

Item: VBFS321F VBFS364F  
 VBFS361F VBNFS361F  
 VBFS322F VBNFS362F  
 VBFS362F VBNFS363F  
 VBFS363F VBNFS364F

Flange Mounted Disconnect Switch

## Installation Instructions

	<p><b>⚠ Danger</b>                  Hazardous Voltage.                  Will cause death or serious injury.</p>	<p><b>⚠ Peligro</b>                  Tensión peligrosa.                  Puede causar la muerte o lesiones graves.</p>	<p><b>⚠ Danger</b>                  Tension dangereuse.                  Danger de mort ou risque de blessures graves.</p>
	<p>Turn off and lock out all power supplying this device before working on this device.                  Replace all covers before power supplying this device is turned on.</p>	<p>Desenergice totalmente antes de instalar o darle servicio.                  Reemplace todas las barreras y cubiertas antes de energizar el interruptor.</p>	<p>Couper l'alimentation de l'appareil et barrer avant de travailler.                  Remplacez tous les couverts avant que l'approvisionnement de pouvoir soit alimenté.</p>

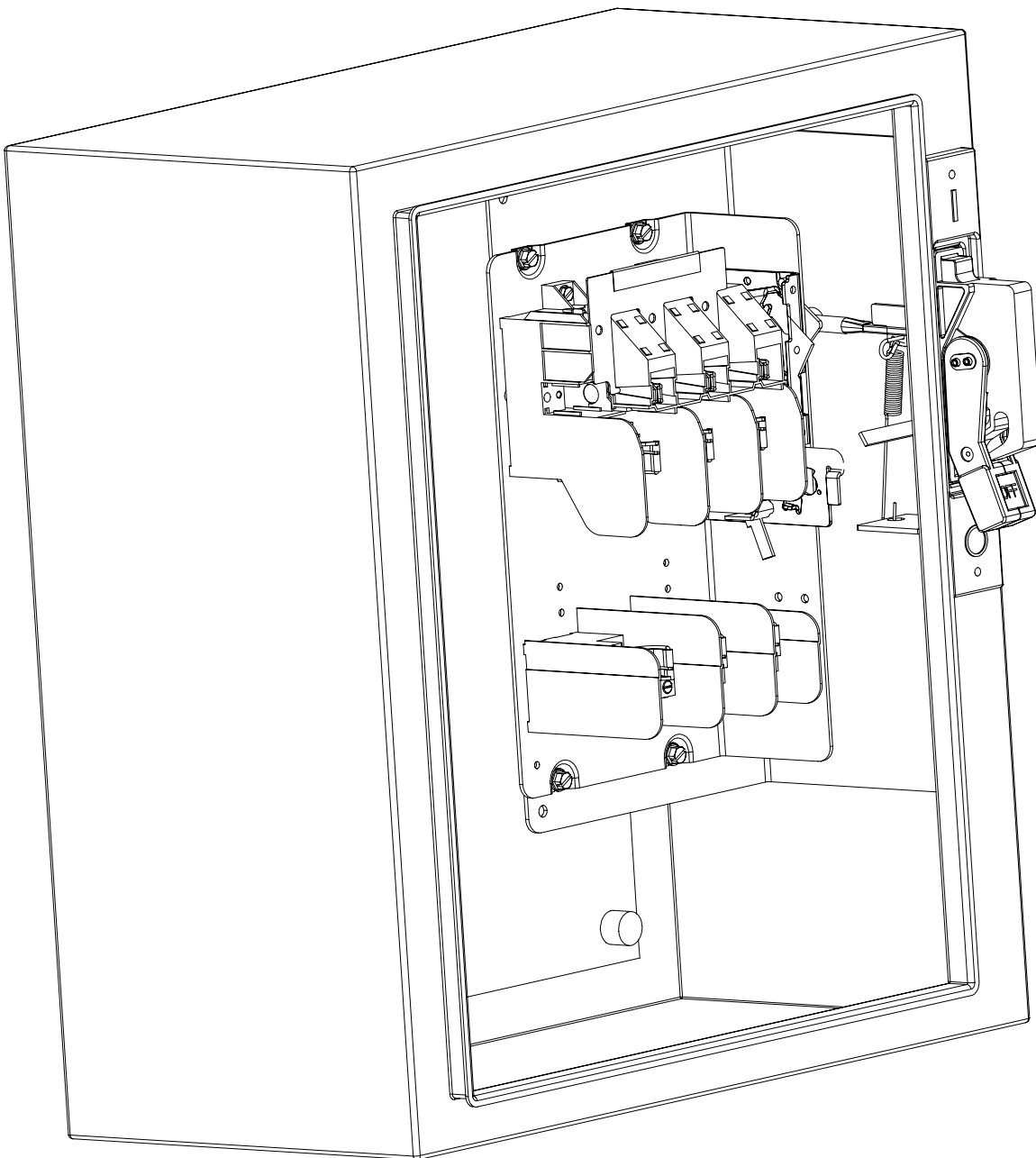

	<p><b>⚠ Danger</b></p>	<p><b>⚠ Peligro</b></p>	<p><b>⚠ Danger</b></p>
	<p><b>Hazardous Voltage.</b> Will cause death or serious injury. Turn off and lock out all power supplying this device before working on this device. Replace all covers before power supplying this device is turned on.</p>	<p><b>Tensión peligrosa.</b> Puede causar la muerte o lesiones graves. Desenergice totalmente antes de instalar o darle servicio. Reemplace todas las barreras y cubiertas antes de energizar el interruptor.</p>	<p><b>Tension dangereuse.</b> Danger de mort ou risque de blessures graves. Couper l'alimentation de l'appareil et barrer avant de travailler. Remplacez tous les couverts avant que l'approvisionnement de pouvoir soit alimenté.</p>

## Part Index

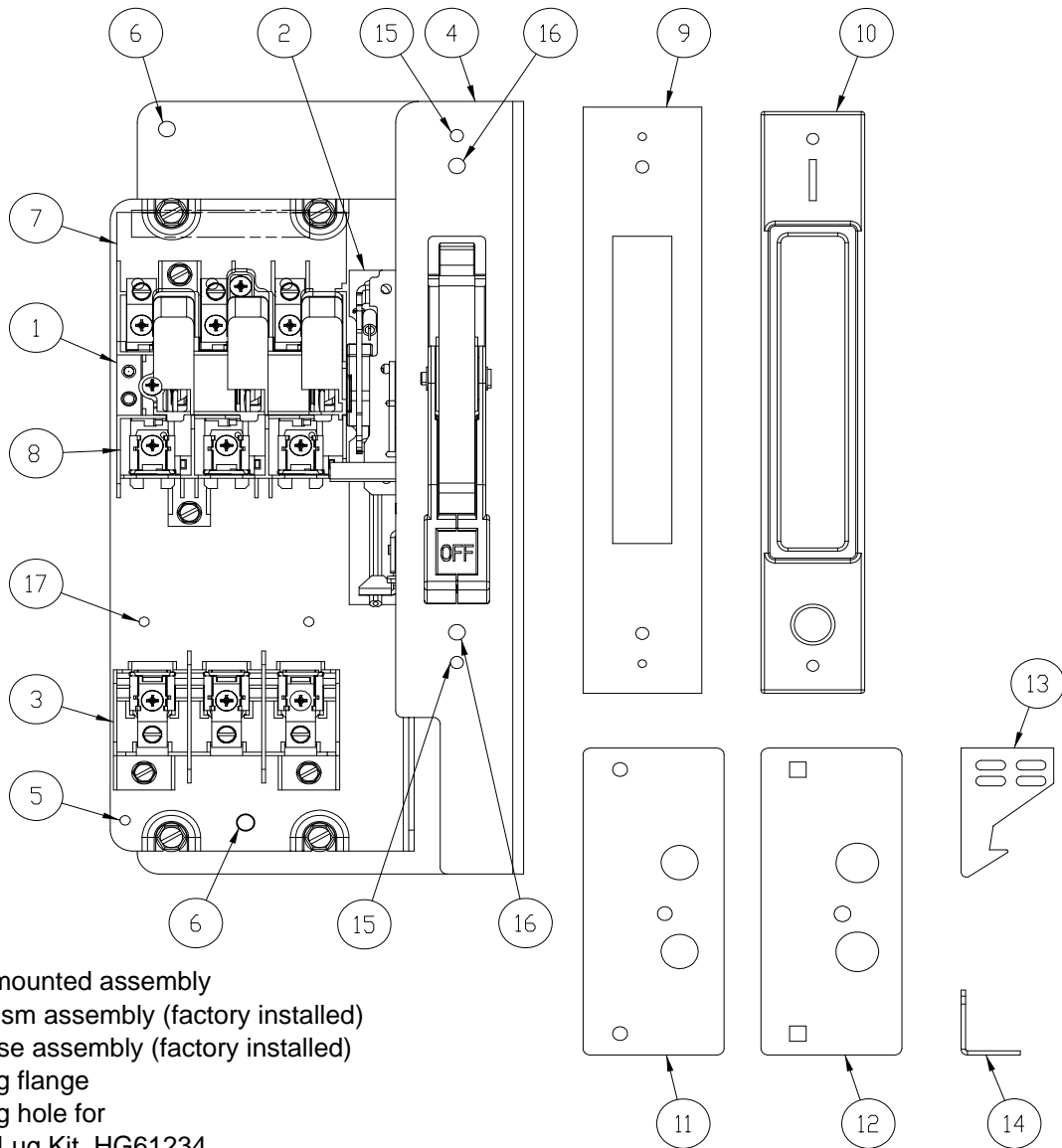

- 1) Flange mounted assembly
- 2) Mechanism assembly (factory installed)
- 3) Load base assembly (factory installed)
- 4) Mounting flange
- 5) Mounting hole for  
Ground Lug Kit, HG61234
- 6) Support mounting hole
- 7) Clear line shield (factory installed)
- 8) Line base assembly (factory installed)
- 9) Handle gasket, required for NEMA Type 12
- 10) Handle cover plate
- 11) Door handle gasket, required for Hoffman A-xxAB enclosures  
or Rittal E-xxAB enclosures
- 12) Door handle plate, required for Hoffman A-xxAB enclosures  
or Rittal E-xxAB enclosures
- 13) Cover interlock
- 14) Cover interlock mounting bracket
- 15) Handle cover plate mounting hole
- 16) Flange mounting hole
- 17) Load base mounting holes, Class "J" fuse

## Hardware Part Index

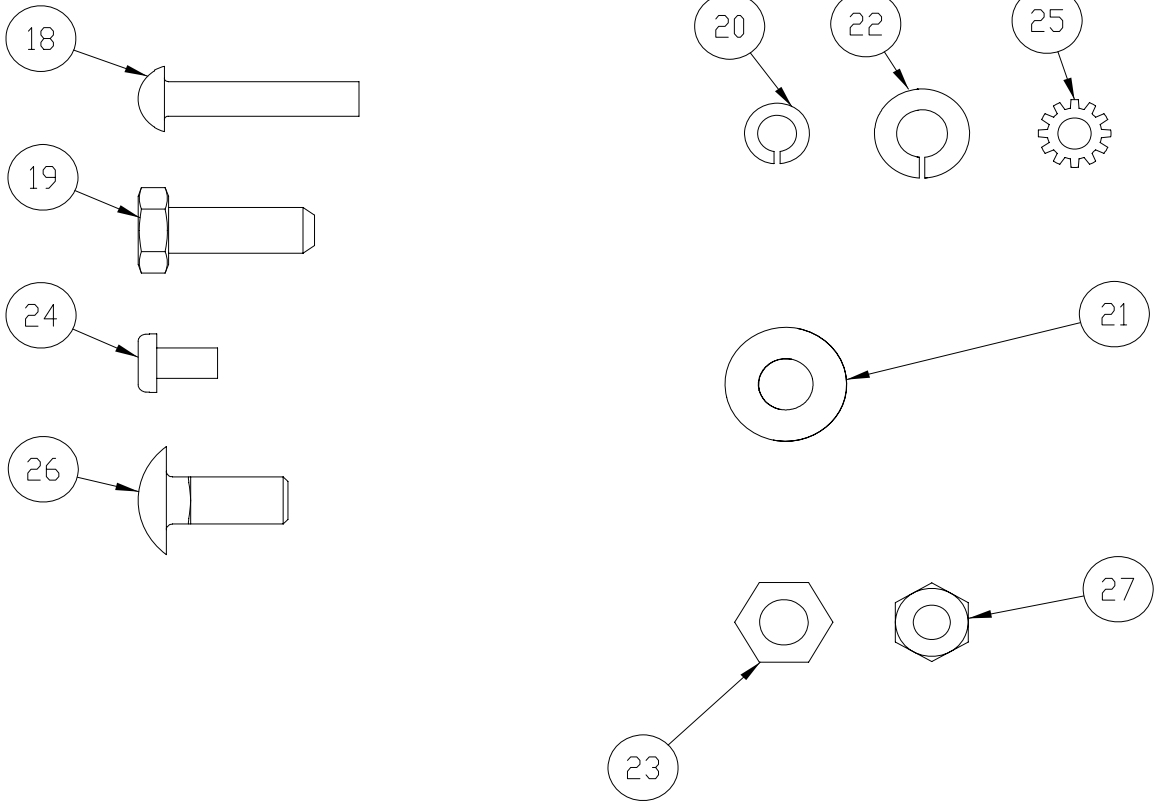

- 18) Machine screws, (2) 10-32 x 1", Handle cover plate
- 19) Machine screws, (2) 1/4-20 x 3/4", Flange mounting
- 20) Lock washers, (2) #10, Handle cover plate
- 21) Flat washers, (6) 1/4", Flange mounting, Door handle plate
- 22) Lock washers, (4) 1/4", Flange mounting, Door handle plate
- 23) Nut, (4) 1/4-20, Flange mounting, Door handle plate
- 24) Machine screws, (2) #8-32 X 5/16 pan head, Cover interlock
- 25) Lockwasher, external tooth, (2) #8, Cover interlock
- 26) Bolt, (2) 1/4-20 X 5/8, round head short square neck, Door handle plate
- 27) Nut, (2) 10-32, Handle cover plate



**Danger**

**Hazardous Voltage.**  
Will cause death or serious injury.  
Turn off and lock out all power supplying this device before working on this device.  
Replace all covers before power supplying this device is turned on.

**Peligro**

**Tensión peligrosa.**  
Puede causar la muerte o lesiones graves.  
Desenergice totalmente antes de instalar o darle servicio.  
Reemplace todas las barreras y cubiertas antes de energizar el interruptor.

**Danger**

**Tension dangereuse.**  
Danger de mort ou risque de blessures graves.  
Couper l'alimentation de l'appareil et barrer avant de travailler.  
Remplacez tous les couverts avant que l'approvisionnement de pouvoir soit alimenté.

**Minimum Enclosure Size**

CATALOG NO.	AMPERAGE	DESCRIPTION	LENGTH	WIDTH	DEPTH
VBFS321F	30	FUSIBLE	14.25	7.00	6.94
VBNFS361F	30	NON-FUSIBLE	11.78	7.00	6.94
VBFS322F	60	FUSIBLE	16.30	9.05	6.94
VBNFS362F	60	NON-FUSIBLE	16.30	9.05	6.94
VBFS363F	100	FUSIBLE	22.00	9.53	6.94
VBNFS363F	100	NON-FUSIBLE	22.00	9.53	6.94
VBFS364F	200	FUSIBLE	30.00	14.50	7.70
VBNFS364F	200	NON-FUSIBLE	30.00	14.50	7.70

**Minimum Wire Bend\***

CATALOG NO.	AMPERAGE	DESCRIPTION	WIRE	TOP	BOTTOM	SIDE
VBFS321F	30	FUSIBLE	14-6	2.00	2.00	1.50
VBNFS361F	30	NON-FUSIBLE	14-6	2.00	2.00	1.50
VBFS322F	60	FUSIBLE	14-2	3.50	3.50	2.50
VBNFS362F	60	NON-FUSIBLE	14-2	3.50	3.50	2.50
VBFS363F	100	FUSIBLE	14-1/0	5.50	5.50	3.50
VBNFS363F	100	NON-FUSIBLE	14-1/0	5.50	5.50	3.50
VBFS364F	200	FUSIBLE	6-300	7.00	7.00	5.00
VBNFS364F	200	NON-FUSIBLE	6-300	7.00	7.00	5.00

\* See NEC for additional requirements.

(All dimensions are in inches)

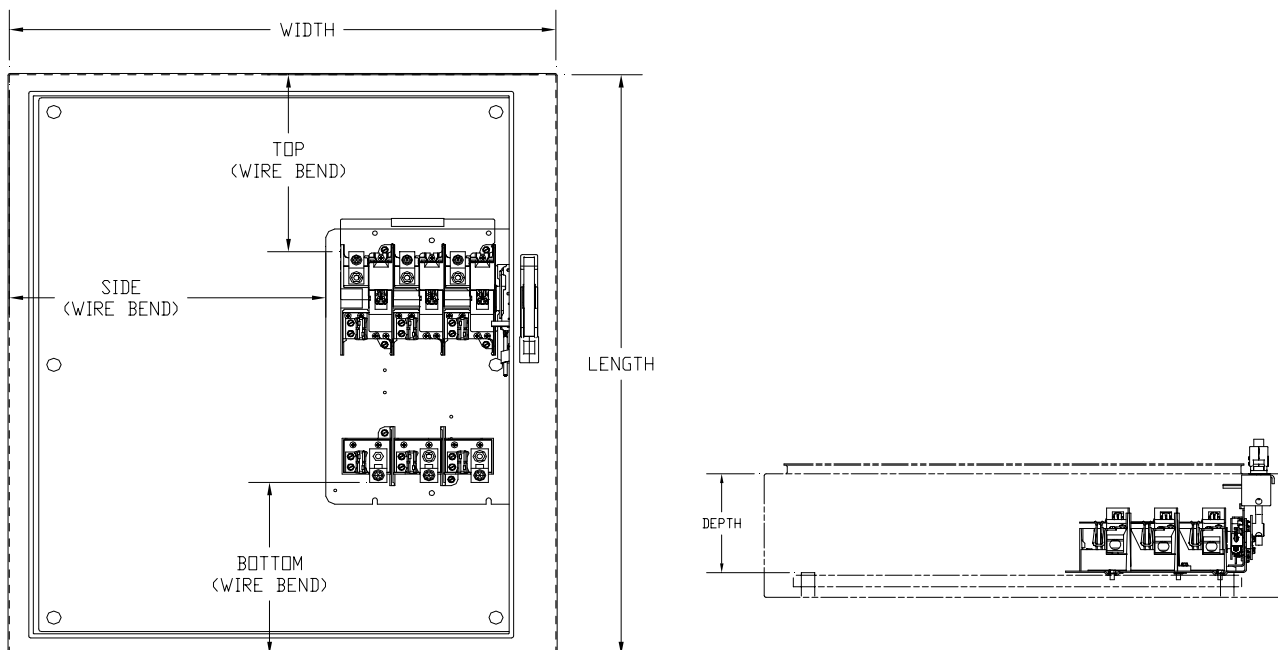

**Mounting and Handle  
Cut-out Dimensions:**

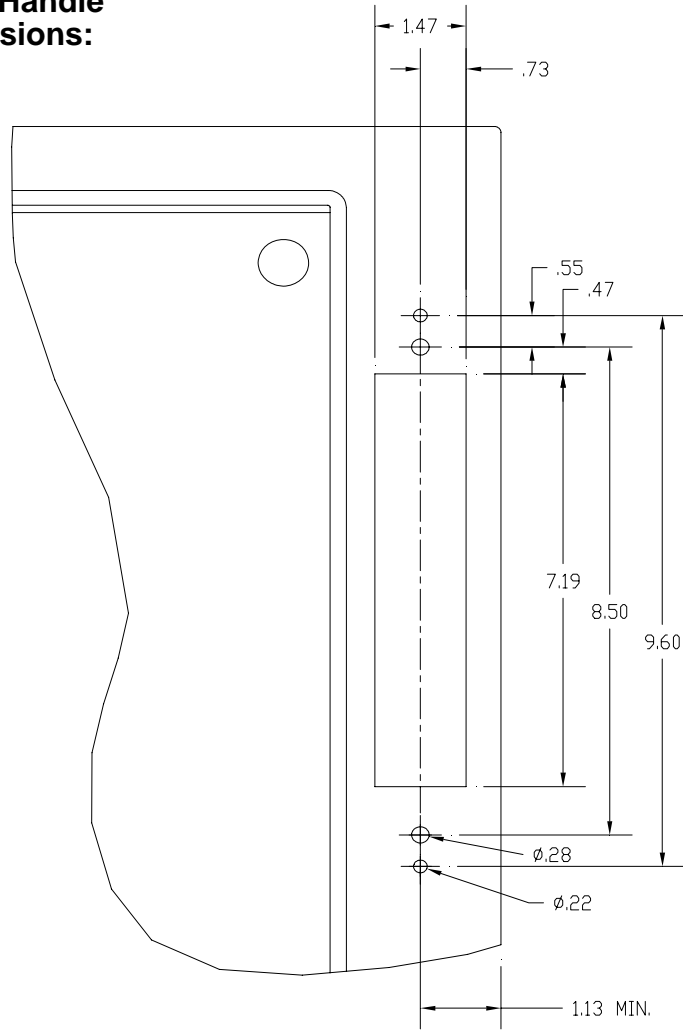

**Optional enclosure cut-outs.**

Handle must be removed during installation to use the cut-outs below.

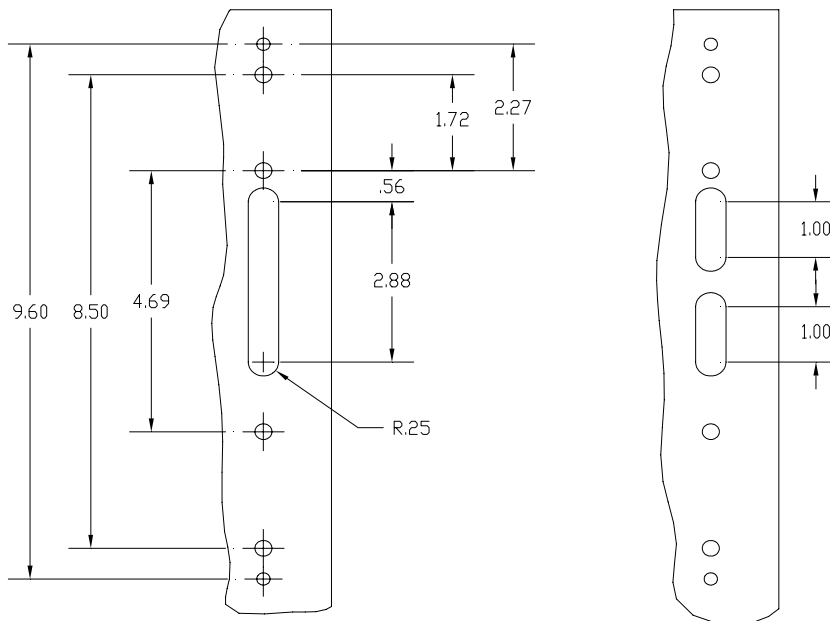

(All dimensions are in inches)

	<p><b>⚠ Danger</b></p>	<p><b>⚠ Peligro</b></p>	<p><b>⚠ Danger</b></p>
	<p><b>Hazardous Voltage.</b>  <b>Will cause death or serious injury.</b>          Turn off and lock out all power supplying this device before working on this device.          Replace all covers before power supplying this device is turned on.</p>	<p><b>Tensión peligrosa.</b>  <b>Puede causar la muerte o lesiones graves.</b>          Desenergice totalmente antes de instalar o darle servicio.          Reemplace todas las barreras y cubiertas antes de energizar el interruptor.</p>	<p><b>Tension dangereuse.</b>  <b>Danger de mort ou risque de blessures graves.</b>          Couper l'alimentation de l'appareil et barrer avant de travailler.          Remplacez tous les couverts avant que l'approvisionnement de pouvoir soit alimenté.</p>

**Gasket installation:**

(Required for Type 12 enclosures only)

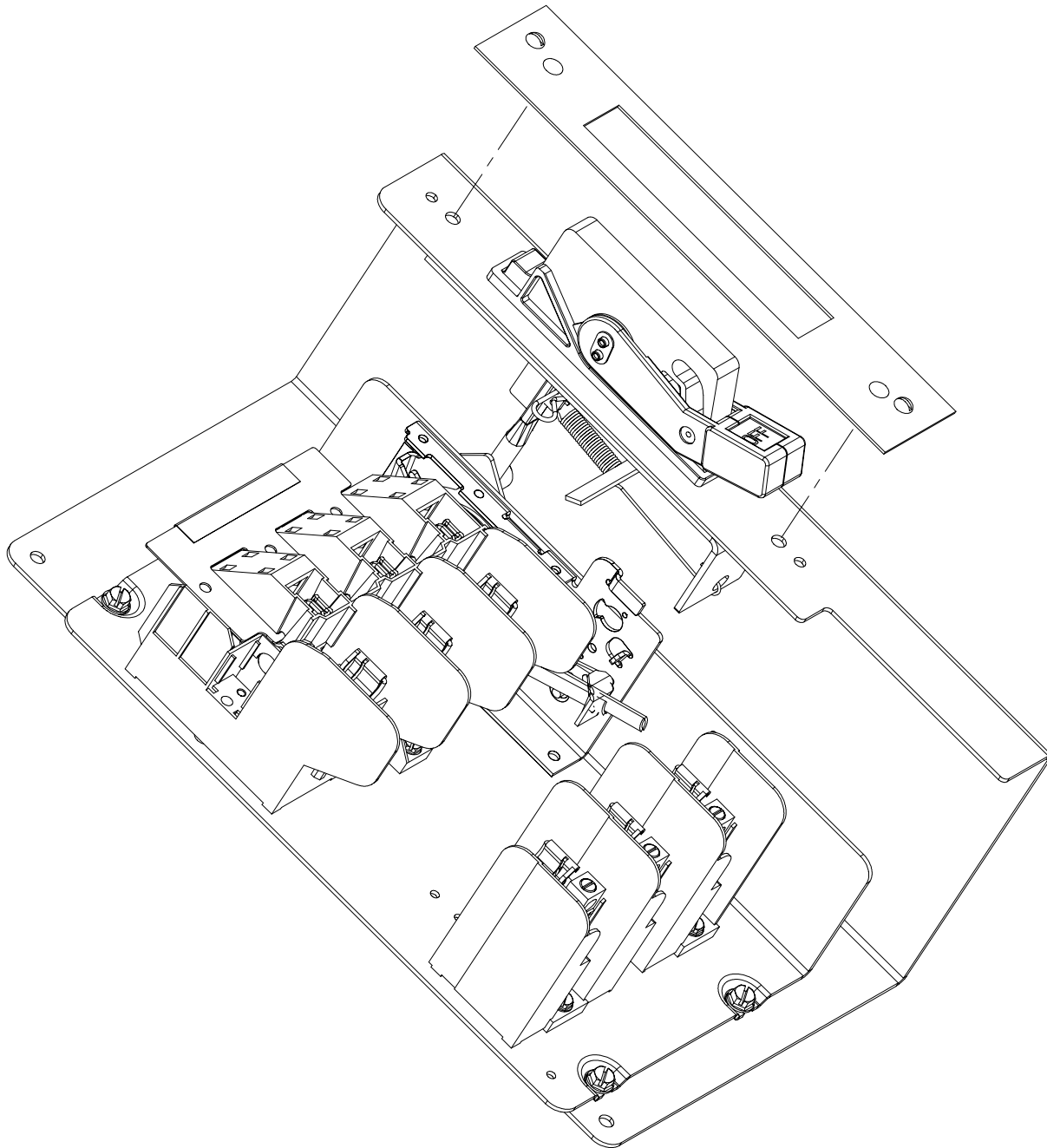

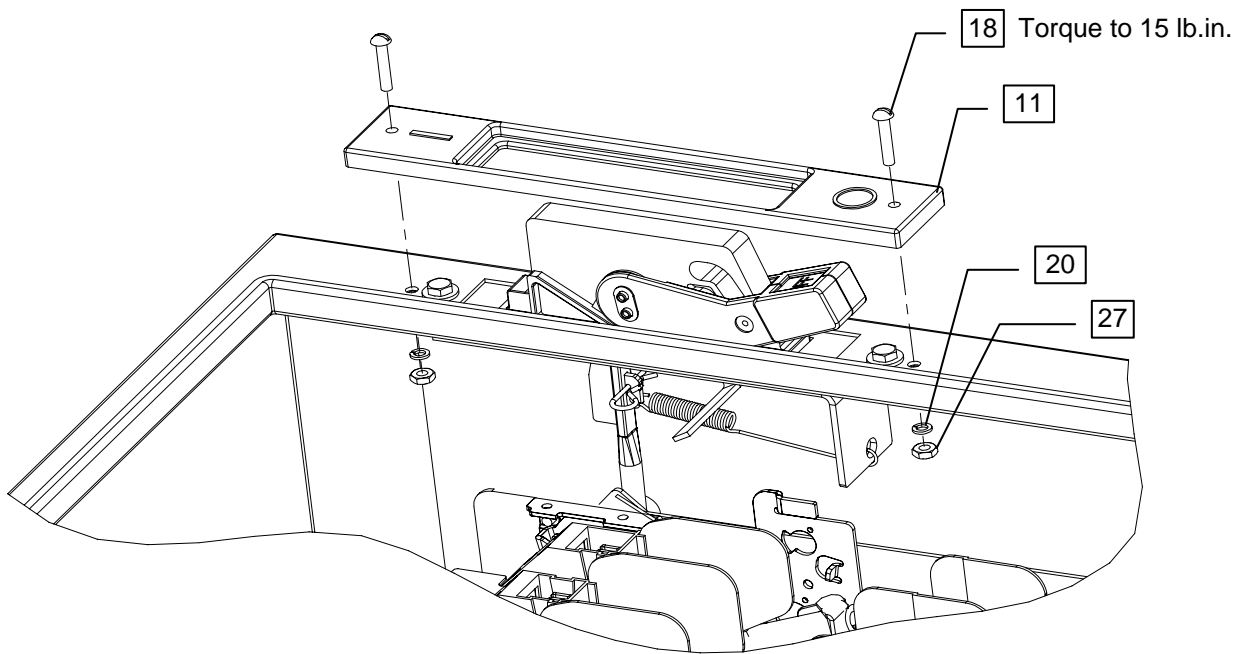
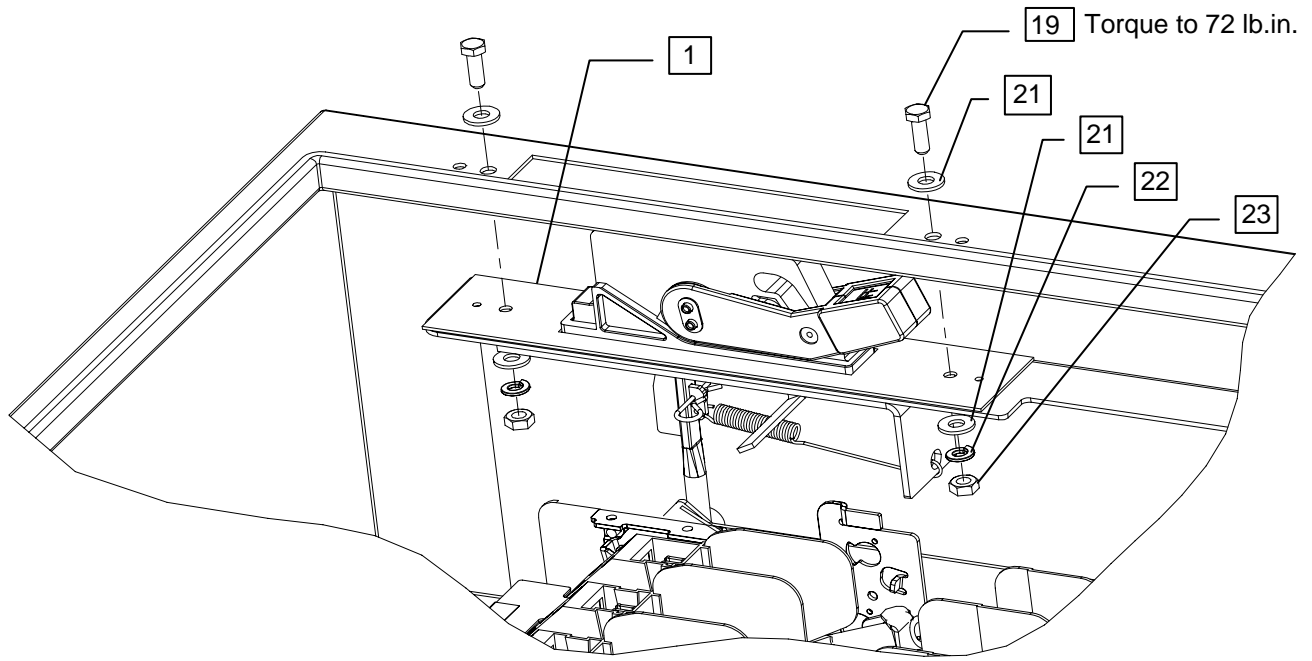

	<p><b>Danger</b></p> <p>Hazardous Voltage. Will cause death or serious injury.</p>	<p><b>Peligro</b></p> <p>Tensión peligrosa. Puede causar la muerte o lesiones graves.</p>	<p><b>Danger</b></p> <p>Tension dangereuse. Danger de mort ou risque de blessures graves.</p>
	<p>Turn off and lock out all power supplying this device before working on this device. Replace all covers before power supplying this device is turned on.</p>	<p>Desenergice totalmente antes de instalar o darle servicio. Reemplace todas las barreras y cubiertas antes de energizar el interruptor.</p>	<p>Couper l'alimentation de l'appareil et barrer avant de travailler. Remplacez tous les couverts avant que l'alprovisionnement de pouvoir soit alimenté.</p>

When installing Siemens door kits DKR2 or DKR3 on Hoffman enclosure series A-xxAB or Rittal enclosure series E xxAB, follow instructions supplied with door handle kit except where indicated

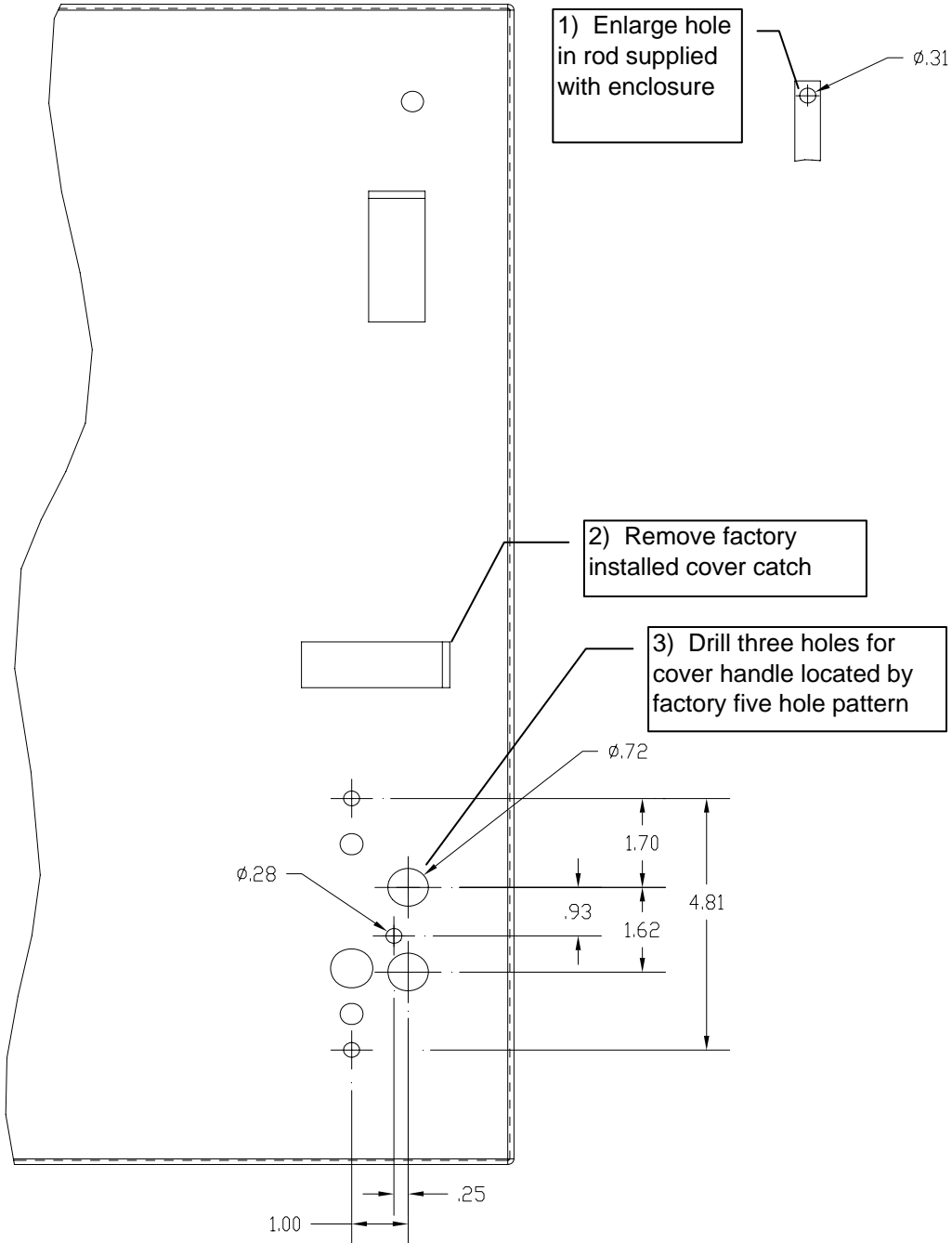



When installing Siemens door kits DKR2 or DKR3 on Hoffman enclosure series A-xxAB or Rittal enclosure series E xxAB, follow instructions supplied with door handle kit except where indicated below:

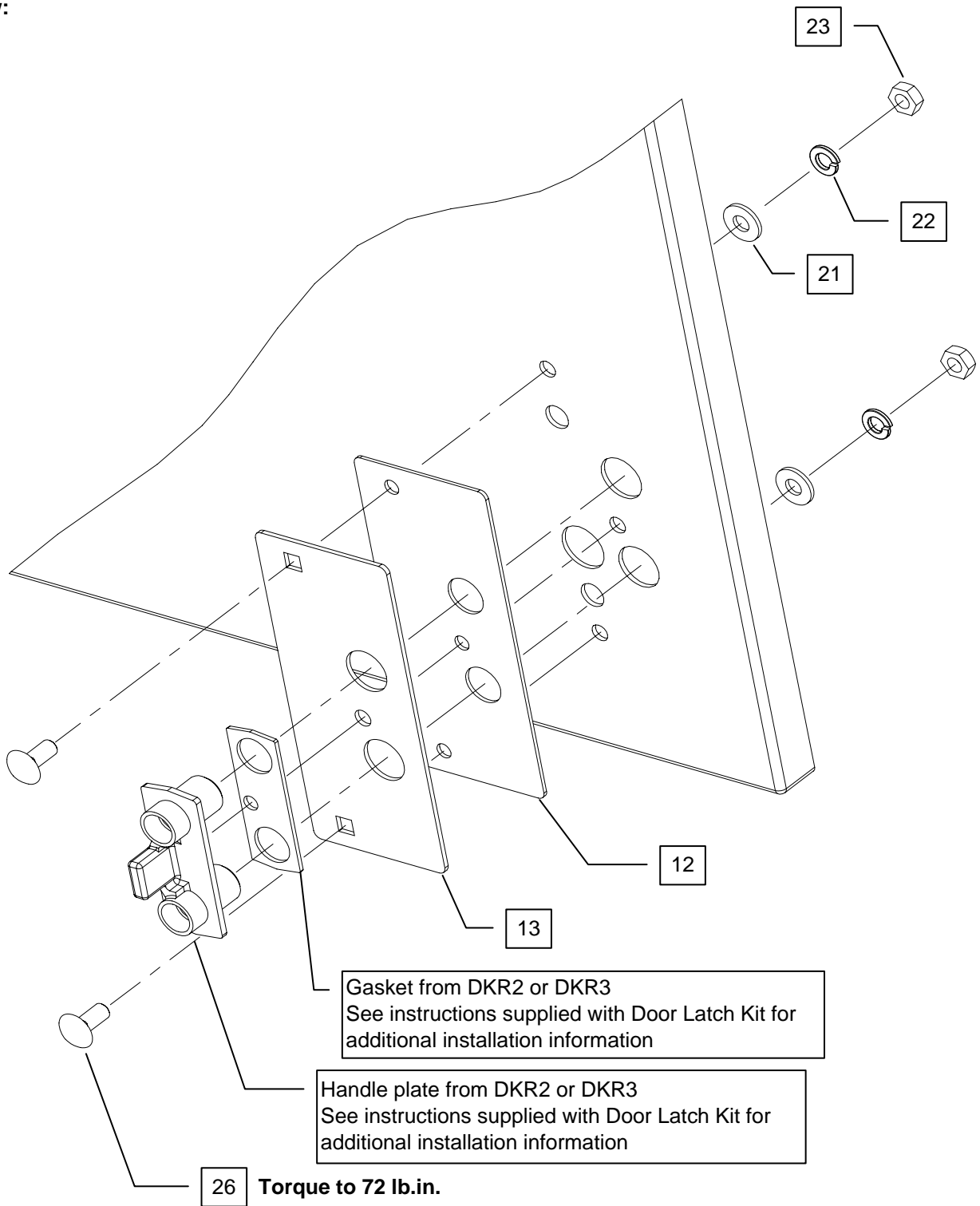

	<p><b>⚠ Danger</b>  <b>Hazardous Voltage.</b>  <b>Will cause death or serious injury.</b></p>	<p><b>⚠ Peligro</b>  <b>Tensión peligrosa.</b>  <b>Puede causar la muerte o lesiones graves.</b></p>	<p><b>⚠ Danger</b>  <b>Tension dangereuse.</b>  <b>Danger de mort ou risque de blessures graves.</b></p>
	<p>Turn off and lock out all power supplying this device before working on this device.          Replace all covers before power supplying this device is turned on.</p>	<p>Desenergice totalmente antes de instalar o darle servicio.          Reemplace todas las barreras y cubiertas antes de energizar el interruptor.</p>	<p>Couper l'alimentation de l'appareil et barrer avant de travailler.          Remplacez tous les couverts avant que l'approvisionnement de pouvoir soit alimenté.</p>

**Installation of Cover Catch**  
**Step 1 - Installation of Cover Catch Mounting Bracket**

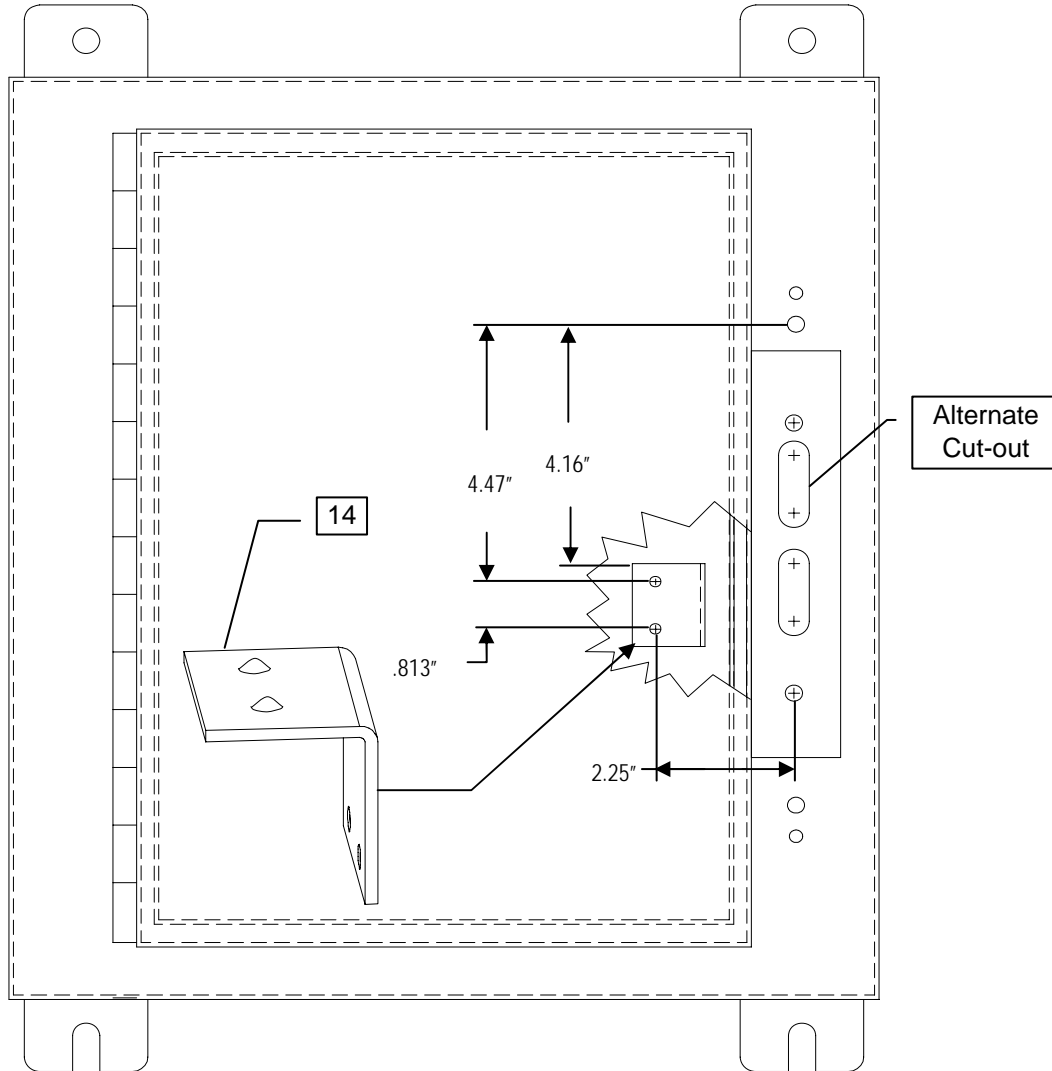

**Dimensions for Welded or Screw mounting the cover catch**

Option:

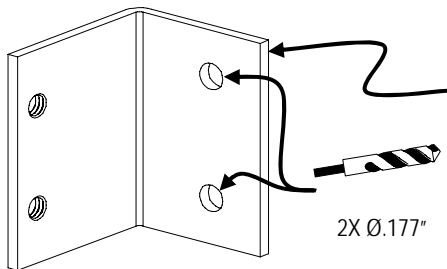

Customer supplied hardware for screw mounting option. Hardware must maintain environmental integrity (NEMA rating) of the enclosure.

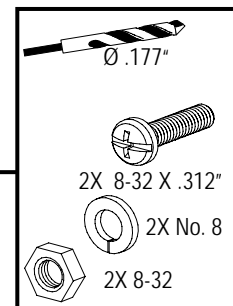

**Installation of Cover Catch**  
**Step 2 - Installation of Cover Catch**

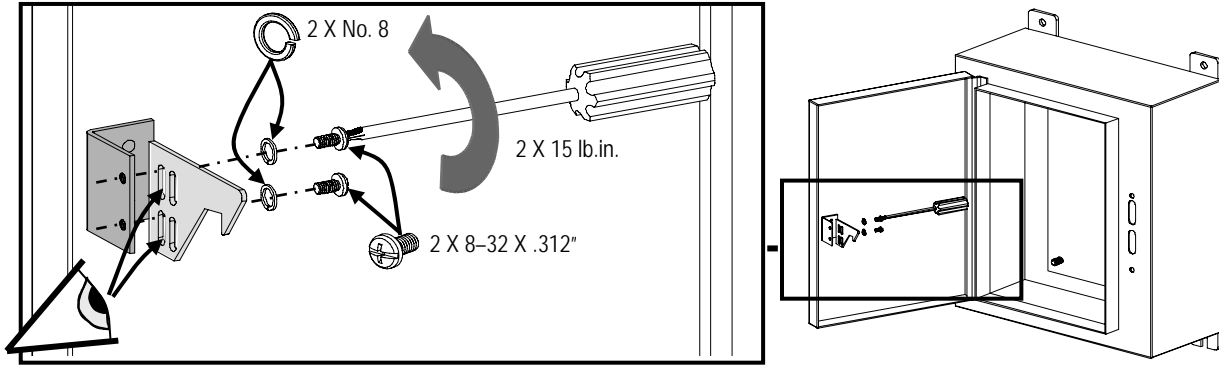

**Step 3 - Verify operation of cover catch ( Switch ON )**

		<b>Result</b>		<b>Go To</b>
<p>OFF / O  ON / I</p>	<p>Cover should remain closed with switch in ON position, 5 lbf max.</p>	 Open	 Closed	
				Step 4

**Step 4 - Adjust Cover Catch Down**

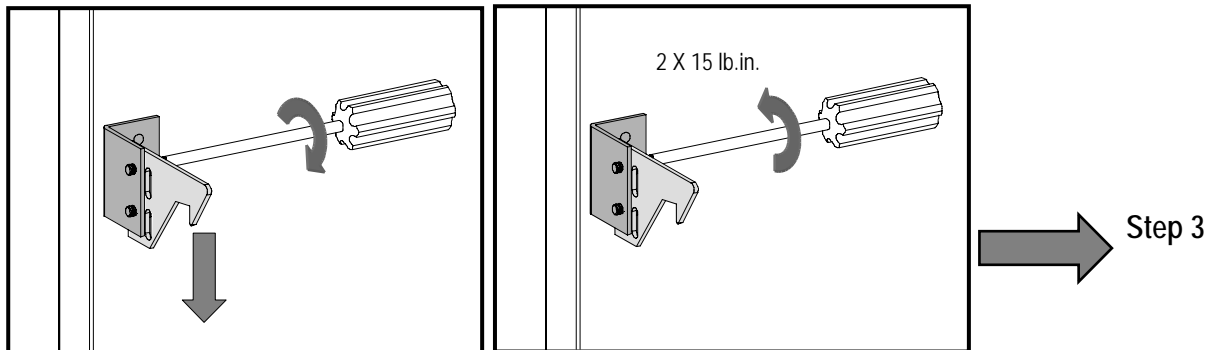

	<p><b>⚠ Danger</b>  <b>Hazardous Voltage.</b>  <b>Will cause death or serious injury.</b></p>	<p><b>⚠ Peligro</b>  <b>Tensión peligrosa.</b>  <b>Puede causar la muerte o lesiones graves.</b></p>	<p><b>⚠ Danger</b>  <b>Tension dangereuse.</b>  <b>Danger de mort ou risque de blessures graves.</b></p>
	<p>Turn off and lock out all power supplying this device before working on this device.          Replace all covers before power supplying this device is turned on.</p>	<p>Desenergice totalmente antes de instalar o darle servicio.          Reemplace todas las barreras y cubiertas antes de energizar el interruptor.</p>	<p>Couper l'alimentation de l'appareil et barrer avant de travailler.          Remplacez tous les couverts avant que l'approvisionnement de pouvoir soit alimenté.</p>

**Step 5 - Verify operation of cover catch ( Switch OFF )**

		<b>Result</b>		<b>Go To</b>
		 Open	 Closed	
ON / I  OFF / O	Cover should open with switch in OFF position, 5 lbf max.			<b>Finished / Ready</b>  <b>Step 6</b>

**Step 6 - Adjust Cover Catch Up**

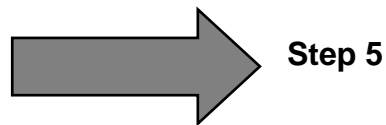
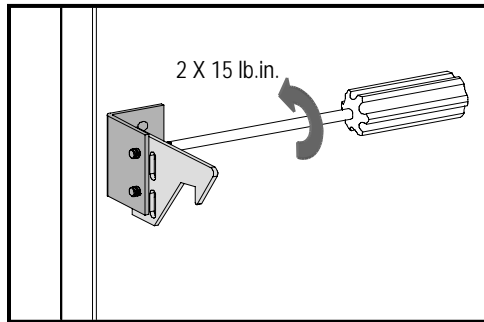
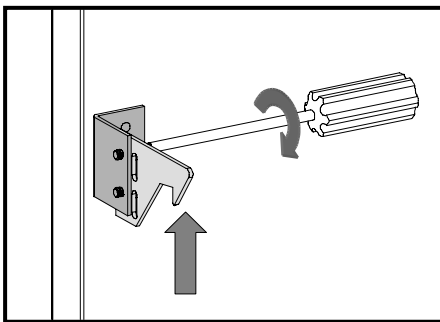
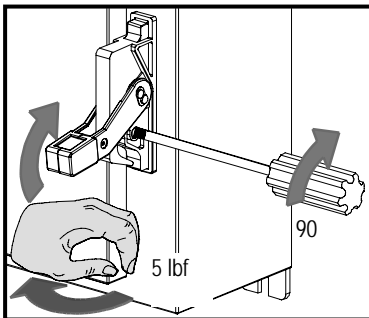

Technical Support: Toll Free: 1-800-241-4453 Internet: <http://www.sea.siemens.com/power>

Subject to change without prior notice  
 © Siemens Energy & Automation Inc. 2006  
 Siemens Energy & Automation Inc. , Bellefontaine, Ohio 43311 U.S.A.