

Installation Instructions / Instructivo de Instalación / Instructions d'installation

 <b>Danger</b>	 <b>Peligro</b>	 <b>Danger</b>
 <p><b>Hazardous Voltage</b> Will cause death or serious injury Turn off and lock out all power supplying this equipment before working on this device. Replace all covers before power supplying this device is turned on.</p>	<p><b>Tensión peligrosa.</b> Puede causar la muerte o lesiones graves. Desenergice totalmente el equipo antes de instalar o darle servicio. Reemplace todas las barreras y cubiertas antes de energizar el interruptor.</p>	<p><b>Tension dangereuse.</b> Provoquera la mort ou des blessures graves. Mettez hors tension et cadenasser verrouiller l'alimentation avant d'intervenir sur cet appareil. Remettez tous les couvercles en place avant de remettre cet appareil sous tension.</p>

Use only with Siemens certified Components.  
Utilizar únicamente con componentes certificados de Siemens.  
À utiliser uniquement avec les composants certifiées Siemens.



**NOTE** - These instructions do not purport to cover all details or variations in equipment, or to provide for every possible contingency to be met in connection with installation, operation or maintenance. Should further information be desired or should particular problems arise, which are not covered sufficiently for the purchaser's purposes, the matter should be referred to the local Siemens sales office. The contents of this instruction manual shall not become part of or modify any prior or existing agreement, commitment or relationship. The sales contract contains the entire obligation of Siemens. The warranty contained in the contract between the parties is the sole warranty of Siemens. Any statements contained herein do not create new warranties or modify the existing warranty.

**Trademarks** - Unless otherwise noted, all names identified by ® are registered trademarks of Siemens AG or Siemens Industry, Inc. The remaining trademarks in this publication may be trademarks whose use by third parties for their own purposes could violate the rights of the owner.

**NOTA** - Estas instrucciones no pretenden incluir todos los detalles o variaciones de los equipos ni indicar cada posible contingencia que pudiese encontrar en relación con la instalación, el funcionamiento o el mantenimiento. Si desea más información o si surgen problemas en particular, que no estén explicados suficientemente para fines del comprador, el asunto se debe referir a la oficina de ventas local de Siemens. El contenido de este manual de instrucciones no debe formar parte ni modificar una relación, acuerdo o compromiso o previo o existente. El contrato de venta contiene toda la obligación por parte de Siemens. La garantía contenida en el contrato establecido entre las partes es la única garantía de Siemens. Las declaraciones contenidas en el presente documento no crean nuevas garantías ni modifican la que está en vigor.

**Marcas comerciales** - A menos que se indique lo contrario, todos los nombres identificados con ® son marcas comerciales registradas de Siemens AG o Siemens Industry, Inc. Las marcas comerciales restantes que aparecen en esta publicación pueden ser marcas comerciales cuyo uso por parte de terceros para sus propios fines podría violar los derechos del propietario.

**REMARQUE** - Ces instructions ne prétendent pas couvrir tous les détails ou les variations de l'équipement, ni prévoir chaque éventualité pouvant être rencontrée lors de la connexion, l'exploitation ou l'entretien. Si plus d'information est désirée ou si des problèmes particuliers surviennent, qui ne sont pas couverts suffisamment aux fins de l'acheteur, il faut adresser ces questions au bureau local de Siemens. Le contenu de ce manuel d'instruction ne fera pas partie de tout accord, engagement ou relation préalable ou existant et ne le modifiera pas. Le contrat de vente contient l'obligation intégrale de Siemens. La garantie contenue dans le contrat entre les parties est la garantie unique offerte par Siemens. Toute autre déclaration contenue aux présentes ne crée pas de nouvelles garanties et ne modifie pas la garantie existante.

**Marques de commerce** – Sauf indication contraire, tous les noms identifiés par MD sont des marques déposées de Siemens AG ou de Siemens Industry, Inc. Les autres marques dans cette publication peuvent être des marques dont l'utilisation par des tiers à leurs propres fins pourrait violer les droits du propriétaire.

	<p><b>Danger</b></p> <p>Hazardous Voltage Will cause death or serious injury</p>	<p><b>Peligro</b></p> <p>Tensión peligrosa. Puede causar la muerte o lesiones graves.</p>	<p><b>Danger</b></p> <p>Tension dangereuse. Provoquera la mort ou des blessures graves.</p>
	<p>Turn off and lock out all power supplying this equipment before working on this device. Replace all covers before power supplying this device is turned on.</p>	<p>Desenergice totalmente el equipo antes de instalar o darle servicio. Reemplace todas las barreras y cubiertas antes de energizar el interruptor.</p>	<p>Mettre hors tension et cadenasser verrouiller l'alimentation avant d'intervenir sur cet appareil. Remettre tous les couvercles en place avant de remettre cet appareil sous tension.</p>

## Installation Instructions

### INTRODUCTION

The PD Frame circuit breaker line includes types SPD6-B and SHPD6-B circuit breaker types. These circuit breakers are listed under UL489 and rated for operating voltages up to 600 VAC, 50/60 Hz. The PD Frame circuit breaker can only be placed into service using the proper connect-all mounting assembly.

### INSTALLATION

The PD Frame circuit breakers (See Fig. 1) are for use in individual enclosures, panelboards, or other approved equipment. The installation procedure consists of inspecting, attaching required accessories, mounting the circuit breaker and connecting and torquing the line and load wire connectors. Mounting hardware and unmounted wire connectors (where required) are available as separate catalog items.

### CIRCUIT BREAKER PREPARATION

- A. Before installing or servicing the breaker, turn off and lock out all power to prevent incidental or accidental contact.
- B. Make sure that the device is suitable for the installation by comparing nameplate ratings with system requirements. Inspect the circuit breaker for completeness and check for any damage before mounting.  
NOTE: Accessory installation should be completed before the circuit breaker is mounted and connected. (See installation instructions supplied with the accessory before proceeding.)
- C. Depress the red trip button (See Fig 4) or turn the breaker off before installation.
- D. Mount circuit breaker onto CONNECT-ALL assembly. Refer to Fig. 2 and 3 for assembly
  1. Remove the load and line terminal shields (D) by loosening the two terminal shield screws (E). Also remove the endplates (J) .
  2. Place breaker onto protruding connect-all terminals and fasten breaker to molded mounting base with four slotted fillister head 3/8-16" x 1-3/4" long screws, washers and lockwashers (G). Tighten mounting screws to a torque of 5 to 6 ft. lbs.
  3. Fasten breaker terminal to connect-all terminals with two hex head 3/8-16" x 1-3/4" long copper alloy bolts, washers and lock washers per terminal. Tighten these bolts to a torque of 9 to 10 ft. lbs.

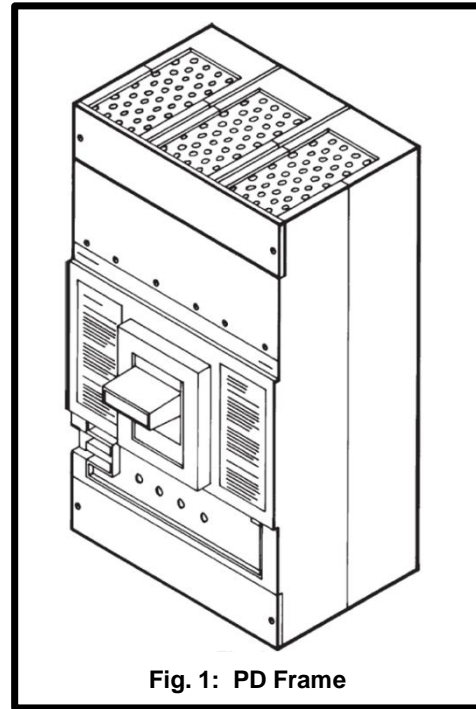

Fig. 1: PD Frame

4. Replace all end plates (J) and line and load terminal shields (D). Tighten terminal shield screws securely.
5. After mounting the device, line and load terminals and accessory terminals should be connected.
6. For escutcheon cut out refer to Fig. 5.

### MANUAL OPERATION

Manual operation of the circuit breaker is controlled by the circuit breaker handle and the PUSH-TO-TRIP button. The circuit breaker handle has three indicating positions, two of which are molded into the handle to indicate ON and OFF. The third position indicates a TRIP position and is between the ON and OFF positions. (See Fig. 4)

- A. Circuit Breaker Reset  
After tripping, the circuit breaker is reset by moving the circuit breaker handle to the reset position and then moving the handle to the ON position.
- B. The PUSH-TO-TRIP Button  
The PUSH-TO-TRIP button checks the tripping function and is used to manually exercise the tripping mechanism.

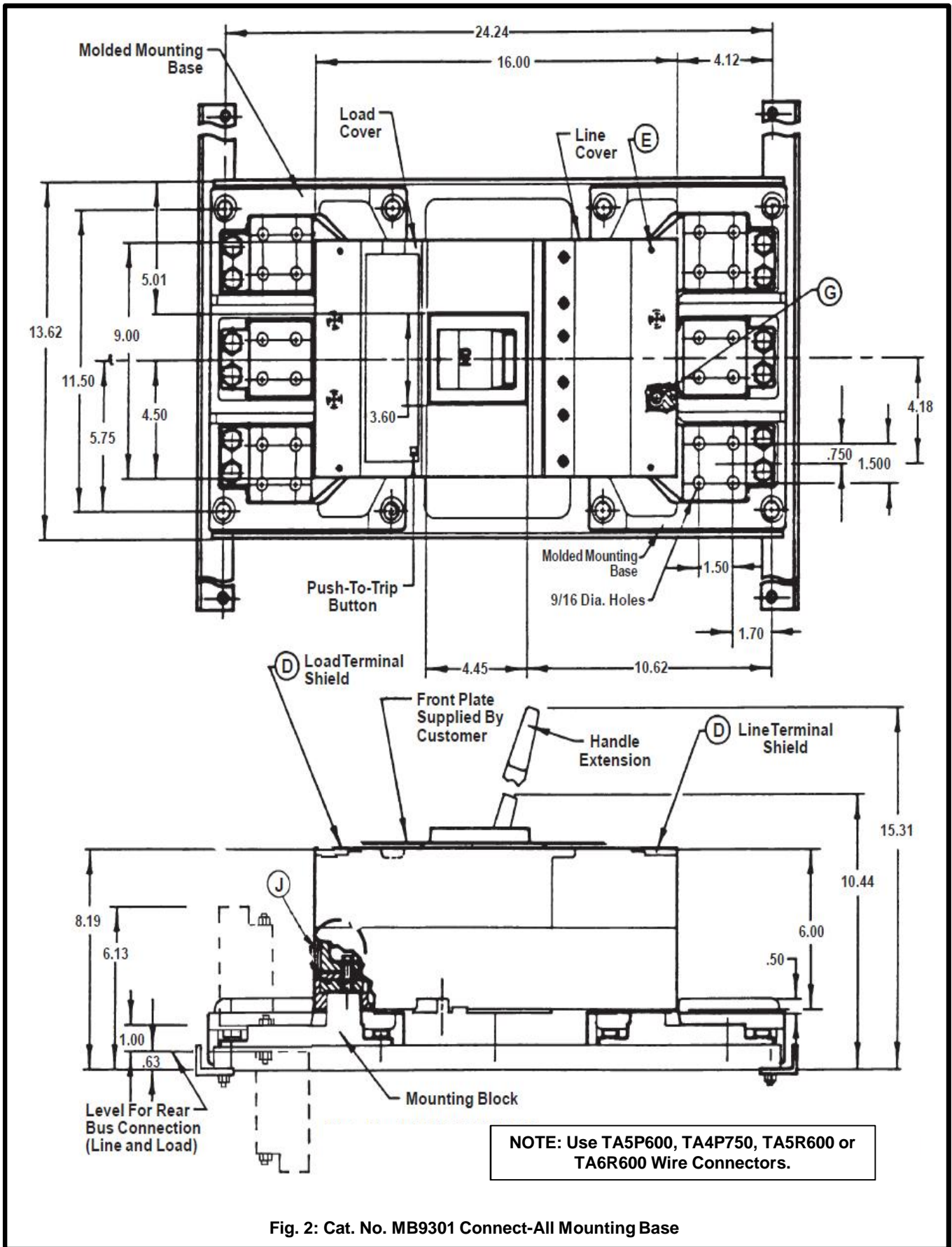

Fig. 2: Cat. No. MB9301 Connect-All Mounting Base



**⚠ Danger**

Hazardous Voltage  
Will cause death or serious injury  
Turn off and lock out all power supplying this equipment before working on this device.  
Replace all covers before power supplying this device is turned on.

**⚠ Peligro**

Tensión peligrosa.  
Puede causar la muerte o lesiones graves.  
Desenergice totalmente el equipo antes de instalar o darle servicio.  
Reemplace todas las barreras y cubiertas antes de energizar el interruptor.

**⚠ Danger**

Tension dangereuse.  
Provoquera la mort ou des blessures graves.  
Mettre hors tension et cadenasser verrouiller l'alimentation avant d'intervenir sur cet appareil.  
Remettre tous les couvercles en place avant de remettre cet appareil sous tension.

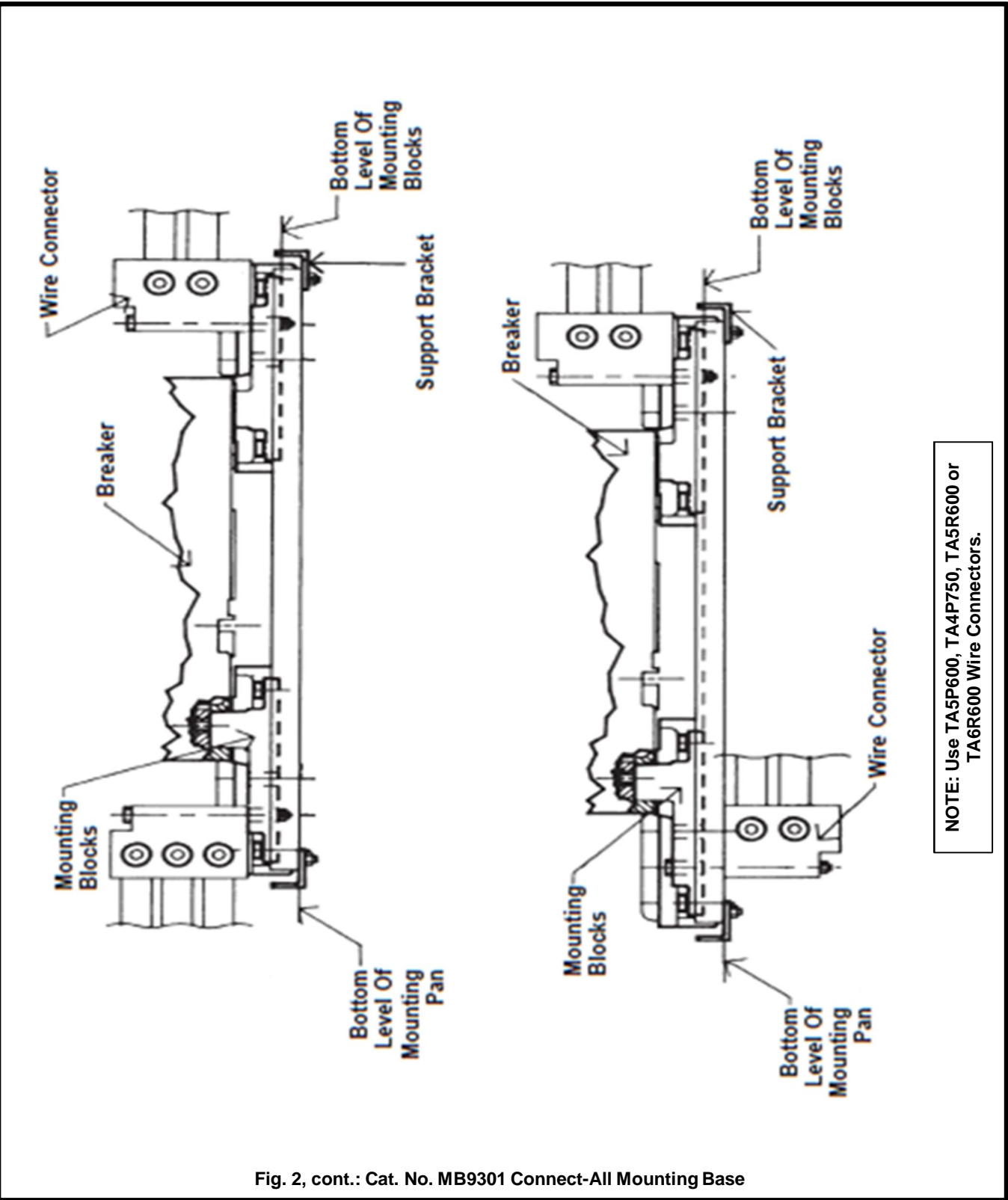

NOTE: Use TA5P600, TA4P750, TA5R600 or TA6R600 Wire Connectors.

Fig. 2, cont.: Cat. No. MB9301 Connect-All Mounting Base

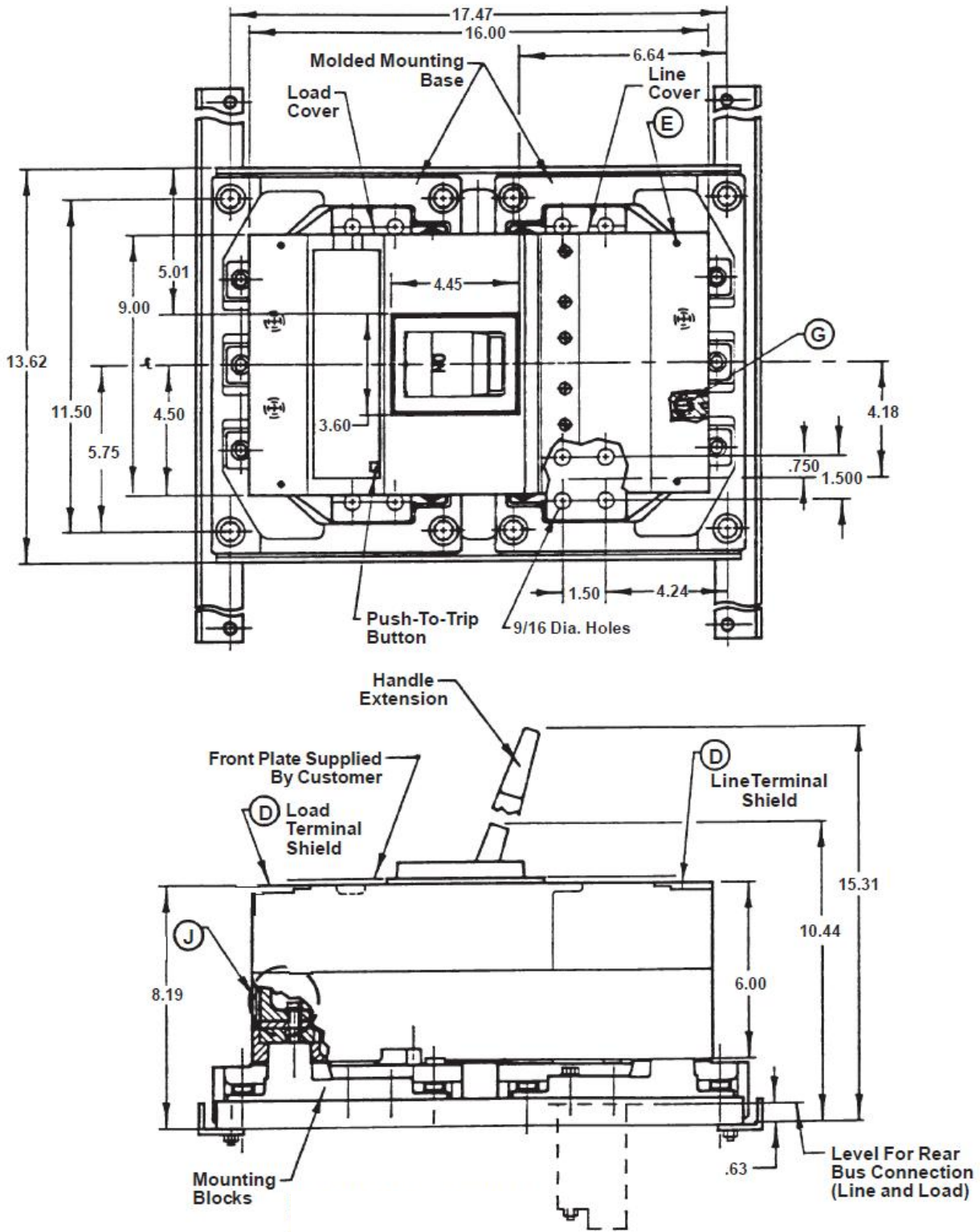

**NOTE: Use TA5P600, TA4P750, TA5R600 or TA6R600 Wire Connectors.**

**Fig. 3: Cat. No. MBR9302 Connect-All Mounting Base**



**⚠ Danger**

Hazardous Voltage  
Will cause death or serious injury  
Turn off and lock out all power supplying this equipment before working on this device.  
Replace all covers before power supplying this device is turned on.

**⚠ Peligro**

Tensión peligrosa.  
Puede causar la muerte o lesiones graves.  
Desenergice totalmente el equipo antes de instalar o darle servicio.  
Reemplace todas las barreras y cubiertas antes de energizar el interruptor.

**⚠ Danger**

Tension dangereuse.  
Provoquera la mort ou des blessures graves.  
Mettre hors tension et cadenasser verrouiller l'alimentation avant d'intervenir sur cet appareil.  
Remettre tous les couvercles en place avant de remettre cet appareil sous tension.

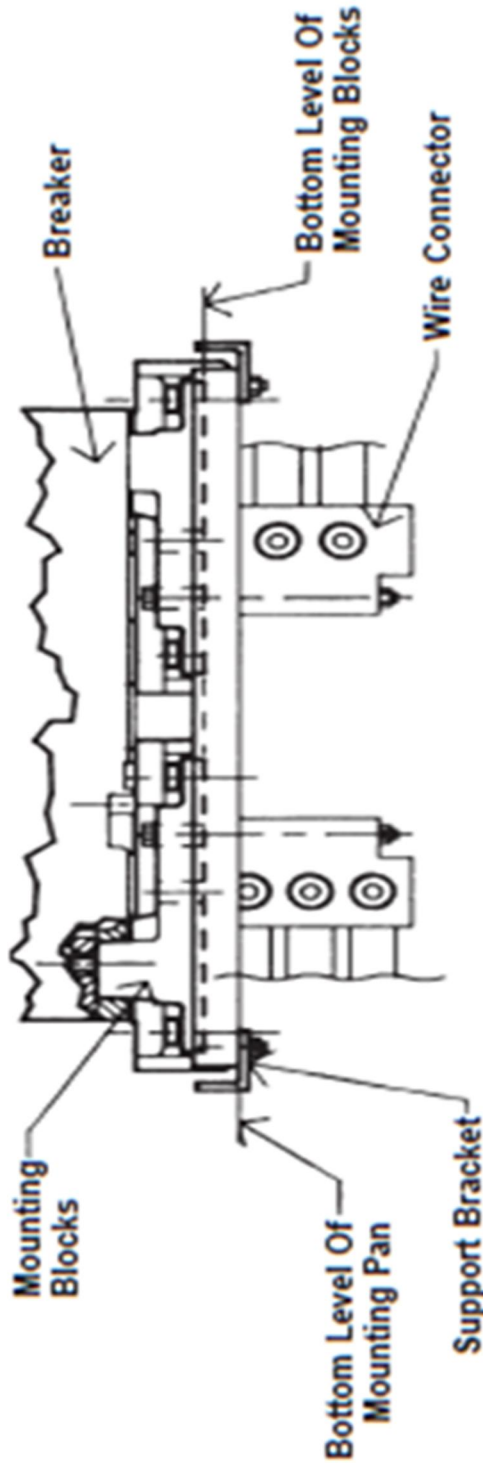

NOTE: Use TA5P600, TA4P750, TA5R600 or TA6R600 Wire Connectors.

Fig. 3, cont.: Cat. No. MBR9302 Connect-All Mounting Base

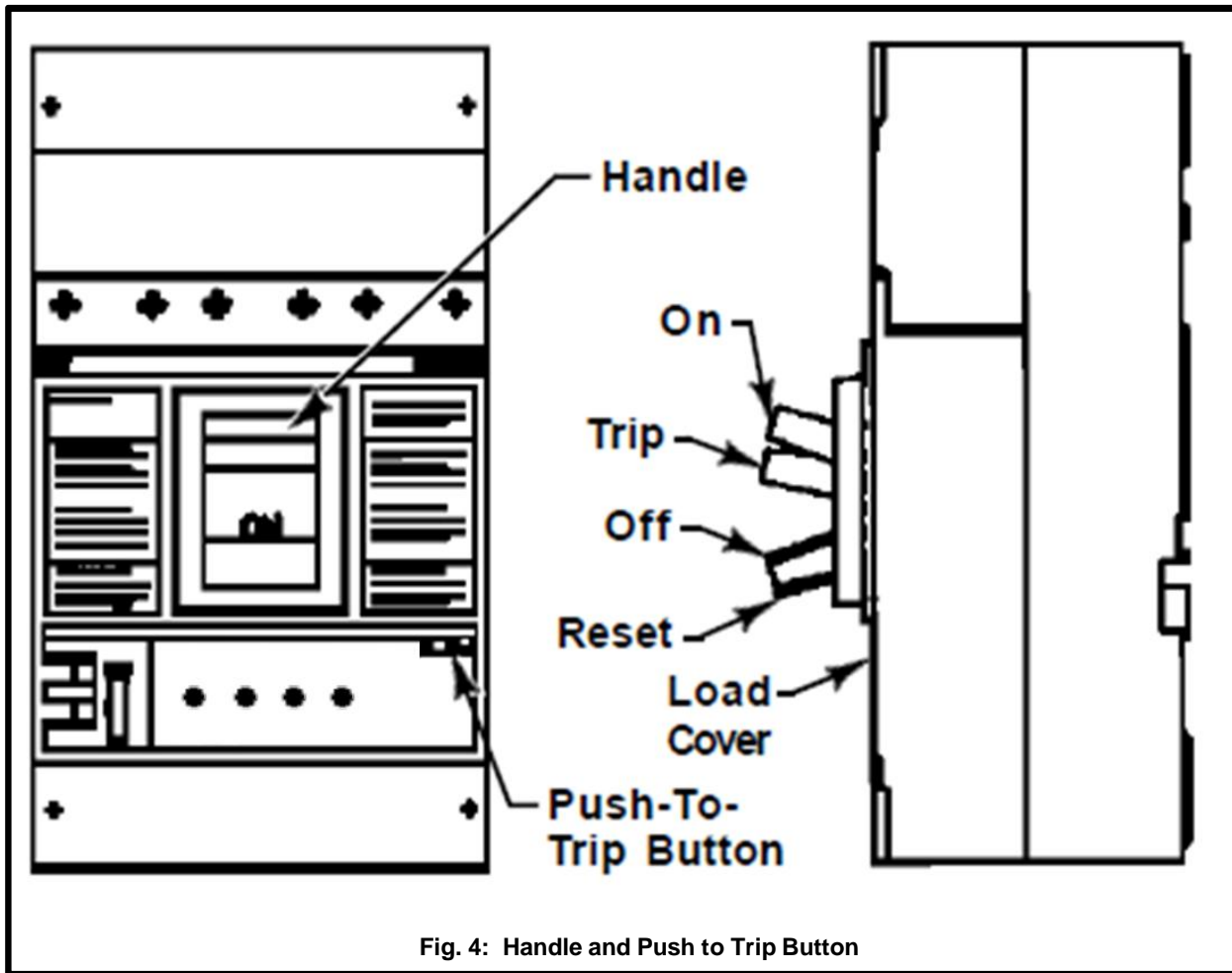

Fig. 4: Handle and Push to Trip Button

### ELECTRONIC OPERATION

All circuit breaker devices have adjustable Continuous Current and Instantaneous Overcurrent protection. Optional features include Short Time Overcurrent and Ground Fault protection.

Breaker functionality is denoted in the catalog number suffixes. There are four types of configurations LI, LSI, LIG and LSIG.

L = Continuous Current ( $I_c$ ) and Long Time Delay ( $t_{ld}$ )

I = Instantaneous Pickup ( $I_i$ )

S = Short Time Pickup ( $I_{sd}$ ) and Short Time Delay ( $t_{sd}$ )

G = Ground Fault Pickup and Ground Fault Delay ( $t_g$ )

The setting dials on the face of the electronic trip unit are rotary switches that must be properly set to mechanical detent (click stop) positions. Dial settings not set to the detent position will cause the setting to be either value between the dial setting and, consequently, may result in unintentional or nuisance tripping. There are ten (10) positions on each rotary switch and the circuit breaker is shipped with all settings in the minimum settings.

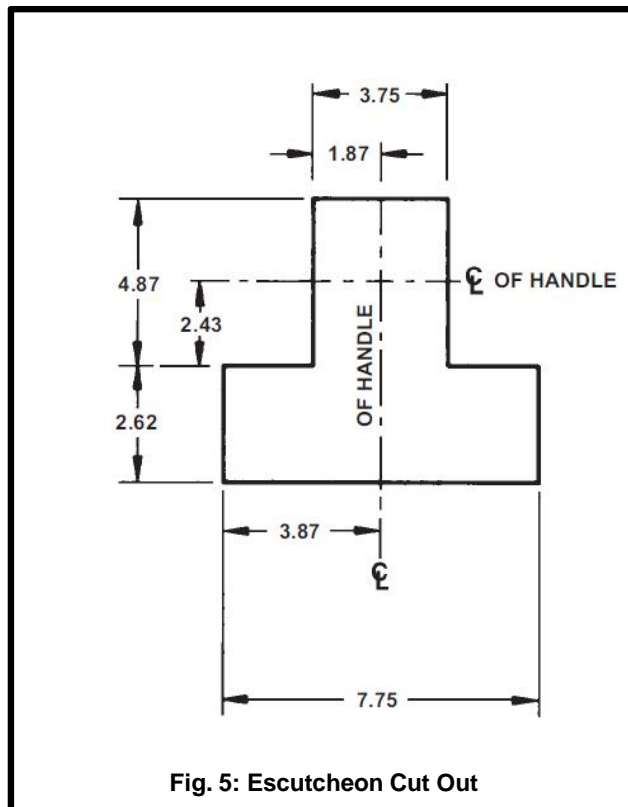

Fig. 5: Escutcheon Cut Out



### Danger

Hazardous Voltage  
Will cause death or serious injury  
Turn off and lock out all power supplying this equipment before working on this device.  
Replace all covers before power supplying this device is turned on.

### Peligro

Tensión peligrosa.  
Puede causar la muerte o lesiones graves.  
Desenergice totalmente el equipo antes de instalar o darle servicio.  
Reemplace todas las barreras y cubiertas antes de energizar el interruptor.

### Danger

Tension dangereuse.  
Provoquera la mort ou des blessures graves.  
Mettre hors tension et cadenasser verrouiller l'alimentation avant d'intervenir sur cet appareil.  
Remettre tous les couvercles en place avant de remettre cet appareil sous tension.

### Continuous Current ( $I_r$ )

All model types have an adjustable Continuous Current dial setting. The first dial is always used to adjust the Continuous Current setting of the circuit breaker and the markings are displayed in Amps. The Long Time Pickup ( $I_{ld}$ ) setting is set to  $I_r \times 1.15$ . LI and LIG configurations have ten (10) adjustable settings and the LSI and LSIG configurations have five (5) adjustable settings. See Fig. 6 for an example of the four 1600A configurations.

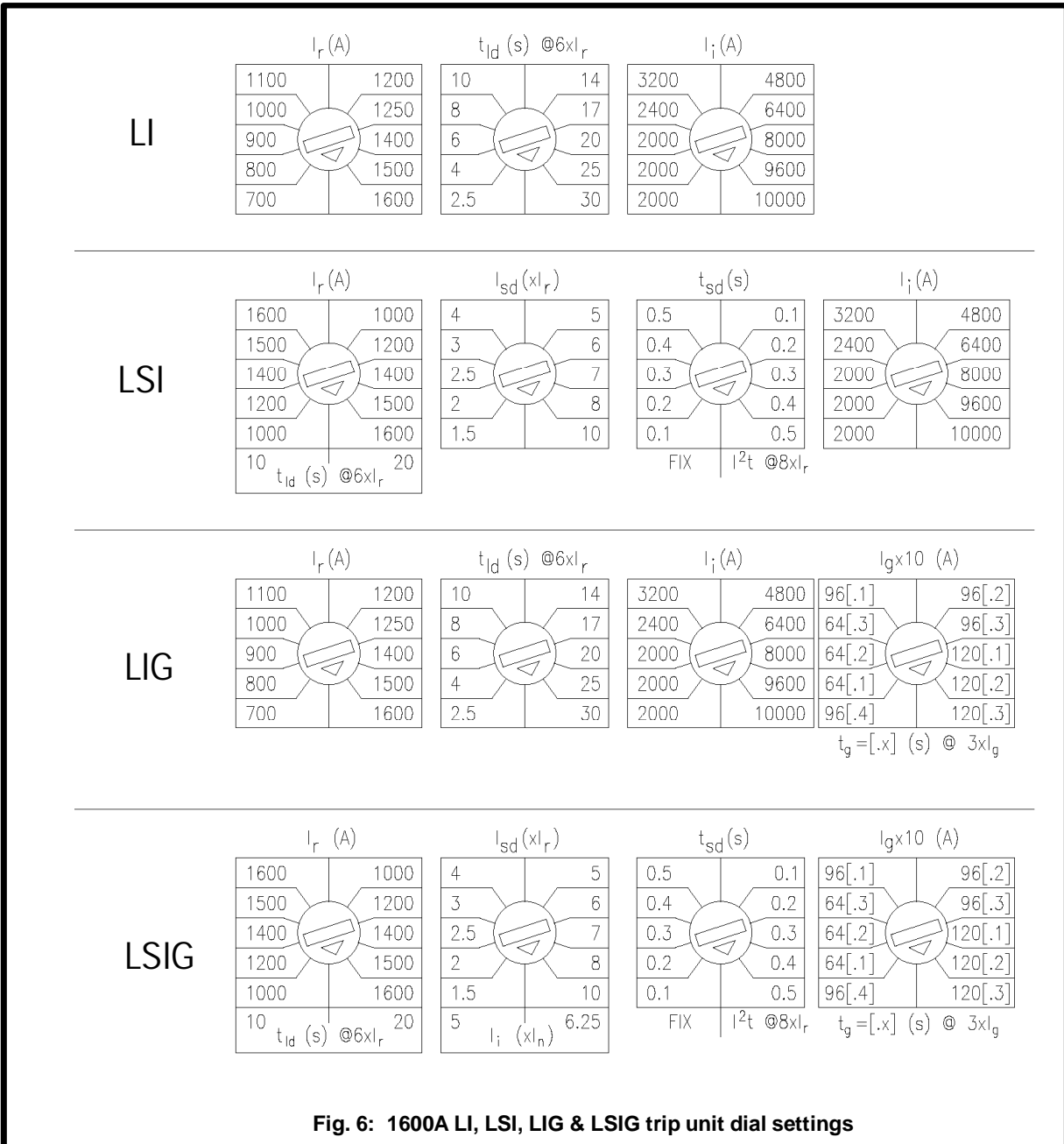
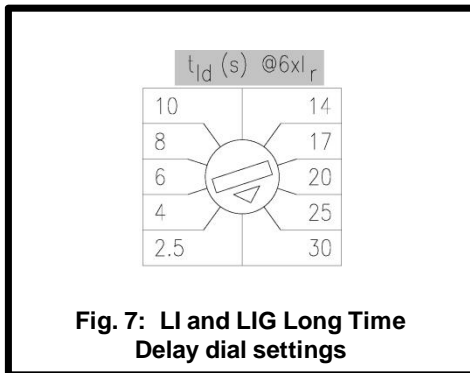

Fig. 6: 1600A LI, LSI, LIG & LSIG trip unit dial settings



### Long Time Delay ( $t_{ld}$ )

All model types have an adjustable Long Time Delay. The Long Time Delay times are an  $I^2t$  function calibrated at 6 times the Continuous Current setting. For LI and LIG breakers (see Fig. 7), there are ten (10) Long Time Delay settings that range from 2.5 to 30 seconds. For LSI and LSIg breakers (see Fig. 8), there are two Long Time Delay settings which are selected based on the Continuous Current setting. As shown in Fig. 8, the Continuous Current settings on the left selects a Long Time Delay setting of 10 seconds and the Continuous Current settings on the right select a Long time Delay setting of 20 seconds.



**Fig. 7: LI and LIG Long Time Delay dial settings**

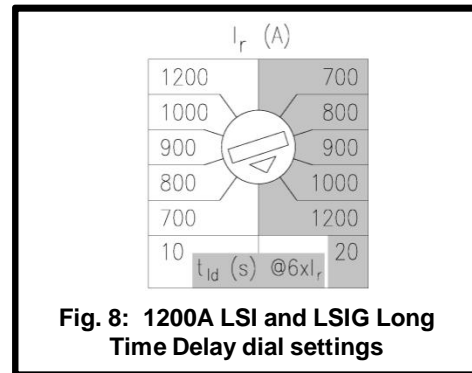

**Fig. 8: 1200A LSI and LSIg Long Time Delay dial settings**

### Instantaneous Pickup ( $I_i$ )

All model types have an adjustable Instantaneous Pickup setting. This adjustment sets the Instantaneous Overcurrent Pickup of the circuit breaker. For LI, LSI, and LIG breakers (see Fig. 9), there are ten (10) Instantaneous Pickup settings that are displayed in Amps. For LSIg breakers (see Fig. 10), there are two Instantaneous Pickup settings which are selected based on the Short Time Pickup setting. These two settings are a multiple of the maximum Frame Rating ( $I_n$ ). As shown in Fig. 10, the Short Time Pickup settings on the left select an Instantaneous Pickup of  $5 \times I_n$  and the Short Time Pickup settings on the right select an Instantaneous Pickup of  $8.33 \times I_n$ .

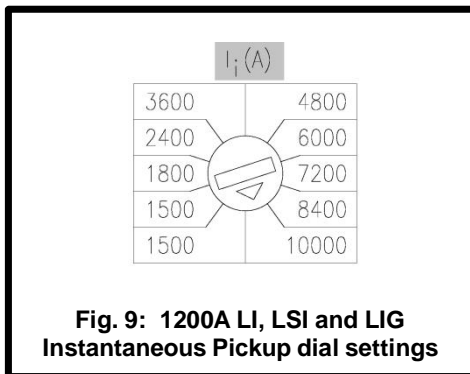

**Fig. 9: 1200A LI, LSI and LIG Instantaneous Pickup dial settings**

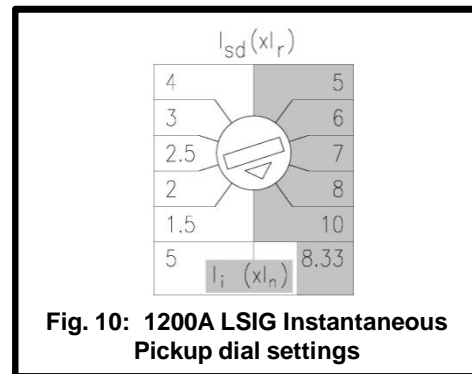

**Fig. 10: 1200A LSIg Instantaneous Pickup dial settings**

### Short Time Pickup ( $I_{sd}$ ) (Optional)

Circuit breakers with the LSI and LSIg catalog number suffixes have an adjustment to set the Short Time Pickup. Short Time Pickup is an overcurrent protection setting with intentional tripping delay. There are ten (10) Short Time Pickup current settings that range from 1.5 to 10 times the Continuous Current ( $I_c$ ) setting (see Fig. 11).

### Short Time Delay ( $t_{sd}$ ) (Optional)

Circuit breakers with the LSI and LSIg catalog number suffixes have an adjustment to set the Short Time Delay. Short Time Delay is either a fixed or  $I^2t$  time delay function. The  $I^2t$  function is based on a calibration point of 8 times the Continuous Current Setting ( $I_c$ ). As shown in Fig. 12, the five (5) settings on the left select the fixed (FIX) Short Time Delay settings and the five (5) settings on the right select the  $I^2t$  Short Time Delay settings.

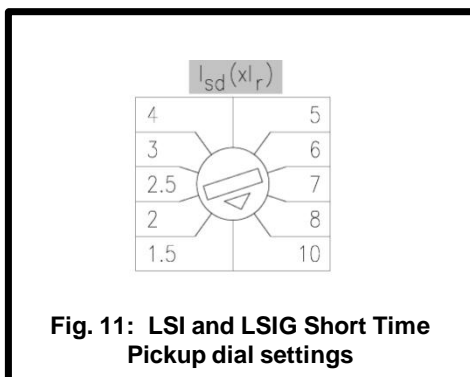

**Fig. 11: LSI and LSIg Short Time Pickup dial settings**

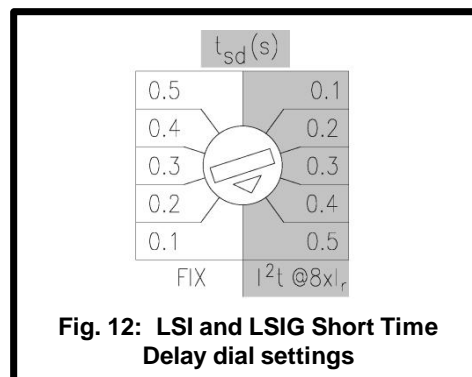
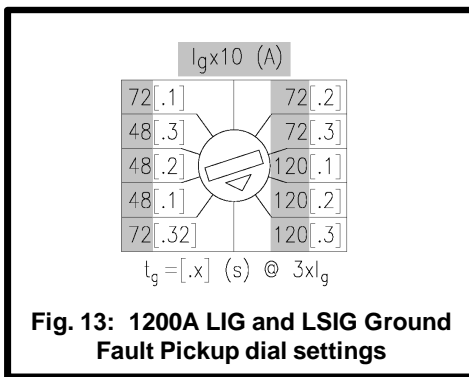

**Fig. 12: LSI and LSIg Short Time Delay dial settings**

	 <b>Danger</b>	 <b>Peligro</b>	 <b>Danger</b>
	<b>Hazardous Voltage</b> Will cause death or serious injury Turn off and lock out all power supplying this equipment before working on this device. Replace all covers before power supplying this device is turned on.	<b>Tensión peligrosa.</b> Puede causar la muerte o lesiones graves. Desenergice totalmente el equipo antes de instalar o darle servicio. Reemplace todas las barreras y cubiertas antes de energizar el interruptor.	<b>Tension dangereuse.</b> Provoquera la mort ou des blessures graves. Mettre hors tension et cadenasser verrouiller l'alimentation avant d'intervenir sur cet appareil. Remettre tous les couvercles en place avant de remettre cet appareil sous tension.

### Ground Fault Pickup ( $I_g$ ) (Optional)

Circuit breakers with the LIG and LSIG catalog number suffixes have integral equipment ground fault protection in compliance with UL1053. The Ground Fault Pickup ( $I_g$ ) setting is displayed in Amps. As shown in Fig. 13, there are three (3) Ground Fault Pickup settings available: 480A, 720A and 1200A.



**Fig. 13: 1200A LIG and LSIG Ground Fault Pickup dial settings**

### Ground Fault Delay ( $t_g$ ) (Optional)

Circuit breakers with the LIG and LSIG catalog number suffixes, have an adjustment to set the Ground Fault Delay. Ground Fault Delay is an I<sup>2</sup>t time delay function based on a calibration point of 3 times the Ground Fault Pickup ( $I_g$ ) setting. As shown in Fig. 14, there are four (4) Ground Fault Delay settings selectable based on the Ground Fault Pickup ( $I_g$ ) setting: .1s, .2s, .3s and .32s.

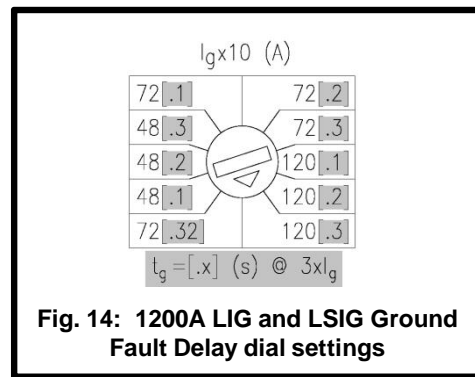

**Fig. 14: 1200A LIG and LSIG Ground Fault Delay dial settings**

### Ground Fault Method

The integral ground fault protection option has two modes of operation. The mode is set by a DIP switch under the trip unit cover with the settings defined as RESIDUAL and GROUND RETURN. See Fig. 18 for switch location.

These two modes function as follows:

**RESIDUAL METHOD** – This is the default position to which the breaker is set when shipped from the factory. With the switch in this position the circuit breaker may be used on 3 phase 3 wire or, with the addition of an external neutral sensing transformer, on 3 phase 4 wire systems. See Neutral Sensing Transformer section for more information.

**GROUND RETURN METHOD** – This setting may only be used for service disconnects or separately derived systems. With the switch in this position, the circuit breaker may be used on 3 phase 3 wire and 3 phase 4 wire systems. An external sensing transformer, which is installed on the main bonding jumper, is required for this method. See Neutral Sensing Transformer section for more information.

### Neutral Sensing Transformer

An external transformer is required for circuit breakers equipped with ground fault protection when operating in the RESIDUAL METHOD on 3 phase 4 wire systems and when operating in the GROUND RETURN METHOD on any system. The sensors listed below must be used for these applications. The sensor catalog number must be matched to the circuit breaker Frame Rating ( $I_n$ ) as shown in the table. Please note that sensors used with other breaker types cannot be used with the SMD/SND circuit breakers. Installation instructions are included with the sensors.

<u>Catalog No.</u>	<u>Frame Rating</u>	<u>Color</u>
N14SPD	1400 Amps	GREEN
N16SPD	1600 Amps	GREEN

**Maintenance Mode**

The National Electrical Code (NFPA 70) mandates that all circuit breakers 1200A and larger be equipped with means to reduce the arc flash energy while a worker is within the circuit breaker arc-flash boundary as defined in NFPA 70E-2012, *Standard for Electrical Safety in the Workplace*. The Sentron Series Sensitrip IV circuit breakers with “6A” included in the catalog number meet this requirement by use of a Maintenance Mode (MM) setting.

**MM Operating Principle**

The MM is initiated by maintenance personnel pressing a normally open (NO) latching “maintenance switch” either before or upon entering a room to perform service. The first circuit breaker interprets the closed contact as a digital input command and immediately enables the MM setting of  $2xI_n$  with no intentional delay and illuminates its local blue LED. The circuit breaker then activates its output signal which is connected to the next circuit breaker in a series chain. The second circuit breaker receives the input and immediately enables its MM and illuminates its local blue LED, and so on. The last circuit breaker in the system activates the “maintenance light” as indication that all the circuit breakers in the system are in MM.

All circuit breakers that receive the input signal shall maintain MM, even with loss of control power, until a valid OFF signal is received. The OFF signal is initiated by maintenance personnel opening the “maintenance switch” with the control power maintained for at least 1 second.

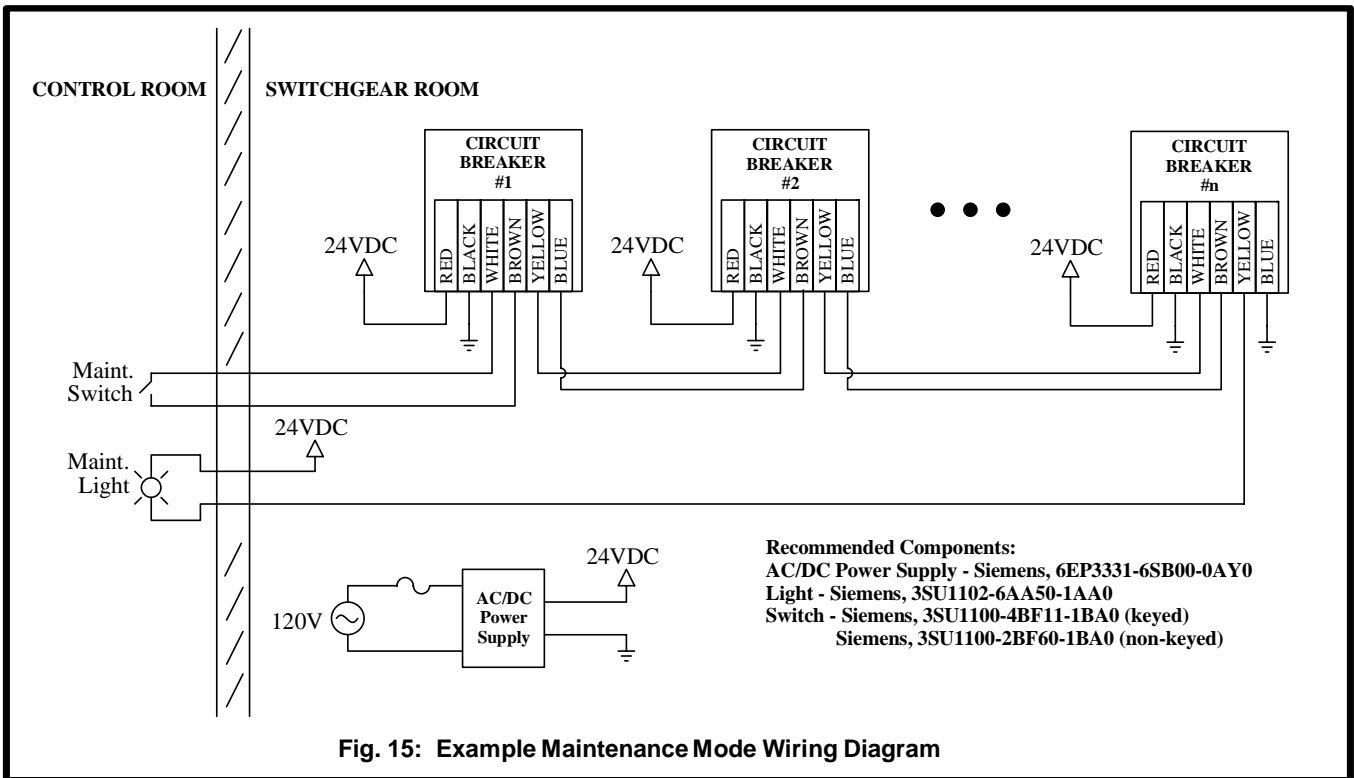

**MM Technical Data**

An external 24VDC, UL Class 2, power supply is required to implement this feature. On the right side of the circuit breaker are six multi-colored, 2-foot length, 18 AWG, wires for connection. It is recommended that the interconnection wiring be 12-18 AWG, shielded, twisted-pair and  $\leq 1000$ -feet (300-meters). Refer to Fig. 15 for an example maintenance mode wiring diagram. In this example, the recommended components listed can support up to 25 circuit breakers.

**MM Configuration**

MM is enabled by a DIP switch under the trip unit cover and the default setting is set to MM. See Fig. 18 for DIP switch configuration.

Wire Color	Function	Rating
RED	24VDC LINE	24VDC $\pm 20\%$
BLACK	24VDC COM	20mA max.
WHITE	INPUT+	24VDC 5mA typ. sunked
BROWN	INPUT- (24VDC COM)	
YELLOW	OUTPUT+	24VDC 100mA max. sourced
BLUE	OUTPUT- (24VDC COM)	

	<b>⚠ Danger</b>	<b>⚠ Peligro</b>	<b>⚠ Danger</b>
	<b>Hazardous Voltage</b> Will cause death or serious injury Turn off and lock out all power supplying this equipment before working on this device. Replace all covers before power supplying this device is turned on.	<b>Tensión peligrosa.</b> Puede causar la muerte o lesiones graves. Desenergice totalmente el equipo antes de instalar o darle servicio. Reemplace todas las barreras y cubiertas antes de energizar el interruptor.	<b>Tension dangereuse.</b> Provoquera la mort ou des blessures graves. Mettre hors tension et cadenasser verrouiller l'alimentation avant d'intervenir sur cet appareil. Remettre tous les couvercles en place avant de remettre cet appareil sous tension.

### Zone Selective Interlocking (Optional)

Sentron Series Sensitrip IV circuit breakers with “6A” included in the catalog number support Zone Selective Interlocking (ZSI). ZSI is a method which allows two or more circuit breakers to communicate with each other so that a short circuit or ground fault will be cleared by the breaker closest to the fault with a minimum time delay. The primary goal of ZSI is to limit stress on the distribution system by clearing a fault in the shortest time without sacrificing coordination. The benefits of ZSI are lower potential costs of system damage due to the reduced time to clear faults and increased uptime because coordination is not sacrificed.

### ZSI Operating Principle

In a distribution system comprised of several levels, each circuit breaker affected by a short-circuit communicates with the circuit breaker directly downstream, to ascertain whether the short-circuit also occurred. All downstream circuit breakers experiencing the short-circuit provide a restraint signal to all circuit breakers upstream so that the circuit breaker closest to the short-circuit clears the fault.

FUNCTION	NON-RESTRAINT TRIPPING TIME
Short Time Delay	$t_{sd}(ZSI) = 50ms$
Ground Fault Delay	$t_g(ZSI) = 100ms$

### ZSI Example

Fig. 16 shows an example of a ZSI system with set Short Time Delay times.

#### Short-circuit at SC1:

Only CB1 establishes that a short-circuit has occurred and does not receive a restraint signal from CB2. For this reason, CB1 trips after  $t_{sd}(ZSI) = 50\text{ ms}$

#### Short-circuit at SC2:

CB1 and CB2 establish that a short-circuit has occurred. CB2 issues a restraint signal to CB1. The  $t_{sd}$  for CB1 will be set to its programmed setting of 300ms. CB2 does not receive a restraint signal from CB4 or CB5. For this reason, CB2 trips after  $t_{sd}(ZSI) = 50\text{ ms}$

#### Short-circuit at SC3:

CB1, CB2 and CB4 establish that a short-circuit has occurred. CB4 issues a restraint signal to CB2 and CB2 issues a restraint signal to CB1. The  $t_{sd}$  for CB1 and CB2 will be set to their programmed setting of 300ms and 200ms, respectively. CB4 does not receive a restraint signal since it is the last circuit breaker in the system. For this reason, CB4 trips after  $t_{sd}(ZSI) = 50\text{ ms}$

### ZSI Technical Data



An external 24VDC, UL Class 2, power supply is required to implement this feature. On the right side of the circuit breaker are six multi-colored, 2-foot length, 18 AWG, wires for connection. It is recommended that the interconnection wiring be 12-18 AWG, shielded, twisted-pair and  $\leq 1000$ -feet (300-meters). Refer to Fig. 17 for an example ZSI wiring diagram. In this example, the recommended components listed can support up to 50 circuit breakers.

Wire Color	Function	Rating
RED	24VDC LINE	24VDC $\pm 20\%$ 20mA max.
BLACK	24VDC COM	
WHITE	INPUT+	24VDC 5mA typ. sinked
BROWN	INPUT- (24VDC COM)	
YELLOW	OUTPUT+	24VDC 100mA max. sourced
BLUE	OUTPUT- (24VDC COM)	

### ZSI Configuration

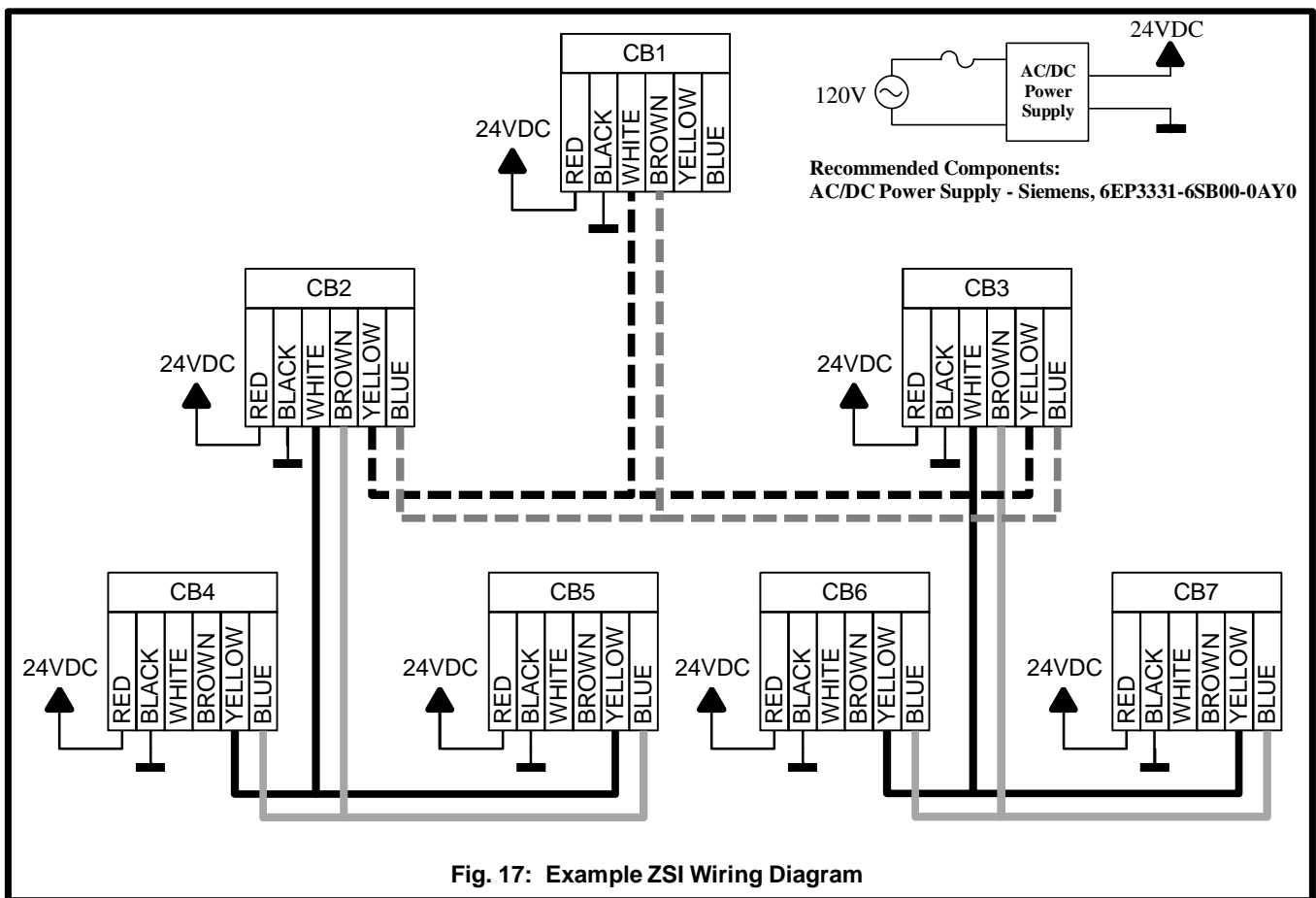
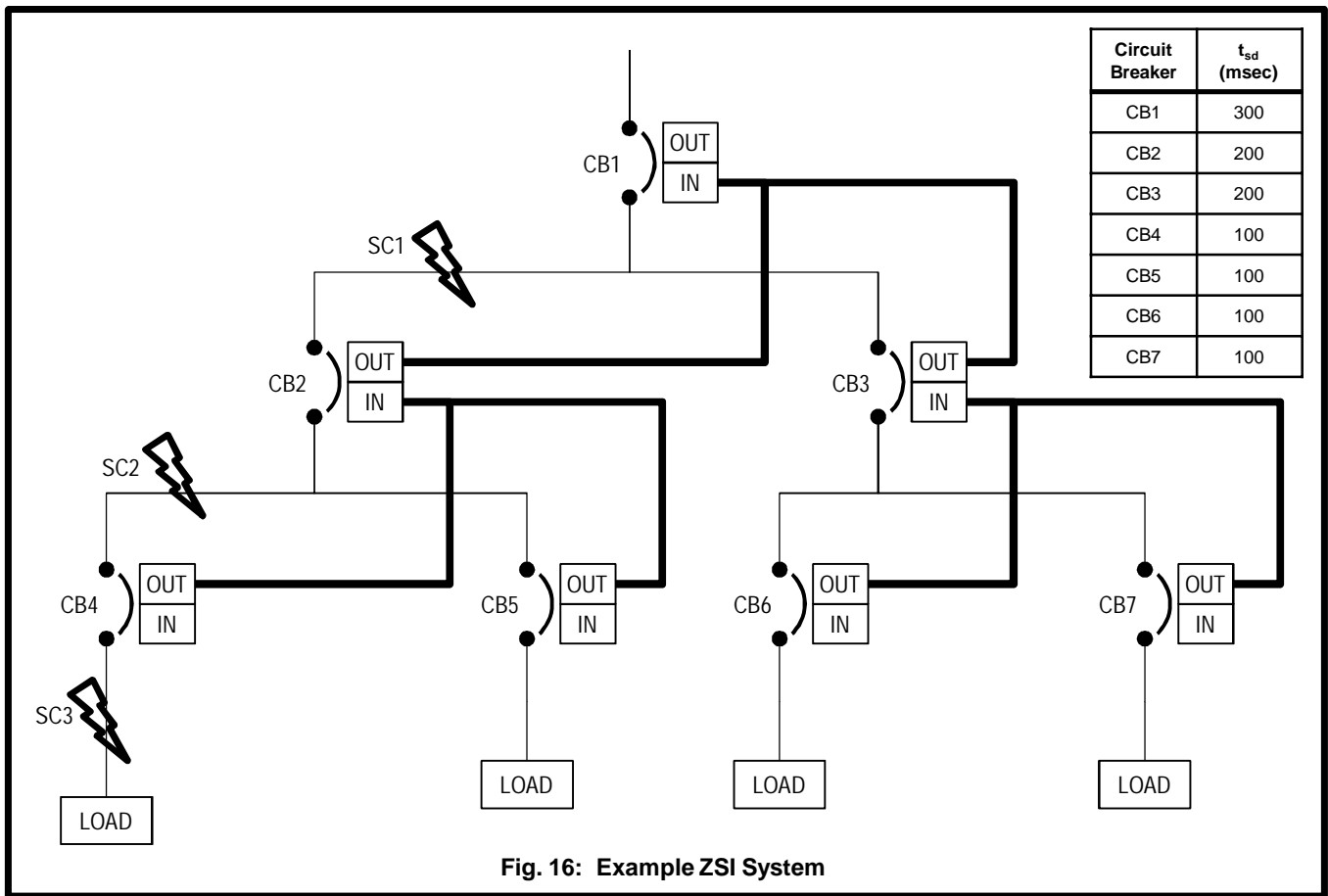
ZSI is enabled by a DIP switch under the trip unit cover and the default setting is set to Maintenance Mode. See Fig. 18 for DIP switch configuration.



	<b>⚠ Danger</b>	<b>⚠ Peligro</b>	<b>⚠ Danger</b>
	<b>Hazardous Voltage</b> Will cause death or serious injury  Turn off and lock out all power supplying this equipment before working on this device. Replace all covers before power supplying this device is turned on.	<b>Tensión peligrosa.</b> Puede causar la muerte o lesiones graves.  Desenergice totalmente el equipo antes de instalar o darle servicio. Reemplace todas las barreras y cubiertas antes de energizar el interruptor.	<b>Tension dangereuse.</b> Provoquera la mort ou des blessures graves.  Mettez hors tension et cadenasser verrouiller l'alimentation avant d'intervenir sur cet appareil. Remettez tous les couvercles en place avant de remettre cet appareil sous tension.

### DIP SWITCH CONFIGURATION

On the front of the Sensitrip IV trip unit there is a 4 position configuration switch for configuring the Maintenance Mode, ZSI Mode and Ground Fault Method (see Fig. 18). Use a small pocket screwdriver to open the access cover. The shipping default of this DIP switch is with all positions in the DOWN position.

Switch #1:

- DOWN = Selects Maintenance Mode
- UP = Selects Zone Selective Interlocking Mode

Switch #2:

- DOWN = Disables Short Time Zone Interlocking
- UP = Enables Short Time Zone Interlocking

Switch #3:

- DOWN = Disables Ground Fault Zone Interlocking
- UP = Enables Ground Fault Zone Interlocking

Switch #4:

- DOWN = Selects Ground Fault Residual Method
- UP = Selects Ground Fault Ground Return Method

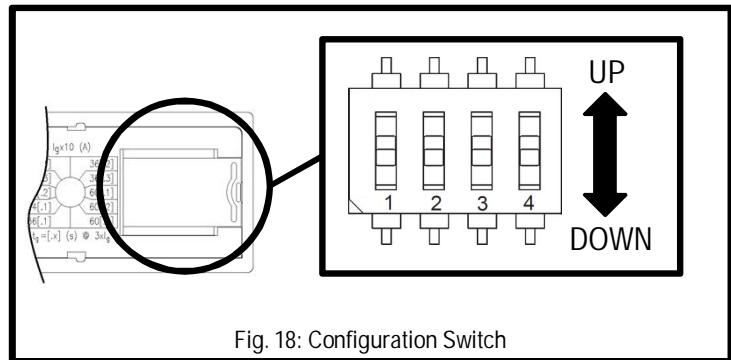

Fig. 18: Configuration Switch

### STATUS INDICATORS

On the front of the Sensitrip IV trip unit there are 3 LED status indicators that display the status of the circuit breaker: Active, Overload and Maintenance Mode. The Active and Overload LEDs are available on all circuit breaker types and the Maintenance Mode LED is only available on circuit breakers with "6A" included in the catalog number. See Fig. 19 for location of LEDs.

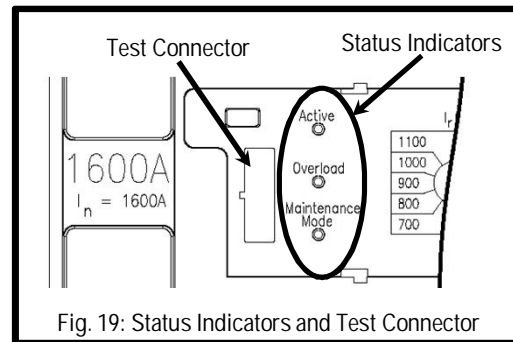

Fig. 19: Status Indicators and Test Connector

LED	State	Trip Unit State
Active	OFF	Ok. $I_{pri} < \min I_{pri}$ to power trip unit
	Flashing GREEN (1 Hz)	Ok. Trip unit fully operational.
	Flashing GREEN (>>1Hz)	Ok. $I_{pri} < \min I_{pri}$ to power trip unit
	Static RED	Trip unit in error state. Contact technical support.
Overload	OFF	Ok
	Flashing AMBER	Trip pending $I_{pri} > I_r$
	Static Amber	Trip pending $I_{pri} > I_r^* 115\%$
Maint. Mode	OFF	Maintenance Mode OFF
	Static BLUE	Maintenance Mode ON

<sup>1</sup>National Electrical Code® is a Registered Trademark of the National Fire Protection Association.

### Electronic Testing

Sensitrip IV solid state molded case circuit breakers may be tested for electronic functionality by the use of ELTPHB or EPSP18V test sets, available from local Siemens sales offices. See Fig. 19 for location of test connector. NOTE: Time current characteristic curves and information on factory installed accessories can be obtained from local Siemens sales offices or Siemens Online.

### Maintenance

MD and ND frame circuit breakers are designed to provide years of maintenance free service. However, some industrial users may choose to establish an inspection and maintenance procedure to be carried out on a regular basis. For detailed information, consult applicable NEMA publication or your local Siemens sales office.

NOTE: Do not spray or allow any petroleum based chemicals, solvents or paints to contact the molded parts or nameplates.