

SIEMENS

SIMATIC Ident

RFID systems



SIMATIC RF310R special version Scanmode

Compact Operating Instructions

Legal information

Warning notice system

This manual contains notices you have to observe in order to ensure your personal safety, as well as to prevent damage to property. The notices referring to your personal safety are highlighted in the manual by a safety alert symbol, notices referring only to property damage have no safety alert symbol. These notices shown below are graded according to the degree of danger.

 DANGER
indicates that death or severe personal injury will result if proper precautions are not taken.
 WARNING
indicates that death or severe personal injury may result if proper precautions are not taken.
 CAUTION
indicates that minor personal injury can result if proper precautions are not taken.
NOTICE
indicates that property damage can result if proper precautions are not taken.

If more than one degree of danger is present, the warning notice representing the highest degree of danger will be used. A notice warning of injury to persons with a safety alert symbol may also include a warning relating to property damage.

Qualified Personnel

The product/system described in this documentation may be operated only by **personnel qualified** for the specific task in accordance with the relevant documentation, in particular its warning notices and safety instructions. Qualified personnel are those who, based on their training and experience, are capable of identifying risks and avoiding potential hazards when working with these products/systems.

Proper use of Siemens products

Note the following:

 WARNING
Siemens products may only be used for the applications described in the catalog and in the relevant technical documentation. If products and components from other manufacturers are used, these must be recommended or approved by Siemens. Proper transport, storage, installation, assembly, commissioning, operation and maintenance are required to ensure that the products operate safely and without any problems. The permissible ambient conditions must be complied with. The information in the relevant documentation must be observed.

1 Features

SIMATIC RF310R special version Scanmode	Characteristics					
	Design	① RS-422 interface ② Status display				
	Field of application	Identification tasks on small assembly lines in harsh industrial environments				
	Read/write distance to transponder	Max. 90 mm				
	Data transmission rate	<table border="1"> <tr> <th>RF300 transponder</th> <th>ISO transponder</th> </tr> <tr> <td>approx. 8000 bytes/s</td> <td>approx. 1500 bytes/s</td> </tr> </table>	RF300 transponder	ISO transponder	approx. 8000 bytes/s	approx. 1500 bytes/s
	RF300 transponder	ISO transponder				
approx. 8000 bytes/s	approx. 1500 bytes/s					
Read						

2 Ordering data

	Order number
RF310R special version Scanmode with RS-422 interface	6GT2801-1AB20-0AX1

3 Safety instructions for the device/system

Note

This device/system may only be used for the applications described in the catalog and the technical documentation "System manual MOBY D, RF200, RF300, RF600 and only in combination with third-party devices and components recommended and/or approved by Siemens.

See also

SIMATIC RF300 System Manual (<http://support.automation.siemens.com/WW/view/en/21738946>)

4 Metal-free area

The RF310R special version can be flush-mounted in metal. Please allow for a possible reduction in the field data values.

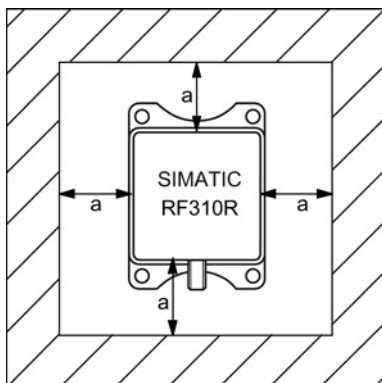
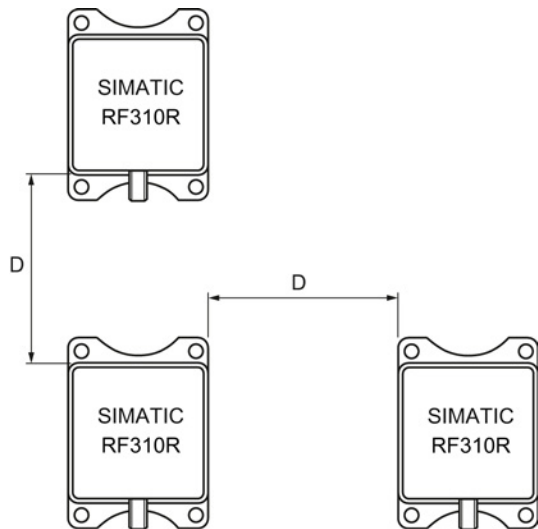

Figure 4-1 Metal-free area for RF310R special version

To avoid any impact on the field data, the distance a should be ≥ 20 mm.

5 Minimum distance between several readers

RF310R special version side by side



$D \geq 150$ mm (with 2 readers)

$D \geq 200$ mm (with more than 2 readers)

Figure 5-1 Minimum distance between RF310R readers

RF310R special version face-to-face

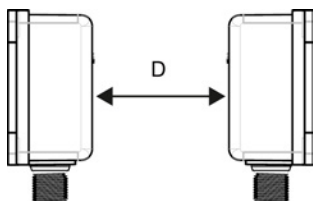

$D \geq 300$ mm

Figure 5-2 Face-to-face distance between two RF310R special version

6 Ensuring reliable data exchange

The "center point" of the transponder must be situated within the transmission window.

7 Field data of transponders and readers

Table 7-1 Field data SIMATIC RF310R special version Scanmode reader

	Diameter of the transmission window (L_d)	Operating distance (S_a)	Limit distance (S_g)
RF320T	30	1...23	26
RF340T	40	2...36	41
RF350T	45	2...47	53
RF360T	45	2...60	68
MDS D100	40	2...93	105
MDS D124	30	2...64	72
MDS D126	90	2...65	73
MDS D139	105	5...96	109
MDS D160	30	1...39	44
MDS D165	130	2...90	102
MDS D200	120	2...84	95
MDS D261	80	2...74	83
MDS D324	30	2...47	63
MDS D339	85	5...74	84
MDS D400	90	2...104	117
MDS D423	55	2...35	45
MDS D424	35	1...70	78
MDS D425	30	1...22	25
MDS D426	90	5...100	113
MDS D428	30	1...43	48
MDS D460	30	1...37	41

All values are in mm

8 Host-reader communication and parameterization

8.1 Introduction

In the scan mode, data are transferred automatically to the host via the serial interface when the reader is switched on. The type of data collection and transfer is preset in the reader using parameters.

The communication protocol described here and its possible parameterization require a reader firmware version of 1.4 or higher.

For commissioning, it is also possible to communicate with the reader during operation. For this, the host sends a telegram via the serial interface that is processed and acknowledged in the reader.

The following functions are available for the commissioning:

- Change parameter
- Read status (incl. parameter)
- Switch on test mode

8.2 Communications

Basic principles

The communication between host and reader occurs using the interface parameters set in the reader. After delivery, the setting is as follows:

- Baud rate 38400
- Parity none
- 8 data bits, 1 stop bit
- Physics
 - RF310R: RS-422
 - RF38xR: RS-232

The additional parameters for data transfer from the reader to the host (ASCII/binary MSB/LSB) are not used for the exchange of telegrams. As described in the following chapters, telegram communication is binary.

Note

Loss of transponder information in host-reader communication during operation

When you start the communication between host and reader during commissioning, make sure that there are no transponders in the antenna field.

If there is a transponder in the antenna field, it is possible that the acknowledgment data (frame from the reader to the host with the parameters of the reader) also includes reply data of a transponder. If this is the case, this reply data of the transponder is lost for the application. In addition to this, the acknowledgment, for example of "Read parameter" is corrupted by transponder data.

Note

Documenting parameter changes

A change in the communication-relevant parameters "baud rate" and "parity" must be well documented, because with unknown interface parameterization, the reader cannot be addressed and can also no longer receive user data.

If the interface setting in the reader is no longer known, the host must search for the setting: e.g. telegram "Read status" - wait for a reply. (Test variants with five baud rates and three parity settings)

Note

No reader communication after interface physics parameter is changed

An unintentional change in the interface physics parameter has the result that no further communication is possible with the reader.

The RF310R Scanmode reader requires an adapter to convert RS-422 to RS-232.

Telegram structure

A telegram from the host to the reader is structured as follows:

Command	Status	Quantity x	1st byte	2nd byte	...	x ... 1st byte	xth byte	BCC
---------	--------	------------	----------	----------	-----	----------------	----------	-----

The acknowledgement from the reader to the host is structured as follows:

Command	Error code	BCC
---------	------------	-----

The acknowledgement is sent by the reader after it has finished performing the command.

Frame transmission

Properties of frame transmission:

- The information about the version is appended to the parameters when reading.
- The calculation of the BCC checksum is performed simply by XORing all bytes.
- If there is a change in an interface parameter (baud rate, parity), an acknowledgment with the old setting is sent. Following this, the new setting takes effect (scan data, next frame).

"Change parameters" telegram

All parameters can be changed, including those for the serial interface. Note the following:

- The acknowledgement from the reader is sent with the old settings
- The following scan data are sent with the new settings

The parameters can be stored in the reader either retentively or non-retentively:

- In retentive parameterization, the transferred data are still available after the reader is restarted.
- In non-retentive parameterization, the data are only changed for current operation. A restart will then occur with the old parameters.

After the parameters are accepted and the acknowledgement is sent, the reader returns automatically to scan mode.

"Change parameters" telegram:

Command	Status	Quantity	1st byte	2nd byte	...	20th byte	21st byte	BCC
0x01	0x00	21	Para	Para	...	Para	Para	

"Change parameters retentively" telegram:

Command	Status	Quantity	1st byte	2nd byte	...	20th byte	21st byte	BCC
0x01	0x01	21	Para	Para	...	Para	Para	

Acknowledgement:

Command	Error code	BCC
0x01		

All parameters must always be transferred together. If the reader configuration is not saved on the host, it is recommended to first read out the parameters saved to the reader.

"Read status" telegram

The status that can be read out from the reader includes version information alongside the parameters.

Either the retentive or the non-retentive parameters can be read out; the version information is always the same.

After the acknowledgement is sent with the requested data, the reader switches automatically back to scan mode.

"Read parameters" telegram:

Command	Status	Quantity	1st byte	2nd byte	...	20th byte	21st byte	BCC
0x02	0x00	21	0x00	0x00	...	0x00	0x00	

"Read parameters retentively" telegram:

Command	Status	Quantity	1st byte	2nd byte	...	20th byte	21st byte	BCC
0x02	0x01	21	0x00	0x00	...	0x00	0x00	

Acknowledgement:

Command	Error code	Quantity	1st byte	2nd byte	...	20th byte	21st byte	22nd byte	23rd byte	24th byte	25th byte	BCC
0x02		25	Para	Para	...	Para	Para	Para	Para	Para	Para	

"Activate test mode" telegram

A test mode can be set to support the commissioning of a reader. The test mode is immediately active in the reader after the acknowledgement is sent and can be deactivated only by switching off the reader or by sending a new parameter set.

In test mode, the reader scans constantly for a tag. Successful scans (a tag has responded) and unsuccessful scans (incorrect or no response from a tag) are counted. The number of successful scans is permanently transferred to the host by the reader. The reference point is 20 scans.

The transferred value provides information about how well a tag is positioned in, or passes through, the reader's HF field.

"Activate test mode" telegram:

Command	Status	Quantity	1st byte	2nd byte	...	20th byte	21st byte	BCC
0x03	0x01	21	0xxx	0xxx	...	0xxx	0xxx	

Acknowledge

Command	Error code	BCC
0x03		

Data

Parameters

The following table lists the parameters available in the reader. The byte count refers to the entry in the "Change parameter" telegram to the reader.

If a parameter value consists of two bytes, the MSB is always transferred first.

xth byte	Value	Meaning	
0	21	21	Current length of the parameters in the telegram (in bytes)
1	1 255 0	ISO general ISO user-defined RF300	"Tag type" parameter Setting of the air interface/tags used
2	30 0-100	30% 0-100%	"Modulation" parameter Optimization of the air interface - setting is only possible by selecting "ISO user-defined"
3	0 1	single double	"Sub Carrier" parameter Optimization of the air interface - setting is only possible by selecting "ISO user-defined"
4	0 1	high low	"Data Rate" parameter Optimization of the air interface - setting is only possible by selecting "ISO user-defined"
5	1 16	Singletag reserved	"Mode of operation" parameter Only the singletag setting is possible, i.e. several tags in the field will not be detected or processed
6	0 1	Continuous Read Single Read	"Scan mode type" parameter Selection of scan mode sequence
7+8	10 1-65535	10 * 100 ms (1..65535) * 100 ms	"Lock Time" parameter Setting of Lock Time duration for Continuous Read Mode

xth byte	Value	Meaning	
9	5 2 3 4 6 7 8	1.25 W 0.5 W 0.75 W 1 W 1.5 W 1.75 2 W	"Transmit power" parameter The transmit power setting to optimize communication with tags is only possible with RF38xR
10	1 2	RS-232 RS-422	"Physical interface" parameter Setting the physical interface is only possible with RF38xR
11	2 0 1 3 5	38400 9600 19200 57600 115200	"Baud rate" parameter Baud rate setting - applies to scan mode, test mode, and telegram communication
12	0 1 2	none even odd	"Parity" parameter Parity bit setting - applies to scan mode, test mode, and telegram communication
13	0 1 2	only UID only user data UID and user data	"Data record" parameter Combination of data that the reader automatically transfers to the host in scan mode
14+15	0 0...8192	0 0...8192	"User data start address" parameter Specification of address from which the user data should be read (on setting <with user data>)
16+17	4 0...8192	4 0...8192	"User data length" parameter Specification of amount of user data that should be read (on setting <with user data>)
18	0 1	ASCII binary	"Data format" parameter Setting the data transfer type: Bytes are transferred as binary bytes or are converted into two ASCII characters. This parameter does not apply to the separator or end character (binary). This parameter also does not apply to telegram traffic.
19	0 2C 1.. FF	CR+LF '.' Any character (not 0)	"Separator" parameter Setting of the separator character that is transferred between data on the setting <UID and user data>; omitted on settings <UID only> and <user data only>
20	0 1.. FF	CR+LF Any character (not 0)	"End character" parameter Sets the end character that is transferred at the end of a data set, thus separating the data of different tags from each other
21	1	LSB first	"Byte sequence" parameter LSB is transferred first (within the block size) This parameter applies only to user data.

Status

The following table lists the status information that can be read out from the reader. The byte count refers to the entry in the acknowledgement of the "Read status" telegram.

xth byte	Value	Meaning	
1.. 21			For parameter contents, refer to the previous table Note: The "Physical interface" and "Transmit power" parameters are supported only by the RF38xR reader. If these parameters are queried on the RF310R, the parameter values or the default values are read out as described in the "Parameters" table.
22+23	xx	V xx.yy	Firmware version
23	yy		
24	'1' .. '9'	ASCII characters	Hardware version
25	xy	V x.y	FPGA version

Error code

An error code is saved in the second byte of the acknowledgement of the reader. If the telegram is processed without error, the error code "00" is stored.

An error code other than zero means that the parameters have not been accepted. The following error codes are defined:

Error code	Meaning
0x01	Command (in the first byte of the telegram) is unknown
0x02	Status (in the second byte of the telegram) is unknown
0x03	A parameter setting is incorrect
0x04	BCC (in the last byte of the telegram) is incorrect
0x05	Data cannot be stored retentively (FEPRM on module is not recognized)
0x06	Data cannot be stored retentively (FEPRM sector cannot be deleted)
0x07	Data cannot be stored retentively (FEPRM sector cannot be programmed)

8.3 Parameter assignment

Parameters for the RF310R Scanmode reader can be set simply using the RF MANAGER Basic. You will find the required software components on the DVD "RFID Systems, Software & Documentation" or on the Internet using the following links:

SIMATIC RF MANAGER Basic V3.0 (<http://support.automation.siemens.com/WW/view/en/64700331>)

SIMATIC RF MANAGER Basic V3.0 Service Pack 1 (<http://support.automation.siemens.com/WW/view/en/78473837>)

Reader parameter assignment

Proceed as follows to set parameters for the RF310R Scanmode reader:

1. Start the RF MANAGER Basic.
2. In the area "Create an empty project", select the country in which the reader will be operated from the drop-down list.

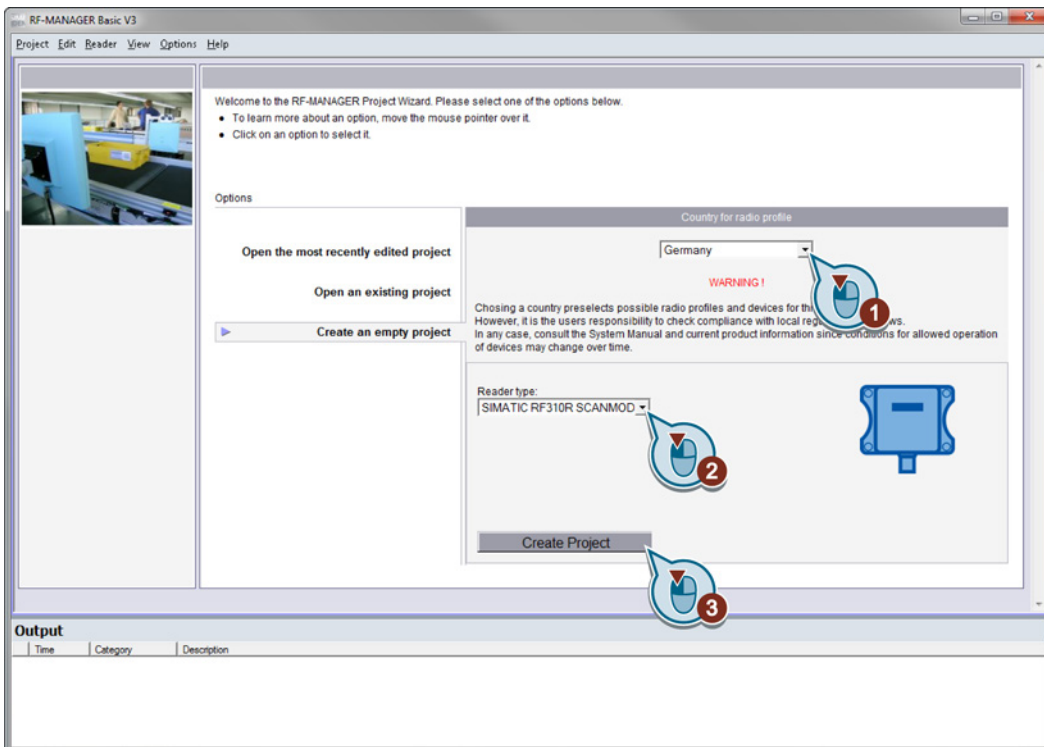

3. In the "Reader type" drop-down list, select the appropriate reader.
4. Click the "Create project" button.
Reaction: A new project window opens.
5. Set the required parameters in the "Properties" area.

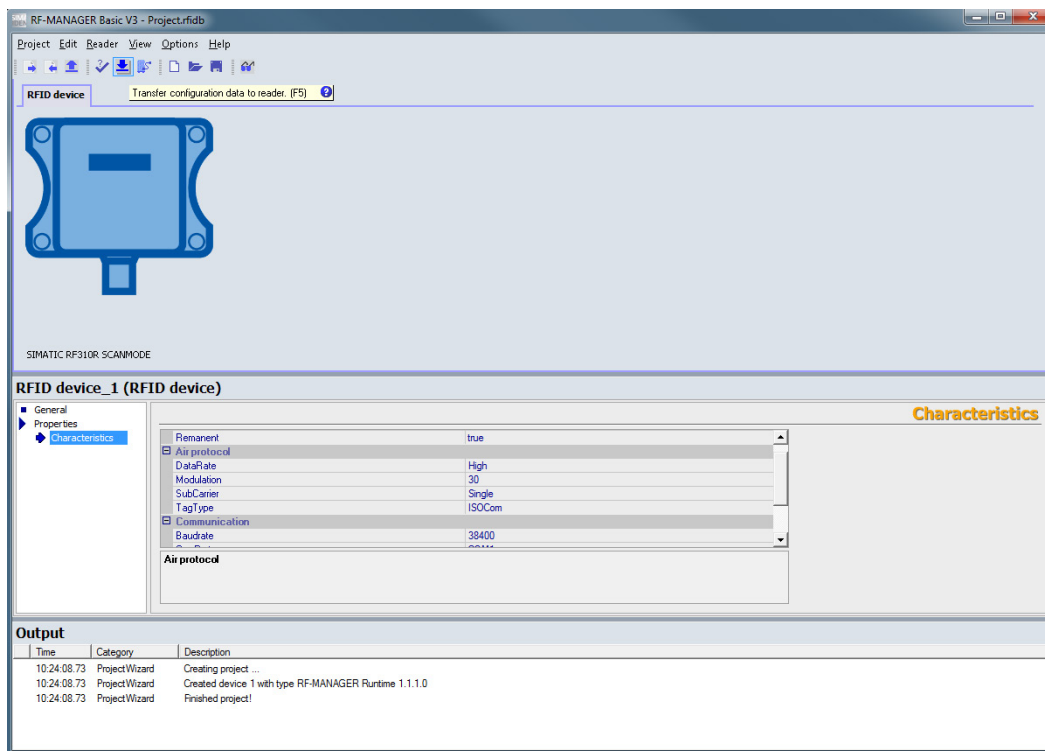

6. Click the  icon in the toolbar to transfer the data to the reader.

With the  icon, you can display the read transponders

9 Pin assignment RF310R special version Scanmode RS422 interface

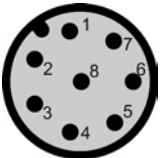
Pin	Pin Device end 8-pin M12	Assignment
	1	+ 24 V
	2	- Transmit
	3	0 V
	4	+ Transmit
	5	+ Receive
	6	- Receive
	7	Unassigned
	8	Earth (shield)

10 Display elements of the reader

Table 10-1 LED display elements on the reader

Color	Meaning
Green	Operating voltage present, reader ready for operation
Yellow	Transponder present
Red	Red LED for error display is activated permanently if correct operation of the reader cannot be guaranteed (e. g. faulty start, checksum error during operation).

11 Technical data

6GT2801-1AB20-0AX1	
Product type designation	RF310R special version Scanmode with RS-422 interface
Inductive interface to the transponder Transmission frequency for power/data	13.56 MHz
Antenna	Integrated
Interface to the communication module	RS-422 (Scanmode)
Baud rate	9600 Bd, 19200 Bd, 38400 Bd, 57600 Bd, 115200 Bd
Cable length reader ↔ communications module	Data cable length max. 1000 m (shielded cable)
Read/write distances of reader	see section Field data of transponders and readers (Page 4)
Minimum distance between two RF310R readers	≥ 100 mm or ≥ 200 mm
Maximum data transmission rate reader ↔ transponder	RF300 transponder ISO transponder
• Read	• approx. 8000 bytes/s • approx. 1500 bytes/s
Functions	Read transponder; Query status and diagnostics information; Query transponder serial numbers
Power supply	24 V DC
Display elements	3-color LED (operating voltage, presence, error)
Plug connector	M12 (8-pin)
Enclosure	
• Dimensions in mm	• 55 x 75 x 30 (without M12 device connector)
• Color	• Anthracite
• Material	• Plastic PA 12
Fixing	4 x M5 screws
Ambient temperature during operation	-25 °C ... +70 °C
during transport and storage	-40 °C ... +85 °C
Degree of protection to EN 60529	IP67
Shock to EN 60721-3-7 Class 7 M2	50 g
Vibration to EN 60721-3-7 Class 7	20 g
Weight	Approx. 170 g

Approvals

Radio to R&TTE guidelines EN 300 330,
EN 301489, CE, FCC

Current consumption

typ. 50 mA

12 Dimension drawing

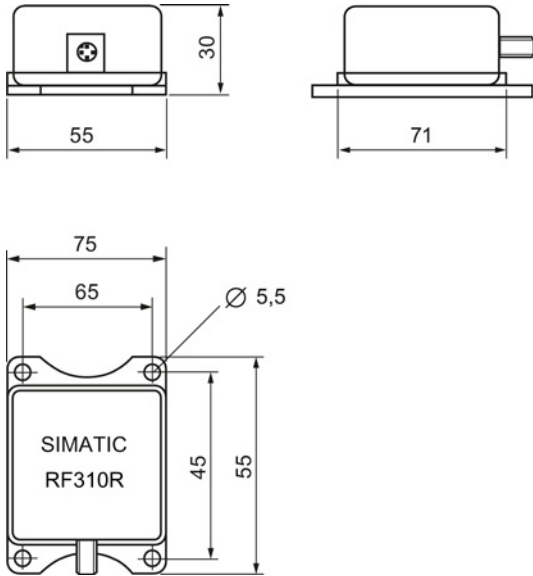

Figure 12-1 Dimension drawing RF310R special version Scanmode

Dimensions in mm

13 Certificates and approvals

13.1 FCC information

Siemens SIMATIC RF310R with RS-422 interface

FCC ID: NXW-RF310R

This device complies with part 15 of the FCC rules. Operation is subject to the following two conditions:

- (1) This device may not cause harmful interference.
- (2) This device must accept any interference received, including interference that may cause undesired operation.

Caution

Any changes or modifications not expressly approved by the party responsible for compliance could void the user's authority to operate the equipment.

13.2 Canada information

This device complies with Industry Canada licence-exempt RSS standard(s). Operation is subject to the following two conditions:

- (1) this device may not cause interference, and
- (2) this device must accept any interference, including interference that may cause undesired operation of the device.

Le présent appareil est conforme aux CNR d'Industrie Canada applicables aux appareils radio exempts de licence. L'exploitation est autorisée aux deux conditions suivantes :

- (1) l'appareil ne doit pas produire de brouillage, et
- (2) l'utilisateur de l'appareil doit accepter tout brouillage radioélectrique subi, même si le brouillage est susceptible d'en compromettre le fonctionnement.

Trademarks

All names identified by ® are registered trademarks of Siemens AG. The remaining trademarks in this publication may be trademarks whose use by third parties for their own purposes could violate the rights of the owner.

Disclaimer of Liability

We have reviewed the contents of this publication to ensure consistency with the hardware and software described. Since variance cannot be precluded entirely, we cannot guarantee full consistency. However, the information in this publication is reviewed regularly and any necessary corrections are included in subsequent editions.

Siemens AG
Industry Sector
Postfach 48 48
90026 NÜRNBERG

SIMATIC RF310R special version Scanmode
J31069-D0236-U001, 10/2013