

AD353-105

Rev 3

April 2012

# Procidia™ Control Solutions

## Combustion Management Solutions

### Boiler Drum Level (Feedwater) Control

#### INTRODUCTION

This paper is the fifth in a series that discusses Combustion Management Solutions. This installment discusses Boiler Drum Level Control.

The benefits of boiler drum level control are:

- ◇ Maximizes steam quality
- ◇ Maintains proper drum level to prevent damage to boiler

#### BACKGROUND

The cylindrical vessel where the water-steam interface occurs is called the boiler drum. Boiler drum level is a critical variable in the safe operation of a boiler. A low drum level risks uncovering the watertubes and exposing them to heat stress and damage. High drum level risks water carryover into the steam header and exposing steam turbines to corrosion and damage.

Drum level control is complicated by the inverse response in level to a change in the firing rate. This phenomenon is known as *swell* and *shrink*. When the firing rate increases, vapor bubbles form at a faster rate and that causes the drum level to rise or swell. A decrease in firing rate causes drum level to shrink.

The problem associated with the swell and shrink phenomenon is that a standard feedback control loop measuring level cannot correct for load changes without wide swings in drum level. When drum level swells, feedwater flow decreases in order to correct for level. However, feedwater should be increasing in order to match the higher steam demand. The level control loop does not

start to correct for the increase in steam flow until after drum level has fallen below setpoint. The risk is that drum level can significantly drop before the control system finally adjusts to the change in steam load.

#### MEASUREMENT

There are three typical control strategies: single-element, two-element, and three-element drum level control. Single-element control measures drum level and regulates the feedwater valve in order to maintain drum level. Two-element control measures drum level and steam flow rate. This is a feedforward control strategy. Feedwater flow tracks steam load while the drum level control loop trims it. Three-element control measures drum level, steam flow, and feedwater flow. It is a refinement over 2-element control that improves drum level control and responds quicker to variations in feedwater flow rate.

##### *Boiler Drum Level [1E, 2E and 3E]*

The boiler drum level has a typical span of 30 inH<sub>2</sub>O, often with some suppression required depending on the physical location of the transmitter. The boiler will be pressurized so the transmitter must be able to operate with a static pressure of up to several thousand PSI. In addition, chemicals injected into the feedwater need to be considered when specifying the transmitter's materials of construction.

##### *Drum Pressure [1E, 2E and 3E]*

Since the density of steam and water at the saturation temperature change with pressure, the drum level calibration will only be accurate at a single boiler drum pressure. The drum level

signal can be compensated for all pressures by using a drum pressure transmitter. Pressure compensation is typically employed with utility boilers that operate at much higher pressures than industrial boilers, but this strategy is useful for either application.

#### *Steam Flow [2E and 3E]*

Steam flow is a mass flow measurement typically in kpph (thousand pounds per hour). This measurement can be made using a differential pressure transmitter across an orifice plate, venturi meter, or nozzle. In order to calculate mass flow, steam density compensation is required. With saturated steam, density can be determined by measuring the upstream static pressure.

#### *Feedwater Flow [3E only]*

Feedwater is pumped from the de-aerator tank. The de-aerator heats feedwater to boiling to remove dissolved oxygen, carbon dioxide and other gases. Dissolved gases contribute to boiler drum corrosion. Feedwater flow is a mass flow measurement and is typically measured using a differential pressure transmitter and primary element.

## **CONTROL**

Typically one of three control strategies is employed to control the boiler drum level.

#### *Single-Element Drum Level Control*

The single-element system is the simplest type used for controlling packaged firetube and watertube boilers. In this strategy, control is based on the boiler drum level measurement only. This does not allow for compensation of shrink or swell and, therefore, is an acceptable control strategy only for fairly constant steam demand applications; for example, small boilers with slow load changes.

#### *Two-Element Drum Level Control*

Two-element drum level control measures drum level and steam flow. It is a feedforward control loop. Feedwater tracks steam flow and responds directly to changes in steam load rather than indirectly by a change in drum level. The drum level trim algorithm uses a PID function block and adjusts feedwater flow to maintain drum level at setpoint. The feedwater control valve must

provide a flow rate that is linear with valve position in order to track steam mass flow. This control method permits tighter drum level control and is more tolerant of load changes.

Typically, steam load is measured as mass flow, kpph. A differential pressure transmitter across an orifice plate or venturi meter can be used to measure mass flow if steam density is taken into consideration. For a saturated steam boiler, density can be determined from the steam pressure. The SAMA<sup>1</sup> diagram in Figure 1 illustrates the flow calculation algorithm. In configuring a Model 353 controller, enable the square root extractor parameter within the analog input function block in order to linearize DP flow measurement. The analog input block is scaled for full mass flow at a reference pressure. The upstream static pressure is used to measure steam density. Referring to the steam tables, a characterizer function block is configured to convert absolute pressure into density. The actual mass flow is the measured flow multiplied by the measured density and divided by the reference density.

In 2-element drum level control, steam mass flow must be converted into percent (%) feedwater valve opening engineering units. In a Model 353, the conversion is performed using a characterizer function block. This permits scaling between steam mass flow measurement and valve position. It also permits linearization of the feedwater control valve.

Drum level trim is the controlled variable from the drum level PID function block. The engineering units are % valve opening. Drum level trim is summed with the feedwater flow in order to regulate feedwater control valve position. In the Model 353, the PID function block supports controlled variable scaling. Set the minimum scale at -100% and the maximum scale at +100%. This will enable the trim control to reduce and increase the flow control valve position.

---

<sup>1</sup> Scientific Apparatus Makers Association

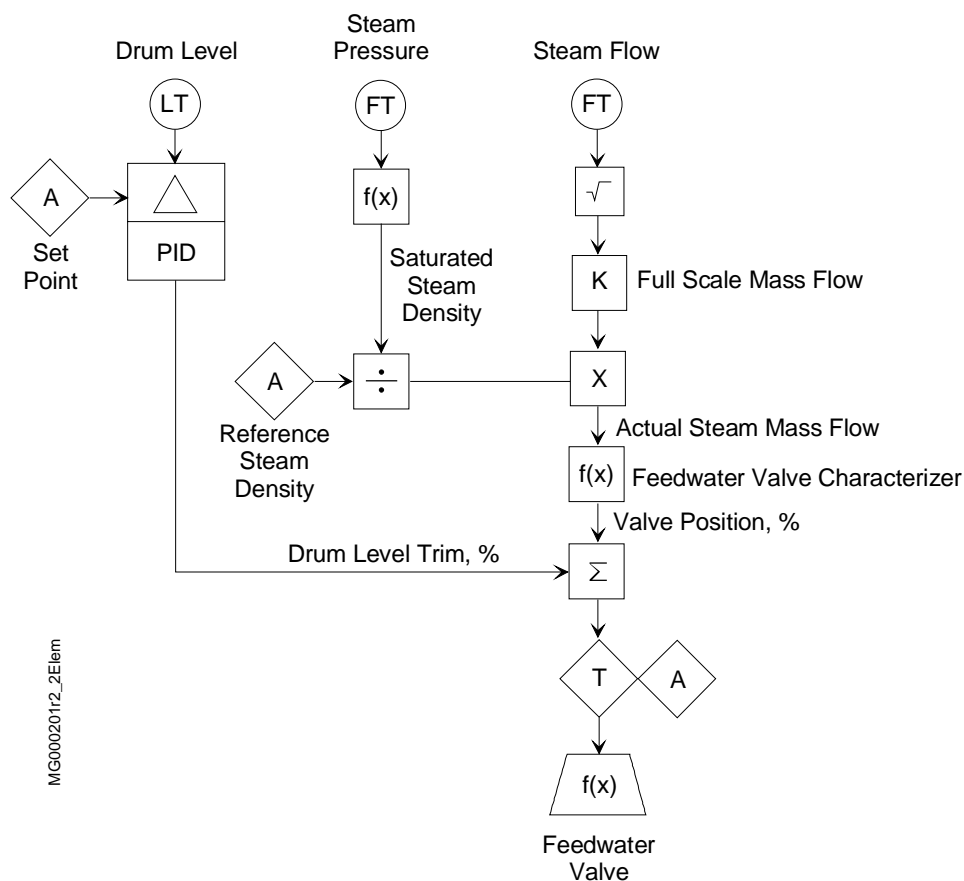

**FIGURE 1 2-Element Drum Level Control**

The PID feedback signal is important because it enables integral action. In 2-element control, the feedback signal is the feedwater control valve position (the output of the A/M function block) minus the equivalent steam flow valve position (feedwater valve characterizer). When the controller is in manual mode, the drum level trim PID function block is forced into tracking mode.

#### *Three-Element Drum Level Control*

Three-element drum level control measures drum level, steam flow, and feedwater flow. In 2-element control, the assumption is that the feedwater valve can provide an equal amount of feedwater to replace steam lost. Deviations between the two flows are compensated for by the reset value in the drum level PID function block. However, this compensation is sluggish due to the tuning parameters required for drum level control. Variations in drum pressure affect the feedwater flow rate and the result is drum level swings.

Three-element drum level control solves this by introducing a feedwater flow control loop. This separates the feedwater flow control from the drum level control, and it permits quick response to variances in feedwater flow without affecting drum level. The setpoint to the feedwater control loop is the sum of the steam load and the drum level trim.

Typically, steam load is measured as mass flow, kpph. A differential pressure transmitter across an orifice plate or venturi meter can be used to measure mass flow if steam density is taken into consideration. For a saturated steam boiler, density can be determined from the steam pressure. The SAMA diagram in Figure 2 illustrates the flow calculation algorithm. In configuring a Model 353 controller, enable the square root extractor parameter within the analog input function block in order to linearize DP flow measurement. The analog input block is scaled for full mass flow at a reference pressure. The

upstream static pressure is used to measure steam density. Referring to the steam tables, a characterizer function block is configured to convert absolute pressure into density. The actual mass flow is the measured flow multiplied by the measured density and divided by the reference density.

The PID function block requires the process variable and setpoint to be in the same engineering units. In 3-element control, the setpoint for the feedwater control loop is the sum of the steam flow and drum level trim. Fortunately, both steam mass flow and feedwater flow are measured in the same units, kpph, and this eliminates any need for flow conversions. The drum level trim must also be expressed in kpph

units. In the Model 353, the PID function block supports controlled variable scaling. Set the minimum scale at -100% of the maximum scale for the feedwater flow analog input function block. Set the maximum scale at +100% of the same value. This will enable the trim control to decrease and increase the feedwater control loop setpoint.

The PID feedback signal is important because it enables integral action. In 3-element control, the feedback signal is the feedwater flow rate minus the steam mass flow rate. When the controller is in manual mode, both the feedwater and drum level trim PID function blocks are forced into tracking mode.

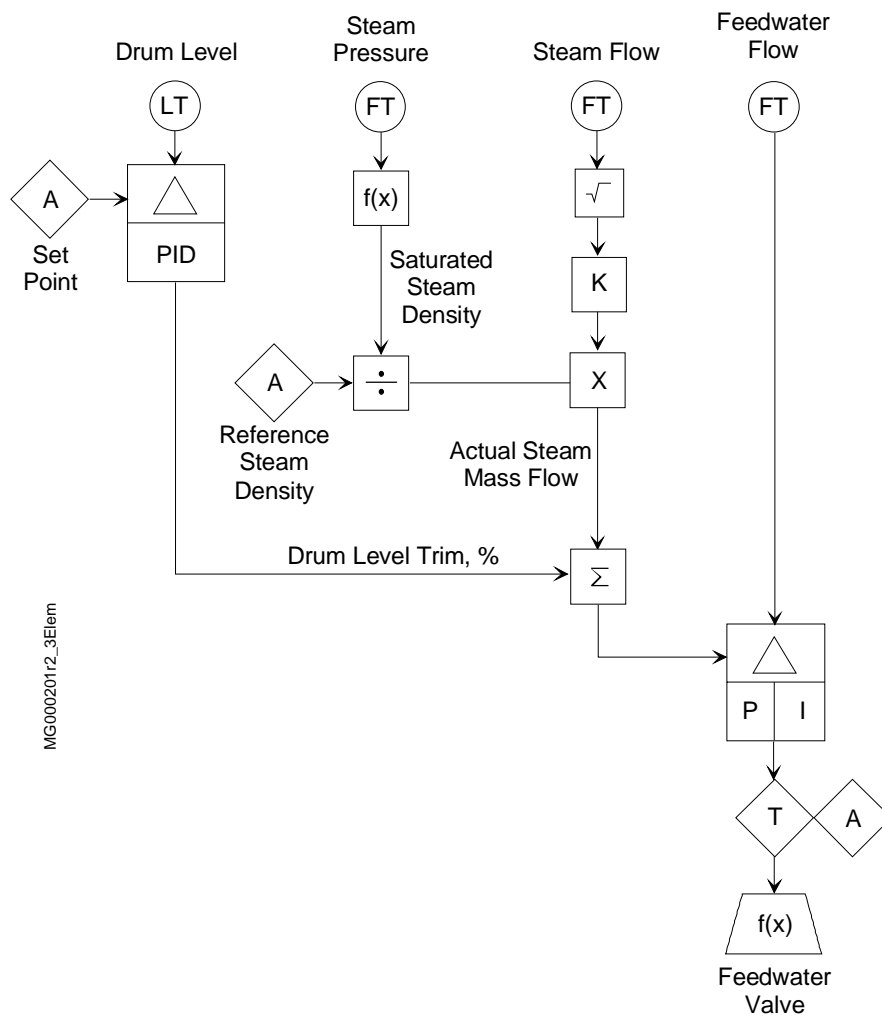

FIGURE 2 3-Element Drum Level Control

## APPLICATION SUPPORT

The next publication in this series is AD353-106, Furnace (Draft) Pressure Control. User manuals for controllers and transmitters, addresses of Siemens sales representatives, and more application data sheets can be found at [www.usa.siemens.com/ia](http://www.usa.siemens.com/ia). To reach the process controller page, click **Process Instrumentation** and then **Process Controllers and Recorders**. To select the type of assistance desired, click **Support** (in the right-hand column).

The control concepts in this publication can be developed into a controller configuration using the Siemens iconfig™ Graphical Configuration Utility.

Combustion management configurations can be created and run in the following Siemens controllers:

- Model 353 Process Automation Controller
- Model 353R Rack Mount Process Automation Controller\*
- ilpac Internet Control System\*
- Model 352*Plus* Single-Loop Digital Controller\*

\* Discontinued model

*All product designations may be trademarks or product names of Siemens Industry, Inc. or other supplier companies whose use by third parties for their own purposes could violate the rights of the owners.*

*Siemens Industry, Inc. assumes no liability for errors or omissions in this document or for the application and use of information in this document. The information herein is subject to change without notice.*

*Siemens Industry, Inc. is not responsible for changes to product functionality after the publication of this document. Customers are urged to consult with a Siemens Industry, Inc. sales representative to confirm the applicability of the information in this document to the product they purchased.*

*Control circuits are provided only to assist customers in developing individual applications. Before implementing any control circuit, it should be thoroughly tested under all process conditions.*

*Copyright © 2012, Siemens Industry, Inc.*