

# SIEMENS

## SIMATIC NET

### Industrial Ethernet switches SCALANCE XR-300M EEC

#### Compact Operating Instructions

<u>Introduction</u>	<b>1</b>
<u>Safety notes</u>	<b>2</b>
<u>Security recommendations</u>	<b>3</b>
<u>Device description</u>	<b>4</b>
<u>Installation and disassembly</u>	<b>5</b>
<u>Connecting</u>	<b>6</b>
<u>Maintenance and cleaning</u>	<b>7</b>
<u>Technical data</u>	<b>8</b>
<u>Dimension drawings</u>	<b>9</b>
<u>Approvals</u>	<b>10</b>
<u>Appendix</u>	<b>A</b>

## Legal information

### Warning notice system

This manual contains notices you have to observe in order to ensure your personal safety, as well as to prevent damage to property. The notices referring to your personal safety are highlighted in the manual by a safety alert symbol, notices referring only to property damage have no safety alert symbol. These notices shown below are graded according to the degree of danger.

 <b>DANGER</b>
indicates that death or severe personal injury <b>will</b> result if proper precautions are not taken.

 <b>WARNING</b>
indicates that death or severe personal injury <b>may</b> result if proper precautions are not taken.

 <b>CAUTION</b>
indicates that minor personal injury can result if proper precautions are not taken.

<b>NOTICE</b>
indicates that property damage can result if proper precautions are not taken.

If more than one degree of danger is present, the warning notice representing the highest degree of danger will be used. A notice warning of injury to persons with a safety alert symbol may also include a warning relating to property damage.

### Qualified Personnel

The product/system described in this documentation may be operated only by **personnel qualified** for the specific task in accordance with the relevant documentation, in particular its warning notices and safety instructions. Qualified personnel are those who, based on their training and experience, are capable of identifying risks and avoiding potential hazards when working with these products/systems.

### Proper use of Siemens products

Note the following:

 <b>WARNING</b>
Siemens products may only be used for the applications described in the catalog and in the relevant technical documentation. If products and components from other manufacturers are used, these must be recommended or approved by Siemens. Proper transport, storage, installation, assembly, commissioning, operation and maintenance are required to ensure that the products operate safely and without any problems. The permissible ambient conditions must be complied with. The information in the relevant documentation must be observed.

### Trademarks

All names identified by ® are registered trademarks of Siemens AG. The remaining trademarks in this publication may be trademarks whose use by third parties for their own purposes could violate the rights of the owner.

### Disclaimer of Liability

We have reviewed the contents of this publication to ensure consistency with the hardware and software described. Since variance cannot be precluded entirely, we cannot guarantee full consistency. However, the information in this publication is reviewed regularly and any necessary corrections are included in subsequent editions.

# Table of contents

<b>1</b>	<b>Introduction</b> .....	<b>5</b>
<b>2</b>	<b>Safety notes</b> .....	<b>11</b>
<b>3</b>	<b>Security recommendations</b> .....	<b>13</b>
<b>4</b>	<b>Device description</b> .....	<b>19</b>
4.1	Product overview .....	19
4.2	Product properties and device views.....	23
4.3	SET/SELECT button .....	24
4.4	LED display .....	25
4.5	C-PLUG .....	28
4.5.1	Area of application and function of the C-PLUG.....	28
4.5.2	Removal and insertion of the C-PLUG (rack devices).....	29
<b>5</b>	<b>Installation and disassembly</b> .....	<b>31</b>
5.1	Safety notices for installation .....	31
5.2	Suitable cables for temperatures above 70 °C - cable 50 °C - 70 °C (ATEX).....	31
5.3	Requirements for the cabinet EN 60529 (ATEX), UKEX, IECEx and CCC-Ex.....	32
5.4	Installation .....	33
5.5	19" rack mounting .....	34
5.6	Installation of modular devices.....	37
5.6.1	Installation and removal of media modules .....	37
5.6.2	SFP installation in SFP media module .....	41
<b>6</b>	<b>Connecting</b> .....	<b>43</b>
6.1	Safety when connecting up.....	43
6.2	Notes on commissioning.....	43
6.3	Wiring rules .....	44
6.4	Grounding .....	45
6.5	Signaling contact .....	46
6.5.1	24 VDC signaling contact (XR-300M EEC) .....	46
6.5.2	Signaling contact 100 to 240 VAC / 60 to 250 VDC.....	47
6.6	Diagnostics port.....	49
6.7	Power supply .....	50
6.7.1	Connecting devices with 24 V DC power supply .....	51
6.7.1.1	PELV .....	51
6.7.1.2	Overview .....	54
6.7.1.3	Connecting the external 24 VDC power supply .....	54
6.7.1.4	Connecting a redundant power supply to the XR300-EEC.....	55

- 6.7.2 Connecting devices with 100 to 240 V AC power supply ..... 57
- 6.7.2.1 Overview ..... 57
- 6.7.2.2 Connecting the 100 to 240 VAC power supply ..... 58
- 7 Maintenance and cleaning ..... 61**
- 8 Technical data ..... 63**
- 8.1 Construction, installation and environmental conditions..... 63
- 8.2 Connectors and electrical data ..... 65
- 8.3 Cable lengths..... 67
- 8.4 Block architecture ..... 68
- 8.5 Other properties ..... 69
- 9 Dimension drawings ..... 71**
- 9.1 XR-300M EEC dimension drawings ..... 71
- 10 Approvals ..... 75**
- 10.1 FDA and IEC XR-300M EEC marking ..... 81
- 10.2 XR-300M EEC mechanical stability (in operation) ..... 83
- A Appendix..... 85**
- A.1 Connector system M12/X-coded according to IEC 61076-2-109..... 85
- Index ..... 87**

# Introduction

## Purpose of the compact operating instructions

These compact operating instructions support you when installing and connecting devices of the XR-300M EEC product group.

## Validity of these compact operating instructions

These compact operating instructions are valid for the following devices:

- SCALANCE XR324-4M EEC

## Designations used

Classification	Description	Terms used
<b>Product line</b>	For all devices and variants of all product groups within the SCALANCE X-300 product line, the term "IE Switches X-300" is used.	IE Switches X-300
<b>Product group</b>	For all devices and variants of a product group, only the product group is used.	XR-300M EEC
<b>Device</b>	For a device, only the device name is used.	XR324-4M EEC
<b>Variant</b>	For a variant of the device, the device name has the appropriate variant added to it in brackets.	XR324-4M EEC (1 x 24 V DC, cable outlet front)

## Overview of technical documentation on the IE switches SCALANCE X-300

You will find the technical documentation for the SCALANCE X-300 product line in the following documents:

- Configuration manual (PH), available as PDF document  
The configuration manual describes the software for the two product lines SCALANCE X-300 and SCALANCE X-400.
- Compact operating instructions (BAK), supplied with the device in printed form  
The compact operating instructions describe devices within a product group.
- Operating instructions (BA), available as PDF document  
The operating instructions describe all devices of the product line and provide generally valid information on the devices.

Type of document	Relevant for the following products	Document identification number	Contents
<b>Configuration Manual</b>			
PH X300/X400	All devices of the SCALANCE X-300 and SCALANCE X-400 product lines	C79000-G89000-C187	Configuration of the device
<b>Operating instructions</b>			
BA X-300	All devices of the SCALANCE X-300 product line	A5E01113043	Device description, technical specifications, information on installing, connecting and commissioning
<b>Compact operating instructions</b>			
BAK X-300	SCALANCE X-300	A5E00982643A	Device description, technical specifications, information on installing, connecting and commissioning
BAK X-300M	SCALANCE X-300M	A5E02630801A	
BAK XR-300M	SCALANCE XR-300M	A5E02661171A	
BAK X-300 EEC	SCALANCE X-300EEC	A5E02661176A	
BAK XR-300M EEC	SCALANCE XR-300M EEC	A5E02630809A	
BAK X-300M PoE	SCALANCE X-300M PoE	A5E02630810A	
BAK XR-300M PoE	SCALANCE XR-300M PoE	A5E02661178A	
BAK MM900	SCALANCE MM900 (media modules)	A5E02630805A	
BAK SFP Information sheet	SCALANCE SFP (plug-in transceivers)	A5E02630804A A5E02648904A	Device description, technical specifications, information on installing, connecting and commissioning

## Documentation on configuration

You will find detailed information on configuring the devices in the configuration manual:

- SIMATIC NET: Industrial Ethernet switches SCALANCE X-300 / X-400 Configuration Manual

You will find the Configuration Manual here:

- On the data medium that ships with some products:
  - Product CD / product DVD
  - SIMATIC NET Manual Collection
- On the Internet pages of Siemens Industry Online Support (<https://support.industry.siemens.com/cs/ww/en/ps/15297/man>).

## Additional documentation

The manual

- "SIMATIC NET Industrial Ethernet Twisted Pair and Fiber Optic Networks (<https://support.industry.siemens.com/cs/ww/en/view/1172207>)"

contains additional information on other SIMATIC NET products that you can operate along with the devices of the SCALANCE X-300 product line in an Industrial Ethernet network.

## Integration in STEP 7 projects

The current GSDML file must be used for integration in STEP 7 V5.4 SP5 projects. This applies to all products covered by these operating instructions.

You can obtain the relevant GSD file from the Internet under the following entry ID:

46183514 (<https://support.industry.siemens.com/cs/ww/en/view/46183514>)

You will find the file for the firmware update V3.3.1 for X-300 under entry ID "46183538".

## Further documentation

In the system manuals "Industrial Ethernet / PROFINET Industrial Ethernet" and "Industrial Ethernet / PROFINET passive network components", you will find information on other SIMATIC NET products that you can operate along with the devices of this product line in an Industrial Ethernet network.

There, you will find among other things optical performance data of the communications partner that you require for the installation.

You will find the system manuals here:

- On the data medium that ships with some products:
  - Product CD / product DVD
  - SIMATIC NET Manual Collection
- On the Internet pages of Siemens Industry Online Support:
  - Industrial Ethernet / PROFINET Industrial Ethernet System Manual (<https://support.industry.siemens.com/cs/ww/en/view/27069465>)
  - Industrial Ethernet / PROFINET Passive Network Components System Manual (<https://support.industry.siemens.com/cs/ww/en/view/84922825>)

## SIMATIC NET manuals

You will find the SIMATIC NET manuals here:

- On the Internet pages of Siemens Industry Online Support (<https://support.industry.siemens.com/cs/ww/en/ps/15247>).

## SIMATIC NET glossary

Explanations of many of the specialist terms used in this documentation can be found in the SIMATIC NET glossary.

You will find the SIMATIC NET glossary here:

- SIMATIC NET Manual Collection or product DVD  
The DVD ships with certain SIMATIC NET products.
- On the Internet under the following address:  
50305045 (<https://support.industry.siemens.com/cs/ww/en/view/50305045>)

## Security information

Siemens provides products and solutions with industrial security functions that support the secure operation of plants, systems, machines and networks.

In order to protect plants, systems, machines and networks against cyber threats, it is necessary to implement – and continuously maintain – a holistic, state-of-the-art industrial security concept. Siemens' products and solutions constitute one element of such a concept.

Customers are responsible for preventing unauthorized access to their plants, systems, machines and networks. Such systems, machines and components should only be connected to an enterprise network or the internet if and to the extent such a connection is necessary and only when appropriate security measures (e.g. firewalls and/or network segmentation) are in place.

For additional information on industrial security measures that may be implemented, please visit

<https://www.siemens.com/industrialsecurity> (<http://www.siemens.com/industrialsecurity>).

Siemens' products and solutions undergo continuous development to make them more secure. Siemens strongly recommends that product updates are applied as soon as they are available and that the latest product versions are used. Use of product versions that are no longer supported, and failure to apply the latest updates may increase customer's exposure to cyber threats.

To stay informed about product updates, subscribe to the Siemens Industrial Security RSS Feed under

<https://www.siemens.com/cert> (<https://www.siemens.com/cert>).

## Catalogs

You will find the article numbers for the Siemens products of relevance here in the following catalogs:

- SIMATIC NET Industrial Communication / Industrial Identification, catalog IK PI
- SIMATIC Products for Totally Integrated Automation and Micro Automation, catalog ST 70
- Industry Mall - catalog and ordering system for automation and drive technology, Online catalog (<https://mall.industry.siemens.com/goos/WelcomePage.aspx?regionUrl=/de&language=en>)

You can request the catalogs and additional information from your Siemens representative.

## Device defective

If a fault develops, send the device to your SIEMENS representative for repair. Repairs on-site are not possible.



## Decommissioning

Shut down the device properly to prevent unauthorized persons from accessing confidential data in the device memory.

To do this, restore the factory settings on the device.

Also restore the factory settings on the storage medium.

## Recycling and disposal



The products are low in pollutants, can be recycled and meet the requirements of the WEEE directive 2012/19/EU for the disposal of electrical and electronic equipment.

Do not dispose of the products at public disposal sites.

For environmentally friendly recycling and the disposal of your old device contact a certified disposal company for electronic scrap or your Siemens contact (Product return (<https://support.industry.siemens.com/cs/ww/en/view/109479891>)).

Note the different national regulations.

SCALANCE, C-PLUG, OLM

## Trademarks

The following and possibly other names not identified by the registered trademark sign ® are registered trademarks of Siemens AG:



## Safety notes

### Read the safety notices

Note the following safety notices. These relate to the entire working life of the device.

You should also read the safety notices relating to handling in the individual sections, particularly in the sections "Installation" and "Connecting up".

 <b>CAUTION</b>
To prevent injury and damage, read the manual before using the device.

### Safety notices on use in hazardous areas

#### General safety notices relating to protection against explosion

 <b>WARNING</b>
<b>EXPLOSION HAZARD</b>
Do not open the device when the supply voltage is turned on.

#### Safety notices when using the device according to Hazardous Locations (HazLoc)

If you use the device under HazLoc conditions you must also keep to the following safety notices in addition to the general safety notices for protection against explosion:

This equipment is suitable for use in Class I, Division 2, Groups A, B, C and D or non-hazardous locations only.

This equipment is suitable for use in Class I, Zone 2, Group IIC or non-hazardous locations only.



# Security recommendations

## NOTICE

### Information security

Connect to the device and change the standard passwords for the users "admin" and "user" before you operate the device. To be able to change passwords you need to be logged in with write access to the configuration data.

To prevent unauthorized access to the device and/or network, observe the following security recommendations.

## General

- Check the device regularly to ensure that these recommendations and/or other internal security policies are complied with.
- Evaluate the security of your location and use a cell protection concept with suitable products (<https://www.industry.siemens.com/topics/global/en/industrial-security/pages/default.aspx>).
- When the internal and external network are disconnected, an attacker cannot access internal data from the outside. Therefore operate the device only within a protected network area.
- No product liability will be accepted for operation in a non-secure infrastructure.
- Use VPN to encrypt and authenticate communication from and to the devices.
- For data transmission via a non-secure network, use an encrypted VPN tunnel (IPsec, OpenVPN).
- Separate connections correctly (WBM, SSH etc.).
- Check the user documentation of other Siemens products that are used together with the device for additional security recommendations.
- Using remote logging, ensure that the system protocols are forwarded to a central logging server. Make sure that the server is within the protected network and check the protocols regularly for potential security violations or vulnerabilities.

## Physical access

- Restrict physical access to the device to qualified personnel because the plug-in data medium can contain sensitive data.
- Lock unused physical interfaces on the device. Unused interfaces can be used to gain access to the plant without permission.

## Software (security functions)

- Keep the firmware up to date. Check regularly for security updates for the device. You can find information on this at the Industrial Security (<https://www.siemens.com/industrialsecurity>) website.
- Inform yourself regularly about security recommendations published by Siemens ProductCERT (<https://www.siemens.com/cert/en/cert-security-advisories.htm>).
- Only activate protocols that you require to use the device.
- Restrict access to the management of the device with rules in an access control list (ACL).
- The option of VLAN structuring provides protection against DoS attacks and unauthorized access. Check whether this is practical or useful in your environment.
- Use a central logging server to log changes and accesses. Operate your logging server within the protected network area and check the logging information regularly.

## Authentication

---

### Note

#### Accessibility risk - Risk of data loss

Do not lose the passwords for the device. Access to the device can only be restored by resetting the device to factory settings which completely removes all configuration data.

---

- Replace the default passwords for all user accounts, access modes and applications (if applicable) before you use the device.
- Define rules for the assignment of passwords.
- Use passwords with a high password strength. Avoid weak passwords, (e.g. password1, 123456789, abcdefgh) or recurring characters (e.g. abcabc). This recommendation also applies to symmetrical passwords/keys configured on the device.
- Make sure that passwords are protected and only disclosed to authorized personnel.
- Do not use the same passwords for multiple user names and systems.
- Store the passwords in a safe location (not online) to have them available if they are lost.
- Regularly change your passwords to increase security.
- A password must be changed if it is known or suspected to be known by unauthorized persons.
- When user authentication is performed via RADIUS, make sure that all communication takes place within the security environment or is protected by a secure channel.
- Watch out for link layer protocols that do not offer their own authentication between endpoints, such as ARP or IPv4. An attacker could use vulnerabilities in these protocols to attack hosts, switches and routers connected to your layer 2 network, for example, through manipulation (poisoning) of the ARP caches of systems in the subnet and subsequent interception of the data traffic. Appropriate security measures must be taken for non-secure layer 2 protocols to prevent unauthorized access to the network. Physical access to the local network can be secured or secure, higher layer protocols can be used, among other things.

## Certificates and keys

---

### Note

#### ECDSA certificates for SCALANCE X300 and SCALANCE X408-2

The following applies to devices of the SCALANCE X-300 product series and devices of the SCALANCE X408-2 type (devices of the SCALANCE X414-3E type are not affected):

As of firmware version V4.1.4, there has been a conversion from RSA certificates to certificates for elliptic curves cryptography ("ECDSA certificates"). Only use ECDSA certificates in PEM format that were generated with the following curves:

- secp256r1 (NIST P-256)
- secp384r1 (NIST P-384)
- secp521r1 (NIST P-521)

RSA certificates are no longer supported as of this firmware version. The existing RSA certificates on the device are automatically replaced with self-signed ECDSA certificates.

---

- On the device there is a preset SSL certificate with the key length 256 bits for the elliptic-curves cryptography. Replace this certificate with a self-made certificate with key. We recommend that you use a certificate signed either by a reliable external or by an internal certification authority.
- Use a certification authority including key revocation and management to sign certificates.
- Make sure that user-defined private keys are protected and inaccessible to unauthorized persons.
- Verify certificates and fingerprints on the server and client to prevent "man in the middle" attacks.
- It is recommended that you use certificates with a key length of at least 256 bits.
- Change certificates and keys immediately if there is a suspicion of compromise.

## Secure/non-secure protocols

- Avoid or disable non-secure protocols, for example Telnet and TFTP. For historical reasons, these protocols are available, however not intended for secure applications. Use non-secure protocols on the device with caution.
- Check whether use of the following protocols and services is necessary:
  - Non authenticated and unencrypted ports
  - MRP, HRP
  - LLDP
  - DHCP Options 66/67

The following protocols provide secure alternatives:

- HTTP → HTTPS
  - TFTP → FTPS
  - Telnet → SSH
  - SNMP → NTP  
Check whether use the use of NTP is necessary. NTP is classified as non-secure. Activate Secure NTP when the NTP server supports this protocol and use the authentication and encryption mechanisms of Secure NTP.
  - SNMPv1/v2c → SNMPv3  
Check whether use of SNMPv1/v2c. is necessary. SNMPv1/v2c are classified as non-secure. Use the option of preventing write access. The device provides you with suitable setting options.  
If SNMP is enabled, change the community names. If no unrestricted access is necessary, restrict access with SNMP.  
Use the authentication and encryption mechanisms of SNMPv3.
- Use secure protocols when access to the device is not prevented by physical protection measures.
  - If you require non-secure protocols and services, operate the device only within a protected network area.
  - Restrict the services and protocols available to the outside to a minimum.
  - For the DCP function, enable the "DCP read-only" mode after commissioning.

## Available protocols

The following list provides you with an overview of the open protocol ports.

The table includes the following columns:

- **Protocol**
- **Port number**
- **Port status**
  - Open
  - Closed



- **Factory setting**  
Indicates the state of the port on delivery or after reset to factory settings.
- **Authentication**  
Specifies whether the communication partner is authenticated.
- **Encryption**  
Specifies whether or not the transfer is encrypted.

Protocol	Port number	Port status	Factory setting	Authentication	Encryption <sup>1)</sup>
FTP	TCP/21	Open	Open	✓	-
SSH	TCP/22	Open	Open	✓	✓
TELNET	TCP/23	Open (when configured)	Closed	✓	-
HTTP	TCP/80	Open (when configured)	Open	✓	-
PROFINET Service	TCP/84	Open	Open	-	-
HTTPS	TCP/443	Open	Open	✓	✓
DHCP	UDP/68	Open (when configured)	Open	-	-
SNTP	UDP/123	Open (when configured)	Closed	-	-
NTP (secure)					✓
SNMP	UDP/161	Open (when configured)	Open	✓	✓ (SNMPv3)
RADIUS	UDP/1812, 1813	Open	Open	✓	-
PROFINET	UDP/34964 UDP/49152, 49153 *)	Open (when configured)	Open	-	-

<sup>1)</sup> You can find additional information on the encryption methods used in the WBM appendix "Ciphers used".

\*) These ports are assigned dynamically and can differ from the values specified here.

## Decommissioning

Shut down the device properly to prevent unauthorized persons from accessing confidential data in the device memory.

To do this, restore the factory settings on the device.

Also restore the factory settings on the storage medium.



## Device description

### 4.1 Product overview

#### Article numbers

Device	Properties	Article number
XR324-4M EEC	1 x 24 to 48 V DC LEDs, connector data cable outlet on front Connector power supply and diagnostics port at rear Pressed-in grounding bolts	6GK5 324-4GG00-1ER2 6GK5 324-4GG10-1ER2
	2 x 24 to 48 V DC LEDs, connector data cable outlet on front Connector power supply and diagnostics port at rear Pressed-in grounding bolts	6GK5 324-4GG00-2ER2 6GK5 324-4GG10-2ER2
	1 x 100 to 240 V AC / 60 to 250 V DC LEDs, connector data cable outlet on front Connector power supply and diagnostics port at rear Pressed-in grounding bolts	6GK5 324-4GG00-3ER2 6GK5 324-4GG10-3ER2
	2 x 100 to 240 V AC / 60 to 250 V DC LEDs, connector data cable outlet on front Connector power supply and diagnostics port at rear Pressed-in grounding bolts	6GK5 324-4GG00-4ER2 6GK5 324-4GG10-4ER2
	1 x 24 to 48 V DC LEDs, connector power supply on front Data cable outlet and diagnostics port at rear Pressed-in grounding bolts	6GK5 324-4GG00-1JR2 6GK5 324-4GG10-1JR2
	2 x 24 to 48 V DC LEDs, connector power supply on front Data cable outlet and diagnostics port at rear Pressed-in grounding bolts	6GK5 324-4GG00-2JR2 6GK5 324-4GG10-2JR2
	1 x 100 to 240 V AC / 60 to 250 V DC LEDs, connector power supply on front Data cable outlet and diagnostics port at rear Pressed-in grounding bolts	6GK5 324-4GG00-3JR2 6GK5 324-4GG10-3JR2
	2 x 100 to 240 V AC / 60 to 250 V DC LEDs, connector power supply on front Data cable outlet and diagnostics port at rear Pressed-in grounding bolts	6GK5 324-4GG00-4JR2 6GK5 324-4GG10-4JR2

### Structure of the type designation

The type designation of an IE Switch X-300 is made up of several parts that have the following meaning:

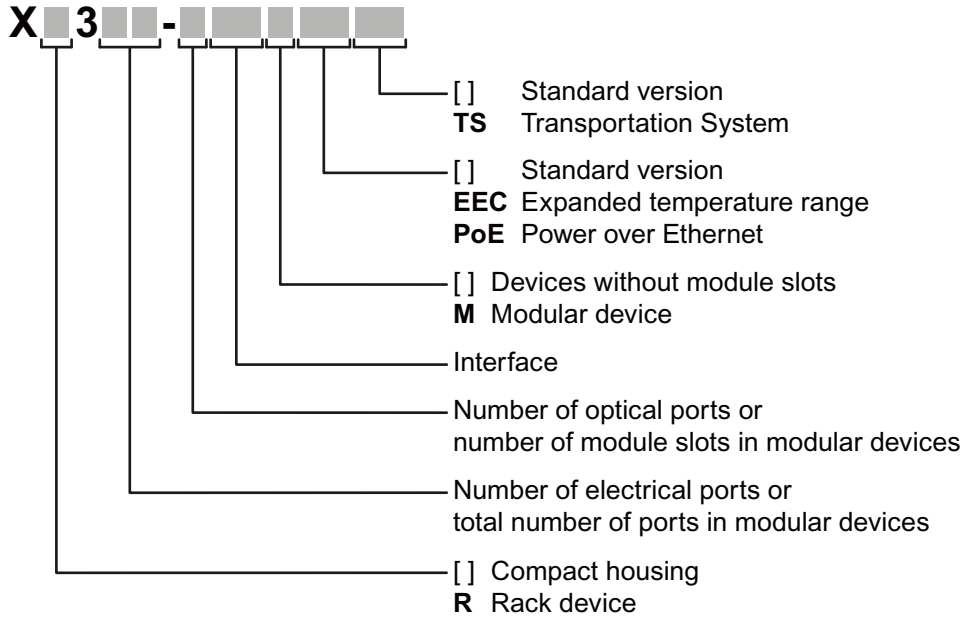

Interfaces of devices without optical ports:

Interface	Property
FE	Electrical RJ-45 port for 10/100 Mbps.
[-]	Electrical RJ-45 port for 10/100 Mbps and 10/100/1000 Mbps.

Interfaces of devices with optical ports:

Interface	Property
FE	SC port 100 Mbps multimode FO cable (up to max. 5 km).
LD FE	SC port 100 Mbps single mode FO cable (up to max. 26 km).
[-]	SC port 1000 Mbps multimode FO cable (up to max. 750 m).
LD	SC port 1000 Mbps single mode FO cable (up to max. 10 km).
LH	SC port 1000 Mbps single mode FO cable (up to max. 40 km).
LH+	SC port 1000 Mbps single mode FO cable (up to max. 70 km).

If information applies to all devices, the term "IE Switches X-300" is used. If information applies to only a particular product group, the relevant names will be used without extra information on the type or number of interfaces. Examples: "X-300" stands for non-modular devices with a compact housing, "XR-300" means all rack devices, "X-300M" means all modular devices etc.

## Unpacking and checking

 <b>WARNING</b>
<b>Do not use any parts that show evidence of damage</b>
If you use damaged parts, there is no guarantee that the device will function according to the specification.
If you use damaged parts, this can lead to the following problems:
<ul style="list-style-type: none"><li>• Injury to persons</li><li>• Loss of the approvals</li><li>• Violation of the EMC regulations</li><li>• Damage to the device and other components</li></ul>
Use only undamaged parts.

1. Make sure that the package is complete.
2. Check all the parts for transport damage.

## Scope of delivery

---

### Note

When shipped, the slots for the media modules have dummy covers fitted.

---

### Note

Labels to identify the installed MM900 media modules are supplied with the modular devices (M).

---

The following components are supplied with a SCALANCE XR-300M EEC:

- 1 x device with one C-PLUG exchangeable medium (article number of the C-PLUG: 6GK1900-0AB00)
- 2x mounting brackets and 8x screws (M3x5 recessed head, drive: Torx) for 19" rack installation
  - With devices with 6GK5 324-4GG00-\*, the mounting brackets ship with the product
  - With devices with 6GK5 324-4GG10-\*, the mounting brackets are premounted
- 1 x connecting cable for the diagnostics port
- 1 x product CD with documentation and software

#### 4.1 Product overview

- With devices with power supply 100 to 240 V AC / 60 to 250 V DC:
  - A 3-pin terminal block (or two terminal blocks for redundant power supply) for the signaling contacts
  - A 3-pin terminal block (or two terminal blocks for redundant power supply) for the power supply
- With devices with power supply 24 V to 48 V DC:
  - A 2-pin terminal block (or two terminal blocks for redundant power supply) for the signaling contacts
  - A 4-pin terminal block (or two terminal blocks for redundant power supply) for the power supply

## 4.2 Product properties and device views

### Connection options with the SCALANCE XR324-4M EEC

The SCALANCE XR324-4M EEC is a partially modular device and has 24 ports.

- **16 fixed ports in the base device:**  
16 RJ-45 jacks for connection of end devices or other network segments.
- **8 modular ports via module slots:**  
4 modules can be combined using slots (S1-S4) depending on the application. End devices and other network segments are connected according to the modules being used.



Figure 4-1 XR324-4M EEC

 <b>CAUTION</b>
<b>Use only approved media modules</b>
If you use media modules that are not approved by Siemens AG, there is no guarantee that the device will function according to the specification.
If you use unapproved media modules, this can lead to the following problems:
<ul style="list-style-type: none"> <li>• Damage to the device</li> <li>• Loss of the approvals</li> <li>• Violation of the EMC regulations</li> </ul>
Use only approved media modules.

<b>Slot number</b>									S1		S2	
<b>Port number</b>	P1	P2	P3	P4	P5	P6	P7	P8	P1	P2	P1	P2
<b>Slot number</b>									S3		S4	
<b>Port number</b>	P9	P10	P11	P12	P13	P14	P15	P16	P1	P2	P1	P2

## 4.3 SET/SELECT button

The SET/SELECT button is located on the top of the housing of devices of the X-300 EEC series. On all other devices, this button is on the front panel of the housing beside the LED display. The SET/SELECT button has several functions that are described below.

### Change the display mode

By pressing the button briefly, you change to the display mode of the LED display. For more detailed information on this topic, refer to the section "LED display".

### Resetting the device to the factory defaults

If you reset, all the changes you have made will be overwritten by factory defaults. Follow the steps outlined below:

1. Turn on display mode A. Display mode A is active when the "DM" LED is not lit. If this LED is lit or flashing, you will need to press the SET/SELECT briefly (possibly several times) until the "DM" LED goes off. If the SELECT/SET button is not pressed for longer than a minute, the device also turns on display mode A.
2. Hold down the SELECT/SET button for 12 seconds. If you release the button before the 12 seconds have elapsed, the reset is canceled.

### Definition of the fault mask

Using the fault mask, you specify an individual "good status" for the connected ports and the power supply. Deviations from this status are then displayed as errors/faults.

1. Turn on display mode A or D. Display mode A is active when the "DM" LED is not lit. Display mode D is active when the "DM" LED flashes yellow/orange. If a different display mode is active, you will need to press the SET/SELECT briefly (possibly several times) until the required display mode is active.
2. Hold down the SET/SELECT button for five seconds. After three seconds, the "DM" LED begins to flash. If you release the button before the five seconds have elapsed, the previous fault mask will be retained.

### Enable/disable the redundancy manager

1. Turn on display mode B. Display mode B is active when the "DM" LED is lit green. If a different display mode is active, you will need to press the SET/SELECT briefly (possibly several times) until display mode B is active.
2. Hold down the SET/SELECT button for five seconds. After three seconds, the "DM" LED begins to flash. If you release the button before the five seconds have elapsed, the action is aborted.
3. The result of the action depends on the initial situation:
  - If the redundancy manager and media redundancy were disabled, media redundancy is also enabled after enabling the redundancy manager.
  - If you disable the redundancy manager, media redundancy remains enabled.



## 4.4 LED display

### The "RM" LED for the "redundancy manager" function

The "RM" LED indicates whether or not the device is operating in the role of redundancy manager and whether or not the ring is operating error-free.

LED color	LED status	Meaning
-	off	The device is not operating in the role of "redundancy manager".
green	on	The device is operating in the role of redundancy manager. The ring is working without problems, monitoring is activated.
green	flashes	The device is operating in the role of redundancy manager. An interruption has been detected on the ring and the device has switched through.

### The "SB" LED for the standby function

This LED shows the status of the standby function.

LED color	LED status	Meaning
-	off	The standby function is disabled.
green	on	The standby function is enabled. The standby section is passive.
green	flashes	The standby function is enabled. The standby section is active.

### The "F" LED for the fault status

The "F" LED (fault) provides information on the error/fault status of the device. While the device is starting up, this LED has the following meaning:

LED color	LED status	Meaning during the device startup
-	off	Device startup completed successfully.
red	on	Device startup not yet completed or a fault/error has occurred.
red	flashes	Bad firmware image.

During normal operation, the "F" LED provides the following information:

LED color	LED status	Meaning during operation
-	off	No operating problems.
red	on	The device has detected an error. The signaling contact opens.

### The "DM" LED for the display mode

The "DM" LED (Display Mode) indicates which of the four display modes A, B, C or D is currently active. The meaning of the L1, L2 and P1, P2, ... LEDs depends on the display mode.

LED color	LED status	Meaning
-	off	Display mode A
green	on	Display mode B
orange	on	Display mode C
yellow/orange	flashes	Display mode D

### Selecting the display mode

Press the SELECT/SET button to set the required display mode. If the SELECT/SET button is not pressed for longer than a minute, the device automatically changes to display mode A.

Pressing the SELECT/SET button starting at display mode A	Status of the "DM" LED	Display mode
-	off	Display mode A (default mode)
Press once	lit green	Display mode B
Press twice	lit orange	Display mode C
Press 3 times	flashes yellow/orange	Display mode D

### The "L1" and "L2" or "L" LEDs for the power supply

Whereas on other devices, the "L1" and "L2" LEDs indicate information about the power, on the SCALANCE X306-1LD FE, this is done by the "L" LED. A redundant power supply for this device can be recognized by the color of the LED.

#### Meaning in display mode A, B or C

LED	Color	Status	Meaning
L1 / L2	-	off	Power supply L1 / L2 lower than 17 V *)
	green	on	Power supply L1 / L2 higher than 17 V *)
L	-	off	Power supplies L1 and L2 less than 17 V or not connected.
	orange	on	Power supply L1 or L2 higher than 17 V (no redundant supply).
	green	on	Power supplies L1 and L2 higher than 17 V (redundant supply).

\*) for the X-300EEC the following applies:

- For devices with power supply unit 24 to 48 VDC: Limit voltage = 17 VDC
- For devices with a multiple range power supply unit 100 to 240 VAC / 60 to 250 VDC: Limit voltage = 46.5 VDC or 80 VAC

### Meaning in display mode D

LED	Color	Status	Meaning
L1 / L2	–	off	Power supply L1 / L2 is not monitored. If L1 / L2 falls below 17 V <sup>*)</sup> , the signaling contact does not respond.
	green	on	Power supply L1 / L2 is monitored. If L1 / L2 falls below 17 V <sup>*)</sup> , the signaling contact responds.
L	-	off	Power supplies L1 and L2 are not monitored. If L1 or L2 falls below 17 V, the signaling contact does not respond.
	orange	on	Power supply L1 or L2 is monitored. If L1 or L2 falls below 17 V, the signaling contact responds.
	green	on	Power supplies L1 and L2 are monitored. If L1 and L2 fall below 17 V, the signaling contact responds.
<sup>*)</sup> for the X-300EEC the following applies: <ul style="list-style-type: none"> <li>• For devices with power supply unit 24 to 48 VDC: Limit voltage = 17 VDC</li> <li>• For devices with a multiple range power supply unit 100 to 240 VAC / 60 to 250 VDC: Limit voltage = 46.5 VDC or 80 VAC</li> </ul>			

### Note

#### Devices of the X-300EEC product group

When using only one power supply unit 24 VDC and two 24 VDC power supplies, the LEDs "L1" and "L2" signal the existence of the power supply L1 and L2.

When using two 24 VDC power supply units, the LEDs "L1" and "L2" signal the existence of the primary voltage and the secondary voltage for both power supply units. If the power supply is intact, a fault occurring on a power supply unit on the secondary side can be recognized.

### The P1, P2, ... LEDs for the port status

The P1, P2, ... LEDs show information on the status of their port (transmission speed, mode, port monitoring). The meaning of these LEDs depends on the display mode ("DM" LED).

#### Meaning in display mode A

LED color	LED status	Meaning
-	off	No valid link to the port (for example station turned off or cable not connected).
green	on	Link exists and port in normal status. In this status, the port can receive and send data.
	flashes once per second	Link exists and port in "blocking" status. In this status, the port only sends and receives management data (no user data).
	flashes 3 times per second	Link exists and port turned off by management. In this status, no data is sent or received via the port.
	flashes 4 times per second	Port exists and is in the "monitor port" status. In this status, the data traffic of another port is mirrored to this port.
yellow	flashes / lit	Receiving data at port. With SCALANCE X-300 devices, both the receipt and the sending of data is indicated for the optical gigabit ports.

**Meaning in display mode B**

LED color	LED status	Meaning
-	off	Port operating at 10 Mbps.
green	on	Port operating at 100 Mbps.
orange	on	Port operating at 1000 Mbps.

If there is a problem on the connection and the type of transmission is fixed (autonegotiation off), the desired status, in other words the set transmission speed (1000 Mbps, 100 Mbps, 10 Mbps) continues to be displayed. If there is a problem on the connection and autonegotiation is active, the port LED goes off.

**Meaning in display mode C**

LED color	LED status	Meaning
-	off	Port operating in half duplex.
green	on	Port operating in full duplex.

**Meaning in display mode D**

LED color	LED status	Meaning
-	off	The port is not monitored; in other words, if a link is not established at the port, this does not trigger the signaling contact.
green	on	The port is monitored, in other words, if no connection was established at the port (for example no cable inserted), this triggers the signaling contact and an error state results.
orange	on	The port is monitored, in other words, when a valid connection exists at the port (for example non-permitted cable inserted), this triggers the signaling contact and an error state results.

## 4.5 C-PLUG

### 4.5.1 Area of application and function of the C-PLUG

#### Area of application

The C-PLUG (configuration plug) that ships with the product is an exchangeable memory medium for storing the configuration data of the device. The device can also be operated without a C-PLUG.

This allows fast and uncomplicated replacement of a device. The C-PLUG is taken from the previous device and inserted in the new device. The first time it is started up, the replacement device has the same configuration as the previous device except for the MAC address set by the vendor.

## Principle

The data remains stored on the C-PLUG even when power is turned off. In terms of using the C-PLUG, there are two ways of operating the device:

- **With unwritten C-PLUG**  
If an empty C-PLUG (factory settings or deleted with the Clean function) is inserted, all the configuration data of the device is saved to it automatically when the device starts up. Changes to the configuration during operation are saved without operator intervention on the C-PLUG if this is in the "ACCEPTED" status. This depends on how you configured your SCALANCE device. In this mode, the internal memory is neither read nor written. This mode is active when a C-PLUG is inserted.
- **With written C-PLUG**  
A device with an accepted C-PLUG inserted uses the configuration data of the C-PLUG automatically when it starts up. Acceptance is possible only when the data was written by a compatible device type.

## Response to errors

Inserting a C-PLUG that does not contain the configuration of a compatible device type, accidentally removing the C-PLUG or general malfunctions of the C-PLUG are signaled by the diagnostics mechanisms of the device (LEDs, Web-based management, SNMP, CLI and PROFINET diagnostics).

### 4.5.2 Removal and insertion of the C-PLUG (rack devices)

<b>NOTICE</b>
A C-PLUG may only be removed or inserted when the device is turned off.

#### Position of the C-PLUG with rack devices

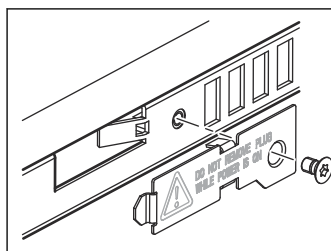

With rack devices, the slot is below a cover on the right-hand side of the housing. After undoing the screw (screw head Torx T10), the cover plate can be removed and the slot is accessible.

### Removing the C-PLUG

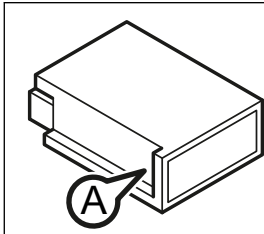

1. Turn off the power to the device.
2. Remove the cover plate on the right-hand side of the device.
3. Insert a screwdriver between the front edge of the C-PLUG (position A) and the slot and release the C-PLUG.
4. Remove the C-PLUG and screw the cover plate firmly in place again.

### Inserting the C-PLUG

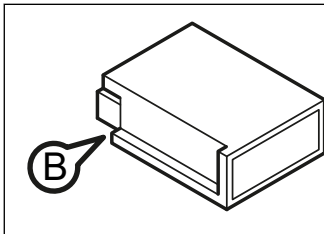

1. Turn off the power to the device.
2. Remove the cover plate on the right-hand side of the device.
3. The housing of the C-PLUG has a protruding ridge on the long side (position B). The slot has a groove at this position. Insert the C-PLUG correctly oriented into the slot.
4. Secure the cover plate again with the screws.

## Installation and disassembly

### 5.1 Safety notices for installation

#### Safety notices

When installing the device, keep to the safety notices listed below.

 **WARNING**

If a device is operated in an ambient temperature of more than 50 °C, the temperature of the device housing may be higher than 70 °C. The device must therefore be installed so that it is only accessible to service personnel or users that are aware of the reason for restricted access and the required safety measures at an ambient temperature higher than 50 °C.

 **WARNING**

If the device is installed in a cabinet, the inner temperature of the cabinet corresponds to the ambient temperature of the device.

### 5.2 Suitable cables for temperatures above 70 °C - cable 50 °C - 70 °C (ATEX)

 **WARNING**

**Suitable cables at high ambient temperatures**

If the temperature of the cable or housing socket exceeds 70 °C or the branching point of conductors exceeds 80 °C, special precautions must be taken.

If the device is operated at ambient temperatures of between 50 °C and 70 °C, only use cables with a maximum permitted operating temperature of at least 80 °C.

**NOTICE**

**Improper mounting**

Improper mounting may damage the device or impair its operation.

- Before mounting the device, always ensure that there is no visible damage to the device.
- Mount the device using suitable tools. Observe the information in the respective section about mounting.

## Safety notices on use in hazardous areas

### General safety notices relating to protection against explosion

 **WARNING**

**EXPLOSION HAZARD**

Replacing components may impair suitability for Class 1, Division 2 or Zone 2.

 **WARNING**

The device is intended for indoor use only.

 **WARNING**

The device may only be operated in an environment of contamination class 1 or 2 (see EN/IEC 60664-1, GB/T 16935.1).

 **WARNING**

When used in hazardous environments corresponding to Class I, Division 2 or Class I, Zone 2, the device must be installed in a cabinet or a suitable enclosure.

### Notes for use in hazardous locations according to ATEX, IECEx, UKEX and CCC Ex

If you use the device under ATEX, IECEx, UKEX or CCC Ex conditions you must also keep to the following safety instructions in addition to the general safety instructions for protection against explosion:

## 5.3 Requirements for the cabinet EN 60529 (ATEX), UKEX, IECEx and CCC-Ex

 **WARNING**

To comply with EU Directive 2014/34 EU (ATEX 114), UK-Regulation SI 2016/1107 or the conditions of IECEx or CCC-Ex, the housing or cabinet must meet the requirements of at least IP54 (according to EN/IEC 60529, GB/T 4208) in compliance with EN IEC/IEC 60079-7, GB 3836.3.



**⚠ WARNING**

If the temperature of the cable or housing socket exceeds 60 °C or the temperature at the branching point of the cables exceeds 80 °C, special precautions must be taken. If the equipment is operated in an air ambient in excess of 60 °C, only use cables with admitted maximum operating temperature of at least 80 °C.

**Additional notes****⚠ CAUTION****Use only approved components**

If you use components and accessories that are not approved for SIMATIC NET devices or their target systems, this may violate the requirements and regulations for safety and electromagnetic compatibility.

Only use components approved for the SIMATIC NET devices.

**NOTICE****Warning and premature aging of the IE switch due to direct sunlight**

Direct sunlight can heat up the device and can lead to premature aging of the IE switch and its cabling.

Provide suitable shade to protect the IE switch against direct sunlight.

**Note**

During installation and operation, keep to the installation guidelines and safety notices described in this document and in the system manuals "Industrial Ethernet / PROFINET Industrial Ethernet" and "Industrial Ethernet / PROFINET passive network components".

You will find information on the system manuals in the section "Introduction", under "Further documentation".

## 5.4 Installation

**Note**

When installing and operating the device, keep to the installation instructions and safety-related notices as described in this document and in the manual "SIMATIC NET Industrial Ethernet Twisted Pair and Fiber Optic Networks (<https://support.industry.siemens.com/cs/ww/en/view/1172207>)".

**Safety requirements for installation**

## 5.5 19" rack mounting

According to the IEC 61131-2 standard and therefore in accordance with the EU directive 2006/95/EC (Low Voltage Directive), the devices are "open equipment" and in accordance with UL/CSA certification, they are an "open type".

To fulfill requirements for safe operation with regard to mechanical stability, flame retardation, stability, and shock-hazard protection, the following alternative types of installation are specified:

- Installation in a suitable cabinet.
- Installation in a suitable enclosure.
- Installation in a suitably equipped, enclosed control room.

## 5.5 19" rack mounting

### CAUTION

#### **Danger of injury by falling objects**

If you do not use the supplied mounting brackets for 19" rack installation, it is not possible to install the device correctly.

Use only the supplied mounting brackets.

There are several ways of fixing the mounting brackets depending on the mounting position required.

## 19" rack mounting

19" rack mounting is possible for all rack devices identified by (XR).

Refer to the technical specifications, Installation options table for each product group. The rack device is installed using two mounting brackets fitted to the front. After fitting the two mounting brackets, the rack device can then be installed in a 19" cabinet.

### NOTICE

#### **Do not cover the ventilation grilles**

During installation, select a mounting position so that the ventilation grilles are always free to achieve adequate cooling. With normal orientation, the ventilation grilles are on the top, bottom and sides of the housing.

If you install more than one rack device, make sure that the permitted ambient conditions are met for all devices in the rack.

## Minimum clearances

If you install the IE Switch in rack devices without forced ventilation or cooling, minimum clearances must be maintained to neighboring devices or the wall of the enclosure. By keeping to the minimum clearances, there is then an adequate stream of air for heat dissipation during operation. Keep to the following minimum clearances to neighboring devices.

Table 5-1 Minimum clearances for installation in rack devices



Minimum clearance to devices below the switch	100 mm
Minimum clearance to devices above the switch	100 mm
Minimum clearance between two SCALANCE XR-300 EEC at an ambient temperature up to 70 °C without external ventilation	100 mm
Minimum clearance between two SCALANCE XR-300 EEC at an ambient temperature up to 60 °C without external ventilation	45 mm (1 height unit)

### NOTICE



#### Four-point mounting

If mechanical load is high, the device should be secured at four points. You will find more detailed information in the section "Mechanical stability in operation".

## Normal orientation

Normal orientation of the device	
<ul style="list-style-type: none"> <li>The LED display is on the left of the front panel of the housing.</li> <li>The Ethernet ports or the slots for the modules are also on the front of the housing. Slots for the modules are fitted with dummy covers.</li> <li>The C-PLUG is on the right behind a protective panel secured with screws. (For more detailed information, refer to the section on the C-PLUG in the X-300 operating instructions.)</li> <li>The ventilation grilles are on the top, bottom and sides of the housing.</li> </ul>	 <p>SCALANCE XR324-4M EEC</p>
<ul style="list-style-type: none"> <li>On the rear of the device, you will find the diagnostics port.</li> <li>The grounding bolt and the connectors for the signaling contact and power supplies are also on the rear of the device. Note that there are different power supplies (see section "Product overview (Page 19)").</li> </ul>	 <p>SCALANCE XR324-4M EEC</p>

### 19" rack mounting with normal orientation

19" rack mounting	
1.	Select the required rack device and the 19" cabinet.
2.	Fix the two mounting brackets with 4 screws each to the sides of the housing. The maximum tightening torque for these screws is 0.5 Nm. <div style="text-align: right;">  </div>
	<p>CAUTION: If you install a rack device with components inserted. The locking mechanisms of components installed in the rack device (for example the handles of media modules or the clips on the SFP) must be closed.</p> <p>See also installation of modular devices:</p> <ul style="list-style-type: none"> <li>- Installing media modules in a slot</li> <li>- Installing an SFP in an SFP media module.</li> </ul> <div style="text-align: right;">  <p>SCALANCE XR324-4M EEC</p> </div>
3.	Insert the rack device in the 19" cabinet and hold the rack device at the required height. Make sure that nothing is obstructing air from entering the ventilation grilles. Fit the securing screws to the two mounting brackets to secure the rack device in the 19" cabinet.
4.	Connect the grounding bolts. On the SCALANCE X-300EEC, the PE connector is on the bottom of the device. On the SCALANCE XR-300M EEC, the PE connector is on the rear of the device between the power connectors.
5.	Fit the connectors for the power supply. Note that the SCALANCE X-300 is available for different power supplies (100 to 240 V AC and 24 V DC variants).
6.	Fit the remaining connectors, for example the signaling contact.

### Removal

Removing from the rack	
1.	Turn off the power supply for the SCALANCE XR-300M.
2.	Disconnect all cables for data traffic and the connectors for the power supply and the grounding cable.
3.	Undo the screws on the mounting bracket and remove the rack device from the 19" cabinet. If necessary, release the locking mechanisms of components inserted in the rack device (for example handles on the media module or clips on the SFP) to be able to remove the media modules (MM900) or the transceiver (SFP).

## 5.6 Installation of modular devices

### 5.6.1 Installation and removal of media modules

#### Safety notices

<b>NOTICE</b>
<b>Use only approved media modules</b> If you use media modules that are not approved by Siemens AG, there is no guarantee that the device will function according to the specification. If you use unapproved media modules, this can lead to the following problems: <ul style="list-style-type: none"><li>• Damage to the device</li><li>• Loss of the approvals</li><li>• Violation of the EMC regulations</li></ul> Use only approved media modules.

<b>NOTICE</b>
<b>Damage due to changing modules while the device is turned on</b> Media modules for SCALANCE devices are not capable of hot plugging. Install or remove media modules only when the power supply of the device is turned off.

#### Note

##### Use media modules only in an approved modular device

Use an MM900 media module only for a device equipped with suitable slots for such modules.  
Example: X308-2M.

##### The names and labeling of the media modules differ

- Example: The device is called, for example, MM992-2SFP [6GK5 992-2AS00-8AA0], the labeling on the device is "9922AS". You will find detailed information on the labeling of the media modules in the "MM900 media modules" compact operating instructions.

 **CAUTION**

**Remember the orientation of media modules.**

On modular devices, there are always two module slots arranged opposite each other. Remember the correct orientation when installing MM900 media modules.

Example:

- Install the first media module in slot 1.
- Install the third media module turned through 180° in slot 2.

On modular devices for rack mounting, pairs of module slots are located one above the other in which modules can be inserted in a specific order:

Example of a rack device:

- Install the first media module in slot 1.
- Install the third media module turned through 180° in slot 3.

Other modules are then installed in slot 2 and 4.

**The permitted operating temperature is decided by the fully equipped device (switch + media module + SFP transceiver).**

With modular devices, it is not only the switch that decides the permitted operating temperature of the overall device but also the temperature ranges of the MM900 media modules and the SFP transceivers. You will find details in the technical specifications of the relevant components.

The following aspects can restrict the maximum permitted operating temperature:

- The orientation of the carrier device.
- The use of SFP transceivers.
- The use of transceivers of the types LH, LH+ or ELH.

**Note**

**SFP transceivers with the SCALANCE XR300M EEC**

In contrast to the information in the product documentation for the SCALANCE MM900, MM992-2SFP media modules can be operated in the SCALANCE XR300M EEC at ambient temperatures up to a maximum of 70 °C if the following requirements are met:

- MM992-2SFP media modules as of hardware product version 02 are suitable. The hardware product version can be found on the device. You can also read out this information with the WBM or the CLI.
- The media modules MM992-2SFP can only be used in conjunction with the media modules MM992-2CUC, MM992-2CU and MM992-2M12.
- Only the following SFP transceivers may be used:
  - SFP991-1
  - SFP991-1LD
  - SFP992-1
  - SFP992-1LD

---

**Note**

**Slot number**

With modular devices, the MM900 media modules must be given a slot number. The slot number labels are supplied with the modular devices.

---

**Installing a media module**

The media module is inserted with the handle pulled out. When the handle is inserted, the media module is locked in the device.

---

**Note**

The figures in the following installation instructions show the installation of a media module in a rack device. The procedure for installation is identical for rack or compact devices.

---

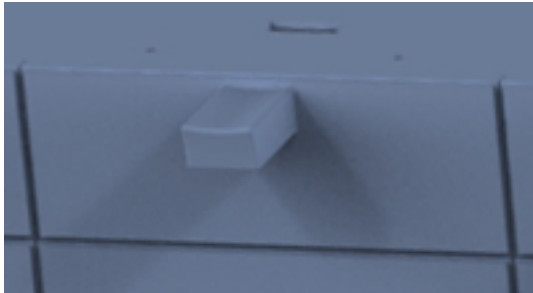
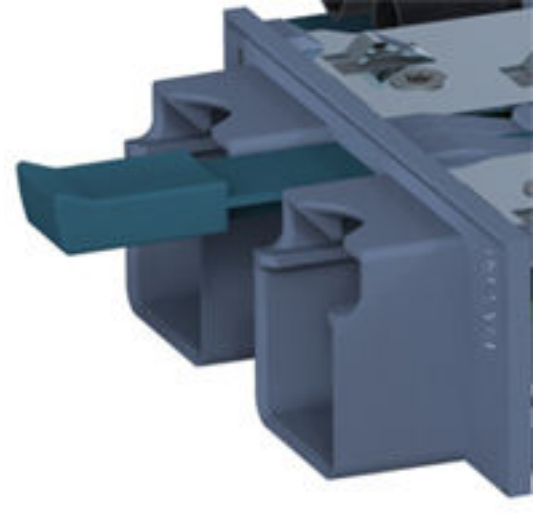
1.	Select the required slot on the device (for example, X308-2M). Remove the dummy cover.	
2.	Pull out the handle on the selected media module.	

5.6 Installation of modular devices

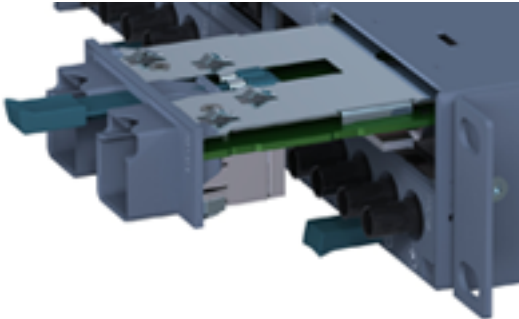
3.	<p>Place the media module in the guide rails of the device slot. The media module is correctly installed when it clips easily into the device.</p>	
4.	<p>Push the handle back into the media module. This locks the media module in the device.</p>	
5.	<p>Insert the connectors.</p>	

Removing a media module

 <b>CAUTION</b>
<b>Risk of burns due to the high temperature of the module housing</b>
Turn off the device and allow the device to cool down before you remove a media module.

1. Remove all connectors from the media module.
2. Pull out the handle of the media module and remove the media module from the device slot.
3. Secure the dummy cover.



## 5.6.2 SFP installation in SFP media module

<b>NOTICE</b>
<p><b>Use only approved SFPs</b></p> <p>If you use SFPs that are not approved by Siemens AG, there is no guarantee that the device will function according to the specification.</p> <p>If you use unapproved SFPs, this can lead to the following problems:</p> <ul style="list-style-type: none"> <li>• Damage to the device</li> <li>• Loss of the approvals</li> <li>• Violation of the EMC regulations</li> </ul> <p>Use only approved SFPs.</p>

You can insert or remove the SFP during ongoing operation.



### Inserting an SFP

#### Note

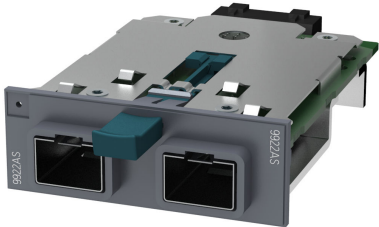
Only the media module MM992-2SFP may be fitted with approved SFPs. The SFP media module can be fitted with up to two SFPs.

Device: Media module	Variant	[Article number] Labeling on the device	Figure
MM992-2SFP (SFP media module)	2 x 100/1000 Mbps	[6GK5 992-2AS00-8AA0] 9922AS	

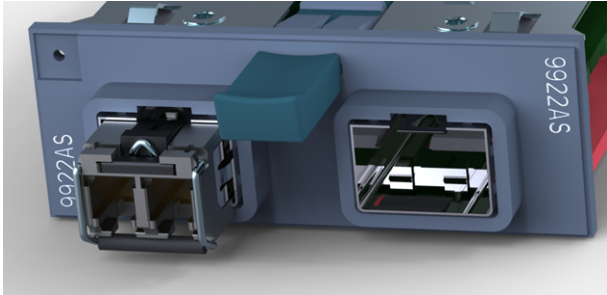
5.6 Installation of modular devices

<p>1.</p>	<p>Select the required SFP media module in the slot of the device. (Example: X-308-2M, slot 2)</p>	 <p>A blue Siemens SCALANCE XR-300-2M EEC device with multiple ports and a central SFP slot.</p>
<p>2.</p>	<p>Insert the SFP with the clip closed in the SFP media module. Notice: Closing the clip after insertion does not lock the device in the rack.</p>	 <p>A close-up view of the SFP slot on the device. A teal clip is shown closing over the SFP module. The model number 9922AS is visible on the side.</p>
<p>3.</p>	<p>The SFP can be heard to lock in place and is therefore firmly secured.</p>	 <p>The same Siemens SCALANCE XR-300-2M EEC device as in step 1, but now with the SFP module installed and secured in the central slot.</p>
<p>4.</p>	<p>Plug the connecting cable into the SFP. The connecting cable can be heard to lock in place and is then firmly secured.</p>	

**Removing an SFP**

1. Remove the cable connected to the SFP.
2. Open the clip on the SFP and remove the SFP from the SFP media module.  
Notice: It must be possible to remove the SFP easy without using force.
3. Fit a blind plug to the SFP.

## Connecting

### 6.1 Safety when connecting up

#### Safety notices

When connecting up the device, keep to the safety notices listed below.

 <b>WARNING</b>
<p><b>Safety notice for connecting with a LAN ID (Local Area Network)</b></p> <p>A LAN or LAN segment with all the interconnected devices should be contained completely in a single low voltage power distribution in a building. The LAN is designed either for "Environment A" according to IEEE802.3 or "Environment 0" according to IEC TR 62102.</p> <p>Do not connect any electrical connectors directly to the telephone network (telephone network voltage) or a WAN (Wide Area Network).</p>

### 6.2 Notes on commissioning

#### Note

##### Commissioning devices with redundancy mechanisms

If you use redundancy mechanisms ("HRP" media redundancy or "MRP" and/or redundant coupling of rings over standby coupling), open the redundant path before you insert a new or replacement device in an operational network. A bad configuration or attachment of the Ethernet cables to incorrectly configured ports causes overload in the network and a breakdown in communication.

A device may only be inserted in a network and connected in the following situations:

- **HRP/MRP:**  
The ring ports of the device being inserted in the ring were configured as ring ports. The required redundancy mode must also be enabled (see "Configuration Manual SCALANCE X-300 / X-400", section "X-300 Ring Configuration"). If the device is intended to operate as the redundancy manager, "Redundancy manager enabled" must also be set.
- **Standby coupling:**  
"Standby connection" must be "enabled" and the "Standby connection name" must match the name of the partner device. You will also need to configure the port with "Enable Standby Port Monitoring" (see "Configuration Manual SCALANCE X-300 / X-400", section "X-300 / X-400 Standby Mask").

<b>NOTICE</b>
<b>Failure of the data traffic due to contamination of optical plug-in connections</b>
Optical sockets and plugs are sensitive to contamination of the end face. Contamination can lead to the failure of the optical transmission network. Take the following precautions to avoid functional impairments:
<ul style="list-style-type: none"> <li>• Clean the end face of field-assembled connectors carefully before connecting. No residues of processing may remain on the connector.</li> <li>• Only remove the dust caps of optical transceivers and pre-configured cables shortly before connecting the cables.</li> <li>• Close unused optical sockets and plugs as well as pluggable transceivers and slots with the supplied protective caps.</li> </ul>

### 6.3 Wiring rules

When wiring use cables with the following AWG categories or cross sections.

Wiring rules for ...		Screw/spring-loaded terminals
connectable cable cross sections for flexible cables ...	without wire end ferrule	0.25 - 2.5 mm <sup>2</sup> AWG: 24 - 13
	with wire end ferrule with plastic ferrule**	0.25 - 2.5 mm <sup>2</sup> AWG: 24 - 13
	with wire end ferrule without plastic ferrule**	0.25 - 2.5 mm <sup>2</sup> AWG: 24 - 13
	with TWIN wire end ferrule**	0.5 - 1 mm <sup>2</sup> AWG: 20 - 17
Stripped length of the cable		8 - 10 mm
Wire end ferrule according to DIN 46228 with plastic ferrule**		8 - 10 mm

\* AWG: American Wire Gauge

\*\* See note "Wire end ferrules"

**Note**

**Wire end ferrules**

Use crimp shapes with smooth surfaces, such as provided by square and trapeze shaped crimp cross sections.

Crimp shapes with wave-shaped profile are unsuitable.

## 6.4 Grounding

### Functional ground

With the devices with a 100 to 240 VAC / 60 to 250 VDC power supply, functional ground must be connected to the grounding bolts or the power supply terminal of every power supply unit. With the devices with 24 to 48 VDC, functional ground must be connected to the grounding bolts or the mounting brackets (XR-300M EEC).

To wire up the functional ground, use a copper cable of category 18-8 AWG or cable with a cross-section of 0.75 to 6 mm<sup>2</sup>.

### Protective ground

When the device is operated with multirange power supply unit 100 to 240 VAC / 60 to 250 VDC, the protective ground is connected in addition to the functional ground.

 <b>CAUTION</b>
<b>Danger from line voltage</b>
Grounding simply via the housing is inadequate.
In this case, connect the functional ground to ensure reliable operation.
With devices with a supply voltage of 100 to 240 VAC / 60 to 250 VDC, you should also connect the protective earth to the grounding bolt.
On the SCALANCE XR-300M EEC, the grounding bolt is on the rear of the housing between the power connectors.

To wire up the protective ground, use a copper cable of category 14-8 AWG or cable with a cross-section of 1.5 to 6 mm<sup>2</sup>.

### Position

The connector for the grounding cable is in the center of the rear panel of the device, see section "Dimension drawings (Page 71)".

### Connecting ground

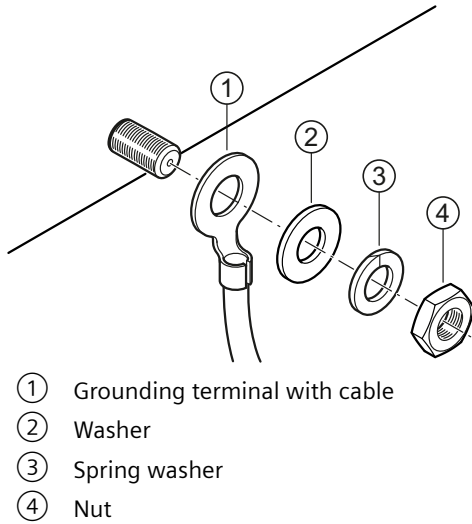

Follow the steps below to connect ground:

1. Put the parts ①, ② and ③ together on the grounding bolt as shown in the drawing.
2. Tighten the nut ④ with a maximum tightening torque of 1.5 Nm.

## 6.5 Signaling contact

The signaling contact (relay contact) is a floating switch with which error/fault states can be signaled by breaking the contact.

### Error indication



- The signaling by the signaling contact is synchronized with the fault LED, in other words, all errors displayed by this LED (freely configurable) are also signaled on the signaling contact.
- If an internal fault occurs, the fault LED lights up and the signaling contact opens.
- The connection or disconnection of a communication node on an unmonitored port does not lead to an error message.
- The signaling contact remains activated until the error/fault is eliminated or until the current status is entered in the fault mask as the new desired status.

### 6.5.1 24 VDC signaling contact (XR-300M EEC)

The signaling contact is connected to a 2-pin plug-in terminal block.

The signaling contact can be subjected to a maximum load of 100 mA (safety extra-low voltage SELV, 24 V DC).

Table 6-1 Pin assignment of the 24 V DC signaling contact

Pin number	Assignment (example)
	
Pin 1	F1
Pin 2	F2

To wire up the signaling contact, use a copper cable of category 18-12 AWG or cable with a cross-section of 0.75 to 2.5 mm<sup>2</sup>.

#### NOTICE

##### Laying the connecting cables of the signaling contact with the XR-300M EEC

To improve the EMC properties (surge protection), the two connecting cables of the signaling contact should be laid together.

## 6.5.2 Signaling contact 100 to 240 VAC / 60 to 250 VDC

#### WARNING

##### Danger from line voltage

The supply voltage for the devices listed is 100 to 240 VAC and 60 to 250 VDC.

This device can only function correctly and safely if it is transported, stored, set up, and installed correctly, and operated and maintained as recommended.

Connecting and disconnecting may only be performed by an electrical specialist.

Connect or disconnect power supply cables only when the power is turned off.

**Signaling contact 100 to 240 VAC / 60 to 250 VDC**

The signaling contact is connected to a 3-pin plug-in terminal block.

<b>NOTICE</b>
<b>Damage to the device due to incorrectly wiring the terminal blocks</b>
With devices with a supply voltage of 100 to 240 VAC and 60 to 250 VDC, the terminal blocks for the power supply and signaling contact are plugged in and screwed down in the device. Both terminal blocks have three pins but coding prevents the two terminal blocks being confused.
Make sure that the cables of the power supply and the cables for the signaling contact are connected to the correct terminal block.

Table 6-2 Pin assignment of the 100 to 240 VAC / 60 to 250 VDC signaling contact

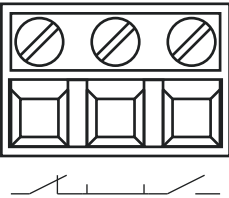
Pin number	Assignment
<p>F1 F2 F3</p> 	
F1	NC contact
F2	Root
F3	NO contact

To wire up the signaling contact, use a copper cable of category 18-8 AWG or cable with a cross-section of 0.75 to 6 mm<sup>2</sup>.

<b>NOTICE</b>
<b>Securing cables with dangerous voltage</b>
Make sure that the connector cannot be released accidentally by pulling on the connecting cable. Lay the cables in cable ducts or cable channels and secure the cables, where necessary, with cable ties.



## 6.6 Diagnostics port

### Description

Rack devices have a diagnostics port on the rear of the housing. This port is designed for an RJ-11 plug. A suitable connecting cable with an RJ-11 plug and a 9-pin D sub female connector for connection to the serial port of the PC ships with the SCALANCE XR-300.

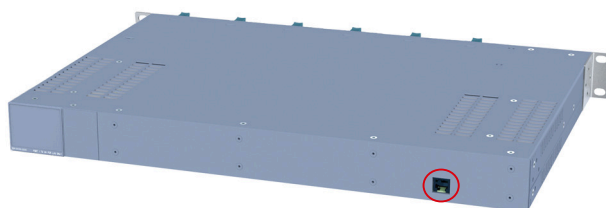

Diagnostics port on the rear of the device

### Pin assignment

The following table shows the pin assignment of the RJ-11 plug and the D sub female connector:

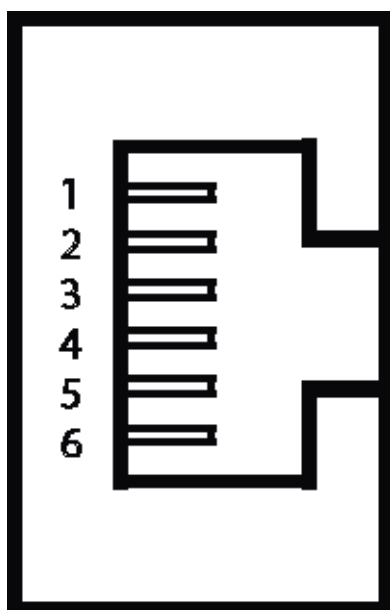

Figure 6-1 RJ-11 jack (schematic)

RJ-11 plug		D-sub 9-pin, female	
Pin	Assignment	Pin	Assignment
1	n. c.	1	n. c.
2	n. c.	2	RD (Receive Data)
3	TD (Transmit Data)	3	TD (Transmit Data)
4	SG (Signal Ground)	4	n. c.
5	RD (Receive Data)	5	SG (Signal Ground)

RJ-11 plug		D-sub 9-pin, female	
Pin	Assignment	Pin	Assignment
6	n. c.	6	n. c.
		7	n. c.
		8	n. c.
		9	n. c.

## 6.7 Power supply

### Power supply of the IE switches X300 EEC / XR300M EEC

#### WARNING

##### **Danger to life: 100 ... 240 V / 60 to 250 VDC**

Please note that the IE switches X300EEC / XR300M EEC can have a 100 to 240 VAC / 60 to 250 VDC - or a 24 to 48 VDC power supply.

You can recognize the type of power supply from the labeling on the device and the labeling of the terminal block for the power supply of the switch.

The 100 to 240 VAC / 60 to 250 VDC and 24 to 48 VDC terminal blocks for the power supply of the X300 EEC / XR300M EEC are coded and cannot be confused when you plug them in.

### Power supply redundancy with the IE switches X300 EEC / XR300M EEC

The IE switches X300 EEC / XR300M EEC provide the following options for redundancy of the 24 to 48 VDC power supply:

- Redundant power supply via one power supply unit (1 x 24 to 48 VDC)  
You can connect a redundant power supply to each 24 V to 48 VDC power supply unit. To do this, use the terminals L1 and L2 of terminal block PS1.
- Redundant power supply units 24 to 48 VDC  
Connect one power supply to a power supply unit.

#### NOTICE

##### **Connection with redundant 24 to 48 VDC power supply units**

If you connect an X-300EEC with redundant 24 to 48 VDC terminal blocks to two power supplies, you will need to use L1 of the PS1 terminal block and L2 of the PS2 terminal block.

The IE switches X300 EEC / XR300M EEC provide the following options for redundancy of the 100 to 240 VAC / 60 to 250 VDC power supply:

- Redundant terminal blocks  
You can order the switch with redundant terminal blocks for the power supply. Each terminal block has only 1 pin for 1 power supply.
- Redundancy of the power infeed is not possible with this version.

### 6.7.1 Connecting devices with 24 V DC power supply

#### WARNING

##### Power supply

The device is designed for operation with a directly connectable safety extra low voltage (SELV) from a limited power source (LPS).

The power supply therefore needs to meet at least one of the following conditions:

- Only safety extra low voltage (SELV) with limited power source (LPS) complying with IEC 60950-1 / EN 60950-1 / VDE 0805-1 or IEC 62368-1 / EN 62368-1 / VDE 62368-1 may be connected to the power supply terminals.
- The power supply unit for the device must meet NEC Class 2 according to the National Electrical Code (r) (ANSI / NFPA 70).

If the equipment is connected to a redundant power supply (two separate power supplies), both must meet these requirements.

#### Note

A power source that supplies safety extra low voltage combined with a following NEC Class 2 power limiter also meets the requirements according to IEC 60950-1 / EN 60950-1 / VDE 0805-1 or NEC Class 2. A suitable power limiter is for example the redundancy module SITOP PSE202U NEC Class 2 (article number 6EP1962-2BA00).

#### 6.7.1.1 PELV

#### Note

##### Safety extra-low voltage

The supply of the devices by PELV (Protective Extra Low Voltage) according to DIN VDE 0100-410 or IEC 60364-4-41 is permitted when the generated nominal voltage does not exceed the voltage limits 25 VAC or 60 VDC.

**Safety notices on use in hazardous areas****General safety notices relating to protection against explosion** **WARNING****EXPLOSION HAZARD**

Do not connect or disconnect cables to or from the device when a flammable or combustible atmosphere is present.

 **WARNING****EXPLOSION HAZARD**

Do not press the SELECT/SET button when there is an explosive atmosphere.

 **WARNING****Suitable cables at high ambient temperatures in hazardous area**

At an ambient temperature of  $\geq 60$  °C, use heat-resistant cables designed for an ambient temperature at least 20 °C higher. The cable entries used on the enclosure must comply with the IP degree of protection required by EN IEC / IEC 60079-0, GB 3836.1.

 **WARNING****Unsuitable cables or connectors**

Risk of explosion in hazardous areas

- Only use connectors that meet the requirements of the relevant type of protection.
- If necessary, tighten the connector screw connections, device fastening screws, grounding screws, etc. according to the specified torques.
- Close unused cable openings for electrical connections.
- Check the cables for a tight fit after installation.

 **WARNING****Lack of equipotential bonding**

If there is no equipotential bonding in hazardous areas, there is a risk of explosion due to equalizing current or ignition sparks.

- Ensure that equipotential bonding is available for the device.

 **WARNING**

**Unprotected cable ends**

There is a risk of explosion due to unprotected cable ends in hazardous areas.

- Protect unused cable ends according to IEC/EN 60079-14.

 **WARNING**

**Improper installation of shielded cables**

There is a risk of explosion due to equalizing currents between the hazardous area and the non-hazardous area.

- Ground shielded cables that cross hazardous areas at one end only.
- Lay a potential equalization conductor when grounding at both ends.

 **WARNING**

**Insufficient isolation of intrinsically safe and non-intrinsically safe circuits**

Risk of explosion in hazardous areas

- When connecting intrinsically safe and non-intrinsically safe circuits, ensure that the galvanic isolation is performed properly in compliance with local regulations (e.g. IEC 60079-14).
- Observe the device approvals applicable for your country.

**Notes for use in hazardous locations according to ATEX, IECEx, UKEX and CCC Ex**

If you use the device under ATEX, IECEx, UKEX or CCC Ex conditions you must also keep to the following safety instructions in addition to the general safety instructions for protection against explosion:

 **WARNING**

**Transient overvoltages**

Take measures to prevent transient overvoltages of more than 40% of the rated voltage (or more than 119 V). This is the case if you only operate devices with SELV (safety extra-low voltage).

**Safety notices when using the device according to Hazardous Locations (HazLoc)**

If you use the device under HazLoc conditions you must also keep to the following safety notices in addition to the general safety notices for protection against explosion:

**⚠ WARNING****EXPLOSION HAZARD**

You may only connect or disconnect cables carrying electricity when the power supply is switched off or when the device is in an area without inflammable gas concentrations.

**6.7.1.2 Overview**

Table 6-3 24 to 48 V DC safety extra low voltage

Device	Device version (power supply)	24 V safety extra-low voltage (SELV)
		can be connected redundantly
XR324-4M EEC	1 x 24 to 48 V DC	●
	2 x 24 to 48 V DC	●

**6.7.1.3 Connecting the external 24 VDC power supply****24 V safety extra-low voltage (SELV)****⚠ WARNING**

- The IE Switch X-300 is designed for operation with safety extra-low voltage (SELV). This means that only SELV complying with IEC 60950-1 / EN 60950-1 / VDE0805 can be connected to the power supply terminals.
- The power supply unit for the IE Switch X-300 power supply must meet NEC Class 2, as described by the National Electrical Code(r) (ANSI/NFPA 70).
- The power of all connected power supply units must total the equivalent of a power source with limited power (LPS limited power source).
- If the device is connected to a redundant power supply (two separate power supplies), both power supplies must meet these requirements.
- The signaling contact can be subjected to a maximum load of 100 mA (safety extra-low voltage (SELV) 24 VDC).
- Never operate the device with AC voltage or DC voltage higher than 58 VDC.

<b>NOTICE</b>
<b>Damage to the device due to overvoltage</b>
One of the tests used to attest the immunity of devices of the IE Switches X300 to electromagnetic interference is the "surge immunity test" according to EN61000 4 5. This test requires overvoltage protection for the power supply lines. A suitable device is, for example, the Dehn Blitzductor BVT AVD 24 article no. 918 422 or a comparable protective element. Manufacturer: DEHN+SÖHNE GmbH+Co.KG, Postfach 1640, D92306 Neumarkt, Germany. Do not operate the SCALANCE X-300 without suitable overvoltage protection.

### Connecting to the power supply (SELV)

- The power supply is connected using a 4-pin plug-in terminal block.
- The power supply can be connected redundantly. Both inputs are isolated. There is no distribution of load. When a redundant power supply is used, the power supply unit with the higher output voltage supplies the IE Switch X-300 alone.
- The power supply is connected over a high resistance with the enclosure to allow an ungrounded set up. The two power inputs are non-floating.

### Terminal block assignment (4-pin)

Table 6-4 Pinout of the 24 to 48 V safety extra-low voltage (SELV)

Pin number	Assignment
Pin 1	L1+ (24...48 VDC)
Pin 2	M1
Pin 3	M2
Pin 4	L2+ (24...48 VDC)

To wire up the power connector, use a copper cable of category 18-12 AWG or cable with a cross-section of 0.75 to 2.5 mm<sup>2</sup>.

#### 6.7.1.4 Connecting a redundant power supply to the XR300-EEC

##### Device variants with 1 or 2 power supply units

There are device variants with one power supply unit or with two power supply units. With device variants with two power supply units, the 2nd power supply unit is also known as the redundant power supply unit.

The connection is made using a 4-terminal plug-in terminal block to which two power supply units can be connected (connected redundantly).

If two power supply units are connected, this is known as a redundant power supply.

Connect two power supplies as described below to achieve a correlation between the pin assignment and LED display.

**Connecting a redundant power supply to 1 power supply unit**

Use "PS1" to connect the power supply of the terminal block.

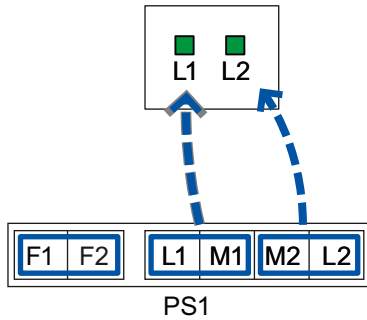

Figure 6-2 Assignment of the LED display to the pins for redundant power supply with devices with one power supply unit

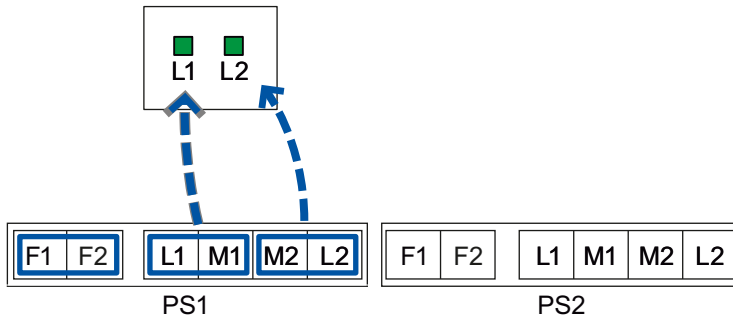

Figure 6-3 Assignment of the LED display to the pins for redundant power supply with devices with two power supply units

- If the power supply fails at pins L1/M1, this is indicated by LED L1.
- If the power supply fails at pins L2/M2, this is indicated by LED L2.

**Connecting a redundant power supply to 2 power supply units**

To connect the power supplies, use pins L1/M1 of the left terminal block "PS1" and pins L2/M2 of the right terminal block "PS2".

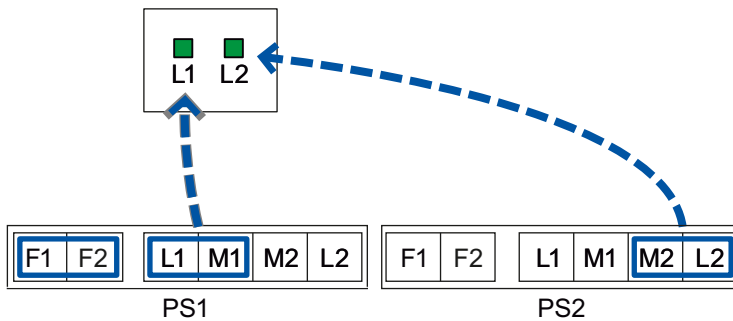

Figure 6-4 Assignment of the LED display to the pins for redundant power supply with devices with two power supply units.





- If the power supply fails at pins L1/M1, this is indicated by LED L1.
- If the power supply fails at pins L2/M2, this is indicated by LED L2.

It would also be possible to use the L1/M1 pins of the right terminal block. In this case, however, identification of the terminal block involved from the LED display is not immediately obvious.

## 6.7.2 Connecting devices with 100 to 240 V AC power supply

### Safety note on devices with 100 to 240 V AC power supply

 <b>WARNING</b>
<b>Danger from line voltage</b>
The supply voltage for the devices listed is 100 to 240 V AC.
This device can only function correctly and safely if it is transported, stored, set up, and installed correctly, and operated and maintained as recommended.
Connecting and disconnecting may only be performed by an electrical specialist.
Connect or disconnect power supply cables only when the power is turned off.

 <b>WARNING</b>
<b>Devices with a 100 to 240 V AC power supply do not have an ATEX or IECEx approval.</b>
Devices with a 100 to 240 V AC power supply are not approved for use in hazardous areas according to 2014/34/EU ATEX or IECEx.

<b>NOTICE</b>
<b>Securing cables with dangerous voltage</b>
Make sure that the connector cannot be released accidentally by pulling on the connecting cable. Lay the cables in cable ducts or cable channels and secure the cables, where necessary, with cable ties.

### 6.7.2.1 Overview

Table 6-5 100 to 240 V AC voltage

Device	Device version (power supply)	100 to 240 V voltage	
		Redundant	Single
XR324-4M EEC	1 x 100 to 240 V AC / 60 to 250 V DC	-	●
	2 x 100 to 240 V AC / 60 to 250 V DC	●	-

### 6.7.2.2 Connecting the 100 to 240 VAC power supply

#### Power supply 100 to 240 VAC / 60 to 250 VDC

The switch is available in the following versions for power supply with the multirange power supply unit 100 to 240 VAC / 60 to 250 VDC:

- With single power supply unit (1 x 100 to 240 VAC / 60 to 250 VDC)
- With redundant power supply unit (2 x 100 to 240 VAC / 60 to 250 VDC)  
Each power supply unit PS1 and PS2 has a separate supply connector.

You can recognize the type of power supply from the labeling on the device and the labeling of the terminal block for the power supply of the switch.

On devices with a 100 to 240 VAC power supply, the connectors of the signaling contact and the power supply are identical. To avoid confusion, the two pins have a different coding.

#### Grounding

 <b>WARNING</b>
<b>Danger from line voltage</b> Grounding simply via the housing is inadequate. In this case, connect the functional ground to ensure reliable operation. With devices with a supply voltage of 100 to 240 VAC / 60 to 250 VDC, you should also connect the protective earth to the grounding bolt. On the SCALANCE X-300EEC, the grounding bolt is on the bottom of the device. On the SCALANCE XR-300M EEC, the grounding bolt is on the rear of the housing between the power connectors.

#### Connecting to the power supply

The connection is made via one (or two) 3-pin connector(s) on the terminal block for the power supply.

<b>NOTICE</b>
<b>Damage to the device due to incorrectly wiring the terminal blocks</b> With devices with a supply voltage of 100 to 240 VAC and 60 to 250 VDC, the terminal blocks for the power supply and signaling contact are plugged in and screwed down in the device. Both terminal blocks have three pins but coding prevents the two terminal blocks being confused. Make sure that the cables of the power supply and the cables for the signaling contact are connected to the correct terminal block.

Table 6-6 Pin assignment at terminal block 100 to 240 VAC / 60 to 250 VDC for the power supply

Pin number	Assignment
Pin 1	L (100 to 240 V)
Pin 2	N
Pin 3	FE (functional earth)

To wire up the power connector, use a copper cable of category 18-8 AWG or cable with a cross-section of 0.75 to 6 mm<sup>2</sup>.

DC voltage is connected at the following terminals:

- Plus to "L"
- M to "N"

Secure the firm seat of connectors and the terminal block by tightening the screws (does not apply to X-300EEC).



 **WARNING**

**Unauthorized repair of devices in explosion-proof design**

Risk of explosion in hazardous areas

- Repair work may only be performed by personnel authorized by Siemens.

 **WARNING**

**Impermissible accessories and spare parts**

Risk of explosion in hazardous areas

- Only use original accessories and original spare parts.
- Observe all relevant installation and safety instructions described in the manuals for the device or supplied with the accessories or spare parts.



 **CAUTION**

**Hot surfaces**

Risk of burns during maintenance work on parts with a surface temperature above 70 °C (158 °F).

- Take appropriate protective measures, for example, wear protective gloves.
- Once maintenance work is complete, restore the touch protection measures.

**NOTICE**

**Cleaning the housing**

If the device is not in a hazardous area, only clean the outer parts of the housing with a dry cloth.

If the device is in a hazardous area, use a slightly damp cloth for cleaning.

Do not use solvents.



## Technical data

### 8.1 Construction, installation and environmental conditions

Table 8-1 Construction

Device	Device version (power supply)	Dimensions (W x H x D)	Weight	Degree of protection
XR324-4M EEC	1 x 24 to 48 VDC	483 x 44 x 305 mm	6500 g	IP20
	2 x 24 to 48 VDC	483 x 44 x 305 mm	6800 g	IP20
	1 x 100 to 240 VAC / 60 to 250 VDC	483 x 44 x 305 mm	6600 g	IP20
	2 x 100 to 240 VAC / 60 to 250 VDC	483 x 44 x 305 mm	7000 g	IP20

Table 8-2 Installation options

Device	Installation options
XR324-4M EEC	19" rack <sup>1)</sup>

<sup>1)</sup> Note: If mechanical load is high, the device should be secured at four points. You will find more detailed information in the section "Mechanical load in operation".

Table 8-3 Permitted ambient conditions

Storage/transport temperature	-40 °C to +85 °C
Max. relative humidity in operation at 25 °C	<= 95% (no condensation)
Max. ambient temperature at operating altitude	2000 m or above: -5 °C of the max. operating temperature <sup>1)</sup> 3000 m or above: -10 °C of the max. operating temperature <sup>1)</sup>

<sup>1)</sup> See table: "Operating temperature depending on the media modules used"

Table 8-4 Operating temperature depending on the media modules used

Media module <sup>1)</sup>	Installation direction	Operating temperature <sup>2)</sup>
Without media module	Horizontal	-40 °C to +70 °C
	Vertical	-40 °C to +50 °C

8.1 Construction, installation and environmental conditions

Media module <sup>1)</sup>	Installation di- rection	Operating temperature <sup>2)</sup>
MM992-2CUC MM992-2CUC (C) MM992-2CU MM992-2M12 (C) MM992-2VD MM991-2 MM991-2FM MM991-2LD MM991-2 (SC) MM991-2LD (SC) MM992-2 MM992-2 (C) MM992-2LD	Horizontal	-40 °C to +70 °C
	Vertical	-40 °C to +50 °C
MM991-2LH+ (SC) MM992-2LH MM992-2LH+ MM992-2ELH	Horizontal	Maximum 2 modules in slots 3 and 4: -40 °C to +60 °C  With more than 2 modules or other slot assign- ment: -40 °C to +50 °C
	Vertical	-40 °C to +50 °C
Media module MM992-2SFP with pluggable transceiver SFP991-1 SFP991-1LD SFP992-1 SFP992-1LD	Horizontal	-40 °C to +70 °C  Pluggable transceivers of this group may only be used in conjunction with media modules MM992-2CUC, MM992-2CU and MM992-2M12. When using other modules: -40 °C to +60 °C
	Vertical	-40 °C to +50 °C
Media module MM992-2SFP with pluggable transceiver SFP991-1LH+ SFP992-1+ SFP992-1LH SFP992-1LH+ SFP992-1ELH SFP991-1ELH200	Horizontal	Max. 2 modules in slots 3 and 4: -40 °C to +60 °C  With more than 2 modules or other slot assign- ment: -40 °C to +50 °C
	Vertical	-40 °C to +55 °C
MM991-2P		Maximum 2 modules in slots 3 and 4: The slot above an MM991-2P may be used as fol- lows: <ul style="list-style-type: none"> <li>• Without media module: - 25 °C to + 50 °C</li> <li>• With media module MM992-2CUC or MM992-2CU: - 25 °C to + 40 °C</li> </ul>

- 1) Only hardware product version 02 of the media modules is permitted.  
The hardware product version is shown on the product. You can also read out this information from the device with the WBM or the CLI.
- 2) The permitted operating temperature depends on how the mounting device was installed. The installation is horizontal if the device labeling is from left to right. With a vertical installation, the device labeling is rotated through 90°.



## 8.2 Connectors and electrical data

Table 8-5 Connection for end devices or network components

Max. number	24 ports
Electrical	16 x RJ-45 jacks 10/100/1000 Mbps
Media module slots	4 x modular (2 ports per slot)
	12 x modular (2 ports per slot)
Transmitter output (optical) and receiver input	The values correspond to those of the permitted MM900 media modules and SFP transceivers.
Diagnostics port	RJ-11 jack

Table 8-6 Electrical data: Power supply

Device version (power supply)	Redundant power supply unit	Redundant power supply possible	Power supply (min./max. range)
1 x 24 to 48 VDC	No	Yes	24 to 48 VDC (19.2 to 57.6 VDC)
2 x 24 to 48 VDC	Yes	Yes	24 to 48 VDC (19.2 to 57.6 VDC)
1 x 100 to 240 VAC / 60 to 250 VDC	No	No	100 to 240 VAC (80 to 276 VAC) 60 to 250 VDC (48 to 300 VDC)
2 x 100 to 240 VAC / 60 to 250 VDC	Yes	No	100 to 240 VAC (80 to 276 VAC) 60 to 250 VDC (48 to 300 VDC)

Table 8-7 Electrical data: Current consumption and power loss

Device version (power supply)	Current consumption	Effective power loss
24 to 48 VDC	1.6 to 0.75 A	40 W
100 to 240 VAC / 60 to 250 VDC	0.6 to 0.37 A (AC)	42 W (AC)
	0.7 to 0.17 A (DC)	42 W (DC)

8.2 Connectors and electrical data

Table 8-8 Electrical data: Overcurrent protection

Device version (power supply)	Overcurrent protection of the power supply Non-replaceable fuse
1 x 24 to 48 VDC	1 x T2H / 250 V
2 x 24 to 48 VDC	2 x T2H / 250 V
1 x 100 to 240 VAC / 60 to 250 VDC	1 x T2H / 250 V (AC) 1 x T2H / 300 V (DC)
2 x 100 to 240 VAC / 60 to 250 VDC	2 x T2H / 250 V (AC) 2 x T2H / 300 V (DC)

Table 8-9 Electrical data: Signaling contact

Device version (power supply)	Voltage via signaling contact	Switching capacity (resistive load)	Resistor between F1-F2
24 to 48 VDC	24 VDC	max. 0.1 A	< 8 Ω
100 to 240 VAC / 60 to 250 VDC	240 VAC	max. 5 A	
	60 VDC	max. 0.4 A	
	125 VDC	max. 0.22 A	
	250 VDC	max. 0.11 A	

Table 8-10 Plug-in terminal block for connectors of the power supply and signaling contact

Device version (power supply)	Power supply	Signaling contact
1 x 24 to 48 VDC	1 x 4-pin	1 x 2-pin
2 x 24 to 48 VDC	2 x 4-pin	2 x 2-pin
1 x 100 to 240 VAC / 60 to 250 VDC	1 x 3-pin	1 x 3-pin
2 x 100 to 240 VAC / 60 to 250 VDC	2 x 3-pin	2 x 3-pin

Table 8-11 Overvoltage category

General	Overvoltage category II
In the application range of EN 60255-27	Overvoltage category III

## 8.3 Cable lengths

Table 8-12 Permitted cable lengths (copper cable - Fast Ethernet)

Cable type	Accessory (plug, outlet, TP cord)	Permitted cable length
IE TP torsion cable	with IE FC Outlet RJ-45 + 10 m TP cord	0 to 45 m + 10 m TP cord
	with IE FC RJ-45 Plug 180	0 to 55 m
IE FC TP Marine Cable IE FC TP Trailing Cable IE FC TP Flexible Cable	with IE FC Outlet RJ-45 + 10 m TP cord	0 to 75 m + 10 m TP cord
	with IE FC RJ-45 Plug 180	0 to 85 m
IE FC TP standard cable	with IE FC Outlet RJ-45 + 10 m TP cord	0 to 90 m + 10 m TP cord
	with IE FC RJ-45 Plug 180	0 to 100 m

Table 8-13 Permitted cable lengths (copper cable - gigabit Ethernet)

Cable type	Accessory (plug, outlet, TP cord)	Permitted cable length
IE FC Standard Cable, 4 × 2, 24 AWG IE FC Flexible Cable, 4 × 2, 24 AWG	with IE FC RJ-45 Plug 180, 4 × 2	0 to 90 m
IE FC Standard Cable, 4 × 2, 22 AWG	with IE FC Outlet RJ-45 + 10 m TP cord	0 to 60 m + 10 m TP cord
IE FC Flexible Cable, 4 × 2, 22 AWG	with IE FC Outlet RJ-45 + 10 m TP cord	0 to 90 m + 10 m TP cord

### Note

#### Permitted cable lengths (fiber-optic cable - Fast Ethernet or gigabit)

The values correspond to those of the permitted MM900 media modules and SFP transceivers.

## 8.4 Block architecture

### Block architecture with SCALANCE XR-300 devices

The XR324-12M and XR324-4M handle the Ethernet frame traffic of the 24 ports with the aid of three switch blocks.

- The three switch blocks are connected in series (block 1 via block 2 to block 3)
- Gigabit wire speed is possible within a block (max. 8 ports per block).
- Between the blocks there is a bandwidth of 1 gigabit/s available, that must be shared by all ports for frame traffic between the blocks.

When operating solely with Fast Ethernet (100 Mbps), the XR devices support full wire speed via all blocks.

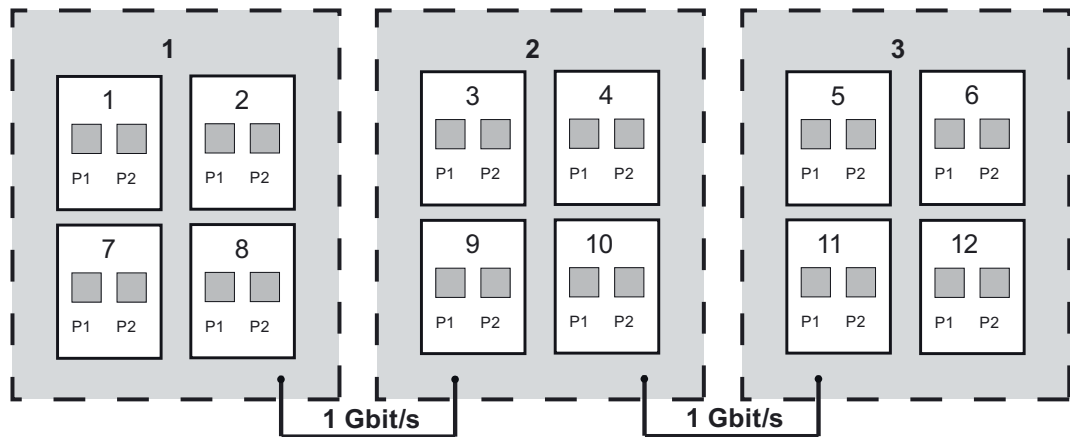

Figure 8-1 Block architecture of the XR324-12M

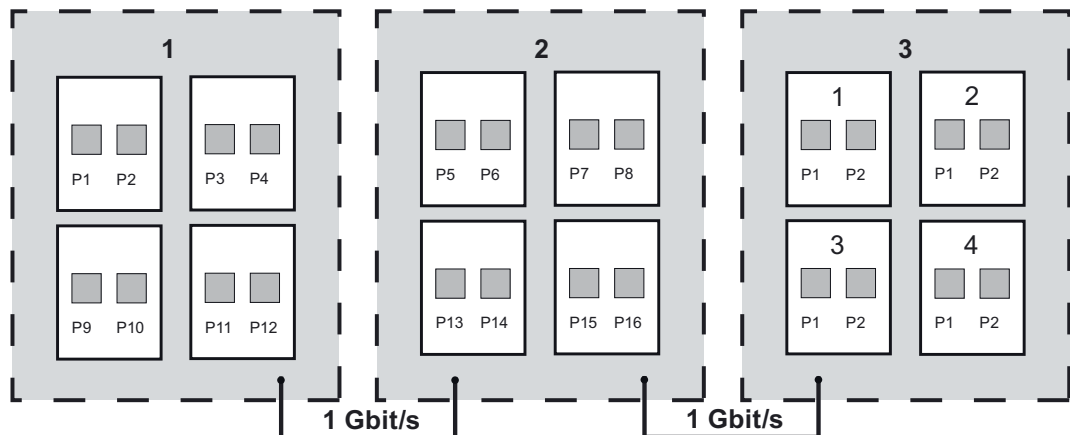

Figure 8-2 Block architecture of the XR324-4M

## 8.5 Other properties

### Switching properties

Max. number of learnable addresses	8000
Aging time	30 sec
Switching technique	Store and forward
Latency	5 µs

### Reconfiguration times for redundancy mechanisms

Redundancy mechanism	Reconfiguration times
HRP	300 ms
Standby link	300 ms
MRP	200 ms

### Mean time between failure (MTBF)

The values in the following table apply to the basic device without media modules.

Device version (power supply)	MTBF <sup>1)</sup>
1 x 24 to 48 V DC or 1 x 100 to 240 V AC / 60 to 250 V DC	> 15 years
2 x 24 to 48 V DC or 2 x 100 to 240 V AC / 60 to 250 V DC	> 15 years <sup>2)</sup>

<sup>1)</sup> These values apply at 40 °C.

<sup>2)</sup> The redundant power supply unit increases the reliability of the system. The MTBF value of the power supply unit is > 20 years.

In the calculation of the MTBF of a modular switch, the standard parts count applies; in other words, the reciprocals of all component failure rates are added.

The reciprocal of this total is the MTBF of the entire assembly.

$$MTBF_{total} = \frac{1}{\left( \frac{1}{MTBF_{basic\ device}} + \frac{1}{MTBF_{module\ 1}} + \dots + \frac{1}{MTBF_{module\ n}} \right)}$$

### Full wire speed switching

Number of frames per second		At a frame length of
At 100 Mbps	At 1000 Mbps	
148810	1488095	64 bytes
84459	844595	128 bytes
45290	452899	256 bytes
23496	234962	512 bytes
11973	119732	1024 bytes

8.5 Other properties

Number of frames per second		At a frame length of
At 100 Mbps	At 1000 Mbps	
9615	96154	1280 bytes
8127	81274	1518 bytes

**Note**

The following applies to IE Switches X-300:

The number of IE Switches X-300 connected in a line influences the frame delay time. When a frame passes through the switch, this is delayed by the Store&Forward function of the IE Switch X-300 by the following values:

- at 64 bytes frame length: Delay of approx. 10 microseconds (at 100 Mbps)
- at 1500 bytes frame length: Delay of approx. 130 microseconds (at 100 Mbps)

This means, the more IE Switches X-300 a frame runs through, the higher the frame delay.

**PRP compatibility**

Device variant	As of version *
XR324-4M EEC	V3.7.0

\* Information about the firmware version (V) as of which PRP is supported.

**Note**

For a device to be used in PRP networks, it must be able to process a frame length of at least 1528 bytes (Jumbo Frames). This value is the maximum frame length including VLAN tag of 1522 bytes plus the length of the PRP trailer of 6 bytes. The following table shows the version as of which the devices are PRP-compatible.

## Dimension drawings

### 9.1 XR-300M EEC dimension drawings

---

**Note**

All dimensions in the drawings are in millimeters.

---

#### Front and rear

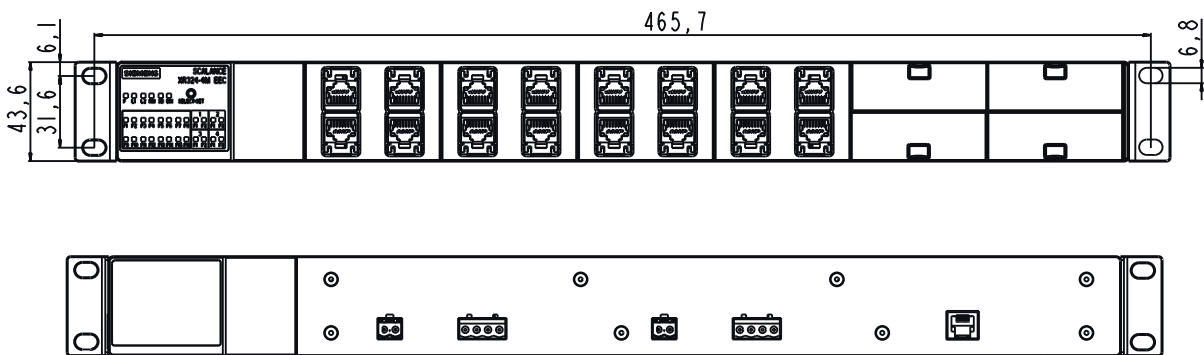

Figure 9-1 Housing front and rear

From above

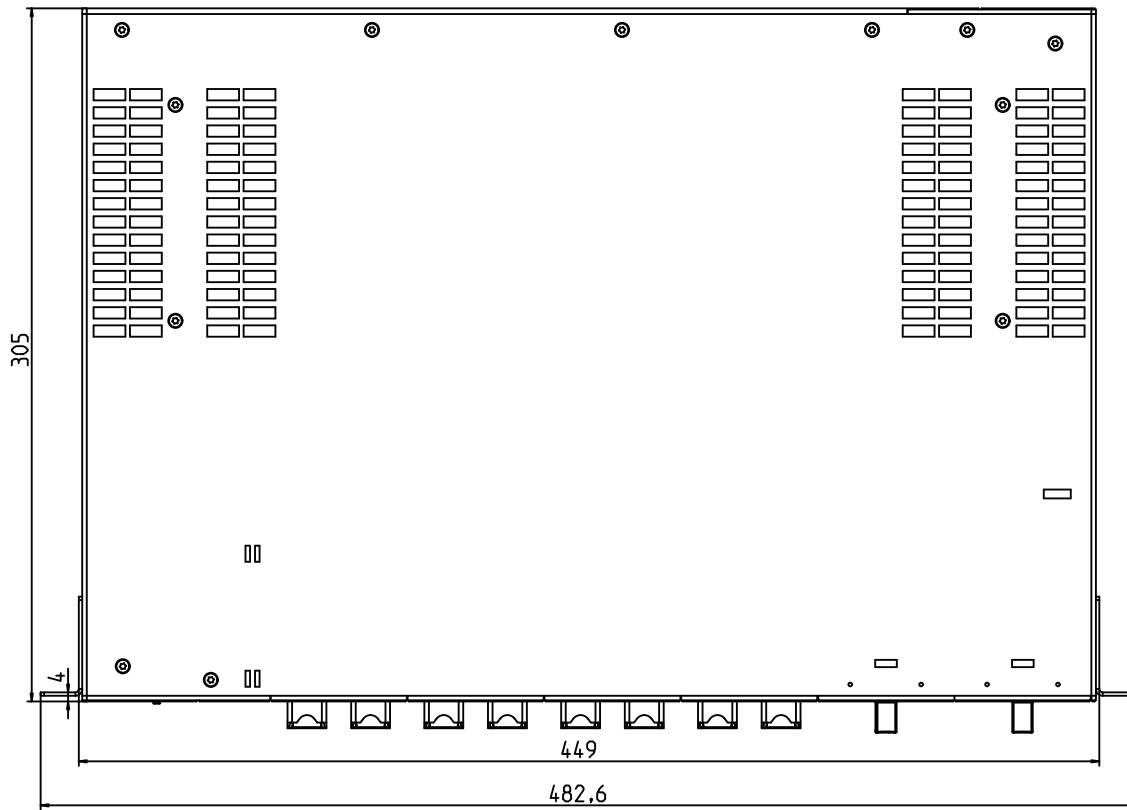

Figure 9-2 Top of the housing

Grounding bolts pressed in (100 to 240 VAC / 60 to 250 VDC)

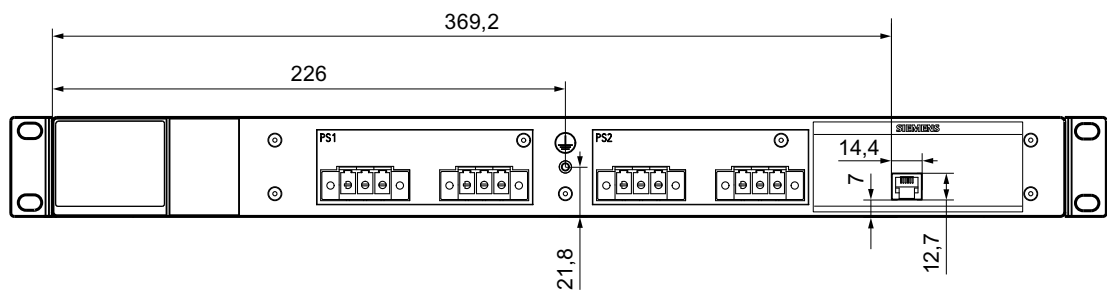

Figure 9-3 Example of a XR324-4M EEC (2 x 100 to 240 VAC, cable outlet front)



Grounding bolts pressed in (24 to 48 VDC)

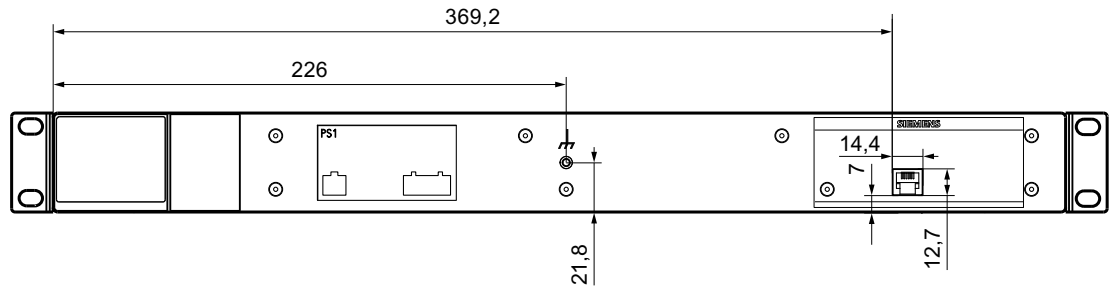
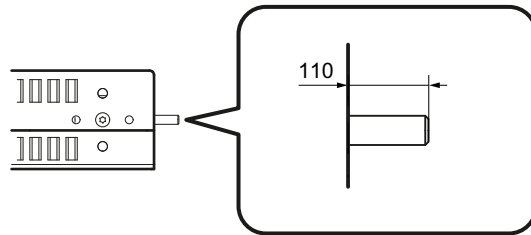

Figure 9-4 Example of a XR324-4M EEC (1 x 24 VDC, cable outlet front)

Grounding bolt





## Approvals

The SIMATIC NET products described in these Operating Instructions have the approvals listed below.

---

### Note

#### Issued approvals on the type plate of the device

The specified approvals apply only when the corresponding mark is printed on the product. You can check which of the following approvals have been granted for your product by the markings on the type plate.

---

### Current approvals on the Internet

You will find the current approvals for the product on the Internet pages of Siemens Industry Online Support (<https://support.industry.siemens.com/cs/ww/en/ps/15302/cert>).

### Notes for the manufacturers of machines

This product is not a machine in the sense of the EC Machinery Directive or the Supply of Machinery (Safety) Regulations (UK).

There is therefore no declaration of conformity relating to the EC Machinery Directive 2006/42/EEC or the Supply of Machinery (Safety) Regulations 2008 (UK) for this product.

If the product is part of the equipment of a machine, it must be included in the procedure for obtaining the EU/UK conformity assessment by the manufacturer of the machine.

### Machinery directive

The product is a component in compliance with the EC Machinery Directive 2006/42/EEC and the Supply of Machinery (Safety) Regulations 2008 (UK).

According to the Machinery Directive respectively the Supply of Machinery (Safety) Regulations (UK), we are obliged to point out that the product described is intended solely for installation in a machine.

Before the final product can be put into operation, it must be tested to ensure that it conforms with the Machinery Directive 2006/42/EEC and the Supply of Machinery (Safety) Regulations 2008 (UK).

### EC declaration of conformity



The SIMATIC NET products described in these operating instructions meet the requirements and safety objectives of the following EU directives and comply with the harmonized

European standards (EN) which are published in the official documentation of the European Union and here.

- **2014/34/EU (ATEX explosion protection directive)**  
Directive of the European Parliament and the Council of 26 February 2014 on the approximation of the laws of the member states concerning equipment and protective systems intended for use in potentially explosive atmospheres, official journal of the EU L96, 29/03/2014, p. 309-356

---

**Note**

Only variants with 24 V DC power supply meet the requirements of this approval.

---

- **2014/35/EU (Low Voltage Directive)**  
Directive of the European Parliament and of the Council of 26 February 2014 on the harmonization of the laws of the Member States relating to the making available on the market of electrical equipment designed for use within certain voltage limits; official journal of the EU L96, 29/03/2014, p. 357-374.

---

**Note**

Only variants with 240 V AC power supply meet the requirements of this approval.

---

- **2014/30/EU (EMC)**  
EMC directive of the European Parliament and of the Council of February 26, 2014 on the approximation of the laws of the member states relating to electromagnetic compatibility; official journal of the EU L96, 29/03/2014, p. 79-106
- **2011/65/EU (RoHS)**  
Directive of the European Parliament and of the Council of 8 June 2011 on the restriction of the use of certain hazardous substances in electrical and electronic equipment, official journal of the EC L174, 01/07/2011, p. 88-110

You will find the EC declaration of conformity for these products on the Internet pages of Siemens Industry Online Support (<https://support.industry.siemens.com/cs/ww/en/ps/15273/cert>).

The EC Declaration of Conformity is available for all responsible authorities at:

Siemens Aktiengesellschaft

Digital Industries  
DE-76181 Karlsruhe  
Germany

## UK Declaration of Conformity



The UK declaration of conformity is available to all responsible authorities at:

Siemens Aktiengesellschaft  
Digital Industries  
Process Automation  
DE-76181 Karlsruhe  
Germany

**Importer UK:**

Siemens plc,  
Manchester M20 2UR

You can find the current UK Declaration of Conformity for these products on the Internet pages under Siemens Industry Online Support (<https://support.industry.siemens.com/cs/ww/en/ps/15273/cert>).

The SIMATIC NET products described in this document meet the requirements of the following directives:

- UK-Regulation  
SI 2016/1107 Equipment and Protective Systems Intended for use in Potentially Explosive Atmospheres Regulations 2016, and related amendments
- EMC Regulation  
SI 2016/1091 Electromagnetic Compatibility Regulations 2016, and related amendments
- RoHS Regulation  
SI 2012/3032 Restriction of the Use of Certain Hazardous Substances in Electrical and Electronic Equipment Regulations 2012, and related amendments

## ATEX, IECEx, UKEX and CCC Ex certification

 <b>WARNING</b>
<b>Risk of explosion in hazardous areas</b>
When using SIMATIC NET products in hazardous area zone 2, make absolutely sure that the associated conditions in the following document are adhered to: "SIMATIC NET Product Information Use of subassemblies/modules in a Zone 2 Hazardous Area". You will find this document
<ul style="list-style-type: none"> <li>• on the data medium that ships with some devices.</li> <li>• on the Internet pages under Siemens Industry Online Support (<a href="https://support.industry.siemens.com/cs/ww/en/view/78381013">https://support.industry.siemens.com/cs/ww/en/view/78381013</a>).</li> </ul>
Enter the document identification number "C234" as the search term.

The markings of the electrical devices are:

UK  
CA



II 3 G Ex ec IIC T4 Gc  
DEKRA 18ATEX0025 X  
DEKRA 21UKEX0001 X  
IECEx DEK 18.0017X

Importer UK:  
Siemens plc,  
Manchester  
M20 2UR  
(Ex ec IIC T4 Gc, not on the nameplate)

The products meet the requirements of the following standards:

- EN/IEC 60079-7, GB 3836.3
- EN IEC/IEC 60079-0, GB 3836.1

You will find the current versions of the standards in the currently valid certificates.

---

**Note**

Only variants with 24 VDC power supply meet the requirements of this approval.

---

**Note for devices with CLASS 1 LASER**

Important note on products certified according to Type Examination Certificate KEMA 07ATEX0145 X as of Issue 95 / DEKRA 18ATEX0025 X and IECEx Certificate of Conformity DEK 14.0025X as of Issue 43 / DEK 18.0017X and containing Class 1 optical radiation sources.

---

**Note**

**CLASS 1 LASER**

The device contains optical radiation sources which comply with the limits of Class 1 according to IEC 60825-1. Fiber-optic cables connected to these optical radiation sources may therefore be routed either to or through hazardous areas requiring Category 2G, 3G, 2D or 3D equipment.

---

**Programmable logic controllers (low voltage directive)**

The SIMATIC NET products described in these operating instructions meet the requirements of EU directive 2014/35/EU "Low Voltage Directive".

Applied standard:

- DIN EN 61131-2 Programmable logic controllers - Part 2: Operating resource requirements and tests.

---

**Note**

Only variants with 100 to 240 V AC power supply meet the requirements of this approval.

---

**EMC (electromagnetic compatibility)**

The SIMATIC NET products described in these operating instructions meet the electromagnetic compatibility requirements according to the EU Directive 2014/30/EU as well as the UK-Regulation SI 2016/1091 and their associated amendments.

Applied standards:

- EN 61000-6-2 Electromagnetic compatibility (EMC) - Part 6-2: Generic standards - Immunity for industrial environments
- EN 61000-6-4 Electromagnetic compatibility (EMC) - Part 6-4: Generic standards - Emission standard for industrial environments

You will find the current versions of the standards in the currently valid EC/UK Declaration of Conformity.

## RoHS

The SIMATIC NET products described in these operating instructions meet the requirements on the restriction of the use of certain hazardous substances in electrical and electronic equipment according to the EU Directive 2011/65/EU as well as the UK-Regulation SI 2012/3032 and their associated amendments.

Applied standard:

- EN IEC 63000

## FM

The product meets the requirements of the standards:

- Factory Mutual Approval Standard Class Number 3611
- FM Hazardous (Classified) Location Electrical Equipment:  
Non Incendive / Class I / Division 2 / Groups A,B,C,D / T4 and  
Non Incendive / Class I / Zone 2 / Group IIC / T4

---

### Note

Only variants with 24 VDC power supply meet the requirements of this approval.

---

## cULus Approval for Information Technology Equipment



cULus Listed I. T. E.

Underwriters Laboratories Inc. complying with

- UL 60950-1 (Information Technology Equipment)
- CSA C22.2 No. 60950-1-03

Report no. E115352

---

### Note

Only variants with 24 VDC power supply meet the requirements of this approval.

---

### cULus approval for industrial control equipment

cULus Listed IND. CONT. EQ.

Underwriters Laboratories Inc. complying with

- UL 508
- CSA C22.2 No. 142-M1987

Report no. E85972

---

#### Note

Only variants with 100 to 240 VAC power supply meet the requirements of this approval.

---

### cULus Approval Hazardous Location



cULus Listed I. T. E. FOR HAZ. LOC.

Underwriters Laboratories Inc. complying with

- UL 60950-1 (Information Technology Equipment)
- ANSI/ISA 12.12.01-2007
- CSA C22.2 No. 213-M1987

Approved for use in

Cl. 1, Div. 2, GP A, B, C, D T4

Cl. 1, Zone 2, GP IIC T4

Report no. E240480

---

#### Note

Only variants with 24 VDC power supply meet the requirements of this approval.

---

### Note for Australia - RCM

The product meets the requirements of the RCM standard.



Applied standards:

- AS/NZS CISPR11 (Industrial, scientific and medical equipment - Radio-frequency disturbance characteristics - Limits and methods of measurement).
- EN 61000-6-4 Electromagnetic compatibility (EMC) - Part 6-4: Generic standards - Emission standard for industrial environments

You will find the current versions of the standards in the currently valid RCM SDoCs (Self-Declaration of Conformity).

### MSIP 요구사항 - For Korea only

#### A급 기기(업무용 방송통신기자재)

이 기기는 업무용(A급) 전자파 적합기기로서 판매자 또는 사용자는 이 점을 주의하시기 바라며, 가정 외의 지역에서 사용하는 것을 목적으로 합니다.

### Marking for the customs union



EAC (Eurasian Conformity)

Eurasian Economic Union of Russia, Belarus, Armenia, Kazakhstan and Kyrgyzstan

Declaration of conformity according to the technical regulations of the customs union (TR ZU)

### IEC 61850-3 (EN55022 / CISPR22 CLASS A)

The product meets the requirements of the standard IEC 61850-3 (EN55022 / CISPR22 CLASS A).

### IEEE 1613

The product meets the requirements of the standard IEEE 1613 CLASS 1 (electrical ports) or IEEE 1613 CLASS 2 (optical ports).

## 10.1 FDA and IEC XR-300M EEC marking

### FDA and IEC marking

The following devices meet the FDA and IEC requirements listed below:

Device	CLASS 1 LASER Product
6GK5 324-4GG00-1ER2	(*)
6GK5 324-4GG10-1ER2	(*)
6GK5 324-4GG00-2ER2	(*)
6GK5 324-4GG10-2ER2	(*)
6GK5 324-4GG00-3ER2	(*)
6GK5 324-4GG10-3ER2	(*)
6GK5 324-4GG00-4ER2	(*)

10.1 FDA and IEC XR-300M EEC marking

Device	CLASS 1 LASER Product
6GK5 324-4GG10-4ER2	(*)
6GK5 324-4GG00-1JR2	(*)
6GK5 324-4GG10-1JR2	(*)
6GK5 324-4GG00-2JR2	(*)
6GK5 324-4GG10-2JR2	(*)
6GK5 324-4GG00-3JR2	(*)
6GK5 324-4GG10-3JR2	(*)
6GK5 324-4GG00-4JR2	(*)
6GK5 324-4GG10-4JR2	(*)

\* For modular devices, you can find the marking in the operating instructions for the media module or plug-in transceiver used.



Figure 10-1 FDA and IEC markings

**⚠ CAUTION**  
 Use of controls or adjustments or performance of procedures other than those specified herein may result in hazardous radiation exposure.

## 10.2 XR-300M EEC mechanical stability (in operation)

The devices of the SCALANCE XR-300M EEC product group meet the following standards (prerequisite: rack mounted with 4 securing points):

- **IEC 60068-2-6**  
(vibrations during transportation and operation)  
Test parameters:  
5 – 9 Hz: 3.5 mm  
9 – 150 Hz: 1 g  
1 octave/min, 20 sweeps
- **IEC 60068-2-27**  
(shocks during operation)  
Test parameters:  
15 g, 11 ms duration  
6 shocks per axis
- **IEC 60068-2-6**  
(vibrations during transportation)  
Test parameters:  
10 – 58 Hz: 0.075 mm  
85 – 150 Hz: 1 g  
1 octave/min, 20 sweeps

### Installation guidelines

The devices meet the requirements if you adhere to the installation and safety instructions contained in this documentation and in the following documentation when installing and operating the devices.

- "Industrial Ethernet / PROFINET Industrial Ethernet" System Manual (<https://support.industry.siemens.com/cs/ww/en/view/27069465>)
- "Industrial Ethernet / PROFINET - Passive Network Components" System Manual (<https://support.industry.siemens.com/cs/ww/en/view/84922825>)
- "EMC Installation Guidelines" configuration manual (<https://support.industry.siemens.com/cs/ww/en/view/60612658>)

#### **WARNING**

##### **Personal injury and property damage can occur**

The installation of expansions that are not approved for SIMATIC NET products or their target systems may violate the requirements and regulations for safety and electromagnetic compatibility.

Only use expansions that are approved for the system.

10.2 XR-300M EEC mechanical stability (in operation)

---

**Note**

The test was performed with a device and a connected communications partner that also meets the requirements of the standards listed above.

When operating the device with a communications partner that does not comply with these standards, adherence to the corresponding values cannot be guaranteed.

---

## Appendix

### A.1 Connector system M12/X-coded according to IEC 61076-2-109

#### Description

M12 connectors with X coding are also suitable for transmission rates up to 10 Gbps (Cat6A) because the shields of the wire pairs can be led into the connectors. A further advantage is the availability of connectors with degree of protection IP67 with which the equipped devices are also suitable for adverse environmental conditions (dust, dampness). Due to the locking technology standardized for the M12 connectors a high resistance to vibration is achieved. Numerous SCALANCE devices therefore provide connection options for X coded M12 connectors.

#### Pin assignment

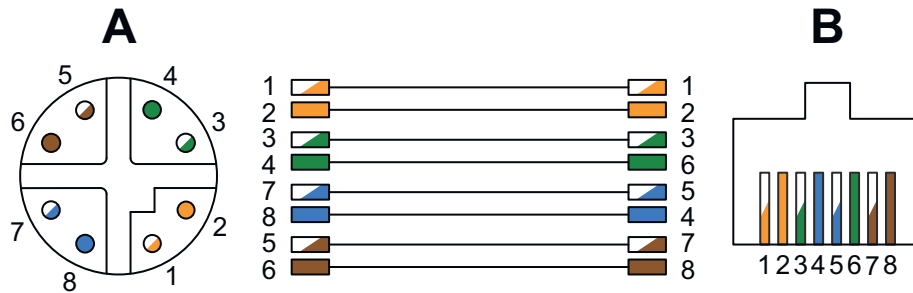

- A** Front view of M12 connector, X coded according to IEC61076-2-109
- B** Front view of RJ-45 connector, latching nose at the top, with pin assignment according to EIA/TIA 568B

Pin	M12/X coded		RJ-45 according to EIA/TIA 568B	
	Wire color	Signal	Wire color	Signal
1	White / orange	TX+	White / orange	TX+
2	Orange	TX-	Orange	TX-
3	White / green	RX+	White / green	RX+
4	Green	RX-	Blue	
5	White / brown		White / blue	
6	Brown		Green	RX-
7	White / blue		White / brown	
8	Blue		Brown	



# Index

## A

Approvals, 75

## B

Bolt, 45

## C

CE mark, 75

## D

Documentation, 5

## G

Glossary, 7

Grounding bolt, 45

## P

Power supply

Redundancy, 58

## R

Redundancy

Power supply, 58

## S

Safety notices

for installation, 31

general, 11

Use in hazardous areas, 11, 31, 43

when connecting up, 43

SIMATIC NET glossary, 7

SIMATIC NET manual, 7

System manual, 7, 33, 83

