

**16 Channel Time Switch (Annual Scheduler)
REG 373**
5WG1 373-5EY01

Product and Applications Description



The 16 channel time switch REG 373 (annual scheduler) with DCF77 and integrated bus coupling unit is a DIN rail mounted device for mounting in distribution boards. The connection to EIB is made via a bus connector. Terminals for the DCF77 antenna AP 390 and for 230V are provided to operate the time switch REG 373 with DCF77.

The time switch offers:

- 500 switching times:
 - daily instructions
 - weekly instructions
 - date instructions
 - priority switching times
 - impulse instructions
 - 1 x instructions for vacation / holidays.
 - moving holidays (like Easter)
 - For each channel, additionally 9 further week programs with priority levels P1 to P9 (priority program)
- Astronomical program with sun rise and sun set times for channels 1...4
- time-limited manual and permanently switched circuit
- random program can be activated for each channel

The period of a priority program is determined by input of a beginning and final date.

The time switch calculates moving holidays (like Easter) automatically for each year.

Accessories

Antenna for DCF77 reception	5WG1 390-3EY01
Programming set Obelisk	5WG1 810-0EY01
Obelisk 2.1 Software	

Priority program

A priority program is a special weekly program. Up to 9 different priority programs can be performed in addition to the normal weekly program. A firm weekly program **P1 ... P9** can be requested at any fixed periods of time.

Programming of the priority programs consists of:

1. Setting the weekly program (see chapter 8.1).
2. Setting commencement and completion date (see chapter 8.2).

Example:

Normal weekly program: daily 8:00 on, 18:00 off

Priority program:

switching times: daily 10:00 on P1, 22:00 of P1
(P1 = Priority 1)

period: P1 12 June until 31 August

The normal weekly program is executed from 01 January until 11 June 24:00 and from 01 September until 31 December.

Within the period from 12 June until 31 August only the priority program is executed and the normal weekly program is disabled.

If time periods of several weekly programs cut across one another, the program with the highest index number prevails e.g. weekly program P9 prevails over weekly program P3.

Example: The weekly program P2 overrides the weekly program P1, i.e. only P2 is executed.

The normal weekly program has no priority, i.e. P0 and as such is overridden by all other priority programs and switching times.

A priority program can be used multiple time if needed, e.g. P1 from 12 June until 31 August and from 22 December until 6 January.

This executes the weekly program P1 in both periods.

General priority rules

Within the same switching time or priority program OFF overrides ON, i.e. weekly program off overrides weekly program on.

Switching times are executed in the following order:

- Permanent switching
- 1x switching times
- Time limited permanent switching
- Date switching times
- Weekly program with priority P9
- Weekly program with priority P8
- Weekly program with priority P7
- Weekly program with priority P6
- Weekly program with priority P5
- Weekly program with priority P4
- Weekly program with priority P3
- Weekly program with priority P2
- Weekly program with priority P1
- Weekly program

Astronomical switching times are overridden while priority periods P5 ... P9 are activated and otherwise are processed like 1x date switching times (see chapter „Astronomical Program“).

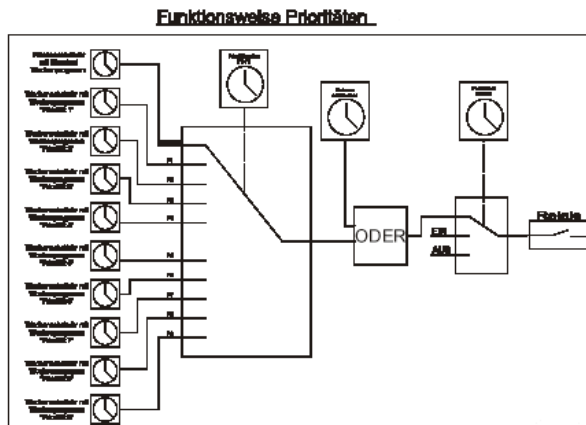

Additional programs

Besides the standard weekly program up to 9 other weekly programs can be entered per channel. These weekly programs can be activated by entering a start and end date.

Example: Weekly program no. 5 from 24 December to 6 January.

Further, date switching times and 1x date switching times can be added to each weekly program.

The switching program can be disabled via priority on and off commands by entering a start and end date. Also, the random program can be activated.

Random program

The random program turns a channel randomly on or off in intervals of 10 to 120 minutes.

The random program must be manually activated for each channel (enter channel number and press the Dat button).

This random switching only happens in those periods where the clock is switched on by the normal switching program.

This function is mainly used for simulation of occupancy (lighting) for premises that are temporarily uninhabited.

Function „1x“

The function „1x“ can be used for date switching times and for priority periods.

By setting the function „1x“ a switching time or priority period is executed only once and then deleted.

A date related switching time is automatically deleted at midnight. A priority period that was set as a 1x function is also deleted after the end of the period.

But the switching times assigned to the priority period are retained in the time switch.

The function „1x“ can be applied to the programming of switching times for vacation and holiday programs as well as moving holidays.

Moving holidays

Using the holiday program moving holidays like Easter can be programmed years ahead.

The Obelisk Software allows to program and store customer specific holidays in the 16 channel time switch.

In principal three different types of holidays exist:

1. fixed holidays: every year on the same date
2. free holidays: e.g. last Wednesday in May
3. moving holidays i.e. dependent on the date of Easter: e.g. Good Friday (2 days before Easter) or Whitsunday (49 days after Easter). Every year the dates of the moving holidays are automatically adjusted by the time switch. Free holidays are calculated by the Obelisk software for a selectable number of years.

Astronomical program

An astronomical program allows for switching dependent on sun rise and sun set times (e.g. for shutters, outdoor lighting, etc.)

With the Obelisk software an astronomical program can be set for each of the channels 1 ... 4 in the REG 373.

With the Obelisk software these conditions can be entered for the astronomical program:

- location (longitude / latitude)
- time zone (e.g. MET)
- entry of an offset of max.. ± 120 minutes (consideration of different location conditions like mountain, valley, etc.)
- blocking times (e.g. for shutter: not before 7:00 in the morning, not after 21:00 in the evening)

Data entry for the most common locations is effortlessly done by picking these from a list.

Additional locations can be set by directly entering longitude and latitude (resolution $0,5^\circ$).

Further the astronomical program can be adjusted any-time with the Obelisk software:

- any single astronomical switching time can be changed manually
- On those days where astronomical switching times are undesired these can be selectively disabled:
 - For one or more days by programming a priority period for P5 ... P9 or permanently on/off
 - or by a 1x date off switching time (for a single astronomical on switching time)

Review

If the time or the date is modified (via keyboard entry, via radio or bus synchronization), a review takes place in the clock. That means in order to avoid switching times being skipped and thus not executed, the clock calculates its switching status again. If the clock detects a modification of the switching conditions, then these are transmit-

**16 Channel Time Switch (Annual Scheduler)
REG 373**

5WG1 373-5EY01

ted. However, with this in principle favorable procedure the following points are to be considered:

- As manual switchings (circuit anticipations) are not in the switching time memory, manual switching can be lost under certain conditions by the review.
- In addition, impulses from the past are not detected by the review.

The review is performed:

- after resets
- after programming
- after deleting or modifying switching times
- after summer / winter time switching

Note

When the clock changes to a new priority period at 0:00 a new **priority related review** is performed.

The clock behaves as if the new priority had been active the day before and immediately assumes the switching condition that would have been active at midnight of that previous day.

Advantage:

Program P1: 22:00 on / 6:00 off from 1 May to 31 May
 Program P2: 23:00 on / 7:00 off from 1 June to 30 June
 Without review the clock would switch to off on 1 June at 0:00 on changing between P1 and P2 because at this time no switching time is programmed. With the review the switching time at 23:00 of the previous day is considered and the channel stays on.

If in certain cases this review is not desired this behavior can be overridden by a date instruction (off) at 0:00 at the beginning of the priority period (here on 1 June).

This measure is only required if in the new priority period the last switching instruction of the day i.e. before 24:00 is an on instruction.

Time synchronization

Time synchronization of the time switch can be chosen to be made via reception of a date and time bus telegram message, or by the DCF77 radio signal (antenna and mains power is required).

If a valid time telegram was received from the bus and the time switch clock was synchronized no further bus synchronization will be performed until the next day. The DCF synchronization is executed each night between just before 2:00 and shortly before 3:00 in the morning.

A forced synchronization (via Bus or DCF) is possible at any time with the manual sender call by pressing the Dat key for ca. 3 seconds.

Bus synchronization

The time switch can receive time (EIS 3) and date (EIS 4) telegrams for time synchronization.

However, during this so-called bus synchronization the following points need to be considered:

- If the clock is additionally synchronized by a DCF signal then bus synchronization is blocked.
- Before any bus synchronization a valid time must have been entered at the device itself at least once.
- Two time windows are available daily between 1:58:44 h and 2:13:00 h as well as between 2:58:44 h and 3:13:00 h within which the clock is ready to receive time and date messages.
- Outside of these two time windows the clock is only ready once to receive time and date messages independently.
- Another possibility is the execution of a so-called manual sender call. By this means, a time window is opened for 14 minutes by pressing the key Dat for 3 seconds. Within this time window, the clock is again ready to receive time and date messages (as often as required). After this time window, the clock is ready only once to receive time and date messages on its own.
- Furthermore note that in case the weekday in the time message deviates by +/- 1 day from the date set on the clock then the date is changed to match the weekday. Time messages with a deviation of more than one weekday are not accepted. The use of time messages without specification of the weekday are accepted but is not recommended, as problems can occur with the transition from one day to the next.

Note

For absolutely exact synchronization between specific clocks in an EIB system use synchronization via the DCF77 signal. With this method bus communication latency (e.g. via several couplers) is avoided. Each REG 372/02 has an input for a DCF77 antenna.

Send time

The time switch can also be used as a time source i.e. date and time are sent onto the bus to slave clocks, display units etc.

Programming of the switching times

Complete switching time programming can be made directly on the device by means of key input or by the PC programming set Obelisk. The software runs under Windows 9x, 2000. With a few mouse clicks, the input of the different switching times is fast and simple.

The transfer of the program is made by an EEPROM memory module (OBELISK 64K), which is programmed at the PC's interface and afterwards is inserted and read into the time switch. This enables also fast copying of a switching program.

The Obelisk software permits e.g.:

**16 Channel Time Switch (Annual Scheduler)
REG 373**

5WG1 373-5EY01

- to easily program switching time, priority, and holiday programs
- to select regional and national holidays from a data-base
- to define and add new holiday programs
- to check the program in a graphical simulation
- to program switching time programs into an EEPROM memory module
- to select switching time programs from the EEPROM memory module
- to archive switching time programs on fixed disk in the PC
- to print out switching time programs in tabular form
- to copy sections from an available switching time program and to insert them into a new or already available program
- to define a new rule for the summer/winter time (if no DCF antenna is attached).

Application program

12 CO Switching, Value, Scene, Temperature 7F0803

- Switch telegram (1Bit)
- 8-bit Value telegram (1 Byte)
- Positive drive telegram (2Bit)
- HVAC mode (1 Byte)
- 8 scenes
- Temperature telegram as part of scenes
- Cyclical sending selectable
- Date and time can be sent every minute, every hour, every day or on request
- Consecutive switching times can be associated with identical switch telegrams i.e. „on“ telegrams do not need to be followed by an „off“ telegram and vice versa.

Connection example

Figure 1 shows the connection of the DCF77 antenna to one or several REG 373, operated with DCF77.

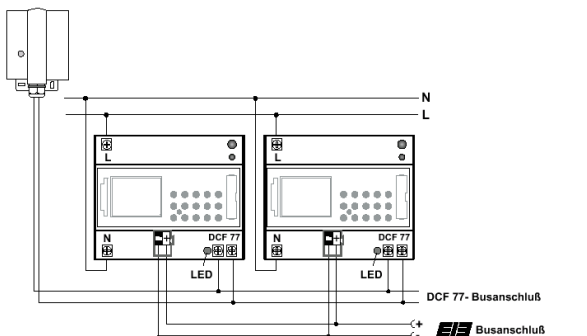

Figure 1: Connection of REG 373 with DCF77 antenna

Technical Specifications

Power supply

Via bus line

REG 373 only: 230V, 50/60 Hz, via screw terminals for DCF77 antenna

Power consumption

ca. 9 mA (at bus voltage)

Functional data

- 16 channels
- time base: radio-controlled (otherwise quartz precision)
- 500 memory locations in EEPROM
- Shortest switching interval: 1 second / minute
- switching accuracy: 1 second
- Shortest impulse 1 second
- Time accuracy: ± 1 Sec./Tag or radio controlled
- Power reserve: Lithium cell ca. 1½ years at 20°C
- Type of Lithium battery: CR 2450
- Daily, weekly, yearly and impulse programs as automatic programs
- Manual overrides:
 - temporary manual override
 - permanent manual override
- Inputs: 1 x DCF 77 antenna
- Programming: Via 10-key keyboard or with PC programming set Obelisk and memory card Obelisk 64k
- block formation:
 - Free block formation of week days and channels
- Summer / Winter time changeover:
 - Automatically or via DCF 77 radio signal

Control elements

- 1 learning button:
 - for switching between normal operating mode and addressing mode
- 15 soft tip buttons:
 - for setting day of week, hour, minute, time, programm entry and 16 manual overrides

Display elements

- 1 red LED: for monitoring bus voltage and displaying mode selected with learning button
- LC Display: for display of time, day of week, day light savings mode, holiday program mode, switching status and manual control mode

Connections

- Bus line: screwless bus connection block 0,6 ... 0,8 mm Ø single core

**16 Channel Time Switch (Annual Scheduler)
REG 373**

5WG1 373-5EY01

Physical specifications

- Polymer casing
- Dimensions: DIN rail mounted device
45 x 105 x 60 mm (H x W x D), width 6 SU
- Weight: ca. 451 g
- Fire load: ca. 10.000 KJ ± 10 %
- installation: rapid mounting on DIN EN 50022-35 x 7,5 rail

Electrical safety

- Fouling class (according to IEC 60664-1): 2
- Protection (according to DIN EN 60 529): IP 20
- Overvoltage class (nach IEC 60664-1): III
- Bus: safety extra low voltage SELV DC 24 V
- Device complies with: EN 50 090-2-2 and EN 60730-2-7

Reliability

Failure rate: 1290 fit at 40°C

Electromagnetic compatibility

Complies with EN 50090-2-2, EN 61000-6-2, EN 61000-6-3

Environmental specifications

- Climatic conditions: EN 50090-2-2
- Ambient temperature operating: - 5 ... + 45 °C (-5 T45)
- Ambient temperature non-operating: - 25 ... + 70 °C
- rel. humidity (non-condensing): 5 % ... 93 %

Certification

EIB certified

CE norm

Complies with the EMC regulations (residential and functional buildings), and low voltage regulations

Dimension Diagram

Dimensions in mm

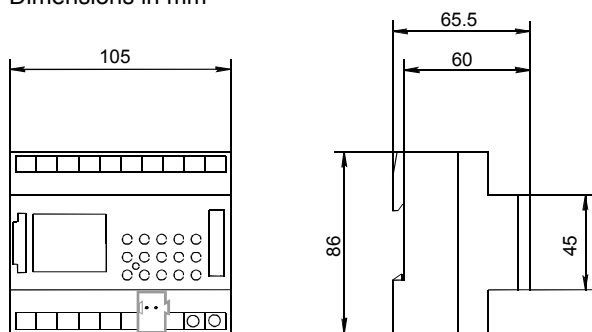

b = 6 SU

1 Standard Unit (SU) = 17,5 mm

Installation Instructions

Despite extensive protection measures exceptionally strong electromagnetic fields can lead to the destruction of the micro-processor controlled time switch.

Therefore we recommend that you observe the following points before installation:

- Use separate lead for the mains voltage supply.
- Suppress inductive loads with suitable RC filters.
- Do not mount product in direct proximity to sources of interference as e.g. transformers, contactors, PCs and TV and communication equipment.
- If interference occurs we recommend that you carry out a RESET (chapter 5.3 of Operating Instructions) before putting the device back into operation.
- Strong heat generating products on the right side of the product shorten the life time of the battery.
- The yearly time switch can be used for stationary installation in dry rooms.

**WARNING**

- The device may be placed into distribution boards (230/400 V) together with appropriate VDE-devices.
- The device must be mounted and commissioned by an authorized electrician.
- Free DIN rail areas with stuck-in data rail must be covered with covers, order no. 5WG1 192-8AA01.
- The prevailing safety and installation rules must be heeded.
- The device must not be opened. A device suspected faulty should be returned to the local Siemens office.

Mounting and WiringGeneral description

The N-system DIN rail device (4 SU) can be installed in N-system distribution boards and any other location or enclosure with DIN EN 50022-35 x 7,5 rails.

The connection to the bus line is established through a front mounted bus connector block.

Mounting the device on a DIN rail (Figure 2)

- Slide the device (B1) onto the DIN rail (B2) and
- swivel the device (B1) back onto the DIN rail until the slide clicks into place audibly.

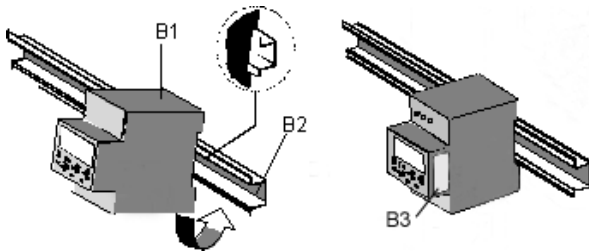

Figure 2: Mounting of DIN rail device

Dismounting the device from the DIN rail (Figure 3)

- Press down the slide (C3) with a screw driver and secure the slide in place by gently pressing it down and
- swivel the device (C1) from the DIN rail (C2) to the front.

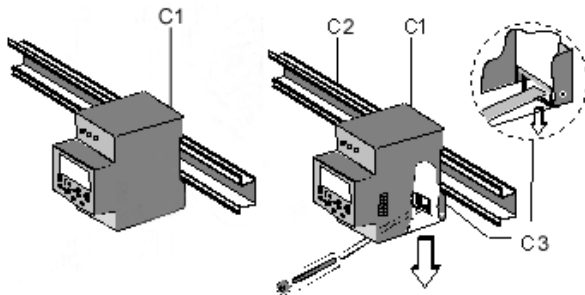

Figure 3: Dismounting of DIN rail device

Insert battery

- Note the polarity of the Lithium battery (type: CR 2450)
- Insert the Lithium battery into the holder.
- Push the battery holder into the battery compartment.
- Press the battery holder down until it audibly clicks in place.

Battery Changing**Note:**

Always change the battery with bus voltage applied.

All memorized program data is maintained when the bus voltage is applied.

- Lift the battery draw with a suitable screw driver.
- Remove battery from the holder.
- Note the polarity of the new Lithium cell.
- Insert the Lithium battery (type: CR 2450) into the holder.
- Push the battery holder into the battery compartment.
- Press the battery holder down until it audibly clicks in place.
- Dispose of Lithium battery in an environmentally friendly way.

Start up of REG 373

A. When operating without DCF77 radio control signal

- Connect the bus wire.
- Set summer / winter time date rule (European dates are pre-set).

B. When operating with DCF 77 radio control signal

- First connect the time switch with 230 V~ and then with the bus wire.
- Only connect the DCF77 antenna AP 390 with the time switch REG 373.
- **The polarity of the connection is important! The polarity is correct when the yellow LED on the DCF77 antenna AP390 is NOT lit.**
- Safety extra low voltage is used for the antenna signal. Proper isolation from mains voltage must be provided for.

C. Orientation of the antenna

- For proper orientation of the antenna swivel the antenna horizontally on the mounting bracket until the LED on the front flashes every second.

16 Channel Time Switch (Annual Scheduler)
REG 373

5WG1 373-5EY01

Operator Elements

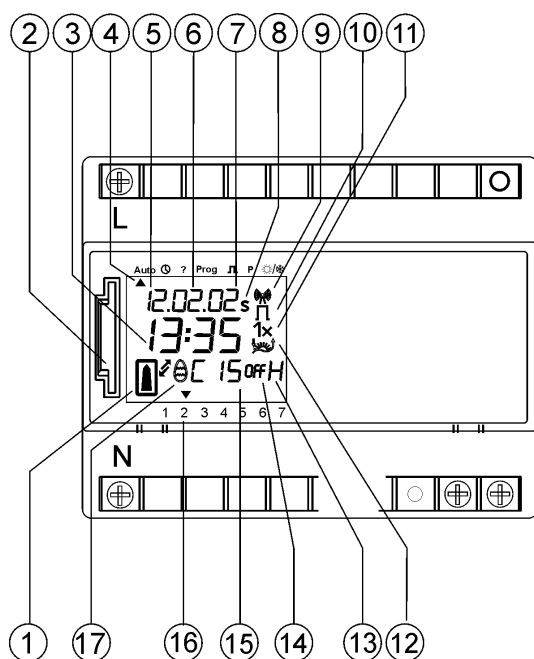

Figure 4a: Location of display and operator elements

- (1) Display data exchange with Obelisk 64k
- (2) Interface for Obelisk 64K
- (3) Hour
- (4) Cursor for menu selection
- (5) Display date day
- (6) Display month
- (7) Display year
- (8) Second symbol
(displays the impulse length in sec. together with 7)
- (9) DCF77 receive display
- (10) Impulse symbol
- (11) Display 1x switching times
- (12) Display for astronomical switching times
(sun rise, sun set)
- (13) Additional information for switching status display
r = random / P 1...9 = priority level /
Manual ON (H + \odot) / Manual OFF (H + \ominus) /
Permanent ON (F+ \odot) / Permanent OFF (F + \ominus)
- (14) Switching status
- (15) Channel number
- (16) Display weekday 1=Monday ...
- (17) Symbol of public holidays without a fixed date

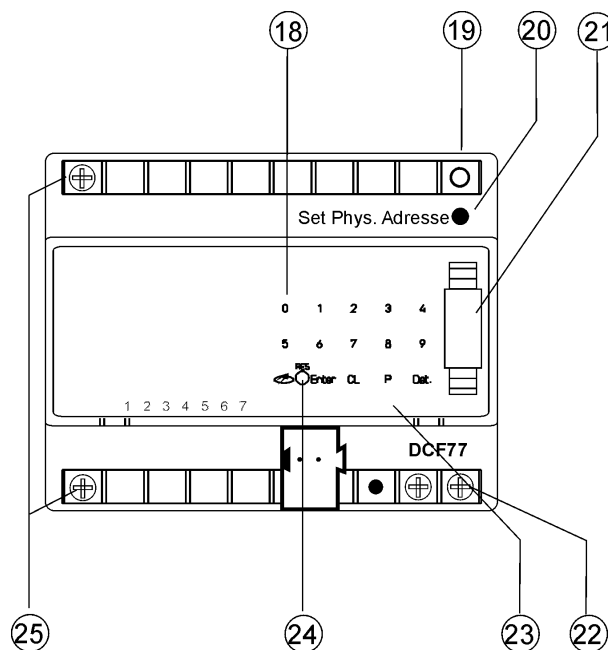

Figure 4b: Location of display and operator elements

- (18) keypad for the operation of the clock
- (19) Programming LED of the BCU
- (20) Programming button of the BCU
- (21) Battery holder
- (22) Terminals for DCF77 antenna
- (23) Bus connection
- (24) Reset button
- (25) Mains terminals for integrated antenna mains unit;
connection necessary only for operation with
DCF77 antenna

instabus EIB

Technical Product Information

March 2004

**16 Channel Time Switch (Annual Scheduler)
REG 373**

5WG1 373-5EY01

Room for notes