

Binary Input GE 262 5WG1 262-4AB02

4 x message contacts, 42 x 28 mm

Issued: March 1999

Product and Applications Description

The GE 262 binary input has an oblong design and is therefore suitable for mounting in devices or for separate mounting. Four inputs are available for volt free signalling contacts. The required scanning voltage is provided by the binary input GE 262 (no additional power supply required).

The binary input GE 262's primary use is the reading of signalling contacts (e.g. window contacts) over long distances.

Each of the inputs can be assigned various tasks depending on the application program used, i.e. the binary input GE 262 consists of the device (hardware) and its application programs (software).

Appropriate application programs are available for the different tasks the binary input GE 262 can handle: e.g. sending on/off telegrams at different edges of the input signal either event-controlled or cyclic with parametrisable repetition intervals.

With the ETS (EIB Tool Software) the application program is selected, its parameters and addresses are assigned appropriately, and downloaded to the binary input GE 262.

Application Programs

See Siemens product database from version E onward

Example of Operation

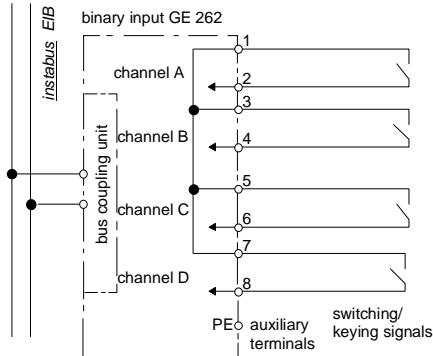

Technical Specifications

Power supply

via bus cable

Inputs

- number: 4 inputs
- input signal current:
 - at closed contact: 6 mA per channel, impulses ($f = \text{approx. } 200 \text{ Hz}$)
- delay of input signal:
 - at leading edge of input signal: max. 35 ms
 - at trailing edge of input signal: max. 5 ms
- input signal length: min. 50 ms
- input characteristic: set in parameter list according to application program
- input signal cable:
 - length: max. 100 m unshielded
 - contact/loop-resistance: max. 60 Ω per channel
 - capacity: max. 120 nF per channel

Control elements

1 learning button: for switching between normal operating mode and addressing mode

Display elements

1 red LED: for monitoring bus voltage and displaying mode, selected with the learning button

Connections

- signal inputs, screwless plug-in terminals:
 - strip insulation for 9 ... 10 mm permissible conductor types/cross sections:
 - 0,5 ... 1,5 mm² single core or flexible conductor, 8 mm ultrasonically compacted
 - 0,5 ... 1,5 mm² flexible conductor with terminal pin, crimped on gas tight
 - 0,5 ... 1,0 mm² flexible conductor with connector sleeve
 - 1,0 mm² plain flexible conductor
- bus line: screwless bus connection block $\varnothing 0,6 \dots 0,8 \text{ mm}$ single core

Physical specifications

- housing: plastic
- dimensions (W x H x L): 42 x 28 x 274,5 mm
- weight: approx. 190 g
- fire load: approx. 3850 kJ \pm 10 %
- installation: screw-mount into devices

Electrical safety

- fouling class (according to IEC 664-1): 2
- protection (according to EN 60529): IP 20
- protection class (according to IEC1140): III
- overvoltage class (according to IEC 664-1): III
- bus: safety extra low voltage SELV DC 24 V
- device complies with EN 50090-2-2 and 60669-2-1

Reliability

rate of failure: 651 fit at 40 °C

Electromagnetic compatibility

complies with EN 50081-1, EN 50082-2 and EN 50090-2-2

Environmental specifications

- climatic conditions: EN 50090-2-2
- ambient temperature operating: - 5 ... + 45 °C
- ambient temperature non-op.: - 25 ... + 70 °C
- relative humidity (non-condensing): 5 % to 93 %

Certification

EIB certificate

CE norm

complies with the EMC regulations (residential and functional buildings), and low voltage regulations

Location and Function of the Display and Operator Elements

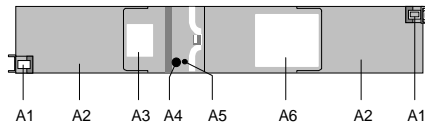

Figure 1: Location of the display and operator elements

- A1 Levers for snapping the cover lids shut
- A2 Cover lids of the connection block compartments
- A3 Label for noting the physical address
- A4 Learning button for switching between normal operating mode and addressing mode for receiving the physical address
- A5 LED for indicating normal operating mode (LED off) and addressing mode (LED on); upon receiving the physical address the device automatically returns to normal operating mode
- A6 Type plate

Installation Instructions

- The device may be used for permanent interior installations in dry locations within casings or other devices, or surface mounted.

WARNING

- The device must be mounted and commissioned by an authorised electrician.
- Take care that 230 V devices that are used in combination with this device provide a basic insulation of 250 V to the line; otherwise a safety distance of 4 mm must be kept. If in doubt, extra insulation should be added.
- Inputs must not be connected to 230 V.
- The prevailing safety rules must be heeded.
- The device must not be opened. A device suspected faulty should be returned to the local Siemens office.

Mounting and Wiring

General description

The devices can be built into casings or mounted separately with two screws, $\varnothing 4 \text{ mm}$.

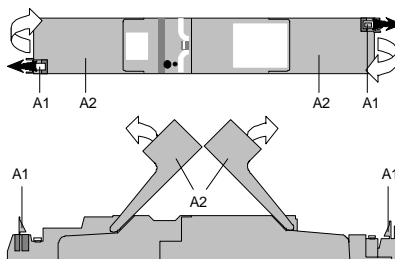

Figure 2: Opening and closing the cover lids

Opening the connection block compartment (Figure 2)

- Press the snap levers (A1) outwards (black arrows) and remove the cover lids (A2) of the compartments.

Closing the connection block compartment (Figure 2)

- Press the cover (A2) down until it clicks into place.

Slipping off bus connection blocks (Figure 3)

- The bus connection block (B3) is situated in the left connection block compartment. It consists of two components (B3.2 and B3.3) with four terminal contacts each. Take care not to damage the two test sockets (B3.1) by accidentally connecting them to the bus cable or with the screw-driver (e.g. when attempting to unplug the bus connection block).
- Carefully put the screw-driver to the wire-inserting slit of the bus connection block's grey component (B3.3) and pull the bus connection block (B3) from the built-in device. When removing the red component of the bus connection block, the black component remains in the compartment.

Note: Don't try to remove the bus connection block from the bottom side! There is a risk of shorting-out the device!

Slipping on bus connection blocks (Figure 3)

- Slip the bus connection block onto the guide slot and press the bus connection block (B3) down to the stop.

Connecting bus cables (Figure 3 "A")

- The bus connection block (B3) can be used with single core conductors $\varnothing 0,6 \dots 0,8 \text{ mm}$.
- Remove approx. 5 mm of insulation from the conductor (B3.4) and plug it into the bus connection block (B3) (red = +, black = -).
- The sheathing of the bus cable must be attached to the casing of the built-in device via the conductor fixing (B1). When using a cable with shielding, it can be screwed onto the terminal (B7, Figure 3).

The recess (B2) can be used to accommodate an overvoltage protection which is connected to the bus connection block in parallel with the bus line (Figure 3).

Disconnecting bus cables (Figure 3 "A")

- Unplug the bus connection block (B3) and remove the bus cable conductor (B3.4) while simultaneously wiggling it.

Connecting input circuits (Figure 3 "B")

- The input circuit is connected to screwless plug-in terminals (B4).
- Remove approx. 9 to 10 mm of insulation from the wire (B4.1) and plug it into the terminal (B4).
- The sheathing of the bus cable must be attached to the casing of the built-in device via the conductor fixing (B5, Figure 3).
- Plug-in terminal assignment:

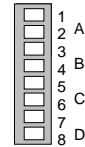

When using shielded signal cables, these can be screwed to the terminal (B5, Figure 3)

Conductor cross sections: see technical specifications

Disconnecting input circuits (Figure 3 "B")

- Press the terminal lock (B4.2) with a screw-driver and remove the connector (B4.1) from the terminal (B4).

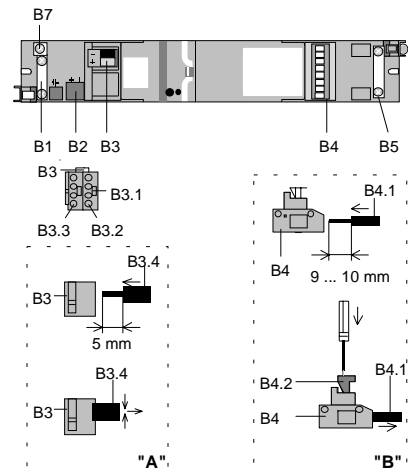

Figure 3: Connections