

SIEMENS

SIMATIC

ET 200S Distributed I/O System
Digital Electronic Module
4DO DC24V/0,5A SINK OUTPUT
(6ES7132-4BD50-0AA0)

Manual

Preface

Properties

1

Diagnostics

2

Safety Guidelines

This manual contains notices you have to observe in order to ensure your personal safety, as well as to prevent damage to property. The notices referring to your personal safety are highlighted in the manual by a safety alert symbol, notices referring only to property damage have no safety alert symbol. These notices shown below are graded according to the degree of danger.

⚠ DANGER
indicates that death or severe personal injury will result if proper precautions are not taken.
⚠ WARNING
indicates that death or severe personal injury may result if proper precautions are not taken.
⚠ CAUTION
with a safety alert symbol, indicates that minor personal injury can result if proper precautions are not taken.
CAUTION
without a safety alert symbol, indicates that property damage can result if proper precautions are not taken.
NOTICE
indicates that an unintended result or situation can occur if the corresponding information is not taken into account.

If more than one degree of danger is present, the warning notice representing the highest degree of danger will be used. A notice warning of injury to persons with a safety alert symbol may also include a warning relating to property damage.

Qualified Personnel

The device/system may only be set up and used in conjunction with this documentation. Commissioning and operation of a device/system may only be performed by **qualified personnel**. Within the context of the safety notes in this documentation qualified persons are defined as persons who are authorized to commission, ground and label devices, systems and circuits in accordance with established safety practices and standards.

Prescribed Usage

Note the following:

⚠ WARNING
This device may only be used for the applications described in the catalog or the technical description and only in connection with devices or components from other manufacturers which have been approved or recommended by Siemens. Correct, reliable operation of the product requires proper transport, storage, positioning and assembly as well as careful operation and maintenance.

Trademarks

All names identified by ® are registered trademarks of the Siemens AG. The remaining trademarks in this publication may be trademarks whose use by third parties for their own purposes could violate the rights of the owner.

Disclaimer of Liability

We have reviewed the contents of this publication to ensure consistency with the hardware and software described. Since variance cannot be precluded entirely, we cannot guarantee full consistency. However, the information in this publication is reviewed regularly and any necessary corrections are included in subsequent editions.

Preface

Purpose of the manual

This manual supplements the *ET 200S Distributed I/O System* Operating Instructions. General functions for the ET 200S are described in the *ET 200S Distributed I/O System* Operating Instructions.

The information in this document along with the operating instructions enables you to commission the ET 200S.

Basic knowledge requirements

To understand these operating instructions you should have general knowledge of automation engineering.

Scope of the manual

This manual applies to this ET 200S module. It describes the components that are valid at the time of publication.

Recycling and disposal

Thanks to the fact that it is low in contaminants, this ET 200S module is recyclable. For environmentally compliant recycling and disposal of your electronic waste, please contact a company certified for the disposal of electronic waste.

Additional support

If you have any questions relating to the products described in these operating instructions, and do not find the answers in this document, please contact your local Siemens representative.

<http://www.siemens.com/automation/partner>

The portal to our technical documentation for the various SIMATIC products and systems is available at:

<http://www.siemens.com/automation/simatic/portal>

The online catalog and ordering system are available at:

<http://www.siemens.com/automation/mall>

Training center

We offer courses to help you get started with the ET 200S and the SIMATIC S7 automation system. Please contact your regional training center or the central training center in D -90327, Nuremberg, Germany.

Phone: +49 (911) 895-3200.

<http://www.siemens.com/sitrain>

Technical Support

You can reach technical support for all A&D projects

- using the support request web form:
<http://www.siemens.com/automation/support-request>
- Phone: + 49 180 5050 222
- Fax: + 49 180 5050 223

For more information about our technical support, refer to our Web site at

<http://www.siemens.de/automation/service>

Service & Support on the Internet

In addition to our documentation services, you can also make use of our comprehensive online knowledge base on the Internet.

<http://www.siemens.com/automation/service&support>

There you will find:

- Our Newsletter, which constantly provides you with the latest information about your products.
- The right documentation for you using our Service & Support search engine.
- The bulletin board, a worldwide knowledge exchange for users and experts.
- Your local contact for Automation & Drives in our contact database.
- Information about on-site services, repairs, spare parts. Lots more can be found on our "Services" pages.

Table of contents

	Preface	3
1	Properties	7
1.1	Digital Electronic Module 4DO DC24V/0,5A SINK OUTPUT (6ES7132-4BD50-0AA0).....	7
2	Diagnostics	11
2.1	Diagnostics using LED display.....	11
	Index	13

Properties

1.1 Digital Electronic Module 4DO DC24V/0,5A SINK OUTPUT (6ES7132-4BD50-0AA0)

Properties

- Digital electronic module with four outputs
- Sink output
- 0.5 A output current per output, 2 A aggregate current
- 24 VDC rated load voltage
- Short-circuit protection
- Suitable for solenoid valves, DC contactors, and indicator lights
- Supports isochronous mode

Distinctive feature

When you connect-in the 24 VDC rated load voltage on the power module by means of a mechanical contact, the digital outputs feed the "1" signal for approximately 50 μ s, depending on the circuit. You need to take this into account if you use the module in combination with fast counters.

General terminal assignment

Note

The 4, 8, A4, A8, A3, and A7 terminals are only available at specified terminal modules.

Terminal assignment for 4DO DC24V/0,5A SINK OUTPUT (6ES7132-4BD50-0AA0)				
Terminal	Assignment	Terminal	Assignment	Notes
1	DO ₀	5	DO ₁	<ul style="list-style-type: none"> DO_n: Output signal, Channel n L+: 24 VDC encoder supply AUX1: Protective-conductor terminal or potential bus (available for use up to 230 VAC)
2	DO ₂	6	DO ₃	
3	L+	7	L+	
4	L+	8	L+	

Available terminal modules

Available terminal modules for 4DO DC24V/0,5A SINK OUTPUT (6ES7132-4BD50-0AA0)				
TM-E15C26-A1 (6ES7193-4CA50-0AA0)	TM-E15C24-A1 (6ES7193-4CA30-0AA0)	TM-E15C24-01 (6ES7193-4CB30-0AA0)	TM-E15C23-01 (6ES7193-4CB10-0AA0)	← Spring terminal
TM-E15S26-A1 (6ES7193-4CA40-0AA0)	TM-E15S24-A1 (6ES7193-4CA20-0AA0)	TM-E15S24-01 (6ES7193-4CB20-0AA0)	TM-E15S23-01 (6ES7193-4CB00-0AA0)	← Screw-type terminal
TM-E15N26-A1 (6ES7193-4CA80-0AA0)	TM-E15N24-A1 (6ES7193-4CA70-0AA0)	TM-E15N24-01 (6ES7193-4CB70-0AA0)	TM-E15N23-01 (6ES7193-4CB60-0AA0)	← Fast Connect
				<p>Sample connections 2-wire</p>

Block diagram

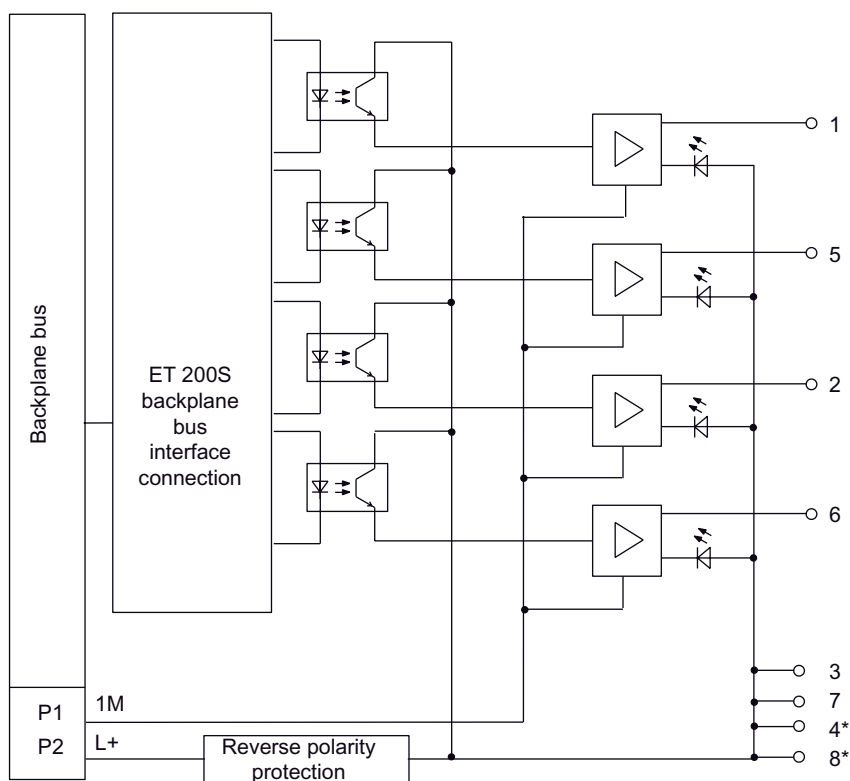

* M only for terminal modules with terminals 4 and 8

Figure 1-1 Block diagram of the 4DO DC24V/0,5A SINK OUTPUT

Technical specifications of 4DO DC24V/0,5A SINK OUTPUT (6ES7132-4BD50-0AA0)

Dimensions and weight	
Width (mm)	15
Weight	Approx. 40 g
Module-specific data	
Supports isochronous mode	Yes
Number of outputs	4
Output type	SINK
Cable length	
• Unshielded	Max. 600 m
• Shielded	Max. 1000 m
Parameter length	1 byte
Address space	1 byte
Address space (packed)	4 bits

Properties

1.1 Digital Electronic Module 4DO DC24V/0,5A SINK OUTPUT (6ES7132-4BD50-0AA0)

Voltages, currents, potentials	
Rated load voltage L+ (from the power module)	24 VDC
• Reverse polarity protection	Yes
Total current of the outputs (per module)	2 A
Electrical isolation	
• Between the channels	No
• Between the channels and backplane bus	Yes
Permissible potential difference	
• Between the different circuits	75 VDC / 60 VAC
Insulation tested	500 VDC
Current consumption	
• From backplane bus	Max. 10 mA
• From load voltage L+ (no load)	Max. 5 mA per channel
Power dissipation of the module	Typ. 0.8 W
Status, interrupts, diagnostics	
Status display	Green LED per channel
Diagnostics function	No
Data for selecting an actuator	
Output voltage	
• For signal "1"	1 V
Output current	
• For signal "1"	
– Rated value	0.5 A
– Permitted range	5 mA to 0.6 A
• For signal "0" (leakage current)	Max. 5 µA
Output delay (for resistive load)	
• For "0" to "1"	Max. 300 µs
• For "1" to "0"	Max. 600 µs
Load resistor range	48 Ω to 3.4 kΩ
Lamp load	Max. 5 W
Connecting two outputs in parallel	
• For redundant triggering of a load	Yes, per module
• To increase performance	No
Control of a digital input	Yes
Switch rate	
• With resistive load	100 Hz
• With inductive load	0.5 Hz
• With lamp load	10 Hz
Limitation (internal) of the voltage induced on circuit interruption	Typ. 47 V
Reverse-voltage protection	No
Short-circuit protection of the output	Yes, per channel
• Threshold on	Typ. 1.5 A

2

Diagnostics

2.1 Diagnostics using LED display

LED display

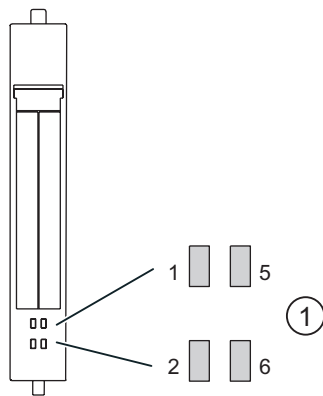

① Status display for output status (green)

Status displays

Event (LEDs)				Cause	Remedy
1	5	2	6		
On				Output on channel 0 activated.	—
	On			Output on channel 1 activated.	—
		On		Output on channel 2 activated.	—
			On	Output on channel 3 activated.	—

Index

B

Basic knowledge requirements, 3
Block diagram, 9

C

Counters, 7

D

Disposal, 3

I

Internet
Service & Support, 4

L

LED display, 11

P

Properties, 7

R

Recycling, 3

S

Scope
Manual, 3
Service & Support, 4
Status displays, 11

T

Technical specifications, 9
Technical Support, 4
Terminal assignment, 8
Terminal modules, 8
Training center, 4

