

# Electromagnetic Flowmeters

SITRANS F M MAG 8000 & MAG 8000 CT

Operating Instructions • 06/2010



SITRANS F

**SIEMENS**



# SIEMENS

## SITRANS F

### Electromagnetic Flowmeters SITRANS F M MAG 8000 & MAG 8000 CT

#### Operating Instructions



<u>Introduction</u>	<b>1</b>
<u>Safety notes</u>	<b>2</b>
<u>Description</u>	<b>3</b>
<u>Installing/Mounting</u>	<b>4</b>
<u>Connecting</u>	<b>5</b>
<u>Commissioning</u>	<b>6</b>
<u>Operation</u>	<b>7</b>
<u>Service and maintenance</u>	<b>8</b>
<u>Troubleshooting/FAQs</u>	<b>9</b>
<u>Technical data</u>	<b>10</b>
<u>Appendix</u>	<b>A</b>

Battery-operated electromagnetic water meter

## Legal information

### Warning notice system

This manual contains notices you have to observe in order to ensure your personal safety, as well as to prevent damage to property. The notices referring to your personal safety are highlighted in the manual by a safety alert symbol, notices referring only to property damage have no safety alert symbol. These notices shown below are graded according to the degree of danger.

 <b>DANGER</b>
indicates that death or severe personal injury <b>will</b> result if proper precautions are not taken.
 <b>WARNING</b>
indicates that death or severe personal injury <b>may</b> result if proper precautions are not taken.
 <b>CAUTION</b>
with a safety alert symbol, indicates that minor personal injury can result if proper precautions are not taken.
<b>CAUTION</b>
without a safety alert symbol, indicates that property damage can result if proper precautions are not taken.
<b>NOTICE</b>
indicates that an unintended result or situation can occur if the corresponding information is not taken into account.

If more than one degree of danger is present, the warning notice representing the highest degree of danger will be used. A notice warning of injury to persons with a safety alert symbol may also include a warning relating to property damage.

### Qualified Personnel

The product/system described in this documentation may be operated only by **personnel qualified** for the specific task in accordance with the relevant documentation for the specific task, in particular its warning notices and safety instructions. Qualified personnel are those who, based on their training and experience, are capable of identifying risks and avoiding potential hazards when working with these products/systems.

### Proper use of Siemens products

Note the following:

 <b>WARNING</b>
Siemens products may only be used for the applications described in the catalog and in the relevant technical documentation. If products and components from other manufacturers are used, these must be recommended or approved by Siemens. Proper transport, storage, installation, assembly, commissioning, operation and maintenance are required to ensure that the products operate safely and without any problems. The permissible ambient conditions must be adhered to. The information in the relevant documentation must be observed.

### Trademarks

All names identified by ® are registered trademarks of the Siemens AG. The remaining trademarks in this publication may be trademarks whose use by third parties for their own purposes could violate the rights of the owner.

### Disclaimer of Liability

We have reviewed the contents of this publication to ensure consistency with the hardware and software described. Since variance cannot be precluded entirely, we cannot guarantee full consistency. However, the information in this publication is reviewed regularly and any necessary corrections are included in subsequent editions.



# Table of contents

<b>1</b>	<b>Introduction.....</b>	<b>7</b>
1.1	Items supplied .....	7
1.2	History .....	8
1.3	Further Information .....	8
<b>2</b>	<b>Safety notes.....</b>	<b>9</b>
2.1	General safety instructions .....	9
2.2	Laws and directives .....	9
2.3	Lithium batteries.....	10
2.4	Installation in hazardous area.....	10
<b>3</b>	<b>Description.....</b>	<b>11</b>
3.1	System components .....	11
3.2	Operating principle .....	11
3.3	Design .....	12
3.4	Benefits .....	13
<b>4</b>	<b>Installing/Mounting.....</b>	<b>15</b>
4.1	Introduction .....	15
4.2	Sensor installation.....	16
4.2.1	Locating the sensor.....	16
4.2.2	Orienting the sensor.....	18
4.2.3	Mounting the sensor .....	20
4.3	Potential equalization.....	22
4.4	Grounding .....	22
4.5	Cathodic-protected pipes .....	25
4.6	Potting and direct burial .....	25
4.7	Transmitter installation.....	27
<b>5</b>	<b>Connecting .....</b>	<b>29</b>
5.1	General safety requirements.....	30
5.2	Remote version .....	30
5.3	Power supply.....	31
5.4	Outputs.....	33
5.5	Communication modules .....	34
5.6	Connection of add-on modules.....	36

<b>6</b>	<b>Commissioning</b> .....	<b>37</b>
6.1	General instructions .....	37
6.1.1	Flow Tool.....	37
6.1.2	SIMATIC PDM.....	38
6.2	Commissioning steps .....	38
6.3	Initial commissioning via Flow Tool.....	38
6.4	Initial commissioning via SIMATIC PDM.....	39
6.5	Configuring device .....	40
6.6	Setting basic parameters .....	41
6.7	Unit selection.....	45
6.8	Output configuration.....	48
<b>7</b>	<b>Operation</b> .....	<b>49</b>
7.1	Meter operation via key and display .....	49
7.2	Display symbols .....	50
7.3	Default display information and accessible display menus.....	51
7.4	Operator menu .....	53
7.5	Data protection.....	58
7.6	Internal data handling.....	59
7.7	Battery-powered operation.....	60
<b>8</b>	<b>Service and maintenance</b> .....	<b>65</b>
8.1	Maintenance.....	65
8.2	MAG 8000 and MAG 8000 CT service guidelines .....	65
8.3	Replacing transmitter or PCB board .....	65
8.4	Battery replacement.....	66
8.5	Power up with battery reset, date and time set up.....	68
8.6	Verification.....	69
8.7	User and verification sealings .....	70
8.8	Technical support.....	71
8.9	Return procedures .....	72
8.10	Battery disposal.....	72
<b>9</b>	<b>Troubleshooting/FAQs</b> .....	<b>73</b>
9.1	Fault codes.....	73
9.2	Built-in functions.....	75
9.3	Flow simulation .....	77

<b>10</b>	<b>Technical data .....</b>	<b>79</b>
10.1	MAG 8000 MAG 8000 CT meter.....	79
10.2	Sensor.....	80
10.3	Transmitter.....	81
10.4	Power supply.....	83
10.5	Modbus RTU.....	84
10.6	Output characteristics .....	85
10.7	Meter uncertainty .....	90
10.8	MAG 8000 CT (7ME6820) (Revenue program) water meter type approval.....	91
10.9	MAG 8000 CT (7ME6820) (Revenue program) MI-001 .....	92
10.10	The effect of temperature MAG 8000 (7ME6810) and MAG 8000 CT (7ME6820) .....	95
10.11	Dimensions and drawings.....	96
<b>A</b>	<b>Appendix.....</b>	<b>103</b>
A.1	Unit conversion table .....	103
A.2	Parameter lists .....	104
A.2.1	1-99 .....	104
A.2.2	100-199 .....	105
A.2.3	200-299 .....	106
A.2.4	300-399 .....	109
A.2.5	400-499 .....	110
A.2.6	500-599 .....	111
A.2.7	600-799 .....	112
A.2.8	800-899 .....	117
A.3	Sizing sensor.....	120
A.3.1	Sizing table DN 25 ... 1200 (1" ... 48") .....	120
A.4	Certificates .....	122
A.4.1	Certificates .....	122
A.5	Spare parts/Accessories .....	123
A.5.1	Ordering .....	123
A.6	Features .....	128
	<b>Index.....</b>	<b>133</b>



# Introduction

# 1

These instructions contain all the information you need for using the device.

The instructions are aimed at persons mechanically installing the device, connecting it electronically, configuring the parameters and commissioning it as well as service and maintenance engineers.

---

## Note

It is the responsibility of the customer that the instructions and directions provided in the manual are read, understood and followed by the relevant personnel before installing the device.

---

## 1.1 Items supplied

- SITRANS F M MAG 8000 or MAG 8000 CT
- Calibration certificate
- Operating Instructions
- SITRANS F M literature CD

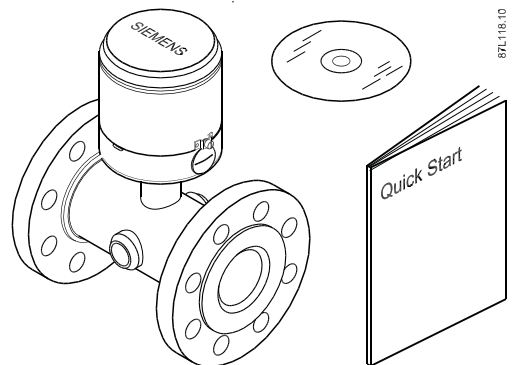

## Inspection

1. Check for mechanical damage due to possible improper handling during shipment. All claims for damage are to be made promptly to the shipper.
2. Make sure the scope of delivery, and the information on the type plate corresponds to the ordering information.

**Device identification**

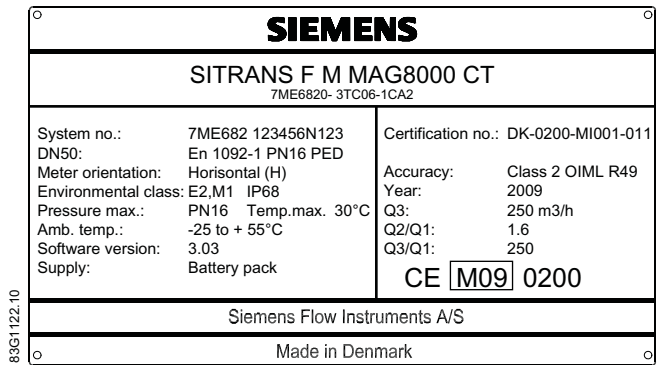

Figure 1-1 MAG 8000 CT type plate example

**1.2 History**

The contents of these instructions are regularly reviewed and corrections are included in subsequent editions. We welcome all suggestions for improvement.

The following table shows the most important changes in the documentation compared to each previous edition.

Edition	Remarks
12 03/2010	<ul style="list-style-type: none"> <li>• Integration of MAG 8000 for irrigation applications</li> <li>• Restructuring of the document</li> </ul>

**1.3 Further Information**

The contents of these Operating Instructions shall not become part of or modify any prior or existing agreement, commitment or legal relationship. All obligations on the part of Siemens AG are contained in the respective sales contract which also contains the complete and solely applicable warranty conditions. Any statements contained herein do not create new warranties or modify the existing warranty.

**Product information on the Internet**

The Operating Instructions are available on the CD-ROM shipped with the device, and on the Internet on the Siemens homepage, where further information on the range of SITRANS F flowmeters may also be found:

Product information on the internet (<http://www.siemens.com/flowdocumentation>)

**Worldwide contact person**

If you need more information or have particular problems not covered sufficiently by the operating instructions, please get in touch with your contact person. You can find contact information for your local contact person on the Internet:

Local contact person (<http://www.automation.siemens.com/partner>)

# Safety notes

# 2

## 2.1 General safety instructions

 <b>CAUTION</b>
Correct, reliable operation of the product requires proper transport, storage, positioning and assembly as well as careful operation and maintenance. Only qualified personnel should install or operate this instrument.

### Note

Alterations to the product, including opening or improper repairs of the product, are not permitted.

If this requirement is not observed, the CE mark and the manufacturer's warranty will expire.

## 2.2 Laws and directives

### General requirements

Installation of the equipment must comply with national regulations. For example EN 60079-14 for the European Community.

### Instrument safety standards

The device has been tested at the factory, based on the safety requirements. In order to maintain this condition over the expected life of the device the requirements described in these Operating Instructions must be observed.

<b>CAUTION</b>
<b>Material compatibility</b> Siemens Flow Instruments can provide assistance with the selection of wetted sensor parts. However, the full responsibility for the selection rests with the customer and Siemens Flow Instruments can take no responsibility for any failure due to material incompatibility.

### CE marked equipment

The CE-mark symbolizes the compliance of the device with the following guidelines:

- EMC-guideline 89/336/EWG
- Low voltage guideline 73/23/EWG
- Pressure equipment directive (PED/DGRL) 93/23/EG
- ATEX Directive 94/9/EG

## 2.3 Lithium batteries

Lithium batteries are primary power sources with high energy content designed to represent the highest possible degree of safety.

 <b>WARNING</b>
<b>Potential hazard</b> Lithium batteries may present a potential hazard if they are abused electrically or mechanically. This is in most circumstances associated with the generation of excessive heat where internal pressure may cause the cell to rupture. Thus the following basic precautions should be observed when handling and using lithium batteries: <ul style="list-style-type: none"><li>• Do not short-circuit, recharge or connect with false polarity.</li><li>• Do not expose to temperature beyond the specified temperature range or incinerate the battery.</li><li>• Do not crush, puncture or open cells or disassemble battery packs.</li><li>• Do not weld or solder to the battery's body.</li><li>• Do not expose contents to water.</li></ul>

## 2.4 Installation in hazardous area

This device is not approved for use in hazardous areas.



## Description

### 3.1 System components

A SITRANS F M MAG 8000 & MAG 8000 CT flowmeter system includes:

- A transmitter and a sensor. The transmitter is either compact mounted (integral) or remote mounted at a distance of maximum 30 m (100 ft).
- An internally or externally mounted battery supply or 115 ... 230 V AC or 12/24 V AC/DC power supply with battery backup.

#### Communication solutions

The following communication modules are available:

- RS 232.
- RS 485 Modbus RTU.
- Encoder interface for AMR solutions.

### 3.2 Operating principle

MAG 8000 is a microprocessor-based water meter with graphical display and key for optimum customer operation and information on site. The transmitter drives the magnetic field in the sensor, evaluates the flow signal from the sensor, and calculates the volume passing through. It delivers the required information via the integrated pulse output or communication interfaces as part of a system solution. Its intelligent functionality, information and diagnostics ensure optimum meter performance and information to optimize water supply and billing.

MAG 8000 and MAG 8000 CT can be ordered as a Basic or an Advanced version. Both versions are configured to achieve up to 6 years\ battery operation in typical revenue applications.

### 3.3 Design

MAG 8000 is a battery-supplied magnetic inductive flowmeter for revenue, district and irrigation metering application.



Figure 3-1 MAG 8000 family

#### Compact



Figure 3-2 MAG 8000 compact

#### Remote



Figure 3-3 MAG 8000 remote

## Custody transfer

Compact and remote versions.



Figure 3-4 MAG 8000 CT

## 3.4 Benefits

- Simple placement of the meter - bury the meter underground or in a floating chamber. The IP 68 (NEMA 6P) design is unaffected by meter position or in-line piping stresses, and there is no requirement for filters.
- Low pressure loss - an unrestricted flow tube ensures minimal pressure loss, even at the highest flow rates. Overall network system pressures can be reduced, helping to prevent leakage from burst pipes and excess stress placed on pumping stations.
- Zero maintenance - designed without moving parts and has a 10-year battery life.
- Measurement in both directions - only one meter required for measuring in both direction.
- Intelligent meter - only one meter for leak detection, data logger function, and self-detection of errors.

*Description*

*3.4 Benefits*

---

# Installing/Mounting

## 4.1 Introduction

SITRANS F flowmeters are suitable for indoor and outdoor installations.

- Make sure that pressure and temperature specifications indicated on the device type plate / label are not exceeded.

### General information

This chapter describes how to install the flowmeter in the compact version as well as in the remote version.

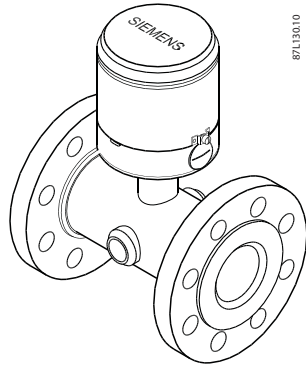

Figure 4-1 Compact installation

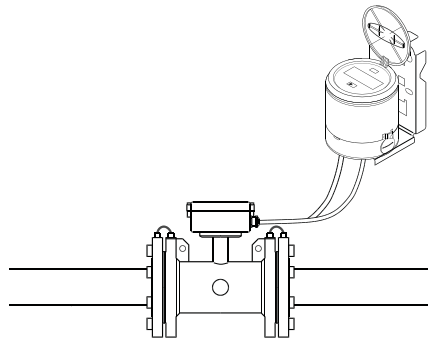

Figure 4-2 Remote installation

The installation consists of two steps:

1. Sensor installation.
2. Transmitter installation (remote version only).

## 4.2 Sensor installation

The sensor installation consists of three steps:

1. Locating the sensor.
2. Orienting the sensor
3. Mounting the sensor

### 4.2.1 Locating the sensor

Ensure that the sensor is located in the most optimum place.

#### Flow direction

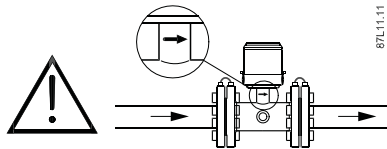

Installation conditions for MAG 8000 CT are different from MAG 8000 installation conditions; for detailed information please see OIML R49 and MI-001 certificates for MAG 8000 CT.

Ensure that sensor is mounted in correct flow direction as indicated on label.

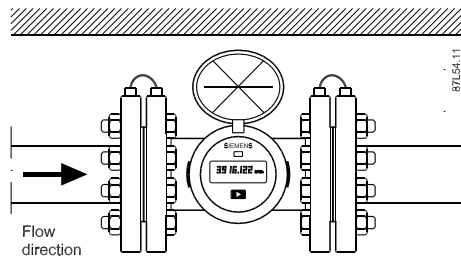

If process flow direction is opposite of flow direction indicated on sensor label, forward flow rates can be restored via software parameter FT327, if factor is adjusted to "-1".

### Inlet and outlet condition

To achieve most accurate flow measurement it is essential to have certain straight inlet and outlet pipe lengths as shown ( $D_i$ : sensor diameter).

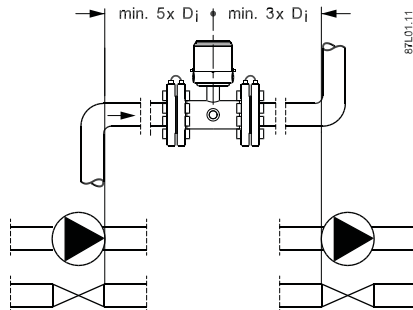

### Sensor must be completely full of liquid

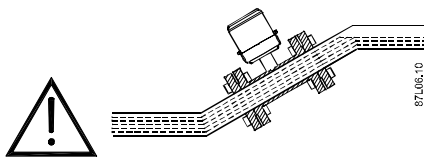

Therefore avoid:

- Air in pipe.
- Installation at the highest point in pipe system.
- Installation in vertical pipes with free outlet.

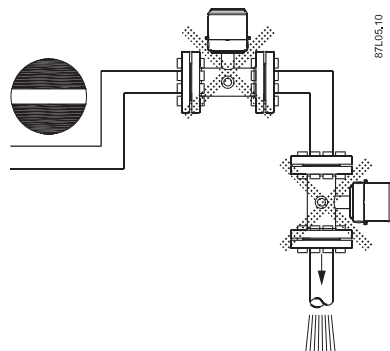

### Partially filled pipes

For partially filled pipes or pipes with downwards flow and free outlet, sensor must be mounted in a U-tube.

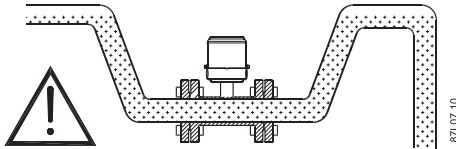

### 4.2.2 Orienting the sensor

 <b>CAUTION</b>
<b>Flow direction</b> Installation conditions for MAG 8000 CT are different from MAG 8000 installation conditions. For detailed information, please see OIML R49 and MI-001 certificates for MAG 8000 CT.

### Horizontal pipes

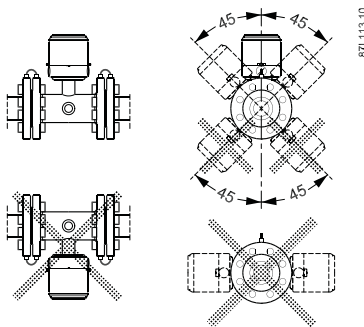

Sensor must be mounted as shown in upper part of figure. Do not mount sensor as shown in lower part of figure as electrodes then will be positioned at top where air bubbles may occur and in bottom, where mud, sludge, sand etc. may deposit.

If "Empty Pipe Detection" is used, sensor should be tilted 45° as shown in upper right figure to maximize full pipe detection and provide accurate volume calculations.

#### Note

Physical installation of battery pack may influence battery capacity. Optimal battery capacity is achieved with battery pack in an upright position. Installation examples marked with dotted cross will affect battery capacity.



### Vertical pipes (MAG 8000)

Recommended installation is in a vertical/inclined pipe to minimize wear and deposits in sensor.

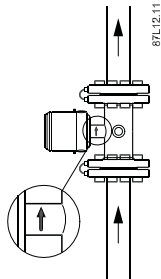

### Installation in large pipes (MAG 8000)

The water meter can be installed between two reducers (e.g. DIN 28545).

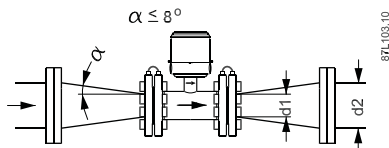

With an 8° reducer, the following pressure drop curve applies. The curves are applicable to water.

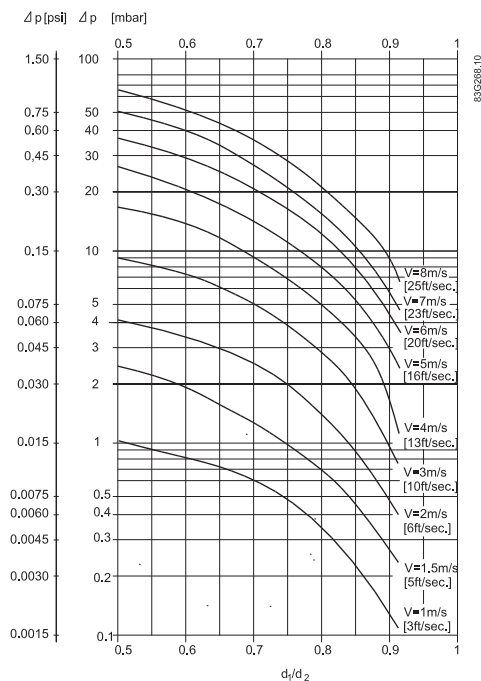

**Example:**

A flow velocity of 3 m/s (10 ft./sec.) (V) in a sensor with a diameter reduction from DN 100 to DN 80 (4" to 3") ( $d_1/d_2 = 0.8$ ) gives a pressure drop of 2.9 mbar (0.04 psi).

### 4.2.3 Mounting the sensor

1. Install gaskets.
2. Ensure connection flange has a smooth surface and is in line with sensor.

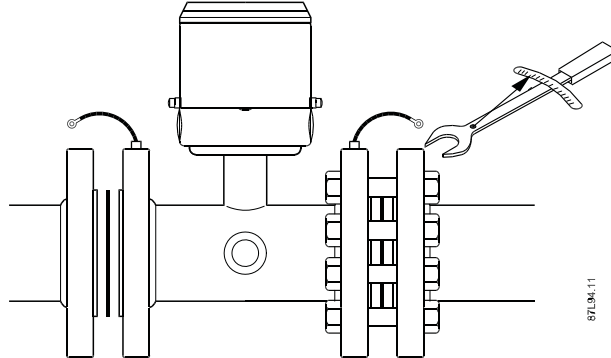

Gaskets are recommended but not included in flowmeter delivery.

#### Advice for gasket selection:

- Only use flat rubber gaskets.
- Thickness 1 ... 6 mm (0.0 ... 0.02 ft) dependent on gap/tolerance.
- Inner diameter must be larger than bore of flowmeter.
- Material should be compatible with process fluid.

Hardness should be maximum 75 Shore A.

### Maximum allowable torques

Standard bolts must be well lubricated and tightened evenly around gasket.

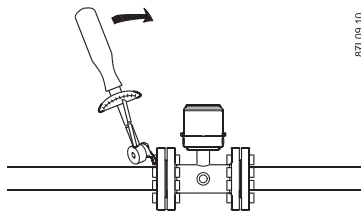

Leakage/damage to flowmeter or piping may arise if bolts are overtightened.

#### Torque calculations

All values are theoretical and are calculated on the assumption that:

- All bolts are new and material selection is according to EN 1515-1 table 2.
- Gasket material not exceeding 75 shore A is used between the flowmeter and mating flanges.
- All bolts are galvanized and adequately lubricated.
- Flanges are made of carbon steel.
- Flowmeter and mating flanges are correctly aligned.

**Torques for 7ME6810 and 7ME6820**

Nominal size		PN 10		PN 16		PN 40		Class 150		AWWA	
Mm	inch	Nm	f/lbs	Nm	f/lbs	Nm	f/lbs	Nm	f/lbs	Nm	f/lbs
25	1"	N/A	N/A	N/A	N/A	10	7	7	5	N/A	N/A
40	1½"	N/A	N/A	N/A	N/A	16	12	9	7	N/A	N/A
50	2"	N/A	N/A	25	18	N/A	N/A	25	18	N/A	N/A
65	2½"	N/A	N/A	25	18	N/A	N/A	25	18	N/A	N/A
80	3"	N/A	N/A	25	18	N/A	N/A	34	25	N/A	N/A
100	4"	N/A	N/A	25	18	N/A	N/A	26	19	N/A	N/A
125	5"	N/A	N/A	29	21	N/A	N/A	42	31	N/A	N/A
150	6"	N/A	N/A	50	37	N/A	N/A	57	42	N/A	N/A
200	8"	50	37	50	37	N/A	N/A	88	65	N/A	N/A
250	10"	50	37	82	61	N/A	N/A	99	73	N/A	N/A
300	12"	57	42	111	82	N/A	N/A	132	97	N/A	N/A
350	14"	60	44	120	89	N/A	N/A	225	166	N/A	N/A
400	16"	88	65	170	125	N/A	N/A	210	155	N/A	N/A
450	18"	92	68	170	125	N/A	N/A	220	162	N/A	N/A
500	20"	103	76	230	170	N/A	N/A	200	148	N/A	N/A
600	24"	161	119	350	258	N/A	N/A	280	207	N/A	N/A
700	28"	200	148	304	224	N/A	N/A	N/A	N/A	200	148
750	30"	N/A	N/A	N/A	N/A	N/A	N/A	N/A	N/A	240	177
800	32"	274	202	386	285	N/A	N/A	N/A	N/A	260	192
900	36"	288	213	408	301	N/A	N/A	N/A	N/A	240	177
1000	40"	382	282	546	403	N/A	N/A	N/A	N/A	280	207
1050	42"	N/A	N/A	N/A	N/A	N/A	N/A	N/A	N/A	280	207
1100	44"	N/A	N/A	N/A	N/A	N/A	N/A	N/A	N/A	290	214
1200	48"	395	292	731	539	N/A	N/A	N/A	N/A	310	229

**Torques for 7ME6880**

Nominal size		EN drilled pattern PN 7		ANSI drilled pattern Class150		AS2091 drilled pattern PN 7	
Mm	inch	Nm	f/lbs	Nm	f/lbs	Nm	f/lbs
50	2"	5	4	5	4	5	4
65	2½"	5	4	7	5	7	6
80	3"	5	4	9	7	9	7
100	4"	7	6	7	6	14	11
125	5"	11	9	12	9	11	9
150	6"	16	12	15	11	12	9
200	8"	24	18	23	17	20	15
250	10"	24	18	26	20	36	27
300	12"	31	23	35	26	31	23
350	14"	32	24	40	30	51	38
400	16"	46	34	50	37	62	46
450	18"	47	35	56	42	79	59

4.3 Potential equalization

Nominal size		EN drilled pattern PN 7		ANSI drilled pattern Class150		AS2091 drilled pattern PN 7	
500	20"	57	43	67	50	72	54
600	24"	89	66	104	77	111	82

### 4.3 Potential equalization

Liquid potential equalization or grounding is accomplished with built-in grounding electrodes and/or grounding rings. The electrodes ensure electrical connection between liquid and meter providing a stable and accurate measurement.

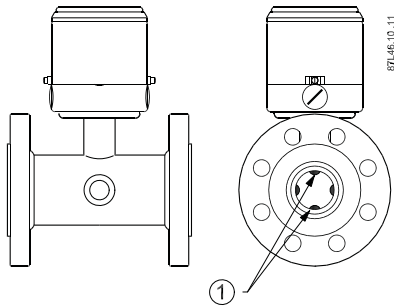

1 Built/in grounding electrode (7ME6810 and 7ME6820)

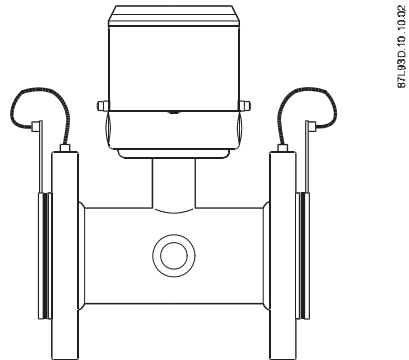

2 Grounding rings mounted on MAG 8000 for irrigation applications (7ME6880)

### 4.4 Grounding

The sensor body must be grounded using grounding/bonding straps and/or grounding rings to protect flow signal against stray electrical noise and/or lightning. This ensures that noise is carried through sensor body and that the measuring area within sensor body is noise-free.

### Irrigation applications

MAG 8000 (7ME6880) for irrigation applications is always delivered with pre-mounted grounding rings.

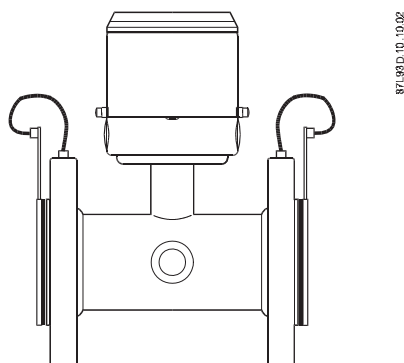

87L100.10.02

### Metal pipes

Connect straps to both flanges with 6 mm (1/4") screws.

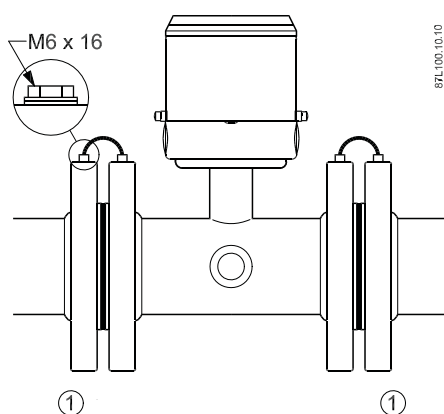

87L100.10.10

1 Metal pipes

Bonding/grounding straps are part of delivery and pre-mounted on flowmeter.

**Plastic pipes and lined metal pipes**

Use optional grounding rings at both ends.

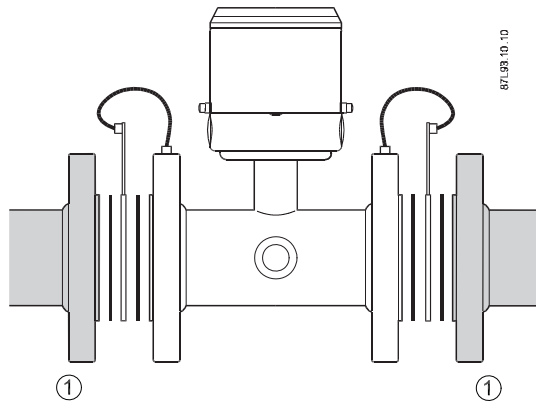

- 1 Plastic pipes or lined metal pipes
- Grounding rings are not included in delivery.

**Combination of metal and plastic pipes**

Use straps for metal pipe and grounding rings for plastic pipe.

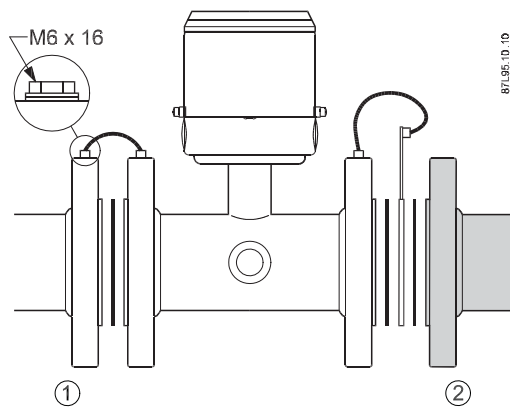

- 1 Metal pipe
- 2 Plastic pipe

Bonding/grounding straps, grounding rings and straps are not included in delivery.

---

**Note**

All straps or grounding wires must be 12 AWG (or heavier) copper wire and connected with 6 mm screws.

---

## 4.5 Cathodic-protected pipes

Pay special attention to meter installation in cathodic-protected pipe.

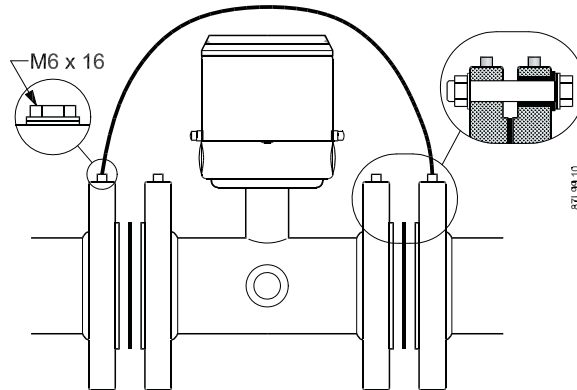

Isolate meter from pipeline by mounting isolation sleeves and washers on flange bolts and connect a wire dimensioned to manage the cathodic current and environmental influence, between pipelines.

## 4.6 Potting and direct burial

### Adequate sealing of sensor electronics

#### CAUTION

Do **not** pot meter before electrical connections have been made.

Meter is rated IP68/NEMA 6P from the factory as standard. If cable glands are used, IP68/NEMA 6P enclosure rating is obtained by potting transmitter bottom with Sylgard potting kit. Otherwise only an IP67/NEMA 4 rating is obtained.

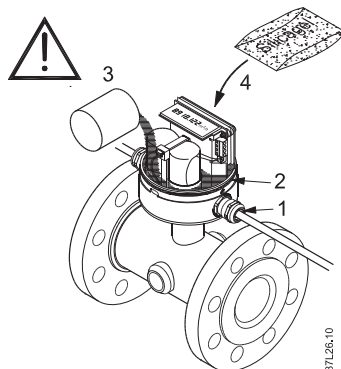

Ensuring IP68/NEMA 6P enclosure rating and preventing water ingress:

1. Select the proper gland size to fit installed cable size.
2. Mount O-ring properly and correctly and grease with gel.
3. Fill Sylgard potting kit in bottom part of casing.
4. Renew Silicagel bag to prevent condensation within meter, if necessary

---

**Note**

**Important**

Ensure not to fill Sylgard potting kit in the space for the battery pack.

Ensure Silicagel bag is not in contact with Sylgard potting.

---

**Suggestions for direct burial of remote sensor**

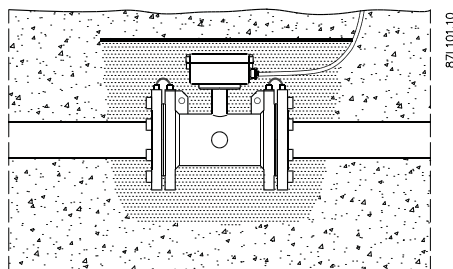

Remote sensor is protected to IP68/NEMA 6P and can be buried.

The use of pea gravel, at least 300 mm (12 inches) all around sensor, is recommended to provide some drainage and to prevent dirt from solidifying on sensor.

It also helps to locate the sensor should excavation be necessary. Before covering pea gravel with earth, use electrical cable identification tape above gravel.

Run remote sensor cable through a plastic conduit of minimum 50 mm (2 inches).



## 4.7 Transmitter installation

Mount bracket on a wall as shown below or on a horizontal or a vertical pipe using ordinary hose clips or duct straps.

### Wall mounting

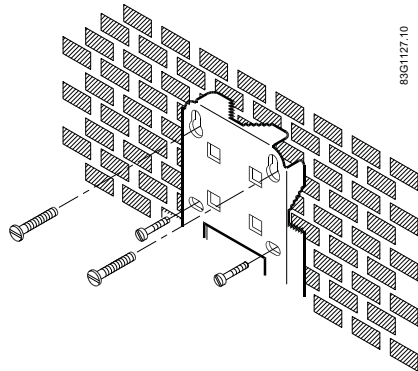

Figure 4-3 Wall mounting

### Pipe mounting

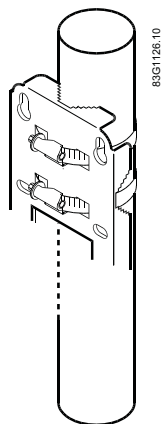

Figure 4-4 Pipe mounting - vertical

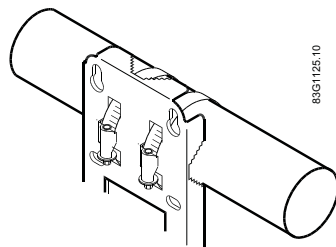

Figure 4-5 Pipe mounting - horizontal



# Connecting

# 5

This chapter consists of general safety requirements as well as a description of how to connect the device.

The connection of the device is done in four steps.

1. Wiring sensor and transmitter (remote version only).
2. Connecting power supply.
3. Connecting outputs.
4. Connecting add-on module.

## Connection diagram

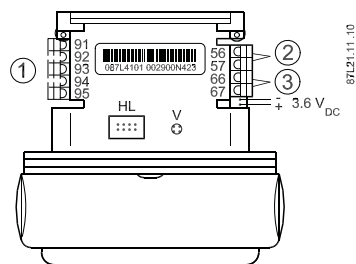

- ① Module Interface (Option)
- ② Output A
- ③ Output B

3.6 V DC battery connector - male and pulse connection terminals are placed in the right side of PCB board - see figure.

Connection for add-on interface modules is placed on the left side.

HL = Hardware lock key connection

V = Push button for verification mode

To configure outputs please see output configuration in Flow Tool (PC-software) ID 400 to 425.

## 5.1 General safety requirements

**⚠ WARNING**

**The pertinent regulations must be observed for electrical installation.**

- Never install the device with the mains voltage switched on!
- Danger of electric shock!
- The electrodes and magnetic current line may only be connected when the device is not connected to the power supply.
- If the housing is under voltage (power supply), the cover may be unscrewed by qualified personnel only.

**⚠ WARNING**

**Mains supply from building installation Class II**

A switch or circuit breaker (max. 15 A) must be installed in close proximity to the equipment and within easy reach of the operator. It must be marked as the disconnecting device for the equipment.

## 5.2 Remote version

### Remote installation

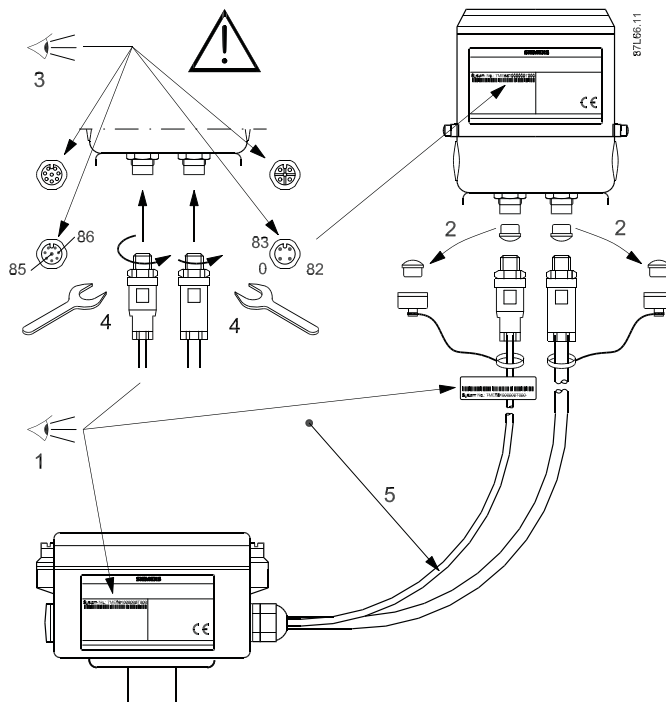

1. Verify that model and serial numbers shown on labels of sensor and transmitter are matched properly.
2. Ensure that cable is safely installed to avoid damage of cable and connectors. Please note the different connector types for coil and electrodes, both having a minimum diameter of 90 mm (3.6 inches). Save dust covers for future use and protection.
3. Ensure connectors are clean.
4. Ensure connectors are fastened securely to achieve a good connection and watertight seal.
5. Min.  $r = 45 \text{ mm}$  ( 1.8")

---

**Note**

If dirt enters connector ends, use plain water for cleaning. Ensure connectors are completely dry before making connections.

---

## 5.3 Power supply

Connection diagram for 115 ... 230 V AC (mains) or 12/24 V AC/DC (line) power supply

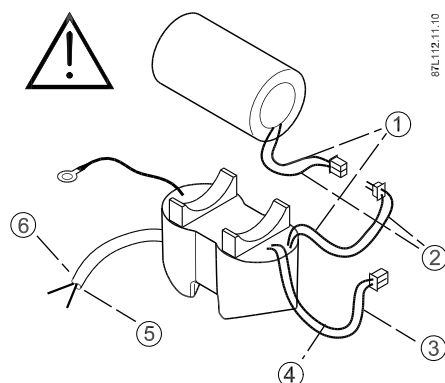

- ① Red
- ② Black
- ③ Blue
- ④ Yellow
- ⑤ Blue - N
- ⑥ Brown - L

**115 ... 230 V AC (mains) power supply**

Mains power input	Factory mounted PUR cable with 2 x 1 mm <sup>2</sup> (brown wire, blue wire) cable length = 3 m
	Brown wire - L (line, hot) and blue wire - N (neutral, cold)
Mains power output	Female battery connector with blue and yellow wires; blue wire is ground. Female battery connector has to be connected to male connector 3.6 V DC on PCB board
Battery backup input	Male battery connector with black and red wires; black wire is ground. Male battery connector has to be connected to female connector on backup battery
Functional ground	Black wire with terminal must be connected to MAG 8000 or MAG 8000 CT encapsulation with a screw
Mains power supply has to be connected to a switch near flowmeter according to IEC 61010-1 clause 5.4.3.d	

**12/24 V AC/DC (line) power supply**

Line power input	Factory mounted PUR cable with 2 x 1 mm <sup>2</sup> (brown wire, blue wire) cable length = 3 m
	Brown wire - L (line, hot, positive) and blue wire - N (neutral, cold, negative)
Line power output	Female battery connector with blue and yellow wires; blue wire is ground. Female battery connector has to be connected to male connector 3.6 V DC on PCB board
Battery backup input	Male battery connector with black and red wires; black wire is ground. Male battery connector has to be connected to female connector on backup battery
Functional ground	Black wire with terminal must be connected to MAG 8000 or MAG 8000 CT encapsulation with a screw

**Cable installation**

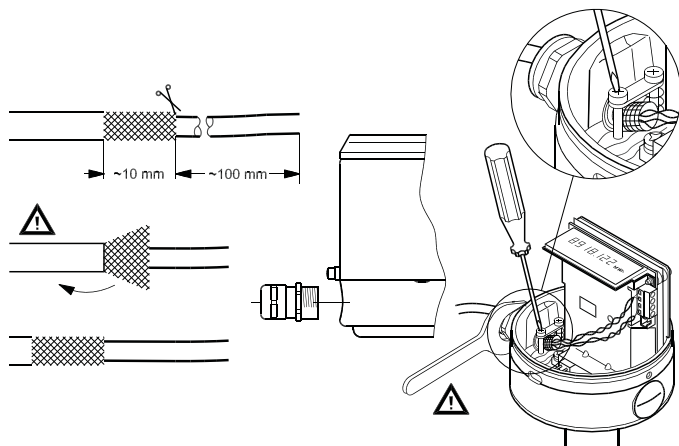

Choose the correct glands for the selected cable type, see Accessories (Page 123) for glands selection. Ensure shield is mounted under cable clamps - do not make pig tails.

<b>NOTICE</b>
Mains or line-powered PUR cable (no shield) has to be mounted under cable clamps. All cable glands have to be sufficiently tightened to ensure IP-rating.

## 5.4 Outputs

### Pulse output connection diagram for MAG 8000 and MAG 8000 CT

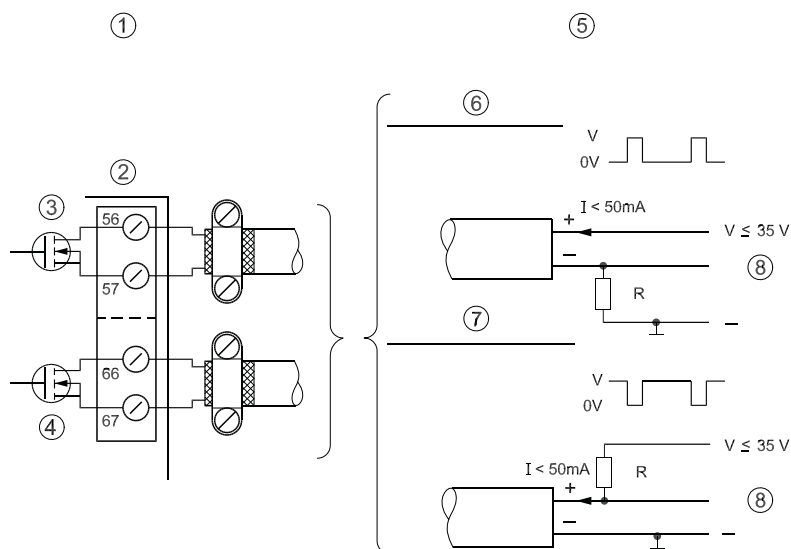

- ① MAG 8000 Internal connection
- ② Passive output - No polarization - Open drain
- ③ Output A
- ④ Output B
- ⑤ External connection - Connection Variant
- ⑥ Positive pulse logic
- ⑦ Negative pulse logic
- ⑧ Signal

Pulse output can be configured as volume, alarm or call-up, see Commissioning (Page 48).

Pulse output is not polarized and can be connected for positive or negative logic.

Pull up/down resistor (R) is selected in relation to power supply voltage (V) and with a max. current (I) of 50 mA.

#### Note

Pulse output must be connected to equipment complying with Low Voltage Directive in order to be considered safe. The isolation within MAG 8000 and MAG 8000 CT pulse output is only a functional isolation.

## 5.5 Communication modules

### RS232 connection diagram

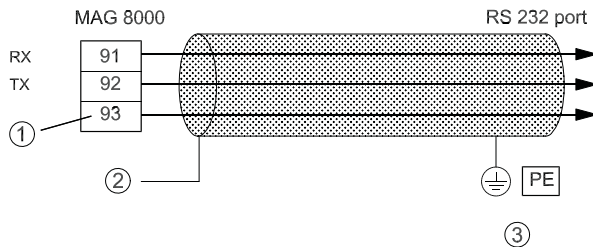

87L109.10.10

- ① Common
- ② Connect shield to encapsulation
- ③ Shield must be connected to protective ground

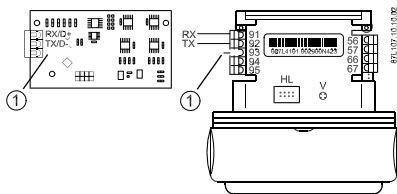

- ① Common

A Modbus over serial line cable must be shielded.

At one end of each cable its shield must be connected to protective ground. If a connector is used at this end, connector shell must be connected to cable shield.

### RS485 connection diagram

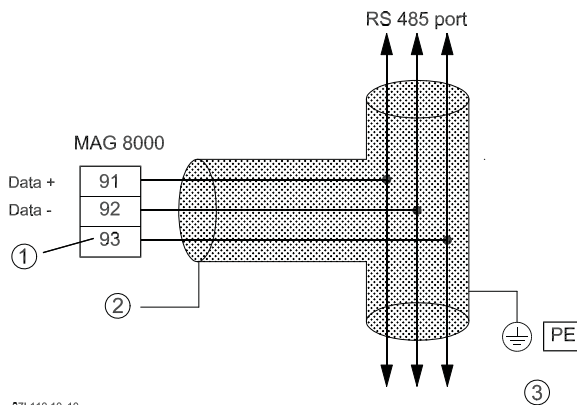

87L110.10.10

- ① Common
- ② Connect shield to encapsulation
- ③ Shield must be connected to protective ground



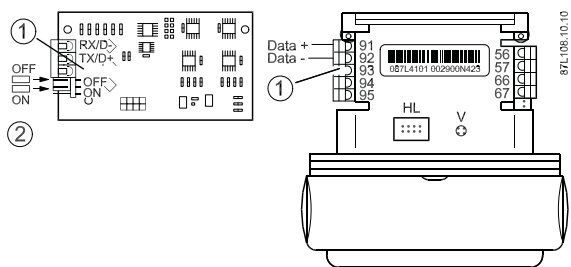

- ① Common
- ② Termination

A Modbus RS485 must use a balanced pair (for D+ - D-) and a third wire (for common).

For the balanced pair used in a RS485 system, a characteristic impedance with a value between 100 and 120 ohms must be used.

Shield must always be connected to MAG 8000 or MAG 8000 CT encapsulation using cable clamp as shown in figure in section cable installation, see Power supply (Page 31).

**Bus termination:**

All RS485-based networks must be terminated correctly to function properly. A termination must be placed at each end of segment.

The Modbus RTU module can add a 120 ohm termination if a jumper is placed beside terminals in position "ON".

Termination is set to "ON" from factory.

**Encoder interface connection diagram**

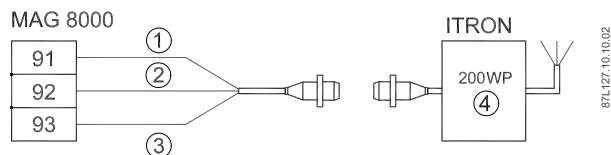

- ① Black wire
- ② Red wire
- ③ Unshielded wire
- ④ Endpoint

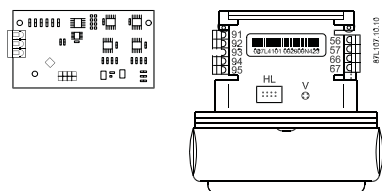

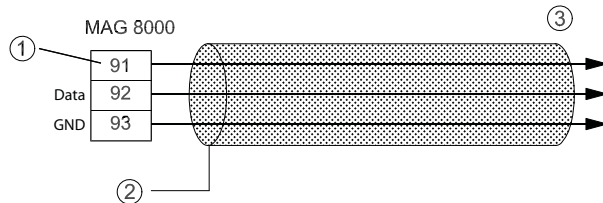

Figure 5-1 Encoder interface cable connection between MAG 8000 and ITRON 200WP with Itron cable

Connect black wire to terminal 91, red wire to terminal 92 and unshielded wire to terminal 93.

 <b>WARNING</b>
It is important that unshielded wire does not touch any metal parts of MAG 8000 housing.

Other radio interface cable has to be a 3-wire cable with a shield connected to MAG 8000 housing (mounting cable shield is shown to the right).



87L129.10.10

- ① Power clock
- ② Radio interface
- ③ Connect shield to encapsulation

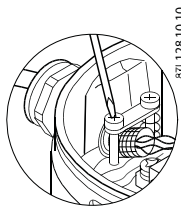

## 5.6 Connection of add-on modules

When the add-on module has been installed, the electrical connections are available on terminal rows 91-97.

### For more information

Refer to the relevant BUS communication Quick Start or Operating Instructions available at the SITRANS F literature CD or on the internet, at : [www.siemens.com/flowdocumentation](http://www.siemens.com/flowdocumentation) ([www.siemens.com/flowdocumentation](http://www.siemens.com/flowdocumentation)).

# Commissioning

## 6.1 General instructions

The meter can be configured using a PC software package - either Flow Tool or SIMATIC PDM.

Both Flow Tool and SIMATIC PDM are software packages for configuring, parameterizing, commissioning and maintaining devices (e.g. transducers) and for configuring networks and PCs.

### 6.1.1 Flow Tool

#### Prerequisites

In order to commission the flowmeter, it is necessary to install the Flow Tool program/software on your computer and connect the IrDA communication adaptor, see Accessories (Page 123), in the built-in IrDA communication interface on transmitter.

Read Flow Tool FAQ and Release Note installed with the Flow Tool software.

Visit [www.siemens.com/flow](http://www.siemens.com/flow) ([www.siemens.com/flow](http://www.siemens.com/flow)), navigate to Battery-operated Flowmeter - Tools & Downloads - SITRANS F M MAG 8000 for newest device drivers, update and support.

#### Device driver

The Device Drivers are related to meter version and is automatically selected in "Automatic" mode. In "Manual" mode, meter version is manually selected and version check is automatically made when data is uploaded or downloaded.

#### Data backup

Meter information is stored in an internal data prom that secures data in case of power failure.

Information like totalizer 1 and 2, date and time, and the statistic data in Advanced version is stored every 10 minutes. Every 4 hours battery consumption is calculated and remaining battery capacity is updated together with "operation time since first power up" and "battery operation time".

### 6.1.2 SIMATIC PDM

Among other features, SIMATIC PDM contains a simple process monitoring of process values, interrupts and status/diagnosis signals of device.

---

**Note**

For instructions on installation and operation of SIMATIC PDM, please refer to the SIMATIC PDM Getting Started

---

## 6.2 Commissioning steps

Commissioning consists of the following steps:

Step	Flow Tool	SIMATIC PDM
1	Connecting PC to meter	Installing EDD files
2	Starting Flow Tool software program	Adding device to communication network
3	Configuring device	
4	Setting basic parameters	

## 6.3 Initial commissioning via Flow Tool

This chapter describes how to start up commissioning via Flow Tool software.

### Connecting PC to meter

Connect IrDa communication adaptor to its interface on transmitter and connect PC to adaptor.

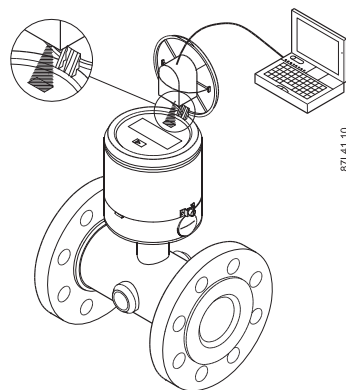
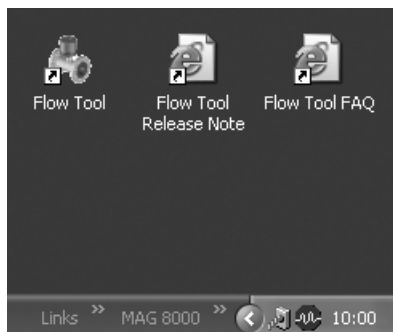

Figure 6-1 MAG 8000 or MAG 8000 CT has a built-in IrDA communication interface on top of meter. IrDA adaptor can be fixed to lid by rubber band.

### Starting Flow Tool software program

Double-click on Flow Tool icon on windows desktop to start program.



---

#### Note

For on-line communication make sure the IrDA symbol is visible in the toolbar status menu before starting Flow Tool.

---

## 6.4 Initial commissioning via SIMATIC PDM

This chapter describes how to start-up commissioning via SIMATIC PDM software.

### Installing EDD files

Procedure for installing PDM device driver consists of the following steps:

- Download update from the Internet on Profibus EDD files (<http://support.automation.siemens.com/WWW/view/en/17320235/133100>) , or copy it from supplied CD into envisaged folder and unzip file.
- Open "Manage Device Catalog" from Start > SIMATIC > SIMATIC PDM.
- Navigate to PDM device driver, select device and click "OK" and driver is installed on PC.

## 6.5 Configuring device

This chapter describes how to set up meter for communication with PC. The options in both Flow Tool and SIMATIC PDM software are the same; only the views on the PC screen differ.

### Setting up meter

1. Click on "Project".
2. Select "New".
3. Select "Flow Meter".

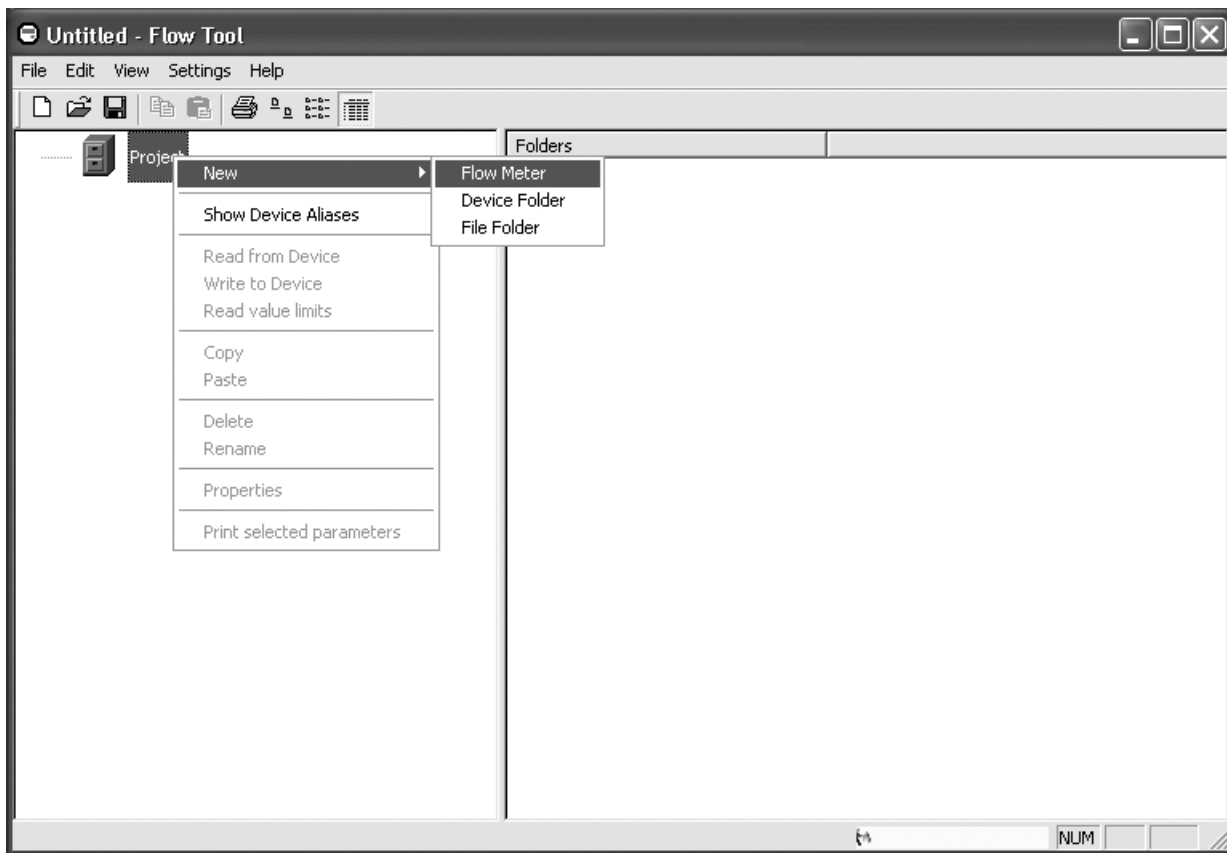

4. Name device.
5. Select configuration type ("Automatic" or "Manual").

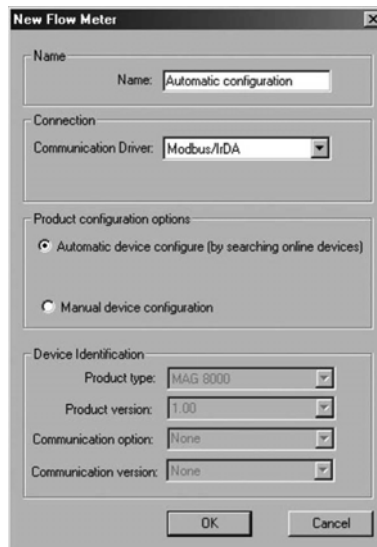

"Automatic" configuration is selected if PC is connected directly to meter.

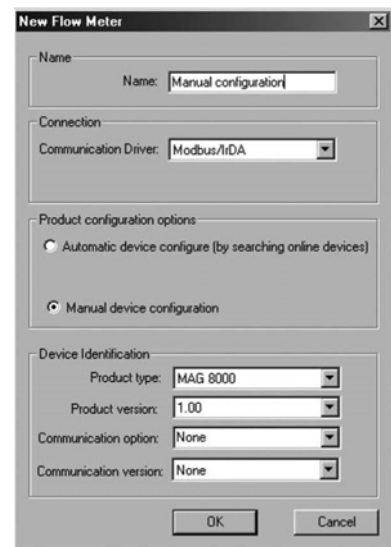

"Manual" configuration is selected if configuration is made without any connection to a meter. Configuration is downloaded to the meter afterwards.

## 6.6 Setting basic parameters

### Note

#### No default factory settings

MAG 8000 is delivered with factory settings that are not stored as default values. Because default values are not present in meter, an automatic return to factory values is not possible.

Default settings are available at [www.siemens.com/flow](http://www.siemens.com/flow) ([www.siemens.com/flow](http://www.siemens.com/flow)). Navigate to Tools & Downloads under MAG 8000.

### Setting parameters

Enter password.

Meter information is password-protected. Default factory password is "1000" and can be changed after gaining access to meter. Password can be reset using the hardware key, see Data protection (Page 58).

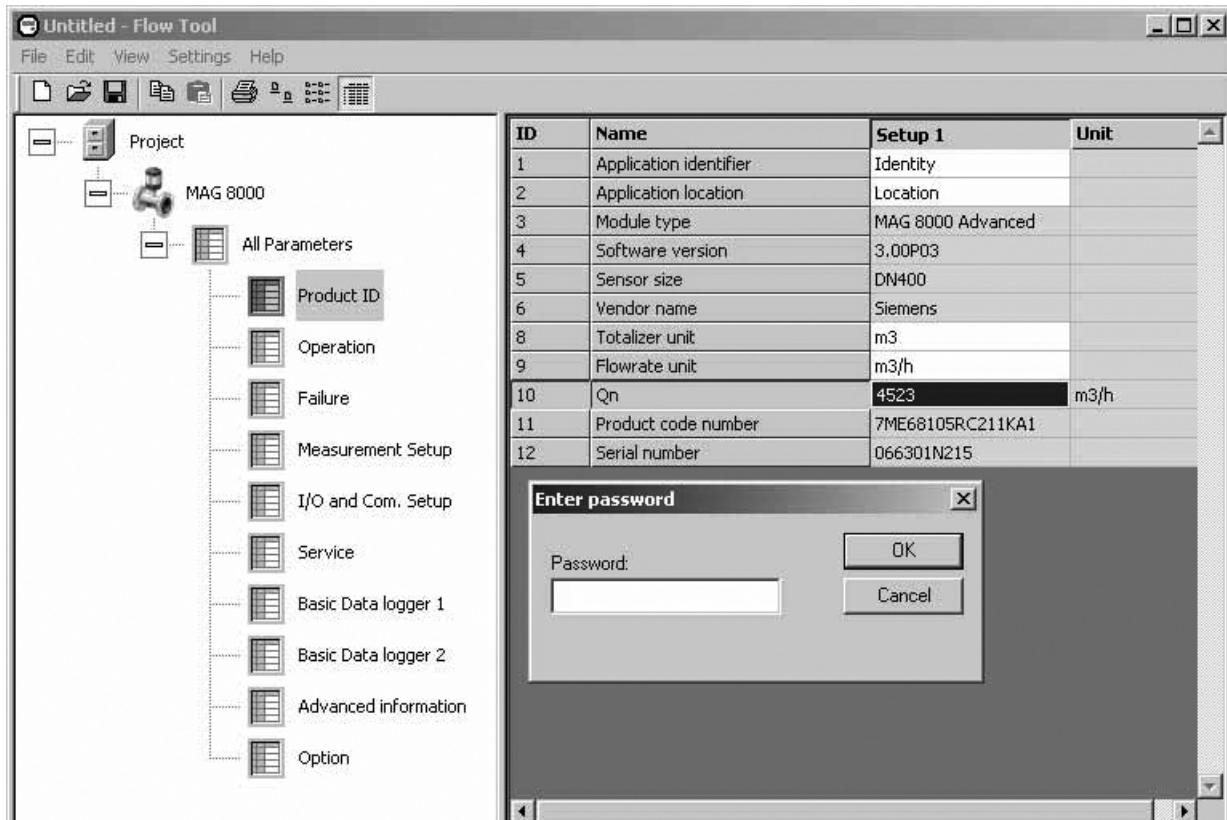



### Read, write, print or export meter data

Select single parameter or a parameter group to be read, written, printed or exported to a CSV file.

Only parameters (data) shown on white background can be changed. Red texts are off-line data which are not stored in the MAG 8000 yet, whereas black texts show the actual meter data.

Each parameter has a description (prompt) advising how the parameter can be programmed and which settings are programmable.

The figure below shows alarm status with the marked alarms enabled.

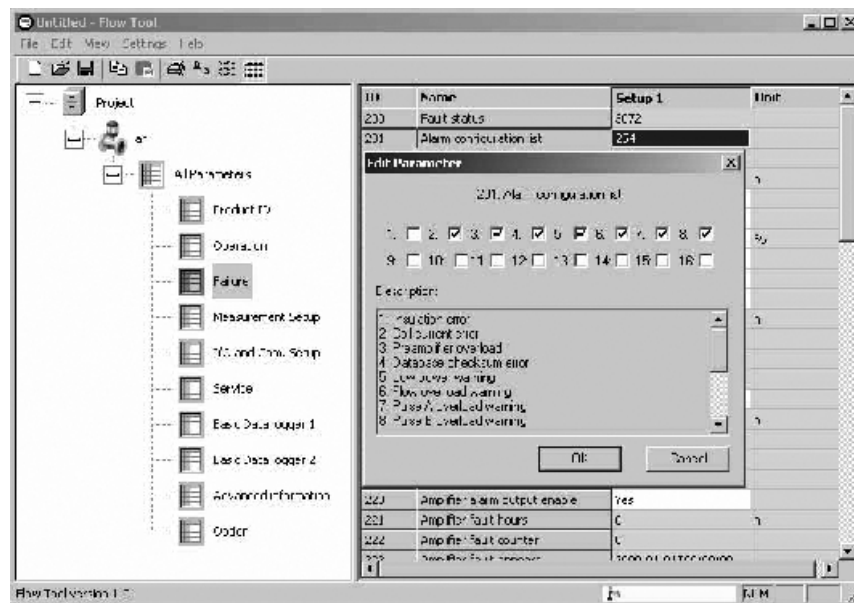

Figure 6-2 Alarm status - marked alarms are enabled

### Customer-selected parameter list

The default parameter list is divided into functional groups with maximum 99 parameters included. For complete parameter lists, see appendix (Page 104).

Your own parameter list can be configured by creating a new parameter folder.

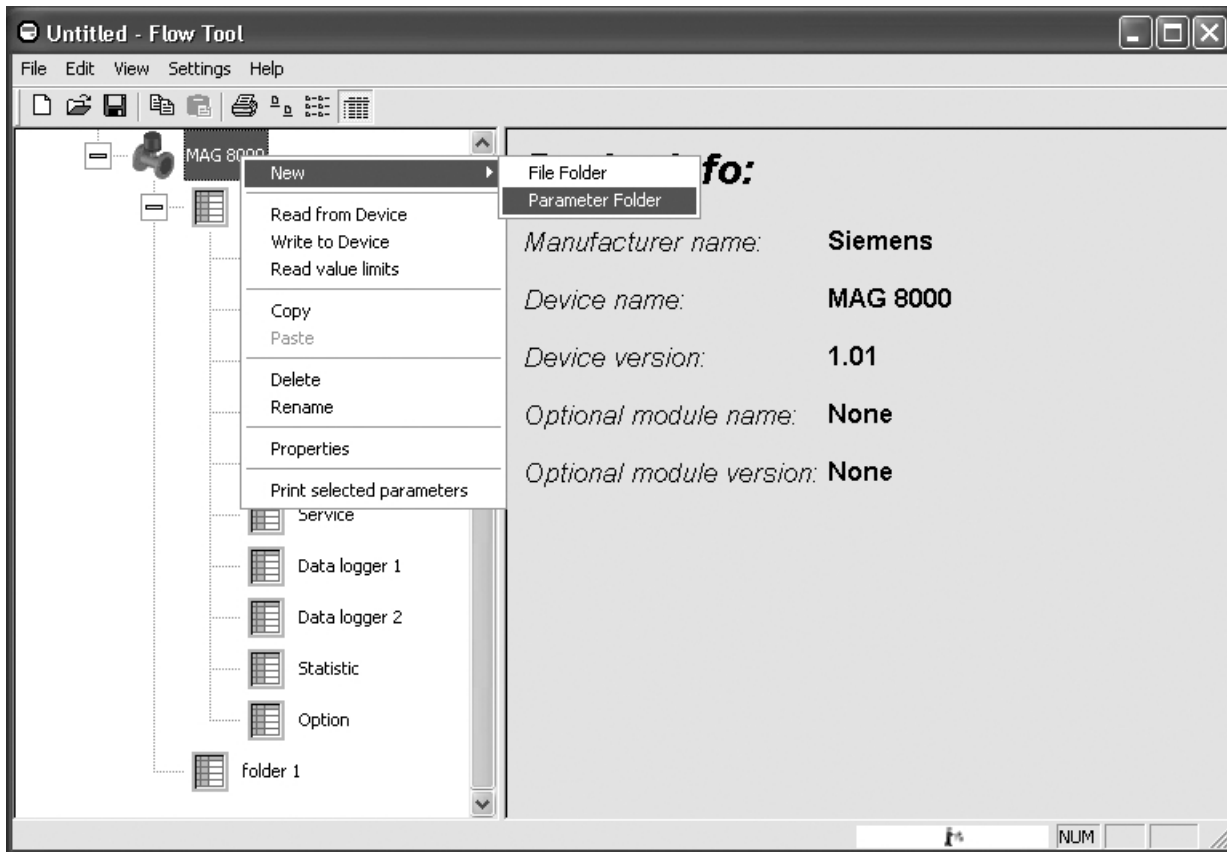

Figure 6-3 Creating new parameter folder

Copy any existing parameter to your own new folder. Parameters are updated and handled as the existing ones and listed in the same order as copied to your parameter list.

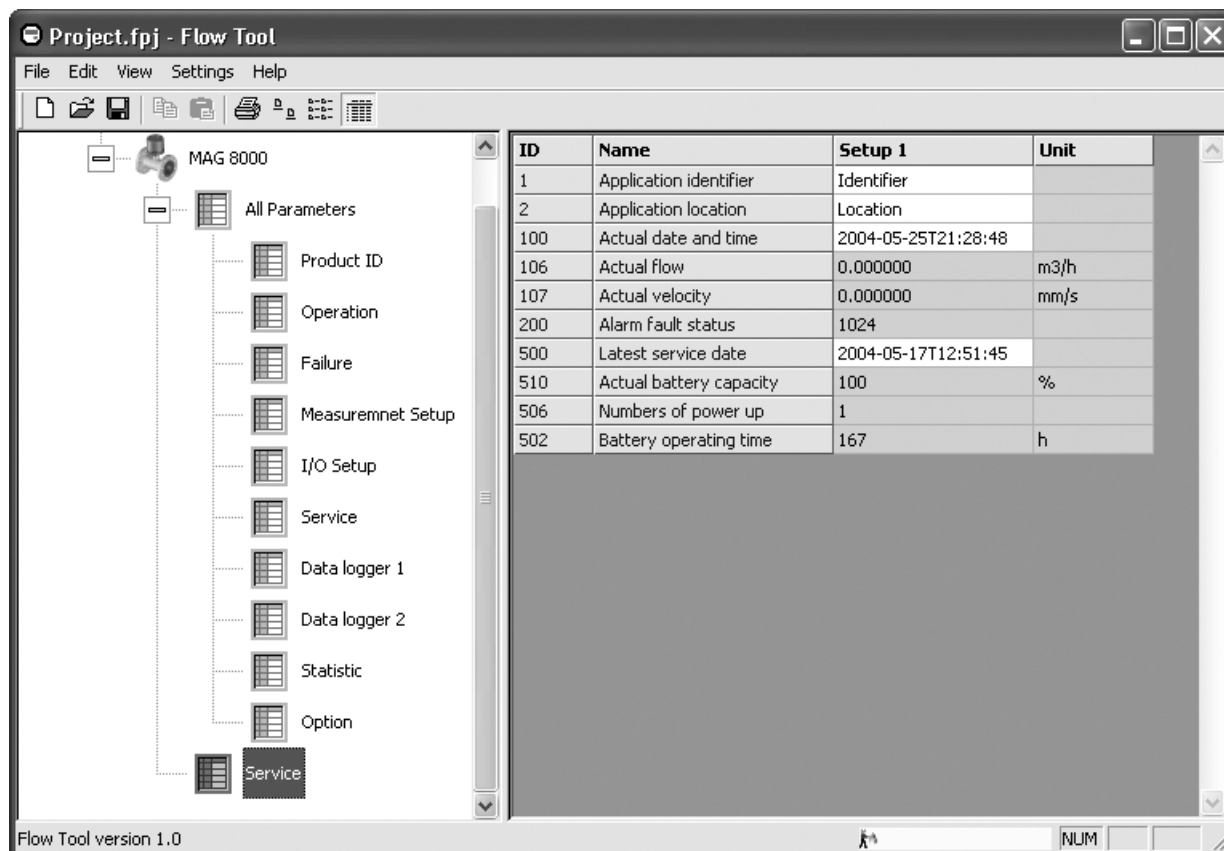

Figure 6-4 Customer-specified parameter list

There is no limitation on the number of customer-specified parameter lists.  
Saving the project will make parameter list configuration available for future use.

**Note**

Saving file with only customer-specified parameter list explored will make future monitoring and changes of parameters easier.

## 6.7 Unit selection

MAG 8000 and MAG 8000 CT are delivered with totalizer and flow rate units as ordered via the MLFB structure.

The standard MAG 8000 units for each region are:

- **Europe:** m<sup>3</sup> for totalizer and m<sup>3</sup>/h for flow rate
- **US:** Gallon for totalizer and GPM (Gallon per minute) for flow rate
- **Australia:** MI for totalizer and MI/d (Mega liters/day) for flow rate

The standard MAG 8000 CT format is:

- **Europe:** m<sup>3</sup> for totalizer and m<sup>3</sup>/h for flow rate

The following MAG 8000 units and combinations are available:

**Volume:** m<sup>3</sup>, m<sup>3</sup> × 100, l × 100, Gallon, G × 100, G × 1000, MG, CF × 100, CF × 1000, AF, AI, kl, MI

**Flow rate:** m<sup>3</sup>/min, m<sup>3</sup>/h, m<sup>3</sup>/d, l/s, l/min, l/h, MI/d, GPS, GPM, GPH, GPD, MGD, CFS, CFM, CFH

To ensure selection of correct conversion factor, see unit conversion table in appendix (Page 103).

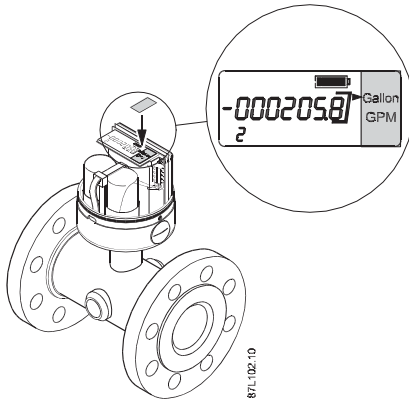

All measurement units are printed on a label affixed to the display (except the European version). Some meter sizes have a factor included to secure the 8 digit display value will not overrun after short time of operation. Manual configuration of new units is allowed. A new sticker showing the new settings must then be affixed to the display.

**Protected parameters**

The following parameters are protected (FT = Flow Tool parameter number, see parameter lists in appendix (Page 104)):

MAG 8000/MAG 8000 CT		MAG 8000 CT (additionally)	
New password		FT101	Totalizer 1
FT5	Sensor tube diameter	FT102	Totalizer 2
FT7	Meter No.	FT303	Operation excitation frequency
FT8	Totalizer unit	FT305	Decimal point place
FT9	Flow unit	FT310	Flow direction totalizer 1
FT10	Qn (Q3)	FT312	Flow direction totalizer 2
FT300	Totalizer unit factor	FT327	Adjustment factor
FT301	Flow unit factor	FT328	Low flow cut-off
FT302	Pipe size	FT332	Empty pipe impedance
FT321	Calibration date	FT550	Coil current active
FT323	Calibration factor	FT551	Fix flow mode active
FT325	Sensor offset		
FT332	Max. sensor frequency excitation		

## Hardware lock

To gain access to protected parameters a hardware lock must be installed. HL (Hardware Lock) hole is located in front part of PCB behind battery, see connection diagram (Page 29).

## Changing units

1. Select service mode and meter version – upload data from meter.
2. Open transmitter.
3. Remove battery (keep connected).
4. Attach hardware key to PCB board (for correct attachment, see upper part of figure).

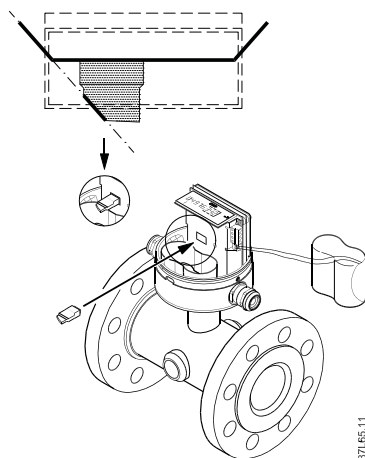

5. Change units description in parameter FT8 and FT9, see Unit conversion table (Page 103).
6. Change units factor in parameter FT300 and FT301, see Unit conversion table (Page 103).
7. Change maximum flow rate Qn (Q3) to new unit selection FT10.
8. Select display unit FT306.
9. Download each parameter to meter.
10. Remove hardware key.
11. Re-assemble meter.

### NOTICE

#### Important

The service mode opens many parameters. If these parameters are changed, it can seriously affect meter accuracy and operation. Be careful when writing new parameter values as meter has **no default settings** to return to.

## 6.8 Output configuration

Pulse output can be configured as volume pulse, alarm or call-up. Default factory setting is with output A enabled for forward flow and output B for alarm output.

### Output configuration in Flow Tool / SIMATIC PDM (PC software)

Select "I/O and Com.Setup". The software window shows the parameters for output configuration. Each parameter has its own guideline for selecting the correct parameter setting.

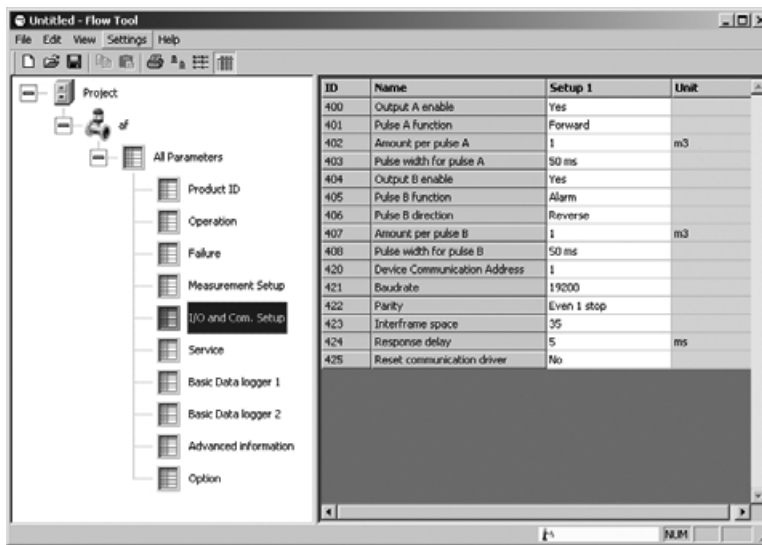

To see how the outputs work, please see "Output characteristics".

## Operation

### 7.1 Meter operation via key and display

The meter is designed with a single key and a symbolic display for optimal dialog.

#### Display

Display is divided into 3 areas.

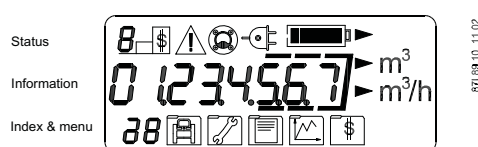

Figure 7-1 Display

- Top area with symbols for status information.
- Middle area with actual information.
- Bottom area with index for actual information and selected menu.

Some of the information has additional information connected and display will automatically toggle between information, see menu overview (Page 53). If key is not pressed for 10 minutes, display will time-out and return to default configured operator menu.

#### Key

There are three different ways the interface key will respond to being pressed:

1. A brief press (less than 2 seconds) will advance screen to next index or menu.
2. A short press (2 to 5 seconds) will enter a menu or escape menu selection.
3. A long press (more than 5 seconds) while in the operator menu (⏏) will activate a reset of selected value (e.g., totalizer or call-up function) indicated by an "r".

A flashing "r" indicates a reset. A request for time and date setup is shown during power-up.

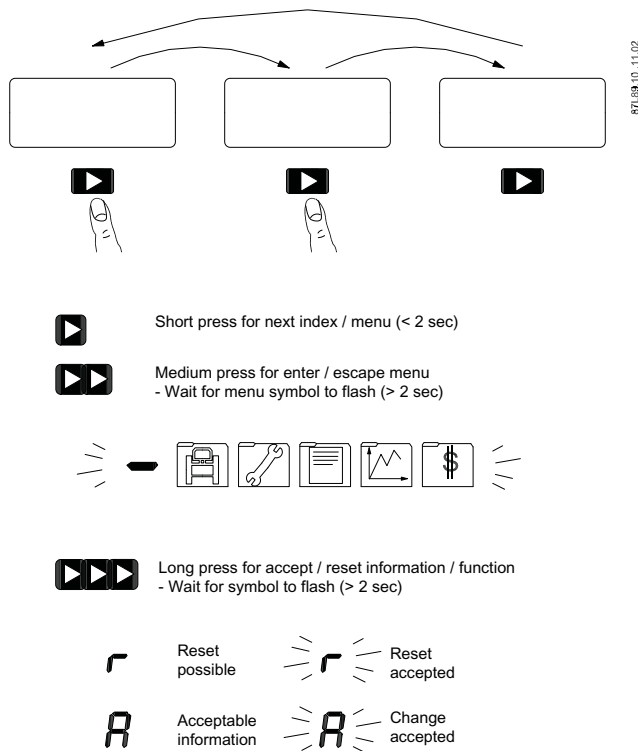

Figure 7-2 Key and display operation

## 7.2 Display symbols

Top area of display shows status bar.

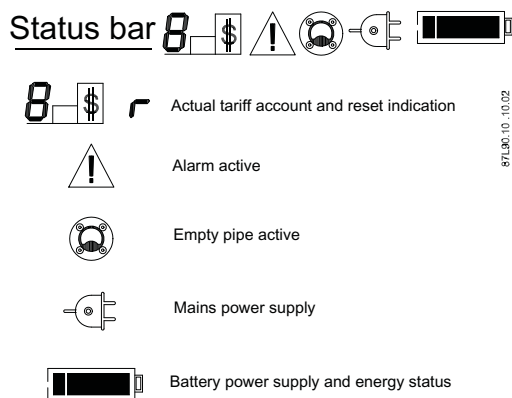

Figure 7-3 Status bar

Status information symbols show actual operation of meter.

**Tariff** symbol shows actual accounting tariff. In operator menu, tariff value will change to "r" if information is resettable, like index "5" - customer totalizer 3.

**Alarm** symbol is active when an alarm is active and shown independently of alarm output configuration.



7.3 Default display information and accessible display menus

**Empty pipe** symbol indicates an empty pipe condition. To conserve power and prevent false readings due to exposed measurement electrodes, flow measurement is disabled until a full pipe is detected and the symbol has disappeared.

Power supply type is automatically detected by meter.

**Plug** symbol indicates that mains power is supplied.

**Battery** symbol indicates that battery power is supplied. It also indicates remaining battery capacity, see Operation menu index 1 (Page 53) for more information.

Bottom part of display shows menu bar.

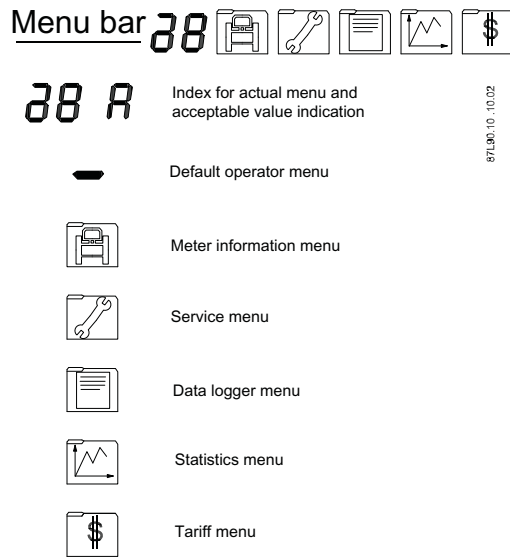

Figure 7-4 Menu bar

The **menu bar icons** indicate actual selected menu and related index for selected information. Display overview shows relation between menu, index and information.

Only operator menu (➡) has information and functions that can be reset. During power-up function battery power can be preset to 100% capacity and time and date can be adjusted - an "A" in index shows acceptable values. The menu shown in each menu index is the menu bar.

### 7.3 Default display information and accessible display menus

Flow tool parameter FT131 defines default display information with selection between

- Totalizer 1 (Index 1)
- Totalizer 2 (Index 2)
- Flow rate (Index 3, updated with selected measuring frequency)
- Fault codes (Index 4)
- Customer totalizer (Index 5 - resettable)

Default information is shown after power-up as well as after no key operation for 10 minutes.

Flow tool parameter FT130 defines accessible menus on display with selection off:

- Operator menu
- Meter info menu
- Service menu
- Data logger menu
- Statistic and leakage menu
- Revenue menu

Disabling display of menu data will not affect operation of functions.

## 7.4 Operator menu

The operator menu consists of several indexes described in the following.

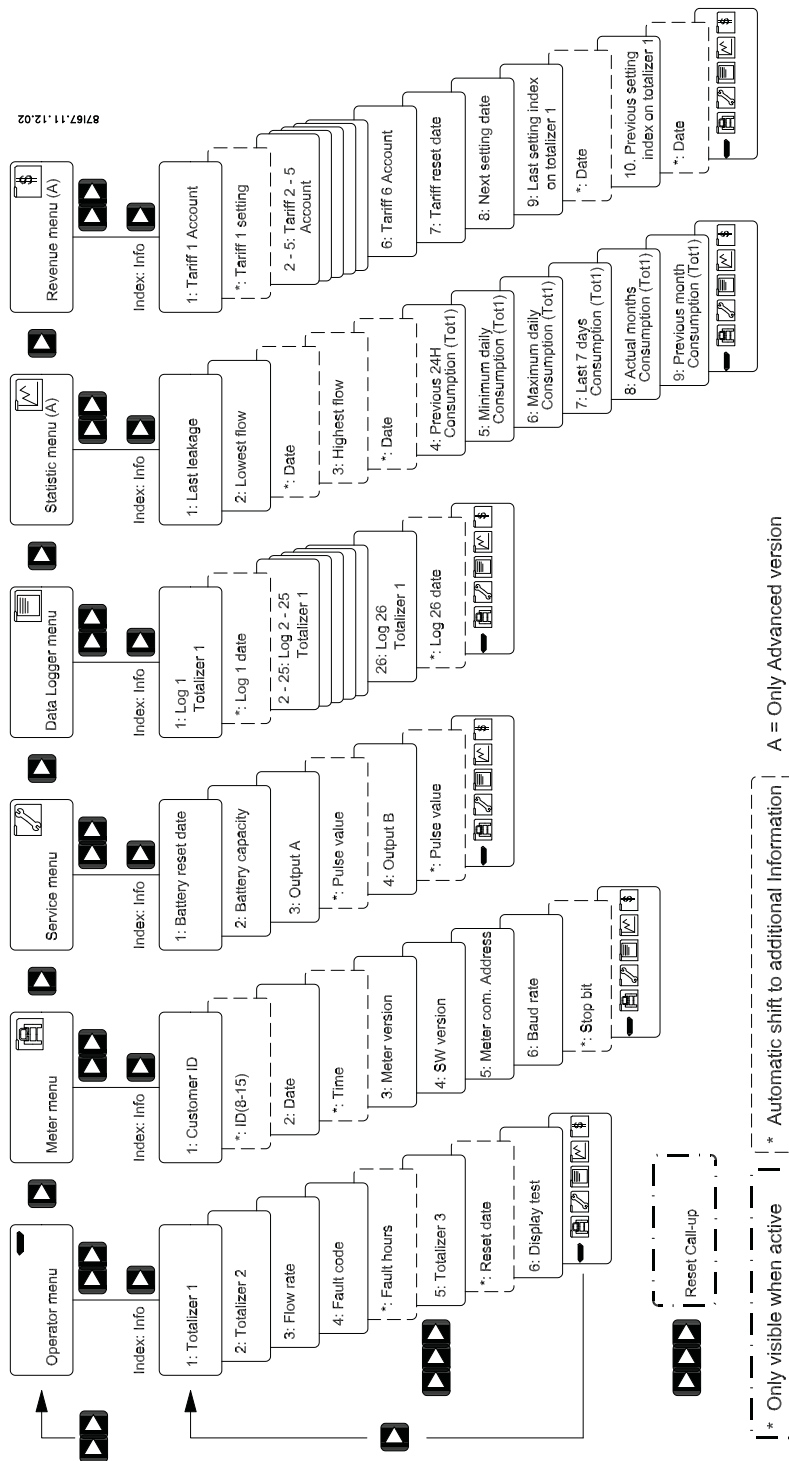

Figure 7-5 Menu overview

### Index 1

#### Totalizer 1

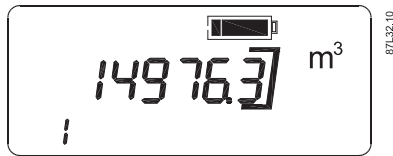

Figure 7-6 Operator menu - Totalizer 1

Flow volume totalizer 1 (factory-configured for forward flow calculation).

#### MAG 8000

The value of totalizer 1 can be reset to zero or set to any value desired (example - replacing an existing old meter).

### Index 2

#### Totalizer 2



Figure 7-7 Operator menu - Totalizer 2

Flow volume totalizer 2 (factory-configured for reverse flow). A negative value indicates reverse flow calculation.

The value of totalizer 2 can be reset to zero or set to any value desired (example - replacing an existing old meter).

### Index 3

#### Flow rate

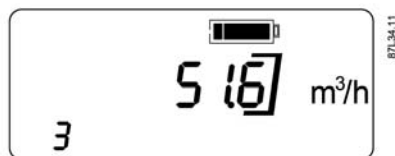

Figure 7-8 Operator menu - Flow rate

Index 3 shows actual flow rate. If a negative value is indicated, flow is in a reverse direction.

#### MAG 8000 CT

The value of totalizer 1 or 2 can only be reset to zero if verification sealing is broken and a hardware lock is mounted on device.

## Index 4

### Active alarm

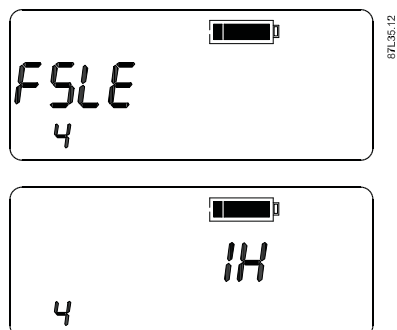

Figure 7-9 Operator menu - Active alarm

Faults are indicated with the lowest number first. The left of display indicates 3 alarm conditions: low power warning (5), leakage warning (L), and empty pipe warning (E).

Faults 1 to 4 affect meter performance and remain active until alarm condition disappears. Faults 5 to d are warnings that will disappear when alarm condition has been corrected and they are reset via communication interface.

Fault evaluation and service guidelines are made in service section.

After all faults have disappeared, display shows total hours of faults until meter was reset.

Fault information. Each number indicates a dedicated fault:

1	Insulation fault
2	Coil current fault*)
3	Preamplifier overload fault*)
4	Data base checksum fault
5	Low power warning (alarm limits are configurable)
6	Flow overload > Qmax. (Q4) (125% Qn) flow overload
7	Pulse output 1 overflow > PF [Hz] pulse output 1 overflow
8	Pulse output 2 overflow > PF [Hz] pulse output 2 overflow
9	Consumption interval warning (alarm limits are configurable)
L	Leakage warning (alarm limits are configurable)
E	Empty pipe / low conductivity - when enabled*
C	High conductivity / low impedance warning (alarm limits are configurable)
d	High flow rate warning (alarm limits are configurable)

\*) Meter disables measurement to reduce power consumption during fatal faults.

Index 5

Customer totalizer

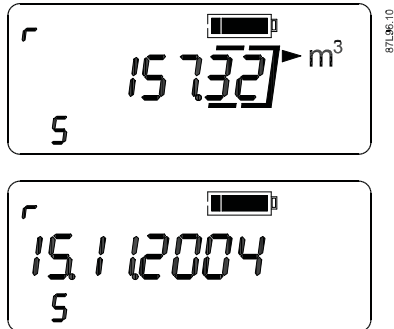

Figure 7-10 Operator menu - Totalizer / Call up reset

Totalizer 3 indicates totalized volume since last reset. Totalized volume follows totalizer 1 and displayed "r" indicates that it can be reset by activating a long press on key. If key is pressed while "r" is flashing, totalizer 3 value will reset to 0 and actual date and time will be stored permanently in memory. Display information will now alternate between totalizer 3 and reset date.

Display test

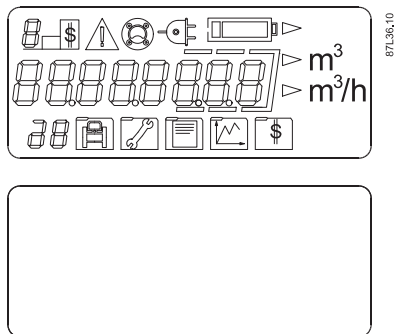
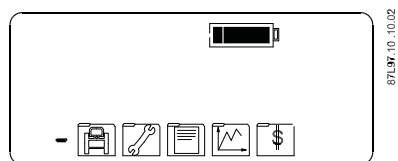

Figure 7-11 Operator menu - Display test

All segments of display are alternately flashed on and off during this test.

## Menu selection



87L06.10 -10.02

▶▶ Short press for enter / escape menu  
- Wait for menu symbol to flash (> 2 sec)



Figure 7-12 Operator menu - Menu selection

If key is pressed shortly (2 to 5 seconds), menu selection will flash indicating that a new selection can be made.

After toggling to desired menu, a short press on key will enable chosen menu.

## Index 0 (when active)

Call up reset



87L06.10 -10.02

▶▶▶ Long press for accept / reset information / function  
- Wait for symbol to flash (> 2 sec)



Figure 7-13 Operator menu - Call up reset

Call-up reset window (index 0) is only shown when call-up function is activated. "r" indicates that it can be reset by a long press on key. When releasing key while "r" is flashing, call-up function will be reset and window disappears.

## 7.5 Data protection

### Using hardware key

A hardware key is installed in the HL hole to change protected parameters. The HL hole is located in the front of the PCB board behind the battery. (FT = Flow Tool parameter number)

**Protected parameters are:**

New Password	
FT5 - Sensor tube diameter	
FT7 - Meter No.	
FT8 - Totalizer unit	
FT9 - Flow unit	
FT10 - Qn (Q3)	
FT300 - Totalizer unit factor	
FT301 - Flow unit factor	
FT302 - Pipe size	
FT321 - Calibration date	
FT323 - Calibration factor	
FT325 - Sensor offset	
FT332 - Max. sensor excitation frequency	
<b>Additional protected CT parameters:</b>	
FT101 - Totalizer 1	
FT102 - Totalizer 2	
FT303 - Operation excitation frequency	
FT305 - Decimal point place	
FT310 - Flow direction totalizer 1	
FT312 - Flow direction totalizer 2	
FT327 - Adjustment factor	
FT328 - Low flow cut-off	
FT332 - Empty pipe impedance	
FT550 - Coil current active	
FT551 - Fix flow mode active	



## 7.6 Internal data handling

### Meter status

Meter status parameter (FT120) gives a fast indication of reliability of revenue data.

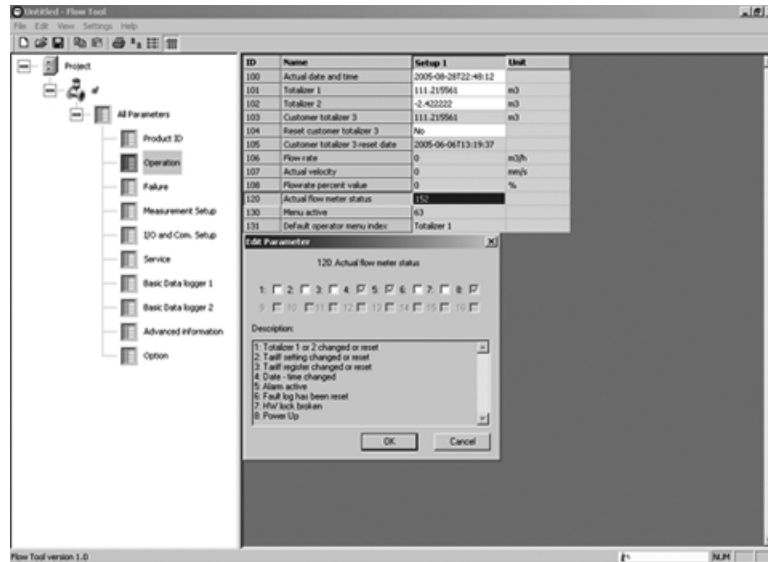

It shows whether important information has been reset or manipulated, for instance if meter has been powered down.

Status information can only be reset while hardware lock key is mounted.

### Data logger / Consumption alarm

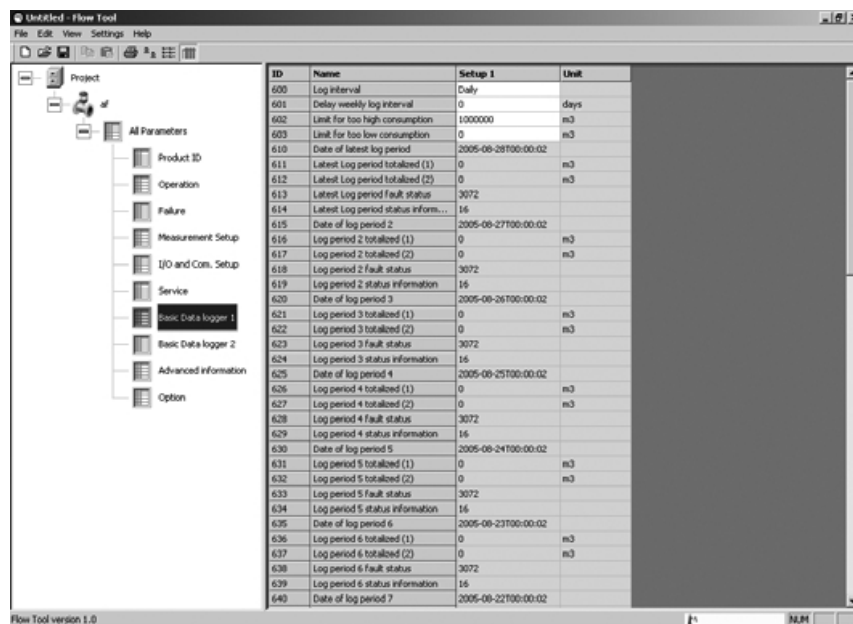

7.7 Battery-powered operation

Integrated data logger has 26 logging periods in which data can be stored daily, weekly or monthly.

Logger stores the consumption for totalizer 1 and totalizer 2 in selected period.

Forward consumption is stored as a positive value and reverse consumption is stored as a negative value.

Alarm and meter status are also stored for the same period to indicate alarms that have been active, or that revenue data has been influenced in the specific period.

ID	Name	Setup 1	Unit
600	Log interval	Daily	
601	Delay log interval	0	days
602	High log consumption alarm	1000000.000000	m3
603	Low log consumption alarm	0.000000	m3
610	Date of last logging 1	2004-05-26T00:00:34	
611	Last Log1 Totalizer 1	0.000000	m3
612	Last Log1 Totalizer 2	0.000000	m3
613	Last Log1 fault status	1024	
614	Last Log1 status information	153	

Logged information has a time and date stamp. Data logger never stops storing data - old data is overwritten following the first in/first out principle. Log 1 is the last stored information which is moved to log 2 when next logging is made and so on.

Consumption alarm indicates that actual consumption on totalizer 1 is above or below consumption limits.

## 7.7 Battery-powered operation

The MAG 8000 (7ME6810) and MAG 8000 CT (7ME6820) are factory-configured for 6 years and MAG 8000 for irrigation applications (7ME6880) for 2 years of typical operation on internal battery pack (1 D-cell). High or low temperature, frequent use of IrDA communication, high pulse output rate, and high excitation frequency in leakage detection mode will reduce actual operation time.

The MAG 8000 and MAG 8000 CT power management function controls each power consuming element and measures the temperature for optimal calculation of remaining battery power capacity.

### Battery status and alarm indication

Battery power capacity for operation is indicated in 3 levels.

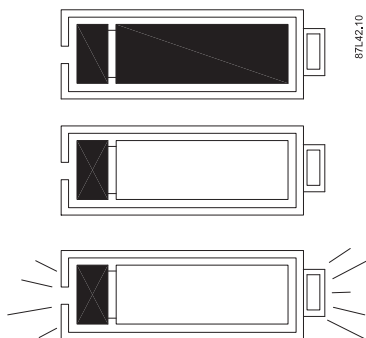

Figure 7-14 Battery status

- Full symbol indicates battery capacity is above battery alarm level (% preset parameter FT206).
- Low symbol indicates that battery should be replaced; however, measurement will remain active. Level is based on a preset alarm level.
- When low symbol is flashing, measurement and communication is disabled until battery pack has been replaced and reset.

"Low battery" is a selectable % parameter (FT206) of 100% full capacity. Meter calculates remaining capacity every four hours, including all consuming elements and influence of temperature changes.

### Consumption and operation time calculation

Battery operation time depends on connected battery pack as well as operation conditions of meter. Every 4 hours the advanced power management system calculates the real power consumption and remaining operation capacity.

Power consumption calculation includes flow measurement, meter dialog (communication and display) and pulse output.

Temperature is also measured to control and adjust its influence on the battery capacity.

For MAG 8000 (7ME6810) and MAG 8000 CT (7ME6820) the internal battery pack has a nominal capacity of 33 Ah giving a typical operation time of 6 years in a revenue application. Nominal capacity of external battery packs is 66 Ah and operation time is limited to battery lifetime - typically 10 years. Configuration and operation conditions for a typical revenue application are shown in the table below.



Scenario - Revenue application	
Output A	Pulse - 10 Hz
Output B	Alarm or Call up
Meter dialog	1 hour per month
Excitation frequency	1/15 Hz
Country main frequency	50 Hz / 60 Hz

**MAG 8000 (7ME6810) and MAG 8000 CT (7ME6820)**

Excitation frequency (24 hours operation)		1/60 Hz	1/30 Hz	1/15 Hz	1/5 Hz	1.5625 Hz	3.125 Hz	6.25 Hz
Two D-Cell battery 33 Ah Internal battery pack	DN 25 ... 150 (1" ... 6")	8 years	8 years	6 years	40 months	8 months	4 months	2 months
	DN 200 ... 600 (8" ... 24")	8 years	6 years	4 years	20 months	4 months	2 months	N/A
	DN 700 ... 1200 (28" ... 48")	6 years	4 years	2 years	1 year	2 months	N/A	N/A
Four D-Cell battery 66 Ah Internal battery pack	DN 25 ... 150 (1" ... 6")	N/A	10 years	10 years	80 months	16 months	8 months	4 months
	DN 200 ... 600 (8" ... 24")	N/A	10 years	10 years	40 months	8 months	4 months	N/A
	DN 700 ... 1200 (28" ... 48")	10 years	8 years	4 years	2 years	4 months	N/A	N/A

Typical operation time of 6 years is based on only 80% battery capacity and an operation time/temperature profile of 5% at 0 °C (32 °F), 80% at 15 °C (59 °F) and 15% at 50 °C (122 °F).

Leakage detection (advanced version only) will affect battery operation time if a higher excitation frequency is selected during leakage period.

The effect of other temperatures are shown in the figure below.

A variation in temperature from 15 °C to 55 °C (59 °F to 131 °F) reduces the capacity by 17% (in the table from 15 Ah to 12½ Ah).

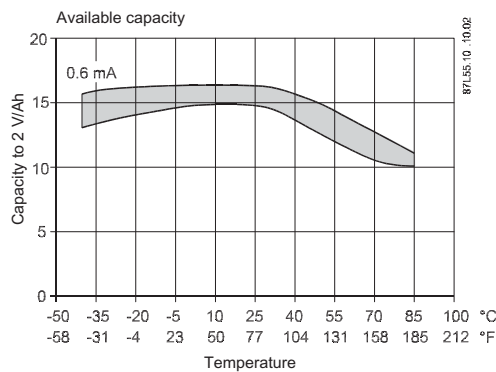

Figure 7-15 Available capacity

**Note**

Installation orientation of battery pack may influence battery capacity. Optimal battery capacity is achieved with battery pack in an upright position.

**MAG 8000 (7ME6880) for irrigation applications**

Excitation frequency (24 hours operation)		1/60 Hz	1/30 Hz	1/15 Hz	1/5 Hz	1.5625 Hz	3.125 Hz
1 D-Cell battery	DN 50 ... 600 (2" ... 24")	52 months	40 months	25 months	12 months	2 months	1 month
Two D-Cell battery 33 Ah Internal battery pack	DN 50 ... 600 (2" ... 24")	105 months	80 months	50 months	24 months	4 months	2 months
Four D-Cell battery 66 Ah Internal battery pack	DN 50 ... 600 (2" ... 24")	200 months	160 months	100 months	48 months	8 months	4 months

Typical operation time of 6 years is based on only 80% battery capacity and an operation time/temperature profile of 5% at 0 °C (32 °F), 80% at 15 °C (59 °F) and 15% at 50 °C (122 °F).

**Battery configuration**

Battery figures (generated as customer parameter list, see section Customer-selected parameter list in chapter Setting basic parameters (Page 41) show power management information.

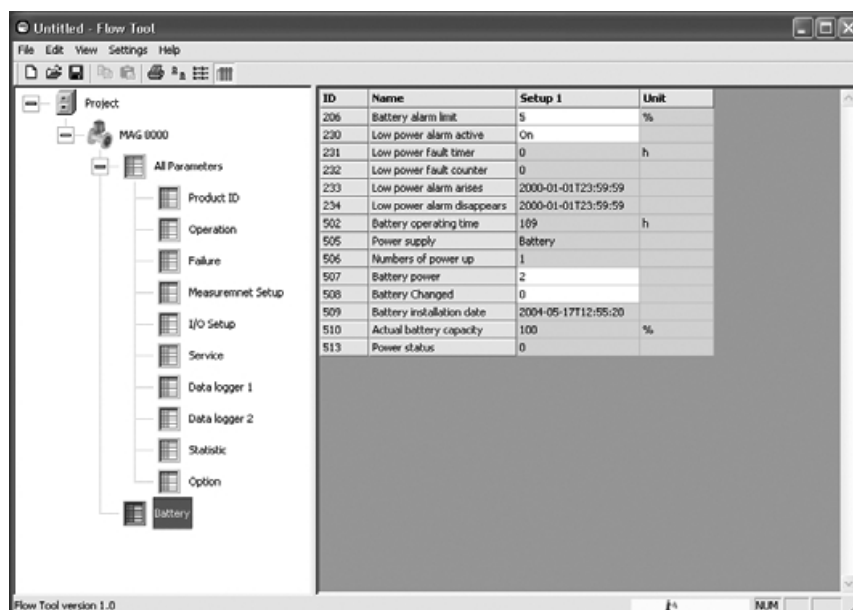

Figure 7-16 Battery configuration

At each battery replacement capacity is reset to 100% (Flow Tool parameter FT508-FT510) which is then reduced with real meter consumption every 4 hours.

Battery limit (FT206) is the level at which low power alarm is activated generating an alarm or call-up (if configured).

Power status (FT513) follows battery symbol on display.

When switching between battery power from internal and external battery packs, "Battery power" (FT507) must be adjusted to match actual number of batteries connected.

## Service and maintenance

### 8.1 Maintenance

The device is maintenance-free, however, a periodic inspection according pertinent directives and regulations must be carried out.

An inspection can include check of:

- Ambient conditions
- Seal integrity of the process connections, cable entries, and cover screws
- Reliability of power supply, lightning protection, and grounds

### 8.2 MAG 8000 and MAG 8000 CT service guidelines

The MAG 8000 and MAG 8000 CT battery-operated water meter is based on a very reliable measurement technology and the advanced alarm monitoring and diagnostics provide valuable information concerning the meter performance, faults, and service conditions.

Optimal meter performance requires proper meter selection, proper installation, and proper commissioning for the particular application. This service guideline section indicates how to detect and solve the most common problems. Meter and application problems are indicated by the alarm program via the main fault and warning symbol on the display and the comprehensive data logging and monitoring available via the communication interface.

Alarm monitoring includes individual registration of each alarm, how many hours the alarm has been active, when the alarm first appeared, and when it disappeared last. The alarm log can be reset with its own date and time registration. A common fault hour counter includes all active alarms in one counter. Additionally, active alarms are logged in the data logger to monitor when the alarms have been activated.

Fatal faults 1 through 4 are the most important to resolve as they influence the operation of the meter. Fatal faults will disappear as soon as the alarm condition is corrected.

### 8.3 Replacing transmitter or PCB board

Since the MAG 8000 and MAG 8000 CT do not have a removable SENSORPROM (EEPROM), special care must be taken when replacing a damaged or defective transmitter or PCB board to ensure proper operation and continued accuracy. There are three ways to achieve an easy and successful replacement meter:

1. Order a complete transmitter as a spare part, which comes configured the same way as the original meter left the factory. The system serial number of the original meter must be provided when ordering the replacement.

2. Order a complete transmitter as a spare part with default settings and a blank product label. Final configuration is done on-site. Missing data and configuration can be uploaded from the old meter or it can be read from the old meter product label.
3. Order only a replacement PCB board. The PCB board can only be order for an advanced version and only with default settings. When making the configuration on site, the service mode must be selected in the Flow Tool/software and the hardware lock key must be mounted on PCB board to change important parameters.

**Note**

If MAG 8000 CT transmitter or sensor has to be replaced, a reverification of the whole meter must be made to obtain custody transfer approval.

## 8.4 Battery replacement

### Replacing battery

1. Loosen screws on transmitter top.
2. Remove transmitter top using a screwdriver.

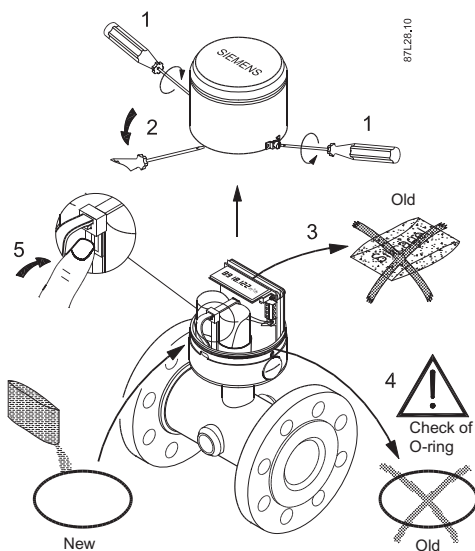

3. Dispose of silica gel bag.
4. Replace O-ring to ensure continued IP68 enclosure rating.
  - Check O-ring for damage or deformity.
  - Smear O-ring with acid-free lubricating gel.



5. Push locking tab and loosen strip.

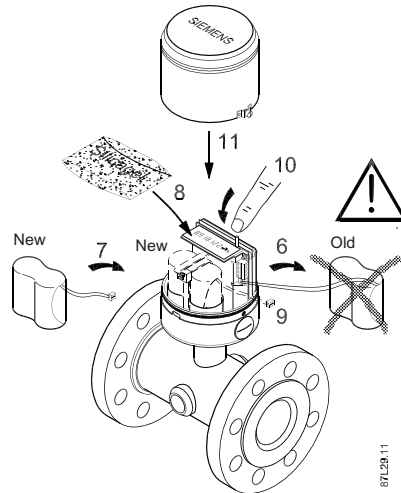

6. Remove battery pack with power still connected.

7. Place and secure new battery pack.

8. Add new Silica gel bag

- Remove plastic bag from new silica gel bag.
- Place new silica gel bag on top of battery pack to prevent condensation within meter.
- To maintain IP68 enclosure the silica gel bag may **not** be in contact with the Sylgard.

9. Disconnect old battery pack and connect new one.

10. Press key within 6 seconds to reset battery (i.e. operating time and remaining capacity) when display shows:



11. Mount top lid.

12. Fasten screws to reassemble meter completely.

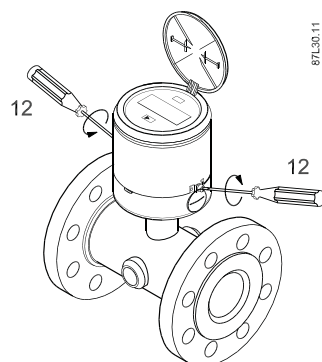

8.5 Power up with battery reset, date and time set up

If necessary, adjust time and date via software, see Battery power-up.

**Note**

All sealed MAG 8000 CT meters have to be re-verified when sealings (marked "A") have been broken.

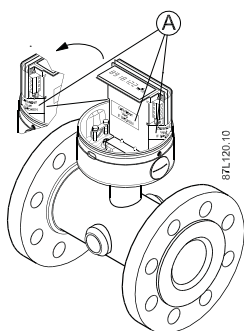
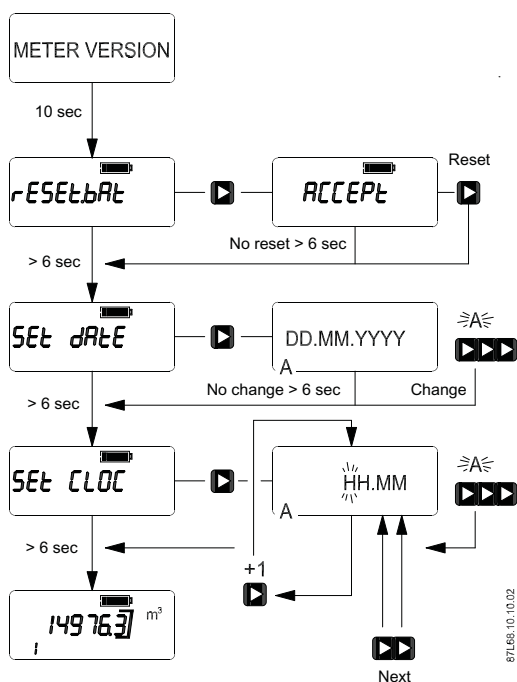

Figure 8-1 Verification sealings

## 8.5 Power up with battery reset, date and time set up



When new batteries have been installed, power-up procedure will enable resetting battery capacity and setting up date and time. Battery capacity reset, date and time can also be corrected via functions FT508 and FT200.

When battery plug is connected, meter will display meter version for 10 seconds. Display will then show "rESEt.bAt" indicating the option to reset internal battery power calculation. To execute reset, press key within 6 seconds. If key is not pressed, meter will proceed to set date, set clock, and finally normal operation mode.

If key is pressed within reset battery time, display will indicate "Accept" to ensure that reset should take place. Reset will take place only if key is pressed again within the next 6 seconds. If not, normal operation will begin.

For setting up date and time, the different key function must be used - see Operator menu index 1 (Page 53). An "A" indicates an acceptable value and a flashing "A" indicates that value is stored when key is released.

Reset function also sets actual date as battery replacement date.

## 8.6 Verification

Verification mode increases measurement frequency to provide maximum measurements per second. This function is especially useful to minimize calibration rig time when validating flowmeter accuracy. Frame around digits will blink slowly to indicate that verification mode is enabled. Maximum pulse rate on output A is increased to 1 kHz and pulse width is set to 1 ms. When verification mode is exited the previous pulse setting is restored. Pulse widths other than 1 ms can be selected by storing new pulse values. This setting remains when verification mode is exited.

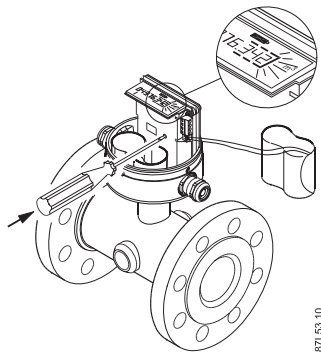

### Activation of verification mode

Verification mode is enabled in one of the following ways:

- Pressing push button through hole in front screen or
- Writing integer '1' to parameter register "CalibrationMode" (FT320).

### Verification mode

The following indicate that meter is in verification mode:

- Frame surrounding digits in LCD starts flashing.
- Excitation frequency is set to maximum allowable frequency.
  - (ExcitationFreqNo = ExcitationFreqNoLimit)
- Resolution in display is set to 3 digits after decimal point.
  - (DecimalPoint = 3)

### Deactivation of verification mode

Verification mode is deactivated in one of the following ways:

- Pressing push button again.
- Writing integer '0' to parameter register "CalibrationMode" (FT320).

Verification mode automatically stops if not manually deactivated within 4 hours.

## 8.7 User and verification sealings

MAG 8000 CT must be sealed to remain custody transfer-approved.

### Sealing device

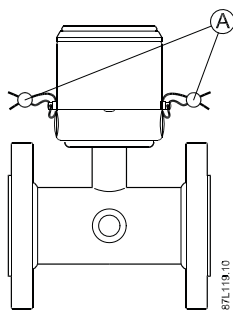

Figure 8-2 MAG 8000 CT user sealings (A)

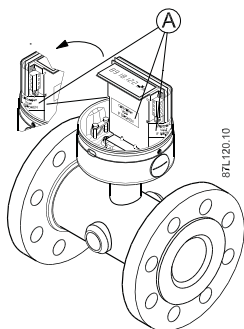

Figure 8-3 MAG 8000 CT verification sealing (A)

## 8.8 Technical support

<b>CAUTION</b>
Repair and service must be carried out by approved Siemens Flow Instruments personnel only.

---

**Note**

Siemens Flow Instruments defines sensors as non-repairable products.

---

### Technical Support

If you have any technical questions about the device described in these Operating Instructions and do not find the right answers, you can contact Technical Support:

- Via the Internet using the **Support Request:**  
Support request (<http://www.siemens.com/automation/support-request>)
- Phone: +49 (0)911 895 7222

Further information about our technical support is available in the Internet at Technical support (<http://support.automation.siemens.com/WW/view/en/16604318>)

### Service & Support on the Internet

In addition to our documentation, we offer a comprehensive knowledge base online on the Internet at:

Service and support (<http://www.siemens.com/automation/service&support>)

There you will find:

- The latest product information, FAQs, downloads, tips and tricks.
- Our newsletter, providing you with the latest information about your products.
- A Knowledge Manager to find the right documents for you.
- Our bulletin board, where users and specialists share their knowledge worldwide.
- You can find your local contact partner for Industry Automation and Drives Technologies in our partner database.
- Information about field service, repairs, spare parts and lots more under "Services."

### Additional Support

Please contact your local Siemens representative and offices if you have additional questions about the device

Find your contact partner at:

Local contact person (<http://www.automation.siemens.com/partner>)

## 8.9 Return procedures

Enclose the delivery note, the cover note for return delivery together with the declaration of decontamination form on the outside of the package in a well-fastened clear document pouch.

### Required forms

- **Delivery Note**
- **Cover Note for Return Delivery** with the following information  
Cover note  
([http://cache.automation.siemens.com/dnl/zY/zY00Tg1AAAA\\_16604370\\_TxtObj/Begleitschein\\_RW\\_AD.pdf](http://cache.automation.siemens.com/dnl/zY/zY00Tg1AAAA_16604370_TxtObj/Begleitschein_RW_AD.pdf))
  - product (ordering number)
  - number of devices or spare parts returned
  - reason for the return

- **Declaration of Decontamination**

Declaration of decontamination

([http://pia.khe.siemens.com/efiles/feldg/files/Service/declaration\\_of\\_decontamination\\_en.pdf](http://pia.khe.siemens.com/efiles/feldg/files/Service/declaration_of_decontamination_en.pdf))

With this declaration you certify *that the returned products/spare parts have been carefully cleaned and are free from any residues.*

If the device has been operated together with toxic, caustic, flammable or water-damaging products, clean the device before return by rinsing or neutralizing. Ensure that all cavities are free from dangerous substances. Then, double-check the device to ensure the cleaning is completed.

We shall not service a device or spare part unless the declaration of decontamination confirms proper decontamination of the device or spare part. Shipments without a declaration of decontamination shall be cleaned professionally at your expense before further proceeding.

You can find the forms on the Internet and on the CD delivered with the device.

## 8.10 Battery disposal

In accordance with EU directive 2006/66/EC, batteries are not to be disposed of using municipal waste disposal services.

Waste industrial batteries are accepted back by Siemens or by the local Siemens representative. Please talk to your local Siemens contact or follow the return procedures of Siemens Flow Instruments.

## Troubleshooting/FAQs

### 9.1 Fault codes

#### Error system

MAG8000 and MAG 8000 CT can detect and report 14 different faults.

The faults are divided into two types: Fatal errors and Warnings.

**Fatal errors: Faults 1, 2, 3, and 4**

**Warnings: Faults 5, 6, 7, 8, 9, L, E, C, d, and 14**

Fault codes	Name/text	Description	Cause	Remedy
1	<b>Insulation fault</b>	"Cross-talk" between coil circuit and electrodes. An insulation fault will result in a offset error on flow measurement (Advanced version only)	<ul style="list-style-type: none"> <li>Defect cables between sensor and transmitter</li> <li>Wrong connections of remote cables</li> <li>Water between coils and electrodes – could be caused by a broken liner</li> <li>Pollution/moisture on PCB caused by water in encapsulation</li> </ul>	<p>Check cable and wiring installation and disturbing elements in the surrounding.</p> <p>Re-activation of insulation test (FT800) will reset alarm and start a new insulation test.</p> <p>During the 4 minute insulation test, measurement is disabled.</p> <p>Alarm remains active until a new test period detects no failures.</p>
2	<b>Coil current fault</b>	<p>Error in the coil circuit. Coil current has not settled within specified period.</p> <p>A short-circuit in the coil can <b>NOT</b> be detected</p>	<ul style="list-style-type: none"> <li>Coils have been disconnected could be caused by broken cable or wires</li> </ul>	<p>Check cable and wiring installation.</p> <p>Alarm remains active until the fault condition is corrected.</p>
3	<b>Preamplifier overload</b>	<p>Input signal is outside expected range.</p> <p>Input amplifier circuit can not provide a stable measurement.</p> <p>A short circuit between the two electrodes or between a electrode and common can <b>NOT</b> be detected</p>	<ul style="list-style-type: none"> <li>Electrodes have been disconnected, or connected to ground</li> </ul>	<p>Check cable and wiring installation.</p> <p>Alarm remains active until the fault condition is corrected.</p>

9.1 Fault codes

Fault codes	Name/text	Description	Cause	Remedy
4	<b>Database checksum</b>	Corrupted data in eeprom detected by checksum test made during power-up	<ul style="list-style-type: none"> <li>Power failure during Eeprom write</li> </ul>	<ol style="list-style-type: none"> <li>Reset checksum repair alarm via FT560 and check data.                             <ul style="list-style-type: none"> <li>All data is checked after operation (e.g., new flow calculation, writing to the EEprom, etc.) with a checksum control. If the checksum result fails, data will not be considered as valid and repair data must be made.</li> </ul> </li> <li>If data is wrong or checksum error reoccurs, replace the PCB board.</li> </ol> <p>The alarm is active until the fault condition is corrected.</p>
5	<b>Low Power Alarm</b>	<p>Battery capacity is below preset threshold (default 10%).</p> <p>Power up (temporary warning – will disappear after 4 hours)</p>	<ul style="list-style-type: none"> <li>Battery capacity low</li> <li>Meter has been powered up</li> </ul>	<p>Check calculated battery capacity (FT510) versus battery alarm limit (FT206) and replace batteries if necessary</p> <p>Flow measurement and communication stop, but display remains active as long as power is available.</p> <p>The alarm remains active until the fault condition is resolved.</p>
6	<b>Flow Overload</b>	Flow rate has exceeded 125% of Q3	<ul style="list-style-type: none"> <li>Wrong sizing – flow sensor too small</li> </ul>	<p>Check meter sizing for actual installation</p> <p>Alarm remains active until fault condition is resolved.</p>
7	<b>PulseA overload</b>	Duty cycle of output A has exceeded maximum possible of 50	<ul style="list-style-type: none"> <li>Wrong settings for output A</li> </ul>	<p>Change volume per pulse to a higher value - see Technical data for pulse selection.</p> <p>Reminder: basic version is limited to 50 Hz maximum; advanced version to 100 Hz maximum.</p> <p>The alarm remains active until output pulse rate drops below maximum pulse rate.</p>
8	<b>PulseB overload</b>	Duty cycle of output B has exceed maximum possible of 50	<ul style="list-style-type: none"> <li>Wrong settings for output B</li> </ul>	<p>Change volume per pulse to a higher value - see Technical data for pulse selection.</p> <p>Reminder: basic version is limited to 50 Hz maximum; advanced version to 100 Hz maximum.</p> <p>The alarm remains active until output pulse rate drops below maximum pulse rate.</p>
9	<b>Consumption Interval</b>	Accumulated volume on totalizer 1 during data log period has exceeded the too low or too high consumption limit	<ul style="list-style-type: none"> <li>Flowrate higher or lower than expected</li> <li>Wrong parameter setup</li> </ul>	<p>Check data logger values and consumption limit.</p> <p>Alarm remains active until it is manually reset via FT209.</p>



Fault codes	Name/text	Description	Cause	Remedy
L	Leakage	Lowest flow rate or volume during leakage period has exceeded leakage detection settings	<ul style="list-style-type: none"> <li>Leakage in water network</li> </ul>	<p>Check setting and pipe installation.</p> <p>Alarm is active until it is manually reset by FT208.</p> <p>Alarm reset resets information as does leakage period reset (FT820).</p>
E	Empty Pipe	Measured electrode impedance has exceeded the empty-pipe detection level (FT540 & FT541 & FT334)	<ul style="list-style-type: none"> <li>Pipe is not filled with water</li> </ul>	<p>Ensure sensor is filled with water.</p> <p>Alarm remains active until fault condition is resolved.</p>
C	Low Conductivity	Measured electrode impedance is below low conductivity threshold (FT542), i.e. water has a high conductivity	<ul style="list-style-type: none"> <li>Water is polluted (e.g. saltwater in fresh water)</li> </ul>	<p>-</p> <p>Alarm is active until water resistance is above low media alarm limit.</p>
d	Flow Limit	The flow rate is greater than the flow alarm limit (FT553).	<ul style="list-style-type: none"> <li>Water network failure – pipe burst</li> </ul>	<p>-</p> <p>Alarm remains active until flow rate drops below flow alarm limit.</p>
	Reverse Flow	Flow rate is below a preset threshold (default -1E9)	<ul style="list-style-type: none"> <li>Water network failure – non-return valve is broken</li> </ul>	

**Note**

Reset of fault log (FT204) also resets all alarms. Once reset, only active alarms become visible again.

## 9.2 Built-in functions

### Empty pipe detection

Electrode impedance is measured with 800 Hz at 50 Hz mains frequency (960 Hz at 60 Hz mains frequency). This is done by toggling the electrode control pin every 6 respectively 5 samples – the sample frequency is 9600 Hz. The impedance value is averaged over 100 measurements. The electrode impedance A and B are measured in turns.

The unfiltered impedance value (a fast warning indication) is compared with a limit and the empty pipe warning is reported when it exceeds this limit – but only if the detection is ON and if there is no overload failure.

During empty pipe detection the coil current is held OFF and the flow value is forced zero.

Default settings for Electrode Impedance Limit is 25 000 ohm corresponding to a water conductivity of 20 µS/cm (10 000 ohm ≈ 50 µS/cm)

### Insulation test

Insulation measurement is working like the normal measurement by excitation of the magnetic coils in the sensor. Value is checked against a limit of 1.25 mm/s. A value above this limit results in a failure report.

Measurement will NOT stop if an insulation fault occurs.

Flow value is freezed during insulation test.

Insulation test interval according to register "Insulation Test Interval". Minimum 1 day between tests.

The insulation test can be enabled/disabled with register "Insulation Test".

When the insulation test is enabled the test starts immediately. All following insulation tests will start at 00:00:00 (midnight).

Duration of insulation test is 2 min 42 sec (1024 samples @ 6.25 Hz)

Insulation test will always be made with an excitation frequency of 6.25 Hz.

---

#### Note

Insulation test cannot be enabled in the MAG 8000 and MAG 8000 CT basic version.

---

### Coil-current test

When H-bridge is turned and just before making samples (4 times each measurement), the coil current is checked via a comparator. If the coil current is not settled, a failure is reported.

During coil current failure the flow value is forced zero.

### Preamplifier test

Overload is possible both from the AD conversion of sensor signal and from the pre-amplifier. These checks are made at each sample and if one of the sample fails with an overload, this measurement is cancelled and a failure is reported.

During overload detection the coil current is held OFF and the flow value is forced zero.

### Checking facilities

The MAG 8000 and MAG 8000 CT are equipped with checking facilities of types P, I, and N. (2.5.5 in OIML R49). The automatic checks are performed without operator intervention.

**Type P** permanent checking facilities are automatic checks performed constantly during meter operation. They include:

- Coil current test
- Preamplifier test
- Empty pipe test
- Flow overload
- Pulse overload

**Type I** intermittent checking facilities are automatic checks performed at certain time intervals or per fixed number of measurements. They include:

- Checksum calculation (10 min. interval on totalizer checksum)
- Insulation test (minimum 24 hour interval)
- Battery capacity check (4 hours interval)

**Type N** non-automatic checking facilities are checks that are **not** performed automatically including all other diagnosis functions in the MAG 8000 and the MAG 8000 CT.

### 9.3 Flow simulation

MAG 8000 and MAG 8000 CT has a built-in flow simulator (FT551 & FT552) to verify and adjust pulse output to any connected device or system.

 <b>WARNING</b>
<p><b>Totalized values are changed during simulation and actual flow is NOT measured.</b></p> <p><b>Simulation continues until it is manually turned off (normal operation restored).</b></p> <p>For MAG 8000 CT flow simulation is only possible when verification sealings are broken.</p>



## Technical data

### 10.1 MAG 8000 MAG 8000 CT meter

#### Technical specifications



Figure 10-1 MAG 8000 / MAG 8000 CT

For further features, see features list in appendix (Page 128).

Meter		MAG 8000 (7ME6810)	MAG 8000 (7ME6880)	MAG 8000 CT (7ME6820)
Accuracy	Standard calibration	± 0.4% of rate ± 2 mm/s	± 0.8% of rate ± 2.5 mm/s	-
	Extended calibration	± 0.2% of rate ± 2 mm/s	-	-
	OIML R49 (DN 50 ... DN 600 (2" ... 24"))	-	-	Class 1 and 2 with turn-down ratio up to Q3/Q1 = 400 at Q2/Q1 = 1.6
	MI-001 (DN 50 ... DN 600 (2" ... 24"))	-	-	Class 2 with turn-down ratio Q3/Q1 = 250, Q3/Q1 = 200, Q3/Q1 = 160 at Q2/Q1 = 1.6
Media conductivity		Clean water > 20 µs/cm		
Temperature	Ambient	-20 ... +60 °C (-4 ... +140 °F)	-	-20 ... +55 °C (-4 ... +131 °F)
	Media	0 ... 70 °C (32 ... +158 °F)	-	0.1 ... 50 °C (32 ... +122 °F)
	Storage	-40 ... +70 °C (-22 ... +158 °F)	-	-40 ... +70 °C (-22 ... +158 °F)

Technical data

10.2 Sensor

Meter		MAG 8000 (7ME6810)	MAG 8000 (7ME6880)	MAG 8000 CT (7ME6820)
Enclosure		IP68/NEMA 6P rating. Cable glands mounted requires Sylgard potting kit to remain IP68/NEMA 6P, otherwise IP67/NEMA 4 rating is obtained. Factory mounted cable provides IP68/NEMA 6P rating		
Approvals	Drinking water approvals	NSF 61 (cold water) USA WRAS (BS 6920 cold water) UK ACS Listed France DVGW W270 Germany Belgaqua (B)	NSF 61 (cold water) USA WRAS (BS 6920 cold water) UK	NSF 61 (cold water) USA WRAS (BS 6920 cold water) UK ACS Listed France DVGW W270 Germany Belgaqua (B)
	Custody transfer approval	OIML R49	NMI10 Australia (under preparation)	OIML R49 OIML R49 MAA MI-001 (DK-0200-MI-001-002 or DK-0200-MI-001-011)
Conformity		-	-	CEN EN 14154 ISO 4064
	PED	97/23EC	-	97/23EC
	EMC		EN 61000-6-3 EN 61000-6-2 EN 61326-1	

## 10.2 Sensor

### Technical specifications

Sensor		MAG 8000 (7ME6810)	MAG 8000 (7ME6880)	MAG 8000 CT (7ME6820)
Size, flange and pressure range	EN 1092-1 (DIN 2501)	DN 25 and DN 40: PN 40 DN 50 ... 150: PN 16 DN 200 ... 1200: PN 10 or PN 16	DN 50 ... 600: Drilled flanges (maximum pressure 7 bar)	DN 50 ... 600: PN 16
	ANSI 16.5 Class 150 lb	1" ... 24": 20 bar (290 psi)	2" ... 24": Drilled flanges (maximum pressure 7 bar)	2" ... 24": 20 bar (290 psi)
	AWWA C-207	28" ... 48": PN 10	-	-
	AS 4087	DN 50 ... 1200: PN 14	-	DN 50 ... 600: PN 16
	AS 2091-1 Table D	-	Drilled flanges (maximum pressure 7 bar)	-

Sensor		MAG 8000 (7ME6810)	MAG 8000 (7ME6880)	MAG 8000 CT (7ME6820)
Max. excitation frequency Basic version	Battery-powered	1/15 Hz for sensor size DN 25 ... 150 (1" ... 6") 1/30 Hz for sensor size DN 200 ... 600 (8" ... 24") 1/60 Hz for sensor size DN 700 ... 1200 (28" ... 48")	1/15 Hz for sensor size DN 50 ... 150 (2" ... 6") 1/30 Hz for sensor size DN 200 ... 600 (8" ... 24")	1/15 Hz for sensor size DN 50 ... 150 (1" ... 6") 1/30 Hz for sensor size DN 200 ... 600 (9" ... 24")
	Mains-powered	6.25 Hz for sensor size DN 25 ... 150 (1" ... 6") 3.125 Hz for sensor size DN 200 ... 600 (8" ... 24") 1.5625 Hz for sensor size DN 700 ... 1200 (28" ... 48")	3.125 Hz for sensor size DN 50 ... 600 (2" ... 24")	6.25 Hz for sensor size DN 25 ... 150 (1" ... 6") 3.125 Hz for sensor size DN 200 ... 600 (8" ... 24")
Max. excitation frequency Advanced version	Battery-powered	1/15 Hz for sensor size DN 25 ... 150 (1" ... 6") adjustable up to 6.25 Hz 1/30 Hz for sensor size DN 200 ... 600 (8" ... 24") adjustable up to 3.125 Hz 1/60 Hz for sensor size DN 700 ... 1200 (28" ... 48") adjustable up to 1.5625 Hz	1/15 Hz for sensor size DN 50 ... 600 (2" ... 24") adjustable up to 3.125 Hz	1/15 Hz for sensor size DN 50 ... 150 (2" ... 6") adjustable up to 6.25 Hz 1/30 Hz for sensor size DN 200 ... 600 (8" ... 24") adjustable up to 3.125 Hz
	Mains-powered	6.25 Hz for sensor size DN 25 ... 150 (1" ... 6") 3.125 Hz for sensor size DN 200 ... 600 (8" ... 24") 1.5625 Hz for sensor size DN 700 ... 1200 (28" ... 48")	3.125 Hz for sensor size DN 50 ... 600 (2" ... 24")	6.25 Hz for sensor size DN 25 ... 150 (1" ... 6") 3.125 Hz for sensor size DN 200 ... 600 (8" ... 24")
Liner		EPDM	Ebonite	EPDM
Electrode and grounding		Hastelloy C276	Stainless steel	Hastelloy C276

## 10.3 Transmitter

Transmitter		MAG 8000 (7ME6810)	MAG 8000 (7ME6880)	MAG 8000 CT (7ME6820)
Installation		Integral (compact) or remote with factory-mounted cable in 2*, 5, 10, 20 or 30 m lengths with IP68/NEMA 6P connectors. Connection is made at the transmitter bottom.		
Material	Top housing	Stainless steel (AISI 316)		
	Bottom	Coated brass		
	Wall mounting bracket	Stainless steel (AISI 304).		
Cable entries		2 x M20 (one gland for one cable of size 6 ... 8 mm (0.02 ... 0.026 ft) is included in the standard delivery)		

Technical data

10.3 Transmitter

Transmitter	MAG 8000 (7ME6810)	MAG 8000 (7ME6880)	MAG 8000 CT (7ME6820)
Display and key	Display	8 digits for main information. Index, menu and status symbols for dedicated information	
	Key	For toggling through information and resetting of customer totalizer and call-up function	
	Menus	Selectable default information and accessible menus: - Operator - Meter - Service - Data Logger - Statistic and leakage (Advanced version only) - Revenue and Tariffs (Advanced version only)	
	Resolution	Totalized information can be displayed with 1, 2 or 3 decimals or automatic adjustment for maximum resolution	
Flow unit	Europe std.	Volume: m <sup>3</sup> Flow rate: m <sup>3</sup> /h	
	US std.	Volume: Gallon Flow rate: GPM	
	Australia std.	Volume MI Flow rate: MI/d	
	Other selectable units	Volume: m <sup>3</sup> x 100, l x 100, G x 100, G x 1000, MG, CF x 100, CF x 1000, AF, AI, kl Flow rate: m <sup>3</sup> /min, m <sup>3</sup> /d, l/s, l/min, l/h, GPS, GPH, GPD, MGD, CFS, CFM, CFH	
		Other units than m <sup>3</sup> and m <sup>3</sup> /h (ordered from factory or manually configured onsite by changing scaling factors) are shown by a label stuck onto display	
Digital output	Nos.	2 passive outputs (MOS), individually galvanically isolated	
	Load	Max. ± 35 V DC, 50 mA short circuit protected	
	Output A	Programmable as: Pulse volume Forward Reverse Forward/net Reverse/net	
	Output B	Programmable as: Pulse volume Forward Reverse Forward/net Reverse/net Alarm Call-up	
	Pulse rate	Basic version: Max. 50 Hz Advanced version: Max. 100 Hz	
	Pulse width	5, 10, 50, 100, 500 ms	



Transmitter		MAG 8000 (7ME6810)	MAG 8000 (7ME6880)	MAG 8000 CT (7ME6820)
Communication	IrDA	Standard integrated infrared communication interface with MODBUS RTU protocol		
	Add-on modules	RS 232 serial interface with MODBUS RTU (Rx/Tx/GND), point to point with max. 15 m cable		
		RS 485 serial interface with MODBUS RTU (+/-/GND), multidrop with up to 32 devices with max. 1000 m cable		
		-	-	Encoder interface module (for Itron 200WP) "Sensus protocol"

\*: Only MAG 8000 (/ME6880)

## 10.4 Power supply

### Technical specifications

Power supply	
Battery power supply <sup>1)</sup>	Auto-detection of power source with displayed symbol for remaining power. In battery mode, excitation frequency is manually selected
	Internal battery pack 21D-Cell 3.6 V / 16 Ah
	Internal battery pack 2 D-Cell 3.6 V / 33 Ah
	External battery pack 4 D-Cell 3.6 V / 66 Ah
12-24 V AC/DC power supply	Input voltage range 12/24 V AC/DC (10 ... 32 V DC)
	Power consumption 2 VA
	Isolation Class II
	Fuse 1000 mA T - Not replaceable
	Short circuit protection Module is protected from short circuit on the output connector. Both during mains and backup supply
	Conformity IEC 61010-1 OIML R49-1 EMC: EN 61000-6-3 EN 61000-6-2

<b>Power supply</b>		
115 ... 230 V AC mains supply	Input voltage range	115 ... 230 V AC, +15% to -20%, 50-60 Hz
	Power consumption	2 VA
	Isolation	Class II
	Fuse	250 mA T - Not replaceable
	Short circuit protection	Module is protected from short circuit on the output connector. Both during mains and backup supply
	Conformity	IEC 61010-1 OIML R49-1 EMC: EN 61000-6-3 EN 61000-6-2
	Input cable for 12/24 V AC/DC and 115 ... 230 V AC power supply	Factory-mounted PUR cable
Resistance		Sunlight and water
Outer diameter		7 mm (0.28")
Rated voltage		300 ... 500 V AC
Testing voltage		2000 V AC
Temperature range		Fixed laying: -40 ... +90 °C (-40 ... 194 °F) Flexible application: -30 ... +80 °C (-22 ... 176 °F)
Bending radius		Min. 28 mm (fixed installation)
Pulling force		Max. 200 N
Output		Female connector
Backup battery		Male connector

<sup>1)</sup> Lithium batteries are subject to special transportation regulations according to United Nations "Regulation of Dangerous Goods, UN 3090 and UN 3091". Special transport documentation is required to observe these regulations. This may influence both transport time and costs.

## 10.5 Modbus RTU

<b>Siemens Flow Instruments Modbus RTU specification for add-on modules</b>	
Device type	Slave
Baud rates	1200, 2400, 4800, 9600, 19 200, 38 400 bits/sec.
Number of stations	Recommended: max. 31 per segment without repeaters
Device address range	1 ... 247
Protocol	RTU (Other Modbus protocols like ASCII, Plus or TCP/IP are not supported)
Electrical interface	RS485, 2-wire and RS232, 2-wire
Connector type	Screw terminals

**Siemens Flow Instruments Modbus RTU specification for add-on modules**

Supported function codes	1: read coils
	3: read holding registers
	5: write single coil
	16: write multiple registers
	17: report slave ID
Broadcast	Yes
Maximum cable length	1200 meters (@38 400 bits/sec.)
Standard	Modbus over serial line v1.0
Certified	No
Device profile	None
Add-on modules comply with	MODBUS over serial line specification & implementation guide v. 1.0 modbus.org 12/02/02 MODBUS application protocol specification v. 1.1 modbus.org 12/06/02
Isolation	500 V AC functional isolation of data signals and common

Add-on modules must be connected to equipment complying with "Low Voltage Directive" in order to be considered safe. The isolation within the MAG 8000 and MAG 8000 CT add-on MODBUS module is only functional isolation.

## 10.6 Output characteristics

This chapter describes how the MAG 8000 and MAG 8000CT outputs work.

### Output A and B as pulse volume

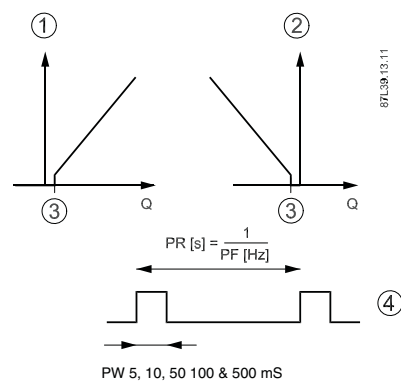

- |   |         |    |                 |
|---|---------|----|-----------------|
| ① | Forward | PR | Pulse rate      |
| ② | Reverse | PF | Pulse frequency |
| ③ | Cut-off | PW | Pulse width     |

**MAG 8000**

10.6 Output characteristics

When output A or B is configured as volume per pulse, the output delivers a pulse when the preset volume based on either Forward/Reverse or Net Forward/Net Reverse flow has passed the sensor in the selected direction. The volume per pulse is freely scalable, from 0.000001 to 10 000 units per pulse, and should not exceed the pulse rate of the output configuration table.

**MAG 8000 CT**

The volume per pulse is defined in the MAG 8000 CT version to 0.001 or 0.01 or 0.1 or 1 m<sup>3</sup> per pulse.

**Output B as alarm output**

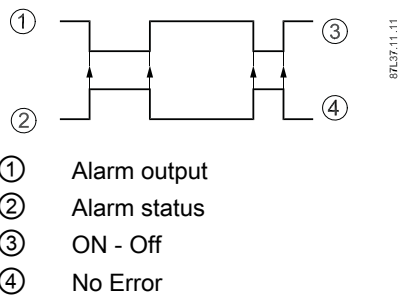

- ① Alarm output
- ② Alarm status
- ③ ON - Off
- ④ No Error

**MAG 8000**

When output B is configured as an "alarm" output, it will follow the internal alarms that were previously chosen in the Alarm Configuration List.

**Note**

Alarm output is inverted to a pulse output providing an alarm if power disappears or cable connection is interrupted.

**Output B as call-up output**

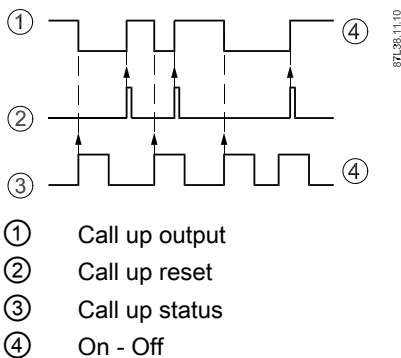

- ① Call up output
- ② Call up reset
- ③ Call up status
- ④ On - Off

When output B is configured as "call-up", the output is activated by an alarm condition and remains on until it is reset via meter display key or communication interface.

A new alarm will not activate a "call-up" function if the "call-up" function is still active from a previous alarm.

---

**Note**

Like alarm output, call-up output inverts to a pulse output providing a call-up if power disappears or cable connection is interrupted.

---

**MAG 8000**

When output B is configured as an "call-up" output, it will follow the internal alarms that were previously chosen in the Alarm Configuration List.

---

**Note**

Call-up output is inverted to a pulse output providing an alarm if power disappears or cable connection is interrupted.

---

**Factory regional settings**

DN mm	size (inch)	Pulse width ms	Europe m <sup>3</sup>	USA Gallons	Australia MI
25, 40, 50	(1", 1½", 2")	50	0.01	1	0.001
65, 80, 100, 125, 150	(2½", 3", 4", 5", 6")	50	0.1	10	0.001
200, 250, 300, 350, 400, 450, 500	(8", 10", 12", 14", 16", 18", 20")	50	1	100	0.01
600, 700, 800, 900, 1000, 1050, 1100, 1200	(24", 28", 30", 32", 36", 40", 42", 44", 48")	50	10	100	0.01

Pulse A is set to ON - Forward flow. Pulse B is set to Alarm.

---

**Note**

Via the MLFB order system is it possible to select other units than the default region units. The pulse output will only be enabled if the pulse settings are selected in the MLFB no.

---

**Pulse output, volume selection (MAG 8000)**

DN (inches)	Max. flow rate Qn (Q3) M <sup>3</sup>	Guidelines for min. volume per pulse at Qn Volume [m <sup>3</sup> ] = Qn [m <sup>3</sup> /s] * (2*PW [s])						
		5 ms PW m <sup>3</sup> [50Hz]	10 ms PW m <sup>3</sup> [50Hz]	50 ms PW m <sup>3</sup> [10Hz]	50 ms PW gallon [10Hz]	50 ms PW MI [10Hz]	100 ms PW m <sup>3</sup> [5Hz]	500 ms PW m <sup>3</sup> [1Hz]
25 (1")	17.67	0.00005	0.0001	0.0005	0.130	0.000001	0.001	0.005
40 (1½")	45	0.0001	0.0003	0.001	0.330	0.000001	0.003	0.013
50 (2")	63	0.0002	0.0004	0.002	0.462	0.000002	0.004	0.018

10.6 Output characteristics

		Guidelines for min. volume per pulse at Qn Volume [m³] = Qn [m³/s] * (2*PW [s])						
65 (2½")	100	0.0003	0.0006	0.003	0.734	0.000003	0.006	0.028
80 (3")	160	0.0004	0.0009	0.004	1.174	0.000004	0.009	0.044
100 (4")	250	0.0007	0.0014	0.007	1.835	0.000007	0.014	0.069
125 (5")	400	0.0011	0.0022	0.011	2.935	0.000011	0.022	0.111
150 (6")	630	0.0018	0.0035	0.018	4.623	0.000018	0.035	0.175
200 (8")	1000	0.0028	0.0056	0.028	7.338	0.000028	0.056	0.278
250 (10")	1600	0.0044	0.0089	0.044	11.741	0.000044	0.089	0.444
300 (12")	2500	0.0069	0.0139	0.069	18.345	0.000069	0.139	0.694
350 (14")	3463	0.0096	0.0192	0.096	25.412	0.000096	0.192	0.962
400 (16")	4523	0.0126	0.0251	0.126	33.190	0.000126	0.251	1.256
450 (18")	5725	0.0159	0.0318	0.159	42.010	0.000159	0.318	1.590
500 (22")	7068	0.0196	0.0393	0.196	51.865	0.000196	0.393	1.963
600 (24")	10178	0.0283	0.0565	0.283	74.687	0.000283	0.565	2.827
700 (28")	13854	0.0385	0.0770	0.385	101.662	0.000385	0.770	3.848
750 (30")	15904	0.0442	0.0884	0.442	116.705	0.000442	0.884	4.418
800 (32")	18095	0.0503	0.1005	0.503	132.782	0.000503	1.005	5.026
900 (36")	22902	0.0636	0.1272	0.636	168.057	0.000636	1.272	6.362
1000 (40")	28274	0.0785	0.1571	0.785	207.477	0.000785	1.571	7.854
1050 (42")	31175	0.0866	0.1732	0.866	228.750	0.000866	1.732	8.659
1100 (44")	34211	0.0950	0.1901	0.950	251.043	0.000950	1.901	9.503
1200 (48")	40715	0.1131	0.2262	1.131	298.770	0.001131	2.262	11.310

PW = pulse width

**Note**

Display volume for 5 ms pulse width is based on a basic version with maximum 50 Hz pulse output rate.

For the advanced version, with maximum 100 Hz pulse rate, the pulse volume values can be reduced to half.

The calculated numbers of pulses are an average of the measuring period.

For MAG 8000 CT please see definition of Q3 flow rates in the certificates for OIML R49 or MI 001.

**Net flow output**

The MAG 8000 has a special net pulse output that includes bi-directional flow calculations.

The example shows that over time, the net pulse output indicates the bi-directional totalizer as calculated internally. The same principle applies for forward and reverse flow calculation. By changing the status of the pulse output, the internal pulse calculator will be reset.

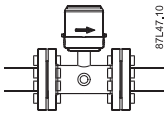
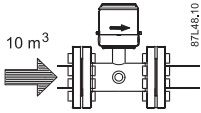
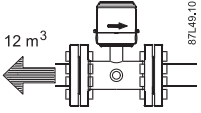
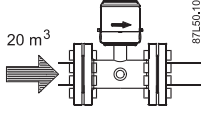
Flow	Net totalizer in meter display (Bi-directional)	Pulse output forward Uni-directional mode Volume [m <sup>3</sup> ]		Pulse output net forward Bi-directional mode Volume [m <sup>3</sup> ]	
	Volume [m <sup>3</sup> ]	Internal calculation	Delivered volume	Internal calculation	Delivered volume
	0	-	0	0	0
	10	-	10	0	10
	-2	-	0	-12	0
	18	-	20	-12+20=	8
Total accounted volume [m <sup>3</sup> ] Forward/Reverse	18F		30F		18F

### Encoder output interface read out

			MSD LSD									
Digits in MAG 8000 CT display			1	2	3	4	5	6	7	8		
Model	Size	Unit	Display configuration								Qmax	Digits after dec. point
7ME 6820 2Y	DN50 (2")	m <sup>3</sup>	0	0	0	0	0	0	0	0	63	1
7ME 6820 3F	DN65 (2½")	m <sup>3</sup>	0	0	0	0	0	0	0	0	100	1
7ME 6820 3M	DN80 (3")	m <sup>3</sup>	0	0	0	0	0	0	0	0	160	1
7ME 6820 3T	DN100 (4")	m <sup>3</sup>	0	0	0	0	0	0	0	0	250	1
7ME 6820 4B	DN125 (5")	m <sup>3</sup>	0	0	0	0	0	0	0	0	400	1
7ME 6820 4H	DN150 (6")	m <sup>3</sup>	0	0	0	0	0	0	0	0	630	1
7ME 6820 4P	DN200 (8")	m <sup>3</sup>	0	0	0	0	0	0	0	0	1000	1
7ME 6820 4V	DN250 (10")	m <sup>3</sup>	0	0	0	0	0	0	0	0	1600	1
7ME 6820 5D	DN300 (12")	m <sup>3</sup>	0	0	0	0	0	0	0	0	1600	1

## 10.7 Meter uncertainty

To ensure continuous accurate measurement, flowmeters must be calibrated.

All measuring instrumentation, used in the calibration of the flowmeters, has either been calibrated by a UKAS or DANAK accredited laboratory or has been calibrated against certified master sensors. This provides an unbroken chain of measurement-traceability to national standards.

Siemens Flow Instruments can provide accredited calibration in the flow range from 0.0001 m<sup>3</sup>/h to 4350 m<sup>3</sup>/h.

The accreditation bodies DANAK and UKAS have signed the ILAC MRA agreement (International Laboratory Accreditation Corporation - Mutual Recognition Arrangement). Therefore the accreditation ensures international traceability and recognition of the test results in 39 countries world-wide, including the US (NIST traceability).

The selected calibration determines the accuracy of the water meter. A MAG 8000 (7ME6810) standard calibration results in max. ±0.4% of rate ±2 mm/s uncertainty. A MAG 8000 (7ME6880) standard calibration results in max. ±0.8% of rate ±2.5 mm/s uncertainty. An extended calibration of the MAG 8000 (7ME6810) sizes DN50 (2") to DN 300 (12") results in a max. ±0.2% of rate ±2 mm/s uncertainty. A calibration certificate is included with every sensor and calibration data is stored within the meter.



10.8 MAG 8000 CT (7ME6820) (Revenue program) water meter type approval

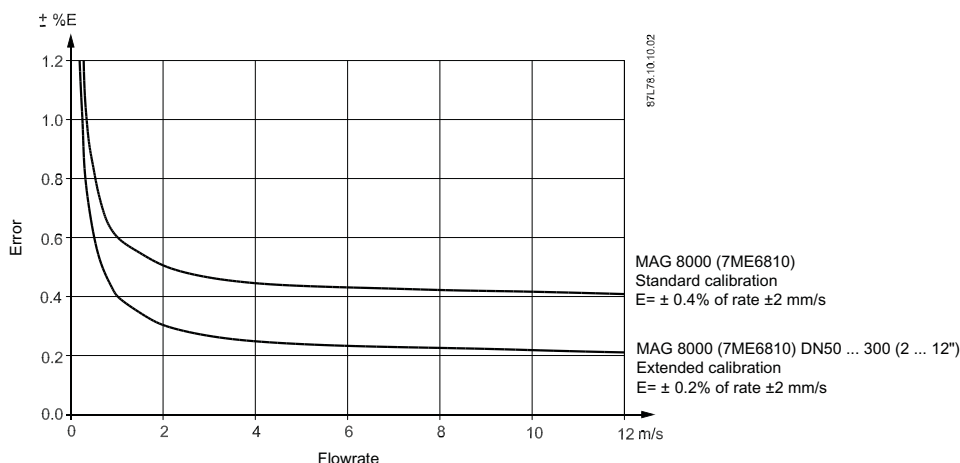

Calibration references conditions (ISO 9104 and DIN EN 29104)

Media temperature: 20°C ± 5K (68°F ± 9°F)

Ambient temperature: 20°C ± 5K (68°F ± 9°F)

Warming-up time: 30 min.

Incorporation in pipe section

Inlet section 10 x DN

Outlet section 5 x DN

Flow conditions: Fully developed flow profile

## 10.8 MAG 8000 CT (7ME6820) (Revenue program) water meter type approval

MAG 8000 CT program is type-approved according to international water meter standard OIML R49. The Custody Transfer program is approved as Class I and Class II, for the sensor program from DN 50 to DN 300, at different Q3 and Q3/Q1.

Q2/Q1 = 1.6 and follows standard OIML R49 specification.

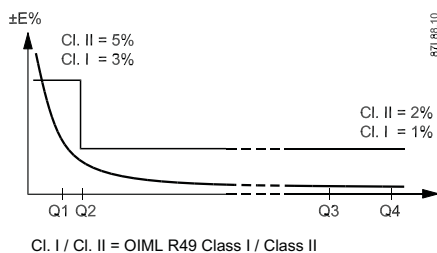

OIML R49 specification for Class I

10.9 MAG 8000 CT (7ME6820) (Revenue program) MI-001

Size	50 (2")	65 (2½")	80 (3")	100 (4")	125 (5")	150 (6")	200 (8")	250 (10")	300 (12")
"R" Q <sup>3</sup> /Q <sub>1</sub>	250	250	250	250	250	250	250	250	160
Q <sub>4</sub> [m <sup>3</sup> /h]	78.75	125	200	312.5	500	787.5	1250	2000	2000
<b>Q<sub>3</sub> [m<sup>3</sup>/h]</b>	<b>63</b>	<b>100</b>	<b>160</b>	<b>250</b>	<b>400</b>	<b>630</b>	<b>1000</b>	<b>1600</b>	<b>1600</b>
Q <sub>2</sub> [m <sup>3</sup> /h]	0.40	0.64	1.00	1.60	2.50	4.00	6.40	10.0	16.0
Q <sub>1</sub> [m <sup>3</sup> /h]	0.25	0.40	0.63	1.00	1.60	2.50	4.00	6.40	10.0

OIML R49 specification for Class II

Size	50 (2")	65 (2½")	80 (3")	100 (4")	125 (5")	150 (6")	200 (8")	250 (10")	300 (12")
"R" Q <sup>3</sup> /Q <sub>1</sub>	400	400	400	400	400	400	400	400	250
Q <sub>4</sub> [m <sup>3</sup> /h]	78.75	125	200	312.5	500	787.5	1250	2000	2000
<b>Q<sub>3</sub> [m<sup>3</sup>/h]</b>	<b>63</b>	<b>100</b>	<b>160</b>	<b>250</b>	<b>400</b>	<b>630</b>	<b>1000</b>	<b>1600</b>	<b>1600</b>
Q <sub>2</sub> [m <sup>3</sup> /h]	0.25	0.40	0.63	1.00	1.60	2.50	4.00	6.40	10.0
Q <sub>1</sub> [m <sup>3</sup> /h]	0.16	0.25	0.40	0.63	1.00	1.60	2.5	4.0	6.4

## 10.9 MAG 8000 CT (7ME6820) (Revenue program) MI-001

MAG 8000 CT program is type approved according to international water meter standard OIML R49. Since 1 November 2006 the MI-001 water meter directive has been in force, which means that all water meters can be sold across the EU borders if the water meters contain a MI-001 label.

The MAG 8000 CT MI-001 verified and labeled products are a Class II approval according to Directive 2004/22/EC of the European Parliament and Council of March 31, 2004 on measuring instruments (MID), Annex MI-001 in the sizes from DN 50 to DN 300.

The MID certification is obtained as a module B and module D approvals according to the above mentioned directive.

Module B : Type approval according to OIML R49

Module D : Quality insurance approval of production

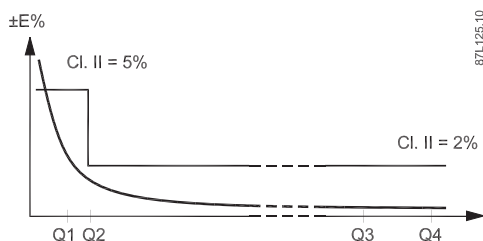

MAG 8000 CT MI-001 verified and labelled products at a given Q<sub>3</sub> and Q<sub>3</sub>/Q<sub>4</sub> = 1.25 and Q<sub>2</sub>/Q<sub>1</sub> = 1.6 measuring ranges see below table:

10.9 MAG 8000 CT (7ME6820) (Revenue program) MI-001

Size	50 (2")	65 (2½")	80 (3")	100 (4")	125 (5")	150 (6")	200 (8")	250 (10")	300 (12")
"R" Q <sup>3</sup> /Q1	25	25	25	25	25	25	25	25	25
Q4 [m <sup>3</sup> /h]	18.75	31.25	50	78.75	125	200	312.5	500	750
<b>Q3 [m<sup>3</sup>/h]</b>	<b>15</b>	<b>25</b>	<b>40</b>	<b>60</b>	<b>100</b>	<b>150</b>	<b>250</b>	<b>400</b>	<b>600</b>
Q2 [m <sup>3</sup> /h]	0.96	1.60	2.60	4.03	6.40	10.24	16.00	25.60	38.4
Q1 [m <sup>3</sup> /h]	0.60	1.00	1.60	2.40	4.0	6.0	10.0	16.0	24.0

Size	50 (2")	65 (2½")	80 (3")	100 (4")	125 (5")	150 (6")	200 (8")	250 (10")	300 (12")
"R" Q <sup>3</sup> /Q1	63	63	63	63	63	63	63	63	63
Q4 [m <sup>3</sup> /h]	18.75	31.25	50	78.75	125	200	312.5	500	750
<b>Q3 [m<sup>3</sup>/h]</b>	<b>15</b>	<b>25</b>	<b>40</b>	<b>60</b>	<b>100</b>	<b>150</b>	<b>250</b>	<b>400</b>	<b>600</b>
Q2 [m <sup>3</sup> /h]	0.38	0.63	1.02	1.60	2.54	4.06	6.35	10.20	15.24
Q1 [m <sup>3</sup> /h]	0.24	0.40	0.63	1.00	1.59	2.54	3.97	6.35	9.52

Size	50 (2")	65 (2½")	80 (3")	100 (4")	125 (5")	150 (6")	200 (8")	250 (10")	300 (12")
"R" Q <sup>3</sup> /Q1	80	80	80	80	80	80	80	80	80
Q4 [m <sup>3</sup> /h]	18.75	31.25	50	78.75	125	200	312.5	500	750
<b>Q3 [m<sup>3</sup>/h]</b>	<b>15</b>	<b>25</b>	<b>40</b>	<b>60</b>	<b>100</b>	<b>150</b>	<b>250</b>	<b>400</b>	<b>600</b>
Q2 [m <sup>3</sup> /h]	0.31	0.50	0.80	1.20	2.00	3.20	5.00	8.00	12.00
Q1 [m <sup>3</sup> /h]	0.19	0.31	0.50	0.75	1.25	2.00	3.13	5.00	7.5

Size	50 (2")	65 (2½")	80 (3")	100 (4")	125 (5")	150 (6")	200 (8")	250 (10")	300 (12")
"R" Q <sup>3</sup> /Q1	160	160	160	160	160	160	160	160	160
Q4 [m <sup>3</sup> /h]	50	78.75	125	200	312.5	500	787.5	1250	2000
<b>Q3 [m<sup>3</sup>/h]</b>	<b>40</b>	<b>63</b>	<b>100</b>	<b>160</b>	<b>250</b>	<b>400</b>	<b>630</b>	<b>1000</b>	<b>1600</b>
Q2 [m <sup>3</sup> /h]	0.40	0.63	1.00	1.60	2.50	4.00	6.30	10.00	16.00
Q1 [m <sup>3</sup> /h]	0.25	0.39	0.63	1.00	1.56	2.50	3.94	6.30	10.00

Size	50 (2")	65 (2½")	80 (3")	100 (4")	125 (5")	150 (6")	200 (8")	250 (10")	300 (12")
"R" Q <sup>3</sup> /Q1	200	200	200	200	200	200	200	200	200
Q4 [m <sup>3</sup> /h]	50	78.75	125	200	312.5	500	787.5	1250	2000
<b>Q3 [m<sup>3</sup>/h]</b>	<b>40</b>	<b>63</b>	<b>100</b>	<b>160</b>	<b>250</b>	<b>400</b>	<b>630</b>	<b>1000</b>	<b>1600</b>
Q2 [m <sup>3</sup> /h]	0.32	0.50	0.80	1.28	2.00	3.20	5.00	8.00	12.60
Q1 [m <sup>3</sup> /h]	0.20	0.32	0.50	0.80	1.25	2.00	3.15	5.00	8.00

Technical data

10.9 MAG 8000 CT (7ME6820) (Revenue program) MI-001

Size	50 (2")	65 (2½")	80 (3")	100 (4")	125 (5")	150 (6")	200 (8")	250 (10")	300 (12")
"R" Q <sup>3</sup> /Q1	250	250	250	250	250	250	250	250	250
Q4 [m <sup>3</sup> /h]	50	78.75	125	200	312.5	500	787.5	1250	2000
<b>Q3 [m<sup>3</sup>/h]</b>	<b>40</b>	<b>63</b>	<b>100</b>	<b>160</b>	<b>250</b>	<b>400</b>	<b>630</b>	<b>1000</b>	<b>1600</b>
Q2 [m <sup>3</sup> /h]	0.26	0.40	0.64	1.02	1.60	2.56	4.00	6.40	10.24
Q1 [m <sup>3</sup> /h]	0.16	0.25	0.40	0.64	1.00	1.60	2.52	4.00	6.40

The label is placed on the side of the encapsulation. An example of a product label is shown below:

<b>SIEMENS</b>	
SITRANS F M MAG8000 CT <small>7ME6820-3TC06-1CA2</small>	
System no.: 7ME682 123456N123	Certification no.: DK-0200-MI001-011
DN50: En 1092-1 PN16 PED	Accuracy: Class 2 OIML R49
Meter orientation: Horizontal (H)	Year: 2009
Environmental class: E2,M1 IP68	Q3: 250 m <sup>3</sup> /h
Pressure max.: PN16 Temp.max. 30°C	Q2/Q1: 1.6
Amb. temp.: -25 to + 55°C	Q3/Q1: 250
Software version: 3.03	<b>CE</b> <b>M09</b> <b>0200</b>
Supply: Battery pack	
Siemens Flow Instruments A/S	
Made in Denmark	

**Note**

Battery packs must be installed with the top part in upwards direction to reach maximum capacity.

10.10 The effect of temperature MAG 8000 (7ME6810) and MAG 8000 CT (7ME6820)

## 10.10 The effect of temperature MAG 8000 (7ME6810) and MAG 8000 CT (7ME6820)

Metric (Pressures in bar)					
Sizes 25 mm, 40 mm and > 300 mm					
Flange spec.	Flange rating	Temperature °C			
		0	10	50	70
EN 1092-1	PN 10	10.0	10.0	9.7	9.4
	PN 16	16.0	16.0	15.5	15.1
	PN 40	40.0	40.0	38.7	37.7
ANSI 16.5	150 lb	19.7	19.7	19.3	18.0
Sizes 50 mm to 300 mm					
EN 1092-1	PN 10	10.0	10.0	10.0	8.2
	PN 16	10.0	16.0	16.0	13.2
ANSI 16.5	150 lb	10.0	19.7	19.7	16.2

Imperial (Pressures in Psi)					
Sizes 1", 1½", and > 12"					
Flange spec.	Flange rating	Temperature °F			
		32	50	122	158
EN 1092-1	PN 10	145	145	141	136
	PN 16	232	232	225	219
	PN 40	580	580	561	547
ANSI 16.5	150 lb	286	286	280	261
Sizes 2" ... 12"					
EN 1092-1	PN 10	145	145	145	119
	PN 16	145	232	232	191
ANSI 16.5	150 lb	145	286	286	235

## 10.11 Dimensions and drawings

### Meter dimensions

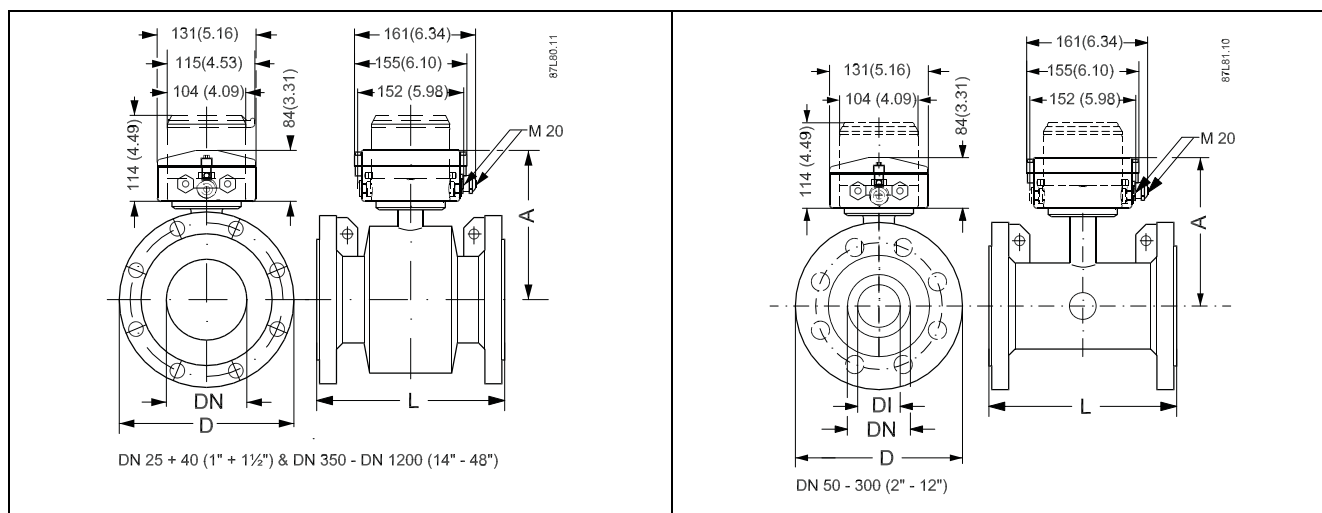

Dimensions for MAG 8000 (7ME6910) and MAG 8000CT (7ME6820).

For MAG 8000 (7ME6880):

Sizes DN 50 ... 300: Add 7 mm (0.28") to length (L) in table below.

Sizes DN 350 ... 600: Add 8 mm(0.31") to length (L) in table below.

Nominal size DN	A	L, lengths							D, diameter		Weight 1)	
		EN 1092-1			ANSI	AS 4087	AWWA	DI	D	AS 4087	PN 16	
		PN 10	PN 16	PN 40	16.5 Cl.150	PN 16						
mm (inch)	mm (inch)	mm	mm	mm	inch	mm	mm	inch	mm (inch)		kg	lbs
25 (1)	194 (7.7)	-	-	200	7.9	200	N/A	N/A	25 (0.98)	<sup>2)</sup>	6	13
40 (1½)	204 (8.1)	-	-	200	7.9	200	N/A	N/A	40 (1.57)	<sup>2)</sup>	9	20
50 (2)	195 (7.7)	-	200	-	7.9	200	N/A	N/A	42 (1.65)	<sup>2)</sup>	11	25
65 (2½)	201 (8)	-	200	-	7.9	200	N/A	N/A	55 (2.17)	<sup>2)</sup>	13	29
80 (3)	207 (8.2)	-	200	-	7.9	200	N/A	N/A	67 (2.64)	<sup>2)</sup>	15	34
100 (4)	214 (8.5)	-	250	-	9.8	250	N/A	N/A	81 (3.19)	<sup>2)</sup>	17	38
125 (5)	224 (8.9)	-	250	-	9.8	250	N/A	N/A	101 (3.98)	<sup>2)</sup>	22	50
150 (6)	239 (9.5)	-	300	-	11.8	300	N/A	N/A	131 (5.16)	<sup>2)</sup>	28	63
200 (8)	264 (10.5)	350	350	-	13.8	350	N/A	N/A	169 (6.65)	<sup>2)</sup>	50	113
250 (10)	291 (11.5)	450	450	-	17.7	450	N/A	N/A	212 (8.35)	<sup>2)</sup>	71	160
300 (12)	317 (12.6)	500	500	-	19.7	500	N/A	N/A	265 (10.43)	<sup>2)</sup>	88	198
350 (14)	369 (14.6)	550	550	-	21.7	550	N/A	N/A	350 (13.78)	<sup>2)</sup>	127	279
400 (16)	394 (15.6)	600	600	-	23.6	600	N/A	N/A	400 (15.75)	<sup>2)</sup>	145	318
450 (18)	425 (16.8)	600	600	-	23.6	600	N/A	N/A	450 (17.72)	<sup>2)</sup>	175	394
500 (20)	450 (17.8)	600	600	-	26.8	600	N/A	N/A	500 (19.68)	<sup>2)</sup>	225	494

Nominal size DN	A	L, lengths							D, diameter		Weight 1)	
		EN 1092-1			ANSI	AS 4087	AWWA	DI	D	AS 4087 PN 16		
		PN 10	PN 16	PN 40	16.5 Cl.150	PN 16				kg	lbs	
mm (inch)	mm (inch)	mm	mm	mm	inch	mm	mm	inch	mm (inch)		kg	lbs
600 (24)	501 (19.8)	600	600	-	32.3	600	N/A	N/A	600 (23.62)	2)	340	747
700 (28)	544 (21.4)	700	875	-	N/A	N/A	700	27.6	700 (27.55)	2)	316	694
750 (30)	571 (22.5)	N/A	N/A	-	N/A	N/A	750	29.5	750 (29.52)	2)	N/A	N/A
800 (32)	606 (23.9)	800	1000	-	N/A	N/A	800	31.5	800 (31.49)	2)	398	1045
900 (36)	653 (25.7)	900	1125	-	N/A	N/A	900	35.4	900 (35.42)	2)	476	1045
1000 (40)	704 (27.7)	1000	1250	-	N/A	N/A	1000	39.4	1000 (39.36)	2)	602	1322
1050 (42)	704 (27.7)	N/A	N/A	-	N/A	N/A	1050	41.3	1050 (41.33)	2)	N/A	N/A
1100 (44)	755 (29.7)	N/A	N/A	-	N/A	N/A	1100	43.3	1100 (43.30)	2)	N/A	N/A
1200 (48)	810 (31.9)	1200	1500	-	N/A	N/A	1200	47.2	1200 (47.23)	2)	887	1996

1) For remote version the sensor weight is reduced with 2 kg (4.5 lb)

2) See flange table (Page 96)

### Remote version

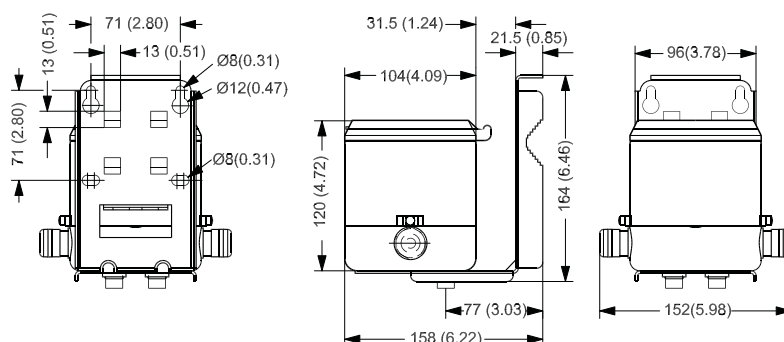
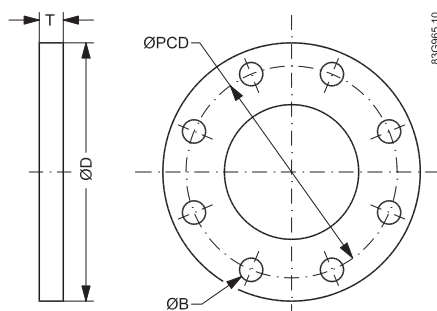

Figure 10-2 Dimensions in mm (inch), weight 3.5 kg (8 lbs)

### Flange dimensions



MAG 8000 (7ME8610) and MAG 8000 (7ME6820)

10.11 Dimensions and drawings

Dimensions mm					Bolting	
Size	D	PCD	T	B	Holes	Bolts
<b>PN 10</b>						
200	340	295	24	22	8	M20
250	395	350	26	22	12	M20
300	445	400	26	22	12	M20
350	505	460	28	22	16	M20
400	565	515	32	26	16	M24
450	615	565	36	26	20	M24
500	670	620	38	26	20	M24
600	780	725	42	30	20	M27
700	895	840	-	30	24	M27
750	-	-	-	-	-	-
800	1015	950	-	33	24	M30
900	1115	1050	-	33	28	M30
1000	1230	1160	-	36	28	M33
1050	-	-	-	-	-	-
1100	-	-	-	-	-	-
1200	1455	1380	-	-39	32	M36
<b>PN 16</b>						
50	165	125	19	18	4	M16
65	185	145	20	18	8	M16
80	200	160	20	18	8	M16
100	220	180	22	18	8	M16
125	250	210	22	18	8	M16
150	285	240	24	22	8	M20
200	340	295	26	22	12	M20
250	405	355	29	26	12	M24
300	460	410	32	26	12	M24
350	520	470	35	26	16	M24
400	580	525	38	30	16	M27
450	640	585	42	30	20	M27
500	715	650	46	33	20	M30
600	840	770	52	36	20	M33
750						
800	1015	950	-	33	24	M30
900	1125	1050	-	39	28	M36
1000	1255	1170	-	42	28	M39
1050	-	-	-	-	-	-
1100	-	-	-	-	-	-
1200	1485	1390	-	48	32	M45



Dimensions mm					Bolting	
Size	D	PCD	T	B	Holes	Bolts
<b>PN 40</b>						
25	115	85	16	14	4	M12
40	150	110	18	18	4	M16

Dimensions Inches					Bolting	
Size	D	PCD	T	B	Holes	Bolts
<b>ANSI Class 150</b>						
1"	4.25	3.12	0.56	0.62	4	9/16"
1 1/2"	5	3.88	0.68	0.62	4	9/16"
2"	6	4.75	0.75	0.75	4	5/8"
2 1/2"	7	5.5	0.88	0.75	4	5/8"
3"	7.5	6	0.94	0.75	4	5/8"
4"	9	7.5	0.94	0.75	8	5/8"
5"	10	8.5	0.94	0.88	8	3/4"
6"	11	9.5	1	0.88	8	3/4"
8"	13.5	11.75	1.12	0.88	8	3/4"
10"	16	14.25	1.19	1.00	12	7/8"
12"	19	17	1.25	1.00	12	7/8"
14"	21	18.75	1.38	1.12	12	1"
16"	23.5	21.25	1.44	1.12	16	1"
18"	25	22.75	1.56	1.25	16	1 1/8"
20"	27.5	25	1.69	1.25	20	1 1/8"
24"	32	29.5	1.88	1.38	20	1 1/4"

**MAG 8000 (7ME6880)**

Dimensions mm					Bolting	
Size	D	PCD	T	B	Holes	Bolts
<b>PN 10 - drilling pattern</b>						
50	165	125	8	18	4	M16
65	185	145	8	18	8	M16
80	200	160	10	18	8	M16
100	220	180	10	18	8	M16
125	250	210	13	18	8	M16
150	285	240	13	22	8	M20
200	340	295	13	22	8	M20
250	395	350	16	22	12	M20
300	445	400	17	22	12	M20
350	505	460	28	22	16	M20
400	565	515	32	26	16	M24
450	615	565	36	26	20	M24

10.11 Dimensions and drawings

Dimensions mm					Bolting	
Size	D	PCD	T	B	Holes	Bolts
500	670	620	38	26	20	M24
600	780	725	42	30	20	M27

Dimensions Inches					Bolting	
Size	D	PCD	T	B	Holes	Bolts
<b>ANSI Class 150 - drilling pattern</b>						
2"	6	4.75	0.32	0.75	4	5/8"
2 ½"	7	5.5	0.32	0.75	4	5/8"
3"	7.5	6	0.40	0.75	4	5/8"
4"	9	7.5	0.40	0.75	8	5/8"
5"	10	8.5	0.52	0.88	8	3/4"
6"	11	9.5	0.52	0.88	8	3/4"
8"	13.5	11.75	0.52	0.88	8	3/4"
10"	16	14.25	0.63	1.00	12	7/8"
12"	19	17	0.76	1.00	12	7/8"
14"	21	18.75	1.38	1.12	12	1"
16"	23.5	21.5	1.44	1.12	16	1"
18"	25	22.75	1.56	1.25	16	1 1/8"
20"	27.5	25	1.69	1.25	20	1 1/8"
24"	32	29.5	1.88	1.38	20	1 1/4"

Dimensions mm					Bolting	
Size	D	PCD	T	B	Holes	Bolts
<b>AS 2129 table D - drilling pattern</b>						
50	150	114	8	18	4	M16
65	165	127	8	18	4	M16
80	185	146	10	18	4	M16
100	215	178	10	18	4	M16
125	255	210	13	18	8	M16
150	280	235	13	18	8	M20
200	335	242	13	18	8	M20
250	405	356	16	22	8	M20
300	455	406	19	22	12	M20
350	525	470	22	26	12	M20
400	580	521	22	26	12	M24
450	640	584	25	26	12	M24
500	705	641	29	26	16	M24
600	825	756	32	30	16	M27

## External battery pack

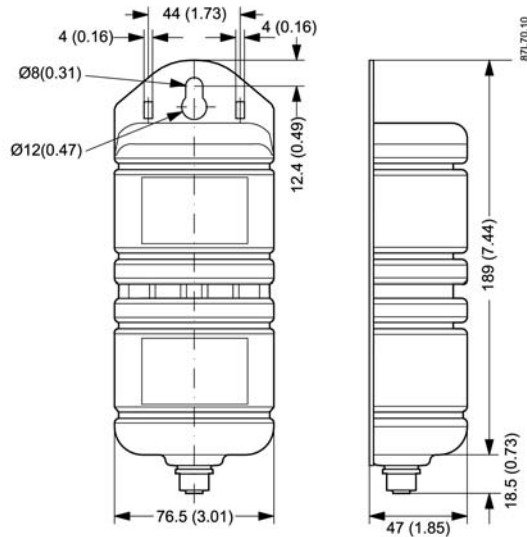

Dimensions in mm (inch), weight 3.5 kg (8 lbs)

### Note

Physical orientation of battery pack may influence battery capacity.

Optimal battery capacity is achieved with battery pack in an upright position as shown.

\* Worn industry batteries may be disposed at the manufacturer or the importer who originally marketed the battery, or where new batteries are bought.

## Grounding rings

Sizes DN 25 ... 300 (7ME6810 and 7ME6820)

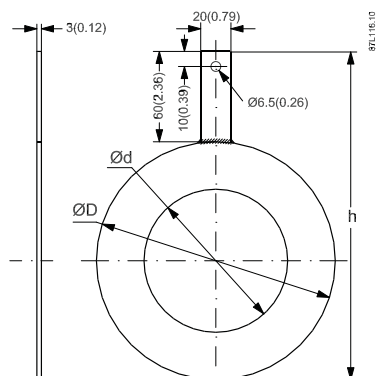

Figure 10-3 Flat ring

Sizes DN 50 ... 300 (7ME6880)

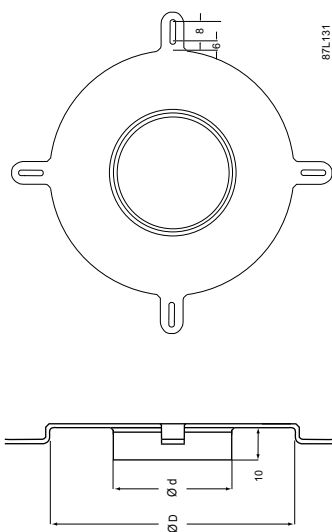

Figure 10-4 Type E grounding ring

Sizes DN 350 ... 600 (7ME6810, 7ME6820 and 7ME6880) and DN 700 ... 1200 (7ME6810)

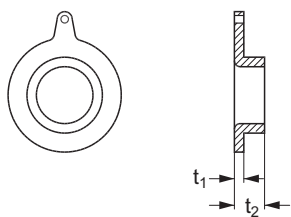

Figure 10-5 Type C grounding ring

## Appendix

### A.1 Unit conversion table

Totalizer / Volume unit (FT8)	Correction factor parameter FT300
Default	1 m <sup>3</sup>
m <sup>3</sup> *100	0.01
Gallon (US)	264.1721
G*100 (100*Gallon)	2.641721
G*1000 (1000*Gallon)	0.2641721
MG (1000000*Gallon)	0.0002641721
AI (Acre Inches)	0.009728558
AF (Acre ft)	0.0008107132
CF*100 (100*ft <sup>3</sup> )	0.3531467
CF*1000 (1000*ft <sup>3</sup> )	0.03531467
l*100 (Liter)	10
kl (1000*Liter)	1
MI (Mega Liter)	0.001

Flow rate unit (FT9)	Correction factor parameter FT301
Default	1 m <sup>3</sup> /s
m <sup>3</sup> /min (m <sup>3</sup> /minute)	60
m <sup>3</sup> /h (m <sup>3</sup> /hour)	3600
m <sup>3</sup> /d (m <sup>3</sup> /day)	86400
GPS (Gallon/second)	264.1721
GPM (Gallon/minute)	15850.32
GPH (Gallon/hour)	951019.4
GPD (Gallon/day)	22824465
MGPD (1000000*Gallon/day)	22.824465
CFS (ft <sup>3</sup> /second)	35.31467
CFM (ft <sup>3</sup> /minute)	2118.882
CFH (ft <sup>3</sup> /hour)	127132.8
l/s (Liter/second)	1000
l/min (Liter/minute)	60000
l/h (Liter/hour)	3600000
MI/d (1000000*Liter/day)	86.4

## A.2 Parameter lists

### Parameter lists

MAG 8000 is delivered with factory settings that are not stored as default values. Because default values are not present in the meter, an automatic return to factory values is not possible.

The default settings are available at [www.siemens.com/flow](http://www.siemens.com/flow) ([www.siemens.com/flow](http://www.siemens.com/flow)). Navigate to Tools & Downloads under MAG 8000.

Visible display information is indicated in the table by menu and index number. Remember to enable displayed menus FT130.

The abbreviations used in the display menu table are: Operator menu = O, Meter menu = M, Service menu = Se, Data Logger menu = L, Statistic menu = St, Revenue menu = R.

### A.2.1 1-99

FT ID number	Meter version	Display view	Parameter/data type	Factory settings	Data range
<b>Fixed parameter or meter data that not are changeable</b>					
1	All	M1	Application identifier	Indetity	Max. 14 characters. Only numbers are visible on the display
2	All	-	Application location	Location	Max. 14 characters
3	All	M3	Module type	MLFB depended	Basic or Advanced
4	All	M4	Software version		x.xxPxx (x.xxPx.x)
5	All	-	Sensor size	Sensor related	DN 25 ... 1200 (1" ... 48")
6	All	-	Vendor name	Siemens	Siemens
8	All		Totalizer unit	MLFB depended	Max. 10 characters
9	All		Flowrate unit	MLFB depended	Max. 10 characters
10	All		Qn (Q3)	Sensor related	0 to 1x10 <sup>9</sup>
11	All		Product code number	7ME6810, 7ME6820 or 7ME6880	
12	All		Serial number	XXXXXXXXXX	

## A.2.2 100-199

FT ID number	Meter version	Display view	Parameter/data type	Factory settings	Data range
<b>Fixed parameter or meter data that not are changeable</b>					
100	All	M2	Actual date and time	PS3 production date and time	year-month-day T hours:minutes:seconds
101	All	O1	Totalizer 1	0	0 ... $\pm 2 \times 10^9$
102	All	O2	Totalizer 2	0	0 ... $\pm 2 \times 10^9$
103	All	O5	Customer totalizer 3	0	0 ... $\pm 2 \times 10^9$
104	All	O5	Reset customer totalizer 3	No	Yes/No
105	All	-	Customer totalizer 3 reset date	PS3 production date and time	year-month-day T hours:minutes:seconds
106	All	-	Flow rate		0 ... 1.25 Qn (Q3)
107	All	-	Actual velocity		0 ... 12500
108	All	-	Flowrate percent value		0 ... 125% (Q4)
120	All	-	Actual flow meter status	0	0 ... 255, binary presented with information 1 for bit 0 1: Totalizer 1 or 2 changed or reset 2: Tariff setting changed or reset, 3: Tariff register changed or reset 4: Date - time changed 5: Alarm have been active 6: Fault log has been reset 7: Hardware key has been activated 8: Meter has been powered up
130	All	-	Menu active	63=all menus active	0 ... 63, binary presented with information 1 for bit 0 1: Operator menu 2: Meter info menu 3: Service menu 4: Log menu 5: Statistic menu 6: Revenue menu
131	All		Default operator menu index	Totalizer 1	Totalizer 1, Totalizer 2, Actual Flow rate, Fault codes, Customer Totalizer

## A.2.3 200-299

FT ID number	Meter version	Display view	Parameter/data type	Factory settings	Data range
<b>Fixed parameter or meter data that not are changeable</b>					
200	All	O4	Fault status	0	0 to 8191, binary presented with information 1 for bit 0 1: Insulation error 2: Coil current error 3: Preamplifier overload 4: Database checksum error 5: Low power warning 6: Flow overload warning 7: Pulse A overload warning 8: Pulse B overload warning 9: Consumption interval warning 10/L: Leakage warning 11/E: Empty pipe warning 12/C: Low impedance (high conductivity) warning 13/d: Flow limit warning
201	All	-	Alarm configuration list	254 = Alarm 2 ... 8 enabled	0 ... 8191, See 200
202	All	-	Date of fault log reset	PS3 production date and time	year-month-day T hours:minutes:seconds
203	All	O4	Non optimal measure time	0	
204	All	-	Reset the fault log and faults	2000-01-01 T 00:00:00	
205	All	-	Call up acknowledge	No	Yes / No
206	All	-	Battery alarm level	10%	0 ... 100%
208	All	-	Reset leakage fault	No	Yes / No
209	All	-	Reset consumption log fault	No	Yes / No
210	All	-	<b>Insulation alarm output enable</b>	No	Yes / No
211	All	-	Insulation fault hours	0	
212	All	-	Insulation fault counter	0	
213	All	-	Insulation fault appears	2000-01-01 T 00:00:00	
214	All	-	Insulation fault disappears	2000-01-01 T 00:00:00	
215	All	-	<b>Coil current alarm output enable</b>	Yes	Yes / No
216	All	-	Coil current fault hours	0	
217	All	-	Coil current fault counter	0	
218	All	-	Coil current fault appears	2000-01-01 T 00:00:00	
219	All	-	Coil current fault disappears	2000-01-01 T 00:00:00	
220	All	-	<b>Amplifier alarm output enable</b>	Yes	Yes / No



FT ID number	Meter version	Display view	Parameter/data type	Factory settings	Data range
				<b>Fixed parameter or meter data that not are changeable</b>	
221	All	-	Amplifier fault hours		
222	All	-	Amplifier fault counter		
223	All	-	Amplifier fault appears	2000-01-01 T 00:00:00	
224	All	-	Amplifier fault disappears	2000-01-01 T 00:00:00	
225	All	-	Database alarm output enable	Yes	Yes / No
226	All	-	Database fault hours	0	
227	All	-	Database fault counter	0	
228	All	-	Database fault appears	2000-01-01 T 00:00:00	
229	All	-	Database fault disappears	2000-01-01 T 00:00:00	
230	All	-	Low power alarm output enable	Yes	Yes / No
231	All	-	Low power fault hours	0	
232	All	-	Low power fault counter	0	
233	All	-	Low power fault appears	2000-01-01 T 00:00:00	
234	All	-	Low power fault disappears	2000-01-01 T 00:00:00	
235	All	-	Flow overflow alarm output enable	Yes	Yes / No
236	All	-	Overflow fault hours	0	
237	All	-	Overflow fault counter	0	
238	All	-	Overflow fault appears	2000-01-01 T 00:00:00	
239	All	-	Overflow fault disappears	2000-01-01 T 00:00:00	
240	All	-	Pulse A overload alarm output enable	Yes	Yes / No
241	All	-	Pulse A overload fault hours	0	
242	All	-	Pulse A overload fault counter	0	
243	All	-	Pulse A overload fault appears	2000-01-01 T 00:00:00	
244	All	-	Pulse A overload fault disappears	2000-01-01 T 00:00:00	
245	All	-	Pulse B overload alarm output enable	Yes	Yes / No
246	All	-	Pulse B overload fault hours	0	
247	All	-	Pulse B overload fault counter	0	
248	All	-	Pulse B overload fault appears	2000-01-01 T 00:00:00	
249	All	-	Pulse B overload fault disappears	2000-01-01 T 00:00:00	
250	All	-	Consumption alarm output enable	No	Yes / No
251	All	-	Consumption fault hours	0	

Appendix

A.2 Parameter lists

FT ID number	Meter version	Display view	Parameter/data type	Factory settings	Data range
				<b>Fixed parameter or meter data that not are changeable</b>	
252	All	-	Consumption fault counter	0	
253	All	-	Consumption fault appears	2000-01-01 T 00:00:00	
254	All	-	Consumption fault disappears	2000-01-01 T 00:00:00	
255	All	-	Leakage alarm output enable	No	Yes / No
256	All	-	Leakage fault hours	0	
257	All	-	Leakage fault counter	0	
258	All	-	Leakage fault appears	2000-01-01 T 00:00:00	
259	All	-	Leakage fault disappears	2000-01-01 T 00:00:00	
260	All	-	Empty pipe alarm output enable	No	Yes / No
261	All	-	Empty pipe fault timer	0	
262	All	-	Empty pipe fault counter	0	
263	All	-	Empty pipe fault appears	2000-01-01 T 00:00:00	
264	All	-	Empty pipe fault disappears	2000-01-01 T 00:00:00	
265	All	-	Low impedance alarm output enable	No	Yes / No
266	All	-	Low impedance fault timer	0	
267	All	-	Low impedance fault counter	0	
268	All	-	Low impedance fault appears	2000-01-01 T 00:00:00	
269	All	-	Low impedance fault disappears	2000-01-01 T 00:00:00	
270	All	-	High flow alarm output enable	No	Yes / No
271	All	-	High flow alarm fault timer	0	
272	All	-	High flow alarm fault counter	0	
273	All	-	High flow alarm fault appears	2000-01-01 T 00:00:00	
274	All	-	High flow alarm fault disappears	2000-01-01 T 00:00:00	

## A.2.4 300-399

FT ID number	Meter version	Display view	Parameter/data type	Factory settings	Data range
<b>Fixed parameter or meter data that not are changeable</b>					
300	All	-	Totalizer volume unit factor	MLFB-dependent	0 ... 1*x0 <sup>10</sup>
301	All	-	Flow unit factor	MLFB-dependent	0 ... 1*x0 <sup>10</sup>
302	All	-	Pipe size	Sensor-related	25 ... 1200
303	All	-	Meter excitation frequency (in battery power mode)	1/15 Hz	1/60 Hz, 1/30 Hz, 1/15 Hz, 1/5 Hz, 1.5625 Hz, 3.125 Hz, 6.25 Hz
304	All	-	Mains frequency	MLFB-dependent	50 or 60 Hz mains
305	All	-	Decimal point	Automatic point adjustment	No point, One digit after point, Two digits after point, Three digits after point, Automatic point adjust
306	All	-	Displayed unit	MLFB-dependent	MLFB-dependent
310	All	-	Flow direction totalizer 1	Forward	forward, reverse or bi-directional net flow
311	All	-	Totalizer 1 changes date	PS3 production date and time	
312	All	-	Flow direction totalizer 2	Reverse	forward, reverse or bi-directional net flow
313	All	-	Totalizer 2 changes date	PS3 production date and time	
320	All	-	Verification mode enable	No	Yes / No
321	All	-	Calibration date	Calibration date	year-month-day T hours:minutes:seconds
323	All	-	Calibration factor	Sensor-related	
324	All	-	Gain correction	Sensor-related	
325	All	-	Sensor offset	Sensor-related	
327	All	-	Adjustment Factor	1	-2 ... 2
328	All	-	Low flow cut off	0.05%	0 ... 9.9%
329	All	-	Filter time constant	5 Tau	1 ... 1000
331	All	-	Excitation frequency limit	6.25 Hz for advanced version and 1/15 Hz for basic version	1/60 Hz, 1/30 Hz, 1/15 Hz, 1/5 Hz, 1.5625 Hz, 3.125 Hz, 6.25 Hz
332	All	-	Excitation frequency sensor limit	Sensor-related	7ME6810 and 7ME6820: 6.25 Hz (DN25 ... 200 (1" ... 8")) 3.125 Hz (DN250 ... 600 (10" ... 24")) 1.5625 Hz (DN700 ... 1200 (28" ... 48")) 7ME6880: 3.125 Hz (DN50 ... 600 (2" ... 24"))
333	All	-	Empty pipe detection enable	Yes	Yes / No
334	All	-	Empty pipe limit	25 000 ohm = 20 µS/cm	0 ... 2.15x10 <sup>9</sup>

## A.2.5 400-499

FT ID number	Meter version	Display view	Parameter/data type	Factory settings	Data range
<b>Fixed parameter or meter data that not are changeable</b>					
400	All	-	Output A enable	Yes	Yes / No
401	All	Se3	Pulse A function	Forward	Forward, Reverse, Forward net, Reverse net
402	All	Se3	Amount per pulse A	Sensor-related	0 ... 1x10 <sup>10</sup>
403	All		Pulse width for pulse A	50 ms	5 ms, 10 ms, 50 ms, 100 ms, 500 ms
404	All		Output B enable	Yes	Yes / No
405	All	Se4	Pulse B function	Alarm	Pulse, Alarm, Call-up
406	All		Pulse B direction	Reverse	Forward, Reverse, Forward net, Reverse net
407	All	Se4	Amount per pulse B	Sensor-related	0 ... 1x10 <sup>10</sup>
408	All		Pulse width for pulse B	Sensor-related	5 ms, 10 ms, 50 ms, 100 ms, 500 ms
420	All	M5	Device Communication Address		1 ... 32
421	All	M6	Baudrate	19 200	1200, 2400, 4800, 9600, 19 200, 38 400
422	All	M7	Parity	Even 1 stop	Even 1 stop, Odd 1 stop, None 1 stop, None 2 stop,
423	All	-	Interframe space	35	35 ... 255
424	All	-	Response delay	5	1 ... 50 ms
425	All	-	Reset communication driver	No	Yes / No

## A.2.6 500-599

FT ID number	Meter version	Display view	Parameter/data type	Factory settings	Data range
<b>Fixed parameter or meter data that not are changeable</b>					
500	All	-	Latest service date	PS3 production date and time	year-month-day T hours:minutes:seconds
501	All	-	Operating hours since power-up	0	hours
502	All	-	Battery operating time	0	hours
505	All	-	Power supply	Power supply level	Battery or mains power
506	All	-	Numbers of power-up	MLFB-dependent	1 to 4 batteries
507	All	-	Battery power		
508	All	-	Battery change enable	No	Yes / No
509	All	Se1	Battery installation date	PS3 production date and time	year-month-day T hours:minutes:seconds
510	All	Se2	Actual battery capacity	100%	100 ... 0%
512	All	-	Excitations no.	0	
513	All	-	Power status	0	Normal operation, 1: Battery alarm. Actual battery capacity is below battery alarm level (% of max capacity) 2: Too low power (enters stand by mode) 3: As value 1 and 2 together 4: External power gone 5: As value 1 and 4 together 6: As value 2 and 4 together 7: As value 1 and 2 and 4 together
514	All	-	Transmitter temperature	Actual degree celsius	
540	All	-	Electrode impedance A	Measured values	0 ... 185 000 ohm
541	All	-	Electrode impedance B	Measured values	0 ... 185 000 ohm
542	All	-	Low medium impedance alarm	0	0 ... 2.15x10 <sup>9</sup>
550	All	-	Coil current disable	No	Yes / No
551	All	-	Fixed flow mode enable	No	Yes / No
552	All	-	Fixed flow value	0	-1x10x10 <sup>9</sup> ... 1x10x10 <sup>9</sup>
553	All	-	Flow alarm limit	1 000 000 000	0 ... 1x10 <sup>9</sup>
560	All	-	Repair checksum	No	Yes / No
570	All	-	Device Product ID	10779	

## A.2.7 600-799

FT ID number	Meter version	Display view	Parameter/data type	Factory settings	Data range
<b>Fixed parameter or meter data that not are changeable</b>					
600	All	-	Log interval	Monthly	Daily, Weekly (7 days), Monthly
601	All	-	Delay weekly log interval	0	0 ... 30
602	All	-	- Limit for too high consumption	1 000 000	-1x10 <sup>9</sup> ... 1x10 <sup>9</sup>
603	All	-	Limit for too low consumption	0	-1x10 <sup>9</sup> ... 1x10 <sup>9</sup>
610	All	L1	Date of latest log period	2000-01-01 T 00:00:00	year-month-day T hours:minutes:seconds
611	All	L1	Latest Log period totalized (1)		
612	All	-	Latest Log period totalized (2)	0	
613	All	-	Latest Log period fault status	0	Active faults in log period; 1: Insulation error 2: Coil current error 3: Preamplifier overload 4: Database checksum error 5: Low power warning 6: Flow overload warning 7: Pulse A overload warning 8: Pulse B overload warning 9: Consumption interval warning 10/L: Leakage warning 11/E: Empty pipe warning 12/C: Low impedance/ high conductivity warning 13/d: High flow limit warning 14/15/16: Not used
614	All	-	Latest Log period status information	0	Meter operation conditions in log periode 1: Totalizer 1 or 2 changed or reset 2: Tariff setting changed or reset 3: Tariff register changed or reset 4: Date - time changed 5: Alarm active in logged period(See alarm fault log for same period) 6: Fault log has been reset 7: HW lock broken 8: Power Up
615	All	L2	Date of log period 2		
616	All	L2	Log period 2 totalized (1)		
617	All	-	Log period 2 totalized (2)		
618	All	-	Log period 2 fault status		See 613

FT ID number	Meter version	Display view	Parameter/data type	Factory settings	Data range
				<b>Fixed parameter or meter data that not are changeable</b>	
619	All	-	Log period 2 status information		See 614
620	All	L3	Date of log period 3		
621	All	L3	Log period 3 totalized (1)		
622	All	-	Log period 3 totalized (2)		
623	All	-	Log period 3 fault status		See 613
624	All	-	Log period 3 status information		See 614
625	All	L4	Date of log period 4		
626	All	L4	Log period 4 totalized (1)		
627	All	-	Log period 4 totalized (2)		
628	All	-	Log period 4 fault status		See 613
629	All	-	Log period 4 status information		See 614
630	All	L5	Date of log period 5		
631	All	L5	Log period 5 totalized (1)		
632	All	-	Log period 5 totalized (2)		
633	All	-	Log period 5 fault status		See 613
634	All	-	Log period 5 status information		See 614
635	All	L6	Date of log period 6		
636	All	L6	Log period 6 totalized (1)		
637	All	-	Log period 6 totalized (2)		
638	All	-	Log period 6 fault status		See 613
639	All	-	Log period 6 status information		See 614
640	All	L7	Date of log period 7		
641	All	L7	Log period 7 totalized (1)		
642	All	-	Log period 7 totalized (2)		
643	All	-	Log period 7 fault status		See 613
644	All	-	Log period 7 status information		See 614
645	All	L8	Date of log period 8		
646	All	L8	Log period 8 totalized (1)		
647	All	-	Log period 8 totalized (2)		
648	All	-	Log period 8 fault status		See 613
649	All	-	Log period 8 status information		See 614
650	All	L9	Date of log period 9		
651	All	L9	Log period 9 totalized (1)		
652	All	-	Log period 9 totalized (2)		
653	All	-	Log period 9 fault status		See 613

Appendix

A.2 Parameter lists

FT ID number	Meter version	Display view	Parameter/data type	Factory settings	Data range
				<b>Fixed parameter or meter data that not are changeable</b>	
654	All	-	Log period 9 status information		See 614
655	All	L10	Date of log period 10		
656	All	L10	Log period 10 totalized (1)		
657	All		Log period 10 totalized (2)		
658	All		Log period 10 fault status		See 613
659	All		Log period 10 status information		See 614
660	All	L11	Date of log period 11		
661	All	L11	Log period 11 totalized (1)		
662	All	-	Log period 11 totalized (2)		
663	All	-	Log period 11 fault status		See 613
664	All	-	Log period 11 status information		See 614
665	All	L12	Date of log period 12		
666	All	L12	Log period 12 totalized (1)		
667	All	L12	Log period 12 totalized (2)		
668	All	-	Log period 12 fault status		See 613
669	All	-	Log period 12 status information		See 614
670	All	L13	Date of log period 13		
671	All	L13	Log period 13 totalized (1)		
672	All	-	- Log period 13 totalized (2)		
673	All	-	Log period 13 fault status		See 613
674	All	-	Log period 13 status information		See 614
675	All	L14	Date of log period 14		
676	All	L14	Log period 14 totalized (1)		
677	All	-	Log period 14 totalized (2)		
678	All	-	Log period 14 fault status		See 613
679	All	-	Log period 14 status information		See 614
680	All	L15	Date of log period 15		
681	All	L15	Log period 15 totalized (1)		
682	All	-	Log period 15 totalized (2)		
683	All	-	Log period 15 fault status		See 613
684	All	-	Log period 15 status information		See 614
685	All	L16	Date of log period 16		
686	All	L16	Log period 16 totalized (1)		
687	All	-	Log period 16 totalized (2)		
688	All	-	Log period 16 fault status		See 613



FT ID number	Meter version	Display view	Parameter/data type	Factory settings	Data range
				<b>Fixed parameter or meter data that not are changeable</b>	
689	All	-	Log period 16 status information		See 614
690	All	L17	Date of log period 17		
691	All	L17	Log period 17 totalized (1)		
692	All	-	Log period 17 totalized (2)		
693	All	-	Log period 17 fault status		See 613
694	All	-	Log period 17 status information		See 614
695	All	L18	Date of log period 18		
696	All	L18	Log period 18 totalized (1)		
697	All	-	Log period 18 totalized (2)		
698	All	-	Log period 18 fault status		See 613
699	All	-	Log period 18 status information		See 614
700	All	L19	Date of log period 19		
701	All	L19	Log period 19 totalized (1)		
702	All	-	Log period 19 totalized (2)		
703	All	-	Log period 19 fault status		See 613
704	All	-	Log period 19 status information		See 614
705	All	L20	Date of log period 20		
706	All	L20	Log period 20 totalized (1)		
707	All	-	Log period 20 totalized (2)		
708	All	-	Log period 20 fault status		See 613
709	All	-	Log period 20 status information		See 614
710	All	L21	Date of log period 21		
711	All	L21	Log period 21 totalized (1)		
712	All	-	Log period 21 totalized (2)		
713	All	-	Log period 21 fault status		See 613
714	All	-	Log period 21 status information		See 614
715	All	L22	Date of log period 22		
716	All	L22	Log period 22 totalized (1)		
717	All	-	Log period 22 totalized (2)		
718	All	-	Log period 22 fault status		See 613
719	All	-	Log period 22 status information		See 614
720	All	L23	Date of log period 23		
721	All	L23	Log period 23 totalized (1)		
722	All	-	Log period 23 totalized (2)		
723	All	-	Log period 23 fault status		See 613

Appendix

A.2 Parameter lists

FT ID number	Meter version	Display view	Parameter/data type	Factory settings	Data range
				<b>Fixed parameter or meter data that not are changeable</b>	
724	All	-	Log period 23 status information		See 614
725	All	L24	Date of log period 24		
726	All	L24	Log period 24 totalized (1)		
727	All	-	Log period 24 totalized (2)		
728	All	-	Log period 24 fault status		See 613
729	All	-	Log period 24 status information		See 614
730	All	L25	Date of log period 25		
731	All	L25	Log period 25 totalized (1)		
732	All	-	Log period 25 totalized (2)		
733	All	-	Log period 25 fault status		See 613
734	All	-	Log period 25 status information		See 614
735	All	L26	Date of log period 26		
736	All	L26	Log period 26 totalized (1)		
737	All	-	Log period 26 totalized (2)		
738	All	-	Log period 26 fault status		See 613
739	All	-	Log period 26 status information		See 614

## A.2.8 800-899

FT ID number	Meter version	Display view	Parameter/data type	Factory settings	Data range
<b>Fixed parameter or meter data that not are changeable</b>					
800	Advanced	-	Insulation test enable	No	Yes / No
801	Advanced	-	Insulation test interval	30	0 ... 65535
802	Advanced	-	Insulation value		
803	Advanced	-	Insulation test date	2000-01-01 T00:00	year-month- day T hours:minutes:seconds
804	Advanced	-	Insulation tests fulfilled	0	
810	Advanced	-	Leakage detection mode	Off	Off / fix value / fix + lowest value
811	Advanced	-	Leakage source	Flow rate	Flow rate / volume
812	Advanced	-	Start period for leakage	120 min = 2:00 [24:00]	0 ... 1430 detection minutes (0 ... 23:50)
813	Advanced	-	Duration leakage detection	12 (120 min = 2 hours)	1 to 144 (10 ... 1440 minutes)
814	Advanced	-	Leakage value unit	Flow / volume unit	
815	Advanced	-	Leakage limit	1	0 ... 1x10 <sup>9</sup>
816	Advanced	-	- Leakage excitation frequency	1.5625 Hz	1/60Hz, 1/30Hz, 1/15Hz, 1/5Hz, 1.5625Hz, 3.125Hz, 6.25Hz,
817	Advanced	-	Leakage status		Leakage status: 1: Finished successfully 2: Leakage detection running 3: Leakage detection failed (SystemStatus have fatal error) 4: Leakage detection failed (Empty-pipe detection disabled) 5: Leakage detection failed (Coil current off) 6: Leakage detection failed (Insulation test was active during detection) 7: Leakage detection stopped because leakage parameter was changed.
818	Advanced	-	Periods with possible leakage		
819	Advanced	-	Leakage periods before alarm	3	0 ... 255
820	Advanced	-	Reset leakage period information	No	Yes / No
821	Advanced	St1	Latest leakage period flowrate	0	
822	Advanced	St1	Latest leakage period volume	0	

Appendix

A.2 Parameter lists

FT ID number	Meter version	Display view	Parameter/data type	Factory settings	Data range
				<b>Fixed parameter or meter data that not are changeable</b>	
823	Advanced	-	Lowest measured leakage value	1 000 000 000	
824	Advanced	-	Date of lowest leakage value	2000-01-01 T00:00	year-month-day T hours:minutes:seconds
825	Advanced	-	Highest measured leakage value	0	
826	Advanced	-	Date of highest leakage value	2000-01-01 T00:00	year-month-day T hours:minutes:seconds
830	Advanced	R8	Next settling date	PS3 production date and time	year-month-day T hours:minutes:seconds
831	Advanced	R9	Latest settling date	PS3 production date and time	year-month-day T hours:minutes:seconds
832	Advanced	R9	Latest totalizer 1 value	0	
833	Advanced	R10	Previous settling date	PS3 production date and time	year-month-day T hours:minutes:seconds
834	Advanced	R10	Previous totalizer 1 value	0	
840	Advanced		Tariff control mode	Off	Off / time / flow / combination
841	Advanced	R7	Date of tariff reset	PS3 production date and time	year-month-day T hours:minutes:seconds
842	Advanced	-	Reset tariff values	No	Yes / No
843	Advanced	R1	Tariff1 volume 1	0	
844	Advanced	R1	Tariff1 period time end	360 min = 6:00 [24:00]	0 ... 1439 minutes (23:59)
845	Advanced	R1	Tariff1 upper limit range	15%	0 ... 100% Qn (Q3)
846	Advanced	R2	Tariff2 volume 2	0	
847	Advanced	R2	Tariff2 period time end	540 min = 9:00 [24:00]	0 ... 1439 minutes (23:59)
848	Advanced	R2	Tariff2 upper limit range	30%	0 ... 100% Qn (Q3)
849	Advanced	R3	Tariff3 volume 3	0	
850	Advanced	R3	Tariff3 period time end	720 min = 12:00 [24:00]	0 ... 1439 minutes (23:59)
851	Advanced	R3	Tariff3 upper limit range	45%	0 ... 100% Qn (Q3)
852	Advanced	R4	Tariff4 volume 4	0	
853	Advanced	R4	Tariff4 period time end	1080min=18:00 [24:00]	0 to 1439 minutes (23:59)
854	Advanced	R4	Tariff4 upper limit range	60%	0 to 100% Qn (Q3)
855	Advanced	R5	Tariff5 volume 5	0	
856	Advanced	R5	Tariff5 period time end	1260 min = 21:00 [24:00]	0 ... 1439 minutes (23:59)
857	Advanced	R5	Tariff5 upper limit range	80%	0 ... 100% Qn (Q3)
858	Advanced	R6	Tariff6 volume 6	0	
860	Advanced	-	Reset date of statistic inf.	PS3 production date and time	year- month-day T hours:minutes:seconds
861	Advanced	-	Reset statistic information	No	Yes / No
862	Advanced	St2	Lowest flowrate	0	
863	Advanced	St2	Date of lowest flowrate	PS3 production date and time	year-month-day T hours:minutes:seconds
864	Advanced	St3	Highest flowrate	0	

FT ID number	Meter version	Display view	Parameter/data type	Factory settings	Data range
				<b>Fixed parameter or meter data that not are changeable</b>	
865	Advanced	St3	Date of highest flowrate	PS3 production date and time	year-month-day T hours:minutes:seconds
866	Advanced	St5	Lowest day consumption	0	
867	Advanced	-	Date of lowest day consumption	PS3 production date and time	year-month-day T hours:minutes:seconds
868	Advanced	St6	Highest day consumption	0	
869	Advanced	-	Date of highest day consumption	PS3 production date and time	year-month-day T hours:minutes:seconds
870	Advanced	St4	Day 1 (yesterday) of last week consumption	0	
871	Advanced	-	Day 2 of last week consumption	0	
872	Advanced	-	Day 3 of last week consumption	0	
873	Advanced	-	Day 4 of last week consumption	0	
874	Advanced	-	Day 5 of last week consumption	0	
875	Advanced	-	Day 6 of last week consumption	0	
876	Advanced	-	Day 7 (7 days ago) of last week consumption	0	
877	Advanced	St7	Latest week consumption	0	
878	Advanced	St8	Actual month consumption	0	
879	Advanced	St9	Latest month consumption	0	
880	Advanced	-	Reset date of consumption profile	PS3 production date and time	year-month-day T hours:minutes:seconds
881	Advanced	-	Reset consumption profile	No	Yes / No
882	Advanced	-	Total time in CP range 1	0	
883	Advanced	-	Upper limit in CP range 1	15%	0 ... 100% Qn (Q3)
884	Advanced	-	Total time in CP range 2	0	
885	Advanced	-	Upper limit in CP range 2	30%	0 ... 100% Qn (Q3)
886	Advanced	-	Total time in CP range 3	0	
887	Advanced	-	Upper limit in CP range 3	45%	0 ... 100% Qn (Q3)
888	Advanced	-	Total time in CP range 4	0	
889	Advanced	-	Upper limit in CP range 4	60%	0 ... 100% Qn (Q3)
890	Advanced	-	Total time in CP range 5	0	
891	Advanced	-	Upper limit in CP range 5	80%	0 ... 100% Qn (Q3)
892	Advanced	-	Total time in CP range 6	0	

## A.3 Sizing sensor

### A.3.1 Sizing table DN 25 ... 1200 (1" ... 48")

The following table shows the relationship between flow velocity (V), flow quantity (Q) and sensor dimension (DN).

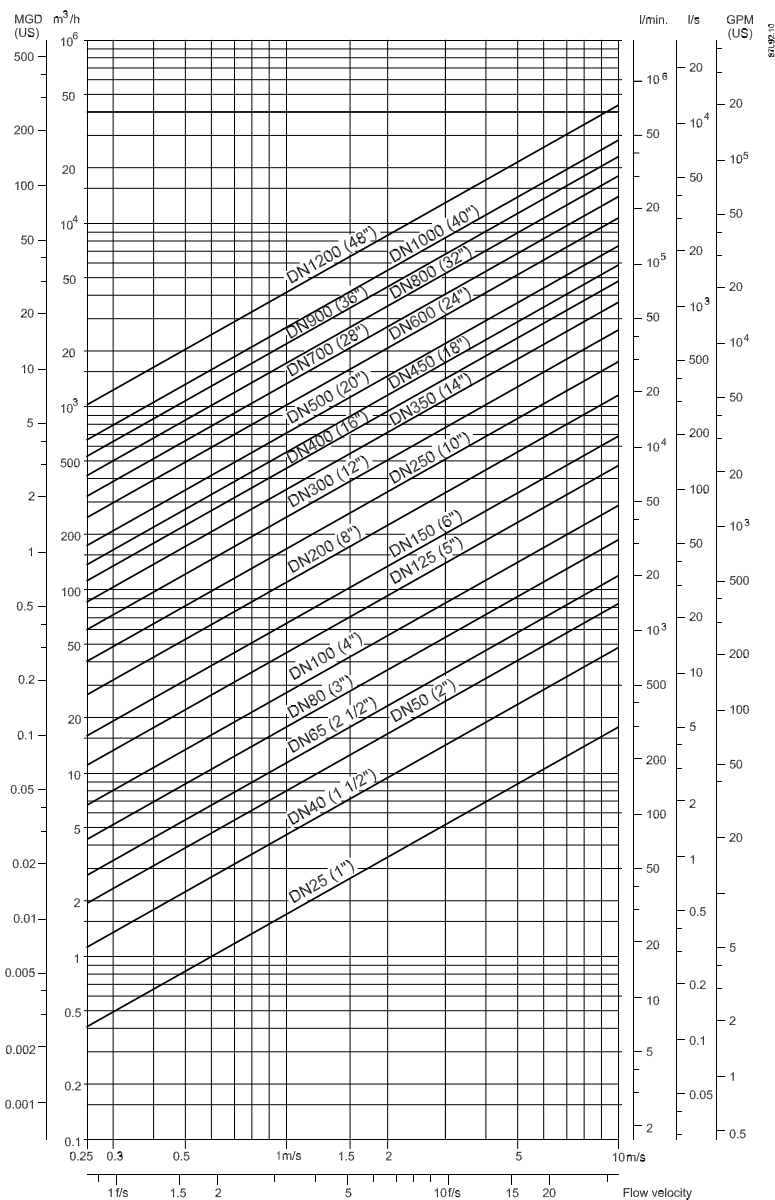

Figure A-1 Sizing table

### Guidelines for selection of sensor

Normally the sensor is selected so that V lies within the measuring range 1 ... 2 m/s (3 ... 7 ft/sec.).

- Min. measuring range: 0 ... 0.25 m/s (0 ... 0.8 ft/sec.)
- Max. measuring range: 0 ... 10 m/s (0 ... 33 ft/sec.)

### Flow velocity calculation formula

- Metric measures:

$$V = 1273.24 \times Q / D_i^2 \quad (V: [\text{m/s}]; Q: [\text{l/s}]; D_i: [\text{mm}])$$

or

$$V = 353.68 \times Q / D_i^2 \quad (V: [\text{m/s}]; Q: [\text{m}^3/\text{h}]; D_i: [\text{mm}])$$

- Imperial measures:

$$V = Q \times 0.408 / (\text{Pipe I.D.})^2 \quad (V: [\text{ft/s}]; Q: [\text{GPM}]; \text{Pipe I.D.}: [\text{inch}])$$

or

$$V = Q \times 283.67 / (\text{Pipe I.D.})^2 \quad (V: [\text{ft/s}]; Q: [\text{MGD}]; \text{Pipe I.D.}: [\text{inch}])$$

## A.4 Certificates

### A.4.1 Certificates

All certificates are posted on the Internet. Additionally, the CE Declaration of Conformity as well as EX approvals are available on the Sitrans F literature CD-ROM Certificates (<http://support.automation.siemens.com/WW/view/en/10806951/134200>)











## A.5 Spare parts/Accessories



### A.5.1 Ordering

In order to ensure that the ordering data you are using is not outdated, the latest ordering data is always available on the Internet: Catalog process instrumentation (<http://www.siemens.com/processinstrumentation/catalogs>)



#### Accessories

Description	
Flow tool CD	
IrDa infrared interface with adapter	
Back-up battery for mains power supply	
Internal battery pack	

Description	
External battery pack	 <p>A black, rectangular external battery pack with a carrying handle on top. The front face has a white label with the Siemens logo and technical specifications. The bottom of the pack has several electrical terminals.</p>
Mains power supply	 <p>A small, grey, rectangular power supply unit with a power cord on one side and two output wires on the other.</p>
Communication module (RS232 or RS485)	 <p>A printed circuit board (PCB) with various electronic components, including a microcontroller, resistors, and connectors.</p>
One cable entry	 <p>A black, cylindrical cable entry fitting with a hexagonal top and a threaded bottom section.</p>
One cable entry with reduction	 <p>Two metal fittings: a larger hexagonal nut-like fitting and a smaller, more complex fitting with a threaded end and a cable entry point.</p>

Description	
Potting kit	
Hardware key	

## Spare parts

Description	
MAG 8000 compact replacement kit (basic and advanced versions)	 A cylindrical, silver and black device with a black lid that is open, revealing a digital display and a small button on the top surface.
Se MAG 8000 remote replacement kit (basic and advanced versions).	 A cylindrical, silver and black device similar to the compact kit, but with a black mounting bracket attached to its side.
PCB replacement kit (basic and advanced versions)	 A printed circuit board (PCB) with various electronic components, including a digital display and a button, mounted on a metal frame.

Description	
Enclosure top including lid, screws and blank product label	
Cable for external battery pack	
Encoder interface cable	
Service tool kit package with various components for service and replacement	
Remote cable set	

## A.6 Features

Features/Version	MAG 8000 and MAG 8000 CT basic	MAG 8000 and MAG 8000 CT advanced
Measuring frequency(battery power)	Max. 1/15 Hz	Max. 6.25 Hz For MAG 8000 (7ME6880): Max. 3.125 Hz
Totalizer	3	3
Pulse output	2, max. 50 Hz	2, max. 100 Hz
Communication	Add-on	Add-on
IrDA	Yes	Yes
Time and date	Yes	Yes
Data protection	Yes	Yes
Data logger	Yes	Yes
Application identifier	Yes	Yes
Alarm handling	Yes	Yes
Meter status	Yes	Yes
Diagnostics	Yes	Yes
Battery power management	Yes	Yes
Insulation test	-	Yes
Leakage detection	-	Yes
Meter utilization	-	Yes
Statistics	-	Yes
Tariff	-	Yes
Settle date (Revenue)	-	Yes

### Features

#### Application Identification (FT1 & FT2)

Tag number (visible on display if numbers are selected) and meter location, up to 15 characters per information.

#### Time and date (FT100)

Real time clock and date (max. 15 min. drift per year)

#### Totalizer (FT101 & FT102 & FT103)

- 2 totalizer: Forward, reverse, bidirectional netflow calculation and freely selectable start value.
- 1 customer totalizer, following totalizer 1 settings and resettable via display key or software with logging of date and time.

#### Measurement (FT300...FT334)

- Freely selectable volume and flow unit, where m<sup>3</sup> and m<sup>3</sup>/h is default in display. All other units are displayed with a display label.
- Excitation frequency in battery operation (manually selected):
  - Basic, max. selectable excitation frequency of 1/15 Hz
  - Advanced, max. selectable excitation frequency of 6.25 Hz and sensor related
  - MAG 8000 (7ME6810) and MAG 8000 CT (7ME6820) default excitation frequency is selected for typically 6 years' operation in a revenue application:
    - 1/15 Hz for DN 25 ... 150 (1" ... 6")
    - 1/30 Hz for DN 200 ... 600 (8" ... 24")
    - 1/60 Hz for DN 700 ... 1200 (28" ... 48")
- Excitation frequency with mains power follows maximum sensor excitation frequency
- Filter constant as numbers of excitations
- Low flow cut off, % of Q<sub>n</sub> (Q<sub>3</sub>)
- Empty pipe detection (active symbol on display when active)
- Filter selection for mains power frequency (50/60 Hz)
- Correction factor for change of flow direction or to adjust flow measurement

#### Data logger (FT600...FT739)

- Logging of 26 records: selectable as daily, weekly or monthly logging
- Each logging includes:
  - Consumption on totalizer 1
  - Consumption on totalizer 2
  - Alarm in current period (13 alarms)
  - Meter status (8 values)
  - Alarm on high or low consumption for selected logging period
  - Totalizer 1 values for all 26 periods can be read on the display

#### Alarm (FT200 ... FT274)

- Active alarm is indicated on the display
- Monitoring of all alarms with statistic recording on each alarm
  - Total hours an alarm has been active
  - Numbers of time the alarm has been activated
  - First time an alarm appears
  - Last time the alarm disappears

- Fatal faults interrupt the measurement, if active
  - Signal insulation – Flow signal immunity is influenced (Advanced version only)
  - Coil current – Fault in driving magnetic sensor field
  - Amplifier – Fault in signal circuit
  - Check sum – Fault in calculation or handling of data
- Warning faults
  - Low Power – Customer-selectable battery alarm level or power drop-out
  - Flow overflow – Flow in sensor exceeds  $Q_{max}$  (125%  $Q_n$  (Q3, Q4))
  - Pulse overflow on output A and B – Selected pulse volume is too small compared to actual flow rate and max. output pulse rate
  - Consumption – Saved data logger consumption exceeds customer selected limit on high or low consumption
  - Leakage – Leakage detected based on customer settings (Advanced version only)
  - Empty pipe – No water in the pipe/sensor
  - Low impedance – Measured electrode impedance below customer low impedance level
  - Flow limit – Actual flow exceeds selected high flow limited

#### **Meter status (FT120)**

Monitoring of important revenue parameters and data

- Changing totalizers 1 and 2
- Changing tariff totalizer
- Changing tariff settings
- Changing date and time
- Alarm has been active (see alarm log for details)
- Fault log has been reset
- Hardware key has been broken
- Meter has been repowered

#### **Data protection**

- All data stored in an EEPROM. Totalizers 1 and 2 are backed up every 10 min., statistic every hour and power consumption and temperature measurement every 4 hours.
- Password protection of all parameters and hardware protection of calibration and revenue parameters.

#### **Battery power management**

- Optimal battery information on remaining capacity.
- Calculated capacity includes all consuming elements and available battery capacity is adjusted related to change in ambient temperature.



### Diagnostic

- Continuous self test including
  - Coil current to drive the magnetic field
  - Signal input circuit
  - Data calculation, handling and storing
- Features
  - Alarm statistics and logging for fault analyzing
  - Electrode impedance to check actual media contact
  - Flow simulation to check pulse and communication signal chain for correct scaling
  - Number of sensor measurements (excitations)
  - Transmitter temperature (battery capacity calculation)
  - Low impedance alarm for change in media
  - Flow alarm when defined high flow exceeds
  - Verification mode for fast measure performance check
- Advanced version includes
  - Insulation "Cross-Talk" test
  - Meter utilization
  - Consumption profile
  - Statistical flow and consumption data

### Insulation test (Advanced version only)

Test of signal immunity against disturbances and poor installations. Test interval is selectable and measurement is interrupted during the test period of 4 min.

### Leakage detection (Advanced version only)

Monitoring the lowest flow or volume during selected time window within 24 hours. Leakage is detected over a selectable period during which monitored values exceed the possible leakage level. Min. and max. values are stored with date registration. Last store value visible on the display.

### Meter Utilization (Advanced version only)

6 registers for monitoring total time the meter has operated in different flow intervals. Registered intervals are freely selectable as % of Qn (Q3).

### Tariff (Advanced version only)

6 tariff registers count the volume delivered within the selected tariff windows, based on time of day, flow rates, or a combination.

Tariff can also be used for consumption profile where consumption is related to different time intervals or flow rates.

Tariff values visible on the display.

**Settling date** (Advanced version only)

On a predefined date, the totalizer 1 index value is stored. Old values are stored to show the latest two totalized 1 index values. Settling values are visible on the display.

**Statistic** (Advanced version only)

- Min. flow rate with time and date registration
- Max. flow rate with time and date registration
- Min. daily consumption with date registration
- Max. daily consumption with date registration
- Latest 7 days' total and daily consumption
- Actual month's consumption
- Latest month's consumption

# Index

## A

Add-on modules  
Electrical connection:Add-on modules, 36

## C

Commissioning  
With Flow Tool, 37  
With PDM, 37  
Compliance, 9  
Contact person, 8  
Customer Support Hotline, 71

## D

Decontamination, 72  
Device identification, 8  
Device inspection, 7

## E

EDD files  
Download, 39  
Installation, 39  
Electrical connection, 36  
Safety instructions, 30

## F

Flow Tool  
Commissioning, 37

## H

History, 8  
Hotline, 71

## I

Installation  
Compact, 15  
Indoor/outdoor, 15  
Remote, 15

## Internet

Contact person, 8, 71  
Flowdocumentation, 8  
Support, 71  
Introduction, 7  
Items supplied, 7

## L

Laws and directives, 9  
Lithium batteries  
Safety, 10

## M

Mains supply, 30  
Maintenance, 65  
Material compatibility, 9

## P

Parameter lists, 104  
PDM  
Commissioning, 37  
Pressure specifications, 15

## R

Repair, 71  
Return procedures, 72

## S

Safety  
Instrument safety standards, 9  
Safety instructions  
Electrical connection, 30  
Safety notes, 9  
Service, 71  
Sizing table, 120  
Support, 71  
System components, 11

**T**

Temperature specifications, 15

Type plate, 8

## For more information

[www.siemens.com/flow](http://www.siemens.com/flow)

Siemens Flow Instruments A/S  
Nordborgvej 81  
DK-6430 Nordborg

Subject to change without prior notice  
Order No.: A5E03071515-01  
Copyright Siemens AG 06.2010  
All rights reserved



[www.siemens.com/processautomation](http://www.siemens.com/processautomation)