

TELEPERM M

Field Multiplexer FM 100

Manual

Order No. C79000-G8076-C012-05

Contents		
Certificate of Conformity	EX-84/2160 X EX-84/2158 X	
Field Multiplexer	C79000-B8076-C090-04	1
Interface Module 6DS1304-8AA	C79000-B8076-C091-03	2
Safety Isolator 6DS3902-8AA	C79000-B8076-C108-03	
Binary Module for Non-floating Contacts 6DS1610-8AA	C79000-B8076-C092-02	3
Binary Input Module with 8 Channels for Non-Contact Transmitters 6DS1611-8AA	C79000-B8076-C093-02	
Analog Input Module for Resistance-type Thermo- meters and Thermocouples 6DS1706-8AA	C79000-B8076-C094-03	4
Analog Input Module for Current and Voltage Sensors 6DS1708-8AA	C79000-B8076-C095-03	
Limit Value Monitor Module 6DS1710-8AA	C79000-B8076-C096-02	5
Binary Output Module 6DS1612-8AA	C79000-B8076-C098-03	6
Analog Output Module 6DS1712-8BA	C79000-B8076-C099-03	7
Scanning Repetition Module 6DS1912-8AA	C79000-B8076-C102-02	8
Interlock Module 6DS1506-8AA	C79000-B8076-C103-01	
Analog Input Module for Pneumatic Standardized Signals 6DS1707-8AA	C79000-B8076-C097-03	9
Parts List	C79000-E8076-C090-03	10

Physikalisch-Technische Bundesanstalt



CERTIFICATE OF CONFORMITY

PTB Nr. Ex-

This certificate is issued for the electrical apparatus

Safety Isolator Type 6 DS 3902-8 AA

manufactured and submitted for certification by

SIEMENS AG, Unternehmensbereich Energie- und Automatisierungstechnik
7500 Karlsruhe 21

This electrical apparatus and any acceptable variation thereto is specified in the Annex to this Certificate.

The Physikalisch-Technische Bundesanstalt (PTB), approved certification body in accordance with Article 14 of the Council Directive of the European Communities of 18 December 1975 (76/117/EEC), confirms that the apparatus has been found to comply with the harmonized European Standards

Electrical apparatus for potentially explosive atmospheres

EN 50 014-1977 / VDE 0171 Part 1/5.78 General Requirements

EN 50 020-1977 / VDE 0171 Part 7/5.78 Intrinsic safety "i"

after having successfully met the examination and test requirements which are recorded in a confidential Test Report.

The apparatus marking shall include the following code

[EEx ib] IIC

The manufacturer has the responsibility to ensure that the apparatus bearing the marking conforms to the specification laid down in the Annex to this Certificate and has satisfied the prescribed routine verifications and tests.

This apparatus may be marked with the Distinctive Community Mark shown above and specified in Annex II to the Council Directive of 6 February 1979 (79/196/EEC).

For and on behalf of PTB

Braunschweig,

(Signature)

Test certificates without signature and official stamp are not valid.

No alteration may be made to copies of this test certificate.

Extracts or changes may be made only with the permission of the Physikalisch-Technische Bundesanstalt, Bundesallee 100, Postfach 3345, D-3300 Braunschweig.

Physikalisch-Technische Bundesanstalt



KONFORMITÄTSBESCHEINIGUNG

PTB Nr. Ex- 84/2160 X

Diese Bescheinigung gilt für das elektrische Betriebsmittel

Sicherheitstrenner Typ 6 DS 3902-8 AA

der Firma SIEMENS AG, Unternehmensbereich Energie-
und Automatisierungstechnik
D-7500 Karlsruhe 21

Die Bauart dieses elektrischen Betriebsmittels sowie die verschiedenen zulässigen Ausführungen sind in der Anlage zu dieser Konformitätsbescheinigung festgelegt.

Die Physikalisch-Technische Bundesanstalt bescheinigt als Prüfstelle nach Artikel 14 der Richtlinie des Rates der Europäischen Gemeinschaften vom 18. Dezember 1975 (76/117/EWG) die Übereinstimmung dieses elektrischer Betriebsmittels mit den harmonisierten Europäischen Normen

Elektrische Betriebsmittel für explosionsgefährdete Bereiche

EN 50 014-1977 / VDE 0171 Teil 1/5.78 Allgemeine Bestimmungen
EN 50 020-1977 / VDE 0171 Teil 7/5.78 Eigensicherheit "i"

nachdem das Betriebsmittel mit Erfolg einer Bauartprüfung unterzogen wurde. Die Ergebnisse dieser Bauartprüfung sind in einem vertraulichen Prüfprotokoll festgelegt.

Das Betriebsmittel ist mit dem folgenden Kennzeichen zu versehen:

[EEEx ib] IIC

Der Hersteller ist dafür verantwortlich, daß jedes derart gekennzeichnete Betriebsmittel in seiner Bauart mit den in der Anlage zu dieser Bescheinigung aufgeführten Prüfungsunterlagen übereinstimmt und daß die vorgeschriebenen Stückprüfungen erfolgreich bestanden wurden.

Das elektrische Betriebsmittel darf mit dem hier abgedruckten gemeinschaftlichen Unterscheidungszeichen gemäß Anhang II der Richtlinie des Rates vom 6. Februar 1979 (79/196/EWG) gekennzeichnet werden.

Im Auftrag

(Dr.-Ing. Johannsmeyer)



Braunschweig, 11.2.1985

Prüfbescheinigungen ohne Unterschrift und ohne Dienststempel haben keine Gültigkeit.

Die Bescheinigungen dürfen nur unverändert weiterverbreitet werden.

Auszüge oder Änderungen bedürfen der Genehmigung der Physikalisch-Technischen Bundesanstalt, Bundesallee 100, Postfach 33 45, D-3300 Braunschweig.

Physikalisch-Technische Bundesanstalt

A N L A G E

zur Konformitätsbescheinigung PTB Nr. Ex-84/2160 X

Der Sicherheitstrenner dient zum Anschluß von bis zu vier Fernleitungen eines Feldmultiplexers und zur Trennung dieser eigensicheren Stromkreise von den nichteigensicheren Stromkreisen des Automatisierungssystems.

Elektrische Daten

Fernleitungsstromkreise..... in Zündschutzart Eigensicherheit EEx ib IIC (Klemmen S+ und S- bzw. E+ und E-) zum Anschluß an die eigensicheren Fernleitungsanschlüsse des Feldmultiplexers Typ FM 100 (PTB Nr. Ex-84/2158 X).

Die Sende- und Empfangsstromkreise sind untereinander galvanisch getrennt.

Die wirksame innere Induktivität und Kapazität sind vernachlässigbar klein.

Stromkreise zum Automatisierungssystem..... Nennwerte: 24 V, 200 mA (Stecker X5 und Klemmen M und L+) (Anschluß an Geräte mit Betriebsspannungen unter 250 V).

Die Fernleitungsstromkreise sind von den Stromkreisen des Automatisierungssystems für einen Scheitelwert der Nennspannung von 375 V sicher galvanisch getrennt.

Physikalisch-Technische Bundesanstalt

Anlage zur Konformitätsbescheinigung PTB Nr. Ex-84/2160 X

Besondere Bedingungen

1. Der Sicherheitstrenner einschließlich seiner Anschlußteile muß so errichtet werden, daß mindestens die Schutzart IP 20 gemäß IEC-Publikation 144 erreicht wird.
2. Der Sicherheitstrenner ist außerhalb des explosionsgefährdeten Bereiches zu errichten.
3. Über die Befestigungsbolzen des Sicherheitstrenners ist die Erdverbindung zu den geerdeten Leiterbahnen auf der Grundplatte herzustellen.

Im Auftrag

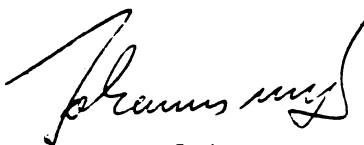

(Dr.-Ing. Johannsmeyer)



Braunschweig, 11.2.1985

Physikalisch-Technische Bundesanstalt



KONFORMITÄTSBESCHEINIGUNG

PTB Nr. Ex- 84/2158 X

Diese Bescheinigung gilt für das elektrische Betriebsmittel

Feldmultiplexer Typ FM 100

der Firma SIEMENS AG, Unternehmensbereich Energie-
und Automatisierungstechnik
D-7500 Karlsruhe 21

Die Bauart dieses elektrischen Betriebsmittels sowie die verschiedenen zulässigen Ausführungen sind in der Anlage zu dieser Konformitätsbescheinigung festgelegt.

Die Physikalisch-Technische Bundesanstalt bescheinigt als Prüfstelle nach Artikel 14 der Richtlinie des Rates der Europäischen Gemeinschaften vom 18. Dezember 1975 (76/117/EWG) die Übereinstimmung dieses elektrischen Betriebsmittels mit den harmonisierten Europäischen Normen

Elektrische Betriebsmittel für explosionsgefährdete Bereiche

EN 50 014-1977 / VDE 0171 Teil 1/5.78	Allgemeine Bestimmungen
EN 50 017-1977 / VDE 0171 Teil 4/5.78	Sandkapselung "q"
EN 50 018-1977 / VDE 0171 Teil 5/5.78	Druckfeste Kapselung "d"
EN 50 019-1977 / VDE 0171 Teil 6/5.78	Erhöhte Sicherheit "e"
EN 50 020-1977 / VDE 0171 Teil 7/5.78	Eigensicherheit "i"

nachdem das Betriebsmittel mit Erfolg einer Bauartprüfung unterzogen wurde. Die Ergebnisse dieser Bauartprüfung sind in einem vertraulichen Prüfprotokoll festgelegt.

Das Betriebsmittel ist mit dem folgenden Kennzeichen zu versehen:

EEx deq [ib] IIC T5

Der Hersteller ist dafür verantwortlich, daß jedes derart gekennzeichnete Betriebsmittel in seiner Bauart mit den in der Anlage zu dieser Bescheinigung aufgeführten Prüfungsunterlagen übereinstimmt und daß die vorgeschriebenen Stückprüfungen erfolgreich bestanden wurden.

Das elektrische Betriebsmittel darf mit dem hier abgedruckten gemeinschaftlichen Unterscheidungszeichen gemäß Anhang II der Richtlinie des Rates vom 6. Februar 1979 (79/196/EWG) gekennzeichnet werden.

Im Auftrag

(Dr.-Ing. Johannsmeyer)



Braunschweig, 11.2.1985

Prüfbescheinigungen ohne Unterschrift und ohne Dienststempel haben keine Gültigkeit.
Die Bescheinigungen dürfen nur unverändert weiterverbreitet werden.

Auszüge oder Änderungen bedürfen der Genehmigung der Physikalisch-Technischen Bundesanstalt, Bundesallee 100, Postfach 33 45, D-3300 Braunschweig.

Physikalisch-Technische Bundesanstalt

A N L A G E

zur Konformitätsbescheinigung PTB Nr. Ex-84/2158 X

Der Feldmultiplexer FM 100 ist eine Automatisierungskomponente für das Prozeßleitsystem TELEPERM M und für den Einsatz innerhalb des explosionsgefährdeten Bereiches vorgesehen.

Der Feldmultiplexer besteht aus Zentralteil(en), Stromversorgungsmodulen und einem bzw. zwei Baugruppenträger(n), in den (die) verschiedene E/A-Baugruppen eingebaut sind.

Das eingebaute Netzfilter, die Zentralteile sowie die Stromversorgungsmodule sind in der Zündschutzart Sandkapselung "q" ausgeführt. Die Netzversorgung wird über Klemmen der Zündschutzart Erhöhte Sicherheit "e" und über Schalter der Zündschutzart Druckfeste Kapselung "d" zu den Zentralteilen bzw. Stromversorgungsmodulen geführt. Alle übrigen Stromkreise, insbesondere die Stromkreise auf der Busplatine und die Datenfernleitung sind eigen-sicher. Das gilt auch für die Eingänge und Ausgänge der E/A-Baugruppen sowie für die E/A-Baugruppen selbst.

Der Feldmultiplexer kann bis zu 108 analoge Meßwerte und bis zu 360 Binärwerte erfassen und zum angeschlossenen Automatisierungssystem übertragen.

Die höchstzulässige Umgebungstemperatur beträgt 60 °C.

Elektrische Daten

A. Grundgerät

Netzanschluß..... 220 V, 48 ... 62 Hz, etwa 170 VA

Fernleitungs-
anschluß..... in Zündschutzart Eigensicherheit EEx ib IIC
(Klemmen S+ u. S-; Höchstwerte(je Stromkreis): $U_{-} \leq 14,7$ V
E+ u. E-) $I_{-} \leq 25$ mA
 $P \leq 370$ mW

höchstzulässige äußere Induktivität 1 mH

höchstzulässige äußere Kapazität 210 nF

bzw.

zwei Fernleitungs-
anschlüsse parallel geschaltet (redundanter Betrieb)

in Zündschutzart Eigensicherheit EEx ib IIC

Höchstwerte: $U_{-} \leq 14,7$ V
 $I_{-} \leq 50$ mA
 $P \leq 740$ mW

höchstzulässige äußere Induktivität 1 mH

höchstzulässige äußere Kapazität 160 nF

Physikalisch-Technische Bundesanstalt

Anlage zur Konformitätsbescheinigung PTB Nr. Ex-84/2158 X

Signalstromkreis
für Not-Aus..... in Zündschutzart Eigensicherheit EEx ib IIC
(Klemmen am Bau-
gruppenträger) Höchstwerte: $U_{-} \leq 25,2 \text{ V}$
 $I_{-} \leq 4 \text{ mA}$
höchstzulässige äußere Induktivität 10 mH
höchstzulässige äußere Kapazität 95 nF

B. E/A-Baugruppen

1. Analogeingabebaugruppe Typ 6DS 1706-8AA
(4 Eingänge für Thermoelemente, Widerstandsthermometer oder
Potentiometer)

Eingang-
stromkreise.. in Zündschutzart Eigensicherheit EEx ib IIC
(Klemmen 1
bis 16) Höchstwerte(je Stromkreis): $U_{-} \leq 44,1 \text{ V}$
 $I_{-} \leq 2 \text{ mA}$
bzw. in einem anderen Störungsfall
 $U_{-} \leq 25,2 \text{ V}$
 $I_{-} \leq 150 \text{ mA}$
 $P \leq 0,57 \text{ W}$
höchstzulässige äußere Induktivität 1,3 mH
höchstzulässige äußere Kapazität 21 nF

2. Analogeingabebaugruppe Typ 6DS 1708-8AA
(4 Eingänge für Strom und Spannung)

Eingang-
stromkreise.. in Zündschutzart Eigensicherheit EEx ib IIC
(Klemmen 1,2;
5,6; 9,10
u.13,14) Höchstwerte(je Stromkreis): $U_{-} \leq 17,6 \text{ V}$
 $I_{-} \leq 1 \text{ mA}$
höchstzulässige äußere Induktivität 1 H
höchstzulässige äußere Kapazität 280 nF
zum Anschluß an bescheinigte eigensichere
Stromkreise mit folgenden Höchstwerten:
Leerlaufspannung $U \leq 19 \text{ V}$
Kurzschlußstrom $I \leq 35 \text{ mA}$
Die höchstzulässigen Werte für die äußere In-
duktivität und Kapazität lauten
 $L \leq 0,5 \text{ mH}$
 $C_a \leq 110 \text{ nF}$,
wenn der Eingangstromkreis mit einem Aus-
gangsstromkreis des Stromversorgungsmoduls
für Meßumformer (Typ 6DS 4418-8AA) parallel-
geschaltet wird.

Physikalisch-Technische Bundesanstalt

Anlage zur Konformitätsbescheinigung PTB Nr. Ex-84/2158 X

3. Grenzwertmelder Typ 6DS 1710-8AA (2 Eingänge, 2 Ausgänge, 2 Prüfausgänge)

Eingangsstromkreise.. in Zündschutzart Eigensicherheit EEx ib IIC
(Klemmen 1,2 und 3,4) Höchstwerte(je Stromkreis): $U_{-} \leq 4,1 \text{ V}$
 $I_{-} \leq 1 \text{ mA}$

Ausgangsstromkreise.. in Zündschutzart Eigensicherheit EEx ib IIC
(Klemmen 5,6) Höchstwerte(je Stromkreis): $U_{-} \leq 25,2 \text{ V}$
 $I_{-} \leq 7 \text{ mA}$
höchstzulässige äußere Induktivität 660 mH
höchstzulässige äußere Kapazität 95 nF

Prüfausgänge.... in Zündschutzart Eigensicherheit EEx ib IIC
Höchstwerte(je Stromkreis): $U_{-} \leq 25,2 \text{ V}$
 $I_{-} \leq 13 \text{ mA}$
höchstzulässige äußere Induktivität 180 mH
höchstzulässige äußere Kapazität 95 nF

4. Binäreingabebaugruppe Typ 6DS 1610-8AA (8 Binäreingänge für elektrische Kontakte)

Eingangsstromkreise.. in Zündschutzart Eigensicherheit EEx ib IIC
(Klemmen 1 bis 16) Höchstwerte(je Stromkreis): $U_{-} \leq 25,2 \text{ V}$
 $I_{-} \leq 4 \text{ mA}$
höchstzulässige äußere Induktivität 1 H
höchstzulässige äußere Kapazität 95 nF

5. Binäreingabebaugruppe Typ 6DS 1611-8AA (8 Binäreingänge für eigensichere Geber)

Eingangsstromkreise.. in Zündschutzart Eigensicherheit EEx ib IIC
(Klemmen 1 bis 16) Höchstwerte(je Stromkreis): $U_{-} \leq 8,6 \text{ V}$
 $I_{-} \leq 27 \text{ mA}$
höchstzulässige äußere Induktivität 40 mH
höchstzulässige äußere Kapazität 3 μF

Physikalisch-Technische Bundesanstalt

Anlage zur Konformitätsbescheinigung PTB Nr. Ex-84/2158 X

Zeichnung Nr.	unterschrieben am
C 79 451-A3224-X1-*-26 Bl. 1)
W 79 040-B1048-C005-*-26 (4 Blatt))
C 79 451-A3224-X180-*-26 Bl. 1)
C 79 451-A3224-X180-*-26 Bl. 2) 31.10.1984
W 79 040-A2060-C001-*-26 (2 Blatt))
C 79 451-A3224-X130-*-26 Bl. 1)
C 79 451-A3224-X130-*-26 Bl. 2)
C 79 451-A3224-X130-*-26 Bl. 3) 22.11.1984
W 79 040-A2060-C002-*-26 (2 Blatt)) 31.10.1984
C 79 451-A3224-X500-*-26 Bl. 1) 22.11.1984
C 79 451-A3224-X500-*-26 Bl. 2)
C 79 451-A3224-X80-*-26 Bl. 1) 31.10.1984
C 79 451-A3224-X186-*-26 Bl. 1)
C 79 165-Z1202-A1-*-26 Bl. 1) 22.11.1984
C 79 458-L442-X60-*-26 Bl. 1)
C 79 458-L442-X60-*-26 Bl. 2)
C 79 458-L442-X60-*-26 Bl. 2a)
CUP P003 A 512) 31.10.1984
C 79 458-L442-X80-*-26 Bl. 1)
C 79 458-L442-X80-*-26 Bl. 2)
C 79 458-L442-X80-*-26 Bl. 2a)
C 79 458-L442-X100-*-26 Bl. 1) 22.11.1984
C 79 458-L442-X100-*-26 Bl. 2) 31.10.1984
C 79 458-L441-X100-*-26 Bl. 1) 22.11.1984
C 79 458-L441-X100-*-26 Bl. 2)
C 79 458-L441-X110-*-26 Bl. 1) 31.10.1984
C 79 458-L441-X110-*-26 Bl. 2)
C 79 458-L441-X110-*-26 Bl. 2a) 22.11.1984
C 79 451-A3224-B50-*-26 Bl. 1)
C 79 451-A3224-X5-*-26 Bl. 1) 31.10.1984
C 79 451-A3224-B55...B56-*-26 Bl. 1)
C 79 451-A3224-B55...B56-*-26 Bl. 2) 22.11.1984
C 79 451-A3224-B55...B56-*-26 Bl. 2a) 31.10.1984
C 79 451-A3224-B55...B56-*-26 Bl. 3) 22.11.1984
C 79 451-A3224-B55...B56-*-26 Bl. 3a)
C 79 451-A3224-X28-*-26 Bl. 1) 31.10.1984
SFH 600)

7. Prüfmuster

Physikalisch-Technische Bundesanstalt

Anlage zur Konformitätsbescheinigung PTB Nr. Ex-84/2158 X

Besondere Bedingungen

1. Da die elektrischen Daten nicht auf dem Typenschild aufgeführt sind, müssen sie dieser Anlage zur Konformitätsbescheinigung entnommen werden (s. unter "Elektrische Daten").
2. Da die eigensicheren Stromkreise (mit Ausnahme des Fernleitungsanschlusses) geerdet sind, ist im gesamten Bereich der Errichtung der Eingangs- und Ausgangsstromkreise mit Ausnahme des Fernleitungsanschlusses Potentialausgleich erforderlich.
3. Dem Feldmultiplexer ist netzseitig eine Sicherung (Schmelzsicherung oder Sicherungsautomat) mit einem Nennstrom von maximal 6,3 A vorzuschalten.

Im Auftrag

Braunschweig, 11.2.1985

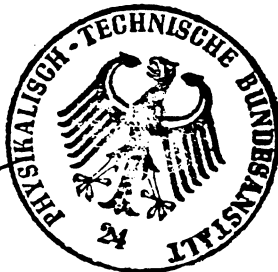

(Dr.-Ing. Johannsmeyer)

Physikalisch-Technische Bundesanstalt

1. N A C H T R A G

zur Konformitätsbescheinigung PTB Nr. Ex-84/2158 X

der Firma SIEMENS AG
Unternehmensbereich Energie- und Automatisierungstechnik
D-7500 Karlsruhe 21

Die Typenreihe der unter B. aufgeführten E/A-Baugruppen wird um folgende Typen erweitert:

B. E/A-Baugruppen

6. Binärausgabebaugruppe Typ 6DS 1612-8AA
(8 Binärausgänge)

Ausgangsstrom-
kreise in Zündschutzart Eigensicherheit EEx ib IIC
(Klemmen 1 bis 17) Höchstwerte (je Stromkreis): $U_- = 25,2 \text{ V}$
 $I_- = 13 \text{ mA}$
höchstzulässige äußere Induktivität 180 mH
höchstzulässige äußere Kapazität 95 nF

7. Analogausgabebaugruppe Typ 6DS 1712-8AA/8BA
(4 Analogausgänge Spannung/Strom)

Ausgangsstrom-
kreise in Zündschutzart Eigensicherheit EEx ib IIC
(Klemmen 1,2; 5,6; 9,10 und 13,14) Höchstwerte (je Stromkreis): $U_- = 15,6 \text{ V}$
 $I_- = 26 \text{ mA}$
höchstzulässige äußere Induktivität 45 mH
höchstzulässige äußere Kapazität 400 nF

8. Verriegelungsbaugruppe Typ 6DS 1506-8AA
(4 Kanäle, 4 Eingänge, 2 Ausgänge)

Eingangsstrom-
kreise in Zündschutzart Eigensicherheit EEx ib IIC
(Klemmen 1,2; 3,4; 5,6 und 7,8) Höchstwerte (je Stromkreis): $U_- = 14 \text{ V}$
 $I_- = 10 \text{ mA}$
höchstzulässige äußere Induktivität 300 mH
höchstzulässige äußere Kapazität 600 nF

Ausgangsstrom-
kreise in Zündschutzart Eigensicherheit EEx ib IIC
(Klemmen 11,12 und 14,15) Höchstwerte (je Stromkreis): $U_- = 14 \text{ V}$
 $I_- = 13 \text{ mA}$
höchstzulässige äußere Induktivität 180 mH
höchstzulässige äußere Kapazität 600 nF

Physikalisch-Technische Bundesanstalt

1. Nachtrag zur Konformitätsbescheinigung PTB Nr. Ex-84/2158 X

9. Abfragewiederholungsbaugruppe Typ 6DS 1912-8AA
(keine äußeren Anschlüsse)

10. Analogeingabebaugruppe für pneumatische Signale
Typ 6DS 1707-8AA
(4 Ausgänge)

Ausgangsstrom-
kreise in Zündschutzart Eigensicherheit EEx ib IIC
(Klemmen 1 bis 8) Höchstwerte (alle vier Strom-
kreise gemeinsam): $U_{-} = 17,1 \text{ V}$
 $I_{-} = 137 \text{ mA}$
höchstzulässige äußere Induktivität $1,5 \text{ mH}$
höchstzulässige äußere Kapazität 300 nF

Die übrigen Daten, die Einbaubedingungen sowie die "Besonderen Bedingungen" gelten unverändert.

Prüfungsunterlagen

unterschrieben am

1. Beschreibung (7 Blatt)	06.08.1985
2. Anhang zur Beschreibung (33 Blatt)	06.08.1985
3. Zeichnung Nr. C79458-L441-X120-*-26 B1.1	06.08.1985
C79458-L441-X120-*-26 B1.2	06.08.1985
C79458-L442-X120-*-26 B1.1	29.08.1985
C79458-L442-X120-*-26 B1.2	29.08.1985
C79458-L440-X 60-*-26 B1.1	06.08.1985
C79458-L440-X 60-*-26 B1.2	06.08.1985
C79458-L444-X120-*-26 B1.1	06.08.1985
C79458-L444-X120-*-26 B1.2	06.08.1985
96 500	06.08.1985
96 500 - Tz. 1	06.08.1985
96 500 - Tz. 2	06.08.1985
96 500 - Tz. 3	06.08.1985
96 500 - T 10	06.08.1985

4. Prüfmuster

Im Auftrag

Braunschweig, 22.10.1985

(Dr.-Ing. Schebsdat)
Oberregierungsrat



SIEMENS

TELEPERM M

Field Multiplexer

FM 100

Instructions

Order No. C79000-B8076-C090-04

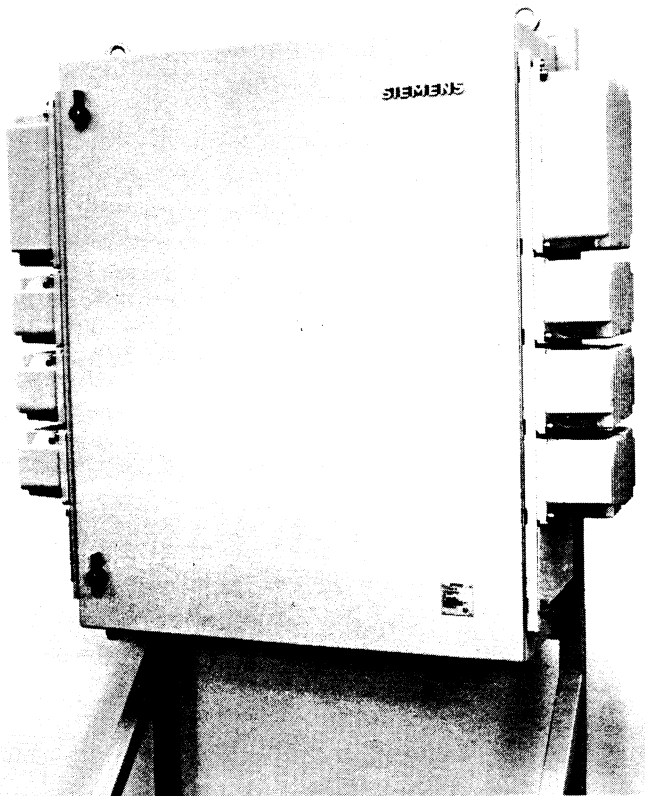

Contents	Page		Page
1 Description	2	2.2.5 Connecting the Field Cables	26
1.1 Application	2	2.2.6 Connecting the Transducers	28
1.2 Design	3	2.2.7 Connecting and Setting the Pneumatic Reducer Assembly	29
1.2.1 Mechanical Design	3	2.2.8 Connecting an External Emergency Stop Switch	29
1.2.2 Electrical Design	5	2.3 Setting	30
1.3 Mode of Application	8	2.4 Commissioning	31
1.3.1 Central Unit	8		
1.3.2 Power Supply Module for I/O Modules	10	3 Maintenance	33
1.3.3 Power Supply Module for Transducers	10	3.1 Method of Operation	33
1.3.4 User Interface for Emergency Stop Operation	10	3.1.1 Central Unit	33
1.3.5 Pneumatic Reducer Assembly	10	3.1.2 I/O Subrack	39
1.4 Field Multiplexer Arrangements	12	3.1.3 +12-V Power Supply Module for I/O Modules	43
1.5 Technical Data	14	3.1.4 Power Supply Module for Transducers	44
		3.1.5 Reaction and Switchover Behaviour of the Different Field Multiplexer Arrangements	46
2 Installation and Commissioning	18	3.2 Checking and Maintenance	49
2.1 Installation	18	3.3 Repair Work	50
2.2 Connection	19	3.3.1 Troubleshooting	50
2.2.1 System Configuration	19	3.3.2 Replacing Powder-filled Functional Units	58
2.2.2 Connecting the Mains Cable	21		
2.2.3 Earthing the Field Multiplexer	21		
2.2.4 Connecting the Remote Cable	22		

1 Description

1.1 Application

The FM 100 field multiplexer of the TELEPERM M automation system is an explosion-proof electrical device, used to reduce field cabling in the immediate vicinity of field devices. It acquires and outputs electrical and pneumatic field signals. Due to its intrinsically-safe, enclosed design, the FM 100 can be used in potentially explosive field areas of zone 1. Data are exchanged between the higher-level automation system (AS) and the field multiplexer via an intrinsically-safe 20-mA interface (4-core connection cable). The remote cable is connected to the higher-level automation system via a safety isolator 6DS3902-8AA in order to isolate the potentially explosive zone (Ex zone) from the maintenance area. Connection to the higher-level automation system is established via the interface module 6DS1304-8AA.

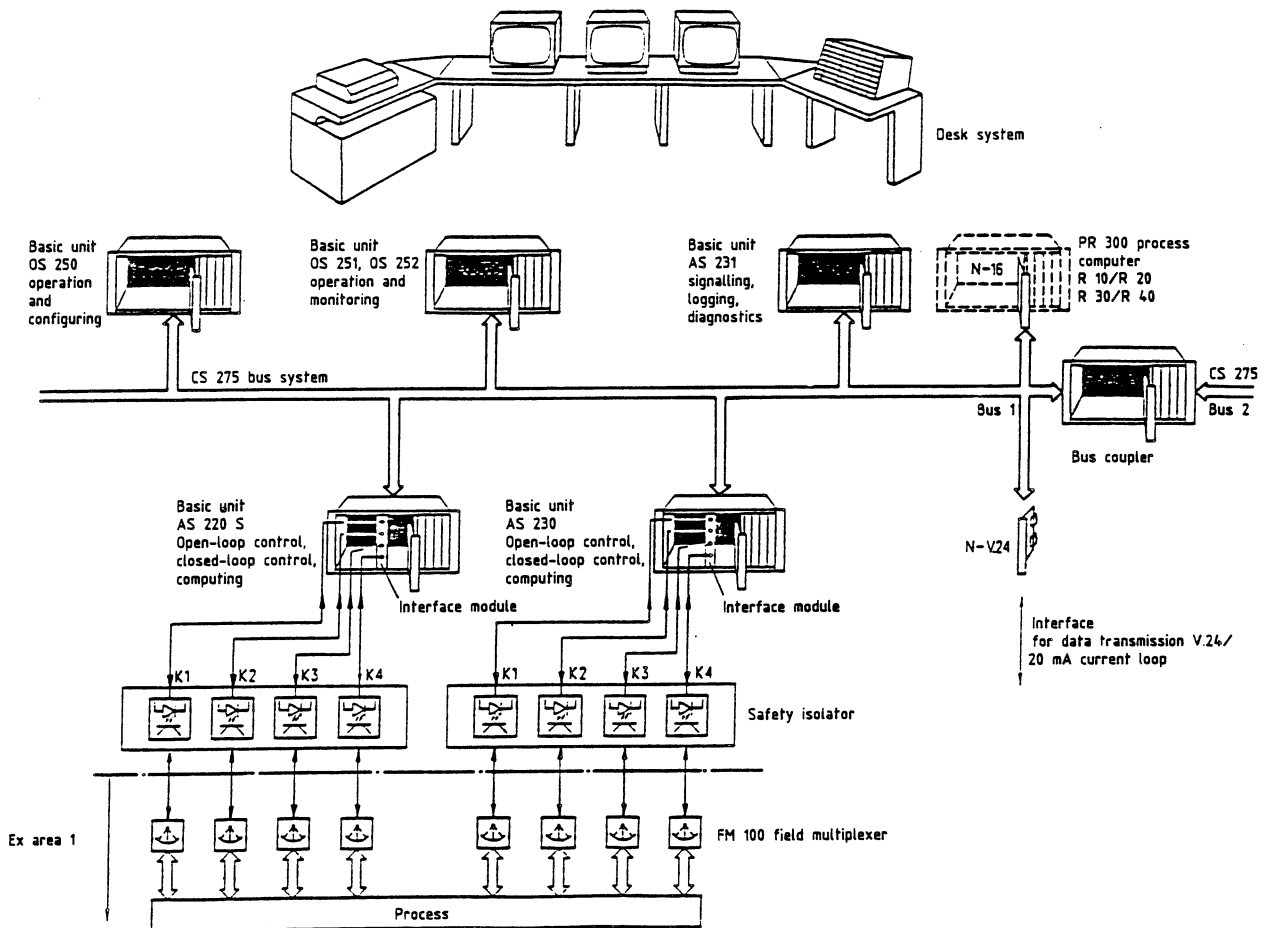

Fig. 1 FM 100 incorporated in an automation system

1.2 Design

1.2.1 Mechanical Design (see Fig. 2)

The FM 100 field multiplexer is designed in a sheet-steel housing for wall-mounting. The housing satisfies the degree of protection IP 55 according to DIN 40050 and is also suitable for open-air mounting, due to its increased corrosion protection.

The central functional units of the field multiplexer - comprising a central unit 6DS4900-8AA, power supply module for I/O modules 6DS4413-8AA and/or a power supply module for transformers 6DS4418-8AA - are accommodated in a separate housing with cooling fins and screwed onto the side of the field multiplexer wall housing.

A redundant central unit and as many additional power supply modules as desired can be mounted on the second side panel to increase availability. Depending on the design, one or two sub-racks are located inside the housing for I/O modules. (Basic frame C79451-A3324-B50 with 24 standard slots, extension frame 6DS9100-8AA with 14 standard slots). The field multiplexer can be delivered with a reducer assembly for supplying the pneumatic output modules.

There is a cable detensioning clamp on the floor of the FM housing for earthing the cable screening.

Mains distribution in the field multiplexer occurs via flameproof, enclosed mains switches and mains terminals for increased safety.

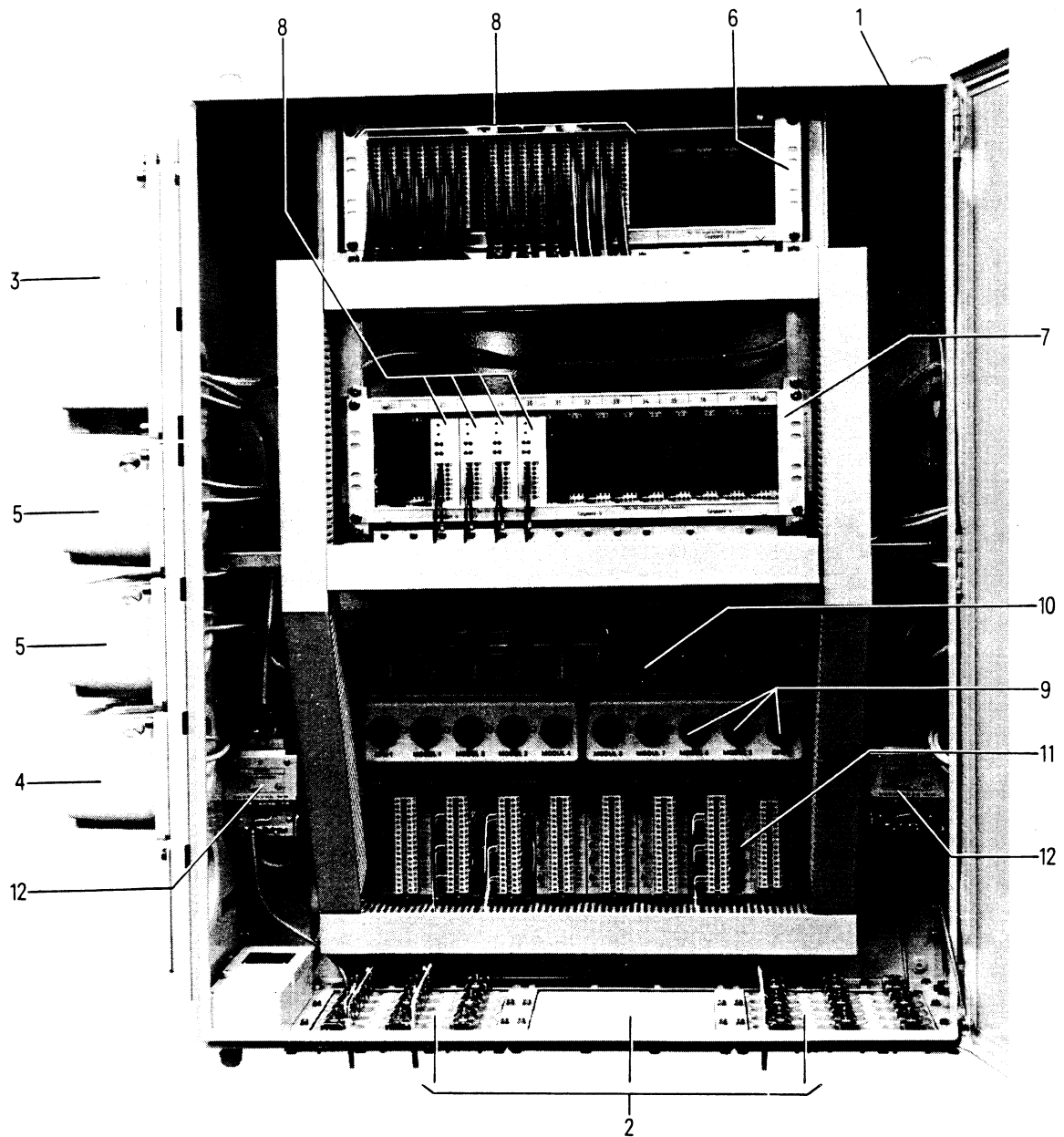

- 1 Wall housing
- 2 Removable base plates
- 3 Central unit with power supply
- 4 Power supply module, e.g. for transducers
- 5 Power supply module, e.g. for I/O modules
- 6 Basic frame
- 7 Extension frame
- 8 I/O modules
- 9 Mains switch, flameproof enclosure
- 10 220-V screw terminals for increased safety
- 11 Mounting panel with terminal blocks for connection of electrical transducers
- 12 Remote cable connection board

Fig. 2 Mechanical design of the field multiplexer

1.2.2 Electrical Design (see Fig. 3)

The core of the field multiplexer consists of a microprocessor-controlled central unit, which communicates with the I/O modules inserted in the basic and extension subracks by means of its intrinsically-safe I/O bus interface.

Data are exchanged between the central unit and higher-level automation system in message form via an intrinsically-safe 20-mA interface (4-core cable connection).

The field multiplexer can be fitted with a second central unit and redundant power supply modules for increased availability. In the case of a redundant design, both central units are simultaneously connected to I/O bus, but operate on the master-slave principle and are linked to each other via special I/O bus control lines. After a voltage increase, only one central unit will function in the operating mode. The second one will be held in standby mode by the active central unit. The sequence in which the central units are started up depends on the corresponding redundancy concept. Should the active master central unit fail, the redundant standby central unit will automatically switch on and continue data traffic with the I/O modules and higher-level automation system.

Up to 38 I/O modules can be inserted into the I/O subracks - according to field requirements. Assembly can be done in any sequence or combination.

The +5 and +22-V voltages necessary for feeding the I/O modules, are supplied by the central units on the I/O bus.

The +12-V voltage supply for the I/O module, is led from the power supply modules 6DS4413-8AA (attached to the side of the FM housing) to the subracks via segment connectors. Segments are subrack circuit board conductor sections for supplying the I/O modules with a +12-V voltage.

The subracks are divided up in the individual power supply segments as follows:

- Basic frame
 - 2 groups (segments 1 and 2) per 10 slots, with a distance of one slot (SEP).
 - 1 group (segment 3) of 4 slots, with a distance of 2 SEPs.
- Extension frame
 - 2 groups (segments 4 and 5) per 5 slots, with a distance of 2 SEPs.
 - 1 group (segment 6) of 4 slots, with a distance of 2 SEPs.

Each segment in the basic and extension frames can be supplied singly or redundantly from the power supply module 6DS4413-8AA, as desired. Parallel power supply segments can also be linked together via connector plugs (see Figs. 4 and 5).

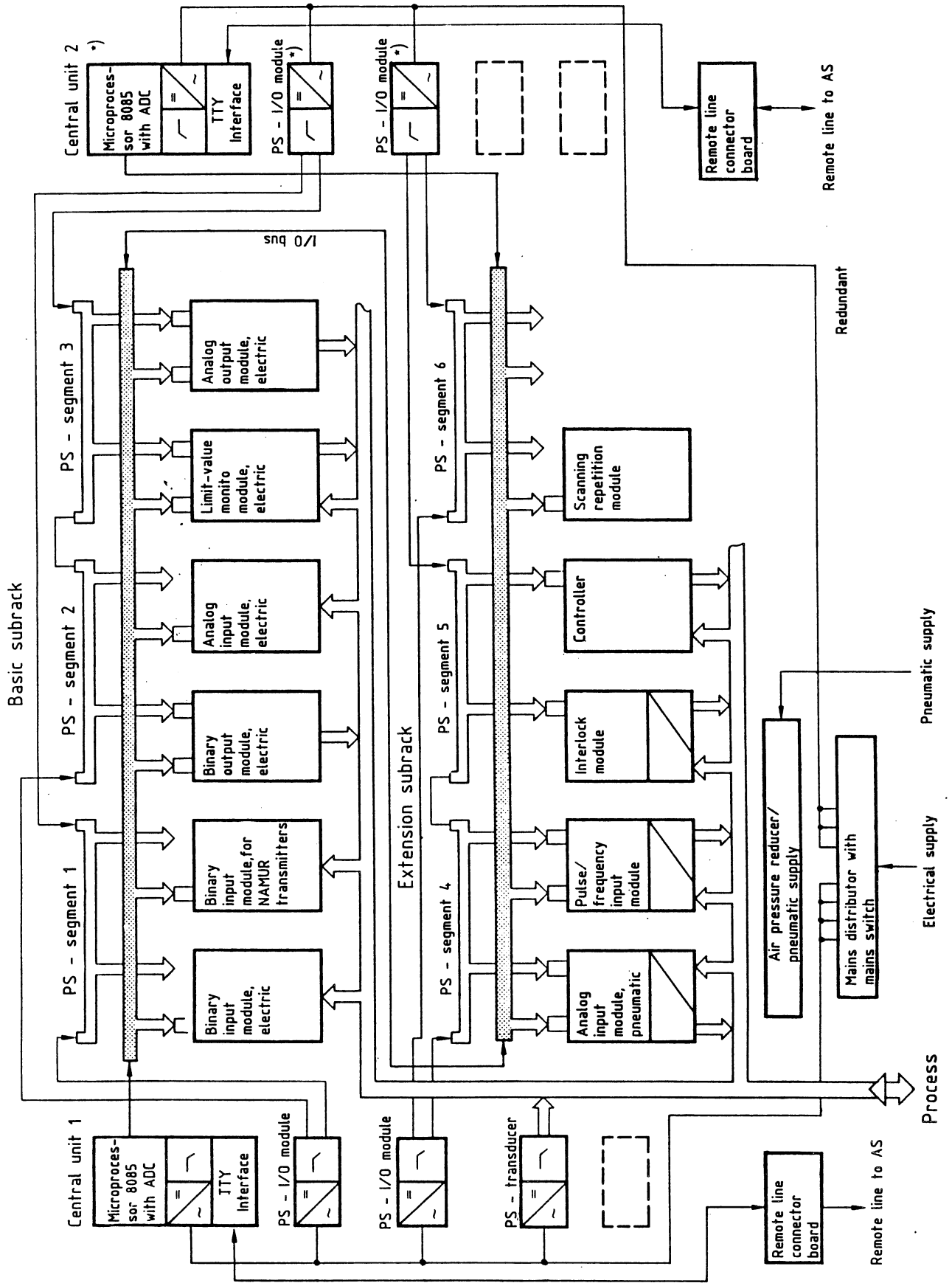
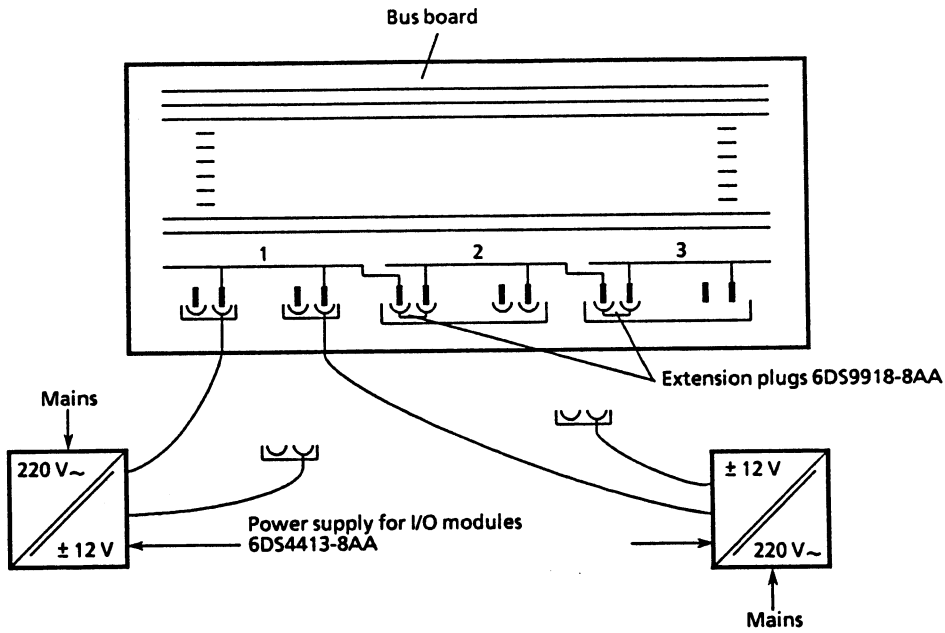
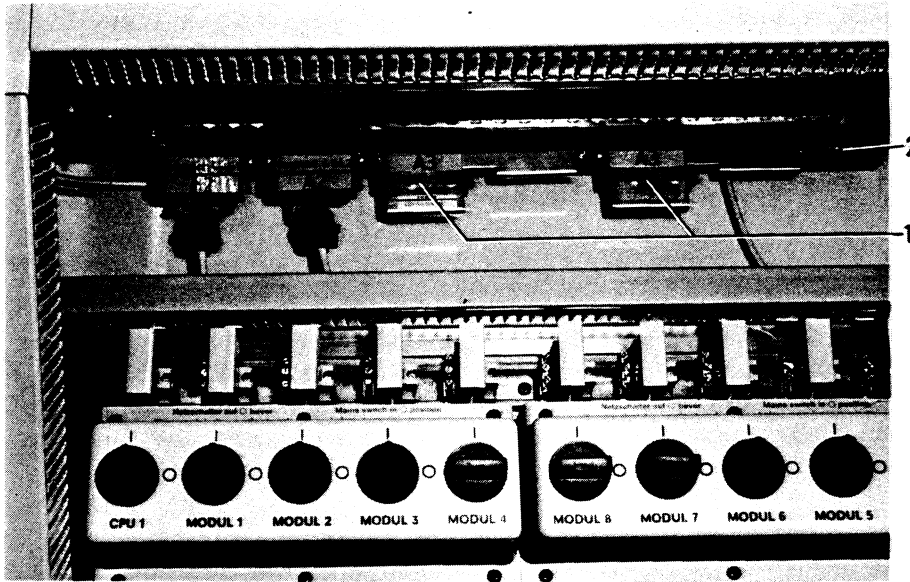

Fig. 3 Electrical design



- Segment 1
- Segment 2 Have a redundant and common supply
- Segment 3

Fig. 4 +12-V supply of the power supply segments (example)



- 1 Connector plug 6DS9918-8AA
- 2 Connecting terminals for external emergency stop switch

Fig. 5 Layout of segment plugs on subrack

1.3 Mode of Operation

1.3.1 Central Unit 6DS4900-8AA

The central unit cyclically processes the input modules in the I/O subracks in order of increasing module address, checks and formats the acquired data into messages, then transfers these to the higher-level automation system via the intrinsically-safe (20 mA) serial interface.

The output data sent from the higher-level automation system are prepared in the central unit and directly output via the output modules.

Message interchange is carried out between the central unit and interface module in the higher-level automation system without interruption.

During pauses in which no useful data is being transferred, check and synchronization messages are cyclically exchanged between the central unit and interface module, in order to monitor the remote cable.

If data traffic to the interface module is faulty, the active central unit is disconnected from the interface module by means of an alarm bit in the transmit message.

In the case of a redundant central unit design, this disconnection procedure activates the second central unit, which thus far has been operating in standby mode.

However, if the central unit is not redundant, the disconnection causes the correspondingly set output modules to switch to a defined safety setting.

● I/O interface

Communication between the central unit and interface modules occurs via the I/O bus connected to the I/O subracks. I/O modules can be inserted into the I/O subrack in any sequence and combination - according to the field requirements.

Analog value acquisition

Depending on the design, analog signals can be acquired with I/O cards in the form of electrical voltages, currents, adaptable resistances or pneumatic signals. The analog values acquired via input modules are converted into a binary value of 11 bits + sign by the central unit, using the analog-digital converter (ADC) with a series-connected, programmable measuring amplifier. The measuring range (set by the user on the analog input modules and transmitted in channel code from the I/O module) is necessary when setting the amplification of the measuring amplifier.

The terminal connections on the input modules serve as reference junctions during temperature acquisition via thermocouples. The temperature of the terminal connections is determined by a temperature sensor (Pt 100) attached to the basic subrack.

Binary value acquisition

Non-floating contacts or transmitters can be connected (according to DIN 19234) as binary value transmitters. Binary signals are acquired by each I/O module in groups of 8 bits.

● Serial interface

Data between the field multiplexer and higher-level automation system are exchanged in message form via a 4-core cable connection using a data rate of 2400 bits/s.

Each message consists of 7 data bytes and contains the following information:

Byte 1	= start character
Byte 2	= channel address
Byte 3 to 8	= data
Byte 7	= fuse information

According to how the output module is assembled, the higher-level automation system transfers analog output values (in digitalized form) and digital output values directly to the FM 100 central unit. Serial data are converted into parallel information in the central unit and output to the addressed output module.

Input data are cyclically acquired by the central unit, converted from parallel to serial and transferred to the higher-level automation system.

Messages to the field multiplexer, as well as those to the higher-level automation system, are of an identical design and are exchanged independently of each other, without interruption.

1.3.2 +12-V Power Supply Module for I/O Modules 6DS4413-8AA

This module supplies the I/O modules with a +12-V voltage. Each module has 2 floating, intrinsically-safe pairs of voltage outputs, which are protected by active limiting circuits. These ensure that the current and voltage do not exceed their given limit values.

The voltage outputs are short-circuit-proof. Up to 2 outputs from different power supply modules can be connected in parallel, to provide the I/O modules with a redundant supply. However, a redundant supply can only be guaranteed if the current consumption of the I/O modules lies within the permissible current load range of one voltage output.

The max. permissible current load of one voltage output on the +12-V side is approx. 10 mA and on the -12-V side, approx. 16 mA. The output voltage will break down abruptly if an overload occurs.

1.3.3 Power Supply Module for Transducers 6DS4413-8AA

This module provides the transducers with a +18-V voltage.

Each module has 6 floating, short-circuit-proof voltage outputs, which are protected by active limiting circuits. The outputs can tolerate a maximum load of 25 mA. Parallel connection of several voltage outputs is **impermissible**. The output voltage will break down abruptly if one of these outputs is overloaded.

1.3.4 User Interface for Emergency Stop Operation

The user can set the field multiplexer to emergency stop operation by means of an external switch. Once this has been done, the outputs of the respective modules (set via coding jumpers) immediately switch to the safety setting or "last value retained" mode.

The outputs will remain in this operating status until the user resets the field multiplexer to normal operation by closing the emergency stop switch contact.

1.3.5 Pneumatic Reducer Assembly 6DS4901-8AC

The pneumatic reducer assembly converts compressed air from the field area into auxiliary pressure, necessary for pneumatic converter modules.

It consists of an air pressure reducer with a pressure-indicating instrument for the auxiliary pressure.

A ventilation and draining outlet is located underneath the reducer assembly to prevent a build-up of pressure inside the housing and for draining the liquid which has collected in the liquid trap. This outlet goes through the base of the housing and into the open air.

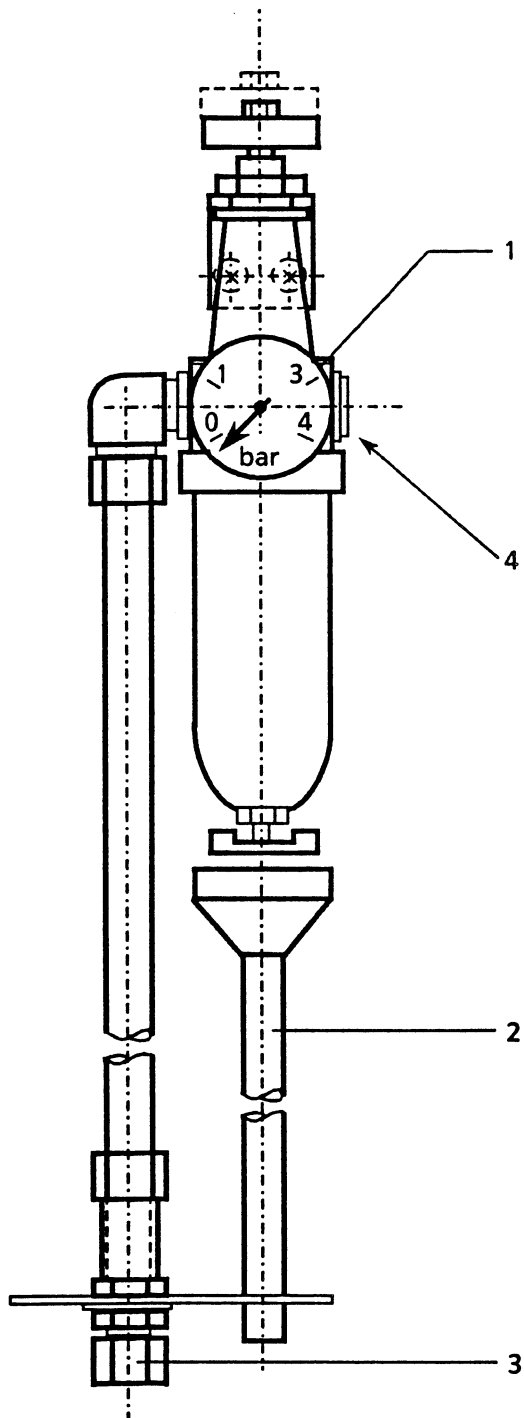

- 1 Air pressure reducer
- 2 Draining and ventilation outlet
- 3 Air inlet
- 4 Connection nipple for compressed-air distributor

Fig. 6 Air supply distributor with pressure reducer

1.4 Field Multiplexer Arrangements

The availability of the FM 100 can be increased by means of a redundant central unit. Three system arrangements are possible (see Fig. 7).

- Arrangement 1:
Operation of FM 100 without central unit redundancy
- Arrangement 2:
Operation of FM 100 with central unit redundancy via a data transmission line.

With arrangement 2, the first central unit to complete startup after mains voltage has been applied is the one which will go into operating mode.

The second central unit is held in standby mode and listens in on the transmission line. The transmitter in the standby central unit is inhibited by the active central unit.

Should the active central unit fail, the standby unit automatically cuts in and signals the central unit failure to the automation system.

- Arrangement 3:
Operation of FM 100 with both central unit and transmission line redundancy.

With arrangement 3, the assigned central unit is switched to standby mode by means of an alarm bit in the transmit message given by the FM 100 interface module.

From this point onwards, the standby module only exchanges check messages with its interface module.

Should a forced changeover of redundancy branches occur (e.g. due to central unit failure), then the resulting cycle interruption in turn causes the FM I/O modules to be temporarily signalled as faulty.

The redundant interface branch must be temporarily activated by switching off the active central unit after power-up or following a voltage failure in the automation system. This ensures that the standby interface, with the linearization parameters necessary for analog value processing, is also supplied.

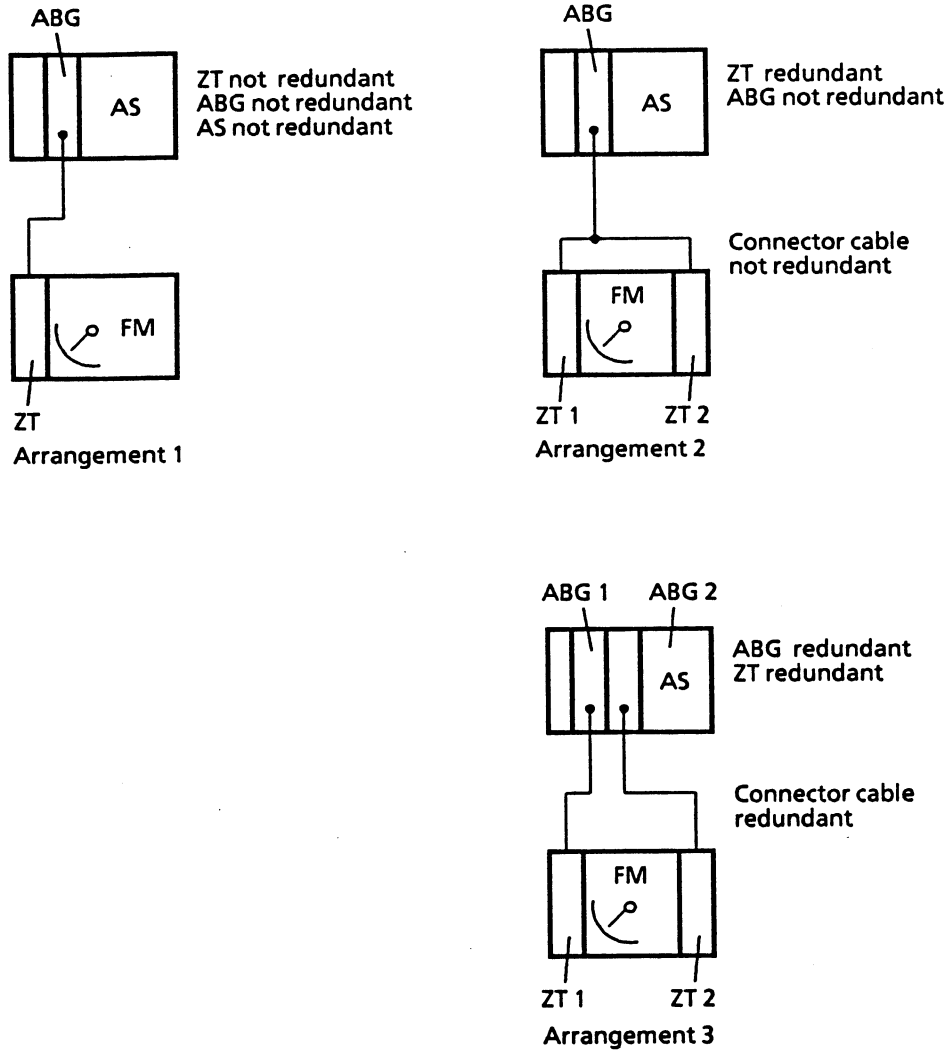

ZT = central unit
 FM = field multiplexer
 ABG = field multiplexer interface module
 AS = automation system

Fig. 7 Field multiplexer arrangements

1.5 Technical Data

1.5.1 FM 100 Complete

Dimensions (w x h x d):	1060 mm x 1100 mm x 333 mm
Weight:	approx. 200 kg with max. configuration
Perm. ambient temperature in operation:	-25 to +60°C
in storage:	-40 to +85°C
Degree of protection	IP 55 (housing)
Explosion protection:	EEx deq [ib] IIC T5
Humidity class:	G to DIN 40040 -25 to +70°C with 100% rel. humidity, moisture condensation permissible
Corrosion resistance:	to DIN 50018
Mains voltage	220 V
Perm. mains voltage tolerance:	+10% / -15%
Mains frequency:	47 to 63 Hz
Power consumption:	< 170 VA (when fully configured)

1.5.2 Central Unit 6DS4900-8AA

Dimensions (w x h x d):	285 mm x 298 mm x 110 mm
Weight:	approx. 14 kg
Perm. ambient temperature in operation:	-25 to +60°C
in storage:	-40 to +85°C
Degree of protection:	IP 55 (only when fully assembled)
Explosion protection:	EEx q [ib] IIC T5 to EN 50014
Humidity class:	G to DIN 40040 -25 to 70°C with 100% rel. humidity, moisture condensation permissible
Mains voltage:	220 V
Perm. mains tolerance voltage:	+10% / -15%
Mains frequency:	47 to 63 Hz
Power consumption:	max. 100 mA eff.

I/O bus: 8 bit address bus
8 bit data bus

Power supplies for I/O modules:

$U_5 \text{ v} = +5\text{V} \pm 2\%$ $I_{\text{max}} < 140 \text{ mA}$
 $I_{\text{max}} < 6.5 \text{ V}$

intrinsically-safe limited to $I_k < 180 \text{ mA}$

$U_{22} \text{ v} = +22 \text{ V}$

intrinsically-safe limited to $U_{\text{max}} < 25.2 \text{ V}$
 $I_k < 75 \text{ mA}$

$U_{\text{ref}} = +10 \text{ V} \pm 0.1\%$
 $T_k < +0.05\% / 10 \text{ K}$ $I_{\text{max}} < 5 \text{ mA}$

intrinsically-safe limited to $U_{\text{max}} = 15.8 \text{ V}$
 $I_k < 19 \text{ mA}$

$I_{\text{Pt } 100} = 2 \text{ mA} \pm 0.1\%$
 $T_k < +0.1\% / 10 \text{ K}$

intrinsically-safe limited to $U_{\text{max}} < 10.6 \text{ V}$
 $I_{\text{max}} < 12.7 \text{ mA}$

Max. perm. load: $< 3 \text{ kohms}$

Serial interface data signalling rate: 2400 bits/s, asynchronous 20 mA

intrinsically-safe limited to $U_{\text{max}} < 14.7 \text{ V}$
 $I_k < 25 \text{ mA}$

Remote cable length: in the Ex area, this is limited by the max. perm. external capacity and inductance according to the PTB conformity certificate No. -84/2158X.

Outside the Ex area, up to 2 km is perm.

Diagnostic displays: 3-color LEDs

Analog value acquisition

measuring ranges: +20 mV to +10 V
 resolution: 11 bits + sign

Precision:

Measuring range	+10 V to +80 mV	+40 mV to +20 mV
Zero error	<0.1% of E	<+0.2% of E
Linearity error	<+0.05% of E	<+0.05% of E
Tk	<+0.1% / 10 K	<+0.15% / 10 K
Coding error	+0.5 digit	+0.5 digit
Additional errors during thermocouple measuring	-	+2 digits *)

*) Caused by terminal temperature acquisition

Common-mode interference suppression: with 50 Hz > 80dB
 with 60 Hz > 80dB

Series-mode interference suppression: with 50 Hz +1% > 40dB
 with 60 Hz +1% > 40dB

Range of series-mode interference suppression: <+15 V

Input resistance
 voltage measurement: > 100 Mohms
 current measurement: 50 ohms

1.5.3 Power Supply Module for Transducers 6DS4418-8AA

Dimensions (w x h x d): 286 mm x 136 mm x 110 mm

Weight: approx. 7 kg

Perm. ambient temperature
 in operation: -25 to +60°C
 in storage: -40 to +85°C

Degree of protection: IP 55 (housing, only when mounted)

Explosion protection: EEx q [ib] ICG T5

Humidity class: G to DIN 40040
 -25 to +70°C with 100% rel. humidity,
 moisture condensation perm.

Mains voltage: 220 V

Perm. mains voltage tolerance: +10% / -15%

Mains frequency: 47 to 63 Hz

Power consumption: max. 70 mA eff.

No. of voltage outputs: 6 pairs (floating with respect to one another, short-circuit-proof, cannot be connected in parallel)

Output voltage: +18 V +5%
 intrinsically-safe limited to $I_{\max} = 25 \text{ mA}$
 $U_{\text{Amax}} < 19 \text{ V}$
 $I_{\text{Amax}} < 35 \text{ mA}$

1.5.4 Power Supply Module for I/O Modules 6DS4413-8AA

Dimensions (w x h x d): 286 mm x 136 mm x 110 mm

Weight: approx. 7 kg

Perm. ambient temperature
 in operation: -25 to +60°C
 in storage: -40 to +85°C

Degree of protection: IP 55 (housing, only when mounted)

Explosion protection: EEx q [ib] IIC T5

Humidity class: G to DIN 40040
 -25 to 70°C with 100% rel.humidity,
 moisture condensation perm.

Mains voltage: 220 V

Perm. mains voltage tolerance: +10% / -15%

Mains frequency: 47 to 63 Hz

Power consumption: max. 70 mA eff.

No. of voltage outputs: 2 pairs (floating, short-circuit-proof, can be connected in parallel)

Output voltages: +12 V +2% $I_{\max} = 90 \text{ mA}$
 -12 V +5% $I_{\max} = 14 \text{ mA}$
 intrinsically-safe limited to $U_{\text{Amax}} = +14.7 \text{ V}$
 $I_{\text{Amax}} < 100 \text{ mA}$
 $U_{\text{Amax}} < -12.6 \text{ V}$
 $I_{\text{Amax}} < 16 \text{ mA}$

1.5.5 I/O Modules

For technical data, see instructions for the I/O modules.

2 Installation and Commissioning

2.1 Installation

The FM 100 field multiplexer is designed for operation in potentially explosive field areas of Ex zone 1. The housing is designed for wall mounting. However, the device should be installed well out of direct sunlight and given enough space alongside for side-mounted functional components to be added or replaced.

If installed in the open air, the housing should be covered by a protective roofing against the sun and rain.

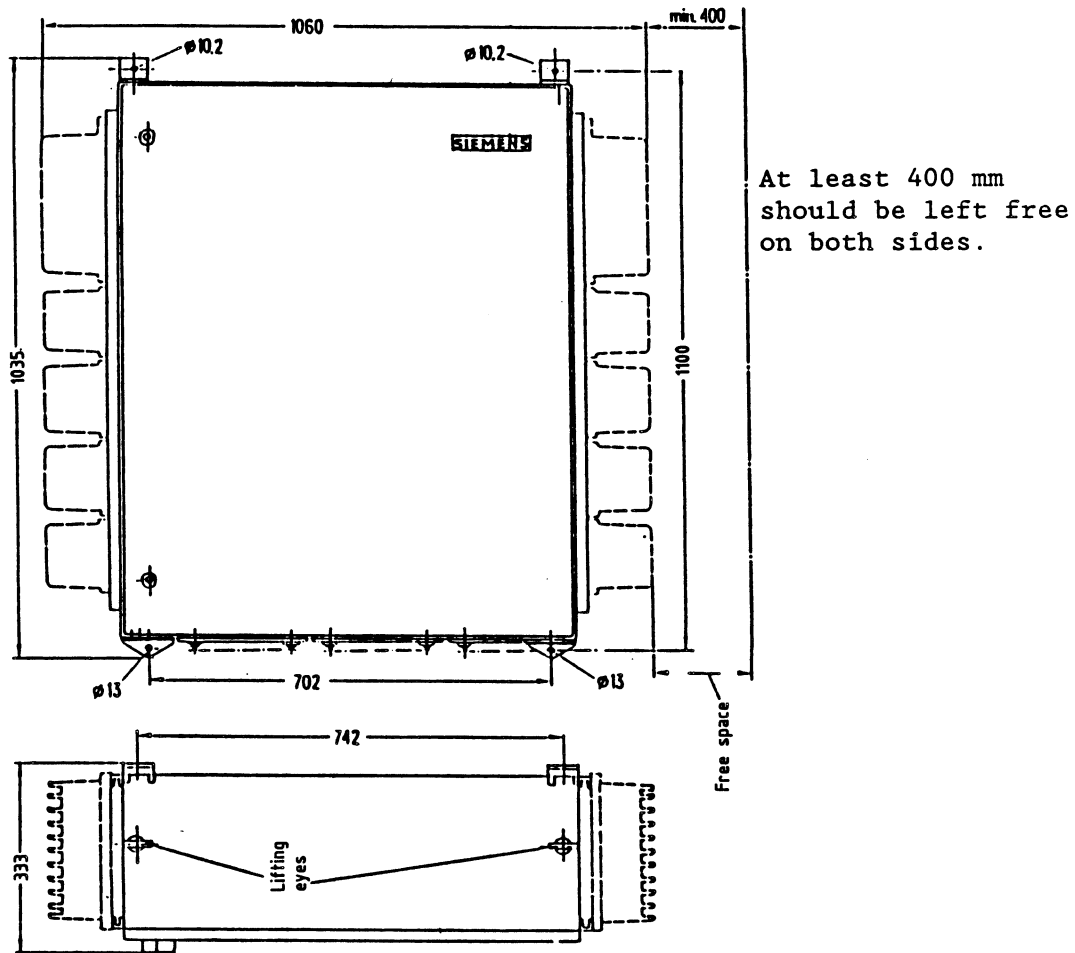

Fig. 8 Layout of fixing clips

2.2 Connection

The following VDE requirements must be observed when connecting and starting up the FM 100 field multiplexer:

- VDE 0100 Installing power systems with rated voltages of up to 1000 V
- VDE 0165 Installing electrical systems in potentially explosive site areas.

The limit values for the inductances and capacities of external power circuits, as stated in the PTB conformity certificate, must also be maintained during operation in the explosive area (Ex zone 1).

Connecting cables belonging to intrinsically-safe power circuits (remote cable, field cables) must be marked light blue, according to VDE 0165.

We recommend using the following Siemens cable as remote and field cables: JE-Y(ST)...X2 2 x 0.8 Bd si bl.

2.2.1 System Configuration

When connecting the field multiplexer, an equipotential bonding must be made on the field side between the AS and the FM 100 (Ex area). The equipotential bonding is only sufficient when the resistance between the system earth of the AS and the FM 100 earth is about factor 10 less than the screen resistance of the remote cable.

If this requirement is not met, a suitable equipotential bonding must be established or a remote cable inserted, whose screen is capable of carrying a current.

If there is a danger of lightning striking due to the kind of installation, lightning protection equipment should be inserted in the remote cable to protect the device electronics of the AS and FM 100.

Only passive networks are permitted as lightning protection equipment in intrinsically-safe power circuits (e.g. lightning conductors from the Dehn Co.).

The permissible limit values of the intrinsically-safe remote cable circuit (capacity, inductance) must be taken into account when installing the lightning protection equipment.

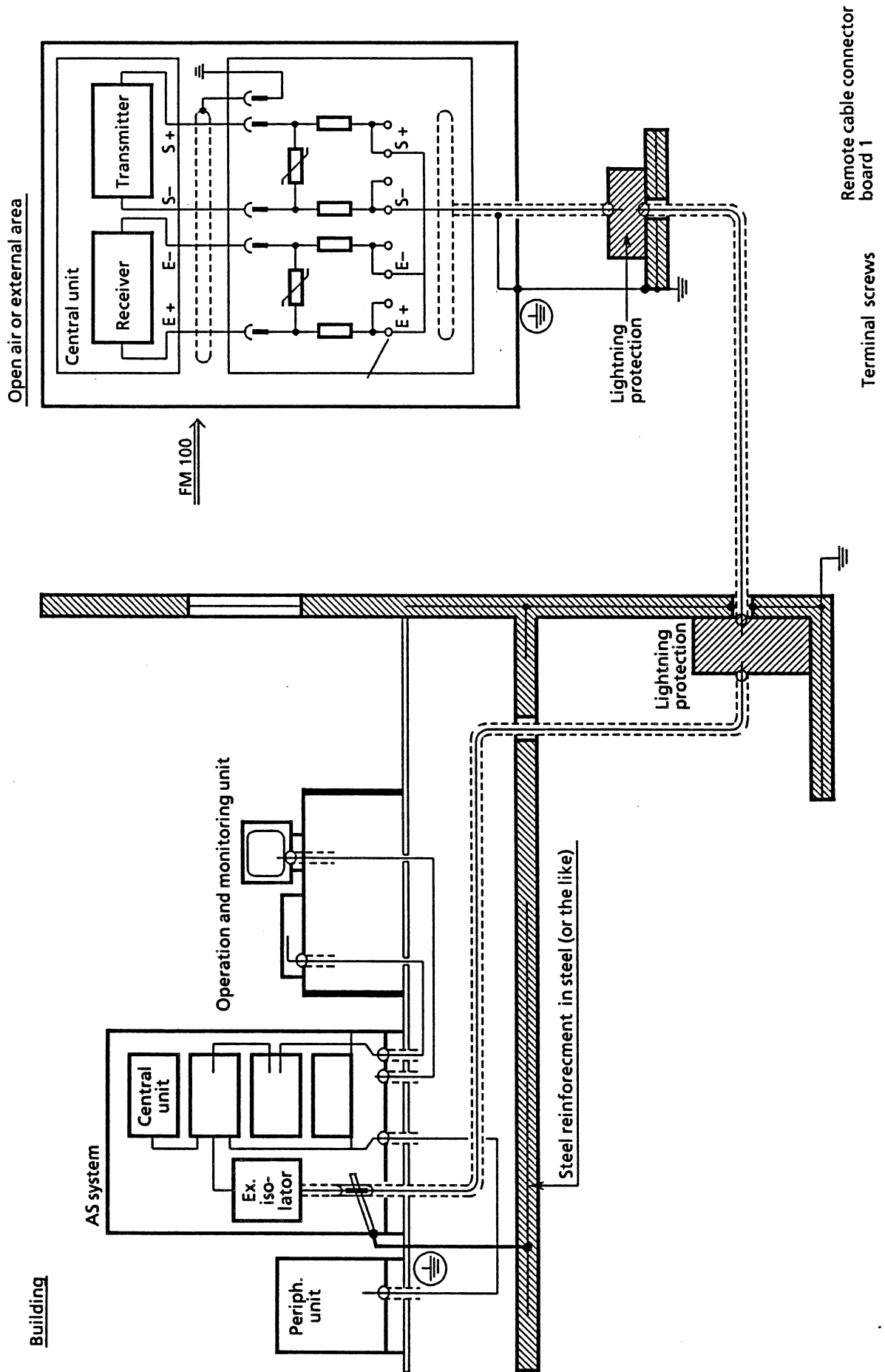

Fig. 9 System configuration with lightning protection

2.2.2 Connecting the Mains Cable

The mains voltage must be supplied via a permanent mains cable with a flameproof outer sheath, according to VDE 0472.

- The mains cable must be protected using a fuse $I_N < 6.3$ A (power consumption when fully assembled < 1 A).
- Unscrew lid of mains connection box
 - Enter mains cable into mains connection box using the PG screw gland (PG 13.5) on the housing base plate and connect in correct phase sequence.

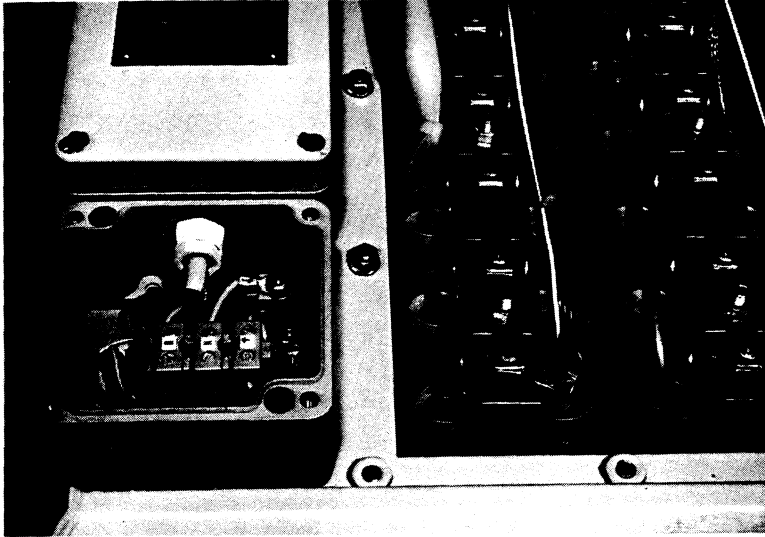
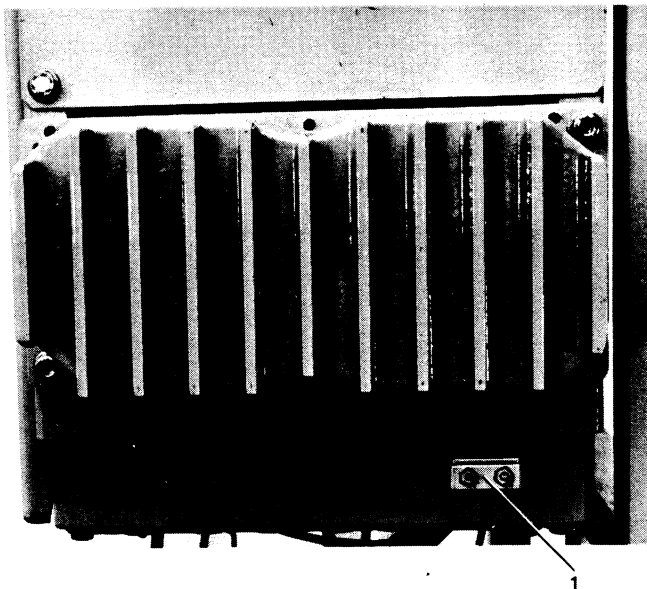

Fig. 10 Connecting the mains cable

2.2.3 Earthing the Field Multiplexer

The field multiplexer housing must be connected to the field earthing system using a copper cable with a diameter of at least 10 mm^2 .



1 Earthing point

Fig. 11 Earthing the field multiplexer

2.2.4 Connecting the Remote Cable

The remote cable must be designed with screened cables, twisted in pairs. The cable sheath must be marked light blue in the Ex area, in accordance with VDE 0165.

The cable screen must be contacted with the cabinet earth in both the FM 100 and AS cabinets.

When installing in the Ex area (Ex zone 1), the length of the remote cable is limited by the maximum cable inductance and capacity values stated in the PTB conformity certificate.

The limit values are:

$L_{\max} = 1 \text{ mH}$ When connecting according to Figs. 13 and 15
 $C_{\max} = 210 \text{ nF}$

$L_{\max} = 1 \text{ mH}$ When connecting according to Fig.14
 $C_{\max} = 160 \text{ nF}$

When the FM 100 is operating outside the Ex area, the permissible length of the remote cable depends on the type of cable installed.

If the recommended cable type is being used, the permissible cable length is max. 2 km.

Connecting the Remote Cable in the FM 100 Cabinet

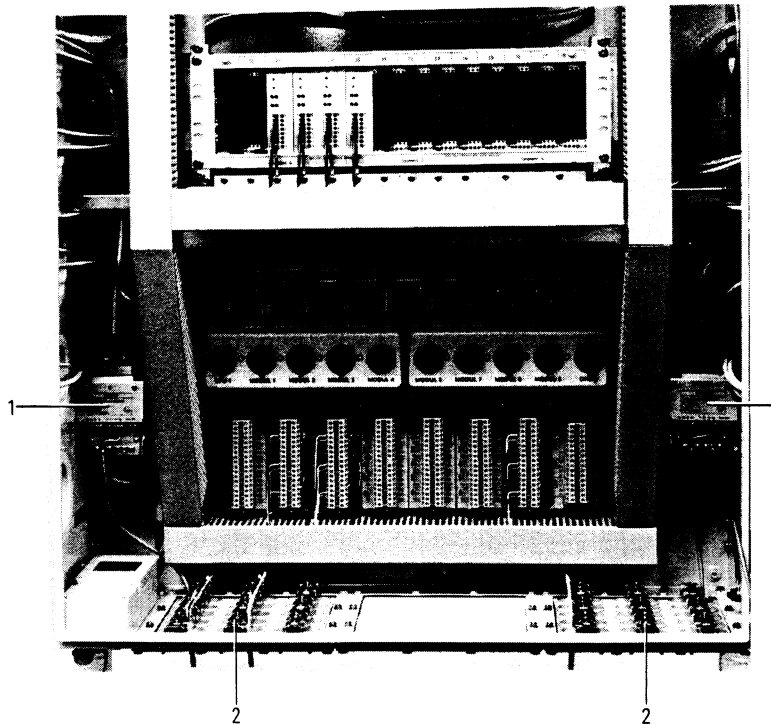

- 1 Remote cable connector boards
- 2 Cable detensioning clamp for screen sheath wire

Fig. 12 Layout of remote cable connector boards

The remote cable must be connected to the FM 100 as shown and mechanically attached to the cable detensioning clamp using cable binds.

In the case of remote cables with foil screening, the screen sheath wire must be connected to the cable detensioning clamp terminal screw. Braided screens must be contacted onto the remote cable detensioning clamp cable grip.

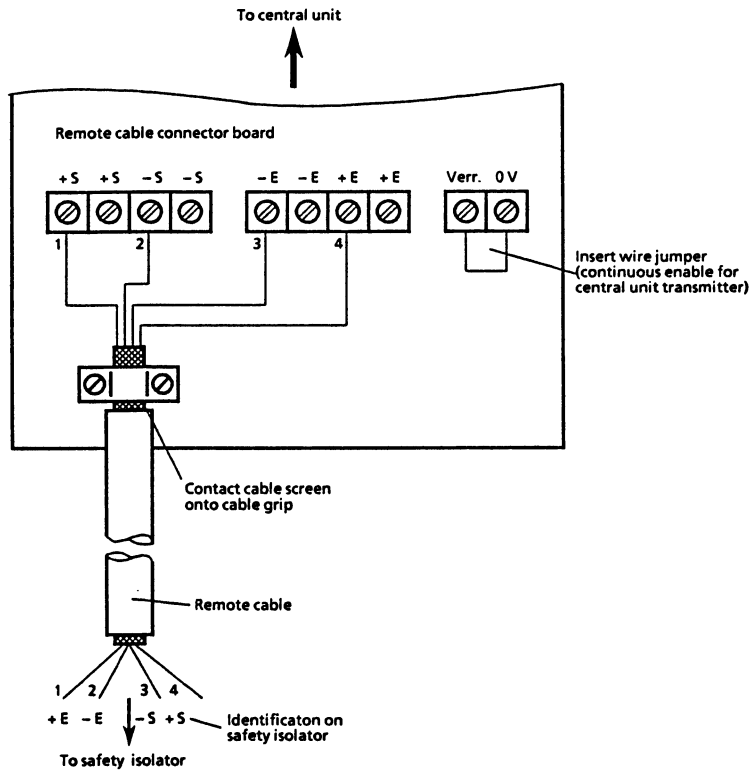
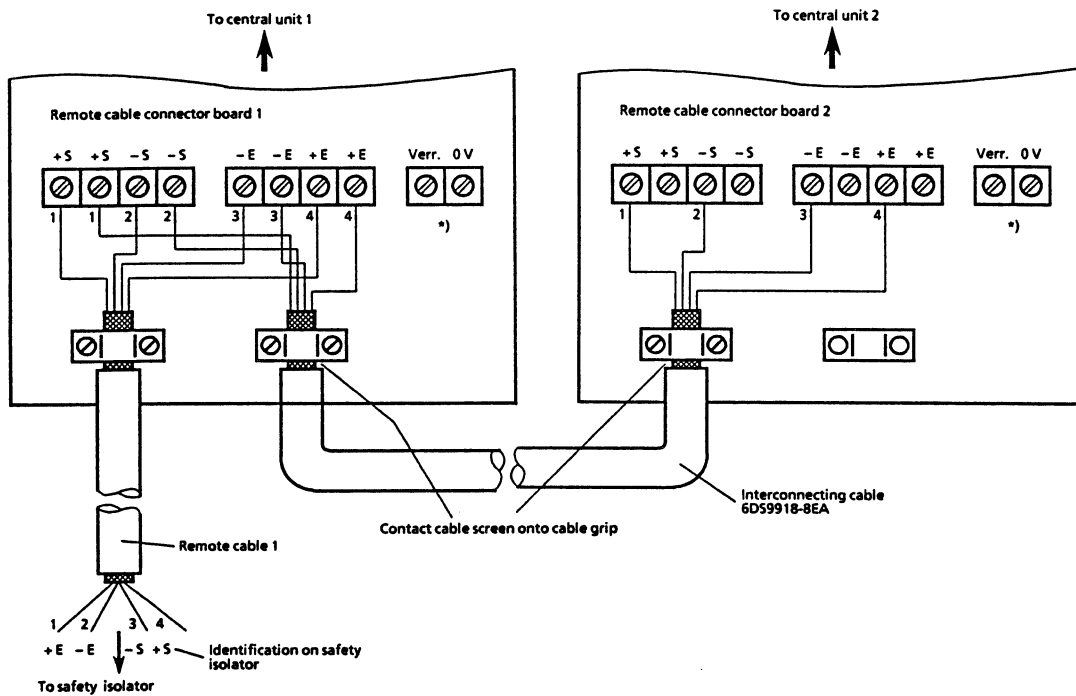

Fig. 13 FM 100 without central unit redundancy (FM arrangement 1)

Verr. = interlocking device input



*) Do not insert a wire jumper between terminals "Verr." and 0 V, as both central units mutually control their transmitters.

Fig. 14 FM 100 with central unit redundancy, control center coupling via one 4-core cable (FM arrangement 2)

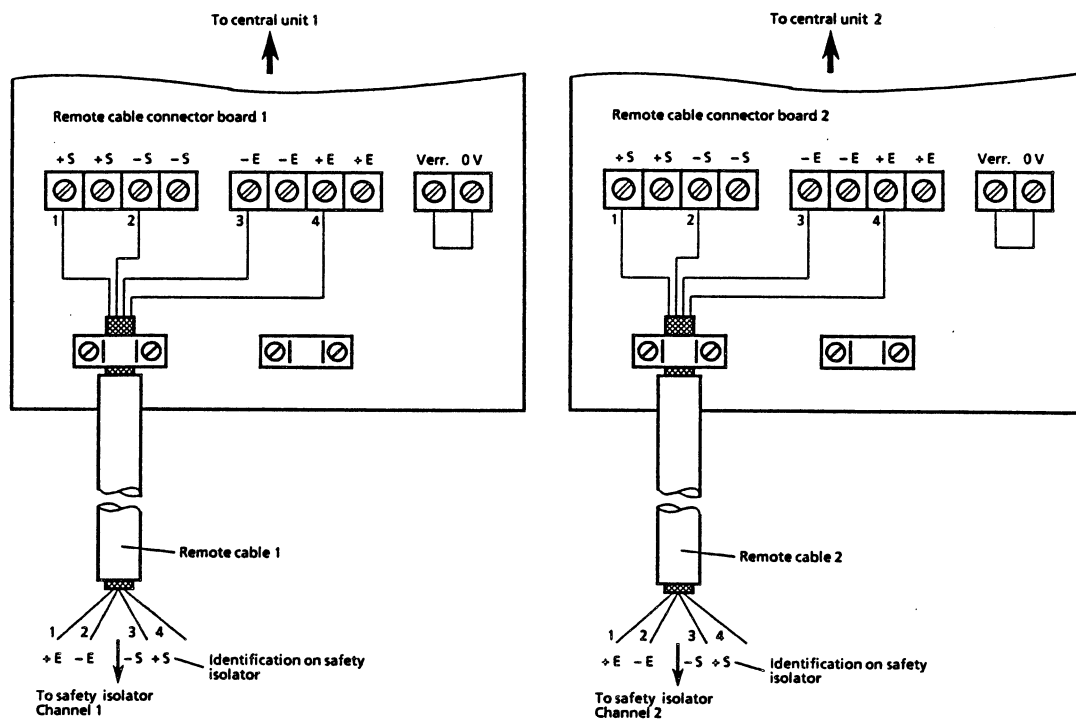

Fig. 15 FM 100 with both central unit and remote cable redundancy (FM arrangement 3)

Connecting the Remote Cable in the AS Cabinet

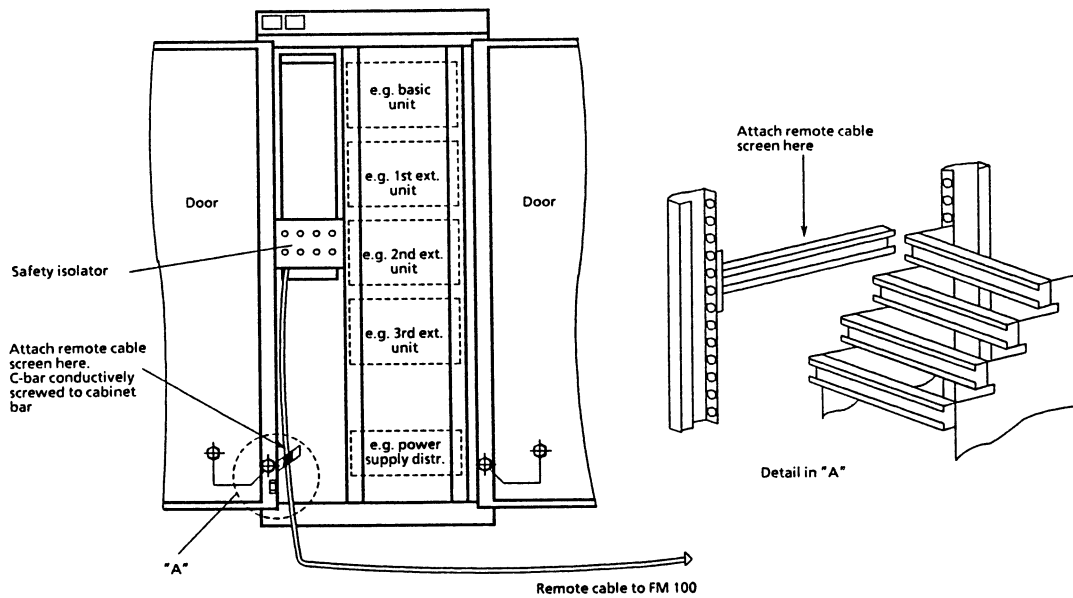

Fig. 16 Installing the remote cable in the AS cabinet

The safety isolator should be mounted next to the subrack containing an interface module and connected to the interface module slot (for wiring details, see instructions for interface module).

The remote cable is led through the cabinet floor and clamped onto the safety isolator terminal screws.

The remote cable screen must also be led right up to the safety isolator in the AS cabinet and attached to the C bar, which is screwed onto the left cabinet bar.

Do not attach to separately installed cable screen detensioning clamp for the process cable or to the safety isolator.

The cable screen must **not** be interrupted at the point of contact.

(Method of establishing contact given in Figs. 17 and 18).

The remote cable need only be mechanically attached to the safety isolator.

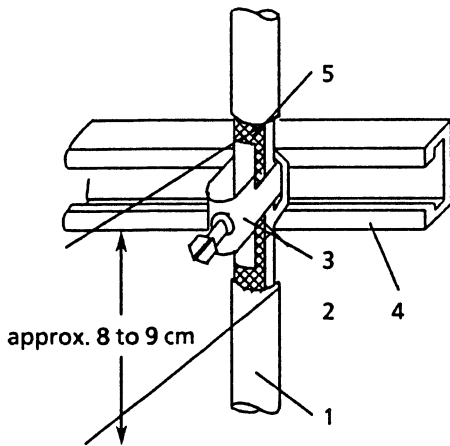

- 1 Remote cable with braided screen
- 2 10 mm-long trough PUK Co. Order No. 14.185
- 3 8-12 mm cable clamp PUK Co. Order No. 1.198
- 4 Cable detensioning clamp (C-bar)
- 5 Braided screen wrapped with bared wire

Fig. 17 Attaching a braided screen

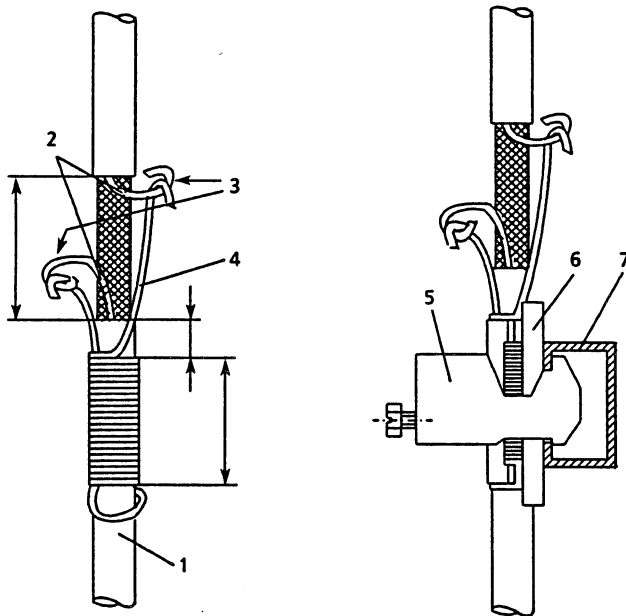

- 1 Remote cable with foil screen
- 2 Screen sheath wire
- 3 Soldering points
- 4 Bared copper wire e.g. remaining screen sheath wire
- 5 8-12 mm cable clamp PUK Co. Order No. 1.198
- 6 10 mm-long trough PUK Co. Order No. 14.185
- 7 Cable detensioning clamp (C-bar)

Fig. 18 Attaching a foil screen

2.2.5 Connecting the Field Cables

The field cables must be led into the field multiplexer housing through the base plates and mechanically secured to the cable detensioning clamp using cable binds. The field cable screen must be attached to the cable detensioning clamp earthing terminals.

The signalling lines are clamped directly onto the front panels of the I/O modules.

Connections on the sensor side must be carried out according to the instructions for I/O modules.

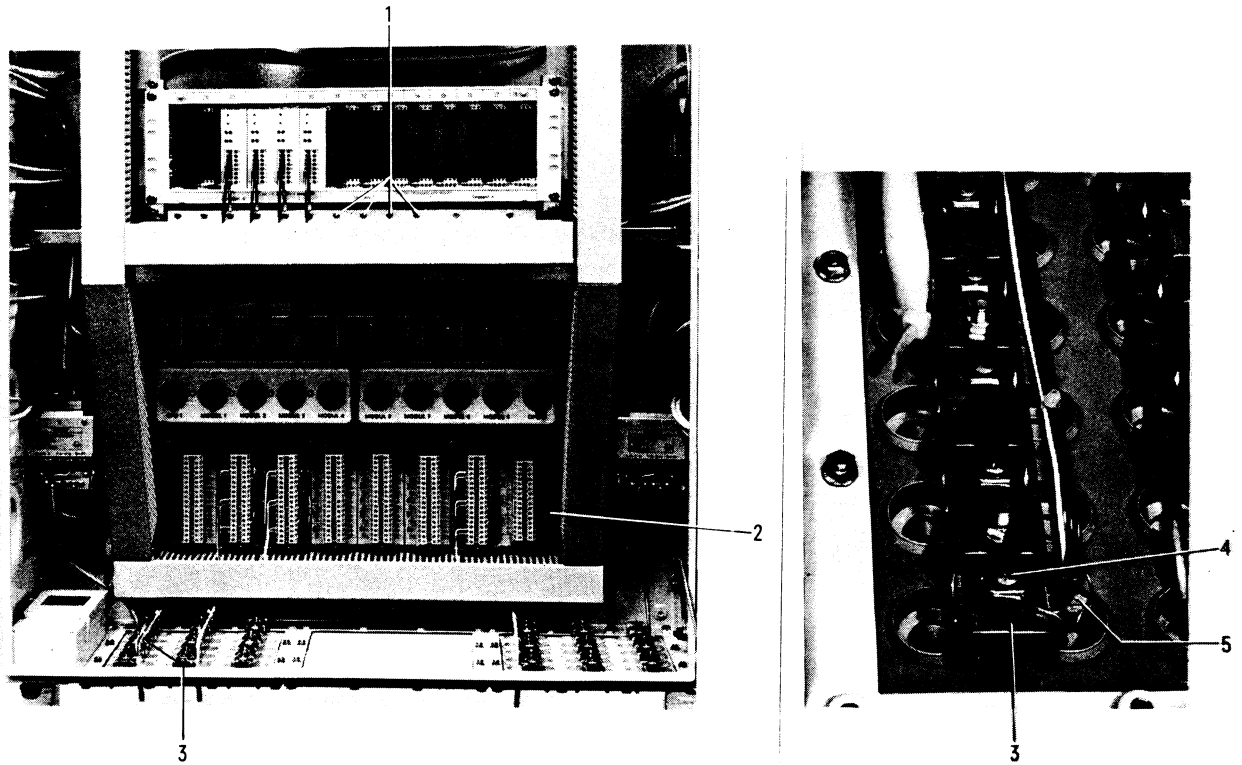

- 1 Earthing terminal for I/O modules
- 2 Terminal strip for connection of transducer
- 3 Cable detensioning clamp
- 4 Screen earthing terminal
- 5 Cable bind

Fig. 19 Connecting the field cables

2.2.6 Connecting the Transducers

Transducers can only be connected if the FM 100 is equipped with power supply modules 6DS4418-8AA.

Each fitted power supply module is assigned an 8-pin terminal strip in the lower section of the FM cabinet (see Fig. 19, part 2). Up to 6 transducers can be connected to this terminal strip.

The following block diagram shows the connection of a transducer to the terminal strip.

The sensor circuit - consisting of a transducer and connecting cable - must not exceed the following capacitive and inductive limit values:

$$L_{\max} = 0.5 \text{ mH}$$

$$C_{\max} = 110 \text{ nF}$$

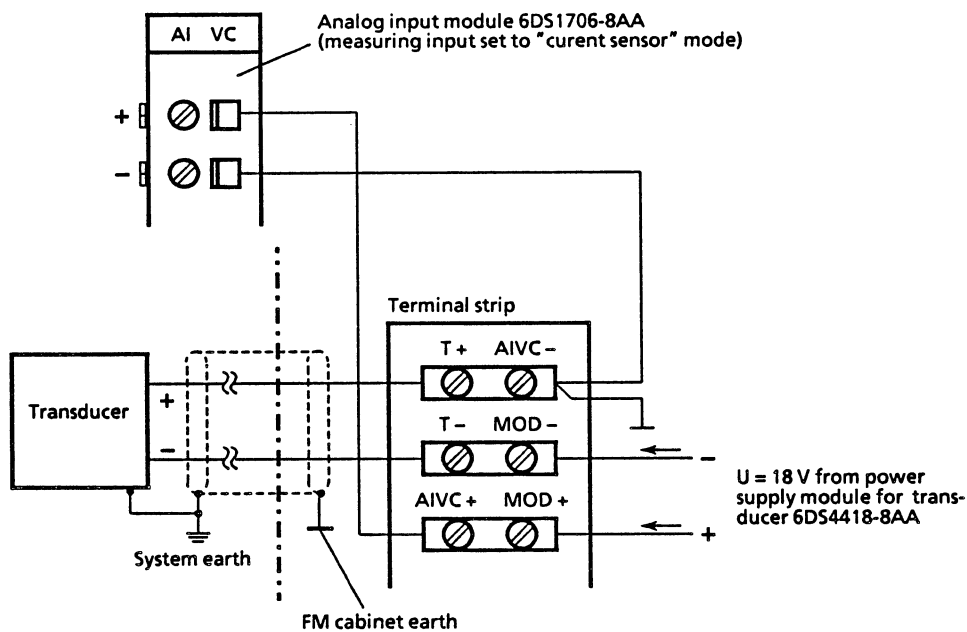

Fig. 20 Connecting a transducer

2.2.7 Connecting and Setting the Pneumatic Reducer Assembly

The air supply necessary for operating the electropneumatic modules must be fed to the pneumatic reducer assembly from a compressed-air system using a maximum pressure of 16 bars.

The pressure regulator must be turned to "closed" (left end stop) before connecting it to the compressed-air system. The air supply pressure must be set to 1.4 bars after connection.

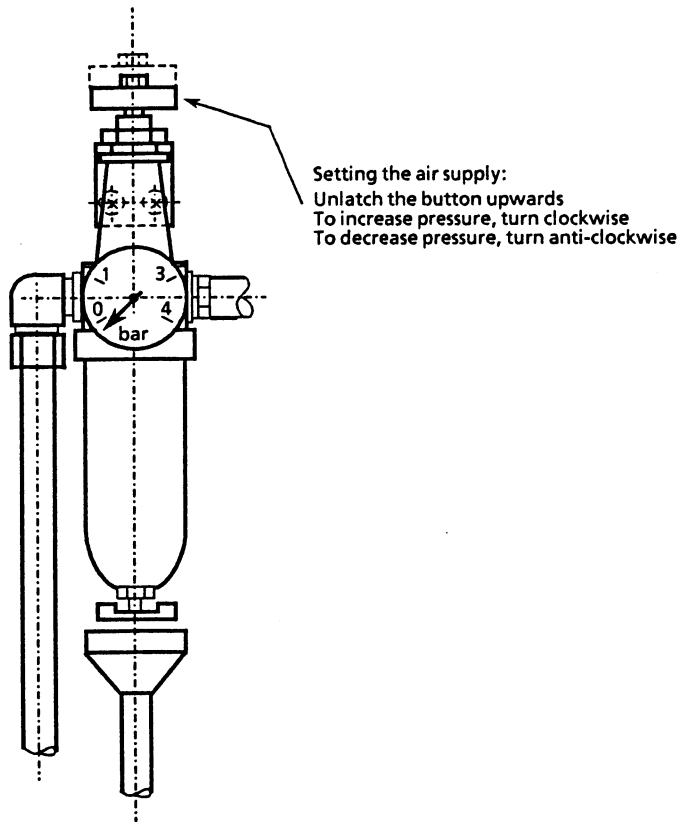

Fig. 21 Setting the air supply

2.2.8 Connecting an External Emergency Stop Switch

This can be done via the emergency stop switch terminals provided on the basic subrack PCB and enables the output modules to be switched over to the "safety setting" or "last value retained" modes. For position of terminals, see Fig. 5.

If an extension subrack is available, its emergency stop switch terminals should be connected in parallel with those of the basic subrack.

The emergency stop switch should be treated like an NC contact, i.e. an opened contact corresponds to the emergency stop setting. If the FM is to be controlled via several emergency stop switches, then these must be connected in sequence.

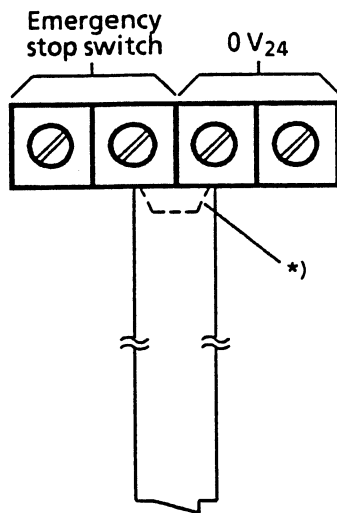

external emergency stop switch

Fig. 22 Connecting the emergency stop switch

The following limit values for line capacitance and inductance must be observed when connecting emergency stop switches:

$$L_{\max} = 10 \text{ mH}$$

$$L_{\max} = 95 \text{ nF}$$

2.3 Setting

Caution

The I/O modules contain electrostatically sensitive components. Regulations about handling such modules must be observed during installation and commissioning, in order to prevent the destruction of any components due to electrostatic charges.

The address of the modules in the subrack is set at the factory, in ascending order or according to the planning documents.

These settings should be re-checked and additional ones made for such things as the measuring range, open-circuit signalling, etc., before connecting the field cable.

For details about setting the I/O modules, see instructions and planning documents on the I/O modules.

The address area of the FM 100 runs from 0 to 44. Due to the design of the FM interface module's transfer RAM, fixed addressing areas, which are set for individual I/O module types, overlap each other.

Double addressing must be avoided, i.e. a fixed address may only be assigned once.

2.4 Commissioning

Once the mains voltage has been applied (mains switch of available central unit and power supply module set to position 1), the field multiplexer is ready for operating.

The central unit conducts an automatic processor startup and finally communicates with the FM interface in the higher-level automation system and the I/O modules in the field multiplexer.

Correct functioning is displayed on the central unit's 3-color LED as follows:

- field multiplexer with one central unit: LED lights green
- field multiplexer with two central units
 - active central unit : LED lights yellow
 - standby central unit: LED lights red

For further LED displays (faults), see Section "Troubleshooting".

Correct functioning of the +12-V power supply module 6DS4413-8AA is signalled by the LED on the power supply module lighting up, while at the same time being monitored by a bus signal (SVÜ) from the central unit.

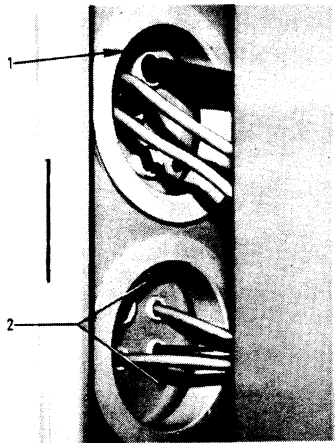

- 1 LED, central unit
- 2 LED, power supply module for I/O modules

Fig. 23 Diagnostic LEDs

Please note:

With FM arrangement 3, the active central unit must be temporarily switched off after power-up (for approx. 30 seconds).

This ensures that the standby interface module becomes active and is supplied by the AS with the linearization parameters necessary for analog value processing.

The original remote cable branch is reset in analog and is done by temporarily switching the active central unit back on.

If this procedure is not carried out after power-up or voltage failure, then the AS will recognize the temporarily non-linearized analog values when activating the standby interface module.

3 Maintenance

3.1 Method of Operation

3.1.1 Central Unit

The accessible central unit interfaces are of an intrinsically-safe design. The housing contains a CPU with the following functional components:

- processor section with both a program and a data memory
- serial interface with USART for coupling the field multiplexer to the higher-level automation system
- I/O interface with I/O block for controlling the I/O modules
- analog/digital converter with programmable measuring amplifier for acquiring analog field signals
- digital/analog converter for cyclic function control
- constant-current source for supplying resistance-type sensors
- reference voltage source for supplying I/O modules (e.g. limit value signaller)
- Monitoring circuit for recognizing faulty operation sequences and supply voltages
- power supply section for supplying the internal central unit logic and I/O modules.

• Serial interface

The serial interface consists of a floating, intrinsically-safe 20 mA interface.

The transmission and receiving line is supplied by the intrinsically-safe central unit current sources.

The remote cable is connected to the interface module 6DS1304-8AA in the higher-level automation system via the safety isolator 6DS3902-8AA in order to isolate the Ex- (zone 1) and maintenance areas.

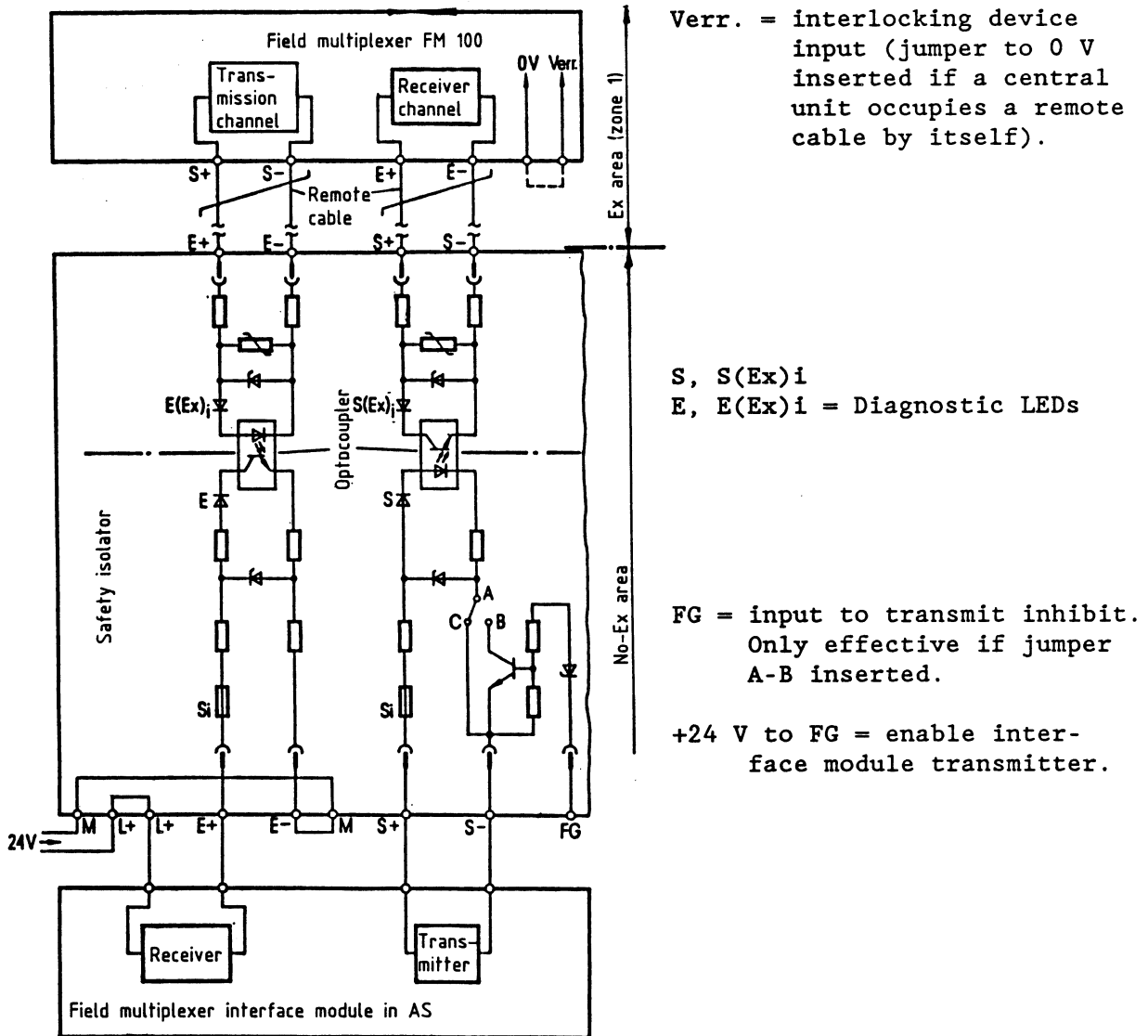
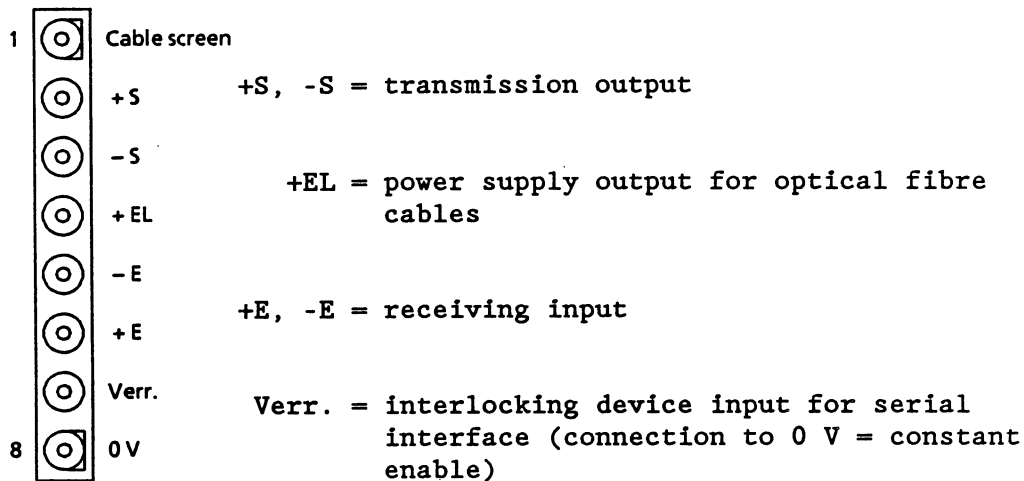

Fig. 25 Basic design of transmission link

Terminal assignment of the serial interface on the central unit.



The interlocking device input "Verr." is always connected to 0 V if a central unit occupies a remote cable by itself. This is done by inserting a wiring jumper in the remote cable connector board in the FM 100.

If two central units are connected to one remote cable for reasons of redundancy, then the interlocking device input must remain unoccupied. When operating in this way, the central units mutually interlock their interfaces via I/O bus connections.

● Monitoring logic

The monitoring logic in the central unit reacts to internal and external operational faults and transmits fault displays in a message to the higher-level automation system as soon as possible.

If serious faults occur and prevent data transmission, then the faulty central unit switches off, thus enabling the redundant central unit (if one is present).

Examples of operational faults which are displayed, but do not cause the central unit to switch over:

- faulty +12-V module
- faulty standby central unit
- defective relay contact or double addressing of I/O modules
- switchover to emergency stop mode

Examples of operational faults which cause the central unit to switch off or switch over to standby mode:

- internal central unit faults, such as RAM, PROM, or microprocessor faults
- faults in data transmission to the automation system
- faults on the I/O bus
- Analog/digital converter (ADC)

The ADC acquires analog values and works in semi-integration with a resolution of 11 bits + sign.

The measuring signal is adapted to the ADC input using a programmable measuring amplifier.

The measuring range code which assigns the amplifier is transmitted in the feedback signal to the central unit by the addressed I/O module (for coding, see instructions to analog input module).

- Constant-current source

The constant-current source ($I_K = 2 \text{ mA}$) which supplies the resistance-type sensor and is connected to the I/O bus, is of an intrinsically-safe design. During analog value acquisition with resistance-type sensors (e.g. Pt 100 sensor), is temporarily switched from the I/O module to the resistance-type sensor. This is done via relay contacts and only during the coding time.

- Terminal temperature sensor

A Pt 100 temperature sensor is fitted to the I/O basic subrack for acquiring the terminal temperature.

The measuring value acquired via these sensors is transmitted to the FM interface module via thermocouples. The FM interface module then uses this value as compensation for the thermoelectromotive voltages which occur at the I/O module terminal connections.

The terminal connection temperature is acquired at the end of an FM acquisition cycle and transmitted to the interface module with the "terminal connection temperature" message.

● I/O bus

Communication between the central unit and I/O module occurs via the I/O bus.

The following pulse diagram shows basically how an I/O sequence operates, using the processing of a 16-bit binary input as an example.

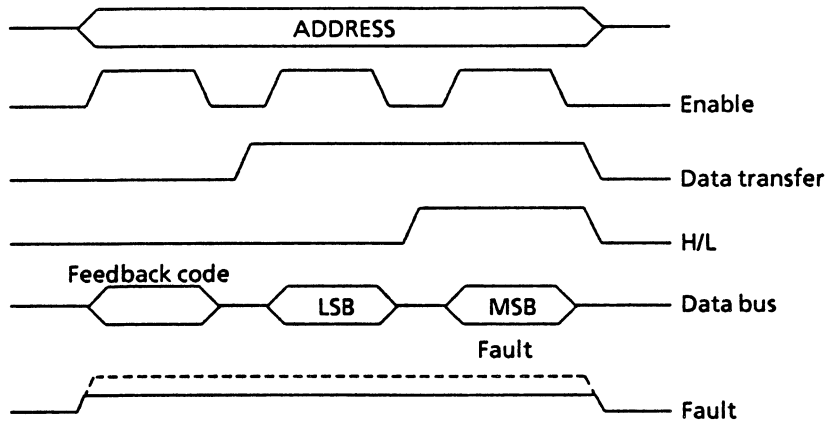

Fig. 26 I/O sequence of a 16-bit input

When transmitting the first enable pulse, the central unit demands a module-specific feedback code from the addressed I/O module.

This feedback code helps the central unit to identify the type of I/O module addressed and thus issue the bus signals necessary for further processing. When data are being exchanged during fault-free operation, the fault line (FE) is located on a level of approx. 24 V. If several I/O modules are erroneously set to the same address (double addressing), the fault line takes up a level of >3 V and identically-set I/O modules suppress their feedback codes.

If it does not receive a feedback code, the central unit checks the fault line and signals the operating fault to the higher-level automation system (fault signal no. * S 776).

During fault-free operation, the central unit, assisted by the feedback code, forms the control signals necessary for data exchange.

For greater details on module-specific I/O sequences, see instructions on corresponding I/O module.

● Monitoring analog inputs

Should a relay on an analog input module be continuously triggered or a relay contact be stuck due to a relay fault, then the corresponding measuring point on the analog bus remains static. If this fault occurs, all further analog value multiplexing must be prevented.

The central unit recognizes such a fault by the signal status on the I/O bus cable "PS". If operation is fault-free when the feedback signal occurs, then the PS signal is always located on the 0 level. In the case of a fault, the PS signal for those measuring channels which are still intact is switched to level 1, thereby preventing these analog channels from being multiplexed.

The central unit recognizes the faulty measuring value channel and faulty measuring point relay by the fact that the PS signal only indicates no fault (PS signal = 0) when addressing the faulty channel.

If it recognizes a relay fault, the central unit transmits a fault message to the higher-level automation system. The AS signals a relay fault using the system signal analog input module fault no. * S7XY (XY = module no.).

3.1.2 I/O Subrack (see Fig. 27)

The I/O subrack wiring consists of a bus PCB with plug connectors located on the side for attaching up to 2 central units.

The subrack socket connectors are used for contacting the I/O modules and are subdivided into 3 segments as far as the +12 V supply voltage is concerned.

Each of these 3 segments has 2 plug connectors for redundantly supplying the I/O modules with +12 V. A plug-in jumper 6DS9918-8AA can be inserted into each 2nd plug connector, thereby establishing a link between segments lying in direct juxtaposition to each other.

Two Pt 100 temperature sensors are mounted to the basic subrack C79451-A3224-B50 for acquiring the terminal temperature. These sensors help the active central unit to determine the terminal connection temperature in the FM housing and transmit these values to the interface module. The interface module compensates the thermo-electromotive voltages occurring at the terminal connections, using the existing values.

The wiring of the extension subrack 6DS9100-8AA is identical to that of the basic subrack.

The extension subrack only differs from the basic one in that it has no temperature sensors or bus terminating resistors and its connector pin locations are not the same.

To install a basic and an extension frame together, the extension frame must be linked to the basic one via a cable connector (join left plug connector of extension frame to right plug connector of basic frame).

If an extension subrack is available, the redundant central unit is connected to the right plug connector of the extension frame.

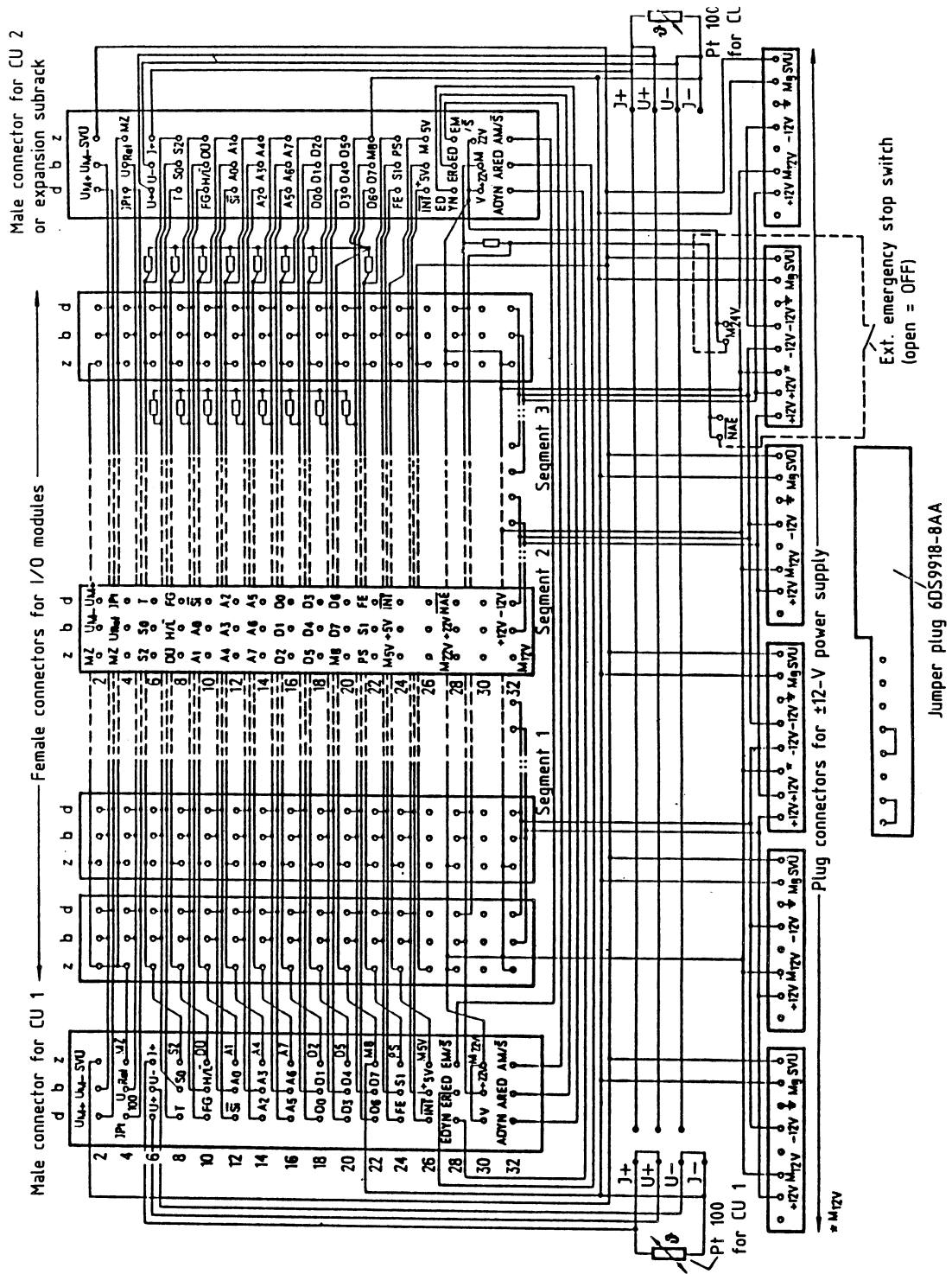

Fig. 27 Wiring of the basic module C79451-A3224-B50

Meaning of the interface circuits on the I/O bus

- A0 to A7 = Address line 0 to 7
- A_{M/S} = Master/slave control output
Used to activate a redundant standby central unit.
(1 = switch redundant central unit to operating mode).
- A_{DYN} = Signal output for dynamic control of serial interface
This signal is used by central unit to inform the redundant central unit about correctly operating data traffic with the AS system
(0 = fault)
- A_{RED} = Signal output for availability
The central units communicate their availability by means of this output (redundancy operation)
(0 = central unit unavailable)
- D0 to D7 = Data lines 0 to 7
- D_Ü = Control signal for I/O cards
D_Ü is used to transmit data between the central unit and I/O cards
- E_{M/S} = Control input for switching over from master to slave operation
(1 or open = master operation)
- E_{DYN} = Input for monitoring the serial interface of the redundant central unit
(0 = data between the redundant central unit and the AS is faulty)
- E_{RED} = Signal input for recognizing when the redundant central unit is ready
(0 or open = central unit redundancy unavailable)
- F_E = Bus line for recognizing double addressing.
(level > 2.4 V when I/O feedback signal is being applied
= double addressing)
- F_G = I/O module enable
- H/L = Discrimination between higher- and lower-value data bytes during transmission of a 16-bit data
(1 = higher-level data byte)
- I+ = Constant-current output for supplying the terminal temperature sensor
(I_k = 2 mA)

$I_{Pt\ 100}$	= Constant-current output for supplying the resistance-type sensors ($I_k = 2\text{ mA}$)
INT	= Interrupt input
MZ	= Analog earth and neg. current path for I+ and $I_{Pt\ 100}$
M_{BUS}	= Earth for logic signals
NAE	= Line for connecting an external emergency stop switch (open = emergency stop operation) When the emergency stop contact is open, the corresponding planned output modules are switched to the safety setting
So	= SOD output central unit - processor (reserve)
S1	= SID input central unit - processor (reserve)
S2	= Control output (reserve)
Si	= Control output for switching output modules over to safety position
SVÜ	= Monitoring input for monitoring the +12 V power supply module (0 = power supply module failure)
T	= Trigger output (reserve)
U_{REF}	= Reference voltage output $U_{REF} = +10\text{ V} + 1\% I_{max} = 5\text{ mA}$
$+U_M, -U_M$	= ADC measuring channel for field signals
$U-, U+$	= ADC measuring channel for terminal temperature sensor
V	= 0 V Informs the central unit that the I/O bus connector is inserted If the I/O bus connector is withdrawn, the central unit switches off
+5 V $M_5\text{ V}$	= Intrinsically-safe 5-V supply voltage for supplying the I/O modules $I_k = 180\text{ mA}$
$U_{22}\text{ V}$ $M_{22}\text{ V}$	= Intrinsically-safe +22-V supply voltage for supplying the I/O modules $I_k = 75\text{ mA}$
+12 V	= Intrinsically-safe +12-V supply voltages (supplied by the +12-V modules)

3.1.3 +12-V Power Supply Module 6DS4413-8AA, for I/O Modules

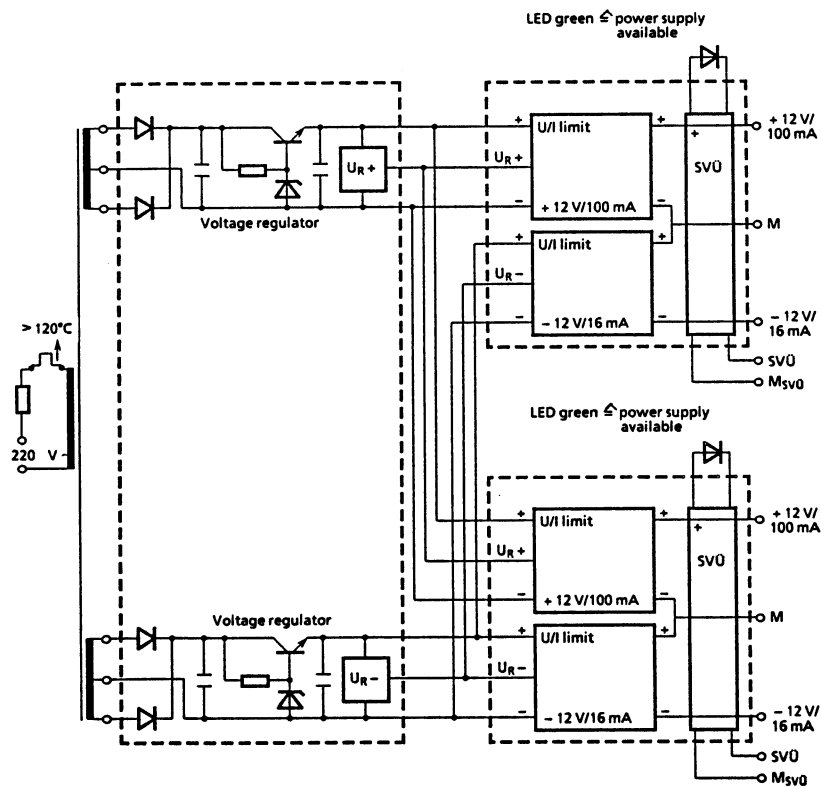
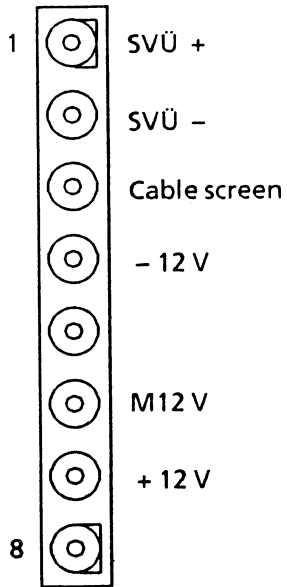

Fig. 28 Block diagram of the +12-V power supply module for I/O modules

Each power supply module has 2 intrinsically-safe pairs of outputs, as shown in the block diagram. When contacted to the subrack, the SVÜ output is connected to the SVÜ input in the central unit and signals the power supply module failure using the 0 V signal.

A redundant supply can be established by the parallel connection of either both outputs of one module or two outputs of different 12-V modules. To do this, link the outputs to a subrack power supply segment.

Cable connector assignment



3.1.4 Power Supply Module 6DS4418-8AA, for Transducers

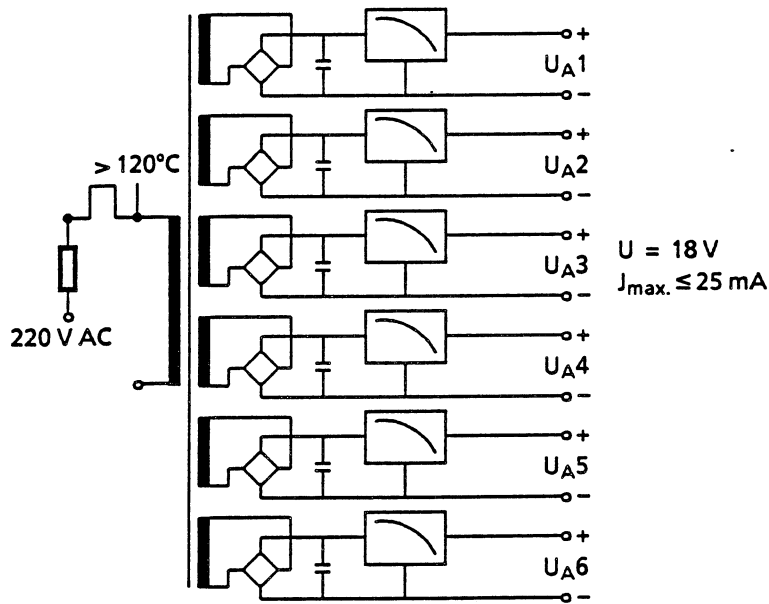

Fig. 29 Block diagram of power supply for transducers

Each power supply module has 6 similar floating outputs, one above the other.

The voltage outputs are intrinsically-safe, short-circuit-proof and have a current limit which operates at $J > 30$ mA.

The operational current load must not exceed 25 mA. The outputs **may not** be connected in parallel.

If an output is overloaded, the output voltage will abruptly break down.

Output cable assignments:

Voltage output		Core color	Bundle
1	+UA1	red	1
	-UA1	blue	
2	+UA2	yellow	
	-UA2	gray	
3	+UA3	green	
	-UA3	brown	
4	+UA4	white	
	-UA4	black	
5	+UA5	red	2
	-UA5	blue	
6	+UA6	yellow	
	-UA6	gray	

3.1.5 Reaction and Switchover Behaviour of the Different Field Multiplexer Arrangements

Abbreviations and terms used:

- AS = automation system
- FM = field multiplexer
- ABG = field multiplexer interface module
- ZT = central unit

Alarm bit = fault bit in message, which signals to the linked unit that the time monitoring has responded on the ABG or in the FM central unit.

Time monitoring in the ABG = responds if the AS does not access the ABG transfer RAM for more than 12 seconds or if the ABG does not recognize a fault-free message for more than 1 second.

Time monitoring in the FM-ZT = responds if no/a faulty receive message from the central unit is recognized for over 1 second.

Arrangement	Fault	Reaction
<p>The diagram shows a vertical stack of components. At the top is a box labeled 'AS' (Automation System) with a smaller box labeled 'ABG' (Field Multiplexer Interface Module) inside it. Below the AS box is a box labeled 'FM' (Field Multiplexer) with a smaller box labeled 'ZT 1' (Central Unit) inside it. A vertical line connects the bottom of the AS box to the top of the FM box, representing the communication link between them.</p>	AS failure	<p>ABG recognizes AS failure via time monitoring and inserts an alarm bit in the message to the FM. The FM goes into standby mode and conducts a dynamic check with the ABG.</p> <p>The FM output modules are switched to safety setting.</p> <p>When the AS recovers, the alarm bit in the message is reset and the ZT enters normal operation.</p>
	ABG failure	<p>AS recognizes ABG failure. FM recognizes ABG failure via time monitoring and goes into standby mode. FM output modules are switched to safety setting.</p> <p>ZT tries to conduct a dynamic check with the ABG. When the ABG recovers, the ZT enters normal operation.</p>
	ZT failure	<p>ABG recognizes ZT failure via time monitoring and signals fault to AS. Output modules are switched to safety setting. When ZT recovers (e.g. after replacing), the FM goes into normal operation.</p>

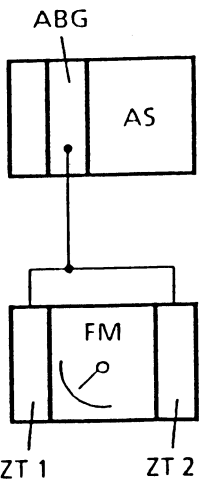
Arrangement	Fault	Reaction
 <p>The diagram illustrates the electrical arrangement. At the top, a rectangular box labeled 'AS' contains a vertical line labeled 'ABG'. A line extends downwards from the 'ABG' line to a second rectangular box labeled 'FM'. The 'FM' box is connected to two vertical lines labeled 'ZT1' and 'ZT2' at the bottom. A switch symbol is shown inside the 'FM' box, indicating a switching mechanism.</p>	<p>AS failure</p>	<p>ABG recognizes AS failure via time monitoring and transmits an alarm bit in a message to the FM, which then switches over from ZT1 to ZT2. ZT1 transmitter is switched off and ZT1 goes into standby mode. ZT2 also recognizes alarm bit, goes into standby operation and switches the output modules to safety setting. ZT2 conducts a dynamic check with the ABG. When the ABG recovers, ZT2 enters normal operation.</p>
	<p>ABG failure</p>	<p>AS recognises ABG failure. ZT1 recognizes ABG failure via time monitoring and switches over to ZT2. ZT2 also recognizes ABG failure and switches to standby mode. Output modules are switched to safety setting. ZT2 tries to conduct dynamic check with the ABG. When the ABG recovers, ZT2 enters normal operation.</p>
<p>ZT1 is the central unit which is switched to normal operation during system startup</p>	<p>ZT1 failure</p>	<p>ZT2 switches to normal operation and signals redundancy failure. When ZT1 recovers, ZT2 remains in operation.</p>
	<p>ZT2 failure</p>	<p>"Redundancy fault" signal to ABG.</p>

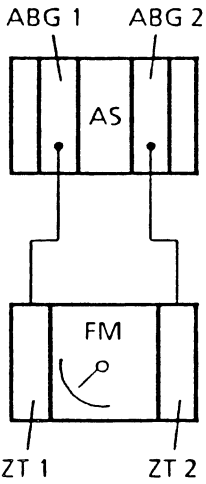
Arrangement	Fault	Reaction
 <p>ZT1 = master ZT2 = slave ABG2 determines this during startup, using an alarm bit.</p>	<p>AS failure</p>	<p>Both ABGs recognize AS failure and transmit an alarm bit to their central units. FM output modules are switched to safety setting. Both ZTs try to conduct a dynamic check with their ABGs. When the AS recovers, ZT1 re-enters normal operation (master).</p>
	<p>ABG1 failure</p>	<p>AS recognizes ABG1 failure and switches over to ABG2. ZT1 recognizes ABG1 failure and switches over to ZT2. ZT1 tries to conduct dynamic check with ABG1. When ABG1 recovers, channel 2 remains active until a fault occurs in it.</p>
	<p>ZT1 failure</p>	<p>FM switches over to ZT2 and signals switchover to ABG2. AS switches over to ABG2. ZT2 signals ZT1 failure to ABG2.</p>
	<p>ZT2 failure</p>	<p>ZT1 signals ZT2 failure to ABG1.</p>

3.2 Checking and Maintenance

The FM may be opened during operation for maintenance and repair work.

When working in the supply cable area, the respective functional branch must be de-energized.

The field multiplexer is not subject to any fixed checking and maintenance cycles.

Should a fault occur, fault displays are transmitted to the higher-level automation system via the serial interface.

If a fault signal can no longer be transmitted to the AS due to a faulty remote cable, then the faulty functional components can be located by means of the diagnostic LEDs in the field multiplexer (see Section "Troubleshooting").

If the field multiplexer has a pneumatic reducer assembly, the following maintenance work must be carried out from time to time:

- air filter must be changed from time to time
(the air filter can be accessed by unscrewing the liquid trap)
- liquid must be drained off.

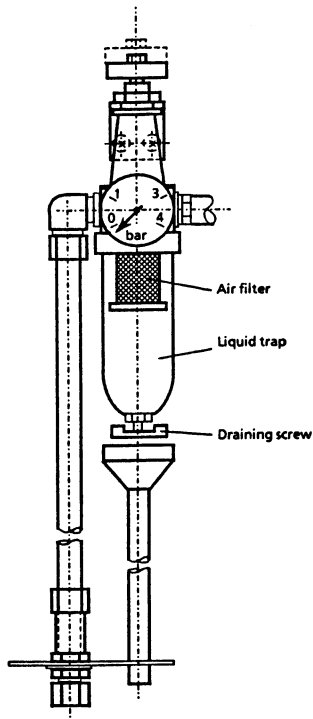

Fig. 30 Compressed-air distributor with pressure reducer

3.3 Repair Work

Repair work is confined to replacing faulty functional components such as the central unit, power supply module or I/O modules. Defective modules which have a supply connection, must be de-energized before replacing. For reasons of Ex safety, only the supplier may open enclosed FM components and repair modules.

3.3.1 Troubleshooting

● Should a fault occur:

- 1 Identify it using the I&C fault messages of the AS
- 2 Check and evaluate the diagnostic LEDs on the central unit and safety isolator, as well as those in the FM front panel (for meaning of LEDs in front panel of FM interface module, see instructions on interface module).

● I&C messages of AS

Message	Meaning	Possible source of fault
FM _{no} * S 770	FM interface module 1 faulty	- Incorrect module type - Interface module 1 defective
FM _{no} * S 771	Data transmission to FM 100 faulty ABG1 -> ZT1	- ABG1 transmitter defective - Safety isolator defective - FM central unit receiver defective
F _{Mno} * S 772	Data transmission to ABG1 faulty ZT1 -> ABG1	- FM central unit transmitter defective - Safety isolator defective
FM _{no} * S 773	FM central unit 1	- Central unit defective
FM _{no} * S 774	Peripheral power supply faulty	- One of the voltages attached to the I/O bus (+12 V, +5 V, +24 V) has been overloaded or has failed
FM _{no} * S 775	FM peripherals faulty	- I/O module blocking I/O bus
FM _{no} * S 776	Double addressing	- Several I/O modules set on same address
FM _{no} * S 777	FM interface system on emergency stop	- Emergency stop switch contact open (output modules in emergency stop operation)
FM _{no} * S 779	ABG cycle overload	
FM _{no} * S 780	Interface module 2 defective	- Interface module 2 defective, incorrect module type
FM _{no} * S 781	Data transmission to FM 100 faulty ABG2 -> ZT2	- ABG2 transmitter defective - Safety isolator defective - ZT2 receiver defective
FM _{no} * S 782	Data transmission to ABG2 faulty ZT2 -> ABG2	- FM central unit transmitter defective - Safety isolator defective - ABG2 receiver defective
FM _{no} * S 783	FM central unit 2 faulty	- Central unit defective
FM _{no} * S 785	Terminal temperature sensor faulty	- Terminal sensor defective or connecting lead interrupted
AEF _{no} * S 7XY	Analog input XY faulty	- Relay fault during analog value acquisition (a relay fault causes all analog inputs to be blocked)
type _{no} * S7XY	I/O module faulty	- Module not inserted - Measuring range overflow - Malfunction as a result of a relay fault

type = driver block (e.g.: AEF, AAF, BAF, BEF)
no = number of FM header or driver block
XY = module number

For general I&C alarms, such as ready delay of the FM interface module etc., see AS description.

● Meaning of LED statuses on central unit and safety isolator.

- Diagnostic LEDs on safety isolator

S = interface module transmitter circuit
 S (Ex)i = field multiplexer receiver circuit
 E = interface module receiver circuit
 E (Ex)i = field multiplexer transmitter circuit

- 3-color LED on central unit

FM 100 with **one** central unit

LED status	Operating status
off	- I/O bus connector on subrack not connected - mains voltage unavailable - hardware fault in central unit
green	Control center working correctly
flashing green	- ZT recognizes faulty receive message - FM driver program in AS not active
flashing yellow	ZT faulty

FM with **two** central units

LED status	Operating status
yellow	ZT in operating mode
red	ZT in standby mode
green	ZT active when central unit redundancy is not present
flashing green	- ZT recognizes faulty receive message when central unit redundancy is not present - FM driver program in AS not active
flashing red	- ZT recognizes faulty receive message when central unit redundancy is present
flashing yellow	ZT faulty when central unit redundancy is not present
off	- Mains voltage unavailable - Hardware fault in central unit - I/O bus connector on subrack not inserted

● Fault location

- Procedure in case of a fault in the remote cable interface

Fault image: data transmission to FM 100 faulty = system message S 771 or S 781.

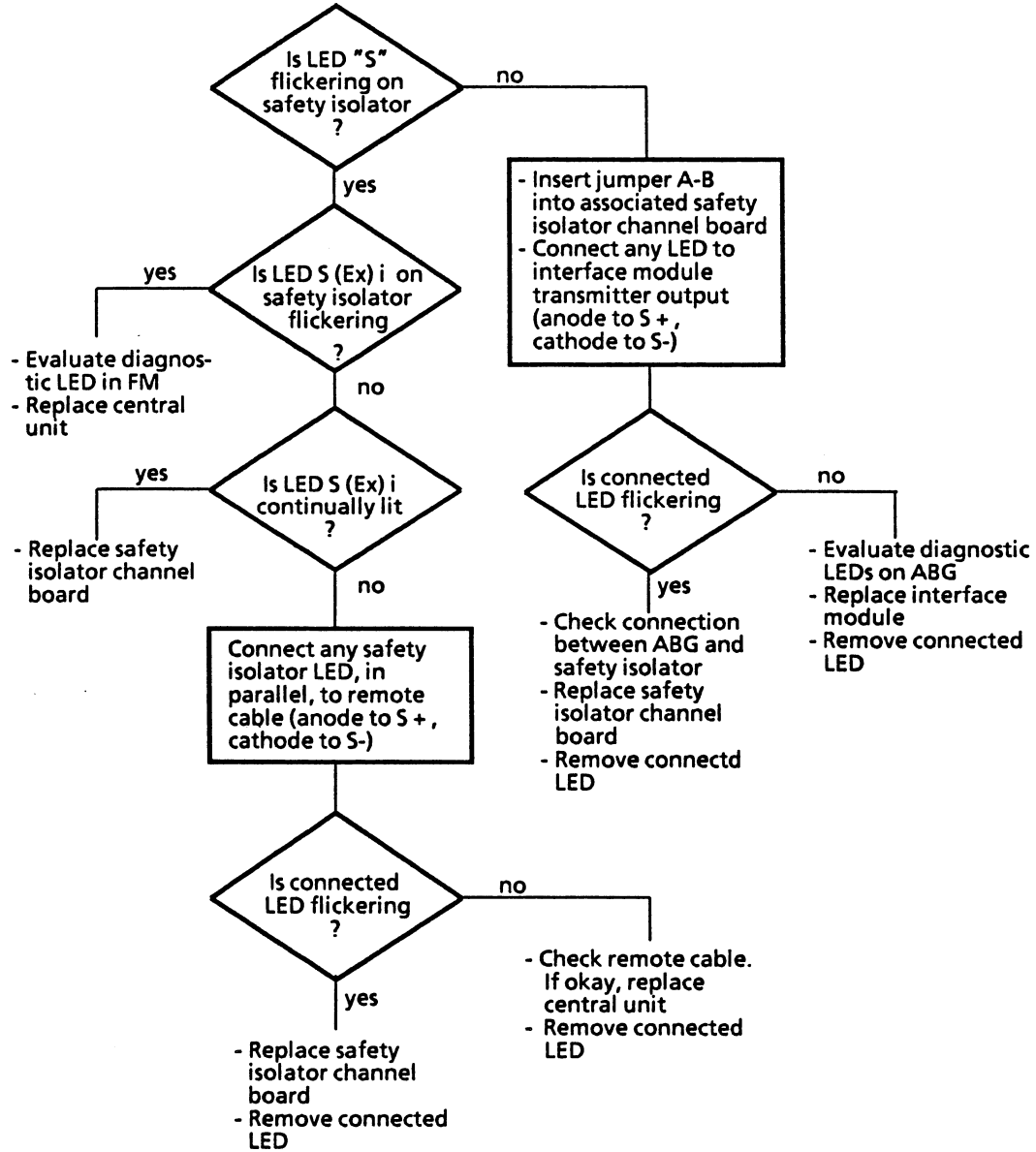

Fault image: data transmission to interface module faulty =
system message S 772 or S 782.

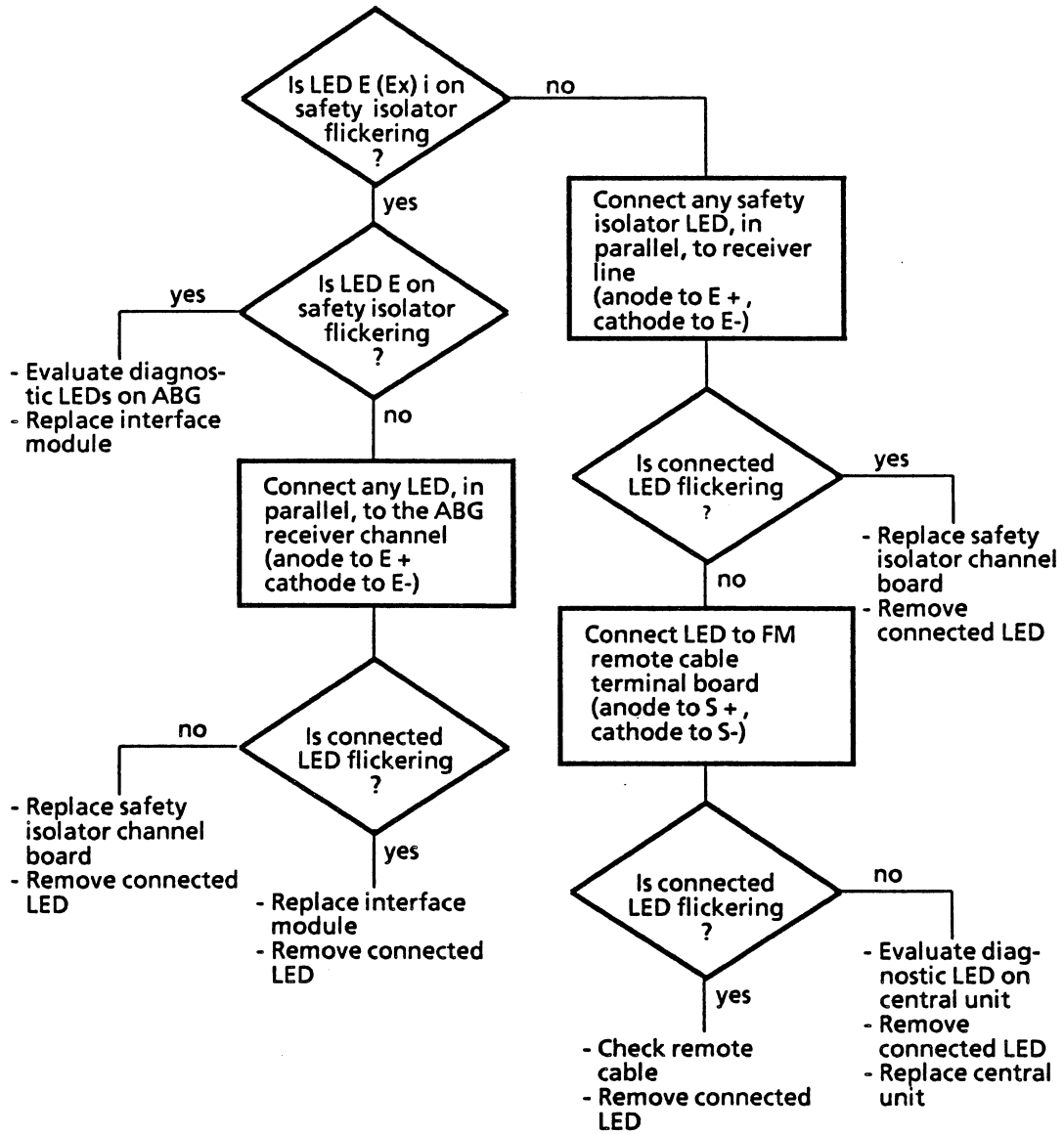

- Procedure in case of a peripheral power supply fault

Fault image: system message S 774

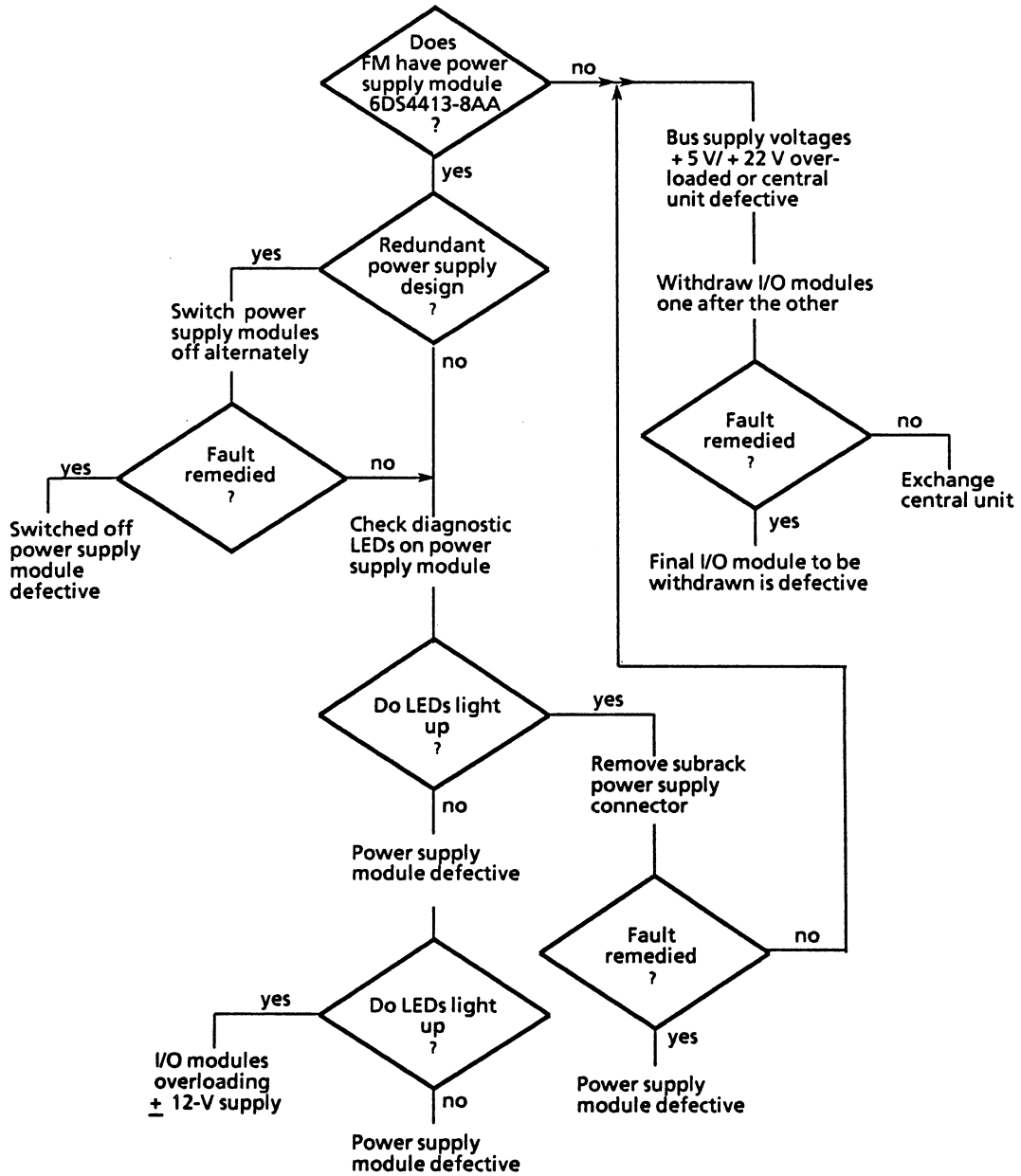

- Procedure in case of double addressing

Fault image: system message S776

- Output FM assignment list on the AS monitor and compare feedback data with assembly of I/O modules.
- One of the I/O modules missing from the assignment list is set to a wrong address or has a defective decoding logic.
- The defective or incorrectly-addressed module can be located by systematically withdrawing the I/O modules missing from the assignment list.

Caution: The assignment list must be re-requested following each withdrawal, as only then will the list be updated.

- Procedure in case of a central unit fault

Fault image: system message S 773 or S 783

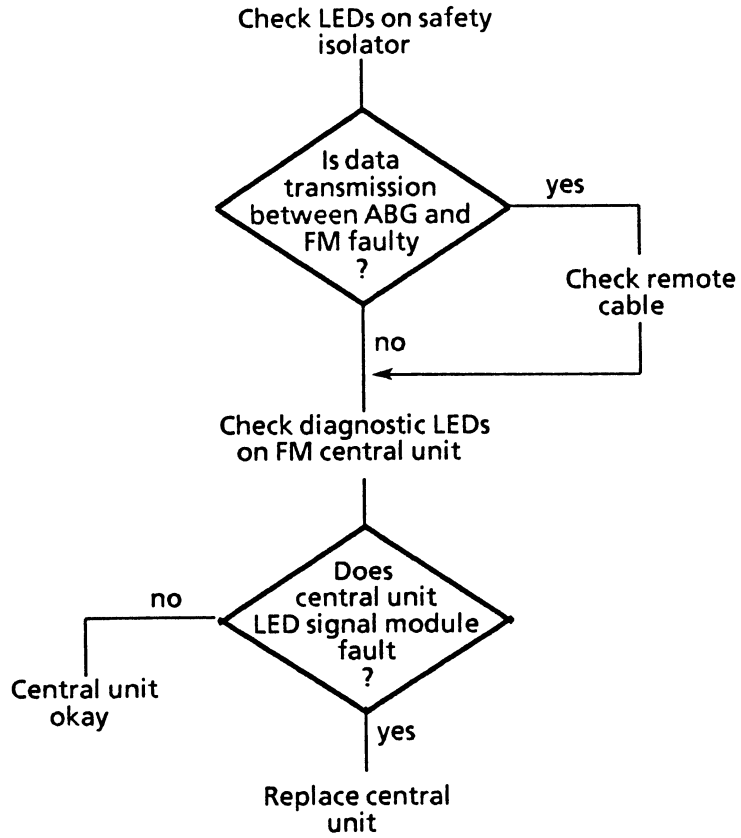

3.3.2 Replacing Powder-filled Functional Units

To replace powder-filled modules mounted on the FM cabinet, proceed as follows:

- set associated mains switch to 0
- disconnect mains cable from the associated terminals above the mains switch and immediately remove from the live device area
- remove signal lines of defective unit from the subrack
- carefully undo the fastening screw and remove the module.

Caution: Due to their powder filling, these modules are considerably heavy.

Central unit approx. 14 kg

Power supply units approx. 7 kg

- When mounting a module, ensure that the rubber seal between the module and the cabinet wall is in place. Damaged rubber seals must be replaced.

TELEPERM M

Field Multiplexer FM 100 Interface Module 6DS1304-8AA

Instructions

Order No. C79000-B8076-C091-03

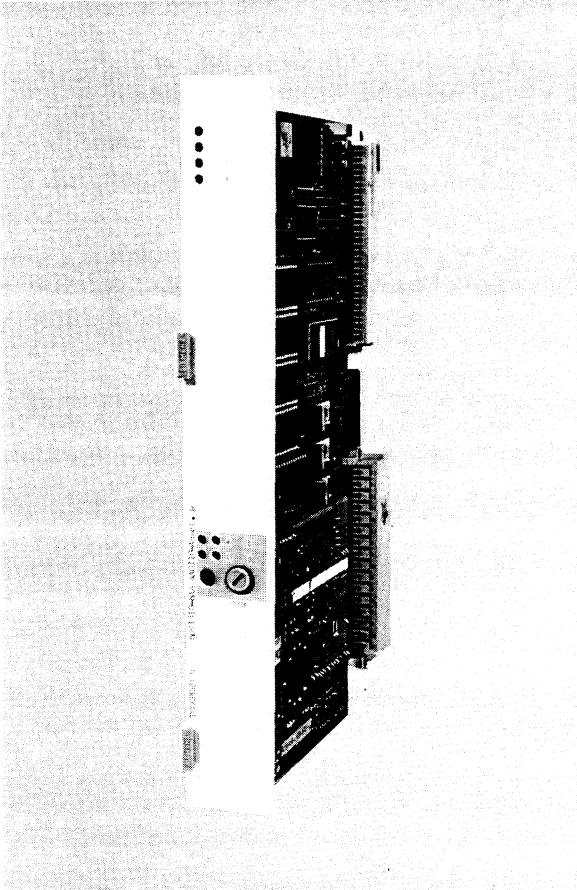

Contents	Page
1 Description	2
1.1 Application	2
1.2 Design	2
1.3 Mode of Operation	3
1.3.1 Data Traffic between the Interface Module and Field Multiplexer	4
1.3.2 Time Monitoring	5
1.3.3 Software Characteristics	6
1.4 Technical Data	7
2 Installation and Operation	8
2.1 Installation	8
2.2 Connection and Setting	8
2.3 Commissioning	12
3 Maintenance	13
3.1 ABG Hardware Design	13
3.2 Connector Pin Assignment	15
3.3 Troubleshooting	17
3.4 Debugging	18

1 Description

1.1 Application

The interface module (ABG), 6DS1304-8AA, in conjunction with a safety isolator 6DS3902-8AA, is used in the TELEPERM M process control system for connecting the FM 100 field multiplexers.

It is installed by means of the I/O bus interface of an AS 220 or AS 230 automation system and enables the connection of up to 4 field multiplexer remote cables.

The interface module can also be used to establish a data link between two automation systems (AS) i.e. back-to-back coupling. In this case, an interface module must be present in each AS and the respective serial interfaces must be connected to each other.

1.1 Design

- PCB in ES 902 system, consisting of mother board and voltage regulator module.
- Front panel width of two standard slots (SEP).
- Front panel with channel-specific LEDs, diagnostics LEDs and common alarm LED.
- Module fuse on front panel.
- Backplane connector 1: 48-pin ES 902 plug connector, occupied by I/O bus.
- Backplane connector 2: 64-pin ES 902 plug connector, occupied by supply voltages and 4 FM terminals.

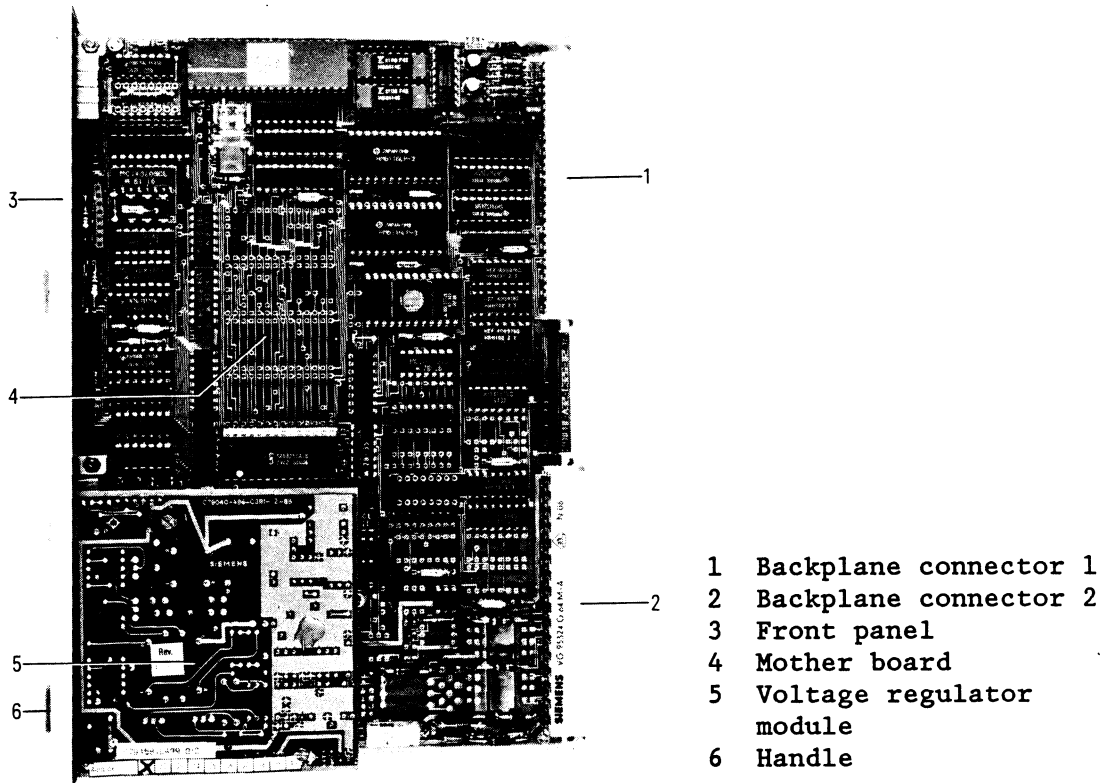

Fig. 1 Mechanical design of the ABG

1.3 Mode of Operation

The interface module (ABG) is used to organize, execute and monitor data traffic between the I/O bus of the TELEPERM M system and up to 4 FM 100 field multiplexers.

In terms of the automation system, the ABG represents a transfer RAM into which output data can be deposited and from which input data can be read.

The output data written into the transfer RAM by the AS, are converted into messages by the ABG and transferred to the field multiplexer by a safety isolator connected in series to the remote cable.

Input data transferred to the ABG by the field multiplexer in the form of messages are deposited in the transfer RAM and can be retrieved from there by the AS.

In addition, the interface module assumes the function of sensor-specific linearization in accordance with the configuration instructions.

The memory capacity of the transfer RAM determines the extension limits in the FM 100 field multiplexer in relation to the I/O module equipment.

During back-to-back coupling the values of the corresponding interface in the transfer RAM are entered into the message without modifications.

The receiving ABG converts the 13-bit representation (fixed point) into the floating point representation of the analog input driver. Binary values are transferred unchanged between transfer RAMs.

1.3.1 Data Traffic between the Interface Module and Field Multiplexer

This is carried out in the form of messages via a serial interface (20 mA current loop). A safety isolator, 6DS3902-8AA, is connected to the transmission line to separate the control room from the plant area (Ex zone 1). Data transmission is executed in full-duplex mode with a transmission rate of 2400 bits/s.

● Message structure

Every message consists of 7 words of 11 bits each, whereby each of the 7 words consists of a start bit ("0-signal"), 8 data bits, a parity bit and a stop bit ("1-signal"). The first word of every message contains the ASCII character "STX". The second word is used to transmit the address of the FM input or output channel or the address of a service message. The last message word contains a test word necessary for the code protection. Words 3 to 6 contain data specific to the message type.

The following message types are defined:

- 1 Analog input
- 2 8-bit binary input
- 3 16-bit binary input
- 4 Output message
- 5 Error message
- 6 Synchronization message
- 7 Message about modules fitted
- 8 Dynamic check
- 9 Terminal temperature

1.3.2 Time Monitoring

The AS and interface module, or interface module and FM 100 field multiplexer, mutually supervise themselves by means of time monitoring routines.

- Time monitoring between the AS and ABG

The AS and ABG cyclically describe a data cell in the transfer RAM of the ABG, then cyclically read the data cell described by the partner in the link. If an AS entry is not recognized for more than 12 seconds, then it is assumed that an AS failure has occurred. When this error occurs the ABG transmits an alarm bit in the message to the FM concerned. This in turn causes the FM to switch either the exits of the corresponding planned output modules to the safety setting or the mode of operation to "hold last value".

As soon as the AS accesses the transfer RAM of the ABG again, the alarm bit is reset and the FM restarts its normal operation.

The maximum time taken between the write cycles of the ABG is one AS cycle. The AS communicates its cyclic time to the ABG as a multiple of 250 ms. Should the ABG fail to keep to the cyclic time, the AS will report the ABG as faulty.

- Time monitoring between the ABG and FM 100

The time monitoring of the message interface responds if the receive message does not appear or no correct receive message is recognized.

The FM 100 signals the response of its time monitoring in the message to the ABG and switches the correspondingly planned output channels to the safety setting.

- Time monitoring during back-to-back coupling

The time monitoring of the message interface responds if the receive message does not appear or no correct receive message is recognized. In this case, the last binary values to be transferred to the PAE and the analog values in the AEF blocks are retained.

1.3.3 Software Characteristics

- Startup program

This program ensures that the module is put into a certain output state when switched on and that, when combined with other functional components of the system, impermissible operating statuses are avoided.

The ABG's PROM and RAM memory is tested during startup and at regular intervals during operation.

Should a memory error occur, a hardware error is signalled on the diagnostic LED's on the front panel of the interface module.

- Dynamic control

The interface module monitors the connected FM's by means of dynamic check. At the same time, analog value messages are issued to the FM under the channel address "FD". Once in the FM, this value is converted into an electrical current, recoded via the FM's ADC and returned to the ABG in a message using the same channel address. If the transmitted and received values within prescribed limits are identical, it is assumed that the FM hardware and software are functioning correctly.

If the value transmitted and is not identical to the one received, the interface module inserts an alarm bit in the message to the FM and ignores the input data sent by this FM. If redundancy is available, the driver block switches over to the redundant connection.

- Input and output of binary and analog values

After examination of the test word and evaluation of the message and status bits, the data transferred by the FM are deposited in the transfer RAM. Analog input data are preprocessed with the help of sensor-specific linearization parameters before being filed in the transfer RAM.

Whilst outputting the data deposited by the AS in the transfer RAM, the ABG generates one message per output channel. Once the transfer RAM has been processed, a dynamic check and synchronization message is generated.

If no new output data occur in the transfer RAM, message traffic is maintained by the cyclical output of check and synchronization messages.

- Synchronization

Both the field multiplexer and the ABG transmit cyclical synchronization messages for synchronizing the receivers in the FM and the ABG.

● Emergency Stop Operation

Using an error message, the FM informs the interface module of the field multiplexer switchover to emergency stop operation and gives it the address of the output channels which have been switched to emergency stop. This information is given as soon as the interface module attempts to output data to an output channel which has been switched off.

Once the error message has appeared, the ABG erases the data cell assigned to this output channel in the transfer RAM.

The AS executes the defined run up from the safety setting when the "emergency stop" status bit in the input message is reset as a result of the emergency switch being externally switched back.

1.4 Technical Data

Dimensions (w x d x h)		30,48 mm (2SEP)1) x 100 mm x 233,4 mm
Voltage supply		
	L+	+24 V- (20 V bis 33 V) including overlaid ripple
		permitted ripple: 15 % of the average of the direct current voltage
Current consumption	L+	typ. 180 mA
	PM	typ. 15 mA
Transmitter active non-floating		20 mA current loop
Receiver passive isolated		20 mA current loop
Trunk line length with back-to-back coupling		2 km maximum
Permitted ambient temperature in operation		0 to +55 °C
in storage		-40 to +70 °C
Weight		approx. 0.5 kg

1) Standard slot

2 Installation and Operation

The interface module for field multiplexer contains electrostatically sensitive components. Regulations about handling such modules must be observed during installation and commissioning.

2.1 Installation

The ABG is inserted into a pre-planned I/O module slot, secured by means of the subrack locking bar and can be withdrawn using two handles.

The interface module may only be withdrawn or inserted when the module fuse has been removed.

2.2 Connection and Setting

● Connecting the safety isolator

A safety isolator 6DS3902-8AA should be connected between the ABG and the remote cable.

Up to 4 remote cables can be connected to the ABG's 4 serial interfaces via the safety isolator. The following block diagram and the wiring tables show the wiring between interface module, safety isolator and field multiplexer.

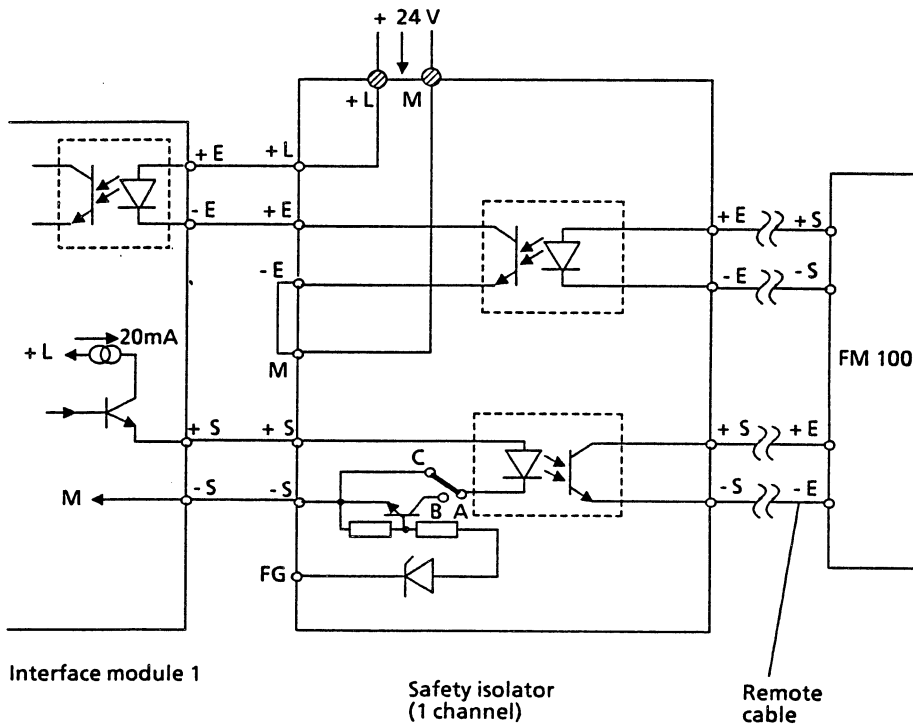
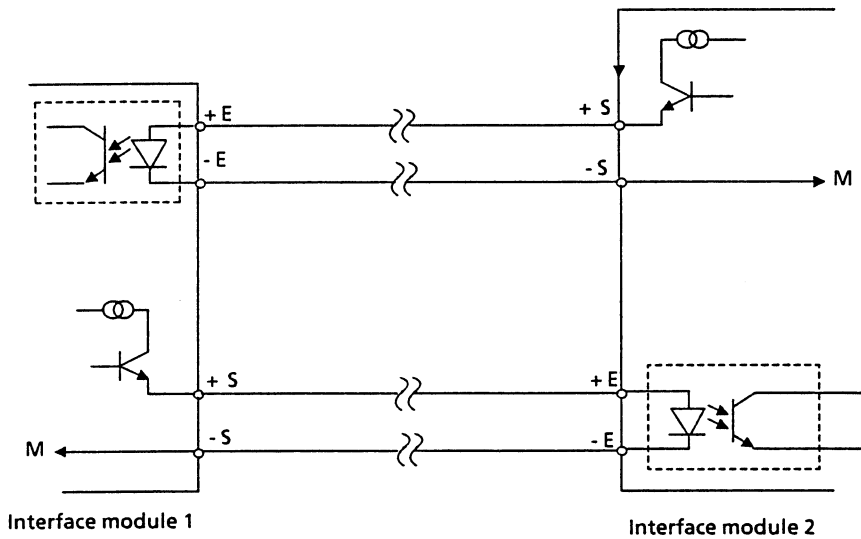

Fig. 2 Connection diagram

Wiring table to Fig. 2

ABG Signal	Pin	Safety isolator Pin	Signal
+ S1	2d6	h3	+ S1
- S1	2f6	h5	- S1
+ E1	2z6	b1	+ L1
- E1	2b6	d3	+ E1
		o d5	- E1
		o b5	M
		h1	FG1
+ S2	2d12	h9	+ S2
- S2	2f12	h11	- S2
+ E2	2z12	b7	+ L2
- E2	2b12	d9	+ E2
		o d11	- E2
		o b11	M
		h7	FG2
+ S3	2d18	h15	+ S3
- S3	2f18	h17	- S3
+ E3	2z18	b13	+ L3
- E3	2b18	d15	+ E3
		o d17	- E3
		o b17	M
		h13	FG3
+ S4	2d24	h21	+ S4
- S4	2f24	h23	- S4
+ E4	2z24	b19	+ L4
- E4	2b24	d21	+ E4
		o d23	- E4
		o b23	M
		h19	FG4
<p>A +24 V supply voltage must be fed to the safety isolator screw terminals L+ and M of the safety isolator (L+ from AS).</p>			

- Connecting the transmission line with back-to-back coupling



The data transmission line must be established using a screened copper cable twisted in pairs and having a conductor cross section of at least 0.8 mm^2 . Immediately after entering the AS cabinet, the conductor screen must be large-surface contacted on both sides to the cabinet earth (do not contact to isolated, built-in cable detensioning clamps for process cables).

Sufficient equipotential bonding is required when connecting the data transmission line between the AS systems to be coupled. The equipotential bonding is sufficient when the resistance between both cabinet earths is about factor 10 less than the screen resistance of the data transmission line.

If this requirement is not met, then a suitable equipotential bonding must be established or a data transmission line inserted, whose screen is capable of carrying a current.

● Setting

Coding jumpers present as standard:

The following soldering jumpers are inserted at the factory and may be not changed by the user:

Jumper E - F = Transmission rate 2400 bits/s

Jumper N - O = EPROM type 2732

Setting the module address:

The ABG module address must be set at the coding plug location 60 as shown:

Module no.								
	16	9	1	8				
0	-	-	-	-	-	-	-	-
1	-	-	-	-	-	-	X	-
2	-	-	-	-	-	X	-	-
3	-	-	-	-	X	-	X	-
4	-	-	-	X	-	-	-	-
.								
.								
.								
46	X	-	X	X	X	-	-	*)
60	X	X	X	X	-	-	-	**)

X = Coding jumper inserted
 - = Coding jumper removed

*) Addressing limit with AS 220
 **) Addressing limit with AS 230

When setting the module address, please note that the interface module is part of the category of I/O modules, fo which each module no. can only be used once.

In a redundant system design with two interface modules (FM arrangement 3), the interface module addresses must lie directly next to each other i.e. module addresses n and n+1 must be assigned. Address n is the module address allocated in the FM driver.

2.3 Commissioning

Once the ABG has been plugged in and the front panel safety device has been inserted, the module is operational and cyclically interchanges messages with the connected field multiplexer .

Correct operation of the interface module is indicated on the LEDs in the front panel of the ABG as follows:

Common alarm LED	(red)	= off
Diagnostic LEDs	(red)	= off
Signal LEDs	(green)	= on

If one of the ABG's 4 serial interfaces is not wired or if the remote cable is interrupted, then the corresponding signal LED will not light up.

- Note about switching on

Whilst starting up (switching on the AS or fitting the module fuse), the interface module tests all message interfaces. If an interface is not connected or its remote cable is interrupted, then the corresponding signal LED will not light up. If an interface has already been recognized as fault-free and later fails, then this failure will be indicated on the diagnostic LEDs and the corresponding signal LED switched off.

3 Maintenance

3.1 ABG Hardware Design

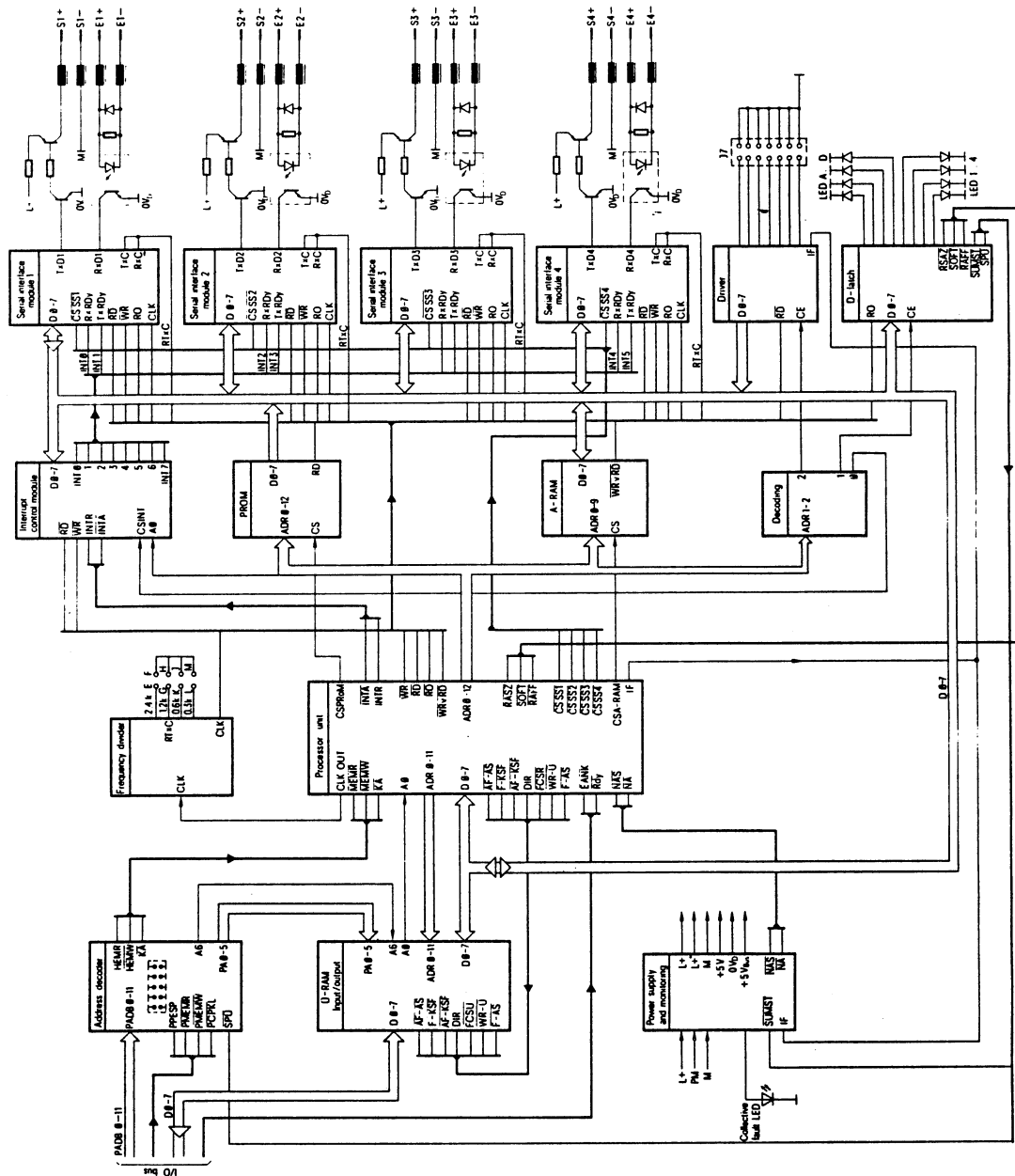

Fig. 3 Functional diagram 6DS1304-8AA

- I/O bus interface

Data exchange between the automation system (AS) and the interface module is carried out via the I/O bus. For details about the I/O traffic on the I/O bus, refer to the I/O bus interface module instructions C79000-B8076-C013.

- Serial interface

The ABG has 4 identically constructed 20 mA interfaces with an active non-floating transmitter tier. The receiver input is floating and passive.

For reasons of Ex-protection the remote cable must be electrically separated from the ABG by means of a safety isolator. The remote cable is supplied via the intrinsically-safe FM message interface.

To be able to supply the ABG receiver, the safety isolator must be fed with $U_V = +24\text{ V (L+)}$. Moreover, by resoldering the wire jumper A-C into position A-B the ABG transmitter can be inhibited or enabled as desired via an external enabling input (FG).

FG = +24 V $\hat{=}$ transmitters released
 FG = 0 V or open $\hat{=}$ transmitter barred

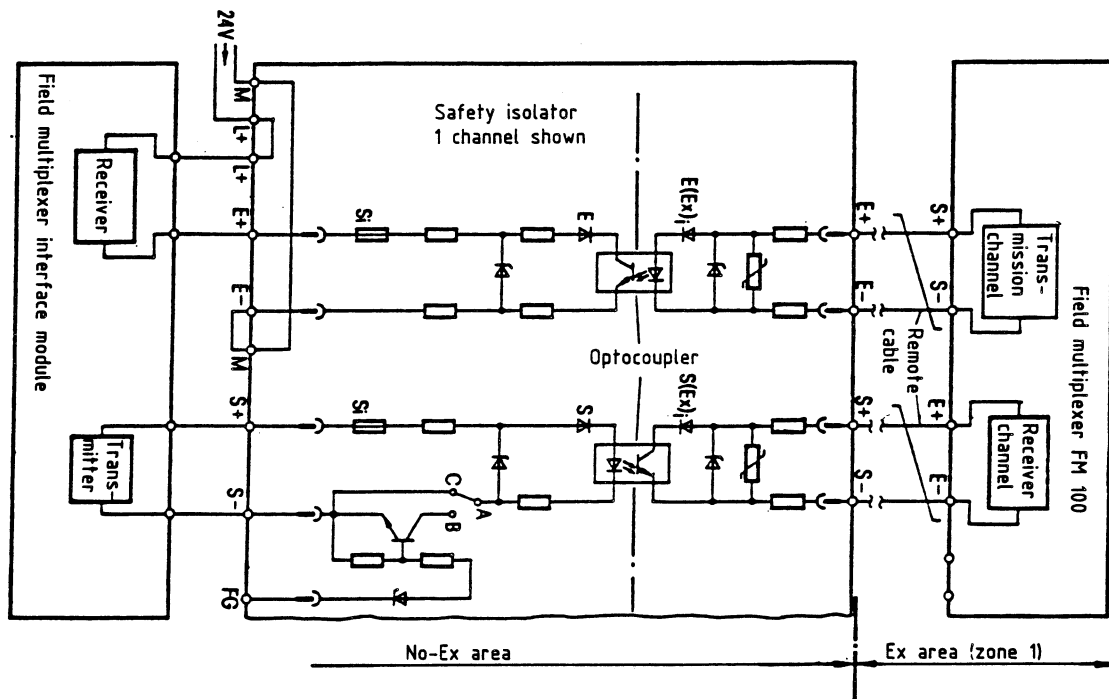

FG Enabling input
 S S (Ex) i Diagnostic LEDs
 E E (Ex) i

Fig. 4 Safety isolator, block diagramm (1 channel illustrated)

3.2 Connector Pin Assignment

Backplane connector 1

Pin	d	b	z
2		0 V	+5 V
4		PMEMR	+5 V
6	0 V	PRDY	
8	PCPKL	Reset	PPESP
10	0 V		
12	EANK		
14	0 V	PDB1	PDB0
16	PDB4	PDB3	PDB2
18	PDB7	PDB6	PDB5
20	0 V	PADB1	PADB0
22	PADB4	PADB3	PADB2
24	PADB7	PADB6	PADB5
26	PADB10	PADB9	PADB8
28		0 V	PADB11
30			
32		0 V	

Backplane connector 2

Pin	f	d	b	z
2				
4				
6	S1-	S1+	E1-	E1+
8				
10				
12	S2-	S2+	E2-	E2+
14				
16				
18	S3-	S3+	E3-	E3+
20				
22				
24	S4-	S4+	E4-	E4+
26				
28				
30	./.	./.	PM	MZ
32	L+	L+	M	M

E = receiver
S = transmitter

3.3 Troubleshooting

The automation system (AS 220 or AS 230) signals ABG faults via system fault messages. There are also LEDs on the front panel of the ABG, which indicate its operating status and can be used for diagnostic purposes.

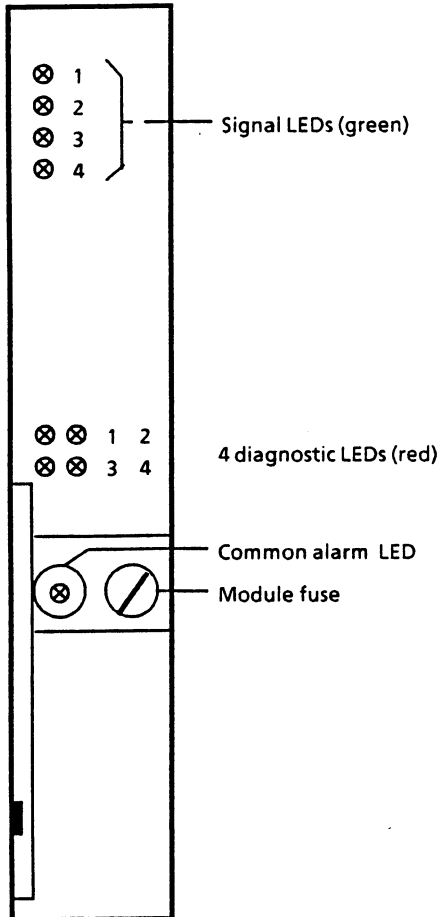

Fig. 5 Layout of the LEDs

- Signal LEDs

Each signal LED is assigned to one of the 4 FM interfaces.

LED lit = channel active
 LED flashing = channel in back-up or FM driver in the AS
 not active
 LED off = channel not connected or faulty

The ABG tests all serial interfaces during startup (i.e whilst the AS is being switched on or the module fuse fitted). If a serial interface is not connected or the remote cable is interrupted, then the corresponding signal LED will not light up. If a serial interface has already been recognized as fault-free and fails later, then this failure will be indicated by the associated signal LED switching off and by the diagnostic LEDs (explanation overleaf).

- Diagnostic LEDs

The following error statuses are indicated by the diagnostic LEDs:

LED display	Meaning
o o ● o	Message traffic in direction of ABG faulty (Time monitoring responded)
● ● ● o	Dynamic check or message traffic in direction of FM faulty
o ● o o	Hardware fault on the ABG (e.g. PROM-, RAM-fault)

● = LED lit

Only one FM interface error status can be indicated on the diagnostic LEDs. The serial interfaces have the following order of priority with respect to the error indicator: 1, 2, 3, 4 (1 = highest priority).

This means, for example, that if interfaces 1 and 3 malfunction, the error status of interface 3 will only be indicated after interface 1 has been repaired.

3.4 Debugging

The on-site repair of a faulty interface module is limited to exchanging a faulty module fuse. All other on-site repairs are pointless. A faulty ABG should be sent for repair with exact information about the error. Please use the returned goods form for this purpose.

TELEPERM M

FM 100 Field Multiplexer

Safety Isolator
6DS3902-8AA

Instructions

Order No. C79000-B8076-C108-03

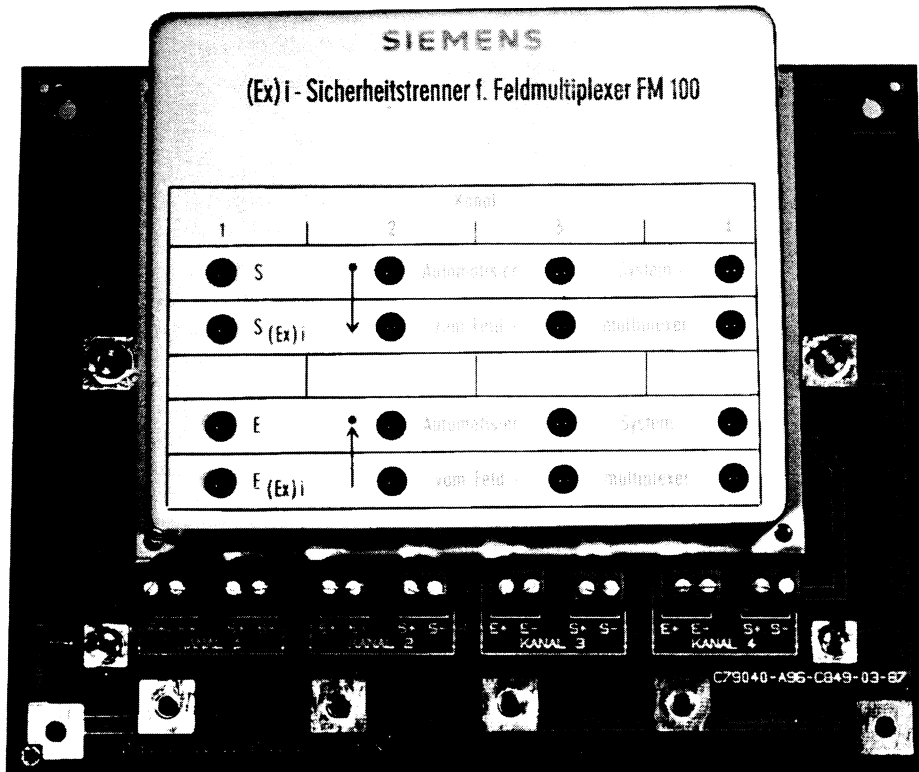

Contents	Page
1 Description	2
1.1 Application	2
1.2 Design	2
1.3 Mode of Operation	2
1.4 Technical Data	3
2 Installation and Commissioning	4
2.1 Connection	4
2.2 Setting	7
2.3 Commissioning	7
3 Maintenance	8
3.1 Method of Operation	8
3.2 Checking and Servicing	8
3.3 Troubleshooting	8
3.4 Debugging	8

1 Description

1.1 Application

The safety isolator 6DS3902-8AA is used to electrically separate the FM 100 field multiplexer from the interface module (ABG) installed in the higher-level automation system. When the field multiplexer is installed in hazardous plant areas, the safety isolator acts as the isolating element between the Ex area (zone 1) and control room area. Outside the Ex area and in the higher-level automation system, it is connected to the remote cable which leads to the field multiplexer. The safety isolator is a functional component of the field multiplexer and is therefore necessary when the field multiplexer is installed outside a hazardous plant area. Up to 4 remote cables can be connected to an automation system by means of a safety isolator.

1.2 Design

The safety isolator 6DS3902-8AA consists of a mother board with 4 channel boards clipped on to it. The channel boards have isolating elements in the form of optical couplers. Screw terminals are arranged on the mother board as connection elements for the remote cables. The interface to the field multiplexer ABG consists of a strip with wrap pins. Diagnostic LEDs are provided on the channel boards to enable visual checking of data traffic between the field multiplexer and automation system.

1.3 Mode of Operation

The safety isolator uses optical couplers to electrically separate the remote cable (coming from Ex zone 1) from the serial interface of the field multiplexer ABG installed in the automation system.

The safety isolator is equipped with additional breakers to protect the remote cables against voltage and current peaks.

The safety isolator can be used to electrically isolate up to 4 remote cables coming from the control room section .

1.4 Technical Data

Dimensions (w x h x d)	194 mm x 152 mm (10 SEP)1) x 93 mm
Number of connectable remote cables	4
Perm. ambient temperature in operation in storage	0 to +55 °C -40 to +85 °C
Voltage supply	+24 V J = approx. 25 mA per channel
Test voltage	1.5 kV AC eff.
Explosion protection of remote cable circuits	EEx ib IIC
Degree of protection	IP20

1) 1 SEP = 15.24 mm

2 Installation and Commissioning

2.1 Connection

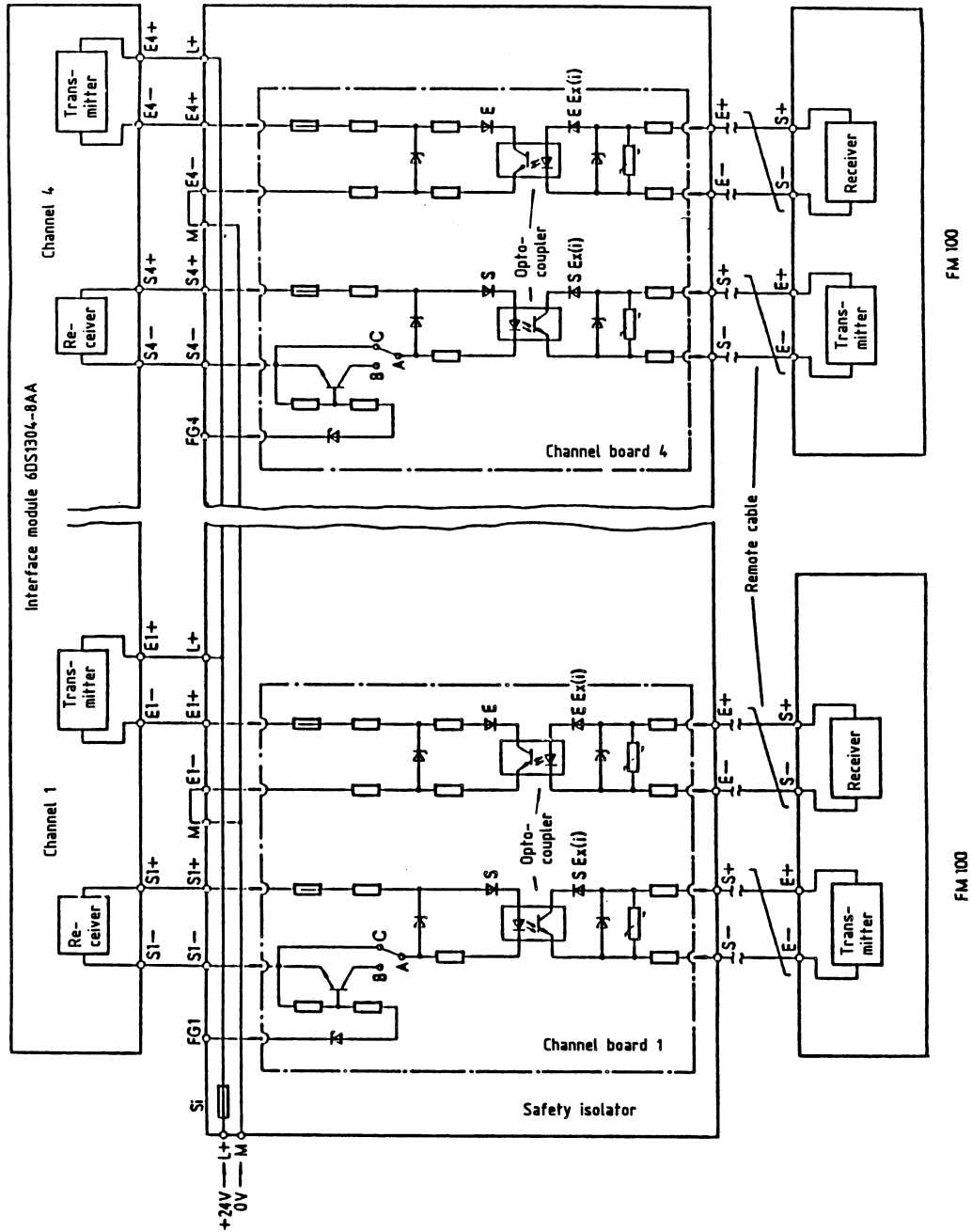

Fig. 2 Connecting the safety isolator

- Connecting to the FM interface module

The safety isolator is wired to the interface module using wrap connections.

The following table shows the wrap connector assignment on the safety isolator as well as the wiring to the interface module.

Assignment of the wrap connector:

Channel	Signal	Terminal pin
1	FG 1	h 1
	S1 +	h 3
	S1 -	h 5
	M	b 5
	E1 -	d 5
	E1 +	d 3
	L +	b 1
	L +	d 1
	L +	f 1
2	FG 2	h 7
	S2 +	h 9
	S2 -	h 11
	M	b 11
	E2 -	d 11
	E2 +	d 9
	L +	b 7
	L +	d 7
	L +	f 7
3	FG 3	h 13
	S3 +	h 15
	S3 -	h 17
	M	b 17
	E3 -	d 17
	E3 +	d 15
	L +	b 13
	L +	d 13
	L +	f 13
4	FG 4	h 19
	S4 +	h 21
	S4 -	h 23
	M	b 23
	E4 -	d 23
	E4 +	d 21
	L +	b 19
	L +	d 19
	L +	f 19

See Section 2.2 "Setting" for explanation of enable inputs FG1 to FG4.

● Wiring table:

Interface module		Safety Switch	
Signal	Pin	Pin	Signal
+ S1	2d6	h3	+ S1
- S1	2f6	h5	- S1
+ E1	2z6	b1	+ L1
- E1	2b6	d3	+ E1
		o d5	- E1
		o b5	M
+ S2	2d12	h9	+ S2
- S2	2f12	h11	- S2
+ E2	2z12	b7	+ L2
- E2	2b12	d9	+ E2
		o d11	- E2
		o b11	M
+ S3	2d18	h15	+ S3
- S3	2f18	h17	- S3
+ E3	2z18	b13	+ L3
- E3	2b18	d15	+ E3
		o d17	- E3
		o b17	M
- S4	2d24	h21	+ S4
- S4	2f24	h23	- S4
+ E4	2z24	b19	+ L4
- E4	2b24	d21	+ E4
		o d23	- E4
		o b23	M
A +24-V supply voltage (L+ from AS) must be fed to the screw terminals L+ and M at the rear of the safety isolator.			

● Connecting the remote cable

The remote cable must be connected and laid as explained in Section 2.2 "Connection and Setting" of the FM 100 instructions.

Ex protection regulations must be strictly observed when doing this.

2.2 Setting

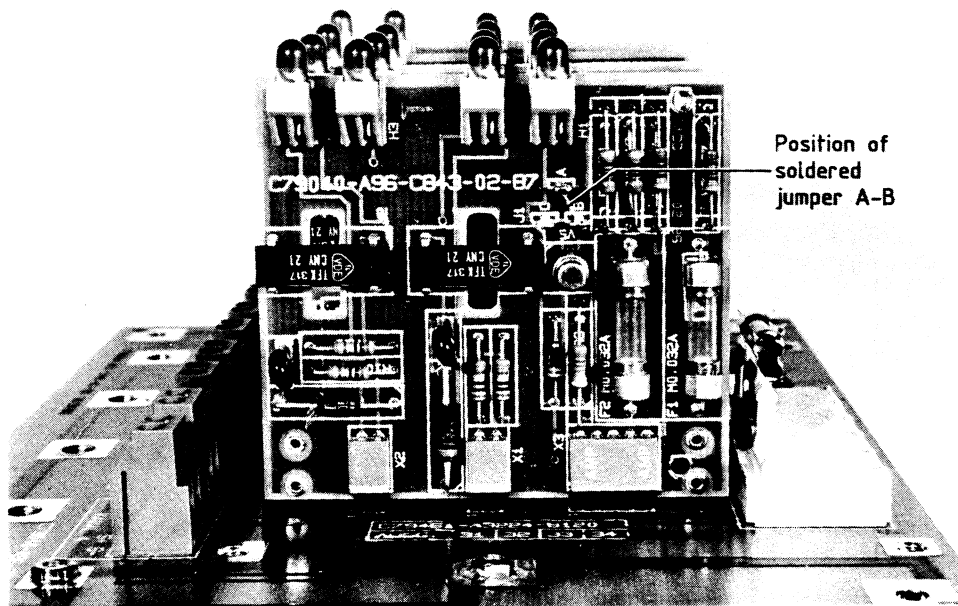

Mode of operation	Coding jumper to be soldered
Transmission path of ABG constantly enabled	A - C *)
Enable input activated	A - B

*) Standard setting on delivery.

When coding jumper A-B is inserted, the corresponding ABG transmission path is blocked.

The enable will only be given after a +24-V voltage has been applied to enable input FG.

2.3 Commissioning

Once it has been correctly wired and a +24-V supply voltage has been applied to terminals M and L+ (L+ = +20 to +33 V), the safety isolator is ready for operation.

3 Maintenance

3.1 Checking and Servicing

The safety isolator is maintenance-free and requires no special servicing. Data traffic on the remote cable can be visually checked by means of diagnostic LEDs on the channel boards.

The following signal statuses are indicated by the diagnostic LEDs:

LED "S": ABG transmission circuit
LED "S Ex (i)": FM 100 receiving circuit
LED "E": ABG receiving circuit
LED "E Ex (i)": FM 100 transmission circuit

3.2 Troubleshooting

Troubleshooting is done with the aid of diagnostic LEDs. The procedure for this is given in the FM 100 instructions.

3.3 Debugging

Faults in the safety isolator should be remedied by replacing the defective functional components (channel board or mother board).

Channel boards can be replaced whilst the system is operational, i.e. without disrupting the intact channels.

For safety reasons, the safety isolator may not be repaired on site. Defective parts must be sent in for repair along with a returned goods form.

TELEPERM M

Field Multiplexer FM 100

Binary Input Module with 8 Channels for Non-Contact Transmitters (BIPS)
according to DIN 19234 (NAMUR)

Instructions

Order No. C79000-B8076-C093-02

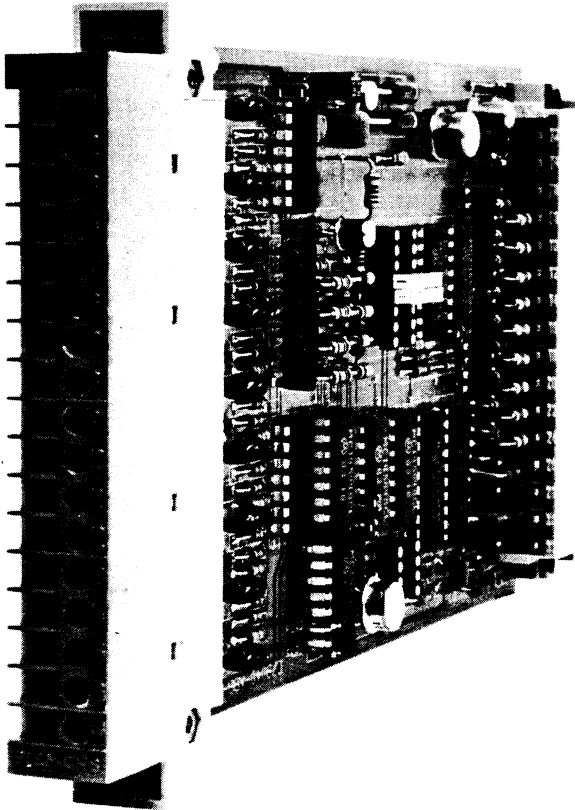

Contents	Page
1 Description	2
1.1 Application	2
1.2 Design	2
1.3 Mode of Operation	2
1.4 Technical Data	3
2 Installation and Commissioning	4
2.1 Setting	4
2.2 Plugging the Module in	5
2.3 Connecting the Field Cables	5
3 Maintenance	7
3.1 Method of Operation	7
3.2 I/O Bus Connector Assignment	9
3.3 Field Interface Design	10
3.4 Troubleshooting	10
3.5 Debugging	10

1 Description

1.1 Application

The binary input module 6DS1611-8AA is an input module of the FM 100 field multiplexer and is used to acquire the statuses of up to 8 non-contact transmitter signals according to DIN 19234 (NAMUR transmitter). The module can be inserted, on the FM 100 I/O bus, into any slot of the basic and extension subrack.

1.2 Design

The binary input module for intrinsically-safe transmitters according to DIN 19234, consists of a printed circuit board measuring 100 mm x 160 mm (h x d) and with a width of 15.24 mm, occupies one standard slot in the field multiplexer subrack. When plugged into the subrack, the binary input module is contacted to the FM I/O bus by means of a 48-pin ES 902 plug connector located at the rear of the module. The front of the module is designed as a 17-pin strip with screw terminals, to which the field cables are connected. For reasons of Ex protection and to shelter it against hostile atmospheric conditions, the binary input module is provided with a protective double enamel coating.

1.3 Mode of Operation

The binary input module communicates with the field multiplexer's central unit via the I/O bus connected to the basic or extension subrack. For each I/O sequence occurring on the I/O bus, the binary input module compares its own module address set using coding jumpers with the address present on the I/O bus. If the addresses match, the binary input module sends a feedback code to the central unit, in which the type of addressed I/O module (8-bit binary input module) and a transmitter response time, adjustable between 20 and 50 ms, are stated. When the I/O cards are activated, the binary value transmitters are energized by the central unit's intrinsically-safe, 22-V voltage source via the I/O card. The FM central unit, with the aid of the card-specific feedback signal, generates the control signals necessary for binary value multiplexing.

If several modules erroneously respond when a specific address is accessed (double addressing), the feedback signal and transmitter power supply are suppressed by the addressed modules. In such a case, the central unit bypasses the addressed module and transfers the fault message "multiple addressing" to the higher-level automation system.

1.4 Technical Data

Dimensions (w x h x d)	15.24 mm (1 SEP) ¹⁾ x 100 mm x 160 mm
Perm. ambient temperature in operation	-25 to +60 °C
in storage	-40 to +85 °C
Perm. humidity	annual mean = 75 % 30 days 90 % no condensation
Degree of protection	IP 00
Explosion protection	EEx ib IIC T5
Voltage supply	Supply from central unit's intrinsically-safe voltage sources U ₁ = +5 V ±2 % I _{max} = 2 mA U ₂ = +22 V when idling
Voltage input	I ₁ ≤ 2 mA I ₂ ≤ 35 mA (all transmitters addressed)
No. of inputs	8 two-way
Input signal	"0" level = J _E = 2.2 mA "1" level = J _E = 1 mA
Connectable transmitter types	non-contact transmitters (NAMUR transmitter) according to DIN 19234

1) SEP = standard slot

2 Installation and Commissioning

The binary input module module contains electrostatically sensitive components. Regulations about handling such modules must be observed during installation and commissioning in order to avoid components being destroyed by electrostatic charges.

2.1 Setting

The following settings must be made before inserting the binary input module into an FM subrack:

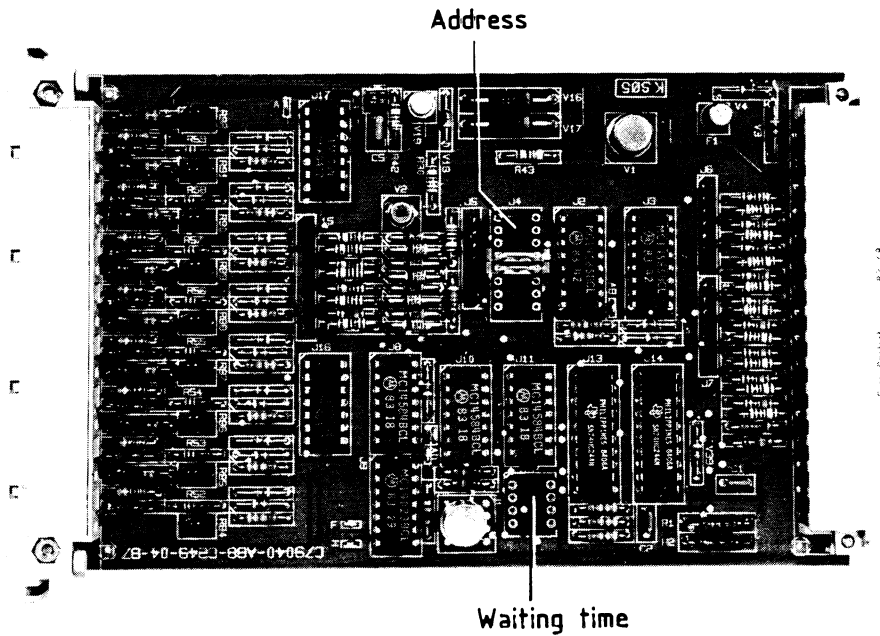

Fig. 1 Position of coding jumpers

- Set the PCB address
(possible address range: 00 to 44)

PCB address	Location J4							
	16							9
	○	○	○	○	○	○	○	○
	○	○	○	○	○	○	○	○
00	-	-	-	-	-	-	-	-
01	-	-	-	-	-	X	-	-
02	-	-	-	-	X	-	-	-
43	X	-	X	-	X	X	-	-
44	X	-	X	X	-	-	-	-

X = Coding jumper inserted
- = Coding jumper removed

Fig. 2 Address assignment

The address is set in binary code using coding jumpers at coding jack J4. When setting the address, please note that jumper 6-11 has a significance of 2° and that jumpers 8-9 and 7-10 are insignificant. The binary input module address range includes the addresses 0 to 44.

- Set the waiting time

The transmitters are only supplied by the intrinsically-safe, module-internal supply voltage at the time of acquisition. To bridge transmitter response times, a transmitter-specific waiting time can be set via coding jumpers at coding jack J 12.

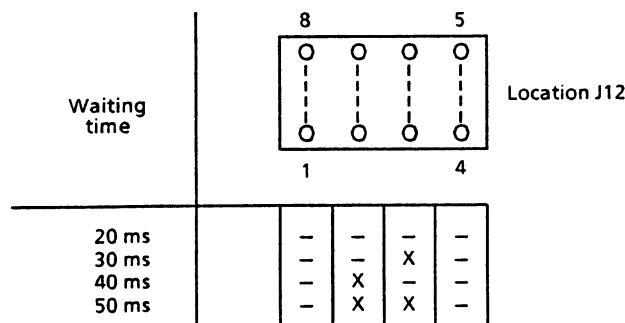

X = Coding jumper inserted
 - = Coding jumper removed

Fig. 3 Setting the waiting time

2.2 Plugging the Module in

The binary input module can be plugged into any slot of the FM's basic or extension subrack. It can also be plugged in whilst the field multiplexer is switched on.

2.3 Connecting the Field Cables

The field cables should only be connected when the module is plugged in. Before doing this, terminal 17 of the front connector must be connected to the earthing bar mounted under the subrack.

This ensures that when the cables are being connected, the breakers provided on the binary input modules are already capable of limiting spurious peaks and excess voltages.

The field cable screens must be contacted to the cable detensioning rail on the base of the FM cabinet.

On the transmitter side, the screens must be connected to the system earth by the shortest possible route.

When connecting the non-contact receivers (NAMUR transmitter), the inductivity and capacity of the transmitter circuit must not exceed the following limit values, as stated in the certificate of conformity:

$$L_{\max} = 40 \text{ mH}$$

$$C_{\max} = 3 \text{ uF}$$

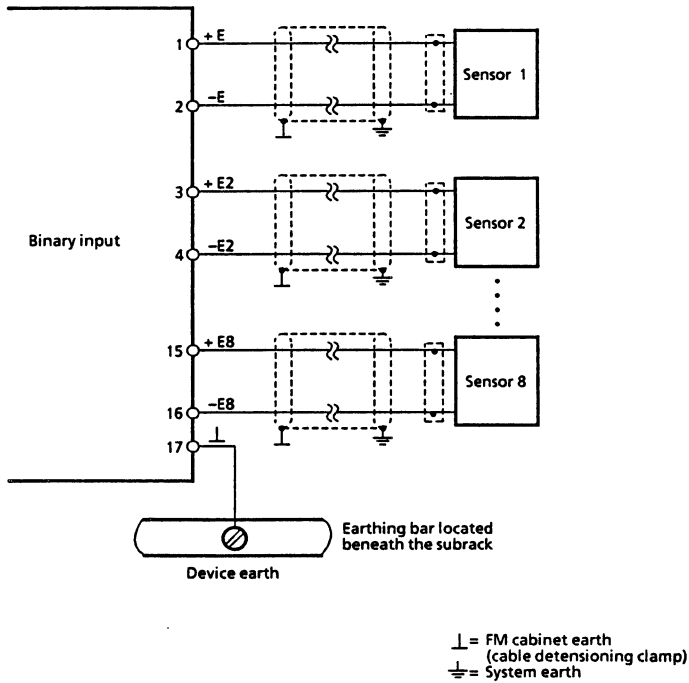

Fig. 4 Connecting the field cables

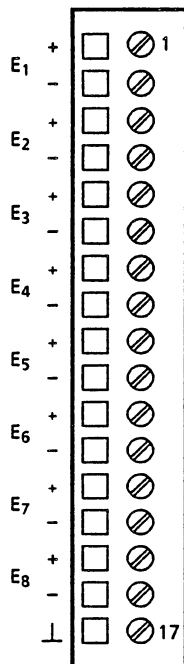

Fig. 5 Front connector assignment

3 Maintenance

3.1 Mode of Operation

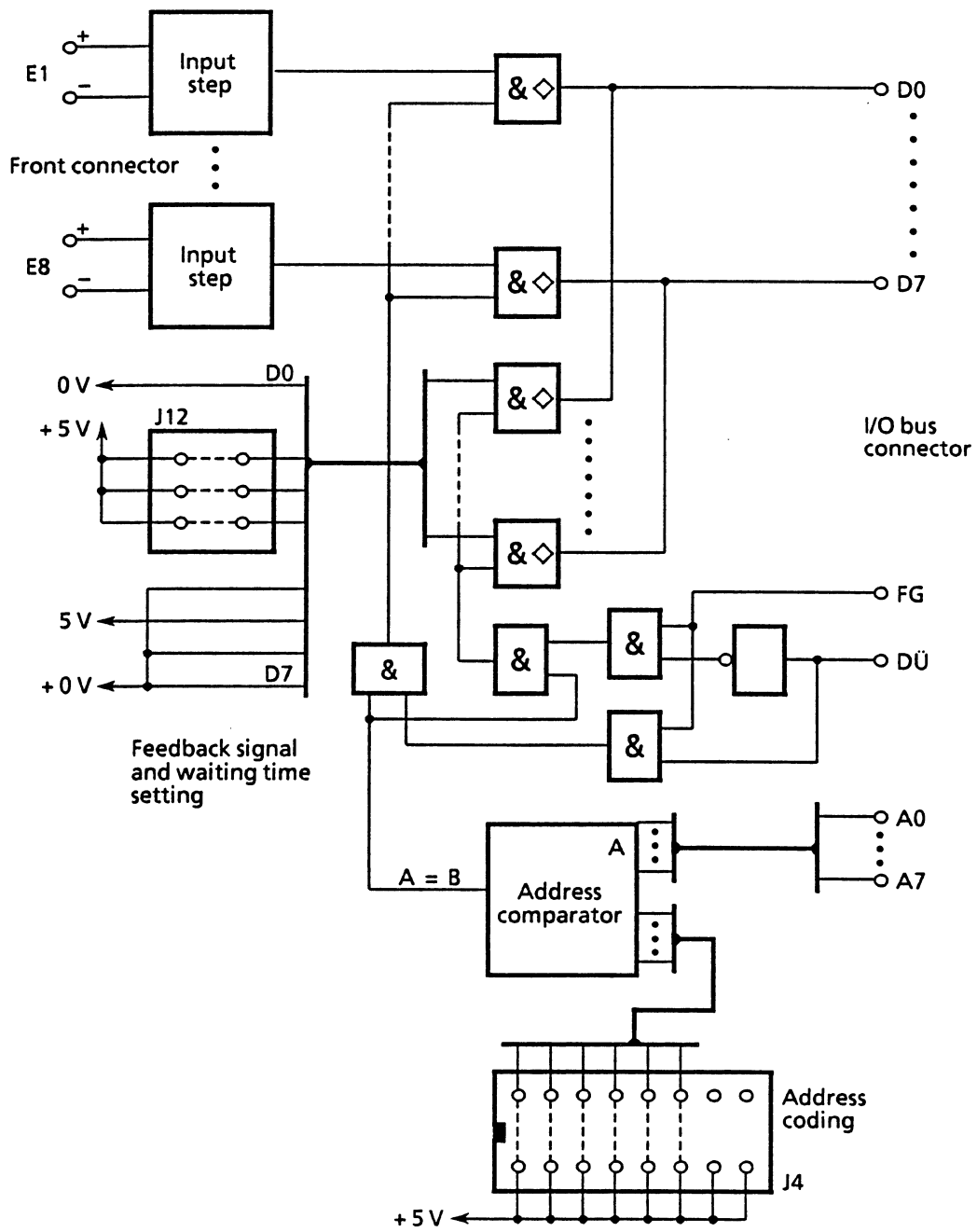
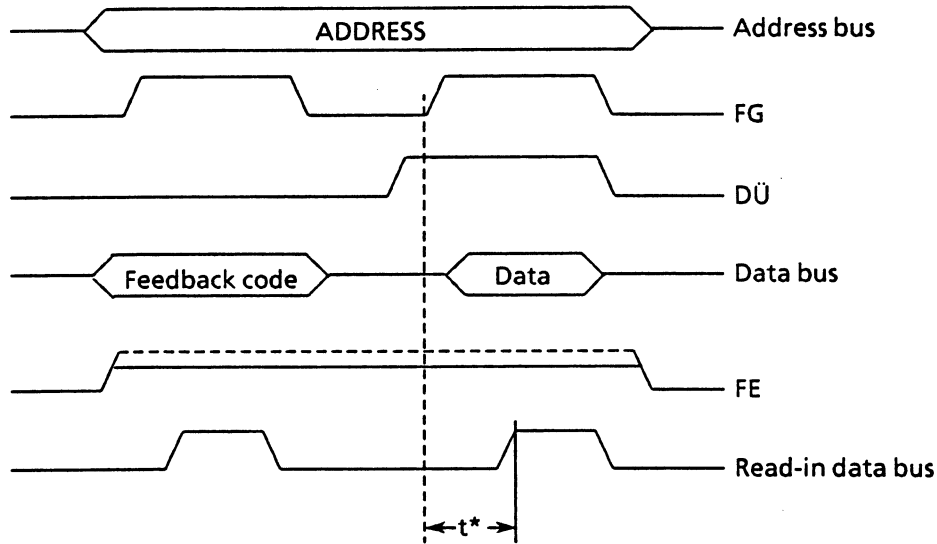

Fig. 6 Block diagram

Data traffic between the central unit and binary input module is carried out via the I/O bus interface. The following pulse diagram shows the I/O sequence of the 8-bit binary input module.



*) Depending on set waiting time

When the first enable pulse is sent, a feedback code consisting of the module type and waiting time is transmitted to the data bus by the binary input module.

D7								D0
0	0	1	0	X	X	X	X	0

Module type
(fixed setting)

Waiting time (adjustable
via coding jumpers)

When the second enable pulse is sent and the data transfer line is active, the binary value is transmitted to the data bus as follows:

D7	D6	D5	D4	D3	D2	D1	D0
----	----	----	----	----	----	----	----

Binary input 8

Binary input 1

"0" level = $J_E > 2.2 \text{ mA}$

"1" level = $J_E < 1 \text{ mA}$

During addressing, the module places the fault line on a voltage level of approx. 2.4 V.

If double addressing occurs, the level on the fault line rises to $U > 3 \text{ V}$. At the same time, the modules suppress the feedback code and the transmitter power supply.

If no feedback code is given, the central unit checks the fault line and transfers the error message "double addressing" to the higher-level automation system.

3.2 I/O Bus Connector Assignment

Pin	d	b	z
2	-	-	-
4	-	-	-
6	-	-	-
8	FG	-	DÜ
10	-	A0	A1
12	A2	A3	A4
14	A5	A6	A7
16	D0	D1	D2
18	D3	D4	D5
20	D6	D7	M _B
22	FE	-	-
24	-	+ 5 V	M _{5V}
26	-	-	-
28	-	+ 22 V	M _{22V}
30	-	-	-
32	-	-	-

3.3 Field Interface Design

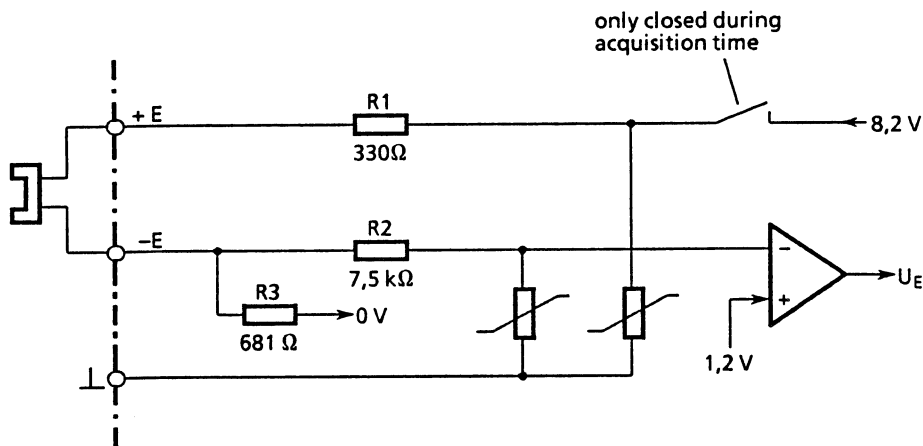

Design of input step

The input voltage results from the product of the current sent by the transmitter and the R 3 resistance.

"0"-signal = $J_E > 2.2 \text{ mA}$

"1"-signal = $J_E < 1 \text{ mA}$

3.4 Troubleshooting

Faulty I/O modules are signalled by the higher-level automation system via I & C messages. For an explanation of the error messages and details on the troubleshooting procedure see the FM 100 field multiplexer instructions.

3.5 Debugging

Faults can be remedied by replacing the defective module, which should then be sent for repair together with a fault description (please use the returned goods form).

On-site repairs are not permitted for reasons of Ex protection.

TELEPERM M

Field Multiplexer FM 100

Binary Module for Non-floating Contacts
6DS1610-8AA

Instructions

Order No. C79000-B8076-C092-02

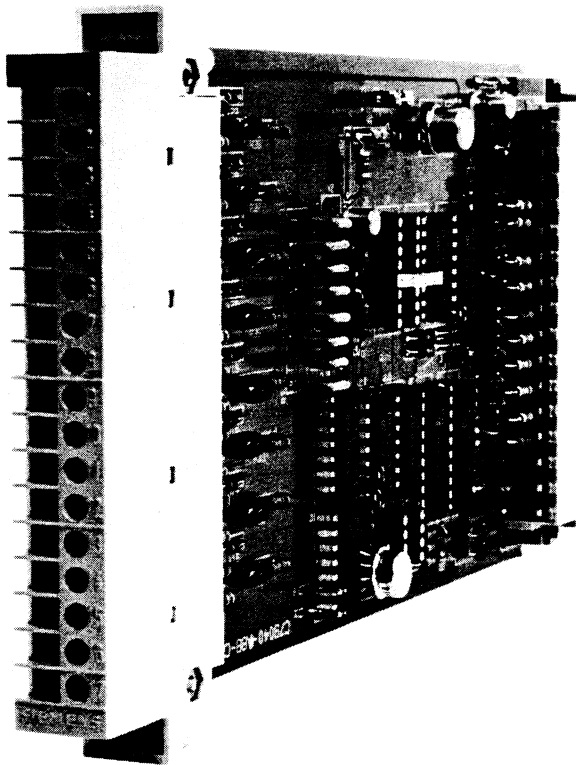

Contents	Page
1 Description	2
1.1 Application	2
1.2 Design	2
1.3 Mode of Operation	2
1.4 Technical Data	3
2 Installation and Commissioning	4
2.1 Setting	4
2.2 Plugging the Module in	5
2.3 Connecting the Field Cables	5
3 Maintenance	7
3.1 Method of Operation	7
3.2 I/O Bus Connector Assignment	9
3.3 Field Interface Design	10
3.4 Troubleshooting	11
3.5 Debugging	11

1 Description

1.1 Application

The binary input module 6DS1610-8AA is an input module of the FM 100 field multiplexer and is used to record the statuses of up to 8 floating binary values or FM-internal active M signals (transistors with open collectors). The module can be inserted, on the FM 100 I/O bus, into any slot of the basic and extension subrack.

The binary values can occur as

- external floating contacts
- external breakers

1.2 Design

The binary input module consists of a printed circuit board measuring 100 mm x 160 mm (h x d) and occupies one standard slot (SEP¹⁾) in the field multiplexer subrack. When plugged into the subrack, the binary input module is contacted to the FM I/O bus by means of a 48-pin ES 902 plug connector located at the rear of the module. The front of the module is designed as a 17-pin strip with screw terminals, to which the field cables are connected. For reasons of Ex protection and to shelter it against hostile atmospheric conditions, the binary input module is provided with a protective double enamel coating.

1.3 Mode of Operation

The binary input module communicates with the field multiplexer's central unit via the I/O bus connected to the basic or extension subrack. For each I/O sequence occurring on the I/O bus, the binary input module compares its own module address set using coding jumpers with the address present on the I/O bus. If the addresses match, the binary input module sends a feedback code to the central unit, in which the type of addressed I/O module (8-bit binary input module) and a transmitter response time, adjustable between 20 and 50 ms, are stated. When the I/O card is activated, the binary value transmitters are simultaneously energized by the central unit's intrinsically-safe, internal voltage source. The FM central unit, with the aid of the card-specific feedback signal, generates the control signals necessary for binary value multiplexing. If several modules erroneously respond when a specific address is accessed (double addressing), the feedback signal and transmitter power supply are suppressed by the addressed modules. The central unit recognizes such a fault and transfers the fault message "multiple addressing" to the higher-level automation system.

1) 1 SEP = 15.24 mm

1.4 Technical Data

Dimensions (w x h x d)	15.24 mm x 100 mm x 160 mm
Perm. ambient temperature in operation	-25 to +60 °C
in storage	-40 to +85 °C
Perm. humidity	annual mean = 75 % 30 days 90 % no condensation
Degree of protection	IP 00
Explosion protection	EEx ib IIC T5
Voltage supply	Supply from central unit's intrinsically-safe voltage sources
	$U_1 = +5 \text{ V} \pm 2 \%$
	$U_2 = +22 \text{ V}$ when idling
	$U_2 \geq +15 \text{ V}$ (All transmitter contacts closed or transistors multiplexed)
Voltage input	$J_1 \leq 2 \text{ mA}$
	$J_2 \leq 23 \text{ mA}$ (All transmitter contacts closed or transistors multiplexed)
No. of inputs	8 two-way
Connectable transmitters	Floating contacts
	FM-internal, active M signals (transistors with open collectors)
Operating points	Log. 1 = $U < 7.5 \text{ V}$ contact closed or transistors multiplexed
	Log. 0 = $U > 13 \text{ V}$ contact open or transistors blocked
Input voltage range	$= -30 \text{ V} \leq U_E < +60 \text{ V}$

2 Installation and Commissioning

The binary input module module contains electrostatically sensitive components. Regulations about handling such modules must be observed during installation and commissioning in order to avoid components being destroyed by electrostatic charges.

2.1 Setting

The following settings must be made before inserting the binary input module into an FM subrack:

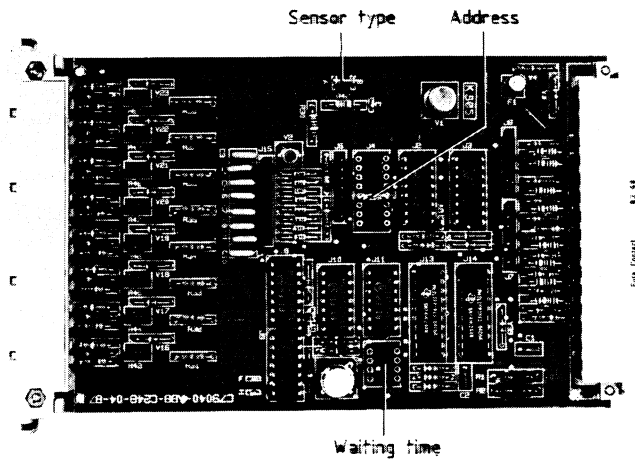

Fig. 1 Position of coding jumpers

- Set the transmitter type
Soldering jumper A-B must be inserted (transmitter type = floating contacts or transistors with open collectors)
- Set the PCB address
(possible address range: 00 to 44)

PCB address	Location J4							
	16	15	14	13	12	11	10	9
00	-	-	-	-	-	-	-	-
01	-	-	-	-	-	X	-	-
02	-	-	-	-	X	-	-	-
...								
43	X	-	X	-	X	X	-	-
44	X	-	X	X	-	-	-	-

X = Coding jumper inserted
- = Coding jumper removed

The address is set in binary code at coding jack J4. When setting the address, please note that jumper 6-11 has a significance of 2° and that jumpers 8-9 and 7-10 are insignificant. The binary input module address range includes the addresses 0 to 44.

- Set the waiting time

A waiting time can be inserted between the multiplexing command being given and the binary value being read in if running time delays of > 20 ms occur due to long field cables. The waiting time should be set as follows:

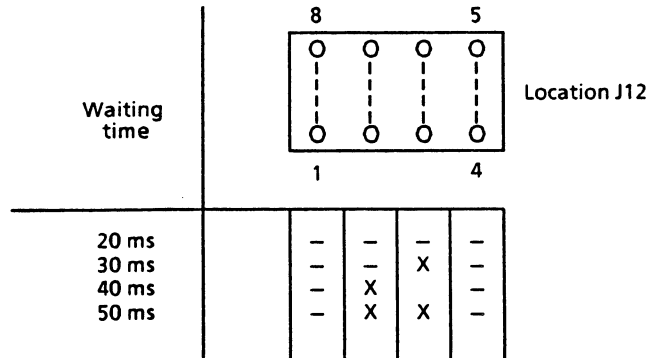

X = Coding jumper inserted
 - = Coding jumper removed

2.2 Plugging the Module in

The binary input module can be plugged into any slot of the FM's basic or extension subrack.

Moreover, it can be plugged in whilst the field multiplexer is switched on.

2.3 Connecting the Field Cables

The field cables should only be connected when the module is plugged in. Before doing this, terminal 17 of the front connector must be connected to the earthing bar mounted under the subrack.

This ensures that when the cables are being connected, the breakers provided on the binary input modules are already capable of limiting spurious peaks and excess voltages.

The field cable screens must be contacted to the cable detensioning rail on the base of the FM cabinet.

On the transmitter side, the screens must be connected to the system earth by the shortest possible route.

When connecting the binary value transmitters the inductivity and capacity of the transmitter circuit must not exceed the following limit values, as stated in the certificate of conformity:

$$L_{max} = 1 \text{ H}$$

$$C_{max} = 95 \text{ nF}$$

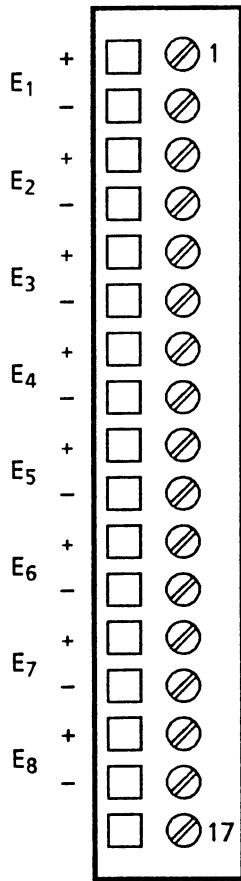

Fig. 2 Front connector assignment

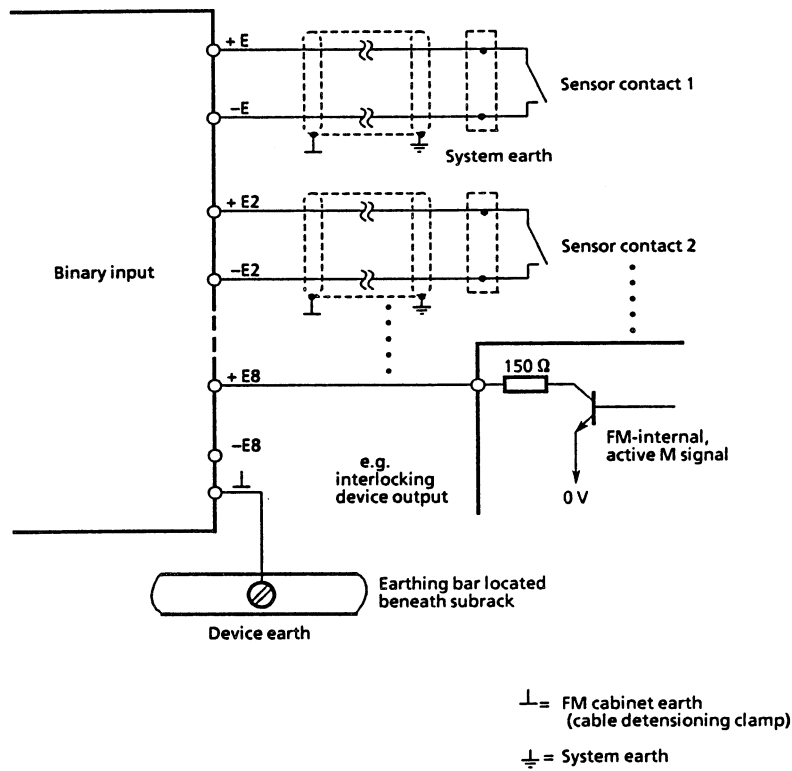

Fig. 3 Connection diagram

3 Maintenance

3.1 Method of Operation

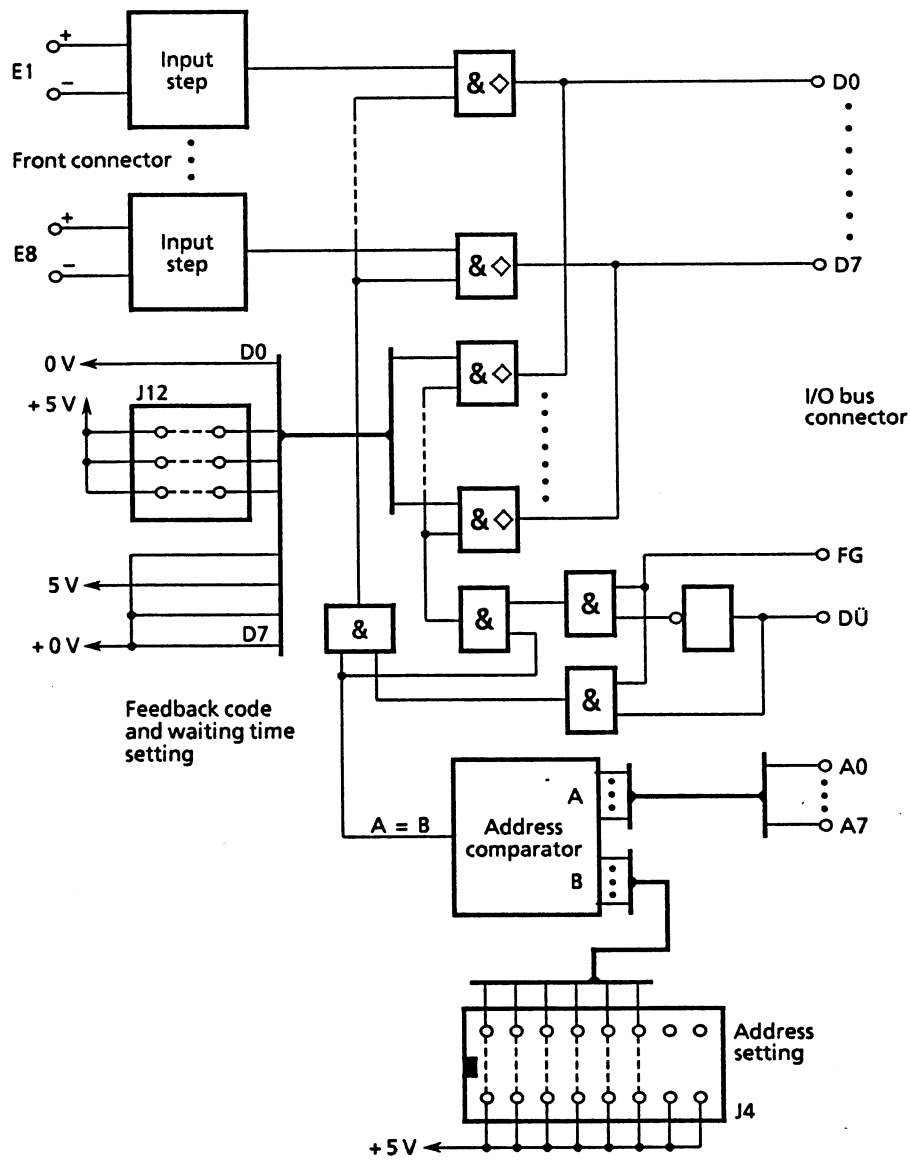
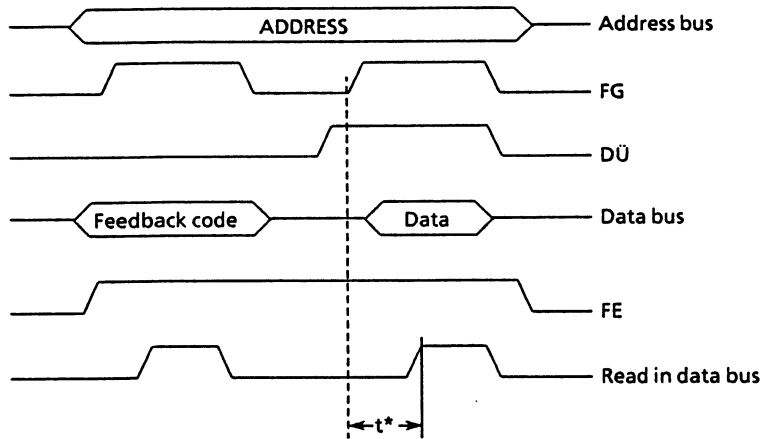

Fig. 4 Block diagram

Data traffic between the central unit and binary input module is carried out via the I/O bus interface. The following pulse diagram shows the I/O sequence of the 8-bit binary input module.



*) depending on set waiting time

Fig. 5 I/O sequence

When the first enable pulse is sent, a feedback code consisting of the module type and waiting time is transmitted to the data bus by the binary input module.

D7							D0
0	0	1	0	X	X	X	0
Module type (fixed setting)				Waiting time (adjustable via coding jumpers)			

When the second enable pulse is sent and the data transfer line is active, the binary value is transmitted to the data bus as follows:

D7	D6	D5	D4	D3	D2	D1	D0
----	----	----	----	----	----	----	----

Binary input 8

Binary input 1

Closed contact = "1" level

Open contact = "0" level

During addressing, the module places the fault line on a voltage level of approx. 2.4 V. If double addressing occurs, the level on the fault line rises to $U > 3$ V. At the same time, the modules suppress the feedback code and the power supply to the transmitter contacts. If no feedback code is given, the central unit checks the fault line and transfers the error message "double addressing" to the higher-level automation system.

3.2 I/O Bus Connector Assignment

Pin	d	b	z
2	-	-	-
4	-	-	-
6	-	-	-
8	FG	-	DÜ
10	-	A0	A1
12	A2	A3	A4
14	A5	A6	A7
16	D0	D1	D2
18	D3	D4	D5
20	D6	D7	M _B
22	FE	-	-
24	-	+ 5 V	M _{5 V}
26	-	-	-
28	-	+ 22 V	M _{22 V}
30	-	-	-
32	-	-	-

3.3 Field Interface Design

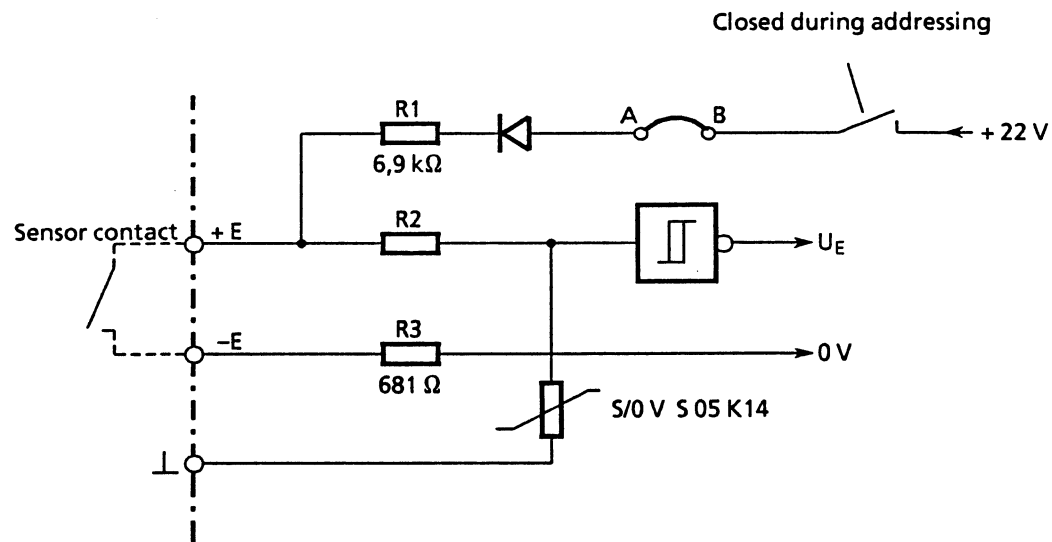

Fig. 6 Design of input step

● Acquisition of contact statuses

When addressing occurs, the central unit's intrinsically-safe +22-V supply voltage is connected (via soldering jumper A-B and transistor T1) to the positive input path and thus also to the transmitter contact.

If the transmitter contact is closed, the resulting input voltage will correspond to the voltage divider ratio of $R1/R3$.

$$\text{"0"-signal} = U_E > 13 \text{ V}$$

$$\text{"1"-signal} = U_E < 7.5 \text{ V}$$

open input = "0"-signal

3.4 Troubleshooting

Faulty I/O modules are signalled by the higher-level automation system via I & C messages. For an explanation of the error messages and details on the troubleshooting procedure see the FM 100 instructions.

3.5 Debugging

Faults can be remedied by replacing the defective module, which should then be sent for repair together with a fault description (please use the returned goods form).
On-site repairs are not permitted for reasons of Ex protection.

SIEMENS

Siemens Aktiengesellschaft

The reproduction, transmission or use of this document or its contents is not permitted without express written authority.
Offenders will be liable for damages. All rights, including rights created by patent grant or registration of a utility model or design, are reserved.

Order No.: C79000-B8076-C092-02

Order from: Gerätewerk Karlsruhe

Printed in the Federal Republic of Germany

© Siemens AG 1989

SIEMENS

TELEPERM M

Field Multiplexer FM 100

Analog Input Module for Resistance-type Thermometers and Thermocouples
6DS1706-8AA

Instructions

Order No. C79000-B8076-C094-03

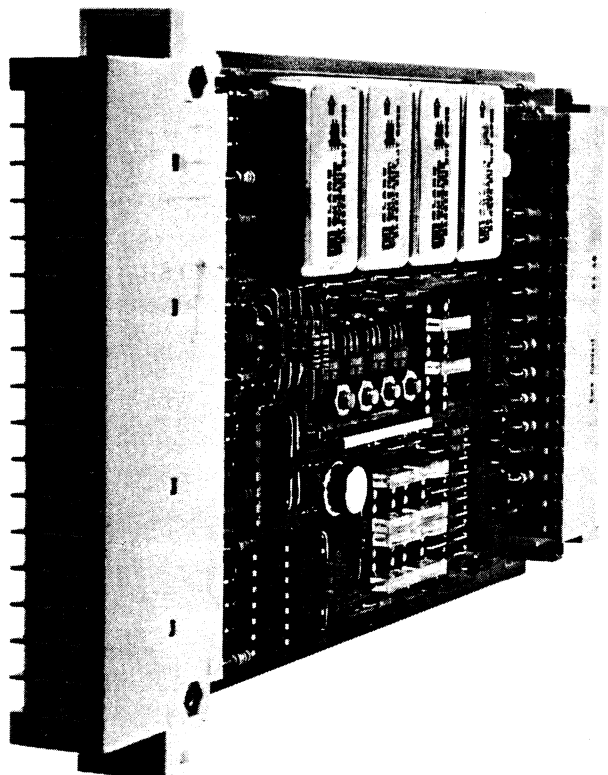

Contents	Page
1 Description	2
1.1 Application	2
1.2 Design	2
1.3 Mode of Operation	2
1.4 Technical Data	4
2 Installation and Commissioning	5
2.1 Setting	5
2.2 Plugging the module in	7
2.3 Connecting the Field Cables	7
3 Maintenance	9
3.1 Method of Operation	9
3.2 I/O bus Connector Assignment	11
3.3 Troubleshooting	12
3.4 Debugging	12

1 Description

1.1 Application

The analog input module 6DS1706-8AA is an input module of the FM 100 field multiplexer and is used for acquiring up to 4 temperature measuring points. The temperature sensors are present in the form of current or voltage signals and can be connected in any combination. The module can be inserted into any slot of the FM 100 basic or extension subrack.

1.2 Design

The analog input module consists of a printed circuit board measuring 100 mm x 160 mm (h x d) and, with a width of 15.24 mm, occupies one standard slot in the subrack. When inserting into the I/O bus, contact is made via a 48-pin ES902 plug connector located at the rear of the module.

The front of the module is designed as a 17-way strip with screw terminals, to which the field cables are connected. For reasons of Ex protection and to shelter it against corrosive atmospheric conditions, the module has a double protective enamel coating.

1.3 Mode of Operation

● Measuring channel multiplexing

Triggered by an initiative from the FM central unit, the analog input module connects the measured value channels, in time-division multiplexing mode (TDM), to the ADC input of the central unit by means of mercury-wetted relay contacts.

Each time a measured-value channel is multiplexed, the central unit's internal, intrinsically-safe constant-current source ($J_k = 2 \text{ mA}$) is connected to the field interface to provide the external resistance-type sensors with a current.

The measuring channels are protected against noise peaks and overvoltages by varistors.

● I/O traffic

The FM central unit communicates with the analog input module via the I/O bus connected to the basic or extension subrack. For each I/O sequence occurring on the I/O bus, the module compares its own address set using coding jumpers with the address present on the I/O bus. If the addresses match, the module sends a feedback code to the data bus. This code includes the module type and channel-specific measuring range set via coding jumpers.

The central unit sets the amplification of the ADC preamplifier using these feedback data and sends the control signals necessary for analog value multiplexing to the I/O bus.

● Fault detection

If several modules erroneously respond when a specific address is accessed (double addressing), the feedback code is suppressed by the addressed modules, thereby simulating an unassigned I/O module address. The central unit detects this error via the I/O bus fault line "FE" and transfers the error message "multiple addressing" to the higher-level automation system. Relay contacts which remain stuck or defective triggered relays (hardware fault) result in all analog value multiplexings being blocked and the formation of parasitic voltages within the connected measured value sensors being avoided.

On detecting a relay fault via the I/O bus line "PS", the central unit transfers the error message "relay fault".

1.4 Technical Data

Dimensions (w x h x d)	15.24 mm (1 SEP) ¹⁾ x 100 mm x 160 mm
Ambient temperature in operation	-25 to +60°C
in storage	-40 to +85°C
Degree of protection	IP 00
Explosion protection	EEx ib IIC T5
Perm. humidity	
Annual mean	75%
30 days	95%
no condensation	
Voltage supply	Supply from central unit's intrinsically-safe voltage sources
	$U_1 = +5 \text{ V } \pm 2\%$
	$U_2 = +22 \text{ V (off-load)}$
	$U_2 > +12 \text{ V (when addressing the module)}$
Current input	$J_1 = \text{max. } 2 \text{ mA}$
	$J_2 = \text{max. } 32 \text{ mA (multiplexing current at measuring point relay)}$
No. of input channels	4
Adjustable measuring ranges	$\pm 20 \text{ mV to } \pm 10 \text{ V}$
Connectable sensor types	
Resistance-type sensor	Pt 100
Thermocouple	NiCr-Ni Fe-CuNi PtRh-Pt
Resistance-type sensor	$R_{\text{max}} = 3 \text{ kOhm}$

1) SEP = standard slot

2 Installation and Commissioning

The analog input contains electrostatically sensitive components. Regulations about handling such modules must be observed during installation and commissioning in order to avoid components being destroyed by electrostatic charges.

2.1 Setting

The following settings must be made before inserting the analog input module into an FM subrack:

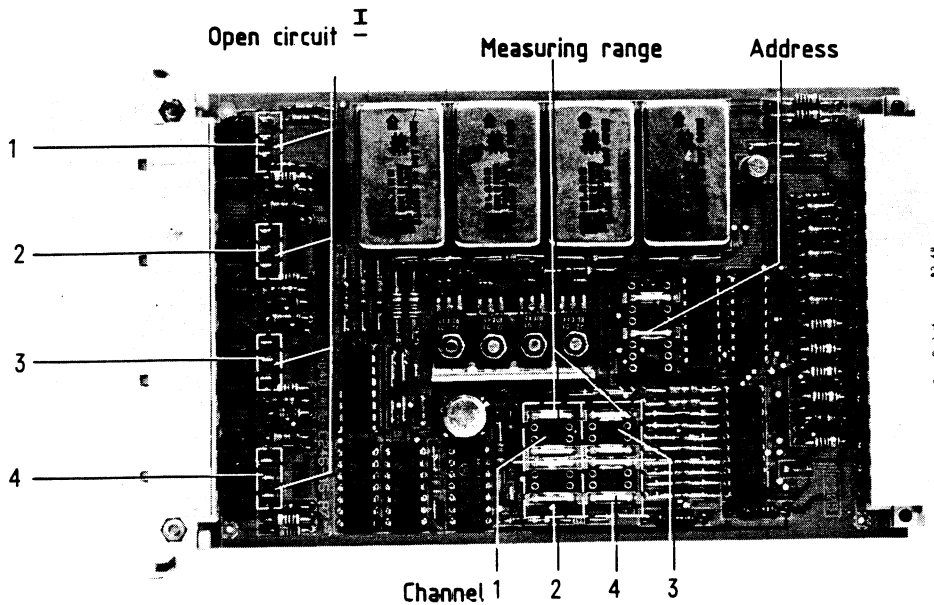

Fig. 1 Position of coding jumpers

- Setting the PCB address
(possible address range 0 to 26)

PCB address	Location J4							
	16							9
00	○	○	○	○	○	○	○	○
01	○	○	○	○	○	○	○	○
02	○	○	○	○	○	○	○	○
...								
25	○	X	X	○	○	X	○	○
26	○	X	X	○	X	○	○	○

X = Jumper inserted
- = Jumper removed

The addresses are set in binary code on the coding jack J4. When setting an address please note that jumper 6-11 has a significance of 2^0 and that jumpers 7-10 and 8-9 are insignificant.

The address range of the analog inputs includes module addresses 0 to 26.

- Setting the measuring range

Each of the 4 measured value channels must be assigned a measuring range which corresponds to the sensor signal range. This is done by inserting coding plugs. Unassigned measuring channels should be set to a measuring range of 10 V.

Adjustable measuring ranges:

Measuring range	Coding jumper			
	3	2	1	0
10 V	-	X	-	X
5 V	-	X	X	-
2,5 V	-	X	X	X
1 V	X	-	-	-
640 mV	X	-	-	X
320 mV	X	-	X	-
160 mV	X	-	X	X
80 mV	X	X	-	-
40 mV	X	X	-	X
20 mV	X	X	X	-

X = Jumper inserted
 - = Jumper removed

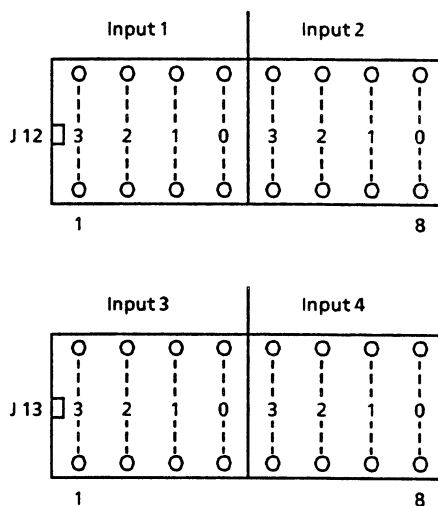

Sensor-specific measuring range assignment

Sensor type	Measuring range
Pt 100	640 mV ¹⁾
Fe-CuNi	40 mV
NiCr-Ni	40 mV
RtRh-Pt	20 mV

1) When internally supplied, with $I_k = 2 \text{ mA}$

- Setting the open-circuit signal (only with thermocouple sensors)

The thermocouple measuring channel must be set to open-circuit signal when inserting the thermocouple sensor. This is done by soldering in the jumpers listed below. Once the signal has been set, the faulty measuring channel is signalled as defective if the sensor circuit is broken.

Measuring channel 1	Solder in jumper A-B
Measuring channel 2	Solder in jumper E-N
Measuring channel 3	Solder in jumper G-H
Measuring channel 4	Solder in jumper K-L

If none of the jumpers listed is soldered in, a free measuring channel input is signalled when a circuit is broken

2.2 Plugging the Module in

The analog input module can be plugged into any slot of the FM's basic or extension subrack. It can also be plugged in whilst the field multiplexer is switched on.

2.3 Connecting the Field Cables

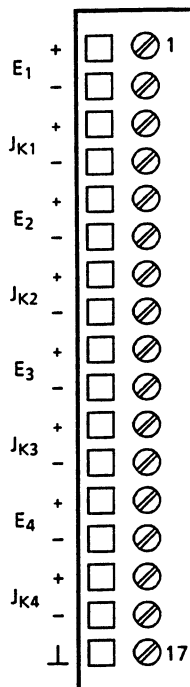

I_k = Constant-current output ($I_k = 2 \text{ mA}$)
 E = Measured value input

Fig. 2 Front connector assignment

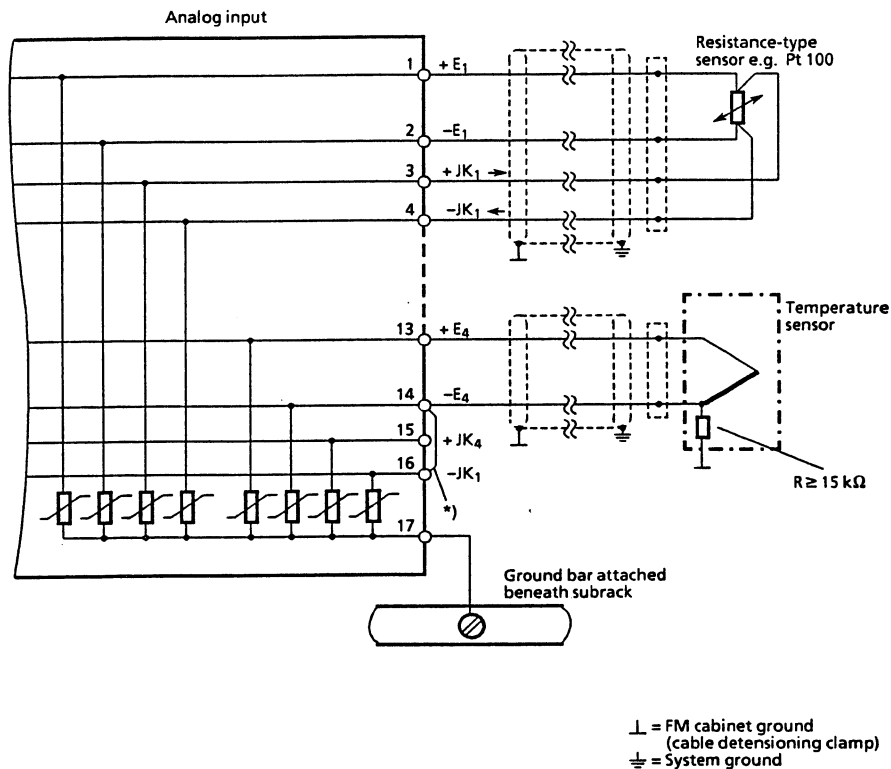

Fig. 3 Connection diagram

Terminal 17 must be connected to the housing earth (earthing bar) before connecting the field cables. This ensures that at the time of commissioning, noise peaks are already limited by varistors to a voltage level harmless to the electronics.

The field cable screens cables must be attached to the cable detensioning rail at the base of the FM cabinet housing.

On the sensor side, the cable screens must be connected to the system earth by the shortest possible route.

According to the PTB certificate of conformity, the following max. inductivity and capacity values of the sensor circuit may not be exceeded when connecting the measured-value sensor:

$$L_{\max} = 1.3 \text{ mH}$$

$$C_{\max} = 21 \text{ nF}$$

Note also when connecting the thermocouple sensors:

Sensor connecting cables must be led up to the module terminal strip as a compensating line, because the compensation sensor is located on the FM 100 subrack.

- If the thermocouple sensor cannot be earthed on-site, for construction reasons, then a short-circuit jumper must be inserted for the channel concerned. This is done on the module terminal strip from terminals -E to -Jk (see ^{*}) in Fig. 3). Shorting jumpers are delivered with the module for this purpose.

3 Maintenance

3.1 Method of Operation

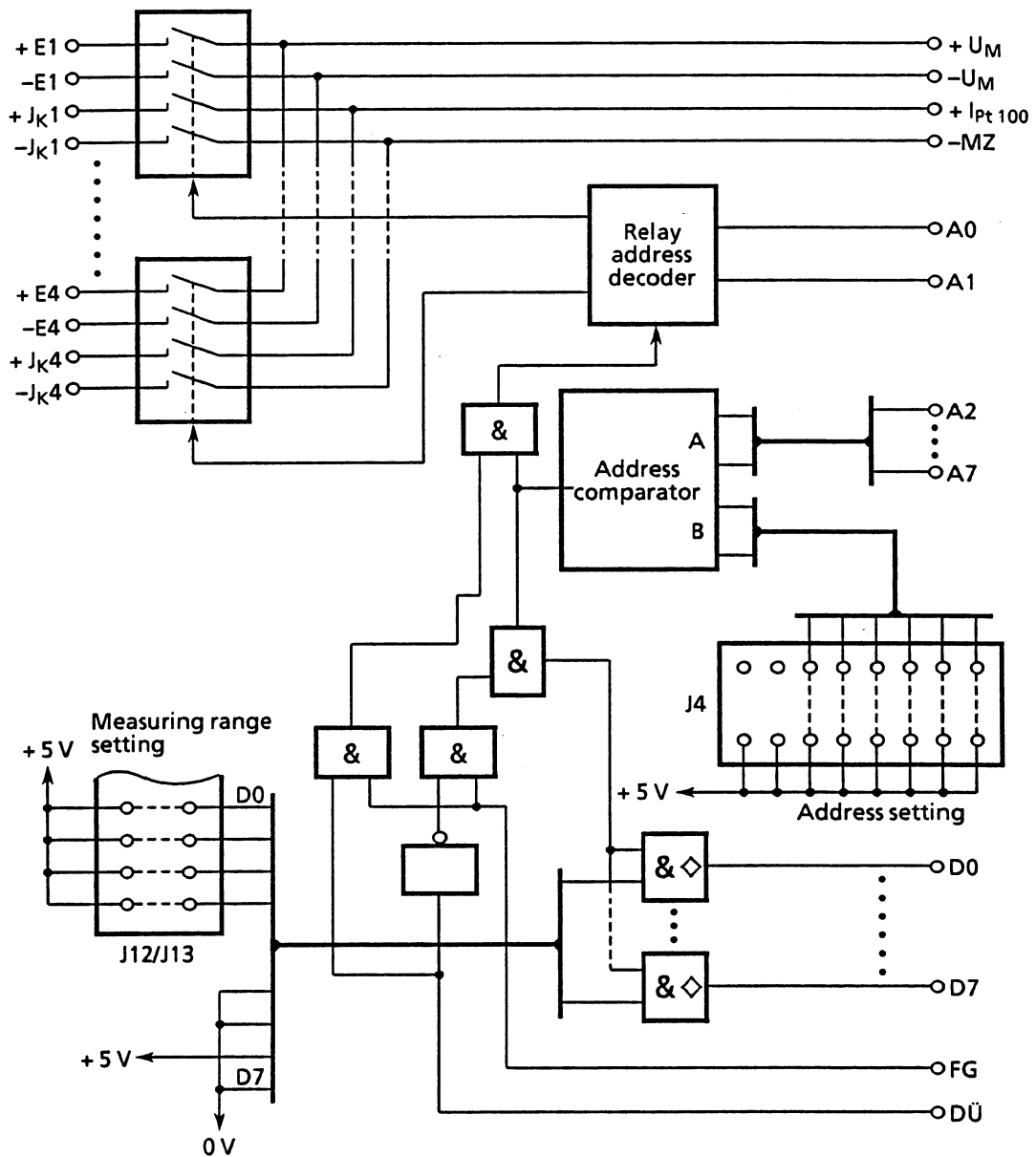

+U_M/-U_M Analog bus
 A1 to A7 Address lines
 D0 to D7 Data lines
 FG Enable
 DÜ Data transfer

Fig. 4 Block diagram

Data traffic between the analog input module and FM central unit is carried out via the I/O bus interface.

The following pulse diagram shows the I/O sequence for the analog input module.

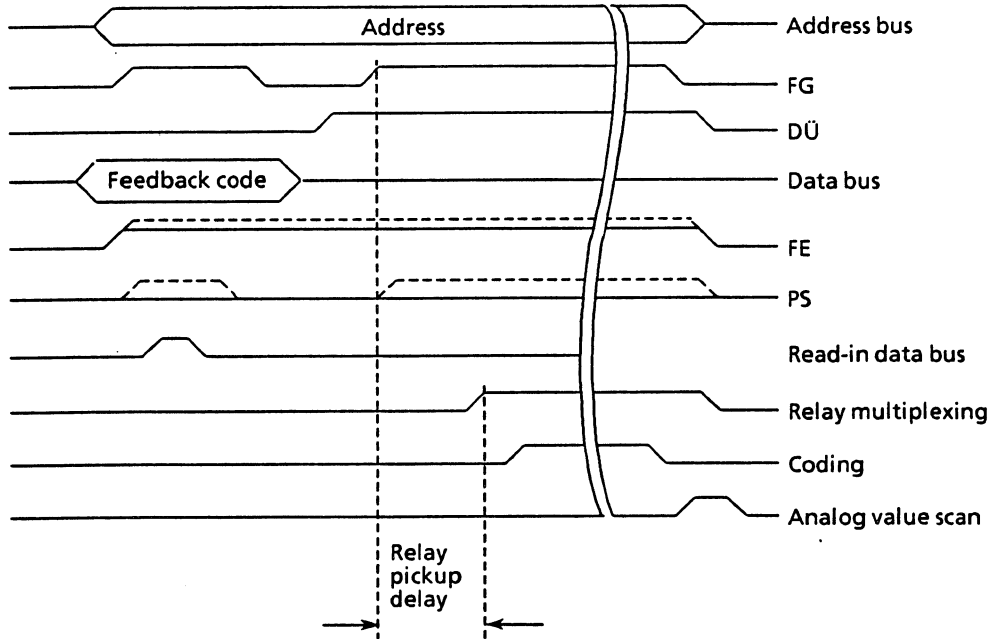

When the first enable pulse (FG) is transmitted, the analog input module sends a channel-specific feedback code to the data bus

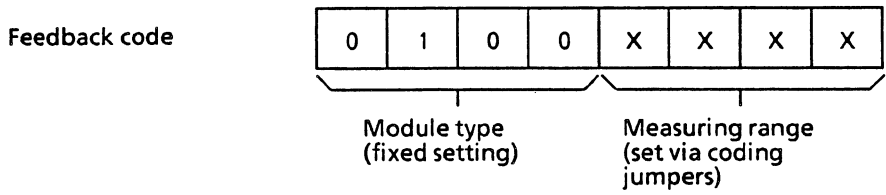

With the second FG pulse and data transfer (DÜ), the analog input module multiplexes the corresponding measuring point relay. After a waiting time (relay pickup delay and ADC response time), the central unit triggers the coding function and transfers the values obtained to the higher-level automation system.

If addressing occurs fault-free, the analog input module generates a voltage level of approx. 2.4 V on the I/O bus fault line.

Should double addressing occur (several I/O modules set to same address), the module feedback signal is suppressed and the voltage level on the fault line rises to $U > 3 \text{ V}$ at the time of addressing.

If a relay contact on an analog input module remains closed (hardware fault), a "1" signal is sent to the bus line "PS" during fault-free triggering of analog input modules and further relay contact multiplexing is prevented. The central unit detects the faulty analog value channel as well as the faulty relay, by the fact that an "0" signal only occurs when the faulty channel responds on the PS line.

Should the faults described above occur, the central unit will transfer error messages to the higher-level automation system.

3.2 I/O Bus Connector Assignment

	d	b	z
2	U_{M+}	U_{M-}	-
4	I_{PT100}	-	M_Z
6	-	-	-
8	FG	-	DÜ
10	-	A0	A1
12	A2	A3	A4
14	A5	A6	A7
16	D0	D1	D2
18	D4	D4	D5
20	D6	D7	M_B
22	FE	-	PS
24	-	+5 V	$M_{5 \text{ V}}$
26	-	-	-
28	-	+22 V	$M_{22 \text{ V}}$
30	-	-	-
32	-	-	-

$I_{PT100} = 2 \text{ mA}$

3.3 Troubleshooting

Faulty I/O modules are signalled to the higher-level automation system via I&C error messages. For an explanation of the error messages and details on the troubleshooting procedure see the FM 100 instructions.

3.4 Debugging

Faults can be remedied by replacing the defective module, which should then be sent for repair together with a fault description (please use returned goods form).

On-site repairs are not permitted for reasons of Ex protection.

SIEMENS

TELEPERM M

FM 100 Field Multiplexer

Analog Input Module for Current and Voltage Sensors
6DS1708-8AA

Instructions

Order No. C79000-B8076-C095-03

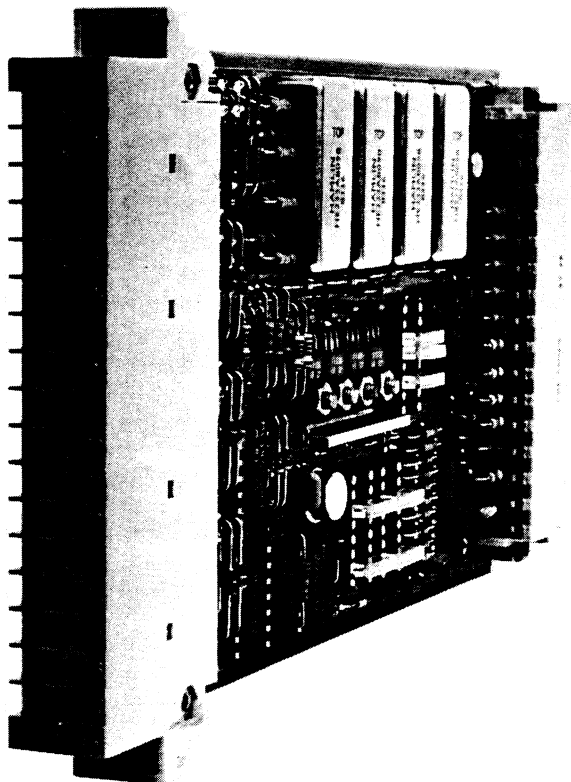

Contents	Page
1 Description	2
1.1 Application	2
1.2 Design	2
1.3 Mode of Operation	2
1.4 Technical Data	4
2 Installation and Commissioning	5
2.1 Setting	5
2.2 Plugging the Module in	7
2.3 Connecting the Field Cables	7
3 Maintenance	9
3.1 Method of Operation	9
3.2 I/O Bus Connector Assignment	11
3.3 Troubleshooting	12
3.4 Debugging	12

1 Description

1.1 Application

The analog input module 6DS1708-8AA is an input module of the FM 100 field multiplexer and is used for acquiring up to 4 analog values, present in the form of current or voltage signals. The module can be inserted into any slot of the FM 100 basic or extension subrack.

1.2 Design

The analog input module consists of a printed circuit board measuring 100 mm x 160 mm (h x d) and, with a width of 15.24 mm, occupies one standard slot in the subrack. When plugged in to the subrack, the I/O module is contacted to the I/O bus by means of a 48-pin ES902 plug connector located at the rear of the module.

The front of the module is designed as a 17-way strip with screw terminals, to which the field cables are connected. For reasons of Ex protection and to shelter it against corrosive atmospheric conditions, the module has a double protective enamel coating.

1.3 Mode of Operation

● Measuring channel multiplexing

Triggered by an initiative from the FM central unit, the analog input module connects the measured value channels, in time-division multiplexing mode (TDM), to the ADC input of the central unit by means of mercury-wetted relay contacts.

If the sensor signals are in the form of currents, a proportional voltage is generated on 50-ohm resistors present in the module and connectable via soldering jumpers. Each measured value channel on the I/O module can be individually adjusted to the respective signal type (current or voltage).

The measuring channels are protected against noise peaks and overvoltages by varistors.

● I/O traffic

The FM central unit communicates with the analog input module via the I/O bus connected to the basic or extension subrack.

For each I/O sequence occurring on the I/O bus, the module compares its own address set using coding jumpers with the address present on the I/O bus. If the addresses match, the module sends a feedback code to the data bus. This code includes the module type and channel-specific measuring range set via coding jumpers.

The central unit sets the amplification of the ADC preamplifier using these feedback data and sends the control signals necessary for analog value multiplexing to the I/O bus.

● Fault detection

If several modules erroneously respond when a specific address is accessed (double addressing), the feedback code is suppressed by the addressed modules, thereby simulating an unassigned I/O module address. The central unit detects this error via the I/O bus error line "FE" and transfers the error message "multiple addressing" to the higher-level automation system. Relay contacts which remain stuck or defective triggered relays (hardware fault) result in all analog value multiplexings being blocked and the formation of parasitic voltages within the connected measured value sensors being avoided.

On detecting a relay fault via the I/O bus line "PS", the central unit transfers the error message "relay fault".

1.4 Technical Data

Dimensions (w x h x d)	15.24 mm (1 SEP) ¹⁾ x 100 mm x 160 mm
Ambient temperature in operation	-25 to +60°C
in storage	-40 to +85°C
Degree of protection	IP 00
Explosion protection	EEx ib IIC T5
Perm. humidity Annual mean	75%
30 days	95%
no condensation	
Voltage supply	Supply from central unit's intrinsically-safe voltage sources
	$U_1 = +5 \text{ V } \pm 2\%$
	$U_2 = +22 \text{ V (off-load)}$
	$U_2 > +12 \text{ V (when addressing the module)}$
Current input	$J_1 = \text{max. } 2 \text{ mA}$
	$J_2 = \text{max. } 32 \text{ mA (multiplexing current at measuring point relay)}$
No. of input channels	4
Adjustable measuring ranges	$\pm 20 \text{ mV to } \pm 10 \text{ V}$ 0 to 20 mA, 4 to 20 mA
Connectable sensor types	Voltage sensors with a signal range of $\pm 20 \text{ mV to } \pm 10 \text{ V}$ and intrinsically-safe output signals
	Intrinsically-safe current sensors 0 to 20 mA or 4 to 20 mA

1) SEP = standard slot

2 Installation and Commissioning

The analog input contains electrostatically sensitive components. Regulations about handling such modules must be observed during installation and commissioning in order to avoid components being destroyed by electrostatic charges.

2.1 Setting

The following settings must be made before inserting the analog input module into an FM subrack:

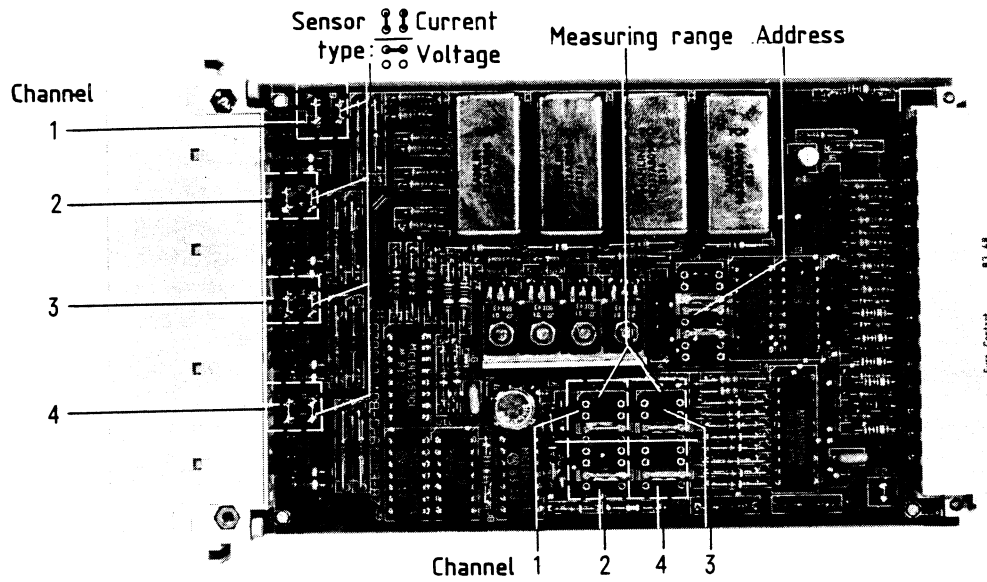
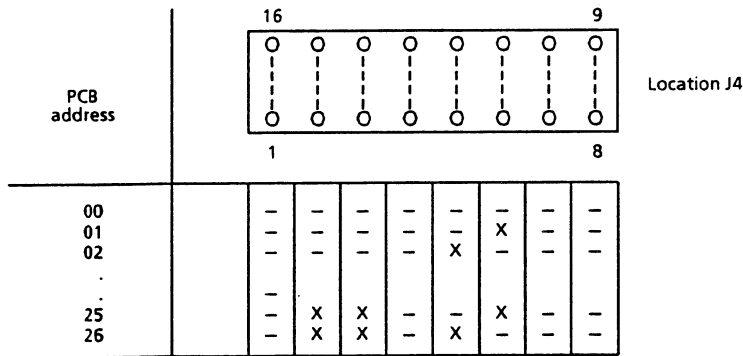

Fig. 1 Position of coding jumpers

- Setting the PCB address



X = Jumper inserted
 - = Jumper removed

The addresses are set in binary code on the coding jack J4. When setting an address please note that jumper 6-11 has a significance of 2^0 and that jumpers 7-10 and 8-9 are insignificant.

The address range of the analog inputs includes module addresses 0 to 26.

- Setting the measuring range

Each of the 4 measured value channels must be assigned a measuring range which corresponds to the sensor signal range. This is done by inserting coding plugs.

Unassigned measuring channels should be set to a measuring range of 10 V.

Measuring range	Coding jumper			
	3	2	1	0
0 ... 20 mA	-	-	X	-
4 ... 20 mA	-	-	X	X
100 V	-	X	-	-
10 V	-	X	-	X
5 V	-	X	X	-
2,5 V	-	X	X	X
1 V	X	-	-	-
640 mV	X	-	-	X
320 mV	X	-	X	-
160 mV	X	-	X	X
80 mV	X	X	-	-
40 mV	X	X	-	X
20 mV	X	X	X	-

X = Jumper inserted
 - = Jumper removed

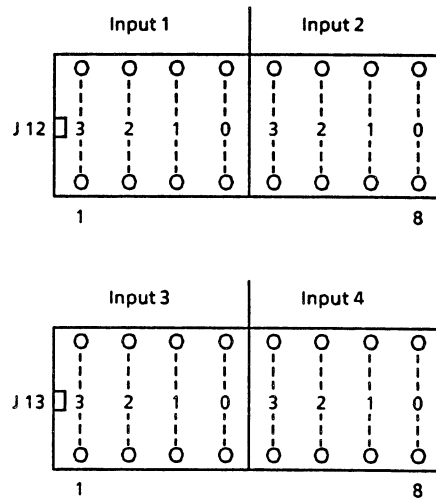

The sensor type is set by means of soldering jumpers as follows:

	Current sensor *)	Voltage sensor
Input 1	A - C B - E	A - B
Input 2	F - H G - K	F - G
Input 3	L - N M - O	L - M
Input 4	P - S R - T	P - R

*) Status on delivery: 50-ohm resistor is connected in parallel to the input. $U_E = J_E \times 50 \text{ ohms}$

2.2 Plugging the Module in

The analog input module can be plugged into any slot of the FM basic or extension subrack. It can also be plugged in whilst the field multiplexer is switched on.

2.3 Connecting the Field Cables

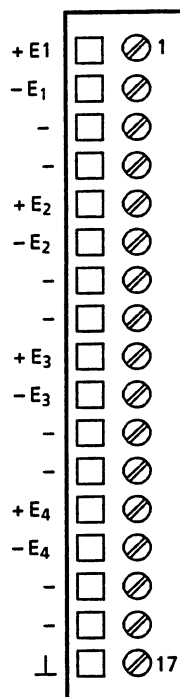

E = Measured value input
= device earth

Fig. 2 Front connector assignment

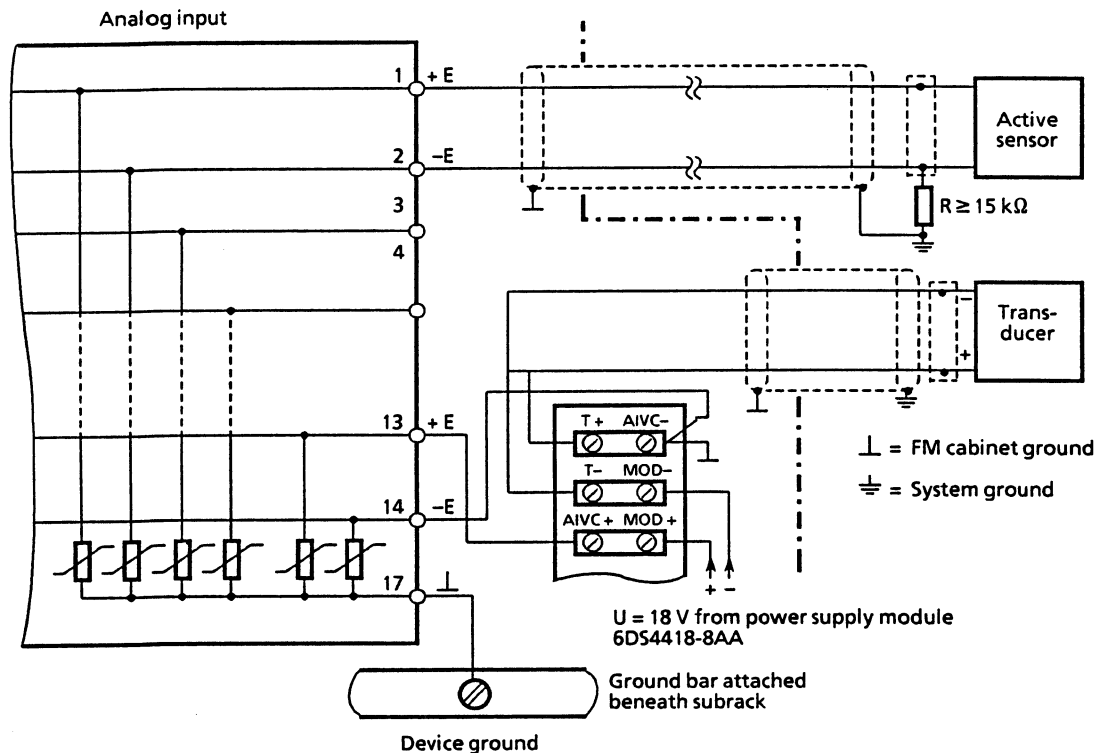

Fig. 3 Connection diagram

Terminal 17 must be connected to the housing earth (earthing bar) before connecting the field cables. This ensures that at the time of commissioning, noise peaks are already limited by varistors to a voltage level harmless to the electronics.

The screens of the sensor connecting cables must be attached to the cable detensioning clamp on the base of the FM cabinet housing.

On the sensor side, the cable screens must be connected to the system earth by the shortest possible route.

● Connecting the active measured value sensors

- Active sensors must be of a floating design.
- The negative sensor output must be connected, on the measured value sensor, to the system earth via a resistor $R \geq 15 \text{ kohms}$.
- Only certified sensors that do not exceed the following individual values may be installed:

No-load voltage	$U_{Lmax} \leq 19 \text{ V}$
Short-circuit current	$J_{Kmax} \leq 35 \text{ mA}$

● Connecting the transducers

The following points must be observed when installing transducers supplied by the FM-internal power supply module 6DS4418-8AA:

- A link must be established between connection terminal AIVC- and the cabinet earth via the connection block in the FM 100.
- The inductivity and capacity of the sensor circuit must not exceed the following limit values:

$$L_{max} = 0.5 \text{ mH}$$

$$C_{max} = 110 \text{ nF}$$

3 Maintenance

3.1 Method of Operation

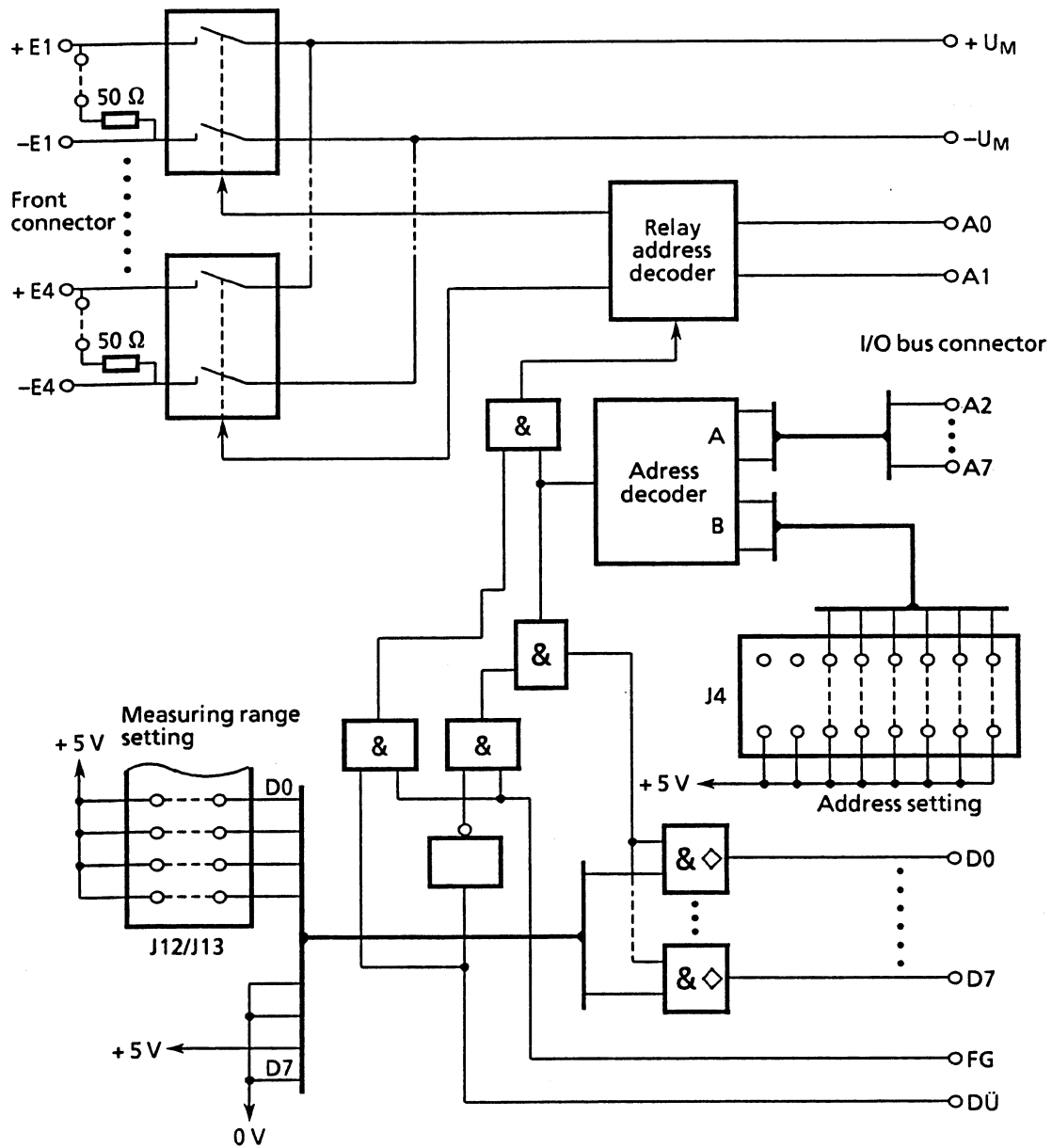

+U_M/-U_M Analog bus
 A1 to A7 Address lines
 D0 to D7 Data lines
 FG Enable
 DÜ Data transfer

Fig. 4 Block diagram

Data traffic between the analog input module and FM central unit is carried out via the I/O bus interface.

The following pulse diagram shows the I/O sequence for the analog input module.

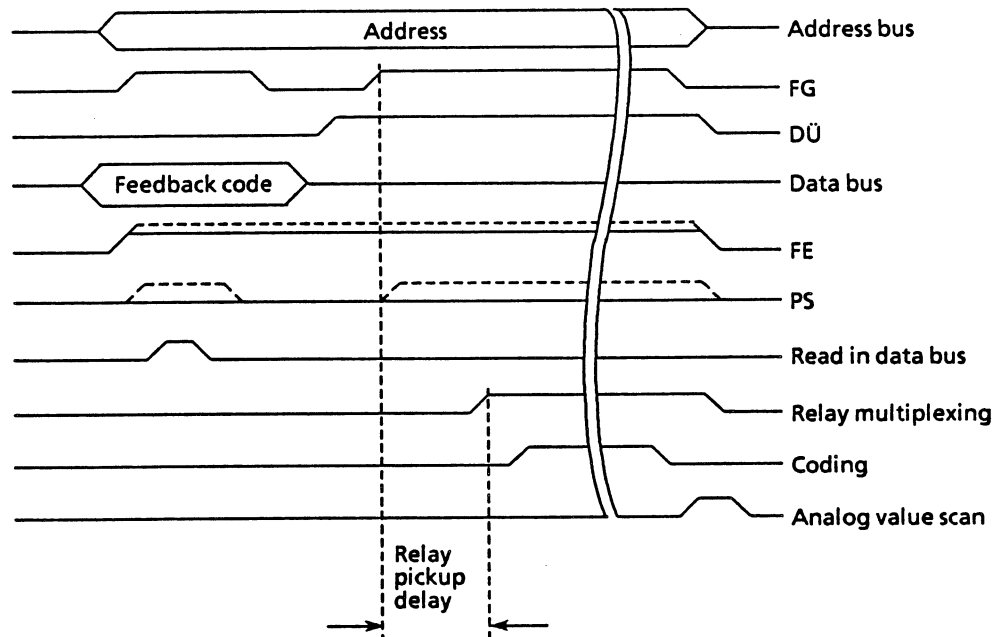

When the first enable pulse (FG) is transmitted, the analog input module sends a channel-specific feedback code to the data bus

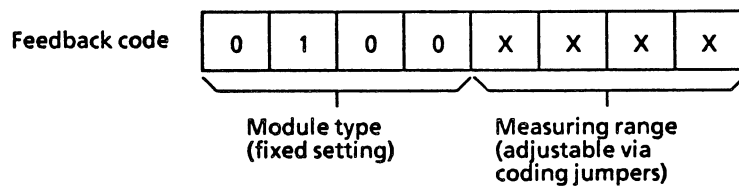

With the second FG pulse and data transfer (DÜ), the analog input module multiplexes the corresponding measuring point relay. After a waiting time (relay pickup delay and ADC response time), the central unit triggers the coding function and transfers the values obtained to the higher-level automation system.

If addressing occurs fault-free, the analog input module generates a voltage level of approx. 2.4 V on the I/O bus fault line.

Should double addressing occur (several I/O modules set to same address), the module feedback signal is suppressed and the voltage level on the fault line rises to $U > 3 \text{ V}$ at the time of addressing.

If a relay contact on an analog input module remains closed (hardware fault), a "1" signal is sent to the bus line "PS" during fault-free triggering of analog input modules and further relay contact multiplexing is prevented. The central unit detects the faulty analog value channel as well as the faulty relay, by the fact that a "0" signal only occurs when the faulty channel responds on the PS line.

Should the faults described above occur, the central unit will transfer error messages to the higher-level automation system.

3.2 I/O Bus Connector Assignment

Pin	d	b	z
2	U_{M+}	U_{M-}	-
4	-	-	-
6	-	-	-
8	FG	-	DÜ
10	-	A0	A1
12	A2	A3	A4
14	A5	A6	A7
16	D0	D1	D2
18	D3	D4	D5
20	D6	D7	M_B
22	FE	-	PS
24	-	+5 V	$M_{5 \text{ V}}$
26	-	-	-
28	-	+22 V	$M_{22 \text{ V}}$
30	-	-	-
32	-	-	-

3.3 Troubleshooting

Faulty I/O modules are signalled to the higher-level automation system via I&C error messages. For an explanation of these messages and details on the troubleshooting procedure, see the FM 100 instructions.

3.4 Debugging

Faults can be remedied by replacing the defective module, which should then be sent in for repair together with a fault description (please use returned goods form).

On-site repairs are not permitted for reasons of Ex protection.

SIEMENS

TELEPERM M

FM 100 Field Multiplexer

Limit Value Monitor Module (LIM. SIG)
6DS1710-8AA

Instructions

Order No. C79000-B8076-C096-02

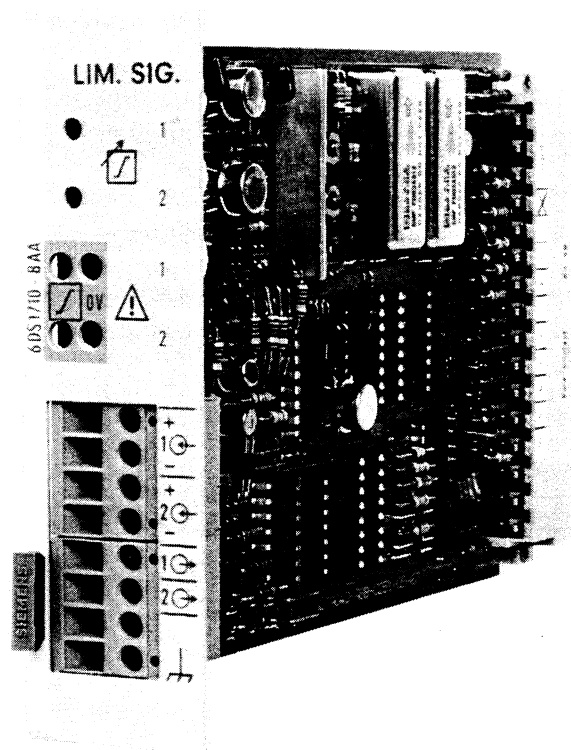

Contents	Page
1 Description	2
1.1 Application	2
1.2 Design	2
1.3 Mode of Operation	2
1.4 Technical Data	4
2 Installation and Commissioning	5
2.1 Setting	5
2.2 Plugging the Module in	8
2.3 Connecting the Field Cables	8
2.4 Setting the Limit Values	9
2.5 Connecting the Signal Outputs	9
3 Maintenance	10
3.1 Method of Operation	10
3.2 I/O Bus Connector Assignment	12
3.3 Troubleshooting	13
3.4 Debugging	13

1 Description

1.1 Application

The limit-value monitor module 6DS1710-8AA is an I/O module of the FM 100 field multiplexer and is used to monitor analog values for limits set by the user.

These analog values can be present as current or voltage signals up to $J_{\max} = +20 \text{ mA}$ or $U_{\max} = +1 \text{ V}$. The limit monitor can be inserted into any slot of the FM basic or extension subrack.

1.2 Design

The limit-value monitor module consists of a printed circuit board measuring 100 mm x 160 mm (h x d) and with a width of 30.48 mm occupies two standard slots (2 SEPs) in the I/O subrack. When plugged into the subrack, the module is contacted with the I/O bus via a 48-pin ES902 plug connector located at the rear of the module. The front of the module is designed as an 8-pin terminal strip with screw terminals to which the field cables are connected.

Test jacks and potentiometers for setting the limit values are also provided on the front connector.

For reasons of Ex protection and to shelter it against corrosive atmospheric conditions, the module is provided with a protective double enamel coating.

1.3 Mode of Operation

The limit-value monitor module functions in the same way as a two-channel analog input module with the measuring ranges +1 V or 0 to 20 mA, with which the measured values present can be monitored for limits set by the user. A lower or upper limit value can be fixed for each measuring channel. If a measured value is to be monitored for a lower and upper limit value, both measuring channels must be connected in parallel.

The response range (signalling of under or overshooting) can be planned by means of coding jumpers. The over or undershooting of a set limit value is signalled to the field multiplexer central unit in the module feedback message at the time of scanning.

Signal outputs are also present in the form of transistors with open collectors on the module front connector for externally processing the limit value messages.

● Measuring channel multiplexing

Triggered by an initiative from the field multiplexer, the limit-value monitor module multiplexes the measured value channels in time-division multiplexing mode (TDM) to the central unit ADC via mercury-wetted relay contacts.

If the field signals are in the form of currents, a proportional voltage is generated on 50-ohm resistors provided on the module and connectable via coding jumpers. Both measured value channels can be separately adjusted to the respective sensor type.

● I/O traffic

The FM central unit communicates with the limit monitor via the I/O bus connected to the basic or extension subrack.

For each I/O sequence occurring on the I/O bus, the I/O module compares its own module address set using coding jumpers with the address present on the I/O bus. If the addresses match, the module sends a feedback code to the data bus. This code includes the module type, limit value status and channel-specific measuring range set via coding jumpers.

The central unit sets the amplification of the ADC pre-amplifier using this feedback data and sends the control signals necessary for analog value multiplexing to the I/O bus.

● Fault detection

If several modules respond when a specific address is accessed (double addressing), the feedback code is suppressed by the addressed modules thereby simulating an unassigned I/O module address.

The central unit detects this error via the I/O bus fault line "FE" and transfers the error message "multiple addressing" to the higher-level automation system. Relay contacts which remain stuck or defective triggered relays (hardware defect) result in all analog value multiplexings being blocked and the formation of parasitic voltages within the connected transmitters being avoided.

On detecting a relay fault via the I/O bus line "PS", the central unit transmits the error message "relay defect".

1.4 Technical Data

Dimensions (w x h x d)	30.48 mm (2 SEP) ¹⁾ x 100 mm x 160 mm
Ambient temperature	
in operation	-25 to +60 °C
in storage	-40 to +85 °C
Degree of protection	IP 00
Explosion protection	E Ex ib IIC T5
Perm. humidity	
Annual mean	75 %
30 days	95 %
No condensation	
Voltage supply	Supply from intrinsically-safe central unit voltage sources
	U ₁ = +5 V +2 %
	U ₂ = 22 V
	U ₂ > +12 V (with multiplexing of measuring point relay)
	U ₃ = +12 V
	U ₄ = -12 V
	Supply from intrinsically-safe 12-V power supply module
Current input	I ₁ ≤ 2 mA
	I ₂ ≤ 32 mA (with multiplexing of measuring point relay)
	I ₃ ≤ 3 mA
	I ₄ ≤ 2 mA
No. of input channels	2
Connectable sensor types	Intrinsically-safe voltage sensors with a signal range of +1 V.
	Intrinsically-safe current sensors with a signal range of +20 mA.
No. of signal outputs	2 (open collectors)
Limit data of signal outputs	U _{CE max} = 14.7 V
	I _{Cmax} results from U _{CE max} : 1.2 kohm

1) SEP = standard slot

2 Installation and Commissioning

The limit-value monitor module contains electrostatically sensitive components. Regulations about handling such modules must be observed during installation and commissioning in order to avoid components being destroyed by electrostatic charges.

2.1 Setting

The following settings must be made before inserting a limit-value monitor module into an FM subrack:

- Location of the coding jumpers

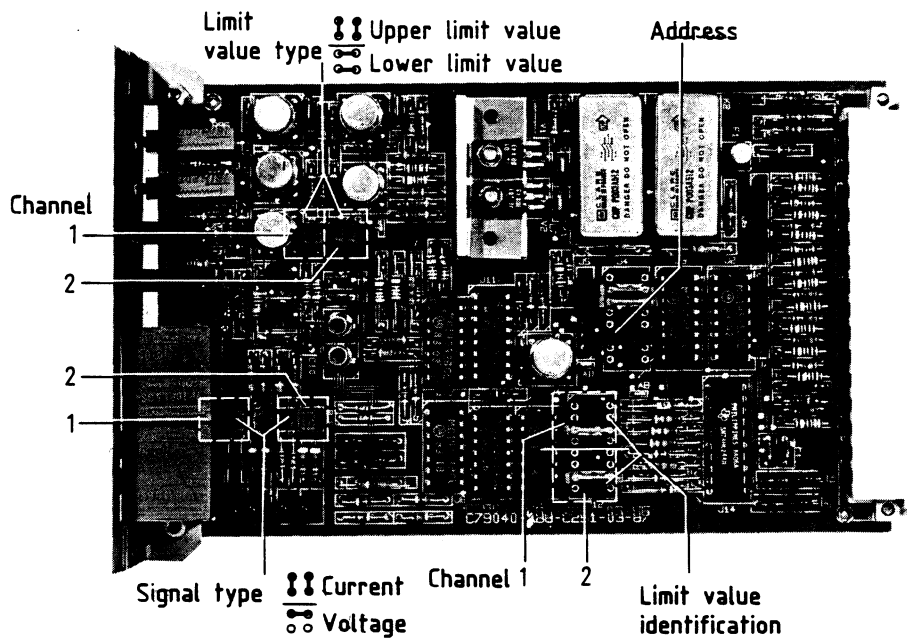
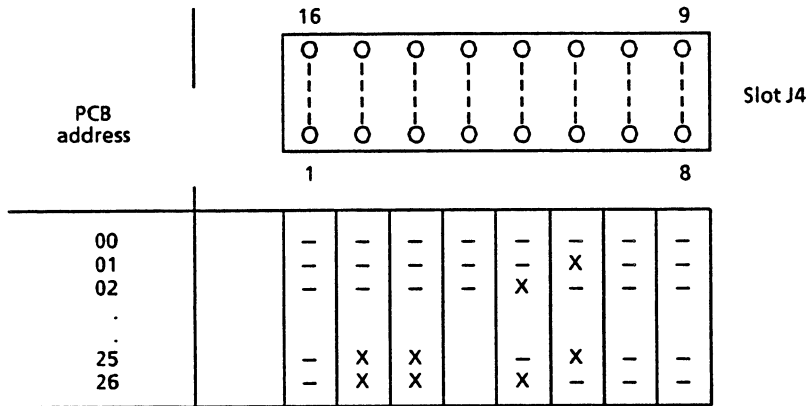

Fig. 1 Location of coding jumpers

● Setting the PCB address

Addresses are set in binary code on the coding jack J4. When setting an address please note that the jumper 6-11 has a significance of 2° and that jumpers 8-9 and 7-10 are insignificant. The address range of the limit-value monitor module includes module addresses 0 to 26.



X = Jumper inserted
 - = Jumper removed

o Setting the limit value type

The choice as to whether or not a limit-value signal should be given if the set limit value is under or overshoot, is made by means of coding jumpers.

	Coding jumpers to be inserted	
	Signal when limit is undershot *)	Signal when limit is overshoot
Measuring channel 0	K - L J - M	J - L K - M
Measuring channel 1	O - P N - Q	N - P O - Q

*) status on delivery

If a measured value is to be monitored for two limit values, then both of the module's measuring channels must be connected in parallel and differently connected in respect to their limit-value type (e.g., channel 1 for upper limit, channel 0 for lower limit).

● Setting the limit-value identification

With limit value identification, the operating mode of the two measuring channels is communicated to the FM central unit. The limit value identification is transferred together with the module code in the feedback message to the FM central unit.

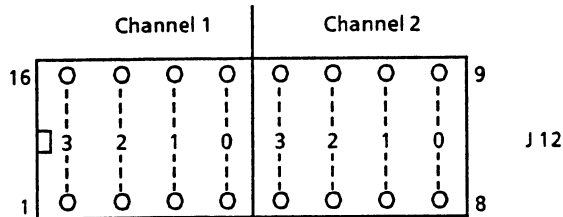

Jumper 3 = insignificant

Jumper 2 inserted = both measuring channels monitoring the same field signal

Jumper 2 free = both measuring channels working independantly of each other

Jumper 1 inserted = monitoring for overshooting

Jumper 1 free = monitoring for undershooting

Jumper 0 inserted = measuring range 4...20 mA

Jumper 0 free = measuring range 0...20 mA or +1 V

● Setting the signal type

The measuring channels are adjusted to the corresponding measured-value sensor by inserting coding jumpers.

	Current sensor *)	Voltage sensor
Measuring channel 0	A - C B - E	A - B
Measuring channel 1	G - S H - T	S - T

*) Status on delivery

When setting to signal type "current sensor", a 50-ohm resistor is connected in parallel to the measured-value channel by means of inserting the coding jumpers. Resulting input voltage:

$$U_E = J_E \times 50 \text{ ohms.}$$

If a current signal is to be monitored on **two** limits (e.g. lower and upper limit), only **one** measuring channel may be set to the signal type "current sensor". If both inputs are erroneously set to "current sensor", an input resistance of 25 ohms results from the parallel connection of both measuring channel input resistors and with it a data falsification by a factor of approximately 0.5.

2.2 Plugging the Module in

The limit-value monitor module can be plugged into any slot of the FM basic or extension subrack. The module can also be inserted or removed during operation.

2.3 Connecting the Field Cables

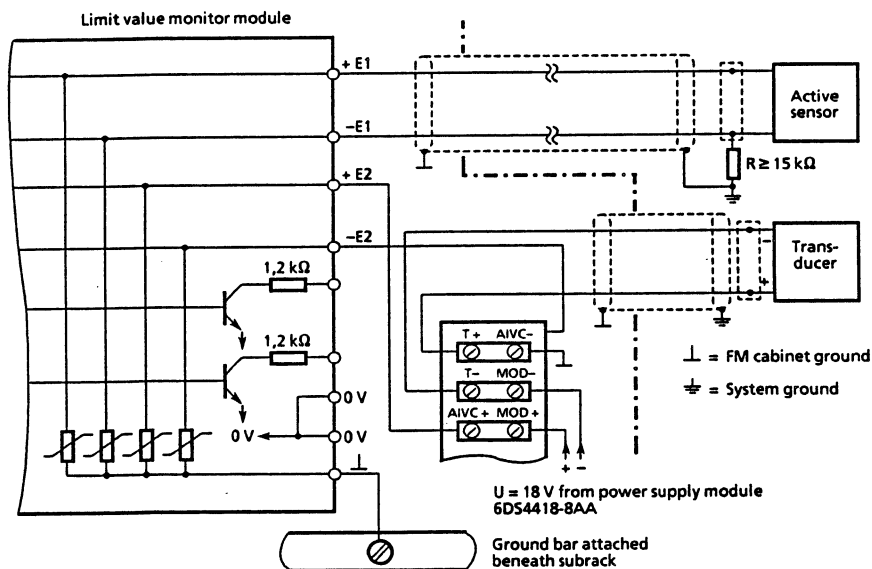

Before attaching the field cable, connect the terminal (|) to the housing earth (earthing bar) by means of the wire jumper supplied. This ensures that at the time of commissioning, spurious peaks are already limited by means of varistors. The screens of the sensor connecting lines must be attached to the cable detensioning clamp at the base of the FM cabinet housing. On the sensor side, the cable screens must be connected to the system earth by the shortest possible route.

● Connecting the active measured-value sensors

- Active sensors must be of a floating design.
- The negative sensor output must be connected, on the measured-value sensor, to the system earth via a resistor of $R \geq 15 \text{ kohm}$
- Only certified, intrinsically-safe sensors which keep within the following limit values may be used in the Ex area (Ex zone 1):

No-load voltage	$U_{L \text{ max}} = 19 \text{ V}$
Short-circuit current	$I_{K \text{ max}} = 35 \text{ mA}$

● Connecting the transducers

The following points must be observed when installing transducers supplied by the FM-internal power supply module 6DS4418-8AA:

- A link must be established via the connection block in the FM 100 between connection terminal AIVC and the cabinet earth.
- The inductivity and capacity of the sensor circuit must not exceed the following limit values:

$$L_{\text{max}} = 0.5 \text{ mH}$$

$$C_{\text{max}} = 110 \text{ nF}$$

2.4 Setting the Limit Values

The limit values can be separately set in the range 0 to 1 V for both limit value channels with the potentiometers accessible from the module front. The limit value can be measured by means of the measuring jacks on the front panel of the module.

When connecting a measuring instrument to these jacks, please note that the measuring instrument to be connected must be approved for the Ex area (Ex zone 1) and that the following limit values for the input capacity and input inductivity of the measuring instrument must be observed:

$$\begin{aligned} L_{\max} &= 180 \text{ mH} \\ C_{\max} &= 95 \text{ nF} \end{aligned}$$

2.5 Connecting the Signal Outputs

The limit value signals of both measuring channels are given on the field interface of the module in order to ensure that they are further processed (e.g. that an interlocking card is triggered when a limit value is overshoot). The signal outputs are designed as transistors with open collectors.

Depending on the limit value type set, the signal output of the corresponding measuring channel is activated when the limit value is under or overshoot.

This means that the output transistor is triggered into a conductive state.

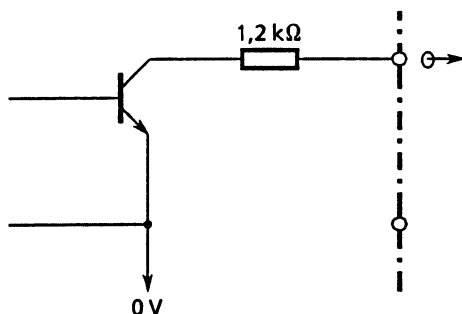

Signal output design

The following limit values must be observed when connecting the signal outputs:

- max. perm. external capacity = 95 nF
- max. perm. external inductivity = 660 mH
- max. perm. collector voltage $U_{\max} = 14.7 \text{ V}$

3 Maintenance

3.1 Method of Operation

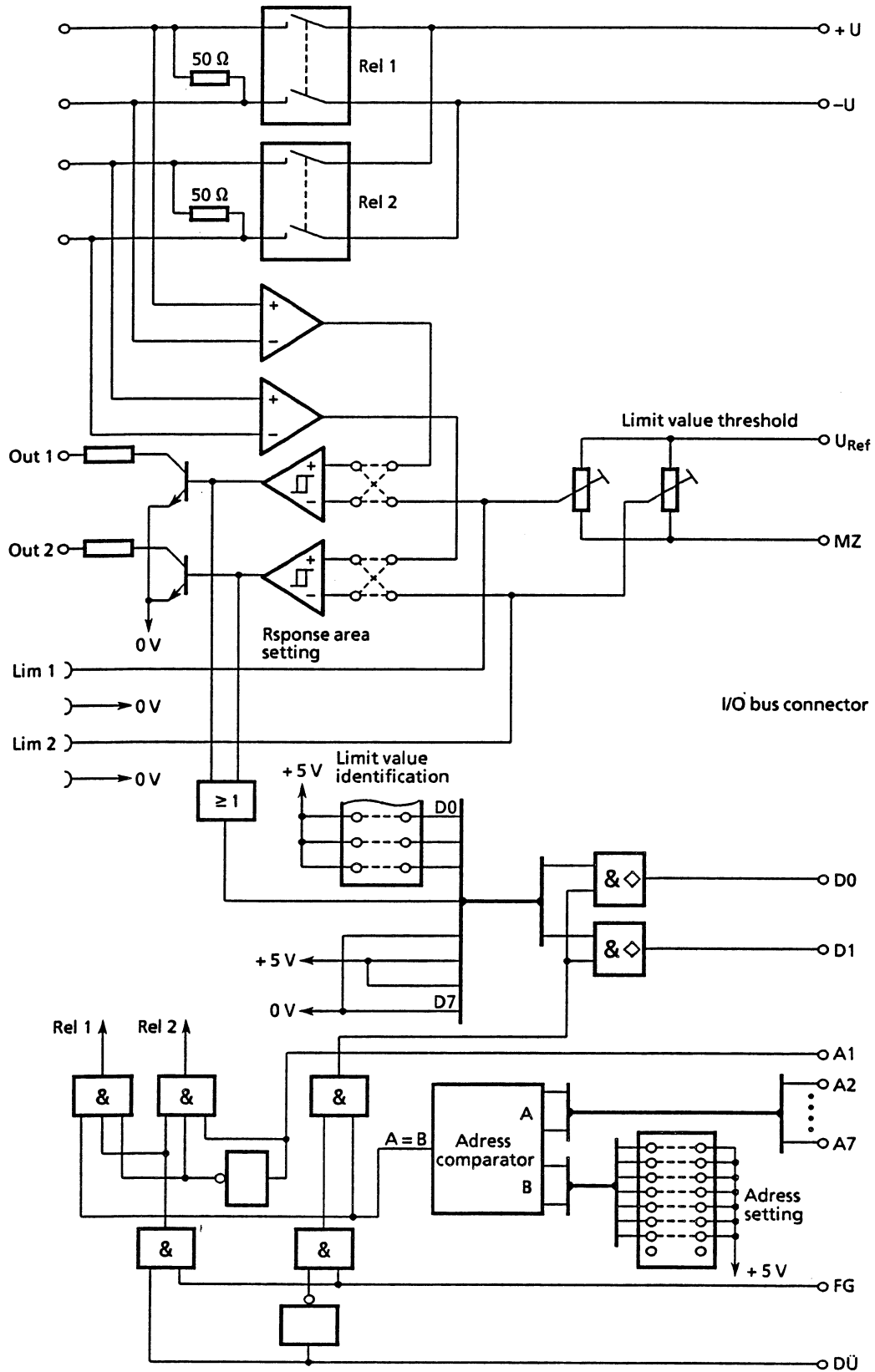

Data traffic between the limit-value monitor module and the FM central unit is carried out via the I/O bus interface. The following pulse diagram shows the I/O sequence for the limit-value monitor module.

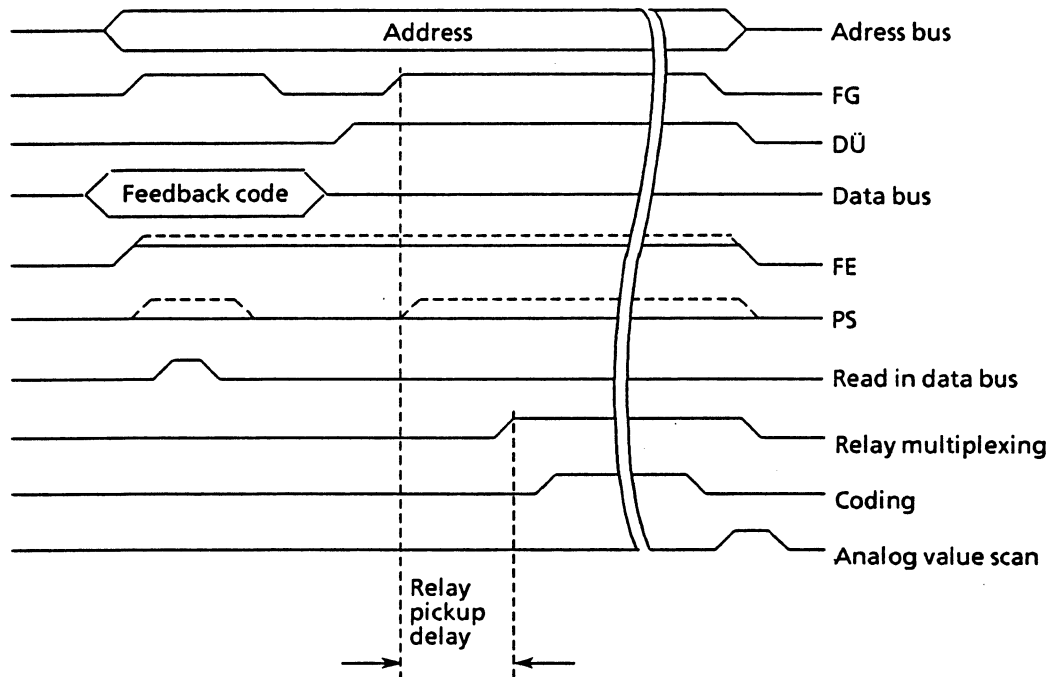

When the first enable pulse (FG) is transmitted, the analog input sends a channel-specific feedback code to the data bus.

Feedback code:

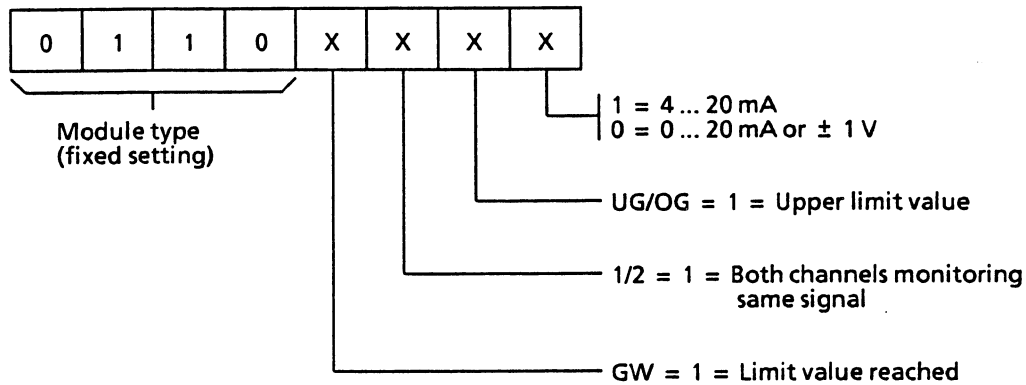

With the second FG pulse and data transfer (DÜ), the analog input module multiplexes the corresponding measuring point relay. After a waiting time (relay pickup delay and ADC response time), the central unit triggers the coding function and transfers the values obtained to the higher-level automation system.

If addressing occurs fault-free, a voltage level of approx. 2.4 V is generated on the I/O bus fault line (FE). Should double addressing occur (as a result of incorrect module address setting), the module feedback signal is suppressed and the voltage level on the FE line rises to $U > 3 \text{ V}$ at the time of addressing.

The central unit checks the FE line and in case of error transfers the error message "double addressing" to the higher-level automation system.

If a relay contact remains permanently closed (hardware defect), a "1" signal is sent to the PS line whilst fault-free analog inputs are being triggered and further relay contact multiplexing is prevented. The central unit recognizes the faulty measured value channel and relay by the fact that a "0" signal only occurs on the PS line whenever the faulty channel responds.

If a defect occurs the central unit transmits the error message "relay defect" to the higher-level automation system.

3.2 I/O Bus Connector Assignment

Stift	d	b	z
2	U_{M+}	U_{M-}	-
4	-	U_{REF}	M_Z
6	-	-	-
8	FG	-	DÜ
10	-	A0	A1
12	A2	A3	A4
14	A5	A6	A7
16	D0	D1	D2
18	D3	D4	D5
20	D6	D7	M_{BUS}
22	FE	-	PS
24	-	+5 V	M_{5V}
26	-	-	-
28	-	+22 V	M_{22V}
30	-	-	-
32	-12 V	M_{12V}	+12 V

3.3 Troubleshooting

Faulty I/O modules are signalled to the higher-level automation system by I & C error messages. For an explanation of the error messages and troubleshooting procedure, see the FM 100 instructions.

3.4 Debugging

Faults can be remedied by replacing the defective module, which should then be sent in for repair together with a fault description (please use returned goods form).
On-site repair is not permitted for reasons of Ex protection.

SIEMENS

Siemens Aktiengesellschaft

The reproduction, transmission or use of this document or its contents is not permitted without express written authority.

Offenders will be liable for damages. All rights, including rights created by patent grant or registration of a utility model or design, are reserved.

Order No.: C79000-B8076-C096-02

Order from: Gerätewerk Karlsruhe

Printed in the Federal Republic of Germany

© Siemens AG 1989

SIEMENS

TELEPERM M

FM 100 Field Multiplexer

Binary Output Module (BOUT)

6DS1612-8AA

Instructions

Order No. C79000-B8076-C098-03

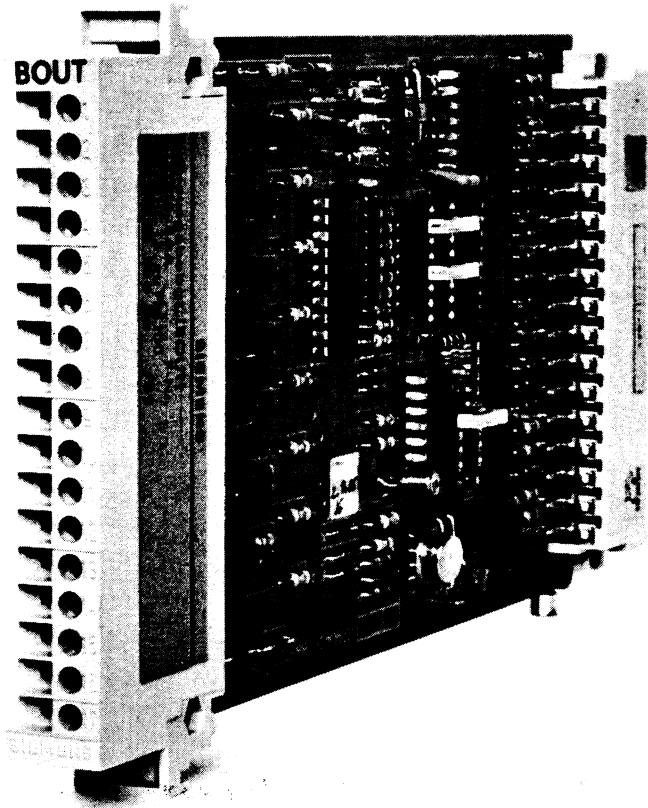

Contents	Page
1 Description	2
1.1 Application	2
1.2 Design	2
1.3 Mode of Operation	2
1.4 Technical Data	4
2 Installation and Commissioning	5
2.1 Setting	5
2.2 Plugging the Module in	7
2.3 Connecting the Field Cables	7
3 Maintenance	10
3.1 Method of Operation	10
3.2 I/O Bus Connector Assignment	12
3.3 Troubleshooting	12
3.4 Debugging	12

1 Description

1.1 Range of Application

The binary output module 6DS1612-8AA is an output module of the FM 100 field multiplexer and is used to output up to 8 binary signals.

The output stages of the binary output module enable the direct triggering of:

- electropneumatic binary signal converters 6DS1911-8AA
- interlocking modules 6DS1506-8AA
- solenoid valves with slight driving power
- LEDs with series resistor

The module can be installed in the field multiplexer by insertion into any slot of the basic and extension subrack.

1.2 Design

The binary output module consists of a PCB measuring 100 mm x 160 mm x 15.24 mm (h x d x w) and occupies one standard slot in the subrack.

At the rear of the module is a 48-pin ES 902 male connector, via which the module is contacted with the I/O bus when plugged in.

The front of the module is designed as a 17-pin strip with screw terminals to which the field cables are directly connected.

For reasons of (Ex)i protection and to shelter it against corrosive atmospheric conditions, the module is provided with a protective double enamel coating.

1.3 Mode of Operation

● I/O traffic

The field multiplexer central unit communicates with the binary output module via the I/O bus connected to the basic or extension subrack. For each I/O sequence occurring on the I/O bus, the module compares its own address set using coding jumpers with the address present at the I/O bus.

If the addresses match, the module sends its feedback code to the data bus. This code is used to transfer module-specific information, concerning module type and reaction of the module in case of malfunction, to the central unit.

On recognizing the module type as "binary output" the central unit multiplexes an 8-bit data to the output module. The output module stores this data in a buffered 8-bit memory until it is updated and triggers its 8 output stages accordingly.

The output stages consist of transistors with open collectors which are overload-proof, due to limiting resistors.

After plugging the module in or following a voltage increase of the field multiplexer, all output stages are set to the safety position, i.e. all output transistors are blocked.

● Reaction in case of malfunction

The binary outputs can be preset, via coding jumpers, to react as follows should a malfunction occur:

- last status transferred is frozen
- module switches over to safety position, i.e. all output transistors are blocked.
- error message is given when +12-V supply voltage fails.

An additional coding jumper can also be used to set the binary output module's reaction when an external emergency stop switch is operated, i.e. whether to ignore it or to switch over to the safety position.

● Troubleshooting

If several modules erroneously respond when an address is accessed (double addressing), the feedback code is suppressed by the addressed modules and the central unit is informed that the currently addressed module has been bypassed.

Both double addressing and failure of the +12-V supply voltages for the output transistors are signalled to the higher-level automation system and displayed in the form of an I & C fault message.

1.4 Technical Data

Dimensions (w x h x d)	15.24 mm x 100 mm x 160 mm
Ambient temperature in operation	-25 to +60°C
in storage	-40 to +85°C
Perm. humidity Annual mean	75%
30 days	95%
no condensation	
Degree of protection	IP00
Explosion protection	E Ex [ib] IIC T5
Voltage supply	Logic supplied by intrinsically-safe voltage supply of central unit
	U = +5 V ±2%
	I = max. 2 mA
	Output transistors supplied by power supply module 6DS4413-8AA
	U = +12 V
	I = max. 16 mA
Number of outputs	8, two-pin
Output signal	"0" level $\hat{=}$ output transistor blocked "1" level $\hat{=}$ output transistor conductive
Max. output current per output channel	$I_{Amax} = 2 \text{ mA}$
Perm. load	$R_{Bmax} \geq 3.65 \text{ kohms}$

2 Installation and Commissioning

The binary output module contains electrostatically sensitive components. Regulations about handling such modules must be observed during installation and commissioning in order to avoid components being destroyed by electrostatic charges.

2.1 Settings

The following settings must be made before plugging the module into the subrack of the field multiplexer.

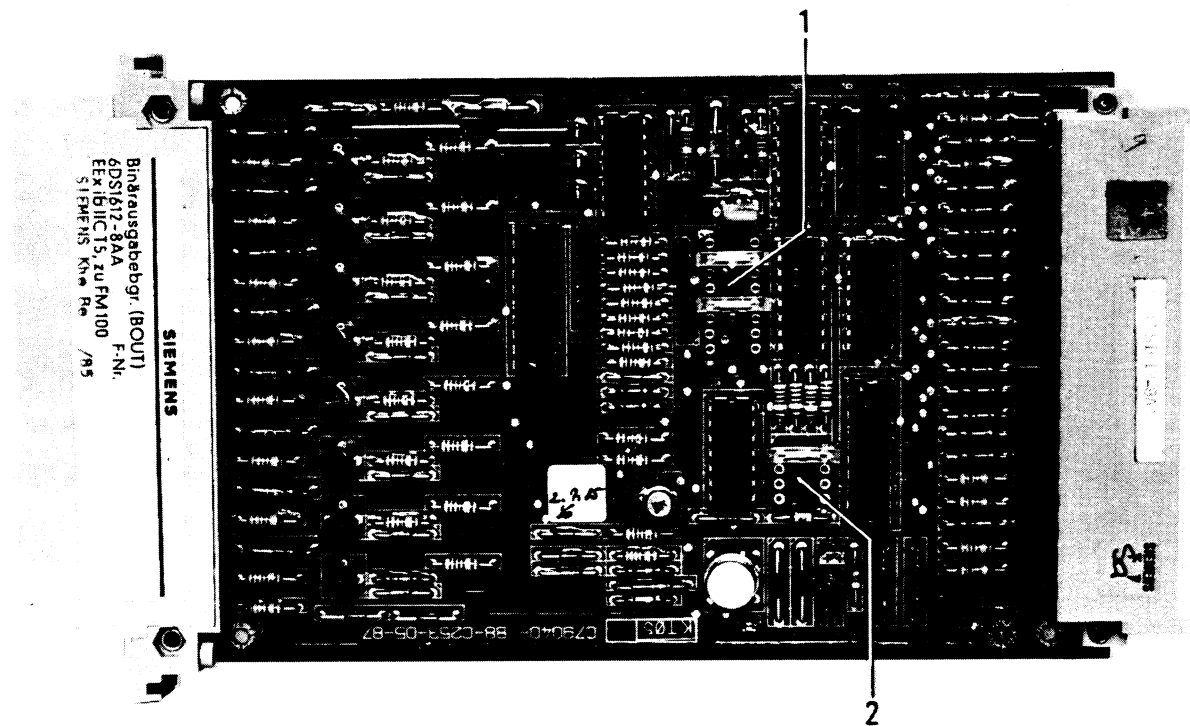

- 1 Address
- 2 Reaction in the case of fault

Fig. 1 Position of the coding jumper

- Setting the PCB address
(possible address range 0 to 44)

PCB address	Location J12							
	16							9
	○	○	○	○	○	○	○	○
	○	○	○	○	○	○	○	○
	1							8
00	-	-	-	-	-	-	-	-
01	-	-	-	-	-	X	-	-
02	-	-	-	-	X	-	-	-
43	X	-	X	-	X	X	-	-
44	X	-	X	X	-	-	-	-

X = Jumper inserted
- = Jumper removed

The address is set in binary code by inserting coding plugs into the coding jack J12.

The address range of the binary output module includes module addresses 0 to 44.

- Reaction in case of malfunction

The following reactions can be preset in case of a malfunction by inserting coding plugs into coding jack J13:

Coding jumper	Reaction
1-8 open	I & C fault message due to failure of +12-V supply voltage
1-8 inserted	No message caused by failure of +12-V supply voltage
2-7 open	No reaction to operation of an emergency stop switch
2-7 inserted	Operation of an external emergency stop switch sets outputs to safety position for as long as the switch is being operated (all output transistors blocked)
3-6 open	Switching of outputs to safety position should a malfunction occur
3-6 inserted	Freezing of last transferred status should a malfunction occur
4-5	Insignificant

2.2 Plugging the Module in

The binary output module can be inserted into any slot of the FM basic or extension subrack. Insertion can also be carried out when the field multiplexer is switched on.

2.3 Connecting the Field Cables

The field cables are introduced into the field multiplexer via the base plate of the housing and connected to the front connector of the module. The screens of the field cables must be connected to the cable detensioning clamp on the base plate of the FM cabinet housing

On the system side, the cable shields must be connected to the system earth via the shortest possible route.

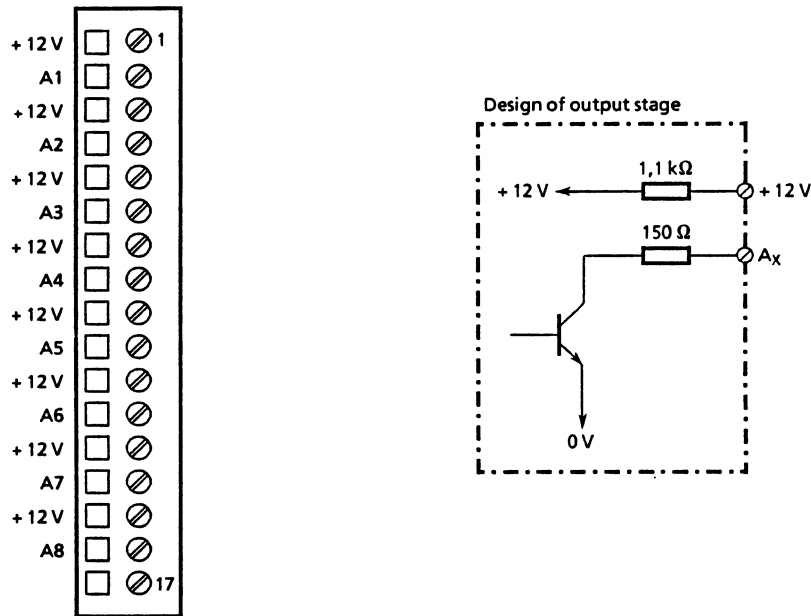
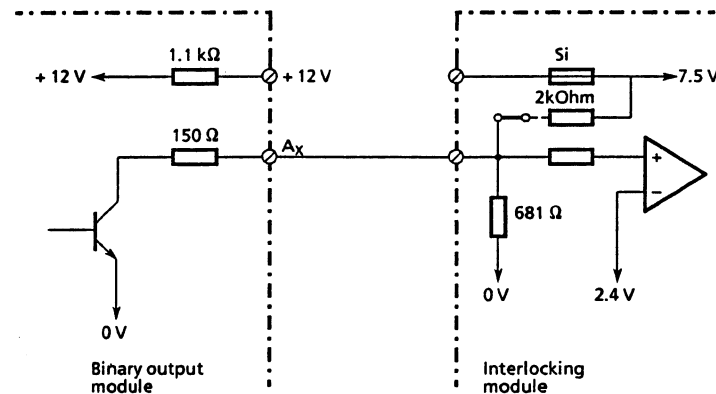

Fig. 2 Front connector assignment

- Triggering an interlocking module 6DS1506-8AA



- Triggering solenoid valves with slight driving power or LEDs

When triggering solenoid valves or LEDs in the Ex area (zone 1), please note that the capacity and inductivity of the connected load circuit may not exceed the following maximum values:

$$C_{\max} = 95 \text{ nF}$$

$$L_{\max} = 180 \text{ mH}$$

Connection of solenoid valves:

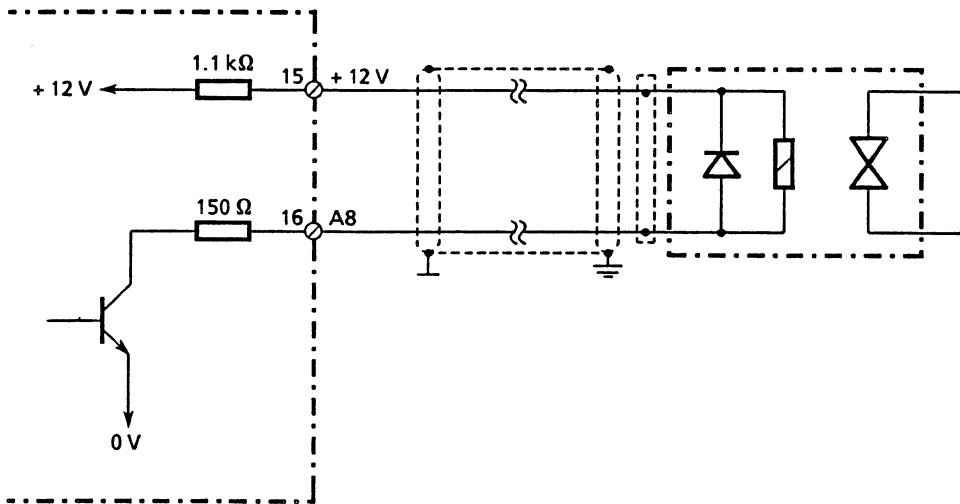
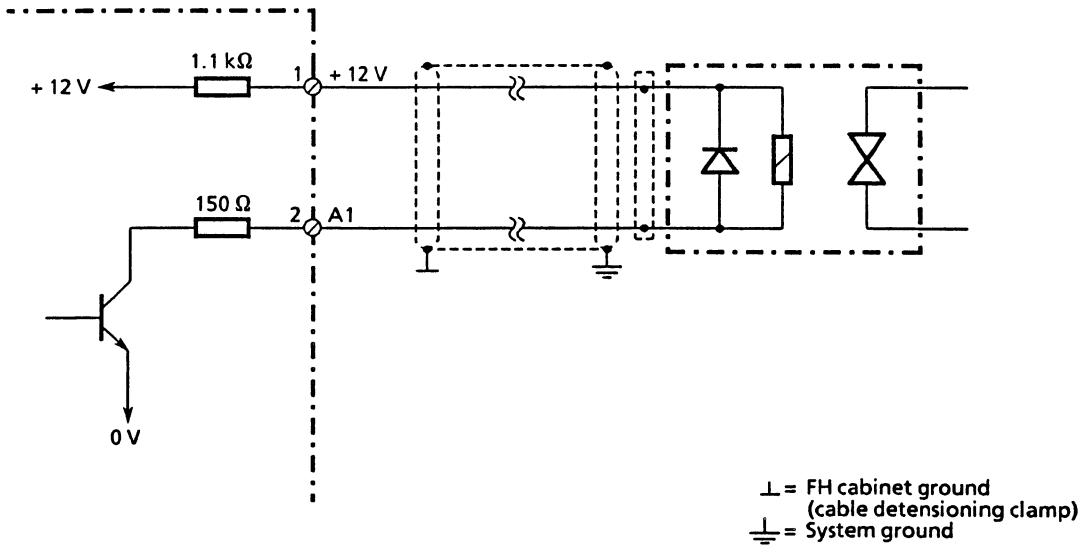

Connection of LEDs:

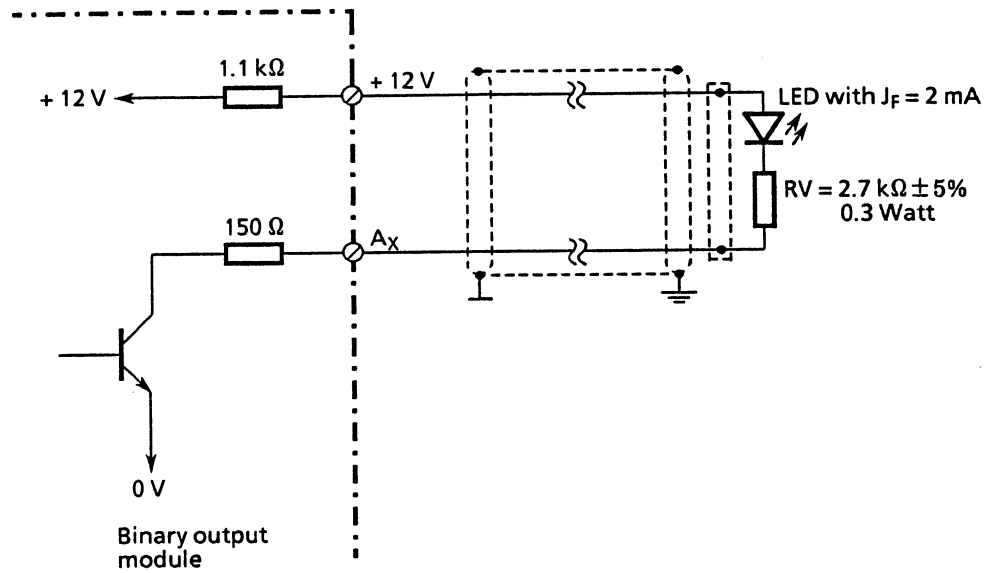

When connecting LEDs, a series resistor of 2.7 kohms /0.3 W must be connected in series with the LED.

For safety reasons, the power loss selected for the series resistor may not be less than 0.3 W.

3 Maintenance

3.1 Method of Operation

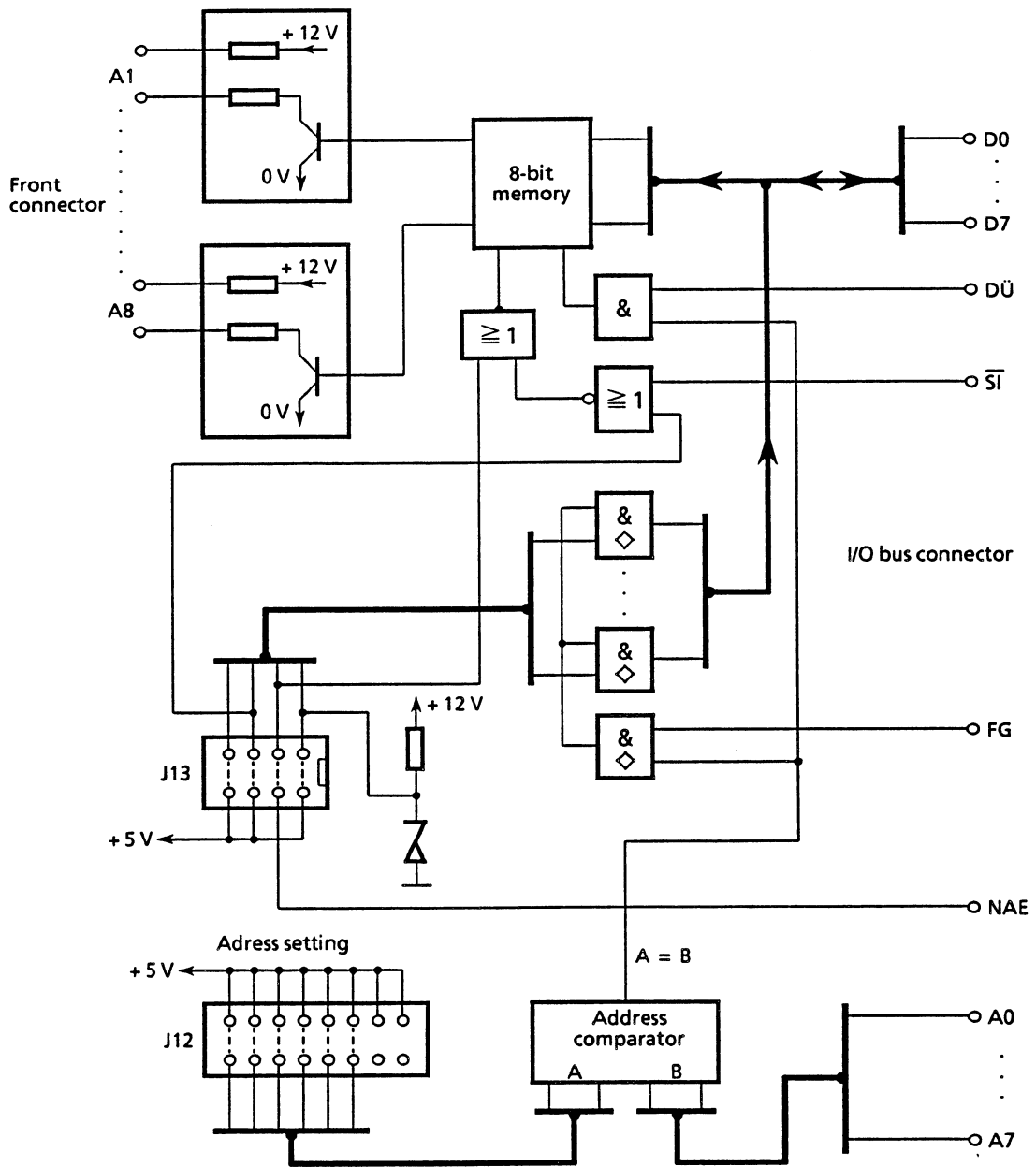
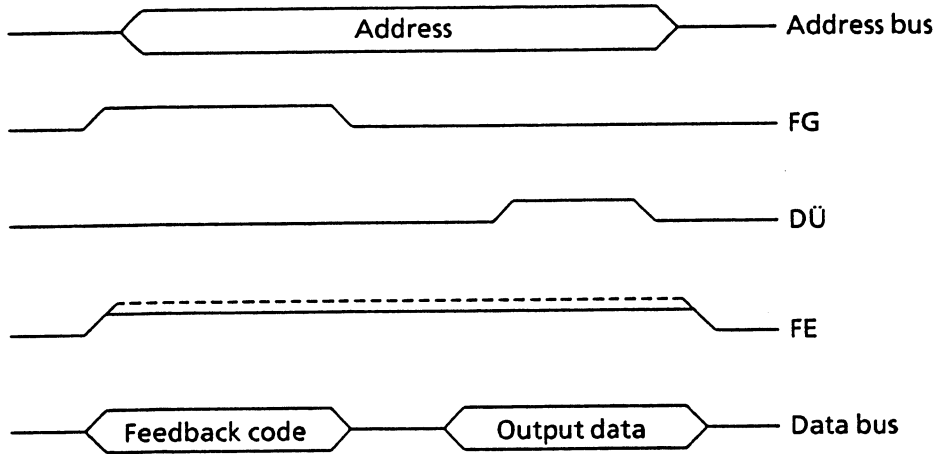
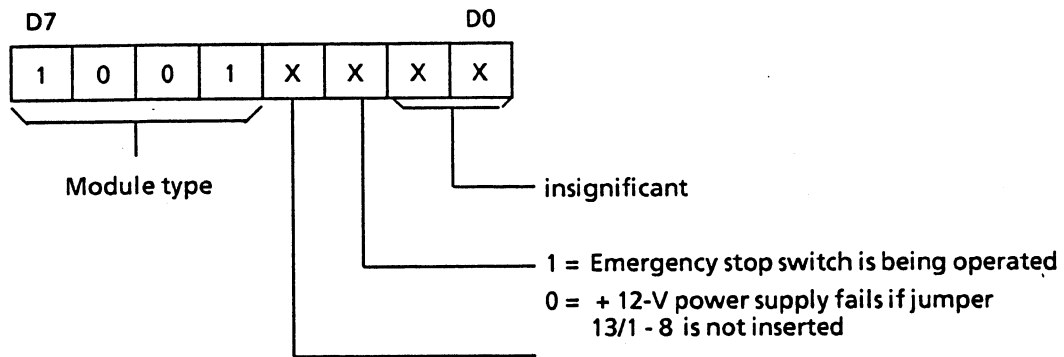

Fig. 3 Block diagram

Data traffic between the central unit and binary output module is carried out via the I/O bus interface. The following pulse diagram shows the I/O sequence for an 8-bit output.



The binary output module sends its feedback code to the data bus with the FG (enable) pulse.



The output data are accepted by the binary output module with the DÜ (data transfer) pulse.

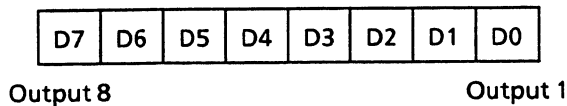

"1" level $\hat{=}$ output transistor conductive
 "0" level $\hat{=}$ output transistor blocked

The module sets the FE (error) line to a level of approx. 2.4 V during addressing.

Should double addressing occur (several modules set to same address), the level increases to $U > 3 \text{ V}$ at the time of addressing and the modules suppress their feedback code.

If the feedback code is missing, the central unit checks the FE line and, in case of fault (level on FE line $> 3 \text{ V}$), transfers the error message "double addressing" to the higher-level automation system.

3.2 I/O Bus Connector Assignment

Pin	d	b	z
2	-	-	-
4	-	-	-
6	-	-	-
8	FG	-	DÜ
10	ST	A0	A1
12	A2	A3	A4
14	A5	A6	A7
16	D0	D1	D2
18	D3	D4	D5
20	D6	D7	-
22	FE	-	-
24	-	+5V	M _{5V}
26	-	-	-
28	NAE	-	-
30	-	-	-
32	-	-	-

3.3 Troubleshooting

Defective modules are signalled by the higher-level automation system via I & C fault messages. For an explanation of the error messages and procedure in the case of a malfunction, see instructions "Field Multiplexer" C79000-B8076-C090.

3.4 Debugging

Faults should be remedied by replacing the defective module.

The defective module must be sent in for repair together with an error description (please use returned goods form).

On-site repair is not permitted, for reasons of Ex protection.

SIEMENS

Siemens Aktiengesellschaft

The reproduction, transmission or use of this document or its contents is not permitted without express written authority.
Offenders will be liable for damages. All rights, including rights created by patent grant or registration of a utility model or design, are reserved.

Order No.: C79000-B8076-C098-03

Order from: Gerätewerk Karlsruhe

Printed in the Federal Republic of Germany

© Siemens AG 1989

SIEMENS

TELEPERM M

FM 100 Field Multiplexer

Analog Output Module with 4 Channels (AOUT)
6DS1712-8BA (0 to 5mA)

Instructions

Order No. C79000-B8076-C099-03

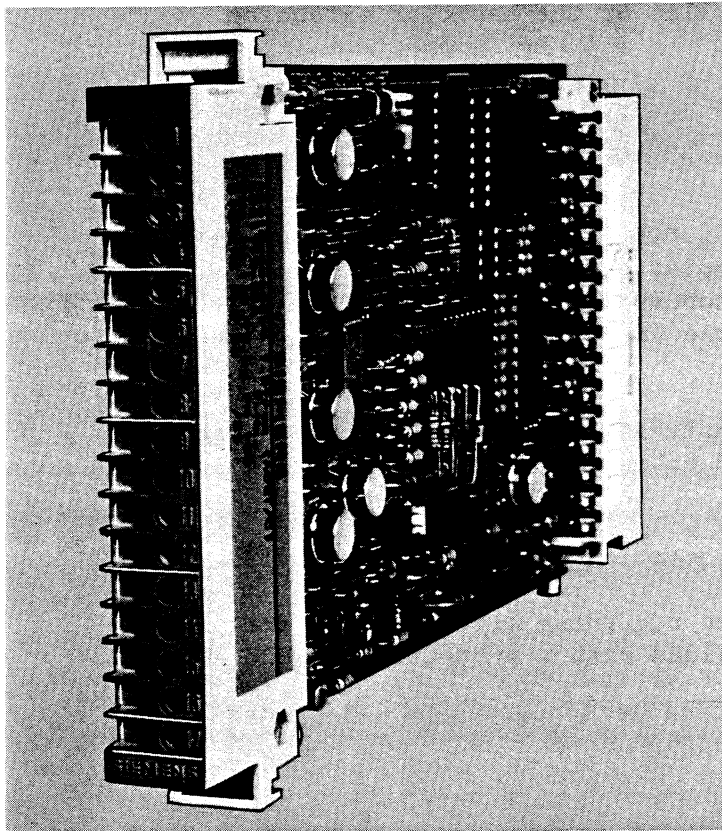

Contents	Page
1 Description	2
1.1 Application	2
1.2 Design	2
1.3 Mode of Operation	2
1.4 Technical Data	4
2 Installation and Commissioning	5
2.1 Setting	5
2.2 Plugging the Module in	7
2.3 Connecting the Field Cables	7
3 Maintenance	9
3.1 Method of Operation	9
3.2 I/O Bus Connector Assignment	11
3.3 Troubleshooting	11
3.4 Debugging	11

1 Description

1.1 Range of Application

The analog output module 6DS1712-8BA supplies output signals of 0 to 5 mA.

Its range of application includes

- setpoint or ratio entry for controllers,
- driving electropneumatic positioners with slight driving power.

The analog output module can be installed in the field multiplexer by insertion into any slot of the basic or extension subrack.

1.2 Design

The analog output module has a PCB measuring 100 mm x 160 mm x 15.24 mm (h x d x w) and occupies one standard slot in the subrack. At the rear of the module is a 48-pin ES 902 male connector, via which the module is connected with the I/O bus when plugged in.

The front of the module is designed as a 17-pin strip with screw terminals, to which the field cables or FM-internal wiring is connected.

The module is of explosion protection type E Ex i b IIc T5.

For reasons of Ex requirements regarding clearance and creepage distances, the module is provided with a protective double enamel coating.

1.3 Mode of Operation

The field multiplexer central unit communicates with the analog output module via the I/O bus connected to the basic or extension subrack. For each I/O sequence occurring on the I/O bus, the module compares its own module address set using coding plugs with the address present at the I/O bus. If the addresses match, the feedback code, depending on the FG (enable) and DÜ (data transfer) control signals, is first sent via the data bus to the central unit. The central unit then outputs the analog value in coded form and with a data length of 8 bits, via the data bus. This routine is completed separately for the four output channels implemented on the module.

Due to the special form of address coding, every analog output module occupies two I/O module addresses (n and n+1), whereby n is always even-numbered. Only address n is set on the module (the software driver has two channels), address n+1 may not be assigned to any further I/O module.

The analog output module contains an 8-bit memory with a D/A converter for each of the four output channels.

When switching on the power supply of the central unit or when set to safety position, the memories are automatically reset via a special logic and the analog value 0 mA is output. The four memories are overwritten with every I/O sequence.

In case of a central unit malfunction, the module outputs can be set to the following operating states by means of a coding jumper:

- output of the last value stored,
- switch to safety position (value output 0 mA)

A further coding jumper enables the output ranges to be switched from live zero (1...5 mA) to dead zero (0...5 mA).

● Troubleshooting

If several modules erroneously respond simultaneously when an address is accessed, the feedback code is suppressed by the addressed modules and the central unit is informed that the current module has been bypassed. Both this state and the failure of the ± 12 -V supply voltages are signalled to the higher-level automation system.

1.4 Technical Data

Dimensions (w x h x d)	15.24 mm x 100 mm x 160 mm
Ambient temperature in operation	-25 to +60°C
in storage	-40 to +85°C
Humidity Annual mean	75%
30 days	95%
no condensation	
Degree of protection	IP 00
Explosion protection	E Ex ib IIC T5
Voltage supply	$U_1 = +5 \text{ V}$ $U_2 = +12 \text{ V}$ $U_3 = -12 \text{ V}$
Current consumption	$I_1 = \text{max. } 4 \text{ mA}$ $I_2 \leq 33 \text{ mA}$ $I_3 \leq 2 \text{ mA}$
Analog outputs	4 isolated output channels 0 to 5 mA (dead zero) 1 to 5 mA (live zero) max. perm. load < 1.2 kohms

2 Installation and Commissioning

The analog output module contains electrostatically sensitive components. Regulations about such modules must be observed during installation and commissioning, in order to avoid components being destroyed by electrostatic charges.

2.1 Setting

The following settings must be made before plugging the module into the subrack of the field multiplexer:

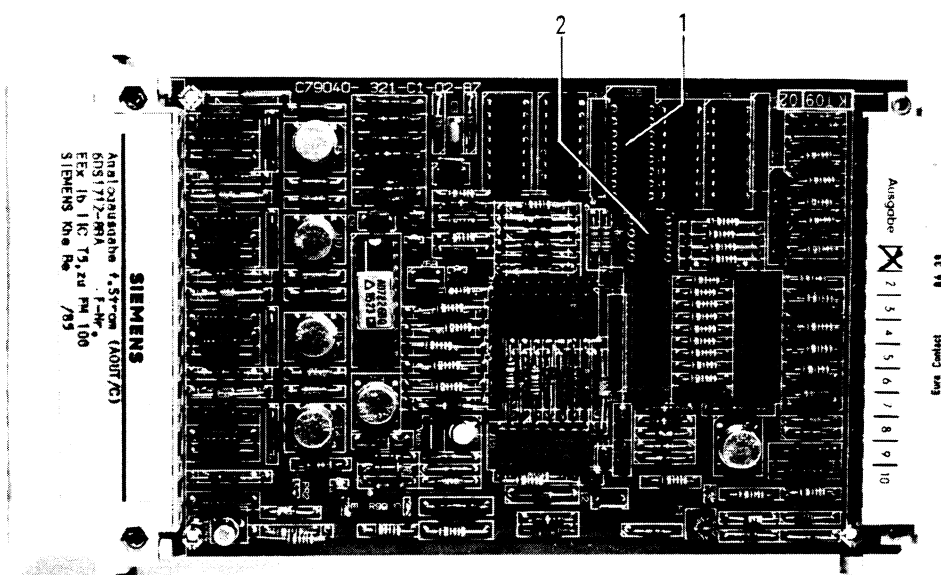

- 1 Address
- 2 Operating modes

Fig. 1 Position of the coding jumpers

- Setting the PCB address
(possible address range 00 to 28)

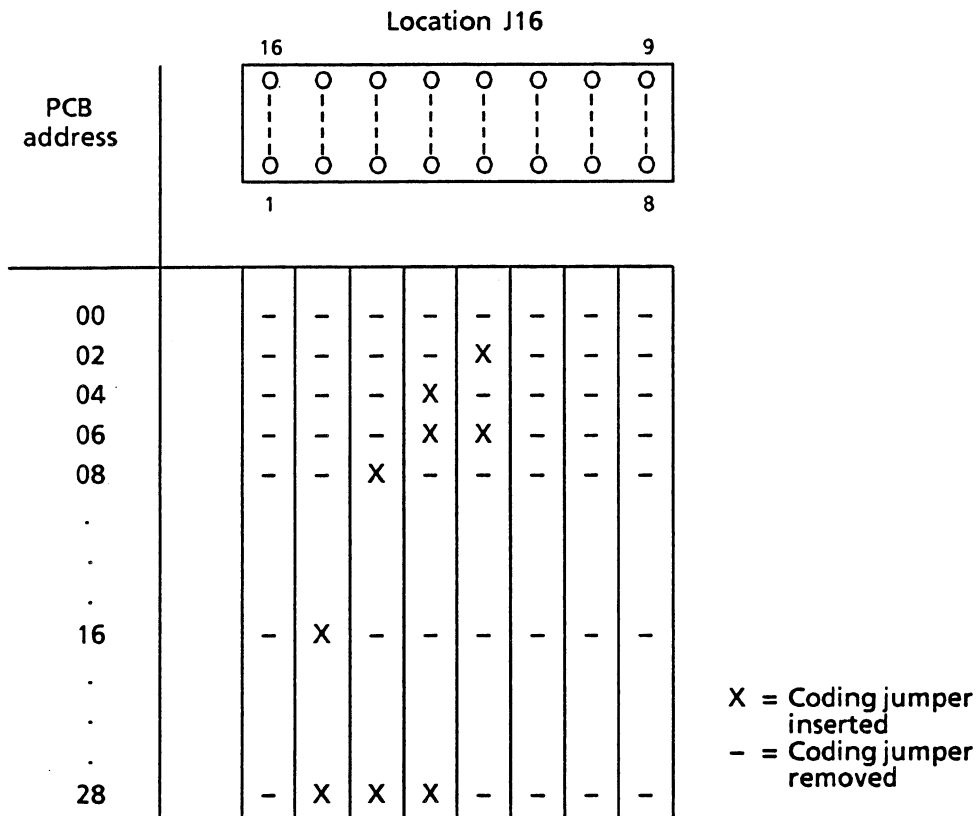

The addresses are set in binary code via coding plugs on the coding jack J16.

When setting addresses, please note that jumper 5-12 has a significance of 2^1 and that jumpers 6-11, 7-10 and 8-9 are insignificant.

Since the analog output module occupies two I/O module addresses, only even-numbered module addresses n are permitted.

The odd-numbered module addresses n+1 must not be assigned. The address range of the analog output module covers module addresses 0 to 28.

- Setting of operating modes

By plugging in coding plugs at the coding socket J 17 the following operating modes can be set:

Coding jumper	Reaction
1-8	Insignificant
2-7 inserted	Operation of an external emergency stop switch sets the outputs to the safety position as long as the switch is being operated (0 mA).
3-6 inserted	Freezes the last value transferred, should a malfunction occur
4-5 inserted	Live zero (1 mA)
4-5 open	Dead zero (0 mA)

2.2 Plugging the Module in

The analog output module can be plugged into any slot of the FM basic or extension subrack. Insertion can also be carried out when the field multiplexer is switched on.

2.3 Connecting the Field Cables

The field cables are introduced into the field multiplexer through the base plate of the housing and directly connected to the front connector of the module. The screens of the field cables must be connected to the earth terminals on the base plate of the housing immediately after being introduced into the cabinet.

When connecting external final control elements or external positioners, the inductivity and capacity of the load circuit (connecting line plus final control element) must not exceed the following limit values, according to the PTB certificate of conformity:

$$L_{\max} = 180 \text{ mH}$$

$$C_{\max} = 95 \text{ nF}$$

Every current output can drive load resistors to a maximum of 1.2 kohms.

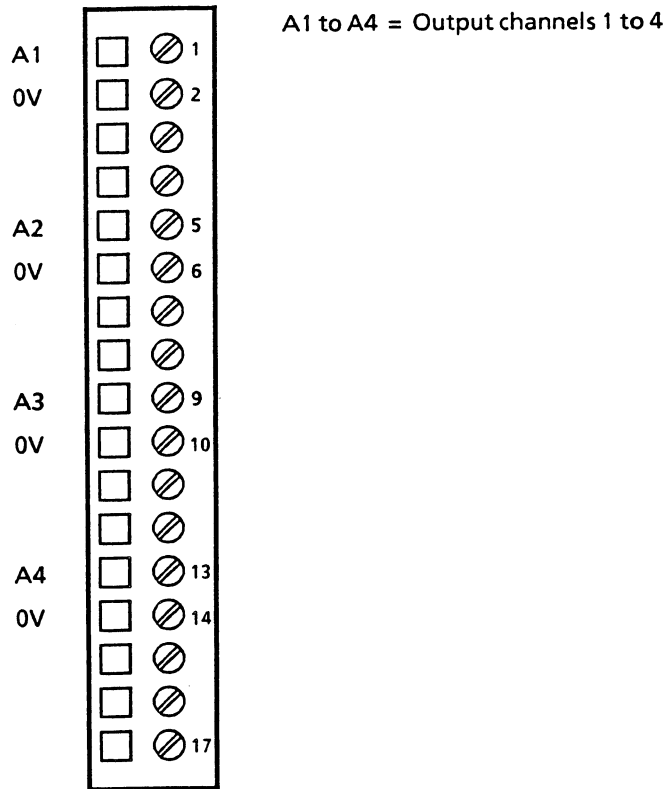
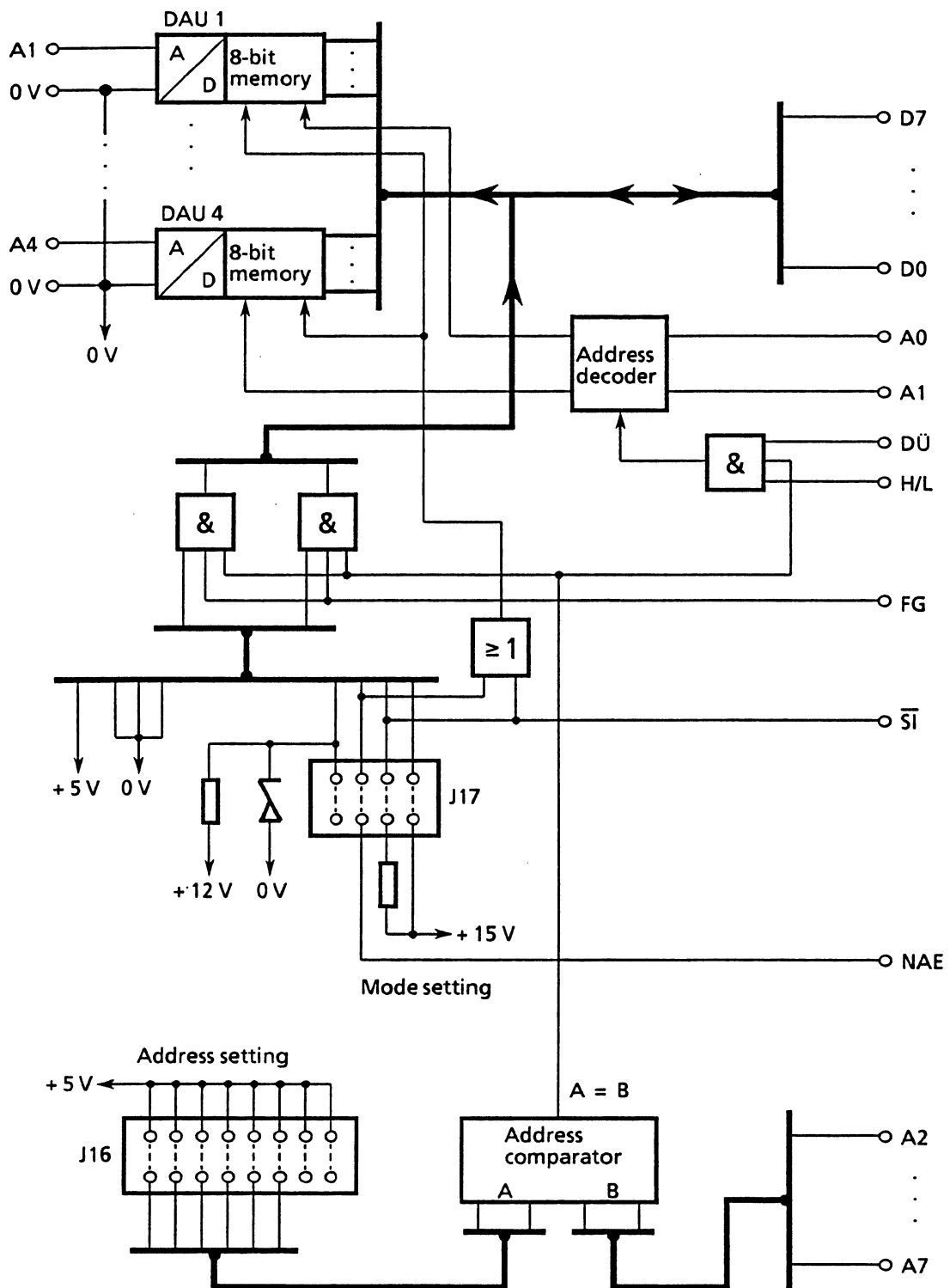

Fig. 2 Front connector assignment

3 Maintenance

3.1 Method of Operation



Data traffic between the analog output module and FM central unit is carried out via the I/O bus interface.

The following pulse diagram shows the I/O sequence for the analog output module.

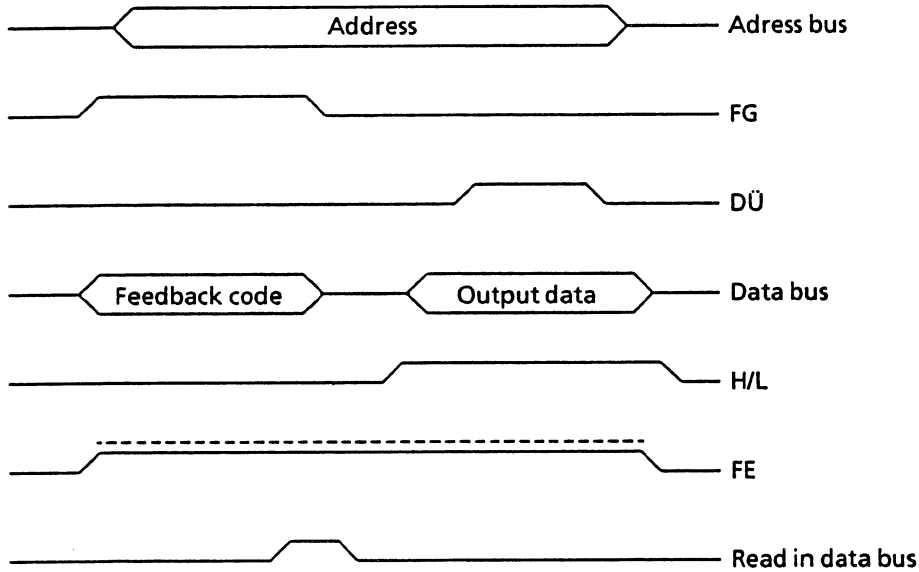

The analog output module sends the module-specific feedback code to the data bus with the FG (enable pulse).

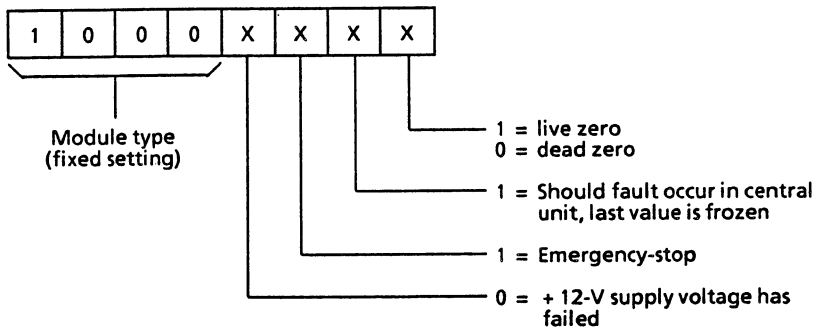

The 8-bit analog value is accepted by the analog output module with the DÜ (data transfer) pulse and H/L line = 1.

The module sets the FE (error) line to a voltage level of approx. 24 V during addressing. Should double addressing occur, the voltage level on the FE line rises to $U > 3$ V and the addressed modules suppress their feedback code. Each time that the feedback code is missing, the central unit checks the FE line and, if a fault is present, transfers the message "double addressing" to the higher-level automation system.

3.2 I/O Bus Connector Assignment

Pin	d	b	z
2	-	-	-
4	-	-	-
6	-	-	-
8	FG	-	DÜ
10	ST	A0	A1
12	A2	A3	A4
14	A5	A6	A7
16	D0	D1	D2
18	D3	D4	D5
20	D6	D7	-
22	FE	-	-
24	-	+5 V	M _{5V}
26	-	-	-
28	-	-	-
30	NAE	-	-
32	-12 V	+12V	M _{12V}

3.3 Troubleshooting

Defective analog output modules are signalled via I & C fault messages by the higher-level automation system.

For an explanation of the I & C fault messages, see "Instructions for the FM 100 Field Multiplexer". The analog outputs of field multiplexers in hazardous areas, may only be checked with measuring instruments approved and certified for use in these areas.

3.4 Debugging

Faults should be remedied by replacing the defective module. The defective module must then be sent in for repair together with a fault description (please use returned goods form). On-site repair is not permitted for reasons of Ex protection.

SIEMENS

Siemens Aktiengesellschaft

The reproduction, transmission or use of this document or its contents is not permitted without express written authority.

Offenders will be liable for damages. All rights, including rights created by patent grant or registration of a utility model or design, are reserved.

Order No.: C79000-B8076-C099-03

Order from: Gerätewerk Karlsruhe

Printed in the Federal Republic of Germany

© Siemens AG 1989

SIEMENS

TELEPERM M

FM 100 Field Multiplexer

Scanning Repetition Module (S.CYC)
6DS1912-8AA

Instructions

Order No. C79000-B8076-C102-02

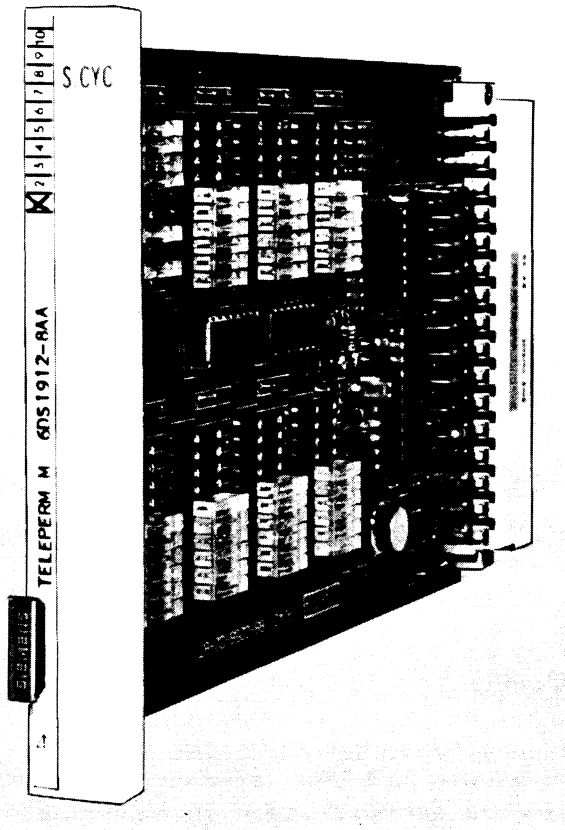

Contents	Page
1 Description	2
1.1 Application	2
1.2 Design	2
1.3 Mode of Operation	2
1.4 Technical Data	4
2 Installation and Commissioning	5
2.1 Setting	5
2.2 Plugging the Module in	6
3 Maintenance	7
3.1 Method of Operation	7
3.2 I/O Bus Connector Assignment	9
3.3 Troubleshooting	9
3.4 Debugging	9

1 Description

1.1 Application

The scanning repetition module 6DS1912-8AA is used to shorten the scanning time of field multiplexer (FM) analog and binary input modules by a factor of 2 to 5. The module can be inserted into the any slot of the FM's basic or extension subrack, preferably in the single-width standard slots of the basic subrack.

1.2 Design

The scanning repetition module is designed as an ES 902 single-tier Eurocard measuring 100 mm x 160 mm (h x d) and having a width of 15.24 mm (1 standard slot). At the rear of the module is a 48-pin ES 902 male connector via which the module is contacted with the I/O bus.

The module is of explosion protection E Ex i b IIc T5.

For reasons of Ex requirements regarding clearance and creepage distances, the module is provided with a protective double enamel coating.

1.3 Mode of Operation

1.3.1 I/O Traffic

The field multiplexer central unit communicates with the scanning repetition module via the I/O bus connected to the basic and extension subrack. For each I/O sequence occurring via the I/O bus, the module compares its own source addresses set using coding plugs with the address present at the I/O bus. If they match, the module is addressed and sends a feedback code to the data bus. Besides information concerning the module type the feedback code contains the target address set via plug-in jumpers.

These feedback data cause the central unit to interrupt the scanning cycle at the source address location and refer to the target address given in the feedback code. The module with the corresponding target address is thereby re-scanned during the same acquisition cycle, independent of the number of channels on the module. The data received from the scanned module are thereby transferred more frequently to the interface module and result in the latter's transfer RAM being updated. No special measures are required when configuring the automation system.

A scanning repetition module enables one freely selectable target address to be accessed out of eight random source addresses. A scanning repetition module can thus result in eight repetitions of up to eight modules.

When configuring, note that repetition means jumping back to a previous target address. The modules to be repeatedly scanned must therefore be set to lower module addresses (range 0 to 15). To optimize the scanning times, the module target and source address(es) for scanning repetition(s) must be evenly distributed in the scanning cycle.

1.3.2 Troubleshooting

If several modules erroneously respond simultaneously when an address is accessed (double addressing), the feedback code is suppressed by the addressed modules and the field multiplexer is informed that the current module has been bypassed.

1.4 Technical Data

Dimensions (w x h x d)	15.24 mm (1 SEP) ¹⁾ x 100 mm x 160 mm
Ambient temperature in operation	-25 to +60°C
in storage	-40 to +85°C
Humidity annual mean	75%
30 days	95%
no condensation	
Degree of protection	IP 00
Explosion protection	E Ex ib IIC T5
Voltage supply	Supply from the central unit's intrinsically-safe 5-V voltage source $U_1 = +5 \text{ V } \pm 2\%$
Current input	$I_1 = \text{max. } 4 \text{ mA}$
Number of scanning repetitions	8

1) 1 SEP = 1 standard slot

2 Installation and Commissioning

The module contains electrostatically sensitive components. Regulations must be observed when handling such modules, in order to avoid components being destroyed by electrostatic charges.

2.1 Setting

Up to 8 different source and target addresses can be set at coding jacks Jx1 to Jx8 before inserting the module. The source address is the one at which a repetition should take place within the FM processing cycle.

The target address is the I/O module address which should be repeated after the cycle interrupt.

The target addresses can only lie within the address range 0 to 15 and must *always* be set *lower* than the corresponding source address.

The source addresses can lie within the address range 1 to 45 and is set by inserting coding jumpers, as shown below.

Source address	Coding jumper to be inserted					
	10	9	8	7	6	5
1	-	-	-	-	-	X
2	-	-	-	-	X	-
.						
.						
10	-	-	X	-	X	-
11	-	-	X	-	X	X
.						
.						
45	X	-	X	X	-	X

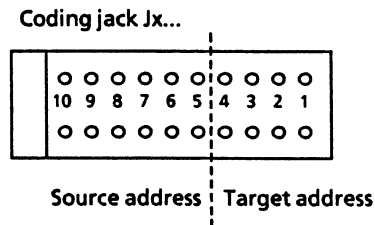

Target address	Coding jumper to be inserted			
	4	3	2	1
0	-	-	-	-
1	-	-	-	X
2	-	-	X	-
.				
.				
14	X	X	X	-
15	X	X	X	X

- = Jumper inserted
X = Jumper removed

Caution: All unused coding jacks must be set to source address 63 (coding jumpers 5 to 10 inserted).

2.2 Plugging the Module in

The scanning repetition module can be inserted into any slot of the basic and extension subrack.

The module may also be inserted while the field multiplexer is switched on.

3 Maintenance

3.1 Method of Operation

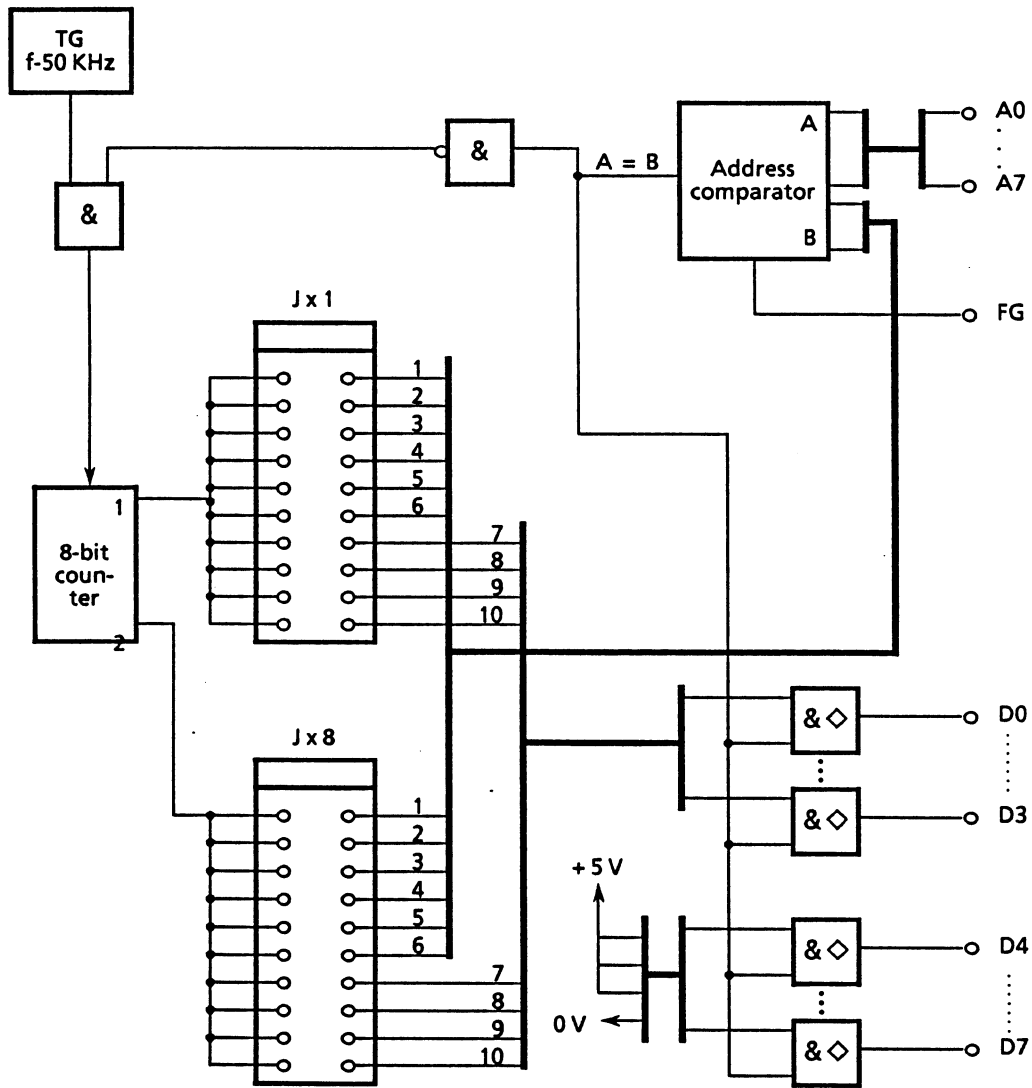
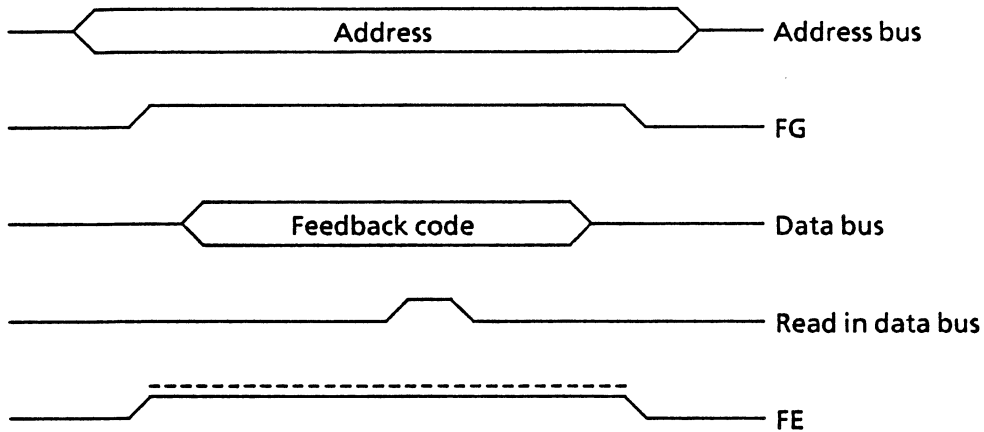
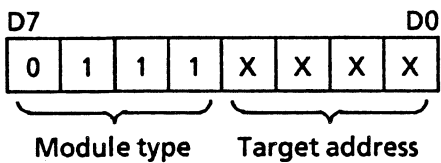

Fig. 1 Block diagram

Data traffic between the scanning repetition module and central unit can be seen in the following pulse diagram.



The module cyclically scans the coding jacks. If the information on the address bus is identical to the set source address at the time of enabling (FG signal), a feedback code, consisting of the module type and set target address, is switched to the data bus as follows:



The module also sets the FE (error) line to a level of approx. 2.4 V during addressing. Should double addressing occur, the level on the FE line increases to $U > 3 V$ and the addressed modules suppress their feedback code. If the feedback code is missing, the central unit checks the FE line and transfers the error message "double addressing" to the higher-level automation system.

3.2 I/O Bus Connector Assignment

Pin	d	b	z
2	-	-	- x)
4	-	-	- x)
6	-	-	-
8	FG	-	D0
10	-	A0	A1
12	A2	A3	A4
14	A5	A6	A7
16	D0	D1	D2
18	D3	D4	D5
20	D6	D7	M ₈
22	FE	-	PS
24	-	+5 V	M _{5V}
26	-	-	-
28	-	-	-
32	-	-	-

3.3 Troubleshooting

Defective scanning repetition modules are signalled via I & C fault messages by the higher-level automation system.

For an explanation of the error messages and troubleshooting procedure, see "Instructions FM 100".

3.4 Debugging

Faults should be remedied by replacing the defective module, which must then be sent in for repair together with a fault description (please use returned goods form).

On-site repairs are not permitted, for reasons of ex protection.

SIEMENS

Siemens Aktiengesellschaft

The reproduction, transmission or use of this document or its contents is not permitted without express written authority.
Offenders will be liable for damages. All rights, including rights created by patent grant or registration of a utility model or design, are reserved.

Order No.: C79000-B8076-C102-02

Order from: Gerätewerk Karlsruhe

Printed in the Federal Republic of Germany

© Siemens AG 1989

SIEMENS

TELEPERM M

FM 100 Field Multiplexer

Interlock Module (LOG)

6DS1506-8AA

Instructions

Order No. C79000-B8076-C103-01

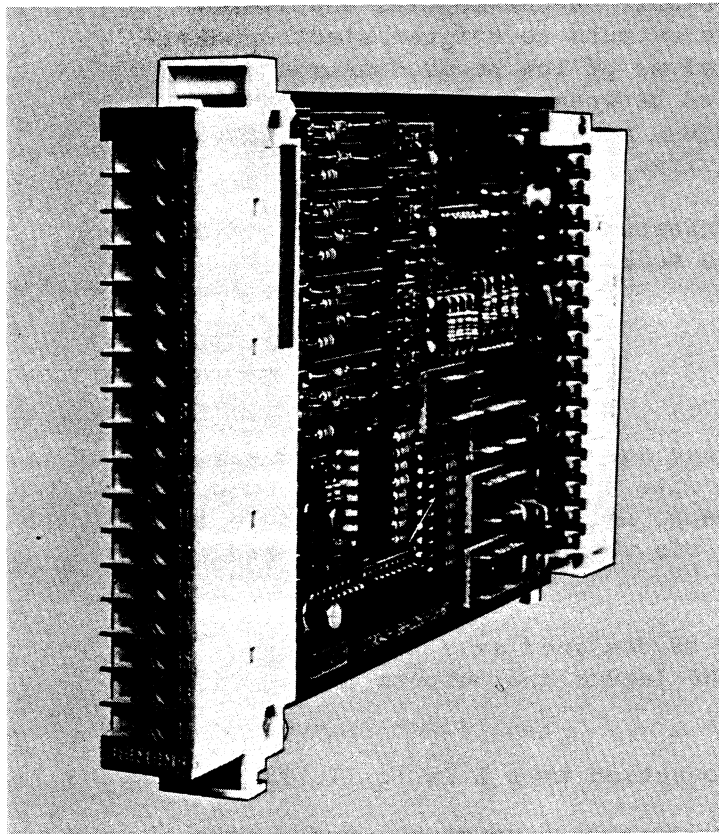

Contents	Page
1 Description	2
1.1 Application	2
1.2 Design	2
1.3 Mode of Operation	2
1.4 Technical Data	4
2 Installation and Commissioning	5
2.1 Setting	5
2.2 Plugging the Module in	7
2.3 Connecting the Field Cables	7
3 Maintenance	9
3.1 Method of Operation	9
3.2 I/O Bus Connector Assignment	11
3.3 Troubleshooting	11
3.4 Debugging	11

1 Description

1.1 Application

The interlock module 6DS1506-8AA is used in the field multiplexer when outputting binary signals to produce local interlock circuits. These circuits must function even when data transfer is faulty. The module, however, is not approved for fail-safe interlock circuits.

The interlock module has four inputs designed for non-contact sensors in acc. with DIN 19 234, floating contacts and outputs of FM-internal modules (such as binary output modules and limit-value monitor modules) and two outputs to trigger electropneumatic converters and solenoid valves of low power consumption. An interlock logic of is installed between the inputs and outputs. It consists of several inverters, as well as AND and OR gates, which can be connected as required.

The interlock module can be inserted into any slot of the field multiplexer basic or extension subrack.

1.2 Design

The interlock module is designed as a one-tier Eurocard measuring 100 mm x 160 mm (h x d) and, with a width of 15.24 mm, occupies one standard slot in the subrack. At the rear of the module is a 48-pin ES 902 male connector, via which the interlock board is supplied with voltage only.

The front panel of the module is designed as a 17-pin screw terminal connector to which the inputs and outputs of the interlock logic are contacted.

The module is of explosion protection type E Ex ib IIc T5.

For reasons of ex requirements regarding clearance and creepage distances, the module is provided with a double enamel coating.

1.3 Mode of Operation

The binary input signals are detected on four channels and converted into a logic-internal level. They are available as direct and inverted signals on two tag blocks, where they can be connected to the logic element inputs (four AND and four OR gates). The direct and inverted output signals of the logic elements are fed to other tag blocks via which they can either be connected to the inputs of other logic elements or to those of logic drivers.

The output drivers can trigger electropneumatic converters or solenoid valves of low power consumption that have been approved as intrinsically safe.

1.4 Technical Data

Dimensions (w x h x d)	15.24 mm ¹⁾ x 100 mm x 160 mm
Ambient temperature	
- in operation	-25 to +60°C
- in storage	-40 to +85°C
Humidity	
- Annual mean	75%
- 30 days no condensation	95%
Degree of protection	IP 00
Explosion protection	E Ex ib IIc T5
Power supply	supplied by intrinsically safe voltage sources of the I/O power supply 6DS4413-8AA via the I/O bus $U_1 = +12\text{ V}$
Current consumption	$I_1 = \text{max. } 30\text{ mA}$
Number of inputs	4
Sensors which can be connected	- non-contact sensors in acc. with DIN 19 234, - floating contacts - FM-internal outputs from binary output modules and limit-value monitor modules
Number of outputs	2
Outputs A1, A2	open collector, negative conducting $R_i = 150\text{ ohms}$
Max. permissible output current per output	$I_{A\text{max}} = 2\text{ mA}$
Permissible load	$R_{B\text{max}} \geq 3.65\text{ kohms}$
Voltage outputs	+12 V via $R_i = 1100\text{ ohms}$ per output
Loads which can be connected	- electropneumatic converters - solenoid valves approved as intrinsically safe

1) One standard slot

2 Installation and Commissioning

The module contains electrostatically sensitive components (EGB). Regulations about handling such modules must be observed in order to avoid components being destroyed by electrostatic charges.

2.1 Settings

User-specific settings can be made by soldering wire jumpers. When doing so, special care must be taken that the work place complies with EGB regulations.

We recommend that the work place be provided with antistatic equipment by EMA (HSMA No. 6Z408 200).

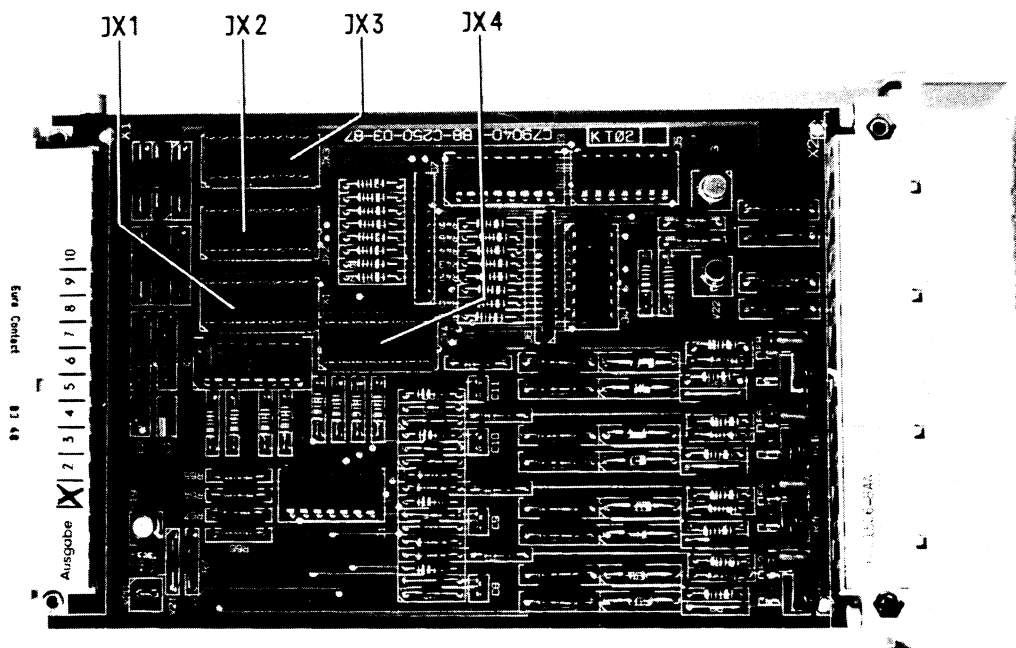

Fig. 1 Position of solder jumpers

- Setting the sensor type

The signal inputs must be adapted to the sensor type connected as follows:

Input	Sensor type	
	Non-contact sensors in acc. with DIN 19 234 or floating contacts	Outputs of FM-internal I/O modules (transistors with open collectors)
1	Jumper E ₁ -E ₂ open	Jumper E ₁ -E ₂ soldered in
2	Jumper E ₃ -E ₄ open	Jumper E ₃ -E ₄ soldered in
3	Jumper E ₅ -E ₆ open	Jumper E ₅ -E ₆ soldered in
4	Jumper E ₇ -E ₈ open	Jumper E ₇ -E ₈ soldered in

- Establishing the interlock logic
The interlock logic is established by interconnecting the tag blocks JX1 to JX4.

Connections can be made as required by the particular application, but with the following restriction:

The outputs of module-internal logic elements must not be connected in parallel. (For module logic design, see Fig. 2)

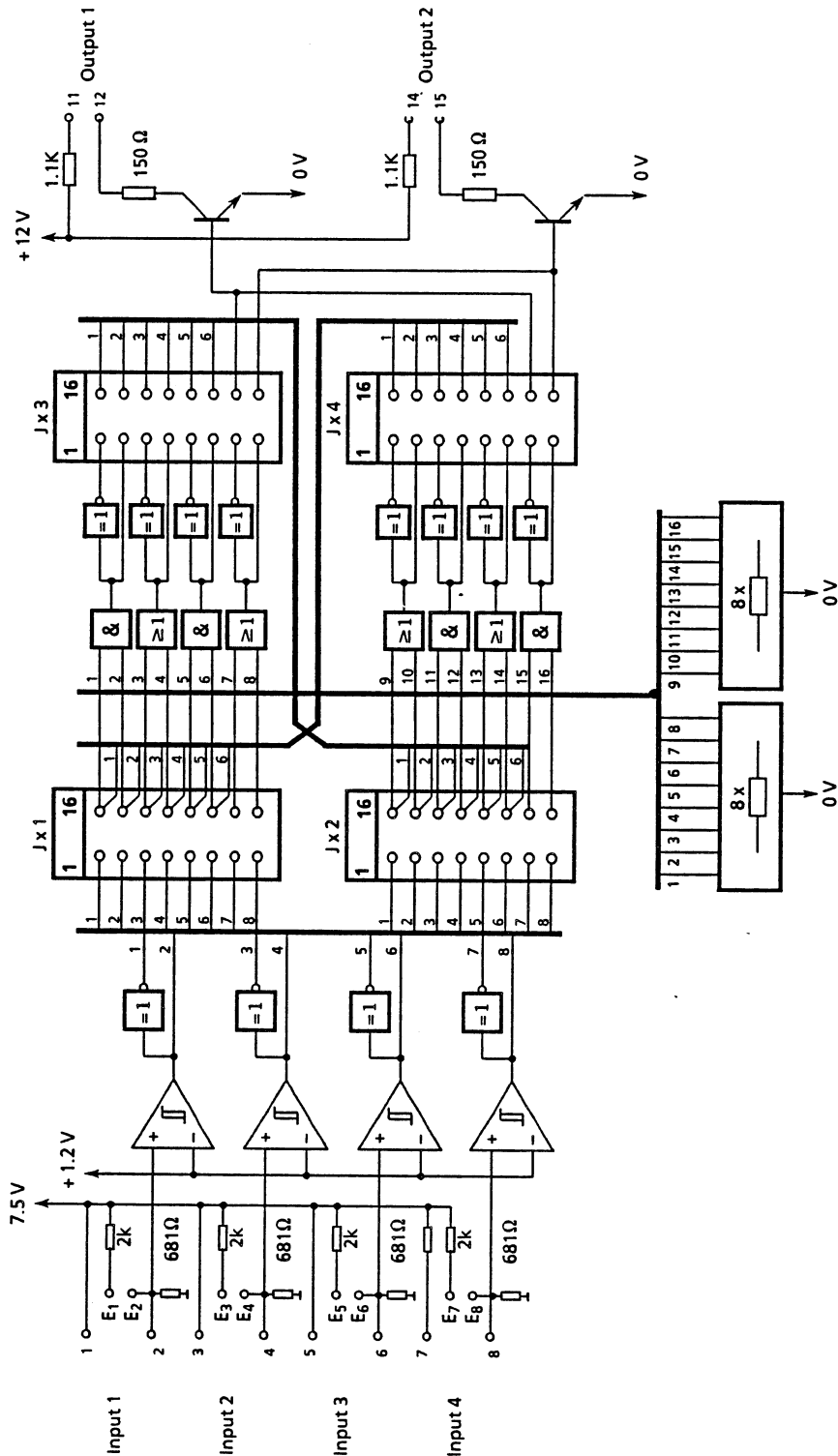

Fig. 2 Module logic

2.2 Plugging the Module in

The interlock module can be inserted into any slot of the FM 100 basic or extension subrack. The module can also be inserted or withdrawn when the FM is ready for operation.

2.3 Connection

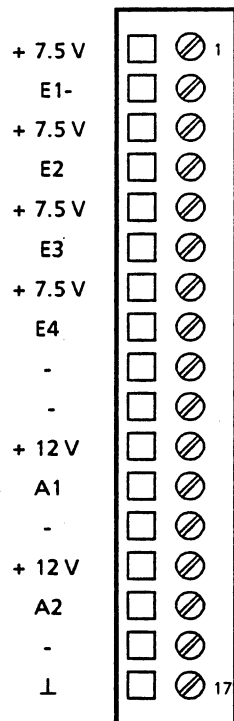

Fig. 3 Front panel assignment

Connecting the inputs

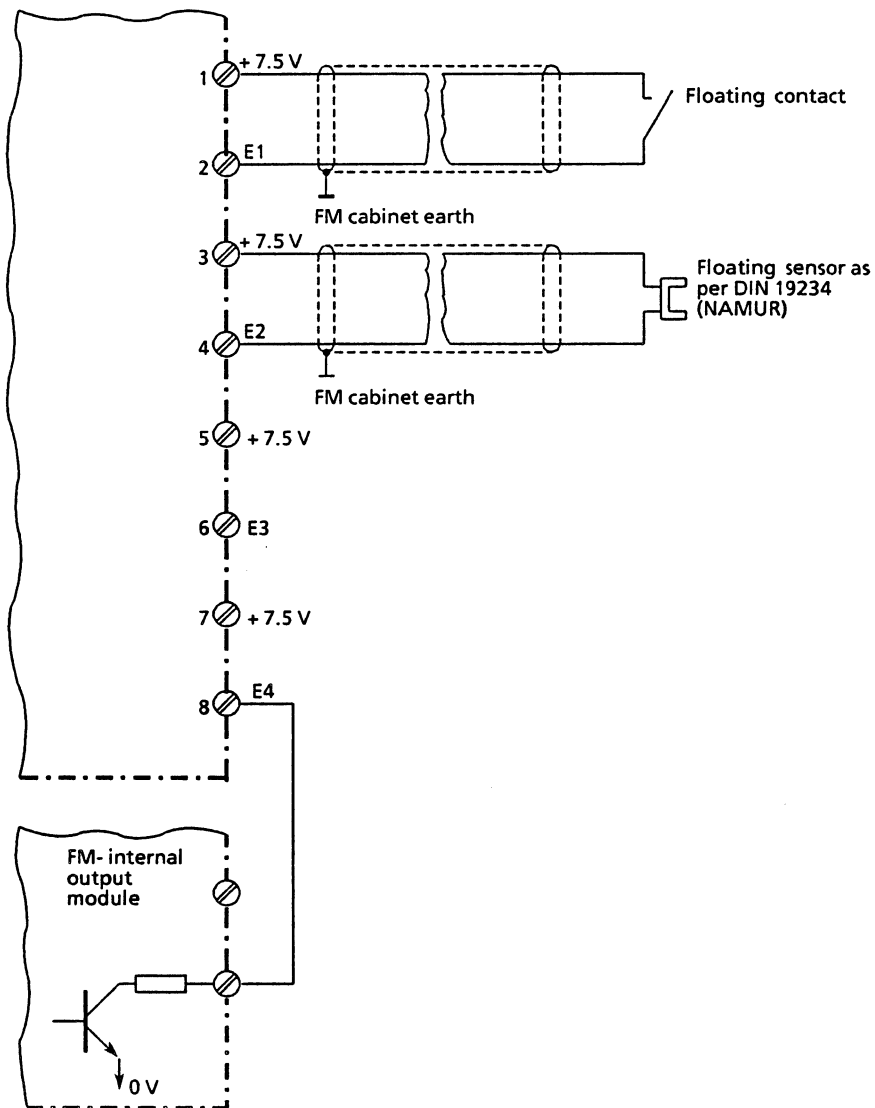

Fig. 4 Connection diagram, inputs

Caution!

When the interlock module is used in potentially explosive areas (ex zone 1), the following limit values for the sensor circuits must be observed in accordance with the PTB certificate of conformity:

max. permissible inductivity = 300 mH
 max. permissible capacity = 600 nF

The connection diagram shows the three possible types of triggering. When connecting make sure that the relevant interlock module input is adapted to the sensor type connected (see Section 2.1 "Settings").

Connecting the outputs

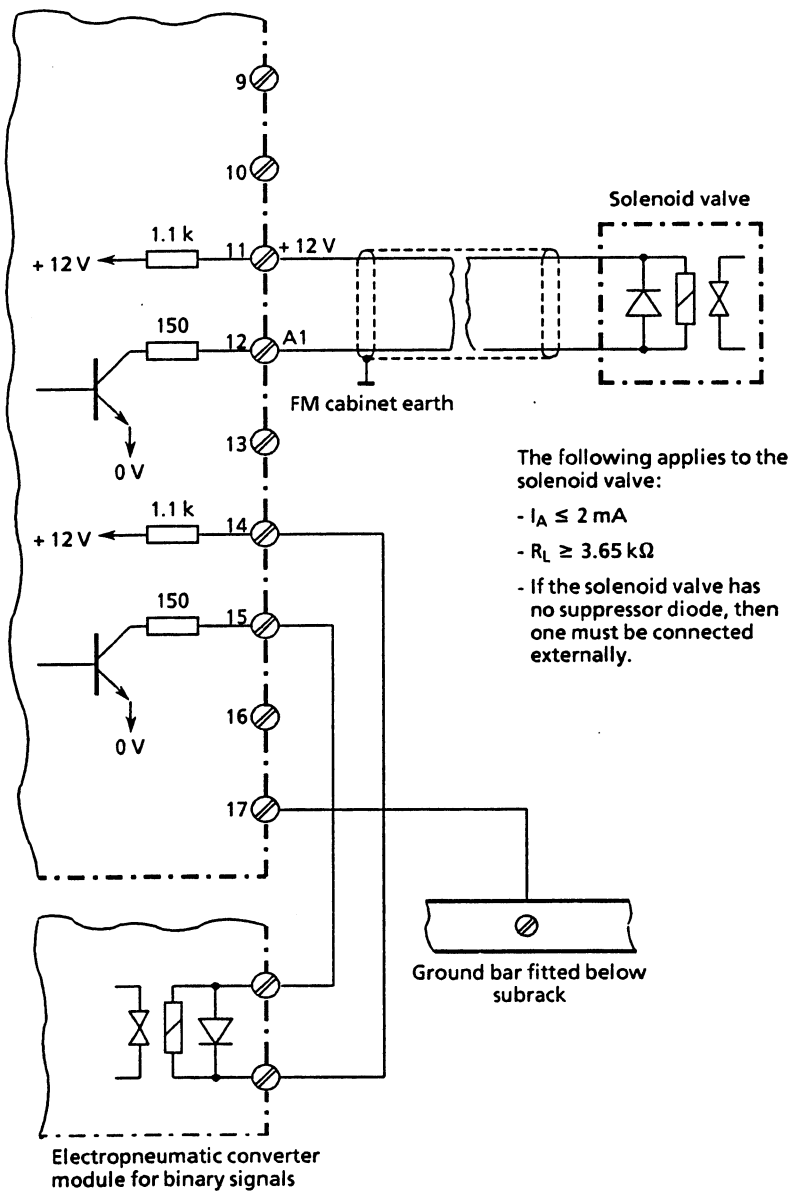

Fig. 5 Connection diagram, outputs

Caution!

When the interlock module is used in potentially explosive areas (ex zone 1), the following limit values for the load circuits must be observed in accordance with the PTB certificate of conformity:

- max. permissible inductivity = 180 mH
- max. permissible capacity = 600 nF

The connection diagram shows the wiring principle of the outputs using the example of triggering a solenoid valve and an electro-pneumatic converter.

3 Maintenance

3.1 Method of Operation

The interlock mode is supplied with +12 V via the bus board of the FM-internal basic or extension subrack. There is no other connection to the FM 100 I/O bus.

The mode of operation of the module logic is shown in Fig. 2.

3.2 I/O Bus Connector Assignment

Pin	d	b	z
2	-	-	-
4	-	-	-
6	-	-	-
8	-	-	-
10	-	-	-
12	-	-	-
14	-	-	-
16	-	-	-
18	-	-	-
20	-	-	-
22	-	-	-
24	-	-	-
26	-	-	-
28	-	-	-
32	-	+12 V	M 12 V

3.3 Troubleshooting

Troubleshooting is limited to detecting the defective module by selectively triggering and checking the signal outputs.

3.4 Debugging

Faults are remedied by replacing the defective module, which must then be sent in for repair together with a fault description (please use returned goods form).

On-site repair is not permitted, for reasons of ex protection.

SIEMENS

Siemens Aktiengesellschaft

The reproduction, transmission or use of this document or its contents is not permitted without express written authority.
Offenders will be liable for damages. All rights, including rights created by patent grant or registration of a utility model or design, are reserved.

Order No.: C79000-B8076-C103-01

Order from: Gerätewerk Karlsruhe

Printed in the Federal Republic of Germany

© Siemens AG 1989

SIEMENS

TELEPERM M

FM 100 Field Multiplexer

Analog Input Module for Pneumatic Standardized Signals (AIPN)
6DS1707-8AA

Instructions

Order No. C79000-B8076-C097-03

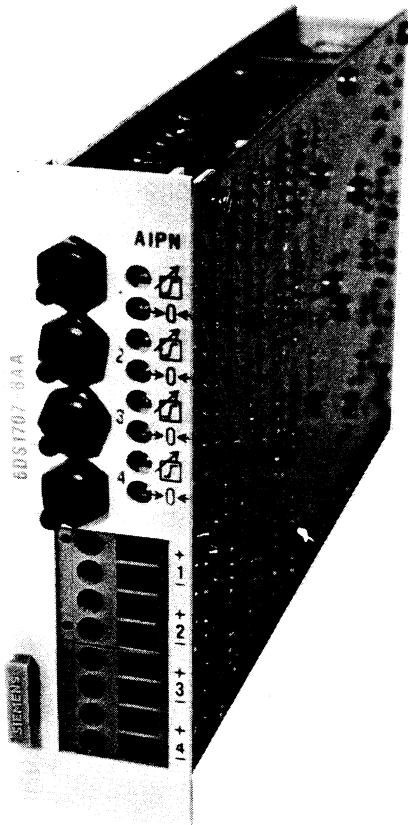

Contents	Page
1 Description	2
1.1 Application	2
1.2 Design	2
1.3 Mode of Operation	2
1.4 Technical Data	4
2 Installation and Commissioning	5
2.1 Setting	5
2.2 Plugging the Module in	6
2.3 Connecting the Field Cables	7
2.4 Calibration	8
3 Maintenance	9
3.1 Method of Operation	9
3.2 I/O Bus Connector Assignment	11
3.3 Troubleshooting	11
3.4 Debugging	12

1 Description

1.1 Application

The 6DS1707-8AA analog input module is an input module of the field multiplexer (FM) which is used acquiring and converting up to 4 pneumatic standardized signals. The module can be inserted into any slot of the FM basic or extension subrack.

1.2 Design

The analog input module is a sandwich module measuring 100 mm x 160 mm (h x d) and with a width of 30.48 mm occupies two standard slots (2 SEPs) in the subrack. The module is contacted with the I/O bus by means of a 48-pin ES902 plug connector located at the rear of the module.

On the front are four hose nipples for connecting pneumatic hoses, potentiometers for correcting of the zero and measuring span of each channel as well as screw terminals for accepting the converted electrical measuring signals.

1.3 Mode of Operation

- Measuring signal conversion

Four electropneumatic converters convert the standardized pneumatic signals supplied via hose nipples on the front panel into standardized electrical signals. The latter are available on the bus interface to the FM central unit.

The converted standardized signals are also present at screw terminals on the front connector for further processing in controllers, limit monitors, etc.

- I/O traffic

The FM central unit communicates with the analog input module via the I/O bus connected to the basic and extension subrack. For each I/O sequence occurring on the I/O bus, the module compares its own address set using coding plugs with the address present on the I/O bus. If the addresses match, the module regards itself as addressed and sends a feedback code to the data bus. This code communicates the module type to the central unit.

The central unit sets the amplification of the ADC preamplifier and sends the analog value to the FM central unit's analog bus using these feedback data.

- Troubleshooting

If several modules erroneously respond when a specific address is accessed (double addressing), the feedback code is suppressed by the addressed modules and the field multiplexer is informed that the currently addressed module has been bypassed. A sticking or defective triggered relay results in all analog input modules being blocked.

1.4 Technical Data

Dimensions (w x h x d)	30.48 mm (2 SEPs) ¹⁾ x 100 mm x 160 mm
Ambient temperature	
in operation	-25 to +60°C
in storage	-40 to +85°C
Humidity	
Annual mean	75 %
30 days	95 %
no condensation	
Degree of protection	IP 00
Explosion protection	E Ex ib IIC T5
Voltage supply	Supply from central unit's intrinsically-safe voltage sources and an I/O power supply via the I/O bus.
	$U_1 = +5 \text{ V } +2 \%$ $U_2 = +22 \text{ V (no-load voltage)}$ $U_2 \geq +10 \text{ V (when addressing the modules)}$ $U_3 = +12 \text{ V}$ $U_4 = -12 \text{ V}$
Current input	$I_1 \leq 0.2 \text{ mA}$ $I_2 \leq 23 \text{ mA (multiplexing current for measuring point relay)}$ $I_3 \leq 12 \text{ mA}$ $I_4 \leq 4 \text{ mA}$
No. of input channels	4
Input signal	0.2 to 1.0 bar 3 to 15 psi
Max. input pressure	2.7 bar
Output signal	0.2 bis 1.0 V
Permissible load	$\geq 1 \text{ kohm}$
Temperature influence	
- Zero	
between -25 and +20°C	$\leq 0.6 \%$ /10 K
between +20 and +60°C	$\leq 0.3 \%$ /10 K
- Measuring span	
between -25 and +20°C	$\leq 0.7 \%$ /10 K
between +20 and +60°C	$\leq 0.3 \%$ /10 K
Linearity and hysteresis	$\leq 0.3 \%$

1) 1 SEP = 1 standard slot width = 15.24 mm

2 Installation and Commissioning

The analog input module for pneumatic standardized signals contains electrostatically sensitive components. Regulations about handling such modules must be observed during installation and commissioning in order to avoid components being destroyed by electrostatic charges.

2.1 Setting

The PCB address must be set before plugging the module into the FM subrack.



- 1 Coding jumper 3
- 2 Coding jumper 8

Fig. 1 Position of the coding jumpers on the coding jack

- Setting the PCB address
(Possible address range 0 to 26)

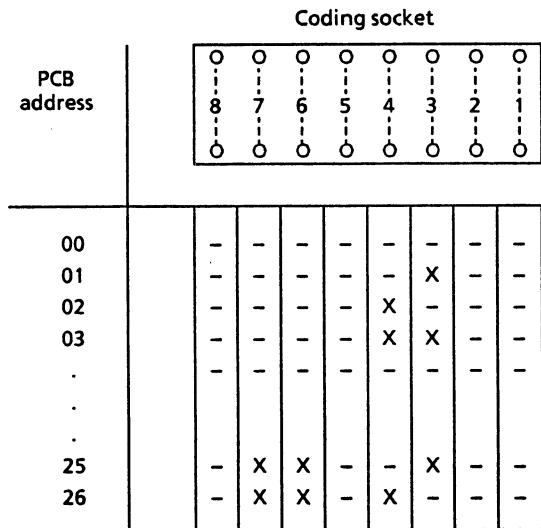

X = Jumper inserted
 - = Jumper removed

The address is set in binary code by inserting coding jumpers into the coding jack shown in Fig. 1. When setting the address, please note that jumper 3 has a significance of 20 and that jumpers 1 and 2 are insignificant.

2.2 Plugging the Module in

The analog input module for standardized pneumatic signals can be inserted into any slot of the FM basic or extension subrack, although preferably into the double width slots of the extension subrack. Insertion can also be carried out whilst the field multiplexer is switched on.

2.3 Connecting the Field Cables

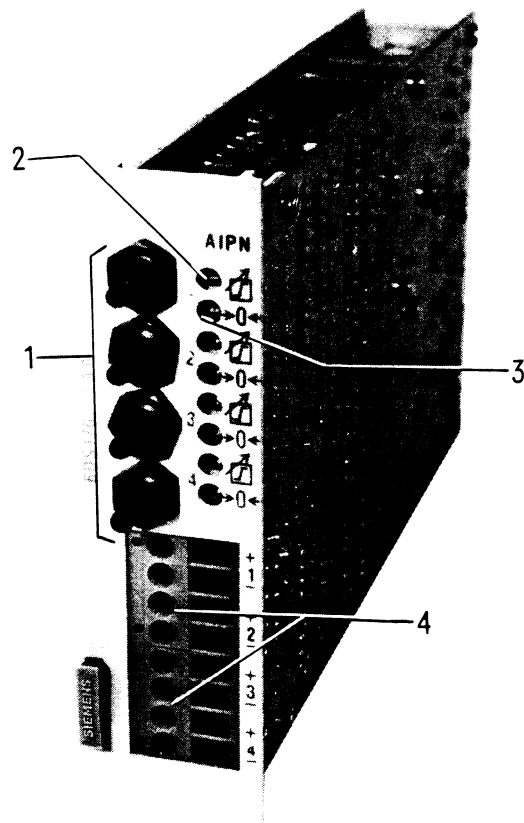

- 1 Hose nipple for pneumatic signals
- 2 Adjuster for measuring span
- 3 Adjuster for zero
- 4 Terminals for output signals

Fig. 2 Front connector assignment

Compressed air hoses (e.g. hose 2 x 1 DIN 7715 Viton) coming from the field system must be attached to the hose nipples on the front panel.

A voltage proportional to the air pressure (0.2 to 1 V) is applied to the front panel terminal for further processing (e.g. monitoring a limit monitor, triggering a closed-loop control module, etc.) and can be directly connected to the analog value inputs of FM-internal modules. The following requirements must be met when connecting the voltage outputs to the inputs of FM-external modules or devices:

- The load to be connected must be greater than 1 kohm.
- When installed in hazardous plant sections (Ex zone 1), the inductivity and capacity of the load circuit may not exceed the limit values listed below.

Max. permitted inductivity	1.5 mA
Max. permitted capacity	300 nF

2.4 Calibration

The electropneumatic converters are factory-set to an output voltage of 0.2 to 1 V with a pneumatic input signal of 0.2 to 1 bar.

Should this setting require changing or slight correction, this can be done for each channel by means of setting potentiometers on the front panel of the module.

The zero point and measuring span must be set sperately.

Any adjustment must be be repeated several times since the compensating potentiometers influence each other reciprocally.

Output values can be checked at the screw terminals on the front panel using a measuring instrument approved for the Ex area.

Data traffic between the pneumatic analog input module and FM central unit is carried out via the I/O bus interface.

The following pulse diagram shows the I/O sequence.

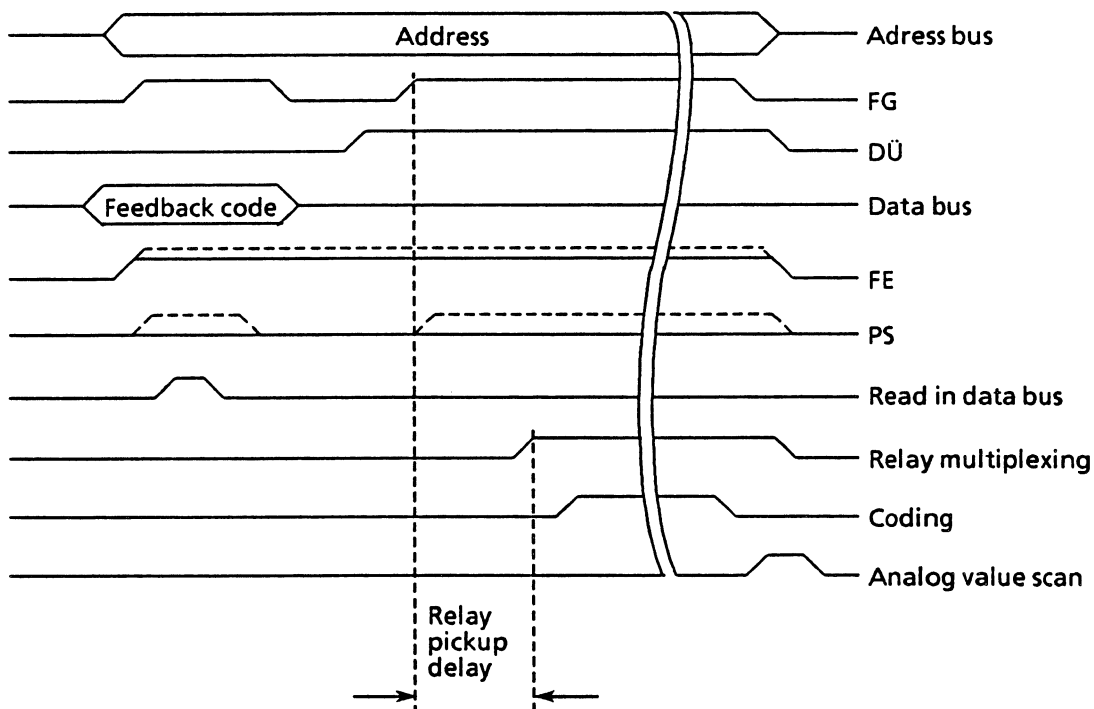

The channel-specific feedback code is sent to the data bus when the first enable pulse (FG) is transmitted.

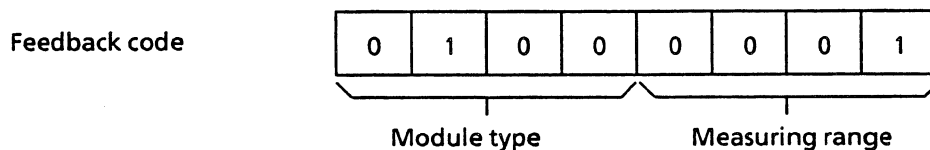

With the second FG pulse and data transfer (DÜ), the pneumatic input module connects the addressed measuring channel to the analog bus. After a waiting time (relay pickup delay + ADC response time), the central unit triggers the coding function and transfers the values obtained to the higher-level automation system.

If addressing occurs fault-free, the pneumatic analog input module generates a voltage level of approx. 2.4 V on the fault line (FE) of the I/O bus.

Should double addressing occur (several I/O modules switched to same address), the channel feedback signal is suppressed and the voltage level on the FE line increases to $U \geq 3$ at the time of addressing.

If the multiplexing relay on an analog input module remains stuck (hardware defect), a "1" signal is sent to the PS line whenever fault-free analog inputs are triggered, thus blocking the multiplexing of further relay contacts. The central unit recognizes the faulty channel relay by the fact that a "0" signal only occurs on the PS line when the faulty channel responds.

Should the faults described above occur, then the central unit transfers error messages to the higher-level automation system.

3.2 I/O Bus Connector Assignment

Pin	d	b	z
2	U _{M+}	U _{M-}	-
4		-	M _Z
6	-	-	-
8	FG	-	DÜ
10	-	A0	A1
12	A2	A3	A4
14	A5	A6	A7
16	D0	D1	D2
18	D4	D4	D5
20	D6	D7	M _B
22	FE	-	PS
24	-	+5 V	M _{5 V}
26	-	-	-
28	-	+22 V	M _{22 V}
30	-	-	-
32	-12 V	+12 V	M _{12V}

3.3 Troubleshooting

Faulty I/O modules are signalled to the higher-level automation system by I & C error messages. For an explanation of the error messages and troubleshooting procedure see the FM 100 instructions (Order No. C79000-B8076-C090).

3.4 Debugging

Faults can be remedied by replacing the defective module, which should then be sent in for repair together with a fault description (please use returned goods form).

On-site repairs are not permitted for reasons of Ex protection.

SIEMENS

TELEPERM M

Field Multiplexer

FM 100

Parts List

Order No. C79000-E8076-C090-03

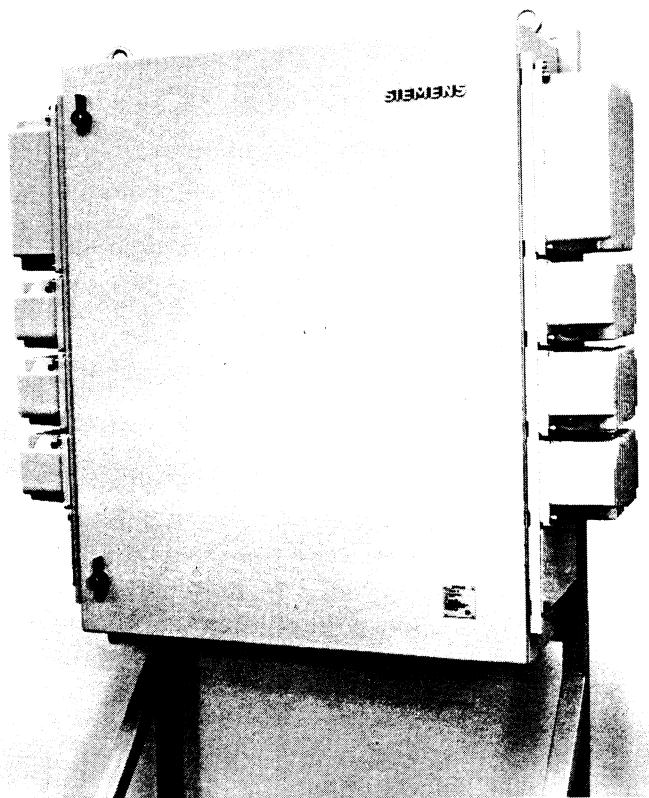

1000000000

1000000000

1000000000

1000000000

1000000000

1000000000

1000000000

1000000000

1000000000

Item	Description	Order No.	Makers designation	Spares group *)	Number per product	Contained in, or applicable from Rev. level	
1	Interface module for FM 100	6DS1304-8AA		R	x)		
2	Mother board for safety isolator	C79451-A3224-B120		N	x)		
3	Channel board for safety isolator	C79451-A3224-B125		R	x)		
4	Central unit module	6DS4900-8AA		R	x)		
5	Power supply module for I/O modules	6DS4413-8AA		R	x)		
6	Power supply modules for transmitters	6DS4418-8AA		N	x)		
7	Mains filter	6DS4408-8CA		N	1		
8	Remote cable connector board	6DS9918-8DA		N	x)		
9	Sealing rubber for central unit and power supply modules	C79451-A3224-Y3		N	x)		
10	Terminal temperature sensor	C79211-A3003-B30		N	2		
11	Switch assembly for mains switch	W79050-X201-UI	Fa. Stahl Peter Henleinstr 8500 Nürnberg Order No. 8008/2-002	N	x)		
12	Fuse, 0.63 A fast blow	W79054-L1010-F630		N	1	Item 1	
13	Fuse, 0.315 A medium delay	W79054-L1010-M315		N	1	Item 2	
	I/O Modules						
14	Binary input module with 8 channels for floating binary transmitters and FM-internal active M signals	6DS1610-8AA		R	x)		
15	Binary input module with 8 channels for non-contact sensors (NAMUR)	6DS6DS1611-8AA		R	x)		
16	Analog input module with 4 channels for thermocouples, resistance thermometers and potentiometers	6DS1706-8AA		R	x)		
17	Analog input module with channels for current/voltage signals and transmitters	6DS1708-8AA		R	x)		
18	Limit monitor module with 2 channels	6DS1710-8AA		R	x)		
19	Binary output module with 8 channels	6DS1612-8AA		R	x)		
20	Interlock module	6DS1506-8AA		R	x)		
21	Scanning repetition module	6DS1912-8AA		R	x)		

*) R0 = Repairable, no exchange part R1 = Repairable N = Not repairable x) system-specific assembly Place of delivery: E MA-ED Erlangen	TELEPERM M FM 100 Field Multiplexer	
	C79000-E8076-C090-03	Sheet: 1
		2 sh

SIEMENS

Siemens Aktiengesellschaft

The reproduction, transmission or use of this document or its contents is not permitted without express written authority.
Offenders will be liable for damages. All rights, including rights created by patent grant or registration of a utility model or design, are reserved.

Order No.: C79000-E8076-C090-03

Order from: Gerätewerk Karlsruhe

Printed in the Federal Republic of Germany

© Siemens AG 1985

Siemens AG
Gerätewerk Karlsruhe, AZP
Postfach 21 12 62
Östliche Rheinbrückenstr. 50

D-7500 Karlsruhe 21

Vorschläge Korrekturen
Suggestions Corrections
Propositions Corrections
Propuestas Correcciones

Für Druckschrift bzw. Handbuch
For instructions or manual
Pour l'imprimé ou le manuel
Para folleto o manual

Titel/Title/Titre/Título

Absender/From/Expéditeur/Expedito
 Name/Name/Nom/Nombre y apellido

Bestell-Nr./Order No./ N° de réf./N° de ped.

Firma/Dienststelle - Company/department - Firme/service - Empresa/Sección

Anschrift/Address/Adresse/Dirección

Telefon/Telephone/Téléphone/Teléfono

Sollten Sie beim Lesen dieser Unterlage auf Druckfehler gestoßen sein, so bitten wir Sie, uns diese mitzuteilen. Ebenso sind wir für Anregungen, Hinweise und Verbesserungsvorschläge dankbar.

Bitte die Bestell-Nr. der betreffenden Druckschrift oder des Handbuches oben eintragen!

If you detect some printing faults while reading this document, please inform us using this form. We would also be grateful for your suggestions, remarks or improvement propositions.

Please fill in the Order No. of the affected document!

Si, lors de la lecture de ce document, vous trouvez des fautes d'imprimerie, nous vous prions de nous en faire part dans ce formulaire. Nous serions aussi reconnaissants de recevoir vos suggestions, remarques et propositions d'amélioration. **Indiquez s.v.p. le n° de référence de l'imprimé ou du manuel concerné.**

Si encuentra Usted erratas de imprenta, por favor, infórmenos utilizando este formulario. Le rogamos que nos comunique también las reclamaciones, indicaciones, y propuestas de mejoramiento.

¡No olvide el n° de ped. del folleto, por favor!

Vorschläge und/oder Korrekturen
Suggestions or/and corrections

Propositions et/ou corrections
Propuestas y/o correcciones

UNIVERSITÄT DUISBURG ESSEN

