

SIEMENS

MICROMASTER 440

0.12 kW - 200 kW

Operating Instructions

Issue 04/02



MICROMASTER 440 Documentation

Getting Started Guide

Is for quick commissioning with SDP and BOP.

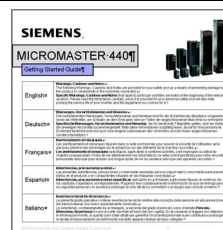

Operating Instructions

Gives information about features of the MICROMASTER 440, Installation, Commissioning, Control modes, System Parameter structure, Troubleshooting, Specifications and available options of the MICROMASTER 440.



Parameter List

The Parameter List contains the description of all Parameters structured in functional order and a detailed description. The Parameter list also includes a series of function plans.

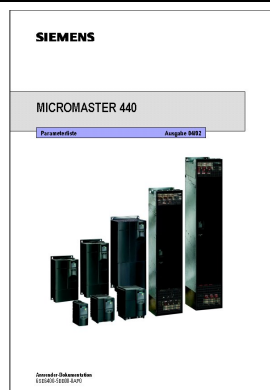

Catalogues

In the catalogue you will find all the necessary information to select an appropriate inverter, as well as filters, chokes, operator panels and communication options.



SIEMENS

MICROMASTER 440

0.12 kW - 200 kW

Operating Instructions
User Documentation

Valid for

Issue 04/02

Inverter Type
MICROMASTER 440
0.12 kW - 200 kW

Software Version
2.0

Issue 04/02

Overview	1
Installation	2
Commissioning	3
Using the MICROMASTER 440	4
System Parameters	5
Troubleshooting	6
MICROMASTER 440 Specifications	7
Available options	8
Electro-Magnetic Compatibility	9
Appendices	A B C D E F
Index	

IMPORTANT NOTICE

Not all inverters currently have UL approval.

UL listing can be determined by examining the inverter's Rating Label.

For UL listed products the following UL mark is used:



Note: UL certification is presently in progress!

Further information can be obtained from Internet website:

<http://www.siemens.de/micromaster>

Approved Siemens Quality for Software and Training is to DIN ISO 9001, Reg. No. 2160-01

The reproduction, transmission or use of this document, or its contents is not permitted unless authorized in writing. Offenders will be liable for damages. All rights including rights created by patent grant or registration of a utility model or design are reserved.

© Siemens AG 2001. All Rights Reserved.

MICROMASTER® is a registered trademark of Siemens

Other functions not described in this document may be available. However, this fact shall not constitute an obligation to supply such functions with a new control, or when servicing.

We have checked that the contents of this document correspond to the hardware and software described. There may be discrepancies nevertheless, and no guarantee can be given that they are completely identical. The information contained in this document is reviewed regularly and any necessary changes will be included in the next edition. We welcome suggestions for improvement.

Siemens handbooks are printed on chlorine-free paper that has been produced from managed sustainable forests. No solvents have been used in the printing or binding process.

Document subject to change without prior notice.

Order number: 6SE6400-5AW00-0BP0

Siemens-Aktiengesellschaft

Foreword

User Documentation



WARNING

Before installing and commissioning the inverter, you must read all safety instructions and warnings carefully including all the warning labels attached to the equipment. Make sure that the warning labels are kept in a legible condition and replace missing or damaged labels.

Information is also available from:

Technical Support Nuremberg

Tel: +49 (0) 180 5050 222

Fax: +49 (0) 180 5050 223

Email: techsupport@ad.siemens.de

Monday to Friday: 7:00 am to 5:00 pm (local time)

Internet Home Address

Customers can access technical and general information at:

<http://www.siemens.de/micromaster>

Contact address

Should any questions or problems arise while reading this manual, please contact the Siemens office concerned using the form provided at the back this manual.

Definitions and Warnings



DANGER

indicates an imminently hazardous situation which, if not avoided, will result in death or serious injury.



WARNING

indicates a potentially hazardous situation which, if not avoided, could result in death or serious injury.



CAUTION

used with the safety alert symbol indicates a potentially hazardous situation which, if not avoided, may result in minor or moderate injury.

CAUTION

used without safety alert symbol indicates a potentially hazardous situation which, if not avoided, may result in a property damage.

NOTICE

indicates a potential situation which, if not avoided, may result in an undesirable result or state.

NOTE

For the purpose of this documentation, "Note" indicates important information relating to the product or highlights part of the documentation for special attention.

Qualified personnel

For the purpose of this Instruction Manual and product labels, a "Qualified person" is someone who is familiar with the installation, mounting, start-up and operation of the equipment and the hazards involved.

He or she must have the following qualifications:

1. Trained and authorized to energize, de-energize, clear, ground and tag circuits and equipment in accordance with established safety procedures.
2. Trained in the proper care and use of protective equipment in accordance with established safety procedures.
3. Trained in rendering first aid.

PE
 = Ground

- ◆ PE – Protective Earth uses circuit protective conductors sized for short circuits where the voltage will not rise in excess of 50 Volts. This connection is normally used to ground the inverter.
- ◆  - Is the ground connection where the reference voltage can be the same as the Earth voltage. This connection is normally used to ground the motor.

Use for intended purpose only

The equipment may be used only for the application stated in the manual and only in conjunction with devices and components recommended and authorized by Siemens.

Safety Instructions

The following Warnings, Cautions and Notes are provided for your safety and as a means of preventing damage to the product or components in the machines connected. This section lists Warnings, Cautions and Notes, which apply generally when handling MICROMASTER 440 Inverters, classified as **General, Transport & Storage, Commissioning, Operation, Repair and Dismantling & Disposal**.

Specific Warnings, Cautions and Notes that apply to particular activities are listed at the beginning of the relevant chapters and are repeated or supplemented at critical points throughout these sections.

Please read the information carefully, since it is provided for your personal safety and will also help prolong the service life of your MICROMASTER 440 Inverter and the equipment you connect to it.

General



WARNING

- ◆ This equipment contains dangerous voltages and controls potentially dangerous rotating mechanical parts. Non-compliance with **Warnings** or failure to follow the instructions contained in this manual can result in loss of life, severe personal injury or serious damage to property.
- ◆ Only suitable qualified personnel should work on this equipment, and only after becoming familiar with all safety notices, installation, operation and maintenance procedures contained in this manual. The successful and safe operation of this equipment is dependent upon its proper handling, installation, operation and maintenance.
- ◆ Risk of electric shock. The DC link capacitors remain charged for five minutes after power has been removed. **It is not permissible to open the equipment until 5 minutes after the power has been removed.**
- ◆ **HP ratings are based on the Siemens 1LA motors and are given for guidance only; they do not necessarily comply with UL or NEMA HP ratings.**



CAUTION

- ◆ Children and the general public must be prevented from accessing or approaching the equipment!
- ◆ This equipment may only be used for the purpose specified by the manufacturer. Unauthorized modifications and the use of spare parts and accessories that are not sold or recommended by the manufacturer of the equipment can cause fires, electric shocks and injuries.

NOTICE

- ◆ Keep these operating instructions within easy reach of the equipment and make them available to all users
- ◆ Whenever measuring or testing has to be performed on live equipment, the regulations of Safety Code VBG 4.0 must be observed, in particular §8 "Permissible Deviations when Working on Live Parts". Suitable electronic tools should be used.
- ◆ Before installing and commissioning, please read these safety instructions and warnings carefully and all the warning labels attached to the equipment. Make sure that the warning labels are kept in a legible condition and replace missing or damaged labels.

Transport & Storage



WARNING

- ◆ Correct transport, storage, erection and mounting, as well as careful operation and maintenance are essential for proper and safe operation of the equipment.
-



CAUTION

- ◆ Protect the inverter against physical shocks and vibration during transport and storage. Also be sure to protect it against water (rainfall) and excessive temperatures (*see table on page 102*).
-

Commissioning



WARNING

- ◆ Work on the device/system by **unqualified** personnel or failure to comply with warnings can result in severe personal injury or serious damage to material. Only suitably qualified personnel trained in the setup, installation, commissioning and operation of the product should carry out work on the device/system.
 - ◆ Only permanently-wired input power connections are allowed. This equipment must be grounded (IEC 536 Class 1, NEC and other applicable standards).
 - ◆ Only type B ELCBs should be used with FSA to FSF. Machines with a three-phase power supply, fitted with EMC filters, must not be connected to a supply via an ELCB (Earth Leakage Circuit-Breaker - *see DIN VDE 0160, section 5.5.2 and EN50178 section 5.2.11.1*).
 - ◆ The following terminals can carry dangerous voltages even if the inverter is inoperative:
 - the power supply terminals L/L1, L1, N/L2, L2, L3
 - the motor terminals U, V, W
 - additionally the terminals DC+/B+, DC-, B- and DC/R+
 - ◆ This equipment must not be used as an 'emergency stop mechanism' (*see EN 60204, 9.2.5.4*)
-



CAUTION

The connection of power, motor and control cables to the inverter must be carried out as shown in Figure 2-13 on page 40, to prevent inductive and capacitive interference from affecting the correct functioning of the inverter.

Operation



WARNING

- ◆ MICROMASTERS operate at high voltages.
 - ◆ When operating electrical devices, it is impossible to avoid applying hazardous voltages to certain parts of the equipment.
 - ◆ Emergency Stop facilities according to EN 60204 IEC 204 (VDE 0113) must remain operative in all operating modes of the control equipment. Any disengagement of the Emergency Stop facility must not lead to uncontrolled or undefined restart.
 - ◆ Wherever faults occurring in the control equipment can lead to substantial material damage or even grievous bodily injury (i.e. potentially dangerous faults), additional external precautions must be taken or facilities provided to ensure or enforce safe operation, even when a fault occurs (e.g. independent limit switches, mechanical interlocks, etc.).
 - ◆ Certain parameter settings may cause the inverter to restart automatically after an input power failure.
 - ◆ Motor parameters must be accurately configured for motor overload protection to operate correctly.
 - ◆ This equipment is capable of providing internal motor overload protection in accordance with UL508C section 42. Refer to P0610 and P0335, i²t is ON by default. Motor overload protection can also be provided using an external PTC (disabled by default P0601).
 - ◆ This equipment is suitable for use in a circuit capable of delivering not more than 10,000 symmetrical amperes (rms), for a maximum voltage of 230 V / 460 V / 575 V when protected by a H or K type fuse (see *Tables starting on page 105*).
 - ◆ This equipment must not be used as an 'emergency stop mechanism' (see *EN 60204, 9.2.5.4*)
-

Repair



WARNING

- ◆ Repairs on equipment may only be carried out by **Siemens Service**, by repair centers **authorized by Siemens** or by qualified personnel who are thoroughly acquainted with all the warnings and operating procedures contained in this manual.
 - ◆ Any defective parts or components must be replaced using parts contained in the relevant spare parts list.
 - ◆ Disconnect the power supply before opening the equipment for access
-

Dismantling & Disposal

CAUTION

- ◆ The inverter's packaging is re-usable. Retain the packaging for future use.
 - ◆ Easy-to-release screw and snap connectors allow you to break the unit down into its component parts. You can then re-cycle these component parts, dispose of them in **accordance with local requirements or return them to the manufacturer.**
-

Table of Contents

1	Overview	15
1.1	The MICROMASTER 440	16
1.2	Features	17
2	Installation	19
2.1	Installation after a Period of Storage.....	21
2.2	Ambient operating conditions.....	22
2.3	Mechanical installation	24
2.4	Electrical installation.....	31
3	Commissioning	41
3.1	Block diagram.....	43
3.2	Commission modes.....	45
3.3	General operation.....	56
4	Using the MICROMASTER 440.....	59
4.1	Frequency setpoint (P1000).....	60
4.2	Command sources (P0700)	61
4.3	OFF and braking functions	61
4.4	Control modes (P1300)	63
4.5	Extended Functions for the MICROMASTER 440	64
4.6	Faults and warnings	64
5	System parameters	65
5.1	Introduction to MICROMASTER system parameters.....	66
5.2	Parameter overview	67
5.3	Parameter list (short form)	68
5.4	Command and Drive Datasets - Overview.....	84
6	Troubleshooting	89
6.1	Troubleshooting with the SDP.....	90
6.2	Troubleshooting with the BOP	91
6.3	Fault messages	92
6.4	Alarm messages.....	97
7	MICROMASTER 440 specifications	101
8	Options	117
8.1	Device-independent options.....	117
8.2	Device-dependent options	117
9	Electro-magnetic compatibility (EMC)	119
9.1	Electro-magnetic compatibility	120

Appendices	125
A Changing the Operator Panel	125
B Removing Covers	126
C Removing the I/O Board	130
D Removing 'Y' Cap	131
E Applicable Standards	137
F List of Abbreviations	138
Index	139

List of Illustrations

Figure 2-1	Forming.....	21
Figure 2-2	Ambient operating temperature	22
Figure 2-3	Installation altitude	22
Figure 2-4	Drill pattern for MICROMASTER 440.....	25
Figure 2-5	Installation dimensions for MICROMASTER 440 Frame size FX	26
Figure 2-6	Installation dimensions for MICROMASTER 440 Frame size GX.....	28
Figure 2-7	Options for the electronic box	30
Figure 2-8	MICROMASTER 440 Connection Terminals	34
Figure 2-9	MICROMASTER 440 connection drawing – frame size FX	35
Figure 2-10	MICROMASTER 440 connection drawing - frame size GX	36
Figure 2-11	Motor and Power Connections.....	37
Figure 2-12	Adaptation of fan voltage	38
Figure 2-13	Wiring Guidelines to Minimize the Effects of EMI	40
Figure 3-1	Inverter block diagram	43
Figure 3-2	Konfiguration der Analogeingänge als Digitaleingänge	44
Figure 3-3	Panels available for the MICROMASTER 440 Inverter.....	45
Figure 3-4	DIP switch.....	45
Figure 3-5	Basic operation with SDP	47
Figure 3-6	Buttons on the BOP	50
Figure 3-7	Changing parameters via the BOP	51
Figure 3-8	Typical Motor Rating Plate Example.....	55
Figure 5-1	Parameter Overview	67

List of Tables

Table 2-1	Dimensions and Torques of MICROMASTER 440	28
Table 3-1	Default settings for operation using the SDP	46
Table 3-2	Default settings for operation using the BOP	49
Table 6-1	Inverter conditions indicated by the LEDs on the SDP	90
Table 7-1	MICROMASTER 440 Performance Ratings	102
Table 7-2	Tightening torques for power terminals.....	103
Table 7-3	Current reduction depending on pulse frequency	104
Table 7-4	MICROMASTER 440 Specifications.....	105
Table 9-1	Permissible harmonic current emissions	121
Table 9-2	Class 1 - General Industrial	122
Table 9-3	Class 2 - Filtered Industrial	122
Table 9-4	Class 3 - Filtered for Residential, Commercial and Light Industry	123
Table 9-5	Compliance Table.....	124

1 Overview

This Chapter contains:

A summary of the major features of the MICROMASTER 440 range.

1.1	The MICROMASTER 440	16
1.2	Features	17

1.1 The MICROMASTER 440

The MICROMASTER 440 are frequency inverters for speed control of three-phase motors. The various models available cover the performance range from 120 W to 200 kW (for constant torque (CT), alternatively up to 250kW (for variable torque (VT)).

The inverters are microprocessor-controlled and use state-of-the-art Insulated Gate Bipolar Transistor (IGBT) technology. This makes them reliable and versatile. A special pulse-width modulation method with selectable Pulse frequency permits quiet motor operation. Comprehensive protective functions provide excellent inverter and motor protection.

With the factory default settings, the MICROMASTER 440 is suitable for many variable speed applications. Using the functionally grouped parameters, the MICROMASTER 440 can be adapted to more demanding applications.

The MICROMASTER 440 can be used in both 'stand-alone' applications as well as being integrated into 'Automation Systems'.

1.2 Features

Main Characteristics

- Easy installation
- Easy commissioning
- Rugged EMC design
- Can be operated on IT line supplies
- Fast repeatable response time to control signals
- Comprehensive range of parameters enabling configuration for a wide range of applications
- Simple cable connection
- Output relays
- Analog outputs (0 – 20 mA)
- 6 Isolated and switchable NPN/PNP digital inputs
- 2 Analog inputs:
 - ◆ AIN1: 0 – 10 V, 0 – 20 mA and -10 to +10 V
 - ◆ AIN2: 0 – 10 V, 0 – 20 mA
- The 2 analog inputs can be used as the 7th and 8th digital inputs
- BiCo technology
- Modular design for extremely flexible configuration
- High switching frequencies for low-noise motor operation
- Detailed status information and integrated message functions
- External options for PC communications, Basic Operator Panel (BOP), Advanced Operator Panel (AOP), PROFIBUS communications module

Performance Characteristics

- Vector Control
 - ◆ Sensorless Vector Control (SLVC)
 - ◆ Vector Control with encoder (VC)
- V/f Control
 - ◆ Flux Current Control (FCC) for improved dynamic response and motor control
 - ◆ Multi-point V/f characteristic
- Fast Current Limitation (FCL) for trip-free operation
- Built-in DC injection brake
- Compound braking to improve braking performance
- Built-in braking chopper (Frame Sizes A to F)
- Ramp function generator
 - ◆ With smoothing
 - ◆ Without smoothing
- Technology controller (PID)
- Parameter set switch-over
 - ◆ Motor data sets (DDS)
 - ◆ Command data sets and setpoint sources (CDS)
- Free Function Blocks
- Kinetic Buffering
- Positioning Ramp down

Protection characteristics

- Overvoltage/undervoltage protection
- Overtemperature protection for the inverter
- Ground fault protection
- Short-circuit protection
- i^2t thermal motor protection
- PTC/KTY for motor protection

2 Installation

This Chapter contains:

- General data relating to installation
- Dimensions of Inverter
- Wiring guidelines to minimize the effects of EMI
- Details concerning electrical installation

2.1	Installation after a Period of Storage.....	21
2.2	Ambient operating conditions.....	22
2.3	Mechanical installation	24
2.4	Electrical installation.....	31



WARNING

- ◆ Work on the device/system by **unqualified** personnel or failure to comply with warnings can result in severe personal injury or serious damage to material. Only suitably qualified personnel trained in the setup, installation, commissioning and operation of the product should carry out work on the device/system.
 - ◆ Only permanently-wired input power connections are allowed. This equipment must be grounded (IEC 536 Class 1, NEC and other applicable standards).
 - ◆ Only type B ELCBs should be used with FSA to FSF. Machines with a three-phase power supply, fitted with EMC filters, must not be connected to a supply via an ELCB (Earth Leakage Circuit-Breaker - see *DIN VDE 0160, section 5.5.2 and EN50178 section 5.2.11.1*).
 - ◆ The following terminals can carry dangerous voltages even if the inverter is inoperative:
 - the power supply terminals L/L1, L1, N/L2, L2, L3
 - the motor terminals U, V, W
 - additionally the terminals DC+/B+, DC-, B- and DC/R+
 - ◆ Always wait **5 minutes** to allow the unit to discharge after switching off before carrying out any installation work.
 - ◆ This equipment must not be used as an 'emergency stop mechanism' (see *EN 60204, 9.2.5.4*)
 - ◆ The minimum size of the earth-bonding conductor must be equal to or greater than the cross-section of the power supply cables.
 - ◆ If the front cover (Frame Sizes FX and GX) has been removed, the fan impeller is exposed. There is danger of injury when the fan is running.
-

CAUTION

The connection of power, motor and control cables to the inverter must be carried out as shown in Figure 2-13 on page 40, to prevent inductive and capacitive interference from affecting the correct functioning of the inverter.

2.1 Installation after a Period of Storage

Following a prolonged period of storage, you must reform the capacitors in the inverter.

Frame Sizes A to F

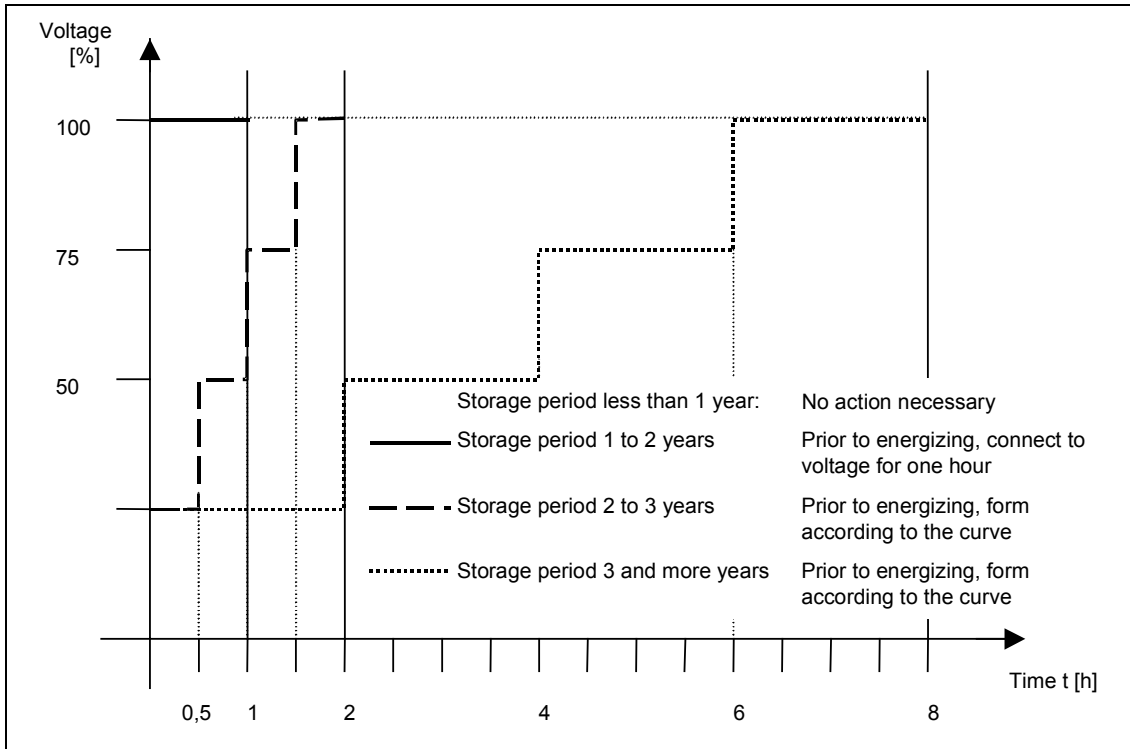

Figure 2-1 Forming

Frame Sizes FX and GX

Reforming the capacitors can be accomplished by applying 85% of the rated input voltage for at least 30 minutes without load.

2.2 Ambient operating conditions

Temperature

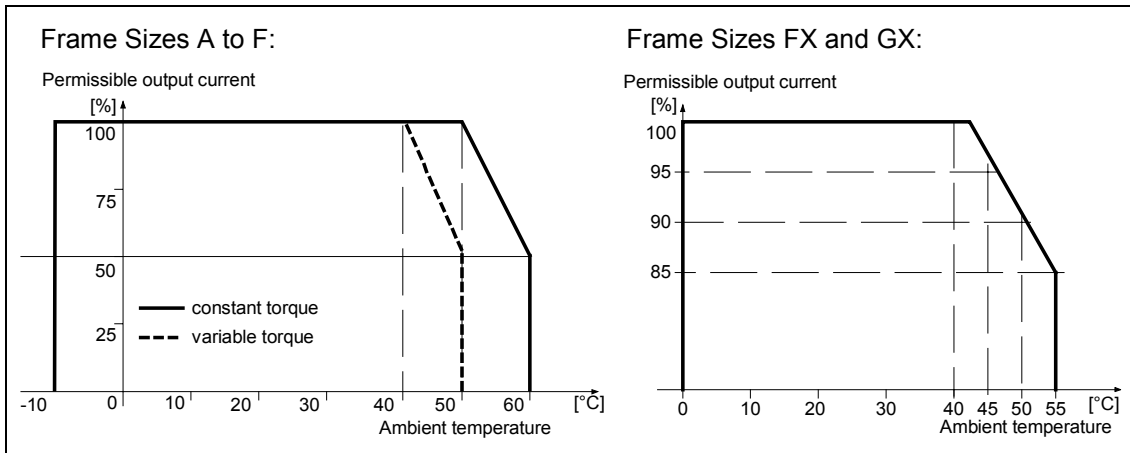

Figure 2-2 Ambient operating temperature

Humidity Range

Relative air humidity ≤ 95 % Non-condensing

Altitude

If the inverter is to be installed at an altitude > 1000 m or > 2000 m above sea level, derating will be required:

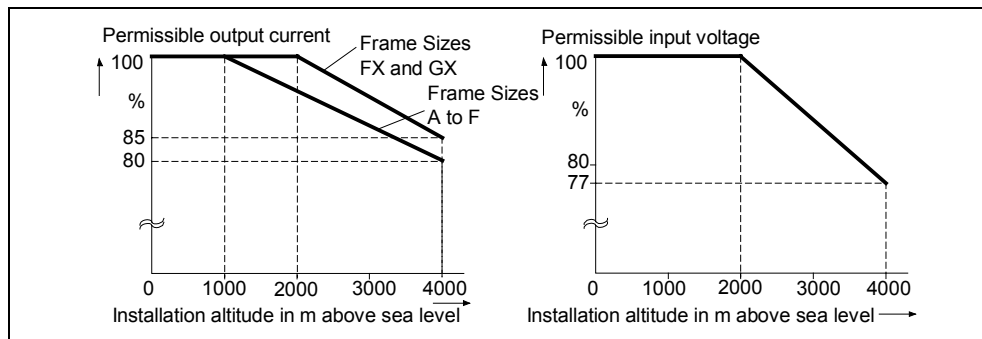

Figure 2-3 Installation altitude

Shock and Vibration

Do not drop the inverter or expose to sudden shock. Do not install the inverter in an area where it is likely to be exposed to constant vibration.

Mechanical strength to DIN IEC 68-2-6

- Deflection: 0.075 mm (10 ... 58 Hz)
- Acceleration: 9.8 m/s² (> 58 ... 500 Hz)

Electromagnetic Radiation

Do not install the inverter near sources of electromagnetic radiation.

Atmospheric Pollution

Do not install the inverter in an environment, which contains atmospheric pollutants such as dust, corrosive gases, etc.

Water

Take care to site the inverter away from potential water hazards, e.g. do not install the inverter beneath pipes that are subject to condensation. Avoid installing the inverter where excessive humidity and condensation may occur.

Installation and cooling

CAUTION

The inverters **MUST NOT** be mounted horizontally.

The inverters can be mounted without any clearance at either side. When mounting inverters one above the other, the specified environmental conditions must not be exceeded.

Independent of this, these minimum distances must be observed.

- Frame Size A, B, C above and below 100 mm
- Frame Size D, E above and below 300 mm
- Frame Size F above and below 350 mm
- Frame Size FX, GX above 250 mm
below 150 mm
in front 100 mm

No equipment that could have a negative effect on the flow of cooling air should be installed in this area. Make sure that the cooling vents in the inverter are positioned correctly to allow free movement of air.

2.3 Mechanical installation



WARNING

- ◆ To ensure the safe operation of the equipment, it must be installed and commissioned by qualified personnel in full compliance with the warnings laid down in these operating instructions.
- ◆ Take particular note of the general and regional installation and safety regulations regarding work on dangerous voltage installations (e.g. EN 50178), as well as the relevant regulations regarding the correct use of tools and personal protective equipment (PPE).
- ◆ The mains input, DC and motor terminals, can carry dangerous voltages even if the inverter is inoperative; wait **5 minutes** to allow the unit to discharge after switching off before carrying out any installation work.
- ◆ The inverters can be mounted without any clearance at either side. When mounting inverters one above the other, the specified environmental conditions must not be exceeded. Independent of this, these minimum distances must be observed.
 - Frame Size A, B, C above and below 100 mm
 - Frame Size D, E above and below 300 mm
 - Frame Size F above and below 350 mm
 - Frame Size FX, GX above 250 mm
below 150 mm
in front 100 mm
- ◆ If the front cover (Frame Sizes FX and GX) has been removed, the fan impeller is exposed. There is danger of injury when the fan is running.

Removing from transport pallet (only for framesize FX and GX)

During transport, the inverter is fastened on the transport pallet with the aid of two iron brackets.



WARNING

Note that the center of gravity of the inverter is not in the middle of the unit. When lifting the pallet, the unit can therefore suddenly change position and swing to the side.

1. Fasten the hoisting crane cable to the hoisting eyes on the inverter (2 eyes on frame size FX, 4 eyes on frame size GX).
2. Remove the two retaining bolts at the top of the front cover.
3. Unscrew the bolts in the iron brackets on the transport pallet and lift the inverter off the pallet.
4. Once installation has been completed and the inverter connected, fasten the two retaining bolts for the front cover at the bottom side of the door.

Frame Sizes A to F

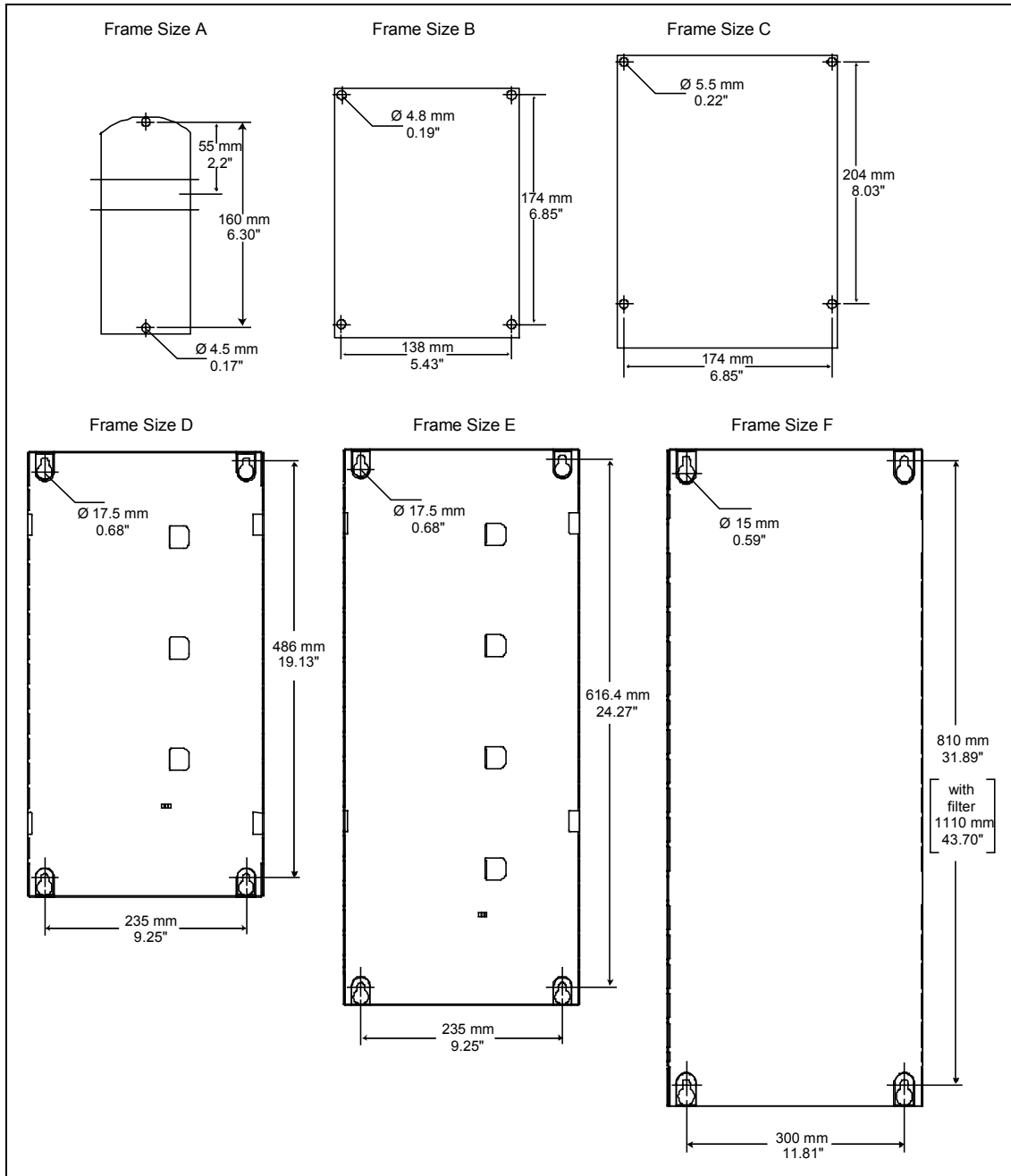

Figure 2-4 Drill pattern for MICROMASTER 440

Frame Size FX

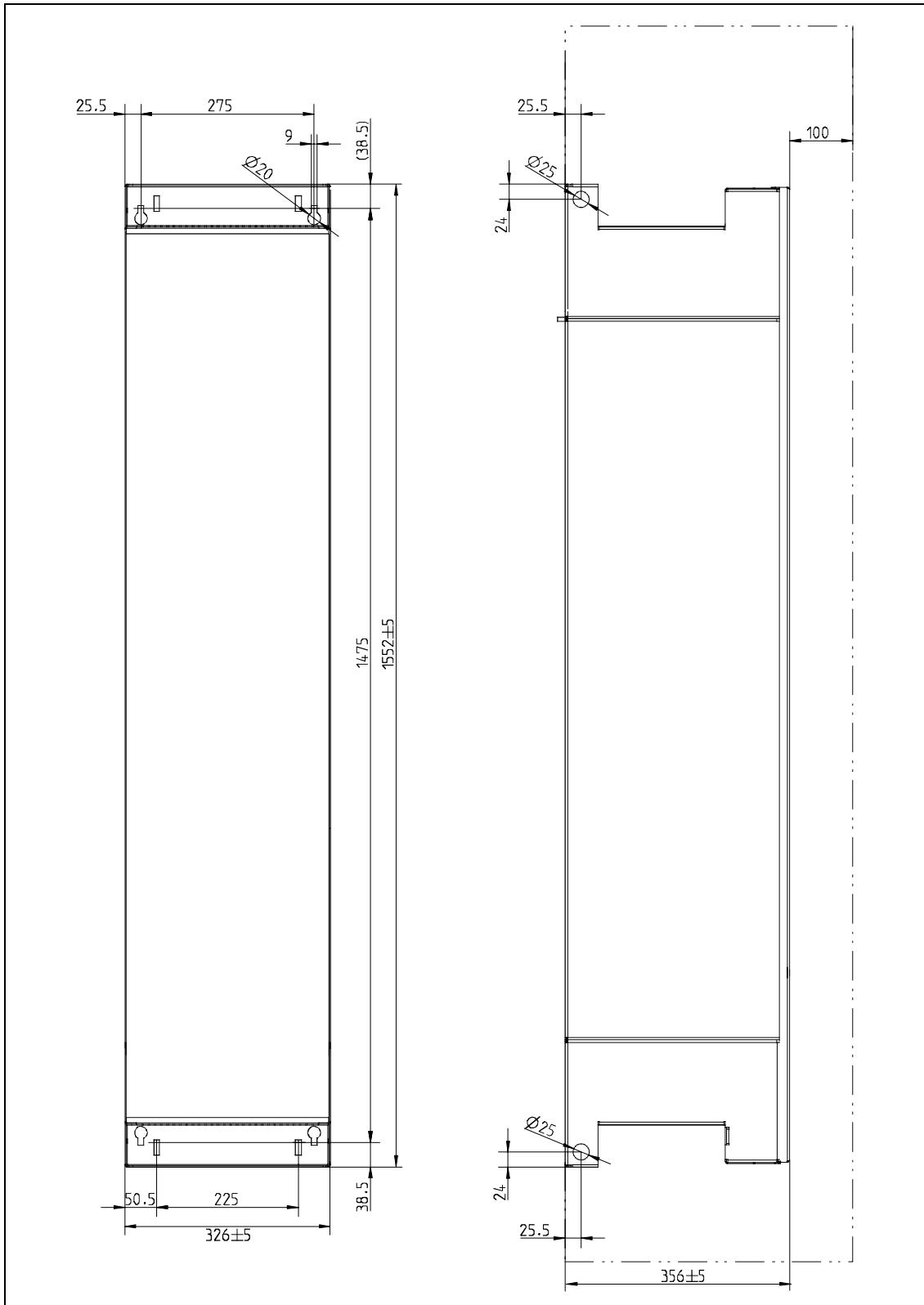
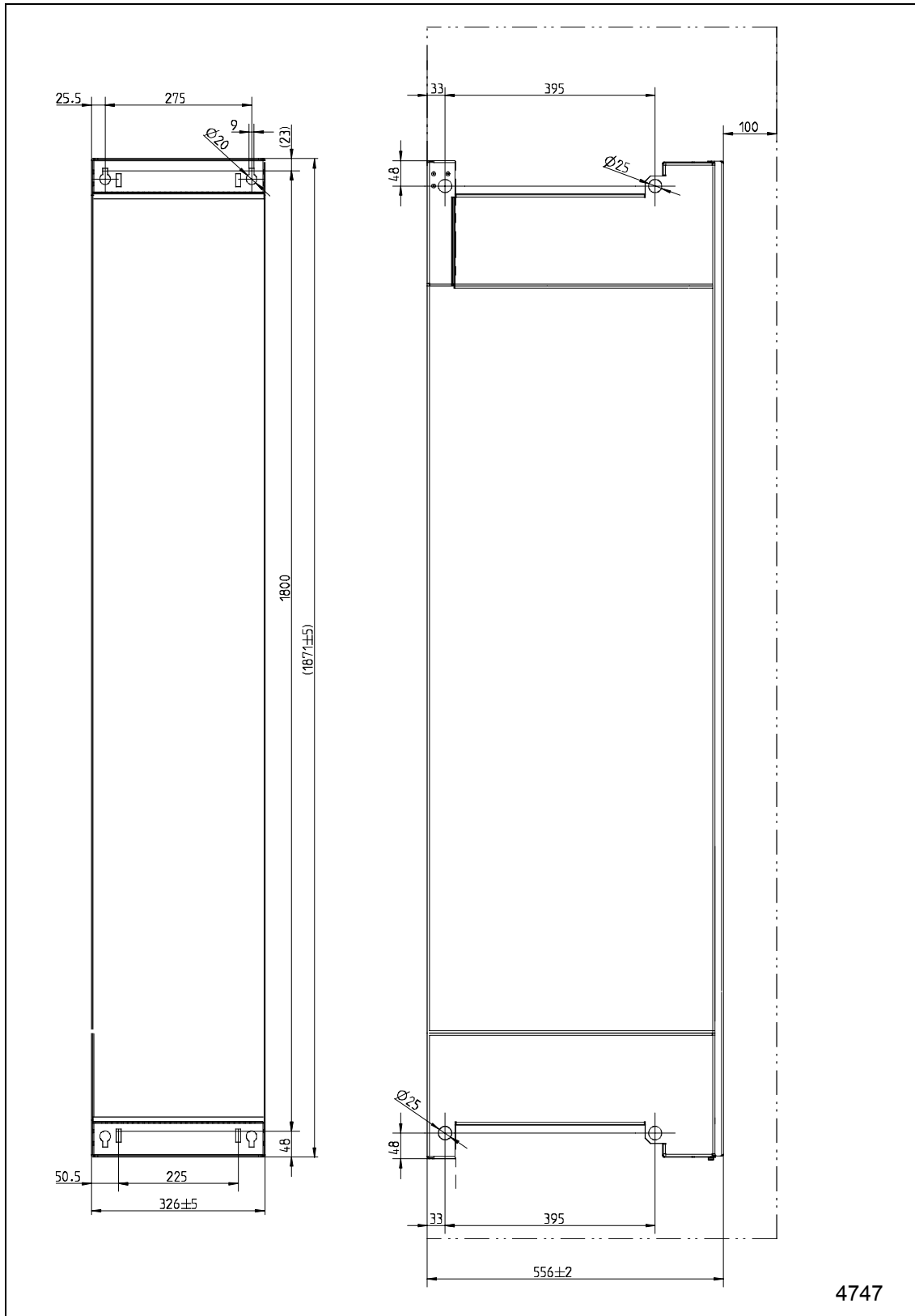

Figure 2-5 Installation dimensions for MICROMASTER 440 Frame size FX

Frame Size GX



4747

Figure 2-6 Installation dimensions for MICROMASTER 440 Frame size GX

Table 2-1 Dimensions and Torques of MICROMASTER 440

Frame-Size		Overall Dimensions		Fixing Method	Tightening Torque
A	Width x Height x Depth	mm	73 x 173 x 149	2 M4 Bolts 4 M4 Nuts 4 M4 Washers or fitting on a standard rail	2,5 Nm with washers fitted
		inch	2,87 x 6,81 x 5,87		
B	Width x Height x Depth	mm	149 x 202 x 172	4 M4 Bolts 4 M4 Nuts 4 M4 Washers	2,5 Nm with washers fitted
		inch	5,87 x 7,95 x 6,77		
C	Width x Height x Depth	mm	185 x 245 x 195	4 M5 Bolts 4 M5 Nuts 4 M5 Washers	2,5 Nm with washers fitted
		inch	7,28 x 9,65 x 7,68		
D	Width x Height x Depth	mm	275 x 520 x 245	4 M8 Bolts 4 M8 Nuts 4 M8 Washers	3,0 Nm with washers fitted
		inch	10,82 x 20,47 x 9,65		
E	Width x Height x Depth	mm	275 x 650 x 245	4 M8 Bolts 4 M8 Nuts 4 M8 Washers	3,0 Nm with washers fitted
		inch	10,82 x 25,59 x 9,65		
F	Width x Height x Depth	mm	350 x 850 mm x 320 height with filter 1150	4 M8 Bolts 4 M8 Nuts 4 M8 Washers	3,0 Nm with washers fitted
		inch	13,78 x 33,46 x 12,60 height with filter 45,28		
FX	Width x Height x Depth	mm	330 x 1555 x 360	4 M8 Bolts 4 M8 Nuts 4 M8 Washers	13 Nm +30 % with washers fitted
		inch	13,0 x 61,22 x 14,2		
GX	Width x Height x Depth	mm	330 x 1875 x 560	4 M8 Bolts 4 M8 Nuts 4 M8 Washers	13 Nm +30 % with washers fitted
		inch	13,0 x 73,82 x 22,05		

2.3.1 Mounting on standard rail, Frame Size A

Fitting the Inverter to a 35 mm standard rail (EN 50022)

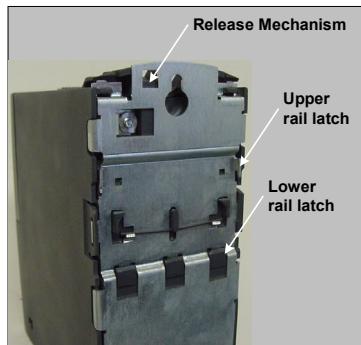

1. Fit the inverter to the rail using the upper rail latch.



2. Push the inverter against the rail and the lower rail latch should click into place.

Removing the Inverter from the rail



1. To disengage the release mechanism of the inverter, insert a screwdriver into the release mechanism.
2. Apply a downward pressure and the lower rail latch will disengage.
3. Pull the inverter from the rail.

2.3.2 Installation of options in the electronic box

The front cover of the MICROMASTER 440 is designed so that the control module (normally the SDP) is almost flush with the opening in the front cover. If more than one option is to be installed in the electronic box, it is necessary to position the entire electronic box further to the rear

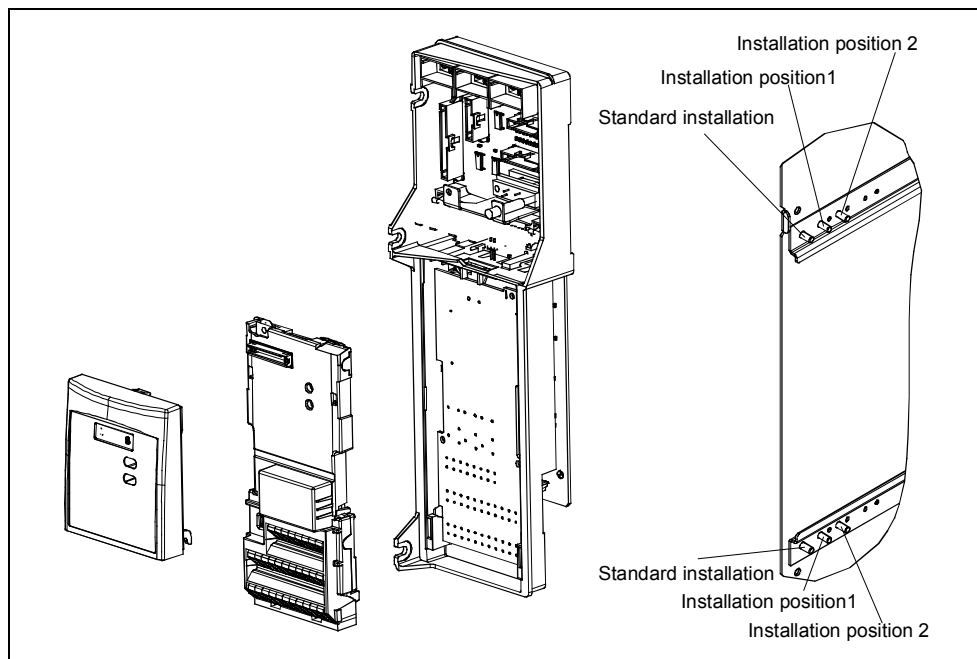

Figure 2-7 Options for the electronic box

Installing the options

- Remove the front cover:
 - Unscrew two screws at the bottom side of the front cover.
 - Lift front cover up and out.
- Remove retaining screws on the electronic box.
- Screw on electronic box in correct installation position as shown in Figure 2-7
- Install additional options.
- Reinstall front cover.

2.4 Electrical installation



WARNING

The inverter must always be grounded.

- ◆ To ensure the safe operation of the equipment, it must be installed and commissioned by qualified personnel in full compliance with the warnings laid down in these operating instructions.
 - ◆ Take particular note of the general and regional installation and safety regulations regarding work on dangerous voltage installations (e.g. EN 50178), as well as the relevant regulations regarding the correct use of tools and personal protective gear.
 - ◆ Never use high voltage insulation test equipment on cables connected to the inverter.
 - ◆ The mains input, DC and motor terminals, can carry dangerous voltages even if the inverter is inoperative; wait **5 minutes** to allow the unit to discharge after switching off before carrying out any installation work.
 - ◆ If the front cover (Frame Sizes FX and GX) has been removed, the fan impeller is exposed. There is danger of injury when the fan is running.
-

CAUTION

The control, power supply and motor leads **must** be laid separately. Do not feed them through the same cable conduit/trunking.

2.4.1 General



WARNING

The inverter must always be grounded. If the inverter is not grounded correctly, extremely dangerous conditions may arise within the inverter which could prove potentially fatal.

Operation with ungrounded (IT) supplies

The use of filtered MICROMASTER 4 drives on unearthed mains supplies is not permitted.

On ungrounded supplies, it will be necessary to remove the 'Y' capacitor from the inside of the unit and fit an output choke. The procedure for removing this capacitor is described in Appendices D.

The MICROMASTER will operate from ungrounded supplies and will continue to operate if an input phase is shorted to ground. If an output phase is shorted to ground, the MICROMASTER will trip and indicate F0001.

Operation with Residual Current Device (Frame Sizes A to F)

If an RCD (also referred to as ELCB or RCCB) is fitted, the MICROMASTER inverters will operate without nuisance tripping, provided that:

- A type B RCD is used.
- The trip limit of the RCD is 300 mA.
- The neutral of the supply is grounded.
- Only one inverter is supplied from each RCD.
- The output cables are less than 50 m (screened) or 100 m (unscreened).

Operation with long cables

All inverters will operate at full specification with cable lengths as follows:

Frame Sizes A to F

- screened: 50 m
- unscreened: 150 m

Frame Sizes FX and GX

- screened: 100 m
- unscreened: 300 m

The following cable lengths are possible using the output chokes specified in catalogue DA 51.2 :

- screened: 200 m
- unscreened: 150 m

2.4.2 Power and motor connections



WARNING

The inverter must always be grounded.

- ◆ Isolate the mains electrical supply before making or changing connections to the unit.
 - ◆ Ensure that the inverter is configured for the correct supply voltage: MICROMASTERS must not be connected to a higher voltage supply.
 - ◆ When synchronous motors are connected or when coupling several motors in parallel, the inverter must be operated with voltage/frequency control characteristic (P1300 = 0, 2 or 3).
-



CAUTION

After connecting the power and motor cables to the proper terminals, make sure that the covers have been replaced properly before supplying power to the unit!

NOTICE

- ◆ Ensure that the appropriate circuit-breakers/fuses with the specified current rating are connected between the power supply and inverter (*see chapter 7, Tables starting on page 105*).
 - ◆ Use Class 1 60/75 °C copper wire only (for UL compliance). For tightening torque see Table 7-2 on page 103.
-

Access to the power and motor terminals

Access to the power supply and motor terminals is possible by removing the covers (See Figure 2-8 and Figure 2-10).

After removing the covers and exposing the terminals, complete power and motor connections as shown in Figure 2-11.

Connection of braking unit (only for framesize FX and GX)

A passage opening for access to the intermediate circuit connections has been provided on the top side of the inverter. It is possible to connect an external braking unit to these terminals. The position is shown in Figure 2-9 and Figure 2-10.

The maximum cross section of connections is 50 mm², but only provided the crimped area of cable shoes on the equipment side is provided with a heat-shrinkable sleeve. This measure is important to ensure that air gaps and creep distances are observed.

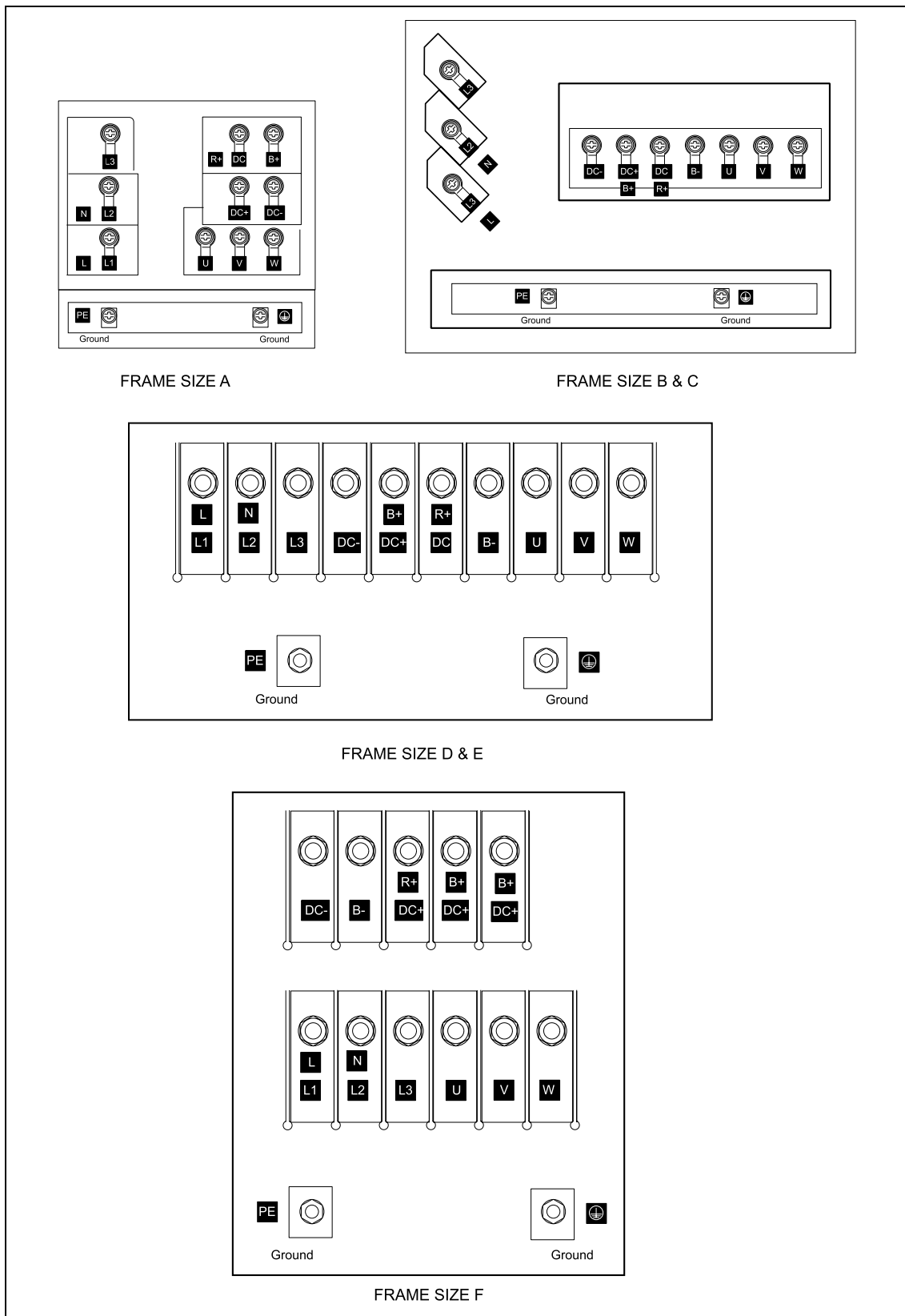

Figure 2-8 MICROMASTER 440 Connection Terminals

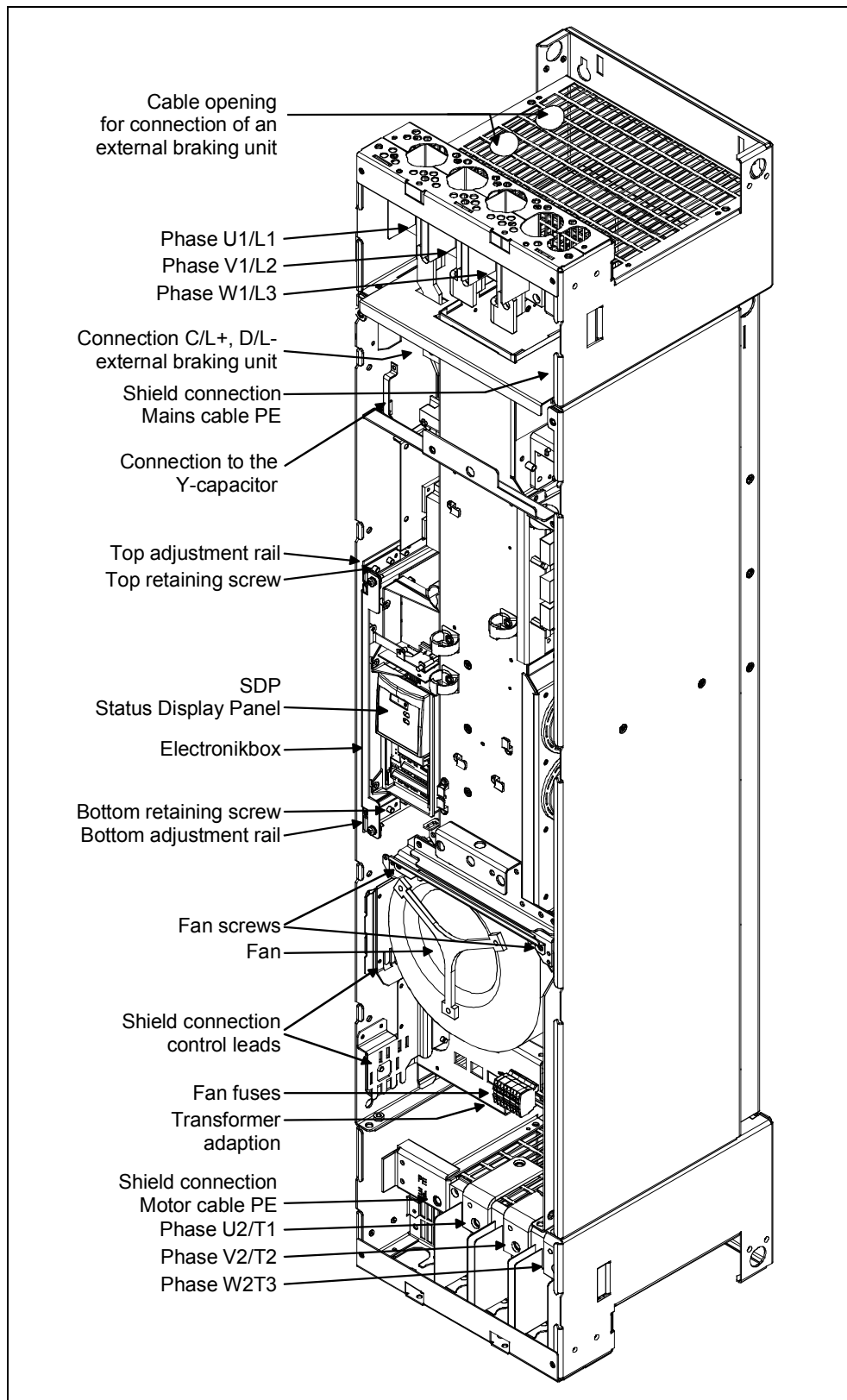

Figure 2-9 MICROMASTER 440 connection drawing – frame size FX

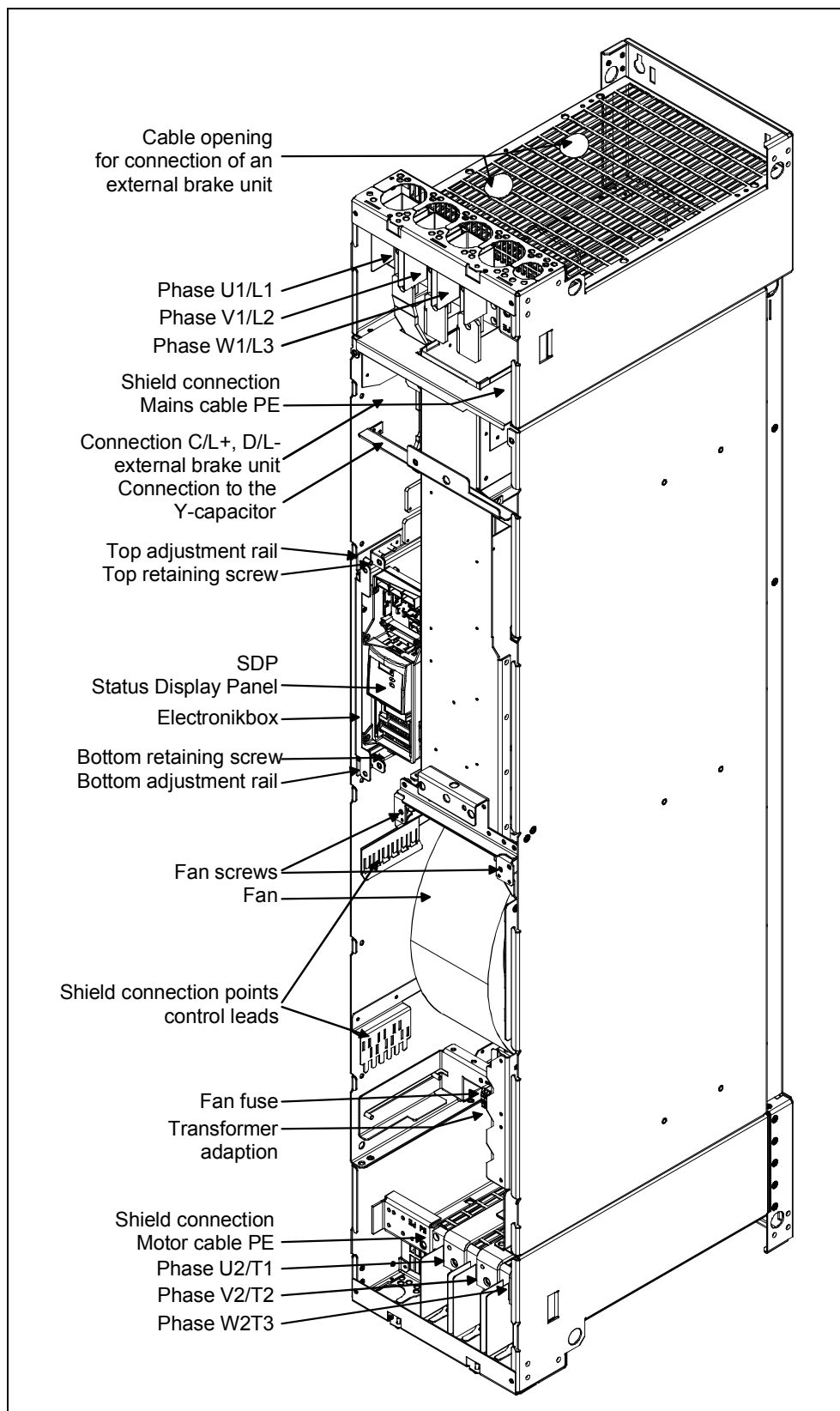
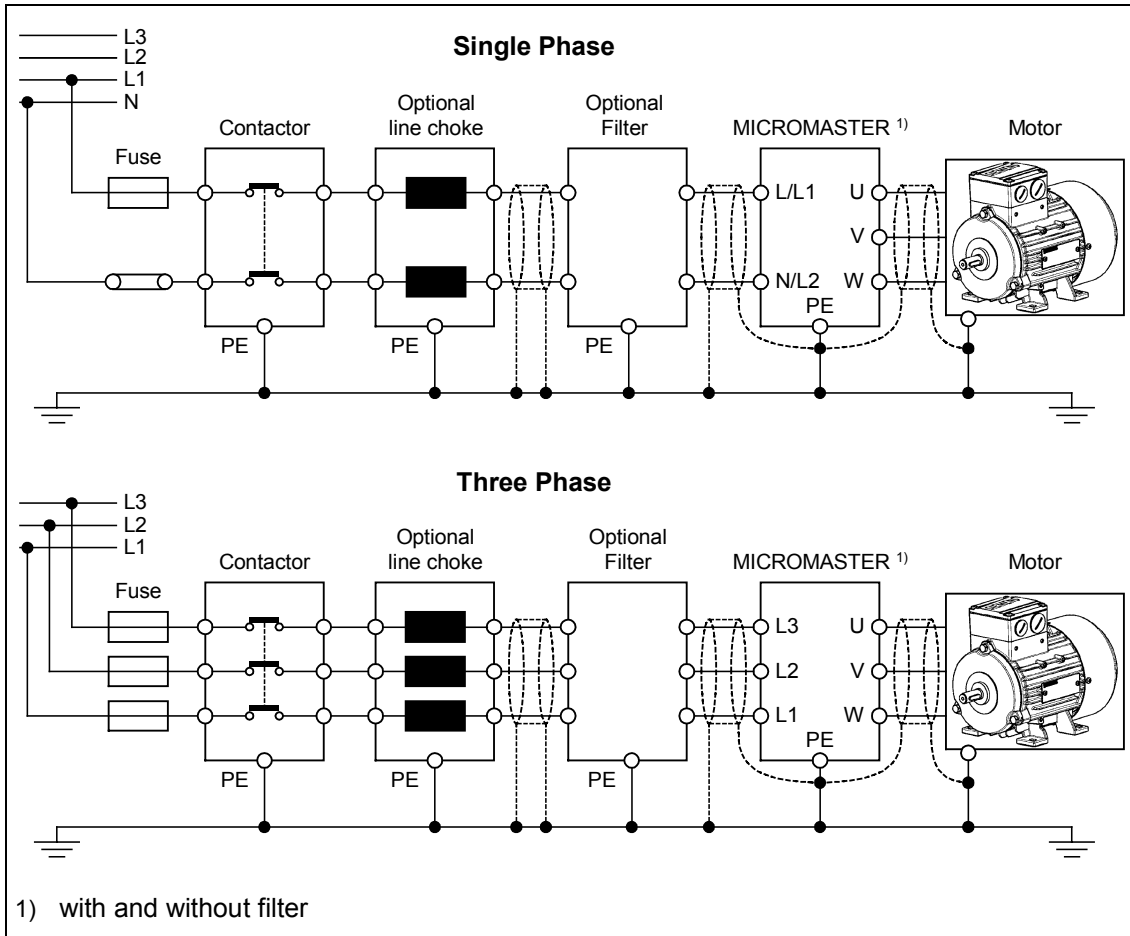

Figure 2-10 MICROMASTER 440 connection drawing - frame size GX

Frame Sizes A to F



Frame Sizes FX and GX

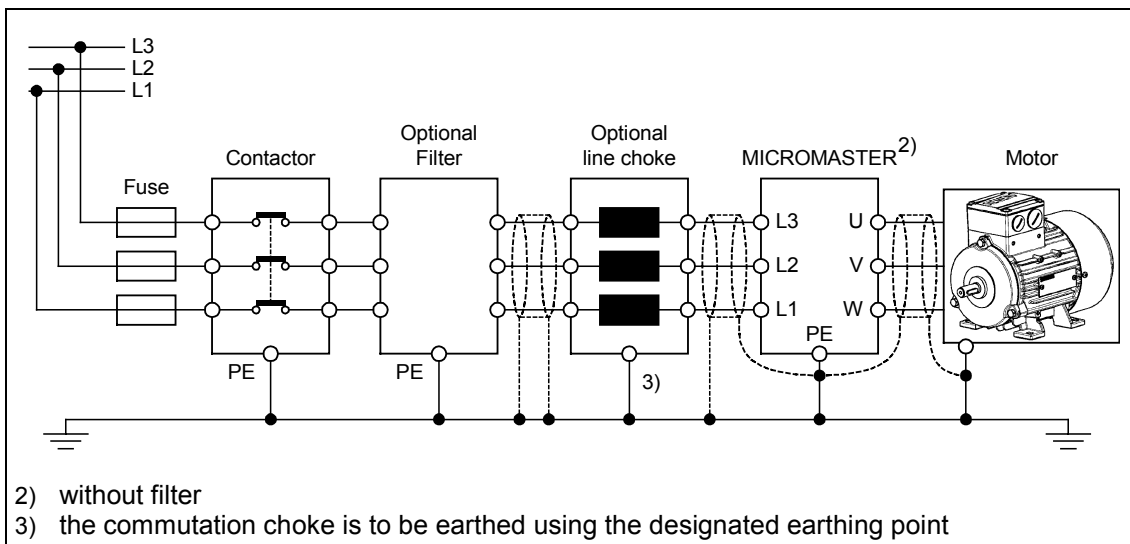

Figure 2-11 Motor and Power Connections

Adaptation of fan voltage (only for framesize FX and GX)

A transformer is installed to adapt the existing line voltage to the fan voltage. It may be necessary to reconnect the transformer terminals on the primary side to coincide with the existing line power.

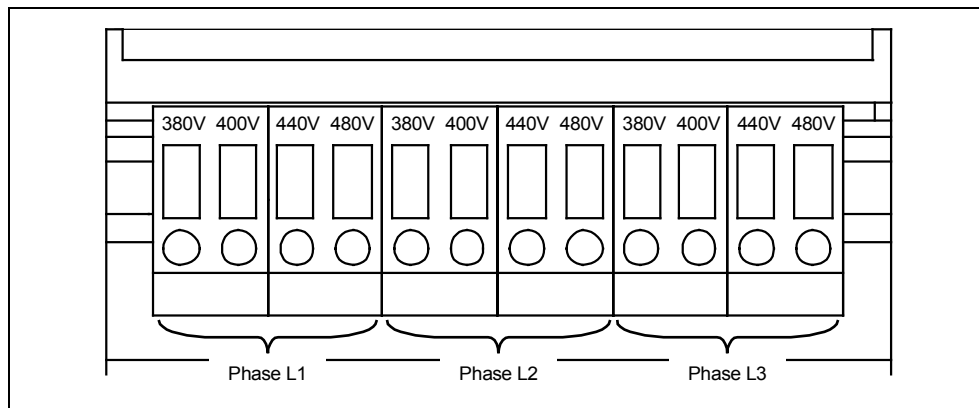

Figure 2-12 Adaptation of fan voltage

CAUTION

If the terminals are not reconnected to the actually present line voltage, the fan fuses can blow.

Replacement for fan fuses

Type Ferraz Gould Shawmut ATQR, 600 V

Frame size	Fuses (3 each)
FX	2 A
GX	2.5 A

2.4.3 Avoiding Electro-Magnetic Interference (EMI)

The inverters are designed to operate in an industrial environment where a high level of EMI can be expected. Usually, good installation practices will ensure safe and trouble-free operation. If you encounter problems, follow the guidelines stated below.

Action to Take

- Ensure that all equipment in the cubicle is well grounded using short, thick grounding cable connected to a common star point or busbar
- Make sure that any control equipment (such as a PLC) connected to the inverter is connected to the same ground or star point as the inverter via a short thick link.
- Connect the return ground from the motors controlled by the inverters directly to the ground connection (PE) on the associated inverter
- Flat conductors are preferred as they have lower impedance at higher frequencies
- Terminate the ends of the cable neatly, ensuring that unscreened wires are as short as possible
- Separate the control cables from the power cables as much as possible, using separate trunking, if necessary at 90° to each other.
- Whenever possible, use screened leads for the connections to the control circuitry
- Ensure that the contactors in the cubicle are suppressed, either with R-C suppressors for AC contactors or 'flywheel' diodes for DC contactors fitted to the coils. Varistor suppressors are also effective. This is important when the contactors are controlled from the inverter relay
- Use screened or armored cables for the motor connections and ground the screen at both ends using the cable clamps



WARNING

Safety regulations **must not** be compromised when installing inverters!

2.4.4 Screening Methods

Frame Sizes A, B and C

For frame sizes A, B and C the Gland Plate Kit is supplied as an option. It allows easy and efficient connection of the necessary screening. See the Gland Plate Installation Instructions contained on the Document CD-ROM, supplied with the MICROMASTER 440.

Screening without a Gland Plate

Should a Gland Plate not be available, then the inverter can be screened using the methodology shown in Figure 2-13.

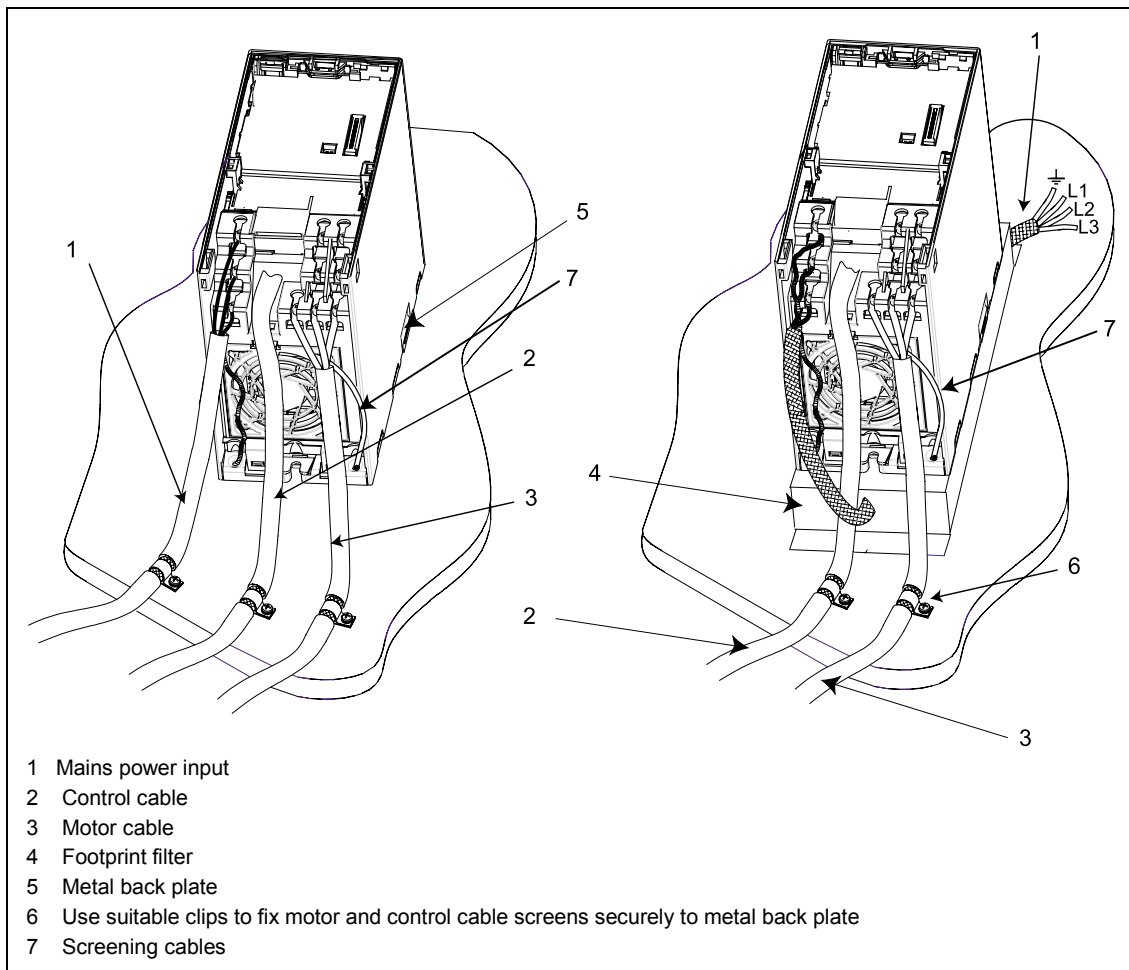

Figure 2-13 Wiring Guidelines to Minimize the Effects of EMI

Frame Sizes D, E and F

The Gland Plate is factory fitted. The installation of the screening is accomplished using the same methodology as in frame sizes A, B and C.

Frame Sizes FX and GX

Connect the wire shields to the shield connection points shown in the connection drawing (see Figure 2-9 and Figure 2-10).

For this purpose twist the motor leads and screw all of them together to the shield connection point for the motor lead.

When using an EMI filter, a power commutating choke is required. The wire shields should be fastened to the metallic mounting surface as close as possible to the components.

3 Commissioning

This Chapter contains:

- A schematic diagram of the MICROMASTER 440
- An overview of the commissioning options and the display and operator panels
- An overview of quick commissioning of the MICROMASTER 440

3.1	Block diagram.....	43
3.2	Commission modes.....	45
3.3	General operation.....	56



WARNING

- ◆ MICROMASTERS operate at high voltages.
 - ◆ When operating electrical devices, it is impossible to avoid applying hazardous voltages to certain parts of the equipment.
 - ◆ Emergency Stop facilities according to EN 60204 IEC 204 (VDE 0113) must remain operative in all operating modes of the control equipment. Any disengagement of the Emergency Stop facility must not lead to uncontrolled or undefined restart.
 - ◆ Wherever faults occurring in the control equipment can lead to substantial material damage or even grievous bodily injury (i.e. potentially dangerous faults), additional external precautions must be taken or facilities provided to ensure or enforce safe operation, even when a fault occurs (e.g. independent limit switches, mechanical interlocks, etc.).
 - ◆ Certain parameter settings may cause the inverter to restart automatically after an input power failure.
 - ◆ Motor parameters must be accurately configured for motor overload protection to operate correctly.
 - ◆ This equipment is capable of providing internal motor overload protection in accordance with UL508C section 42. Refer to P0610 and P0335, i²t is ON by default. Motor overload protection can also be provided using an external PTC (disabled by default P0601).
 - ◆ This equipment is suitable for use in a circuit capable of delivering not more than 10,000 symmetrical amperes (rms), for a maximum voltage of 230 V / 460 V / 575 V when protected by a H or K type fuse (see *Tables starting on page 105*).
 - ◆ This equipment must not be used as an 'emergency stop mechanism' (see *EN 60204, 9.2.5.4*)
-



CAUTION

Only qualified personnel may enter settings in the control panels. Particular attention must be paid to safety precautions and warnings at all times.

3.1 Block diagram

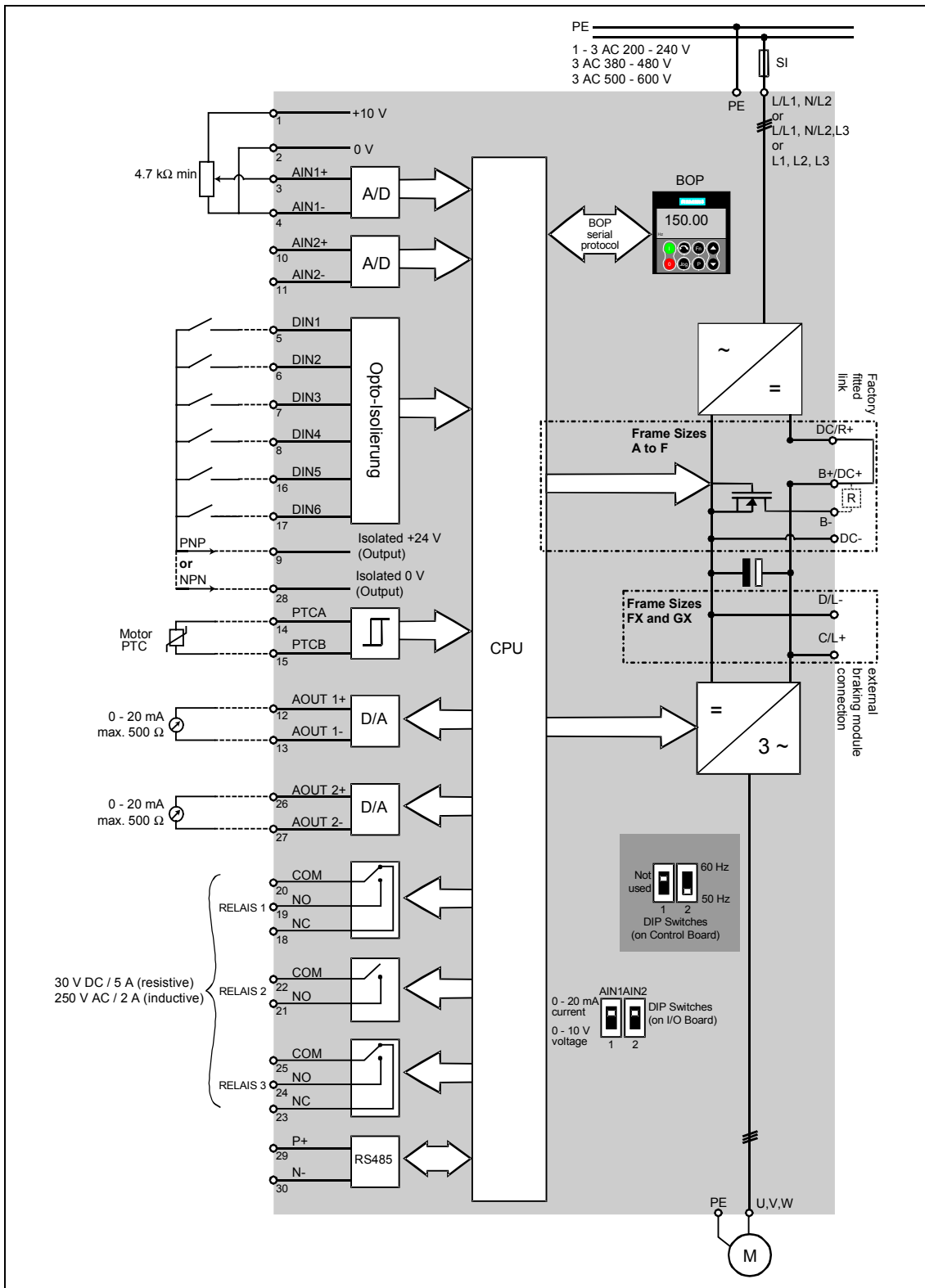

Figure 3-1 Inverter block diagram

3.1.1 Standard settings for the terminals

See Figure 3-2.

3.1.2 Analogue inputs

Analogue input 1 (AIN1) can be used with:

- 0 - 10 V, 0 - 20 mA and -10 V to +10 V

Analogue input 2 (AIN2) can be used with:

- 0 - 10 V and 0 - 20 mA

The analog input circuit can be alternatively configured to provide additional digital inputs (DIN7 & DIN8) as shown:

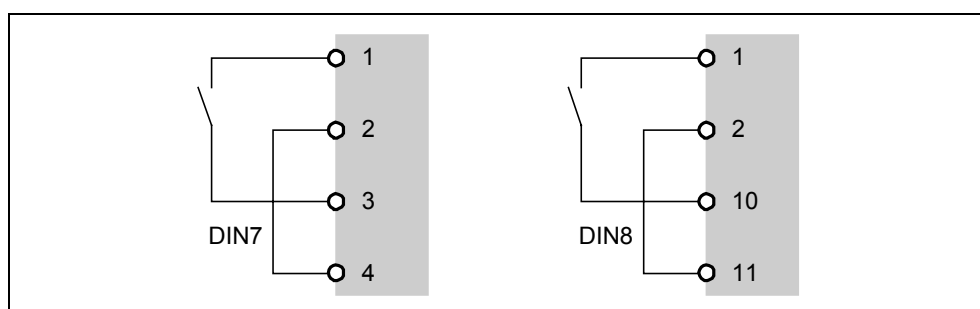

Figure 3-2 Configuration of the analogue input as a digital input

When an analogue input is configured as a digital input the threshold values are as follows:

1.75 V DC = OFF

3.70 V DC = ON

Terminal 9 (24 V) can also be used to drive the analog inputs when used as digital inputs. Terminals 2 and 28 (0 V) must be linked together.

3.2 Commission modes

In the standard version, the MICROMASTER 440 is fitted with the Status Display Panel (SDP) (see Figure 3-3) with which it is possible to use the inverter with the pre-assigned factory settings for a large range of applications. If these factory settings are not suitable, you can adapt them to suit your equipment conditions using the Basic Operator Panel (BOP) (see Figure 3-3) or the Advanced Operator Panel (AOP) (see Figure 3-3). The BOP and AOP are available as options. You can also adjust the factory settings using the PC IBN tool "Drive Monitor" or "STARTER". This software is available on the CD ROM which comes with the documentation of the unit.

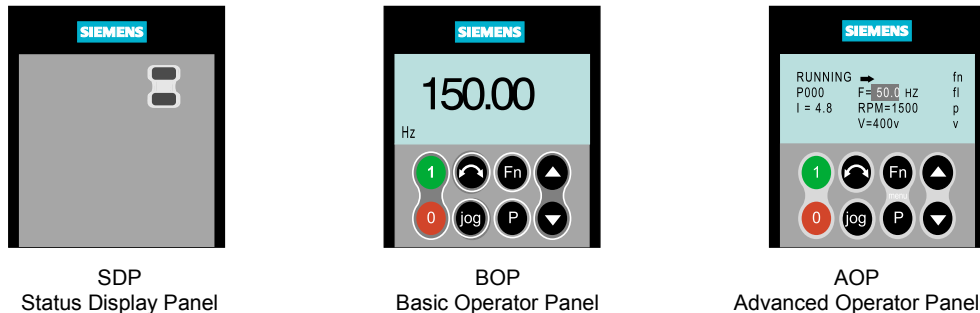

Figure 3-3 Panels available for the MICROMASTER 440 Inverter

NOTICE

The factory frequency setting can be changed with the DIP switches below the SDP. The inverter is delivered as follows:

- DIP switch 2:
 - ◆ Off position: European defaults (50 Hz, kW etc.)
 - ◆ On position: North American defaults (60 Hz, hp etc.)
- DIP switch 1:
 - Not for customer use.

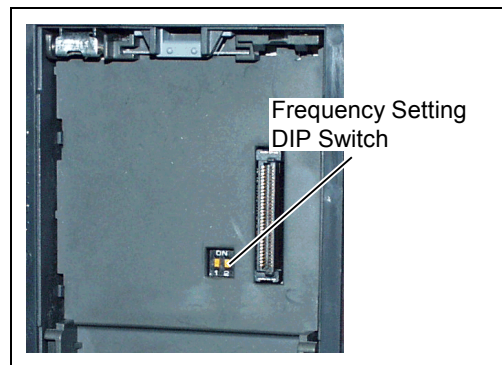
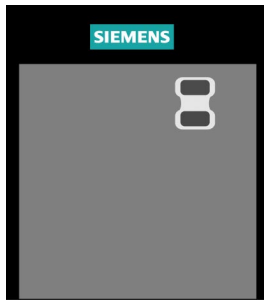

Figure 3-4 DIP switch

3.2.1 Commissioning with the SDP



The SDP has two LEDs on the front which display the current operating status of the inverter (see Section 6.1).

When the SDP is used, the presets of the inverter must be compatible with the following motor data:

- Rated motor power
- Motor voltage
- Rated motor current
- Rated motor frequency

(A conventional Siemens motor is recommended)

In addition, the following conditions must be met:

- Linear V/f motor speed controlled by an analog potentiometer.
- Maximum speed 3000 rpm at 50 Hz (3600 rpm at 60 Hz); can be controlled by a potentiometer via the analog inputs of the inverter.
- Ramp acceleration time/ramp deceleration time = 10 s

Settings for more complex applications can be found in the parameter list and in Section 3.2.2 "Commission Overview with BOP or AOP".

Table 3-1 Default settings for operation using the SDP

	Terminals	Parameter	Default Operation
Digital Input 1	5	P0701 = '1'	ON right
Digital Input 2	6	P0702 = '12'	Reverse
Digital Input 3	7	P0703 = '9'	Fault Acknowledge
Digital Input 4	8	P0704 = '15'	Fixed Frequency
Digital Input 5	16	P0705 = '15'	Fixed Frequency
Digital Input 6	17	P0706 = '15'	Fixed Frequency
Digital Input 7	Via AIN1	P0707 = '0'	Inactive
Digital Input 8	Via AIN2	P0708 = '0'	Inactive

Basic operation with SDP

With the SDP fitted, the following is possible:

- Start and stopping the motor (DIN1 via external switch)
- Reversing the motor (DIN2 via external switch)
- Fault Reset (DIN3 via external switch)

Controlling the speed of the motor is accomplished by connecting the analog inputs as shown in the Figure 3-5.

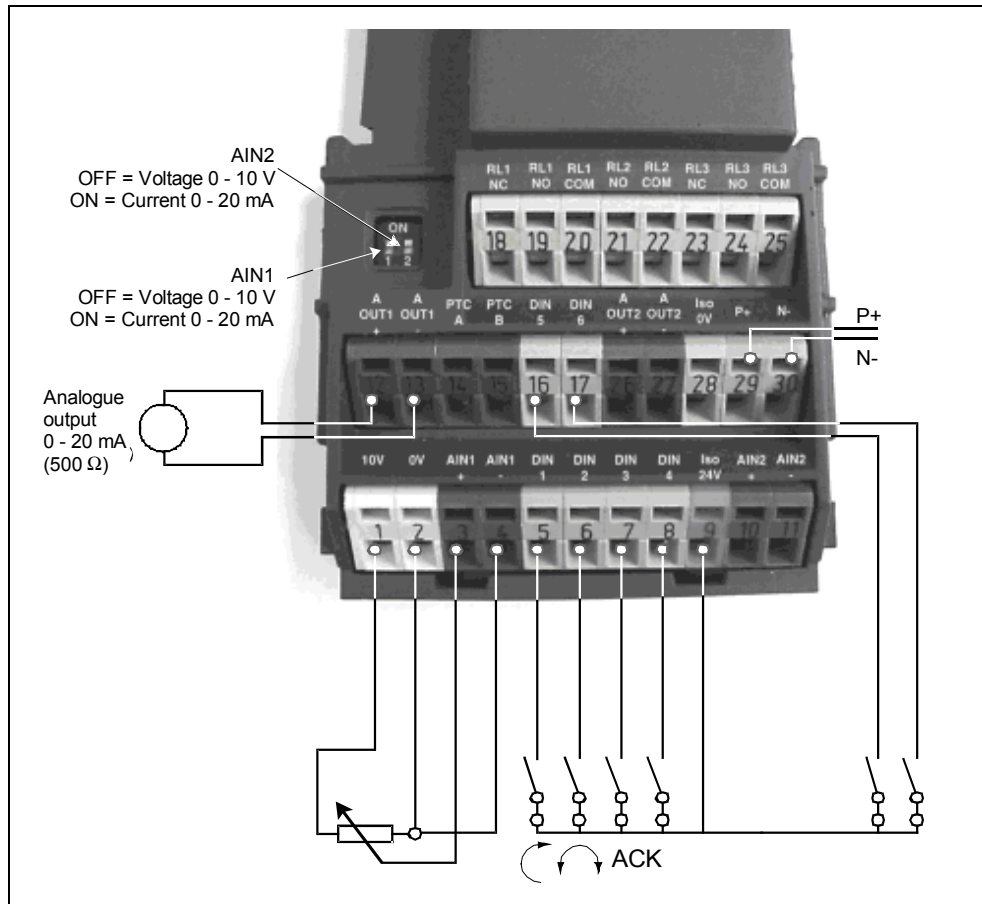
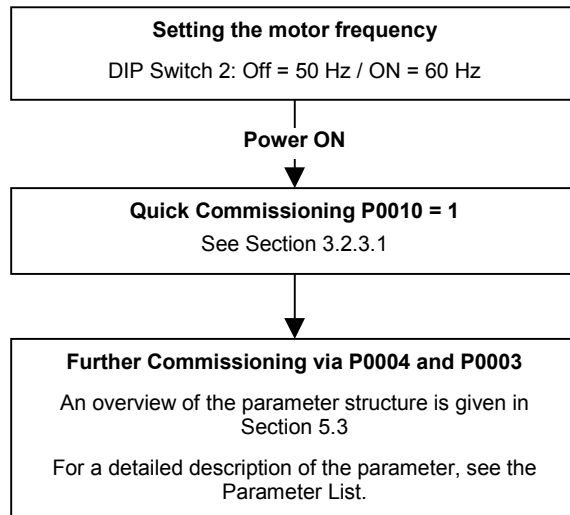

Figure 3-5 Basic operation with SDP

3.2.2 Commission Overview with BOP or AOP

Prerequisites

Mechanical and electrical Installation are completed.



NOTES

We recommend the commissioning according this scheme.

3.2.2.1 Commissioning with the BOP



You can alter parameter values via the BOP. To set parameters on this panel, you must remove the SDP and attach the BOP (see Appendix A).

The BOP features a five-digit, seven-segment display for showing parameter numbers and values, alarm and fault messages and setpoints and actual values. Parameter sets cannot be saved via the BOP.

Table 3-2 shows the factory default settings for operation via the BOP.

NOTICE

- ◆ The BOP motor control functions are disabled by default. To control the motor via the BOP, parameter P0700 should be set to 1 and P1000 set to 1.
- ◆ The BOP can be fitted to and removed from the inverter whilst power is applied.
- ◆ If the BOP has been set as the I/O control (P0700 = 1), the drive will stop if the BOP is removed.

Table 3-2 Default settings for operation using the BOP

Parameter	Meaning	Default Europe (North America)
P0100	Operating Mode Europe/US	50 Hz, kW (60Hz, hp)
P0307	Power (rated motor)	Dimension (kW (Hp)) depending on setting of P0100. [Value depending on variant.]
P0310	Motor frequency rating	50 Hz (60 Hz)
P0311	Motor speed rating	1395 (1680) rpm [depending on variant]
P1082	Maximum Motor Frequency	50 Hz (60 Hz)

Buttons on the BOP

















Panel/Button	Function	Effects
	Indicates Status	The LCD displays the settings currently used by the inverter.
	Start motor	Pressing the button starts the inverter. This button is disabled by default. To enable this button set P0700 = 1.
	Stop motor	OFF1 Pressing the button causes the motor to come to a standstill at the selected ramp down rate. Disabled by default; to enable set P0700 = 1. OFF2 Pressing the button twice (or once long) causes the motor to coast to a standstill. This function is always enabled.
	Change direction	Press this button to change the direction of rotation of the motor. Reverse is indicated by a minus (-) sign or a flashing decimal point. Disabled by default, to enable set P0700 = 1.
	Jog motor	Pressing this button while the inverter has no output causes the motor to start and run at the preset jog frequency. The motor stops when the button is released. Pressing this button when the motor is running has no effect.
	Functions	This button can be used to view additional information. Pressing and holding the button for 2 seconds from any parameter during operation, shows the following: 1. DC link voltage (indicated by d – units V). 2. Output current. (A) 3. Output frequency (Hz) 4. Output voltage (indicated by o – units V). 5. The value selected in P0005 (If P0005 is set to show any of the above (3, 4, or 5) then this will not be shown again). Additional presses will toggle around the above displays. Jump Function From any parameter (rXXXX or PXXXX) a short press of the Fn button will immediately jump to r0000, you can then change another parameter, if required. Upon returning to r0000, pressing the Fn button will return you to your starting point. Quit In case of a fault or alarm the  button resets the fault or alarm message on the operator panel display.
	Access parameters	Pressing this button allows access to the parameters.
	Increase value	Pressing this button increases the displayed value.
	Decrease value	Pressing this button decreases the displayed value.

Figure 3-6 Buttons on the BOP

Changing parameters with the BOP

The procedure for changing the value of parameter P0004 is described below. Modifying the value of an indexed parameter is illustrated using the example of P0719. Follow exactly the same procedure to alter other parameters that you wish to set via the BOP.

Changing P0004 – parameter filter function

Step	Result on display
1 Press  to access parameters	r0000
2 Press  until P0004 is displayed	P0004
3 Press  to access the parameter value level	0
4 Press  or  to the required value	7
5 Press  to confirm and store the value	P0004
6 Only the command parameters are visible to the user.	

Changing P0719 an indexed parameter Selection of command/setpoint source









Step	Result on display
1 Press  to access parameters	r0000
2 Press  until P0719 is displayed	P0719
3 Press  to access the parameter value level	r0000
4 Press  to display current set value	0
5 Press  or  to the required value	12
6 Press  to confirm and store the value	P0719
7 Press  until r0000 is displayed	r0000
8 Press  to return the display to the standard drive display (as defined by the customer)	

Figure 3-7 Changing parameters via the BOP





NOTES

In some cases - when changing parameter values - the display on the BOP shows **buSY**. This means the inverter is busy with tasks of higher priority.

Changing single digits in Parameter values

For changing the parameter value rapidly, the single digits of the display can be changed by performing the following actions:

Ensure you are in the parameter value changing level (see "Changing parameters with BOP").

1. Press  (function button), which causes the right hand digit to blink.
2. Change the value of this digit by pressing  / .
3. Press  (function button) again causes the next digit to blink.
4. Perform steps 2 to 4 until the required value is displayed.
5. Press the  to leave the parameter value changing level.

NOTES

The function button may also be used to acknowledge a fault condition

3.2.2.2 Commissioning with the AOP

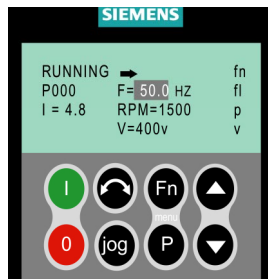

The AOP is available as an option. Its advanced features include the following:

- Multilingual clear text display
- Upload/download of multiple parameter sets
- Programmable via PC
- Multidrop capability to drive up to 30 inverters

Please refer to the AOP Manual for details or contact your local Siemens sales office for assistance.

3.2.3 Commissioning functions with BOP / AOP

3.2.3.1 Quick commissioning (P0010=1)

Mechanical and electrical installation of the inverter must be completed before running „Quick Commissioning“.

It is **important** that parameter P0010 is used for commissioning and P0003 is used to select the access level.

There are three user levels, standard, extended and expert. The lower the access level fewer parameters can be seen while performing Quick commissioning. The values for these parameters are either the default settings or are calculated during quick commissioning.

Quick commissioning includes motor and ramp setting parameters.

Quick Commissioning concludes with P3900, which, when set to 1, will perform the necessary motor calculations and clear all other parameters (not included in P0010 = 1) to the default settings. After completing Quick Commissioning with P3900 = 1, the inverter is then ready to run; this will only happen in the Quick Commissioning mode.

Flow chart Quick Commissioning (QC)

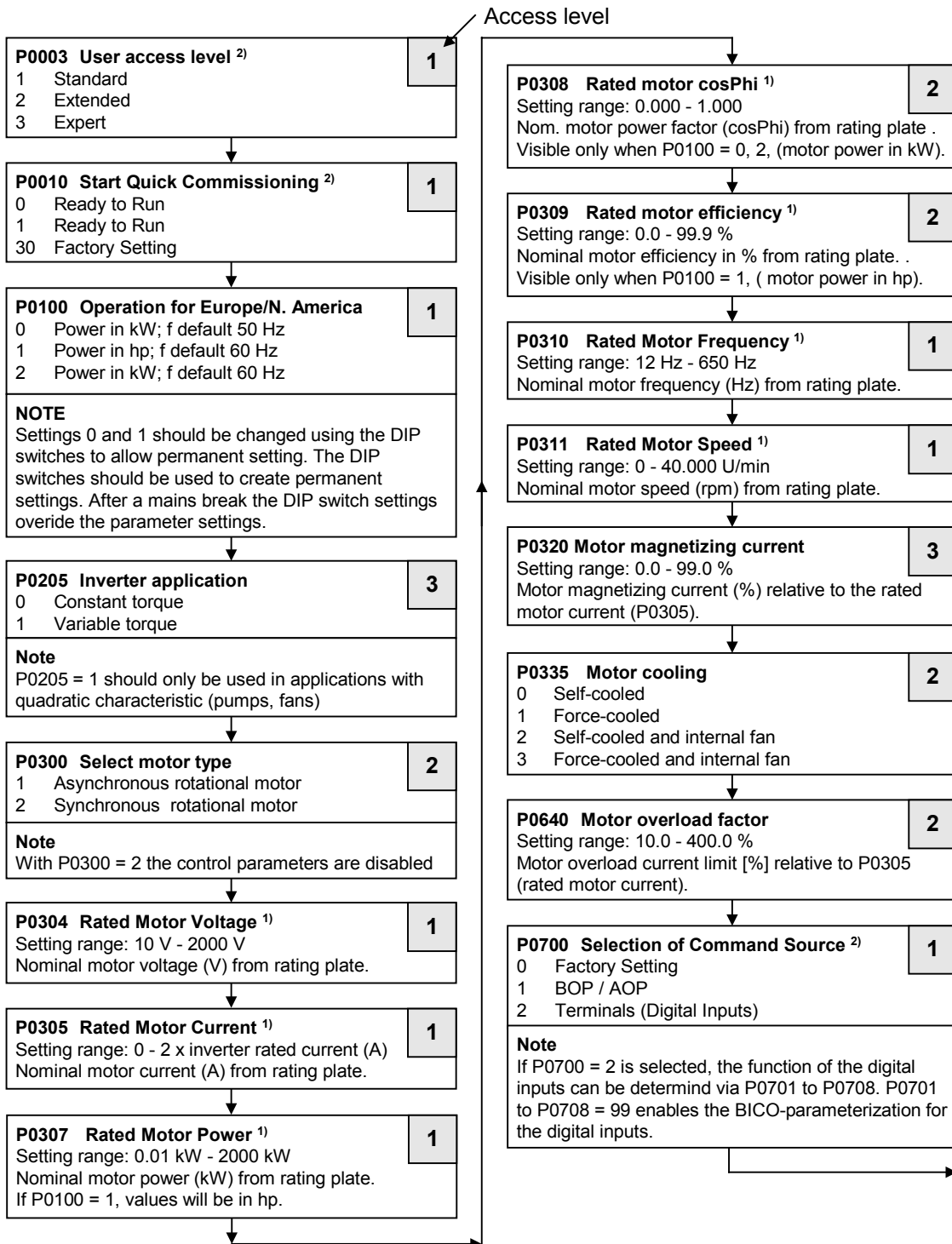

1) Motor-specific parameters – see motor rating plate.

2) The parameters offer more setting options than listed here. See Parameter List for further setting options.

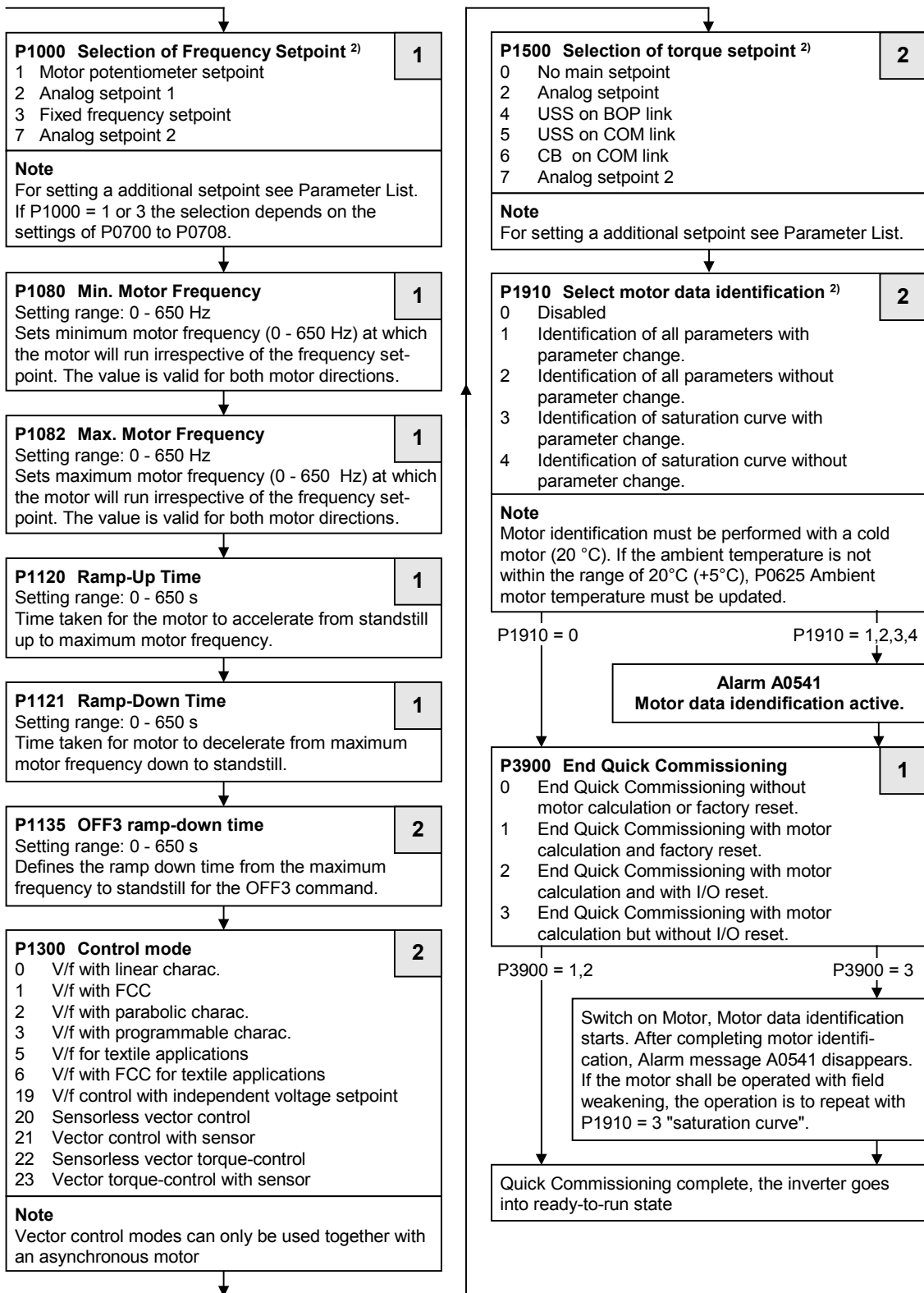

2) The parameters offer more setting options than listed here. See Parameter List for further setting options.

Motor data for parameterization

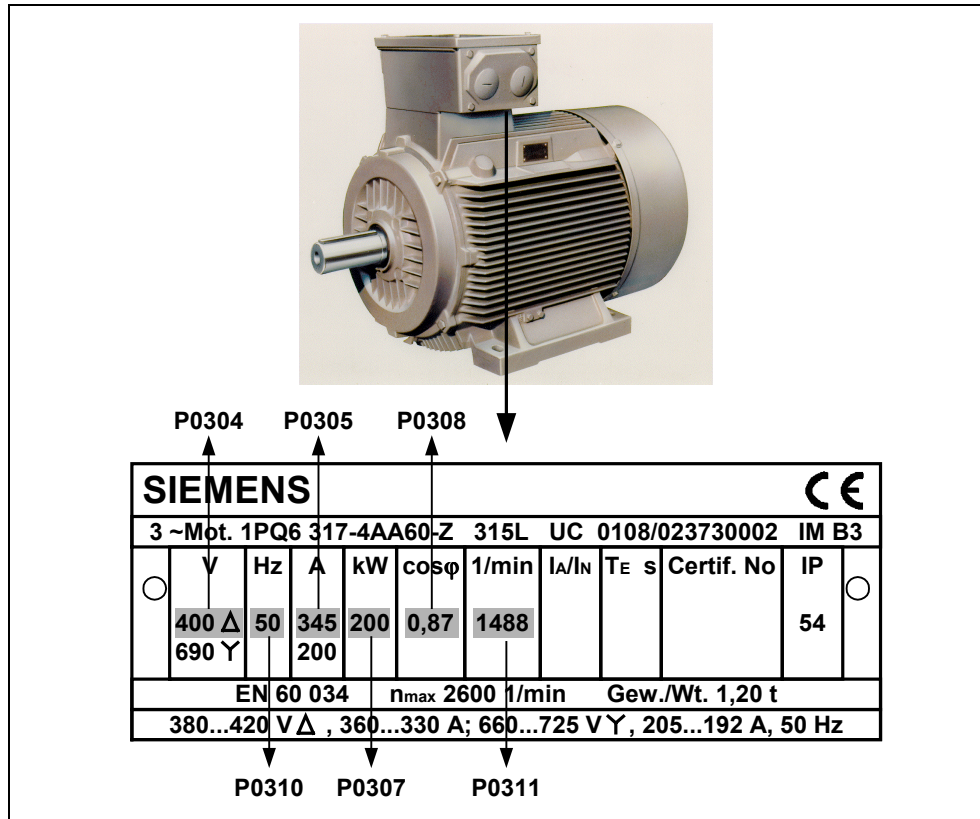

Figure 3-8 Typical Motor Rating Plate Example

NOTICE

- P0308 is only visible if P0003 ≥ 2. Depending on the settings for parameter P0100, only P 0308 or P0309 is displayed.
- P0307 indicates kW or HP depending upon the setting of P0100. For detailed information, please see the Parameter List.
- Changing motor parameters is only possible with P0010 = 1 (factory setting) and P0004 = 0 or 3.
- Ensure that the inverter is configured correctly to the motor.

3.2.4 Reset to Factory default

To reset all parameters to the factory default settings; the following parameters should be set as follows (BOP, AOP or Communication Option needed):

1. Set P0010 = 30
2. Set P0970 = 1

NOTE

The reset process can take up to 3 minutes to complete.

3.3 General operation

For a full description of standard and extended parameters, please refer to the Parameter List.





NOTICE

1. The inverter does not have a main power switch and is live when the mains supply is connected. It waits, with the output disabled, until the RUN button is pressed or for the presence of a digital ON signal at terminal 5 (rotate right).
2. If a BOP or an AOP is fitted and the output frequency is selected to be displayed (P0005 = 21) the corresponding setpoint is displayed approximately every 1.0 seconds while the inverter is stopped.
3. The inverter is programmed at the factory for standard applications on Siemens four-pole standard motors that have the same power rating as the inverters. When using other motors it is necessary to enter the specifications from the motor's rating plate. See Figure 3-8 for details on how to read motor data.
4. Changing motor parameters is not possible unless P0010 = 1.
5. You must set P0010 back to 0 in order to initiate a run.

Basic operation with the BOP/AOP

Prerequisites

- P0010 = 0 (in order to initiate the run command correctly).
 - P0700 = 1 (enables the start/stop button on the BOP).
 - P1000 = 1 (this enables the motor potentiometer setpoints).
-

1. Press the green Button  to start the motor.
2. Press the Button  while the motor is turning. Motor speed increases to 50 Hz.
3. When the inverter reaches 50 Hz, press the Button . Motor speed and display is decreased.
4. Change the direction of rotation with the Button .
5. The red button stops the motor .

External motor thermal overload protection

When operated below rated speed, the cooling effect of fans fitted to the motor shaft is reduced. Consequentially, most motors require de-rating for continuous operation at low frequencies. To ensure that the motors are protected against overheating under these conditions, a PTC temperature sensor must be fitted to the motor and connected to the inverter control terminals.

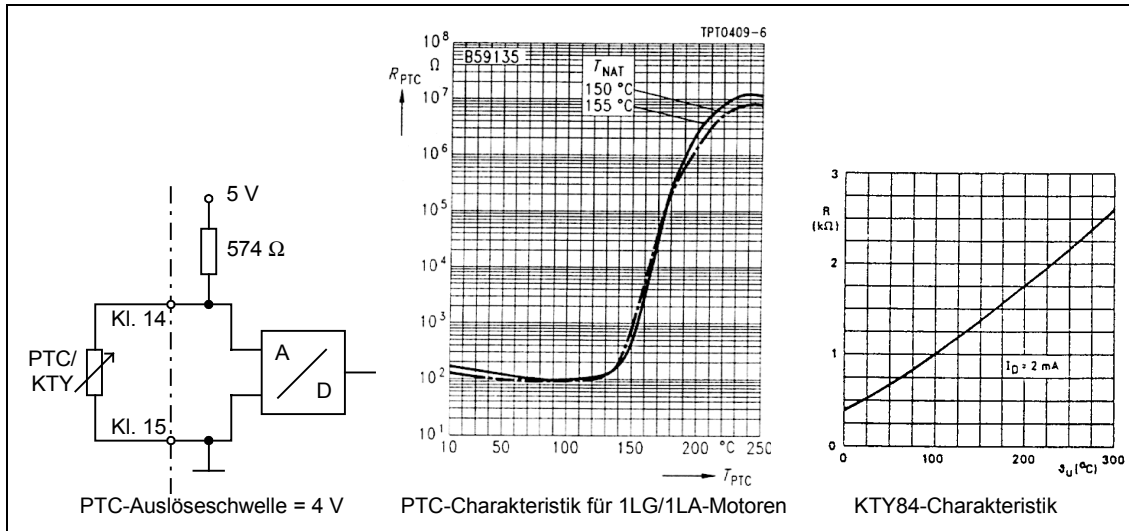

Figure 3-9

With PTC sensor (P0601 = 1)

If the PTC in the motor is connected to the MICROMASTER 440 control terminals 14 (PTCA) and 15 (PTCB) and the PTC function enabled by setting P0601 = 1, then the MICROMASTER 440 will operate as normal providing the resistance at the terminals remains below approximately 1500 Ω. If this value is exceeded, the inverter indicates a warning A0511 and then a fault F0011. The actual resistance value at which this occurs will not be less than 1000 Ω, and not more than 2000 Ω.

With KTY84 sensor (P0601 = 2)

The KTY84 has to be connected so that the diode is forward biased; that is the anode is connected to terminal 14 (PTCA) and the cathode to terminal 15 (PTCB). If the temperature monitoring function is enabled by setting P0601 = 2, the temperature of the sensor (and therefore the motor windings) is written to parameter r0035. The threshold motor temperature can now be set using parameter P0604 (default setting 130 °C).

Connection failure

If the connection to the PTC or KTY84 sensor becomes open circuit or short circuit, a fault will be indicated, and by default the drive will trip.

NOTE

To enable the trip function, set parameter P0701, P0702 or P0703 = 29.

4 Using the MICROMASTER 440

This Chapter contains:

- An explanation of the various methods of controlling the inverter
- A summary of the types of control of the inverter

4.1	Frequency setpoint (P1000).....	60
4.2	Command sources (P0700)	61
4.3	OFF and braking functions	61
4.4	Control modes (P1300)	63
4.5	Extended Functions for the MICROMASTER 440	64
4.6	Faults and warnings	64

**WARNING**

- ◆ When operating electrical devices, it is impossible to avoid applying hazardous voltages to certain parts of the equipment.
- ◆ Emergency Stop facilities according to EN 60204 IEC 204 (VDE 0113) must remain operative in all operating modes of the control equipment. Any disengagement of the Emergency Stop facility must not lead to uncontrolled or undefined restart.
- ◆ Wherever faults occurring in the control equipment can lead to substantial material damage or even grievous bodily injury (i.e. potentially dangerous faults), additional external precautions must be taken or facilities provided to ensure or enforce safe operation, even when a fault occurs (e.g. independent limit switches, mechanical interlocks, etc.).
- ◆ MICROMASTERS operate at high voltages.
- ◆ Certain parameter settings may cause the inverter to restart automatically after an input power failure.
- ◆ Motor parameters must be accurately configured for motor overload protection to operate correctly.
- ◆ This equipment is capable of providing internal motor overload protection in accordance with UL508C section 42. Refer to P0610 and P0335, i²t is ON by default. Motor overload protection can also be provided using an external PTC (disabled by default P0601).
- ◆ This equipment is suitable for use in a circuit capable of delivering not more than 10,000 symmetrical amperes (rms), for a maximum voltage of 230 V / 460 V / 575 V when protected by a H or K type fuse (see *Tables starting on page 105*)
- ◆ This equipment must not be used as an 'emergency stop mechanism' (see *EN 60204, 9.2.5.4*)

4.1 Frequency setpoint (P1000)

- Default: Terminal 3/4 (AIN+/ AIN-, 0...10 V
corresponds to 0...50/60 Hz)
- Other settings: see P1000

NOTES

For USS see Reference Manual, for PROFIBUS see Reference Manual and PROFIBUS Instructions.

4.2 Command sources (P0700)

NOTICE

The ramp times and ramp-smoothing functions also affect how the motor starts and stops. For details of these functions, please refer to parameters P1120, P1121, P1130 – P1134 in the Parameter List.

Starting the motor

- Default: Terminal 5 (DIN 1, high)
- Other settings: see P0700 to P0708

Stopping the motor

There are several ways to stop the motor:

- Default:
 - ◆ OFF1 (4.3.1) Terminal 5 (DIN 1, low)
 - ◆ OFF2 (4.3.2) Off button on BOP/AOP, pressing the Off button once long (two seconds) or twice (with default settings not possible without BOP/AOP)
 - ◆ OFF3 (4.3.3) Not active in the default (factory) setting
- Other settings: see P0700 to P0708

Reversing the motor

- Default: Terminal 6 (DIN 2, high)
- Other settings: see P0700 to P0708

4.3 OFF and braking functions

4.3.1 OFF1

This command (produced by canceling the ON command) causes the inverter to come to a standstill at the selected ramp-down rate.

Parameter to change ramp-down time see P1121

NOTICE

- ON and the following OFF1 command must have the same source.
 - If the ON/OFF1 command is set to more than one digital input, only the last set digital input is valid e.g. DIN3 is active.
 - OFF1 can be combined with DC braking or Compound braking.
-

4.3.2 OFF2

This command causes the motor to coast to a standstill (pulses disabled).

NOTICE

The OFF2 command can have one or more sources. By default the OFF2 command is set to BOP/AOP. This source still exists even if other sources are defined by **one** of the following parameters, P0700 to P0708 inclusive.

4.3.3 OFF3

An OFF3 command causes the motor to decelerate rapidly.

For starting the motor when OFF3 is set, the binary input has to be closed (high). If OFF3 is high, the motor can be started and stopped by OFF1 or OFF2.

If OFF3 is low the motor cannot be started.

➤ Ramp down time: see P1135

NOTICE

OFF3 can be combined with DC braking or Compound braking.

4.3.4 DC braking

DC braking is possible together with OFF1 and OFF3. A DC current is applied to stop the motor quickly and hold the shaft stationary until the end of the braking period.

- Enable DC braking: see P0701 to P0708
- Set DC braking period: see P1233
- Set DC braking current: see P1232
- Set DC braking start frequency: see P1234

NOTICE

If no digital input is set to DC braking and P1233 \neq 0, DC braking will be active after every OFF1 command with the time set in P1233.

4.3.5 Compound Braking

Compound Braking is possible with both OFF1 and OFF3. For Compound Braking a DC component is added to the AC current.

Set the braking current: see P1236

4.3.6 Dynamic braking

Braking with an external resistor (Frame Size A to F using the intrated chopper, framesize FX and FX using and external braking chopper) is a method of braking that allows a smoothed, controlled reduction in motor speed in a linear manner.

4.4 Control modes (P1300)

The various modes of operation of the MICROMASTER 440 control the relationship between the speed of the motor and the voltage supplied by the inverter. A summary of the control modes available are listed below:

- **Linear V/f control,** **P1300 = 0**
Can be used for variable and constant torque applications, such as conveyors and positive displacement pumps.
- **Linear V/f control with FCC (Flux Current Control),** **P1300 = 1**
This control mode can be used to improve the efficiency and dynamic response of the motor.
- **Parabolic V/f control** **P1300 = 2**
This mode can be used for variable torque loads, such as fans and pumps.
- **Multi-point V/f control** **P1300 = 3**
For information regarding this mode of operation, please consult the MM440 Reference Manual.
- **V/f control for textile applications** **P1300 = 5**
There is no slip compensation or resonance damping. The I_{max} controller refers to the voltage instead of frequency.
- **V/f control with FCC for textile applications** **P1300 = 6**
A combination of P1300 = 1 and P1300 = 5.
- **V/f control with independent voltage setpoint** **P1300 = 19**
The voltage setpoint can be given using P1330 independent from the Ramp Function Generator (RFG) output frequency
- **Sensorless Vector Control** **P1300 = 20**
This feature allows the speed of the motor to be controlled with inherent slip compensation. It allows for high torque, improved transient response, excellent speed holding and improved torque at low frequencies. Allows change from vector control to torque control (see P1501).
- **Speed control with Encoder Feedback** **P1300 = 21**
The field orientation control with speed encoder feedback enables :
 - ◆ increased accuracy and improved dynamic response of speed control
 - ◆ improved control characteristics at low speeds
- **Sensorless Vector Torque Control** **P1300 = 22**
This feature allows the inverter to control the torque of a motor. In an application where a constant torque is required, a torque setpoint can be established and the inverter will vary the current delivered to the motor to maintain the required torque.
- **Torque control with Encoder Feedback** **P1300 = 23**
Torque control with encoder feedback enables an increased accuracy and improved dynamic response of torque control.

4.5 Extended Functions for the MICROMASTER 440

Free Function Blocks (P2800 ff)

Using free function blocks, internal signals (Digital inputs, set points, actual values, ...) can be interlinked, to enable application specific control.

Kinetic Buffering (P2800 ff)

Kinetic Buffering provides ride through of power supply faults or interruptions, for as long as the kinetic energy can allow. It also allows for the controlled stop of the drive following a power supply fault.

Positioning Ramp down (P0500 ff)

The positioning ramp down enables the controlled ramp down to a stopping position, for example triggered by an end-switch.

4.6 Faults and warnings

SDP

If an SDP is fitted, the fault states and warnings are indicated by the two LEDs on the panel, see section 6.1 on page 90 for further information.

Fault-free operation of the inverter is indicated by the following sequence of LED displays:

- Green and yellow = Ready to run
- Green = Run

BOP

If a BOP is fitted and a fault occurs, it will be shown on the display. It is possible to view the last 8 fault codes in P0947 and the last 4 warnings in P2110. For further information, please refer to the Parameter List.

AOP

If the AOP is fitted, the fault and warning codes are displayed on the LCD panel.

5 System parameters

This Chapter contains:

- An overview of the parameter structure of the MICROMASTER 440
- A parameter list in short form

5.1	Introduction to MICROMASTER system parameters.....	66
5.2	Parameter overview	67
5.3	Parameter list (short form)	68
5.4	Command and Drive Datasets - Overview.....	84

5.1 Introduction to MICROMASTER system parameters

The parameters can only be changed by using the BOP, the Advance Operator Panel (AOP) or the Serial Interface.

Parameters can be changed and set using the BOP to adjust the desired properties of the inverter, such as ramp times, minimum and maximum frequencies etc. The parameter numbers selected and the setting of the parameter values are indicated on the optional five-digit LCD display.

- rxxxx indicates a display parameter, Pxxxx a setting parameter.
- P0010 initiates “quick commissioning”.
- The inverter will not run unless P0010 is set to 0 after it has been accessed. This function is automatically perform if P3900 > 0.
- P0004 acts as a filter, allowing access to parameters according to their functionality.
- If an attempt is made to change a parameter that cannot be changed in this status, for example, cannot be changed whilst running or can only be changed in quick commissioning, then - - - - - will be displayed.
- **Busy Message**
In some cases - when changing parameter values - the display on the BOP shows buSY for maximum of five seconds. This means the inverter is busy with tasks of higher priority.

5.1.1 Access Levels

There are three access levels available to the user; Standard, Extended and Expert. The level of access is set by parameter P0003. For most applications, Standard (P0003 = 1) or Extended parameters (P0003 = 2) are sufficient.

CAUTION

Some of level 4 parameters are for internal system settings only and should not be modified.

Level 4 parameters should only be modified by authorized personnel.

The number of parameters that appear within each functional group depends on the access level set in parameter P0003. For further details regarding parameters, see the Parameter List on the Documentation CD-ROM.

5.2 Parameter overview

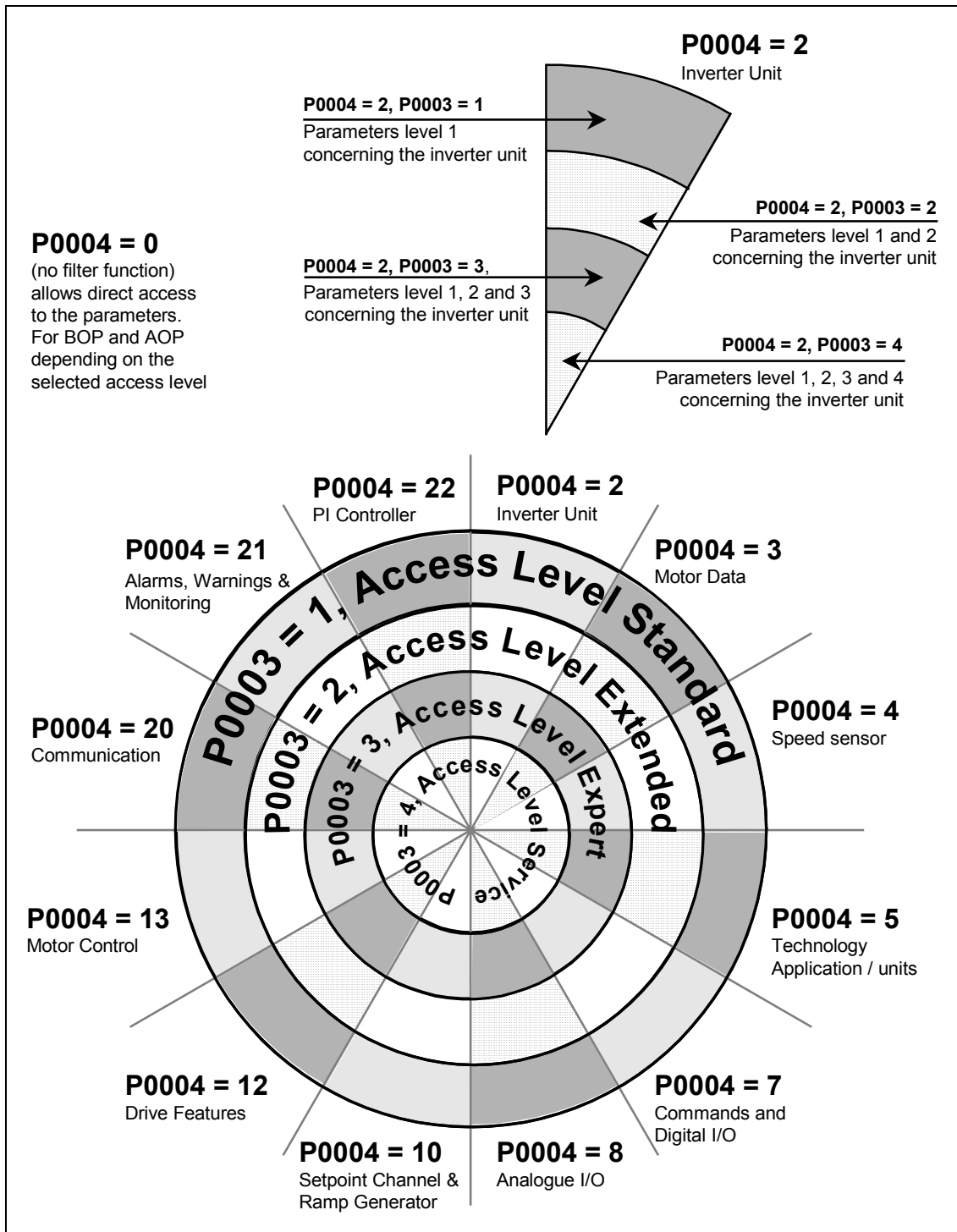

Figure 5-1 Parameter Overview

5.3 Parameter list (short form)

Explanatory information on following table:

- Default: Factory setting
- Level: Access level
- DS Inverter status (Drive State), indicates the inverter state in which a parameter can be modified (see P0010).
 - ◆ C Commissioning
 - ◆ U Run
 - ◆ T Ready to run
- QC Quick Commissioning
 - ◆ Q Parameter can be modified in the Quick Commissioning state.
 - ◆ N Parameter cannot be modified in the Quick Commissioning state.

Always

Par. No.	Parametername	Default	Level	DS	QC
r0000	Drive display	-	1	-	-
P0003	User access level	1	1	CUT	N
P0004	Parameter filter	0	1	CUT	N
P0010	Commissioning parameter	0	1	CT	N
P0014[3]	Store mode	0	3	UT	N
P0199	Equipment system number	0	2	UT	N

Quick Commissioning

Par. No.	Parametername	Default	Level	DS	QC
P0100	Europe / North America	0	1	C	Q
P3900	End of quick commissioning	0	1	C	Q

Parameter Reset

Par.-No.	Parametername	Default	Level	DS	QC
P0970	Factory reset	0	1	C	N

Technological functions

Par.-No.	Parametername	Default	Level	DS	QC
P0500[3]	Technological application	0	3	CT	Q

Inverter Unit (P0004 = 2)

Par. No.	Parametername	Default	Level	DS	QC
r0018	Firmware version	-	1	-	-
r0026[1]	CO: Act. DC-link voltage	-	2	-	-
r0039	CO: Energy consumpt. meter [kWh]	-	2	-	-
P0040	Reset energy consumption meter	0	2	CT	N
r0037[5]	CO: Inverter temperature [°C]	-	3	-	-
r0070	CO: Act. DC-link voltage	-	3	-	-
r0200	Act. power stack code number	-	3	-	-
P0201	Power stack code number	0	3	C	N

Par. No.	Parametername	Default	Level	DS	QC
r0203	Act. inverter type	-	3	-	-
r0204	Power stack features	-	3	-	-
P0205	Inverter application	0	3	C	Q
r0206	Rated inverter power [kW] / [hp]	-	2	-	-
r0207	Rated inverter current	-	2	-	-
r0208	Rated inverter voltage	-	2	-	-
r0209	Maximum inverter current	-	2	-	-
P0210	Supply voltage	230	3	CT	N
r0231[2]	Max. cable length	-	3	-	-
P0290	Inverter overload reaction	2	3	CT	N
P0292	Inverter overload warning	15	3	CUT	N
P1800	Pulse frequency	4	2	CUT	N
r1801	CO: Act. pulse frequency	-	3	-	-
P1802	Modulator mode	0	3	CUT	N
P1820[3]	Reverse output phase sequence	0	2	CT	N
P1911	No. of phase to be identified	3	2	CT	N
r1925	Identified on-state voltage	-	2	-	-
r1926	Ident. gating unit dead time	-	2	-	-

Motor Data (P0004 = 3)

Par. No.	Parametername	Default	Level	DS	QC
r0035[3]	CO: Act. Motor temperature	-	2	-	-
P0300[3]	Select motor type	1	2	C	Q
P0304[3]	Rated motor voltage	230	1	C	Q
P0305[3]	Rated motor current	3.25	1	C	Q
P0307[3]	Rated motor power	0.75	1	C	Q
P0308[3]	Rated motor cosPhi	0.000	2	C	Q
P0309[3]	Rated motor efficiency	0.0	2	C	Q
P0310[3]	Rated motor frequency	50.00	1	C	Q
P0311[3]	Rated motor speed	0	1	C	Q
r0313[3]	Motor pole pairs	-	3	-	-
P0320[3]	Motor magnetizing current	0.0	3	CT	Q
r0330[3]	Rated motor slip	-	3	-	-
r0331[3]	Rated magnetization current	-	3	-	-
r0332[3]	Rated power factor	-	3	-	-
r0333[3]	Rated motor torque	-	3	-	-
P0335[3]	Motor cooling	0	2	CT	Q
P0340[3]	Calculation of motor parameters	0	2	CT	N
P0341[3]	Motor inertia [kg*m^2]	0.00180	3	CUT	N
P0342[3]	Total/motor inertia ratio	1.000	3	CUT	N
P0344[3]	Motor weight	9.4	3	CUT	N
r0345[3]	Motor start-up time	-	3	-	-
P0346[3]	Magnetization time	1.000	3	CUT	N
P0347[3]	Demagnetization time	1.000	3	CUT	N
P0350[3]	Stator resistance (line-to-line)	4.0	2	CUT	N

Par. No.	Parametername	Default	Level	DS	QC
P0352[3]	Cable resistance	0.0	3	CUT	N
r0384[3]	Rotor time constant	-	3	-	-
r0395	CO: Total stator resistance [%]	-	3	-	-
r0396	CO: Act. Rotor resistance	-	3	-	-
P0601[3]	Motor temperature sensor	0	2	CUT	N
P0604[3]	Threshold motor temperature	130.0	2	CUT	N
P0610[3]	Motor I2t temperature reaction	2	3	CT	N
P0625[3]	Ambient motor temperature	20.0	3	CUT	N
P0640[3]	Motor overload factor [%]	150.0	2	CUT	Q
P1910	Select motor data identification	0	2	CT	Q
r1912[3]	Identified stator resistance	-	2	-	-
r1913[3]	Identified rotor time constant	-	2	-	-
r1914[3]	Ident. Total leakage inductance	-	2	-	-
r1915[3]	Ident. Nom. Stator inductance	-	2	-	-
r1916[3]	Identified stator inductance 1	-	2	-	-
r1917[3]	Identified stator inductance 2	-	2	-	-
r1918[3]	Identified stator inductance 3	-	2	-	-
r1919[3]	Identified stator inductance 4	-	2	-	-
r1920[3]	Identified dyn. Leak. Inductance	-	2	-	-
P1960	Speed control optimisation	0	3	CT	Q

Commands and Digital I/O (P0004 = 7)

Par. No.	Parametername	Default	Level	DS	QC
R0002	Drive state	-	2	-	-
r0019	CO/BO: BOP control word	-	3	-	-
r0050	CO: Active command data set	-	2	-	-
r0052	CO/BO: Act. Status word 1	-	2	-	-
r0051[2]	CO: Active drive data set (DDS)	-	2	-	-
r0053	CO/BO: Act. Status word 2	-	2	-	-
r0054	CO/BO: Act. Control word 1	-	3	-	-
r0055	CO/BO: Add. Act. Control word	-	3	-	-
r0403	CO/BO: Encoder status word	-	2	-	-
P0700[3]	Selection of command source	2	1	CT	Q
P0701[3]	Function of digital input 1	1	2	CT	N
P0702[3]	Function of digital input 2	12	2	CT	N
P0703[3]	Function of digital input 3	9	2	CT	N
P0704[3]	Function of digital input 4	15	2	CT	N
P0705[3]	Function of digital input 5	15	2	CT	N
P0706[3]	Function of digital input 6	15	2	CT	N
P0707[3]	Function of digital input 7	0	2	CT	N
P0708[3]	Function of digital input 8	0	2	CT	N
r0720	Number of digital inputs	-	3	-	-
r0722	CO/BO: Binary input values	-	2	-	-
P0719[3]	Selection of cmd. & freq. Setp.	0	3	CT	N
P0724	Debounce time for digital inputs	3	3	CT	N

Par. No.	Parametername	Default	Level	DS	QC
P0725	PNP / NPN digital inputs	1	3	CT	N
r0730	Number of digital outputs	-	3	-	-
P0731[3]	Bl: Function of digital output 1	52:3	2	CUT	N
P0732[3]	Bl: Function of digital output 2	52:7	2	CUT	N
P0733[3]	Bl: Function of digital output 3	0:0	2	CUT	N
r0747	CO/BO: State of digital outputs	-	3	-	-
P0748	Invert digital outputs	0	3	CUT	N
P0800[3]	Bl: Download parameter set 0	0 :0	3	CT	N
P0801[3]	Bl: Download parameter set 1	0 :0	3	CT	N
P0810	Bl: CDS bit 0 (Local / Remote)	0:0	2	CUT	N
P0811	Bl: CDS bit 1	0:0	2	CUT	N
P0809[3]	Copy command data set (CDS)	0	2	CT	N
P0820	Bl: DDS bit 0	0 :0	3	CT	N
P0821	Bl: DDS bit 1	0 :0	3	CT	N
P0819[3]	Copy drive data set (DDS)	0	2	CT	N
P0840[3]	Bl: ON/OFF1	722 :0	3	CT	N
P0842[3]	Bl: ON reverse/OFF1	0 :0	3	CT	N
P0844[3]	Bl: 1. OFF2	1 :0	3	CT	N
P0845[3]	Bl: 2. OFF2	19 :1	3	CT	N
P0848[3]	Bl: 1. OFF3	1 :0	3	CT	N
P0849[3]	Bl: 2. OFF3	1 :0	3	CT	N
P0852[3]	Bl: Pulse enable	1:0	3	CT	N
P1020[3]	Bl: Fixed freq. Selection Bit 0	0 :0	3	CT	N
P1021[3]	Bl: Fixed freq. Selection Bit 1	0 :0	3	CT	N
P1022[3]	Bl: Fixed freq. Selection Bit 2	0 :0	3	CT	N
P1023[3]	Bl: Fixed freq. Selection Bit 3	722 :3	3	CT	N
P1026[3]	Bl: Fixed freq. Selection Bit 4	722 :4	3	CT	N
P1028[3]	Bl: Fixed freq. Selection Bit 5	722 :5	3	CT	N
P1035[3]	Bl: Enable MOP (UP-command)	19 :13	3	CT	N
P1036[3]	Bl: Enable MOP (DOWN-command)	19 :14	3	CT	N
P1055[3]	Bl: Enable JOG right	0 :0	3	CT	N
P1056[3]	Bl: Enable JOG left	0 :0	3	CT	N
P1074[3]	Bl: Disable additional setpoint	0:0	3	CUT	N
P1110[3]	Bl: Inhibit neg. freq. Setpoint	0 :0	3	CT	N
P1113[3]	Bl : Reverse	722 :1	3	CT	N
P1124[3]	Bl: Enable JOG ramp times	0 :0	3	CT	N
P1140[3]	Bl: RFG enable	1 :0	3	CT	N
P1141[3]	Bl: RFG start	1 :0	3	CT	N
P1142[3]	Bl: RFG enable setpoint	1 :0	3	CT	N
P1230[3]	Bl: Enable DC braking	0:0	3	CUT	N
P2103[3]	Bl: 1. Faults acknowledgement	722 :2	3	CT	N
P2104[3]	Bl: 2. Faults acknowledgement	0 :0	3	CT	N
P2106[3]	Bl : External fault	1 :0	3	CT	N
P2220[3]	Bl: Fixed PID setp. Select Bit 0	0 :0	3	CT	N
P2221[3]	Bl: Fixed PID setp. Select Bit 1	0 :0	3	CT	N

Par. No.	Parametername	Default	Level	DS	QC
P2222[3]	Bl: Fixed PID setp. Select Bit 2	0 :0	3	CT	N
P2223[3]	Bl: Fixed PID setp. Select Bit 3	722 :3	3	CT	N
P2226[3]	Bl: Fixed PID setp. Select Bit 4	722 :4	3	CT	N
P2228[3]	Bl: Fixed PID setp. Select Bit 5	722 :5	3	CT	N
P2235[3]	Bl: Enable PID-MOP (UP-cmd)	19 :13	3	CT	N
P2236[3]	Bl: Enable PID-MOP (DOWN-cmd)	19 :14	3	CT	N

Analogue I/O (P0004 = 8)

Par. No.	Parametername	Default	Level	DS	QC
P0295	Inverter fan off delay time	0	3	CUT	N
r0750	Number of ADCs	-	3	-	-
r0752[2]	Act. input of ADC [V] or [mA]	-	2	-	-
P0753[2]	Smooth time ADC	3	3	CUT	N
r0754[2]	Act. ADC value after scaling [%]	-	2	-	-
r0755[2]	CO: Act. ADC after scal. [4000h]	-	2	-	-
P0756[2]	Type of ADC	0	2	CT	N
P0757[2]	Value x1 of ADC scaling [V / mA]	0	2	CUT	N
P0758[2]	Value y1 of ADC scaling	0.0	2	CUT	N
P0759[2]	Value x2 of ADC scaling [V / mA]	10	2	CUT	N
P0760[2]	Value y2 of ADC scaling	100.0	2	CUT	N
P0761[2]	Width of ADC deadband [V / mA]	0	2	CUT	N
P0762[2]	Delay for loss of signal action	10	3	CUT	N
r0770	Number of DACs	-	3	-	-
P0771[2]	Cl: DAC	21:0	2	CUT	N
P0773[2]	Smooth time DAC	2	2	CUT	N
r0774[2]	Act. DAC value [V] or [mA]	-	2	-	-
P0776[2]	Type of DAC	0	2	CT	N
P0777[2]	Value x1 of DAC scaling	0.0	2	CUT	N
P0778[2]	Value y1 of DAC scaling	0	2	CUT	N
P0779[2]	Value x2 of DAC scaling	100.0	2	CUT	N
P0780[2]	Value y2 of DAC scaling	20	2	CUT	N
P0781[2]	Width of DAC deadband	0	2	CUT	N

Setpoint Channel and Ramp Generator (P0004 = 10)

Par. No.	Parametername	Default	Level	DS	QC
P1000[3]	Selection of frequency setpoint	2	1	CT	Q
P1001[3]	Fixed frequency 1	0.00	2	CUT	N
P1002[3]	Fixed frequency 2	5.00	2	CUT	N
P1003[3]	Fixed frequency 3	10.00	2	CUT	N
P1004[3]	Fixed frequency 4	15.00	2	CUT	N
P1005[3]	Fixed frequency 5	20.00	2	CUT	N
P1006[3]	Fixed frequency 6	25.00	2	CUT	N
P1007[3]	Fixed frequency 7	30.00	2	CUT	N
P1008[3]	Fixed frequency 8	35.00	2	CUT	N
P1009[3]	Fixed frequency 9	40.00	2	CUT	N

Par. No.	Parametername	Default	Level	DS	QC
P1010[3]	Fixed frequency 10	45.00	2	CUT	N
P1011[3]	Fixed frequency 11	50.00	2	CUT	N
P1012[3]	Fixed frequency 12	55.00	2	CUT	N
P1013[3]	Fixed frequency 13	60.00	2	CUT	N
P1016	Fixed frequency mode – Bit 0	1	3	CT	N
P1014[3]	Fixed frequency 14	65.00	2	CUT	N
P1017	Fixed frequency mode – Bit 1	1	3	CT	N
P1015[3]	Fixed frequency 15	65.00	2	CUT	N
P1018	Fixed frequency mode – Bit 2	1	3	CT	N
P1019	Fixed frequency mode – Bit 3	1	3	CT	N
r1024	CO: Act. Fixed frequency	-	3	-	-
P1025	Fixed frequency mode – Bit 4	1	3	CT	N
P1027	Fixed frequency mode – Bit 5	1	3	CT	N
P1032	Inhibit reverse direction of MOP	1	2	CT	N
P1031[3]	Setpoint memory of the MOP	0	2	CUT	N
P1040[3]	Setpoint of the MOP	5.00	2	CUT	N
r1050	CO: Act. Output freq. Of the MOP	-	3	-	-
P1058[3]	JOG frequency right	5.00	2	CUT	N
P1059[3]	JOG frequency left	5.00	2	CUT	N
P1060[3]	JOG ramp-up time	10.00	2	CUT	N
P1061[3]	JOG ramp-down time	10.00	2	CUT	N
P1070[3]	CI : Main setpoint	755:0	3	CT	N
P1071[3]	CI : Main setpoint scaling	1:0	3	CT	N
P1075[3]	CI : Additional setpoint	0:0	3	CT	N
r1078	CO: Total frequency setpoint	-	3	-	-
P1076[3]	CI: Additional setpoint scaling	1:0	3	CT	N
r1079	CO: Selected frequency setpoint	-	3	-	-
P1080[3]	Min. frequency	0.00	1	CUT	Q
P1082[3]	Max. frequency	50.00	1	CT	Q
P1091[3]	Skip frequency 1	0.00	3	CUT	N
P1092[3]	Skip frequency 2	0.00	3	CUT	N
P1093[3]	Skip frequency 3	0.00	3	CUT	N
P1094[3]	Skip frequency 4	0.00	3	CUT	N
P1101[3]	Skip frequency bandwidth	2.00	3	CUT	N
r1114	CO: Freq. Setp. After dir. Ctrl.	-	3	-	-
r1119	CO: Freq. Setpoint before RFG	-	3	-	-
P1120[3]	Ramp-up time	10.00	1	CUT	Q
P1121[3]	Ramp-down time	10.00	1	CUT	Q
P1130[3]	Ramp-up initial rounding time	0.00	2	CUT	N
P1131[3]	Ramp-up final rounding time	0.00	2	CUT	N
P1132[3]	Ramp-down initial rounding time	0.00	2	CUT	N
P1133[3]	Ramp-down final rounding time	0.00	2	CUT	N
P1134[3]	Rounding type	0	2	CUT	N
P1135[3]	OFF3 ramp-down time	5.00	2	CUT	Q
r1170	CO: Frequency setpoint after RFG	-	3	-	-

Par. No.	Parametername	Default	Level	DS	QC
P1257[3]	Freq limit for kinetic buffering	2.5	3	CUT	N

Drive Features (P0004 = 12)

Par. No.	Parametername	Default	Level	DS	QC
P0006	Display mode	2	3	CUT	N
P0007	Backlight delay time	0	3	CUT	N
P0005[3]	Display selection	21	2	CUT	N
P0011	Lock for user defined parameter	0	3	CUT	N
P0012	Key for user defined parameter	0	3	CUT	N
P0013[20]	User defined parameter	0	3	CUT	N
P1200	Flying start	0	2	CUT	N
P1202[3]	Motor-current: Flying start	100	3	CUT	N
r1205	Status word: Flying start SLVC	-	3	-	-
P1203[3]	Search rate: Flying start	100	3	CUT	N
P1210	Automatic restart	1	2	CUT	N
P1211	Number of restart attempts	3	3	CUT	N
P1215	Holding brake enable	0	2	T	N
P1216	Holding brake release delay	1.0	2	T	N
P1217	Holding time after ramp down	1.0	2	T	N
P1232[3]	DC braking current	100	2	CUT	N
P1233[3]	Duration of DC braking	0	2	CUT	N
P1234[3]	DC braking start frequency	650.00	2	CUT	N
P1237	Dynamic braking	0	2	CUT	N
P1236[3]	Compound braking current	0	2	CUT	N
r1242	CO: Switch-on level of Vdc-max	-	3	-	-
P1240[3]	Configuration of Vdc controller	1	3	CT	N
P1243[3]	Dynamic factor of Vdc-max	100	3	CUT	N
P1245[3]	Switch on level kin. Buffering	76	3	CUT	N
r1246[3]	CO: Switch-on level kin buffering	-	3	-	-
P1247[3]	Dyn. Factor of kinetic buffering	100	3	CUT	N
P1254	Auto detect Vdc switch-on levels	1	3	CT	N
P1253[3]	Vdc-controller output limitation	10	3	CUT	N
P1256[3]	Reaction of kinetic buffering	0	3	CT	N

Motor Control (P0004 = 13)

Par. No.	Parametername	Default	Level	DS	QC
r0020	CO: Act. frequency setpoint	-	3	-	-
r0021	CO: Act. frequency	-	2	-	-
r0022	Act. rotor speed	-	3	-	-
r0024	CO: Act. output frequency	-	3	-	-
r0025	CO: Act. output voltage	-	2	-	-
r0027	CO: Act. output current	-	2	-	-
r0029	CO: Flux gen. current	-	3	-	-
r0030	CO: Torque gen. current	-	3	-	-
r0031	CO: Act. torque	-	2	-	-

Par. No.	Parametername	Default	Level	DS	QC
r0032	CO: Act. power	-	2	-	-
r0038	CO: Act. power factor	-	3	-	-
r0056	CO/BO: Status of motor control	-	3	-	-
r0061	CO: Act. rotor speed	-	2	-	-
r0062	CO: Freq. setpoint	-	3	-	-
r0063	CO: Act. frequency	-	3	-	-
r0064	CO: Dev. frequency controller	-	3	-	-
r0065	CO: Slip frequency	-	3	-	-
r0066	CO: Act. output frequency	-	3	-	-
r0067	CO: Act. output current limit	-	3	-	-
r0068	CO: Output current	-	3	-	-
r0071	CO: Max. output voltage	-	3	-	-
r0072	CO: Act. output voltage	-	3	-	-
r0075	CO: Current setpoint Isd	-	3	-	-
r0076	CO: Act. current Isd	-	3	-	-
r0077	CO: Current setpoint Isq	-	3	-	-
r0078	CO: Act. current Isq	-	3	-	-
r0079	CO: Torque setpoint (total)	-	3	-	-
r0086	CO: Act. active current	-	3	-	-
r0090	CO: Act. rotor angle	-	2	-	-
P0095[10]	CI: Display PZD signals	0:0	3	CT	N
r0096[10]	PZD signals	-	3	-	-
r1084	Max. frequency setpoint	-	3	-	-
P1300[3]	Control mode	0	2	CT	Q
P1310[3]	Continuous boost	50.0	2	CUT	N
P1311[3]	Acceleration boost	0.0	2	CUT	N
P1312[3]	Starting boost	0.0	2	CUT	N
P1316[3]	Boost end frequency	20.0	3	CUT	N
P1320[3]	Programmable V/f freq. coord. 1	0.00	3	CT	N
P1321[3]	Programmable V/f volt. coord. 1	0.0	3	CUT	N
P1322[3]	Programmable V/f freq. coord. 2	0.00	3	CT	N
P1323[3]	Programmable V/f volt. coord. 2	0.0	3	CUT	N
P1324[3]	Programmable V/f freq. coord. 3	0.00	3	CT	N
P1325[3]	Programmable V/f volt. coord. 3	0.0	3	CUT	N
P1330[3]	CI: Voltage setpoint	0:0	3	T	N
P1333[3]	Start frequency for FCC	10.0	3	CUT	N
r1337	CO: V/f slip frequency	-	3	-	-
P1335[3]	Slip compensation	0.0	2	CUT	N
P1336[3]	Slip limit	250	2	CUT	N
P1338[3]	Resonance damping gain V/f	0.00	3	CUT	N
P1340[3]	Imax controller prop. gain	0.000	3	CUT	N
r1343	CO: Imax controller freq. output	-	3	-	-
P1341[3]	Imax controller integral time	0.300	3	CUT	N
r1344	CO: Imax controller volt. output	-	3	-	-
P1345[3]	Imax controller prop. gain	0.250	3	CUT	N

Par. No.	Parametername	Default	Level	DS	QC
P1346[3]	Imax controller integral time	0.300	3	CUT	N
P1350[3]	Voltage soft start	0	3	CUT	N
P1400[3]	Configuration of speed control	1	3	CUT	N
r1407	CO/BO: Status 2 of motor control	-	3	-	-
r1438	CO: Freq. setpoint to controller	-	3	-	-
P1452[3]	Filter time for act.speed (SLVC)	4	3	CUT	N
P1460[3]	Gain speed controller	3.0	2	CUT	N
P1462[3]	Integral time speed controller	400	2	CUT	N
P1470[3]	Gain speed controller (SLVC)	3.0	2	CUT	N
P1472[3]	Integral time n-ctrl. (SLVC)	400	2	CUT	N
P1477[3]	BI: Set integrator of n-ctrl.	0:0	3	CUT	N
P1478[3]	CI: Set integrator value n-ctrl.	0:0	3	UT	N
r1482	CO: Integral output of n-ctrl.	-	3	-	-
r1490	CO: Droop frequency	-	3	-	-
P1488[3]	Droop input source	0	3	CUT	N
P1489[3]	Droop scaling	0.05	3	CUT	N
P1492[3]	Enable droop	0	3	CUT	N
P1496[3]	Scaling accel. precontrol	0.0	3	CUT	N
P1499[3]	Scaling accel. torque control	100.0	3	CUT	N
P1500[3]	Selection of torque setpoint	0	2	CT	Q
P1501[3]	BI: Change to torque control	0:0	3	CT	N
P1503[3]	CI: Torque setpoint	0:0	3	T	N
r1508	CO: Torque setpoint	-	2	-	-
P1511[3]	CI: Additional torque setpoint	0:0	3	T	N
r1515	CO: Additional torque setpoint	-	2	-	-
r1518	CO: Acceleration torque	-	3	-	-
P1520[3]	CO: Upper torque limit	5.13	2	CUT	N
P1521[3]	CO: Lower torque limit	-5.13	2	CUT	N
P1522[3]	CI: Upper torque limit	1520:0	3	T	N
P1523[3]	CI: Lower torque limit	1521:0	3	T	N
r1526	CO: Upper torque limitation	-	3	-	-
r1527	CO: Lower torque limitation	-	3	-	-
P1525[3]	Scaling lower torque limit	100.0	3	CUT	N
P1530[3]	Motoring power limitation	0.75	2	CUT	N
P1531[3]	Regenerative power limitation	-0.75	2	CUT	N
r1538	CO: Upper torque limit (total)	-	2	-	-
r1539	CO: Lower torque limit (total)	-	2	-	-
P1570[3]	CO: Fixed value flux setpoint	100.0	2	CUT	N
P1574[3]	Dynamic voltage headroom	10	3	CUT	N
P1580[3]	Efficiency optimization	0	2	CUT	N
P1582[3]	Smooth time for flux setpoint	15	3	CUT	N
r1598	CO: Flux setpoint (total)	-	3	-	-
P1596[3]	Int. time field weak. controller	50	3	CUT	N
P1610[3]	Continuous torque boost (SLVC)	50.0	2	CUT	N
P1611[3]	Acc. torque boost (SLVC)	0.0	2	CUT	N

Par. No.	Parametername	Default	Level	DS	QC
P1740	Gain for oscillation damping	0.000	3	CUT	N
r1751	Status word of motor model	-	3	-	-
P1750[3]	Control word of motor model	1	3	CUT	N
P1755[3]	Start-freq. motor model (SLVC)	5.0	3	CUT	N
P1756[3]	Hyst.-freq. motor model (SLVC)	50.0	3	CUT	N
P1758[3]	T(wait) transit to feed-fwd-mode	1500	3	CUT	N
P1759[3]	T(wait) for n-adaption to settle	100	3	CUT	N
P1764[3]	Kp of n-adaption (SLVC)	0.2	3	CUT	N
r1770	CO: Prop. output of n-adaption	-	3	-	-
r1771	CO: Int. output of n-adaption	-	3	-	-
r1782	Output of Rs-adaptation	-	3	-	-
P1780[3]	Control word of Rs/Rr-adaption	3	3	CUT	N
r1787	Output of Xm-adaption	-	3	-	-
P2480[3]	Position mode	1	3	CT	N
P2481[3]	Gearbox ratio input	1.00	3	CT	N
P2482[3]	Gearbox ratio output	1.00	3	CT	N
P2484[3]	No. of shaft turns = 1 Unit	1.0	3	CUT	N
r2489	Act. number of shaft revolutions	-	3	-	-
P2487[3]	Positional error trim value	0.00	3	CUT	N
P2488[3]	No. final shaft turns = 1 Unit	1.0	3	CUT	N

Communication (P0004 = 20)

Par. No.	Parametername	Default	Level	DS	QC
P0918	CB address	3	2	CT	N
P0927	Parameter changeable via	15	2	CUT	N
r0965	Profibus profile	-	3	-	-
r0967	Control word 1	-	3	-	-
r0968	Status word 1	-	3	-	-
r0964[5]	Firmware version data	-	3	-	-
P0971	Transfer data from RAM to EEPROM	0	3	CUT	N
P2000[3]	Reference frequency	50.00	2	CT	N
P2001[3]	Reference voltage	1000	3	CT	N
P2002[3]	Reference current	0.10	3	CT	N
P2003[3]	Reference torque	0.75	3	CT	N
r2004[3]	Reference power	-	3	-	-
P2009[2]	USS normalization	0	3	CT	N
P2010[2]	USS baudrate	6	2	CUT	N
P2011[2]	USS address	0	2	CUT	N
P2012[2]	USS PZD length	2	3	CUT	N
P2013[2]	USS PKW length	127	3	CUT	N
P2014[2]	USS telegram off time	0	3	CT	N
r2015[8]	CO: PZD from BOP link (USS)	-	3	-	-
P2016[8]	CI: PZD to BOP link (USS)	52:0	3	CT	N
r2018[8]	CO: PZD from COM link (USS)	-	3	-	-
r2024[2]	USS error-free telegrams	-	3	-	-

Par. No.	Parametername	Default	Level	DS	QC
P2019[8]	CI: PZD to COM link (USS)	52:0	3	CT	N
r2025[2]	USS rejected telegrams	-	3	-	-
r2026[2]	USS character frame error	-	3	-	-
r2027[2]	USS overrun error	-	3	-	-
r2028[2]	USS parity error	-	3	-	-
r2029[2]	USS start not identified	-	3	-	-
r2030[2]	USS BCC error	-	3	-	-
r2032	BO: CtrlWrd1 from BOP link (USS)	-	3	-	-
r2031[2]	USS length error	-	3	-	-
r2033	BO: CtrlWrd2 from BOP link (USS)	-	3	-	-
r2036	BO: CtrlWrd1 from COM link (USS)	-	3	-	-
r2037	BO: CtrlWrd2 from COM link (USS)	-	3	-	-
P2040	CB telegram off time	20	3	CT	N
P2041[5]	CB parameter	0	3	CT	N
r2050[8]	CO: PZD from CB	-	3	-	-
r2053[5]	CB identification	-	3	-	-
P2051[8]	CI: PZD to CB	52:0	3	CT	N
r2054[7]	CB diagnosis	-	3	-	-
r2090	BO: Control word 1 from CB	-	3	-	-
r2091	BO: Control word 2 from CB	-	3	-	-

Alarms, Warnings and Monitoring (P0004 = 21)

Par. No.	Parametername	Default	Level	DS	QC
r0947[8]	Last fault code	-	2	-	-
r0948[12]	Fault time	-	3	-	-
r0949[8]	Fault value	-	3	-	-
P0952	Total number of faults	0	3	CT	N
P2100[3]	Alarm number selection	0	3	CT	N
P2101[3]	Stop reaction value	0	3	CT	N
r2110[4]	Warning number	-	2	-	-
P2111	Total number of warnings	0	3	CT	N
r2114[2]	Run time counter	-	3	-	-
P2115[3]	AOP real time clock	0	3	CT	N
P2150[3]	Hysteresis frequency f_hys	3.00	3	CUT	N
P2151[3]	CI: Monitoring speed setpoint	0:0	3	CUT	N
P2152[3]	CI: Act. monitoring speed	0:0	3	CUT	N
P2153[3]	Time-constant speed filter	5	2	CUT	N
P2155[3]	Threshold frequency f_1	30.00	3	CUT	N
P2156[3]	Delay time of threshold freq f_1	10	3	CUT	N
P2157[3]	Threshold frequency f_2	30.00	2	CUT	N
P2158[3]	Delay time of threshold freq f_2	10	2	CUT	N
P2159[3]	Threshold frequency f_3	30.00	2	CUT	N
P2160[3]	Delay time of threshold freq f_3	10	2	CUT	N
P2161[3]	Min. threshold for freq. setp.	3.00	2	CUT	N
P2162[3]	Hysteresis freq. for overspeed	20.00	2	CUT	N

Par. No.	Parametername	Default	Level	DS	QC
P2163[3]	Entry freq. for perm. deviation	3.00	2	CUT	N
P2164[3]	Hysteresis frequency deviation	3.00	3	CUT	N
P2165[3]	Delay time permitted deviation	10	2	CUT	N
P2166[3]	Delay time ramp up completed	10	2	CUT	N
P2167[3]	Switch-off frequency f_off	1.00	3	CUT	N
P2168[3]	Delay time T_off	10	3	CUT	N
r2169	CO: Act. filtered frequency	-	2	-	-
P2170[3]	Threshold current I_thresh	100.0	3	CUT	N
P2171[3]	Delay time current	10	3	CUT	N
P2172[3]	Threshold DC-link voltage	800	3	CUT	N
P2173[3]	Delay time DC-link voltage	10	3	CUT	N
P2174[3]	Torque threshold T_thresh	5.13	2	CUT	N
P2176[3]	Delay time for torque threshold	10	2	CUT	N
P2177[3]	Delay time for motor is blocked	10	2	CUT	N
P2178[3]	Delay time for motor pulled out	10	2	CUT	N
P2179	Current limit for no load ident.	3.0	3	CUT	N
P2180	Delay time for no load ident.	2000	3	CUT	N
P2181[3]	Belt failure detection mode	0	2	CT	N
P2182[3]	Belt threshold frequency 1	5.00	3	CUT	N
P2183[3]	Belt threshold frequency 2	30.00	2	CUT	N
P2184[3]	Belt threshold frequency 3	50.00	2	CUT	N
P2185[3]	Upper torque threshold 1	99999.0	2	CUT	N
P2186[3]	Lower torque threshold 1	0.0	2	CUT	N
P2187[3]	Upper torque threshold 2	99999.0	2	CUT	N
P2188[3]	Lower torque threshold 2	0.0	2	CUT	N
P2189[3]	Upper torque threshold 3	99999.0	2	CUT	N
P2190[3]	Lower torque threshold 3	0.0	2	CUT	N
P2192[3]	Time delay for belt failure	10	2	CUT	N
r2197	CO/BO: Monitoring word 1	-	2	-	-
r2198	CO/BO: Monitoring word 2	-	2	-	-

PI Controller (P0004 = 22)

Par. No.	Parametername	Default	Level	DS	QC
P2200[3]	BI: Enable PID controller	0:0	2	CUT	N
P2201[3]	Fixed PID setpoint 1	0.00	2	CUT	N
P2202[3]	Fixed PID setpoint 2	10.00	2	CUT	N
P2203[3]	Fixed PID setpoint 3	20.00	2	CUT	N
P2204[3]	Fixed PID setpoint 4	30.00	2	CUT	N
P2205[3]	Fixed PID setpoint 5	40.00	2	CUT	N
P2206[3]	Fixed PID setpoint 6	50.00	2	CUT	N
P2207[3]	Fixed PID setpoint 7	60.00	2	CUT	N
P2208[3]	Fixed PID setpoint 8	70.00	2	CUT	N
P2209[3]	Fixed PID setpoint 9	80.00	2	CUT	N
P2210[3]	Fixed PID setpoint 10	90.00	2	CUT	N
P2211[3]	Fixed PID setpoint 11	100.00	2	CUT	N

Par. No.	Parametername	Default	Level	DS	QC
P2212[3]	Fixed PID setpoint 12	110.00	2	CUT	N
P2213[3]	Fixed PID setpoint 13	120.00	2	CUT	N
P2214[3]	Fixed PID setpoint 14	130.00	2	CUT	N
P2215[3]	Fixed PID setpoint 15	130.00	2	CUT	N
P2216	Fixed PID setpoint mode - Bit 0	1	3	CT	N
P2217	Fixed PID setpoint mode - Bit 1	1	3	CT	N
P2218	Fixed PID setpoint mode - Bit 2	1	3	CT	N
P2219	Fixed PID setpoint mode - Bit 3	1	3	CT	N
r2224	CO: Act. fixed PID setpoint	-	2	-	-
P2225	Fixed PID setpoint mode - Bit 4	1	3	CT	N
P2227	Fixed PID setpoint mode - Bit 5	1	3	CT	N
P2231[3]	Setpoint memory of PID-MOP	0	2	CUT	N
P2232	Inhibit rev. direct. of PID-MOP	1	2	CT	N
P2240[3]	Setpoint of PID-MOP	10.00	2	CUT	N
r2250	CO: Output setpoint of PID-MOP	-	2	-	-
P2251	PID mode	0	3	CT	N
P2253[3]	CI: PID setpoint	0:0	2	CUT	N
P2254[3]	CI: PID trim source	0:0	3	CUT	N
P2255	PID setpoint gain factor	100.00	3	CUT	N
P2256	PID trim gain factor	100.00	3	CUT	N
P2257	Ramp-up time for PID setpoint	1.00	2	CUT	N
P2258	Ramp-down time for PID setpoint	1.00	2	CUT	N
r2260	CO: PID setpoint after PID-RFG	-	2	-	-
P2261	PID setpoint filter timeconstant	0.00	3	CUT	N
r2262	CO: Filtered PID setp. after RFG	-	3	-	-
P2263	PID controller type	0	3	CT	N
P2264[3]	CI: PID feedback	755:0	2	CUT	N
P2265	PID feedback filter timeconstant	0.00	2	CUT	N
r2266	CO: PID filtered feedback	-	2	-	-
P2267	Max. value for PID feedback	100.00	3	CUT	N
P2268	Min. value for PID feedback	0.00	3	CUT	N
P2269	Gain applied to PID feedback	100.00	3	CUT	N
P2270	PID feedback function selector	0	3	CUT	N
P2271	PID transducer type	0	2	CUT	N
r2272	CO: PID scaled feedback	-	2	-	-
r2273	CO: PID error	-	2	-	-
P2274	PID derivative time	0.000	2	CUT	N
P2280	PID proportional gain	3.000	2	CUT	N
P2285	PID integral time	0.000	2	CUT	N
P2291	PID output upper limit	100.00	2	CUT	N
P2292	PID output lower limit	0.00	2	CUT	N
P2293	Ramp-up /-down time of PID limit	1.00	3	CUT	N
r2294	CO: Act. PID output	-	2	-	-
P2295	Gain applied to PID output	100.00	3	CUT	N
P2350	PID autotune enable	0	2	CUT	N

Par. No.	Parametername	Default	Level	DS	QC
P2354	PID tuning timeout length	240	3	CUT	N
P2355	PID tuning offset	5.00	3	CUT	N
P2800	Enable FFbs	0	3	CUT	N
P2801[17]	Activate FFbs	0	3	CUT	N
P2802[14]	Activate FFbs	0	3	CUT	N
P2810[2]	BI: AND 1	0:0	3	CUT	N
r2811	BO: AND 1	-	3	-	-
P2812[2]	BI: AND 2	0:0	3	CUT	N
r2813	BO: AND 2	-	3	-	-
P2814[2]	BI: AND 3	0:0	3	CUT	N
r2815	BO: AND 3	-	3	-	-
P2816[2]	BI: OR 1	0:0	3	CUT	N
r2817	BO: OR 1	-	3	-	-
P2818[2]	BI: OR 2	0:0	3	CUT	N
r2819	BO: OR 2	-	3	-	-
P2820[2]	BI: OR 3	0:0	3	CUT	N
r2821	BO: OR 3	-	3	-	-
P2822[2]	BI: XOR 1	0:0	3	CUT	N
r2823	BO: XOR 1	-	3	-	-
P2824[2]	BI: XOR 2	0:0	3	CUT	N
r2825	BO: XOR 2	-	3	-	-
P2826[2]	BI: XOR 3	0:0	3	CUT	N
r2827	BO: XOR 3	-	3	-	-
P2828	BI: NOT 1	0:0	3	CUT	N
r2829	BO: NOT 1	-	3	-	-
P2830	BI: NOT 2	0:0	3	CUT	N
r2831	BO: NOT 2	-	3	-	-
P2832	BI: NOT 3	0:0	3	CUT	N
r2833	BO: NOT 3	-	3	-	-
P2834[4]	BI: D-FF 1	0:0	3	CUT	N
r2835	BO: Q D-FF 1	-	3	-	-
r2836	BO: NOT-Q D-FF 1	-	3	-	-
P2837[4]	BI: D-FF 2	0:0	3	CUT	N
r2838	BO: Q D-FF 2	-	3	-	-
r2839	BO: NOT-Q D-FF 2	-	3	-	-
P2840[2]	BI: RS-FF 1	0:0	3	CUT	N
r2841	BO: Q RS-FF 1	-	3	-	-
r2842	BO: NOT-Q RS-FF 1	-	3	-	-
P2843[2]	BI: RS-FF 2	0:0	3	CUT	N
r2844	BO: Q RS-FF 2	-	3	-	-
r2845	BO: NOT-Q RS-FF 2	-	3	-	-
P2846[2]	BI: RS-FF 3	0:0	3	CUT	N
r2847	BO: Q RS-FF 3	-	3	-	-
r2848	BO: NOT-Q RS-FF 3	-	3	-	-
P2849	BI: Timer 1	0:0	3	CUT	N

Par. No.	Parametername	Default	Level	DS	QC
P2850	Delay time of timer 1	0	3	CUT	N
P2851	Mode timer 1	0	3	CUT	N
r2852	BO: Timer 1	-	3	-	-
r2853	BO: Nout timer 1	-	3	-	-
P2854	BI: Timer 2	0:0	3	CUT	N
P2855	Delay time of timer 2	0	3	CUT	N
P2856	Mode timer 2	0	3	CUT	N
r2857	BO: Timer 2	-	3	-	-
r2858	BO: Nout timer 2	-	3	-	-
P2859	BI: Timer 3	0:0	3	CUT	N
P2860	Delay time of timer 3	0	3	CUT	N
P2861	Mode timer 3	0	3	CUT	N
r2862	BO: Timer 3	-	3	-	-
r2863	BO: Nout timer 3	-	3	-	-
P2864	BI: Timer 4	0:0	3	CUT	N
P2865	Delay time of timer 4	0	3	CUT	N
P2866	Mode timer 4	0	3	CUT	N
r2867	BO: Timer 4	-	3	-	-
r2868	BO: Nout timer 4	-	3	-	-
P2869[2]	CI: ADD 1	755:0	3	CUT	N
r2870	CO: ADD 1	-	3	-	-
P2871[2]	CI: ADD 2	755:0	3	CUT	N
r2872	CO: ADD 2	-	3	-	-
P2873[2]	CI: SUB 1	755:0	3	CUT	N
r2874	CO: SUB 1	-	3	-	-
P2875[2]	CI: SUB 2	755:0	3	CUT	N
r2876	CO: SUB 2	-	3	-	-
P2877[2]	CI: MUL 1	755:0	3	CUT	N
r2878	CO: MUL 1	-	3	-	-
P2879[2]	CI: MUL 2	755:0	3	CUT	N
r2880	CO: MUL 2	-	3	-	-
P2881[2]	CI: DIV 1	755:0	3	CUT	N
r2882	CO: DIV 1	-	3	-	-
P2883[2]	CI: DIV 2	755:0	3	CUT	N
r2884	CO: DIV 2	-	3	-	-
P2885[2]	CI: CMP 1	755:0	3	CUT	N
r2886	BO: CMP 1	-	3	-	-
P2887[2]	CI: CMP 2	755:0	3	CUT	N
r2888	BO: CMP 2	-	3	-	-
P2889	CO: Fixed setpoint 1 in [%]	0	3	CUT	N
P2890	CO: Fixed setpoint 2 in [%]	0	3	CUT	N

Encoder

Par. No.	Parametername	Default	Level	DS	QC
P0400[3]	Select encoder type	0	2	CT	N
P0408[3]	Encoder pulses per revolution	1024	2	CT	N
P0491[3]	Reaction on speed signal loss	0	2	CT	N
P0492[3]	Allowed speed difference	10.00	2	CT	N
P0494[3]	Delay speed loss reaction	10	2	CUT	N

5.4 Command and Drive Datasets - Overview

Command Datasets (CDS)

ParNr	Parameter name
P0700[3]	Selection of command source
P0701[3]	Function of digital input 1
P0702[3]	Function of digital input 2
P0703[3]	Function of digital input 3
P0704[3]	Function of digital input 4
P0705[3]	Function of digital input 5
P0706[3]	Function of digital input 6
P0707[3]	Function of digital input 7
P0708[3]	Function of digital input 8
P0719[3]	Selection of cmd. & freq. setp.
P0731[3]	BI: Function of digital output 1
P0732[3]	BI: Function of digital output 2
P0733[3]	BI: Function of digital output 3
P0800[3]	BI: Download parameter set 0
P0801[3]	BI: Download parameter set 1
P0840[3]	BI: ON/OFF1
P0842[3]	BI: ON reverse/OFF1
P0844[3]	BI: 1. OFF2
P0845[3]	BI: 2. OFF2
P0848[3]	BI: 1. OFF3
P0849[3]	BI: 2. OFF3
P0852[3]	BI: Pulse enable
P1000[3]	Selection of frequency setpoint
P1020[3]	BI: Fixed freq. selection Bit 0
P1021[3]	BI: Fixed freq. selection Bit 1
P1022[3]	BI: Fixed freq. selection Bit 2
P1023[3]	BI: Fixed freq. selection Bit 3
P1026[3]	BI: Fixed freq. selection Bit 4
P1028[3]	BI: Fixed freq. selection Bit 5
P1035[3]	BI: Enable MOP (UP-command)
P1036[3]	BI: Enable MOP (DOWN-command)
P1055[3]	BI: Enable JOG right
P1056[3]	BI: Enable JOG left
P1070[3]	CI: Main setpoint
P1071[3]	CI: Main setpoint scaling
P1074[3]	BI: Disable additional setpoint
P1075[3]	CI: Additional setpoint
P1076[3]	CI: Additional setpoint scaling
P1110[3]	BI: Inhibit neg. freq. setpoint
P1113[3]	BI: Reverse
P1124[3]	BI: Enable JOG ramp times

ParNr	Parameter name
P1140[3]	BI: RFG enable
P1141[3]	BI: RFG start
P1142[3]	BI: RFG enable setpoint
P1230[3]	BI: Enable DC braking
P1330[3]	CI: Voltage setpoint
P1477[3]	BI: Set integrator of n-ctrl.
P1478[3]	CI: Set integrator value n-ctrl.
P1500[3]	Selection of torque setpoint
P1501[3]	BI: Change to torque control
P1503[3]	CI: Torque setpoint
P1511[3]	CI: Additional torque setpoint
P1522[3]	CI: Upper torque limit
P1523[3]	CI: Lower torque limit
P2103[3]	BI: 1. Faults acknowledgement
P2104[3]	BI: 2. Faults acknowledgement
P2106[3]	BI: External fault
P2151[3]	CI: Monitoring speed setpoint
P2152[3]	CI: Act. monitoring speed
P2200[3]	BI: Enable PID controller
P2220[3]	BI: Fixed PID setp. select Bit 0
P2221[3]	BI: Fixed PID setp. select Bit 1
P2222[3]	BI: Fixed PID setp. select Bit 2
P2223[3]	BI: Fixed PID setp. select Bit 3
P2226[3]	BI: Fixed PID setp. select Bit 4
P2228[3]	BI: Fixed PID setp. select Bit 5
P2235[3]	BI: Enable PID-MOP (UP-cmd)
P2236[3]	BI: Enable PID-MOP (DOWN-cmd)
P2253[3]	CI: PID setpoint
P2254[3]	CI: PID trim source
P2264[3]	CI: PID feedback

Drive Datasets (DDS)

Number	Parameter name
P0005[3]	Display selection
r0035[3]	CO: Act. motor temperature
P0291[3]	Inverter protection
P0300[3]	Select motor type
P0304[3]	Rated motor voltage
P0305[3]	Rated motor current
P0307[3]	Rated motor power
P0308[3]	Rated motor cosPhi
P0309[3]	Rated motor efficiency
P0310[3]	Rated motor frequency
P0311[3]	Rated motor speed
r0313[3]	Motor pole pairs
P0314[3]	Motor pole pair number
P0320[3]	Motor magnetizing current
r0330[3]	Rated motor slip
r0331[3]	Rated magnetization current
r0332[3]	Rated power factor
r0333[3]	Rated motor torque
P0335[3]	Motor cooling
P0340[3]	Calculation of motor parameters
P0341[3]	Motor inertia [kg*m ²]
P0342[3]	Total/motor inertia ratio
P0344[3]	Motor weight
r0345[3]	Motor start-up time
P0346[3]	Magnetization time
P0347[3]	Demagnetization time
P0350[3]	Stator resistance (line-to-line)
P0352[3]	Cable resistance
P0354[3]	Rotor resistance
P0356[3]	Stator leakage inductance
P0358[3]	Rotor leakage inductance
P0360[3]	Main inductance
P0362[3]	Magnetizing curve flux 1
P0363[3]	Magnetizing curve flux 2
P0364[3]	Magnetizing curve flux 3
P0365[3]	Magnetizing curve flux 4
P0366[3]	Magnetizing curve imag 1
P0367[3]	Magnetizing curve imag 2
P0368[3]	Magnetizing curve imag 3
P0369[3]	Magnetizing curve imag 4
r0370[3]	Stator resistance [%]
r0372[3]	Cable resistance [%]
r0373[3]	Rated stator resistance [%]

Number	Parameter name
r0374[3]	Rotor resistance [%]
r0376[3]	Rated rotor resistance [%]
r0377[3]	Total leakage reactance [%]
r0382[3]	Main reactance [%]
r0384[3]	Rotor time constant
r0386[3]	Total leakage time constant
P0400[3]	Select encoder type
P0408[3]	Encoder pulses per revolution
P0491[3]	Reaction on speed signal loss
P0492[3]	Allowed speed difference
P0494[3]	Delay speed loss reaction
P0500[3]	Technological application
P0530[3]	Unit for positioning signal
P0531[3]	Unit conversion
P0601[3]	Motor temperature sensor
P0604[3]	Threshold motor temperature
P0625[3]	Ambient motor temperature
P0626[3]	Overtemperature stator iron
P0627[3]	Overtemperature stator winding
P0628[3]	Overtemperature rotor winding
r0630[3]	CO: Ambient temperature
r0631[3]	CO: Stator iron temperature
r0632[3]	CO: Stator winding temperature
r0633[3]	CO: Rotor winding temperature
P0640[3]	Motor overload factor [%]
P1001[3]	Fixed frequency 1
P1002[3]	Fixed frequency 2
P1003[3]	Fixed frequency 3
P1004[3]	Fixed frequency 4
P1005[3]	Fixed frequency 5
P1006[3]	Fixed frequency 6
P1007[3]	Fixed frequency 7
P1008[3]	Fixed frequency 8
P1009[3]	Fixed frequency 9
P1010[3]	Fixed frequency 10
P1011[3]	Fixed frequency 11
P1012[3]	Fixed frequency 12
P1013[3]	Fixed frequency 13
P1014[3]	Fixed frequency 14
P1015[3]	Fixed frequency 15
P1031[3]	Setpoint memory of the MOP
P1040[3]	Setpoint of the MOP
P1058[3]	JOG frequency right

Number	Parameter name
P1059[3]	JOG frequency left
P1060[3]	JOG ramp-up time
P1061[3]	JOG ramp-down time
P1080[3]	Min. frequency
P1082[3]	Max. frequency
P1091[3]	Skip frequency 1
P1092[3]	Skip frequency 2
P1093[3]	Skip frequency 3
P1094[3]	Skip frequency 4
P1101[3]	Skip frequency bandwidth
P1120[3]	Ramp-up time
P1121[3]	Ramp-down time
P1130[3]	Ramp-up initial rounding time
P1131[3]	Ramp-up final rounding time
P1132[3]	Ramp-down initial rounding time
P1133[3]	Ramp-down final rounding time
P1134[3]	Rounding type
P1135[3]	OFF3 ramp-down time
P1202[3]	Motor-current: Flying start
P1203[3]	Search rate: Flying start
P1232[3]	DC braking current
P1233[3]	Duration of DC braking
P1234[3]	DC braking start frequency
P1236[3]	Compound braking current
P1240[3]	Configuration of Vdc controller
P1243[3]	Dynamic factor of Vdc-max
P1245[3]	Switch on level kin. buffering
r1246[3]	CO:Switch-on level kin buffering
P1247[3]	Dyn. factor of kinetic buffering
P1250[3]	Gain of Vdc-controller
P1251[3]	Integration time Vdc-controller
P1252[3]	Differential time Vdc-controller
P1253[3]	Vdc-controller output limitation
P1256[3]	Reaction of kinetic buffering
P1257[3]	Freq limit for kinetic buffering
P1300[3]	Control mode
P1310[3]	Continuous boost
P1311[3]	Acceleration boost
P1312[3]	Starting boost
P1316[3]	Boost end frequency
P1320[3]	Programmable V/f freq. coord. 1
P1321[3]	Programmable V/f volt. coord. 1
P1322[3]	Programmable V/f freq. coord. 2
P1323[3]	Programmable V/f volt. coord. 2
P1324[3]	Programmable V/f freq. coord. 3

Number	Parameter name
P1325[3]	Programmable V/f volt. coord. 3
P1333[3]	Start frequency for FCC
P1335[3]	Slip compensation
P1336[3]	Slip limit
P1338[3]	Resonance damping gain V/f
P1340[3]	Imax controller prop. gain
P1341[3]	Imax controller integral time
P1345[3]	Imax controller prop. gain
P1346[3]	Imax controller integral time
P1350[3]	Voltage soft start
P1400[3]	Configuration of speed control
P1442[3]	Filter time for act. speed
P1452[3]	Filter time for act.speed (SLVC)
P1460[3]	Gain speed controller
P1462[3]	Integral time speed controller
P1470[3]	Gain speed controller (SLVC)
P1472[3]	Integral time n-ctrl. (SLVC)
P1488[3]	Droop input source
P1489[3]	Droop scaling
P1492[3]	Enable droop
P1496[3]	Scaling accel. precontrol
P1499[3]	Scaling accel. torque control
P1520[3]	CO: Upper torque limit
P1521[3]	CO: Lower torque limit
P1525[3]	Scaling lower torque limit
P1530[3]	Motoring power limitation
P1531[3]	Regenerative power limitation
P1570[3]	CO: Fixed value flux setpoint
P1574[3]	Dynamic voltage headroom
P1580[3]	Efficiency optimization
P1582[3]	Smooth time for flux setpoint
P1596[3]	Int. time field weak. controller
P1610[3]	Continuous torque boost (SLVC)
P1611[3]	Acc. torque boost (SLVC)
P1654[3]	Smooth time for Isq setpoint
P1715[3]	Gain current controller
P1717[3]	Integral time current controller
P1750[3]	Control word of motor model
P1755[3]	Start-freq. motor model (SLVC)
P1756[3]	Hyst.-freq. motor model (SLVC)
P1758[3]	T(wait) transit to feed-fwd-mode
P1759[3]	T(wait) for n-adaption to settle
P1764[3]	Kp of n-adaption (SLVC)
P1767[3]	Tn of n-adaption (SLVC)
P1780[3]	Control word of Rs/Rr-adaption

Number	Parameter name
P1781[3]	Tn of Rs-adaption
P1786[3]	Tn of Xm-adaption
P1803[3]	Max. modulation
P1820[3]	Reverse output phase sequence
P1909[3]	Ctrl. word of motor data ident.
P2000[3]	Reference frequency
P2001[3]	Reference voltage
P2002[3]	Reference current
P2003[3]	Reference torque
r2004[3]	Reference power
P2150[3]	Hysteresis frequency f_hys
P2153[3]	Time-constant speed filter
P2155[3]	Threshold frequency f_1
P2156[3]	Delay time of threshold freq f_1
P2157[3]	Threshold frequency f_2
P2158[3]	Delay time of threshold freq f_2
P2159[3]	Threshold frequency f_3
P2160[3]	Delay time of threshold freq f_3
P2161[3]	Min. threshold for freq. setp.
P2162[3]	Hysteresis freq. for overspeed
P2163[3]	Entry freq. for perm. deviation
P2164[3]	Hysteresis frequency deviation
P2165[3]	Delay time permitted deviation
P2166[3]	Delay time ramp up completed
P2167[3]	Switch-off frequency f_off
P2168[3]	Delay time T_off
P2170[3]	Threshold current I_thresh
P2171[3]	Delay time current
P2172[3]	Threshold DC-link voltage
P2173[3]	Delay time DC-link voltage
P2174[3]	Torque threshold M_thresh
P2176[3]	Delay time for torque threshold
P2177[3]	Delay time for motor is blocked
P2178[3]	Delay time for motor pulled out
P2181[3]	Belt failure detection mode
P2182[3]	Belt threshold frequency 1
P2183[3]	Belt threshold frequency 2
P2184[3]	Belt threshold frequency 3
P2185[3]	Upper torque threshold 1
P2186[3]	Lower torque threshold 1
P2187[3]	Upper torque threshold 2
P2188[3]	Lower torque threshold 2
P2189[3]	Upper torque threshold 3
P2190[3]	Lower torque threshold 3
P2192[3]	Time delay for belt failure

Number	Parameter name
P2201[3]	Fixed PID setpoint 1
P2202[3]	Fixed PID setpoint 2
P2203[3]	Fixed PID setpoint 3
P2204[3]	Fixed PID setpoint 4
P2205[3]	Fixed PID setpoint 5
P2206[3]	Fixed PID setpoint 6
P2207[3]	Fixed PID setpoint 7
P2208[3]	Fixed PID setpoint 8
P2209[3]	Fixed PID setpoint 9
P2210[3]	Fixed PID setpoint 10
P2211[3]	Fixed PID setpoint 11
P2212[3]	Fixed PID setpoint 12
P2213[3]	Fixed PID setpoint 13
P2214[3]	Fixed PID setpoint 14
P2215[3]	Fixed PID setpoint 15
P2231[3]	Setpoint memory of PID-MOP
P2240[3]	Setpoint of PID-MOP
P2480[3]	Position mode
P2481[3]	Gearbox ratio input
P2482[3]	Gearbox ratio output
P2484[3]	No. of shaft turns = 1 Unit
P2487[3]	Positional error trim value
P2488[3]	Distance / No. of revolutions

6 Troubleshooting

This Chapter contains:

- An overview of the operating statuses of the inverter with the SDP
- Notes on troubleshooting with the BOP
- A list of the alarms and fault messages

6.1	Troubleshooting with the SDP.....	90
6.2	Troubleshooting with the BOP	91
6.3	Fault messages	92
6.4	Alarm messages.....	97

**WARNING**

- ◆ Repairs on equipment may only be carried out by **Siemens Service**, by repair centers **authorized by Siemens** or by qualified personnel who are thoroughly acquainted with all the warnings and operating procedures contained in this manual.
- ◆ Any defective parts or components must be replaced using parts contained in the relevant spare parts list.
- ◆ Disconnect the power supply before opening the equipment for access

6.1 Troubleshooting with the SDP

Table 6-1 explains the meaning of the various states of the LEDs on the SDP.

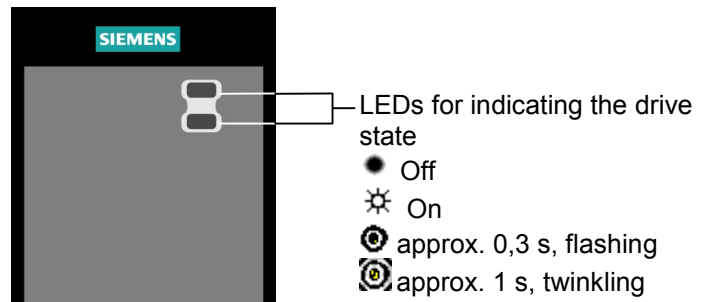

Table 6-1 Inverter conditions indicated by the LEDs on the SDP

●	Mains not present	☀	Fault inverter temperature
☀	Ready to run	☀ (flashing)	Warning current limit - both LEDs twinkling same time
●	Inverter fault - other than the ones listed below	☀ (twinkling)	Other warnings - both LEDs twinkling alternatively
☀	Inverter running	☀ (twinkling)	Undervoltage trip / undervoltage warning
●	Fault overcurrent	☀ (flashing)	Drive is not in ready state
☀ (flashing)	Fault overvoltage	☀ (flashing)	ROM failure - Both LEDs flashing same time
☀ (twinkling)	Fault motor overtemperature	☀ (flashing)	RAM failure - Both LEDs flashing alternatively

6.2 Troubleshooting with the BOP

Warnings and faults are displayed on the BOP with Axxx and Fxxx respectively. The individual messages are shown in Section 6.3.

If the motor fails to start when the ON command has been given:

- Check that P0010 = 0.
- Check that a valid ON signal is present.
- Check that P0700 = 2 (for digital input control) or P0700 = 1 (for BOP control).
- Check that the setpoint is present (0 to 10V on Terminal 3) or the setpoint has been entered into the correct parameter, depending upon the setpoint source (P1000). See the Parameter List for further details.

If the motor fails to run after changing the parameters, set P0010 = 30 then P0970 = 1 and press **P** to reset the inverter to the factory default parameter values.

Now use a switch between terminals **5** and **9** (Figure 3-5). The drive should now run to the defined setpoint by analogue input.

NOTICE

Motor data must relate to the inverter data power range and voltage.

6.3 Fault messages

In the event of a failure, the inverter switches off and a fault code appears on the display.

NOTE

To reset the fault code, one of three methods listed below can be used:

1. Cycle the power to the drive.
2. Press the  button on the BOP or AOP.
3. Via Digital Input 3 (default setting)

Fault	Possible Causes	Diagnose & Remedy	Reaction
F0001 OverCurrent	<ul style="list-style-type: none"> ➤ Motor power (P0307) does not correspond to the inverter power (r0206) ➤ Motor lead short circuit ➤ Earth faults 	Check the following: <ol style="list-style-type: none"> 1. Motor power (P0307) must correspond to inverter power (r0206). 2. Cable length limits must not be exceeded. 3. Motor cable and motor must have no short-circuits or earth faults 4. Motor parameters must match the motor in use 5. Value of stator resistance (P0350) must be correct 6. Motor must not be obstructed or overloaded <ul style="list-style-type: none"> ➤ Increase the ramp time ➤ Reduce the boost level 	OFF2
F0002 OverVoltage	<ul style="list-style-type: none"> ➤ DC-link voltage (r0026) exceeds trip level (P2172) ➤ Overvoltage can be caused either by too high main supply voltage or if motor is in regenerative mode. ➤ Regenerative mode can be cause by fast ramp downs or if the motor is driven from an active load. 	Check the following: <ol style="list-style-type: none"> 1. Supply voltage (P0210) must lie within limits indicated on rating plate . 2. DC-link voltage controller must be enabled (P1240) and parameterized properly. 3. Ramp-down time (P1121) must match inertia of load. 4. Required braking power must lie within specified limits. <p>NOTE Higher inertia requires longer ramp times; otherwise, apply braking resistor.</p>	OFF2
F0003 UnderVoltage	<ul style="list-style-type: none"> ➤ Main supply failed. ➤ Shock load outside specified limits. 	Check the following: <ol style="list-style-type: none"> 1. Supply voltage (P0210) must lie within limits indicated on rating plate. 2. Supply must not be susceptible to temporary failures or voltage reductions. 	OFF2
F0004 Inverter Over Temperature	<ul style="list-style-type: none"> ➤ Ventilation inadequate ➤ Ambient temperature is too high. 	Check the following: <ul style="list-style-type: none"> ➤ Fan must turn when inverter is running ➤ Pulse frequency must be set to default value ➤ Ambient temperature could be higher than specified for the inverter <p>P949 = 1: Rectifier overtemperature P949 = 2: Ambient overtemperature P949 = 3: EBOX overtemperature</p>	OFF2
F0005 Inverter I2T	<ul style="list-style-type: none"> ➤ Inverter overloaded. ➤ Duty cycle too demanding. ➤ Motor power (P0307) exceeds inverter power capability (r0206). 	Check the following: <ol style="list-style-type: none"> 1. Load duty cycle must lie within specified limits. 2. Motor power (P0307) must match inverter power (r0206) 	OFF2

Fault	Possible Causes	Diagnose & Remedy	Reaction
F0011 Motor Over Temperature	Motor overloaded	Check the following: 1. Load duty cycle must be correct 2. Motor nominal overtemperatures (P0626-P0628) must be correct 3. Motor temperature warning level (P0604) must match	OFF1
F0012 Inverter temp. signal lost	Wire breakage of inverter temperature (heatsink) sensor		OFF2
F0015 Motor temperature signal lost	Open or short circuit of motor temperature sensor. If signal loss is detected, temperature monitoring switches over to monitoring with the motor thermal model.		OFF2
F0020 Mains Phase Missing	Fault occurs if one of the three input phases are missed and the pulses are enabled and drive is loaded	Check the input wiring of the mains phases	OFF2
F0021 Earth fault	Fault occurs if the sum of the phase currents is higher than 5 % of the nominal inverter current.		OFF2
F0022 Powerstack fault	UCE failure was detected, when P0947 = 22 and fault value P0949 =12 or 13 or 14, depending on UCE	Check the I/O board. It has to be fully pressed home.	OFF2
F0023 Output fault	One phase of output is disconnected		OFF2
F0024 Rectifier Over Temperature	<ul style="list-style-type: none"> ➤ Ventilation inadequate ➤ Fan inoperative ➤ Ambient temperature is too high. 	Check the following: <ul style="list-style-type: none"> ➤ Fan must turn when inverter is running ➤ Pulse frequency must be set to default value ➤ Ambient temperature could be higher than specified for the inverter 	OFF2
F0030 Fan has failed	Fan no longer working	<ul style="list-style-type: none"> ➤ Fault cannot be masked while options module (AOP or BOP) is connected. ➤ Need a new fan. 	OFF2
F0035 Auto restart after n	Auto restart fault after n-restart try		OFF2
F0040 Automatic Calibration Failure			OFF2

Fault	Possible Causes	Diagnose & Remedy	Reaction
F0041 Motor Data Identification Failure	Motor data identification failed. Alarm value =0: Load missing Alarm value =1: Current limit level reached during identification. Alarm value =2: Identified stator resistance less than 0.1% or greater than 100%. Alarm value =3: Identified rotorresistance less than 0.1% or greater than 100%. Alarm value =4: Identified stator reactance less than 50% and greater than 500% Alarm value =5: Identified main reactance less than 50% and greater than 500% Alarm value =6: Identified rotor time constant less than 10ms or greater than 5 s Alarm value =7: Identified total leakage reactance less than 5% and greater than 50% Alarm value =8: Identified stator leakage reactance less than 25% and greater than 250% Alarm value =9: Identified rotor leakage inductance less than 25% and greater than 250% Alarm value = 20: Identified IGBT on-voltage less than 0.5 or greater than 10 V Alarm value = 30: Current controller at voltage limit Alarm value = 40: Inconsistence of identified data set, at least one identification failed Percentage values based on the impedance $Z_b = V_{mot,nom} / \sqrt{3} / I_{mot,nom}$	0: Check that the motor is connected to the inverter. 1-40: Check if motor data in P304-311 are correct. Check what type of motor wiring is required (star, delta).	OFF2
F0042 Speed Control Optimisation Failure	Motor data identification failed. ➤ Alarm value =0: Time out waiting for stable speed ➤ Alarm value =1: Inconsistent readings		OFF2
F0051 Parameter EEPROM Fault	Read or write failure while saving non-volatile parameter.	➤ Factory Reset and new parameterization ➤ Change drive	OFF2

Fault	Possible Causes	Diagnose & Remedy	Reaction
F0052 power stack Fault	Read failure for power stack information or invalid data.	Change drive	OFF2
F0053 IO Eeprom Fault	Read failure for IO EEPROM information or invalid data.	1. Check data 2. Change IO module	OFF2
F0054 Wrong IO Board	<ul style="list-style-type: none"> ➤ Wrong IO board is connected. ➤ No ID detected on IO board, No data. 	1. Check data 2. Change IO module	OFF2
F0060 Asic Timeout	Internal communications failure	1. If fault persists, change inverter 2. Contact Service Department	OFF2
F0070 CB setpoint fault	No setpoint values from CB (communication board) during telegram off time	Check CB and communication partner	OFF2
F0071 USS (BOP-link) setpoint fault	No setpoint values from USS during telegram off time	Check USS master	OFF2
F0072 USS (COMM link) setpoint fault	No setpoint values from USS during telegram off time	Check USS master	OFF2
F0080 ADC lost input signal	<ul style="list-style-type: none"> ➤ Broken wire ➤ Signal out of limits 		OFF2
F0085 External Fault	External fault triggered via terminal inputs	Disable terminal input for fault trigger.	OFF2
F0090 Encoder feedback loss	Signal from Encoder lost	1. Check encoder fitted. If encoder not fitted, set P400 = 0 and select SLVC mode (P1300 = 20 or 22) 2. Check connections between encoder and inverter 3. Check encoder not faulty (select P1300 = 0, run at fixed speed, check encoder feedback signal in P66) Increase encoder loss threshold in P492	OFF2
F0101 Stack Overflow	Software error or processor failure	Run self test routines	OFF2
F0221 PID Feedback below min. value	PID Feedback below min. value P2268.	Change value of P2268.Adjust feedback gain.	OFF2
F0222 PID Feedback above max. value	PID feedback above max. value P2267.	Change value of P2267.Adjust feedback gain.	OFF2
F0450 BIST Tests Failure	Fault value: 1 Some power section tests have failed 2 Some control board tests have failed 4 Some functional tests have failed 16 Internal RAM failed on power-up check	1. Drive may run but some features will not work properly. 2. Replace drive.	OFF2

Fault	Possible Causes	Diagnose & Remedy	Reaction
F0452 Belt Failure Detected	Load conditions on motor indicate belt failure or mechanical fault.	Check the following: <ol style="list-style-type: none"> 1. No breakage, seizure or obstruction of drive train. 2. If using an external speed sensor, check for correct function. Check parameters: <ul style="list-style-type: none"> ➤ P0409 (pulse per min at rated speed). ➤ P2191 (Belt failure speed tolerance). ➤ P2192 (delay time for permitted deviation) 3. If using the torque envelope, check parameters: <ul style="list-style-type: none"> ➤ P2182 (threshold frequency f1) ➤ P2183 (threshold frequency f2) ➤ P2184 (threshold frequency f3) ➤ P2185 (upper torque threshold 1) ➤ P2186 (lower torque threshold 1) ➤ P2187 (upper torque threshold 2) ➤ P2188 (lower torque threshold 2) ➤ P2189 (upper torque threshold 3) ➤ P2190 (lower torque threshold 3) ➤ P2192 (delay time for permitted deviation) 4. Apply lubrication if required. 	OFF2

6.4 Alarm messages

Alarms	Possible Causes	Diagnose & Remedy
A0501 Current Limit	<ul style="list-style-type: none"> ➤ Motor power does not correspond to the inverter power ➤ Motor leads are too long ➤ Earth faults 	Check the following: <ol style="list-style-type: none"> 1. Motor power (P0307) must correspond to inverter power (r0206). 2. Cable length limits must not be exceeded. 3. Motor cable and motor must have no short-circuits or earth faults 4. Motor parameters must match the motor in use 5. Value of stator resistance (P0350) must be correct 6. Motor must not be obstructed or overloaded <ul style="list-style-type: none"> ➤ Increase the ramp-up-time. ➤ Reduce the boost.
A0502 Overvoltage limit	Overvoltage limit is reached. This warning can occur during ramp down, if the dc-link controller is disabled (P1240 = 0).	If this warning is displayed permanently, check drive input voltage .
A0503 UnderVoltage Limit	Main supply failed Main supply (P0210) and consequently DC-link voltage (R0026) below specified limit (P2172).	Check main supply voltage (P0210).
A0504 Inverter Over-Temperature	Warning level of inverter heat-sink temperature (P0614) is exceeded, resulting in pulse frequency reduction and/or output frequency reduction (depending on parametrization in (P0610)	Check the following: <ol style="list-style-type: none"> 1. Ambient temperature must lie within specified limits 2. Load conditions and duty cycle must be appropriate
A0505 Inverter I2T	Warning level exceeded, current will be reduced if parameterized (P0610 = 1)	Check that duty cycle lies within specified limits
A0506 Inverter duty cycle	Difference between heatsink and IGBT junction temperature exceeds warning limits	Check that duty cycle and shock loads lie within specified limits
A0511 Motor Over-Temperature I2T	<ul style="list-style-type: none"> ➤ Motor overloaded ➤ Load duty cycle too high. 	Independently of the kind of temperature determination check: <ol style="list-style-type: none"> 1. P0604 motor temperature warning threshold 2. P0625 motor ambient temperature 3. If (P601 = 0 or 1) Check the following: <ul style="list-style-type: none"> ➤ Check if name plate data are correct (if not perform quick commissioning) ➤ Accurate equivalent circuit data can be found by performing motor identification (P1910=1). ➤ Check if motor weight (P344) is reasonable. Change if necessary. ➤ Via P626, P627, P628 the standard overtemperatures can be changed, if the motor is not a Siemens standard motor. 4. If (P601 = 2) Check the following: <ul style="list-style-type: none"> ➤ Check if temperature shown in r35 is reasonable. ➤ Check if the sensor is a KTY84 (other sensors are not supported)
A0512 Motor temperature signal lost	Wire break to motor temperature sensor. If a wire breakage is detected, temperature monitoring switches over to monitoring with the motor thermal model.	

Alarms	Possible Causes	Diagnose & Remedy
A0520 Rectifier Over-Temperature	Warning level of rectifier heat-sink temperature (P) is exceeded	Check the following: 1. Ambient temperature must lie within specified limits 2. Load conditions and duty cycle must be appropriate 3. Fan must turn when drive is running
A0521 Ambient Over-Temperature	Warning level of ambient temperature (P) is exceeded	Check the following: 1. Ambient temperature must lie within specified limits 2. Fan must turn when drive is running 3. Fan intake air has to be without any resistance
A0522 I2C read out timeout	The cyclic access to the UCE Values and powerstack temperatures via the i2c bus is disturbed	
A0523 Output fault	One phase of output is disconnected	Warning can be masked.
A0535 Braking Resistor Hot		
A0541 Motor Data Identification Active	Motor data identification (P1910) selected or running	
A0542 Speed Control Optimisation Active	Speed Control Optimisation (P1960) is selected or running	
A0590 Encoder feedback loss warning	Signal from Encoder lost and Inverter has switched to sensorless vector control	Stop inverter and then 1. Check encoder fitted. If encoder not fitted, set P400 = 0 and select SLVC mode (P1300 = 20 or 22) 2. Check connections between encoder and inverter 3. Check encoder not faulty (select P1300 = 0, run at fixed speed, check encoder feedback signal in P66) 4. Increase encoder loss threshold in P492
A0600 RTOS Overrun Warning		
A0700 CB warning 1 see CB manual for details.	CB (communication board) specific	See CB user manual
A0701 CB warning 2 see CB manual for details.	CB (communication board) specific	See CB user manual
A0702 CB warning 3 see CB manual for details.	CB (communication board) specific	See CB user manual
A0703 CB warning 4 see CB manual for details.	CB (communication board) specific	See CB user manual
A0704 CB warning 5 see CB manual for details.	CB (communication board) specific	See CB user manual

Alarms	Possible Causes	Diagnose & Remedy
A0705 CB warning 6 see CB manual for details.	CB (communication board) specific	See CB user manual
A0706 CB warning 7 see CB manual for details.	CB (communication board) specific	See CB user manual
A0707 CB warning 8 see CB manual for details.	CB (communication board) specific	See CB user manual
A0708 CB warning 9 see CB manual for details.	CB (communication board) specific	See CB user manual
A0709 CB warning 10 see CB manual for details.	CB (communication board) specific	See CB user manual
A0710 CB communication error	Communication with CB (communication board) is lost	Check CB hardware
A0711 CB configuration error	CB (communication board) reports a configuration error.	Check CB parameters
A0910 Vdc-max controller de-activated	Vdc max controller has been de-activated, since controller is not capable of keeping DC-link voltage (r0026) within limits (P2172). <ul style="list-style-type: none"> ➤ Occurs if main supply voltage (P0210) is permanently too high. ➤ Occurs if motor is driven by an active load, causing motor to go into regenerative mode. ➤ Occurs at very high load inertias, when ramping down. 	Check the following: <ol style="list-style-type: none"> 1. Input voltage (P0210) must lie within range. 2. Load must be match.
A0911 Vdc-max controller active	Vdc max controller is active; so ramp-down times will be increased automatically to keep DC-link voltage (r0026) within limits (P2172).	
A0912 Vdc-min controller active	Vdc min controller will be activated if DC-link voltage (r0026) falls below minimum level (P2172). <ul style="list-style-type: none"> ➤ The kinetic energy of the motor is used to buffer the DC-link voltage, thus causing deceleration of the drive! ➤ So short mains failures do not necessarily lead to an undervoltage trip. 	

Alarms	Possible Causes	Diagnose & Remedy
A0920 ADC parameters not set properly.	ADC parameters should not be set to identical values, since this would produce illogical results. <ul style="list-style-type: none"> ➤ Index 0: Parameter settings for output identical ➤ Index 1: Parameter settings for input identical ➤ Index 2: Parameter settings for input do not correspond to ADC type 	
A0921 DAC parameters not set properly.	DAC parameters should not be set to identical values, since this would produce illogical results. <ul style="list-style-type: none"> ➤ Index 0: Parameter settings for output identical ➤ Index 1: Parameter settings for input identical ➤ Index 2: Parameter settings for output do not correspond to DAC type 	
A0922 No load applied to inverter	No Load is applied to the inverter. As a result, some functions may not work as under normal load conditions.	
A0923 Both JOG Left and JOG Right are requested	Both JOG right and JOG left (P1055/P1056) have been requested. This freezes the RFG output frequency at its current value.	
A0952 Belt Failure Detected	Load conditions on motor indicate belt failure or mechanical fault.	Apply lubrication if required. Check the following: <ol style="list-style-type: none"> 1. No breakage, seizure or obstruction of drive train. 2. If using an external speed sensor, check for correct function. Check parameters: <ul style="list-style-type: none"> ➤ P0409 (pulse per min at rated speed). ➤ P2191 (Belt failure speed tolerance). ➤ P2192 (delay time for permitted deviation) 3. If using the torque envelope, check parameters: <ul style="list-style-type: none"> ➤ P2182 (threshold frequency f1) ➤ P2183 (threshold frequency f2) ➤ P2184 (threshold frequency f3) ➤ P2185 (upper torque threshold 1) ➤ P2186 (lower torque threshold 1) ➤ P2187 (upper torque threshold 2) ➤ P2188 (lower torque threshold 2) ➤ P2189 (upper torque threshold 3) ➤ P2190 (lower torque threshold 3) ➤ P2192 (delay time for permitted deviation) 4. Apply lubrication if required.
A0936 PID Autotuning Active	PID Autotuning (P2350) selected or running	

7 MICROMASTER 440 specifications

This Chapter contains:

- Table 7.1 contains the general technical specifications for the MICROMASTER 440 inverter
- Table 7-2 contains terminal tightening torques
- Table 7-3 includes various tables of specific technical data for individual MICROMASTER 440 inverters

Table 7-1 MICROMASTER 440 Performance Ratings

Feature		Specification
Mains Operating Voltage & Power Ranges		1 AC 200 to 240 V \pm 10 % CT: 0,12 kW – 3,0 kW (0,16 hp – 4,0 hp)
		3 AC 200 to 240 V \pm 10 % CT: 0,12 kW – 45,0 kW (0,16 hp – 60,0 hp)
		3 AC 380 to 480 V \pm 10 % VT: 5,50 kW – 45,0 kW (7,50 hp – 60,0 hp)
		3 AC 500 to 600 V \pm 10 % CT: 0,37 kW – 200 kW (0,50 hp – 268 hp)
		VT: 7,50 kW – 250 kW (10,0 hp – 335 hp)
		CT: 0,75 kW – 75,0 kW (1,00 hp – 100 hp)
		VT: 1,50 kW – 90,0 kW (2,00 hp – 120 hp)
Input Frequency		47 to 63 Hz
Output frequency		0 Hz to 650 Hz
Power Factor		\geq 0.7
Inverter Efficiency		Frame Sizes A to F: 96 % to 97 % Frame Sizes FX and GX: 97 % to 98 %
Overload Capability	Constant Torque (CT)	Frame Sizes A to F: 1.5 x Nominal output current (i.e. 150 % overload) for 60 s every 300 s and 2 x Nominal output current (i.e. 200 % overload) for 3 s every 300 s Frame Sizes FX and GX: 1.36 x Nominal output current (i.e. 136 % overload) for 57 s every 300 s and 1.6 x Nominal output current (i.e. 160 % overload) for 3 s every 300 s
	Variable Torque (VT)	Frame Sizes A to F: 1.1 x Nominal output current (i.e. 110 % overload) for 60 s every 300 s and 1.4 x Nominal output current (i.e. 140 % overload) for 3 s every 300 s Frame Sizes FX and GX: 1.1 x Nominal output current (i.e. 110% overload) for 59 s every 300 s and 1.5 x Nominal output current (i.e. 150% overload) for 1 s every 300s
Inrush Current		Less than rated input current
Control Method		Linear V/f control, Linear V/f control with FCC, Parabolic V/f control, Multi-point V/f control, V/f control for textile applications, V/f control with FCC for textile applications, V/f control with independent voltage setpoint, Sensorless Vector Control, Senseless Vector Torque Control, Speed control with Encoder Feedback, Torque control with Encoder Feedback
Pulse Frequency		Frame Sizes A to C: 1/3AC 200 V to 5,5 kW (Standard 16 kHz) Frame Sizes A to F: other powers and voltages 2 kHz to 16 kHz (2 kHz steps) (Standard 4 kHz) power reduction see Table 7-3 Frame Sizes FX and GX: 2 kHz to 8 kHz (2 kHz steps) (Standard 2 kHz (VT), 4 kHz (CT)) power reduction see Table 7-3
Fixed Frequencies		15, programmable
Skip Frequencies		4, programmable
Setpoint Resolution		0.01 Hz Digital, 0.01 Hz Serial, 10 bit Analogue (motor potentiometer 0.1 Hz [0.1% (in PID mode)])
Digital Inputs		6, programmable (isolated), switchable active high / active low (PNP/NPN)
Analog Inputs		2, programmable, both are parameterizable as 7th and 8th digital inputs 0 V to 10 V, 0 mA to 20 mA and –10 V to +10 V (AIN1) 0 V to 10 V and 0 mA to 20 mA (AIN2)
Relay Outputs		3, programmable 30 V DC / 5 A (resistive), 250 V AC 2 A (inductive)
Analogue Output		2, programmable (0 to 20 mA)
Serial Interface		RS-485, optional RS-232

Electromagnetic Compatibility	Frame Sizes A to C: optional class A or B filters available according to EN55011 Frame Sizes A to F: inverter with integrated class A filter available Frame Sizes FX and GX: With EMI filter (available as an option) the limiting values of the EN 55011, Class A are fulfilled for conducted emission. (line commutating choke required)
Braking	DC braking, compound braking Dynamic braking Frame Sizes A to F with integrated chopper Frame Sizes FX and GX with external chopper
Protection Level	IP20
Temperature range	Frame Sizes A to F: -10 °C to +50 °C (14 °F to 122 °F) (CT) -10 °C to +40 °C (14 °F to 104 °F) (VT) with power reduction see Figure 2-2 Frame Sizes FX and GX: 0 °C to +40 °C (32 °F to 104 °F), to 55 °C (131 °F) with power reduction see Figure 2-2
Storage Temperature	-40 °C to +70 °C (-40 °F to 158 °F)
Humidity	< 95 % RH – non-condensing
Operational Altitudes	Frame Sizes A to F: Up to 1000 m above sea level without derating Frame Sizes FX and GX: Up to 2000 m above sea level without derating
Protection Features	Undervoltage , Overvoltage, Overload, Ground Faults, Short circuit, Stall Prevention, Motor Blocking Protection, Motor Overtemperature, Inverter Overtemperature, Parameter Interlock
Standards	Frame Sizes A to F: UL, cUL, CE, C-tick Frame Sizes FX and GX: UL (in preparation), cUL (in preparation), CE
CE Marked	Conformity with EC Low Voltage Directive 73/23/EEC and filtered versions also Electromagnetic Compatibility Directive 89/336/EEC

Table 7-2 Tightening torques for power terminals

Frame Sizes A to F

Frame Size		A	B	C	D	E	F
Tightening Torque	[Nm]	1,1	1,5	2,25	10 (max)	10 (max)	50
	[lbf.in]	10	13,3	20	87 (max)	87 (max)	435

Frame Sizes FX and GX

Frame Size		FX	GX
Tightening Torque	[Nm]	50	50
	[lbf.in]	435	435
Pipe cable lug acc. to DIN 46235	mm	10	10
Max. wire cross-section	[mm ²]	1 x 185 or 2 x 120	2 x 240
	[AWG] and [kcmil]	1 x 350 or 2 x 4/0	2 x 400

Table 7-3 Current reduction depending on pulse frequency

Mains voltage	Power (CT) [kW]	Output current in A with a switching frequency of;						
		4 kHz	6 kHz	8 kHz	10 kHz	12 kHz	14 kHz	16 kHz
1/3 AC 200 V	0.12 to 5.5	Factory setting 16 kHz – no derating necessary						
	7.5	28.0	26.6	25.2	22.4	19.6	16.8	14.0
	11	42.0	37.8	33.6	29.4	25.2	21.0	16.8
	15	54.0	48.6	43.2	37.8	32.4	27.0	21.6
	18.5	68.0	64.6	61.2	54.4	47.6	40.8	34.0
	22	80.0	72.0	64.0	56.0	48.0	40.0	32.0
	30	104.0	91.0	78.0	70.2	62.4	57.2	52.0
	37	130.0	113.8	97.5	87.8	78.0	71.5	65.0
3 AC 400 V	45	154.0	134.8	115.5	104.0	92.4	84.7	77.0
	0.37	1.3	1.3	1.3	1.3	1.3	1.2	1.0
	0.55	1.7	1.7	1.7	1.6	1.5	1.4	1.2
	0.75	2.2	2.2	2.2	2.0	1.8	1.5	1.3
	1.1	3.1	2.9	2.8	2.5	2.2	1.9	1.6
	1.5	4.1	3.7	3.3	2.9	2.5	2.1	1.6
	2.2	5.9	5.6	5.3	4.7	4.1	3.5	3.0
	3.0	7.7	6.9	6.2	5.4	4.6	3.9	3.1
	4.0	10.2	9.2	8.2	7.1	6.1	5.1	4.1
	5.5	13.2	11.9	10.6	9.2	7.9	6.6	5.3
	7.5	19.0	18.1	17.1	15.2	13.3	11.4	9.5
	11.0	26.0	23.4	20.8	18.2	15.6	13.0	10.4
	15.0	32.0	30.4	28.8	25.6	22.4	19.2	16.0
	18.5	38.0	34.2	30.4	26.6	22.8	19.0	15.2
	22	45.0	40.5	36.0	31.5	27.0	22.5	18.0
	30	62.0	58.9	55.8	49.6	43.4	37.2	31.0
	37	75.0	67.5	60.0	52.5	45.0	37.5	30.0
	45	90.0	76.5	63.0	51.8	40.5	33.8	27.0
	55	110.0	93.5	77.0	63.3	49.5	41.3	33.0
	75	145.0	112.4	79.8	68.9	58.0	50.8	43.5
90	178.0	131.5	101.1	–	–	–	–	
110	205.0	151.4	116.5	–	–	–	–	
132	250.0	184.7	142.1	–	–	–	–	
160	302.0	223.1	171.6	–	–	–	–	
200	370.0	273.3	210.2	–	–	–	–	
3 AC 500 V	0.75	1.4	1.2	1.0	0.8	0.7	0.6	0.6
	1.5	2.7	2.2	1.6	1.4	1.1	0.9	0.8
	2.2	3.9	2.9	2.0	1.6	1.2	1.0	0.8
	4.0	6.1	4.6	3.1	2.4	1.8	1.5	1.2
	5.5	9.0	6.8	4.5	3.6	2.7	2.3	1.8
	7.5	11.0	8.8	6.6	5.5	4.4	3.9	3.3
	11.0	17.0	12.8	8.5	6.8	5.1	4.3	3.4
	15.0	22.0	17.6	13.2	11.0	8.8	7.7	6.6
	18.5	27.0	20.3	13.5	10.8	8.1	6.8	5.4
	22	32.0	24.0	16.0	12.8	9.6	8.0	6.4
	30	41.0	32.8	24.6	20.5	16.4	14.4	12.3
	37	52.0	39.0	26.0	20.8	15.6	13.0	10.4
	45	62.0	52.7	43.4	40.3	37.2	32.6	27.9
	55	77.0	67.4	57.8	52.0	46.2	42.4	38.5
75	99.0	84.2	69.3	64.4	59.4	52.0	44.6	

Table 7-4 MICROMASTER 440 Specifications

In order to have a UL compliant installation fuses from the SITOR range with the appropriate current rating must be used.

Input voltage range 1 AC 200 V – 240 V, ± 10 % (with built in Class A Filter)

Order No.	6SE6440-	2AB11 -2AA1	2AB12 -5AA1	2AB13 -7AA1	2AB15 -5AA1	2AB17 -5AA1	2AB21 -1BA1	2AB21 -5BA1	2AB22 -2BA1	2AB23 -0CA1
Motor Output Rating	[kW]	0.12	0.25	0.37	0.55	0.75	1.1	1.5	2.2	3.0
	[hp]	0.16	0.33	0.5	0.75	1.0	1.5	2.0	3.0	4.0
Output Power	[kVA]	0.4	0.7	1.0	1.3	1.7	2.4	3.2	4.6	6.0
Output Current Max.	[A]	0.9	1.7	2.3	3.0	3.9	5.5	7.4	10.4	13.6
Input Current	[A]	1.4	2.7	3.7	5.0	6.6	9.6	13.0	17.6	23.7
Recommended Fuse	[A]	10	10	10	16	16	20	20	25	32
		3NA3803	3NA3803	3NA3803	3NA3805	3NA3805	3NA3807	3NA3807	3NA3810	3NA3812
Fuses for UL specified	[A]	*	*	*	*	*	*	*	*	*
Input Cable Min.	[mm ²]	1.0	1.0	1.0	1.0	1.0	1.0	1.5	2.5	4.0
	[awg]	17	17	17	17	17	17	15	13	11
Input Cable Max.	[mm ²]	2.5	2.5	2.5	2.5	2.5	6.0	6.0	6.0	10.0
	[awg]	13	13	13	13	13	9	9	9	7
Output Cable Min.	[mm ²]	1.0	1.0	1.0	1.0	1.0	1.0	1.0	1.0	1.5
	[awg]	17	17	17	17	17	17	17	17	15
Output Cable Max.	[mm ²]	2.5	2.5	2.5	2.5	2.5	6.0	6.0	6.0	10.0
	[awg]	13	13	13	13	13	9	9	9	7
Weight	[kg]	1.3	1.3	1.3	1.3	1.3	3.4	3.4	3.4	5.7
	[lbs]	2.9	2.9	2.9	2.9	2.9	7.5	7.5	7.5	12.5
Dimensions	B [mm]	73.0	73.0	73.0	73.0	73.0	149.0	149.0	149.0	185.0
	H [mm]	173.0	173.0	173.0	173.0	173.0	202.0	202.0	202.0	245.0
	T [mm]	149.0	149.0	149.0	149.0	149.0	172.0	172.0	172.0	195.0
	B [Inches]	2.87	2.87	2.87	2.87	2.87	5.87	5.87	5.87	7.28
	H [Inches]	6.81	6.81	6.81	6.81	6.81	7.95	7.95	7.95	9.65
	T [Inches]	5.87	5.87	5.87	5.87	5.87	6.77	6.77	6.77	7.68

* UL listed fuses such as Class NON from Bussmann are required for use in America

Input voltage range 3 AC 200 V – 240 V, ± 10 % (with built in Class A Filter)

Order No.	6SE6440-	2AC23-0CA1	2AC24-0CA1	2AC25-5CA1
Motor Output Rating	[kW]	3.0	4.0	5.5
	[hp]	4.0	5.0	7.5
Output Power	[kVA]	6.0	7.7	9.6
CT-Output Cur. Max.	[A]	13.6	17.5	22.0
CT Input Current	[A]	10.5	13.1	17.5
VT Input Current	[A]	10.5	17.6	26.5
VT-Output Cur. Max.	[A]	13.6	22.0	28.0
Recommended Fuse	[A]	20	25	35
		3NA3807	3NA3810	3NA3814
Fuses for UL specified	[A]	*	*	*
Input Cable Min.	[mm²]	1.0	2.5	4.0
	[awg]	17.0	13.0	11.0
Input Cable Max.	[mm²]	10.0	10.0	10.0
	[awg]	7.0	7.0	7.0
Output Cable Min.	[mm²]	1.5	4.0	4.0
	[awg]	15.0	11.0	11.0
Output Cable Max.	[mm²]	10.0	10.0	10.0
	[awg]	7.0	7.0	7.0
Weight	[kg]	5.7	5.7	5.7
	[lbs]	12.5	12.5	12.5
Dimensions	B [mm]	185.0	185.0	185.0
	H [mm]	245.0	245.0	245.0
	T [mm]	195.0	195.0	195.0
	B [Inches]	7.28	7.28	7.28
	H [Inches]	9.65	9.65	9.65
	T [Inches]	7.68	7.68	7.68

* UL listed fuses such as Class NON from Bussmann are required for use in America

Input voltage range 1 AC 3 AC 200 V – 240 V, ± 10 % (Unfiltered)

Order No.	6SE6440-	2UC11 -2AA1	2UC12 -5AA1	2UC13 -7AA1	2UC15 -5AA1	2UC17 -5AA1	2UC21 -1BA1	2UC21 -5BA1	2UC22 -2BA1	2UC23 -0CA1
Motor Output Rating	[kW]	0.12	0.25	0.37	0.55	0.75	1.1	1.5	2.2	3.0
	[hp]	0.16	0.33	0.5	0.75	1.0	1.5	2.0	3.0	4.0
Output Power	[kVA]	0.4	0.7	1.0	1.3	1.7	2.4	3.2	4.6	6.0
Output Current Max.	[A]	0.9	1.7	2.3	3.0	3.9	5.5	7.4	10.4	13.6
Input Current, 3 AC	[A]	0.6	1.1	1.6	2.1	2.9	4.1	5.6	7.6	10.5
Input Current, 1 AC	[A]	1.4	2.7	3.7	5.0	6.6	9.6	13.0	17.6	23.7
Recommended Fuse	[A]	10	10	10	16	16	20	20	25	32
		3NA3803	3NA3803	3NA3803	3NA3805	3NA3805	3NA3807	3NA3807	3NA3810	3NA3812
Fuses for UL specified	[A]	*	*	*	*	*	*	*	*	*
Input Cable Min.	[mm ²]	1.0	1.0	1.0	1.0	1.0	1.0	1.5	2.5	4.0
	[awg]	17	17	17	17	17	17	15	13	11
Input Cable Max.	[mm ²]	2.5	2.5	2.5	2.5	2.5	6.0	6.0	6.0	10.0
	[awg]	13	13	13	13	13	9	9	9	7
Output Cable Min.	[mm ²]	1.0	1.0	1.0	1.0	1.0	1.0	1.0	1.0	1.5
	[awg]	17	17	17	17	17	17	17	17	15
Output Cable Max.	[mm ²]	2.5	2.5	2.5	2.5	2.5	6.0	6.0	6.0	10.0
	[awg]	13	13	13	13	13	9	9	9	7
Weight	[kg]	1.3	1.3	1.3	1.3	1.3	3.3	3.3	3.3	5.5
	[lbs]	2.9	2.9	2.9	2.9	2.9	7.3	7.3	7.3	12.1
Dimensions	B [mm]	73.0	73.0	73.0	73.0	73.0	149.0	149.0	149.0	185.0
	H [mm]	173.0	173.0	173.0	173.0	173.0	202.0	202.0	202.0	245.0
	T [mm]	149.0	149.0	149.0	149.0	149.0	172.0	172.0	172.0	195.0
	B [Inches]	2.87	2.87	2.87	2.87	2.87	5.87	5.87	5.87	7.28
	H [Inches]	6.81	6.81	6.81	6.81	6.81	7.95	7.95	7.95	9.65
	T [Inches]	5.87	5.87	5.87	5.87	5.87	6.77	6.77	6.77	7.68

* UL listed fuses such as Class NON from Bussmann are required for use in America

Input voltage range 3 AC 200 V – 240 V, ± 10 % (Unfiltered)

Order No.	6SE6440-	2UC24-0CA1	2UC25-5CA1	2UC27-5DA1	2UC31-1DA1	2UC31-5DA1	2UC31-8EA1	2UC32-2EA1	2UC33-0FA1	2UC33-7FA1	2UC34-5FA1
Motor Output Rating	[kW]	4.0	5.5	7.5	11.0	15.0	18.5	22.0	30.0	37.0	45.0
	[hp]	5.0	7.5	10.0	15.0	20.0	25.0	30.0	40.0	50.0	60.0
Output Power	[kVA]	7.7	9.6	12.3	18.4	23.7	29.8	35.1	45.6	57.0	67.5
CT-Output Cur. Max.	[A]	17.5	22.0	28.0	42.0	54.0	68.0	80.0	104.0	130.0	154.0
CT Input Current	[A]	13.1	17.5	25.3	37.0	48.8	61.0	69.4	94.1	110.6	134.9
VT Input Current	[A]	17.6	26.5	38.4	50.3	61.5	70.8	96.2	114.1	134.9	163.9
VT-Output Cur. Max.	[A]	22.0	28.0	42.0	54.0	68.0	80.0	104.0	130.0	154.0	178.0
Recommended Fuse	[A]	25	35	50	80	80	100	125	160	200	200
	3NA	3810	3814	3820	3824	3824	3830	3032	3836	3140	3140
Fuses for UL specified	[A]			50	80	80	100	125	160	200	200
	3NE	*	*	1817-0	1820-0	1820-0	1021-0	1022-0	1224-0	1225-0	1225-0
Input Cable Min.	[mm ²]	2.5	4.0	10.0	16.0	16.0	25.0	25.0	50.0	70.0	70.0
	[awg]	13.0	11.0	7.0	5.0	5.0	3.0	3.0	0.0	-2.0	-2.0
Input Cable Max.	[mm ²]	10.0	10.0	35.0	35.0	35.0	35.0	35.0	150.0	150.0	150.0
	[awg]	7.0	7.0	2.0	2.0	2.0	2.0	2.0	-5.0	-5.0	-5.0
Output Cable Min.	[mm ²]	4.0	4.0	10.0	16.0	16.0	25.0	25.0	50.0	70.0	95.0
	[awg]	11.0	11.0	7.0	5.0	5.0	3.0	3.0	0.0	-2.0	-3.0
Output Cable Max.	[mm ²]	10.0	10.0	35.0	35.0	35.0	35.0	35.0	150.0	150.0	150.0
	[awg]	7.0	7.0	2.0	2.0	2.0	2.0	2.0	-5.0	-5.0	-5.0
Weight	[kg]	5.5	5.5	17.0	16.0	16.0	20.0	20.0	55.0	55.0	55.0
	[lbs]	12.1	12.1	37.0	35.0	35.0	44.0	44.0	121.0	121.0	121.0
Dimensions	B [mm]	185.0	185.0	275.0	275.0	275.0	275.0	275.0	350.0	350.0	350.0
	H [mm]	245.0	245.0	520.0	520.0	520.0	650.0	650.0	850.0	850.0	850.0
	T [mm]	195.0	195.0	245.0	245.0	245.0	245.0	245.0	320.0	320.0	320.0
	B [Inches]	7.28	7.28	10.83	10.83	10.83	10.83	10.83	13.78	13.78	13.78
	H [Inches]	9.65	9.65	20.47	20.47	20.47	25.59	25.59	33.46	33.46	33.46
	T [Inches]	7.68	7.68	9.65	9.65	9.65	9.65	9.65	12.6	12.6	12.6

* UL listed fuses such as Class NON from Bussmann are required for use in America

Input voltage range 3 AC 380 V – 480 V, ± 10 % (with built in Class A Filter), Part 1

Order No.	6SE6440-	2AD22-2BA1	2AD23-0BA1	2AD24-0BA1	2AD25-5CA1	2AD27-5CA1	2AD31-1CA1	2AD31-5DA1	2AD31-8DA1
Motor Output Rating	[kW]	2.2	3.0	4.0	5.5	7.5	11.0	15.0	18.5
	[hp]	3.0	4.0	5.0	7.5	10.0	15.0	20.0	25.0
Output Power	[kVA]	4.5	5.9	7.8	10.1	14.0	19.8	24.4	29.0
CT-Output Cur. Max.	[A]	5.9	7.7	10.2	13.2	18.4	26.0	32.0	38.0
CT Input Current	[A]	5.0	6.7	8.5	11.6	15.4	22.5	30.0	36.6
VT Input Current	[A]	5.0	6.7	8.5	16.0	22.5	30.5	37.2	43.3
VT-Output Cur. Max.	[A]	5.9	7.7	10.2	18.4	26.0	32.0	38.0	45.0
Recommended Fuse	[A]	16	16	20	20	32	35	50	63
	3NA	3005	3005	3007	3007	3012	3014	3020	3022
Fuses for UL specified	[A]							50	63
	3NE	*	*	*	*	*	*	1817-0	1818-0
Input Cable Min.	[mm ²]	1.0	1.0	1.0	2.5	4.0	6.0	10.0	10.0
	[awg]	17	17	17	13	11	9	7	7
Input Cable Max.	[mm ²]	6.0	6.0	6.0	10.0	10.0	10.0	35.0	35.0
	[awg]	9	9	9	7	7	7	2	2
Output Cable Min.	[mm ²]	1.0	1.0	1.0	2.5	4.0	6.0	10.0	10.0
	[awg]	17	17	17	13	11	9	7	7
Output Cable Max.	[mm ²]	6.0	6.0	6.0	10.0	10.0	10.0	35.0	35.0
	[awg]	9	9	9	7	7	7	2	2
Weight	[kg]	3.4	3.4	3.4	5.7	5.7	5.7	17.0	17.0
	[lbs]	7.5	7.5	7.5	12.5	12.5	12.5	37.0	37.0
Dimensions	B [mm]	149.0	149.0	149.0	185.0	185.0	185.0	275.0	275.0
	H [mm]	202.0	202.0	202.0	245.0	245.0	245.0	520.0	520.0
	T [mm]	172.0	172.0	172.0	195.0	195.0	195.0	245.0	245.0
	B [Inches]	5.87	5.87	5.87	7.28	7.28	7.28	10.83	10.83
	H [Inches]	7.95	7.95	7.95	9.65	9.65	9.65	20.47	20.47
	T [Inches]	6.77	6.77	6.77	7.68	7.68	7.68	9.65	9.65

* UL listed fuses such as Class NON from Bussmann are required for use in America

Input voltage range 3 AC 380 V – 480 V, ± 10 % (with built in Class A Filter), Part 2

Order No.	6SE6440-	2AD32-2DA1	2AD33-0EA1	2AD33-7EA1	2AD34-5FA1	2AD35-5FA1	2AD37-5FA1
Motor Output Rating	[kW]	22.0	30.0	37.0	45.0	55.0	75.0
	[hp]	30.0	40.0	50.0	60.0	75.0	100.0
Output Power	[kVA]	34.3	47.3	57.2	68.6	83.8	110.5
CT-Output Cur. Max.	[A]	45.0	62.0	75.0	90.0	110.0	145.0
CT Input Current	[A]	43.1	58.7	71.2	85.6	103.6	138.5
VT Input Current	[A]	59.3	71.7	86.6	103.6	138.5	168.5
VT-Output Cur. Max.	[A]	62.0	75.0	90.0	110.0	145.0	178.0
Recommended Fuse	[A]	80	100	125	160	200	200
	3NA	3024	3030	3032	3036	3140	3140
Fuses for UL specified	[A]	80	100	125	160	200	200
	3NE	1820-0	1021-0	1022-0	1224-0	1225-0	1225-0
Input Cable Min.	[mm ²]	16.0	25.0	25.0	35.0	70.0	70.0
	[awg]	5	3	3	2	-2	-2
Input Cable Max.	[mm ²]	35.0	35.0	35.0	150.0	150.0	150.0
	[awg]	2	2	2	-5	-5	-5
Output Cable Min.	[mm ²]	16.0	25.0	25.0	50.0	70.0	95.0
	[awg]	5	3	3	0	-2	-3
Output Cable Max.	[mm ²]	35.0	35.0	35.0	150.0	150.0	150.0
	[awg]	2	2	2	-5	-5	-5
Weight	[kg]	17.0	22.0	22.0	75.0	75.0	75.0
	[lbs]	37.0	48.0	48.0	165.0	165.0	165.0
Dimensions	B [mm]	275.0	275.0	275.0	350.0	350.0	350.0
	H [mm]	520.0	650.0	650.0	1150.0	1150.0	1150.0
	T [mm]	245.0	245.0	245.0	320.0	320.0	320.0
	B [Inches]	10.83	10.83	10.83	13.78	13.78	13.78
	H [Inches]	20.47	25.59	25.59	45.28	45.28	45.28
	T [Inches]	9.65	9.65	9.65	12.6	12.6	12.6

Input voltage range 3 AC 380 V – 480 V, ± 10 % (Unfiltered), Part 1

Order No.	6SE6440-	2UD13-7AA1	2UD15-5AA1	2UD17-5AA1	2UD21-1AA1	2UD21-5AA1	2UD22-2BA1	2UD23-0BA1	2UD24-0BA1	2UD25-5CA1	2UD27-5CA1
Motor Output Rating	[kW] [hp]	0.37 0.5	0.55 0.75	0.75 1.0	1.1 1.5	1.5 2.0	2.2 3.0	3.0 4.0	4.0 5.0	5.5 7.5	7.5 10.0
Output Power	[kVA]	0.9	1.2	1.6	2.3	3.0	4.5	5.9	7.8	10.1	14.0
CT-Output Cur. Max.	[A]	1.2	1.6	2.1	3.0	4.0	5.9	7.7	10.2	13.2	18.4
CT Input Current	[A]	1.1	1.4	1.9	2.8	3.9	5.0	6.7	8.5	11.6	15.4
VT Input Current	[A]	1.1	1.4	1.9	2.8	3.9	5.0	6.7	8.5	16.0	22.5
VT-Output Cur. Max.	[A]	1.2	1.6	2.1	3.0	4.0	5.9	7.7	10.2	18.4	26.0
Recommended Fuse	[A]	10	10	10	10	10	16	16	20	20	32
		3NA3003	3NA3003	3NA3003	3NA3003	3NA3003	3NA3005	3NA3005	3NA3007	3NA3007	3NA3012
Fuses for UL specified	[A]	*	*	*	*	*	*	*	*	*	*
Input Cable Min.	[mm ²]	1.0	1.0	1.0	1.0	1.0	1.0	1.0	1.0	2.5	4.0
	[awg]	17	17	17	17	17	17	17	17	13	11
Input Cable Max.	[mm ²]	2.5	2.5	2.5	2.5	2.5	6.0	6.0	6.0	10.0	10.0
	[awg]	13	13	13	13	13	9	9	9	7	7
Output Cable Min.	[mm ²]	1.0	1.0	1.0	1.0	1.0	1.0	1.0	1.0	2.5	4.0
	[awg]	17	17	17	17	17	17	17	17	13	11
Output Cable Max.	[mm ²]	2.5	2.5	2.5	2.5	2.5	6.0	6.0	6.0	10.0	10.0
	[awg]	13	13	13	13	13	9	9	9	7	7
Weight	[kg]	1.3	1.3	1.3	1.3	1.3	3.3	3.3	3.3	5.5	5.5
	[lbs]	2.9	2.9	2.9	2.9	2.9	7.3	7.3	7.3	12.1	12.1
Dimensions	B [mm]	73.0	73.0	73.0	73.0	73.0	149.0	149.0	149.0	185.0	185.0
	H [mm]	173.0	173.0	173.0	173.0	173.0	202.0	202.0	202.0	245.0	245.0
	T [mm]	149.0	149.0	149.0	149.0	149.0	172.0	172.0	172.0	195.0	195.0
	B [Inches]	2.87	2.87	2.87	2.87	2.87	5.87	5.87	5.87	7.28	7.28
	H [Inches]	6.81	6.81	6.81	6.81	6.81	7.95	7.95	7.95	9.65	9.65
	T [Inches]	5.87	5.87	5.87	5.87	5.87	6.77	6.77	6.77	7.68	7.68

* UL listed fuses such as Class NON from Bussmann are required for use in America

Input voltage range 3 AC 380 V – 480 V, ± 10 % (Unfiltered), Part 2

Order No.	6SE6440-	2UD31 -1CA1	2UD31 -5DA1	2UD31 -8DA1	2UD32 -2DA1	2UD33 -0EA1	2UD33 -7EA1	2UD34 -5FA1	2UD35 -5FA1	2UD37 -5FA1
Motor Output Rating	[kW]	11.0	15.0	18.5	22.0	30.0	37.0	45.0	55.0	75.0
	[hp]	15.0	20.0	25.0	30.0	40.0	50.0	60.0	75.0	100.0
Output Power	[kVA]	19.8	24.4	29.0	34.3	47.3	57.2	68.6	83.8	110.5
CT-Output Cur. Max.	[A]	26.0	32.0	38.0	45.0	62.0	75.0	90.0	110.0	145.0
CT Input Current	[A]	22.5	30.0	36.6	43.1	58.7	71.2	85.6	103.6	138.5
VT Input Current	[A]	30.5	37.2	43.3	59.3	71.7	86.6	103.6	138.5	168.5
VT-Output Cur. Max.	[A]	32.0	38.0	45.0	62.0	75.0	90.0	110.0	145.0	178.0
Recommended Fuse	[A]	35	50	63	80	100	125	160	200	200
	3NA	3014	3020	3022	3024	3030	3032	3036	3140	3140
Fuses for UL specified	[A]		50	63	80	100	125	160	200	200
	3NE	*	1817-0	1818-0	1820-0	1021-0	1022-0	1224-0	1225-0	1225-0
Input Cable Min.	[mm ²]	6.0	10.0	10.0	16.0	25.0	25.0	35.0	70.0	70.0
	[awg]	9	7	7	5	3	3	2	-2	-2
Input Cable Max.	[mm ²]	10.0	35.0	35.0	35.0	35.0	35.0	150.0	150.0	150.0
	[awg]	7	2	2	2	2	2	-5	-5	-5
Output Cable Min.	[mm ²]	6.0	10.0	10.0	16.0	25.0	25.0	35.0	70.0	95.0
	[awg]	9	7	7	5	3	3	2	-2	-3
Output Cable Max.	[mm ²]	10.0	35.0	35.0	35.0	35.0	35.0	150.0	150.0	150.0
	[awg]	7	2	2	2	2	2	-5	-5	-5
Weight	[kg]	5.5	16.0	16.0	16.0	20.0	20.0	56.0	56.0	56.0
	[lbs]	12.1	35.0	35.0	35.0	44.0	44.0	123.0	123.0	123.0
Dimensions	B [mm]	185.0	275.0	275.0	275.0	275.0	275.0	350.0	350.0	350.0
	H [mm]	245.0	520.0	520.0	520.0	650.0	650.0	850.0	850.0	850.0
	T [mm]	195.0	245.0	245.0	245.0	245.0	245.0	320.0	320.0	320.0
	B [Inches]	7.28	10.83	10.83	10.83	10.83	10.83	13.78	13.78	13.78
	H [Inches]	9.65	20.47	20.47	20.47	25.59	25.59	33.46	33.46	33.46
	T [Inches]	7.68	9.65	9.65	9.65	9.65	9.65	12.6	12.6	12.6

* UL listed fuses such as Class NON from Bussmann are required for use in America

Input voltage range 3 AC 380 V – 480 V, ± 10 % (Unfiltered), Part 3

Order No.	6SE6440-	2UD38-8FA0	2UD41-1FA0	2UD41-3GA0	2UD41-6GA0	2UD42-0GA0
Motor Output Rating (CT)	[kW]	90	110	132	160	200
	[hp]	125	150	200	250	300
Output Power	[kVA]	145.4	180	214.8	263.2	339.4
CT Output Cur. Max. ^{*)}	[A]	178.0	205.0	250.0	302.0	370.0
CT Input Current	[A]	177	201	246	289	343
VT Input Current	[A]	200	245	297	354	442
VT Output Cur. Max.	[A]	205.0	250.0	302.0	370.0	477.0
Recommended Fuse	[A]	250	315	400	450	560
		3NE1227-0	3NE1230-0	3NE1332-0	3NE1333-0	3NE1435-0
Required cooling air flow rate	l/s	225	225	440	440	440
Weight	[kg]	110	110	190	190	190
	[lbs]					
Dimensions	B [mm]	330	330	330	330	330
	H [mm]	1555	1555	1875	1875	1875
	T [mm]	360	360	560	560	560
	B [Inches]	13	13	13	13	13
	H [Inches]	61.22	61.22	73.82	73.82	73.82
	T [Inches]	14.2	14.2	22.05	22.05	22.05

*) Values are valid for a pulse frequency of 4 kHz

Input voltage range 3 AC 500 V – 600 V, ± 10 % (Unfiltered), Part 1

Order No.	6SE6440 -	2UE17 -5CA1	2UE21 -5CA1	2UE22 -2CA1	2UE24 -0CA1	2UE25 -5CA1	2UE27 -5CA1	2UE31 -1CA1	2UE31 -5DA1	2UE31 -8DA1
Motor Output Rating	[kW]	0.75	1.5	2.2	4.0	5.5	7.5	11.0	15.0	18.5
	[hp]	1.0	2.0	3.0	5.0	7.5	10.0	15.0	20.0	25.0
Output Power	[kVA]	1.3	2.6	3.7	5.8	8.6	10.5	16.2	21.0	25.7
CT-Output Cur. Max.	[A]	1.4	2.7	3.9	6.1	9.0	11.0	17.0	22.0	27.0
CT Input Current	[A]	2.0	3.2	4.4	6.9	9.4	12.3	18.1	24.2	29.5
VT Input Current	[A]	3.2	4.4	6.9	9.4	12.6	18.1	24.9	29.8	35.1
VT-Output Cur. Max.	[A]	2.7	3.9	6.1	9.0	11.0	17.0	22.0	27.0	32.0
Recommended Fuse	[A]	10	10	10	10	16	25	32	35	50
	3NA	3803-6	3803-6	3803-6	3803-6	3805-6	3810-6	3812-6	3814-6	3820-6
Fuses for UL specified	[A]								35	50
	3NE	*	*	*	*	*	*	*	1803-0	1817-0
Input Cable Min.	[mm ²]	1.0	1.0	1.0	1.0	1.5	2.5	4.0	6.0	6.0
	[awg]	17	17	17	17	15	13	11	9	9
Input Cable Max.	[mm ²]	10.0	10.0	10.0	10.0	10.0	10.0	10.0	35.0	35.0
	[awg]	7	7	7	7	7	7	7	2	2
Output Cable Min.	[mm ²]	1.0	1.0	1.0	1.0	1.0	2.5	4.0	4.0	6.0
	[awg]	17	17	17	17	17	13	11	11	9
Output Cable Max.	[mm ²]	10.0	10.0	10.0	10.0	10.0	10.0	10.0	35.0	35.0
	[awg]	7	7	7	7	7	7	7	2	2
Weight	[kg]	5.5	5.5	5.5	5.5	5.5	5.5	5.5	16.0	16.0
	[lbs]	12.1	12.1	12.1	12.1	12.1	12.1	12.1	35.0	35.0
Dimensions	B [mm]	185.0	185.0	185.0	185.0	185.0	185.0	185.0	275.0	275.0
	H [mm]	245.0	245.0	245.0	245.0	245.0	245.0	245.0	520.0	520.0
	T [mm]	195.0	195.0	195.0	195.0	195.0	195.0	195.0	245.0	245.0
	B [Inches]	7.28	7.28	7.28	7.28	7.28	7.28	7.28	10.83	10.83
	H [Inches]	9.65	9.65	9.65	9.65	9.65	9.65	9.65	20.47	20.47
	T [Inches]	7.68	7.68	7.68	7.68	7.68	7.68	7.68	9.65	9.65

* UL listed fuses such as Class NON from Bussmann are required for use in America

Input voltage range 3 AC 500 V – 600 V, ± 10 % (Unfiltered), Part 2

Order No.	6SE6440-	2UE32-2DA1	2UE33-0EA1	2UE33-7EA1	2UE34-5FA1	2UE35-5FA1	2UE37-5FA1
Motor Output Rating	[kW]	22.0	30.0	37.0	45.0	55.0	75.0
	[hp]	30.0	40.0	50.0	60.0	75.0	100.0
Output Power	[kVA]	30.5	39.1	49.5	59.1	73.4	94.3
CT-Output Cur. Max.	[A]	32.0	41.0	52.0	62.0	77.0	99.0
CT Input Current	[A]	34.7	47.2	57.3	69.0	82.9	113.4
VT Input Current	[A]	47.5	57.9	69.4	83.6	113.4	137.6
VT-Output Cur. Max.	[A]	41.0	52.0	62.0	77.0	99.0	125.0
Recommended Fuse	[A]	63	80	80	125	125	160
	3NA	3822-6	3824-6	3824-6	3132-6	3132-6	3136-6
Fuses for UL specified	[A]	63	80	80	125	125	160
	3NE	1818-0	1820-0	1820-0	1022-0	1022-0	1224-0
Input Cable Min.	[mm ²]	10.0	16.0	25.0	25.0	50.0	70.0
	[awg]	7	5	3	3	0	-2
Input Cable Max.	[mm ²]	35.0	35.0	35.0	150.0	150.0	150.0
	[awg]	2	2	2	-5	-5	-5
Output Cable Min.	[mm ²]	10.0	16.0	16.0	25.0	35.0	50.0
	[awg]	7	5	5	3	2	0
Output Cable Max.	[mm ²]	35.0	35.0	35.0	150.0	150.0	150.0
	[awg]	2	2	2	-5	-5	-5
Weight	[kg]	16.0	20.0	20.0	56.0	56.0	56.0
	[lbs]	35.0	44.0	44.0	123.0	123.0	123.0
Dimensions	B [mm]	275.0	275.0	275.0	350.0	350.0	350.0
	H [mm]	520.0	650.0	650.0	850.0	850.0	850.0
	T [mm]	245.0	245.0	245.0	320.0	320.0	320.0
	B [Inches]	10.83	10.83	10.83	13.78	13.78	13.78
	H [Inches]	20.47	25.59	25.59	33.46	33.46	33.46
	T [Inches]	9.65	9.65	9.65	12.6	12.6	12.6

8 Options

An overview of the options available for the MICROMASTER 440 is given in this section. For further information about options, please refer to the catalog or the documentation CD.

8.1 Device-independent options

- Basic Operator Panel (BOP)
- Advanced Operator Panel (AOP)
- PROFIBUS module
- PC to inverter connection kit
- PC to AOP connection kit
- BOP/AOP door mounting kit for single inverter control
- AOP door mounting kit for multiple inverter control
- "DriveMonitor" and "Starter" commissioning tool

8.2 Device-dependent options

Frame Sizes A to F

- EMC filter, Class A
- EMC filter, Class B
- Additional EMC filter, Class B
- Low leakage Class B filter
- Line commutating choke
- Output choke
- Gland plate

Frame Sizes FX and GX

- Line commutating choke
- EMC filter, Class A (power commutating choke required)

9 Electro-magnetic compatibility (EMC)

This Chapter contains:

EMC information.

9.1	Electro-magnetic compatibility	120
-----	--------------------------------------	-----

9.1 Electro-magnetic compatibility

(EMC) All manufacturers / assemblers of electrical apparatus which “performs a complete intrinsic function and is placed on the market as a single unit intended for the end user” must comply with the EMC directive 89/336/EEC.

There are three routes for the manufacturer/assembler to demonstrate compliance:

9.1.1 Self-certification

This is a manufacturer's declaration that the European standards applicable to the electrical environment for which the apparatus is intended have been met. Only standards that have been officially published in the Official Journal of the European Community can be cited in the manufacturer's declaration.

9.1.2 Technical construction file

A technical construction file can be prepared for the apparatus describing its EMC characteristics. This file must be approved by a ‘Competent Body’ appointed by the appropriate European government organization. This approach allows the use of standards that are still in preparation.

9.1.3 EC type examination certificate

This approach is only applicable to radio communication transmitting apparatus. All MICROMASTER units are certified for compliance with the EMC directive, when installed in accordance with the recommendations in Section 2.

9.1.4 EMC Directive Compliance with Imminent Harmonics Regulations

From 1st January 2001 all electrical apparatus covered by the EMC Directive will have to comply with EN 61000-3-2 "Limits for harmonic current emissions (equipment input ≤ 16 A per phase)".

All Siemens variable speed drives of the MICROMASTER, MIDIMASTER, MICROMASTER Eco and COMBIMASTER ranges, which are classified as "Professional Equipment" within the terms of the standard, fulfill the requirements of the standard.

The allowed harmonic currents for "professional equipment" with an input power > 1 kW are not yet defined. Therefore, any electrical apparatus containing the above drives which has an input power > 1 kW will not require connection approval.

Only Frame Sizes A – C

Special considerations for 250 W to 550 W drives with 230 V 1ac mains supplies when used in non-industrial applications:

Units in this voltage and power range will be supplied with the following warning:

"This equipment requires supply authority acceptance for connection to the public supply network". Please refer to EN 61000-3-12 sections 5.3 and 6.4 for further information. Units connected to Industrial Networks¹ do not require connection approval (see EN 61800-3, section 6.1.2.2).

The harmonic current emissions from these products are described in the table below:

Table 9-1 Permissible harmonic current emissions

Rating	Typical Harmonic Current (A)					Typical Harmonic Current (%)					Typical Voltage Distortion		
											Distribution Transformer Rating		
	3 rd	5 th	7 th	9 th	11 th	3 rd	5 th	7 th	9 th	11 th	10 kVA	100 kVA	1 MVA
											THD (%)	THD (%)	THD (%)
250 W 1AC 230 V	2.15	1.44	0.72	0.26	0.19	83	56	28	10	7	0.77	0.077	0.008
370 W 1AC 230 V	2.96	2.02	1.05	0.38	0.24	83	56	28	10	7	1.1	0.11	0.011
550 W 1AC 230 V	4.04	2.70	1.36	0.48	0.36	83	56	28	10	7	1.5	0.15	0.015

The allowed harmonic currents for "professional equipment" with an input power > 1 kW are not yet defined. Therefore, any electrical apparatus containing the above drives which has an input power > 1 kW will not require connection approval.

Alternatively, the necessity to apply for connection approval can be avoided by fitting the input chokes recommended in the technical catalogues (except 550 W 230 V 1ac units).

¹ Industrial Networks are defined as those which do not supply buildings used for domestic purposes.

9.1.5 Classification of EMC performance

General classes of EMC performance are available as detailed below:

Class 1: General Industrial

Compliance with the EMC Product Standard for Power Drive Systems EN 68100-3 for use in **Second Environment (Industrial)** and **Restricted Distribution**.

Table 9-2 Class 1 - General Industrial

EMC Phenomenon		Standard	Level
Emissions:	Radiated Emissions	Frame Sizes A - F EN 55011	Level A1
		Frame Sizes FX, GX EN 68100-3	Second Environment
	Conducted Emissions	Frame Sizes A - F EN 55011	Level A1
		Frame Sizes FX, GX EN 68100-3	Second Environment
Immunity:	Electrostatic Discharge	EN 61000-4-2	8 kV air discharge
	Burst Interference	EN 61000-4-4	2 kV power cables, 1 kV control
	Radio Frequency Electromagnetic Field	IEC 1000-4-3	26-1000 MHz, 10 V/m

Class 2: Filtered Industrial

This level of performance will allow the manufacturer/assembler to self-certify their apparatus for compliance with the EMC directive for the industrial environment as regards the EMC performance characteristics of the power drive system. Performance limits are as specified in the Generic Industrial Emissions and Immunity standards EN 50081-2 and EN 50082-2.

Table 9-3 Class 2 - Filtered Industrial

EMC Phenomenon		Standard	Level
Emissions:	Radiated Emissions	EN 55011	Level A1
	Conducted Emissions	EN 55011	Level A1
Immunity:	Supply Voltage Distortion	IEC 1000-2-4 (1993)	
	Voltage Fluctuations, Dips, Unbalance, Frequency Variations	IEC 1000-2-1	
	Magnetic Fields	EN 61000-4-8	50 Hz, 30 A/m
	Electrostatic Discharge	EN 61000-4-2	8 kV air discharge
	Burst Interference	EN 61000-4-4	2 kV power cables, 2 kV control
	Radio Frequency Electromagnetic Field, amplitude modulated	ENV 50 140	80-1000 MHz, 10 V/m, 80% AM, power and signal lines
	Radio-frequency Electromagnetic Field, pulse modulated	ENV 50 204	900 MHz, 10 V/m 50% duty cycle, 200 Hz repetition rate

Only Frame Sizes A – F

Class 3: Filtered - for residential, commercial and light industry

This level of performance will allow the manufacturer / assembler to self-certify compliance of their apparatus with the EMC directive for the residential, commercial and light industrial environment as regards the EMC performance characteristics of the power drive system. Performance limits are as specified in the generic emission and immunity standards EN 50081-1 and EN 50082-1.

Table 9-4 Class 3 - Filtered for Residential, Commercial and Light Industry

EMC Phenomenon		Standard	Level
Emissions:	Radiated Emissions*	EN 55011	Level B
	Conducted Emissions	EN 55011	Level B
Immunity:	Supply Voltage Distortion	IEC 1000-2-4 (1993)	
	Voltage Fluctuations, Dips, Unbalance, Frequency Variations	IEC 1000-2-1	
	Magnetic Fields	EN 61000-4-8	50 Hz, 30 A/m
	Electrostatic Discharge	EN 61000-4-2	8 kV air discharge
	Burst Interference	EN 61000-4-4	2 kV power cables, 2 kV control
	Radio Frequency Electromagnetic Field, amplitude modulated	ENV 50 140	80-1000 MHz, 10 V/m, 80% AM, power and signal lines
	Radio-frequency Electromagnetic Field, pulse modulated	ENV 50 204	900 MHz, 10 V/m 50% duty cycle, 200 Hz repetition rate

* These limits are dependent on the inverter being correctly installed inside a metallic switchgear enclosure. The limits will not be met if the inverter is not enclosed.

Notes

- To achieve these performance levels, you must not exceed the default Pulse frequency nor use cables longer than 25 m.
- The MICROMASTER inverters are intended **exclusively for professional applications**. Therefore, they do not fall within the scope of the harmonics emissions specification EN 61000-3-2.
- Maximum mains supply voltage when filters are fitted is 460 V.

Table 9-5 Compliance Table

Frame Sizes A - F

Model	Remarks
Class 1 – General Industrial	
6SE6440-2U***.**A0	Unfiltered units, all voltages and powers.
Class 2 – Filtered Industrial	
6SE6440-2A***.**A0	All units with integral Class A filters
6SE6440-2A***.**A0 with 6SE6440-2FA00-6AD0	Frame size A units 400-480 V with external Class A footprint filters
Class 3 – Filtered for residential, commercial and light industry	
6SE6440-2U***.**A0 with 6SE6400-2FB0*.**A0	Unfiltered units fitted with external Class B footprint filters.
* denotes any value is allowed.	

Frame Sizes FX - GX

Model	Remarks
Class 1 – General Industrial	
6SE6440-2U***.**A0	Unfiltered units, all voltages and powers.
Class 2 – Filtered Industrial	
6SE6440-2U***.**A0	With EMI filter (available as an option) the limiting values of the EN 55011, Class A are fulfilled for conducted emission. (line commutating choke required)

Appendices

A Changing the Operator Panel

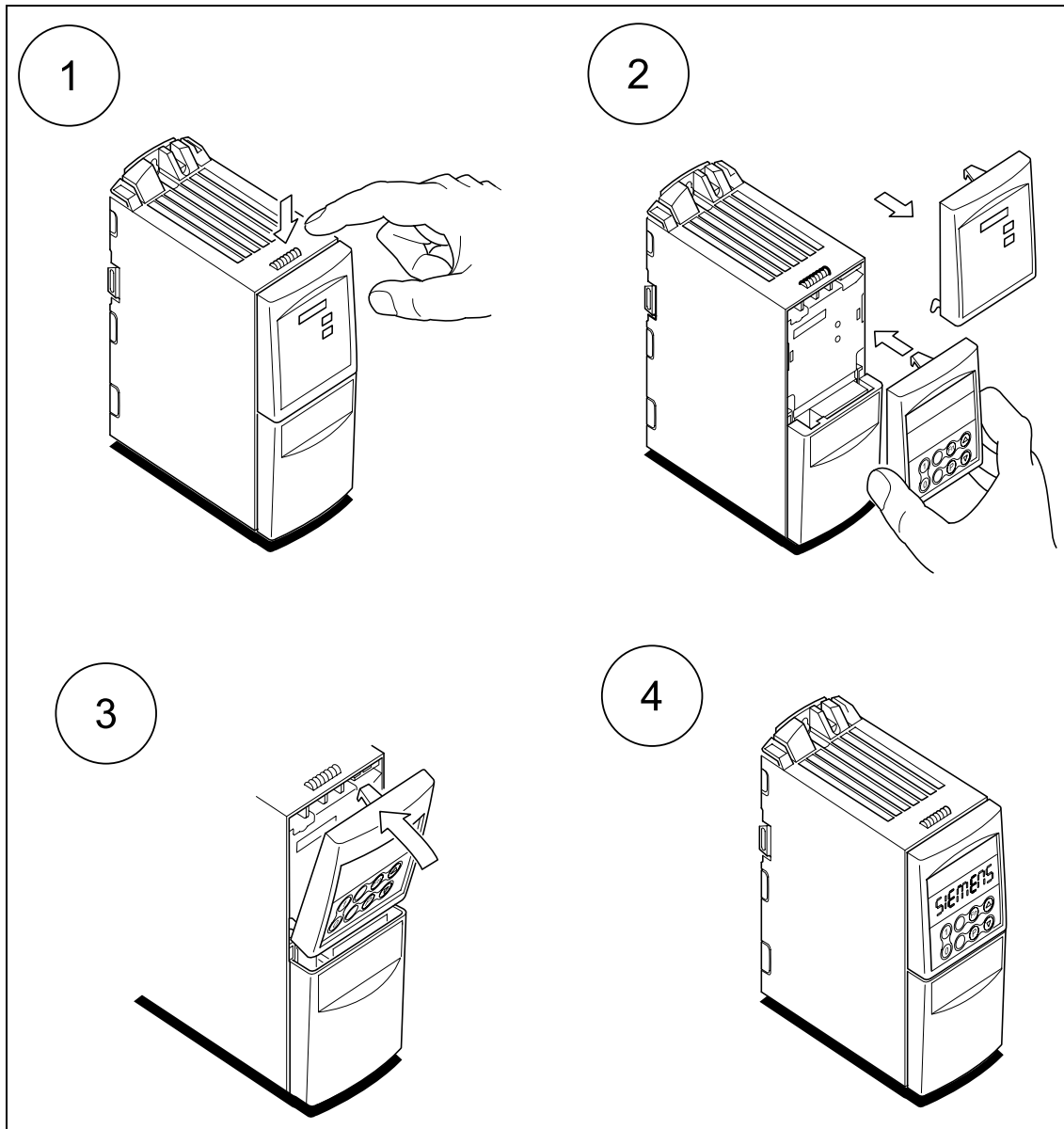

B Removing Covers

B.1 Removing Covers, Frame Size A

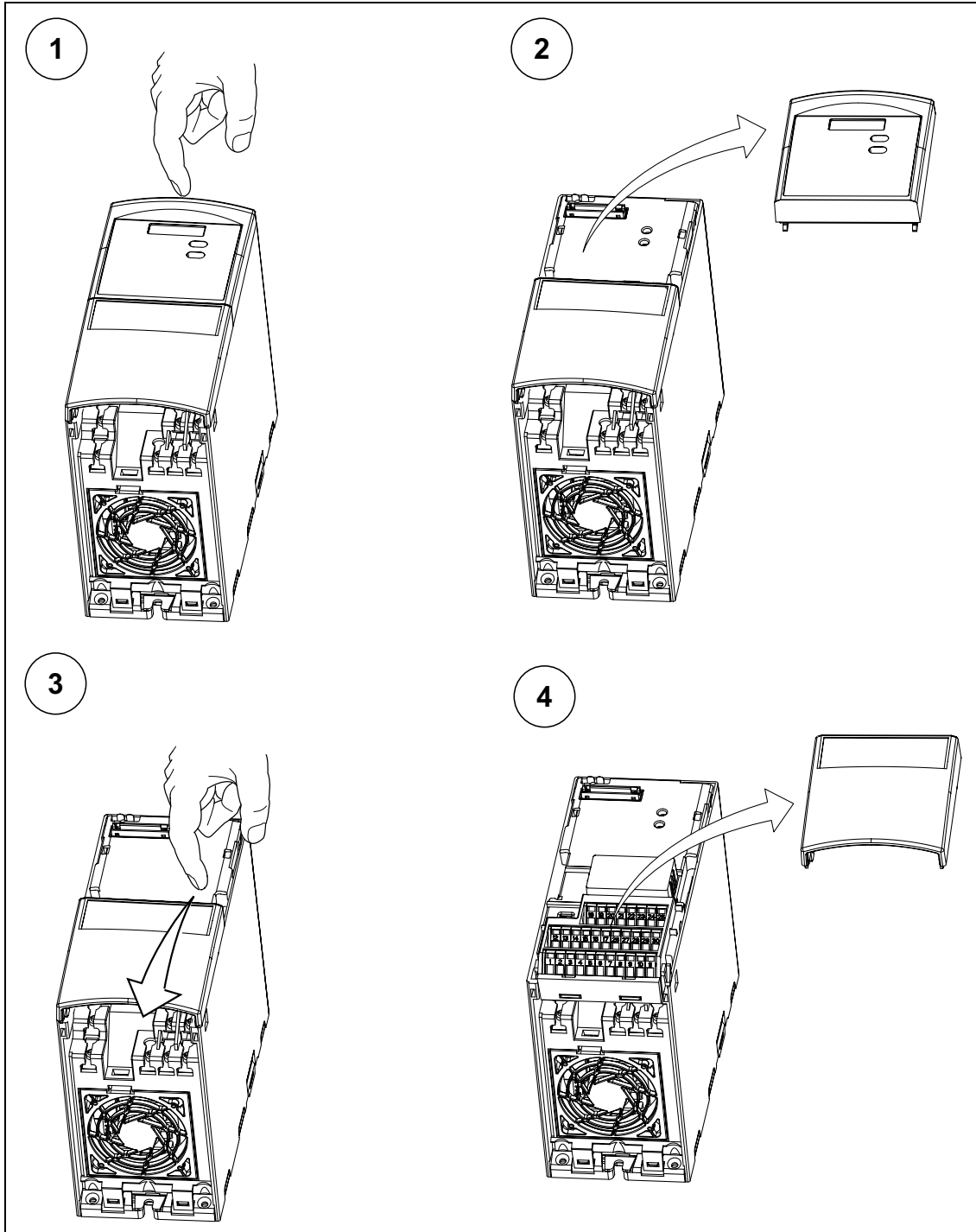

B.2 Removing Covers, Frame Size B und C

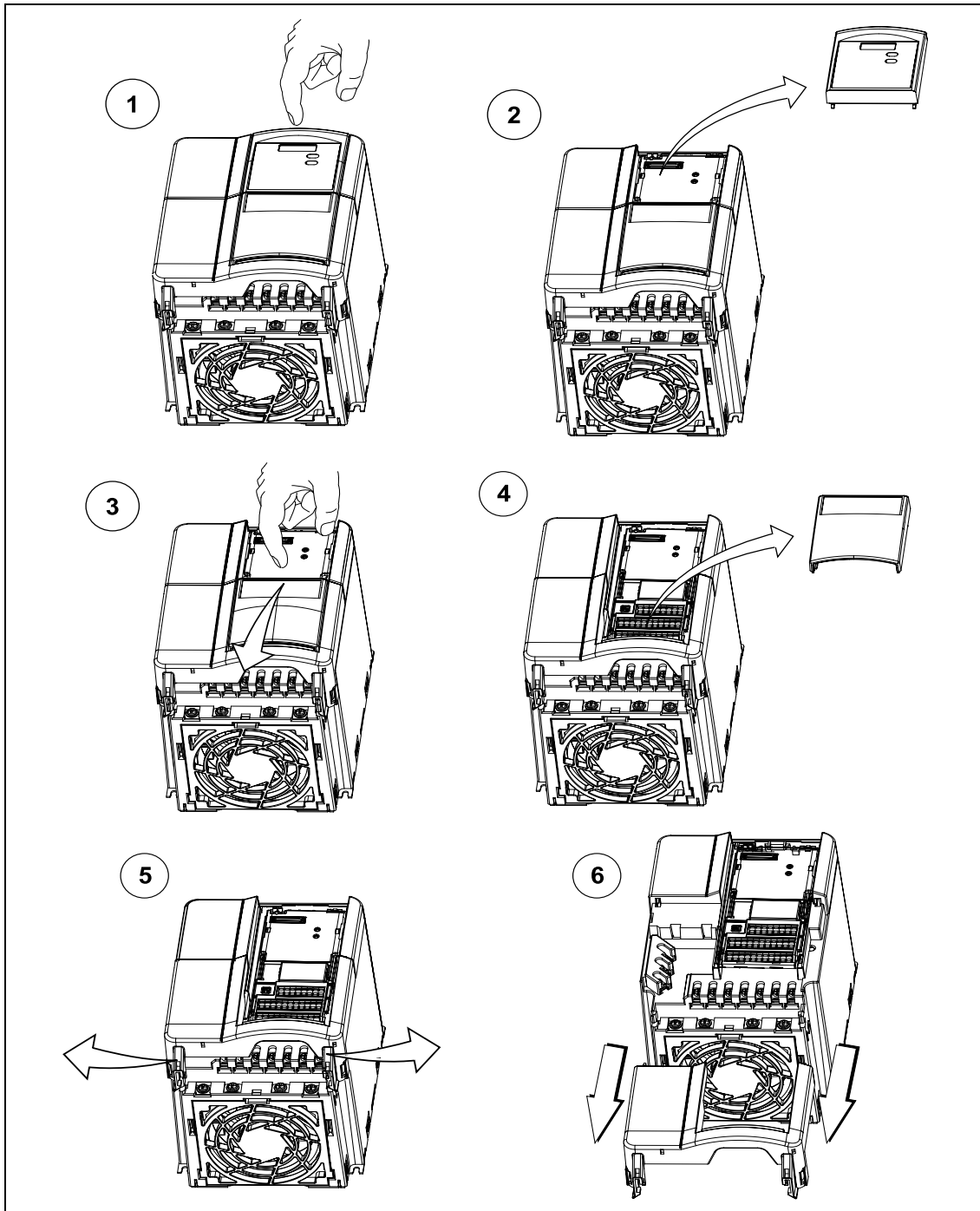

B.3 Removing Covers, Frame Size D und E

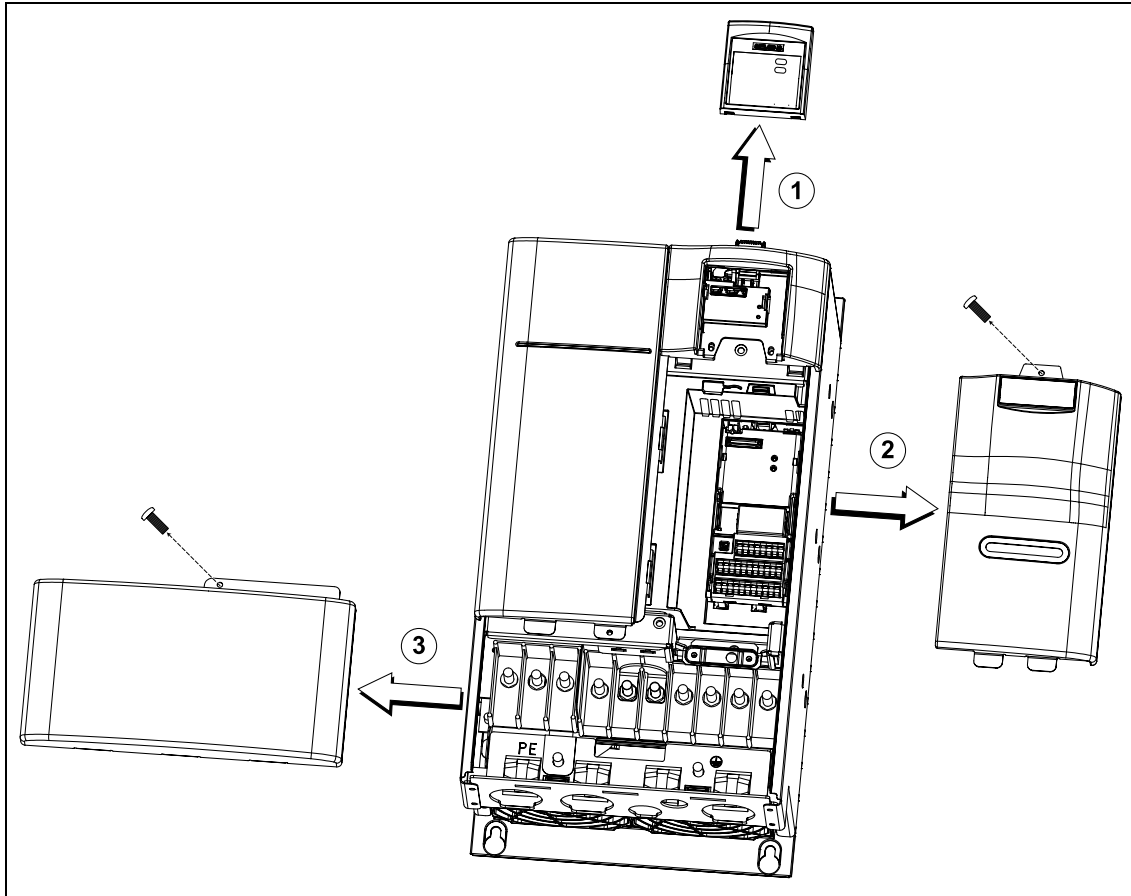

B.4 Removing Covers, Frame Size F

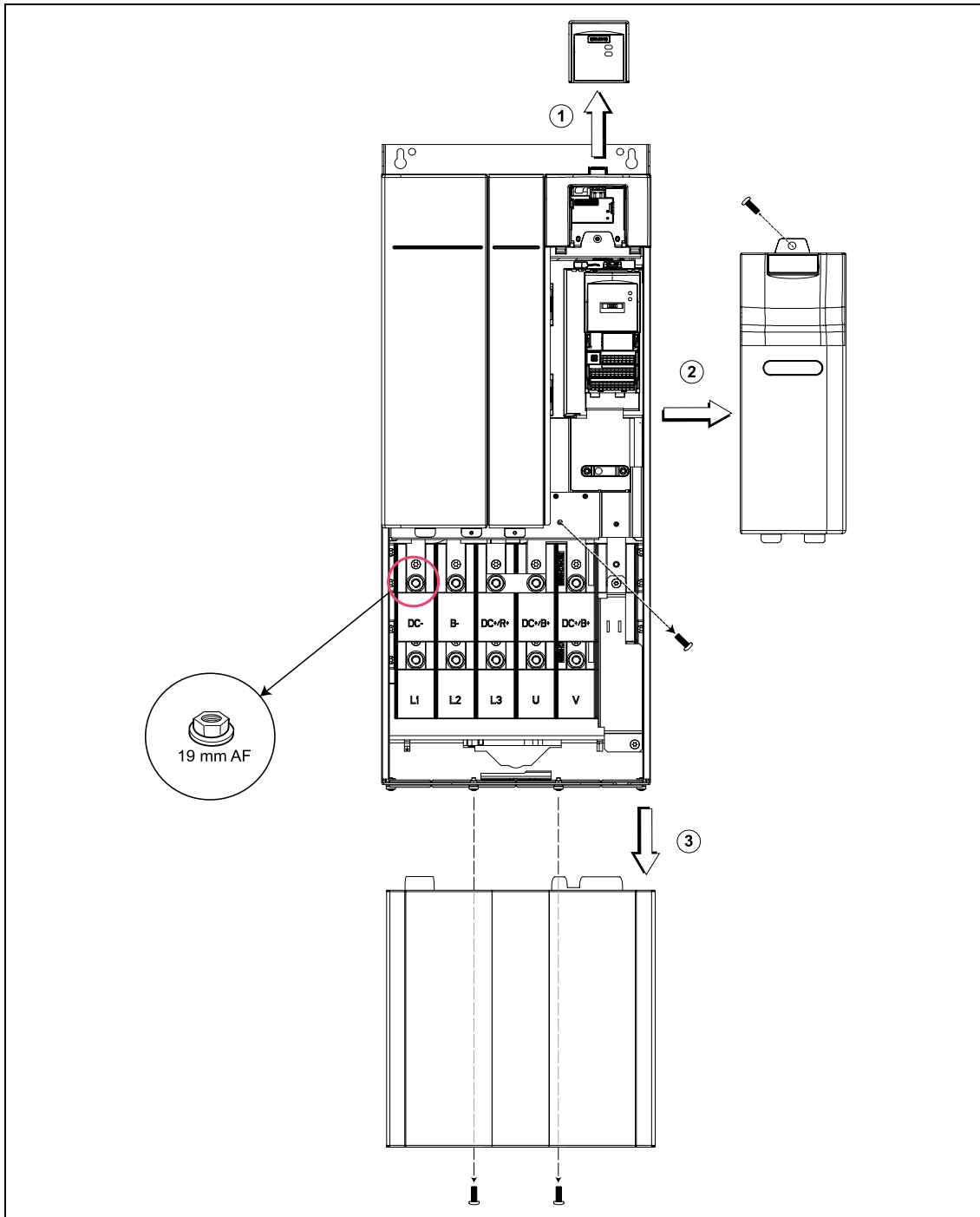

C Removing the I/O Board

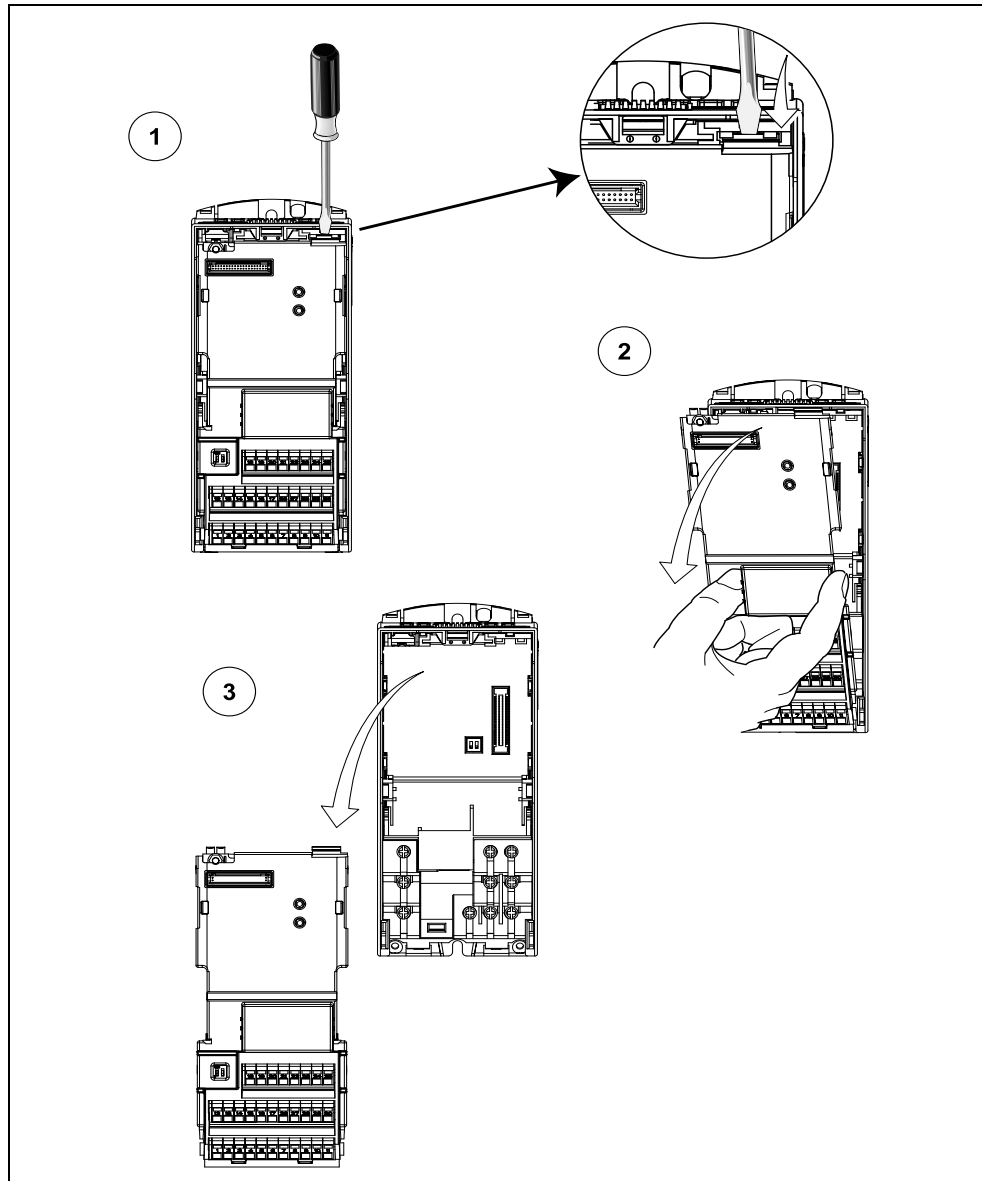

NOTICE

1. Only a small amount of pressure is required to release the I/O Board catch.

D Removing 'Y' Cap

D.1 Removing 'Y' Cap, Frame Size A

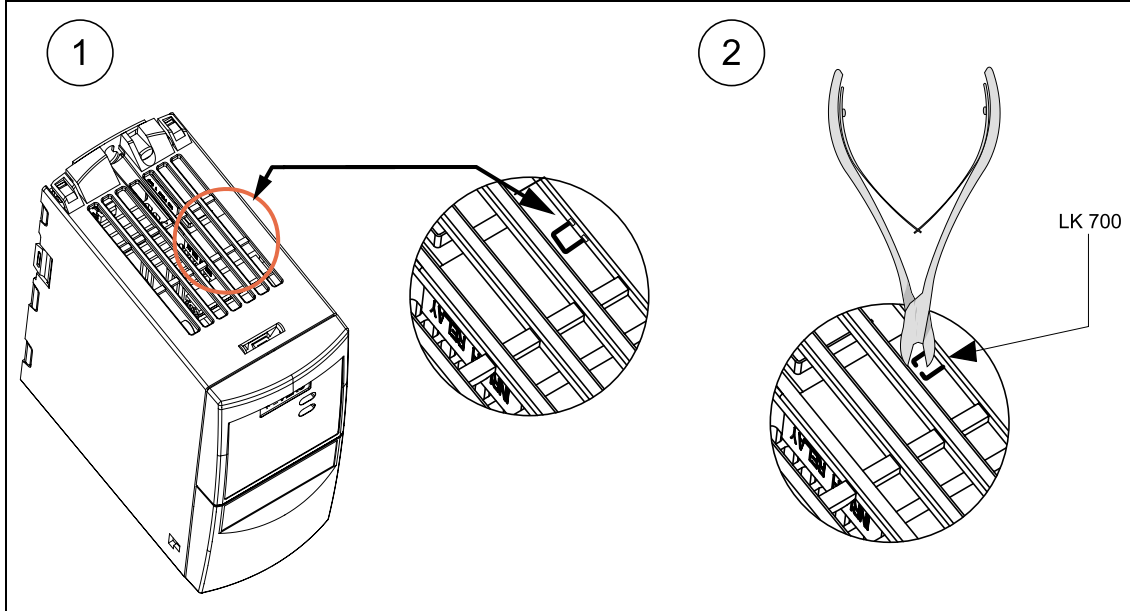

D.2 Removing 'Y' Cap, Frame Size B und C

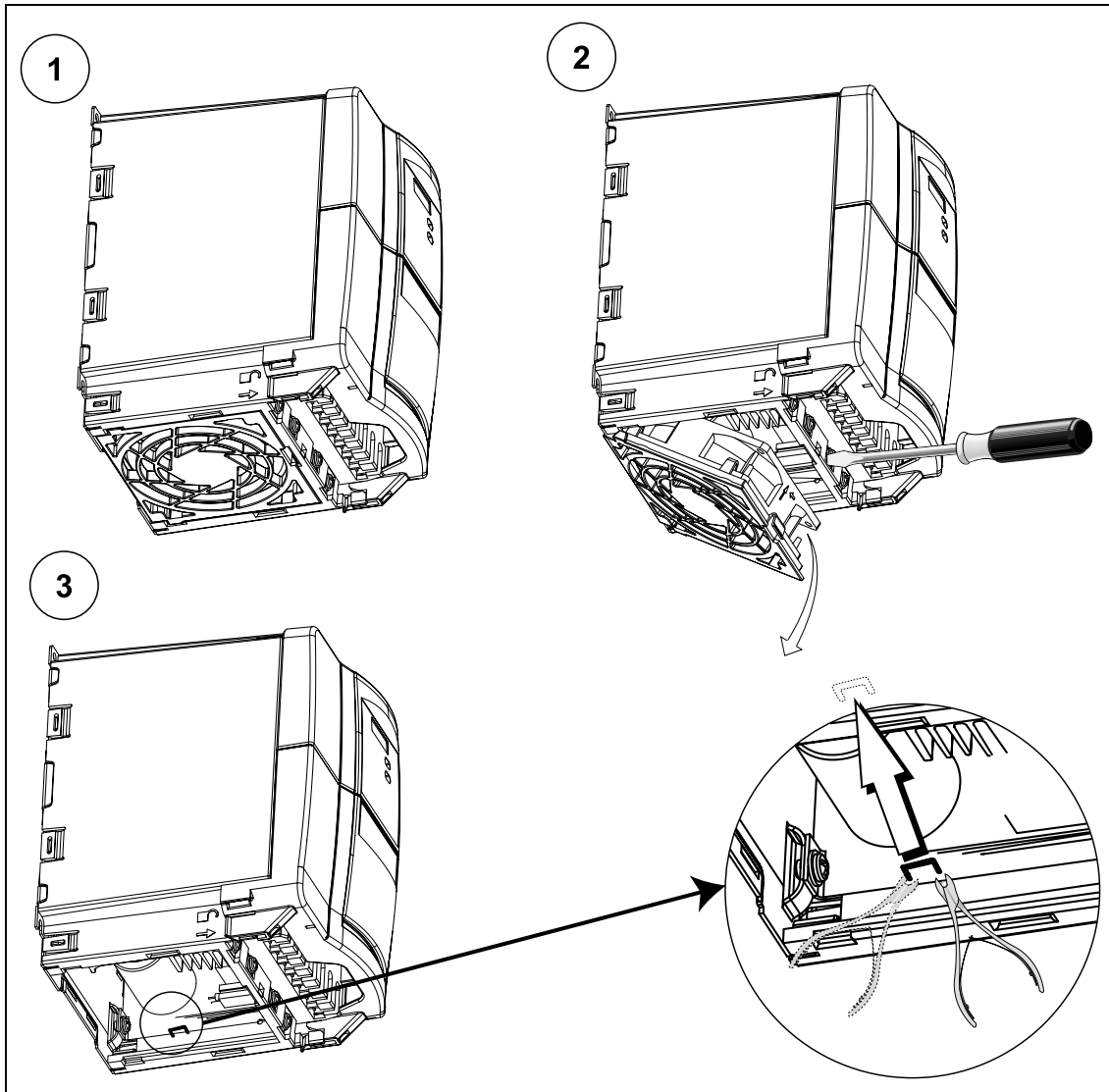

D.3 Removing 'Y' Cap, Frame Size D und E

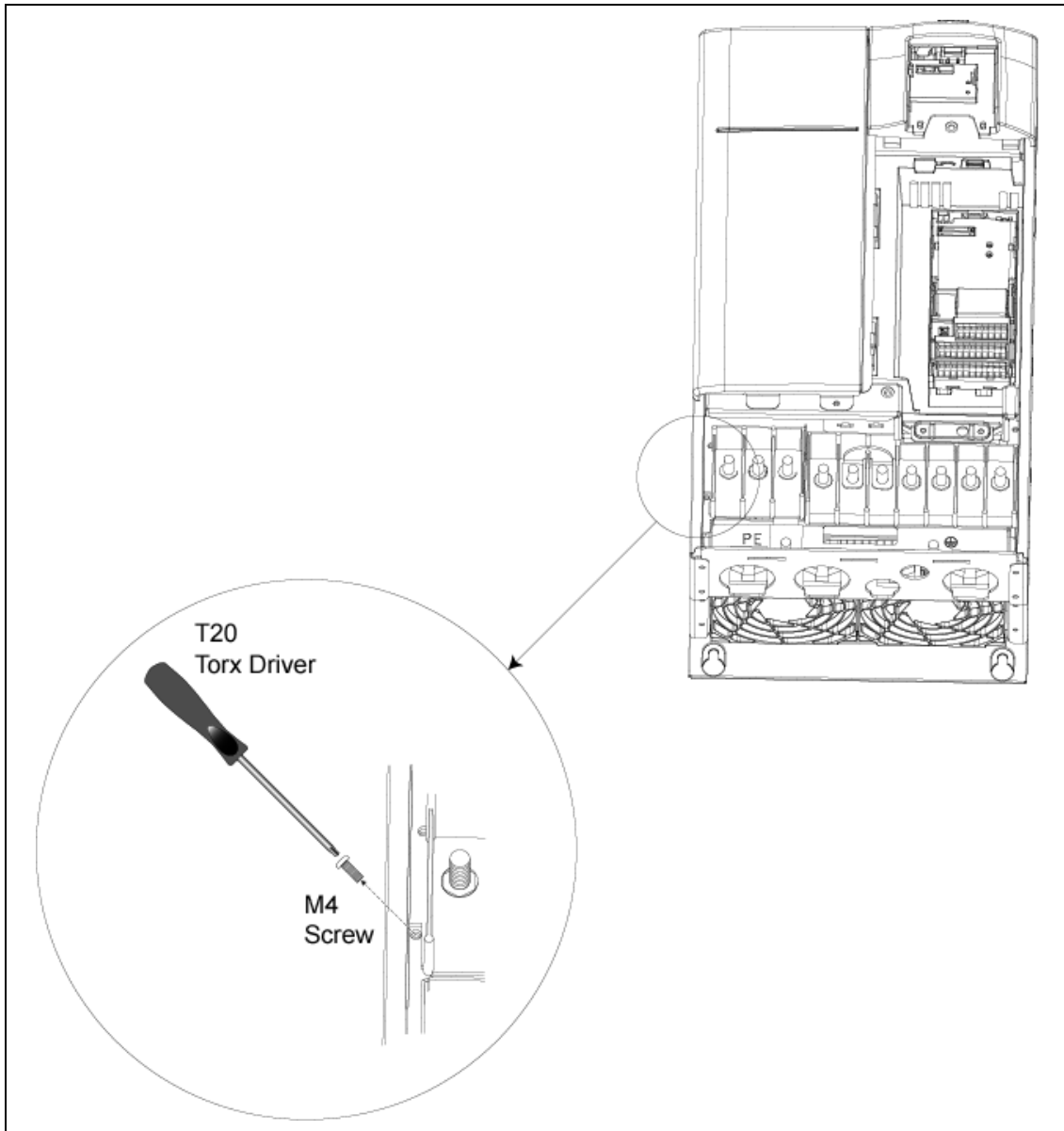

D.4 Removing 'Y' Cap, Frame Size F

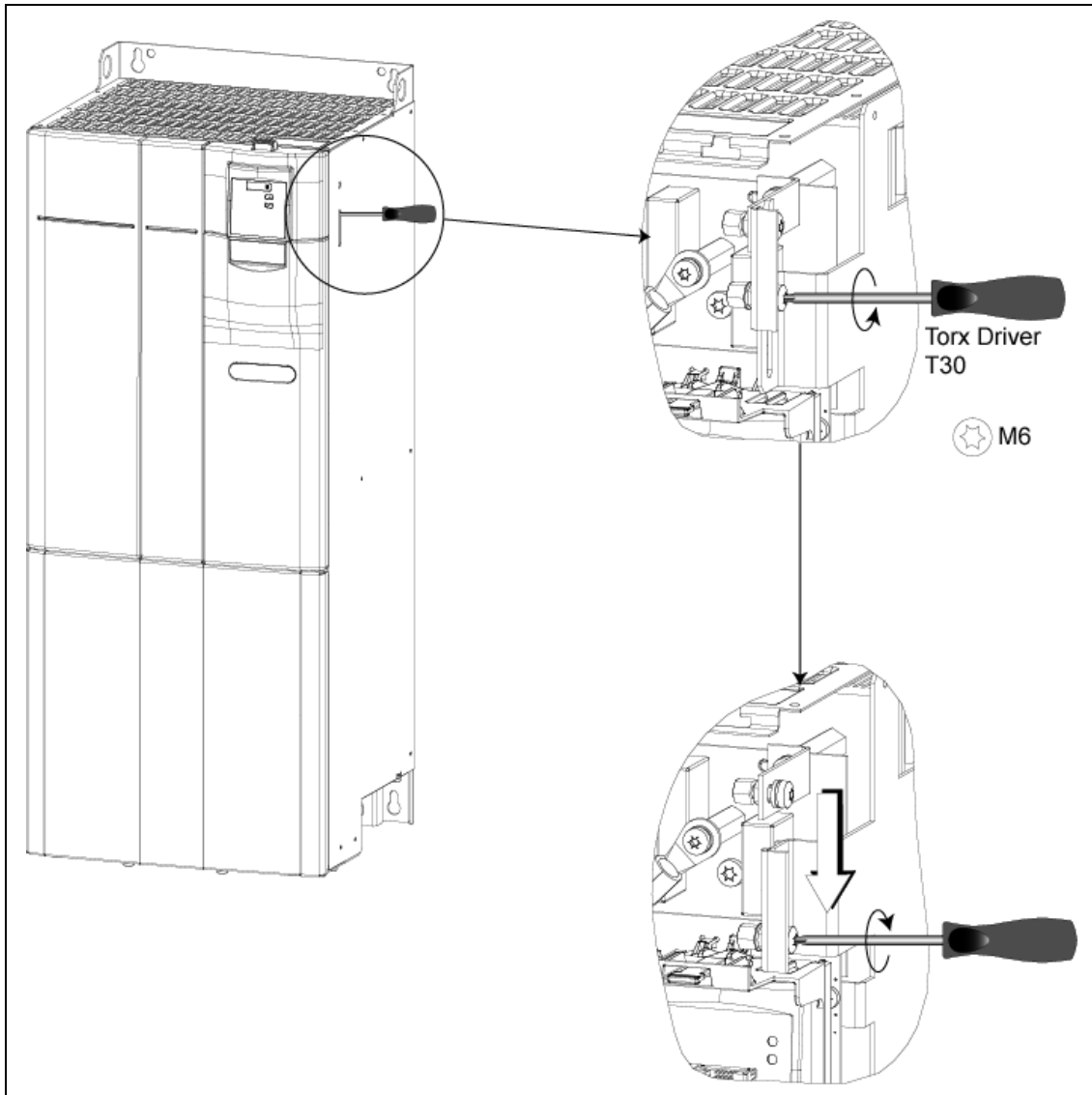

D.5 Removing 'Y' Cap, Frame Size FX

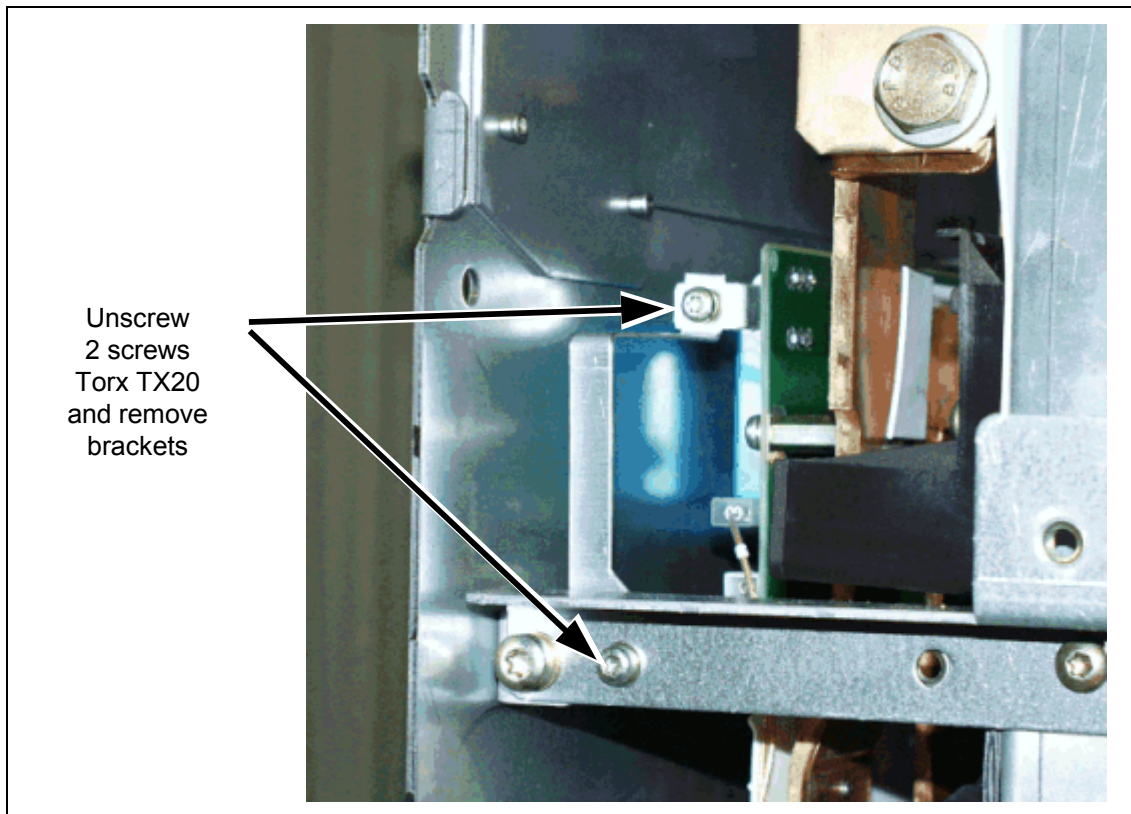

D.6 Removing 'Y' Cap, Frame Size GX

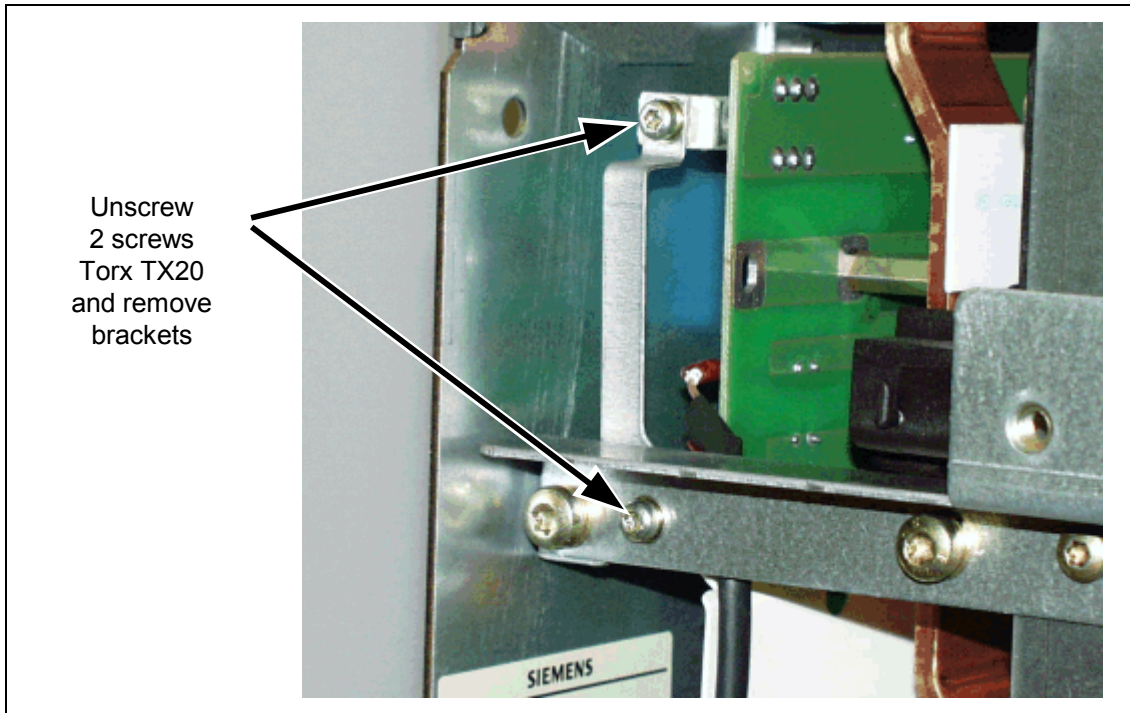

E Applicable Standards



European Low Voltage Directive

The MICROMASTER product range complies with the requirements of the Low Voltage Directive 73/23/EEC as amended by Directive 98/68/EEC. The units are certified for compliance with the following standards:

EN 60146-1-1 Semiconductor inverters - General requirements and line commutated inverters

EN 60204-1 Safety of machinery - Electrical equipment of machines

European Machinery Directive

The MICROMASTER inverter series does not fall under the scope of the Machinery Directive. However, the products have been fully evaluated for compliance with the essential Health & Safety requirements of the directive when used in a typical machine application. A Declaration of Incorporation is available on request.

European EMC Directive

When installed according to the recommendations described in this manual, the MICROMASTER fulfils all requirements of the EMC Directive as defined by the EMC Product Standard for Power Drive Systems EN61800-3.



Underwriters Laboratories

UL and CUL LISTED POWER CONVERSION EQUIPMENT 5B33 for use in a pollution degree 2.

NOTE: UL certification is presently in progress

ISO 9001

Siemens plc operates a quality management system, which complies with the requirements of ISO 9001.

F List of Abbreviations

AC	Alternating Current
AIN	Analog Input
AOP	Advanced Operator Panel
BOP	Basic Operator Panel
CT	Constant Torque
DC	Direct Current
DIN	(Digital Input
DS	Drive State
EEC	European Economic Community
ELCB	Earth Leakage Circuit Breaker
EMC	Electro-Magnetic Compatibility
EMI	Electro-Magnetic Interference
FAQ	Frequently Asked Questions
FCC	Flux Current Control
FCL	Fast Current Limitation
I/O	Input and Output
IGBT	Insulated Gate Bipolar Transistor
LCD	Liquid Crystal Display
LED	Light Emitting Diode
PID	Proportional, Integral und Differential
PLC	Programmable Logic Controller
PTC	Positive Temperature Coefficient
QC	Quick Commissioning
RCCB	Residual Current Circuit Breaker
RCD	Residual Current Device
RPM	Revolutions Per Minute
SDP	Status Display Panel
VT	Variable Torque

Index

- Access Levels 66
- Adaptation of fan voltage 38
- Altitude 22
- Ambient operating conditions
 - Altitude 22
 - Atmospheric Pollution 23
 - Electromagnetic Radiation 22
 - Humidity Range 22
 - Installation und Kühlung 23
 - Shock 22
 - Temperature 22
 - Vibration 22
 - Water hazard 23
- Ambient operating conditions 22
- AOP
 - operation with AOP 52
- Applicable standards
 - European EMC Directive 137
 - European Low Voltage Directive 137
 - European Machinery Directive 137
 - ISO 9001 137
 - Underwriters Laboratories 137
- Atmospheric pollution 23
- Basic operation
 - changing parameters with BOP 51
 - external motor thermal overload protection 55, 57
 - general 56
 - with BOP 56
 - with SDP 47
- BOP
 - default settings with BOP 49
 - operation with BOP 49
- Brake unit 33
- Changing the Operator Panel 125
- Commissioning 41
- Compound Braking 62
- Connection drawing
 - FX 35
 - GX 36
- Connection of brake unit 33
- Connection Terminals 34
- Contact address 5
- Control Modes 63
- Current reduction depending on pulse frequency 104
- DC braking 62
- Default settings 49
- Dimensions and Torques 28
- Drill pattern for MICROMASTER 440 25
- Dynamic braking 62
- Electrical Installation 31
- Electro-Magnetic Compatibility
 - EC type-examination certificate 120
 - general 119, 120
 - self-certification 120
 - technical construction file 120
- Electro-Magnetic Interference 39
 - avoiding EMI 39
- Electromagnetic radiation 22
- EMC 120
- EMC Directive Compliance 121
- EMC performance
 - filtered for residential, commercial and light industry 123
 - filtered industrial class 122
 - general industrial class 122
- EMI 39
- Fan fuses 38
- Fault messages
 - with the BOP fitted 91
 - with the SDP fitted 90
- Faults and warnings
 - AOP fitted 64
 - BOP fitted 64
 - SDP fitted 64
- Features 17
- Flux Current Control 63
- Foreword 5
- Frequency Setpoint 60
- Humidity Range 22
- Installation 19
 - after a period of storage 19, 21
- Installation dimensions for MICROMASTER 440 Version FX 26

- Installation dimensions for MICROMASTER 440 Version GX 28
- Installation of options in the electronic box 30
- Installation und Kühlung 23
- Internet Home Address 5
- Inverter block diagram 43
- Linear V/f control 63
- Long cables
 - operation with 32
- Main characteristics 17
- Mechanical Installation 24
- MICROMASTER 440
 - general 16
 - main characteristics 17
 - performance characteristics 18
 - protection characteristics 18
 - specifications 101
- Motor connections 33
- Motor data 55
- Mounting on Hutschiene 29
- Multi-point V/f control 63
- Operation
 - starting and stopping the motor 61
- Operation with
 - long cables 32
 - Residual Current Device 32
 - ungrounded IT supplies 32
- Operator panels
 - AOP 52
 - BOP 49
 - SDP 46
- Options
 - Device-dependent options 117
 - Device-independent options 117
- Options for electronic box 30
- Overview 15
- Parameters
 - changing parameters with BOP 51
 - system parameters 65
- Performance characteristics 18
- Performance Ratings 102
- Power and motor connections 33
 - single phase 37
- Power connections 33
- Protection characteristics 18
- Quadratic V/f control 63
- Qualified personnel 6
- Quick commissioning 52
- Removing 'Y' Cap
 - Frame Size A 131
 - Frame Size B und C 132
 - Frame Size D und E 133
 - Frame Size F 134
 - Frame Size FX 135
 - Frame Size GX 136
- Removing Covers
 - Frame Size A 126
 - Frame Size B und C 127
 - Frame Size D und E 128
 - Frame Size F 129
- Reset to Factory default 55
- Residual Current Device
 - operation with 32
- Safety instructions 7
- Screening Methods 39
- SDP
 - Default settings 46
 - operation with SDP 46
- Sensorless Vector Control 63
- Shock 22
- Specifications 105
- Technical Support 5
- Terminal Torques 103
- Torque Control 63
- Troubleshooting 89
- Ungrounded (IT) supplies
 - operation with 32
- Warnings, cautions & notes
 - commissioning 8
 - definitions 6
 - dismantling & disposal 9
 - general 7
 - operation 9
 - repair 9
 - transport & storage 8
- Water hazard 23
- Wiring Guidelines EMI 40

Suggestions and/or Corrections

<p>To: Siemens AG Automation & Drives Group SD VM 4 P.O. Box 3269 D-91050 Erlangen Federal Republic of Germany</p> <p>Email: Technical.documentation@con.siemens.co.uk</p>	<p>Suggestions</p> <hr/> <p>Corrections</p> <p>For Publication/Manual: MICROMASTER 440 0.12 kW - 200 kW</p> <hr/> <p>User Documentation</p>
<p>From</p> <p>Name: _____</p> <p>Company/Service Department _____</p> <p>Address: _____ _____ _____</p> <p>Telephone: _____ / _____</p> <p>Telefax: _____ / _____</p>	<p>Operating Instructions</p> <p>Order Number: 6SE6400-5AW00-0BP0</p> <p>Date of Issue: 04/02</p> <hr/> <p>Should you come across any printing errors when reading this publication, please notify us on this sheet.</p> <p>Suggestions for improvement are also welcome.</p>

Order Number

6SE6400-5AW00-0BP0

Drawing Number

G85139-K1790-U249-A1

Siemens AG
Bereich Automation and Drives (A&D)
Geschäftsgebiet Standard Drives (SD)
Postfach 3269, D-91050 Erlangen
Federal Republic of Germany

© Siemens AG, 2002
Subject to change without prior notice

Siemens Aktiengesellschaft

Order No.: 6SE6400-5AW00-0BP0
Date: 04/02

