

SIEMENS



BACnet PTEC Controller

**Unit Conditioner - VAV Pressure
Dependent Cooling or Heating,
Application 6640**

Application Note

Table of Contents

Overview	4
BACnet	5
Hardware Inputs	6
Room Unit Identification	6
Hardware Outputs.....	6
Ordering Notes	6
Sequence of Operation	7
Control Temperature Setpoints	7
CTL STPT Using Standard/Absolute Mode (Digital Room Unit, Revision 26 and later)	8
CTL STPT Using Warmer/Cooler Mode (Digital Room Unit, Revision 26 and later)	8
CTL STPT Using Standard/Absolute Mode (Analog or Digital Room Unit)	9
CTL STPT Using Warmer/Cooler Mode (Analog Room Unit Only)	9
Heating/Cooling Switchover.....	10
Room Temperature, Room Temperature Offset and CTL TEMP.....	10
Day and Night Modes	11
Night Mode Override Switch	11
Control Loops	11
Cooling Operation.....	11
Heating Operation.....	12
Calibration.....	12
Room Unit Operation	12
Sensor Select	12
Room CO2.....	13
Room RH.....	13
Room DEW POINT	13
Auto Discovery.....	13
Auto Addressing	14
PPCL STATUS	14
Fail Mode Operation	14
Application Notes.....	14
Wiring Diagram	15
Application 6640 Point Database	16

Overview



NOTE:

For information on applications with Firmware Revision Bx40 or earlier, see InfoLink and/or Asset Portal for documentation.

In Application 6640, the controller modulates the supply air damper of the terminal box for cooling and heating. In order for it to work properly, the central air-handling unit must provide cool supply air in the cooling mode and warm supply air in the heating mode.

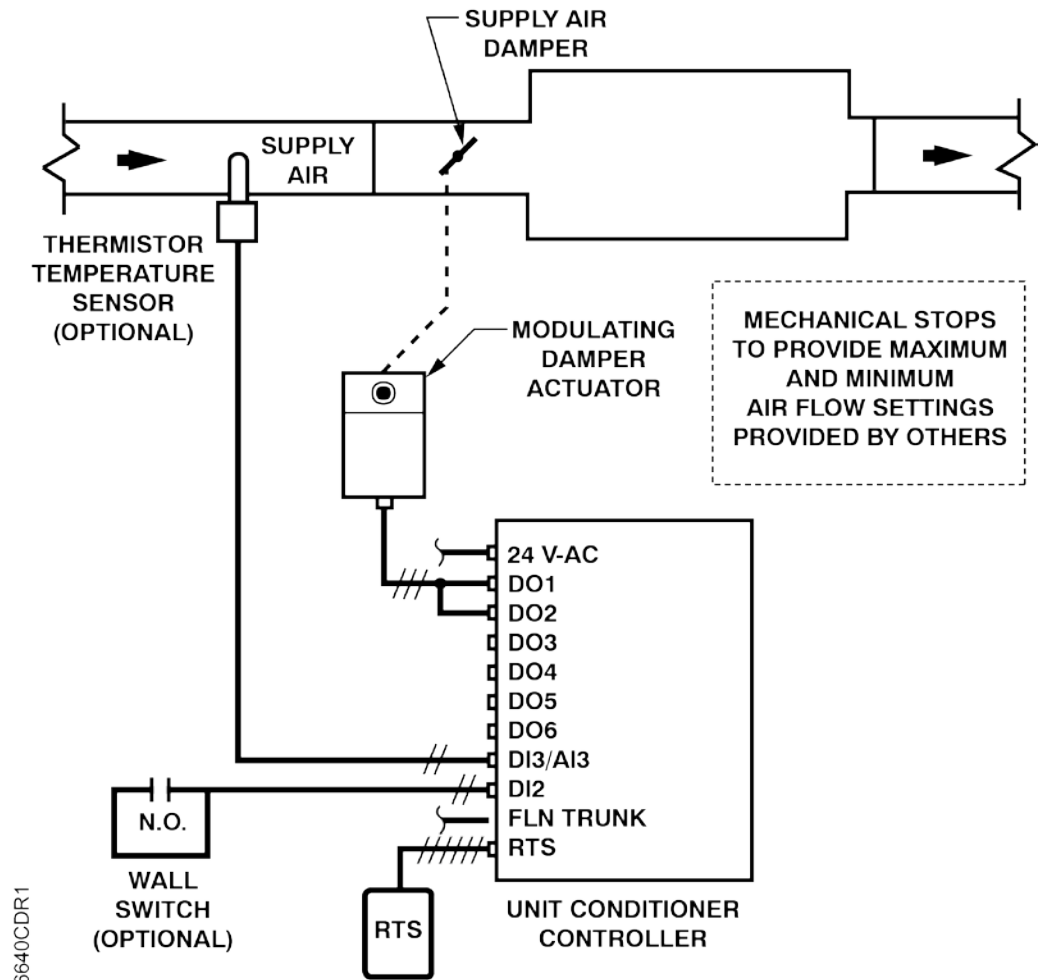

Room unit can also provide monitoring for humidity and/or CO2
Application 6640 – VAV Pressure Dependent Cooling or Heating Control Diagram.

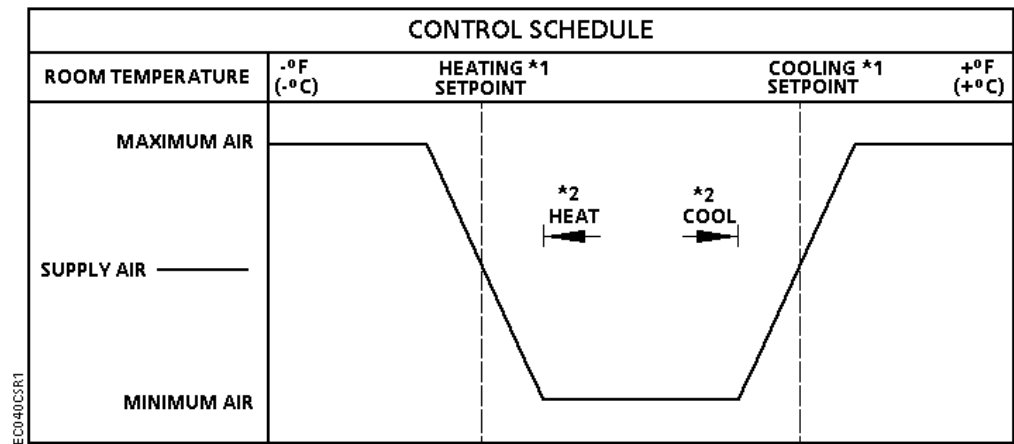

Application 6640 Control Schedule.

BACnet

The controller communicates using BACnet MS/TP protocol for open communications on BACnet MS/TP networks.

Product	Supported BIBBs	BIBB Name
BTEC/PTEC	DS-RP-B B	Data Sharing-Read Property-B
	DS-RPM-B	Data Sharing-Read Property Multiple-B
	DS-WP-B	Data Sharing-Write Property-B
	DM-DDB-B	Device Management-Dynamic Device Binding-B
	DM-DOB-B	Device Management-Dynamic Object Binding-B
	DM-DCC-B	Device Management-Device Communication Control-B
	DM-RD-B	Device Management-Reinitialize Device-B
	DM-BR-B	Device Management-Backup and Restore-B
	DM-OCD-B	Device Management-Object Creation and Deletion-B
	CPT	Confirmed Private Transfer (Auto Discovery)
	UPT	Unconfirmed Private Transfer

Hardware Inputs

Analog

- Duct temperature sensor
- Supply temperature sensor
- Room temperature sensor
- *(Optional)* Room temperature setpoint dial

Digital

- *(Optional)* Night mode override
- *(Optional)* Wall switch



NOTE:

Digital Room Units (Firmware Revision 26 and later) will update their controlled inputs without putting them Out Of Service. However, a command from an external source through the digital room unit will put the associated BACnet Input point Out Of Service.

Room Unit Identification

- For Analog Room Units (Series 1000) – The revision number is visually identified by its case.
- For Digital Room Units (Series 200/2300 Firmware Revision 25 or earlier) – The revision number displays for 5 seconds when the room unit is first powered up. These room units will display `laptop` when a laptop is connected and will no longer update room temperature sensor values.
- For Digital Room Units (Series 2200/2300 Firmware Revision 26 and later) – The revision number displays for 5 seconds when the room unit is first powered up or when a laptop is disconnected. These room units will continue to display and update the room temperature sensor values when a laptop is connected.

Hardware Outputs

Analog

- None

Digital

- Damper actuator

Ordering Notes

550-433PA BACnet PTEC Unit Conditioner Controller

Sequence of Operation

The following paragraphs present the sequence of operation for the BACnet PTEC Unit Conditioner Controller.

Control Temperature Setpoints

This application has a number of different room temperature setpoints (DAY HTG STPT, NGT CLG STPT, RM STPT DIAL, and so on.). The application actually controls using the CTL STPT. CTL STPT is set to different values depending on its override status, the time of day, whether or not a temperature deadband (zero energy band) has been configured, and the type of RTS used.

CTL STPT is Overridden

If CTL STPT is overridden, that value is used regardless of any other settings. This disables the setpoint deadband feature.

CTL STPT in Night Mode

The controller is in Night mode if DAY.NGT = NGT and NGT OVRD = NGT.

When the controller is in Night mode, CTL STPT holds the value of NGT CLG STPT or NGT HTG STPT depending on the value of HEAT.COOL. When the controller is in Night mode, the value of RM STPT DIAL is ignored.

CTL STPT in Day Mode

The controller is in Day mode if DAY.NGT = DAY or NGT OVRD = DAY.

Without setpoint dial:

When the controller is in Day mode and STPT DIAL = NO, CTL STPT holds the value of DAY CLG STPT or DAY HTG STPT depending on the value of HEAT.COOL.

With setpoint dial:

When the controller is in Day mode and STPT DIAL = YES, CTL STPT holds a value based on RM STPT DIAL depending on your room unit model/revision.

The following sections describe the value of CTL STPT based on room unit type and configuration:

- CTL STPT using Standard/Absolute Mode (Digital Room Unit, Revision 26 and later)
- CTL STPT using Warmer/Cooler Mode (Digital Room Unit, Revision 26 and later)
- CTL STPT using Standard/Absolute Mode (Analog or Digital Room Unit)
- CTL STPT using Warmer/Cooler Mode (Analog Room Unit Only)



NOTE:

If RM STPT DIAL is failed, it maintains the last known value.

CTL STPT Using Standard/Absolute Mode (Digital Room Unit, Revision 26 and later)

Digital Room Unit (2200/2300 Series Firmware Revision 26 and later)

For all new digital room units, the value displayed and reported by the room unit is linked to the current heat/cool mode. When the mode changes, the value is automatically updated based on the new heat/cool mode.

When STPT SPAN is set to 0, the room setpoint adjustment on the digital room unit functions in a standard mode. The range of the adjustment is based on RM STPT MIN and RM STPT MAX.

CTL STPT is set equal to RM STPT DIAL. The values for RM STPT MIN and RM STPT MAX are applied to limit RM STPT DIAL before it is copied into CTL STPT.

CTL STPT Using Warmer/Cooler Mode (Digital Room Unit, Revision 26 and later)

Digital Room Unit (2200/2300 Series Firmware Revision 26 and later)



NOTE:

The warmer-cooler function is only available with BACnet PTEC controllers (standard 66xx apps).

CTL STPT is set equal to RM STPT DIAL. The values for RM STPT MIN and RM STPT MAX is applied to limit RM STPT DIAL before it is copied into CTL STPT.

When STPT SPAN is set to a value > 0 , the room setpoint adjustment on the digital room unit will function in a warmer/cooler mode. The range of the adjustment will be calculated based on the current DAY CLG STPT or DAY HGT STPT and the STPT SPAN value. This will allow the Room Setpoint Dial to be incremented up or down from these setpoints by STPT SPAN.

When SPTP SPAN > 0 , the minimum and maximum values for RM STPT DIAL are calculated as follows:

- Minimum lowest adjusted setpoint value is equal to DAY CLG STPT or DAY HTG STPT - STPT SPAN
- Maximum highest adjusted setpoint value is equal to DAY CLG STPT or DAY HTG STPT + STPT SPAN

Example in Cooling Mode

If the STPT SPAN is set to 2.0 degrees, and the DAY CLG STPT is 76°F, you can move the room unit setting up or down to adjust the RM STPT DIAL from 74°F to 78°F.

CTL STPT Using Standard/Absolute Mode (Analog or Digital Room Unit)

Analog (Series 1000) or Digital Room Units (Firmware Revision 25 or earlier)



NOTE:

2200/2300 digital room units with Firmware Revision 25 or earlier are only compatible with standard room unit functionality (no warmer/cooler).

When STPT SPAN is set to 0, CLT STPT is set based on the value of the setpoint dial and the setpoint deadband.

The setpoint deadband exists to allow the controller to provide a separation of the heating and cooling temperature setpoints when a setpoint dial is enabled.

The setpoint deadband is the difference between the cooling and heating day setpoints (DAY CLG STPT DAY – HTG STPT). The setpoint deadband can be disabled by setting DAY HTG STPT equal to DAY CLG STPT. When DAY HTG STPT does not equal DAY CLG STPT, a setpoint deadband (or zero energy band) is used.

The following values are used in the calculation of CTL STPT:

- *Deadband* is the value of the difference between DAY CLG STPT and DAY HTG STPT and is used to establish the current heating and cooling setpoints.
- $Deadband = (DAY\ CLG\ STPT - DAY\ HTG\ STPT)$

CTL STPT is calculated as follows:

With Deadband disabled:

$CTL\ STPT = RM\ STPT\ DIAL$

With Deadband enabled in Heat Mode:

$CTL\ STPT = RM\ STPT\ DIAL - 0.5 * Deadband$

With Deadband enabled in Cool Mode:

$CTL\ STPT = RM\ STPT\ DIAL + 0.5 * Deadband$

CTL STPT is limited between the value of RM STPT MIN and RM STPT MAX

CTL STPT Using Warmer/Cooler Mode (Analog Room Unit Only)

Analog Room Unit (Series 1000)



NOTE:

The warmer-cooler function for analog room units (Series 1000) use the warmer/cooler scale of units with a warmer/cooler housing.

When SPTP SPAN > 0, the minimum and maximum values for RM STPT DIAL are calculated as follows:

- Minimum lowest adjusted setpoint value is equal to DAY CLG STPT or DAY HTG STPT - STPT SPAN
- Maximum highest adjusted setpoint value is equal to DAY CLG STPT or DAY HTG STPT + STPT SPAN

The full range of the analog room unit slider are mapped to a range of minimum setpoint value to maximum setpoint value.

CTL STPT is set equal to RM STPT DIAL. The values for RM STPT MIN and RM STPT MAX are applied to limit RM STPT DIAL before it is copied into CTL STPT.

Example in Cooling Mode

If the STPT SPAN is set to 2.0 degrees, and the DAY CLG STPT is 76°F, the room unit slider will adjust the cooling setpoint from 74°F to 78°F.

Heating/Cooling Switchover

There are three options for the heating/cooling switchover for this application. In order for the controller to function properly, one of the following three options must be used:

1. A temperature sensor is installed in the supply air ductwork. The controller uses the measured temperature point, SUPPLY TEMP, to determine whether it is in heating or cooling mode.
When SUPPLY TEMP < COOL TEMP, the controller sets HEAT.COOL to COOL, switching the controller to cooling mode.
When SUPPLY TEMP > HEAT TEMP, the controller sets HEAT.COOL to HEAT, switching the controller to heating mode.
2. If the controller is connected to a field panel or PPCL in the controller, the field panel or PPCL can command SUPPLY TEMP.
When SUPPLY TEMP is commanded below the value of COOL TEMP, the controller sets HEAT.COOL to COOL, switching the controller to cooling mode.
When SUPPLY TEMP is commanded above the value of HEAT TEMP, the controller sets HEAT.COOL to HEAT, switching the controller to heating mode.
3. If the controller is connected to a field panel or PPCL in the controller, the field panel or PPCL can switch the controller between heating and cooling modes by commanding HEAT.COOL to HEAT or COOL.

Room Temperature, Room Temperature Offset and CTL TEMP

ROOM TEMP is the temperature that is being sensed by the room temperature sensor (RTS).

RMTMP OFFSET (or TEMP OFFSET) is a user-adjustable offset that compensates for deviations between the value of ROOM TEMP and the actual room temperature.

CTL TEMP is the room temperature that is used for control purposes. In other words, the application is trying to maintain CTL TEMP at the control setpoint.

When CTL TEMP is not overridden, CTL TEMP and ROOM TEMP are related by the following equation:

$$\text{CTL TEMP} = \text{ROOM TEMP} + \text{RMTMP OFFSET (or TEMP OFFSET)}$$

If CTL TEMP is not overridden then,

- The current value of ROOM TEMP (normal or overridden) determines the value of CTL TEMP.
- If ROOM TEMP has a status of Failed, then the last known good value of ROOM TEMP determines the value of CTL TEMP.

Day and Night Modes

The day/night status of the space is determined by the status of DAY.NGT. The control of this point differs depending on whether the controller is monitoring the status of a wall switch or if the controller is connected to a field panel.

When a wall switch is physically connected to the termination strip on the controller DI 2 (see the *Control Diagram* in the *Overview* section), and WALL SWITCH = YES, the controller monitors the status of DI 2.) When the status of DI 2 is ON (the switch is closed), then DAY.NGT is set to DAY indicating that the controller is in day mode. When the status of DI 2 is OFF (the switch is open), then DAY.NGT is set to NIGHT indicating that the controller is in night mode.

When WALL SWITCH = NO, the controller does not monitor the status of the wall switch, even if one is connected to it. In this case, if the controller is operating stand-alone, then the controller stays in day mode all the time. If the controller is operating with centralized control (that is, it is connected to a field panel), then the field panel can send an operator or PPCL command to override the status of DAY.NGT. See *Powers Process Control Language (PPCL) User's Manual* (125-1896) and *Field Panel User's Manual* (125-3019) or *BACnet Field Panel User's Manual* (125-3020) for more information.

Night Mode Override Switch

If an override switch is present on the room temperature sensor and a value (in hours) other than zero has been entered into OVRD TIME, pressing the override switch resets the controller to DAY operational mode for the time period that is set in OVRD TIME. The status of NGT OVRD changes to DAY. After the override time elapses, the controller returns to night mode and the status of NGT OVRD changes back to NIGHT. The override switch on the room sensor only affects the controller when it is in Night mode.

Control Loops

The BACnet PTEC Unit Conditioner Controller is controlled by two Proportional, Integral, and Derivative (PID) temperature loops.

The two temperature loops are a cooling loop and a heating loop. The active temperature loop maintains room temperature at the value in CTL STPT. See Control Temperature Setpoints.

Cooling Operation

In cooling mode, the controller uses CTL STPT and CTL TEMP as inputs for the cooling loop.

The central air-handling unit must provide cool supply air. The output of the cooling loop is CLG LOOPOUT, which modulates the supply air damper; DMPR COMD. HTG LOOPOUT is set to 0%.

Heating Operation

In heating mode, the controller uses CTL STPT and CTL TEMP as inputs for the heating loop.

The central air-handling unit must provide warm supply air. The output of the heating loop is HTG LOOPOUT, which modulates the supply air damper; DMPR COMD. CLG LOOPOUT is set to 0%.

Calibration

The controller regularly calibrates the damper based on the value of CAL TIMER. A value of 12 indicates that the controller will calibrate the damper once every 12 hours.

The calibration consists of driving the damper closed, and then resetting the value of DMPR POS to 0. The damper is then released to normal control.

During normal operation: To ensure that all floating control actuators fully stroke, the controller will provide additional opening and closing time when commanded value = 100% and 0%.



NOTE:

If mechanical stops are installed to provide minimum airflow, the damper will be calibrated to those stops.

Floating Control Actuation Auto-correct

In addition to the existing options for floating control actuator full stroke actions, all floating control actuators are provided with additional logic to fully drive open or closed when commanded to 100% or 0%.

Room Unit Operation

Sensor Select

SENSOR SEL is a configurable, enumerated point (values are additive). This point tells the controller what type of room unit is being used and how to handle loss of communication, for more information see Fail Mode Operation. It also provides the ability to enable the optional RH and CO2 sensors and indicates which thermistor type is connected.

Room Temperature, Setpoint, RH and CO2

- When the digital room unit (Series 2200/2300) is used, SENSOR SEL selects the source for temperature and setpoint and enables a loss of communications indication:
 - 1 = enables supervision (from the room unit) for fail communications for temperature and setpoint.
 - 2 = enables supervision (from the room unit) for fail communications for relative humidity.
 - 4 = enables supervision (from the room unit) for fail communications for CO2.

- When the analog room unit (Series 1000/2000) is used, SENSOR SEL values for temperature/setpoint, relative humidity and CO₂ should be left at their default values (0).

Thermistor Inputs

- Default for either input is 10K.
- To enable 100K Ω thermistor on input, see the following table for additive values.

SENSOR SEL Value * (additive)	Description (include values to enable feature)
1	Select Digital Room Unit (for temperature sensing and setpoint dial)
2	Relative Humidity (RH) sensing
4	CO ₂ sensing
8	If short board: 100K Ω thermistor on AI 3 (or input is 10K Ω) If long board: 100K Ω thermistor on AI 5 (or input is 10K Ω)
16	Long board only: 100K Ω thermistor on AI 4 (or input is 10K Ω)

Example 1: Digital Room Unit with temperature, RH, CO₂ and 10K thermistor.
1+2+4+0 = 7

Example 2: Analog Room unit with 100K thermistor. 0+0+0+8 = 8

Room CO₂

RM CO₂ displays the CO₂ value in units of parts-per-million (PPM). RM CO₂ (from the digital 2200/2300 room units) can be used with PPCL in the PTEC/A TEC controller or unbundled for control or monitoring purposes.

Room RH

RM RH displays the relative humidity value in percent. RM RH can be used for PPCL in the PTEC or unbundled for control or monitoring purposes.

RM RH displays the relative humidity value in percent.

Room DEW POINT

The controller provides a calculation for DEW POINT temperature in Fahrenheit degrees (or Celsius degrees) using room temperature (using CLT TEMP) and room humidity (using RM RH). This calculation is valid for ranges of 55°F (12.8°C) to 95°F (35°C) and 20 to 100% relative humidity.

Auto Discovery

Auto Discovery allows you to automatically discover and identify PTEC/A TEC controllers on the BACnet MS/TP Network. There are two basic configurations:

- Devices not configured with an address. (Devices are discovered by their unique serial number.)
- Devices configured with an address and available for modification.

Auto Addressing

Auto Addressing allows you to automatically assign device addresses to a PTEC/ATEC controller on the BACnet MS/TP Network. If a controller is not configured with a MAC address, you have the option to auto-address or manually address the controller. During this time the baud rate is automatically detected by the controller. Controller(s) must be connected on the BACnet/IP network in order for automatic addressing to occur.

PPCL STATUS

PPCL STATUS displays LOADED or EMPTY.

- LOADED = PPCL - programming is present in the controller. A new application number must be assigned (12000 through 12999).
- EMPTY = NO PPCL - programming is present.

The maximum number of PPCL dynamic points is 15.

Fail Mode Operation

If the room temperature sensor fails or the supply air temperature sensor fails, the controller operates using the last known temperature value.

Application Notes

- If temperature swings in the room are excessive or there is trouble maintaining the setpoint, the cooling loop, the heating loop, or both need to be tuned.
- The controller, as shipped from the factory, keeps all associated equipment OFF.
- Spare DOs can be used as auxiliary points that are controlled by the field panel after being defined in the field panel's database. DO 3 and DO 4 or DO 5 and DO 6 may be used as auxiliary motor points. If using a pair of spare DOs to control a motor, you must make sure that the motor setup, motor timing, and motor rotation angle are enabled correctly before you unbundle MTR 2 COMD for DO 3 and DO 4 and point MTR 3 COMD for DO 5 and DO 6.

For more information, contact your local Siemens Industry representative.

Wiring Diagram



NOTE:

The controller's DOs control 24 Vac loads only. The maximum rating is 12 VA for each DO. An external interposing relay is required for any of the following:

- VA requirements higher than the maximum
- 110 or 220 Vac requirements
- DC power requirements
- Separate transformers used to power the load
(for example, part number 540-147, Terminal Equipment Controller Relay Module)



NOTE:

Thermistor inputs are 10K (default) or 100K software selectable (AUX TEMP AI X).

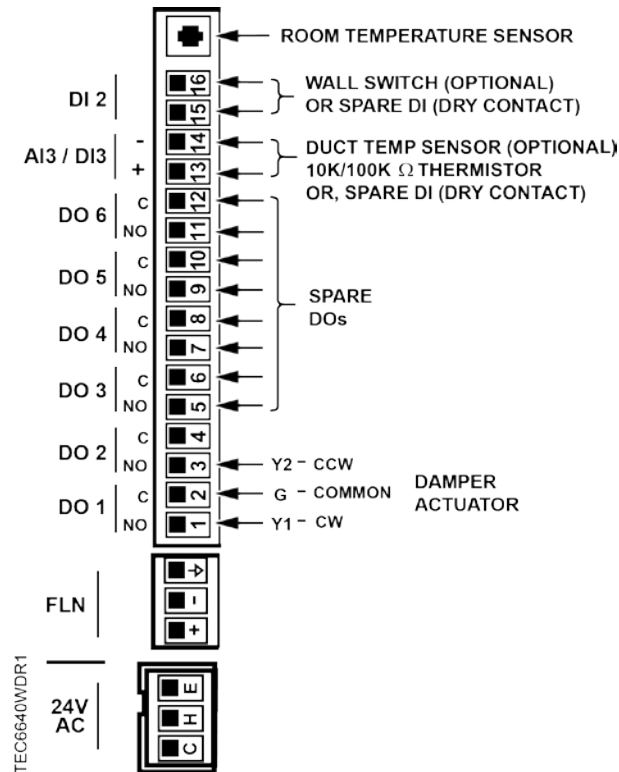

Application 6640 - Variable Air Volume Pressure Dependent Cooling or Heating.

Application 6640 Point Database

Object Type ¹	Object Instance (Point Number)	Object Name (Descriptor)	Factory Default (SI Units) ²	Engr Units (SI Units)	Range	Active Text	Inactive Text
AO	1	CTLR ADDRESS	255	--	0-255	--	--
AO	2	APPLICATION	6689	--	0-32767	--	--
AO	3	RMTMP OFFSET	0.0 (0.0)	DEG F (DEG C)	-31.75-32	--	--
AI	{04}	ROOM TEMP	74.0 (23.44888)	DEG F (DEG C)	48-111.75	--	--
BO	{05}	HEAT.COOL	COOL	--	Binary	HEAT	COOL
AO	6	DAY CLG STPT	74.0 (23.44888)	DEG F (DEG C)	48-111.75	--	--
AO	7	DAY HTG STPT	70.0 (21.20888)	DEG F (DEG C)	48-111.75	--	--
AO	8	NGT CLG STPT	82.0 (27.92888)	DEG F (DEG C)	48-111.75	--	--
AO	9	NGT HTG STPT	65.0 (18.40888)	DEG F (DEG C)	48-111.75	--	--
AO	11	RM STPT MIN	55.0 (12.80888)	DEG F (DEG C)	48-111.75	--	--
AO	12	RM STPT MAX	90.0 (32.40888)	DEG F (DEG C)	48-111.75	--	--
AI	{13}	RM STPT DIAL	74.0 (23.44888)	DEG F (DEG C)	48-111.75	--	--
BO	14	STPT DIAL	NO	--	Binary	YES	NO
AI	{15}	AUX TEMP	74.0 (23.495556)	DEG F (DEG C)	37.5-165	--	--
AO	16	VLV 1 START	0	PCT	0-102	--	--
AO	17	VLV 1 END	100	PCT	0-102	--	--
BO	18	WALL SWITCH	NO	--	Binary	YES	NO
BI	{19}	DI OVRD SW	OFF	--	Binary	ON	OFF
AO	20	OVRD TIME	0	HRS	0-255	--	--
BO	{21}	NGT OVRD	NIGHT	--	Binary	NIGHT	DAY
AO	22	VLV 2 START	0	PCT	0-102	--	--
AO	23	VLV 2 END	0	PCT	0-102	--	--
BI	{24}	DI 2	OFF	--	Binary	ON	OFF
BI	{25}	DI 3	OFF	--	Binary	ON	OFF
BO	{29}	DAY.NGT	DAY	--	Binary	NIGHT	DAY
AO	{37}	VLV 2 COMD	0	PCT	0-102	--	--
AO	{38}	VLV 2 POS	0	PCT	0-102	--	--

Object Type ¹	Object Instance (Point Number)	Object Name (Descriptor)	Factory Default (SI Units) ²	Engr Units (SI Units)	Range	Active Text	Inactive Text
AO	39	MTR 3 TIMING	130	SEC	0-511	--	--
BO	{41}	DO 1	OFF	--	Binary	ON	OFF
BO	{42}	DO 2	OFF	--	Binary	ON	OFF
BO	{43}	DO 3	OFF	--	Binary	ON	OFF
BO	{44}	DO 4	OFF	--	Binary	ON	OFF
BO	{45}	DO 5	OFF	--	Binary	ON	OFF
BO	{46}	DO 6	OFF	--	Binary	ON	OFF
AO	{48}	DMPR COMD	0	PCT	0-102	--	--
AO	{49}	DMPR POS	0	PCT	0-102	--	--
AO	51	MTR 1 TIMING	130	SEC	0-511	--	--
AO	{52}	VLV 1 COMD	0	PCT	0-102	--	--
AO	{53}	VLV 1 POS	0	PCT	0-102	--	--
AO	55	MTR 2 TIMING	130	SEC	0-511	--	--
AO	56	MTR1 ROT ANG	90	--	0-255	--	--
AO	57	MTR2 ROT ANG	90	--	0-255	--	--
AO	58	MTR SETUP	0	--	0-255	--	--
AO	59	DO DIR. REV	0	--	0-255	--	--
AO	63	CLG P GAIN	20.0 (36.0)	--	0-63.75	--	--
AO	64	CLG I GAIN	0.01 (0.018)	--	0-1.023	--	--
AO	65	CLG D GAIN	0 (0.0)	--	0-510	--	--
AO	66	CLG BIAS	0	PCT	0-102	--	--
AO	67	HTG P GAIN	10.0 (18.0)	--	0-63.75	--	--
AO	68	HTG I GAIN	0.01 (0.018)	--	0-1.023	--	--
AO	69	HTG D GAIN	0 (0.0)	--	0-510	--	--
AO	70	HTG BIAS	0	PCT	0-102	--	--
AO	{78}	CTL TEMP	74.0 (23.44888)	DEG F (DEG C)	48-111.75	--	--
AO	{79}	CLG LOOPOUT	0	PCT	0-102	--	--
AO	{80}	HTG LOOPOUT	0	PCT	0-102	--	--
AO	85	SWITCH LIMIT	5.2	PCT	0-102	--	--
AO	86	SWITCH TIME	10	MIN	0-255	--	--
AO	88	VALVE CNT	1	--	0-255	--	--
AO	90	SWITCH DBAND	1.0 (0.56)	DEG F (DEG C)	0-63.75	--	--
AO	{92}	CTL STPT	74.0 (23.44888)	DEG F (DEG C)	48-111.75	--	--
AO	96	CAL TIMER	12	HRS	0-255	--	--

Object Type ¹	Object Instance (Point Number)	Object Name (Descriptor)	Factory Default (SI Units) ²	Engr Units (SI Units)	Range	Active Text	Inactive Text
AO	98	LOOP TIME	5	SEC	0-255	--	--
AO	{99}	ERROR STATUS	0	--	0-255	--	--
AO	106	STPT SPAN	0.0 (0.0)	DEG F (DEG C)	0-63.75	--	--
AO	{121}	DEW POINT	-40.0 (-40.0)	DEG F (DEG C)	-40-1598.35	--	--
AO	124	SENSOR SEL	0	--	0-255	--	--
AI	{125}	RM CO2	1000	PPM	0-8191	--	--
AI	{126}	RM RH	50	PCT	0-102	--	--
BO	{127}	PPCL STATE	EMPTY	--	Binary	LOADED	EMPTY

- 1) Object Types are; Analog Input (AI), Analog Output (AO), Binary Input (BI) and Binary Output (BO).
- 2) A single value in a column means that the value is the same in English units and in SI units.
- 3) Point numbers that appear in brackets { } may be unbundled at the field panel.

Issued by
Siemens Industry, Inc.
Building Technologies Division
1000 Deerfield Pkwy
Buffalo Grove IL 60089
Tel. +1 847-215-1000

© Siemens Industry, Inc., 2015
Technical specifications and availability subject to change without notice.