

SIEMENS

Power Mod™ Indoor/Outdoor Feed-Thru Main Module

Catalog Number

WBTV324X250

Enclosure
Type 3R

WBTV324X250U

Module Rating: 2400 Amps, Max.

Main Vertical Bus Rating: 2400 Amps, Max.

Main Horizontal Bus Rating: 1200 Amps, Max.

Breaker Rating: 250A Max.

208Y/120 Volts~, 3 Phase, 4 Wire

240/120 Volts~, 3 Phase, 4 Wire, Delta (B Phase is High Leg)

CAUTION: The circuit breaker in this enclosure protects the horizontal bus feeding adjacent enclosures. It does not protect the vertical bus or feed through conductors.

For installation by Qualified Person in accordance with all local electrical codes and/or the National Electrical Code®

Circuit breaker trip position is indicated by handle position midway between ON and OFF. To reset, move handle to OFF position, then turn ON.

For overhead or underground feed.

Use 75°C Copper or Aluminum Conductors.

Short Circuit Current Rating

This device has a maximum short circuit current rating of 100,000 Amps RMS symmetrical at 240 Volts~ when protected by 2400 Amp maximum Class L fuses. The actual short circuit current rating is limited to the interrupting rating of the circuit breaker installed. Replacement breakers must be manufactured by Siemens and must be of the correct type and rating as indicated in the table. Use of other circuit breakers in this device will void the warranty.

Breaker Type	Rating
MJAS	85k AIC
HJAS	100k AIC

Lugs for Phase and Neutral Connections (not supplied)

Lug No. ①	MFG	Wire Range	Type	No. Wires per phase	Torque (lb.-in.)
LK36750N2	Siemens	1/0-750 kcmil	Mechanical	6	500
LK38500N2C	Siemens	1/0-500 kcmil Copper	Mechanical	8	500
LK38750N2A	Siemens	1/0-750 kcmil Aluminum	Mechanical	8	500
ALND-700/750-12-134	ILSCO	750 kcmil	Compression	6	NA ②

- Order one mechanical lug kit for mains and neutral. Additional lug kit is required for feed-thru terminals. Contact lug manufacturer for compression lug quantities supplied for each kit.
- See lug manufacturer's instruction sheet supplied with the connector for tool, die, and number of crimps.

Siemens Industry, Inc. Peachtree Corners, Georgia U.S.A. **DH1** 40902081 0101 Rev.00

© The National Electrical Code is a registered trademark of the National Fire Protection Association.
© 2023 Copyright Siemens Industry, Inc.

SIEMENS

For use with other Power Mod modular metering products.

Connect Modules Using: Cat. No. Torque
Quick Connect QC4 400-440 lb-in (35-36 ft.-lb.)

Accessory:

ECMMGBE - Ground Bus Extension

Use HD Type Hubs if required

Trade Size (in)	Catalog No.
2"	EC56854
2-1/2"	EC56855
3"	EC56856
3-1/2"	EC56857
4"	EC56858
Cover Plate	EC56933S

Terminals A, B, C and N:

See Lug Chart on adjacent diagram for applicable lug kits, wire size and torque information.

Ground Terminal G

(Accessory Cat.# ECMLK225):

Wire size #4-300 kcmil.

Torque terminal to 250 lb.-in.

Equip Ground Acc'y Cat. No. ECLX072M

Small Terminals

Wire Range / Torque

10-14 AWG . . . 20 lb-in

8 AWG 25 lb-in

6 AWG 35 lb-in

Large Terminals

Wire Range / Torque

10-14 AWG . . . 35 lb-in

8 AWG 40 lb-in

1/0-6 AWG . . . 45 lb-in

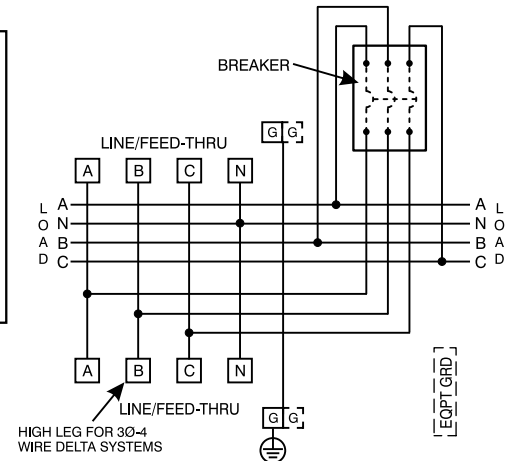

Important: Do not allow petroleum based (hydrocarbon) sprays, chemicals, solvents or any paint to contact interior components. Petroleum based chemicals can cause degradation of electrical insulating materials.

Siemens Industry, Inc. Peachtree Corners, Georgia U.S.A.

40902089 0101 Rev.00

© 2023 Copyright Siemens Industry, Inc.