

Edition

08/2023

Installation Manual

SIMATIC NET

Rugged multi service platforms

RUGGEDCOM RX1500

<https://www.siemens.com/ruggedcom>

SIEMENS

SIMATIC NET

Rugged multi service platforms RUGGEDCOM RX1500

Installation Manual

Preface	
Introduction	1
Installing the Device	2
Device Management	3
Modules	4
Technical Specifications	5
Certification	6

Legal information

Warning notice system

This manual contains notices you have to observe in order to ensure your personal safety, as well as to prevent damage to property. The notices referring to your personal safety are highlighted in the manual by a safety alert symbol, notices referring only to property damage have no safety alert symbol. These notices shown below are graded according to the degree of danger.

 DANGER

indicates that death or severe personal injury will result if proper precautions are not taken.

 WARNING
--

indicates that death or severe personal injury may result if proper precautions are not taken.
--

 CAUTION
--

indicates that minor personal injury can result if proper precautions are not taken.
--

 NOTICE

indicates that property damage can result if proper precautions are not taken.
--

If more than one degree of danger is present, the warning notice representing the highest degree of danger will be used. A notice warning of injury to persons with a safety alert symbol may also include a warning relating to property damage.

Qualified personnel

The product/system described in this documentation may be operated only by **personnel qualified** for the specific task in accordance with the relevant documentation, in particular its warning notices and safety instructions. Qualified personnel are those who, based on their training and experience, are capable of identifying risks and avoiding potential hazards when working with these products/systems.

Proper use of Siemens products

Note the following:

 WARNING
--

Siemens products may only be used for the applications described in the catalog and in the relevant technical documentation. If products and components from other manufacturers are used, these must be recommended or approved by Siemens. Proper transport, storage, installation, assembly, commissioning, operation and maintenance are required to ensure that the products operate safely and without any problems. The permissible ambient conditions must be complied with. The information in the relevant documentation must be observed.
--

Trademarks

All names identified by ® are registered trademarks of Siemens Canada Ltd.. The remaining trademarks in this publication may be trademarks whose use by third parties for their own purposes could violate the rights of the owner.

Disclaimer of liability

We have reviewed the contents of this publication to ensure consistency with the hardware and software described. Since variance cannot be precluded entirely, we cannot guarantee full consistency. However, the information in this publication is reviewed regularly and any necessary corrections are included in subsequent editions.

Table of contents

Preface	v
Related Documents	v
SIMATIC NET glossary	v
Accessing documentation	v
Registered trademarks	v
Warranty	vi
Training	vi
Customer support	vii
Contacting Siemens	vii
1 Introduction	1
1.1 Feature Highlights	1
1.2 Description	1
1.3 Required Tools and Materials	3
1.4 Decommissioning and disposal	3
1.5 Cabling Recommendations	4
1.5.1 Protection On Twisted-Pair Data Ports	4
1.5.2 Gigabit Ethernet 1000Base-TX Cabling Recommendations	4
2 Installing the Device	7
2.1 General Procedure	8
2.2 Unpacking the device	9
2.3 Mounting the Device	9
2.3.1 Mounting the Device to a Rack	9
2.3.2 Mounting the Device on a DIN Rail	11
2.3.3 Mounting the Device to a Panel	11
2.4 Connecting the Failsafe Alarm Relay	12
2.5 Connecting Power	13
2.5.1 Connecting High AC/DC Power	14
2.5.2 Connecting Low DC Power	17
3 Device Management	23
3.1 Connecting to the Device	23
3.2 Configuring the Device	25
3.3 Accessing the CompactFlash Card	25
4 Modules	29
4.1 Requirements and Restrictions	29
4.2 Available Modules	29
4.3 Installing/Removing Line Modules	30

4.4	Installing/Removing Power Modules	32
5	Technical Specifications	35
5.1	Chassis Specifications	35
5.2	Power Supply Specifications	35
5.3	Failsafe Relay Specifications	35
5.4	Operating Environment	36
5.5	Mechanical Specifications	36
5.6	Dimension Drawings	36
6	Certification	39
6.1	Approvals	39
6.1.1	UKCA	39
6.1.2	TÜV SÜD	39
6.1.3	European Union (EU)	40
6.1.4	FCC	41
6.1.5	FDA/CDRH	41
6.1.6	ISED	41
6.1.7	ISO	41
6.1.8	ACMA	42
6.1.9	RoHS	42
6.1.10	Other Approvals	42
6.2	EMC and Environmental Type Tests	43

Preface

This guide describes the RUGGEDCOM RX1500. It describes the major features of the device, installation, commissioning and important technical specifications.

It is intended for use by network technical support personnel who are responsible for the installation, commissioning and maintenance of the device. It is also recommended for use by network and system planners, system programmers, and line technicians.

Related Documents

Other documents that may be of interest include:

Document Title	Link
RUGGEDCOM ROX II CLI Configuration Manual	https://support.industry.siemens.com/cs/ww/en/view/109481699
RUGGEDCOM ROX II Web Interface Configuration Manual	https://support.industry.siemens.com/cs/ww/en/view/109481700
RUGGEDCOM Modules Catalog for RX1500 Series	https://support.industry.siemens.com/cs/ww/en/view/109747072
RUGGEDCOM SFP Transceivers Catalog	https://support.industry.siemens.com/cs/ww/en/view/109482309

SIMATIC NET glossary

The SIMATIC NET glossary describes special terms that may be used in this document.

The glossary is available online via Siemens Industry Online Support (SIOS) at:

<https://support.industry.siemens.com/cs/ww/en/view/50305045>

Accessing documentation

The latest user documentation for RUGGEDCOM RX1500 is available online at <https://support.industry.siemens.com>. To request or inquire about a user document, contact Siemens Customer Support.

Registered trademarks

The following and possibly other names not identified by the registered trademark sign ® are registered trademarks of Siemens Canada Ltd.:

- RUGGEDCOM
- ROS
- RCDP
- Discovery Protocol

Linux® is the registered trademark of Linus Torvalds in the United States and other countries.

The registered trademark Linux® is used pursuant to a sublicense from LMI, the exclusive licensee of Linus Torvalds, owner of the mark on a world-wide basis.

Other designations in this manual might be trademarks whose use by third parties for their own purposes would infringe the rights of the owner.

Warranty

Siemens warrants this product for a period of five (5) years from the date of purchase, conditional upon the return to factory for maintenance during the warranty term. This product contains no user-serviceable parts. Attempted service by unauthorized personnel shall render all warranties null and void. The warranties set forth in this article are exclusive and are in lieu of all other warranties, performance guarantees and conditions whether written or oral, statutory, express or implied (including all warranties and conditions of merchantability and fitness for a particular purpose, and all warranties and conditions arising from course of dealing or usage or trade). Correction of nonconformities in the manner and for the period of time provided above shall constitute the Seller's sole liability and the Customer's exclusive remedy for defective or nonconforming goods or services whether claims of the Customer are based in contract (including fundamental breach), in tort (including negligence and strict liability) or otherwise.

For warranty details, visit <https://www.siemens.com> or contact a Siemens customer service representative.

Training

Siemens offers a wide range of educational services ranging from in-house training of standard courses on networking, Ethernet switches and routers, to on-site customized courses tailored to the customer's needs, experience and application.

Siemens' Educational Services team thrives on providing our customers with the essential practical skills to make sure users have the right knowledge and expertise to understand the various technologies associated with critical communications network infrastructure technologies.

Siemens' unique mix of IT/Telecommunications expertise combined with domain knowledge in the utility, transportation and industrial markets, allows Siemens to provide training specific to the customer's application.

For more information about training services and course availability, visit <https://www.siemens.com> or contact a Siemens Sales representative.

Customer support

Customer support is available 24 hours, 7 days a week for all Siemens customers. For technical support or general information, contact Siemens Customer Support through any of the following methods:



Online

Visit <http://www.siemens.com/automation/support-request> to submit a Support Request (SR) or check on the status of an existing SR.

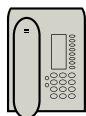

Telephone

Call a local hotline center to submit a Support Request (SR). To locate a local hotline center, visit https://w3.siemens.com/aspa_app/?lang=en.



Mobile app

Install the Industry Online Support app by Siemens AG on any Android, Apple iOS or Windows mobile device and be able to:

- Access Siemens' extensive library of support documentation, including FAQs and manuals
- Submit SRs or check on the status of an existing SR
- Contact a local Siemens representative from Sales, Technical Support, Training, etc.
- Ask questions or share knowledge with fellow Siemens customers and the support community

Contacting Siemens

Address	Siemens Canada Ltd. Digital Industries Process Automation 300 Applewood Crescent Concord, Ontario Canada, L4K 5C7
Telephone	Toll-free: 1 888 264 0006 Tel: +1 905 856 5288 Fax: +1 905 856 1995
E-Mail	info.ruggedcom@siemens.com
Web	https://www.siemens.com

Introduction

The RUGGEDCOM RX1500 is a cost-efficient, rugged Layer 3 switch and router. The RUGGEDCOM RX1500's modular and field replaceable platform can be equipped with WAN, serial, and Ethernet options, making it ideally suited for electric power utilities, the industrial plant floor, and traffic control systems.

The RUGGEDCOM RX1500 is designed to provide a high level of immunity to electromagnetic interference (EMI) and heavy electrical surges typical of the harsh environments found in many industrial applications. An operating temperature range of -40 to 85 °C (-40 to 185 °F) allows the RUGGEDCOM RX1500 to be placed in almost any location.

1.1 Feature Highlights

Reliability in Harsh Environments

- Immunity to EMI and high voltage electrical transients
- -40 to 85 °C (-40 to 185 °F) operating temperature (no fans)
- Failsafe output relay for critical failure or error alarming

Universal Power Supply Options

- Dual redundant, modular, hot-swappable power supplies
- Fully integrated power supplies (no external adapters)
- Input voltage ranges: 13-36 VDC and 37-72 VDC or 85-264 VAC and 88-300 VDC for worldwide operability
- CSA/UL 62368-1 safety approved to 85 °C (185 °F)

Physical Ports

- Field replaceable line modules
- Up to 24 100Base-FX ports
- Up to 24 10/100Base-TX ports
- Up to 12 10Base-FL/100Base-SX ports
- Up to 8 Gigabit Ethernet ports
- Up to 24 serial ports
- Up to 4 T1/E1 RJ48C ports or 2 E1 BNC ports
- Up to 2 DDS (Digital Data Services) ports
- Up to 8 active cellular data interfaces

1.2 Description

The RUGGEDCOM RX1500 features various ports, controls and indicator LEDs on the front panel for connecting, configuring and troubleshooting the device.

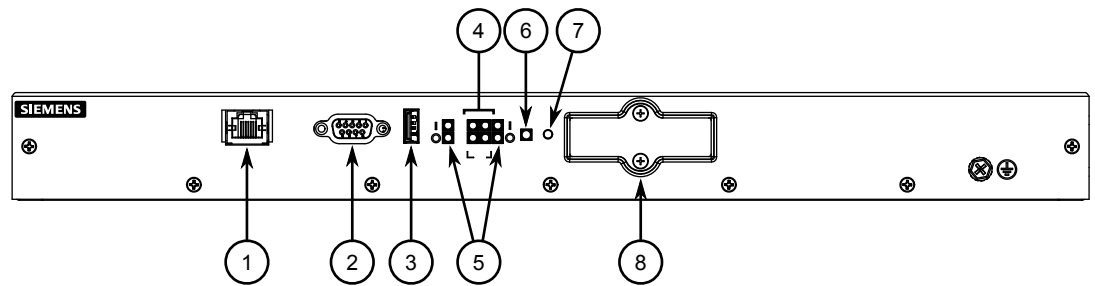

- ① Management Port
- ② RS232 Serial Console Port (DB9)
- ③ Utility USB Port
- ④ Port Status LEDs
- ⑤ Power Status LEDs
- ⑥ Alarm Indicator LED
- ⑦ Lamp Test/Alarm Cut-Off (LT/ACO) Button
- ⑧ Compact Flash Card Port

Figure 1.1 RUGGEDCOM RX1500

Management Port	This 10/100Base-T Ethernet port is used for system management that is out-of-band from the switch fabric.
RS-232 Serial Console Port	The serial console port is for interfacing directly with the device and accessing initial management functions. For information about connecting to the device via the serial console port, refer to "Connecting to the Device" (Page 23).
Utility USB Port	Use the USB port to upgrade the RUGGEDCOM RX1500 software or install files, such as configuration files and feature key files. For more information, refer to the "RUGGEDCOM ROX II Configuration Manual" for the RUGGEDCOM RX1500.
Lamp Test/Alarm Cut-Off (LT/ACO) Button	This button performs two functions: <ul style="list-style-type: none"> • Press and hold this button to test all indicator LEDs • Press and release this button to acknowledge an active alarm
Power Status LEDs	Indicates the status of the power modules. <ul style="list-style-type: none"> • I = The power module is receiving power • O = The power module is supplying power
Port Status LEDs	Indicates when ports are active. <ul style="list-style-type: none"> • Green = OK • Orange = Warning alert • Red = Configuration error
Alarm Indicator LED	Indicates when an alarm condition exists. <ul style="list-style-type: none"> • Green = Alarms cleared/acknowledged • Red = Alarm
Compact Flash Card Port	Houses the CompactFlash (CF) card that contains active and backup installations of RUGGEDCOM RUGGEDCOM RX1500, along with the configuration database and other system data. For more information, refer to "Accessing the CompactFlash Card" (Page 25).

1.3 Required Tools and Materials

The following tools and materials are required to install the RUGGEDCOM RX1500:

Tools/Materials	Purpose
AC/DC power cord (16 AWG)	For connecting power to the device.
Lightning protector	For protecting the device from harmful electrical strikes.
Shielded coaxial cables	For connecting the device to antennas and an Ethernet network.
SIM Card(s) provided by the network carrier	For accessing a network carrier's cellular network. Required only if a cellular modem module is equipped.
Flathead screwdriver	For mounting the device to a DIN rail.
Phillips screwdriver	For mounting the device to a panel.
4 x #6-32 screws	For mounting the device to a panel.
Braided or equivalent ground wire	For grounding the device to safety Earth.

1.4 Decommissioning and disposal

Proper decommissioning and disposal of this device is important to prevent malicious users from obtaining proprietary information and to protect the environment.

Decommissioning

This device may include sensitive, proprietary data. Before taking the device out of service, either permanently or for maintenance by a third-party, make sure it has been fully decommissioned.

For more information, refer to the associated "RUGGEDCOM ROX Configuration Manual".

Recycling and disposal

This device is low in pollutants, can be recycled, and meets the requirements of the WEEE directive 2012/19/EU for the disposal of electrical and electronic equipment.

Do not dispose of devices at public disposal sites.

For environmentally friendly recycling and the disposal of devices, contact a certified disposal company for electronic scrap or your Siemens contact.

For more information, refer to <https://support.industry.siemens.com/cs/ww/en/view/109479891>.

Note the different national regulations.

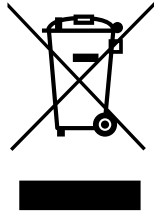

1.5 Cabling Recommendations

Siemens recommends using SIMATIC NET industrial Ethernet shielded cables for all Ethernet ports.

1.5.1 Protection On Twisted-Pair Data Ports

All copper Ethernet ports on RUGGEDCOM products include transient suppression circuitry to protect against damage from electrical transients and conform with IEC 61850-3 and IEEE 1613 Class 1 standards. This means that during a transient electrical event, communications errors or interruptions may occur, but recovery is automatic.

Siemens also does not recommend using copper Ethernet ports to interface with devices in the field across distances that could produce high levels of ground potential rise (i.e. greater than 2500 V), during line-to-ground fault conditions.

1.5.2 Gigabit Ethernet 1000Base-TX Cabling Recommendations

The IEEE 802.3ab Gigabit Ethernet standard defines 1000 Mbit/s Ethernet communications over distances of up to 100 m (328 ft) using all 4 pairs in category 5 (or higher) balanced, unshielded twisted-pair cabling. For wiring guidelines, system designers and integrators should refer to the Telecommunications Industry Association (TIA) TIA/EIA-568-A wiring standard that characterizes minimum cabling performance specifications required for proper Gigabit Ethernet operation. For reliable, error-free data communication, new and pre-existing communication paths should be verified for TIA/EIA-568-A compliance.

The following table summarizes the relevant cabling standards:

Cabling Category	1000Base-TX Compliant	Required Action
< 5	No	New wiring infrastructure required.
5	Yes	Verify TIA/EIA-568-A compliance.
5e	Yes	No action required. New installations should be designed with Category 5e or higher.
6	Yes	No action required.

1.5.2 Gigabit Ethernet 1000Base-TX Cabling Recommendations

Cabling Category	1000Base-TX Compliant	Required Action
> 6	Yes	Connector and wiring standards to be determined.

Follow these recommendations for copper data cabling in high electrical noise environments:

- Data cable lengths should be as short as possible, preferably 3 m (10 ft) in length. Copper data cables should not be used for inter-building communications.
- Power and data cables should not be run in parallel for long distances, and should be installed in separate conduits. Power and data cables should intersect at 90° angles when necessary to reduce inductive coupling.

Installing the Device

This chapter describes how to install the device, including mounting the device, installing/removing modules, connecting power, and connecting the device to the network.



⚠ DANGER

Electrocution hazard – risk of serious personal injury and/or damage to equipment.

Before performing any maintenance tasks, make sure all power to the device has been disconnected and wait approximately two minutes for any remaining energy to dissipate.



⚠ WARNING

Radiation hazard – risk of serious personal injury.

This product contains a laser system and is classified as a *CLASS 1 LASER PRODUCT*. Use of controls or adjustments or performance of procedures other than those specified herein may result in hazardous radiation exposure.



⚠ WARNING

Radiation hazard – risk of Radio Frequency (RF) exposure.

This device is compliant with the requirements set forth in FCC 47 CFR, section 1.1307, addressing Radio Frequency (RF) exposure from radio frequency base stations, as defined in [FCC OET Bulletin 65 \[http://transition.fcc.gov/Bureaus/Engineering_Technology/Documents/bulletins/oet65/oet65.pdf\]](http://transition.fcc.gov/Bureaus/Engineering_Technology/Documents/bulletins/oet65/oet65.pdf). The emitted radiation should be as little as possible. To achieve minimum RF exposure, install the device when it is configured not to transmit and set it to operational mode remotely, rather than having a technician enable transmission on-site. For maintenance of the base station, or other operations which require RF exposure, the exposure should be minimized in time and according to the regulations set forth by the country of installation or the Federal Communications Commission (FCC).

⚠ WARNING

Fire/electrical/burn hazard – risk of serious personal injury and/or damage to the device

Do not use any parts that show evidence of damage. If damaged parts are used, the device may not function according to the specification. Damaged parts can lead to:

- Injury to personnel
- Loss of certification/approvals

- Violation of EMC regulations
- Damage to the device or other components



⚠ CAUTION

Burn hazard – risk of personal injury

The surface of the device may be hot during operation, or as a result of the ambient air temperature.

Wear appropriate personal protective equipment and use caution when working with or around the device.

⚠ NOTICE

This product contains no user-serviceable parts. Attempted service by unauthorized personnel shall render all warranties null and void.

Changes or modifications not expressly approved by Siemens Canada Ltd. could invalidate specifications, test results, and agency approvals, and void the user's authority to operate the equipment.

⚠ NOTICE

This product should be installed in a *restricted access location* where access can only be gained by authorized personnel who have been informed of the restrictions and any precautions that must be taken. Access must only be possible through the use of a tool, lock and key, or other means of security, and controlled by the authority responsible for the location.

2.1 General Procedure

The general procedure for installing the device is as follows:

Note

The user is responsible for the operating environment of the device, including maintaining the integrity of all protective conductor connections and checking equipment ratings. Make sure to review all operating and installation instructions before commissioning or performing maintenance on the device.

1. Review the relevant certification information for any regulatory requirements. For more information, refer to "Approvals" (Page 39).
2. Review the "RUGGEDCOM RX1500 Series Modules Catalog" for special installation or regulatory requirements related to the modules installed in the device. In the case of cellular modem line modules, this includes antenna installation and regulatory requirements.
3. Mount the device.
4. Connect the failsafe alarm relay.

5. Connect power to the device and ground the device to safety Earth.
6. Connect the device to the network.
7. Configure the device.

2.2 Unpacking the device

When unpacking the device, do the following:

1. Inspect the package for damage before opening it.
2. Visually inspect each item in the package for any physical damage.
3. Verify all items are included.

Note

If any item is missing or damaged, contact Siemens for assistance.

2.3 Mounting the Device

The RUGGEDCOM RX1500 is designed for maximum mounting and display flexibility. It can be equipped with connectors that allow it to be installed in a 48 cm (19 in) rack, 35 mm (1.4 in) DIN rail or directly on a panel.

 NOTICE

Heat generated by the device is channeled outwards from the enclosure. As such, it is recommended that 2.5 cm (1 in) of space be maintained on all open sides of the device to allow for some convectonal airflow.
--

Forced airflow is not required. However, any increase in airflow will result in a reduction of ambient temperature and improve the long-term reliability of all equipment mounted in the rack space.
--

Note

For detailed dimensions of the device with either rack, DIN rail or panel hardware installed, refer to "Dimension Drawings" (Page 36).

2.3.1 Mounting the Device to a Rack

For rack mount installations, the RUGGEDCOM RX1500 can be equipped with rack mount adapters at the front or rear of the chassis. Additional adapters are provided for added stability.

⚠ NOTICE

Vibration hazard – risk of damage to the device.

Always use four rack mount adapters (two at the front of the device and two at the rear) when installing the device in high-vibration or seismically active locations.

⚠ NOTICE

Electrical/mechanical hazard – risk of damage to the device.

Before installing the device in a rack, make sure of the following:

- When installing the device in a closed or multi-device rack, be aware that the operating ambient temperature of the rack may be higher than the ambient temperature of the room. Make sure the rack is installed in a suitable environment that can withstand the maximum ambient temperature generated by the rack.
- Do not exceed the maximum number of devices or weight restrictions specified by the rack manufacturer.
- Do not overload the supply circuit. Refer to the over-current protection and power supply ratings specified by the rack manufacturer.
- Make sure the rack and all devices have a proper ground-to-Earth connection. Pay particular attention to power supply connections other than direct connections to the branch circuit (e.g. power strips).

To secure the device to a standard 48 cm (19 in) rack, do the following:

1. Make sure the rack mount adapters are installed on the correct side of the chassis.
 - To make the modules and ports accessible, install the rack mount adapters at the rear of the chassis
 - To make the management ports and LEDs accessible, install the rack mount adapters at the front of the chassis

Note

The chassis features multiple mounting holes, allowing the rack mount adapters to be installed up to 25 mm (1 in) from the face of the device.

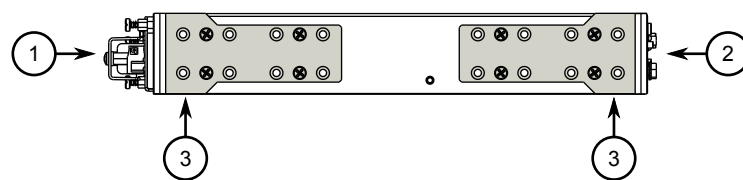

- ① Rear
- ② Front

③ Rack Mount Adapter

Figure 2.1 Rack Mount Adapters

2. If required, install adapters on the opposite side of the device to protect from vibrations.
3. Insert the device into the rack.
4. Secure the adapters to the rack using the supplied hardware.

2.3.2 Mounting the Device on a DIN Rail

For DIN rail installations, the RUGGEDCOM RX1500 can be equipped with panel/DIN rail adapters pre-installed on each side of the chassis. The adapters allow the device to be slid onto a standard 35 mm (1.4 in) DIN rail.

To mount the device to a DIN rail, do the following:

1. Align the adapters with the DIN rails and slide the device into place.

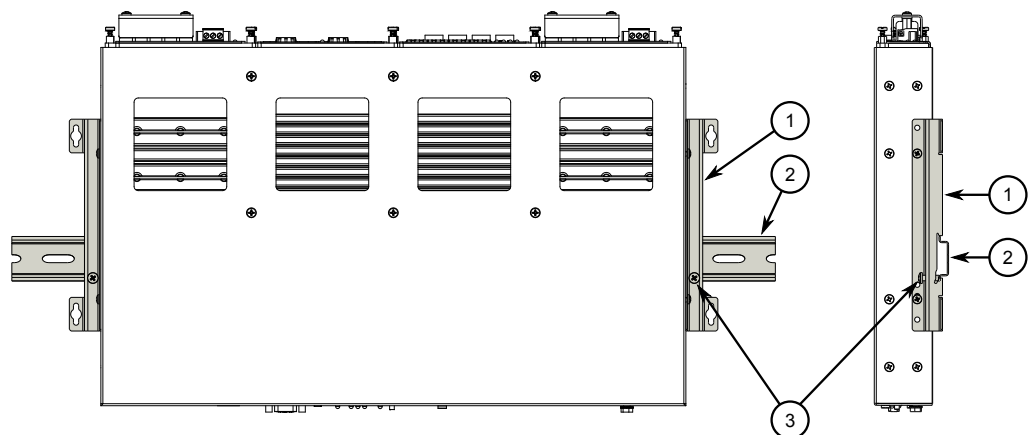

- ① Panel/DIN Rail Adapter
- ② DIN Rail
- ③ Screw

Figure 2.2 DIN Rail Mounting

2. Install one of the supplied screws on either side of the device to secure the adapters to the DIN rails.

2.3.3 Mounting the Device to a Panel

For panel installations, the RUGGEDCOM RX1500 can be equipped with panel/DIN rail adapters pre-installed on each side of the chassis. The adapters allow the device to be attached to a panel using screws.

To mount the device to a panel, do the following:

1. Place the device against the panel and mark the mounting holes on the panel.

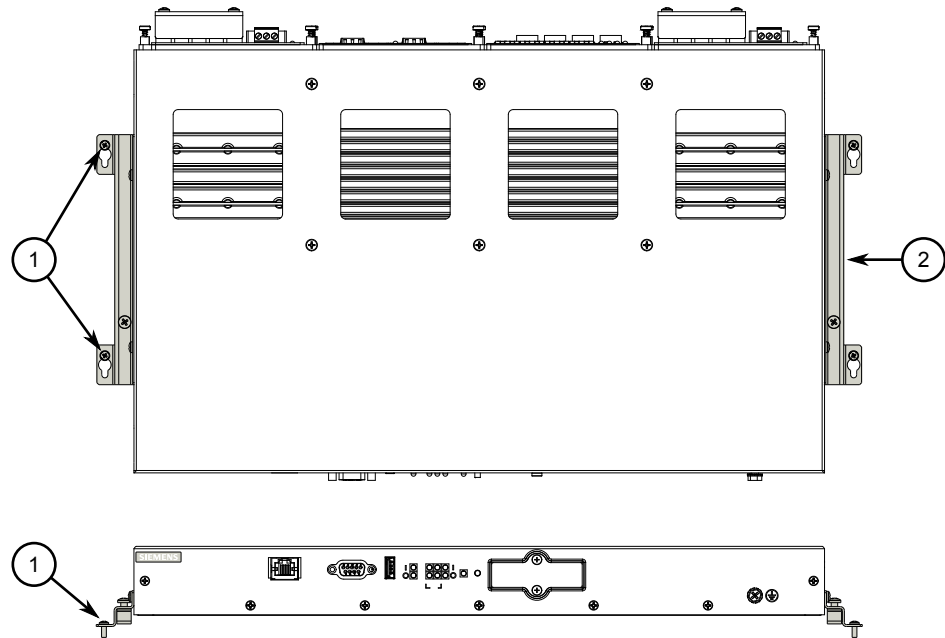

- ① Screw
- ② Panel/DIN Rail Adapter

Figure 2.3 Panel Mounting

2. Prepare the mounting holes
3. Align the device with the mounting holes and secure it to the panel.

2.4 Connecting the Failsafe Alarm Relay

The failsafe relay can be configured to latch based on alarm conditions. The NO (Normally Open) contact is closed when the unit is powered and there are no active alarms. If the device is not powered or if an active alarm is configured, the relay opens the NO contact and closes the NC (Normally Closed) contact.

Note

Control of the failsafe relay output is configurable through RUGGEDCOM RX1500. One common application for this relay is to signal an alarm if a power failure occurs. For more information, refer to the "RUGGEDCOM ROX II Configuration Manual" for the RUGGEDCOM RX1500.

The following shows the proper relay connections.

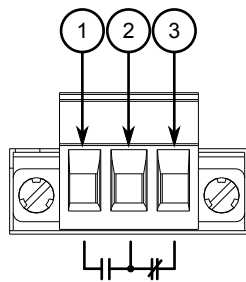

- ① Normally Open
- ② Common
- ③ Normally Closed

Figure 2.4 Failsafe Alarm Relay Wiring

2.5 Connecting Power

The RUGGEDCOM RX1500 supports dual redundant high AC, high DC and/or low DC power modules that can be installed in any combination. The use of two power modules is recommended to provide redundancy and load balancing.

Power modules can be equipped with either a screw or European-style (Euroblock) terminal block. The screw terminal block is installed using Phillips screws and compression plates, allowing either bare wire connections or crimped terminal lugs.

For information about installing or removing a power module, refer to "Installing/Removing Power Modules" (Page 32).

⚠ DANGER

Electrocution hazard – risk of serious personal injury or death

The device may have two power modules equipped, which may be connected to separate power sources. Make sure all power sources are off before servicing the power module terminals.

⚠ NOTICE

- In a high AC/DC and low DC (24/48 V) power module arrangement, the placement of the AC and DC power supplies is not slot-dependent. Either power module slot can be used for AC or DC power.
- For maximum redundancy in a dual power module configuration, use two independent power sources.
- Use minimum #16 gage copper wiring when connecting terminal blocks.
- The maximum wire length between the terminal block and power source must not exceed 6 m (20 ft) for 24 V power supplies or 18 m (60 ft) for 48 V power supplies.

- For 125/230 VAC rated equipment, an appropriately rated AC circuit breaker must be installed.
- For 125/250 VDC rated equipment, an appropriately rated DC circuit breaker must be installed.
- It is recommended to provide a separate 20 A circuit breaker for each power module module.
- Equipment must be installed according to applicable local wiring codes and standards.

2.5.1 Connecting High AC/DC Power

To connect a high AC/DC power supply to the device, do the following:

⚠ DANGER
Electrocution hazard – risk of death, serious personal injury and/or damage to the device
Make sure the supplied cover is always installed over high voltage screw terminal blocks.

⚠ NOTICE
Electrical hazard – risk of damage to equipment
Do not connect AC power cables to a 12, 24 or 48 VDC power supply terminal block. Damage to the power supply may occur.

1. Connect the power supply terminal block to the device.

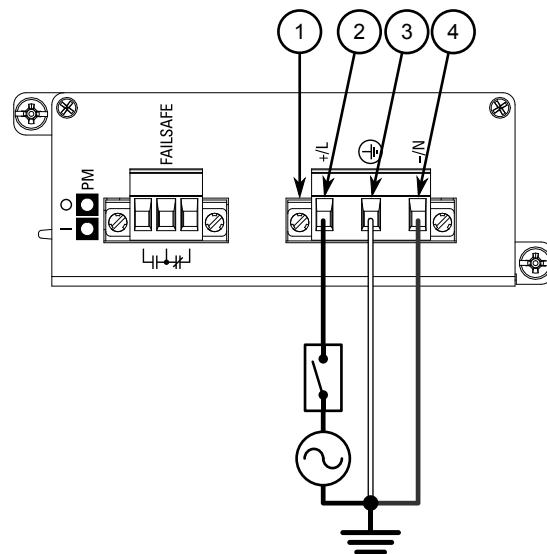

- ① European-style (Euroblock) Terminal Block
- ② Positive/Live (+/L) Terminal

- ③ Ground Terminal
- ④ Negative/Neutral (-/N) Terminal

Figure 2.5 AC Terminal Block Wiring – European-style (Euroblock) Terminal Block for HIP Power Supplies

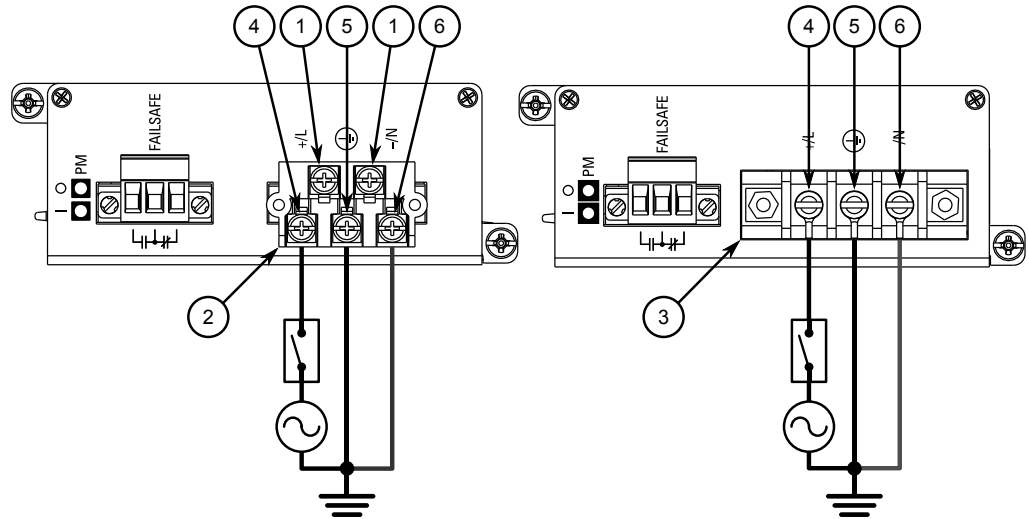

- ① Not Connected
- ② Removable Screw Terminal Block
- ③ Non-removable Screw Terminal Block
- ④ Positive/Live (+/L) Terminal
- ⑤ Ground Terminal
- ⑥ Negative/Neutral (-/N) Terminal

Figure 2.6 AC Terminal Block Wiring – Screw Terminal Block for HI Power Supplies

Note

For secure, reliable connections under severe shock or vibration, use M3.5 ring lugs with a maximum outer diameter of 7 mm (0.28 in). Make sure no bare metal is exposed beyond the safety cover.

2. Connect the positive wire from the power source to the positive/live (+/L) terminal on the terminal block.
3. Connect the negative wire from the power source to the neutral/negative (-/N) terminal on the terminal block.
4. For screw terminal blocks, install the safety cover.

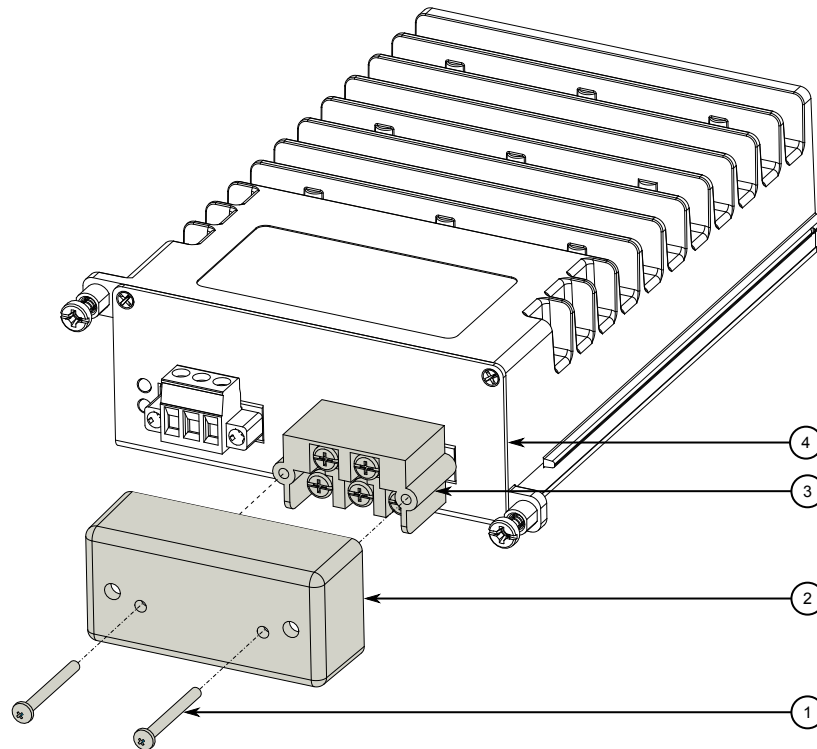

- ① Screw
- ② Safety Cover
- ③ Screw Terminal Block
- ④ RUGGEDCOM RX1500 Device

Figure 2.7 Assembling the Safety Cover

5. Using a braided wire or other appropriate grounding wire, connect the ground terminal to the chassis ground connection.
6. Using a #10 ring lug and #10-32 screw, secure the ground terminal on the power source to the ground connection on the device. Make sure the lug is tightened to 1.1 N·m (9.5 lbf·in).

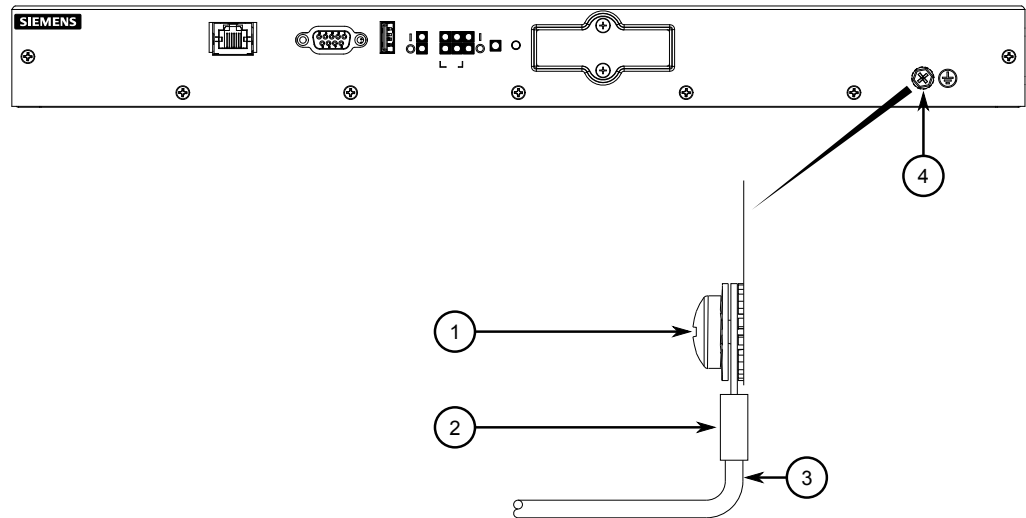

- ① #10 Ring Lug
- ② #10-32 Screw
- ③ Connection from External Power Source
- ④ Ground Connection

Figure 2.8 Ground Connection

7. Install the safety cover over the terminal block.

2.5.2 Connecting Low DC Power

To connect a low DC power supply to the device, do the following:

⚠ NOTICE

Electrical hazard – risk of damage to equipment

Do not connect AC power cables to a 12, 24 or 48 VDC power supply terminal block. Damage to the power supply may occur.

Note

The RUGGEDCOM RX1500 works with both positive VDC power supplies and negative VDC power supplies.

1. Connect the power supply terminal block to the device.

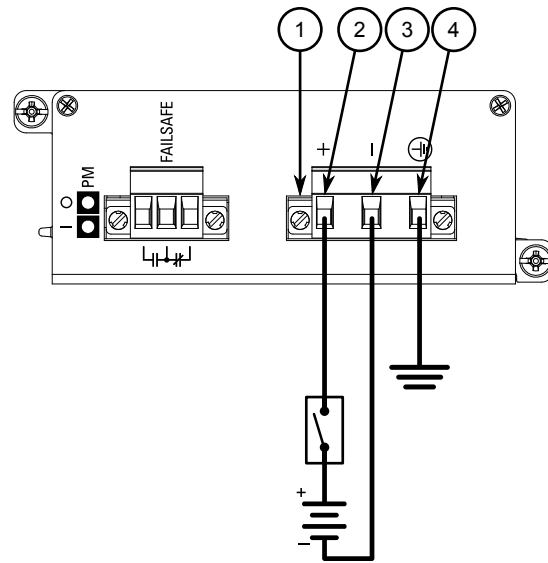

- ① European-style (Euroblock) Terminal Block
- ② Positive (+) Terminal
- ③ Negative (-) Terminal
- ④ Ground Terminal

Figure 2.9 DC Terminal Block Wiring – European-style (Euroblock) Terminal Block for 12P, 24P and 48P Power Supplies

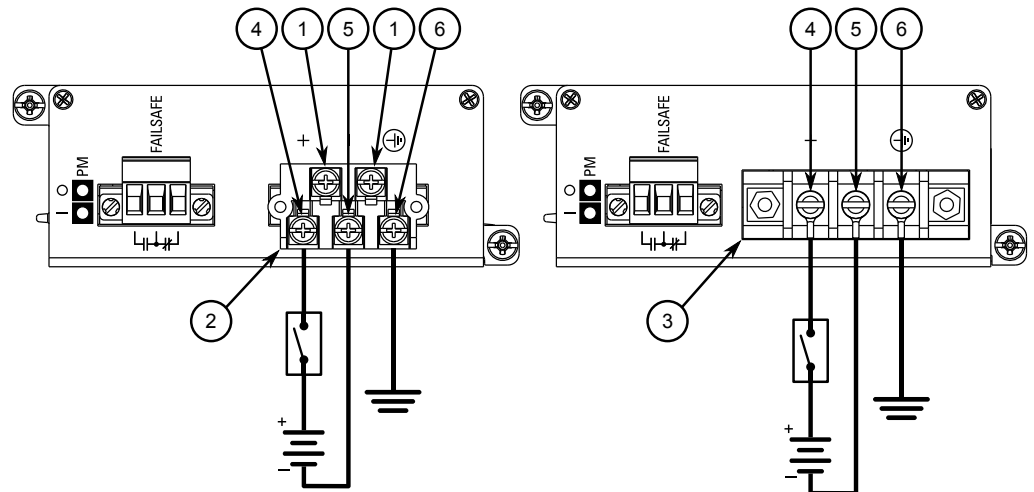

- ① Not Connected
- ② Removable Screw Terminal Block
- ③ Non-removable Screw Terminal Block
- ④ Positive (+) Terminal
- ⑤ Negative (-) Terminal
- ⑥ Ground Terminal

Figure 2.10 DC Terminal Block Wiring – Screw Terminal Block for 12P, 24P and 48P Power Supplies

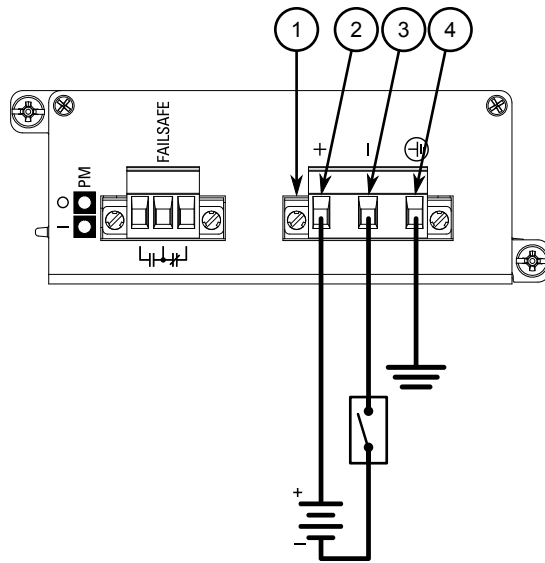

- ① European-style (Euroblock) Terminal Block
- ② Positive (+) Terminal
- ③ Negative (-) Terminal
- ④ Ground Terminal

Figure 2.11 DC Terminal Block Wiring – European-style (Euroblock) Terminal Block for -12P, -24P and -48P Power Supplies

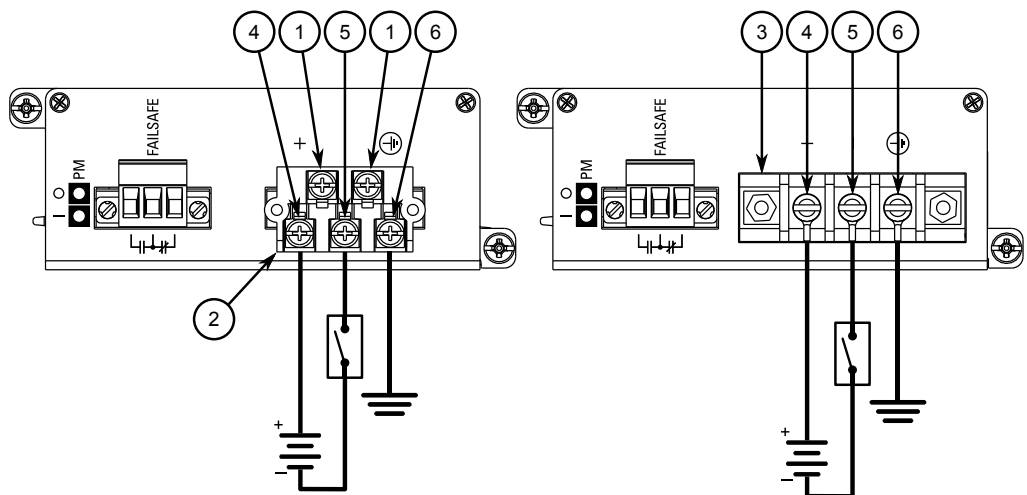

- ① Not Connected
- ② Removable Screw Terminal Block
- ③ Non-removable Screw Terminal Block
- ④ Positive (+) Terminal
- ⑤ Negative (-) Terminal
- ⑥ Ground Terminal

Figure 2.12 DC Terminal Block Wiring – Screw Terminal Block for -12P, -24P and -48P Power Supplies

Note

For secure, reliable connections under severe shock or vibration, use M3.5 ring lugs with a maximum outer diameter of 7 mm (0.28 in). Make sure no bare metal is exposed beyond the safety cover.

2. Connect the positive wire from the power source to the positive (+) terminal on the terminal block.
3. Connect the negative wire from the power source to the negative (-) terminal on the terminal block.
4. For screw terminal blocks, install the safety cover.

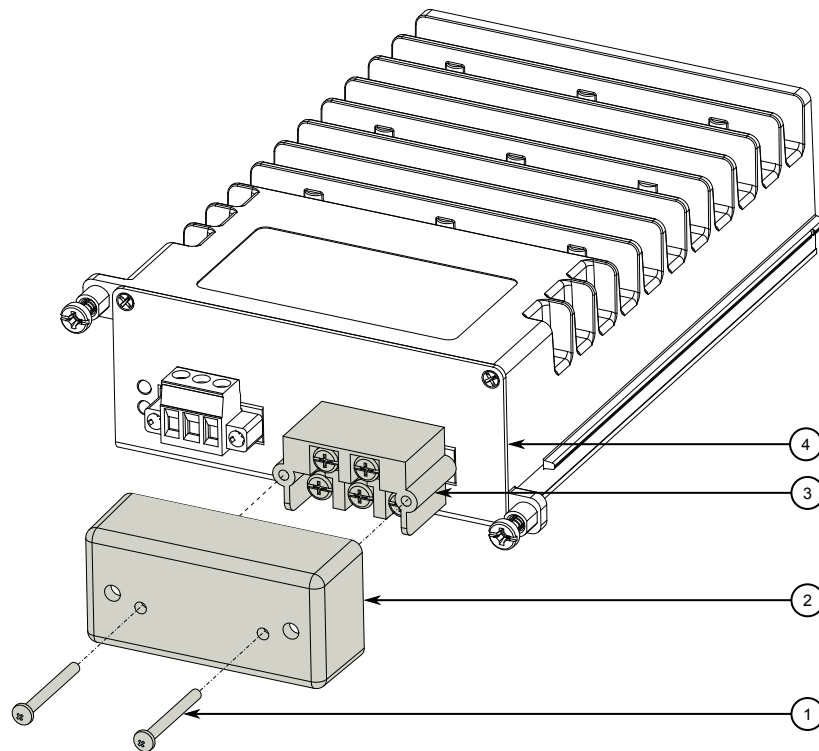

- ① Screw
- ② Safety Cover
- ③ Screw Terminal Block
- ④ RUGGEDCOM RX1500 Device

Figure 2.13 Assembling the Safety Cover

5. Using a #10 ring lug and #10-32 screw, secure the ground terminal on the power source to the ground connection on the device. Make sure the lug is tightened to 2.4 N·m (9.5 lbf·in).

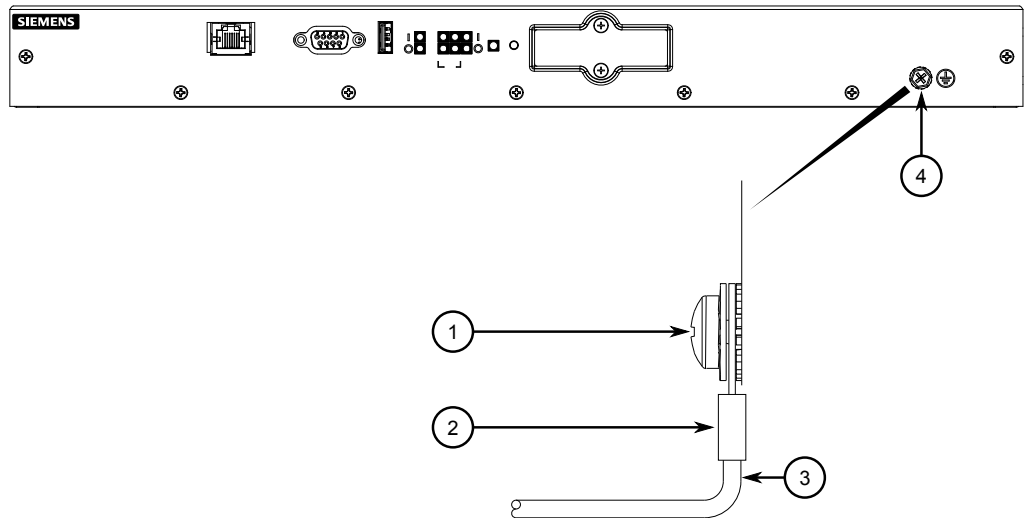

- ① #10 Ring Lug
- ② #10-32 Screw
- ③ Connection from External Power Source
- ④ Ground Connection

Figure 2.14 Ground Connection

6. Install the safety cover over the terminal block. **This is mandatory for 48 VDC and -48 VDC power supplies.**

Device Management

This section describes how to connect to and manage the device.

3.1 Connecting to the Device

The following describes the various methods for accessing the RUGGEDCOM RX1500 console and Web interfaces on the device. For more detailed instructions, refer to the "RUGGEDCOM ROX II Configuration Manual" for the RUGGEDCOM RX1500.

NOTICE

Intermittent LINK DOWN Alarms and RJ45 Connectors

Intermittent LINK DOWN alarms may be caused by an improper physical connection at an RJ45 port. If intermittent LINK DOWN alarms are experienced on an RJ45 port, consider the RJ45 cable in use. On some RJ45 connectors, the slots on the connector where the contacts connect is too short, causing the connector pins in the port to lift before a proper connection is made. It is determined the minimum slot length must be 5.5 mm (0.216 in).

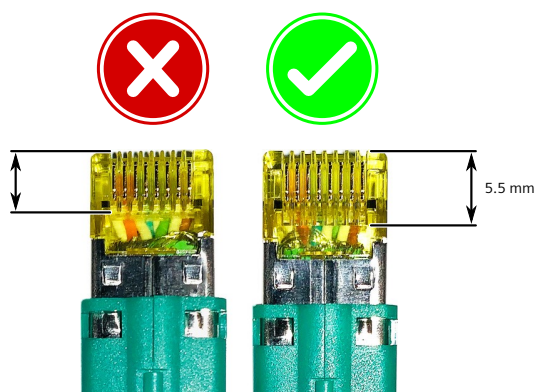

Adjusting the position of the connector in the port, either by wiggling or pulling the connector back, corrects the issue temporarily, but is not recommended. It may cause damage to the contact pins of the RJ45 ports. For a permanent solution, use Siemens 6XV1870-3Qxxx certified cables (manufactured December 2019 or after) or equivalent.

Siemens recommends using Siemens certified cables and connectors for Siemens RUGGEDCOM products. Contact your Siemens RUGGEDCOM representative for more details.

Serial Console and Management Ports

Connect a workstation directly to the serial console or management ports to access the boot-time control and RUGGEDCOM RX1500 interfaces. The serial console port provides access to RUGGEDCOM RX1500's console interface, while the management port provides access to RUGGEDCOM RX1500's console and Web interfaces.

The serial console port implements RS232 DCE (Data Communication Equipment) on a DB9 connector. The following is the pin-out for the port:

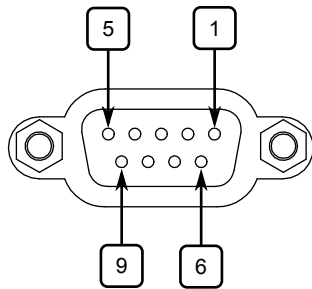

Figure 3.2 Serial DB9 Console Port

Pin	Name	Description
1	DCD	Data Carrier Detect
2	RX	Receive Data
3	TX	Transmit Data
4	DTR	Data Terminal Ready
5	GND	Signal Ground
6	DSR	Data Set Ready
7	RTS	Request to Send
8	CTS	Clear To Send
9	Reserved (Do Not Connect)	

For information about how to connect to the device via the serial console port, refer to the "RUGGEDCOM ROX II CLI Configuration Manual" for the RUGGEDCOM RX1500.

For information about how to connect to the device via the management port, refer to either the "RUGGEDCOM ROX II Web Interface Configuration Manual" or the "RUGGEDCOM ROX II CLI Configuration Manual" for the RUGGEDCOM RX1500.

The management port is a 10/100Base-TX copper Ethernet port with an RJ-45 connector. The following is the pin-out for the management port:

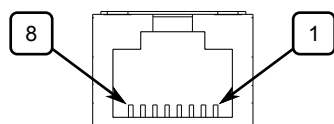

Figure 3.3 RJ-45 Management Port

Pin	Name	Description
1	RX+	Receive Data+
2	RX-	Receive Data-
3	TX+	Transmit Data+
4		Reserved (Do Not Connect)
5		Reserved (Do Not Connect)
6	TX-	Transmit Data-
7		Reserved (Do Not Connect)
8		Reserved (Do Not Connect)

Communication Ports

Connect any of the available Ethernet ports on the device to a management switch and access the RUGGEDCOM RX1500 console and Web interfaces via the device's IP address. The factory default IP address for the RUGGEDCOM RX1500 is <https://192.168.0.2>.

For more information about available ports, refer to "Modules" (Page 29).

Note

Single-mode fiber ports only support Ultra Physical Contact (UPC) cable connectors.

3.2 Configuring the Device

Once the device is installed and connected to the network, it must be configured. All configuration management is done via the RUGGEDCOM RX1500 interface. For more information about configuring the device, refer to the "RUGGEDCOM ROX II Configuration Manual" associated with the installed software release.

3.3 Accessing the CompactFlash Card

The RUGGEDCOM RX1500 features a removable CompactFlash (CF) card that stores configuration files, firmware (active and backup versions), file-based feature keys and other system files.

 NOTICE

Configuration hazard – risk of data corruption/loss
--

Do not remove or insert the CF card when the device is powered on.
--

The CF card should only be removed in the following scenarios:

- The chassis is defective (with the exception of power and media modules)
- The CF card is deemed defective or corrupt

- The device is rendered non-functional due to a serious configuration error, data corruption, or hardware fault

⚠ NOTICE
Configuration hazard – risk of data corruption/loss
The following will void the warranty and potentially result in configuration data corruption/loss:
<ul style="list-style-type: none">• Using a CF card not approved by Siemens for use with this device• Removing the CF card in any scenario other than those described in this section

Inserting the CF card

To insert the CF card into the device, do the following:

⚠ NOTICE
The device should only be powered on when the CF card is present.

1. Make sure the device is powered down.
2. Remove the CF card access panel.
3. Insert the CF card into the slot until it is fully seated.

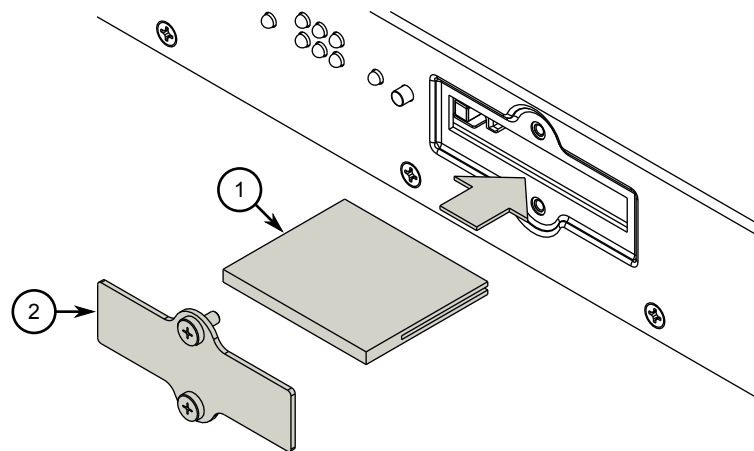

- ① CompactFlash Card
- ② Access Panel

Figure 3.4 Inserting the CF Card

4. Secure the CF card access panel to the chassis.

Removing the CF card

To remove the CF card from the device, do the following:

1. Make sure the device is powered down.

2. Remove the CF card access panel.

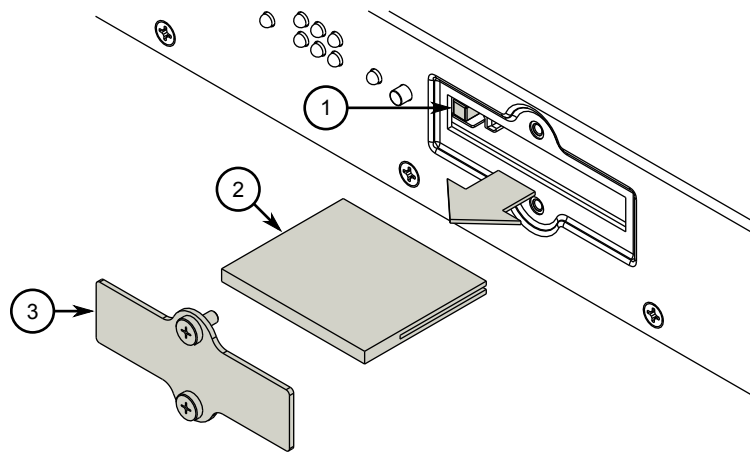

- ① Ejector Button
- ② CompactFlash Card
- ③ Access Panel

Figure 3.5 Removing the CF Card

3. Remove the CF card.
 - If the device features an ejector button, press the button to eject the card.
 - If the device does not feature an ejector button, pull the tab affixed to the card. If the tab is missing, use a flat head screwdriver to carefully remove the card.
4. Secure the CF card access panel to the chassis.

Modules

The RUGGEDCOM RX1500 features slots for up to four field-replaceable line modules, which can be used to expand and customize the capabilities of the device to suit specific applications.

A variety of modules are available, each featuring a specific type of communication port: copper Ethernet, fiber optic Ethernet, SFP, WAN, cellular modem and DDS. The RUGGEDCOM APE (Application Processing Engine) line module, a utility-grade computing platform for running third-party applications directly from within the RUGGEDCOM RX1500, is also available.

Use the RUGGEDCOM ROX II software to determine which ports are equipped on the device. For more information, refer to the "RUGGEDCOM ROX II Configuration Manual" for the device.

4.1 Requirements and Restrictions

Before installing modules in the device, consider the following restrictions and requirements.

Module Support

- Only one T1/E1 WAN module and up to two DDS modules are supported
- Up to two RUGGEDCOM APE modules are supported

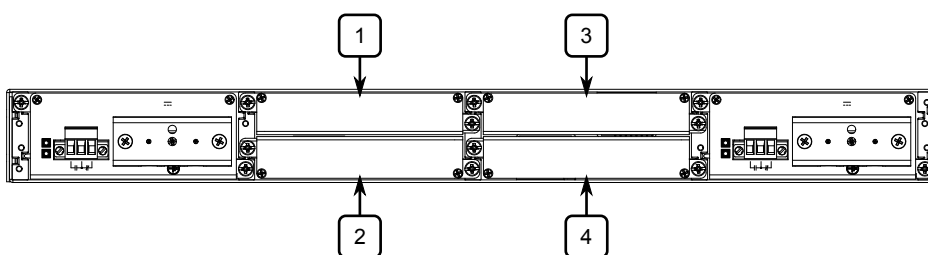

Figure 4.1 Available Chassis Slots

4.2 Available Modules

A variety of modules are available for use with the RUGGEDCOM RX1500.

For more information, refer to the "RUGGEDCOM Modules Catalog [<https://support.industry.siemens.com/cs/us/en/view/109747072>]" for the RUGGEDCOM RX1500.

4.3 Installing/Removing Line Modules

Upon installing a new line module in the device, all features associated with the module are available in RUGGEDCOM RX1500. For more information, refer to the "RUGGEDCOM ROX II Configuration Manual" for the RUGGEDCOM RX1500.

Once a line module is removed, all the features associated with the module are hidden or disabled in RUGGEDCOM RX1500.

<p> NOTICE</p> <p>Electrical hazard – risk of power failure</p> <p>When installing more than one line module in the device, make sure the total power consumption of all line modules does not exceed 41.5 W (i.e. the total power made available to the modules by the chassis). If the total power consumption exceeds this value, power fluctuations and irregular shut downs may occur.</p> <p>For the maximum power consumption of each line module, refer to "Available Modules" (Page 29).</p>
--

<p> NOTICE</p> <p>Contamination hazard – risk of equipment damage</p> <p>Prevent the ingress of water, dirt and other debris that may lead to premature equipment failure. Always make sure slots are not left empty and open ports are protected with plugs or covers.</p>
--

Note

Only one WAN line module is supported per chassis.

Removing a Module

To remove a line module, do the following:

1. [Optional] If the device is installed in a rack, remove it from the rack.
2. Loosen the screws that secure the module.
3. Pull the module from the chassis to disconnect it.

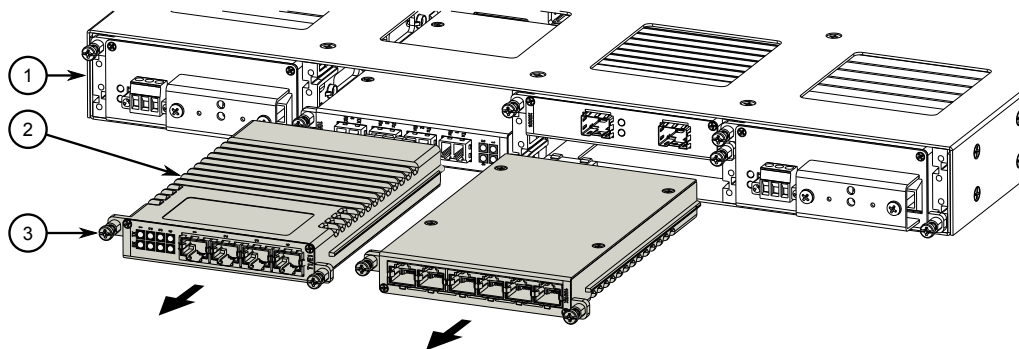

- ① Module
- ② Chassis
- ③ Screw

Figure 4.2 Removing a Module

4. Install a new module or a blank module (to prevent the ingress of dust and dirt).
5. [Optional] If necessary, install the device in the rack.

Installing a Module

To install a line module, do the following:

1. [Optional] If the device is installed in a rack, remove it from the rack.
2. Remove the current module from the slot.
3. Insert the new module into the slot.

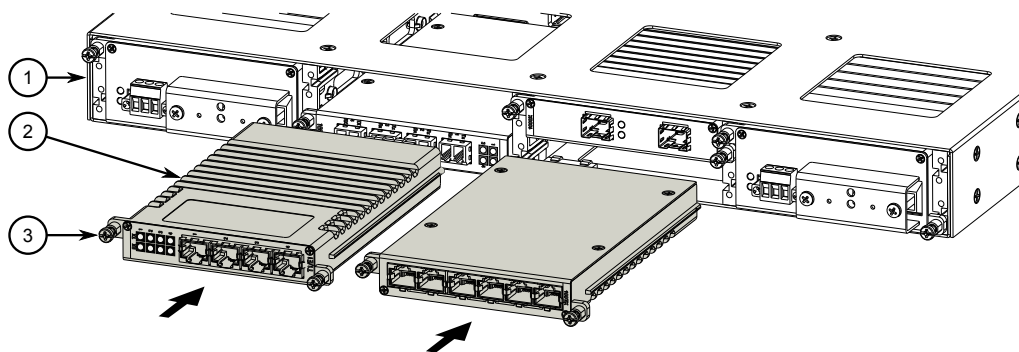

- ① Module
- ② Chassis
- ③ Screw

Figure 4.3 Installing a Module

4. Tighten the screws to secure the module.
5. [Optional] If necessary, install the device in the rack.

4.4 Installing/Removing Power Modules

The RUGGEDCOM RX1500 supports dual redundant power supply modules.

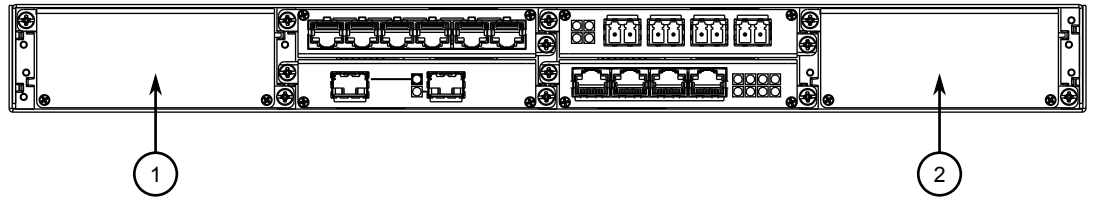

- ① Slot PS1
- ② Slot PS2

Figure 4.4 Power Modules

⚠ NOTICE

Contamination hazard – risk of equipment damage

Prevent the ingress of water, dirt, and other debris that may lead to premature equipment failure. Always make sure slots are not left empty.

Note

Power modules are hot swappable. When installing/removing a power module, it is not necessary to turn off power to the redundant power module.

Removing a Power Module

To remove a power module, do the following:

⚠ DANGER

Electrocution hazard – risk of serious personal injury or death

Make sure power to the module is turned off before servicing the power supply terminal.

1. Turn off power to the module.
2. Loosen the screws that secure the module to the chassis until the module can be removed.

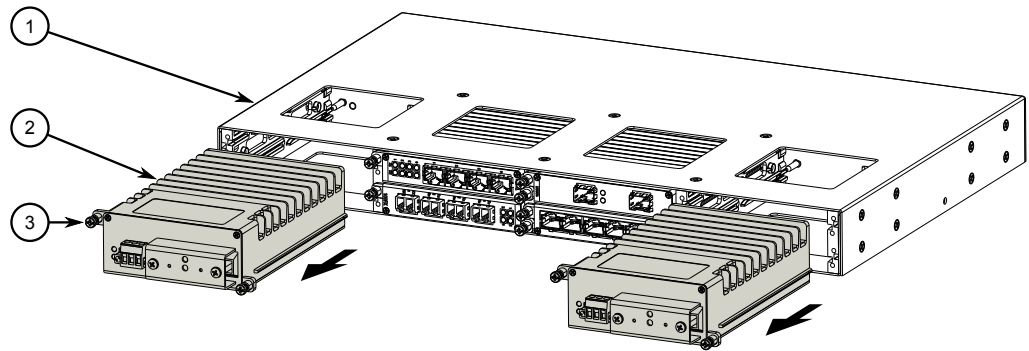

- ① Chassis
- ② Power Supply
- ③ Screws

Figure 4.5 Removing a Power Supply

3. Slide the module out of the chassis.
4. Disconnect the power supply wiring from the terminal block. Alternatively, for convenience, remove the terminal block with the wiring still connected and set it aside to be connected later to the new module.
5. Install a new or blank module to prevent the ingress of dust and dirt.

Installing a Power Module

To install a power module, do the following:

1. If equipped, remove the existing module.
2. If applicable, connect the supplied terminal block to the module or connect the terminal block from the previous module.
3. Confirm or connect the wiring from the power supply to the module. For more information, refer to "Connecting Power" (Page 13).
4. Insert the module into the empty slot.

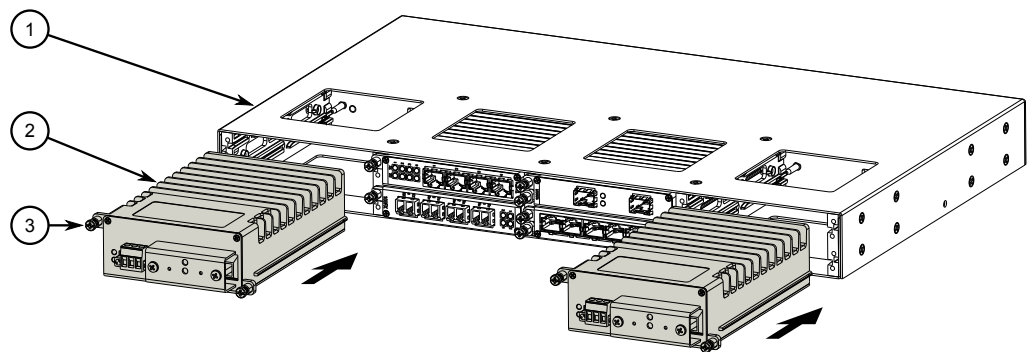

- ① Chassis
- ② Power Module

4.4 Installing/Removing Power Modules

③ Screws

Figure 4.6 Installing a Power Module

5. Hand-tighten the screws to secure the power module to the chassis.
6. Turn on power to the device and confirm the module is receiving and supplying power. This is indicated by the LEDs on the module.

LED	State	Description
O	Green	The module is supplying power
I	Green	The module is receiving power

Technical Specifications

This section provides important technical specifications related to the device.

5.1 Chassis Specifications

Power Consumption	10 W
-------------------	------

5.2 Power Supply Specifications

Note

When determining cable lengths, make sure the nominal input voltage for the power supply is provided at the power source.

Power Supply Type	Input Range		Internal Fuse Rating	Maximum Power Consumption ^a	Insulation
	Min	Max			
HI	88 VDC	300 VDC	3.15 A(T) ^b	65 W	2800 VDC for 1 minute
	85 VAC	264 VAC			
HIP	88 VDC	300 VDC	3.15 A(T) ^b	65 W	
	85 VAC	264 VAC			
24	13 VDC	36 VDC	10 A(T) ^b	63.5 W	1500 VDC for 1 minute
24P					
48	36 VDC	72 VDC	3.15 A(T) ^b	60 W	
48P					
12	9 VDC	15 VDC	12 A	67 W	1500 VAC or 2121 VDC for 1 minute
12P					

^a Power consumption varies based on the device configuration.

^b (T) denotes time-delay fuse.

5.3 Failsafe Relay Specifications

Maximum Switching Voltage	Rated Switching Current	Isolation
30 VDC	5 A	2800 VDC for 1 minute between coil and contacts
125 VDC	0.1 A ^a , 0.15 A ^b	

5.4 Operating Environment

Maximum Switching Voltage	Rated Switching Current	Isolation
250 VAC	6.25 A	

^a Inductive load R/L = 7 ms

^b Resistive load

5.4 Operating Environment

The RUGGEDCOM RX1500 is rated to operate under the following environmental conditions.

Note

Temperature limits for select line modules may differ from that which can be withstood by the RUGGEDCOM RX1500. Make sure the selected modules are rated for the expected environmental conditions before deployment. For more information, refer to the "RUGGEDCOM RX1500 Series Modules Catalog".

Ambient Operating Temperature^{abc}	-40 to 85 °C (-40 to 185 °F)
Ambient Storage Temperature	-40 to 85 °C (-40 to 185 °F)
Ambient Relative Humidity^d	5% to 95%
Maximum Altitude	12192 m (40000 ft)

^a Maximum ambient operating temperature is 70 °C (158 °F) when the device is installed along with Underwriter Laboratories (UL) listed devices.

^b Measured from a 30 cm (12 in) radius surrounding the center of the enclosure.

^c Operating temperature may vary based on the limitations of installed SFPs. Refer to the "RUGGEDCOM SFP Transceivers Catalog" for SFP temperature ratings.

^d Non-condensing.

5.5 Mechanical Specifications

Weight	Approximately 4.7 kg (10.3 lb)
Ingress Protection	IP30
Enclosure	Aluminum

5.6 Dimension Drawings

Note

All dimensions are in millimeters, unless otherwise stated.

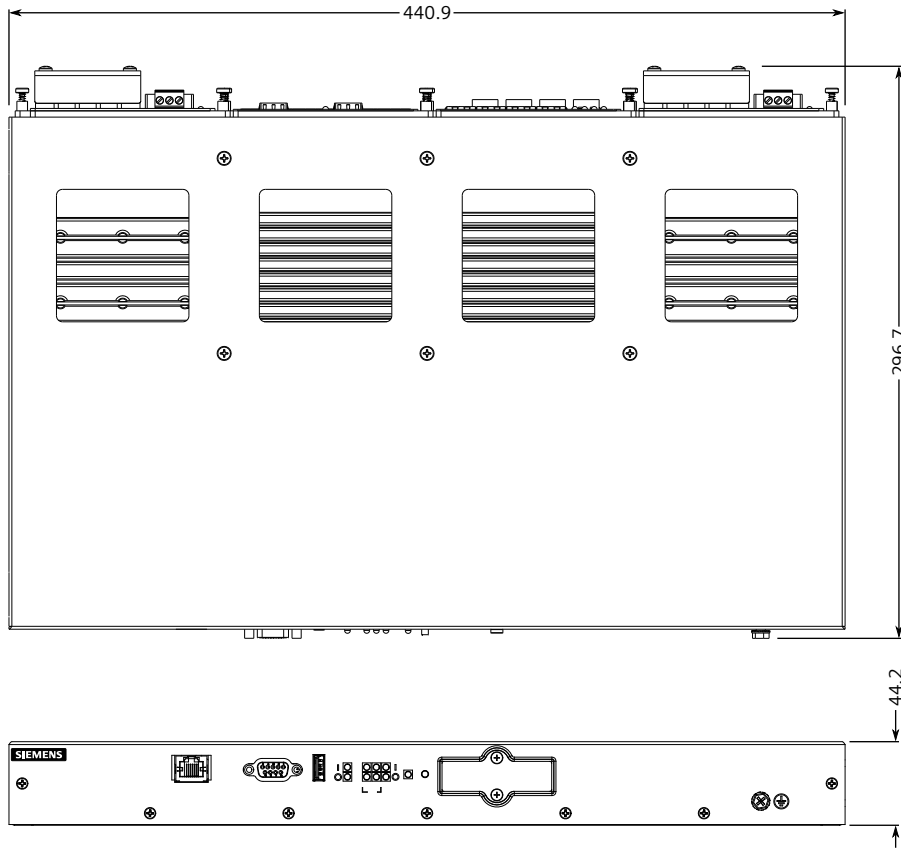

Figure 5.1 Overall Dimensions

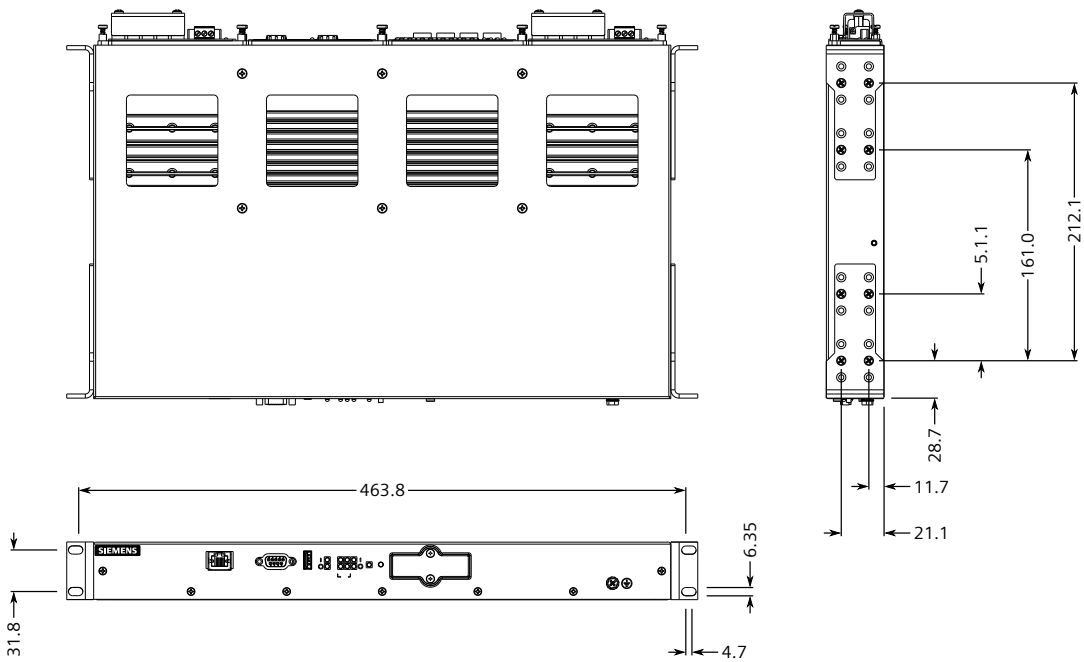

Figure 5.2 Rack Mount Dimensions

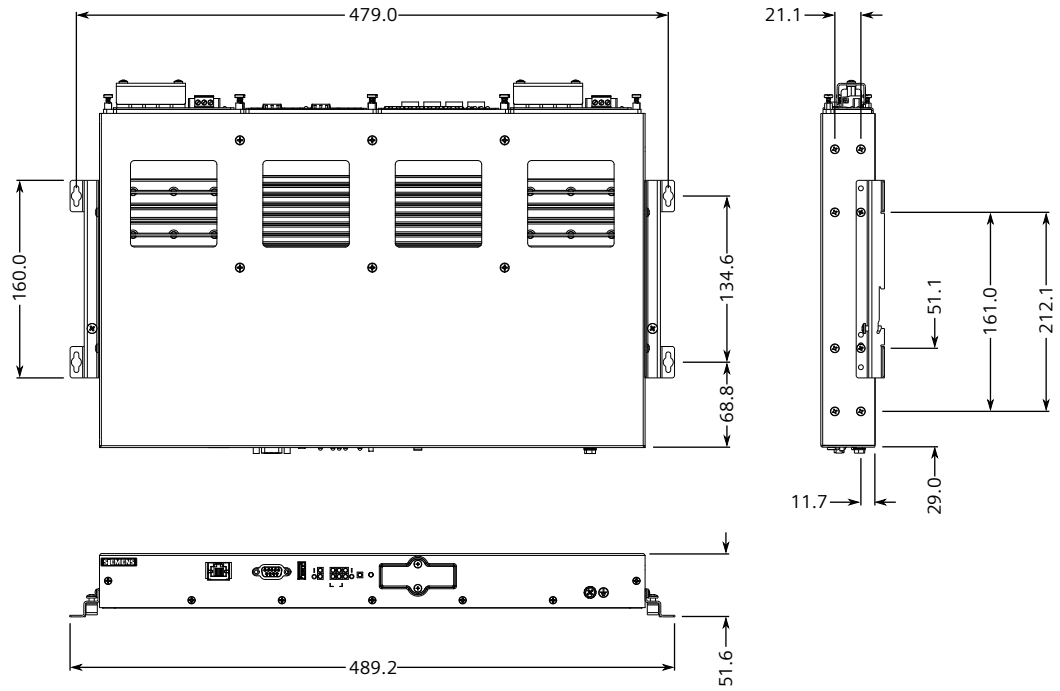

Figure 5.3 Panel and Din Rail Mount Dimensions

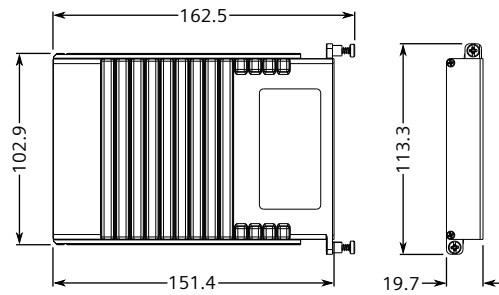

Figure 5.4 Line Module Dimensions

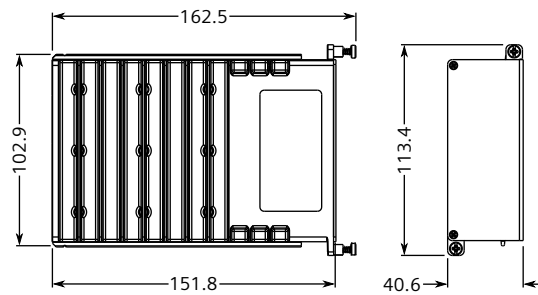

Figure 5.5 Power Module Dimensions

Certification

The RUGGEDCOM RX1500 device has been thoroughly tested to guarantee its conformance with recognized standards and has received approval from recognized regulatory agencies.

Note

Certifications related to individual modules are detailed in the "RUGGEDCOM Modules Catalog" for the device available online.

6.1 Approvals

This section details the standards to which the RUGGEDCOM RX1500 complies.

Note

All relevant certificates and test reports are available on [Siemens Industry Online Support \[https://support.industry.siemens.com/cs/ww/en/ps/16008/cert\]](https://support.industry.siemens.com/cs/ww/en/ps/16008/cert).

6.1.1 UKCA

This device is certified for use in Great Britain and bears the United Kingdom Certified Assessed (UKCA) marking. The marking is printed on the body of the device.



6.1.2 TÜV SÜD

This device is certified by TÜV SÜD to meet the requirements of the following standards:

- **CAN/CSA-C22.2 NO. 62368-1 (R2014)**
Information Technology Equipment – Safety – Part 1: General Requirements (Bi-National standard, with UL 62368-1)
- **UL 62368-1**
Information Technology Equipment – Safety – Part 1: General Requirements

6.1.3 European Union (EU)

This device is declared by Siemens Canada Ltd. to comply with essential requirements and other relevant provisions of the following EU directives:

- **Directive 2014/30/EU**
Directive 2014/30/EU of the European Parliament and of the Council of 26 February 2014 on the harmonisation of the laws of the Member States relating to electromagnetic compatibility (recast) Text with EEA relevance
- **Directive 2014/35/EU**
Directive 2014/35/EU of the European Parliament and of the Council of 26 February 2014 on the harmonisation of the laws of the Member States relating to the making available on the market of electrical equipment designed for use within certain voltage limits Text with EEA relevance
- **Directive 2011/65/EU**
Directive 2011/65/EU of the European Parliament and of the Council of 8 June 2011 on the restriction of the use of certain hazardous substances in electrical and electronic equipment Text with EEA relevance
- **Directive 1999/5/EC**
Directive 1999/5/EC of the European Parliament and of the Council of 9 March 1999 on radio equipment and telecommunications terminal equipment and the mutual recognition of their conformity
- **EN 62368-1**
Information Technology Equipment – Safety – Part 1: General Requirements
- **EN 61000-3-2**
Electromagnetic compatibility (EMC) – Part 3-2: Limits – Limits for harmonic current emissions (equipment input current ≤ 16 A per phase)
- **EN 61000-3-3**
Electromagnetic compatibility (EMC) – Part 3-3: Limits – Limitation of voltage changes, voltage fluctuations and flicker in public low-voltage supply systems, for equipment with rated current ≤ 16 A per phase and not subject to conditional connection
- **EN 61000-6-2**
Electromagnetic Compatibility (EMC) – Part 6-2: Generic Standards – Immunity for Industrial Environments
- **EN 60825-1**
Safety of Laser Products – Equipment Classification and Requirements
- **EN 63000**
Technical Documentation for the Assessment of Electrical and Electronic Products with Respect to the Restriction of Hazardous Substances
- **CISPR 32/EN 55032**
Electromagnetic Compatibility of Multimedia Equipment – Emission Requirements

The device is marked with a CE symbol and can be used throughout the European community.



6.1.4 FCC

This device has been tested and found to comply with the limits for a Class A digital device, pursuant to Part 15 of the FCC Rules. These limits are designed to provide reasonable protection against harmful interference when the equipment is operated in a commercial environment.

This device generates, uses and can radiate radio frequency energy and, if not installed and used in accordance with the instruction manual, may cause harmful interference to radio communications. Operation of this equipment in a residential area is likely to cause harmful interference in which case users will be required to correct the interference at their own expense.

Note

Changes or modifications not expressly approved by the party responsible for compliance could void the user's authority to operate this device.

6.1.5 FDA/CDRH

This device meets the requirements of the following U.S. Food and Drug Administration (FDA) standard:

- Title 21 Code of Federal Regulations (CFR) – Chapter I – Sub-chapter J – Radiological Health

6.1.6 ISED

This device is declared by Siemens Canada Ltd. to meet the requirements of the following ISED (Innovation Science and Economic Development Canada) standard:

- CAN ICES-3 (A)/NMB-3 (A)

6.1.7 ISO

This device was designed and manufactured using a certified ISO (International Organization for Standardization) quality program that adheres to the following standard:

- **ISO 9001:2015**
Quality management systems – Requirements

6.1.8 ACMA

This device meets the requirements of the following Australian Communications and Media Authority (ACMA) standards under certificate ABN 98 004 347 880:

- Radiocommunications (Compliance Labeling – Devices) Notice 2014 made under section 182 of the Radiocommunications Act 1992
- Radiocommunications Labeling (Electromagnetic Compatibility) Notice 2017 made under section 182 of the Radiocommunications Act 1992
- Radiocommunications (Compliance Labeling – Electromagnetic Radiation) Notice 2014 made under section 182 of the Radiocommunications Act 1992
- Telecommunications (Labeling Notice for Customer Equipment and Customer Cabling) Instrument 2015 made under section 407 of the Telecommunication Act 1997

The device is marked with an RCM symbol to indicate compliance when sold in the Australian region.



A copy of the Declaration of Conformity is available via Siemens Industry Online Support at <https://support.industry.siemens.com/cs/ww/en/view/89855782>.

6.1.9 RoHS

This device is declared by Siemens Canada Ltd. to meet the requirements of the following RoHS (Restriction of Hazardous Substances) directives for the restricted use of certain hazardous substances in electrical and electronic equipment:

- **EU RoHS Directives (EU) 2011/65 and (EU) 2015/863**
European Directive for Restriction of Hazardous Substances
- **China RoHS (relating to SJ/T 11364)**
Management Methods for the Restriction of the Use of Hazardous Substances in Electrical and Electronic Products

Declarations of conformity for each directive are available online via [Siemens Industry Online Support \[https://support.industry.siemens.com/\]](https://support.industry.siemens.com/)>.

6.1.10 Other Approvals

This device meets the requirements of the following additional standards:

- **IEEE 1613**
IEEE Standard Environmental and Testing Requirements for Communications Networking Devices in Electric Power Substations

- **IEC 61000-6-2**
Electromagnetic Compatibility (EMC) – Part 6-2: Generic Standards – Immunity for Industrial Environments
- **IEC 61850-3**
Communication Networks and Systems in Substations – Part 3: General Requirements

6.2 EMC and Environmental Type Tests

The RUGGEDCOM RX1500 has passed the following Electromagnetic Compatibility (EMC) and environmental tests.

EMC Type Test for IEC 61850-3

Test	Description		Test Levels	Severity Levels
IEC 61000-4-2	ESD	Enclosure Contact	± 8 kV	4
		Enclosure Air	± 15 kV	
IEC 61000-4-3	Radiated RFI	Enclosure Ports	20 V/m	Note ^a
IEC 61000-4-4	Burst (Fast Transient)	Signal ports	± 4 kV @ 2.5 kHz	4
		DC Power Ports	± 4 kV	
		AC Power Ports		
		Earth ground ports		
IEC 61000-4-5	Surge	Signal ports	± 4 kV Line-to-Ground ± 2 kV Line-to-Line	4
		DC Power Ports	± 2 kV Line-to-Ground ± 1 kV Line-to-Line	3
		AC Power Ports	± 4 kV Line-to-Ground ± 2 kV Line-to-Line	4
IEC 61000-4-6	Induced (Conducted) RFI	Signal ports	10 V	3
		DC Power Ports		
		AC Power Ports		
		Earth ground ports		
IEC 61000-4-8	Magnetic Field	Enclosure Ports	100 A/m, continuous 1000 A/m for 1 s	Note ^a
			1000 A/m for 1 s	5
IEC 61000-4-11	Voltage Dips and Interrupts	AC Power Ports	30% for 1 period 60% for 50 periods	
IEC 61000-4-12	Damped Oscillatory	Signal ports	2.5 kV common, 1 kV differential mode @1 MHz	3
		DC Power Ports		
		AC Power Ports		
IEC 61000-4-16	Mains Frequency Voltage	Signal ports	30 V Continuous	4
		DC Power Ports	300 V for 1 s	

6.2 EMC and Environmental Type Tests

Test	Description		Test Levels	Severity Levels
IEC 61000-4-17	Ripple on DC Power Supply	DC Power Ports	10%	3
IEC 61000-4-29	Voltage Dips and Interrupts	DC Power Ports	30% for 0.1 s 60% for 0.1 s 100% for 0.05 s	
IEC 60255-5	Dielectric Strength	Signal ports	2 kV (Failsafe Relay output)	
		DC Power Ports	1.5 kV	
		AC Power Ports	2 kV	
	HV Impulse	Signal ports	5 kV (Failsafe Relay output)	
		DC Power Ports	5 kV	
		AC Power Ports		

^a Siemens-specified severity levels.

EMC Immunity Type Tests for IEEE 1613

Note

RUGGEDCOM products meet Class 1 requirements for copper Ethernet configurations and Class 2 for fiber Ethernet configurations. Class 1 allows for temporary communication loss, while Class 2 requires error-free and interrupted communications.

Description		Test Levels
HV Impulse	Signal ports	5 kV (Failsafe Relay Output)
	DC Power Ports	5 kV
	AC Power Ports	
Dielectric Strength	Signal ports	2 kV
	DC Power Ports	1.5 kV
	AC Power Ports	2 kV
Fast Transient	Signal ports	± 4 kV @ 2.5 kHz
	DC Power Ports	± 4 kV
	AC Power Ports	
	Earth ground ports	
Oscillatory	Signal ports	2.5 kV common mode @1MHz
	DC Power Ports	2.5 kV common
	AC Power Ports	1 kV differential mode @ 1 MHz
Radiated RFI	Enclosure ports	35 V/m
ESD	Enclosure Contact	± 8 kV
	Enclosure Air	± 15 kV

Environmental Type Tests

Test	Description		Test Levels	Severity Levels
IEC 60068-2-1	Cold Temperature	Test Ad	-40 °C (-40 °F), 16 Hours	
IEC 60068-2-2	Dry Heat	Test Bd	85 °C (185 °F), 16 Hours	
IEC 60068-2-30	Humidity (Damp Heat, Cyclic)	Test Db	95% (non-condensing), 55 °C (131 °F), 6 cycles	
IEC 60255-21-1	Vibration		2 g @ 10-150 Hz	Class 2
IEC 60255-21-2	Shock		30 g @ 11 ms	Class 2
	Bump		10 g @ 16 ms	Class 1
IEC 60255-21-3	Seismic		Method A	Level 2

For more information

Siemens RUGGEDCOM

<https://www.siemens.com/ruggedcom>

Industry Online Support (service and support)

<https://support.industry.siemens.com>

Industry Mall

<https://mall.industry.siemens.com>

Siemens Canada Ltd.

Digital Industries

Process Automation

300 Applewood Crescent

Concord, Ontario, L4K 4E5

Canada

© 2023 Siemens Canada Ltd.

Subject to change