

# SIEMENS

## Telecommunication Products SWT 3000 Teleprotection

V3.8 and higher

Equipment Manual

---

Preface

---

Table of Contents

---

Safety Instructions

1

Functional Description

2

Installation and Commissioning

3

Diagnostics and Error Handling

4

PowerSys and Auxiliary Software Tools

5

SNMP and Remote Access

6

Processing Unit Module

7

Interface Command Module

8

Digital Line Equipment

9

Copper Line Equipment Module

10

Fiber Optic Module

11

Alarm Module

12

Power Supply

13

Technical Data

14

Appendix

A

Index

---

**NOTE**

For your own safety, observe the warnings and safety instructions contained in this document, if available.

---

**Disclaimer of Liability**

Subject to changes and errors. The information given in this document only contains general descriptions and/or performance features which may not always specifically reflect those described, or which may undergo modification in the course of further development of the products. The requested performance features are binding only when they are expressly agreed upon in the concluded contract.

Document version: C53000-G6040-C615-3.00

Edition: 09.2022

Version of the product described: V3.8 and higher

**Copyright**

Copyright © Siemens 2022. All rights reserved.

The disclosure, duplication, distribution and editing of this document, or utilization and communication of the content are not permitted, unless authorized in writing. All rights, including rights created by patent grant or registration of a utility model or a design, are reserved.

# Preface

## Purpose of the Manual

This manual describes the control and monitoring functions for Smart Communications.

## Target Audience

Smart Communications engineers, protection system engineers, commissioning engineers, persons entrusted with the setting, testing and maintenance of automation, selective protection and control equipment, and operating personnel in electrical installation and power plants.

## Scope

This manual is valid for the SWT 3000 device family.

## Further Documentation

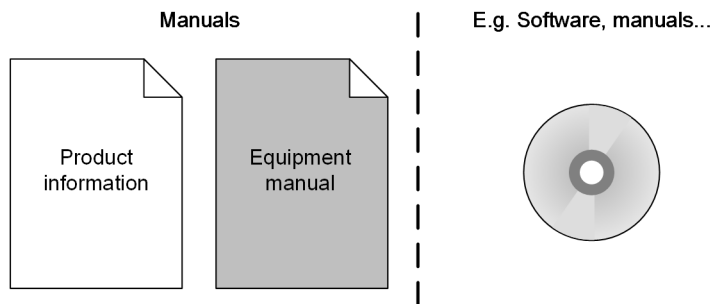

[dw\_Product-overview\_SWT3000\_Equipment-manual, 2, en\_US]

- **Product Information**  
The **Product Information** includes general information about device installation, technical data, limit values for input and output modules, and conditions when preparing for operation. This document is delivered with each device.
- **Equipment Manual**  
The **Equipment Manual** describes the functions and applications of SWT 3000 devices.

## Indication of Conformity



This product complies with the directive of the Council of the European Communities on harmonization of the laws of the Member States relating to electromagnetic compatibility (EMC Directive 2014/30/EU) and concerning electric equipment for use within specified voltage limits (Low Voltage Directive 2014/35/EU).  
This conformity has been proved by tests performed according to the Council Directive in accordance with the generic standards EN 61000-6-2 and EN 61000-6-4 (for EMC directive), and with the standard EN 62368-1 (for Low Voltage Directive) by Siemens AG.  
The device is designed and manufactured for application in an industrial environment. The product conforms with the international standards of IEC 60870.

The device is designed and manufactured for application in industrial environment:

- Emitted interference: EN 61000-6-4: 2001
- Immunity to interference: EN 61000-6-2: 2001

For use in residential areas you also need the individual authorization of a national authority or test agency with respect to emitted interference.

The test and connection jacks accessible at the front are not isolated interfaces and are only used for maintenance purposes. The usual ESD measures must be observed in use. This also applies for the use of telephone connection sockets (if present).

---



**NOTE**

All signal and data cables are shielded and connection of the shielding over a large area must be provided at both ends.

---

The products and systems listed here are manufactured and marketed using a DQS-certified quality management system in accordance with ISO 9001.

**Additional Support**

For questions about the system, contact your Siemens sales partner.

**Customer Support Center**

Our Customer Support Center provides a 24-hour service.

Siemens AG

Smart Infrastructure – Protection Automation

Customer Support Center

Tel.: +49 911 2155 4466

E-Mail: [energy.automation@siemens.com](mailto:energy.automation@siemens.com)

---

**Notes on Safety**

This document is not a complete index of all safety measures required for operation of the equipment (module or device). However, it comprises important information that must be followed for personal safety, as well as to avoid material damage. Information is highlighted and illustrated as follows according to the degree of danger:

---



**DANGER**

**DANGER** means that death or severe injury **will** result if the measures specified are not taken.

- ✧ Comply with all instructions, in order to avoid death or severe injuries.
- 



**WARNING**

**WARNING** means that death or severe injury **may** result if the measures specified are not taken.

- ✧ Comply with all instructions, in order to avoid death or severe injuries.
- 



**CAUTION**

**CAUTION** means that medium-severe or slight injuries **can** occur if the specified measures are not taken.

- ✧ Comply with all instructions, in order to avoid moderate or minor injuries.
-



## CAUTION



**ESD** (Electrostatic sensitive devices) means that a device or component **can** be damaged by common static charges built up on people, tools, and other non-conductors or semiconductors.

- ✧ Comply with all instructions, in order to avoid moderate or minor injuries.

## NOTICE

**NOTICE** means that property damage **can** result if the measures specified are not taken.

- ✧ Comply with all instructions, in order to avoid property damage.



## NOTE

Important information about the product, product handling or a certain section of the documentation which must be given attention.

### Selection of Used Symbols on the Device

No.	Symbol	Description
1	===	Direct current, IEC 60417, 5031
2	~	Alternating current, IEC 60417, 5032
3	⎓	Direct and alternating current, IEC 60417, 5033
4	⏏	Earth (ground) terminal, IEC 60417, 5017
5	⏏	Protective conductor terminal, IEC 60417, 5019
6	⚡	Caution, risk of electric shock
7	⚠	Caution, risk of danger, ISO 7000, 0434
8	□	Protective Insulation, IEC 60417, 5172, Safety Class II devices
9	ⓧ	Guideline 2002/96/EC for electrical and electronic devices
10	CE	Guideline for the Eurasian Market
11	Ⓜ	Mandatory Conformity Mark for Electronics and Electrotechnical Products in Morocco

## OpenSSL

This product includes software developed by the OpenSSL Project for use in OpenSSL Toolkit (<http://www.openssl.org/>).

This product includes software written by Tim Hudson ([tjh@cryptsoft.com](mailto:tjh@cryptsoft.com)).

This product includes cryptographic software written by Eric Young ([ey@cryptsoft.com](mailto:ey@cryptsoft.com)).

# Table of Contents

	<b>Preface.....</b>	<b>3</b>
<b>1</b>	<b>Safety Instructions.....</b>	<b>17</b>
1.1	Scope of Delivery.....	18
1.2	Transport, Package, Storage.....	19
1.2.1	Unpacking the Device.....	19
1.2.2	Repacking the Device.....	19
1.2.3	Storing the Device.....	19
1.3	Incoming Inspection.....	20
1.3.1	Safety Notes.....	20
1.3.2	Performing a Follow-Up Inspection on a Device.....	20
1.3.3	Checking Rated Data and Functions.....	20
1.4	Electrical Inspection.....	21
1.4.1	Device Protection.....	21
1.4.2	Grounding a Device.....	21
1.4.3	Connecting the Device.....	21
1.4.4	Safety Notes.....	22
1.4.5	Performing the Electrical Inspection.....	22
1.5	Electrostatic Sensitive Devices.....	23
1.6	Installation.....	25
1.6.1	Preparing Installation.....	25
1.6.2	Power Supply.....	25
1.6.3	Installation of Plug-In Module.....	26
1.6.4	Completing Installation.....	26
1.7	Replacement.....	27
1.7.1	Preparing for Replacement.....	27
1.7.2	Completing Replacement.....	28
<b>2</b>	<b>Functional Description.....</b>	<b>29</b>
2.1	Device Description and Features.....	30
2.1.1	Overview.....	30
2.1.2	Quick Overview of the Features.....	30
2.2	Applications for Transmission.....	32
2.2.1	Applications for Digital Transmission.....	32
2.2.2	Applications for Analog and/or Digital Transmission.....	32
2.2.3	Combination of Analog and Digital Interfaces.....	33
2.2.4	Transmission Paths.....	33
2.2.5	Modes of Operation.....	34
2.2.5.1	Analog Mode Operation.....	34

2.2.5.2	Digital Mode Operation.....	34
2.2.6	Features.....	34
2.3	Operating Modes with PLC Equipment.....	36
2.3.1	Overview.....	36
2.3.2	Single Purpose Operation.....	36
2.3.3	Multi-Purpose Operation.....	36
2.3.4	Alternate Multi-Purpose Operation.....	36
2.4	Equipment Versions.....	38
2.4.1	Overview.....	38
2.4.2	Broadband Version.....	38
2.4.3	Narrow-Band Version.....	39
2.4.4	Applications for Narrow-Band Devices.....	39
2.5	Possible Ways of Using the SWT 3000.....	42
2.5.1	Analog Transmission Path.....	42
2.5.2	Digital Transmission Path.....	43
2.5.3	Analog and Digital Transmission Path.....	44
2.5.4	Integrated Into the PowerLink PLC System.....	45
2.6	Monitoring.....	47
2.7	Protection Modes.....	48
2.7.1	Overview.....	48
2.7.2	Unblocking Mode.....	48
2.7.3	Description of the Protection Operating Modes.....	49
2.7.3.1	Overview.....	49
2.7.3.2	Mode 1 (Double System Protection).....	49
2.7.3.3	Mode 2 (Single Phase Protection).....	50
2.7.3.4	Mode 3 (4 Commands with Priority).....	50
2.7.3.5	Mode 3a (4 Independent Commands, 4iC).....	51
2.7.3.6	Mode 3b (2 plus 2).....	52
2.7.3.7	Mode 4 (Only One Command Active).....	55
2.7.3.8	Mode 5A (3 Independent Commands).....	55
2.7.3.9	Mode 5D (Only for Digital Transmission Paths).....	56
2.7.3.10	Mode 7a (8 Independent Commands, 8iC).....	56
2.8	Frequency Overview.....	58
2.8.1	Broadband Devices in the VF Range [kHz].....	58
2.8.2	Narrow-Band Devices in the VF Range [kHz].....	58
2.8.3	Frequency Diagram for Broadband and Narrow-Band Devices.....	60
2.8.4	Command Duration for Single-Purpose Operation.....	60
2.8.4.1	Mode 1, Mode 2, Mode 3a, Mode 3b, Mode 4, Mode 5A, Mode 7a.....	60
2.8.4.2	4 Commands with Priority Mode 3.....	61
2.8.5	Command Duration for Alternate Multi-Purpose Operation.....	61
2.9	Fiber-Optic Connection.....	62
2.9.1	Overview.....	62
2.9.2	Connection to the PowerLink PLC System.....	62
2.9.3	Connection to a Multiplexer supporting IEEE C37.94 Protocol.....	63
2.9.4	Direct Connection via Fiber-Optic Cable.....	64
2.10	Remote Monitoring, Service Channel, and IP Network.....	65
2.10.1	RM with Analog Interface.....	65
2.10.2	RM with Digital Interface.....	66



2.10.3	Service Channel.....	66
2.10.4	IP Interface to SWT 3000.....	66
2.11	IEC 61850.....	68
2.11.1	Ethernet EN100 Module with IEC 61850 Protocol.....	68
2.11.2	IEC 61850 Introduction.....	69
2.11.3	Logical Nodes.....	73
2.12	Teleprotection Over Packet TPoP.....	78
2.12.1	Introduction.....	78
2.12.2	Cyber Security.....	79
2.12.3	Protection Command Transmission.....	80
2.12.4	RM Transmission.....	81
2.12.5	Line Clock Synchronization.....	81
2.12.6	Line Quality Supervision.....	82
2.12.7	QoS (Quality of Service).....	83
2.13	Cyber Security.....	85
2.13.1	Overview.....	85
2.13.2	Certification.....	85
2.13.3	HTTPS Connection.....	86
2.14	Power Supply.....	89
2.14.1	Stand-Alone Unit.....	89
2.14.2	Integrated Unit.....	89
2.15	Virtual Display.....	90
2.16	T-Scheme.....	91
2.17	O-Scheme (G704).....	93
2.18	Command Loop Test.....	95
<b>3</b>	<b>Installation and Commissioning.....</b>	<b>97</b>
3.1	Installation.....	98
3.1.1	Connecting Plugs.....	98
3.1.2	Equipment of the Subrack.....	99
3.1.3	Cable Installation.....	100
3.2	Pinouts of SWT 3000 Modules.....	101
3.2.1	Pinout of the IFC-x Module.....	101
3.2.2	Pinout of the PU4 Module.....	102
3.2.3	Connection of Digital Line Interfaces.....	104
3.2.4	Signals for the Digital Line Interface 1.....	104
3.2.5	Signals for the Digital Line Interface 2.....	105
3.2.6	Pinout of the SC interface.....	106
3.2.7	Pinout of the SSB interface.....	106
3.2.8	Pinout of the CLE Module.....	106
3.2.9	Pinout of the ALR Module.....	107
3.2.10	Pinout of the Fiber-Optic Module.....	108
3.3	Jumper Settings for SWT 3000 Modules.....	110
3.3.1	General Information.....	110
3.3.2	Jumper Settings for IFC Modules.....	110
3.3.2.1	Overview.....	110
3.3.2.2	DIP Switches on IFC Modules.....	112

3.3.3	Jumper Settings for the PU4 Module.....	113
3.3.4	Jumper Settings for the DLE Module.....	114
3.3.4.1	Overview.....	114
3.3.4.2	Jumper Settings for the Selection of Digital Line Interfaces LID-1.....	114
3.3.4.3	Jumper Settings for the Selection of Digital Line Interfaces LID-2.....	114
3.3.4.4	Selection of the Input Gain for G703.6 Interfaces.....	115
3.3.4.5	DLE Settings for the LID-x Connection via FOM.....	115
3.3.5	Jumper Settings for the CLE Module.....	115
3.3.6	Jumper Settings of the ALR Module.....	116
3.3.7	Power Supply Jumper Settings.....	117
3.4	Start Commissioning.....	118
3.4.1	Before Starting the Commissioning.....	118
3.4.2	Switching on the Power Supply.....	118
3.4.3	Switching on the Device (with PU4 Module).....	118
3.4.4	Connecting the Service PC.....	120
3.4.5	PowerSys.....	120
3.5	Device Configuration.....	126
3.5.1	New Configuration.....	126
3.5.2	System Configuration.....	128
3.5.2.1	Operation Mode.....	128
3.5.2.2	Line Interface.....	129
3.5.2.3	Command Interface.....	133
3.5.3	Input Allocation.....	138
3.5.4	Output Allocation.....	139
3.5.5	Signaling Allocation.....	140
3.5.6	RM Configuration.....	140
3.5.7	Timer Configuration.....	142
3.5.7.1	System Timer.....	142
3.5.7.2	Command Input Timer .....	143
3.5.7.3	Command Output Timer.....	146
3.5.7.4	Broadband Versions.....	148
3.5.7.5	Narrow-Band Versions.....	150
3.5.8	TPoP Configuration.....	151
3.5.9	Clock Synchronization.....	156
3.5.10	IP Network Configuration.....	158
3.5.11	Alarm Configuration.....	160
3.5.11.1	Alarm Output Allocation for ALR.....	160
3.5.11.2	Alarm Output Allocation for IFC.....	163
3.5.11.3	Alarm Output Allocation for IEC 61850 / SNMP.....	164
3.5.11.4	Setting Options for SWT 3000 Alarms.....	165
3.5.11.5	Unblocking Impulse Allocation for IFC.....	166
3.5.12	T-Scheme Configuration.....	167
3.5.13	O-Scheme Configuration.....	170
3.5.14	Periodic transmission time test configuration.....	174
3.6	Online Parameter Adjustment.....	175
3.6.1	Overview.....	175
3.6.2	Level Adjustment for Analog Interface.....	175
3.6.2.1	Tx Level Adjustment.....	175
3.6.2.2	Rx Level Adjustment.....	175
3.6.3	Level Adjustment for Connection via VFx Module.....	177
3.6.3.1	Overview.....	177

3.6.3.2	Connection via a VFX Module.....	177
3.6.4	Setting Parameters of Measuring Points.....	177
3.6.5	Time and Date.....	178
3.6.6	Command Blocking.....	178
<b>4</b>	<b>Diagnostics and Error Handling.....</b>	<b>181</b>
4.1	Control and Signaling Elements.....	182
4.1.1	Control and Signaling for PU4 Module.....	182
4.1.1.1	Front Panel.....	182
4.1.1.2	Significance of LEDs on the PU4 Module.....	183
4.1.1.3	IP (Ethernet) and Local (Service) Interface.....	184
4.1.2	Control and Signaling for CLE Module.....	184
4.1.2.1	Alarm Displays.....	184
4.1.2.2	Test Sockets.....	185
4.1.3	Control and Signaling for FOM Module.....	186
4.1.3.1	Signification of the Alarm LED on the FOM.....	186
4.1.4	IFC Control and Signaling.....	187
4.1.5	Control and Signaling for ALR Module.....	188
4.1.5.1	Relay Outputs.....	188
4.1.5.2	Visual Indication.....	188
4.1.5.3	Test Switch S1.....	188
4.1.6	Control and Signaling for Power Supply.....	189
4.1.6.1	Displays.....	189
4.2	IFC Test Mode.....	191
4.3	PU4 Test Command.....	192
4.4	Possible Reasons for the Alarms.....	195
4.5	Display of the Entries in the Event Log.....	196
4.6	Alarm Messages in the Service Program PowerSys.....	198
4.7	Diagnosis of Ethernet EN100 Module.....	199
4.8	FOM SFP Alarm Supervision.....	202
<b>5</b>	<b>PowerSys and Auxiliary Software Tools.....</b>	<b>205</b>
5.1	PowerSys.....	206
5.1.1	Installation.....	206
5.1.2	User Management.....	207
5.1.3	Firmware Overview .....	211
5.1.4	Parameter Compatibility.....	213
5.1.5	Release Upgrade Check.....	213
5.1.6	Multiple Language Support.....	214
5.2	MemTool Installation.....	215
5.2.1	General Information.....	215
5.2.1.1	Overview.....	215
5.2.1.2	System Requirements.....	215
5.2.1.3	Version of MemTool.....	215
5.2.2	Installation of MemTool.....	215
5.2.3	Basic Settings.....	217
5.2.3.1	Starting MemTool.....	217
5.2.3.2	MemTool Settings.....	218
5.2.4	Getting Started.....	225

5.3	PU4 Firmware Upgrade with Mem Tool.....	227
5.3.1	Connecting the PC.....	227
5.3.2	Starting MemTool.....	227
5.3.3	Connection to the SWT 3000 Target.....	229
5.3.4	Programming the Application into the Flash Memory.....	229
5.3.5	Trouble Shooting.....	233
5.4	Firmware Update With PowerSys.....	235
5.5	EN100 Firmware Upgrade.....	236
5.6	SWTStraps for Jumper Settings.....	238
5.6.1	Overview.....	238
5.6.2	SWTStraps Input Form.....	238
5.6.3	The Straps Settings windows.....	240
5.7	MergeTool for IEC 61850.....	242
5.7.1	Overview.....	242
5.7.2	Parameter Generator.....	242
5.7.3	EN100 Settings.....	248
5.8	SWT vDisp for Virtual Display.....	253
5.8.1	Installation.....	253
5.8.2	Dashboard.....	253
5.8.3	Display Command Counter.....	254
5.8.4	Display Event Log / Alarm.....	256
<b>6</b>	<b>SNMP and Remote Access.....</b>	<b>259</b>
6.1	Remote Access and Remote Monitoring.....	260
6.1.1	Overview.....	260
6.1.2	Remote Access via Intranet (TCP/IP).....	260
6.1.3	Remote Monitoring/Maintenance via Inband RM-Channel.....	261
6.2	SNMP.....	262
6.2.1	SNMP Function.....	262
6.2.2	Spontaneous Indication SNMP Traps.....	264
6.2.3	Simple Network Management Protocol Version 3 (SNMPv3).....	267
6.2.3.1	SNMPv3 Overview.....	267
6.2.3.2	USM User Management.....	268
6.2.3.3	VACM Management.....	270
6.2.3.4	Key Reset.....	273
6.2.3.5	Notification.....	273
6.2.4	SNMP Configuration in SWT 3000 Web Interface.....	276
6.2.4.1	Overview.....	276
6.2.4.2	SNMP V2 Trap-Destination Table.....	277
6.2.4.3	Access Password.....	278
6.2.4.4	Activation of Settings.....	279
6.2.5	NMS Commissioning.....	280
6.3	Remote Access.....	281
6.3.1	General Information.....	281
6.3.1.1	Overview.....	281
6.3.1.2	Remote Access Example.....	281
6.3.2	Inband RM-Channel.....	282
6.3.3	Route Coupling via SSB.....	283

6.4	Web Interface.....	285
6.4.1	Overview.....	285
6.4.2	Ethernet Interface Settings.....	286
6.4.3	NTP Settings.....	287
6.4.4	NTP Daylight Saving Time.....	288
6.4.5	SNMP Settings.....	289
6.4.6	Access Password.....	289
6.4.7	Activation of Settings.....	291
<b>7</b>	<b>Processing Unit Module.....</b>	<b>293</b>
7.1	Functions of the PU4 module.....	294
7.1.1	Overview.....	294
7.1.2	Functional Units.....	298
7.1.3	Internal Power Supply.....	298
7.1.4	Controller.....	298
7.1.5	Analog Line Interface.....	298
7.1.6	Self-test.....	299
7.1.7	Interference-Level Evaluation.....	299
7.1.8	Event Memory and Real-Time Clock.....	299
7.1.9	Clock Synchronization.....	300
7.1.10	Front Panel.....	300
7.1.11	IP (Ethernet) and Local (Service) Interface.....	301
7.1.11.1	Access to the Stand-alone SWT 3000.....	301
7.1.11.2	Access to the Integrated SWT 3000 (iSWT).....	301
<b>8</b>	<b>Interface Command Module.....</b>	<b>303</b>
8.1	General Information.....	304
8.1.1	Overview.....	304
8.1.2	Exclusively Analog Transmission Interface or Analog Secondary Path.....	304
8.1.3	Exclusively Digital Transmission Interfaces.....	304
8.1.4	Description of Operation.....	304
8.1.4.1	Overview.....	304
8.1.4.2	Connection Principle.....	305
8.1.5	Controller.....	307
8.1.6	Test Mode.....	307
8.1.6.1	Overview.....	307
8.1.6.2	Displays.....	307
8.1.7	Slot and Module Identifier.....	307
8.1.8	Signal Acquisition via Binary Inputs.....	309
8.1.9	Signal Output from the IFC-D/P Module.....	310
8.1.10	Signal Output from IFC-S Module.....	311
8.1.11	Pinout of the IFC-x Module.....	311
8.2	Block Diagrams of IFC Modules.....	313
8.2.1	IFC-D Module.....	313
8.2.2	IFC-P Module.....	314
8.2.3	IFC-S Module.....	315
<b>9</b>	<b>Digital Line Equipment.....</b>	<b>317</b>
9.1	Overview.....	318

9.2	Transmission Concept.....	319
9.3	Interface X.21.....	320
9.4	Interface G703.1 (64 Kbps).....	321
9.5	Interface G703.6 (2 Mbps HDB3).....	322
9.6	Jumper Settings.....	323
<b>10</b>	<b>Copper Line Equipment Module.....</b>	<b>325</b>
10.1	Function Description.....	326
10.1.1	Overview.....	326
10.1.2	The Receive Section.....	327
10.1.3	The Transmit Section.....	327
10.1.4	Alarm Displays.....	328
10.1.5	S6 Control Wires.....	329
10.1.6	Test Sockets.....	329
10.1.7	Inhibit Line.....	329
10.2	Connection of an External SWT 3000 to the PowerLink 50/100.....	330
<b>11</b>	<b>Fiber Optic Module.....</b>	<b>331</b>
11.1	Fiber-Optic Module.....	332
<b>12</b>	<b>Alarm Module.....</b>	<b>335</b>
12.1	Overview.....	336
12.2	Inputs and Outputs.....	337
12.2.1	Block Diagram.....	337
12.2.2	Binary Inputs.....	337
12.2.3	Relay Outputs.....	338
12.2.4	Visual Indication.....	338
12.2.5	Test Switch S1.....	338
<b>13</b>	<b>Power Supply.....</b>	<b>341</b>
13.1	Functional Description.....	342
13.1.1	Overview.....	342
13.1.2	General Description.....	343
13.1.3	Displays.....	343
13.2	Connection of the Power Supply.....	345
13.2.1	Pinout of the Connectors SV-1 and SV-2.....	345
13.2.2	Redundant Power Supply.....	346
13.2.3	Inhibit Loop.....	347
<b>14</b>	<b>Technical Data.....</b>	<b>349</b>
14.1	Command Input/Output.....	350
14.2	Terminals of IFC Modules.....	352
14.3	Transmission Line - Digital Networks.....	353
14.4	Transmission Line - Fiber-Optic.....	354
14.5	Transmission - Analog Networks.....	356
14.6	Common System Data.....	358
14.7	Standards.....	360
14.8	Electromagnetic Compatibility EMC.....	361

---

14.9	Ambient Conditions.....	362
<b>A</b>	<b>Appendix.....</b>	<b>363</b>
A.1	Abbreviation List.....	364
	<b>Index.....</b>	<b>369</b>





# 1 Safety Instructions

1.1	Scope of Delivery	18
1.2	Transport, Package, Storage	19
1.3	Incoming Inspection	20
1.4	Electrical Inspection	21
1.5	Electrostatic Sensitive Devices	23
1.6	Installation	25
1.7	Replacement	27

## 1.1 Scope of Delivery

The equipment is delivered with:

- The **Product Information** with a system description and instructions for installation, commissioning and operation, decommissioning and disposal.
- The corresponding software package (formerly delivered on DVD) is available for download on [SIOS](#) (Siemens Industry Online Support) platform free of charge, a registration is required.
- Test protocols are available for download under [Energy Automation Testreports](#)  
Enter BF code of device to view the requested test protocol in pdf format. The installed firmware package version loaded into the device can be seen in the protocol.

For further details, see the information that can be found in the manual.

## 1.2 Transport, Package, Storage

### 1.2.1 Unpacking the Device



#### NOTE

Devices are tested prior to delivery. The verification certificate is part of the device and can be called up with the product.

Devices are packed on site in a way that meets the requirements.

- ✧ Check the packing for external transport damage. Damaged packing may indicate that the devices inside have also a damage.
- ✧ Unpack devices carefully; do not use force.
- ✧ Visually check the devices to ensure that they are in perfect mechanical condition.
- ✧ Check the enclosed accessories against the delivery note to make sure that everything is complete.
- ✧ Keep the packing in case the devices must be stored or transported elsewhere.
- ✧ Return damaged devices to the manufacturer, stating the defect. Use the original packaging or transport packaging that meets the requirements.

### 1.2.2 Repacking the Device

- ✧ If you store devices after incoming inspection, pack them in suitable storage packaging.
- ✧ If devices are to be transported, pack them in transport packing.
- ✧ Put the accessories supplied and the test certificate in the packing with the device.

### 1.2.3 Storing the Device

- ✧ Only store devices on which you have carried out an incoming inspection, thus ensuring that the warranty remains valid. For incoming inspection refer to chapter Incoming inspection.
- ✧ The device must be stored in rooms, which are clean, dry, and dust-free. Devices or associated spare parts must be stored at a temperature between  $-40^{\circ}\text{C}$  and  $+70^{\circ}\text{C}$ .
- ✧ Siemens recommends that you observe a restricted storage temperature range of  $+10^{\circ}\text{C}$  to  $+35^{\circ}\text{C}$  in order to prevent the electrolytic capacitors used in the power supply from aging prematurely.
- ✧ If the device shall be stored for a long time, connect it every 2 years to an auxiliary voltage for 1 to 2 days. This will cause the electrolytic capacitors to form on the printed circuit board assemblies again.
- ✧ If devices must be shipped elsewhere, you can reuse their transport packaging. If using other packaging, ensure that the transport requirements are met.

## 1.3 Incoming Inspection

### 1.3.1 Safety Notes

---



#### DANGER

Danger during incoming inspection.

**If you do not comply with the safety notes, this will result in death, severe injury, or considerable material damage.**

- ✧ Comply with all given safety notes when carrying out the incoming inspection.
  - ✧ If you identify a defect during incoming inspection, do not correct it yourself. Repack the device and return it to the manufacturer, stating the defect. Use the original packaging or transport packaging that meets the requirements.
- 

Siemens recommends that you check the device and the connectors which are not assembled.

#### Double Pole/Neutral Fusing

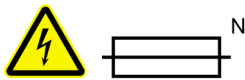

[dwfusesa-191211-01.tif, 1, en\_US]

---



#### CAUTION

The fuse is used in the neutral of single-phase equipment either permanently connected or provided with a non-reversible plug.

After operation of the fuse, parts of the equipment that remain energized might represent a hazard during servicing.

**If you do not comply with the safety notes, this will result in medium severe or slight injuries.**

- ✧ Comply with all instruction in order to avoid moderate or minor injuries.
- 

### 1.3.2 Performing a Follow-Up Inspection on a Device

- ✧ Visually check for external damage as soon as you have unpacked the devices; they must not show any signs of dents or cracks.

### 1.3.3 Checking Rated Data and Functions

- ✧ Check the rated data and functions using the complete order designation/the product code. The **Equipment Manual** contains all technical data and a description of the functions.
- ✧ Check the information provided on the name plate too. The device features a product label sticker, which contains the technical data.
- ✧ Make sure that the rated data of the device properly matches the system data. You can find the necessary information in the **Equipment Manual**.

## 1.4 Electrical Inspection

### 1.4.1 Device Protection

---



#### DANGER

Danger when connecting the device.

**If you do not comply with the safety notes, this will result in death, severe injury, or considerable material damage.**

- ✧ The device must be situated in the operating area for at least 2 hours before you connect it to the power supply for the first time. This avoids condensation to occur in the device.

- 
- ✧ Perform the electrical inspection (refer to [1.4.5 Performing the Electrical Inspection](#)).

### 1.4.2 Grounding a Device

The device has to be connected to the protective earthing conductor of the cabinet prior to commissioning.

---



#### CAUTION

The cross-section of the ground wire must be equal to or greater than the cross-section of any other control conductor connected to the device. The cross-section of the ground wire must be at least 2.5 mm<sup>2</sup> (AWG14).

**The following consequences can occur if the cross-section of the ground wire is not properly installed:**

- The device can be damaged.
- Touching the device can cause a flashover and health damage if the device is not sufficiently grounded.
- A faulty activation can occur by undefined states.

- ✧ The cross section of the ground wire and the laying of the wire must comply with the regulations applicable for the place of installation.

---

Ground the device with solid low-resistance system grounding (cross-section  $\geq 4.0$  mm<sup>2</sup>, grounding area  $\geq M4$ ).

### 1.4.3 Connecting the Device

- ✧ Connect all cables and lines. Use the connection diagrams stated in the **Equipment Manual**.
- ✧ Tighten the terminal screws.

### 1.4.4 Safety Notes

---



#### **DANGER**

Danger during electrical inspection.

**If you do not comply with the safety notes, this will result in death, severe injury, or considerable material damage.**

- ❖ Comply with all given safety notes when carrying out the electrical inspection.
  - ❖ Note that hazardous voltages are present when you perform the electrical inspection.
- 
- ❖ During the electrical inspection, check that the device becomes ready for operation once it has been connected to the power supply.
- 



#### **DANGER**

Danger of over voltage.

##### **To prevent the risk of possible over voltage**

- ❖ The cable shield of the communication cable between Line Matching Unit (LMU, AKE) and the power line carrier communication devices (PowerLink, PowerLink with iSWT or detached SWT 3000) must be grounded on both ends.
  - ❖ The grounding of the cable shield must be carried out on the LMU side itself and once again before entering the station building or a ground connection within the building in which the PowerLink devices or any other powerline carrier communication device are installed.
- 
- ❖ The grounding must be carried out using a connection that cannot be detached without tools. The grounding of the cable shields must not be removed until it is ensured that by closing the short circuit switch on the LMU and attaching an additional grounding rod to the HV input, the LMU is voltage-free and safely grounded.
- 

### 1.4.5 Performing the Electrical Inspection

- ❖ Connect the power supply.
- ❖ Activate the power supply.
- ❖ The device must have the normal operating state (process mode) if the configuration, connection, and transmission have been set up successfully. The device must communicate with the PC. If not, disconnect and check the installation of the device and the installation and configuration of the service program PowerSys (refer to *Chapter 4*).
- ❖ If a defect of the device is suspected, please contact the Customer Support prior to a return to manufacturer. If the suspect for a defect is confirmed by Customer Support, pack the device and return it to the manufacturer, stating the defect. Use transport packaging that meets the requirements.

## 1.5 Electrostatic Sensitive Devices



### NOTE

This Manual is written for **service and operation personnel** in the high voltage power line environment. All existing safety instructions in the **environment of the user** must be observed and **only trained and instructed** personnel shall be allowed to work with the equipment.



### CAUTION



Electrostatic sensitive devices are protected against destruction by electrostatic charge with protective structures at the inputs and outputs. In unfavorable cases, however, plastic floor coverings, non-conductive work surfaces, or clothing containing artificial fibers can result in such high charges.

**These charges can damage or even destroy the electrostatic sensitive devices despite the protective networks mentioned. If a device is damaged, its reliability decreases drastically although the effects of the damage are noticeable a long time before.**

- ◇ In order to ensure that electrostatic charges are completely eliminated when working on the system, comply with the following instructions in order to avoid moderate or minor damage:
- ◇ - Before carrying out any work on the system, ground yourself with a wrist strap.
- ◇ - When working on modules, always place them on a grounded conductive surface.
- ◇ - Transport modules only in suitable protective bags.

The following points must also be observed during **installation**:

- Before installing the device, lay and connect the grounding wire to ground potential.
- Connect the grounding wire immediately after installing the device or setting up the cabinet.
- Use shoe grounding strips.



### DANGER

The device can be damaged if not installed in a locked room.

**Death or severe injuries can occur if a foreign person has access to the equipment.**

- ◇ Install the device in a locked room with admission for commissioning personnel and trained operating personnel only.

### NOTICE

The temperature in the room shall not exceed the temperatures specified in the operating rules.

**The device can be damaged if it is not operated in accordance with regulations of the operation.**

- ◇ Provide sufficient cooling or heating (for outside operation in cold areas or during cold times).



## WARNING

There is a risk of electrostatic discharge until the grounding wire has been connected, even if you are wearing a wrist strap.

**The grounding wire must not be disconnected until all work has been completed if you are disassembling the system.**

- ✧ If possible, do not touch the modules and wiring before the work has been completed.
-



## 1.6 Installation

### 1.6.1 Preparing Installation



#### DANGER

Danger due to live voltage when installing the plug-in modules.

**If you do not comply with the safety advice, this will result in death or severe injuries.**

- ✧ Install plug-in modules on the electrically deactivated device only.
- 



#### CAUTION

This equipment is suitable for mounting on concrete or other non-combustable surface only.

- ✧ In case the Powerlink System is mounted on a combustable surface, the use of the mounting kit (7VR9656, Fire prevention kit) is obligatory.
- 



#### CAUTION

Exercise caution with laser beams of the optical plug-in modules.

**The laser beams can damage your eyes. If you do not comply with the safety notes, this will result in medium severe or slight injuries.**

- ✧ Do not look directly into the optical fiber terminals of the active optical plug-in modules, not even with optical devices.
- 
- ✧ De-energize the device.
- 



#### NOTE

Laser class 1 is adhered to in compliance with EN 60825-1 and EN 60825-2, in the case of  $\leq 62.5 \mu\text{m}$ /  
 $125 \mu\text{m}$  optical fibers.

---

- ✧ Undo the fastening screw and remove the cover plate from the plug-in module position.
- 

### 1.6.2 Power Supply

- ✧ Dangerous voltages are present within this power supply. Perform the installation/removal following the safety notes.
- 



#### DANGER

Do not connect the redundant power supply while the equipment is powered.

**If you do not comply with the safety notes, this will result in death, severe injury, or considerable material damage.**

- ✧ Make sure that the power is turned OFF before installing or removing the power supply.
-

- ✧ If delivered separately, plug the power supply into the device without any modification.

### 1.6.3 Installation of Plug-In Module

- ✧ Check the jumper settings prior to installation.
- ✧ Remove the front plate from the device.
- ✧ Push in the plug-in module on the inner guide as far as it is possible.
- ✧ Then check for secure attachment of the connectors.
- ✧ Mount and fasten the front plate of the device.

### 1.6.4 Completing Installation

- ✧ Set the jumpers of the module for operation mode.
- ✧ The device shall recognize the new plug-in module.
- ✧ In case you installed a new module, configure the settings of the new module in PowerSys.



**NOTE**

Only qualified electrical engineering personnel is authorized to reset the hardware parameters.

---

## 1.7 Replacement

### 1.7.1 Preparing for Replacement

#### General Information

The device can be supplied as stand-alone device or installed in a cabinet together with other system components. If the device is **delivered in a cabinet**, the entire cabling of the individually installed devices is installed at the factory up to the connection terminals on the assembly board. In this case, the **connection points for the cabling can be found in the supplied documentation**.



#### NOTE

The modules available for reordering are not preconfigured.

#### Laser Guide



### CAUTION

Exercise caution with laser beams of the optical plug-in modules.

**If you do not comply with the safety notes, this will result in medium severe or slight injuries.**

✧ Do not look directly into the optical fiber terminals of the active optical plug-in modules, not even with optical devices. The laser beams can damage your eyes.

✧ De-energize the device.



#### NOTE

Laser class 1 is adhered to in compliance with EN 60825-1 and EN 60825-2, in the case of  $\leq 62.5 \mu\text{m}/125 \mu\text{m}$  optical fibers.



#### NOTE

If you have not cabled the optical fiber plug-in modules, then seal the terminals with protective covers. This prevents soiling of the terminals.

#### Replacement Description



### DANGER

Danger due to live voltage when replacing the plug-in modules.

**If you do not comply with the safety notes, this will result in death or severe injuries.**

✧ Install plug-in modules on the electrically deactivated device only.

✧ Remove the front plate from the device.

✧ Carefully pull out the plug-in module.

✧ Configure the jumper settings prior to installation.

✧ Push in the new plug-in module on the inner guide as far as it is possible.

## 1.7 Replacement

- ✧ Connect the leads to the terminals.
- ✧ Then check for secure attachment of the connectors.
- ✧ Mount and fasten the front plate on the device.

### 1.7.2 Completing Replacement

- ✧ Set the jumpers of the module for operation mode.
- ✧ The device shall recognize the new plug-in module.
- ✧ In case you installed a new module, configure the settings of the new module in PowerSys.



#### **NOTE**

Only qualified electrical engineering personnel is authorized to reset the hardware parameters.

---

## 2 Functional Description

2.1	Device Description and Features	30
2.2	Applications for Transmission	32
2.3	Operating Modes with PLC Equipment	36
2.4	Equipment Versions	38
2.5	Possible Ways of Using the SWT 3000	42
2.6	Monitoring	47
2.7	Protection Modes	48
2.8	Frequency Overview	58
2.9	Fiber-Optic Connection	62
2.10	Remote Monitoring, Service Channel, and IP Network	65
2.11	IEC 61850	68
2.12	Teleprotection Over Packet TPop	78
2.13	Cyber Security	85
2.14	Power Supply	89
2.15	Virtual Display	90
2.16	T-Scheme	91
2.17	O-Scheme (G704)	93
2.18	Command Loop Test	95

## 2.1 Device Description and Features

### 2.1.1 Overview

The network protection disconnects the faulty part of the system as quick as possible in a selective way. These faults occurring in high-voltage systems are simultaneously stored in an event list. As a consequence of higher power plant outputs and the increasingly close interconnection of high-voltage power systems, high demands are placed on network protection systems in terms of reliability and availability. Therefore, network protection systems with absolute selectivity need a reliable and fast transmission system for the transfer of information between the stations.

The SWT 3000 for teleprotection signaling in **analog and digital communication networks** offers the required maximum security and reliability together with the shortest command transmission time. The SWT 3000 (in release **SWT 3000R3.5 or higher**) replaces all earlier SWT 3000 releases.

The device can be used as a **stand-alone** unit or can also be integrated in the **PowerLink Power Line Carrier (PLC) system**.

Combinations of analog and digital interfaces are possible in both cases. The analog interface is operated in the Voice Frequency (VF) range. The digital interfaces can be configured for X.21, G703.1 (64 Kbps), G703.6 (2 Mbps) or fiber-optic connection.

### 2.1.2 Quick Overview of the Features

Table 2-1 Quick Overview of the Features

Feature	Digital	Analog
Number of commands	Up to 16	Up to 4
<b>Digital line interface</b>		
64 Kbps (X.21 or G703.1)	x	-
2 Mbps (G703.6 sym. 120 Ω, G703.6 asym. 75 Ω)	x	-
<b>Ethernet line interface</b>		
100 Base-TX (electrical)	x	-
100 Base-FX (optical, short-range; 1310 nm)	x	-
<b>Analog line interface</b>		
4-wire	-	x
2-wire	-	x
<b>Fiber-optic interface</b>		
Long-range (single-mode, 1550 nm)	x	-
Short-range (single-mode, 1310 nm)	x	x
Short-range (multi-mode, 850 nm)	x	x
<b>Transmission paths</b>		
Digital network	x	-
Direct connection to PDH/SDH multiplexer	x	-
Direct connection to Ethernet network (TPoP)	x	-
Fiber-optic cable	x	x
Power line carrier	-	x
Pilot cable	-	x
Integrated path protection (1 + 1)	x	x
Integration into PowerLink PLC system	x	x
Redundant power supply (hot standby)	x	x
Addressing for increased security	x	-

Feature	Digital	Analog
Impulse Noise Compression (INC)	-	x
Configuration of SWT 3000 with a service PC (intuitive Windows-based user interface)	x	x
Software-upgrade via service PC (download)	x	x
Free programmable output allocation	x	x
Remote access to SWT 3000 devices via TCP/IP link	x	x
Remote access to SWT 3000 devices via inband RM-Channel	x	x
Real-time clock integrated and synchronizable from external sources (for example, GPS, IRIG-B, and NTP) and via the transmission link	x	x
Event recorder (date stamped and time stamped) with guaranteed data storage when the power supply is switched off	x	x
Remote readout of the event recorder	x	x
Easy upgrade from analog to digital and digital to analog	x	x
Simple Network Management Protocol (SNMP) agent for Network Management System (NMS) integration	x	x
Coded tripping (CT) for up to 4 independent commands	-	x
IEC 61850	x	x
Service channel option	x	-
Point to multipoint operation, T-scheme and O-scheme	x	-
Command Loop Test, transmission time measurement	x	x

## 2.2 Applications for Transmission

### 2.2.1 Applications for Digital Transmission

2 Digital Line Interfaces (LID-1 and LID-2) are available through expansion of the Processing Unit (PU4) module with the interface module to digital transmission paths, Digital Line Equipment (DLE).

The hardware interfaces X.21 (64 Kbps), G703.1 (64 Kbps), and G703.6 (2 Mbps HDB3-coded and balanced or coaxial) are selectable on every LID, although only one can be used per LID.

The LID-1 can be operated alone or jointly with the LID-2 (multipath transmission). With multipath transmission, **different line interfaces** can be used for **LID-1** and **LID-2**.

When using exclusively digital interfaces, up to **16 signal inputs** can be transmitted transparently to the distant station with **operating mode 5D** and can be routed to signal outputs there. 4 Interface Command Modules IFC-P/D (for Binary I/O) or one EN 100 interface (for GOOSE I/O) are necessary for this application.

### 2.2.2 Applications for Analog and/or Digital Transmission

The SWT 3000 system is used for fast and reliable transmission of several commands for protection and special switching functions in supply networks.

Protection functions (Mode 1, Mode 2)	Commands can be transmitted for the protection of two 3-phase systems (double system protection) or one 3-phase system (single phase protection). High-voltage circuit breakers can be operated with selective protection relays. This operation is designated as a <b>permissive protection system</b> . Direct switch operation is also possible. This operation is known as <b>intertripping, transfer tripping, or direct tripping</b> .
4 commands with priority (Mode 3)	It is possible to transmit 4 individual commands. Several commands can be activated simultaneously. They are arranged according to priority (input 1, 2, 3, and 4) and output one after the other.
Only one command active (Mode 4)	Only one of the signal inputs 1 to 3 can be active in this operating mode. Input 4 has priority and is treated independently of the states of input 1 to 3. Therefore, if input 4 is active, the state of the other inputs is insignificant. If more than one of the signal inputs 1 to 3 is active and input 4 is inactive, an input error occurs. The guard tone continues to be transmitted.
3 independent commands, 3iC (Mode 5A)	3 signal inputs are available in this operating mode. On the transmit side, every possible combination of signal input is assigned to one specific protection frequency. On the receive side, each protection frequency can be assigned to one or more signal outputs (1 to 4).
4 independent commands, 4iC (Mode 3a)	4 signal inputs are available in this operating mode. On the transmit side, every possible combination of signal input is assigned to a pair of protection frequencies. On the receive side, each pair of protection frequencies is assigned to one or more signal outputs. This function is only available with the coded tripping feature.
2 plus 2 (Mode 3b)	This mode offers the transmission of 2 double systems. One is transmitted in the fast permissive underreach transfer trip (PUTT), the other in the external trip initiation using the CT feature.



16 independent commands (Mode 5D)	When using digital interfaces exclusively, up to 16 independent command inputs can be transmitted transparently to the distant station with operating mode 5D and can be routed to commands outputs there. 4 Interface Command Modules IFC-P/D (for Binary I/O) or one EN 100 interface (for GOOSE I/O) are necessary for this application.
8 Independent Commands, 8iC (Mode 7a)	This operation mode is available for the transmission of eight independent commands. Commands are always transmitted coded with the application permissive or direct tripping (selectable per iSWT device).

You can find information on assignment of the frequencies for the individual operating modes in the section *Protection Modes* [2.7.1 Overview](#).

### 2.2.3 Combination of Analog and Digital Interfaces

Multipath transmission can also be configured in the SWT 3000 system by using the analog line interface (LIA) and digital line interface (LID-1). This combination (like only analog or digital transmission) is possible for stand-alone SWT 3000 units and for units integrated (**iSWT**) in the PowerLink PLC system.

You can find a detailed **overview of the equipment combinations** with the resulting applications in the section [2.5.1 Analog Transmission Path](#).

### 2.2.4 Transmission Paths

The following transmission paths can be used depending on the nature of the supply networks:

- High-voltage overhead lines
- High-voltage cables
- Aerial and (buried) underground cables
- Radio relay routes
- Digital networks (SDH/PDH)
- Fiber-Optic Module (FOM)
- Ethernet networks

It results in the following possible applications:

Table 2-2 Possible Applications of the SWT 3000

Configuration	Option
SWT 3000 stand-alone for analog path	Digital alternate path
SWT 3000 stand-alone for digital path	Analog or digital alternate path
SWT 3000 integrated in PowerLink PLC unit analog	Digital alternate path
SWT 3000 integrated in PowerLink PLC unit digital	Analog alternate path
SWT 3000 stand-alone with connection via FOM	Analog or digital alternate path
SWT 3000 stand-alone with connection via FOM to the PowerLink	Digital alternate path
SWT 3000 stand-alone with connection of the digital interface via FOM to a PDH or SDH multiplexer	Analog or digital alternate path

## 2.2.5 Modes of Operation

### 2.2.5.1 Analog Mode Operation

F6 Modulation	The principle of F6 modulation (Frequency-Shift Keying (FSK)) is applied with the SWT 3000. Therefore, only one of the possible frequencies is ever transmitted. This transmission method enables the available transmit power to be used to the full.
Security	The influence of burst interferences with amplitudes that can be greater than the desired signal is suppressed. This suppression is achieved by limiting the amplitude of the input signal with the largest possible bandwidth and then analyzing the frequency with a small bandwidth. Burst interferences are generated, for example, by lightning strike or by switching operations in high-voltage systems. An optimum setting of the evaluation thresholds and the integration times warrants maximum security against unwanted tripping and a high degree of reliability at the same time. Protection commands are still transmitted in time despite serious interference.
Coded Tripping (CT)	The CT function is available for the analog line interface. The command codes consist of 2 simultaneously transmitted trip frequencies (parallel coding).

### 2.2.5.2 Digital Mode Operation

General	The digital line interfaces LID-1 and LID-2 are needed for transmitting the protection commands via a digital network. The data for the Remote Maintenance (RM) and the Service Channel (SC) interfaces and the system-internal control information are transmitted additionally.
Transmission concept	Information is transmitted via the digital interface with the periodic transmission of 4 message types with constant length. The messages have the following priority among each other: <ul style="list-style-type: none"> <li>• Tripping command information = priority 1</li> <li>• Service channel = priority 2</li> <li>• Remote maintenance = priority 3</li> <li>• System-internal control information = priority 4</li> </ul>
Command transmission	Each command message is transmitted 4 times with a hamming distance of 4. The receiving end checks whether 3 identical command messages have been received. The command is not valid until this check has been successfully carried out.



#### NOTE

RM is also possible in an analog operation mode.

## 2.2.6 Features

The transmission features are as follows:

- Frequency generation and evaluation by digital signal processor (DSP)
- Full utilization of the available transmit power since only one of the possible frequencies is ever transmitted
- Burst interferences with greater amplitudes than the desired signal are largely suppressed
- Noise analysis in the unused desired signaling circuits
- Analog and digital line interfaces

- Alternative paths possible by combination of analog and digital interfaces
- Event memory (data retention > 20 years)
- Possible remote readout of the event memory via RM
- Configuration of the device with PC

## 2.3 Operating Modes with PLC Equipment

### 2.3.1 Overview

Power system protection signals can be transmitted over the high-voltage overhead line. These signals are protected within the PLC equipment. For this purpose, the devices of the SWT 3000 system are connected to special inputs and outputs of the PLC unit. If you are using a PowerLink system, the integration of SWT 3000 is only possible in a PowerLink system with CSPI.

When using PLC equipment, several variants of teleprotection signaling are possible as described in the following cases:

- Single Purpose (SP) operation
- Multi-Purpose (MP) operation
- Alternate Multi-Purpose (AMP) operation

### 2.3.2 Single Purpose Operation

In this operating mode, the transmission band of the PowerLink is used exclusively for teleprotection signaling. The greatest transmission distances are reachable in this mode with maximum security against impulse noise and minimum signal transmission time.

The following equipment combinations are possible:

- SWT 3000 remote with VF or optical connection to PowerLink
- SWT 3000 integrated in PowerLink

### 2.3.3 Multi-Purpose Operation

In this operating mode, the teleprotection signals are simultaneously transmitted with voice and data signals. The distribution of the available transmission power (between the services, which must be transmitted) results in shorter transmission ranges. The command transmission times are the same as in single purpose operation.

The following equipment combinations are possible:

- SWT 3000 remote with VF or optical connection to PowerLink
- SWT 3000 integrated in the PowerLink

### 2.3.4 Alternate Multi-Purpose Operation

Normal operation	In this operating mode, the transmission band is used for the transmission of voice (F2) and data, or Data Pump (DP) as long as there is no protection case. In the idle state, that is, the high-voltage system is operating the signals of all services including the guard tone are transmitted simultaneously. The pilot of the PLC system is used as the guard tone in this operating mode.
Protection mode	While the protection command is being transmitted, the voice or DP transmission is interrupted. This operating mode saves frequency space but results in shorter transmission ranges and higher signal transmission times than with single purpose or multi-purpose operation.

The following equipment combinations are possible:

- SWT 3000 remote at short distance with VF coupling to PowerLink  
Keep the connecting cable between SWT 3000 and PowerLink as short as possible.

- SWT 3000 remote with fiber-optic connection to the PowerLink or PowerLink IP
- SWT 3000 integrated in PowerLink or PowerLink IP

## 2.4 Equipment Versions

### 2.4.1 Overview

Equipment is available in broadband and narrow-band versions depending on the application.

### 2.4.2 Broadband Version

Application	This equipment version is intended for operation over all communication paths (4-wire connection), preferably over PLC links. It offers a high level of security against impulse interference and disturbance voltages.
Frequency space	In this equipment version, the desired frequencies are distributed over the complete available frequency space. With PLC, transmission frequency space in the 2.5-kHz or 4-kHz channel arrangement is required for each operating direction.  With Carrier Frequency (CF), radio relay routes, and cable connections, an ITU-T voice band from 0.3 kHz to 3.4 kHz is used for each operating direction.
VF cable connections	The following diagram shows a 4-wire connection over a VF cable. Broadband variants VF1, VF1_M5A, VF3_M5A, VF1_CT, and VF3_CT can be used.

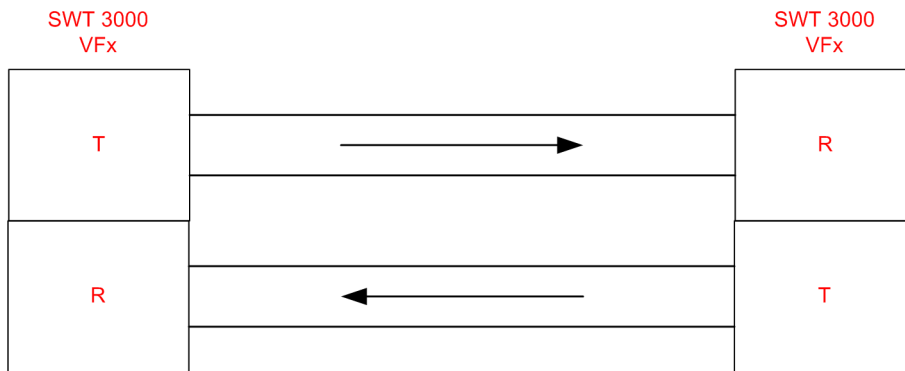

[dwswtvfc-120911-01.tif, 1, en\_US]

Figure 2-1 SWT 3000 4-Wire Connection via VF Cable

- VFx Frequency variants VF1, VF1\_M5A, VF3\_M5A, VF1\_CT, and VF3\_CT can be used
- T Transmitter
- R Receiver

#### PLC Connections

Variants VF1, VF1\_M5A, VF3\_M5A, VF1\_CT, and VF3\_CT are used with PowerLink PLC systems depending on the assignment of the transmission band. For more information, refer to [2.8.1 Broadband Devices in the VF Range \[kHz\]](#).

### 2.4.3 Narrow-Band Version

Application	Equipment in the narrow-band version can be operated on VF links and over CF and radio relay routes. Security against impulse noise and disturbance voltages is a little lower than with the broadband version.
Frequency space	The desired frequencies are closer together in this equipment version. As a result up to 3 of the 4 possible channels (channel 1, 2, 3) can be operated simultaneously within an ITU-T voice band of 3.1-kHz bandwidth (0.3 kHz to 3.4 kHz).
Multi-purpose	The use with PLC transmission is possible in multi-purpose operation. However, a smaller range (transmit level distribution for all services) and less security against interference must be expected compared with the broadband version.
Alternate multi-purpose	The use with PLC transmission is not possible in alternate multi-purpose operation.
Channel 4	<p>Channel 4 can be used within a 4-kHz frequency space.</p> <p>The position of channel 4 in the VF frequency band is defined for the following operations:</p> <ul style="list-style-type: none"> <li>• Operation in the upper half of the transmission bands 2.67 kHz to 3.7 kHz (voice band limitation 2.4 kHz with pilot 2.58 kHz)</li> <li>• Operation in the upper half of the transmission bands 2.1 kHz to 3.6 kHz (voice band limitation 2.0 kHz with pilot 3.78 kHz)</li> </ul> <p>In the second case, another four 50-Bd WT channels can be accommodated between the voice band and the channel 4.</p>

### 2.4.4 Applications for Narrow-Band Devices

#### 4-Wire connection

The operation of several units in parallel at one connection is possible by using Narrow-Band (NB) devices.

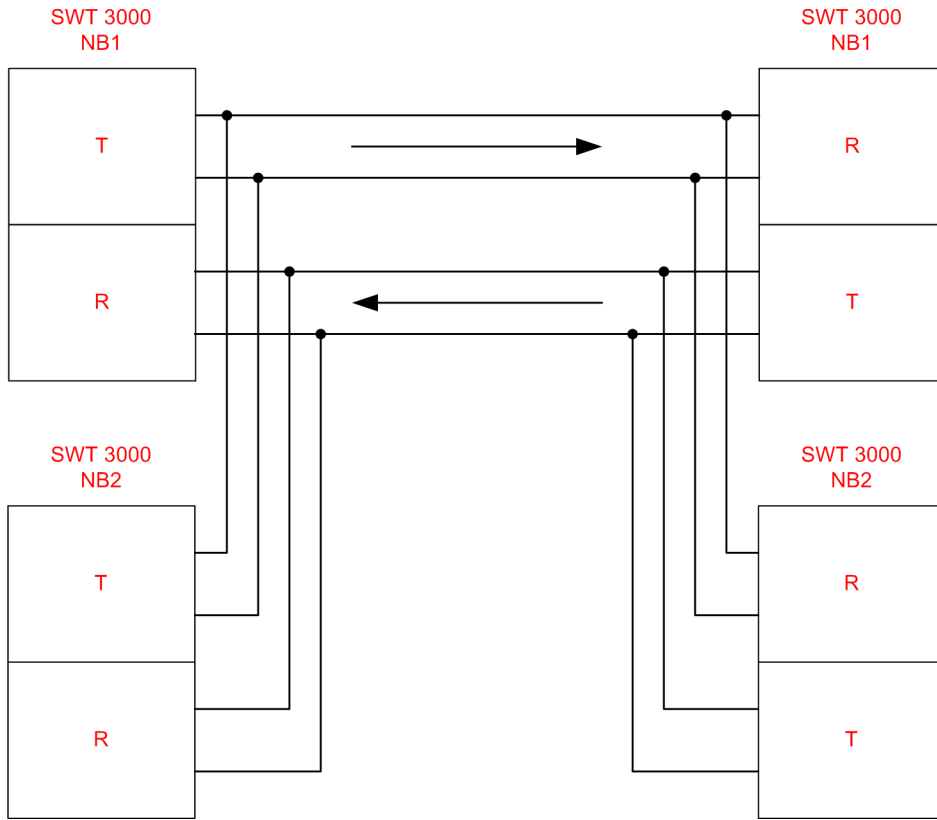

[dwswtmbs-120911-01.tif, 1, en\_US]

Figure 2-2 Parallel Connection of Several SWT 3000 Units at One Connection

**2-Wire Connections**

2-wire cable connections can be implemented with the narrow-band versions of the SWT 3000.

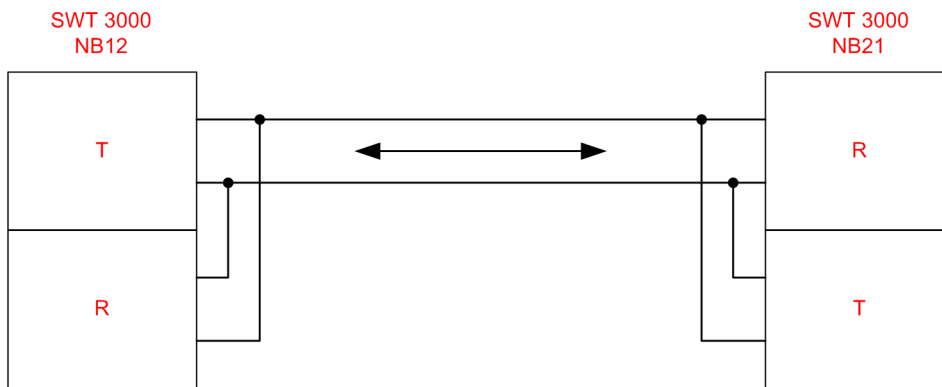

[dwswtmb2-120911-01.tif, 1, en\_US]

Figure 2-3 Example of a 2-Wire Connection with Narrow-Band Versions

NBx      Narrow-Band version

In this case, the receiver input of the SWT 3000 is connected parallel to the transmitter output. Since there is only one wire pair available for the transmit and receive direction, use different frequencies.

The variants listed in the following table are provided for the 2-wire connections.

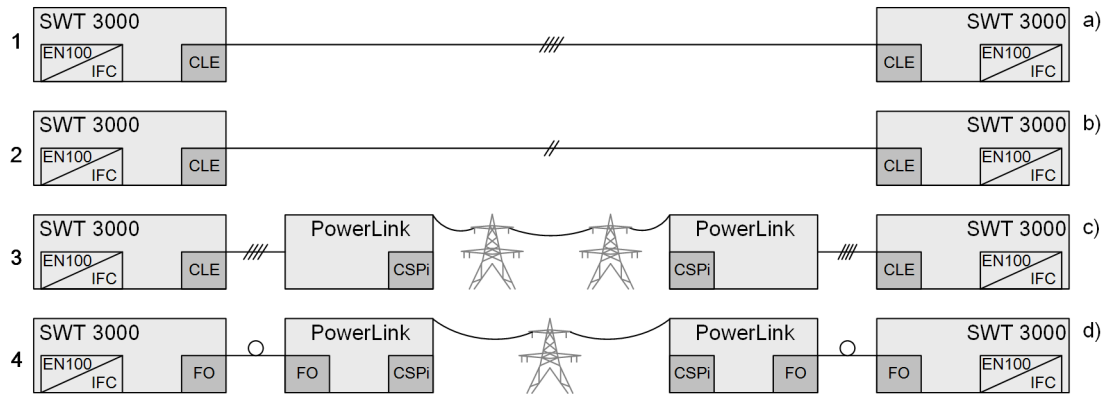

Table 2-3 Narrow-Band Variants for VF 2-Wire Connections

Direction	Variant NB12	Transmit channel 1	Receive channel 2
Reverse direction	Variant NB21	Transmit channel 2	Receive channel 1
Direction	Variant NB13	Transmit channel 1	Receive channel 3
Reverse direction	Variant NB31	Transmit channel 3	Receive channel 1
Direction	Variant NB23	Transmit channel 2	Receive channel 3
Reverse direction	Variant NB32	Transmit channel 3	Receive channel 2

## 2.5 Possible Ways of Using the SWT 3000

### 2.5.1 Analog Transmission Path



[dwanatra\_new, 1, en\_US]  
 Figure 2-4 Examples Using Analog Transmission Path

- CLE Copper line equipment module
- CSPi Central signal processing unit
- FO Fiber-optic module
- a) 4-wire Link
- b) 2-wire Link
- c) Power line analog
- d) Power line via fiber optic

#### Examples 1 and 2:

##### Pilot cable connections

For operation via pilot cable, 2 SWT 3000 devices can be linked directly through the analog interfaces (CLE).

#### Example 3:

##### Analog connection between SWT 3000 and PowerLink

The analog interfaces (CLE) between 2 SWT 3000 devices can also be a PLC link. Depending on the device configuration, SWT 3000 can be used with PowerLink in alternate multi-purpose, simultaneous multi-purpose, or single purpose mode.

#### Example 4:

##### Fiber-optic connections between SWT 3000 and PowerLink

A connection between an SWT 3000 and Siemens PowerLink PLC terminal can be realized via an integrated fiber-optic module. In this case, an SWT 3000 stand-alone system provides the same advanced functionality as the version integrated into PowerLink. Each PowerLink can be connected to 2 SWT 3000 devices via fiber-optics.

## 2.5.2 Digital Transmission Path

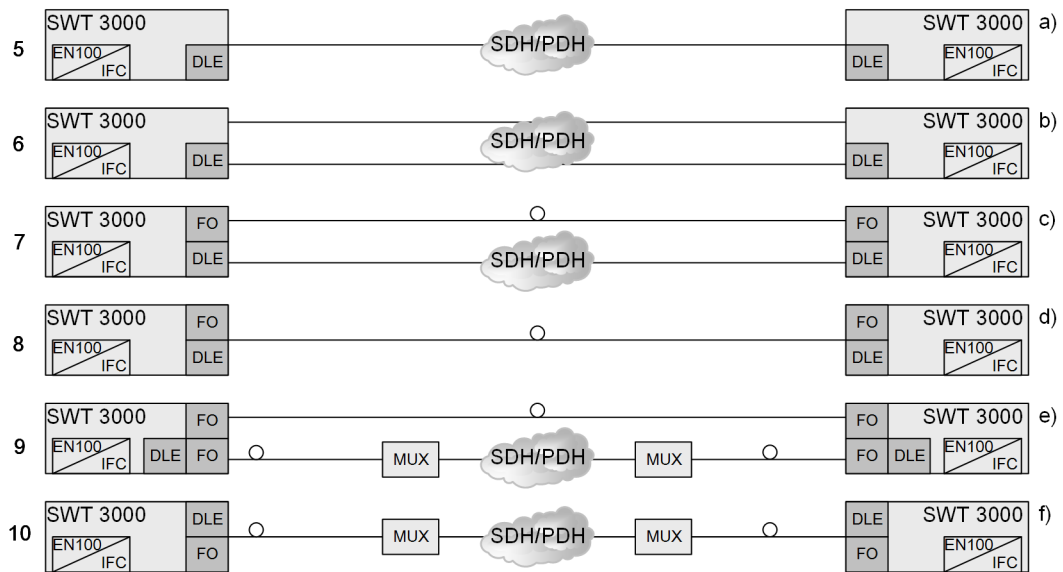

[dw\_examples\_digital\_transmission\_path\_1\_en\_US]

Figure 2-5 Examples Using Digital Transmission Path

- DLE Digital line equipment module
- CSPi Central signal processing unit
- PDH Plesiochronous digital hierarchy
- SDH Synchronous digital hierarchy
- MUX Multiplexer
- a) Digital network
- b) 2 routes via digital network
- c) One path via fiber optic cable; second path via digital network
- d) Fiber optic module integrated
- e) One path via integrated fiber optic; second via fiber optic, MUX and digital network
- f) Through digital network via MUX and fiber optic C37.94

### Example 5:

#### SWT 3000 digital connections

The digital interface allows the transmission of the protection signals over a PDH or SDH network.

### Example 6 and 7:

#### SWT 3000 digital connections

The digital interface allows the transmission of the protection signals over a PDH or SDH network.

#### Direct fiber-optic connection between 2 SWT 3000 devices

The SWT 3000 protection signaling incorporates an internal fiber-optic module for long-distance transmission. The maximum distance between 2 SWT 3000 devices is < 150 km (depending on the optical attenuation).

**Alternative transmission routes**

SWT 3000 enables transmission of protection signals via 2 different routes. Both routes are constantly used. If one route fails, the second route immediately takes over without any loss of time.

**Example 8:**

**Direct fiber-optic connection between 2 SWT 3000 devices**

The SWT 3000 protection signaling incorporates an internal fiber-optic module for long-distance transmission. The maximum distance between 2 SWT 3000 devices is < 150 km (depending on the optical attenuation).

**Example 9:**

**Alternative transmission routes**

SWT 3000 enables transmission of protection signals via 2 different routes. Both routes are constantly used. If one route fails, the second route immediately takes over without any loss of time.

**Direct fiber-optic connection between 2 SWT 3000 devices**

The SWT 3000 protection signaling incorporates an internal fiber-optic module for long-distance transmission. The maximum distance between 2 SWT 3000 devices is < 150 km (depending on the optical attenuation).

**Fiber-optic connection between SWT 3000 and a Multiplexer**

A short-distance connection of up to 2 km between an SWT 3000 and a multiplexer can be realized via an integrated C37.94 fiber-optic module.

**Example 10:**

**Fiber-optic connection between SWT 3000 and a Multiplexer supporting IEEE C37.94**

A short-distance connection of up to approx. 2 km between an SWT 3000 and a multiplexer that supports the optical protocol IEEE C37.94 can be realized via an integrated fiber-optic module of specific type.

**2.5.3 Analog and Digital Transmission Path**

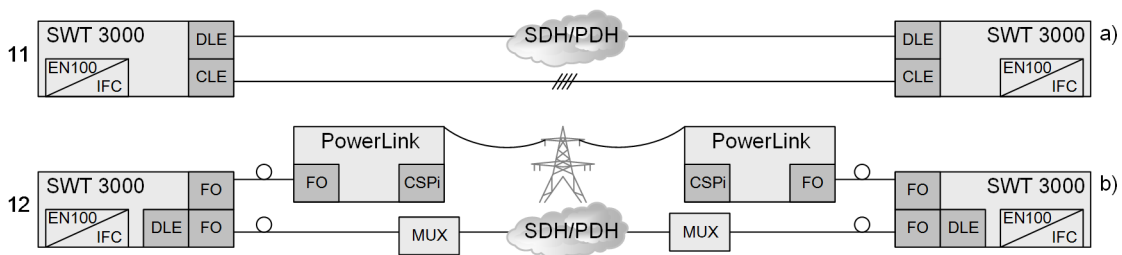

[dwanditr\_new\_1\_en\_US]

Figure 2-6 Examples for Using Analog and Digital Transmission Path

- DLE Digital line equipment module
- CLE Copper line equipment module
- CSPi Central signal processing unit
- PDH Plesiochronous digital hierarchy
- SDH Synchronous digital hierarchy
- MUX Multiplexer

- a) One path via digital network; second path via 4-wire (or 2-wire)
- b) One path via power line and fiber optic; second path via fiber optic and digital network

**Example 11:**

**SWT 3000 digital connections**

The digital interface allows the transmission of the protection signals over a PDH or SDH network.

**Alternative transmission routes**

SWT 3000 enables transmission of protection signals via 2 different routes. Both routes are constantly used. If one route fails, the second route immediately takes over without any loss of time.

**Example 12:**

**Fiber-optic connections between SWT 3000 and PowerLink**

A connection between an SWT 3000 and Siemens PowerLink PLC terminal can be realized via an integrated fiber-optic module. In this case, an SWT 3000 stand-alone system provides the same advanced functionality as the version integrated into PowerLink. Each PowerLink can be connected to 2 SWT 3000 devices via fiber-optics.

**Alternative transmission routes**

SWT 3000 enables transmission of protection signals via 2 different routes. Both routes are constantly used. If one route fails, the second route immediately takes over without any loss of time.

**Fiber-optic connection between SWT 3000 and a Multiplexer**

A connection of up to 2 km between an SWT 3000 and a multiplexer can be realized via an integrated C37.94 fiber-optic module.

**2.5.4 Integrated Into the PowerLink PLC System**

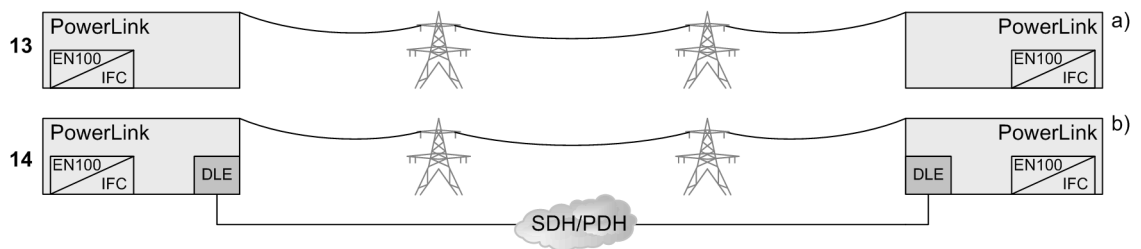

[dwintplc-211011-01.tif, 2, en\_US]

Figure 2-7 Examples of Integrated SWT 3000

- a) Power line
- b) One path via power line; second path via digital network.

**Examples 13 und 14:**

**SWT 3000 integration into the PowerLink PLC system**

An SWT 3000 system can be integrated into the PowerLink equipment through the following interfaces:

- The analog interface
- The digital interface
- A combination of the analog and the digital interfaces

**Alternative transmission routes**

SWT 3000 enables transmission of protection signals via 2 different routes. Both routes are constantly used. If one route fails, the second route immediately takes over without any loss of time.

## 2.6 Monitoring

### Overview

The monitoring functions of the device are as follows:

- **Operating voltage**  
All outgoing information (TX and command outputs) are blocked as long as the operating voltages of the equipment are not within the specified ranges.
- **Switching command duration**  
If a switching command with a duration of > 500 ms is received, the command outputs are disabled and an alarm is triggered. The switching command duration can be configured.
- **Guard tone failure alarm**  
If there is no valid command frequency present, a guard tone failure alarm is triggered after about 10 ms.
- **Signal to Noise (S/N) ratio**  
If the configured threshold of the S/N ratio is exceeded, a signal to noise alarm can be triggered. During alternate multi-purpose operation the S/N supervision is not performed.
- **Transmit level monitoring**  
The level of the transmit amplifier is monitored.
- **Operating state**  
The operating state of the device is displayed on the front panel with differently colored LED.
- **Control contacts for external equipment**  
A floating make contact or break contact (alarm contact) is available at the device terminals for signaling the following alarms:
  - Non-urgent alarm (NU-alarm, NUALR, or NDALR)
  - Receiver alarm (RXALR or EALR)
  - General alarm (GALR or GENALR)
- **Signaling modules IFC-S can be provided additionally as an option.** With the aid of this module, any operation of the local circuit can be signaled externally via an auxiliary contact.



#### NOTE

Maximum 2 IFC-S modules are possible.

- **Measuring options**  
Decoupled measuring points at which the operating values can be monitored are arranged on the modules for start-up and maintenance of the unit.
- **Input pulse suppression**  
In order to be accepted as an input signal, commands must be applied at the input for at least 1 ms. You can increase this minimum time to 100 ms in steps of 1 ms. The input pulse suppression can be configured.
- **Minimum transmission duration**  
Each command is transmitted for at least 15 ms. The minimum transmission time can be configured.

## 2.7 Protection Modes

### 2.7.1 Overview

The SWT 3000 system has the following different protection operating modes:

- Protection operating mode 1 (double system protection) for the analog and digital transmission interface. The commands can be transmitted coded or uncoded with the application permissive or direct tripping (selectable per SWT 3000 device).
- Protection operating mode 2 (single phase protection) for the analog and digital interface. The commands can be transmitted coded or uncoded with the application permissive or direct tripping (selectable per SWT 3000 device).
- Protection operating mode 3 (4 commands with priority) for the analog and digital interface. The commands are transmitted uncoded with the application permissive or direct tripping (selectable per SWT 3000 device).
- Protection operating mode 3a (4 independent commands, 4iC) for the analog and digital transmission interface. Transmission of 4 independent commands. The commands are always transmitted coded with the application permissive or direct tripping (selectable per SWT 3000 device).
- Protection operating mode 3b (2 plus 2) for the analog and digital transmission interface. This mode offers the transmission of mode 1 twice. 2 commands are transmitted in the fast permissive underreach transfer trip, the other 2 are transmitted in the direct trip application and using the CT feature.
- Protection operating mode 4 (only one command active) for analog and digital transmission interfaces. The commands can be transmitted coded or uncoded with the application permissive or direct tripping (selectable per SWT 3000 device).
- Protection operating mode 5A (3 independent commands) for analog and digital transmission interfaces. The commands are transmitted uncoded with the application permissive or direct tripping (selectable per SWT 3000 device).
- Protection operating mode 5D (16 independent commands) only for operation with digital transmission interfaces.

### 2.7.2 Unblocking Mode

The unblocking mode is a release procedure. Short circuits on overhead lines can cause a disturbance of PLC links. In this case, in order to warrant the release of the permissive protection device, the unblocking impulse ( $t_{unbl.}$ ) is used.

If the signal to be transmitted does not reach the other line end, the receiver recognizes a fault and emits the unblocking impulse. The reason for the unreached signal is because a short circuit on the line causes excessive attenuation or reflection of the signal. The unblocking impulse is connected to the unblocking logic of the protection relay. For Mode 1 and 2, the unblocking impulse is carried out via the interface module IFC-P/D command output 4. For other Modes, it is carried out via alarm module RX alarm output. If there is a fault, the unblocking logic of the protection device ensures the release (for  $t_{unbl.} = 10 \text{ ms to } 300 \text{ ms}$ ).



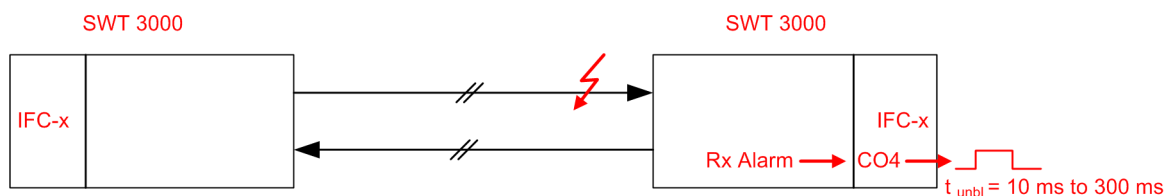

[dwprunbm-010711-01.tif, 1, en, US]

Figure 2-8 Principle of the Unblocking Mode

The unblocking function is activated when the time for the unblocking impulse is more than 0 ms ( $t_{unbl.} > 0$  ms).

## 2.7.3 Description of the Protection Operating Modes

### 2.7.3.1 Overview

The following abbreviations are used in the description of the modes.

Uncoded	Frequencies to be transmitted in the uncoded mode: <ul style="list-style-type: none"> <li><math>f_g</math> is the guard tone</li> <li><math>f_s</math> is the frequency for clock synchronization</li> </ul>
Coded	Frequencies to be transmitted in the coded mode: <ul style="list-style-type: none"> <li><math>f_g</math> is the guard tone</li> </ul>
$t_{unbl.}$	Duration of the unblocking impulse: <ul style="list-style-type: none"> <li>unblocking inactive when <math>t_{unbl.} = 0</math></li> <li>unblocking active when <math>t_{unbl.} &gt; 0</math></li> </ul>
BI[x]	Binary input 1 to 4
CO[x]	Command output 1 to 4

### 2.7.3.2 Mode 1 (Double System Protection)

Table 2-4 Logic Scheme for the Mode 1

Activated Input	Transmission Uncoded	Transmission Coded	Command Output in the Remote Station without Unblocking	Command Output in the Remote Station with Unblocking $T_{unbl.} > 0^{1)}$
All off	$f_g$	$f_g$	–	CO3
BI1	$f_1$	$f_s + f_4$	CO1 + CO3	CO1
BI2	$f_2$	$f_s + f_5$	CO2 + CO4	CO2
BI1 + BI2	$f_4$	$f_s + f_6$	CO1 + CO2 + CO3 + CO4	CO1 + CO2
BI3	$x^{2)}$	$x^{2)}$	–	–
–	–	–	Alarm signaling <sup>3)</sup>	Alarm signaling + unblocking impulse at CO4
BI4 <sup>4)</sup>	$f_g$	$f_g$	–	CO3

Activated Input	Transmission Uncoded	Transmission Coded	Command Output in the Remote Station without Unblocking	Command Output in the Remote Station with Unblocking $T_{unbl.} > 0^{1)}$
USYNC <sup>5)</sup>	$f_s$	$f_s + f_7$	–	–

<sup>1)</sup>If an invalid frequency or code is received, or in case of guard tone alarm: If  $t_{unbl.} > 0$ , output of the unblocking impulse ( $t_{unbl.}$  = Duration of the unblocking impulse)  
<sup>2)</sup>x = No reaction (does not trigger alarm)  
<sup>3)</sup>If an invalid frequency or code is received or in case of guard tone alarm  
<sup>4)</sup>With AMP operation (PLC connection), signal S6 is also activated through **BI4 = on** and voice transmission is interrupted.  
<sup>5)</sup>Clock synchronization (USYNC)

2.7.3.3 Mode 2 (Single Phase Protection)

Table 2-5 Logic Scheme for the Mode 2

Activated Input	Transmission Uncoded	Transmission Coded	Command Output in the Remote Station without unblocking	Command Output in the Remote Station with Unblocking $T_{unbl.} > 0^{1)}$
All off	$f_g$	$f_g$	CO4	-
BI1	$f_1$	$f_s + f_4$	CO1	CO1
BI2	$f_2$	$f_s + f_5$	CO2	CO2
BI3	$f_3$	$f_s + f_6$	CO3	CO3
BI1 + BI2 or BI1 + BI3 or BI2 + BI3 or BI1 + BI2 + BI3	$f_4$	$f_s + f_7$	CO1 + CO2 + CO3	CO1 + CO2 + CO3
-	-	-	Alarm signaling <sup>2)</sup>	Alarm signaling <sup>1)</sup> + unblocking impulse at CO4
BI4 <sup>3)</sup>	$f_g$	$f_g$	CO4	-
USYNC	$f_s$	$f_1 + f_4$	-	-

<sup>1)</sup>If an invalid frequency or code is received, or in case of guard tone alarm: If  $t_{unbl.} > 0$ , output of the unblocking impulse ( $t_{unbl.}$  = Duration of the unblocking impulse).  
<sup>2)</sup>If an invalid frequency or code is received or in case of guard tone alarm.  
<sup>3)</sup>In AMP operation (PLC connection), signal S6 is also activated (**energized**) through BI4 = on and voice transmission is interrupted.

2.7.3.4 Mode 3 (4 Commands with Priority)



**NOTE**

For this mode, coded tripping is not available.

In Mode 3, if more than one of the command inputs BI1 to BI4 is active, the command information is transmitted alternately. The signal inputs also have different priorities (BI1 = Prio1, BI2 = Prio2, BI3 = Prio3, and BI4 = Prio4). That is, if several signal inputs are active at the same time, the priority control determines the sequence in which the commands are transmitted.

Table 2-6 Logic Scheme for the Mode 3

Activated Input	Transmission Uncoded	Transmission Coded	Command Output in the Remote Station without unblocking	Command Output in the Remote Station with Unblocking $T_{unbl.} > 0^{1)}$
All off	$f_g$	-	-	-
BI1	$f_1$	-	CO1	CO1
BI2	$f_2$	-	CO2	CO2
BI3	$f_3$	-	CO3	CO3
BI4	$f_4$	-	CO4	CO4
BI1 and/or BI2 and/or BI3 and/or BI4	$f_1$ and/or $f_2$ and/or $f_3$ and/or $f_4$ alternating	-	CO1 and/or CO2 and/or CO3 and/or CO4 alternating <sup>2)</sup>	CO1 and/or CO2 and/or CO3 and/or CO4 alternating <sup>2)</sup>
-	-	-	Alarm signaling <sup>3)</sup>	Alarm signaling <sup>1)</sup> + unblocking impulse at RXALR
USYNC	$f_s$	-	-	-

<sup>1)</sup>If an invalid frequency or code is received, or in case of guard tone alarm: If  $t_{unbl.} > 0$ , output of the unblocking impulse ( $t_{unbl.}$  = Duration of the unblocking impulse). The unblocking impulse is distributed via the RXALR output of the ALR board.

<sup>2)</sup>If more than one input is active, command transmission is alternating. The priority control dictates the sequence in which the command frequencies are transmitted. Setting the output extension to  $\geq 100$  ms on the receive side prevents the output relays releasing during alternating command transmission.

<sup>3)</sup>If an invalid frequency or code is received or in case of guard tone alarm.

### 2.7.3.5 Mode 3a (4 Independent Commands, 4iC)



#### NOTE

This mode is always transmitted in the coded tripping function.

Table 2-7 Logic Scheme for the Mode 3a

Activated Input	Transmission Uncoded	Transmission Coded	Command Output in the Remote Station <sup>1)</sup> without Unblocking	Command Output in the Remote Station <sup>1)</sup> with Unblocking <sup>2)</sup> $T_{unbl.} > 0$
All off	-	$f_g$	-	-
BI1	-	$f_s + f_4$	CO1	CO1
BI2	-	$f_1 + f_4$	CO2	CO2
BI3	-	$f_2 + f_4$	CO3	CO3
BI4	-	$f_3 + f_4$	CO4	CO4
BI1 + BI2	-	$f_s + f_5$	CO1 + CO2	CO1 + CO2
BI1 + BI3	-	$f_2 + f_5$	CO1 + CO3	CO1 + CO3
BI1 + BI4	-	$f_3 + f_6$	CO1 + CO4	CO1 + CO4

Activated Input	Transmission Uncoded	Transmission Coded	Command Output in the Remote Station <sup>1)</sup> without Unblocking	Command Output in the Remote Station <sup>1)</sup> with Unblocking <sup>2)</sup> $T_{unbl.} > 0$
BI2 + BI3	-	$f_1 + f_5$	CO2 + CO3	CO2 + CO3
BI2 + BI4	-	$f_3 + f_5$	CO2 + CO4	CO2 + CO4
BI3 + BI4	-	$f_2 + f_6$	CO3 + CO4	CO3 + CO4
BI1 + BI2 + BI3	-	$f_1 + f_6$	CO1 + CO2 + CO3	CO1 + CO2 + CO3
BI1 + BI2 + BI4	-	$f_3 + f_6$	CO1 + CO2 + CO4	CO1 + CO2 + CO4
BI1 + BI3 + BI4	-	$f_5 + f_7$	CO1 + CO3 + CO4	CO1 + CO3 + CO4
BI2 + BI3 + BI4	-	$f_1 + f_7$	CO2 + CO3 + CO4	CO2 + CO3 + CO4
BI1 + BI2 + BI3 + BI4	-	$f_2 + f_7$	CO1 + CO2 + CO3 + CO4	CO1 + CO2 + CO3 + CO4
USYNC	-	$f_3 + f_7$	-	-
-	-	-	Alarm signaling <sup>3)</sup>	Alarm signaling + unblocking impulse at RXALR <sup>2)</sup>

<sup>1)</sup>If output allocation 1:1 is adjusted.  
<sup>2)</sup>If an invalid frequency or code is received, or in case of guard tone alarm: If  $t_{unbl.} > 0$ , output of the unblocking impulse ( $t_{unbl.}$  = Duration of the unblocking impulse). The unblocking impulse is distributed via the RXALR output of the ALR board.  
<sup>3)</sup>If an invalid frequency or code is received or in case of guard tone alarm.



**NOTE**

In device configurations with EN100 and IFC (Mixed mode) the first input ports are always allocated to the pre-configured EN100 channels. The remaining input ports (depending on the number of assigned EN100 channels) are allocated to the input ports of IFC module in ascending order, IFC-1/IN1, IFC-1/IN2, etc.

**2.7.3.6 Mode 3b (2 plus 2)**

The commands 1, 2 and 1+2 are permissive tripping commands, which are always transmitted uncoded. The commands 3, 4 and any combination with commands 3, 4 (e.g. 1+2+3+4) are direct tripping commands, which are always transmitted coded.

The transmission time of direct tripping command is approx. 5 ms longer than permissive tripping command in order to increase transmission security.

The mode 3b has been enhanced with the setting for fast transmission of permissive commands.

Table 2-8 Logic Scheme for the Mode 3b

Activated Input	Transmission Uncoded	Transmission Coded	Command Output in the Remote Station without Unblocking	Command Output in the Remote Station with Unblocking $T_{unbl.} > 0^1)$
All off	$f_g$	-	-	-
BI1	$f_1$	-	CO1	CO1
BI2	$f_2$	-	CO2	CO2
BI1 + BI2	$f_3$	-	CO1 + CO2	CO1 + CO2

Activated Input	Transmission Uncoded	Transmission Coded	Command Output in the Remote Station without Unblocking	Command Output in the Remote Station with Unblocking $T_{unbl.} > 0^{1)}$
BI3	-	$f_s + f_4$	CO3	CO3
BI4	-	$f_s + f_5$	CO4	CO4
BI3 + BI4	-	$f_s + f_6$	CO3 + CO4	CO3 + CO4
BI1 + BI3	-	$f_1 + f_4$	CO1 + CO3	CO1 + CO3
BI1 + BI4	-	$f_1 + f_5$	CO1 + CO4	CO1 + CO4
BI1 + BI3 + BI4	-	$f_1 + f_6$	CO1 + CO3 + CO4	CO1 + CO3 + CO4
BI1 + BI2 + BI3	-	$f_1 + f_7$	CO1 + CO2 + CO3	CO1 + CO2 + CO3
BI2 + BI3	-	$f_2 + f_4$	CO2 + CO3	CO2 + CO3
BI2 + BI4	-	$f_2 + f_5$	CO2 + CO4	CO2 + CO4
BI2 + BI3 + BI4	-	$f_2 + f_6$	CO2 + CO3 + CO4	CO2 + CO3 + CO4
BI1 + BI2 + BI4	-	$f_3 + f_4$	CO1 + CO2 + CO4	CO1 + CO2 + CO4
BI1 + BI2 + BI3 + BI4	-	$f_3 + f_5$	CO1 + CO2 + CO3 + CO4	CO1 + CO2 + CO3 + CO4
USYNC	-	$f_s + f_7$	-	-
-	-	-	Alarm signaling <sup>2)</sup>	Alarm signaling + unblocking impulse at RXALR <sup>1</sup>

<sup>1)</sup>If an invalid frequency or code is received, or in case of guard tone alarm: If  $t_{unbl.} > 0$ , output of the unblocking impulse ( $t_{unbl.}$  = Duration of the unblocking impulse). The unblocking impulse is distributed via the RXALR output of the ALR board.  
<sup>2)</sup>If an invalid frequency or code is received or in case of guard tone alarm.

### Command Duration of Mode 3b

The single command applied at the device input is transmitted for at least 15 ms or 20 ms. The next command is then transmitted, or the same command is continuously transmitted if no other command input active. If next command input is active at same time or within the time interval of 2 ms, the transmit signal is shifted to the frequency corresponding to this input combination. Otherwise, the next command will be transmitted after minimal transmission duration.

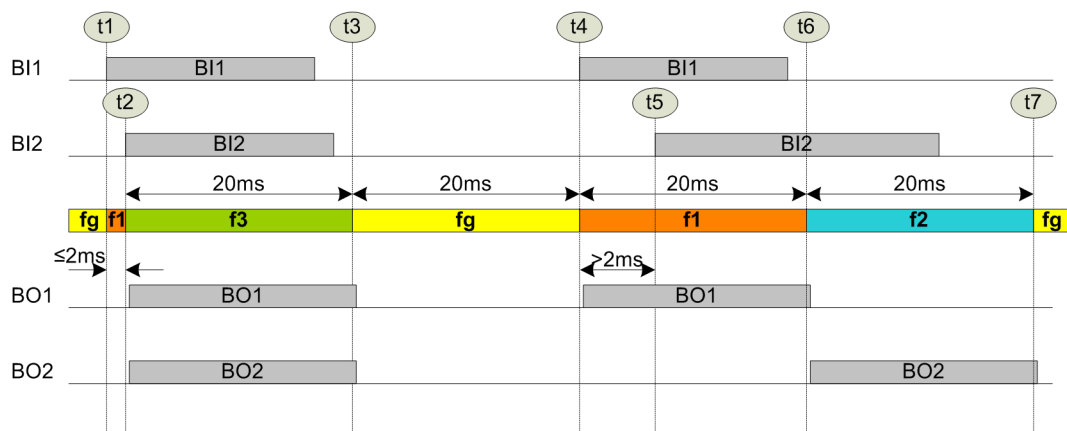

[DwpermComm-Q20215\_1\_en\_US]

Figure 2-9 Permissive Command 1+2 Transmission

Table 2-9 Command Transmission Timeline Description

Timeline	Description
t1	BI1 active, start transmission of command 1.
t2	BI2 active within time interval 2 ms, switch to transmit command combination of 1+2, BO1+2 active after command transmission time.
t3	Transmission duration time-out, BO1+2 inactive after command transmission time.
t4	BI1 active, start transmission of command 1.
t5	BI2 active after time interval 2 ms, continue transmission of command 1.
t6	Transmission duration time-out, switch to transmit command 2, BO1 inactive after command transmission time.
t7	Transmission duration time-out, BO2 inactive after command transmission time, switch to transmit guard command.

It is possible to enable fast transmission of permissive command with additional setting in PowerSys as below:

- "BI1+2 interrupt single command BI1 or BI2 without delay" is enabled. Permissive command 1 or 2 transmission can switch to input combination 1+2 without waiting for minimal transmission duration time-out.
- Transmission duration for permissive command is set to 20 ms. Permissive command is transmitted for at least 20 ms.
- Pulse suppression for permissive command is set to 0 ms. Permissive command input is accepted without additional delay by suppression timer.

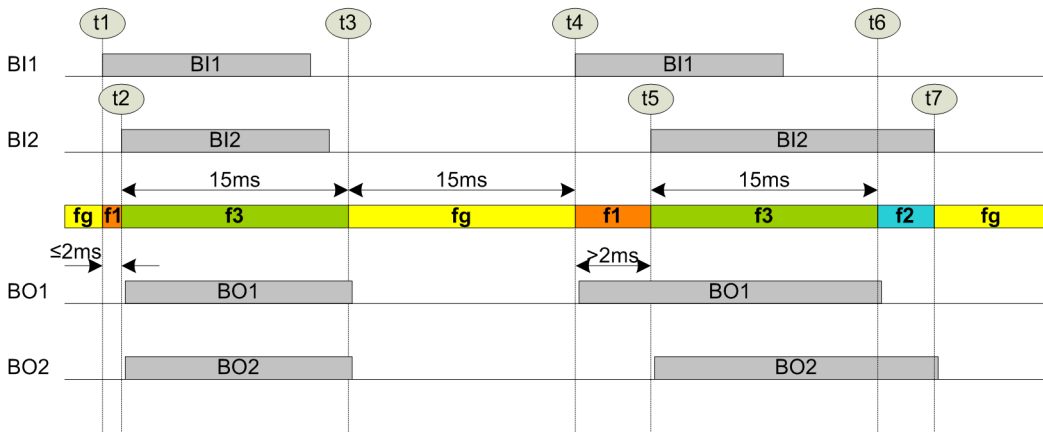

[DwFastComm020215, 1, en\_US]

Figure 2-10 Fast Transmission of Permissive Command 1+2

Table 2-10 Fast Command Transmission Timeline Description

Timeline	Description
t1	BI1 active, start transmission of command 1.
t2	BI2 active within time interval 2 ms, switch to transmit command combination of 1+2, BO1+2 active after command transmission time.
t3	Transmission duration time-out, BO1+2 inactive after command transmission time.
t4	BI1 active, start transmission of command 1, BO1 active after command transmission time.
t5	BI2 active after time interval 2 ms, switch to transmit command combination of 1+2, BO2 active after command transmission time.

Timeline	Description
t6	Transmission duration time-out, switch to transmit command 2, BO1 inactive after command transmission time.
t7	BI2 inactive, switch to transmit guard command, BO2 inactive after command transmission time.

### 2.7.3.7 Mode 4 (Only One Command Active)

Table 2-11 Logic Scheme for the Mode 4

Activated Input	Transmission Uncoded	Transmission Coded	Command Output in the Remote Station without Unblocking	Command Output in the Remote Station with Unblocking $T_{unbl.} > 0^{1)}$
All off	$f_g$	$f_g$	-	-
BI1	$f_1$	$f_s + f_4$	CO1	CO1
BI2	$f_2$	$f_1 + f_4$	CO2	CO2
BI3	$f_3$	$f_2 + f_4$	CO3	CO3
BI4	$f_4$	$f_3 + f_4$	CO4	CO4
BI1 + BI2 or BI1 + BI3 or BI2 + BI3 or BI1 + BI2 + BI3	$f_g^{2)}$	$f_g^{2)}$	-	-
BI4 + BIx	$f_4$	$f_3 + f_4$	CO4	CO4
-	-	-	Alarm signaling <sup>3)</sup>	Alarm signaling <sup>1)</sup> + unblocking impulse at RXALR
USYNC	$f_s$	$f_s + f_7$	-	-

<sup>1)</sup>If an invalid frequency or code is received, or in case of guard tone alarm: If  $t_{unbl.} > 0$ , output of the unblocking impulse ( $t_{unbl.}$  = Duration of the unblocking impulse) The unblocking pulse is distributed via the RXALR output (ALR1-3 resp. ALR2-3 contact if activated in the ALR configuration).

<sup>2)</sup>Input error. If more than one input is activated  $f_g$  is transmitted.

<sup>3)</sup>If an invalid frequency or code is received, or in case of guard tone alarm.

#### Explanation

The PU4 checks the state of input signals BI1 to BI4 from the protection device for **plausibility**. Only 1 of the signal inputs BI1 to BI3 can be active. If more than 1 of the signal inputs BI1 to BI3 is active and BI4 is inactive, an **input error** occurs (prohibited input combination).

**BI4 has priority** and is treated independently of the states of BI1 to BI3. That is, if BI4 is active, the state of BI1 to BI3 is not significant. If BI4 is active, the frequency  $f_4$  is transmitted regardless of the state of BI1 to BI3.

The guard tone ( $f_g$ ) is transmitted in the case of an **input error** and an entry is generated in the event memory with specification of the **prohibited input combination**. The unblocking function can be activated for Mode 4 in the same way as with the other operating modes.

### 2.7.3.8 Mode 5A (3 Independent Commands)



#### NOTE

For this mode, coded tripping is not available.

3 signal inputs are available for the operating mode **3 independent commands**. 9 frequencies are needed for transmitting **3 independent commands** via the analog line interface.

**At the transmit end**, every possible combination of signal inputs BI1 to BI3 is permanently assigned to a protection frequency.

**At the receive end**, every protection frequency can be assigned to one or more signal outputs (CO1 to CO4).

Table 2-12 Logic Scheme for the Mode 5A

Activated Input	Transmission Uncoded	Transmission Coded	Command Output in the Remote Station <sup>1)</sup> without Unblocking	Command Output in the Remote Station <sup>1)</sup> with Unblocking $T_{unbl.} > 0$ <sup>2)</sup>
All off	$f_g$	-	-	-
BI1	$f_1$	-	CO1	CO1
BI2	$f_2$	-	CO2	CO2
BI3	$f_3$	-	CO3	CO3
BI1 + BI2	$f_4$	-	CO1 + CO2	CO1 + CO2
BI1 + BI3	$f_5$	-	CO1 + CO3	CO1 + CO3
BI2 + BI3	$f_6$	-	CO2 + CO3	CO2 + CO3
BI1 + BI2 + BI3	$f_7$	-	CO1 + CO2 + CO3	CO1 + CO2 + CO3
USYNC	$f_s$	-	-	-
-	-	-	Alarm signaling <sup>3)</sup>	Alarm signaling <sup>2)</sup> + unblocking impulse at RXALR

<sup>1)</sup>If output allocation 1:1 is adjusted.  
<sup>2)</sup>If an invalid frequency or code is received, or in case of guard tone alarm: If  $t_{unbl.} > 0$ , output of the unblocking impulse ( $t_{unbl.}$  = Duration of the unblocking impulse). The unblocking impulse is distributed via the RXALR output of the ALR board.  
<sup>3)</sup>If an invalid frequency or code is received, or in case of guard tone alarm.

### 2.7.3.9 Mode 5D (Only for Digital Transmission Paths)

When using digital interfaces exclusively, up to 16 independent command inputs can be transmitted transparently to the distant station with operating mode 5D and can be routed to commands outputs there. 4 Interface Command Modules IFC-P/D (for Binary I/O) or one EN 100 interface (for GOOSE I/O) are necessary for this application.

The default program setting is 1:1 transparent. That is BI1 = CO1, BI2 = CO2 ... BI16 = CO16



**NOTE**

In device configurations with EN100 and IFC (mixed mode) the first input ports are always allocated to the pre-configured EN100 channels. The remaining input ports (depending on the number of assigned EN100 channels) are allocated to the input ports of IFC module in ascending order, IFC-1/IN1, IFC-1/IN2, etc.

### 2.7.3.10 Mode 7a (8 Independent Commands, 8iC)

This operation mode is only in combination with PowerLink IP available.

It allows the transmission of eight independent commands. Commands are always transmitted coded with the application permissive or direct tripping (selectable per device). There are 255 command combinations. Every possible combination of signal input is assigned to a protection frequency and are defined as code number (Cxxx) in below table:



Table 2-13 Code number definition for all signal inputs

code no.	BI8	BI7	BI6	BI5	BI4	BI3	BI2	BI1
C1	-	-	-	-	-	-	-	X
C2	-	-	-	-	-	-	X	-
C3	-	-	-	-	-	-	X	X
C4	-	-	-	-	-	X	-	-
...	...	...	...	...	...	...	...	...
C254	X	X	X	X	X	X	X	-
C255	X	X	X	X	X	X	X	X
C256	USYNC							

## 2.8 Frequency Overview

### 2.8.1 Broadband Devices in the VF Range [kHz]

Table 2-14 Command Frequencies of Broadband Devices

Command Frequency	VF1	VF1_M5A	VF3_M5A
Guard tone $f_g$	2.615	2.615	3.810
USYNC $f_s^{1)}$	1.920	0.365	0.444
$f_1$	1.700	1.920	2.000
$f_2$	1.475	1.700	1.780
$f_3$	0.810	1.475	1.555
$f_4$	1.030	1.250	1.335
$f_5$	-	1.030	1.110
$f_6$	-	0.810	0.890
$f_7$	-	0.585	0.665

<sup>1)</sup>Frequency  $f_s$  is used for clock synchronization (master-slave) between 2 SWT 3000 units and is transmitted from the master to the slave unit once every 24 h at a configurable hour.

Table 2-15 Coded Tripping Variants in the VF Range

Command Frequency	VF1_CT	VF3_CT
Guard tone $f_g$	2.615	3.810
USYNC $f_s^{1)}$	1.920	2.000
$f_1$	1.700	1.780
$f_2$	1.475	1.555
$f_3$	1.250	1.335
$f_4$	1.030	1.110
$f_5$	0.810	0.890
$f_6$	0.585	0.665
$f_7$	0.365	0.444

<sup>1)</sup>Frequency  $f_s$  is used for clock synchronization (master-slave) between 2 SWT 3000 units and is transmitted from the master to the slave unit once every 24 h at a configurable hour.

### 2.8.2 Narrow-Band Devices in the VF Range [kHz]

Table 2-16 Command Frequencies of Narrow-Band Devices

Command Frequency	NB Ch1	NB Ch2	NB Ch3	NB Ch4
Guard tone $f_g$	1.263	2.274	3.284	3.789
USYNC $f_s^{1)}$	1.137	2.147	3.158	3.663
$f_1$	1.011	2.021	3.032	3.537
$f_2$	0.884	1.895	2.905	3.411
$f_3$	0.758	1.768	2.779	3.284

Command Frequency	NB Ch1	NB Ch2	NB Ch3	NB Ch4
$f_4$	0.632	1.642	2.653	3.158
<sup>1)</sup> Frequency $f_s$ is used for clock synchronization (master-slave) between 2 SWT 3000 units and is transmitted from the master to the slave once every 24 h at a configurable hour.				

The parameters in the following table can be set for narrow-band devices for a 2-wire operation.

Table 2-17 Narrow-Band Versions for VF 2-Wire Connections

Variant NB Ch12	Transmit channel 1	Receive channel 2
Variant NB Ch21	Transmit channel 2	Receive channel 1
Variant NB Ch13	Transmit channel 1	Receive channel 3
Variant NB Ch31	Transmit channel 3	Receive channel 1
Variant NB Ch23	Transmit channel 2	Receive channel 3
Variant NB Ch32	Transmit channel 3	Receive channel 2



**NOTE**

For integrated SWT 3000 (iSWT) in PowerLink only Narrow-Band Variant NB Ch1 (NB1) is applicable with single purpose and multi-purpose operation.

The use of Narrow-Band variants with PLC transmission in alternate multi-purpose operation is not possible.

### 2.8.3 Frequency Diagram for Broadband and Narrow-Band Devices

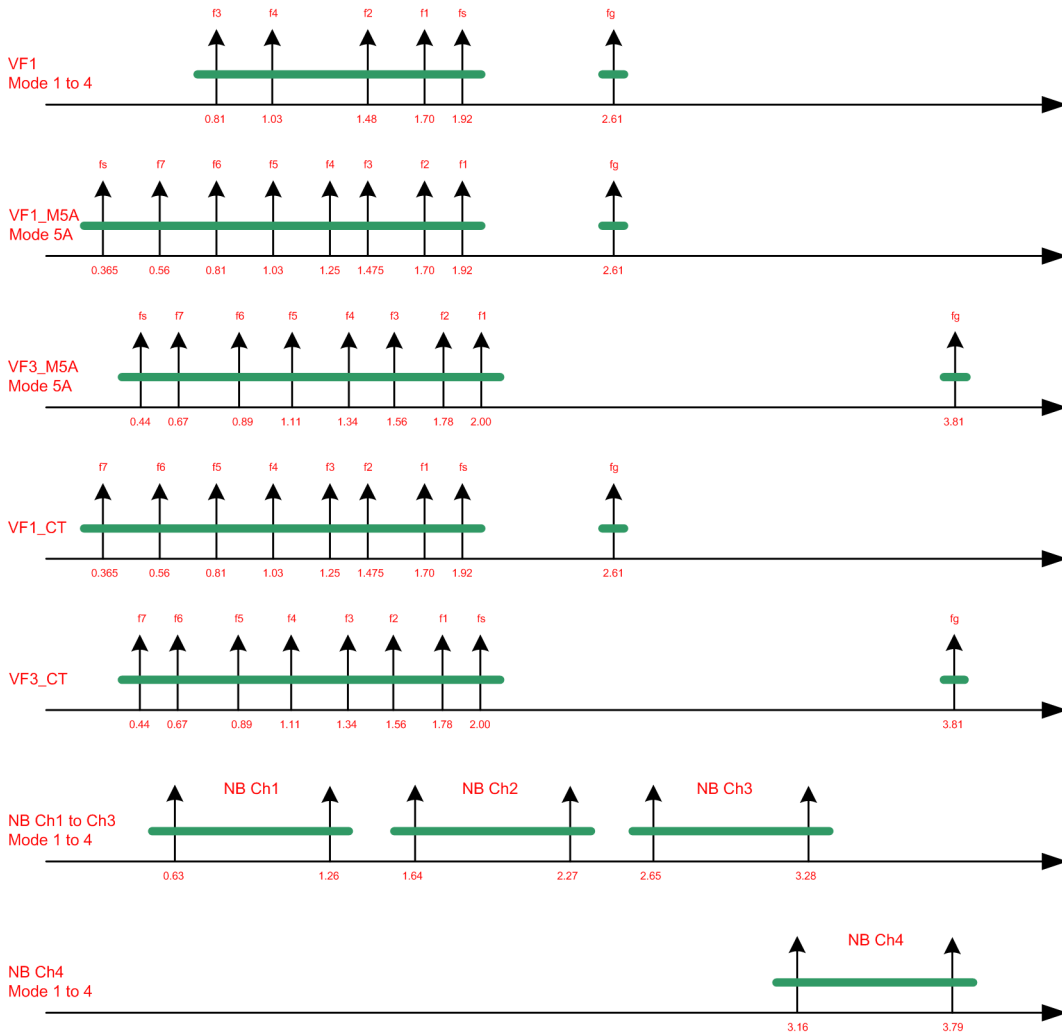

[dwfregdi-290711-01.tif, 2, en\_US]

Figure 2-11 Frequency Diagram for Broadband and Narrow-Band Devices

- fg Guard tone
- fs Clock synchronization
- Mode 5A Operating mode 5A
- VFx\_CT Frequencies for coded tripping used for operating mode 1, 2, 3a, 3b, and 4
- NB Ch1 - Ch3 Narrow-band channels 1 to 3
- Mode 1 - 4 Operating modes 1 to 4

### 2.8.4 Command Duration for Single-Purpose Operation

#### 2.8.4.1 Mode 1, Mode 2, Mode 3a, Mode 3b, Mode 4, Mode 5A, Mode 7a

In these modes, a signal applied to the device input is transmitted as long as the input circuit is activated. If another input signal is received while one is still applying, the transmit signal is shifted to the frequency corresponding to this input combination. The signal output at the receive side can optionally be interrupted at the receiver output after 500 ms.

If the output relay must be activated for a minimum time on reception of a command, an increase in the command output time can be set. The increase in the command output time can be set in steps of 5 ms up to maximum 2000 ms.

#### **2.8.4.2 4 Commands with Priority Mode 3**

In this mode, any command applied at the device input is transmitted for 20 ms or for the time set in time slot. The next command is then transmitted or the same command is transmitted again (only if there is no other command active at the inputs) depending on the priority. The command output can optionally be extended at the receiver output in steps of 5 ms to maximum 2000 ms. To avoid that the output relays drops a prolongation time  $\geq 100$  ms must be set. This extension makes it possible to transmit commands from all input combinations depending on priority.

### **2.8.5 Command Duration for Alternate Multi-Purpose Operation**

The command duration for SWT 3000 is automatically adjusted to a default value of 1000 ms. Inputs can be activated for a longer time but the transmission of the signal is limited to 1000 ms. The transmission of the commands is switched off due to the limited command duration even though the command is active at the input of the device.

## 2.9 Fiber-Optic Connection

### 2.9.1 Overview

With the integrated Fiber-Optic Modules (FOM), it is possible to connect an SWT 3000 to the PowerLink PLC system or a multiplexer via fiber-optic cables. The communication of 2 SWT 3000 units via fiber-optic cables is also possible. A distance of up to 150 km can be covered.

2 fiber-optic modules (FOM-1 and FOM-2) for the main and alternate path can be integrated into the SWT 3000 system.

Alternatively, the Copper Line Equipment (CLE) module for the wired analog transmission can be inserted at slot FOM-1.

With the fiber-optic modules, the following cases of operation can be carried out:

- Connection to the PowerLink PLC system
- Connection to a multiplexer
- Direct connection via fiber-optic

### 2.9.2 Connection to the PowerLink PLC System

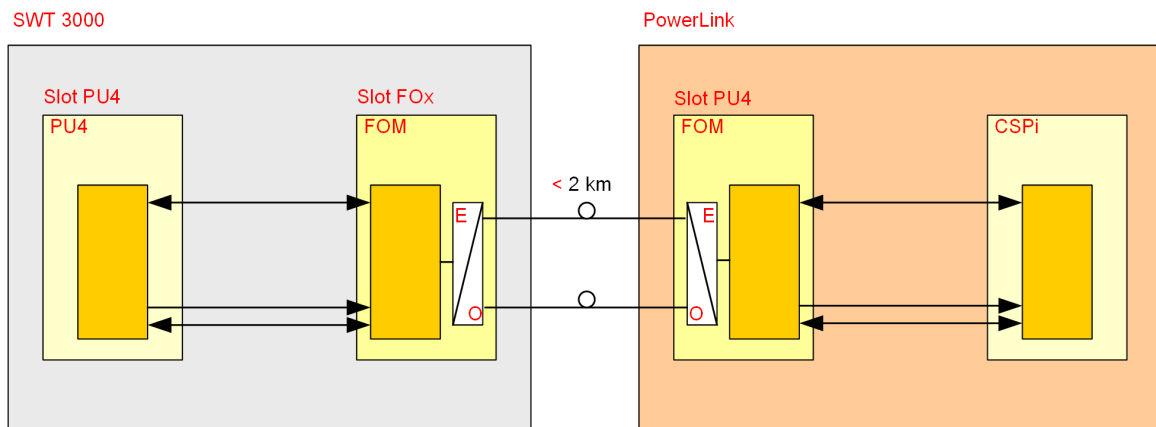

[idw\_SWT\_conswp\_2\_en\_US]

Figure 2-12 Connection of the SWT 3000 via Fiber-Optic Cable to the PowerLink

The SWT 3000 is connected via fiber-optic cables (for each transmission direction one fiber) to the PowerLink. The functional performance of the SWT 3000 is like an integrated SWT 3000 (iSWT). That is, all possible variants with iSWT can be carried out with the stand-alone SWT 3000 via fiber-optic cables. **The programming of the SWT 3000 in this case is only possible via PowerLink and the service program PowerSys.** In the PowerLink system, 2 SWT 3000 can be connected via fiber-optic cables (iSWT-1 and iSWT-2). The fiber-optic modules in Power Link are installed in the slots of the PU4.



#### NOTE

In order to integrate an SWT 3000 with PU4 into the PowerLink system, a PowerLink with CSPI (release 3.5.xxx) is necessary.

The main transmission path of the SWT 3000 via Fiber-Optic cable is the PLC connection of the PowerLink via high-voltage line.

You can connect a digital alternative path of the SWT 3000 as follows:

- Direct electrical connection to the remote SWT 3000 device
- Optical connection via a second FOM

The S6 pilot wire for the switchover in the Alternate Multi-Purpose (AMP) operation is transmitted from the FOM to PowerLink.

Fiber-optic module	Small Form-factor Pluggable (SFP) module
Fiber type	Multi-mode with modules using 850-nm wavelength, single-mode with modules using 1300-nm wavelength
Wavelength	850 nm or 1300 nm
Optical connector	LC-connector
Range	Up to 2 km at 850 nm (depending on the attenuation of the fiber) No minimum attenuation limit for 1300 nm
2 x LED	Tx-Alarm and Rx-Alarm (RX + F6UE-Alarm)

### 2.9.3 Connection to a Multiplexer supporting IEEE C37.94 Protocol

The functionality of C37.94 for SWT 3000 supports only the standalone device.

The SWT 3000 is operating via optical fiber with multiplexer or data converter that supports IEEE C37.94. For each transmission direction, a separate fiber is necessary.

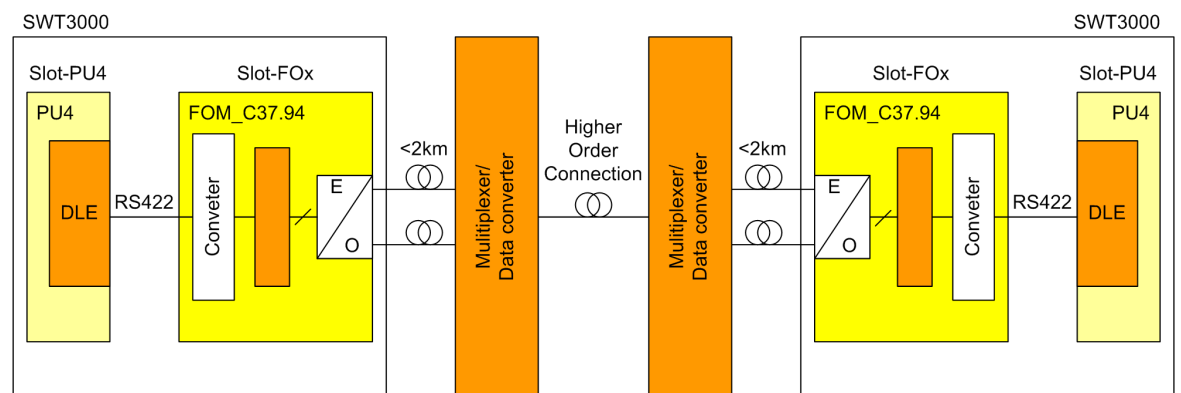

[dwsfpm0d-300414-01.tif, 1, en\_US]

Figure 2-13 SWT 3000 Configuration with C37.94

Table 2-18 Specification of the Fiber-Optic Module FOS-3

Fiber type	Multi-mode with modules using 850 nm-wavelength
Wavelength	850 nm
Optical connector	LC connector
Range	Approx. 2 km at 850 nm (depending on the fiber used)
2 x LED	TX and RX-Alarm
Clock	FOM_C37.94 is DTE (for test purpose, a switchover to DCE is possible)



#### NOTE

- Both SWT 3000 must have the same FOM C37.94 module and the same configuration (that means the same data rate).
- FOM C37.94 can be used as primary or secondary path and in any combination with other digital or analog interfaces on another path.



**CAUTION**

Exercise caution with laser beams of the optical plug-in modules.

**The laser beams can damage your eyes. If you do not comply with the safety notes, this will result in medium severe or slight injuries.**

- ✧ Do not look directly into the optical fiber terminals of the active optical plug-in modules, not even with optical devices.



**NOTE**

Laser class 1 is adhered to in compliance with EN 60825-1 and EN 60825-2, in the case of  $\leq 62.5 \mu\text{m}/125 \mu\text{m}$  optical fibers.

**2.9.4 Direct Connection via Fiber-Optic Cable**

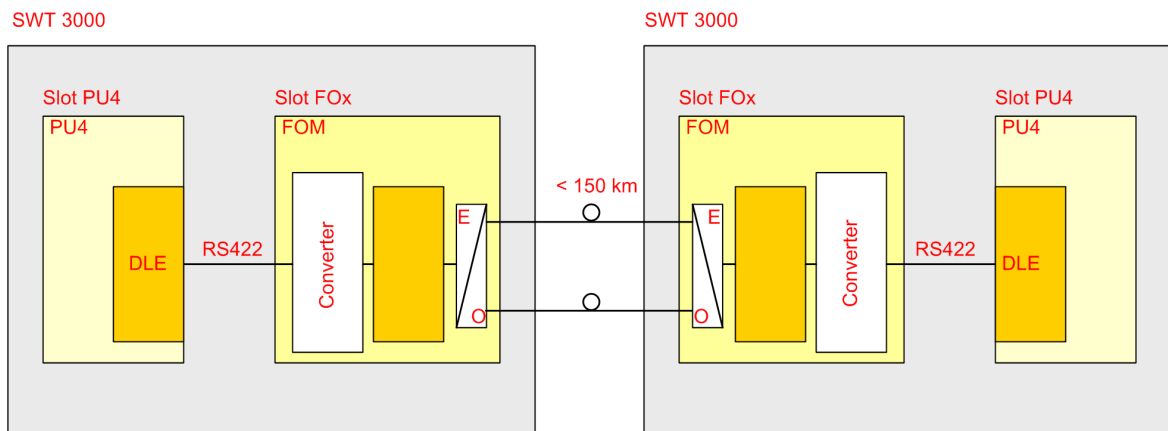

[dwccosw-290711-01.tif, 1, en\_US]

Figure 2-14 Connection of the SWT 3000 via fiber-optic cable to another SWT 3000

2 SWT 3000 are directly connected via fiber-optic cable. The transmission is carried out with 64 Kbps or 2 Mbps.

Table 2-19 Specification of the Fiber-Optic Modules

Fiber-optic module	SFP module
Fiber type	single-mode
Wavelength	1300 nm or 1500 nm
Optical connector	LC-connector
Range	Depending on SFP module, optical attenuation, and bit rate
2 x LED	Tx-Alarm and Rx-Alarm (RX + F6UE-Alarm)
Bit rate	64 Kbps or 2 Mbps
Clock	DTE or DCE adjustable



**NOTE**

For long-distance SFP configuration, for example direct FO connection with 64 Kbps or 2 Mbps, a loss of signal alarm (LOS) is not evaluated by FOM module. There is no LED indication in FOM module for fiber-optic connection error. The Rx alarm is only indicated via LID-1/2 LED on PU4 module.



## 2.10 Remote Monitoring, Service Channel, and IP Network

### 2.10.1 RM with Analog Interface

The Remote Monitoring (RM) function offers the option of accessing equipment data at the SWT 3000 via a USB connection with the service PC. With RM, it is possible to transmit equipment data between the terminals of one or more transmission routes. Transmission is possible in both directions.

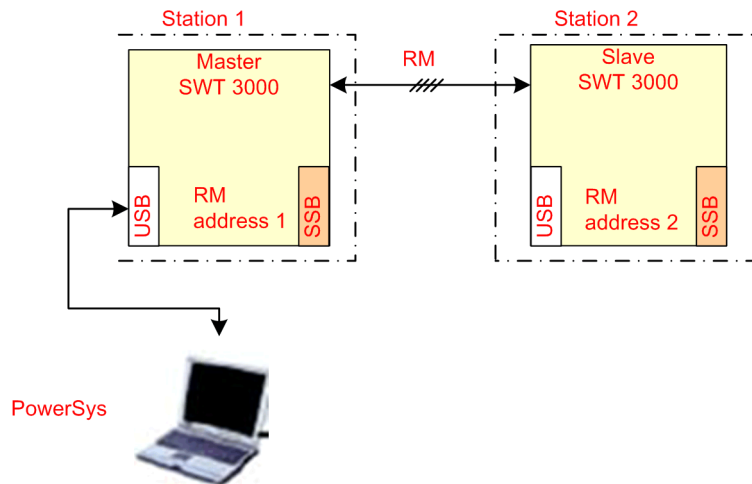

[dwrm4swt-040711-01.tif, 1, en\_US]

Figure 2-15 RM Communication between Connected SWT 3000 Units

- ↔ Protection signal transmission path
- USB Local interface
- SSB Remote monitoring interface
- RM Inband RM-Channel
- //// 4-wire link

The SWT 3000 unit in station 1 can read out the event memory of the SWT 3000 unit in station 2, if an RM is adjusted via PowerSys with a service PC.

For this purpose, the units are assigned an RM address and a master-slave connection must be configured.

RM communication over several transmission routes is also possible by connecting 2 units via the remote monitoring interface (SSB).

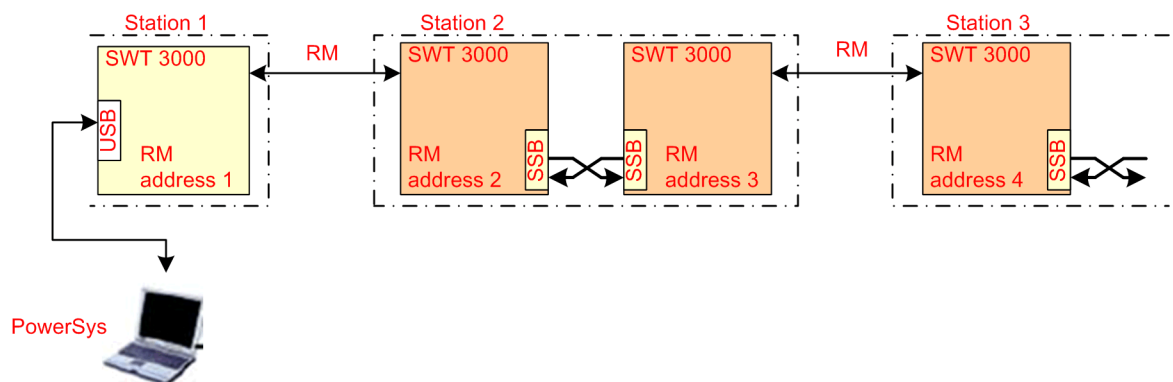

[dw\_SWT\_comswt, 1, en\_US]

Figure 2-16 Communication over 2 SWT 3000 Connection Routes

↔	Protection signal transmission path
USB	Local interface
SSB	Remote monitoring interface
RM	Inband RM-Channel

RM signaling can only be transmitted at 50 Bd via the analog interface. In this case, the guard tone frequency is used for transmitting the RM data.

Therefore you must observe the following points:

- RM only works when the guard tone is transmitted.
- Every command tone interrupts the RM transmission.
- RM operation is not possible with continuous signaling.
- Maximum number of addressable stations is 249

## 2.10.2 RM with Digital Interface

RM signals can be transmitted via digital line interfaces LID-1 and LID-2 at 50 Bd or 300 Bd.

RM signaling is at 300 Bd with all digital operations. In mixed analog/digital operation, transmission is at 50 Bd.

## 2.10.3 Service Channel

The Service Channel (SC) is a transparent data transmission channel with the format 9600 bps, 8 data bits, 1 start bit, 1 stop bit, and no parity. The data transmission channel is only available when using a digital line interface (LID-1 and LID-2). It is available to the user as an asynchronous serial RS232 interface. The SC is electrically connected via the PU4 line connector. Transmission is always carried out via the active digital line interface.



### NOTE

The service channel in digital line interfaces is not supported in release P3.5.180 or higher. It is possible to recover SC function by downgrade DLEFPGA to former release via Memtool. The firmware image is located at latest PowerSys Px.y.zzz > Firmware > Package\_zzz.cab > Pu4DleFpga\_v00\_01\_32.jnk.

## 2.10.4 IP Interface to SWT 3000

The SWT 3000 takes advantage of the latest technology to simplify operation and improve reliability. Using standard TCP/IP network protocols, administrators can easily access each SWT 3000 device from anywhere via the intranet. The system can interface with your own network security system and firewall providing you with the exact level of security your company requires.

With easy authorized access to the SWT 3000 from almost anywhere, users can now:

- Perform remote maintenance operations
- Read the event recorder from any location
- Monitor the network in real time with SNMP

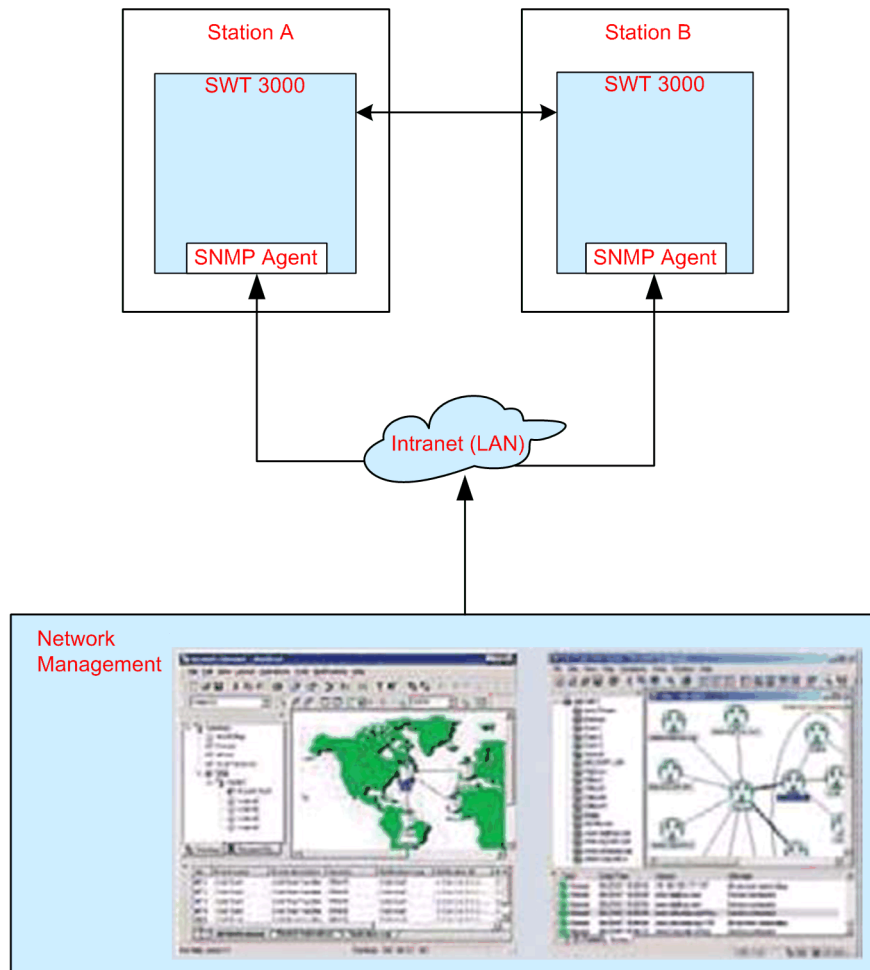

[dwswtoms-050711-01.tif, 1, en\_US]

Figure 2-17 SWT 3000 Integration in a Network Management System

The Windows-based PowerSys software is both intuitive and easy to learn, running on all standard computers. Power utilities increasingly rely on the real-time, comprehensive management capabilities of their networks to ensure optimum performance and data communication. Based on the SNMP standards, Siemens teleprotection devices can be smoothly integrated to replace proprietary solutions or unmanaged components.

A selection of device data is available for SNMP power-system management administration as follows:

- Inventory management (hardware data and configuration data)
- Performance management (event recorder)
- Configuration management (reset command)
- Alarm management (local alarms)

## 2.11 IEC 61850

### 2.11.1 Ethernet EN100 Module with IEC 61850 Protocol

The **Ethernet EN100 module** (EN100 module) enables the integration of SWT 3000 into 100-Mbit communication networks. These networks are used by process control, automation systems, and communications systems with the protocols according to International Electrotechnical Commission (IEC) 61850 standard. This standard permits uniform communication of the devices without gateways and protocol converters.

With 2 RJ45 connectors or with 2 Duplex-LC interfaces for a 1300-nm fiber-optic connection, 2 module types are available.

The following figures show the mechanical design of the EN100 module with electrical interfaces and fiber-optic interfaces for internal installation:

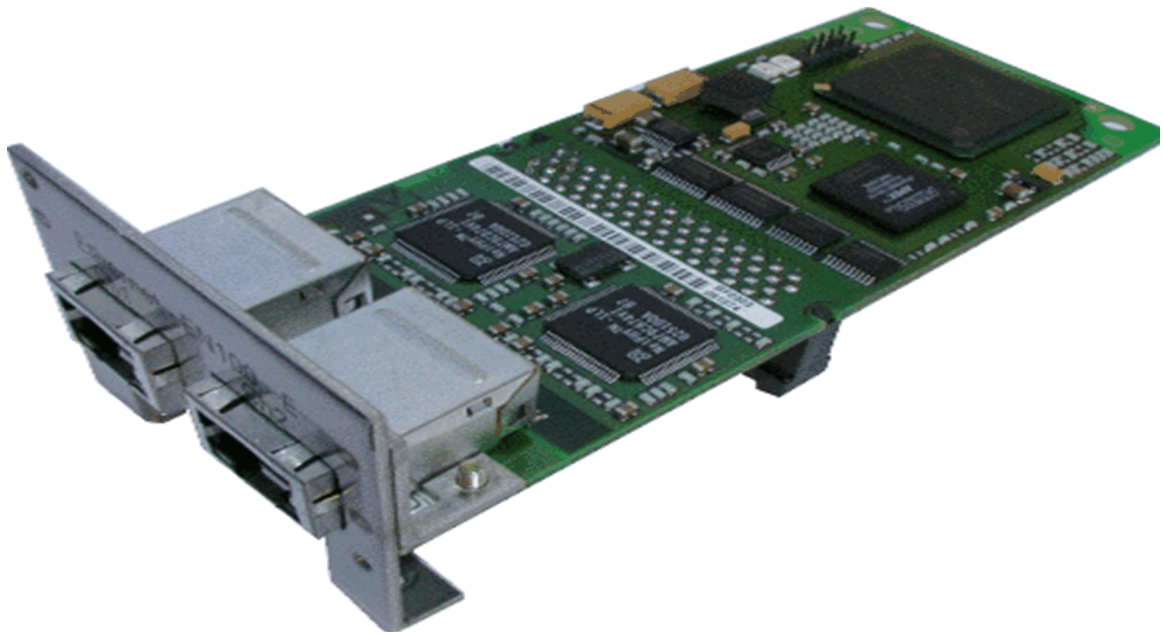

[scen100m-310111-01.tif, 1, en\_US]

Figure 2-18 EN100 Module with Ethernet Interfaces (RJ45) for internal Installation

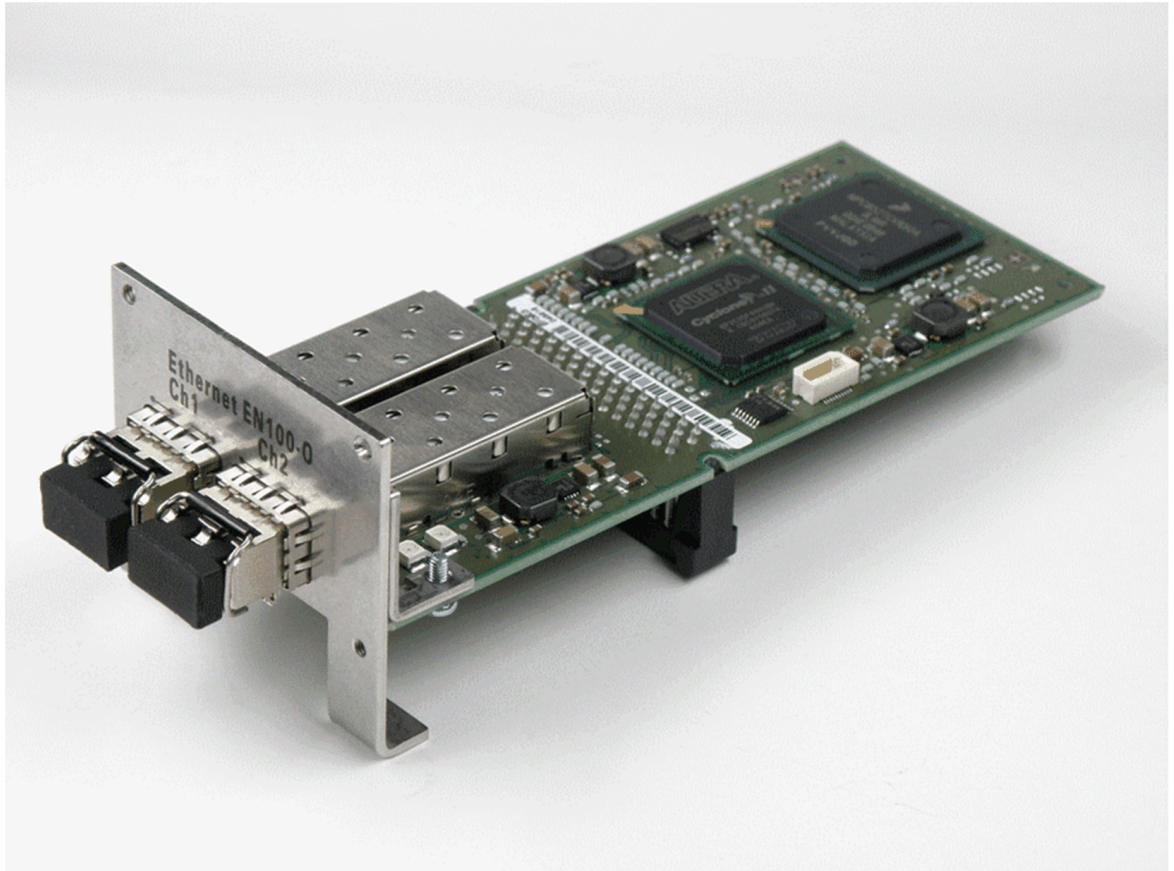

[scen1opt-210211-01.tif, 1, en\_US]

Figure 2-19 EN100 Module with Duplex-LC Interfaces for internal Installation

The preceding modules can be used in the SWT 3000 device and are mounted on the solder side of the PU4 module via connector. These modules are connected electrically to the PU4 module via a D-sub plug connection and screwed to the PU4 module and device front panel.

The physical interface is always duplicated to permit redundant structures. One of the 2 interfaces is always active while the other interface is monitored passively. If a fault occurs on the active interface, switchover to the other interface is performed in a matter of milliseconds.

Both Ethernet connectors of the module with RJ45 interfaces and also the fiber-optic module interfaces are accessible from the front of the device. The fiber-optic version of the module comprises the entire functionality of the module with the electrical interfaces.

## 2.11.2 IEC 61850 Introduction

### Overview

IEC 61850 is a standard to exchange information between protection devices in substations via Ethernet communication. It can be used as communication protocol between substations with the help of SWT 3000. In this case, SWT 3000 is used as IEC 61850 gateway to transmit GOOSE commands to remote stations via Power Line Carrier (PLC), copper line or SDH/PDH network.

Both IEC 61850 Editions 1 and 2 are supported in SWT 3000. A maximum of 16 GOOSE commands can be transmitted.

In the IEC 61850 parameterization workflow following 3 roles are defined:

- **SIPROTEC Expert<sup>1</sup>**: Responsible for the parameterization of the SIPROTEC<sup>2</sup> device using DIGSI<sup>3</sup> 4 or 5.
- **IEC 61850 Substation Planner**: Responsible for the configuration of the IEC 61850 Station. The tasks assigned are: **add IEC 61850 device, network setting, GOOSE mapping** etc.
- **SWT 3000 Expert**: Responsible for the parameterization of the SWT 3000 device using PowerSys and the MergeTool. The tasks assigned are: **Generate EN100 BIN / CFG file, import EN100 BIN / CFG file and configure SWT 3000**.

The **EN100 BIN file** is the binary format parameter file for EN100 modules. It contains all necessary information that is parameterized in the IEC 61850 system configurator.

The **EN100 CFG file** is the plaintext format file for PU4 modules. It contains the EN100 IP address and assigned Tx/Rx commands etc.

With the help of PowerSys, the **EN100 BIN file** and **EN100 CFG file** can be transferred to the SWT 3000 device.

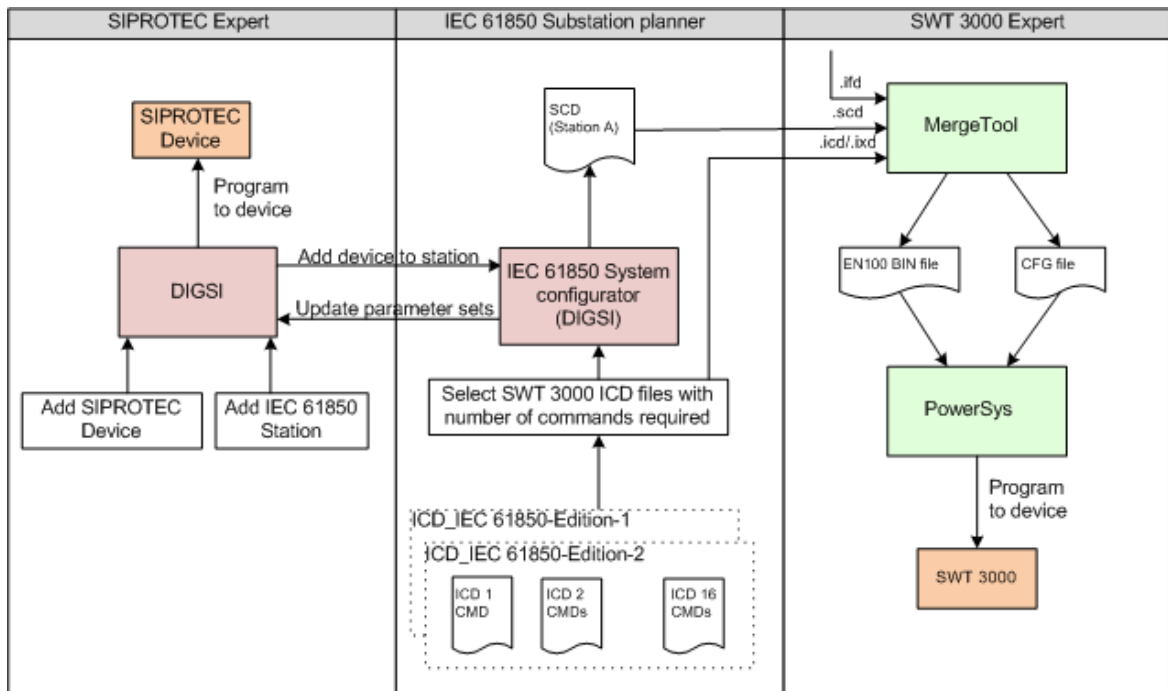

[Dw\_SWT\_Workflow, 1, ...]

## IEC 61850 Edition 2

SWT 3000 ICD/IXD/IFD files are stored at MergeTool installation path: **PowerSys Installation > \Util\Merge-Tool**

- **ICD\_IEC61850-Edition-1\*.icd.**  
 SWT 3000 ICD files for IEC 61850 Edition 1 with number of commands 1 to 8, and 16.  
 Depending on the required number of GOOSE commands, use the correct ICD file in the IEC 61850 system configurator. Later, use the same ICD file in MergeTool to generate EN100 BIN and CFG files.

1 SIPROTEC and DIGSI are used as examples to show how to connect to SWT 3000 via IEC 61850 . According to the IEC 61850 standard, any other protection device can also be used to connect to SWT 3000.  
 2 SIPROTEC is a protection and monitoring device developed and marketed by SIEMENS.  
 3 DISGI is an engineering and substation planning tool developed and marketed by SIEMENS.

- ICD\_IEC61850-Edition-1\\*.ixd.  
SWT 3000 IXD files for IEC 61850 Edition 1 with number of commands 1 to 8, and 16. It extends Siemens proprietary elements based on the ICD file and is used only by MergeTool for both EN100 BIN and CFG file generations. When selecting an ICD file in MergeTool, the related IXD file with the same number of commands is selected implicitly.
- ICD\_IEC61850-Edition-2\\*.icd.  
SWT 3000 ICD files for IEC 61850 Edition 2 with number of commands 1 to 8, and 16.
- ICD\_IEC61850-Edition-2\\*.ixd.  
SWT 3000 IXD files for IEC 61850 Edition 2 with number of commands 1 to 8, and 16. It extends Siemens proprietary elements based on the ICD file and is used only by MergeTool for both EN100 BIN and CFG file generations. When selecting an ICD file in MergeTool, the related IXD file with the same number of commands will be selected implicitly.
- \*.ifd file  
EN100 interface setting file to configure HTTP/SNMP service and redundancy settings

To support more than 8 GOOSE commands, the ICD file swt3000\_c16\_ed1/2.icd shall be used. If the allocated GOOSE commands are less than 16, the remaining commands still can be allocated to IFC-D/P board. This is the so called "Mixed mode".

For IEC 61850 station with Edition 2, use the ICD files from folder **ICD\_IEC61850-Edition 2** in both DIGSI and MergeTool. If EN100 module of SWT 3000 is parametrized correctly for IEC 61850 Edition 2, you find an entry in EN100 startup log via the EN100 Web homepage, for example <https://192.168.20.101/startuplog>.

**NOTE**

+++ 00011 00179049 Su 2.01.1994 00:00:59:048 Starting in **Edition 2** modus

**Report and GOOSE**

The LN ITPC (Teleprotection Communication Interfaces) comprises all information for communication channel supervision. This information can be grouped in a dataset. A report is sent out if the status value or quality attribute is changed.

GOOSE message is a peer-to-peer communication to transmit or receive protection commands between a protection device and SWT 3000. In the SWT 3000 system, alarms (General, Rx and Non-urgent alarms) are distributed via 3 relay contacts of ALR module. If IEC 61850 communication networks are used, these alarms can also be distributed using GOOSE messages.

An example for a IEC 61850 system configuration is shown in [Figure 2-20](#).

It is parameterized as shown below:

- Report mapping of assignment of LN ITPC data attribute to data set.
- GOOSE Mapping of protection commands between protection and SWT 3000  
To optimize the GOOSE command transmission time, it is recommended to group max. 8 command data objects in one dataset and group other commands under a second dataset.
- GOOSE Mapping of device failure alarm (ITPC.AlarmGen) from SWT 3000 to protection
- Monitoring quality attribute of alarm GOOSE message in protection to indicate a IEC 61850 communication link failure (e.g. using CFC block SI\_GET\_STATUS of DIGSI)

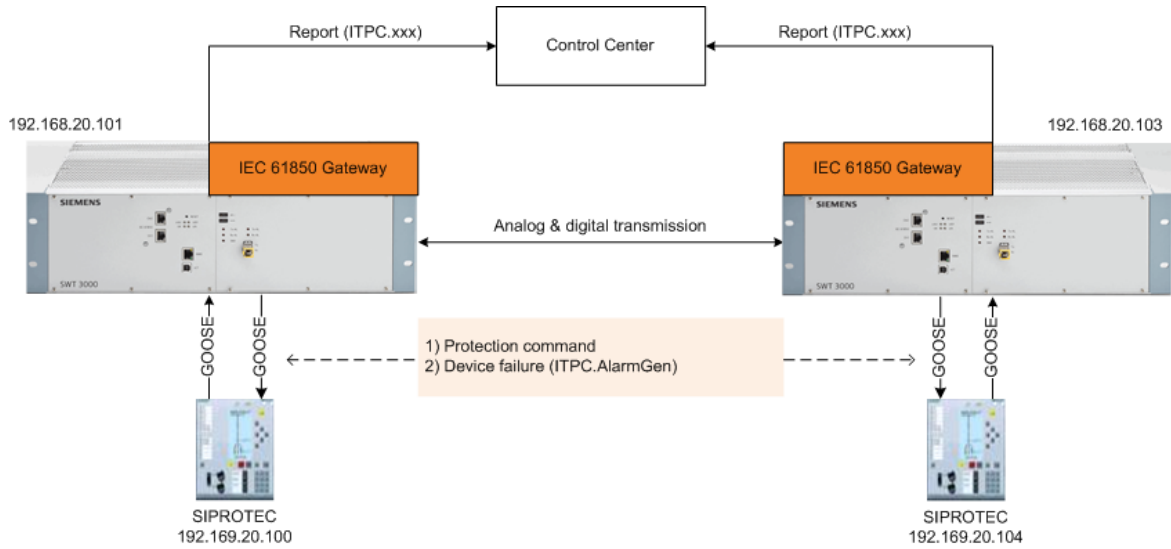

[DwReportGoo, 1, en\_US]

Figure 2-20 Example for a Report and GOOSE Communication

**Redundancy**

The EN100 communication module supports several operating modes Line, RSTP, PRP, HSR and OSM. This allows integrating a SWT 3000 device into nearly all network structures. Redundancy is important for the reliability of an entire communications system. If the link of the active channel is interrupted, switchover to the other interface is automatic. If all channels are interrupted, SWT 3000 device will report a non-urgent alarm (EN100\_QUAL: EN100 communication quality is not OK).

A change of the redundancy type needs a power off and power on device for activation.

Channel Switchover in Line Mode

- EN100 channel 1 is activated by default if both channels are connected.
- Disconnecting Ethernet cable on channel 1 will switchover to channel 2 automatically. The switchover time is about 10 ms.
- Connecting back Ethernet cable on channel 1, no switchover back. Channel 2 is always activated until reset device.
- Switchover is controlled by EN100. The channel status is displayed on PowerSys > Information > EN100 info.

For example, Line 8: Chan 1/2=UpRes/UpAct

UpRes: Link is up on standup mode

UpAct: Link is up and activated as primary

MergeTool provides following setting file which enables different redundancy settings.

Setting file	Operating mode	Redun- dancy type	SNMP service	HTTP service
swt3000_en100_settings_LINE_SnmpOFF_HttpOFF.ifd	Line	---	OFF	OFF
swt3000_en100_settings_LINE_SnmpON_HttpON.ifd	Line	---	ON	ON
swt3000_en100_settings_RSTP_SnmpON_HttpON.ifd	Switch	RSTP	ON	ON
swt3000_en100_settings_PRP_SnmpON_HttpON.ifd	Switch	PRP	ON	ON
swt3000_en100_settings_HSR_SnmpON_HttpON.ifd	Switch	HSR	ON	ON



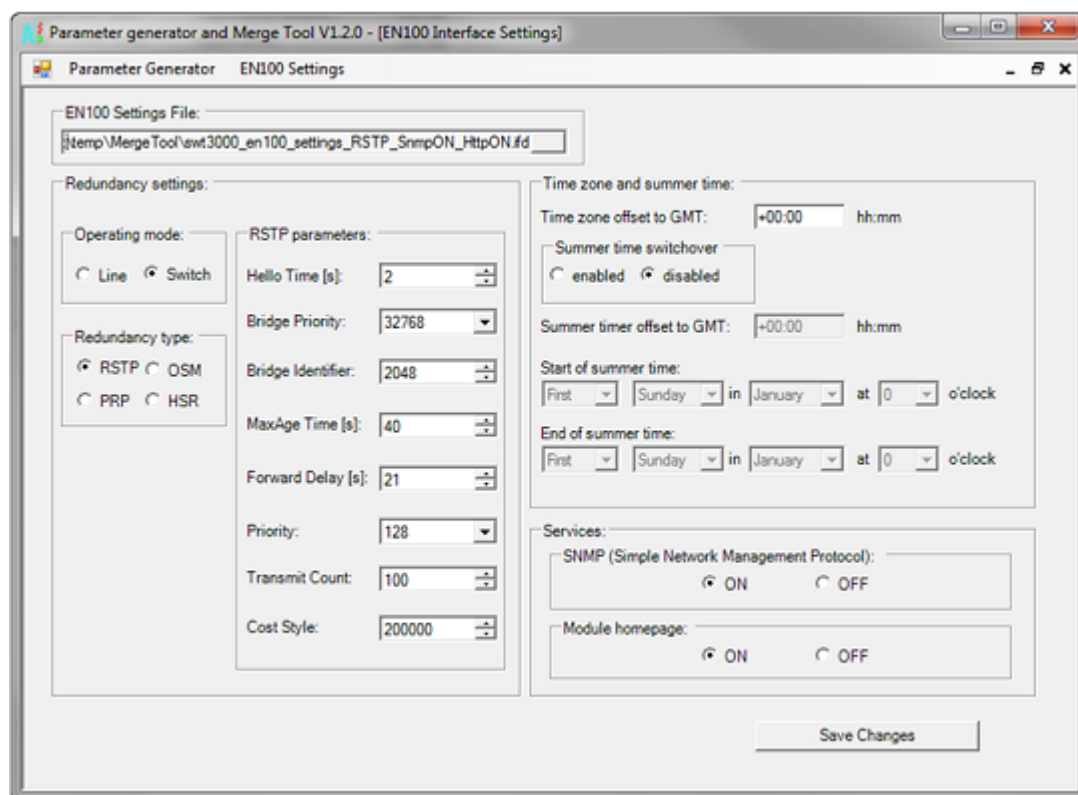

[sc\_EN100\_Interface\_Settings, 1, ---]

Figure 2-21 MergeTool > EN100 Interface Settings

### 2.11.3 Logical Nodes

According to the IEC 61850 model logical nodes are the building blocks of an Intelligent Electronic device (IED). A Logical Node (LN) represents the function within a physical device; it performs some operations for that function and is object defined by its data and methods. The users view of the logical nodes is the ICD file of the SWT 3000. A fixed set of ICD files is provided for SWT 3000.

Since the SWT 3000 related settings (communication interfaces, CMD timers) are configured via the service program PowerSys and thus 'outside' the IEC 61850 world only a minimal set of Logical Node (LN) according to the IEC 61850 model is used for the teleprotection signaling with EN100 GOOSE communication and for supervision. Refer to the following tables for the major data objects of Logical Nodes used in SWT 3000.

LLN: TXC\_GGIO - Transmit command

Table 2-20 LLN: TXC\_GGIO - Transmit command

GGIO class				
Data object name	Common data class	Explanation	T	M/O
LNNName		Name composed of the class name, the LN-Prefix and LN-Instance- ID according to IEC 61850-7-2		
<b>Data objects</b>				
Common Logical Node Information				
Measured values				
Status Information				
Controls				
SPCSO1	SPC	Single point controllable status output. Command input 1, which acts as an input for the local SWT processing. Attribute ctIVal is assigned to the SWT command input. The input status is not transferred transparent to the remote side! It depends on the actual SWT-Mode, how a change of ctIVal influences the command outputs on the remote SWT.		O
SPCSO2	SPC	Command input 2		O
SPCSO3	SPC	Command input 3		O
SPCSO4	SPC	Command input 4		O
SPCSO5	SPC	Command input 5		O
SPCSO6	SPC	Command input 6		O
SPCSO7	SPC	Command input 7		O
SPCSO8	SPC	Command input 8		O
SPCSO9	SPC	Command input 9		O
SPCSO10	SPC	Command input 10		O
SPCSO11	SPC	Command input 11		O
SPCSO12	SPC	Command input 12		O
SPCSO13	SPC	Command input 13		O
SPCSO14	SPC	Command input 14		O
SPCSO15	SPC	Command input 15		O
SPCSO16	SPC	Command input 16		O

LN: RXC\_GGIO - Receive command

Table 2-21 LN: RXC\_GGIO - Receive command

GGIO class				
Data object name	Common data class	Explanation	T	M/O
LNNName		Name composed of the class name, the LN-Prefix and LN-Instance- ID according to IEC 61850-7-2		
<b>Data objects</b>				
Common Logical Node Information				
Measured values				
Status Information				
Controls				
SPCSO1	SPC	Single point controllable status output. Command input 1, which acts as an input for the local SWT processing. Attribute ctlVal is assigned to the SWT command input. The input status is not transferred transparent to the remote side! It depends on the actual SWT-Mode, how a change of ctlVal influences the command outputs on the remote SWT.		O
SPCSO2	SPC	Command output 2		O
SPCSO3	SPC	Command output 3		O
SPCSO4	SPC	Command output 4		O
SPCSO5	SPC	Command output 5		O
SPCSO6	SPC	Command output 6		O
SPCSO7	SPC	Command output 7		O
SPCSO8	SPC	Command output 8		O
SPCSO9	SPC	Command output 9		O
SPCSO10	SPC	Command output 10		O
SPCSO11	SPC	Command output 11		O
SPCSO12	SPC	Command output 12		O
SPCSO13	SPC	Command output 13		O
SPCSO14	SPC	Command output 14		O
SPCSO15	SPC	Command output 15		O
SPCSO16	SPC	Command output 16		O

Table 2-22 LN: ITPC - Communication Interface

ITPC class				
Data object Name	Common data class	Explanation	T	M/O
LNNName		Name composed of the class name, the LN-Prefix and LN-Instance- ID according to IEC 61850-7-2		
<b>Data objects</b>				
EEHealth	ENS	External equipment health. It reflects the alarm status of the SWT device. Possible values: 1: Ok (Green) no alarms active 2: Warning (Yellow) only none urgent alarms active 3: Alarm (Red) at least one urgent alarm is active		O

ITPC class				
Status information				
AlarmGen	SPS	SWT 3000 general alarm TRUE: (Alarm is active)		0
AlarmNU	SPS	SWT 3000 non-urgent alarm TRUE: (Alarm is active)		0
AlarmRx	SPS	SWT 3000 receive alarm TRUE: (Alarm is active)		0
LosSig	SPS	Alarm situation: No signal received, indicates a channel problem of analog communication. Possible values: TRUE: RXALR of PU4 LIA is active. FALSE: RXALR of PU4 LIA is inactive.		0
LosSyn1	SPS	Alarm situation: Loss of synchronism of LID-1 Indicates that there is no synchronization between the transmitter and the receiver, i.e., no communication is possible. Used in case of a digital communication channel. Possible values: TRUE: LID-1 Sync-Loss alarm is active. FALSE: LID-1 Sync-Loss alarm is inactive.		0
LosSyn2	SPS	Alarm situation: Loss of synchronism of LID-2		0
TxCmdCnt1	INS	For diagnostics: Transmitted command 1 counters.		0
TxCmdCnt2	INS	For diagnostics: Transmitted command 2 counters.		0
TxCmdCnt3	INS	For diagnostics: Transmitted command 3 counters.		0
TxCmdCnt4	INS	For diagnostics: Transmitted command 4 counters.		0
TxCmdCnt5	INS	For diagnostics: Transmitted command 5 counters.		0
TxCmdCnt6	INS	For diagnostics: Transmitted command 6 counters.		0
TxCmdCnt7	INS	For diagnostics: Transmitted command 7 counters.		0
TxCmdCnt8	INS	For diagnostics: Transmitted command 8 counters.		0
TxCmdCnt9	INS	For diagnostics: Transmitted command 9 counters.		0
TxCmdCnt10	INS	For diagnostics: Transmitted command 10 counters.		0
TxCmdCnt11	INS	For diagnostics: Transmitted command 11 counters.		0
TxCmdCnt12	INS	For diagnostics: Transmitted command 12 counters.		0
TxCmdCnt13	INS	For diagnostics: Transmitted command 13 counters.		0
TxCmdCnt14	INS	For diagnostics: Transmitted command 14 counters.		0
TxCmdCnt15	INS	For diagnostics: Transmitted command 15 counters.		0
TxCmdCnt16	INS	For diagnostics: Transmitted command 16 counters.		0
RxCmdCnt1	INS	For diagnostics: Received command 1 counters.		0
RxCmdCnt2	INS	For diagnostics: Received command 2 counters.		0
RxCmdCnt3	INS	For diagnostics: Received command 3 counters.		0
RxCmdCnt4	INS	For diagnostics: Received command 4 counters.		0
RxCmdCnt5	INS	For diagnostics: Received command 5 counters.		0
RxCmdCnt6	INS	For diagnostics: Received command 6 counters.		0
RxCmdCnt7	INS	For diagnostics: Received command 7 counters.		0
RxCmdCnt8	INS	For diagnostics: Received command 8 counters.		0
RxCmdCnt9	INS	For diagnostics: Received command 9 counters.		0
RxCmdCnt10	INS	For diagnostics: Received command 10 counters.		0
RxCmdCnt11	INS	For diagnostics: Received command 11 counters.		0
RxCmdCnt12	INS	For diagnostics: Received command 12 counters.		0
RxCmdCnt13	INS	For diagnostics: Received command 13 counters.		0
RxCmdCnt14	INS	For diagnostics: Received command 14 counters.		0
RxCmdCnt15	INS	For diagnostics: Received command 15 counters.		0

ITPC class				
RxCmdCnt16	INS	For diagnostics: Received command 16 counters.		O
NumTxCmd	INS	Numbers of used binary transmit commands. Possible values: 0...16		O
NumRxCmd	INS	Numbers of used binary receive commands. Possible values: 0...16		O
TpcTxMod	ENS	Teleprotection application mode in Transmit direction for each command. Possible values: 0: Direct tripping 1: Permissive tripping		O
TpcRxMod	ENS	Teleprotection application mode in Receive direction for each command. Possible values: 0: Direct tripping 1: Permissive tripping		O
Measured values				
FerCh1	MV	Frame Error Rate of the communication channel LID-1. Used in case of a digital communication channel. This attribute is mapped to BER of DLE.		O
FerCh2	MV	Frame Error Rate of the communication channel LID-2.		O
CarLev	MV	Power of received signal (in dB), used in case of an analogue communication channel.		O
SigNsRat	MV	Signal to noise ratio (in dB), used in case of analogue communication channel.		O

## 2.12 Teleprotection Over Packet TPoP

### 2.12.1 Introduction

The legacy infrastructures based on SDH/PDH are being migrated to packet-based networks (for example, MPLS-TP). One method is to convert and tunnel Time Division Multiplexing (TDM) traffic (such as E1/T1) over MPLS labeled frames. The transmitted data are formed into packets when entering a network and regenerated to original TDM traffic when leaving the network. This method adds fixed packetization delay of 1 ms to 5 ms. If the packet size is too small, the packet header overhead is increased and the network bandwidth is reduced. The other method is mapping the payload to Ethernet packet directly, therefore, this method reduces the packetization delay and required network bandwidth. This method is realized in TPoP (TeleProtection over Packet) protocol of the SWT 3000 device.

The following figure shows all supported transmission paths in standalone SWT 3000. In addition to existing analog and digital transmission lines, a new Ethernet transmission line is available.

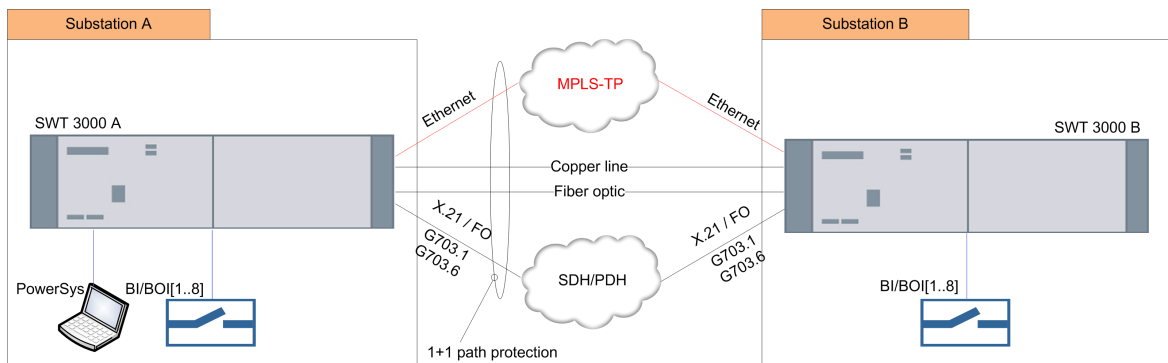

[DwNewEth\_27032014-1, 1, --]

Figure 2-22 New Ethernet Line Interface

Multi-protocol Label Switching Transport Profile (MPLS-TP) is a mechanism in high-performance telecommunication networks that forwards data from one network node to next based on short path labels rather than long network addresses, avoiding lookups in a routing table. A label is assigned based on the destination IP address or a QoS parameter (for example ToS/DSCP in IP Header or CoS (Class of Service) in IEEE 802.1Q tagged Ethernet frame).

MPLS-TP enables a network service provider to guarantee network latency and service quality. So the protection command packets are forwarded as fast as possible. An SWT 3000 device for example, can connect to MPLS-TP enabled network as shown in the following figure, and SWT 3000 can communicate only to one remote end SWT 3000 at the same time with the predefined peer IP address.



#### NOTE

The TPoP is available only in SWT 3000 standalone.

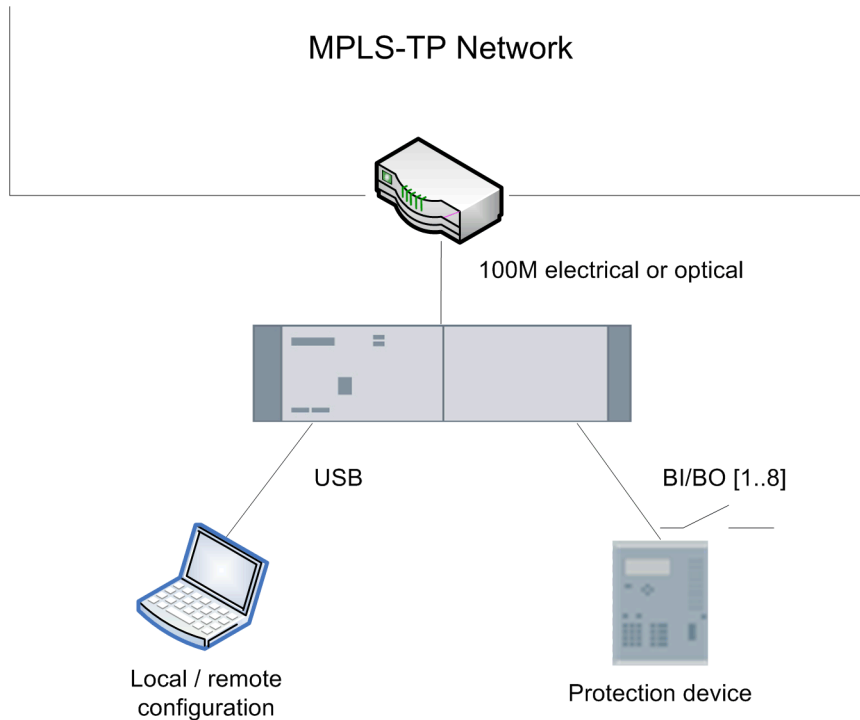

[DwMPLS-27032014-1, 1, ...]

Figure 2-23 MPLS-TP Network Diagram

The SWT 3000 TPoP Ethernet line interface is based on Ethernet module EN100, which has 2 ports for an electrical or an optical 10/100-Mbits interface. For optical interface, the pluggable SFP module can be changed to electrical interface. The EN100 communication module supports Line and PRP redundancy types. The 2 Ethernet ports can communicate via 2 Ethernet cables, but not simultaneously. The second interface is supported as alternative path.

The change of the redundancy type needs a power off and power on device for activation.

All the data of existing analog and digital lines can be transmitted in Ethernet lines including up to 16 protection commands.

The Ethernet line interface cannot be used for NMS access via SNMP or for connection of the Element manager (service program PowerSys). EN100 for TPoP is delivered with different MLFB numbers as EN100 for IEC 61850. A different firmware image is preloaded in it. SWT 3000 detects if the right EN100 type is used. If type is mismatched, the hardware alarm occurs.

## 2.12.2 Cyber Security

There are several threats to network protocols which are important for TPoP service:

- **Modification of information**  
The modification threat is that some unauthorized entity can change the transmitted command or RM message. It can generate a lost or unwanted command, or change the device configuration.
- **Masquerade**  
The masquerade threat is that the message is not from an authorized peer SWT 3000 device.
- **Modification of message stream**  
The TPoP protocol is based on connectionless service (UDP). So the modification of message stream threat is that messages may be maliciously re-ordered, delayed or replayed.

Based on these possible threats in networks, several methods are designed to protect command and RM messages against such threats:

- Authentication protocol: HMAC-SHA256 authentication protocol is supported.  
**Keyed-Hash Message Authentication Code (HMAC)** is a mechanism for calculating Message Authentication Code (MAC) using crypto hash function with a secret crypto key. It is used to verify both data integrity and authentication of a message. The used underlying hash function is SHA-256, which is more secure than its predecessor SHA-1. The 2 communication parties share the same secure key in order to authenticate the message. The key is produced from a password and a salt according to the Password-based Encryption standard (PKCS #5) defined in RFC 2898. For every outgoing command and RM messages, the HMAC is calculated and filled in the packet payload. The receiving SWT 3000 authenticates the message integrity and drops it if the authentication has failed
- Anti-replay attack using a sequence number  
The sequence number is increased by one every time when sending a message. If the receiving message has a lower sequence number, it is dropped.
- Closing unused TCP/IP service port  
The opened port number is TPop(10101) and HTTP(80). It is recommended to close HTTP(80) after EN100 TPop FW upgrade is finished. It can be disabled in PowerSys under **SWT 3000 > Configuration > Ethernet line interface > Configuration** .



**NOTE**

If HMAC-SHA256 is enabled, the command transmission time is prolonged for about 1.5 ms.



**NOTE**

HMAC-SHA256 is used in TPop transmissions only and not in the alternative path with analog or TDM transmissions.

### 2.12.3 Protection Command Transmission

Ethernet line transmission is supported for all protection modes of stand-alone SWT 3000 devices. Up to 16 binary command input and output from IFC interface are connected to SWT 3000. If there is no tripping command activated, the guard command packet is always transmitted with predefined interval period. If the trip command is activated, it sends out multiple trip command packets at short intervals to ensure no command lost under bad Ethernet condition with high packet loss rate.

Cycle command transmission is shown in following figure.

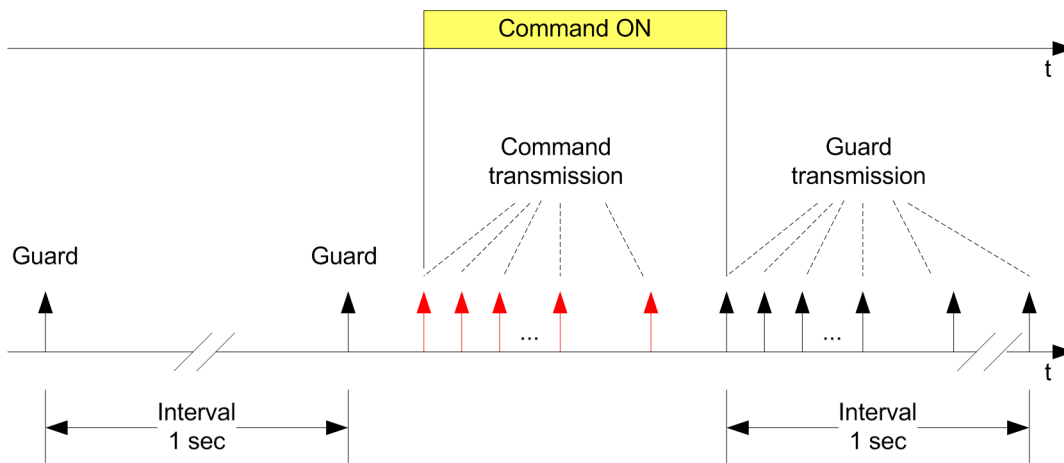

[ldw\_SWT\_ComTrans, 1, --]

Figure 2-24 Cycle Command Transmission



In order to improve the cyber security of SWT 3000 against the injection of spoofed command packet into Ethernet line, a message authentication mechanism (HMAC-SHA256) using secure crypto hash function is implemented. Only the messages from authenticated far end SWT 3000 are accepted.  
The SWT 3000 Ethernet line interface is compliant to IEC 60834 standards for digital transmission.



**NOTE**

The Ethernet line interface will prolong the digital transmission time for about 2 ms.

### 2.12.4 RM Transmission

Remote monitoring (RM) provides the possibility for the user to configure far end SWT 3000 in the communication link via PowerSys. RM transmission via Ethernet line interface is much faster than the existing analog (50 bps) and digital (50 bps to 300 bps) line interface, which depends on the bandwidth of the Ethernet channel. For every outgoing RM message, the keyed-hash message authentication is appended similar to the command packet. The receiving SWT 3000 authenticates the RM message integrity and drops it if the message is corrupted.

Figure 2-25 shows the example RM connection for 4 SWT 3000.

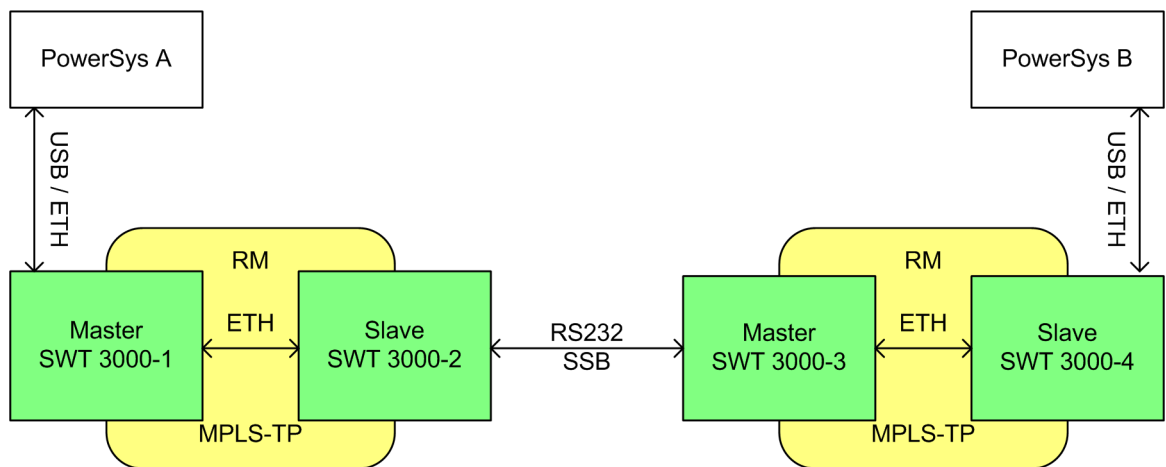

[DwRMTrans-28032014-1, 1, ...]

Figure 2-25 RM Transmission

For further information about Remote monitoring, refer to the Equipment Manual SWT 3000.



**NOTE**

The Service Channel (SC) is not available on the Ethernet line interface.

### 2.12.5 Line Clock Synchronization

The line clock synchronization between 2 SWT 3000 devices is possible over Ethernet transmission line as well. The Master SWT 3000 sends a line synchronization command to the slave SWT 3000 at a configured time every 24 hours.

For further information about Line Clock Synchronization, refer to [Line-Clock Synchronization, Page 157](#).

## 2.12.6 Line Quality Supervision

SWT 3000 provides the ability to measure and monitor the performance metrics for Ethernet transmission line, for example, packet loss, packet transmission time, and throughput. If the transmission line condition is too bad (for example, because the packet loss rate is too high), the related alarm occurs.

More data fields are added in the command packet to measure the packet loss rate and round-trip time at predefined time interval (for example, 1 sec).

Idle packets are transmitted at a very short interval to monitor whether the Ethernet line connection is still alive. If no idle packet is received after the predefined time has elapsed, SWT 3000 will trigger the connection loss alarm and switch over to the secondary transmission path (for example, analog or digital) if available.

[Table 2-23](#) lists all possible line quality alarms.

Table 2-23 Line Quality Alarm

Alarms	Reason
Packet loss rate alarm	Alarm occurs if measured packet loss rate is higher than the predefined threshold.
Command delay alarm	Alarm occurs if measured command transmission time is higher than the predefined threshold.
Connection loss alarm	Alarm occurs if no command or idle packet is received within the predefined time interval.

Ethernet line quality data are stored in a non-volatile RAM, it means that no data are lost even if SWT 3000 is powered off. Maximum 10,000 quality data entries can be stored. The record time interval is configurable in PowerSys.

The quality data is shown in PowerSys under **SWT 3000 > EN100 > TPoP quality data** in the following figure.



[sc: TPoP\_quality\_data, 1, ->]

Figure 2-26 Ethernet Line Quality Data

Table 2-24 Description of Ethernet Line Quality Data

Parameter	Comments
Min del	Minimum command transmission time (ms) in the time interval.
Max del	Maximum command transmission time (ms) in the time interval.
Ave del	Average command transmission time (ms) in the time interval.
Min los	Minimum packet loss rate (%) in the time interval.
Max los	Maximum packet loss rate (%) in the time interval.
Ave los	Average packet loss rate (%) in the time interval.
Min kbytes/s	Minimum received kbytes per second in the time interval.
Max kbytes/s	Maximum received kbytes per second in the time interval.
Ave kbytes/s	Average received kbytes per second in the time interval.
Del ala	Command transmission time alarm count in the time interval.
PLR ala	Packet loss rate alarm count in the time interval.
Conn ala	Connection loss alarm count in the time interval.

Ethernet statistics data can be shown in PowerSys under **SWT 3000 > EN100 > TPoP statistic data** in the following figure.

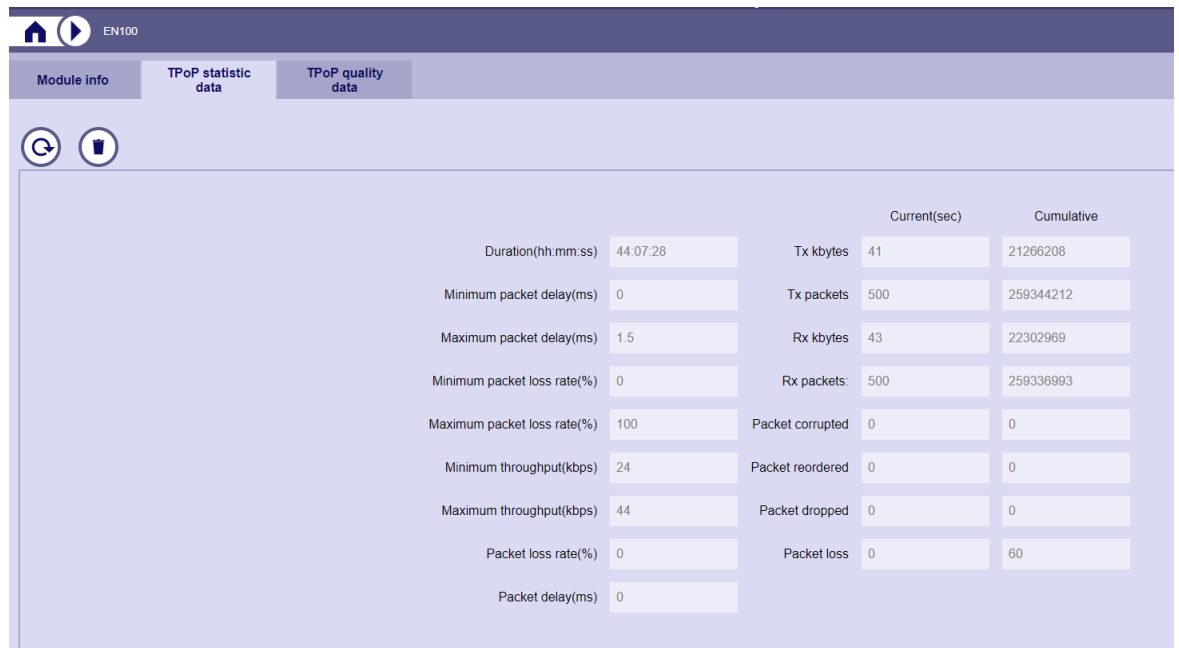

[sc\_TPoP\_statistic\_data, 1, ...]

Figure 2-27 Ethernet Line Statistic Data

Table 2-25 Description of TPoP statistic data

Parameter	Comments
Duration	Elapsed time since last clear
Packet delay statistics	Minimum / maximum command transmission time since last clear.
Packet loss rate statistics	Minimum / maximum packet loss rate since last clear.
Throughput statistics	Minimum / maximum receiving kbps since last clear.
Tx kbytes/s	Transmission kbytes per second and cumulative transmission kbytes.
Tx packets	Transmission packet number per second and cumulative transmission packet number.
Rx kbytes/s	Receiving kbytes per second and cumulative receiving kbytes.
Rx packets	Receiving packet number per second and cumulative receiving packet number.
Packet corrupted	Corrupted packet number per second and cumulative value.
Packet reordered	Reordered packet number per second and cumulative value.
Packet dropped	Dropped packet number per second and cumulative value.
Packet loss	Lost packet number per second and cumulative value.
Packet loss rate	Packet loss rate per second.
Packet delay	Command transmission time in ms.
Read	Read Ethernet statistic data
Clear	Clear all Ethernet statistic data

## 2.12.7 QoS (Quality of Service)

Quality of Service (**QoS**) defines several features for different services to enable fast and preferred transmission of high-priority traffic rather than low-priority traffic. For SWT 3000, protection command is a time critical message that must be transmitted with highest priority to ensure the minimum transmission time.

There are 2 different types of Quality of Service:

- The QoS used for teleprotection signaling
- The QoS used for remote monitoring and web-based configuration.

DSCP, ToS and VLAN-Priorities can be assigned to the 2 classes of QoS.

The Differentiated Services Code Point (**DSCP**) or Type of Service (**ToS**) in the IP header field is used for IP layer 3 classification purposes. The network node can select the appropriate path to forward IP packets according to the value of DSCP or ToS.

IEEE 802.1Q is the networking standard supporting Virtual LAN and CoS Priorities in Ethernet networks. The standard defines a system of VLAN and Priority tagging of Ethernet frames. The bridges and switches handle such frames according to the priority value in VLAN tag and the quality of service prioritization schema.

All ingress IP packets are assigned with the predefined DSCP/ToS and IEEE 802.1Q settings, if the QoS option is enabled. The network switch evaluates the priority field of incoming telegrams and depends on the priority recognized, and furthermore pushes the data into a high-priority processing path or into a normal priority path.

HTTPS uses the same VLAN of RM service. If VLAN is enabled, the EN100 module homepage can be accessed via Ethernet switch. The user PC is connected to the switch and the port connected to SWT 3000 is enabled with IEEE 802.1Q VLAN tag support (trunk port). So the ingress HTTPS untagged frame from the switch (access port) is tagged by switching to the same VLAN ID of RM.

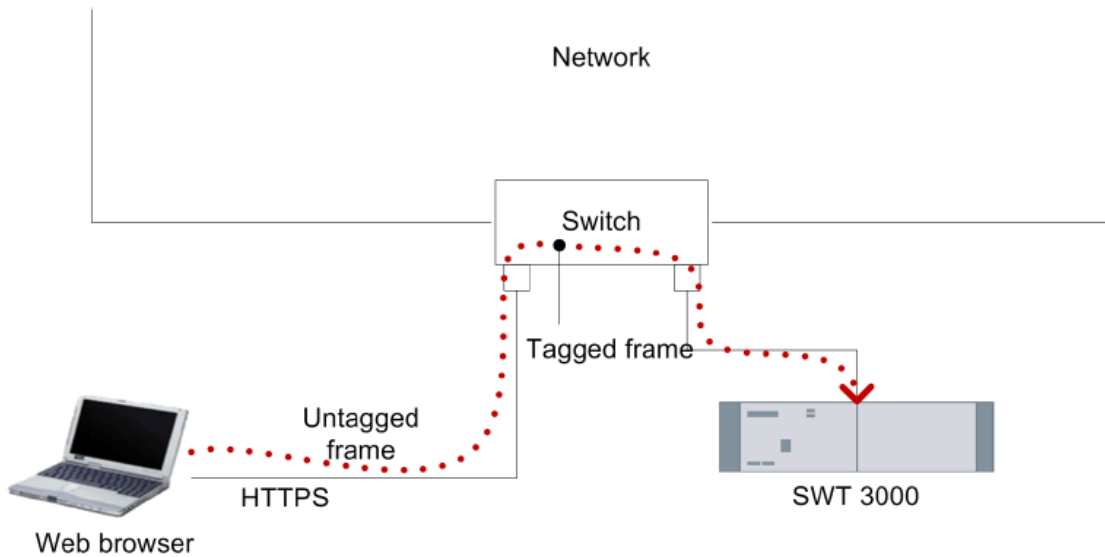

[sc\_tagged\_https\_frame\_switch, 1, -->]

Figure 2-28 Tagged HTTPS Frame by Switch

## 2.13 Cyber Security

### 2.13.1 Overview

Cyber security is designed to protect SWT 3000 devices against common IT security threats and to minimize the impact of these threats on system operations. If SWT 3000 devices are under network attack, no device reset and telecommunication interruption should occur.

Table 2-26 List of Communication Protocols of SWT 3000 Service Interface

Service	Layer 4 Protocol	Layer 7 Protocol	Client	Client Port	Server	Server Port
Web Server	TCP	HTTP	Web browser	>1024	SWT 3000	80
Web Server with SSL Encryption	TCP/TLS	HTTPS	Web browser	>1024	SWT 3000	443
Time Synchronization	UDP	NTP	SWT 3000	>1024	NTP Server	123
DHCP Client	UDP	DHCP	SWT 3000	68	DHCP Server	67
SNMP	UDP	SNMP	NMS	>1024	SWT 3000	161
SNMP Trap/Inform	UDP	SNMP	SWT 3000	161	SNMP Trap Receiver	162
SNMP Inform Acknowledge	UDP	SNMP	SNMP Trap Receiver	162	SWT 3000	161
SWT 3000 Configuration	TCP	PowerSys Protocol (Proprietary)	PowerSys	>1024	SWT 3000	10001
SWT 3000 Configuration with SSL Encryption	TCP/TLS	PowerSys Protocol (Proprietary)	PowerSys	>1024	SWT 3000	10001



#### NOTE

The communication protocols of SWT 3000 are disabled in the default configuration of PowerSys.

- HTTP (80)
- HTTPS (443)
- SNMP (161)

### 2.13.2 Certification

Each device creates a self-signed certificate which has to be trusted on all clients used to access this device. The IP addresses of both service port and user port are part of this certificate. Therefore, create the certificate once again after the IP address is changed. Otherwise, a certificate warning message is shown with an IP address mismatch in the Web browser.



[sccreatc-080513-01.tif, 1, en, US]

Figure 2-29 Parameter: Create Certificate

The certificate creation is done via the device web page: **PowerLink > Service Interface Settings** or **SWT 3000 > Ethernet Interface Settings**.

After having activated the settings, the certificate is created and stored into flash. The system is restarted automatically.



**NOTE**

Due to the processing power limitation of the PU4 controller, creating a certificate can take several minutes.



**NOTE**

If HTTPS is enabled and no valid certificate is created before, a default certificate will be created for Power-Link and SWT 3000 after the system startup.

### 2.13.3 HTTPS Connection

HTTPS connection is configured in **SWT 3000 > Configuration > Ethernet > TCP/IP connection**.

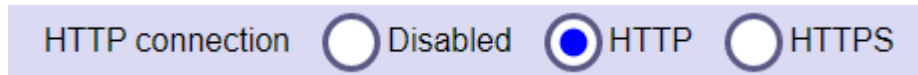

[sc\_http\_connection, 1, -\_-]

Figure 2-30 Parameter: HTTP Connection

- Disabled HTTP and HTTPS are disabled
- HTTP HTTP is enabled (default option).  
You can access the web page via HTTP protocol (e.g. http://192.168.20.200)
- HTTPS HTTPS is enabled.  
You can access the web page via HTTPS protocol (e.g. https://192.168.20.200)

When accessing the device web page using an HTTPS protocol for the first time, an error message occurs mentioning that the certificate is not trusted. In order to enable the trust, you have to install the certificate in **Trusted Root Certification Authorities Store**. Continue to this website as shown in [Figure 2-31](#).

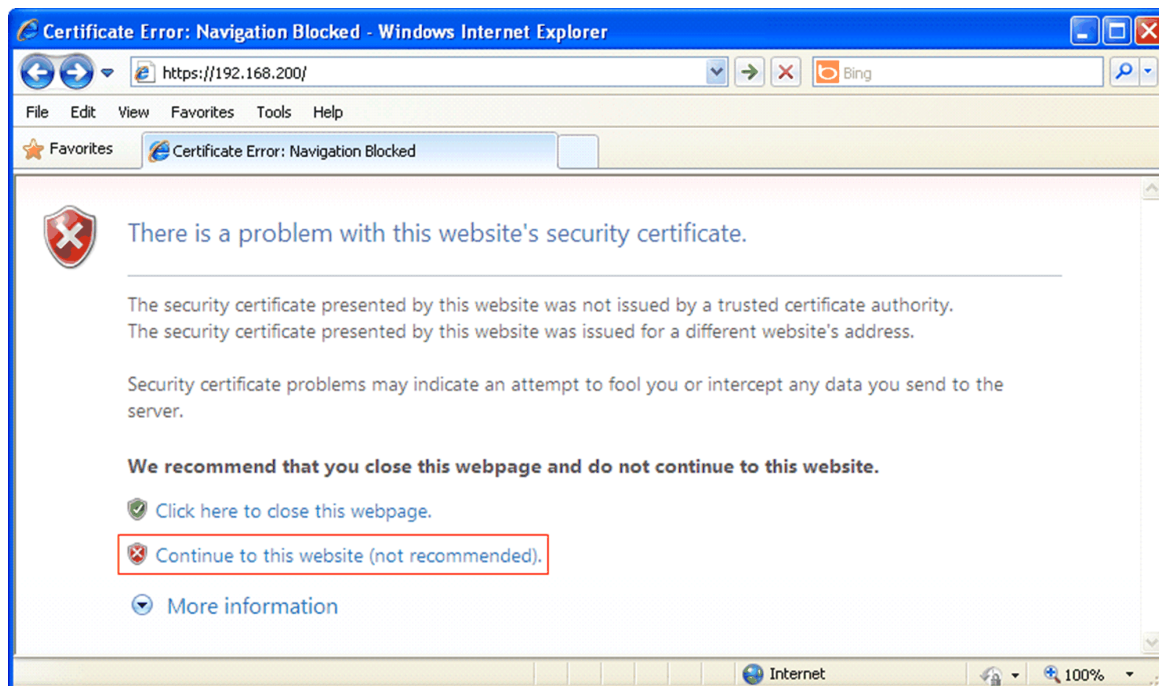

[scerrorm-080513-01.tif, 1, en\_US]

Figure 2-31 Certificate Error Message

The device homepage can now be opened.

Open the certificate window by clicking on the certificate error message in the address bar of the Web browser (see [Figure 2-32](#)).

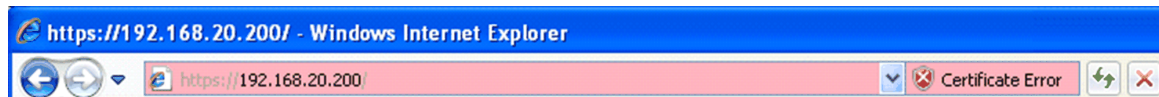

[scuntrus-080513-01.tif, 1, en\_US]

Figure 2-32 Untrusted Certificate

You can view the detailed certificate information in the opened certificate window (see [Figure 2-33](#)).

By clicking on the **Install Certificate** button and afterwards on the **OK** button in the certificate import wizard, the certificate will be installed in the **Trusted Root Certification Authorities Store** automatically.

You can find the installed certificate under **IE browser > Internet Options > Content > Certificates > Trusted Root Certification Authorities**.



[sccertwi-080513-01.tif, 1, en\_US]

Figure 2-33 Certificate Window

After the certification has been successfully installed, no error message occurs again when reopening the device homepage again (see [Figure 2-34](#)).

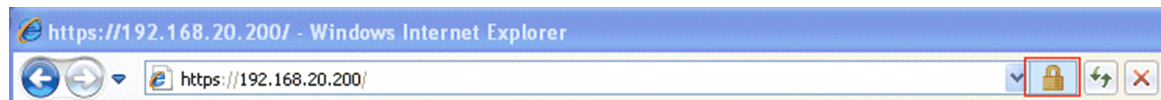

[sctrucer-080513-01.tif, 1, en\_US]

Figure 2-34 Trusted Certificate



## 2.14 Power Supply

### 2.14.1 Stand-Alone Unit

1 or alternatively 2 power supplies can be used in the SWT 3000 system. They are decoupled via diodes on the backplane. In order to detect failure of a power supply unit, the PU4 module monitors the output voltages from Power Supplies PS-1 and PS-2. The interface modules (IFC) are supplied via the PU4.

#### Monitoring Loop

An inhibit loop monitors the presence of the PU4, FOM and CLE modules. Pulling the PU4, FOM and the CLE causes the interruption of the monitoring loop and the secondary voltages from PS-1 and PS-2 (if available) are disconnected.



#### NOTE

An On/Off switch (PS) on the PU4 (not accessible from outside) also interrupts this monitoring loop.

If the CLE or FOM-1 is not used, insert the jumper X41 in position 1-2.

If the FOM2 is not used, insert the jumper X42 in position 1-2.

---

### 2.14.2 Integrated Unit

If the SWT 3000 is used in the PowerLink system (as iSWT), the PU4 unit is supplied via the central power supply of the PowerLink. The IFC modules are supplied via the PU4.



#### NOTE

It is neither required nor it is possible to use a separate power supply for the integrated unit.

---

## 2.15 Virtual Display

SWT 3000 virtual display is an APP running on any Android mobile phone. You can easily read out device status, command counter, and alarm / errors from the attached SWT 3000 via USB OTG (On-The-Go) cable connection. There is no need to take a laptop for the regular maintenance check.



[sc\_virtual\_display\_usb\_connection, 1, --]

The major features supported in SWT vDisp:

- Display command counter (input / output) for up to 16 commands
- Display event log, alarm / error and device information
- Reset trip counter
- Login before connection if the user authentication is enabled
- Easy to use, runs on all standard Android mobile phones (Android 4.1 or higher)
- APP opens automatically when SWT 3000 is connected
- Ready to use without firmware update (compatible with all firmware release P3.5.xxx)

SWT vDisp is only supported for stand-alone SWT 3000. It cannot be used for iSWT or external SWT 3000 connected to PowerLink.

## 2.16 T-Scheme

SWT 3000 is usually operated as peer to peer communication with symmetrical configuration on both, local and remote devices. But it is also possible to support multi-point command communications. For T-scheme feature, the teleprotection commands can be transmitted to different directions or repeated to next link over two digital line interfaces (LID-1/2). The terminal devices and T-devices could have asymmetric configurations and HW assembly (for example, different number of IFC modules).

In the case of T-device, both LID interfaces will set to primary connection, and no secondary or redundancy path is available.

T-scheme is supported in mode 5D with free allocation only.

### Transmit command to different directions

For example if T-scheme is enabled:

- Device sends command 1..8 to remote device at left direction
- Device sends command 9..16 to remote device at right direction

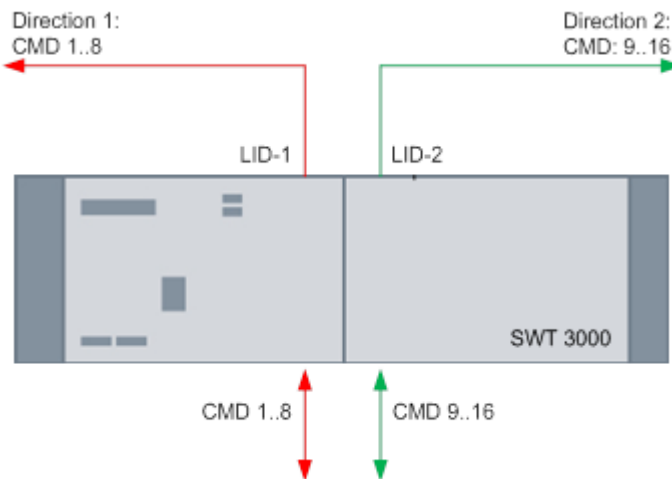

[sc\_transmit\_command\_to\_different\_directions, 1, -,-]

The commands can be transmitted to left, right or both directions. It is configured in PowerSys > SWT 3000 > Configuration > Output Allocation.

### Repeat command

For example if T-scheme is enabled in middle device 2:

- Device 1 sends command 1..8 to device 2
- Device 1 sends command 9..16 to device 3. The commands are repeated from link 1 to link 2.

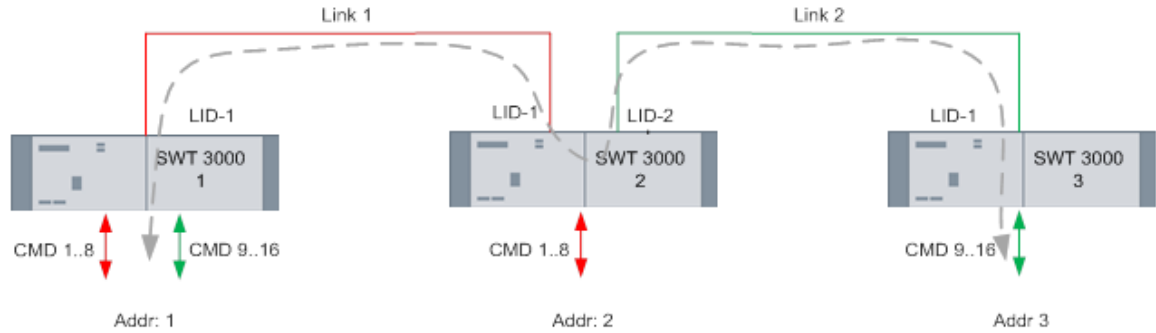

[sc\_repeat\_command, 1, --]

It is possible to have more than one T-device in the digital transmission path. For each T-device, command transmission time is extended by 0.1 ms for 2 Mbps data rate and 2.5 ms for 64 Kbps data rate. If all commands are repeated to next link, there is no need to install command interface modules (IFC or EN100).

### RM connection

PowerSys can access configuration data of any linked device over the RM channel.

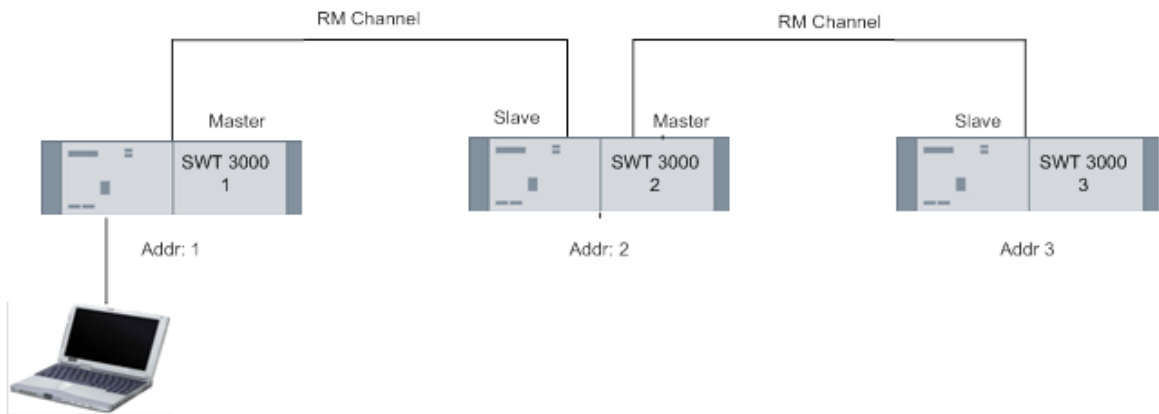

[sc\_RM\_connection, 1, --]

The RM channel is in routing state by default in T-device, so the remote alarm (REM) of end terminal device is displayed in PowerSys.

### Service Channel

The service channel in digital line interfaces is not supported in release P3.5.180 or higher. It is possible to recover SC function by downgrade DLEFPGA to former release via Memtool. But T-Scheme feature cannot be used anymore.

The firmware image is located at latest PowerSys Px.y.zzz > Firmware > Package\_zzz.cab > Pu4DleFpga\_v00\_01\_32.jnk.

For more details contact our customer support.

## 2.17 O-Scheme (G704)

The rate at the E1 interface is 2.048 Mbps. E1 uses Pulse Code Modulation (PCM) to encode voice or data. In the E1 line, 32 timeslots compose a frame. One timeslot (DS0) has 64 Kbit/s data rate for single 8-bit voice data. SWT 3000 transmits E1 data in unframed mode (G703) or framed mode (G704). 2 Mbps E1 data is channelized as 4 channels in SWT 3000. Each channel contains 5 time slots (5 \* 64 Kbps = 320 Kbps). The channelized E1 (CE1) can carry teleprotection commands towards up to 4 different directions as below figure. In this case, each channel transmits up to 4 commands with 16 commands in total.

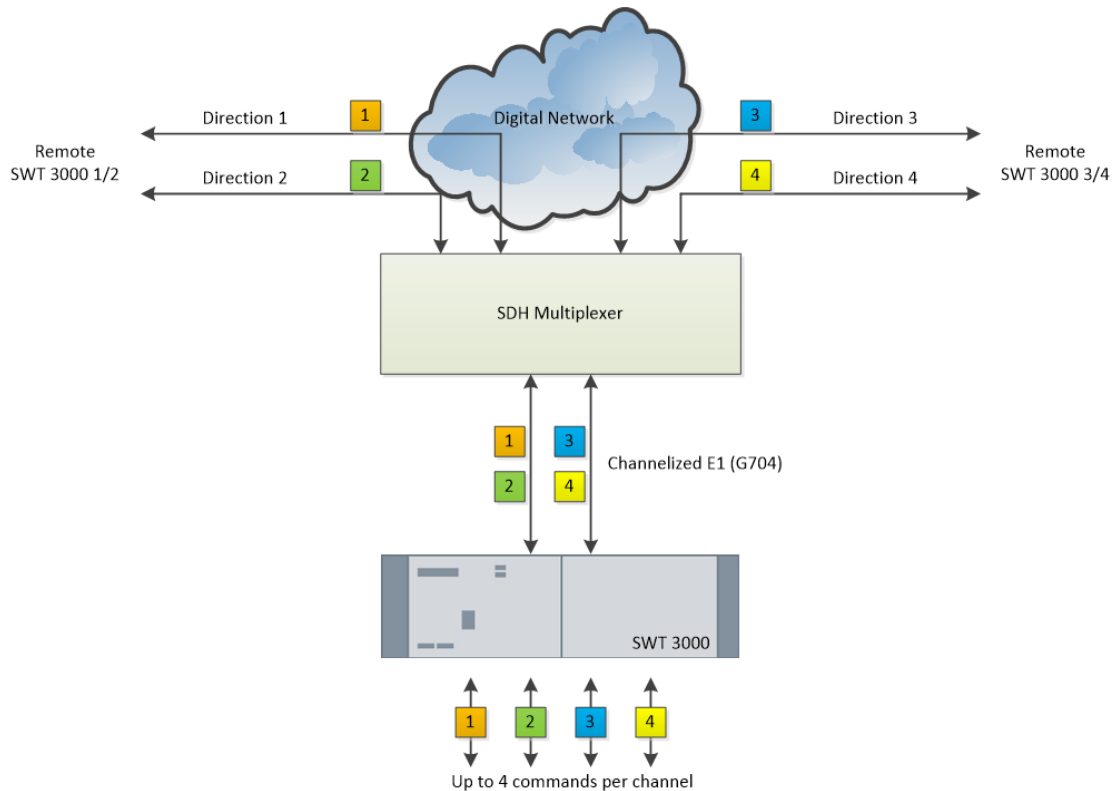

[sc\_G704\_overview, 1, -,-]

Figure 2-35 Command transmission to 4 directions

SWT 3000 adds commands into different channels of E1 interfaces. SDH device receives E1 frames and multiplexes the E1 channel into different directions using DS0 cross-connection function. So one SWT 3000 device can transmit commands to 4 remote devices. The command transmission time for G704 (320 Kbps) is less than 3 ms.

G704 can be configured as different operation modes:

- Double primary paths. Both LID interfaces will be used as primary path towards 4 different directions. No redundant path available.
- 1 + 1 path protection. One LID interface will be used as primary path towards 2 different directions. The second one is the redundant path.

In following example, each device transmits 8 commands into 2 directions.

- Command 1..4 between device 1 <> 3
- Command 5..8 between device 1 <> 2
- Command 9..12 between device 2 <> 3

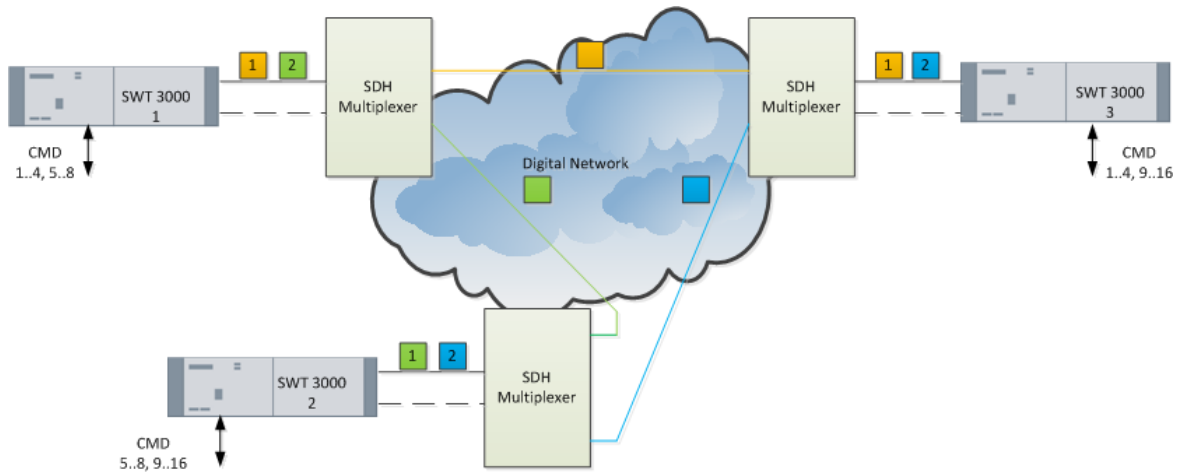

[sc\_example\_G704, 1, -,-]

Figure 2-36 Example one-point to two-point command transmission

## 2.18 Command Loop Test

Command loop test provides a function to measure the command transmission time without using any other test equipment, and there is no need to activate a real command input/output. It can be used for stand-alone SWT 3000 and SWT 3000 integrated in PowerLink.

It is only activated in the current transmission line, if a redundant transmission line is configured.

If a command loop test is triggered, a test signal is generated inside PU4 and sent to the remote side over the command transmission path. At the remote side, the test signal is reflected. One-trip time is calculated at the local side when receiving the reflected signal.

Note that, the measured time does not include the time taken from input/output interface of IFC or EN100 module, so there is a gap between the end to end command transmission time and the measured time. The interface time are list in below table.

Interface	Additional time (ms)
IFC-P	1.2
IFC-D	5.2
GOOSE	1.9

The end to end time = measured time + interface time.

The measured time can be viewed in PowerSys > Information > Counter. The value is between 0 ms ~25.5 ms. 0 means that the test is not available, while 25.5 ms means that the line is broken.

Command loop test can be executed in two ways. One is the periodic loop test, that can only be enabled in digital transmission line. It is triggered automatically at a configurable interval. The test result (OK/fail) is recorded in event log.

Another is the single test, it is triggered manually by PowerSys test command.





## 3 Installation and Commissioning

3.1	Installation	98
3.2	Pinouts of SWT 3000 Modules	101
3.3	Jumper Settings for SWT 3000 Modules	110
3.4	Start Commissioning	118
3.5	Device Configuration	126
3.6	Online Parameter Adjustment	175

### 3.1 Installation

#### 3.1.1 Connecting Plugs

Table 3-1 Arrangement of the Connecting Plugs of the SWT 3000

Connecting Plug	Module	Pinout
IFC-1	IFC-D/P	Pinout of the IFC-x Module
IFC-2	IFC-D/P/S	Pinout of the IFC-x Module
IFC-3	IFC-D/P	Pinout of the IFC-x Module
IFC-4	IFC-D/P/S	Pinout of the IFC-x Module
X4	LID1/LID2	Signals for the Digital Line Interface 1 and Signals for the Digital Line Interface 2
X3	CLE	Pinout of the CLE Module PinoutCLE
X2	ALR	Pinout of the ALR Module PinoutALR
X1	Power supply (PS)	Pinout of the H11 Connector PinoutPower Supply (H11 Connector and Redundant Power Supply)



#### WARNING

The faulty wiring and installation of the backplanes and subracks can cause a defect or lead to death.

**If the circuits are not properly separated from each other, a short-circuit can occur.**

- ✧ Make sure that an easily accessible separator in the supply circuit with a contact distance of minimum 3 mm is available.

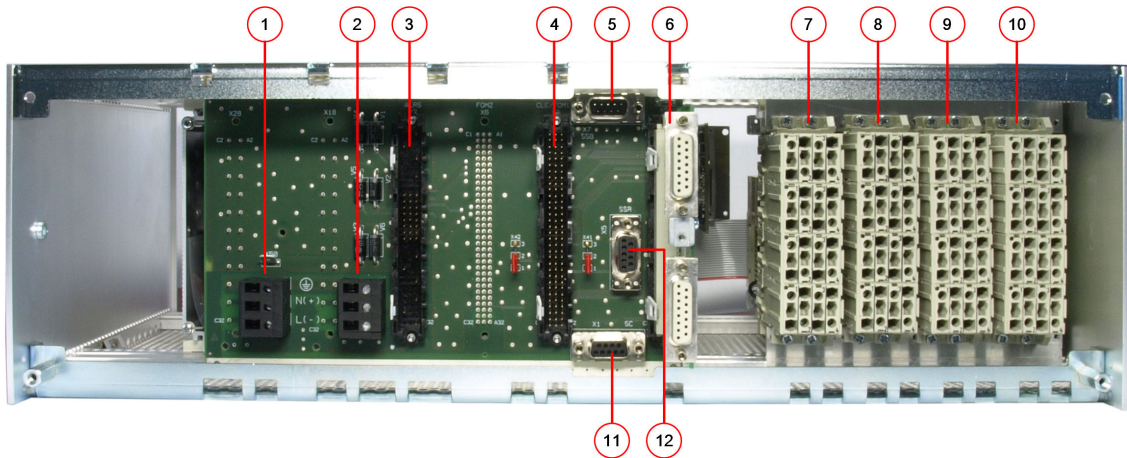

[ie\_backplane, 1, en\_US]

Figure 3-1 View of an SWT 3000 Backplane

- (1) Power Supply (redundant)
- (2) Main Power Supply
- (3) ALR
- (4) CLE
- (5) SSB (Remote Monitoring Interface Connector)
- (6) Connector for DSUB Adapter with LID1 and LID2
- (7) IFC-4

- (8) IFC-3
- (9) IFC-2
- (10) IFC-1
- (11) SC (Service Channel Interface SWT 3000)
- (12) SSR (Debug console for PU4)

### 3.1.2 Equipment of the Subrack

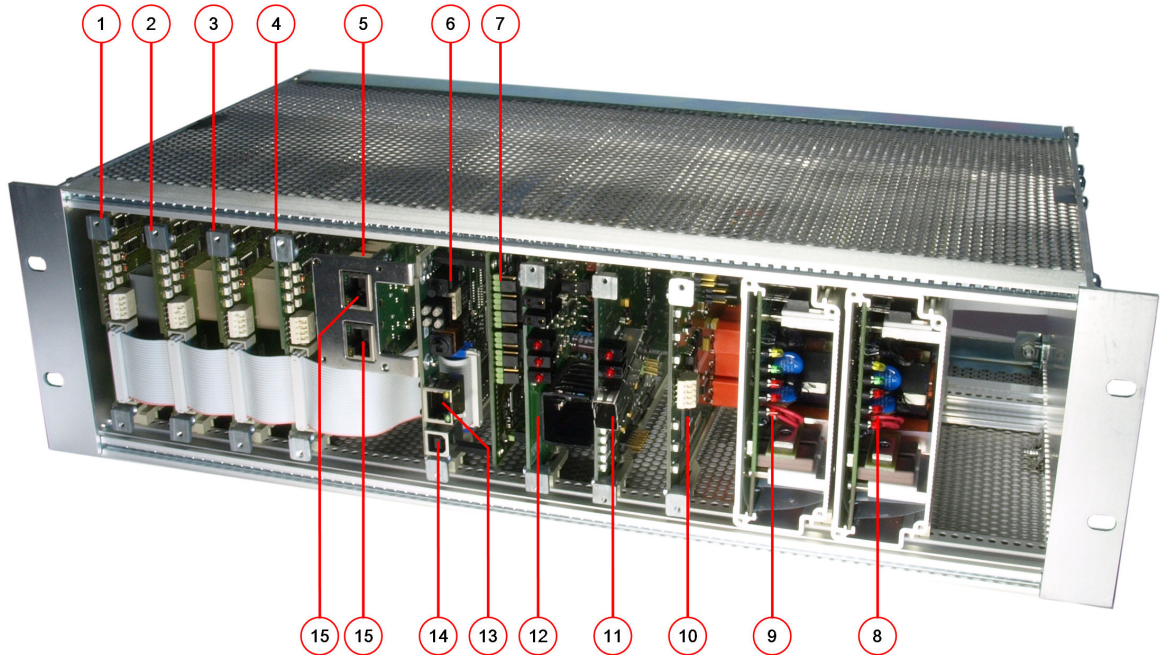

[le\_equipment\_subrack\_1\_en\_US]

Figure 3-2 Equipment of the Subrack with an SWT 3000 System

- (1) IFC-1 in slot 1 for interface module IFC-x (optional)
- (2) IFC-2 in slot 2 for interface module IFC-x (optional)
- (3) IFC-3 in slot 3 for interface module IFC-x (optional)
- (4) IFC-4 in slot 4 for interface module IFC-x (optional)
- (5) Ethernet EN100 module for IEC 61850 or TPOp (optional)
- (6) Processing unit module (PU4)
- (7) Digital line equipment module (DLE) (optional, if digital data transmission is desired)
- (8) Redundant power supply module (PS-2) (optional)
- (9) Power supply module (PS-1)
- (10) Alarm module (ALR)
- (11) Fiber-optic module (FOM-2) (optional, if digital or analog data transmission is desired)
- (12) Copper line equipment module (CLE) or optionally fiber-optic module (FOM-1) (optional, if digital or analog data transmission is desired)
- (13) RJ45 socket for PU4 Ethernet interface
- (14) USB socket (type B)
- (15) RJ45 sockets for electrical EN100 Ethernet interface (IEC 61850 or TPOp)  
SFP sockets if optical EN100 Ethernet interface (IEC 61850 or TPOp) are used

### 3.1.3 Cable Installation

Installed cables have to be mounted at the device frame by using the cable ties at the rear side of the device. (Depending on frame type optional cable clamps, delivered with dedicated frame.)

Dismantle the outer insulation of twisted and shielded cables for a window of approximately 20 mm length and fix the cable ties to connect the shield to the frame ground.

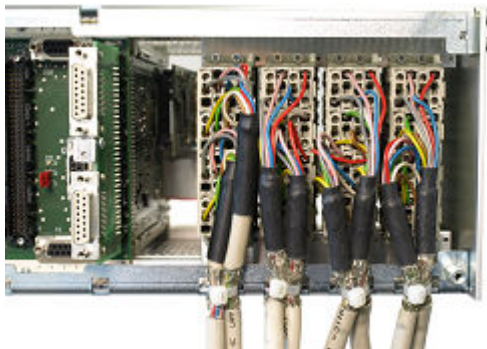

[ph\_cable\_installation, 1, -\_-]

Figure 3-3 Cable installation with cable ties

## 3.2 Pinouts of SWT 3000 Modules

### 3.2.1 Pinout of the IFC-x Module

The IFC interface modules must be connected from the protective relay to the connector X1 (modular terminal block). The cable cross section must be up to 1.5 mm<sup>2</sup>. **At least 2** twisted and shielded cables must be tied immediately at the terminals.

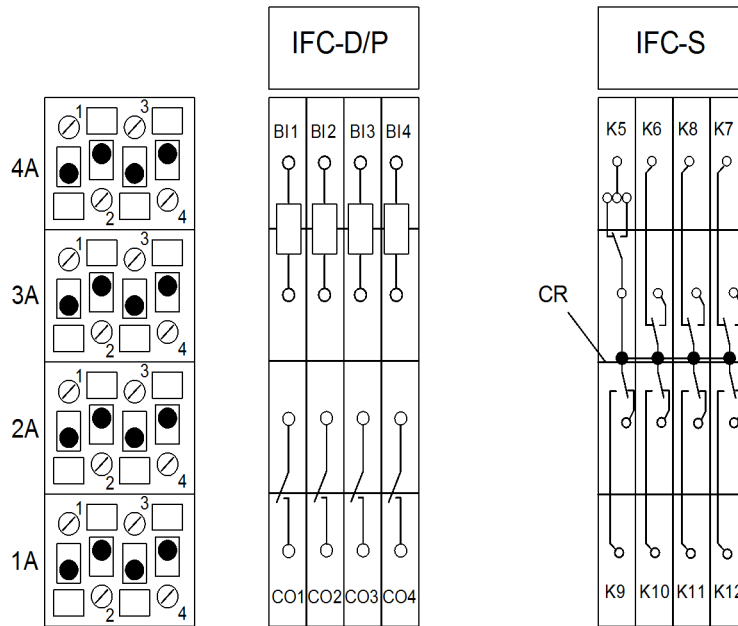

[dwpinifc-060711-01.tif, 1, en\_US]

Figure 3-4 Pinout of the IFC-x Modules

IFC-D	Interface module direct tripping
IFC-P	Interface module permissive tripping
IFC-S	Interface module signaling
CR	Common root of relays K5 to K12
1A-4A	Modular terminal block
BI1-BI4	Binary inputs 1 to 4
CO1-CO4	Command outputs 1 to 4
K5-K8	Signaling of the binary inputs 1 to 4
K9-K12	Signaling of the command outputs 1 to 4

The following figure shows the connection principle of the IFC-D/P binary inputs:

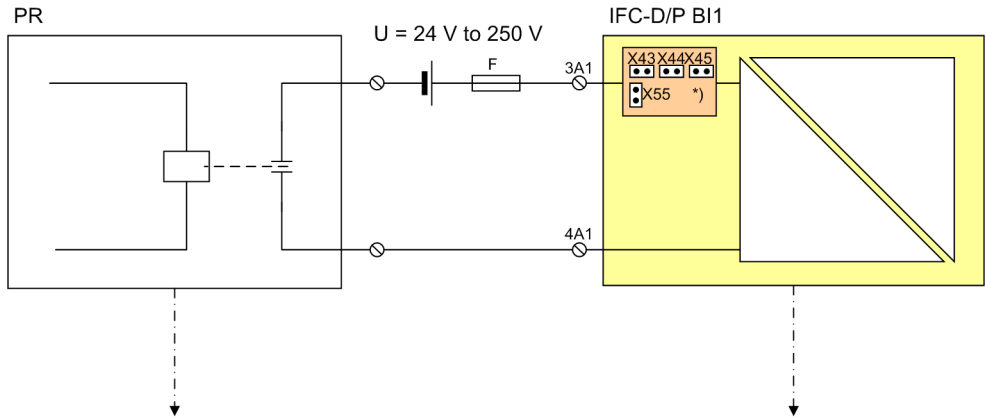

[dw\_SWT\_baseco\_1\_en\_US]

Figure 3-5 Basic Connection of the binary Inputs on IFC-D and IFC-P Modules (example for BI1)

- \* Settings of the nominal input voltage
- PR Protection Relay
- BI1 Binary Input 1
- F Fuse

### 3.2.2 Pinout of the PU4 Module

Table 3-2 Pinout of the PU4, X1

Pin	A	B	C
1	GNDS		GNDS
2			
3	GND	GND	GND
4	P5_PS-1 (+5 V)	P5 (+5 V)	P5_PS-2 (+5 V)
5		LID_25	
6	P12_PS-1 (+12 V)	LID_26	P12_PS-2 (+12 V)
7			
8	LID_11		LID_12
9	LID_13		LID_14
10	LID_15	LID_27	LID_16
11	LID_17		LID_18
12	LID_21	LID_28	LID_22
13			
14	LID_23	N12_PS-2 (-12 V)	LID_24
15			
16	N12_PS-1 (-12 V)		P5 (+5 V)
17			P5 (+5 V)
18	P12 (+12 V)		N12 (-12 V)
19			
20	GND		P12 (+12 V)
21	INHIBIT		INHIBIT
22	N12 (-12 V)	GND	GND
23		S6OUT_N	P12 (+12 V)
24	LID_SC_TX	F6VF_IN	

Pin	A	B	C
25		GND_ANA	
26	LID_SC_RX	F6VF_OUT	
27		GND_ANA	GND
28		ETH_RXM	
29	ETH_RXP	ETH_TXP	ETH_TXM
30	LID_SC_RTS		
31	GNDS	LID_SC_CTS	GNDS
32			

P5_x	Power supply (PS-1, PS-2)
N12_x	Power supply (PS-1, PS-2)
LID_x	Digital line interface (X.21, G703.1, or G703.6)
LID_SC_x	Digital line interface Service Channel
P12_x	Power supply (PS-1, PS-2)

### Signals of the Analog Line Interface

Table 3-3 Pinout for Interface LIA

Pin PU4 X1	Signal
B26	<b>Output:</b> F6 signal in VF range to the CLE module F6VF_OUT
B27	Reference potential for F6 signal in VF range to the CLE module GND_ANA
B24	<b>Input:</b> F6 signal in VF range from the CLE module F6VF_IN
B25	Reference potential for F6 signal in VF range from the CLE module GND_ANA
B23	<b>Output:</b> Control signal S6 for AMP operation to the CLE or FOM transmission module S6OUT_N
A3, B3, C3, A20, B22, C22	Signal reference potential GND

### 3.2.3 Connection of Digital Line Interfaces

The signals at the digital interfaces are fed via a plug connector from the PU4 to the D-sub sockets LID-1 and LID-2.

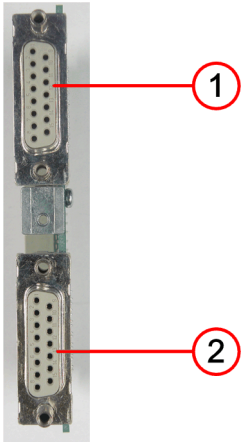

[le\_solids, 1, en\_US]

Figure 3-6 Connection Sockets (D-sub) for the Digital Interfaces LID-1 and LID-2

- (1) D-sub sockets LID-1
- (2) D-sub sockets LID-2



**NOTE**

Every wire pair in the connecting cables used for the digital interfaces must be twisted and shielded. For the minimum requirements, twist and completely shield all wire pairs.

### 3.2.4 Signals for the Digital Line Interface 1

The signals for the digital line interface 1 are fed via a plug connector from the PU4 to the D-sub socket LID-1 to the backplane of the device. The pinout depends on the interface used.

Table 3-4 Pinout for the LID-1

Terminal	PU4 X1 Cable Connector	D-sub Socket LID-1 Pin	X.21 Signal	G703.1 Signal	G703.6 Signal
LID_11	A8	4	X21_RxD_A1	DI11	DI11
LID_12	C8	11	X21_RxD_B1	DI12	DI12
LID_13	A9	2	X21_TxD_A1	DO11	DO11
LID_14	C9	9	X21_TxD_B1	DO12	DO12
LID_15	A10	6	X21_RxC_A1		
LID_16	C10	13	X21_RxC_B1		
LID_17	A11	7	X21_TxC_A1		
LID_18	C11	14	X21_TxC_B1		
GNDS/Shield	A31/C31	1	GNDS/Shield	GNDS	GNDS
GND/Signal	A3/C3	8	GND/Signal	GND	GND



Table 3-5 Signals for the X-21 Interface

Signal Name	Function	
X21_RxD_A1	<b>Input:</b>	X.21 Receive data signal a
X21_RxD_B1	<b>Input:</b>	X.21 Receive data signal b
X21_TxD_A1	<b>Output:</b>	X.21 Transmit data signal a
X21_TxD_B1	<b>Output:</b>	X.21 Transmit data signal b
X21_RxC_A1	<b>Input:</b>	X.21 Receive clock signal a
X21_RxC_B1	<b>Input:</b>	X.21 Receive clock signal b
X21_TxC_A1	<b>Output:</b>	X.21 Transmit clock signal a
X21_TxC_B1	<b>Output:</b>	X.21 Transmit clock signal b
GNDS	Signal reference potential	
GND	Shielding	

Table 3-6 Signals for the G703.1 Interface and G703.6 Interface

Signal Name	Function	
DI11	<b>Input:</b>	Data in signal 1
DI12	<b>Input:</b>	Data in signal 2
DO11	<b>Output:</b>	Data out signal 1
DO12	<b>Output:</b>	Data out signal 2
GNDS	Shielding	
GND	Signal reference potential	

### 3.2.5 Signals for the Digital Line Interface 2

The signals for the digital line interface 2 are fed via a plug connector from the PU4 to the D-sub socket LID-2 to the backplane of the device. The pinout depends on the interface used.

Table 3-7 Pinout for the LID-2

Terminal	PU4 X1 Cable Connector	D-sub Socket LID-2 Pin	X.21 Signal	G703.1 Signal	G703.6 Signal
LID_21	A12	4	X21_RxD_A2	DI21	DI21
LID_22	C12	11	X21_RxD_B2	DI22	DI22
LID_23	A14	2	X21_TxD_A2	DO21	DO21
LID_24	C14	9	X21_TxD_B2	DO22	DO22
LID_25	B5	6	X21_RxC_A2		
LID_26	B6	13	X21_RxC_B2		
LID_27	B10	7	X21_TxC_A2		
LID_28	B12	14	X21_TxC_B2		
GNDS/Shield	A31/C31	1	GNDS/Shield	GNDS	GNDS
GND/Signal	A3/C3	8	GND/Signal	GND	GND

Table 3-8 Signals for the X-21 Interface

Signal Name	Function	
X21_RxD_A2	<b>Input:</b>	X.21 Receive data signal a
X21_RxD_B2	<b>Input:</b>	X.21 Receive data signal b
X21_TxD_A2	<b>Output:</b>	X.21 Transmit data signal a

Signal Name	Function	
X21_RxC_B2	<b>Output:</b>	X.21 Transmit data signal b
X21_RxC_A2	<b>Input:</b>	X.21 Receive clock signal a
X21_RxC_B2	<b>Input:</b>	X.21 Receive clock signal b
X21_TxC_A2	<b>Output:</b>	X.21 Transmit clock signal a
X21_TxC_B2	<b>Output:</b>	X.21 Transmit clock signal b
GNDS	Signal reference potential	
GND	Shielding	

Table 3-9 Signals for the G703.1 Interface and G703.6 Interface

Signal Name	Function	
DI21	<b>Input:</b>	Data in signal 1
DI22	<b>Input:</b>	Data in signal 2
DO21	<b>Output:</b>	Data out signal 1
DO22	<b>Output:</b>	Data out signal 2
GNDS	Signal reference potential	
GND	Shielding	

### 3.2.6 Pinout of the SC interface

Table 3-10 Signals for the Service Channel Interface

Signal Name	SC Connector Pin	Function
LID_SC_RX	2	<b>Output:</b> Service channel receive data
LID_SC_TX	3	<b>Input:</b> Service channel transmit data
GND	5	Signal reference potential
LID_SC_RTS	7	Handshake signals
LID_SC_CTS	8	Handshake signals

### 3.2.7 Pinout of the SSB interface

RM communication over several transmission routes is also possible by connecting 2 units via the back RM interface (SSB) (refer also to chapter *Remote Monitoring, Service Channel, and IP Network 2.10.1 RM with Analog Interface*).

Table 3-11 Pinout of the Remote Monitoring Interface SSB

Signal Name	SSB Connector Pin	Function
RxD	2	Receive data
TxD	3	Transmit data
GND	5	GND

### 3.2.8 Pinout of the CLE Module

Table 3-12 Pinout of the CLE Module

Pin	A	B	C
1	Shield GNDS		GNDS
2			

Pin	A	B	C
3	Ground GND		Control wire S6 (S6AB) <sup>1)</sup>
4			
5			Control wire S6 (S6AB_GND) <sup>1)</sup>
6			
7			Protection receive signal A <sup>2)</sup>
8			
9			Protection receive signal B <sup>2)</sup>
10			
11			Protection transmit signal A <sup>2)</sup>
12			
13			Protection transmit signal B <sup>2)</sup>
14			
15		DC value transmit signal	
16	S/N alarm	DC value transmit signal GND	P5V (+5 V)
17	RXAL alarm		P5V (+5 V)
18	P12V (+12 V)		M12V (-12 V)
19	TXAL alarm		
20	GND12		P12V (+12 V)
21	INHIBIT		INHIBIT
22	M12V (-12 V)		GND12
23	Enable transmitter output	S6 control line from PU4	
24		VF signal from PU4	
25		VF signal from PU4 GND	
26		VF signal to PU4	
27		VF signal to PU4 GND	Ground GND
28			S6 control wire from PU4
29			
30			
31	Shield GNDS		Shield GNDS
32			

<sup>1)</sup>Additionally for PLC alternate multi-purpose operation  
<sup>2)</sup>Input and output signals for cable connection

### 3.2.9 Pinout of the ALR Module

Table 3-13 Pinout of the ALR Module

PIN	Signal Name	PIN	Signal Name	PIN	Signal Name
A1	BI1_A	B1		C1	
A2		B2		C2	
A3		B3		C3	BI1_B
A4		B4		C4	
A5	BI2_A	B5		C5	
A6		B6		C6	
A7		B7		C7	
A8	BI2_B	B8		C8	
A9		B9		C9	

PIN	Signal Name	PIN	Signal Name	PIN	Signal Name
A10		B10		C10	
A11		B11		C11	
A12	FGND	B12	FGND	C12	FGND
A13		B13		C13	ALA1_OUT_L
A14	B11_IN_L	B14		C14	ALA2_OUT_L
A15	B12_IN_L	B15		C15	ALA3_OUT_L
A16	P5V (+5 V)	B16	P5V (+5 V)	C16	P5V (+5 V)
A17	GND	B17	GND	C17	GND
A18	P12V (+12 V)	B18	P12V (+12 V)	C18	P12V (+12 V)
A19		B19		C19	
A20		B20		C20	
A21	ALA1_A	B21		C21	
A22		B22		C22	
A23		B23		C23	ALA1_B
A24		B24		C24	
A25	ALA2_B	B25		C25	
A26		B26		C26	
A27		B27		C27	
A28	ALA2_A	B28		C28	
A29		B29		C29	
A30		B30		C30	ALA3_B
A31		B31		C31	
A32	ALA3_A	B32		C32	

The cable shield of the alarm cable is connected to the device frame by using cable ties.

### 3.2.10 Pinout of the Fiber-Optic Module

Table 3-14 Pinout of the Fiber-Optic Module

PIN	Signal Name	PIN	Signal Name	PIN	Signal Name
A1	GNDS	B1	RM_TXD	C1	GNDS
A2	I2C_SDA	B2	RM_RXD	C2	I2C_SCL
A3	GND	B3		C3	
A4	I2C_SCL	B4		C4	P48VISO
A5		B5		C5	GNDISO
A6		B6		C6	
A7		B7		C7	AREL_MAK
A8	RDP_LID	B8		C8	
A9	TDP_LID	B9		C9	
A10	RCP_LID	B10		C10	AREL_BRK
A11	TCP_LID	B11		C11	
A12	RDM_LID	B12		C12	
A13	TDM_LID	B13		C13	AREL_COM
A14	RCM_LID	B14		C14	
A15	TCM_LID	B15		C15	
A16		B16		C16	P5V
A17	F6SVRALR_N	B17	PSDIN	C17	P5V

PIN	Signal Name	PIN	Signal Name	PIN	Signal Name
A18		B18	PLRCK	C18	
A19		B19	PSDOUT	C19	
A20	GND	B20		C20	
A21	INHIBIT	B21	PSCLK	C21	INHIBIT
A22		B22		C22	GND
A23		B23	S6_N	C23	
A24		B24		C24	
A25	ILAN	B25		C25	RESET
A26		B26		C26	
A27	FOMADR	B27		C27	GND
A28	GND	B28		C28	S6_N
A29		B29		C29	
A30		B30		C30	FOMALR_N
A31	GNDS	B31		C31	GNDS
A32		B32	ESB_SWT_N	C32	

## 3.3 Jumper Settings for SWT 3000 Modules

### 3.3.1 General Information



#### NOTE

The program SWTStraps can be used as a graphical utility to find the correct jumper settings for the SWT 3000 modules. The program is supplied with PowerSys in folder \Utilities.  
For details refer to chapter [5.6 SWTStraps for Jumper Settings](#) and following.

### 3.3.2 Jumper Settings for IFC Modules

#### 3.3.2.1 Overview

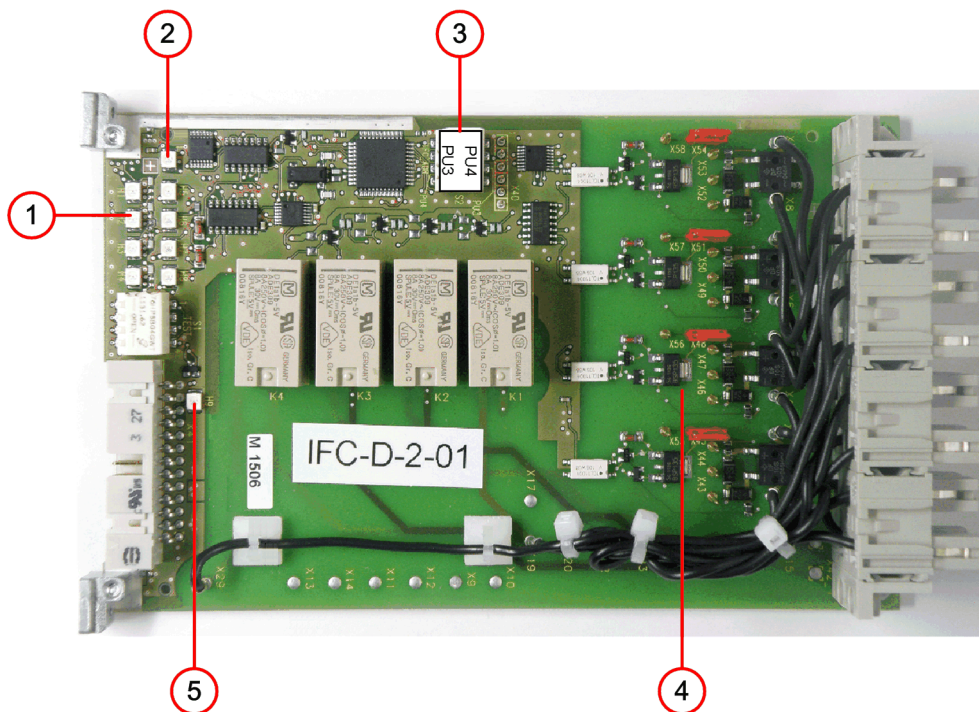

[scjumper-220513-01.tif, 2, en\_US]

Figure 3-7 Position of Jumpers for the IFC-Modules

- (1) LED H1 to H4 (red): activated outputs  
LED H5 to H8 (green): activated inputs
- (2) Test Operation Display (H10)
- (3) S2: IFC Slot Address Selection (S2.1, S2.2) and PU3 / PU4 switch:  
S2.3: closed/down - PU3  
S2.3: open/up - PU4
- (4) Jumpers X43 to X58
- (5) Operating LED (H9)

Table 3-15 Assignment of Jumpers X43 to X58

Signal Input	250 V	110 V	48 V/60 V	24 V
BI1	<b>X55 = inserted</b> X43 = open X44 = open X45 = open	X55 = open <b>X43 = inserted</b> X44 = open X45 = open	X55 = open X43 = open <b>X44 = inserted</b> X45 = open	X55 = open X43 = open X44 = open <b>X45 = inserted</b>
BI2	<b>X56 = inserted</b> X46 = open X47 = open X48 = open	X56 = open <b>X46 = inserted</b> X47 = open X48 = open	X56 = open X46 = open <b>X47 = inserted</b> X48 = open	X56 = open X46 = open X47 = open <b>X48 = inserted</b>
BI3	<b>X57 = inserted</b> X49 = open X50 = open X51 = open	X57 = open <b>X49 = inserted</b> X50 = open X51 = open	X57 = open X49 = open <b>X50 = inserted</b> X51 = open	X57 = open X49 = open X50 = open <b>X51 = inserted</b>
BI4	<b>X58 = inserted</b> X52 = open X53 = open X54 = open	X58 = open <b>X52 = inserted</b> X53 = open X54 = open	X58 = open X52 = open <b>X53 = inserted</b> X54 = open	X58 = open X52 = open X53 = open <b>X54 = inserted</b>

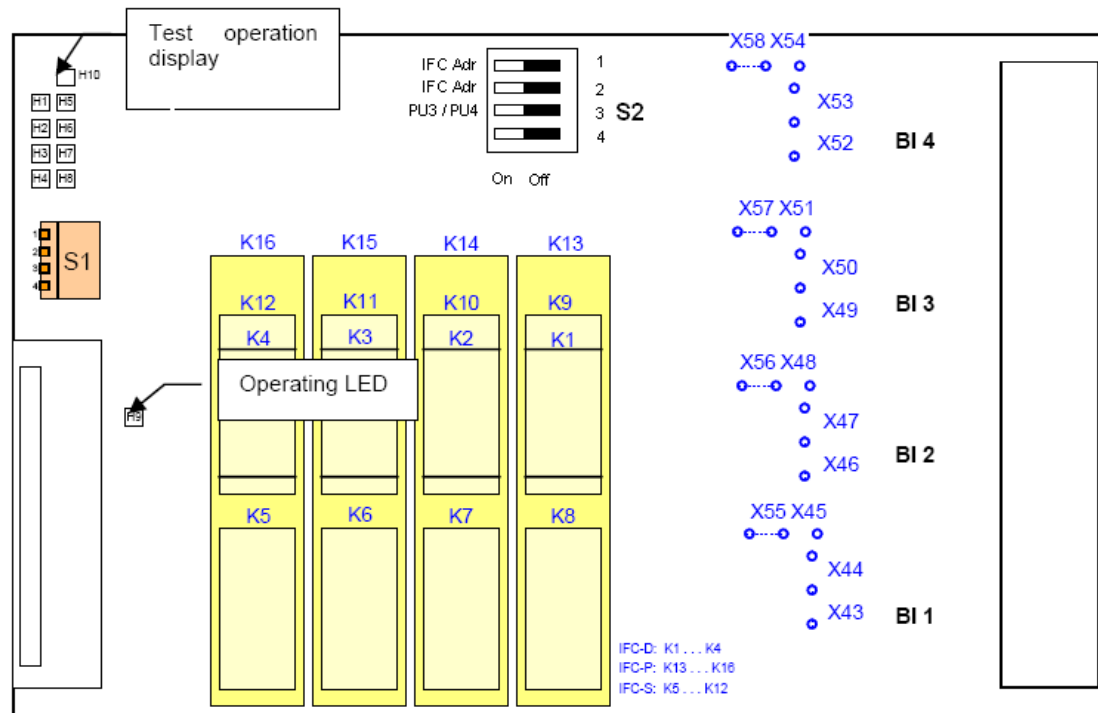

Figure 3-8 Position of jumpers X43 to X58

The second interface module is used in the case of an **IFC-D/P** module for doubling the output contacts. The binary inputs are only connected to **one** module (in slot IFC-1 or IFC-3).

**If the IFC-S module is used, jumpers X43 to X58 are not provided because the binary inputs do not exist.** The module contains 8 signaling relays. For 7 relays, one change-over contact is brought out in each case. The

contact of relay K5 can be used as a make contact or a break contact with jumper X42. All 8 signaling contacts have a **common root (3A1)**.

### 3.3.2.2 DIP Switches on IFC Modules

There are 2 Dual Inline Package (DIP) switches added to each IFC modules:

- DIP switch S1 for the **Test Mode**.  
 The activated output relays are displayed with LEDs H1 to H4 (red), and the activated binary inputs with LEDs H5 to H8 (green).  
 For more detailed information, refer to [8.1.6.1 Overview](#).
- DIP switch S2 for the selection of PU3 and PU4 module and to indicate the slot address of each IFC module.  
 For more detailed information, refer to [8.1.7 Slot and Module Identifier](#).

Table 3-16 Function of S2 Switch

Switch	Function
S2.1	IFC slot address selection
S2.2	IFC slot address selection
S2.3	PU3 or PU4 selection
S2.4	Not connected

Table 3-17 IFC Slot Address

Selection	S2.1 Position	S2.2 Position
IFC-1	Open = up position = OFF	Open = up position = OFF
IFC-2	Close = down position = ON	Open = up position = OFF
IFC-3	Open = up position = OFF	Close = down position = ON
IFC-4	Close = down position = ON	Close = down position = ON

Table 3-18 PU3 or PU4 Selection

Selection	S2.3 Position
PU3	Close = down position = ON
PU4	Open = up position = OFF



## CAUTION

Changing the position of an IFC module without changing its address may lead to a failure in the transmission.

**The IFC module will be detected on a wrong slot. No information or wrong information may be transmitted to the corresponding protection relay.**

✧ Make sure that the IFC module is in the right slot.



## NOTE

The slots IFC-3 and IFC-4 are available only in PU4-mode of stand alone SWT 3000.



### 3.3.3 Jumper Settings for the PU4 Module

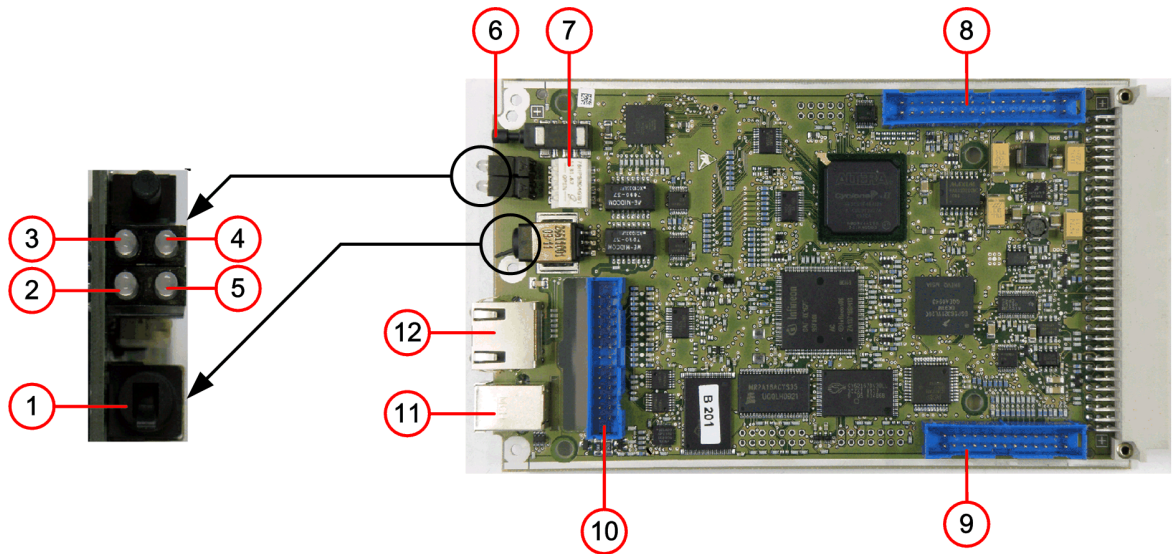

[le\_pu4jum, 1, en\_US]

Figure 3-9 Position of Jumpers, Input and Signaling Elements on the PU4 Module

- 1 S2: Power ON/OFF
- 2 LED OK/GBAL
- 3 LED Status Interface LID-2
- 4 LED Status Interface LID-1
- 5 LED Status Interface LIA
- 6 S1: Reset button
- 7 S3 (3.1 to 3.4)
- 8 Connection on DLE
- 9 Connection on DLE
- 10 Connection of the IFC Modules
- 11 LCT: Service Interface (USB)
- 12 NMS: Ethernet Interface

The Digital line equipment is not applicable for PowerLink 50.

Table 3-19 Function of the S3 DIP Switch on the PU4 Module

Switch Number	Position	Function
S3.1	OFF	Normal operation
	ON	Programming with Memtool
S3.2	OFF	Monitor inactive
	ON	Monitor active
S3.3	OFF	Disable debugger
	ON	Enable debugger
S3.4	OFF	Disable initialization in monitor
	ON	Enable initialization in monitor



**NOTE**

For normal operation all switches must be in the **OFF**-position.

### 3.3.4 Jumper Settings for the DLE Module

#### 3.3.4.1 Overview

When using digital line interfaces, links must be set on the DLE module. Module DLE is designed as a self-contained PC board that is connected electrically to the PU4 via a ribbon cable and mechanically via spacer sleeves. All external interfaces are routed via the PU4 module.

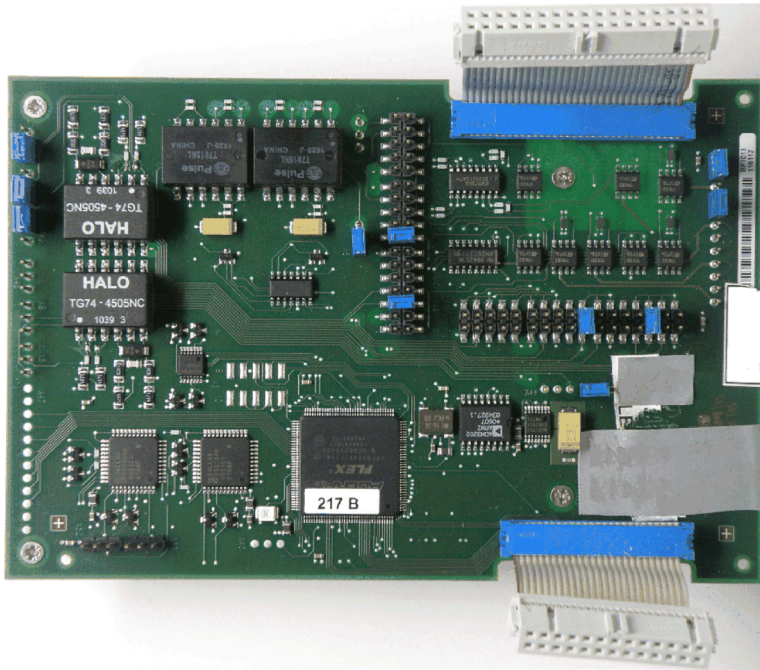

[scalejum-301111-01.tif, 1, en\_US]

Figure 3-10 Position of the Jumpers on the DLE Module

#### 3.3.4.2 Jumper Settings for the Selection of Digital Line Interfaces LID-1

Table 3-20 Interface Selection for the LID-1

Interface	X48	X49	X42	X43	X6	X4	X5	X20	X21
X.21	1-2 11-12	1-2 11-12	1-2	2-3	2-3	2-3	2-3	1-2	1-2
G703.1	3-4 13-14	3-4 13-14	1-2	2-3	2-3	2-3	2-3	2-3	2-3
G703.6 symmetric	5-6 15-16	5-6 15-16	1-2	2-3	2-3	2-3	2-3	2-3	2-3
G703.6 asymmetric	7-8 15-16	5-6 15-16	2-3	1-2	1-2	1-2	1-2	1-2	1-2

#### 3.3.4.3 Jumper Settings for the Selection of Digital Line Interfaces LID-2

Table 3-21 Interface Selection for the LID-2

Interface	X48	X49	X46	X44	X7	X8	X9	X22	X23
X.21	19-20 29-30	19-20 29-30	1-2	2-3	2-3	2-3	2-3	1-2	1-2
G703.1	21-22 31-32	21-22 31-32	1-2	2-3	2-3	2-3	2-3	2-3	2-3

Interface	X48	X49	X46	X44	X7	X8	X9	X22	X23
G703.6 symmetric	23-24 33-34	23-24 33-34	1-2	2-3	2-3	2-3	2-3	2-3	2-3
G703.6 asymmetric	25-26 33-34	23-24 33-34	2-3	1-2	1-2	1-2	1-2	1-2	1-2

### 3.3.4.4 Selection of the Input Gain for G703.6 Interfaces

This setting controls the sensitivity of the receive equalizer.

Table 3-22 Selection of the Input Gain for G703.6 Interfaces

Input gain	LID-1	LID-2
12 dB (for short haul)	X53 / 2-3	X52 / 2-3
43 dB (for long haul)	X53 / 1-2	X52 / 1-2

### 3.3.4.5 DLE Settings for the LID-x Connection via FOM



#### NOTE

If there is a connection of the LID-x via fiber-optic modules, always select the X.21 interface on the DLE module.

When LID-x is connected via fiber-optic modules, no electrical cable must be connected at the corresponding LID-x connector.

### 3.3.5 Jumper Settings for the CLE Module

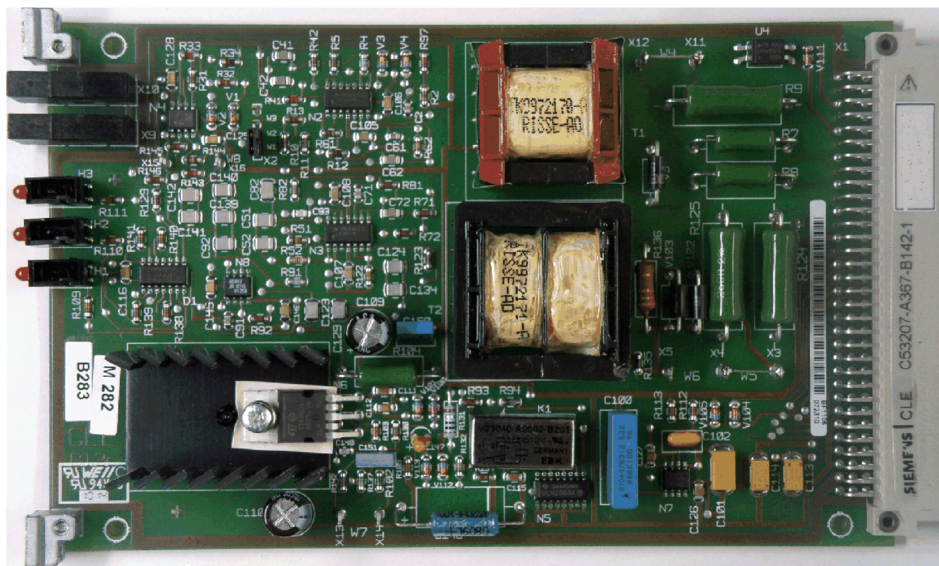

[scclejum-301111-01.tif, 1, en\_US]

Figure 3-11 Position of the Jumpers on the CLE Module

Table 3-23 Jumper Setting for the Input and Output Impedance

Setting	600 Ω	≥ 5 kΩ
Input impedance	W4	Without W4
Output impedance	W5	W6, W7, W8

Table 3-24 Jumper Setting for the Receive Signal Gain

Receive Signal Gain [dB]	Jumper X2 in Position
0	W1
+6	W2
+12	W3

### 3.3.6 Jumper Settings of the ALR Module

The function of the ALR jumpers is shown in the following table:

Table 3-25 Setting Options for the ALR Module

Jumpers					
	X2	X3	X4	X5 to X13	X14 to X17
<b>Binary Input 1 - used for Synchronization with Sync Pulse</b>					
250 V	X2 – 7-8 *)	Open	-	-	X14-X15 *)
110 V	X2 – 1-2	Open	-	-	X14-X15
48 V/60 V	X2 – 3-4	Open	-	-	X14-X15
24 V	X2 – 5-6	Open	-	-	X14-X15
Debounce time		≈ 0,6 ms ≈ 1.0 ms	X18 – 3-4 X18 – 1-2		
<b>Binary Input 1 - used for IRIG-B</b>					
24 V	Open	X3 – 1-2	-	-	X16-X17
12 V	Open	X3 – 3-4	-	-	X16-X17
5 V	Open	X3 – 5-6	-	-	X16-X17
<b>Binary Input 2 - for future application</b>					
250 V	-	-	X4 – 7-8 *)	-	-
110 V	-	-	X4 – 1-2	-	-
48 V or 60 V	-	-	X4 – 3-4	-	-
24 V	-	-	X4 – 5-6	-	-
Debounce time		≈ 0,6 ms ≈ 1.0 ms	X19 – 3-4 X19 – 1-2		
<b>Alarm Output 1 Relay K1</b>					
NC	-	-	-	X5-X6 *)	-
NO	-	-	-	X6-X7	-
<b>Alarm Output 2 Relay K2</b>					
NC	-	-	-	X8-X9 *)	-
NO	-	-	-	X9-X10	-
<b>Alarm Output 3 Relay K3</b>					
NC	-	-	-	X11-X12 *)	-
NO	-	-	-	X12-X13	-

NC (normally closed) Break contact

NO (normally open) Make contact

\*) Default setting

### 3.3.7 Power Supply Jumper Settings

#### Monitoring Loop

An inhibit loop monitors the presence of the PU4, FOM and CLE modules. Pulling the PU4, FOM and the CLE causes the interruption of the monitoring loop and the secondary voltages from PS-1 and PS-2 (if available) are disconnected.

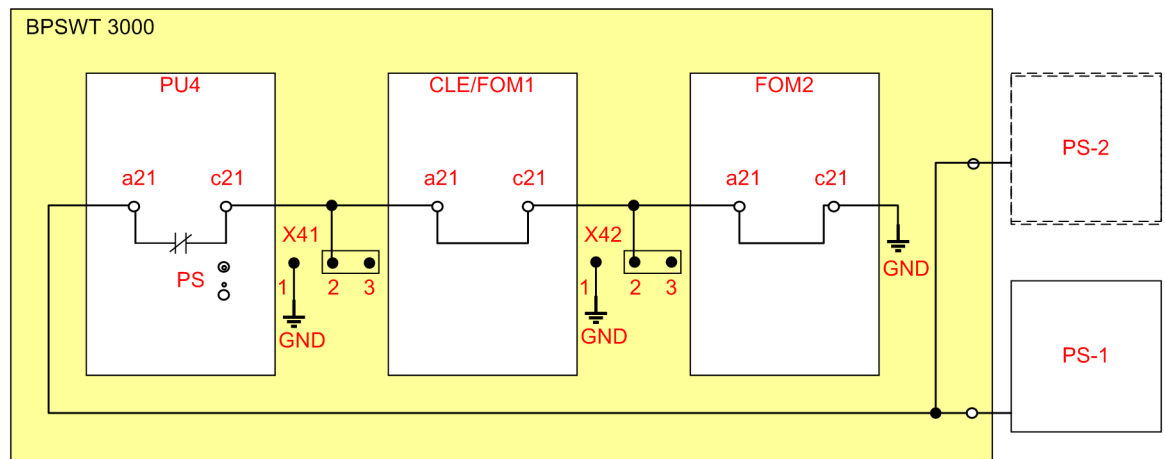

[dwinhloo-190115-01, 1, en\_US]

Figure 3-12 Inhibit Loop for the Power Supplies



#### NOTE

An On/Off switch (PS) on the PU4 (not accessible from outside) also interrupts this monitoring loop. If the CLE or FOM-1 is not used, insert the jumper X41 in position 1-2. If the FOM2 is not used, insert the jumper X42 in position 1-2.

## 3.4 Start Commissioning

### 3.4.1 Before Starting the Commissioning

The SWT 3000 device is designed to be inserted in a subrack and needs an additional mechanical and electrical enclosure.



**NOTE**

Make sure that a overvoltage category II environment is available.

---



**NOTE**

Incorporate an easily accessible bipolar disconnect device in the building installation wiring.

---



**NOTE**

Provide a prominent marking located close to the entry in order to easily gain access to the hazardous parts. This marking will indicate which disconnected device isolates the equipment completely and which disconnected device can be used to isolate each section of the equipment.

---



**NOTE**

Make sure that a sufficient cooling is provided. The allowed ambient air temperature shall not be exceeded.

---



**WARNING**

This equipment can be powered by and connected to different independent energy sources.

**Death or severe injuries can occur if specified instructions are not observed.**

✧ Before any maintenance work, the device must be isolated with the specified separators.

---

### 3.4.2 Switching on the Power Supply

The steps how to do the commissioning of the power supply is described as follows:

- In order to switch on the power supply of the SWT 3000, switch the external voltage separator in the cabinet or rack to ON position.  
The device is still switched off because the ON/OFF switch on the PU4 module is in down position (refer to [Figure 3-9](#)).
- The yellow LED (disabled) lights up on the power supply units.

### 3.4.3 Switching on the Device (with PU4 Module)

The steps how to do the commissioning of the device is described as follows:

- In order to switch on the device, put the ON/OFF switch on the PU4 module in up position (refer to [Figure 3-13](#)).
- The operate LED (green) must light up on the power supply unit and the OK LED (green or red) must light up on the PU4 module.

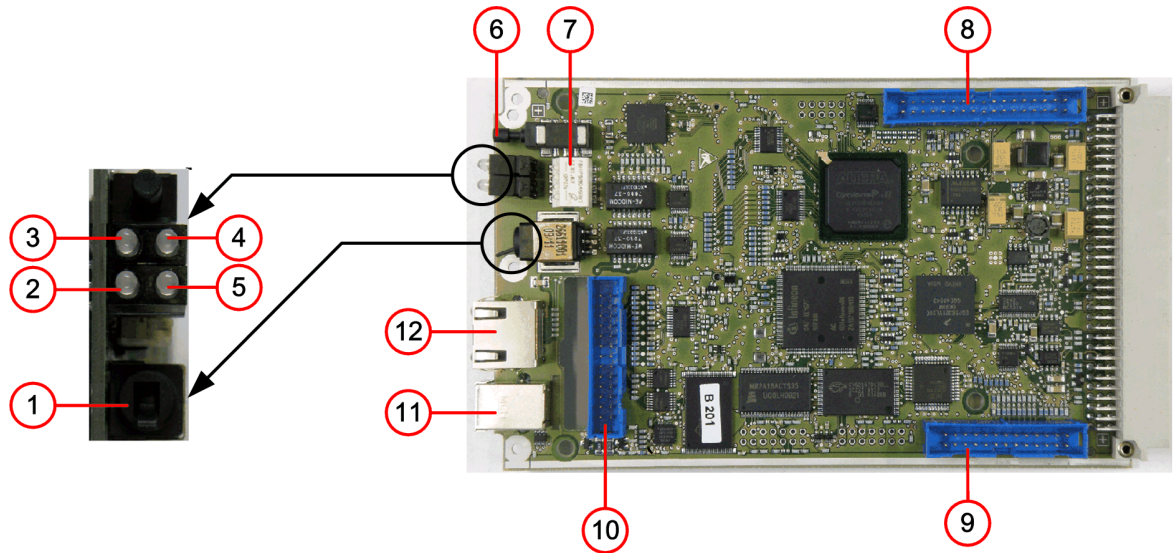

[le\_pu4jum, 1, en\_US]

Figure 3-13 Position of Jumpers, Input and Signaling Elements on the PU4 Module

- |    |                               |
|----|-------------------------------|
| 1  | S2: Power ON/OFF              |
| 2  | LED OK/GBAL                   |
| 3  | LED Status Interface LID-2    |
| 4  | LED Status Interface LID-1    |
| 5  | LED Status Interface LIA      |
| 6  | S1: Reset button              |
| 7  | S3 (3.1 to 3.4)               |
| 8  | Connection on DLE             |
| 9  | Connection on DLE             |
| 10 | Connection of the IFC Modules |
| 11 | LCT: Service Interface (USB)  |
| 12 | NMS: Ethernet Interface       |



**NOTE**

If an EN100 module is equipped and no physical Ethernet connection to the IEC61850 port is established, the SWT 3000 device start-up may be delayed by up to 60 seconds.



**DANGER**

Even if the switch of the PU4 module is in the OFF position and the device is still connected to a voltage supply source, the power supply is still energized.

**If you do not comply with the safety notes, this will result in death, severe injury, or considerable material damage.**

- ✧ Do not open and touch the power supply!



## DANGER

Even if the switch of the PU4 module is in the OFF position, the IFC modules can still be energized.

**If you do not comply with the safety notes, this will result in death, severe injury, or considerable material damage.**

✧ Do not open and touch the modules in the device!



## NOTE

When the switch of the PU4 module is in the OFF position, a squealing sound can occur, coming from the power supply. This is neither a danger nor a damage.

### 3.4.4 Connecting the Service PC

A service PC and the service program PowerSys are needed for startup, maintenance, and diagnostic purposes of the PowerLink or SWT 3000 units. The service PC is connected to the USB socket on the front panel of the PU4 module with a USB A/B plug cable.

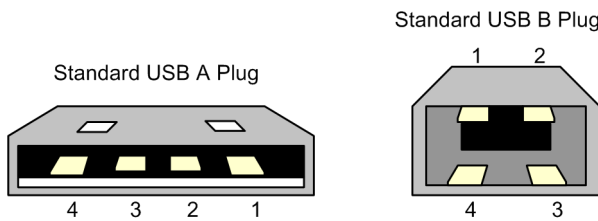

[dwpinout-300811-01.tif, 1, en\_US]

Figure 3-14 USB A/B Plug Cable

- (1) Pin 1 is  $V_{CC}$  (+5 V)
- (2) Pin 2 is Data- (D-)
- (3) Pin 3 is Data+ (D+)
- (4) Pin 4 is ground (-)

You can find a description of the service program PowerSys and for the communication to the device via the **serial** interface from the service PC or via a **TCP/IP** connection in chapter [3.4.5 PowerSys](#).

For the the installation of the Service program PowerSys refer to chapter [5.1.1 Installation](#).

### 3.4.5 PowerSys

The Service program PowerSys is required for commissioning, maintenance, and diagnosis of the PowerLink or SWT 3000 device.



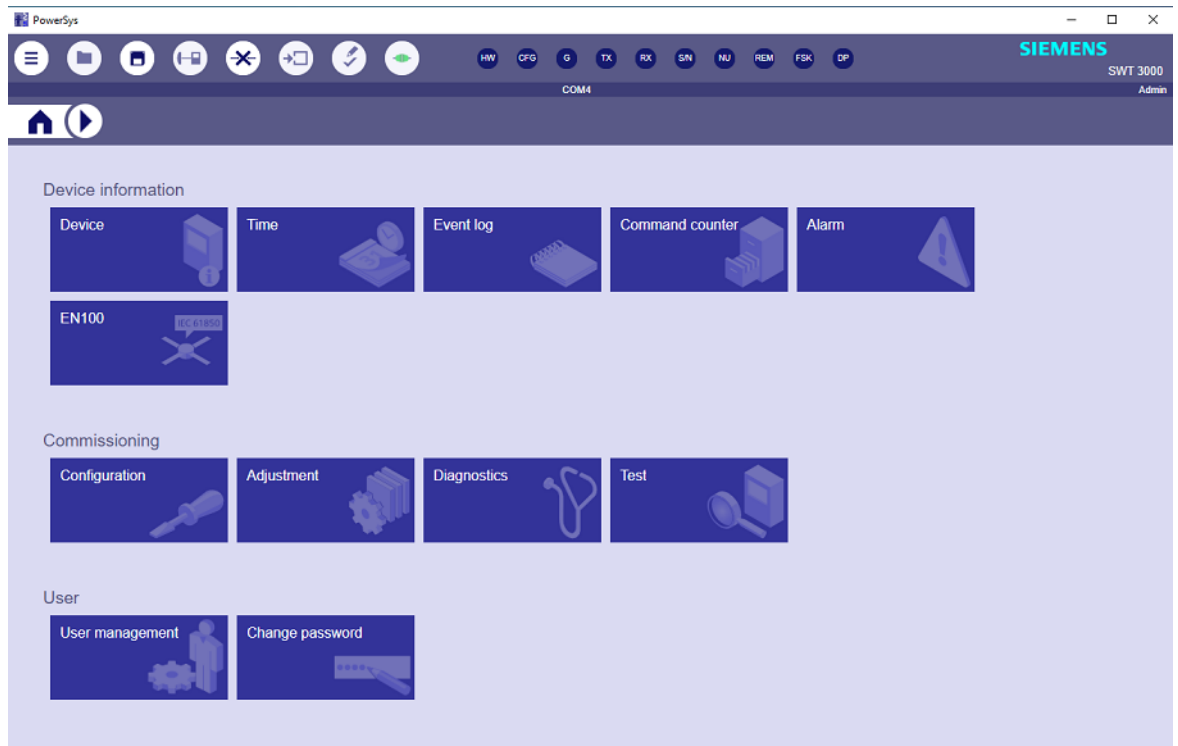

[sc\_powersys\_dashboard, 1, ---]

Figure 3-15 PowerSys dashboard

## Header

It is always located on top and contains a toolbar with iconic buttons. It provides a drop-down menu, toolbar and alarm status bar. Additionally, it holds the Siemens logo and the product name.



The shown product name is changed dynamically depending on the loaded device database (SWT 3000 or PowerLink).

A toolbar is a prominently visible panel containing controls such as iconic buttons that directly invoke frequently used application functions.



[sc\_powersys\_header, 1, ---]

Toolbar button	Description
Main menu	Drop down menu provides device connection and file operation functions.
Open	Open the parameter from a configuration file (.ddb). After the file has been loaded, the data can be modified or programmed to the device.
Save	Save the changes to the configuration file.
Connect	Establishing the connection to the device. The program attempts to establish a connection to the device and then loads the data into PC. The program detects from which device (PowerLink or SWT 3000) the data were read and automatically changes to the appropriate dashboard view.
Disconnect	Disconnecting the established connection.
Send configuration	Send the offline configuration file or online changed parameters to device. Device is programmed and reset automatically after send offline configuration file.

Toolbar button	Description
Program device	Program the changed parameters to device. Device is reset automatically after programming is successful and ready for operation again afterwards. If changing an existing PowerLink or SWT 3000 configuration, use the "Clear device setting" test command before programming the new configuration to device.
Connection status	Indicates the connection  Device is online.  Device is offline.

The main menu contained cover all available application functionality, including actions for control of the application.

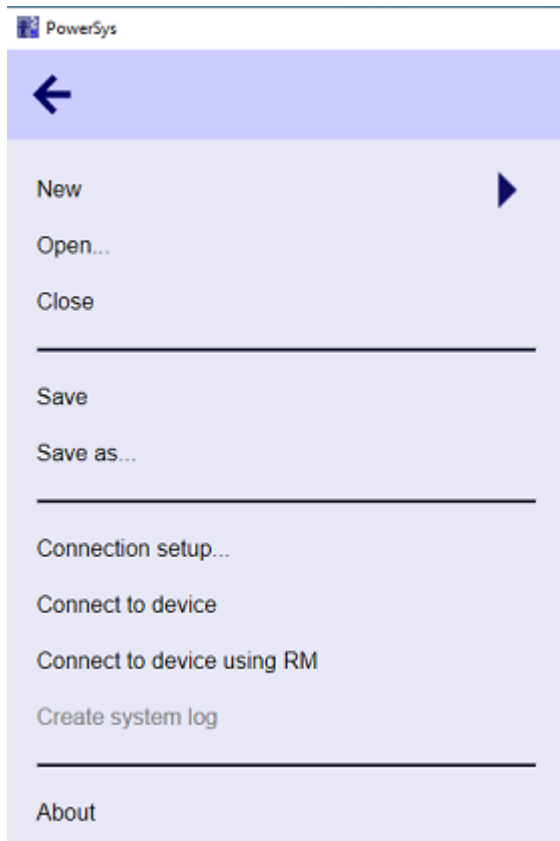

[sc\_powersys\_menu, 1, ...]

Menu	Description
Menu > New	Create a device configuration file (.ddb). Select device type and parameter release version. After that, choose the name and place of storage of the configuration file in which the data is stored.
Menu > Open...	Same function as Open toolbar button.
Menu > Close	Same function as Close toolbar button.
Menu > Save	Same function as Save toolbar button.
Menu > Save as...	Save the changes as another configuration file without replace existing file.

Menu	Description
Menu > Connection setup...	<p>The communication to the device can be carried out either via the serial interface or via a TCP/IP connection from the service PC.</p> <ul style="list-style-type: none"> <li>For a configuration of the serial interface, select the proper serial port with the Serial port to device list box.</li> <li>For a configuration of the TCP/IP interface, select the proper IP address, port number and with or without SSL.</li> </ul> <p>The selection must be in accordance with device settings. The configuration is done after clicking the Ok button.</p> <p>User preference settings (Connect method, COM, IP address, RM, Language, Last accessed file path...) will be stored in user profile for next use.</p>
Menu > Connect to device	Same function as Connect toolbar button.
Menu > Connect to device using RM	<p>Establishing the connection to the remote device using RM. RM must be configured in device. RM link must be established.</p> <p>The RM address of the connected remote device is set with the Connection setup menu.</p> <p>After the connection is established, all data of the remote device are downloaded. The duration of this procedure depends on the transmission data rate (50 bps or 300 bps).</p> <p>With the remote monitoring function, device data can be transmitted between one of the following cases:</p> <ul style="list-style-type: none"> <li>The terminals of one or more carrier frequency (CF) routes</li> <li>2 PowerLink or SWT 3000 units</li> <li>RM connection can be established over a chain of equipment</li> </ul>
Menu > Create system log	<p>If problems occur in a PowerLink or SWT 3000 connection, this function can be used to create a zip file containing important system information including the device configuration or the event log from the device.</p> <p>Select the folder for storing the zip file.</p> <p>To create the system log takes several minutes to complete, depending on the size of the log file.</p>
Menu > About	About information (release version and date)

### Alarm status bar

An alarm status bar displays the frequently monitored alarm status, like virtual LED of the device. The alarm is monitored periodically. If alarm is detected, the related alarm icon is changed to red color.



[sc\_powersys\_alarmstatus\_bar, 1, --]

Alarm	Description
HW	Hardware alarm
CFG	Configuration fault
G	General alarm
TX	Transmitter alarm
RX	Receiver alarm
S/N	Signal to noise alarm
NU	Non urgent alarm
REM	Fault in the remote device

Alarm	Description
FSK	FSK alarm (available only in PowerLink if FSK is used)
DP	DP switched to secondary bitrate (available only in PowerLink if DP is used)

### Info bar

The info bar is located between the header and the breadcrumb path. In the info bar provide short messages to the user. It shows on the left the opened file name, on the middle the COM port number, IP address and device name and on the right the name of the user that is currently logged in. The normal mode indicates normal operation mode.



[sc\_infobar\_normal\_mode, 1, ...]

Figure 3-16 Normal mode

The attention mode indicates that the application is not in the normal mode in order to avoid misunderstandings (e.g. IFC-Test).



[sc\_infobar\_attention\_mode, 1, ...]

Figure 3-17 Attention mode

### Breadcrumb

A breadcrumb is used for navigating and showing the current path within the current task. It can be used to step higher via the home icon or path element. Furthermore, it is possible to navigate quickly via tap on the separator elements between the single path elements.



[sc\_powersys\_breadcrumb, 1, ...]

### Dashboard

A dashboard gives the user an overview of all available areas and helps him to navigate through the application. It consists of several tiles which are grouped by theme.

The dashboard is changed dynamically when different device database are loaded (SWT 3000 or PowerLink).

The navigated working area is the screen space available for viewing or editing the content which is represented by breadcrumb path. In this area everything is shown with which the user works in the application, e.g. logs, configurations.

- Device information - Group for device information, alarm status and event log.
- Commissioning - Group for device configuration, adjustment, diagnostic and test commands.
- User management - Group for user management and change password.

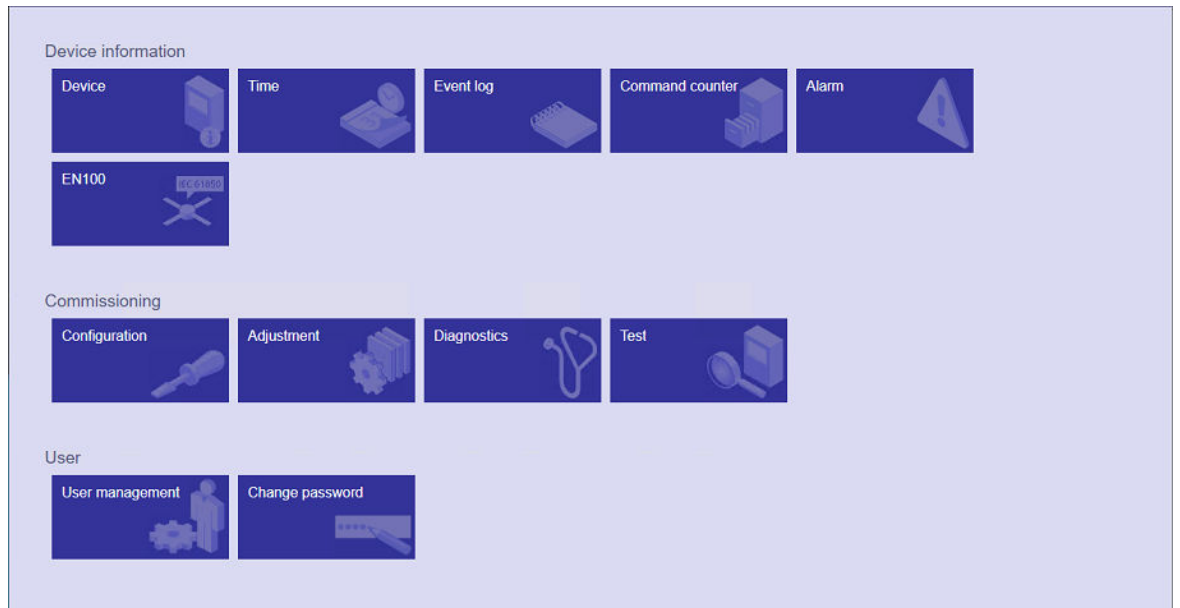

[sc\_explanation\_dashboard, 1, -,-]

Figure 3-18 PowerSys dashboard

## 3.5 Device Configuration

### 3.5.1 New Configuration

Start the new configuration selecting **Menu > New**.

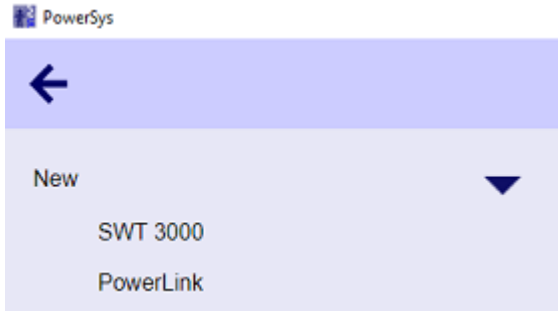

[sc\_select\_device, 1, ---]

Figure 3-19 Select device

The program asks you to select the parameter database version which is matched to your actual device. The latest version is selected by default.

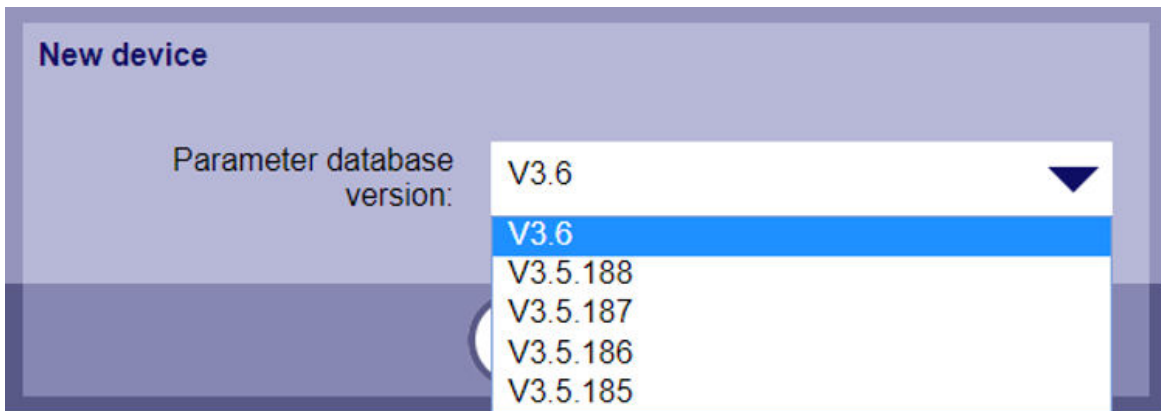

[sc\_parameter\_database\_version, 2, ---]

Figure 3-20 Select database version

When you have confirmed the selection by clicking OK, the dashboard is available for starting configuration. To finish the configuration, you can click the save button, then the save dialog will pop-up.

The following dashboard menus are available:

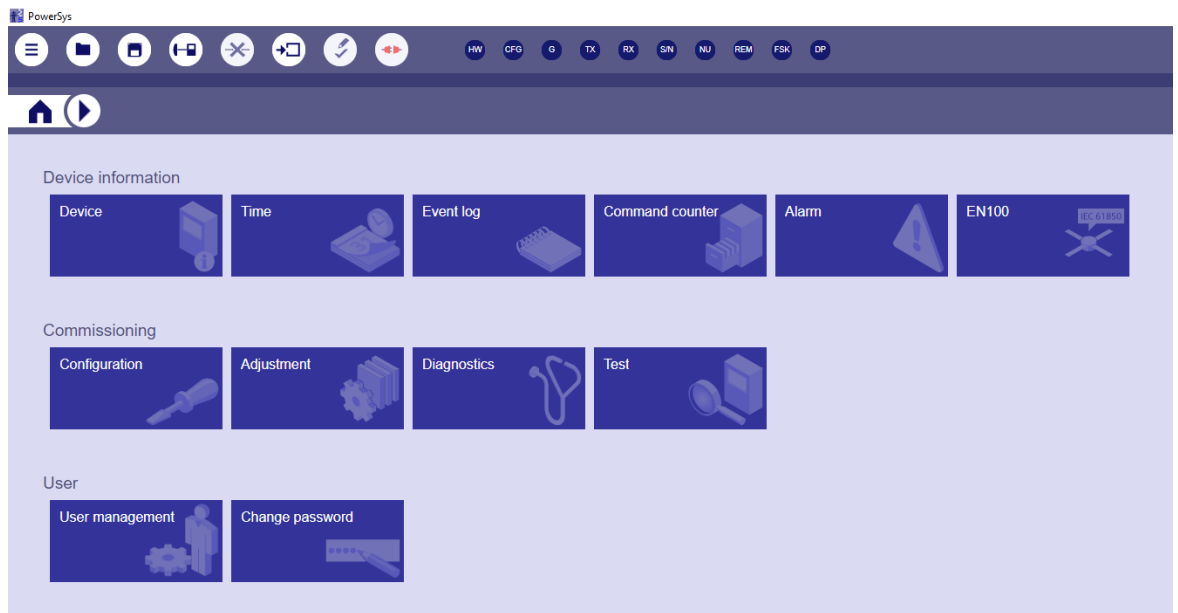

[sc swt3000\_menus, 1, --]

Figure 3-21 Dashboard menu

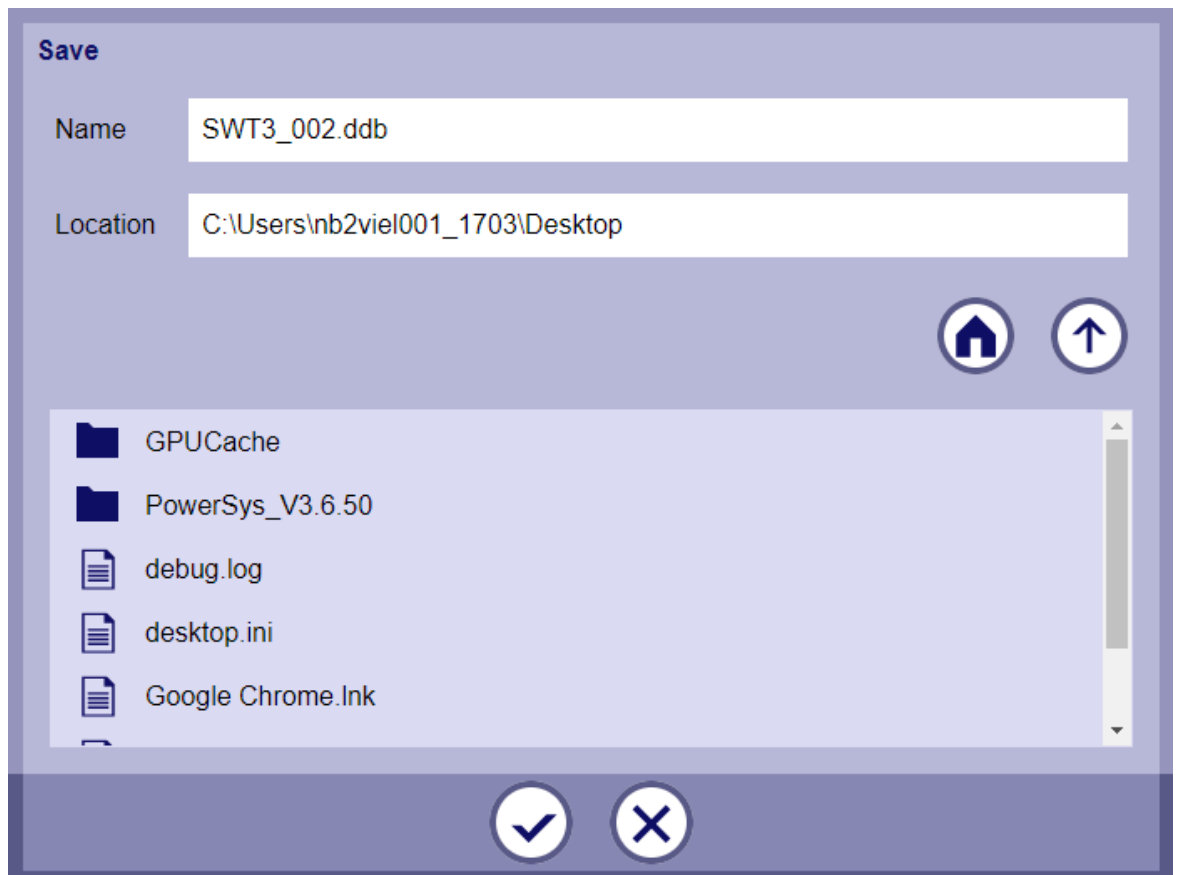

[sc\_save\_dbb, 1, --]

Figure 3-22 Save configuration file

## 3.5.2 System Configuration

### 3.5.2.1 Operation Mode

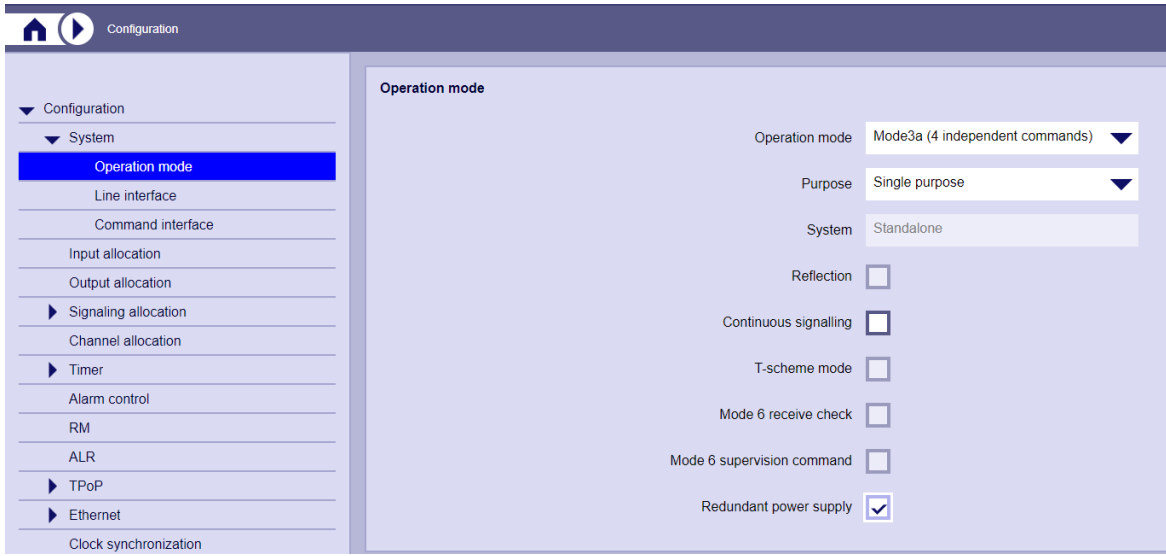

[sc\_select\_operation\_mode, 1, ...]

Figure 3-23 Operation mode configuration

Table 3-26 Selection of the Operation Modes

Operating mode	Comment
Mode 1 (double system protection)	Possible with all variants
Mode 2 (single phase protection)	Possible with all variants
Mode 3 (switching functions)	Possible with all variants except VF1_CT and VF3_CT
Mode 3a (4 independent commands)	Only possible with the variants VF1_CT or VF3_CT
Mode 3b (2 plus 2)	Only possible with the variants VF1_CT or VF3_CT
Mode 4 (only one command active)	Possible with all variants
Mode 5A (3 independent commands)	Only possible with the variants VF1 M5A or VF3 M5A
Mode 5D	Only for digital transmission paths
Mode 7a (8 independent commands)	Possible for PL IP

Possible options for system mode are:

- Stand-alone
- Integrated in PowerLink
- Via FOM

If the SWT 3000 device is not integrated in PowerLink, it is possible to configure the device as **stand-alone** or **via FOM**.

On the other hand, if the device is inserted in PowerLink (iSWT), the system mode must be fixed as **integrated in PowerLink** and allows no change.

The teleprotection signaling parameter is set as **single purpose** for stand-alone devices. The setting **alternate multi-purpose** is also possible with a Siemens PLC system depending on the configuration and parameters of the Siemens PLC system.

#### Reflection

Reflection is configurable for all protection operating modes except of Mode 3, Mode 4, Mode 5D and Mode 6. With activated **Reflection** the SWT 3000 transmits the received commands back to the equipment at the



opposite side, as long no excitation input is activated. Therefore **Reflection** may be configured only in one SWT 3000 device of a connection.

Reflection of received commands is only executed, if the excitation signal is not active and is terminated immediately with activation of the excitation input for control of the S6 signaling. The excitation of the S6 signal is provided by activation of binary input BI4 in the operating modes Mode 1 and Mode 2. In Mode 3a, Mode 3b and Mode 5A the S6 signaling is activated automatically with activation of any binary input.

Menu Option	Setting	Description
<b>Reflection</b>	No (default) <input type="checkbox"/>	The received commands activate the local outputs of SWT 3000.
	Yes <input checked="" type="checkbox"/>	The received commands activate the local outputs of SWT 3000. As long the excitation input is <b>not</b> activated during the command reception, SWT 3000 transmits the received commands back to the equipment at the opposite side.

Select **Apply** for the acceptance of all settings. If you click **Cancel**, the previous settings are retained. By clicking **OK**, the settings are accepted and the input tab is closed.



#### NOTE

If reflection of received commands shall be used, the PowerSys checkbox **Reflection** must be activated only in one SWT 3000 device of a connection.

### Continuous Signaling (Analog Transmission Path)

If persistent commands must be transmitted with the device in case of analog command transmission, activate also the option **continuous signaling**.

In this case, the transmitter of the device sends instead of the command frequency the guard tone for 180 ms at cyclical intervals. Consequently a connection can be reestablished automatically after a line interruption or failure of a device. In this case, the **command output time must be increased accordingly** (refer to [3.5.7.3 Command Output Timer](#)).

Menu Option	Setting	Description
<b>Continuous signaling</b>	No (default) <input type="checkbox"/>	Normal command transmission
	Yes <input checked="" type="checkbox"/>	Command transmission is cyclically interrupted by transmitting guard

Select **Apply** for the acceptance of all settings. If you click **Cancel**, the previous settings are retained. By clicking **OK**, the settings are accepted and the input tab is closed.

### Power Supply

If the SWT 3000 is operated with 2 power supplies, monitoring of the second power supply must be activated under **Operation mode** by selecting **Redundant power supply**.

#### 3.5.2.2 Line Interface

The menu option **Line interface** offers the following setting options:

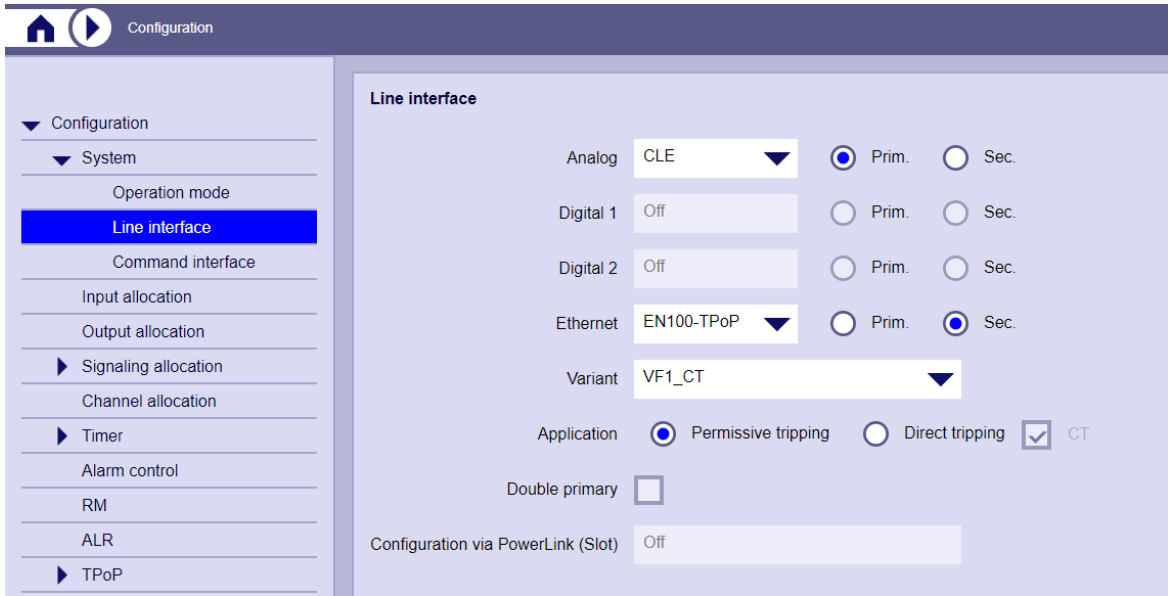

[sc\_select\_line\_interface, 1, --]

Table 3-27 Setting Options for Analog Connection of the PU4 Module

Connection Analog	Comment
off	No analog interface
CLE (only with system setting <b>stand-alone</b> )	Stand-alone devices with cable connection, or connection to a Siemens PLC system via the CLE module
via CSPI (dig)	If integrated in the PowerLink system
FOM-1 analog	Stand-alone device with FOM connection to a PowerLink system

Table 3-28 Setting Options for Digital Connection of the PU4 Module

Connection Digital 1/2	Comment
X.21 DTE / DCE	Digital interface X.21 DTE or DCE
G703.1 DTE / DCE	Digital interface G703.1 64 Kbps DTE or DCE
G703.6 DTE / DCE	Digital interface G703.6 2 Mbps DTE or DCE
G704	Digital interface with framed E1 mode
FOM 64k DTE / DCE	Fiber-optic connection between 2 SWT 3000 with 64 Kbps
FOM 2M DTE / DCE	Fiber-optic connection between 2 SWT 3000 with 2 Mbps
FOBox 64k	Fiber-optic connection to the FOBox bit rate 64 Kbps (discontinued)
FOBox 2M	Fiber-optic connection to the FOBox bit rate 2 Mbps (discontinued)
C37.94-DTE / DCE	Fiber-optic connection between 2 SWT 3000 with C37.94 protocol

PU4 module types:

- PU4-LIA for analog, digital and Ethernet interfaces
- PU4-LID for digital and Ethernet interfaces only. It cannot be used as spare part of iSWT

If only digital or Ethernet interfaces are required in customer order, the PU4-LID board is delivered by production.

In case of analog or mixed interfaces, the PU4-LIA board is delivered.

A primary and an optional, secondary connection interface for path redundancy can be configured. By default, path redundancy is set according to priority as Digital 1 / 2 > Ethernet > Analog. In case of double digital lines, 2 Mbps data rate > 64 Kbps data rate.



**NOTE**

The digital fiber-optic interface can be adjusted to FOM\_64k/2M-DCE/DTE, C37.94\_DCE/DTE. On the DLE module the X.21 jumpers must be selected. For G704 the DLE jumpers must be set to G703.6.

Table 3-29 Setting Options for Ethernet Connection of SWT 3000 devices

Connection Ethernet	Comment
off	No Ethernet connection
EN100-TPoP	Ethernet line interface via EN100-TPoP

Table 3-30 Setting Options for Application

Application	Comment
<b>Direct tripping</b>	This setting offers enhanced transmission security of the analog interface and must be selected for teleprotection systems with direct tripping. The transmission time is about 5 ms longer compared with the setting <b>permissive tripping</b> .
<b>Permissive tripping</b>	This setting must be selected for permissive protection systems.
<b>Coded Transmission</b>	Switchover from the F6 modulation to the coded transmission. Refer to <i>Functional Description</i> ). For the operating modes 3, 5A, or 6, the coded transmission is not adjustable.

The following figure shows the connection of 2 SWT 3000 systems via the fiber-optic modules. In this case, the digital interface LID-1 or LID-2 of the SWT 3000 is used.

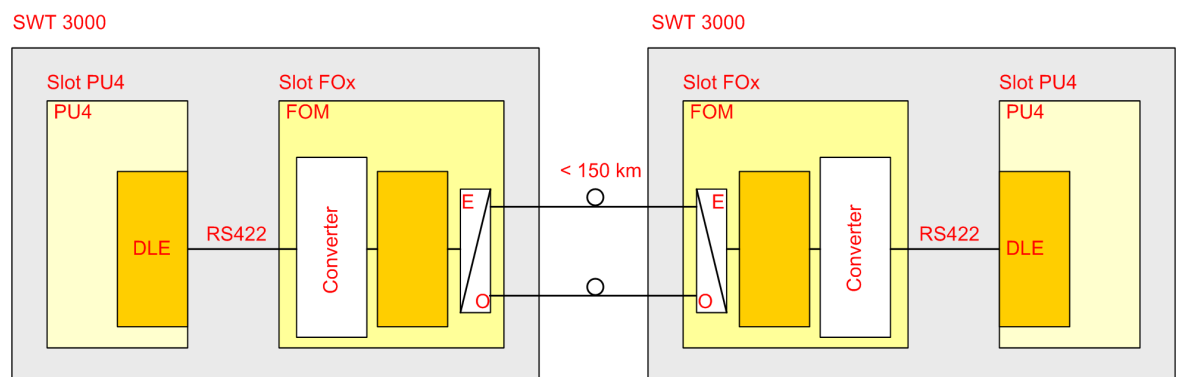

[dwcossww-071111-01.tif, 1\_en\_US]

Figure 3-24 Connection of 2 SWT 3000 via FOM

The digital interface can be adjusted to 64 Kbps (FOM 64k-DCE or DTE) or 2 Mbps (FOM 2M-DCE or DTE). All setting options for the interfaces are shown in [3.5.2.2 Line Interface](#). On the DLE module **in each case, the X.21 interface** must be selected.

Refer also to [3.3.4.2 Jumper Settings for the Selection of Digital Line Interfaces LID-1](#) and [3.3.4.3 Jumper Settings for the Selection of Digital Line Interfaces LID-2](#)).

### C37.94 Data rate 1/2

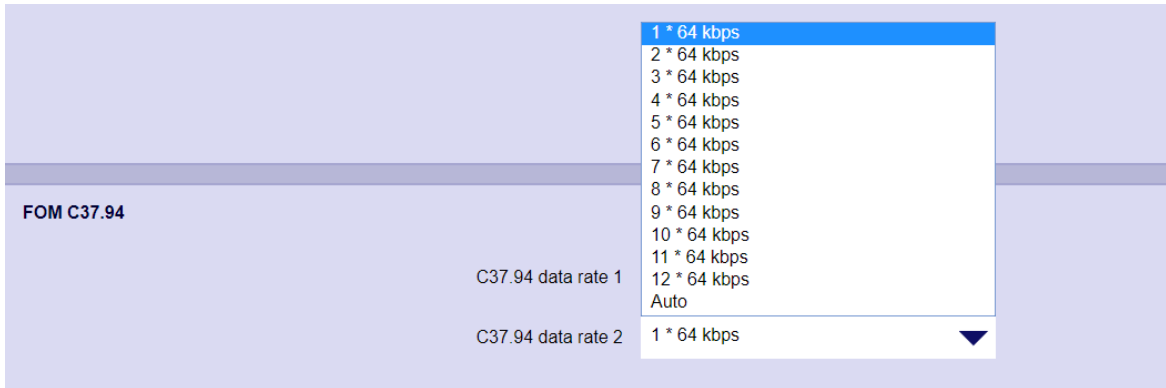

[sc\_fom\_data\_rate, 1, --]

The data rate must be 1 to 12 x 64 Kbps. For C37.94 DTE, it is also possible to detect the data rate of the DCE device automatically by selecting Auto in the data rate field.

If only one interface has been selected, only the corresponding data rate field is enabled. The other one is disabled.

### Transmitter and Receiver Address for digital interfaces



[sc\_digital\_line\_addresses, 1, --]

When several SWT 3000 links are connected in the same digital network via multiplexers a unique addressing of transmitting and receiving device avoids unwanted operation of SWT 3000 devices due to incorrect routing, switching or cabling in the digital network. Associated local and remote SWT 3000 devices are identified within the network by the address bits transmitted with the DLE data stream.

Configure a unique transmitter address and the receiver address of the associated SWT 3000 device for digital or fiber-optic connections via the LID-interfaces of the DLE. The following figure shows the principle of addressing for associated devices.

The range for TX- and RX- addresses is 1 ... 255. The address range is reduced to 127, if line clock sync or command loop test is enabled. The device address settings apply to both digital connection interfaces simultaneously.

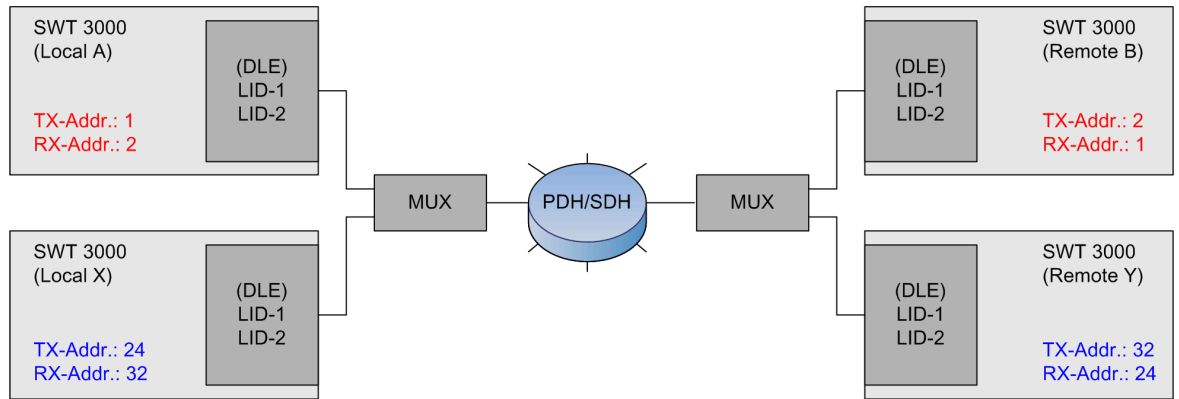

Local SWT 3000 „A“ (addr.=1) associated to Remote SWT 3000 „B“ (addr. = 2)  
Local SWT 3000 „X“ (addr.=24) associated to Remote SWT 3000 „Y“ (addr. = 32)

[dwlidadr-300414-01.tif, 1, en\_US]

Figure 3-25 Examples for Setting of Transmitter and Receiver address



**NOTE**

Wrong or invalid address settings may cause malfunction of the teleprotection signaling in associated and/or non-associated devices of the digital network.

**3.5.2.3 Command Interface**

The number and type of the interface module IFC-x is defined in **Command interface**.  
If an EN100 module is equipped, you can activate the EN100 and select the proper files.  
You can also activate the test mode.

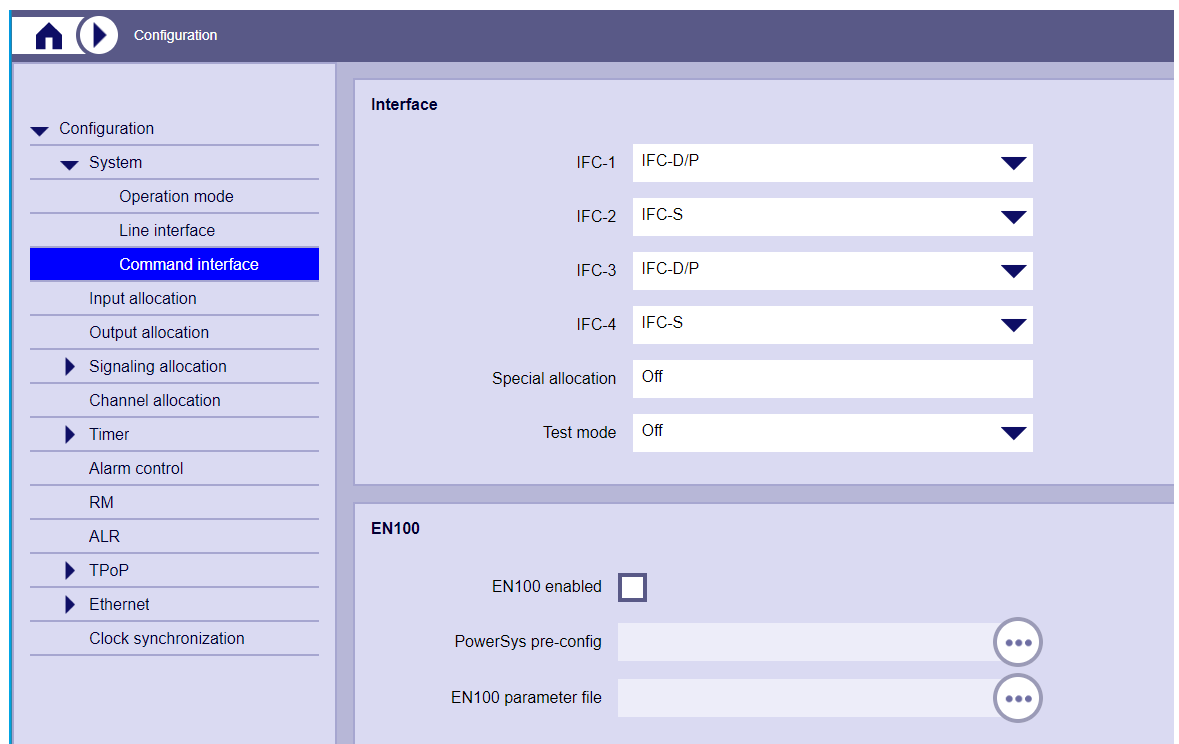

[sc\_command\_interface, 1, -\_-]

Figure 3-26 Dialog for the SWT 3000 Command interface configuration

**Binary Command Interface**

*IFC-1 and IFC-3* Slots IFC-1 and IFC-3 must be equipped with an interface module IFC-D (high contact load) or IFC-P (normal contact load). The commands to be transmitted by the protective relay are also connected here (binary inputs). Output of the received commands to the protective relay is also via these modules.

*IFC-2 and IFC-4* Additional slots for IFC-2 and IFC-4 are available. These additional slots can be equipped with one of the following IFC types:

- IFC-D
- IFC-P
- IFC-S (signaling)

If these slots are equipped with an IFC-D or IFC-P, the relays of these modules can be used (in case of analog transmission) for doubling the command output contacts. In case of contact doubling the inputs are not used.

If these slots are equipped with an IFC-S module, these modules are used for one of the following cases:

- For signaling commands that are entered (activation of binary inputs)
- For signaling commands that are output (binary output)



**NOTE**

Use flyback diodes for any relays that are connected to an output SWT to avoid EMC influences.

Table 3-31 Equipment Options for Slots IFC-1 to IFC-4

Slot	Equipment	Application
IFC-1	IFC-D or IFC-P	Command input/command output
IFC-2	IFC-D, IFC-P, or IFC-S	Doubling of command output contacts slot IFC-1 or status messages. Command input/command output only with digital interfaces.
IFC-3	IFC-D or IFC-P	Command input/command output
IFC-4	IFC-D, IFC-P, or IFC-S	Doubling of command output contacts slot IFC-3 or status messages. Command input/command output only with digital interfaces.

**GOOSE Command Interface**

When the EN100 module is equipped, generate the preconfiguration file (CFG) and the EN100 parameter file (BIN) using the MergeTool. For more information about IEC 61850 configuration in MergeTool and DIGSI refer to [5.7.2 Parameter Generator](#).

In order to activate the **Configuration > System > Command interface > EN100**, select the **EN100**  check box.

Click on **PowerSys Pre-Config** to upload the CFG file.

The following dialog appears:

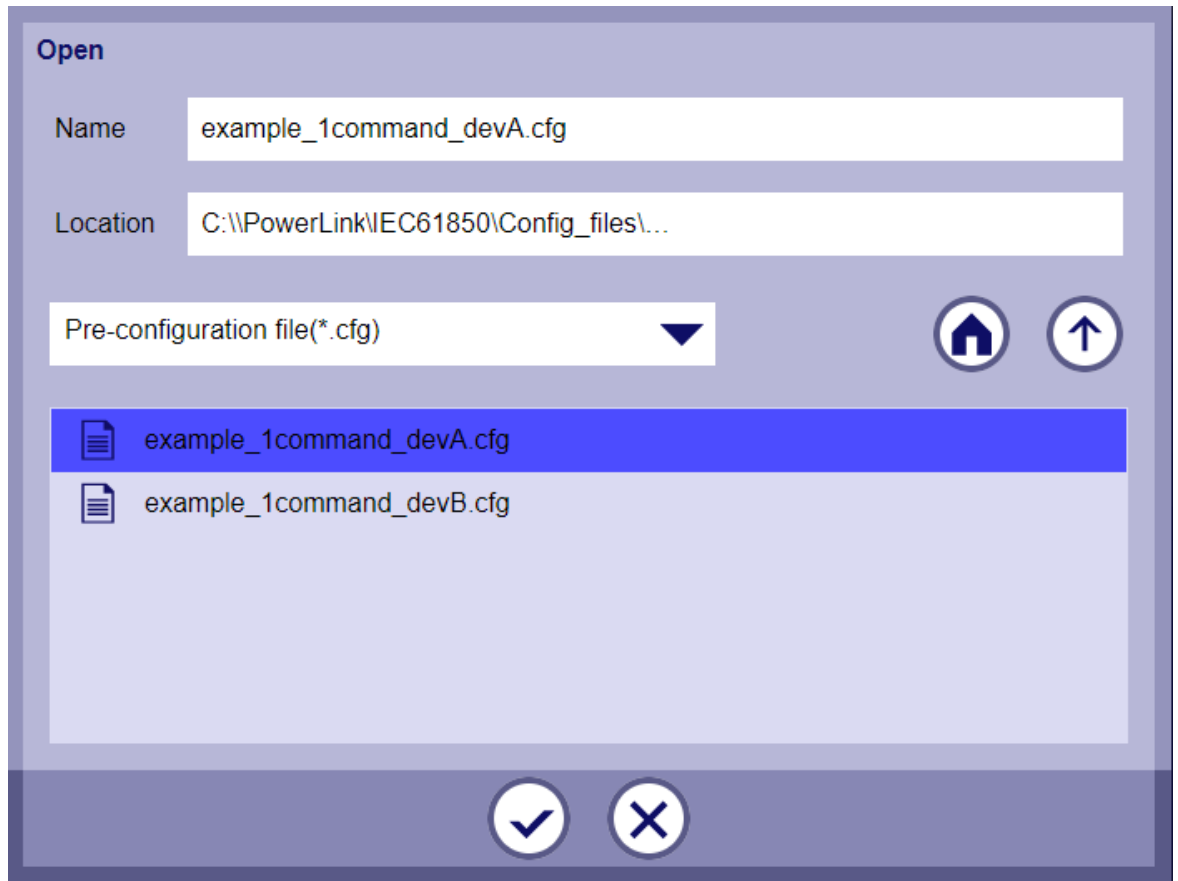

[sc\_en100\_upload\_preconfig\_file, 1, --]

Figure 3-27 Select EN100 CFG file

Select the proper **CFG File**.

Click the **EN100 Parameter File** button to upload the BIN file.

The following dialog appears:

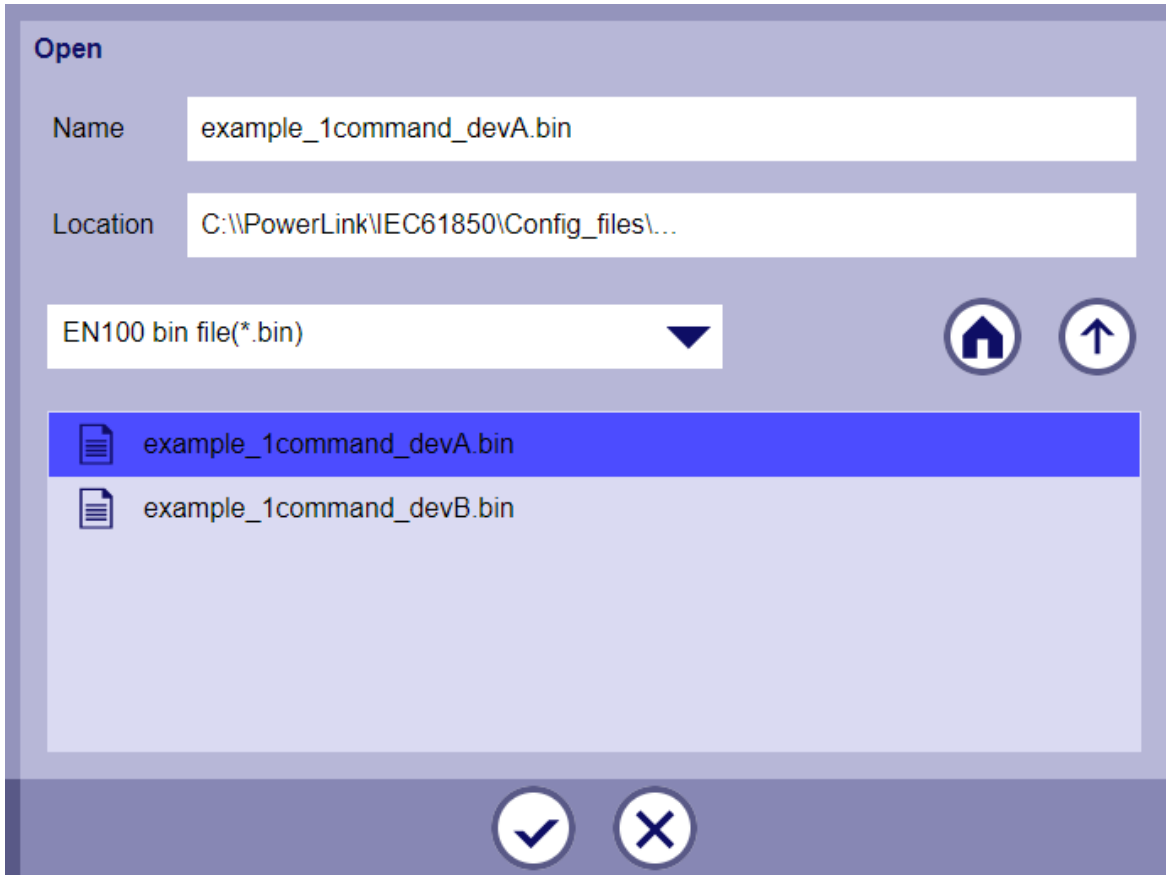

[sc\_en100\_upload\_bin\_file, 1, ---]

Figure 3-28 Select EN100 BIN file

Select the proper **BIN File**.

With saving the configuration file (ddb-file), the BIN file is merged into the ddb-file automatically. If you want to configure another SWT 3000 device with the same configuration data, load the saved ddb-file in PowerSys. You can program the BIN file now into the device in order to configure the EN100 module.

You can insert only IFC-D or IFC-P modules in slot IFC-1 and IFC-3 in the subrack. Slot IFC-2 and IFC-4 can also be equipped with the IFC-D/P modules or alternatively with the IFC-S module. When an IFC-S module is configured the IFC-S signaling outputs are automatically enabled with a default (1:1) allocation. Check the configuration in menu **Signaling Allocation**. For more detailed information about the interface modules refer to *Interface Modules* of this Equipment Manual.

**Contact Doubling**

If using 2 or more IFC-D/P modules, Contact Doubling can be configured in one of the following cases:

- If there is an analog transmission interface or analog secondary path, only the output relays of the module at the IFC-2 slot are used for contact doubling. The inputs are not used because the maximum number of commands is 4 commands for an analog transmission interface or an analog secondary path. The function **Contact doubling** can be activated in the **Special allocation** list box.

If Interface modules IFC-D/P are configured for the slots IFC-3 and IFC-4, the unused outputs of these modules can be individually configured as signaling outputs in **PowerSys - Configuration - Signaling Allocation**.

Refer also to [8.1.2 Exclusively Analog Transmission Interface or Analog Secondary Path](#).



- In operating mode 5D with digital transmission path, there are 8 inputs and outputs available. With special allocation **Contact doubling** and 4 Interface modules IFC-D/P the IFC-1 output commands OUT1 to OUT4 are doubled to outputs on IFC-2. The IFC-3 output commands OUT5 to OUT8 are doubled on IFC-4. **Contact doubling** with only 2 Interface modules IFC-D/P is possible, but the transmittable commands are reduced to 4 commands then. The available output commands OUT1 to OUT4 of IFC-1 are doubled to outputs on IFC-2.

Refer also to [8.1.3 Exclusively Digital Transmission Interfaces](#).

Operation mode 3a / 3b / 5D are based on free allocation and each command can be allocated with any vacant IFC ports. In this case, the option "contact doubling" is just a preset configuration and the user is still able to reallocate the ports if necessary.



**NOTE**

Check the **Input Configuration** submenu in the SWT 3000 > Configuration menu.  
The special allocation **Contact doubling** can only be enabled when IFC-S is not configured.

**2CMD+ACK**

With the function **Two Commands with Acknowledge** (2CMD+ACK) the first input on each Interface module IFC-D/P is fixed allocated to a signaling output in the local SWT 3000 device. Additionally the first command output relay of each Interface module IFC-D/P is fixed allocated to another signaling output at local side.

[Figure 3-29](#) shows the scheme of signaling allocation for the acknowledge of the corresponding command inputs and outputs.

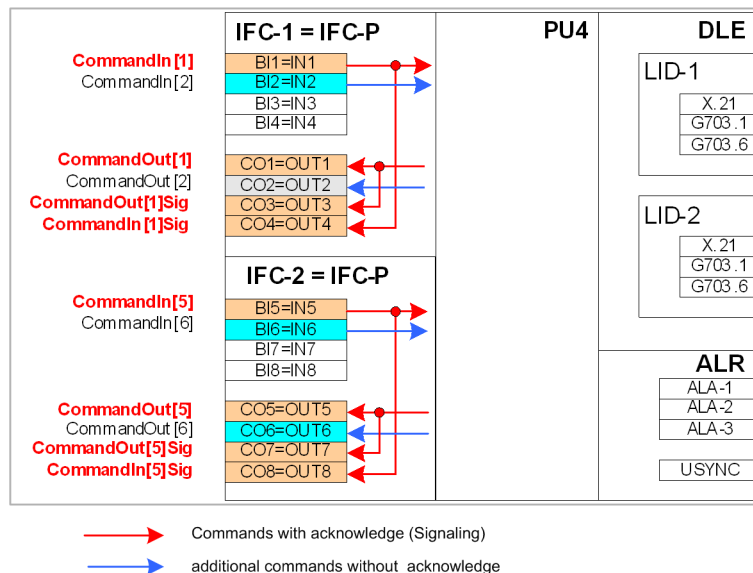

[dw\_SWT\_2cmdac\_1\_en\_US]

Figure 3-29 Two Commands with Acknowledge (2CMD+ACK)

Originally designed for 2 IFC modules the feature is enhanced for the transmission of up to 4 commands with acknowledge and 4 additional commands without acknowledge, if 4 IFC-D/P modules are inserted in SWT 3000. There are 8 inputs from IFC-1 to IFC-4 available in operating mode 5D while 2CMD+ACK is configured in the **Special allocation** list box. Only the first 2 binary inputs of each IFC modules are enabled. In the following table, the enabled inputs and their allocation to Signaling outputs at the local side ("Acknowledge") and command outputs at remote side are listed:

Table 3-32 Default allocation of Outputs for 2CMD+ACK

Input	Output at the Local Side (Signaling)	Output at the Remote Sides
BI1	CO4	CO1 + CO3
BI2	X	CO2
BI5	CO8	CO5 + CO7
BI6	X	CO6
BI9	CO12	CO9 + CO11
BI10	X	CO10
BI13	CO16	CO13 + CO15
BI14	X	CO14

X = Not available

Every combination of these inputs is possible for transmission. The input/output allocation of each IFC module is similar. The function **2CMD+ACK** can also be used with only 1 Interface module IFC-D/P for transmission of 1 command with acknowledge and second command without acknowledge.



**NOTE**

The special allocation 2CMD+ACK can only be enabled in the operating **Mode 5D** and only, if no IFC-S modules are configured.

**IFC-S Signaling**

When an IFC-S module is configured, the IFC-S signaling outputs are automatically enabled with a default (1:1) allocation

Slot	Equipment	Application
IFC-2	IFC-S	IFC-2 / OUT1 : Signaling of IFC-1 command input 1 IFC-2 / OUT2 : Signaling of IFC-1 command input 2 IFC-2 / OUT3 : Signaling of IFC-1 command input 3 IFC-2 / OUT4 : Signaling of IFC-1 command input 4 IFC-2 / OUT5 : Signaling of IFC-1 command output 1 IFC-2 / OUT6 : Signaling of IFC-1 command output 2 IFC-2 / OUT7 : Signaling of IFC-1 command output 3 IFC-2 / OUT8 : Signaling of IFC-1 command output 4
IFC-4	IFC-S	IFC-4 / OUT1 : Signaling of IFC-3 command input 1 IFC-4 / OUT2 : Signaling of IFC-3 command input 2 IFC-4 / OUT3 : Signaling of IFC-3 command input 3 IFC-4 / OUT4 : Signaling of IFC-3 command input 4 IFC-4 / OUT5 : Signaling of IFC-3 command output 1 IFC-4 / OUT6 : Signaling of IFC-3 command output 2 IFC-4 / OUT7 : Signaling of IFC-3 command output 3 IFC-4 / OUT8 : Signaling of IFC-3 command output 4

**3.5.3 Input Allocation**

Free allocation is enabled in mode 3a / 3b and mode 5D by default. The command input and output can be allocated to any free port of 4 IFC modules (e.g. command 1 = IFC-1/Port-1, command 2 = IFC-2/Port-1). If an external SWT 3000 is connected to PowerLink via FOM, the maximum 4 commands can be allocated to 4 IFC modules (one command for one IFC).

The command input is configured in Menu **Input allocation**.

When one command input is enabled, the IFC input port selection area shows all available IFC input ports. The unavailable or assigned IFC ports are invisible. After selection, the command input is assigned to the selected IFC port.

Input	Enable	Input port	Invert	Name	Input	Enable	Input port	Invert
(1)	<input checked="" type="checkbox"/>	IFC-1/IN1 ▼	<input type="checkbox"/>	IED X POTT TX	(9)	<input type="checkbox"/>		<input type="checkbox"/>
(2)	<input checked="" type="checkbox"/>	IFC-1/IN2 ▼	<input type="checkbox"/>	IED X DEF TX	(10)	<input type="checkbox"/>		<input type="checkbox"/>
(3)	<input checked="" type="checkbox"/>	IFC-1/IN3 ▼	<input type="checkbox"/>	IED Y POTT TX	(11)	<input type="checkbox"/>		<input type="checkbox"/>
(4)	<input checked="" type="checkbox"/>	IFC-1/IN4 ▼	<input type="checkbox"/>	IED Y DEF TX	(12)	<input type="checkbox"/>		<input type="checkbox"/>
(5)	<input type="checkbox"/>		<input type="checkbox"/>		(13)	<input type="checkbox"/>		<input type="checkbox"/>
(6)	<input type="checkbox"/>		<input type="checkbox"/>		(14)	<input type="checkbox"/>		<input type="checkbox"/>
(7)	<input type="checkbox"/>		<input type="checkbox"/>		(15)	<input type="checkbox"/>		<input type="checkbox"/>
(8)	<input type="checkbox"/>		<input type="checkbox"/>		(16)	<input type="checkbox"/>		<input type="checkbox"/>

[sc\_input\_allocation, 2, ---]

Figure 3-30 Command Input Allocation

Each command input / output has a naming text field with maximum 16 characters. The configured command name will be displayed in timer configuration, command counter, event log and SNMP trap message. It is helpful to better understand offline without circuit diagram which command has been configured or tripped. Command name is only configurable in free allocation mode (Mode 3a / 3b / 5D).

The configuration of the command output is similar to the command input: **PowerSys SWT 3000 > Configuration > Output Allocation.**

### 3.5.4 Output Allocation

Output	Enable	Output port	Name	Output	Enable	Output port	Name
(1)	<input checked="" type="checkbox"/>	IFC-1/OUT1 ▼	IED X POTT RX	(9)	<input type="checkbox"/>		
(2)	<input checked="" type="checkbox"/>	IFC-1/OUT2 ▼	IED X DEF RX	(10)	<input type="checkbox"/>		
(3)	<input checked="" type="checkbox"/>	IFC-1/OUT3 ▼	IED Y POTT RX	(11)	<input type="checkbox"/>		
(4)	<input checked="" type="checkbox"/>	IFC-1/OUT4 ▼	IED Y DEF RX	(12)	<input type="checkbox"/>		
(5)	<input type="checkbox"/>			(13)	<input type="checkbox"/>		
(6)	<input type="checkbox"/>			(14)	<input type="checkbox"/>		
(7)	<input type="checkbox"/>			(15)	<input type="checkbox"/>		
(8)	<input type="checkbox"/>			(16)	<input type="checkbox"/>		

[sc\_output\_allocation, 2, ---]

Figure 3-31 Command output allocation

In analog operation, every possible combination of binary inputs is permanently assigned to a protection frequency depending on the operating mode (Mode 1 to Mode 5A) and the function unblocking **On** or **Off**. At the receiving end, every protection frequency can be assigned to one or more signal outputs (CO1 to CO4) according to the output allocation.

In digital operation, it is also possible to assign the outputs to the activated binary inputs for the operating mode **Mode 5D**.

This assignment is **permanently set** for the operating modes **Mode 1, 2, 3, and Mode 4** and **cannot** be changed with the output allocation.

In device configurations **Mode 3a** or **Mode 5D** with EN100 and IFC (Mixed mode) the first input ports are always allocated to the pre-configured EN100 channels.

The remaining input ports (depending on the number of assigned EN100 channels) are allocated to the input ports of IFC module in ascending order, IFC-1/IN1, IFC-1/IN2, etc.

### 3.5.5 Signaling Allocation

The submenu **Signaling Allocation** is used to configure in a flexible way the output ports of IFC-D/P/S as command signaling outputs for any input or output command or alarm signaling.

Signaling allocation affects the following allocations:

- 2CMD+ACK
- Contact doubling
- IFC-S signaling

In the following example, you can see an example of the operating **Mode 5D** with IFC-1 and IFC-3 equipped as IFC-D/P boards while IFC-2 and IFC-4 are IFC-S boards.

Idx	IFC 2-1	IFC 2-2	IFC 2-3	IFC 2-4	IFC 2-5	IFC 2-6	IFC 2-7	IFC 2-8	IFC 4-1	IFC 4-2	IFC 4-3	IFC 4-4	IFC 4-5	IFC 4-6	IFC 4-7	IFC 4-8
OUT 1	<input type="checkbox"/>	<input type="checkbox"/>	<input type="checkbox"/>	<input type="checkbox"/>	<input checked="" type="checkbox"/>	<input type="checkbox"/>	<input type="checkbox"/>	<input type="checkbox"/>	<input type="checkbox"/>	<input type="checkbox"/>	<input type="checkbox"/>	<input type="checkbox"/>	<input type="checkbox"/>	<input type="checkbox"/>	<input type="checkbox"/>	<input type="checkbox"/>
OUT 2	<input type="checkbox"/>	<input type="checkbox"/>	<input type="checkbox"/>	<input type="checkbox"/>	<input type="checkbox"/>	<input checked="" type="checkbox"/>	<input type="checkbox"/>	<input type="checkbox"/>	<input type="checkbox"/>	<input type="checkbox"/>	<input type="checkbox"/>	<input type="checkbox"/>	<input type="checkbox"/>	<input type="checkbox"/>	<input type="checkbox"/>	<input type="checkbox"/>
OUT 3	<input type="checkbox"/>	<input type="checkbox"/>	<input type="checkbox"/>	<input type="checkbox"/>	<input type="checkbox"/>	<input type="checkbox"/>	<input checked="" type="checkbox"/>	<input type="checkbox"/>	<input type="checkbox"/>	<input type="checkbox"/>	<input type="checkbox"/>	<input type="checkbox"/>	<input type="checkbox"/>	<input type="checkbox"/>	<input type="checkbox"/>	<input type="checkbox"/>
OUT 4	<input type="checkbox"/>	<input type="checkbox"/>	<input type="checkbox"/>	<input type="checkbox"/>	<input type="checkbox"/>	<input type="checkbox"/>	<input type="checkbox"/>	<input checked="" type="checkbox"/>	<input type="checkbox"/>	<input type="checkbox"/>	<input type="checkbox"/>	<input type="checkbox"/>	<input type="checkbox"/>	<input type="checkbox"/>	<input type="checkbox"/>	<input type="checkbox"/>
OUT 5	<input type="checkbox"/>	<input type="checkbox"/>	<input type="checkbox"/>	<input type="checkbox"/>	<input type="checkbox"/>	<input type="checkbox"/>	<input type="checkbox"/>	<input type="checkbox"/>	<input type="checkbox"/>	<input type="checkbox"/>	<input type="checkbox"/>	<input type="checkbox"/>	<input checked="" type="checkbox"/>	<input type="checkbox"/>	<input type="checkbox"/>	<input type="checkbox"/>
OUT 6	<input type="checkbox"/>	<input type="checkbox"/>	<input type="checkbox"/>	<input type="checkbox"/>	<input type="checkbox"/>	<input type="checkbox"/>	<input type="checkbox"/>	<input type="checkbox"/>	<input type="checkbox"/>	<input type="checkbox"/>	<input type="checkbox"/>	<input type="checkbox"/>	<input type="checkbox"/>	<input checked="" type="checkbox"/>	<input type="checkbox"/>	<input type="checkbox"/>
OUT 7	<input type="checkbox"/>	<input type="checkbox"/>	<input type="checkbox"/>	<input type="checkbox"/>	<input type="checkbox"/>	<input type="checkbox"/>	<input type="checkbox"/>	<input type="checkbox"/>	<input type="checkbox"/>	<input type="checkbox"/>	<input type="checkbox"/>	<input type="checkbox"/>	<input type="checkbox"/>	<input type="checkbox"/>	<input checked="" type="checkbox"/>	<input type="checkbox"/>
OUT 8	<input type="checkbox"/>	<input type="checkbox"/>	<input type="checkbox"/>	<input type="checkbox"/>	<input type="checkbox"/>	<input type="checkbox"/>	<input type="checkbox"/>	<input type="checkbox"/>	<input type="checkbox"/>	<input type="checkbox"/>	<input type="checkbox"/>	<input type="checkbox"/>	<input type="checkbox"/>	<input type="checkbox"/>	<input type="checkbox"/>	<input checked="" type="checkbox"/>

[sc\_output\_signaling, 1, ...]

Figure 3-32 Configuration Menu **Signaling allocation - Output signaling**, e.g. for Operating Mode 5D

When an IFC-S module is configured (as IFC-2 and/or IFC-4) the IFC-S signaling is automatically enabled with a default allocation. The signaling allocation can be modified individually.

Unused command outputs of the Interface modules IFC-P, IFC-D or IFC-S can be flexible configured for signaling outputs in all protection operating modes.

### 3.5.6 RM Configuration

Device data can be transmitted between the terminal devices of one or more SWT 3000 routes using RM. This transmission makes it possible to import the parameter settings, the measuring points, and the event list of the station from an SWT 3000 with the service PC.

The binary frequency shift keying (FSK) of the guard tone transmits the device data via the analog interface or via the frame of the digital interface. The RM function is activated in the **Configuration > RM** dialog. The device must also be assigned to an RM address.

For using the RM channel the **Remote Maintenance** check box must be activated.

For remote configuration via the RM channel, the **Config. via inband RM-Channel: yes/no** must be activated.

[sc\_rm\_configuration, 1, ~~~]

Figure 3-33 Configuration > RM Dialog

Table 3-33 Setting Options for RM Configuration

Menu Option	Setting Options	Comment
Remote Maintenance	<input checked="" type="checkbox"/>	RM activated
	<input type="checkbox"/>	RM deactivated
Device Address	0 to 249	RM address
Interface RM	Master	Setting remote station <b>Slave</b>
	Slave	Setting remote station <b>Master</b>
Interface SSB	Master	Setting remote station <b>Slave</b>
	Slave	Setting remote station <b>Master</b>
Config. via inband RM-Channel: yes/no	<input checked="" type="checkbox"/>	Configuration of the remote device via RM channel enabled
	<input type="checkbox"/>	Configuration of the remote device via RM channel disabled (default setting)



**NOTE**

If **Continuous signaling** is configured (refer to chapter [Continuous Signaling \(Analog Transmission Path\)](#), [Page 129](#)), **Remote Maintenance** cannot be activated.

### 3.5.7 Timer Configuration

#### 3.5.7.1 System Timer

**System timer**

Duration of unblocking impulse  ms

Delay of unblocking impulse  ms

Delay of receiver alarm  ms

Delay of S/N and/or BE alarm  ms

Transmit duration  ms

Supervision duration of transmission  s

Limit of supervision command  s

Tansmit duration for permissive command  ms

BI 1+2 interrupt single command BI or BI2 without delay

[sc\_system\_timer, 1, --]

Figure 3-34 SWT 3000 System Timer

Table 3-34 Setting Options of the SWT 3000 Timer Configuration

Selection	Setting Options	Comment
Duration of unblocking impulse	0 ms to 300 ms In steps of 10 ms	0 = no unblocking impulse. <b>Note:</b> Different assignment of the IF4 output relays in operating modes 1 and 2 when using the unblocking impulse. For further information, refer to chapter <i>Functional Description</i> , <a href="#">2.1.1 Overview</a> of the SWT 3000 Equipment Manual.
Delay of unblocking impulse	10 ms to 100 ms In steps of 1 ms	
Delay of receiver alarm	0 ms to 2000 ms In steps of 50 ms	Time delay until the receiver alarm relay is activated.
Delay of S/N and/or BE alarm	0 ms to 2000 ms In steps of 50 ms	Time delay until the S/N alarm is activated.
Transmit Duration <sup>1)</sup>	15 ms to 100 ms In steps of 5 ms	Transmission time of each activated single command.
Supervision duration of Transmission	5 s to 30 s In steps of 1 s	Supervision time for the transmission of all MCM commands in the transmit buffer. Exceeding the adjusted value is causing Tx alarm and switches the transmission back from command transmission to normal operation. The supervision command transmission time is not included in this evaluation.

Selection	Setting Options	Comment
<b>Limit of Supervision Command</b>	0 s to 15 s In steps of 1 s	Supervision time for the transmission of the Supervision Command. Exceeding the adjusted value is causing a non-urgent alarm. If the option <b>Blocking Outputs on Limit of Supervision Command</b> (in <b>Alarms Control</b> submenu) is active, the transmission of the supervision command is also stopped. 0 means no limitation.
Transmit Duration for permissive command	15 ms or 20 ms	Only for Mode 3b. (Default is 20 ms)
BI1+2 interrupt single command BI1 or BI2 without delay	Enabled	Only for Mode 3b. (Default is unchecked) <b>Checked:</b> Permissive command 1 or 2 transmission can switch to input combination 1+2 without waiting for minimal transmission duration time-out. <b>Unchecked:</b> Function not enabled.
1)Only if switching functions in the system configuration or MCM is parameterized.		



**NOTE**

The MCM mode is only available in the integrated PowerLink.

**3.5.7.2 Command Input Timer**

There are 3 different timers under command input timer:

- Input limitation
- Input extension min
- Input suppression

Input	Time		Input	Time		Input	Time	
(1)	0	ms	(9)	0	ms	(17)	0	ms
(2)	0	ms	(10)	0	ms	(18)	0	ms
(3)	0	ms	(11)	0	ms	(19)	0	ms
(4)	0	ms	(12)	0	ms	(20)	0	ms
(5)	0	ms	(13)	0	ms	(21)	0	ms
(6)	0	ms	(14)	0	ms	(22)	0	ms
(7)	0	ms	(15)	0	ms	(23)	0	ms
(8)	0	ms	(16)	0	ms	(24)	0	ms

[sc\_timer\_input\_limitation, 1, ...]

Figure 3-35 Setting Options for the Input Limitation

Table 3-35 Setting Options for Input Limitation

Selection	Setting Options	Comment
<b>Limitation of input commands</b>	0 ms to 2000 ms In steps of 1 ms	Longer input activation results in non-urgent alarm and the command transmission is interrupted.

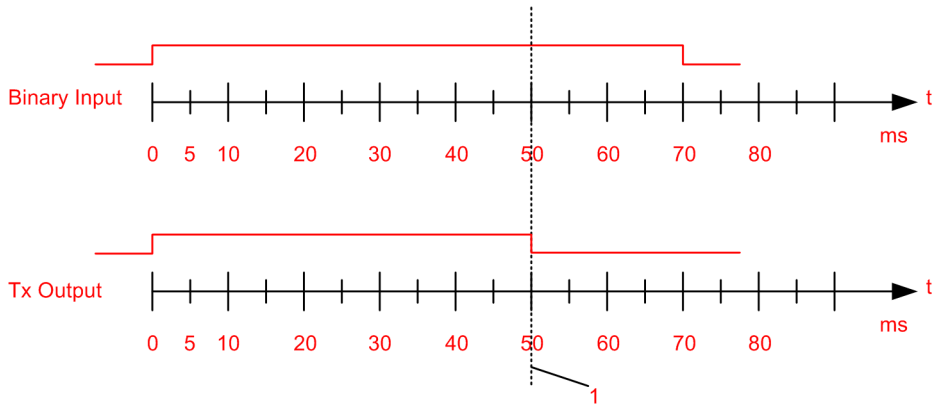

[dwinplim-150711-01.tif, 1, en\_US]  
 Figure 3-36 Example for Input Limitation Set to 50 ms

(1) Input extension to minimum

Input	Time		Input	Time		Input	Time	
(1)	20	ms	(9)	20	ms	(17)	20	ms
(2)	20	ms	(10)	20	ms	(18)	20	ms
(3)	20	ms	(11)	20	ms	(19)	20	ms
(4)	20	ms	(12)	20	ms	(20)	20	ms
(5)	20	ms	(13)	20	ms	(21)	20	ms
(6)	20	ms	(14)	20	ms	(22)	20	ms
(7)	20	ms	(15)	20	ms	(23)	20	ms
(8)	20	ms	(16)	20	ms	(24)	20	ms

[sc\_timer\_input\_extension, 1, --]  
 Figure 3-37 Setting Options for the Input Extension

Table 3-36 Setting Options for Input Command Extension to Minimum

Selection	Setting Options	Comment
<b>Input command extension min.</b>	0 ms to 100 ms In steps of 1 ms	0 = no extension Default = 20 ms

If the commands at the binary input are shorter, they are extended to adjusted value. If they are longer, this adjustment is irrelevant.

The following figure shows one command (red) at the binary input with a length of 10 ms. This command is extended to 15 ms. The next command (blue) has a length of 30 ms. This command is not extended.



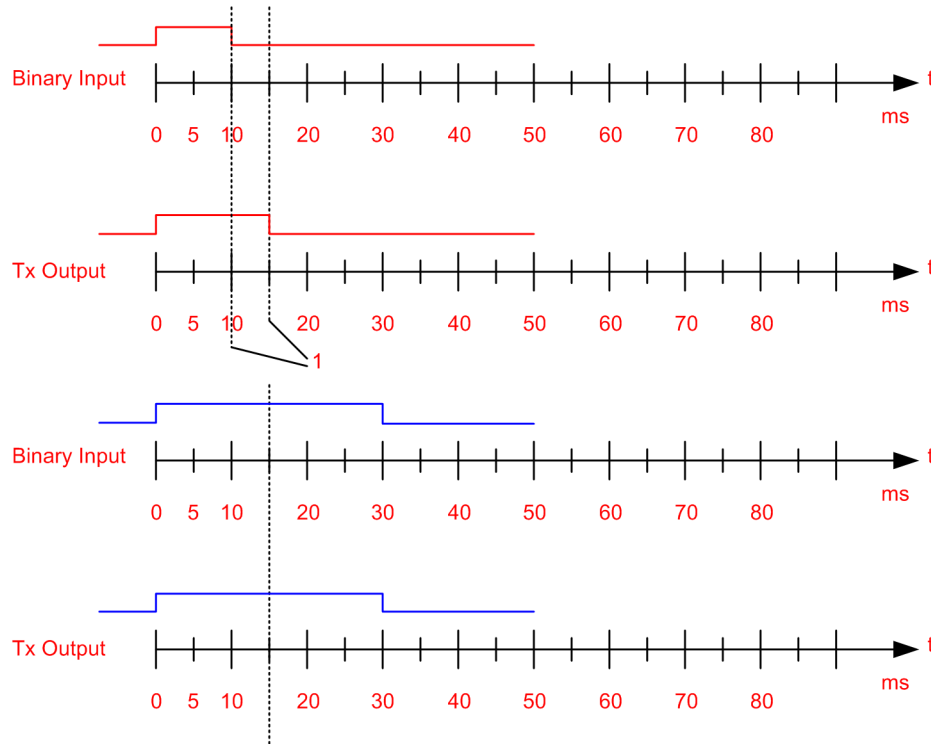

[dwinpext-130911-01.tif, 1, en\_US]

Figure 3-38 Example for an Input Command Extension to Minimum 15 ms

(1) Input pulse suppression

With **Input suppression**, a pulse suppression in the range of 0 ms to 100 ms in steps of 1 ms can be adjusted for each released binary input.

Input	Time	Input	Time	Input	Time
(1)	0 ms	(9)	0 ms	(17)	0 ms
(2)	0 ms	(10)	0 ms	(18)	0 ms
(3)	0 ms	(11)	0 ms	(19)	0 ms
(4)	0 ms	(12)	0 ms	(20)	0 ms
(5)	0 ms	(13)	0 ms	(21)	0 ms
(6)	0 ms	(14)	0 ms	(22)	0 ms
(7)	0 ms	(15)	0 ms	(23)	0 ms
(8)	0 ms	(16)	0 ms	(24)	0 ms

[sc\_timer\_input\_suppression, 1, --]

Figure 3-39 Setting Options for the Pulse Suppression

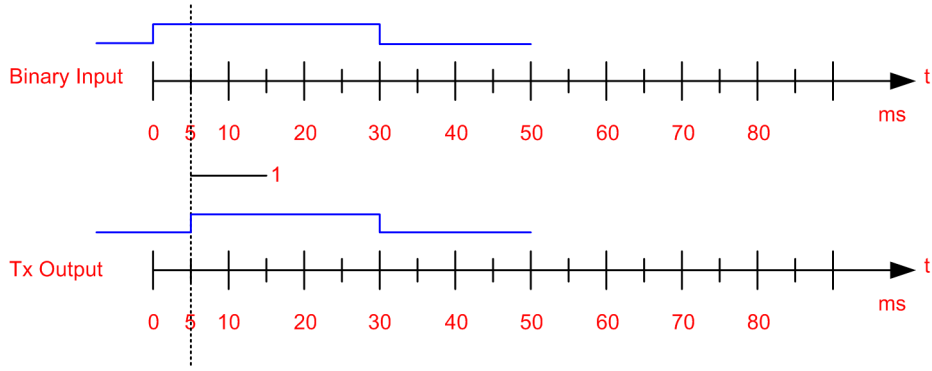

[dwpulssu-150711-01.tif, 1, en\_US]

Figure 3-40 Example for a Pulse Suppression of 5 ms



**NOTE**

The SWT 3000 does **not** transmit the commands, which are **shorter** than the adjusted pulse suppression time.

**3.5.7.3 Command Output Timer**

Output	Time		Output	Time		Output	Time	
(1)	0	ms	(9)	0	ms	(17)	0	ms
(2)	0	ms	(10)	0	ms	(18)	0	ms
(3)	0	ms	(11)	0	ms	(19)	0	ms
(4)	0	ms	(12)	0	ms	(20)	0	ms
(5)	0	ms	(13)	0	ms	(21)	0	ms
(6)	0	ms	(14)	0	ms	(22)	0	ms
(7)	0	ms	(15)	0	ms	(23)	0	ms
(8)	0	ms	(16)	0	ms	(24)	0	ms

[sc\_timer\_output\_limitation, 1, --]

Figure 3-41 Setting Options for Limitation of the Output Command

Table 3-37 Setting Options for Limiting or Increasing the Output Time

Selection	Setting Options	Comment
Limitation of output command	0 ms or 500 ms	0 = no limitation For mode3 and mode6, it is fixed to 0 ms.

The command in the following example is received continuously for 700 ms (Tx output). With the activated output limitation, the command output is switched off after 500 ms.

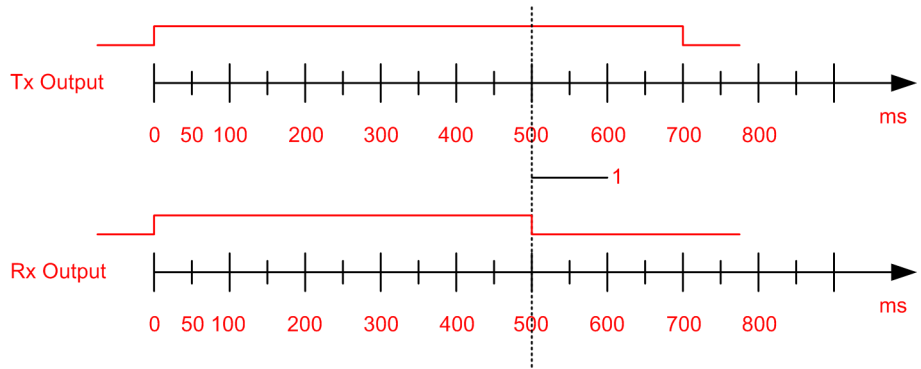

[dwoutlim-150711-01.tif, 1, en\_US]

Figure 3-42 Example of an Activated Output Command Limitation

- (1) Move to start position of output limitation



**NOTE**

Any interruption of receiving a command (Rx output changed, e.g. from BO1+BO2 to BO2), the timer for output limitation will restart from the beginning.



**NOTE**

Due to the limitation of 500 ms, an additional Rx-alarm occurs.

Output	Time		Output	Time		Output	Time	
(1)	15	ms	(9)	15	ms	(17)	15	ms
(2)	15	ms	(10)	15	ms	(18)	15	ms
(3)	15	ms	(11)	15	ms	(19)	15	ms
(4)	15	ms	(12)	15	ms	(20)	15	ms
(5)	15	ms	(13)	15	ms	(21)	15	ms
(6)	15	ms	(14)	15	ms	(22)	15	ms
(7)	15	ms	(15)	15	ms	(23)	15	ms
(8)	15	ms	(16)	15	ms	(24)	15	ms

[sc\_timer\_output\_extension, 1, ...]

Figure 3-43 Setting Options for the Output Command Extension

Table 3-38 Setting Options for the Output Command Extension

Selection	Setting Options	Comment
Output command extension	0 ms to 2000 ms In steps of 5 ms	-

The command in the following example is transmitted for 50 ms (Tx output). With the output command extension on the Rx output, the command is extended for 200 ms.

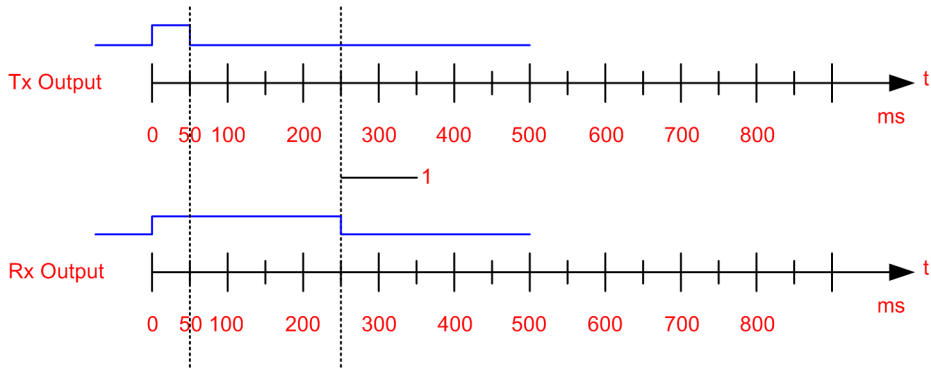

[dwoutext-150711-01.tif, 1, en\_US]

Figure 3-44 Example for an Output Extension of 200 ms

- (1) Move to the start position of output extension.

### 3.5.7.4 Broadband Versions

Table 3-39 Timer Settings for Broadband Versions

Single Purpose Operation	Timer			Command Input		Command Output	
	Duration of the Unblocking Impulse	RXALR Relay Delay [ms]	S/N Alarm Delay [s]	Pulse Suppression [ms]	Command Extension to Minimum [ms]	Limiting of Output Time [ms]	Increase in Output Time by [ms] <sup>4</sup>
Double system protection	0	2000	2	0	20	to 500	0
Single phase protection	0	2000	2	0	20	to 500	0
Switching functions <sup>5</sup>	0	2000	2	0	20	none	100

<sup>4</sup> If continuous signaling is activated, the increase in the output time must be set to min. 180 ms

<sup>5</sup> Switching functions: Transmit Duration 20 ms

Table 3-40 Alarm Settings for Broadband Versions

Single Purpose Operation	Alarms			
	Threshold for RXALR in [dB]	If there is an S/N Alarm, Activate RXALR	If there is an S/N Alarm, Disable the Outputs	If there is a GAL, Switch NUALR Relay
Double system protection	-30	yes	no	no
Single phase protection	-30	yes	no	no
Switching functions	-30	yes	no	no

Table 3-41 Timer Settings for Alternate Multi-purpose Operation

Alternate Multi-purpose Operation	Timer			Command Input		Command Output	
	Duration of the Unblocking Impulse	RXALR Relay Delay [ms]	S/N Alarm Delay [s]	Pulse Suppression [ms]	Command Extension to Minimum [ms]	Limiting of Output Time [ms]	Increase in Output Time by [ms] <sup>6</sup>
Double system protection	0	2000	2	0	20	to 500	0
Single phase protection	0	2000	2	0	20	to 500	0
Switching functions <sup>7</sup>	0	2000	2	0	20	none	100

<sup>6</sup> If continuous signaling is activated, the increase in the output time must be set to min. 180 ms.

<sup>7</sup> Switching functions: Transmit Duration 20 ms

Table 3-42 Alarm Settings for Alternate Multi-purpose Operation

Alternate Multi-purpose Operation	Alarms			
	Threshold for RXALR in [dB]	If there is an S/N Alarm, Activate RXALR	If there is an S/N Alarm, Disable the Outputs	If there is a GAL, Switch NUALR Relay
Double system protection	-20	yes	yes	no
Single phase protection	-20	yes	yes	no
Switching functions	-20	yes	yes	no

3.5.7.5 Narrow-Band Versions

Table 3-43 Timer Settings for Narrow-Band Versions

Single Purpose Operation	Timer			Command Input		Command Output	
	Duration of the Unblocking Impulse	RXALR Relay Delay [ms]	S/N Alarm Delay [s]	Pulse Suppression [ms]	Command Extension to Minimum [ms]	Limiting of Output Time [ms]	Increase in Output Time by [ms] <sup>8</sup>
Double system protection	0	2000	2	0	25	to 500	0
Single phase protection	0	2000	2	0	25	to 500	0
Switching functions <sup>9</sup>	0	2000	2	0	25	none	200

<sup>8</sup> If continuous signaling is activated, the increase in the output time must be set to min. 180 ms.

<sup>9</sup> Switching functions: Transmit Duration 25 ms

Table 3-44 Alarm Settings for Narrow-Band Versions

Single Purpose Operation	Alarms			
	Threshold for RXAL in [dB]	If there is an S/N Alarm, Activate RXALR	If there is an S/N Alarm, Disable the Outputs	If there is a GAL, Switch NUALR Relay
Double system protection	-30	yes	no	no
Single phase protection	-30	yes	no	no
Switching functions	-30	yes	no	no

### 3.5.8 TPoP Configuration

Ethernet line interface is enabled in PowerSys **SWT 3000 > Configuration > System > Line interface** in [Figure 3-45](#).

It supports 1+1 path protection (PRP) with analog or digital transmission path. The LED for unused LID-1 or LID-2 is used for indication of Ethernet line connection status as described in [Figure 3-46](#). The LED must be in green color after the configuration is finished.



[sc\_system\_ethernet\_TPoP, 1, ...]

Figure 3-45 Ethernet Connection Selection

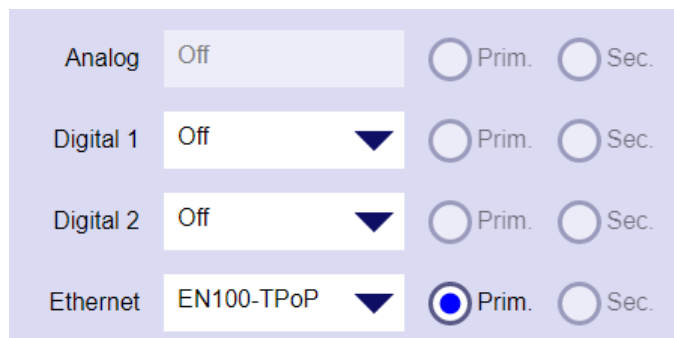

[sc\_example\_ethernet\_configuration\_LED, 1, ...]

Figure 3-46 Examples of Configuration and LED Indications of the Ethernet Connection

Table 3-45 Description of the Ethernet Connection Selection

Parameter	Comments
Ethernet connection	<b>EN100-TPoP</b> : EN100-TPoP is enabled. <b>Off</b> : EN100-TPoP is not enabled
Path protection (1+1)	Analog + Digital 1 or 2 Digital 1 + Digital 2 Analog + Ethernet Ethernet + Digital 1 or 2 Ethernet (EN100-TPoP) can be configured as primary or secondary connection. Ethernet + Ethernet (PRP)



**NOTE**

The EN100-IEC 61850 feature is disabled if EN100-TPoP is configured. Only binary command input and output can connect to SWT 3000.

---

Ethernet line interface parameters are configured in PowerSys under **SWT 3000 > Configuration > TPoP > TPoP configuration** (see next figure).



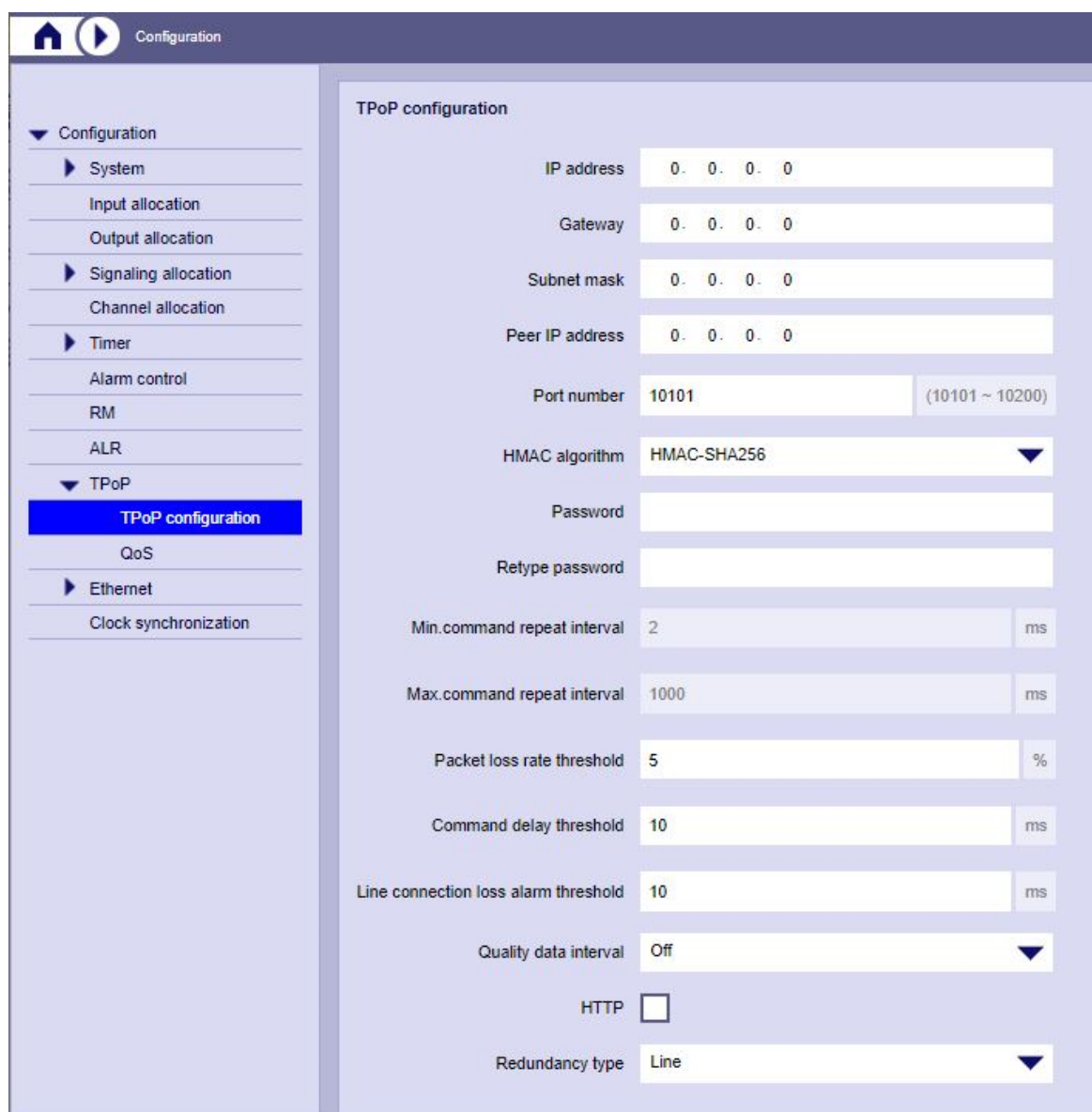

[sc\_TPoP\_configuration, 1, \_-\_-]

Figure 3-47 Ethernet Line Configuration

Table 3-46

Parameter	Comments
IP address	User-defined IP address For a pair of SWT 3000 devices A+B: <b>Device A:</b> 192.168.100.11 (Subnet: 255.255.255.0) <b>Device B:</b> 192.168.100.12 (Subnet: 255.255.255.0)
Gateway	User-defined default gateway
Subnet mask	User-defined subnet mask
Peer IP address	User-defined IP address of remote SWT 3000 device
Port number	User-defined UDP port number for TPOp service

Parameter	Comments
HMAC algorithm	Authentication algorithm used in Ethernet communication. Default value is HMAC-SHA256. <b>Off</b> : HMAC are not enabled <b>HMAC-SHA256</b> : Message authentication using hash function SHA256 is enabled.
Password	Secure password used in HMAC algorithm. It must not be empty if HMAC is enabled and must be the same for remote SWT 3000 devices.
Retype password	Retyped password must be the same as the original password.
Min. command repeat interval [read-only]	Minimum transmission time interval for repeat command packet. Default value is <b>2 ms</b> .
Max. command repeat interval [read-only]	Maximum transmission time interval for repeat command packet. Default value is <b>1000 ms</b> .
Packet loss rate threshold	Packet loss rate alarm threshold. If it is set to zero, the packet loss rate alarm is switched off. Default value is <b>5%</b> . Possible value: <b>0 to 100% in steps of 1%</b> .
Command delay threshold	Command transmission time alarm threshold. If it is set to zero, the command transmission time alarm is switched off. Default value is <b>10 ms</b> . Possible value: <b>0 ms to 100 ms in steps of 1 ms</b> .
Line connection loss alarm threshold	Connection loss alarm threshold. If it is set to zero, the connection loss alarm is switched off. Default value is <b>10 ms</b> . Possible value: <b>10 ms to 1000 ms in steps of 1 ms</b> .
Quality data interval	Quality data of Ethernet line interface is recorded in this time interval. Default value is <b>off</b> . Possible value: <b>off   1 sec   1 min   15 min</b> .
HTTP	EN100 module homepage for EN100 diagnostics and firmware upload. Default value is <b>disabled</b> . Checked: <b>HTTP is enabled</b> Unchecked: <b>HTTP is disabled</b>
Redundancy type	Default value is <b>Line</b> . Possible value: <b>Line   PRP</b>

QoS can be set individually for command and RM. It is configured in PowerSys of **SWT 3000 > Configuration > TPoP > QoS** (see next figure).

**QoS**

VLAN

	Command	RM
VLAN ID	11	12
Priority	6	3
serviceType	DSCP	DSCP
Precedence	0	0
TOS	Normal service	Normal service
DSCP value	EF	AF21
Hex value		

[sc.TPoP\_QoS\_1...]

Figure 3-48 QoS Configuration

Parameter	Comments
VLAN	VLAN for TPoP service (command and RM telegram) Checked: <b>VLAN is enabled</b> Unchecked: <b>VLAN is disabled</b> VLAN is disabled by default. If VLAN is enabled: VLAN ID = 1, Priority = 0 by default. ToS Precedence = 0 by default
VLAN ID	IEEE 802.1Q VLAN ID. Possible value: <b>1 to 4094</b> <b>VLAN ID = 1</b> VLAN ID = 1 means the default Port VLAN Identifier (PVID) value is used for classifying frames ingress through a Bridge Port. It is recommended to change PVID (Port VLAN Identifier) = 1 by Equipment Management Operation. Working with factory default VID = 1 in all switches of the same L2 Broadcast Domain leads to the fact that no VLAN is working! <b>VLAN ID = 2 to 4094</b> VLAN Identifiers for general use as a PVID (Port VLAN Identifier) or a member of a VID Set.
Priority	IEEE 802.1Q Priority. Possible value: <b>0 (lowest) to 7 (highest)</b> CoS7 is typically allocated to or is used for network internal OAM traffic and should not be assigned to customers edge traffic. CoS6 is recommended for the highest teleprotection command traffic.
ToS	Type of Service value in IP header. Possible value for Precedence: <b>0 (lowest) to 7 (highest)</b> Possible value for TOS: <b>Normal   Minimum cost   Maximum reliability   Maximum throughput   Minimum delay</b>

Parameter	Comments
DSCP	Differentiated Services Code Point (DSCP) in IP header. Default value is <b>0</b> . DSCP = EF (46) is recommended for the highest priority teleprotection command traffic.
Hex	Hex value of the whole ToS byte in IP header Default value is <b>0</b> . Possible value: <b>0x00 to 0xFF</b>



**NOTE**

The minimum required MPLS network throughput for TPop communication is 512 Kbps. MPLS path redundancy is recommended and the path switchover time should be minimized through appropriate measures.

### 3.5.9 Clock Synchronization

**Overview**

An external clock can synchronize the system-internal clock. The clock synchronization input (binary input1 (B1) or USYNC) on the ALR module (pin A1 or C3) is provided for this application. Either an external synchronization pulse is connected (jumping X14-X15) or the input is alternatively configurable as an input for entering IRIG-B signals (jumping X16-X17). For further information, refer to [3.3.6 Jumper Settings of the ALR Module](#) and to [Alarm Module 12.1 Overview](#)) of this Equipment Manual.

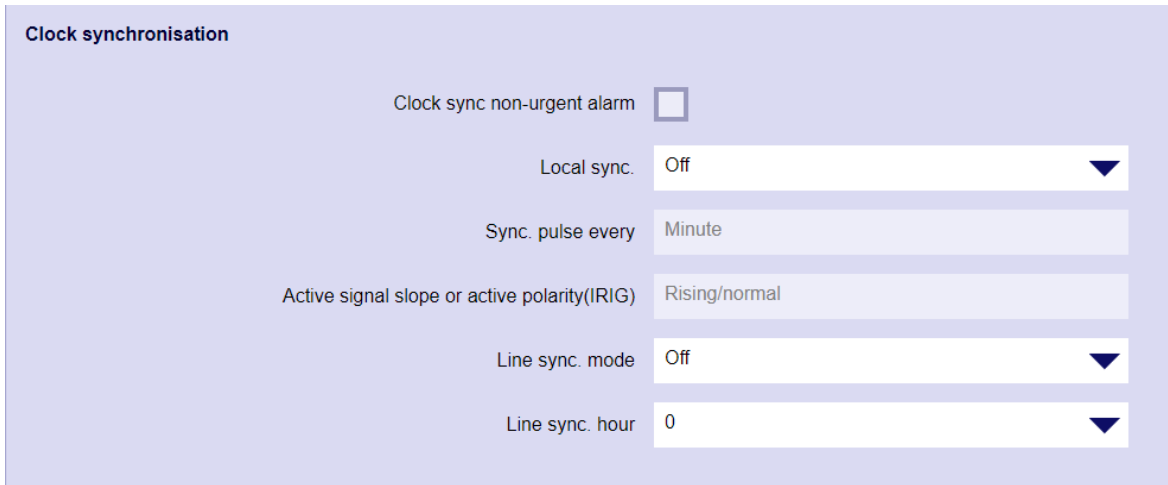

[sc\_configuration\_clocksynchronization, 1, --]

Figure 3-49 Options for the SWT 3000 Clock Synchronization

Table 3-47 Setting Options for the Local Clock Synchronization of the iSWT

Adjustment Local sync.	Comment
<b>off</b>	No local clock synchronization
<b>USYNC signal (minute or hour)</b>	An external impulse is received via the USYNC input every minute or hour. The active signal slope rising or falling is synchronizing the Real-Time Clock (RTC) seconds.
<b>IRIG-B00x (sync. only)</b>	The IRIG-B message is received via the USYNC input and is decoded. With each change of the IRIG-B minutes, the RTC seconds are synchronized.

Adjustment Local sync.	Comment
<b>IRIG-B000 (RTC time adj.)</b>	The IRIG-B message is received via the USYNC input and is decoded. With each change of the IRIG-B minutes, the RTC seconds are synchronized. Additionally, the IRIG-B time (hour, minutes, and seconds) is compared with the RTC time of the iSWT. If there is a difference, the IRIG-B values are taken over into the RTC.
<b>IRIG-B004 (RTC time&amp;date adj.)</b>	The IRIG-B message is received via the USYNC input and is decoded. With each change of the IRIG-B minutes, the RTC seconds are synchronized. Additionally, the IRIG-B-time and date are compared with the RTC time and date of the iSWT. If there is a difference, the IRIG-B values are taken over into the RTC.
<b>NTP-Sync</b>	Synchronization of the RTC with the network time protocol. For the NTP settings. Refer to chapter <i>SNMP and Remote Access</i> <a href="#">6.1.1 Overview</a> section <i>Web Login</i> <a href="#">6.4.3 NTP Settings</a> .

If there is a USYNC failure, you can activate an additional Non-Urgent alarm (NUALR or NU-alarm) in the clock synchronization view.

### Line-Clock Synchronization

It is also possible to synchronize the clock via the connecting route (**Line sync. mode off, Master, and Slave**) in one of the devices. The device that is to perform the synchronization is designated as the **Master** and the device to be synchronized as the **Slave**.

That means it is only necessary to synchronize **one** device (the **Master** externally).

The line synchronization is performed once every 24 h at a configurable hour defined with **Line sync. hour** by transmitting the synchronizing tone (fs). The difference in time between **Master** and **Slave** must not be greater than  $\pm 30$  s. Otherwise clock synchronization is not possible. The maximum difference in the time between master and slave is thus the signal runtime.

If both devices are provided with external synchronizing pulses, select **off** in the **Line sync. mode** list box for both devices. In this case, the synchronization between the devices is **not** activated.

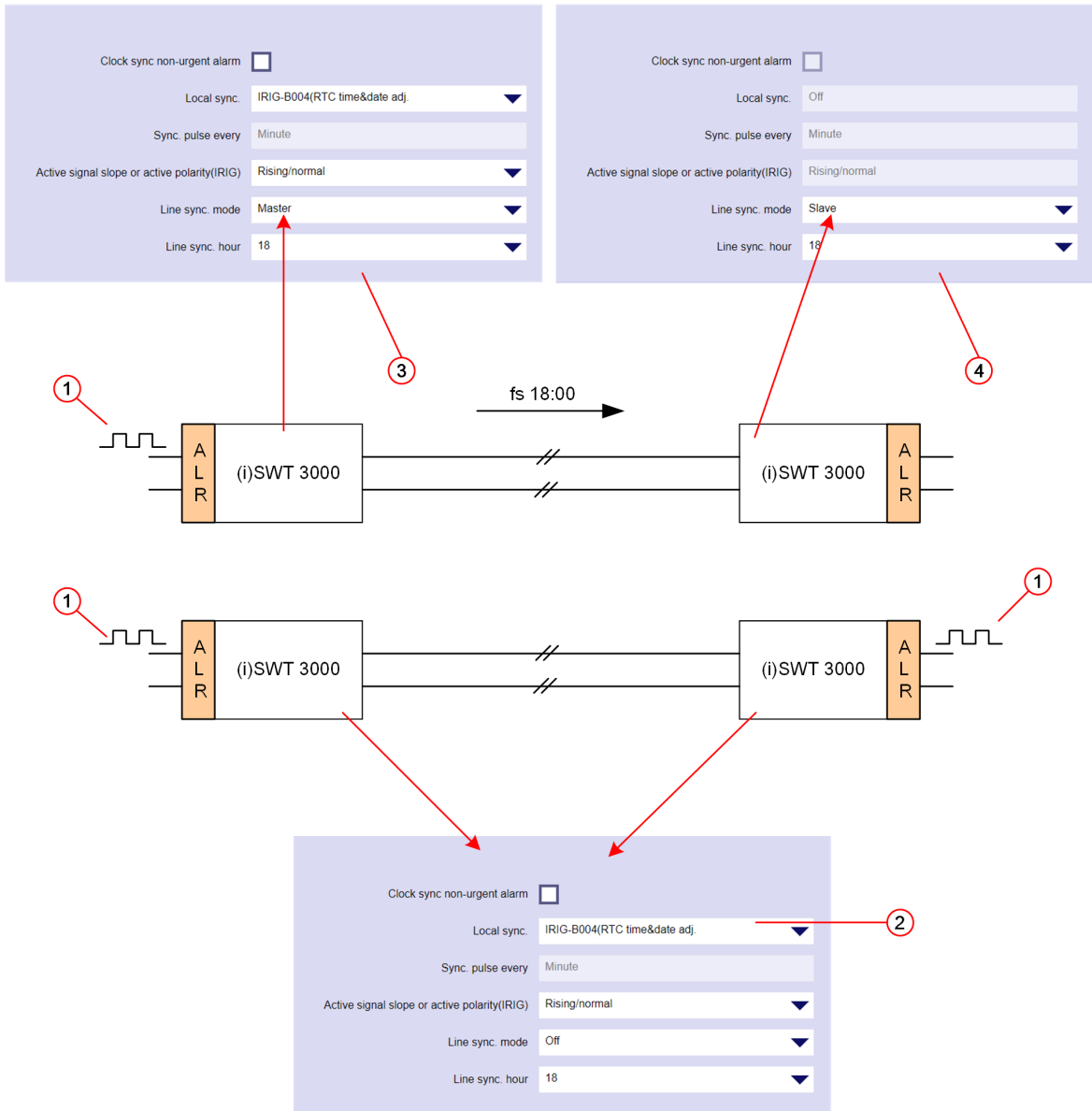

[dw\_line\_clock\_synchronization, 1, ...]  
 Figure 3-50 Possibilities for Clock Synchronization

- (1) External synchronizing pulse
- (2) **Line sync. mode off**
- (3) **Line sync. mode Master**
- (4) **Line sync. mode Slave**

### 3.5.10 IP Network Configuration

The Ethernet parameters can be configured in both PowerSys and web interface (chapter 6.4.1 Overview). But enable or disable TCP/IP service only can be done via PowerSys.

Table 3-48 Menu <SWT 3000 - Configuration - Net Configuration>, Tab <IP configuration>

Selection	Setting Option	Comment
HTTP Connection	Disabled	HTTP and HTTPS are disabled
	HTTP	HTTP is enabled (default option). You can access the web interface via HTTP protocol (e.g. http://192.168.20.200)
	HTTPS	HTTPS is enabled. You can access the web interface via HTTPS protocol (e.g. https://192.168.20.200) The installation of security certificates on the Service PC is required.
PowerSys TCP/IP Connection > SSL Encryption	<input type="checkbox"/>	SSL Encryption for PowerSys connection to device disabled (default setting)
	<input checked="" type="checkbox"/>	SSL Encryption for PowerSys access enabled in PowerLink. The setting requires a SSL encrypted PowerSys connection: Select SSL Encryption in PowerSys > Options > Connection

For Details, refer to Chapter *Cyber Security*.

**TCP/IP connection**

IP-Address resolution mode  DHCP  Predefined

IP address

Subnet mask

Gateway address

Actual IP address

Actual subnet mask

Actual gateway address

Configuration port  (10000 ~ 10100)

HW address

HTTP connection  Disabled  HTTP  HTTPS

PowerSys TCP/IP connection  SSL Encryption

[sc\_ethernet\_tcpip\_connection.1, ...]

Figure 3-51 Configuration > Ethernet > TCP/IP configuration

The device access via SNMP v1/2 resp. SNMP v3 has to be enabled in PowerSys via the configuration menu <SNMP>.

Table 3-49 Menu Configuration > SNMP

Selection	Setting Option	Comment
SNMP	Disabled	SNMP access disabled (default setting)
	SNMP Version 1/2	SNMP access enabled, SNMP v1/2
	SNMP Version 3	SNMP access enabled, SNMP v3

**SNMP agent**

SNMP  Disabled  SNMP version 1/2  SNMP version 3

Engine ID

Read only Community strings

Read write Community strings

Trap min. active time  s

Trap max. active time  s

---

**Trap destination**

	Address	Community string	
NMS-Address 1	0. 0. 0. 0	public	
NMS-Address 2	0. 0. 0. 0	public	
NMS-Address 3	0. 0. 0. 0	public	
NMS-Address 4	0. 0. 0. 0	public	
NMS-Address 5	0. 0. 0. 0	public	
NMS-Address 6	0. 0. 0. 0	public	

[sc\_configuration\_ethernet\_snmp, 1, --]

Figure 3-52 Configuration > Ethernet > SNMP

### 3.5.11 Alarm Configuration

#### 3.5.11.1 Alarm Output Allocation for ALR

##### Default Setting

The allocation of the system alarms to the relays of the ALR module is configurable. The default settings for the alarm output allocation are shown in [Figure 3-53](#).



Name	ALR1-1	ALR1-2	ALR1-3
RX ALR	<input checked="" type="checkbox"/>	<input type="checkbox"/>	<input type="checkbox"/>
NU ALR	<input type="checkbox"/>	<input checked="" type="checkbox"/>	<input type="checkbox"/>
GEN_ALR	<input type="checkbox"/>	<input type="checkbox"/>	<input checked="" type="checkbox"/>
TX ALR	<input type="checkbox"/>	<input type="checkbox"/>	<input type="checkbox"/>
LID_BER ALR	<input type="checkbox"/>	<input type="checkbox"/>	<input type="checkbox"/>
LID_SYNC ALR	<input type="checkbox"/>	<input type="checkbox"/>	<input type="checkbox"/>
LID_CF_ALR	<input type="checkbox"/>	<input type="checkbox"/>	<input type="checkbox"/>
LID_AIS ALR	<input type="checkbox"/>	<input type="checkbox"/>	<input type="checkbox"/>
SNR ALR	<input type="checkbox"/>	<input type="checkbox"/>	<input type="checkbox"/>
IFC-1 ALR	<input type="checkbox"/>	<input type="checkbox"/>	<input type="checkbox"/>
IFC-2 ALR	<input type="checkbox"/>	<input type="checkbox"/>	<input type="checkbox"/>
IFC-3 ALR	<input type="checkbox"/>	<input type="checkbox"/>	<input type="checkbox"/>
IFC-4 ALR	<input type="checkbox"/>	<input type="checkbox"/>	<input type="checkbox"/>
HW ALR	<input type="checkbox"/>	<input type="checkbox"/>	<input type="checkbox"/>
PF ALR	<input type="checkbox"/>	<input type="checkbox"/>	<input type="checkbox"/>
IEC61850 ALR	<input type="checkbox"/>	<input type="checkbox"/>	<input type="checkbox"/>
TPoP ALR	<input type="checkbox"/>	<input type="checkbox"/>	<input type="checkbox"/>
REM ALR	<input type="checkbox"/>	<input type="checkbox"/>	<input type="checkbox"/>

[sc\_alr\_default, 1, --]

Figure 3-53 Default Settings for the Alarm Output Allocation

### System Alarms for Allocation

It is possible to change the default setting and to allocate alarms listed in [Table 3-50](#) to any relay output of an ALR module. Multiple alarms can be allocated to the same relay output.

Table 3-50 System Alarm Description

System Alarm	Description
RXALR	Receive alarm
NUALR	Non-urgent alarm
GENALR	General alarm
TXALR	Transmission alarm
LID_BER ALR	LID bit error alarm in primary digital line. (Bit error rate > 1e-3)
LID_SYNC ALR	LID Loss of synch in primary digital line.
LID_CF ALR	LID clock failure in primary digigital line.
LID_AIS ALR	LID alarm indication signal detected in primary digital line. (All received bits all ones).
SNR ALR	Signal noise ratio alarm in primary analog line.
IFC-1 ALR	IFC-1 module alarm (hardware alarm)
IFC-2 ALR	IFC-2 module alarm (hardware alarm)
IFC-3 ALR	IFC-3 module alarm (hardware alarm)
IFC-4 ALR	IFC-4 module alarm (hardware alarm)
HW ALR	Any board alarm or startup failure
PF ALR	Redundant power supply failed
IEC 61850 ALR	EN100 module with IEC 61850 general alarm
TPoP ALR	EN100 module with teleprotection over packet protocol alarm in primary Ethernet line
REM ALR	Remote alarm Indicates the remote side has at least one of the Rx/Tx/Nu/Gen alarms when RM connection is build.

**Example Alarm Output Allocation**

*Figure 3-54* shows a setting example for a IFC alarm allocation.

Name	ALR1-1	ALR1-2	ALR1-3
RX ALR	<input checked="" type="checkbox"/>	<input type="checkbox"/>	<input type="checkbox"/>
NU ALR	<input checked="" type="checkbox"/>	<input type="checkbox"/>	<input type="checkbox"/>
GEN_ALR	<input checked="" type="checkbox"/>	<input type="checkbox"/>	<input type="checkbox"/>
TX ALR	<input type="checkbox"/>	<input type="checkbox"/>	<input type="checkbox"/>
LID_BER ALR	<input type="checkbox"/>	<input type="checkbox"/>	<input type="checkbox"/>
LID_SYNC ALR	<input type="checkbox"/>	<input type="checkbox"/>	<input type="checkbox"/>
LID_CF_ALR	<input type="checkbox"/>	<input type="checkbox"/>	<input type="checkbox"/>
LID_AIS ALR	<input type="checkbox"/>	<input type="checkbox"/>	<input type="checkbox"/>
SNR ALR	<input type="checkbox"/>	<input type="checkbox"/>	<input type="checkbox"/>
IFC-1 ALR	<input type="checkbox"/>	<input checked="" type="checkbox"/>	<input type="checkbox"/>
IFC-2 ALR	<input type="checkbox"/>	<input type="checkbox"/>	<input checked="" type="checkbox"/>
IFC-3 ALR	<input type="checkbox"/>	<input type="checkbox"/>	<input type="checkbox"/>
IFC-4 ALR	<input type="checkbox"/>	<input type="checkbox"/>	<input type="checkbox"/>
HW ALR	<input type="checkbox"/>	<input type="checkbox"/>	<input type="checkbox"/>
PF ALR	<input type="checkbox"/>	<input type="checkbox"/>	<input type="checkbox"/>
IEC61850 ALR	<input type="checkbox"/>	<input type="checkbox"/>	<input type="checkbox"/>
TPoP ALR	<input type="checkbox"/>	<input type="checkbox"/>	<input type="checkbox"/>
REM ALR	<input type="checkbox"/>	<input type="checkbox"/>	<input type="checkbox"/>

[sc\_alr\_example, 1, ~-]

Figure 3-54 Example Settings for the IFC Alarm Output Allocation

ALR1-1 relay out indicates if one of 3 alarms (RXALR, NUALR, and GENALR) occurred.

ALR1-2 indicates an IFC-1 module alarm and ALR1-3 indicates an IFC-2 module alarm.

### 3.5.11.2 Alarm Output Allocation for IFC

The protection scheme requires an alarm signaling relay contact which indicates the healthiness of the command path. That means any failure at any point starting from the near- end command module to the far-end command module should operate that unique relay contact. The alarm can be signaling to:

- Any free relay contacts of command module IFC-D/P
- Eight relay contacts of command module IFC-S
- Three relay contacts of alarm module ALR

The alarm output allocation for IFC is possible for operation mode 3a / 3b / 5D.

**Enable Signaling Output**

**IFC relay output assignment for command ack. signaling:**

- IFC-1 relay output 2 : ack. signaling of command output 1
- IFC-1 relay output 3 : ack. signaling of command input 1
- IFC-2 relay output 2 : ack. signaling of command output 2
- IFC-2 relay output 3 : ack. signaling of command input 2
- Relay open indicates no signaling.
- Relay close indicates ack. signaling.

**IFC relay output assignment for alarm signaling:**

- IFC-2 relay output 4 : alarm signaling of IFC-2 alarm + General alarm (GEN) + Rx alarm
- IFC-4 relay output 4 : alarm signaling of IFC-4 alarm + General alarm (GEN) + Rx alarm
- Relay close indicates no alarm occurred.
- Relay open indicates alarm is occurred.
- Multiple alarms (GEN + Rx + IFC) are signaling to single relay output. An alarm signaling relay contact which indicates the healthiness of the command path.

Idx	IFC 2-1	IFC 2-2	IFC 2-3	IFC 2-4	IFC 2-5	IFC 2-6	IFC 2-7	IFC 2-8	IFC 4-1	IFC 4-2	IFC 4-3	IFC 4-4	IFC 4-5	IFC 4-6	IFC 4-7	IFC 4-8
RX ALR	<input type="checkbox"/>	<input type="checkbox"/>	<input type="checkbox"/>	<input checked="" type="checkbox"/>	<input type="checkbox"/>	<input type="checkbox"/>	<input type="checkbox"/>	<input type="checkbox"/>	<input type="checkbox"/>	<input type="checkbox"/>	<input type="checkbox"/>	<input checked="" type="checkbox"/>	<input type="checkbox"/>	<input type="checkbox"/>	<input type="checkbox"/>	<input type="checkbox"/>
NU ALR	<input type="checkbox"/>	<input type="checkbox"/>	<input type="checkbox"/>	<input type="checkbox"/>	<input type="checkbox"/>	<input type="checkbox"/>	<input type="checkbox"/>	<input type="checkbox"/>	<input type="checkbox"/>	<input type="checkbox"/>	<input type="checkbox"/>	<input type="checkbox"/>	<input type="checkbox"/>	<input type="checkbox"/>	<input type="checkbox"/>	<input type="checkbox"/>
GEN ALR	<input type="checkbox"/>	<input type="checkbox"/>	<input type="checkbox"/>	<input checked="" type="checkbox"/>	<input type="checkbox"/>	<input type="checkbox"/>	<input type="checkbox"/>	<input type="checkbox"/>	<input type="checkbox"/>	<input type="checkbox"/>	<input type="checkbox"/>	<input checked="" type="checkbox"/>	<input type="checkbox"/>	<input type="checkbox"/>	<input type="checkbox"/>	<input type="checkbox"/>
TX ALR	<input type="checkbox"/>	<input type="checkbox"/>	<input type="checkbox"/>	<input type="checkbox"/>	<input type="checkbox"/>	<input type="checkbox"/>	<input type="checkbox"/>	<input type="checkbox"/>	<input type="checkbox"/>	<input type="checkbox"/>	<input type="checkbox"/>	<input type="checkbox"/>	<input type="checkbox"/>	<input type="checkbox"/>	<input type="checkbox"/>	<input type="checkbox"/>
LID_BER ALR	<input type="checkbox"/>	<input type="checkbox"/>	<input type="checkbox"/>	<input type="checkbox"/>	<input type="checkbox"/>	<input type="checkbox"/>	<input type="checkbox"/>	<input type="checkbox"/>	<input type="checkbox"/>	<input type="checkbox"/>	<input type="checkbox"/>	<input type="checkbox"/>	<input type="checkbox"/>	<input type="checkbox"/>	<input type="checkbox"/>	<input type="checkbox"/>
LID_SYNC ALR	<input type="checkbox"/>	<input type="checkbox"/>	<input type="checkbox"/>	<input type="checkbox"/>	<input type="checkbox"/>	<input type="checkbox"/>	<input type="checkbox"/>	<input type="checkbox"/>	<input type="checkbox"/>	<input type="checkbox"/>	<input type="checkbox"/>	<input type="checkbox"/>	<input type="checkbox"/>	<input type="checkbox"/>	<input type="checkbox"/>	<input type="checkbox"/>
LID_CF ALR	<input type="checkbox"/>	<input type="checkbox"/>	<input type="checkbox"/>	<input type="checkbox"/>	<input type="checkbox"/>	<input type="checkbox"/>	<input type="checkbox"/>	<input type="checkbox"/>	<input type="checkbox"/>	<input type="checkbox"/>	<input type="checkbox"/>	<input type="checkbox"/>	<input type="checkbox"/>	<input type="checkbox"/>	<input type="checkbox"/>	<input type="checkbox"/>
LID_AIS ALR	<input type="checkbox"/>	<input type="checkbox"/>	<input type="checkbox"/>	<input type="checkbox"/>	<input type="checkbox"/>	<input type="checkbox"/>	<input type="checkbox"/>	<input type="checkbox"/>	<input type="checkbox"/>	<input type="checkbox"/>	<input type="checkbox"/>	<input type="checkbox"/>	<input type="checkbox"/>	<input type="checkbox"/>	<input type="checkbox"/>	<input type="checkbox"/>
SNR ALR	<input type="checkbox"/>	<input type="checkbox"/>	<input type="checkbox"/>	<input type="checkbox"/>	<input type="checkbox"/>	<input type="checkbox"/>	<input type="checkbox"/>	<input type="checkbox"/>	<input type="checkbox"/>	<input type="checkbox"/>	<input type="checkbox"/>	<input type="checkbox"/>	<input type="checkbox"/>	<input type="checkbox"/>	<input type="checkbox"/>	<input type="checkbox"/>
IFC-1 ALR	<input type="checkbox"/>	<input type="checkbox"/>	<input type="checkbox"/>	<input type="checkbox"/>	<input type="checkbox"/>	<input type="checkbox"/>	<input type="checkbox"/>	<input type="checkbox"/>	<input type="checkbox"/>	<input type="checkbox"/>	<input type="checkbox"/>	<input type="checkbox"/>	<input type="checkbox"/>	<input type="checkbox"/>	<input type="checkbox"/>	<input type="checkbox"/>
IFC-2 ALR	<input type="checkbox"/>	<input type="checkbox"/>	<input type="checkbox"/>	<input checked="" type="checkbox"/>	<input type="checkbox"/>	<input type="checkbox"/>	<input type="checkbox"/>	<input type="checkbox"/>	<input type="checkbox"/>	<input type="checkbox"/>	<input type="checkbox"/>	<input type="checkbox"/>	<input type="checkbox"/>	<input type="checkbox"/>	<input type="checkbox"/>	<input type="checkbox"/>
IFC-3 ALR	<input type="checkbox"/>	<input type="checkbox"/>	<input type="checkbox"/>	<input type="checkbox"/>	<input type="checkbox"/>	<input type="checkbox"/>	<input type="checkbox"/>	<input type="checkbox"/>	<input type="checkbox"/>	<input type="checkbox"/>	<input type="checkbox"/>	<input type="checkbox"/>	<input type="checkbox"/>	<input type="checkbox"/>	<input type="checkbox"/>	<input type="checkbox"/>
IFC-4 ALR	<input type="checkbox"/>	<input type="checkbox"/>	<input type="checkbox"/>	<input type="checkbox"/>	<input type="checkbox"/>	<input type="checkbox"/>	<input type="checkbox"/>	<input type="checkbox"/>	<input checked="" type="checkbox"/>	<input type="checkbox"/>	<input type="checkbox"/>	<input type="checkbox"/>	<input type="checkbox"/>	<input type="checkbox"/>	<input type="checkbox"/>	<input type="checkbox"/>
HW ALR	<input type="checkbox"/>	<input type="checkbox"/>	<input type="checkbox"/>	<input type="checkbox"/>	<input type="checkbox"/>	<input type="checkbox"/>	<input type="checkbox"/>	<input type="checkbox"/>	<input type="checkbox"/>	<input type="checkbox"/>	<input type="checkbox"/>	<input type="checkbox"/>	<input type="checkbox"/>	<input type="checkbox"/>	<input type="checkbox"/>	<input type="checkbox"/>
PF ALR	<input type="checkbox"/>	<input type="checkbox"/>	<input type="checkbox"/>	<input type="checkbox"/>	<input type="checkbox"/>	<input type="checkbox"/>	<input type="checkbox"/>	<input type="checkbox"/>	<input type="checkbox"/>	<input type="checkbox"/>	<input type="checkbox"/>	<input type="checkbox"/>	<input type="checkbox"/>	<input type="checkbox"/>	<input type="checkbox"/>	<input type="checkbox"/>
IEC61850 ALR	<input type="checkbox"/>	<input type="checkbox"/>	<input type="checkbox"/>	<input type="checkbox"/>	<input type="checkbox"/>	<input type="checkbox"/>	<input type="checkbox"/>	<input type="checkbox"/>	<input type="checkbox"/>	<input type="checkbox"/>	<input type="checkbox"/>	<input type="checkbox"/>	<input type="checkbox"/>	<input type="checkbox"/>	<input type="checkbox"/>	<input type="checkbox"/>
TPoP ALR	<input type="checkbox"/>	<input type="checkbox"/>	<input type="checkbox"/>	<input type="checkbox"/>	<input type="checkbox"/>	<input type="checkbox"/>	<input type="checkbox"/>	<input type="checkbox"/>	<input type="checkbox"/>	<input type="checkbox"/>	<input type="checkbox"/>	<input type="checkbox"/>	<input type="checkbox"/>	<input type="checkbox"/>	<input type="checkbox"/>	<input type="checkbox"/>
REM ALR	<input type="checkbox"/>	<input type="checkbox"/>	<input type="checkbox"/>	<input type="checkbox"/>	<input type="checkbox"/>	<input type="checkbox"/>	<input type="checkbox"/>	<input type="checkbox"/>	<input type="checkbox"/>	<input type="checkbox"/>	<input type="checkbox"/>	<input type="checkbox"/>	<input type="checkbox"/>	<input type="checkbox"/>	<input type="checkbox"/>	<input type="checkbox"/>

[sc\_alarm\_signaling, 1, --]

Figure 3-55 SWT 3000 > Configuration > Signaling Allocation > Alarm signaling

**3.5.11.3 Alarm Output Allocation for IEC 61850 / SNMP**

For pure Ethernet based IEC 61850 network, there is no hard-wired cable connected ALR relay output port. It is possible to check the status information in ITPC logic nodes of IEC 61850. The device failure alarm

(ITPC.AlarmGen) can be mapped to GOOSE command and sent to the connected protection device. For details, please refer to chapter 2.11.

If the SNMP is enabled, the alarm notification will be send to specified NMS automatically when alarm state is changed (on or off). For details, please refer to chapter 6.2.

### 3.5.11.4 Setting Options for SWT 3000 Alarms

[sc\_alarm\_control, 1, --]

Figure 3-56 SWT 3000 Alarms Control Dialog

Table 3-51 Setting Options for SWT 3000 Alarms Control

Selection	Setting Options	Comment
<b>Threshold for receiver alarm</b>	-30 dB to -10 dB in steps of 5 dB (default: <b>-20 dB</b> )	When the PU4 input level drops about the adjusted value, this condition causes receiver alarm.
<b>Threshold for S/N alarm</b>	-20 dB to -10 dB in steps of 5 dB (default: <b>-15 dB</b> )	If there is a worse SNR than adjusted, this condition causes S/N alarm. -20 dB is the most sensitive adjustment.
<b>S/N-Time</b>	1 sec up to 30 sec in steps of 1 sec (default: <b>3 sec</b> )	Measuring time for the signal to noise ratio evaluation
<b>Force receiver alarm on S/N and/or BE alarm</b>	<input checked="" type="checkbox"/>	If there is an S/N alarm or bit error alarm, receiver alarm relay is activated (default setting).
	<input type="checkbox"/>	Function deactivated
<b>Blocking outputs on S/N and/or BE alarm</b>	<input checked="" type="checkbox"/>	If there is an S/N alarm or bit error alarm, command outputs are disabled (default setting).
	<input type="checkbox"/>	Function deactivated (command outputs not blocked)

Selection	Setting Options	Comment
Blocking outputs on Limit of Supervision Command	<input checked="" type="checkbox"/>	In addition to the non-urgent alarm caused by exceeding the adjusted value of supervision command, the transmission of the supervision command is stopped.
	<input type="checkbox"/>	Supervision command transmission not influenced by the <b>Limit of Supervision Command</b> (in <b>Timer</b> submenu).
Switch NU-Relay on GAL	<input checked="" type="checkbox"/>	If there is a general alarm, non-urgent alarm relay is additionally activated
	<input type="checkbox"/>	Function deactivated (default setting)
Alarm output RXALR used for	Receiver alarm (RXALR)	Allocation of the receiver alarm to the alarm output RXALR (default setting)
	Unblocking (UNBL)	Allocation of the unblocking impulse to the alarm output RXALR (for unblocking impulse. Refer to <a href="#">Table 3-34</a> )
	Input limitation alarm (INPLIM)	Allocation of the input limitation alarm to the alarm output RXALR (for the adjustment of the input limitation. Refer to <a href="#">Table 3-35</a> )
Auto reset delay	0 to 60 sec in steps of 1 sec	Delay system reset to the setting value if a hardware alarm occurs. (Default is 0 sec). 0 s: The system is reset immediately if a hardware alarm occurs. If a hardware alarm occurs, the SWT 3000 device resets automatically and tries to recover the system back to the normal operation. In this case, it is not possible to indicate which alarms are output to the ALR relay output. It is recommended to set <b>Auto reset delay</b> to non-zero (for example, 60 seconds) if an IFC or another board alarm is allocated.

### 3.5.11.5 Unblocking Impulse Allocation for IFC

#### Overview

The activated unblocking impulse (for more details refer to [2.7.2 Unblocking Mode](#) and to [Table 3-34](#)) can be connected via the IFC-D/P card when using the operating modes 1 and 2. When working with other operating modes, the following system behavior must be observed:

#### Stand-alone Equipment

In the stand-alone unit, an **activated unblocking impulse** ( $t_{unbl} > 0$ ) (in the operating **modes 3, 3a, 3b, 4 and 5A**) is executed via the RXALR relay on the ALR module. That means, there is **no** relay left for the **receiver alarm**. The receiver alarm is indicated as general alarm **GENALR**.

#### SWT 3000 Integrated in the PowerLink System

The receiver alarm output of the PU4 module (RXALR) can be routed to the unblocking impulse in the service program PowerSys (refer to [3.5.11.4 Setting Options for SWT 3000 Alarms](#)).  
 The RXALR output can be ranked to an alarm relay.  
 If there is an unblocking signaling via RXALR and ALR card, the active position of the relay must be considered (an alarm is active when the relay is de-energized).

### 3.5.12 T-Scheme Configuration

Basic system configuration of T-scheme in SWT 3000:

Operation Mode		Mode5D
Connection	digital 1	X.21 or G.703 or FO
	digital 2	X.21 or G.703 or FO
Special transmission		T-scheme mode
Special allocation		off
Address	Transmitter	<Own address>
	Receiver	<Remote address from LID-1 line>
	Receiver 2	Only possible in T-scheme mode. <Remote address from LID-2 line>

Digital 1 and 2 could use different connection types. For example, digital 1 is an electrical and digital 2 is a fiber-optic connection.

#### Command Allocation

The command input and output allocation is configured according to the user requirement.

In T-Scheme mode, one command can be configured with additional properties:

- Line 1: the command can be transmitted on LID-1. Unchecking the configuration will disable command transmission on LID-1
- Line 2: the command can be transmitted on LID-2. Unchecking the configuration will disable command transmission on LID-2
- T command: the command can be forwarded to another transmission line. This configuration takes effect on both lines. It would disable the local input / output automatically by setting a command as forward; and it would need to be manually re-enabled, if the user really intended to have a command allocated to local ports while being forwarded.

For example:

- Command 1..4: Both device 1<>2 and device 2<>3
- Command 5..8: Device 1 <> 2, and device 1 <> 3 (routed via device 2)
- Command 9..12: Device 3 <> 2, and device 3 <>1 (routed via device 2)
- Command 13..16: Device 1<>3

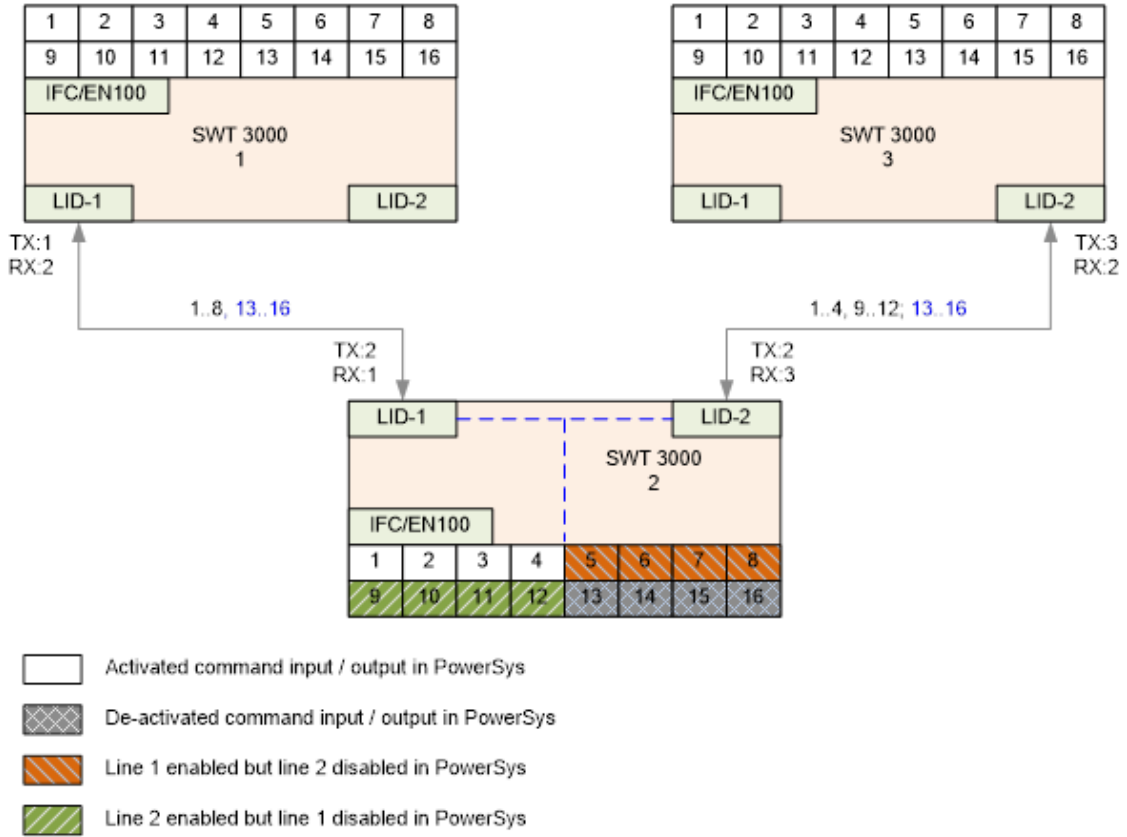

[sc\_command\_input\_output\_allocation, 2, -,-]

The forwarded command and line selections are configured in the form of PowerSys > SWT 3000 > Configuration > Channel allocation. In this example, four different groups of commands are configured.

Configuration												
Idx	LID-1	LID-2	Forward	Idx	LID-1	LID-2	Forward	Idx	LID-1	LID-2	Forward	
(1)	<input checked="" type="checkbox"/>	<input checked="" type="checkbox"/>	<input type="checkbox"/>	(9)	<input type="checkbox"/>	<input checked="" type="checkbox"/>	<input checked="" type="checkbox"/>	(17)	<input type="checkbox"/>	<input type="checkbox"/>	<input type="checkbox"/>	
(2)	<input checked="" type="checkbox"/>	<input checked="" type="checkbox"/>	<input type="checkbox"/>	(10)	<input type="checkbox"/>	<input checked="" type="checkbox"/>	<input checked="" type="checkbox"/>	(18)	<input type="checkbox"/>	<input type="checkbox"/>	<input type="checkbox"/>	
(3)	<input checked="" type="checkbox"/>	<input checked="" type="checkbox"/>	<input type="checkbox"/>	(11)	<input type="checkbox"/>	<input checked="" type="checkbox"/>	<input checked="" type="checkbox"/>	(19)	<input type="checkbox"/>	<input type="checkbox"/>	<input type="checkbox"/>	
(4)	<input checked="" type="checkbox"/>	<input checked="" type="checkbox"/>	<input type="checkbox"/>	(12)	<input type="checkbox"/>	<input checked="" type="checkbox"/>	<input checked="" type="checkbox"/>	(20)	<input type="checkbox"/>	<input type="checkbox"/>	<input type="checkbox"/>	
(5)	<input checked="" type="checkbox"/>	<input type="checkbox"/>	<input checked="" type="checkbox"/>	(13)	<input type="checkbox"/>	<input type="checkbox"/>	<input checked="" type="checkbox"/>	(21)	<input type="checkbox"/>	<input type="checkbox"/>	<input type="checkbox"/>	
(6)	<input checked="" type="checkbox"/>	<input type="checkbox"/>	<input checked="" type="checkbox"/>	(14)	<input type="checkbox"/>	<input type="checkbox"/>	<input checked="" type="checkbox"/>	(22)	<input type="checkbox"/>	<input type="checkbox"/>	<input type="checkbox"/>	
(7)	<input checked="" type="checkbox"/>	<input type="checkbox"/>	<input checked="" type="checkbox"/>	(15)	<input type="checkbox"/>	<input type="checkbox"/>	<input checked="" type="checkbox"/>	(23)	<input type="checkbox"/>	<input type="checkbox"/>	<input type="checkbox"/>	
(8)	<input checked="" type="checkbox"/>	<input type="checkbox"/>	<input checked="" type="checkbox"/>	(16)	<input type="checkbox"/>	<input type="checkbox"/>	<input checked="" type="checkbox"/>	(24)	<input type="checkbox"/>	<input type="checkbox"/>	<input type="checkbox"/>	

[sc\_Tscheme, 1, -,-]

Figure 3-57 Example configuration T-Scheme



CMD	Device 1 (Terminal)			Device 2 (T scheme)			Device 3 (Terminal)		
	Input	Output	Forward	Input	Output	Forward	Input	Output	Forward
1	X	X	-	X	X	-	-	-	-
2	X	X	-	X	X	-	-	-	-
3	X	X	-	X	X	-	-	-	-
4	X	X	-	X	X	-	-	-	-
5	X	X	-	X	X	-	-	-	-
6	X	X	-	X	X	-	-	-	-
7	X	X	-	X	X	-	-	-	-
8	X	X	-	X	X	-	-	-	-
9	X	X	-	-	-	X	X	X	-
10	X	X	-	-	-	X	X	X	-
11	X	X	-	-	-	X	X	X	-
12	X	X	-	-	-	X	X	X	-
13	-	-	-	X	X	-	X	X	-
14	-	-	-	X	X	-	X	X	-
15	-	-	-	X	X	-	X	X	-
16	-	-	-	X	X	-	X	X	-

[sc\_example\_configuration\_output\_allocation, 1, --]

### RM Configuration

RM is directly routed through the T-device, no external cable connections (SSB) are necessary. Settings for RM master/slave are still valid for T-scheme.

**RM**

Remote maintenance

Device address

Interface RM

Interface SSB

Config. via inband RM-Channel:yes/no

[sc\_rm\_config\_t-scheme, 1, --]

Setting	
Interface RM LID-1	Master / slave for LID-1 interface. If it is set to slave, the remote end connection shall be set to master.
Interface RM LID-2	Master / slave for LID-2 interface. It has to be set to different as local interface LID-1. If it is set to master, the remote end connection has to be set to slave, and the local LID-1 interface set to slave

All other RM settings stay the same as with non-T-scheme devices.

### 3.5.13 O-Scheme Configuration

#### System Configuration

G704 in SWT 3000 basic system configuration:

Operation Mode	Mode 5D
Connection: digital 1	G704 (fixed as clock slave DTE)
digital 2	G704 (fixed as clock slave DTE)
Double primary paths	Checked: Both LID-1/2 are used as primary paths for up to 4 channels Unchecked: 1 + 1 path protection for up to 2 channels. One LID is primary, the other one is secondary
Address: Transmitter	<Own device address>
Receiver 1	<Remote device address from channel 1 / LID-1>
Receiver 2	<Remote device address from channel 2 / LID-1>
Receiver 3	<Remote device address from channel 3 / LID-2>
Receiver 4	<Remote device address from channel 4 / LID-2>

#### Command allocation

For double primary path, 16 commands are allocated to 4 channels in default as below figure. Each channel can have up to 4 commands. It is possible to allocate command to any other channels in SWT 3000 > Configuration > Channel allocation.

Idx	Channel	Idx	Channel
(1)	LID-1 Ch1 ▼	(9)	LID-2 Ch1 ▼
(2)	LID-1 Ch1 ▼	(10)	LID-2 Ch1 ▼
(3)	LID-1 Ch1 ▼	(11)	LID-2 Ch1 ▼
(4)	LID-1 Ch1 ▼	(12)	LID-2 Ch1 ▼
(5)	LID-1 Ch2 ▼	(13)	LID-2 Ch2 ▼
(6)	LID-1 Ch2 ▼	(14)	LID-2 Ch2 ▼
(7)	LID-1 Ch2 ▼	(15)	LID-2 Ch2 ▼
(8)	LID-1 Ch2 ▼	(16)	LID-2 Ch2 ▼

[sc\_default\_double\_primary, 1, ---]

Figure 3-58 Default channel allocation for double primary

For 1 + 1 path protection, 16 commands are allocated to 2 channels in default as below figure. Each channel can have up to 8 commands, the same commands are transmitted in secondary path.

Idx	Channel	Idx	Channel
(1)	LID1&2 Ch1 ▼	(9)	LID1&2 Ch2 ▼
(2)	LID1&2 Ch1 ▼	(10)	LID1&2 Ch2 ▼
(3)	LID1&2 Ch1 ▼	(11)	LID1&2 Ch2 ▼
(4)	LID1&2 Ch1 ▼	(12)	LID1&2 Ch2 ▼
(5)	LID1&2 Ch1 ▼	(13)	LID1&2 Ch2 ▼
(6)	LID1&2 Ch1 ▼	(14)	LID1&2 Ch2 ▼
(7)	LID1&2 Ch1 ▼	(15)	LID1&2 Ch2 ▼
(8)	LID1&2 Ch1 ▼	(16)	LID1&2 Ch2 ▼

[sc\_default\_redundancy, 1, --]

Figure 3-59 Default channel allocation for 1+1 path

### Configuration in SDH Multiplexer

E1 port configuration	
Frame attribute	PCM31
CRC4	Not supported
DSO cross-connection (Each channel occupy 5 time slots)	
Channel 1 / LID-1 time slot	E1 port 1 - DSO_1..5
Channel 2 / LID-1 time slot	E1 port 1 - DSO_6..10
Channel 3 / LID-2 time slot	E1 port 2 - DSO_1..5
Channel 4 / LID-2 time slot	E1 port 2 - DSO_6..10

### Alarm control

If one of channels has following alarms detected, only general alarm (GEN) output will be activated.

- Loss of synchronization (SYNC)
- Wrong received DLE telegram address
- Bit error rate (BER) alarm when bit error > 10<sup>-3</sup>

The command outputs on this channel will be blocked. However, the commands on other channels still can be received. If all channels are failed, the receive alarm (RX) will be activated and all command outputs are blocked.

### Jumper Settings

To use G704 function, DLE module must be adjusted to same jumper settings as G703.6 (symmetric or asymmetric).

### Firmware upgrade

There are three different DLE FPGA components to realize different functions:

FW version	Function
Pu4DleFpga_v00_01_81.jnk	T-scheme without service channel (SC) function. It is standard release included in AllInOne_PU4 image and delivered by production.
DleFpga_v00_01_32.jnk	SC function without T-scheme and G704 function. To use SC function, DLE FPGA must be downgraded to version 0.1.32 using Memtool.
DleFpga_v00_02_00.jnk	O-scheme G704 function To use G704, DLE FPGA must be upgraded to version 0.2.0 using Memtool.

DLE FPGA component can be found in PowerSys Installation folder.  
If the firmware version is mismatched, the HW alarm is activated.

### Upgrade DLE FPGA component for O-Scheme

- The DLE FPGA components are listed in the file system.

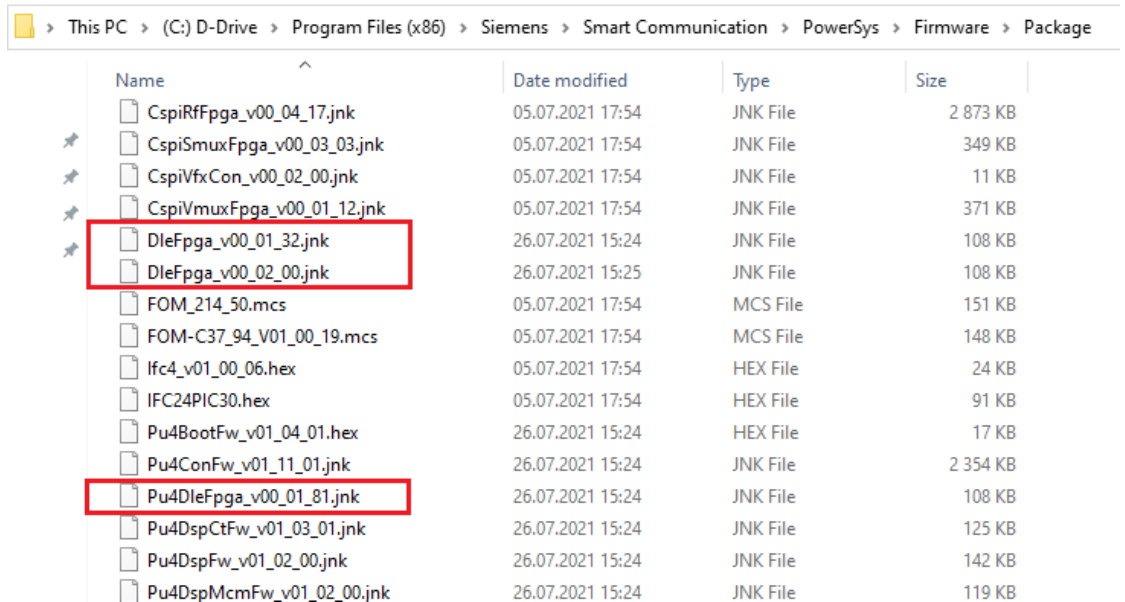

[sc\_list\_fwfiles, 1, ...]

Figure 3-60 DLE FPGA components

- Upgrade with Memtool
  - Start Memtool via the Windows Main menu Start – Programs – UDE Memtool, select target configuration to “Siemens SWT 3000 – PU4”.
  - Open File DleFpga\_v00\_02\_00.jnk
  - Connect to the SWT 3000 target
  - Select all flash sectors in firmware file with **Select All** and click **Add Sel. >>**
  - Select Flash memory device to external flash.
  - Program

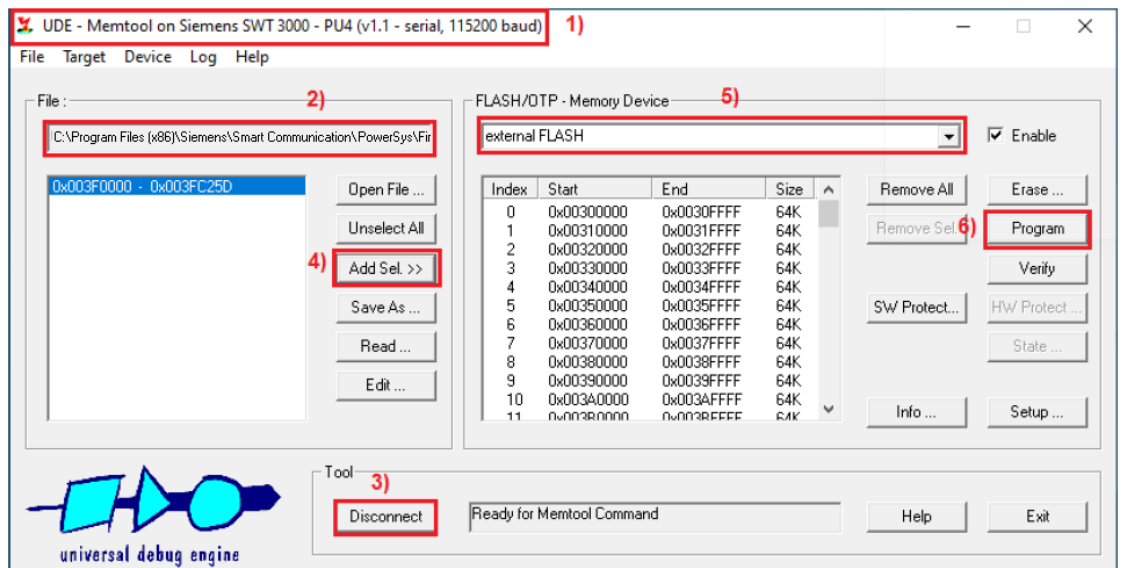

[sc\_program\_external\_flash, 1, ...]

- Check, if correct DLE FPGA version for O-Scheme is displayed in PowerSys > Device > General (DLE FPGA = 00.02.00)

For DLE FPGA firmware update via PowerSys see chapter [5.4 Firmware Update With PowerSys](#)

### 3.5.14 Periodic transmission time test configuration

The periodic command transmission time test works for the digital transmission line only. It triggers command transmission time tests at a configurable interval. The actual command transmission is not affected. The test result (OK/fail) is recorded in event log.

SWT3000 > Configuration > System > Line interface	
Connection: digital 1/2	At least one digital is selected
Address	Transmitter/Receiver < 128
SWT3000 > Configuration > Clock Synchronisation	
Command periodic transmission time test mode	One side is master, the other side is slave
Command periodic transmission time test interval	Not OFF at the master side (If interval is off, no automatically loop test is triggered )

## 3.6 Online Parameter Adjustment

### 3.6.1 Overview

The settings described in the following are based on the assumption that the device is already configured. A complete new configuration is described in more detail in the section [3.5.1 New Configuration](#).

### 3.6.2 Level Adjustment for Analog Interface

#### 3.6.2.1 Tx Level Adjustment

After connecting the device to the transmission cable or to the PLC system via an analog interface, the output level must be set with the service PC.

Select **Adjustment > Levelling**.

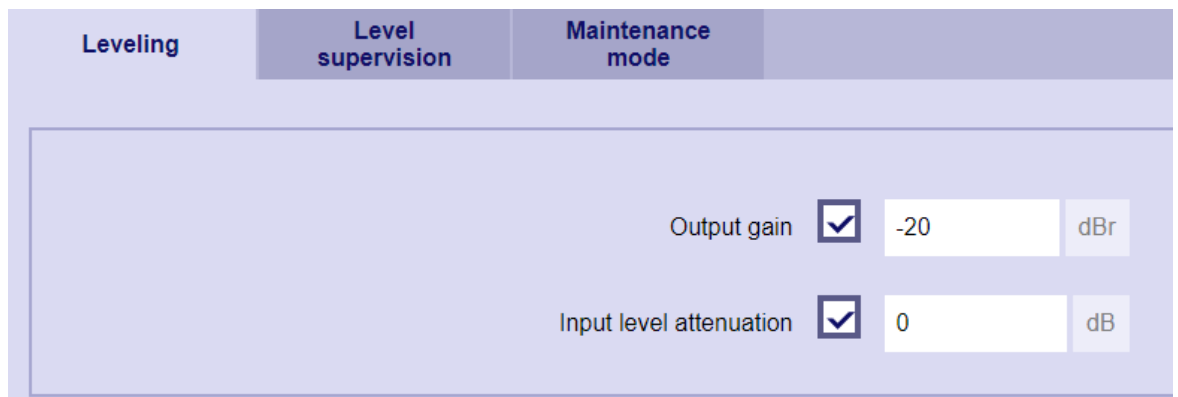

[sc\_leveling, 2, --]

Figure 3-61 Setting the PU4 Output Level

The output level can now be set in steps of 0.1 dB in the range of -60 dBr to +4 dBr with the menu option **Output gain**.

#### Transmit Level



Measurement: At output socket ↗ of the CLE module  
Setting: -10 dB



#### NOTE

The level set at the PU4 will be further amplified by about +11 dB on the CLE module.

#### 3.6.2.2 Rx Level Adjustment

The incoming receive level on the trunk line can be measured at the input socket ↗ of the CLE and amplified by 0 dB, 6 dB, or 12 dB with straps W1 - W3.

Refer also to the table [Table 3-52](#).

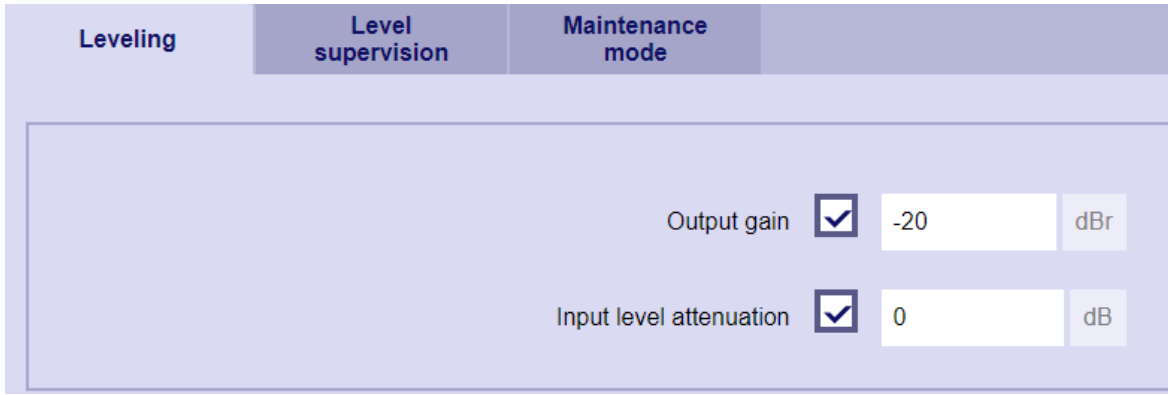

[sc\_leveling, 2, -->]  
 Figure 3-62 Setting the Input Level Attenuation

You can set the input level attenuation from 0.0 dBr to -60.0 dBr in steps of 0.1 dB. This value is used for checking the receive level reserve.



**NOTE**

During normal operation, set the input level attenuation to 0.0 dB. This parameter must only be used for testing during commissioning

**Receive Level Setting**



Measurement: At the input socket → of the CLE and PU4  
 Function range: +4 dB to -33 dB at the input of the PU4

When using a PowerLink, straps W1 - W3 on the CLE must be set to give 0 dB at the input of the PU4. Set the operating thresholds for the receive level alarm and the option of disabling the output in case of an S/N alarm by clicking on **Configuration > Alarm control**.

Table 3-52 Setting Options for Receiver Alarm

Menu Option	Setting Options	Comment
Threshold for receiver alarm	-30 dB / -25 dB / -20 dB / -15 dB / -10 dB	Receive level on the CLE amplified by 0 dB (W1) → effective setting: -30 dB / -25 dB / -20 dB / -15 dB / -10 dB
		Receive level on the CLE amplified by 6 dB (W2) → effective setting: -36 dB / -31 dB / -26 dB / -21 dB / -16 dB
		Receive level on the CLE amplified by 12 dB (W3) → effective setting: -42 dB / -37 dB / -32 dB / -27 dB / -22 dB
Force receiver alarm on S/N and/or BE alarm	Yes <sup>1)</sup> No	Relay receiver alarm is also activated in case of S/N or BE alarm
Blocking outputs on S/N and/or BE alarm	Yes <sup>1)</sup> No	Command output disabled in case of S/N or BE alarm
Switch NU-Relays on GAL	Yes No <sup>1)</sup>	Relay NU is also activated in case of general alarm
<sup>1)</sup> As delivered state		





**NOTE**

**Adjustment > Leveling** and **Leveling supervision** are only available for the Stand-alone SWT 3000 system. The levels of an integrated (i)SWT 3000 system are controlled by the Central Signal Processing unit (CSPI) of the PowerLink.

### 3.6.3 Level Adjustment for Connection via VFx Module

#### 3.6.3.1 Overview

When using the SWT 3000 with the PowerLink PLC system, the following settings must be made depending on the configuration:

#### 3.6.3.2 Connection via a VFx Module

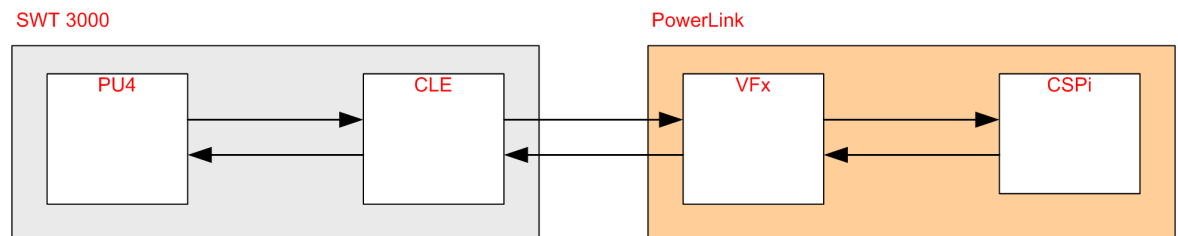

[dw\_SWT\_convfx\_1\_en\_US]

Figure 3-63 Setting Options for the Protection Transmit Level for Connection via VFx Module

A level of -10 dB is required at the input of the VFx module. The levels in PowerLink are set automatically from the system depending on the device configuration. They are displayed in PowerSys in the menu **Information > Services** and can be measured at the Central Signal Processing innovation (CSPI) unit or PowerLink PowerAmplifier (PLPA) output.

Table 3-53 SWT 3000 Transmit Level

Measuring Point	Level [dB]	Comment
CLE module output	-10	Setting with service PC on the SWT 3000 PU4 module
VFx input	-10	Setting with service PC in PowerLink
CSP or CSPI module output	Depending on device configuration	Automatic Tx level adjustment within the PowerLink



**NOTE**

If a coded tripping (CT) variant is used, the PU4 transmit level must be adjusted to 6 db less. This adjustment causes also 6 dB less level at the output of the CLE.

### 3.6.4 Setting Parameters of Measuring Points

Once you have set the levels on the device and teleprotection signaling is working properly, you can set the alarm operating thresholds for monitoring the PU4 and CLE outputs.

Set these alarm operating thresholds in the menu **Adjustment > Level supervision**.

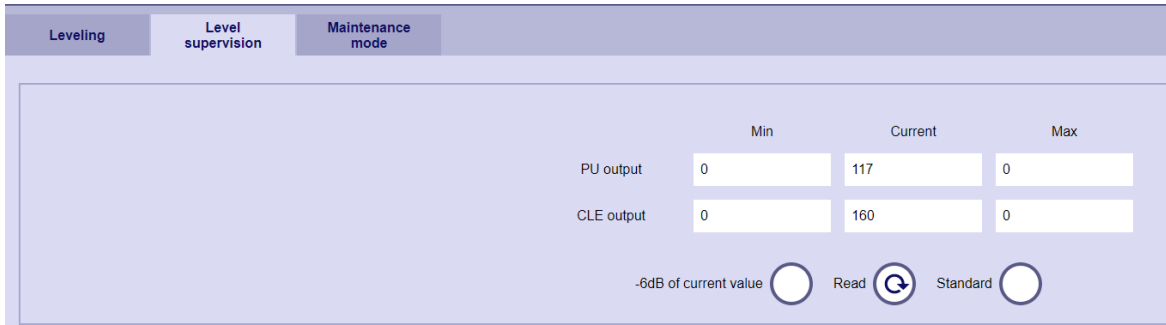

[sc\_level\_supervision, 2, ...]

Figure 3-64 Setting Alarm Thresholds

Table 3-54 Setting Options for Measuring Points

Menu Option	Comment
Standard	Default values stored in the program are imported for the individual measuring points
Read	The current measured values are read from the measuring points in the SWT 3000 device
-6 dB of current value	The current measured values are halved and entered in the <b>min.</b> field as the threshold value for the measuring point alarm

Entering **0** in the **min.** field deactivates monitoring. Siemens recommends that if the system is working properly, the current level values must be accepted with **Read** and the alarm thresholds defined with **-6dB of current value**.

Failure on the PU4 output level activates the display on the PU4 module (flashing red LED of the used interface) and transmitter alarm (Tx-AL) on the CLE module.

### 3.6.5 Time and Date

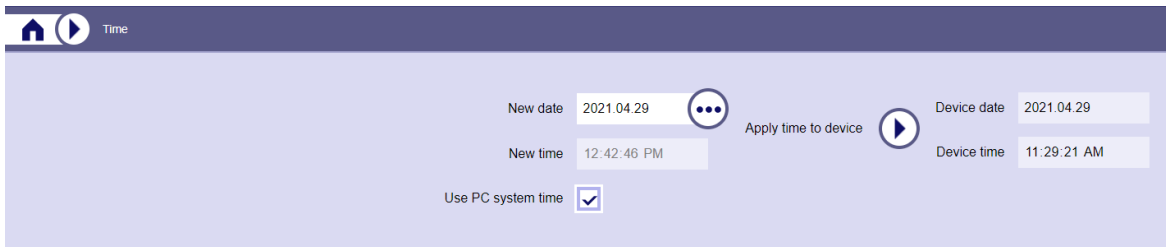

[sc\_time, 1, ...]

Figure 3-65 Setting of Date and Time of an SWT 3000

For the time adjustment, use the option **use PC system time** or a manual adjusted **new date** or **new time**. The internal clock is adjusted by clicking on **Apply** or **OK**.

### 3.6.6 Command Blocking

Each command can be blocked independently for maintenance purpose. The control will be managed manually via software configuration (on / off) or any unused binary IFC input. Command input block is to cut off command transmission to remote side and command output block is to cut off command output on local side. The non-blocked commands are in normal operation.

If the command is activated during blocking on, the command will not be transmitted. If the command is already in transmission before blocking on, the transmitting command will not be blocked.

Block control is configurable for all protection mode under PowerSys > Adjustment > Maintenance mode. The changes are online parameter without device reset.

Command	Input	Output	Blocking
(1)	<input checked="" type="checkbox"/>	<input type="checkbox"/>	On ▼
(2)	<input type="checkbox"/>	<input checked="" type="checkbox"/>	On ▼
(3)	<input checked="" type="checkbox"/>	<input checked="" type="checkbox"/>	On ▼
(4)	<input checked="" type="checkbox"/>	<input type="checkbox"/>	IFC-1/IN1 ▼
(5)	<input type="checkbox"/>	<input checked="" type="checkbox"/>	IFC-1/IN2 ▼
(6)	<input checked="" type="checkbox"/>	<input checked="" type="checkbox"/>	IFC-1/IN3 ▼
(7)	<input type="checkbox"/>	<input type="checkbox"/>	Off ▼
(8)	<input type="checkbox"/>	<input type="checkbox"/>	Off ▼

[sc\_command\_blocking, 1, --]

Figure 3-66 Command Blocking

Command	Blocking
(1)	Command input is blocked (On = blocked)
(2)	Command output is blocked
(3)	Command input and output are blocked
(4)	Command input is blocked by binary input IFC-1/IN 1 state (BI on = blocked, BI off = unblocked)
(5)	Command output is blocked by binary input IFC-1/IN 2 state
(6)	Command input and output are blocked by binary input IFC-1/IN 3 state
(7)..(24)	Remaining commands are in normal operation without blocking. (Off = unblocked)

Command block state is indicated by:

- PU4 LED\_OK slow blinking (At least one command is blocking)
- Event log entry (command input/output block on/off for maintenance [xxx])  
Internal message for command during blocking.



## 4 Diagnostics and Error Handling

4.1	Control and Signaling Elements	182
4.2	IFC Test Mode	191
4.3	PU4 Test Command	192
4.4	Possible Reasons for the Alarms	195
4.5	Display of the Entries in the Event Log	196
4.6	Alarm Messages in the Service Program PowerSys	198
4.7	Diagnosis of Ethernet EN100 Module	199
4.8	FOM SFP Alarm Supervision	202

## 4.1 Control and Signaling Elements

### 4.1.1 Control and Signaling for PU4 Module

#### 4.1.1.1 Front Panel

Control and display elements are mounted on the module. The front panel covers some of them. For example, in order to prevent the unit being accidentally disconnected, the front panel covers the On/Off switch for the power supply.

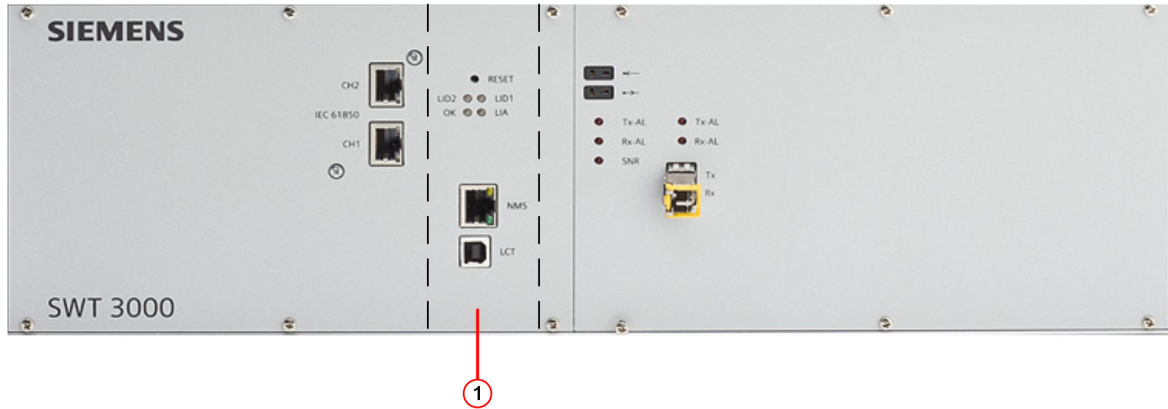

[scpu4dlis-160911-01.tif, 1, ...]  
 Figure 4-1 Front Panel of a Unit with Analog Line Interface, CLE, and FOM Module

(1) PU4

The PU4 controller and hence the entire SWT 3000 unit is reset with the reset button.

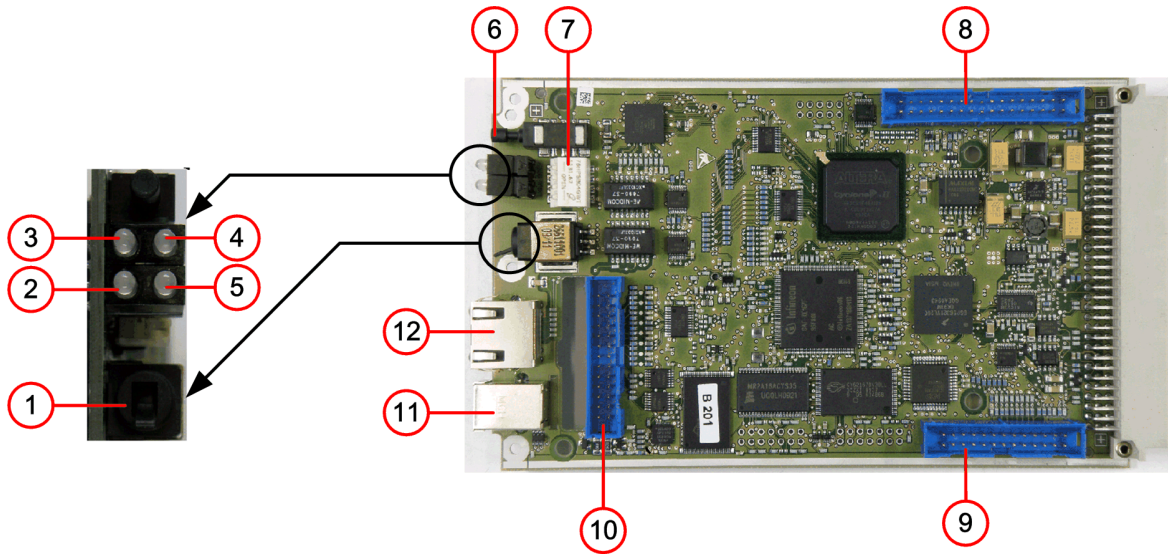

[le\_pu4jum, 1, en\_US]  
 Figure 4-2 Position of Jumpers, Input and Signaling Elements on the PU4 Module

- 1 S2: Power ON/OFF
- 2 LED OK/GBAL
- 3 LED Status Interface LID-2
- 4 LED Status Interface LID-1
- 5 LED Status Interface LIA

6	S1: Reset button
7	S3 (3.1 to 3.4)
8	Connection on DLE
9	Connection on DLE
10	Connection of the IFC Modules
11	LCT: Service Interface (USB)
12	NMS: Ethernet Interface

#### 4.1.1.2 Significance of LEDs on the PU4 Module

- The 2-color LIA LED is needed for displaying the status of the LIA. The following states can be displayed:

Table 4-1 Significance of the LIA LED Displays

State	Significance
Off	LIA is not configured
Red static	LIA is not ready for operation (for example, primary path receiver alarm)
Red flashing	LIA is only operational to a limited extent (for example, secondary path receiver alarm)
Green static	LIA is working correctly and used as main path.
Green flashing	LIA is working correctly and used as secondary path.



#### NOTE

Red flashing always means that the secondary path is not working correctly.

- The 2-color LID-1 LED is used for displaying the status of the LID-1. The following states can be displayed:

Table 4-2 Significance of the LED LID-1 Displays

State	Significance
Off	LID-1 is not configured
Red static	LID-1 is not ready for operation
Red flashing	LID-1 is only operational to a limited extent (for example, receiver alarm)
Green static	LID-1 is functioning correctly
Green flashing	Secondary path

- The 2-color LID-2 LED is used for displaying the status of the LID-2. The following states can be displayed:

Table 4-3 Significance of the LID-2 LED Displays

State	Significance
Off	LID-2 is not configured
Red static	LID-2 is not ready for operation
Red flashing	LID-2 is only operational to a limited extent (for example, receiver alarm)
Green static	LID-2 is functioning correctly
Green flashing	Secondary path

- The 2-color OK/BGAL LED is needed for displaying the PU4 module status. The following states can be displayed:

Table 4-4 Significance of the OK/BGAL LED Displays

State	Significance
Off	Power supply is disconnected or faulty
Red static	Module is not ready for operation
Red flashing	General alarm module is only operational to a limited extent
Green static	Normal operation
Green slow flashing	Test operation or remote alarm active
Green fast flashing	Ethernet port of PU4 is not ready for operation

### 4.1.1.3 IP (Ethernet) and Local (Service) Interface

The IP (Ethernet) interface of the PU4 module is used for:

- The communication between the NMS and SWT 3000
- Remote PowerSys session

The Ethernet interface (as RJ45 socket) can also be used for local Web login. It is located at the front of the PU4 module.

A USB local (service) interface in form of a standard USB B plug is fitted at the PU4 for the communication between the service PC and SWT 3000. The service PC is connected to the USB socket on the front panel of the PU4 module with a USB A/B plug cable.

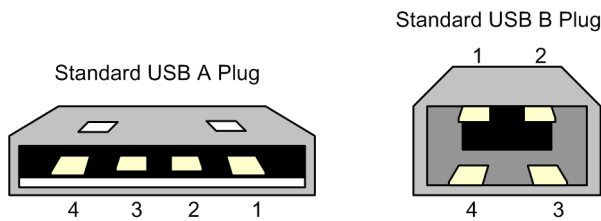

[dwpinout-300811-01.tif, 1, en\_US]

Figure 4-3 USB A/B Plug Cable

- (1) Pin 1 is  $V_{CC}$  (+5 V)
- (2) Pin 2 is Data- (D-)
- (3) Pin 3 is Data+ (D+)
- (4) Pin 4 is ground (-)

## 4.1.2 Control and Signaling for CLE Module

### 4.1.2.1 Alarm Displays

The alarm signals generated by the PU4 module are displayed via red LED on the front panel of the SWT 3000. LED are provided for the following alarms:



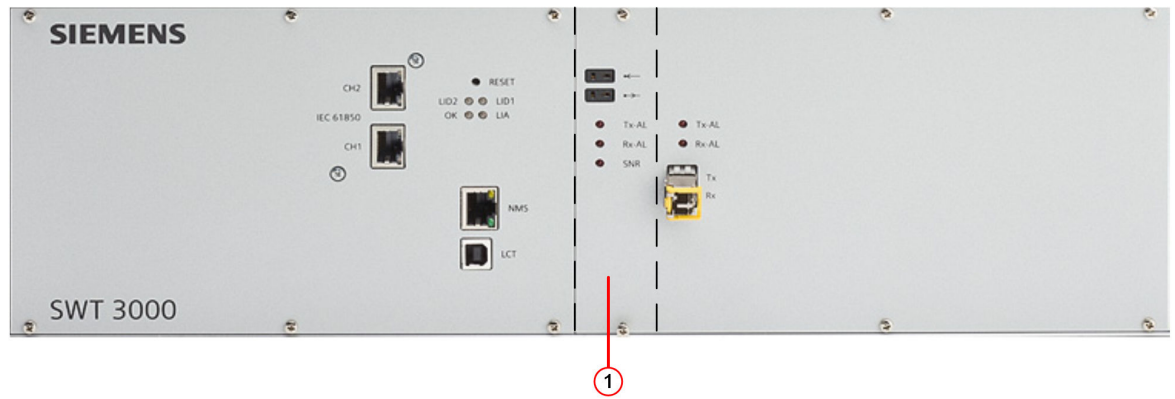

[scledis-160911-01.tif, 1, ---]

Figure 4-4 Displays on the CLE Module

1	Copper Line Equipment module (CLE)
Tx-AL	Transmitter alarm
Rx-AL	Receiver alarm
SNR	S/N alarm

The signals are low active and are fed to the LED drive via an integrated inverter module with a +5 V supply voltage.

#### 4.1.2.2 Test Sockets

The following test sockets are provided on the front panel of the CLE module:

- 1 ISEP socket for measuring the level of the receive signal
- 1 ISEP socket for measuring the level of the transmit signal

The level at the sockets is measured on a high impedance basis and corresponds to the value at the measuring point. Incorrect operations such as short circuiting or inserting a signal ( $U \leq 5 \text{ V}$ ) at the measuring sockets does not result in interruption of teleprotection signaling.

### 4.1.3 Control and Signaling for FOM Module

#### 4.1.3.1 Signification of the Alarm LED on the FOM

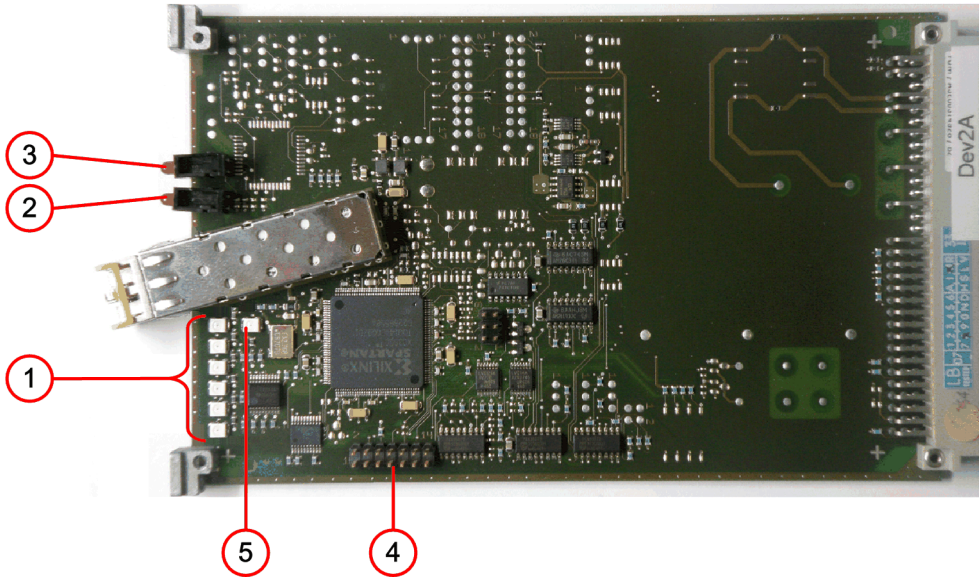

[scfomled-220513-01.tif, 1, en\_US]

Figure 4-5 Position of the LED on the FOM

- (1) LED H4 to H9: Diagnosis
- (2) LED H3 Rx-Alarm
- (3) LED H2 Tx-Alarm
- (4) Programming Interface
- (5) LED H1: FPGA Readiness

Table 4-5 Signification of the Alarm LED on the FOM

LED		LED Indication when Lighted	LED Indication with FOS3 for C37.94
H1	red	FPGA not ready	FPGA not ready
H2	red	<b>Tx-Alarm</b> F6 supervisory alarm	<b>Tx-Alarm</b> F6 supervisory alarm
H3	red	<b>Rx-Alarm</b>	<b>Rx-Alarm</b>
H4	yellow	ILAN high	<b>LOS alarm</b> ("lose of signal" alarm) LED on: DCE and DTE not synchronized or when in sync state, there are at least two bit errors in consecutive 8 C37.94 frames
H5	yellow	BUF alarm Buffer overflow or under run Source: Supervisory circuit of FPGA	<b>AIS alarm</b> ("Alarm Indication Signal" alarm) LED on: "all ones" received. The multiplexer lost the higher order link, it will send all one in the data bits to SWT3000.
H6	yellow	MOD-alarm Modulation alarm, carrier frequency at the optical receiver not detected	<b>RDI alarm</b> ("remote defect indicator" alarm) LED on: remote side of C37.94 connection entered a LOS alarm state.
H7	yellow	COM-alarm Communication alarm at the electrical interface	Debug information (for test purpose)

LED	LED Indication when Lighted	LED Indication with FOS3 for C37.94
H8	yellow SFP_LOS The received optical power is below the receiver sensitivity Loss of signal	Debug information (for test purpose)
H9	yellow S6 asserted	Debug information (for test purpose)

#### 4.1.4 IFC Control and Signaling

##### Diagnostic LED

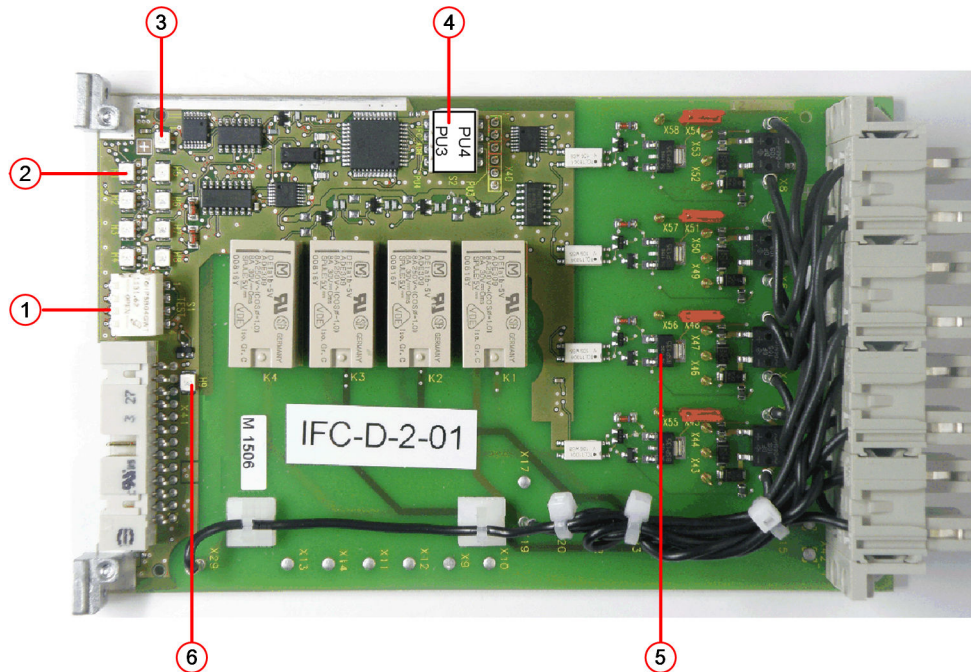

[le\_ifc\_control\_signaling, 1, -,-]

Figure 4-6 Signaling elements and DIL-switches of the IFC module, e.g. IFC-D

- (1) S1: Activate command input 1 to 4 (S1.1 to S1.4)  
open/up - deactivated (default)  
closed/down - activated
- (2) LED H1 to H4 (red): activated outputs  
LED H5 to H8 (green): activated inputs
- (3) Test Operation Display (H10)
- (4) S2: IFC Slot Address Selection (S2.1, S2.2) and PU3 / PU4 switch:  
S2.3: closed/down - PU3  
S2.3: open/up - PU4
- (5) Jumpers X43 to X58
- (6) Operating LED (H9)

### 4.1.5 Control and Signaling for ALR Module

#### 4.1.5.1 Relay Outputs

The alarm module comprises also 3 alarm outputs, switched by relay (K1 to K3). The 3 relays provide change-over contacts. In the standard setup the break contacts (NC) are used.

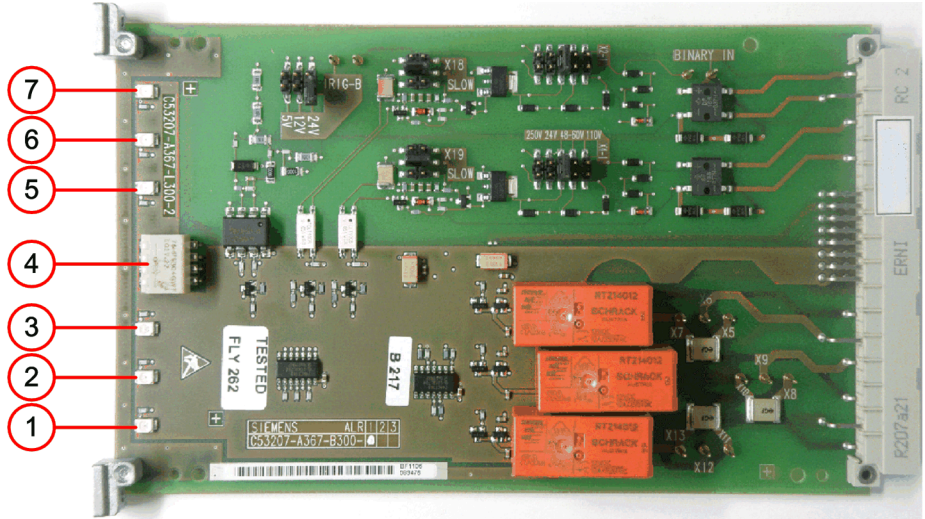

[scalrmod-220513-01.tif, 1, en\_US]

Figure 4-7 Display and Setting Elements on the ALR Module

- (1) LED H1: Output ALA3
- (2) LED H2: Output ALA2
- (3) LED H3: Output ALA1
- (4) Test Switch S1
- (5) LED H4: Input BI2
- (6) LED H5: Input BI1
- (7) LED H6: IRIG-B Input

#### 4.1.5.2 Visual Indication

The ALR module provides a LED for visual indication of the state for each binary input and for each alarm output. They are visible after removal of the front panel. The significations are shown in the following table:

Table 4-6 ALR Indication

LED	Indication
H6	IRIG-B input energized
H5	Binary input 1 energized
H4	Binary input 2 energized
H3	Alarm output 1 activated
H2	Alarm output 2 activated
H1	Alarm output 3 activated

#### 4.1.5.3 Test Switch S1

For test purposes, the ALR module provides a switch for each of the binary input circuits and for the IRIG-B circuit. Closing a switch sets the output of the assigned circuit to the active state.

Table 4-7 Functions of the ALR Test Switch

Switch	Function
S1.1	Binary input 2 test
S1.2	Binary input 1 test
S1.3	Not used
S1.4	IRIG-B test

## 4.1.6 Control and Signaling for Power Supply

### 4.1.6.1 Displays

LEDs on Power Supply Unit, visible after removal of the front panel.



[ph\_power\_supply\_leds, 1, --]

Figure 4-8 Front view of the Power Supply

Table 4-8 Significance of the LEDs on the Power Supply Unit

LED	Conditions	Significance
Operate	$U_{i \min} \leq U_i \leq U_{i \max}$ $I_o \leq I_{o \text{ nom}}$ $T_c \leq T_{c \max}$ $U_{inh} \leq 0.8 \text{ V}$	Unit in normal operation
Operate and overload 1, 2, or 3	$U_{i \min} \leq U_i \leq U_{i \max}$ $T_c \leq T_{c \max}$ $U_{inh} \leq 0.8 \text{ V}$	Current at output Uout1, Uout2, or Uout3 too high

LED	Conditions	Significance
Disable	$U_{i \min} \leq U_i \leq U_{i \max}$ $I_o \leq I_{o \text{ nom}}$ $T_C \leq T_{c \max}$	$U_{inh} > 0.8 \text{ V}$ Unit switched off or PU4 or CLE not inserted
Disable	$U_{i \min} \leq U_i \leq U_{i \max}$ $I_o \leq I_{o \text{ nom}}$ $U_{inh} \leq 0.8 \text{ V}$	Temperature monitoring has operated
Disable	$I_o \leq I_{o \text{ nom}}$ $T_C \leq T_{c \max}$ $U_{inh} \leq 0.8 \text{ V}$	Undervoltage or overvoltage monitoring has operated

$U_i$  = Input voltage

## 4.2 IFC Test Mode

In order to switchover from normal to test mode with the service program PowerSys, select the **IFC-Test** in the **Testmode** list box. In this mode, you can enter commands on the IFC module for each input with the DIP switches S1.1 to S1.4

The screenshot shows a configuration interface titled "Interface" with the following settings:

IFC-1	IFC-D/P	▼
IFC-2	IFC-D/P	▼
IFC-3	---	▼
IFC-4	---	
Special allocation	Contact doubling	▼
Test mode	Off	▼
	Off	
	IFC-Test	

[sc\_ifc\_test, 1, ---]

Figure 4-9 Selection of Testmode > IFC-Test



### NOTE

For security reasons, after switching over to test mode, the controller signals all inputs as **off** regardless of the actual switch position. The state **on** can only be reached by switching from **off** to **on** position. All switches must be in the **off** position beforehand.

Also a General Alarm is given as long as the test mode is active. Furthermore the OK-LED is slowly blinking during active test mode.

## 4.3 PU4 Test Command



### NOTE

The **Test** dialog is **only online available** (when connected to SWT 3000).

It is possible to select lines, enable LID/FOM Loops, or to enable the AMP measuring.

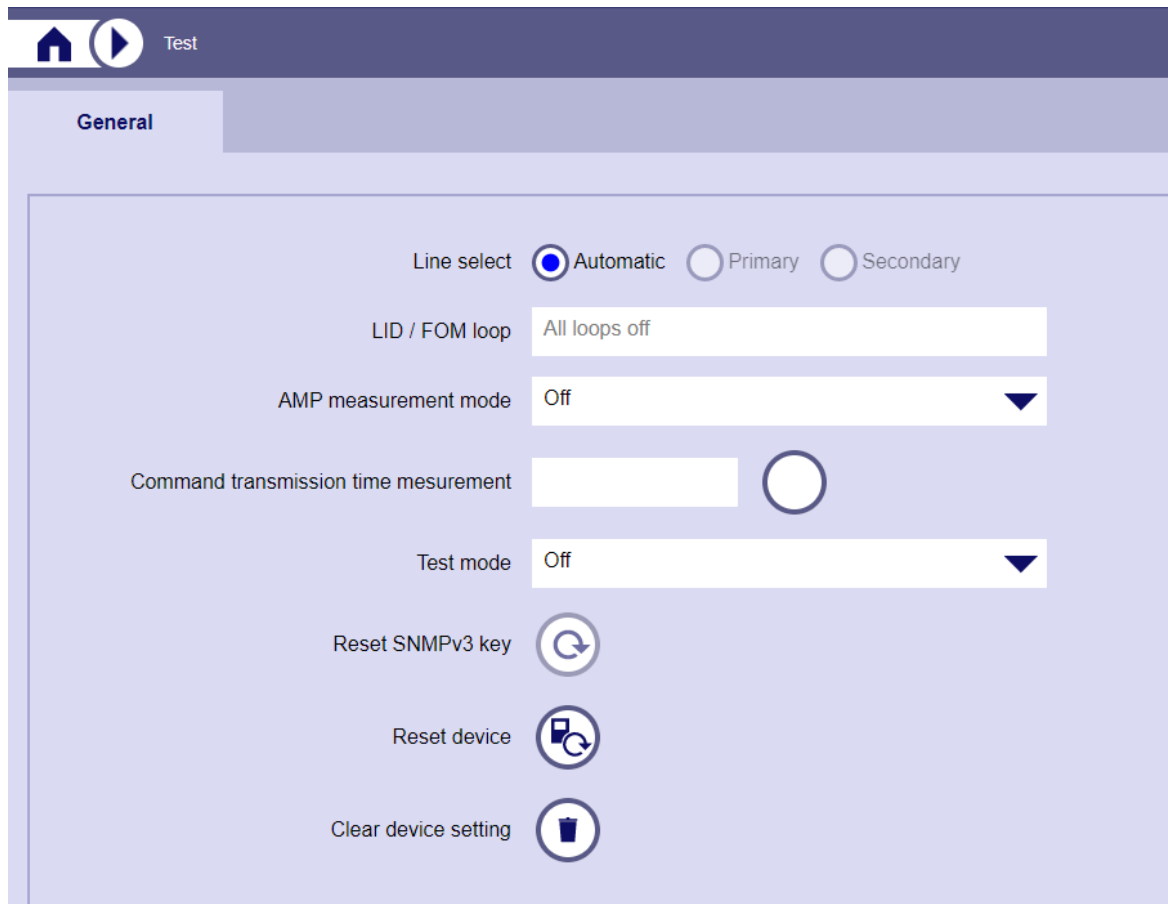

[sc\_command\_test, 1, --]

### Command Test

The **Test** dialog is divided into the following areas:

- Line selection **automatic** (only if 2 transmission links are activated)  
Automatic selection of the (primary) transmission line. If there is a fault, switchover to the alternative (secondary) line.
- Line selection **primary** (only if 2 transmission links are activated)  
The SWT 3000 receiver is fixed to the primary transmission line. If there is a line interrupt, switchover is not possible. This **setting causes the general alarm**.
- Line selection **secondary** (only if 2 transmission links are activated)  
The SWT 3000 receiver is fixed to the secondary transmission line. If there is a line interrupt, switchover is not possible. This **setting causes the general alarm**.



- **AMP Meas Off or On**  
Disables the input limitation from the binary inputs (which is automatically activated in the AMP mode of SWT 3000) when adjusted to **on**. It is now possible to send persistent commands for measuring the trip frequencies.  
If the **AMP Meas** is adjusted to **on**, the **general alarm is activated**.
- **Command transmission time measurement**  
Single test provides a method to measure command transmission time over the current active line. It is available for both analog and digital transmission lines, but not for Ethernet transmission line (TPoP).
- **Reset SNMPv3 key**  
The key reset operation deletes all created SNMPv3 users, and new working users are cloned again from the initial user template.
- **Clear device setting**  
The command clear device setting **clears the complete configuration** stored in the PU4 module. After the command is executed, you may receive hardware and/or configuration fault alarm. If there is a new configuration from an existing SWT 3000 or after a firmware update, execute the function to clear all former settings.
- **Reset device**  
Reset of the SWT 3000 via the service PC. After **Reset device**, the service program is automatically connected back to the SWT 3000.

### Command Input Test

Command input test is a test function to verify command input / output during the commissioning phase. It must be switched off in normal operation. To avoid unwanted command by incident, the command input test can only be enabled when:

- IFC-Test mode configured (GEN alarm activated)
- PU4 switch S3.4 is enabled for test purpose

If the command input test is enabled, command input from IFC or EN100 port is ignored. Instead, the input from the test page is assigned to a protection frequency and transmitted as in normal operation.

The command input test page is only available when iSWT is active. Any command input combinations can be triggered on by enabling the corresponding inputs and then clicking 'Activate selected commands on device' button. Disable all command inputs and click 'Activate selected commands on device' button will trigger all commands off.

General		Command input test			
					
Input	Enabled	Input	Enabled	Input	Enabled
(1)	<input type="checkbox"/>	(9)	<input type="checkbox"/>	(17)	<input type="checkbox"/>
(2)	<input type="checkbox"/>	(10)	<input type="checkbox"/>	(18)	<input type="checkbox"/>
(3)	<input type="checkbox"/>	(11)	<input type="checkbox"/>	(19)	<input type="checkbox"/>
(4)	<input type="checkbox"/>	(12)	<input type="checkbox"/>	(20)	<input type="checkbox"/>
(5)	<input type="checkbox"/>	(13)	<input type="checkbox"/>	(21)	<input type="checkbox"/>
(6)	<input type="checkbox"/>	(14)	<input type="checkbox"/>	(22)	<input type="checkbox"/>
(7)	<input type="checkbox"/>	(15)	<input type="checkbox"/>	(23)	<input type="checkbox"/>
(8)	<input type="checkbox"/>	(16)	<input type="checkbox"/>	(24)	<input type="checkbox"/>

[sc\_command\_input\_test, 1, ...]

Figure 4-10 Command input test



**NOTE**

Any test command input should work according to the actual configuration. For example, if mode 3a is selected, only input 1 to 4 can be transmitted.

Another example, if command 1 is not assigned to a valid input port in input command allocation, command 1 will never be sent.

## 4.4 Possible Reasons for the Alarms

Table 4-9 Alarm Relays and Possible Alarm Reasons

Relay	Possible Reason	Comment
GALR	Normal operation interrupted	
	PU4 measuring point alarm (MAL)	Additional non-urgent alarm
	Transmission path faulty, no alternative path	Additional RXALR
	Primary and secondary path not available	Additional RXALR and non-urgent alarm
	IFC test operation	OK LED on PU4 green blinking
	Module alarm or configuration alarm	OK LED red
RXALR	Guard alarm, transmission path not available, no alternative path	Additional GALR
	Guard alarm, primary and secondary path not available	Additional GALR and non-urgent alarm
	Time limit for the command output exceeded	The command output is interrupted. The alarm is deactivated when the command transmission is canceled.
	Output of the unblocking impulse (when activated) at operating mode 3 to 5A	
NUALR	Primary path not available but secondary path existing.	Switchover to the alternative path
	Primary and secondary path not available	Additional GALR and RXALR
	Power failure of one power supply in case of redundant power supply	No interrupt as long as the second power supply is working
	LIA signal to noise alarm	Command outputs blocked (depending on settings)
	LID bit error alarm (bit error rate is $> 1 \times 10^{-6}$ )	Command outputs blocked (depending on settings)
	<b>Switch NU-Relay on GAL</b> is activated in the alarms control configuration	Additional contact in case of GALR. Refer to <a href="#">3.5.11.4 Setting Options for SWT 3000 Alarms</a> ). This function is <b>not available</b> when <b>2 transmission paths</b> are used.
	Time limit for the command input exceeded	The command transmission is interrupted. The alarm is deactivated when the command input is canceled.
	IP alarm	IP alarm is activated if errors occur in SNMP, NTP, WebServer, and DHCP

## 4.5 Display of the Entries in the Event Log

### General Information

Protection commands and alarms of SWT 3000 are provided with time, date, and a registration number before they are entered in the event memory.

The following events are entered:

- Incoming protection commands from IFC-D/P
- Outgoing protection commands to the IFC-D/P
- Detected alarms
- Program restart
- Changing date and/or time
- Changing the configuration

Up to 8000 non volatile event entries with a time resolution of 1 ms are possible. The service PC reads out the entries. The readout is also possible from the remote station with remote monitoring. If there is an overflow, the oldest entry in the event memory is overwritten.





The event log can only be read when the PowerSys program is connected to the device (PowerLink with integrated SWT 3000 or stand-alone SWT 3000).

No.	Date	Time	Group-Event	Description
	2022-01-13	11:49:38.0	1/1	program started
	2021-08-18	12:55:32.141	3/20	clock synchronisation (local or remote) successful
	2022-01-13	11:49:36.671	3/25	device configuration programmed in FLASH
	2022-01-13	11:49:40.71	3/91	active line from now on is LID1
8120	2022-01-14	11:35:04.543	3/36	PowerSys connected
8119	2022-01-14	11:33:50.573	3/37	PowerSys disconnected
8118	2022-01-14	11:32:40.590	3/36	PowerSys connected
8117	2022-01-14	10:46:39.855	3/37	PowerSys disconnected
8116	2022-01-14	10:24:20.528	3/36	PowerSys connected
8115	2022-01-13	15:10:30.11	3/37	PowerSys disconnected
8114	2022-01-13	14:55:12.433	3/36	PowerSys connected
8113	2022-01-13	14:55:07.458	2/25	IED X POTT RX (command output 1 OFF)
8112	2022-01-13	14:55:07.443	2/17	IED X POTT TX (command input 1 OFF)
8111	2022-01-13	14:55:07.443	3/37	PowerSys disconnected

[tc\_event\_log, 2, ...]

Figure 4-11 Event log

Function	
<input type="text" value="All events"/>	Event log type filter for all events, command only or alarm only. Only supported for SWT event log.
<input type="text" value="24"/>	Select how many entries of event log you want to read out, default number is 24.

	Function
	Start or reload event log.
	Stop event log reading.
	Export loaded event log as offline PDF.
	Confirm and delete all entries in the event log.

The number and type of events is selectable as shown in the preceding figure. In the first 4 lines, the **fixed records** are displayed **without** event number.

Table 4-10 Fixed entries in the event recorder

No.	Grp	Evt	Description
1	1	1	Last start-up of the PU4 firmware
2	3	20	Last successful clock synchronization (if activated)
3	3	25	Last change of the device data (not date or time change!)
		90	Last change of the line selection to LIA
4	3	91	Last change of the line selection to LID1
		92	Last change of the line selection to LID2

Each record is marked with **[Date]** (year.month.day), **[Time]** (hour:minute:second.hundredth.thousandth), **[Grp]** (group identifier), **[Evt]** (event identifier), and **[Description]**. The event record numbers **[No]** are entered from the PU4 module from 0 to 9999. After 9999, the event-counter restarts with 0.

For a better understanding of the event log entries, set the time and date on the PU4 with PowerSys before starting operation. During power off, time and date are saved on the PU4 for about 96 hours. The recorded event entries are non volatile.

Table 4-11 Group Numbers

Grp	Description
1	System control
2	Teleprotection commands
3	Alarms
4	Alarms
128 to 255	Internal system messages



**NOTE**

The displayed comments show the same signification as the combination of group and event identifier. If there is a comment with the message **Internal system message**, contact the Siemens Customer Support.

## 4.6 Alarm Messages in the Service Program PowerSys

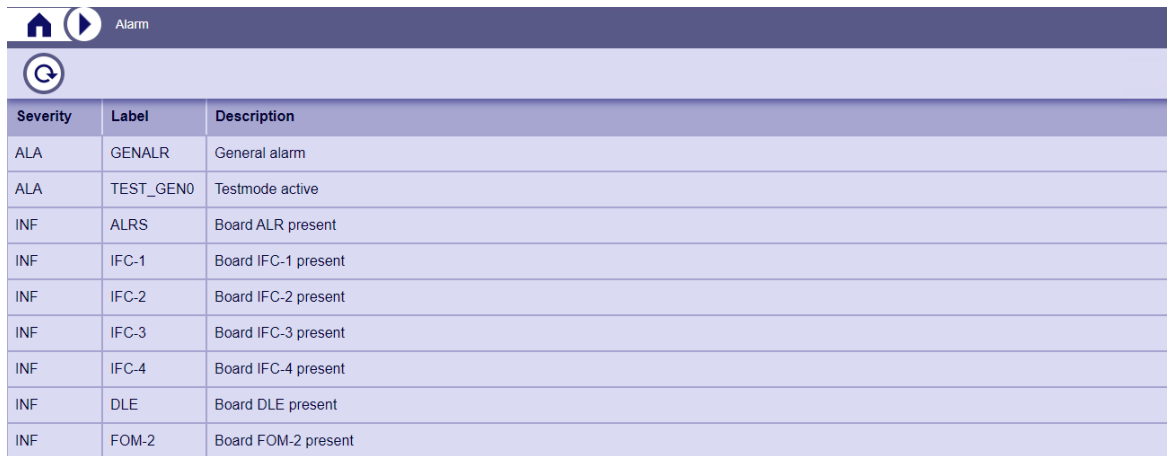

Severity	Label	Description
ALA	GENALR	General alarm
ALA	TEST_GEN0	Testmode active
INF	ALRS	Board ALR present
INF	IFC-1	Board IFC-1 present
INF	IFC-2	Board IFC-2 present
INF	IFC-3	Board IFC-3 present
INF	IFC-4	Board IFC-4 present
INF	DLE	Board DLE present
INF	FOM-2	Board FOM-2 present

[sc\_alarm, 1, --]

Figure 4-12 Alarm messages

If there is a fault, which makes it impossible to run the normal operation the system produces fault indications. These indications are displayed in the **Alarms** submenu. The display is refreshed with the **Read** button.

## 4.7 Diagnosis of Ethernet EN100 Module

### EN100 Information in PowerSys

If an Ethernet module EN100 for IEC 61850 is configured with the SWT 3000, **PowerSys > EN100 > Module info** displays the most important information about addresses and connection status of the module.

The EN100 information can only be read when the PowerSys program is connected to the device (stand-alone SWT 3000 or integrated SWT 3000 in PowerLink).

Index	Value
1	CRC value= 9d 71 ac 7f
2	EN100_E+ IEC61850
3	MAC 00098efb7f68
4	IP 192.168.020.144
5	NM 255.255.255.000
6	GW 000.000.000.000
7	Corrupt parameter
8	Chan1/2=Down /UpAct
9	Rx/TxCnt=00208/00026
10	Rx/TxErr=00000/00000
11	Rx/Tx10s=0104/0019
12	CPU load= 8%
13	
14	
15	Line

[sc\_EN100\_moduleInfo, 1, --]

Figure 4-13 EN100 Info

The following EN100 information is displayed:

Table 4-12 EN100 Information

Line/IDX	Information
IDX 1	CRC value (EN100 BIN parameter file checksum)
IDX 2	Module type
IDX 3	Hardware address (MAC)
IDX 4, IDX 5, IDX 6	Ethernet channel addresses: IP address, Network mask, Gateway address
IDX 7	EN100 clock synchronisation status (NTP1/2)
IDX 8	Physical link status and data rate of connected Ethernet channel (Phy1/ Phy2)
IDX 9, IDX 10, IDX 11	Communication status: Statistics and error counters
IDX 12	CPU load rate

The status information is updated by pressing the Read button.

### EN100 Firmware Version Information

You can check the firmware version of the Ethernet module EN100 in **Device > General**.

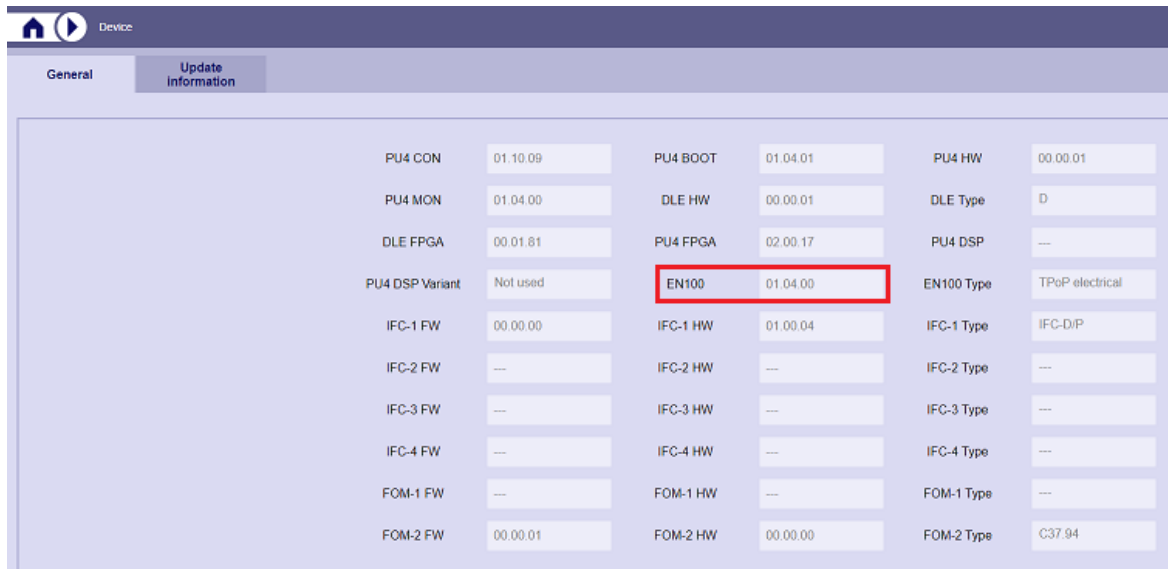

[sc\_EN100\_firmware\_version, 1, ...]

Figure 4-14 EN100 FW version information in Device > General

### EN100 Module Homepage

The EN100 modules are provided with a homepage, which can be invoked on all devices using the respective IP address. Fig. 9-2 shows an example of a homepage. The homepage is invoked by entering the IP address of the device combined with home in the address line of the browser on the PC (e.g.: <http://192.168.0.55/home> for the EN100 default IP address)



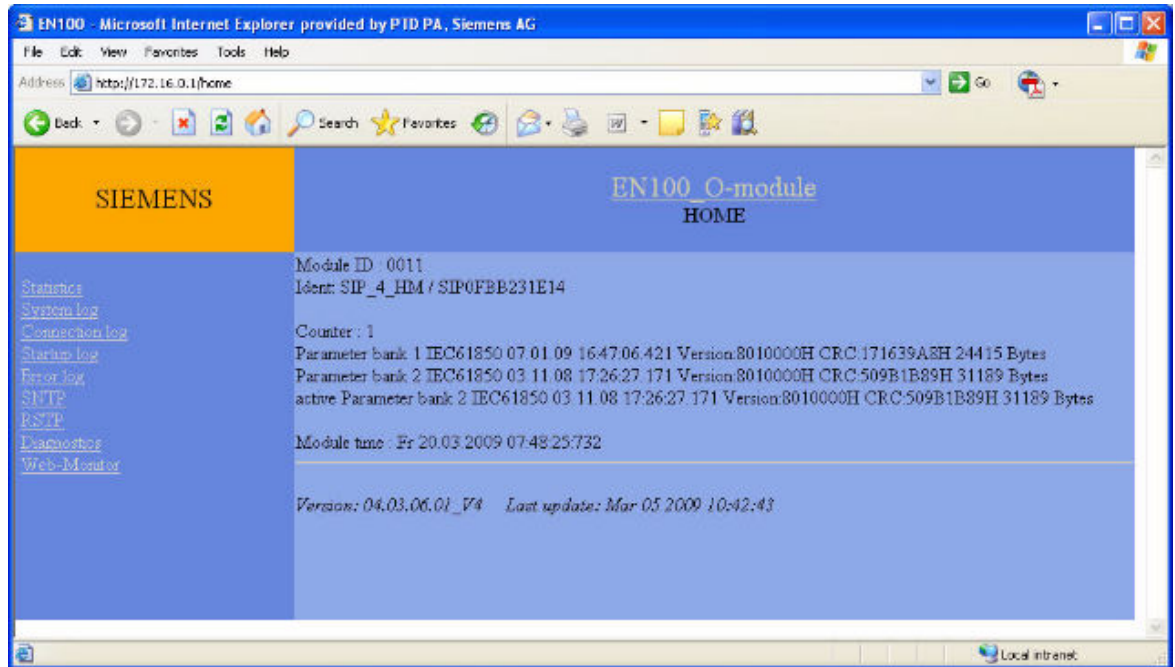

Figure 4-15 Homepage of the EN100 modules



**NOTE**

With a factory pre-configuration of EN100 in SWT 3000 devices the following generic IP addresses are programmed to the module: 192.168.100.11 and 192.168.100.12.

You can check the actual IP address of the EN100 module in **EN100 Info** (refer to **EN100 Information in PowerSys**).

The EN100 module homepage always shows at its end the version and creation date of the software version loaded on the module. With the links on the left area of the EN100 homepage you can browse to following subpages, which contain information for commissioning, operational information and internal error messages.

Table 4-13 Linked pages of the EN100 module homepage

Page	Description
Statistics-page	shows relevant information of Ethernet
System log-page	shows information of system behavior, being produced from operation time
Connection log-page	contains information about Client-Server-Connection and DIGSI-Accesses
Startup-page	contains information about run-up behavior and configuration settings respecting network- and GOOSE-Parameters
Error log-page	contains internal error messages

Refer to **SIPROTEC 4 EN100-Module - Manual IEC 61850** for description of the pages.

You may find a copy of the manual on the PowerSys package in folder /IEC61850/Manual.

Check the SIPROTEC webpage for the latest manual version:

Internet: [www.siprotec.com](http://www.siprotec.com)

## 4.8 FOM SFP Alarm Supervision

SWT 3000 FOM module is equipped with a SFP transceiver for fiber-optic connection. The SFP with a digital diagnostic monitoring interface (DDMI) is allowed to read out real-time diagnostic information and alarm status. The DDMI interface is only available if SFP module is compliant with SFP-8472.

### Enable DDMI function

By default, DDMI monitor is disabled. It can be enabled in SWT 3000 SNMP MIB (SIEMENS-SWT3000R35.MIB) by SNMP SET command. The MIB OID is defined as below:

OID	Description
swtInfoSfp1Enable	= enabled(1): Enable SFP-1 DDMI monitor functionality
swtInfoSfp2Enable	= enabled(1): Enable SFP-2 DDMI monitor functionality
swtIpActivationReq	Enable SFP-2 DDMI monitor functionality Store setting in flash and restart device.

### Supervise SFP alarm

If DDMI monitor is disabled or DDMI interface is not supported with used SFP module, alarm supervision is skipped. SFP alarm status is monitored periodically. If alarm flag is set, general alarm is triggered. If warning flag is set, non-urgent alarm is triggered. The active alarm / warning is displayed in PowerSys: SWT 3000 > Information > Alarms / Errors.

Severity	Label	Explanation
WAR	TEMP_WAR	SFP-1/2: Temperature high or low warning
WAR	VCC_WAR	SFP-1/2: Voltage high or low warning
WAR	BIAS_WAR	SFP-1/2: Tx bias current high or low warning
WAR	TXW_WAR	SFP-1/2: Tx power high or low warning
WAR	RXW_WAR	SFP-1/2: Rx power high or low warning
ALA	TEMP_ALA	SFP-1/2: Temperature high or low alarm
ALA	VCC_ALA	SFP-1/2: Voltage high or low alarm
ALA	BIAS_ALA	SFP-1/2: Tx bias current high or low alarm
ALA	TXW_ALA	SFP-1/2: Tx power high or low alarm
ALA	RXW_ALA	SFP-1/2: Rx power high or low alarm

For long-distance SFP (for example up to 150 km), FOM module is running exceeding the default Rx power threshold. There is permanent Rx power alarm reported from DDMI interface. In this case, the SFP DDMI monitor function shall be disabled. The Tx / Rx power state can be polled by NMS tool and compared with customized threshold.

### Read diagnostic information

SFP-1/2 real-time diagnostic information and alarm threshold can be readout from SWT 3000 SNMP MIB via SNMP GET command. The example value queried from DDMI interface (Avago AFCT-5765ATPZ) is listed as below:

swtInfoSfpIndex	swtInfoSfpType	swtInfoSfpValue	swtInfoSfpLowAlarmThreshold	swtInfoSfpLowWarnThreshold	swtInfoSfpHighWarnThreshold	swtInfoSfpHighAlarmThreshold
1	Temperature(C)	35.0	-46.0	-41.0	95.0	100.0
2	Voltage(V)	3.2	2.9	3.0	3.6	3.7
3	Tx Bias(mA)	10.4	0.0	0.4	39.8	44.8
4	Tx Power(dBm)	-11.0	-15.5	-15.1	-8.0	-7.5
5	Rx Power(dBm)	-29.2	-31.5	-30.9	0.0	0.4



## 5 PowerSys and Auxiliary Software Tools

5.1	PowerSys	206
5.2	MemTool Installation	215
5.3	PU4 Firmware Upgrade with Mem Tool	227
5.4	Firmware Update With PowerSys	235
5.5	EN100 Firmware Upgrade	236
5.6	SWTStraps for Jumper Settings	238
5.7	MergeTool for IEC 61850	242
5.8	SWT vDisp for Virtual Display	253

## 5.1 PowerSys

### 5.1.1 Installation

The service program PowerSys is delivered as a zip file on our SIOS Internet platform for download. Run the setup.exe for the installation. The program leads you through the installation.



[sc\_setup\_splashscreen\_powersys, 2, -,-]

Figure 5-1 Setup Splash Screen of the Service Program PowerSys

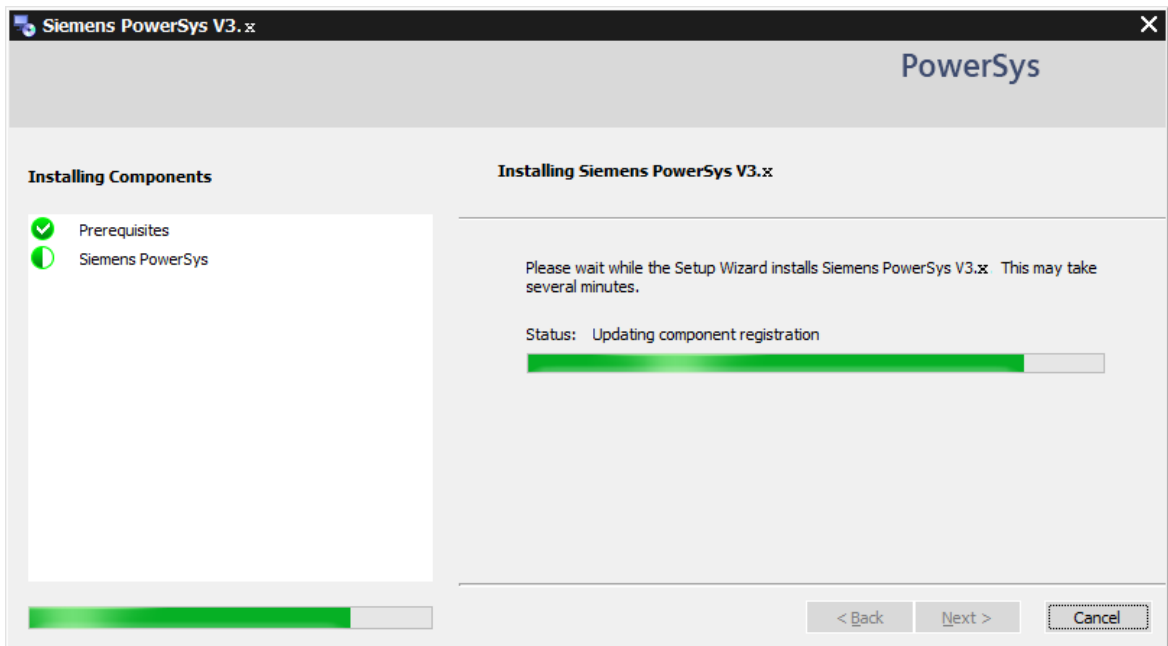

[sc\_installation\_powersys, 2, -,-]

Figure 5-2 Installation of the Service Program PowerSys

New installed software PowerSys, MeasurementTool and MergeTool are located at Windows Startup Menu > Siemens Smart Communication.

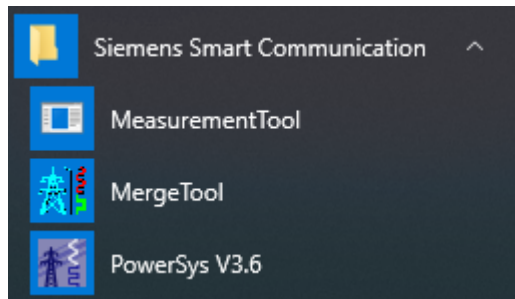

[sc\_windows\_startup\_menu, 1, ...]

Figure 5-3 Windows Startup Menu

With the installation setup of the PowerSys software a hardware PU4 USB driver is installed automatically. The driver is required for the connection of the service PC to the USB interface of the SWT 3000 on PU4 module. The installation and activation of the driver is managed automatically by the Windows hardware installation wizard for Plug-and-Play devices with first connection of the PC to the SWT 3000. The COM-port number is assigned automatically to the next free serial port.

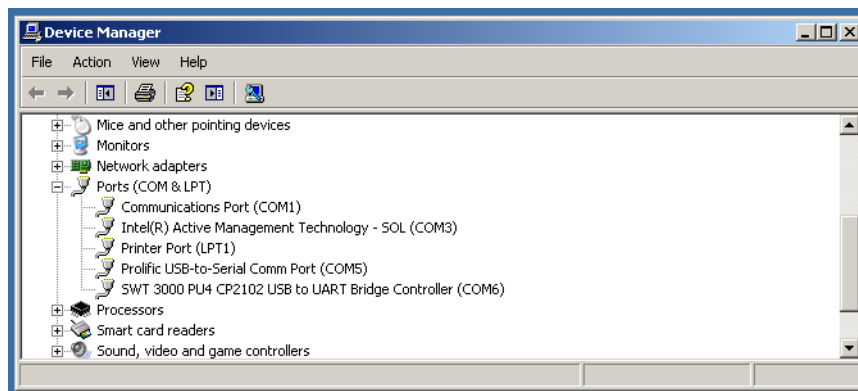

[scdeport-260313-01.tif, 1, en\_US]

Figure 5-4 SWT 3000 PU4 USB to UART Bridge Controller

## 5.1.2 User Management

### User Management

For access to device, 3 different user levels are available, each with an individual password. PowerSys does not require a password for operation. The offline configuration of a device is possible without a password.

- **Control**  
The configuration and settings of device can only be read. Changing of settings is not possible.
- **Expert**  
The user level Expert is allowed to configure the device. A reset of the device via the service PC is possible. Password change is not permitted.
- **Admin**  
The user level Admin enables full access to the device including password change and firmware update.

The device is delivered by factory without passwords. You can set a password for each user for the connection optionally.

To assign an initial password for the first time, leave the field current password blank and select one of the 3 different users. Each user can be assigned with an individual password.

If a password protects the device, perform the following instructions to change the password:

- Enter the current password.
- Enter the new password.
- Confirm the new password in the field Confirm password.

The password is requested from the device before the connection between the service PC and the device is established. Without entering the correct password, a connection to the device is not possible. PowerSys does not require a password for offline configuration.

If the password is lost, send the CSPi or the PU4 module to the factory for resetting it to the default values. Admin user can change all user passwords in menu user management.



[sc\_user\_management, 1, --]

Figure 5-5 User management

Each user can change their own password in the change password dialog. You must click "Program device" toolbar button after changing the password. Otherwise, the password is lost after the reset of device.



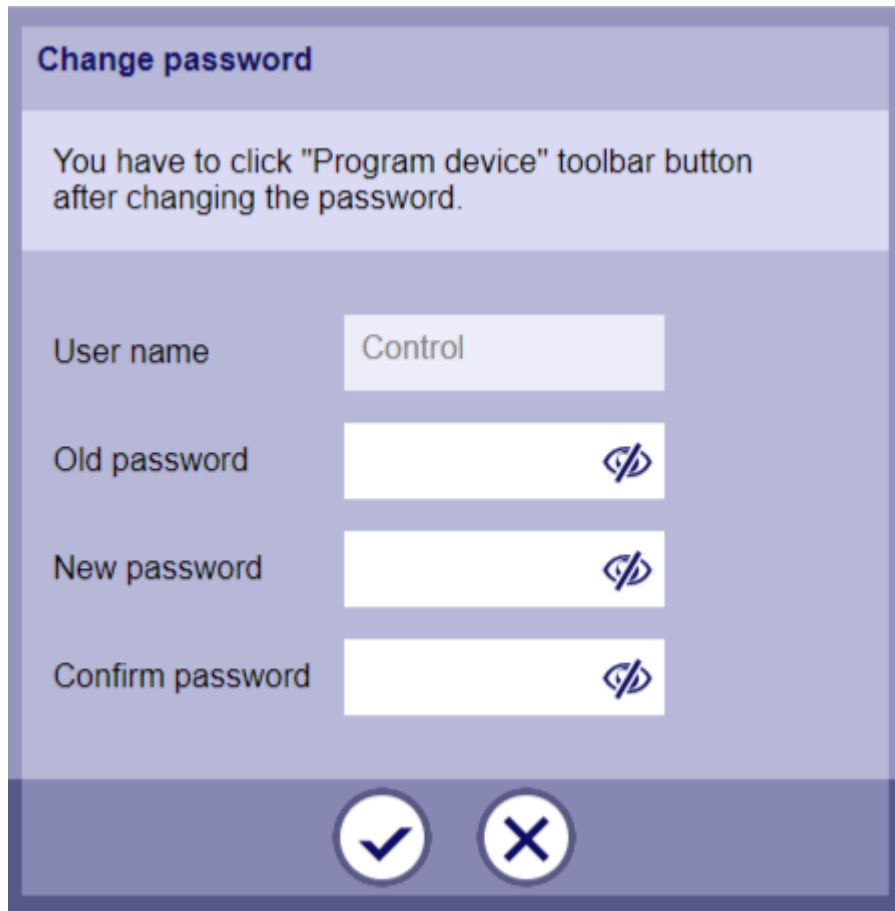

[sc\_change\_password, 1, -\_-]

Figure 5-6 Change password dialog

## Logon

If the password is set for the user, the logon dialog is prompted when connecting to the device. Enter the right username and password before logon to the device.

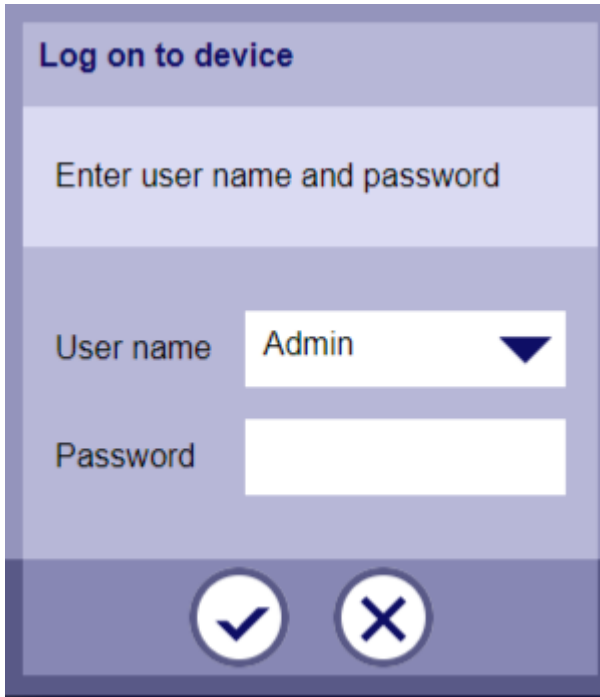

[sc\_log\_on\_to\_device, 1, -,-] Figure 5-7 Log on to device dialog



**Password complexity**

Password complexity is not enforced by PowerSys. It is possible to access the device without password or with an unsecure password. When setting the new password, the password complexity indication (low / middle / high) is shown near the password entry field.

It is recommended to set the password according to the highest password complexity (high).

Password complexity and rules for indication check:

- a) Minimum password length of 8 characters (max. length 20 characters)
- b) At least one upper case letter
- c) At least one lower case letter
- d) At least one digit
- e) At least one special character (e.g. !@#%)

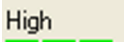
Password complexity indication	Comments
Low 	2 or less of these rules matched
Medium 	3 rules matched with mandatory rule a)
High 	4 or more rules matched with mandatory rule a)

Device is delivered by factory without passwords. Optionally you can set a password for each user level for the connection. For assigning of an initial password for the first time, leave the field current password blank and select one of the 3 different user levels. Each user level can be assigned with an individual password.

If a password protects the device, perform the following instructions to change the password:

- Enter the current password.
- Enter the new password.
- Confirm the new password in the field Retype Password.

The password is requested from the device before the connection between the service PC and the device is established. Without entering the correct password, a connection to the device is not possible.

If the password is lost, send the CSPI or the PU4 module to the factory for resetting to the standard values.

### 5.1.3 Firmware Overview

With the device information view, you can check if the firmware release of the device (Actual) corresponds with the firmware release of the connected service program PowerSys (Target).

When the firmware release of the device (Actual) or one of its firmware components does not correspond with the firmware release of the service program PowerSys (Target), the shown version is marked yellow and shows a target version in tooltips. That means, the firmware release of the device (Actual) has a newer or older version than the Target of the service program PowerSys (For example a firmware hotfix is programmed to the device.)

Device overview information shows three version numbers:

- PowerSys version
- Device parameter database (DDB) version (306 means V3.6)
- Firmware version

Verify the PowerSys current and new release and upgrade the device firmware to the matching version.



Overview					
PowerSys	V3.7.23	DDB	306	Firmware	V3.7.23

[sc\_device\_general\_overview, 2, -,-]

Figure 5-8 Device > General > Overview

Component					
	Target version: 01.11.01				
PU4 CON	01.10.09	PU4 BOOT	01.04.01	PU4 HW	00.00.01
PU4 MON	01.04.00	DLE HW	00.00.02	DLE Type	D
DLE FPGA	00.01.81	PU4 FPGA	02.00.17	PU4 DSP	---
PU4 DSP Variant	Not used	EN100	00.00.00	EN100 Type	---
IFC-1 FW	00.00.00	IFC-1 HW	01.00.06	IFC-1 Type	IFC-D/P
IFC-2 FW	00.00.00	IFC-2 HW	01.00.06	IFC-2 Type	IFC-D/P
IFC-3 FW	00.00.00	IFC-3 HW	01.00.06	IFC-3 Type	IFC-D/P
IFC-4 FW	00.00.00	IFC-4 HW	01.00.06	IFC-4 Type	IFC-D/P
FOM-1 FW	---	FOM-1 HW	---	FOM-1 Type	---
FOM-2 FW	00.00.02	FOM-2 HW	00.00.00	FOM-2 Type	FOM

[sc\_swt\_device\_general\_component, 1, --]

Figure 5-9 SWT 3000 or iSWT > Device > General > Component

Component			
CSPI-HW-Release	2	MODDSP	00.02.00
CSPCON-Boot	00.00.10	DPDSP	00.00.32
CSPCON-Monitor	00.00.34	FSKDSP	00.10.00
CSPCON-Application	00.06.03	RFFPGA	00.04.17
CIFPLD	2	SMUXFPGA	00.03.03
VFXCON	00.02.00	iMUXFPGA	00.01.05
IPCON-Bootloader	00.02.02	iMUXIECFPGA	00.01.04
IPCON-Kernel	00.03.02	EMUXFPGA	00.02.01
IPCON-Kernel-HW	00.01.04	VMUXFPGA	00.01.12
IPCON-Application	00.06.02		

[sc\_pl\_device\_general\_component, 1, --]

Figure 5-10 PowerLink > Device > General > Component

VMUX-HW-Release	1	MUXDSP	00.14.01
VMUXCON-Boot	4	CODDSP	00.13.00
VMUXCON-Monitor	00.01.01	VMUX-IOFPGA	00.02.02
VMUXCON-Application	00.45.01		

[sc\_pl\_vmux\_general, 1, --]

Figure 5-11 PowerLink > vMUX > General

## 5.1.4 Parameter Compatibility

With the service program PowerSys versions V3.6 and higher, multiple installation is not possible. Older versions shall be uninstalled via Start > Control Panel > Add or Remove Programs. Versions less than V3.6 (e.g., P3.5.188) can be installed in parallel.

One PowerSys supports full read only access to all P3.5.xxx firmware release and full read / write access since P3.5.185 firmware.

The device firmware is located under PowerSys installation path: ...PowerSys\Firmware

File name	Description
AllInOne_PU4_Vx.y.z.jnk	All in one firmware image for SWT 3000 / PU4 board.
AllInOne_CSPI_Vx.y.z.jnk	All in one firmware image for PowerLink / CSPI board.
AllInOne_VMUX_Vx.y.zzz.jnk	All in one firmware image for PowerLink / vMUX board.
Package\*.*	Firmware image for individual firmware component, e.g. DLE, SWT_TPOP

In normal case, the version number of PowerSys, firmware and parameter database shall be matching. If want to upgrade firmware release (e.g. V3.6), you need to follow these steps:

- Install PowerSys V3.6 on your PC (Setup.exe)
- Upgrade device firmware V3.6 (AllInOne\_\*.jnk) using Memtool
- Upgrade parameter database release

When creating a device parameter database file, the latest version is used by default. But it is possible to select a previous release.

PowerSys will check parameter compatibility as following procedure when sending offline configuration to device or online change the device configurations:

Check if programmed DDB file is matched with actual device parameter database release. In case of mismatch DDB version, a message dialog will prompt. Click "Yes" will update device parameter database to matched version.

*PowerSys does not match with device parameter database v3.5.xxx. Do you want to update device parameter database to v3.7.xxx?  
Please check if device firmware is already updated to same version as PowerSys.  
If do not want to update parameter database version, you must use matched PowerSys release.*

Check if PowerSys supports actual device parameter database release. In case of connecting to an unsupported old firmware release. A message dialog will prompt to switch to read-only access. Click "Yes" button disable all the configurations for editing.

*PowerSys does not support the configuration of device parameter database v3.5.xxx. Do you want to continue with read-only access?*

Check if configured parameters are supported in actual device firmware. PowerSys will check if the configured parameters for new features are supported in actual device firmware. A message dialog will prompt in case of mismatch. Clicking "Yes" button will discard these unsupported parameters.

*Some configured parameters do not support in actual device firmware v3.6.xxx. Do you want to ignore these parameters and continue the configuration?*

## 5.1.5 Release Upgrade Check

After updating the firmware of the device with MemTool, connect the PowerSys to the PowerLink RM-1 interface or SWT 3000 USB interface.

If the firmware release is mismatched with device parameter database, PowerSys will activate the release update message dialog:

*Firmware v3.7.xxx does not match with device parameter database v3.6.111. Do you want to update device parameter database to v3.7.xxx?*

Verify the current firmware version and device parameter database release, click Yes for updating the release information in the device.

### 5.1.6 Multiple Language Support

From PowerSys main menu, you can select your preferred language.

Currently supported languages: English / German / Russian.

The UI text and event log in PowerSys is displayed in the selected language immediately.



[sc\_multiple\_language\_support, 2, --]

## 5.2 MemTool Installation

### 5.2.1 General Information

#### 5.2.1.1 Overview

This description is the upgrade instruction for the controller card of SWT 3000. For firmware download of SWT 3000, a dedicated FLASH-PROM programming tool can be used. The MemTool flash programming software is provided with the PowerSys package and ensures easy and quick product upgrade if required. Program files are delivered as AllInOne\*.jnk. Typically the files are part of the PowerSys software package. After installing the service program PowerSys, the files are saved in the folder Hard disk\Program Files \PowerSys\Px.y.z\Firmware.

#### 5.2.1.2 System Requirements

To run MemTool, the following minimum system configuration is required:

Operating system	MS Windows 7, 8 or 10
Processor	Pentium or better (or processor with equivalent performance)
Clock	Minimum 1 GHz
System memory	1 GB
Ethernet interface	10/100Base-T
Serial (local) interface	USB
Printer interface	LPTx (optional)

#### 5.2.1.3 Version of MemTool

MemTool release V3.0 or higher

### 5.2.2 Installation of MemTool



#### NOTE

It is necessary to install MemTool under administrator rights. Furthermore, it is required to remove previous MemTool versions before installation.

---

In order to install MemTool, change to the PowerSys package \ MemTool directory and observe the following instructions:

- Start **setup.exe** from PowerSys\MemTool.
- Click **Next** to continue the installing process or click **Cancel** to abort.

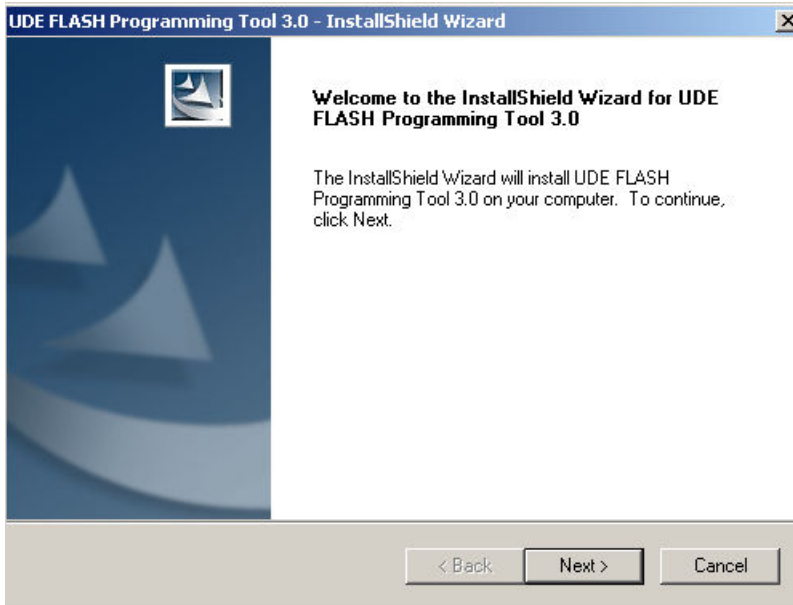

[scnemtin-201113-01.tif, 1, en\_US]

Figure 5-12 Starting the MemTool Installation

- Accept the terms of license agreement and click **Next** and once again **Next**.
- Select the destination folder via **Browse**. Select an empty or new directory for the MemTool software.
- Click **Next**.
- Select the program folder and click **Next** to continue.
- Click **Install** to begin the installation.
- Click **Finish** to continue and end the installation process.



## 5.2.3 Basic Settings

### 5.2.3.1 Starting MemTool

In order to launch MemTool as a stand-alone tool, execute Memtool.exe via the Windows main menu **Start > Programs > UDE MemTool**.

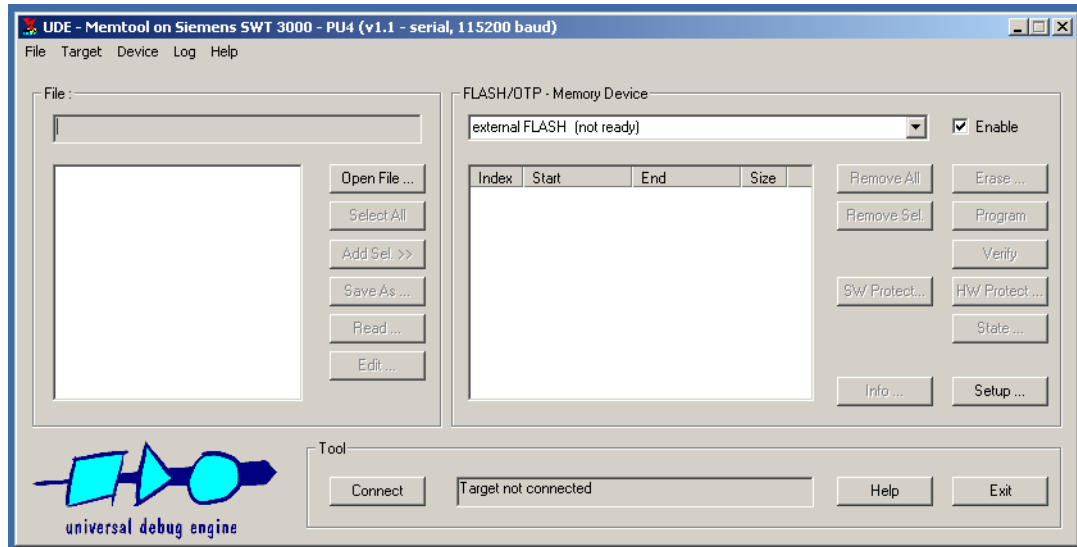

[scstrmem-020413-01.tif, 1, en\_US]

Figure 5-13 Starting the MemTool Program

### 5.2.3.2 MemTool Settings

When starting MemTool for the first time, the **Select Target Configuration** dialog is displayed. Otherwise, you can reach the dialog via the menu bar **Target > Change**.

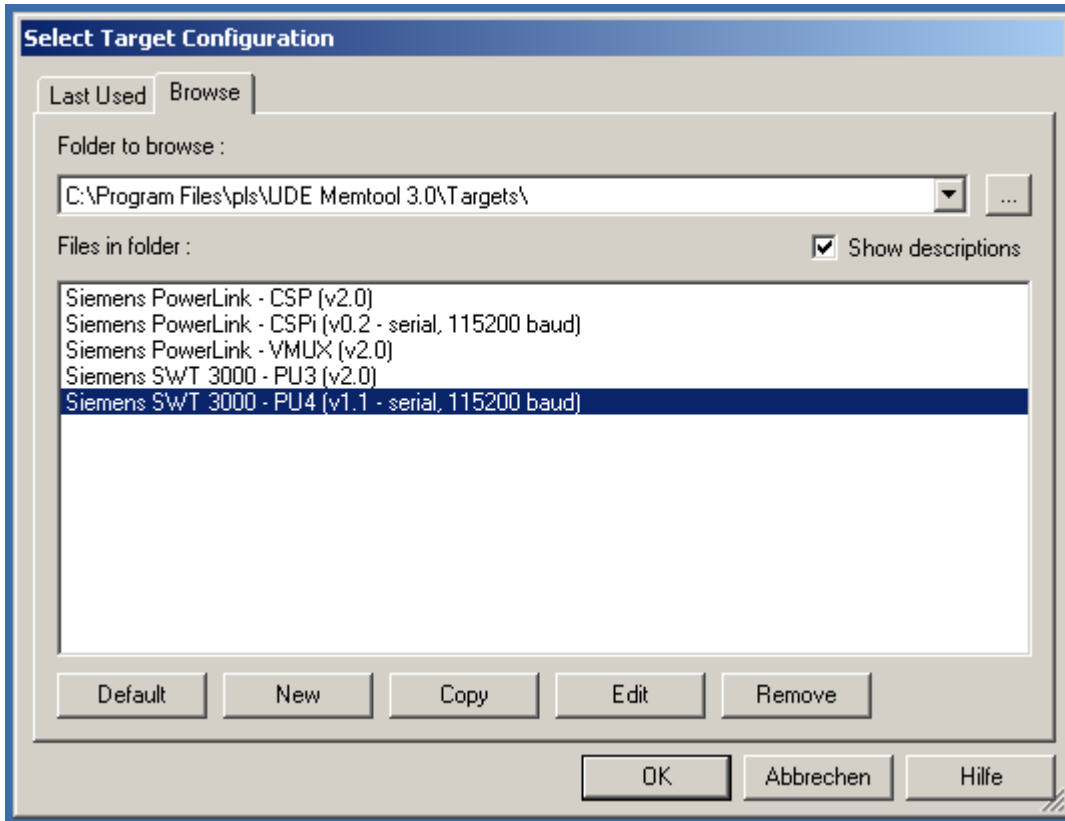

[sctarget-020413-01.tif, 1, en\_US]

Figure 5-14 Target Selection

The installation of MemTool provides target files for the selection of Siemens CSP, CSPi, vMUX (PowerLink), PU3, and PU4 (SWT 3000) systems.

Click the **Edit** button in the **Select Target Configuration** dialog. The **Edit Target Configuration** dialog appears.

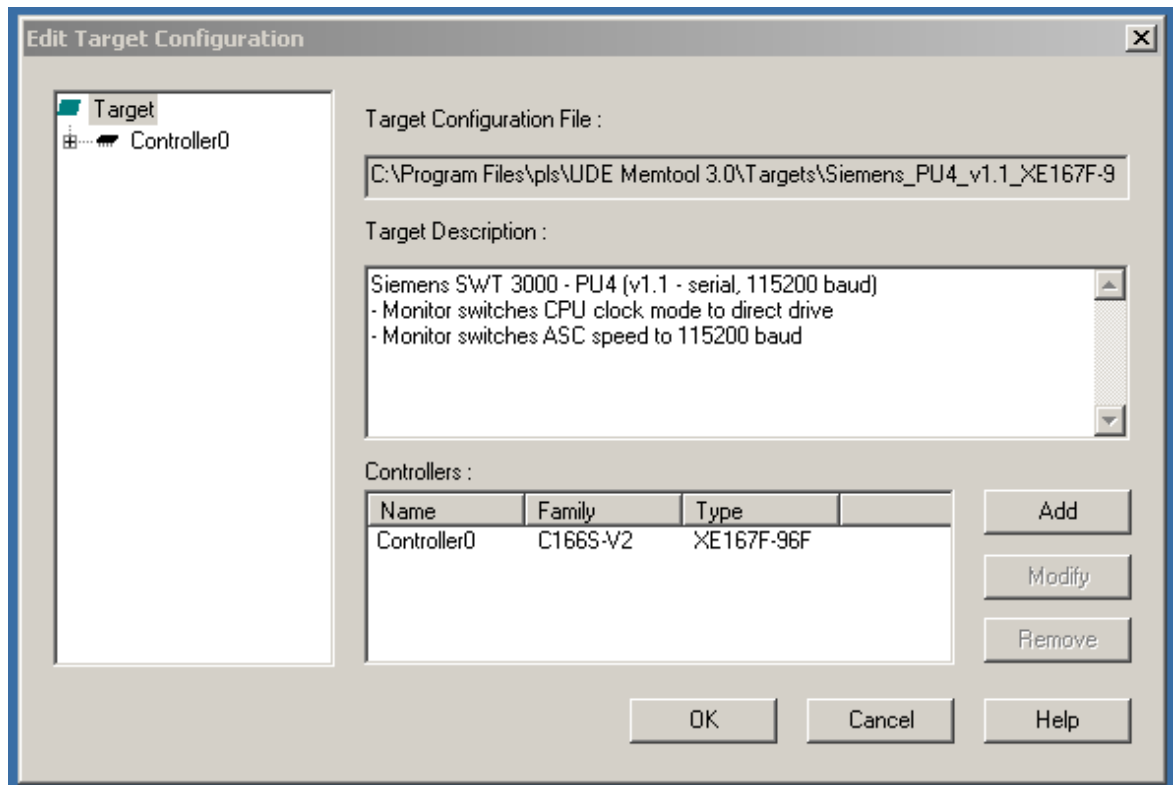

[sctrgrcon-020413-01.tif, 1, en, US]

Figure 5-15 Edit Target Configuration Dialog

Verify if the default CPU type **XE167F-96F** in the **Type** check box is set and click **OK**.  
Select **Siemens SWT 3000 - PU4 (v1.1 - serial, 115200 baud)** and click **OK**.

Select **File > Setup** in the menu bar and enable the **Create Verify Protocol File** check box. Afterwards, click **OK**.

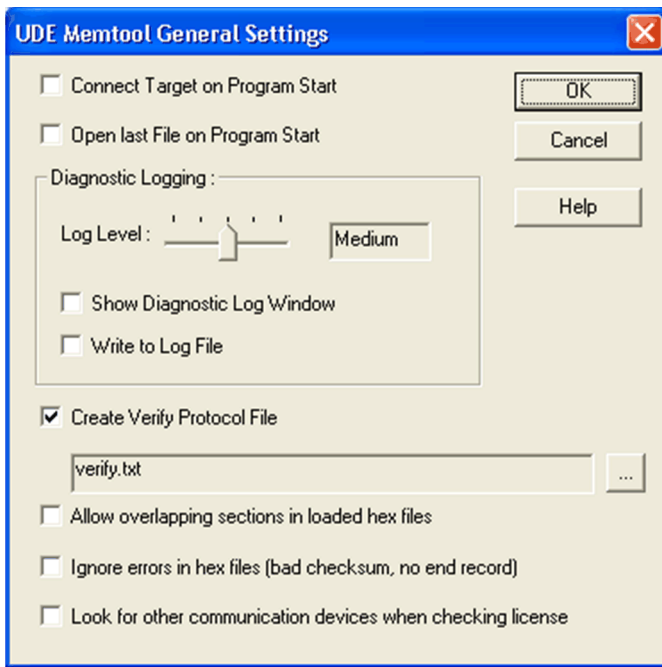

[scgenset-200711-01.tif, 1, en\_US]

Figure 5-16 MemTool General Settings

Select **Target > Setup** in the menu bar and select the COM-Port of the Access Device "SWT 3000 PU4 CP2102 USB to UART Bridge Cor" in the list box (for example **COM6**) in the **General** tab as follows:

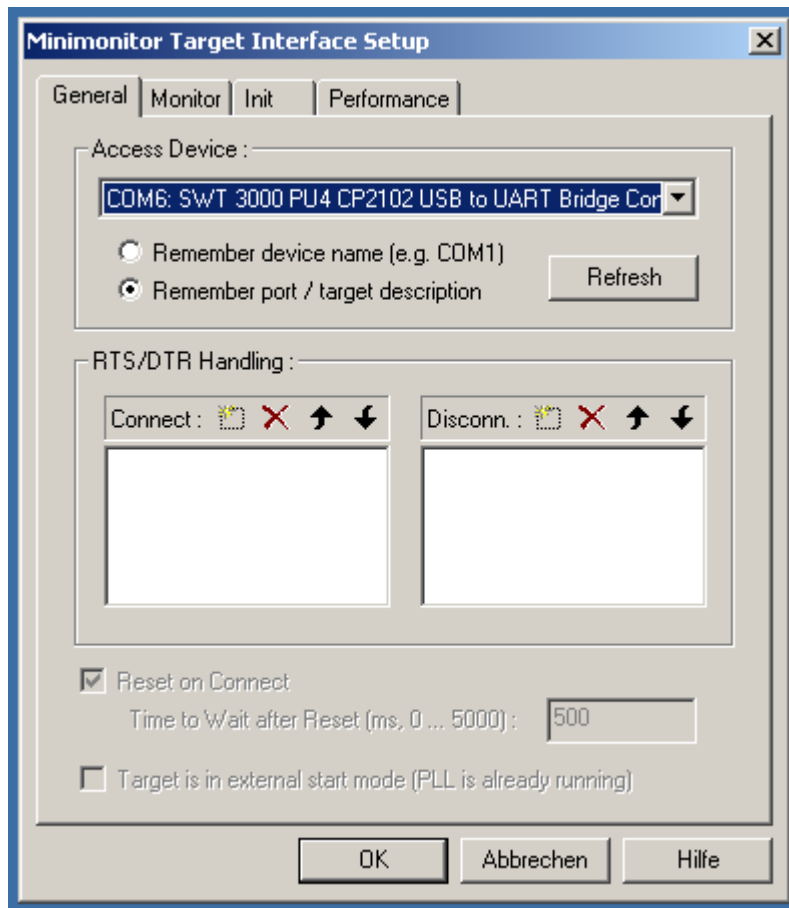

[sctasege-020413-01.tif, 1, en\_US]

Figure 5-17 Target > Setup > General

Settings in the **Setup > Monitor** and **Setup > Init** tabs are defaults and remain unchanged.



**NOTE**

The baud rate in **Setup > Monitor** is set automatically according to the selected Target file (115 200 for CSPi, 57 600 for vMUX and CSP, and 115 200 for PU4).

Manual changes are saved by clicking **OK**.

Select **Device > Setup > Mapping** in the menu bar and enable the **Also Remap Read Accesses** and **Allow overwriting of buffered Data** check boxes as follows:

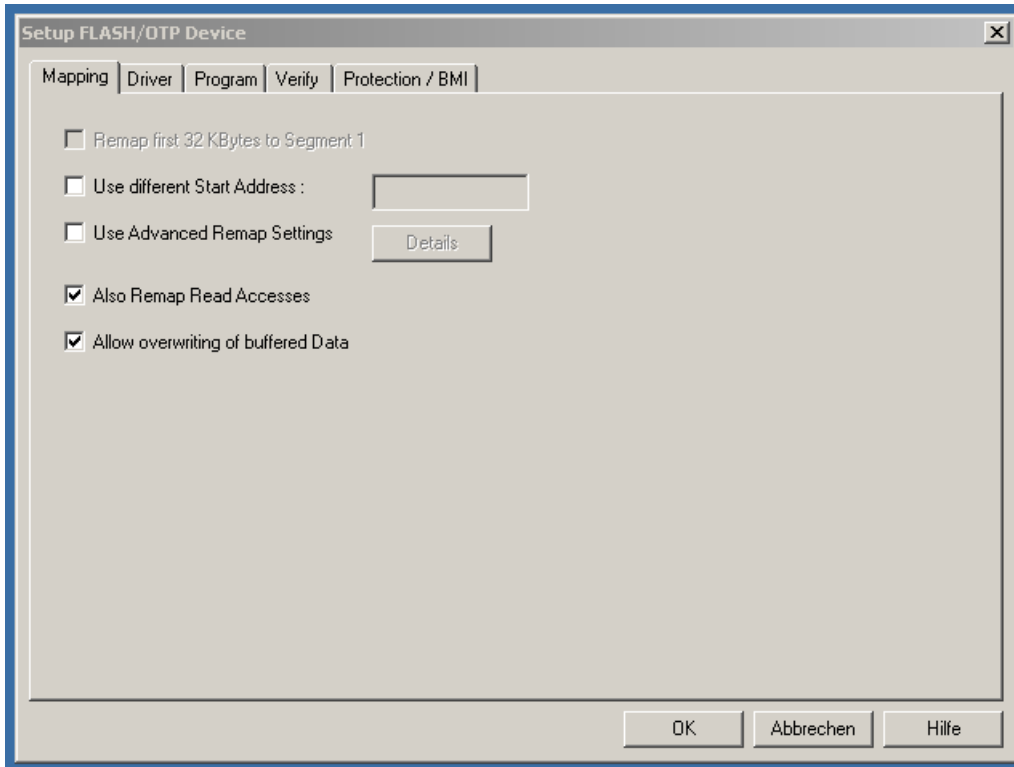

[scdesema-260313-01.tif, 1, en\_US]

Figure 5-18 Device > Setup > Mapping

Settings for the **Driver** tab are default and remain unchanged.

Select the **Program** tab and enable the **Automatic Sector Erase before Program** and **Automatic Verify after Program** check boxes as follows:

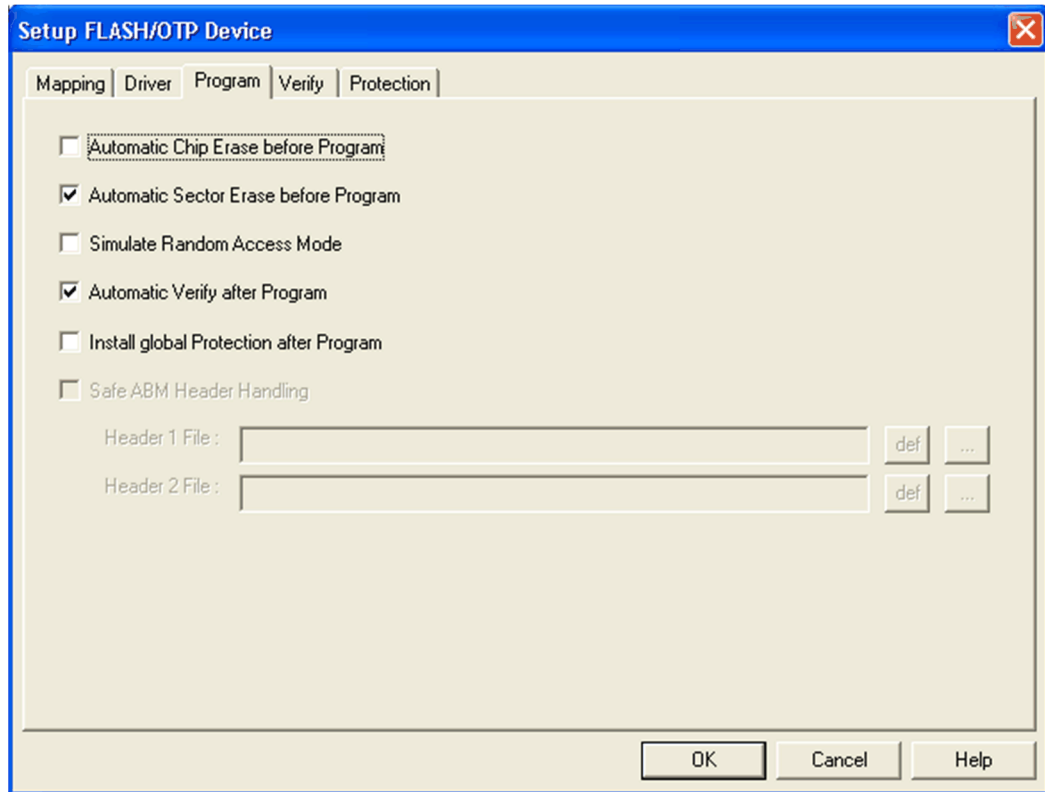

[scdesepr-200711-01.tif, 1, en\_US]

Figure 5-19 Device > Setup > Program

Select the **Verify** tab and enable the **Try to use Checksum Calculation for Verify** check box as follows:

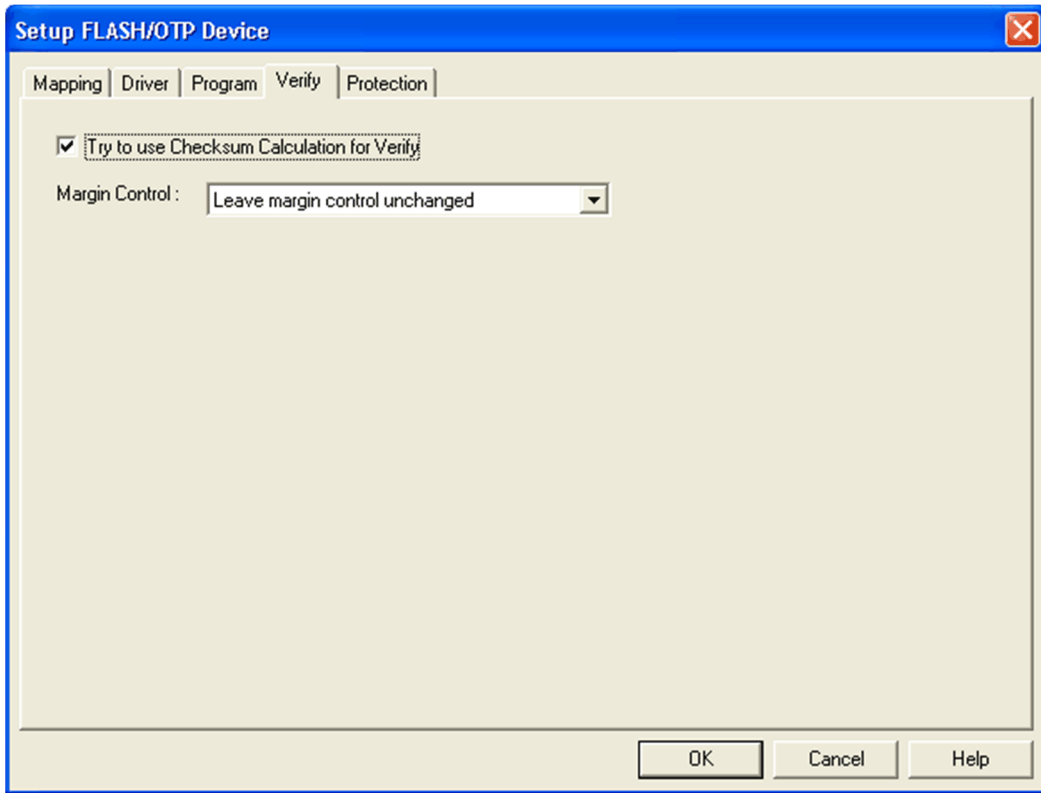

[scdeseve-200711-01.tif, 1, en\_US]

Figure 5-20 Device > Setup > Verify

Manual changes are saved by clicking **OK**.

Exit the menu **Device > Setup**. Change the MemTool FLASH/OTP - Memory Device to 764 KByte on-chip Program FLASH as follows:

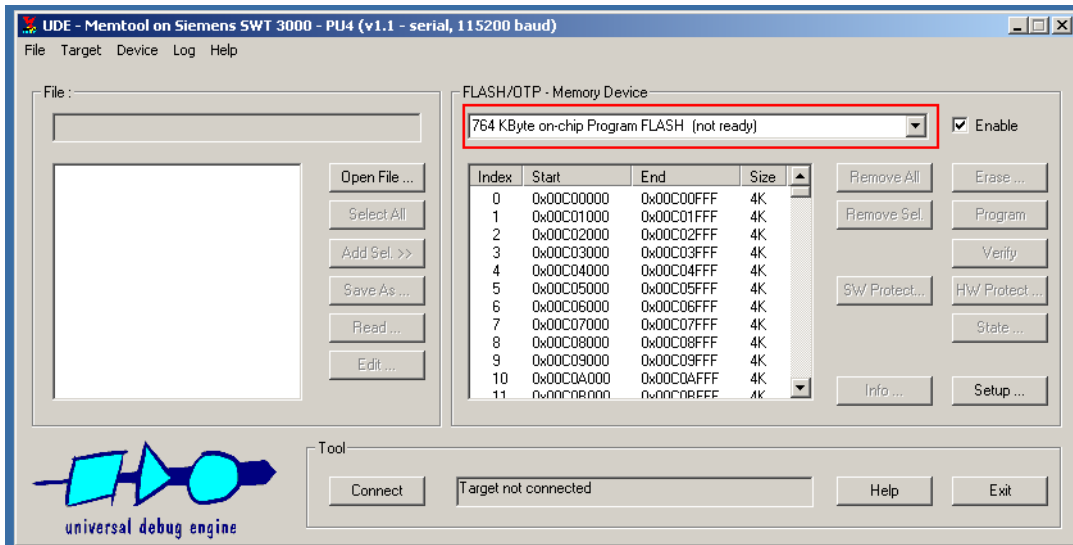

[scfidemt-260313-01.tif, 1, en\_US]

Figure 5-21 Select Flash/OTP - Memory Device 764 KByte on-chip



Select **Device > Setup > Protection/BMI** in the menu bar and **disable** the option **Try to disable protection when FLASH handling is activated**. Save manual changes by clicking **OK**.

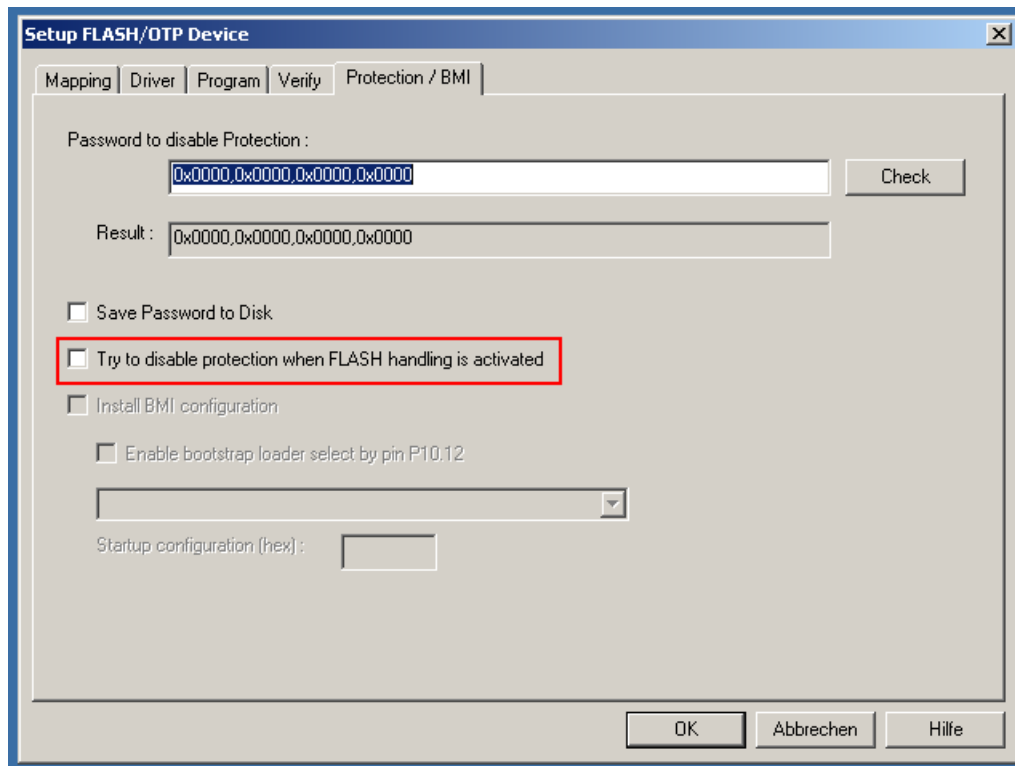

[scdeprmt-260313-01.tif, 1, en\_US]

Figure 5-22 Device > Setup > Protection / BMI



## WARNING

- ✧ If the option **Try to disable protection when FLASH handling is activated** is enabled in MemTool there is a risk of unintended deletion of protected FLASH memory sectors of the PU4, which store device specific data (e.g. MAC address).



## NOTE

With MemTool target file version Siemens **SWT 3000 - PU4, v1.1** the option is deactivated by default.

## 5.2.4 Getting Started

To perform the upgrade, verify if the required firmware type and version for the upgrade are available. At least one or all of the following files must be available:

AllInOne_CSPi_Px.y.z.jnk	Required for PowerLink upgrade (module CSPi)
AllInOne_VMUX_Px.y.z.jnk	Required for PowerLink upgrade (module vMUX)
AllInOne_PU4_Px.y.z.jnk	Required for SWT 3000 upgrade (module PU4)

The firmware (AllInOne\*.jnk- file) package is stored:

- As a part of the PowerSys installation package.
- On the service PC with the upgraded new version of PowerSys (default destination folder *C:\Program Files\Siemens\Smart Communication\PowerSys\Firmware*).
- On a folder of own choice while receiving the upgrade version by email or download.



**NOTE**

The term **Px.y.z** is the **PowerSys release version**.

---

## 5.3 PU4 Firmware Upgrade with Mem Tool

### 5.3.1 Connecting the PC

In order to program the PU4 module of SWT 3000, use the **USB connector of the PU4 module**. The connection to the service PC is established with the USB connecting cable supplied with the device. The SWT 3000 PU4 CP2102 USB to UART Bridge Controller must have been installed with installation of the service program PowerSys on the PC (refer to chapter [5.1.1 Installation](#)).

In order to program the PU4 module, perform the following instructions:

- Turn off the device with the **S2** switch on the PU4 module.
- To enable the programming with MemTool, set the **S3.1 of S3 DIL switch on the PU4 module to ON position**.
- Turn on the device with the **S2** switch on the PU4 module.
- Press the **S1** reset button on the PU4 to proceed the upgrade.



#### NOTE

If SWT 3000 is integrated into PowerLink (as iSWT), perform the following instructions:

- Turn off the device with the **S1** switch on the CSPi module.
- To enable the programming with MemTool, set the **S5.2 on the CSPi module to ON position**.
- To enable the programming with MemTool, set the **S3.1 of S3 DIL switch on the PU4 module to ON position**.
- Turn on the device with the **S1** switch on the CSPi module.
- Press the **S1** reset button on the PU4 to proceed the upgrade.



#### CAUTION

- ✧ During the update operations with MemTool the device (SWT 3000 or PowerLink with iSWT) will be out of regular service.

---

### 5.3.2 Starting MemTool

In order to launch MemTool as a stand-alone tool, execute Memtool.exe via the Windows main menu **Start > Programs > UDE MemTool**.

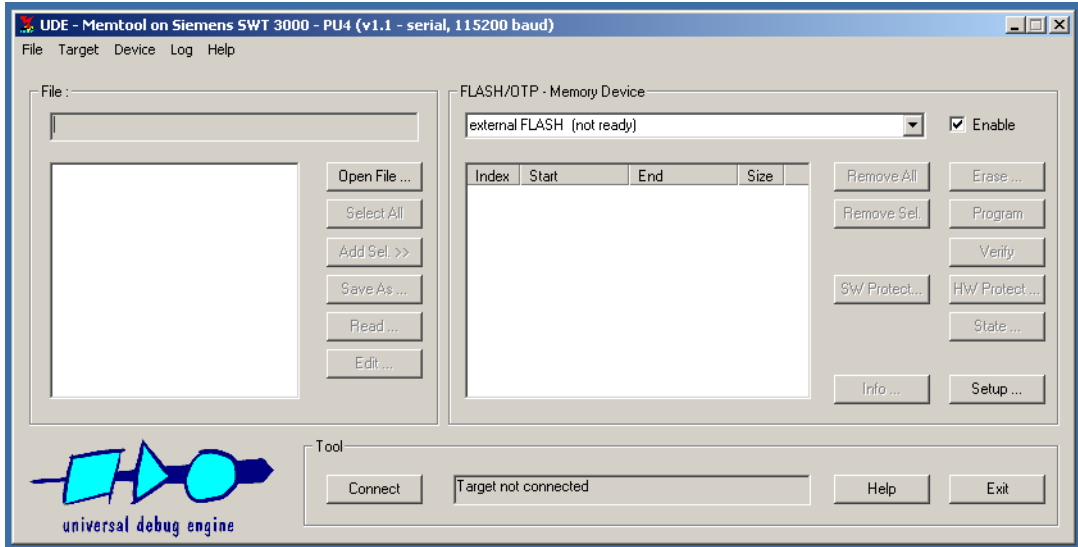

[scstrmem-020413-01.tif, 1, en\_US]

Figure 5-23 MemTool with the PU4 Target

When starting MemTool for the first time, the **Select Target Configuration** dialog is displayed. Otherwise, you can reach this dialog via the menu bar **Target > Change**.

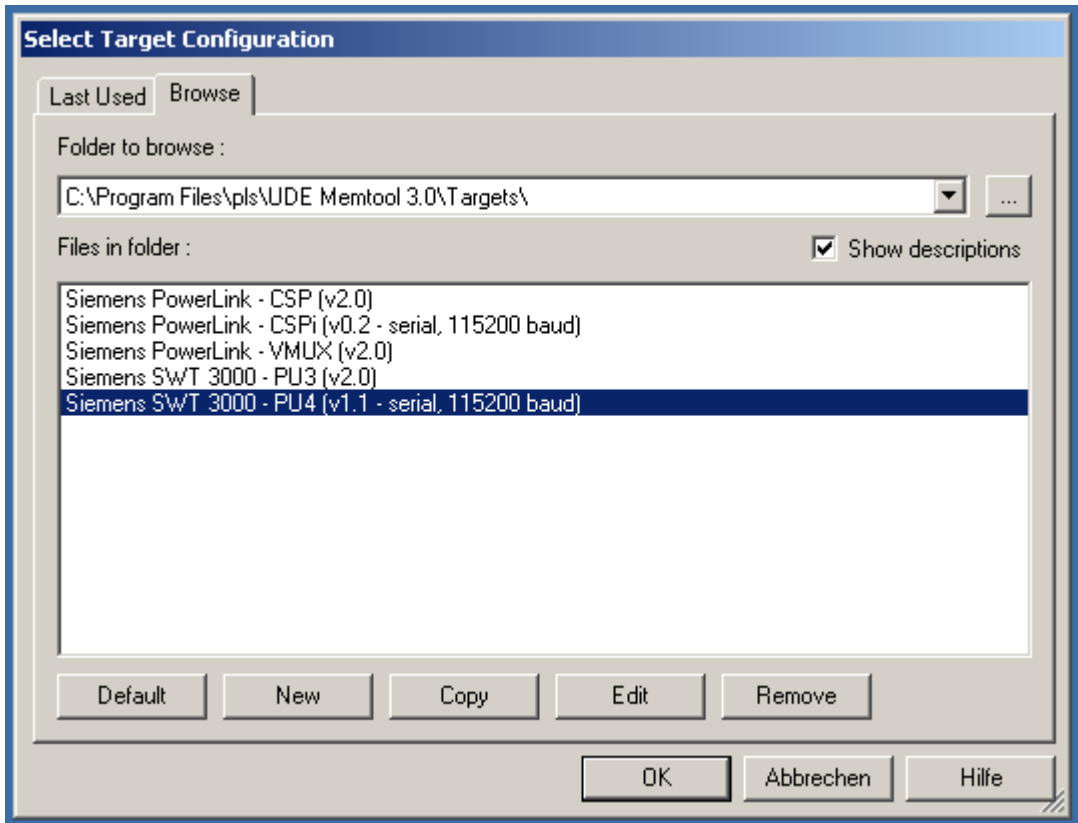

[sctarget-020413-01.tif, 1, en\_US]

Figure 5-24 Selecting the Siemens SWT 3000 - PU4 (v0.1 - serial, 115200 baud)

Select **Siemens SWT 3000 - PU4 (v1.1 - serial, 115200 baud)** and click **OK**.



**NOTE**

Wrong target selection results in unsuccessful flash programming. Verify that the **selected target** is the **physically connected device**.

Refer to [5.2.3.2 MemTool Settings](#) to get more detailed information.

### 5.3.3 Connection to the SWT 3000 Target

The PU4 memory consists of an internal FLASH (on-chip flash) and an external FLASH module. Both are programmed sequential with the same procedure.

For **764 KByte on-chip Program FLASH** module, the sector table is created after determining the actual type of the FLASH and clicking **Connect**.

Select **764 KByte on-chip Program FLASH (not ready)** in the **Flash/OTP - Memory Device** list box.

Click **Connect** to establish a connection to the target SWT 3000 system. The sector list box contains now the sector table of the selected FLASH module. The **Connect** button changes to **Disconnect**.

If the connection fails, reset the PU4 module and try again. For more detailed information, refer to [5.3.5 Trouble Shooting](#).

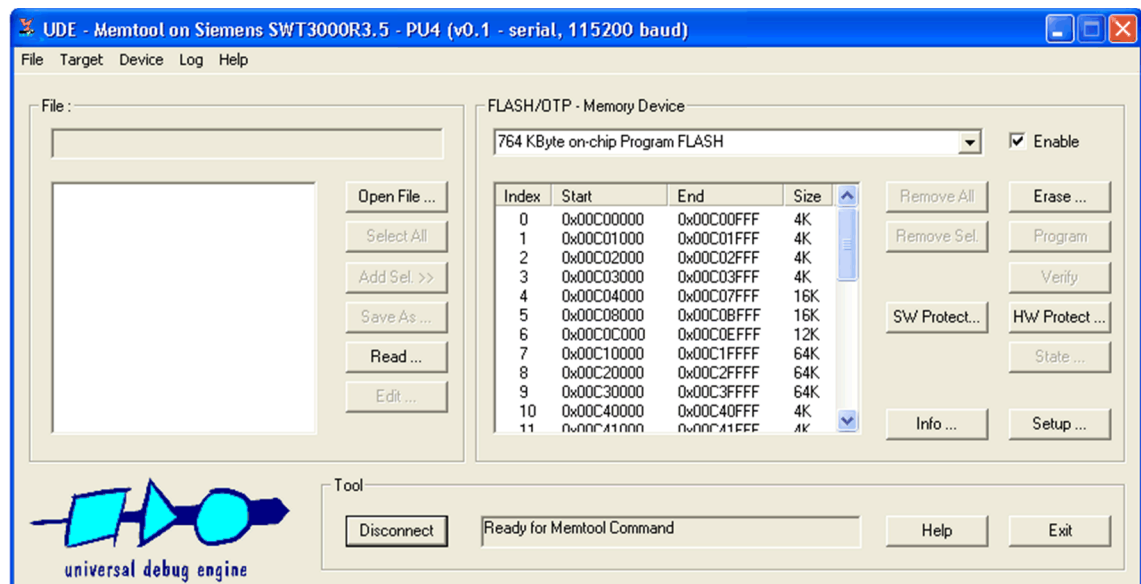

[sdcicow-171011-01.tif, 1, en\_US]

Figure 5-25 Dialog of the Connection to SWT 3000 for 764 KByte On-Chip Program FLASH

### 5.3.4 Programming the Application into the Flash Memory

Click **Open File** and select the AllInOne\_PU4\_Px.y.z.jnk.

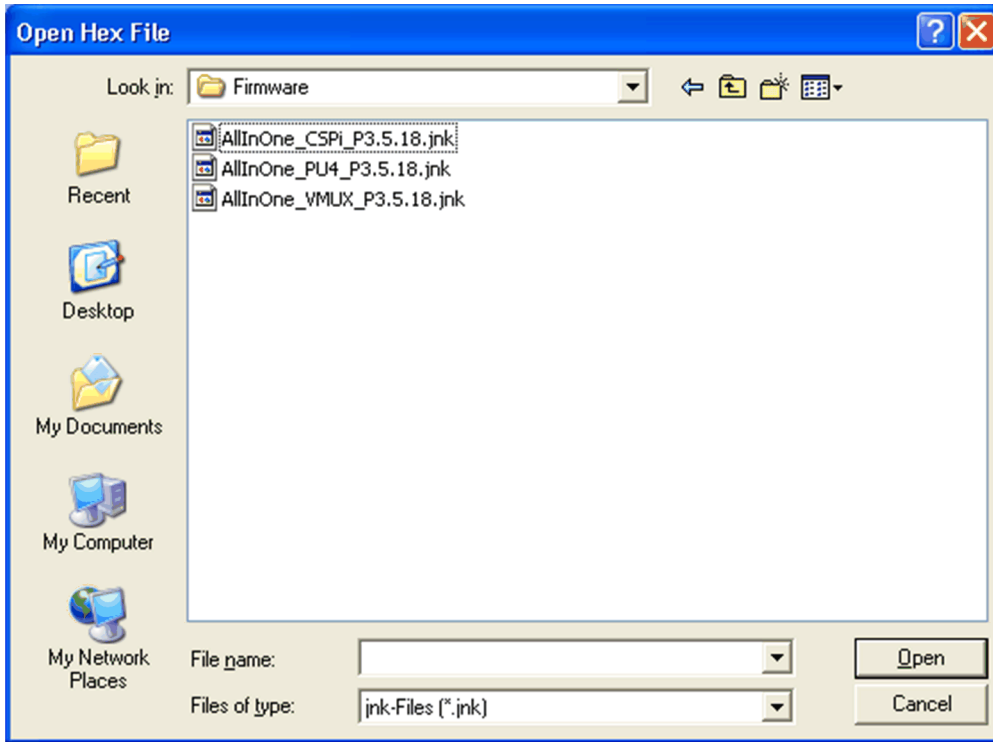

Figure 5-26 Selection of the AllInOne\_PU4\_Px.y.z.jnk File



**NOTE**

For the first time, it can be possible that you have to select **All Files** or **jnk Files** in the **Files of type** list box and navigate to the source folder. For more detailed information, refer to [5.2.4 Getting Started](#).

Click **Open**.

After loading this file in the left part of the MemTool main dialog, the file name and a list of sectors of the application are displayed.

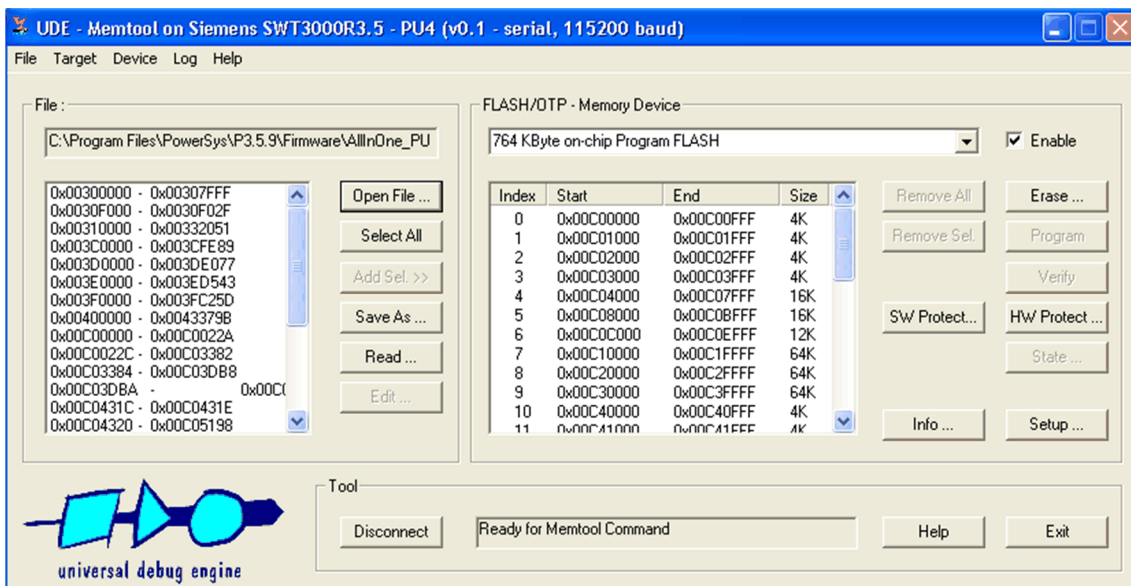
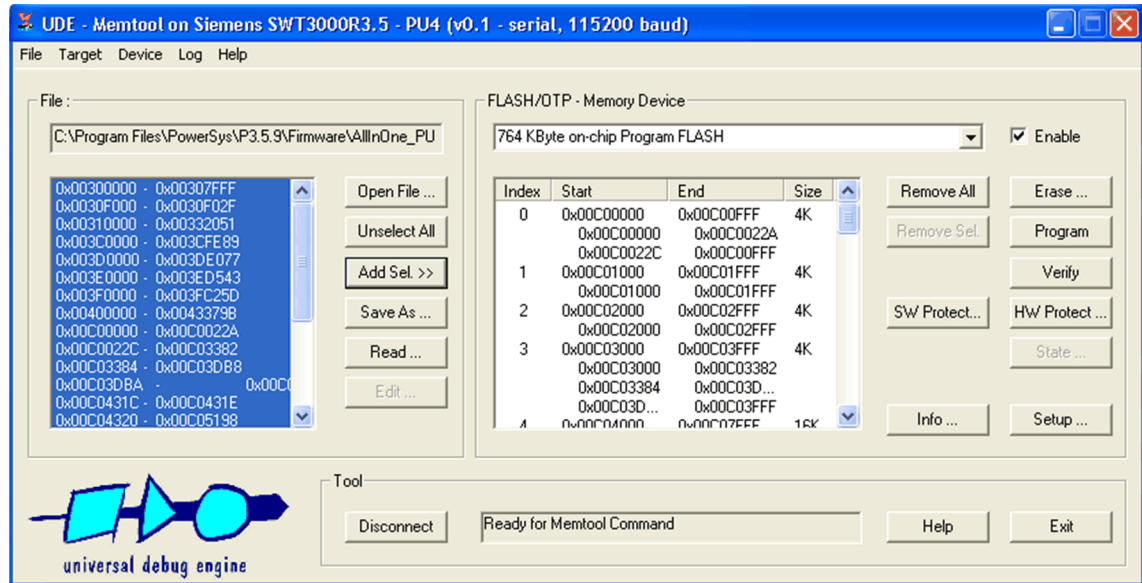

Figure 5-27 After Selection of the AllInOne\_PU4\_Px.y.z.jnk File

Click **Select All** and then **Add Sel. >>**. The sectors of the application are displayed (according to the sectors they belong to) in the list box on the right-hand side.



[scaddsel-171011-01.tif, 1, en, US]

Figure 5-28 Dialog of the Sectors in the List Box After clicking Add Selection



**NOTE**

Wrong file selection results in unsuccessful flash programming. Verify that the **selected file matches to the target**, the correct FLASH memory device is selected and enabled and the device is physically connected.

Click **Program** to start the programming cycle. The **Execute MemTool Command** dialog appears and shows the programming progress. The upgrade starts with programming and verification.

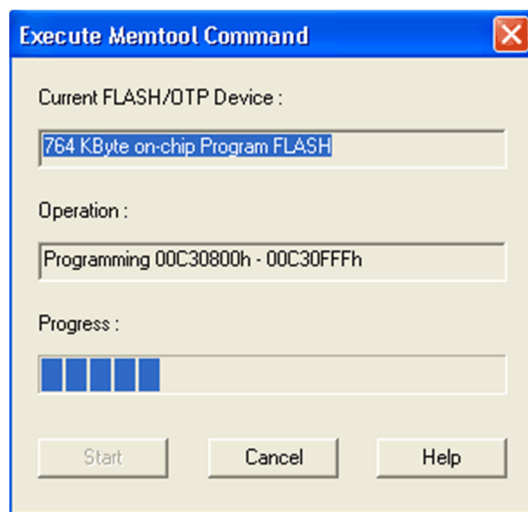

[scstprog-250711-01.tif, 1, en, US]

Figure 5-29 Starting of the Programming Process

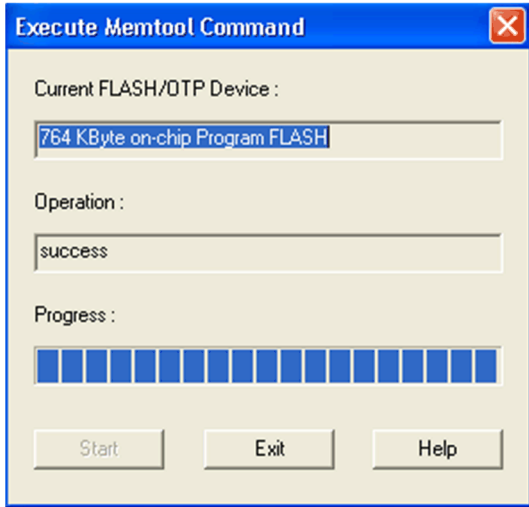

[scsucpro-250711-01.tif, 1, en\_US]  
 Figure 5-30 Dialog After a Successful Programming

After successful upgrade, click **Exit**.

For **external FLASH** module, the sector table is created after determining the actual type of the FLASH. Select **ext FLASH** in the **Flash/OTP - Memory Device** list box.

**If the connection fails**, reset the PU4 module and try again. For more detailed information, refer to [5.3.5 Trouble Shooting](#).

Click **Erase ...** to erase the external FLASH.

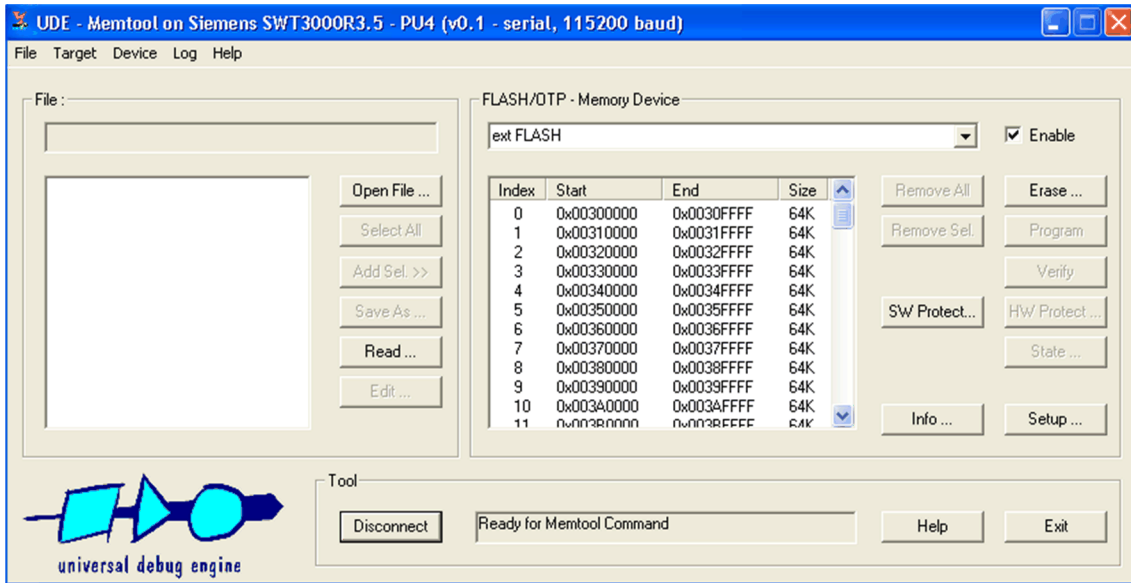

[scdicose-150911-01.tif, 1, en\_US]  
 Figure 5-31 Dialog of the Connection to SWT 3000 for External FLASH

Click **Program** to start the programming cycle. The **Execute MemTool Command** dialog appears and shows the programming progress. The upgrade starts with programming and verification.

After successful upgrade, click **Exit**.

Click **Disconnect** and then **Exit** to close the MemTool main dialog.





**NOTE**

Turn off the device with the **S2** switch on the PU4 module.  
Set the **S3.1 of S3 DIL switch on the PU4 module to OFF position.**  
Turn on the device with the **S2** switch on the PU4 module (PU4-Reset).



**NOTE**

If **SWT 3000** is integrated into **PowerLink** (as **iSWT**), perform the following instructions:

- Turn off the device with the **S1** switch on the CSPI module.
- Set the **S3.1 of S3 DIL switch on the PU4 module to OFF position.**
- Set the **S5.2 on the CSPI module to OFF position.**
- Turn on the device with the **S1** switch on the CSPI module (CSPI-Reset).

### 5.3.5 Trouble Shooting

If the connection to the target is not established, click **View** and verify the connection failed report.

Reset the device with **S1 on the PU4** or **S4 on the CSPI**.

Check if the USB cable (PU4) or RS232 cable (CSPI) is plugged in and if the serial port is selected correctly.

Press **Retry** for the connection to the device.

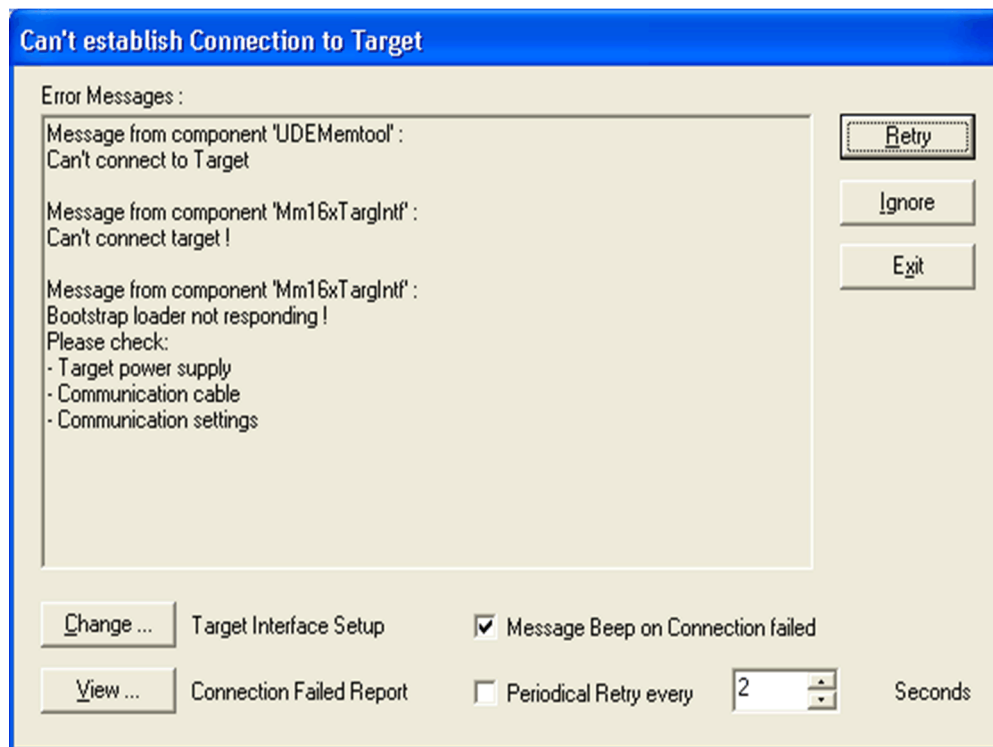

[scnoconn-271011-01.tif, 1, en\_US]

Figure 5-32 Dialog of No Connection to the Target Device



#### NOTE

MemTool always **starts with the last used target selection**. If the upgrade fails, **check that the target** (in menu bar Target > Change) and the file selection (in menu bar File > Open) **correspond to the device physically connected**.. For **SWT 3000** is the target **SWT 3000-PU4** and the file **AllInOne\_PU4\_Px.y.z.jnk**.

Select the target and file of the devices as follows:

- For **PowerLink** is the target **PowerLink-CSPi** and the file **AllInOne\_CSPi\_Px.y.z.jnk**.
- For **PowerLink-vMUX** is the target **PowerLink-vMUX** and the file **AllInOne\_VMUX\_Px.y.z.jnk**.
- For **SWT 3000** is the target **SWT 3000-PU4** and the file **AllInOne\_PU4\_Px.y.z.jnk**.

If there is a wrong combination, **repeat** the download after correcting the selection.

---

## 5.4 Firmware Update With PowerSys

The firmware update of SWT 3000 can be carried out with Memtool (as described in chapter [5.3 PU4 Firmware Upgrade with Mem Tool](#)) or PowerSys program.

The PowerSys connection to the SWT 3000 must be established before the firmware update.

Start the update from PowerSys main menu > Update firmware, select the PU4 firmware file and click OK button to update the firmware in the device. Depending on the selected firmware image size, the "All in one" image will take about 30 minutes for a whole update cycle. A restart of the device is required to activate the new firmware image. The first start time will be prolonged to about 1 minute to copy the new image from backup into working area. When the device start is finished, check if the device firmware version is correct.

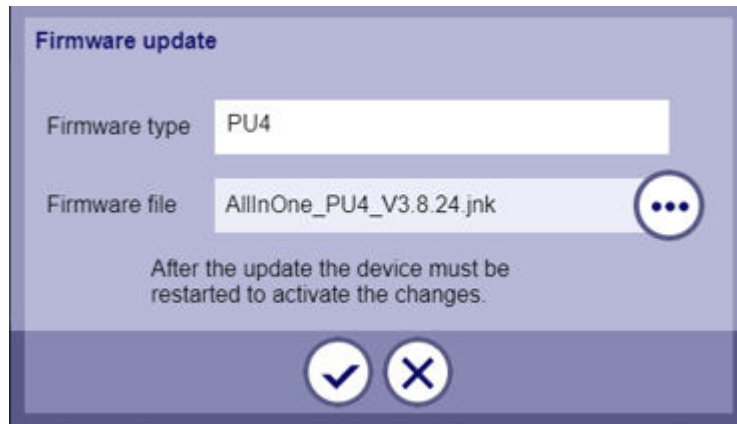

[sc\_fw\_update\_with\_powersys.1\_--=]

Figure 5-33 FW update with PowerSys

Setting	Comments
Firmware type: PU4	<p>For PU4 firmware updates an "All in one" image or an individual component image can be selected from folder:</p> <p>\PowerSys\Firmware</p> <ul style="list-style-type: none"> <li>• Pu4BootFw_vxx_yy_zz.hex</li> <li>• Pu4MonFw_vxx_yy_zz.jnk</li> <li>• Pu4ConFw_vxx_yy_zz.jnk</li> <li>• Pu4DspCtFw_vxx_yy_zz.jnk</li> <li>• Pu4DspNuCtFw_vxx_yy_zz.jnk</li> <li>• Pu4Fpga_vxx_yy_zz.jnk</li> <li>• Pu4DleFpga_vxx_yy_zz.jnk</li> <li>• DleFpga_vxx_yy_zz.jnk</li> </ul>

## 5.5 EN100 Firmware Upgrade

The firmware upgrade is not part of PU4 upgrade with Memtool. It is done in EN100 module homepage according to following steps:

- ✧ Open the upload page in the Web browser by entering the IP address of the module (see [Figure 5-34](#)), for example <https://192.168.20.103/upload>.

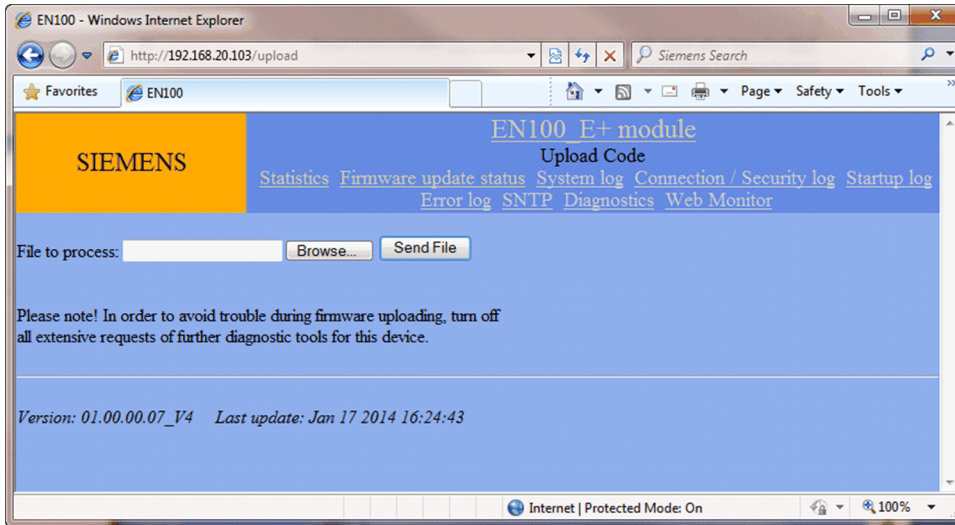

[ScUpload-28032014-1, 1, -,-]  
Figure 5-34 EN100 Module Upload Page

- ✧ Select the EN100 TPoP firmware image, which is located on the PowerSys Installation **Path>\PowerSys\IP3.5.xxx\Firmware\Package\_xxx.cab\SWT\_TPoP\_Vxx.yy.zz.cms**. The package\_xxx.cab can be unzipped by any file archive tool, for example 7-Zip.
- ✧ Click the **Send File** button. The page redirects you to the firmware update status
- ✧ Click the **refresh upload statistics** link to check whether the upload is finished. If the page shows the result as **result: Update finished** and **progress: 100 percent**, then the upload progress is done.



[ScFWStatus-28032014-1, 1, -,-]  
Figure 5-35 EN100 Module Firmware Upload Status Page



**NOTE**

During the upload processing, do not close the upload web page; do not switch off the power of the device or disconnect the network cable. Otherwise, the firmware upload will fail and EN100 cannot boot up anymore.

---

## 5.6 SWTStraps for Jumper Settings

### 5.6.1 Overview

The program SWTStraps can be used as a graphical utility to find the correct jumper settings for the SWT 3000 modules. The program is supplied with the PowerSys package in folder \Utilities. The program has to be installed on the PC by execution of the setup file in folder : \Utilities\SWTStraps. The Setup Wizard leads you through the installation process. With installation of the SWTStraps program a shortcut in the Programs folder and a desktop icon are created.

### 5.6.2 SWTStraps Input Form

With program start the SWTStraps Start Window is opened. You can either chose to load a new Input Form by click on **<New Configuration>** or to open a earlier saved configuration by **<Load Configuration>**.



[scstraw-010813-01.tif, 1, en\_US]

Figure 5-36 The SWTStraps start window

With selection of **<New Configuration>** a blank Input Form is opened. Earlier saved configuration inputs can be uploaded via the **<Load Configuration>** button.

With the blank input form the standard modules of an (i)SWT 3000 are displayed with their configurable parameters for the straps settings: IFC, PU4/DLE and ALR. Fill all parameters for the modules according to the requirements of your SWT 3000 system.



#### NOTE

Unsupported features or hardware of PowerLink 50 are not blocked in SWTStraps.

---

[scstripb-010813-01.tif, 1, en\_US]

Figure 5-37 SWTStraps Input Form

When selecting the checkboxes of the optional SWT 3000 modules CLE and FOM the corresponding input forms become visible. Optionally then the parameters for CLE or FOM-1 can be entered. The inputs for an (optional) second FOM module can be made separately.

For exercise you can open a sample configuration by click on the button <Sample/Default>.

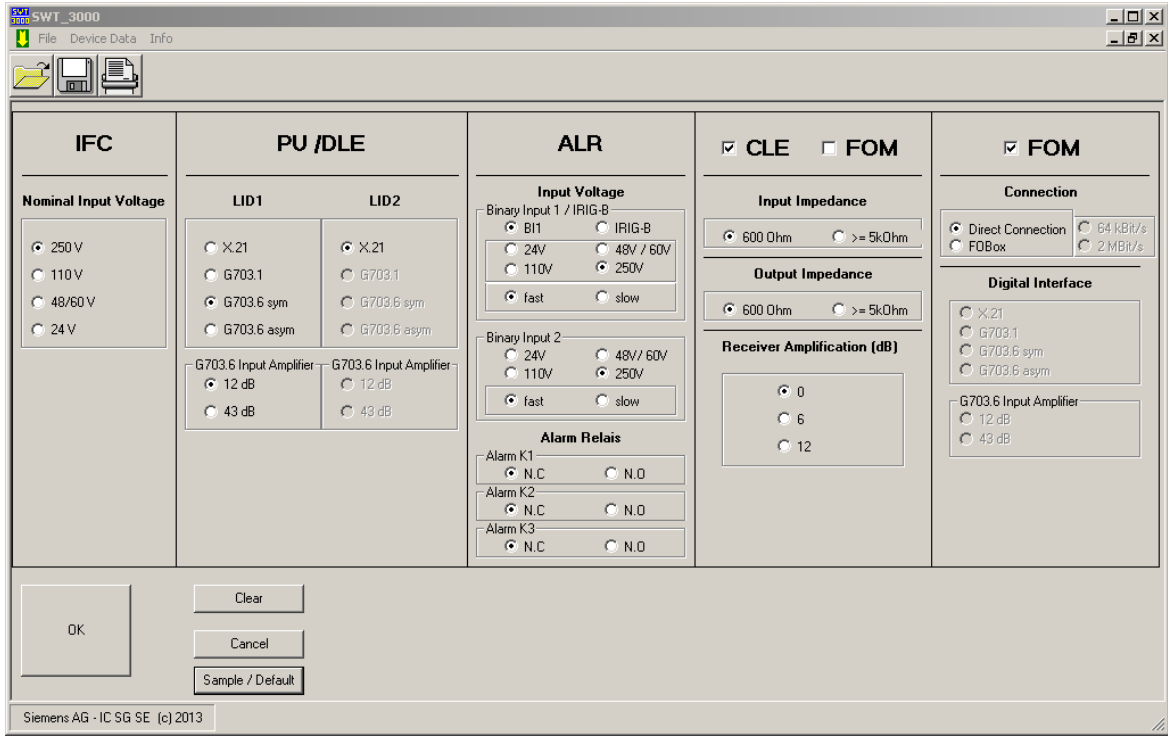

[scstrips-010813-01.tif, 1, en\_US]  
 Figure 5-38 SWTStraps Input Form (Sample)



**NOTE**

For an iSWT 3000 integrated in PowerLink it is sufficient to enter the inputs for IFC, PU4/DLE and ALR module.

If the configuration of the device data is completed, click the <OK> button.

In the SWTStraps menu >File resp. >Print (or by click on the icons) you can **Save** or **Print** the device data inputs. From the >File menu it is also possible to **Open** saved input datafiles or to **Clear** the recent configuration.

You can edit the device data inputs of the recent configuration anytime via >Device Data > Edit.

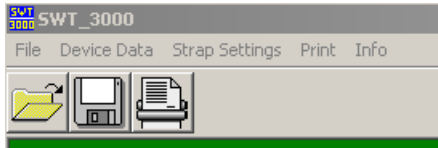

[scstrmen-010813-01.tif, 1, en\_US]  
 Figure 5-39 The SWTStraps main menu

**5.6.3 The Straps Settings windows**

The straps setting windows for the configured (i)SWT 3000 modules can be selected via the main menu >Straps Settings. From here you can open the displays with the required straps settings for the modules IFC(-P/D/S), PU4/DLE, ALR and (if configured) CLE.

The following figures show examples.



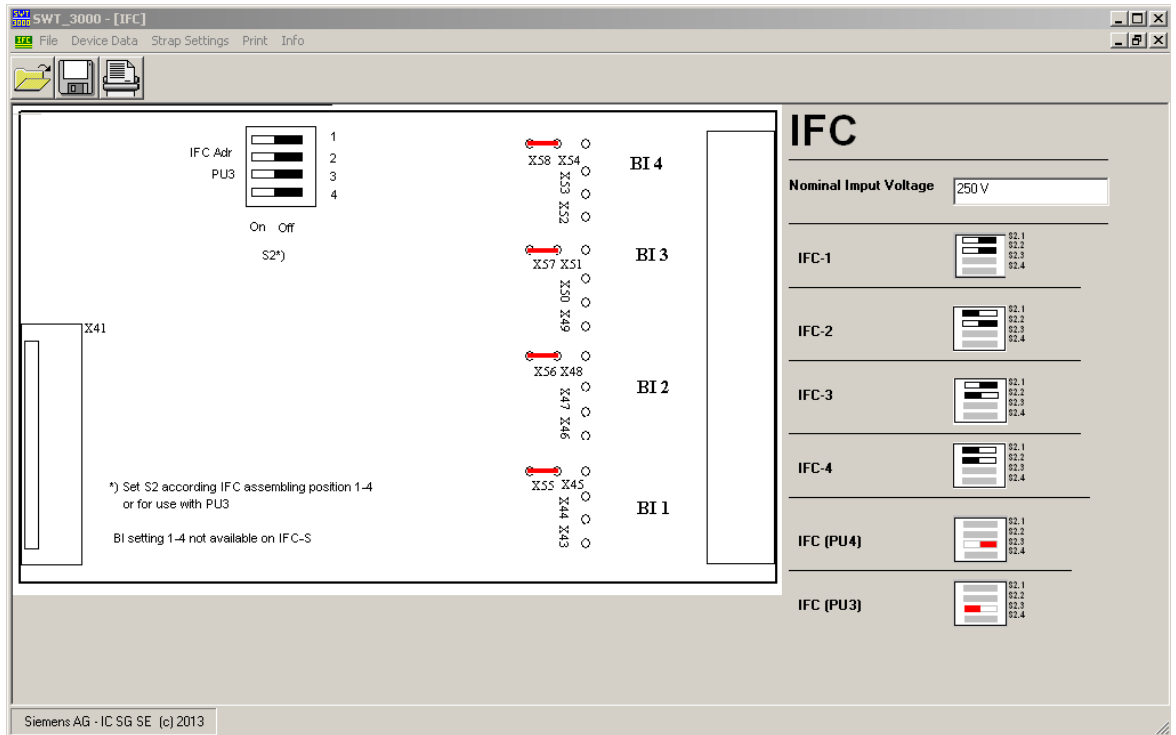

[scstrifc-010813-01.tif, 1, en\_US]

Figure 5-40 Straps Settings for a IFC module (example)

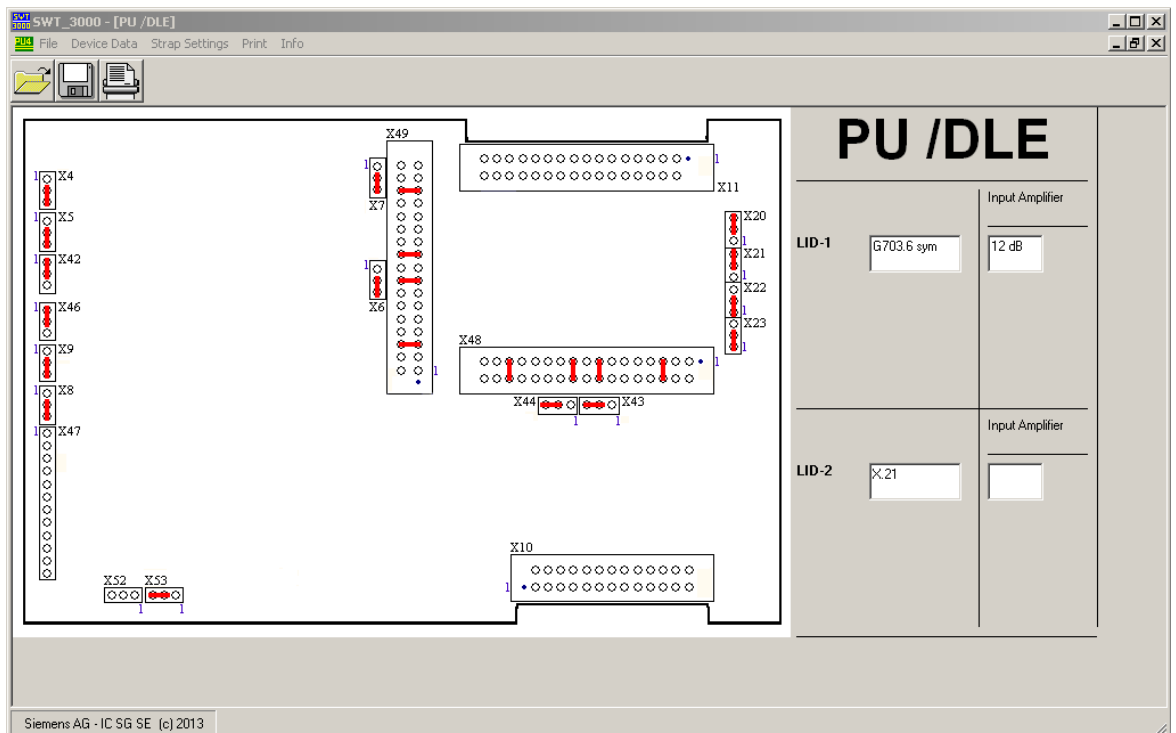

[scstrdie-010813-01.tif, 1, en\_US]

Figure 5-41 Straps Settings for the DLE (example)

You can print the straps settings of the configured (i)SWT 3000 modules to paper-print via menu >Print or the printer icon.

## 5.7 MergeTool for IEC 61850

### 5.7.1 Overview

The IEC 61850 Intelligent Electronic Device (IED) configuration philosophy of SWT 3000 is to have a separate static IED Capability Description (ICD) file for each possible SWT 3000 I/O configuration. These ICD files are imported in the IEC 61850 system configurator (DIGSI®) for substation configuration.

When the substation configuration is finished, the **MergeTool**<sup>10</sup> reads the Station Configuration Description (SCD) file (of the substation configuration) and generates the following 2 files:

- EN100 parameter file (BIN file)
- PowerSys preconfiguration file (CFG file)

PowerSys imports these 2 files into PU4 board.

The **MergeTool** dialog contains the **Parameter Generator** and **EN100 Settings** buttons.

### 5.7.2 Parameter Generator

Select the **Parameter Generator** button in the **MergeTool** dialog.

The following **MergeTool > [Parameter Generator]** dialog appears:

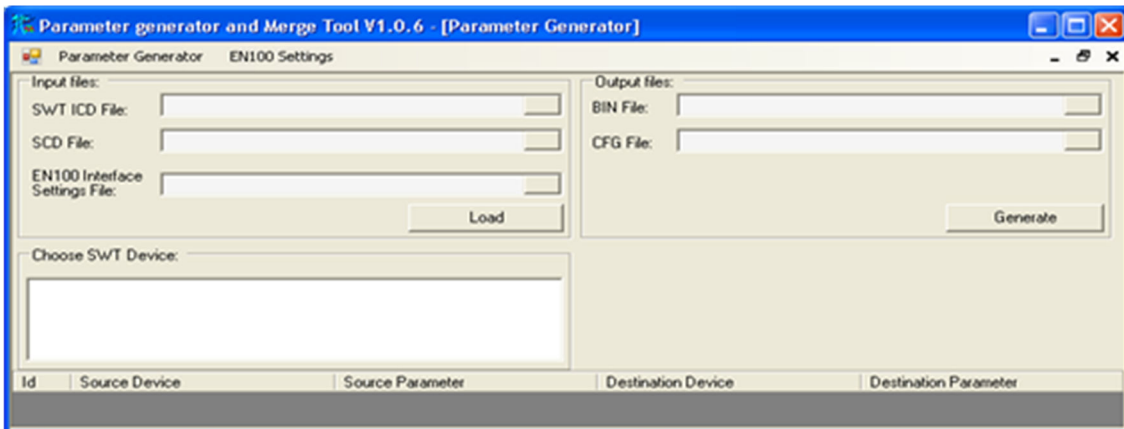

[scpargen-141011-01.tif, 1, en\_US]

Figure 5-42 MergeTool > [Parameter Generator] Dialog

<sup>10</sup> MergeTool covers the offline configuration of the IEC 61850 related settings for SWT 3000.

Table 5-1 Parameter Generator Settings

Parameter	Description	Selection
Input files > SWT ICD File	The <b>SWT ICD File</b> (a mapping of the device in a standard compliant file) is the precondition for work in the system configurator (DIGSI), which is based on these files. The ICD files describe the communication properties of the device according to IEC 61850. The ICD file of the SWT 3000 device is used for station configuration.	One of maximum 9 different available ICD files. Each file describes maximum amount of transmittable and receivable commands.
Input files > SCD File	Several devices form a complete station. They can also include a master unit. These components have various communication connections between them that must be parameterized. The description of all devices, their settings, and interrelations are grouped together in the SCD file. The SCD file itself is created and processed using the system configurator (DIGSI).	SCD file of the station
Input files > EN100 Interface Settings File	The <b>EN100 Interface Settings File (IFD file)</b> contains the interface settings for the EN100 module.	IFD file for the EN100 module A default IFD file for the selection of input file is presented to the MergeTool user in the PowerSys installation folder <b>\Px.y.zzz\Util\MergeTool\v01.00.11</b> .
Choose SWT Device	The present SWT 3000 devices appear in this window. For the generation of output files, select one of the SWT 3000 devices. After selecting the desired SWT 3000 device, the source device, source parameter, destination device, and destination parameter are listed in the option table.	One of the SWT 3000 devices
Output files > BIN File	The configuration for the EN100 module is provided via EN100 parameter file (binary parameter file, <b>BIN file</b> ) EN100par.bin.	Select a folder for storage of the BIN file.
Output files > CFG File	The configuration for PowerSys is provided via PowerSys preconfiguration file ( <b>CFG file</b> ).	Select a folder for storage of the CFG file.



**NOTE**

There are maximum 9 different ICD files available. Each file describes maximum amount of transmittable and receivable commands. The ICD files are available in the PowerSys installation folder **\Px.y.zzz\Util\MergeTool\v01.00.11** and on the PowerSys package in folder **\IEC61850\Config\_files**.

Table 5-2 Selection of different ICD Files

Selection	Comment
SWT3000_c1_ed1/2.icd	Maximum 1 GGIO command is transmittable and receivable
SWT3000_c2_ed1/2.icd	Maximum 2 GGIO commands are transmittable and receivable
SWT3000_c3_ed1/2.icd	Maximum 3 GGIO commands are transmittable and receivable
SWT3000_c4_ed1/2.icd	Maximum 4 GGIO commands are transmittable and receivable
SWT3000_c5_ed1/2.icd	Maximum 5 GGIO commands are transmittable and receivable
SWT3000_c6_ed1/2.icd	Maximum 6 GGIO commands are transmittable and receivable
SWT3000_c7_ed1/2.icd	Maximum 7 GGIO commands are transmittable and receivable
SWT3000_c8_ed1/2.icd	Maximum 8 GGIO commands are transmittable and receivable
SWT3000_c16_ed1/2.icd	Maximum 16 GGIO commands are transmittable and receivable

Select the files in the **Input files** area in the following order:

- Click the **SWT ICD File** button.  
The following dialog appears:

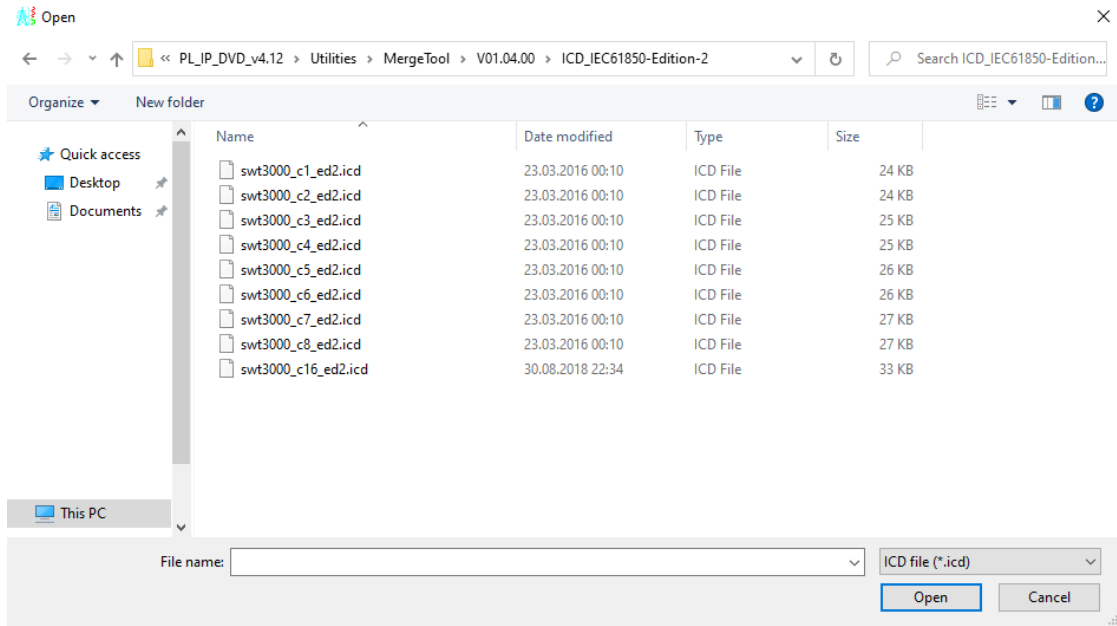

[sc\_ICD\_Fileselection, 1, -,-]

Figure 5-43 ICD File Selection of SWT 3000

Select the proper **SWT ICD File**, which was used in station configuration.  
After selection of the **SWT ICD File**, click **Open**.

- Click the **SCD File** button.  
The following dialog appears:

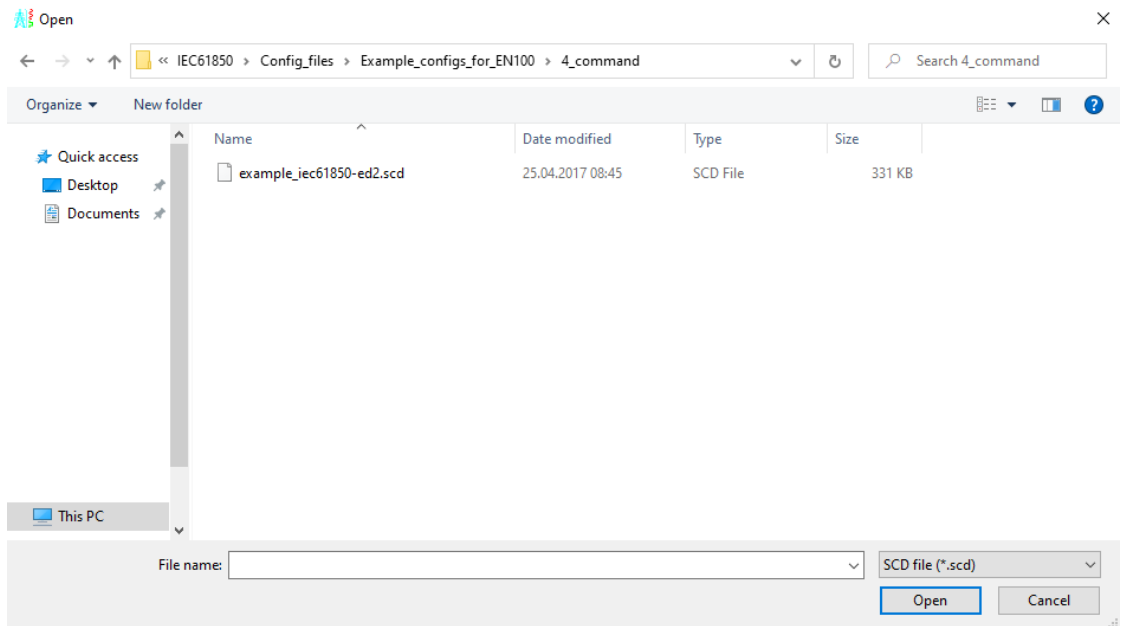

[sc\_SCD\_Fileselection, 1, --]   
Figure 5-44 SCD File Selection of the Station

Select the proper **SCD File** of the station.  
After selection of the **SCD File**, click **Open**.

- In the third step, click the **EN100 Interface Settings File (IFD file)** button.  
The following dialog appears:

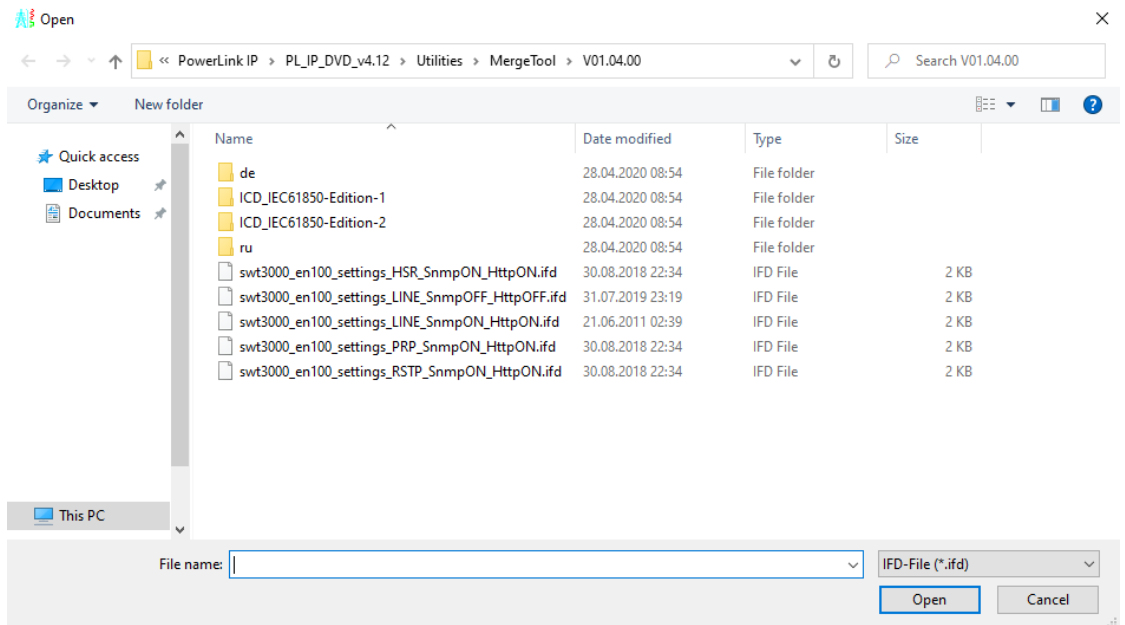

[sc\_EN100\_Settingsselection, 1, --]   
Figure 5-45 IFD File Selection of the EN100 Module

Explanation for the default IFD files:

- xxx\_SnmpOFF\_HttpOFF.ifd: EN100 SNMP and HTTP services are enabled
- xxx\_SnmpOn\_HttpON.ifd: EN100 SNMP and HTTP services are disabled

Select the proper **IFD file** of the EN100 module.  
 After selection of the **IFD file**, click **Open**.



**NOTE**

A default IFD file for the selection of input file is presented to the MergeTool user in the PowerSys installation folder `\Px.y.zzz\Util\MergeTool`.

After selecting the **Input files**, click the **Load** button. If multiple matching SWT 3000 devices are found in the local station, they are listed in the **Choose SWT Device** area.

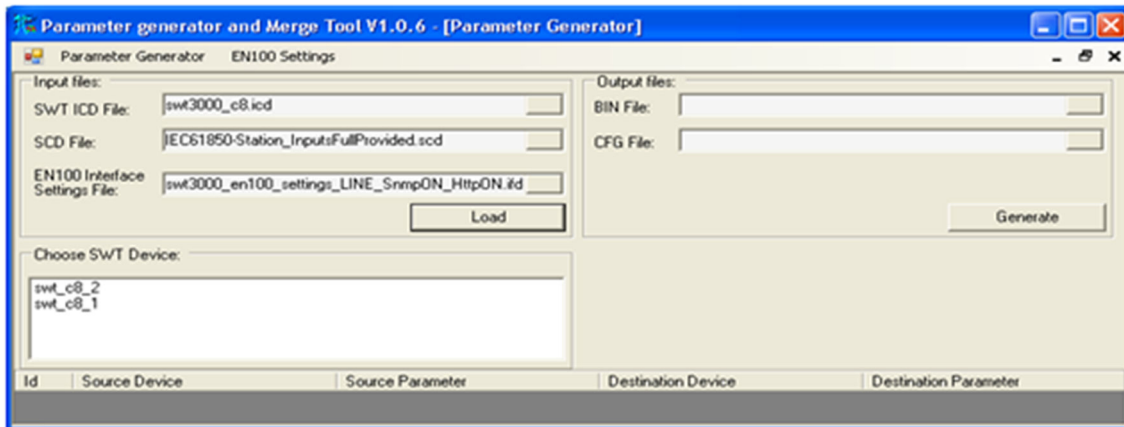

[scmtswwd-141011-01.tif, 1, en\_US]

Figure 5-46 [Parameter Generator] Dialog with Choose SWT Device area

With clicking the desired device, the **Source Device**, **Source Parameter**, **Destination Device**, and **Destination Parameter** are listed in the option table.

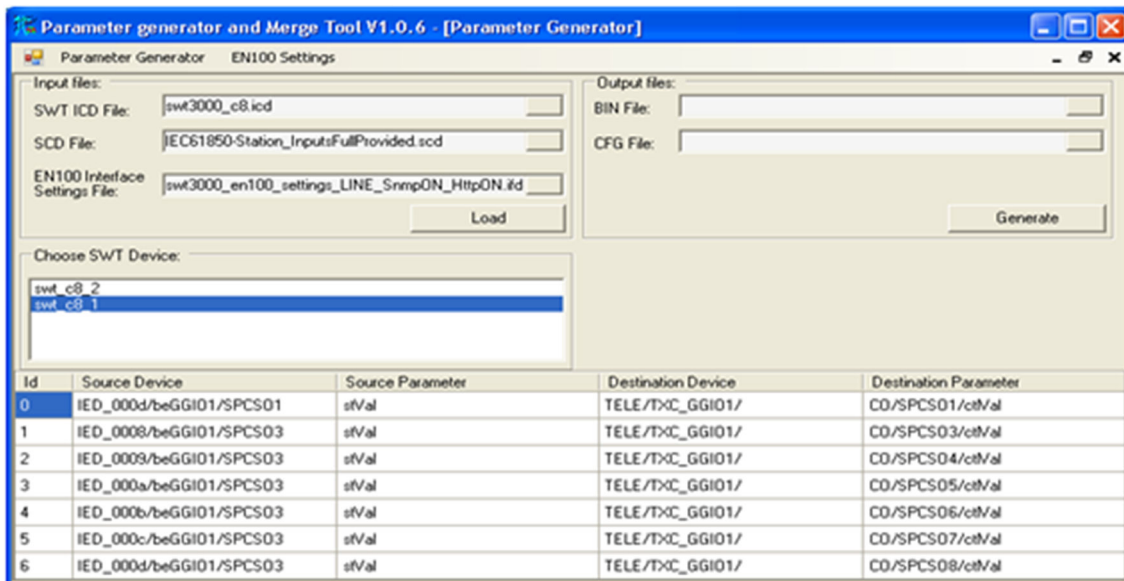

[scmtopta-141011-01.tif, 1, en\_US]

Figure 5-47 [Parameter Generator] Dialog with Option Table area



**NOTE**

If the SCD file does not contain the intAddr and daName tags for the inputs sections (so the substation configurator does not provide this information), manual selection of the source and destination parameters in the option table is necessary. Click the **Source Parameter** or **Destination Parameter** list box and select the specific parameters.

When using the EN100 module, it is necessary to generate the EN100 parameter file (BIN file) and PowerSys preconfiguration file (CFG file) and save them in a proper folder. The mentioned files can be uploaded to PowerSys in the SWT 3000 > Configuration > System-2 submenu. Store the content of the BIN file then in PU4 Flash. With each startup of SWT 3000, the BIN file is transferred to volatile memory of the EN100 module. In order to generate the desired **Output files**, define the name and place of storage of the **Output files** area as follows:

- Click the **BIN File** button.  
The following dialog appears:

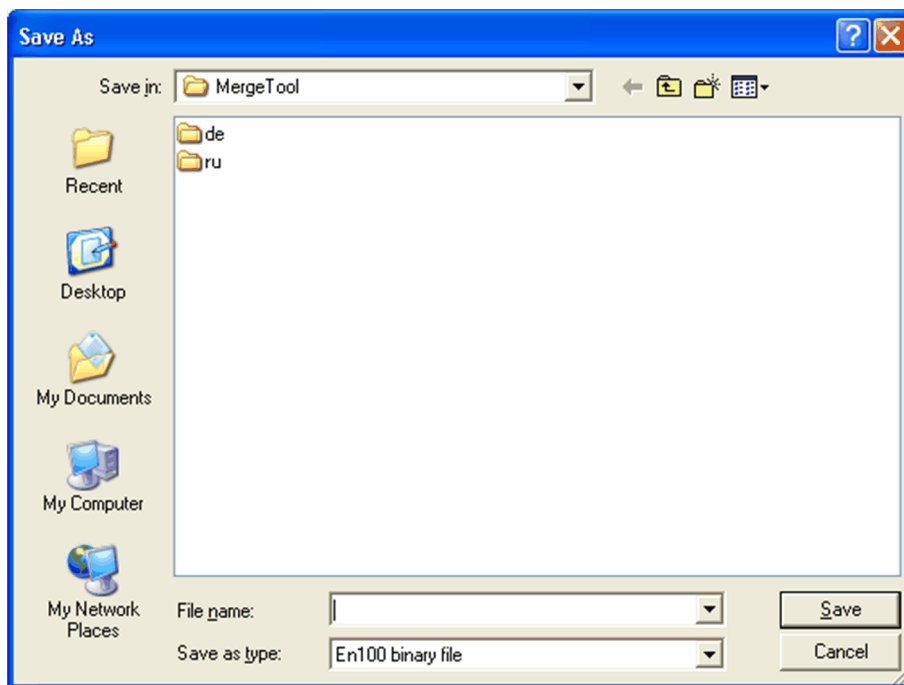

[scbinsel-080911-01.tif, 1, en\_US]

Figure 5-48 Selection of Name and Place of the BIN File

Define the name and place of storage of the BIN file.  
Afterwards, click **Save**.

- Click the **CFG File** button.  
The following dialog appears:

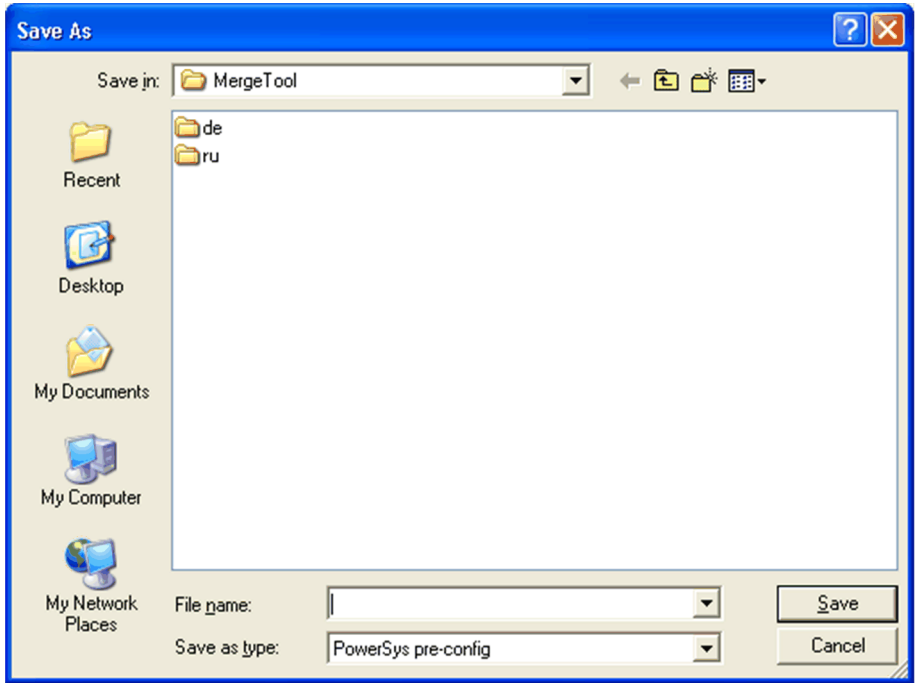

[scdfgse1-080911-01.tif, 1, en\_US]  
Figure 5-49 Selection of Name and Place of the CFG File

Define the name and place of storage of the CFG file.  
Afterwards, click **Save**.

In order to generate the EN100 parameter file (BIN file) and PowerSys preconfiguration file (CFG file), click the **Generate** button.



**NOTE**

If SWT 3000 is equipped with an EN100 module, the BIN file and CFG file are configured in **PowerSys > SWT 3000 > Configuration > System-2 > EN100** area.

### 5.7.3 EN100 Settings

When using the EN100 module, there are some additional (none IEC 61850) configuration settings for the EN100 module. These settings have to be put in the parameter file downloaded to the EN100 module at startup.

Therefore, the MergeTool provides a Graphical User Interface (GUI) for the configuration of EN100 settings and stores these settings in a separate file. This option provides the implementation of the GUI elements processing the user interaction for the EN100 settings file manipulation.



**NOTE**

It is not necessary to create an EN100 settings file (IFD file). A default IFD file for the selection of the input file is presented to the MergeTool user.

If there is a new IFD file needed, proceed like described in the following.

Select the **EN100 Settings** button in the **MergeTool** dialog.  
The following **MergeTool > [EN100 Interface Settings]** dialog appears:



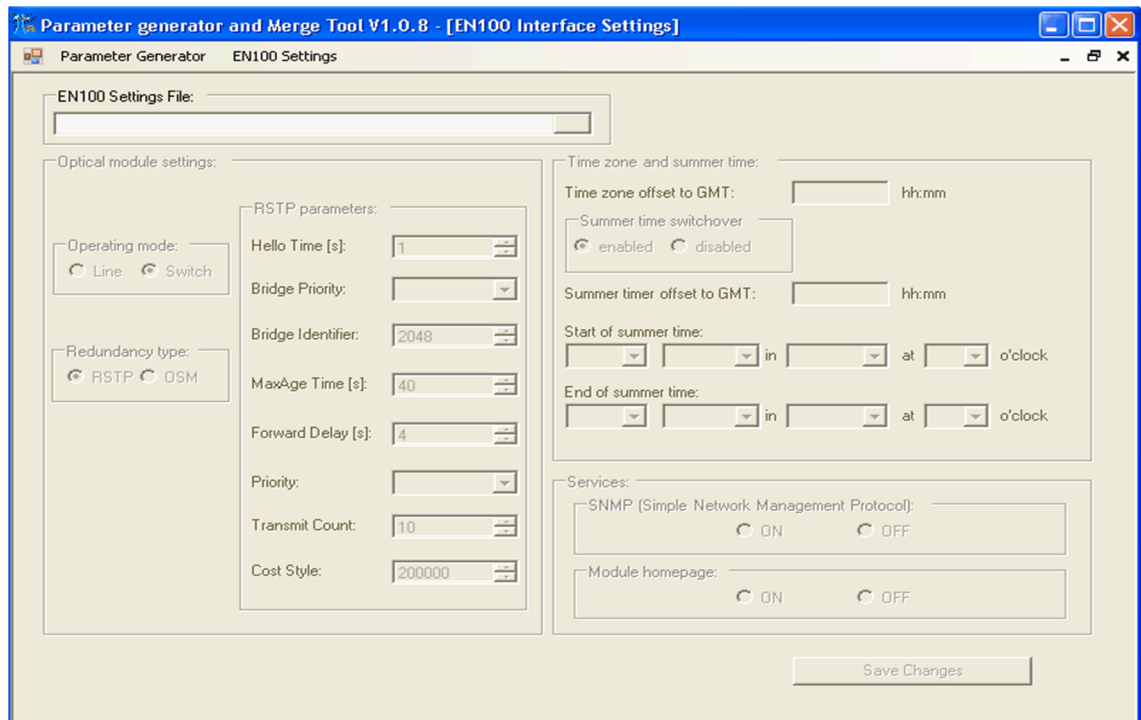

[scen100s-150911-01.tif, 1, en\_US]

Figure 5-50 MergeTool > [EN100 Interface Settings] Dialog

Copy the presented default IFD file into a desired folder.

Rename this IFD file for creation of a new IFD file and save this file in the desired folder of database.

In order to select the new created IFD file, click the button in the **EN100 Settings File** area. Select the newly created IFD file from the folder in database. You can edit now the IFD file settings.

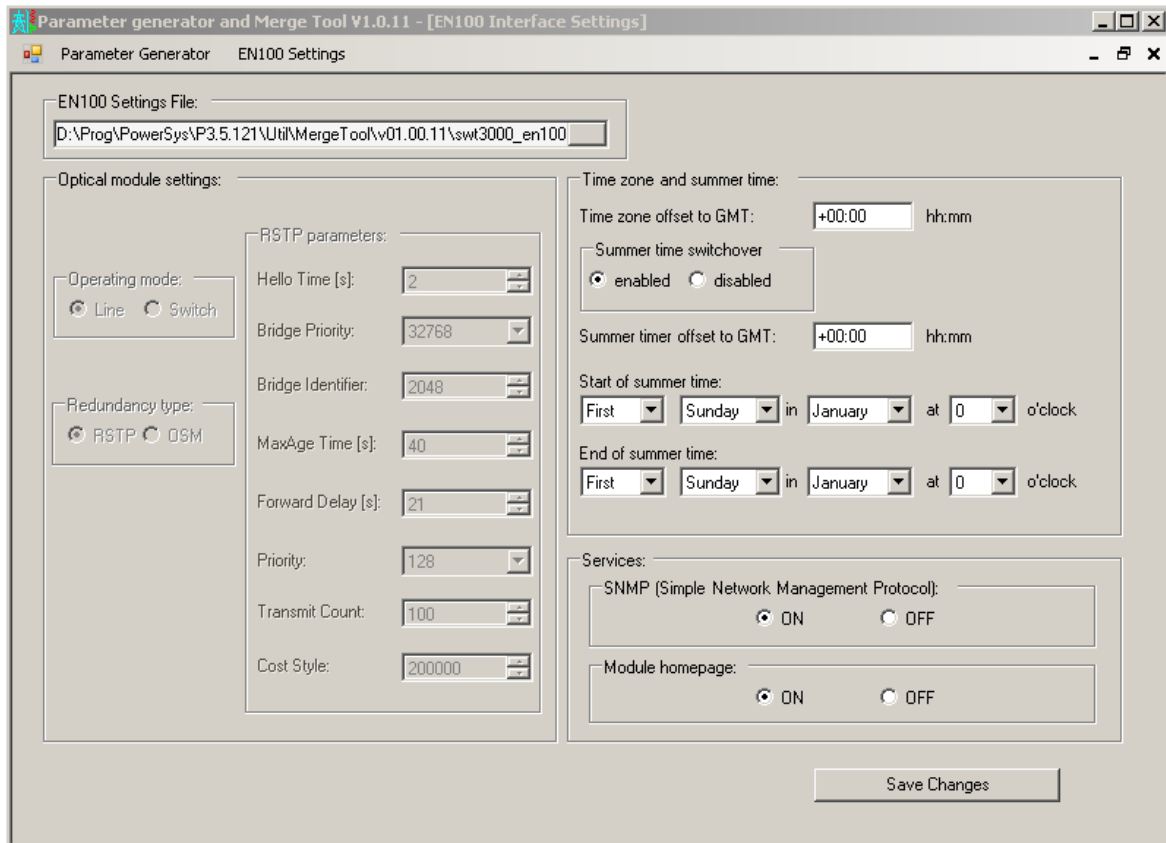

[scen100i-200513-01.tif, 1, en\_US]

Figure 5-51 MergeTool > [EN100 Interface Settings] Dialog with Selected IFD File

Edit the **Optical module settings** as follows:

Table 5-3 Optical Module Settings of EN100 Settings

Parameter	Description	Setting Range or Selection
<b>Operating mode</b>	The operating mode for SWT 3000 is set to <b>Line</b> by default. The <b>Line</b> mode is equivalent to the functions of the EN100 module with electrical interface.	<b>Line</b>
<b>Redundancy type</b>	If the <b>Switch</b> mode has been selected, set the <b>Redundancy type</b> next. Available <b>Redundancy types</b> are <b>Rapid Spanning Tree Protocol (RSTP)</b> and <b>Optical Switch Module (OSM)</b> . The redundancy type depends on the ring structure.  <b>Redundancy type OSM</b> is a proprietary procedure of the Siemens AG. The OSM type can only be used in combination with at least one external switch that can control this type of redundancy. Set one of the external switches as master.  <b>Redundancy type RSTP</b> is used world-wide and supported by nearly all switches.	<b>RSTP or OSM</b>

Parameter	Description	Setting Range or Selection
RSTP parameter > Hello Time [s]	If no test message is received 3 times in a row during the specified monitoring time, the connection is considered faulty. The link status is also monitored. It leads to an immediate detection of an interruption with subsequent changeover. Permissible values are from 1 s to 10 s (the standard recommends a default setting of 2 s).	From 1 s to 10 s Change the RSTP parameter settings only if this change is necessary. In particular, use the settings recommended in this manual.
RSTP parameter > Bridge Priority	This value represents a priority for a switch. Every switch in the ring network has a specific priority that has been set equally for all switches by default. Furthermore, this priority is linked to the MAC address within the switch, which always yields different priorities. The lowest priority defines the logical separation of the ring network. Here, the messages are output from the ring network. The highest priority (identified by zero) marks the root switch. If messages are output or input there, both logical lines must have the same length. Permissible values are: 0, 4096, 8192, 12 288, 16 384, 20 480, 24 576, 28 672, 32 768, 36 864, 40 960, 45 056, 49 152, 53 248, 57 344, and 61 440 (the standard recommends a default setting of 32768 s).	From 0 s to 61 440 s (in increments of 4096)
RSTP parameter > Bridge Identifier	Enter a number from 0 to 4 294 967 295 as an identifier for the switch (default setting: 2048).	From 0 to 2 <sup>32</sup>
RSTP parameter > MaxAge Time [s]	Set a time from 6 s to 40 s. After this time has elapsed, older messages will be removed from the network (default setting: 40 s).	From 6 s to 40 s
RSTP parameter > Forward Delay [s]	The ports of the module remain in one of the conditions - discarding, learning, and forwarding - not longer than for the time set here. Permissible values are from 4 s to 30 s (the standard recommends a setting of 21 s).	From 4 s to 30 s
RSTP parameter > Priority	Every switch in the ring network has a specific priority that has been set equally for all switches by default. The priority is preset by the switch manufacturer. Furthermore, this priority is linked to the MAC address within the switch, which always yields different priorities. The lowest priority defines the logical separation of the ring network. Here, the messages are output from the ring network. The highest priority (identified by zero) marks the root switch. If messages are output or input there, both logical lines must have the same length (default setting: 128).	From 0 to 240 (in increments of 16)
RSTP parameter > Transmit Count	Maximum number of configuration messages sent for a specific event (structural reconfiguration). This number must exceed the number of existing switches in the ring network. Permissible values are from 3 to 128 (the standard recommends a setting of 10).	From 3 to 128
RSTP parameter > Cost Style	This value is a variable that depends on the speed of the link controlling the reconfiguration algorithm. A value of 200000 is fixed for 200 Mbits. Changes are necessary only in special cases and if Spanning Tree Protocol (STP) switches are used. The value -1 is the identifier for the automatic mode.	200000

Edit the **Time zone and summer time** as follows:

Table 5-4 Time Zone and Summer Time Settings of EN100 Settings

Parameter	Description	Setting Range or Selection
<b>Time zone offset to GMT</b>	The time offset of your time to the Greenwich Mean Time (GMT).	From -12 h to +12 h
<b>Summer time switchover</b>	Select the option <b>enabled</b> or <b>disabled</b> summer time switchover if you do or do not wish to change to daylight saving time.	enabled or disabled
<b>Summer time offset to GMT</b>	The time offset of your time to the GMT.	From 0 h to +23 h
<b>Start of summer time</b>	Date for the change to daylight saving time.	
<b>End of summer time</b>	Date for the change from daylight saving time.	

Edit the **Services** as follows:

Table 5-5 Service Settings of EN100 Settings

Parameter	Description	Selection
<b>SNMP</b>	You can use this setting to activate or deactivate the SNMP protocol.	ON or OFF
<b>Module homepage</b>	You can use this setting to activate or deactivate the module homepage.	ON or OFF

## 5.8 SWT vDisp for Virtual Display

### 5.8.1 Installation

The installation package (.apk) can be found within the PowerSys package. Copy the latest apk file to mobile phone and click file to install. After successful installation, the new icon can be found on the mobile phone.

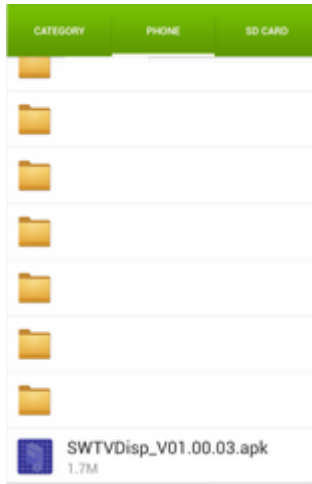

[sc\_virtual\_display\_installation, 1, -\_-]



#### NOTE

The phone has to allow the installation of apps from unknown sources (Settings > Security > Unknown sources = enabled) before you start the installation.

### 5.8.2 Dashboard

After connecting USB OTG cable to the device, SWT vDisp is running automatically. The alarm status bar at the top displays the active alarm (red color for active alarm)

HW	Module alarm
CFG	Configuration fault
G	General alarm
TX	Transmitter alarm
RX	Receiver alarm
NU	Non urgent alarm
REM	Fault in the remote station

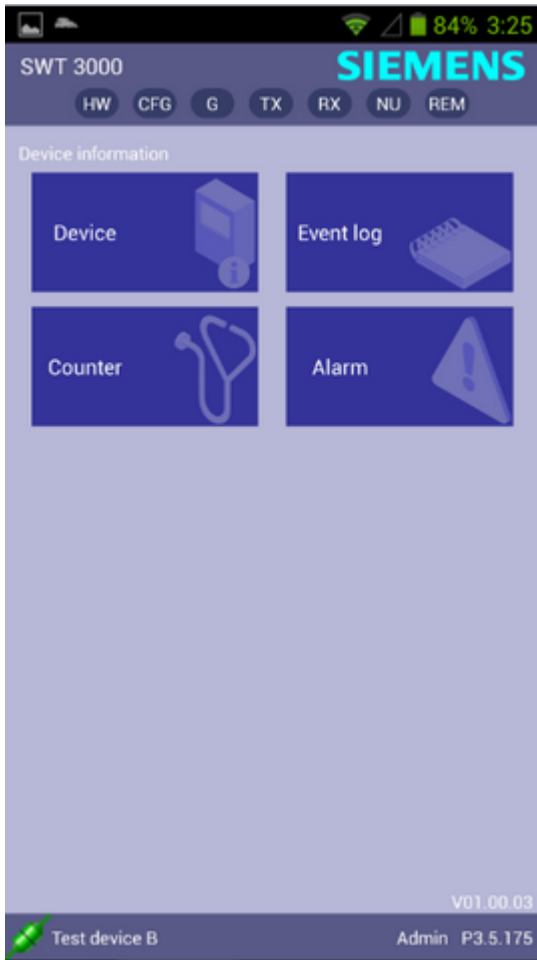

[sc\_virtual\_display\_dashboard, 1, --]

The status bar at the bottom displays the connection state, device name or IP address, login account and firmware release version. The connection icon will change to red color if the connection failed.

### 5.8.3 Display Command Counter

The command counter page displays the total trip counter for up to 16 command input / output. These counters can be reset to zero when you press the “Reset” button.

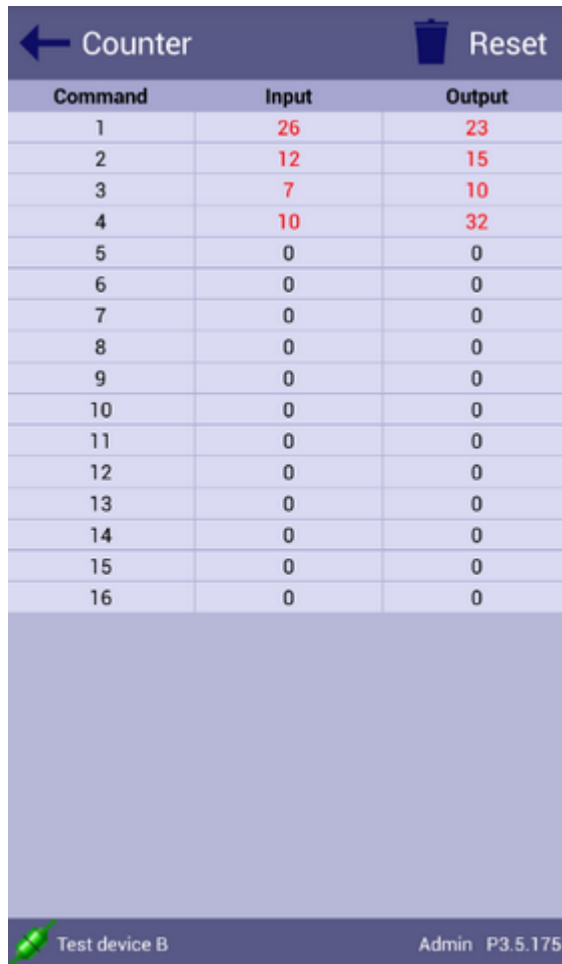

Command	Input	Output
1	26	23
2	12	15
3	7	10
4	10	32
5	0	0
6	0	0
7	0	0
8	0	0
9	0	0
10	0	0
11	0	0
12	0	0
13	0	0
14	0	0
15	0	0
16	0	0

Test device B Admin P3.5.175

[sc\_virtual\_display\_counter, 1, --]

The device information page displays the device information and component version. The device information includes device name, IP address, date/time of last reset, date/time of last parameter change, and so on.

Information	
Device name	Test device B
IP address	192.168.20.147
Customer	Internal user
Date of last reset	02/01/1970 21:51:27
Date of last modify	09/01/2019 12:19:21
Date of device	02/01/2070 21:56:59
Comments	Comments from test device B

Firmware overview	
Package number	P3.5.175
PU4 CON	01.05.04
PU4 BOOT	01.02.02
PU4 DLE	Type:D HW:00.00.02 FPGA:00.01.32
PU4 MON	01.01.00
PU4 DSP	01.01.01
PU4 FPGA	02.00.17
FOM1 Type	0
FOM2 Type	0
EN100 FW	00.00.00
EN100 Type	not equipped

Test device B Admin P3.5.175

[sc\_virtual\_display\_deviceinformation, 1, --]

### 5.8.4 Display Event Log / Alarm

The event log page displays the important events during running (for example commands on/off). The first event is fixed log which is always located top of the page. More events are reloaded, when you scroll down near the end of the page.



← Event recorder

100 of 370 logs loaded

Gr	Id	Time	Description
1	1	02/01/1970 21:51:27.000	program started
3	20	20/12/2018 21:00:00.001	clock synchronisation (local or remote) successful
3	25	02/01/1970 05:28:08.891	device configuration programmed in FLASH
3	90	02/01/1970 21:51:32.481	active line from now on is LIA
3	90	02/01/1970 21:51:32.482	active line from now on is LIA
3	111	02/01/1970 21:51:31.532	ETH startup finished
4	73	02/01/1970 21:51:31.532	non urgent alarm off
3	47	02/01/1970 21:51:29.492	tele-protection-signalling unlocked
3	36	02/01/1970 21:51:29.344	PowerSys connected
3	91	02/01/1970 21:51:29.244	active line from now on is LID1
3	63	02/01/1970 21:51:29.244	LID-1: sync
4	71	02/01/1970 21:51:29.244	general alarm off
4	75	02/01/1970 21:51:29.244	receiver alarm off
3	90	02/01/1970 21:51:29.153	active line from now on is LIA
3	62	02/01/1970 21:51:29.153	LID-1: nosync

192.168.20.147 Admin P3.5.175

[sc\_virtual\_display\_eventrecorder, 1, -\_-]

The alarm page displays the active alarms.

Severity	Label	Explanation
ALA	GENALR	General alarm
ALA	NDALR	Non-urgent alarm
ALA	EALR	Receive alarm

192.168.20.147 Admin P3.5.175

[sc\_virtual\_display\_alarm, 1, --]

# 6 SNMP and Remote Access

6.1	Remote Access and Remote Monitoring	260
6.2	SNMP	262
6.3	Remote Access	281
6.4	Web Interface	285

## 6.1 Remote Access and Remote Monitoring

### 6.1.1 Overview

The following examples show the possibilities for remote access or remote monitoring of the SWT 3000 system.

### 6.1.2 Remote Access via Intranet (TCP/IP)

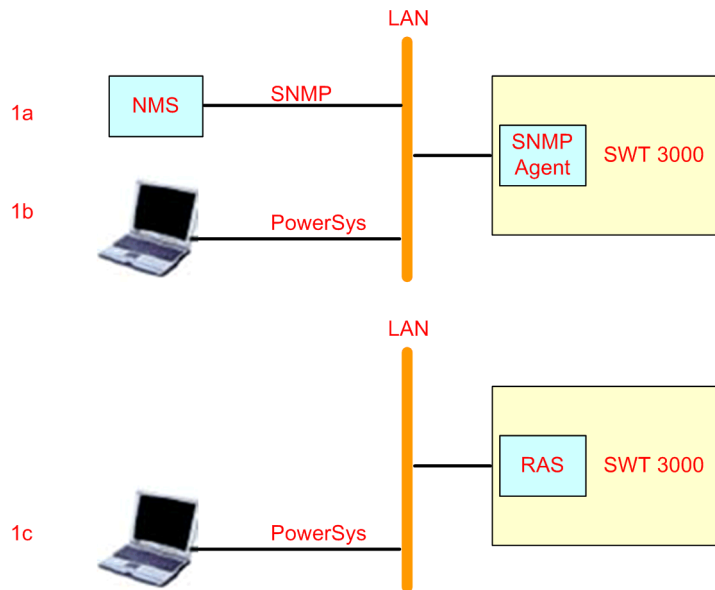

[dwremint-080611-01.tif, 1, en\_US]

Figure 6-1 Remote Access via Intranet

- 1a Remote access via SNMP agent and Network Management System (NMS)
- 1b Remote access via SNMP agent and service program PowerSys
- 1c Remote access via RAS and service program PowerSys

### 6.1.3 Remote Monitoring/Maintenance via Inband RM-Channel

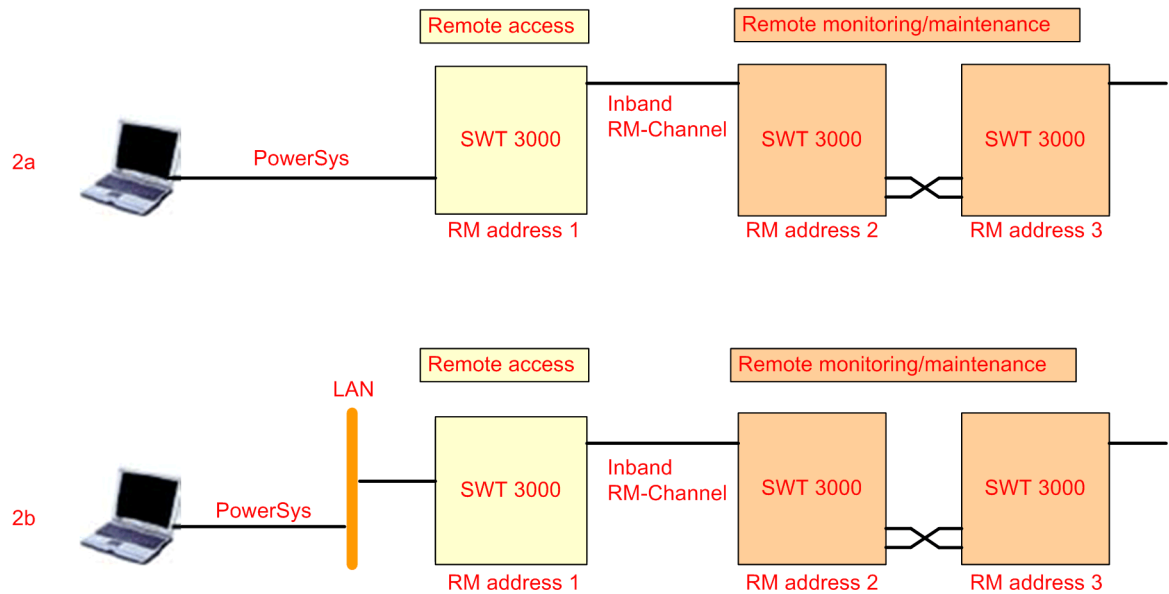

[dwrmmmc-211011-01.tif, 1, en\_US]

Figure 6-2 Remote Monitoring/Maintenance via Inband RM-Channel

- 2a Remote monitoring via inband RM-Channel and service program PowerSys
- 2b Remote monitoring via inband RM-Channel and service program PowerSys with Intranet (LAN) remote access

## 6.2 SNMP

### 6.2.1 SNMP Function

The SNMP agent allows the request of system parameters and a limited control (commands) of the SWT 3000 from a central NMS via TCP/IP. The SNMP agent provides an image of the SWT 3000 status. Spontaneous alarm indications (traps) are transmitted to the NMS.

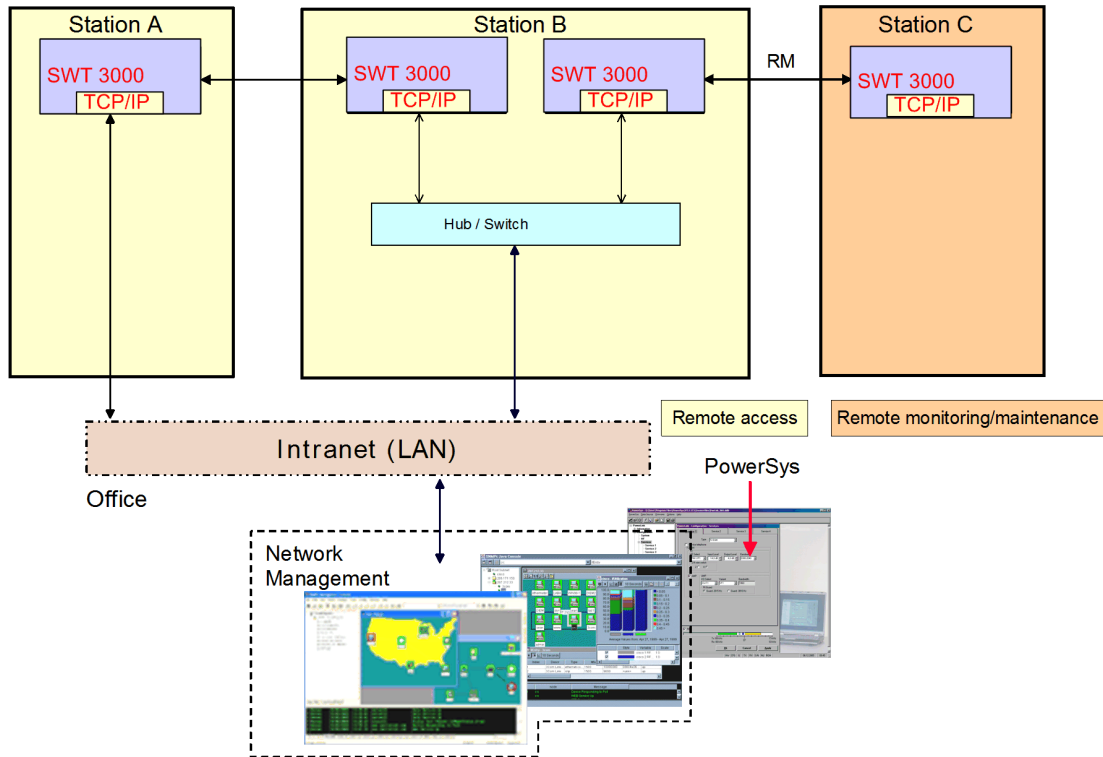

[dwsnmrem-080611-01.tif, 1, en\_US]

Figure 6-3 SNMP & Remote Access via IP Network

↔ Protection signal transmission path  
 RM Inband remote monitoring/maintenance channel

The minimum setting of the SNMP agent is:

- Local IP address
- Trap destinations IP address
- Trap delay and repetition suppression
- Community string
- Configuration via Web browser (password protected)

## Functional Diagram

The following figure displays a functional diagram of the SNMP system:

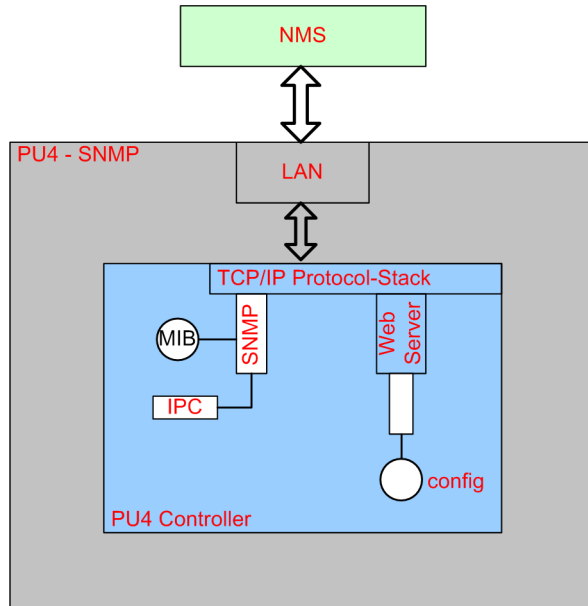

[dwsnmdia-080611-01.tif, 1, en\_US]

Figure 6-4 SNMP Functional Diagram

The components of the SNMP system are as follows:

- TCP/IP protocol stack  
The TCP/IP protocol stack handles the internet communication of the LAN.
- SNMP  
Handling of the SNMP command (get/set) and spontaneous indication (traps)
- MIB  
The Management Information Base (MIB) contains the status information of the SWT 3000 system.
- IPC  
Inter-Process Communication (IPC) for communication and synchronization of the processes
- Config.  
Configuration database of SWT 3000

## SWT 3000 Read General Information

The following information is available:

- SWT 3000 hardware information  
PU4 hardware release, DLE hardware release, IFC-1 hardware release, IFC-2 hardware release, IFC-3 hardware release, IFC-4 hardware release, and EN100 module information
- SWT 3000 counter (maximum 24 inputs and outputs)  
Input number and counter value, output number and counter value
- SWT 3000 event recorder  
Recorder sequence number, time stamp, event group, event number, and event description

### SWT 3000 Read Configuration

The following configuration options are available:

- System configuration  
 Operating mode, purpose, VF variant, analog interface, digital interface, primary path, secondary path, Tx / Rx address, coded transmission, permissive or direct tripping, and IFC-1/-2/-3/-4 types
- RM configuration  
 RM address, master, and slave

### SWT 3000 Set IP Configuration

You can set the following IP configuration:

- Network configuration  
 IP address, subnet mask, gateway, enable DHCP client, and RAS port number
- SNMP configuration  
 Read and write community string, trap destination, trap delay, and repetition suppression
- NTP configuration  
 Enable NTP client, NTP server address, timezone offset, and poll time interval

### SWT 3000 Set Commands

You can set the following commands from the NMS:

- Reset device
- SWT 3000 line select

## 6.2.2 Spontaneous Indication SNMP Traps

Spontaneous indications from the SWT 3000 device are transmitted from the SNMP agent to the configured NMS. You can configure up to 6 NMS for receiving these traps.

### Alarm trap

If there is a status change during a configured time range, the alarm state (active or not active) is assigned to each alarm and transmitted to the programmed NMS. The cyclic repetitive alarms within an adjustable time range are transmitted only once. Each alarm contains the severity level and a short description of the alarm.

Alarm table (*swtAlarmTable*) contains four device alarm states:

alarmIndex	alarmDescription	alarmTrapEnabled	alarmValue	alarmTimes-tamp	alarmSeverity
1	General alarm	enabled	noactive	YYYY-MM-DD HH:MM:SS	critical
2	Non-urgent alarm	enabled	noactive	YYYY-MM-DD HH:MM:SS	critical
3	Transmit alarm	enabled	noactive	YYYY-MM-DD HH:MM:SS	critical
4	Receive alarm	enabled	noactive	YYYY-MM-DD HH:MM:SS	critical

alarmTrapEnabled is read-write access for enable or disable alarm trap sending

alarmValue indicates the state of alarm (active = 1 / not active = 2)

alarmSeverity indicates the different severity from 1 to 5

alarmDescription indicates the alarm description and detailed fault reason for active alarm

Some example fault reasons in alarmDescription for different alarm:



- General alarm: receive alarm on
- Non-urgent alarm: input-limitation alarm on
- Transmit alarm: TXAL [PU4] coming (off->on)
- Receive alarm: LID-1: nosync

When alarm state is changed from inactive to active or vice versa, the alarm trap is sent out with binding objects in alarm table. The example received alarm trap is like below:

<b>Source:</b>	192.168.20.140	<b>Timestamp:</b>	1 hour 52 minutes 29 seconds	<b>SNMP Version:</b>	2
<b>Trap OID:</b>	.iso.org.dod.internet.private.enterprises.siemensPtdEa.communicationSolutions.swt3000R35.swtTraps.alarmNonUrgent			<b>Community:</b>	public
<b>Variable Bindings:</b>					
<b>Name:</b>	.iso.org.dod.internet.mgmt.mib-2.system.sysUpTime.0				
<b>Value:</b>	[TimeTicks] 1 hour 52 minutes 29 seconds (674914)				
<b>Name:</b>	snmpTrapOID				
<b>Value:</b>	[OID] alarmNonUrgent				
<b>Name:</b>	.iso.org.dod.internet.private.enterprises.siemensPtdEa.communicationSolutions.swt3000R35.swtTraps.swtAlarmTable.swtAlarmEntry.alarmDescription.2				
<b>Value:</b>	[OctetString] Non-urgent alarm: Secondary line error	Alarm with detail fault reason			
<b>Name:</b>	.iso.org.dod.internet.private.enterprises.siemensPtdEa.communicationSolutions.swt3000R35.swtTraps.swtAlarmTable.swtAlarmEntry.alarmValue.2				
<b>Value:</b>	[Integer] active (1)	alarm state			
<b>Name:</b>	.iso.org.dod.internet.private.enterprises.siemensPtdEa.communicationSolutions.swt3000R35.swtTraps.swtAlarmTable.swtAlarmEntry.alarmTimestamp.2				
<b>Value:</b>	[OctetString] 2021-11-23 18:55:52				
<b>Name:</b>	.iso.org.dod.internet.private.enterprises.siemensPtdEa.communicationSolutions.swt3000R35.swtTraps.swtAlarmTable.swtAlarmEntry.alarmSeverity.2				
<b>Value:</b>	[Integer] major (2)				
<b>Name:</b>	.iso.org.dod.internet.snmpV2.snmpModules.snmpMIB.snmpMIBObjects.snmpTrap.snmpTrapEnterprise.0				
<b>Value:</b>	[OID] swt3000R35				
<b>Description:</b>	Trap sent when NonUrgent-alarm is raised or cleared.				

[sc\_snmp\_example\_alarmtrap, 1, ...]

Figure 6-5 Example SNMP alarm trap

Table 6-1 Alarm Severity

Alarm Severity	Signification
1	Critical
2	Major
3	Minor
4	Warning
5	Normal

### Event trap

In addition to four alarm traps, the following event traps are also supported.

- Incoming protection commands
- Outgoing protection commands
- Alarm on / off state change
- Program restart
- Changing the configuration
- Transmission lines switch over

Trap OID	Description
eventAlarmGeneralOn	Event happened: general alarm on.
eventAlarmGeneralOff	Event happened: general alarm off.
eventAlarmNonUrgentOn	Event happened: non-urgent alarm on.

Trap OID	Description
eventAlarmNonUrgentOff	Event happened: non-urgent alarm off.
eventAlarmRxOn	Event happened: receive alarm on.
eventAlarmRxOff	Event happened: receive alarm off.
eventAlarmTxOn	Event happened: transmit alarm on.
eventAlarmTxOff	Event happened: transmit alarm off.
eventDeviceStarted	Event happened: device reset.
eventCommandInputOn	Event happened: command input activated. The command name and counter of changed command inputs are sent with variable-bindings.
eventCommandOutputOn	Event happened: command output activated. The command name and counter of changed command outputs are sent with variable-bindings.
eventPowerSysConnected	Event happened: PowerSys connected to device.
eventPowerSysDisconnected	Event happened: PowerSys disconnected from device.
eventActiveLineNone	Event happened: no active line from now.
eventActiveLineLia	Event happened: active line from now on is LIA.
eventActiveLineLid1	Event happened: active line from now on is LID1.
eventActiveLineLid2	Event happened: active line from now on is LID2.
eventActiveLineLid12	Event happened: active line from now on is LID1 and LID2 (Double primary path).
eventActiveLineEth	Event happened: active line from now on is ETH.
eventConfigUnsaved	Event happened: changes in database not saved.
eventConfigChanged	Event happened: device configuration programmed in FLASH.
eventFirmwareChanged	Event happened: firmware download finished.
eventSnmpKeyReset	Event happened: SNMPv3 key reset.

Event traps do not have the binding objects of description, severity, timestamp, and alarm value. The example received event trap for incoming command is like below:

<b>Source:</b>	192.168.20.140	<b>Timestamp:</b>	1 minute 53 seconds	<b>SNMP Version:</b>	2
<b>Trap OID:</b>	iso.org.dod.internet.private.enterprises.siemensPtdEa.communicationSolutions.swt3000R35.swtTraps.eventCommandInputOn			<b>Community:</b>	public
<b>Variable Bindings:</b>					
<b>Name:</b>	iso.org.dod.internet.mgmt.mib-2.system.sysUpTime.0				
<b>Value:</b>	[TimeTicks] 1 minute 53 seconds (11374)				
<b>Name:</b>	snmpTrapOID				
<b>Value:</b>	[OID] eventCommandInputOn				
<b>Name:</b>	iso.org.dod.internet.private.enterprises.siemensPtdEa.communicationSolutions.swt3000R35.swtInfo.swtInfoCounterInputTable.swtInfoCounterInputEntry.swtInfoCounterInputName.1				
<b>Value:</b>	[OctetString] IED X POTT TX	<b>Changed command name</b>			
<b>Name:</b>	iso.org.dod.internet.private.enterprises.siemensPtdEa.communicationSolutions.swt3000R35.swtInfo.swtInfoCounterInputTable.swtInfoCounterInputEntry.swtInfoCounterInputValue.1				
<b>Value:</b>	[Gauge] 7	<b>Actual command counter</b>			
<b>Name:</b>	iso.org.dod.internet.snmpV2.snmpModules.snmpMIB.snmpMIBObjects.snmpTrap.snmpTrapEnterprise.0				
<b>Value:</b>	[OID] swt3000R35				
<b>Description:</b> Event happened:command input activated. The counter of changed command inputs are sent with variable-bindings.					

[isc\_snmp\_example\_eventtrap, 1, ...]

Figure 6-6 Example SNMP event trap

### Enable / disable trap sending

By default, alarm traps are enabled, and event traps are disabled. It can be changed via SNMP set command to following OID:

Trap OID	Description
alarmTrapEnabled.<AlarmIndex>	Enable(1) / disable(2) individual alarm trap sending
swtItpSnmpEventTrapEnabled	Enable(1) / disable(2) all event traps sending
swtItpActivationReq	storeToFlashAndRestart(1): Apply and store the changes into flash

## 6.2.3 Simple Network Management Protocol Version 3 (SNMPv3)

### 6.2.3.1 SNMPv3 Overview

Authentication in SNMP version 1 and version 2 is nothing more than a password (community string) which is sent in plaintext between the network manager and the SNMP agent. It is simple to intercept the community string because the SNMPv2 is a kind of unprotected protocol. Once the community string is known read out and modification of the device configuration or even shutdown might be possible.

The Simple Network Management Protocol Version 3 (**SNMPv3**) addresses the cryptographic security weakness of SNMPv1 and SNMPv2 using following methods:

- **User-based Security Model (USM):**  
Each user has a name, authentication key and privacy key. **MD5** or **SHA-1** authentication protocol is used to authentication SNMPv3 message. SNMPv3 agent authenticates the incoming request message with authentication key, and rejects the access if the authentication has failed.  
The SNMPv3 message data is encrypted and decrypted with privacy key using DES protocol.
- **View-based Access Control Model:**  
It is used to control the access of USM user to the managed object of **MIB**.

SNMPv3 is supported in both **PowerLink** and **SWT 3000** (release  $\geq$  **P3.5.120**). Additionally, the notification can be sent out through both **SNMP Trap and Inform**.

The standard MIB modules are used for SNMPv3 and notification operation.

Table 6-2 Standard MIB Modules

MIB	Comments
SNMP-FRAMEWORK-MIB	SNMP Management Architecture MIB (RFC 3411).
SNMP-NOTIFICATION-MIB	This MIB module provides mechanisms to remotely configure the notification parameters (RFC 3413).
SNMP-TARGET-MIB	This MIB module provides mechanisms to remotely configure the target addresses and security parameters (RFC 3413).
SNMP-USER-BASED-SM-MIB	This MIB module provides mechanisms to remotely configure User-based Security Model (RFC 3414).
SNMP-VIEW-BASED-ACM-MIB	This MIB module provides mechanisms to remotely configure View-based Access Control Model (RFC 3415).

The private MIB modules are used to access **PowerLink** and **SWT 3000** device configurations.

Table 6-3 Private MIB Modules of PowerLink and SWT 3000

MIB	Comments
SIEMENS-POWERLINK-CSPI-MIB	This MIB module provides mechanisms to access PowerLink CSPI settings.
SIEMENS-POWERLINK-CSPI-IPCON-MIB	This MIB module provides mechanisms to access PowerLink CSPI IP related settings.
SIEMENS-POWERLINK-CSPI-VMUX-MIB	This MIB module provides mechanisms to access PowerLink vMux settings.

MIB	Comments
SIEMENS-POWERLINK-CSPI-ISWT3000R3_5-MIB	This MIB module provides mechanisms to access integrated <b>SWT 3000</b> settings.
SIEMENS-SWT3000R35-MIB	This MIB module provides mechanisms to access standalone <b>SWT 3000</b> settings.

It is possible to configure PowerLink and SWT 3000 via PowerSys application whether with SNMPv2 or SNMPv3. If SNMPv3 is configured, the USM users, VACM, and notification parameters are managed through SNMP GET/SET command instead of PowerSys or Web server.

### 6.2.3.2 USM User Management

#### Using the USM

Network Management System (NMS) usually has a user management tool, which is used to easily manage SNMPv3 USM user configuration on remote SNMPv3 agents, e.g. clone a new user, change the password etc. USM needs to be configured in a SNMPv3 NMS client and configuration is sent and stored in the SNMPv3 agent (PowerLink or SWT 3000) afterwards.

All these operations are accomplished through SNMP by setting **SNMP-USER-BASED-SMMIB::usmUserTable MIB object**.

3 initial users are provided in **SWT 3000** devices for connection to **SNMPv3 agent**.

User Name	Auth Protocol	Auth Password	Priv Protocol	Priv Password
initial	MD5	cssnmpv3auth	DES	cssnmpv3priv
templateMD5	MD5	cssnmpv3auth	DES	cssnmpv3priv
templateSHA	SHA	cssnmpv3auth	DES	cssnmpv3priv

After having been successfully connected to the SNMPv3 agent, the initial users are listed as follows:

	User Name	Auth Protocol	Priv Protocol	Storage	Status
1	initial	HMAC-MD5	DES	nonVolatile (3)	active (1)
2	templateMD5	HMAC-MD5	DES	nonVolatile (3)	active (1)
3	templateSHA	HMAC-SHA-1	DES	nonVolatile (3)	active (1)

[scusersta-140912-01.tif, 1, en\_US]

Figure 6-7 USM User Table List

Network Management System (NMS) usually has a user management tool, which is used to easily manage SNMPv3 USM user configuration on remote SNMPv3 agents, e.g. clone a new user, change the password etc. USM needs to be configured in a SNMPv3 NMS client and configuration is sent and stored in the SNMPv3 agent (PowerLink or SWT 3000) afterwards.

All these operations are accomplished through SNMP by setting **SNMP-USER-BASED-SMMIB::usmUserTable MIB object**.

3 initial users are provided in **SWT 3000** devices for connection to **SNMPv3 agent**.

User Name	Auth Protocol	Auth Password	Priv Protocol	Priv Password
initial	MD5	cssnmpv3auth	DES	cssnmpv3priv
templateMD5	MD5	cssnmpv3auth	DES	cssnmpv3priv
templateSHA	SHA	cssnmpv3auth	DES	cssnmpv3priv

After having been successfully connected to the SNMPv3 agent, the initial users are listed as follows:

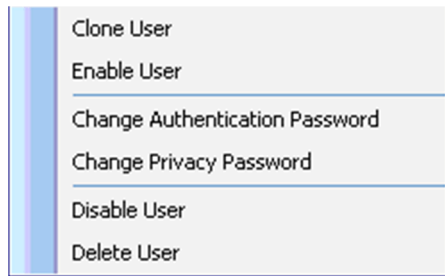

[scuserop-140912-01.tif, 1, en\_US]

Figure 6-8 USM User Operation

Table 6-4 USM User Table

Operation	Comments
Clone User	Create new SNMPv3 users from existing one.
Enable User	Enable a disabled SNMPv3 user.
Change Authentication Password	Change the authentication password to a new one.
Change Privacy Password	Change the privacy password to a new one.
Disable User	Disable the active SNMPv3 user and change the row status from "active(1)" to "notInService(2)".
Delete User	Delete the existing SNMPv3 user.



#### NOTE

Because the initial user name and password are printed on paper and are well known for other people, you must create at least one working user from the initial user template, change the default authentication, and the privacy password as soon as possible. After all needed working users are created, the initial and template users should be deleted.

#### Example: Create New User

This example shows the workflow of creating a new user "testuser" using iReasoning MIB Browser.

- 1 - Open the SNMPv3 user management tool from MIB Browser.
- 2 - All users of the remote agent are listed in the user management tool.
- 3 - Select the user template you want to clone from:  
**templateMD5**: user template with MD5 authentication protocol and DES privacy protocol  
**templateSHA**: user template with SHA authentication protocol and DES privacy protocol.
- 4 - Click on clone user operation and enter a new user name in the text box.

	User Name	Auth Protocol	Priv Protocol	Storage	Status
1	initial	HMAC-MD5	DES	nonVolatile (3)	active (1)
2	templateMD5	HMAC-MD5	DES	nonVolatile (3)	active (1)
3	templateSHA	HMAC-SHA-1	DES	nonVolatile (3)	active (1)

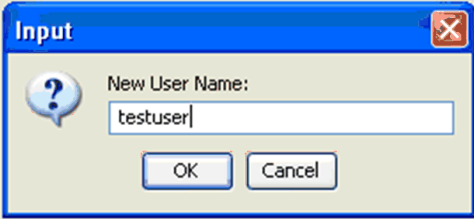
[sccloneu-140912-01.tif, 1, en\_US]

Figure 6-9 Clone New User

- 5 - The new user “testuser” is cloned from templateMD5, whose authentication and privacy passwords are same as templateMD5.

	User Name	Auth Protocol	Priv Protocol	Storage	Status
1	initial	HMAC-MD5	DES	nonVolatile (3)	active (1)
2	testuser	HMAC-MD5	DES	nonVolatile (3)	active (1)
3	templateMD5	HMAC-MD5	DES	nonVolatile (3)	active (1)
4	templateSHA	HMAC-SHA-1	DES	nonVolatile (3)	active (1)

[scusmuse-140912-01.tif, 1, en\_US]

Figure 6-10 USM User Table List

- 6 - Change the authentication password and the privacy password. For example:  
 Auth password: “testuser\_auth”  
 Priv password: “testuser\_priv”



**NOTE**

It is recommended to have at least 8 characters for the password.

- 7 - Assign access right for the new cloned user (see **Example: Assign Access Right**)



**NOTE**

This step is not needed for the **SWT 3000** standalone device. The new cloned user has full access right to complete MIB modules and it cannot be changed by the user via VACM.

- 8 - Check if new working user can connect to SNMP agent. Remove initial and template users as soon as all desired working users have been created.
- 9 - Store all the configurations to flash and restart system through SNMP by setting following MIB object: SIEMENS-SWT3000R35-MIB::swtIplActivationReq.0 = storeToFlashAndRestart(1)



**NOTE**

For all detail operation steps, check the user manual of your MIB Browser.

**6.2.3.3 VACM Management**

**Definition**

VACM controls the access right of the user to the MIB object, which is accomplished through SNMP by setting MIB module SNMP-VIEW-BASED-ACM-MIB.

Configure the VACM in a SNMPv3 NMS client. The configuration is sent and stored in the SNMPv3 agent afterwards.

The initial user has the full access right to complete MIB modules by default.



#### NOTE

VACM is not supported in the **SWT 3000** device. All SNMPv3 users in **SWT 3000** have the full access right to complete MIB modules by default.

#### Example: Assign Access Right

This example shows the workflow of assigning full access rights for a new user "testuser" using iReasoning MIB Browser.

- 1 - Open SNMP-VIEW-BASED-ACM-MIB::vacmSecurityToGroupTable in MIB Browser table view
- 2 - Create a new row with the cloned user name "testuser".

	vacmSecurityModel	vacmSecurityName	vacmGroupName	vacmSecurityToGroupStorageType	vacmSecurityToGroupStatus
1	1	comm1	grpcomm1	4	1
2	1	comm2	grpcomm2	4	1
3	2	comm1	grpcomm1	4	1
4	2	comm2	grpcomm2	4	1
5	3	initial	grpinitial	4	1
6	3	templateMD5	grptemplateMD5	4	1
7	3	templateSHA	grptemplateSHA	4	1

[sccreate-140912-01.tif, 1, en\_US]

Figure 6-11 Create New Row in vacmSecurityToGroupTable

- 3 - Assign "testuser" to the existing group name "grpinitial".

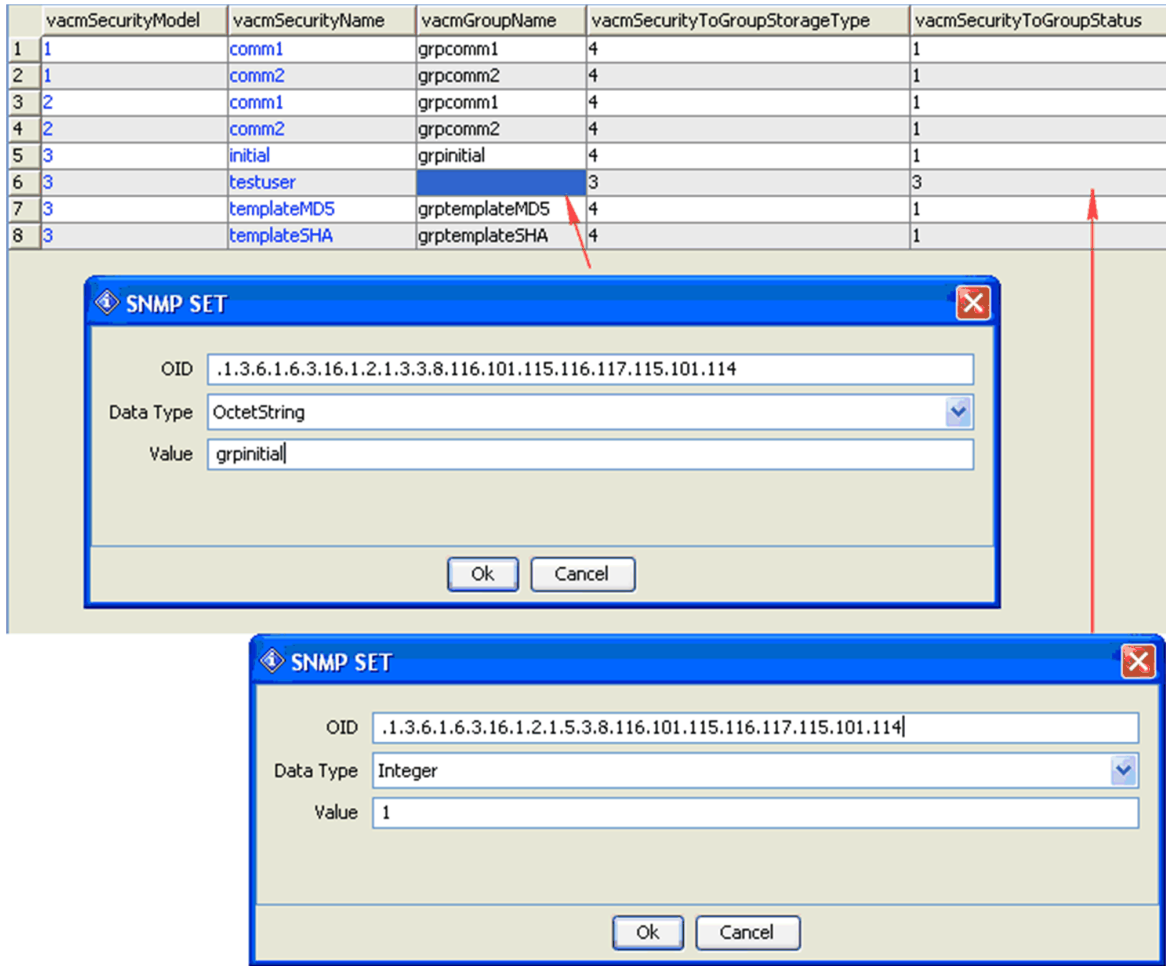

[scchange-140912-01.tif, 1, en\_US]

Figure 6-12 Change Group Name and Row Status

Table 6-5 vacmSecurityToGroupTable Settings

Field	Value
vacmGroupName	grpinitial
vacmSecurityToGroupStatus	active(1)

- "testuser" is added into table vacmSecurityToGroupTable.

	vacmSecurityModel	vacmSecurityName	vacmGroupName	vacmSecurityToGroupStorageType	vacmSecurityToGroupStatus
1	1	comm1	grpcomm1	4	1
2	1	comm2	grpcomm2	4	1
3	2	comm1	grpcomm1	4	1
4	2	comm2	grpcomm2	4	1
5	3	initial	grpinitial	4	1
6	3	testuser	grpinitial	3	1
7	3	templateMD5	grptemplateMD5	4	1
8	3	templateSHA	grptemplateSHA	4	1

[scvacmse-140912-01.tif, 1, en\_US]

Figure 6-13 vacmSecurityToGroupTable List

- 5 - Store all the configurations to flash and restart system through SNMP by setting following MIB object:  
 SIEMENS-POWERLINK-CSPI-IPCON-MIB::ipSettingsActivationReq.0 = storeToFlashAndRestart(1)



- 6 - Connect SNMPv3 agent with new user "testuser", and check if the user has full access right for private and standard MIB modules.  
SIEMENS-POWERLINK-CSPI-IPCON-MIB::ipSettingsActivationReq.0 = storeToFlashAndRestart(1)

#### 6.2.3.4 Key Reset

In case of any security incident which has affected the SNMPv3 communication, a key reset should be executed. With the key reset operation the initial users can be retrieved in PowerSys application.



#### NOTE

After key reset operation, all created SNMPv3 users will be deleted from SNMP-USER-BASED-SM-MIB::usmUserTable MIB object.

The new working users have to be cloned again from the initial user template after key reset operation (see **Example: Create new user**).

The key reset operation is as follow:

- 1 - Open **SWT 3000 > Commands**
- 2 - Click the **Reset SNMPv3 key** button.

#### 6.2.3.5 Notification

##### Definition

A notification is a way for an agent to inform the SNMP Master Agent, e.g. Network Manager System (NMS) that some alarms occurred in the system.

Configure the notification in a SNMPv3 NMS client. The configuration is sent and stored in the SNMPv3 agent afterwards.

There are 2 types of notification:

- **SNMP Trap**  
Agent sends traps to NMS if an alarm event occurs. No acknowledgement is sent from NMS to the agent. So the agent has no possibility to know if the trap is received.
- **SNMP Inform**  
It is nothing more than an acknowledged trap. If the trap is not received and acknowledged by the NMS, the agent will retransmit it until timeout.

Depending on the configured SNMP version by PowerSys the notification is handled in different methods:

- **SNMPv1/2**  
Only SNMP Trap is supported, the function is the same as the former released version.  
Trap destination is configured through web pages or SNMP by setting private MIB object SIEMENS-SWT3000R35-MIB::swtIpSnmptTrapDestTable for **SWT 3000**.
- **SNMPv3**  
Both SNMP Trap and Inform are supported. The notification parameters including trap addresses are moved to standard MIB module SNMP-NOTIFICATION-MIB and SNMP-TARGET-MIB.  
All configurations must be done through SNMP set operation.

##### Example: Create Notification Entry through SNMP

This example shows the workflow of sending an SNMP Trap to 2 destinations through both SNMPv2c and SNMPv3 protocols using iReasoning MIB Browser.

- 1 - Create a new row in the table SNMP-NOTIFICATION-MIB::snmpNotifyTable.

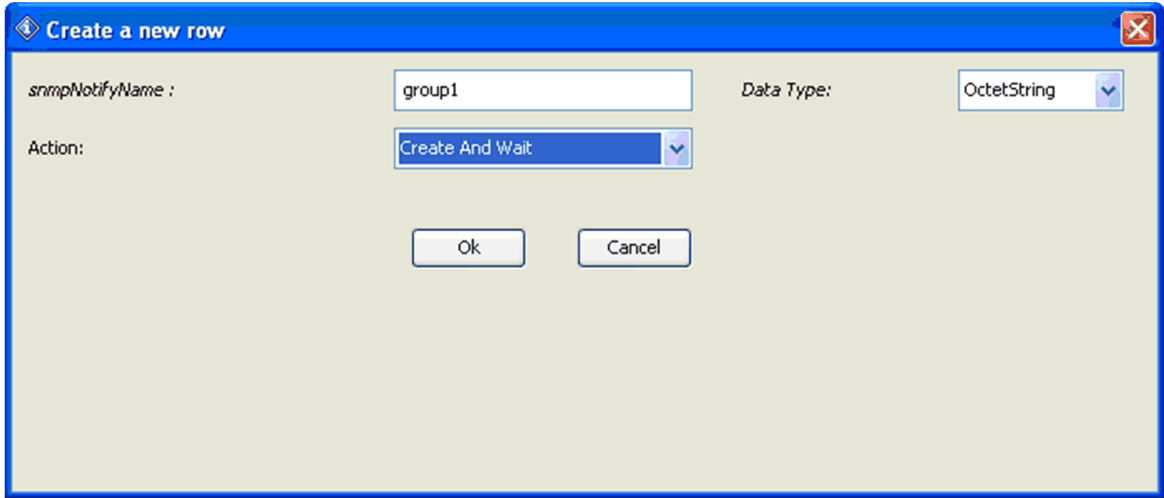

[scnewrow-140912-01.tif, 1, en\_US]

Figure 6-14 Create New Row in snmpNotifyTable

	snmpNotifyName	snmpNotifyTag	snmpNotifyType	snmpNotifyStorageType	snmpNotifyRowStatus
1	group1	group1	trap	3	1

[scnotify-140912-01.tif, 1, en\_US]

Figure 6-15 snmpNotifyTable List

Table 6-6 snmpNotifyTable Settings

Field	Value
snmpNotifyName	group1
snmpNotifyTag	group1
snmpNotifyType	trap(1)
snmpNotifyRowStatus	active(1)

- 2 - Create a new row in table SNMP-TARGET-MIB::snmpTargetParamsTable

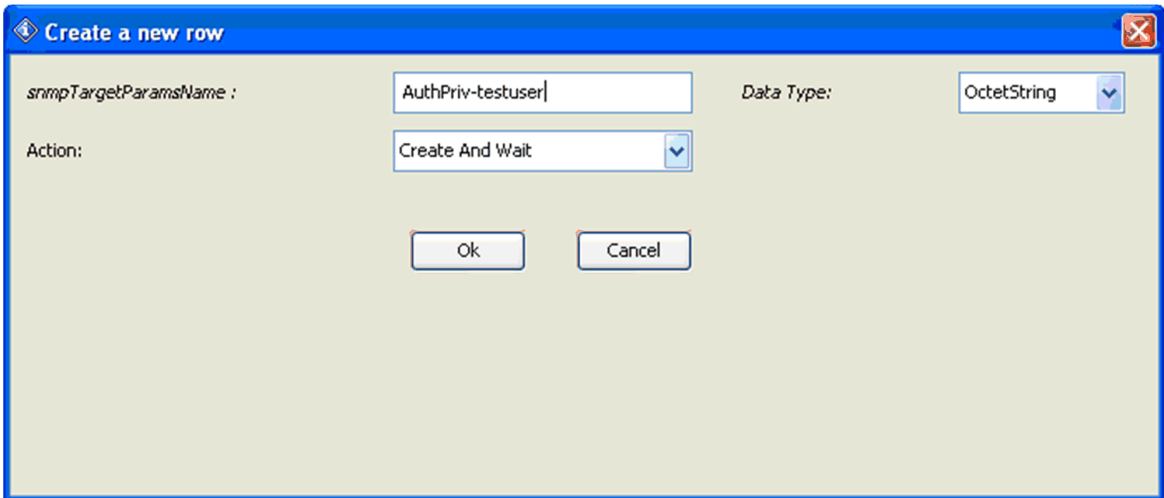

[scparame-140912-01.tif, 1, en\_US]

Figure 6-16 Create New Row in snmpTargetParamsTable

	snmpTargetPar...	snmpTargetParamsMPModel	snmpTargetParamsSecurityModel	snmpTargetParams...	snmpTarget...	snmpTargetPa...	snmpTargetParams...
1	AuthPriv-testuser	3	3	testuser	authPriv	3	1
2	NoAuthNoPriv	1	2	public	noAuthNoPriv	3	1

[scpartab-140912-01.tif, 1, en\_US]

Figure 6-17 snmpTargetParamsTable Settings

Table 6-7 snmpTargetParamsTable Settings

Field	Value
<b>Target Paramter 1</b>	
snmpTargetParamsMPModel	SNMPv3(3)
snmpTargetParamsSecurityModel	USM(3)
snmpTargetParamsSecurityName	testuser
snmpTargetParamsSecurityLevel	authPriv(3)
snmpTargetParamsRowStatus	active(1)
<b>Target Parameter 2</b>	
snmpTargetParamsMPModel	SNMPv2c(1)
snmpTargetParamsSecurityModel	SNMPv2c(2)
snmpTargetParamsSecurityName	public
snmpTargetParamsSecurityLevel	noAuthNoPriv(1)
snmpTargetParamsRowStatus	active(1)

- 3 - Create 2 new rows in table SNMP-TARGET-MIB::snmpTargetAddrTable

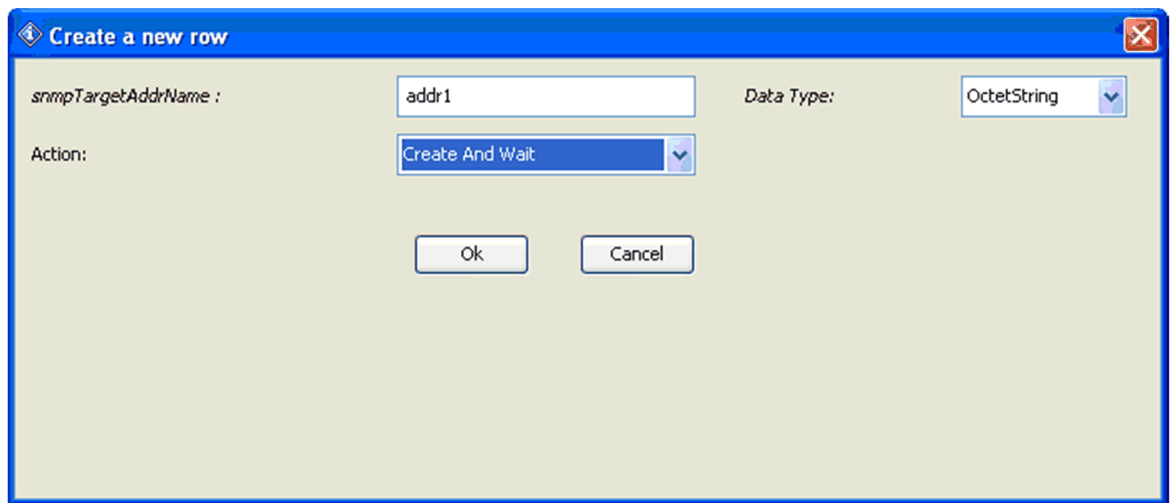

[scsnmpta-140912-01.tif, 1, en\_US]

Figure 6-18 Create New Row in snmpTargetAddrTable

	snmpTarget...	snmpTargetAddrTD...	snmpTargetAddrAd...	snmpTargetAd...	snmpTargetA...	snmpTargetAd...	snmpTargetAd...	snmpTargetAd...	
1	addr1	snmpUDPDomain	CO-A8-14-0A-00-A2	1500	3	group1	AuthPriv-testuser	3	1
2	addr2	snmpUDPDomain	CO-A8-14-0B-00-A2	1500	3	group1	NoAuthNoPriv	3	1

[scsnmpad-140912-01.tif, 1, en\_US]

Figure 6-19 snmpTargetAddrTable List

Table 6-8 snmpTargetAddrTable Settings

Field	Value
<b>Target Address 1</b>	
snmpTargetAddrName	addr1
snmpTargetAddrTDomain	snmpUDPDomain(.1.3.6.1.6.1.1)
snmpTargetAddrTAddress	192.168.20.10:162 (192.168.20.10:162)

Field	Value
snmpTargetAddrTagList	group1
snmpTargetAddrParams	AuthPriv-testuser
snmpTargetAddrRowStatus	active(1)
<b>Target Address 2</b>	
snmpTargetAddrName	addr2
snmpTargetAddrTDomain	snmpUDPDomain(.1.3.6.1.6.1.1)
snmpTargetAddrTAddress	192.168.20.11:162 (192.168.20.11:162)
snmpTargetAddrTagList	group1
snmpTargetAddrParams	NoAuthNoPriv
snmpTargetAddrRowStatus	active(1)

- 4 - Start trap receiver on target address "192.168.20.10" on port 162.
  - 5 - Start trap receiver on target address "192.168.20.11" on port 162.
- Configure following security parameters on the receiver:

User Name	Auth Protocol	Auth Password	Priv Protocol	Priv Password
testuser	MD5	testuser_auth	DES	testuser_priv

## 6.2.4 SNMP Configuration in SWT 3000 Web Interface

### 6.2.4.1 Overview

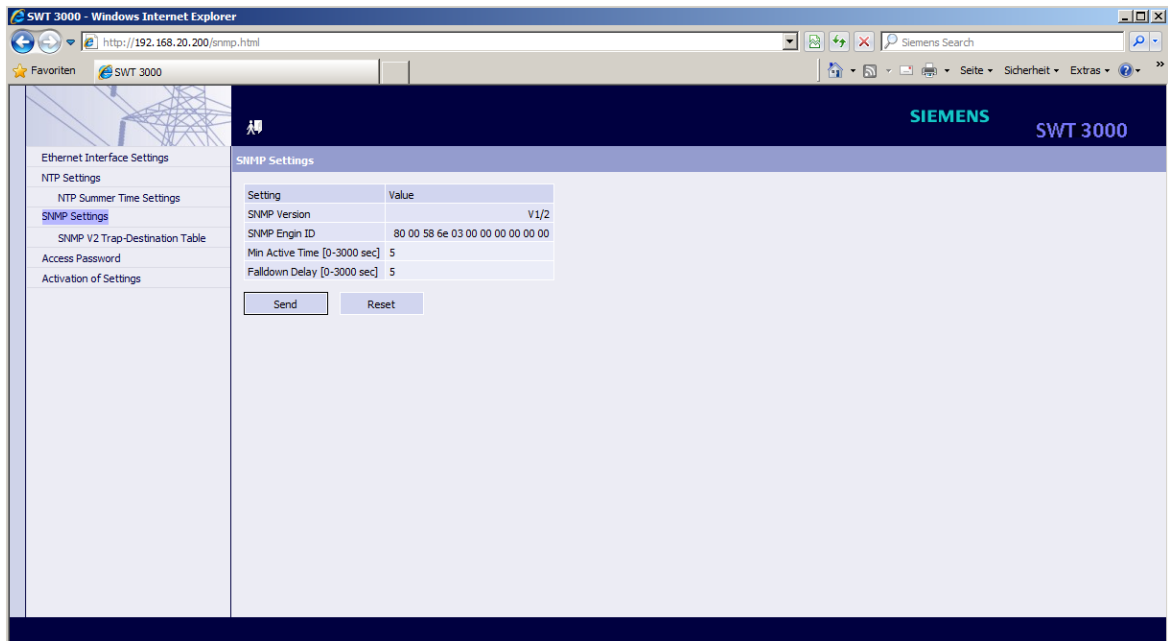

[scsnmset-300414-01, 1, en\_US]  
 Figure 6-20 SNMP Settings

Table 6-9 SNMP Settings

Settings	Defaults	Comments
SNMP Version	V1/2 or V3 or Disabled	Information about the SNMP version as configured by PowerSys program
SNMP Engine ID		Displays the unique identifier of SNMP engine. It contains following parts: <ul style="list-style-type: none"> <li>• Start bit : 0x8000</li> <li>• Enterprise OID: 0x586E</li> <li>• Indicator for identifier: 0x03</li> <li>• Identifier &lt;MAC address&gt;</li> </ul>
Min Active Time [0 - 3000 sec]	5	The <b>Min Active Time</b> (adjustable from 0 to 3000 s), is the minimum time that the alarm must be active before a rising trap is sent. This adjustment is used to prevent a sequence of events in case of cyclic alarm indications.
Falldown Delay [0 - 3000 sec]	5	The <b>Falldown Delay</b> (adjustable from 0 to 3000 s), is the minimum time that the alarm must be inactive before a falling trap is sent. This adjustment is used to prevent a sequence of events in case of cyclic alarm indications.
Send	-	Send the values to the PU4 module.
Reset	-	Reject the changes.

#### 6.2.4.2 SNMP V2 Trap-Destination Table

You can set up to 6 destinations. The SNMP traps are sent automatically to these addresses.

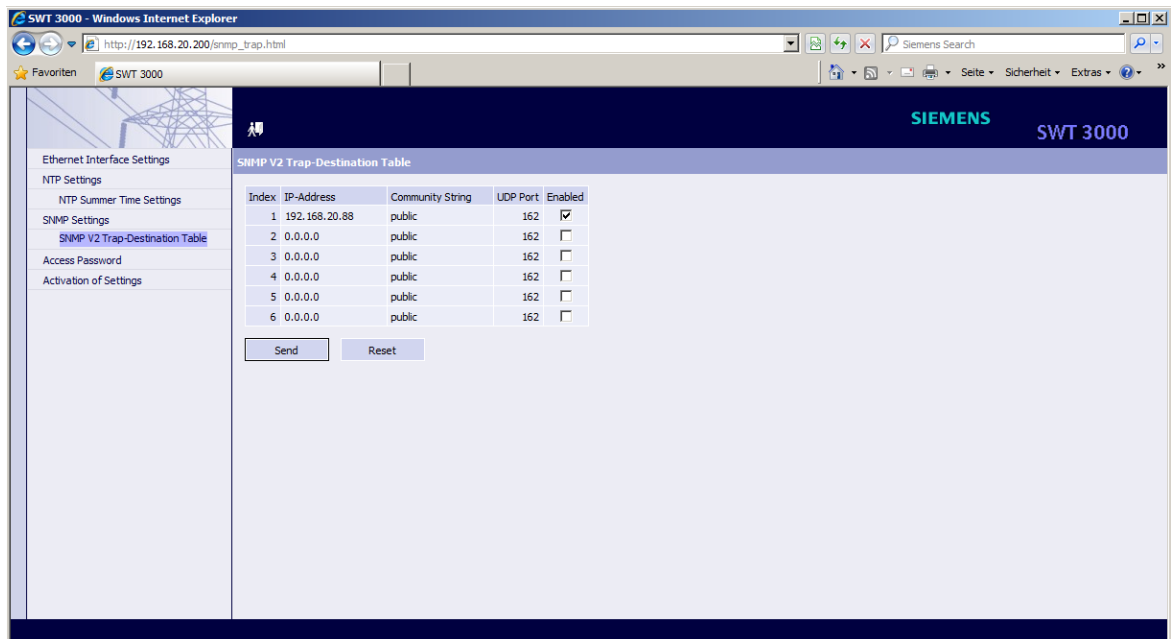

[scsnmtrp-300414-01, 1, en\_US]

Figure 6-21 SNMP V2 Trap-Destination Table

Table 6-10 SNMP V2 Trap-Destination Table

Settings	Comments
Index	1 to 6
IP-Address	IP address of trap destination (NMS)
Community String	Actual community string Must be identically with the community string in the NMS
UDP Port	Range: from 1024 to 65 535 <sup>11</sup> Default: 162 (well known port for traps) Must be identically with the number in the NMS
Enabled	On (☑) or off (☐) Default: off (☐)
Send	Send the values to the PU4 module.
Reset	Reject the changes.

The NMS addresses as well as the community string for SNMP **get** or **set** command must be adjusted via web logon and must match between the SNMP agent and the NMS.

### 6.2.4.3 Access Password

Within this menu, you can set the SNMP read-only and read-write community string. The read-write community string can also be used as the password for web login.

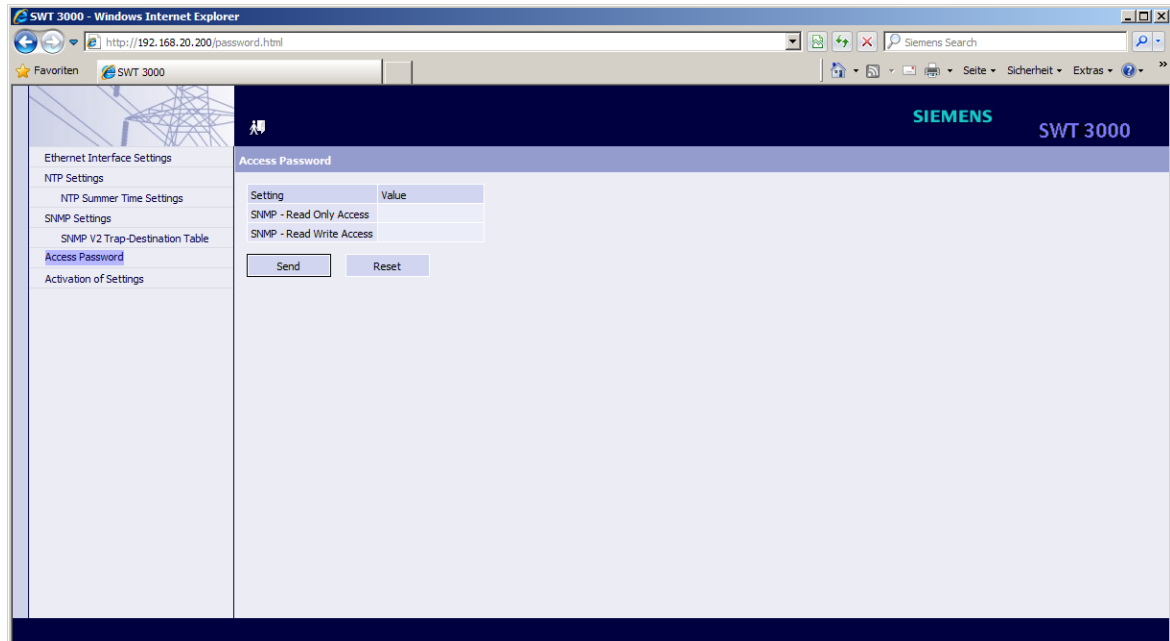

[scaccpas-300414-01, 1, en\_US]

Figure 6-22 Access Password

<sup>11</sup> Range for UDP Port: 0 to 65 535, but well known ports up to 1023 must not be used. Exception for SNMP: Port 161: get and set, Port 162: traps

Table 6-11 Access Password

Settings	Comments
SNMP - Read Only Access	<p>The read community, write community, and trap community must meet the following criteria:</p> <ul style="list-style-type: none"> <li>English uppercase characters (from A to Z)</li> <li>English lowercase characters (from a to z)</li> <li>Numerals (from 0 to 9)</li> </ul> <p>A mixture of characters and numerals is permitted. Character string: maximum 10 characters Default: <b>swtread</b> Must be identically with the community string in the NMS</p>
SNMP - Read Write Access	<p>The read community, write community, and trap community must meet the following criteria:</p> <ul style="list-style-type: none"> <li>English uppercase characters (from A to Z)</li> <li>English lowercase characters (from a to z)</li> <li>Numerals (from 0 to 9)</li> </ul> <p>A mixture of characters and numerals is permitted. Character string: maximum 10 characters Default: <b>swtwrite</b> Must be identically with the community string in the NMS</p>
Send	Send the values to the PU4 module.
Reset	Reject the changes.

#### 6.2.4.4 Activation of Settings

Within this menu, you can program all the settings to the flash of SWT 3000. Programming the device causes a reset of SWT 3000.

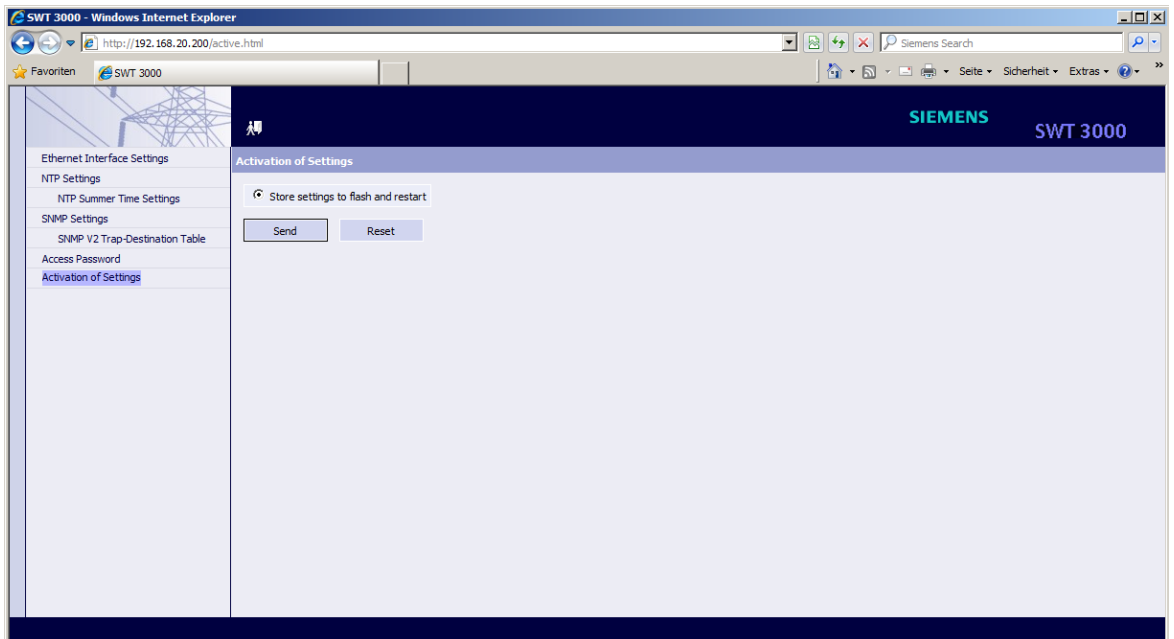

[scactset-300414-01, 1, en\_US]

Figure 6-23 Activation of Settings

Table 6-12 Activation of Settings

Settings	Comments
Store settings to flash and restart	Save all actual settings in the PU4 module and restart the PU4 module.
Send	Send the values to the PU4 module.
Reset	Reject the changes.

## 6.2.5 NMS Commissioning

The necessary MIBs are available within the PowerSys package provided with the SWT 3000 system. They must be integrated in the NMS. After the NMS has been configured, traps from the SNMP agent are received. It is also possible to read the general information and configuration of the SWT 3000 system (refer to [6.2.1 SNMP Function](#)).

Commands and IP configuration can also be set from the NMS (refer to [SWT 3000 Set Commands, Page 264](#) and [SWT 3000 Set IP Configuration, Page 264](#)).

If SWT 3000 as well as PowerLink devices are managed by the NMS, it is proposed to import the provided MIB files to the MIB compiler of your NMS in the following sequence:

- 1. SIEMENS-POWERLINK-CSPI.MIB
- 2. SIEMENS-POWERLINK-CSPI-IPCON.MIB
- 3. SIEMENS-POWERLINK-CSPI-VMUX.MIB
- 4. SIEMENS-POWERLINK-CSPI-ISWT3000R3\_5.MIB
- 5. SIEMENS-SWT3000R35.MIB



## 6.3 Remote Access

### 6.3.1 General Information

#### 6.3.1.1 Overview

The TCP/IP connection via Intranet as well as a RAS connection serves complete system functionality administration identical to local on-site operation. Standard TCP/IP network protocols are used for easy access to each SWT 3000 from anywhere within a company Intranet. The system can interface with your own network security systems and firewalls, providing you with just the right security level your company requires.

The remote access to the SWT 3000 is possible with the service program PowerSys. With menu **Connection setup**, the connection to the device via TCP/IP must be configured.

For a TCP/IP connection, select TCP/IP.

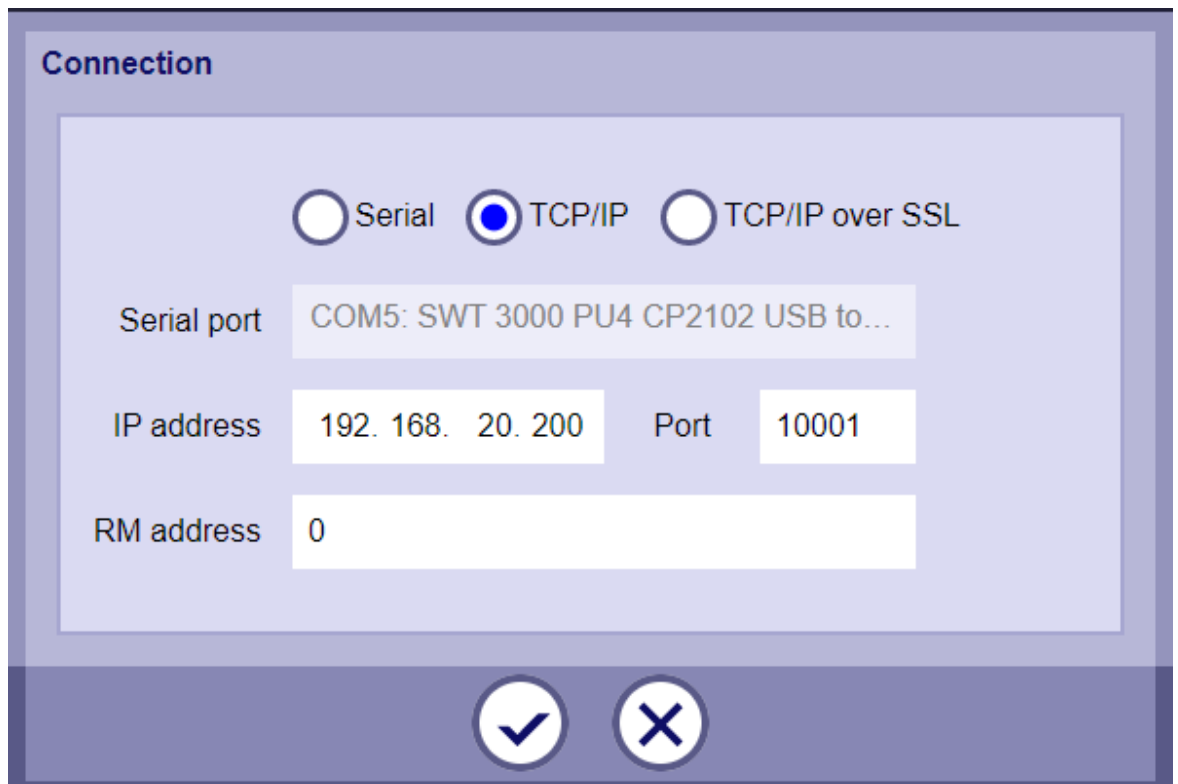

[sc\_connection\_tcpip\_1, 1, 1]

Figure 6-24 Configuration Example for the TCP/IP Connection

Enter the IP address and port of the RAS or SWT 3000 device.

For the PowerSys connection, select **Connect to device**

#### 6.3.1.2 Remote Access Example

The following figure shows a TCP/IP connection to the SWT 3000 device in station A and B. If the RM function is activated, information from the SWT 3000 device in station C can be read via inband RM-Channel.

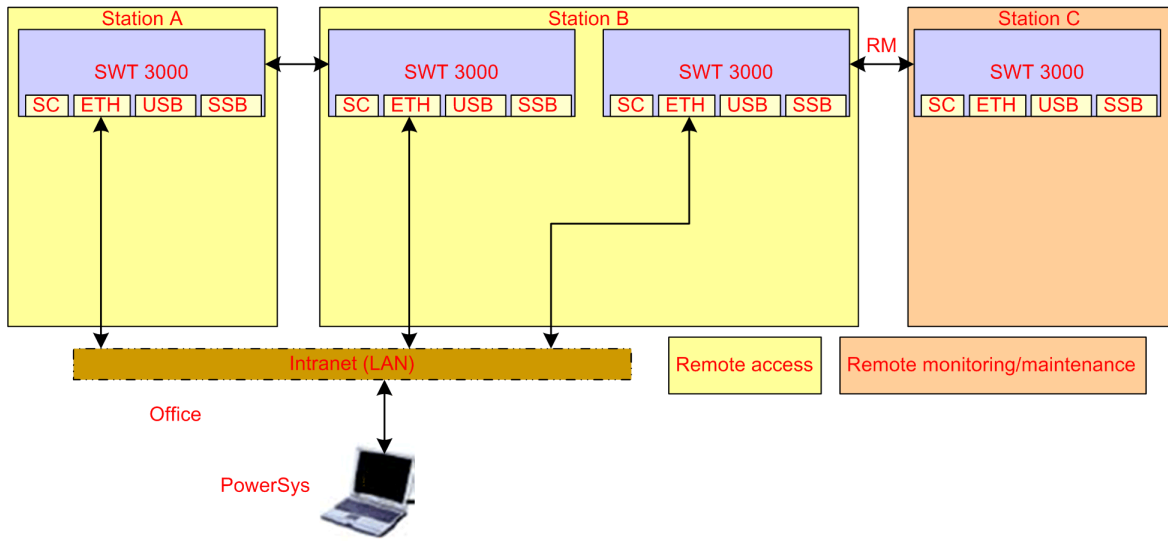

[dwitcpipc-080611-01.tif, 1, en\_US]

Figure 6-25 TCP/IP Connection to the SWT 3000 Devices in the Station A and B and Remote Access to the Station C via Inband RM-Channel

- ↔ Protection signal transmission path
- SC Service channel
- ETH Ethernet interface (TCP/IP)
- USB Local interface
- SSB Remote monitoring interface
- RM Inband RM-Channel

### 6.3.2 Inband RM-Channel

If there are no intranet or modems available, you can still monitor or configure remote terminals using the inband RM-Channel. With the optional service Remote Monitoring (RM), data can be transmitted between the devices of one or more SWT 3000 routes.

The RM function enables the user to have access via a USB or TCP/IP connection with the service program to the following function:

- Query of the device data (configuration, parameter, and status) of the remote device
- Temporary adjustments (for example, test loops)
- Producing a reset

Changing of the configuration and parameter (except date or time of the SWT 3000 device) in the remote device is possible if the configuration via inband RM-Channel is activated:

**RM**

Remote maintenance

Device address

Interface RM

Interface SSB

Config. via inband RM-Channel:yes/no

[sc\_inband\_rm\_channel, 1, --]

Figure 6-26 Configuration via Inband RM-Channel

### 6.3.3 Route Coupling via SSB

Via an additional interface (SSB), up to 5 transmission routes can be coupled.

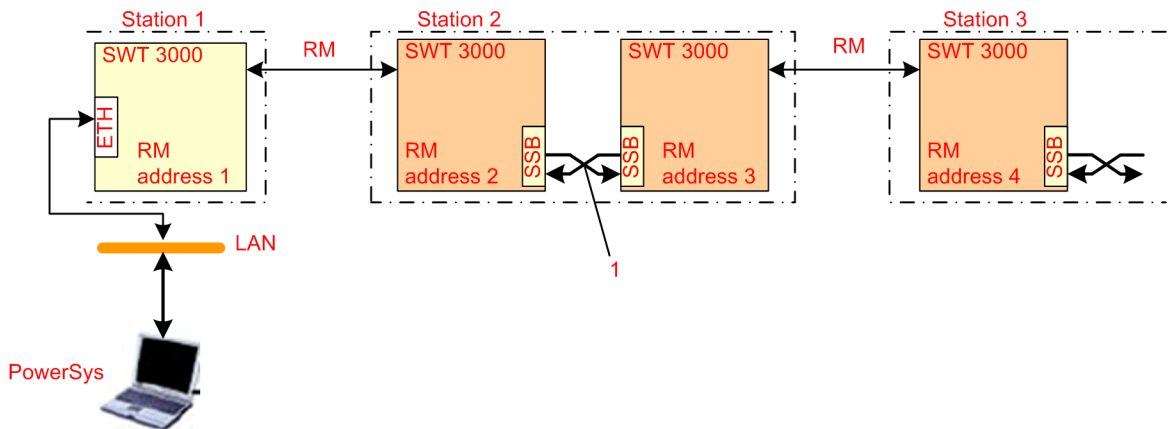

[dwroutco-080611-01.tif, 1, en\_US]

Figure 6-27 Example of a Route Coupling with the RM Function

- 1 Coupling of 2 SWT 3000 routes
- ↔ Protection signal transmission path
- ETH Ethernet interface (TCP/IP)
- SSB Remote monitoring interface
- RM Inband RM-Channel

**If Service PC is connected to distant SWT 3000 (address 2, 3 or 4)**

Activation of an SSB data transmission from another SWT 3000 is possible without influencing the service PC connection at the Ethernet (ETH) or local (USB) interface. Because the SSB connection is the second one, only read permission is available, while the first connection (service PC) has read and write access.

**If RM data transmission is active in distant SWT 3000 via SSB (address 3 or 4)**

Connection of the service PC to the Ethernet (ETH) or local (USB) interface does not block the SSB transmission. Because the connection is the second one, only read permission is available, while the first connection (SSB) has read and write access (if configured).

The SSB interface of the SWT 3000 system has the same characteristics as the RM-2 interface of the PowerLink systems.

The following figure shows the remote connection to the SWT 3000 in station A via TCP/IP connection. The access to the SWT 3000 devices in station B and C is possible when the inband RM-Channel is activated.

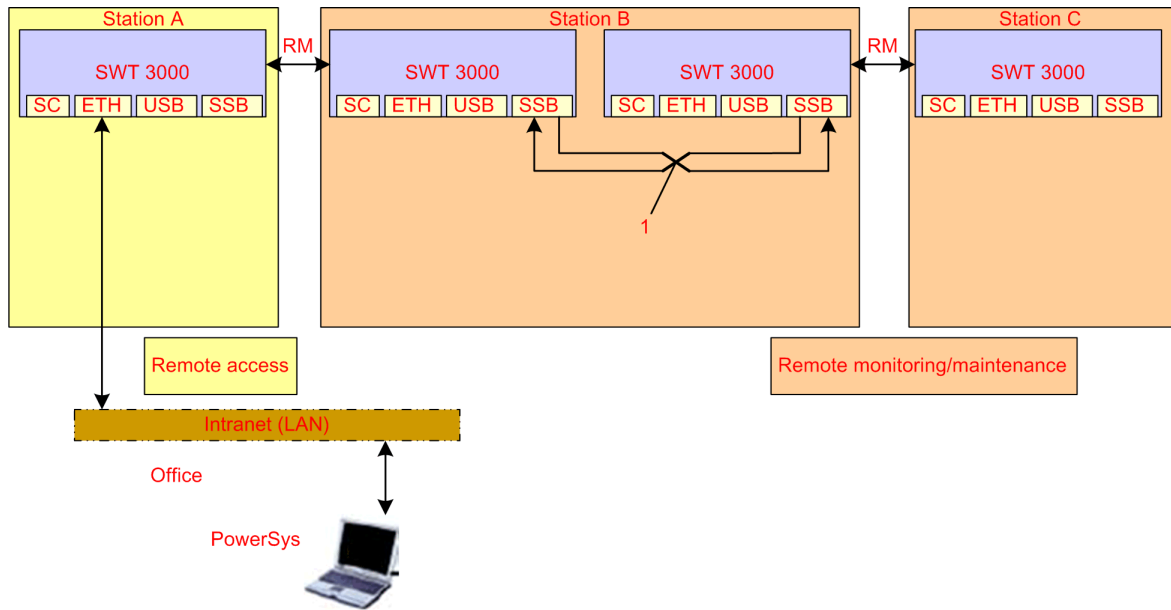

[dlw\_SWT\_conrmf\_1\_en\_US]

Figure 6-28 Connection to SWT 3000 in Station B and C with the RM Function

- 1 Master and slave connection with crossed cable
- ↔ Protection signal transmission path
- SC Service channel
- ETH Ethernet interface (TCP/IP)
- USB Local interface
- SSB Remote monitoring interface
- RM Inband RM-Channel

Use a crossed cable for the SSB to SSB connection in station B (refer to [3.2.7 Pinout of the SSB interface](#)).  
 Configure one of the SSB interfaces as **Slave** and the other one as **Master**.  
 For the service program PowerSys connection, select **Connect to device using RM**.

## 6.4 Web Interface

### 6.4.1 Overview

You can access the Web server via the front Ethernet interface of PU4 module.

Start the Web browser (for example Internet Explorer) and enter `http://192.168.20.200`. You can also change the default IP address `192.168.20.200`.

Log on with the password **swtwrite** (you can change the default password) and click **Send** in the SWT 3000 Web interface dialog.



#### NOTE

For security reasons it is recommended to enable a safe https-connection for the access to the Web interface or to disable the Web server access via the service program PowerSys in configuration menu **SWT 3000 > Configuration > Ethernet configuration > IP Configuration**.

For details, please refer to the chapters [3.5.10 IP Network Configuration](#).

Without knowing the password, access to the SWT 3000 Web interface is not possible. You can restore the default password after clicking on **Clear CDB** in PowerSys commands dialog.

Change the default password via:

- Web server in the **Access Password** page or
- SNMP

The default IP address of the device is `192.168.20.200`.

Change the default IP address via:

- Web server in the **Ethernet Interface Settings** page or
- SNMP

You can only read the password and IP address via:

- **SNMP Agent** dialog in PowerSys **SWT 3000 > Configuration > Ethernet configuration > IP Configuration**.
- **IP Configuration** dialog in PowerSys **SWT 3000 > Configuration > Ethernet configuration > IP Configuration**.

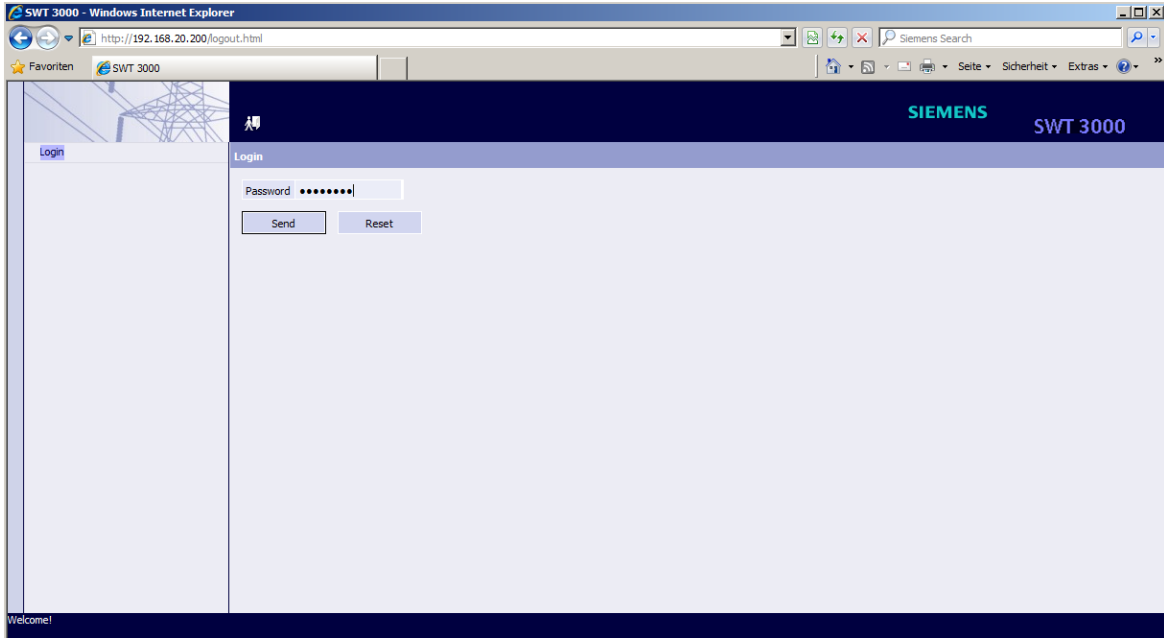

[scwebser-300414-01, 1, en\_US]  
 Figure 6-29 Start Page of SWT 3000 Web interface

### 6.4.2 Ethernet Interface Settings

The Ethernet interface is used for:

- The communication between the NMS and SWT 3000
- Remote PowerSys session

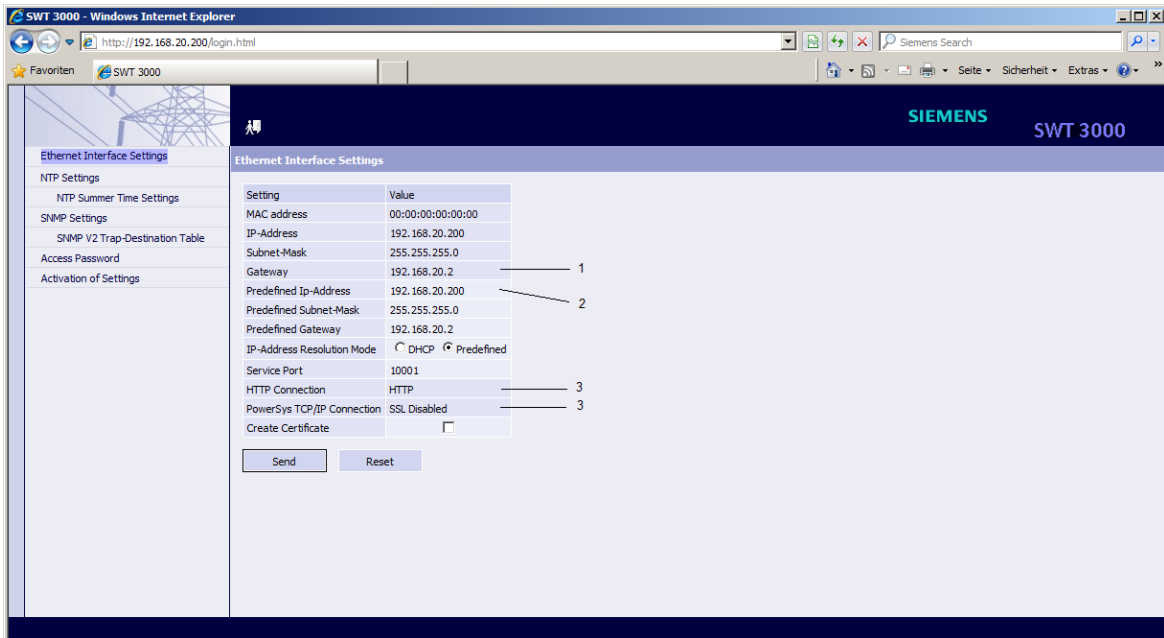

[scethset-300414-01, 1, en\_US]  
 Figure 6-30 Ethernet Interface Settings

- (1) You can not change the fields with the dark blue color.
- (2) You can change the fields with the light blue color.
- (3) Fields have to be activated in PowerSys program

Table 6-13 Ethernet Interface Settings

Settings	Comments
MAC address	Actual MAC address of the PU4 Ethernet interface
IP-Address	Actual IP address of the PU4 Ethernet interface
Subnet-Mask	Actual Subnet Mask
Gateway	Actual gateway
Predefined IP-Address	User defined IP address
Predefined Subnet-Mask	User defined subnet mask
Predefined Gateway	User defined gateway
IP-Address Resolution Mode <ul style="list-style-type: none"> <li>• DHCP</li> <li>• Predefined</li> </ul>	<ul style="list-style-type: none"> <li>• Ethernet interface is connected to a DHCP server and expects an IP address.</li> <li>• IP address and subnet mask and gateway address for the Ethernet interface defined by the user.</li> </ul> <p>The values given in the fields <b>Predefined</b> are written to the PU4 module after clicking the <b>SEND</b> button in the <b>Activation of Settings</b> page. After restart of SWT 3000, this user given values are valid as actual IP address and subnet mask.</p>
Service Port	RAS port number
HTTP Connection	Read-only field, displays the connection option to the Web interface as <b>configured by PowerSys program</b> : http / https or disabled
PowerSys TCP/IP Connection	Read-only field, displays the TCP/IP connection option for PowerSys as <b>configured by PowerSys program</b> : ssl encryption or no ssl encryption
Create Certificate	Option to create a Trusted Certificate for Secure Connection.
Send	Send the values to the PU4 module.
Reset	Reject the changes.

**NOTE**

The default IP address of the device is 192.168.20.200.  
You can change the default IP address via:

- Web server in the **Ethernet Interface Settings** page
- SNMP

### 6.4.3 NTP Settings

Network Time Protocol (NTP) is a networking protocol to synchronize the clock between an NTP server and a SWT 3000 device.

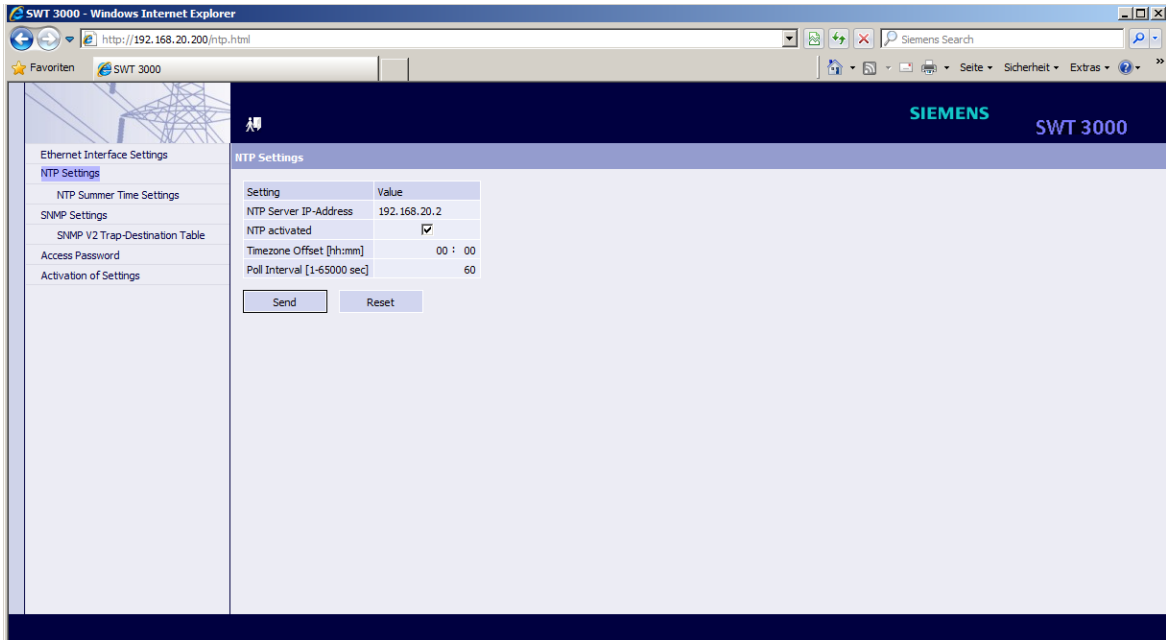

[scnrtpsset-300414-01, 1, en\_US]

Figure 6-31 NTP Settings

Table 6-14 NTP Settings

Settings	Comments
NTP Server IP-Address	Actual Network Time Protocol (NTP) server. The NTP server is the PC in the network providing the time. Enter either the IP address or the Internet address.
NTP activated	Activation of the NTP (NTP activated check box <b>on</b> <input checked="" type="checkbox"/> ) offers the possibility to synchronize the time of the SWT 3000 via NTP protocol. Default: NTP activated check box <b>off</b> ( <input type="checkbox"/> )
Timezone Offset [hh:mm]	The time zone is always the GMT. Select the local deviation (up to ±12 h).
Poll Interval [1-65000 sec]	The poll interval describes how often the time is read from the NTP server.
Send	Send the values to the PU4 module.
Reset	Reject the changes.

The **NTP Server IP-Address** must be set according to the customers network.

### 6.4.4 NTP Daylight Saving Time

Network Time Protocol (NTP) is a networking protocol to synchronize the clock between an NTP server and a SWT 3000 device. No information of time zone or daylight saving time (summer time) is provided by NTP, which has to be configured manually using the Web server or SNMP SET command.

The Universal Time Coordinated (UTC) received from the NTP server will be adjusted with the setting of local time zone or daylight saving time.



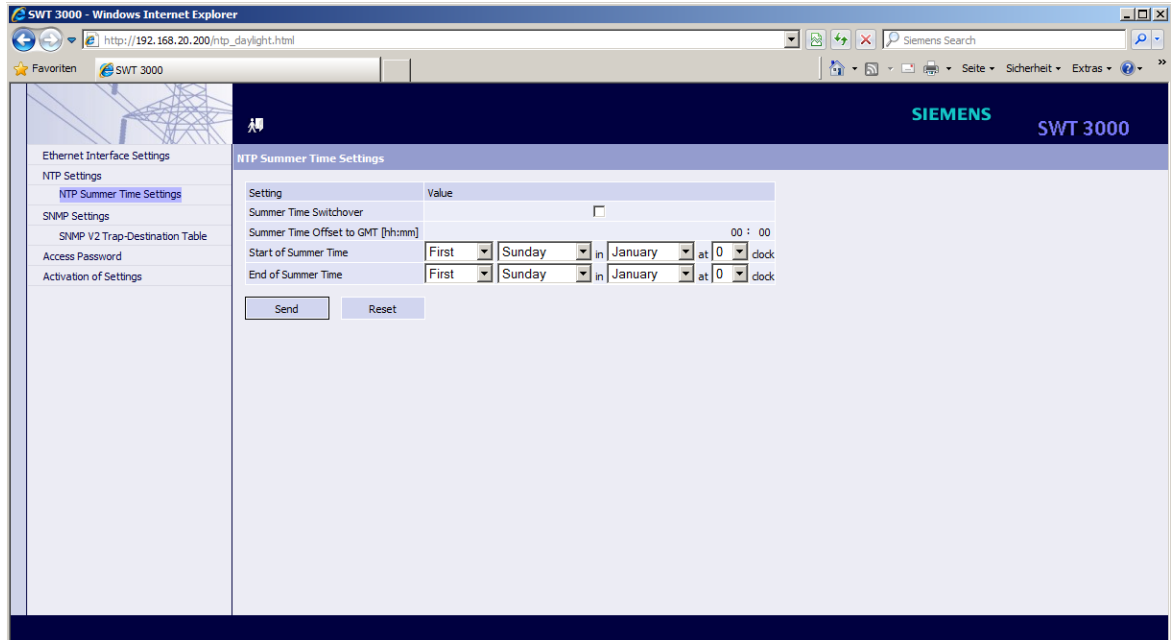

[sctdaylig-300414-01, 1, en\_US]

Figure 6-32 SWT 3000 NTP Daylight Saving Time Setting using the Web Server

Settings	Comments
Summer Time Switchover	This enables daylight saving time switchover, it is only relevant for NTP. If it is enabled, you have to configure the summer time offset, the begin and the end of summer time also.
Summer Time Offset to GMT [hh:mm]	Daylight saving time offset to GMT (Greenwich Mean Time). The possible range of value: -12:00 to 12:00
Start of Summer Time	Define daylight saving start time
End of Summer Time	Define daylight saving end time

### 6.4.5 SNMP Settings

For configuration of the SNMP settings in the Web server, refer to chapter [6.2.1 SNMP Function](#) and following.

### 6.4.6 Access Password

Within this menu, you can set the SNMP read-only and read-write community string. The read-write community string can also be used as the password for web login.

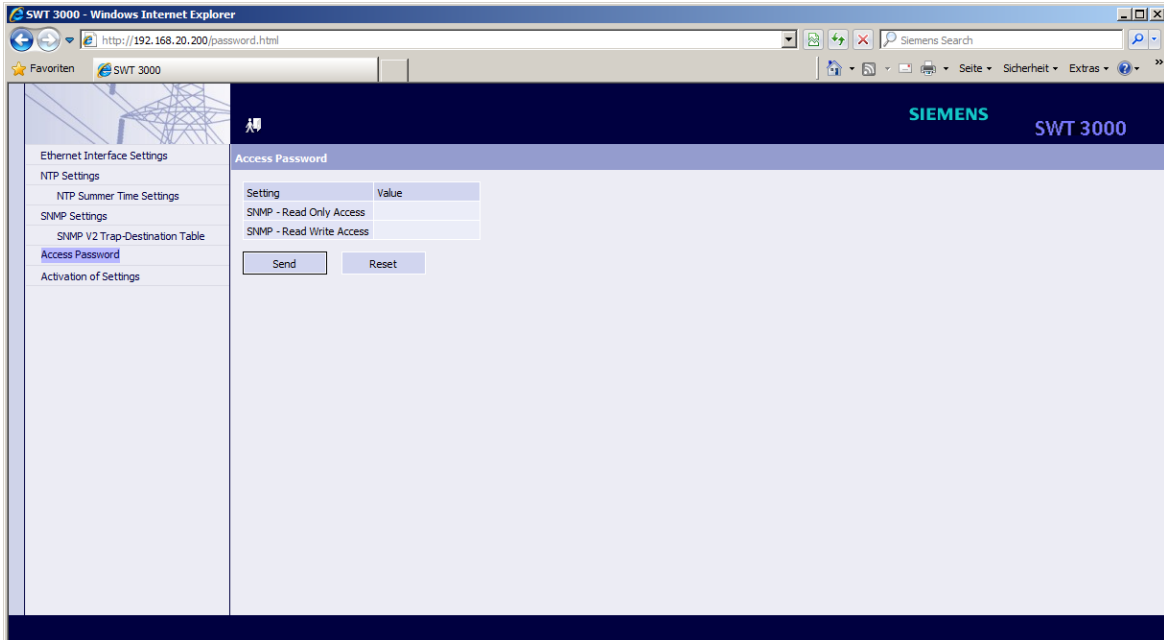

[scaccpas-300414-01, 1, en, US]

Figure 6-33 Access Password

Table 6-15 Access Password

Settings	Comments
SNMP - Read Only Access	<p>The read community, write community, and trap community must meet the following criteria:</p> <ul style="list-style-type: none"> <li>English uppercase characters (from A to Z)</li> <li>English lowercase characters (from a to z)</li> <li>Numerals (from 0 to 9)</li> </ul> <p>A mixture of characters and numerals is permitted.                      Character string: maximum 10 characters                      Default: <b>swtread</b>                      Must be identically with the community string in the NMS</p>
SNMP - Read Write Access	<p>The read community, write community, and trap community must meet the following criteria:</p> <ul style="list-style-type: none"> <li>English uppercase characters (from A to Z)</li> <li>English lowercase characters (from a to z)</li> <li>Numerals (from 0 to 9)</li> </ul> <p>A mixture of characters and numerals is permitted.                      Character string: maximum 10 characters                      Default: <b>swtwrite</b>                      Must be identically with the community string in the NMS</p>
Send	Send the values to the PU4 module.
Reset	Reject the changes.

## 6.4.7 Activation of Settings

Within this menu, you can program all the settings to the flash of SWT 3000. Programming the device causes a reset of SWT 3000.

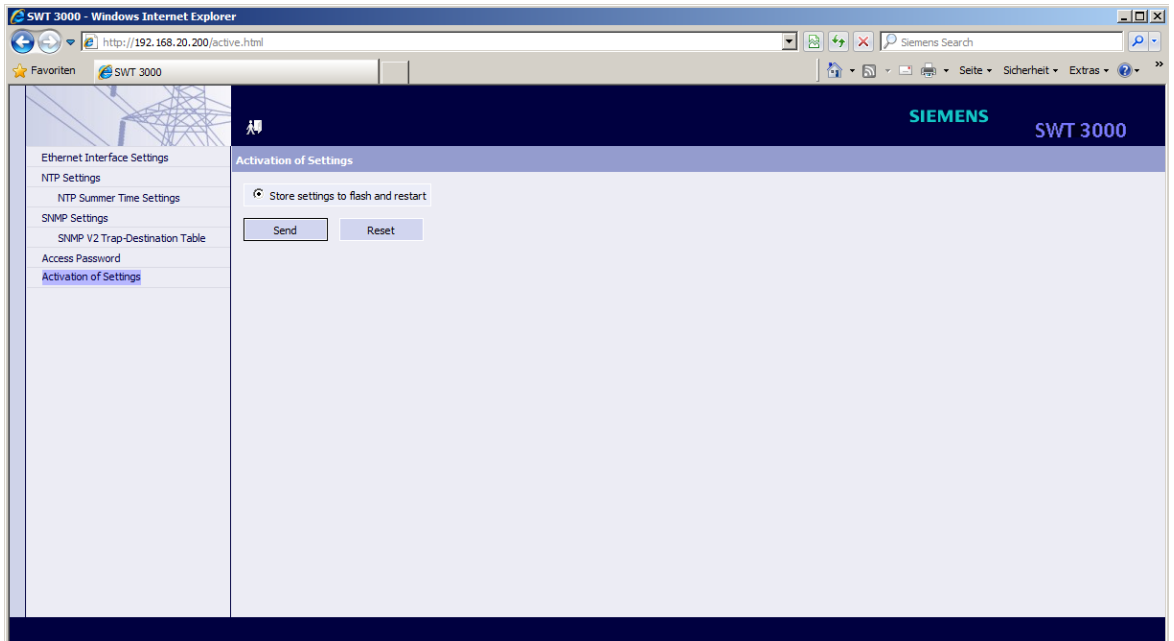

[sactset-300414-01, 1, en\_US]

Figure 6-34 Activation of Settings

Table 6-16 Activation of Settings

Settings	Comments
Store settings to flash and restart	Save all actual settings in the PU4 module and restart the PU4 module.
Send	Send the values to the PU4 module.
Reset	Reject the changes.



# 7 Processing Unit Module

---

7.1	Functions of the PU4 module	294
-----	-----------------------------	-----

---

## 7.1 Functions of the PU4 module

### 7.1.1 Overview

The Processing Unit PU4 is the central control module of the SWT 3000 unit.

The protection commands are received via an interface module IFC-D or IFC-P and/or an EN100 module.

**At the transmit side**, PU4 converts protection commands or commands at digital transmission lines into one of the following cases:

- Tones of a defined frequency
- A digital code in case of digital transmission

If the PU4 is housed in a stand-alone SWT 3000 unit, the commands are transmitted to the remote station by:

- analog transmission via CLE and/or
- digital transmission via the Digital Line Interfaces (LID) and/or
- digital transmission via fiber-optic module (FOM)

It is also possible to transmit commands of a stand-alone SWT 3000 unit via a PowerLink PLC system by:

- connecting the CLE with a VFX- Interface of the PowerLink or
- a fiber-optic connection with FOM modules in SWT 3000 and PowerLink

The PU4 of an integrated (i)SWT 3000 unit in a PowerLink PLC system is processing the commands via the CSPI for transmission via the high voltage line of the PLC link. Optionally a digital transmission via the LID- Interface is possible with additional digital transmission lines, e.g. for a secondary transmission path.

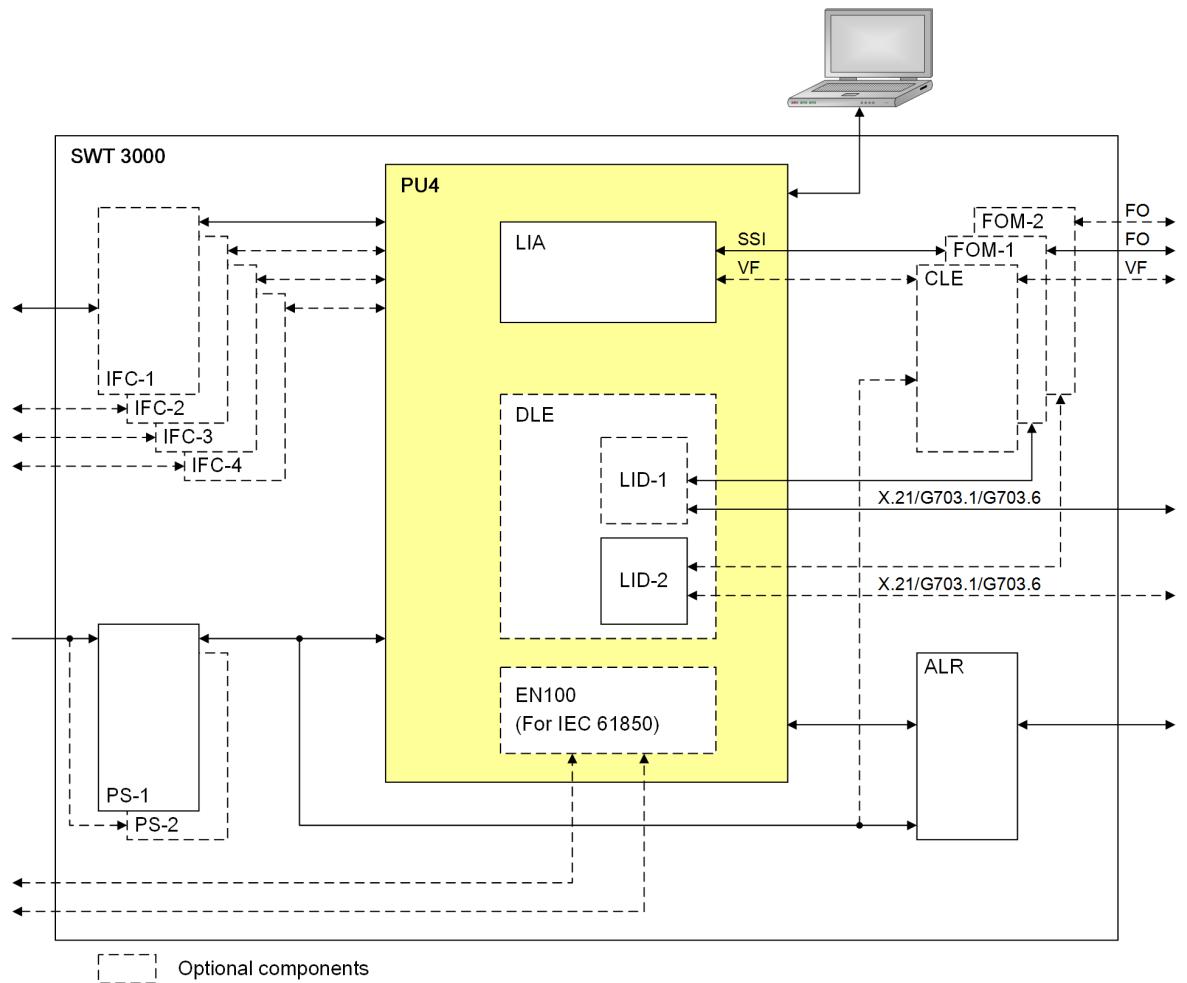

[dw\_block\_diagram\_sw3000\_1\_en\_US]

Figure 7-1 Block Diagram of the SWT 3000 Unit

IFC	Interface command module
PS	Power supply
PU4	Processing unit module
LIA	Analog line interface
DLE	Digital line equipment
LID	Digital line interface
EN100	Ethernet EN100 module for IEC 61850
FOM	Fiber-optic module
CLE	Copper line equipment
ALR	Alarm module
SSI	Serial synchronous interface
VF	Voice frequency
FO	Fiber-optic connection

A DLE submodule can optionally expand the PU4 module for digital transmission paths accommodating the 2 digital line interfaces LID-1 and LID-2. These interfaces are used for transmitting the protection commands via a digital network (SDH/PDH). They can also be directly connected without network. You can also connect the LID to a multiplexer system via a FOM module.

If the PU4 and the IFC modules are integrated in the PowerLink unit, the frequencies are forwarded directly to the CSPI module via the SSI interface without D/A - A/D conversion.

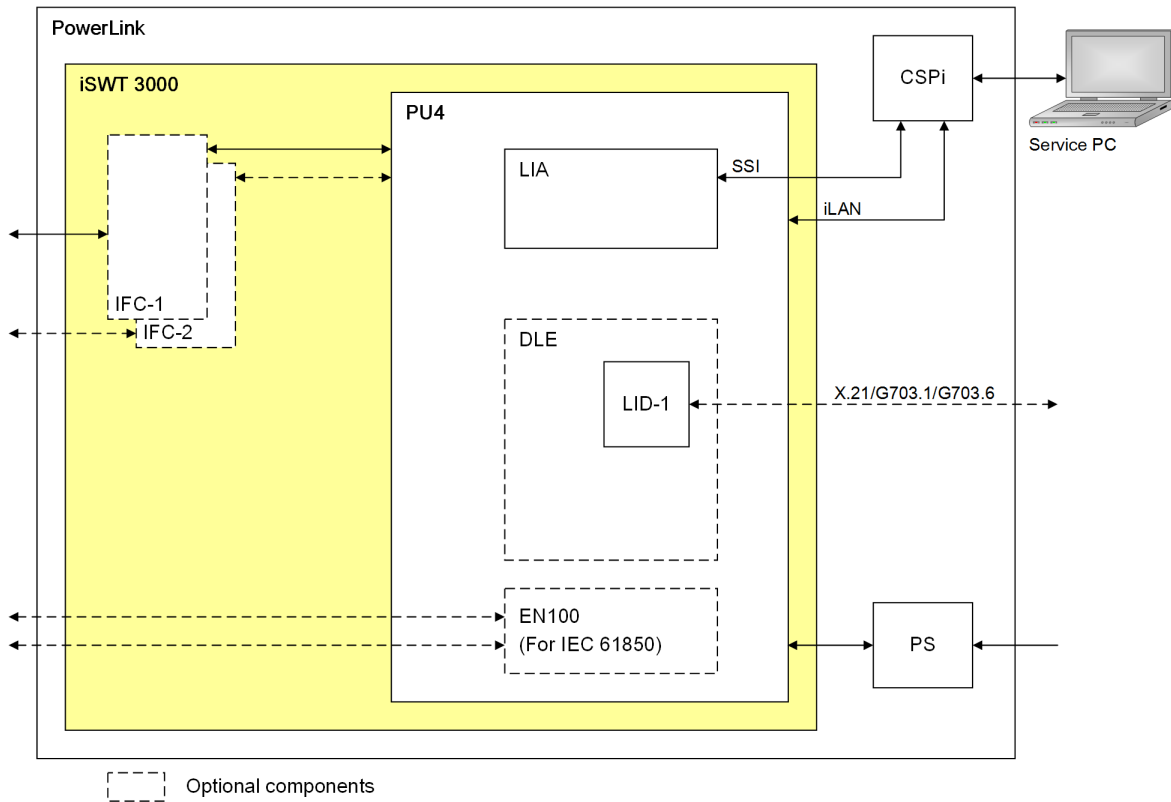

[dw\_block\_diagram\_iSWT\_1\_en\_US]

Figure 7-2 Block Diagram of the SWT 3000 Unit Integrated in the PowerLink

IFC	Interface command module
PU4	Processing unit module
LIA	Analog line interface
DLE	Digital line equipment
LID	Digital line interface
EN100	Ethernet EN100 module for IEC 61850
SSI	Serial synchronous interface
iLAN	Internal LAN
CSPi	Central signal processing unit
PS	Power supply

**At the receive side**, the incoming commands are received in the VF range or digital depending on the operating mode.

These commands are converted into one of the following cases:

- Binary protection commands, and forwarded to the IFC-D/P module for command output.
- GOOSE command and forwarded to EN100 module for command output

Apart from coding and decoding of protection commands, the PU4 also performs various **monitoring functions**.

For example, the receive and transmit levels are fed via measuring points to the PU4 where they are compared with the permissible values. If these levels are not reached, the PU4 activates an alarm. In the normal situation, that is, if there is no protection command transmitted, the guard signal is sent to the remote station.

Loss of a wanted signal (command or guard tone) triggers a receive alarm at the receive side and causes the relay outputs of the device to block. This alarm state can only be canceled by receiving the guard signal again.



When the unit is started, a self-test is carried out. A watchdog also monitors the functionality of the internal Digital Signal Processor (DSP). If there are failures, the transmitter output and the relay outputs of the unit are blocked. An overview of the functional units of the PU4 is shown in the following diagram:

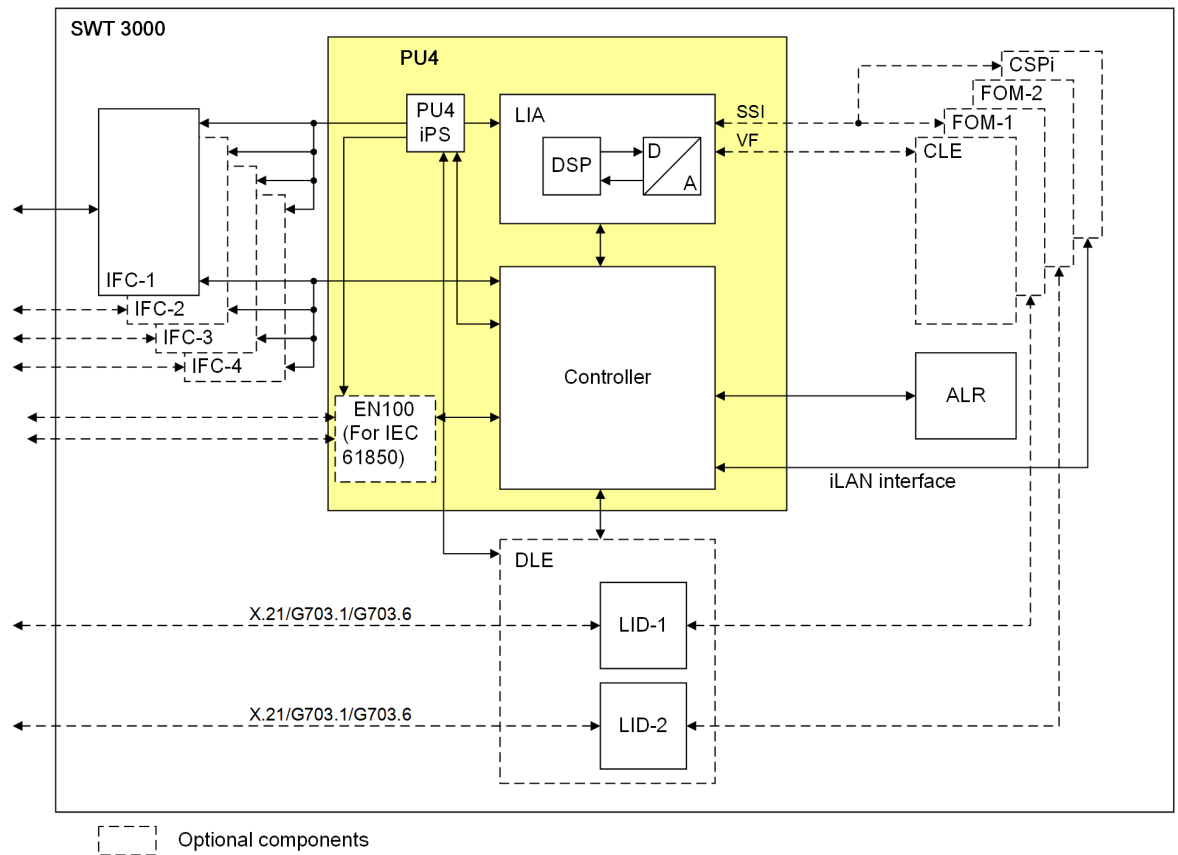

[dw\_functional\_units\_PU4\_1\_en\_US]

Figure 7-3 Functional Units of the PU4 Module

IFC	Interface command module
PU4 iPS	Internal power supply of the processing unit module
PU4	Processing unit module
LIA	Analog line interface
DSP	Digital signal processor
DLE	Digital line equipment
LID	Digital line interface
EN100	Ethernet EN100 module for IEC 61850
FOM	Fiber-optic module
CLE	Copper line equipment
ALR	Alarm module
CSPI	Central signal processing unit
SSI	Serial synchronous interface
VF	Voice frequency

## 7.1.2 Functional Units

The PU4 module consists of the following functional units:

- Internal power supply
- Controller
- Analog line interfaces with digital signal processor
- Digital line equipment, which intercommunicates via an interface
- Ethernet EN100 module (optional)

## 7.1.3 Internal Power Supply

The internal power supply generates the voltages needed on the module that are not fed externally:

- Supply voltages for the analog line interface
- Switched 12 V supply voltage for the relays on the IFC modules

The 12 V operating voltage for the IFC modules can be switched from the controller and allows selective disabling of the output relays. The operating voltages on the module are monitored. Loss of a voltage generates a reset and an alarm on the module.

## 7.1.4 Controller

The controller is the central element of the PU4. It controls communication with the analog line interface, the digital line unit, the local (service) interface for the service PC, the LAN, and the alarm interface. You can load equipment variants and user data via the local interface or via the iLAN interface. The service program PowerSys is responsible for the administration of the possible equipment variants for the DSP.

The controller carries out the entire administration of memory space. Available RAM/PROM:

- NV-RAM for event recorder
- SRAM for working memory
- FEPROM for program memory

The controller also implements the data exchange in the transmit and receive direction with the interface module IFC-D/P and IFC-S. The controller reads the data from the IFC module, which is fed via an input buffer into a register. The controller writes the data relating to the IFC module also into this register per interrupt. The data reaches the IFC module via an output buffer.

If an error is detected in the SWT 3000 unit, a message to this effect is output via an interface to the alarm module ALR. If the PU4 is used in PowerLink, the alarms are forwarded to the CSPi and the alarm is output on the ALR module of PowerLink.

## 7.1.5 Analog Line Interface

The LIA sets up the connection of the module to the analog protection command transmission and consists of a DSP, operational amplifiers, and analog switches.

DSP generates the necessary command frequencies and communicates with the transmission interfaces. Depending on the equipment variant, these transmission interfaces are the interfaces to the Intermediate Frequency (IF) modules or to the CLE.

All necessary information is loaded with the equipment variant via the service program. The controller writes the information into the DSP via an interface. During operation, this interface is used to transmit protection commands and parameters. The controller can read and write DSP memory cells, and can also transfer commands and trigger various interrupts.

The controller triggers an interrupt in the DSP for the transmission of outgoing protection commands. For the receiving of incoming protection commands, the DSP triggers an interrupt in the controller. The controller continuously monitors the functionality of the DSP with a watchdog function.

### 7.1.6 Self-test

Self-test functions are executed in the **self-test** phase after every program restart. If there is a fault, it enables the fault to be reliably pinpointed at the module level.

The following tests are performed in the self-test:

- Checking the program and data memory of the controller and DSP for functionality
- Checking of the configuration and parameter data for plausibility
- Checking interfaces and communication between controller and DSP
- Checking the controller IFC module interface
- Checking interfaces to the CLE (as far as possible)

If a fault is detected in the self-test phase, all inputs and outputs of the interface modules are disconnected and the corresponding alarms are activated (LED, and relays). You can interrogate the internal alarm trace with the service program PowerSys via the local interface.

### 7.1.7 Interference-Level Evaluation

The interference-level evaluation records the level of interference signals applied for a long time and superimposed on the wanted signal. If a fixed level threshold is exceeded, the interference-level alarm (SNALR) is signaled. In the **switching functions** mode, the interference-level evaluation is only activated if a single tone is transmitted (guard or command tone).

### 7.1.8 Event Memory and Real-Time Clock

Protection commands and alarms are provided with time, date, and a registration number before they are entered in the event memory. The service PC reads them out. The remote station can also read them out with remote maintenance.

The following events are entered:

- Incoming protection commands from IFC-D/P and EN100
- Outgoing protection commands to the IFC-D/P and EN100
- Detected alarms
- Program restart
- Changing date and/or time
- Changing the configuration

If there is an overflow, the oldest entry in the event memory is overwritten.

For more information about the event memory, refer to chapter [4.5 Display of the Entries in the Event Log](#).

## 7.1.9 Clock Synchronization

### Overview

The system-internal clock of the PU4 can be synchronized by an external clock source or via the connecting route to another SWT 3000 (Line-Clock Synchronization). For local clock synchronization one of the following methods can be used:

- USYNC pulse signal
- IRIG-B signal
- NTP synchronization

## 7.1.10 Front Panel

Control and display elements are mounted on the module. The front panel covers some of them.

For example, in order to prevent the unit being accidentally disconnected, the front panel covers the On/Off switch for the power supply.

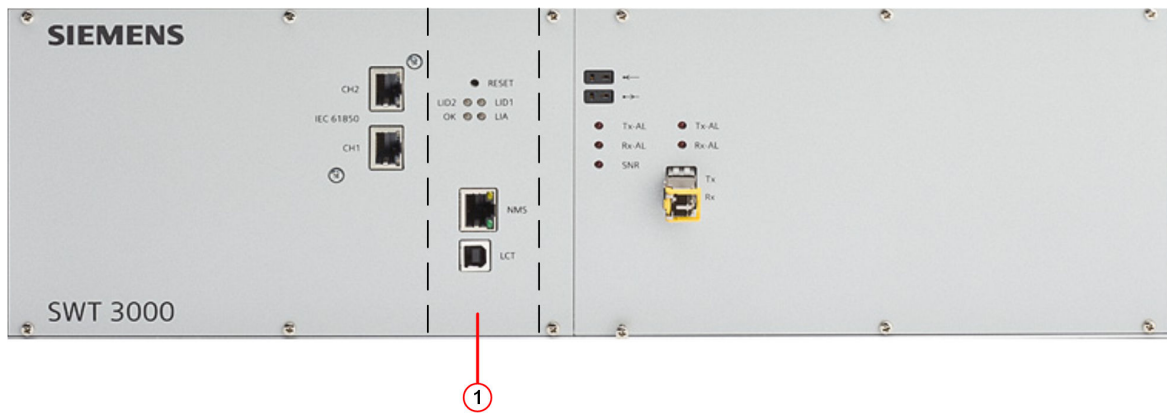

[scpu4dis-160911-01.tif, 1, -\_-]

Figure 7-4 Front Panel of a Unit with Analog Line Interface, CLE, and FOM Module

(1) PU4

The PU4 controller and hence the entire SWT 3000 unit is reset with the reset button.

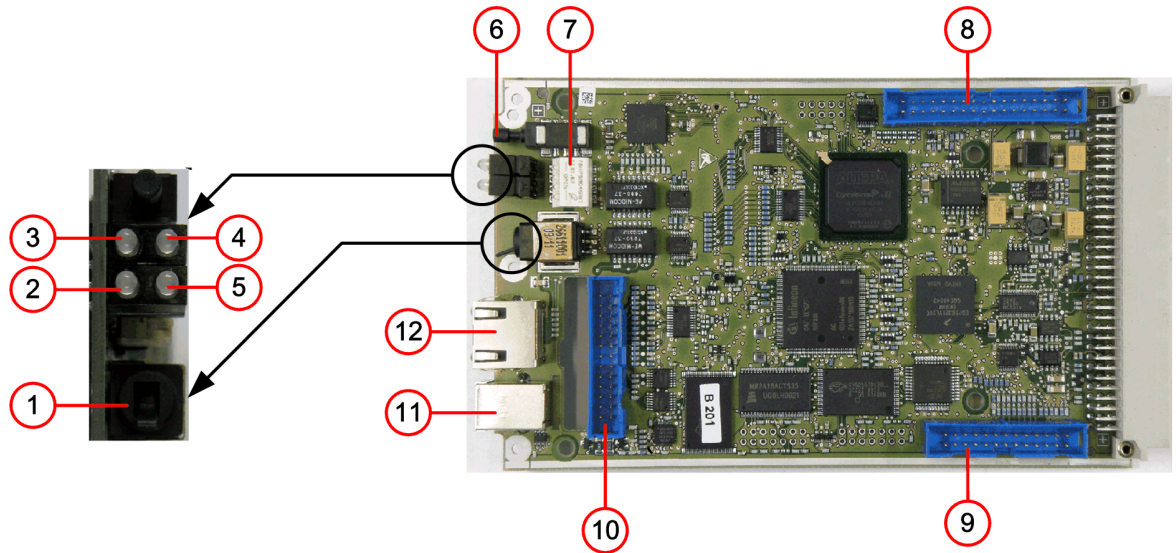

[le\_pu4jum, 1, en\_US]

Figure 7-5 Position of Jumpers, Input and Signaling Elements on the PU4 Module

- |    |                               |
|----|-------------------------------|
| 1  | S2: Power ON/OFF              |
| 2  | LED OK/GBAL                   |
| 3  | LED Status Interface LID-2    |
| 4  | LED Status Interface LID-1    |
| 5  | LED Status Interface LIA      |
| 6  | S1: Reset button              |
| 7  | S3 (3.1 to 3.4)               |
| 8  | Connection on DLE             |
| 9  | Connection on DLE             |
| 10 | Connection of the IFC Modules |
| 11 | LCT: Service Interface (USB)  |
| 12 | NMS: Ethernet Interface       |

## 7.1.11 IP (Ethernet) and Local (Service) Interface

### 7.1.11.1 Access to the Stand-alone SWT 3000

The local interface is fitted to the front panel of the PU4 module.

If a PC is connected to the local interface, a busy detection circuit automatically switches over to this interface.

### 7.1.11.2 Access to the Integrated SWT 3000 (iSWT)

In this operating mode, the local (service) interface is connected to the controller of the CSPi module of the PowerLink unit via iLAN. The user-service interface is located on the CSPi from which the parameters of the PU4 module are also set. The USB plug on the front panel of the PU4 is not used.



## 8 Interface Command Module

8.1	General Information	304
8.2	Block Diagrams of IFC Modules	313

## 8.1 General Information

### 8.1.1 Overview

The interface module IFC is used for communication between protection equipment and the iSWT. The following versions are available:

- Interface Command module **IFC-D** (high contact load, e.g. for direct tripping)
- Interface Command module **IFC-P** (normal contact load, e.g. for permissive tripping)
- Interface Command module **IFC-S** (for signaling)

### 8.1.2 Exclusively Analog Transmission Interface or Analog Secondary Path

You can insert only IFC-D or IFC-P modules into slot IFC-1 and IFC-3 in the subrack. Slot IFC-2 and IFC-4 can also be equipped with the IFC-D/P modules or alternatively with the IFC-S module.

If using 2 IFC-D/P modules, only the output relays of the module at the IFC-2 or IFC-4 slot are used for contact doubling. The inputs are not used because the maximum number of commands is 4. In this case, activate the function **Contact doubling** in the **Special allocation** list box.

### 8.1.3 Exclusively Digital Transmission Interfaces

You can insert only IFC-D or IFC-P modules into slot IFC-1 and IFC-3 in the subrack. Slot IFC-2 and IFC-4 can also be equipped with the IFC-D/P modules or alternatively with the IFC-S module.

If using 4 IFC-D/P modules, there are 16 inputs and outputs available (in operating mode 5D).

### 8.1.4 Description of Operation

#### 8.1.4.1 Overview

IFC-D	The IFC-D module has 4 binary inputs for receiving contact information from the protection devices. Up to 4 circuit breaker coils can also be operated with this module. It is thus possible to implement the trigger commands <b>directly</b> from a distant station, for example, without a protection device. This module is preferably used for direct tripping mode but the use in protection systems with permissive tripping is also possible.
IFC-P	The IFC-P module is preferably used in protection systems with permissive tripping. When observing the maximum switching power of the relays, direct tripping of circuit breaker coils is also possible (refer to <i>Technical Data</i> ). There are similarly 4 binary inputs and 4 command contact outputs available. The contact rating of the output relays is lower compared to the IFC-D module but operating times are shorter. IFC-D and IFC-P modules are pin-compatible.
IFC-S	The IFC-S is used for signaling. Each command input as well as each command output in the corresponding IFC-D/P is activating a relay on the IFC-S. If there are digital transmission paths, it can be necessary to use 2 IFC-S cards. The IFC-S module is used for: <ul style="list-style-type: none"><li>• Signaling commands that are entered (binary inputs)</li><li>• Signaling commands that are output (binary output)</li></ul>



### 8.1.4.2 Connection Principle

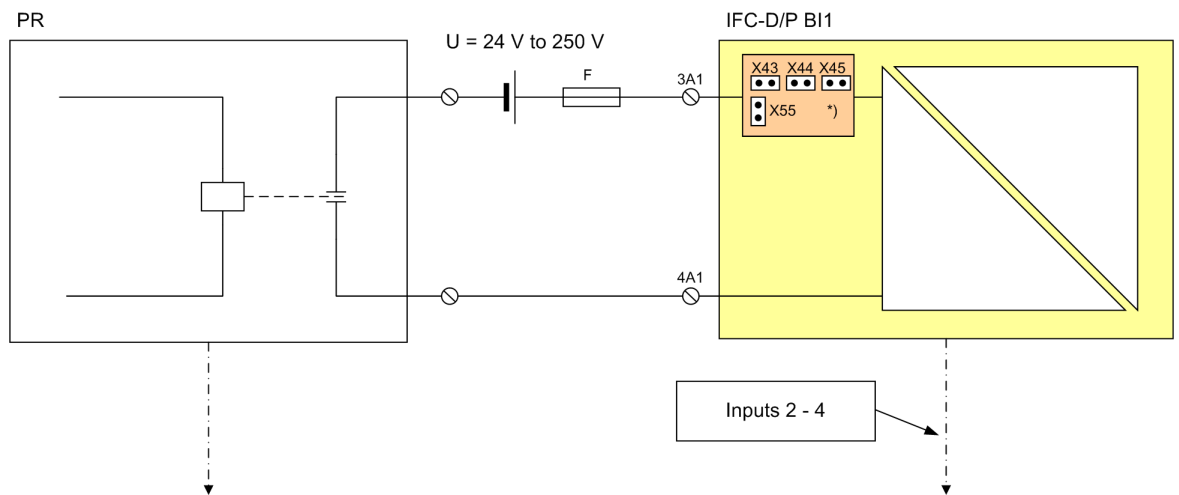

[dw\_SWT\_baseim\_1\_en\_US]

Figure 8-1 Basic Connection of IFC-D or IFC-P Modules

\*) Setting the rated voltage 24 V, 48 V/60 V, 110 V, 250 V

IFC-D/P BI 1 IFC Binary Input 1  
PR Protection Relay  
3A1 - 4A1 Terminals Binary Input 1  
F Fuse

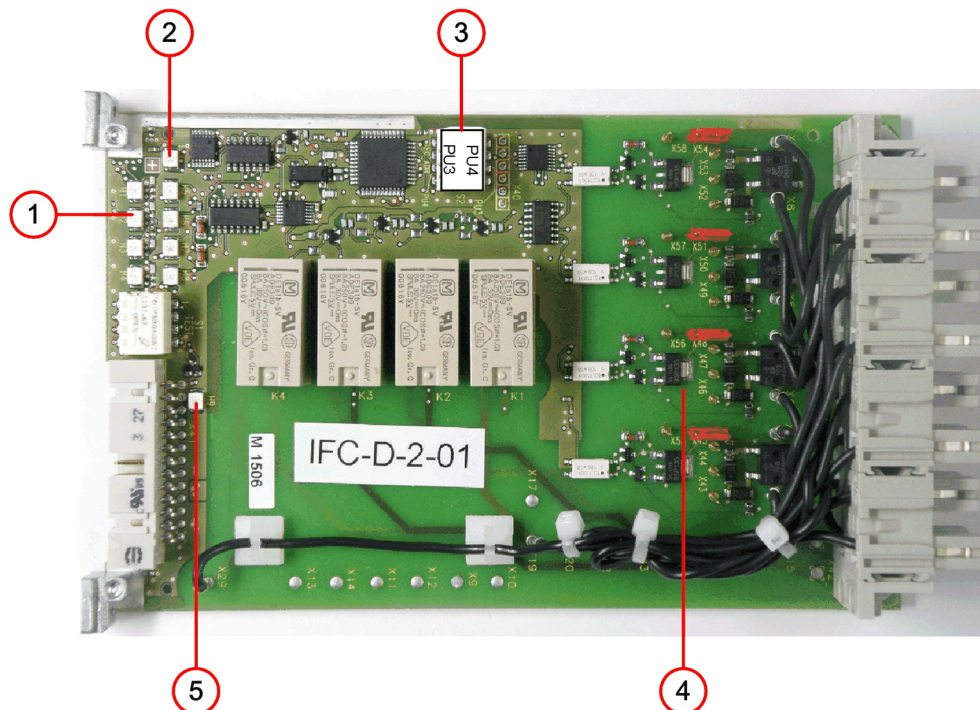

[scjumper-220513-01.tif\_2\_en\_US]

Figure 8-2 Signaling elements and DIL-switches of the IFC module, e.g. IFC-D

- (1) LED H1 to H4 (red): activated outputs  
LED H5 to H8 (green): activated inputs
- (2) Test Operation Display (H10)

- (3) S2: IFC Slot Address Selection (S2.1, S2.2) and PU3 / PU4 switch:  
 S2.3: closed/down - PU3  
 S2.3: open/up - PU4
- (4) Jumpers X43 to X58
- (5) Operating LED (H9)

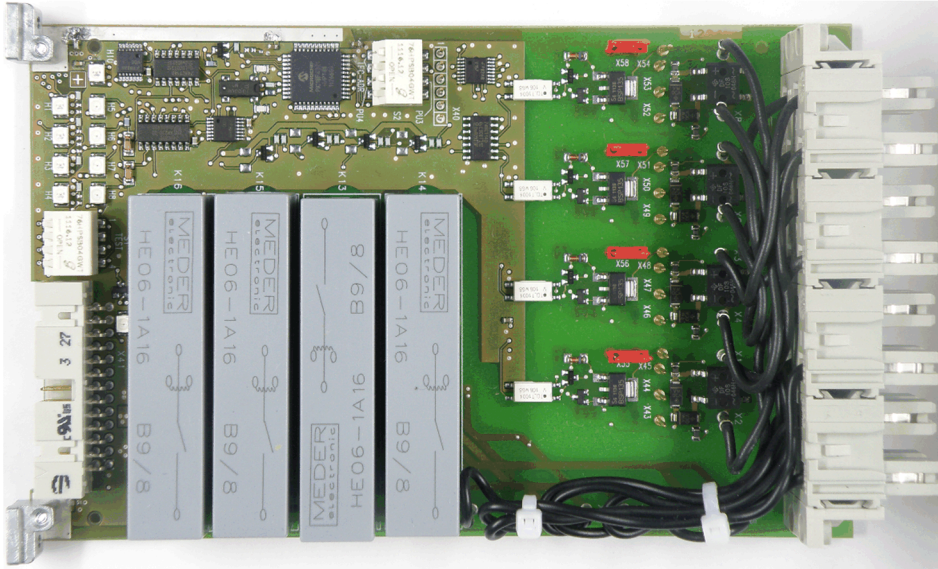

[scifcpju-300112-01.tif, 1, en\_US]

Figure 8-3 IFC-P Module

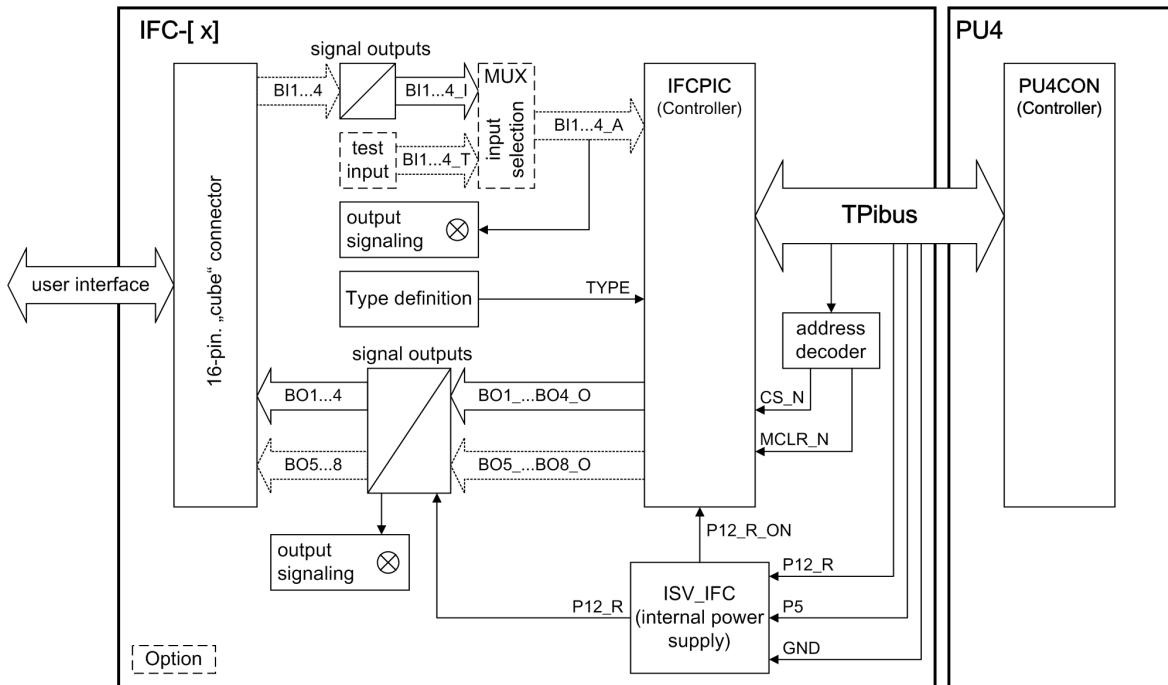

[dwifcblc-051011-01.tif, 1, en\_US]

Figure 8-4 Block Diagram of IFC Modules

- TPi-Bus Internal bus
- MUX Multiplexer
- ISV\_IFC Internal power supply IFC

P12_R	12-V supply voltage for relays
P5	5-V supply voltage
P12_R_ON	12-V supply voltage available

## 8.1.5 Controller

A controller is used on all IFC interface modules for the following functions:

- Control of the data traffic from and to the PU4
- Sampling the signal inputs 1 to 4 and triggering an interrupt at the PU4 if there are changes
- Switching the command relays via the signal outputs
- Supervision functions

The controller is connected to the PU4 controller via an internal bus.

## 8.1.6 Test Mode

### 8.1.6.1 Overview

In order to switch over from normal to test mode with the service program PowerSys, select the **IFC-Test** in the **Testmode** list box under **Configuration > Command interface**. In this mode, you can enter commands on the IFC module for each input with the Dual Inline Package (DIP) switches S1.1 to S1.4.



#### NOTE

For security reasons, after switching over to test mode, the controller signals all inputs as **off** regardless of the actual switch position. You can reach the state **on** by switching from **off** to **on** position. All switches must be in the **off** position beforehand. As long as test mode is active the IFC inputs are disabled.

### 8.1.6.2 Displays

The activated output relays are displayed with LEDs H1 to H4 (red), and the activated binary inputs with LEDs H5 to H8 (green).

Refer to [Figure 8-2](#) for more details.

## 8.1.7 Slot and Module Identifier

The new IFC modules can also communicate with the old TPI-Bus (PU3). For this purpose, no additional signal from PU4CON (PU4 controller) can be used for IFC addressing.

A DIP switch S2 is added to each IFC module to indicate its slot address.

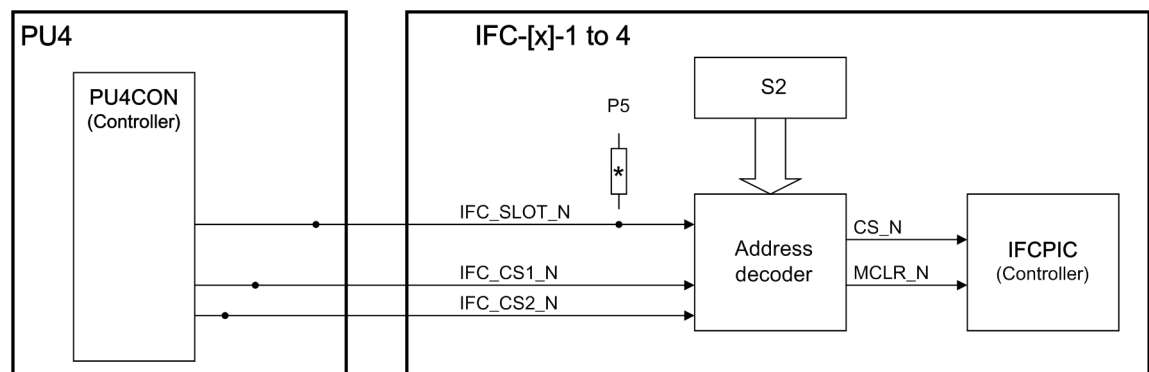

[dwifcadd-051011-01.tif, 1, en, US]

Figure 8-5 IFC Addressing Used for SWT 3000

Table 8-1 Function of S2 Switch

Switch	Function
S2.1	IFC slot address selection
S2.2	IFC slot address selection
S2.3	PU3 or PU4 selection
S2.4	Not connected

IFC slot address is configured by changing the state of DIL switches, and it is independent of the position where it is located. The 4 slot addresses are mapped into different switching states. The assembled IFCs must have individual addressing, even when they are not configured.

Table 8-2 IFC Slot Address

Selection	S2.1 Position	S2.2 Position
IFC-1	Open = up position = OFF	Open = up position = OFF
IFC-2	Close = down position = ON	Open = up position = OFF
IFC-3	Open = up position = OFF	Close = down position = ON
IFC-4	Close = down position = ON	Close = down position = ON



**NOTE**

The Slot addresses IFC-3 and IFC-4 are only applicable in SWT 3000 stand-alone devices.

IFC modules can be used as spare in actual SWT 3000 with the PU3 module.

Table 8-3 PU3 or PU4 Selection

Selection	S2.3 Position
PU3	Close = down position = ON
PU4	Open = up position = OFF

The function of address decoder in IFC module is adapted as follows:

- Input
  - Input signals from DIP switches, which indicate the slot address of IFC module
  - Input signals from PU4CON (PU4 controller), which specify the required slot address for accessing IFC module
- Process
 

Compare the required slot address with local address to see if it is matched.
- Output
 

Output signals to IFCPIC (IFC controller) to indicate if the slot is selected.

IFC_SLOT_N	IFC_CS1_N	IFC_CS2_N	Function
1	0	0	Reset PIC on IFC-1 to IFC-4
0	0	1	Select IFC-1
0	1	0	Select IFC-2
0	1	1	Select IFC-3
0	0	0	Select IFC-4



**NOTE**

The Slot addresses IFC-3 and IFC-4 are only applicable in SWT 3000 stand-alone devices.

For connecting the redesigned IFCs to PU4, all IFCs are connected in parallel on a ribbon cable (26 pins) for TPI-Bus to the PU4 module.



**NOTE**

If the new IFC board is used as spare part in SWT 3000 with the PU3 module, use a suitably configured ribbon cable for the slot identification function.

For more details, refer to table [Table 8-3](#) For the selection of PU3 on the IFC module..

The IFC controller manages the input register (IFC\_EREg) which is readable by PU4 controller. The PU4 controller can identify the IFC type (IFC-D/P or IFC-S) by reading the content of IFC\_EREg. IFC-P, IFC-D and IFC-S boards are based on the same Printed Circuit Board (PCB). The type depends on the various hardware assembling options. The assembling options can be identified via the status of the **TYPE** input of the IFC controller.

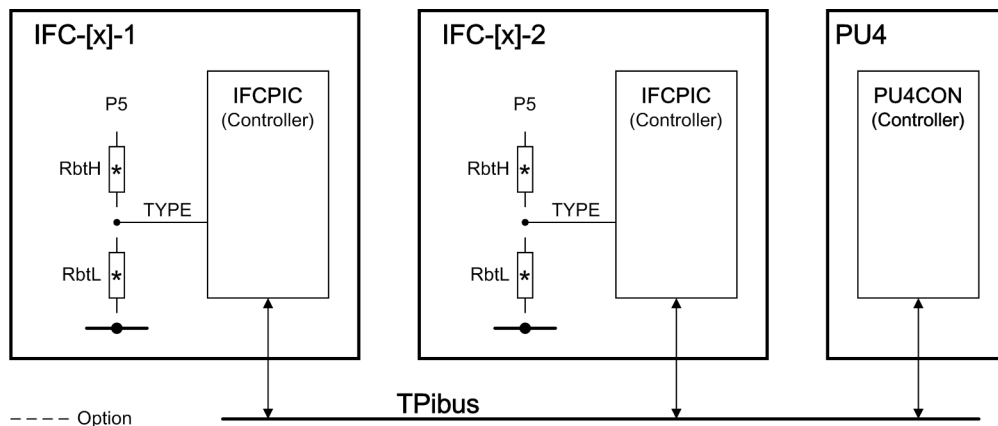

[dwifctyp-051011-01.tif, 1, en\_US]

Figure 8-6 Principle of IFC Type Identification

The assembling of the resistors RbtH and RbtL depends on the specific board type. The state of the board type input is readable by PU4 controller.

Table 8-4 IFC Type Configuration

RbtH	RbtL	TYPE	Comment
Not installed	0 Ω	0	IFC-D or IFC-P
22 KΩ	Not installed	1	IFC-S

### 8.1.8 Signal Acquisition via Binary Inputs

If the binary inputs (BI1 to BI4) of the module detect a signal, an interrupt request is sent to the PU4. The IFC module is connected to the PU4 via a ribbon cable via connector X3 at the front. If an interrupt is detected, PU4 can read the status of the binary inputs.

In order to suppress interference pulses, a signal must be applied to the binary input for at least 1 ms before the interrupt request is sent. The following figure shows the block diagram of a binary input:

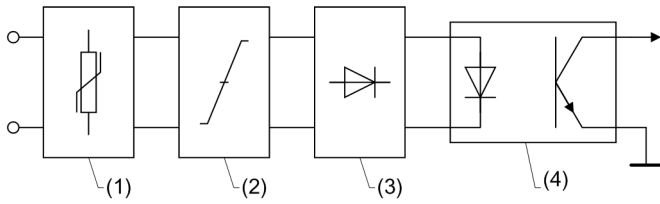

[dwcsem34-051011-01.tif, 1, en\_US]

Figure 8-7 Binary Inputs of Modules IFC-D and IFC-P

- (1) Protective circuit  
 The protective circuit provides the required security against destruction and interference.
- (2) Setting of the input rated voltage  
 You can set the input rated voltage to the values DC 24 V, DC 48/60 V, DC 110 V, and DC 250 V with the jumpers X43 to X58. The operating point is at 80 % of the selected voltage.  
 Refer to [3.3.2.1 Overview](#) for more details
- (3) Rectifier  
 Rectification ensures that the input signal is polarity-neutral.
- (4) Optocoupler  
 The optocoupler isolates the input circuit electrically from the electronic system.

### 8.1.9 Signal Output from the IFC-D/P Module

If there is an IFC-D module, the commands from the remote station are distributed via the relays K1 to K4. If there is an IFC-P module, the commands from the remote station are distributed via the relays K13 to K16. Compared with the IFC-P module, the relays of the IFC-D module are slower but they can switch more power.

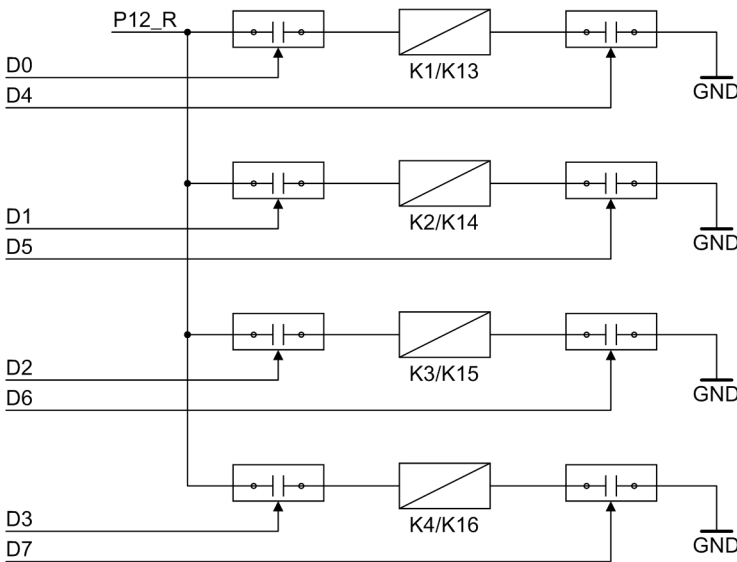

[dwcsem35-051011-01.tif, 1, en\_US]

Figure 8-8 Block Diagram of the Output Circuit of IFC-D/P

- K1 - K4 Output Relays of Module IFC-D
- K13 - K16 Output Relays of Module IFC-P
- D0 - D7 Operation of the IFCx Controller

The following security systems are incorporated for sending commands without interference:

- PU4 must enable the supply voltage P12\_R
- Relays are operated on a 2-pole basis

### 8.1.10 Signal Output from IFC-S Module

The messages are transmitted via the relays K5 to K12. These relays are identical with those relays on the IFC-D module. For 7 relays, one change-over contact per relay is brought out. The contact of relay K5 can be used as a make contact or break contact with jumper X42. All 8 signal relay contacts have a **common root (3A1)**. The PU4 must enable the excitation voltage P12\_R of the relay coils.

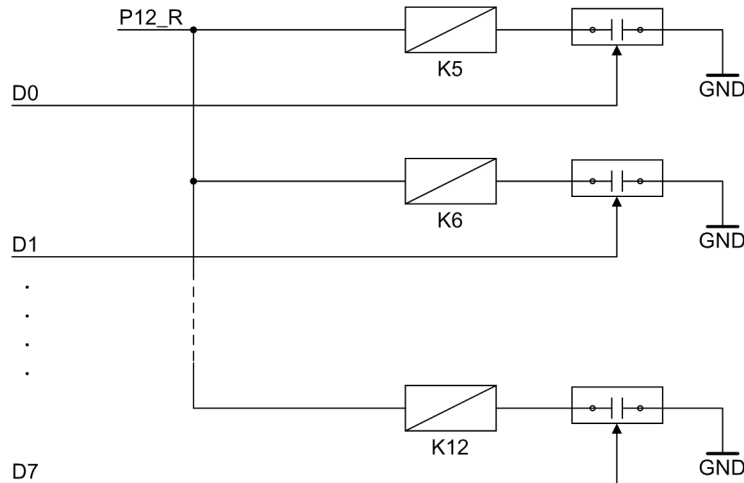

[dwcsem36-051011-01.tif, 1, en\_US]

Figure 8-9 Block Diagram of the Output Circuit of IFC-S

### 8.1.11 Pinout of the IFC-x Module

The interface modules must be connected from the protective relay to the connector X1 (modular terminal block). The cable cross section must be up to 1.5 mm<sup>2</sup>. **At least** 2 cables must be tied immediately at the terminals.

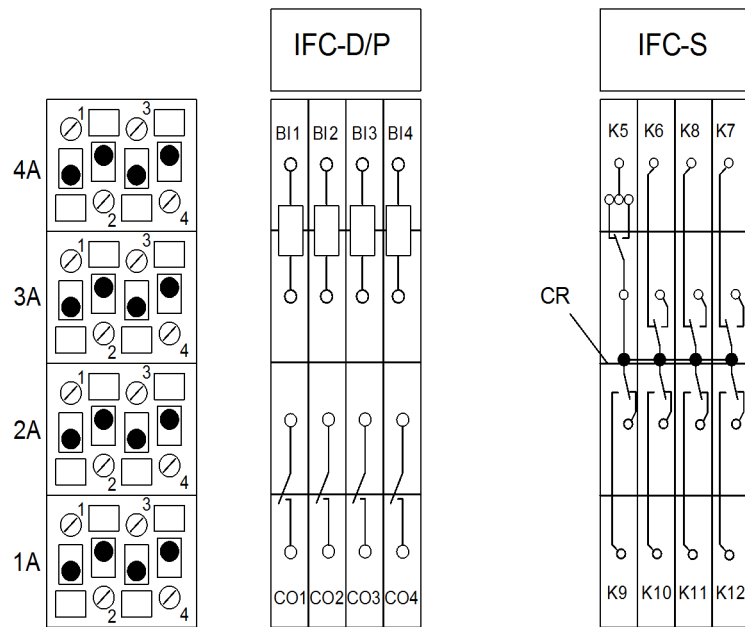

[dwpinifc-060711-01.tif, 1, en\_US]

Figure 8-10 Pinout of the IFC-x Modules

- IFC-D Interface module direct tripping
- IFC-P Interface module permissive tripping
- IFC-S Interface module signaling
- CR Common root of relays K5 to K12
- 1A to 4A Modular terminal block
- BI1 to BI4 Binary inputs 1 to 4
- CO1 to CO4 Command outputs 1 to 4
- K5 to K8 Signaling of the binary inputs 1 to 4
- K9 to K12 Signaling of the command outputs



## 8.2 Block Diagrams of IFC Modules

### 8.2.1 IFC-D Module

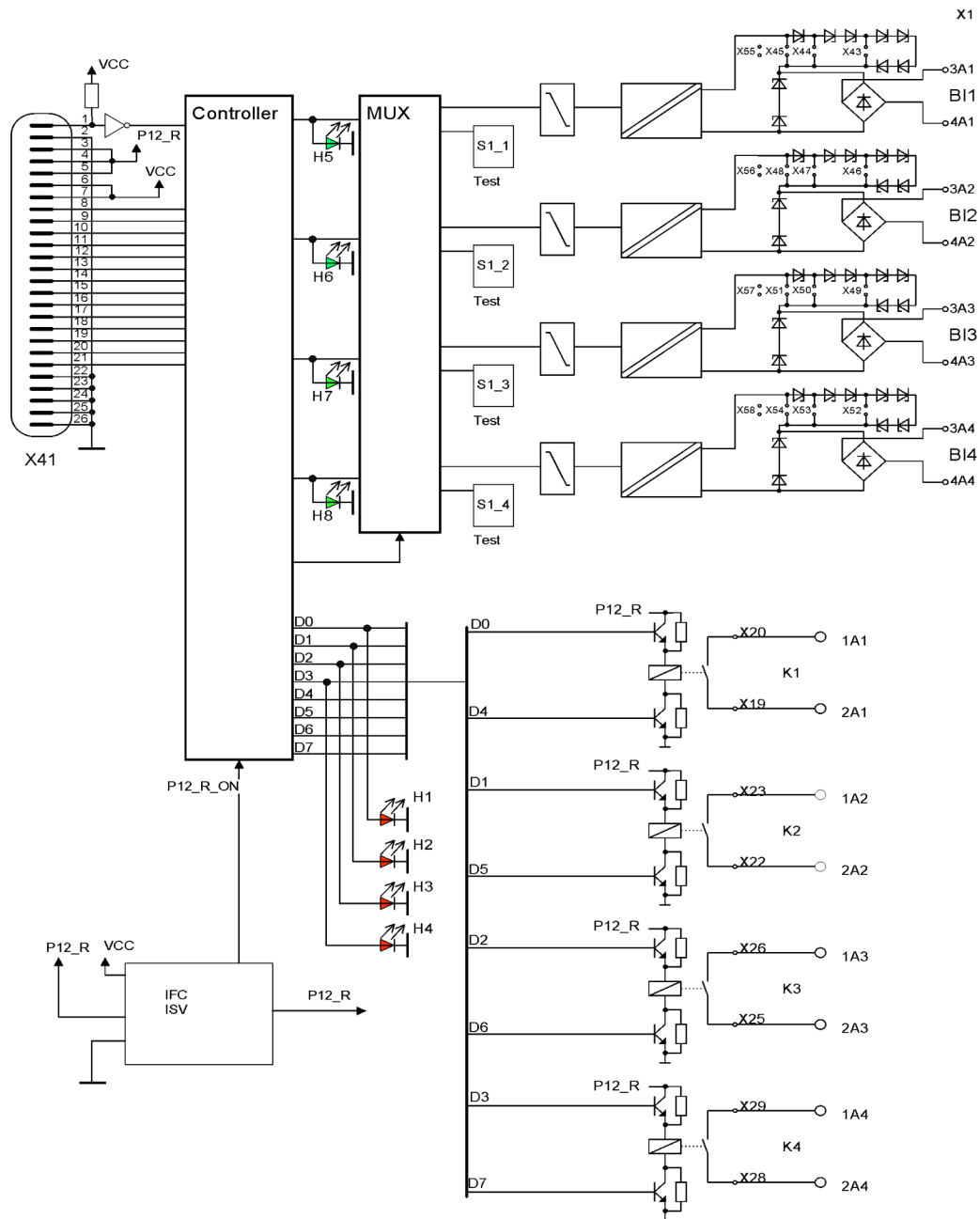

[dw\_rgcsem01\_1\_en\_US]

Figure 8-11 Block Diagram of the IFC-D Module

### 8.2.2 IFC-P Module

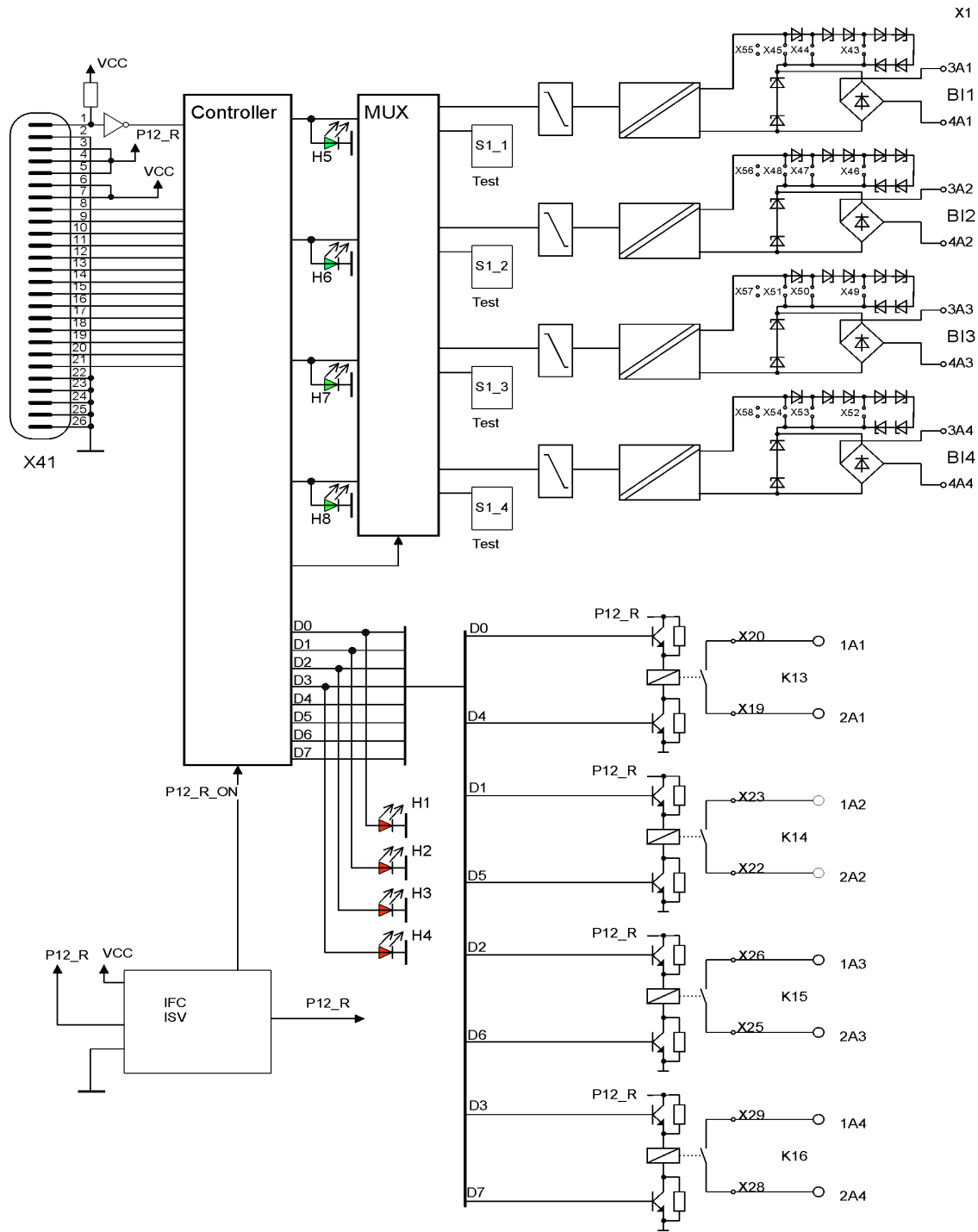

[dw\_rgcsem02, 1, en\_US]

Figure 8-12 Block Diagram of the IFC-P Module

### 8.2.3 IFC-S Module

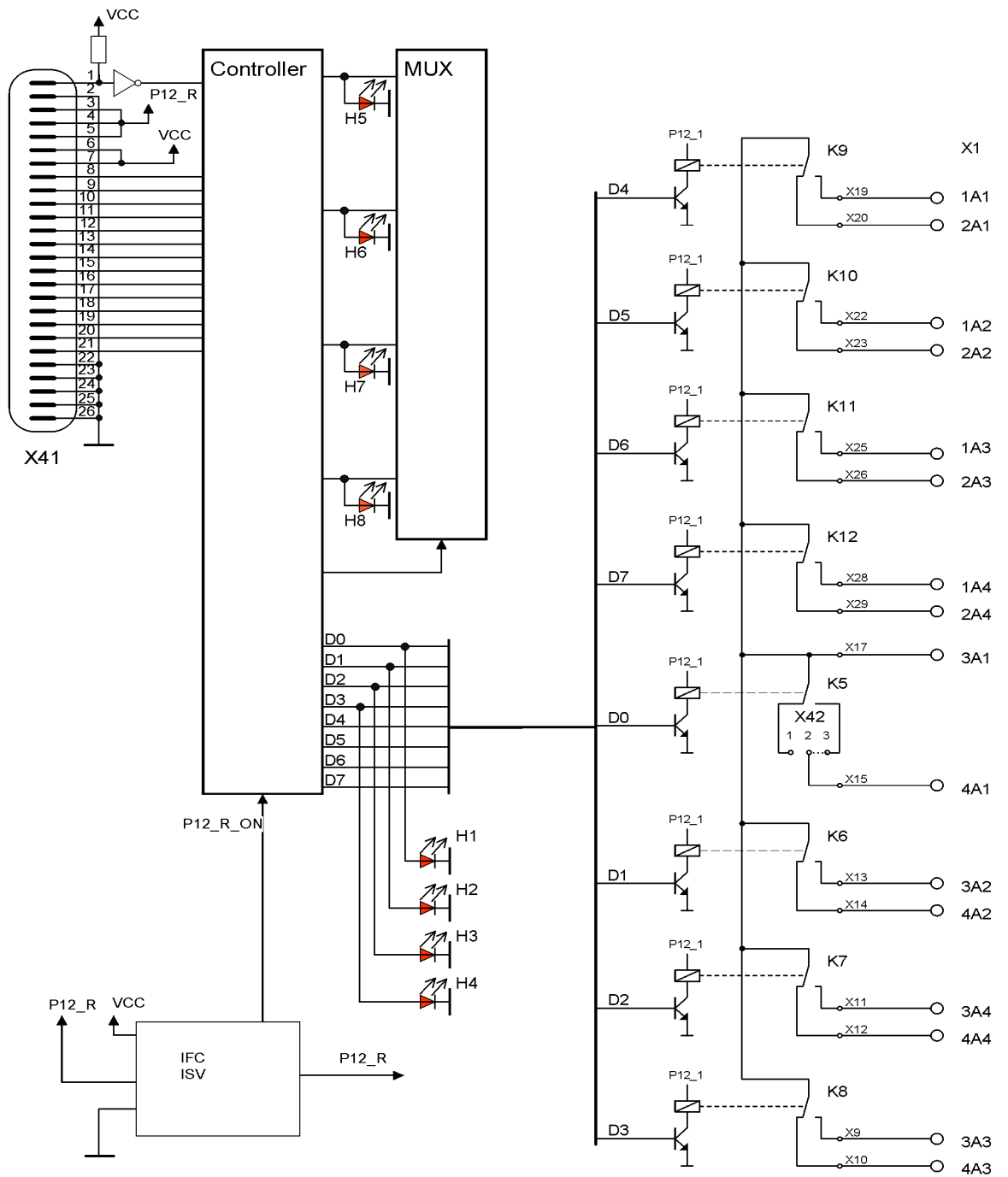

[dw\_rgcsem03.1.en\_US]

Figure 8-13 Block Diagram of the IFC-S Module



## 9 Digital Line Equipment

9.1	Overview	318
9.2	Transmission Concept	319
9.3	Interface X.21	320
9.4	Interface G703.1 (64 Kbps)	321
9.5	Interface G703.6 (2 Mbps HDB3)	322
9.6	Jumper Settings	323

## 9.1 Overview

The digital line interfaces LID-1 and LID-2 of the SWT 3000 system are implemented on the DLE module. These interfaces enable the transmission of the protection commands via a digital network (SDH/PDH). The data for the remote maintenance and the service channel interfaces and the system-internal control information are transmitted additionally.

The DLE module is designed as a self-contained PC board connected electrically to the PU4 via a ribbon cable and mechanically via spacer sleeves. All external interfaces are routed via the PU4 module.

The following hardware interfaces are available for each LID:

- X.21 (64 Kbps)
- G703.1 (64 Kbps)
- G703.6 (2 Mbps)

LID-1 can be operated alone or jointly with the LID-2 (multipath transmission) on the DLE. With multipath transmission, different line interfaces can be used for LID-1 and LID-2.



### NOTE

Up to 2 line interfaces at the same time are possible. Only one of them can be analog.

LIA (CLE) + LID-1

LIA (CLE) + LID-2

LIA (CLE) + FOM-2

FOM-1 + FOM-2

FOM-1 + LID-2

LID-1 + LID-2

---

## 9.2 Transmission Concept

On the DLE, a data stream is generated at the transmit side from the protection commands, RM, SC, and the system-internal control information. The data stream is sent with the periodic transmission of 4 message types with constant length. The data stream is split up again at the receive side into protection commands, RM, SC, and system-internal control information.

The messages have the following elements:

Priority 1 = Tripping command information      Type 3

Priority 2 = Service channel                      Type 2

Priority 3 = Remote maintenance              Type 1

Priority 4 = System-internal control information      Type 0

Table 9-1      Composition of Messages

Byte 1	Byte 2	Byte 3	Byte 4	Byte 5
Frame alignment signal	Type code 0	User data	User data	User data
Frame alignment signal	Type code 1	RM data	RM data	RM data
Frame alignment signal	Type code 2	SC data	SC data	SC data
Frame alignment signal	Type code 3	Device address	Command information	Checksum

### 9.3 Interface X.21

The X.21 interface is structured according to the RS422 standard (ITU-T V.11) and consists of the data lines TxD and RxD and the clock lines TxC and RxC.

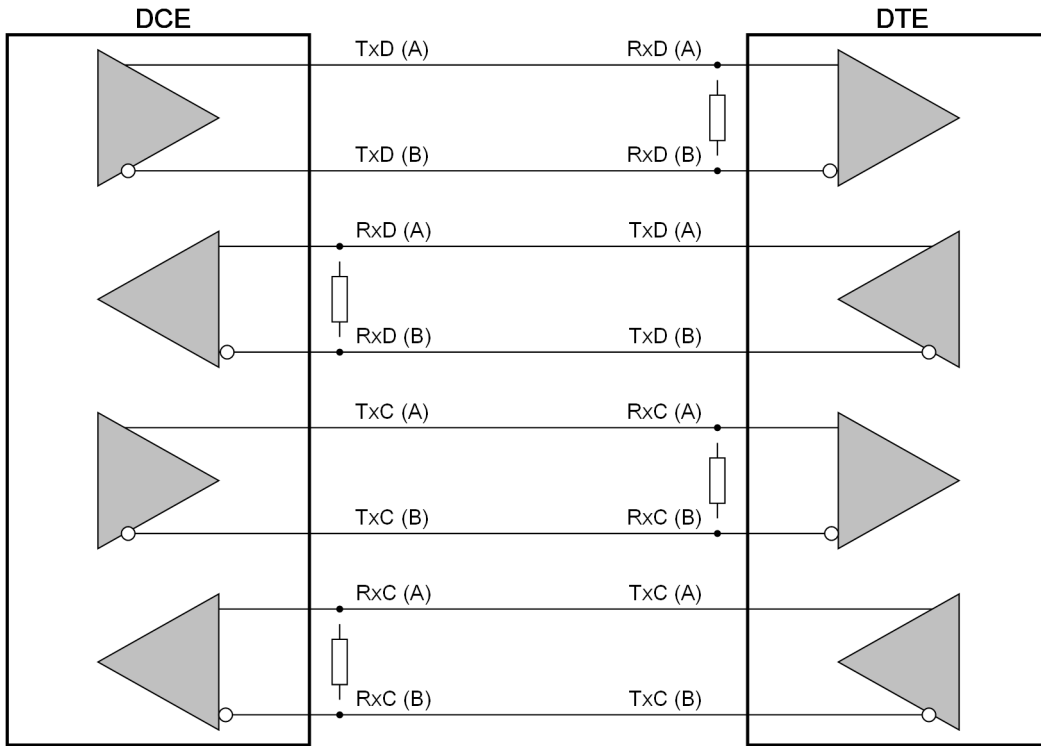

[ldw\_structure\_of\_X21, 1, -,-]

Figure 9-1 Structure of the X.21 Interface

The high transmission reliability of the interface is achieved by evaluating the differential voltage between a twisted wire pair in each case. The electrical levels of the data lines are defined with 0.3 V to -6 V for **logic 1** and with +0.3 V to +6 V for **logic 0**. The voltage between the measuring points (A) and (B) defines the signal state.

Terminations of 100 Ω at the receiver inputs not only prevent reflections on the transmission line, but also contribute to transmission reliability through the resulting pronounced current.

**Characteristics:**

- Number of signal lines: 8  
 For each balanced pair for data and clock pulse, for transmit and receive direction in each case
- Levels: < 6 V  
 Maximum voltage of each line to GND (absolute)  
 > 2 V  
 Differential voltage between the lines
- Line run: Twisted in pairs and shielded, joint shield for all 4 line pairs
- Bit rate: 64 Kbps



## 9.4 Interface G703.1 (64 Kbps)

Coding in accordance with G703.1 permits simultaneous transmission of the data of a 64-kHz and an 8-kHz clock pulse and is carried out according to the following scheme:

- Division of a 64-kbit period into 4 identical intervals
- A binary **1** is coded as a block of four 1100
- A binary **0** is coded as a block of four 1010
- The binary signal is converted into an AMI-coded signal, with alternating polarity of consecutive blocks of 4. AMI is the abbreviation for **A**lternate **M**ark **I**nversion. The code is generated from the NRZ code by representing the code elements of the logic **1** state alternately through pulses with positive or negative voltage.
- The change of polarity of every eighth block is suppressed for marking the byte (8-kHz clock).

The nominal data rate is 64 Kbps. The bit rate on the line is 256 Kbps due to the conversion of the bits into a block of 4.

### Characteristics:

Number of signal lines:	4 (one balanced pair for transmit and receive direction)
Level, transmitter side:	<b>Space</b> 0 V ± 0.1 V, <b>Mark</b> 1 V
Level, receiver side:	0 dB to 3 dB
Impedance:	120 Ω
Bit rate:	64 Kbps (gross bit rate = 4 x 64 Kbps = 256 Kbps)
Coding:	AMI

## 9.5 Interface G703.6 (2 Mbps HDB3)

Coding in accordance with G.703.6 is also known as HDB3-code (**H**igh **D**ensity **B**ipolar of order **3**). Longer sequences of zeros, such as can occur with the AMI code are avoided here. If there are 4 consecutive binary zeros, the infringement of the AMI coding regulation changes the fourth character. This means that a maximum of 3 consecutive binary values of **0** can occur with the HDB3 code. The polarity of the changed code elements alternates. The HDB3 code is one of the voltage-free codes.



### NOTE

It is possible to select between a balanced line (120 Ω) and an unbalanced line (75 Ω, connected to GND potential). The line impedances are set with links.

### Characteristics:

<b>Balanced line</b>	Number of signal lines:	4 (one balanced pair each for transmit and receive direction)
	Level, transmitter side:	<b>Space</b> 0 V ± 0.1 V, <b>Mark</b> 1 V
	Level, receiver side:	Loss at 1024 kHz 0 dB to 6 dB
	Impedance:	120 Ω
<b>Unbalanced line</b>	Number of signal lines:	4 (one unbalanced line each for transmit and receive direction)
	Level, transmitter side:	<b>Space</b> 0 V ± 0.237 V, <b>Mark</b> 2.37 V
	Level, receiver side:	Loss at 1024 kHz 0 dB to 6 dB
	Impedance:	75 Ω
	Line lengths:	short = indoor, long = outdoor
	Bit rate:	2 Mbps
	Coding:	HDB3

## 9.6 Jumper Settings

All necessary jumper settings are shown in chapter *Installation and commissioning 3.3.4 Jumper Settings for the DLE Module* of this Equipment Manual. They are also available in the SWTStraps program, that can be manually installed in addition to the service program PowerSys. SWTStraps is useful to find the jumper settings for the SWT 3000 or iSWT modules. For a description of SWTStraps program see chapter *5.6 SWTStraps for Jumper Settings*.



## 10 Copper Line Equipment Module

10.1	Function Description	326
10.2	Connection of an External SWT 3000 to the PowerLink 50/100	330

## 10.1 Function Description

### 10.1.1 Overview

The Copper Line Equipment module (CLE) provides the interface between an SWT 3000 unit (operated as a stand-alone unit) and a copper transmission line for analog transmission. The teleprotection signal is transmitted in the VF range from 300 Hz to 4000 Hz.

The following equipment configurations are possible:

- Connection of 2 SWT 3000 stand-alone units each containing one CLE module.
- Connection of an SWT 3000 stand-alone unit to a PowerLink unit. The SWT 3000 unit contains a CLE module as interface and the PowerLink unit a VFx card. The S6 control wire for modules CLE and VFx makes alternate multi-purpose operation possible.

The CLE module contains 2 independent circuit sections:

- A transmit amplifier
- A receive filter

The CLE is connected to the PU4 module in the SWT 3000 unit. The PU4 generates the VF signal which must be transmitted. The VF signal is fed onto the transmission line by the transmit amplifier of the CLE. In the opposite direction, the VF signal is forwarded from the transmission route to the PU4 via the receive filter.

The CLE does not have any control elements but 3 alarm displays and 2 test sockets on the front panel. The CLE module does not generate any alarms but displays alarms generated by the PU4.

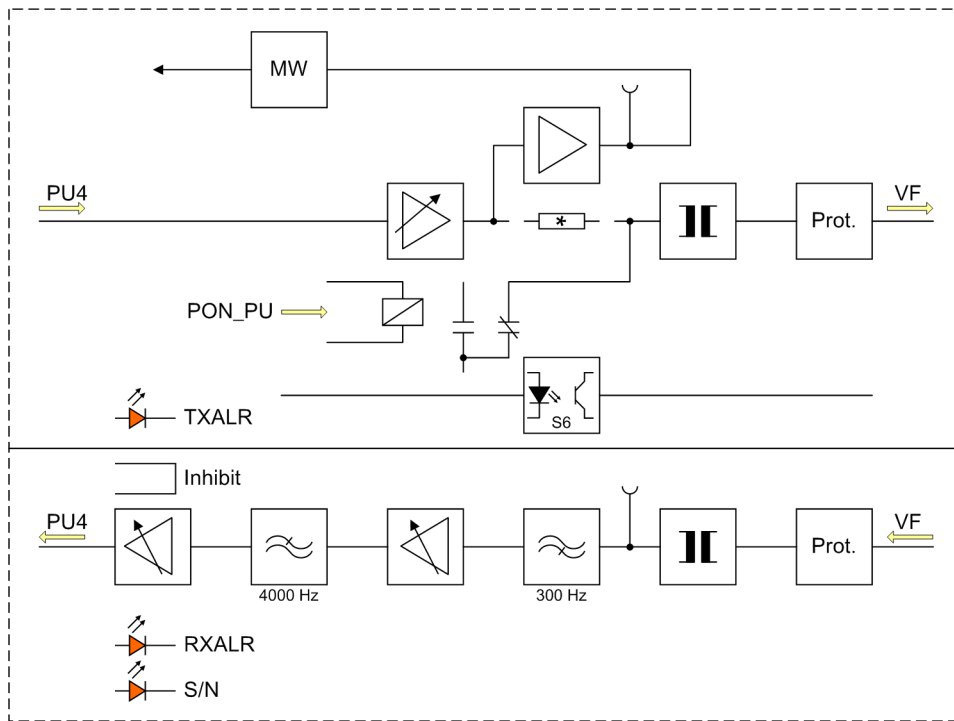

[dw\_SWT\_biccle, 1, en\_US]

Figure 10-1 Block Diagram of the CLE Module

TXALR	Transmitter alarm
RXALR	Receiver alarm
S/N	S/N alarm
Prot.	Protection circuit

MW	Measuring transformer
S6	Control wire for alternate multi-purpose operation

### 10.1.2 The Receive Section

The incoming VF signal from the copper line or from a Siemens PLC equipment is fed in at the receive section. The input is protected against overvoltages up to 2 kV that can be transferred to the transmission route by coupling. The input impedance can be switched over from 600 Ω to approximately 5 kΩ.

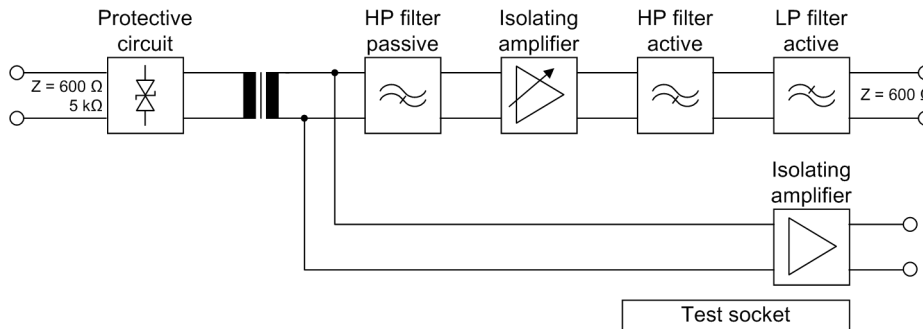

[dwinpclr-051011-01.tif, 1, en\_US]

Figure 10-2 The Input Circuit of the CLE Module

The desired signal is filtered out from any interference signals. The attenuation tolerance diagram of a band pass filter is preset for the input filter. The pass band is from 300 Hz to 4000 Hz. The band-pass filter is implemented by cascading an active low-pass and high-pass filter.

You can set the forward amplifier to 0 dB, +6 dB, and +12 dB with solder bridges. Greater immunity to 50-Hz interference is obtained with the series-connected high-pass filter.

The signal is then transferred to the PU4. The receive signal can be measured at a test socket. The test socket is decoupled via an isolating amplifier so that there is no interference of the desired signal through short-circuits or insertion of signals. The same voltage level prevails at the test socket as at the input. The adjustable thresholds for the level alarm relate to the input of the PU4 and not to the input of the CLE.

### 10.1.3 The Transmit Section

The desired signal supplied by the PU4 is amplified in the transmit section. There is no filtering as there is in the receive section since the signal supplied does not have interference of this type. The PU4 supplies a level up to +4 dB. The input signal is amplified by 11 dB to the range up to +15 dB.

The signal is extracted without voltage via a transformer with winding ratios that can be set to 1:2 or 1:16 and matched to the output impedance. This impedance can be set to 600 Ω or 5 kΩ with links with the corresponding output circuit.

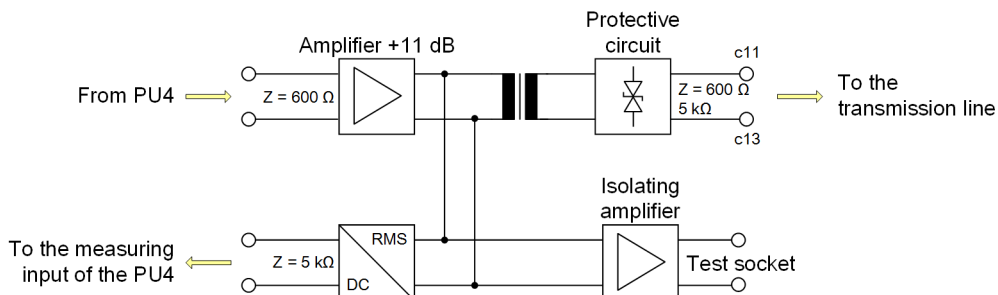

[dwblctam-051011-01.tif, 2, en\_US]

Figure 10-3 Block Diagram of the Transmit Amplifier

The output of the transmit section is again protected against any interference voltages from the transmission path. The desired signal can be measured via an isolating amplifier. Depending on the frequency, a correction value has to be added to the measured signal level to get the amplitude of the output signal to the PU4 module for test purposes. Interpolate linearly between the frequency points.

Table 10-1 Correction values

dB	Hz
6.8	300
5.1	350
5.2	400
5.3	450
4.9	500
4.3	550
3.7	600
1.8	800
0.8	1000
0.1	1300
-0.4	2300
-0.8	2800
-0.9	3300
-1.4	3800
-1.5	3900
-1.7	4000

The PU4 monitors this measured value and generates the transmitter alarm from it. The output voltage for the 100 % value is 4.5 V. A protective circuit restricts this voltage to maximum +5 V.

If any faults occur in the SWT 3000 unit, faulty signals must not under any circumstances be transmitted to the distant station. For this reason, the transmitter output can be short-circuited via a relay. The PU4 module (PON\_PU signal) drives this relay, which is only enabled if the unit is operating properly.

### 10.1.4 Alarm Displays

The alarm signals generated by the PU4 module are displayed via red LED on the front panel of the SWT 3000. LED are provided for the following alarms:

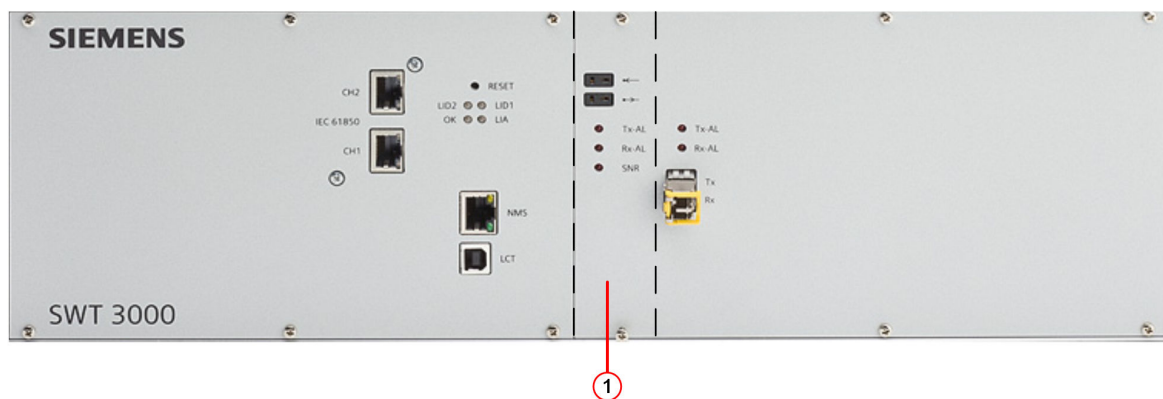

Figure 10-4 Displays on the CLE Module

- 1 Copper Line Equipment module (CLE)
- Tx-AL Transmitter alarm



Rx-AL Receiver alarm  
SNR S/N alarm

The signals are low active and are fed to the LED drive via an integrated inverter module with a +5 V supply voltage.

### 10.1.5 S6 Control Wires

The CLE module contains an optocoupler for the S6 control wire. The S6 control wire is used for disconnecting voice and data signals in a Siemens PLC equipment in alternate multi-purpose mode.

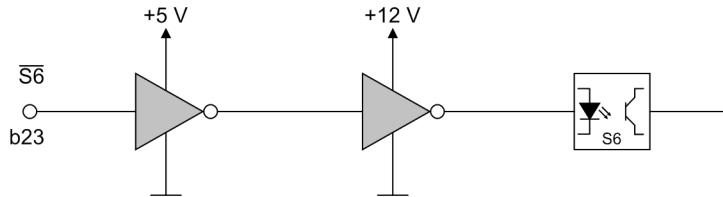

[dw\_SWT\_contro, 1, en\_US]

Figure 10-5 Block Diagram of the S6 Control

The circuit is driven on a low-active basis. The optocoupler is activated during transmission of protection data (S6 control wire = low).

### 10.1.6 Test Sockets

The following test sockets are provided on the front panel of the CLE module:

- 1 ISEP socket for measuring the level of the receive signal
- 1 ISEP socket for measuring the level of the transmit signal

The level at the sockets is measured on a high impedance basis and corresponds to the value at the measuring point. Incorrect operations such as short circuiting or inserting a signal ( $U \leq 5\text{ V}$ ) at the measuring sockets does not result in interruption of teleprotection signaling.

### 10.1.7 Inhibit Line

An inhibit line is routed via the CLE module, which acts on the inhibit input of the power supply. If there is no CLE module (if only a device with digital interfaces exists), insert the jumper X41 in position 1-2 in the subrack.

## 10.2 Connection of an External SWT 3000 to the PowerLink 50/100

The connection of an external SWT 3000 to the VF- interface of a PowerLink device is carried out via the back-plane connector of the CLE and the D-Sub sockets (VFx) on the connector panel of the PowerLink. The principle is shown in the following figures. In this case, the VFx ports 3 or 4 must be used.

### VFx port 3

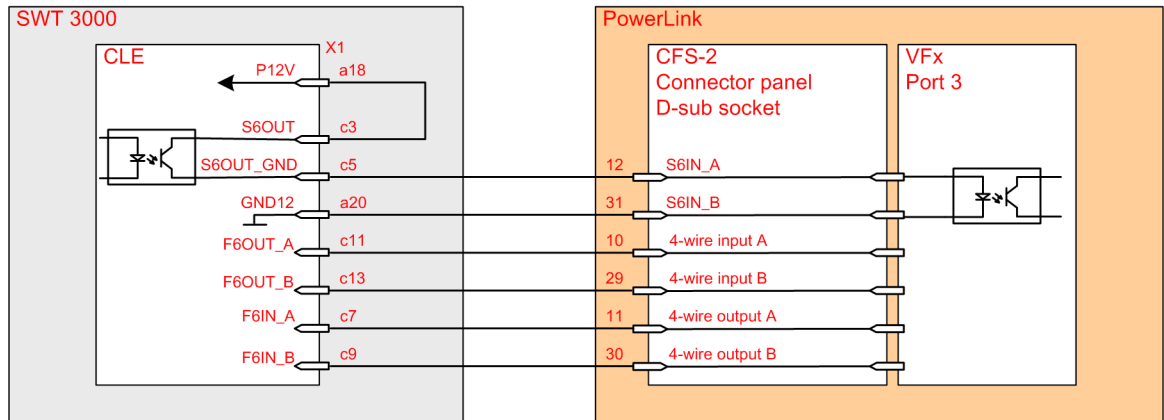

[dwcovfx3-110711-01.tif, 1, en\_US]

Figure 10-6 Connecting an External SWT 3000 to Port 3 of the VFx Modules

### VFx port 4

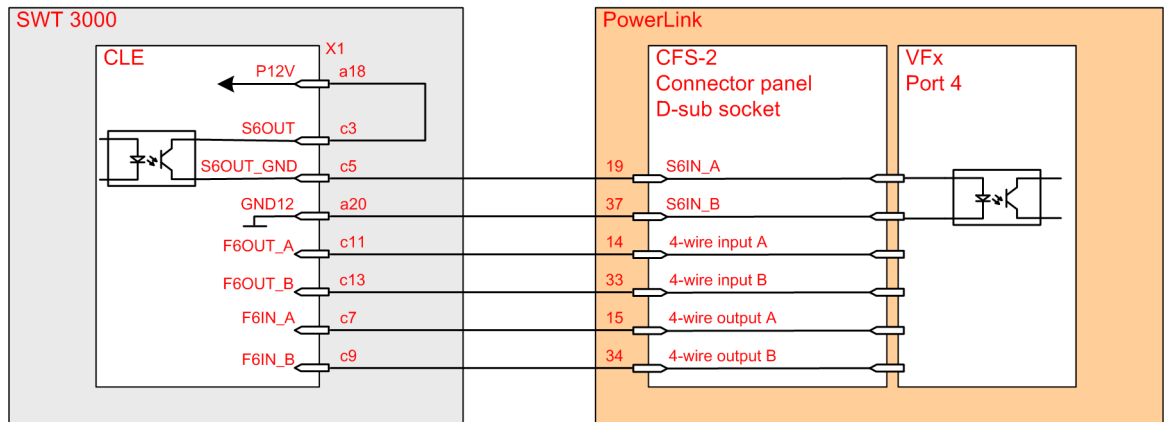

[dwcovfx4-110711-01.tif, 1, en\_US]

Figure 10-7 Connecting an External SWT 3000 to Port 4 of the VFx Modules

# 11 Fiber Optic Module

---

11.1	Fiber-Optic Module	332
------	--------------------	-----

---

## 11.1 Fiber-Optic Module

With the FOM, it is possible to connect up to 2 external SWT 3000 via fiber-optic cable to the PowerLink PLC system (for each transmission direction one fiber).

In the PowerLink 100 system, 2 SWT 3000 can be connected via fiber-optic cables (iSWT-1 and iSWT-2).

Fiber-optic modules are installed in the slots of the PU4.

In the PowerLink 50 system, the connection of an iSWT 3000 via fiber-optic cables is not supported.

The PU4 in the external SWT 3000 is connected to the iLAN interface and its Serial Synchronous Interface (SSI) via FOM to PowerLink. From the point of view of the PowerLink, the external SWT 3000 is considered **like integrated**, because the internal iLAN of the system is extended through the fiber-optic connection.

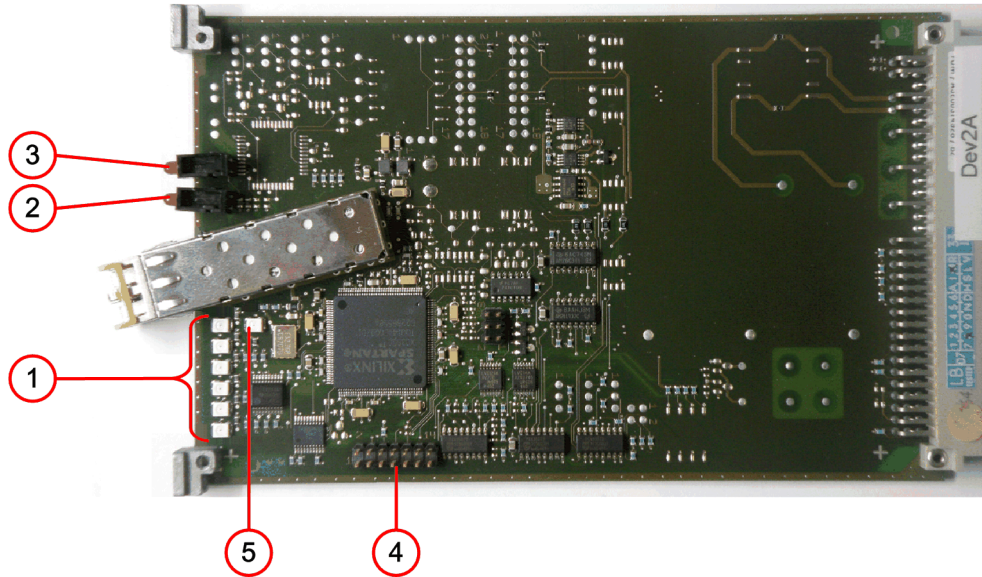

[scfomled-220513-01.tif, 1, en\_US]

Figure 11-1 Position of the LED on the FOM

- (1) LED H4 to H9: Diagnosis
- (2) LED H3 Rx-Alarm
- (3) LED H2 Tx-Alarm
- (4) Programming Interface
- (5) LED H1: FPGA Readiness

On the FOM, no jumper settings are required. The LED indications are described in the following table:

Table 11-1 Signification of the Alarm LED on the FOM

LED	LED Indication when Lighted	LED Indication with FOS3 for C37.94
H1	red FPGA not ready	FPGA not ready
H2	red Tx-Alarm F6 supervisory alarm	Tx-Alarm F6 supervisory alarm
H3	red Rx-Alarm	Rx-Alarm
H4	yellow iLAN high	LOS alarm ("lose of signal" alarm) LED on: DCE and DTE not synchronized or when in sync state, there are at least two bit errors in consecutive 8 C37.94 frames

LED		LED Indication when Lighted	LED Indication with FOS3 for C37.94
H5	yellow	BUF alarm Buffer overflow or under run Source: Supervisory circuit of FPGA	<b>AIS alarm</b> ("Alarm Indication Signal" alarm) LED on: "all ones" received. The multiplexer lost the higher order link, it will send all one in the data bits to SWT3000.
H6	yellow	MOD-alarm Modulation alarm, carrier frequency at the optical receiver not detected	<b>RDI alarm</b> ("remote defect indicator" alarm) LED on: remote side of C37.94 connection entered a LOS alarm state.
H7	yellow	COM-alarm Communication alarm at the electrical interface	Debug information (for test purpose)
H8	yellow	SFP_LOS The received optical power is below the receiver sensitivity Loss of signal	Debug information (for test purpose)
H9	yellow	S6 asserted	Debug information (for test purpose)



**NOTE**

If there is a FOM connection to PowerLink, the configuration of the external SWT 3000 is executed via the PowerLink with the **service program PowerSys**. **The service interface of the PU4 in the external SWT 3000 cannot be used.**



## 12 Alarm Module

12.1	Overview	336
12.2	Inputs and Outputs	337

## 12.1 Overview

The ALR module provides 3 alarm relays and 2 binary inputs. The input voltage is adjustable to DC 24 V, DC 48/60 V, DC 110 V, or DC 250 V. The binary input 1 is used for the clock synchronization of the SWT. Either an external synchronization pulse is connected (jumping X14-X15) or the input is alternatively configurable as an input for entering IRIG-B signals (jumping X16-X17). Additionally the ALR module provides an LED for visual indication of the state for each binary input and for each alarm output. The LEDs are visible after removal of the front panel.



## 12.2 Inputs and Outputs

### 12.2.1 Block Diagram

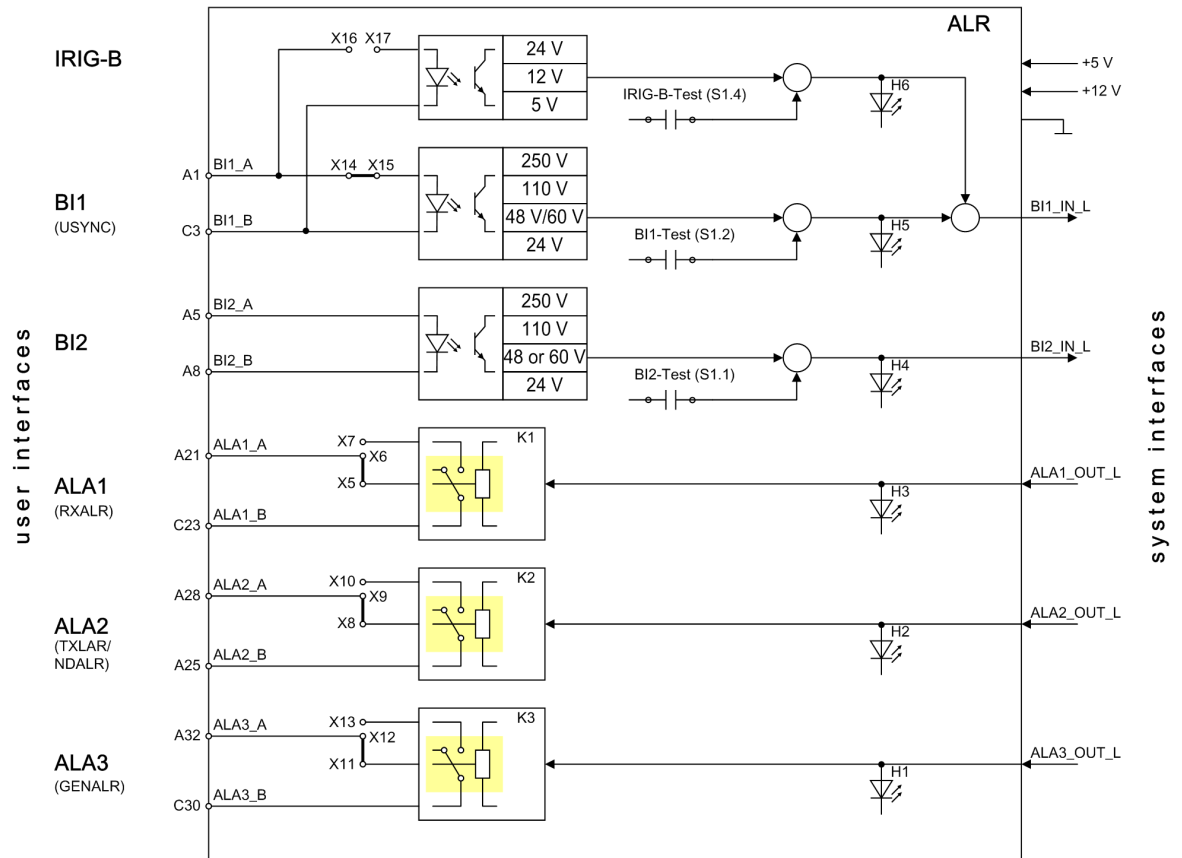

[dw\_SWT\_bcalr, 1, en\_US]

Figure 12-1 Block Diagram of the ALR Module

### 12.2.2 Binary Inputs

The module ALR provides 2 electrically isolated inputs BI1 and BI2 with selectable input voltage levels. As the circuits for the binary inputs comprise rectification, differential DC input signals of either polarity can be connected. The output signals of the circuits have TTL level. Binary input BI1 is alternatively configurable as an input for entering IRIG-B signals.



**NOTE**

Binary input BI2 is for future use.

### 12.2.3 Relay Outputs

The alarm module comprises also 3 alarm outputs, switched by relay (K1 to K3). The 3 relays provide change-over contacts. In the standard setup the break contacts (NC) are used.

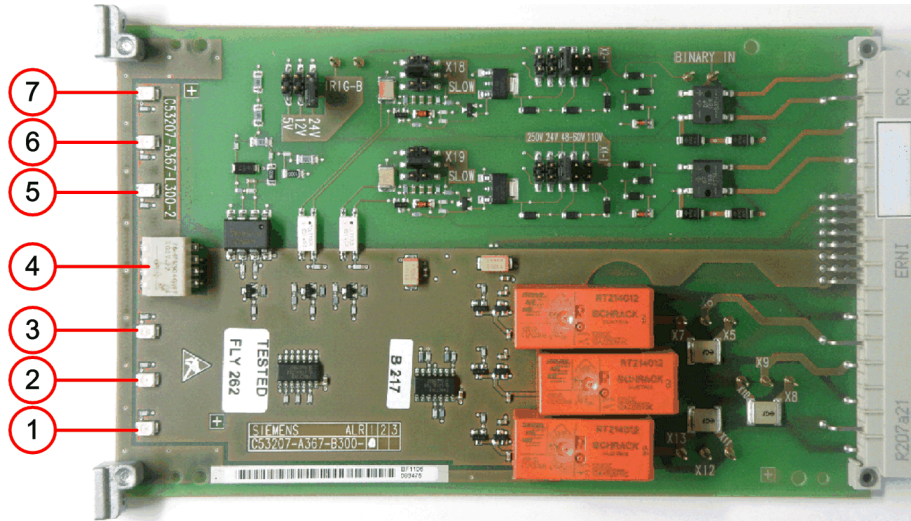

Figure 12-2 Display and Setting Elements on the ALR Module

- (1) LED H1: Output ALA3
- (2) LED H2: Output ALA2
- (3) LED H3: Output ALA1
- (4) Test Switch S1
- (5) LED H4: Input BI2
- (6) LED H5: Input BI1
- (7) LED H6: IRIG-B Input

### 12.2.4 Visual Indication

The ALR module provides a LED for visual indication of the state for each binary input and for each alarm output. They are visible after removal of the front panel. The significations are shown in the following table:

Table 12-1 ALR Indication

LED	Indication
H6	IRIG-B input energized
H5	Binary input 1 energized
H4	Binary input 2 energized
H3	Alarm output 1 activated
H2	Alarm output 2 activated
H1	Alarm output 3 activated

### 12.2.5 Test Switch S1

For test purposes, the ALR module provides a switch for each of the binary input circuits and for the IRIG-B circuit. Closing a switch sets the output of the assigned circuit to the active state.

Table 12-2 Functions of the ALR Test Switch

Switch	Function
S1.1	Binary input 2 test
S1.2	Binary input 1 test
S1.3	Not used
S1.4	IRIG-B test



# 13 Power Supply

13.1	Functional Description	342
13.2	Connection of the Power Supply	345

## 13.1 Functional Description

### 13.1.1 Overview

The input voltage is fed to the input capacitor via a fuse, an input filter, and an inrush current limiting element. This capacitor supplies the switching transistor of the single-ended converter. Each output is supplied from a separate winding. The secondary voltage is rectified. The output voltage ripple is minimized with a storage choke and subsequent output filter.

#### Control Circuit

The control circuit monitors the output voltage  $U_{out1}$ . It also generates the control signal for the switching transistor on the primary side taking into account the maximum permissible output currents. The control signal is fed back to the switching transistor via a transformer for electrical isolation. The secondary outputs  $U_{out2}$  and  $U_{out3}$  are controlled individually and independently and each have their own current limiting system. If one of the secondary outputs is operating in current limiting mode, the voltages of the other outputs are also reduced.

#### Fuse

The fuse protects the unit against major damage. For input voltages  $\geq 200$  V, an external fuse or a protection switch at system level is recommended additionally.

#### Disconnection

An internal inhibit signal disconnects the outputs as follows:

- Auxiliary voltage below  $0.8 \times U_{min}$
- Auxiliary voltage above  $1.1 \times U_{max}$

#### Inrush Current

When switching on for the first time, an NTC thermistor in the input circuit reduces the inrush current surge by a factor of about 5 to 10. This reduction protects connector junctions and switches against possible damage. Repeated start-up operations at short intervals reduce the effect of the NTC with the result that the inrush current surge increases.

#### Inhibit Input

The inhibit input enables the output voltages to be switched on and off with logic signal  $U_{inh}$  (TTL, CMOS). The inhibit input (Number 2) must be connected to the minus pole of output 1 (Number 23) in order to enable the outputs. This connection is routed via the module slots in the SWT 3000 system. If a module is removed or not correctly installed, the power supply to the unit is disconnected.

#### Installation

The power supply connection must comply with the regulations in force in the particular country. Only the socket connector must be used for the cabling. Other types of connection do not warrant compliance with the safety regulations in every case. The units correspond to protection class 1. Installations in compliance with protection class 2 require additional insulating access protection around the housing of the power supply.



#### NOTE

If the SWT 3000 is used in the PowerLink system (as iSWT) it is supplied via the central power supply of the PowerLink.

It is neither required nor it is possible to use a separate power supply for the integrated unit.

---



**NOTE**

If an additional fuse is necessary, this fuse must be inserted in the incoming line to the pin 29 of the power supply unit.

### 13.1.2 General Description

2 different power supplies are available for the SWT 3000 units:

Operating voltage:	DC 24 V to 60 V	DC 110 V to 250 V AC 115 V to 230 V
Converter type:	PSMM50 48T512	PSMM50 230T512

50 W AC-DC/DC-DC converters are used.

- Wide input voltage ranges
- Efficient input filters
- AC (RMS) 3 kV isolating voltage
- Individually regulated outputs
- AC input and DC input galvanically isolated
- Reverse polarity protection in order to protect against the inadvertent inversion of power supply voltage

Properties	Benefits
High efficiency	Minimum heat development and low thermal rating
Input/output and output/output electrically isolated	Safety in conformance with IEC 60950-1 / IEC 62368-1, VDE 0850
Wide input voltage ranges	Use without matching to the supply voltage
Permanently proof against low load and short circuit	Simple handling, optimum equipment self-protection
No reduction of load	Full output power in spec. temperature range
Input undervoltage disconnection	No failures of the outputs
Temperature monitoring	Over temperature protection through disconnection
Closed metal case	Additional cooling not necessary

The converters are versatile power supplies suitable for industrial use where high requirements apply.

- High efficiency, which remains practically constant over the entire input voltage range
- Maximum reliability
- Small residual ripple
- Good dynamic control properties

They are suitable for installation in 19" subracks (DIN 41949-compliant).

In order to conform with the safety regulations currently applicable, the units must be connected via a socket connector.

### 13.1.3 Displays

LEDs on Power Supply Unit, visible after removal of the front panel.



[ph\_power\_supply\_leds, 1, ...]

Figure 13-1 Front view of the Power Supply

Table 13-1 Significance of the LEDs on the Power Supply Unit

LED	Conditions	Significance
Operate	$U_{i \min} \leq U_i \leq U_{i \max}$ $I_o \leq I_{o \text{ nom}}$ $T_C \leq T_{c \max}$ $U_{inh} \leq 0.8 \text{ V}$	Unit in normal operation
Operate and overload 1, 2, or 3	$U_{i \min} \leq U_i \leq U_{i \max}$ $T_C \leq T_{c \max}$ $U_{inh} \leq 0.8 \text{ V}$	Current at output Uout1, Uout2, or Uout3 too high
Disable	$U_{i \min} \leq U_i \leq U_{i \max}$ $I_o \leq I_{o \text{ nom}}$ $T_C \leq T_{c \max}$	$U_{inh} > 0.8 \text{ V}$ Unit switched off or PU4 or CLE not inserted
Disable	$U_{i \min} \leq U_i \leq U_{i \max}$ $I_o \leq I_{o \text{ nom}}$ $U_{inh} \leq 0.8 \text{ V}$	Temperature monitoring has operated
Disable	$I_o \leq I_{o \text{ nom}}$ $T_C \leq T_{c \max}$ $U_{inh} \leq 0.8 \text{ V}$	Undervoltage or overvoltage monitoring has operated

$U_i$  = Input voltage



## 13.2 Connection of the Power Supply

### 13.2.1 Pinout of the Connectors SV-1 and SV-2

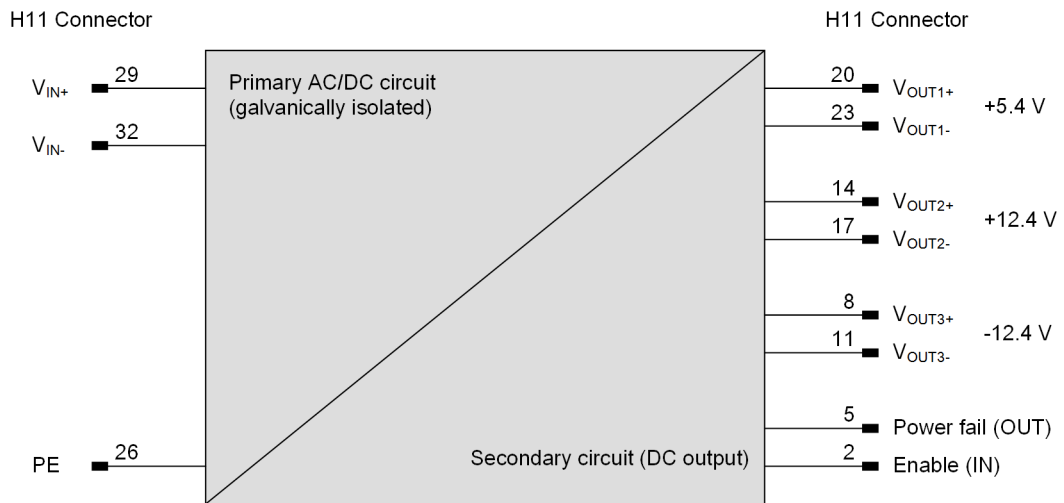

[dw\_blockdiagram\_power\_supply\_1\_...]

Figure 13-2 Block diagram of the power supply module

Table 13-2 Pinout of the H11 Connectors SV-1 and SV-2

Pin Number	Function	Signal name	Comments
2	Enable	INH	A logical low enables the output voltages of the power supply. The primary circuit remains powered regardless of the enabled signal.
5	Power fail	PON_SV(x)	This open collector output indicates the loss of primary power by a logical low level.
8	$V_{OUT3+}$	GND	Positive output voltage of 12.4 V with respect to $V_{OUT3-}$ .
11	$V_{OUT3-}$	N12_PS(x)	Reference potential for $V_{OUT3+}$ .
14	$V_{OUT2+}$	N12_PS(x)	Positive output voltage of 12.4 V with respect to $V_{OUT2-}$ .
17	$V_{OUT2-}$	GND	Reference potential for $V_{OUT2+}$ .
20	$V_{OUT1+}$	P5_PS(x)	Positive output voltage of 5.4 V with respect to $V_{OUT1-}$ .
23	$V_{OUT1-}$	GND	Reference potential for $V_{OUT1+}$ .
26	PE	GND, GNDS	Protection Earth
29	$V_{IN+}$	$V_{IN+}$ N/+	Positive input voltage with respect to $V_{IN-}$ .
32	$V_{IN-}$	$V_{IN-}$ L/-	Negative input voltage with respect to $V_{IN+}$ .

### 13.2.2 Redundant Power Supply

One or 2 power supplies can be used in the SWT 3000 system. They are decoupled via diodes on the back-plane. In order to detect failure of a power supply unit, the PU4 module monitors the output voltages from power supplies PS-1 and PS-2. The interface modules are supplied via PU4.

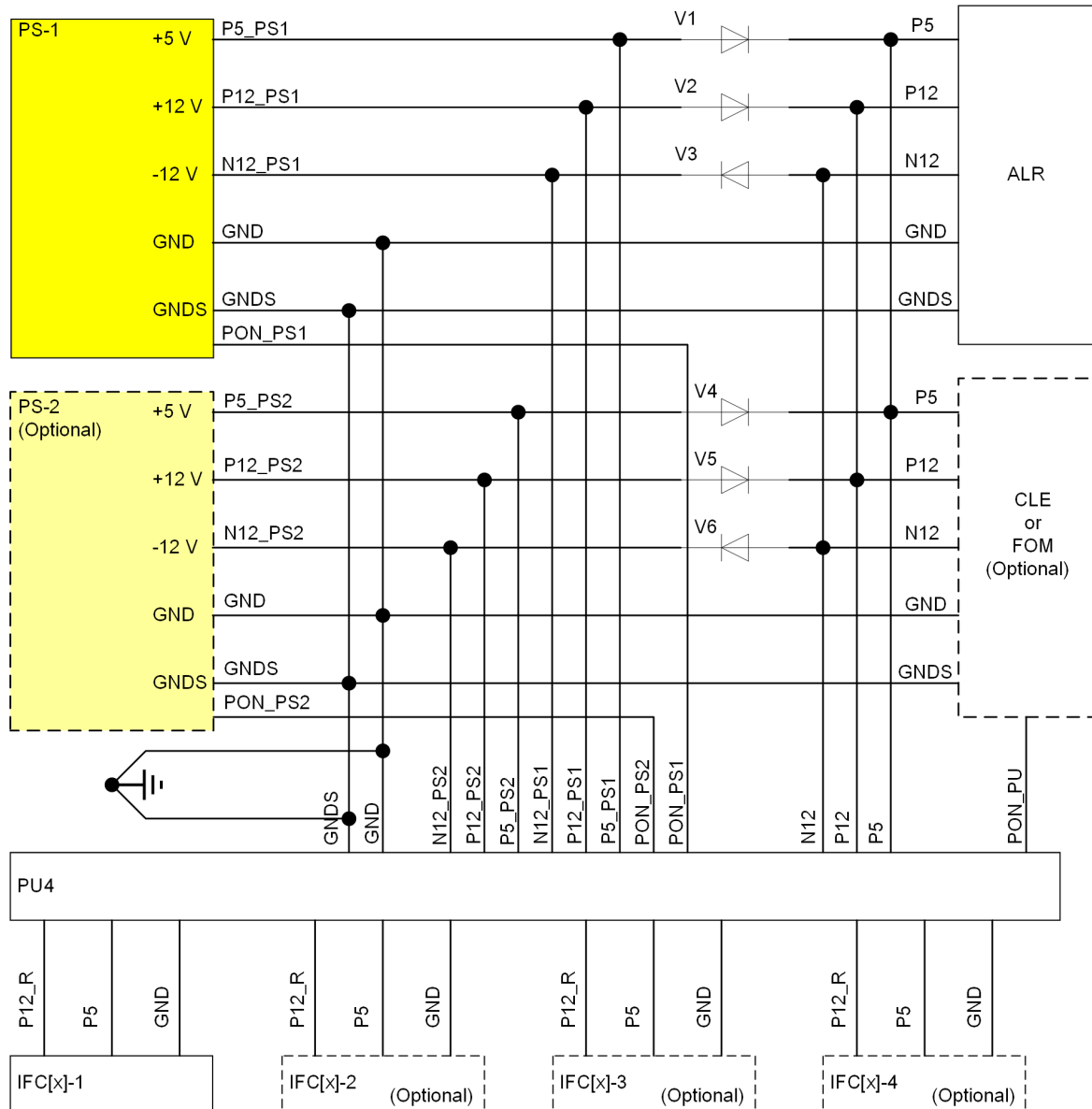

[tdw\_block\_diagram\_redundant\_ps\_1\_en\_US]

Figure 13-3 Block Diagram of the Redundant Power Supply

### 13.2.3 Inhibit Loop

An inhibit loop monitors the presence of the PU4, CLE and FOM modules. Pulling the PU4 and/or the CLE and/or FOM causes the interruption of the monitoring loop and the secondary voltages from PS-1 and PS-2 (if available) are disabled.

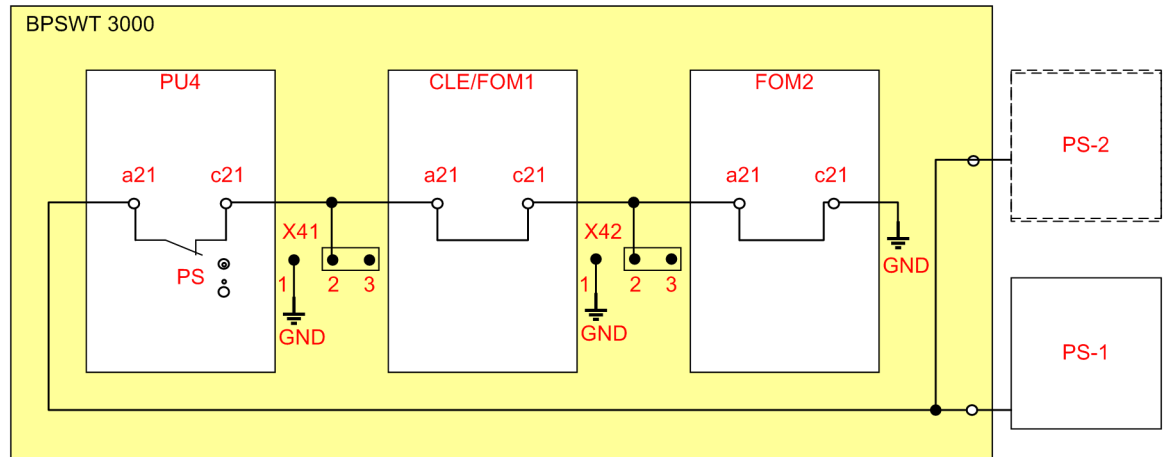

[dwinhloc-180314, 1, de\_DE]

Figure 13-4 Inhibit Loop for the Power Supplies



#### NOTE

An On/Off switch (PS) on the PU4 (not accessible from outside) also interrupts this monitoring loop. If only the CLE/FOM1 module is not used, the jumper X41 must be inserted in position 1-2. If the FOM2 is not used, the jumper X42 must be inserted in position 1-2.



#### DANGER

The ON/OFF switch on the PU4 powers down the device, but does NOT cut the primary supply voltage (auxiliary voltage). Dangerous voltages may be present even if the device has been powered off via the PU4.

**If you do not comply with the safety notes, this will result in death, severe injury, or considerable material damage.**

- ✧ Make sure that the power is turned OFF by switching the external voltage separator in the cabinet or rack to OFF position.



## 14 Technical Data

14.1	Command Input/Output	350
14.2	Terminals of IFC Modules	352
14.3	Transmission Line - Digital Networks	353
14.4	Transmission Line - Fiber-Optic	354
14.5	Transmission - Analog Networks	356
14.6	Common System Data	358
14.7	Standards	360
14.8	Electromagnetic Compatibility EMC	361
14.9	Ambient Conditions	362

## 14.1 Command Input/Output

### Binary Command Input IFC-P/IFC-D

Input voltage range <sup>12</sup>	DC 24 V to 250 V (tolerance -20 % to +20 %)	
Input per module	4	
<b>Nominal Input Voltage</b>	<b>Typical Threshold Voltage</b>	<b>Tolerance</b>
24 V	17.0 V	+/- 10 %
48 V or 60 V	33.0 V	+/- 10 %
110 V	75.0 V	+/- 10 %
220 V or 250 V	155.0 V	+/- 10 %
Polarity	Independent	
Pulse suppression	1 ms to 100 ms (programmable in steps of 1 ms)	
Input current	Max. 2 mA	

### Binary Command Output IFC-P for normal contact load

Contact type	Relay NO, normally open
Contacts per module	4
Contact material	Ruthenium
Switching power	250 W/250 VA
Switching voltage	AC/DC 250 V
Switching current	AC/DC 1.5 A
Carry current < 2.5 ms	AC/DC 5 A
Carry current	AC/DC 1.5 A
Insulation withstand voltage	AC 3 kV
Contact configuration	Single pole, normally open
Connection cable	≤ 2.5 mm <sup>2</sup> (modular terminal block)
Pickup time including contact-chatter time maximum	2 ms
Electric strength of contacts/coil	AC 3000 V

### Binary Command Output IFC-D for high contact load

Contact type	Relay NO, normally open
Contacts per module	4
Contact material	Silver Tin Oxide
Switching power	150 W/1250 VA
Switching voltage	AC/DC 250 V
Switching current	AC/DC 5 A (30 A ≤ 0.5 ms)
Carry current	AC/DC 5 A
Insulation withstand voltage	AC 3 kV
Contact configuration	Single pole, normally open
Connection cable	≤ 2.5 mm <sup>2</sup> (modular terminal block)
Electric strength of contacts/coil	AC 3000 V

<sup>12</sup> Regardless of the configured nominal input voltage, the maximum voltage of DC 287.5 V can be connected.

### Binary Command Output IFC-S for Signaling

Contact type	Relay CO, changeover with common root
Contacts per module	8
Contact material	Silver Tin Oxide
Switching power	150 W/1250 VA
Switching voltage	AC/DC 250 V
Switching current per contact	AC/DC 5 A (30 A $\leq$ 0.5 ms)
Carry current	AC/DC 1 A
Switching current per IFC-S module	8 A
Insulation withstand voltage	AC 3 kV
Contact configuration	Single pole, configurable: normally open or normally closed Common reference voltage
Connection cable	$\leq$ 2.5 mm <sup>2</sup> (modular terminal block)
Electric strength of contacts/coil	AC 3000 V

### Binary Input IFC-MCM Basis and Sub Module for PowerLink 100

Rated input voltage *)	DC 24 V to DC 250 V (tolerance: -20 % to +20 %)
Threshold	70 % of rated DC input voltage (24 V, 48/60 V, 110 V, 220 V)
Polarity independence	Yes
Pulse suppression	1 ms additionally up to 100 ms programmable in steps of 1 ms
Hardware debounce time	0.6 ms or 1 ms adjustable with jumpers

\*) Regardless of the adjusted input voltage the max. voltage of DC 287.5 V can be connected

### Command Output IFC-MCM (Relay) for PowerLink 100

Contact type	Relay, make contact
Switching power	150 W (DC) 1250 VA (AC)
Switching voltage	220 V (DC)
Switching current	5 A (DC or peak AC)
Carry current	5 A (DC or peak AC)

### Command Output IFC-MCM (Solid State Relay) for PowerLink 100

Contact type	Semi-conductor electrically isolated, make contact
Switching power	50 VA
Switching voltage	250 V (DC or peak AC)
Switching current	2 A (DC or peak AC)
Carry current	2 A (DC or peak AC)

### IEC 61850 Command Input/Output EN100

Electrical interface	RJ45, 100BaseT, max. range 20 m
Optical interface	1300 nm, LC connector, max. range 1.5 km, Multimode
Transmission rate	100 Mbps (Fast Ethernet)

## 14.2 Terminals of IFC Modules

### Screwed connection

Wire cross section	< 1.5 mm <sup>2</sup> (> AWG 16)
Bare Wire without conductor sleeve Stripping Length L	12 mm (0.47 inch)
Stranded Wire with conductor sleeve Stripping Length L	10 mm (0.39 inch)
Terminal screw tightening torque	0.8 Nm (7.1 lb. inch)
Sleeve length (wire range) / Type	> 10 mm (0.39 inch) e.g. DIN 46228-E1,5-10
Sleeve Type	Acc. EN 60947-7 class 1

### Crimped connection

0.5 to 1.0 mm <sup>2</sup> (AWG 20 to 18) Recommended Contact Type	Weidmueller Order. No. 162552 (Tape), 162556 (single contact)
1.5 to 2.5 mm <sup>2</sup> (AWG 15, 14) Recommended Contact Type	Weidmueller Order. No. 162550 (Tape), 162551 (single contact)
Recommended Crimp Tool	Weidmueller Order. No. 9014140000
Recommended Unlocking Tool	Weidmueller Order. No. 1359000000



## 14.3 Transmission Line - Digital Networks

### Digital Interface DLE

Data rate	64 Kbps	X21 or G703.1
	2 Mbps	G703.6 sym. 120 Ω G703.6 asym. 75 Ω
Path protection (1+1)	Digital and digital line Digital and FO line Digital and analog line Digital and Ethernet line	

### Internet Line Interface (EN100 - TPoP) \*

ETH electrical	100TX/100 Base-T two RJ45 ports max. range 20 m
ETH optical	100FX/100 Base-FX two ports LC connector SFP transceiver 1,310 nm max. range 1.5 km
Path protection (1+1)	TPoP and digital line TPoP and FO line TPoP and analog line TPoP and TPoP (PRP)

\* Ethernet Line Interface (TPoP) is not applicable for integration into PLC system PowerLink or in combination with IEC 61850 command interface.

### Transmission Time\*

64 Kbps	$t_o \leq 5 \text{ ms}$
2 Mbps	$t_o \leq 3 \text{ ms}$

\* Values are given for the IFC-P module.

If the IFC-D module is used, all specified signal transmission times are prolonged by about 4 ms.

With fiber-optic connections the transmission times are prolonged by about 1 ms.

If the EN100 module is used as GOOSE interface, the transmission times are prolonged by about 1 ms.

Ethernet line interface prolongs the digital transmission time about 2 ms.

### Security and Dependability

Security	$P_{UC} < 10^{-8}$
Dependability	$P_{MC} < 10^{-4}$ at BER of $10^{-6}$

## 14.4 Transmission Line - Fiber-Optic

### Fiber-Optic Interface FOM

Date rate	64 Kbps and 2 Mbps for direct connection N = 1 to 12 x 64 Kbps acc. IEEE C37.94 <sup>13</sup> for connection to Multiplexer
Optical module	SFP-Transceiver – Single mode, Multimode
Connector	LC
Path protection (1+1)	FO line and digital line FO line and FO line FO line and analog line FO line and Ethernet line

### Long Range Single-Mode FOL1

Wavelength	1550 nm
<b>Optical Budget</b>	
At 64 Kbps	43 dB
At 2 Mbps	33 dB
<b>Range<sup>14</sup></b>	
At 64 Kbps	154 km
At 2 Mbps	118 km
<b>Average output power</b>	max 0 dBm, min -5 dBm
<b>Input power</b>	
At 64 Kbps	max -10 dBm, min -48 dBm
At 2 Mbps	max -10 dBm, min -38 dBm

### Short Range Single-Mode FOS1

Wavelength	1310 nm
<b>Optical Budget</b>	
At 64 Kbps	33 dB
At 2 Mbps	17 dB
To PowerLink	13 dB
<b>Range<sup>15</sup></b>	
At 64 Kbps	87 km
At 2 Mbps	45 km
To PowerLink	34 km
<b>Average output power</b>	max -8 dBm, min -15 dBm
<b>Input power</b>	
At 64 Kbps	max -8 dBm, min -48 dBm
At 2 Mbps	max -8 dBm, min -32 dBm
To PowerLink	max -8 dBm, min -28 dBm

<sup>13</sup> Release  $\geq 3.5$

<sup>14</sup> Assumed fiber attenuation 0.28 dB/km

<sup>15</sup> Assumed fiber attenuation 0.38 dB/km

**Short Range Multi-Mode FOS2**

Wavelength	850 nm
<b>Optical Budget</b>	
To PowerLink	7 dB
<b>Range<sup>16</sup></b>	
To PowerLink	2 km
<b>Average output power</b>	max -3 dBm, min -10 dBm
<b>Input power</b>	max -0 dBm, min -17 dBm

**Short Range Multi-Mode FOS3**

Wavelength	850 nm
<b>Optical Budget</b>	
For C37.94	10 dB
<b>Range<sup>17</sup></b>	
For C37.94	2 km
<b>Average output power</b>	max -11 dBm, min -19 dBm
<b>Input power</b>	max -11 dBm, min -29 dBm

<sup>16</sup> Assumed fiber attenuation 3.5 dB/km

<sup>17</sup> Assumed fiber attenuation 3.5 dB/km

## 14.5 Transmission - Analog Networks

### Analog Interface CLE

<b>Modulation Type</b>	
F6 Frequency shift keying (FSK) or Coded Tripping (CT)	
<b>Broadband Modulation</b>	
Trip frequencies	0.3 kHz to 2.03 kHz
Guard	2.61 kHz or 3.81 kHz
<b>Narrow-Band Modulation</b>	
Channel 1	0.63 kHz to 1.26 kHz
Channel 2	1.64 kHz to 2.27 kHz
Channel 3	2.65 kHz to 3.28 kHz
Channel 4	3.16 kHz to 3.79 kHz
<b>Voice Frequency Interface</b>	
Transmitter	Level max: +15 dBm Impedance 600 Ω or 5 kΩ
Receiver	Level range: -40 dB to +4 dB Impedance 600 Ω or 5 kΩ
Path protection (1+1)	Analog and digital line Analog and FO line Analog and Ethernet line

### Transmission Time - (SWT 3000 Stand-Alone)\*

<b>Broadband Modulation</b>	
Single purpose	$t_o \leq 10$ ms (F6, CT)
Alternate multi-purpose (voice)	$t_o \leq 15$ ms (F6, CT)
<b>Narrow-band Modulation</b>	
	$t_o \leq 15$ ms (F6)

\* Values are given for the IFC-P module and permissive tripping. If the IFC-D module is used for increased contact load, all specified signal transmission times are prolonged by about 4 ms. For direct tripping schemes the transmission time increases about 5 ms.

### Transmission Time - (SWT 3000 integrated into PowerLink)\*

<b>Broadband Modulation</b>	
Single purpose	$t_o \leq 10$ ms (F6, CT)
Alternate multi-purpose (F2+AMP)	$t_o \leq 15$ ms (F6, CT);
Alternate multi-purpose (DP+AMP)	$t_o \leq 19$ ms (F6, CT);
Simultaneous multi-purpose	$t_o \leq 10$ ms (F6, CT)
<b>Narrow-band modulation</b>	$t_o \leq 15$ ms (F6)

\* Values are given for the IFC-P module and permissive tripping. If the IFC-D module is used for increased contact load, all specified signal transmission times are prolonged by about 4 ms. For direct tripping schemes the transmission time increases about 5 ms. With fiber-optic connection between SWT 3000 and PowerLink the transmission times are prolonged by about 1 ms.

### Security and Dependability

Security - Direct tripping	$P_{UC} < 10^{-6}$
Dependability - Direct tripping	$P_{MC} < 10^{-4}$ at SNR of 6 dB
Security - Blocking/permissive tripping	$P_{UC} < 10^{-4}$
Dependability - Blocking/permissive tripping	$P_{MC} < 10^{-3}$ at SNR of 6 dB

## 14.6 Common System Data

### Power Supply

Input voltage	DC 24 V to 60 V (-20 % / +20 %) or DC 110 V/220 V/250 V (-20 % / +20 %) or AC 115 V/230 V (-20 % to +10 %) 47 Hz to 63 Hz Input galvanically isolated, reverse polarity protection.
Power consumption	Approx. 30 W/VA
Cable cross-section	Max. 2.5 mm <sup>2</sup>

Characteristic	Conditions	MLFB: 7VR9514/CC	MLFB: 7VR9515/CC
Input voltage range $U_i$	AC DC	- DC 19.2 V to 72 V	AC 85 V to 264 V DC 88 V to 300 V
Input voltage nominal	DC	24 V, 48 V, and 60 V	110 V, 220 V, and 250 V
Input current	$U_{nom}$	$\leq 3.9$ A	$\leq 1.2$ A
Input fuse <sup>18</sup>	slow-blowing	6.3 A	6.3 A

### Alarm Output ALR Module

Contact type	Relay CO, changeover
Contacts per module	3
Switching power	300 W 1000 VA
Switching voltage	DC 250 V or AC
Carry current	DC 5 A or AC

### Binary Input ALR Module

Nominal voltage BI1/BI2	DC 24 V to 250 V (-20 % to +20 %)
Polarity	Independent

### Clock-Synchronization Input

Sync Pulse	Min/hour
IRIG-B	B00x, B000, B004
Ethernet	Network Time Protocol (NTP)
Nominal voltage binary input	DC 24 V to 250 V (-20 % to +20 %)
Nominal voltage IRIG-B input	DC 5 V, DC 12 V, and DC 24 V

### Event Recorder

Events	8192 Non volatile 1 ms time resolution
Trip counter	Individual counter for each received and transmitted command Size 128

<sup>18</sup> The fuse must have a safety certification for DC voltages.

### Element Manager

Interface	USB, Type B, 115 Kbps, local front access RS232 local/remote, rear Ethernet, RJ45, 100BaseT local/remote, front
Application	PowerSys
Operating system	MS Windows 7, 8 or 10

### Network Management

Interface	Ethernet, local, RJ45, 100BaseT local/remote, front
NMS integration	SNMPv2/3

### Mechanical Design

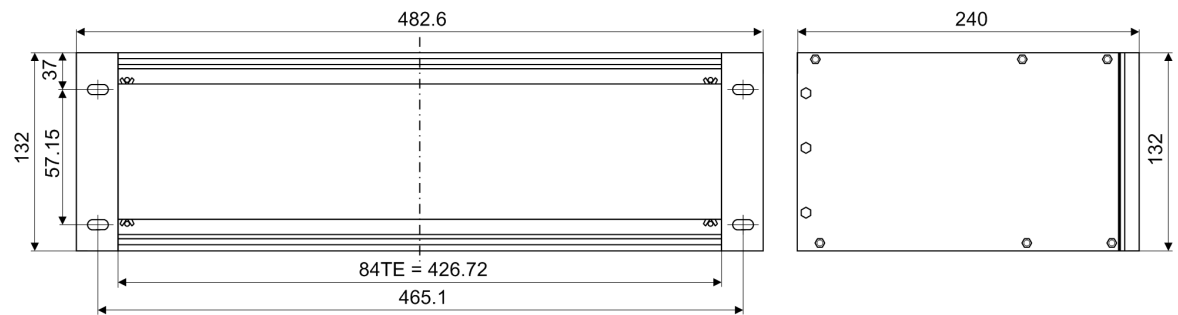

[dwwmechdi-051011-01.tif, 2, en\_US]

Dimensions	Height: 132 mm/3U Width: 482.6 mm/19 inch Depth: 240 mm
Weight	Approx. 5 kg
Colour	White aluminium, RAL 9006

## 14.7 Standards

### Performance/EMC/Environmental/Safety

Performance and testing of teleprotection equipment	IEC 60834-1
Electromagnetic compatibility (EMC)	IEC 61000-6-2 IEC 61000-6-4
Environmental conditions	IEC 60721-3
Product safety	IEC 60950-1 / IEC 62368-1
NMS integration	SNMPv2/3



## 14.8 Electromagnetic Compatibility EMC

### Immunity IEC 61000-6-2, IEC 61000-6-4, IEC 61000-4-2/3/4/5/6/8/12

Electrostatic discharge	8 kV (contact discharge) 15 kV (air discharge)
Radiated electromagnetic fields	10 V/m, (80 MHz to 2 GHz)
<b>Bursts</b>	
Power supply	2 kV
Data lines	2 kV
<b>Surges</b>	
Common mode	2 kV (line-to-ground)
Differential mode	1 kV (line-to-line)
Direct coupling into shield	2 kV (communication cable)
<b>Conducted disturbances</b>	AC 10 V, 150 kHz to 80 MHz
<b>Damped oscillatory waves</b>	
Common mode	2.5 kV (line-to-ground)
Differential mode	2.5 kV (line-to-line)
Direct coupling into shield	2.5 kV (communication cable)

### Emission IEC 61000-6-4, CISPR 11 / 22, IEC 60834-1

RF disturbance emission radiated	Limit class A, 20 MHz to 1000 MHz (air discharge)
Conducted emission	CISPR class A, power supply and signal cable
Conducted noise	IEC 60834-1, 3 mV, 0 Hz to 4 kHz

### Insulation Withstand Voltage IEC 60950-1 / IEC 62368-1

VF input/output	AC 500 V
Power supply	AC 3 kV
Command input/output	AC 3 kV
Alarm outputs	AC 3 kV
G703.1	AC 500 V
G703.6 sym.	AC 500 V

### Impulse Withstand Level 1,2/50µs IEC 60950-1 / IEC 62368-1

VF input/output	1 kV
Digital input/output	1 kV
Power supply	5 kV
Command input/output	5 kV
Alarm outputs	5 kV

## 14.9 Ambient Conditions

### Climatic IEC 60721-3

During operation	-5°C to + 55°C
During storage and transport	-40°C to +70°C
Relative humidity	5 % to 95 %
Absolute humidity	29 g/m <sup>3</sup> no condensation

### Mechanical Conditions IEC 60721-3-3 and IEC 60529

Degree of protection	IP 20 <sup>19</sup>
Vibration stationary use	Class 3M3 2 Hz to 9 Hz: 1.5 mm 9 Hz to 200 Hz: 0.5 g
Vibration transport	Class 2M1 2 Hz to 9 Hz: 3.5 mm 9 Hz to 200 Hz: 1.0 g 200 Hz to 500 Hz: 1.5 g
Shock - stationary use	Class 3M1 Pulse duration: 22 ms Acceleration: 4 g
Shock - resistance	2M1 Pulse duration: 11 ms Acceleration: 10 g

<sup>19</sup> Except for the cable entry on the rear and bottom side

# A Appendix

---

A.1	Abbreviation List	364
-----	-------------------	-----

---

## A.1 Abbreviation List

<b>A</b>	
AC	Alternative current
AFC	Automatic Frequency Control
AGC	Automatic Gain Control
ALR	Alarm
AMP	Alternate Multi-Purpose
AXC	Automatic Crosstalk Cancellation
<b>B</b>	
BI	Binary Input
BPLC	Broadband Power Line Carrier
<b>C</b>	
CC	Control Centre
CD	Compact Disc
CD-ROM	Compact Disc – Read Only Memory
CE	Conformité Européenne – European Conformity
CF	Carrier Frequency
CFG	Configuration Fault
CLE	Copper Line Equipment
CO	Command Output
CSPI	Central Signal Processing Innovation
CT	Coded Tripping
<b>D</b>	
DC	Discontinuous current
DCE	Data Communication Equipment
DIGSI	System Configurator
DIP	Dual Inline Package
DP	Data Pump
DSP	Digital Signal Processor
DTE	Data Terminal Equipment
DVD	Digital Versatile Disc
<b>E</b>	
E1	ITU Signal Level 1 (2.048Mbps)
E1-120	E1 120 $\Omega$ cable from M2ME to SDF (Krone type)
E1-75	E1 75 $\Omega$ cable from M2ME to external connector panel with BNC connectors, incl. baluns for impedance adaptation
E1-Y120	E1 120 $\Omega$ Y cable from two M2ME to SDF (Krone type)
EALR	Receiver Alarm
ETH	Ethernet interface (TCP/IP)
<b>F</b>	
FO	Fiber-optic connection
FOB	Fiber-Optic Box
FOM	Fiber-Optic Module
<b>G</b>	
G703.1	Digital interface (bitrate: 64 Kbps)
G703.6	Digital interface (bitrate: 2 Mbps)
GAL	General alarm

GGIO	Generic Generic I/O
GLINK	Serial Ethernet oriented Gigabit High Speed Link over the backplane
GMT	Greenwich Meridian Time
GND	Ground
GOOSE	Generic Object Oriented Substation Event
GUI	Graphical User Interface
<b>H</b>	
HBUS	TDM oriented virtual High Speed Bus over the backplane (virtual bus distributing and switching TDM traffic on 64k time slot level between tributary and trunk ports)
HDB3	High Debsity Bipolar of order 3
HDLC	High Level Data Link Control
HF	High Frequency
<b>I</b>	
ICD	IED Capability Description
IEC	International Electrotechnical Commission
IED	Intelligent Electronic Device
IEEE	Institute of Electrical and Electronics Engineers
IFD	EN100 Internet Settings File
iFWT	integrated FWT Alarm
INC	Impulse Noise Compression
IP	Internet Protocol
	Intellectual Property
IPC	Inter-Process Communication
iSWT	Integrated SWT
ITU-T	International Telecommunication Union - Telecom
<b>J</b>	
JAT	Jitter Attenuator
JTAG	Joint Test Action Group
<b>L</b>	
LAN	Local Area Network
LCT	Local Craft Terminal
LED	Light Emitting Diode
LIA	Analog Line Interface
LID	Digital Line Interface
LLC	Logical Link Control
<b>M</b>	
MIB	Management Information Base
MX21	4x X.21 Module
<b>N</b>	
NB	Narrow Band
NC	Normally Closed (Break Contact)
NMS	Network Management System
NDALR	Non-urgent alarm
NO	Normally Open (Make Contact)
NTP	Network Time Protocol (an IP protocol for distributing time and date information)
NU-Alarm	Non-urgent alarm

<b>O</b>	
OSM	Optical Module Switch
OSS	Open Source Software.
<b>P</b>	
PDH	Plesiochronous Digital Hierarchy (ITU and ANSI standardized)
PLC	Power Line Carrier
PS	Power Supply
PU4	Processor Unit (4th generation)
PON_PU	Power On – Processing Unit (PU4)
<b>Q</b>	
QR	Query Reply
<b>R</b>	
RM	Inband RM-Channel
RSTP	Rapid Spanning Tree Protocol
Rx-Alarm	Receiver Alarm
RXALR	Receiver alarm
<b>S</b>	
SALR	Transmitter alarm
SC	Service channel
SCD	Station Configuration Description
SDH	Synchronous Digital Hierarchy (ITU standardized)
S/N	Signal-to-noise alarm
SNMP	Simple Network Management Protocol
SSB	Remote monitoring interface
SSI	Serial synchronuous interface
SWT	Schutz-WechselstromTelegraphie (protection AC telegraphy)
<b>T</b>	
TCP/IP	Transmission Control Protocol/Internet Protocol
TPoP	Teleprotection over packet
TRAP	Transmit Tributary Alarm Processor
TU	ITU Tributary Unit
Tx-Alarm	Transmitter Alarm
<b>U</b>	
UI	User Interface
USN	Universal Substation Node
USYNC	Clock Synchronization
<b>V</b>	
VF	Voice frequency
VLAN	Virtual Local Area Network
vMUX	Versatile Multiplexer
VOIP	Voice over Internet Protocol
<b>W</b>	
-	-
<b>X</b>	
X.21	Digital interface (bitrate: 64 Kbps)

~ Number	
21E1-120	Cable from T2M to SDF (Krone type) for 21 E1, 75 $\Omega$
21E1-75	Cable from T2M to connector panel for 21 E1, 75 $\Omega$ , BNC connector, incl. baluns for impedance adaptation





# Index

## A

- Alarm
  - Possible Reasons 195
  - PowerSys 198
  - Threshold 177

## B

- Band Version
  - Broadband Version 38, 148
  - Narrow-Band Version 39, 150
- Binary Input 143

## C

- Commissioning 118
  - Power Supply 118
  - PU4 118
- Configuration
  - IP 158
  - Net 158
  - NTP 158
  - Operating Mode 128
  - SNMP 158
  - SWT 3000 126
- Copper Line Equipment (CLE) 326
  - Alarm 184, 328
  - Inhibit Line 329
- Cyber Security 85

## D

- Digital Line Equipment (DLE) 318
  - Interface G703.1 321
  - Interface G703.6 322
  - Interface X.21 320
  - Transmission Concept 319

## E

- EN100
  - IEC 61850 68
  - Settings 248

## F

- Firmware Upgrade 213
- Frequency 58

## I

- IFC 304
  - Configuration 307
  - IFC-D 313
  - IFC-D 304
  - IFC-P 304, 314
  - IFC-S 304, 315
- IP Interface to SWT 3000 66

## J

- Jumper Settings
  - CLE 115
  - DLE 323
  - IFC 110
  - LID-1 114
  - LID-2 114
  - PU4 113

## M

- Master 81
- MemTool 215
- MergeTool 242
- Module
  - CLE 115
  - FOM 332
  - PU4 113

**P**

Password 210  
Pinout  
    ALR 107  
    CLE 106  
    FOM 108  
    IFC 101, 311  
    PU4 102  
PLPA Straps  
    DLE 240  
    FO 240  
    IFC 240  
Plug 98  
Power Supply 89, 129, 342  
    Inhibit Loop 347  
PowerLink PLC System 45, 62, 177  
Protection Operating Modes 49  
PU4 294  
    Controller 298  
    Flash Memory 229  
    Power Supply 298  
    Programming of the PU4 227

**R**

Remote Access  
    TCP/IP 260  
Remote Monitoring 261  
RM  
    Analog Interface 65  
    Digital Interface 66  
    SSB 106  
    SWT 3000 140

**S**

Service Channel 66  
Slave 81  
Slot 62  
Slot Identifier 307  
SNMP 262  
    Password 278, 289  
    Settings 276  
    SNMP Traps 264  
Subrack 99  
SWTStraps 238  
System Configuration  
    Reflection 128

**T**

Transmission

Analog and Digital Transmission Path 44  
    Analog Transmission 32, 304  
    Analog Transmission Path 42  
    Digital Transmission 32, 304  
    Digital Transmission Path 43  
Trouble Shooting 233  
Tx Output 143

**U**

Upgrade 213