

Desigo® Fire Safety Detectors and Peripherals

Multi-Criteria Fire Detector Model FDOT421

Architect & Engineer Specifications

- UL 268 7th Edition Listed
- Built-in **ISOtechnology™**
- 252 Isolation devices per SLC
- Each detector is self-testing:
 - complete diagnostics performed every 10 seconds
 - self-monitored for sensitivity within UL Listed limits
- Listed, approved as a heat detector:
 - Rate-of-Rise Detection: 15°F / min. (8.3°C / min.)
 - Fixed: 135°F (57°C)
- Superior electromagnetic interference (EMI) and radio-frequency interference (RFI) immunity
- Field programmable as rate-of-rise or fixed temperature, per 'Alarm Source 2' | Standard parameter
- Tri-color detector-status light-emitting diode (LED) with 360° view
- Compatible with Model DPU (device programmer / loop tester)
- Polarity insensitive via **SureWire™** technology (in non-isolator mode)
- Functions with Model DB-11-series mounting bases
- Restriction of Hazardous Substances (RoHS compliant)
- Automatic environment compensation
- UL Listed | FM, CSFM Approved
 - UL 268: 'Open Area Smoke Detection'
 - UL 268A (Duct) - 'Direct-in-Duct' use
 - UL 521: 'Open Area Heat Detection'
 - UL-C5529: 'System Smoke Detector'
 - UL-C5530: 'Heat Actuated Fire Detection'
 - FM 3230: 'Open Area Smoke Detection'
 - FM 3210: 'Open Area Heat Detection'
 - CSFM | File: 7272-0067:0258

Product Overview

The Photoelectric | Thermal (Heat) Detector (Model FDOT421) is an intelligent, addressable multi-criteria detector that incorporates optical and thermal sensors, and uses signals in a neural network to create an intelligent multi-criteria detector. The encompassing result is a detector that provides enhanced detection to a wide range of products of combustion.

Model FDOT21 is UL 268 7th Ed. listed and incorporates advanced built-in **ISOtechnology™** - True Class-X SLC operation (use is optional) greatly improves reliability, circuit integrity and provides advanced addressable fault finding.

The multi-criteria detector additionally has state-of-the-art microprocessor circuitry (with error check), as well as detector self-diagnostics and supervision programs that is used on Desigo Fire Safety Modular | FireFinder XLS/V and on Model FC/FV20-series Desigo Fire Safety fire-alarm control panels (FACPs).

Additionally, Model FDOT421 is a plug-in and addressable two-wire multi-criteria detector (with both photoelectric and thermal sensors) whose value is increased with built-in **ISOtechnology** feature, that is compatible with all current Siemens intelligent, addressable systems.

Operation

Model FDOT421 utilizes an infrared light emitting diode (IRLED), and infrared light-sensing photodiode. Under normal conditions, light transmitted by the LED is directed away from the photodiode and scattered through the smoke chamber in a controlled pattern.

The smoke chamber is designed to manage light dissipation and extraneous reflections from dust particles or other non-smoke, airborne contaminants in such a way as to maintain stable, consistent detector operation. When smoke enters the detector chamber, light emitted from the IRLED is scattered by the smoke particles, and is received by the photodiode.

Model FDOT421 also utilizes a modern, accurate and shock-resistant thermistor to sense temperature changes.

The signal processing with detection algorithms allows the detector to first gather smoke and thermal data, and then analyze this information in the detector's 'neural network.' By comparing data received with the common characteristics of fires or fire signatures, Model FDOT421 can compare these signals to those of deceptive phenomena that cause other detectors to trigger a false alarm.



Model FDOT421
Multi-Criteria Fire Detector

Each Model FDOT421 detector provides three (3) pre-programmed parameter sets that can be selected by the FACP.



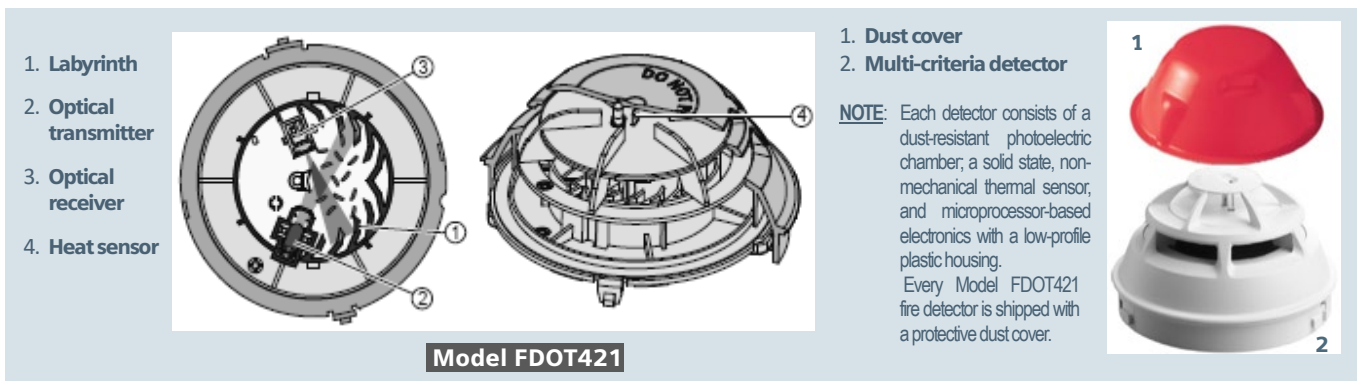

Profile Overview

Model FDOT421 provides two (2) different alarm sources that can be selected individually (ON or OFF) by the control panel.

Alarm Source 1 (Neural Network) – Combines smoke (heat) with the following field-selectable profiles:

- *Standard*
- *Duct*

Standard: This parameter set, which is practically ideal for normal office, hotel-lobby-type applications, is the default setting. This parameter set additionally offers improved resistance to false alarms in areas where misleading deceptive sources and helps reduce cooking nuisance alarms (UL 268 7th Ed. Listed)

Duct: When using this detector direct in air duct applications, be sure the detector is set to the parameter “Duct”.

Alarm Source 2 (Thermistor) – Heat only; provides the following:

- Static / fixed at 135°F (57°C), default setting
- Rate-of-Rise detection at 15°F / min. (8.3°C / min.)

If the detector is not programmed, Model FDOT421 will default to a ‘standard’ profile setting, which allows operation for a normal office-type environment. Model FDOT421 contains a tri-color LED indicator, capable of flashing any one (1) of three (3) distinct colors: **GREEN** | **YELLOW** | **RED**. During each flash interval, the microprocessor-based detector monitors the following fire-system conditions:

- Smoke in its sensing chamber
- Smoke sensitivity is within the range indicated on the nameplate label
- Internal sensors and electronics

Based on the results of the monitoring, the LED indicator flashes the following:

FLASH COLOR	CONDITION	FLASH INTERVAL [in seconds]
GREEN* :	Normal supervisory operation. Smoke sensitivity is within rated limits.	10
YELLOW:	Detector is in trouble and needs replacement.	4
RED:	‘Alarm’ condition	1
NO FLASH:	Detector is not powered.	–

* denotes LED can be turned OFF
Please follow the corresponding description of the panel used.

A quick visual inspection is sufficient to indicate the condition of the detector at any time. If more detailed information is required, a printed report can be provided from the respective Desigo Fire Safety Modular | Model FC20-series | FireFinder XLS/V FACPs that indicates the status and settings assigned to each detector.

Installation

All Model FDOT421 detectors use a surface-mounting base | Model DB2-HR | DB-11 or Model DB-11E. Each base mounts onto a 4-inch (10.2 cm.) octagonal, square or single-gang electrical box. The base utilizes screw-clamp contacts for electrical connections and self-wiping contacts for increased reliability.

The Model DB-11 detector base can be used with the optional Siemens Model LK-11 detector locking kit, which contains 50 detector locks and an installation tool to prevent unauthorized removal of the detector head. Model DB-11 has aesthetically conducive plugs to cover the outer mounting-screw holes.

Model FDOT421 may be installed on the same initiating circuit with the following [when used with Desigo Fire Safety Modular Model FC20-series | FireFinder XLS/V FACP] –

- XTRI Series interface modules
- HTRI series interface modules
- HMS & XMS series manual stations
- HFP-11, HFPT-11 detection devices
- HCP output control modules
- HZM conventional zone module

Each detector is shipped with a protective dust cover, consists of the following:

- Built-in **ISOtechnology** for True-Class-X SLC performance
- Dust-resistant photoelectric chamber
- Solid State, non-mechanical thermal sensor
- Microprocessor-based electronics with a low-profile plastic housing

All Model FDOT421 detectors are approved for operation within the UL-specified temperature range of 32°F to 100°F (0 – 38°C).

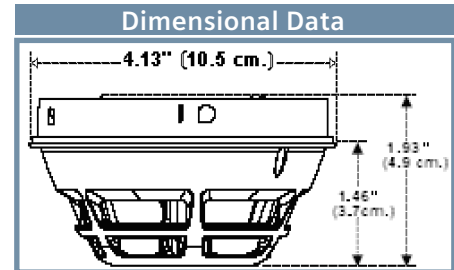

Application Data

Installation of Model FDOT421 intelligent, addressable multi-criteria detectors requires a two-wire circuit. In many retrofit cases, existing wiring may be used. ‘T-tapping’ is permitted only for Style 4 (Class B) wiring. Model FDOT421 is polarity insensitive, which can greatly reduce installation and debugging times. When operating in NFPA 72 Class-X applications SLC polarity must be maintained to support up to 252 isolation ready devices per loop. When used in mixed mode a maximum of 30 non-isolated devices between isolation devices (wired in polarity-insensitive mode). See control panel install document for further details.

Model FDOT421 can be applied within the maximum 50-feet (15.24 m.) center spacing (2,500 sq. ft. [232.2 sq. m.]) per Underwriters’ Laboratories. This application guide is based on ideal conditions, specifically, smooth-ceiling surfaces, minimal air movement, and no physical obstructions between potential fire sources and the actual detector. Do not mount detectors near to heating | ventilation | air-conditioning (HVAC) outlets. Exposed joists or beamed ceilings may also affect safe spacing limitations for detectors.

Should questions arise regarding detector placement, observe NFPA 72 guidelines. Good fire-protection system engineering and common sense dictate how and when fire detectors are installed and used. Contact your local Siemens – Fire Safety distributor or sales office whenever you need assistance applying Model FDOT421 in unusual applications.

Be sure to follow NFPA guidelines and UL Listed / ULC Listed installation instructions – included with every Siemens – Fire Safety detector – and local codes for all fire-protection equipment.

Specifications

Model FDOT421 is a plug-in, (2) two-wire Photoelectric | Thermal (heat) detector, compatible with Model FC20-series Desigo Fire Safety Modular Model FC20-series | FireFinder XLS/V FACP. Each Model FDOT421 detector has microcomputer-chip technology and highly stable, solid-state electronic circuitry. Model FDOT421 detectors utilize a modern, accurate and shock-resistant thermistor to sense temperature changes. This electronic-sensing method virtually eliminates thermal lag associated with mechanical temperature-sensing devices, and provides almost instantaneous temperature status to the FACP.

Model FDOT421 provides seven (7) field-selectable, pre-programmed temperature settings:

- Fixed 135°F (57°C)
- Rate-of-Rise: 15°F / min. (8.3°C)

This feature is compatible with Model FC20-series Desigo Fire Safety Modular Model FC20-series | FireFinder XLS/V systems, as well as with FC / FV2025 or FC / FV2050 FACP.

Field-Device Programmer / Test Unit

Model FDOT421 is compatible with the Siemens field-device programmer / test unit (Model DPU), which is a compact, portable and menu-driven accessory for electronically programming and testing these addressable detectors promptly and reliably. For instance, the field technician selects the accessory's program mode, and enters the desired address.

Model DPU eliminates the need for cumbersome, unreliable mechanical programming methods (e.g. – dials and rotary switches), and reduces installation and service costs by electronically programming and testing the detector prior to installation. When set in 'test' mode, Model DPU will perform a series of diagnostic tests without altering the address or other stored data, allowing technicians to determine if the detector is operating properly.

Each field-device programmer / test unit operates on AC power or rechargeable batteries, providing flexibility and convenience in the programming / testing of fire-safety equipment from practically any location. Additionally, with the use of a Model DPU unit, there is no longer a cause for concern with any vibration, corrosion and other deteriorating conditions that can accompany the vitality of a mechanical-addressing mechanism.

The encompassing result is an intelligent detector that provides enhanced detection capability to a wide range of products of combustion – while offering unsurpassed rejection to nuisance-alarm sources, including: dust | steam | aerosols and other deceptive phenomena that could cause false alarms.

Technical Data	
OPERATING TEMPERATURE:	+32° – +100°F (0° – +38°C)
RELATIVE HUMIDITY:	0 – 95% (non-condensing)
AIR PRESSURE:	No effect
INPUT VOLTAGE RANGE:	16VDC – 30VDC
'ALARM' CURRENT, MAX.:	410µA
'STANDBY' CURRENT, MAX.:	250µA
MAXIMUM SPACING:	30–ft. (9.144 m.) centers (900 sq. ft. 83.6 sq. m.), per NFPA 72 and ULC-S524
THERMAL RATING:	<ul style="list-style-type: none"> Fixed 135°F (57°C) Rate-of-Rise: 15°F / min. (8.3°C) at fixed 135°F (57°C)
DETECTOR WEIGHT:	0.317 Lbs. (0.144 kg.)
MECHANICAL PROTECTION GUARD:	UL Listed / ULC Listed with STI Guard Model STI-9604
SENSITIVITY RANGE:	<ul style="list-style-type: none"> UL268 3.52-4.17% / ft obs. ULC 3.52-4.27% / ft obs. UL268A 2.32-2.84% / ft obs. (direct in-duct)

Panel Compatibilities		
MODEL OR TYPE	DATA SHEET	PANEL
XLS	6300	FireFinder® (fire-only overview)
XLSV	6340	FireFinder (fire w/ voice)
Desigo Modular	7300	Desigo Modular (system overview)
FC901	6813	Desigo Fire Safety 50-point addressable
FC2025	6815	Desigo Fire Safety 252-pt. addressable (fire)
FC2050		Desigo Fire Safety 504-pt. addressable (fire)
FV2025	6821	Desigo Fire Safety 252-point addressable (fire w/ Intelligent Voice Communication [IVC])
FV2050		504-pt. addressable (fire w/ Intelligent Voice Communication [IVC])

Details for Ordering		
MODEL OR TYPE	PART NUMBER	PRODUCT
FDOT421	S54320-F6-A1	Addressable Multi-Criteria Fire Detector
Compatible Devices:		
MODEL OR TYPE	PART NUMBER	PRODUCT
ABHW-4B	S54320-F13-A1	Sounder base with Loop-Power Option
ABHW-4S	S54320-F14-A1	Sounder base for Sleeping Areas
ADB-BOX	500-698360	Surface Mount Adapter Box for Audible Base
DB2-HR	S54370-F12-A1	Relay base compatible with Siemens standard and advanced detectors
DB-11	500-094151	Detector Mounting Base (for Series 11)
DB-11E	500-094151E	Detector Base (small)
RL-HW	500-033310	Remote Alarm Indicator: Single-gang-box mount, red
RL-HC	500-033230	Remote Alarm Indicator: 4" (10.2 cm.) octagon-box mount, red
LK-11	500-695350	Base Locking Kit (for Series 11)
See: www.STI-USA.com for further details on ordering Model STI-9604		
In Canada order:		
MODEL OR TYPE	PART NUMBER	PRODUCT
DB-11C	500-095687	Detector Mounting Base, ULC Listed

This Page Left Intentionally Blank

NOTICE – The information contained in this data-sheet document is intended only as a summary, and is subject to change without notice. The product(s) described here has/have a specific instruction sheet(s) that cover various technical, limitation and liability information.

Copies of install-type, instruction sheets – as well as the *General Product Warning and Limitations* document, which also contains important data, are provided with the product, and are available from the Manufacturer.

Data contained in the aforesaid type of documentation should be consulted with a fire-safety professional before specifying or using the product.

Any further questions or assistance concerning particular problems that might arise, relative to the proper functioning of the equipment, please contact the Manufacturer.

SIEMENS

Desigo® Fire Safety

Siemens Industry, Inc.

Smart Infrastructure - Building Products
2 Gatehall Drive • Parsippany, NJ 07054
Tel: (973) 593-2600

February - 2023

(Rev. 15)