

## SED2 VFD NEMA Type 3R and Type 3R Harsh Environment (3RHE) Bypass



### Description

The NEMA Type 3R Bypasses are companion packages for the family of SED2 Variable Frequency Drives (VFD). NEMA Type 3R/3RHE enclosed bypasses are manufactured for outdoor locations that are not in direct sunlight.

Two primary styles of 3R cabinets are provided. The standard 3R rating provides protection from falling rain to the enclosed SED2 VFD and electrical control components. The harsh environment 3R rating is identical to the standard, but it is supplied with a more robust NEMA 12 SED2 drive suitable for corrosion and coastal environments.

A heater is supplied in the Type 3R models to protect against condensation. The standard package is rated to 104°F (40°C). A high temperature package, rated to 122°F (50°C), is available.

The SED2 is designed specifically for HVAC applications and supports a variety of digital and analog I/O and provides built-in PID features to control pumps and fans. For information on the family of SED2 VFDs, see the *SED2 Variable Frequency Drives Submittal Sheet (154-042)*.



### Features

#### Bypass Power

3-Contactor: Input, Output and Bypass

- Overload protection in bypass mode.
- Step-down transformer with fused primary and secondary.
- Contactors electrically and mechanically interlocked.
- Drive test function.
- Complete electrical isolation of drive.

Input Device

- Fused disconnect.
- All doors are interlocked and padlockable.

Reactor Options

- Line reactor mounted in bypass enclosure.
- Line reactor supplied separately (in NEMA Type 3R enclosure).
- Load reactor (in NEMA Type 3R enclosure) supplied separately.

#### Bypass Control

Auto Bypass

- Relay logic allows user to send the motor to bypass mode based on the drive's programmable relay.

Enable Input

- Generally used for safety tie-ins; the motor will not operate the drive or bypass when open.

Common Remote Start/Stop

- Can be used in both drive and bypass mode.

Essential Services Mode

- Typically used for smoke purge; the motor goes to bypass regardless of the selected mode.
- No call to stop will have an effect, including open safety or stop commands.
- Only turning the power off or opening this contact will stop the motor.

#### Bypass – Door Mounted Control Devices

- Drive-Off-Bypass selector
- Bypass pilot light
- Drive Test On-Off selector

**Accessories**

SED2 NEMA Type 3R VFD & Bypass EMC Filter  
 Assembly for Enclosure Size ABC, PN 994-830  
 SED2 NEMA Type 3R VFD & Bypass EMC Filter  
 Assembly for Enclosure Size DEF, PN 994-831  
 NEMA Type 3R Reactor Enclosure, Small,  
 PN 994-816

NEMA Type 3R Reactor Enclosure, Medium,  
 PN 994-817  
 NEMA Type 3R Reactor Enclosure, Large,  
 PN 994-818  
 Floor Mounting Kit, PN 994-809

**Product Numbers**

<b>Your Product Number:</b>																				
<b>Example Product Number:</b>		V	B	A	3	4	0	.	F	3	3	0	X							
<b>Model</b>	VB	VFD with Bypass																		
<b>Series</b>	A	Conventional Bypass																		
<b>Voltage</b>	1	208 V																		
	2	230 to 240 V																		
	3	380 to 480 V																		
	4	500 to 600 V																		
<b>HP rating</b>	1.0, 1.5, 2.0, 3.0, 4.0, 5.0, 7.5, 10, 15, 20, 25, 30, 40, 50, 60, 75, 100, 125 [See Note 1 for these selections]																			
<b>Disconnect</b>	F	Fused Disconnect																		
<b>NEMA rating</b>	3	NEMA Type 3R																		
<b>Contactor</b>	0	None																		
	3	3 Contactors																		
<b>Reactor</b>	[See Note 2]																			
	0	None																		
	3	Line Reactor																		
<b>Filter</b>	X	Factory Required Designator																		
<b>Options</b>	(If no option is required, leave field blank)																			
	HT1	High Temperature (See Note 3)																		
	HE2	Harsh Environment NEMA 3R (see Note 4)																		
	HT2	Harsh Environment NEMA 3R - High Temperature Rating (see Note 5)																		

Notes:

1. Available only with Voltage Codes 3 and 4.
2. Only an input line reactor can be installed in a bypass enclosure.  
 If a load reactor is required, a separate enclosed reactor is required.
3. HT1 (122°F, 50°C) is not available for all ratings. 208V, and 230 to 240V, to 3hp are all HT1; 480V to 5 hp are all HT1.
4. HE2 available only with Voltage Codes 3 and 4.
5. HT2 (122°F, 50°C) is not available for all ratings. 480 to 5 hp are all HT2.

Example Shown:

VBA340.F330X =  
 VBA Conventional Bypass, 480V, 40 hp, fused disconnect,  
 NEMA Type 3R, 3 contactors, no reactor.

**Dimensions**

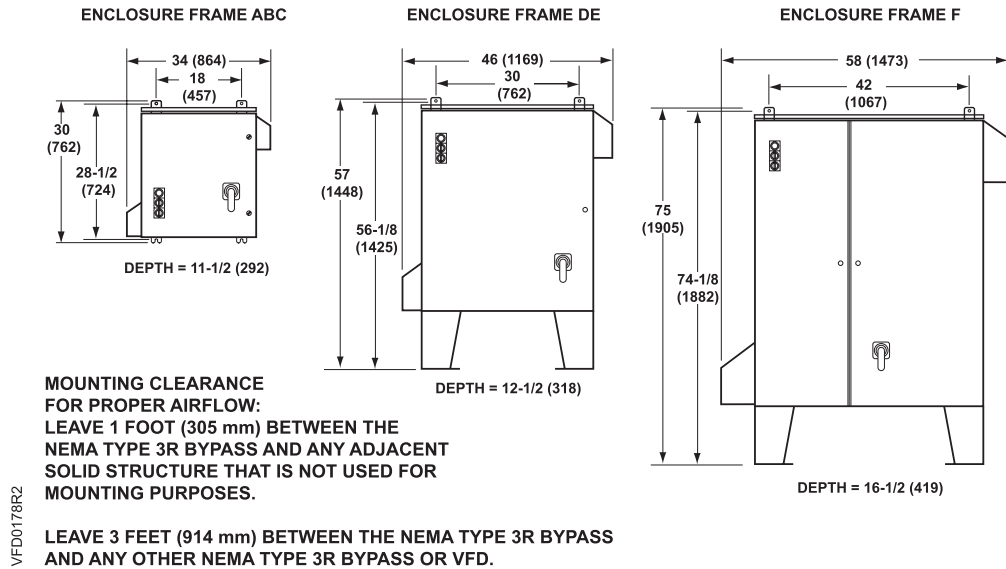

Figure 1. NEMA Type 3R Enclosure Dimensions in Inches (Millimeters).

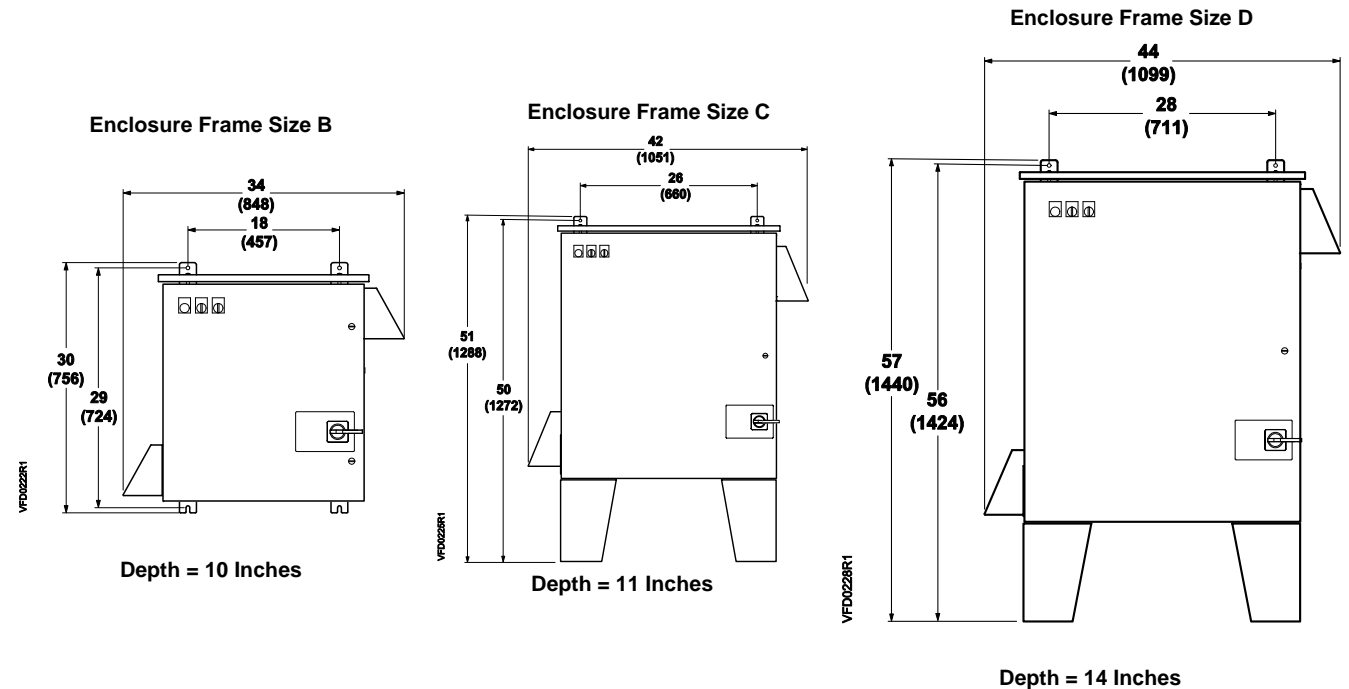

Figure 2. NEMA Type 3RHE Enclosure Dimensions in Inches (Millimeters).

Table 1.

3R Frame Size	Wt. lb (kg)
ABC	130 (59)
DE	300 (136)
F	550 (249)

Table 2.

3RHE Frame Size	Wt. lb (kg)
B	150 (68)
C	220 (100)
D	330 (150)

**NOTE:** Exact weight will be affected by actual horsepower/voltage and selected power options.

**Table 3. NEMA Type 3R Bypass Non-HT1 Enclosure Frame Sizes and Power Ranges.**

HP	1	1.5	2	3	4	5	7.5	10	15	20	25	30	40	50	60	75	100	125
kW	.75	1.1	1.5	2.2	3	4	5.5	7.5	11	15	19	22	30	37	45	55	75	90
VFD0179R2	208/ 230V	(Rated as HT1, High Temperature package)					ABC			DE			F			N/A		
	480V	(Rated as HT1, High Temperature package)					ABC			DE			F			F		
	575V	ABC									DE			F			F	

**Table 4. NEMA Type 3R Bypass HT1 Enclosure Frame Sizes and Power Ranges.**

HP	1	1.5	2	3	4	5	7.5	10	15	20	25	30	40	50	60	75	100	125
kW	.75	1.1	1.5	2.2	3	4	5.5	7.5	11	15	19	22	30	37	45	55	75	90
VFD0180R2	208/ 230V	ABC					DE			F			N/A			N/A		
	480V	ABC					DE			F			N/A			N/A		
	575V	ABC					DE			F			N/A			N/A		

**Table 5. NEMA 3RHE Bypasses HE2.**

HP	1.5	2	3	4	5	7.5	10	15	20	25	30	40	50	60	75	100	125		
kW	1.1	1.5	2.2	3	4	5.5	7.5	11	15	19	22	30	37	45	55	75	90		
VFD0241R1	208/ 230V	N/A																	
	480V	N/A			C			D			N/A			N/A			N/A		
	575V	N/A																	

**Table 6. NEMA 3RHE Bypasses HT2.**

HP	1.5	2	3	4	5	7.5	10	15	20	25	30	40	50	60	75	100	125		
kW	1.1	1.5	2.2	3	4	5.5	7.5	11	15	19	22	30	37	45	55	75	90		
VFD0242R1	208/ 230V	N/A																	
	480V	B			C			D			N/A			N/A			N/A		
	575V	N/A																	

**Table 7. NEMA Type 3R/3RHE Bypass Output Current Ratings (Amps)—Per NEC Motor Tables.**

HP	1	1.5	2	3	5	7.5	10	15	20	25	30	40	50	60	75	100	125
*208V	3.9	5.5	7.4	10.4	16.7	22	28	42	54	68	80	104	130	154	—	—	—
*240V	3.9	5.5	6.8	9.6	15.2	22	28	42	54	68	80	104	130	154	—	—	—
480V	2.1	3.0	3.4	4.8	7.6	11	14	21	27	34	40	52	65	77	96	124	156
*575V	1.4	2.1	2.7	3.9	6.1	9	11	17	22	27	32	41	52	62	77	99	125

\*Not available in 3RHE models.

**NOTE:** Drives are current rated devices. Verify that the listed ratings are ≥ the motor full load current rating.

**Typical Specifications**

SED2 Bypasses shall send the motor to bypass mode based on an easily accessible door-mounted selector or based on the drive’s programmable relay. A bypass pilot light shall provide indication of the bypass mode. The bypass mode shall provide overload protection. Contactors shall be electrically and mechanically interlocked. An essential services mode shall send the motor to bypass regardless of the selected mode.

**Wiring Diagrams**

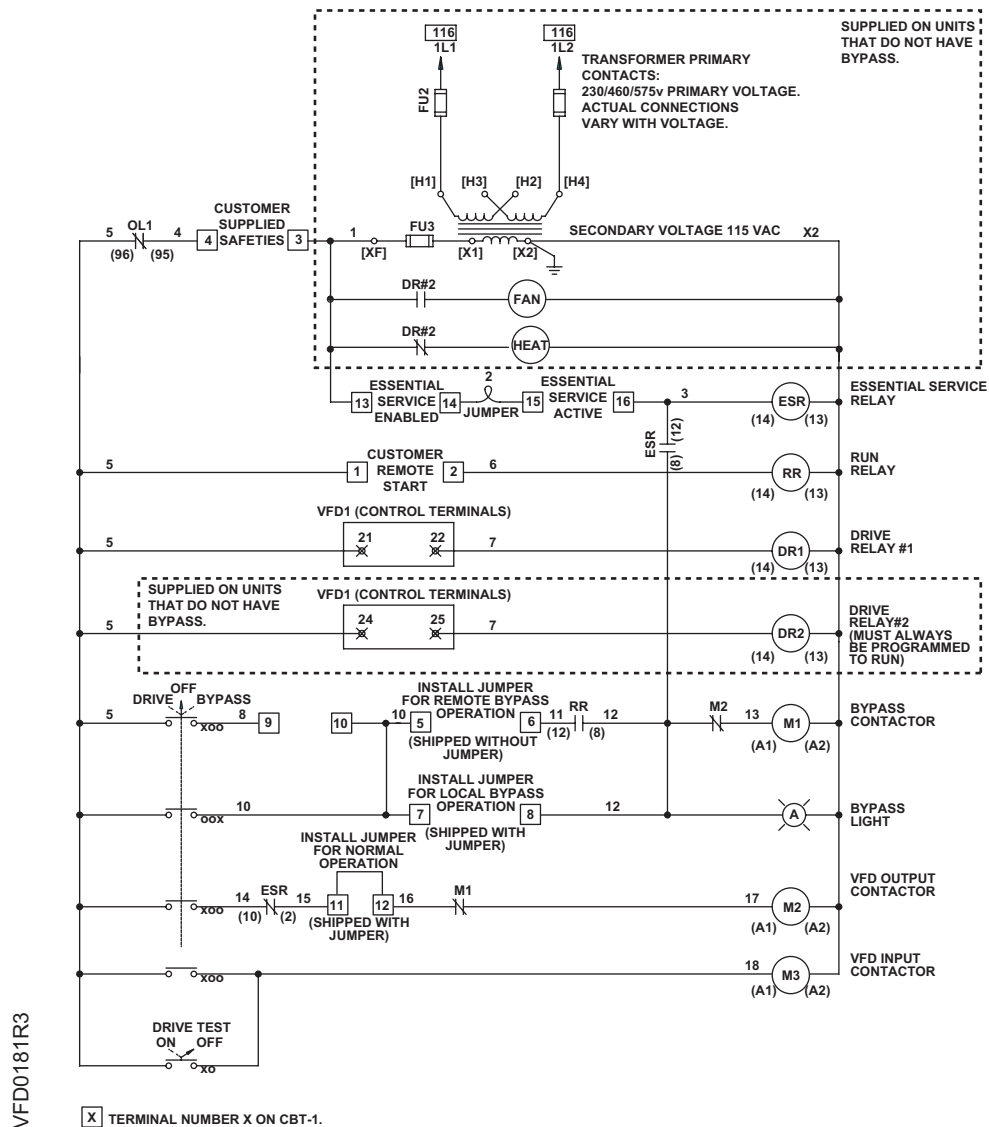

**Figure 3. NEMA Type 3R/3RHE Bypass 120 Vac Control Circuit.**

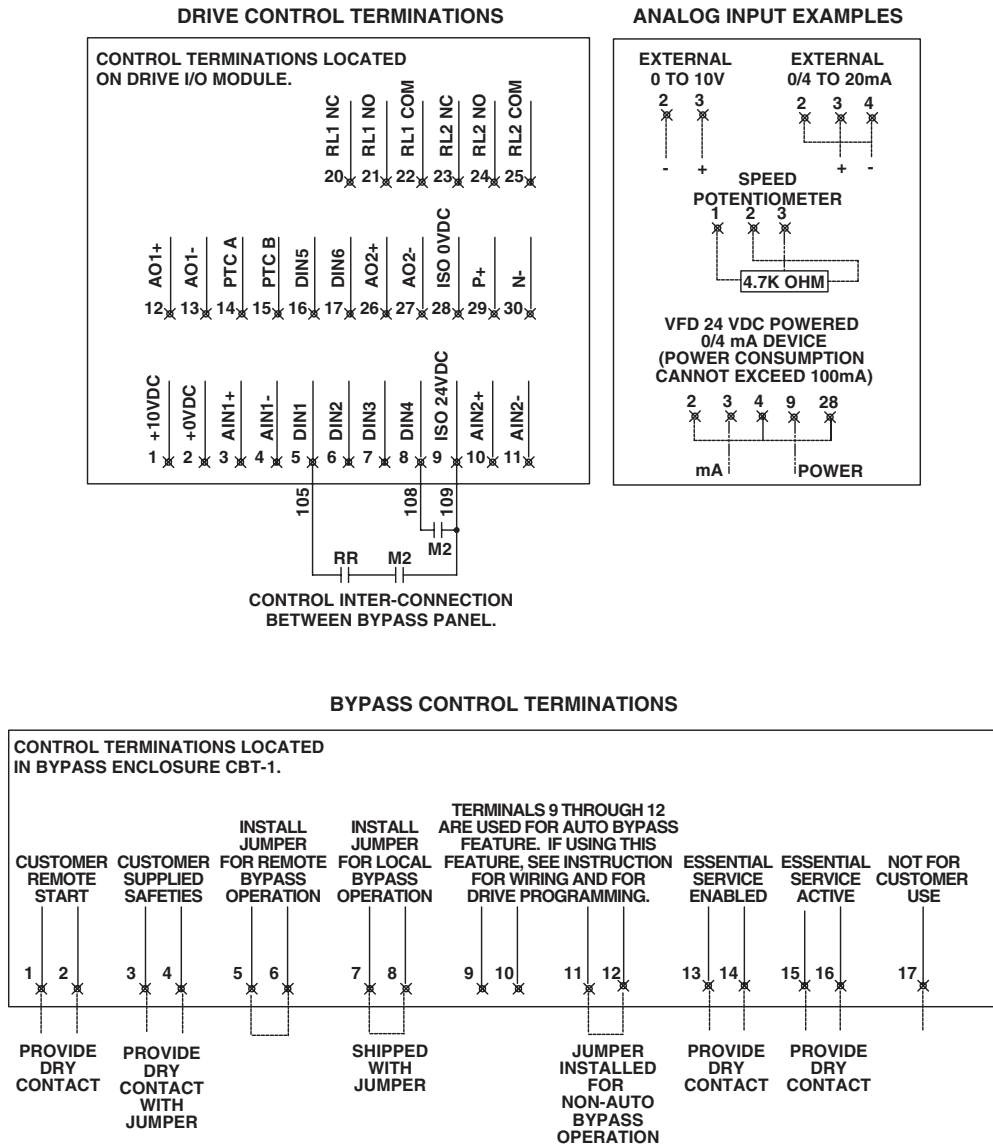

Figure 4. NEMA Type 3R/3RHE Bypass Terminations.

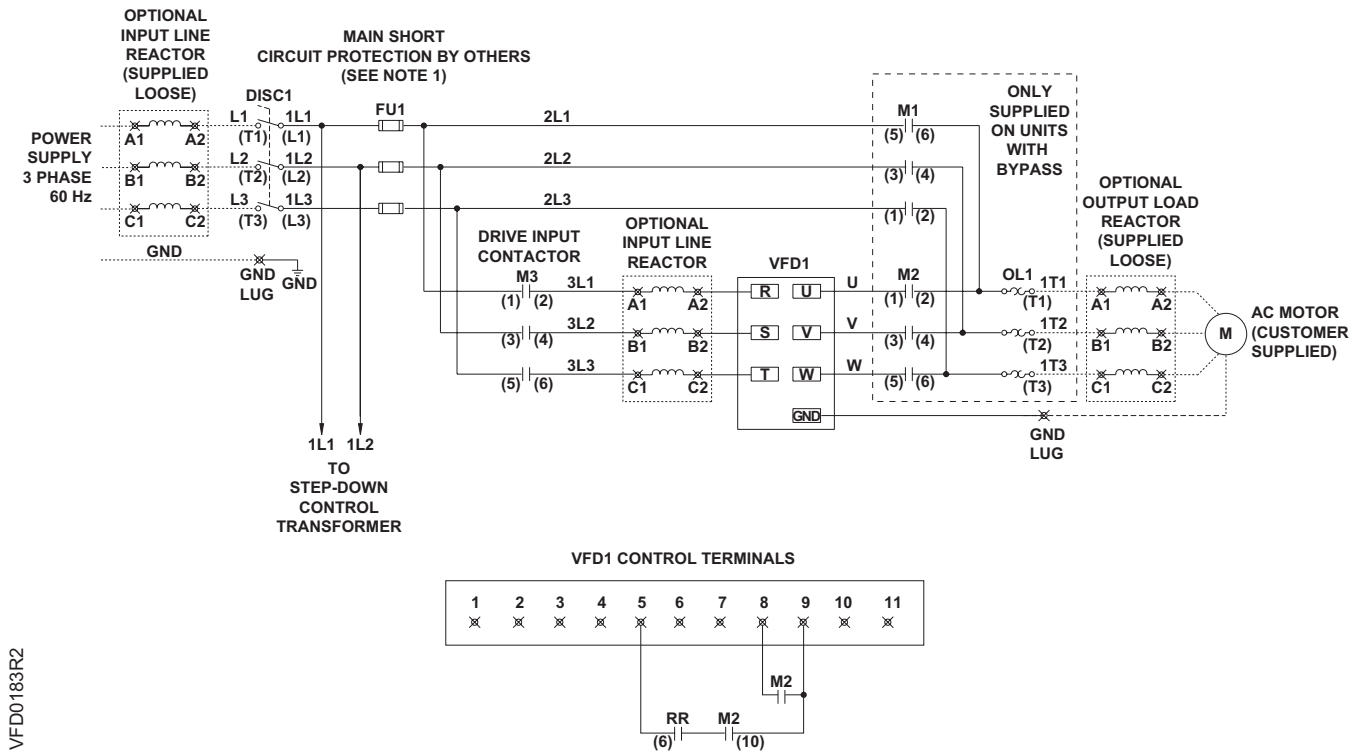

Figure 5. NEMA Type 3R/3RHE Bypass Power Circuit.

**NOTES for Figure 3:**

1. Branch circuit protection to be provided by installer, per UL508A, if not provided with drive.
2. For bypass operation, modify these drive parameters: P0704 (0) and P0704 (1) = 3.
3. Control and communication wiring should be 300V UL minimum.
4. Communication wiring should be run with maximum separation possible from all other wiring.
5. Essential service mode operates the motor full speed (bypass) with no protection for the motor or system.
6. Ensure that automatic bypass will not damage the system before activating.
7. See Siemens Publication No. 125-3377 for proper fuse and wire sizes.
8. See Siemens Publication No. 125-3201 for SED2 VFD input/output signal wiring details.

**Table 8. NEMA Type 3R/3RHE Bypass Specifications.**

NEMA Type 3R Bypass Specification	Description
Input Voltage (3 phase)	208V, 3 AC ±10% * 1 hp to 60 hp (3.9 amps to 154 amps)
	240V, 3 AC ±10% * 1 hp to 60 hp (3.9 amps to 154 amps)
	480V, 3 AC ±10% 1 hp to 125 hp (2.1 amps to 178 amps)
	575V, 3 AC ±10%* 1 hp to 125 hp (2.1 amps to 125 amps)
Temperature	Operating: 14°F to 104°F (-10°C to 40°C), HT1 to 122°F (50°C)
	Storage: -40°F to 158°F (-40°C to 70°C)
High-Temperature Model	Operating: 14°F to 122°F (-10°C to 50°C)
	Storage: -40°F to 158°F (-40°C to 70°C)
Humidity	0 to 95% rh, non-condensing

\*Not available in the 3RHE models.

**Table 9. Drive Specifications.**

Drive Specification	Description
Input voltage and power ranges (3 phase) Amps	*200V and 230V to 240V, 3 AC ± 10% 1 hp to 60 hp (3.9 Amps to 154 Amps)
	380V to 480V, 3 AC ± 10% 1 hp to 125 hp (2.1 Amps to 178 Amps)
	*500V to 600V, 3 AC ± 10% 1 hp to 125 hp (2.1 Amps to 125 Amps)
Input frequency	47 Hz to 63 Hz
Output frequency	0 Hz to 150 Hz
Power factor	≥0.9 total, ≥0.97 displacement
VFD degree of efficiency	96% to 97%
Switch-on current	Less than nominal input current
Auxiliary supply 24V	Galvanically separated, unregulated auxiliary supply (18V to 32V) 100 mA
Overload capacity	110% for 60 seconds
Control method	Linear, parabolic and programmable V/f; and flux current control low-power mode
PWM frequency	2k Hz to 16k Hz (adjustable in 2k Hz increments)
Fixed frequencies	15 programmable
Skip frequency bands	4 programmable
Setpoint resolution	0.01 Hz digital
	0.01 Hz serial
	10 bit analog
Digital inputs (sink/source)	6: fully programmable and scalable isolated digital inputs, switchable
Analog inputs	2: 0 to 10 Vdc, 0/4 mA to 20 mA, can also be configured as digital inputs or Ni 1000 input
Relay outputs	2: configurable 30 Vdc/5A (resistive), 250 Vac 2A (inductive)
Analog outputs	2: programmable (0/4 mA to 20 mA or 0V to 10 Vdc)
Serial interface	RS-485; Protocols: Siemens, P1 and Johnson, N2; Transmission rate: Up to 38.4k Baud
Protection level	IP20: NEMA Type 1 (with protective shield and gland plate installed)
	IP54: NEMA Type 12 (400V and 500V series only)
Temperature ranges	Operating: 14°F to 104°F (-10°C to 40°C)
	Storage: -40°F to 158°F (-40°C to 70°C)
Humidity	95% rh, non-condensing
Operational altitudes	Up to 3280 ft (1000 m) above sea level without de-rating
Protection features	Under-voltage, Over-voltage, Overload, Ground fault, Short circuit, Stall prevention, Locked motor, Motor overtemperature I <sup>2</sup> t PTC, Over-temperature, Parameter PIN protection.
Standards	UL, cUL
CE conformity	Conformity with EC Low Voltage Directive 73/23/EEC

\*Not available in the NEMA Type 3RHE models.

**NOTE:** SED2 Compliance with EN61000-3-12:  
 From September 1st, 2005 all electrical apparatus covered by the EMC directive will have to comply with EN61000-3-12 "Limits for harmonic currents produced by equipment connected to public low voltage systems with input currents > 16A and =< 75 A per phase".

Siemens Industry, Inc. variable speed drives of the product range SED2 (Micromaster 436) fulfill the requirements of the EN 61000-3-12 (without the need for external line reactors) regarding the THD values of Table 3 under the pre condition of Rsc > 190. The required PWhd values will not be achieved. Due to this fact it is recommended to apply for connection approval at the local electricity board.

The local electricity board will evaluate among many other data the content of the 5th harmonic current and the Line Power Factor "Lambda", which is the ratio of active power and apparent power.

Siemens Industry, Inc. frequency inverters are optimized in design and operation characteristics regarding energy efficiency and less interference with line supplies.



