

SIEMENS

LPJSPDNUT01

Installation Instructions for J-type Speed Nut
for use in enclosures and other applications.



KIT INCLUDES: Qty. (25) J-type Speed Nuts (p/n: 11-A-1820-01)

1. Lock off ALL power supplying this equipment before working on it.
2. Remove the Front/Trim mounting screws from the panel. Retain the screws for re-use.
NOTE: Any damaged or incorrect screws should be replaced.
3. Carefully remove the Front/Trim assembly and place in a secure location.
4. If speed nut is missing, proceed to step 5. (The J-type Speed Nuts are either along the edge of the Deadfront or along the flange of the Enclosure, depending on the style of Front/Trim being used. See diagrams for reference.) Otherwise, remove and discard any old or damaged J-type Speed Nuts by prying them off.
NOTE: Careful use of a flat-tip screwdriver may aid in lifting the catch on the front side of the J-type Speed Nut that engages the rim of the hole.
5. Review which holes require a J-type Speed Nut for proper assembly.
NOTE: Not every hole needs a J-type Speed Nut. Compare the holes on the Front/Trim to the J-type Speed Nut locations on the Deadfront/Enclosure and ensure that the corresponding hole on the Deadfront/Enclosure has a good J-type Speed Nut.
6. Orient the new J-type Speed Nut such that the opening of its C-shape engages the edge of the Deadfront or Enclosure flange.
NOTE: The longer leg of the C shape is the back of the speed nut. Mounting hardware will penetrate the speed nut from the side with the short leg.
7. Push on the back of the J-type Speed Nut until the catch on the underside of the front face engages the rim of the hole.
8. Re-assemble with proper hardware, ensuring that screws are properly secured into each J-type Speed Nut.
9. **Before energizing the panel**, ensure that any barriers and fillers are in place and secure, that the deadfront is installed, that the trim is in place, and the door is closed and locked.

Front View of Sample Deadfront

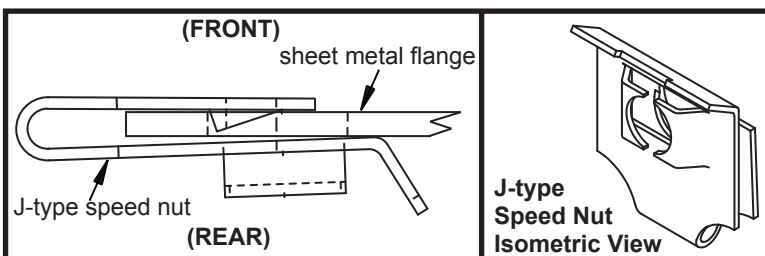
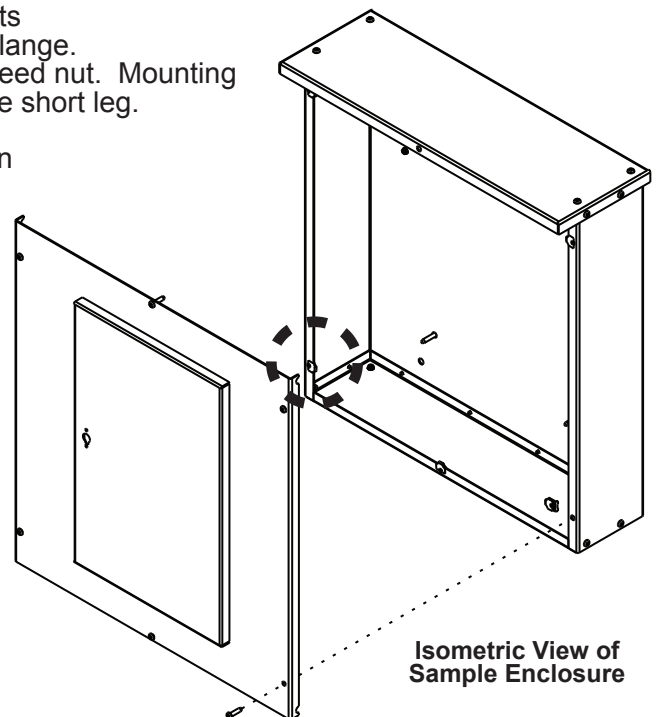
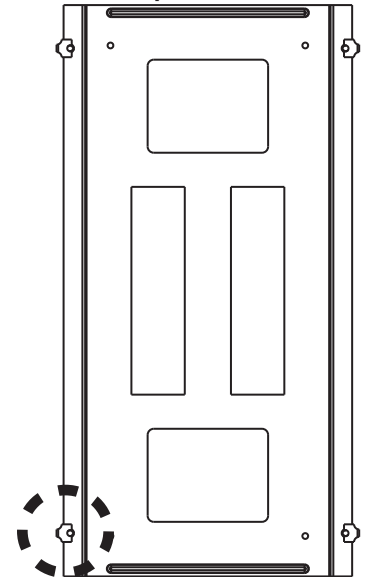

Contact Siemens Sales Office if considering usage in applications other than as shown.

These instructions do not purport to cover all details or variations in equipment, or to provide for every possible contingency to be met in connection with installation, operation or maintenance. Should further information be desired or should particular problems arise, which are not covered sufficiently for the purchaser's purposes, the matter should be referred to the local Siemens sales office. The contents of this Instruction manual shall not become part of or modify any prior or existing agreement, commitment or relationship. The sales contract contains the entire obligation of Siemens. The warranty contained in the contract between the parties is the sole warranty of Siemens. Any statements contained herein do not create new warranties or modify the existing warranty.

Trademarks-Unless otherwise noted, all names identified by © are registered trademarks of Siemens AG or Siemens Industry, Inc. The remaining trademarks in this publication may be trademarks whose use by third parties for their own purposes could violate the rights of the owner.