

Weighing systems

Electronic weighing system SIWAREX WP321

Operating Instructions



7MH4138-6AA00-0BA0

Introduction	1
Safety notes	2
Description	3
Application planning	4
Mounting	5
Connecting	6
Commissioning	7
Scale parameters and functions	8
Messages	9
Command lists	10
Communication in SIMATIC S7-300/400/1200/1500	11
Technical data	12
Ordering data	13
Certificates and support	A
ESD guidelines	B
Abbreviations	C

Legal information

Warning notice system

This manual contains notices you have to observe in order to ensure your personal safety, as well as to prevent damage to property. The notices referring to your personal safety are highlighted in the manual by a safety alert symbol, notices referring only to property damage have no safety alert symbol. These notices shown below are graded according to the degree of danger.

 DANGER
indicates that death or severe personal injury will result if proper precautions are not taken.
 WARNING
indicates that death or severe personal injury may result if proper precautions are not taken.
 CAUTION
indicates that minor personal injury can result if proper precautions are not taken.
NOTICE
indicates that property damage can result if proper precautions are not taken.

If more than one degree of danger is present, the warning notice representing the highest degree of danger will be used. A notice warning of injury to persons with a safety alert symbol may also include a warning relating to property damage.

Qualified Personnel

The product/system described in this documentation may be operated only by **personnel qualified** for the specific task in accordance with the relevant documentation, in particular its warning notices and safety instructions. Qualified personnel are those who, based on their training and experience, are capable of identifying risks and avoiding potential hazards when working with these products/systems.

Proper use of Siemens products

Note the following:

 WARNING
Siemens products may only be used for the applications described in the catalog and in the relevant technical documentation. If products and components from other manufacturers are used, these must be recommended or approved by Siemens. Proper transport, storage, installation, assembly, commissioning, operation and maintenance are required to ensure that the products operate safely and without any problems. The permissible ambient conditions must be complied with. The information in the relevant documentation must be observed.

Trademarks

All names identified by ® are registered trademarks of Siemens AG. The remaining trademarks in this publication may be trademarks whose use by third parties for their own purposes could violate the rights of the owner.

Disclaimer of Liability

We have reviewed the contents of this publication to ensure consistency with the hardware and software described. Since variance cannot be precluded entirely, we cannot guarantee full consistency. However, the information in this publication is reviewed regularly and any necessary corrections are included in subsequent editions.

Table of contents

1	Introduction	9
1.1	Purpose of this documentation.....	9
1.2	Document history	9
1.3	Product compatibility	10
1.4	Checking the consignment.....	10
1.5	Security information	10
1.6	Transportation and storage.....	11
1.7	Notes on warranty	11
1.8	Basic knowledge required	12
2	Safety notes	13
2.1	General safety instructions.....	13
3	Description	15
3.1	Product overview.....	15
3.2	Area of application	15
3.3	System integration in SIMATIC	15
3.4	Customer benefits	16
4	Application planning	19
4.1	Functions.....	19
4.2	Parameter assignment options	19
4.2.1	Parameter assignment with the PC.....	19
4.2.2	Parameter assignment with the SIMATIC Panel.....	20
5	Mounting	21
5.1	Safety notices for installation	21
5.2	Safety information according to FM and UL.....	21
5.3	Installation guideline.....	22
5.4	EMC-compliant setup.....	22
5.4.1	Introduction	22
5.4.2	Possible effects of interference	23
5.4.3	Coupling mechanisms.....	23
5.4.4	Five basic rules for securing EMC	23
5.5	Mounting on the SIMATIC ET 200SP	24
5.6	Configuration of the hardware in SIMATIC	25

6	Connecting	27
6.1	24 V connection	27
6.2	Connection of analog load cells	27
6.2.1	Connecting SIWAREX JB to the electronic weighing system and load cell	28
6.2.2	Wiring diagrams	28
6.2.2.1	Load cells with four-wire system	28
6.2.2.2	Load cells with six-wire system	30
6.2.3	Connecting the cable	31
6.3	Shield connection	31
6.4	Connection of RS485 serial interface	32
6.5	Connection of Siebert display via RS485	33
6.6	Connection of the SIWAREX DB	34
6.6.1	Connect SIWAREX DB to SIWAREX WP electronic weighing system and load cell	34
6.6.2	Connect the cable	35
7	Commissioning	37
7.1	Factory-set parameters	37
7.2	Commissioning tools	37
7.3	5-minute quick start with the operator panel and the Ready-for-Use software	38
7.3.1	Start	38
7.3.2	Factory setting of the parameters	39
7.3.3	Selecting the calibration method	40
7.3.4	Defining the calibration weights	41
7.3.5	Setting calibration points	42
7.3.6	Calibrating the scale automatically	43
7.3.7	Performing the automatic calibration	44
7.3.8	Checking the scale following calibration	44
7.4	Fast commissioning (Quick Start) with SIWATOOL	45
7.4.1	Service with the SIWATOOL program	45
7.4.2	Establish communication to SIWAREX WP321	45
7.4.3	Calibration	46
7.4.3.1	Selecting the calibration method	46
7.4.3.2	Calibration with calibration weight	47
7.4.3.3	Automatic calibration (without calibration weight)	50
7.4.4	Receive all data	55
7.5	Service with the SIWATOOL program	56
7.5.1	Windows and functions of SIWATOOL	56
7.5.2	Offline parameter assignment	57
7.5.3	Online parameter assignment	57
7.5.4	Available help options	58
7.5.5	Entering parameters with SIWATOOL	58
8	Scale parameters and functions	59
8.1	Parameters and functions	59
8.2	Assigning parameters to the electronic weighing system with SIWAREX DB	59
8.3	DR 2 command code	60

8.4	DR 3 calibration parameters	60
8.4.1	Scale name	62
8.4.2	Unit of weight	63
8.4.3	Gross identifier	63
8.4.4	Maximum weighing range	63
8.4.5	Calibration weights 0, 1, 2 and calibration digits 0, 1, 2	63
8.4.6	Scale interval.....	63
8.4.7	Automatic zero adjustment.....	63
8.4.8	Decimal places for process values.....	64
8.4.9	Maximum tare load.....	64
8.4.10	Maximum negative zeroing limit.....	64
8.4.11	Maximum positive zeroing limit	64
8.4.12	Standstill range	64
8.4.13	Standstill time	65
8.4.14	Standstill waiting time.....	65
8.4.15	Low-pass filter limit frequency.....	66
8.4.16	Low-pass filter number	66
8.4.17	Mean value filter depth.....	67
8.5	Calibration procedure.....	67
8.5.1	Calibration with calibration weights	67
8.5.2	Automatic calibration	70
8.6	DR 4 Output of calculated calibration digits	70
8.6.1	Calibration digits 0, 1, 2 (calculated)	71
8.7	DR 5 zeroing memory	71
8.7.1	Effective tare weight - from specification.....	72
8.7.2	Effective tare weight (semi-automatic)	72
8.7.3	Zero weight (semi-automatic).....	72
8.7.4	Current zero tracking weight	73
8.7.5	Dead load.....	73
8.8	DR 6 limit value settings.....	73
8.8.1	Limit reference	74
8.8.2	Limit value 1 ON, limit value 2 ON, limit value 1 OFF, limit value 2 OFF	75
8.8.3	Limit value "Empty" ON.....	75
8.8.4	Delay time for limits.....	76
8.9	DR 9 module information	76
8.10	DR 10 load cell parameters.....	77
8.10.1	Selection of the sampling rate.....	78
8.10.2	Number of support points.....	79
8.10.3	Load cell characteristic value	80
8.10.4	Rated load of a load cell.....	80
8.11	DR 13 RS485 parameters	80
8.11.1	RS485 protocol	81
8.11.2	RS485 baud rate	81
8.11.3	RS485 character parity	81
8.11.4	Decimal place for Siebert indicator	81
8.12	DR 14 SIMATIC interface parameters	81
8.12.1	Selection of process value 1, 2	82

8.13	DR 15 manual tare specification	83
8.13.1	Specification of tare weight	84
8.14	DR 30 current process values	84
8.14.1	Gross process weight.....	86
8.14.2	Net process weight.....	86
8.14.3	Tare process weight.....	86
8.14.4	Gross / net weight	86
8.14.5	Gross / net weight with increased resolution (x 10)	86
8.14.6	Tare weight	86
8.14.7	Refresh counter for process values	87
8.15	DR 31 advanced current process values	87
8.15.1	Unfiltered digit value.....	87
8.15.2	Filtered digit value	88
8.15.3	Refresh counter for process values	88
8.16	DR 32 Message display	88
8.16.1	Error bytes 0 to 7.....	90
8.17	DR 34 ASCII main display value	90
8.17.1	Content of main display as ASCII string	91
8.18	DR 70 SIWAREX DB parameter	91
8.19	DR 80 SIWAREX DB process status	92
8.20	DR 81 SIWAREX DB process status advanced.....	95
8.21	DR 82 SIWAREX DB device information	96
9	Messages	97
9.1	Message types	97
9.2	Message paths.....	97
9.3	Evaluating messages with the help of SIWATOOL.....	98
9.4	Evaluating messages with the help of SIMATIC FB.....	98
9.5	Message list	98
9.5.1	System status message list.....	98
9.5.2	Technology error message list.....	99
9.5.3	Data and operating errors message list	99
9.5.4	Messages by LEDs on the module	100
10	Command lists	101
11	Communication in SIMATIC S7-300/400/1200/1500.....	103
11.1	General information.....	103
11.2	Structure of the program "Ready for use"	103
11.3	Advantages of task sharing	103
11.4	Hardware configuration of the electronic weighing system	104
11.5	Calling of function block	106
11.6	Working with the function block.....	107

11.7	I/O interface of function block.....	110
11.8	Error codes of function block.....	110
11.9	Diagnostics messages	111
11.10	Diagnostics interrupts.....	111
11.11	Hardware interrupts.....	112
12	Technical data	115
12.1	Technical data	115
12.2	Electrical, EMC and climatic requirements.....	117
12.3	Reliability	120
12.4	Approvals	120
13	Ordering data.....	123
A	Certificates and support.....	125
A.1	Technical support.....	125
B	ESD guidelines	127
B.1	ESD Guidelines	127
C	Abbreviations.....	129
C.1	List of abbreviations	129
	Index.....	131

Introduction

1.1 Purpose of this documentation

These instructions contain all information required to commission and use the device. Read the instructions carefully prior to installation and commissioning. In order to use the device correctly, first review its principle of operation.

The instructions are aimed at persons mechanically installing the device, connecting it electronically, configuring the parameters and commissioning it, as well as service and maintenance engineers.

 CAUTION
--

To prevent injury, read the manual before use.
--

1.2 Document history

The most important changes in the documentation when compared with the respective previous edition are given in the following table.

Manual edition	Note
08/2019	Information on SIWAREX DB added
09/2018	<ul style="list-style-type: none"> • Section "Safety notes (Page 13)" revised • Section "Mounting (Page 21)" revised • Section "Scale parameters and functions (Page 59)" revised <ul style="list-style-type: none"> – DR 3 (Page 60): "Limit frequency of low-pass filter 2" and "Order no. low pass filter 2" new • Data types renamed as follows: FLOAT --> REAL USHORT --> UINT SHORT --> INT LONG --> DINT CHAR --> STRING

See also

Connection of Siebert display via RS485 (Page 33)
 DR 32 Message display (Page 88)
 Technology error message list (Page 99)
 Reliability (Page 120)
 Approvals (Page 120)

- Calibration procedure (Page 67)
- DR 10 load cell parameters (Page 77)
- DR 14 SIMATIC interface parameters (Page 81)
- Communication in SIMATIC S7-300/400/1200/1500 (Page 103)
- DR 6 limit value settings (Page 73)
- Automatic calibration (without calibration weight) (Page 50)

1.3 Product compatibility

The following table describes compatibility between manual edition, device revision, and the engineering system.

Manual edition	Comment	Device revision	Engineering system
08/2019	New characteristics	FW: 1.4.0 HW: FS 1 or higher	STEP 7 TIA Portal V15.1 or higher
09/2018	New characteristics	FW: 1.3.0 HW: FS 1 or higher	STEP 7 TIA Portal V14 or higher

1.4 Checking the consignment

1. Check the packaging and the delivered items for visible damages.
2. Report any claims for damages immediately to the shipping company.
3. Retain damaged parts for clarification.
4. Check the scope of delivery by comparing your order to the shipping documents for correctness and completeness.

 WARNING
Using a damaged or incomplete device Risk of explosion in hazardous areas. <ul style="list-style-type: none">• Do not use damaged or incomplete devices.

1.5 Security information

Siemens provides products and solutions with industrial security functions that support the secure operation of plants, systems, machines and networks.

In order to protect plants, systems, machines and networks against cyber threats, it is necessary to implement – and continuously maintain – a holistic, state-of-the-art industrial security concept. Siemens' products and solutions constitute one element of such a concept.

Customers are responsible for preventing unauthorized access to their plants, systems, machines and networks. Such systems, machines and components should only be connected to an enterprise network or the internet if and to the extent such a connection is necessary and only when appropriate security measures (e.g. firewalls and/or network segmentation) are in place.

For additional information on industrial security measures that may be implemented, please visit <https://www.siemens.com/industrialsecurity>.

Siemens' products and solutions undergo continuous development to make them more secure. Siemens strongly recommends that product updates are applied as soon as they are available and that the latest product versions are used. Use of product versions that are no longer supported, and failure to apply the latest updates may increase customer's exposure to cyber threats.

To stay informed about product updates, subscribe to the Siemens Industrial Security RSS Feed under <https://www.siemens.com/industrialsecurity>.

1.6 Transportation and storage

To guarantee sufficient protection during transport and storage, observe the following:

- Keep the original packaging for subsequent transportation.
- Devices/replacement parts should be returned in their original packaging.
- If the original packaging is no longer available, ensure that all shipments are properly packaged to provide sufficient protection during transport. Siemens cannot assume liability for any costs associated with transportation damages.

NOTICE

Insufficient protection during storage

The packaging only provides limited protection against moisture and infiltration.

- Provide additional packaging as necessary.

Special conditions for storage and transportation of the device are listed in Technical data (Page 115).

1.7 Notes on warranty

The contents of this manual shall not become part of or modify any prior or existing agreement, commitment or legal relationship. The sales contract contains all obligations on the part of Siemens as well as the complete and solely applicable warranty conditions. Any statements regarding device versions described in the manual do not create new warranties or modify the existing warranty.

The content reflects the technical status at the time of publishing. Siemens reserves the right to make technical changes in the course of further development.

1.8 Basic knowledge required

Knowledge of weighing technology as well as general knowledge of the SIMATIC system including the TIA Portal are necessary in order to understand the manual.

Safety notes

2.1 General safety instructions

 WARNING
--

Non-compliance with warning notes or non-qualified handling of the system
--

Failure to observe the warning notes or handling of the device/system by non-qualified personnel can result in serious injury or damage to property. This means only qualified personnel are permitted to handle this device/system.
--

 WARNING
--

Permission for installation in machines
--

Start-up/commissioning is absolutely prohibited until it has been ensured that the machine in which the component described here is to be installed fulfills the regulations/specifications of Machinery Directive 89/392/EEC.
--

Note

The specifications of the manual for the SIMATIC ET 200SP system apply for configuration, installation and commissioning in the SIMATIC environment. This chapter includes additional information on hardware configuration, installation and preparation for operation of the SIWAREX WP321.

The safety notes must be observed.

Note

The device was developed, manufactured, tested and documented in compliance with the relevant safety standards. The device does usually not pose any risks of material damage or personal injury.

Safety notices when using the device according to Hazardous Locations (HazLoc)

If you use the device under HazLoc conditions you must also keep to the following safety notices in addition to the general safety notices for protection against explosion:

This equipment is suitable for use in Class I, Zone 2, Group IIC or non-hazardous locations only.

This equipment is suitable for use in Class I, Division 2, Groups A, B, C and D or non-hazardous locations only.

2.1 General safety instructions

Description

3.1 Product overview

SIWAREX WP321 is a versatile and flexible weighing module that can be operated as a static weighing instrument.

The electronic weighing system can be used in SIMATIC ET 200SP and uses all features of a modern automation system, such as integrated communication, operation and monitoring, the diagnostics system as well as the configuration tools in the TIA Portal or SIMATIC STEP, WinCC flexible and PCS7.

3.2 Area of application

The electronic weighing system described here is the perfect solution for applications in which signals from weighing or force sensors are acquired and processed. The SIWAREX WP321 is a very accurate electronic weighing system with high measuring speed.

It can be used in almost all industrial weighing applications not requiring official calibration. Use in potentially explosive atmospheres (with Ex interface SIWAREX IS) it's also possible.

3.3 System integration in SIMATIC

The electronic weighing system described here is a technology module for SIMATIC ET 200SP. It can be used as desired in the configuration of the automation solution, including the weighing application. You can create optimal solutions for small and medium-sized plants by combining the suitable SIMATIC modules. You can create customized or industry-specific solutions in no time with the help of the configuration package available under the "Ready for use" application for SIMATIC.

Solutions are possible with S7-300, S7-400, S7-1200 as well as S7-1500 CPUs. TIA Portal, Step 7 Classic or PCS7 can be used as the configuration software.

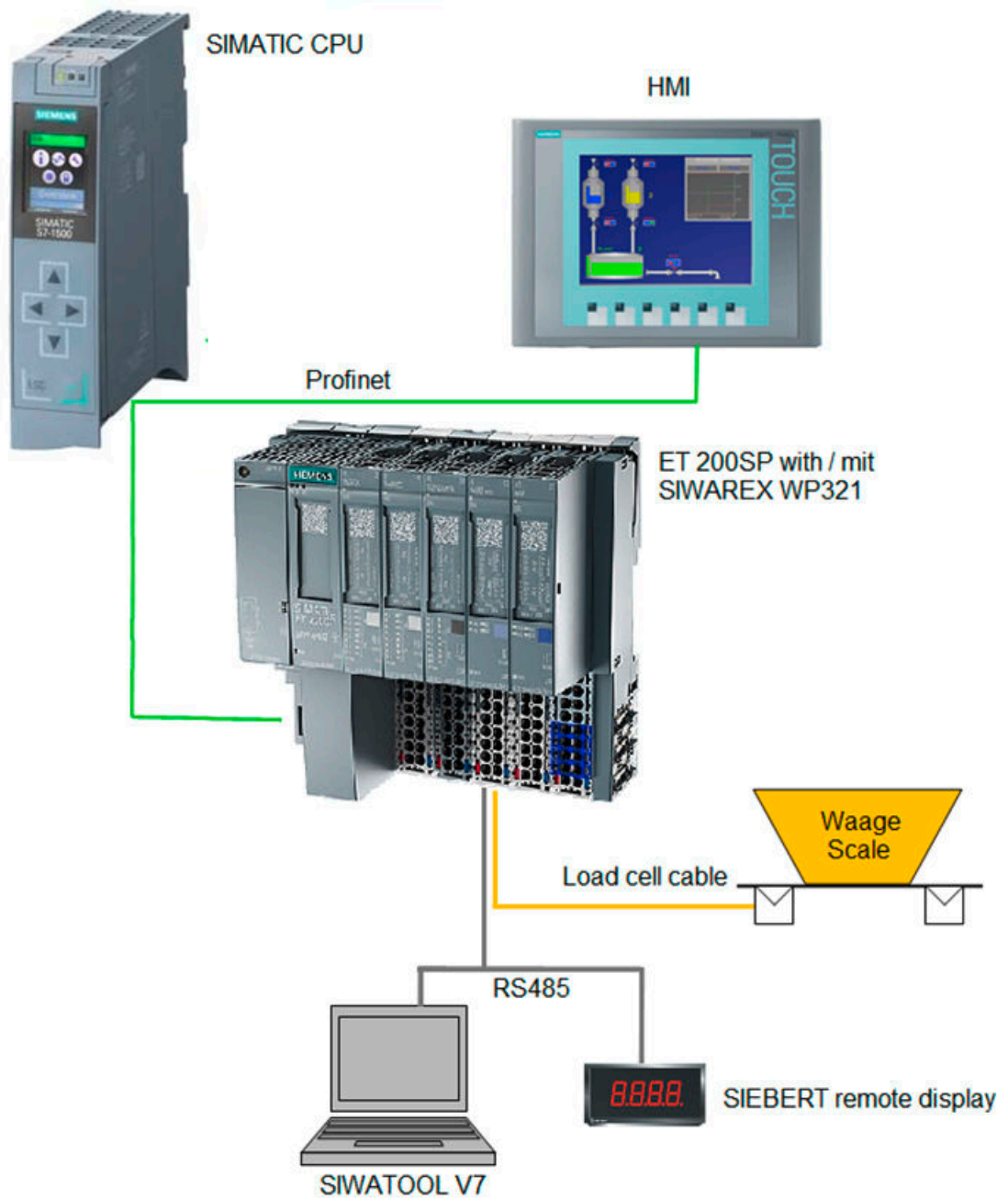

Figure 3-1 System overview

3.4 Customer benefits

The electronic weighing system described here is characterized by decisive advantages:

- Uniform design technology and consistent communication in SIMATIC ET 200SP
- Parameter assignment by means of an operator panel, STEP7 user program or PC
- Uniform configuration option in the SIMATIC TIA Portal, SIMATIC STEP7 or PCS7

- Measuring of weight with a resolution of up to +/- 2 million parts
- High accuracy 0.05%
- High measuring rate of 100/120/600 Hz
- Limit monitoring
- Flexible adaptation to varying requirements
- Easy calibration of the scales using the SIWATOOL program
- Automatic calibration is possible without the need for calibration weights
- Module replacement is possible without recalibrating the scales
- Use in Ex Zone 2 / ATEX approval
- Intrinsically safe load cell supply for Ex Zone 1 (SIWAREX IS option)
- Diagnostics functions

Description

3.4 Customer benefits

Application planning

4.1 Functions

The primary task of the electronic weighing system is the measurement and registration of the current weight value. The integration in SIMATIC gives you the option to process the weight value directly in the PLC (Programmable Logic Controller).

The SIWAREX WP321 is calibrated at the factory. This allows for automatic calibration of the scale without the need for calibration weights and replacement of modules without the need for recalibrating the scale.

A PC for setting the parameters of the electronic weighing system can be connected via the RS485 interface.

The SIWAREX WP321 electronic weighing system can also be used in potentially explosive atmospheres (Zone 2). The load cells are supplied intrinsically safe in Zone 1 applications when you use the optional Ex interface SIWAREX IS.

4.2 Parameter assignment options

4.2.1 Parameter assignment with the PC

You can set the scale parameters with the convenience of the familiar Windows interface by using the "SIWATOOL" PC parameter assignment software.

You can use the program for commissioning the scale without any knowledge of automation technology. When servicing is required, you can analyze and test the processes in the scale independently of the automation system or Operator Panel with the help of the PC. You can read out the diagnostic buffer from the SIWAREX module to assist you in the event analysis.

The figure below illustrates the structure of the individual program windows.

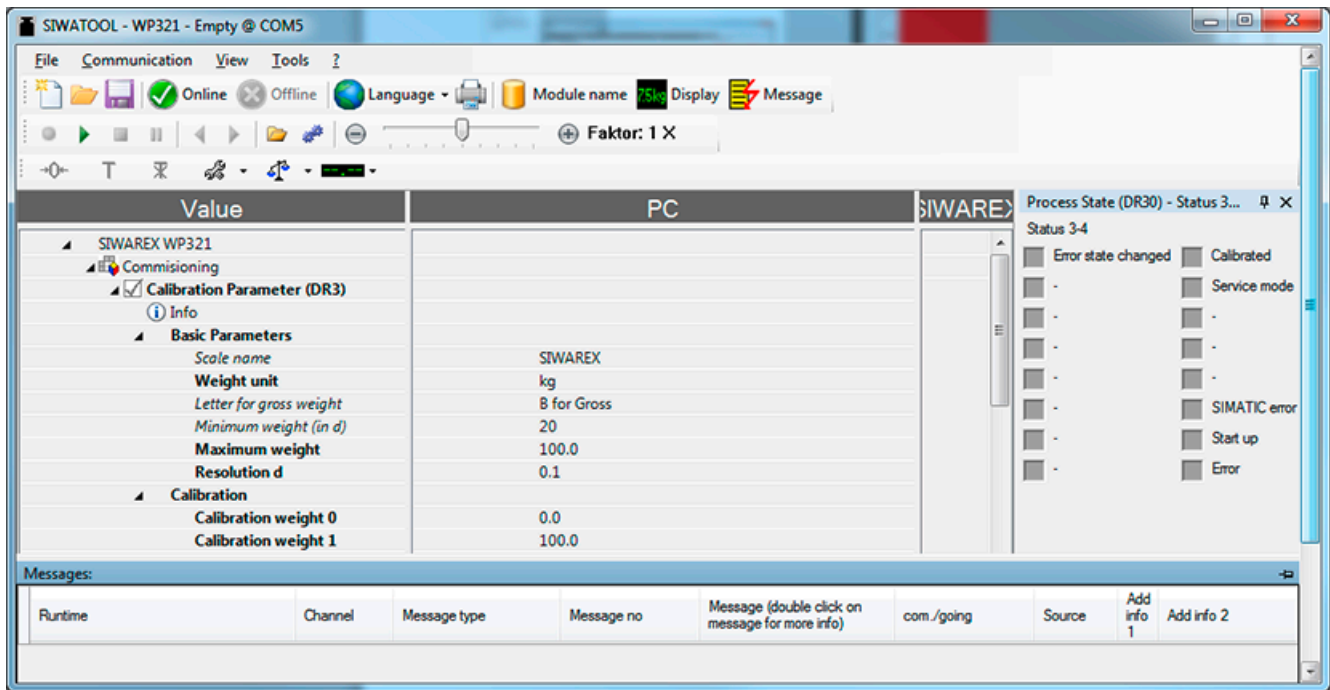

Figure 4-1 SIWATOOL overview

SIWATOOL does not only offer support when you set the scale but also when you analyze the diagnostic buffer that can be saved after being read out of the module together with the parameters. The display of the current scale status can be configured.

You can switch between several languages in the program.

You require an RS485/USB converter (see Ordering data (Page 123)).

4.2.2 Parameter assignment with the SIMATIC Panel

SIWAREX WP321 parameters can be assigned using a SIMATIC Panel connected to the SIMATIC CPU. The "Ready-for-use" application software is used for this.

Mounting

5.1 Safety notices for installation

Safety notices

When installing the device, keep to the safety notices listed below.

 WARNING
--

If a device is operated in an ambient temperature of more than 50 °C, the temperature of the device housing may be higher than 70 °C. The device must therefore be installed so that it is only accessible to service personnel or users that are aware of the reason for restricted access and the required safety measures at an ambient temperature higher than 50 °C.

 WARNING
--

If the device is installed in a cabinet, the inner temperature of the cabinet corresponds to the ambient temperature of the device.

Safety notices on use in hazardous areas

General safety notices relating to protection against explosion

 WARNING
--

EXPLOSION HAZARD

Replacing components may impair suitability for Class 1, Division 2 or Zone 2.
--

 WARNING
--

Substitution of components may impair suitability of the equipment.

5.2 Safety information according to FM and UL

Safety information for use according to FM and UL

If you use the device under FM conditions you must also keep to the following safety notices in addition to the general safety notices for protection against explosion:

 WARNING
Substitution of components may impair suitability for Division 2.

 WARNING
Do not remove or replace while circuit is live when a flammable or combustible atmosphere is present.

 WARNING
Explosion hazard
Do not disconnect equipment when a flammable or combustible atmosphere is present.

 WARNING
EXPLOSION HAZARD
The device is designed for operation in closed housing or control cabinet. The inner service temperature of the enclosure/control cabinet corresponds to the ambient temperature of the module. Use cables with a maximum permitted operating temperature of at least 20 °C higher than the maximum ambient temperature.

5.3 Installation guideline

When assembling the SIMATIC components together with the electronic weighing system described here, the setup, installation and wiring guidelines for the SIMATIC ET 200SP must be observed (see system manual "SIMATIC ET 200SP, ET 200SP distributed I/O system", order no.: A5E03576848).

This manual describes additional installation and wiring aspects specific to the electronic weighing system.

5.4 EMC-compliant setup

5.4.1 Introduction

The electronic weighing system described here was developed for use in industrial environments and complies with high EMC requirements. It ensures safe operation even in harsh environmental conditions. Nevertheless, you should still carry out EMC planning before installing your devices in order to determine any sources of interference and include them in your considerations.

EMC

EMC (electromagnetic compatibility) describes the capability of electrical equipment to operate without errors in a given electromagnetic environment, without being subject to external influence and without influencing external devices in any way.

5.4.2 Possible effects of interference

Electromagnetic interferences can influence the electronic weighing system described here in various ways:

- Electromagnetic fields having a direct influence on the system
- Interferences transported by communication cables
- Interferences having an effect via process cables
- Interferences entering the system via the power supply and/or protective ground

Interferences can impair the fault-free functioning of the electronic weighing system.

5.4.3 Coupling mechanisms

Depending on the propagation medium (conducted or non-conducted) and the distance between the interference source and the device, interferences can enter the faulty device through four different coupling mechanisms:

- Electrical coupling
- Capacitive coupling
- Inductive coupling
- Radiation coupling

5.4.4 Five basic rules for securing EMC

Observe these five basic rules to secure EMC.

Rule 1: Large area grounding contact

- When installing the devices, make sure that the surfaces of inactive metal parts are properly bonded to chassis ground (see following sections).
- Bond all inactive metal parts to chassis ground, ensuring large area and low-impedance contact (large cross-sections).
- When using screw connections on varnished or anodized metal parts, support contact with special contact washers or remove the protective insulating finish on the points of contact.

- Wherever possible, avoid the use of aluminum parts for ground bonding. Aluminum oxidizes very easily and is therefore less suitable for ground bonding.
- Provide a central connection between chassis ground and the ground/protective conductor system.

Rule 2: Proper cable routing

- Organize your wiring system into cable groups (high-voltage/power supply/signal/measurement/data cables).
- Always route high-voltage and data cables in separate ducts or in separate bundles.
- Install the measurement cables as close as possible to grounded surfaces (e.g. supporting beams, metal rails, steel cabinet walls).

Rule 3: Fixing the cable shielding

- Ensure proper fixation of the cable shielding.
- Always use shielded data cables. Always connect both ends of the data cable shielding to ground on a large area.
- Keep unshielded cable ends as short as possible.
- Always use metal/metalized connector housings only for shielded data cables.

Rule 4: Special EMC measures

- All inductors that are to be controlled should be connected with suppressors.
- For cabinet lighting in the immediate range of your controller, use interference suppressed fluorescent lamps.

Rule 5: Homogeneous reference potential

- Create a homogeneous reference potential and ground all electrical equipment.
- Use sufficiently dimensioned equipotential bonding conductors if potential differences exist or are expected between your system components. Equipotential bonding is absolutely mandatory for applications in hazardous areas.

5.5 Mounting on the SIMATIC ET 200SP

The electronic weighing system described here is a module of the SIMATIC ET 200SP series and can be directly connected to the automation system's bus system. The 15 mm wide module has very low installation and cabling requirements.

The module is snapped onto the ET 200SP base unit (BU). You must use base units of type A0 (→ Industry Mall (<https://mallstage.industry.siemens.com/mall/en/b0/Catalog/Products/10229887?tree=CatalogTree>)).

The load cells, power supply and serial interfaces are connected via the terminal box.

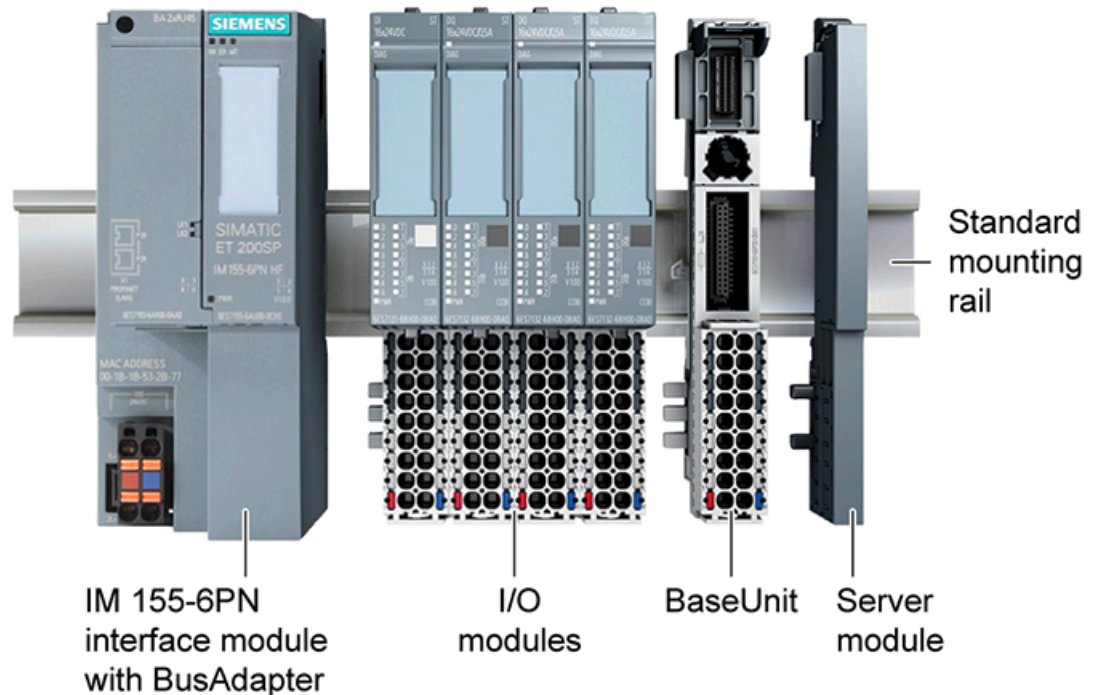

Figure 5-1 Installation of the I/O or SIWAREX modules

5.6 Configuration of the hardware in SIMATIC

A station has a maximum width of 1 m, and you can use up to 64 modules depending on the type of PN head-end, or up to 15 modules with the Profibus version. Observe the system conditions when planning the configuration.

Each SIWAREX electronic weighing system requires 16 bytes of the I/O area. Address assignment is carried out in the TIA Portal or in the SIMATIC Manager during hardware configuration.

Connecting

All external connections are made via the terminal box.

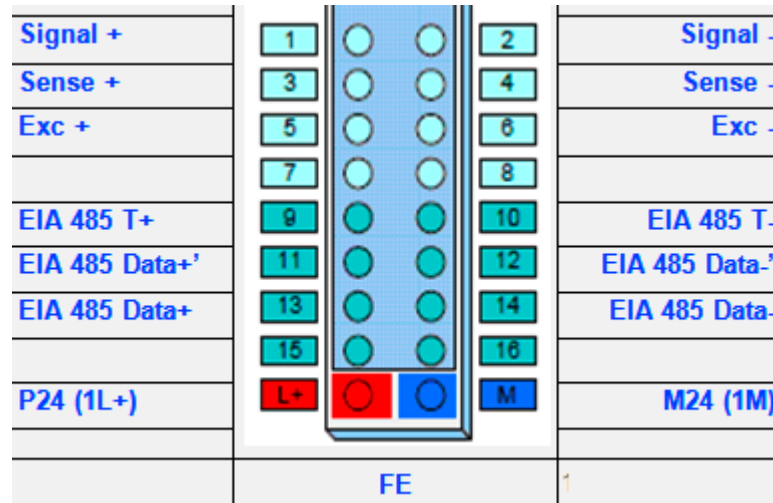

Figure 6-1 SIWAREX WP321 process terminals on the base unit

6.1 24 V connection

The 24 V DC supply voltage is connected by means of the corresponding terminals on the base unit.

Table 6-1 Connection of the 24 V supply

Labeling	Function
L +	+24 V voltage supply
M	Ground voltage supply

6.2 Connection of analog load cells

Sensors equipped with strain gauges (DMS full bridge) can be connected to the electronic weighing system. These sensors meet the requirements in section Technical data (Page 115).

Labeling	Function	Connection pin
Sig-	Measurement cable load cell -	2
Sig+	Measurement cable load cell -	1
Sen-	Sensor cable load cell -	4
Sen+	Sensor cable load cell +	3

Labeling	Function	Connection pin
Exc-	Supply load cell -	6
Exc+	Supply load cell +	5

6.2.1 Connecting SIWAREX JB to the electronic weighing system and load cell

Procedure

1. Open the cover of the SIWAREX JB.
2. Screw in an M16 x 1.5 cable gland for each load cell.
3. Screw in an M20 x 1.5 EMC cable gland for the signal cable to the electronic weighing system.
4. Wire the SIWAREX JB to the load cell and the electronic weighing system in accordance with Wiring diagrams (Page 28).
To learn how to connect the cable, see section Connecting the cable (Page 31).
5. Close any unused opening in the enclosure with a blanking plug.
6. Connect the equipotential bonding conductor to the outside of the enclosure.
Use shielded cable lugs.
7. Close the cover of the SIWAREX JB according to the tightening torque.

6.2.2 Wiring diagrams

6.2.2.1 Load cells with four-wire system

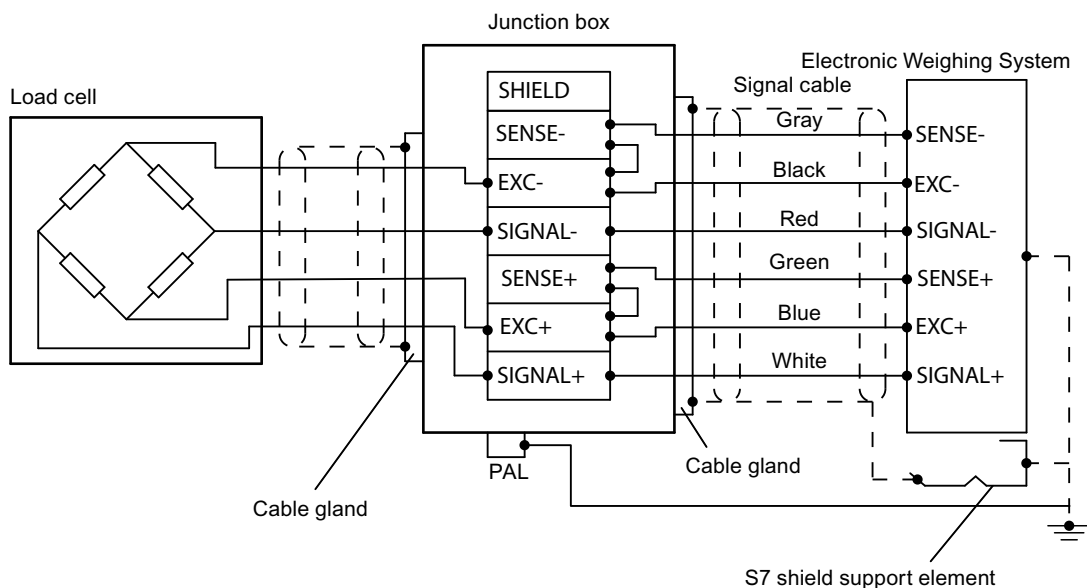

Figure 6-2 Shield of the signal cable connected to EMC shield terminal

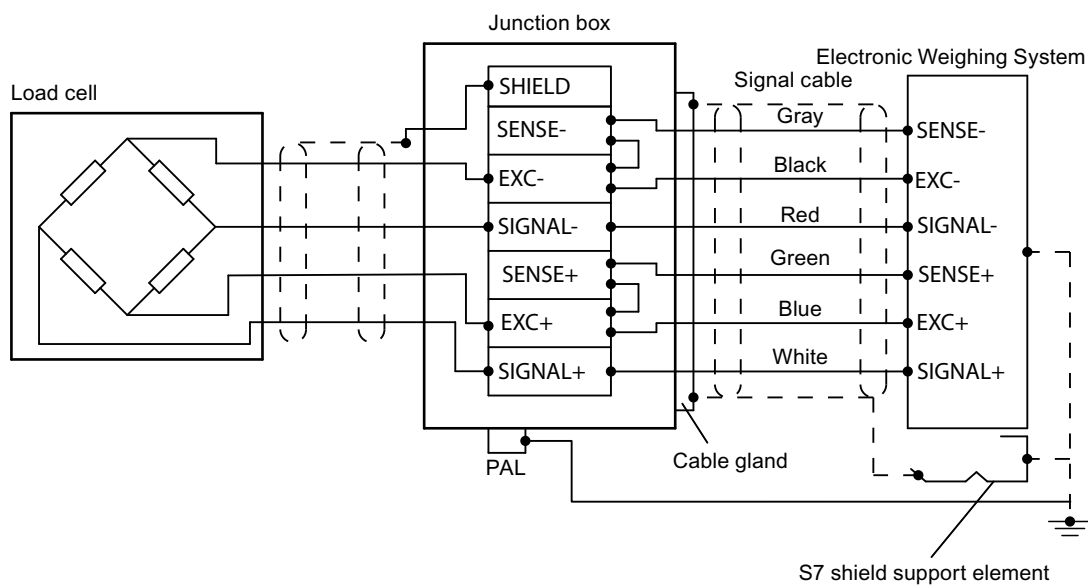

Figure 6-3 Shield of the signal cable connected to shield terminal

The following jumpers are set by default:

Jumper	From terminal	To terminal
1	EXC-	SENSE-
2	EXC+	SENSE+

Note

If the jumpers are missing, the electronic weighing system reports a wire break.

6.2.2.2 Load cells with six-wire system

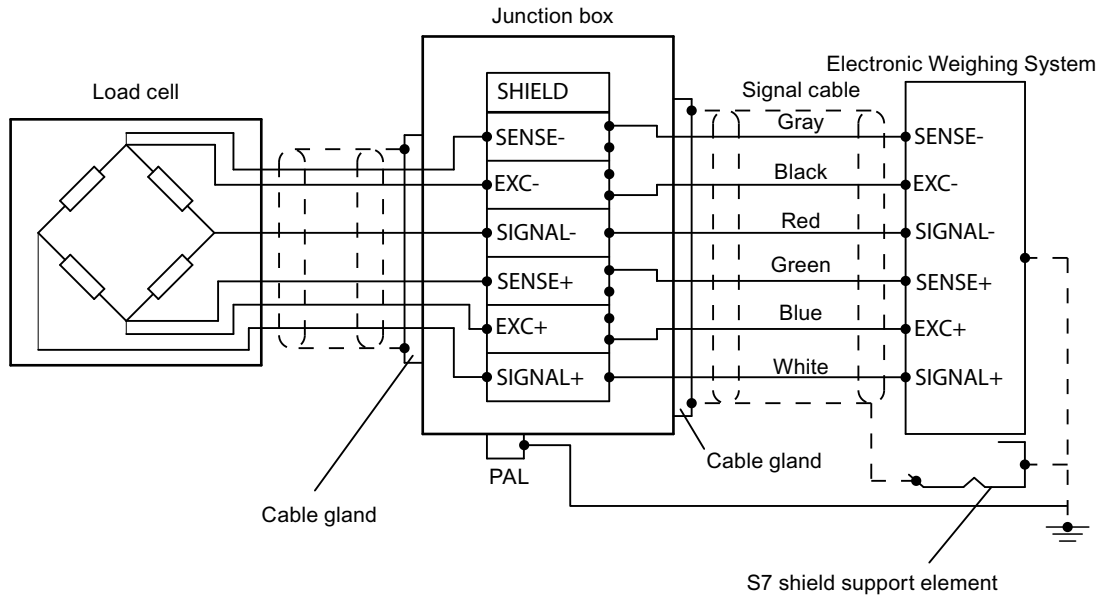

Figure 6-4 Shield of load cell cable connected to EMC shield terminal

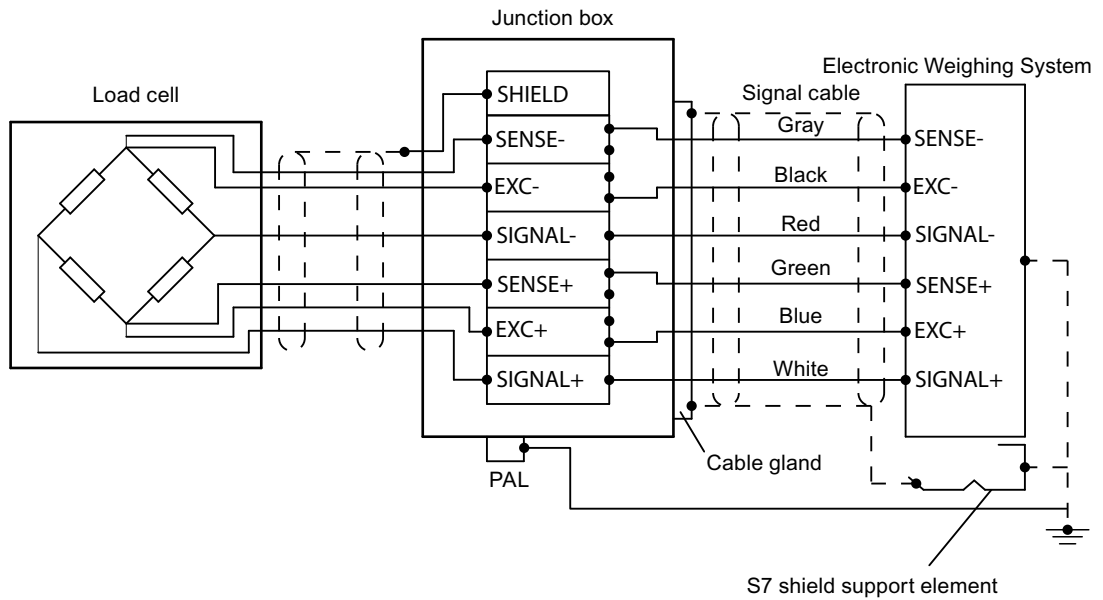

Figure 6-5 Shield of load cell cable connected to shield terminal

- Disconnect the following jumpers:

Jumper	From terminal	To terminal
1	EXC-	SENSE-
2	EXC+	SENSE+

6.2.3 Connecting the cable

Requirement

You require a screwdriver with a maximum blade width of 3.5 mm.

Procedure

1. In EMC cable glands, lay the cable shielding over a large area.

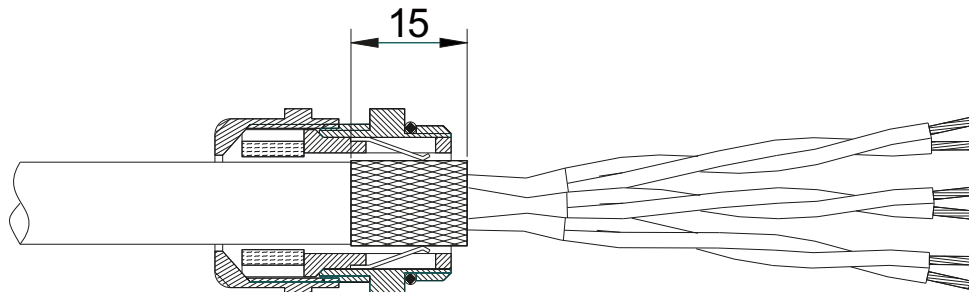

Figure 6-6 Place the cable shield in the EMC cable gland.

2. With plastic cable glands, place the corresponding wire of the SIWAREX load cell on the shield terminal.
3. Strip at least 6 mm of insulation from the load cell cable.

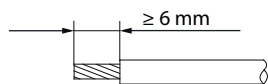

Figure 6-7 Strip cable

4. Insert the stripped load cell cable into the square opening of the screw terminal as far as it will go.
5. Tighten the screws with the specified tightening torque.

Result

The tightened screw firmly holds the stripped wire and establishes the contact.

6.3 Shield connection

Make sure you observe the correct design of the shield support for the shielded cables. It is the only way to ensure immunity of the system.

A cable is shielded to attenuate the effects of magnetic, electrical and electromagnetic interference on the cable. Interference currents on cable shielding are diverted to ground by conductive isolation rails. To avoid interference as a result of these currents, it is imperative to provide a low-impedance connection to the ground.

Only use cables equipped with a shielding braid. Shielding density must be at least 80%.

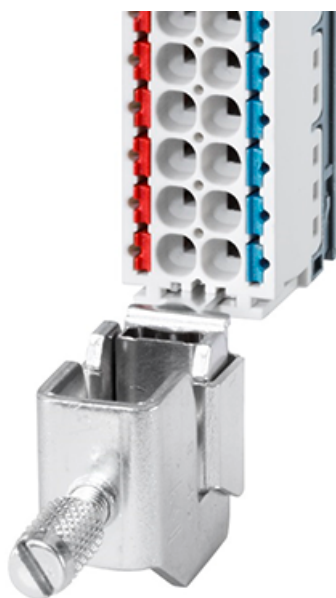

Figure 6-8 Shield connection and shield terminal

6.4 Connection of RS485 serial interface

Devices can be connected to the serial interface RS485 in accordance with the information in section Technical data (Page 115).

Table 6-2 Termination of RS485 serial interface

Labeling	Function	Connection pin
RS485: T+	RS485 termination +: Is used at the physical end of the bus for inserting termination jumpers	9
RS485: T-	RS485 termination -: Is used at the physical end of the bus for inserting termination jumpers	10
RS485: D+'	RS485 data line +': Is used at the physical end of the bus for inserting termination jumpers and in between for looping through the bus cables	11
RS485: D-'	RS485 data line -': Is used at the physical end of the bus for inserting termination jumpers and in between for looping through the bus cables	12
RS485: D+	RS485 data cable +	13
RS485: D-	RS485 data cable -	14

If a SIWAREX WP321 module is connected to SIWATOOL or a Siebert display, insert wire jumpers between the T+ and D+' terminals and between the T- and D-'

6.5 Connection of Siebert display via RS485

A Siebert display S102 with the order no. S102-W6/14/0R-000/0B-SM can be connected to the RS485 interface of the weighing module. Connect a 24 V DC supply to the Siebert display. Connect the latter to the RS485 interface of the weighing module as shown in the figure below.

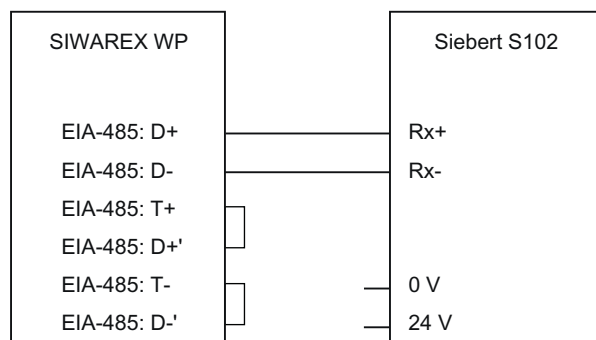

Figure 6-9 Connection of Siebert display S102

The RS485 interface in the DR 13 of the SIWAREX WP is set as follows:

- RS485 protocol: Siebert display S102
- Baud rate: 9600 bps
- Character parity: Even

The S102 is set as follows:

Table 6-3 Settings of Siebert display S102

Menu item	Setting	Meaning
1 Interface	485	RS485 interface
9 Station address	01	Address meaning:
		Address Weight value
		01 Weight
		02 Total
		03 Net
04 Tare		
t Timeout	2	e.g. timeout after 2 seconds
C	0.0	No decimal point
F Segment test	----*	No segment test when switching on
	8.8.8	Segment test when switching on

6.6 Connection of the SIWAREX DB

6.6.1 Connect SIWAREX DB to SIWAREX WP electronic weighing system and load cell

Procedure

1. Open the cover of the SIWAREX DB.
2. Screw in an M16 x 1.5 cable gland for each load cell.
3. Screw in an M20 x 1.5 EMC cable gland for the signal cable to the SIWAREX WP electronic weighing system.
4. Attach the cables from SIWAREX DB to the load cell and the SIWAREX WP electronic weighing system.
Connect the cable (Page 35)

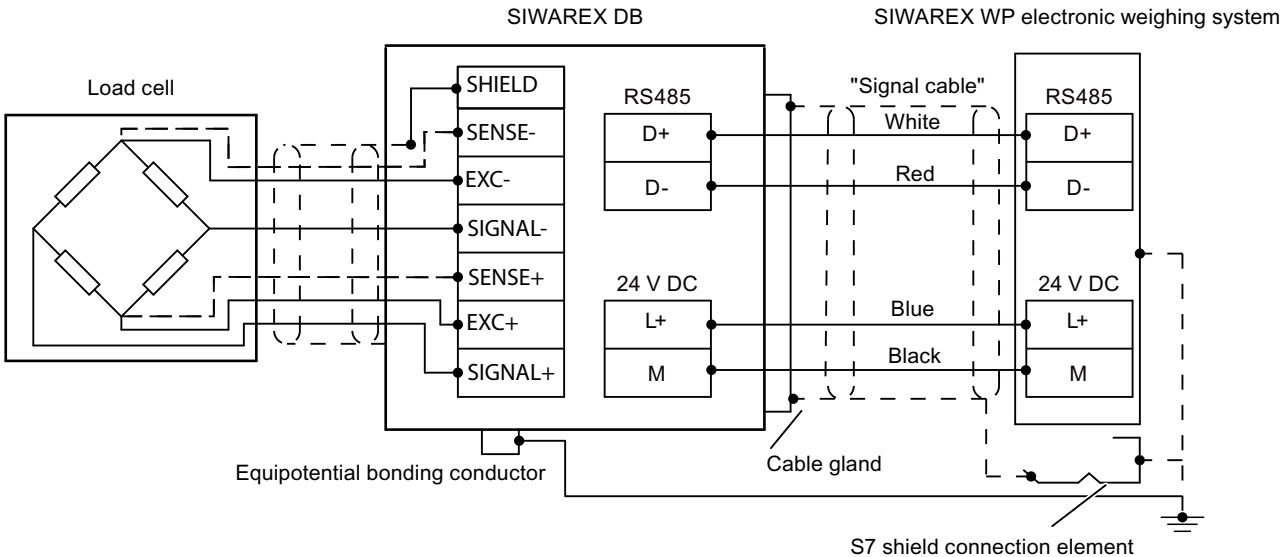
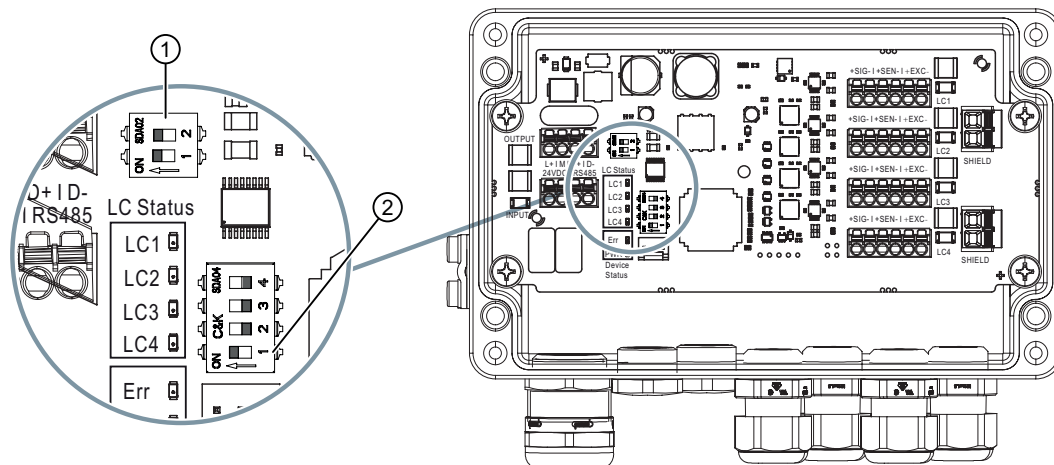

Figure 6-10 Connect SIWAREX DB to SIWAREX WP electronic weighing system and load cell

5. Activate the terminating resistor RS-485 ① by setting both DIP switches to ON.

- Set the RS485 address by setting the DIP switch 1 ② to ON.



- Close any unused opening in the enclosure with a blanking plug.
- Connect the equipotential bonding conductor to the outside of the enclosure. Use shielded cable lugs.
- Close the cover of the SIWAREX DB according to the tightening torque 1.5 to 2 Nm.

6.6.2 Connect the cable

Condition

You require a screwdriver with a maximum blade width of 2.5 mm.

You can use the SIWAREX cable for supply voltage and RS-485 communications. Ordering data (Page 123)

Procedure

- Place the cable shield in the EMC cable gland over a large area.

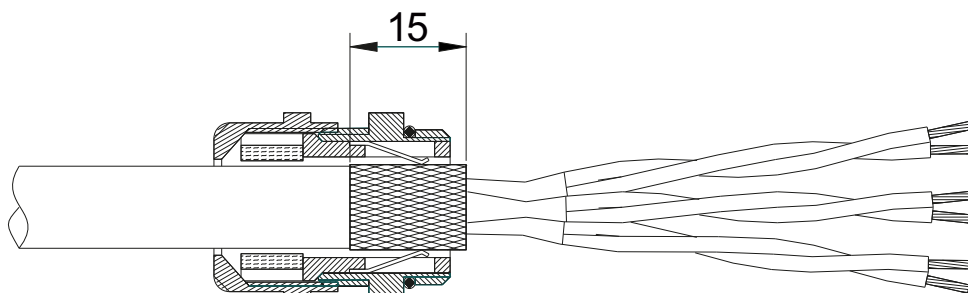

Figure 6-11 Place the cable shield in the EMC cable gland.

- For plastic cable glands, connect the corresponding wire of the SIWAREX load cell to the shield terminal.
- Strip the cable ends at least 6 mm.

6.6 Connection of the SIWAREX DB

4. Push the screwdriver into the rectangular opening of the terminals.
5. Insert the stripped cable into the round opening as far as it will go.
6. Remove the screwdriver from the rectangular opening.

Commissioning

Commissioning essentially comprises:

- Checking the scale construction
- Specifying the parameters
- Calibration
- Verifying the envisaged functionality

7.1 Factory-set parameters

The electronic weighing system described here is provided with factory-set parameters. The parameters have been provided for a typical 100 kg scale based on three load cells. Parameters which can be entered in % or time are preset in such a way that they provide good results for most applications.

With these default parameters, commissioning can be carried out in 5 minutes (see chapter 5-minute quick start with the operator panel and the Ready-for-Use software (Page 38)).

7.2 Commissioning tools

Commission the electronic weighing system using the following alternatives:

- Touch panel und SIWAREX WP321 function block in S7-300/400/1200 or 1500
A free example project is available for download online at TIA Portal project "Ready-for-use" for SIWAREX WP321 (<https://support.industry.siemens.com/cs/ww/en/view/94109373>).
- Commissioning with SIWATOOL V7
SIWATOOL V7 is included in the WP configuration package available for purchase, Ordering data (Page 123). To communicate between SIWAREX WP and SIWATOOL V7, use an additional interface converter USB/RS485.

Use SIWATOOL V7 to commission the scale without SIMATIC expertise with a standard PC. Backup files can also be created and loaded. In the event of a fault, additional SIWATOOL diagnostics functions enable fast analysis of the cause.

7.3 5-minute quick start with the operator panel and the Ready-for-Use software

7.3.1 Start

The 5 minutes of quick start is performed in this example with a TP700 Comfort Panel connected directly to the electronic weighing system. The Panel communicates directly over MODBUS TCP/IP or via the SIMATIC S7-1200 CPU.

To carry out the quick start, select the "1.0 Setup" function in the main menu and then "1.2 Quick Start". You will be guided through the individual tasks for setting the most important parameters.

The remaining parameters are factory-set in such a way that they can be used in most cases without any changes.

You can download the HMI software used below as free TIA Portal project "Ready-for-use" for SIWAREX WP321 (<https://support.industry.siemens.com/cs/ww/en/view/94109373>).

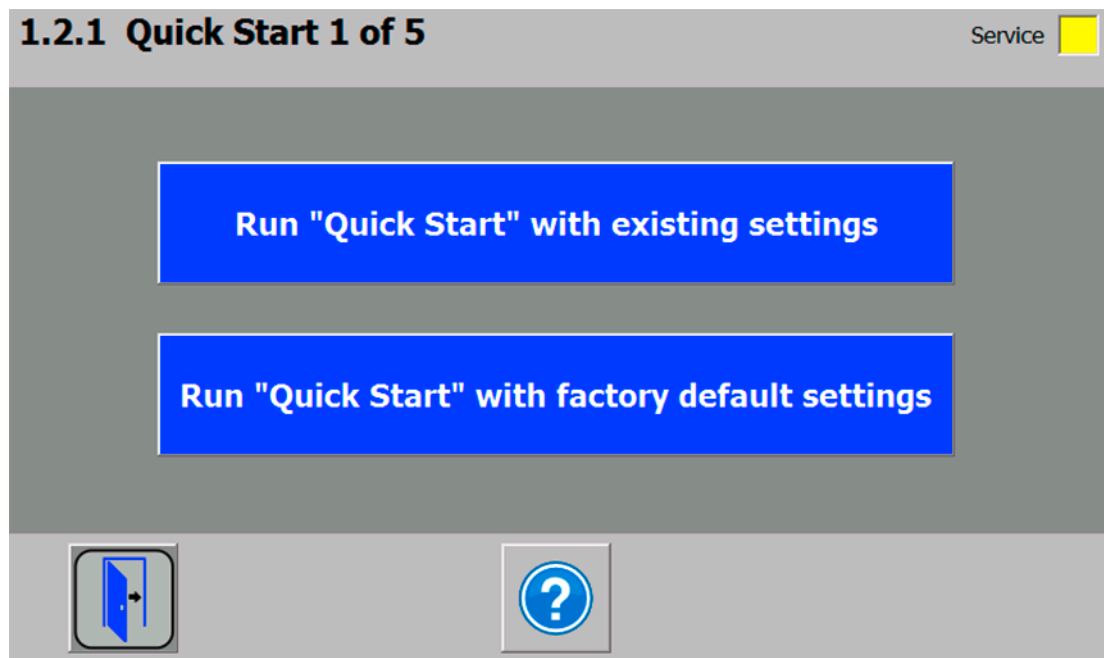

Figure 7-1 Quick start step 1

7.3.2 Factory setting of the parameters

The quick start is based on the factory setting of the parameters. Therefore, the previous parameter settings must be reset prior to the quick setup. Service mode must be switched on first. Resetting to the factory setting can then be carried out.

1.2.2 Quick Start 2 of 5 Service

Scale Name	<input type="text"/>
Weight unit	<input type="text" value="kg"/>
Indicator for Gross ("B" or "G")	<input type="text" value="B for Gross"/>
Resolution	<input type="text" value="0.1000"/>
Minimum weight (in d)	<input type="text" value="20"/>
Maximum weight	<input type="text" value="100.0000"/> kg





Navigation icons:    

Figure 7-2 Quick start step 2

7.3.3 Selecting the calibration method

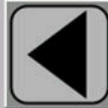
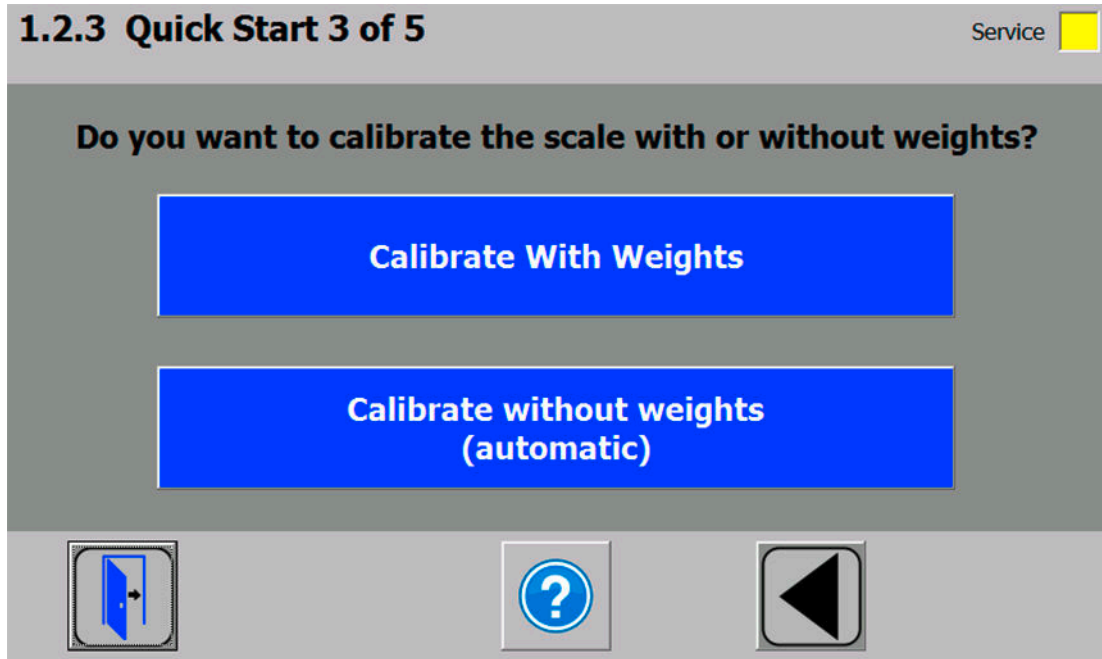

Figure 7-3 Quick start step 3

The module can always be calibrated in two different ways:

- Using reference weights: in the case of a calibration with weights, mechanical influences of the scale construction are also partially taken into account.
- Without weights, using the technical specifications of the connected load cell(s): in the case of automatic calibration, the accuracy of the scale is influenced by the mechanical properties to a greater extent than with calibration using reference weights.

With both methods, make sure that the mechanical properties of the scale are flawless prior to calibration.

7.3.4 Defining the calibration weights

1.2.4 Quick Start - Calibration Weights 4 of 5 Service

Calibration weight 0	0.000	kg
Calibration weight 1	100.000	kg
<i>Calibration weight 2 (optional)</i>	0.000	kg











Figure 7-4 Quick start step 4a

In step 4 you enter the calibration weights which are to be positioned on the scale during the calibration. If the scale is not empty and the current contents are known, you can define an "Calibration weight 0" with the current contents of the scale. With an empty scale, this parameter remains as 0 kg. "Calibration weight 1" usually defines the first reference point of the scale characteristic. A further reference point ("Calibration weight 2") can also be set in addition. This is optional, and may not be necessary depending on the mechanical properties of the scale.

Note that the interval between the calibration weights must be at least 2% of the nominal load of the scale. With a 1 000 kg scale, a calibration weight of at least 20 kg must therefore be used.

7.3.5 Setting calibration points

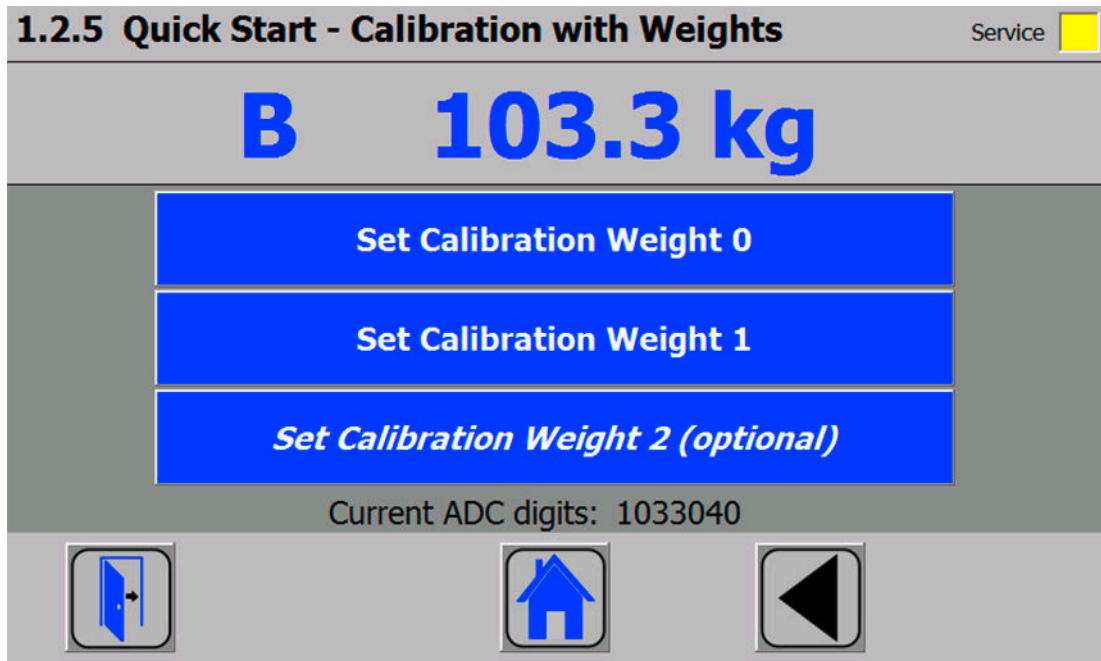

Figure 7-5 Quick start step 5a

Carry out the calibration commands at the end of the quick start:

1. Carry out the "Set calibration weight 0" command. The "Calibration weight 0" defined in step 4 is now visible in the display.
2. Place the "Calibration weight 1" defined in step 4 on the scale construction, and execute the "Set calibration weight 1" command.
3. If an "Calibration weight 2" was selected:
Place "Calibration weight 2" defined in step 4 on the scale construction, and execute the "Set calibration weight 2" command.
4. Calibration of the scale is now complete. Return to the start screen by clicking on the house icon.

7.3.6 Calibrating the scale automatically

The scale can also be calibrated without weights. To do this, it is necessary to enter data specific to the load cells. In addition, it is essential that the scale is empty.

1.2.6 Quick Start 4 of 5 - Load Cells Parameters Service

Number of support points	3	
Average of all characteristic values (mV/V)	2.000000	
Nominal load of one single load cell	60.0	kg

Figure 7-6 Quick start step 4b

The number of points of support corresponds with a silo, for example, to the number of clamps or feet of the silo. A quadratic platform scale with a load cell at each corner has 4 support points. The characteristic values of the individual load cells are required to calculate the average characteristic value of the cells.

The equation for the calculation is as follows:

$$(\text{characteristic of cell 1} + \text{characteristic of cell 2} + \text{characteristic of cell n}) / n$$

If the exact characteristic values are unknown, it is permissible to also use rounded-off numbers (e.g. 1.0 mV/V, 2.0 mV/V). The nominal load of an individual load cell (not the nominal load of the complete scale!) must subsequently be defined.

7.3.7 Performing the automatic calibration

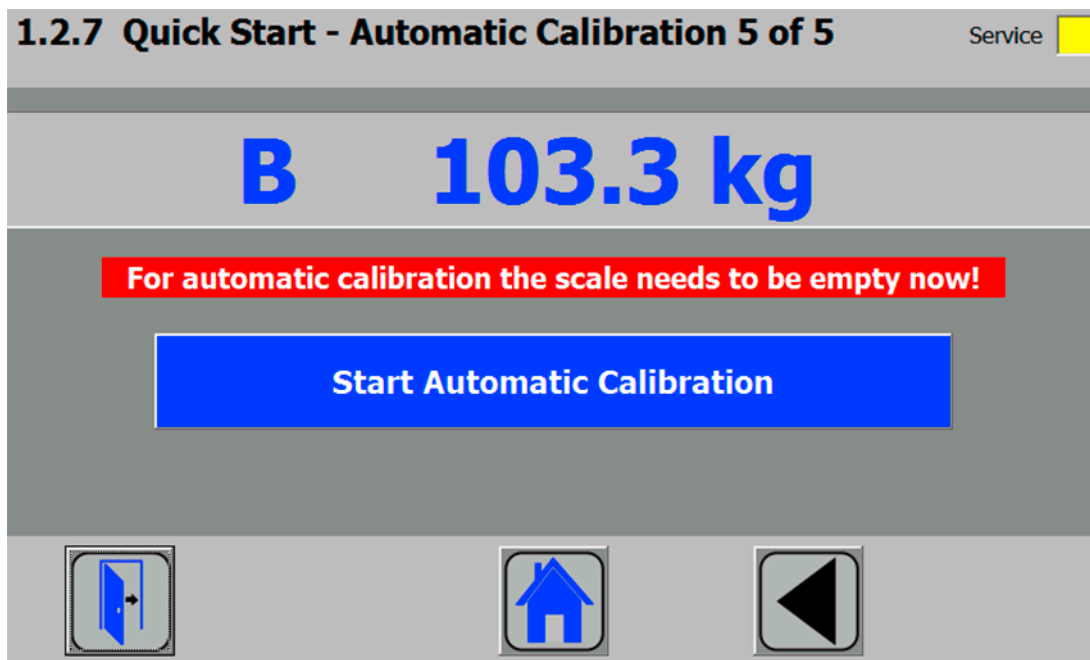

Figure 7-7 Quick start step 5b

Subsequently enter the "Perform automatic calibration" command with the scale empty. The scale is calibrated directly, and clicking on the house icon returns you to the start screen.

7.3.8 Checking the scale following calibration

If the scale is only used for company-internal purposes, a simple check is sufficient.

Perform the following steps:

1. The scale is unloaded and shows "0 kg".
2. Place a known reference weight on the scale.
Check the displayed value.
3. If a second known reference weight is available, place it on the scale in addition.
Check whether the scale displays the sum of the reference weights.
4. Remove the reference weights from the scale.
Check that the display is "0 kg" again.

7.4 Fast commissioning (Quick Start) with SIWATOOL

7.4.1 Service with the SIWATOOL program

You can use the SIWATOOL program to commission the scale independent of the SIMATIC automation system. The program is included in the configuration package.

Install the SIWATOOL program (SIWATOOL folder) on your PC for commissioning.

The SIWATOOL program is described in the section Service with the SIWATOOL program (Page 56).

You require an RS485-USB converter from Siemens in order to connect the PC to the SIWAREX (see section Ordering data (Page 123)). You can then connect the RS485 interface of the SIWAREX to the USB port of the PC.

- Close the RS485-USB converter proposed by Siemens (see section Ordering data (Page 123)) at the base unit of SIWAREX WP321 as follows:

RS485-USB converter	Base unit of SIWAREX WP321
Terminal A	Terminal 13 (D+)
Terminal B	Terminal 14 (D-)
Terminal X	-
-	Bridge between terminals 9 (T+) and 11 (D+)
-	Bridge between terminals 10 (T-) and 12 (D-)

7.4.2 Establish communication to SIWAREX WP321

- After starting the SIWATOOL program, select the SIWAREX WP321 from the "Device selection" window.

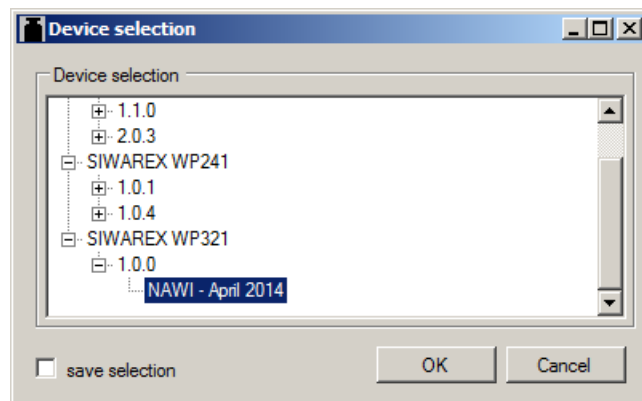
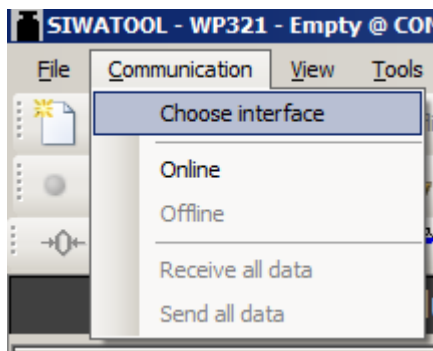

Figure 7-8 SIWATOOL: Device selection window

- Select the menu command "Communication" > "Choose interface".



- Select the COM port of your PC used for the RS485-USB converter (for example: COM3).

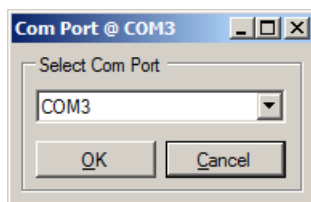
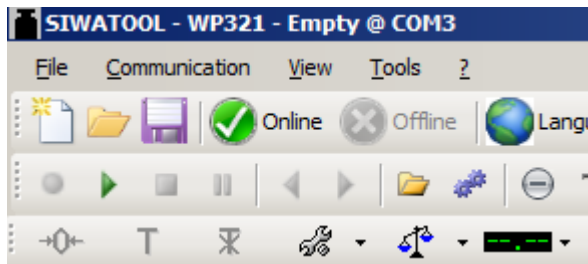

Figure 7-9 SIWATOOL: Select Com port window

- Click on the "Online" button



⇒ The communication to SIWAREX WP321 is established.

7.4.3 Calibration

7.4.3.1 Selecting the calibration method

You can calibrate the SIWAREX module in two different ways:

- Calibration with calibration weight (Page 47) When calibrating with calibration weights, mechanical influences of the scale construction are also taken into account.
- Automatic calibration (without calibration weight) (Page 50) When calibrating without calibration weights, the technical specifications of the connected load cell(s) are taken into account. With automatic calibration, the accuracy of the scale depends on the mechanical properties of the scale.

With both methods, make sure that the mechanical properties of the scale are flawless prior to calibration.

7.4.3.2 Calibration with calibration weight

Define calibration parameters

- Enter the marked and described calibration parameters.

Calibration Parameter (DR3)	
	Info
Basic Parameters	
	Scale name
①	Weight unit kg
	Letter for gross weight B for Gross
	Minimum weight (in d) 20
②	Maximum weight 100.0
③	Resolution d 0.1
Calibration	
	Calibration weight 0 0.0
④	Calibration weight 1 100.0
	Calibration weight 2 0.0
	Calibration digits 0 (real) 0
	Calibration digits 1 (real) 2000000
	Calibration digits 2 (real) 0
	Additional Parameters

- ① The defined weight unit applies to all weight specifications. You can specify a string with up to 4 digits as the weight unit, e.g.: t, kg, lbs.
- ② Exceeding the maximum weight (= maximum material to be weighed) is indicated in DS30, status 1-2, at parameter "Max 9e". If the maximum weight is exceeded, this bit is set to TRUE.
- ③ The resolution d is used for the weight display in the SIWATOOL program. You can set the resolution d in accordance with EN 45501 (0.0001 to 50).
- ④ Calibration weight 1 and its corresponding calibration digits define the characteristic curve of the scale.
Use a minimum calibration weight as calibration weight 1, with a load cell characteristic value of:
 - 1 mV/V: 4 % of the total rated load of all load cells
 - 2 mV/V: 2 % of the total rated load of all load cells
 - 4 mV/V: 1 % of the total rated load of all load cells

Example

Number of load cells: 3

Nominal load of one single load cell: 100 kg

Load cell characteristic value: 2 mV/V

Use the following **minimum calibration weight** for calibration:

$$2\% \times 3 \times 100 \text{ kg} = 6 \text{ kg}$$

Figure 7-10 SIWATOOL: Calibration parameters for calibration with calibration weight

Send calibration parameters

- Send the calibration parameters set on your PC to SIWAREX.
- Select "Service mode on" in the Service menu. The calibration parameter (DR3) can only be sent and the calibration commands executed with service mode switched on.

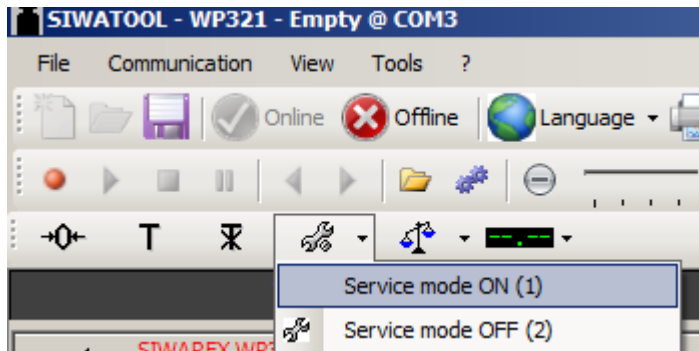

⇒ After switching on service mode, the following red wrench icon is displayed in the SIWATOOL next to the weight value.



Figure 7-11 SIWATOOL: Symbol for service mode

NOTICE

Parameters overwritten

It is not possible to send or receive individual parameters within a data record. The complete data record must initially be received for every change to parameters within it. The desired parameter can then be edited and the data record sent again.

If not all the data can be received from the scale before the parameter change, the active offline parameters in the scale can be overwritten by the "Send data record" function. Therefore, proceed as follows:

1. Select the "Receive data record" function.
2. Change the parameters.
3. Select the "Send data record" function.

- Right-click on "Calibration parameter (DR3)" and select "Send data record".

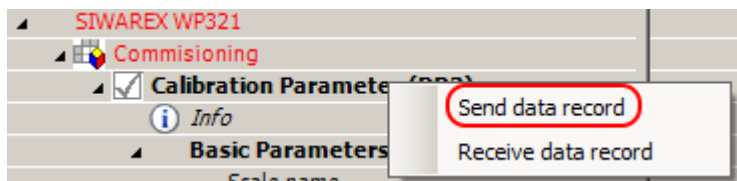
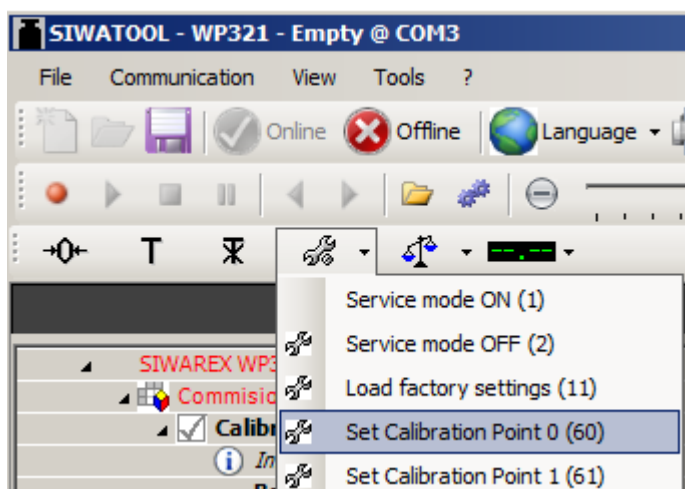

Figure 7-12 SIWATOOL calibration parameters: Send data record

⇒ All parameter settings in DR3 are identical between PC and SIWAREX. All calibration parameters (DR3) are shown in black.

Assign calibration weight

- After sending the calibration parameters to SIWAREX, select "Set Calibration Point 0" in the Service menu with an empty scale. Empty scale means only the mechanical dead load (e.g. empty container) rests on the load cells.



- Place the previously defined "Calibration weight 1" on the scale
- Select "Set Calibration Point 1" in the Service menu.

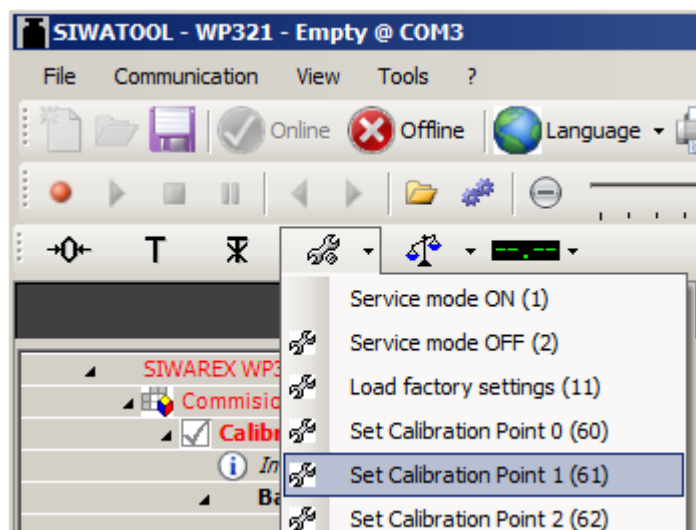

- Select "Service mode off" in the Service menu.

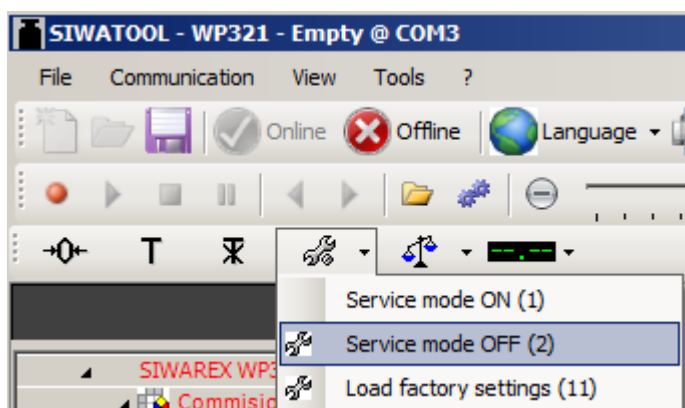

⇒ The calibration is finished and the correct weight value is now displayed in the SIWATOOL program.

Receiving calibration parameters

During the calibration, the SIWAREX internally changes its calibration digits. This means that SIWATOOL now has obsolete parameter values. Obsolete calibration parameters are marked in red.

The calibration parameter (DR3) must be read back in order once again obtain the calibration digits in the SIWATOOL which are consistent with the SIWAREX.

Calibration Parameter (DR3)	
<i>Info</i>	
Basic Parameters	
Calibration	
Calibration weight 0	0.0
Calibration weight 1	130.0
Calibration weight 2	0.0
Calibration digits 0 (real)	0
Calibration digits 1 (real)	2000000
Calibration digits 2 (real)	0

Figure 7-13 SIWATOOL: Obsolete calibration parameters

- Right-click on "Calibration parameter (DR3)" and select "Receive data record".

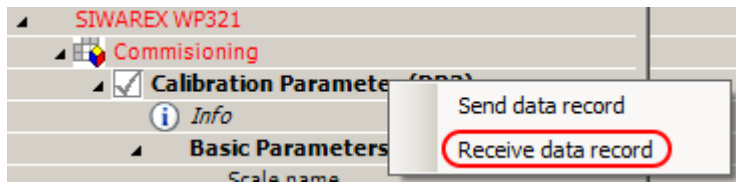

Figure 7-14 SIWATOOL calibration parameters: Receive data record

Checking the scale following calibration

If the scale is to be used for business purposes only, check it as follows:

1. The scale is unloaded and the display shows "0 kg".
2. Place one or more known test weights on the scale. To check other weight points of the scale in addition to the calibration weight, do not use the calibration weight.
3. Check the displayed weight value in the SIWATOOL program.
4. Remove the test weights from the scale.
5. Check that the display of the scale is 0 kg again.

7.4.3.3 Automatic calibration (without calibration weight)

The scale can also be calibrated without a weight. To do this, the parameters marked in bold in DR3 / basic parameters are checked or entered, and the data specific to the load cells are specified in DR10.

Requirement:

The scale is empty.

Procedure

- Enter the marked and described calibration parameters.

Calibration Parameter (DR3)			
Info			
Basic Parameters			
	Scale name		
①	Weight unit	kg	kg
	Gross indicator	B for Gross	B for Gross
	Minimum weight (in d)	20	20
②	Maximum weight	100.0	100.0
③	Resolution d	0.1	0.1
Calibration			
④	Calibration weight 0	0.0	0.0

- ① The defined weight unit applies to all weight specifications. You can specify a string with up to 4 digits as the weight unit, e.g.: t, kg, lbs.
- ② Exceeding the maximum weight (= maximum material to be weighed) is indicated in DS30, status 1-2, at parameter "Max 9e". If the maximum weight is exceeded, this bit is set to TRUE.
- ③ The resolution d is used for the weight display in the SIWATOOL program. You can set the resolution d in accordance with EN 45501 (0.0001 to 50).
- ④ If the scale is not empty during automatic calibration, but the material weight on the scale is known (e.g. after conversion to SIWAREX WP321), the known material weight can be specified as calibration weight 0. This means the material weight is taken into account during automatic calibration.

NOTE: If the specified material weight is incorrect (old electronic weighing system was not calibrated correctly, for example), the weighing result of SIWAREX WP321 will be distorted or incorrect!

Figure 7-15 SIWATOOL: Calibration parameters for automatic calibration (without calibration weight)

Send calibration parameters

- Send the calibration parameters set on your PC to SIWAREX.
- Select "Service mode on" in the Service menu. The calibration parameter (DR3) can only be sent and the calibration commands executed with service mode switched on.

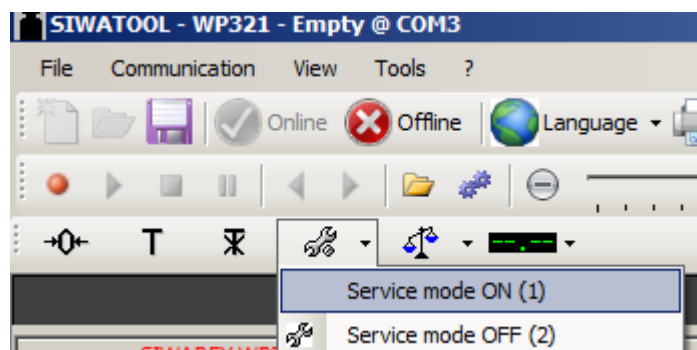

⇒ After switching on service mode, the following red wrench icon is displayed in the SIWATOOL next to the weight value.



Figure 7-16 SIWATOOL: Symbol for service mode

NOTICE

Parameters overwritten

It is not possible to send or receive individual parameters within a data record. The complete data record must initially be received for every change to parameters within it. The desired parameter can then be edited and the data record sent again.

If not all the data can be received from the scale before the parameter change, the active offline parameters in the scale can be overwritten by the "Send data record" function. Therefore, proceed as follows:

1. Select the "Receive data record" function.
2. Change the parameters.
3. Select the "Send data record" function.

- Right-click on "Calibration parameter (DR3)" and select "Send data record".

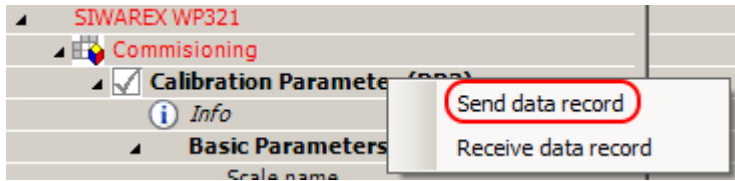

Figure 7-17 SIWATOOL calibration parameters: Send data record

⇒ All parameter settings in DR3 are identical between PC and SIWAREX. All calibration parameters (DR3) are shown in black.

Defining load cell parameters

- Enter the marked and described load cell parameters (DR10) in DS10.

<input checked="" type="checkbox"/> Load Cells Parameter (DR10)	
<i>Info</i>	
	Sampling rate 100Hz (50Hz grid frequency)
①	No. of mechanical support points 3
②	Averaged characteristic value (mV/V) 2.0
③	Nominal load of one single load cell 60.0

- ① The No. of mechanical support points corresponds with a silo, for example, to the number of clamps or feet of the silo. A quadratic platform scale with a load cell at each corner has four support points.
- ② Averaged characteristic value (mV/V) This parameter is the mean value of the characteristic values of all connected load cells (for example, Identifier = 2.018 mV/V). You can obtain the exact characteristic value of a load cell from its test report or read it directly at the load cell. If the characteristic values of the individual load cells are unknown, you can assume the value "1.0" for 1 mV/V load cells, the value "2.0" for 2 mV/V load cells, etc.
- ③ Specify the Nominal load of one single load cell.

Figure 7-18 SIWATOOL load cell parameters (DR10)

- Right-click on "Load cells parameter (DR10)" and select "Send data record".

<input checked="" type="checkbox"/> Load Cells Parameter (DR10)		<input type="button" value="Send data record"/>
<input type="button" value="Info"/> Info		<input type="button" value="Receive data record"/>
Sampling rate		(0Hz grid frequency)
No. of mechanical support points	3	
Averaged characteristic value (mV/V)	2.0	
Nominal load of one single load cell	60.0	

Figure 7-19 SIWATOOL load cell parameters: Send data record

⇒ All parameter settings in DR10 are identical between PC and SIWAREX. All load cell parameters (DR10) are shown in black.

NOTICE

Parameters overwritten

It is not possible to send or receive individual parameters within a data record. The complete data record must initially be received for every change to parameters within it. The desired parameter can then be edited and the data record sent again.

If not all the data can be received from the scale before the parameter change, the active offline parameters in the scale can be overwritten by the "Send data record" function.

Therefore, proceed as follows:

1. Select the "Receive data record" function.
2. Change the parameters.
3. Select the "Send data record" function.

Run automatic calibration

- After sending the calibration parameters to SIWAREX, select "Automatic calibration" in the Service menu with an empty scale. Empty scale means only the mechanical dead load (e.g. empty container) rests on the load cells.

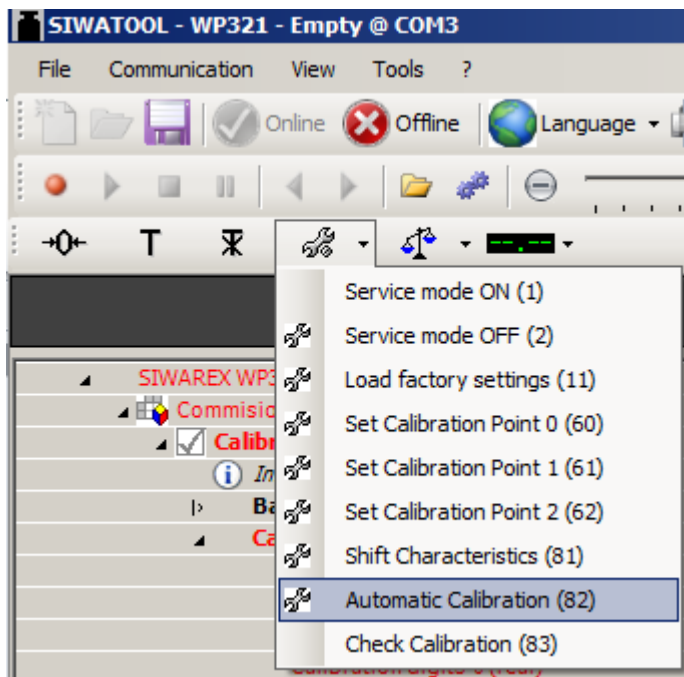

- Select "Service mode off" in the Service menu.

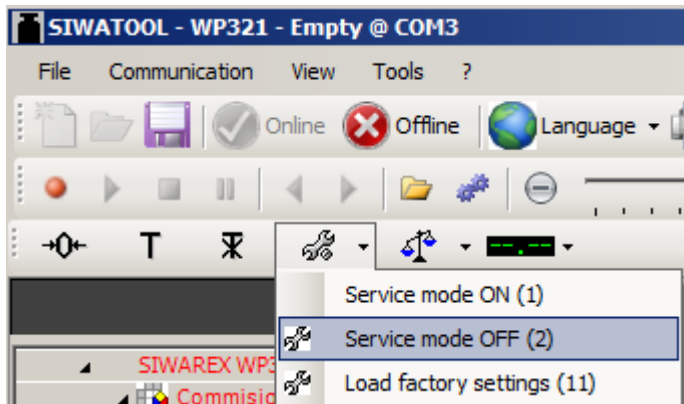

⇒ The calibration is finished and the correct weight value is now displayed in the SIWATOOL program.

Receiving calibration parameters

During the calibration, the SIWAREX internally changes its calibration digits. This means that SIWATOOL now has obsolete parameter values. Obsolete calibration parameters are marked in red.

The calibration parameter (DR3) must be read back in order once again obtain the calibration digits in the SIWATOOL which are consistent with the SIWAREX.

▲ <input checked="" type="checkbox"/> Calibration Parameter (DR3)	
(i) Info	
▶ Basic Parameters	
▲ Calibration	
Calibration weight 0	0.0
Calibration weight 1	130.0
Calibration weight 2	0.0
Calibration digits 0 (real)	0
Calibration digits 1 (real)	2000000
Calibration digits 2 (real)	0

Figure 7-20 SIWATOOL: Obsolete calibration parameters

- Right-click on "Calibration parameter (DR3)" and select "Receive data record".

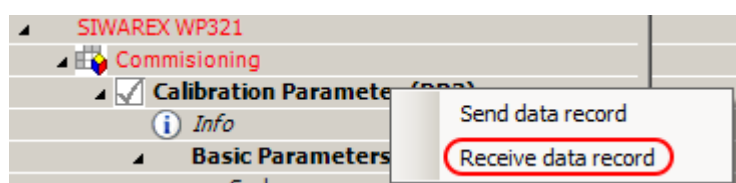

Figure 7-21 SIWATOOL calibration parameters: Receive data record

Checking the scale following calibration

If the scale is to be used for business purposes only, check it as follows:

1. The scale is unloaded and the display shows "0 kg".
2. Place one or more known test weights on the scale. To check other weight points of the scale in addition to the calibration weight, do not use the calibration weight.
3. Check the displayed weight value in the SIWATOOL program.
4. Remove the test weights from the scale.
5. Check that the display of the scale is 0 kg again.

7.4.4 Receive all data

- Activate the "Receive all data" function in the "Communication" menu.

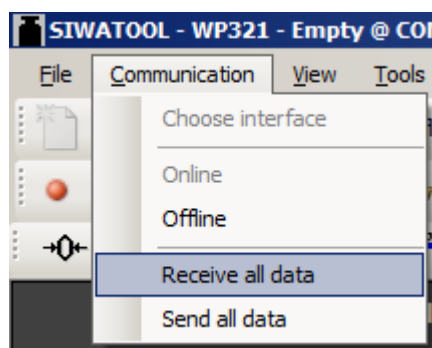

⇒ All parameters can be saved as a backup file on the hard disk. If a module is replaced, the backup file can be downloaded to the new module within a few seconds. The new module is right back to the calibrated state - without repeated calibration.

7.5 Service with the SIWATOOL program

You can use the SIWATOOL program to commission the scale independently of the SIMATIC automation system. You require an RS485/USB converter in order to connect the PC to the SIWAREX (see section Ordering data (Page 123)). You can then connect the RS485 interface of the SIWAREX to the USB port of the PC.

The SIWATOOL program is included in the configuration package.

Install SIWATOOL for commissioning (part of the SIWAREX WP321 configuration package, see section Ordering data (Page 123)) on your PC.

7.5.1 Windows and functions of SIWATOOL

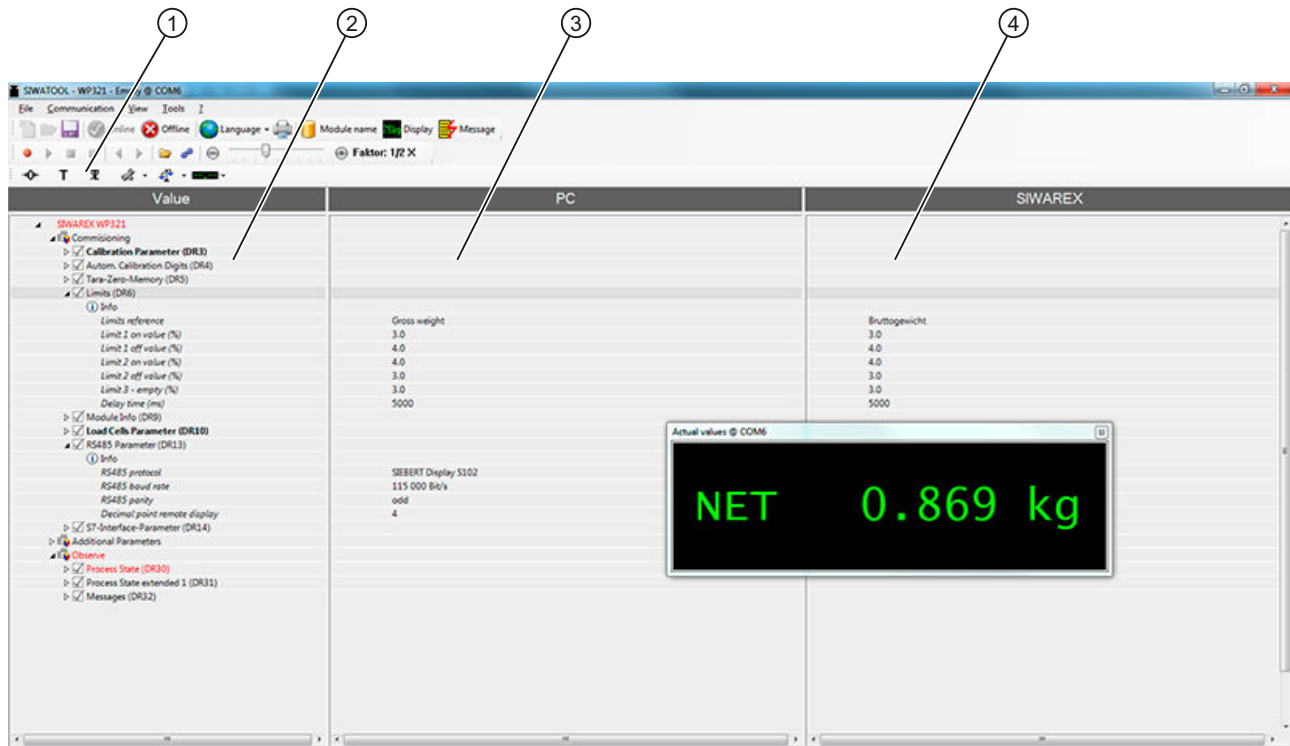

- ① Control elements for SIWATOOL and operation of the scale
- ② Parameter list of the SIWATOOL module
- ③ Offline values of the SIWAREX module
- ④ Online values of the connected SIWAREX module

Figure 7-22 Layout of the SIWATOOL user interface

For sending, receiving and transferring, select the corresponding data record and call the command list with a right mouse click.

The complete data record (all parameters of the data record) is always transferred, not just individual parameters.

Parameters marked in bold are relevant for typical application cases.

7.5.2 Offline parameter assignment

All scale parameters can be edited and saved without an electronic weighing system.

This reduces the setup time. You can thus prepare the parameters for several scales in your office, and subsequently transfer them to the electronic weighing system during setup.

Data from one scale currently in operation can be exported and used to set up another scale.

7.5.3 Online parameter assignment

To switch to online mode, connect the PC to the SIWAREX module via an RS485/USB converter. Set the appropriate interface in the communication menu.

You can change all parameters in the SIWAREX module in online mode. The message window shows the current contents of the message buffer of the SIWAREX module. The current process values are displayed in the "Online" column.

For test purposes, you can send various commands to the SIWAREX module. Differences between the online/offline data are marked in red by SIWATOOL. This affects both the associated data record and the individual parameter.

In order to archive data, all data can be exported from the SIWAREX module and saved as a file or printed.

Note

You can edit all data in the SIWAREX module in online mode. The changes are not automatically imported to the corresponding scale data block in the SIMATIC CPU.

To download the data to the SIWAREX module, select the data record with a right mouse click and send it explicitly to the SIWAREX module.

Online parameter trends can be recorded and played back using the recorder function located at the top right-hand edge of SIWATOOL. You can use the "Configure recorder" button to select the data records to be recorded and to set the save parameters. The playback speed can be set using a slider.

7.5.4 Available help options

SIWATOOL offers various help options for operation:

- Info card
You can select the "Info" item directly underneath the individual data records in the navigation tree. This info card explains how the data record influences the scale behavior.
- Tooltip
If you move the mouse over a button or parameter, a corresponding help text is displayed.
- Help
Click on the menu option "Help" to call up the SIWATOOL help. The Help can be opened separately.

7.5.5 Entering parameters with SIWATOOL

There is a defined procedure for handling parameters. The current parameters in the SIWAREX module are displayed in the right-hand window, while the parameter values on the PC are displayed in the left-hand window. The new parameter value is entered first in the left-hand window. If several parameters of the data record are to be changed, they are entered consecutively. The data record is subsequently selected in the tree view and sent to the SIWAREX modules using the right mouse button.

Parameters are always changed as complete data records, rather than individually.

Scale parameters and functions

8.1 Parameters and functions

All parameters are set to default values in the factory. You can restore the configuration to factory settings using the "Load factory settings" command.

The scales are ready for operation with the default parameter settings. You do not need to re-enter all parameters. The advantage of this solution is that you can decide the default values to be retain and the parameters that need to be adapted for your application.

All parameters are divided into data records (DR). The data records are organized in steps (tasks) to be implemented during commissioning or during the process.

The scale functions governed by the parameters are also described in the parameter description below.

First, the parameters of a given data record are displayed in a table. The detailed parameter description for the parameters of this data record then follows.

When it receives new parameters, the SIWAREX module runs a validation check. In the event of a parameter assignment error, the data record is not applied (not saved) by the SIWAREX module and a data/operator error is reported.

8.2 Assigning parameters to the electronic weighing system with SIWAREX DB

Introduction

You can assign parameters to the SIWAREX WP electronic weighing systems using the SIMATIC HMI, the SIWATOOL or the SIMATIC S7 control system. The procedure described for you is oriented to the data records (DS) from SIWATOOL and the SIMATIC S7 control system.

Procedure

1. Set the Load cell type parameter to SIWAREX DB in data record DR03. (Not relevant for SIWAREX WP321)
2. Set the RS 485 protocol parameter to SIWAREX DB and the RS 485 baud rate to 115 200 bits/s in data record DR13.
3. Activate the load cell input for every connected load cell in the data record DR70.
4. Specify whether 4- or 6-wire load cells are connected for the Sensor type parameter in data record DR70.

8.4 DR 3 calibration parameters

5. In order to identify the load cell type and the installation location of your load cells enter the Load cell manufacturer, Load cell order number and Location Designation of Sensor in the data record DR70.
6. The details of the data data records and parameters are specified in the parameter assignment tables.

8.3 DR 2 command code

DR 2 is a special data record used to transfer commands to the SIWAREX module by SIWATOOL.

8.4 DR 3 calibration parameters

The calibration parameters need to be checked and if necessary modified for all scales. The scale is basically defined by calibration parameters and calibration operation.

Procedure

- Check all parameters and modify them as required.
- Transfer the DR 3 data record from SIWATOOL to the scale.
- Calibrate the scale.
- Transfer the DR 3 data record from the scale to SIWATOOL.

Table 8-1 Assignment of data record 3

Variable	Note	Type	Length (bytes)	Rw	Default	Min.	Max.
Data record number	Contains no. of data record	UINT	2	r	3	-	-
Length	Data record length information	UINT	2	r	124	-	-
Application	Information on which application the DR belongs to	UINT	2	r	201	-	-
Version identifier	Information on the current data record version	UINT	2	r	1	1	65 635
Scale name header	Maximum length and actual length of string for scale name	UBYTE[2]	2	rw	12,12	-	-
Scale name (Page 62)	Scale name specified by user	STRING[12]	12	rw	" "	-	-
Weight unit header	Maximum length and actual length of string for weight unit (for example, g, kg, t, ...)	UBYTE[2]	2	rw	04,04	-	-
Unit of weight (Page 63) ¹⁾	Weight unit	STRING[4]	4	rw	"kg••"	-	-

Variable	Note	Type	Length (bytes)	Rw	Default	Min.	Max.
Gross identifier header	Maximum length and actual length of string for weight unit	UBYTE[2]	2	rw	02,02	-	-
Gross identifier (Page 63)	Abbreviation of gross (B or G), only one byte is used!	STRING[2]	2	rw	"B"	"B"	"G"
Reserve	Reserve	UINT	8	rw	0	-	-
Maximum weighing range (Page 63) ¹⁾	Maximum weight	REAL	4	rw	100	> wb_min* ZIF.step	maximum number range
Calibration weights 0, 1, 2 and calibration digits 0, 1, 2 (Page 63)	Calibration weight 0 ¹⁾ (usually the zero point)	REAL	4	rw	0	1	9 999 999
	Calibration weight 1 ¹⁾	REAL	4	rw	100	1	9 999 999
	Calibration weight 2	REAL	4	rw	0	1	9 999 999
	Calibration digits 0 determined during calibration with calibration weight 0	DINT	4	rw	0	-3 999 999	+3 999 999
	Calibration digits 1 determined during calibration with calibration weight 1	DINT	4	rw	2 000 000	0	+3 999 999
Calibration digits 2 determined during calibration with calibration weight 2	DINT	4	rw	0	0	+3 999 999	
Scale interval (Page 63) ¹⁾	Resolution weighing range 1 (1*10**k, 2*10**k, 5*10**k]; k: -3 ... 2)	REAL	4	rw	0.1	0.001	50
Reserve	Bit 1: Reserve	BIT	2	rw	0	0	1
Reserve	Bit 2: Reserve	BIT	0	rw	0	0	1
Automatic zero adjustment (Page 63)	Automatic zero tracking (zero tracking device) 0: Autom. zeroing off 1: Autom. zeroing on	BIT	0	rw	0	0	1
Reserve (13 bits)	Bit 3: Reserve	BIT	0	rw	0	0	1
Decimal places for process values (Page 64)	0: No rounding 1: Rounding to 1 decimal place 2: Rounding to 2 decimal places 3: Rounding to 3 decimal places 4: Rounding to 4 decimal places 5: Rounding to 5 decimal places 6: Rounding to 6 decimal places	UINT	2	rw	0	0	6
Maximum tare load (Page 64)	Range of subtractive tare unit [in % of max. weighing range]	REAL	4	rw	0	0	250
Reserve	Reserve	REAL	8	rw	1.0	0	100.0
Maximum negative zeroing limit (Page 64)	Negative range of semi-automatic zeroing device [in % of max. weighing range]	REAL	4	rw	1	0	100.0

Variable	Note	Type	Length (bytes)	Rw	Default	Min.	Max.
Maximum positive zeroing limit (Page 64)	Positive range of semi-automatic zeroing device [in % of max. weighing range]	REAL	4	rw	3.0	0	100.0
Standstill range (Page 64)	Standstill range (in d)	REAL	4	rw	0.1	0	maximum number range+
Standstill time (Page 65)	Standstill time 1 in ms	TIME	4	rw	2 000	10	10 000
Standstill waiting time (Page 65)	Waiting time until standstill. 0: standstill-dependent scale command, if there is no standstill, immediately rejected. > 0: Maximum waiting time until command is executed	TIME	4	rw	2 000	0	10 000
Limit frequency low pass filter 1 (Page 66)	Low-pass filter cut-off frequency: 0: Filter disabled	REAL	4	rw	1	0.01	200
Order no. low pass filter 1 (Page 66)	Filter number	UINT	2	rw	4	0	4
Reserve	Reserve	UINT	2	rw	0	-	-
Limit frequency low pass filter 2 (Page 66)	Low-pass filter limit frequency: 0: Filter disabled	REAL	4	rw	0	0.01	200
Order no. low pass filter 2 (Page 66)	Filter number	UINT	2	rw	4	0	4
Mean value filter depth (Page 67)	Filter for digit values, Permissible filter depth: 0 ... 250	UINT	2	rw	10	0	500

¹⁾ Parameter for calculation of calibration points

8.4.1 Scale name

You can select any name, but it may not exceed 12 characters. You can enter any designation.

8.4.2 Unit of weight

A string with up to four digits can be specified as the unit of weight, e.g.: t, kg, lbs. The defined unit of weight applies to all weight specifications. Entries are not be converted if the unit of weight has changed. Entries must be left-aligned.

8.4.3 Gross identifier

The gross identifier specifies the letter, B (for brutto) or G (for gross), to be used in the display for gross weights.

8.4.4 Maximum weighing range

The weight can only be used with the defined scale interval below the maximum weight (+ 9 d, d = scale interval). The maximum weight is defined during commissioning. Exceeding the maximum weight is indicated in the status (DR30).

The maximum weight depends on the number and type of load cells used.

8.4.5 Calibration weights 0, 1, 2 and calibration digits 0, 1, 2

The calibration weights and corresponding calibration digits define the characteristic curve of the scales. A detailed description can be found in section Calibration procedure (Page 67).

8.4.6 Scale interval

The scale interval for the weighing range can be defined in accordance with EN 45501 (0.0001 to 50).

8.4.7 Automatic zero adjustment

If required, you can carry out semi-automatic zeroing of the scale using the "Zeroing" command.

The automatic adjustment sets the scale to zero without a further command in the event of slow zero drifting. Slow drift is assumed if the OIML R76 criteria are met.

Note

If this function is enabled, the scale may eventually read zero after a slow drift even if they are fully loaded. The function can, however, be limited by specifying a maximum and minimum weight for zeroing.

8.4.8 Decimal places for process values

This parameter is used to specify the number of decimal places to which the process values are to be rounded. This value decouples the main display of the weight values from the values used in the control software.

8.4.9 Maximum tare load

The weighing module accepts any external tare specification which is less than the maximum tare load (percentage of maximum weighing range). Tare commands are also accepted provided that the current gross weight is less than the configured maximum tare load.

8.4.10 Maximum negative zeroing limit

Zeroing defines the current weight of the scales as zero.

You can limit the effect of the zeroing function. The limitation is based not on the current gross weight, but rather on the weight which the scales would display had there been no zeroing (time of scale calibration).

8.4.11 Maximum positive zeroing limit

You can limit the effect of the zeroing function. The limitation is based not on the current weight, but rather on the weight which the scales would display had there been no zeroing (time of scale calibration).

8.4.12 Standstill range

Standstill monitoring checks whether the scales are correctly balanced. Scale standstill is registered if the weight changes by less than a specified fluctuation in d (standstill value) over a specified time (standstill time). Standstill monitoring is used in static scale mode (commands: zeroing, taring). The diagram below illustrates how standstill monitoring works.

The current weight can only be registered in legal trade applications if standstill is reached.

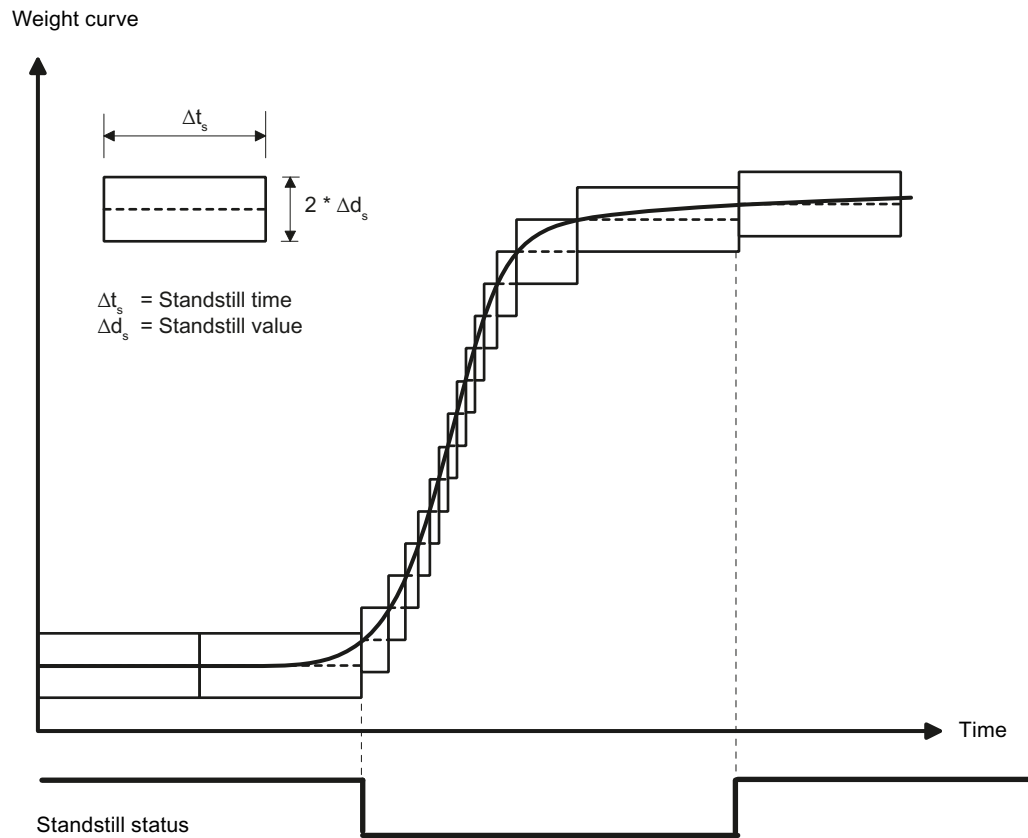

Figure 8-1 Standstill monitoring

8.4.13 Standstill time

Standstill monitoring checks whether the scales are correctly balanced. Scale standstill is registered if the weight changes by less than a specified fluctuation in d (standstill value) over a specified time (standstill time). Standstill monitoring is used in static scale mode (with the following commands: zeroing, taring).

8.4.14 Standstill waiting time

Standstill waiting time is a maximum waiting time for standstill on execution of a command which depends on standstill (taring, zeroing). A technology message is generated if the command cannot be executed during the standstill waiting time because there is no standstill.

If the standstill waiting time is equal to zero, a command requiring standstill is rejected immediately if there is no standstill.

8.4.15 Low-pass filter limit frequency

There is a critically damped low-pass filter for suppressing faults. The diagram below shows the step response of the filter ($f_g = 2$ Hz). The entry "0" means that the filter is switched off. The setting range of the limit frequency is 0.01 to 50.0 Hz.

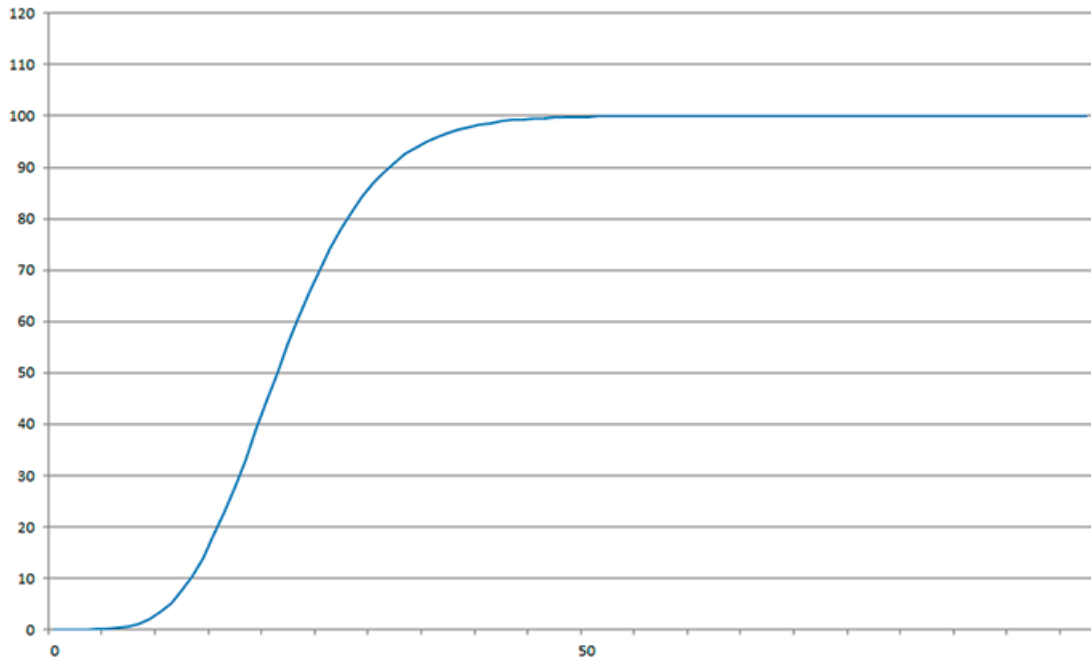

Figure 8-2 Step response of the digital low-pass filter when $f_g = 2$ Hz

When you define the limit frequency, it is extremely important for the suppression of faults. Defining the limit frequency defines the "speed" of the scale's response to changes in the measured value.

A value of 5 Hz, for example, results in a relatively rapid response to a change in weight. A value of 0.5 Hz, for example, makes the scale "slower".

Note

Process values filtered with low-pass filter 1 are available at the SIMATIC I/O (DR 14) and in the DR 30. Process values filtered with low-pass filter 2 can only be set to the SIMATIC I/O with the corresponding selection in DR 14.

8.4.16 Low-pass filter number

The number of the filter defines the effect of damping. The values 2 and 4 can be set. The higher the selected filter number, the higher the effect.

8.4.17 Mean value filter depth

The mean value filter is used to steady the weight against random interference. The weight is the mean value of n ($n = \text{max. } 250$) weights which are recorded by the weighing module every 10 ms, e.g. when $n = 10$, the mean of 10 weights is calculated. Every 10 ms, the oldest value is discarded and the newest value included in the calculation.

8.5 Calibration procedure

8.5.1 Calibration with calibration weights

The incoming analog measured value from the load cells is converted into a digital value in an analog-to-digital converter. A weight is calculated using this digital value. This weight is then used by all weighing module functions for messages and for determining the status.

The characteristic curve of the measuring system must be defined before the weight can be calculated from the digital value. In the simplest case, the characteristic curve is defined with points 0 and 1. The first working point (point 0) is defined by the empty scale (no load) at their own weight. The load cells return a voltage measurement to the weighing module as a result of the weight of the scales themselves. Following analog-to-digital conversion of the measured voltage, the zero point is assigned to the digital value (calibration digits for the zero point).

If the scales are loaded with a defined standard weight (e.g. 50% of the measuring range), the new digital value returned by the analog-to-digital converter is assigned the standard weight.

The characteristic curve can also be determined with a third point, which must be higher than point 1.

Make sure that the difference between two calibration weights is at least 40 000 digits, as the calibration command may otherwise be rejected.

The calibration procedure involves the following steps:

- Activation of service mode using the "Service mode on" command.
- Define the calibration weight and other parameters of the DR 3 data record.
- Transfer the DR 3 data record to the scales.
- Trigger "Adjustment weight 0 valid" for empty scales.
- Load the scale with the defined standard weight.
- Trigger "Adjustment weight 1 valid".
- Transfer data record DR 3 from the scale to SIWATOOL and save the data on a data medium.

You must follow the correct calibration sequence with increasing calibration weights.

Example

Zero point = 0.0 kg (always)	equals 326348 digits
Calibration weight 1 = 100 kg	equals 1324765 digits

8.5 Calibration procedure

Load cell characteristic value	Calibration digit 1 (ca.) when rated load is
1 mV/V	500 000
2 mV/V	1 000 000
4 mV/V	2 000 000

This defines the characteristic curve and the scale can now calculate weights for the full measuring range.

The diagram below illustrates the relationship between calibration digits and the calibration weight.

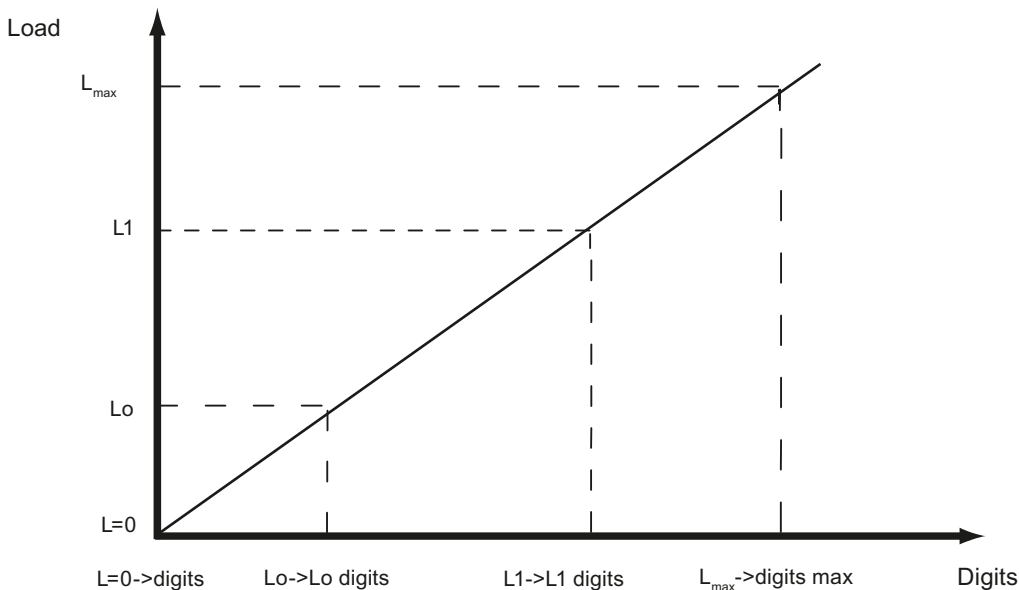

Figure 8-3 Calibration digits and calibration weight

Load	Comment	Load	Digits
L=0	Load cells empty		Approx. 0
Lo	Calibration weight 0 "Zero point"	0 kg	e.g. 70 682 for calibration point 0
L1	Calibration weight 1	e.g. 60 kg	e.g. 308 452 for calibration digits 1
L _{max}	Rated load of the load cell(s)	e.g. 100 kg	1 000 000
L _{max} + 10 %	Rated weight + approximately 10%	e.g. approximately 110 kg	1 090 000

You do not need to perform calibration if the calibration digits and the calibration weights are known to the weighing module described here. They are simply sent to SIWAREX by data record DR 3 and the scale is ready for use immediately.

The SIWATOOL program facilitates rapid calibration.

Following commissioning and calibration, all data records must be read from the weighing module and saved as a scale file.

Identical scales can be put into operation immediately. Connect the PC to the new scale and enable the "Send all data records" function in service mode. This transfers the parameters for

calibration weights and calibration digits, and the characteristic curve is determined immediately. The same applies when you change a weighing module.

Note

Two working points are usually sufficient for determining the scale's characteristic curve. An additional working point is only required for non-linear systems.

Specification of negative calibration points is not possible. However, the characteristic can also be used in the negative range down to -2 000 000 digits. To achieve this, the characteristic curve generated in the positive range is extended into the negative range.

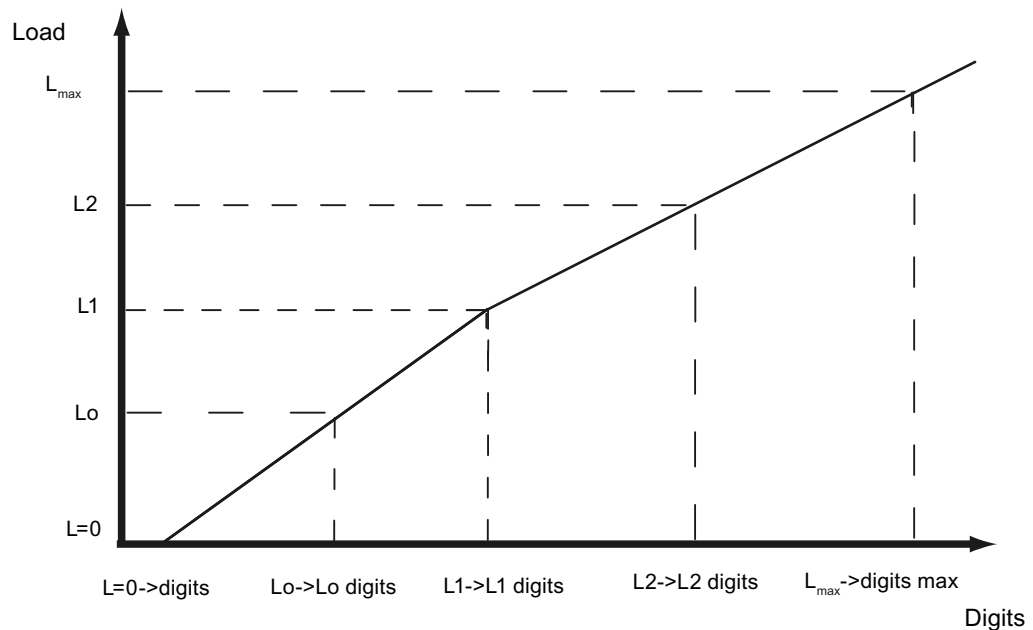

Figure 8-4 Linearizing the scale's characteristic curve

Load	Comment	Load	Digits
L=0	Load cells empty		Approx. 0
L0	Calibration weight 0 "Zero point"	0 kg	e.g. 76 082 for calibration point 0
L1	Calibration weight 1	e.g. 60 kg	e.g. 386 452 for calibration digits 1
L2	Calibration weight 2	e.g. 80 kg	e.g. 451 367 for calibration digits 2
L _{max}	Rated load of the load cell(s)	e.g. 100 kg	1 000 000
L _{max} +10 %	Rated weight + approximately 10%	e.g. approximately 110 kg	1 090 000

8.5.2 Automatic calibration

Scales can be rapidly commissioned with automatic calibration. The accuracy of the scale greatly depends on the entered parameters and the mechanical properties of the scale. However, you achieve the best level of accuracy for the scales by using calibration weights.

During initial commissioning with automatic calibration, you must reset the module using the "Load factory settings" command.

Subsequently specify the basic parameters in DR 3 and the load cell parameters in data record 10. See also the section: Automatic calibration (without calibration weight) (Page 50). Command 82 "Perform automatic calibration" then uses this data and the currently applied dead load to calculate the characteristic curve of the scale. The characteristic curve is active immediately.

Note

The characteristic curve data in data record 3 active prior to execution of command 82 is directly overwritten.

Automatic calibration requires the following criteria:

- Correct mechanical installation of the scale
- Scale is empty (only mechanical installation (= dead load) present on the cells) or the material weight in/on the scale is known (e.g. after conversion to WP321).
- Load cells are evenly loaded
- There are no shunt circuits

8.6 DR 4 Output of calculated calibration digits

Date record DR 4 outputs the digits calculated from automatic scale calibration.

This data record cannot be sent to the scale.

Table 8-2 Assignment of data record 4

Variable	Note	Type	L	Rw	Default	Min.	Max.
Data record number	Contains no. of data record	UINT	2	r	4	-	-
Length	Data record length information	UINT	2	r	28	-	-
Application	Information about which application the DR belongs to	UINT	2	r	201	-	-
Version identifier	Information on the current data record version	UINT	2	r	1	1	65635

Variable	Note	Type	L	Rw	Default	Min.	Max.
Calibration digits 0, 1, 2 (calculated) (Page 71)	Calibration digits 0 (calculated): Calibration digits calculated in "Automatic Calibration"	DINT	4	r	?		
	Calibration digits 1 (calculated): Calibration digits calculated in "Automatic Calibration"	DINT	4	r	0		
	Calibration digits 2 (calculated): Calibration digits calculated in "Automatic Calibration"	DINT	4	r	0		
Reserve 1	Reserve	INT	2	r	0	-	-
Reserve 2	Reserve	UINT	2	r	0	-	-
Reserve 3	Reserve	REAL	4	r	0	-	-

8.6.1 Calibration digits 0, 1, 2 (calculated)

The calculation is based on the parameters from DR 3 and DR 10 identified by bold font and is activated by the command no. 82.

8.7 DR 5 zeroing memory

Data record DR 5 displays the current values in the tare memory and the zeroing memory.

Procedure

- Check all parameters
- Transfer the data record to the scale

Table 8-3 Assignment of data record 5

Variable	Note	Type	L	Rw	Default	Min.	Max.
Data record number	Contains no. of data record	UINT	2	r	5	-	-
Length	Data record length information	UINT	2	r	40	-	-
Application	Information about which application the DR belongs to	UINT	2	r	201	-	-
Version identifier	Information on the current data record version	UINT	2	r	1	1	65635

8.7 DR 5 zeroing memory

Variable	Note	Type	L	Rw	Default	Min.	Max.
Effective tare weight - from specification (Page 72)	Current tare weight from specification as process value	REAL	4	rw	0	0	Depends on specification in DR 3
Effective tare weight (semi-automatic) (Page 72)	Current tare weight from semi-automatic mode as process value	REAL	4	rw	0	0	Depends on specification in DR 3
Reserve	Reserve	REAL	4	rw	0	-	-
Zero weight (semi-automatic) (Page 72)	Current zeroing weight (affected by zeroing)	REAL	4	rw	0	Depends on specification in DR 3	Depends on specification in DR 3
Current zero tracking weight (Page 73)	Zero point correction weight affected by automatic zeroing	REAL	4	rw	0	Depends on specification in DR 3	Depends on specification in DR 3
Dead load (Page 73)	Dead load determined during calibration	REAL	4	r	0	Depends on specification in DR 3	Depends on specification in DR 3
Reserve 1	Reserve	INT	2	rw	0	-	-
Reserve 2	Reserve	UINT	2	rw	0	-	-
Reserve 3	Reserve	REAL	4	rw	0	-	-

8.7.1 Effective tare weight - from specification

A tare weight can be specified in data record DR 15. You activate the specified tare weight with a command (see command 1013). From this point on, the activated tare weight is factored into the weight calculations. The "Delete tare" command deactivates the active tare weight. This does not delete the specification in data record DR 15.

8.7.2 Effective tare weight (semi-automatic)

The corresponding command (see command 1011) applies the current gross weight as the active tare weight. From this point on, the activated tare weight is factored into the weight calculations. The "Delete tare" command deactivates the active tare weight.

8.7.3 Zero weight (semi-automatic)

The zero weight command (see command 1001) entered by the user sets the current gross weight to "Zero" provided it is within the defined zero setting limits. The current gross weight is saved as the zero weight. The zeroing weight must be within the specified range (usually +3 / -1 % of the set zero point).

8.7.4 Current zero tracking weight

The current zero tracking weight is recorded in this parameter if automatic zero tracking is activated.

8.7.5 Dead load

The characteristic curve of the scales is determined during calibration. When there is no load, the main display returns "0". The dead load is the weight of the empty scales, i.e. the weight of the scales themselves.

8.8 DR 6 limit value settings

The switch-on and switch-off values for the limits are configured in data record DR 6.

Procedure

- Check all parameters and modify them as required
- Transfer the data record to the scale

Table 8-4 Assignment of data record 6

Variable	Note	Type	L	Rw	Default	Min.	Max.
Data record number	Contains no. of data record	UINT	2	r	6	-	-
Length	Data record length information	UINT	2	r	60	-	-
Application	Information on which application the DR belongs to	UINT	2	r	201	-	-
Version identifier	Information on the current data record version	UINT	2	r	1	1	65 635
Limit reference (Page 74)	Reference value for limits 0: Gross weight in % of max. weighing range 1: Net weight in % of max. weighing range 2: Gross weight, absolute 3: Net weight, absolute	UINT	2	rw	0	0	1
Reserve	Reserve	UINT	2	rw	0	0	-
Limit value 1 ON (Page 75)	Switch-on point for Limit 1	REAL	4	rw	0	maximum number range	maximum number range
Reserve	Reserve	TIME	4	rw	0	0	maximum number range+

8.8 DR 6 limit value settings

Variable	Note	Type	L	Rw	Default	Min.	Max.
Limit value 1 OFF (Page 75)	Switch-off point for Limit 1	REAL	4	rw	0	maximum number range	maximum number range
Reserve	Reserve	TIME	4	rw	0	0	maximum number range+
Limit value 2 ON (Page 75)	Switch-on point for Limit 2	REAL	4	rw	0	maximum number range	maximum number range
Reserve	Reserve	TIME	4	rw	0	0	maximum number range+
Limit value 2 OFF (Page 75)	Switch-off point for Limit 2	REAL	4	rw	0	maximum number range	maximum number range
Reserve	Reserve	TIME	4	rw	0	0	maximum number range+
Limit value "Empty" ON (Page 75)	Limit value "empty" ON With limit reference 0 and 1: Based on the gross weight in % of max. weighing range With limit reference 2 and 3: in relation to absolute gross weight	REAL	4	rw	0	maximum number range	maximum number range
Delay time for limits (Page 76)	Uniform delay time for limits in ms	TIME	4	rw	0	0	maximum number range+
Reserve	Reserve	UINT	2	rw	0	-	-
Reserve	Reserve	UINT	2	rw	0	-	-
Reserve	Reserve	REAL	4	rw	0	-	-

8.8.1 Limit reference

Value	Limit values relate to
0	Gross weight in % of max. weighing range
1	Net weight in % of max. weighing range
2	Absolute gross weight
3	Absolute net weight

The limit value "Empty" always relates to gross weight zero.

8.8.2 Limit value 1 ON, limit value 2 ON, limit value 1 OFF, limit value 2 OFF

The switch-on and switch-off points can be specified separately for each limit as a percentage of the measuring range or as absolute values (based on "Limit reference" parameter setting). This allows both minimum and maximum value violation monitoring with hysteresis. A delay time for switch-on and switch-off can also be specified. Either the current net weight or the current gross weight can be selected as the reference value for limits 1 and 2. Negative limits are only possible with input of absolute values. Negative limits as percentage are rejected.

Maximum value monitoring is implemented with the following specifications:

- Switch-on value > switch-off value

Minimum value monitoring is implemented with the following specification:

- Switch-on value < switch-off value

The diagram below illustrates the function of limit values 1 and 2.

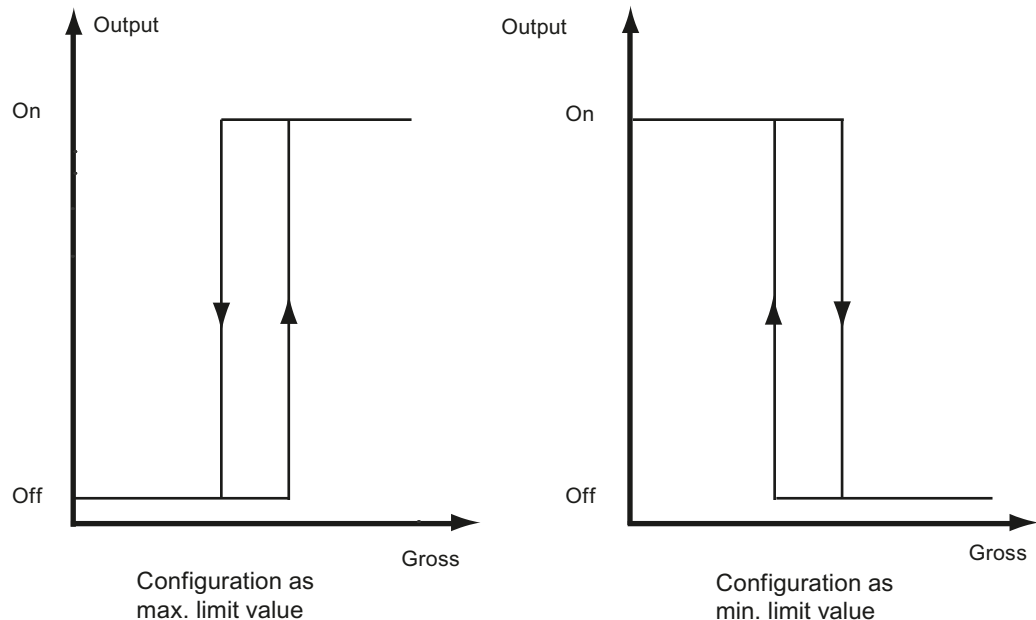

Figure 8-5 Limit value configuration

8.8.3 Limit value "Empty" ON

The value for the empty range is a limit value below which the weighing module registers and returns the status "empty". The values are entered as a percentage of the measuring range. The "Empty" limit always refers to the current gross weight in the scale.

The setting, whether absolute or a percentage, also affects the "Empty" limit.

8.8.4 Delay time for limits

If the weight reaches the specified switch value, a delay time (defined in ms) is launched. Once the delay time is over, the limit switch changes status provided the weight still reaches the specified switch value.

This delay time applies to the switch-on and switch-off values 1 and 2 and to the switch-on limit for the empty value. The empty value does not have a switch-off delay.

8.9 DR 9 module information

No entries can be made in data record DR 9. This data record provides information on the inner workings of the SIWAREX module. This information is used to identify the module at the manufacturer plant (e.g. in the event of repairs). The entries in the data record are of no importance to the user for operation.

Table 8-5 Assignment of data record 9

Variable	Note	Type	L	Rw	Default	Min.	Max.
Data record number	Contains no. of data record	UINT	2	r	9	-	-
Length	Data record length information	UINT	2	r	68	-	-
Application	Information about which application the DR belongs to	UINT	2	r	201	-	-
Version identifier	Information on the current data record version	UINT	2	r	1	1	65635
Order number - header	Maximum and current string length for the order number	UBYTE[2]	2	r	16,16	-	-
Order number	Order number of the module 7MH ..	STRING[16]	16	r	"7MH ..."	-	-
Serial number - header	String header	UBYTE[2]	2	r	12,12	-	-
Serial number	Serial number "XXX00001"	STRING[12]	12	r	" "	-	-
Firmware type - header	String header	UBYTE[2]	2	r	2.2	-	-
Firmware type	Reference V - Release B - Test etc.	STRING[2]	2	r	'V '	-	-
FW version - 1st digit	Version 1.	UINT	2	r	1	-	-
FW version - 2nd digit	Version 2.	UINT	2	r	0	-	-
FW version - 3rd digit	Version 3.	UINT	2	r	0	-	-

Variable	Note	Type	L	Rw	Default	Min.	Max.
Hardware version number	ES hardware version number (e.g. 03)	UINT	2	r	1	-	-
OS version header	String header	UBYTE[2]	2	r	2.2	-	-
OS version (loader) - designation	Reference V - Release B - Test etc.	STRING[2]	2	r	'V'	-	-
OS version (loader) - designation	e.g. version n	UINT	2	r	'V'	-	-
Reserve	Reserve	UINT	6	r	0	-	-
Reserve 4	0	REAL	4	r	0	-	-

8.10 DR 10 load cell parameters

The parameters of the analog load cells must be checked prior to the automatic calibration and modified if necessary. Only the parameters identified by bold font and asterisk (*) need be entered.

Procedure

- Check the parameters and modify them as required
- Transfer the data record to the scale
- Adjust the scales

Table 8-6 Assignment of data record 10

Variable	Note	Type	L	Rw	Default	Min.	Max.
Data record number	Contains no. of data record	UINT	2	r	10	-	-
Length	Data record length information	UINT	2	r	44	-	-
Application	Information about which application the DR belongs to	UINT	2	r	201	-	-
Version identifier	Information on the current data record version	UINT	2	r	1	1	65635
Reserve		UINT	2	rw	1	1	6
Selection of the sampling rate (Page 78)	Parameter code 0: Sampling rate 100 Hz (preferably with line frequency of 50 Hz) Parameter code 1: 120 Hz (preferably with line frequency of 60 Hz) Parameter code 2: 600 Hz for fast measurements	UINT	2	rw	0	0	1
Number of support points (Page 79) ¹⁾	Number of support points	UINT	2	rw	0	0	8
Reserve		UINT	2	rw	0	0	0

8.10 DR 10 load cell parameters

Variable	Note	Type	L	Rw	Default	Min.	Max.
Load cell characteristic value (Page 80) ¹⁾	Characteristic value of the load cell (n) [mV/V], the mean value is used if there is more than one cell.	REAL	4	rw	2	> 0.1	10
Reserve		REAL	4	rw	0		
Rated load of a load cell (Page 80) ¹⁾	Rated load of a load cell	REAL	4	rw	60	-	-
Reserve	Reserve	REAL	4	rw	0	-	-
Reserve	Reserve	REAL	4	rw	0	-	-
Reserve	Reserve	INT	2	rw	0	-	-
Reserve	Reserve	UINT	2	rw	0	-	-
Reserve	Reserve	REAL	4	rw	0	-	-

¹⁾ Parameter for calculation of calibration points with theoretical calibration

8.10.1 Selection of the sampling rate

For better suppression of interferences, set the measuring rate and the line frequency as follows:

Measuring rate	Line frequency
100 Hz	50 Hz (parameter code 0)
120 Hz	60 Hz (parameter code 1)

Interferences can be caused by the power supply grid.

For fast measurements, you can select a measuring rate of 600 Hz (parameter code 2) as of firmware V1.2.0.

The setting has an effect on the frequency response of the signal path.

The following diagrams show the frequency response:

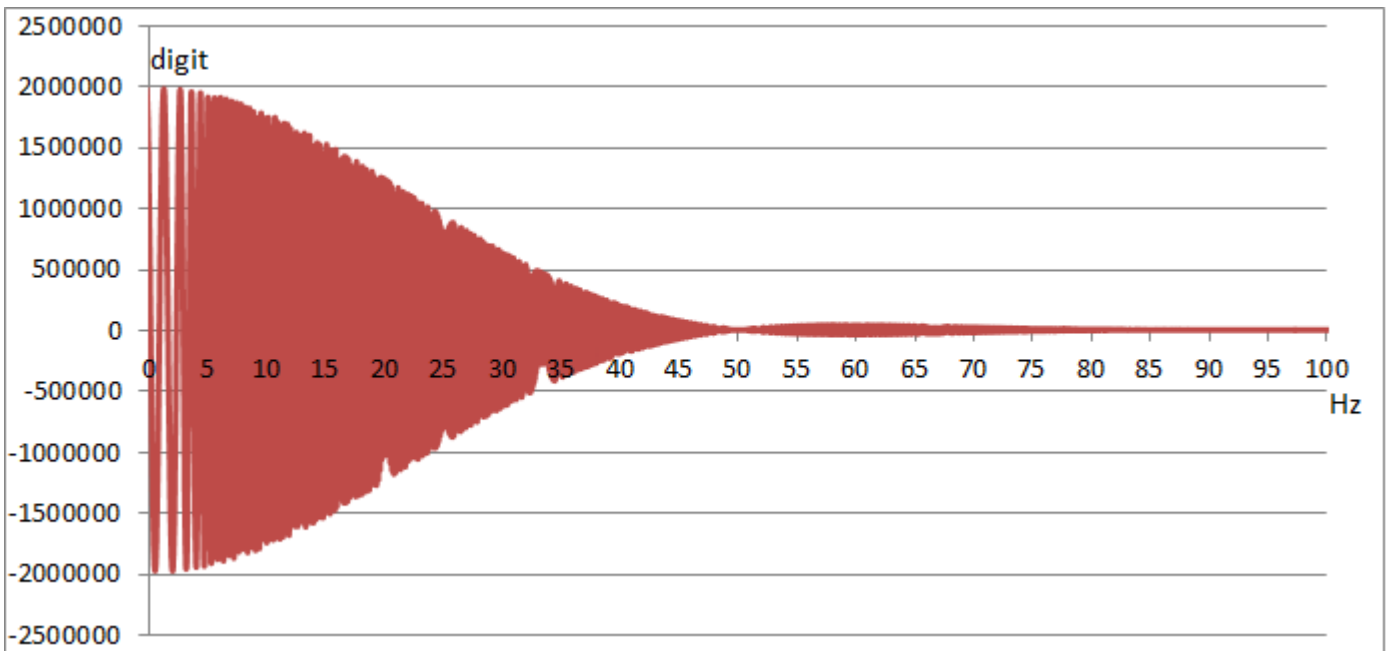

Figure 8-6 Signal behavior SIWAREX WP321: Sampling rate 50 Hz (unfiltered)

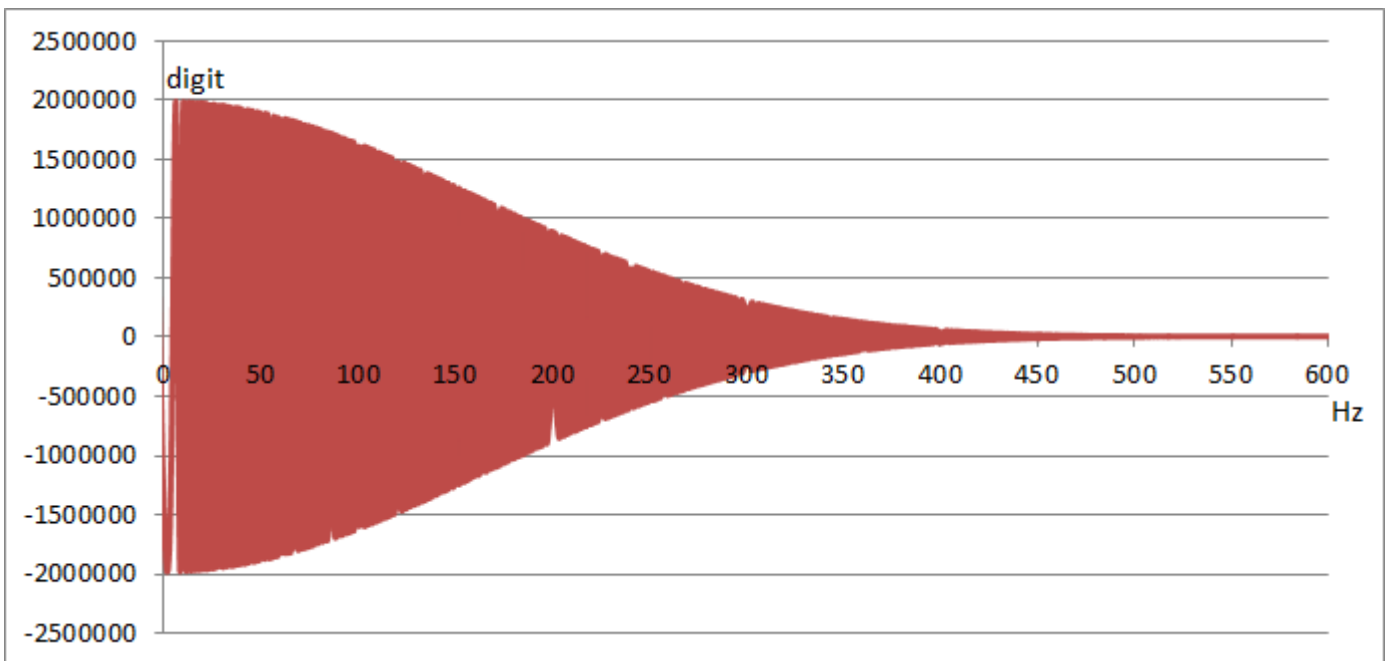

Figure 8-7 Signal behavior SIWAREX WP321: Sampling rate 600 Hz (unfiltered)

8.10.2 Number of support points

If no anchor points are used, the number of support points is equal to the number of load cells.

If anchor points are used in addition to load cells, the number of support points is equal to the total number of load cells and fixed support points.

8.10.3 Load cell characteristic value

The load cell characteristic value is required to correctly interpret the output voltage from the load cell. This specification is also necessary for determining load cell overload. The exact value can be entered if the measurement log for the load cell is available. The mean value can be entered if there is more than one load cell.

Example

Characteristic value = 2.018 mV/V

8.10.4 Rated load of a load cell

The rated load of a load cell is required for checking the maximum weighing range of the scales. The rated load is entered in the specified units of weight.

8.11 DR 13 RS485 parameters

The parameters which define the response of the RS485 interface are specified in data record DR 13. If the interface is not used, the default values can be retained.

Procedure

- Check the parameters and modify them as required
- Transfer the data record to the scale

Table 8-7 Assignment of data record 13

Variable	Note	Type	L	Rw	Default	Min.	Max.
Data record number	Contains no. of data record	UINT	2	r	13	-	-
Length	Data record length information	UINT	2	r	24	-	-
Application	Information about which application the data record belongs to	UINT	2	r	201	-	-
Version identifier	Information on the current data record version	UINT	2	r	1	1	65635
RS485 protocol (Page 81)	0: No log 2: SIEBERT display 6: SIWAREX DB	UINT	2	rw	1	0	2
RS485 baud rate (Page 81)	0: 9 600 bps 1: 19 200 bps 2: 38 400 bps 3: 57 600 bps 4: 115 200 bps (for SIWAREX DB)	UINT	2	rw	3	0	6
RS485 character parity (Page 81)	Character parity 0: even (for SIWAREX DB) 1: Odd	BIT	2	rw	0	0	1
Bit 1		BIT	0	rw	0	0	1

Variable	Note	Type	L	Rw	Default	Min.	Max.
Bit 2		BIT	0	rw	0	0	1
Reserve (13 bits)	Reserve	BIT	0	rw	0	0	1
Reserve	Reserve	UINT	2	rw	20	1	255
Decimal place for Siebert indicator (Page 81)	Decimal place for Siebert display	INT	2	rw	0	-	-
Reserve	Reserve	UINT	2	rw	0	-	-
Reserve	Reserve	REAL	4	rw	0	-	-

8.11.1 RS485 protocol

This parameter defines the protocol for communication via the RS485 interface.

8.11.2 RS485 baud rate

This parameter defines the baud rate for the RS485 interface.

8.11.3 RS485 character parity

This parameter defines the character parity for the RS485 interface.

8.11.4 Decimal place for Siebert indicator

A fixed decimal place must be specified if a Siebert indicator is used. The following values are permitted: 0 ... 4

8.12 DR 14 SIMATIC interface parameters

The parameters which define the response of the SIMATIC interface are specified in data record DR 14. It is possible to define the process values to be output on the basis of the I/O area.

Procedure

- Check the parameters and modify them as required
- Transfer the data record to the scale

8.12 DR 14 SIMATIC interface parameters

Table 8-8 Assignment of data record 14

Variable	Note	Type	L	Rw	Default	Min.	Max.
Data record number	Contains no. of data record	UINT	2	r	14	-	-
Length	Data record length information	UINT	2	r	16	-	-
Application	Information on which application the DR belongs to	UINT	2	r	201	-	-
Version identifier	Information on the current data record version	UINT	2	r	1	1	65 635
Selection of process value 1, 2 (Page 82)	Code for the selection of the process variable to be updated	UINT	2	rw	4	0	10
Selection of process value 1, 2 (Page 82)	Code for the selection of the process variable to be updated	UINT	2	rw	3	0	10
Reserve 1	Reserve	INT	2	rw	0	0	-
Reserve 2	Reserve	UINT	2	rw	0	0	-

8.12.1 Selection of process value 1, 2

Read the current process values to the SIMATIC CPU with the DR 30 and DR 31 data records and the FB SIWA function block. The transfer of a larger data record is based on "acyclic services". It may take several SIMATIC CPU cycles and therefore have a negative effect on system performance.

The I/O interface of the SIWAREX module is the best option if a process value is to be rapidly transferred to the SIMATIC CPU as soon as it is created in the SIWAREX module. Data is applied cyclically by FB321 and provided as a tag in the scales data block.

The relevant code from the table below must be entered to define the tag for output via the I/O interface.

Table 8-9 Selection table for process value 1,2

Process value	Decimal code	From DR	Format
No process selected	0	-	-
Gross process (after low-pass filter 1)	1	30	REAL
Net process (after low-pass filter 1)	2	30	REAL
Tare process	3	30	REAL

Process value	Decimal code	From DR	Format
G/N weight (after low-pass filter 1)	4	30	REAL
G/N weight_x10	5	30	REAL
Unfiltered digit value	9	31	DINT
filtered digit value (after low-pass filter 1)	10	31	DINT
Refresh counter	12	30	UINT
Async. Error bits (32-bit): bits 0..15: operator error Bits 16..31: technology error	15	32	DINT
Gross process (after low-pass filter 2)	7	-	REAL
Net process (after low-pass filter 2)	8	-	REAL
Filtered digit value (after low-pass filter 2)	11	-	DINT

8.13 DR 15 manual tare specification

Data recorder DR 15 is used for an external specification of a tare weight.

Procedure

- Enter the tare weight
- Transfer the data record to the scale
- Enable the tare weight using command 1013

Table 8-10 Assignment of data record 15

Variable	Note	Type	L	Rw	Default	Min.	Max.
Data record number	Contains no. of data record	UINT	2	r	15	-	-
Length	Data record length information	UINT	2	r	16	-	-
Application	Information about which application the DR belongs to	UINT	2	r	201	-	-
Version identifier	Information on the current data record version	UINT	2	r	1	1	65635
Specification of tare weight (Page 84)	Tare specification memory (manual tare value)	REAL	4	rw	0	0	Depends on specification in DR 3
Reserve	Reserve	REAL	4	rw	0	0	-

8.13.1 Specification of tare weight

You can enter a tare weight. If a tare weight is to be applied, it must be enabled with the corresponding command. The tare weight must not exceed the maximum tare load specified in data record DR 3.

8.14 DR 30 current process values

Current states and process values in the scales can be monitored using process values and advanced process values from data record DR 31. Monitoring selected data during commissioning is extremely useful as it helps you to optimize parameters.

Procedure

- Read data record DR 30 cyclically or on a time-triggered basis
- Display/analyze the required tags

It is not always necessary to cyclically read data record DR 30. If the relevant process tags have already been selected in data record DR 14 (→ DR 14 SIMATIC interface parameters (Page 81)), they are immediately transferred via the I/O interface. In this case, these tags and all status bits and messages are accessible without data record communication.

Table 8-11 Assignment of data record 30

Variable	Note	Type	L	Rw	Default	Min.	Max.
Data record number	Contains no. of data record	UINT	2	r	30	-	-
Length	Data record length information	UINT	2	r	44	-	-
Application	Information on which application the data record belongs to	UINT	2	r	201	-	-
Version identifier	Information on the current data record version	UINT	2	r	1	1	255
1/4d zero	Set if gross is less than $\pm 0.25e$	BIT	2	r	0	-	-
9e max	Set if the weight has exceeded the gross weighing range by more than 9 display steps (d)	BIT	0	r	0	-	-
Tared	Set if tare memory is not equal to zero	BIT	0	r	0	-	-
Manual tare set (pT)	Set if the tare memory is assigned an external specified value	BIT	0	r	0	-	-
Reserve		BIT	0	r	0	-	-
Waiting for standstill	Set if module is waiting for standstill to execute command	BIT	0	r	0	-	-
Standstill	Set if standstill condition is met	BIT	0	r	0	-	-
Reserve		BIT	0	r	0	-	-
Empty	Set if "Empty" condition is met	BIT	0	r	0	-	-
Limit value 1	Limit value 1 has responded	BIT	0	r	0	-	-

Variable	Note	Type	L	Rw	Default	Min.	Max.
Limit value 2	Limit value 2 has responded	BIT	0	r	0	-	-
Reserve (5 bits)		BIT	0	r	0	-	-
DS32 error status change	Is set interface-specific with each DS32 change	BIT	2	r	0	-	-
SIWAREX DB – EXC Error	Set if the supply voltage for the load cells is less than 4.7 V	BIT	0	r	0	-	-
SIWAREX DB – Impedance warning	Impedance value of the load cells outside the defined range	BIT	0	r	0	-	-
SIWAREX DB - Temperature warning	Temperature of SIWAREX DB outside the defined range	BIT	0	r	0	-	-
Reserve (4 bits)		BIT	0	r	0	-	-
Calibrated	SIWAREX is calibrated	BIT	0	r	0	-	-
Service mode	Service mode is enabled	BIT	0	r	0	-	-
Reserve (3 bits)		BIT	0	r	0	-	-
SIMATIC connection inactive	Set if no connection to the SIMATIC exists on the part of the application	BIT	0	r	0	-	-
Startup	Startup has taken place (is deleted again after 5 seconds)	BIT	0	r	0	-	-
Fault status	Operating fault	BIT	0	r	0	-	-
Gross process weight (Page 86)	Gross weight (process value)	REAL	4	r	0	-	-
Net process weight (Page 86)	Net weight (process value)	REAL	4	r	0	-	-
Tare process weight (Page 86)	Tare weight (process value)	REAL	4	r	0	-	-
Gross / net weight (Page 86)	Gross or net weight	REAL	4	r	0	-	-
Gross / net weight with increased resolution (x 10) (Page 86)	Legal trade G/N weight with 10x resolution	REAL	4	r	0	-	-
Refresh counter for process values (Page 87)	Cycle counter incremented by 1 if weight values have been changed	UINT	2	r	0	-	-
Operating time (hours)	Total operating time of the module (hours)	UINT	2	r	0	-	-

8.14 DR 30 current process values

Variable	Note	Type	L	Rw	Default	Min.	Max.
Operating time (minutes)	Total operating time of the module (minutes)	UINT	2	r	0	-	-
Reserve 3	Reserve	REAL	4	r	0	-	-

8.14.1 Gross process weight

The current gross weight. Values are rounded as specified in data record DR 3 with the "Decimal places for process values" (Page 64) parameter.

8.14.2 Net process weight

The current net weight. Values are rounded as specified in data record DR 3 with the "Decimal places for process values" (Page 64) parameter.

8.14.3 Tare process weight

The current tare weight. Values are rounded as specified in data record DR 3 with the "Decimal places for process values" (Page 64) parameter.

8.14.4 Gross / net weight

The current weight for the main display. The resolution corresponds to the scale interval (Page 63) specified in data record DR 3.

8.14.5 Gross / net weight with increased resolution (x 10)

The current weight for the main display in higher resolution. The resolution corresponds to the scale interval specified in data record DR 3 x 10.

8.14.6 Tare weight

The current tare weight (scale interval from DR 3). The resolution corresponds to the scale interval specified in data record DR 3.

8.14.7 Refresh counter for process values

Measured values are calculated every 10 ms in the SIWAREX module. A counter is incremented by 1 each time. Once the counter reaches the value 65536, it starts again from zero. The counter can be used as a time stamp for data record DR 30.

8.15 DR 31 advanced current process values

Current states and process values in the scales can be monitored using advanced process values and process values (DR 30). This data is not required for standard operation of the scales.

Monitoring selected data during trial operation is extremely useful as it helps you to optimize parameters.

Procedure

- Read data record DR 31
- Display/analyze the required tags

Table 8-12 Assignment of data record 31

Variable	Note	Type	L	Rw	Default	Min.	Max.
Data record number	Contains no. of data record	UINT	2	r	31	-	-
Length	Data record length information	UINT	2	r	24	-	-
Application	Information about which application the data record belongs to	UINT	2	r	201	-	-
Version identifier	Information on the current data record version	UINT	2	r	1	1	65635
Unfiltered digit value (Page 87)	Unfiltered digit value of AD converters / digital load cells	DINT	4	r	0	-	-
Filtered digit value (Page 88)	Filtered digit value of AD converters or digital load cells after dig. filter 1	DINT	4	r	0	-	-
Reserve 1		INT	2	r	0	-100	100
Refresh counter for process values (Page 88)	Refresh counter incremented by 1 if weight values have been changed	UINT	2	r	0	-	-
Reserve 2		REAL	4	r	0	-	-

8.15.1 Unfiltered digit value

The unfiltered digit value is the internal measured value immediately before filtering.

8.15.2 Filtered digit value

The filtered digit value is the internal measured value immediately after filtering.

8.15.3 Refresh counter for process values

Measured values are calculated every 10 ms in the SIWAREX module. A counter is incremented by 1 each time. Once the counter reaches the value 65536, it starts again from zero. The counter can be used as a time stamp for data record DR 31.

8.16 DR 32 Message display

Data record 32 indicates all pending message bits. The bit "Error status changed" is present in the status bits of the DR30. If this bit is set, the message area of the DR32 has been changed.

The DR32 indicates which message has been newly added or deleted. The data record is automatically read by the SIMATIC FB in the event of an error. Following successful reading, the status bit is reset in DR30.

Table 8-13 Assignment of data record 32

Variable	Note	Type	L	Rw	De- fault	Min.	Max.
Data record number	Contains no. of data record	UINT	2	r	32	-	-
Length	Data record length information	UINT	2	r	26	-	-
Application	Information about which application the data record belongs to	UINT	2	r	101	-	-
Version identifier	Information on the current data record version	UINT	2	r	1	1	65635
1000	Operator error	BIT		r	0	0	1
Reserve	-	BIT		r	0	0	1
1104	Undervoltage	BIT		r	0	0	1
Reserve	-	BIT		r	0	0	1
1105	Overload	BIT		r	0	0	1
1106	Underload	BIT		r	0	0	1
1002	RAM error	BIT		r	0	0	1
1102	ADC error	BIT		r	0	0	1
1005	Hardware interrupt lost	BIT		r	0	0	1
1003	Checksum error data	BIT		r	0	0	1
Reserve	-	BIT		r	0	0	1
1004	Checksum error program	BIT		r	0	0	1
Reserve	-	BIT		r	0	0	1
1001	RESET / restart following error (watch-dog)	BIT		r	0	0	1
1110	No communication with SIWAREX DB	BIT		r	0	0	1

Variable	Note	Type	L	Rw	De- fault	Min.	Max.
Reserve	-	BIT		r	0	0	1
2000	Technology error	BIT		r	0	0	1
2001	Taring or zeroing timeout	BIT		r	0	0	1
Reserve (3 bits)	-	BIT		r	0	0	1
2005	Cold restart after voltage recovery	BIT		r	0	0	1
Reserve (10 bits)		BIT		r	0	0	1
5000	Data or operating error exists	BIT		r	0	0	1
5001	Command code or data record unknown	BIT		r	0	0	1
Reserve	-	BIT		r	0	0	1
5003	Leaving calibration mode not possible	BIT		r	0	0	1
5004	Command or data transmission only available in service mode	BIT		r	0	0	1
5005	Command or data transmission not possible because service mode is active	BIT		r	0	0	1
5006	Command or data transmission not possible because BUSY	BIT		r	0	0	1
5007	Command or data transmission not possible because module is faulty or ODIS is active	BIT		r	0	0	1
Reserve	-	BIT		r	0	0	1
Reserve	-	BIT		r	0	0	1
5101	Command is not permissible in this operating state	BIT		r	0	0	1
5102	Command not possible because not at standstill	BIT		r	0	0	1
5104	Command not possible because range is exceeded	BIT		r	0	0	1
5105	Load cell parameter not plausible	BIT		r	0	0	1
Reserve		BIT		r	0	0	1
5107	Shifting characteristic not possible	BIT		r	0	0	1
7000	Permitted number range violated	BIT		r	0	0	1
Reserve	-	BIT		r	0	0	1
Reserve	-	BIT		r	0	0	1
7002	Specifications of string lengths not plausible	BIT		r	0	0	1
Reserve	-	BIT		r	0	0	1
Reserve	-	BIT		r	0	0	1
7006	Command only possible in test field	BIT		r	0	0	1
7007	The calibration weights or calibration digits are not plausible	BIT		r	0	0	1
7008	Zeroing/zero setting or tare parameter not plausible	BIT		r	0	0	1

8.17 DR 34 ASCII main display value

Variable	Note	Type	L	Rw	De- fault	Min.	Max.
7009	Standstill range / standstill wait time not plausible	BIT		r	0	0	1
7010	Scale interval / rounding not plausible	BIT		r	0	0	1
7011	Filter parameter not plausible	BIT		r	0	0	1
7014	Time input not plausible	BIT		r	0	0	1
Reserve	-	BIT		r	0	0	1
Reserve	-	BIT		r	0	0	1
7019	RS485 parameter error	BIT		r	0	0	1
Reserve	-	UINT	2	r	0	-	-
Reserve	-	UINT	2	r	0	-	-
Reserve	-	UINT	2	r	0	-	-

8.16.1 Error bytes 0 to 7

In these areas, messages are represented by bits. A set bit means that the corresponding message is activated. The message bit is set following a data or operator error and automatically reset approximately 3 seconds later.

Message bits are analyzed by the operator panel message system.

The data/operator errors (error numbers 1xxx) are present in the first two bytes. These are followed by two bytes with technology errors (error numbers 2xxx) and six bytes with data and operator errors (error numbers 5xxx and 7xxx).

8.17 DR 34 ASCII main display value

The ASCII weight corresponds to the value on the main display of the scales and can be used for a supplementary display as well as the main display.

Table 8-14 Assignment of data record 34

Variable	Note	Type	L	Rw	Default	Min.	Max.
Data record number	Contains no. of data record	UINT	2	r	34	-	-
Length	Data record length information	UINT	2	r	26	-	-
Application	Information about which application the DR belongs to	UINT	2	r	201	-	-
Version identifier	Information on the current data record version	UINT	2	r	1	1	65635
ASCII display string header	Maximum length and actual length of string	UBYTE[2]	2	r	16,2	-	-
Content of main display as ASCII string (Page 91)	For display of the weight value and other current values (see below)	STRING[16]	16	r	" "	-	-

8.17.1 Content of main display as ASCII string

The following values can be displayed:

Variable	Command
Switch on increased resolution	701
Current tare weight	705
Gross/net display	710
Net process value	714
Gross process value	715
Serial number	871
Firmware version	875

Below are some display examples. Commands are used to toggle the display values.

The values to be displayed are suppressed if a fault is present.

	Value designation		Blank	Display value										Unit of weight (from DR 3)
	N: Net, B/G: Gross, T: Tare, pT: Preset tare, S: Sum, ...													
Weight (Tare ≠ 0)	N	•	•	•	•	•	•	2	2	0	,	5	0	•kg•
Neg. weight (Tare = 0)	B	•	•	•	•	•	•	-	0	,	0	3	•t••	
Weight in increased resolution	•	•	•	•	•	•	•	1	0	,	0	0	3	HIGH
Operator error	B	•	•	•	•	•	•	l	r	r	o	r	****	
Tare display activated (pt)	p	T	•	•	•	•	•	5	0	,	5	0	•kg•	
Tare display activated	T	•	•	•	•	•	•	5	0	,	5	0	•kg•	

8.18 DR 70 SIWAREX DB parameter

The parameters which define the response in combination with SIWAREX DB are specified in data record DR 70.

If SIWAREX DB is not used, the default settings can be accepted.

Table 8-15 Assignment of data record DR 70

Variable	Note	Data type	Length (bytes)	Rw	Default	Min.	Max.
Data record number [DR_NO]	Contains no. of data record	USHORT	2	R	70	-	-
Length [DR_LEN]	Data record length information	USHORT	2	R	180	-	-
Application [APPL_ID]	Information on which application the data record belongs to	USHORT	2	R	101	-	-
Version identifier [DR_VERSION]	Information on the current data record version	USHORT	2	r	1	1	65635

8.19 DR 80 SIWAREX DB process status

Variable	Note	Data type	Length (bytes)	Rw	Default	Min.	Max.
Load cell manufacturer [LOAD_CELL_MANUFACTURER]	Load cell manufacturer	CHAR[24]	24	r/w	” ”	-	-
Load cell order number [LOAD_CELL_ORDER_NUMBER]	Load cell order number	CHAR[24]	24	r/w	” ”	-	-
Load cell input 1: Location designation of sensor [LOAD_CELL_INPUT_1_LOCATION_TAG]	Location designation of sensor	CHAR[24]	24	r/w	” ”	-	-
Load cell input 2: Location designation of sensor		CHAR[24]	24	r/w	” ”	-	-
Load cell input 3: Location designation of sensor		CHAR[24]	24	r/w	” ”	-	-
Load cell input 4: Location designation of sensor		CHAR[24]	24	r/w	” ”	-	-
Channel active [LOAD_CELL_ENABLE]	Bit 0: Load cell input 1 [INPUT_1] Bit 1: Load cell input 2 [INPUT_2] Bit 2: Load cell input 3 [INPUT_3] Bit 3: Load cell input 4 [INPUT_4]	USHORT	2	r/w	15	0	15
Sensor type [SENSOR_TYPE]	0: 4-wire sensor 1: 6-wire sensor	USHORT	2	r/w	0	0	1
Total capacity of all load cells [NOMINAL_LOAD]	Total capacity of all load cells	FLOAT	4	r/w	1000	tbd	tbd

8.19 DR 80 SIWAREX DB process status

In data record DR 81, monitor the current statuses and process values in the scales with the help of the SIWAREX DB. To optimize the parameters, monitor selected data when commissioning the scales.

It is not always necessary to cyclically read data record DR 80. Messages and status bits are automatically read out by the function block when a change occurs.

Table 8-16 Assignment of data record DR 80

Variable	Note	Type	Length (bytes)	Rw	Default	Min.	Max.
Data record number [DR_NO]	Contains no. of data record	USHORT	2	R	80	-	-
Length [DR_LEN]	Data record length information	USHORT	2	R	76	-	-

Variable	Note	Type	Length (bytes)	Rw	Default	Min.	Max.
Application [APPL_ID]	Information on which application the data record belongs to	USHORT	2	R	101	-	-
Version identifier [DR_VERSION]	Information on the current data record version	USHORT	2	r	1	1	65635
Refresh counter [REFRESH_COUNTER]	Cycle counter of the SIWAREX DB incremented by 1 if process values have been changed.	USHORT	2	r	0	0	0xFFFF
Device status [MODULE_ERROR_INFORMATION]	Bit 0: QI flag Bit 1: Load cell input faulty Bit 2: Checksum error Bit 3: Checksum error (data) Bit 4: Watchdog error Bit 5: ADC error Bit 6: Temperature warning Bit 7: Firmware update error	USHORT	2	r	0	-	-
Load cell input 1: Status [LOAD_CELL_INPUT_1_DIAGNOSTIC_INFORMATION]	Bit 0: QI flag Bit 1: Underload Bit 2: Overload Bit 3: SEN error Bit 4: Impedance error Bit 5: EXC short circuit Bit 6: Power supply failure	USHORT	2	r	0	-	-
Load cell input 1: filtered digit value [LOAD_CELL_INPUT_1_DIGITS_FILTERED]	Filtered digit value of AD converter from SIWAREX DB to dig. filter 1	LONG	4	r	0x7FFF FFFF	0x8000 0000	0x7FFF FFFE
Load cell input 1: Load (%) [LOAD_CELL_INPUT_1_PERCENTAGE_LOAD]	Current percentual load of the load cell in relation to the rated load of the load cell	FLOAT	4	r	0	-200	200
Load cell input 1: Signal voltage SIG (mV) [LOAD_CELL_INPUT_1_LOAD_CELL_SIGNAL]	Currently measured load cell signal	Float	4	r	0	-200	200
Load cell input 2: Status	Bit 0: QI flag Bit 1: Underload Bit 2: Overload Bit 3: SEN error Bit 4: Impedance error Bit 5: EXC short circuit Bit 6: Power supply failure	USHORT	2	r	0	-	-

8.19 DR 80 SIWAREX DB process status

Variable	Note	Type	Length (bytes)	Rw	Default	Min.	Max.
Load cell input 2: Filtered digit value	Filtered digit value of AD converter from SIWAREX DB to dig. filter 1	LONG	4	r	0x7FFF FFFF	0x8000 0000	0x7FFF FFFE
Load cell input 2: Load (%)	Current percentual load of the load cell in relation to the rated load of the load cell	FLOAT	4	r	0	-200	200
Load cell input 2: Signal voltage SIG (mV)	Currently measured load cell signal	Float	4	r	0	-200	200
Load cell input 3: Status	Bit 0: QI flag Bit 1: Underload Bit 2: Overload Bit 3: SEN error Bit 4: Impedance error Bit 5: EXC short circuit Bit 6: Power supply failure	USHORT	2	r	0	-	-
Load cell input 3: filtered digit value [LOAD_CELL_INPUT_3_DIGITS_FILTERED]	Filtered digit value of AD converter from SIWAREX DB to dig. filter 1	LONG	4	r	0x7FFF FFFF	0x8000 0000	0x7FFF FFFE
Load cell input 3: Load (%)	Current percentual load of the load cell in relation to the rated load of the load cell	FLOAT	4	r	0	-200	200
Load cell input 3: Signal voltage SIG (mV)	Currently measured load cell signal	Float	4	r	0	-200	200
Load cell input 4: Status	Bit 0: QI flag Bit 1: Underload Bit 2: Overload Bit 3: SEN error Bit 4: Impedance error Bit 5: EXC short circuit Bit 6: Power supply failure	USHORT	2	r	0	-	-
Load cell input 4: Filtered digit value	Filtered digit value of AD converter from SIWAREX DB to dig. filter 1	LONG	4	r	0x7FFF FFFF	0x8000 0000	0x7FFF FFFE
Load cell input 4: Load (%)	Current percentual load of the load cell in relation to the rated load of the load cell	FLOAT	4	r	0	-200	200
Load cell input 4: Signal voltage SIG (mV)	Currently measured load cell signal	Float	4	r	0	-200	200

8.20 DR 81 SIWAREX DB process status advanced

Current states and process values in the scales can be monitored using SIWAREX DB specific advanced process values and process values from data record DR 80.

Table 8-17 Assignment of data record DR 81

Variable	Note	Type	Length (bytes)	Rw	Default	Min.	Max.
Data record number [DR_NO]	Contains no. of data record	USHORT	2	R	81	-	-
Length [DR_LEN]	Data record length information	USHORT	2	R	64	-	-
Application [APPL_ID]	Information on which application the data record belongs to	USHORT	2	R	101	-	-
Version identifier [DR_VERSION]	Information on the current data record version	USHORT	2	r	1	1	65635
Excitation voltage EXC (V) [EXCITATION_VOLTAGE]	Excitation voltage EXC (V) with which the load cells are supplied	FLOAT	4	r	0	0	10000
Load cell input 1: Impedance (Ohm) [LOAD_CELL_INPUT_1_IMPEDANCE]	Current impedance (Ohm) of connected load cell	FLOAT	4	r	0	0	20000
Load cell input 2: Impedance (Ohm)		FLOAT	4	r	0	0	20000
Load cell input 3: Impedance (Ohm)		FLOAT	4	r	0	0	20000
Load cell input 4: Impedance (Ohm)		FLOAT	4	r	0	0	20000
Load cell input 1: Sense voltage SEN (V) [LOAD_CELL_INPUT_1_SENSE_VOLTAGE]	Current voltage (V) which is measured between SENSE+ and SENSE- of the load cell	FLOAT	4	r	0	0	10000
Load cell input 2: Sense voltage SEN (V)		FLOAT	4	r	0	0	10000
Load cell input 3: Sense voltage SEN (V)		FLOAT	4	r	0	0	10000
Load cell input 4: Sense voltage SEN (V)		FLOAT	4	r	0	0	10000

8.21 DR 82 SIWAREX DB device information

Variable	Note	Type	Length (bytes)	Rw	Default	Min.	Max.
Load cell input 1: Excitation current (mA) [LOAD_CELL_INPUT_1_EXCITATION_CURRENT]	Current excitation current (mA) which is required for the supply of the load cell	FLOAT	4	r	0	0	1999
Load cell input 2: Excitation current (mA)		FLOAT	4	r	0	0	1999
Load cell input 3: Excitation current (mA)		FLOAT	4	r	0	0	1999
Load cell input 4: Excitation current (mA)		FLOAT	4	r	0	0	1999
Temperature (°C) [TEMPERATURE]	Current temperature (°C) of the SIWAREX DB electronic system	FLOAT	4	r	0.0	-50	+150.0

8.21 DR 82 SIWAREX DB device information

You cannot make any entries in data record DR 82. This data record only provides information on the inner workings of the SIWAREX DB. This information is used to identify SIWAREX DB at the manufacturer plant. The entries in the data record are of no importance to the user for operation.

Table 8-18 Assignment of data record DR 82

Variable	Note	Type	Length (bytes)	Rw	Default	Min.	Max.
Data record number [DR_NO]	Contains no. of data record	USHORT	2	R	82	-	-
Length [DR_LEN]	Data record length information	USHORT	2	R	184	-	-
Application [APPL_ID]	Information on which application the data record belongs to	USHORT	2	R	101	-	-
Version identifier [DR_VERSION]	Information on the current data record version	USHORT	2	r	1	1	65635
Order number [ORDER_NO]	Order number SIWAREX DB	CHAR[32]	32	r	""	-	-
Serial number [SERIAL_NO]	Serial number SIWAREX DB	CHAR[32]	32	r	""	-	-
FW version number [FW_VERSION]	FW version number SIWAREX DB	CHAR[16]	16	r	""	-	-
HW version [HW_VERSION]	HW version SIWAREX DB	CHAR[16]	16	r	""	-	-
Hardware device ID [HW_DEVICE_ID]	Hardware device ID SIWAREX DB	USHORT	2	r	0	0	31

Messages

9.1 Message types

The messages in the electronic weighing system described here are divided into three types.

System status messages

System status messages can be generated spontaneously at any time by an unexpected event. They include internal and external hardware problems which can occur spontaneously during weighing.

Data and operating errors

The data and operating errors are always a response to a command due to a plausibility check.

These are data errors if a plausibility error has been detected in a data packet which was sent to the module and receipt of the packet has been rejected by the module.

These are operating errors if the module cannot execute the sent command in its current operating state.

Technology errors

Technology errors occur spontaneously due to the process flow of a weighing.

Status bits, on the other hand, are not messages. The status displays describe the status of the scale during normal operation and can be monitored or evaluated at any time.

9.2 Message paths

You can read out the messages using different paths. You define the path for forwarding and processing of messages during configuration.

The messages are processed for two basic purposes:

- For display or recording on an operator panel for the operator
- For linking in the control software to control specific reactions in the process.

The following message paths are possible:

- Output of the message buffer to the SIWATOOL program (takes place automatically)
- Output by means of function block as bit field in Scale data block
- Certain operating errors can be transmitted as diagnostic interrupts to the SIMATIC CPU and evaluated by OB82

9.3 Evaluating messages with the help of SIWATOOL

The electronic weighing system has a message buffer that can hold up to 10 entries. If the number of alarms in the alarm buffer exceeds 10, the oldest entry is overwritten. The message buffer can be read out at any time with the help of SIWATOOL (menu item "Receive all data") and saved together with the scale parameters. This facilitates the detection, analysis and correction of errors in the system.

SIWAREX DB

If you use SIWAREX DB, the type of error of the load cell input affected is reported in SIWATOOL via Supplementary info 1.

9.4 Evaluating messages with the help of SIMATIC FB

All messages of the electronic weighing system can be completely detected and processed in the SIMATIC controller with the help of the SIWAREX WP321 function block (FB). The messages can be evaluated directly in a signaling system by means of a bit signaling area in the scale data block. The message texts are stored in the signaling system. The message text is output when a bit becomes "1".

9.5 Message list

The message list is an overview of all messages that the SIWAREX module can generate. A message can be quickly identified by the message code (number).

9.5.1 System status message list

Operator error (code 1000 to 1999)	Error code	Description and remedy
1000 operating error exists	1000	Group message, at least one operating error exists.
1001 Watchdog	1001	Watchdog, error is displayed for at least 10 seconds. A serious error has occurred in the function of the electronic weighing system, e.g. program error, severe electromagnetic influence on device, etc. Contact the SIWAREX Support if the error occurs multiple times.
1002 RAM error	1002	RAM error. An error has occurred in the memory; the memory content is no longer correct. The electronic weighing system must be switched off. If the error occurs again, the electronic weighing system is defective.
1003 Checksum incorrect parameter	1003	Checksum error at parameter. Critical error because the parameters are no longer safe.
1004 Checksum incorrect program	1004	Checksum error program code. Critical error because the program is no longer safe.

Operator error (code 1000 to 1999)	Error code	Description and remedy
1102 ADU error	1102	AD converter error when reading in the measured value. If the error occurs again, make sure that the EMC recommendations are observed (chapter EMC-compliant setup (Page 22)).
1104 Undervoltage	1104	Undervoltage at sensor cables
1105 Overload	1105	Overload of scale (ca. 110%)
1106 Underload	1106	Underload of scale (ca. -10%)
1110 No communication with SIWAREX DB	1110	No communication with SIWAREX DB

9.5.2 Technology error message list

Technology error (code 2000 to 4999)	Error code	Description and remedy
2000 Technology error exists	2000	Group message, at least one technology error exists
2001 Taring/zeroing timeout	2001	Taring of scale or set to zero is not possible because a standstill was not reached during the standstill time. The command was discarded.
2005 Reboot after power reset	2005	Reboot after voltage recovery or FW update

9.5.3 Data and operating errors message list

Data and command errors (code 5000 to 8999)	Error code	Description and remedy
5000 Data or comand error exists	5000	Group error, a bit is set in the data and operating error bits
5001 Data record or comand unknown	5001	Command code or data record is not known with current application
5003 Cannot exit service mode	5003	Cannot exit service mode; calibration incomplete
5004 Command or data transfer only permitted in service mode	5004	Activation of service mode is required to execute command or transmit data
5005 Command or data transmission not possible because service mode is active	5005	Command can currently not be executed because service mode is active
5006 Command or data transfer not possible while BUSY	5006	Command can currently not be executed because module is BUSY (data record or command transmission already active, ...)
5007 Command or data transmission not possible because module is faulty or SIMATIC CPU stop	5007	Command can currently not be executed because of a problem or SIMATIC CPU stop
5101 Command is not permissible in this operating state	5101	Command is not permissible in the current operating state
5102 Comand not possible while not standstill	5102	Scale command (set to zero, tare, log, ...) cannot be executed because standstill is missing.
5104 Command not possible while limit exceeded	5104	Command (e.g. set to zero, tare, calibrate command) cannot be executed because the permitted range has been exceeded.
5105 Load cell parameters not plausible	5105	Load cell parameters in data record DR 10(a) or data record DR 11(d) not plausible (number, supporting points, load specifications, etc.).





Messages

9.5 Message list

Data and command errors (code 5000 to 8999)	Error code	Description and remedy
5107 Calibration characteristic shift not possible	5107	Characteristic cannot be moved due to possibility of range violation.
7000 Permitted number range violated	7000	The permitted number range, such as for weight values, was violated.
7002 Length of ASCII string not plausible	7002	The string header in a specified string variable is not plausible.
7007 Calibration weights / Calibration digits not plausible	7007	Specifications for calibration weights or digits in data record DR 3 are incorrect (minimum distance, reversal of incline).
7008 Zeroing or tare parameter not plausible	7008	The specifications (data record DR 3) or tare specifications (data record DR 15) are not plausible.
7009 Standstill range / standstill wait time	7009	Standstill range or standstill wait time are not plausible.
7010 Scale interval / rounding	7010	Resolution or selection for rounding to decimal places is not plausible.
7011 Filter parameters	7011	Specification of filter parameters is not plausible.

9.5.4 Messages by LEDs on the module

The LEDs on the front of the SIWAREX module signal the following status and error messages.

Item	Color	Labeling	Function
Line 1			
H1	red	DIAG	System fault
H2	Green		Ready
H11	yellow		Limit 1 responded
H12	yellow		Service mode
H13	yellow		Limit 2 responded
H14			Not used
H15	yellow	{E}	Empty message
H16			Not used
H17	Green		Standstill triggered
H18			Not used
H19	Green	0	¼ d zero status
H20			Not used
H21		Max	Weighing range exceeded
H22			Not used
H23	Green	LC	Load cell(s) ready for operation (LED off = load cells faulty)
H24			Not used
H25	yellow	Rx/Tx	EIA-RS485 communication active
H26			Not used
H40	Green	PRW	Status of local 24 V supply

Command lists

The commands for the electronic weighing system described here can be transmitted by several interfaces:

- From the operator panel via the controller to the SIWAREX module
- From SIWATOOL direct to the SIWAREX module

A data or command error is signaled if a command cannot be executed or if the sent data record is rejected.

Command code	Command	Description	Service
1... 99	Service commands		
1	Service mode On	Turn on service mode	x
2	Service mode Off	Turn off service mode	x
11	Load factory setting	The command resets the SIWAREX to the "Ex factory" status: - All parameters and saved data are loaded with the default values. - All message buffers are reset.	x
60	Set Calibration Point 0	Set Calibration Point 0 / save values for calibration point 0.	x
61	Set Calibration Point 1	Set Calibration Point 1 / save values for calibration point 1.	x
62	Set Calibration Point 2	Set Calibration Point 2 / save values for calibration point 2.	x
81	Characteristic shift	Move calibration characteristic. The command defines the current weight of the scale as the new zero point (0 kg) and shifts the complete characteristic without changing the gradient. The command can be used, for example, in order to compensate parts used for mounting calibration weights on the scale at the end of the calibration.	x
82	Perform automatic calibration	Calculating the scale characteristic curve with reference to the load cell from data record 10. The calculated characteristic curve is entered directly in data record 3 and 4, and thus activated immediately after executing the command.	x
83	Perform calibration check	The command calculates the theoretical digital values in relation to the calibration weights using the load cell parameters from data record 10 and the adjustment weights 0, 1 and 2 from data record 3. The output of these theoretical digits is made in data record 4. The function can be used to check the plausibility of adjustment digits in data record 3, which have been determined in a legal-for-trade calibration.	
700 ... 899	HMI display switching		

Command code	Command	Description	Service
701	Increased resolution	Activate increased resolution on main display (x 10)	x
705	Display current tare weight	Display current tare weight on main display	x
710	Activate standard display	Activate standard display gross/net	x
711	G/N display	Display gross/net weight on main display	x
712	N display		
713	G display		
714	N process value	Display net process weight on main display	x
715	B process value	Display gross process weight on main display	x
871	Show serial number	The serial number of the module is displayed	
875	Display FW version	Show firmware version in current display	x
1000 ...	Basic functions for weighing commands		
1001	Set to zero	Set to zero	x
1011	Tare	Tare	x
1012	Delete tare	Delete current tare weight	x
1013	Tare specification valid	Activate specification of tare weight	x
1016	S7 tare specification valid	Activate specification of S7 tare weight	

The following commands can be triggered in the scale data block SCALE_DB in the area CMD1 to CMD3:

Table 10-1 Command groups of the SIWAREX WP321

Command group	Description
1 ... 99	Commands are forwarded from the FB_SIWA via data record DR 2 to the module (scale commands, weighing commands, log commands). The meaning of the commands corresponds to the command list.
2000 + X	Reading of a data record, X corresponds to the data record number. Example: Data record 3 transmitted by SIWAREX module to the SIMATIC CPU → 2000 + 3 = command code 2003
4000 + X	Writing of a data record, X corresponds to the data record number. Example: Data record 3 transmitted by SIMATIC CPU to the SIWAREX module → 4000 + 3 = command code 4003
7001	Read all data records from SIWAREX into CPU (only for SIMATIC FB)
7002	Write all data records 3, 4, 5, 6, 10, 13, 14 and 15 from CPU into SIWAREX (module must be in service mode, only for SIMATIC FB)

Additional information on transmission of commands from the control program by means of the SIMATIC interface is available in chapter Communication in SIMATIC S7-300/400/1200/1500 (Page 103).

11.1 General information

A SIWAREX WP321 occupies 16 bytes each in the I/O areas of the CPU. Communication between SIWAREX and SIMATIC CPU is supported by the FB.

Table 11-1 Memory requirements of the function block

	FB 1, WP321DR
Read weight and status	YES
Send commands	YES
Send parameters	YES
Main memory requirements in CPU	11 600 byte + n x 1 232 byte
Load memory requirements in CPU	138 788 byte + n x 28 470 byte

n = number of WP321 modules

The function block described above including HMI configuring can be downloaded as a predefined example project ("Ready-for-use") from the Siemens Customer Support.

11.2 Structure of the program "Ready for use"

There is one program for Step 7 Classic and another for TIA Portal. The two programs each consist of two parts:

- STEP 7 software for the SIMATIC CPU
- WinCC project (integrated in SIMATIC Manager)

All messages are saved as bit information. The message system can thus directly access the bit fields and display the message texts.

See also

SIWAREX WP321 "Ready for use" (<https://support.industry.siemens.com/cs/ww/en/ps/17799/dl>)

11.3 Advantages of task sharing

The weight is calculated in the SIWAREX module like in a separate electronic weighing system. However, thanks to integration in SIMATIC, it is possible to directly transfer the weight value to the PLC program. This results in sensible sharing of tasks: the weighing functions are performed in the SIWAREX module, while interlocking and signal linking are performed in the PLC.

SIWAREX "Ready for use" takes over the task of a standardized program in the SIMATIC S7.

11.4 Hardware configuration of the electronic weighing system

An FB handle several tasks:

- It controls communication between the SIMATIC CPU and the SIWAREX module
- It transfers commands and adjustment values to the SIWAREX module according to the process trend
- It prepares the scale data for visualization

11.4 Hardware configuration of the electronic weighing system

The electronic weighing system can be found in the directory PLC/SIMATIC ET 200SP/ technology modules/weighing modules of the hardware catalog.

The following basic properties of the electronic weighing system are defined during hardware configuration in the TIA Portal. Ensure that the electronic weighing system is always completely in the process image of the CPU.

- Installation location of the electronic weighing system
- Address in I/O area
- Diagnostics interrupts
- Hardware interrupts
- I&M (Identification & Maintenance) data

The electronic weighing system occupies 16 bytes in the input/output area.

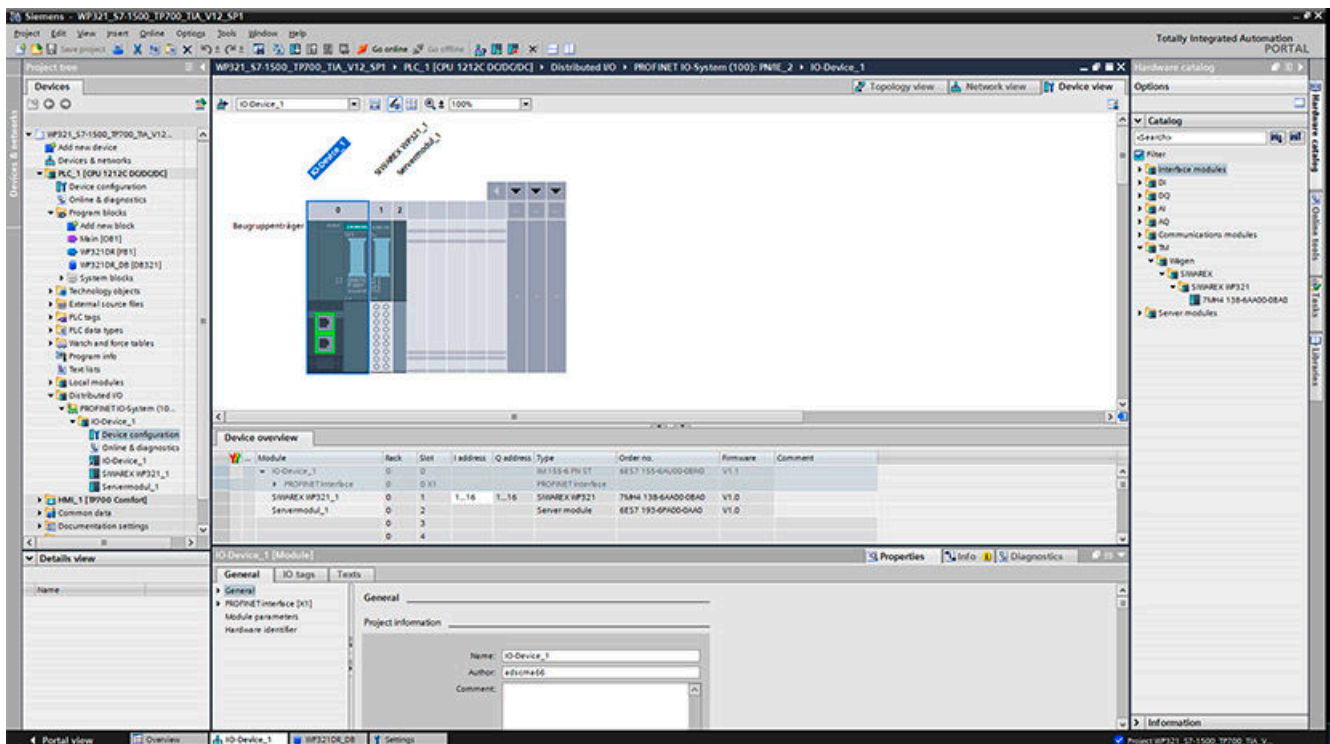

Figure 11-1 Hardware configuration in the TIA Portal

TIA Portal automatically assigns a separate I/O start address and a HW ID for every electronic weighing system present in the project. These two parameters are relevant for calling the function block, and can be obtained from the properties of the respective electronic weighing system.

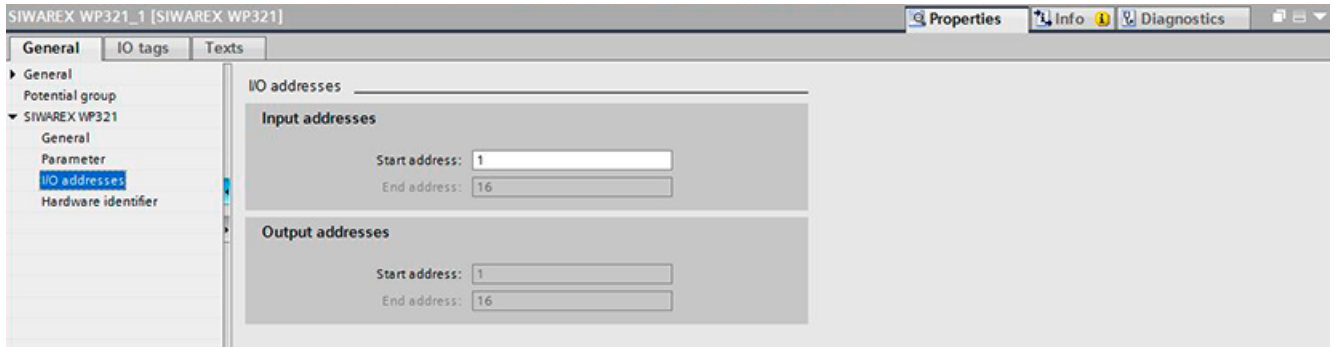

Figure 11-2 Start address of the electronic weighing system in TIA Portal

Diagnostics interrupts can be optionally enabled or deactivated in the properties of the electronic weighing system. The configuration scope for diagnostics and hardware interrupts depends on the SIMATIC CPU used (S7-300, S7-400, S7-1200 or S7-1500) → Diagnostics interrupts (Page 111) and Hardware interrupts (Page 112)

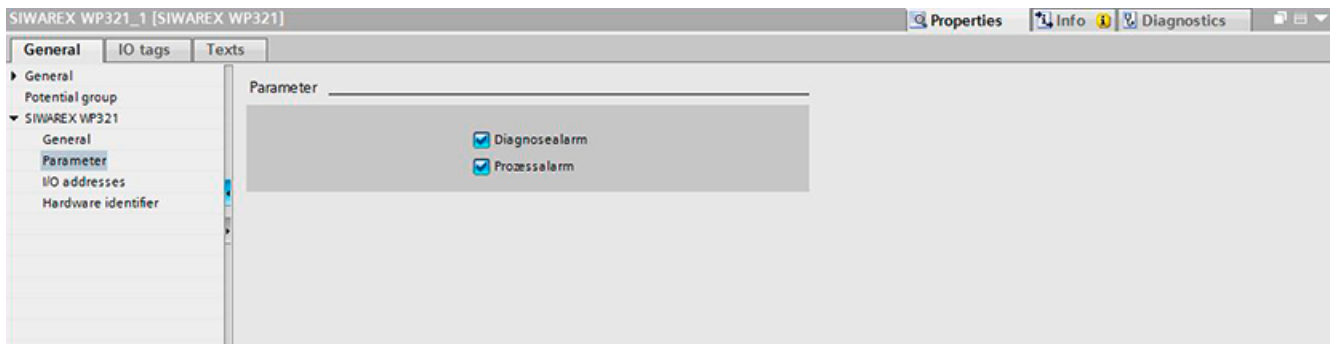

Figure 11-3 Configuration of interrupts in TIA Portal

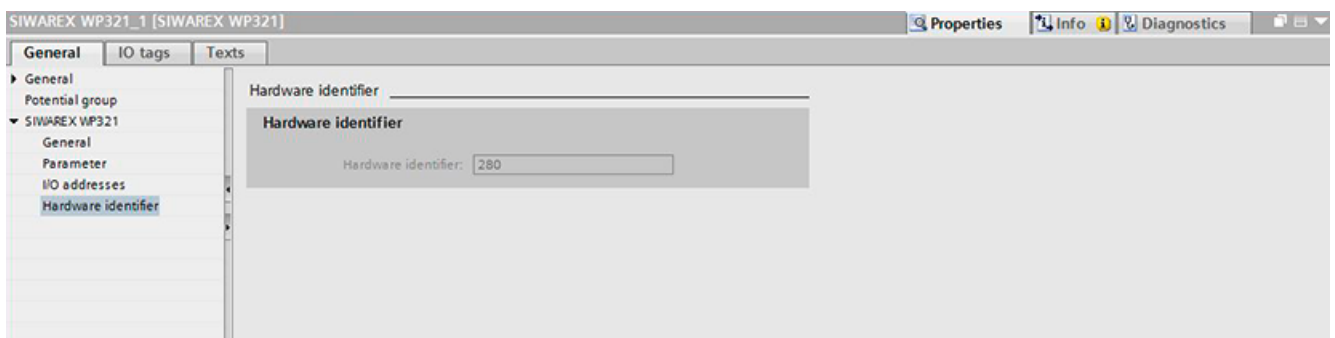

Figure 11-4 HW ID of the electronic weighing system in TIA Portal (up to TIA Portal V14)

11.5 Calling of function block

This description is based on use of the WP321DR block with data record communication and the following data:

- **Start address** SIWAREX WP321: 1 (see → Hardware configuration of the electronic weighing system (Page 104))
- **HW ID** SIWAREX WP321: 280 (see → Hardware configuration of the electronic weighing system (Page 104))
- **Instance data block number** of SIWAREX WP321 function block: DB321

The function block can be integrated at the desired position in the user program using drag and drop. Calling of the FB must be carried out cyclically in the control program.

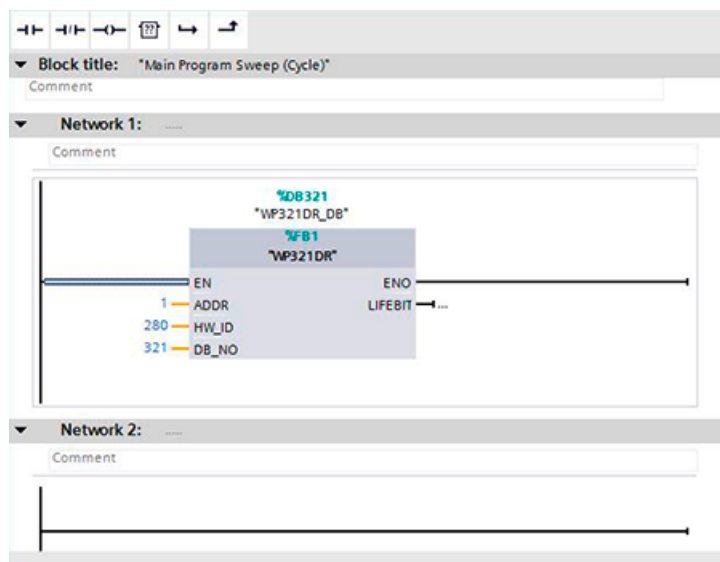

Figure 11-5 Calling WP321 DR block (V1.x and V2.x) in the user program

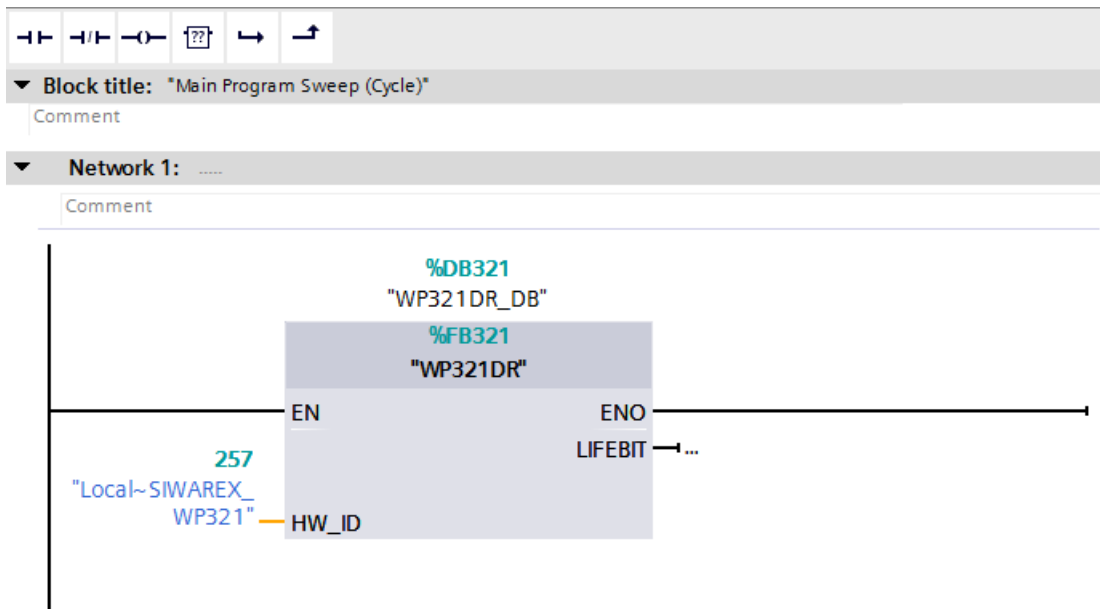

Figure 11-6 Calling WP321 DR block (V3.x) in the user program

Function block parameter	Description
ADDR	Start address WP321 (see → Hardware configuration of the electronic weighing system (Page 104))
HW_ID	HW ID WP321 (see → Hardware configuration of the electronic weighing system (Page 104))
DB_NO	Number of FB-internal instance DB
LIFE BIT	Optional status bit can be used to monitor communication

The generated instance DB (WP321 in this case) contains all data records of the WP321 as well as all parameters required to exchange data between CPU and weighing module.

A separate FB call must be made in the user program for each weighing module. In this manner, each scale receives its own instance DB which provides the respective scale parameters. The input and output parameters of the FB must be matched to the respective WP321 for each call.

11.6 Working with the function block

Data records in SIWAREX weighing modules

All parameters in SIWAREX weighing modules are structured in data records. These data records must be considered as connected packages and can only be respectively read into the CPU or written to the SIWAREX as complete packages. Reading or writing of a single parameter within a data record is not possible. You can find a description of all data records and their parameters in chapter → Scale parameters and functions (Page 59).

Reading and writing of data records is performed using special command codes which can be sent with three command mailboxes handled according to priority within the instance DB:

11.6 Working with the function block

	Name	Data type	Offset	Start value	Re
13	▼ s_CMD1	Struct	446.0		
14	i_CMD_CODE	Int	0.0	0	
15	bo_CMD_TRIGGER	Bool	2.0	false	
16	bo_CMD_InProgress	Bool	2.1	false	
17	bo_CMD_FinishedOK	Bool	2.2	false	
18	bo_CMD_FinishedError	Bool	2.3	false	
19	▼ s_CMD2	Struct	450.0		
20	i_CMD_CODE	Int	0.0	0	
21	bo_CMD_TRIGGER	Bool	2.0	false	
22	bo_CMD_InProgress	Bool	2.1	false	
23	bo_CMD_FinishedOK	Bool	2.2	false	
24	bo_CMD_FinishedError	Bool	2.3	false	
25	▼ s_CMD3	Struct	454.0		
26	i_CMD_CODE	Int	0.0	0	
27	bo_CMD_TRIGGER	Bool	2.0	false	
28	bo_CMD_InProgress	Bool	2.1	false	
29	bo_CMD_FinishedOK	Bool	2.2	false	
30	bo_CMD_FinishedError	Bool	2.3	false	
31	▼ s_CMD_curr	Struct	458.0		
32	i_CMD_CODE	Int	0.0	0	
33	bo_CMD_TRIGGER	Bool	2.0	false	
34	bo_CMD_InProgress	Bool	2.1	false	
35	bo_CMD_FinishedOK	Bool	2.2	false	
36	bo_CMD_FinishedError	Bool	2.3	false	
37	bo_CMD_ERR	Bool	462.0	false	

Figure 11-7 CMD command mailboxes

As shown in the graphics, a command mailbox always consists of a command code (Int) and four bits (Bool). A command is set by entering the desired command code in the "i_CMD_CODE" parameter and setting the respective command trigger "bo_CMD_TRIGGER". The status bits "bo_CMD_InProgress" (command being processed), "bo_CMD_FinishedOk" (command finished without errors) and "bo_CMD_FinishedError" (command rejected or finished with error) can be evaluated in the user program.

In addition, the three command mailboxes are managed and processed according to priority. CMD1 has the highest priority, CMD3 has the lowest priority. If all three command mailboxes are triggered simultaneously by the user program, for example, the function block initially processes CMD1, then CMD2, and finally CMD3. Cyclic triggering of command mailbox 3 is also interrupted by intermediate sending of a command in mailbox 2 or 1 for processing of the respective command.

Note

Cyclic triggering of the CMD1 command mailbox makes it impossible to send commands in mailbox 2 or 3.

A summary of all existing command codes can be found in chapter →Command lists (Page 101).

The following equation for generation of a corresponding command code applies to the reading of data records from the SIWAREX to the data block:

Command code = 2000 + X (X = desired data record number)

The following equation for generation of a corresponding command code applies to the writing of data records from the data block to the SIWAREX:

Command code = 4000 + X (X = desired data record number)

Example

The following example clarifies the actions with command mailboxes and data records:

"Calibration weight" is to be set to a value of 60.5 by the CPU. Since "Calibration weight" is a parameter of data record 3 (see chapter → Scale parameters and functions (Page 59)), service mode must first be activated. This is possible using command code "1" (see chapter → Command lists (Page 101)).

The variable "i_CMD_CODE" must therefore be assigned the value "1" and the associated "bo_CMD_TRIGGER" set to TRUE. Subsequently, the module is directly in service mode (DIAG LED flashes green):

```
i_CMD_CODE = 1
```

```
bo_CMD_TRIGGER = TRUE
```

Since only complete data records can be read or written, it is recommendable to now read data record 3 into the CPU. This is carried out using command code 2003 (see chapter → Command lists (Page 101)):

```
i_CMD_CODE = 2003
```

```
bo_CMD_TRIGGER = TRUE
```

All current data from data record 3 are now present in the data block. The calibration weight is then set as desired to a value of 60.5:

```
CALIBRATION_WEIGHT = 60.5
```

The modified data record 3 must now be written into the SIWAREX again. This is carried out using command code 4003 (see chapter → Command lists (Page 101)):

```
i_CMD_CODE = 4003
```

```
bo_CMD_TRIGGER = TRUE
```

The new calibration weight is now present in the SIWAREX and can be used. Service mode for the module should subsequently be switched off again using the command "2".

This procedure for reading and writing data records or parameters is identical for all data records.

11.7 I/O interface of function block

The following scale parameters are available cyclically in the data block in the controller without special reading of data records or can be sent to the scale without sending of data records:

Table 11-2 I/O data of the function block

Parameter (read)	Meaning
SCALE_STATUS_1 (UINT)	Bytes 0 & 1 of the scale status (→ DR 30 current process values (Page 84))
SCALE_STATUS_2 (UINT)	Bytes 2 & 3 of the scale status (→ DR 30 current process values (Page 84))
Process value 1	Selection → Selection of process value 1, 2 (Page 82)
Process value 2	Selection → Selection of process value 1, 2 (Page 82)
Parameter (write)	
S7 tare specification	Specified value for tare weight. The value is applied by using the "Tare specification valid (1016)" command.

11.8 Error codes of function block

Table 11-3 Statuses/errors when working with the function block

Error bit	Error description
bo_ApplIDError	Address module does not match the function block
bo_ApplIDDERror	Data record does not match the inserted module
bo_SFBEror	Runtime error during transmission of data record
bo_RdPerError	Reading of I/O data failed
bo_LifeBitError	SIWAREX no longer responds
bo_StartUpError	Command was sent although StartUp is still TRUE
bo_WrongFW	Data record version does not match the firmware
bo_InvalidCMD	An invalid command code was sent
bo_DataOperationError	Synchronous data operation error has occurred
bo_StartUp	Startup synchronization of module running
bo_InvalidHW_ID	An invalid hardware ID was created at the function block call ("HW_ID" input).

Note

If execution of the function block is faulty, the variables shown do not correspond to the actual status in the module.

11.9 Diagnostics messages

The DIAG LED flashes red when a diagnostics message is present. Diagnostics messages are displayed as plain text in STEP 7 (TIA Portal) by means of online and diagnostics views. You can evaluate the error codes by means of the user program.

The following diagnostics messages can be signaled:

Table 11-4 Diagnostics messages

Diagnostics message	Error code	Meaning	Remedy
Fault	9H	Internal module fault, defective	Replace technology module
Load voltage missing	11H	L+ for technology module missing	Check supply voltage on BaseUnit
Hardware interrupt lost	16H	Technology module cannot send an interrupt because the previous interrupt has not yet been processed	Change interrupt processing in the CPU, change technology module parameter settings.
Module temporarily not available	1FH	Normal operation of module not possible because, for example, a FW update is being carried out.	Wait until the module assumes normal operation.
Undervoltage	02H	Undervoltage of sense lines	Voltage drop up to the load cell is too large. Find out why.
Load high	07H	Upper limit for sensor voltage exceeded	Eliminate scale overload
Underload	08H	Lower limit for sensor voltage fallen below	Check mechanics of the scale, check the wiring of the sensor.
Checksum error in parameter	0DH	The checksum for the integrity of the parameters is incorrect	Download factory setting of the parameters.
Checksum error program	0EH	The checksum for the integrity of the parameters is incorrect	Download firmware again, replace module

11.10 Diagnostics interrupts

The enable for triggering of diagnostics interrupts is possible for all SIMATIC CPUs (S7-300, S7-400, S7-1200, S7-1500) and is assigned in the device configuration.

The diagnostics interrupts can be evaluated to detect fault events in the SIMATIC CPU.

Fault events (operating faults) are signaled by a diagnostics interrupt to the S7 CPU if the diagnostics interrupt is enabled (in the HW Config). You can evaluate the diagnostics messages using the local data of OB82. Contrary to the S7-1200 and S7-1500, the CPUs of the S7-300 and S7-400 systems enter the stop status following a diagnostics interrupt if the OB82 is not loaded.

Detailed information can be obtained using the "RALRM" instruction (read interrupt status).

11.11 Hardware interrupts

You can configure which events during operation are to trigger a hardware interrupt for the SIWAREX module. Based on the configuration, the SIWAREX module triggers a hardware interrupt for specific events/limits. When a hardware interrupt occurs, the CPU interrupts execution of the user program and processes the associated hardware interrupt OB. The event that triggered the interrupt is entered by the CPU into the start information of the associated hardware interrupt OB.

Activation of the hardware interrupts

For the device configuration of the SIWAREX module, activate the hardware interrupts in the TIA Portal under "Parameters".

Lost hardware interrupt

When an event that triggers a hardware interrupt occurs and a previous event of the same kind has not yet been processed, no further hardware interrupt is triggered. The hardware interrupt is lost. This may lead to the "Hardware interrupt lost" diagnostics interrupt, depending on the parameterization.

No hardware interrupts are activated by default. One result of triggering a hardware interrupt is that the following two variables are entered in the start information of the associated hardware interrupt OB:

- EventType: One byte with a set bit
- IChannel: Number of the channel that triggered the hardware interrupt

Table 11-5 Table of event bits

Hardware interrupt	Event type bit
Limit 1 OFF → ON 0	0
Limit 1 ON → OFF 1	1
Limit 2 OFF → ON 2	2
Limit 2 ON → OFF 3	3

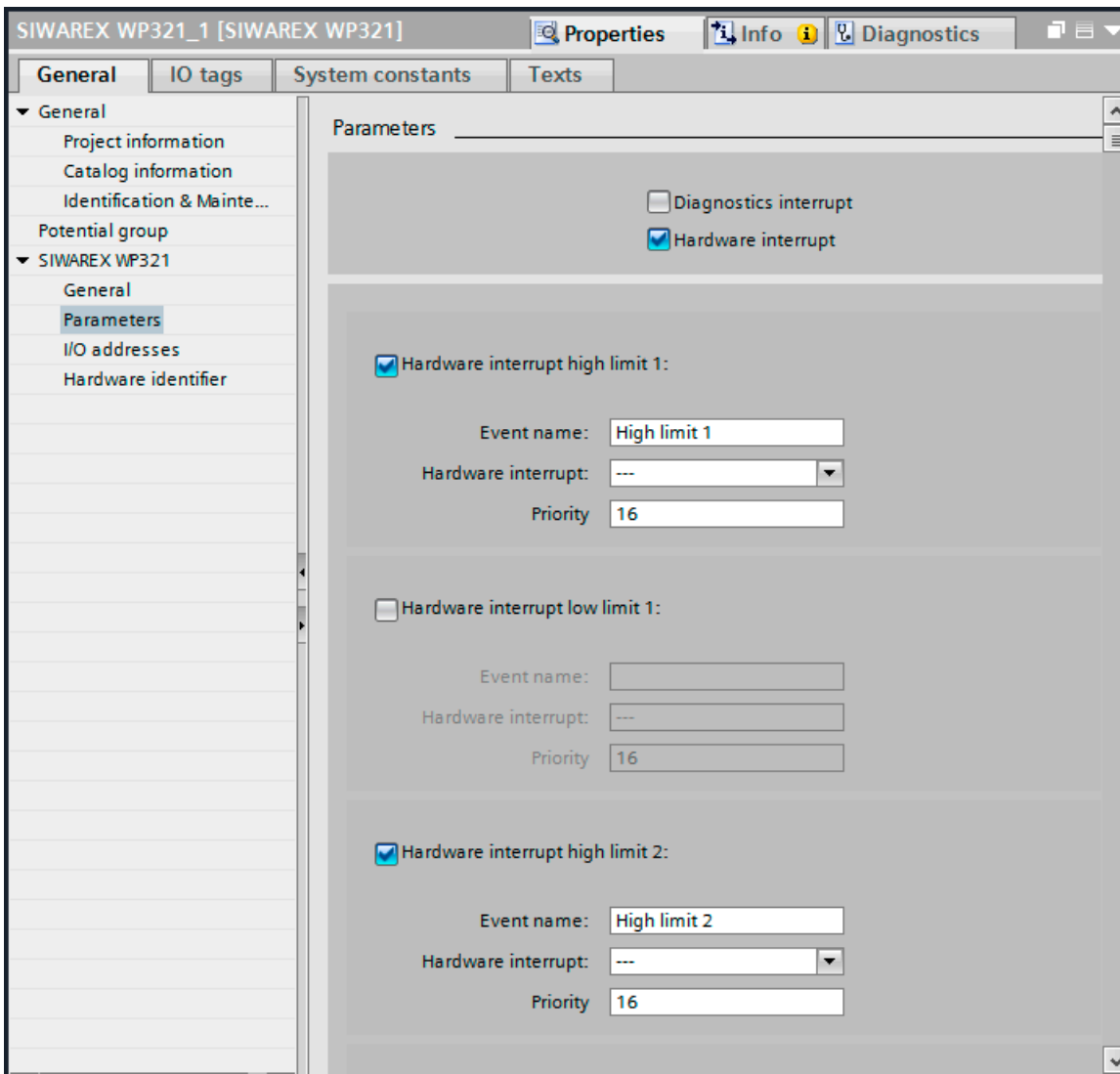

Figure 11-8 Configuration of hardware interrupts for S7-1500

Technical data

12.1 Technical data

24 V power supply

Note

A protective extra-low voltage (to EN 60204-1) is to be ensured by system power supply.

Rated voltage	24 V DC
Static low / high limits	19.2 V DC / 28.8 V DC
Dynamic low / high limits	18.5 V DC / 30.2 V DC
Non-periodic overvoltages	35 V DC for 500 ms with a recovery time of 50 s
Maximum current consumption	100 mA with 24 V DC
Typical power consumption of the module	2 W

Power supply from SIMATIC S7 backplane bus

Power consumption from SIMATIC S7 backplane bus	Typically 20 mA
---	-----------------

Analog load cell interface connection

Error limit to DIN1319-1 at 20 °C +10 K	≤ 0.05% v.E. ¹⁾
Accuracy according to OIML R76 (no approval for measurements requiring verification)	
• Class	III and IV
• Resolution (d=e)	3000d
• Error percentage pi	0.4
• Step voltage	0.5 µV/e
Accuracy delivery state ²⁾	typ. 0.1% v.E.
Sampling rate	100/120/600 Hz (depending on parameterization)
Input signal resolution	± 2 000 000 (for cells with 4 mV/V)
Measuring range	± 4 mV/V
Common mode voltage range	0.25 to 4.75 V
DMS supply ³⁾	4.85 V DC ±2 %
Short-circuit and overload protection	Yes
Connection	6-wire
Sensor voltage monitoring	≤ 4 V
min. DMS input resistance	

• without Ex-i interface SIWAREX IS	40 Ω
• with Ex-i interface SIWAREX IS	50 Ω
min. DMS output resistance	4 100 Ω
Temperature coefficient range	≤ ± 5 ppm/K v. E.
Temperature coefficient zero point	≤ ± 0.1 μV/K
Linearity error	≤ 0.01%
Measured value filtering	Low pass
Electrical isolation	500 V AC
50 Hz / 60 Hz noise suppression CMRR	> 80 dB
Input resistance	
• Signal cable	typ. 4*10 ⁶ Ω
• Sensor cable	typ. 2*10 ⁶ Ω

¹⁾ Relative accuracy! (Absolute accuracy is only achieved by calibration on-site with calibration standard)

²⁾ Accuracy for module replacement or theoretical calibration decisive

³⁾ Value valid at sensor; voltage drops on cables are compensated up to 5 V

Cable length

Maximum cable length	500 m with SIWAREX cable, → Ordering data (Page 123).
----------------------	---

RS485 interface

Standard	EIA-485
Baud rate	Up to 115 Kbps
Parity	even odd none
Terminating resistors (can be activated)	390 Ω / 220 Ω / 390 Ω
Electrical isolation	500 V AC
Transfer protocol	<ul style="list-style-type: none"> • Display from the Siebert company, type S102 See section: Connection of Siebert display via RS485 (Page 33) • Operator Panels or other HMI devices with RS485 and Modbus protocol RTU • SIWAREX DB See section: Connection of the SIWAREX DB (Page 34)
Cable length	≤ 115 kbps max. 1 000 m (fieldbus cable 2-wire, shielded, e.g. 6XV1830-0EH10)

Dimensions and weights

Dimensions	
• Width	15 mm
• Weight, approx.	31 g

Mechanical requirements and data

Testing	Standards	Test values
Vibrational load during operation	IEC 61131-2 IEC 60068-2-6 Test Fc	<ul style="list-style-type: none"> • 5 to 8.4 Hz: 3.5 mm out. • 8.4 to 150 Hz: 9.8 m/s² (=1G)
Shock load during operation	IEC 61131-2 IEC 60068-2-27 Test Ea	<ul style="list-style-type: none"> • 150 m/s² (approx. 15 g), half sine
Vibration load during transport	IEC 60068-2-6 Test Fc	<ul style="list-style-type: none"> • 5 to 8.4 Hz: 3.5 mm out. • 8.4 Hz to 500 Hz: 9.8 m/s²
Shock load during transport	IEC 60068-2-27: Test Ea	<ul style="list-style-type: none"> • 250 m/s² (25G), half sine
Free fall	IEC 61131-2 IEC 60068-2-31: Test Ec, procedure 1	<ul style="list-style-type: none"> • In product packaging: 300 mm drop height • In shipping package: 1.0 m drop height

12.2 Electrical, EMC and climatic requirements

Electrical protection and safety requirements

Fulfilled requirement	Standards	Comments
Safety regulations	IEC 61010-1 IEC 61131-2; UL 508 CSA C22.2 No.142 IEC 61010-2-201 FM3611	
Protection class	IEC 61140	Module is operated with protective extra-low voltage. The protective conductor connection serves only a functional earth to dissipate interference currents
IP rating	IP 20 to IEC 60529	<ul style="list-style-type: none"> • Protection against contact with standard probe • Protection against solid bodies with diameters greater than 12.5 mm • No special protection against water

Fulfilled requirement	Standards	Comments
Air gaps and creepage distances	IEC 60664 IEC 61131-2 IEC 61010-1 UL 508 CSA C22.2 No. 145 EN 50156-1	<ul style="list-style-type: none"> • Overvoltage category II • Pollution degree 2
Isolation stability	IEC 61131-2 CSA C22.2, No. 142 UL508	Test voltage: 500 V AC or 707 V DC

Electromagnetic compatibility

Table 12-1 Interference emission (industrial area): EN 61000-6-4

Comments	Standard	Limits
Emission of radio interferences (electromagnetic fields)	Class A industrial environment: EN 61000-6-4 IEC/CISPR 16-2-3: 2008	<ul style="list-style-type: none"> • 30 ... 230 MHz, 40 dB (µV/m) Q • 230 ... 1 000 MHz, 47 dB (µV/m) Q
Emission on power supply cables 24 V	Class A: Industrial environment: EN 61000-6-4 IEC/CISPR 16-2-1: 2010; EN 55016-2-1: 2009	Class A: Industrial environment <ul style="list-style-type: none"> • 0.15 ... 0.5 MHz, 79 dB (µV) Q • 0.15 ... 0.5 MHz, 66 dB (µV) M • 0.5 ... 30 MHz, 73 dB (µV) Q • 0.5 ... 30 MHz, 60 dB (µV) M

Table 12-2 Interference immunity (industrial environment): EN 61000-6-2

Comments	Standard	Severity class
Burst pulses on power supply cables	EN45501 OIML R 76 EN 61000-4-4 NAMUR NE21	<ul style="list-style-type: none"> • 1 kV • 1 min. per priority
Burst pulses on data and signal cables	EN 61000-4-4 NAMUR NE21 EN 61326	<ul style="list-style-type: none"> • 2.0 kV, opt. 2.4 kV • 5/50 ns / 5 kHz
Electrostatic discharge (ESD)	EN 61000-4-2 NAMUR NE21 EN 61326 EN 45501	<ul style="list-style-type: none"> • 6 kV direct/indirect • ≥ 10 discharges pos/neg • < 1 s repeat time
Electrostatic air discharge (ESD)	EN 61000-4-2 NAMUR NE21 EN 61326 EN 45501	8 kV
Surge on power supply cables	EN 61000-4-5 IEC 61131-2 NAMUR NE21 EN 61326	<ul style="list-style-type: none"> • 1 kV symmetric¹⁾ • 2 kV asymmetric¹⁾ • 1.2/50 µs (8/20) µs pos./neg. • Internal generator resistance: 2 Ω

Comments	Standard	Severity class
Surge on data and signal cables	EN 61000-4-5 IEC 61131-2 NAMUR NE21 EN 61326	<ul style="list-style-type: none"> • 2 kV asymmetric
HF irradiation amplitude modulated	IEC61000-4-3 NAMUR NE21 OIML R76 EN 45501*3	<ul style="list-style-type: none"> • 80 to 2 000 MHz: 20 V/m
HF irradiation, cell phone frequencies	IEC 61000-4-3	<ul style="list-style-type: none"> • 900 MHz (± 5 MHz) • 1.89 Ghz (± 10 MHz) • 20 V/m
HF voltage on data, signal and power supply cables 0.15 to 80 MHz	IEC 61000-4-6 NAMUR NE21 EN 61326 OIML R 76	<ul style="list-style-type: none"> • 10 kHz to 80 MHz: 10 V_{rms} • Mod.: 80% AM with 1 kHz

- 1) An external protection element has to be installed to meet the requirement (e.g.: Blitzductor VT AD24V, Dehn&Söhne)
- 2) •Not applicable for shielded cables and symmetric ports

NOTICE
Radio interference is possible
This is a device of class A. The device may cause radio interference in residential areas. Implement appropriate measures (e.g.: use in 8MC cabinets) to prevent radio interference.

Ambient conditions

The use of SIWAREX WP321 is intended under the following conditions in SIMATIC ET 200SP.

Table 12-3 Operating conditions to IEC 60721

Mode	IEC60721-3-3 <ul style="list-style-type: none"> • Class 3M3, stationary use, weather-proofed 	
Storage/transport	IEC 60721-3-2 class 2M2 without precipitation	
Contaminant concentration	SO ₂ : < 0.5 ppm H ₂ S: < 0.1 ppm;	RH < 60%, no condensation

Table 12-4 Climatic requirements

Comments	Ambient conditions	Application areas
Operating temperature:		
<ul style="list-style-type: none"> • Horizontal installation in S7 	-25 ... +60 °C	The S7 standard modules may not be operated at temperatures below 0 °C.
<ul style="list-style-type: none"> • Vertical installation in S7 	-25 ... +50 °C	

Comments	Ambient conditions	Application areas
Storage and transport temperature	-40 ... +85 °C	
Relative humidity	5 ... 95 %	No condensation; corresponds to relative humidity (RH) stress level 2 to DIN IEC 61131-2
Air pressure during operation	IEC 60068-2-13	1 080 ... 795 hPa (operation) (-1 000 ... +2 000 m above sea level)
Air pressure during transport and storage	IEC 60068-2-13	1 080 to 660 hPa (storage) (-1 000 to +3 500 m above sea level)

12.3 Reliability

Mean Time Between Failure (MTBF)

The MTBF calculation results in the following value:

Table 12-5 MTBF

Electronic Weighing System	MTBF in years
SIWAREX WP321	1495 years @TA = 40 °C

12.4 Approvals

NOTICE







Safety guidelines for applications in hazardous areas

For applications in hazardous areas, read the safety instructions in the document "Product Information - Use of SIWAREX Modules in a Zone 2 Hazardous Area (<https://support.industry.siemens.com/cs/ww/en/>)".

Note

The current approvals for your device can be found on the nameplate.

	→ CE approval (https://support.industry.siemens.com/cs/ww/de/view/102423743/en)
	→ UL approval USA (https://support.industry.siemens.com/cs/ww/de/view/19248974/en) → UL approval Canada (https://support.industry.siemens.com/cs/ww/de/view/89339055/en)

	<p>→ FM approval (https://support.industry.siemens.com/cs/ww/de/view/109476227/en)</p>
	<p>→ ATEX certificate (https://support.industry.siemens.com/cs/de/de/view/22750040/en)</p>
	<p>→ IECEx certificate (https://support.industry.siemens.com/cs/ww/de/view/109476230/en)</p>
	<p>→ EAC certificate (https://support.industry.siemens.com/cs/ww/de/view/109476219/en)</p>
	<p>→ Tick mark for Australia and New Zealand</p>
	<p>→ KCC approval</p>
	<p>→ The modules are RoHS-compliant according to EU Directive 2016/65/EU</p>

Ordering data

You can order accessories online: Industry Mall (<https://mallstage.industry.siemens.com/mall/en/b0/Catalog/Products/10229887?tree=CatalogTree>)

The following accessories are not included in the scope of delivery:

- **Digital remote display**
The digital remote displays can be connected directly to the SIWAREX WP321 through the RS485 interface.
Suitable remote display: S102
Siebert Industrieelektronik GmbH
Postfach 1180
D-66565 Eppelborn, Germany
Tel.: 06806/980-0
Fax: +49 (0)6806/980-999
Internet: Siebert (<http://www.siebert-group.com>)
You can obtain more detailed information from the manufacturer.
- **RS485/USB converter**
Commercially available converter with FTDI chip,
e.g. USB-Nano-485 from CTI (<http://www.cti-shop.com/RS485-Konverter/USB-Nano-485>)

Certificates and support

A.1 Technical support

Technical support

If this documentation does not provide complete answers to any technical questions you may have, contact Technical Support at:

- Support request (<http://www.siemens.com/automation/support-request>)
- More information about our Technical Support is available at Technical support (<http://www.siemens.com/automation/csi/service>)

Internet Service & Support

In addition to our documentation, Siemens provides a comprehensive support solution at:

- Service&Support (<http://www.siemens.com/automation/service&support>)

Personal contact

If you have additional questions about the device, please contact your Siemens personal contact at:

- Partner (<http://www.automation.siemens.com/partner>)

To find the personal contact for your product, go to "All Products and Branches" and select "Products & Services > Industrial Automation > Process Instrumentation".

Documentation

You can find documentation on various products and systems at:

- Instructions and manuals (<https://support.industry.siemens.com/cs/ww/en/ps/17781/man>)

See also

Process instrumentation catalog (<http://www.siemens.com/processinstrumentation/catalogs>)

SIWAREX support

- E-mail (<mailto:hotline.siwarex@siemens.com>)
- Phone: +49 (721) 595-2811 CET 8:00 to 17:00

ESD guidelines

B.1 ESD Guidelines

Definition of ESD

All electronic modules are equipped with large-scale integrated ICs or components. Due to their design, these electronic elements are highly sensitive to overvoltage, and thus to any electrostatic discharge.

The electrostatic sensitive components/modules are commonly referred to as ESD devices. This is also the international abbreviation for such devices.

ESD modules are identified by the following symbol:



NOTICE

ESD devices can be destroyed by voltages well below the threshold of human perception. These static voltages develop when you touch a component or electrical connection of a device without having drained the static charges present on your body. The electrostatic discharge current may lead to latent failure of a module, that is, this damage may not be significant immediately, but in operation may cause malfunction.

Electrostatic charging

Anyone who is not connected to the electrical potential of their surroundings can be electrostatically charged.

The figure below shows the maximum electrostatic voltage which may build up on a person coming into contact with the materials indicated. These values correspond to IEC 801-2 specifications.

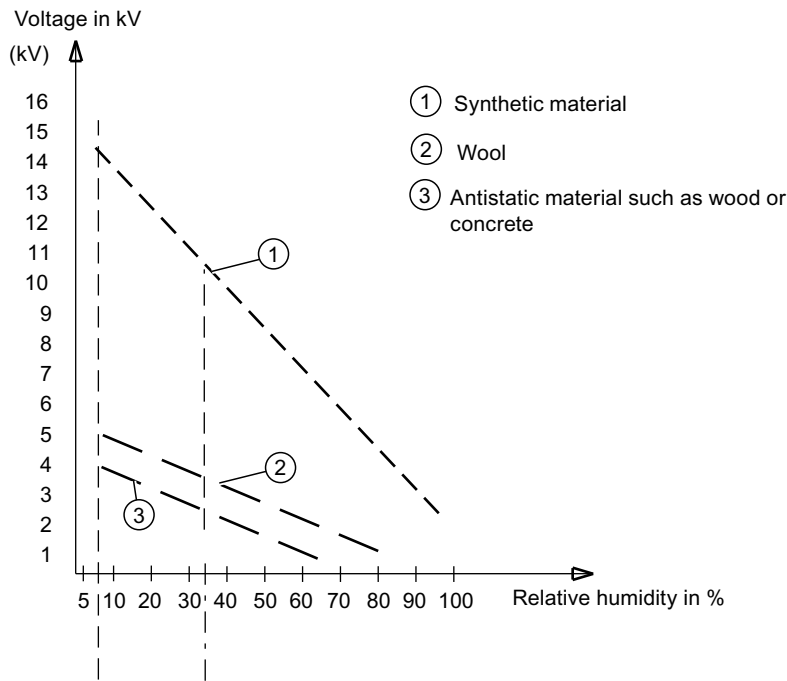

Figure B-1 Electrostatic voltages which an operator can be subjected to

Basic protective measures against electrostatic discharge

- Ensure good equipotential bonding:
When handling electrostatic sensitive devices, ensure that your body, the workplace and packaging are grounded. This prevents electrostatic charge.
- Avoid direct contact:
As a general rule, only touch electrostatic sensitive devices when this is unavoidable (e.g. during maintenance work). Handle the modules without touching any chip pins or PCB traces. In this way, the discharged energy can not affect the sensitive devices. Discharge your body before you start taking any measurements on a module. Do so by touching grounded metallic parts. Always use grounded measuring instruments.

Abbreviations

C.1 List of abbreviations

ASCII	American Standard Code for Information Interchange
B	Gross weight
CPU	Central processor, in this case SIMATIC CPU
DB	Data block
FB	SIMATIC S7 function block
HMI	Human machine interface (e.g. SIMATIC Operator Panel)
HW	Hardware
NAWI	Non-automatic weighing instrument
NAW	Non-automatic scales
OIML	Organisation Internationale de Metrologie Legale
OP	Operator Panel (SIMATIC)
PC	Personal computer
pT	Preset tare (predefined tare weight with manual taring)
RAM	Random access memory
PLC	Programmable logic controller
STEP 7	Programming device software for SIMATIC S7
T	Tare weight
TM	Technology module
TP	Touch Panel (SIMATIC)
UDT	Universal Data Type (S7)
WRP	Write protection
LC	Load cell(s)
NR	Numerical range

Index

C

Compact Operating Instructions, 125
Customer Support, (Refer to Technical support)

D

Documentation, 125
Edition, 9

E

ESD guidelines, 127

G

Guidelines
ESD guidelines, 127

H

History, 9
Hotline, (Refer to Support request)

I

Instructions and manuals, 125

M

Manuals, 125
MTBF, 120

O

Operating Instructions, 125

R

Reliability, 120

S

Safety notices
for installation, 21
Use in hazardous areas, 21
Scope of delivery, 10
Service, 125
Service & Support, 125
Internet, 125
Support, 125
Support request, 125

T

Technical support, 125
Partner, 125
Personal contact, 125

W

Warranty, 11

