

# SIEMENS

## SINUMERIK

### SINUMERIK 840D sl Operator panel front: OP 015 black

Manual

Fundamental safety instructions	1
Description	2
Mounting	3
Connecting	4
Networking	5
Service and maintenance	6
Technical data	7
Spare parts/accessories	8

Valid for: SINUMERIK 840D sl / 840DE sl control

## Legal information

### Warning notice system

This manual contains notices you have to observe in order to ensure your personal safety, as well as to prevent damage to property. The notices referring to your personal safety are highlighted in the manual by a safety alert symbol, notices referring only to property damage have no safety alert symbol. These notices shown below are graded according to the degree of danger.

 <b>DANGER</b>
---

indicates that death or severe personal injury <b>will</b> result if proper precautions are not taken.
--

 <b>WARNING</b>
--

indicates that death or severe personal injury <b>may</b> result if proper precautions are not taken.
---

 <b>CAUTION</b>
--

indicates that minor personal injury can result if proper precautions are not taken.
--

<b>NOTICE</b>
---------------

indicates that property damage can result if proper precautions are not taken.
--

If more than one degree of danger is present, the warning notice representing the highest degree of danger will be used. A notice warning of injury to persons with a safety alert symbol may also include a warning relating to property damage.

### Qualified Personnel

The product/system described in this documentation may be operated only by **personnel qualified** for the specific task in accordance with the relevant documentation, in particular its warning notices and safety instructions. Qualified personnel are those who, based on their training and experience, are capable of identifying risks and avoiding potential hazards when working with these products/systems.

### Proper use of Siemens products

Note the following:

 <b>WARNING</b>
--

Siemens products may only be used for the applications described in the catalog and in the relevant technical documentation. If products and components from other manufacturers are used, these must be recommended or approved by Siemens. Proper transport, storage, installation, assembly, commissioning, operation and maintenance are required to ensure that the products operate safely and without any problems. The permissible ambient conditions must be complied with. The information in the relevant documentation must be observed.
--

### Trademarks

All names identified by ® are registered trademarks of Siemens AG. The remaining trademarks in this publication may be trademarks whose use by third parties for their own purposes could violate the rights of the owner.

### Disclaimer of Liability

We have reviewed the contents of this publication to ensure consistency with the hardware and software described. Since variance cannot be precluded entirely, we cannot guarantee full consistency. However, the information in this publication is reviewed regularly and any necessary corrections are included in subsequent editions.

# Table of contents

<b>1</b>	<b>Fundamental safety instructions</b> .....	<b>5</b>
1.1	General safety instructions.....	5
1.2	Equipment damage due to electric fields or electrostatic discharge .....	8
1.3	Warranty and liability for application examples .....	8
1.4	Industrial security .....	9
1.5	Residual risks of power drive systems .....	11
<b>2</b>	<b>Description</b> .....	<b>13</b>
2.1	Overview .....	13
2.2	Operator controls and displays .....	14
2.2.1	View .....	14
2.2.2	Operation .....	15
2.2.3	Keyboard.....	17
2.2.4	Screen saver .....	18
2.3	Interfaces .....	19
<b>3</b>	<b>Mounting</b> .....	<b>21</b>
<b>4</b>	<b>Connecting</b> .....	<b>27</b>
4.1	Pin assignment of the interfaces .....	27
4.2	Handling membrane connectors .....	33
<b>5</b>	<b>Networking</b> .....	<b>35</b>
5.1	System settings.....	35
5.1.1	Thin Client Unit (TCU).....	35
5.1.2	Settings for SINUMERIK solution line.....	36
5.1.3	System boot with system network.....	38
5.1.4	Factory default settings .....	39
5.2	Commissioning TCU .....	41
5.2.1	Key assignment.....	41
5.2.2	Settings in the "TCU.ini" file .....	42
5.2.3	Displacement mechanism for TCUs.....	43
5.2.4	Disable switchover between TCU via PLC.....	44
5.2.5	Example: How to select the behavior of the TCUs during boot up.....	47
5.3	Network configuration .....	48
5.3.1	Permissible network topologies.....	48
5.3.2	Networks without connection to the company network .....	49
5.3.2.1	Configuration 1: NCU and TCU.....	49
5.3.3	Networks with NCU connection to the company network .....	50
5.3.3.1	Configuration 2: NCU and TCU.....	50
5.3.3.2	Configuration 3: PCU/IPC with TCU on NCU.....	51
5.3.3.3	Connecting the programming device (PG) to the NCU .....	52

5.3.4	Example: Configuring a VNC connection to a PC .....	52
5.4	Service and diagnostics .....	54
5.4.1	Using the TCU's main menu .....	54
5.4.2	Operating the TCU menu "Service sessions" .....	57
5.4.3	Operating the TCU menu "Service menu" .....	59
5.4.4	Operating the TCU menu "Modify settings" .....	62
5.4.5	Operating the menu for a new TCU or spare part TCU .....	63
5.4.6	How to register a TCU on the system network.....	68
5.4.7	This is how you register a spare part TCU.....	71
5.4.8	Booting of the TCU .....	72
5.4.8.1	Messages during booting .....	72
5.4.8.2	Diagnostics options during booting .....	73
<b>6</b>	<b>Service and maintenance .....</b>	<b>75</b>
<b>7</b>	<b>Technical data .....</b>	<b>77</b>
7.1	Secondary electrical conditions.....	78
7.1.1	Power supply.....	78
7.1.2	Grounding concept.....	79
7.1.3	EMC compatibility .....	80
7.1.4	EMC limit values in South Korea.....	81
7.2	Ambient climatic and mechanical conditions.....	81
7.2.1	Transport and storage conditions.....	81
7.2.2	Operating conditions .....	83
7.2.3	Cooling .....	84
7.3	Standards and approvals .....	86
7.4	Recycling and disposal .....	87
<b>8</b>	<b>Spare parts/accessories .....</b>	<b>89</b>
	<b>Index.....</b>	<b>91</b>

# Fundamental safety instructions

## 1.1 General safety instructions



### WARNING

#### Electric shock and danger to life due to other energy sources

Touching live components can result in death or severe injury.

- Only work on electrical devices when you are qualified for this job.
- Always observe the country-specific safety rules.

Generally, the following six steps apply when establishing safety:

1. Prepare for disconnection. Notify all those who will be affected by the procedure.
2. Isolate the drive system from the power supply and take measures to prevent it being switched back on again.
3. Wait until the discharge time specified on the warning labels has elapsed.
4. Check that there is no voltage between any of the power connections, and between any of the power connections and the protective conductor connection.
5. Check whether the existing auxiliary supply circuits are de-energized.
6. Ensure that the motors cannot move.
7. Identify all other dangerous energy sources, e.g. compressed air, hydraulic systems, or water. Switch the energy sources to a safe state.
8. Check that the correct drive system is completely locked.

After you have completed the work, restore the operational readiness in the inverse sequence.



### WARNING

#### Electric shock due to connection to an unsuitable power supply

When equipment is connected to an unsuitable power supply, exposed components may carry a hazardous voltage. Contact with hazardous voltage can result in severe injury or death.

- Only use power supplies that provide SELV (Safety Extra Low Voltage) or PELV- (Protective Extra Low Voltage) output voltages for all connections and terminals of the electronics modules.



**⚠ WARNING**

**Electric shock due to equipment damage**

Improper handling may cause damage to equipment. For damaged devices, hazardous voltages can be present at the enclosure or at exposed components; if touched, this can result in death or severe injury.

- Ensure compliance with the limit values specified in the technical data during transport, storage and operation.
- Do not use any damaged devices.



**⚠ WARNING**

**Electric shock due to unconnected cable shields**

Hazardous touch voltages can occur through capacitive cross-coupling due to unconnected cable shields.

- As a minimum, connect cable shields and the cores of cables that are not used at one end at the grounded housing potential.



**⚠ WARNING**

**Electric shock if there is no ground connection**

For missing or incorrectly implemented protective conductor connection for devices with protection class I, high voltages can be present at open, exposed parts, which when touched, can result in death or severe injury.

- Ground the device in compliance with the applicable regulations.

**⚠ WARNING**

**Spread of fire from built-in devices**

In the event of fire outbreak, the enclosures of built-in devices cannot prevent the escape of fire and smoke. This can result in serious personal injury or property damage.

- Install built-in units in a suitable metal cabinet in such a way that personnel are protected against fire and smoke, or take other appropriate measures to protect personnel.
- Ensure that smoke can only escape via controlled and monitored paths.

 **WARNING****Unexpected movement of machines caused by radio devices or mobile phones**

When radio devices or mobile phones with a transmission power  $> 1$  W are used in the immediate vicinity of components, they may cause the equipment to malfunction. Malfunctions may impair the functional safety of machines and can therefore put people in danger or lead to property damage.

- If you come closer than around 2 m to such components, switch off any radios or mobile phones.
- Use the "SIEMENS Industry Online Support app" only on equipment that has already been switched off.

 **WARNING****Fire due to inadequate ventilation clearances**

Inadequate ventilation clearances can cause overheating of components with subsequent fire and smoke. This can cause severe injury or even death. This can also result in increased downtime and reduced service lives for devices/systems.

- Ensure compliance with the specified minimum clearance as ventilation clearance for the respective component.

**NOTICE****Overheating due to inadmissible mounting position**

The device may overheat and therefore be damaged if mounted in an inadmissible position.

- Only operate the device in admissible mounting positions.

 **WARNING****Unexpected movement of machines caused by inactive safety functions**

Inactive or non-adapted safety functions can trigger unexpected machine movements that may result in serious injury or death.

- Observe the information in the appropriate product documentation before commissioning.
- Carry out a safety inspection for functions relevant to safety on the entire system, including all safety-related components.
- Ensure that the safety functions used in your drives and automation tasks are adjusted and activated through appropriate parameterizing.
- Perform a function test.
- Only put your plant into live operation once you have guaranteed that the functions relevant to safety are running correctly.

**Note**

**Important safety notices for Safety Integrated functions**

If you want to use Safety Integrated functions, you must observe the safety notices in the Safety Integrated manuals.

## 1.2 Equipment damage due to electric fields or electrostatic discharge

Electrostatic sensitive devices (ESD) are individual components, integrated circuits, modules or devices that may be damaged by either electric fields or electrostatic discharge.



**NOTICE**

**Equipment damage due to electric fields or electrostatic discharge**

Electric fields or electrostatic discharge can cause malfunctions through damaged individual components, integrated circuits, modules or devices.

- Only pack, store, transport and send electronic components, modules or devices in their original packaging or in other suitable materials, e.g. conductive foam rubber or aluminum foil.
- Only touch components, modules and devices when you are grounded by one of the following methods:
  - Wearing an ESD wrist strap
  - Wearing ESD shoes or ESD grounding straps in ESD areas with conductive flooring
- Only place electronic components, modules or devices on conductive surfaces (table with ESD surface, conductive ESD foam, ESD packaging, ESD transport container).

## 1.3 Warranty and liability for application examples

Application examples are not binding and do not claim to be complete regarding configuration, equipment or any eventuality which may arise. Application examples do not represent specific customer solutions, but are only intended to provide support for typical tasks.

As the user you yourself are responsible for ensuring that the products described are operated correctly. Application examples do not relieve you of your responsibility for safe handling when using, installing, operating and maintaining the equipment.



## 1.4 Industrial security

---

### Note

#### Industrial security

Siemens provides products and solutions with industrial security functions that support the secure operation of plants, systems, machines and networks.

In order to protect plants, systems, machines and networks against cyber threats, it is necessary to implement – and continuously maintain – a holistic, state-of-the-art industrial security concept. Products and solutions from Siemens constitute one element of such a concept.

Customers are responsible for preventing unauthorized access to their plants, systems, machines and networks. Such systems, machines and components should only be connected to an enterprise network or the Internet if and to the extent such a connection is necessary and only when appropriate security measures (e.g. using firewalls and/or network segmentation) are in place.

For additional information on industrial security measures that can be implemented, please visit:

Industrial security (<https://www.siemens.com/industrialsecurity>)

Siemens' products and solutions undergo continuous development to make them more secure. Siemens strongly recommends that product updates are applied as soon as they become available, and that only the latest product versions are used. Use of product versions that are no longer supported, and failure to apply the latest updates may increase customer's exposure to cyber threats.

To stay informed about product updates, subscribe to the Siemens Industrial Security RSS Feed at:

Industrial security (<https://www.siemens.com/industrialsecurity>)

---

Further information is provided on the Internet:

Industrial Security Configuration Manual (<https://support.industry.siemens.com/cs/ww/en/view/108862708>)

 <b>WARNING</b>
<b>Unsafe operating states resulting from software manipulation</b>
Software manipulations, e.g. viruses, Trojans, or worms, can cause unsafe operating states in your system that may lead to death, serious injury, and property damage.
<ul style="list-style-type: none"><li>• Keep the software up to date.</li><li>• Incorporate the automation and drive components into a holistic, state-of-the-art industrial security concept for the installation or machine.</li><li>• Make sure that you include all installed products into the holistic industrial security concept.</li><li>• Protect files stored on exchangeable storage media from malicious software by with suitable protection measures, e.g. virus scanners.</li><li>• On completion of commissioning, check all security-related settings.</li><li>• Protect the drive against unauthorized changes by activating the "Know-how protection" converter function.</li></ul>

## 1.5 Residual risks of power drive systems

When assessing the machine- or system-related risk in accordance with the respective local regulations (e.g., EC Machinery Directive), the machine manufacturer or system installer must take into account the following residual risks emanating from the control and drive components of a drive system:

1. Unintentional movements of driven machine or system components during commissioning, operation, maintenance, and repairs caused by, for example,
  - Hardware and/or software errors in the sensors, control system, actuators, and cables and connections
  - Response times of the control system and of the drive
  - Operation and/or environmental conditions outside the specification
  - Condensation/conductive contamination
  - Parameterization, programming, cabling, and installation errors
  - Use of wireless devices/mobile phones in the immediate vicinity of electronic components
  - External influences/damage
  - X-ray, ionizing radiation and cosmic radiation
2. Unusually high temperatures, including open flames, as well as emissions of light, noise, particles, gases, etc., can occur inside and outside the components under fault conditions caused by, for example:
  - Component failure
  - Software errors
  - Operation and/or environmental conditions outside the specification
  - External influences/damage
3. Hazardous shock voltages caused by, for example:
  - Component failure
  - Influence during electrostatic charging
  - Induction of voltages in moving motors
  - Operation and/or environmental conditions outside the specification
  - Condensation/conductive contamination
  - External influences/damage
4. Electrical, magnetic and electromagnetic fields generated in operation that can pose a risk to people with a pacemaker, implants or metal replacement joints, etc., if they are too close
5. Release of environmental pollutants or emissions as a result of improper operation of the system and/or failure to dispose of components safely and correctly
6. Influence of network-connected communication systems, e.g. ripple-control transmitters or data communication via the network

For more information about the residual risks of the drive system components, see the relevant sections in the technical user documentation.



## Description

### 2.1 Overview

The SINUMERIK OP 015 black operator panel front has a touch-sensitive glass surface with multiple finger operator control. The integrated TCU enables the operator panel front and control to be installed separately.

The OP 015 black operator panel front is linked to the PCU/NCU via Ethernet as thin client in a dedicated subnet (via DHCP server on the PCU/NCU). The distance to the operator panel fronts is determined by the maximum distance between two network nodes / access points (100 m). Mixed operation with several TCUs and one operator panel front directly on the PCU is possible.

The operator panel front is secured from the rear using special clamps supplied with the panel.

### Validity

This description applies to:

Type	Description	Article number
OP 015 black	Operator panel front as thin client with touch screen	6FC5303-0AF14-0AA0

### Features

- Ethernet 10/100/1000 Mbit/s
- 3 x USB (max. high speed) on the rear
- 15" LCD flat screen (color) in widescreen format
- Multiple finger operation in the screen area
- Printed keyboard with alphabetic, numeric, cursor and control keypad
- Status LEDs for power supply, key feedback and keylock / Caps lock key
- Panel cutout (W x H): 450 x 290 mm
- Can be installed by one person (see Section "Mounting (Page 21)")
- Degree of protection: IP65 / IP66
- Attachment: Tension jacks at the rear
  - Min./max. thickness of the wall 1.5 to 6 mm

**Note**

**Connecting USB devices**

The OP 015 black does not have any USB interfaces on the front. If required, the rear USB interfaces can be routed to the front via a USB extension (see Section "Keyboards and additional components").

**Naming convention**

The following generic term is used in this documentation:

- PCU: Describes the SINUMERIK PCU 50 or the SIMATIC IPC 427E, in each case including PCU basic software.

## 2.2 Operator controls and displays

### 2.2.1 View

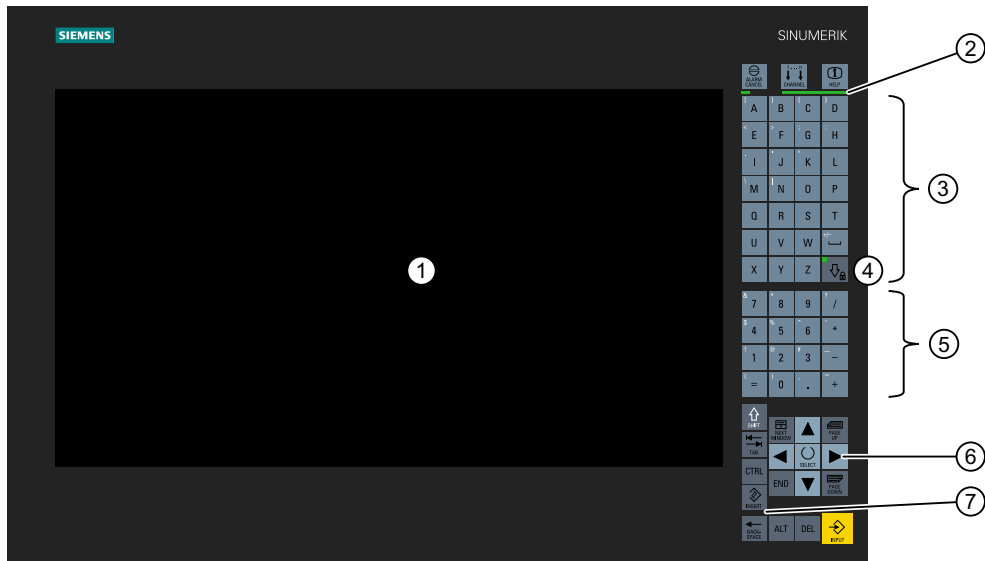

- ① Multiple finger operating area for operating software (softkeys) in the display area
- ② Green LED bars for POWER OK (left) and key feedback (right)
- ③ Alphabetic key group
- ④ Caps lock key incl. keylock - green LED (displays keylock active or Caps lock key)
- ⑤ Numeric key group
- ⑥ Cursor key group
- ⑦ Control key group

Figure 2-1 Front view of the OP 015 black operator panel front

## 2.2.2 Operation

The operator panel front is operated through finger contact with the touch-sensitive glass surface:

- Depending on the application-specific functions shown in the display area, for example, by:
  - pressing a softkey or a displayed button
  - gestures with up to eight fingers
- Depending on the displayed keys. Two keys (plus modifier keys) can be pressed simultaneously.
  - Modifier: CTRL, ALT, SHIFT

 **WARNING**

**Unexpected machine movements caused by incorrect operation**

Incorrect operation of devices with a touch screen can lead to unexpected machine movements. This can result in death, serious injury and material damage.

- Prevent unintentional incorrect operation by appropriate configuration of the user interface, e.g. by placing the buttons for starting and stopping machine components far enough apart.
- Configure the machine so that safety-related functions are not operated with the touch screen.

**Note**

**Notes on operation of the touch-sensitive glass surface with multi-finger operation function using gestures**

Observe the following notes in order to avoid incorrect operation of the touch-sensitive glass surface with multi-finger operation function. Otherwise, entries made at the device will either be incorrectly identified/implemented - or not at all.

- The OP 015 black does not support safety-relevant functions and these may also not be implemented in the touch-sensitive glass surface.
- The touch-sensitive glass surface reacts to contact with its surface, not to pressure. Therefore, do not subsequently attach a protective film to the touch-sensitive glass surface. Also remove all protective and packaging films, as these have a negative impact/prevent data from being entered and initiate incorrect operator entries.
- Only operate the touch-sensitive glass surface with your finger tips, not with your fingernails.
- Touch the touch-sensitive glass surface either perpendicularly or at a maximum angle of 45° to the surface.
- Avoid unintentional multiple touches, e.g. with the knuckles or by leaning on or against the display.
- Make sure that the surface of the touch-sensitive glass screen does not get dirty. Cleaning information can be found on the Internet in the following article in the Service & Support portal of Siemens Industry:  
<http://support.automation.siemens.com/WW/view/en/39718397>.

Always check whether the executed operator actions have been recognized by the device.

---

**Note**

Please observe the valid C standards for the particular machine type (e.g. for turning machines: EN ISO 23125-2010, pages 36 and 49). These state that a button that initiates motion with the protective door open must be implemented using an additional acknowledgment device; this is because for single-channel keyboards – such as the OP 015 black – generally no PL (performance level) "d" can be achieved.

---

**Displaying the TCU menu**

To display the TCU menu, simultaneously touch the left-hand and right-hand lower corner of the active display area in order to display the TCU menu.

If you have connected a USB PC keyboard to the OP 015 black, you can also display the TCU menu by simultaneously pressing keys F9 and F10.

**Gloves**

Do not wear thick gloves, such as work gloves, when operating the touch-sensitive glass surface. You can wear thin gloves made of cotton or gloves for touch-sensitive glass surfaces with capacitive touch function.

You can wear the following gloves for operating the touch-sensitive glass user interface of the operator panel:

- Dermatril L
- Camatril Velours Art. 730



- Uvex Profas Profi ENB 20A
- Comasec PU 900 (4342)
- Camapur Comfort Art. 619
- KCL Men at Work Art. 301
- Carex Art. 1505/k (leather)
- Cotton Cat. 1

---

**Note**

The gloves listed here are recommendations only. The type designations can change.

---

**Keylock**

E.g. it is advisable to use the keylock when cleaning the device:

- Activate the keylock by pressing the Caps lock key for at least five seconds, the LED flashes.
- Deactivate the keylock by pressing the Caps lock key again for at least five seconds.

The keylock can also be triggered by the software.

---

**Note**

The keylock only applies to the keys next to the display and not for the display touch.

---

**2.2.3 Keyboard****Keyboard**

Several keys and keypads are installed on the operator panel front:























- The alphabetic block contains the letters A - Z, the space character and the Caps lock key with keylock.
- The numeric block contains the digits 0 - 9, and the characters "/", "\*", "-", "+", "=" and ".".
- The cursor key group is used to navigate on the screen.
- The control key group includes special functions.

**Switching between upper and lower case**

Upper case is always activated as standard. To toggle between upper and lower case letters, press the Caps lock key.

**Overview of the key symbols**

The key symbols used on the operator panel front are shown below along with the corresponding function keys on the PC keyboard.

Key	Function corresponds to the PC key function	Key	Function corresponds to the PC key function
	Esc		End
	F11		Backspace
	F12		Tab
	Space		(only intended for internal keyboard changeover)
	Caps lock		Ctrl key
	Home		Alt key
	Page up		Delete
	Page down		Insert
	Cursor up		Enter
	Cursor left		5 (in numeric key group)
	Cursor right	A, ..., Z	<Shift> A, ..., Z
	Cursor down		

**Display**

Pixel error according to DIN EN ISO 9241-307, Error class II.

**2.2.4 Screen saver**

If an image with high contrast is displayed without change for longer than one hour, the dark-ON function must be activated for energy efficiency reasons.

The time can be adapted individually. Further information can be found at:  
Commissioning of Basic Software and Operating Software, SINUMERIK Operate (IM9)

## 2.3 Interfaces

The OP 015 black operator panel front has the following interfaces:

Interface name	Connector name	Speed	Permissible total length	Connector type
Ethernet interface	X202	1000 Mbps	Max. 100 m	8-pin RJ45 socket
Double USB interface 1	X203, X204	480 Mbps each	Max. 1.8 m	Double USB socket
24 V power supply	X206	-	max. 30 m	3-pin Combicon connector
USB interface 2	X213	480 Mbps	Max. 1.8 m	Single USB socket

### Rear

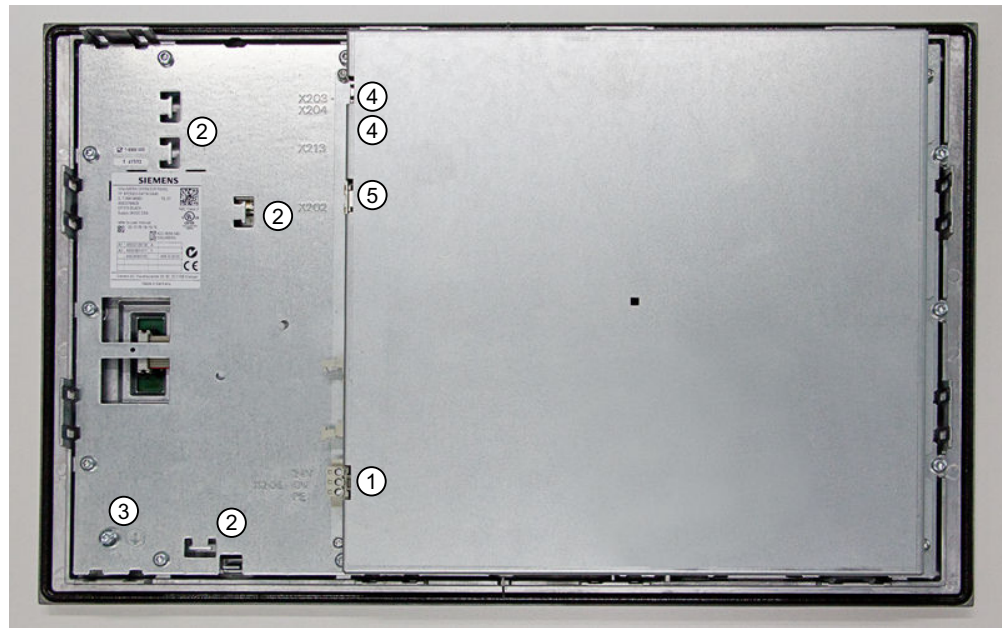

- ① X206 Power supply (with connector that can be screwed in place)
- ② - Strain relief for connecting cables
- ③ - M5 grounding screw (for screw connection with cable lug)
- ④ X203 / X 204 / X213 USB interfaces
- ⑤ X202 Ethernet interface

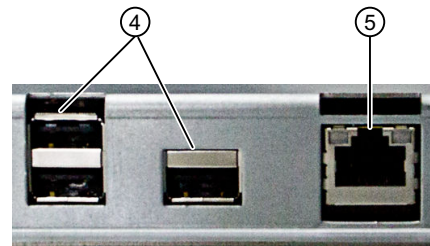

*2.3 Interfaces*

Figure 2-2 OP 015 black - rear with interfaces

**Pin assignment**

The pin assignments of the interfaces can be found in the Section "Connecting".

 **WARNING**

**Electric shock in the event of an individual error when grounding is insufficient**

If the panel is installed with inadequate grounding in an environment with hazardous voltages, this may cause an electric shock in the event of an individual error. This can result in death, serious injury and material damage.

Adequately ground the conductive parts of the panel in accordance with the nationally applicable regulations. When dimensioning the protective conductor connection, note the fuse ratings of the electrical circuits with hazardous voltages, which would have an effect in possible individual error scenarios.

 **WARNING**

**Unexpected machine movements caused by defective grounding**

A defective or non-existent ground connection can lead to malfunction of the touch screen. The malfunction can trigger an unexpected machine movement, or a machine movement can no longer be stopped.

Ground the touch screen with the shortest possible cable with a minimum conductor cross-section of 2.5 mm<sup>2</sup>.

 **WARNING**

**Parasitic voltage**

If the device is installed with inadequate insulation in an environment with higher/more hazardous voltages, parasitic voltages may occur. This can result in death, serious injury and material damage.

Insulate the cables appropriately for the highest voltage coming into consideration.

The safety of a system with an integrated operator panel front is the responsibility of the system installer.

The installation is performed in accordance with the installer's instructions.

Observe all the relevant information from this manual regarding installation.

Dimensions

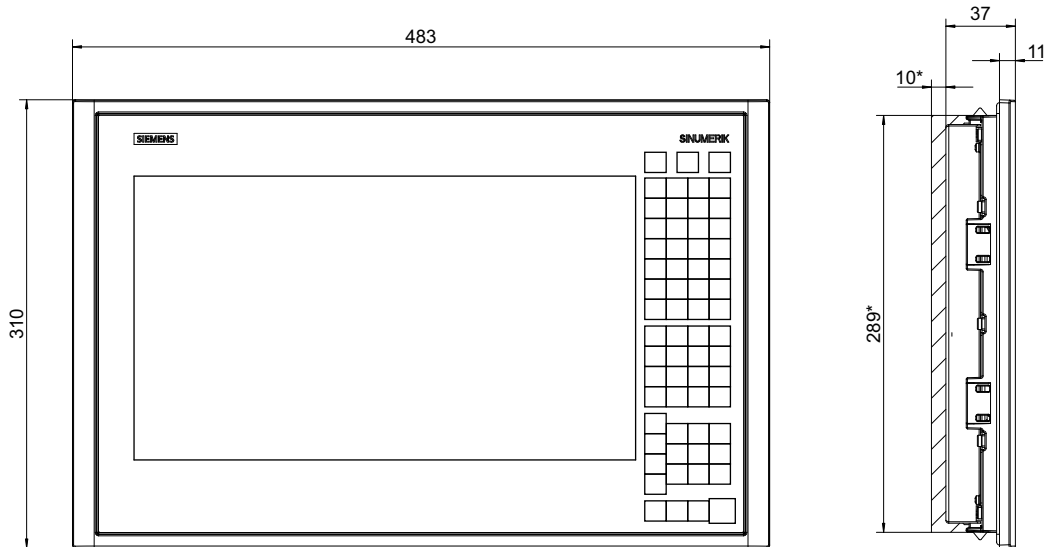

OP 015 black with TCU (integrated)  
 \* Clearance for cable and ventilation

Table 3-1 Dimensions of the mounting opening

Width (mm)	Height (mm)	Mounting depth + clearance (mm)
450	290	37 + 10

The OP 015 black is mounted using the tension jacks provided (2.5 mm profile; 20 mm long). When using the tension jacks, holes or threaded holes are not required.

This mounting method also enables the IP65/IP66 degree of protection if the mounting panel corresponds to the requirements specified in the dimension drawing. The seal (PU foam seal) to the mounting panel is already provided on the OP 015 black.

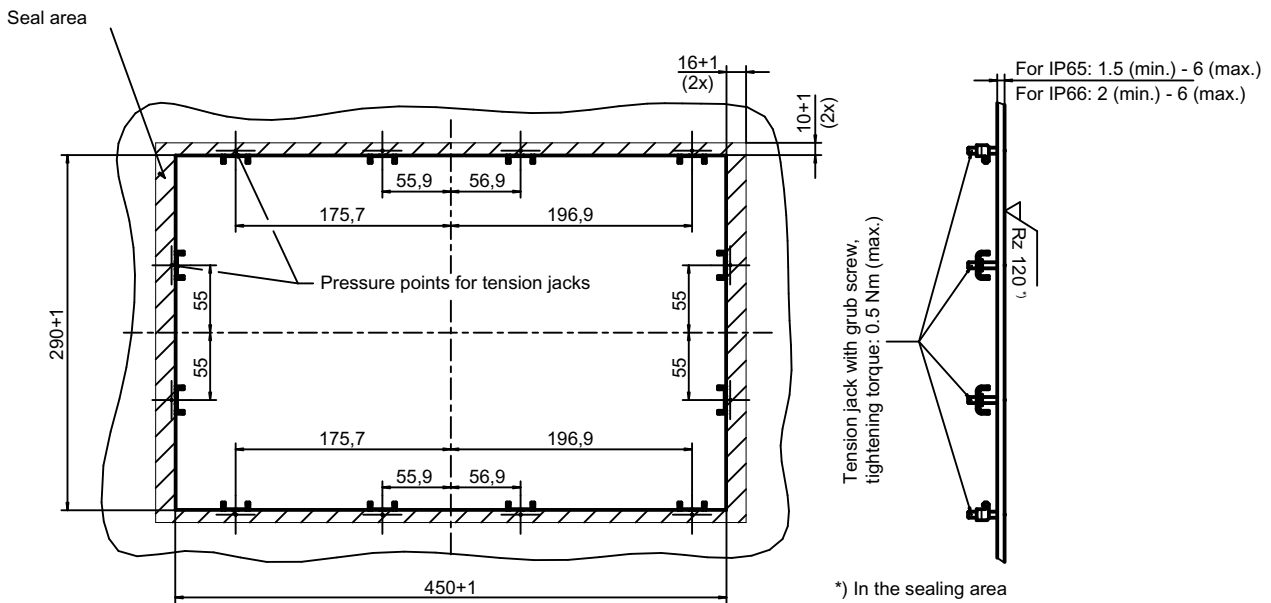

Figure 3-1 Dimension drawing for installing the OP 015 black operator panel front

### One person installation

You should also observe the data provided in Section "General information and networking" → "Application planning" → "Climatic and mechanical environmental conditions" → "Cooling".

#### NOTICE

##### Impermissible mounting positions can cause malfunctions

Observe the permissible mounting position: Deviating by up to 45° from the vertical.

#### NOTICE

##### Damage to the glass front

Do not use suction grippers to lift the glass front.

1. Insert the operator panel front in the panel cutout from the front.



Figure 3-2 Inserting the operator panel

**NOTICE**

**Damage to the sealing**

The seal must not be damaged when installing the device so that the maximum achievable degree of protection can be fulfilled. Therefore, insert the OP 015 black centered in the panel cutout.

2. Tilt and press the operator panel front into the panel cutout. The catches must be pressed down.



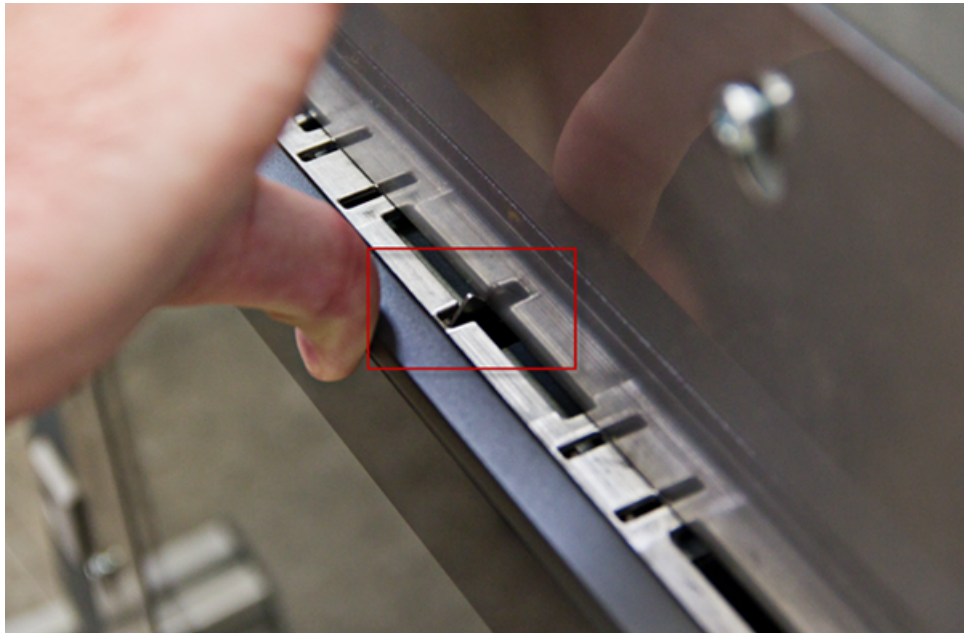

Figure 3-3 Tilting and pressing in

3. Make sure that the operator panel front sits firmly in the panel cutout and cannot fall out before you secure it at the rear with the tension jacks.
4. Secure the operator panel front in the panel cutout from the rear using the 12 tension jacks by tightening the setscrews (torque 0.4 - 0.5 Nm).



Figure 3-4 Tightening the tension jacks



## Connecting

### 4.1 Pin assignment of the interfaces

The pins of the component interfaces are assigned as specified in the tables below. Any deviations are indicated at the relevant point.

Signal type:

I	Input
O	Output
B	Bidirectional (inputs/outputs)
V	Power supply
-	Ground (reference potential) or N.C. (not connected)

#### Power supply X206

Connector designation:	X206
Connector type:	3-pin Combicon connector
Total cable length:	30 m

Pin	Name	Type	Meaning
1	P24 (+)	V/V/-	24 VDC potential (20.4 to 28.8 VDC)
2	M24 (-)		0 V
3	Functional earth		Connection for grounding the housing

#### X203, X204 and X213 USB interfaces

The USB interfaces are implemented as sockets and comply with the generally valid standard. The version information (1.1, 2.0 etc.), the maximum velocity (low speed, full speed, etc.) and the socket type (A or B) are documented in the individual sections for the associated devices.

4.1 Pin assignment of the interfaces

In principle, USB interfaces have the following characteristics:

- Integrated power supply up to 500 mA for each socket.
- Maximum cable length 3 m (Length including the supply cable to the hub and the connected terminal device; only 1 hub at maximum is permitted. It should be noted that some keyboards already have a hub.)

**NOTICE**

**Cables that are too long can cause the screen to freeze**

Observe the following restrictions for the USB front interface for connecting operator panels to the keyboard, mouse or USB FlashDrive:

- Maximum cable length: 1.8 m
- Extension cables are not permissible

- Hot-plugging-capable devices are connected during operation and are identified automatically.

**Note**

Correct identification is only guaranteed for USB I/Os that comply to 100% with the USB specification.

Table 4-1 Assignment of the USB interface

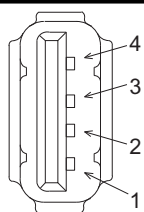
Type A socket	Pin	Name	Type	Remark
	1	P5V_fused	V	+ 5 V (fused)
	2	Data-	B	Data -
	3	Data+		Data +
	4	GND	V	Ground (reference potential)

**USB sticks**

If you want to connect a USB flash drive to the USB interface, you can use a USB flash drive of any memory size. It must, however, meet the following minimum requirements:

- File system: FAT16 or FAT32
- Partitioning: only in PC partition format (MBR)

USB sticks that deviate from these requirements have not been tested and may not be recognized by the NCU.

## Ethernet RJ45 interface X202

Connector type:	Standard RJ45 socket
Max. data transmission rate:	10/100/1000 Mbit/s
Max. cable length:	100 m

Table 4-2 Assignment of the Ethernet RJ45 interface 1000 Mbit/s

Connector	Pin	Name	Type	Remark	
	1	DA+	B	Bidirectional pair A+	
	2	DA-		Bidirectional pair A-	
	3	DB+		Bidirectional pair B+	
	4	DC+		Bidirectional pair C+	
	5	DC-		Bidirectional pair C-	
	6	DB-		Bidirectional pair B-	
	7	DD+		Bidirectional pair D+	
	8	DD-		Bidirectional pair D-	
	Shield	-		-	On connector housing
	-	Green LED (right)		-	Illuminated orange: 1000 Mbps Off: No or faulty connection
-	Orange LED (left)	-	Illuminated: Data exchange Off: No data exchange		

### Note

Connection is only possible on an LAN, not on telecommunication networks.

## I/O USB interface

All signals required for connecting operator panel fronts, with the exception of the display interface, are assigned to this interface.

Associated interface cable: K1  
 Connector type: 2 x 13-pin socket connector

4.1 Pin assignment of the interfaces

Table 4-3 Allocation of the I/O USB interface

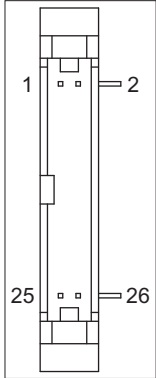
Connector	Pin	Name	Type	Meaning	
	1	GND	VO	Ground	
	2	P12C		+power supply for backlight inverter	
	3	BL_ON	O	Backlight On	
	4	P5V_fused	VO	+5 V VCC (fused in PCU/TCU)	
	5	GND	VO	Ground	
	6	P3V3_fused	VO	+3.3 V VCC (fused in PCU/TCU)	
	7 - 10	N.C.	-	Not connected	
	11	P5V_fused	VO	+5 V VCC (fused in PCU/TCU)	
	12	USB_D1M	B	USB data- Channel 1	
	13	USB_D1P		USB data+ Channel 1	
	14	GND	VO	Ground	
	15	LCD_SEL0	I	Display type select signal	1
	16	LCD_SEL1			2
	17	LCD_SEL2			3
	18	LCD_SEL3			4
	19	RESET_N		Reset signal (low active)	
	20	reserved	-	Reserved	
	21	HD_LED	O	HD LED, anode with 1 kΩ in series on the motherboard	
	22	DP_LED	O	MPI/DP LED, anode with 1 kΩ in series on the motherboard	
	23	Ethernet_LED	O	Ethernet LED, anode with 1 kΩ in series on the motherboard	
	24	TEMP_ERR	O	LED temperature sensor; anode with 1 kΩ in series on the board	
	25	RUN_R *)	O	Watchdog error LED, anode with 1 kΩ in series on the motherboard	
	26	RUN_G	O	Watchdog OK LED, anode with 1 kΩ in series on the motherboard	

LVDS display interface channel 1

Used to connect operator panel fronts with TFT displays with 640 x 480 pixels (VGA), 800 x 600 pixels (SVGA) or 1024 x 768 pixels (XGA).

Associated interface cable: K2, max. length: 0.5 m  
 Connector type: 2 x 10-pin socket connector

Table 4-4 Allocation of the LVDS display interface

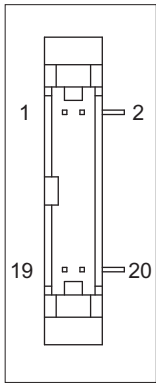
Connector	Pin	Name	Type	Meaning	
	1/2	P5V_D_fused	VO	+5 V display supply voltage (fused in PCU/TCU)	
	3	RXIN0-	I	LVDS input signal	Bit 0 (-)
	4	RXIN0+			Bit 0 (+)
	5/6	P3V3_D_fused	VO	+3.3 V display supply voltage (fused in PCU/TCU)	
	7	RXIN1-	I	LVDS input signal	Bit 1 (-)
	8	RXIN1+			Bit 1 (+)
	9/10	GND	-	System ground (reference potential)	
	11	RXIN2-	I	LVDS input signal	Bit 2 (-)
	12	RXIN2+			Bit 2 (+)
	13/14	GND	-	System ground (reference potential)	
	15	RXCLKIN-	O	LVDS cycle clock signal	(-)
	16	RXCLKIN+			(+)
	17/18	GND	-	System ground (reference potential)	
	19/20	N.C.	-	Not connected	

## Interfaces for direct keys

X11 on the operator panel (OP) fronts can be used to fetch the state of the direct keys. The connection of a 20-pin ribbon cable allows the direct keys to evaluate the following components:

- Direct key module (DTM)
- X70 in the machine control panels (MCP, MPP) and the handwheel connection module (HAM)
- X205 on the Thin Client Unit (TCU)

The signals are then forwarded to the control over the various communications networks. Note that DTM and HAM can be operated only with PROFIBUS DP.

4.1 Pin assignment of the interfaces

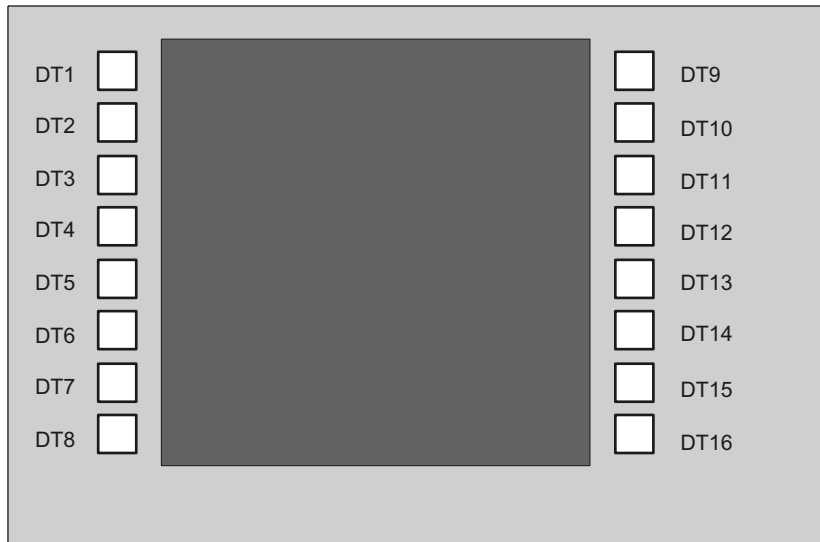

Figure 4-1 Assignment of the direct keys to the vertical softkeys of an operator panel front  
16 digital inputs (5 V) can be fetched via the X11 connector.

Connector designation: **X11**  
 Connector type: 20-pin plug connector  
 Max. cable length: 0.85 m

Table 4-5 Assignment of connector X11

Pin	Name	Type	Meaning
1	DT1	O	Direct key 1
...	...		...
16	DT16		Direct key 16
17	P5V	V	+ 5 V (fused)
18	P5V		+ 5 V (fused)
19	GND		Ground
20	GND		Ground

16 digital inputs can be polled by the X70/X205/DTM connector.

Connector designation: **X70/X205/DTM**  
 Connector type: 20-pin plug connector  
 Max. cable length: 0.85 m

Table 4-6 Assignment of connector X70 (MCP, MPP, HAM) / X205 (TCU) / DTM

Pin	Name	Type	Meaning
1	DT1	I <sup>1)</sup>	Direct key 1
...	...		...
16	DT16		Direct key 16



Pin	Name	Type	Meaning
17	P5V / CON1 <sup>2)</sup>	V	+ 5 V input voltage <sup>3)</sup>
18	P5V / CON2 <sup>2)</sup>		+ 5 V input voltage <sup>3)</sup>
19	GND		Ground
20	GND		Ground

<sup>1)</sup> The inputs are electrically isolated for MCP / MPP / HAM and DTM.

<sup>2)</sup> For the TCU, it is evaluated whether the direct keys have been connected.

<sup>3)</sup> Power consumption: 100 mA for MCP / MPP / HAM; 500 mA for DTM

Table 4-7 Signal level

HIGH level:	5 V or open
Low level	$\leq 0.8$ V

## 4.2 Handling membrane connectors

When replacing parts it can sometimes be necessary to disconnect membrane connectors from the boards and reconnect them again.

This should be done as follows:

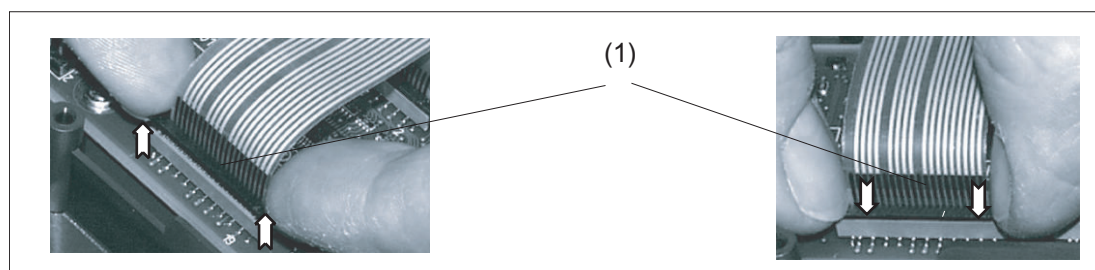

(1) Clamping frame of socket

Figure 4-2 Removing (left) and attaching (right) a membrane connector

### Unplugging the membrane connector

1. Loosen the dark clamping frame of the socket by pushing it up with your fingernails until it engages in its upper, unlocked position (Fig. left).
2. Carefully pull off the membrane connector upward.

### Plugging in the membrane connector

1. With the clamping frame in the upper position, carefully plug the membrane connector into the socket.
2. Lock it in place by pushing down the clamping frame (Figure right).



# Networking

## 5.1 System settings

### 5.1.1 Thin Client Unit (TCU)

#### TCU overview

The Thin Client Unit (TCU) for the distributed configuration permits spatial separation of the SINUMERIK operator panel front (OP/TP) and the SINUMERIK PCU/SIMATIC IPC or NCU. With SINUMERIK solution line, the TCU is used to visualize the user interface of the PCU 50, SIMATIC IPC for SINUMERIK with PCU basic software or NCU.

One TCU can be connected to multiple PCUs/IPC/NCUs. All TCUs and PCUs/IPC/NCUs that are connected to one other via a Gigabit switch form the "system network". The user interface of a PCU/IPC/NCU is copied to several OPs each with one TCU. This means that all TCUs display the same screen. Operator actions can only be performed on one TCU at a time. This TCU then has user authorization. The PCU can also have its own OP connected directly to it.

The classic operator panel fronts can be used with an IPC 427E if a TCU is available.

The following diagram shows a **configuration example** for a distributed topology:

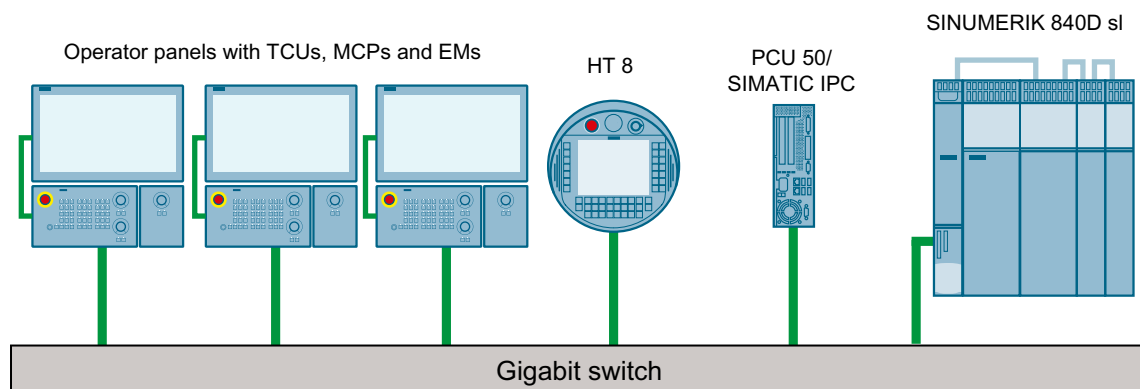

The mobile SINUMERIK HT 8 handheld terminal works on the thin client principle and combines the functions of an operator panel with a machine control panel.

The configuration and cabling of the whole system based on a permissible configuration is described in Section "Network configurations (Page 48)".

## Supplementary conditions

The following supplementary conditions apply for the operation of a TCU:

- In the system network, the number of **active** thin clients is limited:
  - A maximum of 2 TCUs: NCU 710.3 PN
  - A maximum of 4 TCUs: NCU 720.3 PN or NCU 730.3 PN
  - A maximum of 4 TCUs: PCU/IPC

Any number of TCUs can be operated in the system network.

- CompactFlash Cards cannot be used on the TCU.
- A 16 bit or 32 bit depth of color setting may be selected.
- If a PC keyboard is connected to the TCU, it is not possible to ensure that all special keys, e.g. multi-media keys, will be transferred to the software of the NCU/PCU/IPC.
- Machine control panels connected via a PROFIBUS network are not supported for switchover.
- Distributed memory media that are connected to the TCU via USB can be used.
- The TOP Panels must be networked on the basis of the Gigabit standard, e.g. Gigabit switch or Ethernet cable according to CAT 6 or higher.

### 5.1.2 Settings for SINUMERIK solution line

#### Fundamentals

The system network for SINUMERIK solution line is structured as a star topology with a central Ethernet switch, to which all Ethernet-based components of the system are connected.

For an NCU, the connection is via the X120 Ethernet socket, for an IPC/PCU, it is via the "Ethernet 2" or "X2" or "X2 P1" connection. There is no default for all other components with two Ethernet connections. These components have an internal 2-port switch and may be used to connect an additional operator component. Thus, in this case, there can be deviations from the strict star topology.

#### System network

In the system network, the IP address 192.168.214.xxx with subnet mask 255.255.255.0 is pre-selected. Here there is precisely one DHCP server with DNS that can run on one NCU or one PCU/IPC. The server ensures assignment of IP addresses to the Ethernet components in the system network (DHCP clients) from a specified address band.

The following rules apply for assignment of IP addresses in the system network:

- For all NCUs and/or PCUs/IPC, the commissioning engineer assigns fixed IP addresses in the associated address bands, as well as appropriate computer names (host names). All other operator components are automatically assigned an IP address by the DHCP server. Its name is generated automatically (for MCP, MPP, HT 8), or is entered at commissioning (TCU).
- If there are multiple NCUs, IPCs and/or PCUs in the system network, depending on the boot sequence, the system automatically specifies the DHCP server and automatically ensures synchronization of all necessary data, so that the next time the system boots any other NCU, IPC, or PCU could take on the role of DHCP server. However it is better to specify a DHCP master. This is an NCU, IPC, or PCU in the system network that is available on each system boot and which regularly takes over the task of the DHCP server and DNS server. Synchronization of data takes place in any event so that any other NCU, IPC, or PCU can take over this task, unless you deactivate this option in the DHCP configuration. All non-master NCUs/IPC/PCUs wait while the system boots for a preset time for the master to become available.

---

**Note**

In a system network or on a boot server, i.e. on the NCU, IPC, or PCU that accommodates the active DHCP server, a maximum of 30 operator stations may be operated simultaneously with the TCU.

A maximum of 10 operator stations with a TCU may connect up simultaneously with the same HMI application when powering up.

---

## Connection to a company network

Each NCU can be connected via X130, and each PCU/IPC can be connected via "Ethernet 1" to a company network. The company network is used to exchange operating software with servers or to execute part-programs directly from servers in the company network. Company network and system network should always be logically and also physically separated.

## Service interface X127

The service interface X127 of the NCU is used for direct connection of a PG/PC for service purposes. Here, access with STEP 7 to the PLC, and with NCU 7x0.3 PN also to PROFINET is possible.

With direct connection (peer-to-peer) of a PG/PC to X127 it is absolutely necessary that the PG is operated as a DHCP client.

### 5.1.3 System boot with system network

#### System behavior at boot

The system boot behavior is based on the following principle:

- For the configuration of an NCU 7x0 with a PCU/IPC, the default for a network configuration is as follows: The NCU keeps the default IP address 192.168.214.1 on X120, the PCU/IPC keeps the default IP address 192.168.214.241 on Eth2.
- For a configuration of more than one NCU 7x0 without PCU/IPC, with one or more PCUs/ IPCs, a distinction must be made between two cases:
  - All address conflicts and DHCP conflicts are resolved automatically when booting and the system is ready for operation. In this configuration there is **no** guarantee that all NCUs and PCUs/IPCs will always receive the same IP address at each system boot.
  - If the user requires all NCUs, and possibly also the PCU/IPC, to have a defined constant IP address at each boot, for example, because the IP address is stated explicitly in the PLC program, the user must configure a fixed IP address in the adapter settings in the Windows Control Panel for each affected NCU 7x0/PCU/IPC.
- You can specify a DHCP master in the basesys.ini file.
- Assigning names:
  - Assign meaningful names for all NCUs in the basesys.ini file otherwise the names will be generated automatically.
  - A PCU/IPC always has a computer name, which you can change if required.
- The IP addresses of the TCU, MCP/MPP, EKS, HT2, and HT8 are freely assigned within the specified address range on each boot. MCP/MPP, HT2, and HT8 are identified in the PLC via their DIP switch settings.

#### Using DNS name service

Availability of the DNS (Domain Name System) name service offers the following advantages for system network administration:

- The name service enables easier configuration with names instead of IP addresses for management of operating units: All components in the system network can be addressed via a symbolic computer name. This name can to some extent be freely assigned, to some extent it is derived automatically from a DIP switch setting (MCP, MPP, EKS, HT 8, HT 2).
- A computer node in the system network (NCU, PCU/IPC, TCU, MCP, HT 8, etc.) can be addressed solely through assignment of the IP address, either via a freely selectable name or via an internally generated name in the system network, and thus becomes independent from its network address in the system network. Thus a change in the network address does not necessarily necessitate a series of additional setting changes.
- In addition, the name service is used by the system for address resolution for MCP/MPP, direct keys, and EKS when changing the user authorization.

## 5.1.4 Factory default settings

Meaning of the symbols:

- Eth 1 as a DHCP client
- Eth 2 as a DHCP server
- Eth 2 with a fixed IP address

### Preconfiguration of the TCU

The TCU is configured as a DHCP client and primarily accepts IP addresses from SINUMERIK components, from the DHCP server of such components that are inherent to SINUMERIK, for example, an NCU at X120 or a PCU/IPC on the system network or from a standard DHCP server. The behavior of the TCU cannot be changed here.

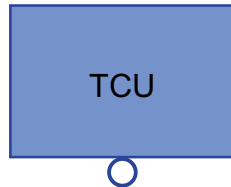

A TCU is a SINUMERIK DHCP client.  
The TCU has a single Ethernet connection.

A TCU executes a boot via the network. The boot server is the computer node from which the TCU also obtains its IP address.

### Pre-configuration of the PCU

A PCU has two Ethernet interfaces with default settings for use with SINUMERIK solution line:

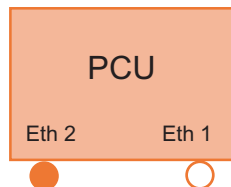

Eth 1 is pre-selected as a default DHCP client for connection to a company network.

Eth 2 is pre-selected as a SINUMERIK DHCP server for connection to a system network. On Eth 2 the fixed IP address 192.168.214.241 is pre-selected.

### Preconfiguration of the IPC

An IPC has two Ethernet interfaces with default settings for use with SINUMERIK solution line:

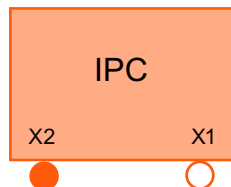

X1 is preset as the standard DHCP client for connection to a company network.

X2 is preset as a SINUMERIK DHCP server for connection to a system network. The fixed IP address 192.168.214.241 is preset on X2.

## Preconfiguration of the NCU

On the X120, the NCU is preconfigured for the SINUMERIK DHCP protocol. The NCU is pre-selected here as a SINUMERIK DHCP server. On X120, the NCU occupies the fixed IP address 192.168.214.1 with the subnet mask 255.255.255.0 in its capacity as a DHCP server. The DHCP server of the NCU assigns IP addresses from the range 192.168.214.10 – 192.168.214.239 to the DHCP clients.

It is also possible to make the NCU a DHCP client. The configured IP address in basesys.ini is a "requested" IP address, which is rejected in the case of an address conflict and replaced by a dynamic IP from the address range.

In large system networks, it makes sense to set an NCU/PCU/IPC as the DHCP master. If an additional 2-3 hosts are used (NCU/PCU/IPC), the user sets the DHCP priority to "ON\_HIGH". For the other hosts, the user sets DHCP priority to "ON\_CLIENT\_SYNC" or "ON\_CLIENT\_NO\_SYNC".

Restricting the available address band that is managed by the DHCP server of the NCU frees up IP addresses 192.168.214.2 to 192.168.214.9 as well as addresses 192.168.214.241 to 192.168.214.254 for network nodes with fixed IP addresses.

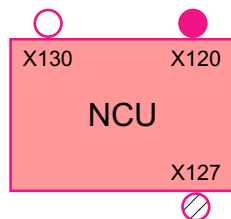

The NCU has three Ethernet connections:

- X120 to connect to the system network with an active DHCP server (Eth 0)
- X130 to connect to the company network as the standard DHCP client (Eth 1)
- X127 as a service connection with an active DHCP server (Ibn 0)

On X130, the NCU is set as a default DHCP client for the address reference from a company network. The IP address received here is specified by the DHCP server from the company network.

On X127, an NCU is a standard DHCP server in contrast to the SINUMERIK DHCP server. On X127, the NCU has the fixed IP address 192.168.215.1 with the subnet mask 255.255.255.224 as Service input. The IP addresses 192.168.215.2 – 192.168.215.23 are dynamically assigned to the DHCP clients. The range 192.168.215.24 - 192.168.215.30 is reserved, and can be used by stations on the network with a fixed IP address, e.g. by a modem.



## IP address ranges reserved for NCU and PCU/IPC

The following defaults apply on delivery:

- Connection to the system network with subnet mask 255.255.255.0:

IP address	Network station	Remark
192.168.214.1	NCU on X120	Default
192.168.214.2 – 9	For additional NCUs with a fixed IP address on the system network	Not assigned
192.168.214.10 – 239	For additional TCUs, later for additional PCUs, IPCs, NCUs, MCPs, MPPs	DHCP clients
192.168.214.240	Reserved for EKS (Electronic Key System)	Default
192.168.214.241	Fixed IP address of PCU/IPC on Eth 2	Default
192.168.214.242 – 249	For additional PCUs/IPCs with a fixed IP address	Not assigned
192.168.214.250 – 254	For PGs with a fixed IP address (Service connection)	Not assigned

- Service connection with subnet mask 255.255.255.224:







IP address	Network station	Remark
192.168.215.1	NCU on X127	Default
192.168.215.2 – 23	For service purposes with PG, PC	DHCP clients
192.168.215.24 – 30	Fixed IP address, e.g. for a modem	Not assigned



## 5.2 Commissioning TCU

### 5.2.1 Key assignment

#### Key assignment

Functions of the keys and softkeys in the "Operator panel service system":

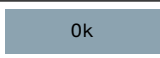
Softkey	Key on OP	External key-board	Description
	HSK1	<F1>	Moves the cursor down a row
	HSK2	<F2>	Moves the cursor up a row
Page 	HSK3	<F3>	Moves the cursor down a page
Page 	HSK4	<F4>	Moves the cursor up a page
Char 	HSK5	<F5>	Inserts text or digits
Char 	HSK6	<F6>	Inserts text or digits

Softkey	Key on OP	External key-board	Description
	VSK7	←	Cancel / Return
	VSK8	→	OK / Confirm
---		Pos1	Moves the cursor to the top row
---		End	Moves the cursor to the bottom row

Exceptions to the above are mainly the result of input fields. Where these are present, the left/right cursor keys move the input cursor rather than performing an OK/cancel function. The Return key takes you to the next field (like the "down" key) rather than closing the entire dialog with OK. There are also Backspace (deletes character to the left) and Delete (deletes character to the right) keys for editing text and numbers. The F5, F6, Backspace, Delete, and Select keys (between the cursor keys) can be used to switch between Yes/No fields.

#### Note

##### Special function for Touch Panels without additional keys

Letters and numbers in input fields can be edited with HSK5/HSK6, which switch one character forward or backward. With a touch screen, you can activate all the softkeys and even select rows in a menu simply by touching them.

For operator panel fronts without keys, a virtual keyboard automatically appears.

## 5.2.2 Settings in the "TCU.ini" file

### Directories

The tcu.ini file is created in the following directories:

#### NCU:

../siemens/system/etc/tcu.ini

../user/system/etc/tcu.ini

../oem/system/etc/tcu.ini

#### PCU/IPC (Windows 7 and Windows 10):

C:\ProgramData\Siemens\MotionControl\siemens\System\etc\tcu.ini

C:\ProgramData\Siemens\MotionControl\user\System\etc\tcu.ini

---

C:\ProgramData\Siemens\MotionControl\oem\System\etc\tcu.ini

---

### Note

The following entries are evaluated by SINUMERIK Operate:

- VNCServer/VetoMode
  - VNCServer/AlarmBoxTimeOut
  - VNCServer/FocusTimeout
  - VNCServer/AdaptResolution
  - VNCServer/MaxActiveTCUs
  - VNCViewer/ExternalViewerSecurityPolicy
- 

## Restrictions

Restrictions for such external operator control units are:

- Neither MCP and direct keys nor an EKS system can be assigned. This also means that these devices cannot be activated to be an operator control unit in the system.
- Direct keys cannot be triggered, i.e. the softkeys to the direct keys can be triggered in the operating software. However, the keys do not appear in the direct key image to the PLC.
- There is no config.ini configuration file, as for a TCU, i.e. a configuration for a TCU is not possible for such an operator control unit (power-up behavior, displacement, t:m:n); however, the displacement mechanism on the external operator control units is effective.
- An external operator control unit is never signaled as active operator station in the PLC.

Configuring the external operator control units in the tcu.ini file in section:

```
[externalTcu]
# EXTERNAL TCU IP-ADDRESSES
# List of accepted TCUs in IP-V4-format (index 1 to maximal 16)
ExternalTcuIP_1=
```

You can also set the desired screen resolution in the tcu.ini file:

```
[VNCServer]
Resolution = ...
```

### 5.2.3 Displacement mechanism for TCUs

To operate a machine with more operating stations than the maximum number, the displacement mechanism ensures that **only the permitted number of TCUs are active** in a shadowing group. The remaining TCUs are switched to passive mode, which means they no longer represent a load with regard to the resources. Thus the number of TCUs that can be connected to one HMI application is practically no longer limited. The limitation is the number of concurrently active TCUs.

### Supplementary conditions

The following supplementary conditions apply when operating the TCU:

2 active TCU connected in parallel to NCU 710.3 PN

4 active TCU connected in parallel to NCU 720.3 PN, NCU 730.3 PN

4 active TCUs connected in parallel to PCU/IPC

### Displacement rules

You configure the displacement mechanism in SINUMERIK Operate in the "Setup" operating area > menu forward key > "OPs" softkey for the respective operator panel.

The TCU can assume the following states:

- **The TCU is active and has user authorization:** This can be identified as the TCU shows the screen of the operating software and the screen is bright.
- **The TCU is active,** is in the monitoring mode and has no user authorization: This can be identified as the TCU shows the screen of the operating software, however, it is darkened in comparison to the TCU with user authorization.
- **The TCU is passive:** The TCU shows the selection menu of the possible connections instead of a screen of the operating software, and the softkey for selection of the last active connection of the TCU is shown in color.

When powering up, the TCU always attempts to establish the first connection. The TCUs from a shadowing group establish their specified connection one after the other as long as the maximum number of permissible active operator units is not exceeded.

If a TCU encounters the situation that this number is already reached in its power up, then it attempts to obtain a connection via the displacement mechanism. If it can displace a formerly active operator unit then it takes on the active status itself, otherwise it transitions to passive status immediately after booting.

## 5.2.4 Disable switchover between TCU via PLC

### Overview

The TCU switchover disable offers the option of dynamically disabling switchover from one TCU to the next when the system is running via the PLC. For the duration of the disable, a user authorization request to change user authorizations between TCUs will be ignored by the system and rejected.

The rejected user authorization request causes a message to be output in the dialog line of the HMI, in the form of a feedback message for the requester. The message disappears after five seconds.

## HMI ↔ PLC data interface

The "switchover disable" function is always active and does not have to be switched on explicitly. The function is controlled by a data bit in the PLC. The HMI transfers the active OP to the PLC, thus forming the basis of the control function in the PLC.

The control bits and control information for this function are stored in the m:n data interface of the PLC. In terms of m:n, this function can be operated separately for the currently overridden HMIs in both m:n online interfaces (DB19.DBW120 ff for HMI1 and DB19.DBW130 ff for HMI2). If a system is not running an m:n, only the first m:n online interface is used for this function.

Switchover disable is controlled by a TCU\_SHIFT\_LOCK bit, managed by the user, on each HMI in the PLC. The bit address for the first HMI is DB19.DBB126.6 and DB19.DBB136.6 for the second HMI.

The PLC m:n online interface is expanded so that byte DB19.DBB118 is also assigned to the first interface and byte DB19.DBB119 to the second. These bytes acquire the index of the active TCU/OP for the appropriate HMI. The byte is called TCU\_INDEX. The appropriate HMI uses the TCU index configured for the active TCU to describe the TCU\_INDEX byte.

The TCU\_SHIFT\_LOCK bit is monitored by the appropriate HMI. A value = 1 triggers the switchover disable. Switchover is enabled if the value returns to 0. The TCU\_SHIFT\_LOCK bit can be set, for example, to the PLC by the user pressing a key or it can be managed by the PLC user program according to its own logic. The TCU\_SHIFT\_LOCK bit is managed in the PLC exclusively by the user; the HMI only accesses this bit in read-only mode.

The HMI assigns the TCU\_INDEX field with the configured index to the TCU or PCU/IPC with an OP that currently possesses user authorization in the shadow group. If no OP is active, a value of 0 is entered in TCU\_INDEX.

If no TCU index is configured for the active TCU/OP, the value 255 = undefined is transferred as a TCU index. This means that the values 0 and 255 may not be configured as the TCU index.

## Configuration

The TCU index is configured on the PCU/IPC in the same way as a machine control panel address (MCP address). The TCU index is set in the "OP Properties" dialog of the "System Network Center" program.

## Operating principle

If the TCU\_SHIFT\_LOCK bit is set for switchover disable, a user authorization request is not carried out independently of the mode set on the HMI for allocation of user authorizations (veto mode), i.e. a change of user authorization is rejected.

This message appears on all OPs for approximately 5 seconds:

```
"No switchover: Switchover disable set in current PLC."
```

While this message is displayed, operations on the OP with the user authorization can still be carried out unaffected.

---

**Note****Active switching of an OP to another PCU/IPC is possible**

The switchover disable only relates to changing the user authorization on the OPs in a shadowing group on a PCU/IPC.

**This means that active switching away from one OP to another PCU/IPC is not prevented.**

---

## Special features

The following special cases should be noted:

- Even if switchover disable is set, the TCU\_INDEX field value may change in the PLC. This is the case under the following circumstances:
  - If the OP in possession of the user authorization is actively switched to another PCU/IPC. Depending on whether another TCU takes over the user authorization or whether no TCU is currently active, the index of the TCU or the PCU/IPC itself (if its directly connected OP becomes active) is entered, in exactly the same way as when there is a switchover of user authorization. This can also be the value 255, if no TCU index is available for the OP. 0 is entered if an OP is no longer available in the shadow group.
  - If an m:n switchover is in progress. The HMI program of the incoming PCU/IPC deactivates the HMI program which is active on it. Therefore, an OP from the shadow group of the new (incoming) PCU/IPC must receive the user authorization. The TCU index of this OP is entered in the TCU\_INDEX field.
  - If a PCU/IPC is disconnected from an NCK/PLC in the context of m:n. No HMI program and, therefore, no OP with user authorization is then available on the exited NCK/PLC. This is signaled independently of a switchover disable by entering the value 0 into the TCU\_INDEX field.
- If a TCU is actively switched over to another PCU/IPC, it can be deactivated there, i.e. it does not receive user authorization if a switchover disable is set for the destination PCU/IPC.
- With an m:n PCU/IPC switchover – the PCU/IPC is switched to another NCK and, therefore, to another PLC – the PCU/IPC accepts the switchover disable settings of that PLC.
- The m:n interlock options on the PLC side have priority over the TCU switchover disable, so that a set TCU switchover disable cannot prevent an m:n switchover. If necessary, the m:n interference options should be synchronized here with those for the TCU in the PLC. It may, for example, be practical to set or remove the m:n displacement disable simultaneously with the TCU switchover disable.

## Obtaining user authorization

At a TCU, which has no user authorization, press any key. The operating software does not evaluate this key; this only serves to request user authorization.

The settings for the right to veto are stored in file tcu.ini and are only effective if the operating software is installed on the PCU/IPC. You can use the operating software on the OP or TCU in the same way as on an OP connected directly to the PCU/IPC.

## 5.2.5 Example: How to select the behavior of the TCUs during boot up

### Example: Distributing boot support across two PCUs/IPCs

Make the following settings to distribute the boot support across two PCUs/IPCs:

- On PCU\_1/IPC\_1, select "Boot support runtime and configuration only (TFTP/FTP)"
- On PCU\_2/IPC\_2, select "Boot support IP address only (DHCP)"
- On PCU\_3/IPC\_3, select the configuration "No boot support"

TCU_1	TCU_2	TCU_3	TCU_4
192.168.214.10	192.168.214.11	192.168.214.12	192.168.214.13
<b>VNC connections:</b> 192.168.214.241 192.168.214.242 192.168.214.243	<b>VNC connections:</b> 192.168.214.241 192.168.214.243	<b>VNC connections:</b> 192.168.214.241 192.168.214.243	<b>VNC connections:</b> 192.168.214.241 192.168.214.242
Switch to system network			
PCU_1/IPC_1	PCU_2/IPC_2	PCU_3/IPC_3	
192.168.214.241	192.168.214.242	192.168.214.243	
Services: X DHCP ✓ TFTP ✓ FTP ✓ VNC	Services: ✓ DHCP X TFTP X FTP ✓ VNC	Services: X DHCP X TFTP X FTP ✓ VNC	
Company network			

In this case, PCU\_2/IPC\_2 serves as the DHCP server which provides the IP addresses for the connected TCUs. PCU\_3/IPC\_3 is not involved in booting the TCUs, it is however displayed by the TCUs using VNC.

## 5.3 Network configuration

### 5.3.1 Permissible network topologies

#### Ethernet connection

A SINUMERIK 840 D sl can only be operated as a network within which the individual components communicate with one another via Ethernet connections. This network must be set up.

The individual components are factory-set so that the most frequently occurring standard configurations can be operated without changing the settings related to the network.

#### Division into system network and company network

On the SINUMERIK solution line, the components are generally split into a company network on the one hand and a system network on the other.

The connection to the company network provides access to the network drives, for example. On the system network, process data communication and image transmission runs from the components with operator software to the display units of the respective TCU.

This separation is performed via the following specified use of the Ethernet interfaces on the components:

- A TCU is connected exclusively to the system network.
- An NCU is always connected to the system network via X120.
- Ethernet interface Eth 2/X2 of the PCU/IPC is preconfigured for connection to the system network; while Ethernet interface Eth 1/X1 is used for connection to the company network.
- An NCU is connected to the company network via X130.

Meaning of the connections:

- Eth 1/X1 as DHCP client
  - Eth 2/X2 as DHCP server
  - Eth 2/X2 with fixed IP address
- Green connection      Uncrossed Ethernet cable  
Gray connection      Crossed Ethernet cable (crossover)



## 5.3.2 Networks without connection to the company network

### 5.3.2.1 Configuration 1: NCU and TCU

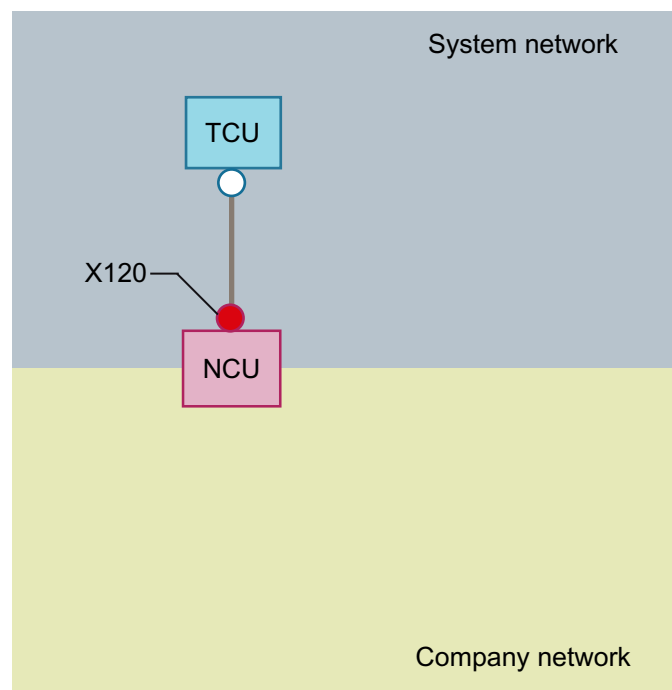

A direct Ethernet connection is used to connect a TCU to X120 of the NCU. NCU and TCU are suitably preconfigured with IP addresses.

The IP addresses are not significant for further operation.

The TCU is connected to the NCU via a **crossed** Ethernet cable.

The direct connection of the NCU via X120 to the TCU automatically establishes a simple system network consisting of two computer nodes.

### 5.3.3 Networks with NCU connection to the company network

#### 5.3.3.1 Configuration 2: NCU and TCU

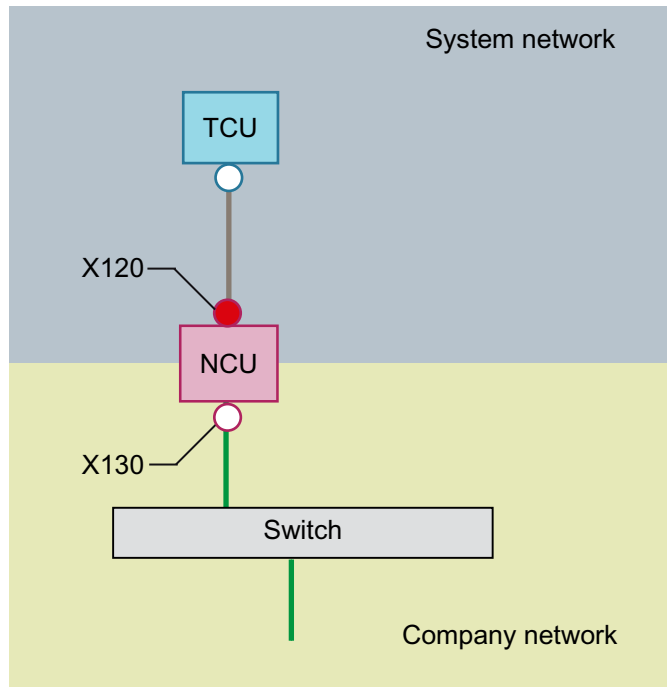

The TCU is directly connected to the NCU via a **crossed** Ethernet cable. On X120, the NCU is connected to a switch to the company network with a straight cable.

As in configuration 1, there is a direct Ethernet connection between a TCU and X120 of the NCU. NCU and TCU are suitably preconfigured with IP addresses. The IP addresses used here are not significant for further operation.

#### IP configuration: DHCP server on the company network

On the X130, the NCU is set to the address reference via DHCP. If the company network has a DHCP server that provides the NCU with an IP address/configuration, the NCU is integrated in the company network.

Depending on the infrastructure available or the level of network administration of the company network, the following network parameters must be set for the NCU on X130:

- Computer name on the company network
- The address of a DNS server
- The address of a gateway (default router)

The IP address of the NCU on this connection is also assigned via the network administration.

If the company network offers a low level of administration, in the worst case scenario the network has only one DHCP server that assigns the addresses from a predefined address range, the NCU receives an IP address that is initially unknown.

## 5.3.3.2 Configuration 3: PCU/IPC with TCU on NCU

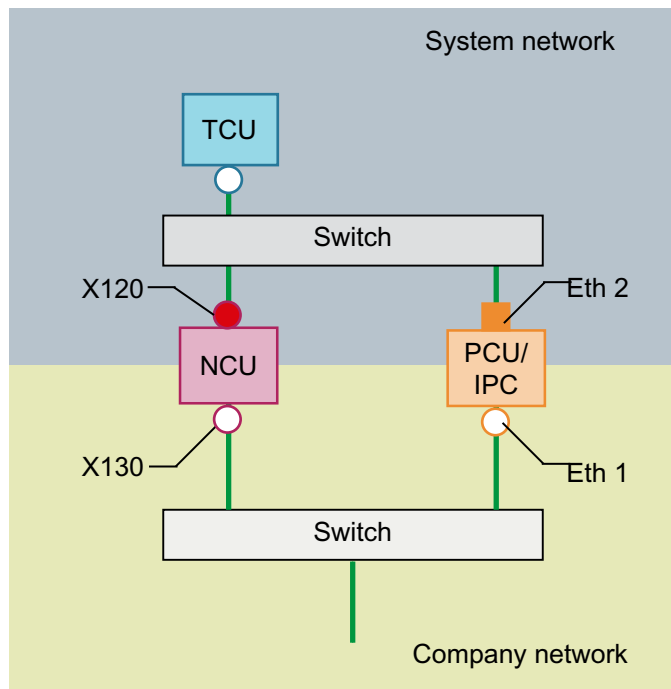

In this configuration, a switch is also required for the system network. All components are connected using straight Ethernet cables.

On X120, the NCU occupies the fixed IP address 192.168.214.1 in its capacity as a DHCP server (not used in this configuration). For this configuration on Eth 2, the PCU/IPC is assigned a static IP address in the range 192.168.214.241 – 192.168.214.249 with a subnet mask 255.255.255.0. The DHCP server of the NCU supplies the TCU with an IP address and serves as a boot server for the TCU.

The observations made for configuration 2 apply here with regard to the connection to the company network. The connection to a switch on the company network is made via a **patch cable** for Ethernet.

To connect one TCU to both HMI systems you must create an additional connection to the NCU for the TCU.

### 5.3.3.3 Connecting the programming device (PG) to the NCU

#### Description

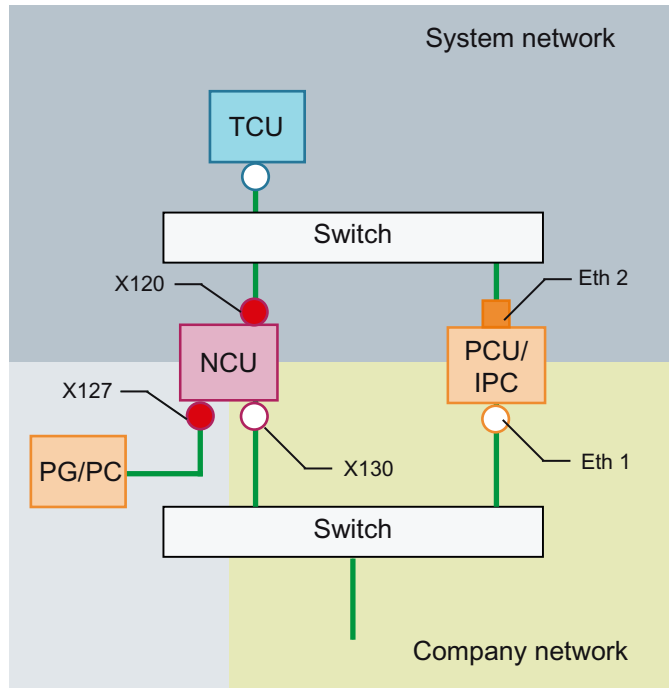

For service purposes a programming device is connected to the NCU at X127 as a standard DHCP client (automatically obtain an IP address). An NCU is a standard DHCP server on X127. On X127, the NCU occupies the fixed IP address 192.168.215.1 with the subnet mask 255.255.255.224.

At X127, IP addresses from 192.168.215.2 onwards are assigned via DHCP; e.g. to connect a programming device. This is the reason that a fixed IP address must not be set at the programming device.

### 5.3.4 Example: Configuring a VNC connection to a PC

#### Requirements

In order to use a TCU to get visual access to a computer from a SINUMERIK system via VNC, the following requirements apply:

- The VNC connections should be configured in the HMI.
- The boot server (active DHCP server) in the system network must be an NCU.
- This NCU must be integrated via X130 or X120, i.e. in the network that contains the computer to be monitored.

- The computer to be monitored must be configured in the config.ini configuration file of the TCU according to the general configuration for a TCU in a separate host section as a switchover target for this TCU.  
Where necessary, a password has to be specified in the configuration, if the VNC server requires one on the target system (see below).
- To ensure that the TCU recognizes the new switchover target, the TCU requires a restart and reboot.
- The screen resolution of the observed computer must be adjusted to the characteristics of the TCU. Otherwise the TCU scales the image it receives to match the display area available to the TCU, which impairs the quality of the display on the TCU.

## Configuration

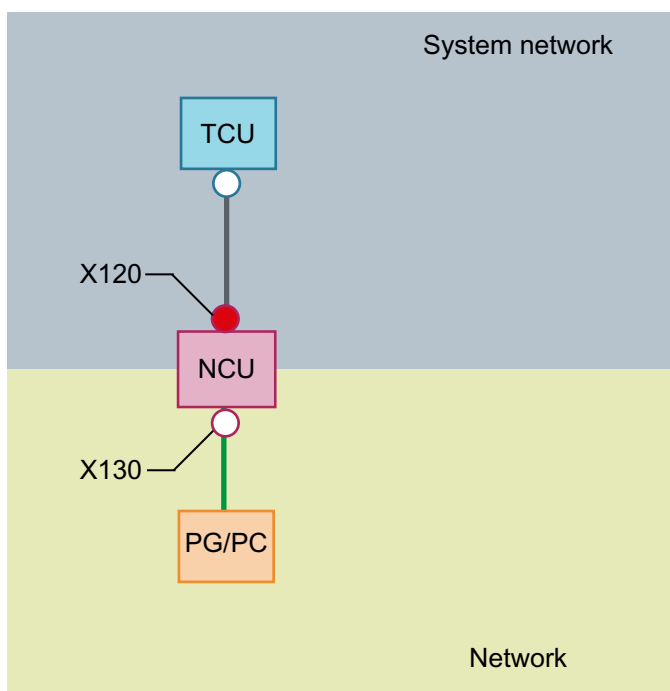

Figure 5-1 Configuration example

## Configuration

The config.ini file is located in the following directory:

NCU:

```
/user/common/tcu/<TCU name>/common/tcu
```

PCU/IPC (Windows 7 and Windows 10):

```
C:\ProgramData\Siemens\MotionControl\user\common\tcu\<TCU name>\common\tcu
```

The config.ini file must be stored on the boot server (active DHCP).

**Example:**

```
[Station]
maxhostindex=2          /* Number of nodes that are defined under
                        [host_1] and [host_2].

mcpIndex=192
tcuIndex=1
eksIndex=0
[host_1]
Address=192.168.214.1   /* Address of the NCU to which the
                        connection is established during booting.

[host_2]
Address=157.163.230.202 /* Address of the PC
password=123456         /* Password of the VNC server on the PC
```

**Switching over between the nodes**



With the menu back key + MENU SELECT, the following actions are triggered:

- The TCU name is displayed in the header of the displayed window, e.g. TCU1.
- A selection list for connecting to the other nodes is displayed on the TCU.

## 5.4 Service and diagnostics

### 5.4.1 Using the TCU's main menu

**"Main menu"**



The "Main menu (TCU1)" dialog is started with the menu back key and the <MENU SELECT> key:

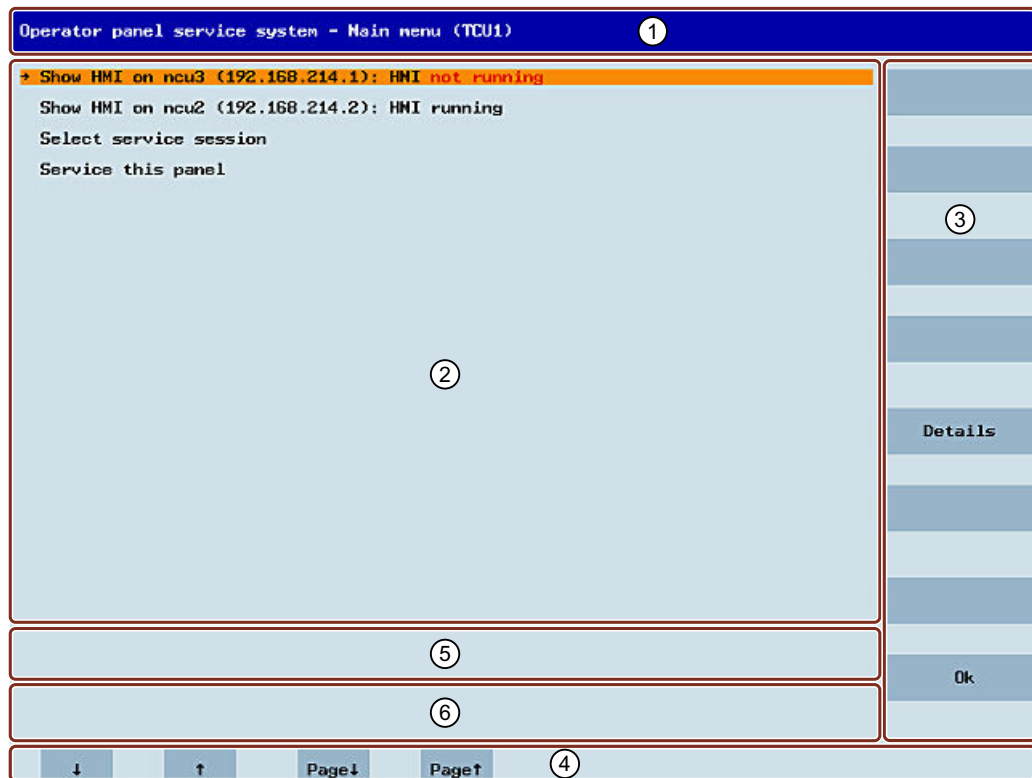

- ① "Main menu" title followed by the TCU name in brackets
- ② Central area with the list of servers and two further permanent items, "Select service session" and "Service this panel":
  - "Select service session" triggers a server scan which detects all the VNC servers in the local system network. These are then displayed in a session menu which largely reflects the main menu.
  - "Service this panel" opens the "Service menu for operator panel" submenu.
- ③ Eight vertical softkeys for use depending on the context
- ④ Four horizontal softkeys for navigating with the cursor
- ⑤ Message line whose content can be set via HWS commands from the servers
- ⑥ Error line in which error messages as well as transient status messages are output

Figure 5-2 TCU menu: Main menu

"Details" softkey

The following connection data for the selected device appears when the "Details" softkey is pressed:

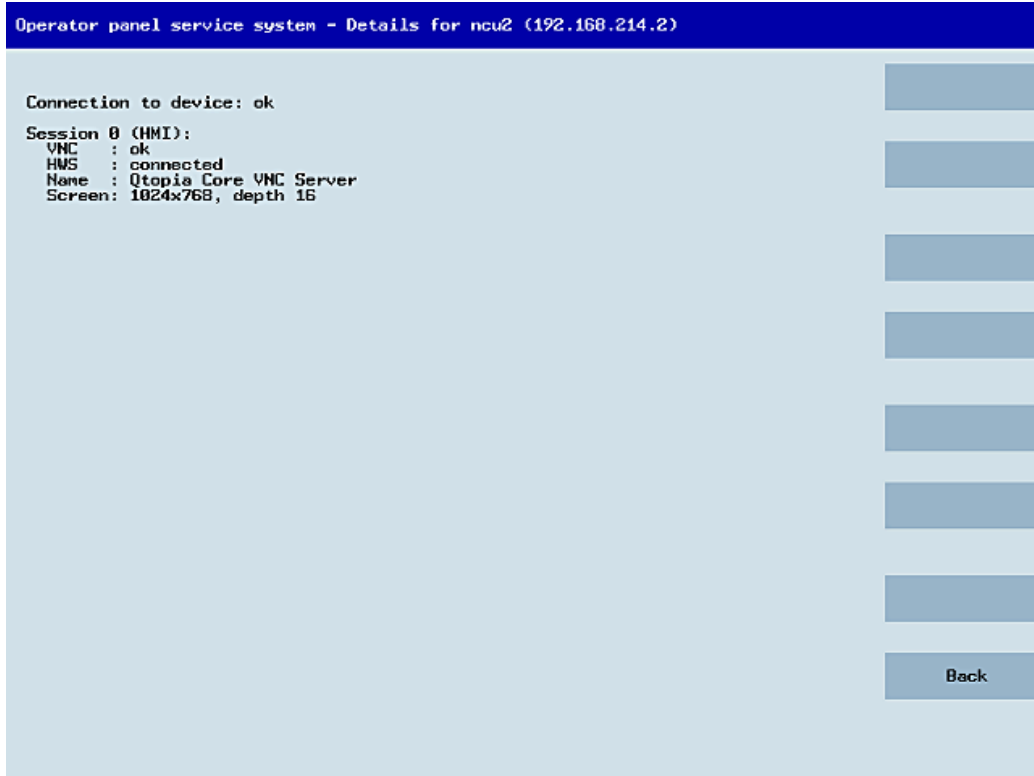

Figure 5-3 TCU menu: Connection data



## 5.4.2 Operating the TCU menu "Service sessions"

### "Service sessions" dialog

When "Select service session" is selected from the main menu, the resulting process begins by triggering a server scan:

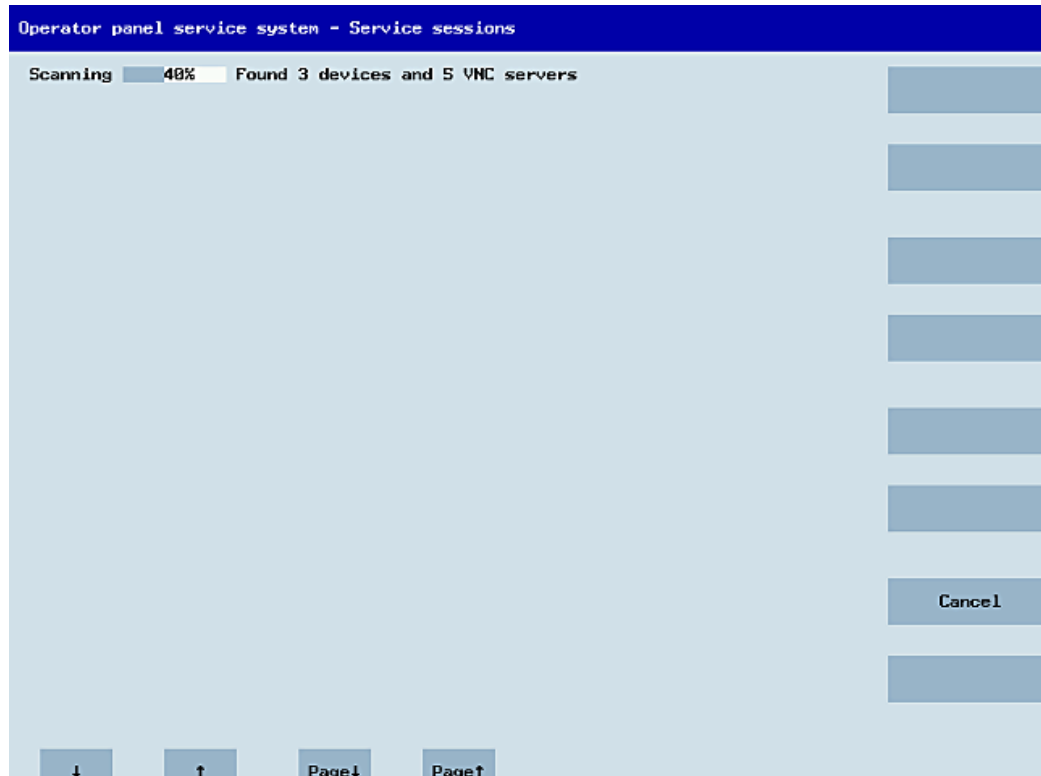

Figure 5-4 TCU menu: Scanning

After this, the following dialog appears:

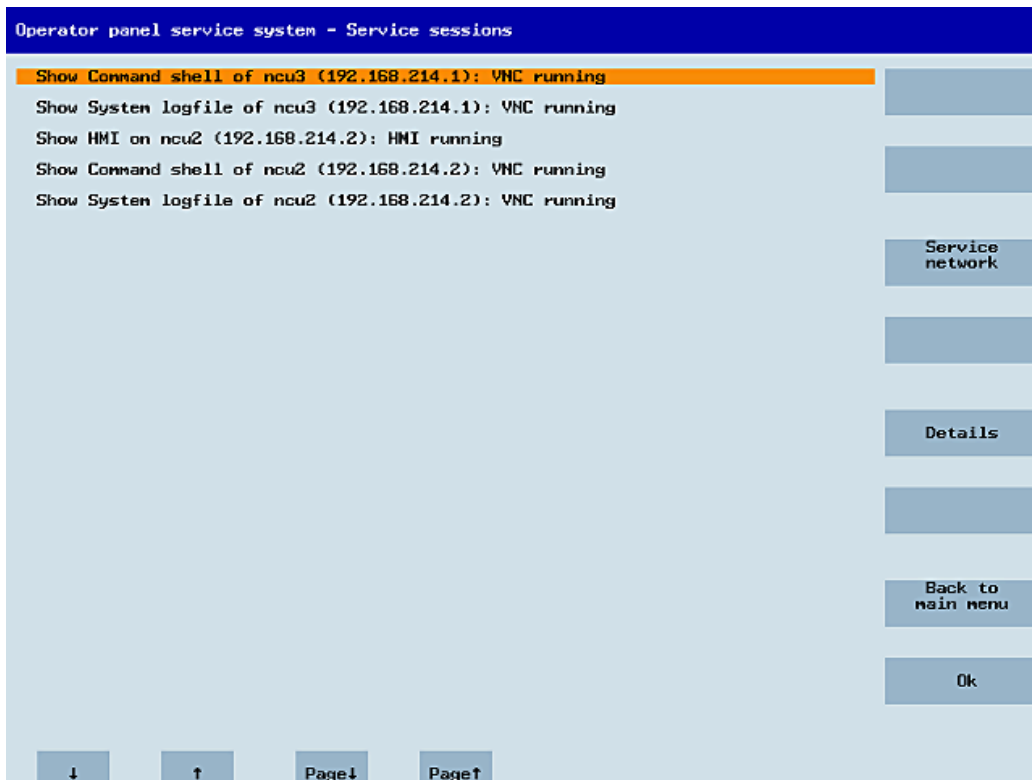

Figure 5-5 TCU menu: Active sessions

**Central area with the server list:**

The individual server lines contain either "Show WHAT on NAME (IP)" or the IP address only where the name is unknown.

Session number	VNC server
Session 0	HMI
Session 4	Command shell
Session 5	System logfile
Session 6	System Network Center (SNC)
...	
Session <N>	Other servers

These details are followed by a status message regarding the accessibility of the VNC server.

- "Connection not ok" appears if it is already impossible to access the server from the IP side (if switched off, for example).
- "HMI running/ not running", if an HMI VNC server is accessible.

The VSK8, Return or right cursor keys can be used to launch a VNC viewer for the selected server.

**Connection status:**

Further details on the connection status can be called with the "Details" softkey. In the next dialog, "not ok" or "not running" are accompanied by an additional error message with more

precise details on the reason for the loss of function. With more favorable scenarios, the session name for the VNC server will also be specified along with its resolution.

The connection and HMI status are monitored on a regular basis in the background. This may mean that these specifications change spontaneously if a change is made on the relevant server, e.g. it may be switched off, the HMI may become available, etc.

### 5.4.3 Operating the TCU menu "Service menu"

#### "Service menu for operator panel (TCU)" dialog

The following dialog appears when "Service this panel" is selected from the main menu:

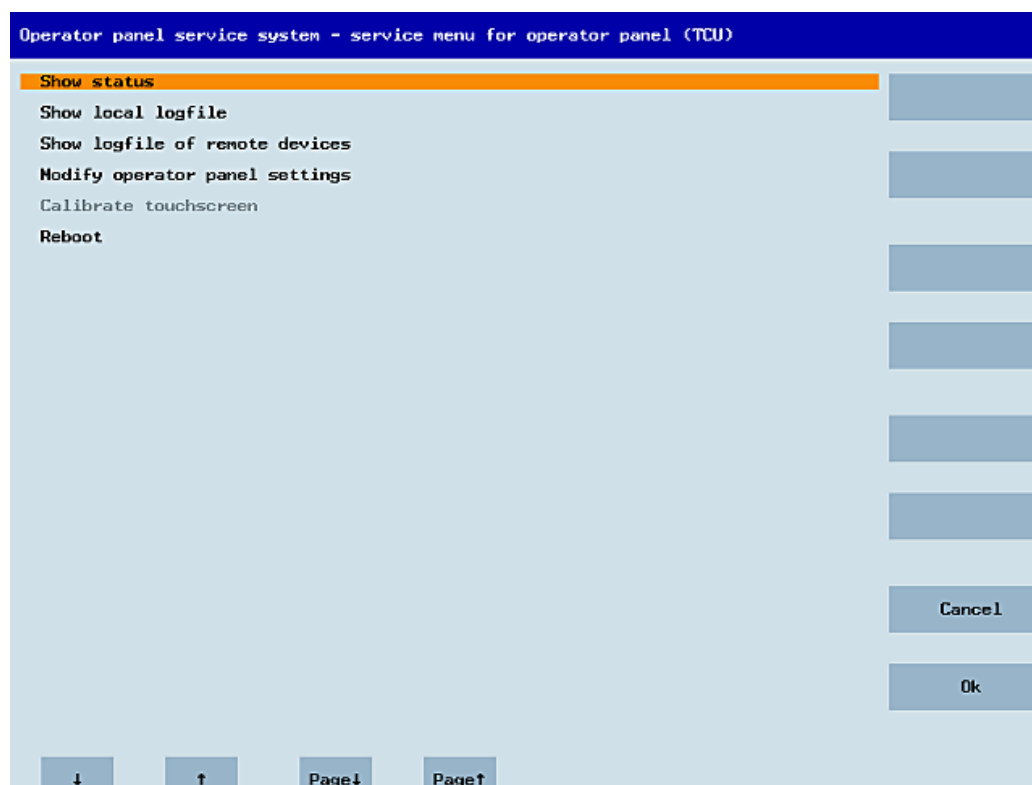

Figure 5-6 TCU menu: Service menu

The following menu items are available here:

- "Show status" shows status information, for example: Software version, hardware information, TCU network data, and their configuration:

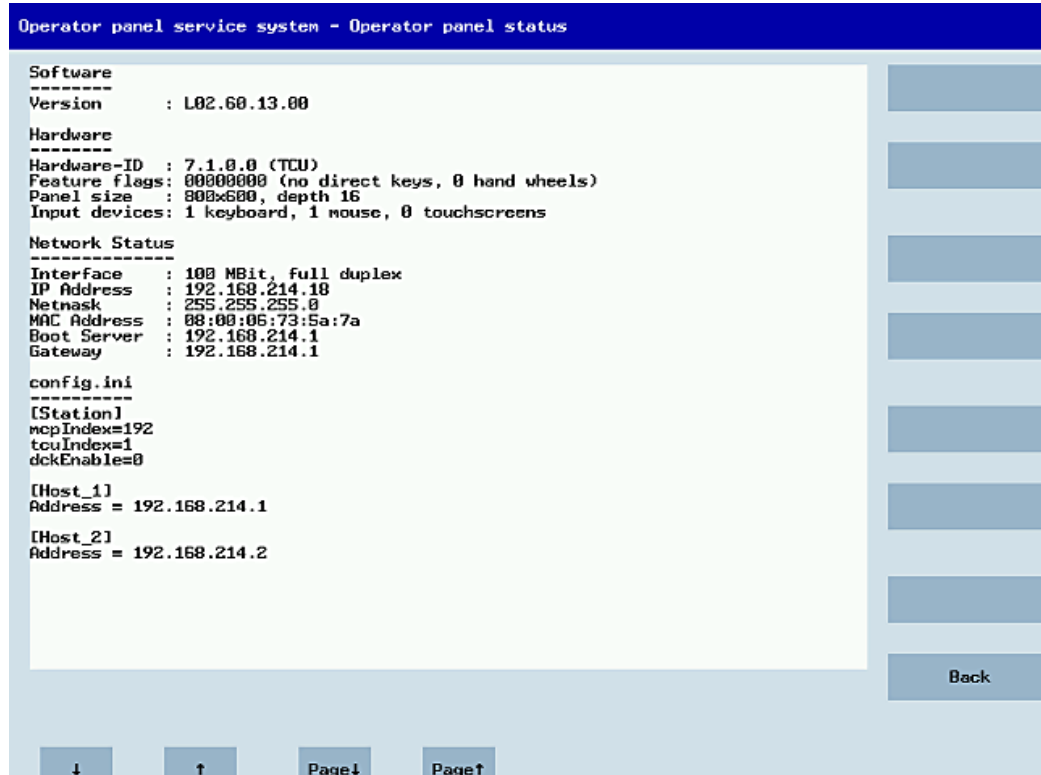

Figure 5-7 TCU menu: OP status

- "Show local logfile" shows a filtered version of the system log file in the `/var/log/messages` directory, which contains only the messages of the local TCUs. Syslog messages received via the network are not displayed.

```

Operator panel service system - Local logfile
00:06:06 syslogd started: BusyBox v1.00 (2008.10.14-21:56+0000)
00:06:06 kernel: process 'syslogd' is using obsolete setsockopt SO_BSDCOMPAT
00:06:06 udhcpd[821]: udhcp client (v0.9.7) started
00:06:08 udhcpd[821]: Lease of 192.168.214.18 obtained, lease time 864000
00:06:08 dhcpc: eth0 bound to 192.168.214.18 (server: 192.168.214.1 )
00:06:09 sntp[973]: using NTP server ? (192.168.214.1)
00:06:09 sntp[973]: NTP server is unsynchronized
00:06:12 sysinit: basic system initialization finished
00:06:13 kernel: i2c adapter i2c-0: timeout in state quick
00:06:13 tcodatad[1076]: i2c_write_1b: Input/output error
00:06:13 tcodatad[1076]: have_eeprom: failure, assuming no EEPROM
00:06:13 tcodatad[1076]: no EEPROM and no CF card, nothing to do
00:06:13 sysinit: starting subsystem /system/vncviewer: VNC Viewer version 02.60.→
10.00
00:06:14 startvnc[1186]: waiting for default server (192.168.214.1:0) being avail→
able
00:06:14 startvnc[1186]: HMS connection to 192.168.214.2:0 established
00:06:14 startvnc[1186]: HMS connection to 192.168.214.1:0 established
00:06:31 sntp[973]: NTP server is unsynchronized
00:06:47 lshd[1047]: lshd: publickey authentication for user root succeeded.
00:06:53 sntp[973]: NTP server is unsynchronized
00:07:15 sntp[973]: NTP server is unsynchronized
00:07:19 startvnc[1186]: default server connection aborted manually
00:07:37 sntp[973]: NTP server is unsynchronized
00:07:59 sntp[973]: NTP server is unsynchronized
00:08:21 sntp[973]: NTP server is unsynchronized
00:08:25 lshd[1047]: lshd: publickey authentication for user root succeeded.
00:08:43 sntp[973]: NTP server is unsynchronized
00:09:05 sntp[973]: NTP server is unsynchronized
00:09:13 lshd[1047]: lshd: publickey authentication for user root succeeded.
00:09:27 sntp[973]: NTP server is unsynchronized
00:09:49 sntp[973]: no acceptable packets received
00:12:20 lshd[1047]: lshd: publickey authentication for user root succeeded.
00:13:20 lshd[1047]: lshd: publickey authentication for user root succeeded.
00:14:02 lshd[1047]: lshd: publickey authentication for user root succeeded.
00:14:39 last message repeated 1 times

```

Back

↓   ↑   Page↓   Page↑

Figure 5-8 TCU menu: Local log file

- "Show logfile of remote devices" shows the log file of the other devices in the network: The syslog messages of devices in the system network which send syslog messages by broadcast, such as NCU 7x0, ...
- "Modify operator panel settings" opens another submenu, see next section.
- "Calibrate touch screen" is only active if there is a touch screen. This menu item recalibrates an available touch screen.
- "Reboot" initiates a restart of the TCU.

### Note

Long lines are broken and wrapped around.

Lines that are longer than the space available wrap round onto the next line so that you do not have to scroll horizontally. When this occurs, the line has a right-facing arrow at its right edge.

## 5.4.4 Operating the TCU menu "Modify settings"

### "Modify settings for operator panel (TCU)" dialog

The following dialog appears when "Modify settings" is selected from the main menu:

Setting	Value
Operator panel index - TCU [0-255]	1
Machine control panel address - MCP [0-255]	192
Electronic key system index - EKS [0-255]	0
Enable direct keys	No
Virtual Keyboard	Auto
Software Caps-Lock	Auto
Screen Rotation	Auto(from panel)
Old VNC Password (needed to change or remove the password)	
Set VNC Password	
Repeat Password	
Enable touch capability	No

Figure 5-9 TCU menu: Settings

The following TCU parameters are set here during the first commissioning:

- "HT 8 individual mode" (yes/no)  
This is only visible with HT 8, and is used to switch between Auto Mode and Individual Mode. You do not have to make settings for an HT 8 in Auto Mode because the name is generated automatically: ("DIP<n>") MCP address and TCU index are derived from the DIP setting ("DIP<n>").
- "Operator panel index - TCU" (0-255)  
Defines the TCU index; see column "TCU" on the user interface.
- "Machine control panel address - MCP" (0-255)  
Specifies the address of the associated MCP; see column "MCP" on the user interface.
- "Electronic key system index - EKS" (0-255)  
Specifies the index of the associated EKS; see column "EKS" on the user interface.
- "Enable direct keys" (yes/no)  
Specifies whether direct keys are registered with the PLC (yes) or are treated as ordinary keys (no); see column "DCK" on the user interface.

- "Virtual Keyboard" (Auto/On/Off)  
Specifies whether a virtual keyboard is shown on the screen for touch screens. Depending on the panel features (Auto), the HMI decides whether a touch screen or keyboard is available.  
This parameter can also be set manually (On/Off).
- "Software Caps-Lock" (Auto/On/Off)  
The HMI can manage the Caps-Lock status of a keyboard in the software itself, when, for example, the key is not available. This is normally (Auto) switched on via a display machine data item. This machine data item can be overwritten individually for the TCU with the setting (On/Off).
- "Emulation Type" (TCU/TCU20.2/TCU30.3, only for modular TCU30.3)  
Specifies which TCU type is to be emulated when the TCU30.3 is operated as replacement device for an older TCU or as new device on a software version older than 4.7 SP2.
- "Screen Rotation" (0°/90°/180°/-90°/Auto)  
Specifies in which angle the screen is to be rotated in the software. This is useful when the panel is to be rotated during installation.  
For the "Auto" setting, the rotation of the display is taken from the panel.
- "Old VNC Password"  
If a password has already been set, it must be entered here so that it can be changed. If no password has been set, this field is grayed-out. The existing password can also be deleted if, after entering the old password, no new password is to be entered at "Set VNC Password" and "Repeat Password".
- "Set VNC Password"  
Assign a password which is stored in the TCU and, if required, sent to the server when the VNC connection is established.
- "Repeat Password"  
Repeat the password entered at "Set VNC Password".
- "Enable touch capability" (yes/no)  
Specifies whether the screen can be operated by touch. If you deactivate this option, you will need a keyboard to reactivate it.

The values are applied and stored with "OK". You can also make any subsequent adaptations or changes via the user interface in the "Setup" operating area > menu forward key > "OPs" softkey.

## 5.4.5 Operating the menu for a new TCU or spare part TCU

### Registering a new TCU

When an unknown TCU, i.e. not yet registered with the boot server, is started, a selection menu containing both the "New" and "Replacement for existing panel" items is displayed. The accessibility of all the registered TCUs is tested in the background.

The status of this test is displayed in the message line: "(0/3 panels inactive)".

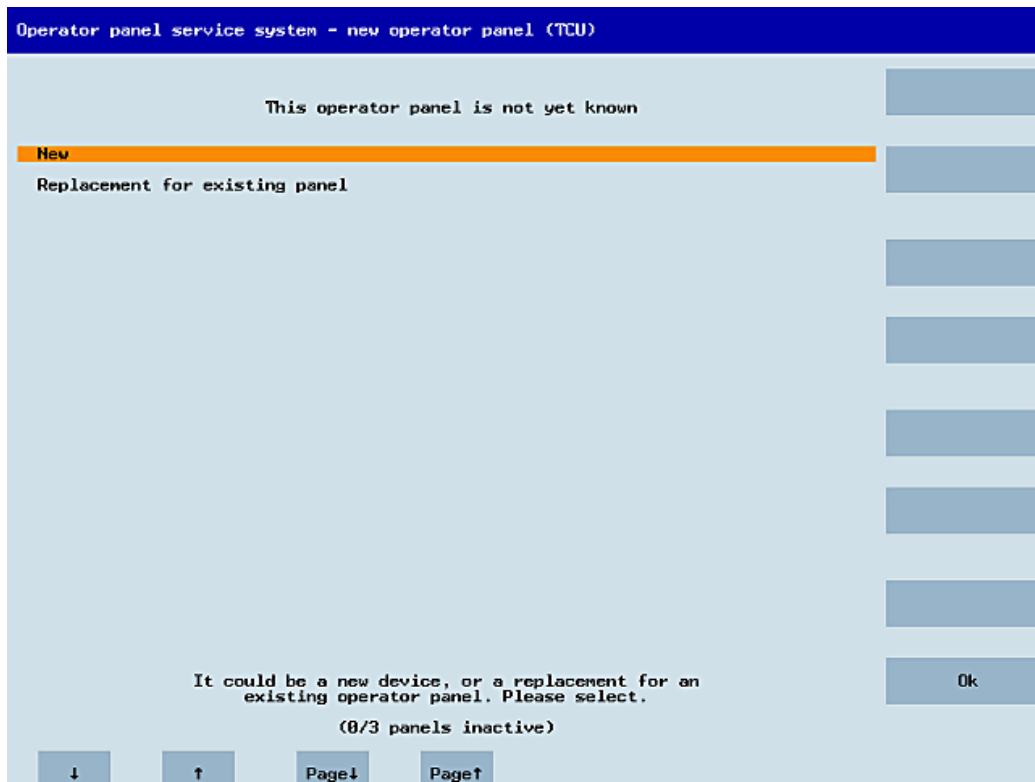

Figure 5-10 TCU menu: New TCU

If all TCUs are active, the new TCU cannot be a spare part. The system will then automatically switch to the name assignment phase after a set period of time has elapsed.



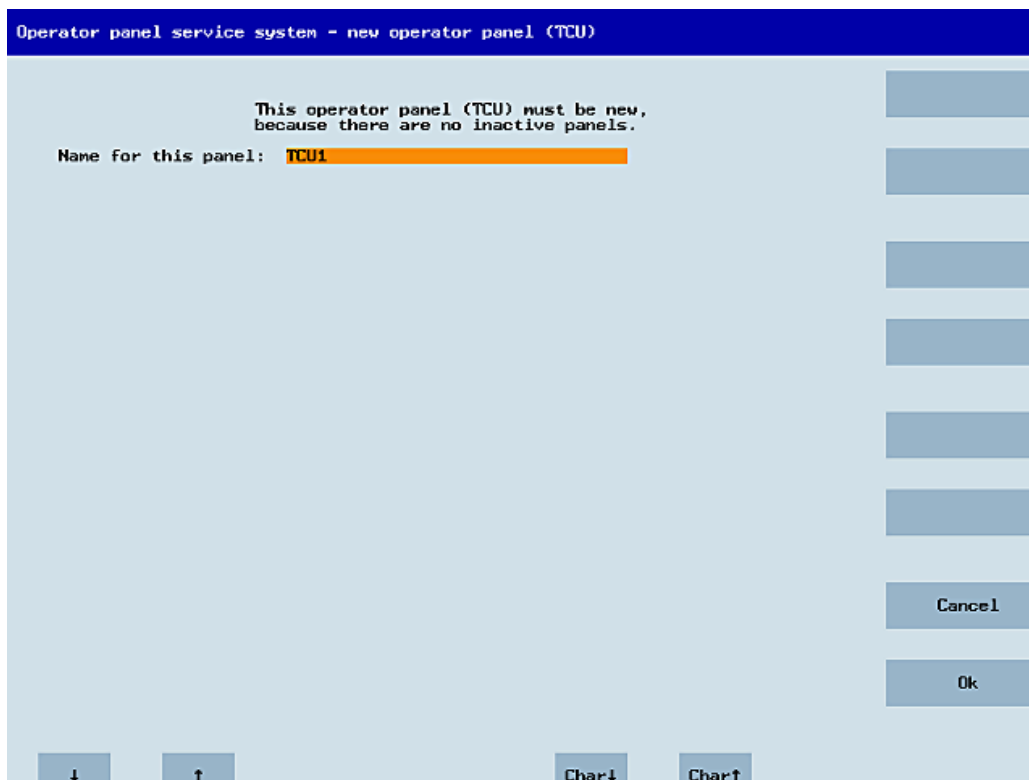

Figure 5-11 TCU menu: Name of TCU

If a TCU30.3 is to be operated with a software version < 4.7 SP2, the TCU is operated in compatibility mode. If required, you can view and change the emulation type in the settings.

## Replacing a device

If "Replacement" is selected, all the registered TCUs will appear in a selection menu. Those which are active in the network are grayed out. They are functioning and should not be replaced by a spare part. The cursor automatically defaults to the first line for selection.

As the accessibility test is still running in the background, the active status of the lines may change if panels are switched on or off.

If a name is ultimately chosen, it will be applied to the new TCU along with the associated saved settings.

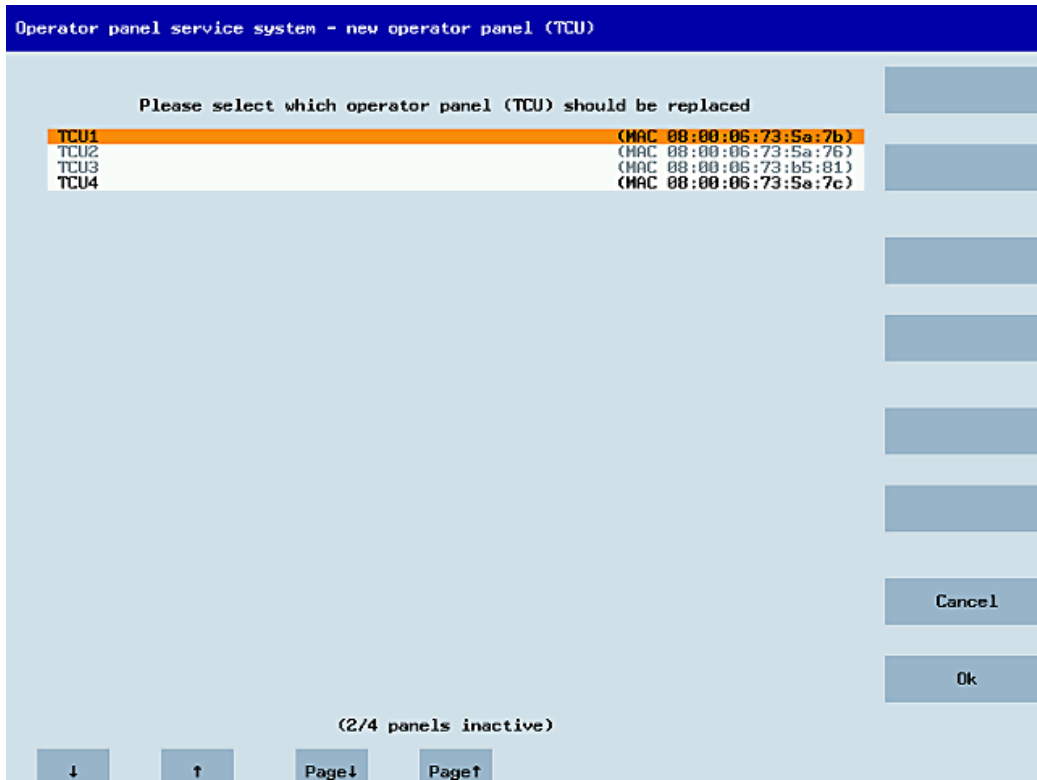
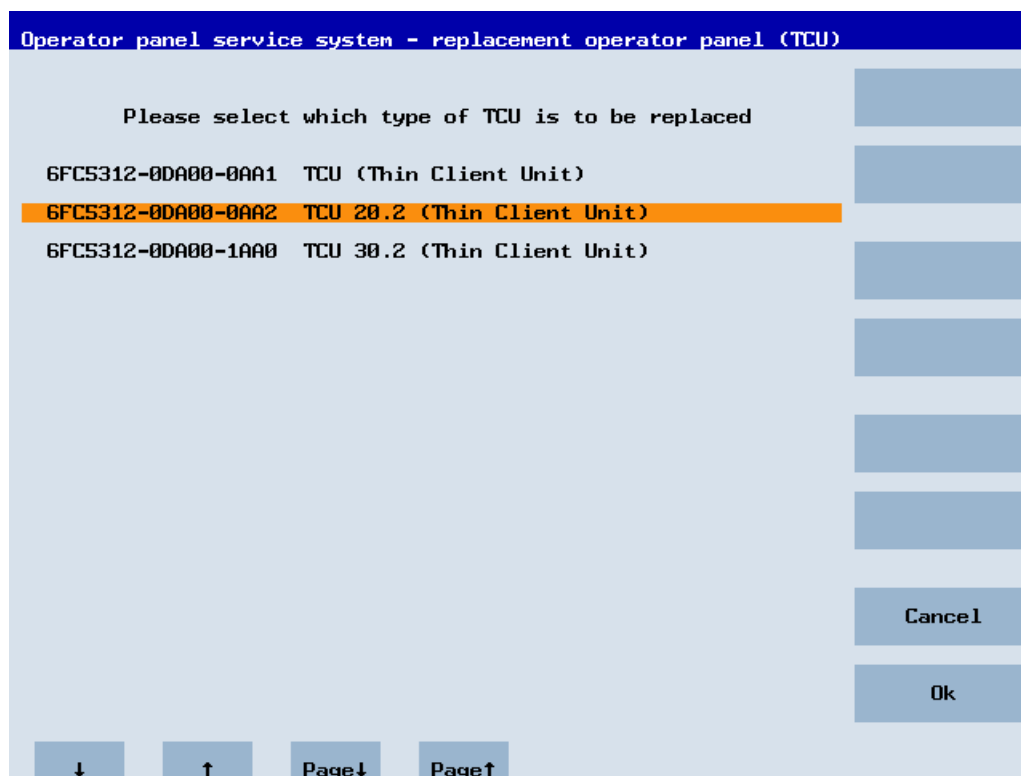

Figure 5-12 TCU menu: Replacement TCU

With the TCU30.3, after selecting the TCU to be replaced, a further dialog to select the emulation type can be displayed in compatibility mode:



If a static.ini of the TCU to be replaced (as of SW4.5) is found on the server, then the type of the old TCU is preselected based on the HW ID found there. If this is not the case, the TCU20.2 type is selected.

The following TCU types can be emulated:

- TCU
- TCU 20.2
- TCU 30.2

Note that if an older TCU is to be replaced by a TCU30.3, some interfaces cannot be used when the HMI version is older than V4.7. The following interfaces are affected:

TCU to be replaced	Interfaces that cannot be used
TCU	X212, X213 (because they do not exist in the TCU)
TCU 20.2	X212 (because it does not exist in the TCU 20.2)
TCU 30.2	X211 (because it does not exist in the TCU 30.3)

### Assigning a name

If, as described above, the system automatically follows the "New" path, an additional message will appear: "This operator panel (TCU) must be new, because there are no inactive panels." This message will not appear if "New" is selected manually.

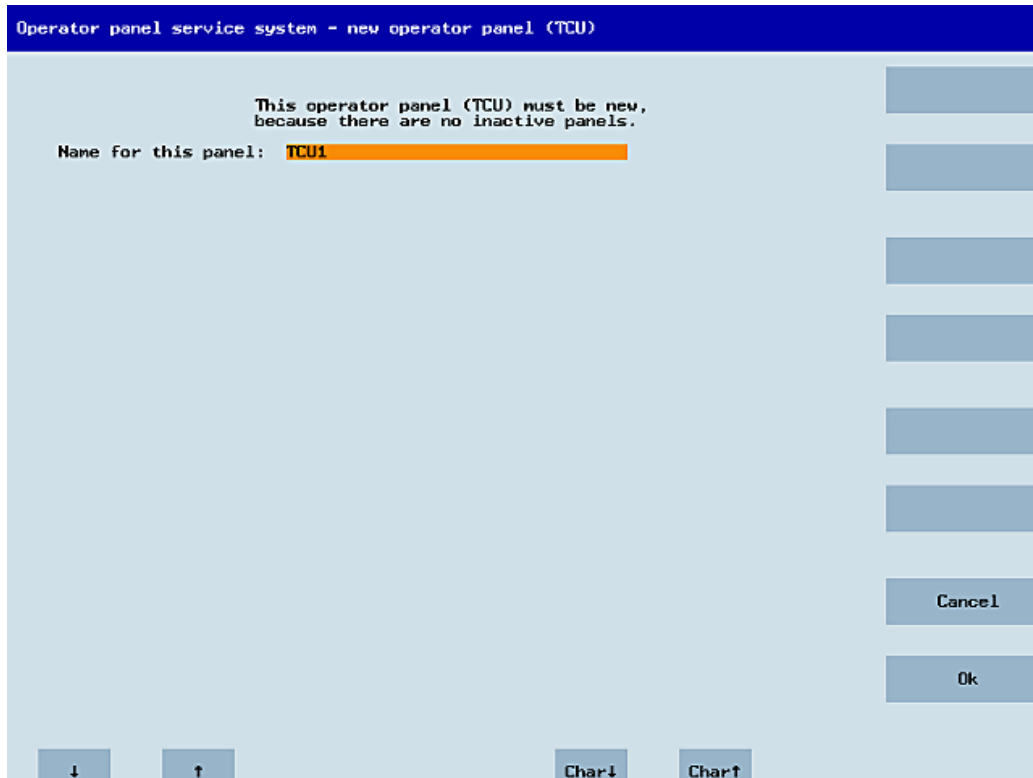

Figure 5-13 TCU menu: Name of TCU

An available TCU name is suggested in the input field, although the user is able to change this. The default name is "TCU<N>", where <N> is the lowest number yet to be used. If, however, the name is already allocated after the OK softkey has been pressed, which may happen if a number of TCUs log on at the same time, and the suggestion has not changed, a new and unused name will be specified.

If the name selected was still available, this will now be allocated, and the TCU settings can still be adapted if required. To enable any changes to be made, a new dialog appears in which all the parameters have been pre-assigned their default values. You can make any changes you like or just select "OK" to accept the existing values.

### 5.4.6 How to register a TCU on the system network

#### Requirement

The boot server (NCU or PCU 50/IPC) defined in the system network as a DHCP master must be switched on and available in the network.

## Using the TCU

Procedure:

1. Connect the TCU.  
This opens the "New operator panel (TCU)" dialog.
2. Select "New" to connect a new TCU and "OK" to confirm.
3. In the next dialog, accept the name suggested by the system or enter a name and confirm this with "OK".

The following parameters are preselected for the TCU:

Operator panel service system - Modify settings for operator panel (TCU)

Operator panel index - TCU [0-255]	1
Machine control panel address - MCP [0-255]	192
Electronic key system index - EKS [0-255]	0
Enable direct keys	No
Virtual Keyboard	Auto
Software Caps-Lock	Auto
Emulation Type	TCU20.2
Set VNC Password	
Repeat Password	

Ok

↓ ↑ Char↓ Char↑ ← →

4. Restart the TCU to apply the new settings.
5. If you want to change the parameters, select "Main menu" > "Service this panel" > "Modify operator panel settings".

**Procedure for the HT 8**

1. Connect the HT 8 to a connection module and calibrate the touch screen. Additional softkeys are available for convenient touch panel operation:
  - "OK" has the same function as the <INPUT> key
  - Select "DEF" to save the "Default" settings.
  - "Edit" has the same effect as the <F10> or <MENU SELECT> key.
2. Select HT 8 Individual Mode:  
According to the default setting for an HT 8, "HT 8 Individual Mode" is deselected with "No". This means "Auto" mode is activated for automatic detection in the system network. The HT 8 is automatically detected based on its name "DIP\_". If "HT 8 Individual Mode" is activated with "Yes", the HT 8 is identified by its MAC address on the system network.
3. For an HT 8, confirm the "DIP..." name proposed by the system or adapt the name. You can select any other characters.  
Press the <INPUT> key to apply the following values as default settings for the HT 8:

HT8 Individual Mode	No
Operator panel index - TCU [0-255]	10
Machine control panel address - MCP [0-255]	10
Electronic key system index - EKS [0-255]	0
Enable direct keys	No

The following message will then appear: "New TCU 'DIP10' registered."

**Note**  
**TCU index for the HT 8**

The TCU index is used to evaluate the direct keys. Direct keys can only be activated by appropriate devices. For an HT 8 the TCU index cannot be set, but is assigned by the system.

**Activate direct keys**

The signals from pressing the direct keys are sent directly to the PLC. In the PLC, the keys appear as 16 digital inputs.

Additional information on programming the PLC is provided in:  
SINUMERIK Basic Functions Function Manual, Basic PLC Program (P3)

**Definition: Operator panel**

The term operator station designates a unit that consists of an OP/TP, a TCU or PCU/IPC and a machine control panel (MCP), which are connected to each other via Ethernet.

All TCUs, PCU 50s and IPCs can be used along with the OP/TP with "integrated TCU", e.g. OP 08T, OP 015T, TP 015AT.

## Specifying settings without machine control panel

If a PCU, IPC or TCU does not have a machine control panel (MCP), one of the two following options must be set:

- MCP address = 0 or no entry  
After the change of user authorization, there is no switchover of the machine control panel; the previously active MCP remains active.
- MCP address = 255  
If the user authorization is transferred to this PCU, IPC or TCU, the previous machine control panel is deactivated, and there is no active machine control panel as from this point.

### 5.4.7 This is how you register a spare part TCU

To connect the spare part TCU, proceed as follows:

1. Connect the new TCU.  
The "New operator panel (TCU)" dialog opens.  
This dialog lists the TCUs on the system network along with their "active" or "inactive" status:

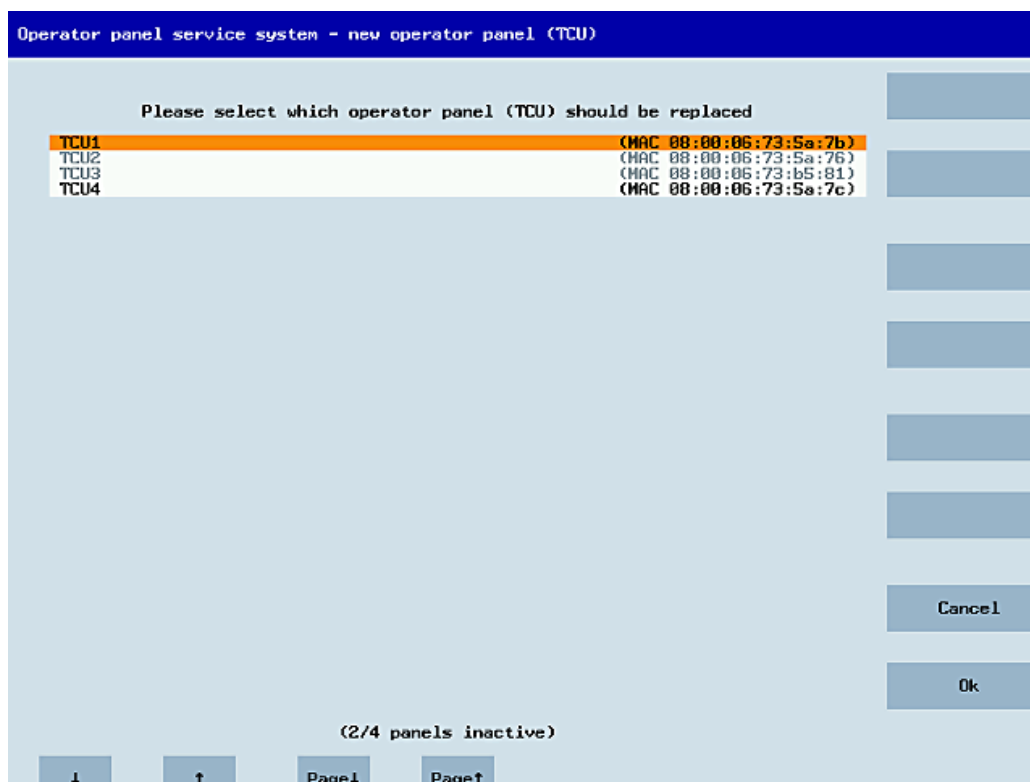

2. Select the name previously assigned to the defective TCU. As a result, the new TCU is recognized on the network and acquires all of the configuration settings from the TCU that has been replaced.

## 5.4.8 Booting of the TCU

### 5.4.8.1 Messages during booting

#### Messages when booting

While the TCU boots, a progress indicator is displayed with messages showing the current status after the BIOS has been loaded and before the operating system is started. While the IP address is being determined via DHCP and the TFTP is being downloaded (boot image), a progress bar indicates that booting of the TCU is not yet complete, or that a fault has occurred.

The figure below shows the structure of these messages:

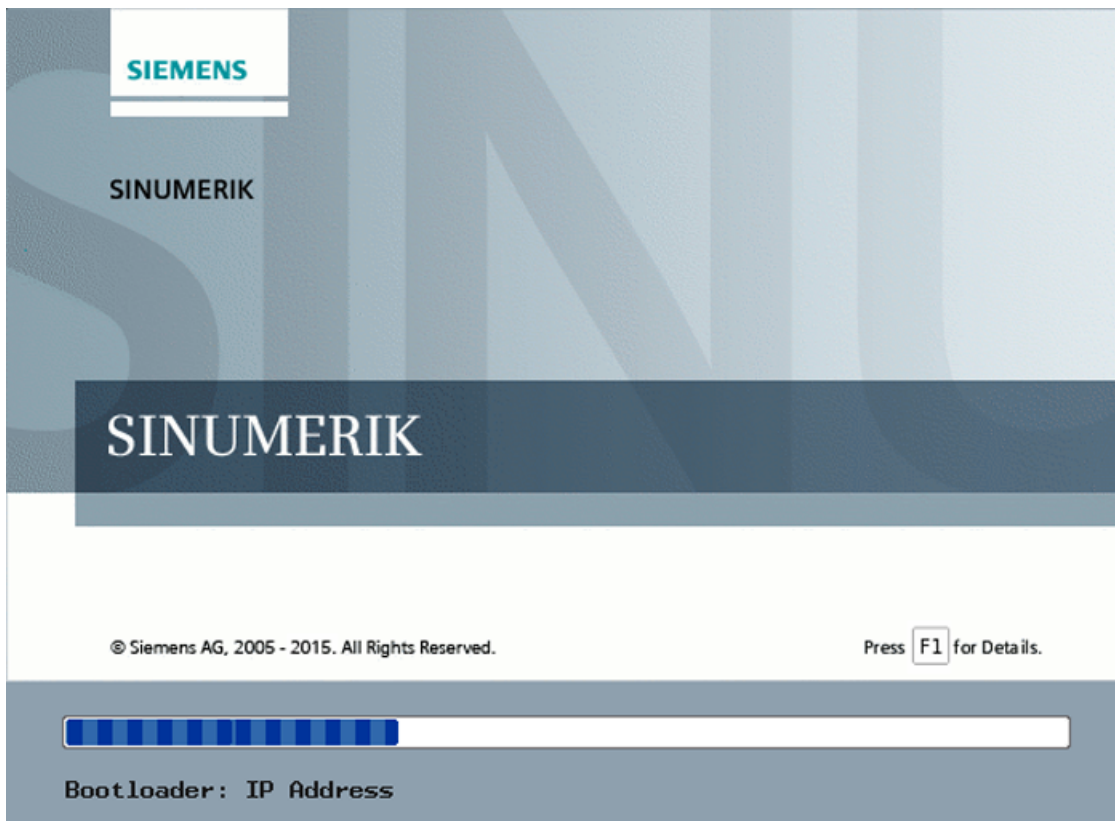

You can see the current boot phase below the progress bar. If a fault occurs, you can call further information by touching the "F1" field.



### 5.4.8.2 Diagnostics options during booting

#### Diagnostics while booting supplementary conditions

In the following supplementary conditions, the diagnostics window is displayed and booting of the TCU is interrupted:

- When the <1 / F1> function is selected during booting
- When a warning message is displayed
- When a fault occurs

You can select functions <1 / F1> to <8 / F8> mentioned below by tapping on the Panel. Alternatively, you can do this via the corresponding function keys of a connected USB keyboard.

#### Using the <1 / F1> function

```
Thin Client Bootloader V05.00.45.00

Boot Progress

BIOS Version V15.00.00.00
MAC Address 08:06:00:F1:F7:F8
Hardware-ID 7.9.2.0
Network link 1000MB, full duplex
Boot from USB no device found
IP Address 192.168.214.14
Netmask 255.255.255.0
DHCP Server 192.168.214.1
Boot Server 192.168.214.1
Image Metadata 71 bytes
Image Version V05.00.46.00
Linux Image (linux.bin) 3295436 bytes
Image Kind from boot server
Booting ready

<1/F1> protocol <2/F2> Readme_OSS <7/F7> continue <8/F8> reboot
```

Key / text	Meaning
F1 protocol	Display detailed information
F2 Readme_OSS	Details of the Open Source licenses
F7 continue	Continue booting of the TCU
F8 reboot	Restart the TCU

**Press <1 / F1> to continue**

If you select function <F1> in the diagnostics window, the, detailed diagnostic information is output.

<b>Key / text</b>	<b>Meaning</b>
F1 ... F6	Navigate within the window (alternatively, the relevant keys on the OP can be used).
F7 -detail	Display less information
F8 +detail	Display more information
F9 back	Return to diagnostics window

## Service and maintenance

### Cleaning the device

The operator panel front is designed for low-maintenance operation. Nevertheless, you must regularly clean the display.

---

**Note****Switch the device off for cleaning**

Clean the device only when it is switched off. This way, you ensure that you cannot unintentionally trigger any functions by touching the touch-sensitive glass surface.

---

For cleaning, use a soft cloth moistened either with water or a mild cleaning agent. Only use dish soap or foaming screen detergent as cleaning agents.

**Procedure**

Spray the cleaning agent on to a cleaning cloth. Never use caustic solvents or abrasive cleaners.

---

**Note****Avoid damage**

Do not clean the device using compressed air or steam jets because they can damage it.

---

### Checking the device

In order to prevent foreign bodies or liquids entering the device, regularly check the device for the following:

- Ensure that all the housing screws are in place and tight
- For damage to the housing
- For damage to the cable cover or cable entry

### Protect the device from environmental effects

Protect the device against the following environmental factors:

- Direct sunshine and heat sources
- Mechanical vibration and shock
- Dust
- Humidity
- Strong magnetic fields

## **Spare parts**

There are no parts of this device that can be replaced by the user.

## **Suspected malfunction**

If you suspect a malfunction due to unusual product reactions, isolate the device from power. Immediately inform qualified personnel to check the function and ensure that the product functions correctly.

The following signs can indicate a malfunction:

- Unusual or no functioning
- Unusual heat generation
- Smoke development

## **Repair**

Send the device back to the manufacturer for repair. The device must only be repaired there.

## Technical data

<b>Safety</b>			
Safety class	III; PELV according to EN 50178		
Degree of protection according to EN 60529	Front: IP65 / IP66 Rear: IPXXB		
Approvals	CE / cULus		
<b>Electrical data</b>			
Power supply <sup>1)</sup>	24 VDC (20.4 V ... 28.8 V)		
Current consumption	Typical, approx. 1.0 A Maximum, approx. 2.0 A		
Power consumption	Typical, approx. 24 W Maximum, approx. 42 W		
<b>Mechanical data</b>			
Dimensions	Width: 483 mm	Height: 310 mm	Depth: 48 mm
Weight	Approx. 7 kg		
Tightening torques, max.	Tension jack screws: 0.5 Nm	M3 screws: 0.8 Nm	M4 screws: 1.8 Nm
	M5 grounding screw: 3 Nm		
<b>Permissible ambient temperatures</b>			
Operation	0 ... 45 °C (front) 0 ... 55 °C (rear)		
Storage	-20 to 60° C		
<b>Mechanical environmental conditions</b>			
Classification of the mechanical environment	Class 3M1 in accordance with EN 60721-3-3		
Vibrational load during operation	Frequency range: 10 – 200 Hz Deflection at 10 – 58 Hz: 0.075 mm Acceleration at 58 – 200 Hz: 1 g		
Shock load during operation with shock-sensitive components	Acceleration: 5 g Shock duration: 30 ms Load: 3 x in each direction		
<b>Display</b>			
Size / resolution	15.6" / 1366 x 768 pixels		
MTBF backlight	Typical 70 000 h at 25° C (dependent on the temperature)		

<sup>1)</sup> The power supply must be provided as protective extra low-voltage with safe isolation (according to EN 60204-1, PELV).

---

**Note**

Information about the climatic and mechanical environmental conditions is contained in the associated section under:

"General notes and interconnection" → "Operational planning".

---

## 7.1 Secondary electrical conditions

### 7.1.1 Power supply

#### Requirements for DC power supplies

 **WARNING**

**Electric shock due to connection of an unsuitable power supply**

When equipment is connected to an unsuitable power supply and/or insufficiently grounded or rear cover, exposed components may carry a hazardous voltage that might result in serious injury or death.

- Only use power supplies that provide SELV (Safety Extra Low Voltage) or PELV (Protective Extra Low Voltage) output voltages acc. to UL 61010 for all connections and terminals of the electronics modules.

 **WARNING**

**Inadequately fused supply cables can be life-threatening**

In the case of supply lines >30 m, protectors must be installed at the device input to protect against lightning (surge).

The DC power supply must be connected to the ground/shield of the NC for EMC and/or functional reasons. For EMC reasons, this connection should only be made at one point. As a rule, the connection is provided as standard in the S7-300 I/Os. In exceptional circumstances when this is not the case, the ground connection should be made on the grounding rail of the NC cabinet (also refer to /EMC/EMC Installation Guide.)

Table 7-1 Requirements of the DC power supply

Rated voltage	According to EN 61131-2 Voltage range (mean value) Voltage ripple, peak/peak Ramp-up time when switched on	24 VDC 20.4 VDC to 28.8 VDC 5% (unsmoothed 6-pulse rectification) any
Non-periodic overvoltages	Period of overvoltage Recover time Events per hour	≤ 35 V ≤ 500 ms ≥ 50 s ≤ 10
Transient voltage interruptions	Downtime Recovery time Events per hour	≤ 3 ms ≥ 10 s ≤ 10

## 7.1.2 Grounding concept

### Components

The SINUMERIK 840D sl system consists of a number of individual components which have been designed so that the system complies with the appropriate EMC and safety standards. The individual system components are:

- Numerical Control Unit (NCU)
- Machine Control Panel (MCP), Machine Pushbutton Panel (MPP)
- Keyboard
- Operator panels (operator panel front + TCU/PCU)
- Distributor box and handheld unit
- S7-300 I/O with IM 153 interface module

### Grounding measures

The individual modules are attached to a metal cabinet panel. Insulating paints on the mounting points (e.g. tension jacks) must be removed.

It is permissible to cluster the operator control components regarding connection/potential bonding.

Example: The control panel on the swivel arm.

It is sufficient in this instance to connect the ground connections of, for example, the PCU, TCU, and operator panel front using a cable and to route a shared grounding conductor to the central ground connection in the control cabinet.

Please note that interruption of the grounding during maintenance work is not permissible.

---

#### Note

Proper grounding of the device and the machine corresponding to the EMC Design Guidelines is absolutely necessary for the function of the touch screen.

---

## Additional references

EMC Design Guidelines

### 7.1.3 EMC compatibility

In addition to the protective grounding of system components, special precautions must be taken to guarantee safe, trouble-free operation of the system. These measures include shielded signal lines, special equipotential bonding connections, and isolation and shielding measures.

#### Shielded signal cables

- For safe and fault-free operation of the system, the specified cables must be used.
- For digital signal transmission, the shield must have a conductive connection at both sides of the housing.

#### Cable definition

Definition:

- Signal cables (example)
  - Data cables (Ethernet, PROFIBUS, sensor cables, etc.)
  - Digital I/Os
  - Cables for safety functions (emergency stop, enabling)
- Power cables (example)
  - Low-voltage supply lines (230 VAC, +24 VDC, etc.)
  - Motor cables

#### Rules for routing cables

In order to achieve the greatest possible EMC compatibility for the complete system (control, power unit, machine), the following EMC measures must be carefully observed:

- If necessary, signal and power cables may cross one another (if possible at an angle of 90°), but must never be laid close or parallel to one another.
- Only use cables approved by SIEMENS for the signal lines from and to the Control Unit.
- Signal cables must not be routed close to strong external magnetic fields (e.g. motors and transformers).



- If signal lines cannot be routed a sufficient distance away from other cables, they must be installed in grounded cable ducts (metal).
- The operator panel fronts, MCPs, MPPs, and full keyboards must be installed in metallicly enclosed EMC-compatible housings.

**Note**

For further information on interference suppression measures and the connection of shielded cables, please refer to the EMC Installation Guide.

### 7.1.4 EMC limit values in South Korea

이 기기는 업무용(A급) 전자파적합기기로서 판매자 또는 사용자는 이 점을 주의하시기 바라며, 가정외의 지역에서 사용하는 것을 목적으로 합니다.  
 For sellers or other users, please bear in mind that this device is an A-grade electromagnetic wave device.  
 This device is intended to be used in areas other than at home.

The EMC limit values to be observed for Korea correspond to the limit values of the EMC product standard for variable-speed electric drives EN 61800-3 of category C2 or the limit value class A, Group 1 according to EN 55011. By implementing appropriate additional measures, the limit values according to category C2 or limit value class A, Group 1, are observed. Further, additional measures may be required, for instance, using an additional radio interference suppression filter (EMC filter).

The measures for EMC-compliant design of the system are described in detail in this manual respectively in the Installation Guideline EMC.

Please note that the final statement on compliance with the standard is given by the respective label attached to the individual unit.

## 7.2 Ambient climatic and mechanical conditions

### 7.2.1 Transport and storage conditions

The components of the SINUMERIK 840D sl system exceed the requirements according to EN 61800-2 with regard to shipping and storage conditions.

The following data applies under the following conditions:

- Long-term storage in the transport and product packaging:  
At weather-protected locations that have continuous contact with outside air through openings.
- Transport in the transport packaging:
  - In unventilated containers under conditions not protected from weather effects.
  - In the "cold" in accordance with outside air.
  - Air transport in the air-conditioned cargo hold.

Table 7-2 Ambient conditions during storage and transport

Type of condition	Permissible range/class		
	Transport	Storage	
Classification	EN 60721-3-2	EN 60721-3-1	
Climate class	2K4	1K4	
Ambient temperature <sup>1)</sup>	-40° C ... +70° C	-25° C ... +55° C	
Biological environmental conditions	2B1 <sup>2)</sup>	1B1 <sup>2)</sup>	
Chemically active environmental conditions	2C2 <sup>3)</sup>	1C2 <sup>3)</sup>	
Mechanical environmental conditions	Class 2M3 according to EN 60721-3-2, in transport packaging <sup>4)</sup>	Class 1M2 according to EN 60721-3-1, in product packaging <sup>5)</sup>	
Maximum permissible temperature change	Direct interaction in air/air: -40°/+30° C at 95% relative humidity	30 k/h	
Relative humidity (without condensation)	5 to 95%		
Precipitation, rain	6 mm/min <sup>2)</sup>	Not permissible	
Water other than rain	1 m/s and wet loading surfaces <sup>6)</sup>	Not permissible <sup>7)</sup>	1 m/s and wet loading surfaces <sup>6)</sup>
Height	Max. 4,000 m above sea level		
Condensation, splash water, icing, salt spray	Permissible	Not permissible <sup>7)</sup>	Permissible <sup>6)</sup>

- 1) Transport and storage of operator panel fronts and diskette drives: -20° C to +55° C.
- 2) Mold growth, slime, rodents, termites and other animal vermin are not permissible.
- 3) In marine- and weather-resistant transport packaging (container).
- 4) Transport packaging is either packaging that is directly suitable for transport or secondary packaging, which together with the product packaging, satisfies the requirements for transport.
- 5) Product packaging (storage packaging) is an individual packaging for storage and does not satisfy the requirements for transport. As a consequence, product packaging is therefore not suitable for shipping.
- 6) For storage in the transport packaging.
- 7) For storage in the product packaging.

**Note**

Remove the transport protective foil and packaging material before installing the components.

## 7.2.2 Operating conditions

The components of the SINUMERIK 840D sl system are intended for a weatherproof, fixed location. The documented environmental conditions apply to the climate in the immediate vicinity of the units and to the entry of the cooling air. They exceed the requirements according to EN 60204-1, EN 61800-2, EN 61131-2 and IEC 62477-1.

<b>NOTICE</b>	
<b>Damage to components by coolants and lubricants</b>	
<p>The SINUMERIK operator components have been designed for industrial use, particularly on machine tools and production machines. This also takes into account the use of commercially available coolants and lubricants. The use of aggressive compounds and additives can damage components and result in their failure.</p> <p>Contact between the operator components and coolants and lubricants should be avoided as far as possible, as resistance to all coolants and lubricants cannot be guaranteed.</p>	

<b>Ambient climatic conditions</b>	
Climate class according to EN 60721-3-3	Better than class 3K3
Temperature	0 ... 55° C (without derating)
Installation altitude	Up to 1000 m without derating From 1000 m to 3000 m with linear ambient temperature derating, -0.5 K per 100 m
Relative humidity	5 ... 95% (no condensation)
Oil mist, salt mist, ice formation, condensation, dripping water, spraying water, splashing water and water jets	Not permitted

<b>Biological, chemical, electrical and mechanical influences, pollutants</b>	
Biological environmental conditions	Class 3B1 according to EN 60 721-3-3: Mold, mold growth, slime, rodents, termites and other animal vermin are not permissible.
Chemically active environmental conditions	Class 3C1 according to EN 60721-3-3
Mechanically active environmental conditions	Class 3M1 according to EN 60721-3-3: Conductive dust not permissible.
Classification of the mechanical environment	3M3 for components on the machine 3M1/3M2 for components in the control cabinet
Vibration test in operation	According to IEC 60068-2-6 test Fc (sinusoidal) <ul style="list-style-type: none"> <li>• 10...57 Hz: 0.075 mm deflection amplitude</li> <li>• 57...150 Hz: 1 g acceleration amplitude</li> <li>• 10 frequency cycles per axis</li> </ul>

<b>Biological, chemical, electrical and mechanical influences, pollutants</b>	
Shock test in operation	According to IEC 60068-2-27 test Ea (half-sine) <ul style="list-style-type: none"> <li>• 5 g peak acceleration</li> <li>• 30 ms duration</li> <li>• 3 shocks in all three axes in both directions</li> </ul>
Degree of contamination	2 (only use indoors)
EMC conducted / radiation	Class C2 according to EN 61800-3

**Note**

The user must consider radio interference for the complete system. Particular attention should be paid to cabling. Please contact your sales representative for assistance and support.

**Note**

In a residential environment, this product can cause high-frequency interference, which may make interference suppression measures necessary.

Have the installation and commissioning with appropriate radio interference suppression measures performed by qualified personnel.

**7.2.3 Cooling**

To calculate the heat dissipation, the total power loss  $P_{Vtotal}$  of all heat-generating components in a housing must be taken into account.

Total power loss  $P_{Vtotal} = P_{V1} + P_{V2} + P_{V3} + \dots$  [W]

Convection surface area  $A$  [m<sup>2</sup>]:

The surface areas of the front and bottom sides are not included in the convection surface area calculation.

**Note**

A recommended value for the power loss of the operator control components is contained in the "Technical data" section of the associated component (see "Power consumption").

**Means of heat dissipation**

Heat dissipation can take place as follows:

- Heat dissipation by natural convection
- Heat dissipation by natural convection and internal air turbulence
- Heat dissipation by open-circuit cooling
- Heat dissipation by open-circuit ventilation

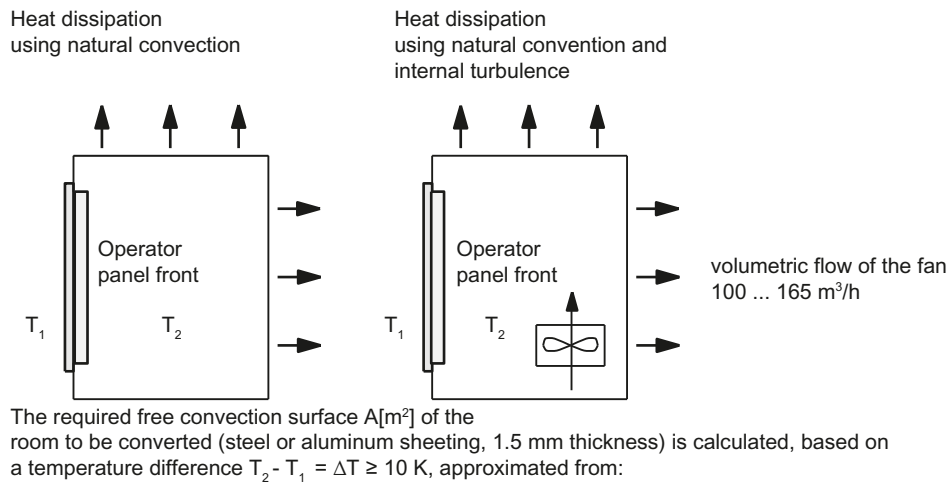

$$A \text{ [m}^2\text{]} = \frac{PV_{\text{ges}} \text{ [W]}}{5 * \Delta T \text{ [K]}}$$

$$A \text{ [m}^2\text{]} = \frac{PV_{\text{ges}} \text{ [W]}}{10 * \Delta T \text{ [K]}}$$

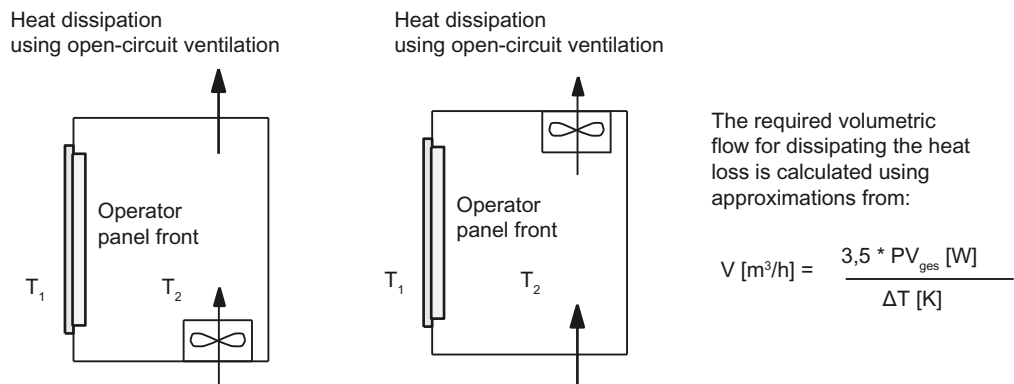

$$V \text{ [m}^3\text{/h]} = \frac{3,5 * PV_{\text{ges}} \text{ [W]}}{\Delta T \text{ [K]}}$$

Figure 7-1 Means of heat dissipation

### Fan design

- The fan must be positioned to produce an optimum heat dissipation. A clearance of 10 mm must be maintained in front of the fan.
- The inlet and outlet slots must remain free for the open-circuit ventilation.
- Air filters must be provided to maintain the permitted environmental conditions.

#### NOTICE

#### Damage to the operating components caused by temperatures that are too high or too low

Contaminated air filters impair the desired heat dissipation. For handling the air filters, pay attention to:

- Proper handling
- Regular replacement
- Correct disposal

### Guidelines

If the convection area  $A$  [m<sup>2</sup>] does not suffice for the "heat dissipation using natural convection", then use:

- "Heat dissipation using natural convection and internal turbulence" for hot spots and heat concentrations in housings subject to space constraints. The total power loss  $P_{Ltot}$  for thermally critical applications can be determined as follows:
  - Current measurement for a 24 V supply voltage
  - Power loss  $P_{Ltot}$  [W] = U (24 V) \* |measured value in ampères|
- Heat dissipation using open-circuit ventilation

### Calculation of the volumetric flow

The power loss (thermal) dissipated by the components in an operator unit is to be dissipated using open-circuit ventilation. The volumetric flow  $V$  required for this should be calculated at a difference in temperature of  $T_2 - T_1 = \Delta T \geq 10K$ .

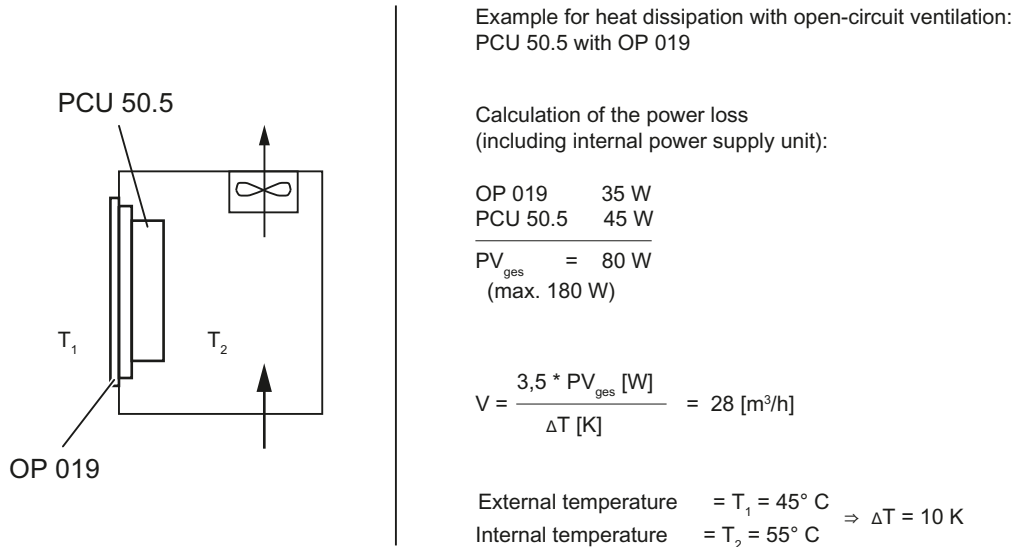

Figure 7-2 Calculating heat dissipation for PCU 50.5 with OP 019

## 7.3 Standards and approvals

### Approvals

CE approval



Figure 7-3 CE marking

The operator panels and the safety-relevant accessories satisfy the requirements and protection objectives of the following EC directives. The operator panels and the safety-relevant accessories comply with the harmonized European standards (EN), promulgated in the Official Journals of the European Community:

- 2004/108/EC "Electromagnetic Compatibility" (EMC directive)
- Directive 2006/42/EC of the European Parliament and Council of May 17, 2006, on machinery, and Directive 95/16/EC (amendment)

#### China RoHS

The products comply with the China RoHS directive Further information on this can be found on the Internet at the following link: SIOS (<https://support.industry.siemens.com/cs/document/109738656/china-rohs-manufacturer?dti=0&lc=en-VW>)

### Risk assessment

The following standards must be used to perform the risk assessment:

- EN ISO 12100-1:2003 and EN ISO 12100-2:2003, General Design Guidelines for Machines
- EN ISO 14121-1:2007, Risk Assessment for Machinery
- EN ISO 13849-1:2008, Safety-related Parts of Machines

These considerations result in a category (B, 1, 2, 3, 4) and a performance level (PL a to e) in accordance with EN ISO 13849-1:2008 that ultimately dictate how the safety-related parts of the system to be monitored must be constructed.

The connection examples with different monitoring units in "Handheld units", Section: "HT 2", Section: "Connections" → "Connection examples for acknowledgment button and Emergency Stop button" can also be used for other operator panels and demonstrate how Category 3, PL d according to EN ISO 13849-1:2008 can be attained with the safety-related parts of the operator panels. Note that the overall concept of the installation must be designed with this in mind.

## 7.4

### Recycling and disposal



For environmentally friendly recycling and disposal of your old device, please contact a company certified for the disposal of electrical and electronic waste and dispose of the device in accordance with the regulations in your country.





## Spare parts/accessories

The following can be ordered for the OP 015 black:

- Spare part: Tension jacks 6FC5248-0AF14-0AA0 (9 units)
- Accessories: USB extension 6FC5347-0AF01-1AA0



# Index

## A

- Assembly
  - Mounting opening, 22
  - One person installation, 23

## B

- Boot server, 51

## C

- Care, 75
- Cleaning product, 75
- CompactFlash Card, 36
- Company network, 37
- Connecting a PG, 52
- Connection conditions
  - EMC measures, 78
  - End user interface, 78
  - Membrane connectors, 33
  - Protective separation, 78

## D

- DCK (Direct Control Keys), 70
- DHCP client, 39
- DHCP server, 39
- Direct keys, 70
- DNS (Domain Name System), 38

## E

- EMC measures, 80
  - Connection conditions, 78
- End user interface
  - Connection conditions, 78
- Ethernet connection, 48
- Ethernet interface, 48

## F

- Factory default settings, 39
- Faults when booting, 73

## G

- Gestures
  - Displaying the TCU menu, 16

## H

- Heat dissipation
  - Means of heat dissipation, 84
- HT 8 rotary coding switch, 70

## I

- Interfaces, 19

## K

- Keyboard, 17

## M

- Maintenance, 75
- Membrane connectors
  - Connection conditions, 33
- Messages during TCU booting, 72

## N

- Network topology, 48

## O

- OP 015 black
  - Accessories, 89
  - Features, 13
  - Order number, 13
  - Spare parts, 89
- Operation
  - Gloves, 16
  - Keylock, 17

## P

- Potential equalization, 79

Protective separation  
  Connection conditions, 78

## **S**

Scope of maintenance, 75  
Signal cables, 80  
SINUMERIK DHCP client, 39  
SINUMERIK DHCP server, 40  
Star structure, 36  
Starting up the system, 38  
Switchover disable, 44  
System network, 36  
  Configuring, 68

## **T**

### TCU

  Assign index, 45  
  Assign name, 68  
  Booting messages, 72  
  Main menu, 54  
  Settings, 68  
  Supplementary conditions, 36  
  Thin Client Unit, 35  
TCU diagnostics, 72  
Technical specifications  
  Dimensions, 77  
  Power consumption, 77  
  Tightening torques, 77

## **U**

User authorization, 35, 46

## **V**

View, 15