

### Terminal Box Controller - Electronic Output

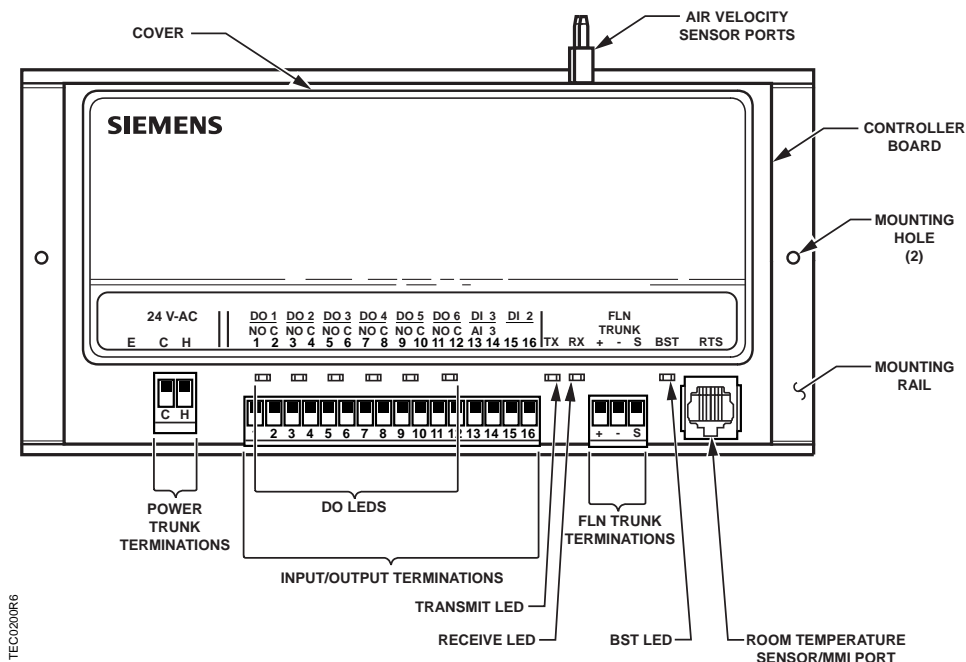

Figure 1. Terminal Box Controller - Electronic Output.

### Control Applications

2020 through 2027

2120 through 2127 (Secure Mode Applications)

### Product Description

These instructions explain how to field install or replace a Terminal Box Controller — Electronic Output with or without an Autozero Module or Secure Mode (540–X00C only).

Shipping carton includes a controller assembly (controller board and cover), a mounting rail, Autozero Module with bracket (optional), and two self-tapping screws.

### Product Numbers

540-100	Terminal Box Controller - Electronic Output
540-800	Terminal Box Controller - Electronic Output for Trane
540-100C	Terminal Box Controller - Electronic Output with Secure Mode
540-200	Terminal Box Controller - Electronic Output with Autozero module.
540-200C	Terminal Box Controller - Electronic Output with Autozero module and Secure Mode.



#### CAUTION:

Keep the unit in its static-proof bag until installation.

## Accessories

540-658P25 Low cost temporary temperature sensor that enables space control if the permanent room or duct sensor is not installed.

### Parts for CE Compliance:

550-705 Clamp-on ferrite filter (10 pack)  
 588-100 series Approved 2-RJ11 RTS cable in 25', 50', or 100' (7.6-m, 15.2-m, 30.48-m).  
 540-155 Metal Small Equipment Controller Enclosure  
 550-002 Large Equipment Controller Enclosure

## Warning/Caution Notations



### WARNING:

Personal injury/loss of life may occur if you do not follow the procedures as specified.



### CAUTION:

Equipment damage or loss of data may occur if you do not follow the procedures as specified.

## Expected Installation Times

10 minutes.

## Required Tools and Materials

- Flat-blade screwdriver (1/8-inch blade width).
- Small flat-blade screwdriver
- Cabling and connectors. See the section.
- Cordless drill/driver set

## Prerequisites

- Wiring conforms to NEC and local codes and regulations. For further information refer to the Wiring Guidelines manual (125-3002).
- 24 Vac Class II power source available.
- Supply power to the controller is OFF.

- Any application specific hardware or devices installed.
- Room temperature sensor installed (optional). (If desired, a low-cost temporary temperature sensor is available that plugs into the RTS port of the TEC (P/N 540-658P25), providing temperature input and actual space control until the permanent room or duct sensor is installed.)



If the controller is being installed on a box with 1 or more stages of electric heat, the 550-809 MOV with pre-terminated spade connectors must be installed across the manufacturer-supplied airflow switch. MOVs can be installed at the time the controller is factory mounted; coordinate with the box manufacturer prior to order placement. For field installation, see Metal Oxide Varistor Kit Installation Instructions (540-986).

## Instructions

1. Secure the mounting rail (Figure 1) in the controller's desired location.
2. Place the ESD wrist strap on your wrist and attach it to a good earth ground.
3. Remove the controller from the static proof bag and snap it into place on the mounting rail.
4. Connect the FLN (Figure 2).

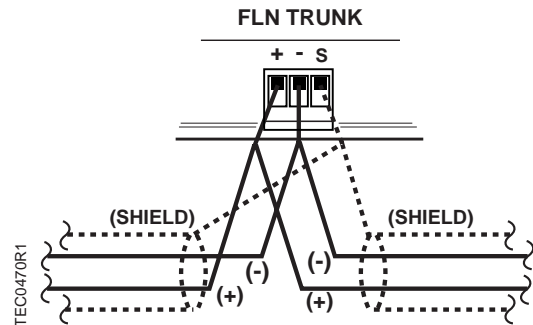

Figure 2. FLN Wiring.



### CAUTION:

Do not ground the shield.

5. Connect the point wiring (see Wiring Diagrams).

6. **540-200 and 540-200C:** Install the Autozero Module and connect the wires to DO6 (Figure 5). See installation instructions 540-199.
7. Plug the room temperature sensor cable into the RTS port (Figure 1).
8. Connect the power trunk (Figure 3). **DO NOT** apply power to the controller.

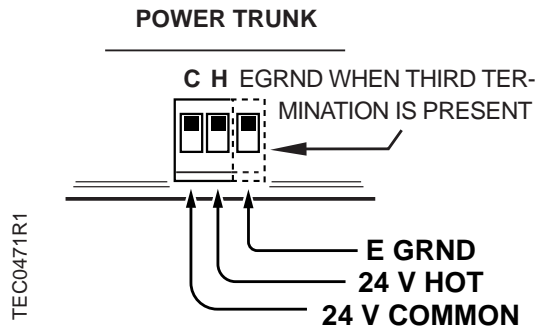

**Figure 3. Power Trunk Wiring.**



As a standard grounding procedure, ensure that 3"-5" ground wire is connected directly on the common terminal on the secondary side of the 24 Vac transformer.

9. Connect the tubing from the air velocity sensor pickups to the ports on the controller or Autozero Module (Figure 5). Connect HI to HI and LO to LO.

The installation is complete.

## Smoke Control Compliance

If used for Smoke Control seunce install Smoke Control Listed product, enclosure and transformer (see *Product Numbers and Accessories* sections).

## CE Compliance

If CE compliance is required, the Equipment Controller must be mounted in a grounded metal enclosure and a ferrite filter must be placed approximately 1 cm from the end of the cable being shielded (RTS cable and the point wiring for AI3) (Figure 4).

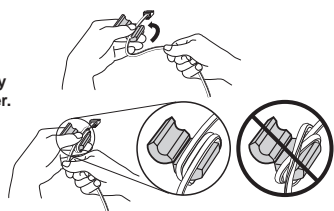
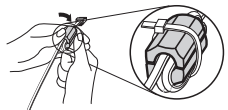
- 1 Place the filter 1-2 cm from the end of the cable or wiring to be shielded. 
- 2 Wind the cable tightly twice around the filter. 
- 3 Close the filter and wrap with a zip tie. 

**Figure 4. Ferrite filter(s) for CE Compliance.**

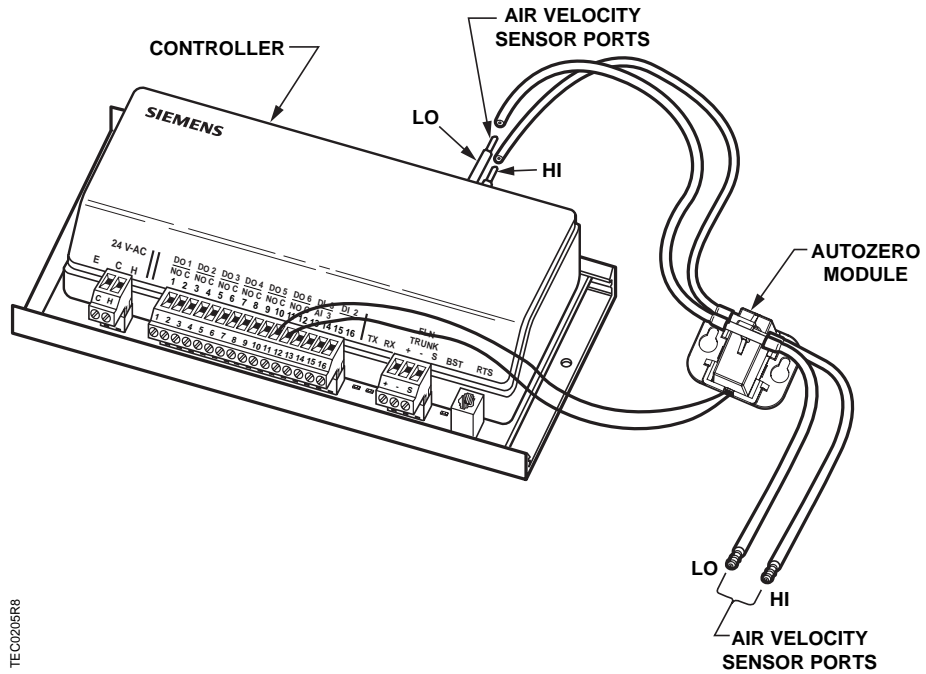

TEC0205R8

Figure 5. Terminal Box Controller - Electronic Output with Autozero Module.

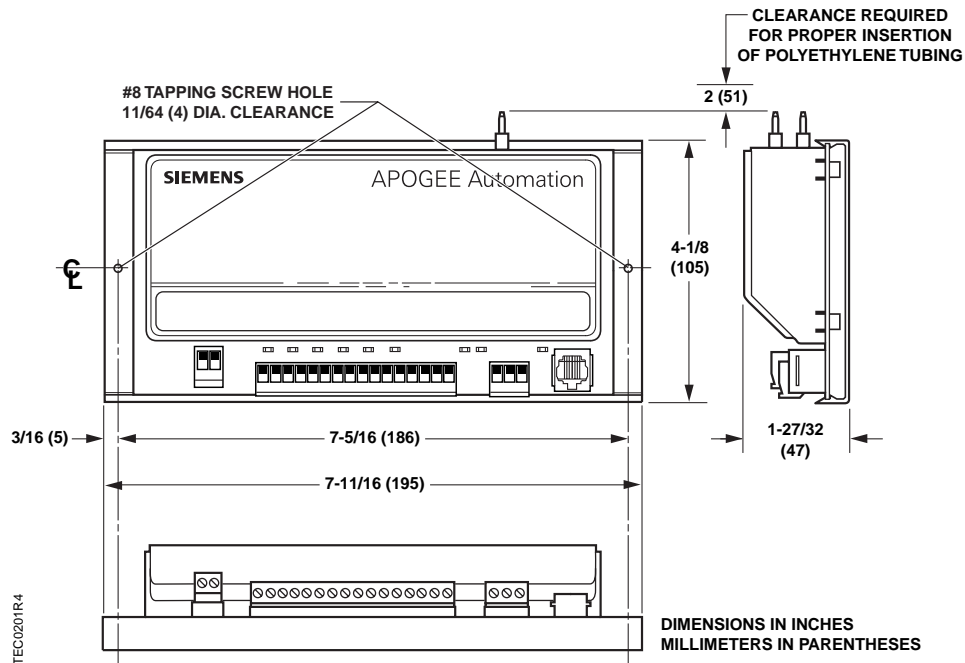

TEC0201R4

Figure 6. Dimensions.

## Wiring Diagrams



### CAUTION:

The controller's DOs control 24 Vac loads only. The maximum rating is 12 VA for each DO. Use an interposing 24 Vac relay module (such as P/N 550-054) for any of the following:

- VA requirements higher than 12 VA
- Separate transformers to power the load
- Direct current (DC) power requirements

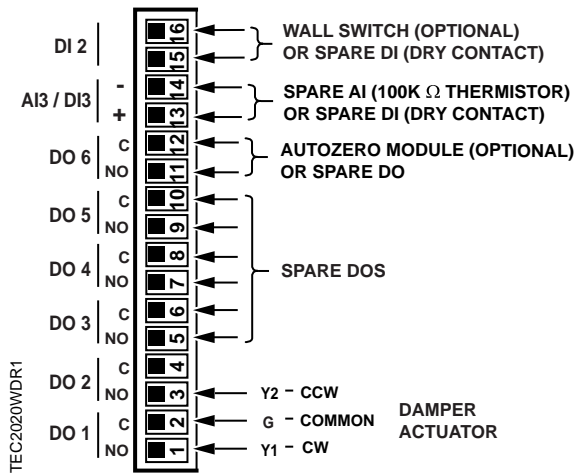

Figure 7. Application 2020 and 2120 Wiring Diagram (Cooling Only).

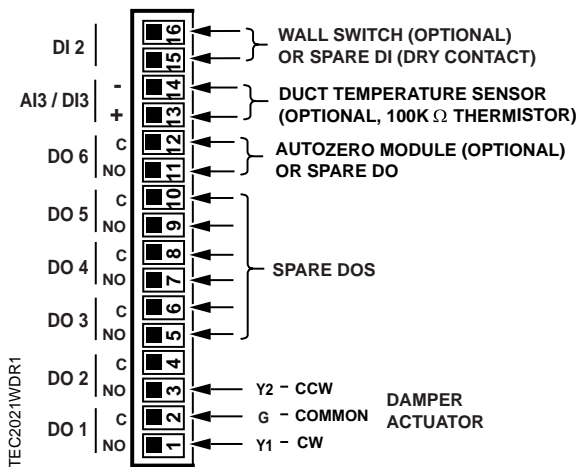

Figure 8. Application 2021 and 2121 Wiring Diagram (Heating or Cooling).

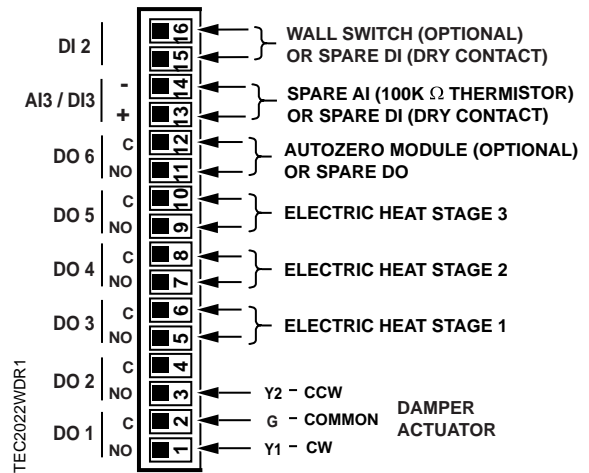

Figure 9. Application 2022 and 2122 Wiring Diagram (Electric Heat).

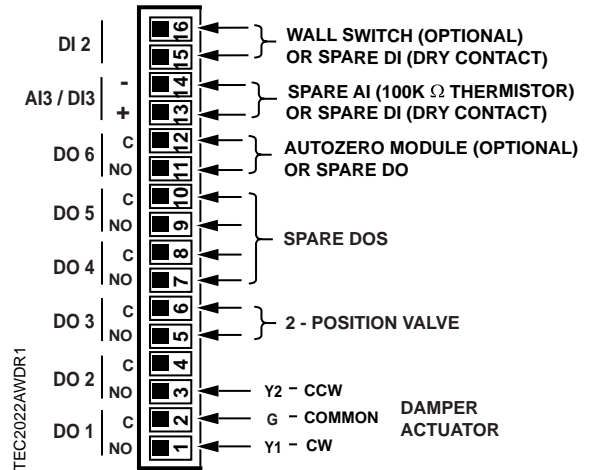

Figure 10. Application 2022 and 2122 Wiring Diagram (Baseboard Radiation).

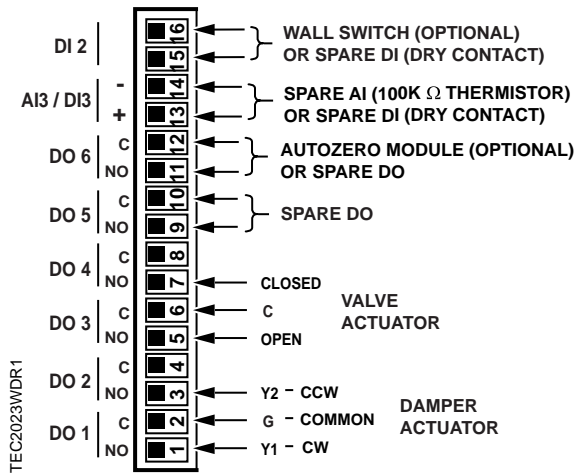

Figure 11. Application 2023 and 2123 Wiring Diagram (Hot Water Heat).

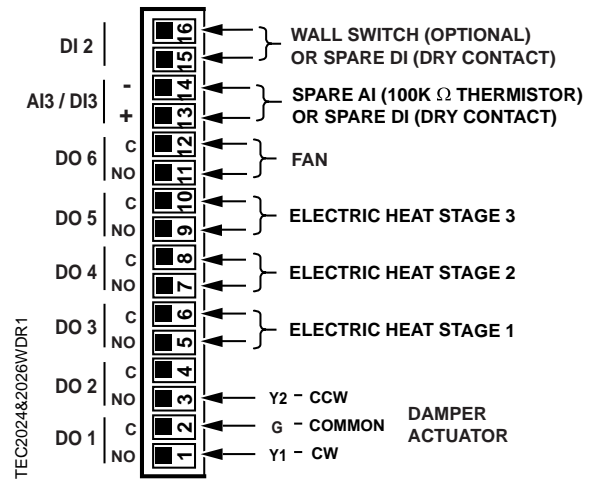

Figure 13. Applications 2024/2026 and 2124/2126 Wiring Diagram (Series Fan and Parallel Fan with Electric Heat).

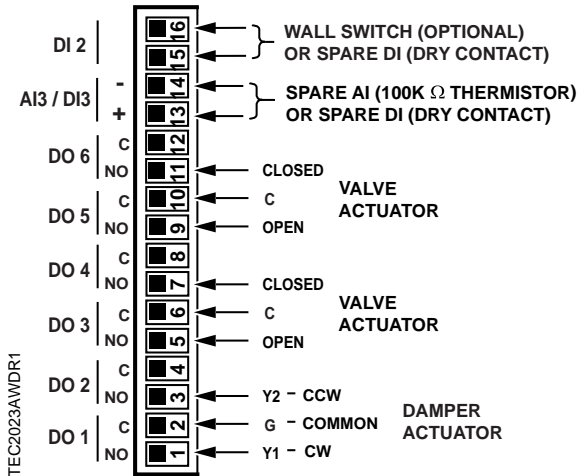

Figure 12. Application 2023 and 2123 Wiring Diagram (Hot Water Heat with 3 motors).

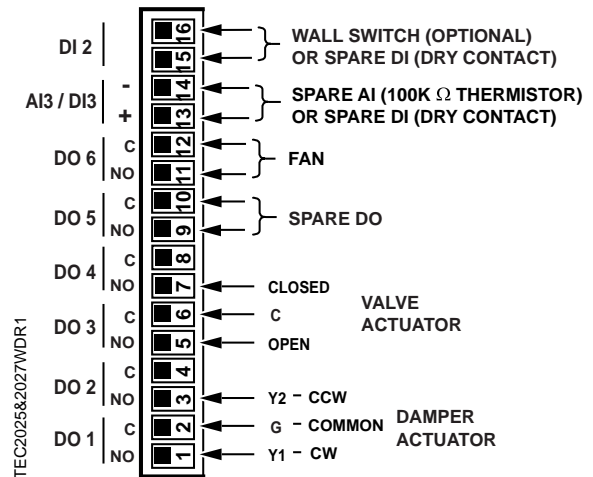

Figure 14. Application 2025/2027 and 2125/2127 Wiring Diagram (Series Fan and Parallel Fan with Hot Water Heat).

Information in this document is based on specifications believed correct at the time of publication. The right is reserved to make changes as design improvements are introduced. Product or company names mentioned herein may be the trademarks of their respective owners.  
 © 2009 Siemens Building Technologies, Inc.