

SIEMENS

SIPROTEC 5 Compact Universal Protection 7SX800

V9.70 and higher

Manual

C53000-G5340-C003-8

Preface

Table of Contents

Introduction

1

Basic Structure of the Function

2

System Functions

3

Applications

4

Function-Group Types

5

General Protection and Automation Functions

6

Motor-Protection Functions

7

Capacitor Bank Protection Functions

8

Control Functions

9

Supervision Functions

10

Measured Values, Energy Values, and
Supervision of the Primary System

11

Power Quality – Basic

12

Functional Tests

13

Technical Data

14

Appendix

A

Literature

Glossary

Index

**NOTE**

For your own safety, observe the warnings and safety instructions contained in this document, if available.

Disclaimer of Liability

Subject to changes and errors. The information given in this document only contains general descriptions and/or performance features which may not always specifically reflect those described, or which may undergo modification in the course of further development of the products. The requested performance features are binding only when they are expressly agreed upon in the concluded contract.

Document version: C53000-G5340-C003-8.01

Edition: 12.2023

Version of the product described: V9.70 and higher

Copyright

Copyright © Siemens 2023. All rights reserved.

The disclosure, duplication, distribution and editing of this document, or utilization and communication of the content are not permitted, unless authorized in writing. All rights, including rights created by patent grant or registration of a utility model or a design, are reserved.

Trademarks

SIPROTEC, DIGSI, SIGRA, SIGUARD, SIMEAS, SAFIR, SICAM Insights Hub, and OT Companion are trademarks of Siemens. Any unauthorized use is prohibited.

Preface

Purpose of the Manual

This manual describes the protection, automation, control, and monitoring functions of the SIPROTEC 5 Compact devices.

Target Audience

Protection system engineers, commissioning engineers, persons entrusted with the setting, testing and maintenance of automation, selective protection and control equipment, and operational crew in electrical installations and power plants.

Scope

This manual applies to the SIPROTEC 5 Compact device family.

Further Documentation

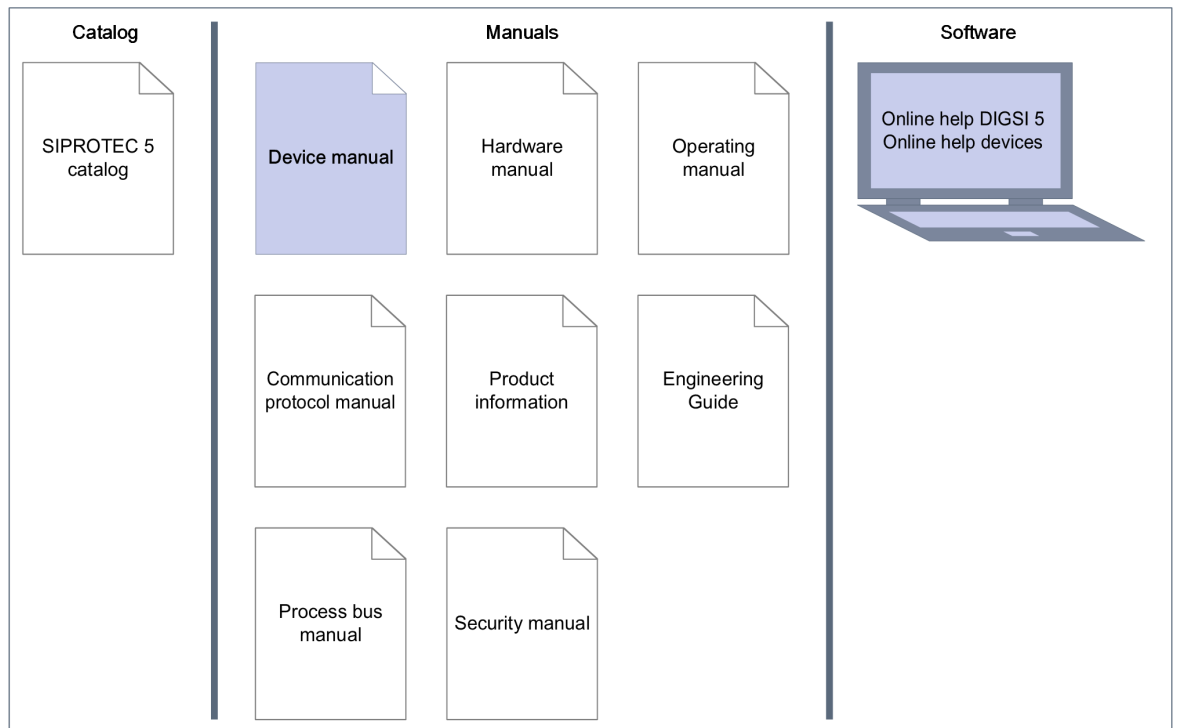

[dw_product-overview_SIP5_compact-manual, 1, en_US]

- **Device manuals**
Each Device manual describes the functions and applications of a specific SIPROTEC 5 device. The printed manual and the online help for the device have the same informational structure.

- **Hardware manual**
The Hardware manual describes the hardware building blocks and device combinations of the SIPROTEC 5 device family.
- **Operating manual**
The Operating manual describes the basic principles and procedures for operating and assembling the devices of the SIPROTEC 5 range.
- **Communication protocol manual**
The Communication protocol manual contains a description of the protocols for communication within the SIPROTEC 5 device family and to higher-level network control centers.
- **Security manual**
The Security manual describes the security features of the SIPROTEC 5 devices and DIGSI 5.
- **Process bus manual**
The process bus manual describes the functions and applications specific for process bus in SIPROTEC 5.
- **Product information**
The Product information includes general information about device installation, technical data, limiting values for input and output modules, and conditions when preparing for operation. This document is provided with each SIPROTEC 5 device.
- **Engineering Guide**
The Engineering Guide describes the essential steps when engineering with DIGSI 5. In addition, the Engineering Guide shows you how to load a planned configuration to a SIPROTEC 5 device and update the functionality of the SIPROTEC 5 device.
- **DIGSI 5 online help**
The DIGSI 5 online help contains a help package for DIGSI 5 and CFC.
The help package for DIGSI 5 includes a description of the basic operation of software, the DIGSI principles and editors. The help package for CFC includes an introduction to CFC programming, basic examples of working with CFC, and a reference chapter with all the CFC blocks available for the SIPROTEC 5 range.
- **SIPROTEC 5 catalog**
The SIPROTEC 5 catalog describes the system features and the devices of SIPROTEC 5.

Indication of Conformity



This product complies with the directive of the Council of the European Communities on harmonization of the laws of the Member States concerning electromagnetic compatibility (EMC Directive 2014/30/EU), restriction on usage of hazardous substances in electrical and electronic equipment (RoHS Directive 2011/65/EU), and electrical equipment for use within specified voltage limits (Low Voltage Directive 2014/35/EU).

This conformity has been proved by tests performed according to the Council Directive in accordance with the generic standards EN 61000-6-2 and EN 61000-6-4 (for EMC directive), the standard EN IEC 63000 (for RoHS directive), and with the product standard EN 60255-27 (for Low Voltage Directive) by Siemens.

The device is designed and manufactured for application in an industrial environment.

The product conforms with the international standards of IEC 60255 and the German standard VDE 0435.

Standards

IEEE Std C 37.90

The technical data of the product is approved in accordance with UL.

For more information about the UL database, see ul.com

You can find the product with the **UL File Number E194016**.



IND. CONT. EQ.
69CA

Additional Support

For questions about the system, contact your Siemens sales partner.

Customer Support Center

Our Customer Support Center provides a 24-hour service.

Siemens Electrification & Automation

Global Support

Single entry point

Phone: +49 9131 1743072

E-mail: support.ea.si@siemens.com

Training Courses

Inquiries regarding individual training courses should be addressed to our Training Center:

Siemens AG

Siemens Power Academy TD

Humboldtstraße 59

90459 Nuremberg

Germany

Phone: +49 911 9582 7100

E-mail: poweracademy@siemens.com

Internet: www.siemens.com/poweracademy

Notes on Safety

This document is not a complete index of all safety measures required for operation of the equipment (module or device). However, it comprises important information that must be followed for personal safety, as well as to avoid material damage. Information is highlighted and illustrated as follows according to the degree of danger:



DANGER

DANGER means that death or severe injury **will** result if the measures specified are not taken.

- ◇ Comply with all instructions, in order to avoid death or severe injuries.



WARNING

WARNING means that death or severe injury **may** result if the measures specified are not taken.

- ◇ Comply with all instructions, in order to avoid death or severe injuries.



CAUTION

CAUTION means that medium-severe or slight injuries **can** occur if the specified measures are not taken.

- ◇ Comply with all instructions, in order to avoid moderate or minor injuries.

NOTICE

NOTICE means that property damage **can** result if the measures specified are not taken.

- ✧ Comply with all instructions, in order to avoid property damage.



NOTE

Important information about the product, product handling or a certain section of the documentation which must be given attention.

Qualified Electrical Engineering Personnel

Only qualified electrical engineering personnel may commission and operate the equipment (module, device) described in this document. Qualified electrical engineering personnel in the sense of this document are people who can demonstrate technical qualifications as electrical technicians. These persons may commission, isolate, ground and label devices, systems and circuits according to the standards of safety engineering.

Proper Use

The equipment (device, module) may be used only for such applications as set out in the catalogs and the technical description, and only in combination with third-party equipment recommended and approved by Siemens.

Problem-free and safe operation of the product depends on the following:







- Proper transport
- Proper storage, setup and installation
- Proper operation and maintenance

When electrical equipment is operated, hazardous voltages are inevitably present in certain parts. If proper action is not taken, death, severe injury or property damage can result:

- The equipment must be grounded at the grounding terminal before any connections are made.
- All circuit components connected to the power supply may be subject to dangerous voltage.
- Hazardous voltages may be present in equipment even after the supply voltage has been disconnected (capacitors can still be charged).
- Operation of equipment with exposed current-transformer circuits is prohibited. Before disconnecting the equipment, ensure that the current-transformer circuits are short-circuited.
- The limiting values stated in the document must not be exceeded. This must also be considered during testing and commissioning.

Selection of Used Symbols on the Device

Nr.	Symbol	Beschreibung
1		Direct current, IEC 60417, 5031
2		Alternating current, IEC 60417, 5032
3		Direct and alternating current, IEC 60417, 5033
4		Earth (ground) terminal, IEC 60417, 5017
5		Protective conductor terminal, IEC 60417, 5019

Nr.	Symbol	Beschreibung
6		Caution, risk of electric shock
7		Caution, risk of danger, ISO 7000, 0434
8		Protective insulation, IEC 60417, 5172, safety class II devices
9		Guideline 2002/96/EC for electrical and electronic devices
10		Guideline for the Eurasian market
11		Mandatory conformity mark for electronics and electrotechnical products in Morocco
12		Extra low voltage (ELV), IEC 60417, 5180, Safety Class III devices

OpenSSL

This product includes software developed by the OpenSSL Project for use in OpenSSL Toolkit (<http://www.openssl.org/>).

This product includes software written by Tim Hudson (tjh@cryptsoft.com).

This product includes cryptographic software written by Eric Young (eay@cryptsoft.com).

Table of Contents

	Preface	3
1	Introduction	43
	1.1 General.....	44
	1.2 Properties of SIPROTEC 5 Compact.....	45
2	Basic Structure of the Function	47
	2.1 Embedding of Functions in the Device.....	48
	2.2 Application Templates/Adaptation of Functional Scope.....	51
	2.3 Function Control.....	53
	2.4 Text Structure and Reference Number for Settings and Indications.....	59
	2.5 Information Lists.....	61
3	System Functions	63
	3.1 Indications.....	64
	3.1.1 General.....	64
	3.1.2 Reading Indications on the On-Site Operation Panel.....	64
	3.1.3 Reading Indications from the PC with DIGSI 5.....	66
	3.1.4 Displaying Indications.....	67
	3.1.5 Logs.....	70
	3.1.5.1 General.....	70
	3.1.5.2 Operational Log.....	71
	3.1.5.3 Fault Log.....	73
	3.1.5.4 Switching-Device Log.....	74
	3.1.5.5 Ground-Fault Log.....	75
	3.1.5.6 Setting-History Log.....	77
	3.1.5.7 User Log.....	78
	3.1.5.8 Security Log.....	80
	3.1.5.9 Device-Diagnosis Log.....	81
	3.1.5.10 Communication Log.....	82
	3.1.5.11 Communication-Supervision Log.....	83
	3.1.5.12 Motor-Starting Log.....	85
	3.1.6 Saving and Deleting the Logs.....	86
	3.1.7 Spontaneous Indication Display in DIGSI 5.....	88
	3.1.8 Spontaneous Fault Display on the On-Site Operation Panel.....	88
	3.1.9 Stored Indications in the SIPROTEC 5 Device.....	90
	3.1.10 Resetting Stored Indications of the Function Group	91
	3.1.11 Application Mode/Test Mode and Influence of Indications on Substation Automation Technology.....	91
	3.2 Measured-Value Acquisition	92
	3.3 Sampling-Frequency Tracking.....	94
	3.3.1 Overview.....	94

3.3.2	Sampling-Frequency Tracking.....	94
3.4	Processing Quality Attributes.....	97
3.4.1	Overview.....	97
3.4.2	Quality Processing/Affected by the User for Received GOOSE Values.....	99
3.4.3	Quality Processing/Affected by the User in CFC Charts.....	105
3.4.4	Quality Processing/Affected by the User in Internal Device Functions.....	109
3.5	Fault Recording.....	114
3.5.1	Overview of Functions	114
3.5.2	Structure of the Function.....	114
3.5.3	Function Description.....	114
3.5.4	Application and Setting Notes.....	117
3.5.5	Settings.....	119
3.5.6	Information List.....	120
3.6	Date and Time Synchronization.....	121
3.6.1	Overview of Functions.....	121
3.6.2	Structure of the Function.....	121
3.6.3	Function Description.....	121
3.6.4	Application and Setting Notes.....	124
3.6.5	Settings.....	127
3.6.6	Information List.....	127
3.7	User-Defined Objects.....	129
3.7.1	Overview.....	129
3.7.2	Basic Data Types.....	130
3.7.3	Pulse and EnergyMetered Values.....	132
3.7.4	Additional Data Types.....	133
3.7.5	External Signals.....	133
3.8	Other Functions.....	135
3.8.1	Signal Filtering and Chatter Blocking for Input Signals.....	135
3.8.2	Acquisition Blocking and Manual Updating.....	139
3.8.3	Persistent Commands.....	141
3.8.4	Device Logout.....	142
3.8.4.1	Overview.....	142
3.8.4.2	Application and Setting Notes.....	143
3.8.4.3	Information List.....	145
3.9	General Notes for Setting the Threshold Value of Protection Functions.....	146
3.9.1	Overview	146
3.9.2	Modifying the Transformer Ratios in DIGSI 5.....	146
3.9.3	Changing the Transformation Ratios of the Transformer on the Device.....	153
3.10	Device Settings.....	155
3.10.1	General Device Settings.....	155
3.10.1.1	Overview.....	155
3.10.1.2	Application and Setting Notes.....	156
3.10.1.3	Settings.....	158
3.10.1.4	Information List.....	161
3.10.2	Settings-Group Switching.....	162
3.10.2.1	Overview of Functions	162
3.10.2.2	Structure of the Function.....	162
3.10.2.3	Function Description.....	163

	3.10.2.4	Application and Setting Notes.....	163
	3.10.2.5	Settings.....	164
	3.10.2.6	Information List.....	164
4	Applications.....		167
	4.1	Overview.....	168
	4.2	Application Templates and Functional Scope for Device 7SX800.....	169
5	Function-Group Types.....		173
	5.1	Function-Group Type Voltage/current 3-Phase.....	174
	5.1.1	Overview.....	174
	5.1.2	Structure of the Function Group.....	174
	5.1.3	Application and Setting Notes.....	177
	5.1.4	Write-Protected Settings.....	178
	5.1.5	Settings.....	179
	5.1.6	Information List.....	179
	5.2	Function-Group Type Voltage/current 1-Phase.....	180
	5.2.1	Overview.....	180
	5.2.2	Structure of the Function Group.....	180
	5.2.3	Application and Setting Notes.....	184
	5.2.4	Write-Protected Settings.....	185
	5.2.5	Settings.....	185
	5.2.6	Information List.....	186
	5.3	Function-Group Type Voltage 3-Phase.....	187
	5.3.1	Overview.....	187
	5.3.2	Structure of the Function Group.....	187
	5.3.3	Application and Setting Notes.....	188
	5.3.4	Settings.....	188
	5.3.5	Information List.....	189
	5.4	Function-Group Type Motor.....	190
	5.4.1	Overview.....	190
	5.4.2	Structure of the Function Group.....	190
	5.4.3	Application and Setting Notes.....	196
	5.4.4	Information List.....	196
	5.4.5	Motor Monitor.....	197
	5.4.5.1	Overview of Functions.....	197
	5.4.5.2	Structure of the Function.....	197
	5.4.5.3	Current-Flow Criterion.....	198
	5.4.5.4	Application and Setting Notes (Current-Flow Criterion).....	198
	5.4.5.5	Circuit-Breaker Condition for the Motor.....	198
	5.4.5.6	Closure Detection.....	199
	5.4.5.7	Motor-State Detection.....	200
	5.4.5.8	Settings.....	202
	5.4.5.9	Information List.....	203
	5.4.5.10	Cold-Load Pickup Detection (Optional).....	204
	5.4.5.11	Application and Setting Notes (Cold-Load Pickup Detection).....	205
	5.4.5.12	Settings.....	206
	5.4.5.13	Information List.....	206
	5.4.6	Thermal Replica Rotor.....	206
	5.4.6.1	Overview of Functions.....	206
	5.4.6.2	Structure of the Function.....	206

5.4.6.3	Function Description.....	207
5.4.6.4	Application and Setting Notes.....	210
5.4.6.5	Settings.....	214
5.4.6.6	Information List.....	215
5.4.7	Settings.....	215
5.4.8	Information List.....	216
5.5	Function-Group Type Capacitor Bank.....	217
5.5.1	Overview.....	217
5.5.2	Structure of the Function Group.....	218
5.5.3	Application and Setting Notes.....	225
5.5.4	Write-Protected Settings.....	226
5.5.5	Settings.....	227
5.5.6	Information List.....	227
5.6	Function-Group Type Analog Units.....	228
5.6.1	Overview.....	228
5.6.2	Structure of the Function Group.....	228
5.6.3	20-mA Unit Ethernet.....	229
5.6.3.1	Overview	229
5.6.3.2	Structure of the Function.....	229
5.6.3.3	Communication with 20-mA Unit Ethernet.....	230
5.6.3.4	Application and Setting Notes.....	231
5.6.3.5	20-mA Channel.....	232
5.6.3.6	Application and Setting Notes.....	234
5.6.3.7	Settings.....	235
5.6.3.8	Information List.....	237
5.6.4	20-mA Unit Serial.....	237
5.6.4.1	Overview	237
5.6.4.2	Application and Setting Notes.....	238
5.6.4.3	Settings.....	239
5.6.4.4	Information List.....	241
5.6.5	Communication with 20-mA Unit.....	241
5.6.5.1	Integration of a Serial 20-mA Unit.....	241
5.6.5.2	Integration of a 20-mA Unit Ethernet.....	244
5.6.6	RTD Unit Ethernet.....	246
5.6.6.1	Overview.....	246
5.6.6.2	Structure of the Function.....	246
5.6.6.3	Communication with an RTD Unit.....	247
5.6.6.4	Application and Setting Notes.....	248
5.6.6.5	Temperature Sensor.....	249
5.6.6.6	Application and Setting Notes	249
5.6.6.7	Settings.....	250
5.6.6.8	Information List.....	250
5.6.7	RTD Unit, Serial.....	251
5.6.7.1	Overview	251
5.6.7.2	Application and Setting Notes.....	251
5.6.7.3	Settings.....	251
5.6.7.4	Information List.....	252
5.6.8	Communication with RTD Unit.....	252
5.6.8.1	Integration of a Serial RTD Unit (Ziehl TR1200).....	252
5.6.8.2	Integration of an RTD Unit Ether. (TR1200 IP).....	254
5.6.8.3	Temperature Simulation without Sensors	256
5.6.9	Temperature Acquisition via Protocols.....	256
5.6.9.1	Overview.....	256

5.6.9.2	Structure of the Function.....	257
5.6.9.3	Stage Temperature Acquisition via IEC 61850.....	257
5.6.9.4	IEC 61850 Configuration for the Temperature Acquisition.....	258
5.6.9.5	Stage Temperature Acquisition via GOOSE.....	261
5.6.9.6	GOOSE Configuration for the Temperature Acquisition.....	262
5.6.9.7	Application and Setting Notes.....	274
5.6.9.8	Settings.....	275
5.6.9.9	Information List.....	275
5.7	Function-Group Type Circuit Breaker.....	276
5.7.1	Overview.....	276
5.7.2	Structure of the Function Group.....	276
5.7.3	Application and Setting Notes.....	278
5.7.4	Settings.....	279
5.7.5	Information List.....	279
5.7.6	Trip Logic.....	280
5.7.6.1	Function Description.....	280
5.7.6.2	Application and Setting Notes.....	281
5.7.6.3	Settings.....	282
5.7.6.4	Information List.....	282
5.7.7	Circuit Breaker.....	282
5.7.7.1	Overview.....	282
5.7.7.2	Tripping, Opening and Closing the Circuit Breaker.....	283
5.7.7.3	Acquisition of Circuit-Breaker Auxiliary Contacts and Further Information.....	284
5.7.7.4	Circuit-Breaker Tripping Alarm Suppression.....	286
5.7.7.5	Tripping and Opening Information.....	287
5.7.7.6	Application and Setting Notes.....	288
5.7.7.7	Settings.....	290
5.7.7.8	Information List.....	290
5.7.8	Circuit-Breaker Position Recognition for Protection-Related Auxiliary Functions.....	291
5.7.8.1	Overview.....	291
5.7.9	Detection Manual Closure (for AREC and Process Monitor).....	292
5.7.9.1	Function Description.....	292
5.7.9.2	Application and Setting Notes.....	293
5.7.9.3	Settings.....	293
5.7.9.4	Information List.....	293
5.8	Function-Group Type Circuit Breaker [without Current].....	295
5.8.1	Overview.....	295
5.8.2	Structure of the Function Group.....	295
5.8.3	Application and Setting Notes.....	297
5.8.4	Settings.....	297
5.8.5	Trip Logic.....	297
5.8.5.1	Function Description.....	297
5.8.5.2	Application and Setting Notes.....	298
5.8.5.3	Settings.....	299
5.8.5.4	Information List.....	299
5.8.6	Circuit Breaker.....	299
5.8.6.1	Overview.....	299
5.8.6.2	Tripping, Opening, and Closing the Circuit Breaker.....	299
5.8.6.3	Detection of Circuit-Breaker Auxiliary Contacts and Further Information.....	301
5.8.6.4	Circuit-Breaker Tripping Alarm Suppression.....	303
5.8.6.5	Tripping and Opening Information.....	304
5.8.6.6	Application and Setting Notes.....	304
5.8.6.7	Settings.....	307
5.8.6.8	Information List.....	307

5.8.7	Circuit-Breaker Position Recognition for Protection-Related Auxiliary Functions.....	307
5.8.7.1	Overview.....	307
5.8.8	Detection Manual Closure (for Processor Monitor).....	308
5.8.8.1	Function Description.....	308
5.8.8.2	Application and Setting Notes.....	309
5.8.8.3	Settings.....	310
5.8.8.4	Information List.....	310
5.9	Function-Group Recording.....	311
5.9.1	Overview.....	311
5.9.2	Structure of the Function Group.....	311
5.10	Process Monitor.....	313
5.10.1	Overview of Functions.....	313
5.10.2	Structure of the Function.....	313
5.10.3	Current-Flow Criterion.....	314
5.10.4	Application and Setting Notes (Current-Flow Criterion).....	315
5.10.5	Circuit-Breaker Condition for the Protected Object.....	315
5.10.6	Closure Detection.....	316
5.10.7	Information List.....	316
5.10.8	Cold-Load Pickup Detection (Optional).....	317
5.10.9	Application and Setting Notes (Cold-Load Pickup Detection)	318
5.10.10	Settings.....	319
5.10.11	Information List.....	319
6	General Protection and Automation Functions.....	321
6.1	Power-System Data.....	323
6.1.1	Overview.....	323
6.1.2	Structure of the Power-System Data.....	323
6.1.3	Application and Setting Notes – General Settings.....	323
6.1.4	Application and Setting Notes for Measuring Point Current 3-Phase (I-3ph).....	324
6.1.5	Application and Setting Notes for Measuring Point Current 1-Phase (I-1ph).....	326
6.1.6	Application and Setting Notes for Measuring Point Voltage 3-Phase (V-3ph).....	327
6.1.7	Application and Setting Notes for Measuring Point Voltage 1-Phase (V-1ph).....	331
6.1.8	Disconnection of Measuring Points.....	333
6.1.8.1	Overview.....	333
6.1.8.2	Description.....	334
6.1.8.3	Application and Setting Notes.....	334
6.1.8.4	Settings.....	336
6.1.8.5	Information List.....	336
6.1.9	Settings.....	337
6.1.10	Information List.....	344
6.2	Group Indications of Overcurrent Protection Functions.....	348
6.2.1	Description	348
6.3	Overcurrent Protection, Phases.....	350
6.3.1	Overview of Functions	350
6.3.2	Structure of the Function	350
6.3.3	Filter for RMS Value Gain.....	350
6.3.3.1	Description.....	350
6.3.3.2	Application and Setting Notes.....	351
6.3.3.3	Settings.....	352
6.3.3.4	Information List.....	352

6.3.4	Stage with Definite-Time Characteristic Curve.....	353
6.3.4.1	Description	353
6.3.4.2	Application and Setting Notes.....	357
6.3.4.3	Settings.....	360
6.3.4.4	Information List.....	363
6.3.5	Stage with Inverse-Time Characteristic Curve.....	365
6.3.5.1	Description	365
6.3.5.2	Application and Setting Notes	370
6.3.5.3	Settings.....	372
6.3.5.4	Information List.....	375
6.3.6	Stage with User-Defined Characteristic Curve.....	376
6.3.6.1	Description	376
6.3.6.2	Application and Setting Notes	377
6.3.6.3	Settings.....	378
6.3.6.4	Information List.....	381
6.3.7	Blocking of the Tripping by Device-Internal Inrush-Current Detection.....	382
6.3.7.1	Description	382
6.3.7.2	Application and Setting Notes	382
6.3.8	Influence of Other Functions via Dynamic Settings.....	383
6.3.8.1	Description	383
6.3.8.2	Application and Setting Notes (Advanced Stage)	384
6.4	Voltage-Dependent Overcurrent Protection, Phases.....	385
6.4.1	Overview of Functions.....	385
6.4.2	Structure of the Function.....	385
6.4.3	Stage with Inverse-Time Overcurrent Protection, Voltage-Dependent.....	386
6.4.3.1	Description.....	386
6.4.3.2	Application and Setting Notes.....	388
6.4.3.3	Settings.....	390
6.4.3.4	Information List.....	390
6.4.4	Stage with Inverse-Time Overcurrent Protection, Voltage-Released.....	392
6.4.4.1	Description.....	392
6.4.4.2	Application and Setting Notes.....	393
6.4.4.3	Settings.....	394
6.4.4.4	Information List.....	394
6.4.5	Stage with Definite-Time Overcurrent Protection, Undervoltage Seal-In.....	396
6.4.5.1	Description.....	396
6.4.5.2	Application and Setting Notes.....	397
6.4.5.3	Settings.....	398
6.4.5.4	Information List.....	399
6.4.6	Stage with Definite-Time Overcurrent Protection, Voltage-Released Under- voltage Seal-In.....	400
6.4.6.1	Description.....	400
6.4.6.2	Application and Setting Notes.....	401
6.4.6.3	Settings.....	403
6.4.6.4	Information List.....	404
6.5	Overcurrent Protection, Ground.....	405
6.5.1	Overview of Functions.....	405
6.5.2	Structure of the Function.....	405
6.5.3	General Functionality.....	405
6.5.3.1	Description.....	405
6.5.3.2	Application and Setting Notes	406
6.5.3.3	Settings.....	406
6.5.4	Stage with Definite-Time Characteristic Curve.....	407
6.5.4.1	Description	407

6.5.4.2	Application and Setting Notes	409
6.5.4.3	Settings.....	412
6.5.4.4	Information List.....	417
6.5.5	Stage with Inverse-Time Characteristic Curve.....	418
6.5.5.1	Description	418
6.5.5.2	Application and Setting Notes	421
6.5.5.3	Settings.....	423
6.5.5.4	Information List.....	426
6.5.6	Stage with User-Defined Characteristic Curve.....	426
6.5.6.1	Description	426
6.5.6.2	Application and Setting Notes	428
6.5.6.3	Settings.....	429
6.5.6.4	Information List.....	431
6.5.7	Blocking of the Tripping by Device-Internal Inrush-Current Detection.....	432
6.5.7.1	Description.....	432
6.5.7.2	Application and Setting Notes	433
6.5.8	Influence of Other Functions via Dynamic Settings.....	434
6.5.8.1	Description	434
6.5.8.2	Application and Setting Notes (Advanced Stage)	435
6.6	Directional Overcurrent Protection, Phases.....	436
6.6.1	Overview of Functions	436
6.6.2	Structure of the Function	436
6.6.3	Stage Control.....	436
6.6.3.1	Description	436
6.6.3.2	Application and Setting Notes	437
6.6.4	Stage with Definite-Time Characteristic Curve.....	438
6.6.4.1	Description	438
6.6.4.2	Application and Setting Notes	441
6.6.4.3	Settings.....	443
6.6.4.4	Information List.....	448
6.6.5	Stage with Inverse-Time Characteristic Curve.....	450
6.6.5.1	Description	450
6.6.5.2	Application and Setting Notes	453
6.6.5.3	Settings.....	455
6.6.5.4	Information List.....	458
6.6.6	Stage with User-Defined Characteristic Curve.....	459
6.6.6.1	Description	459
6.6.6.2	Application and Setting Notes	460
6.6.6.3	Settings.....	461
6.6.6.4	Information List.....	464
6.6.7	Direction Determination.....	464
6.6.7.1	Description	464
6.6.7.2	Application and Setting Notes	467
6.6.8	Influence of Other Functions via Dynamic Settings	467
6.6.9	Application Notes for Parallel Lines	468
6.6.10	Application Notes for Directional Comparison Protection	468
6.7	Directional Overcurrent Protection, Ground.....	470
6.7.1	Overview of Functions.....	470
6.7.2	Structure of the Function.....	470
6.7.3	General Functionality.....	472
6.7.3.1	Measured-Value Selection.....	472
6.7.3.2	Direction Determination.....	473
6.7.3.3	Application and Setting Notes.....	475

6.7.3.4	Settings.....	477
6.7.3.5	Information List.....	478
6.7.4	Stage Control.....	478
6.7.4.1	Description.....	478
6.7.4.2	Application and Setting Notes.....	479
6.7.5	Stage with Definite-Time Characteristic Curve.....	480
6.7.5.1	Description.....	480
6.7.5.2	Application and Setting Notes.....	483
6.7.5.3	Settings.....	486
6.7.5.4	Information List.....	486
6.7.6	Stage with Inverse-Time Characteristic Curve.....	487
6.7.6.1	Description.....	487
6.7.6.2	Application and Setting Notes.....	491
6.7.6.3	Settings.....	494
6.7.6.4	Information List.....	494
6.7.7	Stage with Inverse-Time Overcurrent Protection with Logarithmic-Inverse Characteristic Curve.....	496
6.7.7.1	Description.....	496
6.7.7.2	Application and Setting Notes.....	498
6.7.7.3	Settings.....	499
6.7.7.4	Information List.....	501
6.7.8	Stage with Knee-Point Characteristic Curve.....	503
6.7.8.1	Description.....	503
6.7.8.2	Application and Setting Notes.....	504
6.7.8.3	Settings.....	505
6.7.8.4	Information List.....	506
6.7.9	Stage with User-Defined Characteristic Curve.....	507
6.7.9.1	Description.....	507
6.7.9.2	Application and Setting Notes.....	508
6.7.9.3	Settings.....	509
6.7.9.4	Information List.....	512
6.7.10	Influence of Other Functions via Dynamic Settings.....	513
6.8	Inrush-Current and 2nd Harmonic Detection.....	514
6.8.1	Inrush-Current Detection.....	514
6.8.1.1	Overview of Functions.....	514
6.8.1.2	Structure of the Function	514
6.8.1.3	Function Description.....	514
6.8.1.4	Application and Setting Notes.....	518
6.8.1.5	Settings.....	519
6.8.1.6	Information List.....	520
6.8.2	2nd Harmonic Ground Detection.....	520
6.8.2.1	Overview of Functions.....	520
6.8.2.2	Structure of the Function.....	521
6.8.2.3	Function Description.....	521
6.8.2.4	Application and Setting Notes.....	522
6.8.2.5	Settings.....	522
6.8.2.6	Information List.....	522
6.8.3	2nd Harmonic Detection 1-Phase.....	523
6.8.3.1	Overview of Functions.....	523
6.8.3.2	Structure of the Function.....	523
6.8.3.3	Function Description.....	524
6.8.3.4	Application and Setting Notes.....	525
6.8.3.5	Settings.....	525
6.8.3.6	Information List.....	525

6.9	Instantaneous High-Current Tripping.....	526
6.9.1	Overview of Functions.....	526
6.9.2	Structure of the Function.....	526
6.9.3	Standard Release Procedure.....	527
6.9.4	Application and Setting Notes.....	528
6.9.5	Settings.....	529
6.9.6	Information List.....	530
6.10	Instantaneous Tripping at Switch onto Fault.....	531
6.10.1	Overview of Functions	531
6.10.2	Structure of the Function.....	531
6.10.3	Stage Description.....	532
6.10.4	Application and Setting Notes.....	532
6.10.5	Settings.....	533
6.10.6	Information List.....	533
6.11	Overcurrent Protection, 1-Phase.....	534
6.11.1	Function Overview	534
6.11.2	Structure of the Function	534
6.11.3	Stage with Definite-Time Characteristic Curve.....	536
6.11.3.1	Description	536
6.11.3.2	Application and Setting Notes	537
6.11.3.3	Settings.....	537
6.11.3.4	Information List.....	538
6.11.4	Stage with Inverse-Time Characteristic Curve.....	539
6.11.4.1	Description	539
6.11.4.2	Application and Setting Notes	540
6.11.4.3	Settings.....	541
6.11.4.4	Information List.....	542
6.11.5	Stage with Inverse-Time Overcurrent Protection with Logarithmic-Inverse Characteristic Curve.....	543
6.11.5.1	Description.....	543
6.11.5.2	Application and Setting Notes.....	545
6.11.5.3	Settings.....	546
6.11.5.4	Information List.....	546
6.11.6	Stage with User-Defined Characteristic Curve.....	547
6.11.6.1	Description	547
6.11.6.2	Application and Setting Notes	548
6.11.6.3	Settings.....	549
6.11.6.4	Information List.....	549
6.11.7	Fast Stage.....	549
6.11.7.1	Description	549
6.11.7.2	Application and Setting Notes	550
6.11.7.3	Settings.....	551
6.11.7.4	Information List.....	551
6.11.8	Blocking of the Tripping by Device-Internal Inrush-Current Detection.....	551
6.11.8.1	Description.....	551
6.11.8.2	Application and Setting Notes	552
6.11.9	Application Example: High-Impedance Restricted Ground-Fault Protection.....	553
6.11.9.1	Description	553
6.11.9.2	Application and Setting Notes	555
6.11.10	Application Example: Tank Leakage Protection.....	559
6.11.10.1	Description	559
6.11.10.2	Application and Setting Notes	559

6.12	Positive-Sequence Overcurrent Protection.....	560
6.12.1	Overview of Functions	560
6.12.2	Structure of the Function	560
6.12.3	Stage with Definite-Time Characteristic Curve.....	561
6.12.3.1	Description.....	561
6.12.3.2	Application and Setting Notes.....	562
6.12.3.3	Settings.....	564
6.12.3.4	Information List.....	564
6.12.4	Stage with Inverse-Time Characteristic Curve.....	566
6.12.4.1	Description.....	566
6.12.4.2	Application and Setting Notes	567
6.12.4.3	Settings.....	568
6.12.4.4	Information List.....	568
6.13	Non-Directional Intermittent Ground-Fault Protection.....	570
6.13.1	Overview of Functions.....	570
6.13.2	Structure of the Function.....	570
6.13.3	Stage Description.....	571
6.13.4	Application and Setting Notes.....	575
6.13.5	Settings.....	577
6.13.6	Information List.....	578
6.14	Directional Intermittent Ground-Fault Protection.....	579
6.14.1	Overview of Functions.....	579
6.14.2	Structure of the Function.....	579
6.14.3	Stage Description.....	580
6.14.4	Application and Setting Notes.....	586
6.14.5	Settings.....	589
6.14.6	Information List.....	589
6.15	Sensitive Ground-Fault Detection.....	591
6.15.1	Overview of Functions.....	591
6.15.2	Structure of the Function.....	591
6.15.3	General Functionality.....	594
6.15.3.1	Description.....	594
6.15.3.2	Application and Setting Notes.....	597
6.15.3.3	Settings.....	599
6.15.3.4	Information List.....	599
6.15.4	Directional 3I0 Stage with Cos ϕ or Sin ϕ Measurement.....	600
6.15.4.1	Description.....	600
6.15.4.2	Application and Setting Notes.....	606
6.15.4.3	Settings.....	609
6.15.4.4	Information List.....	610
6.15.5	Directional Transient Ground-Fault Stage.....	610
6.15.5.1	Description	610
6.15.5.2	Application and Setting Notes.....	615
6.15.5.3	Settings.....	618
6.15.5.4	Information List.....	618
6.15.6	Directional 3I0 Stage with ϕ ($V_0,3I_0$) Measurement.....	619
6.15.6.1	Description	619
6.15.6.2	Application and Setting Notes.....	623
6.15.6.3	Settings.....	625
6.15.6.4	Information List.....	625

6.15.7	Directional YO Stage with G0 or B0 Measurement.....	626
6.15.7.1	Description.....	626
6.15.7.2	Application and Setting Notes.....	631
6.15.7.3	Settings.....	635
6.15.7.4	Information List.....	636
6.15.8	Directional Stage with Phasor Measurement of a Harmonic.....	636
6.15.8.1	Description.....	636
6.15.8.2	Application and Setting Notes.....	641
6.15.8.3	Settings.....	643
6.15.8.4	Information List.....	644
6.15.9	Non-Directional VO Stage with Zero-Sequence Voltage/Residual Voltage.....	645
6.15.9.1	Description	645
6.15.9.2	Application and Setting Notes.....	646
6.15.9.3	Settings.....	649
6.15.9.4	Information List.....	649
6.15.10	Non-Directional 3I0 Stage.....	649
6.15.10.1	Description	649
6.15.10.2	Application and Setting Notes	651
6.15.10.3	Settings.....	653
6.15.10.4	Information List.....	653
6.15.11	Non-Directional YO Stage.....	653
6.15.11.1	Description.....	653
6.15.11.2	Application and Setting Notes.....	656
6.15.11.3	Settings.....	657
6.15.11.4	Information List.....	657
6.15.12	Non-Directional 3I0 Harmonic Stage.....	658
6.15.12.1	Description.....	658
6.15.12.2	Application and Setting Notes.....	659
6.15.12.3	Settings.....	660
6.15.12.4	Information List.....	661
6.15.13	Pulse-Pattern Detection Stage.....	661
6.15.13.1	Description.....	661
6.15.13.2	Application and Setting Notes.....	666
6.15.13.3	Settings.....	669
6.15.13.4	Information List.....	669
6.15.14	Intermittent Ground-Fault Blocking Stage.....	670
6.15.14.1	Description.....	670
6.15.14.2	Application and Setting Notes.....	671
6.15.14.3	Settings.....	672
6.15.14.4	Information List.....	672
6.16	Undercurrent Protection.....	673
6.16.1	Overview of Functions.....	673
6.16.2	Structure of the Function	673
6.16.3	Stage Description.....	674
6.16.4	Application and Setting Notes	675
6.16.5	Settings.....	677
6.16.6	Information List.....	677
6.17	Negative-Sequence Protection.....	679
6.17.1	Overview of Functions	679
6.17.2	Structure of the Function	679
6.17.3	General Functionality.....	680
6.17.3.1	Description.....	680
6.17.3.2	Application and Setting Notes.....	680

6.17.4	Stage with Definite-Time Characteristic Curve.....	682
6.17.4.1	Stage Description	682
6.17.4.2	Application and Setting Notes	683
6.17.4.3	Settings.....	683
6.17.4.4	Information List.....	684
6.17.5	Stage with Inverse-Time Characteristic Curve.....	686
6.17.5.1	Description.....	686
6.17.5.2	Application and Settings Notes.....	687
6.17.5.3	Settings.....	688
6.17.5.4	Information List.....	688
6.18	Directional Negative-Sequence Protection.....	689
6.18.1	Overview of Functions.....	689
6.18.2	Structure of the Function	689
6.18.3	Function Description.....	689
6.18.4	Application and Setting Notes for Direction Determination	694
6.18.5	Application and Setting Notes for Stages.....	695
6.18.6	Settings.....	697
6.18.7	Information List.....	698
6.19	Thermal Overload Protection, 3-Phase - Advanced.....	699
6.19.1	Overview of Functions.....	699
6.19.2	Structure of the Function.....	699
6.19.3	Filter for RMS Value Gain.....	699
6.19.3.1	Description.....	699
6.19.3.2	Application and Setting Notes.....	700
6.19.3.3	Settings.....	701
6.19.3.4	Information List.....	702
6.19.4	Stage with Thermal Overload Protection, 3-Phase - Advanced.....	703
6.19.4.1	Description	703
6.19.4.2	Application and Setting Notes.....	708
6.19.4.3	Settings.....	710
6.19.4.4	Information List.....	711
6.20	Thermal Overload Protection, User-Defined Characteristic Curve.....	712
6.20.1	Overview of Functions.....	712
6.20.2	Structure of the Function.....	712
6.20.3	Function Description.....	712
6.20.4	Application and Setting Notes.....	718
6.20.5	Settings.....	721
6.20.6	Information List.....	722
6.21	Thermal Overload Protection, 1-Phase.....	724
6.21.1	Overview of Functions.....	724
6.21.2	Structure of the Function.....	724
6.21.3	Function Description.....	725
6.21.4	Application and Setting Notes.....	729
6.21.5	Settings.....	733
6.21.6	Information List.....	734
6.22	Unbalanced-Load Protection.....	735
6.22.1	Overview of Functions.....	735
6.22.2	Structure of the Function.....	735
6.22.3	Function Description.....	736

6.22.4	Application and Setting Notes.....	738
6.22.5	Settings.....	740
6.22.6	Information List.....	740
6.23	Overvoltage Protection with 3-Phase Voltage.....	742
6.23.1	Overview of Functions	742
6.23.2	Structure of the Function.....	742
6.23.3	Stage with Definite-Time Characteristic Curve.....	743
6.23.3.1	Description	743
6.23.3.2	Application and Setting Notes	744
6.23.3.3	Settings.....	746
6.23.3.4	Information List.....	747
6.23.4	Stage with Inverse-Time Characteristic Curve.....	749
6.23.4.1	Description	749
6.23.4.2	Application and Setting Notes	752
6.23.4.3	Settings.....	754
6.23.4.4	Information List.....	754
6.24	Overvoltage Protection with Zero-Sequence Voltage/Residual Voltage.....	755
6.24.1	Overview of Functions	755
6.24.2	Structure of the Function	755
6.24.3	Stage Description	756
6.24.4	Application and Setting Notes.....	757
6.24.5	Settings.....	760
6.24.6	Information List.....	760
6.25	Overvoltage Protection with Positive-Sequence Voltage.....	761
6.25.1	Overview of Functions.....	761
6.25.2	Structure of the Function.....	761
6.25.3	Stage Description	762
6.25.4	Application and Setting Notes.....	762
6.25.5	Settings.....	763
6.25.6	Information List.....	763
6.26	Overvoltage Protection with Negative-Sequence Voltage.....	765
6.26.1	Overview of Functions	765
6.26.2	Structure of the Function	765
6.26.3	General Functionality.....	765
6.26.3.1	Description.....	765
6.26.3.2	Application and Setting Notes.....	766
6.26.3.3	Settings.....	767
6.26.3.4	Information List.....	767
6.26.4	Stage with Negative-Sequence Voltage.....	768
6.26.4.1	Description.....	768
6.26.4.2	Application and Setting Notes.....	768
6.26.4.3	Settings.....	770
6.26.4.4	Information List.....	771
6.27	Overvoltage Protection with Any Voltage.....	772
6.27.1	Overview of Functions.....	772
6.27.2	Structure of the Function.....	772
6.27.3	Stage Description.....	773
6.27.4	Application and Setting Notes.....	774
6.27.5	Settings.....	776

6.27.6	Information List.....	777
6.28	Overvoltage Protection with Negative-Sequence Voltage/Positive-Sequence Voltage	778
6.28.1	Overview of Functions.....	778
6.28.2	Structure of the Function	778
6.28.3	General Functionality.....	778
6.28.3.1	Description.....	778
6.28.3.2	Application and Setting Notes.....	779
6.28.3.3	Settings.....	780
6.28.3.4	Information List.....	780
6.28.4	Stage with Negative-Sequence Voltage/Positive-Sequence Voltage	781
6.28.4.1	Description.....	781
6.28.4.2	Application and Setting Notes.....	781
6.28.4.3	Settings.....	783
6.28.4.4	Information List.....	784
6.29	Undervoltage Protection with 3-Phase Voltage.....	785
6.29.1	Overview of Functions.....	785
6.29.2	Structure of the Function	785
6.29.3	Stage with Definite-Time Characteristic Curve.....	786
6.29.3.1	Description.....	786
6.29.3.2	Application and Setting Notes.....	788
6.29.3.3	Settings.....	791
6.29.3.4	Information List.....	792
6.29.4	Stage with Inverse-Time Characteristic Curve.....	794
6.29.4.1	Description.....	794
6.29.4.2	Application and Setting Notes.....	798
6.29.4.3	Settings.....	801
6.29.4.4	Information List.....	801
6.30	Undervoltage Protection with Positive-Sequence Voltage.....	802
6.30.1	Overview of Functions	802
6.30.2	Structure of the Function	802
6.30.3	Stage Description	803
6.30.4	Application and Setting Notes	804
6.30.5	Settings.....	806
6.30.6	Information List.....	807
6.31	Undervoltage Protection with Any Voltage.....	808
6.31.1	Overview of Functions.....	808
6.31.2	Structure of the Function.....	808
6.31.3	Stage Description.....	809
6.31.4	Application and Setting Notes.....	810
6.31.5	Settings.....	812
6.31.6	Information List.....	813
6.32	Rate-of-Voltage-Change Protection.....	815
6.32.1	Overview of Functions	815
6.32.2	Structure of the Function.....	815
6.32.3	General Functionality.....	816
6.32.3.1	Description.....	816
6.32.3.2	Application and Setting Notes.....	816
6.32.4	Stage Description.....	817
6.32.4.1	Description.....	817
6.32.4.2	Application and Setting Notes.....	818

6.32.5	Settings.....	819
6.32.6	Information List.....	820
6.33	Overfrequency Protection.....	822
6.33.1	Overview of Functions.....	822
6.33.2	Structure of the Function.....	822
6.33.3	Overfrequency-Protection Stage.....	823
6.33.4	Application and Setting Notes.....	824
6.33.5	Settings.....	825
6.33.6	Information List.....	825
6.34	Underfrequency Protection.....	827
6.34.1	Overview of Functions.....	827
6.34.2	Structure of the Function.....	827
6.34.3	Underfrequency-Protection Stage.....	828
6.34.4	Application and Setting Notes.....	829
6.34.5	Settings.....	829
6.34.6	Information List.....	830
6.35	Underfrequency Load Shedding.....	832
6.35.1	Overview of Functions.....	832
6.35.2	Structure of the Function.....	832
6.35.3	General Functionality.....	833
6.35.3.1	Description.....	833
6.35.3.2	Application and Setting Notes.....	836
6.35.4	Stage Description.....	839
6.35.4.1	Description.....	839
6.35.4.2	Application and Setting Notes.....	841
6.35.5	Settings.....	842
6.35.6	Information List.....	843
6.36	Rate of Frequency Change Protection.....	844
6.36.1	Overview of Functions	844
6.36.2	Structure of the Function.....	844
6.36.3	General Functions (Undervoltage Test, df/dt Calculation).....	844
6.36.3.1	Description.....	844
6.36.3.2	Application and Setting Notes.....	845
6.36.4	Stage Description.....	846
6.36.4.1	Description.....	846
6.36.4.2	Application and Setting Notes.....	847
6.36.5	Settings.....	848
6.36.6	Information List.....	848
6.37	Vector-Jump Protection.....	850
6.37.1	Overview of Functions.....	850
6.37.2	Structure of the Function.....	850
6.37.3	General Functionality.....	850
6.37.3.1	Description.....	850
6.37.3.2	Application and Setting Notes.....	853
6.37.3.3	Settings.....	853
6.37.3.4	Information List.....	853
6.37.4	$\Delta\varphi$ Stage.....	854
6.37.4.1	Description.....	854
6.37.4.2	Application and Setting Notes.....	855

6.37.4.3	Settings.....	856
6.37.4.4	Information List.....	856
6.37.5	I1 < Release Stage	856
6.37.5.1	Description.....	856
6.37.5.2	Application and Setting Notes.....	857
6.37.5.3	Settings.....	857
6.37.5.4	Information List.....	857
6.38	Power Protection (P,Q), 3-Phase.....	858
6.38.1	Overview of Functions	858
6.38.2	Structure of the Function	858
6.38.3	Active Power Stage	859
6.38.4	Reactive Power Stage	861
6.38.5	Application Example.....	862
6.38.6	Setting Notes for the Active Power Stage.....	862
6.38.7	Setting Notes for the Reactive Power Stage.....	863
6.38.8	Settings.....	863
6.38.9	Information List.....	865
6.39	Reverse-Power Protection.....	867
6.39.1	Overview of Functions.....	867
6.39.2	Structure of the Function.....	867
6.39.3	General Functionality.....	868
6.39.3.1	Description	868
6.39.3.2	Application and Setting Notes.....	869
6.39.3.3	Settings.....	871
6.39.3.4	Information List.....	871
6.39.4	Stage Description.....	872
6.39.4.1	Description	872
6.39.4.2	Application and Setting Notes.....	873
6.39.4.3	Settings.....	873
6.39.4.4	Information List.....	874
6.40	Overexcitation Protection.....	875
6.40.1	Overview of Functions	875
6.40.2	Structure of the Function	875
6.40.3	Stage with Dependent Characteristic Curve (Thermal Stage).....	876
6.40.3.1	Function Description.....	876
6.40.3.2	Application and Setting Notes.....	879
6.40.3.3	Settings.....	880
6.40.3.4	Information List.....	881
6.40.4	Stage with Independent Characteristic Curve.....	882
6.40.4.1	Function Description.....	882
6.40.4.2	Application and Setting Notes	882
6.40.4.3	Settings.....	883
6.40.4.4	Information List.....	883
6.41	Undervoltage-Controlled Reactive-Power Protection.....	885
6.41.1	Overview of Functions.....	885
6.41.2	Structure of the Function.....	885
6.41.3	Protection Stage.....	886
6.41.3.1	Description.....	886
6.41.3.2	Application and Setting Notes.....	887
6.41.3.3	Settings.....	889
6.41.3.4	Information List.....	890

6.41.4	Reclosure Stage.....	891
6.41.4.1	Description.....	891
6.41.4.2	Application and Setting Notes.....	892
6.41.4.3	Settings.....	893
6.41.4.4	Information List.....	893
6.42	Circuit-Breaker Failure Protection.....	894
6.42.1	Overview of Functions.....	894
6.42.2	Structure of the Function.....	894
6.42.3	Function Description.....	895
6.42.4	Application and Setting Notes.....	902
6.42.5	Settings.....	910
6.42.6	Information List.....	912
6.43	Circuit-Breaker Restrike Protection.....	913
6.43.1	Overview of Function.....	913
6.43.2	Structure of the Function.....	913
6.43.3	Function Description.....	913
6.43.4	Application and Setting Notes.....	917
6.43.5	Settings.....	920
6.43.6	Information List.....	921
6.44	Restricted Ground-Fault Protection.....	922
6.44.1	Overview of Functions.....	922
6.44.2	Structure of the Function.....	922
6.44.3	Function Description.....	923
6.44.4	Application and Setting Notes.....	929
6.44.5	Settings.....	939
6.44.6	Information List.....	939
6.45	External Trip Initiation 3-Pole.....	940
6.45.1	Overview of Functions.....	940
6.45.2	Structure of the Function.....	940
6.45.3	Stage Description.....	941
6.45.4	Application and Setting Notes.....	941
6.45.5	Settings.....	941
6.45.6	Information List.....	942
6.46	Automatic Reclosing Function.....	943
6.46.1	Overview of Functions.....	943
6.46.2	Structure of the Function.....	944
6.46.3	Cooperation of the Automatic Reclosing Function and Protection Functions.....	946
6.46.4	Cyclic Automatic Reclosing Function.....	947
6.46.4.1	Operating Modes for Cyclic Automatic Reclosing Function.....	947
6.46.4.2	Structure of the Cyclic Automatic Reclosing Function.....	950
6.46.4.3	Input Logic for Operating Modes with Tripping	951
6.46.4.4	Input Logic for Operating Modes with Pickup.....	952
6.46.4.5	Start.....	953
6.46.4.6	Cycle Control with Operating Mode 1: With Tripping/With Action Time.....	954
6.46.4.7	Cycle Control with Operating Mode 2: With Pickup/With Action Time.....	956
6.46.4.8	Cycle Control with Operating Mode 3: With Tripping/Without Action Time.....	958
6.46.4.9	Cycle Control with Operating Mode 4: With Pickup/Without Action Time.....	959
6.46.4.10	Stage Release.....	960
6.46.4.11	Dead Time for Operating Modes with Tripping.....	961

6.46.4.12	Dead Time for Operating Modes with Pickup.....	963
6.46.4.13	Evolving-Fault Detection During the Dead Time.....	965
6.46.4.14	Closing Indication and Close Command.....	967
6.46.4.15	Reclaim Time.....	969
6.46.4.16	Circuit-Breaker Readiness and Circuit-Breaker Position.....	970
6.46.4.17	Blockings.....	972
6.46.4.18	Dead-Line Checking (DLC) and Reduced Dead Time (RDT).....	976
6.46.4.19	Settings.....	978
6.46.4.20	Information List.....	980
6.46.5	Automatic Reclosing Function with Adaptive Dead Time (ADT).....	982
6.46.5.1	Description.....	982
6.46.5.2	Settings	983
6.46.5.3	Information List.....	984
6.46.6	Cooperation with External Automatic Reclosing Function.....	985
6.46.6.1	Description	985
6.46.6.2	Information List.....	986
6.46.7	Application and Setting Notes for General Settings.....	987
6.46.8	Application and Setting Notes for 1 Cycle of the Cyclic Automatic Reclosing Function	994
6.47	Fault Locator.....	997
6.47.1	Overview of Functions.....	997
6.47.2	Structure of the Function.....	997
6.47.3	Function Description.....	998
6.47.4	Application and Setting Notes.....	1006
6.47.5	Settings.....	1010
6.47.6	Information List.....	1011
6.48	Fault Locator Plus.....	1012
6.48.1	Overview of Functions.....	1012
6.48.2	Structure of the Function.....	1012
6.48.3	Function Description.....	1014
6.48.4	Application and Setting Notes.....	1017
6.48.5	Settings.....	1024
6.48.6	Information List.....	1025
6.49	Temperature Supervision.....	1026
6.49.1	Overview of Functions	1026
6.49.2	Structure of the Function	1026
6.49.3	Function Description	1027
6.49.4	Application and Setting Notes	1028
6.49.5	Settings.....	1029
6.49.6	Information List.....	1033
6.50	Phase-Sequence Switchover.....	1036
6.50.1	Overview of Functions.....	1036
6.50.2	Structure of the Function	1036
6.50.3	Function Description.....	1036
6.50.4	Application and Setting Notes.....	1039
6.50.5	Settings.....	1040
6.50.6	Information List.....	1041
6.51	Current-Jump Detection.....	1042
6.51.1	Overview of Functions.....	1042
6.51.2	Structure of the Function	1042

6.51.3	Function Description.....	1042
6.51.4	Application and Setting Notes	1043
6.51.5	Settings.....	1044
6.51.6	Information List.....	1044
6.52	Voltage-Jump Detection.....	1045
6.52.1	Overview of Functions.....	1045
6.52.2	Structure of the Function	1045
6.52.3	Function Description.....	1045
6.52.4	Application and Setting Notes	1046
6.52.5	Settings.....	1047
6.52.6	Information List.....	1047
6.53	Voltage Measuring-Point Selection.....	1049
6.53.1	Overview of Functions.....	1049
6.53.2	Function Description.....	1049
6.53.3	Application and Setting Notes.....	1050
6.53.4	Information List.....	1051
6.54	Protection and Automation Functions (CEI 0-16 Standard).....	1052
6.54.1	Introduction.....	1052
6.55	Overvoltage Protection with 3-Phase Voltage (CEI 0-16 Standard).....	1053
6.55.1	Structure of the Function.....	1053
6.55.2	General Functionality.....	1053
6.55.2.1	Description.....	1053
6.55.3	Stage with Definite-Time Characteristic Curve, 10-Min RMS Value.....	1054
6.55.3.1	Description.....	1054
6.55.3.2	Application and Setting Notes	1055
6.55.4	Stage with Definite-Time Characteristic Curve, Fundamental Component.....	1056
6.55.4.1	Description.....	1056
6.55.4.2	Application and Setting Notes	1057
6.55.5	Settings.....	1057
6.55.6	Information List.....	1058
6.56	Frequency Protection (CEI 0-16 Standard)	1060
6.56.1	Structure of the Function.....	1060
6.56.2	General Functionality.....	1061
6.56.2.1	Description.....	1061
6.56.2.2	Application and Setting Notes	1063
6.56.3	Overvoltage-Protection Stage with Zero-Sequence Voltage/Residual Voltage	1067
6.56.3.1	Description.....	1067
6.56.3.2	Application and Setting Notes	1068
6.56.4	Frequency Protection S1 Stages	1069
6.56.4.1	Description.....	1069
6.56.4.2	Application and Setting Notes	1070
6.56.5	Frequency Protection S2 Stages.....	1071
6.56.5.1	Description.....	1071
6.56.5.2	Application and Setting Notes	1072
6.56.6	Settings.....	1073
6.56.7	Information List.....	1075
6.57	Undervoltage Protection with 3-Phase Voltage (CEI 0-16 Standard)	1077
6.57.1	Structure of the Function.....	1077

6.57.2	General Functionality.....	1077
6.57.2.1	Description.....	1077
6.57.2.2	Application and Setting Notes	1078
6.57.3	Stage with Definite-Time Characteristic Curve.....	1079
6.57.3.1	Description.....	1079
6.57.3.2	Application and Setting Notes	1080
6.57.4	Settings.....	1081
6.57.5	Information List.....	1081
6.58	PI Trip Logic (CEI 0-16 Standard) in FG Circuit Breaker	1083
6.58.1	Description.....	1083
6.58.2	Information List.....	1084
7	Motor-Protection Functions.....	1085
7.1	Motor-Starting Time Supervision.....	1086
7.1.1	Overview of Functions.....	1086
7.1.2	Structure of the Function.....	1086
7.1.3	Stage with Inverse-Time Characteristic Curve.....	1087
7.1.3.1	Description.....	1087
7.1.3.2	Application and Setting Notes.....	1089
7.1.3.3	Settings.....	1092
7.1.3.4	Information List.....	1092
7.1.4	Stage with User-Defined Characteristic Curve.....	1093
7.1.4.1	Description.....	1093
7.1.4.2	Application and Setting Notes.....	1094
7.1.4.3	Settings.....	1095
7.1.4.4	Information List.....	1095
7.2	Motor Restart Inhibit.....	1096
7.2.1	Overview of Functions.....	1096
7.2.2	Structure of the Function.....	1096
7.2.3	Thermal Stage.....	1097
7.2.3.1	Description.....	1097
7.2.3.2	Application and Setting Notes.....	1100
7.2.3.3	Settings.....	1100
7.2.3.4	Information List.....	1101
7.2.4	Counter Stage.....	1102
7.2.4.1	Description.....	1102
7.2.4.2	Application and Setting Notes.....	1103
7.2.4.3	Settings.....	1104
7.2.4.4	Information List.....	1104
7.2.5	Timer Stage.....	1105
7.2.5.1	Description.....	1105
7.2.5.2	Application and Setting Notes.....	1106
7.2.5.3	Settings.....	1106
7.2.5.4	Information List.....	1107
7.3	Load-Jam Protection Motor.....	1108
7.3.1	Overview of Functions.....	1108
7.3.2	Structure of the Function.....	1108
7.3.3	Stage Description.....	1110
7.3.4	Application and Setting Notes.....	1111
7.3.5	Settings.....	1113
7.3.6	Information List.....	1113

7.4	Thermal Overload Protection, Rotor.....	1114
7.4.1	Overview of Functions.....	1114
7.4.2	Structure of the Function.....	1114
7.4.3	Function Description.....	1114
7.4.4	Application and Setting Notes.....	1115
7.4.5	Settings.....	1115
7.4.6	Information List.....	1115
8	Capacitor Bank Protection Functions.....	1117
8.1	Introduction.....	1118
8.2	Current-Unbalance Protection for Capacitors, 1-Phase.....	1119
8.2.1	Overview of Functions.....	1119
8.2.2	Structure of the Function.....	1119
8.2.3	General Functions and Measuring-Point Selection.....	1119
8.2.3.1	Description.....	1119
8.2.3.2	Application and Setting Notes.....	1125
8.2.3.3	Settings.....	1129
8.2.3.4	Information List.....	1129
8.2.4	Overcurrent-Protection Stage I>.....	1130
8.2.4.1	Description.....	1130
8.2.4.2	Application and Setting Notes.....	1132
8.2.4.3	Settings.....	1132
8.2.4.4	Information List.....	1133
8.2.5	Counter Stage.....	1134
8.2.5.1	Description.....	1134
8.2.5.2	Application and Setting Notes.....	1135
8.2.5.3	Settings.....	1136
8.2.5.4	Information List.....	1136
8.3	Peak Overvoltage Protection for Capacitors.....	1138
8.3.1	Overview of Functions.....	1138
8.3.2	Structure of the Function.....	1138
8.3.3	Stage with Inverse-Time Characteristic Curve.....	1139
8.3.3.1	Description.....	1139
8.3.3.2	Application and Setting Notes.....	1141
8.3.3.3	Settings.....	1143
8.3.3.4	Information List.....	1143
8.3.4	Stage with Definite-Time Characteristic Curve.....	1145
8.3.4.1	Description.....	1145
8.3.4.2	Application and Setting Notes.....	1146
8.3.4.3	Settings.....	1147
8.3.4.4	Information List.....	1147
8.3.5	Stage with User-Defined Characteristic Curve.....	1147
8.3.5.1	Description.....	1147
8.3.5.2	Application and Setting Notes.....	1148
8.3.5.3	Settings.....	1149
8.3.5.4	Information List.....	1149
9	Control Functions.....	1151
9.1	Introduction.....	1152
9.1.1	Overview.....	1152
9.1.2	Concept of Controllables.....	1152

9.2	Switching Devices.....	1155
9.2.1	General Overview.....	1155
9.2.2	Switching Device Circuit Breaker.....	1155
9.2.2.1	Structure of the Circuit-Breaker Switching Device.....	1155
9.2.2.2	Application and Setting Notes.....	1158
9.2.2.3	Connection Variants of the Circuit Breaker.....	1161
9.2.2.4	Settings.....	1163
9.2.2.5	Information List.....	1165
9.2.3	Disconnecter Switching Device.....	1167
9.2.3.1	Structure of the Disconnecter Switching Device.....	1167
9.2.3.2	Application and Setting Notes.....	1170
9.2.3.3	Trigger Variants of the Disconnecter.....	1172
9.2.3.4	Settings.....	1175
9.2.3.5	Information List.....	1176
9.3	Control Functionality.....	1178
9.3.1	Command Checks and Switchgear Interlocking Protection.....	1178
9.3.2	Command Logging.....	1197
9.3.3	Settings.....	1201
9.3.4	Information List.....	1201
9.4	Synchronization Function.....	1202
9.4.1	Overview of Functions.....	1202
9.4.2	Structure of the Function.....	1202
9.4.3	Connection and Definition.....	1203
9.4.4	General Functionality.....	1205
9.4.4.1	Description.....	1205
9.4.4.2	Application and Setting Notes.....	1209
9.4.4.3	Settings.....	1216
9.4.5	Sequence of Functions.....	1217
9.4.6	Stage Synchrocheck.....	1219
9.4.6.1	Description.....	1219
9.4.6.2	Application and Setting Notes.....	1220
9.4.6.3	Settings.....	1220
9.4.6.4	Information List.....	1221
9.4.7	Stage Synchronous/Asynchronous.....	1222
9.4.7.1	Description.....	1222
9.4.7.2	Application and Setting Notes.....	1226
9.4.7.3	Settings.....	1228
9.4.7.4	Information List.....	1229
9.4.8	Stage Synchronous/Asynchronous with Balancing Commands.....	1230
9.4.8.1	Description.....	1230
9.4.8.2	Application and Setting Notes.....	1237
9.4.8.3	Settings.....	1247
9.4.8.4	Information List.....	1249
9.4.9	Expanded Checks (df/dt and Smoothing of Oscillations).....	1250
9.4.10	Closing at De-Energized Line/Busbar.....	1251
9.4.10.1	Description.....	1251
9.4.10.2	Application and Setting Notes.....	1253
9.4.11	Direct Close Command	1254
9.4.12	Interaction with Control and External Triggering.....	1255
9.4.13	External Synchronization.....	1256
9.4.13.1	Description.....	1256
9.4.13.2	Application and Setting Notes (External Synchronization).....	1259

9.4.13.3	Settings.....	1260
9.4.13.4	Information List.....	1262
9.4.14	Settings.....	1262
9.4.15	Information List.....	1264
9.5	Switching Sequences.....	1267
9.5.1	Overview of Functions	1267
9.5.2	Function Description.....	1267
9.5.3	Application and Setting Notes.....	1269
9.5.4	Settings.....	1273
9.5.5	Information List.....	1273
9.6	User-Defined Function Block [Control].....	1274
9.6.1	Overview of Functions.....	1274
9.6.2	Function Description.....	1274
9.6.3	Application and Setting Notes.....	1275
9.6.4	Settings.....	1277
9.6.5	Information List.....	1277
9.7	CFC-Chart Settings.....	1279
9.7.1	Overview of Functions.....	1279
9.7.2	Function Description.....	1279
9.7.3	Application and Setting Notes.....	1280
9.7.4	Settings.....	1280
9.7.5	Information List.....	1280
9.8	Tap Changers.....	1281
9.8.1	Function Description.....	1281
9.8.2	Application and Setting Notes.....	1285
9.8.3	Settings.....	1292
9.8.4	Information List.....	1292
9.9	Point-on-Wave Switching.....	1293
10	Supervision Functions.....	1295
10.1	Overview.....	1296
10.2	Resource-Consumption Supervision.....	1297
10.2.1	Load Model.....	1297
10.2.2	Function Points.....	1298
10.2.3	CFC Resources.....	1298
10.3	Supervision of the Secondary System.....	1301
10.3.1	Overview.....	1301
10.3.2	Measuring-Voltage Failure.....	1301
10.3.2.1	Overview of Functions.....	1301
10.3.2.2	Structure of the Function.....	1302
10.3.2.3	Unbalanced Measuring-Voltage Failure.....	1303
10.3.2.4	3-Phase Measuring-Voltage Failure.....	1304
10.3.2.5	Switching onto a 3-Phase Measuring-Voltage Failure, Low Load.....	1305
10.3.2.6	Application and Setting Notes.....	1306
10.3.2.7	Settings.....	1307
10.3.2.8	Information List.....	1308
10.3.3	Signaling-Voltage Supervision.....	1308
10.3.3.1	Overview of Functions.....	1308
10.3.3.2	Structure of the Function.....	1309

10.3.3.3	Function Description.....	1309
10.3.3.4	Application and Setting Notes.....	1311
10.3.3.5	Settings.....	1312
10.3.3.6	Information List.....	1313
10.3.4	Voltage-Transformer Circuit Breaker.....	1314
10.3.4.1	Overview of Functions.....	1314
10.3.4.2	Structure of the Function	1314
10.3.4.3	Function Description.....	1314
10.3.4.4	Application and Setting Notes.....	1315
10.3.4.5	Settings.....	1315
10.3.4.6	Information List.....	1315
10.3.5	Voltage-Balance Supervision.....	1315
10.3.5.1	Overview of Functions	1315
10.3.5.2	Structure of the Function.....	1316
10.3.5.3	Function Description.....	1316
10.3.5.4	Application and Setting Notes.....	1317
10.3.5.5	Settings.....	1318
10.3.5.6	Information List.....	1318
10.3.6	Voltage-Sum Supervision.....	1318
10.3.6.1	Overview of Functions	1318
10.3.6.2	Structure of the Function	1319
10.3.6.3	Function Description.....	1319
10.3.6.4	Application and Setting Notes.....	1321
10.3.6.5	Settings.....	1321
10.3.6.6	Information List.....	1321
10.3.7	Voltage Phase-Rotation Supervision.....	1321
10.3.7.1	Overview of Functions	1321
10.3.7.2	Structure of the Function	1321
10.3.7.3	Function Description.....	1322
10.3.7.4	Application and Setting Notes	1323
10.3.7.5	Settings.....	1323
10.3.7.6	Information List.....	1323
10.3.8	Voltage-Comparison Supervision.....	1323
10.3.8.1	Overview of Functions.....	1323
10.3.8.2	Structure of the Function.....	1324
10.3.8.3	Description.....	1324
10.3.8.4	Application and Setting Notes.....	1328
10.3.8.5	Settings.....	1328
10.3.8.6	Information List.....	1329
10.3.9	Broken-Wire Detection.....	1329
10.3.9.1	Overview of Functions.....	1329
10.3.9.2	Structure of the Function.....	1329
10.3.9.3	Function Description.....	1329
10.3.9.4	Application and Setting Notes.....	1330
10.3.9.5	Settings.....	1331
10.3.9.6	Information List.....	1331
10.3.10	Current-Balance Supervision.....	1331
10.3.10.1	Overview of Functions	1331
10.3.10.2	Structure of the Function.....	1331
10.3.10.3	Function Description.....	1332
10.3.10.4	Application and Setting Notes.....	1333
10.3.10.5	Settings.....	1334
10.3.10.6	Information List.....	1334
10.3.11	Current-Sum Supervision.....	1334
10.3.11.1	Overview of Functions.....	1334
10.3.11.2	Structure of the Function.....	1335

10.3.11.3	Function Description.....	1335
10.3.11.4	Application and Setting Notes.....	1337
10.3.11.5	Settings.....	1337
10.3.11.6	Information List.....	1338
10.3.12	Current Phase-Rotation Supervision.....	1338
10.3.12.1	Overview of Functions	1338
10.3.12.2	Structure of the Function	1338
10.3.12.3	Function Description.....	1339
10.3.12.4	Application and Setting Notes.....	1340
10.3.12.5	Settings.....	1340
10.3.12.6	Information List.....	1340
10.3.13	Trip-Circuit Supervision.....	1340
10.3.13.1	Overview of Functions.....	1340
10.3.13.2	Structure of the Function	1341
10.3.13.3	Trip-Circuit Supervision with 2 Binary Inputs.....	1341
10.3.13.4	Trip-Circuit Supervision with 1 Binary Input.....	1342
10.3.13.5	Application and Setting Notes	1345
10.3.13.6	Settings.....	1346
10.3.13.7	Information List.....	1346
10.3.14	Closing-Circuit Supervision.....	1346
10.3.14.1	Overview of Functions.....	1346
10.3.14.2	Structure of the Function.....	1347
10.3.14.3	Closing-Circuit Supervision with 3 Binary Inputs.....	1347
10.3.14.4	Closing-Circuit Supervision with 2 Binary Inputs.....	1352
10.3.14.5	Closing-Circuit Supervision with 1 Binary Input.....	1353
10.3.14.6	Application and Setting Notes.....	1356
10.3.14.7	Settings.....	1356
10.3.14.8	Information List.....	1357
10.4	Supervision of the Device Hardware.....	1358
10.4.1	Overview.....	1358
10.4.2	Analog-Channel Supervision via Fast Current-Sum.....	1359
10.4.2.1	Overview of Functions.....	1359
10.4.2.2	Structure of the Function.....	1359
10.4.2.3	Function Description.....	1360
10.5	Supervision of Device Firmware.....	1363
10.6	Supervision of Hardware Configuration.....	1364
10.7	Supervision of Communication Connections.....	1365
10.8	Error Responses and Corrective Measures.....	1366
10.8.1	Overview.....	1366
10.8.2	Defect Severity 1.....	1367
10.8.3	Defect Severity 2.....	1371
10.8.4	Defect Severity 3.....	1372
10.8.5	Defect Severity 4 (Group Alarm).....	1373
10.9	Group Indications.....	1374
11	Measured Values, Energy Values, and Supervision of the Primary System.....	1377
11.1	Overview of Functions.....	1378
11.2	Structure of the Function.....	1379
11.3	Operational Measured Values.....	1380
11.4	Fundamental and Symmetrical Components.....	1382
11.5	THD and Harmonics.....	1383
11.5.1	Overview of Functions.....	1383

11.5.2	Structure of the Function.....	1383
11.5.3	Function Description.....	1384
11.5.4	Information List.....	1385
11.6	Average Values.....	1388
11.6.1	Function Description of Average Values.....	1388
11.6.2	Application and Setting Notes for Average Values.....	1388
11.7	Minimum/Maximum Values.....	1391
11.7.1	Function Description of Minimum/Maximum Values.....	1391
11.7.2	Application and Setting Notes for Minimum/Maximum Values.....	1392
11.8	Energy Values.....	1393
11.8.1	Function Description of Energy Values.....	1393
11.8.2	Application and Setting Notes for Energy Values.....	1394
11.9	User-Defined Metered Values.....	1396
11.9.1	Function Description of Pulse-Metered Values.....	1396
11.9.2	Application and Setting Notes for Pulse-Metered Values.....	1397
11.10	Statistical Values of the Primary System.....	1400
11.11	Circuit-Breaker Monitoring	1401
11.11.1	Overview of Functions.....	1401
11.11.2	Structure of the Function.....	1401
11.11.3	General Functionality.....	1402
11.11.3.1	Description.....	1402
11.11.3.2	Application and Setting Notes.....	1403
11.11.3.3	Settings.....	1404
11.11.3.4	Information List.....	1404
11.11.4	Σ Method.....	1405
11.11.4.1	Description.....	1405
11.11.4.2	Application and Setting Notes.....	1407
11.11.4.3	Settings.....	1407
11.11.4.4	Information List.....	1407
11.11.5	2P Method.....	1411
11.11.5.1	Description.....	1411
11.11.5.2	Application and Setting Notes.....	1414
11.11.5.3	Settings.....	1415
11.11.5.4	Information List.....	1416
11.11.6	I _{2t} Method.....	1419
11.11.6.1	Description.....	1419
11.11.6.2	Application and Setting Notes.....	1420
11.11.6.3	Settings.....	1420
11.11.6.4	Information List.....	1420
11.11.7	Make Time.....	1424
11.11.7.1	Description.....	1424
11.11.7.2	Application and Setting Notes.....	1425
11.11.7.3	Settings.....	1425
11.11.7.4	Information List.....	1426
11.11.8	Break Time.....	1430
11.11.8.1	Description.....	1430
11.11.8.2	Application and Setting Notes.....	1431
11.11.8.3	Settings.....	1431
11.11.8.4	Information List.....	1432
11.11.9	Pole Scatter Time Open.....	1435
11.11.9.1	Description.....	1435

11.11.9.2	Application and Setting Notes.....	1436
11.11.9.3	Settings.....	1436
11.11.9.4	Information List.....	1437
11.11.10	Mechanical Switching Time Open.....	1438
11.11.10.1	Description.....	1438
11.11.10.2	Application and Setting Notes.....	1440
11.11.10.3	Settings.....	1441
11.11.10.4	Information List.....	1442
11.11.11	Mechanical Switching Time Close.....	1446
11.11.11.1	Description.....	1446
11.11.11.2	Application and Setting Notes.....	1448
11.11.11.3	Settings.....	1449
11.11.11.4	Information List.....	1450
11.11.12	Operation counter.....	1453
11.11.12.1	Description.....	1453
11.11.12.2	Application and Setting Notes.....	1454
11.11.12.3	Settings.....	1454
11.11.12.4	Information List.....	1454
11.12	Disconnecter-Switch Monitoring.....	1458
11.12.1	Overview of Functions	1458
11.12.2	Structure of the Function.....	1458
11.12.3	General Functionality.....	1458
11.12.3.1	Description.....	1458
11.12.3.2	Application and Setting Notes.....	1458
11.12.3.3	Settings.....	1458
11.12.3.4	Information List.....	1459
11.12.4	Mechanical Switching Time Open.....	1460
11.12.4.1	Description.....	1460
11.12.4.2	Application and Setting Notes.....	1461
11.12.4.3	Settings.....	1462
11.12.4.4	Information List.....	1462
11.12.5	Mechanical Switching Time Close.....	1463
11.12.5.1	Description.....	1463
11.12.5.2	Application and Setting Notes.....	1464
11.12.5.3	Settings.....	1465
11.12.5.4	Information List.....	1465
12	Power Quality – Basic.....	1467
12.1	Voltage Variation.....	1468
12.1.1	Overview of Functions	1468
12.1.2	Structure of the Function.....	1468
12.1.3	General Functionality.....	1469
12.1.3.1	Description.....	1469
12.1.4	Stage Dip.....	1469
12.1.4.1	Description.....	1469
12.1.4.2	Application and Setting Notes.....	1474
12.1.4.3	Settings.....	1474
12.1.4.4	Information List.....	1474
12.1.5	Stage Swell.....	1475
12.1.5.1	Description.....	1475
12.1.5.2	Application and Setting Notes.....	1478
12.1.5.3	Settings.....	1478
12.1.5.4	Information List.....	1478

12.1.6	Stage Interruption.....	1479
12.1.6.1	Description.....	1479
12.1.6.2	Application and Setting Notes.....	1482
12.1.6.3	Settings.....	1482
12.1.6.4	Information List.....	1482
12.2	Voltage Unbalance.....	1484
12.2.1	Overview of Functions.....	1484
12.2.2	Structure of the Function.....	1484
12.2.3	Stage V2/V1.....	1485
12.2.3.1	Description.....	1485
12.2.3.2	Application and Setting Notes.....	1488
12.2.3.3	Settings.....	1489
12.2.3.4	Information List.....	1490
12.2.4	Stage V0/V1.....	1491
12.2.4.1	Description.....	1491
12.2.4.2	Application and Setting Notes.....	1494
12.2.4.3	Settings.....	1495
12.2.4.4	Information List.....	1495
12.3	THD and Harmonics.....	1497
12.3.1	Overview of Functions.....	1497
12.3.2	Structure of the Function.....	1497
12.3.3	Stage Current.....	1498
12.3.3.1	Function Description.....	1498
12.3.3.2	Information List.....	1499
12.3.4	Stage Voltage.....	1499
12.3.4.1	Function Description.....	1499
12.3.4.2	Application and Setting Notes.....	1504
12.3.4.3	Settings.....	1504
12.3.4.4	Information List.....	1504
12.4	Total Demand Distortion.....	1506
12.4.1	Overview of Functions.....	1506
12.4.2	Structure of the Function.....	1506
12.4.3	Stage Current.....	1507
12.4.4	Application and Setting Notes.....	1509
12.4.5	Settings.....	1510
12.4.6	Information List.....	1510
13	Functional Tests.....	1511
13.1	General Notes.....	1512
13.2	Enabling/Disabling the Application/Test Mode for the Entire Device.....	1513
13.3	Direction Test of the Phase Quantities (Current and Voltage Connection).....	1515
13.4	Direction Test of Ground Quantities for Directional Ground-Fault Functions.....	1516
13.4.1	Overview.....	1516
13.4.2	Directional Testing for Solid or Resistive-Grounded Systems.....	1516
13.4.3	Directional Testing for Isolated or Resonant-Grounded Systems.....	1518
13.5	Functional Test of Thermal Overload Protection	1520
13.6	Primary and Secondary Tests of the Circuit-Breaker Failure Protection.....	1522
13.7	Circuit-Breaker Test.....	1525
13.8	Functional Test of the Inrush-Current Detection	1528
13.9	Functional Test of Transient Ground-Fault Protection	1529

13.10	Functional Test of the Trip-Circuit Supervision	1530
13.11	Functional Test for the Phase-Rotation Reversal.....	1531
13.12	Functional Test for Overvoltage Protection with Zero-Sequence Voltage/Residual Voltage	1532
13.13	Primary and Secondary Testing of the Synchronization Function.....	1534
13.14	Testing the Negative-Sequence Current	1538
13.15	Functional Test for Reverse-Power Protection.....	1539
13.15.1	Secondary Test.....	1539
13.15.2	Primary Test.....	1539
13.16	Functional Test for Overexcitation Protection	1542
14	Technical Data.....	1543
14.1	General Device Data.....	1546
14.1.1	Analog Inputs.....	1546
14.1.2	Supply Voltage.....	1546
14.1.3	Binary Inputs.....	1547
14.1.4	Relay Outputs.....	1548
14.1.5	Design Data.....	1548
14.2	Date and Time Synchronization.....	1550
14.3	Function Group Analog Units.....	1551
14.4	Overcurrent Protection, Phases.....	1552
14.4.1	Stage with Definite-Time Characteristic Curve.....	1552
14.4.2	Stage with Inverse-Time Characteristic Curve.....	1554
14.4.3	Stage with User-Defined Characteristic Curve	1562
14.5	Voltage-Dependent Overcurrent Protection, Phases.....	1566
14.6	Overcurrent Protection, Ground.....	1569
14.6.1	Stage with Definite-Time Characteristic Curve	1569
14.6.2	Stage with Inverse-Time Characteristic Curve.....	1570
14.6.3	Stage with User-Defined Characteristic Curve	1572
14.7	Directional Overcurrent Protection, Phases.....	1574
14.7.1	Stage with Definite-Time Characteristic Curve.....	1574
14.7.2	Stage with Inverse-Time Characteristic Curve.....	1575
14.7.3	Stage with User-Defined Characteristic Curve.....	1578
14.8	Directional Overcurrent Protection, Ground.....	1581
14.8.1	Stage with Definite-Time Characteristic Curve.....	1581
14.8.2	Stage with Inverse-Time Characteristic Curve.....	1582
14.8.3	Stage with Inverse-Time Overcurrent Protection with Logarithmic-Inverse Characteristic Curve.....	1584
14.8.4	Stage with Knee-Point Characteristic Curve	1586
14.8.5	Stage with User-Defined Characteristic Curve.....	1589
14.9	Inrush-Current Detection.....	1591
14.10	2nd Harmonic Detection Ground.....	1593
14.11	2nd Harmonic Detection 1-Phase.....	1595
14.12	Instantaneous High-Current Tripping.....	1597
14.13	Instantaneous Tripping at Switch onto Fault.....	1598

14.14	Overcurrent Protection, 1-Phase.....	1599
14.14.1	Stage with Definite-Time Characteristic Curve.....	1599
14.14.2	Stage with Inverse-Time Characteristic Curve.....	1600
14.14.3	Stage with Inverse-Time Overcurrent Protection with Logarithmic-Inverse Characteristic Curve.....	1602
14.14.4	Stage with User-Defined Characteristic Curve	1604
14.15	Overcurrent Protection, 1-Phase (Fast Stage).....	1606
14.16	Positive-Sequence Overcurrent Protection.....	1607
14.16.1	Stage with Definite-Time Characteristic Curve.....	1607
14.16.2	Stage with Inverse-Time Characteristic Curve.....	1608
14.17	Non-Directional Intermittent Ground-Fault Protection.....	1610
14.18	Directional Intermittent Ground-Fault Protection.....	1612
14.19	Sensitive Ground-Fault Detection.....	1614
14.19.1	General.....	1614
14.19.2	Directional 3I0 Stage with $\cos \varphi$ or $\sin \varphi$ Measurement.....	1615
14.19.3	Directional Transient Ground-Fault Stage.....	1616
14.19.4	Directional 3I0 Stage with $\varphi(V0, 3I0)$ Measurement.....	1617
14.19.5	Directional Y0 Stage with G0 or B0 Measurement (Admittance).....	1618
14.19.6	Directional Stage with Phasor Measurement of a Harmonic.....	1619
14.19.7	Non-Directional V0 Stage with Zero-Sequence Voltage/Residual Voltage.....	1620
14.19.8	Non-Directional 3I0 Stage.....	1621
14.19.9	Non-Directional Y0 Stage.....	1621
14.19.10	Non-Directional 3I0 Harmonic Stage.....	1622
14.19.11	Pulse-Pattern Detection Stage.....	1623
14.19.12	Intermittent Ground-Fault Blocking Stage.....	1624
14.20	Undercurrent Protection.....	1626
14.21	Negative-Sequence Protection.....	1628
14.21.1	Stage with Definite-Time Characteristic Curve.....	1628
14.21.2	Stage with Inverse-Time Characteristic Curve.....	1629
14.22	Directional Negative-Sequence Protection with Definite-Time Delay.....	1632
14.23	Thermal Overload Protection, 3-Phase – Advanced.....	1634
14.24	Thermal Overload Protection, User-Defined Characteristic Curve.....	1637
14.25	Thermal Overload Protection, 1-Phase.....	1638
14.26	Unbalanced-Load Protection.....	1640
14.27	Overcurrent Protection for Capacitor Banks.....	1642
14.27.1	Stage with Definite-Time Characteristic Curve.....	1642
14.27.2	Stage with Inverse-Time Characteristic Curve.....	1644
14.27.3	Stage with User-Defined Characteristic Curve	1652
14.28	Current-Unbalance Protection for Capacitors, 1-Phase.....	1656
14.29	Overvoltage Protection with 3-Phase Voltage.....	1658
14.30	Overvoltage Protection with Zero-Sequence Voltage/Residual Voltage.....	1660
14.31	Overvoltage Protection with Positive-Sequence Voltage	1663
14.32	Overvoltage Protection with Negative-Sequence Voltage	1664
14.33	Overvoltage Protection with Any Voltage.....	1665
14.34	Peak Overvoltage Protection for Capacitors.....	1667

14.35	Overvoltage Protection with Negative-Sequence Voltage/Positive-Sequence Voltage	1669
14.36	Undervoltage Protection with 3-Phase Voltage.....	1670
14.37	Undervoltage Protection with Positive-Sequence Voltage.....	1673
14.38	Undervoltage Protection with Any Voltage	1675
14.39	Rate-of-Voltage-Change Protection.....	1677
14.40	Overfrequency Protection.....	1679
14.41	Underfrequency Protection.....	1680
14.42	Underfrequency Load Shedding.....	1681
14.43	Rate of Frequency Change Protection.....	1683
14.44	Vector-Jump Protection.....	1685
14.45	Power Protection (P,Q), 3-Phase.....	1686
14.46	Reverse-Power Protection.....	1688
14.47	Overexcitation Protection.....	1689
14.48	Undervoltage-Controlled Reactive-Power Protection.....	1691
14.49	Circuit-Breaker Failure Protection	1693
14.50	Circuit-Breaker Restrike Protection.....	1695
14.51	Restricted Ground-Fault Protection.....	1696
14.52	External Trip Initiation.....	1698
14.53	Automatic Reclosing.....	1699
14.54	Fault Locator.....	1700
14.55	Fault Locator Plus.....	1701
14.56	Protection and Automation Functions (CEI 0-16 Standard).....	1702
14.56.1	Overvoltage Protection with 3-Phase Voltage (CEI 0-16 Standard).....	1702
14.56.2	Frequency Protection (CEI 0-16 Standard).....	1702
14.56.3	Undervoltage Protection with 3-Phase Voltage (CEI 0-16 Standard).....	1704
14.57	Temperature Supervision.....	1706
14.58	Current-Jump Detection.....	1707
14.59	Voltage-Jump Detection.....	1708
14.60	Synchronization Function.....	1709
14.61	Current-Balance Supervision.....	1712
14.62	Voltage-Balance Supervision	1713
14.63	Current-Sum Supervision.....	1714
14.64	Voltage-Sum Supervision.....	1715
14.65	Current Phase-Rotation Supervision	1716
14.66	Voltage Phase-Rotation Supervision	1717
14.67	Voltage-Comparison Supervision.....	1718
14.68	Trip-Circuit Supervision	1719
14.69	Closing-Circuit Supervision.....	1720
14.70	Analog Channel Supervision via Fast Current Sum	1721
14.71	Measuring-Voltage Failure Detection.....	1722
14.72	Voltage-Transformer Circuit Breaker	1724
14.73	Operational Measured Values and Statistical Values.....	1725
14.74	Power Quality – Basic.....	1730
14.74.1	Voltage Variation.....	1730

14.74.2	Voltage Unbalance.....	1730
14.74.3	THD and Harmonics.....	1731
14.74.4	Total Demand Distortion.....	1732
14.75	Energy Values.....	1733
14.76	Circuit-Breaker Monitoring.....	1734
14.77	Disconnecter Supervision.....	1735
14.78	CFC.....	1736
A	Appendix.....	1741
A.1	Order Configurator and Order Options.....	1742
A.2	Function Packages.....	1743
A.3	Accessories.....	1746
A.4	Typographic and Symbol Conventions.....	1747
A.5	Standard Variants for 7SX800.....	1750
A.6	Requirements for Current Transformers for Network Protection Applications with Overcurrent Protection.....	1752
A.7	Requirements for Current Transformers for Motor-Protection Applications with Overcurrent Protection.....	1758
A.8	Connection Examples for Current Transformers.....	1765
A.9	Connection Examples of Voltage Transformers	1772
A.10	Preroutings for Overcurrent-Protection Applications.....	1776
A.11	Preroutings for Motor and Power-System Decoupling Applications.....	1777
	Literature.....	1779
	Glossary.....	1781
	Index.....	1783

1 Introduction

1.1	General	44
1.2	Properties of SIPROTEC 5 Compact	45

1.1 General

The digital multifunctional protection and bay controllers of the SIPROTEC 5 Compact device series are fitted with a powerful microprocessor. As a result, all tasks, from acquiring measurands to entering commands in the circuit breaker, are processed digitally.

Analog Inputs

The measuring inputs transform the currents and voltages sent by the instrument transformers and adapt them to the internal processing level of the device. A SIPROTEC 5 Compact device consists of inputs for measuring current and voltage. The current inputs are intended for the detection of phase currents and ground current. The ground current can be detected sensitively using a core balance current transformer. The voltage inputs detect the measuring voltage of device functions requiring voltage measured values.

The analog values are digitized in the microprocessor for data processing.

Microprocessor System

All device functions are processed in the microprocessor system.

This includes, for example:

- Filtering and preparation of the measurands
- Constant monitoring of the measurands
- Monitoring of the pickup conditions for the individual protection functions
- Querying of limiting values and time sequences
- Control of signals for logic functions
- Control of open and close commands
- Recording of indications, fault data, and fault values for fault analysis
- Administration of the operating system and its functions, for example data storage, real-time clock, communication, interfaces
- External distribution of information

Binary Inputs and Outputs

Using the binary inputs and outputs, the device receives information from the system or from other devices (such as locking commands). The most important outputs include the commands to the switching devices and the indications for remote signaling of important events and states.

Front Elements

For devices with an integrated operation panel, LEDs and an LC display on the front provide information on the device function and report events, states, and measured values. In conjunction with the LC display, the integrated keypad enables on-site operation of the device. All device information such as setting parameters, operating and fault indications or measured values can be displayed, and setting parameters changed. In addition, system equipment can be controlled via the user interface of the device.

Serial Interfaces

The serial interface in the front panel enables communication with a personal computer when using the DIGSI operating program. As a result, the operation of all device functions is possible. An additional interface on the rear is used to implement various communication protocols.

Power Supply

The individual functional units of the device are powered by an internal power supply. Brief interruptions in the supply voltage, , are bridged by capacitor storage (see also the Technical Data).

1.2 Properties of SIPROTEC 5 Compact

The SIPROTEC 5 Compact devices at the bay level can be installed directly in medium and high-voltage switchgear. They are characterized by comprehensive integration of protection and control functions.

General Properties

- Powerful microprocessor
- Fully digital measured-value processing and control, from sampling and digitizing of measurands to closing and tripping decisions for the circuit breaker
- Complete galvanic and interference-free isolation of the internal processing circuits from the system measuring, control, and supply circuits through instrument transformers, binary input and output modules, and DC and AC voltage converters
- Easy operation using an integrated operator and display panel, or using a connected personal computer with user interface
- Continuous display of measured and metered values at the front
- Storage of min/max measured values (slave pointer function) and storage of long-term average values
- Storage of fault indications for system incidents (faults in system) with real-time assignment and instantaneous values for fault recording
- Continuous monitoring of the measurands as well as the device hardware and software
- Communication with central control and storage devices possible via the device interface
- Battery-buffered, synchronizable clock

Modular Concept

The SIPROTEC 5 Compact modular concept ensures the consistency and integrity of all functionalities across the entire device series. Significant features here include:

- Module system design in the software
- Functional integration of various applications, such as protection, control, and fault recorder
- Innovative terminal technology with easy assembly and interchangeability and the highest possible degree of safety
- The same functions can be configured individually across the entire family of devices
- Ability to upgrade with innovations possible at all times through libraries
- Open, scalable architecture for IT integration and new functions
- Multi-layered security mechanisms in all links of the security chain
- Self-monitoring routines for reliable localization and indication of device faults
- Automatic logging of access attempts and security-critical operations on the devices and systems

Redundant Communication

SIPROTEC 5 Compact devices maintain full communication redundancy:

- Redundant and independent protocols to control centers possible (such as IEC 61850, either single or redundant)
- Redundant time synchronization (such as IRIG B, SNTP).

2 Basic Structure of the Function

2.1	Embedding of Functions in the Device	48
2.2	Application Templates/Adaptation of Functional Scope	51
2.3	Function Control	53
2.4	Text Structure and Reference Number for Settings and Indications	59
2.5	Information Lists	61

2.1 Embedding of Functions in the Device

General

SIPROTEC 5 devices offer great flexibility in the handling of functions. Functions can be individually loaded into the device. Additionally, it is possible to copy functions within a device or between devices. The necessary integration of functions in the device is illustrated by the following example.



NOTE

The availability of certain settings and setting options depends on the device type and the functions available on the device!

Several predefined function packages that are tailored to specific applications exist for each device family. A predefined functional scope is called an **application template**. The existing application templates are offered for selection automatically when you create a new device in DIGSI 5.

Function Groups (FG)

Functions are arranged in function groups. This simplifies handling of functions (adding and copying). The function groups are assigned to primary objects, such as a line, transformer, or circuit breaker.

The function groups bundle functions with regard to the following basic tasks:

- Assignment of functions to current and/or voltage transformers (assignment of functions to the measuring points and thus to the protected object)
- Exchange of information between function groups

When a function is copied into a function group, it automatically works with the measuring points assigned to the function group. Their output signals are also automatically included in the configured interfaces of the function group.

EXAMPLE

The selected application template **Directional definite-time overcurrent protection/inverse-time overcurrent protection grounded** contains 2 function groups:

- Protection function group **Voltage/Current 3-Phase**
- Circuit-breaker function group **QA 1**

The following figure shows the embedding of functions via function groups.

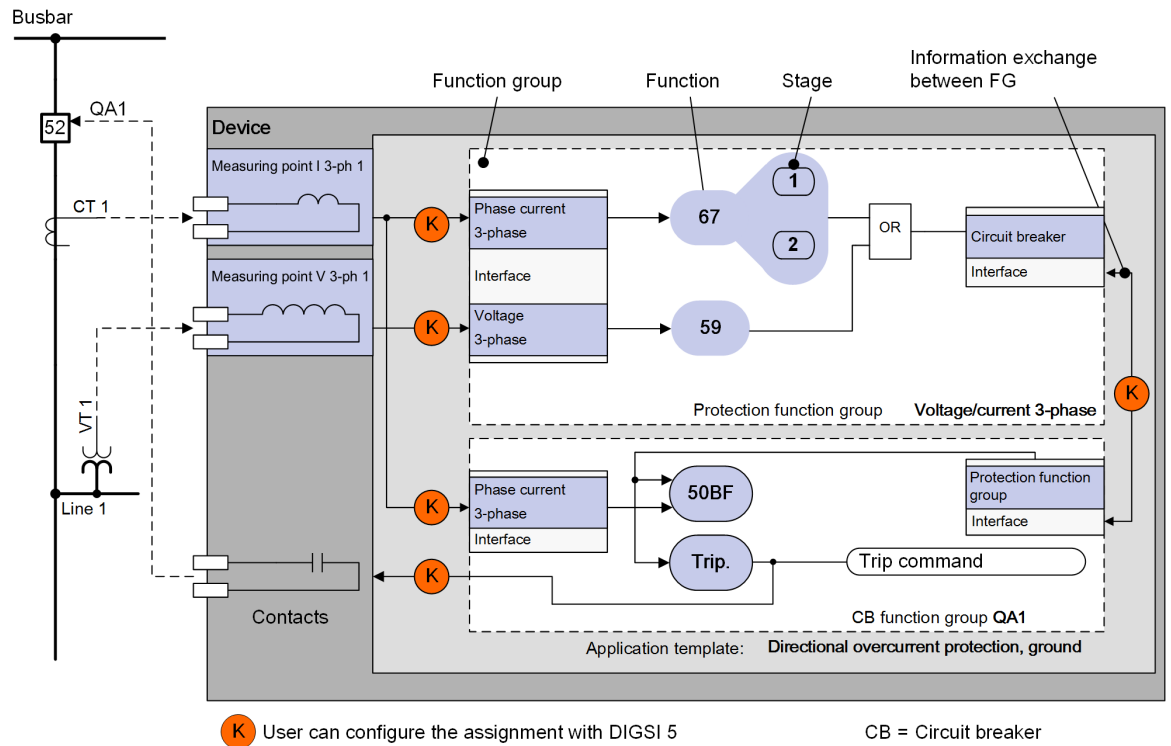

[dw_function_embedding_SIP5_comp_1_en_US]

Figure 2-1 Embedding the Functions via Function Groups

Depending on the type of device, there are different types of function groups:

- Protection function groups
- Circuit-breaker function groups

Protection function groups bundle functions that are assigned to one protected object – for example to . Depending on the device type and nature of the protected object, there are different types of protection function groups (for example line, voltage/current 3-phase, transformer, motor, generator).

Circuit-breaker function groups bundle functions assigned to the local switches – for example, circuit breakers and disconnectors (such as processing of tripping, circuit-breaker failure protection).

The number and type of function groups differ in the respective application templates, depending on the type of the device and application. You can add, copy, or even delete function groups for a specific application. You can also adapt the functional scope within a function group according to the use case. For detailed information on this, refer to the DIGSI 5 Online Help manual.

Interface Between Function Group and Measuring Point

The function groups receive the measurands of the current and voltage transformers from measuring points. For this, the function groups are connected to 1 or more measuring points.

The number of measuring points and the assignment of function groups to the measuring points are preset by the selected application template in accordance with the specific application. Therefore, this specifies which measuring point(s) and the corresponding measurands have to be used by which function within the function group.

You can change the assignment on demand, that is, function groups can be assigned to any available measuring points of the device.

To check or change the assignment of measuring points to the function groups, double-click **Function-group connections** in the DIGSI 5 project tree.

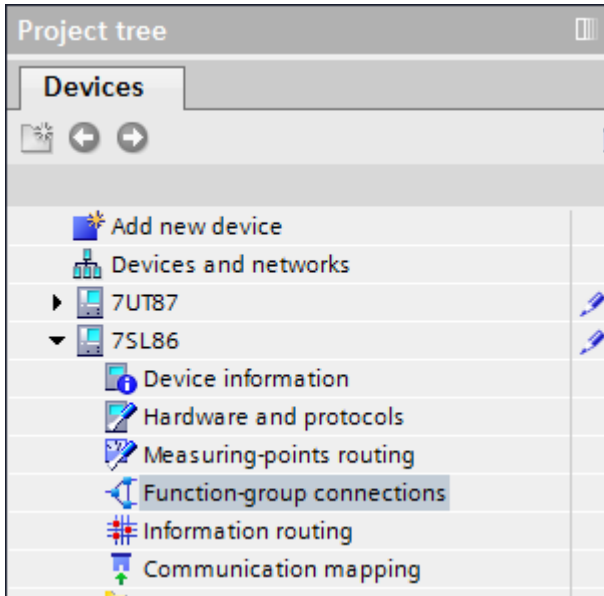

[sc_fgverb, 1, en, US]

Figure 2-2 Project Tree in DIGSI 5 (Detail)

The window for routing of the measuring points opens in the working area (see the following figure, does not correspond to the example).

▼ Connect measuring points to function group					
Measuring point	Line 1			Circuit breaker 1	
	Voltage 3-phase	Line current 3-phase		Voltage	Line current 3-phase
(All...)	(All...)	(All...)		(All...)	(All...)
Meas.point I-3ph 1		X			X
Meas.point V-3ph 1	X			X	

[scmscofg-180311-01.tif, 1, en, US]

Figure 2-3 Connecting Measuring Points and Function Groups

Functions (FN), Tripping Stages/Function Blocks (FB)

As already illustrated in [Figure 2-1](#), functions are assigned to the protected objects or other primary objects via function groups.

Functions can be further subdivided. For example, protection functions often consist of multiple protection stages (for example, the Overcurrent-protection function). Other functions can contain one or more function blocks.

Each stage, each function block, and each function (without stages/function blocks) can be individually switched into specific operating modes (for example, switch on/off). This is termed function control and is explained in [2.3 Function Control](#).

To adjust the functionality to the specific application, functions, stages, and function blocks can be added, copied, and deleted (see [2.2 Application Templates/Adaptation of Functional Scope](#)).

2.2 Application Templates/Adaptation of Functional Scope

Application Template

The application template defines the preconfigured functional scope of the device for a specific use case. A certain number of application templates is predefined for each device type. DIGSI 5 automatically offers the application templates for selection when a new device is installed. The available application templates with the respective functional scope are described in more detail in [4 Applications](#).

The selection of the application template first predefines which function groups and functions are present in the device (see also in [2.1 Embedding of Functions in the Device](#)).

You can adjust the functional scope to your specific application.

Adjusting the Functional Scope

Adjust the functional scope based on the selected application template. You can add, copy or delete functions, tripping stages, function blocks, or complete function groups.

In the DIGSI 5 project tree, this can be done via the following Editors:

- Single-line configuration
- Information routing
- Function settings

Siemens recommends the **Single-line configuration** Editor to adjust the functional scope.

Complete missing functionalities from the Global DIGSI 5 Library. Then, the default settings of the added functionality are active. You can copy within a device and between devices as well. Settings and routings are also copied when you copy functionalities.



NOTE

If you delete a parameterized function group, function, or stage from the device, all settings and routings will be lost. The function group, function, or tripping stage can be added again, but then the default settings are active.

In most cases, the adaptation of the functional scope consists of adding and deleting functions, stages, and function blocks. As previously described, the functions, tripping stages, and function blocks automatically connect themselves to the measuring points assigned to the function group.

In few cases, it may be necessary to add a protection or circuit-breaker function group. These newly added function groups do not contain (protection) functions. You must individually load the (protection) functions for your specific application. You must also connect the protection or circuit-breaker function group to one or more measuring points (see [2.1 Embedding of Functions in the Device](#)). You must connect newly added protection function groups to a circuit-breaker function group (see [2.1 Embedding of Functions in the Device](#)).

Functions, tripping stages, function blocks, and function groups can be added up to a certain maximum number. The maximum number can be found in the respective function and function-group descriptions.

Function Points

Function points (FP) are assigned to specific functions, but not to other functions. You can find more detailed information in the description of application templates, in [4 Applications](#).

The device is supplied with the acquired function-point credit. Functions with function points can be loaded into the device only within the available function-point credit. The functional scope cannot be loaded into the device if the required number of points of the functional scope is higher than the function-point credit. You must either delete functions or upgrade the function-point credit of the device.

In addition to function-point classes (10, 20, 30, 40, 50, 75, 100 to 500) beginning with firmware version V09.20, any function-point values in the range from 0 to 500 are supported as a credit in the device. Thus, the precise function-point credit required can be loaded into the device by the Function-Point Manager.

Extending the Function-Point Credit

You can reorder function points if the function-point credit for the device is not enough. Proceed as follows:

- Determine the function-point requirement of certain functions, for example, with DIGSI 5 or the SIPROTEC 5 Configurator.
- Create a signed license file for your device with the SIPROTEC Function-Point Manager at www.siprotec-function-point-manager.siemens.com or order the license file from your sales partner.
- Once you have ordered the license file using the Function-Point Manager, you can download it from there directly.
- Once you have ordered the license file from your sales partner, you will receive it by e-mail or to download.
- Use DIGSI 5 to load the signed license file onto your device. The procedure is described in the Online Help of DIGSI 5.

2.3 Function Control

Function control is used for:

- Functions that do not contain stages or function blocks
- Stages within functions
- Function blocks within functions



NOTE

Simplifying **functions** and **function control** will be discussed in the following. The description also applies to tripping stage control and function block control.

Functions can be switched to different operating modes. You use the parameter **Mode** to define whether you want a function to run (**on**) or not (**off**). In addition, you can temporarily block a function. For the purpose of commissioning, you can switch it into test mode (parameter **Mode = test**).

Devices with the activated IEC 61850 allow you to switch the operating mode by using the logical node zero **LLN0**. Depending on the option **LDevice Mod controllable**¹ in DIGSI 5 under **Settings > Device settings**, the logical devices (as well as the child logical devices and logical nodes) can be set to one of the following operating modes:

- *On*
- *Off*
- *Test*
- *Relay blocked*
- *Test/Relay blk.*

The following table describes the relationship between the LLN0 and the setting **LDevice Mod controll-able**.

LLN0.Mod	Setting LDevice Mod controllable	
	Deactivated	Activated
Application/LLN0.Mod	Controllable	Controllable
Logical device/LLN0.Mod	Status only	Controllable
Child logical device/LLN0.Mod	Status only	Controllable
Logical node/LLN0.Mod	Status only	Controllable
_:51 Mode (controllable) of an individual tripping stage of a protection function	Controllable	Controllable

With the setting **LDevice Mod controllable** being activated, the behavior of a logical device (as well as the child logical devices and logical nodes) can be controlled also by the parameter **SetMod** (**SetMod = on**: behavior = on; **SetMod = off**: behavior = off) of the LLN0.

The function shows the current status – such as an *Alarm* – via the *Health* signal.

For more details, refer to the Application Notes *SIPROTEC 5 IEC 61850 Mod/Beh*.

The following explains the different operating modes and mechanisms and how you set the functions into these modes. The function control is shown in [Figure 2-4](#). It is standardized for all functions. Therefore, this control is not discussed further in the individual function descriptions.

¹ This parameter is only applicable if IEC 61850 is active.

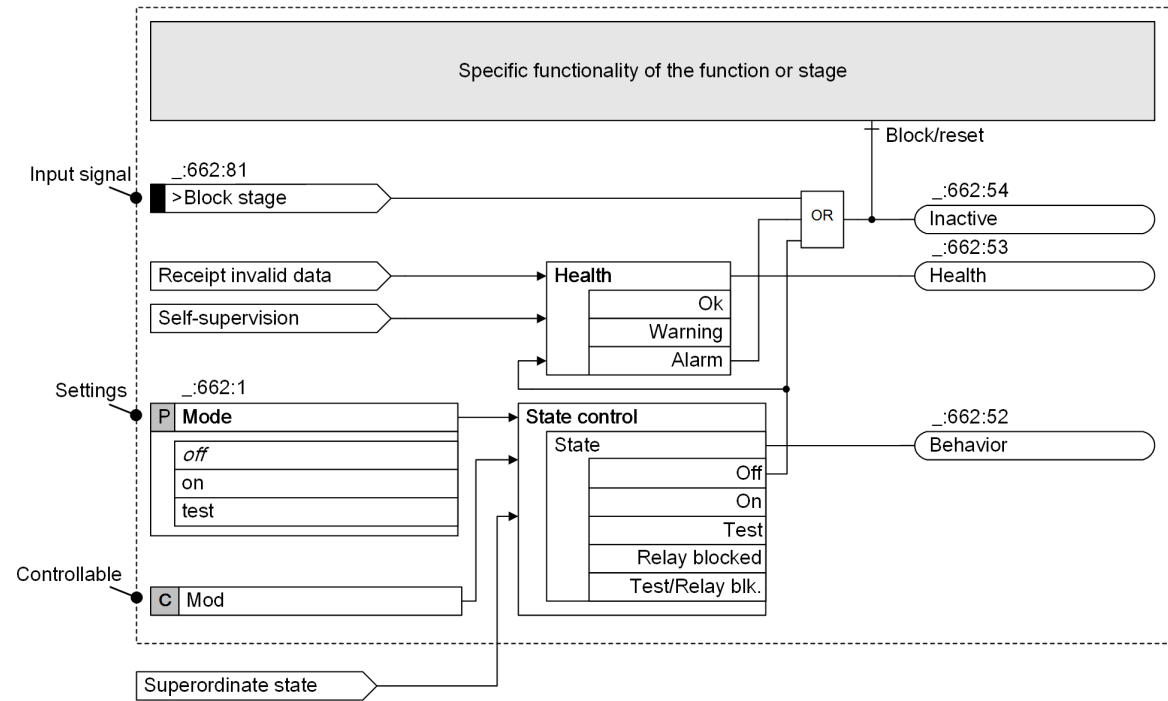

[[io_steurg, 2, en_US]
Figure 2-4 General Control of a Function

State Control

You can control the state of a function via the parameter **Mode**, the controllable **Mod** and the input **Superordinate state**.

The superordinate state is also influenced by the state of the superordinate logical devices (LD) of the IEC 61850 structure.

You set the specified operating state of the function via the parameter **Mode**. You can set the function mode to **on**, **off** and **test**. The operating principle is described in [Table 2-2](#). You can set the parameter **Mode** via:

- DIGSI 5
- On-site operation at the device
- Browser-based user interface
- Certain systems control protocols (IEC 61850)

You can also set the set point operating state of the function through the controllable **Mod**. You can set the function mode to **On**, **Off**, **Test**, **Relay blocked** and **Test/Relay blk.**. The operating principle is described in [Table 2-2](#). You can set the controllable **Mod** via:

- IEC 61850-8-1
- CFC

The **superordinate state** can accept the values **On**, **Relay blocked**, **Test** and **Test/Relay blk.**.

The state of the function resulting from the parameter **Mode**, the controllable **Mod** and the **Superordinate state** is shown in the following table. The resulting state of the function results from the combination of all sources (parameters **Mode**, Controllable **Mod** and **Superordinate state**). For simplicity, the table represents only the combination of 2 sources.

Table 2-1 Resulting State of the Function

Inputs		State of the Function
Source A	Source N	
On	On	On
On	Off	Off
On	Test	Test ²
On	Relay blocked	Relay blocked
On	Test/Relay blk.	Test/Relay blk.
Test	On	Test ²
Test	Off	Off
Test	Test	Test ²
Test	Relay blocked	Test/Relay blk.
Test	Test/Relay blk.	Test/Relay blk.
Off	On	Off
Off	Off	Off
Off	Test	Off
Off	Relay blocked	Off
Off	Test/Relay blk.	Off
Relay blocked	On	Relay blocked
Relay blocked	Off	Off
Relay blocked	Test	Test/Relay blk.
Relay blocked	Relay blocked	Relay blocked
Relay blocked	Test/Relay blk.	Test/Relay blk.
Test/Relay blk.	On	Test/Relay blk.
Test/Relay blk.	Off	Off
Test/Relay blk.	Test	Test/Relay blk.
Test/Relay blk.	Relay blocked	Test/Relay blk.
Test/Relay blk.	Test/Relay blk.	Test/Relay blk.

**NOTE**

The browser-based user interface shows an easy-to-read list of the states of all functions if they deviate from the state *On*.

The following table describes the possible states of a function:

² With the parameter (;151) **Oper.bin.outp. under test**, you define whether functions in test mode can activate relay outputs. If the parameter (;151) **Oper.bin.outp. under test** and the test mode are activated for the entire device, all functions – including the relay outputs – are in **Test** state. If the parameter (;151) **Oper.bin.outp. under test** is not active and the test mode is activated for the entire device, all functions – except the relay outputs – are in **Test** state. The relay outputs adopt the **Test/Relay blk.** state.

Table 2-2 Possible States of a Function

State of the Function	Explanation
On	The function is activated and operating as defined. The prerequisite is that the health of the function is OK .
Relay blocked	The function is activated and operating as defined. The prerequisite is that the health of the function is OK . All outputs of indications of this function to relays are blocked. Note: Logics outside this function block, for example, superordinate group indications, are not affected by the blocking. Their output to a relay still leads to an activation.
Off	The function is turned off. It does not create any information. The health of a disabled function always has the value OK .

State of the Function	Explanation														
Test	<p>The function is set to test mode. This state supports the commissioning. All outgoing information from the function (indications and, if present, measured values) is provided with a test bit. This test bit significantly influences the further processing of the information, depending on the target.</p> <p>For instance, among other things, it is possible to implement the functionality Blocking of the command relay known from SIPROTEC 4.</p> <p>When leaving the state Test, functions that process measured values are briefly reset for ~500 ms and blocked internally. This state is documented by the message <i>Inactive</i> and other function-specific messages, where appropriate.</p>														
	<table border="1"> <thead> <tr> <th data-bbox="486 538 778 606">Target of the Information</th> <th data-bbox="778 538 1479 606">Processing</th> </tr> </thead> <tbody> <tr> <td data-bbox="486 606 778 644">Log</td> <td data-bbox="778 606 1479 644">The indication is labeled as Test in the log.</td> </tr> <tr> <td data-bbox="486 644 778 740">Binary output</td> <td data-bbox="778 644 1479 740">An indication routed to binary outputs does not control the switching contact, unless the behavior of the binary output is in test state.</td> </tr> <tr> <td data-bbox="486 740 778 808">Light-emitting diode (LED)</td> <td data-bbox="778 740 1479 808">An indication routed to the LED triggers the LED (normal processing)</td> </tr> <tr> <td data-bbox="486 808 778 1287">CFC</td> <td data-bbox="778 808 1479 1287"> <p>Here, the behavior depends on the state of the CFC chart.</p> <ul style="list-style-type: none"> • CFC chart itself is not in test state: The CFC chart is not triggered by a status change of information with a set test bit. The initial state of the information (state before test bit was set) is not processed during execution of the CFC chart. • CFC chart itself is in test state: The CFC chart continues to process the information (indication or measured value) normally. The CFC outgoing information is provided with a test bit. The definitions in this table apply to its continued processing. <p>A CFC chart can be set to the test state by switching the entire device to test mode or by using the CFC block CHART_STATE to switch a single CFC chart to Test mode.</p> </td> </tr> <tr> <td data-bbox="486 1287 778 1527">Protocol</td> <td data-bbox="778 1287 1479 1527"> <p>Indication and measured value are transmitted with set test bit, provided that the protocol supports this functionality.</p> <p>If an object is transmitted as a GOOSE message, the test bit is set spontaneously and the GOOSE message is transmitted immediately. The receiver of the GOOSE message is automatically notified of transmitter test mode.</p> </td> </tr> <tr> <td data-bbox="311 1527 486 1815">Test/Relay blk.</td> <td data-bbox="486 1527 1479 1815"> <p>The function works as described under Test. All output information (indications) of this function which is routed to a relay is blocked.</p> <p>All output information from the function (indications and, if available, measured values) is provided with a test bit. This test bit significantly influences the further processing of the information, depending on the target.</p> <p>Logics outside this function block, for example, superordinate group indications, are not affected by the blocking. If the state of these functions allows the processing of indications with a test bit (target function in the state Test or Test/Relay blk.), the output information routed to a relay continues to the control of the relays.</p> </td> </tr> </tbody> </table>	Target of the Information	Processing	Log	The indication is labeled as Test in the log.	Binary output	An indication routed to binary outputs does not control the switching contact, unless the behavior of the binary output is in test state.	Light-emitting diode (LED)	An indication routed to the LED triggers the LED (normal processing)	CFC	<p>Here, the behavior depends on the state of the CFC chart.</p> <ul style="list-style-type: none"> • CFC chart itself is not in test state: The CFC chart is not triggered by a status change of information with a set test bit. The initial state of the information (state before test bit was set) is not processed during execution of the CFC chart. • CFC chart itself is in test state: The CFC chart continues to process the information (indication or measured value) normally. The CFC outgoing information is provided with a test bit. The definitions in this table apply to its continued processing. <p>A CFC chart can be set to the test state by switching the entire device to test mode or by using the CFC block CHART_STATE to switch a single CFC chart to Test mode.</p>	Protocol	<p>Indication and measured value are transmitted with set test bit, provided that the protocol supports this functionality.</p> <p>If an object is transmitted as a GOOSE message, the test bit is set spontaneously and the GOOSE message is transmitted immediately. The receiver of the GOOSE message is automatically notified of transmitter test mode.</p>	Test/Relay blk.	<p>The function works as described under Test. All output information (indications) of this function which is routed to a relay is blocked.</p> <p>All output information from the function (indications and, if available, measured values) is provided with a test bit. This test bit significantly influences the further processing of the information, depending on the target.</p> <p>Logics outside this function block, for example, superordinate group indications, are not affected by the blocking. If the state of these functions allows the processing of indications with a test bit (target function in the state Test or Test/Relay blk.), the output information routed to a relay continues to the control of the relays.</p>
	Target of the Information	Processing													
	Log	The indication is labeled as Test in the log.													
	Binary output	An indication routed to binary outputs does not control the switching contact, unless the behavior of the binary output is in test state.													
	Light-emitting diode (LED)	An indication routed to the LED triggers the LED (normal processing)													
CFC	<p>Here, the behavior depends on the state of the CFC chart.</p> <ul style="list-style-type: none"> • CFC chart itself is not in test state: The CFC chart is not triggered by a status change of information with a set test bit. The initial state of the information (state before test bit was set) is not processed during execution of the CFC chart. • CFC chart itself is in test state: The CFC chart continues to process the information (indication or measured value) normally. The CFC outgoing information is provided with a test bit. The definitions in this table apply to its continued processing. <p>A CFC chart can be set to the test state by switching the entire device to test mode or by using the CFC block CHART_STATE to switch a single CFC chart to Test mode.</p>														
Protocol	<p>Indication and measured value are transmitted with set test bit, provided that the protocol supports this functionality.</p> <p>If an object is transmitted as a GOOSE message, the test bit is set spontaneously and the GOOSE message is transmitted immediately. The receiver of the GOOSE message is automatically notified of transmitter test mode.</p>														
Test/Relay blk.	<p>The function works as described under Test. All output information (indications) of this function which is routed to a relay is blocked.</p> <p>All output information from the function (indications and, if available, measured values) is provided with a test bit. This test bit significantly influences the further processing of the information, depending on the target.</p> <p>Logics outside this function block, for example, superordinate group indications, are not affected by the blocking. If the state of these functions allows the processing of indications with a test bit (target function in the state Test or Test/Relay blk.), the output information routed to a relay continues to the control of the relays.</p>														

Health

Health signals if a selected function can perform its designated functionality. If so, the health is *OK*. In case the functionality is only possible in a limited way or not at all, due to state or problems within the device, the health will signal *warning* (limited functionality) or *Alarm* (no functionality).

Internal self-monitoring can cause functions to assume the health state *Alarm* (see [10 Supervision Functions](#)). If a function assumes the health state *Alarm*, it is no longer active (indication *not active* is generated).

Only a few functions can signal the health state *warning*. The health state *warning* results from function-specific supervision and - where it occurs - it is explained in the function description. If a function assumes the *warning* status, it will remain active, that is, the function can continue to work in a conditional manner and trip in the case of a protection function.

Not Active

The indication *Inactive* signals that a function is currently not working. The indication *Inactive* is active in the following cases:

- Function is disabled
- The function is in the health state *Alarm*
- Function is blocked by an input signal (see [Figure 2-4](#))
- All protection-function steps are disabled via the *Enable protection* controllable (state = false). The indication *Protection inactive* is active.
- The function is briefly *Inactive* when exiting the state *Test*.

Blocking of the Operate Indication, No Fault Recording at Pickup

With the parameter **Blk. Op. Ind. & Fault Rec.**, you define whether a function works as a protection or a monitoring function. Further, you use this to determine the type and scope of the logging (see following table).

Parameter Value	Description
No	The function works as a protection function. It generates an operate indication and starts fault recording with pickup. During fault recording, a fault is created and logged as a fault record in the fault log.
Yes	The function works as a supervision function. The logic runs normally, but without creating the operate indication. The time-out indication is still generated and can be processed further if necessary. No fault recording starts with pickup.



NOTE

With the IEC 61850 structure editor, you can assign the logical nodes (LN) of the stages of a function to different logical devices (LD).

Always assign all LNs of a function to the same LD.

2.4 Text Structure and Reference Number for Settings and Indications

Each parameter and each indication has a unique reference number within every SIPROTEC 5 device. The reference number gives you a clear reference, for example, between an indication entry in the buffer of the device and the corresponding description in the manual. You can find the reference numbers in this document, for example, in the application and setting notes, in the logic diagrams, and in the parameter and information lists.

In order to form unique texts and reference numbers, each function group, function, function block/stage, and indication or parameter has a text and a number. This means that structured overall texts and numbers are created.

The structure of the texts and reference numbers follows the hierarchy:

- Function group:Function:Stage/Function Block:Indication
- Function group:Function:Stage/Function Block:Parameter

The colon serves as a structure element to separate the hierarchy levels. Depending on the functionality, not all hierarchy levels are always available. Function Group and Stage/Function block are optional. Since the function groups, functions as well as tripping stages/function blocks of the same type can be created multiple times, a so-called instance number is added to these elements.

EXAMPLE

The structure of the text and reference number is shown in the protection-function group **Line** as an example of the parameter **Threshold value** and the indication **Pickup** of the 2nd definite-time overcurrent protection stage of the function **Overcurrent protection, phases** (see [Figure 2-5](#)). Only one function and one function group exist in the device. The representation of the stage is simplified.

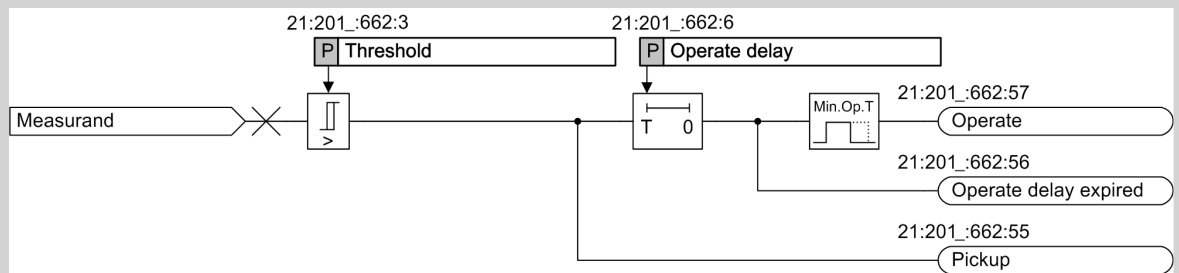

[to_staumz_1_en_US]

Figure 2-5 Stage of the Overcurrent Protection Function, Phases (without Representation of Stage Control)

The following table shows the texts and numbers of the hierarchy elements concerned:

	Name	Number of the Type	Instance Number
Protection function group	Line	2	1
Function	Overcurrent 3ph	20	1
Stage	Definite-time overcurrent protection	66	2
Settings	Threshold value	3	–
Indication	Pickup	55	–

The instance numbers arise as follows:

- Function group: Line 1
1 instance, because only one **Line** function group exists in the device
- Function: Overcurrent 3ph 1
1 instance, because only one **Overcurrent 3ph** function exists in the **Line** function group

- Stage: Definite-time overcurrent protection **2**
2 instances, because 2 definite-time overcurrent protection stages exist in the **Overcurrent 3ph** function (here the 2nd instance as an example)

This results in the following texts and numbers (including the instance numbers):

Parameter:	Number
Line 1:Overcurrent 3-ph 1:Definite-time overcurrent protection 2:Threshold value	21:201:662:3
Indication:	Number
Line 1:Overcurrent 3-ph 1:Definite-time overcurrent protection 2:Pickup	21:201:662:55

The structure is simplified accordingly for parameters and indications with fewer hierarchy levels.

2.5 Information Lists

For the function groups, functions, and function blocks, settings and miscellaneous signals are defined that are shown in the settings and information lists.

The information lists merge the signals. The data type of the information may differ. Possible data types are ENS, ACD, ACT, SPS and MV.

One type is assigned to the individual data types. The following table shows the possible types:

Type	Meaning
I	Input – input signal
O	Output – output signal
C	Controllable – control signal

EXAMPLE:

The following table shows the types for some data types as examples:

Data Type	Type
ENS	O
ACD	O
ACT	O
SPS	I or O
SPC	C
MV	O

For further information, refer to [3.7.2 Basic Data Types](#).

3 System Functions

3.1	Indications	64
3.2	Measured-Value Acquisition	92
3.3	Sampling-Frequency Tracking	94
3.4	Processing Quality Attributes	97
3.5	Fault Recording	114
3.6	Date and Time Synchronization	121
3.7	User-Defined Objects	129
3.8	Other Functions	135
3.9	General Notes for Setting the Threshold Value of Protection Functions	146
3.10	Device Settings	155

3.1 Indications

3.1.1 General

During operation, indications deliver information about operational states. These include:

- Measured data
- Power-system data
- Device supervisions
- Device functions
- Function procedures during testing and commissioning of the device

In addition, indications give an overview of important fault events after a failure in the system. All indications are furnished with a time stamp at the time of their occurrence.

Indications are saved in logs inside the device and are available for later analyses. The following number of indications are saved at least in the respective buffer (depending on the scope of the indications):

- Operational log 2000 indications
- Fault log 1000 indications
- Switching-device log 2000 indications
- Ground-fault log 100 indications
- User-defined log 200 indications
- Motor-starting log 200 indications

If the maximum capacity of the user-defined log or of the operational log is exhausted, the newest entries overwrite the oldest entries. If the maximum capacity of the fault log or of the ground-fault log is reached, the number of the last fault is output via the signal **Fault recording buffer is full**. You can route this signal in the information routing. If indications in the information routing of DIGSI 5 are routed to a log, then they are also saved. During a supply-voltage failure, recorded data are securely held by means of battery buffering or storage in the flash memory. You can read and analyze the log from the device with DIGSI 5. The device display and navigation using keys allow you to read and analyze the logs on site.

Indications can be output spontaneously via the communication interfaces of the device and through external request via general interrogation. In DIGSI 5, indications can be tracked spontaneously during online mode in a special indication window. Indications can be made accessible to higher-level control systems through mapping on various communication protocols.



NOTE

All indications are assigned to certain device functions. The text of each indication contains the corresponding function designation. You can find explanations of the meaning of indications in the corresponding device functions. However, you can also define indications yourself and group them into your own function blocks. These can be set by binary inputs or CFC logic.

Reading Indications

To read the indications of your SIPROTEC 5 device you can use the on-site operation panel of the device or a PC on which you have installed DIGSI 5. The subsequent section describes the general procedure.

3.1.2 Reading Indications on the On-Site Operation Panel

Procedure

The menus of the logs begin with a header and 2 numbers at the top right corner of the display. The number after the slash signifies the number of indications that are available. The number before the slash indicates

how many indications have just been selected or shown. The end of the indication list is closed with the entry ***END***.

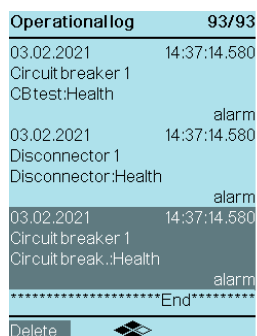

[sc_oprlogcc, 1, en_US]

Figure 3-1 On-Site Display of an Indication List (Example: Operational Indications)

Menu Path	Log
Main menu → Indications →	Operational log Fault log Switch. device log Ground-fault log Setting-history log User log 1 User log 2 Motor-starting log Com supervision log
Main Menu → Test & Diagnosis → Log →	Device diagnosis Security log Communication log

To reach the desired log from the main menu, use the navigation keys of the on-site operation panel.

- ✧ Navigate inside the log using the navigation keys (top/bottom). You will find the most current indication at the top of the list. The selected indication is shown with a dark background.

Which indications can be shown in the selected log depends on the assignments in the DIGSI 5 information routing matrix or is predefined. Every indication contains date, time, and its state as additional information.

You will find information about this in chapter [3.1.5.1 General](#).

In some logs, you are given the option of deleting the entire indication list by softkey in the footer of the display. To learn more about this, read chapter [3.1.6 Saving and Deleting the Logs](#).



NOTE

No password entry is necessary to read indications from the device.

3.1.3 Reading Indications from the PC with DIGSI 5

Procedure

Menu Path (Project)	Log
Project → Device → Process data → Log →	Operational log Fault log Switch. device log Ground-fault log Setting-history log User log 1 User log 2 Motor-starting log Com supervision log
Online access → Device → Device information → Logs tab →	Device-diagnosis log Security indications
Online access → Device → Test suite → Communica- tion module → Hardware ³	Communication log

To read the indications with DIGSI 5 your PC must be connected via the **USB user interface** of the on-site operation panel or via an **Ethernet interface** of the device. You can establish a direct connection to your PC via the Ethernet interfaces. It is also possible to access all connected SIPROTEC 5 devices via a data network from your DIGSI 5 PC.

- ✧ You reach the desired logs of the SIPROTEC 5 device using the project-tree window. If you have not created the device within a project, you can also do this via the **Online access** menu item.

After selecting the desired log, you are shown the last state of the log loaded from the device. To update, it is necessary to synchronize with the log in the device.

- ✧ Synchronize the log. For this purpose, click the appropriate button in the headline of the log (see the ground-fault indications example in [Figure 3-2 a\)](#)).

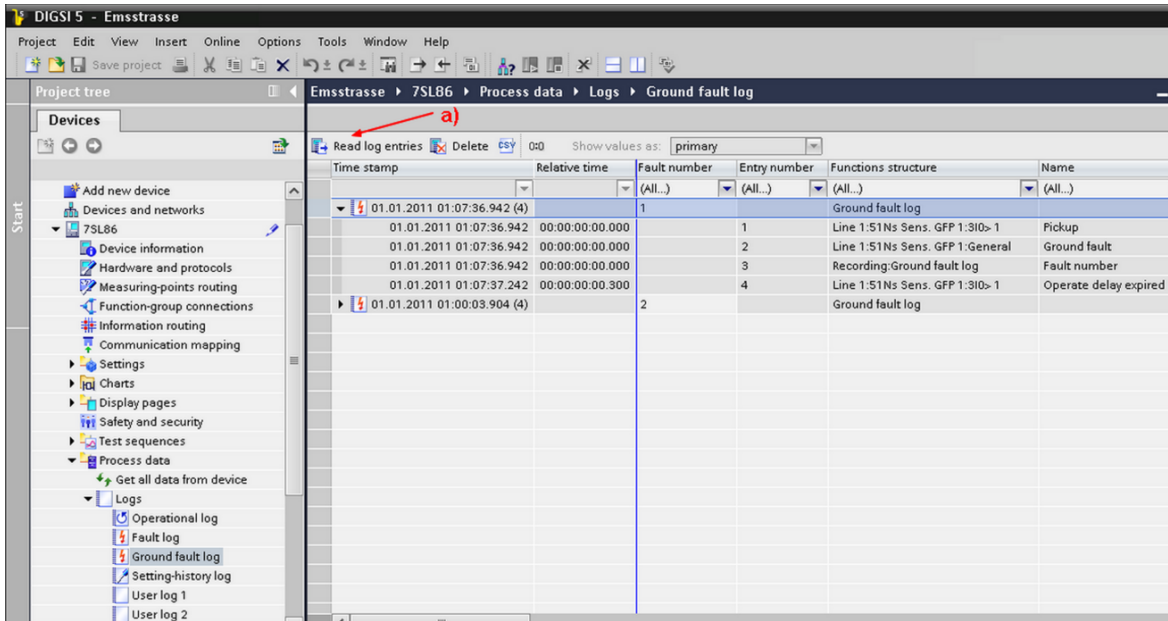

[sc_grfimd, 1, en_US]

Figure 3-2 DIGSI 5 Display of an Indication List (Example of Ground-Fault Log)

³ There may potentially be several communication modules to select from

You will find additional information about deleting and saving logs in chapter [3.1.6 Saving and Deleting the Logs](#).

Which indications can be shown in the selected log depends on the assignments in the DIGSI 5 information routing matrix or is predefined. You will find information about this in chapter [3.1.5.1 General](#).

Setting Relative Time Reference

- ✧ Reference the display of log entries, if needed, to the real time of a specific entry. In this way, you determine a relative time for all other indications. The real-time stamps of events remain unaffected.

3.1.4 Displaying Indications

Displayed indications are supplemented in DIGSI 5 and on the on-site operation panel with the following information:

Table 3-1 Overview of Additional Information

Indications in	DIGSI 5 Information	Device Display Information
Log for operational indications and log for user-defined and switching-device indications	Time stamp (date and time), Relative time, Entry number, Function structure, Name, Value, Quality, Cause, Number	Time stamp (date and time), Function structure, Name, Value
Log for fault indications	Time stamp (date and time), Relative time, Fault number, Entry number, Function structure, Name, Value, Quality, Cause, Number	Time stamp (date and time), Fault number, Value
Log for motor-starting indications	Time stamp (date and time), Motor-starting time, Starting current, Starting voltage, Starting duration	Time stamp (date and time), Function structure, Name, Value

Indications in	DIGSI 5 Information	Device Display Information
Log for ground-fault indications	Time stamp (date and time), Relative time, Fault number, Entry number, Function structure, Name, Value, Indication number, Quality, Cause, Number	Time stamp (date and time), Fault number, Value
Log for parameter changes	Time stamp (date and time), Relative time, Entry number, Function structure, Name, Value, Quality, Cause, Number	Time stamp (date and time), Function structure, Name, Value
Spontaneous indication window (DIGSI 5)	Time stamp (date and time), Relative time, Indication, Value, Quality, Additional Information	Time stamp (date and time), Fault number, Value
Log for safety indications ⁴	Time stamp (date and time), Indication number, Indication	Time stamp (date and time), Indication
Log for device-diagnostic indications ⁴	Time stamp (date and time), Indication number, Indication	Time stamp (date and time), Indication
Log for communication indications ⁴	Time stamp (date and time), Indication number, Indication	Time stamp (date and time), Indication
Log for communication supervision (GOOSE)	Time stamp (date and time), Relative time, Entry number, Function structure, Name, Value, Quality, Cause, Number	Time stamp (date and time), Function structure, Name, Value

⁴ Only online access

Overview of Displayed Quality Attributes

If values are shown on the device display or in DIGSI, the following quality attributes are different for measured values and metered values.

Table 3-2 Measured Values

IEC 61850			Device Display/ DIGSI	Description	
Detail Quality	Validity				
	Good	Invalid	Questionable		
–	X			Value	The measured value is valid.
Failure		X		Fault	The device is defective. Contact Support.
Inaccurate			X	---	The measured value was not calculated (for example, the angle between current and voltage if 1 of the 2 variables is missing).
Bad Reference			X	≈ Value	The measured value can be inaccurate (for example, outside the frequency-tracking range).
Out of Range			X	> Value	The measured value exceeds the measuring range.

Table 3-3 Metered Values

IEC 61850			Device Display/ DIGSI	Description
Validity				
Good	Invalid	Questionable		
X			Value	The metered value is invalid.
	X		---	The metered value was not calculated.
		X	≈ Value	The metered value has no reference.

Indication Columns

The following table shows the meaning of the individual columns in the log:

Indication Column	Meaning
Time stamp	Time stamp of the indication in device time using the local time zone of the device or the query time for the motor log
Relative time	Relative time to a reference entry
Error number	Number of the error that occurred in the device. This number increments continuously.
Entry number	Entry identification of buffer entries. This identification displays the sequence of buffer entries.
Indication number	Number of the indication that occurred in the device. This number increments continuously and is necessary for an analysis by Siemens.
Indication	Indication text
Function structure	Path of the signal with the signal name
Name	Signal name
Value	Current state of the command. Also pay attention to the value quality to check whether the value is up to date.

Indication Column	Meaning
Quality	The quality of the value shows the source of the value and whether the value is up to date.
Cause	Additional information such as the cause and validity
Number	DIGSI address of the signal
Motor startup time	Time of motor starting
Starting current	Current needed by the motor to start up
Starting voltage	Voltage needed by the motor to start up
Start duration	Time needed by the motor to start up

3.1.5 Logs

3.1.5.1 General

Indications are saved in logs inside the device and are available for later analyses. Different logs allow categorization of indication logging based on operating states (for example, operational and fault logs) and based on fields of application.

Table 3-4 Log Overview

Log	Logging
Operational log	Operational indications
Fault log	Fault indications
Switching-device log	Switching operation and circuit-breaker statistics
Ground-fault log	Ground-fault indications
Setting-history log	Setting changes
User-defined log	User-defined indication scope
Security log	Access with safety relevance
Device-diagnosis log	Error of the device (software, hardware) and the connection circuits
Communication log	Status of communication interfaces
Motor-starting log	Information on the motor starting
Communication-supervision log	Communication supervision (GOOSE)

Log Management

Logs have a ring structure and are automatically managed. If the maximum capacity of a log is exhausted, the oldest entries disappear before the newest entries. If the maximum capacity of the fault or ground-fault log is reached, the number of the last fault is output via the signal **Fault recording buffer is full**. You can route this signal in the information routing. If indications in the information routing of DIGSI 5 are routed to a log, then they are also saved. During a supply-voltage failure, recorded data are securely held by means of battery buffering or storage in the flash memory. You can read and analyze the log from the device with DIGSI 5. The device display and the navigation allow you to read and evaluate the logs on site using keys.

Configurability of Logs

The indication capacity to be recorded in configurable logs (for example, ground-fault log) is laid down in columns of the information routing (matrix) of DIGSI 5 specifically defined for this purpose.

Procedure

To reach the information routing of your SIPROTEC 5 device, use the project-tree window. Access is only through the project:

- Open the information routing.
Project → Device → **Information routing**

- Select the appropriate routing column.
Destination → Logs → Column **Ground-fault log (G)**

The routing of the selected indication is done via right click.

- Select one of the options in the list box shown:
 - Routed (X)
 - Unrouted

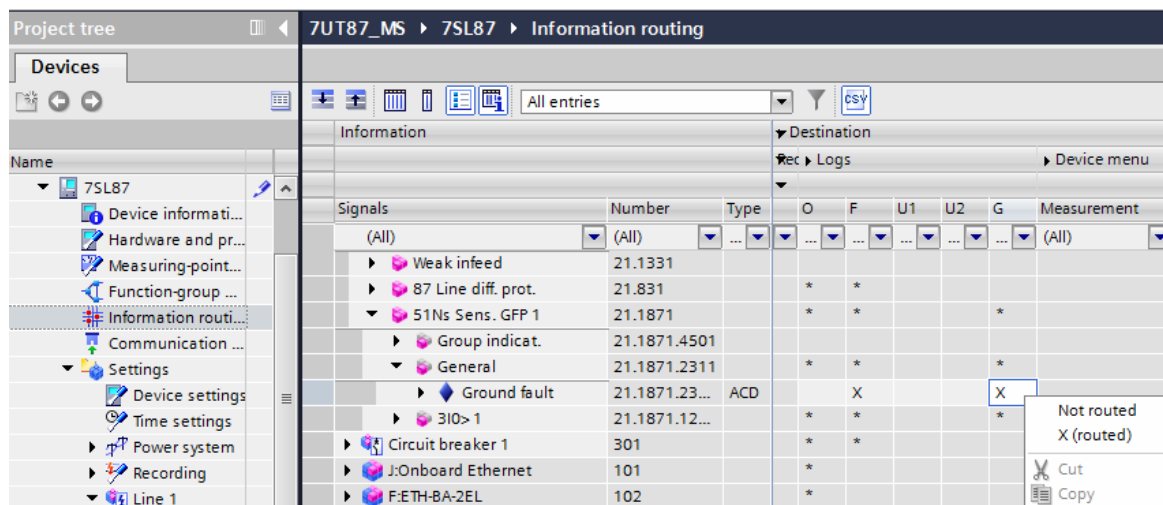

[sc_infuf, 2, en_US]

Figure 3-3 Indication Configuration in DIGSI 5 (Example: Ground-Fault Log, Column G)

For non-configurable logs (for example, setting-history logs) scope and type of logged indications are described separately (see following chapter about logs).

3.1.5.2 Operational Log

Operational indications are information that the device generates during operation. This includes information about:

- State of device functions
- Measured data
- Power-system data

Exceeding or dropping below limiting values is output as an operational indication. Short circuits in the network are indicated as an operational indication **Fault** with sequential fault number. For detailed information about the recording of system incidents, refer to the description of the fault log (chapter [3.1.5.3 Fault Log](#)). Up to 2000 indications can be stored in the operational log.

Reading from the PC with DIGSI 5

- To reach the operational log of your SIPROTEC 5 device, use the project-tree window.
Project → Device → Process Data → Log → **Operational log**
- The status of the operational log last loaded from the device is shown to you. To update (synchronization with the device), click the button **Read log entries** in the headline of the indication list ([Figure 3-4 a](#)).

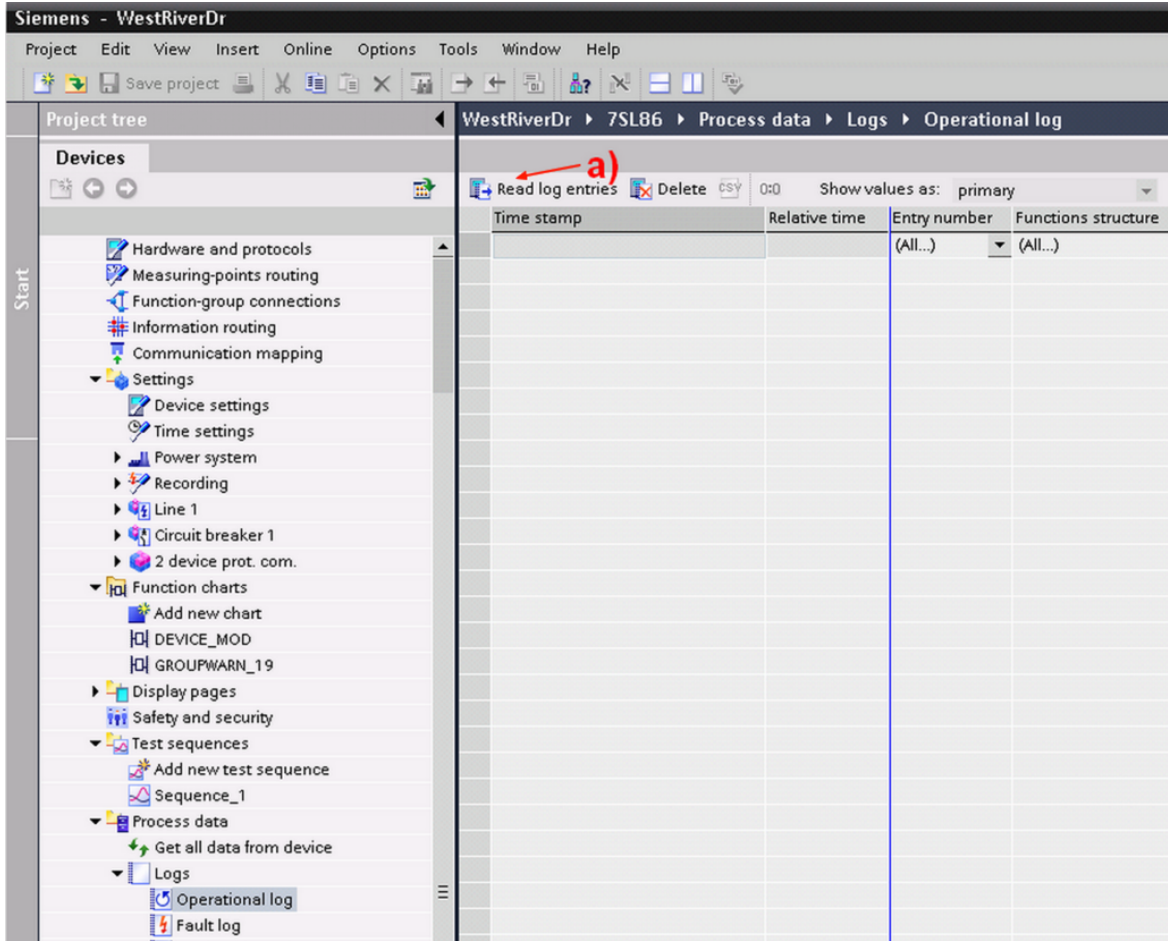

[sc_betrmtd, 1, en_US]

Figure 3-4 Reading the Operational Log with DIGSI 5

Reading on the Device via the On-Site Operation Panel

- To reach the operational log via the main menu, use the navigation keys of the on-site operation panel. Main Menu → Indications → **Operational log**
- You can navigate within the displayed indication list using the navigation keys (up/down) on the on-site operation panel.
- Using the **Info** softkey, you can retrieve auxiliary information on the entry depending on the context.

Operationallog		93/93
03.02.2021	14:37:14.580	
Circuit breaker 1		
CBtest:Health		
		alarm
03.02.2021	14:37:14.580	
Disconnecter 1		
Disconnecter:Health		
		alarm
03.02.2021	14:37:14.580	
Circuit breaker 1		
Circuit break.:Health		
		alarm
*****End*****		
Delete		

[sc_oprlogcc, 1, en_US]

Figure 3-5 On-Site Display of an Indication List (Example: Operational Indications)

Deletability

The operational log of your SIPROTEC 5 device can be deleted. This is done usually after testing or commissioning the device. To know more about this, read chapter [3.1.6 Saving and Deleting the Logs](#).

Configurability

The indication scope of the operational log is configured in a specifically defined column of the information routing (matrix) of DIGSI 5:

Target → Log → **Operational log** column

Selected application templates and functions from the library bring with them a predefined set of operational indications which you can adjust individually at any time.

3.1.5.3 Fault Log

Fault indications are events which arise during a fault. They are logged in the fault log with real-time stamp and relative-time stamp (reference point: fault occurrence). Faults are numbered consecutively in rising order. With fault recording engaged, a corresponding fault record with the same number exists for every fault logged in the fault log. A maximum of 128 fault logs can be stored. A maximum of 1000 indications can be recorded in each fault log.

Fault Definition

In general, a fault is started by the raising pickup of a protection function and ends with the cleared pickup after the trip command.

When using an automatic reclosing function, the complete reclosing cycle (successful or unsuccessful) is preferably integrated into the fault. If evolving faults appear within reclosing cycles, the entire clearing process is logged under one fault number even in multiple pickup cycles. Without automatic reclosing function every pickup is also recorded as its own fault.

User-defined configuration of a fault is also possible.



NOTE

The definition of the fault is done through settings of the fault recording (see Device manual). Events are logged in the fault log even when fault recording is switched off.

Apart from the recording of fault indications in the fault log, spontaneous display of fault indications of the last fault on the device display is also done. You will find details about this in chapter [3.1.8 Spontaneous Fault Display on the On-Site Operation Panel](#).

Deletability

The fault log of your SIPROTEC 5 device can be deleted. For more details about this, refer to chapter [3.1.6 Saving and Deleting the Logs](#).

Reading on the Device through the On-Site Operation Panel

- To reach the fault log from the main menu, use the navigation keys of the on-site operation panel.
Main Menu → Indications → **Fault logs**
- You can navigate within the displayed indication list using the navigation keys (up/down) on the on-site operation panel.

Fault log	1/14
09.02.2021 16:44:01.118	FRA00014 01
09.02.2021 16:43:36.118	FRA00013 02
09.02.2021 16:43:12.118	FRA00012 03
09.02.2021 16:42:49.118	FRA00011 04
09.02.2021 16:42:27.118	FRA00010 05
09.02.2021 16:42:06.118	FRA00009 06
09.02.2021 16:41:45.618	

[sc_faultlogc, 1, en_US]

Figure 3-6 Reading the Fault Log on the On-Site Operation Panel of the Device

Configurability

The indication scope of the fault log is configured in a specifically defined column of the information routing (matrix) of DIGSI 5:

Target → Log → **Fault log** column

Selected application templates and functions from the library already bring a predefined set of operational indications with them which you can adjust individually at any time.

The operational measured values and the measured values of the fundamental components and symmetrical components (see Device Manual) are calculated every 9 cycles (at 50 Hz, this is every 180 ms). However, this can mean that the data are not synchronized with the sampled values of the analog channels. The recording of these measured values can be used to analyze the slowly changing processes.

3.1.5.4 Switching-Device Log

Statistic values and position changes for switching devices such as circuit breakers and disconnectors are logged in the switching-device log. Up to 2000 indications can be stored in the switching-device log.

Reading from the PC with DIGSI 5

- To reach the switching-device log of your SIPROTEC 5 device, use the project-tree window.
Project → Device → Process data → Logs → **Switch. device log**

The statuses of the switching-device log last loaded from the device is shown to you.

- To update (synchronization with the device) click the button **Read log entries** in the headline of the indication list (*Figure 3-7*).

Time stamp	Relative time	Entry number	Functions structure	Name	Value	Quality
25.01.2021 14:21:19.824...				Switch. device log		
30.11.2030 02:19:56.1...	00:00:00:01.204	14	Circuit breaker 1:Circuit break.	Op.ct.	5	good (process)
30.11.2030 02:19:56.1...	00:00:00:01.204	13	Circuit breaker 1:Control	Cmd. with feedback	SPN open	good (process)
30.11.2030 02:19:56.1...	00:00:00:01.203	12	Circuit breaker 1:Circuit break.	Tripopen cmd.	off	good (process)
30.11.2030 02:19:56.1...	00:00:00:01.202	11	Circuit breaker 1:Circuit break.	Position	SPN open	good (process)
30.11.2030 02:19:55.4...	00:00:00:00.439	10	Circuit breaker 1:Circuit break.	Break. current 3I0IN	1 A	good (process)
30.11.2030 02:19:55.4...	00:00:00:00.439	9	Circuit breaker 1:Circuit break.	Break. current phs C	1000 A	good (process)
30.11.2030 02:19:55.4...	00:00:00:00.439	8	Circuit breaker 1:Circuit break.	Break. current phs B	1001 A	good (process)
30.11.2030 02:19:55.4...	00:00:00:00.439	7	Circuit breaker 1:Circuit break.	Break. current phs A	1000 A	good (process)
30.11.2030 02:19:55.4...	00:00:00:00.439	6	Circuit breaker 1:Circuit break.	Break. voltage phs C	230.87 kV	good (process)
30.11.2030 02:19:55.4...	00:00:00:00.439	5	Circuit breaker 1:Circuit break.	Break. voltage phs B	231.07 kV	good (process)
30.11.2030 02:19:55.4...	00:00:00:00.439	4	Circuit breaker 1:Circuit break.	Break. voltage phs A	230.84 kV	good (process)
30.11.2030 02:19:55.4...	00:00:00:00.426	3	Circuit breaker 1:Circuit break.	Tripopen cmd.	on	good (process)
30.11.2030 02:19:54.9...	00:00:00:00.000	2	Circuit breaker 1:Control	Cmd. with feedback	SPN closed	good (process)
30.11.2030 02:19:54.9...	00:00:00:00.000	1	Circuit breaker 1:Circuit break.	Position	SPN closed	good (process)

[sc_switch_device_log, 1, en_US]

Figure 3-7 Reading the Switching-Device Log with DIGSI 5

Reading on the Device through the On-Site Operation Panel

- To reach the switching-device log from the main menu, use the navigation keys on the on-site operation panel.
Main menu → Indications → **Switch. device log**
- You can navigate within the displayed indication list using the navigation keys (up/down) on the on-site operation panel.

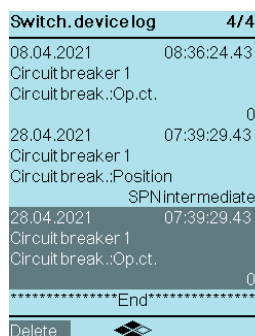

[sc_switch_device_log]_cc_1_en_US]

Figure 3-8 Reading the Switching-Device Log on the On-Site Operation Panel of the Device

Deletability

The switching-device log of your SIPROTEC 5 device can be deleted. Read details about this in chapter [3.1.6 Saving and Deleting the Logs](#).

Configuring a Switching-Device Log

The indication scope of the switching-device log is configured in a specifically defined column of the information routing (matrix) of DIGSI 5:

Target → Log → Column **Switching-device log**

Selected application templates and functions from the library already bring a predefined set of switching-device indications with them which you can adjust individually at any time. Specific statistic measured values for the circuit breaker are prerouted and cannot be removed.

3.1.5.5 Ground-Fault Log

Ground-fault indications are events which arise during a ground fault. They are logged in the ground-fault log with real-time stamp and relative-time stamp (reference point: ground-fault occurrence). Ground faults are numbered consecutively in rising order. A maximum of 10 ground-fault logs are stored, and for each ground-fault log it is guaranteed that at least 100 indications are recorded.

The following functions can start the logging of a ground fault with the raising ground-fault indication:

- Directional sensitive ground-fault protection for deleted and isolated systems (67Ns)**
- Sensitive ground current protection with I0 (50Ns/51Ns)**
- Intermittent ground-fault protection**

The logging ends with the clearing ground-fault indication.

Reading from the PC with DIGSI 5

- To reach the ground-fault log of your SIPROTEC 5 device, use the project-tree window.
Project → Device → Process data → Logs → **Ground-fault log**

The status of the device-diagnosis log last loaded from the ground-fault log is shown to you.

- To update (synchronization with the device) click the button **Read log entries** in the headline of the indication list ([Figure 3-9 a](#)).

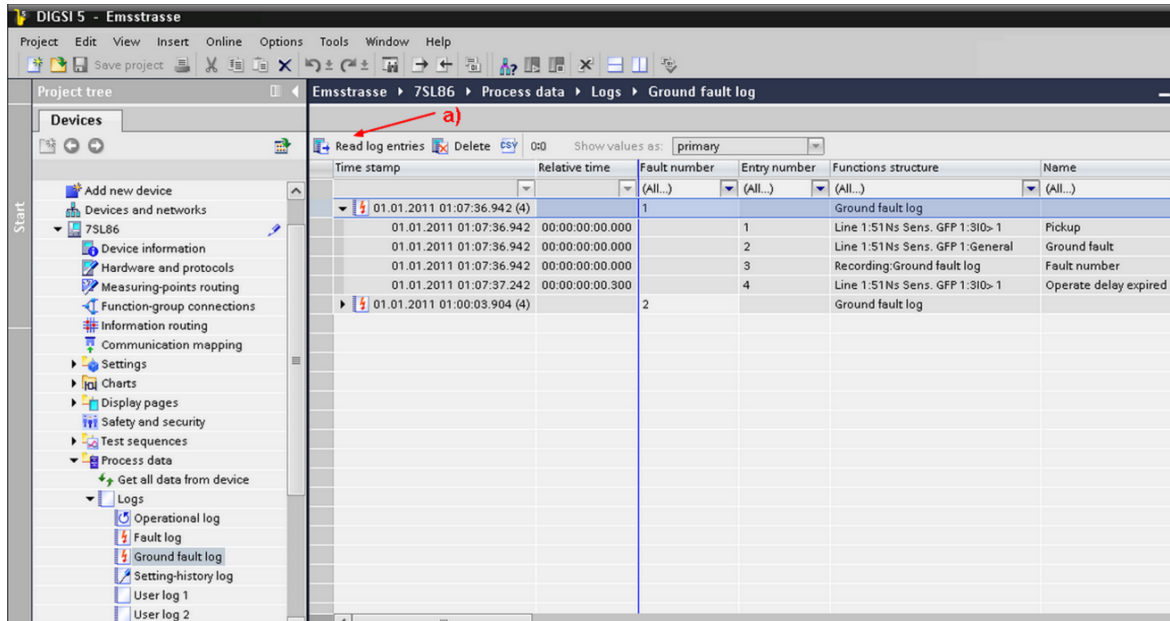

[sc_grfimd, 1, en_US]
Figure 3-9 Reading the Ground-Fault Log with DIGSI 5

Reading on the Device through the On-Site Operation Panel

- To reach the ground-fault log from the main menu, use the navigation keys of the on-site operation panel.
Main menu → Indications → **Ground-fault indication**
- You can navigate within the displayed indication list using the navigation keys (up/down) on the on-site operation panel.

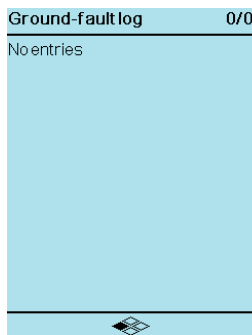

[scgflg1cc-280421, 1, en_US]
Figure 3-10 Reading the Ground-Fault Log on the On-Site Operation Panel of the Device

Deletability

The ground-fault log of your SIPROTEC 5 device can be deleted. Read details about this in chapter [3.1.6 Saving and Deleting the Logs](#).

Configurability

The indication scope of the ground-fault log is configured in a specifically defined column of the information routing (matrix) of DIGSI 5:

Target → Log → Column **Ground-fault log**

Selected application templates and functions from the library already bring a predefined set of operational indications with them which you can adjust individually at any time.

3.1.5.6 Setting-History Log

All individual setting changes and the downloaded files of entire parameter sets are recorded in the log for setting changes. This enables you to determine setting changes made are associated with events logged (for example faults). On the other hand, it is possible to obtain verification with fault analyses, for example, that the current status of all settings truly corresponds to their status at the time of the fault. Up to 200 indications can be stored in the setting-history log.

Reading from the PC with DIGSI 5

- To reach the log for setting changes of your SIPROTEC 5 device, use the project-tree window.
Project → Device → Process data → Log → **Setting changes**

The status of the setting-history log last loaded from the device is shown to you.

- To update (synchronization with the device), click the **Read log entries** button in the headline of the indication list (*Figure 3-11*).

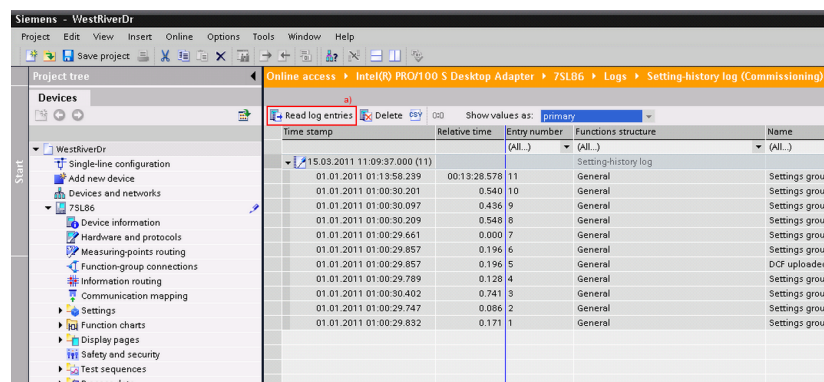

[sc_paramd, 1, en_US]

Figure 3-11 Reading the Setting-History Log with DIGSI 5

Reading on the Device through the On-Site Operation Panel

- To reach the setting-history log from the main menu, use the navigation keys of the on-site operation panel.
Main menu → Indications → **Setting changes**
- You can navigate within the displayed indication list using the navigation keys (up/down) on the on-site operation panel.

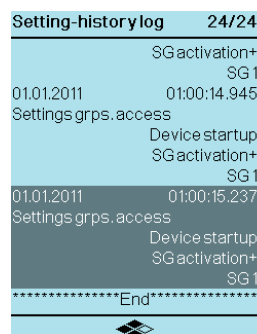

[sc_histlogg, 1, en_US]

Figure 3-12 Reading the Setting-History Log on the On-Site Operation Panel of the Device

Indication Categories in the Setting-History Log

For this log, there is selected information that is stored in case of successful as well as unsuccessful setting changes. The following list gives you an overview of this information.

Table 3-5 Overview of Indication Types

Displayed Information	Explanation
Selection edit+	Selection of settings group to be edited
Cancelation+	Cancelling of all changes successful
SG activation+	SG activation via command successful
SG activation-	SG activation via command failed
Set+	Parameter value was changed
Confirmation+	Confirmation of change successful
Confirmation-	Confirmation of change failed
DCF uploaded	DCF loaded into device
SG 1	Settings group 1
SG 2	Settings group 2
SG 3	Settings group 3
SG 4	Settings group 4
SG 5	Settings group 5
SG 6	Settings group 6
SG 7	Settings group 7
SG 8	Settings group 8



NOTE

- The logged indications are preconfigured and cannot be changed!
- The log, which is organized as a ring buffer, cannot be deleted by the user!
- If you want to archive security-relevant information of the device without loss of information, you must regularly read this log.
- You cannot route additional indication objects to the setting-history log.

3.1.5.7 User Log

With the user-defined log (up to 2), you have the possibility of individual indication logging parallel to the operational log. This is helpful, for example, in special monitoring tasks but also in the classification into different areas of responsibility of the logs. Up to 200 indications can be stored in the user-defined log.

Reading from the PC with DIGSI 5

- To reach the user-defined log of your SIPROTEC 5 device, use the project-tree window.
Project → Device → Process Data → Log → **User log 1/2**

The status of the user-defined log last loaded from the device is shown to you.

- To update (synchronization with the device), click the **Read log entries** button in the headline of the indication list (*Figure 3-13 a*).

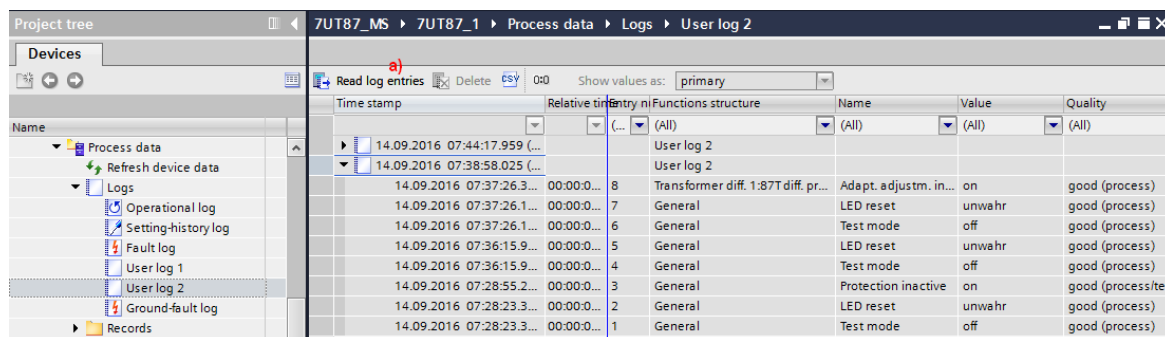

[sc_application_md, 2, en_US]

Figure 3-13 Reading the User-Defined Log with DIGSI 5

Reading on the Device through the On-Site Operation Panel

- To reach user-specific logs from the main menu, use the navigation keys of the on-site operation panel.
Main Menu → Indications → **User-defined log 1/2**
- You can navigate within the displayed indication list using the navigation keys (up/down) on the on-site operation panel.
- Using the **Info** softkey, you can retrieve auxiliary information on the entry depending on the context.

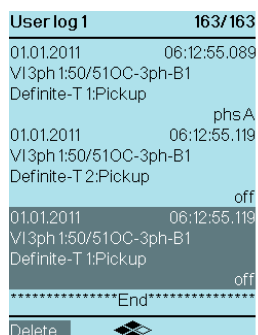

[sc_userlog1cc, 1, en_US]

Figure 3-14 Reading the User-Defined Log on the On-Site Operation Panel of the Device

Deletability

The user-defined log of your SIPROTEC 5 device can be deleted. You will find details about this in chapter [3.1.6 Saving and Deleting the Logs](#).

Configuration of a User-Defined Log

The indication capacity of a created user-defined log can be configured freely in the associated column of the information routing (matrix) of DIGSI 5:

Target → Log → U1 or U2

Signals	Number	Type	LEDs				Signal	Recorder		Logs				Device
			1.13	1.14	1.15	1.16		O	F	U1	U2	G	Measure	
(All)	(All)	(All)	(All)	
Switch onto fault 1	21.1341					*		*	*					
External trip 1pole 1	21.291					*		*	*					
50/51 OC-3ph 1p 1	21.221					*		*	*					
50N/51N OC-gnd-A1	21.211					*		*	*					
50 high-speed 1pol 1	21.981					*		*	*					
67N GFP gnd.sys.1	21.1111					*		*	*	*	*			
Group indicat.	21.1111.4501					*		*	*	*	*			
General	21.1111.2311							*						
>Test of direction	21.1111.23...	SPS						X						
Test direction	21.1111.23...	ACD												
Definite-T1	21.1111.4861							*	*	*	*			
>Block stage	21.1111.48...	SPS						X						
Inactive	21.1111.48...	SPS						X						
Behavior	21.1111.48...	ENS						X						
Health	21.1111.48...	ENS						X						
Mode 1p dead-tm...	21.1111.48...	SPS								X				
Prot.PU blocks op...	21.1111.48...	SPS									X			
Pickup	21.1111.48...	ACD							X					
Operate delay exp...	21.1111.48...	ACT								X				
Operate	21.1111.48...	ACT									X			

[sc_diu1u2, 1, en_US]

Figure 3-15 Indication Configuration in DIGSI 5 (Example: User-Defined Log U1/2)

3.1.5.8 Security Log

Access to areas of the device with restricted access rights is recorded in the security log. Unsuccessful and unauthorized access attempts are also recorded. Up to 2048 indications can be stored in the security log.

Reading from the PC with DIGSI 5

- To reach the security log of your SIPROTEC 5 device, use the project-tree window. The device must be in Online access.

Project → Online access → Device → Device Information → **Logs** tab → Security logs

The state of the security log last loaded from the device is displayed.

- Before this, refresh the contents by clicking the update arrows in the headline.

Time stamp	Message number	Severity	Indication
26.06.2018 10:02:40...	9	Warning	'7UT85_S': A user has ended an interactive session.
26.06.2018 10:02:40...	4	Warning	'7UT85_S': A user has initiated a remote session from '...
26.06.2018 10:12:38...	4	Warning	'7UT85_S': A user has initiated a remote session from '...
26.06.2018 10:12:45...	9	Warning	'7UT85_S': A user has ended an interactive session.
26.06.2018 10:29:36...	4	Warning	'7UT85_S': A user has initiated a remote session from '...
26.06.2018 10:30:46...	9	Warning	'7UT85_S': A user has ended an interactive session.
26.06.2018 11:36:56...	4	Warning	'7UT85_S': A user has initiated a remote session from '...
26.06.2018 11:37:04...	63	Alert	'7UT85_S': Restart initiated from '192.168.100.100' [...]
26.06.2018 11:38:01...	29	Warning	'7UT85_S': Configuration settings were uploaded from...
26.06.2018 11:38:01...	63	Alert	'7UT85_S': Restart initiated from '192.168.100.100' [...]
26.06.2018 11:38:01...	9	Warning	'7UT85_S': A user has ended an interactive session.
26.06.2018 11:38:04...	4	Warning	'7UT85_S': A user has initiated a remote session from '...
26.06.2018 11:38:41...	4	Warning	'7UT85_S': A user has initiated a remote session from '...
26.06.2018 11:38:47...	9	Warning	'7UT85_S': A user has ended an interactive session.

[sc_secmlid, 2, en_US]

Figure 3-16 Reading the Security Indications with DIGSI 5

Reading on the Device through the On-Site Operation Panel

- To reach the security log from the main menu, use the navigation keys of the on-site operation panel.
Main menu → Test & Diagnosis → Logs → **Security log**
- You can navigate on the on-site operation panel using the navigation keys (top/bottom) inside the displayed indication list.

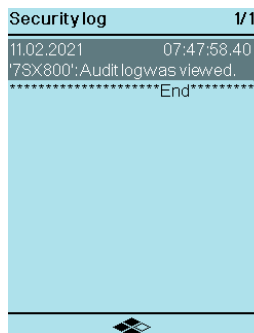

[sc_seclogcc, 1, en_US]

Figure 3-17 Reading the Security Log on the On-Site Operation Panel of the Device



NOTE

- The logged indications are preconfigured and cannot be changed!
- This log, which is organized as a ring buffer, cannot be deleted by the user!
- If you want to archive security-relevant information of the device without loss of information, you must regularly read this log.

3.1.5.9 Device-Diagnosis Log

Concrete take-action instructions are logged and displayed in the device-diagnosis log for the following items:

- Required maintenance (for example, battery supervision)
- Identified hardware defects
- Compatibility problems

Up to 500 indications can be stored in the device-diagnosis log. In normal operation of the device, it is sufficient for diagnostic purposes to follow the entries of the operational log. This specific significance is assumed by the device-diagnosis log when the device is no longer ready for operation due to hardware defect or compatibility problems and the fallback system is active.

Reading from the PC with DIGSI 5 in Normal Operation

- To reach the device-diagnosis log of your SIPROTEC 5 device, use the project-tree window.
Project → Online access → Device → Device information → **Logs** tab → Device-diagnosis log

The status of the device-diagnosis log last loaded from the device is shown to you.

- Before this, refresh the contents by clicking the update arrows in the headline.

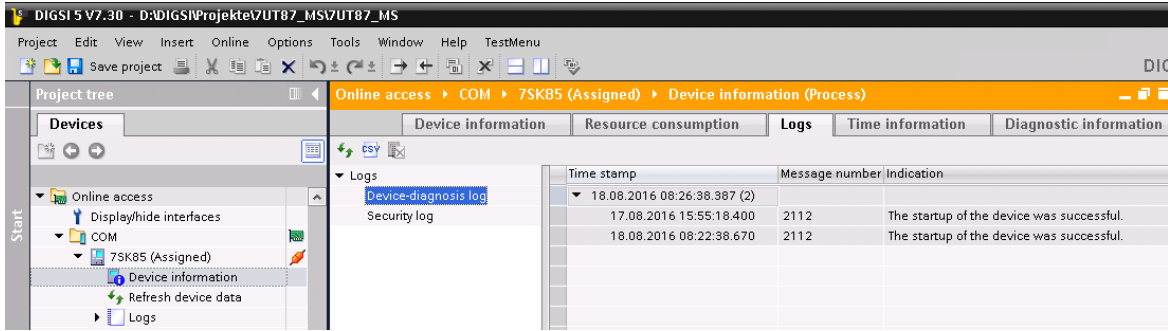

[sc_devdia, 1, en_US]

Figure 3-18 Reading the Device-Diagnosis Log with DIGSI 5

Reading on the Device through the On-Site Operation Panel in Normal Operation

- To reach the diagnosis log from the main menu, use the navigation keys of the on-site operation panel.
Main Menu → Test & Diagnosis → Logs → **Device diagnosis**
- You can navigate on the on-site operation panel using the navigation keys (top/bottom) inside the displayed indication list.

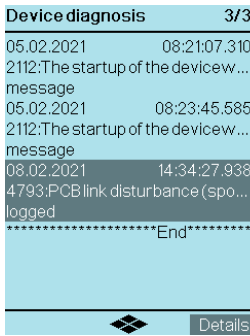

[sc_devdiacc, 1, en_US]

Figure 3-19 Reading the Device-Diagnosis Log on the On-Site Operation Panel of the Device



NOTE

- The device-diagnosis log cannot be deleted!
- The logged indications are preconfigured and cannot be changed!

3.1.5.10 Communication Log

The logging of the respective status such as ensuing faults, test and diagnosis operation, and communication capacity utilizations is done for all hardware-based configured communication interfaces. Up to 500 indications can be stored in the communication log. Logging occurs separately for each communication port of the configured integrated communication interface.

Reading from the PC with DIGSI 5

- Use the project-tree window to reach the communication logs of your SIPROTEC 5 device.
Online access → Device → Test suite → Communication module
- Then select:
F:Onboard Ethernet → **Communication log**

The communication log is shown to you in the state last loaded from the device.

- Before this, refresh the contents by clicking the update arrows in the headline.

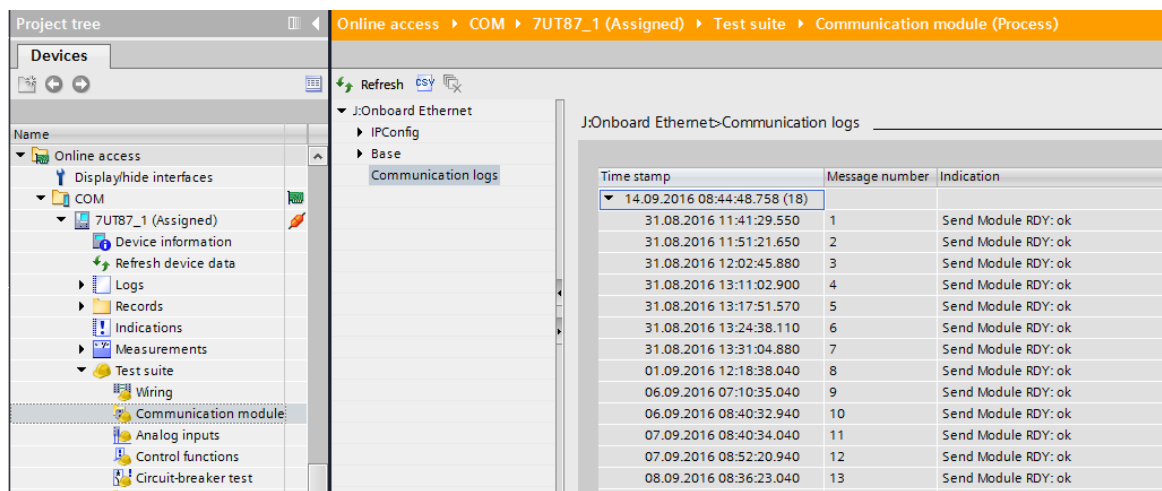

[sc_compuf, 2, en_US]

Figure 3-20 Reading the Communication Log with DIGSI 5

Reading on the Device through the On-Site Operation Panel

- To reach the communication log from the main menu, use the navigation keys on the on-site operation panel.
Main Menu → Test & Diagnosis → Logs → **Communication logs**
- You can navigate within the displayed indication list using the navigation keys (up/down) on the on-site operation panel.

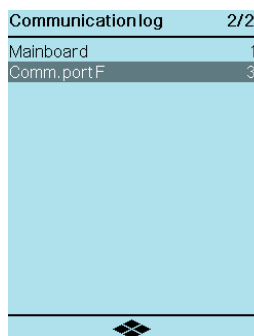

[sc_commlgcc, 2, en_US]

Figure 3-21 Reading the Communication Log on the On-Site Operation Panel of the Device

Deletability

The communication logs of your SIPROTEC 5 device can be deleted. Read details about this in chapter [3.1.6 Saving and Deleting the Logs](#).

Configurability

The communication logs are not freely configurable. The entries are preconfigured.

3.1.5.11 Communication-Supervision Log

The communication-supervision log is used to log communication events. The following events are currently logged:

- Status for each GOOSE subscription (if configured)
A log is kept of whether the GOOSE subscription has received valid messages or not.
- Aggregated status for all GOOSE subscriptions
The status is **TRUE** if at least one GOOSE subscription does not receive any valid message.

- Subscriber in simulation mode
GOOSE messages are processed with a simulation flag. The status is **TRUE** if at least one GOOSE subscription processes simulated messages.

Reading from the PC with DIGSI 5

- To reach the communication-supervision log of your SIPROTEC 5 device, use the project-tree window. Project → Device → Process data → Logs → **Com supervision log**

The status of the communication-supervision log last loaded from the device is shown.

- To update (synchronization with the device), click the button **Read log entries** in the headline of the indication list.

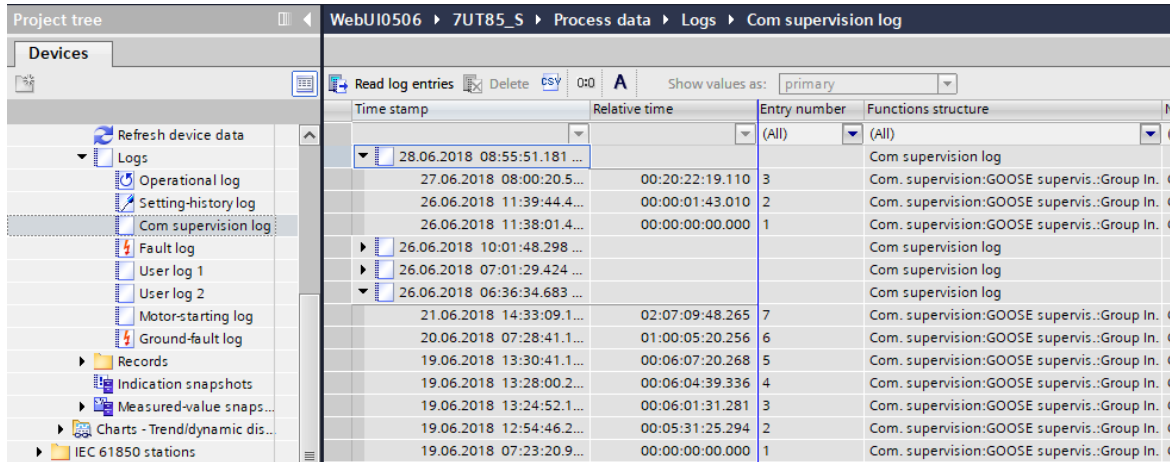

[sc_comsuperv, 1, en_US]

Figure 3-22 Reading the Communication-Supervision Log with DIGSI 5

Reading on the Device through the On-Site Operation Panel

- To reach the communication-supervision log from the main menu, use the navigation keys on the on-site operation panel. Main menu → Logs → **Com supervision log**
- You can navigate within the displayed indication list using the navigation keys (up/down) on the on-site operation panel.

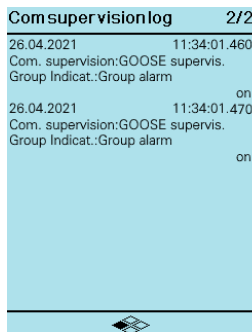

[sc_com_supervlg_cc, 1, en_US]

Figure 3-23 Reading the Communication-Supervision Log on the On-Site Operation Panel of the Device

Deletability

The communication-supervision log of your SIPROTEC 5 device can be deleted. Read details about this in chapter 3.1.6 Saving and Deleting the Logs.

Configurability

The communication-supervision log cannot be freely configured. The entries are preconfigured.

3.1.5.12 Motor-Starting Log

The motor-starting log records the starting current, starting voltage and the start duration each time a motor starts. The motor-starting current and the motor-starting voltage are displayed as primary values. Up to 200 indications can be stored in the motor-starting log.

Measurement of the motor statistics starts when the motor state changes to **Start**. Measurement of the motor starting time ends as soon as the motor state changes to **Standstill** or **Running**. The motor state is obtained from the **Motor-state detection** function.

No entry is recorded in the motor-starting log if the motor state changes to **Start** and the current drops below the motor starting current within 500 ms.

Table 3-6 Motor-Starting Log

Measured Values		Primary
Start duration	Motor starting time	s
Starting current	Motor-starting current (primary)	A (or kA)
Starting voltage	Motor-starting voltage (primary)	V (or kV)

Reading from the PC with DIGSI 5

- Use the project-tree window to reach the motor-starting log of your SIPROTEC 5 device.
Project → Device → Process data → Logs → **Motor-starting log**

The state of the motor-starting log last loaded from the device is shown to you.

- To update (synchronization with the device), click the **Read log entries** button in the headline of the indication list ([Figure 3-24](#)).

Time stamp	Motor starting time	Starting current	Starting voltage	Starting duration
(All)				
04.07.2018 10:54:45.678				
▼ Motor 1				
Last startup	04.07.2018 10:53:25.1...	1114.95 A	6.00 kV	5.24 s
2nd Last startup	04.07.2018 10:52:52.1...	1194.87 A	6.00 kV	5.22 s
3rd Last startup	04.07.2018 10:52:19.2...	1190.91 A	6.00 kV	4.83 s
4th Last startup	04.07.2018 10:51:10.6...	1180.83 A	6.00 kV	4.72 s
5th Last startup	04.07.2018 10:50:39.2...	1198.63 A	6.00 kV	5.02 s
6th Last startup	04.07.2018 10:49:42.7...	1218.87 A	6.00 kV	4.03 s
7th Last startup	04.07.2018 10:48:00.5...	1198.92 A	6.00 kV	4.03 s
8th Last startup	04.07.2018 10:47:21.9...	1198.84 A	6.00 kV	4.02 s
9th Last startup	04.07.2018 10:46:12.8...	1198.84 A	6.00 kV	4.02 s
▶ 04.07.2018 10:52:29.154				
▶ 04.07.2018 10:50:58.606				
▶ 04.07.2018 10:49:23.191				
▶ 04.07.2018 10:48:42.208				
▶ 04.07.2018 10:47:34.218				

[scmotmlp-160713-01_2_en_US]

Figure 3-24 Reading the Motor-Starting Log with DIGSI 5

Reading on the Device through the On-Site Operation Panel

- To reach the motor-starting log from the main menu, use the navigation keys of the on-site operation panel.
Main Menu → Indications → **Motor-starting log**
- You can navigate within the displayed indication list using the navigation keys (up/down) on the on-site operation panel.

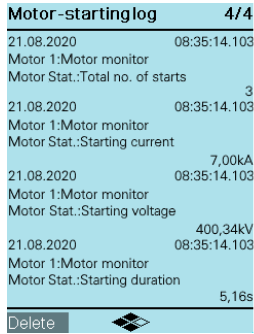

[scmotlogcc-280421, 1, en_US]

Figure 3-25 Reading the Motor-Starting Log on the On-Site Operation Panel of the Device

Deletability

The motor-starting log of your SIPROTEC 5 device can be deleted. Read details about this in chapter [3.1.6 Saving and Deleting the Logs](#).

Configurability

The motor-starting log is only present in the **Motor** function group. There is no column for the motor-starting log in the DIGSI information routing. The entries in the motor-starting log are preconfigured and cannot be changed.

3.1.6 Saving and Deleting the Logs

Deleting the logs of the device in the operating state is unnecessary. If storage capacity is no longer sufficient for new indications, the oldest indications are automatically overwritten with new incoming events. In order for the memory to contain information about the new faults in the future, for example, after a revision of the system, a deletion of the log makes sense. Resetting the logs is done separately for the various logs.



NOTE

Before you delete the content of a log on your SIPROTEC 5 device, save the log with DIGSI 5 on the hard disk drive of your PC.



NOTE

Not all logs of your SIPROTEC 5 device can be deleted. These limitations apply especially to logs with relevance for security and after-sales (security log, device-diagnosis log, setting-history log).



NOTE

If you delete any files directly from the fault log or fault record, the error number for new fault records continues incrementing up to the maximum number 2^{32} . It does not reset to 0.
If you initialize flash partitioning of the fault log and fault record, the error number for new fault records resets to 0.



NOTE

If the device executes an initial start, for example after an update of the device software, the following logs are automatically deleted:

- Operational log
- Fault log
- Switching-device log
- Ground-fault log
- Setting-history log
- User-defined log
- Motor-starting log
- Communication-supervision log

Back up the deletable logs using DIGSI 5.



NOTE

If a ground fault is currently active, the ground-fault log cannot be deleted.

Deleting Logs on the On-Site Operation Panel

- To reach the selected log from the main menu, use the navigation keys of the on-site operation panel (example operational log):

Main menu → Logs → **Operational log**

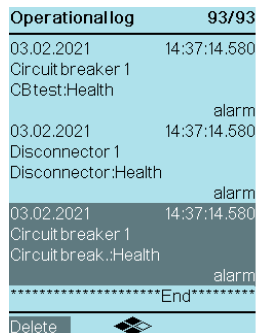

[sc_oprlogcc_1_en_US]

Figure 3-26 Deleting the Operational Log on the On-Site Operation Panel

- You can navigate within the displayed indication list using the navigation keys (up/down) on the on-site operation panel.
- The option to delete the entire log is offered to you in the footer of the display at the bottom left. Use the softkeys below under the display to activate the command prompts. Confirm the request to **Delete**.
- After being requested, enter the password and confirm with **Enter**.
- After being requested, confirm the **Deletion of all entries** with **Ok**.

Deleting Logs from the PC with DIGSI 5

- To reach the selected log of your SIPROTEC 5 device, use the project-tree window (for example operational log).

Project → Device → Process data → Logs → **Operational log**

3.1.7 Spontaneous Indication Display in DIGSI 5

With DIGSI 5 you have the possibility of displaying all currently transmitted indications of the selected device in a special indication window.

Procedure

- Call up the spontaneous indications of your selected device in the navigation window under Online access.
- Click **Indications** in the path:
 Online access → Interface → Device → **Indications**
- The raising indications appear immediately without you having to wait for a cyclical update or initiate the manual update.

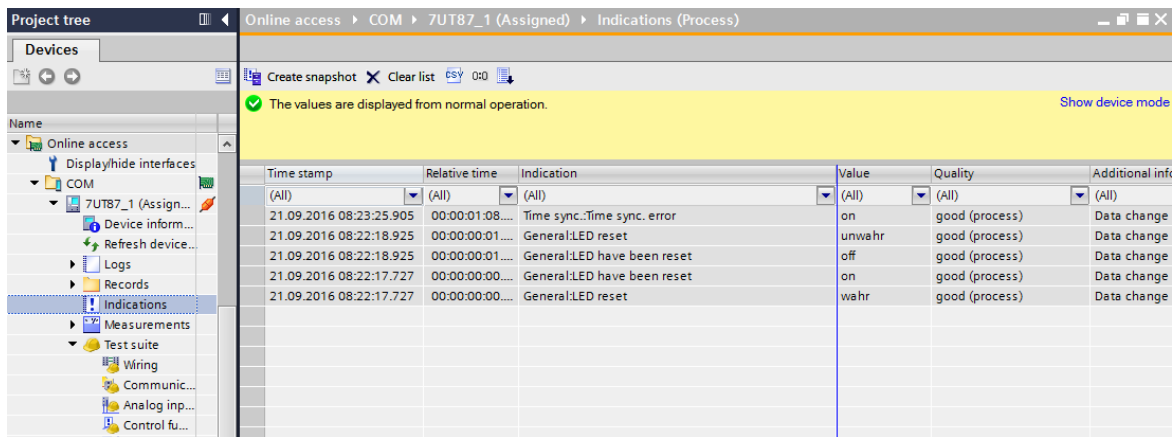

[sc_spmnid, 2, en_US]

Figure 3-27 Displaying Spontaneous Device Indications in DIGSI 5

3.1.8 Spontaneous Fault Display on the On-Site Operation Panel

After a fault, the most important data of the last fault can be displayed automatically on the device display without further operational measures. In SIPROTEC 5 devices, protected objects and even circuit breakers can be freely created and configured depending on the application (even several instances). In DIGSI 5, several spontaneous fault displays can be configured, depending on the application, with each individual one being assigned a particular circuit breaker. These displays remain stored in the device until they are manually confirmed or released by LED reset.

Configuration of a Spontaneous Fault Display with DIGSI 5

- To reach the **Fault-display configuration** of your SIPROTEC 5 device, use the project-tree window.
 Project → Device → Display pages → **Fault-display configuration**
- In the main window, all configured circuit breakers are displayed. A list of a maximum of 6 configurable display lines is offered for each circuit breaker. The activation of a spontaneous fault display occurs for each circuit breaker by selection via checkmark in the column **Display**.
- With the parameter (**_:139**) **Fault-display** (under Device → Parameter → Device settings) you determine whether spontaneous fault displays should be shown for each pickup or only pickups with the trip command.

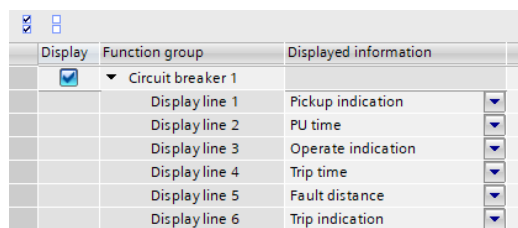

[sc_konstf_2_en_US]

Figure 3-28 Configuration of the Spontaneous Fault Display on the Device

For every display line the following display options can be selected:

Table 3-7 Overview of Display Options

Displayed Information	Explanation
Pickup indication	Display of the first function stage picked up in a fault, as needed with auxiliary information (phases, ground, direction)
PU time	Display of the entire pickup duration of the fault
Operate indication	Display of the first function stage triggered in a fault, as needed with auxiliary information (phases)
Trip time	Display of the operate time related to the beginning of the fault (pickup start)
Fault distance	Display of the measured fault-location distance
Operate result indication	Display of the control or switching device triggered in a fault, with auxiliary information (phases) where necessary

Acknowledgment of the Spontaneous Fault Display on the Device

After faults, the last occurred fault is always displayed to you. In cases where more than one circuit breaker is configured, several stored fault displays can be present after faults, with the latest being displayed. These displays remain stored in the device until manual acknowledgment or release by LED reset.

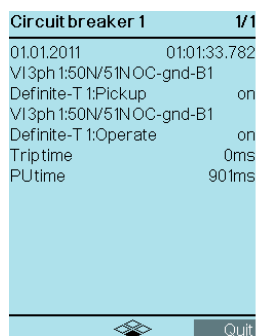

[sc_stfanzzc_1_en_US]

Figure 3-29 Spontaneous Fault Display on the Device

Method 1: Manual acknowledgment

- Press the softkey button **Quit** in the base bar of the display. The display is irretrievably closed. Repeat this step until no further spontaneous fault displays appear.
- After completion of all confirmations the last display view is showed before the faults.

Method 2: Acknowledgment via LED reset

- An LED reset (device) causes the reset of all stored LEDs and binary output contacts of the device and also to the confirmation of all fault displays stored in the display.

You can find more details on the topic of LED reset in chapter [3.1.9 Stored Indications in the SIPROTEC 5 Device](#)

3.1.9 Stored Indications in the SIPROTEC 5 Device

In your SIPROTEC 5 device, you can also configure indications as **stored**. This type of configuration can be used for LEDs as well as for output contacts. The configured output (LED or contact) is activated until it is acknowledged. Acknowledgment occurs via:

- On-site operation panel
- DIGSI 5
- Binary input
- Protocol of substation automation technology

Configuration of Stored Indications with DIGSI 5

In the **Information Routing** of each device set up in DIGSI 5, you can route binary signals, among others, to LEDs and output contacts.

- To do this, proceed in the project tree to:
 Project → Device → **Information routing**
- Right-click the routing field of your binary indication in the desired LED or binary output column in the routing range of the targets.

You are offered the following options:

Table 3-8 Overview of Routing Options

Routing Options		LEDs	BOs	BIs	Description
H	(active)			X	The signal is routed as active with voltage.
L	(active)			X	The signal is routed as active without voltage.
V	(unlatched)	X	X		The signal is routed as unlatched. Activation and reset of the output (LED, BO) occurs automatically via the binary-signal value.
G	(latched)	X	X		The binary signal is latched when the output (LED) is activated. To reset, a targeted confirmation must occur.

Routing Options		LEDs	BOs	BlS	Description
NT	(conditioned latching)	X			<p>Fault indications are stored during control of the output (LED) as a function of the parameter (_ : 91 : 139) Fault-display. In the event of a new fault, the previously stored states are reset.</p> <ul style="list-style-type: none"> • If the fault gets terminated via a trip command from the assigned circuit breaker, the status of an indication remains as latched with the setting option with trip. Without a trip command, the status is displayed before the fault (if necessary, the status of the last fault) is restored. • With the setting option with pickup the current indication image of a pickup gets stored. The image comprises all indications of functions that are effective in the event of tripping on the same circuit breaker, like the picked up function.
TL	(stored only with tripping)		X		<p>Routing option TL (tripping stored) is only possible for the switching object circuit breaker.</p> <p>The output is saved with protection tripping. The contact remains activated until acknowledged.</p> <p>Control commands are not affected. A control command is pending above the parameterized command period until feedback has been successfully received.</p> <p>Note: You can realize the functionality of the Lockout (ANSI 86) by storing the output relay with the routing option TL.</p>

3.1.10 Resetting Stored Indications of the Function Group

You can configure indications of individual functions as "stored" in a function group. This type of configuration can be used for LEDs as well as for output contacts. The configured output (LED or contact) is activated until it is acknowledged.

The protection and the circuit-breaker function groups contain the block **Reset LED FG**. The block **Reset LED FG** is visible only in the Information routing under the corresponding function group in DIGSI 5. You use the binary input signal **>Reset LED** to reset the stored LEDs in the respective function group. The configured outputs (contacts) are not reset.

3.1.11 Application Mode/Test Mode and Influence of Indications on Substation Automation Technology

With the controllable *Application mode = Test* or *Test/Relay blk.*, you switch on or off the test mode for the entire device.

For further information, refer to [13.2 Enabling/Disabling the Application/Test Mode for the Entire Device](#).

If the test mode of the device or of individual functions is switched on, the SIPROTEC 5 device marks indications sent to substation automation technology station control system with an additional test bit. This test bit makes it possible to determine that an indication was set during a test.

3.2 Measured-Value Acquisition

Basic Principle

SIPROTEC 5 devices are equipped with a powerful measured-value acquisition function. In addition to a high sampling frequency, they have a high measurand resolution. This ensures a high degree of measuring accuracy across a wide dynamic range. The 24-bit sigma/delta analog-digital converter represents the core of measured-value acquisition. In addition, the oversampling function supports the high measurand resolution. Depending on the requirements of the individual method of measurement, the sampling frequency is reduced (**Downsampling**).

In digital systems, deviations from the rated frequency lead to additional errors. In order to avoid this, 2 algorithm-dependent processes are used in all SIPROTEC 5 devices:

- Sampling-frequency tracking:
 The analog input channels are scanned for valid signals in cycles. The current power frequency is determined and the required sampling frequency is defined by using a **resampling algorithm**. The tracking is effective in the frequency range between 10 Hz and 90 Hz.
- Fixed sampling frequency – correction of the filter coefficients:
 This method operates in a limited frequency range ($f_{rated} \pm 5 \text{ Hz}$). The power frequency is determined and, depending on the degree of the frequency deviation, the filter coefficients are corrected.

The following figure shows the basics of dealing with sampled values (SAV) in the measured-value acquisition chain. *Figure 3-30* shows to whom the various sampling frequencies are made available. In order to limit the bandwidth of the input signals, a low-pass filter (anti-aliasing filter to maintain the sampling theorem) is installed downstream. After sampling, the current input channels are adjusted. Meaning that magnitude, phase, and transformer time constant are corrected. The compensation is designed to ensure that the current transformer terminal blocks can be exchanged randomly between the devices.

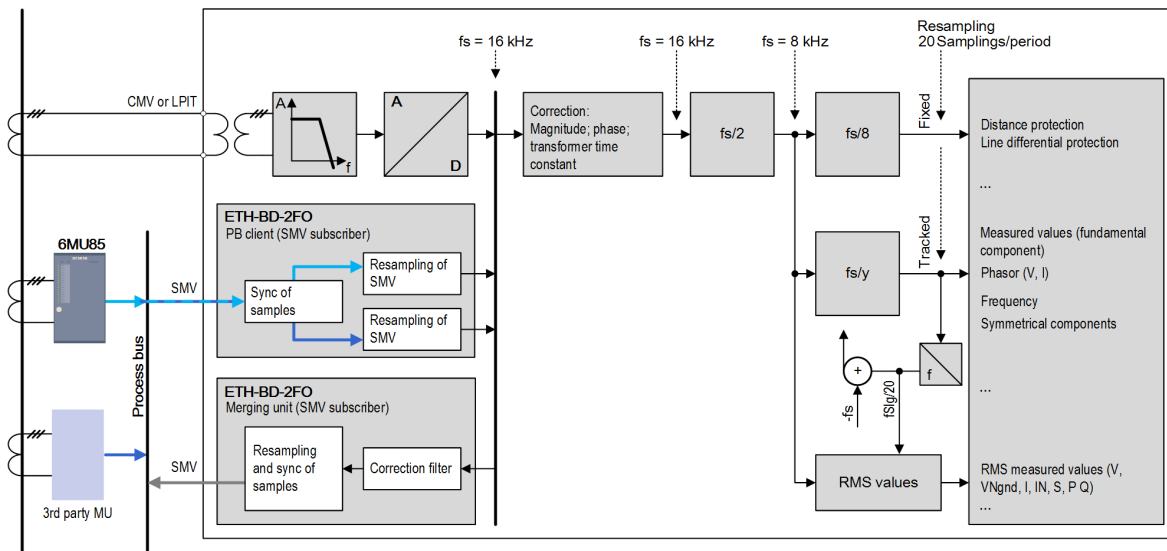

[dw_meserf_2_en_US]

Figure 3-30 Measured-Value Acquisition Chain

f_a	Sampling frequency
SMV	Sampled measured value
CMV	Conventional measured value
LPIT	Low-power instrument transformer

The internal sampling frequency of the SIPROTEC 5 devices is fixed at 16 kHz (sampling rate: 320 samplings per 50 Hz cycle). All current and voltage inputs are sampled. If magnitude, phase, and transformer time

constant are corrected, the sampling frequency is reduced to 8 kHz (160 samplings per 50-Hz cycle). This is the basic sampling frequency to which various processes, such as fault recording, RMS measured values, refer. For the RMS measurement, the measured-value window is adjusted on the basis of the power frequency. For numerous measurement and protection applications, 20 samplings per cycle are sufficient (if $f_{\text{rated}} = 50$ Hz): sampling every 1 ms, at $f_{\text{rated}} = 60$ Hz: sampling every 0.833 ms). This sampling rate is an adequate compromise between accuracy and the parallel processing of the functions (multi-functionality).

The 20 samplings per cycle will be made available to the algorithms processed in the function groups in 2 variants:

- Fixed (not resampled)
- Resampled (frequency range from 10 Hz to 90 Hz)

Depending on the algorithms (see function descriptions), the respective data flow is considered. A higher sampling frequency is used for selected methods of measurement. You can find detailed information in the corresponding function description.

**NOTE**

The **Power-system data** (starting in [6.1 Power-System Data](#)) contain the measuring points for current and voltage. Each measuring point has its own parameters.

3.3 Sampling-Frequency Tracking

3.3.1 Overview

The chapter [3.3.2 Sampling-Frequency Tracking](#) provides the necessary hints on the operating principle of sampling-frequency tracking and its application.

3.3.2 Sampling-Frequency Tracking

SIPROTEC 5 devices are equipped with powerful sampling-frequency tracking as explained in [3.2 Measured-Value Acquisition](#). This ensures high measuring accuracy over a wide frequency operating range (10 Hz to 90 Hz).

To determine the actual sampling frequency, the voltage and current measuring points are checked for valid input signals, the actual power frequency is determined and the tracking frequency (sampling frequency = 20 · tracking frequency) is adapted. The method is implemented in such a way that the number of samplings per actual power frequency or the frequency of the system is always constant. The number of samplings is 20 per cycle, as described in [3.2 Measured-Value Acquisition](#).

During engineering, you set the parameters specifying which measuring points are used for frequency tracking. All 3-phase voltage and current measuring points and 1-phase voltage and current measuring points are allowed.



NOTE

Using a measuring point for sampling-frequency tracking requires this measuring point to be suitable for reliably determining the power frequency. This is the case, as long as the measuring point has been connected to the power system and the rated voltages and currents are measured. If the measured values for the rated voltages and currents are unavailable, sampling-frequency tracking must be switched off for this measuring point.

Examples of these kind of conditions are as follows:

- 1-phase measuring points: Measuring points that measure zero-sequence voltages or zero-sequence currents must not be used for frequency tracking.
- 3-phase measuring points: Measuring points that measure unbalanced currents and voltages for a capacitor bank must not be used for frequency tracking.

The following figure shows where you set the parameters for the corresponding measuring point and activate sampling-frequency tracking in the DIGSI 5 project tree under **Settings** → **Power-system data**.

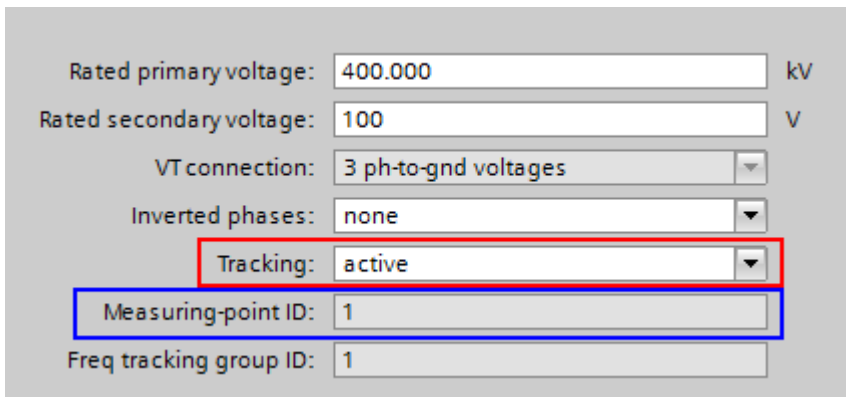

[sc_MP_Powersys trackfreq_1_en_US]

Figure 3-31 Using the Measuring Point to Determine the Sampling Frequency

If the parameter **Tracking = active**, the measuring point is used to determine the actual tracking frequency. If the parameter **Tracking** is set to **active** for several measuring points, the ID of the measuring point determines the sequence in which these are checked for valid input signals. The algorithm starts with the lowest ID number, as follows:

- First, the 3-phase measuring points are scanned. If no valid voltage is found, the selected current measuring points are next. In this case, the following sequence applies:
3-phase voltage measuring point → 3-phase current measuring point → 1-phase voltage measuring point → 1-phase current measuring point
If a trigger signal comes from a current measuring point, the voltage measuring points are still continuously scanned for valid voltages and switched immediately if a voltage is found.
- If the true RMS value is greater than 2.5 % of the set secondary device rated value, a measuring point is valid. For example, this is 2.5 V at 100 V, 25 mA at 1 A or 125 mA at 5 A.
- A 3-phase measuring point is scanned in the sequence of phase A → phase B → phase C.
In the case of the voltage measuring points, the phase-to-phase voltage V_{AB} , V_{BC} , and V_{CA} is always used for evaluation. The phase-to-phase voltage is calculated in the event of a phase-to-ground connection.
- The tracking frequency is tracked using different interval steps. If the tracking frequency deviates only slightly from the measured frequency, the frequency is tracked using small steps of 0.010 Hz. In the case of greater deviations, the interval is 1 Hz. To react faster in the event of larger deviations, for example in switchover conditions, tracking occurs in 5-Hz steps. When switching on measurands immediately the measured tracking frequency is used.
- If no tracking frequency can be determined, the appropriate rated frequency of the electrical power system is used as the tracking frequency. This case occurs before the measurands are switched on, after they are switched off or when the device is powered on. If the measurands are switched on, the starting frequency is the set power frequency, for example 50 Hz or 60 Hz. Since rated-frequency input variables can be assumed for most applications, the measuring algorithms start with the fixed sampling frequency, for example, 1 kHz for 50 Hz and 1.2 kHz for 60 Hz.

Figure 3-32 shows the behavior of sampling-frequency tracking across the frequency band and at the frequency limits.

The x-axis shows the actual power frequency (f_{sys}) and the y-axis shows the set tracking frequency (f_{track}). Between 10 Hz and 90 Hz, the relationship is linear. If the actual power frequency is less than 10 Hz, the tracking frequency is kept at 10 Hz. In this case, sampling occurs at $20 \cdot 10 \text{ Hz} = 200 \text{ Hz}$. If the power frequency is greater than 90 Hz, the tracking frequency is kept constant at 90 Hz.

If the frequency is outside the frequency operating range (10 Hz to 90 Hz), frequency tracking generates the indication *Freq. out of range*. The individual protection functions evaluate this indication. If an overfunction can occur, the protection functions are blocked internally to avoid a failure.

You can find more detailed information on the behavior of the protection functions in [14 Technical Data](#).

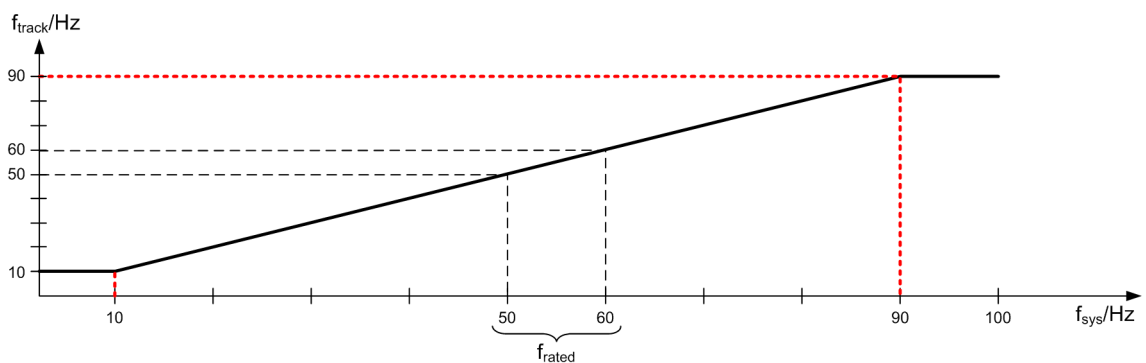

[dw_working-area_sampling-frequency-tracking_2_en_US]

Figure 3-32 Operating Range of Sampling-Frequency Tracking

Siemens recommends routing the calculated power frequency (f_{sys}) and the determined tracking frequency (f_{track}) as a measured value trace in the fault record. In this way, you can document the behavior of the device

in transient conditions. The following figure shows that you find the both measured values in the information routing under **Power-system data** → **General**:

Information			▼ S	► Destination		
				▼ BO	▼ LED	Recorder
Signals	Number	Type				Signal
(All) ▼	(All) ▼	... ▼	▼	▼	▼	(All) ▼
► General	91					
► Device	4171					
► Alarm handling	5971					
► Time managem.	8821					
► Time sync.	8851					
► Res. bin. out.	4711					
► LED not in FG	7411					
▼ Power system	11					*
▼ General	11.2311					*
>Phs-rotation reversal	11.2311.500	SPS				
>Invert Phases	11.2311.501	SPS				
Phase sequence ABC	11.2311.319	SPS				
Phase sequence ACB	11.2311.320	SPS				
Freq.out of oper.range	11.2311.321	SPS				
f _{sys}	11.2311.322	MV				X
f _{track}	11.2311.323	MV				X

[sc_rout_meas_freq_1_en_US]

Figure 3-33 Routing of the Frequency Measured Values

EXAMPLE:

Figure 3-34 shows the behavior of sampling-frequency tracking using an example.

The voltage was reduced linearly from 57.7 V (100 V phase-to-phase) to 35 V (60.6 V phase-to-phase) and, at the same time, the frequency was reduced from 50 Hz to 35 Hz, for example motor coasting down. Then, an abrupt switch to the rated values of 57.7 V at 50 Hz was made.

The upper trace shows the power-system voltage on 1 phase (A) as an example. The center trace is the calculated power frequency and the lower trace is the determined tracking frequency. If you multiply the determined tracking frequency of the lower trace by 20, you can determine the sampling frequency.

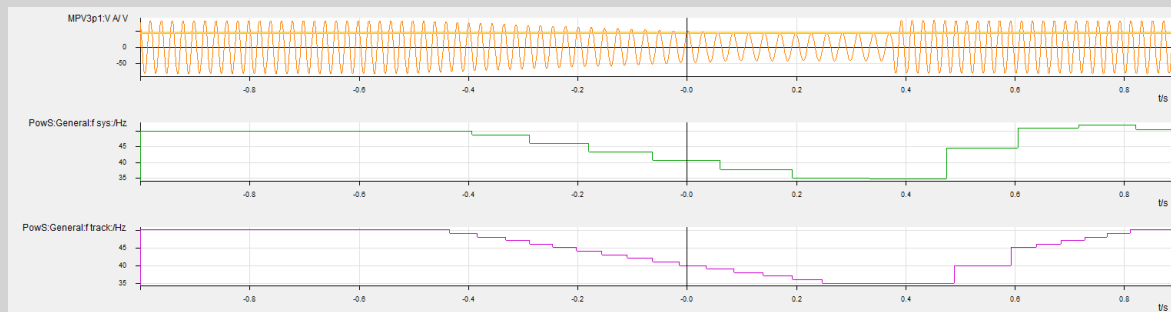

[sc_example_freqtrack_1_en_US]

Figure 3-34 Example of Frequency Tracking and Reaction to a Step Change in the Input Variable

3.4 Processing Quality Attributes

3.4.1 Overview

The IEC 61850 standard defines certain quality attributes for data objects (DO), the so-called Quality. The SIPROTEC 5 system automatically processes some of these quality attributes. In order to handle different applications, you can influence certain quality attributes and also the values of the data objects depending on these quality attributes. This is how you can ensure the necessary functionality.

The following figure describes roughly the general data flow within a SIPROTEC 5 device. The following figure also shows at which points the quality can be influenced. The building blocks presented in the figure are described in more detail in the following.

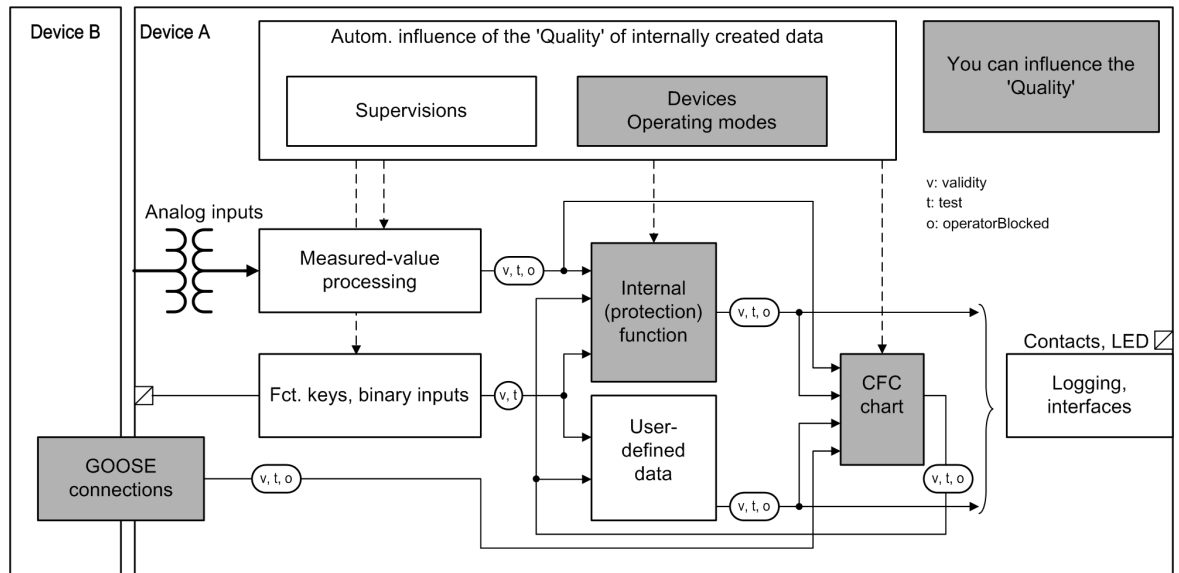

[to_qual1, 2, en_US]

Figure 3-35 Data Flow within a SIPROTEC 5 Device

Supported Quality Attributes

The following quality attributes are automatically processed within the SIPROTEC 5 system.

- **Validity** using the values *good* or *invalid*

The **Validity** quality attribute shows if an object transferred via a GOOSE message is received (valid, invalid) or not received (invalid). The *invalid* state can be suppressed in the receiver device by also setting a substitute value for the object that is not received (see [3.4.2 Quality Processing/Affected by the User for Received GOOSE Values](#)). The substitute value is forwarded to the functions.

If the device receives one of these values, it is replaced by the *invalid* value and thus processed further as *invalid*.

If one of the detailed quality attributes (detailQual) has the value *TRUE*, then **Validity** is set to the *invalid* value, unless this was already done at the transmitter end.

- **Test** using the values *TRUE*, *FALSE*

The **Test** quality attribute indicates to the receiver device that the object received via a GOOSE message was created under test conditions and not operating conditions.

- **OperatorBlocked** using the values *TRUE, FALSE*
The **OperatorBlocked** quality attribute indicates whether an object transferred via GOOSE message originates from a device that is in a *functional logoff* state. When the sending device is switched off, the object is no longer being received and assumes the *invalid* state. However, since the **OperatorBlocked** quality was previously identified on the receiver device, the object can be treated differently at the receiving end (see [3.4.2 Quality Processing/Affected by the User for Received GOOSE Values](#)). At the receiving end, the object may be treated like a dropped signal.
- **Source** using the values *process, substituted*
The **Source** quality attribute indicates whether the object was updated in the sending device. You can find more detailed information in [3.8.2 Acquisition Blocking and Manual Updating](#).

Influencing Quality by the Operating Modes

In addition to the normal operation, the device also supports further operating modes that influence quality:

- **Test mode of the device**
You can switch the entire device to test mode. In this case, all data objects generated in the device (state values and measured values) receive the quality attribute **Test = TRUE**.
The CFC charts are also in test mode and all output data receive the quality attribute **Test = TRUE**.
- **Test mode for individual functions, stages, or function blocks**
You can switch individual functions, stages, or function blocks into test mode. In this case, all data objects generated by the function, stage, or function block (state values and measured values) receive the quality attribute **Test = True**.
- **Functional logoff of the device**
If you take the device out of operation and want to isolate it from the supply voltage, you can functionally log off the device ahead of time. Once you functionally log off the device, all data objects generated in the device (state values and measured values) receive the quality attribute **OperatorBlocked = TRUE**. This also applies to the output from CFC charts.
If objects are transferred via a GOOSE message, the receiver devices can assess the quality. The receiver device detects a functional logoff of the transmitting device. After shutting down the sending device, the receiver device identifies that the sending device has been logged off operationally and did not fail. Now the receiving objects can automatically be set to defined states (see chapter [3.4.2 Quality Processing/Affected by the User for Received GOOSE Values](#)).
- **Switching off individual functions, stages, or function blocks**
You can switch off individual functions, stages, or function blocks. In this case, all data objects generated by the function, stage, or function block (state values or measured values) receive the device-internal quality attribute **Off**. The states of the inputs and measured values remain unchanged in this case; input changes are not processed. As the quality attribute **Off** is not provided for in communication protocol IEC 61850, the data objects are transferred with the quality attribute *Invalid*.

Influencing the Quality through Hardware Supervision

Supervision functions monitor the device hardware (see [10.4 Supervision of the Device Hardware](#)). If the supervision functions identify failures in the data acquisition of the device, then all recorded data will receive the quality attribute **Validity = invalid**.

Influencing the Quality through Voltage-Transformer Circuit Breakers

If tripping of the voltage-transformer circuit breaker is detected (see [10.3.4 Voltage-Transformer Circuit Breaker](#)), all recorded data will receive the quality attribute **Validity = invalid**.

Influencing the Quality by the User

You can influence the processing of data and their quality differently. In DIGSI 5, this is possible at the following 3 locations:

- In the **Information routing** editor for external signals from GOOSE connections
- In the CFC chart
- In the **Information routing** editor for binary input signals of device-internal functions

The following chapters describe in more detail the options regarding this influence as well as the automatic quality processing.

If a GOOSE connection is the data source of a binary input signal of a device-internal function, you can influence processing of the quality at 2 locations: at the GOOSE connection and at the input signal of the function. This is based on the following: A GOOSE data can be distributed within the receiving device to several functions. The GOOSE connection setting (influence) affects all functions. However, if different functions require customized settings, these are then set directly at the binary input signal of the function.

3.4.2 Quality Processing/Affected by the User for Received GOOSE Values

The properties of quality processing have changed with the introduction of GOOSE Later Binding. You can find information about the former quality processing in [Previous Quality Processing/Affected by the User for Received GOOSE Values, Page 103](#).

In the **Information Routing** Editor, you can influence the data value and quality of all data types. The following figure shows the possible influence using the example of a DPC data type. All setting options are effective for the device receiving the data.

- In the DIGSI 5 project tree, double-click **Information Routing**.
- Select either the desired signal in the **External Signals** group or the signal of a function activated via the GOOSE column.
- Open the **Properties** window and select the **Processing Quality Attributes** sheet.

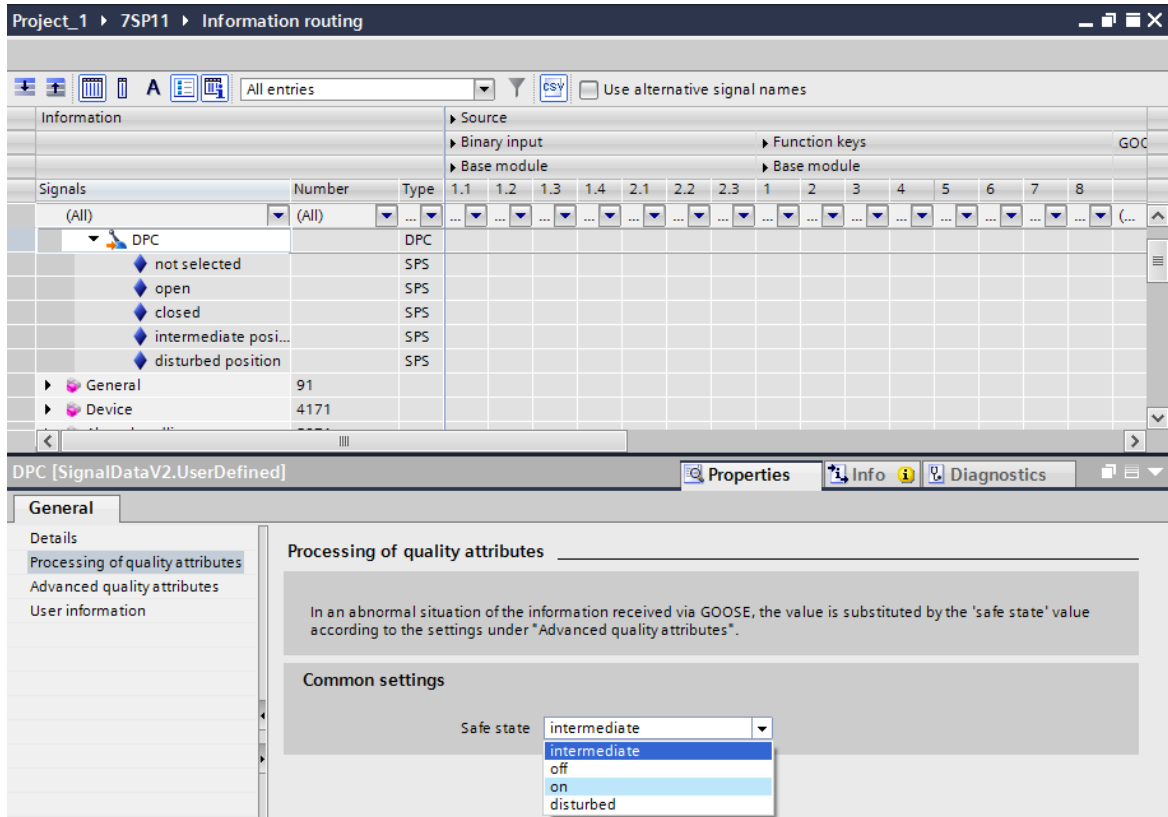

[sc_LB_GOOSE_2_2_en_US]

Figure 3-36 Influence Option When Linking a DPC Type Data Object

Depending on the selected data type of the object, various selection options are offered to you for the **Safe state** item in the **Common settings** section. At this point, you select the manually updated values that allow a safe operating state as soon as the data access via the communication path is disturbed.

- Select the property for the selected data object.

You can also set the **Advanced quality attributes** of the data object for GOOSE Later Binding. The following figure shows the advanced quality attributes using the example of a DPC data type.

- Open the **Properties** window and select the **Advanced quality attributes** sheet.

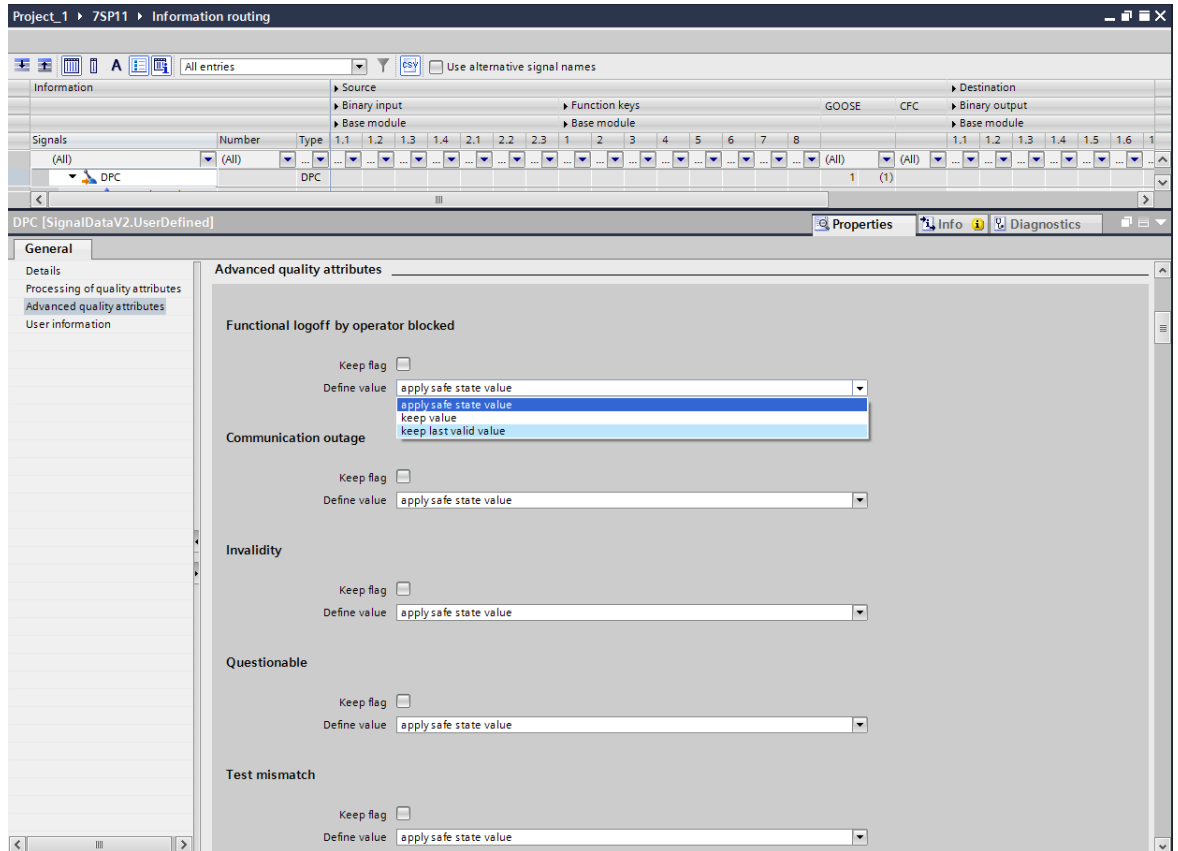

[sc_LB_GOOSE_1_2_en_US]

Figure 3-37 Advanced Quality Attributes for GOOSE Later Binding

With the following advanced quality attributes, you can filter the transmitted GOOSE indications and check and set their quality. The values that have been adapted, if necessary, are forwarded to the receiver. For the tests, you can select from the following setting options depending on the data type.

Table 3-9 Value Definitions

Setting Value	Description
<i>Apply safe state value</i>	The value configured in the Safe state is forwarded as valid to the application as soon as communication disturbance occurs.
<i>Keep value</i>	The disturbed quality attribute is overwritten with <i>good</i> and the received value is forwarded as valid to the application. If no value was received, the output value is assumed being in safe state.
<i>Keep last valid value</i>	If an invalid quality attribute is received, the last valid value is forwarded to the application. If no value has yet been received, the output value is assumed being in safe state.
<i>Set value to "false"</i>	Applies only to Boolean communication objects. Every invalid quality attribute causes the valid value <i>false</i> to be forwarded to the application.
<i>Set value to "true"</i>	Applies only to Boolean communication objects. Every invalid quality attribute causes the valid value <i>true</i> to be forwarded to the application.

These settings of the **Advanced quality attributes** apply to the advanced quality attributes listed below. The selection can vary depending on the data type.

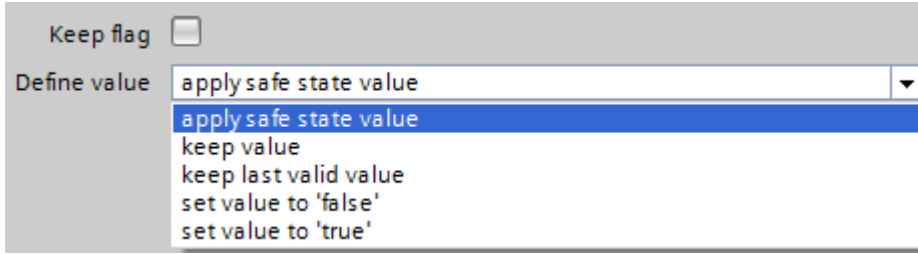

Figure 3-38 Value Definition of a Data Object of the SPS Type

You can also forward the quality attributes unchanged. To do this, you must mark the **Keep flag** check box.



NOTE

By default, the **Keep flag** checkbox is disabled when the signal is routed to the LED or the binary output.

Functional Logoff by Operator Blocked

You have set the *Operation mode* to *Device logoff= true* in the transmitting device. As a result, every indication issued from the functions and subject to *Device logoff* is transmitted with the quality information *operator blocked* and *Validity = good*. The receiver recognizes this for this indication and reacts according to the settings (Table 3-9). A different quality processing can take place only once you have set the *Operation mode* to *Device logoff= false* in the transmitting device.

Communication Outage

There is communication disturbance (time allowed to live) between the transmitter and the receiver indicated by the transmitter. The indication is set in accordance with the settings (Table 3-9).

Invalidity

The transmitting device sends this indication with the quality information *Validity = invalid*. The receiver recognizes this for this indication and reacts according to the settings (Table 3-9).

Questionable

The transmitting device sends this indication with the quality information *Validity = questionable*. The receiver recognizes this for this indication and reacts according to the settings (Table 3-9).

Test Mismatch

The transmitting device or the function in the transmitting device that issues this indication is in test mode. As a result, the indication is transmitted with the quality information *test*. The receiving function block recognizes this for this indication and reacts, depending on its own test-mode state (specified in IEC 61850-7-4 Annex A), according to the settings (Table 3-9).



NOTE

Follow the sequence of tests. First, the **Functional logoff by operator blocked** is tested. Then comes **Communication outage** and so on. If a case is recognized as *active*, the test chain is canceled with the configured setting for the active case.

In the case of **Invalidity**, the tests are first performed for **Functional logoff by operator blocked** (not applicable) and then for **Communication outage** (not applicable) and canceled with the configured action for **Invalidity**.

If an indication is routed into the log, manual updating of a value is also logged based on the conditions listed above and on the reason for the manual update. Manually updating a value based on the conditions listed

above causes a change in the *Health Warning* function block, inherited up to *Device health* (specified in IEC 61850-7-4).

Keep Flag

The quality attributes and values indicated by the transmitter are accepted without change. Quality processing must be performed by the user via a logic diagram. The outputs of the logic diagram following the user-specific quality processing can be connected to the function-block inputs as before.

Data Substitute Values

Depending on the data type, different data substitute values must be used.

Data Type	Possible Data Substitute Values	
ACD, ACT	general	0 (False), 1 (True) The directional information is manually updated with <i>unknown</i> if the option <i>Apply safe state value, Set value to "false"</i> , and <i>Set value to "true"</i> are selected; or maintain the received value with the options <i>Keep value</i> or <i>Keep last valid value</i> selected. PhsA, phsB, phsC, and neut are manually updated with the same value just like how the general value is set.)
BAC, APC	mxVal	Floating-point range and range of values according to IEEE 754 (single precision)
BCR	actVal	-2^{63} to $2^{63} - 1$
CMV	mag, ang	Floating-point range and range of values according to IEEE 754 (single precision)
DPC, DPS	stVal	0, 1, 2, 3 (intermediate-state, off, on, bad-state)
INC	stVal	$-2\ 147\ 483\ 648$ to $2\ 147\ 483\ 647$
INS	stVal	$-2\ 147\ 483\ 648$ to $2\ 147\ 483\ 647$
ISC, BSC	valWTr.posVal	-64 to 64
	valWTr.transInd	0 (False), 1 (True)
SPC, SPS	stVal	0 (False), 1 (True)
MV	mag	Floating-point range and range of values according to IEEE 754 (single precision)

For controllable types, the following substitute values apply in addition to the settable state values or measured values:

```

ctlNum      = 0
stSeld      = False
origin.orIdent = Substituted by quality processing
origin.orCat  = AUTOMATIC_BAY
  
```

Previous Quality Processing/Affected by the User for Received GOOSE Values

In the **Information Routing** editor, you can influence the data value and quality of all data types. The following figure shows the possible influence using the example of a DPC data type.

- In the DIGSI 5 project tree, double-click **Information Routing**.
- Select the desired signal in the **External Signals** group.
- Open the **Properties** window and select the **Processing Quality Attributes** sheet.

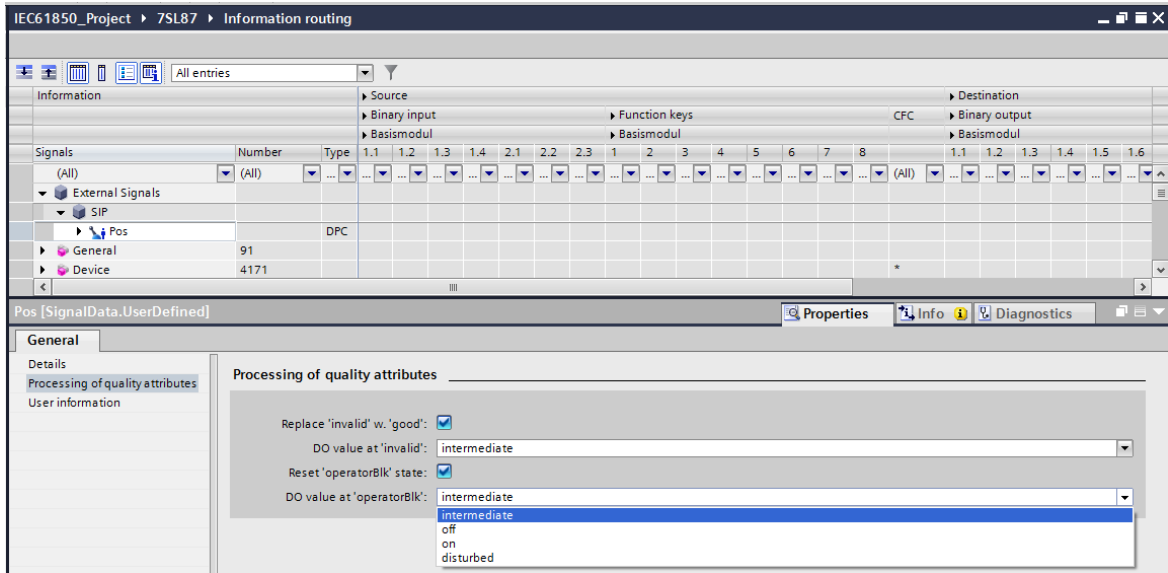

[sc, GOOSE values, 1, en_US]

Figure 3-39 Influence Option When Linking a DPC Type Data Object

The setting options work for the device receiving the data.

Quality Attribute: Validity	
The validity values <i>reserved</i> and <i>questionable</i> are replaced at the receiving end by the <i>invalid</i> value.	
<ul style="list-style-type: none"> • Check box is not set. • Check box is set and receipt of Validity = good 	The validity attribute and data value are forwarded without change.
Check box is set and receipt of Validity = invalid is set (also applies to values <i>reserved</i> and <i>questionable</i>).	<ul style="list-style-type: none"> • The validity attribute is set to <i>good</i> and processed further using this value. • The data value is set to the defined substitute value and processed further using this substitute value.
Quality Attribute: OperatorBlocked (opBlk)	
<ul style="list-style-type: none"> • Check box is not set. • Check box is set and received OperatorBlocked = FALSE 	The OperatorBlocked attribute and data value are forwarded without change.
Check box is set and received OperatorBlocked = TRUE	<ul style="list-style-type: none"> • The OperatorBlocked attribute is set to <i>FALSE</i> and processed further using this value. • The data value is set to the defined substitute value and processed further using this substitute value.

Interaction of the Quality Attribute Validity and OperatorBlocked	
OperatorBlocked check box is set and receipt of OperatorBlocked = TRUE	Regardless of whether the validity check box is set or not, and regardless of the current validity, the validity attribute is set to <i>good</i> and the substitute value of the OperatorBlocked data object is set. That is, the OperatorBlocked settings overwrite the Validity settings.
OperatorBlocked check box is not set and receipt of OperatorBlocked = TRUE	The OperatorBlocked attribute remains set and is forwarded. If the Validity check box is set and the receipt of validity = <i>invalid</i> is set, the respective data object substitute value is used. For continued signal processing and influence, it must be taken into account that in this configuration the data object substitute value for validity = <i>invalid</i> is set, but the quality attribute OperatorBlocked is not yet set.

3.4.3 Quality Processing/Affected by the User in CFC Charts

In DIGSI 5, you can control the quality processing of CFC charts. In the project tree, you can find the CFC building block (see the following figure) under **Device name** → **Settings** → **Device settings** in the editor:

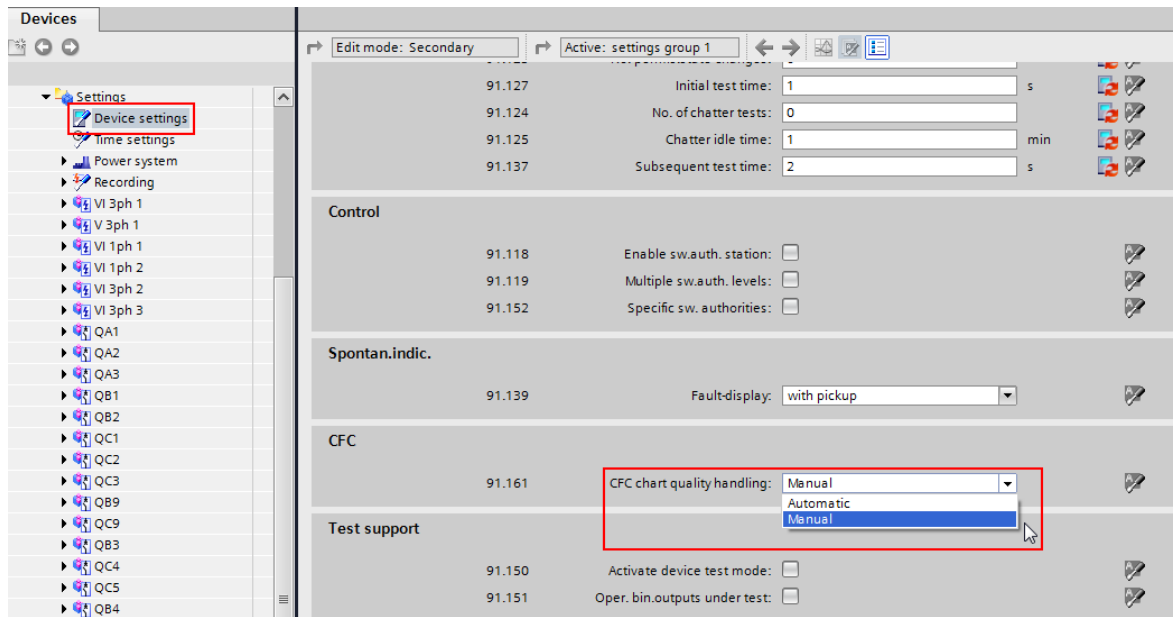

[sc_quali_cfc, 1, en_US]

Figure 3-40 Influencing CFC Quality Handling in DIGSI 5

With the **CFC chart quality handling** parameter, you control whether you want to influence the quality of CFC charts in a **Manual** or **Automatic** (default setting) manner.

If you select **Manual**, the quality attribute of the CFC chart is always valid regardless of the quality of individual signals (**Validity = good**)!

Only the **Test** quality attribute of the CFC chart is processed. If the device is in test mode or the input TEST of the CHART_STATE CFC building block is set, the quality attribute of the CFC chart is set to **Test**.

If you select **Automatic**, the quality processing of the CFC charts is influenced as follows:

In the case of CFC charts, a distinction has to be made between the general quality processing and certain CFC building blocks that are specifically designed for quality processing.

General Processing

Most of the CFC building blocks do not have an explicit quality processing. For these building blocks, the following general mechanisms shall apply.

Quality Attribute: Validity	
If one <i>invalid</i> signal is received in the case of CFC input data, then all CFC output data will also be set to <i>invalid</i> if they originate from building blocks without explicit quality processing. In other words, the quality is not processed sequentially from building block to building block but the output data are set globally. This does not apply to CFC output data that originate from building blocks with explicit quality processing (see next section).	

Quality Attribute: Test	
CFC chart is in normal state.	CFC input data with the Test = TRUE attribute are ignored. When the CFC chart is executed, then the data value that was used before the Test = TRUE attribute is used. The quality of this old value is also processed. This means that on the output side, the attribute Test = FALSE .
CFC chart is in Test ¹⁾ state.	If the CFC chart is executed, then the attribute Test = TRUE is set for all data leaving the CFC chart. This does not depend on whether the data are formed via CFC building blocks with or without quality processing.

¹⁾A CFC chart can be switched to the test state by switching the entire device to test mode or the input TEST of the CFC building block CHART_STATE is set.

Quality Attribute: OperatorBlocked	
CFC chart is in normal state.	In CFC charts for incoming data, the OperatorBlocked attribute is ignored.
CFC chart is in functionally logged off ¹⁾ state .	In CFC charts for incoming data, the OperatorBlocked attribute is ignored. All CFC output data are labeled as functionally logged off.

¹⁾ This state only occurs if the device is functionally logged off. In this case, the quality attributes of all CFC outputs are labeled as **functionally logged off**.

Quality Processing Building Blocks (Condition Processing)

The first 3 building blocks (x_SPS) process the quality automatically according to the stated logic. The other building blocks are used to isolate the quality from a data object and add them back after separate logical processing.

Building Blocks	Description																																																
OR_SPS AND_SPS NEG_SPS	<p>The building blocks also process the supported quality attributes according to their logic. The following tables describe the logic using input values in connection with the quality attribute Validity. The input values are 0 or 1, the quality attribute Validity can have the value <i>good</i> (=g) or <i>invalid</i> (=i).</p> <p>x = placeholder for the input value and quality attribute Validity</p> <p>OR_SPS</p> <table border="1"> <thead> <tr> <th>A (Value, Attribute)</th> <th>B (Value, Attribute)</th> <th>Q (Value, Attribute)</th> </tr> </thead> <tbody> <tr> <td>0, i</td> <td>0, x</td> <td>0, i</td> </tr> <tr> <td>0, g</td> <td>0, g</td> <td>0, g</td> </tr> <tr> <td>1, g</td> <td>x, x</td> <td>1, g</td> </tr> <tr> <td>1, i</td> <td>0, x</td> <td>1, i</td> </tr> <tr> <td>1, i</td> <td>1, i</td> <td>1, i</td> </tr> </tbody> </table> <p>The output thus has the logical value 1 with Validity = <i>good</i> as soon as at least 1 input has the logical value 1 with Validity = <i>good</i>. Otherwise, the inputs are treated according to the OR operation and the INVALID bit is OR-gated for the quality.</p> <p>AND_SPS</p> <table border="1"> <thead> <tr> <th>A (Value, Attribute)</th> <th>B (Value, Attribute)</th> <th>Q (Value, Attribute)</th> </tr> </thead> <tbody> <tr> <td>0, g</td> <td>x, x</td> <td>0, g</td> </tr> <tr> <td>0, i</td> <td>1, x</td> <td>0, i</td> </tr> <tr> <td>1, i</td> <td>1, x</td> <td>1, i</td> </tr> <tr> <td>1, g</td> <td>1, g</td> <td>1, g</td> </tr> </tbody> </table> <p>The output thus has the logical value 0 with Validity = <i>good</i> as soon as at least 1 input has the logical value 0 with Validity = <i>good</i>. Otherwise, the inputs are treated according to the AND operation and the INVALID bit is OR-gated for the quality.</p> <p>NEG_SPS</p> <table border="1"> <thead> <tr> <th>A (Value, Attribute)</th> <th>Q (Value, Attribute)</th> <th></th> </tr> </thead> <tbody> <tr> <td>0, i</td> <td>1, i</td> <td></td> </tr> <tr> <td>0, g</td> <td>1, g</td> <td></td> </tr> <tr> <td>1, i</td> <td>0, i</td> <td></td> </tr> <tr> <td>1, g</td> <td>0, g</td> <td></td> </tr> </tbody> </table>	A (Value, Attribute)	B (Value, Attribute)	Q (Value, Attribute)	0, i	0, x	0, i	0, g	0, g	0, g	1, g	x, x	1, g	1, i	0, x	1, i	1, i	1, i	1, i	A (Value, Attribute)	B (Value, Attribute)	Q (Value, Attribute)	0, g	x, x	0, g	0, i	1, x	0, i	1, i	1, x	1, i	1, g	1, g	1, g	A (Value, Attribute)	Q (Value, Attribute)		0, i	1, i		0, g	1, g		1, i	0, i		1, g	0, g	
A (Value, Attribute)	B (Value, Attribute)	Q (Value, Attribute)																																															
0, i	0, x	0, i																																															
0, g	0, g	0, g																																															
1, g	x, x	1, g																																															
1, i	0, x	1, i																																															
1, i	1, i	1, i																																															
A (Value, Attribute)	B (Value, Attribute)	Q (Value, Attribute)																																															
0, g	x, x	0, g																																															
0, i	1, x	0, i																																															
1, i	1, x	1, i																																															
1, g	1, g	1, g																																															
A (Value, Attribute)	Q (Value, Attribute)																																																
0, i	1, i																																																
0, g	1, g																																																
1, i	0, i																																																
1, g	0, g																																																
SPLIT_SPS SPLIT_DPS SPLI_XMV	<p>The building blocks isolate the data value and quality of a data object.</p> <p>The requirement is that the quality is available from the input end. This is the case if the building block is interconnected with CFC input data, or is connected downstream with a quality processing building block (x_SPS). In other cases, the CFC editor does not allow a connection.</p>																																																
SPLIT_Q	<p>The building block performs binary separation of the quality into <i>good</i>, <i>bad</i> (= <i>invalid</i>), <i>test</i>, <i>off</i> and <i>operatorBlocked</i>.</p> <p>These 5 attributes can then be processed individually in a binary operation. The building block must be connected downstream to a SPLIT_(DO) building block.</p>																																																

Building Blocks	Description
BUILD_Q	The building block enters a binary value for <i>good</i> and <i>bad</i> (= <i>invalid</i>) in each quality structure. Thus, with this building block the quality attributes <i>good</i> and <i>bad</i> (= <i>invalid</i>) can be set explicitly, for example, as the result of a monitoring logic. All other quality attributes are set to the default state, for instance, Test = <i>FALSE</i> . If, for example, the entire CFC chart is in the test state (see <i>Quality Attribute: Test Under General Processing</i>), this default status can again be overwritten on the CFC output side. The building block is normally connected downstream to a BUILD_(DO) building block.
BUILD_ACD	These building blocks merge data value and quality. The building-block output is generally used as a CFC output. Generally, the BUILD_Q building block is connected upstream from these building blocks.
BUILD_ACT	
BUILD_BSC	
BUILD_DPS	
BUILD_ENS	
BUILD_SPS	
BUILD_XMV	

CFC charts have a standard behavior in the processing of signals. If an input signal of the CFC chart has the quality *invalid*, all output signals of the CFC chart also get the quality *invalid*. This standard behavior is not desirable in some applications. If you use the building blocks for quality processing, the quality attributes of the input signals in the CFC chart are processed.

EXAMPLE: Switchgear Interlocking via GOOSE

The following conditions apply to the example:

- The interlocking condition for switchgear interlocking protection is stored in the device as a CFC chart.
- The removed device sends the release signal for the interlocking condition via a GOOSE telegram.

If the communication connection has been interrupted, the release signal (**GOOSEStr**) incoming via the GOOSE telegram gets the quality *invalid*. If the CFC chart obtains an invalid input signal, there are the following possibilities: The last signal valid before the communication interruption is used (quality = *good*) or a substitute data value with the quality *good* is used (True, False).

To do this, you have to create a separate CFC chart in addition to the interlocking plan of the switchgear interlocking. Use the building blocks for quality processing in a separate CFC chart. With the SPLIT_SPS building block, split the input signal (data type = SPS) into data value and quality information. You can then continue to process these signals separately in the CFC chart. Use the quality information as an input signal for a BUILD_SPS building block and assign the quality *good* to the signal. You obtain an SPS signal as a result, with the quality *good*. You can use this to process release messages correctly. You can process the release messages with the quality *good* in the CFC chart of the actual interlocking. Therefore, the release signal for a switch illustrated in the interlocking logic is available as a valid result with the quality *good*. The following figure shows an example of the CFC chart with the building blocks for quality processing:

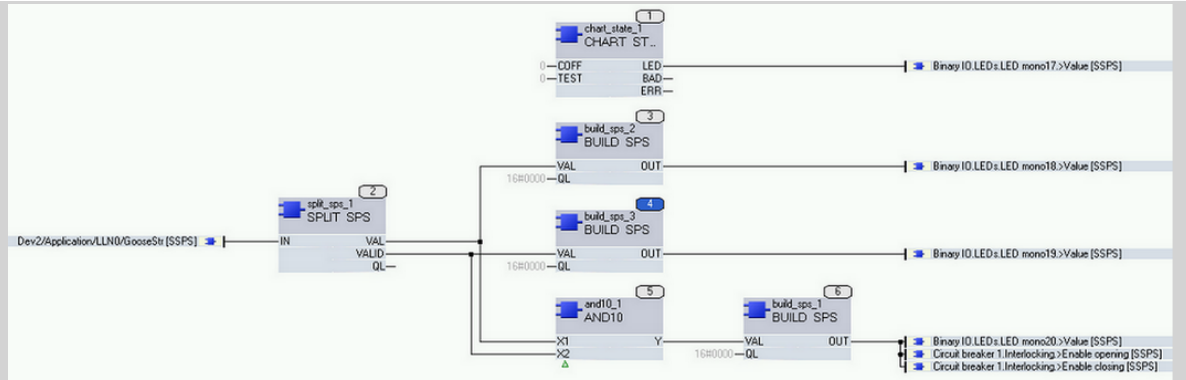

[sc_cfc_ran_1_en_US]
Figure 3-41 CFC Chart with Building Blocks for Quality Processing (Switchgear Interlocking via GOOSE)

If you do not want to convert the invalid release signal to a valid signal, as described, during the communication interruption, you can also assign a defined data value to the release signal. Proceed as follows: With the SPLIT_SPS building block, split the input signal (data type = SPS) into data value and quality information. Link the VALID output of the SPLIT_SPS building block with the data value of the input signal (AND gate). This way, you can set the value to a non-risk state with the valid input signals. In the example, the output of the CFC chart is set to the value *FALSE* when the input signal is invalid.

3.4.4 Quality Processing/Affected by the User in Internal Device Functions

Figure 3-42 provides an overview for processing the quality of data objects within a device-internal function. A function can receive internal data or input data that is routable by the user (binary input signal or double commands). The respective quality attributes supported are evaluated by the function on the input side. The attributes are not passed through the specific algorithm/the specific logic of the function. The output data are supplied with a quality that is specified by the function state and device-operating mode.



NOTE

Take into account that pickup of chatter blocking (see chapter 3.8.1 *Signal Filtering and Chatter Blocking for Input Signals*) sets the corresponding **Validity** attribute to *invalid*.

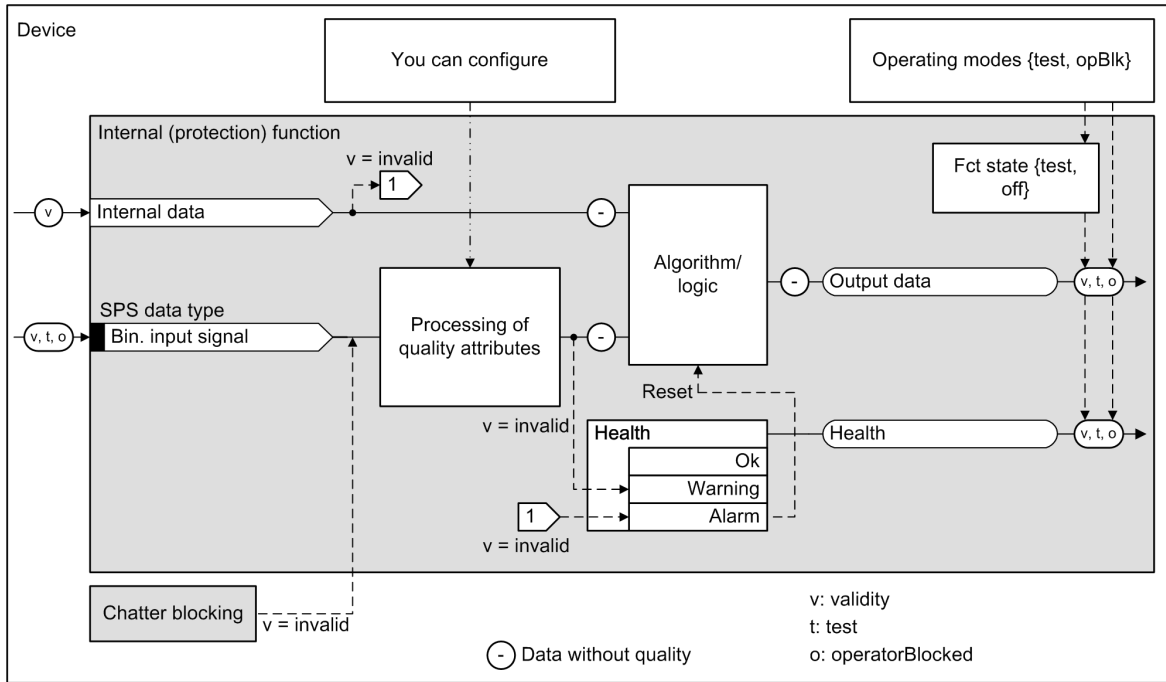

[lo_qual3.2.en_US]

Figure 3-42 Overview for Processing Quality within an Internal Function

Internal Input Data

The quality processing is automatic for internal input data.

Supported Quality Attributes	Description
Validity	<ul style="list-style-type: none"> At the receiving end, internal values can only be <i>invalid</i> or <i>good</i>. If <i>invalid</i>, the function health is set to Alarm and the function is reset. <p>Causes for invalid internal data are, for example:</p> <ul style="list-style-type: none"> The frequency operating range of the device was left. The device is not calibrated. The A/D converter monitoring identified an error.

Routable Binary Input Signals (SPS Data Type)

Figure 3-43 shows the possible sources for connecting a binary input signal. Depending on the source, different quality attributes can be set:

- CFC chart: See description in chapter 3.4.3 Quality Processing/Affected by the User in CFC Charts
- GOOSE connection: See description in chapter 3.4.2 Quality Processing/Affected by the User for Received GOOSE Values
- Device hardware: No quality attributes are set and supported.

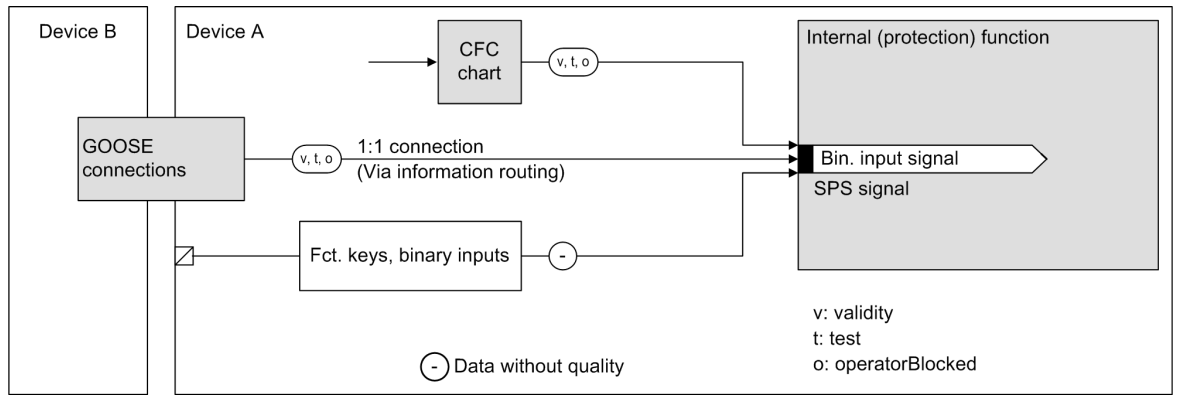

[to_quali2, 2, en_US]

Figure 3-43 Sources for Connecting a Binary Input Signal

For this signal type (SPS), you can influence the processing of the quality, see overview in [Figure 3-42](#). The following figure shows the possible influence on a binary input signal of a protection stage.

- In the DIGSI 5 project tree, double-click **Information routing**.
- In the operating range, select the desired binary input signal.
- In the **Properties** window, select the **Details** entry. There, you will find the item **Processing quality attributes**.

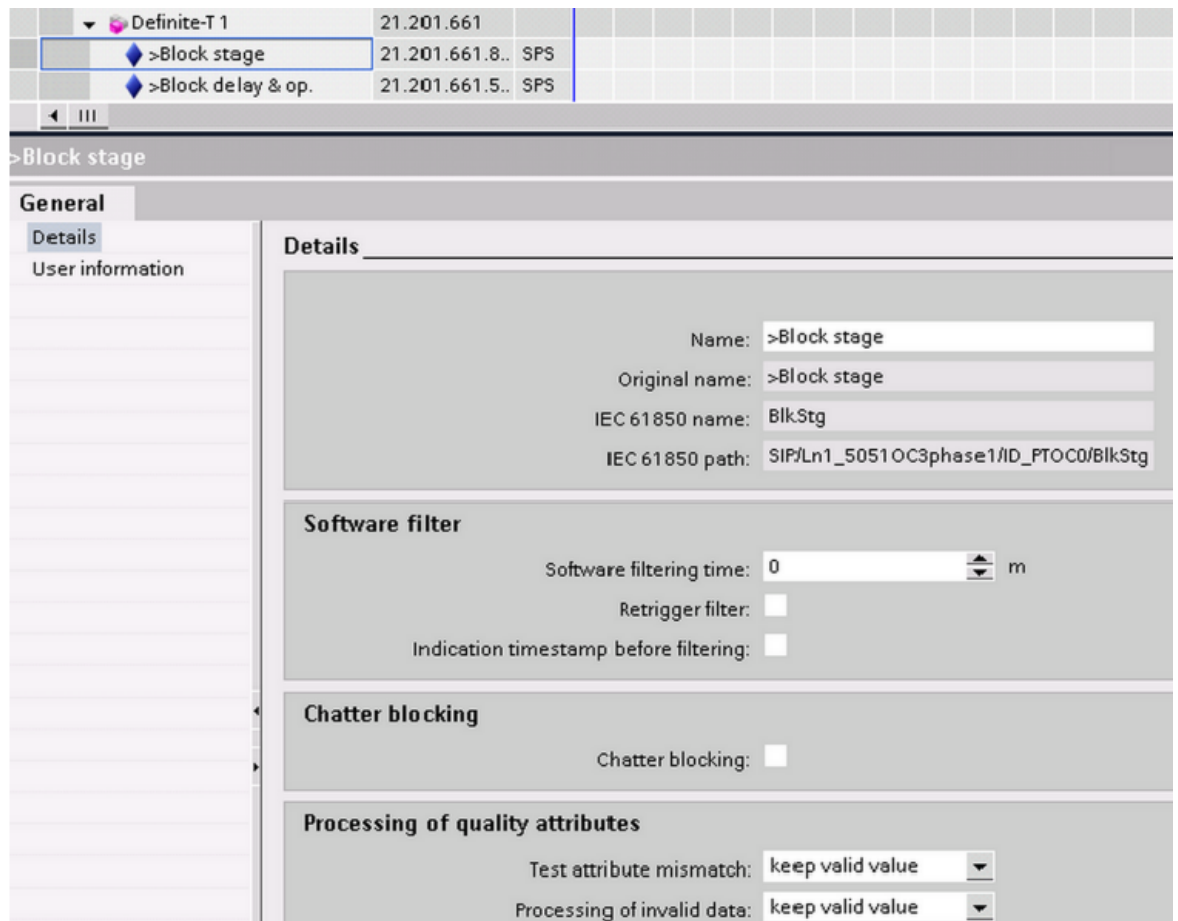

[sc_influence, 1, en_US]

Figure 3-44 Influence Options for a Binary Input Signal (SPS Input Signal)

Quality Attribute: Validity	
The Validity attribute can have the values <i>good</i> or <i>invalid</i> (<i>reserved</i> and <i>questionable</i> were already replaced at the input end of the device by the value <i>invalid</i>).	
The input signal source is <i>invalid</i> .	The current data value of the source signal is ignored. You can select between the following options: <ul style="list-style-type: none"> • Further process last valid data value of the source signal (this is the default setting with only a few exceptions) • Set the binary value to be processed further to 0. • Set the binary value to be processed further to 1. This configuration option is necessary to satisfy different applications. The function health switches to Warning.
The input signal source is <i>good</i> .	The source signal data value is processed further.

Quality Attribute: Test	
<ul style="list-style-type: none"> • The input signal source and processed function are in test state. • The input signal source is not in test state and the function to be processed is in test state. 	The source signal data value is processed further.
The input signal source is in a test state and the function to be processed is in normal state.	The data value of the source signal is ignored. You can select between the following options: <ul style="list-style-type: none"> • Further processing of the last valid source signal data value, before the source switches to the test state (that is the default setting) • The binary value to be processed further is set to 0. • The binary value to be processed further is set to 1. This configuration option is necessary to satisfy different applications.

Quality Attribute OperatorBlocked
The quality cannot be influenced at this position and does not lead to a response within the logic

Output Data

The quality is not processed through the actual algorithm/logic of the function. The following table displays the conditions required to set the quality of output signals of a function.

Cause	D0 Value	Quality Attribute	
		After internal (to the SIPROTEC 5 system, for example, in the direction of a CFC chart)	To the IEC 61850 interface, in buffer
Functional state = Test (thus, result of device operating mode = Test or function mode = Test)	Unchanged	Test = TRUE	Test = TRUE
Functional state = Off (thus, result of device operating mode = Off)	Function-specific, corresponding to the definition for switched off	Validity = good	Validity = invalid

Cause	D0 Value	Quality Attribute	
Function health = Alarm (for example, result of invalid receive data)	Function-specific, corresponding to the definition for reset	Validity = good	Validity = invalid
Device operating mode = functionally logged off	Unchanged	Validity = good OperatorBlocked = TRUE	Validity = good detailQual = oldData OperatorBlocked = TRUE

3.5 Fault Recording

3.5.1 Overview of Functions

All SIPROTEC 5 devices have a fault memory in which fault recordings are kept securely. Fault recording documents operations within the power system and the way in which protection devices respond to them. You can read out fault recordings from the device and analyze them afterwards using evaluation tools such as SIGRA.

A fault record contains the following information:

- Sample values of the analog input channels
- Measured values calculated internally
- Any binary signals (for example, pickup signals and trip signals of protection functions)

You can individually configure the signals to be recorded. Furthermore, you can define the starting condition, the record duration, and the saving criterion of a recording. Fault records saved in the device are also available after a loss of auxiliary voltage.

3.5.2 Structure of the Function

The **Fault recorder** function is a central device function. Both the recording criterion and the measured-value and binary channels to be recorded are functionally preconfigured through the application templates. You are able to individually adapt the configuration in DIGSI 5. The fault recording and the fault log are subject to the same control. This ensures that real time, relative time, and numbering of the fault data are synchronized.

This means that all fault recordings function on the same real-time and relative-time basis.

The data read out via the DIGSI-PC are saved in COMTRADE format. Fault recording data can be transferred to the substation automation technology by request in accordance with the standards via existing communication connections (such as IEC 61850). The central device analyzes the data using appropriate programs.

3.5.3 Function Description

The **Fault recorder** function records the sampled values, specific to each device, of all analog inputs, the internally calculated measured values, and the binary signals. The configuration, which is predefined for each device via an application template, can be adapted individually.



NOTE

For detailed information about selecting and deleting fault records, refer to the Operating Manual (C53000-G5040-C003).

The fault memory of the device is automatically updated with every recording. When the fault memory is filled completely, the oldest recordings are overwritten automatically. Thus, the most recent recordings are always stored safely. The maximum number of recordings is 128.

Sampling Frequency

The analog measuring channels are sampled at a different sampling rate for fault recording. The **Sampling frequency** parameter is used to set the desired sampling frequency. Possible setting values are 1 kHz, 2 kHz, 4 kHz, and 8 kHz. This setting value applies only to fault recording and does not affect protection functions or calculated measured values.



NOTE

If a pickup signal is present continuously, the fault record is closed after the **Maximum record time** expires and the fault recording is not restarted!

Saving the Recording

Not every fault recording that is started actually needs to be saved. With the **Storage** parameter, you specify whether you want to save the fault recording that has started. You can also save only fault data for which the pickup of a protection function also caused a tripping. With this setting, faults beyond the self-protection range will not lead to replacing fault recordings that have already been saved.

Configuration of Signals to Be Recorded

All analog inputs of the device that have been configured (currents and voltages) are recorded as sampled channels.

Function-specific binary signals (for example, pickup and trip signals) and measured value channels can be configured individually for recording in the DIGSI information-routing matrix. For this purpose, a separate **Recorder** column is available.

You can rename the signals in the DIGSI Information-routing matrix. You can change the order of the binary signals and measured-value channels to be recorded in DIGSI under **Signal order**. You can find more detailed information on this in the DIGSI 5 Online Help, version V07.50 and higher (Order number: C53000-D5000-C001-D).

The operational measured values and the measured values of the fundamental components and symmetrical components (see the Device Manual, chapters [11.3 Operational Measured Values](#) and [11.4 Fundamental and Symmetrical Components](#)) are calculated every 9 cycles (at 50 Hz, this is every 180 ms). However, this can mean that the data are not synchronized with the sampled values of the analog channels. The recording of these measured values can be used to analyze the slowly changing processes.

Numbering and Time Stamping

All fault recordings saved are automatically numbered in ascending order and assigned a real-time stamp for the start time. The fault recording logs the fault with a relative time. The reference-time point is the start of the recording. Every fault recording has a corresponding fault log with the same number. This ensures that the fault recording can be uniquely assigned to the event log.



NOTE

When the **Fault recorder** function detects a negative time stamp of the measurand or the binary signal, an entry is added in the **Device-diagnosis log** in DIGSI. Meanwhile, the fault recording continues. The entry for an incorrect measurand or binary signal shows the prefix **Bad quality**.

Fault Memory

The device manages its available fault memory dynamically, so that the maximum recording capacity is always available. When exceeding the limits of the fault memory, the oldest recordings are automatically overwritten. This means that the most recent recordings are always available. The sampling rate, type, and number of measured value trends to be recorded are the crucial variables when it comes to restricting the length and number of recordings possible. Parallel to the sampled tracks, up to 50 tracks with function-specific measured values and up to 200 binary tracks can be recorded. The following table provides an overview of the maximum storage capacities, in seconds, for different connection variations of the protection devices.

Table 3-10 Maximum Length of All Stored Recordings

Connection Examples	Sampling 1 kHz	Sampling 2 kHz	Sampling 4 kHz	Sampling 8 kHz
Feeder: 4I, 6 measured values, 20 binary tracks	1365 s	819 s	455 s	241 s
Feeder: 4I, 4V, 20 binary tracks	1125 s	566 s	284 s	142 s
Feeder: 4I, 4V, 6 measured values, 20 binary tracks	890 s	500 s	266 s	137 s

Input and Output Signals

The **Fault recorder** function provides several input signals that allow the precise starting, deleting of recordings. The output signals provide information about the function status.

In the following table, you can find input signals of the **Fault recorder** function:

Name	Type	Description
Control: Start recording	SPC	Start recording via the function key
Control: Reset memory	SPC	Delete all recording via the function key. The error numbers are reset.
Control: Delete memory	SPC	Delete all recording via the function key. The error numbers remain as is.
Control: >External start	SPS	Start recording with an external binary signal, for example, by the trip command of an external protection device. The set pre-trigger and post-trigger time are taken into account.
Control: >Manual start	SPS	Start a recording of fixed duration (parameter Manual record time) by way of an external binary signal, for example, manually via the function key or by an external binary signal.

In the following table, you can find output signals of the **Fault recorder** function:

Name	Type	Description
Control: Error number	INS	The indication of the current error number allows a unique allocation of entries in the message buffers for the recorded fault records.
Control: Recording started	SPS	Fault recording running
Control: Recording done	SPS	Fault recording done
Control: Tmax reduced	SPS	Fault recording ends before the set Maximum record time expires, because the fault log is full.
Control: Fault log is full	INS	The fault log is full.

Configuring Stored Indications Using DIGSI 5

- In the **Information Routing** of each device set up in DIGSI 5, you can route binary signals to LEDs and output contacts. To do this, open the project tree.
Project -> Device -> **Information routing**
- Right-click the routing field of your binary indication in the desired LED or binary output column in the routing range of the targets.

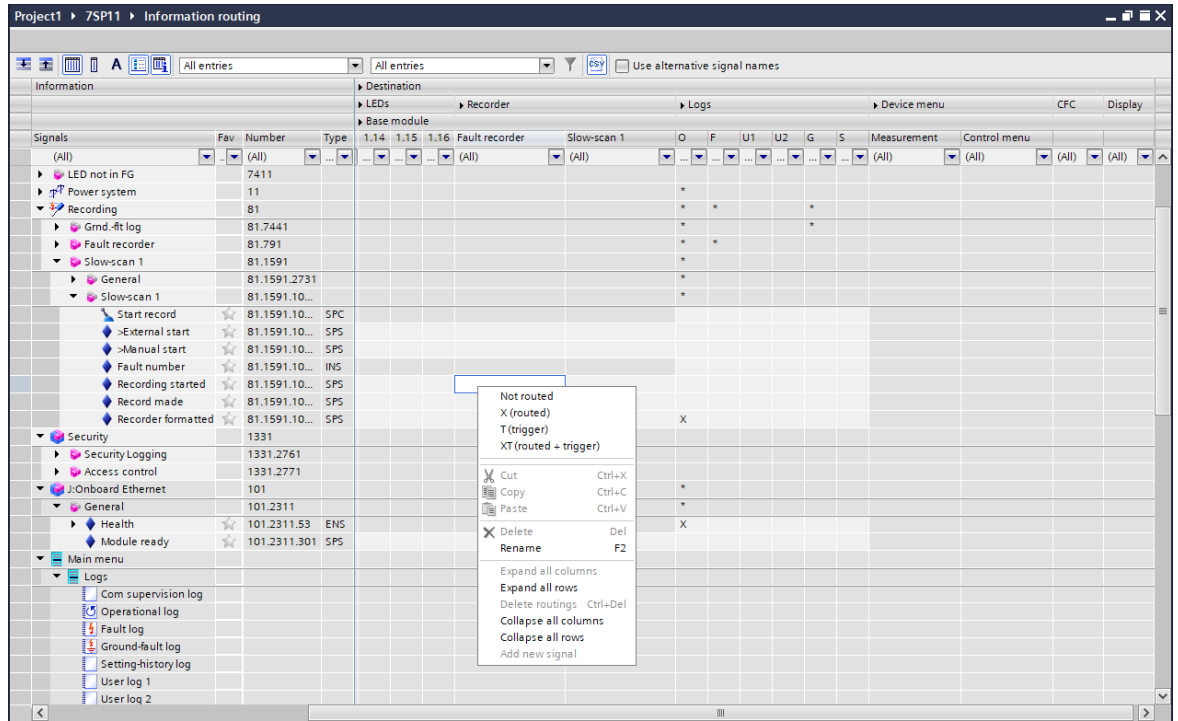

[sc_FR_information routing, 1, en_US]

Figure 3-45 Routing of the Signals in the Information Routing

3.5.4 Application and Setting Notes

Parameter: Storage

- Recommended setting value (_:2761:131) **Storage = always**

With the **Storage** parameter, you define the storage criterion for a fault recording that has already started.

Parameter Value	Description
always	Each fault recording that has been started is saved.
with trip	If at least one protection function issues an operate indication during the record time, any fault recording that has been started is saved.

Parameter: Maximum record time

- Default setting (_:2761:111) **Maximum record time = 5.00 s**

With the **Maximum record time** parameter, you configure the maximum record duration for an individual fault recording. When the time configured expires, an ongoing fault recording is canceled. This parameter merely limits the duration of the fault recording. It does not affect the logging of faults in the fault log.

Parameter: Pre-trigger time

- Recommended setting value (_:2761:112) **Pre-trigger time = 0.50 s**

With the **Pre-trigger time** parameter, you configure the pre-trigger time for an individual fault recording. The set pre-trigger time is prepended to the actual recording criterion for the fault recording.

Parameter: Post-trigger time

- Recommended setting value (_:2761:113) **Post-trigger time = 0.50 s**

With the **Post-trigger time** parameter, you configure the post-trigger time for an individual fault recording. The post-trigger time that has been configured is added to the actual recording criterion for the fault recording after the dropout.

The following table shows how the setting range changes for the **Post-trigger time** parameter depending on the **Sampling frequency**.

Sampling Frequency	Setting Range for the Post-trigger time Parameter
8 kHz	0.05 s to 4 s
4 kHz	0.05 s to 8 s
2 kHz	0.05 s to 16 s
1 kHz	0.05 s to 24 s

Parameter: Manual record time

- Recommended setting value (`_:2761:116`) **Manual record time = 0.50 s**

With the **Manual record time** parameter, you set the length of a recording if the fault recording is activated dynamically (edge-triggered) via a separately configured input signal `>Manual start`. In this case, pre-trigger and post-trigger times do not take effect.

Parameter: Sampling frequency

- Recommended setting value (`_:2761:140`) **Sampling frequency = 8 kHz**

With the **Sampling frequency** parameter, you define the sampling frequency of fault records that you want to download via DIGSI 5. Possible setting values are 8 kHz, 4 kHz, 2 kHz, and 1 kHz.

Parameter: Sampl. freq. IEC 61850 rec.

- Recommended setting value (`_:2761:141`) **Sampl. freq. IEC 61850 rec. = 8 kHz**

With the parameter **Sampl. freq. IEC 61850 rec.**, you define the sampling frequency of the fault record that you want to download using the IEC 61850 communication protocol. Possible setting values are 8 kHz, 4 kHz, 2 kHz, and 1 kHz.

You cannot set the parameter **Sampl. freq. IEC 61850 rec.** to be greater than the set value of the parameter **Sampling frequency**. The setting options of the parameter **Sampl. freq. IEC 61850 rec.** which are greater than the set value of the parameter **Sampling frequency** are invisible.

If the size of the COMTRADE file exceeds the maximum permissible storage capacity of the device, the original recording is truncated. The truncated data are discarded.



NOTE

If you have created a fault record with a certain sampling frequency and then set the sampling frequency to a lower value, you can no longer download this fault record using the IEC 61850 communication protocol. You must reset the sampling frequency to the original value. Then you can download the fault record again using the IEC 61850 communication protocol.

Parameter: Cal.zero.seq.cur.channel

- Default setting (`_:2761:129`) **Cal.zero.seq.cur.channel = no**

With the **Cal.zero.seq.cur.channel** parameter, you determine whether the calculated zero-sequence current $3I_0$ or $-3I_0$ is recorded in a separate channel or not. The separate channel is visible in the DIGSI 5 Information routing under the **I 3-phase** measuring point.

The zero-sequence currents can be calculated only with the following current-transformer connection types:

- 3-phase + IN-separate**
- 3-phase + IN**
- 3-phase**

Parameter Value	Description
<i>no</i>	The zero-sequence current calculated from the sampled values of the currents is not recorded.
<i>-3I0</i>	The calculated zero-sequence current <i>-3I0</i> is recorded for each I 3-phase measuring point. <i>-3I0</i> is calculated from the sampled current values using the following equation: $-3I0 = -(I_A + I_B + I_C)$.
<i>3I0</i>	The calculated zero-sequence current <i>3I0</i> is recorded for each I 3-phase measuring point. <i>3I0</i> is calculated from the sampled current values using the following equation: $3I0 = (I_A + I_B + I_C)$.

Parameter: Cal.zero seq.volt.channel

- Default setting (`_:2761:132`) **Cal.zero seq.volt.channel = no**

With the **Cal.zero seq.volt.channel** parameter, you determine whether the calculated zero-sequence voltage *v0* or *3v0* is recorded in a separate channel or not. The separate channel is visible in the DIGSI 5 Information routing under the **V 3-ph** measuring point.

The zero-sequence voltages can be calculated only with the following current-transformer connection types:

- *3 ph-to-gnd volt. + VN*
- *3 ph-to-gnd voltages*

Parameter Value	Description
<i>no</i>	The zero-sequence voltage calculated from the sampled voltage values is not recorded.
<i>v0</i>	The calculated zero-sequence voltage <i>v0</i> is recorded for each V 3-ph measuring point. <i>v0</i> is calculated from the sampled voltage values using the following equation: $V0 = (V_A + V_B + V_C)/3$.
<i>3v0</i>	The calculated zero-sequence voltage <i>3v0</i> is recorded for each V 3-ph measuring point. <i>3v0</i> is calculated from the sampled voltage values using the following equation: $3V0 = (V_A + V_B + V_C)$.

3.5.5 Settings

Addr.	Parameter	C	Setting Options	Default Setting
<i>Control</i>				
<code>_:2761:130</code>	Control:Fault recording		<ul style="list-style-type: none"> • with pickup • with pickup & AR cyc. • user-defined 	with pickup
<code>_:2761:131</code>	Control:Storage		<ul style="list-style-type: none"> • always • with trip 	always
<code>_:2761:111</code>	Control:Maximum record time		0.20 s to 20.00 s	5.00 s
<code>_:2761:112</code>	Control:Pre-trigger time		0.05 s to 4.00 s	0.50 s
<code>_:2761:113</code>	Control:Post-trigger time		0.05 s to 0.50 s	0.50 s
<code>_:2761:116</code>	Control:Manual record time		0.20 s to 20.00 s	0.50 s

Addr.	Parameter	C	Setting Options	Default Setting
_:2761:140	Control:Sampling frequency		<ul style="list-style-type: none"> • 8 kHz • 4 kHz • 2 kHz • 1 kHz 	2 kHz
_:2761:141	Control:Sampl. freq. IEC 61850 rec.		<ul style="list-style-type: none"> • 8 kHz • 4 kHz • 2 kHz • 1 kHz 	1 kHz
_:2761:129	Control:Cal.zero.seq.cur.channel		<ul style="list-style-type: none"> • no • -3I0 • 3I0 	no
_:2761:132	Control:Cal.zero seq.volt.channel		<ul style="list-style-type: none"> • no • V0 • 3V0 	no

3.5.6 Information List

No.	Information	Data Class (Type)	Type
_:2761:300	Control:Start record	SPC	C
_:2761:305	Control:Reset memory	SPC	C
_:2761:306	Control:Clear memory	SPC	C
_:2761:502	Control:>External start	SPS	I
_:2761:503	Control:>Manual start	SPS	I
_:2761:310	Control:Fault number	INS	O
_:2761:311	Control:Recording started	SPS	O
_:2761:314	Control:Record made	SPS	O
_:2761:327	Control:Tmax reduced	SPS	O
_:2761:324	Control:Fault log is full	INS	O

3.6 Date and Time Synchronization

3.6.1 Overview of Functions

Timely recording of process data requires precise time synchronization of the devices. The integrated date/time synchronization allows the exact chronological assignment of events to an internally managed device time that is used to time stamp events in logs, which are then transmitted to a substation automation technology. A clock module internal to the device and having battery backup is synchronized cyclically with the current device time so that the right device time is available and used even in case of auxiliary-voltage failure. At the same time, this permits hardware-supported monitoring of the device time.

3.6.2 Structure of the Function

The integrated date/time synchronization is a supervisory device function. Setting parameters and indications can be found in the following menus for the DIGSI and the device:

Set date and time:

- DIGSI: Online access -> Interface -> Device -> Device Information -> **Time Information**
- Device: Main menu → Device functions → **Date & Time**

Parameter:

- DIGSI: Project -> Device -> Parameter -> **Time Settings**

Indications:

- DIGSI: Project -> Device -> Information routing -> **Time keeping** or **Time Sync.**

3.6.3 Function Description

Every SIPROTEC 5 device maintains an internal device time with date. The date and time can also be set on the device via the on-site operation panel or via DIGSI 5. Within a system, or even beyond, it is usually necessary to record the time of process data accurately and to have exact time synchronization of all devices. For SIPROTEC 5 devices, the sources of time and synchronization options can be configured.

Configurable Synchronization Options:

- **None** (default setting)
The device functions without any external time synchronization. The internal time synchronization continues to work with the help of the back-up battery even when the auxiliary voltage is shut down temporarily. The time can be adjusted manually.
- **Telegram**
The time is synchronized via a telegram with an appropriately configured communication interface in accordance with the IEC 60870-5-103 protocol.
- **Connection to a radio clock**
The time synchronization takes place with the set time telegram from an external IRIG B receiver via the time synchronization interface of the device.
- **Ethernet via Port F**
The time synchronization is done via Ethernet-based SNTP protocol (Simple Network Time Protocol), for example with IEC 61850 stations.
- **Connecting from external IRIG B**
The connection of an external IRIG B via the serial Port E is done with a special adaptor cable.

Configurable Time Sources:

- 2 time sources can be taken into consideration with the SIPROTEC 5 devices. For each time source, the synchronization type may be selected based on the options provided.
- **Time source 1** takes precedence over **Time source 2**, that is, **Time source 2** will be effective for the synchronization of the device time only if **Time source 1** fails. If only one time source is available and it fails, then only the internal clock continues unsynchronized. The status of the time sources is indicated.
- For every time source, it is possible to define via the **Time zone time source 1** parameter (or **Time zone time source 2**) if this source transmits its time by UTC (universal time) or if the settings correspond to the local time zone of the device.

**NOTE**

Make sure that the settings for the time sources coincide with the actual hardware configuration of your SIPROTEC 5 device. In any event, incorrect settings cause the status indications of time sources to pick up.

Configurable Date Format

Regardless of a feed time-synchronization source, a uniform format is maintained internally within the device. The following options are available for the customary local representation of the date format:

- Day.Month.Year: 24.12.2009
- Month/Day/Year: 12/24/2009
- Year-Month-Day: 2009-12-24

Taking Local Time Zones into Account

The internal device time is maintained in universal time (UTC). To display time stamps in DIGSI and on the device display, you can define the local time zone of the device (parameter Offset time zone for GMT), including the applicable daylight saving times (start, end, and offset of daylight saving time) using parameters. This allows the display of the local time.

**NOTE**

- For time sources that transmit the status of the switch to daylight saving time, this will be taken into account automatically when creating the internal device time in the UTC format. The differential time of the daylight saving time set in the device (parameter Offset daylight saving time) is taken into consideration. However, in contrast, the settings of the start of daylight saving time and end of the daylight saving times are ignored when converting into the device internal UTC format.
 - For active time sources, it is not possible to set the time via the device display or DIGSI 5. An exception is setting the calendar year for active time protocol IRIG B.
-

Status, Supervision, and Indications of Time Management

Your SIPROTEC 5 device generates status and monitoring indications that provide important information regarding the correct configuration of the time source and the status of the internal time management during startup and device operation.

Internal time synchronization is monitored cyclically. Important synchronization processes, the status of the time sources and errors detected are reported. A device time that has become invalid will be marked accordingly so that affected functions can go to a safe state.

Indication	Description
Device: <i>Clock fail</i>	This indication signals a high difference between the internally managed time and the time of the clock module that is not permissible. The pickup of the indication can point to a defect in the clock module or to an unacceptable high drift of the system quartz crystal. The time maintained internally is marked as invalid.
Time management: <i>Daylight saving time</i>	This indication signals whether daylight saving time has been enabled.
Time management: <i>Clock set manually</i>	This indication signals that the device time has been set manually via the on-site operation panel or via DIGSI 5.
Time synchronization: <i>Status time source 1</i> <i>Status time source 2</i>	These 2 indications signal whether the active time sources are recognized as valid and active from the device point of view. When the indications pick up, it can also be an indication that an incorrect configuration of the port or channel numbers was done at the on-site operation panel.
Time synchronization: <i>Time sync. error</i>	This indication signals after the parameterized time Fault indication after that synchronization using an external time source has failed.
Time synchronization: <i>Leap second</i>	This indication signals that a Leap second has occurred during time synchronization using an external GPS receiver (protocol variant IRIG B 005(004) with extension according to IEEE C37.118-2005).
Time synchronization: <i>High accuracy</i>	This indication signals that the device is synchronized with an accuracy better than 1 μ s. The indication is only of significance when the PMU function is used.

**NOTE**

In case of a missing or discharged battery, the device starts without active external time synchronization with the device time 2011-01-01 00:00:00 (UTC).

For the device, DIGSI 5 provides a compact overview of the status of the time synchronization of your SIPROTEC 5 device in online mode. All displays are updated continuously. You can access the overview in the project-tree window via Online access.

DIGSI: Online access -> Interface -> Device -> Device Information -> **Time Information**

[sc_time_dg_1_en_US]

Figure 3-46 Time Information in DIGSI

For every time source, you see the following:

- Last received time (with date)
- Receipt time of the last received time telegram
- Configured type of timer
- Indication of timer outage or failure
- Whether the device time is currently synchronized from the time source

The lower section displays the device time, which is continuously updated. If the internal device time and the infed time source were synchronous at the time of telegram receipt, both displayed times are identical.



NOTE

All times displayed (also the time source) take into consideration the local time settings (zone and daylight saving time of the device) in the form of a numerical offset for UTC (universal time).

3.6.4 Application and Setting Notes

Parameter: Date Format

- Default setting **Date format** = *YYYY-MM-DD*

With the parameter **Date format**, you define the local customary format of the date display.

Parameter Value	Description
<i>DD.MM.YYYY</i>	Day.Month.Year: Typical European display Example: 24.12.2010
<i>MM/DD/YYYY</i>	Month/Day/Year: Typical US representation Example: 12/24/2010
<i>YYYY-MM-DD</i>	Year-Month-Day: Typical Chinese display Example: 2010-12-24

Parameter: Time zone time source 1, Time zone time source 2

- Default setting **Time zone time source 1** = *local*, **Time zone time source 2** = *local*

With the parameters **Time zone time source 1** and **Time zone time source 2**, you define the handling of time zones of the external timer.

Parameter Value	Description
<i>local</i>	Local time zone and daylight saving time are considered as time zone offsets to GMT.
<i>UTC</i>	Time format according to UTC (universal time)

Parameter: Time source 1, Time source 2

- Default setting **Time source 1 = none, Time source 2 = none**

With the parameters **Time source 1** and **Time source 2**, you can configure an external timer. The prerequisite is to have the corresponding hardware configuration of the communication interfaces of your SIPROTEC 5 device. This is listed as a prefix when making a selection in DIGSI 5.

Parameter Value	Description
<i>none</i>	The time source is not configured.
<i>IRIG-B</i>	<p>Time synchronization by an external GPS receiver: SIPROTEC 5 devices support several protocol variants of the IRIG-B standard:</p> <ul style="list-style-type: none"> • IRIG-B 002(003) The control function bits of the signal are not occupied. The missing year is formed from the current device time. In this case, it is possible to set the year via the online access in DIGSI 5. • IRIG-B 006(007) The bits for the calendar year are not equal to 00. The calendar year is set automatically by the time protocol. • IRIG-B 005(004) with extension according to IEEE C37.118-2005 If, in the time signal, other control function bits are occupied in addition to the calendar year, then the device takes the additional information into consideration for leap seconds, daylight saving time, time offset (zone, daylight saving time), and time accuracy. Time zone time source 1 or Time zone time source 2: The value of this setting is not evaluated by the device, since this protocol either transmits in UTC or in the case of local time, specifies the appropriate offset to UTC in each set time telegram.
<i>SNTP</i>	<p>The time synchronization is done via the Ethernet service SNTP (SNTP server or via IEC 61850).</p> <p>SIPROTEC 5 devices support both Edition1 and Edition2 in accordance with IEC 61850-7-2. In Edition2, the logical attributes LeapSecondsKnown, Clock-Failure, ClockNotSynchronized, and the value TimeAccuracy are maintained in each time stamp. For Edition1, these signals contain default settings. Thus, the interoperability for substation automation technology is ensured for both editions!</p> <p>The SNTP service must be enabled during configuration of Ethernet interfaces so that it is available as an option for the time synchronization.</p> <p>Time zone time source 1 or Time zone time source 2 = UTC</p>

Parameter Value	Description
IEC 60870-5-103	The time is synchronized via telegram with an appropriately configured communication interface in accordance with the IEC 60870-5-103 protocol. Time zone time source 1 or Time zone time source 2 = local However, there are also T103 systems that send the UTC.
DNP3	The time is synchronized via telegram with the appropriately configured communication interface in accordance with the DNP3 protocol. 2 characteristics are supported in the process: <ul style="list-style-type: none"> • Time synchronization via UTC • Time synchronization with local time The daylight saving time status is not transmitted. The device assumes that the DNP3 master follows the same rules for the start and end of the daylight saving time as those that were set for the device. Time zone time source 1 or Time zone time source 2 = UTC is the current implementation, local concerns older implementations.

Parameter: Fault indication after

- Default setting **Fault indication after = 600 s**

With the parameter **Fault indication after**, you set the time delay after which the unsuccessful attempts of time synchronization with external time sources configured are indicated.

Parameter: Time Zone and Daylight Saving Time

This parameter block contains all the settings for the local time zone and daylight saving time of your SIPROTEC 5 device. In addition to the individual parameters, configure the basic settings by preselecting via the option buttons or check box.

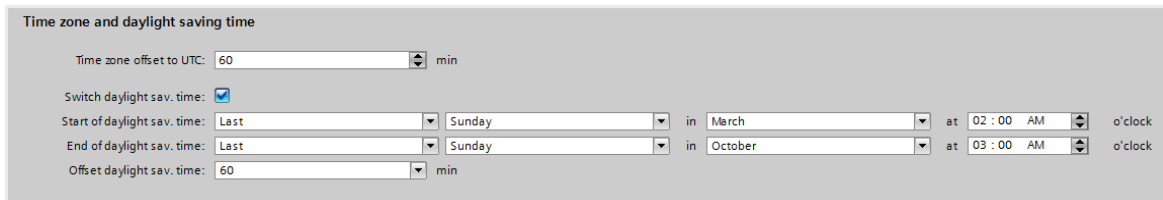

[sc_time_zo, 1, en_US]

Figure 3-47 Settings for Time Zone and Daylight Saving Time in DIGSI

Selection Button	Description
Manual settings (local time zone and daylight saving time regulation)	This setting must be selected if you want to select the local time zone and daylight saving time zone regulations of your SIPROTEC 5 device regardless of the PC settings. Input: Offset time zone for GMT [min] Selection: Switchover to daylight saving time [yes/no] via check box <div style="border: 1px solid gray; padding: 5px; margin: 10px 0;"> <input checked="" type="checkbox"/> Switch daylight sav. time </div> <ul style="list-style-type: none"> • Input: Start of daylight saving time [Day and time] • Input: End of daylight saving time [Day and time] • Input: Offset daylight saving time [min] • Default settings as in the picture above

3.6.5 Settings

Addr.	Parameter	C	Setting Options	Default Setting
<i>Time sync.</i>				
_:102	Time sync.:Time source 1		<ul style="list-style-type: none"> • none • IRIG-B • SNTP • IEC 60870-5-103 • Modbus • DNP3 • IEC 60870-5-104 	none
_:103	Time sync.:Time source 1 port		<ul style="list-style-type: none"> • port F • port E 	
_:104	Time sync.:Time source 1 channel		<ul style="list-style-type: none"> • Ch1 • Ch2 	
_:105	Time sync.:Time source 2		<ul style="list-style-type: none"> • none • IRIG-B • SNTP • IEC 60870-5-103 • Modbus • DNP3 • IEC 60870-5-104 	none
_:106	Time sync.:Time source 2 port		<ul style="list-style-type: none"> • port F • port E 	
_:107	Time sync.:Time source 2 channel		<ul style="list-style-type: none"> • Ch1 • Ch2 	
_:108	Time sync.:Time zone time source 1		<ul style="list-style-type: none"> • UTC • local 	local
_:109	Time sync.:Time zone time source 2		<ul style="list-style-type: none"> • UTC • local 	local
_:101	Time sync.:Fault indication after		0 s to 3600 s	600 s

3.6.6 Information List

No.	Information	Data Class (Type)	Type
<i>Time managem.</i>			
_:300	Time managem.:Daylight saving time	SPS	O
_:301	Time managem.:Clock set manually	SPS	O

No.	Information	Data Class (Type)	Type
<i>Time sync.</i>			
_:303	Time sync.:Status time source 1	SPS	O
_:304	Time sync.:Status time source 2	SPS	O

No.	Information	Data Class (Type)	Type
_:305	Time sync.:Time sync. error	SPS	0
_:306	Time sync.:Leap second	SPS	0
_:307	Time sync.:High accuracy	SPS	0

3.7 User-Defined Objects

3.7.1 Overview

With help from user-defined function groups and user-defined functions you can group user-defined objects, for example user-defined function blocks. 2 user-defined function blocks are available (see following figure).

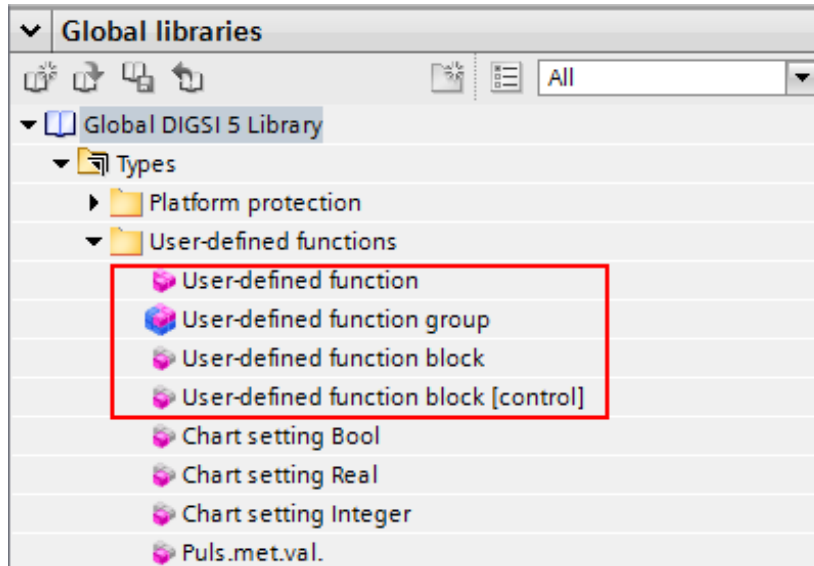

[sc_undef_lib, 1, en_US]

Figure 3-48 User-Defined Objects in the DIGSI 5 Library

The **user-defined function block** allows you to add (see following figure) single-point indications, pickup indications, operate indications (ADC, ACT), single and double commands, commands with a controllable whole number as well as measured values. You can assign the group a superordinate name (for example **process indications** for a group of single-point indications which are read via binary inputs). This function can be deactivated using the mode. The standby mode is also analyzed or displayed.

The user-defined function blocks can be instantiated at the highest level (alongside other function groups) as well as within function groups and functions.

In addition, there is a **user-defined function block [control]**. Alongside the aforementioned possibilities presented by **user-defined function blocks**, this block offers additional tests for user-defined control signals, for example SPC or DPC.

These are described in chapter [9.6.1 Overview of Functions](#).

Information			Source								
			Binary input								
			Base module								
Signals	Number	Type	1.1	1.2	1.3	1.4	1.5	1.6	1.7	1.8	2.1
(All...)	(All...)
Process indic	851.6361								*	*	*
Mode (controllable)	851.6361.51	EHIC									
Behavior	851.6361.52	ENIS									
Health	851.6361.53	ENIS									
SF6 Alarm L1		SPS							H		
SF6 Alarm L2		SPS								H	
SF6 Alarm L3		SPS									H

[sc_user, 1, en_US]

Figure 3-49 Information Routing with Incorporated User-Defined Function Block: Process Indications and some Single-Point Indications

3.7.2 Basic Data Types

The following data types are available for user-defined objects in the DIGSI 5 library under the heading **User-defined signals**. Additionally, a folder for external signals is available (see chapter [3.7.5 External Signals](#)).

User-Defined Signals

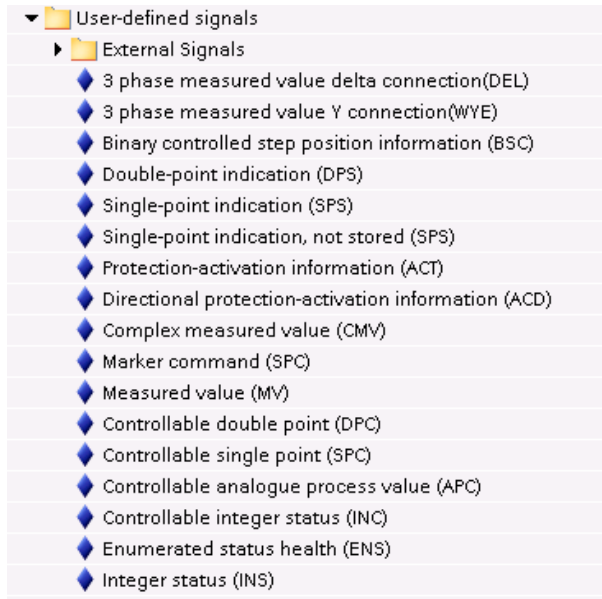

[sc_LB_userdefsig, 1, en_US]

Figure 3-50 User-Defined Signals

Single-Point Indication (Type SPS: Single-Point Status)

The status of a binary input can be registered in the form of a single-point indication or forwarded as the binary result from a CFC chart.

EXAMPLE

Acquisition using binary input, further processing in a CFC and/or signaling using an LED.

Single-Point Indication (Type SPS unsaved: Single-Point Status Unsaved)

In contrast to **SPS** single-point indications, the state of the **SPS unsaved** indication is not maintained after the device restarts.

For this purpose, go to **Properties > Details > Initialization > Restart** and set the **value**.

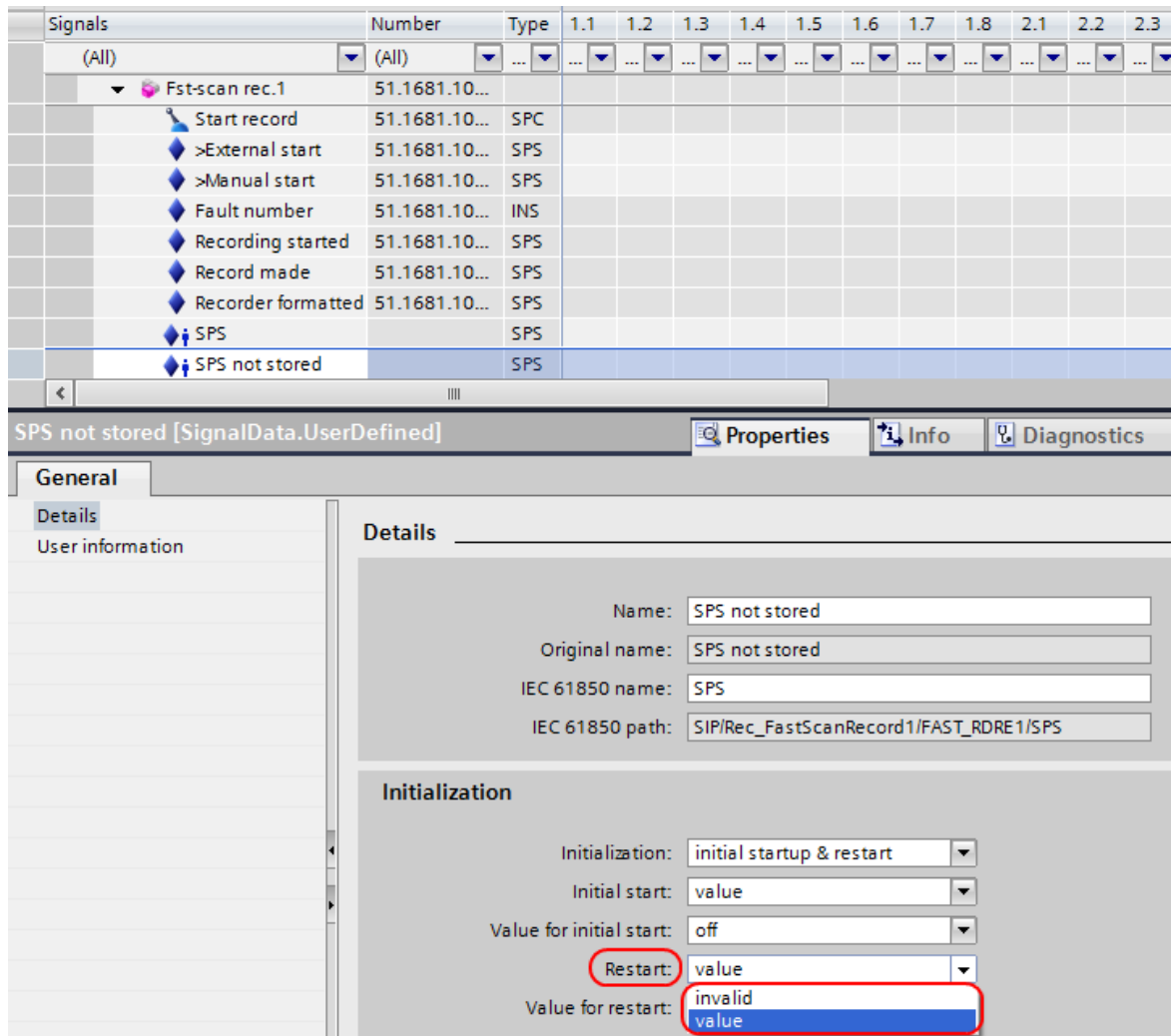

[sc_spsfas, 1, en_US]

Figure 3-51 Single-Point Indication SPS Unsaved (Example: 7KE85 Fault Recorder)

Double-Point Indication (Type DPS: Double-Point Status)

When using a double-point indication, the status of 2 binary inputs can be captured simultaneously and mapped in an indication with 4 possible conditions (*ON, Intermediate position, OFF, Disturbed position*).

EXAMPLE

Acquisition of a disconnector or circuit-breaker switch position.

Marker Command (Type SPC, Single-Point Controllable)

This data type can be used as a command without feedback for simple signaling or as an internal variable (marker).

Integer Status Value (Type INS)

The data type **INS** is used to create a whole number that represents a CFC result.

EXAMPLE

The output of the CFC block **ADD_D** can, for example, be connected with the data type **INS**. The result can be shown on the display of the device.

State of an Enumeration Value (Type ENS)

The data type **ENS** is used to create an enumerated value that represents a CFC result.

Controllable Single-Point Indication (SPC, Single-Point Controllable)

This can be used to issue a command (to one or several relays, selectable under information routing) that is monitored via a single feedback.

Command with Double-Point Feedback (DPC, Double-Point Controllable)

This can be used to issue a command (to one or several relays, selectable under information routing) that is monitored via double-point indication as feedback.

Command with a Whole Number (INC, Controllable Integer Status)

This can be used to issue a command (to one or more relays, selectable under information routing) that is monitored via a whole number as feedback.

Complex Measured Values (CMV)

This data type provides a complex measured value that can be used as a CFC result, for example.

Measured Values (MV)

This data type provides a measured value that can be used as a CFC result, for example.



NOTE

Additional data types can be found under other headings in the DIGSI 5 library as well as in the corresponding function blocks. This applies to the following data types:

- Pulse-metered values (see **User-defined functions** in the DIGSI 5 library)
- Transformer taps
- Metered values

Phase-to-Ground Measured Values (WYE)

This data type represents the phase-to-ground measured values of a 3-phase system.

Phase-to-Phase Measured Values (DEL, Delta)

This data type represents the phase-to-phase measured values of a 3-phase system.

3.7.3 Pulse and EnergyMetered Values

Pulse-Metered Values

Pulse-metered values are available as data types **BCR** (Binary Counter Reading) in the DIGSI library under **User-defined Functions**.

You can find the functionality and the settings of the pulse-metered values in [11.9.1 Function Description of Pulse-Metered Values](#).

Energy-Metered Values

Energy-metered values no longer need to be created by the user separately. They are available as active and reactive power in each **Line** function group for reference and output direction. The calculation is based on the current and voltage transformers associated with the protected object.

You can find more detailed information in [11.8.1 Function Description of Energy Values](#).

3.7.4 Additional Data Types

The following data types are also used in the system but are not available for general use as user-defined signals in the library:

- **ENC** (Enumerated Setting Controllable)
The data type **ENC** models a command with which the user can set predefined values.
- **SEQ** (Sequence)
- **BSC** (Binary Controlled Step Position)
The data type **BSC** can, for example, be used to control a transformer tap changer. The commands **up**, **down** can be given.



NOTE

Transformer taps are included in the **Transformer tap changer** switching element. If this switching element is created in the device, the transformer tap position is available as a data object of type **BSC** (binary controlled step position information).

3.7.5 External Signals

User-defined signals of different types (see [Figure 3-52](#)) are available for GOOSE Later Binding. After instantiation in a logical node, an external reference is generated during IID export and provided to a IEC 61850 system tool (for example, System Configurator) for GOOSE Later Binding (according to the Later-Binding procedure specified in IEC 61850-6).

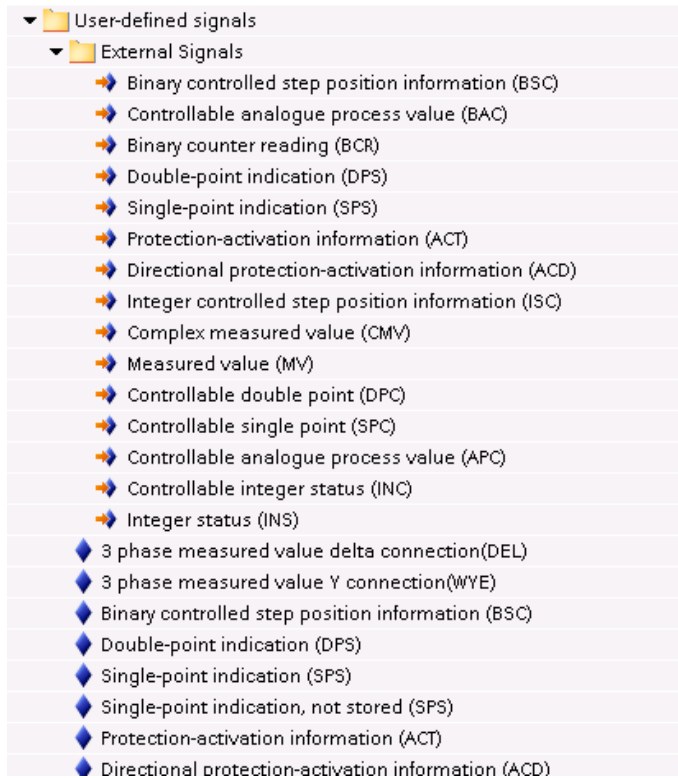

[sc_lb_extsign, 1, en_US]

Figure 3-52 External Signals

**NOTE**

Consider the chapter on GOOSE Later Binding in the DIGSI Online Help. User-defined signals exist as external signals and as preconfigured inputs that have been activated via the GOOSE column.

3.8 Other Functions

3.8.1 Signal Filtering and Chatter Blocking for Input Signals

Input signals can be filtered to suppress brief changes at the binary input. Chatter blocking can be used to prevent continuously changing indications from clogging the event list. After an adjustable number of changes, the indication is blocked for a certain period.

The settings for indication filtering can be found at the individual signals. The next figure shows the settings using the example of a controllable (circuit-breaker switch position).



NOTE

The software filtering time is available only for the circuit breaker and disconnecter in the controllable **Cmd. with feedback (control function block)**, as this is used for logging purposes. The controllable **position (circuit breaker or disconnecter function block)** is used for interlocking conditions and must always show the unfiltered position of the switching object.

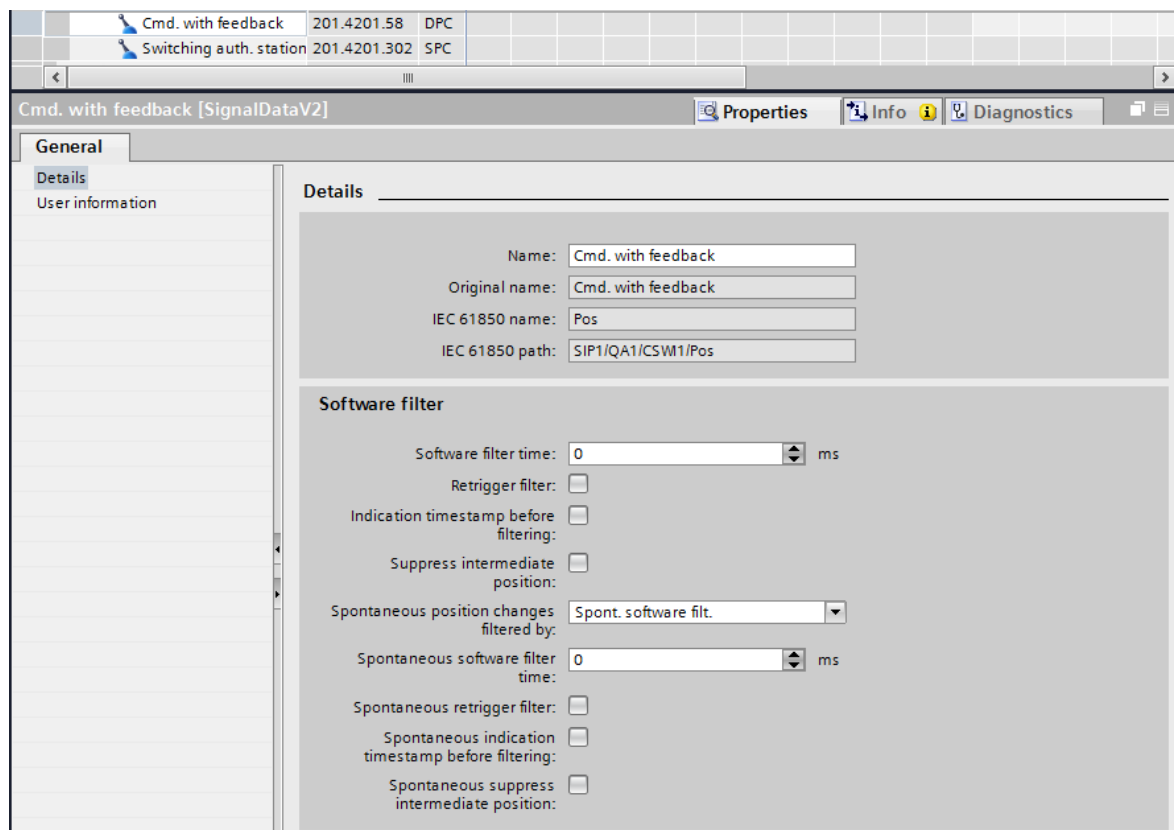

[sc_posi, 1, en_US]

Figure 3-53 Settings for Circuit-Breaker Switch Position

The setting range for the **Software filter time** parameter ranges from 0 ms to 100 000 ms in ms increments. The **Retrigger filter** check box can be used to select whether to restart the filtering time whenever a status change is performed within the software filtering time. When activated, the **Indication timestamp before filtering** check box backdates the time stamp by the set software filtering time. In this case, the time stamp corresponds to the actual status change of the signal. If you activate the **Suppress intermediate position** check box, the intermediate position is suppressed for the duration of this software filtering time.

If you leave the software filtering time at 0 ms, the time for the suppression of the intermediate position is also 0 ms. The activated **Suppress intermediate position** check box then remains ineffective.

If you do not activate the **Suppress intermediate position** check box, the software filtering time affects the **on**, **off**, **intermediate**, and **disturbed** positions of the circuit breaker or disconnecter switch. With the parameter **Spontaneous position changes filtered by:**, you set how such position changes are to be filtered. Spontaneous position changes are caused by external switching commands, for example. If you select the **General software filter** setting, the general settings for software filtering of spontaneous position changes and for position changes caused by a switching command apply. The settings for spontaneous position changes then cannot be edited. A separate filtering for spontaneous position changes is activated with the **Spontaneous software filter** setting and you can edit the settings for this.

Chatter blocking can be activated or deactivated as an input parameter, for example as a parameter of the position in the **Circuit breaker** or **Disconnecter** function block.

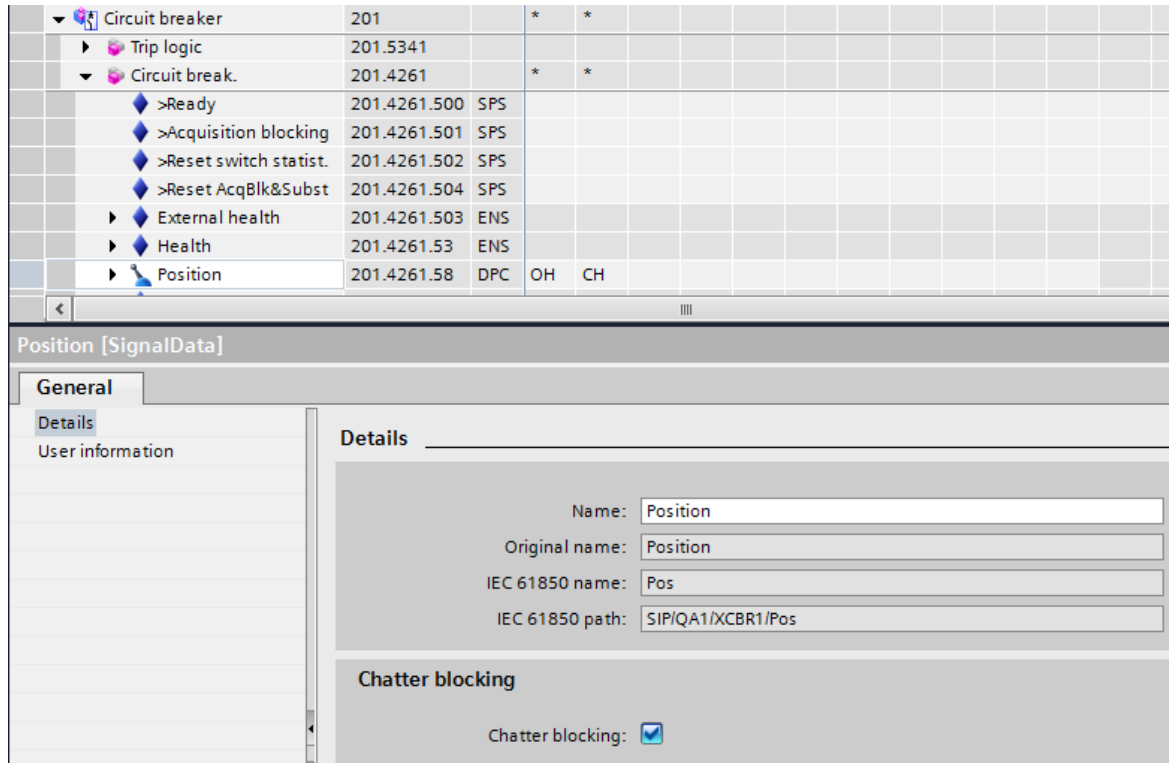

[sc_flatte, 1, en_US]
 Figure 3-54 Setting Chatter Blocking

The settings for the chatter blocking function are set centrally for the entire device in DIGSI. They are accessible as settings in the **General** function group (see the following figure). The chatter-blocking settings have the following meaning (see also [Figure 3-55](#) and [Figure 3-56](#) in the examples shown in the following):

- No. permis.state changes**

This number specifies how often the state of a signal may toggle within the chatter-test time and the chatter-checking time. If this number is exceeded, the signal will be or remains blocked. Enter a number from 0 to 65535 in this field. If the entry is 0, chatter blocking is essentially inactive.
- Initial test time**

During this time, the number of times a signal changes its status is checked. This time is started if chatter blocking is configured for at least one signal and this signal changes its status. If the configured number of permissible status changes is exceeded during the initial test time, the signal is temporarily blocked and the indication *Chatter blocking* is set. Enter a number from 1 to 65535 in this field. The number entered corresponds to the time in seconds. When the set time has expired, the timer restarts automatically (cycle time).

- **No. of chatter tests**

This number specifies the maximum number of test cycles to be run. If the number of permissible status changes of the signal stays exceeded during the initial test time of the last test cycle, the signal is finally blocked. In this case, the indication *Group warning* (**Alarm handling** group and **Device** group) is set additionally to the *Chatter blocking* indication after expiry of the set number. Restarting the devices removes this block again.

Enter a number from 0 to 32767 in this field. The value Infinite (∞) is also permissible here.

Enter this value as character string oo.

- **Chatter idle time**

If the number of permissible status changes for a signal is exceeded during the initial test time or the subsequent test time, the **Chatter idle time** starts. Within this time, this signal is blocked temporarily and the *Chatter blocking* indication is set. The blocked input signal is assigned the **oscillatory** quality.

Enter a number from 1 to 65535 in this field. The number entered corresponds to the time in minutes. An entry here is only considered if the number of chatter tests does not equal 0.

- **Subsequent test time**

During this second test time, the number of times a signal changes its status is checked once again.

The time begins when the **Chatter idle time** expires. If the number of status changes is within the permissible limits, the signal is released. Otherwise, an additional dead time begins, unless the maximum number of chatter tests has been reached.

Enter a number from 2 to 65535 in this field. The number entered corresponds to the time in seconds. An entry here is only considered if the number of chatter tests does not equal 0.

Example 1: Permanent Blocking

The chatter-blocking settings are set as follows:

- **No. permis.state changes** = 4
- **No. of chatter tests** = 2

After more than 4 state changes within the **Initial test time**, the input signal is set to the original state by the chatter blocking and the **oscillatory** quality is assigned. Additionally, a corresponding indication is added to the operational log. At the same time, the *Chatter blocking* indication is set. After expiry of the settable **Chatter idle time**, during the following **Subsequent test time**, it is checked whether the input signal is still chattering. This check is repeated, as the **No. of chatter tests** is set to 2 in this example.

If, during the 2nd **Subsequent test time**, it has been detected that the number of status changes of the input signal exceeds the set **No. permis.state changes**, the chatter blocking detects a persistent violation of the signal stability and sets the *Group warning* indication. The original state of the signal is permanently frozen. Only a device restart removes the chatter blocking again.

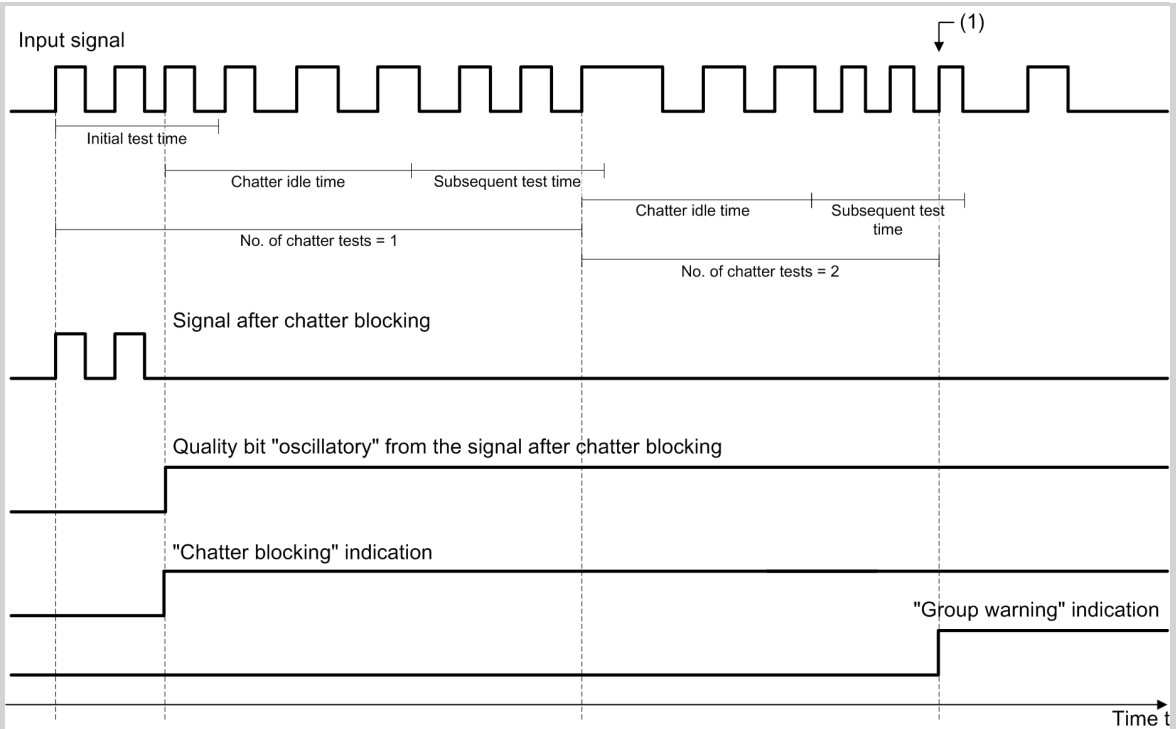

[dw_chatter-block-01_1_en_US]

Figure 3-55 Signal Change during Chatter Blocking with too Important Number of Signal State Changes During 2nd Subsequent Test Time

(1) The input signal is permanently blocked starting from this point in time.

Example 2: Temporary Blocking

The chatter-blocking settings are set as follows:

- **No. permis.state changes = 4**
- **No. of chatter tests = 2**

After more than 4 state changes within the **Initial test time**, the input signal is set to the original state by the chatter blocking and the **oscillatory** quality is assigned. Additionally, a corresponding indication is added to the operational log. At the same time, the *chatter blocking* indication is set. After expiry of the settable **Chatter idle time**, during the following **Subsequent test time**, it is checked whether the input signal is still chattering. This check is repeated, as the **No. of chatter tests** is set to 2 in this example.

If, during the 2nd **Subsequent test time**, it has been detected that the number of state changes of the input signal is within the set **No. permis.state changes**, the temporary blocking of state changes of the signal is removed and the actual signal state is released.

The quality bit **oscillatory** is removed and the *Chatter blocking* indication is reset. As the temporary blocking of the signal is removed, the *Group warning* indication is not set. The chatter test starts again.

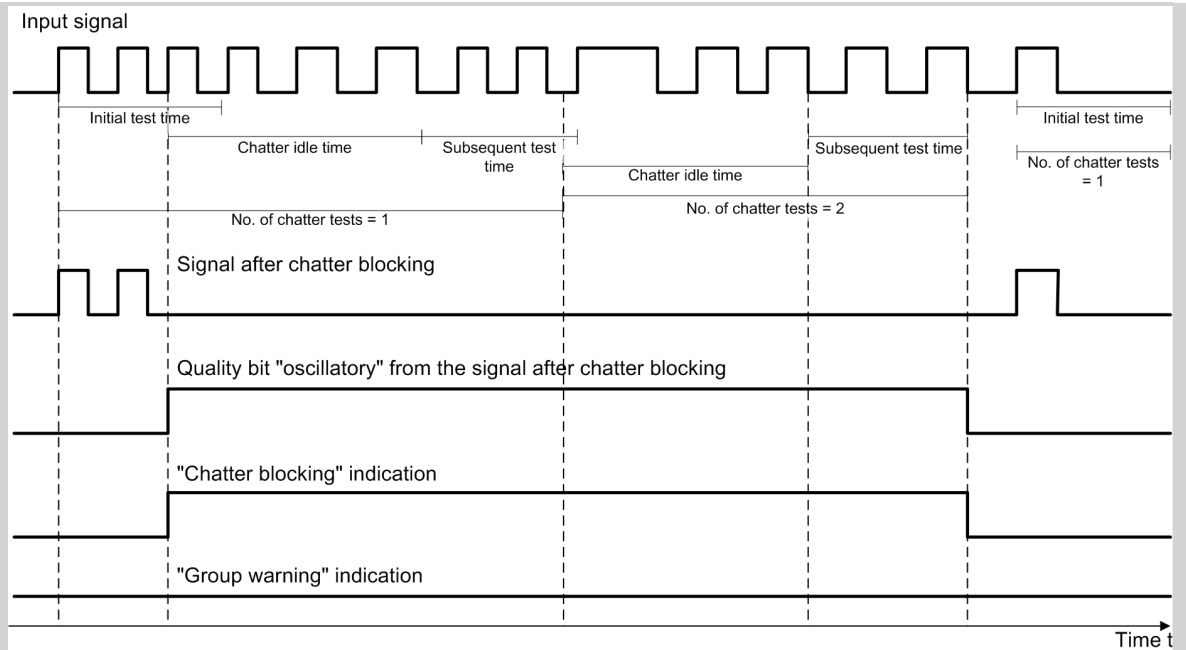

[hw_chatter-block-02_1_en_US]

Figure 3-56 Signal Change during Chatter Blocking with Permissible Number of Signal State Changes During 2nd Subsequent Test Time

3.8.2 Acquisition Blocking and Manual Updating

During commissioning, maintenance, or testing, a brief interruption of the connection between the logical signals and binary inputs may be useful. It allows you to manually update the status of a switching device that is not providing feedback correctly. Before this can take place, you must first set acquisition blocking.

To set the acquisition blocking, proceed as follows:

- Using the navigation keys, move in the **main menu** of the device display to **Commands**→**Equipment**→**Aq.blkman. update**.
- Select the appropriate device (for example, a circuit breaker) from among the several switching devices using the navigation keys.
- Press the **Change** softkey.
- Enter the confirmation ID (not relevant for active role-based access control (RBAC) in the device).
- Confirm the process with the softkey marked **OK** in the display.

After entering the confirmation ID (only with the RBAC inactive), acquisition blocking is switched on.

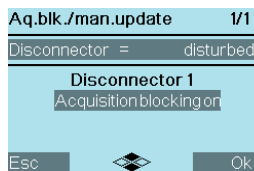

[sc_detection_cc_1_en_US]

Figure 3-57 Activating the Acquisition Blocking

Manual updating of the switching device is possible from within the same menu.

- Select **Manual update** (Figure 3-58) using the navigation keys.
- Select the switching device setting to be manually updated using the navigation keys (for example, **off**, Figure 3-59).
- Confirm the process with the softkey marked **Ok** in the display.

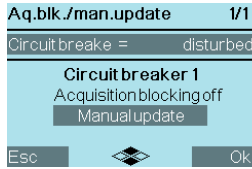

[sc_status_cc_1, en_US]

Figure 3-58 Activating Manual Update

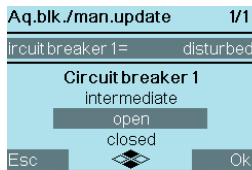

[sc_status2cc_1, en_US]

Figure 3-59 Selecting Position

The manually updated position of the switching device will be displayed.



[sc_status3cc_1, en_US]

Figure 3-60 Position of the Switching Device



NOTE

For security reasons, manual updating is possible only directly through the on-site operation panel of the device and not through DIGSI 5.



NOTE

Setting acquisition blocking and the subsequent manual updating are also possible via the IEC 61850 system interface.

You can set acquisition blocking also via a binary input. If you want to put in the feeder or the switching device in revision, you can set the acquisition blocking with an external toggle switch for one or more switching devices. For this purpose, every switching device in the **Switch** function block (circuit breaker or disconnect switch) has the input signal **>Acquisition blocking**. This signal can also be set from the CFC.

Information			Source										Destination				
			Binary input										CFC				
			Base module										Binary output				
			Base module										Base module				
Signals	Number	Type	1.1	1.2	1.3	1.4	1.5	1.6	1.7	1.8	2.1	2.2	2.3	1.1	1.2	1.3	
(All)	(All)		(All)
▶ Trip logic	201.5341																
▼ Circuit break.	201.4261		*	*										*	*		
▶ >Ready	201.4261.500	SPS															
▶ >Acquisition blocking	201.4261.501	SPS															
▶ >Reset switch statist.	201.4261.502	SPS															
▶ >Reset AcqBlk&Subst	201.4261.504	SPS															
▶ External health	201.4261.503	ENS															

[sc_beerfa, 1, en_US]

Figure 3-61 Input Signals >Acquisition Block and >Release Acquisition Block & Manual Updating on the Switching Device



NOTE

Interlockings are carried out with the status changes of the switching device. Remove acquisition blocking again manually. Otherwise, position changes of the switching device are not detected and interlockings are ineffective.

If the acquisition blocking and the manually updated position are set using the operation panel of the device or the system interface IEC 61850, these are retained until the acquisition blocking is manually deactivated. When you initially start the device, the acquisition blocking is deactivated.

Except for a restart, the acquisition blocking and the manually updated position are retained.

If the acquisition blocking is activated via the input signal **>Acquisition blocking**, it is retained as long as the binary input is active.

To set the acquisition blocking of a switching device, the following sources are possible:

- Operation panel of the device
- System interface IEC 61850
- Input signal **>Acquisition blocking**

All sources undergo OR operations, that is, the acquisition blocking remains set until all the sources are deactivated.

After deactivation of the acquisition blocking, the actual position of the switching device is adopted and displayed in the operation panel of the device.



NOTE

When the acquisition blocking is activated or the switching device updated manually while the entire device or the switching device is in application mode, these states are not saved. The acquisition blocking and the manual updating are not retained after a restart.

The acquisition blocking and the manual update for the circuit breaker, the disconnecter, and the tap changer are reset by way of the **>Reset AcqBlk&Subst** binary input. Setting acquisition blocking and manual update is blocked with the input activated.

3.8.3 Persistent Commands

In addition to the switching commands, which are issued as pulse commands, and stored for the standard switching devices (circuit breaker, disconnecter switch), persistent commands are also possible. In this case, a distinction must be drawn between controllables with the **Continuous output** operating mode and a stored signal output that is immune to reset.

You can change a controllable from pulse to persistent command with the **Command output** parameter.

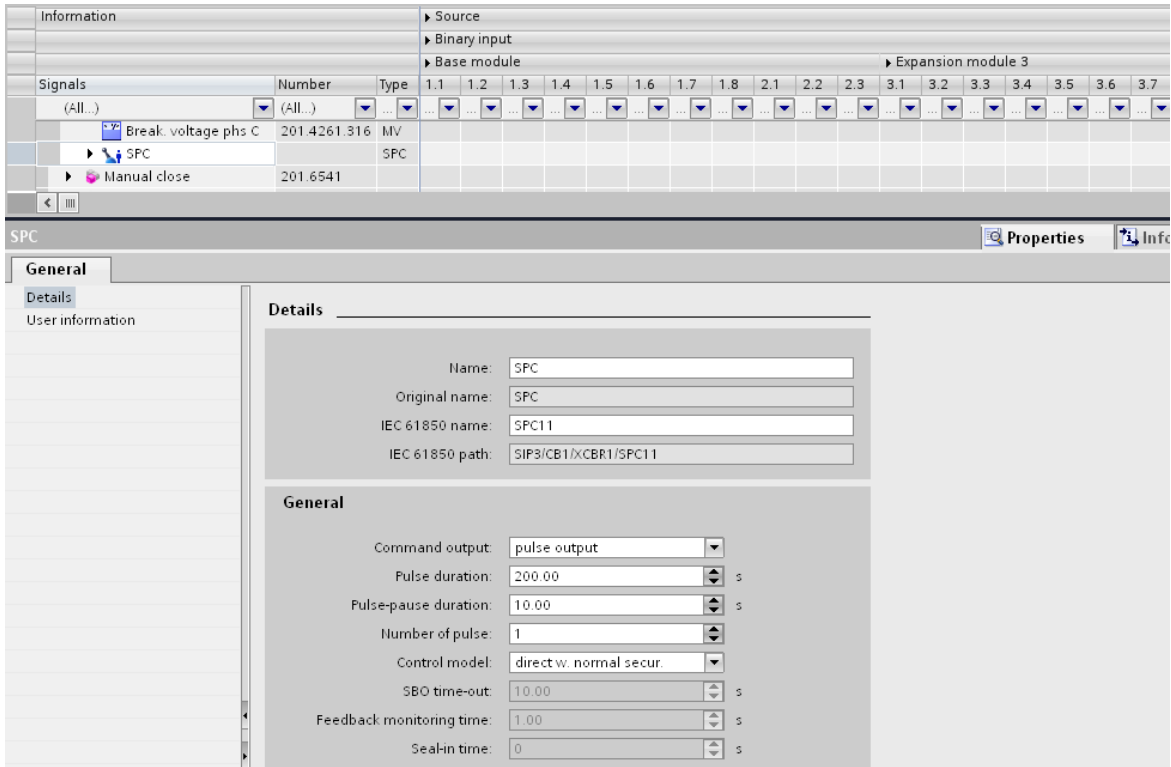

[sc_command, 1, en_US]

Figure 3-62 Setting the Command Type in DIGSI 5

Select **Pulse output** or **Continuous output** for the command output type. If a persistent command is selected, the Pulse parameter is irrelevant.

3.8.4 Device Logout

3.8.4.1 Overview

In the case of multibay functions, a device uses information from one or more other devices. For some applications, it may be necessary for you to remove a device with all effective functions temporarily from the plant and even to switch it off. These applications are, for example:

- Maintenance work
- System upgrades
- Testing the local protection functions, for example, the local line differential protection

The **Device Logout** functionality informs the receiver devices about the imminent disconnection of the transmitter devices. To do this, the last valid received information is stored in the receiver devices and used for the multibay functions.



NOTE

If you need to remove a device temporarily from the plant, you must log off the device. Protection functions distributed to several devices operate in a healthy manner with the remaining devices only if you have logged off the device.

You can log off the device as follows:

- Via the on-site operation panel
- Via a communication interface using the *Device Logout* (`_:319`) controllable
- Via the binary inputs, general: `>Dev. funct.logout on` (`_:507`) or `>Dev. funct.logout off` (`_:508`)

You can find the controllable and the binary inputs in the DIGSI 5 project tree under **Name of the device** → **Information routing** in the working area in the **General** block.

During the log-off process, the device checks whether all conditions for a logout have been met. If the conditions for the log off have not been met, the logout is rejected.



NOTE

The path used to log the device off is stored in the operational log. Even if you switch off the device after logout, the *Device Logged off* (`_:315`) state is stored.

If you want to establish the initial state again after logging off the device, you must log on the device again. To log on the device, you must use the same option used for logout. For example, if you have logged off the device via binary inputs, you must log it on again via the binary inputs. This applies in similar manner if you have logged off the device via DIGSI or via on-site operation.

3.8.4.2 Application and Setting Notes

Logoff Options for a Device

You can log a device off as follows:

- Via the on-site operation panel
- Via communication through the controllable *Device Logout* (`_:319`)
- Via the binary inputs, general: `>Dev. funct.logout on` (`_:507`) or `>Dev. funct.logout off` (`_:508`)

Conditions for Logging off the Device

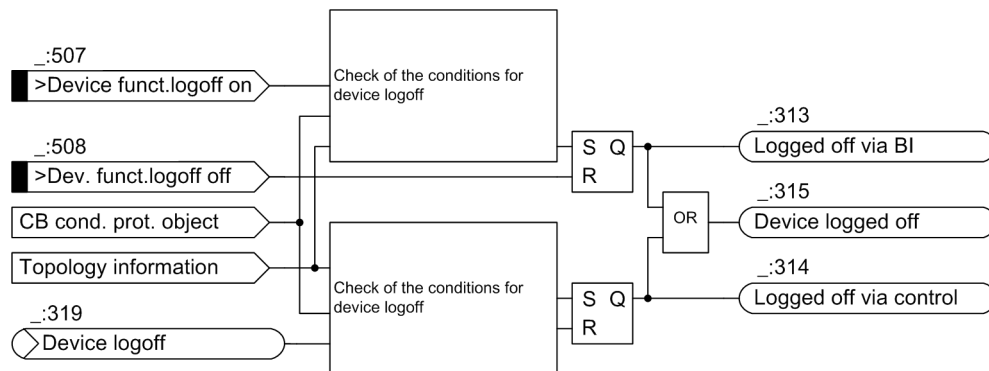

[to_functional_logoff_device, 1_en_US]

Figure 3-63 Logic for Logging off the Device

The conditions for a successful logout of the device result from the conditions for every activated protection function.

Logoff of a Device from a Device Combination with Communication via the IEC 61850-8-1 (GOOSE) Protocol

If devices are exchanging data using the IEC 61850-8-1 (GOOSE) protocol – for example in the case of substation interlocking – for each received data point the value of this data point can be set in the receiver device when the transmitter device logs off. This value remains effective in the receiver device until the

logout is canceled by the transmitter device, even if the transmitter and/or the receiver are switched off in the meantime.

Logging Off a Device from a Protection Application with Line Differential Protection

If you are using the **Line differential protection** function, you must ensure that the functionality is still effective even after a device in a device combination is logged off and switched off. The following example describes the procedure:

EXAMPLE:

The following line formation is protected by the **Line differential protection** with 3 devices.

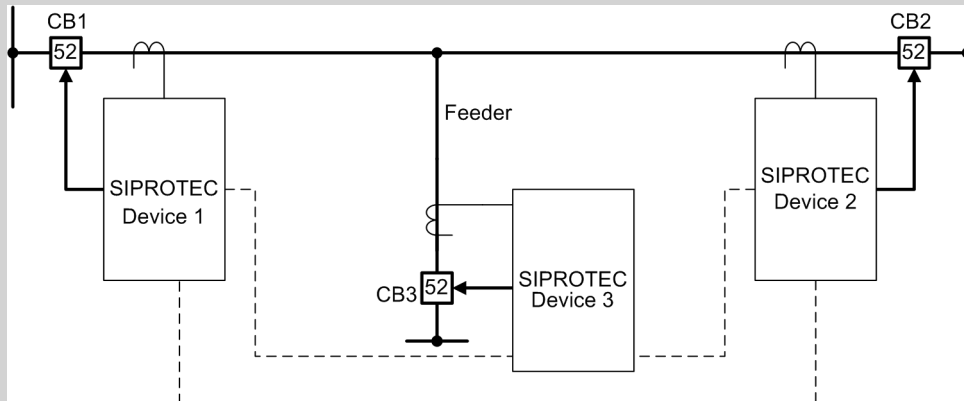

[dsw_example_logoff_diff_2_en_US]

Figure 3-64 Differential Protection with 3 Devices for a Line with a Feeder

In the example, the feeder is to be decommissioned for maintenance or modification work. Device 3 should therefore also be switched off. Without additional measures, the **Line differential protection** will no longer function and sends an ineffective indication.

For this use case, the **Line differential protection** function must be logged off in Device 3.



NOTE

Before logging off, you must de-energize the feeder protected by the local **Line differential protection**.

Line differential protection in device 3 can only be logged off if no current is flowing through the feeder. Device 3 checks during the log-off process whether the circuit breaker 3 is really switched off.

The **Circuit-breaker position recognition** in the function group **Circuit breaker (CB)** provides the circuit-breaker position using the internal signal *CB state protected obj.*

If a protected object is supplied via 2 circuit breakers (CBs), for example with the 1 1/2 circuit-breaker layout, then the circuit-breaker position of the protected object must be determined with the aid of both circuit breakers. In this case, the Circuit-breaker position function block performs linking of the individual CB positions for the protected object.

If one of the following 2 conditions is met, the *CB status protected object* internal signal assumes the position *Open*:

- All connected circuit breakers signal internally the position *Open*.
- The binary input signal *>Disconnector open* is active.

For further information refer to [5.10.5 Circuit-Breaker Condition for the Protected Object](#).

If the **Line differential protection** is logged off in device 3, the remaining devices 1 and 2 will save this state and the total current for the Kirchoff's current law will then be calculated with the currents in devices 1 and 2 only.

If device 3 is successfully logged off, you can switch it off. The logoff of device 3 will also be saved in the remaining devices after it is switched off. If you switch device 3 on again, you must log it on again in the device combination.

Logout via Binary Inputs

The following diagrams show potential variants on how to control binary inputs. If you want to use push-buttons, switch on this function as shown in the following figure. Log off the device using the push-button **Key2**; log on the device again with the push-button **Key1**.

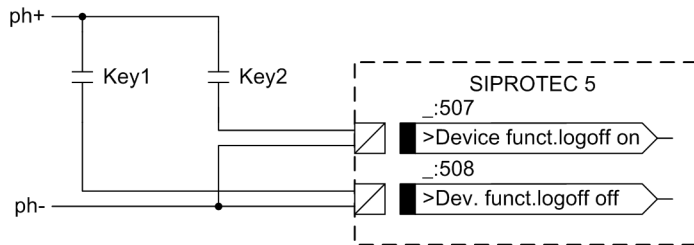

[lo_extta logoff device, 1, en_US]

Figure 3-65 External Push-Button Wiring for Logging off the Device

If a switch is being used for control, route the binary input *>Dev. funct.logout on* as **H (active with voltage)** and the binary input *>Dev. funct.logout off* as **L (active without voltage)**. If the switch **S** is closed, the device is logged off.

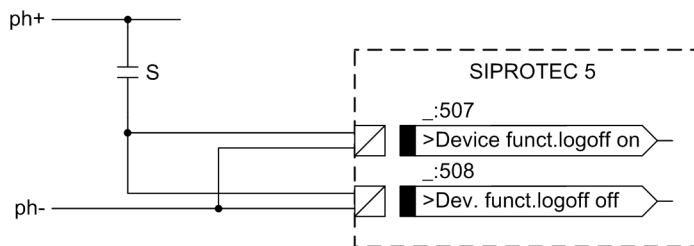

[lo_extsx logoff device, 1, en_US]

Figure 3-66 External Switch Wiring for Logging off the Device

Indications

The logged-off device reports the status (*_:315 Device logged off*) and cause of the logout.

If you have logged off the device using binary inputs, the indication (*_:313 Logged off via BI*) results.

If you have logged off the device using on-site operation or via DIGSI 5, the indication (*_:314 Logged off via control*) is issued.

The indications are stored in the operational log.

3.8.4.3 Information List

No.	Information	Data Class (Type)	Type
General			
_:507	General:>Dev. funct.logout on	SPS	I
_:508	General:>Dev. funct.logout off	SPS	I
_:319	General:Device logout	SPC	C
_:313	General:Logged off via BI	SPS	O
_:314	General:Logged off via control	SPS	O
_:315	General:Device logged off	SPS	O

3.9 General Notes for Setting the Threshold Value of Protection Functions

3.9.1 Overview

You can set the threshold values of protection functions directly on the device or by using DIGSI 5.

An innovative design was implemented for the protection settings.

You can switchover the edit mode between the following setting views:

- Primary
- Secondary
- Percent

If you change settings in a setting view, DIGSI 5 calculates the settings of the 2 inactive views in the background. If you wish to save, for example, conversion to secondary values, then select the primary view. Configure all the settings and switchover to the secondary view.

Edit Mode: Primary

The parameters are set as primary values and thus refer directly to the primary system. The manual conversion on the secondary circuit omitted.

Edit Mode: Secondary

The settings refer to the secondary circuit of the transformer. This means that the settings must be converted. The secondary setting is the customary setting view. For secondary tests, the pickup values can be read directly.

Edit Mode: Percent

This setting type is beneficial for electric machines (generators, transformers, motors, and busbars). The setting values can be standardized regardless of the machine size. The reference values for the percentage settings are the rated values of the function groups, for example, rated voltage and rated current or rated apparent power. The setting values are, thus, related exclusively to the primary settings. If other reference values are used, then this is documented for the respective protection function in the application and setting notes.

If parameters are selected it may happen that they are set only in percent in all 3 setting views.

Recommendation for Setting Sequence

When setting the protection function, Siemens recommends the following procedure:

- First, set the transformation ratios of the transformers. You can find these under **Power-system data**.
- Subsequently, set the reference parameters for the percent setting. You will find these parameters in function group .
- Next, set the parameter of the protection functions.

If the transformer data have changed after completing the protection setting, remain in the setting sheet (for example, primary setting) and change the transformer data. In the background, DIGSI 5 obtains the new settings in the inactive setting views (for example, new secondary values).

The following section explains, by way of an example, how to modify the transformer ratios in DIGSI 5 using the corresponding alternatives.

3.9.2 Modifying the Transformer Ratios in DIGSI 5

In the delivery setting, DIGSI 5 is set to the edit mode **Secondary**.

The following setting example shows how you can change the transformer ratio in DIGSI 5, and what impact this has on the settings in the setting views **Primary** and **Secondary**. The protection setting is observed in the example of the function **Overcurrent protection**.

The following output data are assumed:

Current transformer: 1000 A/1 A
 Protection pickup 1.5 A
 value:

The following figure shows the protection setting of the function **Overcurrent protection** in the secondary view. The threshold value of the stage is set to 1.5 A.

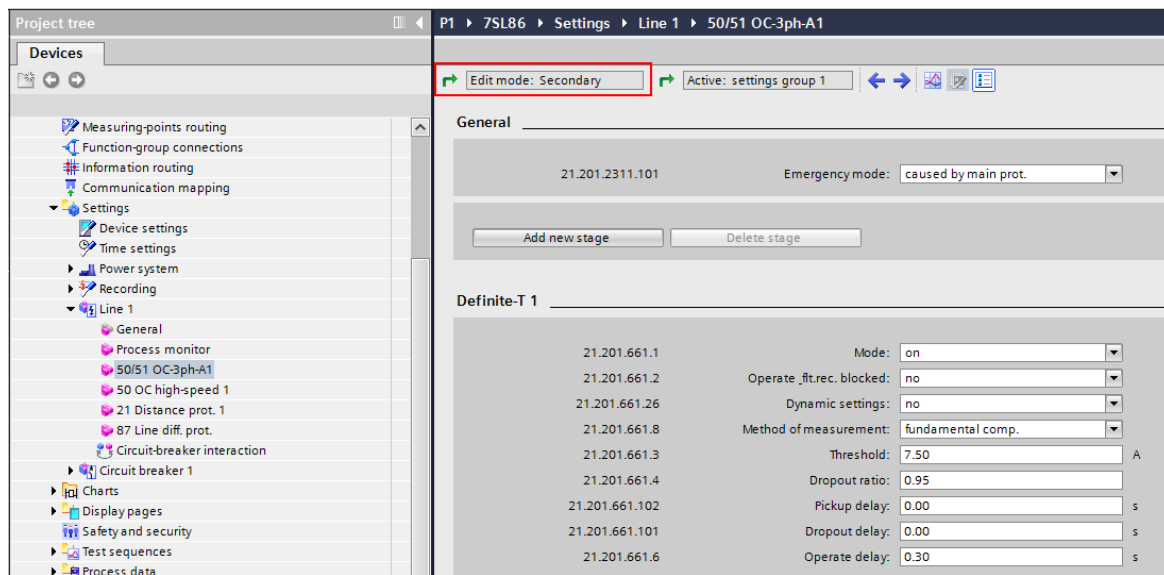

[scmodsek_1, 1, en_US]

Figure 3-67 Protection Setting, Display of the Active Setting Sheet

When you click the green arrow in the setting sheet at the upper left, you get to the window for switching over to the setting view (see the following figure). Select the setting view you prefer.

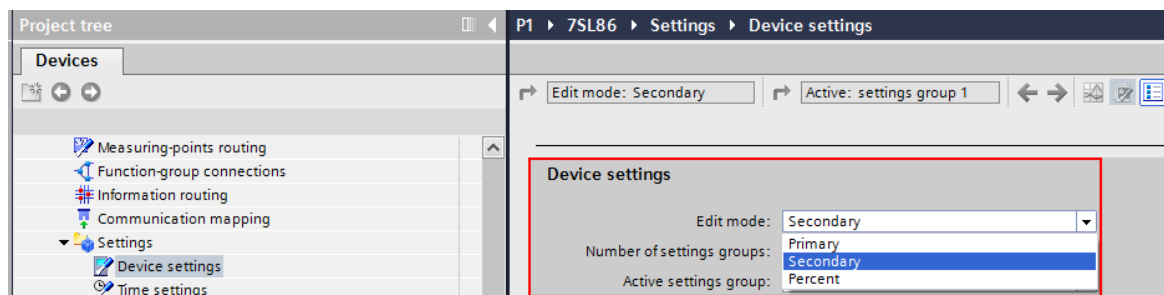

[scmodums_2, 1, en_US]

Figure 3-68 Switchover to the Desired Setting View

The following figures show the setting sequence in the edit mode **Primary**. Set the transformer data. In the example, the current transformer has a transformation ratio of 1000 A/1 A.

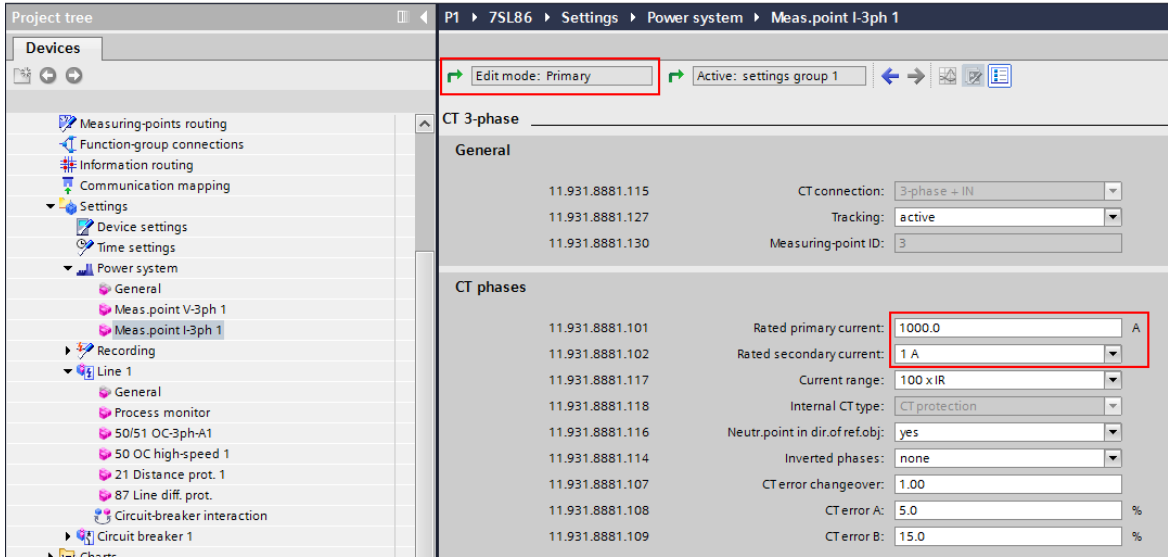

[scpwandl_3_1_en_US]

Figure 3-69 Setting Sheet: Transformer Data

In the function group (see following figure). Rated current, rated voltage are the reference variables for the percent setting.

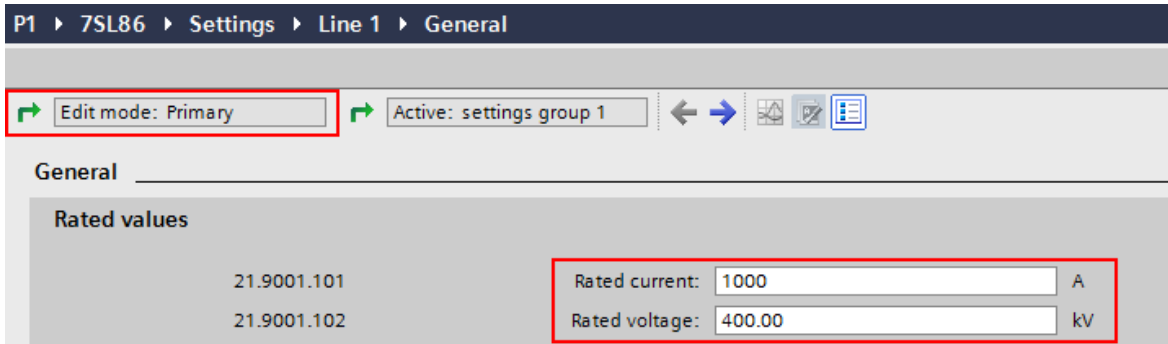

[scproref_4_1_en_US]

Figure 3-70 Reference Data for Percentage Settings

The following figure shows the threshold value of the function **Overcurrent protection** in the primary view at 1500 A.

The screenshot shows the configuration interface for a protection function. At the top, there are two buttons: "Edit mode: Primary" (highlighted with a red box) and "Active: settings group 1". Below these are navigation arrows and icons. The main interface is divided into two sections: "General" and "Definite-T 1".

General

21.201.2311.101 Emergency mode:

Definite-T 1

21.201.661.1	Mode:	<input type="text" value="on"/>	
21.201.661.2	Operate_fit.rec. blocked:	<input type="text" value="no"/>	
21.201.661.26	Dynamic settings:	<input type="text" value="no"/>	
21.201.661.8	Method of measurement:	<input type="text" value="fundamental comp."/>	
21.201.661.3	Threshold:	<input type="text" value="1500"/>	A
21.201.661.4	Dropout ratio:	<input type="text" value="0.95"/>	
21.201.661.102	Pickup delay:	<input type="text" value="0.00"/>	s
21.201.661.101	Dropout delay:	<input type="text" value="0.00"/>	s
21.201.661.6	Operate delay:	<input type="text" value="0.30"/>	s

[scumzpri_5_1_en_US]

Figure 3-71 Example of the Threshold Value of the Definite-Time Overcurrent Protection Stage (Edit Mode: Primary)

When switching over to the percent view, the result should be the following value:

$$1500 \text{ A} / 1000 \text{ A} \cdot 100 \% = 150 \%$$

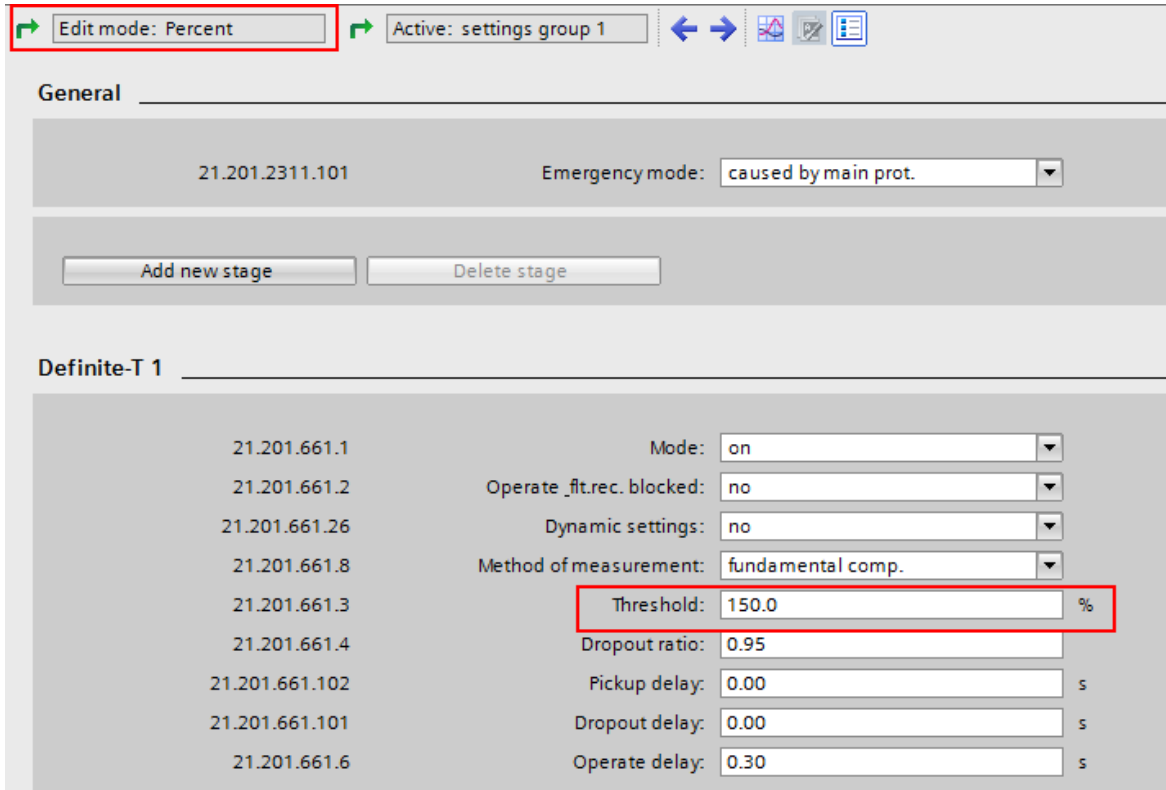

[scumzpro_6, 1, en_US]

Figure 3-72 Example of the Threshold Value of the Definite-Time Overcurrent Protection Stage (Edit Mode: Percent)

When switching over to the secondary view, the result should be the following value:

$$1500 \text{ A} / (1000 \text{ A} / 1 \text{ A}) = 1.5 \text{ A}$$

The screenshot shows the 'Edit mode: Secondary' interface for a protection function. The 'Active: settings group 1' is selected. The 'General' section shows the IP address 21.201.2311.101 and the 'Emergency mode' set to 'caused by main prot.'. Below this are 'Add new stage' and 'Delete stage' buttons. The 'Definite-T 1' section contains a table of settings for various IP addresses:

IP Address	Mode	Operate_ft.rec. blocked	Dynamic settings	Method of measurement	Threshold	Dropout ratio	Pickup delay	Dropout delay	Operate delay
21.201.661.1	on								
21.201.661.2		no							
21.201.661.26			no						
21.201.661.8				fundamental comp.					
21.201.661.3					1.500 A				
21.201.661.4						0.95			
21.201.661.102							0.00 s		
21.201.661.101							0.00 s		
21.201.661.6								0.30 s	

[scumzsek_7_1_en_US]

Figure 3-73 Example of the Threshold Value of the Definite-Time Overcurrent Protection Stage (Edit Mode: Secondary)

If you only want to work in the secondary view, DIGSI 5 supports you if the transformer ratio changes during the project phase.

In the example, the current-transformer ratio changes from 1000 A/1 A to 1000 A/5 A. Change the secondary rated current of the current transformer in the setting sheet of the transformer data from 1 A to 5 A (Edit mode: Secondary). If you change the transformer data, a window will appear (see the following figure) that will ask you for the action desired.

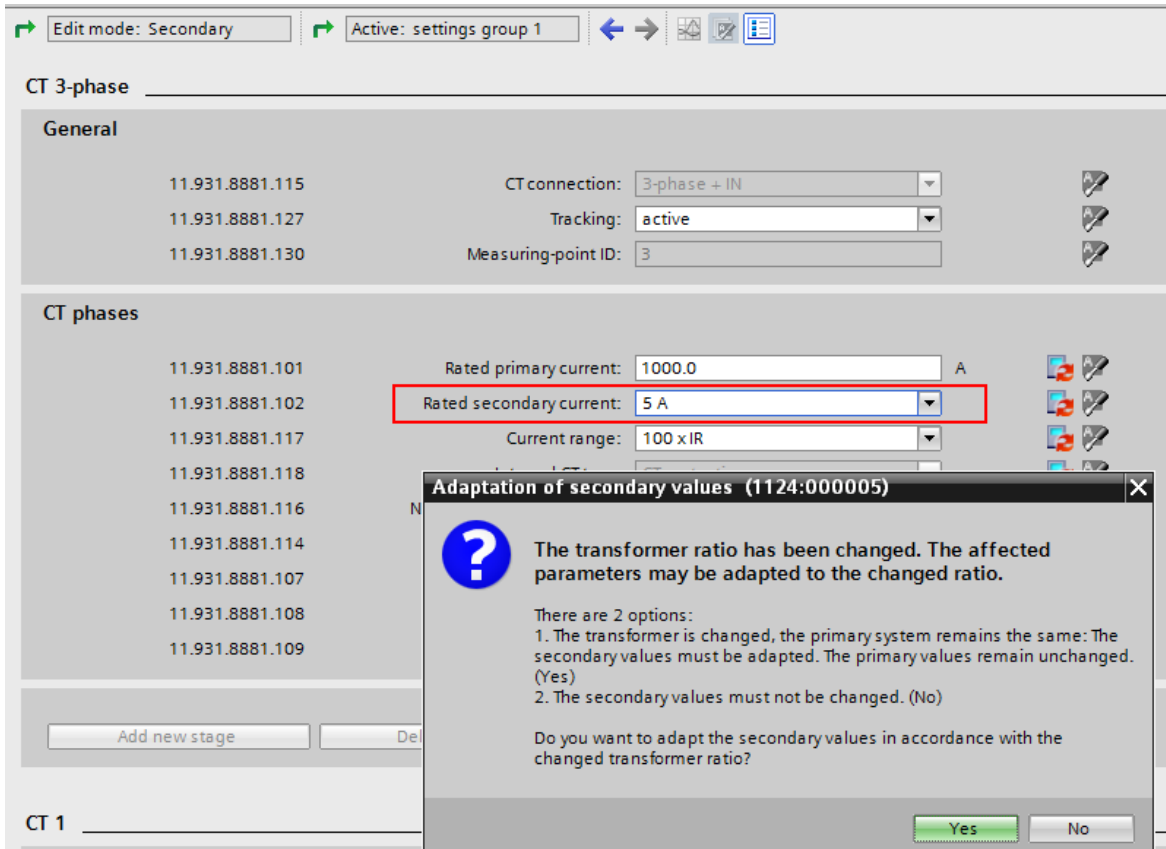

[sctfragew_8_1_en_US]

Figure 3-74 Query after Changing the Transformer Data (Setting View: Secondary)

If you answer the question with **Yes**, then DIGSI 5 will recalculate the pickup values (threshold values) in the active secondary view. For the new secondary transformer current 5 A, the new secondary threshold value obtained is 7.5 A ($1.5 \text{ A} * 5 = 7.5 \text{ A}$). The primary and percent values remain unchanged.

The following figure shows the newly calculated threshold value in the secondary view.

The screenshot displays the configuration interface for protection functions. At the top, it indicates 'Edit mode: Secondary' and 'Active: settings group 1'. The 'General' section shows the IP address '21.201.2311.101' and 'Emergency mode' set to 'caused by main prot.'. Below this are 'Add new stage' and 'Delete stage' buttons. The 'Definite-T 1' section lists several protection stages with their respective settings:

Stage ID	Mode	Operate _flt.rec. blocked	Dynamic settings	Method of measurement	Threshold	Dropout ratio	Pickup delay	Dropout delay	Operate delay
21.201.661.1	on								
21.201.661.2		no							
21.201.661.26			no						
21.201.661.8				fundamental comp.					
21.201.661.3					7.50				
21.201.661.4						0.95			
21.201.661.102							0.00		s
21.201.661.101								0.00	s
21.201.661.6									0.30

[scsekneu_9_1_en_US]

Figure 3-75 Automatically Recalculated Secondary Values After Changes in the Transformer Data

If you have already set the settings in the secondary view by including the new transformation ratio of the transformer in the calculation, then answer the question with **No**. In this case, the protection settings in the secondary view remain unchanged. DIGSI 5 recalculates the settings (threshold values) of the primary view. In the example, the primary threshold value is then 300 A ($1.5 \text{ A} \cdot 1000 \text{ A}/5 \text{ A} = 300 \text{ A}$).

In the example, the current-transformer ratio changes from 1000 A/1 A to 1000 A/5 A. The following table summarizes the pickup values that DIGSI 5 will recalculate in the setting view. The new values (in bold) depend on the reply to your question (refer to [Figure 3-74](#)).

	Reply to the Question	
	Yes	No
Threshold value secondary (active setting view)	7.5 A	1.5 A
Threshold value primary (covered setting view)	1500 A	300 A

Changing the Transformer Ratio in the Single-Line Editor

If you want to change the primary or secondary rated currents of the current transformer in the Single-Line Editor, select the current transformer. You can view and change the currents in the tab **Properties** of the object bar.

If you change the rated currents, the corresponding field has a red border to indicate currents that differ between the Single-Line Editor and the power-system data. During **synchronization** in the Single-Line Editor, these rated currents are adopted into the power-system data.

3.9.3 Changing the Transformation Ratios of the Transformer on the Device

In the delivery setting, the device is preset to secondary values. Only secondary values can be set directly on the device.

If you change transformer data directly on the device, it is not followed by a query, like in DIGSI 5 (see [Figure 3-74](#)). Instead, the device assumes that all settings remain unchanged in the secondary view.



NOTE

If the device works with IEC 61850 protocol, then change the transformer data only via DIGSI 5 and not directly on the device. If you change the transformer data directly on the device, the IEC 61850 configuration of the measurement and metered values can be faulty.

3.10 Device Settings

3.10.1 General Device Settings

3.10.1.1 Overview

In **Device settings** in DIGSI 5, you find the following general settings.

General		
Device		
91.101	Rated frequency:	50 Hz
91.102	Minimum operate time:	0.00 s
91.138	Block monitoring dir.:	off

[sc_deSeDe1, 1, en_US]

Chatter blocking		
91.123	No. permis.state changes:	0
91.127	Initial test time:	1 s
91.124	No. of chatter tests:	0
91.125	Chatter idle time:	1 min
91.137	Subsequent test time:	2 s

[sc_deSeAl, 4, en_US]

Measurements		
91.111	Energy restore interval:	10 min
91.112	Energy restore time:	none
91.120	Energy restore:	latest value
91.121	Energy restore by A.time:	<input type="checkbox"/>
91.104	Average calc. interval:	60 min
91.105	Average update interval:	60 min
91.106	Average synchroniz. time:	hh:00

[sc_measurement, 1, en_US]

Control		
91.118	Enable sw.auth. station:	<input type="checkbox"/>
91.119	Multiple sw.auth. levels:	<input type="checkbox"/>
91.152	Specific sw. authorities:	<input type="checkbox"/>
91.166	Shows interlock.cond. HMI:	<input type="checkbox"/>

[sc_control, 1, en_US]

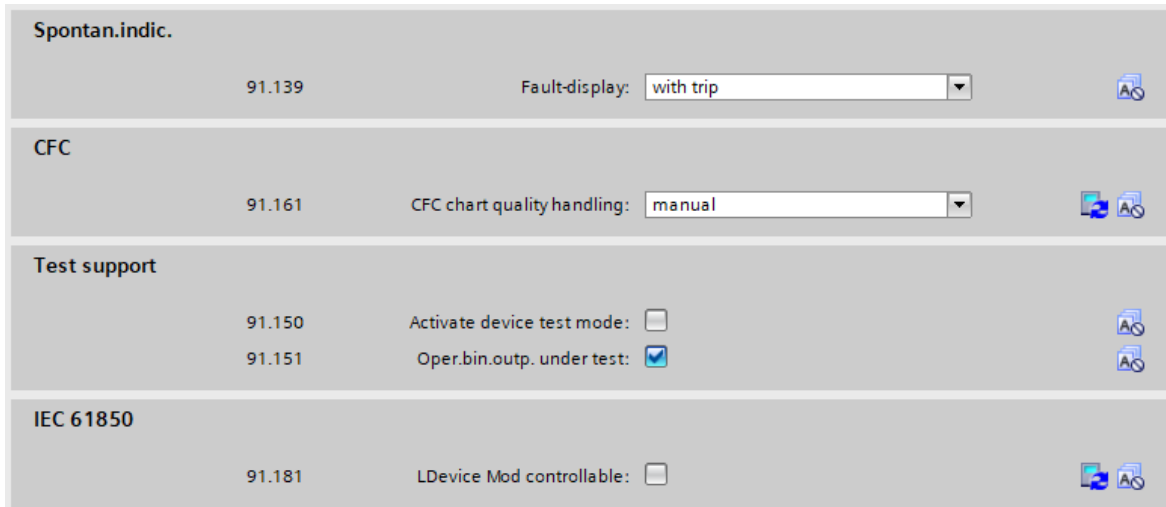

[sc_deSeBB, 2, en_US]

Figure 3-76 General Device Settings

The following list shows you the chapters containing the desired information. You can find more about:

- **Chatter blocking** in [3.8.1 Signal Filtering and Chatter Blocking for Input Signals](#).
- **Control** in [9.3 Control Functionality](#).
- **Spontaneous indications** in [3.1.7 Spontaneous Indication Display in DIGSI 5](#).
- **Continuous Function Chart Quality Treatment** in [3.4.3 Quality Processing/Affected by the User in CFC Charts](#).

Under **Device**, you set the parameters for the device that are valid across functions.

With **Test support**, indications issued via communication interfaces are labeled with an additional test bit, if this is supported by the protocol. With this test bit you can determine whether an indication is generated in a test and all or individual functions of the device are in the test mode. In this manner the reactions that are necessary in normal operation due to an indication can be suppressed in other devices that receive these indications. You can also permit, for example, a trip command to close an energized binary output for test purposes. Siemens recommends deactivating the **Test support** again after the test phase.

From version **DIGSI V09.70** on, you can control the state of the logical nodes (LLNO) in a logical device (LD) under **IEC 61850** with the parameter **LDevice Mod controllabile**. If you want to test and change the behavior of logical nodes individually, place a checkmark on the parameter **LDevice Mod controllabile**.

3.10.1.2 Application and Setting Notes

The major portion of the settings is described in the chapters cited above. Then, the parameters on the section **Device**, **Spontaneous indication** and **Test support** are described.

Parameter: Rated frequency

- Default setting (`_:101`) **Rated frequency** = 50 Hz

With the parameter **Rated frequency**, you set the rated frequency of the electrical power system.

Parameter: Minimum operate time

- Default setting (`_:102`) **Minimum operate time** = 0.00 s

With the parameter **Minimum operate time**, you set the minimum duration for the trip command of the functions. The trip command is maintained for the set duration.

Parameter: Block monitoring dir.

- Default setting (`_:138`) **Block monitoring dir.** = *off*

With the parameter **Block monitoring dir.**, you set whether indications are output via the system interface(s) of the SIPROTEC 5 device or not.

If transmission blocking is switched on, no indications are output via the system interface(s) of a SIPROTEC 5 device, except via the IEC 61850 interface(s).

To avoid receiving IEC 61850 data, the corresponding IEC 61850 Client must stop the reporting or freeze the data. You can find more information in the Communication Protocols Manual (C53000-L1840-C055-3).

Parameter: Fault-display

- Default setting (`_:139`) **Fault-display** = *with pickup*

With the parameter **Fault-display**, you set whether spontaneous fault indications which are signed as **NT (conditioned latching)** in the matrix, get stored with every pickup or only for one tripping.

Keep the DIGSI 5 routing options in chapters [3.1.7 Spontaneous Indication Display in DIGSI 5](#) and [3.1.9 Stored Indications in the SIPROTEC 5 Device](#) in mind.

Parameter: Activate device test mode

- Default setting (`_:150`) **Activate device test mode** = *inactive*

With the parameter **Activate device test mode**, you can activate the test mode for the complete device. This means that all indications generated in the device are given a test bit.

For further information, refer to [13.2 Enabling/Disabling the Application/Test Mode for the Entire Device](#).

Apart from activating the test mode via this parameter, you can also activate the test mode using the IEC 61850-8-1 protocol. For more information, refer to the manual *SIPROTEC 5 Communication protocol*.

When the test mode is activated for the complete device, but the parameter **Oper.bin.outp. under test** is not, the routed relay outputs of the device are not activated by the generated the indications.

**NOTE**

The device remains in test mode during every restart until you intentionally set the device back into process mode or you have carried out an initial start.

You can set the process mode by switching the parameter **Activate device test mode** to inactive again (removing the check mark) or by deactivating the test mode again via the protocol IEC 61850-8-1.

**NOTE**

Besides the cross device test mode, you also have the option to place an individual function or stage into test mode depending on the supported operating modes of a function or stage. To do this, see the description of the relevant function or stage.

When you place an individual function or stage into the test mode, all indications issued by this function or stage are given a test bit.

When you activate the test mode for an individual function or stage, but not the parameter **Oper.bin.outp. under test**, the routed relay outputs of the function or stage are not activated by the generated indications.

An individual function or stage remains in the test mode during every restart until you have intentionally deactivated the test mode for this function or stage again or carried out an initial start.

Parameter: Oper.bin.outp. under test

- Default setting (`_:151`) **Oper.bin.outp. under test** = *inactive*

If you activate the parameter **Oper.bin.outp. under test**, the indications generated in the device and marked with a test bit can be issued to a routed relay output of the device, that is, you enable the relay outputs of the device to be opened and closed.

If only one individual function or stage of the device is in test mode, that is, the cross device tested mode has not been activated, only the indications of this function or stage are marked with a test bit and the routed relay outputs of the device are activated.

With the parameter (`_:151`) **Oper.bin.outp. under test**, you define whether the functions in **Test** state can activate relay outputs. If the parameter (`_:151`) **Oper.bin.outp. under test** and the test mode are activated for the entire device, all functions – including the relay outputs – are in **Test** state. If the parameter (`_:151`) **Oper.bin.outp. under test** is not active and the test mode is activated for the entire device, all functions – except the relay outputs – are in **Test** state. The relay outputs adopt the **Test/Relay blk.** state.

Output Signal: Functions in Test mode

Normally, the output signal *Functions in Test mode* is prerouted to the last LED of the device base module. If one or more protection or control functions are in test mode, the output signal *Functions in Test mode* is generated and the corresponding LED of the device lights up red.

Parameter: LDevice Mod controllable

- Default setting (`_:181`) **LDevice Mod controllable** = inactive

With the parameter **LDevice Mod controllable**, you control the state of the logical nodes (LLNO) in a logical device (LD). If you want to test and change the behavior of logical nodes individually, place a checkmark on the parameter **LDevice Mod controllable**.

Once the checkmark is placed, the **LLNO:Mode** can be controlled in a logical device.

3.10.1.3 Settings

Addr.	Parameter	C	Setting Options	Default Setting
Device				
<code>_:101</code>	General:Rated frequency		<ul style="list-style-type: none"> • 50 Hz • 60 Hz 	50 Hz
<code>_:102</code>	General:Minimum operate time		0.00 s to 60.00 s	0.00 s
<code>_:138</code>	General:Block monitoring dir.		<ul style="list-style-type: none"> • off • on 	off
<code>_:164</code>	General:Station name		Freely editable text	
Chatter blocking				
<code>_:123</code>	General:No. permis.state changes		0 to 65 535	0
<code>_:127</code>	General:Initial test time		1 s to 65 535 s	1 s
<code>_:124</code>	General:No. of chatter tests		0 to 32 767; ∞	0
<code>_:125</code>	General:Chatter idle time		1 min to 65 535 min	1 min
<code>_:137</code>	General:Subsequent test time		2 s to 65 535 s	2 s
Change group				
<code>_:113</code>	General:Number settings groups		1 to 8	1

Addr.	Parameter	C	Setting Options	Default Setting
_:114	General:Activat. of settings group		<ul style="list-style-type: none"> • via control • via binary input • settings group 1 • settings group 2 • settings group 3 • settings group 4 • settings group 5 • settings group 6 • settings group 7 • settings group 8 	settings group 1
_:162	General:Blk setting change		<ul style="list-style-type: none"> • 0 • 1 	false
_:163	General:Reserv.time for com.prot.		0 s to 65 535 s	120 s
Measurements				
_:111	General:Energy restore interval		0 min to 60 min	10 min
_:112	General:Energy restore time		<ul style="list-style-type: none"> • none • hh:00 • hh:15 • hh:30 • hh:45 	none
_:120	General:Energy restore		<ul style="list-style-type: none"> • latest value • delta value 	latest value
_:121	General:Energy restore by A.time		<ul style="list-style-type: none"> • 0 • 1 	false
_:104	General:Average calc. interval		1 min to 60 min	60 min
_:105	General:Average update interval		<ul style="list-style-type: none"> • 1 min • 2 min • 3 min • 4 min • 5 min • 6 min • 10 min • 15 min • 20 min • 30 min • 60 min 	60 min
_:106	General:Average synchroniz. time		<ul style="list-style-type: none"> • hh:00 • hh:15 • hh:30 • hh:45 	hh:00

Addr.	Parameter	C	Setting Options	Default Setting
_:107	General:Min/Max cyclic reset		<ul style="list-style-type: none"> no yes 	yes
_:108	General:Min/Max reset each		1 day(s) to 365 day(s)	1 day(s)
_:109	General:Min/Max reset minute		0 min to 1439 min	0 min
_:110	General:Min/Max days until start		1 day(s) to 365 day(s)	1 day(s)
Control				
_:118	General:Enable sw.auth. station		<ul style="list-style-type: none"> 0 1 	false
_:119	General:Multiple sw.auth. levels		<ul style="list-style-type: none"> 0 1 	false
_:152	General:Specific sw. authorities		<ul style="list-style-type: none"> 0 1 	false
_:153	General:Specific sw.auth. valid for		<ul style="list-style-type: none"> station station/remote remote 	station/remote
_:154	General:Num. of specific sw.auth.		2 to 5	2
_:156	General:Ident. sw.auth. 1		Freely editable text	
_:157	General:Ident. sw.auth. 2		Freely editable text	
_:158	General:Ident. sw.auth. 3		Freely editable text	
_:159	General:Ident. sw.auth. 4		Freely editable text	
_:160	General:Ident. sw.auth. 5		Freely editable text	
_:155	General:Multiple specific sw.auth.		<ul style="list-style-type: none"> 0 1 	false
_:166	General:Show int.lck.cond. on HMI		<ul style="list-style-type: none"> 0 1 	false
Spontan. indic.				
_:139	General:Fault-display		<ul style="list-style-type: none"> with pickup with trip 	with pickup
CFC				
_:161	General:CFC chart quality handling		<ul style="list-style-type: none"> automatic manual 	manual
Test support				
_:150	General:Activate device test mode		<ul style="list-style-type: none"> 0 1 	false
_:151	General:Oper.bin.outp. under test		<ul style="list-style-type: none"> 0 1 	false

Addr.	Parameter	C	Setting Options	Default Setting
IEC 61850				
_:181	General:LDevice Mod controllable		<ul style="list-style-type: none"> • 0 • 1 	false

3.10.1.4 Information List

No.	Information	Data Class (Type)	Type
General			
_:500	General:>SG choice bit 1	SPS	I
_:501	General:>SG choice bit 2	SPS	I
_:502	General:>SG choice bit 3	SPS	I
_:503	General:>Sw. authority local	SPS	I
_:504	General:>Sw. authority remote	SPS	I
_:505	General:>Sw. mode interlocked	SPS	I
_:506	General:>Sw. mode non-interl.	SPS	I
_:510	General:>Test mode on	SPS	I
_:511	General:>Test mode off	SPS	I
_:507	General:>Dev. funct.logout on	SPS	I
_:508	General:>Dev. funct.logout off	SPS	I
_:512	General:>LED reset	SPS	I
_:513	General:>Light on	SPS	I
_:514	General:>Block relays	SPS	I
_:300	General:Act. settings group 1	SPC	C
_:301	General:Act. settings group 2	SPC	C
_:302	General:Act. settings group 3	SPC	C
_:303	General:Act. settings group 4	SPC	C
_:304	General:Act. settings group 5	SPC	C
_:305	General:Act. settings group 6	SPC	C
_:306	General:Act. settings group 7	SPC	C
_:307	General:Act. settings group 8	SPC	C
_:318	General:Active settings group	INS	O
_:308	General:Switching auth. station	SPC	C
_:324	General:Enable sw. auth. 1	SPC	C
_:325	General:Enable sw. auth. 2	SPC	C
_:326	General:Enable sw. auth. 3	SPC	C
_:327	General:Enable sw. auth. 4	SPC	C
_:328	General:Enable sw. auth. 5	SPC	C
_:311	General:Switching authority	ENS	O
_:312	General:Switching mode	ENS	O
_:309	General:Sw.authority key/set	ENS	O
_:310	General:Sw.mode key/set	ENS	O
_:330	General:Acq.blocking active	SPS	O
_:331	General:Manual update active	SPS	O
_:52	General:Behavior	ENS	O
_:53	General:Health	ENS	O
_:51	General:Test mode	ENC	C
_:56	General:Application mode	ENC	C

No.	Information	Data Class (Type)	Type
_:321	General:Protection on	SPC	C
_:54	General:Protection inactive	SPS	O
_:319	General:Device logout	SPC	C
_:313	General:Logged off via BI	SPS	O
_:314	General:Logged off via control	SPS	O
_:315	General:Device logged off	SPS	O
_:323	General:LED reset	SPC	C
_:320	General:LED have been reset	SPS	O
_:509	General:>Block monitoring dir.	SPS	I
_:317	General:Block monitoring dir.	SPS	O
_:329	General:Functions in Test mode	SPS	O

3.10.2 Settings-Group Switching

3.10.2.1 Overview of Functions

For different applications you can save the respective function settings in so-called **Settings groups**, and if necessary enable them quickly.

You can save up to 8 different settings groups in the device. In the process, only one settings group is active at any given time. During operation, you can switch between settings groups. The source of the switchover can be selected via a parameter.

You can switchover the settings groups via the following alternatives:

- Via the on-site operation panel directly on the device
- Via an online DIGSI connection to the device
- Via binary inputs
- Via a communication connection to the substation automation technology.
The communication protocols IEC 60870-5-103, IEC 60870-5-104, IEC 61850, DNP, or Modbus TCP can be used for switching the settings groups.

A settings group includes all switchable settings of the device. Except for a few exceptions (for example, general device settings such as rated frequency), all device settings can be switched.

For detailed information about the settings groups, refer to the *Operating Manual* and to the *DIGSI 5 Online Help*.

3.10.2.2 Structure of the Function

The function of the **Settings group switching** is a supervisory device function. Accordingly, the settings and indications of the settings group switching can be found in DIGSI 5 and at the on-site operation panel of the device, below the general device settings respectively.

If you want to switchover a settings group, navigate to DIGSI 5 or proceed on the on-site operation panel of the device, as follows:

- Via the project tree in DIGSI 5:
Project -> Device -> Settings -> Device settings
- Via the on-site operation panel of the device:
Main menu → Settings → General → Group switchover

The indications for the settings group switching can be found in the DIGSI 5 project tree under:

Project → Device → Information routing → General

3.10.2.3 Function Description

Activation

If you want to use the **Settings group switching** function, you must first set at least 2 settings groups in DIGSI 5 (parameter **Number of settings groups** > 1). You can set up a maximum of 8 settings groups. The settings groups set in DIGSI 5 are subsequently loaded into the device.

Mechanism of the Switchover

When switching over from one settings group to another, the device operation is not interrupted. With the parameter **Active settings group** you are either specifying a certain settings group or you allow switching *via control* (IEC 60870-5-103, IEC 61850) or *via binary input*.

Switching via Control

When using the **Control** function for switching, the settings groups can be switched via a communication connection from the substation automation technology or via a CFC chart.

The communication protocols IEC 60870-5-103, IEC 60870-5-104, IEC 61850, DNP, or Modbus TCP can be used for switching the settings groups via a communication connection.

In order to use a CFC chart for switching, you must create a new CFC chart in DIGSI 5. Create the CFC chart in the DIGSI 5 project tree under **Name of the device** → **Charts** → **Add new chart**. Link the signals that control settings group switching in the CFC chart.

Switching via Binary Input

There are 3 appropriate input signals available for switching via binary inputs. These input signals allow selection of the settings group via a binary code. If one of the 3 signals changes, the signal image present will, after 100 ms (stabilization time), result in switching over to the appropriate settings group. If only 2 settings groups must be switched over, only 1 binary input is required. The following table shows the possible binary codes (BCD) and applicable settings groups (PG).

Table 3-11 Binary Codes of the Input Signals and Applicable Settings Groups

BCD Code via Binary Inputs	PG 1	PG 2	PG 3	PG 4	PG 5	PG 6	PG 7	PG 8
>PG selection bit 3	0	0	0	0	1	1	1	1
>PG selection bit 2	0	0	1	1	0	0	1	1
>PG selection bit 1	0	1	0	1	0	1	0	1

Copying and Comparing Settings Groups

In DIGSI 5, you can copy or compare settings groups with each other.

If you want to copy settings groups, select a source and target parameter group in DIGSI 5 in the device settings, and then start the copy process. The device settings can be found in the DIGSI 5 project tree under Project → Device → Settings → Device settings.

If you want to compare settings groups, it is possible to do so in all setting sheets for settings. You will then select in addition to the active settings group, a 2nd settings group for comparison. Active setting values and the comparable values are displayed next to each other. For settings that cannot be switched over, no comparable values are displayed.

Indication of Settings Group Switchings

Every settings group shows an applicable binary indication as well as its activation and deactivation. The process of settings group switching is also logged in the log for settings changes.

3.10.2.4 Application and Setting Notes

Parameter: Number settings groups

- Default setting (**_ :113**) **Number settings groups = 1**

With the parameter **Number settings groups**, you can set the number of available settings groups; you can switch between these.

Parameter: Activat. of settings group

- Default setting (**_:114**) **Activat. of settings group = settings group 1**

With the parameter **Activat. of settings group**, you specify the settings groups that you want to activate, or the mechanisms via which the switchover is allowed. You can switchover only between the settings groups specified with the parameter **Number settings groups**.

Parameter Value	Description
<i>via control</i>	The switchover between the settings groups can only be initiated via a communication connection from a substation automation technology or via a CFC chart. The communication protocols IEC 60870-5-103, IEC 60870-5-104, IEC 61850, DNP, or Modbus TCP can be used for switching the settings groups via a communication connection.
<i>via binary input</i>	The switchover between the settings groups functions exclusively via the binary input signals routed to the settings group switching.
<i>settings group 1</i> ... <i>settings group 8</i>	They define the active settings groups. You can define the active settings groups in DIGSI 5, or directly on the device via the on-site operation.

3.10.2.5 Settings

Addr.	Parameter	C	Setting Options	Default Setting
<i>Change group</i>				
_:113	General:Number settings groups		1 to 8	1
_:114	General:Activat. of settings group		<ul style="list-style-type: none"> • via control • via binary input • settings group 1 • settings group 2 • settings group 3 • settings group 4 • settings group 5 • settings group 6 • settings group 7 • settings group 8 	settings group 1

3.10.2.6 Information List

No.	Information	Data Class (Type)	Type
<i>General</i>			
_:500	General:>SG choice bit 1	SPS	I
_:501	General:>SG choice bit 2	SPS	I
_:502	General:>SG choice bit 3	SPS	I
_:300	General:Act. settings group 1	SPC	C
_:301	General:Act. settings group 2	SPC	C
_:302	General:Act. settings group 3	SPC	C
_:303	General:Act. settings group 4	SPC	C

No.	Information	Data Class (Type)	Type
_:304	General:Act. settings group 5	SPC	C
_:305	General:Act. settings group 6	SPC	C
_:306	General:Act. settings group 7	SPC	C
_:307	General:Act. settings group 8	SPC	C

4 Applications

4.1	Overview	168
4.2	Application Templates and Functional Scope for Device 7SX800	169

4.1 Overview

The Global DIGSI 5 library provides application templates for the applications of the devices. The application template

- Supports the fast realization of complete protection solutions for applications
- Contains the basic configuration for the use case
- Contains functions and default settings for the use case

[Figure 2-1](#) in the [2.1 Embedding of Functions in the Device](#) provides an example for the structure of an application template.

When using an application template, note the following:

- Adapt the application template to your specific use (check/adapt default settings, delete/add functions). For more detailed information on this, refer to [2.1 Embedding of Functions in the Device](#).
- Check the routing of binary outputs with respect to fast and normal relays.
- Check the CFC charts for the group-warning indications and group-fault indications.

The following describes the application templates and maximum functional scope for the devices shown in this manual.



NOTE

The availability of certain settings and setting options depends on the device type and the functions available on the device!

4.2 Application Templates and Functional Scope for Device 7SX800

Application templates are available in **DIGSI 5** for 7SX800 device applications. The application templates contain the basic configurations, required functions, and default settings.

The following application templates are available in the **DIGSI 5** function library:

Application Template	
Template 1	Non-directional overcurrent protection (4*I)
Template 2	Non-directional overcurrent protection (4*I, 4*V)
Template 3	Directional overcurrent protection, grounded system
Template 4	Directional overcurrent protection, arc suppression coil/isolated system
Template 5	Motor: Current measurement
Template 6	Motor: Current and voltage measurement
Template 7	System decoupling protection

The following table shows the functional scope and the function-point requirements of the application templates for the device 7SX800:

Table 4-1 Functional Scope of the Application Templates for the Device 7SX800

ANSI	Function	Abbr.	Available	Template 1	Template 2	Template 3	Template 4	Template 5	Template 6	Template 7
	Protection functions for 3-pole tripping	3-pole	x	x	x	x	x	x	x	x
14	Locked rotor		x					x	x	
24	Overexcitation protection	V/f	x							
25	Synchrocheck, synchronization function	Sync	x							
27	Undervoltage protection, 3-phase	V<	x						x	x
27	Undervoltage protection, positive-sequence system	V1<	x							
27	Undervoltage protection, 3-phase, universal, Vx	Vx<	x							
27	Undervoltage protection, 1-phase, universal, Vx	Vx<	x							
27R, 59R	Rate of voltage change protection	dV/dt	x							
27/Q	Undervoltage-controlled reactive power protection	QU	x							
32R	Reverse-power protection	-P<	x							
32, 37	Power protection active/reactive power	P<>, Q<>	x							
37	Undercurrent protection, minimum power	I<, P<	x							
38	Temperature supervision	Θ>	x					x	x	
46	Negative-sequence system overcurrent protection	I2>	x							
46	Unbalanced-load protection (thermal)	I2 ² t>	x					x	x	
46	Negative-sequence overcurrent protection with direction	I2>, <(V2, I2)	x							
47	Overvoltage protection, negative-sequence system	V2>	x							
	Overvoltage protection with negative-sequence voltage/positive-sequence voltage	V2/V1>	x							

ANSI	Function	Abbr.	Available	Template 1	Template 2	Template 3	Template 4	Template 5	Template 6	Template 7
48	Starting time supervision for motors	I ² Startup	x					x	x	
49	Thermal overload protection	Θ, I^2t	x					x	x	
	Thermal overload protection, user-defined characteristic curve	Θ, I^2t	x							
49R	Thermal overload protection, rotor	ΘR	x					x	x	
49	Thermal overload protection for RLC filter circuit elements of a capacitor bank	Θ, I^2t	x							
50TD/ 51	Overcurrent protection, phases – Advanced	I>	x							
50TD/ 51	Overcurrent protection, phases – Basic	I>	x	x	x	x	x	x	x	
SOTF	Instantaneous tripping at switch onto error	SOTF	x	x	x	x	x	x	x	
50TD/ 51	Positive-sequence system overcurrent protection		x							
50TD/ 51	3-phase overcurrent protection for RLC elements		x							
50NTD/ 51N	Overcurrent protection, ground – Advanced	IN>	x							
50NTD/ 51N	Overcurrent protection, ground – Basic	IN>	x	x	x	x		x	x	
50N/ 51N	Overcurrent protection, 1-phase – Advanced	I>1pA	x							
50N/ 51N	Overcurrent protection, 1-phase – Basic	I>1pB	x							
50HS	Instantaneous high-current tripping	I>>>	x							
50Ns/ 51Ns	Sensitive ground-current protection for systems with resonant or isolated neutral	INs>	x							
50BF	Circuit-breaker failure protection		x							
50L	Load-jam protection	I>L	x					x	x	
RBRF	Restrike protection		x							
51V	Overcurrent protection, 3-phase, voltage-dependent		x							
59	Overvoltage protection, 3-phase	V>	x							x
59	Overvoltage protection, positive-sequence system	V1>	x							
59N	Overvoltage protection, zero-sequence system	V0>	x							x
59	Overvoltage protection, 3-phase or 1-phase, universal, Vx	Vx>	x							
60	Voltage-comparison supervision		x							
59C	Peak overvoltage protection for capacitors		x							
60C	Current unbalance protection for 3-phase capacitor banks	Iunbal>	x							
60C	Current unbalance protection for 1-phase capacitor banks	Iunbal>	x							

ANSI	Function	Abbr.	Available	Template 1	Template 2	Template 3	Template 4	Template 5	Template 6	Template 7
66	Restart inhibit for motors	I^2t	x					x	x	
67	Directional overcurrent protection, phases – Advanced	$I>, \angle(V, I)$	x							
67	Directional overcurrent protection, phases – Basic	$I>, \angle(V, I)$	x			x	x			
67N	Directional overcurrent protection, ground – Advanced	$IN>, \angle(V, I)$	x							
67N	Directional overcurrent protection, ground – Basic	$IN>, \angle(V, I)$	x			x				
67Ns	Dir. ground-fault detection for resonant and isolated systems	$IN>, \angle(V, I)$	x				x		x	
67Ns	Dir. sensitive ground-fault detection via admittance measurement for systems with resonant or isolated neutral	$GO>, B0>$	x							
67Ns	Transient ground fault-function, for transient and permanent ground faults in resonant-grounded or isolated systems	$W0p, tr>$	x							
67Ns	Sensitive ground-fault detection for systems with resonant or isolated neutral with phasor measurement of the 3rd or 5th harmonic	$V0>, \angle(V_{harm.}, I_{harm.})$	x							
67Ns	Sensitive ground-fault detection for systems with resonant or isolated neutral via 3I0 pulse-pattern detection	IN pulse	x							
67Ns	Intermittent ground-fault blocking for directional sensitive ground-fault detection		x							
74TC	Trip-circuit supervision	TCS	x							
79	Automatic reclosing	AREC	x							
81O	Overfrequency protection	$f>$	x							x
81U	Underfrequency protection	$f<$	x							x
81U	Underfrequency load shedding		x							
81R	Rate of frequency change protection	df/dt	x							
	Vector-jump protection	$\Delta\phi>$	x							
86	Lockout		x	x	x	x	x	x	x	
87NT	Restricted ground-fault protection	ΔIN	x							
DIGFP	Directional intermittent sensitive ground-fault protection		x							
IGFP	Intermittent ground-fault protection		x							
FL	Fault locator, single-side	FL-one	x							
	Fault locator plus	FO+								
	Measured values, standard		x	x	x	x	x	x	x	x
	Measured values, extended: min, max, avg (function points per type)		x							

ANSI	Function	Abbr.	Available	Template 1	Template 2	Template 3	Template 4	Template 5	Template 6	Template 7
	Power Quality – Basic: <ul style="list-style-type: none"> Voltage Variation Voltage Unbalance THD and Harmonics Total Demand Distortion 		x							
	Switching statistic counters		x							
Monit	Circuit-breaker monitoring		x							
	CFC (standard, control)		x							
	CFC arithmetic		x							
	Switching sequence function		x							
	Inrush-current detection		x	x	x	x	x	x	x	
	External trip initiation		x							
	Control		x	x	x	x	x	x	x	x
	Fault recording of analog and binary signals		x	x	x	x	x	x	x	x
	Slow-scan recorder							x	x	
	Monitoring and supervision		x			x	x		x	
	Circuit breaker		x	x	x	x	x	x	x	x
	Disconnect/grounding-conductor status		x							
20 mA MT	20-mA unit Ethernet		x							
20 mA MS	20-mA unit serial		x							
RTD MT	RTD unit Ethernet		x							
RTD MS	RTD unit serial		x							
	Access control		x							
	Security logging		x							
	Temperature detection via communication protocol		x							
	Sum of function points:			0	40	40	40	15	55	40

5 Function-Group Types

5.1	Function-Group Type Voltage/current 3-Phase	174
5.2	Function-Group Type Voltage/current 1-Phase	180
5.3	Function-Group Type Voltage 3-Phase	187
5.4	Function-Group Type Motor	190
5.5	Function-Group Type Capacitor Bank	217
5.6	Function-Group Type Analog Units	228
5.7	Function-Group Type Circuit Breaker	276
5.8	Function-Group Type Circuit Breaker [without Current]	295
5.9	Function-Group Recording	311
5.10	Process Monitor	313

5.1 Function-Group Type Voltage/current 3-Phase

5.1.1 Overview

In the **Voltage-current 3-phase** function group, you can use all the functions for protection and supervision of a protected object or equipment that allows 3-phase current and voltage measurement. The function group also contains the operational measurement for the protected object or equipment (on this topic, see chapter [11 Measured Values, Energy Values, and Supervision of the Primary System](#)).

You will find the **Voltage-current 3-phase** function group under each device type in the Global DIGSI 5 library. You will find all protection and supervision functions that you can use for this function-group type in the function group **Voltage-current 3-phase**.

For more information about the embedding of the functions in the device, refer to chapter [2 Basic Structure of the Function](#). For information regarding the functional scope of the application templates for the various device types, refer to chapter [4 Applications](#).

5.1.2 Structure of the Function Group

The function group always contains the following blocks:

- Protected object/equipment data (FB General)
- Operational measured values
- Process monitor
- Output logic of the function group
- Reset the LED group

These blocks are essential for the function group under all circumstances, so they cannot be loaded or deleted. You can load the protection and supervision functions required for your application in the function group. The functions are available in the function library in DIGSI 5. Functions that are not needed can be deleted from the function group.

The following figure shows the structure of the function group **Voltage-current 3-phase**:

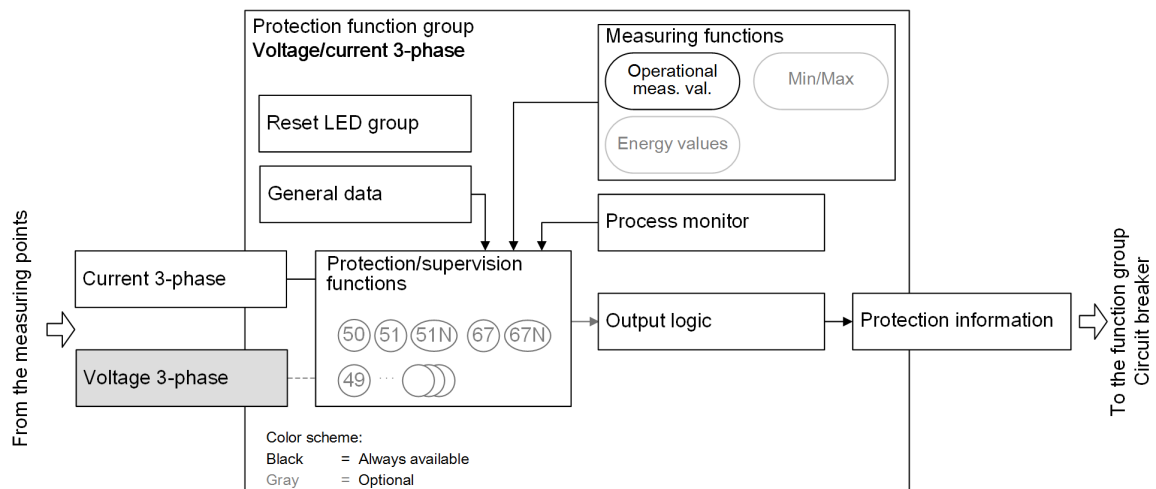

[dw_fg_ui3p_compact, 1, en_US]

Figure 5-1 Structure of the Voltage-Current 3-Phase Function Group

The function group has interfaces with:

- **Measuring points**
- Function group **Circuit breaker**

Interface with Measuring Points

The function group receives the required measured values via its interfaces with the measuring points. If you are using an application template, the function group is already connected to the necessary measuring points. If you add functions to the function group, they will automatically receive the measured values from the correct measuring points. If you add protection functions to the function group but the necessary measuring point is not connected, DIGSI 5 reports an inconsistency. Configure the measuring points in DIGSI 5 via the **Function-group connections** Editor. For more detailed information, refer to [2 Basic Structure of the Function](#). The function group has the following interfaces with the measuring points:

- **3-phase current**

The measurands from the 3-phase current system are supplied via this interface. Depending on the connection type of the transformers, these are, for example, I_A , I_B , I_C , I_N or $3I_0$. All values that can be calculated from the measurands are also provided via this interface. The function group must always be connected to the **I-3ph** measuring point.

You can connect the **3-phase current** interface to a maximum of **four** 3-phase current measuring points, (for example, for 1 1/2 circuit-breaker layouts). If 2 current measuring points have been connected with the **3-phase current** interface, the total current is also determined from measured values from both measuring points in the function group. All functions in the function group have access to these values.

- **3-phase voltage (optional)**

The measurands from the 3-phase voltage system are supplied via this interface. There are various types of transformer connections possible. All values that can be calculated from the measurands are also provided via this interface. Connecting the function group to the **V-3ph** measuring point is optional.

You can connect multiple measuring points with this interface. For more information, refer to [6.53 Voltage Measuring-Point Selection](#).

If you want to test or change the connection between the voltages and the V-3ph measuring point, double-click in the DIGSI 5 project tree → **(Name of the device) > Measuring point routing** (Connection type = 3 phase-to-ground voltage). For more information, refer to the description of the power-system data starting with [6.1 Power-System Data](#).

Interface to the Circuit-Breaker Function Group

All required data are exchanged between the function groups **Voltage-current 3-phase** and **Circuit breaker** via the interface of the **Circuit-breaker** function group.

This data includes, for example, the pickup and operate indications of the protection functions sent in the direction of the Circuit-breaker function group and, for example, the circuit-breaker position information in the direction of the protection function groups.

The **Voltage-current 3-phase** function group is connected to one or more Circuit-breaker function groups. This connection generally determines:

- Which circuit breaker(s) is/are activated by the protection functions of the protection function group
- Starting the Circuit-breaker failure protection function (if available in the Circuit-breaker function group) through the protection functions of the connected protection function group
- Starting the Automatic reclosing function (AREC, if available in the Circuit-breaker function group) through the protection functions of the connected Protection function group

Besides the general allocation of the protection function group to the Circuit-breaker function groups, you can also configure the interface for certain functionalities in detail. Configure the details in DIGSI 5 using the **Circuit-breaker interaction** Editor in the protection function group.

In the detail configuration of the interface, you define:

- Which operate indications of the protection functions go into the generation of the trip command
- Which protection functions start the Automatic reclosing function
- Which protection functions start the Circuit-breaker failure protection function

If you are using an application template, the function groups are already connected to each other, because this connection is absolutely essential to ensure proper operation. You can modify the connection in DIGSI 5 via the **Function-group connections** Editor.

Protected Object/Equipment Data (FB General)

The rated voltage and rated current as well as the neutral-point treatment of the protected object or the equipment are defined here. These data apply to all functions in the **Voltage-current 3-phase** function group.

Resetting the LED Group

Using the **Reset the LED group** function, you can reset the stored LEDs of the functions in one specific function group while the activated, stored LEDs of other functions in other function groups remain activated. For more detailed information, refer to [3.1.10 Resetting Stored Indications of the Function Group](#).

Process Monitor

The process monitor is always present in the **Voltage-current 3-phase** function group and cannot be removed.

The process monitor provides the following information in the **Voltage-current 3-phase** function group:

- Current-flow criterion:
Detection of an open/activated protected object/equipment based on the flow of leakage current
- Closure detection:
Detection of the switching on of the protected object/equipment
- Cold-load pickup detection (optional, only for protection devices):

This information applies to all functions available in the **Voltage-current 3-phase** function group.

The description of the process monitor begins with [5.10 Process Monitor](#).

Operational Measured Values

The operational measured values are always present in the **Voltage-current 3-phase** function group and cannot be deleted.

The following table shows the operational measured values of the **Voltage-current 3-phase** function group:

Table 5-1 Operational Measured Values of the Voltage-Current 3-Phase Function Group

Measured Values		Primary	Secondary	% Referenced to
$I_{A'}, I_{B'}, I_{C'}$	Phase currents	A	A	Rated operating current of the primary values
3I ₀	Calculated zero-sequence current	A	A	Rated operating current of the primary values
I_N	Neutral-point phase current	A	A	Rated operating current of the primary values
I_{NS}	Sensitive ground current	A	mA	Rated operating current of the primary values
$V_{A'}, V_{B'}, V_{C'}$	Phase-to-ground voltages	kV	V	Rated operating voltage of the primary values/ $\sqrt{3}$
$V_{AB'}, V_{BC'}, V_{CA'}$	Phase-to-phase voltages	kV	V	Rated operating voltage of the primary values
V_0	Zero-sequence voltage	kV	V	Rated operating voltage of the primary values/ $\sqrt{3}$
V_{NG}	Neutral-point displacement voltage	kV	V	Rated operating voltage of the primary values/ $\sqrt{3}$
f	Frequency	Hz	Hz	Rated frequency
P_{total}	Active power (total power)	MW	W	Active power of the primary values $\sqrt{3} \cdot V_{rated} \cdot I_{rated}$
Q_{total}	Reactive power (total power)	Mvar	var	Reactive power of the primary values $\sqrt{3} \cdot V_{rated} \cdot I_{rated}$
S_{total}	Apparent power (total power)	MVA	VA	Apparent power of the primary values $\sqrt{3} \cdot V_{rated} \cdot I_{rated}$

Measured Values		Primary	Secondary	% Referenced to
$\cos \varphi$	Active factor	(abs)	(abs)	100 % corresponds to $\cos \varphi = 1$
$P_{A'}, P_{B'}, P_{C'}$	Phase-related active power	MW	W	Active power of the phase $V_{\text{rated phsx}} \cdot I_{\text{rated phsx}}$
$Q_{A'}, Q_{B'}, Q_{C'}$	Phase-related reactive power	Mvar	var	Reactive power of the phase $V_{\text{rated phsx}} \cdot I_{\text{rated phsx}}$
$S_{A'}, S_{B'}, S_{C'}$	Phase-related apparent power	MVA	VA	Apparent power of the phase $V_{\text{rated phsx}} \cdot I_{\text{rated phsx}}$

For a more detailed explanation of the operational measured values, refer to [11.3 Operational Measured Values](#).

Output Logic

The output logic treats the pickup and trip signals of the protection and supervision functions that are available in the function group separately, in a pickup logic and a trip logic, respectively. The pickup and trip logic generate the overreaching indications (group indications) of the function group. These group indications are transferred via the **Protection information** interface to the **Circuit-breaker** function group and are processed further there.

The pickup signals of the protection and supervision functions in the **Voltage-current 3-phase** function group are combined in a phase-selective manner and output as a group indication.

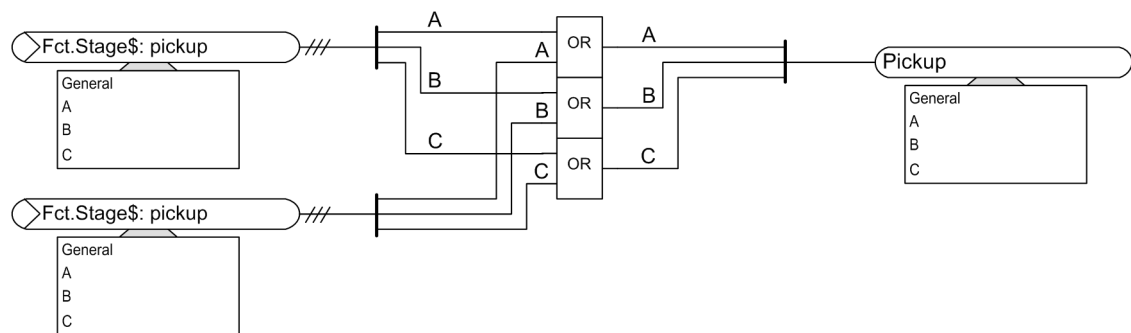

[to_anrlin, 3, en_US]

Figure 5-2 Creation of the Pickup Indication of the Voltage-Current 3-Phase Function Group

The trip signals from the protection and supervision functions of the **Voltage-current 3-phase** function group always result in 3-pole tripping of the device.

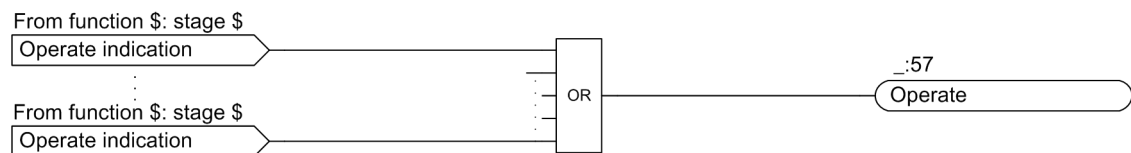

[to_auslin, 3, en_US]

Figure 5-3 Creation of the Operate Indication of the Voltage-Current 3-Phase Function Group

5.1.3 Application and Setting Notes

Interface to the Circuit-Breaker Function Group

With this, you define which circuit breaker(s) is/are affected by the protection functions of the Protection function group. A feasible default setting has already been provided in the application templates. You can find more information in chapter 2.

Protected Object/Equipment Data (FB General)

The set data applies to all functions in the function group.

Set the protected object/equipment data for your specific application.

Parameter: Rated current

- Default setting (`_:9451:101`) **Rated current** = *1000 A*

With the parameter **Rated current**, you can set the primary rated current of the protected object or equipment. The parameter **Rated current** is significant for protection functions if current values are set in percentages. In this case, it is the reference value. In addition it is the reference value for the measured values in percent.

If the device works with the IEC 61850 protocol, then you change only the setting value of the parameter via DIGSI 5 and not directly on the device. If you change the setting value directly on the device, then the IEC 61850 configuration of the metered values can be faulty.

Parameter: Rated voltage

- Default setting (`_:9451:102`) **Rated voltage** = *400.00 kV*

With the parameter **Rated voltage**, you can set the primary rated voltage of the protected object or equipment. The parameter **Rated voltage** is significant for protection functions if current values are set in percentages. In this case, it is the reference value. In addition it is the reference value for the measured values in percent.

If the device works with the IEC 61850 protocol, then you change only the setting value of the parameter via DIGSI 5 and not directly on the device. If you change the setting value directly on the device, then the IEC 61850 configuration of the metered values can be faulty.

Parameter: Power-sys. neutral point

- Default setting (`_:9451:149`) **Power-sys. neutral point** = *grounded*

With the parameter **Power-sys. neutral point**, you specify whether the system neutral is *grounded*, *isolated*, or *suppress. coil grounded* (grounded via arc-suppression coil). Currently, the parameter does not affect any protection function; only if the **Automatic reclosing function** uses the voltage measurement.

For more information, refer to [6.46.1 Overview of Functions](#).

5.1.4 Write-Protected Settings

Parameter: Rated apparent power

- Default setting (`_:103`) **Rated apparent power** = *692.82 MVA*

With the parameter **Rated apparent power**, you can set the primary rated apparent power for the auto transformer to be protected. The parameter **Rated apparent power** is relevant for the main protection function of the device. The **Rated apparent power** set here is the reference value for the percentage-measured values and setting values made in percentages.



NOTE

If the device works with the IEC 61850 protocol, then you change the setting value of the parameter only via DIGSI 5 and not directly on the device. If you change the setting value directly on the device, then the IEC 61850 configuration of the metered values can be faulty.

The settings listed here are used primarily for understanding during configuration of the function groups. They are calculated on the basis of other settings and cannot be directly changed.

Addr.	Parameters	C	Range of Values	Default Setting
Network data				
_:103	General:rated apparent power		0.20 MVA to 5 000.00 MVA	692.82 MVA

**NOTE**

For more detailed information on the process monitor, refer to [5.10 Process Monitor](#).

5.1.5 Settings

Addr.	Parameter	C	Setting Options	Default Setting
Rated values				
_:9451:101	General:Rated current		1.00 A to 100000.00 A	1000.00 A
_:9451:102	General:Rated voltage		0.10 kV to 1200.00 kV	400.00 kV
Power-system data				
_:9451:149	General:Power-sys. neutral point		<ul style="list-style-type: none"> • grounded • suppress. coil grounded • isolated 	grounded
Measurements				
_:9451:158	General:P, Q sign		<ul style="list-style-type: none"> • not reversed • reversed 	not reversed

5.1.6 Information List

No.	Information	Data Class (Type)	Type
General			
_:9451:52	General:Behavior	ENS	O
_:9451:53	General:Health	ENS	O
Group indicat.			
_:4501:55	Group indicat.:Pickup	ACD	O
_:4501:57	Group indicat.:Operate	ACT	O
_:4501:52	Group indicat.:Behavior	ENS	O
_:4501:53	Group indicat.:Health	ENS	O
Reset LED Group			
_:7381:500	Reset LED Group:>LED reset	SPS	I
_:7381:320	Reset LED Group:LED have been reset	SPS	O
_:7381:52	Reset LED Group:Behavior	ENS	O
_:7381:53	Reset LED Group:Health	ENS	O
Closure detec.			
_:1131:4681:500	Closure detec.:>Disconnecter open	SPS	I
_:1131:4681:300	Closure detec.:Closure	SPS	O
_:1131:4681:52	Closure detec.:Behavior	ENS	O
_:1131:4681:53	Closure detec.:Health	ENS	O

5.2 Function-Group Type Voltage/current 1-Phase

5.2.1 Overview

In the **Voltage-current 1-phase** function group, all functions can be used for protecting and for monitoring a protection object or equipment that allow a 1-phase current and voltage measurement or a zero-sequence voltage measurement via the 3-phase voltage measuring point. The function group also contains the operational measurement for the protected object or equipment (see chapter [11 Measured Values, Energy Values, and Supervision of the Primary System](#)).

5.2.2 Structure of the Function Group

The function group **Voltage-current 1-phase** has interfaces to the measuring points and the function group **Circuit breaker**.

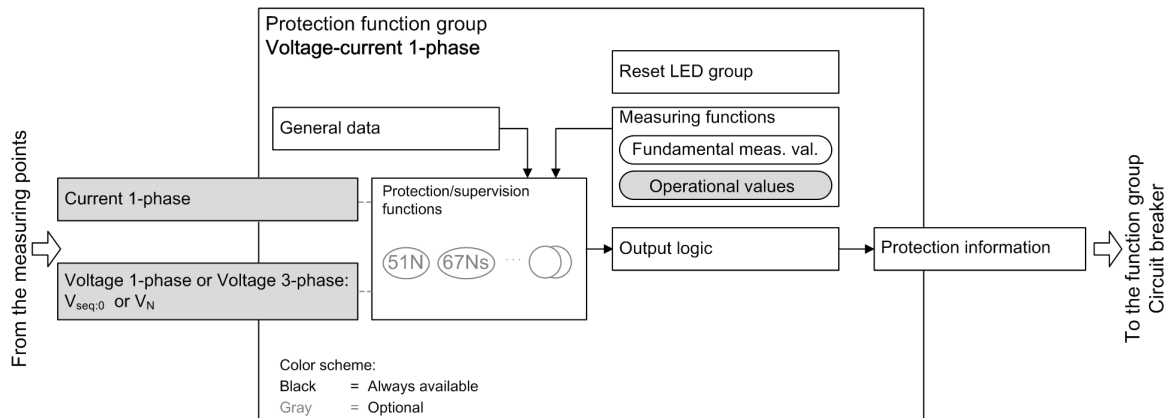

[dww_1spstr_1_en_US]

Figure 5-4 Structure of the Function Group Voltage-Current 1-Phase

Interface with Measuring Points

You connect the function group **Voltage-current 1-phase** to the current and voltage measuring points via the interfaces to the measuring points. At least one measuring point has to be connected. The other is optional. This assignment can only be made in DIGSI via **Project tree** → **Function group connections**. To connect the interfaces, set a cross at the intersection between the row and column in the matrix.

The function group has the following interfaces to the measuring points:

- 1-phase current**
 The 1-phase current measured values are provided via this interface.
 You can only connect a 1-phase current measuring point to the interface **1-phase current**.
- Voltage 1-phase or Voltage 3-phase**
 You can connect the voltage interface of the function group **Voltage-current 1-phase** with a 1-phase or a 3-phase measuring point. The calculated zero-sequence voltage or the measured residual voltage is available for connection with a 3-phase measuring point. The phase-to-ground voltages are not available in the function group **Voltage-current 1-phase**. You can use both connection types at the same time.
 You configure the 1-phase voltage measuring points via the voltage interface (see the following figure).

Connect measuring points to function group					
	Circuit breaker 1		VI 1ph 1		
Measuring point	V sync1	V sync2	V	I 1ph	
(All)	(All)	(All)	(All)	(All)	(All)
Meas.point I-1ph 1[ID 1]					X
Meas.point V-1ph 1[ID 2]			X		

[scVI1ph_V1ph_1_en_US]

Figure 5-5 Connecting Measuring Points to the Function Group Voltage-Current 1-Phase

If you select the voltage type **VN broken-delta** for the 1-phase voltage measuring point in the measuring point routing (see the following figure), the device measures the residual voltage V_N at the broken-delta winding. The residual voltage is converted into the voltage equivalent of the zero-sequence voltage. This converted voltage is used as the voltage input for all functions in the function group **Voltage-current 1-phase**.

Voltage-measuring points					
Base module					
1B					
1B1-1B2 1B3-1B4 1B5-1B6 1B7-1B8					
Measuring point	Connection type	V 1.1	V 1.2	V 1.3	V 1.4
(All)	(All)	(All)	(All)	(All)	(All)
Meas.point V-3ph 1	3 ph-to-ph volt. + VN	V AB	V BC	V CA	VN broken-delta
Meas.point V-1ph 1					
Add new					

[scvnopen_1_en_US]

Figure 5-6 Selection of the **VN broken-delta** Voltage Type for the 1-Phase Voltage Measuring Point

The zero-sequence voltage calculated from the 3-phase voltage system or the measured residual voltage is available via the voltage interface (see the following figure).

The zero-sequence voltage calculated from the 3-phase voltage system is available via the voltage interface (see the following figure).

Connect measuring points to function group					
	Circuit breaker 1		VI 1ph 1		
Measuring point	V sync1	V sync2	V	I 1ph	
(All)	(All)	(All)	(All)	(All)	(All)
Meas.point I-1ph 1[ID 1]					X
Meas.point V-3ph 1[ID 2]			X		

[scVI1ph_V3ph_1_en_US]

Figure 5-7 Connecting Measuring Points 3-Phase Voltage and 1-Phase Current to the Function Group 1-Phase Voltage-Current

You can connect the voltage interface of the function group **Voltage-current 1-phase** with precisely one 3-phase voltage measuring point. 3 types of 3-phase voltage measuring-point connection are supported.

With the different connection types, the type of voltage input for the functions in the function group **Voltage-current 1-phase** also changes.

The following table shows the properties of the voltage input for the function group **Voltage-current 1-phase** depending on the connection types.

Connection Type of the 3-Phase Voltage Measuring Point	Voltage Input
3 ph-to-gnd voltages	The zero-sequence voltage is calculated from the phase-to-ground voltages and used as a voltage input for all functions.
3 ph-to-gnd volt. + VN	The residual voltage VN is converted into the voltage equivalent of the zero-sequence voltage. This converted voltage is used as a voltage input for functions.
3 ph-to-ph volt. + VN	

Interface to the Circuit-Breaker Function Group

All required data is exchanged between the function group **Voltage-current 1-phase** and the function group **Circuit breaker** via the interface of the function group **Circuit breaker**.

In this example, the pickup and operate indications of the protection functions are exchanged in the direction of the Circuit-breaker function group.

You must connect the function group **Voltage-current 1-phase** with the function group **Circuit breaker**. This assignment can only be made in DIGSI via **Project tree** → **Function group connections**. To connect the interfaces, set a cross at the intersection between the row and column in the matrix. If the interface is not connected, the functions operate as supervision functions in the function group **Voltage-current 1-phase**.

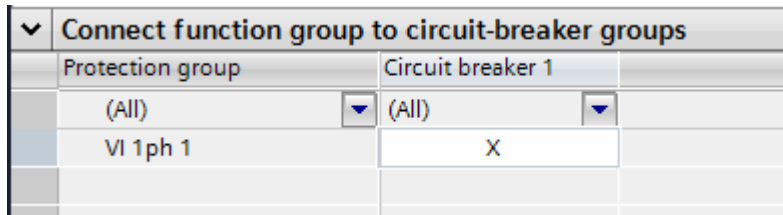

[sc_1stspc_1_en_US]

Figure 5-8 Connecting Function Group Voltage-Current 1-Phase with Function Group Circuit Breaker

Fundamental Components

The fundamental components are always present in the function group **Voltage-current 1-phase** and cannot be deleted.

The following table shows the fundamental components of the function group **Voltage-current 1-phase**:

Table 5-2 Fundamental Components of the Function Group Voltage-Current 1-Phase

Measured Values		Primary	Secondary	% Referring to
I	1-phase current	A	A	Parameter Rated operating current
V ⁵	1-phase voltage	kV	V	Parameter Rated operating voltage
V ₀ ⁶	Zero-sequence voltage	kV	V	Parameter Rated operating voltage/√3
V _N ⁷	Residual voltage	kV	V	Parameter Rated operating voltage/√3

⁵ The 1-phase voltage V is only visible if it is connected to a 1-phase voltage measuring point.

⁶ The zero-sequence voltage V0 is only visible if it is connected to a 3-phase voltage measuring point with the connection type 3-phase phase-to-ground voltage.

⁷ The residual voltage VN is only visible if it is connected to a 3-phase voltage measuring point with the connection type 3-phase phase-to-ground voltage + VN or 3-phase phase-to-phase voltage + VN.

You can find the parameters **Rated operating current** and **Rated operating voltage** in the function block **General** of the function group **Voltage-current 1-phase**.

Operational Measured Values

The operational measured values are not preconfigured in the function group **Voltage-current 1-phase**. You can instantiate them in the function group or delete them from the function group. You can find the operational measured values in the DIGSI library, in the folder **FG Voltage-current 1-phase** under **Measurements** → **Operational values**.

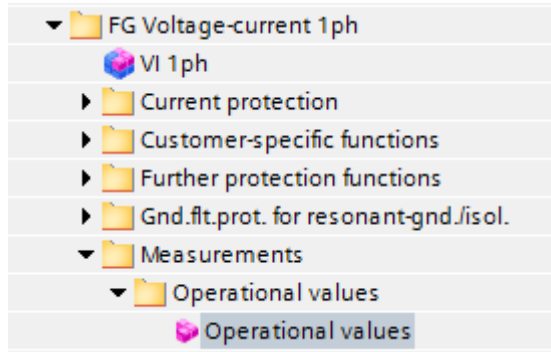

[scui1pom, 1, en_US]

Figure 5-9 Operational Measured Values

Table 5-3 Operational Measured Values of the Function Group Voltage-Current 1-Phase

Measured Values		Primary	Secondary	% Referring to
I	1-phase current	A	A	Parameter Rated operating current
V^8	1-phase voltage	kV	V	Parameter Rated operating voltage
V_N^9	Residual Voltage	kV	V	Parameter Rated operating voltage / $\sqrt{3}$
V_0^{10}	Zero-sequence voltage	kV	V	Parameter Rated operating voltage / $\sqrt{3}$
f	Frequency	Hz	Hz	Parameter Rated frequency
P	Active power	MW	W	Parameter Rated apparent power
Q	Reactive power	Mvar	var	Parameter Rated apparent power

You can find the parameters **Rated operating current**, **Rated operating voltage**, and **Rated apparent power** in the function block **General** of the function group **Voltage-current 1-phase**. You can find the parameter **Rated frequency** in the function block **General** of the **Device settings**.



NOTE

The frequency can be calculated from the voltage or current measured value.

The active and reactive power are only displayed if the voltage and the 1-phase current are connected to the function group. If the connected voltage is a phase-to-ground voltage (VA, VB, VC) or any voltage Vx, the specific power values are displayed. Otherwise the power is displayed as not available.

⁸ V is only visible if it is connected to a 1-phase voltage measuring point.

⁹ V_N is only visible if it is connected to a 3-phase voltage measuring point of the type 3 ph-to-gnd volt. + V_N or 3 ph-to-ph volt. + V_N .

¹⁰ V_0 is only visible if it is connected to a 3-phase voltage measuring point of the type 3 ph-to-gnd voltages.

5.2.3 Application and Setting Notes



NOTE

Before creating the protection functions in the function group, you should connect them to the suitable function group **Circuit breaker**.

Parameter: Rated current

- Default setting (`_:9421:101`) **Rated current** = *1000 A*

With the parameter (`_:9421:101`) **Rated current**, you set the primary rated current of the protected object. The parameter (`_:9421:101`) **Rated current** set here is the reference value for the percentage measured values and setting values made in percentages.

Parameter: Rated voltage

- Default setting (`_:9421:102`) **Rated voltage** = *400.00 kV*

With the parameter **Rated voltage**, you set the primary rated voltage of the protected object. The parameter **Rated voltage** set here is the reference value for all voltage-related percentage values in the function group **Circuit breaker**.

If you connect the **Voltage-current 1-phase** function group to the 1-phase measuring point the following applies:

- With connection type V_{AB} , V_{BC} , V_{CB} , or V_N , you set the parameter **Rated voltage** as the phase-to-phase voltage.
- With the connection type V_A , V_B , V_C , or V_N (broken-delta winding) you set the parameter **Rated voltage** as phase-to-ground voltage.
- With the connection type V_X , you set the parameter **Rated voltage** as either the phase-to-phase voltage or the phase-to-ground voltage

Parameter: P, Q sign

- Default setting (`_:9421:150`) **P, Q sign** = *not reversed*

The power values are set at the factory so that power in the direction of the protected object is considered positive. You can also define the power output by the protected object as positive. You can invert the signs of active and reactive power with the parameter **P, Q sign**. This inversion has no effect on the protection functions.

Parameter: Rated current (Write Protected)

- Default setting (`_9421:104`) **Rated current** = *1000 A*

With the parameter **Rated current**, you can set the primary rated current. The **Rated current** set here is the reference value for the percentage measured values and setting values made in percentages.



NOTE

If an interface to a 3-phase function group exists and voltage transformers or current transformers are assigned, the write-protected parameters: (`_9421:104`) **Rated current** and (`_:9421:105`) **Rated voltage** are present. The parameters (`_:9451:101`) **Rated current** and (`_:9421:102`) **Rated voltage** are hidden.

Parameter: Rated voltage (Write Protected)

- Default setting (`_:9421:105`) **Rated voltage** = *400.00 kV*

With the parameter **Rated voltage**, you set the primary voltage to which all voltage-related percentage values in the function group **Circuit breaker** are related.

Parameter: Rated apparent power (Write Protected)

- Default setting (`_:91:103`) **Rated apparent power** = *692.82 MVA*

With the parameter **Rated apparent power**, you can set the primary rated apparent power of the transformer to be protected.

The parameter **Rated apparent power** is relevant for the main protection function of the device. The parameter **Rated apparent power** set here is the reference value for the percentage measured values and setting values made in percentages.

Parameter: M I-1ph uses MeasP with ID (Write Protected)

- Default setting (`_:91:214`) **M I-1ph uses MeasP with ID** = *0*

The parameter **M I-1ph uses MeasP with ID** shows you which 1-phase measuring point is connected to the transformer side. Every measuring point is assigned a unique ID.

Parameter: Scale Factor M I-1ph (Write Protected)

- Default setting (`_:91:223`) **Scale factor M I-1ph** = *0.000*

The parameter **Scale factor M I-1ph** shows you the magnitude scaling of the transformer neutral-point current.

5.2.4 Write-Protected Settings

The settings listed here are used primarily for understanding during configuration of the function groups. They are calculated on the basis of other settings and cannot be directly changed.

Addr.	Parameter	C	Setting Options	Default Setting
Rated values				
<code>_:9421:103</code>	General:Rated apparent power		-1.00 MVA to -1.00 MVA	0.00 MVA
Power-system data				
<code>_:9421:214</code>	General:M I-1ph uses MeasP with ID		0 to 100	0
<code>_:9421:223</code>	General:CT mismatch M I-1ph		0.00 to 100.00	0.00

5.2.5 Settings

Addr.	Parameter	C	Setting Options	Default Setting
Rated values				
<code>_:9421:101</code>	General:Rated current		1 A to 100 000 A	1000 A
<code>_:9421:102</code>	General:Rated voltage		0.10 kV to 1200.00 kV	400.00 kV
Measurements				
<code>_:9421:150</code>	General:P, Q sign		<ul style="list-style-type: none"> • not reversed • reversed 	not reversed

5.2.6 Information List

No.	Information	Data Class (Type)	Type
General			
_:9421:52	General:Behavior	ENS	0
_:9421:53	General:Health	ENS	0
Group indicat.			
_:4501:55	Group indicat.:Pickup	ACD	0
_:4501:57	Group indicat.:Operate	ACT	0
_:4501:52	Group indicat.:Behavior	ENS	0
_:4501:53	Group indicat.:Health	ENS	0
Reset LED Group			
_:13381:500	Reset LED Group:>LED reset	SPS	I
_:13381:320	Reset LED Group:LED have been reset	SPS	0
_:13381:52	Reset LED Group:Behavior	ENS	0
_:13381:53	Reset LED Group:Health	ENS	0

5.3 Function-Group Type Voltage 3-Phase

5.3.1 Overview

In the **Voltage 3-phase** function group, all functions can be used for protecting and for monitoring a protected object or equipment which allows a 3-phase voltage measurement. The function group also contains the operational measurement for the protected object or equipment (on this topic, see chapter [11 Measured Values, Energy Values, and Supervision of the Primary System](#)). Applicable functions are, for example, Voltage protection or Frequency protection.

5.3.2 Structure of the Function Group

The function group **Voltage 3-phase** has interfaces to the measuring points and the function group **Circuit breaker**.

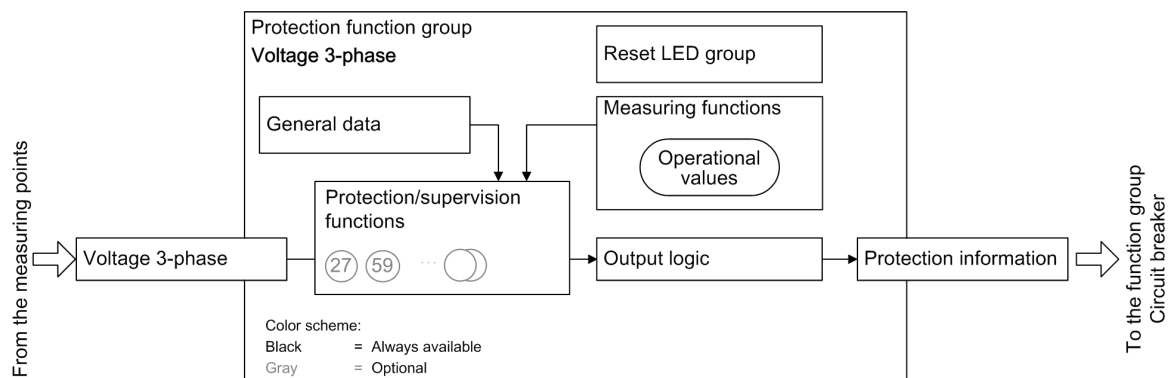

[dcr_3phase_voltage_1_en_US]

Figure 5-10 Structure of the Function Group Voltage 3-Phase

Interface with Measuring Points

You connect the function group **Voltage 3-phase** to the voltage measuring points via the interface to the measuring points. This assignment can only be made in DIGSI via **Project tree** → **Function group connections**. To connect the interfaces, set a cross at the intersection between the row and column in the matrix.

Connect measuring points to function group							
Measuring point	Circuit breaker 1		Circuit breaker 2		V 3ph 1		
	V sync1	V sync2	V	V sync1	V sync2	V 3ph	
(All)	(All)	(All)	(All)	(All)	(All)	(All)	
Meas.point V-3ph 1 [ID 3]	X		X	X			X

[sc_3_voltage1_1_en_US]

Figure 5-11 Connecting Measuring Points to the Voltage 3-Phase Function Group

If you add functions to the function group **Voltage 3-phase**, these are connected to the measuring point automatically.

You can connect multiple measuring points with this interface. For more information, refer to chapter [6.53 Voltage Measuring-Point Selection](#).

The measurands from the 3-phase voltage system are supplied via the interface **V 3-ph**. Depending on the connection type of the transformers, for example, V_A , V_B , V_C , V_{gnd} . All values that can be calculated from the measurands are also provided via this interface.

Interface to the Function Group Circuit Breaker

All required data is exchanged between the function group **Voltage 3-phase** and the function group **Circuit breaker** via the interface of the function group **Circuit breaker**.

In this example, the pickup and operate indications of the protection functions are exchanged in the direction of the function group Circuit breaker.

You must connect the function group **Voltage 3-phase** with the function group **Circuit breaker**. This assignment can be made in DIGSI only via **Project tree** → **Connect function group**. To connect the interfaces, set a cross at the intersection between the row and column in the matrix.

Connect function group to circuit-breaker groups			
Protection group	Circuit breaker 1	Circuit breaker 2	
(All)	(All)	(All)	
V 3ph 1	X		

[sc_3_voltage2_1_en_US]

Figure 5-12 Connecting the Function Group Voltage 3-Phase with the Function Group Circuit Breaker

Operational Measured Values

The operational measured values are always present in the function group **Voltage 3-phase** and cannot be deleted.

The following table shows the operational measured values of the function group **Voltage 3-phase**:

Table 5-4 Operational Measured Values of the Voltage 3-Phase Function Group

Measured Values		Primary	Secondary	% with respect to
V_A, V_B, V_C	Phase-to-ground voltages	kV	V	Operating rated voltage of primary values/ $\sqrt{3}$
V_{AB}, V_{BC}, V_{CA}	Phase-to-phase voltage	kV	V	Rated operating voltage of the primary values
V_0	Zero-sequence voltage	kV	V	Operating rated voltage of primary values/ $\sqrt{3}$
V_{NG}	Neutral-point displacement voltage	kV	V	Operating rated voltage of primary values/ $\sqrt{3}$
f	Frequency	Hz	Hz	Rated frequency

5.3.3 Application and Setting Notes



NOTE

Before creating the protection functions in the function group, you should connect them to the appropriate **Circuit-breaker** function group.

Parameter: Rated voltage

- Default setting (`_:9421:102`) **Rated voltage** = 400.00 kV

With the **Rated voltage** parameter, you set the primary rated voltage. The parameter **Rated voltage** set here is the reference value for the percentage-measured values and setting values made in percentages.

5.3.4 Settings

Addr.	Parameter	C	Setting Options	Default Setting
Rated values				
_:9421:102	General:Rated voltage		0.10 kV to 1200.00 kV	400.00 kV

5.3.5 Information List

No.	Information	Data Class (Type)	Type
General			
_:9421:52	General:Behavior	ENS	O
_:9421:53	General:Health	ENS	O
Group indicat.			
_:4501:55	Group indicat.:Pickup	ACD	O
_:4501:57	Group indicat.:Operate	ACT	O
_:4501:52	Group indicat.:Behavior	ENS	O
_:4501:53	Group indicat.:Health	ENS	O
Reset LED Group			
_:7381:500	Reset LED Group:>LED reset	SPS	I
_:7381:320	Reset LED Group:LED have been reset	SPS	O
_:7381:52	Reset LED Group:Behavior	ENS	O
_:7381:53	Reset LED Group:Health	ENS	O

5.4 Function-Group Type Motor

5.4.1 Overview

In the **Motor** function group, all of the functions that are necessary for protecting and supervising a motor can be used. The function group **Motor** also contains the measuring functions and the interface to the **Circuit-breaker** function group.

You can find the **Motor** function group under certain device type in the Global DIGSI 5 Library. The **Motor** function group contains all of the protection functions and supervision functions that you can use for this device type.

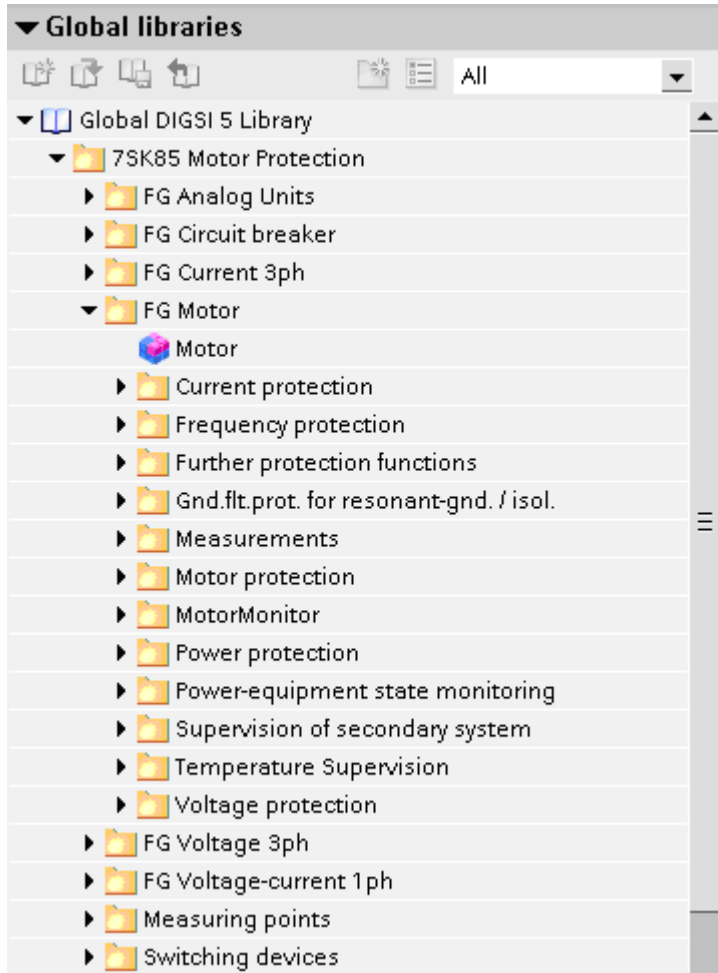

[scrfgmot-230812-02.tif, 1, en_US]

Figure 5-13 Motor Function Group - Functional Scope for Device Type 7SK85

For more information about the embedding of the functions in the device, refer to *Chapter 2*. For information about the overall functional scope of the application templates for the various device types, refer to *Chapter 4*.

5.4.2 Structure of the Function Group

The **Motor** function group always contains the following :

- General data
- Operational measured values

- Motor monitor
- Thermal replica rotor
- Output logic of the function group
- Reset LED group

These blocks are essential for the **Motor** function group, so they cannot be loaded or deleted.

You can load the protection functions and supervision functions required for your application in the **Motor** function group. The functions are available from the Global DIGSI 5 Library. Functions that are not needed can be deleted from the function group.

The following figure shows the structure of the **Motor** function group:

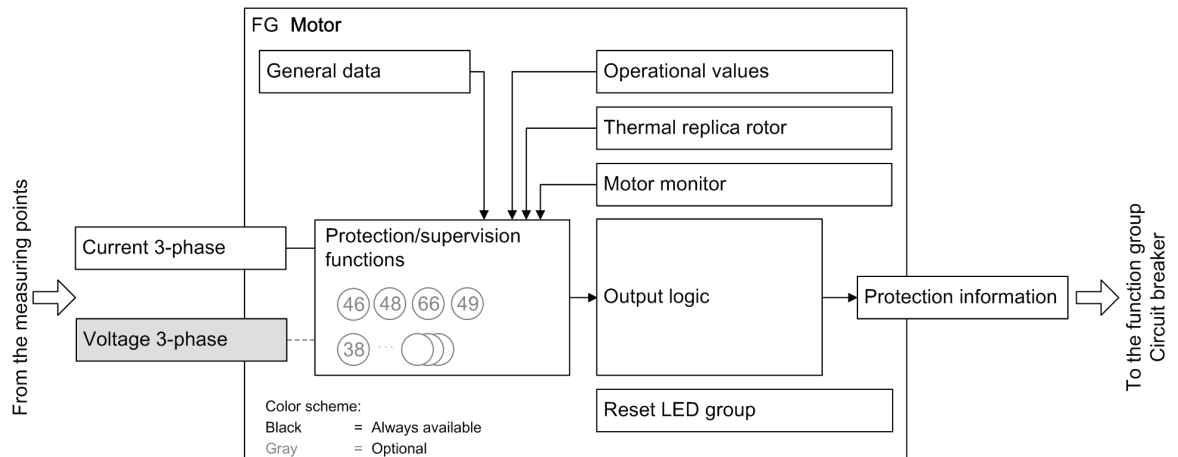

[dw_strfgmot, 1, en_US]

Figure 5-14 Structure of the Motor Function Group

The **Motor** function group has interfaces with the following parts:

- **Measuring points**
- **Circuit-breaker** function group

Interfaces with the Measuring Points

The **Motor** function group receives the required measured values via the interfaces with the measuring points. If you are using an application template, the **Motor** function group is already connected to the necessary measuring points.

If you add functions to the **Motor** function group, the functions automatically receive the measured values from the corresponding measuring points. If you add protection functions to the function group but the necessary measuring point is not connected, DIGSI 5 reports an inconsistency. Configure the measuring points in DIGSI 5 using the **Function group connections** editor.

You can find more detailed information starting from [2.1 Embedding of Functions in the Device](#).

The **Motor** function group has the following interfaces with the measuring points:

- **3-phase current:**
The measurands from the 3-phase current system are supplied via this interface. Depending on the connection type of the current transformers, the measurands can be for example $I_{A'}$, $I_{B'}$, $I_{C'}$, $I_{N'}$ or $3I_0$. All values that can be calculated from the measurands are also provided via this interface.
The **Motor** function group must always be connected to an **I-3ph measuring point**. You can connect the **3-phase current** interface to a maximum of 2 **I-3ph measuring points** (for special applications). If 2 current measuring points have been connected to the **3-phase current** interface, the total current is determined by adding the measured values from both measuring points in the function group. All functions in the **Motor** function group use the total current.

• **3-phase voltage:**

The measurands from the 3-phase voltage system are supplied via this interface. Depending on the connection type of the voltage transformers, these can be for example $V_{A'}$, $V_{B'}$, $V_{C'}$, $V_{N'}$, or $3V_0$. All values that can be calculated from the measurands are also provided via this interface.

The connection of the **3-phase voltage** interface is optional. This connection is only required if protection functions or supervision functions are applied, which require voltage measurements.

You can connect the **Motor** function group to the current and voltage measuring points via interfaces. You make this assignment in DIGSI via **Project tree** → **Function group connections**. To connect the interfaces, set a cross at the intersection between the row and column in the matrix.

▼ Connect measuring points to function group				
Measuring point	Motor 1		Circuit breaker 1	
	V 3ph	I 3ph	V	I 3ph
(All...)	(All...)	(All...)	(All...)	(All...)
Meas.point I-3ph 1 [ID 1]		X		X
Meas.point V-3ph 1 [ID 2]	X			

[screenshot-230812-02.tif, 1, en_US]

Figure 5-15 Connecting Measuring Points to the Motor Function Group

Interfaces with the Circuit-Breaker Function Group

All required data are exchanged between the protection function group and the **Circuit-breaker** function group via the interface with the **Circuit-breaker** function group. These data include, for example, the pickup and operate indications of the protection functions sent in the direction of the **Circuit-breaker** function group and, for another example, the information about the circuit-breaker condition sent in the direction of the protection function group.

The **Motor** function group is usually connected to one **Circuit-breaker** function group. This connection generally determines:

- Which circuit breaker is activated by the protection functions of the **Motor** function group
- Starting of the **Circuit-breaker failure protection** function (if available in the **Circuit-breaker** function group) through the protection functions of the connected **Motor** function group
- Starting of the **Automatic reclosing** function (if available in the **Circuit-breaker** function group) through the protection functions of the connected **Motor** function group



NOTE

For motor protection, the **Automatic reclosing** function is not applied in most cases. However, due to flexibility and standardization, the respective interface is offered.

▼ Connect function group to circuit-breaker groups		
Protection group	Circuit breaker 1	
(All...)	(All...)	
Motor 1	X	

[sc_cfgcb, 1, en_US]

Figure 5-16 Connecting Motor Function Group with Circuit-Breaker Function Group

Besides the general assignment of the **Motor** function group to the **Circuit-breaker** function group, you can also configure the interface for certain functionalities in detail. Configure the details in DIGSI 5 using the **Circuit-breaker interaction** editor in the **Motor** function group.

In the detailed configuration of the interface, define:

- Which operate indications of the protection functions go into the generation of the trip command
- Which protection functions start the **Automatic Reclosing** function
- Which protection functions start the **Circuit-breaker failure protection** function

▼ Circuit-breaker interaction			
Circuit breaker 1			
Protection group	Start auto.recl.	Blk. auto.recl.	Trip
50/51 OC-3ph 1 ▼	(All...) ▼	(All...) ▼	(All...) ▼
▼ 50/51 OC-3ph 1			X
Definite-T 1			X
Definite-T 2			X
Inverse-T 1			X

[srddefcb-230812-02.tif, 1, en_US]

Figure 5-17 Connecting Detailed Function Using Circuit-Breaker Interaction Editor

If an application template is used, the function groups have already been connected to each other because this link is essential to ensure proper operation. You can modify the link in DIGSI 5 using the **Function-group connections** editor.

You can find more information in chapter [2.1 Embedding of Functions in the Device](#). If this link is missing, DIGSI 5 reports an inconsistency.

General Data

The rated motor data is defined as well as the system neutral-point type. The data applies for all functions in the **Motor** function group. For further information, refer to chapter [5.4.3 Application and Setting Notes](#).

Reset LED Group

The **Reset LED group** function block allows you to reset only the stored LEDs of the functions contained in the respective function group while stored LEDs activated from functions in other function groups remain active. For more information refer to chapter [3.1.10 Resetting Stored Indications of the Function Group](#).

Motor Monitor

The **Motor monitor** function is always available in the **Motor** function group and cannot be removed. **Motor monitor** provides the following information in the **Motor** function group:

- Closure detection:
Detection of the closure of the circuit breaker (starting the motor)
- Motor-state detection:
Detection of the following motor states: running, starting or standstill
- Cold-load pickup detection (optional):
Detection of the reconnection of the network after a long period of disconnection (such as a blackout)

The information is used by certain functions.

For a detailed description of **Motor monitor**, refer to chapter [5.4.5.1 Overview of Functions](#).

Thermal Replica Rotor

The function block calculates the thermal replica of the rotor. The replica is used by certain motor protection functions.

For a detailed description of the **Thermal replica rotor** function block, refer to chapter [5.4.6.1 Overview of Functions](#).

Operational, Fundamental, Symmetrical Components and Functional Measurements

The operational fundamental, symmetrical components and functional measurements are always available in the **Motor** function group and cannot be deleted.

The following tables show the measured values of the **Motor** function group.

Table 5-5 Operational Measured Values (True RMS) of the Function Group Motor

Measured values		Primary	Secondary	% referred to
$I_{A'}, I_{B'}, I_{C'}$	Phase currents	A	A	Rated operating current of the primary system
I_N	Neutral-point phase current	A	A	Rated operating current of the primary system
$3I_0$	Residual current	A	A	Rated operating current of the primary system
$V_{A'}, V_{B'}, V_{C'}$	Phase-to-ground voltages	kV	V	Rated operating voltage of the primary system/ $\sqrt{3}$
$V_{AB'}, V_{BC'}, V_{CA}$	Phase-to-phase voltage	kV	V	Rated operating voltage of the primary system
V_0	Zero-sequence voltage	kV	V	Rated operating voltage of the primary system/ $\sqrt{3}$
V_{NG}	Neutral-point displacement voltage	kV	V	Rated operating voltage of the primary system/ $\sqrt{3}$
f	Frequency	Hz	Hz	Rated frequency
P_{tot}	Active power (total power)	MW	–	Rated operating voltage and rated operating current of the primary system $\sqrt{3} \cdot V_{rated} \cdot I_{rated}$
Q_{tot}	Reactive power (total power)	MVar	–	Rated operating voltage and rated operating current of the primary system $\sqrt{3} \cdot V_{rated} \cdot I_{rated}$
S_{tot}	Apparent power (total power)	MVA	–	Rated operating voltage and rated operating current of the primary system $\sqrt{3} \cdot V_{rated} \cdot I_{rated}$
$\cos \phi$	Active factor	(abs)	(abs)	100 % corresponds to $\cos \phi = 1$
$P_{A'}, P_{B'}, P_{C'}$	Phase-segregated active power	MW	–	Apparent power of the phase $V_{rated Lx} \cdot I_{rated Lx}$
$Q_{A'}, Q_{B'}, Q_{C'}$	Phase-segregated reactive power	MVar	–	Apparent power of the phase $V_{rated Lx} \cdot I_{rated Lx}$
$S_{A'}, S_{B'}, S_{C'}$	Phase-segregated apparent power	MVA	–	Apparent power of the phase $V_{rated Lx} \cdot I_{rated Lx}$

Table 5-6 Fundamental and Symmetrical Components Measurement Values of the Function Group Motor

Measured values		Primary	Secondary	% referred to
$I_{A'}, I_{B'}, I_{C'}$	Phase currents	A	A	Rated operating current of the primary system
I_N	Neutral-point phase current	A	A	Rated operating current of the primary system
$I_{seq;0}$	Zero-sequence current	A	A	Rated operating current of the primary system

Measured values		Primary	Secondary	% referred to
$I_{seq:1}$	Positive-sequence current	A	A	Rated operating current of the primary system
$I_{seq:2}$	Negative-sequence current	A	A	Rated operating current of the primary system
$V_{A'}, V_{B'}, V_{C'}$	Phase-to-ground voltages	kV	V	Rated operating voltage of the primary system/ $\sqrt{3}$
$V_{AB'}, V_{BC'}, V_{CA'}$	Phase-to-phase voltage	kV	V	Rated operating voltage of the primary system
V_N	Neutral-point phase voltage	kV	V	Rated operating voltage of the primary system/ $\sqrt{3}$
$V_{seq:0}$	Zero-sequence voltage	kV	V	Rated operating voltage of the primary system/ $\sqrt{3}$
$V_{seq:1}$	Positive-sequence voltage	kV	V	Rated operating voltage of the primary system/ $\sqrt{3}$
$V_{seq:2}$	Negative-sequence voltage	kV	V	Rated operating voltage of the primary system/ $\sqrt{3}$

Voltage and power measurements are only available if a **V-3ph measuring point** is connected to the **Motor** function group.

The energy measurements are not predefined. If required, they must be loaded from the Global DIGSI 5 Library.

Measured values		Primary	Secondary	% referred to
Θ	Rotor temperature	%	%	Rotor temperature in percentage value

Further functional measurements will be available depending on the applied protection functions and supervision functions. The functional values are listed in the **Information list** of the individual protection function or supervision function (refer to more detailed information starting from [6.1.1 Overview](#)).

Output Logic

The output logic treats the pickup and operate indications of the protection functions and supervision functions in the **Motor** function group separately, in a pickup logic and an output logic respectively. The pickup and output logics generate the group indications of the function group. These group indications are transferred to the **Circuit-breaker** function group via the **protection-information** interface and are processed further there.

The pickup and operate indications of the protection functions and the supervision functions in the **Motor** function group are combined according to the following figures and output as a group indication.

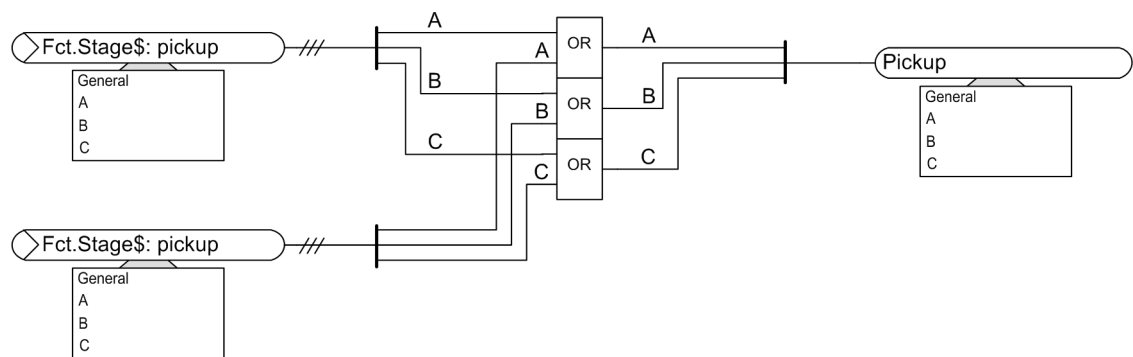

[to_gapiin_02_1_en_US]

Figure 5-18 Generation of the Pickup Indication of the Motor Function Group

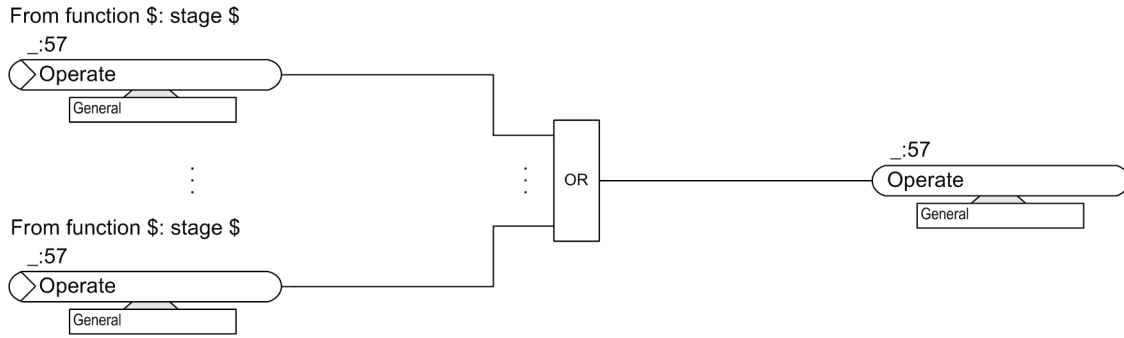

[lo_geopin_02_1_en_US]

Figure 5-19 Generation of the Operate Indication of the Motor Function Group

5.4.3 Application and Setting Notes

Interface to the Circuit-Breaker Function Group

The **Motor** function group is usually connected to 1 **Circuit-breaker** function group. The **Circuit-breaker** function group is assigned to the circuit breaker of the motor.

General Data (Rated Motor Data, Power-sys. neutral point)

The following application and setting notes apply for the general data of the motor. The data are configured in the **General** function block of the **Motor** function group and apply for all functions in the function group.

Parameter: Motor rated current

- Default setting (_:1781:9451:101) **Motor rated current** = 1000 A

With the **Motor rated current** parameter, you set the rated current of the motor to be protected. The **Motor rated current** specified here is the reference value for the percentage-measured values and setting values made in percentages.

Parameter: Motor rated voltage

- Default setting (_:1781:9451:102) **Motor rated voltage** = 400.00 kV

With the **Motor rated voltage** parameter, you set the rated voltage of the motor to be protected. The **Motor rated voltage** specified here is the reference value for the percentage-measured values and setting values made in percentages.

Parameter: Power-sys. neutral point

- Default setting (_:1781:9451:149) **Power-sys. neutral point** = grounded

With the **Power-sys. neutral point** parameter, you specify whether the power system neutral point is *grounded*, *suppress. coil grounded* (grounded via arc-suppression coil), or *isolated*. However, the parameter has currently no effect on any motor protection function. Therefore the setting is irrelevant for the device functionality (the parameter is intended for future usage).

5.4.4 Information List

No.	Information	Data Class (Type)	Type
<i>Group indicat.</i>			
._:4501:55	Group indicat.:Pickup	ACD	O
._:4501:57	Group indicat.:Operate	ACT	O

No.	Information	Data Class (Type)	Type
_:4501:52	Group indicat.:Behavior	ENS	O
_:4501:53	Group indicat.:Health	ENS	O
Reset LED Group			
_:7381:500	Reset LED Group:>LED reset	SPS	I
_:7381:320	Reset LED Group:LED have been reset	SPS	O
_:7381:52	Reset LED Group:Behavior	ENS	O
_:7381:53	Reset LED Group:Health	ENS	O

5.4.5 Motor Monitor

5.4.5.1 Overview of Functions

The **Motor monitor** function:

- Detects the circuit breaker as open or closed via the current flow (**Current-flow criterion**)
- Detects the closure of the circuit breaker, that is the starting of the motor (**Closure detection**)
- Detects the following motor states: running, starting, standstill, or slowdown (**Motor-state detection**)
- Detects the reconnection of the network after a long period of disconnection (**Cold-load pickup detection**)

5.4.5.2 Structure of the Function

The **Motor monitor** function is used in the **Motor** function group. The **Motor monitor** function is preconfigured by the manufacturer with 1 **Current-flow criterion**, 1 **Closure-detection**, and 1 **Motor-state detection**. These function blocks cannot be removed or loaded from the DIGSI library. 1 **Cold-load pickup detection** function block can be optionally loaded from the DIGSI library.

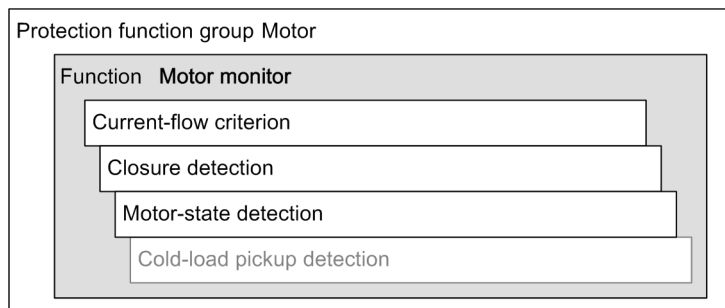

[dw_motmo_1_en_US]

Figure 5-20 Function Structure/Embedding of the Function

5.4.5.3 Current-Flow Criterion

Logic

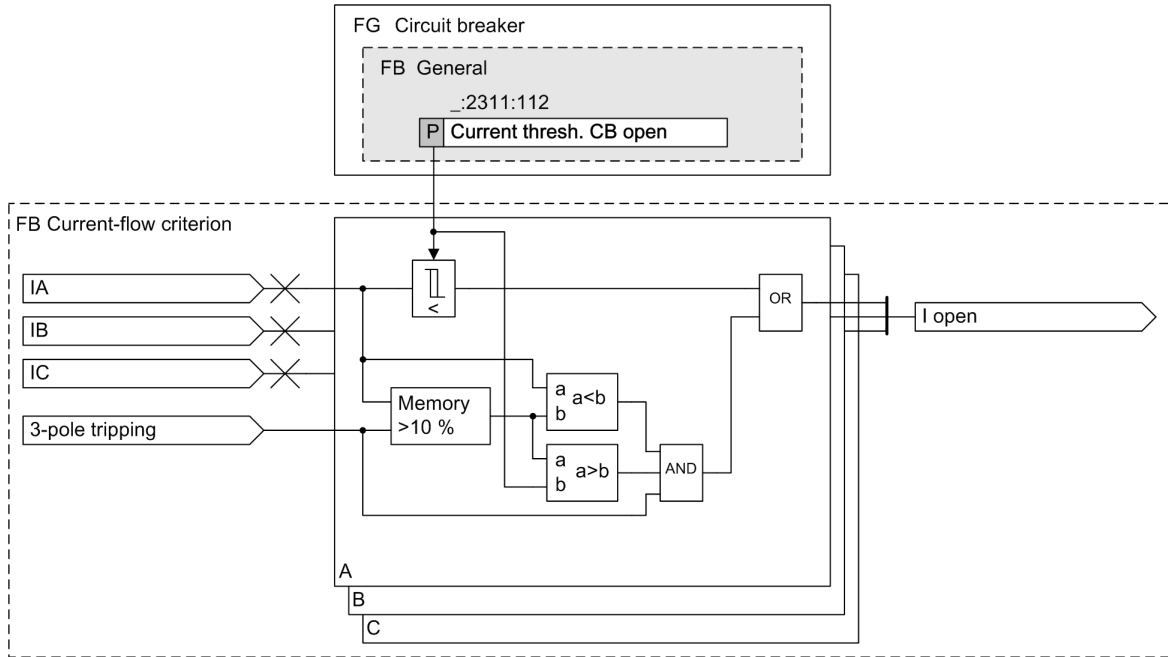

[ilo_cbprot_23_1_en_US]

Figure 5-21 Logic Diagram of the Current-Flow Criterion Function Block

The *I open* signal of one phase is generated if one of the following conditions is met:

- One phase current falls below the threshold of the **Current thresh. CB open** parameter. The hysteresis stabilizes the signal.
- The corresponding phase current falls below 10 % of the phase current when the trip command arrives. If the current does not drop until after a delay due to current transformer influences, an open phase can therefore be detected quickly even after a high-current fault on the motor.

With the **Current thresh. CB open** parameter, you define the minimum current as the criterion for an open circuit breaker and respectively a deactivated motor. The parameter is located in the **Circuit-breaker** function group. It acts both in the **Circuit-breaker** function group (for example, circuit-breaker position recognition) and also for the **Motor monitor** function in the **Motor** function group.

5.4.5.4 Application and Setting Notes (Current-Flow Criterion)

Parameter: **Current thresh. CB open**

For a detailed description of the setting note for the parameter **Current thresh. CB open**, refer to Chapter [5.7.3 Application and Setting Notes](#) of the **Circuit Breaker** function group.

5.4.5.5 Circuit-Breaker Condition for the Motor

The following logic is only applicable in a very rare case where the switching state of the motor (protected object) depends on the condition of more than one circuit breaker.

Logic

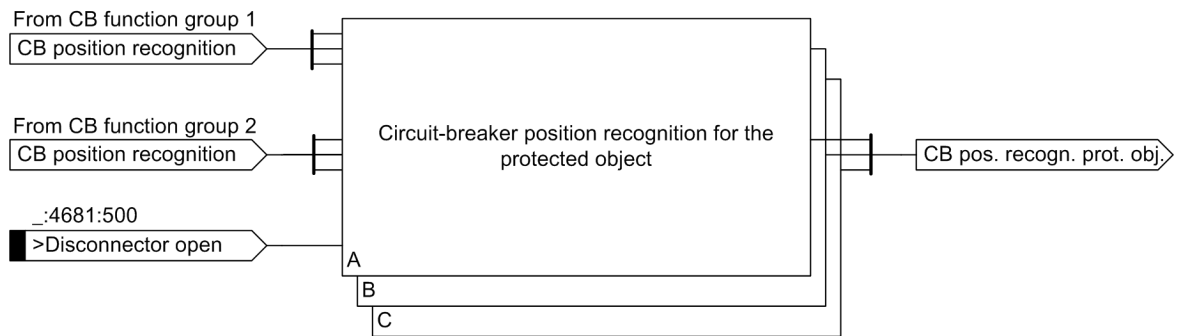

[fo_cbprot, 1, en_US]

Figure 5-22 Logic Diagram of the Circuit-Breaker Condition for the Protected-Object Function Block

The **Circuit-breaker condition** function block in the **Circuit-breaker** function group provides the circuit-breaker condition (*CB condition* indication). When a protected object is supplied via 2 circuit breakers (for example, 1 1/2 circuit-breaker layout), then the switching state of the protected object must be determined with the position of both circuit breakers. In this case, the circuit-breaker position for the **Protected object** function block performs linking of the individual CB positions. It provides the *CB-pos. protected object* information to the other functions which require this information. These are the **Measuring-voltage failure detection** function and the **Cold-load pickup detection** function block.

If one of the following 2 conditions is met, the *CB state protected object* indication assumes the *Open* state:

- All connected circuit breakers signal the open state.
- The *>Disconnecter open* input signal is active.

If one of the following 2 conditions is met, the *CB state protected object* indication assumes the *Closed* state:

- At least one of the connected circuit-breaker signals the closed state.
- The *>Disconnecter open* input signal is not active.

5.4.5.6 Closure Detection

Logic



[fo_clodet, 1, en_US]

Figure 5-23 Logic Diagram of the Closure-Detection Function Block

With the **Closure-detection** function block, the device detects whether the protected object is being connected to the power system by closing the circuit breaker.

The *Closure* indication and the internal signal *Release (closing)* become active as soon as the internal signal *Manual close detected* (obtained from the **Manual close** function block in the **Circuit-breaker** function group) becomes active.

By using of the signal *Release (closing)*, the function **Instantaneous high-current tripping** can operate immediately in the event of a closure to a short circuit.

For more information about the function, refer to chapter [6.9.1 Overview of Functions](#)

5.4.5.7 Motor-State Detection

Logic

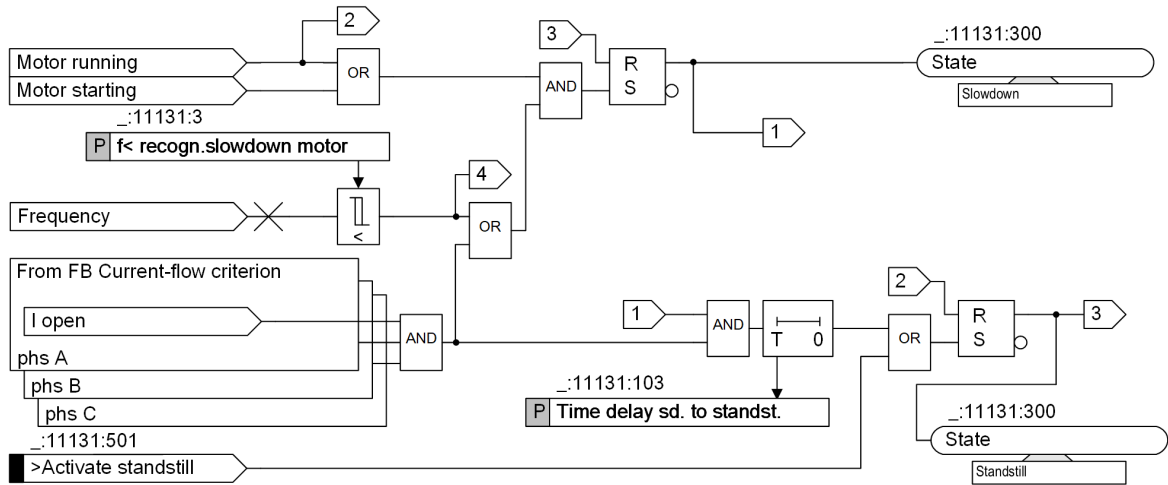

[lo_mostde_5_en_US]

Figure 5-24 Logic Diagram of the Motor-State Detection, Part 1

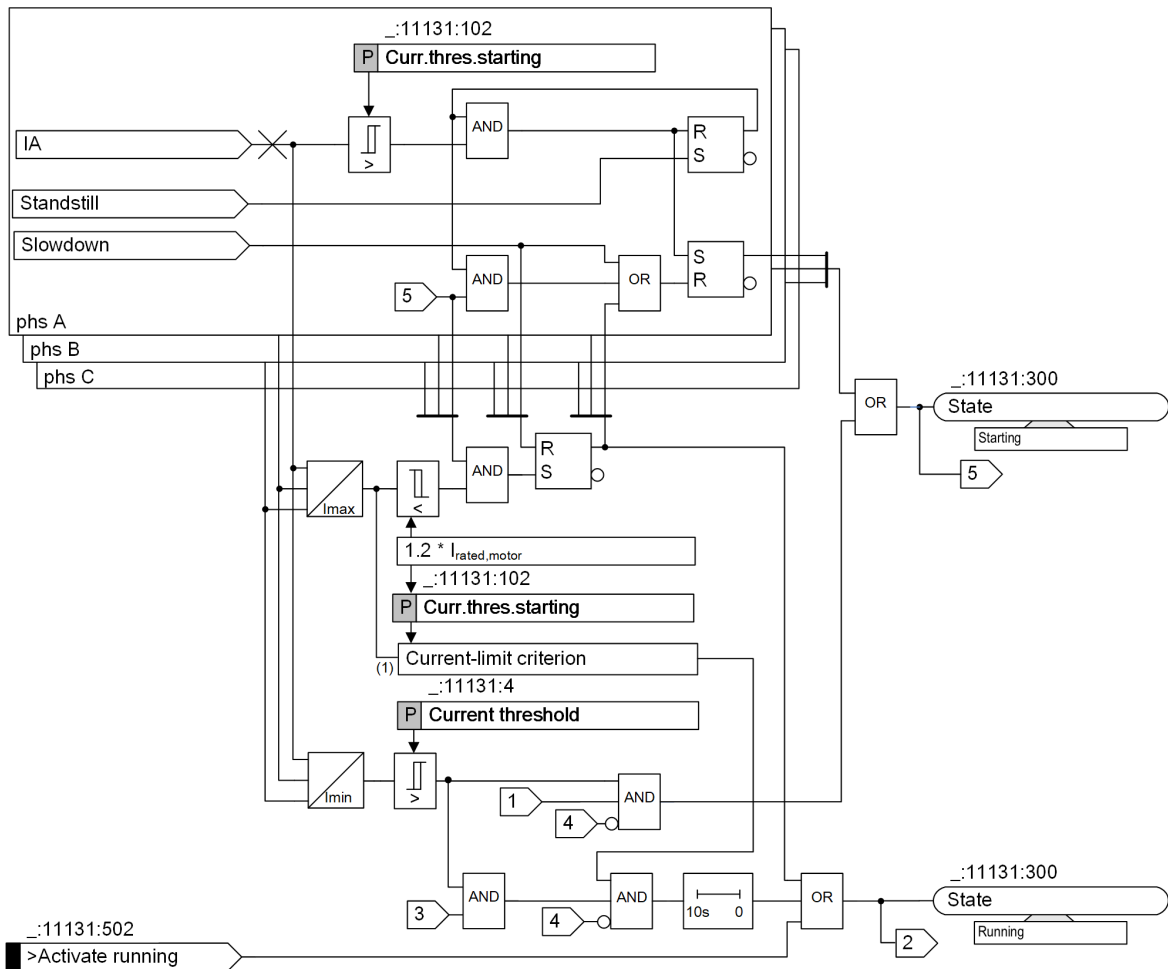

[lo_mostde_2_1_en_US]

Figure 5-25 Logic Diagram of the Motor-State Detection, Part 2

- (1) The current-limit criterion indicates that the currents of the 3 phases are smaller than the larger of the 2 values: 0.8 times I_{starting} and 1.2 times $I_{\text{rated, motor}}$.

Motor State

The information about the motor state is used by certain motor protection functions, for example:

- The function **Motor-starting time supervision** activates when the motor state is *starting*.
- The function **Load-jam protection** activates when the motor state is *running*.
- The function **Motor restart inhibit** activates when the motor state is *standstill*.

Furthermore, the information is available via the indication *State*. The function block **Motor-state detection** determines the following motor states: *starting*, *running*, *slowdown*, and *standstill*.

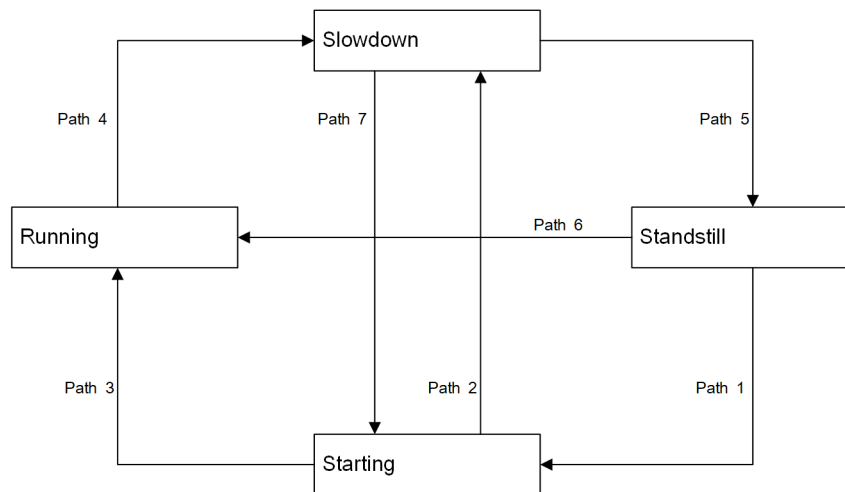

[dw_path, 1, en_US]

Figure 5-26 Motor State Machine

The 4 motor states are dependent on each other. The conditions of the changes among the motor states are as follows:

- Path 1, from *standstill* to *starting*
If the motor state is *standstill* and the maximum current of the 3 phases is larger than the parameter **Curr. thres. starting**, the motor changes to the state *starting*.
- Path 2, from *starting* to *slowdown*
If the motor state is *starting* and either of the following conditions is met, the motor changes to the state *slowdown*:
 - 3 phases are open and the currents of the 3 phases are smaller than the parameter **Current threshold CB open**.
For more information on the parameter **Current threshold CB open**, refer to [5.4.5.3 Current-Flow Criterion](#).
 - The frequency is smaller than the parameter **f < recogn. slowdown motor**.
- Path 3, from *starting* to *running*
If the motor state is *starting* and the currents of the 3 phases are smaller than 1.2 times the motor rated current, the motor changes to the state *running*.

- Path 4, from *running* to *slowdown*
 If the motor state is *running* and either of the following conditions is met, the motor changes to the state *slowdown*:
 - 3 phases are open and the currents of the 3 phases are smaller than the parameter **Current threshold CB open**.
 - The frequency is smaller than the parameter **f< recogn slowdown motor**.
- Path 5, from *slowdown* to *standstill*
 If the motor state is *slowdown* and the following conditions are met, the motor changes to the state *standstill*:
 - 3 phases are open and the currents of the 3 phases are smaller than the parameter **Current threshold CB open**.
 - The set **Time delay sd. to standst.** is expired.
- Path 6, from *standstill* to *running*
 If the motor state is *standstill* and the following conditions are met, the motor changes to the state *running* after a 10-s delay:
 - The currents of the 3 phases are larger than the parameter **Current threshold**.
 - The currents of the 3 phases are smaller than the larger of the 2 values: 0.8 times $I_{starting}$ and 1.2 times $I_{rated, motor}$.
 - The frequency is larger than the parameter **f< recogn slowdown motor**.
- Path 7, from *slowdown* to *starting*
 If the motor state is *slowdown* and the following conditions are met, the motor changes to the state *starting*:
 - The currents of the 3 phases are larger than the parameter **Current threshold**.
 - The frequency is larger than the parameter **f< recogn slowdown motor**.
- From any state to *running* or *standstill*
 With the signal *>Activate standstill* or *>Activate running* activated, the motor state changes to *standstill* or *running* directly.

5.4.5.8 Settings

Addr.	Parameter	C	Setting Options	Default Setting
State detect.				
_:11131:102	State detect.:Curr.thres.starting	1 A @ 100 Irated	0.500 A to 20.000 A	5.000 A
		5 A @ 100 Irated	2.50 A to 100.00 A	25.00 A
		1 A @ 50 Irated	0.500 A to 20.000 A	5.000 A
		5 A @ 50 Irated	2.50 A to 100.00 A	25.00 A
		1 A @ 1.6 Irated	0.017 A to 1.600 A	5.000 A
		5 A @ 1.6 Irated	0.083 A to 8.000 A	25.000 A
_:11131:3	State detect.:f< recogn slowdown motor		26.00 Hz to 49.00 Hz	48.50 Hz

Addr.	Parameter	C	Setting Options	Default Setting
_:11131:4	State detect.:Current threshold	1 A @ 100 Irated	0.070 A to 1.000 A	0.200 A
		5 A @ 100 Irated	0.35 A to 5.00 A	1.00 A
		1 A @ 50 Irated	0.070 A to 1.000 A	0.200 A
		5 A @ 50 Irated	0.35 A to 5.00 A	1.00 A
		1 A @ 1.6 Irated	0.002 A to 1.000 A	0.200 A
		5 A @ 1.6 Irated	0.012 A to 5.000 A	1.000 A
_:11131:103	State detect.:Time delay sd. to standst.		0.5 s to 30.0 s	1.0 s

5.4.5.9 Information List

No.	Information	Data Class (Type)	Type
<i>State detect.</i>			
_:11131:501	State detect.:>Activate standstill	SPS	I
_:11131:502	State detect.:>Activate running	SPS	I
_:11131:300	State detect.:State	ENS	O
_:11131:52	State detect.:Behavior	ENS	O
_:11131:53	State detect.:Health	ENS	O

5.4.5.10 Cold-Load Pickup Detection (Optional)

Logic

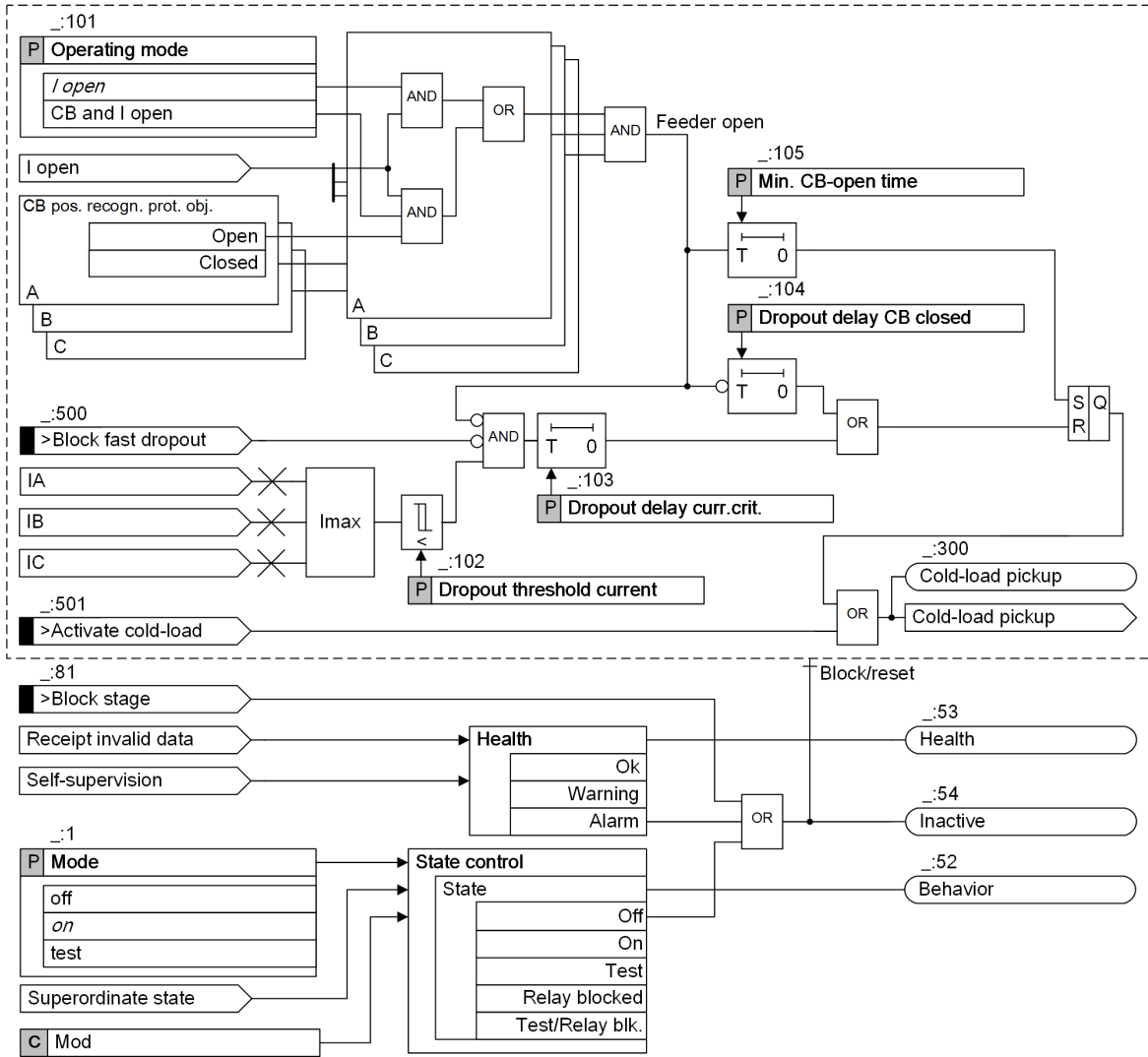

[la_colade_3_en_US]

Figure 5-27 Logic Diagram of the Cold-Load Pickup Detection Function Block

The **Cold-load pickup detection** function block detects that a specific time has been exceeded after deactivation of the protected object. If you want to connect the protected object again, note that an increased load-current requirement exists for a limited time after connection. This results from the nature of the load.

The **Cold-load pickup detection** function block ensures that different parameters are used for an adjustable time after connection. For example, for the time of the **Min. CB-open time** parameter, you can increase the threshold value of a protection function or you can select a special characteristic curve.

If the **Cold-load pickup detection** function block detects an open feeder and the set time of the **Min. CB-open time** has elapsed, the *cold-load pickup* indication is generated. Via the *>Activate cold-load* signal, you can also activate the *cold-load pickup* indication directly.

With the *cold-load pickup* indication, you can activate a parameter set of the **Cold load state estimation** function.

If the **Cold-load pickup detection** function block detects closure and the corresponding load current, it starts the time set in the **Dropout delay CB closed** parameter. The *cold-load pickup* indication and the activated parameter set are deactivated after this time has elapsed.

If, for the period set in the **Dropout delay curr.crit.** parameter, the maximum phase current falls below the threshold value **Dropout threshold current**, the parameter set for the **Cold-load pickup detection** function block is also deactivated. As a result, if the load current is very low, the action time **Dropout delay curr.crit.** of the *Cold-load pickup* indication can be shortened.

5.4.5.11 Application and Setting Notes (Cold-Load Pickup Detection)



NOTE

The settings and indications described in this chapter are only available when using the optional **Cold-load pickup detection** function block.

Parameter: Operating Mode

- Default setting (**_:101**) **Operating mode = I open**

With the **Operating mode** parameter, you set the criteria with which the **Cold-load pickup detection** function block operates.

Parameter Value	Description
<i>I open</i>	When the Current-flow criterion function block detects a going open condition, the decision is made for closure. For this setting, make sure that the Current thresh. CB open parameter is set lower than the possible load current. If this is not the case, Open is detected continuously and each fault current that exceeds the Current thresh. CB open parameter is interpreted as closure.
<i>CB and I open</i>	Closure is detected if the following conditions are met: <ul style="list-style-type: none"> • Analysis of the circuit-breaker auxiliary contact detects a going open condition in at least one phase. • The current-flow criterion detects a going open condition.

Parameter: Dropout threshold current

- Default setting (**_:102**) **Dropout threshold current = 1.00 A**

With the **Dropout threshold current** parameter, you set the threshold at which the output signal *Cold-load pickup* is deactivated when the current in at least one phase falls below this threshold.

Parameter: Dropout delay curr.crit.

- Default setting (**_:103**) **Dropout delay curr.crit. = 600 s**

With the **Dropout delay curr.crit.** parameter, you set the time for which the actual value must be below the **Dropout threshold current** threshold so that the output signal *Cold-load pickup* can be deactivated prematurely.

Parameter: Dropout delay CB closed

- Default setting (**_:104**) **Dropout delay CB closed = 3600 s**

With the **Dropout delay CB closed** parameter, you set the action time for the dynamic parameter set switching in the event of cold-load pickup detection.

Parameter: Min. CB-open time

- Default setting (**_:105**) **Min. CB-open time = 3600 s**

With the **Min. CB-open time** parameter, you set the time after which the dynamic parameter set is activated in the event of *Cold-load pickup* when the line is opened.

5.4.5.12 Settings

Addr.	Parameter	C	Setting Options	Default Setting
<i>Cold-load PU</i>				
_:1	Cold-load PU:Mode		<ul style="list-style-type: none"> off on test 	off
_:101	Cold-load PU:Operating mode		<ul style="list-style-type: none"> I open CB and I open 	I open
_:102	Cold-load PU:Dropout threshold current	1 A @ 100 Irated	0.030 A to 10.000 A	1.000 A
		5 A @ 100 Irated	0.150 A to 50.000 A	5.000 A
		1 A @ 50 Irated	0.030 A to 10.000 A	1.000 A
		5 A @ 50 Irated	0.150 A to 50.000 A	5.000 A
		1 A @ 1.6 Irated	0.001 A to 1.600 A	1.000 A
		5 A @ 1.6 Irated	0.005 A to 8.000 A	5.000 A
_:103	Cold-load PU:Dropout delay curr.crit.		1 s to 600 s	600 s
_:104	Cold-load PU:Dropout delay CB closed		1 s to 21600 s	3600 s
_:105	Cold-load PU:Min. CB-open time		0 s to 21600 s	3600 s

5.4.5.13 Information List

No.	Information	Data Class (Type)	Type
<i>Cold-load PU</i>			
_:81	Cold-load PU:>Block stage	SPS	I
_:500	Cold-load PU:>Block fast dropout	SPS	I
_:501	Cold-load PU:>Activate cold-load	SPS	I
_:54	Cold-load PU:Inactive	SPS	O
_:52	Cold-load PU:Behavior	ENS	O
_:53	Cold-load PU:Health	ENS	O
_:300	Cold-load PU:Cold-load pickup	SPS	O

5.4.6 Thermal Replica Rotor

5.4.6.1 Overview of Functions

The **Thermal replica rotor** function block:

- Calculates the rotor temperature of the motor
- Determines the state (warm/cold) of the motor rotor
- Calculates the rotor-restart limit of the motor
- Calculates the motor-restart time
- Maintains a timer for temperature equilibrium during which the motor is not allowed to restart

5.4.6.2 Structure of the Function

The **Thermal replica rotor** function block is used in the **Motor** function group. The function block is preconfigured and cannot be deleted. Only 1 **Thermal replica rotor** function block can operate within this function group.

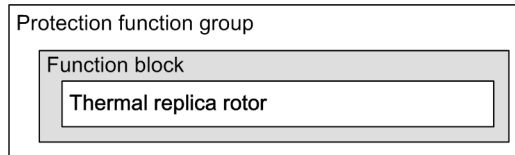

[dw_rthere, 1, en_US]

Figure 5-28 Structure/Embedding of the Function

5.4.6.3 Function Description

Logic

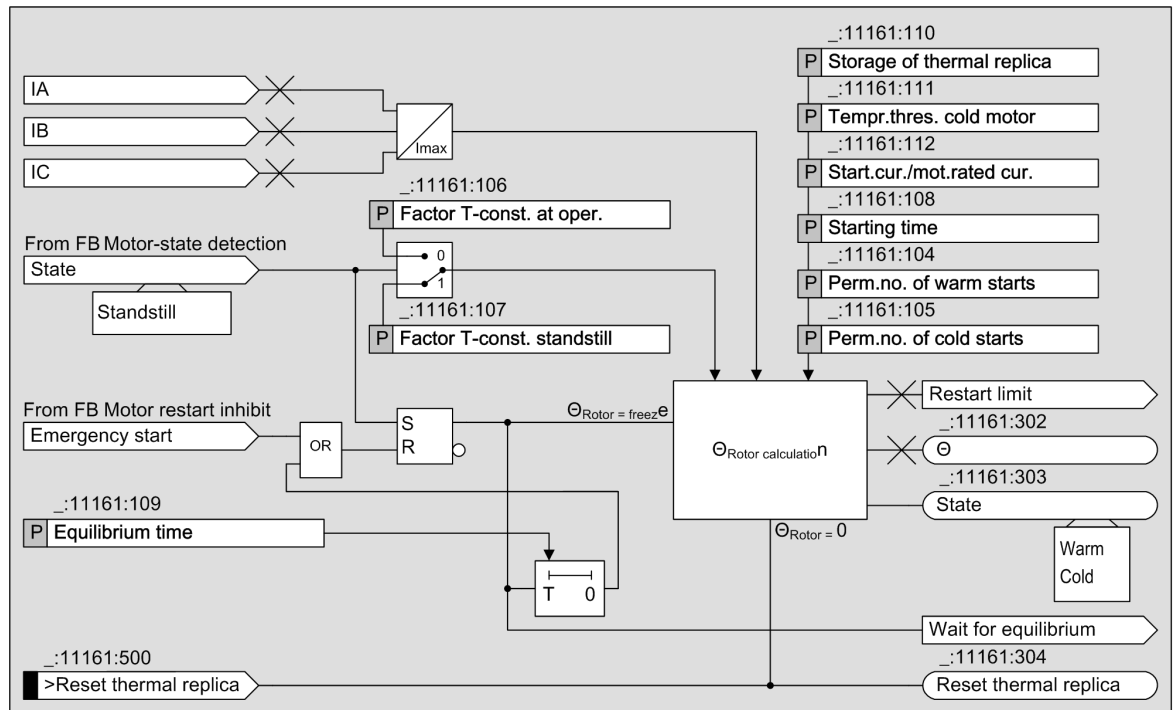

[lo_rthere, 1, en_US]

Figure 5-29 Logic Diagram of the Thermal Replica Rotor Function Block

Temperature Curve of the Motor Rotor during Repeated Motor-Starting Attempts

Although the heat distribution on the rotor bars can severely differ during motor starting, the different maximum temperatures in the rotor are not relevant for the **Motor restart inhibit** function (see [Figure 5-30](#)). It is much more important to establish a thermal replica, after a complete motor start, which corresponds to the thermal state of the rotor. [Figure 5-30](#) shows, as an example, the heating processes during repeated motor starts (3 starts from cold operating condition) as well as the thermal replica in the protection device.

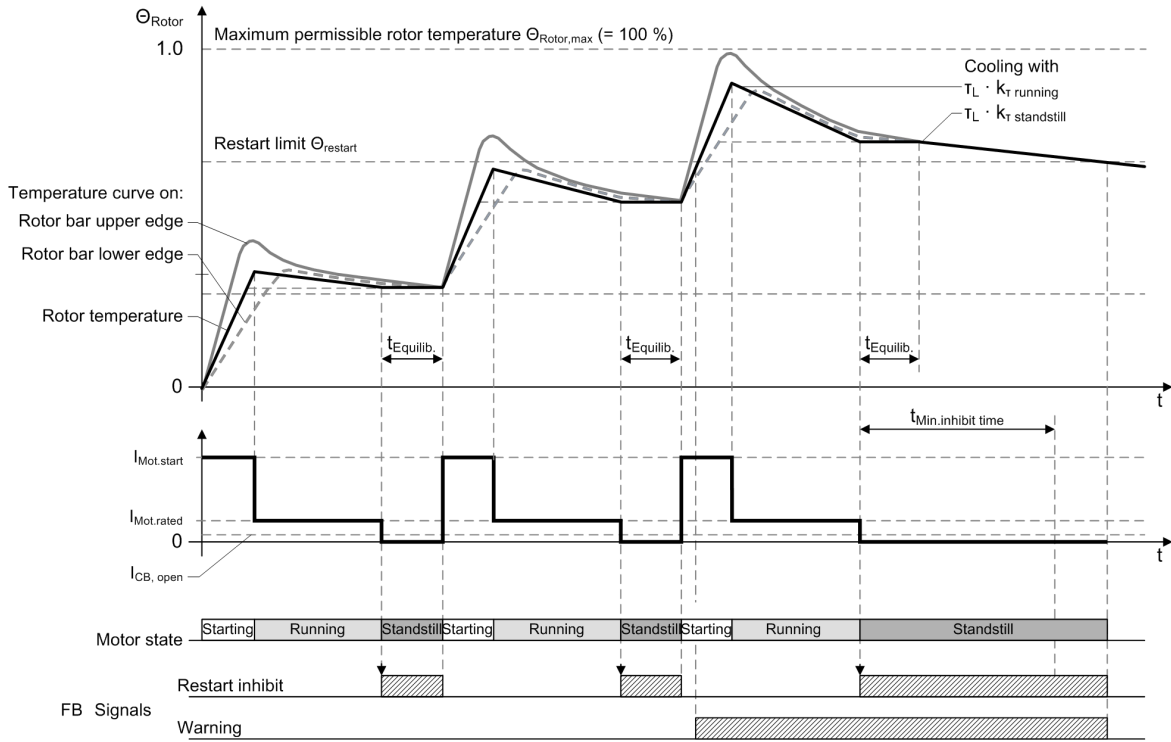

[dhw_prrelo_1_en_US]

Figure 5-30 Rotor-Temperature Curve and Relevant Information during Repeated Motor-Starting Attempts

Determining the Rotor Temperature

Since the rotor current cannot be measured directly, the stator current must be used to generate a thermal replica of the rotor. The RMS values of the currents are used as measurands. The rotor temperature Θ_{Rotor} is calculated using the largest of the 3 phase currents.

Restart Limit (Θ_{restart})

Based on the specified motor parameters, the function block calculates the normalized restart limit Θ_{restart} :

$$\Theta_{\text{restart}} = \left(\frac{I_{\text{starting}} / I_{\text{rated,motor}}}{k_R} \right)^2 \cdot \left(1 - e^{-\frac{(n_c - 1) \cdot t_{\text{starting}}}{\tau_R}} \right)^2 \approx \frac{n_c - 1}{n_c}$$

[fo_rresil_1_en_US]

With:

Θ_{restart}	Restart limit
k_R	k factor of the rotor, calculated internally
$I_{\text{starting}} / I_{\text{rated,motor}}$	Per-unit value of rated starting current of the motor with motor rated current as reference (parameter Start.cur./mot.rated cur.)
$I_{\text{rated,motor}}$	Motor rated current (parameter Motor rated current)
t_{starting}	Maximum permissible starting time (parameter Starting time)
τ_R	Thermal time constant of the rotor, calculated internally
n_c	Maximum permissible number of cold starts (parameter Perm.no. of cold starts)

If the rotor temperature Θ exceeds the restart limit Θ_{restart} , the motor must not be restarted. The indication *Restart inhibit* is generated by the **Motor restart inhibit** function.

For more information, refer to chapter *Motor restart inhibit*.

Thermal Cooling Time ($T_{\text{Therm.}}$)

If the rotor temperature Θ_{Rotor} exceeds the restart limit Θ_{restart} and the motor is shut down, the *Restart inhibit* indication is generated by the **Thermal stage** of the **Restart inhibit** function. It lasts a certain time $T_{\text{Therm.}}$ until the rotor temperature Θ_{Rotor} has fallen below the restart limit Θ_{restart} .

The thermal cooling time $T_{\text{Therm.}}$ is calculated as follows:

$$T_{\text{Therm.}} = k_{\text{rStop}} \cdot \tau_L \cdot \ln \left(\frac{\left(\frac{I_{\text{eff}}}{k_{\text{LN}} \cdot I_{\text{rated}}} \right) - \theta_{\text{pre}}}{\left(\frac{I_{\text{eff}}}{k_{\text{LN}} \cdot I_{\text{rated}}} \right) - \theta_{\text{restart}}} \right)$$

[fo_thermal replica, 1, en_US]

With:

$T_{\text{Therm.}}$	Thermal cooling time
k_{rStop}	Extension of time constant at motor stop (parameter Factor T-const. standstill)
I_{rated}	Primary rated current of the current transformer (parameter Motor rated current)
I_{eff}	Maximum effective current of the 3-phase motor, measured
k_{LN}	k factor for the rotor, normalized to I_{rated} , calculated internally
Θ_{pre}	Thermal replica of the motor switched off, calculated internally
Θ_{restart}	Restart limit, calculated internally
τ_L	Thermal time constant of the rotor, calculated internally

Equilibrium Time ($T_{\text{Equil.}}$)

Each time the motor is shut down, the equilibrium time $T_{\text{Equil.}}$ starts. The timer takes into account the different thermal conditions of the motor parts at the moment of the shutdown. In this time the temperature of the rotor components will be equalized. During the equilibrium time, the thermal replica of the rotor is not updated. In the equilibrium process of the rotor, the motor cannot be restarted. The thermal replica cools down with the factor defined via parameter **Factor T-const. standstill**.

Extension of Cooling Time Constants

In order to take into account properly the reduced heat exchange when a self-ventilated motor is stopped, the cooling time constants can be increased relative to the time constants for a machine with the factor **Factor T-const. standstill**. While the motor stops, the thermal cooling time $T_{\text{Therm.}}$ is modeled with the time constant $\tau_L \cdot k_{\text{rStop}}$ (parameter **Factor T-const. standstill**). The calculation of $T_{\text{Therm.}}$ is described in the above section **Thermal Cooling Time ($T_{\text{Therm.}}$)**.

Rotor State

If the calculated motor thermal replica exceeds the parameter **Tempr. thres. cold motor**, the rotor state is determined as *warm*. Otherwise, the rotor state is determined as *cold*.

Emergency Start

If, for operational or emergency reasons, motor starting must take place, the restart inhibit can be terminated via the *>Emergency start* signal (part of the **Restart inhibit** function), thus allowing a new starting attempt. In such a case the equilibrium time is reset and the calculating of the rotor temperature Θ_{Rotor} continues to work, and the calculated overtemperature of the rotor can be observed for risk assessment.

Reset Thermal Replica

The motor thermal replica is reset to 0 when *>Reset thermal replica* is activated. This has an effect on all protection functions using this thermal replica.

Behavior in Case of a Power Supply Failure

Depending on the parameter **Storage of thermal replica**, the value of the thermal replica is either reset to 0 (**Storage of thermal replica = no**) if the supply voltage fails, or cyclically buffered in a non-volatile memory (**Storage of thermal replica = yes**). It is maintained in the event of an auxiliary supply voltage failure. In the latter case, when the supply voltage is restored, the thermal replica uses the stored value for calculation and matches it to the operating conditions. The default setting of the parameter **Storage of thermal replica** is *no*.

5.4.6.4 Application and Setting Notes

Parameter: **Perm.no. of warm starts, Perm.no. of cold starts**

- Default setting (`_:104`) **Perm.no. of warm starts = 2**
- Default setting (`_:105`) **Perm.no. of cold starts = 3**

The numbers of permissible warm and cold starts are obtained from the technical data sheet of the motor.

Parameter: **Tempr.thres. cold motor**

- Default setting (`_:111`) **Tempr.thres. cold motor = 25 %**

The **Tempr.thres. cold motor** parameter is used to set the threshold for the cold motor. If the rotor temperature exceeds the **Tempr.thres. cold motor** setting, the motor is in *Warm* state. Otherwise, the motor state is in *Cold* state. The setting value of the **Tempr.thres. cold motor** parameter depends on the permissible numbers of the cold and warm starts, refer to the below example.

Parameter: **Start.cur./mot.rated cur., Starting time**

- Default setting (`_:112`) **Start.cur./mot.rated cur. = 4.9**
- Default setting (`_:108`) **Starting time = 10 s**

The starting current is entered via the parameter **Start.cur./mot.rated cur.** in per unit with the motor rated current as reference. The parameter **Starting time** defines the maximum permissible starting time of the motor. Both values are obtained from the technical data sheet of the motor.

Parameter: **Factor T-const. at oper., Factor T-const. standstill**

- Default setting (`_:106`) **Factor T-const. at oper. = 2.0**
- Default setting (`_:107`) **Factor T-const. standstill = 5.0**

In order to take into account properly the reduced heat exchange when a self-ventilated motor is stopped, the cooling time constants can be increased relative to the time constants for a running machine with the **Factor T-const. standstill**.

If no difference between the time constants is to be used (for example, for externally-ventilated motors), then the extension **Factor T-const. standstill** should be set to 1.

While the motor is running, the heating of the thermal replica is modeled with the time constant τ_R calculated from the motor data. The cooling is calculated with the time constant τ_R **Factor T-const. at oper..**

In this way, the function takes into account that the cooling is slower than the heating of the rotor (slow temperature equilibrium).

The motor manufactures or the user requirements determine the settings for the time constants during thermal replica cooling. If there are no other specifications made, the following settings are recommended:

Factor T-const. at oper. = 2.0

Factor T-const. standstill = 5.0

Parameter: Equilibrium time

- Recommended setting value (_:109) **Equilibrium time = 1.0 min**

For the rotor temperature equilibrium time, a setting time of approximate 1 min has proven to be a good value. Siemens recommends a setting of **1.0 min**.

Parameter: Storage of thermal replica

- Default setting **Storage of thermal replica = no**

Set the parameter **Storage of thermal replica** to **yes** to save all thermal replicas in the event of a supply voltage failure. After the supply voltage is restored, the thermal replicas will resume operation using the stored values. Set the parameter **Storage of thermal replica** to **no** to reset the calculated overtemperature values of all thermal replicas to 0 if the supply voltage fails.

EXAMPLE

The following data and diagrams are excerpted from the technical data sheet of a 2 MV 3-phase induction motor with squirrel-cage rotor, relevant for determining the function settings.

The motor with the following data is given in the data sheet:

Motor rated current	$I_{\text{rated,motor}} = 430 \text{ A}$
Starting time	44.0 s at V_{rated}
Permissible numbers of cold start	3
Permissible numbers of warm start	2

The following parameters are directly derived from the above data:

Starting time = 44 s

Perm.no. of cold starts = 3

Perm.no. of warm starts = 2

The setting value of the **Tempr.thres. cold motor** parameter can be calculated as follows:

$$\text{Tempr.thres.cold motor} \approx \frac{\text{Perm.no. of cold starts} - \text{Perm.no. of warm starts}}{\text{Perm.no. of cold starts}} \cdot 100 \%$$

[fo_rth-eco_1_en_US]

Tempr.thres. cold motor $\approx (3-2)/3 = 33.3 \%$. Set the parameter **Tempr.thres. cold motor** smaller than 33 % which leads to the setting 25 %.

The starting current is obtained from the starting-data diagram, which shows the starting current in dependency to the motor speed:

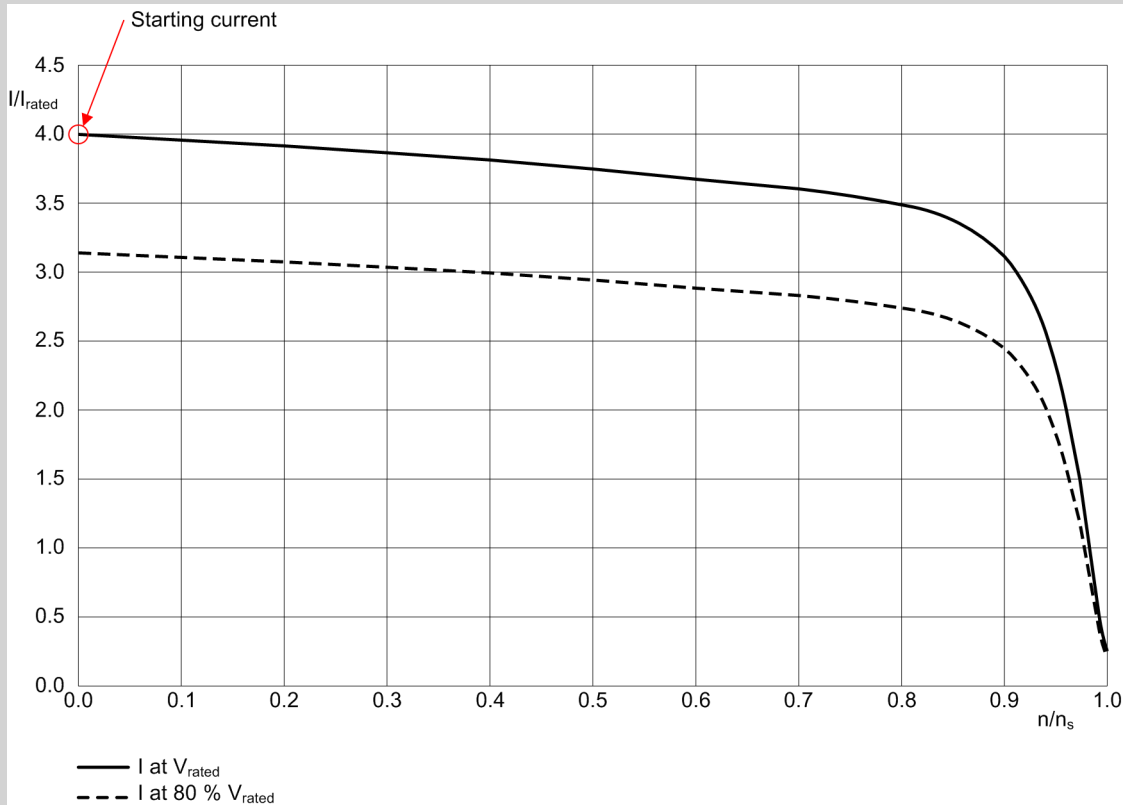

[idw_start_03_1_en_US]

Figure 5-31 Starting-Data Diagram

According to the starting-data diagram, the starting current $I_{\text{starting}} = 4 \cdot I_{\text{rated,motor}}$. As the starting current is given in per unit of the motor rated current, the parameter **Start.cur./mot.rated cur.** can be set directly:

Start.cur./mot.rated cur. = 4

Since no specific requirements for the cooling process are known from the data sheet or the user, Siemens recommends using the default settings:

Factor T-const. at oper. = 2.0

Factor T-const. standstill = 5.0

Temperature Behavior during Changing Operating States

For a better understanding of the above considerations, several possible operating conditions in 2 different operating areas will be discussed in the following paragraph. Settings indicated above are to be used prevailing 3 cold and 2 warm starting-attempts have resulted in the restart limit reaching 66.7 %.

A) Below the restart limit Θ_{restart}

- A normal start brings the thermal replica of the motor to far below the restart limit Θ_{restart} . Then the motor is stopped. The stop launches the equilibrium time T_{Equil} and generates the indication *Restart inhibit*. The equilibrium time expires and the indication *Restart inhibit* drops off. During the equilibrium time, the thermal replica remains frozen (see [Figure 5-32](#), Example A.1). After the equilibrium time the thermal replica is cooling.

- A further normal start brings the thermal replica of the motor to still below the restart limit Θ_{restart} . Then the motor is stopped and is started by an emergency start without waiting for the equilibrium time to expire. The equilibrium time is reset, the thermal replica is released and the indication *Restart inhibit* is generated as going (see [Figure 5-32](#), Example A.2).

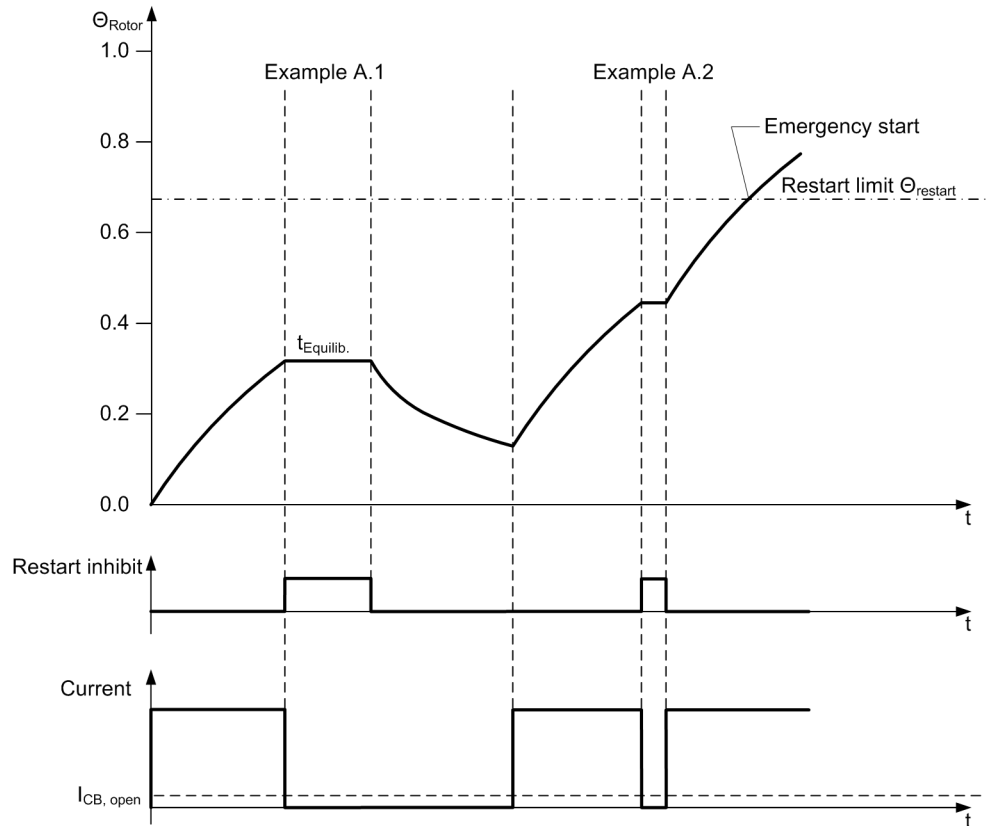

[dw_starta, 1, en_US]

Figure 5-32 Starting According to Examples A.1 and A.2

B) Above the restart limit Θ_{restart}

- A start brings the thermal replica of the motor far above the restart limit Θ_{restart} and the motor is stopped. The minimum inhibit time and the equilibrium time are started and the indication *Restart inhibit* is generated. The temperature cooling below the restart limit Θ_{restart} takes longer than the minimum restart inhibit time and the equilibrium time, so that the time passing until the temperature falls below the restart limit Θ_{restart} is the decisive factor for the going indication *Restart inhibit*. The thermal replica remains frozen while the equilibrium time expires (see [Figure 5-33](#), Example B.1).

- A start brings the thermal replica of the motor to just above the restart limit Θ_{restart} and the motor is stopped. The minimum restart inhibit time and the equilibrium time are started and the indication *Restart inhibit* is generated. Although the temperature soon falls below the restart limit Θ_{restart} , the indication *Restart inhibit* is preserved until the equilibrium time and the minimum restart inhibit time have expired (see [Figure 5-33](#), Example B.2).

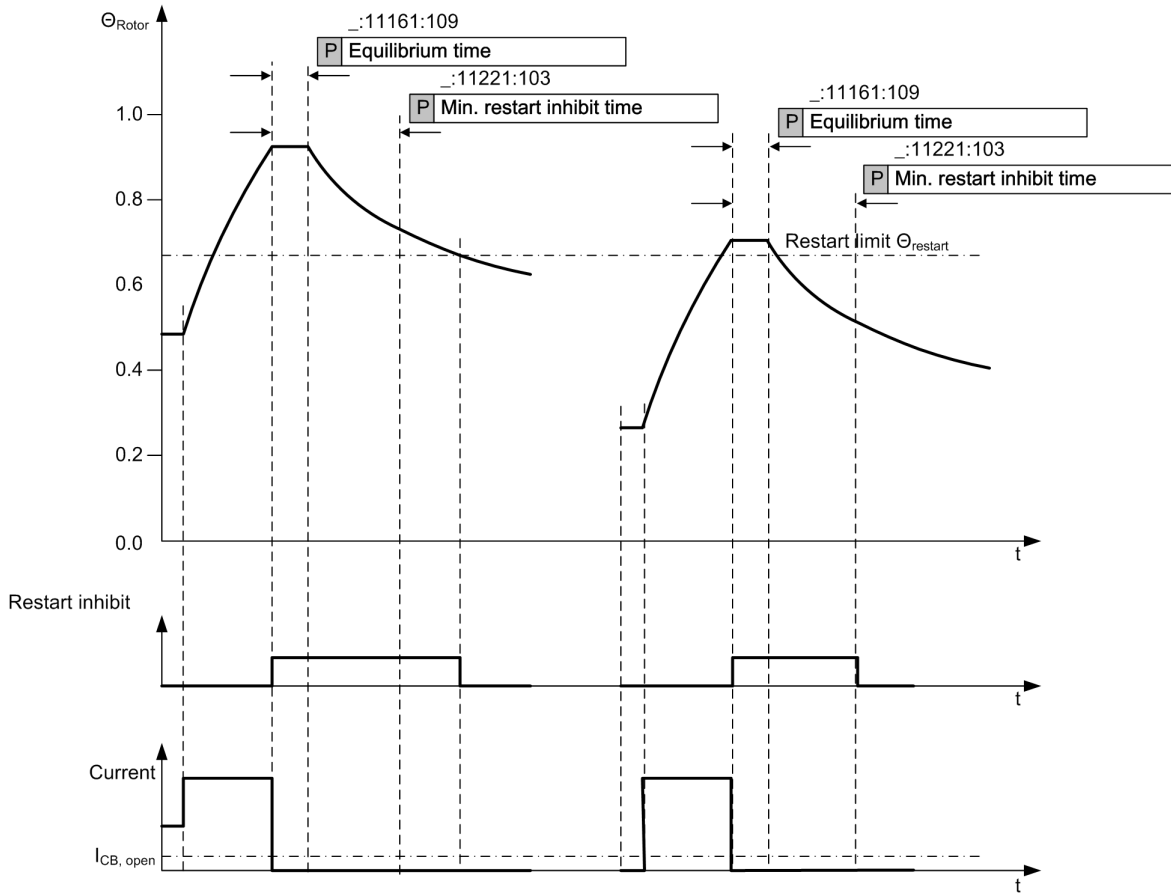

[ldw_startb, 1, en_US]

Figure 5-33 Starting According to Examples B.1 and B.2

5.4.6.5 Settings

Addr.	Parameter	C	Setting Options	Default Setting
Th.repli.rotor				
_:104	Th.repli.rotor:Perm.no. of warm starts		1 to 4	2
_:105	Th.repli.rotor:Perm.no. of cold starts		2 to 6	3
_:106	Th.repli.rotor:Factor T-const. at oper.		0.2 to 100.0	2.0
_:107	Th.repli.rotor:Factor T-const. standstill		0.2 to 100.0	5.0
_:108	Th.repli.rotor:Starting time		3 s to 320 s	10 s
_:109	Th.repli.rotor:Equilibrium time		0.0 min to 320.0 min	1.0 min
_:110	Th.repli.rotor:Storage of thermal replica		<ul style="list-style-type: none"> • no • yes 	no
_:111	Th.repli.rotor:Tempr.thres. cold motor		0 % to 100 %	25 %
_:112	Th.repli.rotor:Start.cur./mot.rated cur.		1.1 to 20.0	4.9

5.4.6.6 Information List

No.	Information	Data Class (Type)	Type
<i>Th.repli.rotor</i>			
_:500	Th.repli.rotor:>Reset thermal replica	SPS	I
_:304	Th.repli.rotor:Reset thermal replica	SPS	O
_:303	Th.repli.rotor:State	ENS	O
_:302	Th.repli.rotor:Θ	MV	O

5.4.7 Settings

Addr.	Parameter	C	Setting Options	Default Setting
<i>State detect.</i>				
_:1711:11131 :102	State detect.:Curr.thres.starting	1 A @ 100 Irated	0.501 A to 20.000 A	5.000 A
		5 A @ 100 Irated	2.51 A to 100.00 A	25.00 A
		1 A @ 50 Irated	0.501 A to 20.000 A	5.000 A
		5 A @ 50 Irated	2.51 A to 100.00 A	25.00 A
		1 A @ 1.6 Irated	0.017 A to 1.600 A	5.000 A
		5 A @ 1.6 Irated	0.084 A to 8.000 A	25.000 A
<i>Rated values</i>				
_:1781:9451:101	General:Motor rated current		1.00 A to 100000.00 A	1000.00 A
_:1781:9451:102	General:Motor rated voltage		0.20 kV to 1200.00 kV	400.00 kV
_:1781:9451:103	General:Rated apparent power		-1.00 MVA to -1.00 MVA	0.00 MVA
<i>Power-system data</i>				
_:1781:9451:149	General:Power-sys. neutral point		<ul style="list-style-type: none"> • grounded • suppress. coil grounded • isolated 	grounded
<i>Measurements</i>				
_:1781:9451:158	General:P, Q sign		<ul style="list-style-type: none"> • not reversed • reversed 	not reversed
<i>Th.repli.rotor</i>				
_:1781:11161:104	Th.repli.rotor:Perm.no. of warm starts		1 to 4	2
_:1781:11161:105	Th.repli.rotor:Perm.no. of cold starts		2 to 6	3
_:1781:11161:106	Th.repli.rotor:Factor T-const. at oper.		0.2 to 100.0	2.0
_:1781:11161:107	Th.repli.rotor:Factor T-const. standstill		0.2 to 100.0	5.0
_:1781:11161:108	Th.repli.rotor:Starting time		3 s to 320 s	10 s
_:1781:11161:109	Th.repli.rotor:Equilibrium time		0.0 min to 320.0 min	1.0 min
_:1781:11161:110	Th.repli.rotor:Storage of thermal replica		<ul style="list-style-type: none"> • no • yes 	no

Addr.	Parameter	C	Setting Options	Default Setting
_:1781:11161:111	Th.repli.rotor:Tempr.thre s. cold motor		0 % to 100 %	25 %
_:1781:11161:112	Th.repli.rotor:Start.cur./ mot.rated cur.		1.1 to 20.0	4.9

5.4.8 Information List

No.	Information	Data Class (Type)	Type
Group indicat.			
_:4501:55	Group indicat.:Pickup	ACD	O
_:4501:57	Group indicat.:Operate	ACT	O
RDT			
_:7381:500	Reset LED Group:>LED reset	SPS	I
_:7381:320	Reset LED Group:LED have been reset	SPS	O
Closure detec.			
_:1711:4681:500	Closure detec.:>Disconnecter open	SPS	I
_:1711:4681:300	Closure detec.:Closure	SPS	O
State detect.			
_:1711:11131:300	State detect.:State	ENS	O
General			
_:1781:9451:52	General:Behavior	ENS	O
_:1781:9451:53	General:Health	ENS	O
Th.repli.rotor			
_:1781:11161:500	Th.repli.rotor:>Reset thermal replica	SPS	I
_:1781:11161:304	Th.repli.rotor:Reset thermal replica	SPS	O
_:1781:11161:303	Th.repli.rotor:State	ENS	O
_:1781:11161:302	Th.repli.rotor:Ø	MV	O

5.5 Function-Group Type Capacitor Bank

5.5.1 Overview

In the **Capacitor bank** function group, all the functions that are necessary for protecting and monitoring a capacitor bank can be used.

You can find the **Capacitor bank** function group under 7SJ82/7SJ85 device types in the Global DIGSI 5 Library. The **Capacitor bank** function group contains all of the protection and supervision functions that you can use for this device type.

Some of these functions are exclusively used for protecting capacitor banks, and others are universal standard functions which can be used for other protected objects as well. You find the exclusive protection functions in the directory **Capacitor-bank protection**.

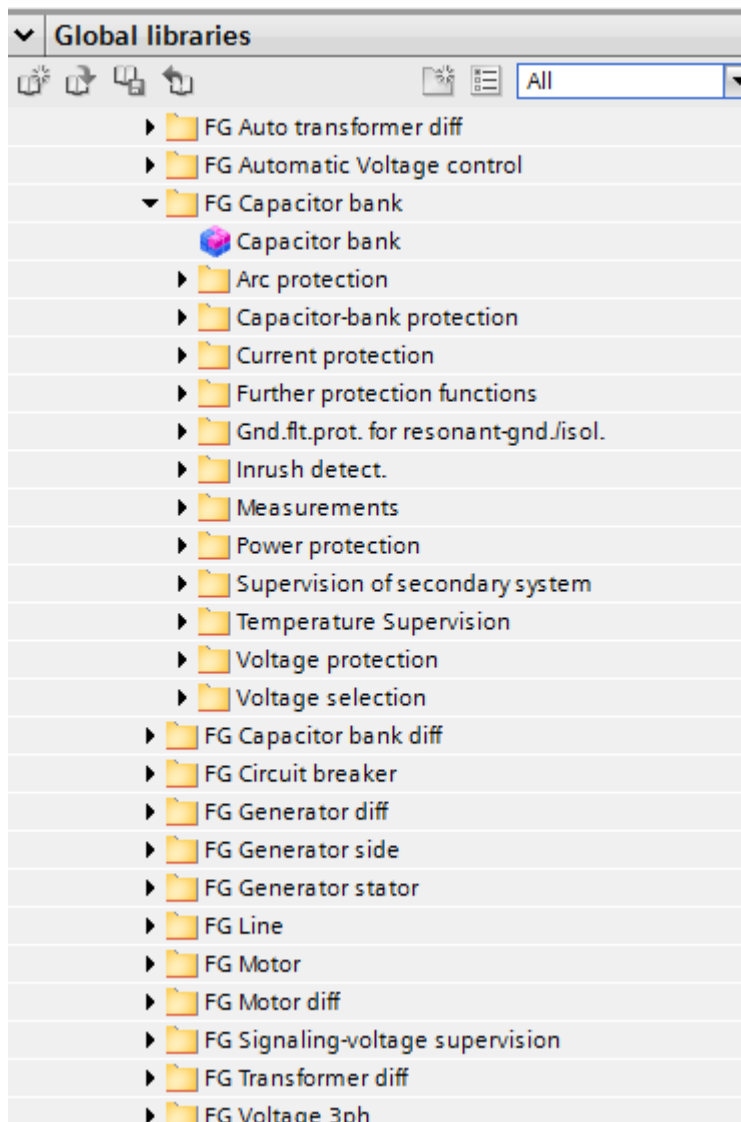

[scfgcapb-250314-01, 2, en_US]

Figure 5-34 Capacitor Bank Function Group - Functional Scope for Device Type 7SJ85

For more information about the embedding of the functions in the device, refer to chapter 2. For information about the overall functional scope of the application templates for the various device types, refer to chapter 4.

5.5.2 Structure of the Function Group

The **Capacitor bank** function group always contains the following functionality:

- Protected object/equipment data (function block **General**)
- Operational measured values
- Capacitor bank device status and blocking of circuit-breaker closing during discharging (function block **General**)
- Process monitor
- Global compensation (function block **General**)
- Output logic of the function group
- Reset LED group

This functionality is essential for the **Capacitor bank** function group, so it cannot be loaded or deleted. You can load the protection functions and supervision functions required for your application in the **Capacitor bank** function group. The functions are available from the Global DIGSI 5 Library. Functions that are not needed can be deleted from the function group.

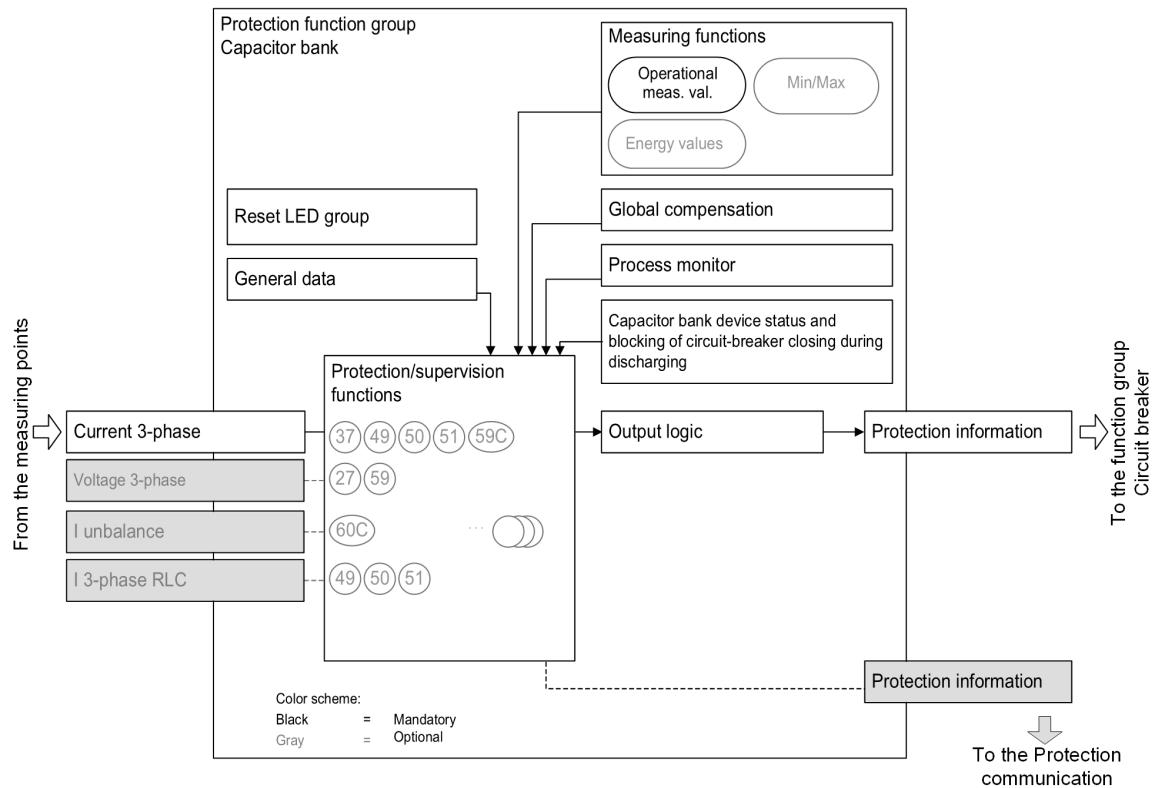

[dw_str_cap_comp, 1, en_US]
 Figure 5-35 Structure of the Capacitor Bank Function Group

The **Capacitor bank** function group has interfaces with the following parts:

- **Measuring points**
- **Circuit-breaker function group**

Interfaces with the Measuring Points

The **Capacitor bank** function group receives the required measured values via the interfaces with the measuring points. If you are using an application template, the **Capacitor bank** function group is already connected to the specific measuring points.

You can find more detailed information in *Chapter 2*.

The **Capacitor bank** function group has the following 6 interfaces with the measuring points. The universal standard functions only work with the standard interfaces **3-phase current** and/or **3-phase voltage**; the other 4 interfaces are provided for the functions which are exclusively used for the capacitor banks. Refer also to the example given below.

The **Capacitor bank** function group has the following interfaces with the measuring points:

- **3-phase current:**

The measurands from the 3-phase current system are supplied via this interface. Depending on the connection type of the current transformers, the measurands can be for example $I_{A'}$, $I_{B'}$, $I_{C'}$, $I_{N'}$, or $3I_0$. All values that can be calculated from the measurands are also provided via this interface.

The **Capacitor bank** function group must always be connected to the **3-phase current measuring point**. You can connect the **3-phase current measuring point** interface to the maximum of two **3-phase current measuring points**. If 2 current measuring points have been connected to the 3-phase current interface, the total current is determined by adding the measured values from both measuring points in the function group. The functions in the **Capacitor bank** function group evaluate the total current.

For a **3-phase current measuring point** connected to the **3-phase current** interface of the **Capacitor bank** function group, the following connection types are not allowed:

- *3-phase, 2 primary CT*
- *3ph, 2prim.CT + IN-sep*
- *2ph, 2p. CT + IN-sep*

- **3-phase voltage** (optional):

The measurands from the 3-phase voltage system are supplied via this interface. Depending on the connection type of the voltage transformers, these can be for example $V_{A'}$, $V_{B'}$, $V_{C'}$, $V_{N'}$, or $3V_0$. All values that can be calculated from the measurands are also provided via this interface.

The connection of the **3-phase voltage** interface is optional. This connection is only required if protection functions or supervision functions are applied, which require voltage measurements.

- **Current unbalance** (optional):

The unbalanced-current measurands are supplied via this interface.
The connection of the **current unbalance** interface is optional.

- **3-phase current RLC** (optional)

The measurands from a tuning or filtering section (R, L, or C) of a capacitor bank are supplied via this interface.

The connection of the **3-phase current RLC** interface is optional.

You can connect the **Capacitor bank** function group to the current and voltage measuring points via interfaces. You make this assignment in DIGSI via **Project tree** → **Function group connections**. To connect the interfaces, set a cross at the intersection between the row and column in the matrix.

For the protection functions applied on the interfaces **3-phase current** and **3-phase voltage**, if you add these functions to the **Capacitor bank** function group, these functions will automatically receive the measured values from the correct measuring points. If you add protection functions to the function group but the necessary interface is not connected to any measuring point, DIGSI 5 reports an inconsistency. Configure the measuring points in DIGSI 5 using the **Function group connections** editor.

For the protection functions applied on the interfaces **Current unbalance** and **3-phase current**, you have to select the desired measuring points via a setting **MP selection**, which offers a list of all measuring points connected to the specific interface. The setting **MP selection** is located on the setting page of the protection function.

The following figure shows an overview of the protection functions and the interface assignment in the **Capacitor bank** function group.

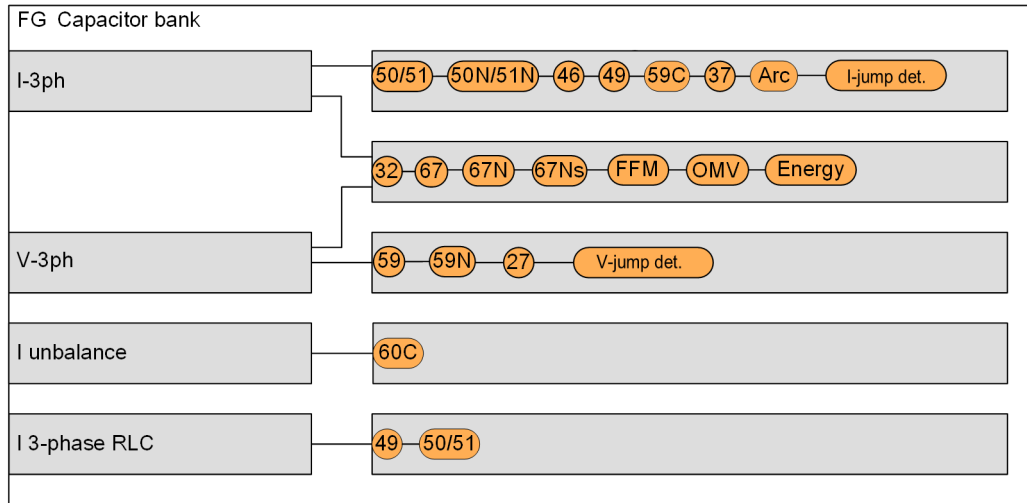

- 27 Undervoltage protection
- 32 General power protection
- 37 Undercurrent protection
- 46 Negative-sequence protection
- 49 Overload protection
- 50/51 Overcurrent protection, phases
- 50N/51N Overcurrent protection, ground
- 59 Overvoltage protection
- 59C Peak overvoltage protection
- 60C Current-unbalance protection
- 67/67N Directional overcurrent protection for ground faults
- 67Ns Directional sensitive ground-fault detection
- OMV Operational values
- FFM Fuse-failure monitor
- 59N Overvoltage protection with zero-sequence voltage/residual voltage

[dsw_cap_bank_comp_1_en_US]

Figure 5-36 Overview of the Protection Functions and Interface Assignment in the Capacitor Bank Function Group

Interfaces with Circuit-Breaker Function Group

All required data are exchanged between the protection function group and the **Circuit-breaker** function group via the interface with the **Circuit-breaker** function group. These data include, for example, the pickup and operate indications of the protection functions sent in the direction of the **Circuit-breaker** function group and, for another example, the information about the circuit-breaker condition sent in the direction of the protection function group.

The **Capacitor bank** function group is connectable to a **Circuit-breaker** function group. This connection generally determines:

- Which circuit breaker is activated by the protection functions of the **Capacitor bank** function group
- Starting of the **Circuit-breaker failure protection** function (if available in the **Circuit-breaker** function group) through the protection functions of the connected **Capacitor bank** function group
- Starting of the **Automatic reclosing** function (if available in the **Circuit-breaker** function group) through the protection functions of the connected **Capacitor bank** function group



NOTE

For capacitor bank protection, the **Automatic reclosing** function is not applied in most cases. However, due to flexibility and standardization, the respective interface is offered.

Connect function group to circuit-breaker groups	
Protection group	Circuit breaker 1
(All)	(All)
Capacitor bank 1	X

[screcnb1-180713-01.tif, 1, en_US]

Figure 5-37 Connecting Capacitor Bank Function Group with Circuit-Breaker Function Group

Besides the general assignment of the **Capacitor bank** function group to the **Circuit-breaker** function group, you can also configure the interface for certain functionalities in detail. Configure the details in DIGSI 5 using the **Circuit breaker interaction** editor in the Capacitor bank function group.

In the detailed configuration of the interface, define:

- Which operate indications of the protection functions go into the generation of the trip command
- Which protection functions start the **Circuit-breaker failure protection** function
- Which protection functions start the **Automatic reclosing** function

		Circuit breaker 1	
		Trip logic	50BF CB fail.1
Protection group	Trip	Start CB failure	
(All)	(All)	(All)	(All)
50/51 OC-3ph-A1	X	X	X
Definite-T 1	X	X	X
Definite-T 2	X	X	X
Inverse-T 1	X	X	X

[sc_concap, 2, en_US]

Figure 5-38 Connecting Protection Functions and Stage Using the Circuit-Breaker Interaction Editor

If an application template is used, the function groups have already been connected to each other because this link is essential to ensure proper operation. You can modify the link in DIGSI 5 using the **Function-group connections** editor.

You can find more information in chapter [2.1 Embedding of Functions in the Device](#). If this link is missing, DIGSI 5 reports an inconsistency.

Protected Object/Equipment Data (FB General)

Capacitor-bank rated and reference data are defined as well as further protected object/equipment data. The data applies for all functions in the **Capacitor bank** function group.

For further information, refer to chapter [5.5.3 Application and Setting Notes](#).

Capacitor Bank Device Status and Blocking of Circuit-breaker Closing during Discharging (FB General)

The functionality detects whether a capacitor bank is **online** or **offline**. When the status of the capacitor bank changes from **online** to **offline**, the signal *Discharge* is issued during the capacitor-bank discharging time.

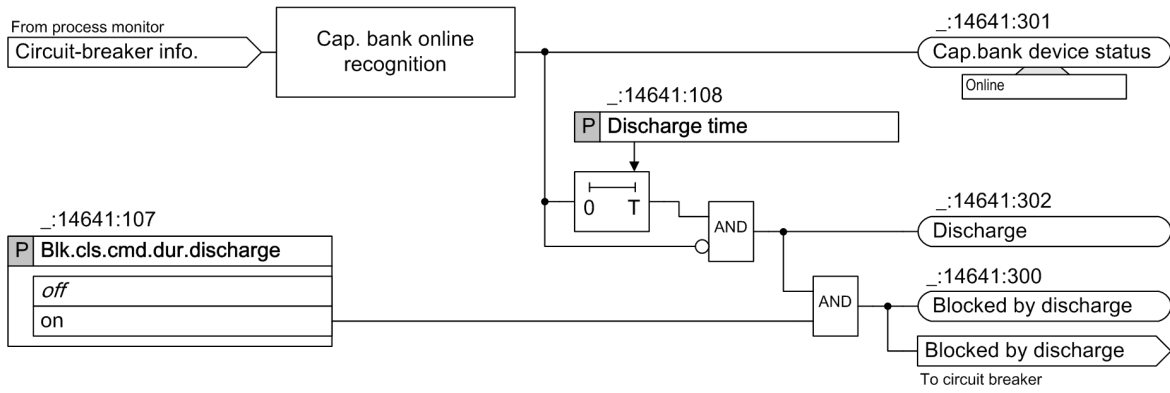

[lo_cap_zap_1_en_US]

Figure 5-39 Logic Diagram of Capacitor Bank Device Status and Blocking of Circuit-breaker Closing during Discharging

The device can block the closing of the circuit breaker automatically when a capacitor bank discharges. The configuration is made with the parameter **Blk.cls.cmd.dur.discharge**. If the parameter **Blk.cls.cmd.dur.discharge** is set to **on**, the device generates a trip/open command during the discharge time and blocks closing commands additionally, see the following figure. This blocking condition is signaled via the message *Blocked by discharge*.

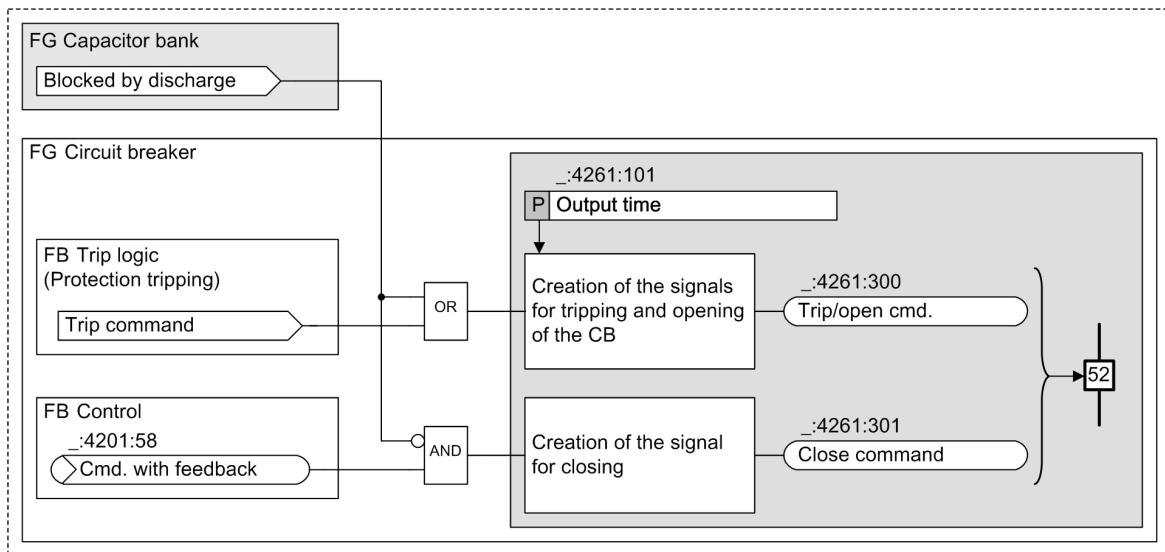

[lo_discharge_1_en_US]

Figure 5-40 Logic Diagram of Processing the Blocked by Discharge Signal

Global Compensation (FB General)

The **Global compensation** function block provides the binary input signal *>Compensate* to carry out the manual compensation for all functions in the FG using compensated measuring values.

In addition, the binary input signal *>Reset comp. val.* is provided to reset all compensation values for the functions using compensated measuring values.

Process Monitor

The **Process monitor** detects the current state of the protected object. It is always present in the function group and cannot be removed.

For detailed description of the **Process monitor**, refer to [5.10.1 Overview of Functions](#).

Reset LED Group

The **Reset LED group** function block allows you to reset only the stored LEDs of the functions contained in the respective function group, while stored LEDs activated from functions in other function groups remain active. For more information refer to chapter [3.1.10 Resetting Stored Indications of the Function Group](#).

Operational, Fundamental, Symmetrical Components Measurements

The operational fundamental, symmetrical components and functional measurements are always available in the **Capacitor bank** function group and cannot be deleted.

Table 5-7 Operational Measured Values (True RMS) of the Function Group Capacitor Bank

Measured Values		Primary	Secondary	% Referenced to
$I_{A'}, I_{B'}, I_{C'}$	Phase currents	A	A	Rated operating current of the primary system
I_N	Neutral-point phase current	A	A	Rated operating current of the primary system
$3I_0$	Residual current	A	A	Rated operating current of the primary system
$V_{A'}, V_{B'}, V_{C'}$	Phase-to-ground voltages	kV	V	Rated operating voltage of the primary system/ $\sqrt{3}$
$V_{AB'}, V_{BC'}, V_{CA'}$	Phase-to-phase voltage	kV	V	Rated operating voltage of the primary system
V_0	Zero-sequence voltage	kV	V	Rated operating voltage of the primary system/ $\sqrt{3}$
V_{NG}	Neutral-point displacement voltage	kV	V	Rated operating voltage of the primary system/ $\sqrt{3}$
f	Frequency	Hz	Hz	Rated frequency
P_{tot}	Active power (total power)	MW	–	Rated operating voltage and rated operating current of the primary system $\sqrt{3} \cdot V_{rated} \cdot I_{rated}$
Q_{tot}	Reactive power (total power)	MVar	–	Rated operating voltage and rated operating current of the primary system $\sqrt{3} \cdot V_{rated} \cdot I_{rated}$
S_{tot}	Apparent power (total power)	MVA	–	Rated operating voltage and rated operating current of the primary system $\sqrt{3} \cdot V_{rated} \cdot I_{rated}$
$\cos \varphi$	Active factor	(abs)	(abs)	100 % corresponds to $\cos \varphi = 1$
$P_{A'}, P_{B'}, P_{C'}$	Phase-related active power	MW	–	Apparent power of the phase $V_{rated} L_x \cdot I_{rated} L_x$
$Q_{A'}, Q_{B'}, Q_{C'}$	Phase-related reactive power	MVar	–	Apparent power of the phase $V_{rated} L_x \cdot I_{rated} L_x$
$S_{A'}, S_{B'}, S_{C'}$	Phase-related apparent power	MVA	–	Apparent power of the phase $V_{rated} L_x \cdot I_{rated} L_x$

Table 5-8 Fundamental and Symmetrical Components Measurement Values of the Function Group Capacitor Bank

Measured Values		Primary	Secondary	% Referenced to
$I_{A'}, I_{B'}, I_C$	Phase currents	A	A	Rated operating current of the primary system
I_N	Neutral-point phase current	A	A	Rated operating current of the primary system
$I_{seq:0}$	Zero-sequence current	A	A	Rated operating current of the primary system
$I_{seq:1}$	Positive-sequence current	A	A	Rated operating current of the primary system
$I_{seq:2}$	Negative-sequence current	A	A	Rated operating voltage of the primary system
$V_{A'}, V_{B'}, V_C$	Phase-to-ground voltages	kV	V	Rated operating voltage of the primary system/ $\sqrt{3}$
$V_{AB'}, V_{BC'}, V_{CA}$	Phase-to-phase voltage	kV	V	Rated operating voltage of the primary system
V_N	Neutral-point phase voltage	kV	V	Rated operating voltage of the primary system/ $\sqrt{3}$
$V_{seq:0}$	Zero-sequence voltage	kV	V	Rated operating voltage of the primary system/ $\sqrt{3}$
$V_{seq:1}$	Positive-sequence voltage	kV	V	Rated operating voltage of the primary system/ $\sqrt{3}$
$V_{seq:2}$	Negative-sequence voltage	kV	V	Rated operating voltage of the primary system/ $\sqrt{3}$

Voltage and power measurements are only available if **V-3ph measuring point** connected to the **Capacitor bank** function group.

The energy measurements are not predefined. If required, they must be loaded from the Global DIGSI 5 Library.

Inversion of Power-Related Measured and Statistical Values (FB General)

The following values calculated in operational measured values are defined positively in the direction of the protected object.

- Power
- Power factor
- Energy
- Minimum, maximum values of the power
- Average values of the power

With the **P, Q sign** setting, you can invert the sign of these operational measured values such that a power flow from the line to the busbar is displayed positively.

More information can be found in Chapter [11.1 Overview of Functions](#).

Output Logic

The output logic treats the pickup and operate indications of the protection functions and supervision functions in the **Capacitor bank** function group separately, in a pickup logic and an output logic respectively. The pickup and output logics generate the group indications of the function group. These group indications are transferred to the **Circuit-breaker** function group via the **protection-information** interface and are processed further there.

The pickup and operate indications of the protection functions and the supervision functions in the **Capacitor bank** function group are combined according to the following figures of group indications.

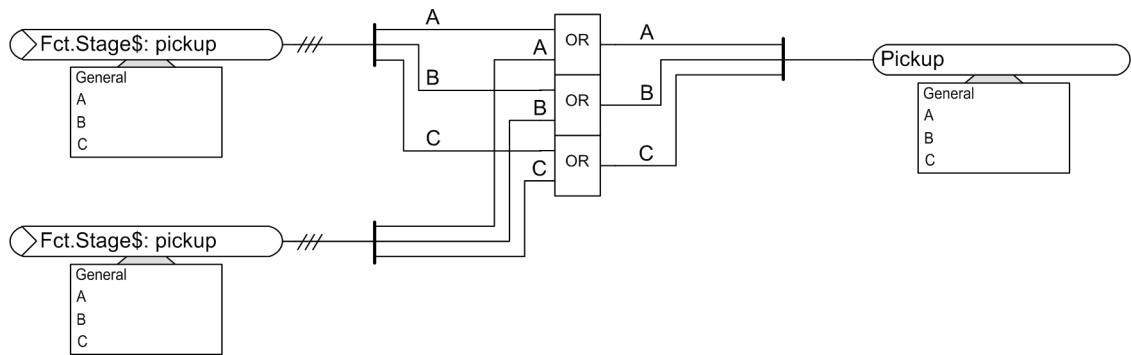

[to_gepin_02_1_en_US]

Figure 5-41 Generation of the Pickup Indication of the Capacitor Bank Function Group

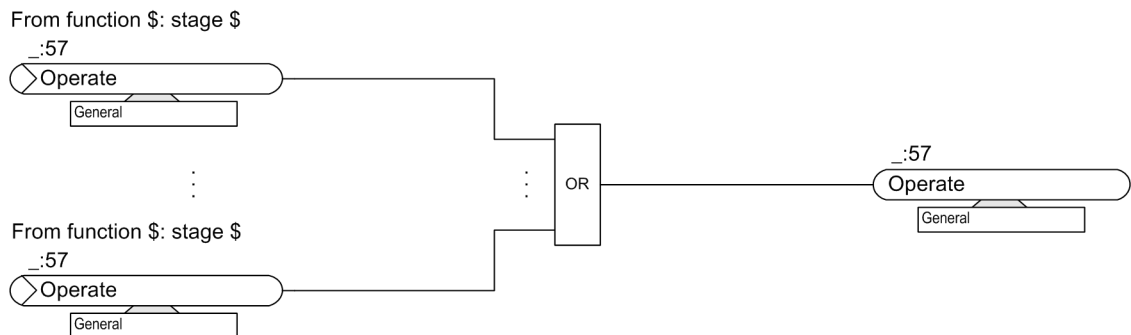

[to_gepin_02_1_en_US]

Figure 5-42 Generation of the Operate Indication of the Capacitor Bank Function Group

5.5.3 Application and Setting Notes

Interface to Circuit-Breaker Function Group

The **Capacitor bank** protection function group is linked to one **Circuit-breaker** function group. This **Circuit-breaker** function group is assigned to the circuit breaker of the capacitor bank.

Protected Object/Equipment Data (FB General)

The following application and setting notes apply for the general data. The data are configured in the function block **General** of the **Capacitor bank** function group and apply for all functions in the function group.

Parameter: Capacitor reference curr.

- Default setting (`_:14641:101`) **Capacitor reference curr.** = **1000 A**

With the **Capacitor reference curr.** parameter, you set the reference current for the capacitor bank to be protected. This **Capacitor reference curr.** specified here is the reference value for the percentage-measured values and setting values made in percentages.

Depending on the user philosophy, the reference value could be the capacitor-bank rated current, which includes harmonics, or the capacitor-bank fundamental current.

Parameter: Capacitor reference volt.

- Default setting (`_:14641:102`) **Capacitor reference volt.** = **400.00 kV**

With the parameter **Capacitor reference volt.**, you set the reference voltage of the capacitor bank to be protected. This **Capacitor reference volt.** specified here is the reference value for the percentage-measured values and setting values made in percentages.

Depending on the user philosophy, the reference value could be the system rated voltage (bus voltage), or the capacitor rated voltage

Parameter: Capacitor element type

- Default setting (`_:14641:106`) **Capacitor element type** = *fused*

With the parameter **Capacitor element type**, you set if the capacitor elements contain internal fuses or not. This information is required in the current-unbalance protection for the fault position annunciation.

Parameter: Blk.cls.cmd.dur.discharge

- Default setting (`_:14641:107`) **Blk.cls.cmd.dur.discharge** = *off*

With the parameter **Blk.cls.cmd.dur.discharge**, you set whether closing of the circuit breaker is blocked automatically or not when a capacitor bank discharges.



NOTE

If the parameter **Blk.cls.cmd.dur.discharge** is set to *on*, the device generates a trip/open command during the discharge time.

Parameter: Discharge time

- Default setting (`_:14641:108`) **Discharge time** = *300 s*

With the parameter **Discharge time**, you define capacitor-bank discharging duration. You get the value from the capacitor manufacturer.

Parameter: Cap.-bank neutral point

- Default setting (`_:14641:109`) **Cap.-bank neutral point** = *isolated*

With the parameter **Cap.-bank neutral point**, you can specify whether the neutral point of capacitor bank is *isolated* or *grounded*. This information is required when applying the function **87V voltage differential protection**.

Parameter: P, Q sign

- Default setting (`_:14611:158`) **P, Q sign** = *not reversed*

The power and energy values are defined by the manufacturer such that power in the direction of the protected object is considered positive. You can also define the power output by the protected object as positive. With the **P, Q sign** parameter, you can invert the sign for these components. This inversion does not influence any protection function.

5.5.4 Write-Protected Settings

The settings listed here are primarily to aid understanding when configuring the function groups. They are calculated as a function of other settings and cannot be changed directly.

Addr.	Parameter	C	Setting Options	Default Setting
<i>Rated values</i>				
_:14641:103	General:Rated apparent power		-1.00 MVA to -1.00 MVA	0.00 MVA



NOTE

You can find more detailed information on the Process monitor in chapter [5.7.1 Overview](#).

5.5.5 Settings

Addr.	Parameter	C	Setting Options	Default Setting
Rated values				
_:14641:101	General:Capacitor reference curr.		1.00 A to 100000.00 A	1000.00 A
_:14641:102	General:Capacitor reference volt.		0.10 kV to 1200.00 kV	400.00 kV
Cap.bank data				
_:14641:106	General:Capacitor element type		<ul style="list-style-type: none"> • fused • unfused 	fused
_:14641:107	General:Blk.cls.cmd.dur. discharge		<ul style="list-style-type: none"> • off • on 	off
_:14641:108	General:Discharge time		1 s to 1200 s	300 s
_:14641:109	General:Cap.-bank neutral point		<ul style="list-style-type: none"> • grounded • isolated 	isolated
Measurements				
_:14611:158	Further settings:P, Q sign		<ul style="list-style-type: none"> • not reversed • reversed 	not reversed

5.5.6 Information List

No.	Information	Data Class (Type)	Type
Group indicat.			
_:4501:55	Group indicat.:Pickup	ACD	O
_:4501:57	Group indicat.:Operate	ACT	O
_:4501:52	Group indicat.:Behavior	ENS	O
_:4501:53	Group indicat.:Health	ENS	O
Reset LED Group			
_:7381:500	Reset LED Group:>LED reset	SPS	I
_:7381:320	Reset LED Group:LED have been reset	SPS	O
_:7381:52	Reset LED Group:Behavior	ENS	O
_:7381:53	Reset LED Group:Health	ENS	O
General			
_:1781:14641:500	General:>Compensate	SPS	I
_:1781:14641:501	General:>Reset comp. val.	SPS	I
_:1781:14641:300	General:Blocked by discharge	SPS	O
_:1781:14641:302	General:Discharge	SPS	O
_:1781:14641:303	General:Cap.bank device status	SPS	O
_:1781:14641:52	General:Behavior	ENS	O
_:1781:14641:53	General:Health	ENS	O

5.6 Function-Group Type Analog Units

5.6.1 Overview

The function group **Analog units** is used to map analog units and communicate with them. Analog units are external devices, such as RTD units, or analog modules or measuring-transducer modules.

You can find the function group **Analog units** in the Global DIGSI 5 library.

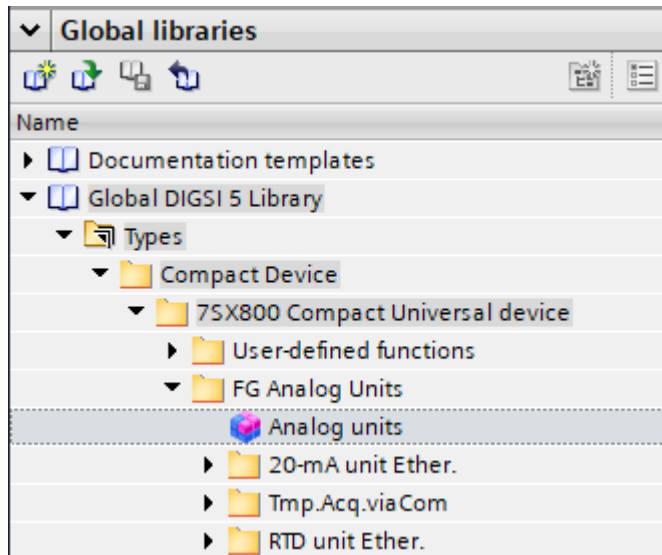

[sc_FG_AU_1_en_US]

Figure 5-43 Analog Unit Function Group in DIGSI

5.6.2 Structure of the Function Group

If the device has a measuring transducer, it is automatically mapped in the function group **Analog units**. If one or more RTD units are connected to the device, you have to load one or more **RTD unit Ether.** or **RTD unit serial** functions from the Global DIGSI 5 library in order to map the RTD units.

If the device is connected to a power-plant control system or another protection device, you must load one or more **Temperature acquisition via protocols** functions from the Global DIGSI 5 library to form the protocols. The following figure shows the structure of the function group.

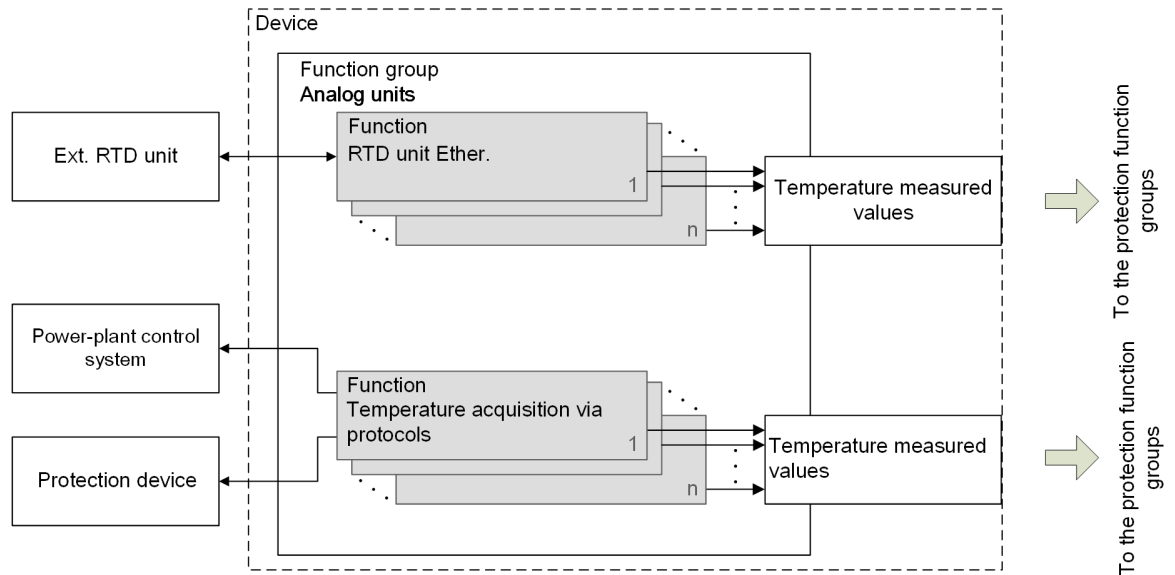

[dw_struct_fg_analog_unit_02_1_en_US]

Figure 5-44 Structure of the Function Group Analog Unit

The function group **Analog units** has interfaces to protection function groups. The function group **Analog units** provides, for example, measured temperature values that come from an external RTD unit, a measuring transducer or via protocols. These measured temperature values are available for all protection function groups in which a temperature monitoring function works.

The function **RTD unit Ether.** is not preconfigured by the manufacturer. A maximum of 20 function instances can operate simultaneously.

The structure of the function **RTD unit serial** is identical to the structure of the function **RTD unit Ether.**

The function **20-mA unit Ether.** is not preconfigured by the manufacturer. A maximum of 4 function instances can operate simultaneously. The structure of the function **20 mA serial unit** is identical to the structure of the function **20-mA unit Ether.**

The function **Temperature acquisition via protocols** has 2 stage types: The **Temperature acquisition via PROFINET IO or IEC 61850** and the **Temperature acquisition via GOOSE**. One instance of the **Temperature acquisition via PROFINET IO or IEC 61850** is preconfigured by the manufacturer. A maximum of 12 instances can operate simultaneously for both stage types.

5.6.3 20-mA Unit Ethernet

5.6.3.1 Overview

The function **20-mA unit Ether.:**

- Communicates in series with a 20-mA unit via the Slave Unit Protocol (SUP) and records the values measured by the 20-mA unit
- Transforms the measured 20-mA values into slowly changing process tags such as temperature or gas pressure
- Makes the recorded process tags available to CFC, GOOSE, protocols and the device display
- Monitors communication with the 20-mA unit

5.6.3.2 Structure of the Function

The function **20-mA unit Ether.** can only work in the function group **Analog units**. A maximum of 4 function instances can work simultaneously. Each instance contains 12 preconfigured channel function blocks.

The function **20-mA unit Ether.** contains input and output channels which can be configured independently of one another.

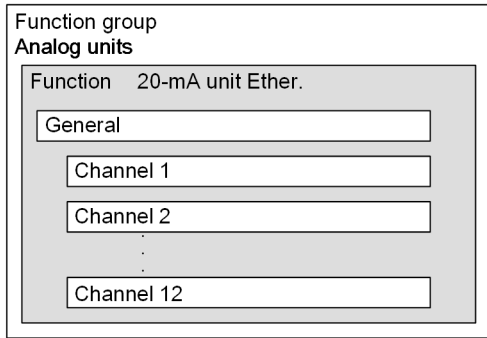

[dw_struct_fg_analog_unit_1_en_US]

Figure 5-45 Structure/Embedding of the Function

5.6.3.3 Communication with 20-mA Unit Ethernet

Logic

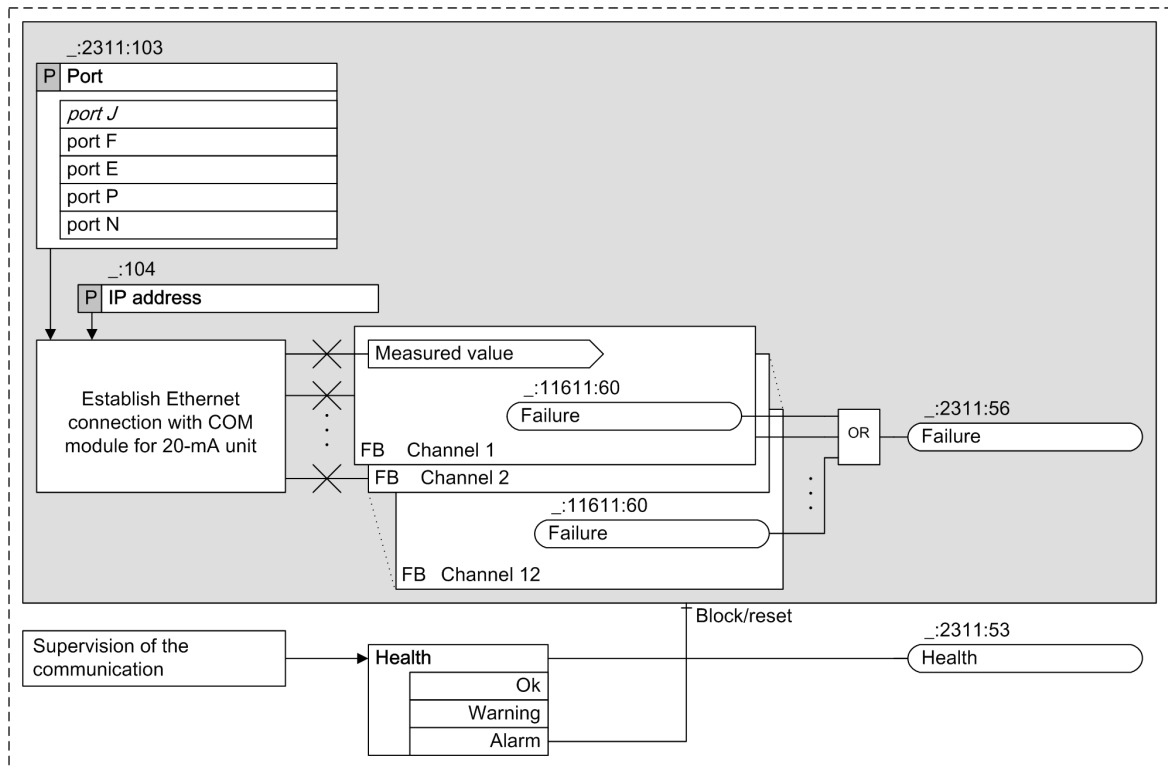

[lo_20mtcp_1_en_US]

Figure 5-46 Logic of the Function 20-mA Unit Ethernet



NOTE

In SIPROTEC 5 Compact devices, only port F is available to connect to the 20-mA unit Ethernet.

Communication with 20-mA Unit

The function is used to communicate with a 20-mA unit connected via an Ethernet connection. When a connection of the function to an external 20-mA unit via an Ethernet interface has successfully been established, the 20-mA unit sends the measured values of all connected channels to the function **20-mA unit Ether..** For the connection to be established successfully, specific communication settings must be specified. You can find more detailed information in [5.6.3.4 Application and Setting Notes](#).

The 20-mA measuring unit **7XV5674** is supported.

Error Responses

The following table lists the conditions under which the status *Health* transitions to the Alarm or Warning state.

Table 5-9 Error Responses

Error Description	Status Health
The function 20-mA unit Ether. cannot establish a connection with the integrated Ethernet interface.	Alarm
The function 20-mA unit Ether. sends TCP settings to the integrated Ethernet interface, which evidently would like to connect to the 20-mA unit via a serial protocol. The integrated Ethernet interface does not establish a connection to the 20-mA unit.	Alarm
The connection between the integrated Ethernet interface and the 20-mA unit causes a time-out indication.	Warning
The integrated Ethernet interface has not received any more data from the 20-mA unit for 9 sec.	Warning

The signal *Failure* is issued as soon as one of the channel function blocks reports a failure.

5.6.3.4 Application and Setting Notes

Parameter: Port

- Default setting (`_ :2311:103`) **Port = port F**

With the parameter **Port**, you define the port connecting the 20-mA unit to the SIPROTEC 5 Compact device.

Parameter: IP address

- Default setting (`_ :2311:104`) **IP address = 10.16.60.1**

With the parameter **IP address**, you set the IP address of the 20-mA unit connected to the integrated Ethernet interface via the TCP protocol. You must assign each 20-mA unit an unambiguous IP address. The IP address to be set depends on your network configuration. You can set any valid IPv4 address that does not cause conflicts with other IP addresses in the network. First set an IP address for the **7XV5674 20-mA unit**. Then specify the parameter **IP address** for the integrated Ethernet interface to the same address.

Settings on the 20-mA Unit

Set the **7XV5674 20-mA unit** with a Web browser on the laptop computer via the latter's Ethernet interface. Set **Modbus TCP** as a bus protocol/operating mode.

You can find detailed notes on the settings in the 7XV5674 manual that accompanies the 20-mA unit. The documents are also available in the SIPROTEC download area (www.support.industry.siemens.com).

5.6.3.5 20-mA Channel

Logic

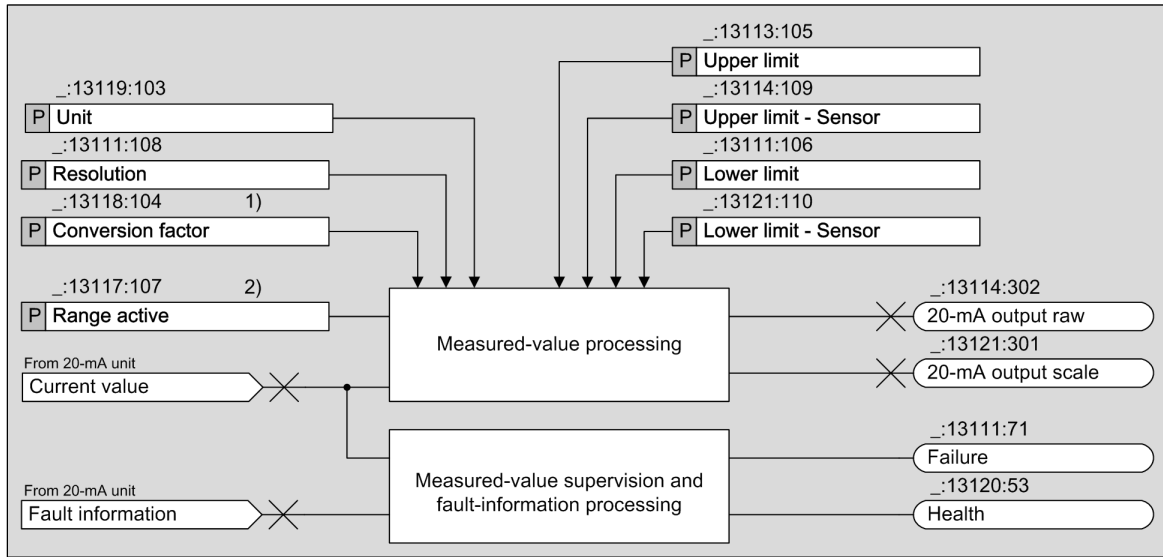

[lo_20mcha:1, en_US]

Figure 5-47 Logic Diagram of the Function 20-mA Channel

- (1) If the setting **Range active** is set to *test*, the setting **Transformation ratio** is not displayed.
- (2) If the setting **Range active** is set to *false*, the settings **Upper limit**, **Transformation ratio upper limit**, **Lower limit** and **Transformation ratio** are not displayed.

Measured-Value Calculation

The function **20-mA channel** processes a single 20-mA current signal supplied by the 20-mA unit of the corresponding channel. The 20-mA current measured value is converted into the correct physical quantities such as temperature or pressure. In each 20-mA functional unit (Ether. and serial) there are always 12 of the 20-mA channel function blocks, even if fewer channels are connected with the 20-mA unit. The calculated values are available for further processing via CFC, GOOSE, protocols, and the display image.

Measured-Value Processing

The 20-mA unit typically transmits a value which represents a physical quantity, such as a temperature or a pressure. Therefore, the device must contain a characteristic curve that maps the physical quantity to the 20-mA value. If you do not activate the **Range active** setting (no x in the check box), the function operates over the range 0 mA to 20 mA. If a value smaller than 0 mA or greater than 20 mA is active at the input of the 20-mA unit, the measured value is identified as invalid. The setting of the range for the scaled value goes from a usable range of 0 mA to 20 mA. The following figure shows an example.

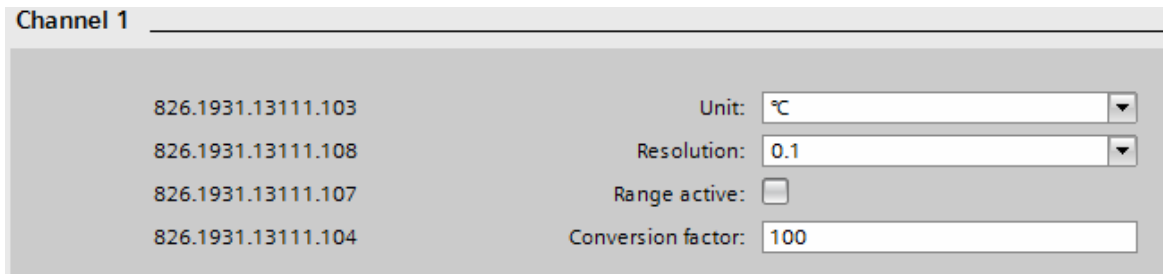

[sckanumw-190214-01, 1, en_US]

Figure 5-48 Settings for Example 1

In this example, the measured value 0 mA means a temperature of 0 °C and the measured value 20 mA means a temperature of 100 °C. So enter as **Unit** = °C and **Conversion factor** = 100. The resolution (decimal place) of the temperature value can be chosen; for a decimal place, select **Resolution** = 0.1.

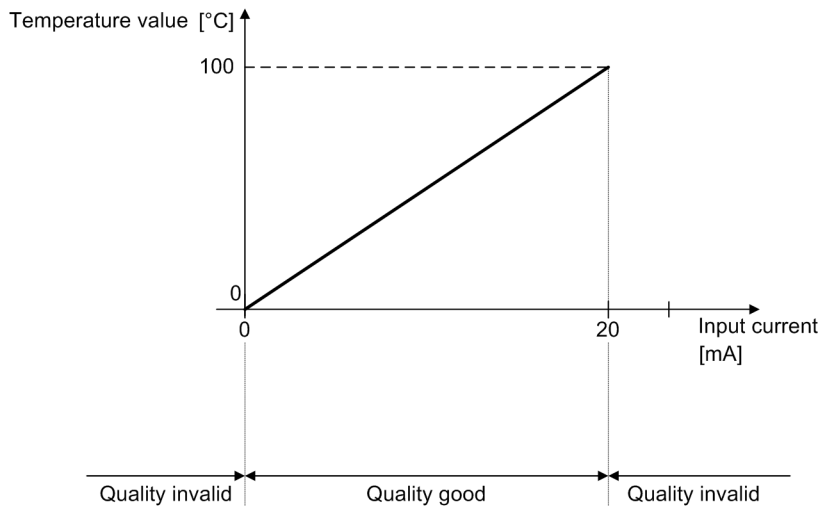

[dw_knges3, 1, en_US]

Figure 5-49 Characteristic Curve of a 20-mA Input (Example 1)

If you activate the **Range active** setting, then 4 additional parameters **Upper limit**, **Lower limit**, **Upper limit - Sensor**, and **Lower limit - Sensor** appear. The parameters **Upper limit** and **Lower limit** indicate the range of the input current in mA. The setting **Upper limit - Sensor** is the calculated measured value if the input current corresponds to the value in the **Upper limit** setting. The setting **Lower limit - Sensor** is the calculated measured value if the input current corresponds to the value in the **Lower limit** setting. The setting of the range for the scaled value corresponds to the useable range between **Lower limit** and **Upper limit** (see following figure).

Channel 1	
826.1931.13111.103	Unit: °C
826.1931.13111.108	Resolution: 0.1
826.1931.13111.107	Range active: <input checked="" type="checkbox"/>
826.1931.13111.105	Upper limit: 20.000 mA
826.1931.13111.109	Upper limit conv. factor: 55
826.1931.13111.106	Lower limit: 4.000 mA
826.1931.13111.110	Lower limit conv. factor: -33

[sckanumf-190214-01, 1, en_US]

Figure 5-50 Settings for Example 2

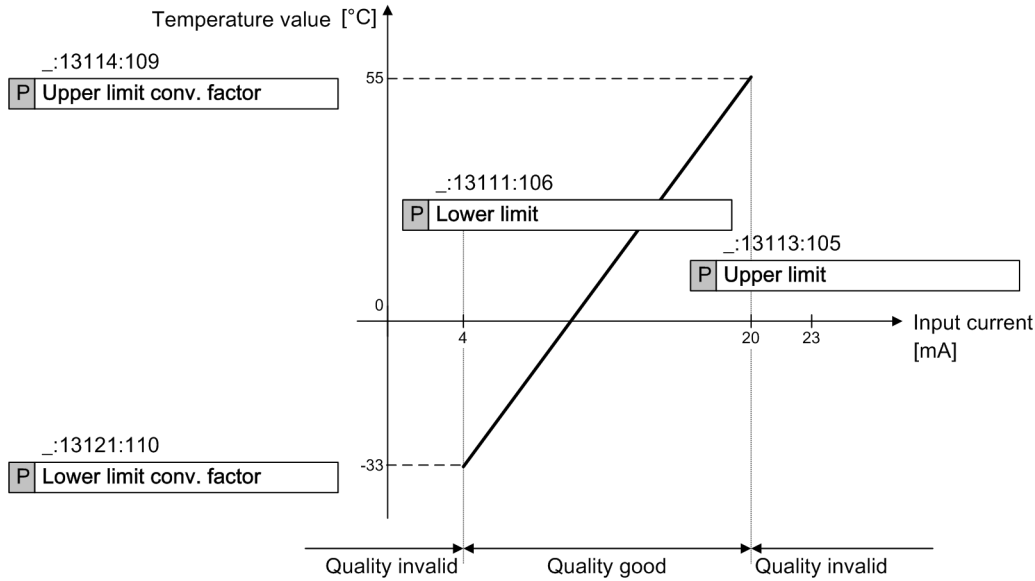

[dw_knges2_1_en_US]
 Figure 5-51 Characteristic Curve of a 20-mA Unit (Example 2)

In this example, the **Range active** setting is selected. The setting **Upper limit** is at 20 mA, the setting **Lower limit** is at 4 mA. The setting **Upper limit - Sensor** is at 55 and the setting **Lower limit - Sensor** is at -33. If the input current is smaller than 4 mA or greater than 20 mA, the quality of the scaled measured value in this example is invalid.

Each 20-mA channel makes available the scaled measured value in the information routing (these are the temperature values in the examples) and the original current measured value in mA for further processing. The 20-mA values can be displayed in the display page and processed with CFC charts.

Error Responses

If the current input value is determined to be incorrect, the quality attribute of the output value is set to *invalid*. That status for *Health* and the defect status assume the states displayed in the table.

Table 5-10 Error Responses

Error Description	Status <i>Health</i>	Error Status
The input value lies outside the given limits	OK	Yes
Channel not connected	OK	No

5.6.3.6 Application and Setting Notes

Parameter: Unit

- Default setting (_:13111:103) **Unit** = °C
- With the **Unit** parameter, you set the physical unit of measurement the measured values. The possible setting values are listed in the settings table.

Parameter: Conversion factor

- Default setting (_:13111:104) **Conversion factor** = 100
- With the **Conversion factor** parameter, you set the conversion factor for the measuring transducer.

Parameter: Resolution

- Default setting (_:13111:108) **Resolution** = 0.1

With the **Resolution** parameter, you set the resolution of the scaled values.

Parameter: Range active

- Default setting (`_:13111:107`) **Range active** = *false*

If you do not activate the parameter **Range active** (no x in the check box), the function operates over the range 0 mA to 20 mA. The setting of the range for the scaled value goes from a usable range of 0 mA to 20 mA.

If you activate the parameter **Range active**, the 4 additional parameters **Upper limit**, **Upper limit - Sensor**, **Lower limit**, and **Lower limit - Sensor** appear.

Parameter: Upper limitLower limitUpper limit - Sensor and Lower limit - Sensor

- Default setting (`_:13111:105`) **Upper limit** = *20.000 mA*
- Default setting (`_:13111:109`) **Upper limit - Sensor** = *100*
- Default setting (`_:13111:106`) **Lower limit** = *4.000 mA*
- Default setting (`_:13111:110`) **Lower limit - Sensor** = *100*

If you activate the parameter **Range active**, the 4 additional parameters **Upper limit**, **Lower limit**, **Upper limit - Sensor**, and **Lower limit - Sensor** appear. The parameter **Upper limit - Sensor** is the calculated measured value if the input current corresponds to the value in the **Upper limit** setting. The parameter **Lower limit - Sensor** is the calculated measured value if the input current corresponds to the value in the **Lower limit** setting.

The following settings and information table shows only 1 of the 12 channels, as the setting possibilities of the 12 channels do not differ.

5.6.3.7 Settings

Addr.	Parameter	C	Setting Options	Default Setting
<i>General</i>				
<code>_:2311:103</code>	General:Port		<ul style="list-style-type: none"> • port F 	port F

Addr.	Parameter	C	Setting Options	Default Setting
Channel 1				
_:13111:103	Channel 1:Unit		<ul style="list-style-type: none"> • % • ° • °C • °F • Ω • Ω/km • Ω/mi • 1/s • A • As • cos φ • cycles • dB • F/km • F/mi • h • Hz • Hz/s • in • J • J/Wh • K • l/s • m • mi • min • p.u. • Pa • periods • rad • rad/s • s • V • V/Hz • VA • VAh • var • varh • Vs • W 	m

Addr.	Parameter	C	Setting Options	Default Setting
			<ul style="list-style-type: none"> W/s Wh 	
_:13111:108	Channel 1:Resolution		<ul style="list-style-type: none"> 1 0.1 0.01 0.001 	0.1
_:13111:107	Channel 1:Range active		<ul style="list-style-type: none"> 0 1 	false
_:13111:104	Channel 1:Conversion factor		1 to 1000000	100
_:13111:105	Channel 1:Upper limit		0.00 mA to 20.00 mA	20.00 mA
_:13111:109	Channel 1:Upper limit - Sensor		-1000000 to 1000000	100
_:13111:106	Channel 1:Lower limit		0.00 mA to 20.00 mA	4.00 mA
_:13111:110	Channel 1:Lower limit - Sensor		-1000000 to 1000000	100

5.6.3.8 Information List

No.	Information	Data Class (Type)	Type
General			
_:2311:52	General:Behavior	ENS	O
_:2311:53	General:Health	ENS	O
_:2311:56	General:Failure	SPS	O
Channel 1			
_:13111:50	Channel 1:Behavior	ENS	O
_:13111:53	Channel 1:Health	ENS	O
_:13111:71	Channel 1:Failure	SPS	O
_:13111:301	Channel 1:20-mA output scale	MV	O
_:13111:302	Channel 1:20-mA output raw	MV	O

5.6.4 20-mA Unit Serial

5.6.4.1 Overview

The function **20-mA unit Serial**:

- Provides serial communications with a 20-mA unit via the Modbus protocol and records the values measured by the 20-mA unit
- Transforms the measured 20-mA values into slowly changing process variables such as temperature or gas pressure
- Makes the recorded process tags available to CFC, GOOSE, protocols and the device display
- Monitors communication with the 20-mA unit

The function **20-mA unit Serial** is structured in the same way as the function **20-mA Unit Ether..** The mode of operation is also identical. The only difference is that the measured values are transferred to the communication module via a serial connection instead of an Ethernet connection.

You can find more information in Chapter [5.6.3.2 Structure of the Function](#).

5.6.4.2 Application and Setting Notes

Parameter: Port

- Default setting (`_:2311:103`) **Port** = *Port E*

With the parameter **Port**, you specify the slot for the communication module that will be used for the connection with an external 20-mA unit.

Parameter: Channel number

- Default setting (`_:2311:105`) **Channel number** = *1*

With the parameter **Channel number**, you specify the channel number used to connect the 20-mA unit to the device. The communication module inputs are labeled with the channel numbers.

Parameter: Slave address

- Default setting (`_:2311:106`) **Slave address** = *1*

With the parameter **Slave address**, you define the device address of the 20-mA unit. If only one 20-mA unit is connected to the serial bus, the default value *1* can be used. Set the same device address as used with the 20-mA unit. The device address is important for distinguishing several 20-mA units that are connected to a serial bus. Set an unambiguous device address on every 20-mA unit, for example, 1, 2 and 3 when connecting 3 of the 20-mA units. On every 20-mA unit, set for the parameter **Slave address** in the 3 functions **20-mA Unit Serial**.

Parameter: Unit

- Default setting (`_:13111:103`) **Unit** = *°C*

With the parameter **Unit**, you set the physical unit of measurement the measured values. The possible setting values are listed in the settings table.

Parameter: Conversion factor

- Default setting (`_:13111:104`) **Conversion factor** = *100*

With the parameter **Conversion factor**, you set the conversion factor for the measuring transducer.

Parameter: Resolution

- Default setting (`_:13111:108`) **Resolution** = *0.1*

With the parameter **Resolution**, you set the resolution of the scaled values.

Parameter: Range active

- Default setting (`_:13111:107`) **Range active** = *false*

If you do not activate the parameter **Range active** (no x in the check box), the function operates over the range 0 mA to 20 mA. The setting of the range for the scaled value goes from a usable range of 0 mA to 20 mA.

If you activate the parameter **Range active**, the 4 additional parameters **Upper limit**, **Upper limit - Sensor**, **Lower limit**, and **Lower limit - Sensor** appear.

Parameter: Upper limit, Lower limit, Upper limit - Sensor, and Lower limit - Sensor

- Default setting (`_:13111:105`) **Upper limit** = *20 mA*
- Default setting (`_:13111:109`) **Upper limit - Sensor** = *100*
- Default setting (`_:13111:106`) **Lower limit** = *4 mA*
- Default setting (`_:13111:110`) **Lower limit - Sensor** = *100*

If you activate the parameter **Range active**, the 4 additional parameters **Upper limit**, **Lower limit**, **Upper limit - Sensor**, and **Lower limit - Sensor** appear. The parameter **Upper limit - Sensor** is the calculated measured value if the input current corresponds to the value in the **Upper limit** setting. The parameter **Lower limit - Sensor** is the calculated measured value if the input current corresponds to the value in the **Lower limit** setting.

The following settings and information table shows only 1 of the 12 channels, as the setting possibilities of the 12 channels do not differ.

5.6.4.3 Settings

Addr.	Parameter	C	Setting Options	Default Setting
<i>General</i>				
_:2311:103	General:Port		• port E	port E
_:2311:105	General:Channel number		1 to 2	1
_:2311:106	General:Slave address		1 to 247	1

Addr.	Parameter	C	Setting Options	Default Setting
Channel 1				
_:13111:103	Channel 1:Unit		<ul style="list-style-type: none"> • % • ° • °C • °F • Ω • Ω/km • Ω/mi • 1/s • A • As • cos φ • cycles • dB • F/km • F/mi • h • Hz • Hz/s • in • J • J/Wh • K • l/s • m • mi • min • p.u. • Pa • periods • rad • rad/s • s • V • V/Hz • VA • VAh • var • varh • Vs • W 	m

Addr.	Parameter	C	Setting Options	Default Setting
			<ul style="list-style-type: none"> • W/s • Wh 	
_:13111:108	Channel 1:Resolution		<ul style="list-style-type: none"> • 1 • 0.1 • 0.01 • 0.001 	0.1
_:13111:107	Channel 1:Range active		<ul style="list-style-type: none"> • 0 • 1 	false
_:13111:104	Channel 1:Conversion factor		1 to 1000000	100
_:13111:105	Channel 1:Upper limit		0.00 mA to 20.00 mA	20.00 mA
_:13111:109	Channel 1:Upper limit - Sensor		-1000000 to 1000000	100
_:13111:106	Channel 1:Lower limit		0.00 mA to 20.00 mA	4.00 mA
_:13111:110	Channel 1:Lower limit - Sensor		-1000000 to 1000000	100

5.6.4.4 Information List

No.	Information	Data Class (Type)	Type
General			
_:2311:52	General:Behavior	ENS	O
_:2311:53	General:Health	ENS	O
_:2311:56	General:Failure	SPS	O
Channel 1			
_:13111:50	Channel 1:Behavior	ENS	O
_:13111:53	Channel 1:Health	ENS	O
_:13111:71	Channel 1:Failure	SPS	O
_:13111:301	Channel 1:20-mA output scale	MV	O
_:13111:302	Channel 1:20-mA output raw	MV	O

5.6.5 Communication with 20-mA Unit

5.6.5.1 Integration of a Serial 20-mA Unit

Connection of the Communication Lines

[Figure 5-52](#) shows how to connect the 20-mA unit to the SIPROTEC 5 Compact device. Note that Pin 1 of the RJ45 plug is connected to RTD-B and Pin 2 is connected to RTD-A.

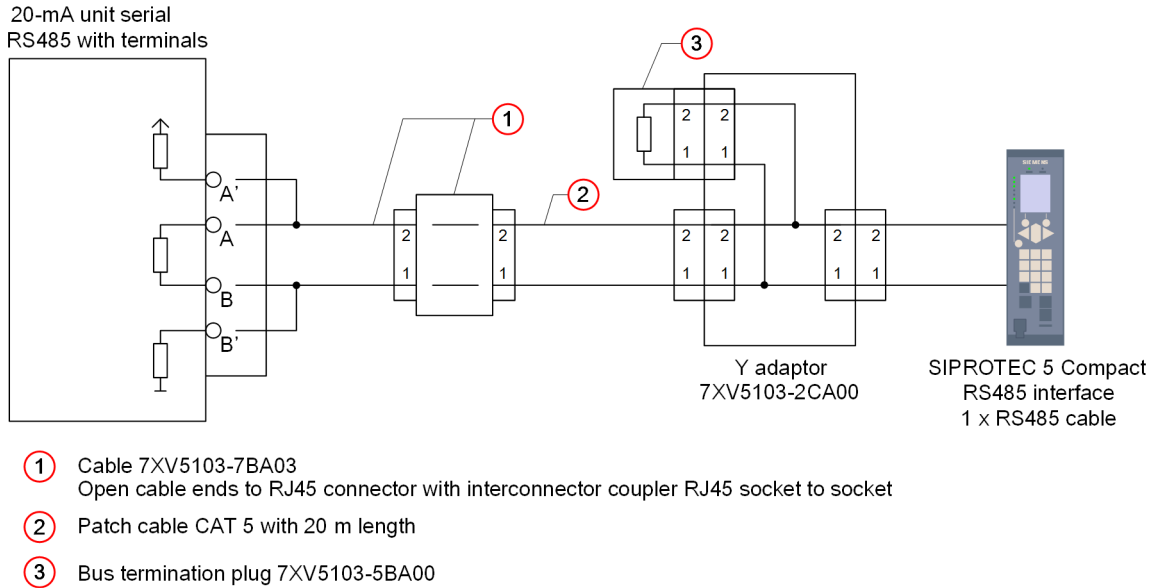

[dw_ve20aucmpct, 1, en_US]

Figure 5-52 Connection of the 20-mA Unit to the SIPROTEC 5 Compact Device

Selecting the SUP Protocol

Select the Slave Unit Protocol (SUP). This protocol is responsible for the communication between the SIPROTEC 5 device and the 20-mA unit.

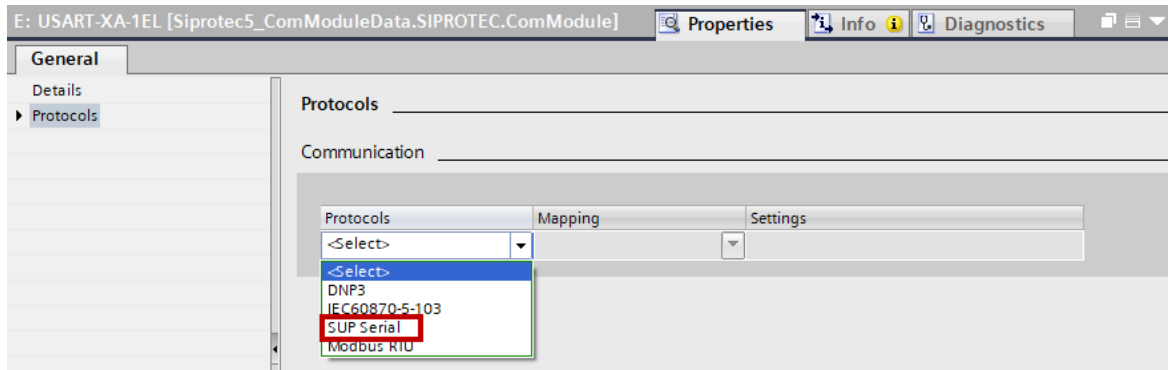

[sc_supp01_75X800, 1, en_US]

Figure 5-53 Selecting the SUP Protocol

Communication Settings

Make the communications settings for the relevant serial channels. For this, use the default settings specified by the 20-mA unit. Normally, you must adapt only the parameterization of the SIPROTEC 5 device to the settings of the 20-mA unit. Make sure that the setting values in both devices are the same. The setting of the parameter **Non-flickering light (on/off)** : is not relevant for the RS485 interface.



NOTE

The driver of the serial interface for the SUP protocol is not preinstalled as standard for the initial use of this interface (following the firmware update).

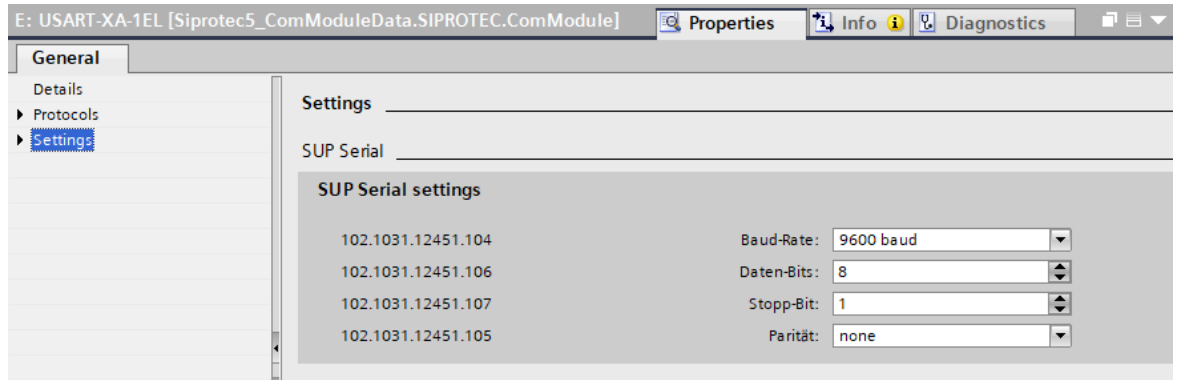

[sc_supprot02_75X800, 1, en_US]

Figure 5-54 Making the Communication Settings

With the selection of the SUP protocol for the 20-mA unit DIGSI automatically adds the function group **Analog units** to your device configuration. You can now instantiate the function **20-mA unit serial 1** (see the following figure).

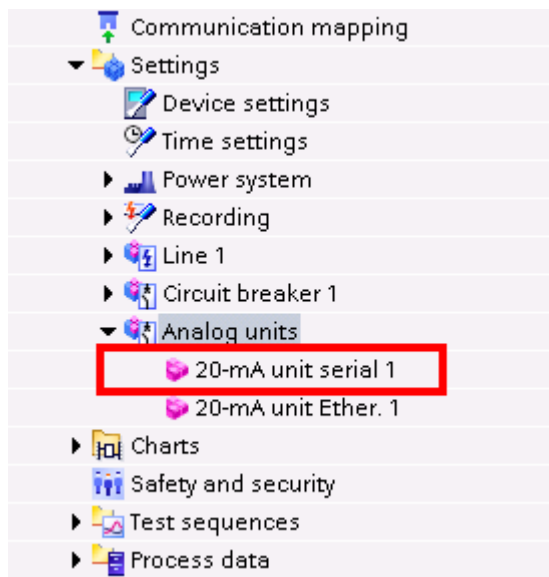

[sc20ser6-220114-01-DE, 1, en_US]

Figure 5-55 Insertion of the Function 20-mA Unit Serial 1

Now, set the channel number over which the SUP protocol runs. In addition, set the slave address of the 20-mA unit. This address must be set with the same value in the 20-mA unit (refer to the following figure). For the first use of the 20-mA unit, the following device configuration must be set on the 20-mA unit:

- Bus protocol: mod
- Device address: 1
- Baud rate: 9600
- Parity: no

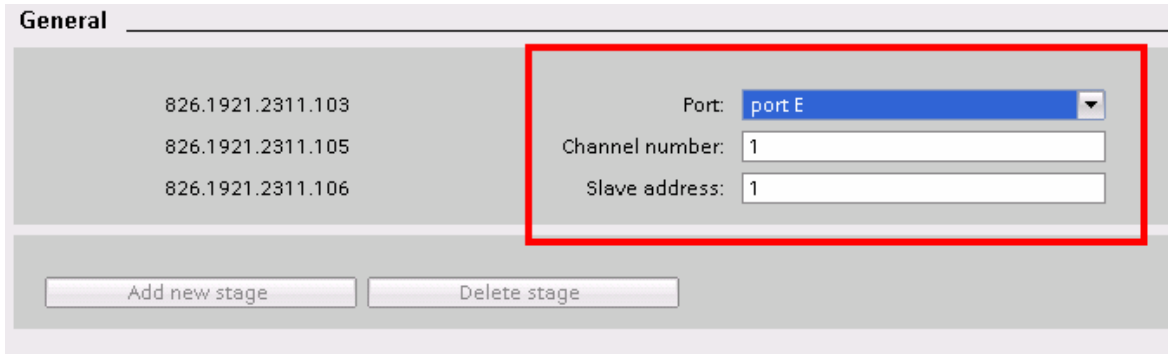

[scauser7a, 1, en_US]

Figure 5-56 Setting the Port, Channel Number, and Device Address

Finally, load the configuration in the device.

5.6.5.2 Integration of a 20-mA Unit Ethernet

Device Configuration

Connect the 20-mA unit Ethernet via port E.

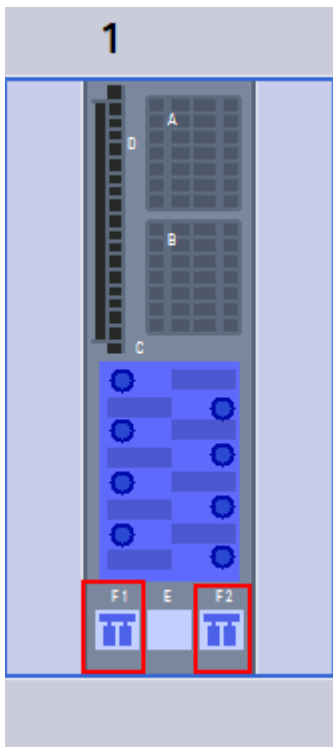

[sc_PortF, 1, --]

Figure 5-57 Possible Connection Ports for the 20-mA Unit Ethernet

Communication Settings

Activate the SUP Ethernet protocol for the integrated Ethernet interface.

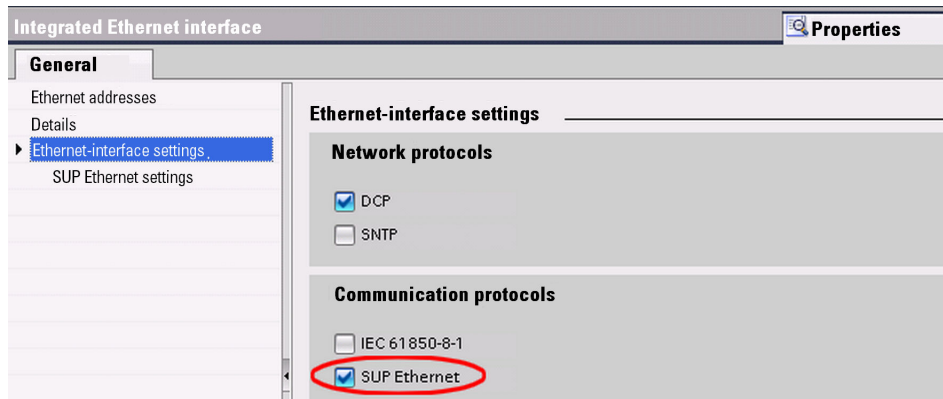

[sc_autcp3, 1, en_US]

Figure 5-58 Selection of the Protocol

With the selection of the SUP protocol for the 20-mA unit, DIGSI automatically adds the **Analog units** function group and the **20-mA unit Ether. 1** function to your device configuration (refer to the following figure).

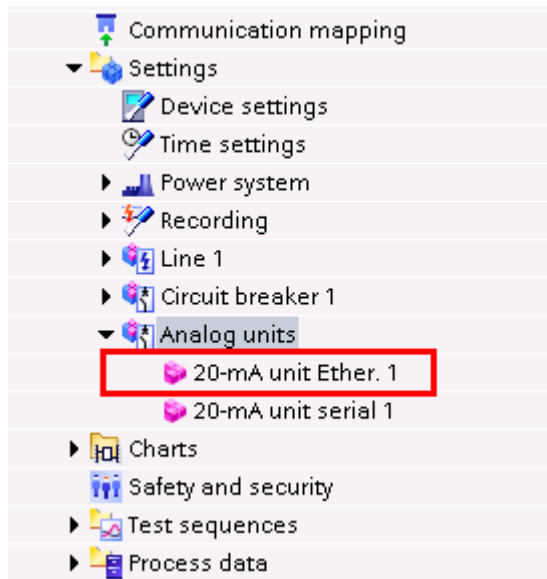

[sc_20tcp4, 1, en_US]

Figure 5-59 Insertion of the Function 20-mA Unit Ether. 1

Now, set the port over which the SUP protocol runs. In addition, set the IP address of the 20-mA unit (refer to the following figure). This address must be set with the same value in the 20-mA unit.

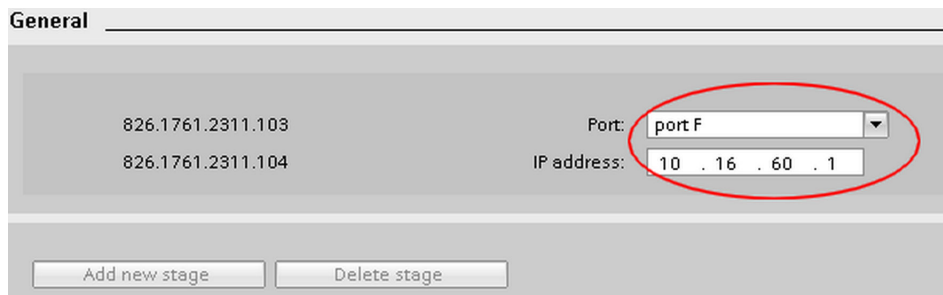

[sc_autcp5, 1, en_US]

Figure 5-60 Setting the Port and IP Address

Finally, load the configuration in the device.

5.6.6 RTD Unit Ethernet

5.6.6.1 Overview

The **RTD unit Ether.** function:

- Communicates with an external RTD unit via the Slave Unit Protocol (SUP) and records the measured temperatures from the RTD unit
- Provides the captured temperatures to the temperature monitoring function
- Monitors communication with the RTD unit

5.6.6.2 Structure of the Function

The **RTD unit Ether.** function can only work in the **Analog units** function group. A maximum of 20 function instances can work simultaneously. Each instance contains 12 preconfigured sensor function blocks.

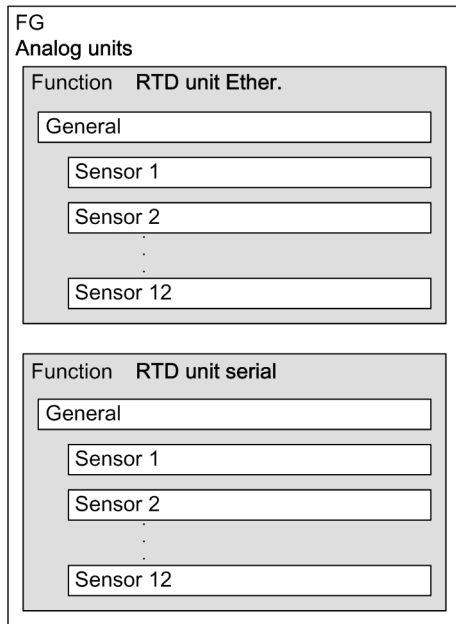

[dw_str_fnc_2_en_US]

Figure 5-61 Structure/Embedding of the Function

5.6.6.3 Communication with an RTD Unit

Logic

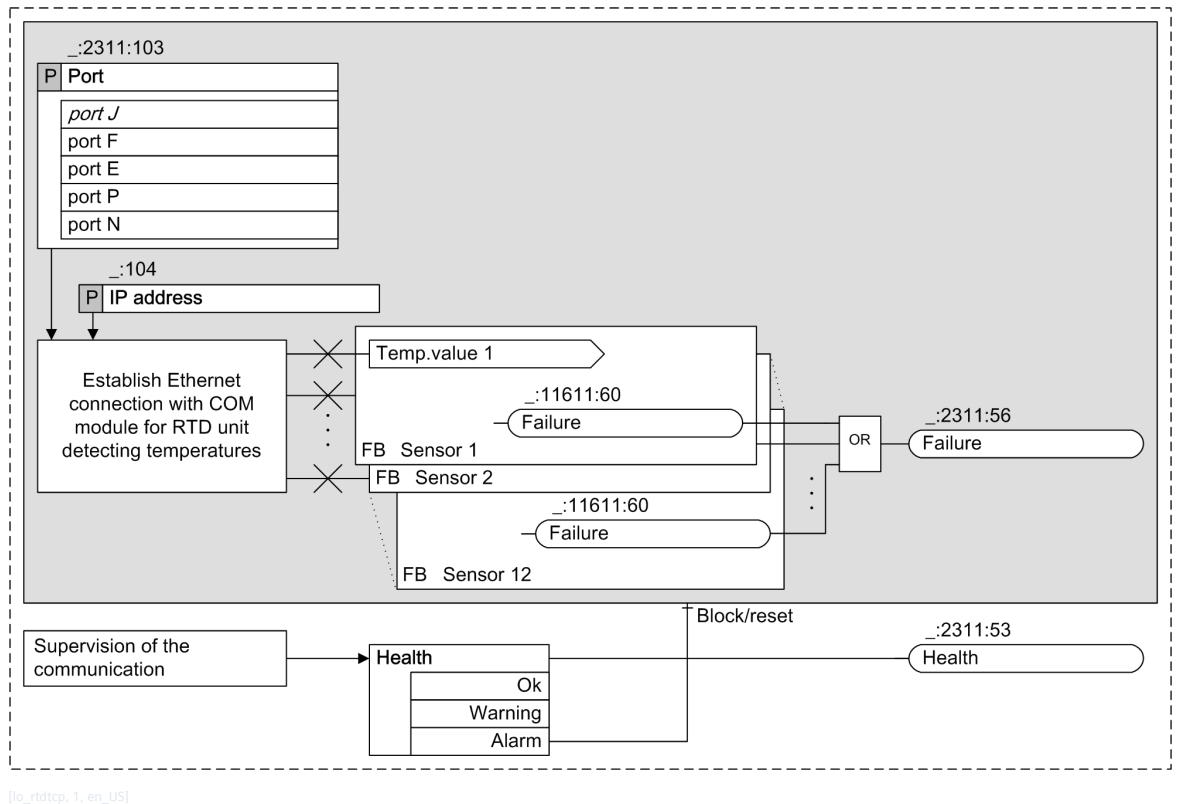

Figure 5-62 Logic of the RTD Unit Ether. Function



NOTE

In SIPROTEC 5 Compact devices, only port F port is available to connect to the RTD unit Ethernet.

Communication with an RTD Unit

The function is used to communicate with an RTD unit connected via an Ethernet connection. If the connection of the function is successfully established to the external RTD unit via the Ethernet interface, the RTD unit transmits the temperatures of all connected sensors to the **RTD unit Ether**. function. For the connection to be established successfully, specific communication settings must be set, see chapter [5.6.6.4 Application and Setting Notes](#).

The RTD unit **Ziehl TR1200 IP** supports only an Ethernet connection of 10 MBit/s. A direct connection to an integrated Ethernet interface is therefore not possible. For this reason, you must connect the RTD unit to the integrated Ethernet interface via a 10/100 MBit/s autosensing switch which automatically recognizes the transmission rates and adapts them accordingly. Further information can be found in the Application and setting notes, see chapter [5.6.6.4 Application and Setting Notes](#).

Error Responses

The following table lists the conditions under which the *Health* status transitions to the Alarm or Warning state.

Table 5-11 Error Responses

Error Description	Status Health
The RTD unit Ether. function cannot establish a connection with the integrated Ethernet interface.	Alarm
The connection between the integrated Ethernet interface and the RTD unit causes a time-out.	Warning
The integrated Ethernet interface has not received any more data from the RTD unit for 9 sec.	Warning

The *Failure* signal is issued as soon as one of the sensor function blocks reports a failure.

5.6.6.4 Application and Setting Notes

Parameter: Port

- Default setting (`_:2311:103`) **Port** = *port F*

With the parameter **Port**, you define the port connecting the 20-mA unit to the SIPROTEC 5 Compact device.

Parameter: IP address

- Default setting (`_:2311:104`) **IP address** = *10.16.60.1*

With the parameter **IP address**, you set the IP address of the RTD unit connected to the integrated Ethernet interface via the SUP protocol. Every RTD unit has to be assigned a unique IP address. The IP address to be set depends on your network configuration. You can set any valid IPv4 address that does not cause conflicts with other IP addresses in the network. Set an appropriate IP address first at the **Ziehl TR1200 IP** RTD unit. Then specify the parameter **IP address** for the integrated Ethernet interface to the same address.

Settings on the RTD Unit

The **Ziehl TR1200 IP** RTD unit is set with the front keys or in a Web browser on a laptop computer via its Ethernet interface. Set the connection type of the sensors (3-wire connection or resistance value for 2-wire connection), the idle state of the fault-indication relay, as well as the IP interface setting.

The code lock has to be switched off for parameterization. This is only possible using the front keys of the RTD unit. The code lock is **off** (switched off) in as-delivered condition and has pin **504**.

For detailed information on the settings, refer to the TR1200 IP manual that comes with the RTD unit. The documents are also available in the SIPROTEC download area (<http://www.siprotec.de>) under **Accessories -> 7XV5662-xAD**.

For an Ethernet connection to a SIPROTEC 5 device communicating with the RTD unit TR1200 IP via the **SUP protocol** (Slave Unit Protocol), the **Modbus TCP** setting must be activated in the RTD unit. You can activate the Modbus TCP protocol using the function keys under the **tcp**. → **Mod / on** menu item or with the Web browser in the **TCP/UDP Config** tab. The **RTD** (RTD protocol) and **UDP Port** settings have no effect here. The Modbus TCP port is permanently set to 502 and cannot be changed.

5.6.6.5 Temperature Sensor

Logic

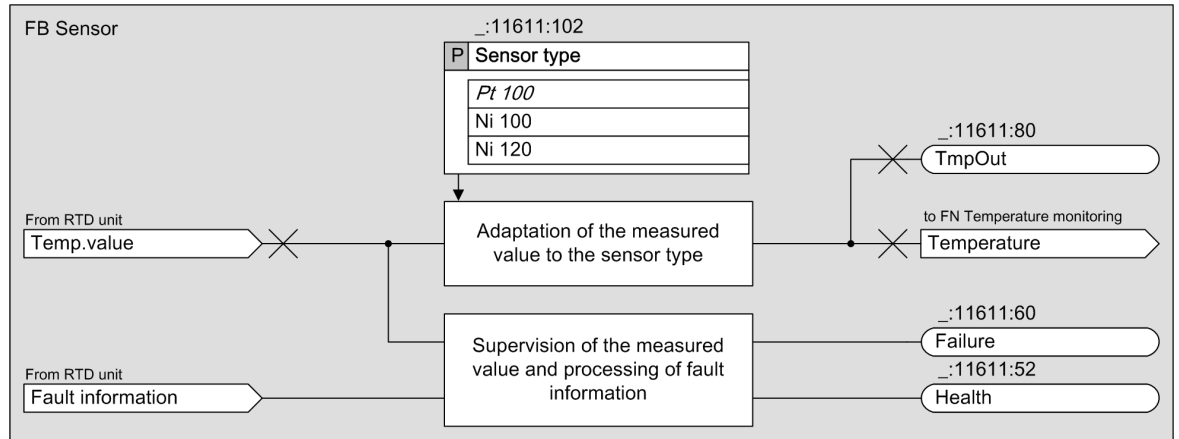

[to: tmpval,], en_US

Figure 5-63 Logic Diagram of the Temperature Sensor Function Block

Measured Temperature Value

The **Temperature sensor** function block processes one single measured temperature value delivered from the RTD unit for the assigned sensor. 12 temperature sensor function blocks are always available in each RTD unit function (both via Ethernet and serial), even if fewer sensors are connected to the RTD unit.

Various temperature sensor types are supported: Pt100, Ni100, and Ni120 sensors. The function block is notified regarding the selection of connected type via the **Sensor type** parameter.

The function block delivers a measured temperature value in °C or °F as an output variable. The measured temperature value is available as an operational measured value and can be monitored by the **Temperature supervision** function.

Error Responses

If the measured input value is determined to be incorrect, the quality attribute of the output measured temperature value is set to *invalid*. The statuses for Health and Error take the statuses in accordance with the following table:

Table 5-12 Error response

Error Description	Health Status	Error Status
Sensor or line short circuited	Alarm	Yes
Sensor or line interrupted	Alarm	Yes
Measured temperature value outside the valid measuring range specified in the technical data. The valid measuring range depends on the sensor type.	Alarm	Yes
Sensor not connected	OK	No

5.6.6.6 Application and Setting Notes

Parameter: Sensor type

- Default setting (`_:11611:102`) **Sensor type** = *Pt 100*

The **Sensor type** parameter is used to set the sensor element used. You can select between *Pt 100*, *Ni 100* and *Ni 120*.

Parameter: Temperature unit

To change the display and evaluation of measured temperature values from °C to °F, adapt the DIGSI user default settings accordingly.

Proceed as follows:

- In DIGSI select the menu item **Extras --> Settings**.
- In the **Settings** view select the menu item **DIGSI 5 User preferences**.
- Under **Standard unit system** change the setting value of the unit system used from *SI units* to *US units*.

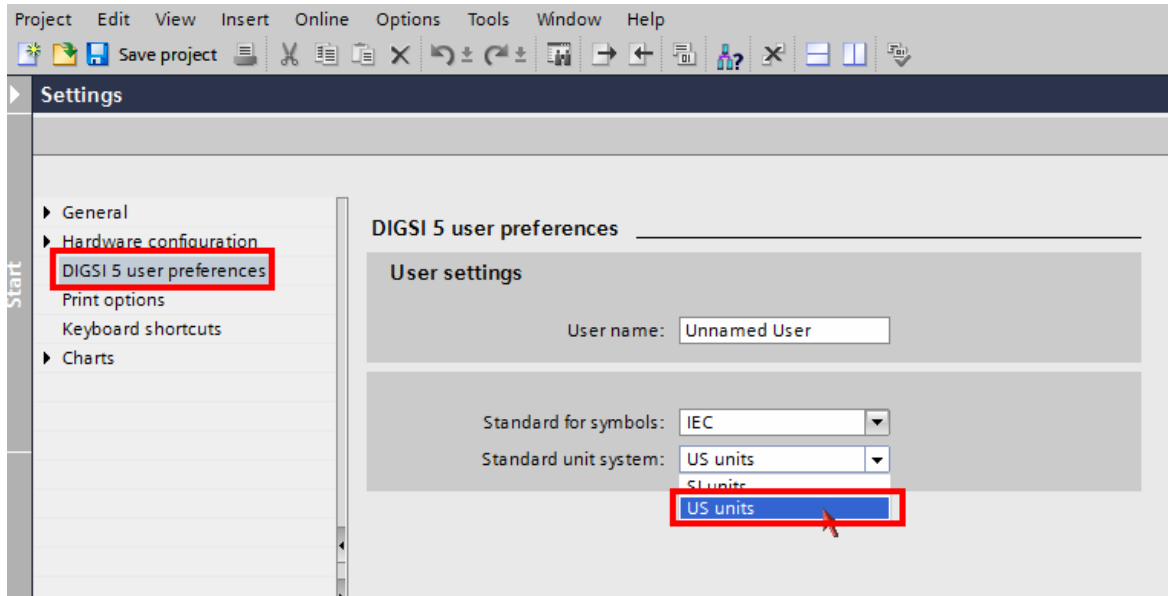

[scafahrt-190214-01, 1, en_US]

Figure 5-64 Change of the Display Between °C and °F

The following settings and information table shows only 1 of the 12 sensors, as the setting possibilities of the 12 sensors do not differ.

5.6.6.7 Settings

Addr.	Parameter	C	Setting Options	Default Setting
<i>General</i>				
_:2311:103	General:Port		• port F	port F
<i>Sensor 1</i>				
_:11611:102	Sensor 1:Sensor type		• Pt 100 • Ni 100 • Ni 120	Pt 100

5.6.6.8 Information List

No.	Information	Data Class (Type)	Type
<i>General</i>			
_:2311:52	General:Behavior	ENS	O
_:2311:53	General:Health	ENS	O
_:2311:56	General:Failure	SPS	O

No.	Information	Data Class (Type)	Type
<i>Sensor 1</i>			
_:11611:51	Sensor 1:Behavior	ENS	O
_:11611:52	Sensor 1:Health	ENS	O
_:11611:60	Sensor 1:Failure	SPS	O
_:11611:80	Sensor 1:TmpOut	MV	O

5.6.7 RTD Unit, Serial

5.6.7.1 Overview

The **RTD unit serial** function:

- Communicates with an external RTD unit serial via the Slave Unit Protocol (SUP) and records the measured temperatures from the RTD unit
- Provides the captured temperatures to the temperature supervision function
- Monitors communication with the RTD unit

The **RTD unit Serial** function is set up structurally in the same manner as the **RTD unit Ether.** function. The mode of operation is also identical (see [5.6.6.3 Communication with an RTD Unit](#)).

5.6.7.2 Application and Setting Notes

Parameter: Port

- Default setting (_:2311:103) **Port** = *E*

With the parameter **Port**, you set the slot for the communication module that will be used for the connection with an external RTD unit.

If you want to connect the external RTD unit to the serial interface, set the parameter **Port** = **Port E**.

Parameter: Channel number

- Default setting (_:2311:105) **Channel number** = *1*

With the parameter **Channel number**, you specify the channel number via which an RTD unit is connected to the device. The communication-module inputs are labeled with the channel numbers.

Parameter: Slave address

- Default setting (_:2311:106) **Slave address** = *1*

With the parameter **Slave address**, you define the device address of the RTD unit. If only one RTD unit is connected to the serial bus, the default value *1* can be used. The same device address has to be set on the RTD unit. The device address is important for distinguishing among several RTD units connected to a serial bus. Set a unique device address (for example 1, 2, and 3 when connecting 3 RTD units) for each RTD unit and the same device address for the parameter **Slave address** in the 3 **RTD unit serial** functions.

The following settings and information table shows only 1 of the 12 sensors, as the setting possibilities of the 12 sensors do not differ.

5.6.7.3 Settings

Addr.	Parameter	C	Setting Options	Default Setting
<i>General</i>				
_:2311:103	General:Port		• port E	port E
_:2311:105	General:Channel number		1 to 2	1
_:2311:106	General:Slave address		1 to 247	1

Addr.	Parameter	C	Setting Options	Default Setting
Sensor 1				
_:11611:102	Sensor 1:Sensor type		<ul style="list-style-type: none"> Pt 100 Ni 100 Ni 120 	Pt 100

5.6.7.4 Information List

No.	Information	Data Class (Type)	Type
General			
_:2311:52	General:Behavior	ENS	O
_:2311:53	General:Health	ENS	O
_:2311:56	General:Failure	SPS	O
Sensor 1			
_:11611:51	Sensor 1:Behavior	ENS	O
_:11611:52	Sensor 1:Health	ENS	O
_:11611:60	Sensor 1:Failure	SPS	O
_:11611:80	Sensor 1:TmpOut	MV	O

5.6.8 Communication with RTD Unit

5.6.8.1 Integration of a Serial RTD Unit (Ziehl TR1200)

Connection of the Communication Lines

Figure 5-65 shows how you connect the RTD unit to the SIPROTEC 5 Compact device. Note that Pin 1 of the RJ45 plug is connected to RTD-B and Pin 2 is connected to RTD-A.

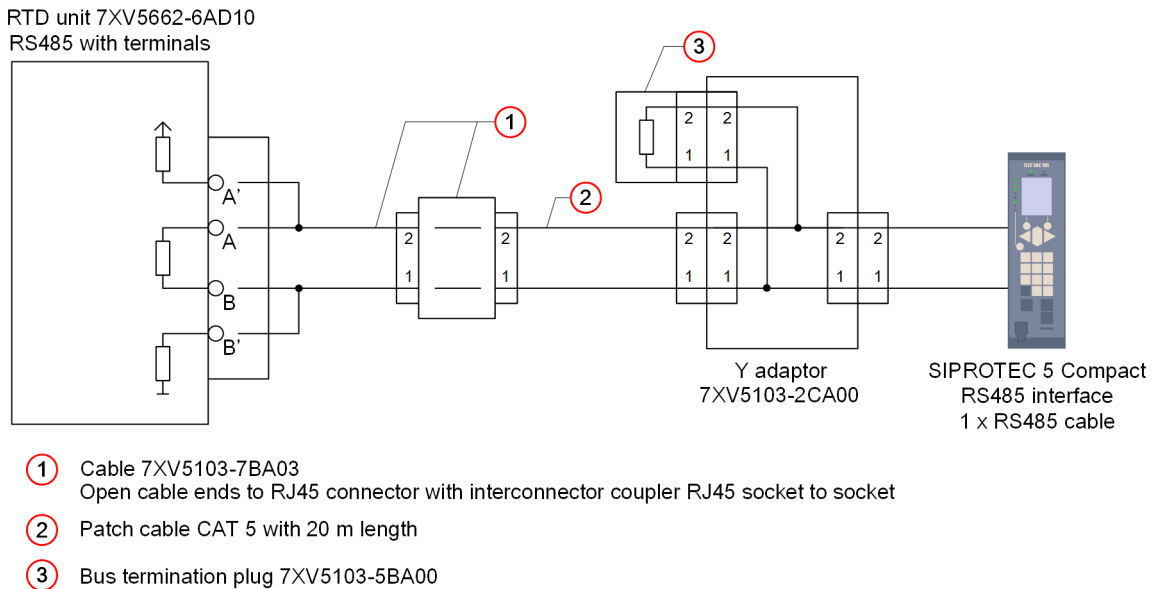

[dsw_verbaucmpct_1_en_US]

Figure 5-65 Connection of the RTD Unit to the SIPROTEC 5 Compact Device

Selecting the SUP Protocol

Select the Slave Unit Protocol (SUP). This protocol is responsible for the communication between the SIPROTEC 5 device and the RTD Unit.

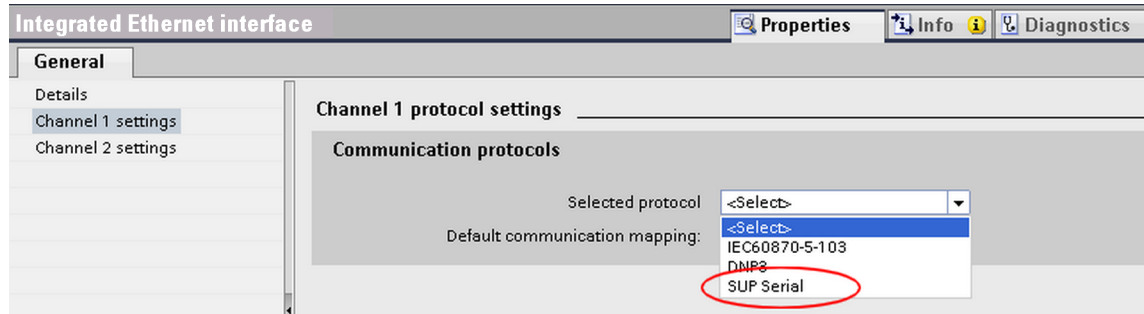

[scauser4-020323, 1, en_US]

Figure 5-66 Selecting the SUP Protocol

Communication Settings

Make the communications settings for the relevant serial channels. For this, use the default settings specified by the RTD box. Normally, you must adapt only the parameterization of the SIPROTEC 5 device to the settings of the RTD box. Make sure that the setting values in both devices are the same. The setting of the parameter **Non-flickering light (on/off)** : is not relevant for the RS485 interface.



NOTE

The driver for the USART module for the SUP protocol is not preinstalled as standard for the initial use of this interface (following the firmware update).

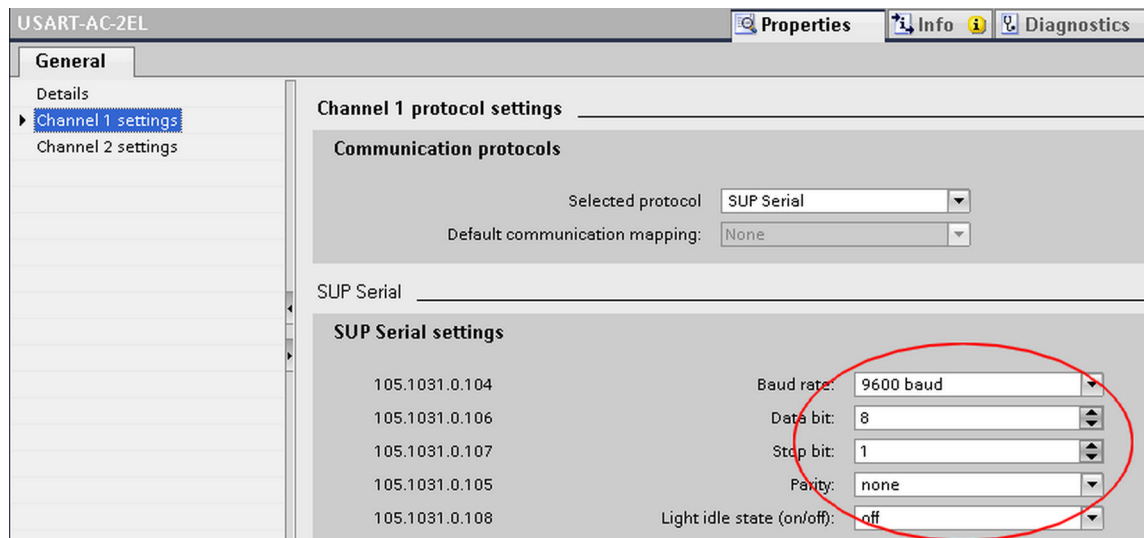

[scauser5-301012-01.tif, 1, en_US]

Figure 5-67 Making the Communication Settings

With the selection of the SUP protocol for the RTD box DIGSI automatically adds the function group **Analog units** to your device configuration. You can now instantiate the function **RTD unit serial 1** (refer to the following figure).

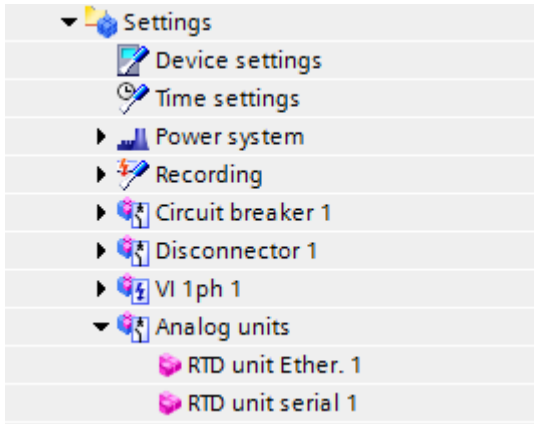

[sc_auser6, 1, en_US]

Figure 5-68 Analog-Unit Instance

Now, set the channel number over which the SUP protocol runs. In addition, set the slave address of the RTD unit. This address must be set with the same value in the RTD box (refer to the following figure).

The following device configuration must be set on the TR1200 RTD unit when the RTD unit is used for the first time:

- Bus protocol: mod
- Device address: 1
- Baud rate: 9600
- Parity: no

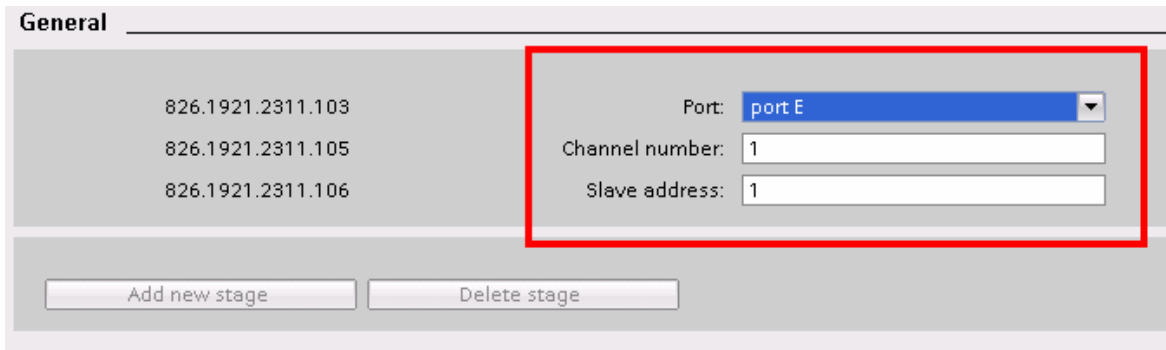

[scauser7a, 1, en_US]

Figure 5-69 Setting the Port, Channel Number, and Slave Address

Finally, load the configuration in the device.

5.6.8.2 Integration of an RTD Unit Ether. (TR1200 IP)

Device Configuration

Connect the RTD unit via port E.

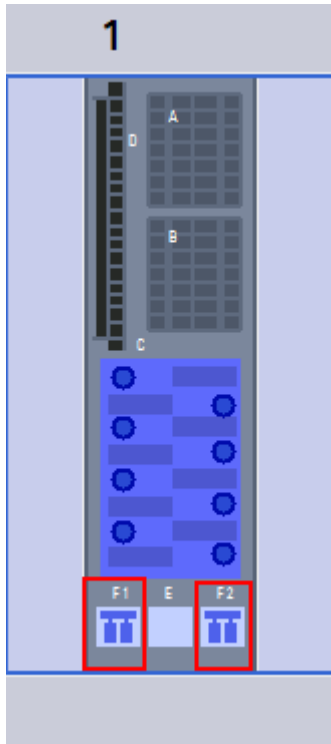

[sc_PortF, 1, _-]

Figure 5-70 Possible Connection Ports for the RTD Unit

Communication Settings

Activate the SUP Ethernet protocol for the integrated Ethernet interface.

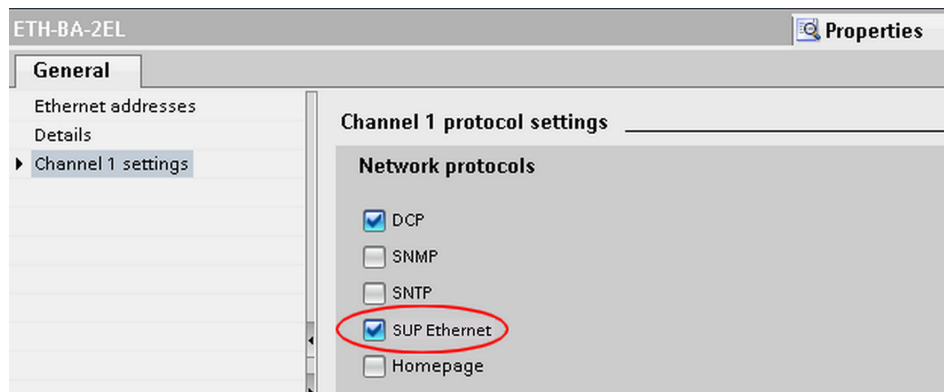

[sc_autcp2, 1, en_US]

Figure 5-71 SUP Ethernet Protocol Activation

With the selection of the SUP protocol for the RTD unit, DIGSI automatically adds the **Analog units** function group and the **RTD unit Ether.** function to your device configuration (refer to the following figure).

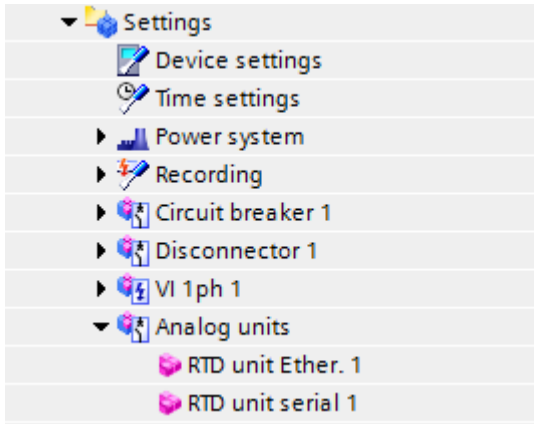

[sc_auser6, 1, en_US]

Figure 5-72 Analog Unit Instance

Now, set the port over which the SUP protocol runs. In addition, set the IP address of the RTD unit (refer to the following figure). This address must be set with the same value in the RTD unit.

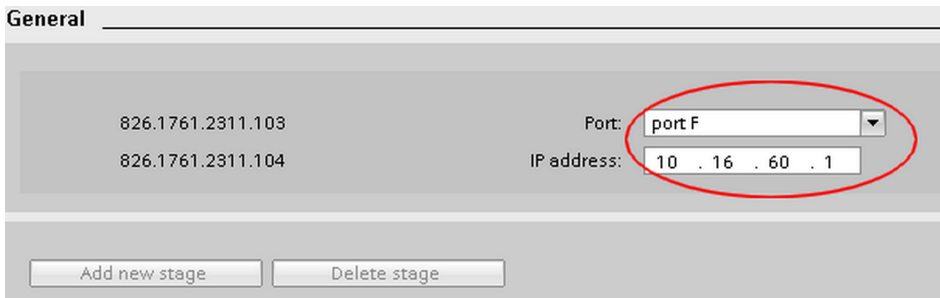

[sc_autcp5, 1, en_US]

Figure 5-73 Setting the Port and IP Address

Finally, load the configuration in the device.

5.6.8.3 Temperature Simulation without Sensors

Connect a resistor on the sensor terminals of the RTD unit. Using this resistor, simulate a constant temperature. The resistance value should be around 50 Ω to 200 Ω.

If you want to simulate a changeable temperature, connect an adjustable resistor of maximum 470 Ω instead of a fixed resistor.

5.6.9 Temperature Acquisition via Protocols

5.6.9.1 Overview

The function **Temperature acquisition via protocols**:

- Obtains the temperature from a power-plant control system or from another protection device
- Processes the temperature, for example, supervises the temperature in the CFC
- Transfers the temperature to other protection devices

5.6.9.2 Structure of the Function

The function **Temperature acquisition via protocols** can work only in the function group **Analog units**. In this function, the following stages can operate simultaneously:

- 12 stages **Temperature acquisition via IEC 61850**
The stage can obtain the temperature from a power-plant control system via the IEC 61850 protocol.
- 12 stages **Temperature acquisition via GOOSE**
The stage can obtain the temperature from another SIPROTEC 5 protection device via the GOOSE protocol.

The function **Temperature acquisition via protocols** comes factory-set with 1 stage **Temperature acquisition via IEC 61850**.

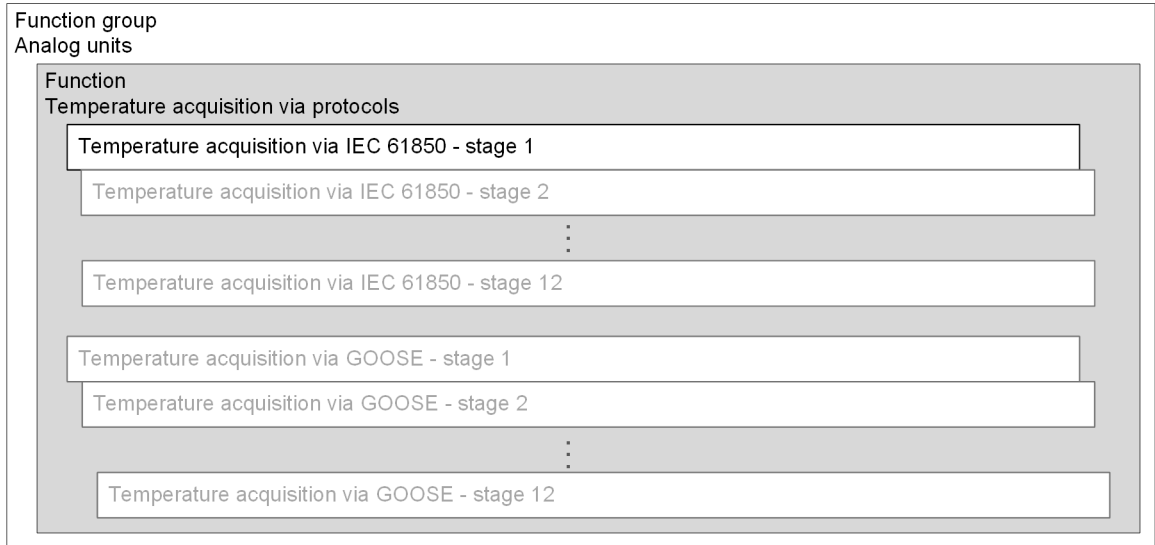

[dw_structure_TmpviaProt_compact, 1, en_US]

Figure 5-74 Structure/Embedding of the Function

5.6.9.3 Stage Temperature Acquisition via IEC 61850

Logic

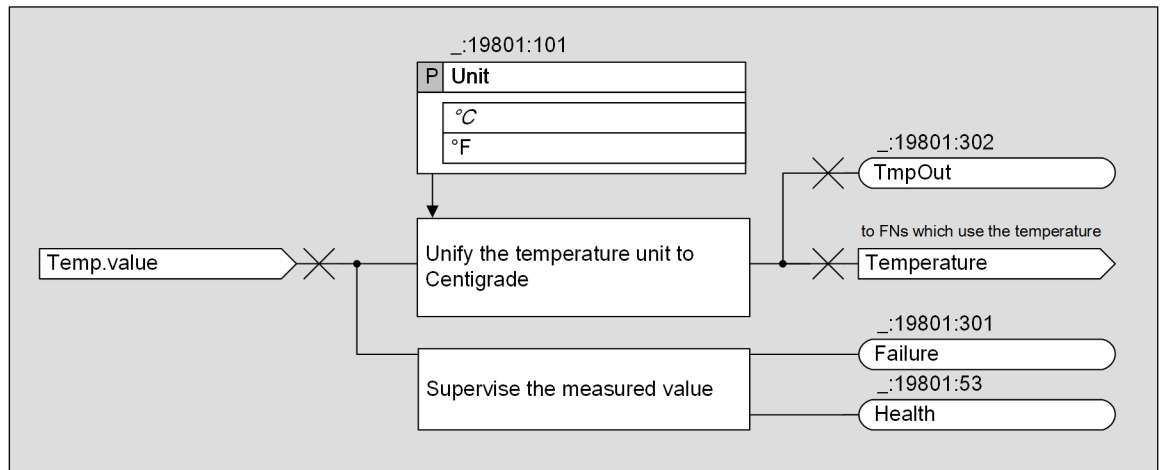

[lo_tmpval, 1, en_US]

Figure 5-75 Logic Diagram of the Stage

The stage processes the transmitted temperature via IEC 61850. Via IEC 61850, the analog value of the temperature, the quality of the temperature, and the time stamp are transmitted.

Invalid Temperature Indication

If the received temperature is invalid, the failure indication *Temperature failure* is issued.

Stage Application

You can use the stage **Temperature acquisition via IEC 61850** for the following purposes:

- Acquire the cold-gas temperature from the power-plant control system
- Process the received cold-gas temperature value
- Send the processed cold-gas temperature value to other functions for further processing

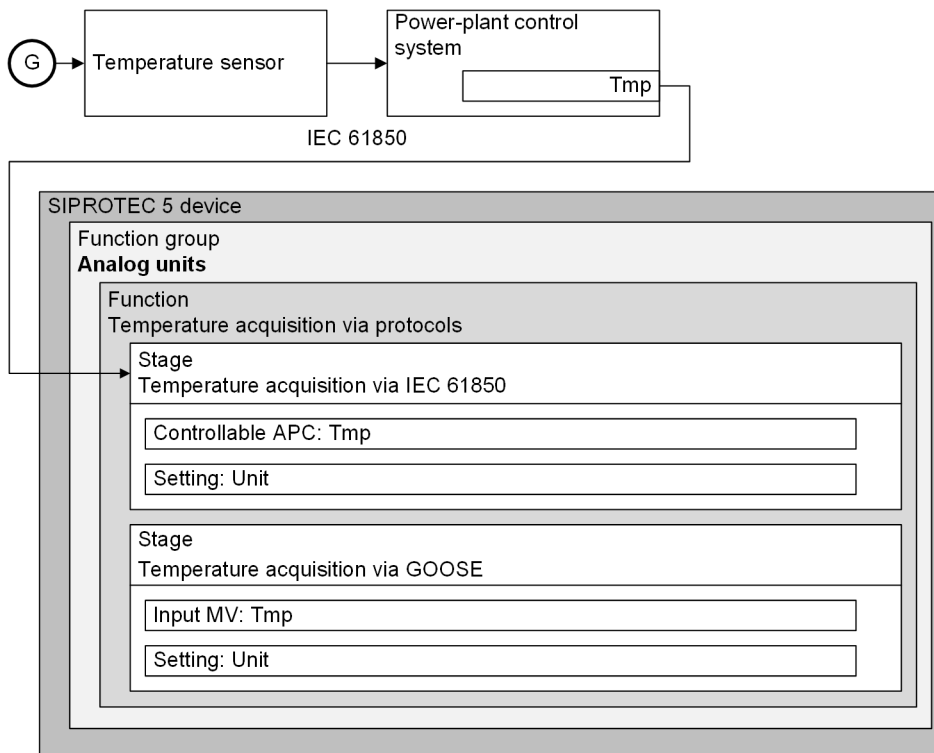

[dw_app-example_iec_compact_1_en_US]
 Figure 5-76 Application Example

The following table explains the data.

Data Name	Description
Tmp	With this variable, you can set the IEC 61850 protocol for the temperature acquisition. In the stage Temperature acquisition via IEC 61850 , the data type is APC.
Unit	With this parameter, you can select the unit °F or °C for the temperature which is acquired from the power-plant control system.

5.6.9.4 IEC 61850 Configuration for the Temperature Acquisition

With the stage **Temperature acquisition via PROFINET IO or IEC 61850**, to acquire the cold-gas temperature via the IEC 61850 protocol, the following configurations are necessary.

IEC 61850 Edition Selection

- ✧ In the project tree, navigate to your device and double-click **Device information**.

- ✧ In the **Device information** tab, set the parameter **Edition** to **IEC 61850 Edition 2** or a higher edition.

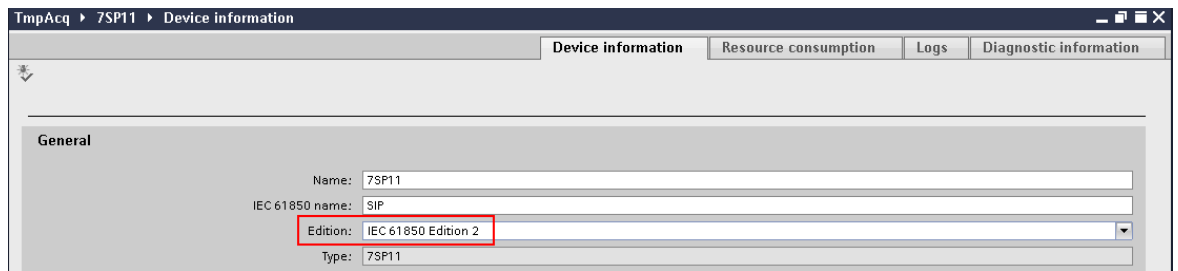

[sc_iec_edition, 1, en_US]

Figure 5-77 IEC 61850 Edition

IP-Address Configuration and Protocol Selection

- ✧ In the project tree, navigate to your device and double-click **Hardware and protocols**.
- ✧ In the **Device view** tab, select the communication interface for which you want to configure the IEC 61850 protocol.
- ✧ In the **Properties** tab of the communication interface, select **General > IP interface settings**.
- ✧ Set the **IP address** for the communication interface.

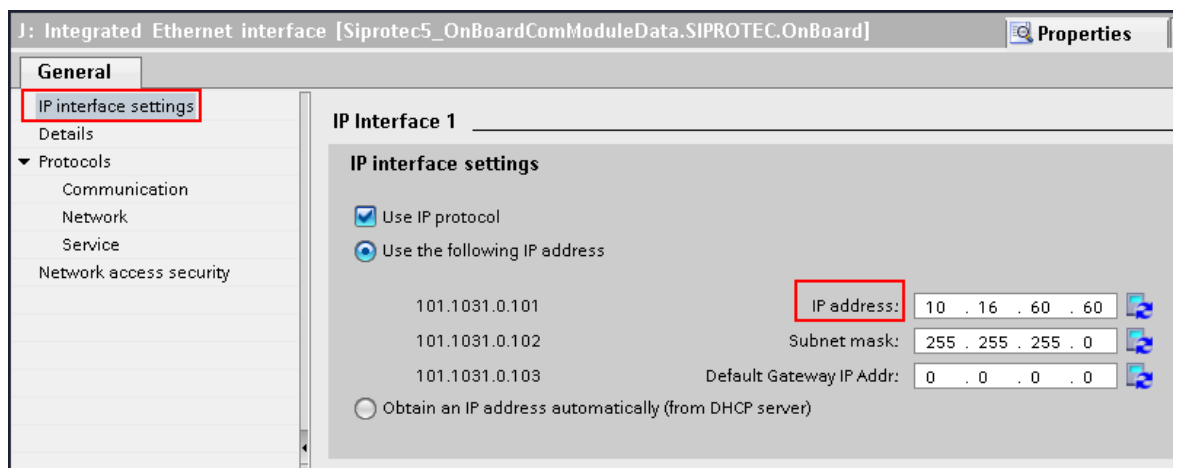

[sc_iec_61850_ip, 2, en_US]

Figure 5-78 IP-Address Configuration

- ✧ Select **General > Protocols > Communication**.
- ✧ Under **IEC61850**, select the item **IEC 61850-8-1**.

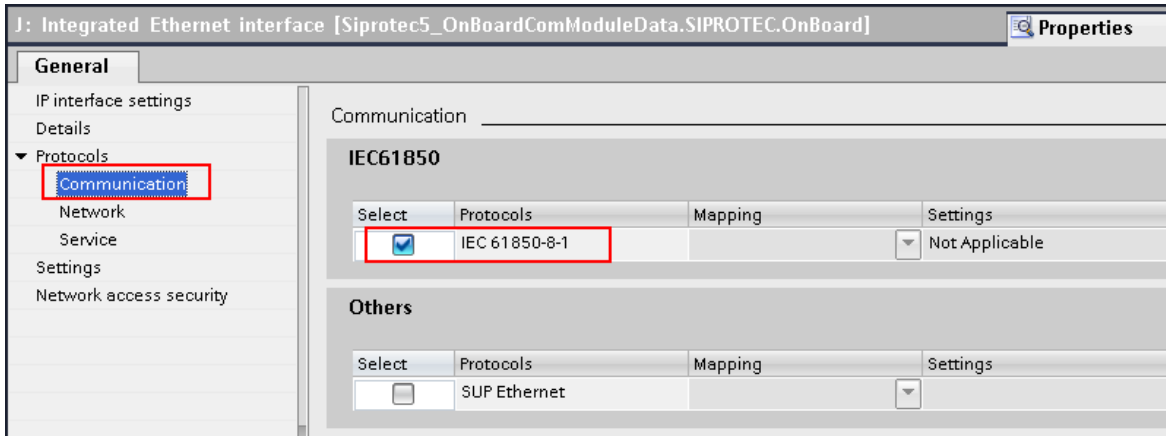

[sc_iec_61850_sel, 2, en_US]
 Figure 5-79 Protocol Selection

Function Instantiation

- ✧ In the project tree, navigate to your device and select **Settings > Analog units**. If there is no function group **Analog units**, instantiate one.
- ✧ Instantiate the function **Tmp.Acq.viaCom** in the function group **Analog units**.
- ✧ Instantiate the function that requires the cold-gas temperature in the corresponding function group. The function **49R RotorTOLP** is taken as an example in the following steps.
- ✧ Under **General** of the function **49R RotorTOLP**, set the parameter **Temperature acquisition** to **Protocol COM**.
- ✧ Set the parameter **Temperature via protocol** to **Analog units.Tmp.Acq.viaCom 1.Tmp.Ct1 1**.

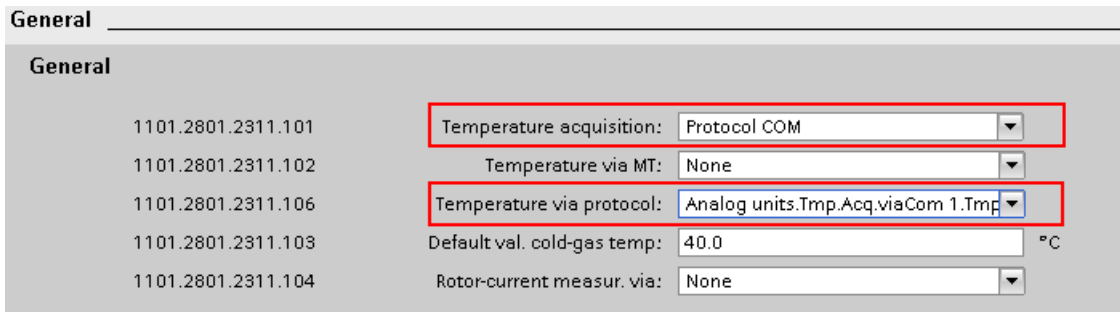

[sc_iec_61850_3, 2, en_US]
 Figure 5-80 Parameter Configuration

Configuration in the IEC 61850 structure

- ✧ In the project tree, navigate to your device and double-click **IEC 61850 structure**.
- ✧ In the column **Name**, select **AnUn_TmpAcqCom 1 > VIAC_STMP1 > CTmp**.

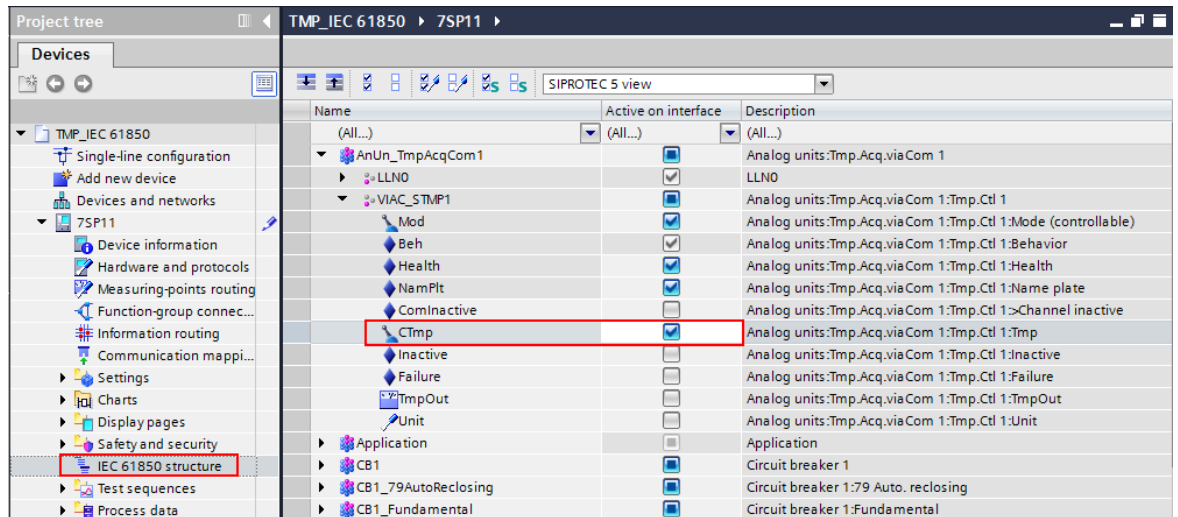

[sc_iec_61850_cgt, 1, en_US]

Figure 5-81 Data Selection

5.6.9.5 Stage Temperature Acquisition via GOOSE

Logic

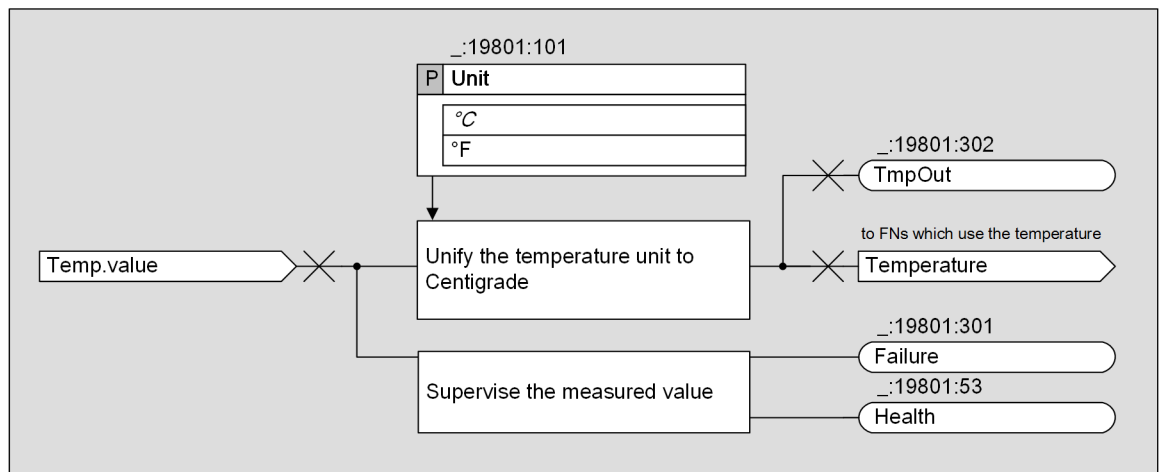

[lo_tmpval, 1, en_US]

Figure 5-82 Logic Diagram of the Stage

Invalid Temperature Indication

If the received temperature is invalid, the failure indication *Temperature failure* is issued.

Stage Application

The following terms are used for the stage **Temperature acquisition via GOOSE**:

- Source device
SIPROTEC 5 protection device that provides data
- Target device
SIPROTEC 5 protection device that requests data from the source device

In the target device, you can use the stage **Temperature acquisition via GOOSE** for the following purposes:

- Acquire the cold-gas temperature from the source device
- Process the received cold-gas temperature value
- Send the processed cold-gas temperature value to other functions for further processing

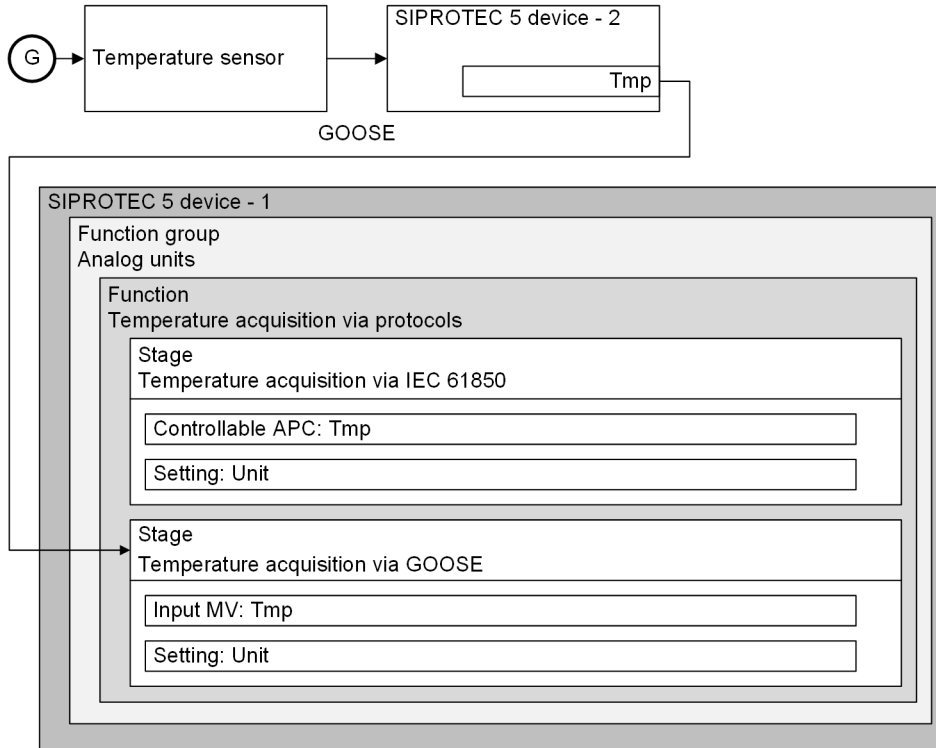

[dw_app-example_GOOSE_compact_1_en_US]

Figure 5-83 Application Example

The following table explains the data.

Data Name	Description
Tmp	With this variable, you can set the GOOSE protocol for the temperature acquisition. In the stage Temperature acquisition via GOOSE , the input measured value with a COM template is designed to acquire the data from another SIPROTEC 5 protection device.
Unit	With this parameter, you can select the unit °F or °C for the temperature which is acquired from another SIPROTEC 5 protection device.

5.6.9.6 GOOSE Configuration for the Temperature Acquisition

To acquire the cold-gas temperature with the stage **Temperature acquisition via GOOSE**, the following configurations are necessary.

IEC 61850 Edition Selection – Source Device

- ✦ In the project tree, select the source device and double-click **Device information**.
- ✦ In the **Device information** tab, set the parameter **Edition** to *IEC 61850 Edition 2* or a higher edition.

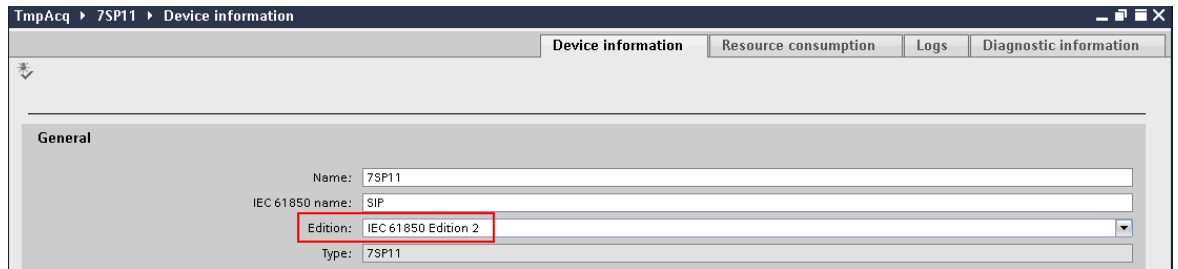

[sc_iec_edition, 1, en_US]

Figure 5-84 IEC 61850 Edition

IP-Address Configuration and Protocol Selection – Source Device

- ✧ In the project tree, select the source device and double-click **Hardware and protocols**.
- ✧ In the **Device view** tab, select the communication interface for which you want to configure the IEC 61850 protocol.
- ✧ In the **Properties** tab of the communication interface, select **General > IP interface settings**.
- ✧ Set the **IP address** for the communication interface.

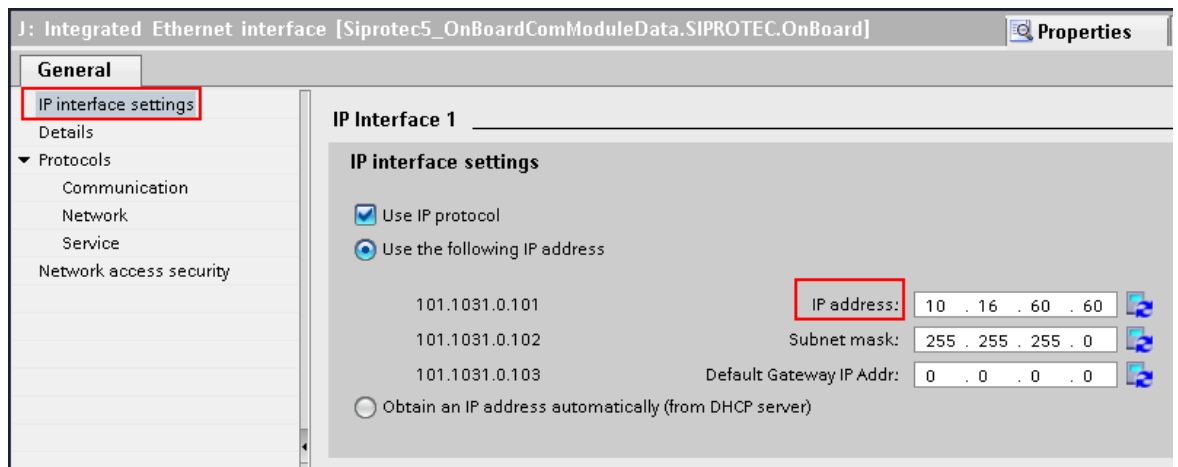

[sc_iec_61850_ip, 2, en_US]

Figure 5-85 IP-Address Configuration

- ✧ Select **General > Protocols > Communication**.
- ✧ Under **IEC61850**, select the item **IEC 61850-8-1**.

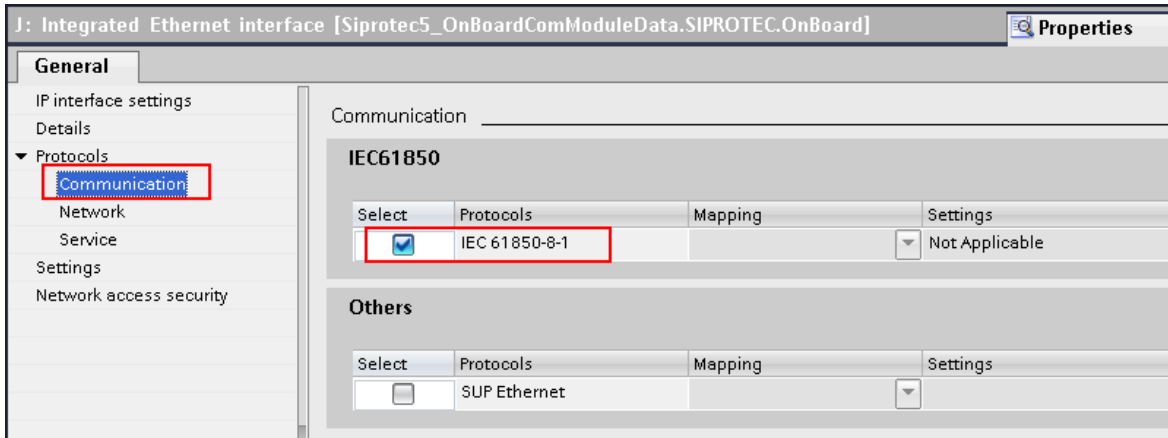

[sc_iec_61850_sel_2_en_US]

Figure 5-86 Protocol Selection

Configuration in IEC 61850 structure – Source Device

- ✧ In the project tree, select the source device and double-click **IEC 61850 structure**.
- ✧ In the column **Name**, select **AnUn_TmpAcqCom 1 > VIAC_STMP1 > CTmp**.

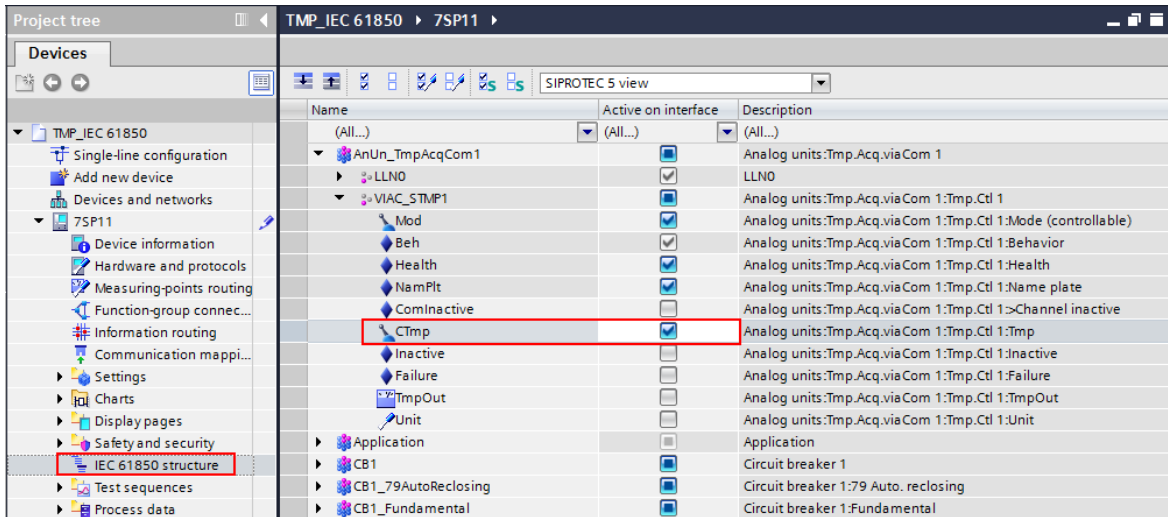

[sc_iec_61850_cgt_1_en_US]

Figure 5-87 Data Selection

Now, the device can be used to send the cold-gas temperature to other devices.

IEC 61850 Edition Selection – Target Device

- ✧ In the project tree, select the target device and double-click **Device information**.
- ✧ In the **Device information** tab, set the parameter **Edition** to **IEC 61850 Edition 2** or a higher edition.

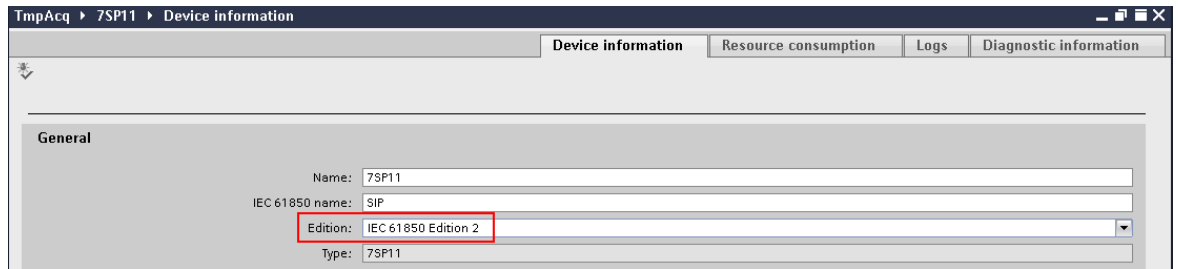

[sc_iec_edition, 1, en_US]

Figure 5-88 IEC 61850 Edition

IP-Address Configuration and Protocol Selection – Target Device

- ✧ In the project tree, select the target device and double-click **Hardware and protocols**.
- ✧ In the **Device view** tab, select the communication interface for which you want to configure GOOSE.
- ✧ In the **Properties** tab of the communication interface, select **General > IP interface settings**.
- ✧ Set the **IP address** for the communication interface.

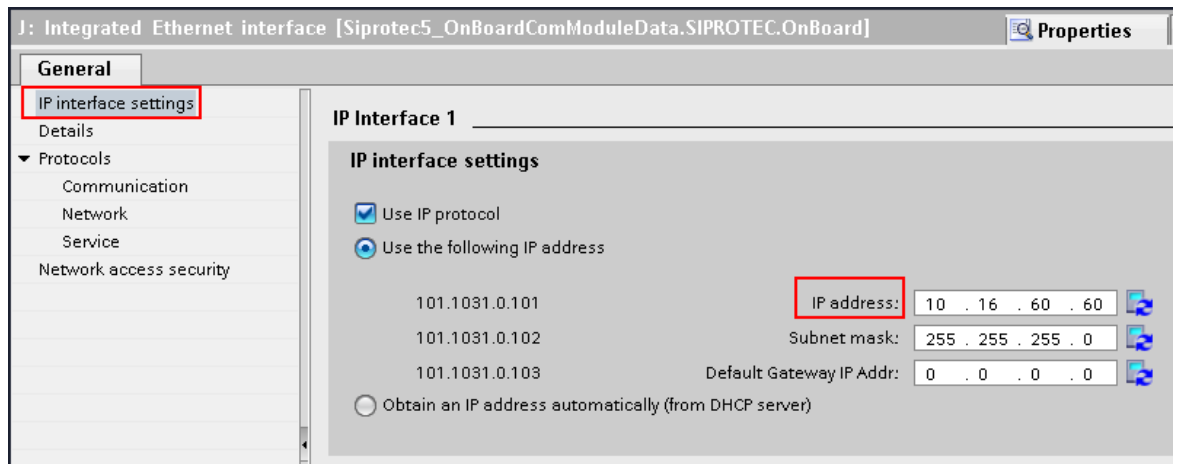

[sc_iec_61850_ip, 2, en_US]

Figure 5-89 IP-Address Configuration

- ✧ Select **Protocols > Communication > IEC 61850-8-1**.

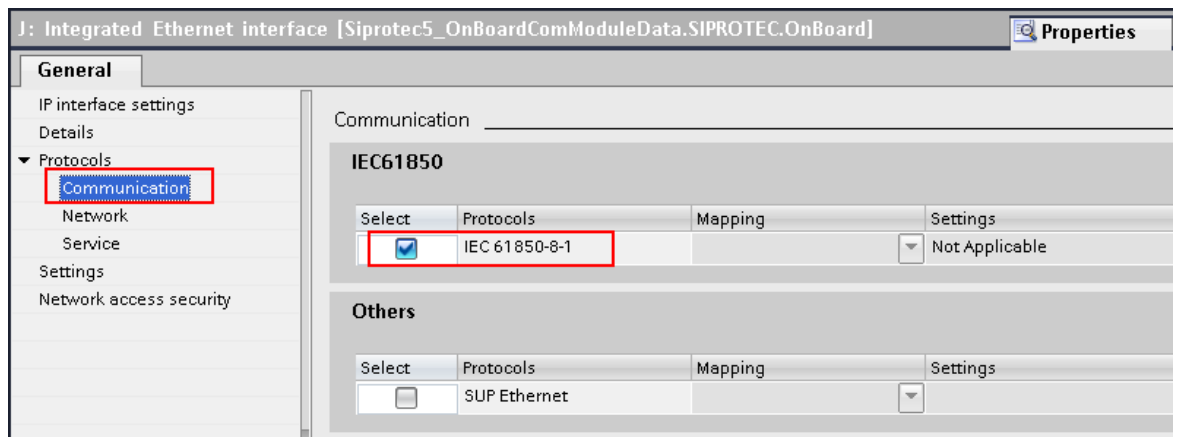

[sc_iec_61850_sel, 2, en_US]

Figure 5-90 Protocol Selection

Function Instantiation – Target Device

- ✧ In the project tree, select the target device and select **Settings > Analog units**.
 If there is no function group **Analog units**, instantiate one.
- ✧ Instantiate the function **Tmp.Acq.viaCom** in the function group **Analog units**.
- ✧ Instantiate the stage **Tmp.GOOSE** in the function **Tmp.Acq.viaCom**.

Configuration in Information Routing – Target Device

- ✧ In the project tree, select the target device and double-click **Information routing**.
- ✧ In the column **Signals**, select **Analog units > Tmp.Acq.viaCom 1 > Tmp.Goose 1**.
- ✧ Set the value to **1** in the column **GOOSE** for the data **Tmp**.

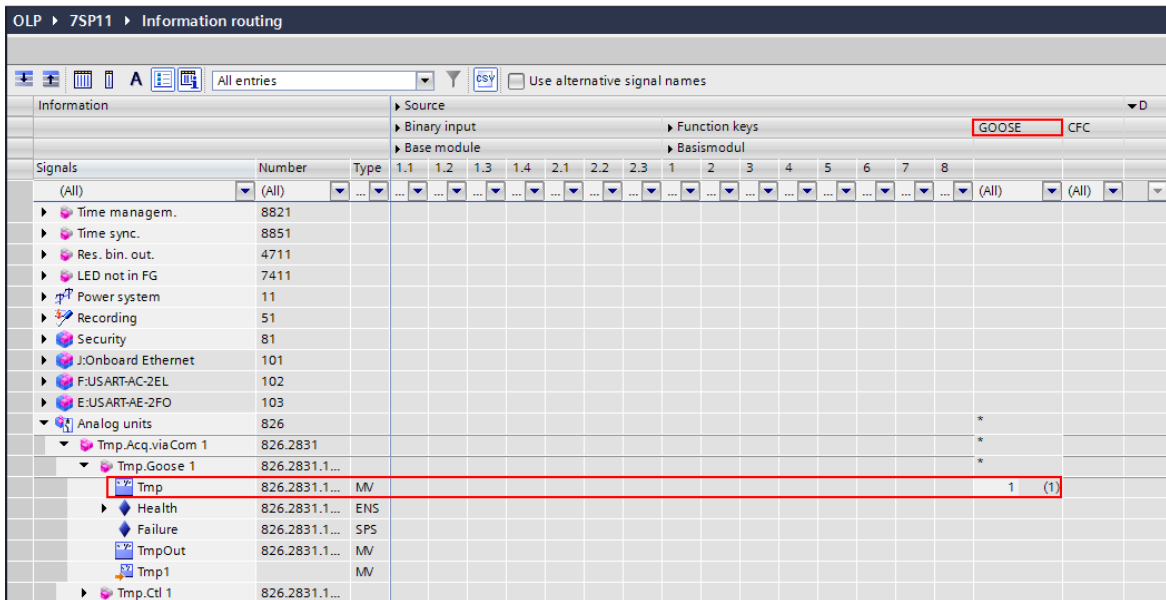

[sc_station_10, 1, en_US]

Configuration of the Protection Function – Target Device

- ✧ Instantiate the function that requires the cold-gas temperature in the corresponding function group.
 The function **49R RotorTOLP** is taken as an example in the following steps.
- ✧ Under **General** of the function **49R RotorTOLP**, set the parameters **Temperature acquisition** to **Protocol COM**.
- ✧ Set the parameter **Temperature via protocol** to **Analog units.Tmp.Acq.viaCom 1.Tmp.GOOSE 1**.

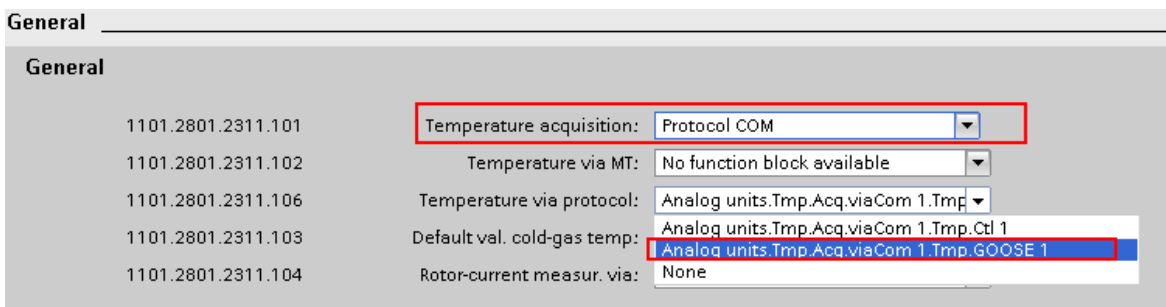

[sc_GOOSE_CGT, 2, en_US]

Figure 5-91 Parameter Configuration

Connection of the Source Device and the Target Device

- ✧ In the project tree, select **IEC 61850 stations > IEC station 1**.
If there is no station, double-click **Add new station** and create one.
- ✧ Double-click **IEC station 1** and set the parameter **IEC Edition** to **IEC 61850 Edition 2** or a higher edition in the **Properties** tab.

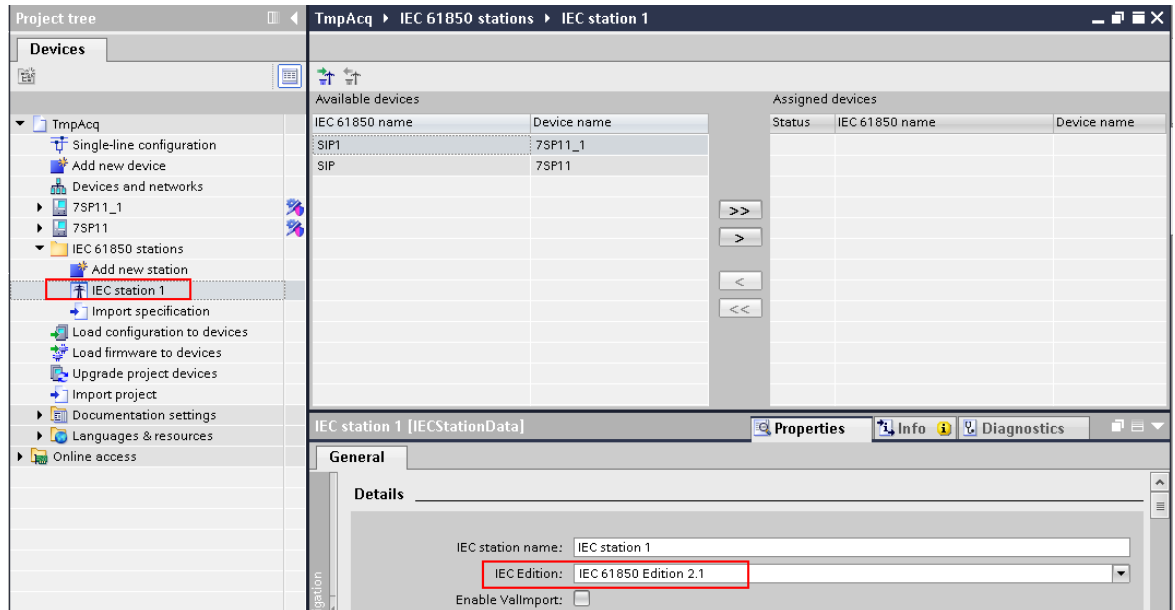

[sc_iec_station, 2, en_US]

Figure 5-92 IEC 61850 Edition

- ✧ Assign the available devices to the IEC station.

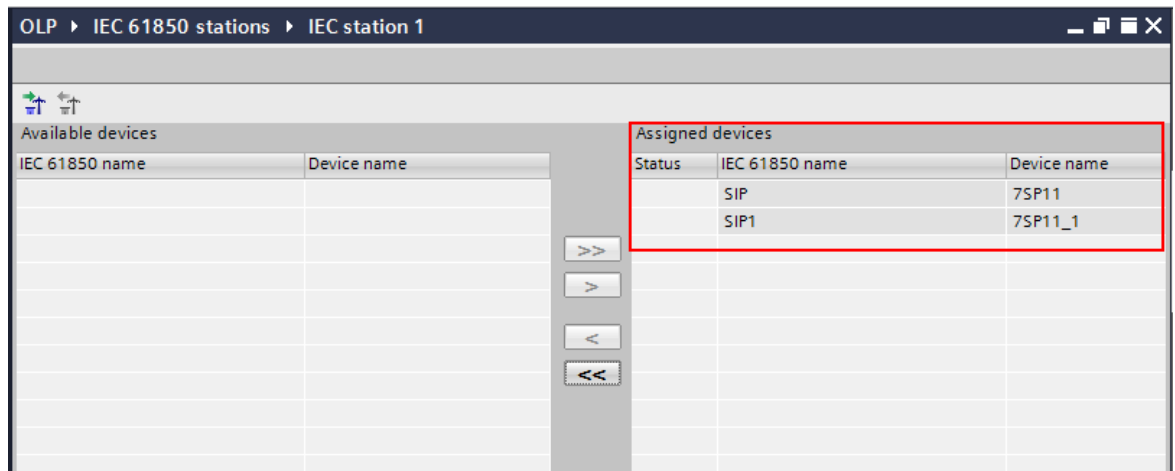

[sc_device_assign, 1, en_US]

Figure 5-93 Device Assignment

- ✧ Right-click the station and select **Export changes to IEC 61850 System Configurator** in the context menu.

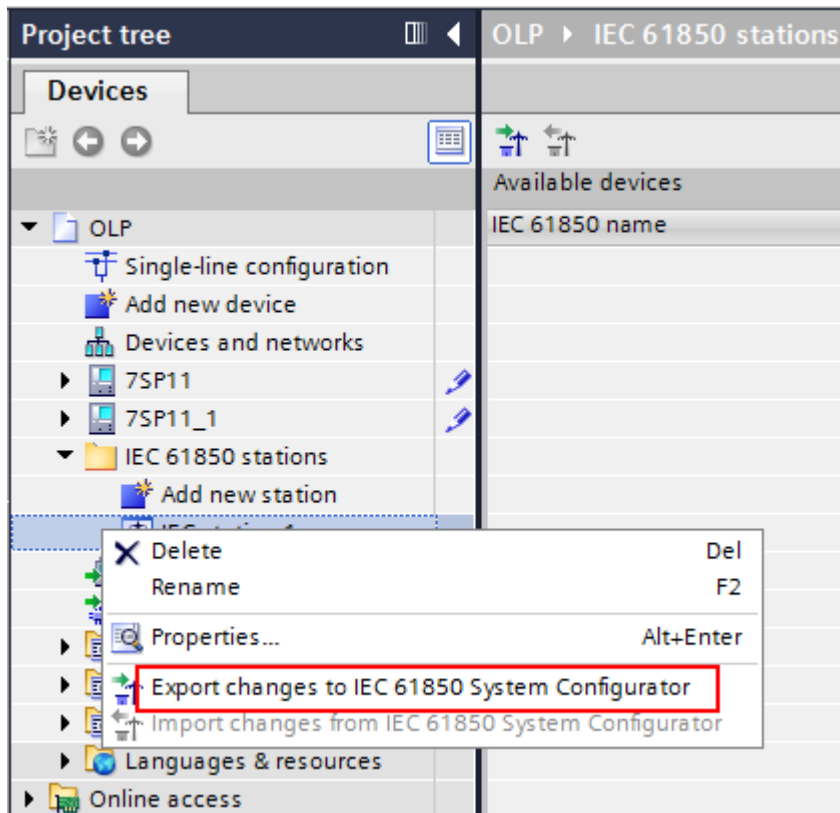

[sc_export_iec, 1, en_US]

Figure 5-94 Export Changes to IEC 61850 System Configurator

- ✧ If the following dialog appears, click **OK** and save the SCD file to a folder.

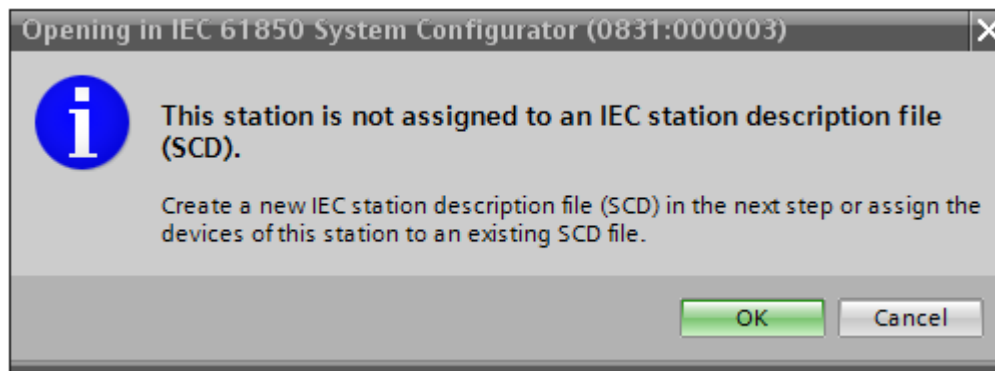

[sc_iec_confirm, 1, en_US]

Figure 5-95 SCD File Creation

- ✧ In the opened **IEC 61850 System Configurator** window, select **GOOSE** in the toolbar.

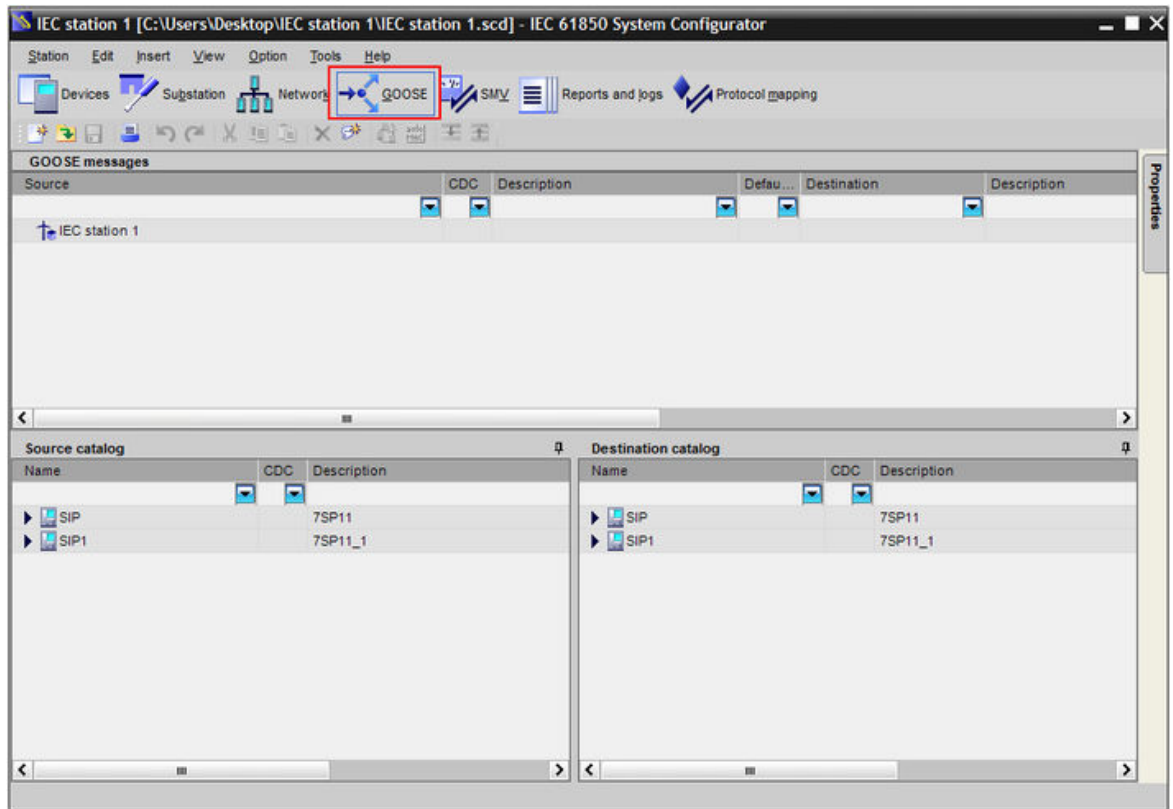

[sc_station_01_2_en_US]

Figure 5-96 GOOSE-Function Selection

- ✧ In the **GOOSE messages** view, right-click the IEC station and select **GOOSE application** in the context menu.

The **GOOSE** application is listed under the IEC station.

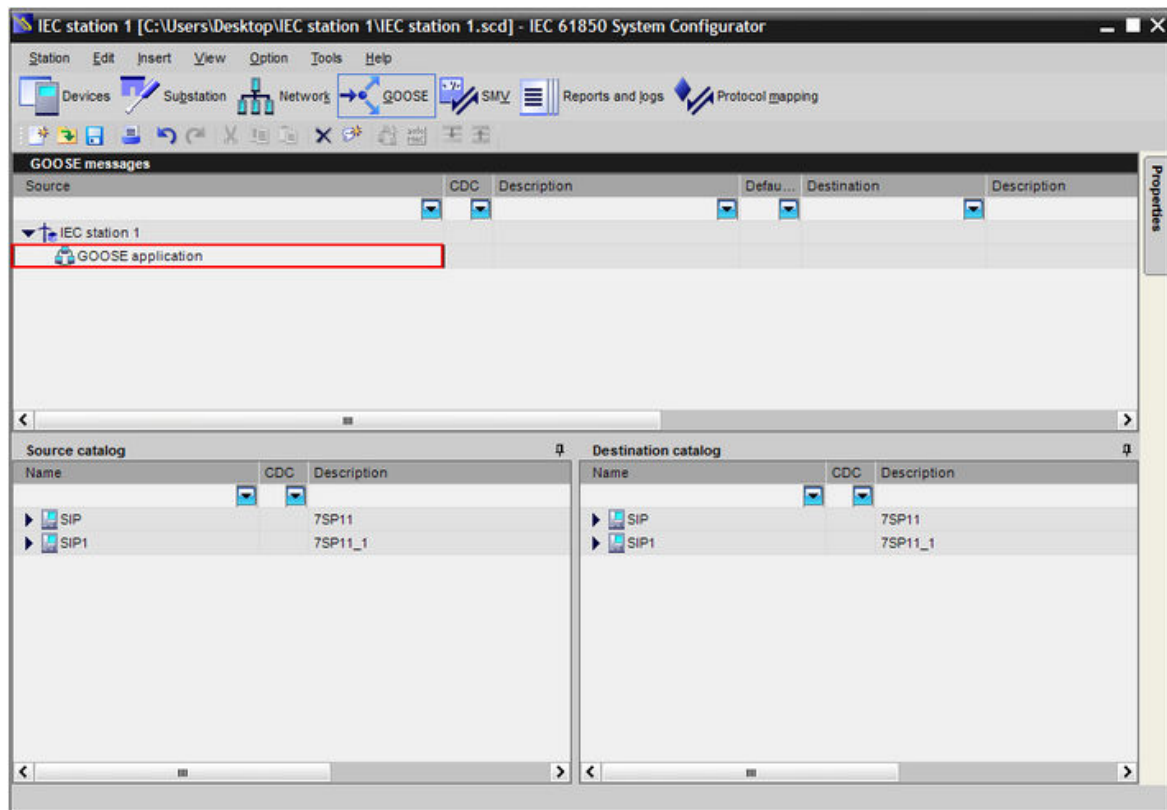

[sc_station_02_2_en_US]

Figure 5-97 GOOSE Application Creation

- ✧ In the **Source catalog** area, navigate to the source device and select **AnUn_TmpAcqCom 1 > VIAC_STMP1 > CTmp**.

Name	CDC	Description
SIP		7SP11
SIP1		7SP11_1
AnUn_TmpAcqCom1		AnUn_TmpCom 1
LLN0		LLN0
VIAC_STMP1		Tmp.Ctl 1
Mod	ENC	Mode (controllable)
Beh	ENS	Behavior
Health	ENS	Health
CTmp	APC	Tmp
Application		Application
CB1		CB1
CB1_Fundamental		CB1_FdOMV
Mod1		J:Onboard Ethernet
Mod1_Channel1		J:Onboard Ethernet_Chap.1
Mod2		F:USART-AC-2EL
Mod2_Channel1		F:USART-AC-2EL_Chap.1
Mod2_Channel2		F:USART-AC-2EL_Chap.2

[sc_station_03, 1, en_US]

Figure 5-98 Source-Data Selection

✧ Drag the data **CTmp** and drop it to **GOOSE application** in the **GOOSE messages** view.

You can see the assigned source data.

Source	CDC	Description	Defau...	Destination
IEC station 1				
GOOSE application				
SIP1/AnUn_TmpAcqCom1/LLN0/DataSet (2/100)				

[sc_station_04, 1, en_US]

Figure 5-99 Source-Data Assignment

✧ Unfold the assigned source data.

✧ In the **Destination catalog** area, navigate to the target device and select **AnUn_TmpAcqCom1 > RxTmp1**.

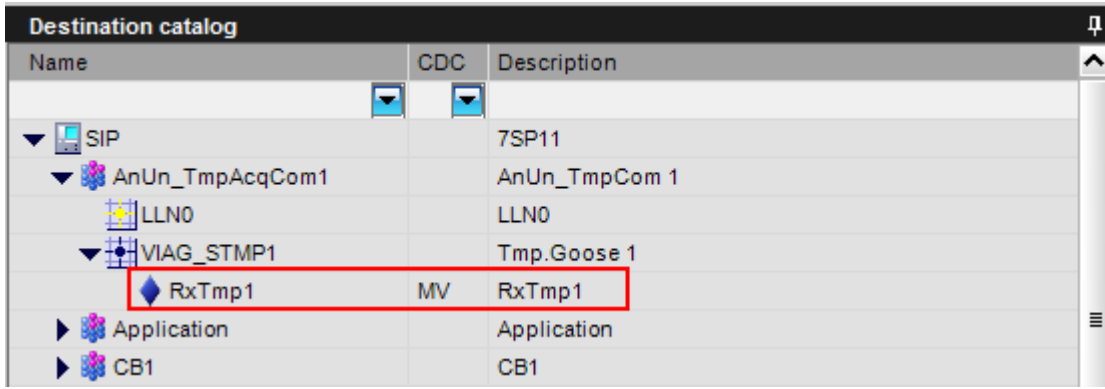

[sc_station_06_1_en_US]

Figure 5-100 Target-Data Selection

✧ Drag the data **RxTmp1** and drop it to the assigned source data.

Now, the target data is connected with the source data.

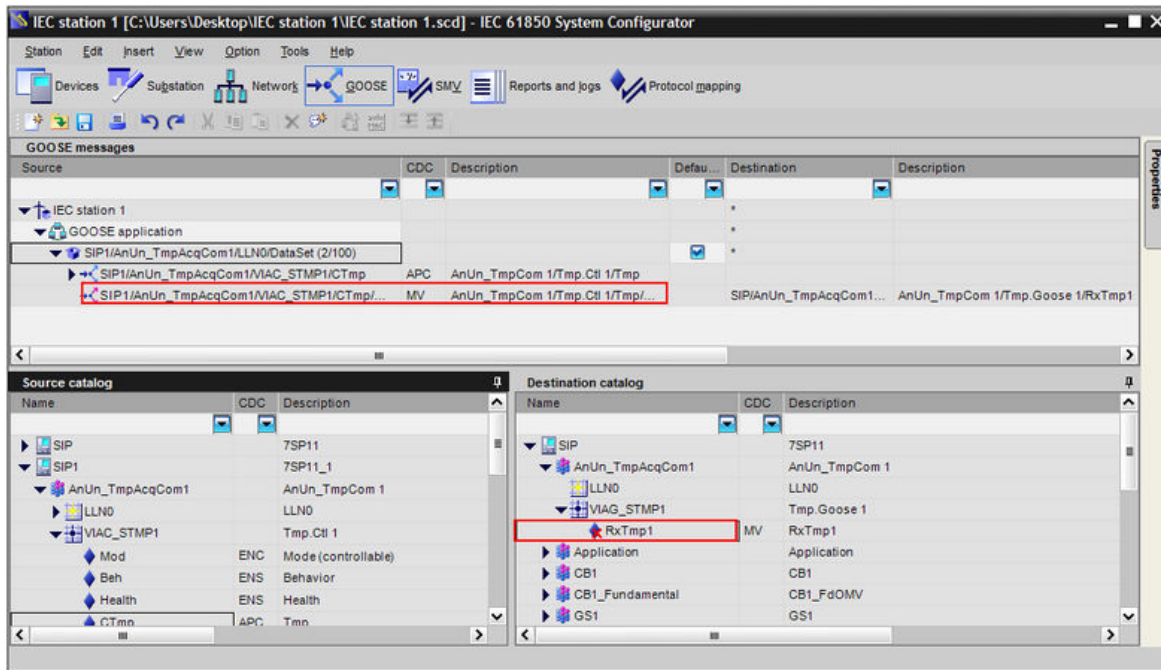

[sc_station_11_2_en_US]

Figure 5-101 Destination-Data Assignment

✧ Save the configurations.

✧ In DIGSI 5 in the project tree, right-click the IEC station and select **Import changes from IEC 61850 System Configurator** in the context menu.

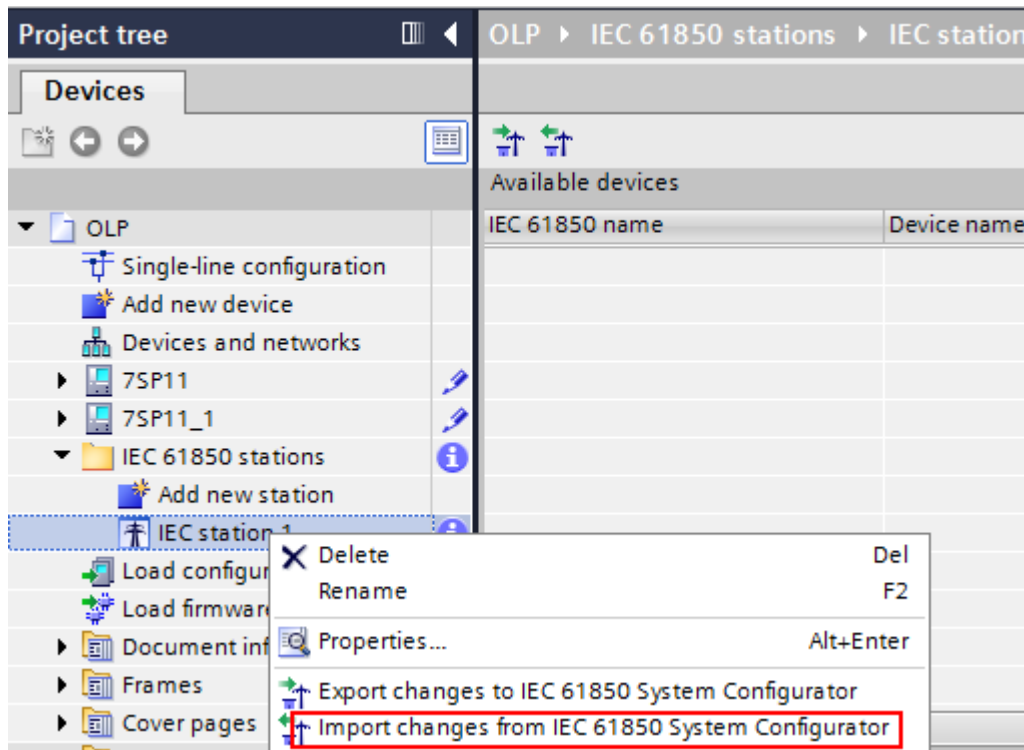

[sc_station_08, 1, en_US]

Figure 5-102 Import Changes from IEC 61850 System Configurator

If the following dialog appears, the source device and the target device are successfully connected.



[sc_End, 1, en_US]

Figure 5-103 Successful Device Connection

✧ Click **OK** to finish the connection.

5.6.9.7 Application and Setting Notes

Change of the Temperature Unit

Commonly, the temperature unit °C is used in the display and evaluation of measured temperature values.

- To change the temperature unit from °C to °F for all devices in the current DIGSI project, proceed as follows:
 - In DIGSI, select the menu item **Options > Settings**.
 - In the **Settings** view, select the menu item **DIGSI 5 user preferences**.
 - Set the parameter **Standard unit system** to **US units**.

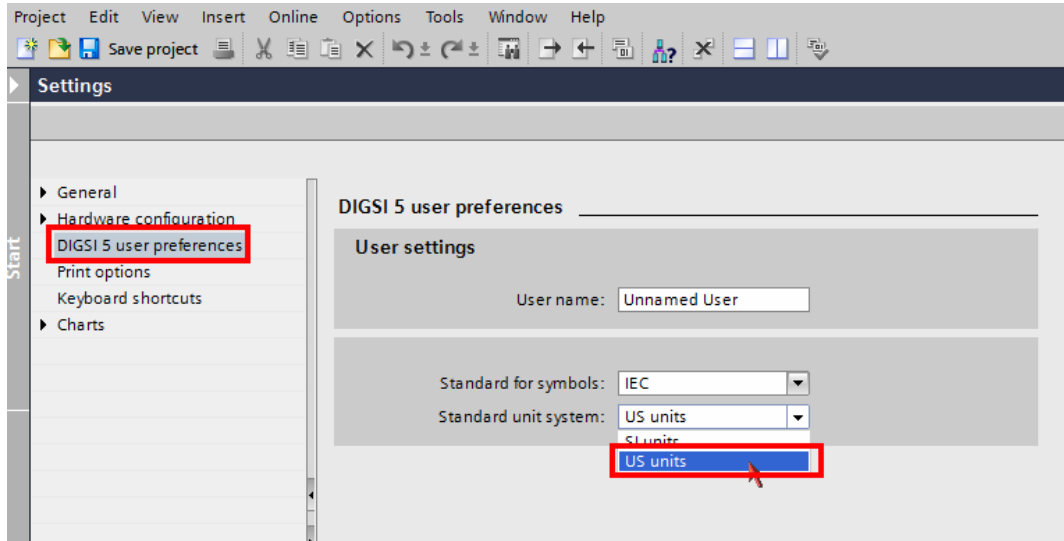

[scfahrit-190214-01, 1, en_US]

Figure 5-104 Change of the Temperature Unit between °C and °F for all Devices

- To change the temperature unit from °C to °F for 1 device, proceed as follows:
 - In the project tree, navigate to your device and select **Settings > Device settings**.
 - In the **Device settings** view, navigate to the menu item **Localization**.
 - Set the parameter **Unit system** to **ANSI**.

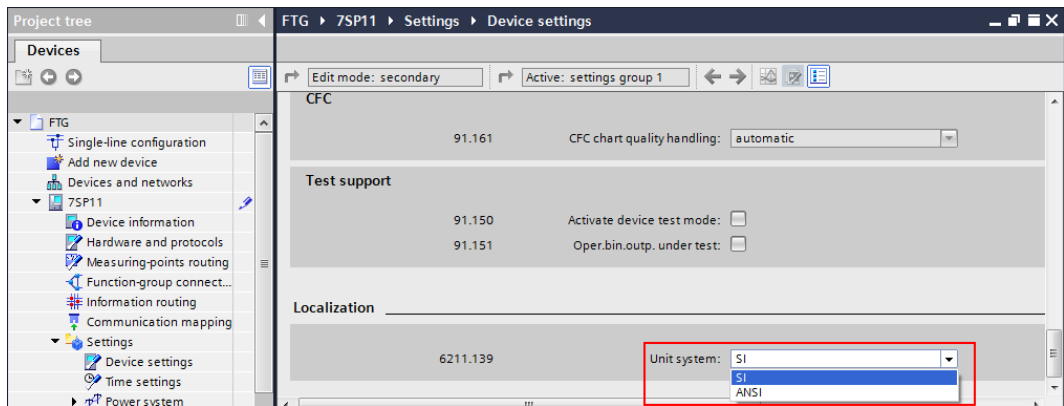

[sc_SITmp, 1, en_US]

Figure 5-105 Change of the Temperature Unit between °C and °F for 1 Device



NOTE

If the parameter **Unit system** is set to **ANSI**, only the unit of the measuring values and parameters changes to °F.

The unit of the following data is still °C:

- Other temperature data in the device
- The temperature thresholds in DCF

Parameter: Unit

- Default setting (**_:19801:101**) **Unit** = °C

You use the setting **Unit** to specify which physical unit of the source data the measured values represent. The possible setting values are listed in the settings table.

5.6.9.8 Settings

Addr.	Parameter	C	Setting Options	Default Setting
<i>Tmp.Ctl 1</i>				
_:19801:101	Tmp.Ctl 1:Unit		<ul style="list-style-type: none"> • °C • °F 	°C

5.6.9.9 Information List

No.	Information	Data Class (Type)	Type
<i>Tmp.Ctl 1</i>			
_:19801:501	Tmp.Ctl 1:>COM channel inactive	SPS	I
_:19801:300	Tmp.Ctl 1:Tmp	APC	C
_:19801:52	Tmp.Ctl 1:Behavior	ENS	O
_:19801:53	Tmp.Ctl 1:Health	ENS	O
_:19801:301	Tmp.Ctl 1:Failure	SPS	O
_:19801:302	Tmp.Ctl 1:TmpOut	MV	O

5.7 Function-Group Type Circuit Breaker

5.7.1 Overview

The **Circuit-breaker** function group combines all the user functions that relate to a circuit breaker. You will find the **Circuit-breaker** function group under each device type in the function library in DIGSI 5. The **Circuit-breaker** function group contains all of the protection, control, and supervision functions that you can use for this device type. The following figure shows, for example, the functional scope of the **Circuit-breaker** function group.

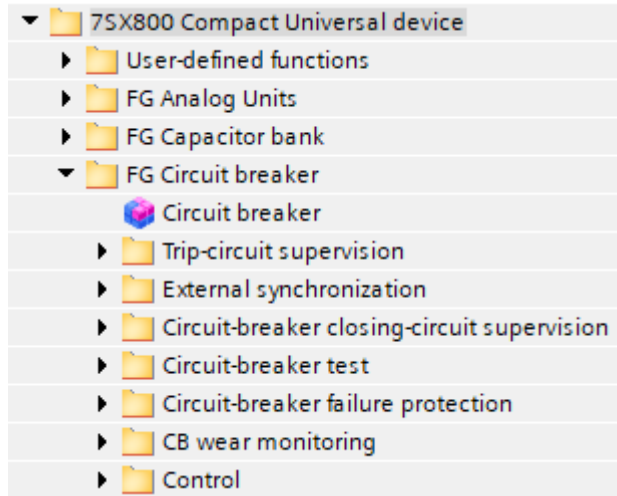

[sc_FG_LScomp, 1, en_US]

Figure 5-106 Circuit-Breaker Function Group – Example of the Functional Scope

The circuit-breaker type can accept additional basic function blocks for protection functions.

5.7.2 Structure of the Function Group

Besides the user functions, the **Circuit-breaker** function group contains certain functionalities that are essential for general purposes and therefore cannot be loaded or deleted:

- Trip logic
- Mapping the physical circuit breaker
- Circuit-breaker position recognition for protection functions
- Detection of manual closure
- General settings

The following figure shows the structure of the **Circuit-breaker** function group. The individual function blocks in the image are described in the following chapters.

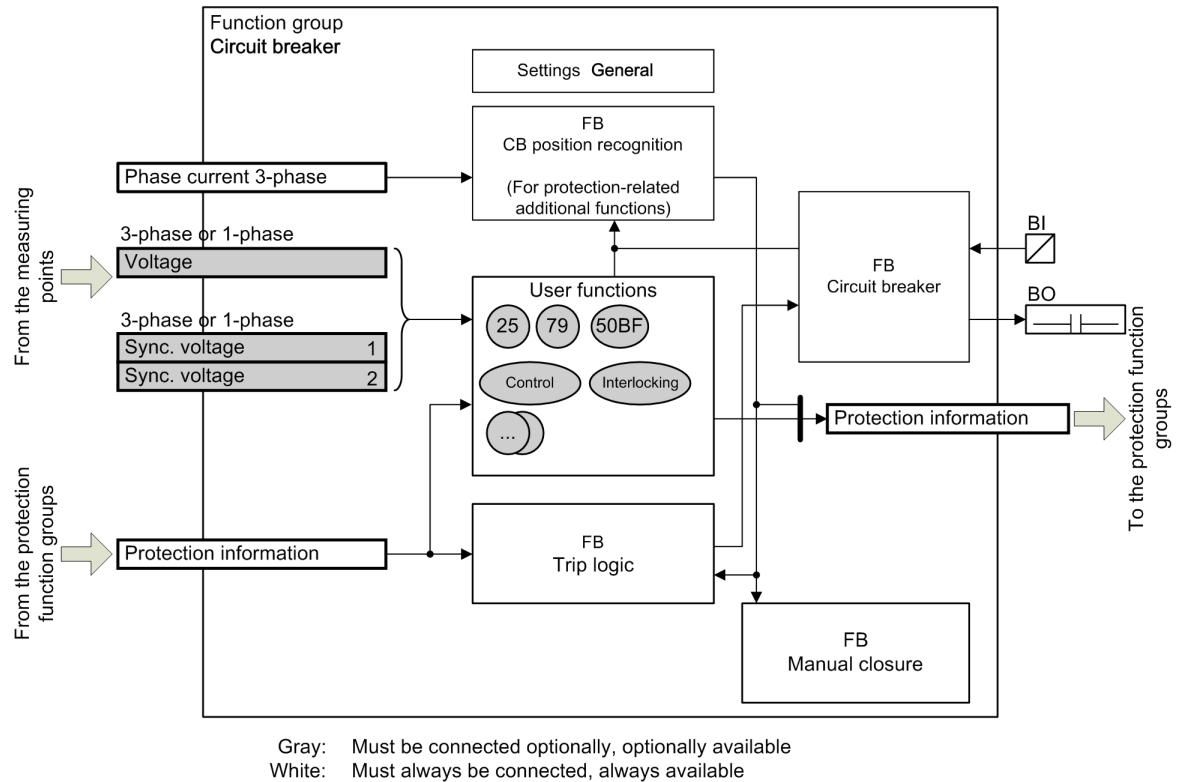

[dw_fg_stru, 1, en_US]

Figure 5-107 Structure of the Circuit-Breaker Function Group

The **Circuit-breaker** function group has interfaces with:

- Measuring points
- Protection function groups

Interfaces with Measuring Points

The function group contains the measured values needed from the measuring points associated with this function group.

If an application template is used, the function group is connected to the measuring point of the 3-phase current because this connection is essential. It can be necessary to connect additional measuring points to the function group, depending on the nature of the user functions used. The configuration is done via the **Function-group connections** editor in DIGSI 5.

If a user function, for example, synchronization, is used in the function group but the required measuring point has not linked to it, DIGSI 5 reports an inconsistency. This inconsistency provides an indication of the missing measuring-point connection.

The function group **Circuit breaker** has interfaces with the following measuring points:

- **3-phase line current**
The measurands from the 3-phase current system are supplied via this interface. The function group must always be connected to this measuring point.
- **Voltage**
The measurands from the 3-phase voltage system are supplied via this interface. Depending on the connection type of the transformers, in the 3-phase voltage system these are, for example, V_A , V_B , V_C of the line or the feeder. The connection of the function group to this measuring point is optional.

- **Sync. Voltage1, Sync. Voltage2**

A 1-phase synchronization voltage (for example, voltage of the busbar with a 1-phase connection) or a 3-phase synchronization voltage (for example, voltage of the busbar with a 3-phase connection) is supplied via this interface.

The connection to the corresponding measuring point is necessary only if synchronization is used.

Interface with Protection-Function Groups

All required data are exchanged between the protection function group and the function groups **Circuit breaker** via the interfaces of the function group **Circuit breaker**. This data includes, for example, the pickup and operate indications of the protection functions sent in the direction of the function group circuit-breaker and, for example, the circuit-breaker position information in the direction of the protection function groups. If an application template is used, the function groups are connected to each other because this connection is essential to ensure proper operation. You can modify the connection using the **Function-group connections** Editor in DIGSI 5.

If the linkage is missing, DIGSI 5 reports an inconsistency.

Besides the general assignments of the protection function group or groups to the Circuit-breaker function groups, you can also configure the interface for certain functionalities in detail:

- Which operate indications of the protection functions are included when the trip command is generated?
- Which protection functions activate the **Automatic reclosing** function?
- Which protection functions activate the **Circuit-breaker failure protection** function?

5.7.3 Application and Setting Notes

Interface with Measuring Points

The interface with the 3-phase current system must have been configured. Otherwise, DIGSI 5 supplies an inconsistency message.

If the function **Synchronization** is used, the measuring points that represent voltages V1 and V2 of the power-supply units to be synchronized must be connected.

For further information refer to [9.4 Synchronization Function](#).

Interface with Protection-Function Groups

The protection-function group is connected to 2 circuit breakers (2 function groups **Circuit breaker**) for 1 1/2 circuit-breaker layouts.

Parameter: I Reference for % Values

- Default setting (`_:2311:101`) **Rated normal current** = `1000.00 A`

With the parameter **Rated normal current**, you set the primary current, which serves as a reference for all current-related % values within the function group Circuit breaker. This applies both for operational measured values and for setting values in %.

Enter the primary rated current of the protected object here.

If the device works with the IEC 61850 protocol, then you change the setting value of the parameter only via DIGSI 5 and not directly on the device. If you change the setting value directly on the device, then the IEC 61850 configuration of the metered values can be faulty.

Parameter: V Reference for % Values

- Default setting (`_:2311:102`) **Rated voltage** = `400.00 kV`

With the parameter **Rated voltage**, you set the primary voltage, which serves as a reference for all voltage-related % values within the function group Circuit breaker. This applies both for operational measured values and for setting values in %.

Enter the primary rated voltage of the protected object (for example, the line) here.

If the device works with the IEC 61850 protocol, then you change the setting value of the parameter only via DIGSI 5 and not directly on the device. If you change the setting value directly on the device, then the IEC 61850 configuration of the metered values can be faulty.

Parameter: Current Threshold Circuit Breaker Open

- Default setting (`_:2311:112`) **Current thresh. CB open = 0.10 A**

With the parameter **Current thresh. CB open**, you specify the current threshold below which the circuit-breaker pole or the circuit breaker is recognized as open.

Set the parameter **Current thresh. CB open** so that the current measured when the circuit-breaker pole is open will certainly fall below the parameterized value. If parasitic currents (for example, due to induction) are excluded with the line deactivated, you can make a secondary setting of the value with a high degree of sensitivity, to **0.05 A** for example.

If no special requirements exist, Siemens recommends retaining the setting value of **0.10 A** for secondary purposes.

5.7.4 Settings

Addr.	Parameter	C	Setting Options	Default Setting
<i>Ref. for %-values</i>				
_:2311:101	General:Rated normal current		0.20 A to 100000.00 A	1000.00 A
_:2311:102	General:Rated voltage		0.10 kV to 1200.00 kV	400.00 kV
<i>Breaker settings</i>				
_:2311:112	General:Current thresh. CB open	1 A @ 100 Irated	0.030 A to 10.000 A	0.100 A
		5 A @ 100 Irated	0.15 A to 50.00 A	0.50 A
		1 A @ 50 Irated	0.030 A to 10.000 A	0.100 A
		5 A @ 50 Irated	0.15 A to 50.00 A	0.50 A
		1 A @ 1.6 Irated	0.001 A to 1.600 A	0.100 A
		5 A @ 1.6 Irated	0.005 A to 8.000 A	0.500 A
_:2311:136	General:Op. mode BFP		<ul style="list-style-type: none"> • unbalancing • l> query 	unbalancing

5.7.5 Information List

No.	Information	Data Class (Type)	Type
<i>Circuit break.</i>			
_:4261:500	Circuit break.:>Ready	SPS	I
_:4261:501	Circuit break.:>Acquisition blocking	SPS	I
_:4261:502	Circuit break.:>Reset switch statist.	SPS	I
_:4261:504	Circuit break.:>Reset AcqBlk&Subst	SPS	I
_:4261:505	Circuit break.:>Trip release BBP	SPS	I
_:4261:506	Circuit break.:>Manual start HSBT	SPS	I
_:4261:503	Circuit break.:External health	ENS	I
_:4261:52	Circuit break.:Behavior	ENS	O

No.	Information	Data Class (Type)	Type
_:4261:53	Circuit break.:Health	ENS	O
_:4261:58	Circuit break.:Position	DPC	C
_:4261:300	Circuit break.:Trip/open cmd.	SPS	O
_:4261:301	Circuit break.:Close command	SPS	O
_:4261:302	Circuit break.:Command active	SPS	O
_:4261:303	Circuit break.:Definitive trip	SPS	O
_:4261:326	Circuit break.:BBP trip relays blocked	SPS	O
_:4261:327	Circuit break.:no release of trip cmd	SPS	O
_:4261:304	Circuit break.:Alarm suppression	SPS	O
_:4261:306	Circuit break.:Op.ct.	INS	O
_:4261:307	Circuit break.:ΣI Brk.	BCR	O
_:4261:308	Circuit break.:ΣIA Brk.	BCR	O
_:4261:309	Circuit break.:ΣIB Brk.	BCR	O
_:4261:310	Circuit break.:ΣIC Brk.	BCR	O
_:4261:311	Circuit break.:Break.-current phs A	MV	O
_:4261:312	Circuit break.:Break.-current phs B	MV	O
_:4261:313	Circuit break.:Break.-current phs C	MV	O
_:4261:317	Circuit break.:Break. current 3I0/IN	MV	O
_:4261:314	Circuit break.:Break. voltage phs A	MV	O
_:4261:315	Circuit break.:Break. voltage phs B	MV	O
_:4261:316	Circuit break.:Break. voltage phs C	MV	O
_:4261:322	Circuit break.:CB open hours	INS	O
_:4261:323	Circuit break.:Operating hours	INS	O

5.7.6 Trip Logic

5.7.6.1 Function Description

The **Trip logic** function block receives the group operate indication from the Protection function group or Protection function groups and forms the protection trip command that is transmitted to the **Circuit-breaker** function block.

The **Circuit-breaker** function block activates the device contact and thus causes the circuit breaker to open (see [5.7.7 Circuit Breaker](#)). The command output time is also effective here.

The trip logic also decides when the protection trip command is reset (see [Figure 5-109](#)).

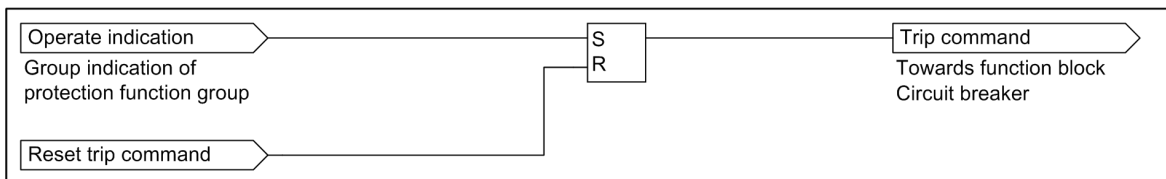

[lio_ausbef, 1, en_US]

Figure 5-108 Trip Command

Trip-Command Reset

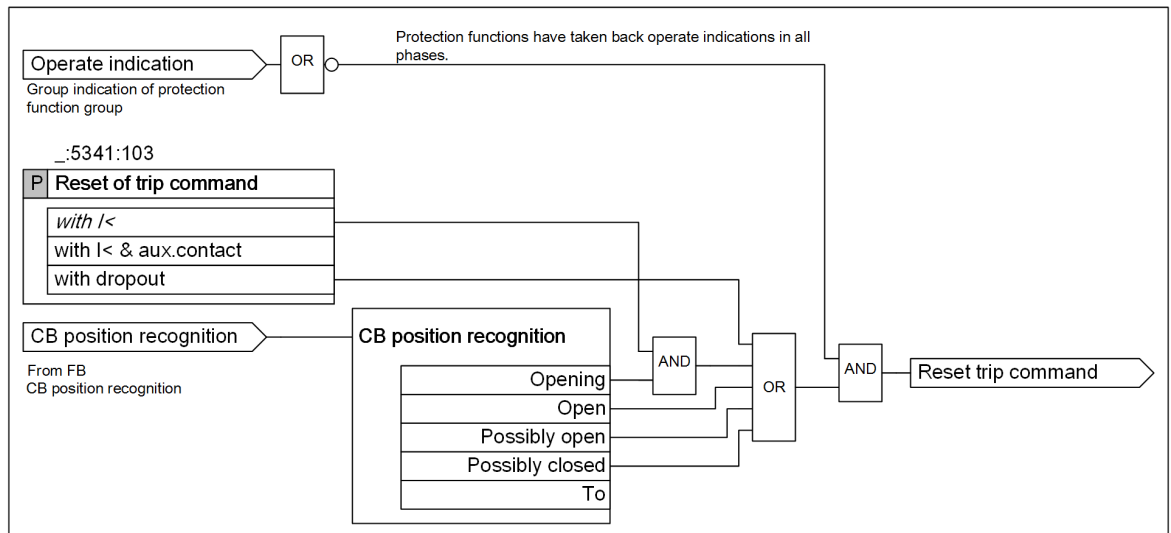

[lo_befe3p, 1, en_US]

Figure 5-109 Trip-Command Reset

Once a trip command is issued, it is stored (see [Figure 5-108](#)).

You determine the criteria for resetting a trip command that has been issued with the parameter **Reset of trip command**. The following setting options are possible:

- **with dropout**

If the function that initiated tripping resets its operate indication the trip command is reset. This occurs typically with dropout. Command reset of the trip command takes place regardless of verification of the circuit-breaker condition.

- **with I<**

- **with I< & aux.contact**

For these criteria, the state of the circuit breaker is also taken into account as a further criterion in addition to the dropout of the tripping function (operate indication is reset by command). You can select whether the state is determined by means of the current (**with I<**) or by means of the current in conjunction with the circuit-breaker auxiliary contacts (**with I< & aux.contact**). The behavior of these setting options only differs in one situation of the circuit-breaker state. If the circuit breaker is in the **opening** state, the trip command is reset in the case of the option **with I<**, whereas it is not reset yet in the case of the option with **with I< & aux.contact**. The **opening** state is detected if the auxiliary contacts still detect the circuit breaker as being closed and opening is detected via the decreasing current flow.

As long as the circuit breaker is detected unambiguously as closed (**fully closed**), the trip command will not be reset with these setting options.

The information about the condition of the circuit breaker and the determination of the various conditions is supplied by the **Circuit-breaker position recognition** function block. You can find further information in chapter [5.7.8 Circuit-Breaker Position Recognition for Protection-Related Auxiliary Functions](#).

5.7.6.2 Application and Setting Notes

Parameter: Reset of trip command

- Recommended setting value (`_:5341:103`) **Reset of trip command = with I<**

Parameter Value	Description
<i>with I<</i>	The trip command is reset under the following conditions: <ul style="list-style-type: none"> Dropout of the tripping function The current falls short of the value set in the parameter (<code>_:2311:112</code>) Current thresh. CB open
<i>with I< & aux.contact</i>	The trip command is reset under the following conditions: <ul style="list-style-type: none"> The current falls short of the value set in the parameter (<code>_:2311:112</code>) Current thresh. CB open The circuit-breaker auxiliary contact reports that the circuit breaker is open. <p>This setting assumes that the setting of the auxiliary contact has been routed via a binary input (for more information, see 5.7.7.3 Acquisition of Circuit-Breaker Auxiliary Contacts and Further Information).</p>
<i>with dropout</i>	If the load current in the system cannot be interrupted during the protection device test and the test current is fed in parallel with the load current this setting is useful.
	The setting can be selected for special applications in which the trip command does not result in complete interruption of the current in every case. In this case, the trip command is reset if the pickup of the tripping protection function drops out.

5.7.6.3 Settings

Addr.	Parameter	C	Setting Options	Default Setting
<i>Trip logic</i>				
_:103	Trip logic:Reset of trip command		<ul style="list-style-type: none"> with I< with I< & aux.contact with dropout 	with I<

5.7.6.4 Information List

No.	Information	Data Class (Type)	Type
<i>Trip logic</i>			
_:300	Trip logic:Trip indication	ACT	O
_:52	Trip logic:Behavior	ENS	O
_:53	Trip logic:Health	ENS	O

5.7.7 Circuit Breaker

5.7.7.1 Overview

The function block **Circuit breaker** represents the physical switch in the SIPROTEC 5 device.

The basic tasks of this function block are:

- Operation of the circuit breaker (CB)
- Acquisition of the circuit-breaker auxiliary contacts
- Acquisition of other circuit-breaker information

The function block **Circuit breaker** provides the following information:

- Number of switching cycles
- Breaking current, breaking voltage, and breaking frequency
- Summation breaking current

5.7.7.2 Tripping, Opening and Closing the Circuit Breaker

The circuit breaker is operated in the following situations:

- Tripping of the circuit breaker as a result of a protection trip command
- Opening of the circuit breaker as a result of control operations
- Closing of the circuit breaker as a result of an automatic reclosing or of control operations

Tripping is always the result of a protection function. The operate indications of the individual protection functions are summarized in the **Trip logic** function block. The trip command that causes the tripping in the function block **Circuit breaker** is generated there.

For the operational handling of the circuit breaker, the function block **Circuit breaker** provides the output signals that must be routed to the corresponding binary outputs of the device (see [Table 5-13](#)).

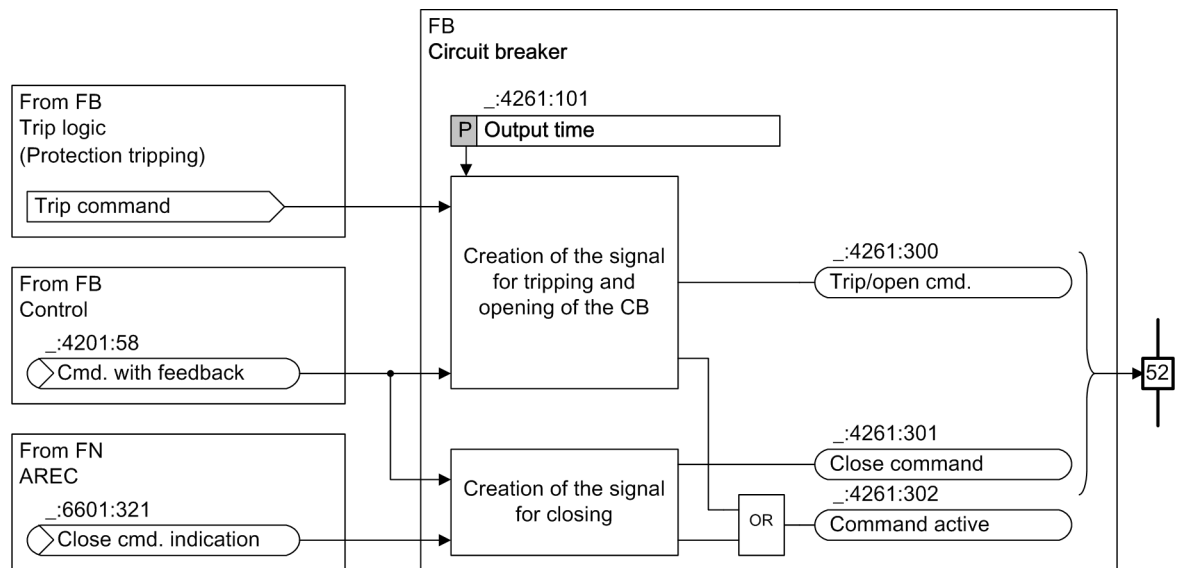

[to_ausssc, 1, en_US]

Figure 5-110 Tripping, Opening, and Closing the Circuit Breaker

Table 5-13 Description of the Output Signals

Signal	Description	Routing Options
Trip/open cmd.	<p>This signal executes all tripping and opening operations.</p> <p>The Output time parameter affects the signal.</p> <p>The signal is pending for the duration of the output time, with the following exceptions:</p> <ul style="list-style-type: none"> • Only when switched off by the control: The signal is reset before expiration of the period if the auxiliary contacts report that the circuit breaker is open before expiration of the period. • Only in the event of protection tripping: <ul style="list-style-type: none"> – The signal remains active as long as the trip command is still active after expiration of the period (see also). If the trip signal is no longer active and the auxiliary contacts report that the circuit breaker is open before expiration of the period, the signal is canceled before expiration of the period. – With the routing option Only saved in the event of tripping, the signal remains pending until it is acknowledged manually. This only applies for protection tripping. 	<ul style="list-style-type: none"> • Unlatched • Only saved in the event of protection tripping (not when opened)
Close command	<p>This signal executes all closing operations.</p> <p>The Output time parameter affects the signal.</p> <p>The signal is pending for the duration of the output time, with the following exception: The signal is canceled before expiration of the period if the auxiliary contacts report that the circuit breaker is closed before expiration of the period.</p>	Normal routing
Command active	<p>This signal is active if one of the following binary outputs is active:</p> <ul style="list-style-type: none"> • Trip/open cmd. • Close command <p>The binary outputs are active as long as a switching command is being executed by the control.</p>	Normal routing

5.7.7.3 Acquisition of Circuit-Breaker Auxiliary Contacts and Further Information

To determine the circuit-breaker position, the function block **Circuit breaker** provides position signals. These signals are of the **Double-point indication** (DPC) type. A double-point indication can be routed to 2 binary inputs so that the open and closed circuit-breaker switch positions can be reliably acquired.

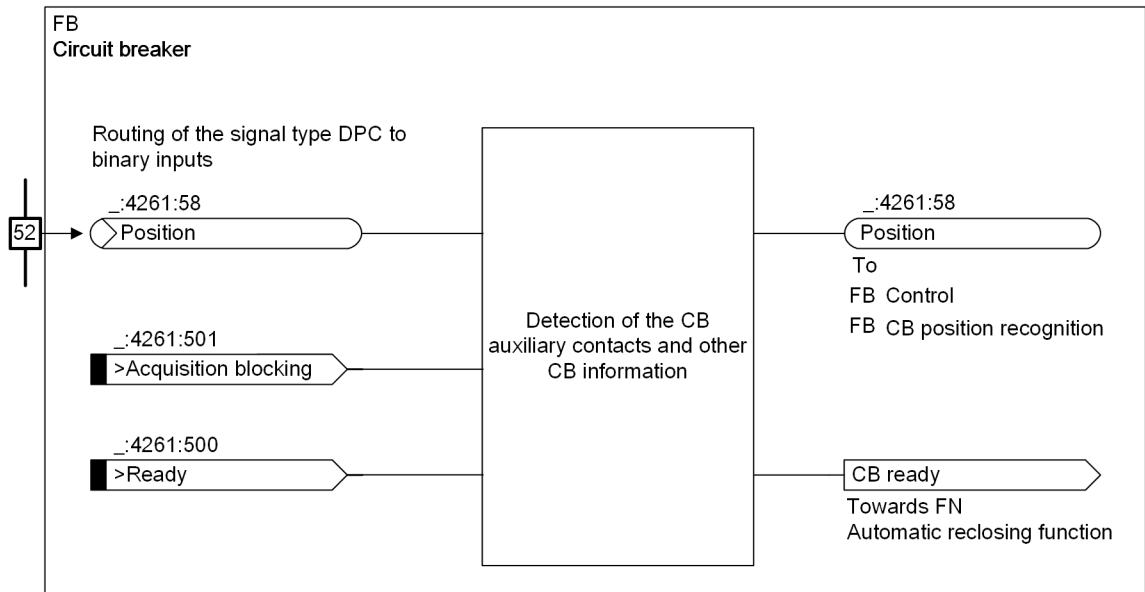

[lo_erfass_2_en_US]

Figure 5-111 Acquisition of the Circuit-Breaker Information

Signal	Type	Description
Position	DPC	Acquisition of the circuit-breaker switch position The switch position CB 3-pole open and/or the position CB 3-pole closed can be detected by routing to 1 or 2 binary inputs.

The signals must be routed to the binary input that is with the CB auxiliary contacts. The **open** and **closed** signals do not necessarily have to be routed in parallel. The advantage of parallel routing is that it can be used to determine an intermediate or disturbed position. If you route only one signal (**open** or **closed**), you cannot determine an intermediate position or a disturbed position.

In the monitoring direction, the position signals generate the following information when the **open** and **closed** positions are detected (see following table). This information is further processed by the **Circuit-breaker position recognition** and **Control** function blocks.

Information	Type	Description
Open	SPS	The circuit-breaker switch position is opened .
Closed	SPS	The circuit-breaker switch position is closed .
Intermediate position	SPS	The circuit-breaker switch position is in the intermediate position . The signal open and the signal closed have not been set.
Disturbed position	SPS	The circuit-breaker switch position is in the disturbed position . The signal open and the signal closed have been set simultaneously.
Not selected	SPS	The circuit breaker is not selected for a control operation.

The following table shows the additional input signals:

Signal	Type	Description
> Acquisition blocking	SPS	This is used to activate acquisition blocking of the circuit-breaker auxiliary contacts (see <i>Other Functions 3.8.3 Persistent Commands</i> for a description of acquisition blocking).
> Reset AcqBlk&Subst	SPS	This is used to reset acquisition blocking and manual update of the circuit breaker. If the signal is active, acquisition blocking and manual update are reset.
> Ready	SPS	The active signal indicates that the circuit breaker is ready for an Open-Closed-Open cycle. The signal remains active as long as the circuit breaker is unable to trip. The signal is used in the Automatic reclosing and Circuit-breaker test functions.

The following table shows one additional output signal:

Signal	Type	Description
External health	ENS	This can be used to indicate the health of the physical circuit breaker. For this, all failure information of the circuit breaker must be detected via a binary input. This failure information can set the appropriate state of the External health signal with a CFC chart (using the BUILD_ENS block). The signal has no effect on the health of the function block.

5.7.7.4 Circuit-Breaker Tripping Alarm Suppression

Circuit-Breaker Tripping Alarm Suppression

In certain systems, the user may wish to actuate an alarm (for example, a horn) when tripping (circuit-breaker tripping) occurs. This alarm should not be issued if it is to be reclosed automatically after tripping, or if it is to be closed or opened via the control. The alarm is only to be issued in the event of definitive tripping.

Depending on how the alarm is generated (for example, triggered by a fleeting contact of the circuit breaker), the *Alarm suppression* signal can be used to suppress the alarm.

If one of the following conditions is met, the *Alarm suppression* signal is generated:

- The definitive protection tripping is not present.
- The integrated automatic reclosing function executes a closure.
- The integrated control executes a closure or opening action.
- The function **Manual close** detects an external closing.

For further information about its use, refer to [5.7.9.2 Application and Setting Notes](#).

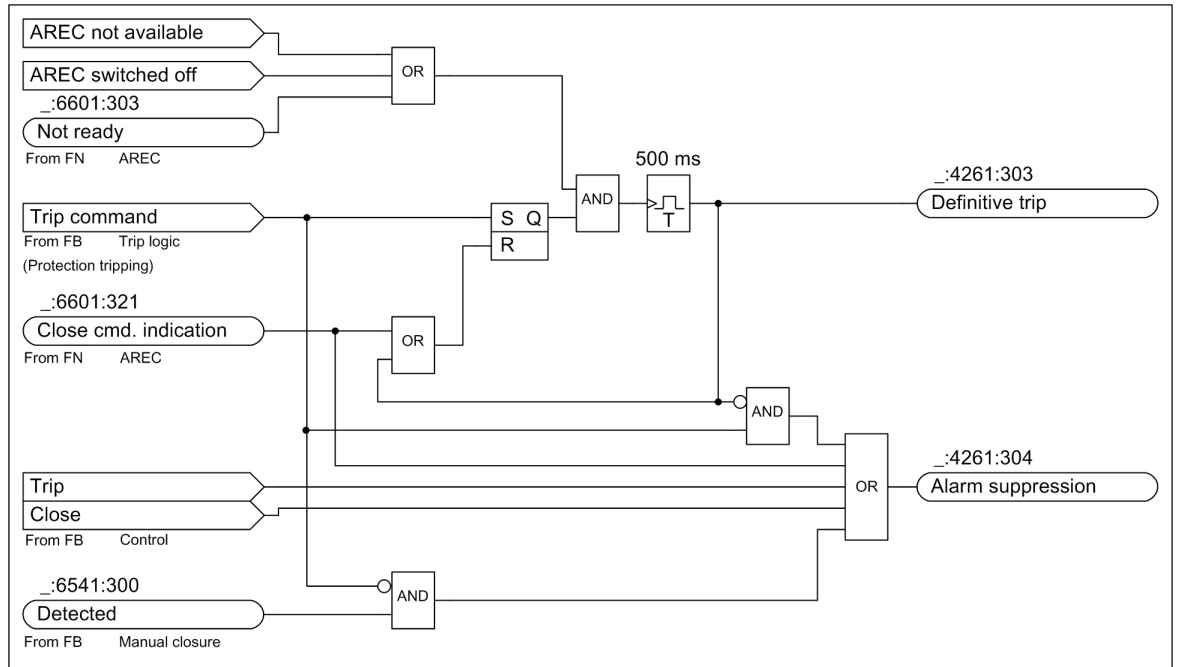

[lo_unterd, 2, en_US]

Figure 5-112 Definitive Tripping and Circuit-Breaker Tripping Alarm Suppression

5.7.7.5 Tripping and Opening Information

When a trip or opening command is issued, the breaking information shown in the next figure is saved in the fault log.

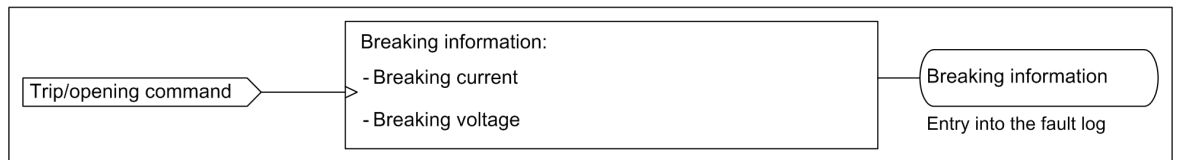

[lo_ausloe, 2, en_US]

Figure 5-113 Breaking Information

The following statistics information is saved for the circuit breaker:

- Number of switching cycles:
All tripping, opening, and closing operations are counted.
- Number of closing operations by the automatic reclosing function
- Total of breaking currents

The statistics information can be individually set and reset via the device control. It is also possible to reset all values via the binary input signal `>Reset switch statist..`

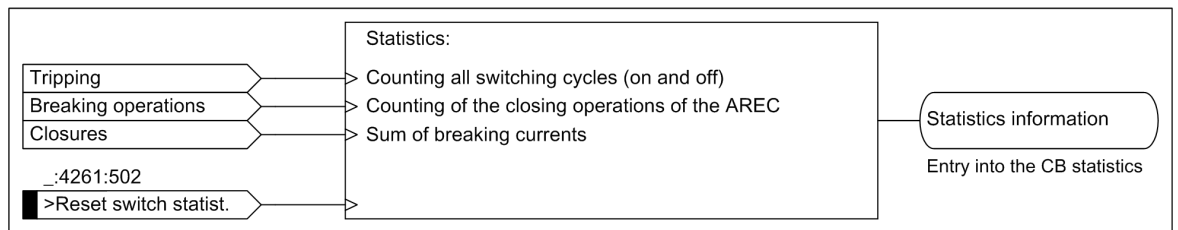

[lo_statistics information circuit-breaker, 2, en_US]

Figure 5-114 Statistics Information About the Circuit Breaker

5.7.7.6 Application and Setting Notes

Routing to Evaluate the Circuit-Breaker Switch Position

For certain functions of the device, it is useful to detect the circuit-breaker switch position via its auxiliary contacts. The following shows a number of examples:

- **Circuit-breaker position recognition** function block
- **Circuit-breaker failure protection** function
- **Control** function block

The operating principle of the auxiliary contacts is described in the individual functions.

Siemens recommends capturing the information *Circuit breaker is open in 3 poles* and *Circuit breaker is closed in 3 poles* via auxiliary contacts. This is the optimal configuration for the control functionality. For purely protection applications, it is also sufficient to acquire just one of the 2 circuit-breaker switch positions. When used as a protection and control device, Siemens recommends the following evaluation of the circuit-breaker switch position:

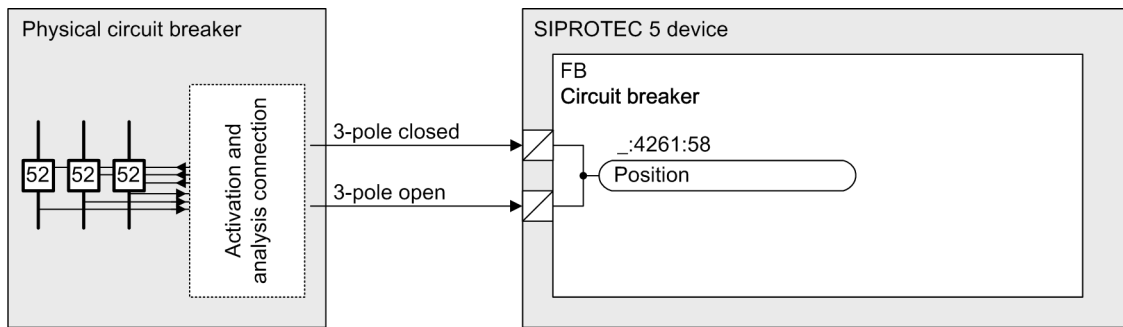

[lo_evaluation2, 1, en_US]

Figure 5-115 Recommended Evaluation of the Circuit-Breaker Switch Position

The following diagram shows the recommended routing, in which **OH** stands for **active with voltage**.

Information				Source							
				Binary input							
				Base module							
Signals	Fav	Number	Type	1.1	1.2	1.3	1.4	1.5	1.6	1.7	1.8
(All)	..	(All)
Position	☆	201.4261.58	DPC	CH	OH						

[sc_polg3p, 1, en_US]

Figure 5-116 Routing for Acquisition of the Circuit-Breaker Switch Position via 2 Auxiliary Contacts

The device can also function without the analysis from the circuit-breaker auxiliary contacts, that is, routing of the auxiliary contacts is not absolutely necessary. However, this is a requirement for control functions.

Parameter: Output Time

- Default setting (_:101) **Output time = 0.10 s**

The **Output time** parameter acts on the signals for tripping, opening, and closing of the circuit breaker.



CAUTION

Do not set a time that is too short.

If you set a time that is too short, there is a danger that the device contacts will interrupt the control circuit. If this happens, the device contacts will burn out.

- ✧ Set a time that is long enough to ensure that the circuit breaker reliably reaches its final position (**open** or **closed**) after a control operation.

Parameter: Indicat. of breaking values

- Default setting (`_:105`) **Indicat. of breaking values = *always***

With the parameter **Indicat. of breaking values**, you specify whether the measured values are to be reported if the circuit breaker is opened via the control function.

Parameter Value	Description
<i>always</i>	With this setting, the measured values are reported if the circuit breaker is opened either via the control function or via the trip command of a protection function.
<i>with trip</i>	With this setting, the measured values are only reported if the circuit breaker is opened via the trip command of a protection function.

Measured Values

When a protection function opens the circuit breaker, the following measured values can be stored in the fault log:

- *Break.-current phs A*
- *Break.-current phs B*
- *Break.-current phs C*
- *Break. current 3I₀/I_N*
- *Break. voltage phs A*
- *Break. voltage phs B*
- *Break. voltage phs C*

The measured value *Break. current 3I₀/I_N* is the neutral-point current. Dependent on the connection type of the **measuring point I-3ph** that is connected with the function group **Circuit breaker**, the neutral-point current differs as follows:

Connection Type of the Measuring Point I-3ph	Neutral-Point Current
3-phase	Calculated zero-sequence current $3I_0$
3-phase + IN	Measured neutral-point current I_N
3-phase + IN-separate 3ph,2prim.CT + IN-sep 2ph, 2p. CT + IN-sep	If the secondary ground current exceeds the linear section of the sensitive measuring input (1.6 Irated) with sensitive current transformers, the neutral-point current of the measured I_N is switched to the calculated $3I_0$.

Output Signal: Indication Suppression

Whereas in the case of feeders without an automatic reclosing function every trip command is final due to a protection function, the use of an automatic reclosing function should only cause the motion detector of the circuit breaker (fleeting contact on the circuit breaker) to trigger an alarm if tripping of the circuit breaker is definitive (see next figure for more details). Likewise, a tripping alarm should not be triggered for switching operations by the control.

For this, the alarm activation circuit should be looped via a suitably routed output contact of the device (output signal **Alarm suppression**). In the idle state and when the device is switched off, this contact is always closed. For this, an output contact with a break contact must be routed. The contact opens whenever the output signal **Alarm suppression** becomes active, so that tripping or a switching operation does not cause an alarm.

You can find more detailed information in the logic in [5.7.7.3 Acquisition of Circuit-Breaker Auxiliary Contacts and Further Information](#).

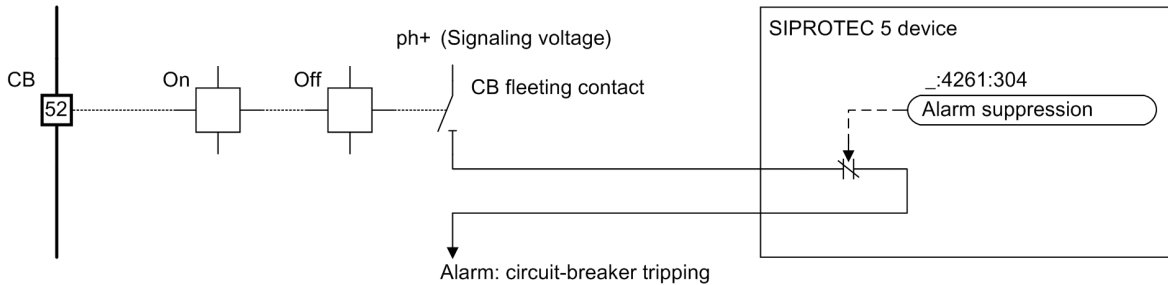

[lo_schalt, 2, en_US]

Figure 5-117 Circuit-Breaker Tripping Alarm Suppression

5.7.7.7 Settings

Addr.	Parameter	C	Setting Options	Default Setting
Circuit break.				
_:101	Circuit break.:Output time		0.02 s to 1800.00 s	0.10 s
_:105	Circuit break.:Indicat. of breaking values		<ul style="list-style-type: none"> with trip always 	always

5.7.7.8 Information List

No.	Information	Data Class (Type)	Type
Circuit break.			
_:500	Circuit break.:>Ready	SPS	I
_:501	Circuit break.:>Acquisition blocking	SPS	I
_:502	Circuit break.:>Reset switch statist.	SPS	I
_:504	Circuit break.:>Reset AcqBlk&Subst	SPS	I
_:503	Circuit break.:External health	ENS	I
_:52	Circuit break.:Behavior	ENS	O
_:53	Circuit break.:Health	ENS	O
_:58	Circuit break.:Position	DPC	C
_:300	Circuit break.:Trip/open cmd.	SPS	O
_:301	Circuit break.:Close command	SPS	O
_:302	Circuit break.:Command active	SPS	O
_:303	Circuit break.:Definitive trip	SPS	O
_:304	Circuit break.:Alarm suppression	SPS	O
_:306	Circuit break.:Op.ct.	INS	O
_:307	Circuit break.:ΣI Brk.	BCR	O
_:308	Circuit break.:ΣIA Brk.	BCR	O
_:309	Circuit break.:ΣIB Brk.	BCR	O
_:310	Circuit break.:ΣIC Brk.	BCR	O
_:311	Circuit break.:Break.-current phs A	MV	O

No.	Information	Data Class (Type)	Type
_:312	Circuit break.:Break.-current phs B	MV	O
_:313	Circuit break.:Break.-current phs C	MV	O
_:317	Circuit break.:Break. current 3I0/IN	MV	O
_:314	Circuit break.:Break. voltage phs A	MV	O
_:315	Circuit break.:Break. voltage phs B	MV	O
_:316	Circuit break.:Break. voltage phs C	MV	O
_:322	Circuit break.:CB open hours	INS	O
_:323	Circuit break.:Operating hours	INS	O

5.7.8 Circuit-Breaker Position Recognition for Protection-Related Auxiliary Functions

5.7.8.1 Overview

This function block calculates the position of the circuit breaker from the evaluation of the auxiliary contacts and the current flow.

This information is needed in the following protection-related additional functions:

- Trip logic (see)
- Detection of manual closing (see [5.7.9.1 Function Description](#))
- Process monitor (see)

The specified chapters describe the way the protection-related additional functions are processing the information of this function block.

The control does not use this information. The control evaluates the circuit-breaker auxiliary contacts.

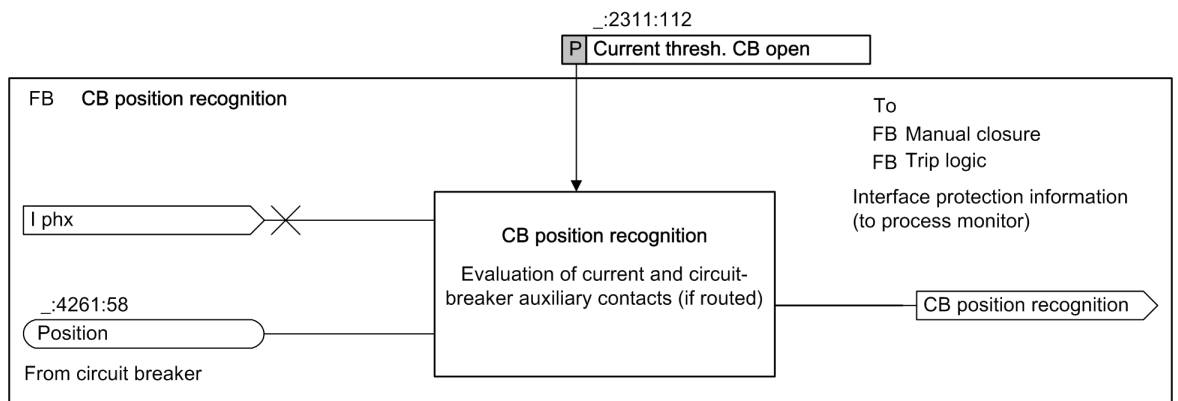

[to_zust3p_1_en_US]

Figure 5-118 Overview of the Circuit-Breaker Condition Position Function

Based on the link between the information from the auxiliary contacts and the current flow, shown in [Figure 5-118](#), the circuit breaker can assume the following positions. The following table shows the possible circuit-breaker conditions:

Circuit-Breaker Condition	Description
Open	The circuit-breaker pole is detected unambiguously as open according to both criteria.
Closed	The circuit-breaker pole is detected unambiguously as closed according to both criteria.

Circuit-Breaker Condition	Description
<i>Possibly open, possibly closed</i>	These conditions can occur if the information is incomplete due to the routing of the auxiliary contacts and the condition can no longer be determined reliably. These <i>uncertain conditions</i> are evaluated differently by certain functions.
<i>Opening</i>	This is a dynamically occurring condition that results when, while a trip command is active and the auxiliary contact is still closed, the current is detected to have fallen below the threshold value. The reason for that is that the current-flow criterion takes effect faster than the auxiliary contact can open.

5.7.9 Detection Manual Closure (for AREC and Process Monitor)

5.7.9.1 Function Description

Detection of Manual Closure (for Process Monitor)

The **Manual closure** function block detects any closure carried out by hand. This information is used in **Process monitor** functions (within protection function groups).

You can find detailed information in the chapter *Process monitor*.

The following figure shows the logic for manual closure detection.

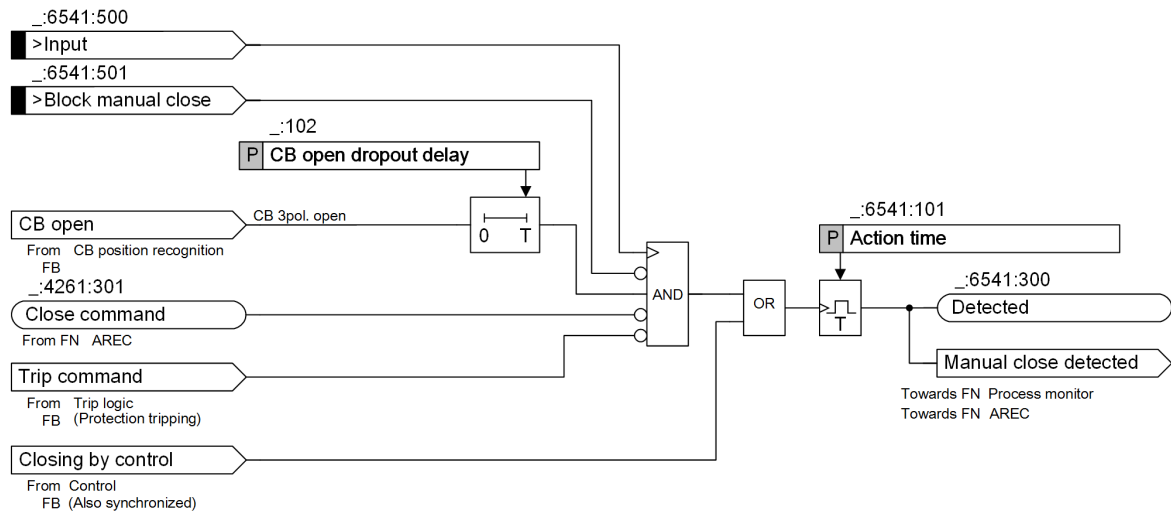

[lo_hand_3p_4_en_US]

Figure 5-119 Logic for Manual Closure Detection

External Manual Closure

An external manual closure is communicated to the device via the input signal **>Input**. The input signal can also be connected directly to the control circuit of the circuit-breaker closing coil. Detection via the input signal **>Input** is also blocked if the circuit breaker is closed or if a protection trip is active.

Internal Manual Closure

Manual closure is detected in all cases if a close command is transmitted by the internal control function of the device. This is possible because the control carries out plausibility checks itself and is also subject to interlocking.

5.7.9.2 Application and Setting Notes

Input Signals: >Input, >Blocking of Manual Closure

In practice, the input signal **>Input** is connected directly to the control circuit of the circuit-breaker closing coil (see following figure).

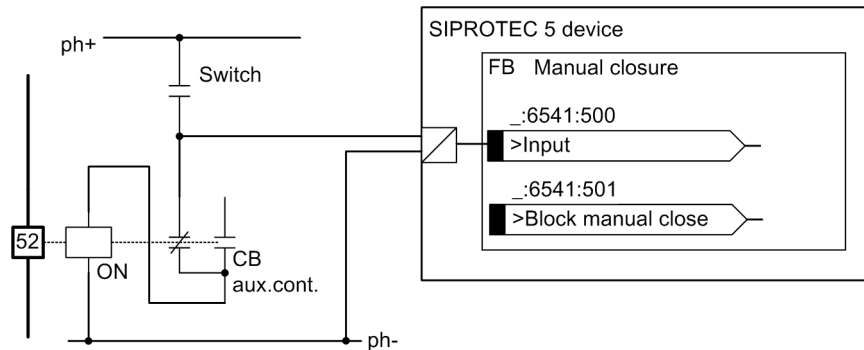

[to_steuer, 1, en_US]

Figure 5-120 Connection of the Input Signal to the Control Circuit of the Circuit-Breaker Closing Coil

Every closure of the circuit breaker is recorded in the process.

If external close commands are possible (actuation of the circuit breaker by other devices), which are not intended to promptly detect a manual closure, this can be ensured in 2 ways:

- The input signal is connected in such a way that it is not activated in the event of external close commands.
- The external close command is connected to the blocking input **>Block manual close** for manual closure detection.

Parameter: Action time

- Recommended setting value (**._:101**) **Action time = 0.30 s**

In order to ensure independence from manual activation of the input signal, the detection function is extended for a defined length of time using the parameter **Action time**.

Siemens recommends an action time of **0.30 s**.

Parameter: CB open dropout delay

- Default setting (**._:102**) **CB open dropout delay = 0.00 s**

With the **CB open dropout delay** parameter, you can maintain the effectiveness of internal indication **CB open** for the set time. If the input signal **>Input** becomes active after external delayed manual closure, the indication (**._:300**) **Detected** is output as long as the dropout delay is effective.

5.7.9.3 Settings

Addr.	Parameter	C	Setting Options	Default Setting
Manual close				
._:101	Manual close:Action time		0.01 s to 60.00 s	0.30 s

5.7.9.4 Information List

No.	Information	Data Class (Type)	Type
Manual close			
._:501	Manual close:>Block manual close	SPS	I

No.	Information	Data Class (Type)	Type
_:500	Manual close:>Input	SPS	I
_:300	Manual close:Detected	SPS	O

5.8 Function-Group Type Circuit Breaker [without Current]

5.8.1 Overview

The function group **Circuit breaker [without current]** is a circuit-breaker function group that does not measure the primary current of the circuit breaker. For the applications that do not need to monitor the current information of circuit breakers, the function group **Circuit breaker [without current]** is a good option. You can find the function group **Circuit breaker [without current]** under the device types in the Global DIGSI 5 Library.

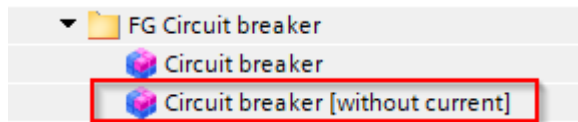

[sc_fg cb without |_7x81_7sx800, 1, en_US]

Figure 5-121 Function Group Circuit Breaker [without Current]

The following functions are available in the function group **Circuit breaker [without current]**:

- Circuit-breaker control
- Circuit-breaker interlocking
- Circuit-breaker test
- Synchronization
- External synchronization
- Trip-circuit supervision
- Closing-circuit supervision
- Voltage measuring-point selection

5.8.2 Structure of the Function Group

Besides the user functions, the function group **Circuit breaker [without current]** contains certain functionalities that are essential for general purposes. These functionalities cannot be loaded or deleted:

- Trip logic
- Mapping the physical circuit breaker
- Circuit-breaker position recognition for protection functions
- Detection of manual closure
- General settings

The following figure shows the structure of the function group **Circuit breaker [without current]**. The individual function blocks in the figure are described in the following chapters.

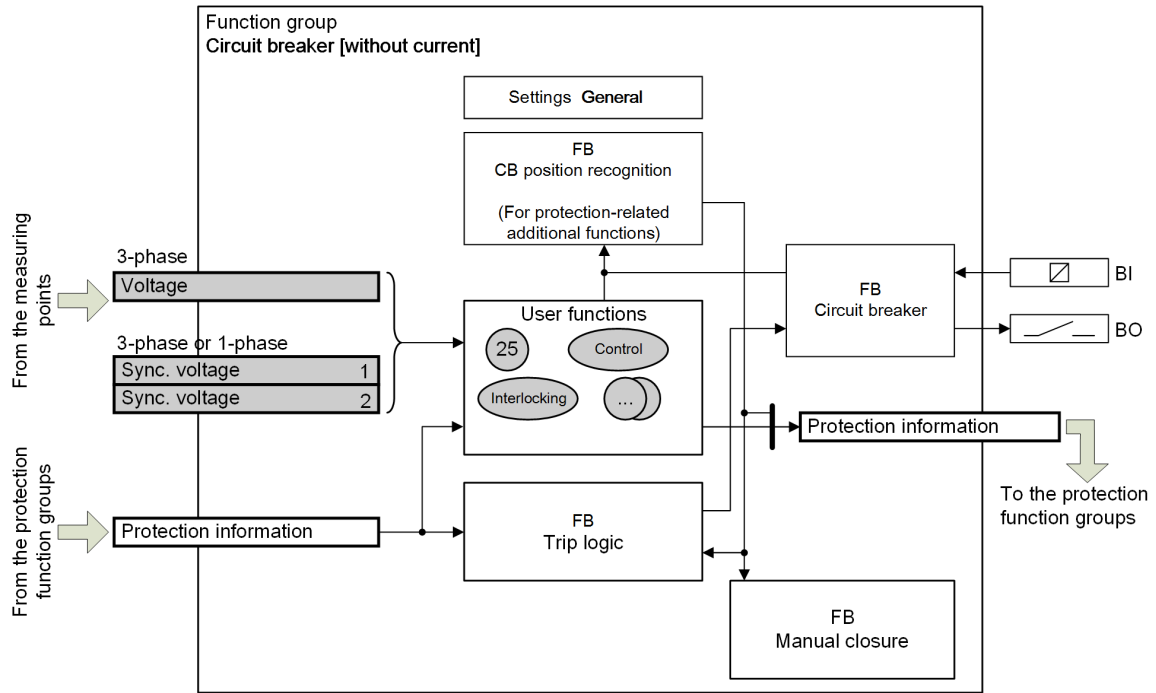

[dw_fg_stru_1_en_US]

Figure 5-122 Structure of the Function-Group Type Circuit breaker [without current]

Gray: Optionally connected

The function group **Circuit breaker [without current]** has interfaces with the following items:

- Measuring points
- Function groups

Interfaces with Measuring Points

The function group receives the required measured values from the measuring points which are connected to this function group.

If a user function, for example, the function **Synchronization**, is used in the function group, but the required measuring point is not linked to the function group, DIGSI 5 reports an inconsistency. This inconsistency provides an indication of the missing measuring-point connection.

The function group **Circuit breaker [without current]** has interfaces with the following measuring points:

- **3-phase voltage**
 The measurands of the 3-phase voltage system are supplied via this interface. The voltages are different due to the different connection types of the voltage transformers, for example, $V_{A'}$, $V_{B'}$, and V_C in one 3-phase voltage system, but $V_{AB'}$, $V_{BC'}$, and V_{CA} in another 3-phase voltage system.
 The connection to the corresponding measuring point is necessary only if a function that needs the measurand of the 3-phase voltage system is used.
- **Sync. voltage1, Sync. voltage2**
 A 1-phase synchronization voltage (for example, voltage of the busbar with a 1-phase connection) or a 3-phase synchronization voltage (for example, voltage of the busbar with a 3-phase connection) is supplied via this interface.
 The connection to the corresponding measuring point is necessary only if the function **Synchronization** is used.

Interface with Function Groups

All required data is exchanged between the function group **Circuit breaker [without current]** and the other function groups via the interfaces of the function group **Circuit breaker [without current]**. This data includes, for example, the circuit-breaker position information in the direction of the other function groups.

If an application template is used, the function groups are connected to each other because this connection is essential to ensure proper operation. You can modify the connection using the Editor **Function-group connections** in DIGSI 5. If the connection is missing, DIGSI 5 reports an inconsistency.

Besides the general assignments of other function groups to the circuit-breaker function groups, you can assign the protection functions to the desired circuit-breaker function groups for the tripping operation in the Editor **Circuit-breaker interaction** under the corresponding protection function group.

For more information, refer to [2.1 Embedding of Functions in the Device](#).

5.8.3 Application and Setting Notes

Interface with Measuring Points

If the function **Synchronization** is used, the measuring points that represent voltages V1 and V2 of the parts of the electrical power systems to be synchronized must be connected.

You can find more detailed information in [9.4 Synchronization Function](#).

Parameter: Rated voltage

- Default setting (`_:2311:102`) **Rated voltage** = **400.00 kV**

With the parameter **Rated voltage**, you set the primary rated voltage of the protected object. The primary rated voltage serves as a reference for all voltage-related % values within the function group **Circuit breaker [without current]**. This setting applies both for the operational measured values and for the setting values in %.

If the device works with the IEC 61850 protocol, you can only change the setting value of the parameter via DIGSI 5. If you change the setting value directly on the device, the IEC 61850 configuration of the metered values can be faulty.

5.8.4 Settings

Addr.	Parameter	C	Setting Options	Default Setting
<i>Ref. for %-values</i>				
_:2311:102	General:Rated voltage		0.10 kV to 1200.00 kV	400.00 kV

5.8.5 Trip Logic

5.8.5.1 Function Description

The **Trip logic** function block receives the operate group indication from the protection function groups and forms the protection trip command that is transmitted to the **Circuit-breaker** function block.

The **Circuit-breaker** function block activates the device contact and thus causes the circuit breaker to open (see [5.7.7 Circuit Breaker](#)). The command output time is also effective here.

The trip logic also decides when the protection trip command is reset (see [Figure 5-124](#)).

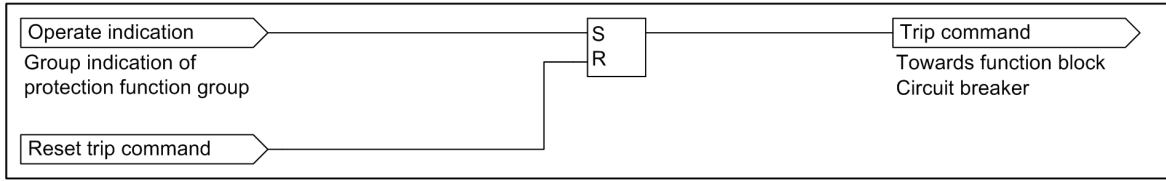

[lo_ausbef_1_en_US]

Figure 5-123 Trip Command

Trip-Command Reset

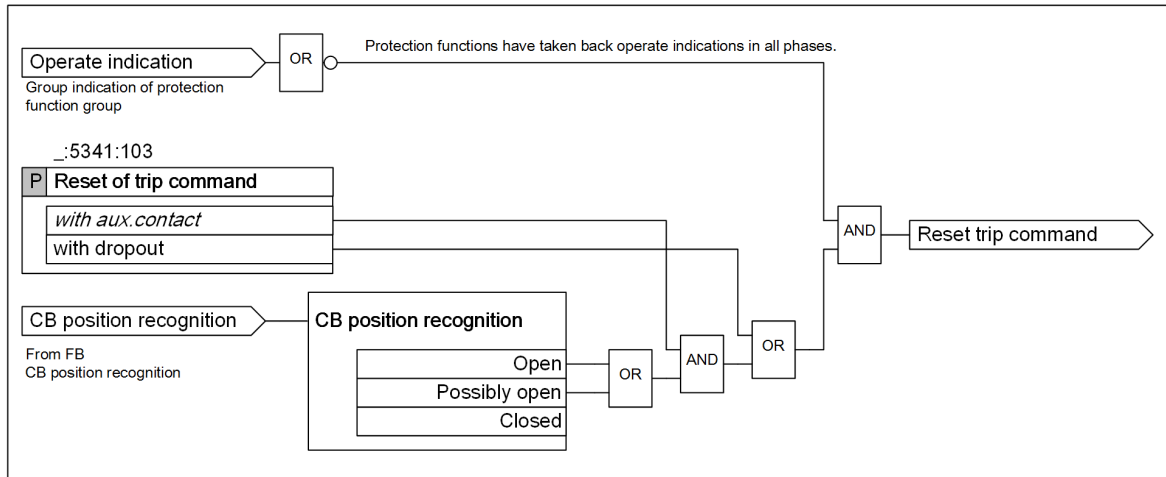

[lo_befe3p_4CB_without_1_1_en_US]

Figure 5-124 Trip-Command Reset

Once a trip command is issued, it is stored (see [Figure 5-123](#)).

You determine the criteria for resetting a trip command that has been issued with the parameter **Reset of trip command**. The following setting options are possible:

- **with dropout**
If the function that initiated tripping resets its operate indication the trip command is reset. This occurs typically with dropout. Command reset of the trip command takes place regardless of verification of the circuit-breaker condition.
- **with aux.contact**
For this criteria, the state of the circuit breaker is also taken into account as a further criterion in addition to the dropout of the tripping function (operate indication is reset). The state is determined by the circuit-breaker auxiliary contacts (**with aux.contact**).
As long as the circuit breaker is detected unambiguously as closed (**fully closed**), the trip command will not be reset with this setting option.
The information about the condition of the circuit breaker and the determination of the various conditions is supplied by the **Circuit-breaker position recognition** function block. You can find further information in chapter [5.7.8 Circuit-Breaker Position Recognition for Protection-Related Auxiliary Functions](#).

5.8.5.2 Application and Setting Notes

Parameter: Reset of trip command

- Default setting (`_:5341:103`) **Reset of trip command** = *with aux.contact*

Parameter Value	Description
<i>with aux.contact</i>	The trip command is reset if the state of the circuit-breaker auxiliary contact indicates that the circuit breaker is open. This setting assumes that the setting of the auxiliary contact has been routed via a binary input. For more information, refer to 5.8.6.3 Detection of Circuit-Breaker Auxiliary Contacts and Further Information .
<i>with dropout</i>	The trip command is reset if the pickup of the tripping protection function drops out.

5.8.5.3 Settings

Addr.	Parameter	C	Setting Options	Default Setting
<i>Trip logic</i>				
_:103	Trip logic:Reset of trip command		<ul style="list-style-type: none"> with aux.contact with dropout 	with aux.contact

5.8.5.4 Information List

No.	Information	Data Class (Type)	Type
<i>Trip logic</i>			
_:300	Trip logic:Trip indication	ACT	O
_:52	Trip logic:Behavior	ENS	O
_:53	Trip logic:Health	ENS	O

5.8.6 Circuit Breaker

5.8.6.1 Overview

The function block **Circuit breaker** represents the physical switch in the SIPROTEC 5 device.

The basic tasks of this function block are:

- Operation of the circuit breaker
- Acquisition of the circuit-breaker auxiliary contacts
- Acquisition of other circuit-breaker information

The function block **Circuit breaker** provides the following information:

- Number of switching cycles
- Breaking voltage and breaking frequency

5.8.6.2 Tripping, Opening, and Closing the Circuit Breaker

The circuit breaker is operated in the following situations:

- Tripping of the circuit breaker as a result of a protection trip command
- Opening of the circuit breaker as a result of control operations
- Closing of the circuit breaker as a result of control operations

Tripping is always the result of a protection function. The operate indications of the individual protection functions are summarized in the **Trip logic** function block. The trip command that causes the tripping in the function block **Circuit breaker** is generated there.

To operate the circuit breaker, the **Circuit-breaker** function block provides the output signals that must be routed to the corresponding binary outputs of the device (see [Table 5-13](#)).

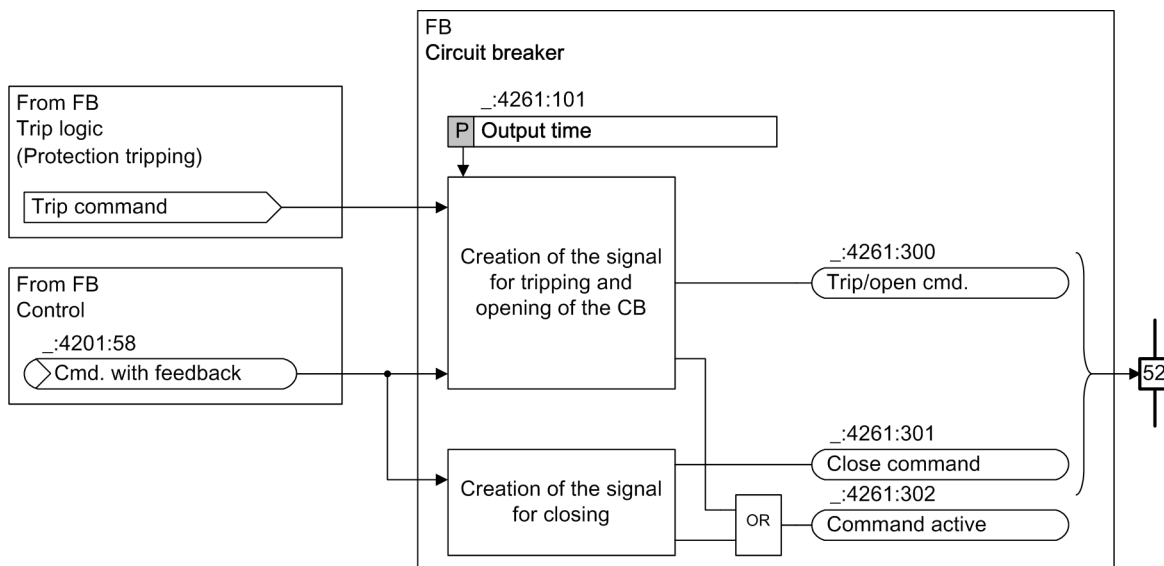

[lo_CB_tripping-opening-closing_1_en_US]

Figure 5-125 Tripping, Opening, and Closing the Circuit Breaker

Table 5-14 Description of the Output Signals

Signal	Description	Routing Options
Trip/open cmd.	<p>This signal executes all tripping and opening operations.</p> <p>The Output time parameter affects the signal.</p> <p>The signal is pending for the duration of the output time, with the following exceptions:</p> <ul style="list-style-type: none"> • Only when switched off by the control: The signal is reset before expiration of the period if the auxiliary contacts report that the circuit breaker is open before expiration of the period. • Only in the event of protection tripping: <ul style="list-style-type: none"> – The signal remains active as long as the trip command is still active after expiration of the period (see also). – If the trip signal is no longer active and the auxiliary contacts report that the circuit breaker is open before expiration of the period, the signal is canceled before expiration of the period. – With the routing option Only saved in the event of tripping, the signal remains pending until it is acknowledged manually. This only applies for protection tripping. 	<ul style="list-style-type: none"> • Unlatched • Only saved in the event of protection tripping (not when opened)
Close command	<p>This signal executes all closing operations.</p> <p>The Output time parameter affects the signal.</p> <p>The signal is pending for the duration of the output time, with the following exception: The signal is canceled before expiration of the period if the auxiliary contacts report that the circuit breaker is closed before expiration of the period.</p>	Normal routing
Command active	<p>This signal is active if one of the following binary outputs is active:</p> <ul style="list-style-type: none"> • Trip/open cmd. • Close command <p>The binary outputs are active as long as a switching command is being executed by the control.</p>	Normal routing

5.8.6.3 Detection of Circuit-Breaker Auxiliary Contacts and Further Information

To determine the circuit-breaker position, the function block **Circuit breaker** provides position signals. These signals are of the **Double-point indication (DPC)** type. A double-point indication can be routed to 2 binary inputs so that the open and closed circuit-breaker switch positions can be reliably acquired.

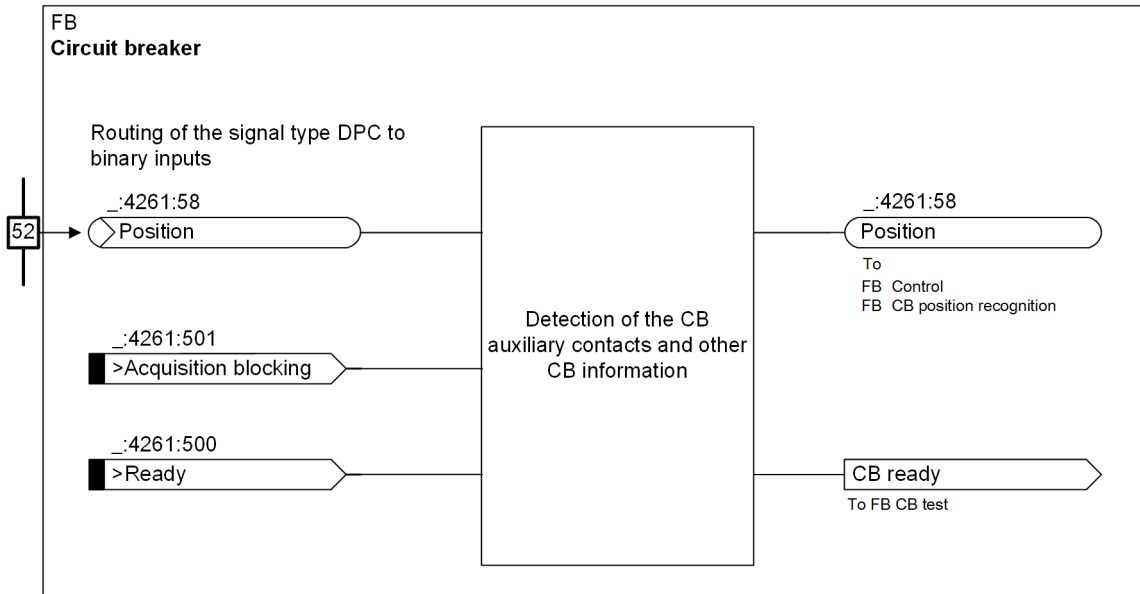

[lo_erfass_4CB_withoout_l_1_en_US]

Figure 5-126 Acquisition of the Circuit-Breaker Information

Signal	Type	Description
Position	DPC	Acquisition of the circuit-breaker switch position The switch position CB 3-pole open and/or the position CB 3-pole closed can be detected by routing to 1 or 2 binary inputs.

The signals must be routed to the binary input that is with the CB auxiliary contacts. The **open** and **closed** signals do not necessarily have to be routed in parallel. The advantage of parallel routing is that it can be used to determine an intermediate or disturbed position. If you route only one signal (**open** or **closed**), you cannot determine an intermediate position or a disturbed position.

In the monitoring direction, the position signals generate the following information when the **open** and **closed** positions are detected (see following table). This information is further processed by the **Circuit-breaker position recognition** and **Control** function blocks.

Information	Type	Description
Open	SPS	The circuit-breaker switch position is opened .
Closed	SPS	The circuit-breaker switch position is closed .
Intermediate position	SPS	The circuit-breaker switch position is in the intermediate position . The signal open and the signal closed have not been set.
Disturbed position	SPS	The circuit-breaker switch position is in the disturbed position . The signal open and the signal closed have been set simultaneously.
Not selected	SPS	The circuit breaker is not selected for a control operation.

The following table shows the additional input signals:

Signal	Type	Description
>Acquisition blocking	SPS	This is used to activate acquisition blocking of the circuit-breaker auxiliary contacts (see <i>Other Functions 3.8.3 Persistent Commands</i> for a description of acquisition blocking).
>Reset AcqBlk&Subst	SPS	This is used to reset acquisition blocking and manual update of the circuit breaker. If the signal is active, acquisition blocking and manual update are reset.
>Ready	SPS	The active signal indicates that the circuit breaker is ready for an Open-Closed-Open cycle. The signal remains active as long as the circuit breaker is unable to trip. The signal is used in the Circuit-breaker test function.

The following table shows one additional output signal:

Signal	Type	Description
External health	ENS	This can be used to indicate the health of the physical circuit breaker. For this, all failure information of the circuit breaker must be detected via a binary input. This failure information can set the appropriate state of the External health signal with a CFC chart (using the BUILD_ENS block). The signal has no effect on the health of the function block.

5.8.6.4 Circuit-Breaker Tripping Alarm Suppression

Circuit-Breaker Tripping Alarm Suppression

In certain systems, you possibly want to actuate an alarm (for example, a horn) when tripping (circuit-breaker tripping) occurs. This alarm should not to be issued if the control is used to switch on or off. The alarm is only to be issued in the event of final tripping.

Depending on how the alarm is generated (for example, triggered by a fleeting contact of the circuit breaker), the *Alarm suppression* signal can be used to suppress the alarm.

If one of the following conditions is met, the *Alarm suppression* signal is generated:

- The definitive protection tripping is not present.
- A close command is issued via the **Circuit-breaker test** function.
- The integrated control executes a closure or opening action.
- External closing is detected via the **Manual close** function.

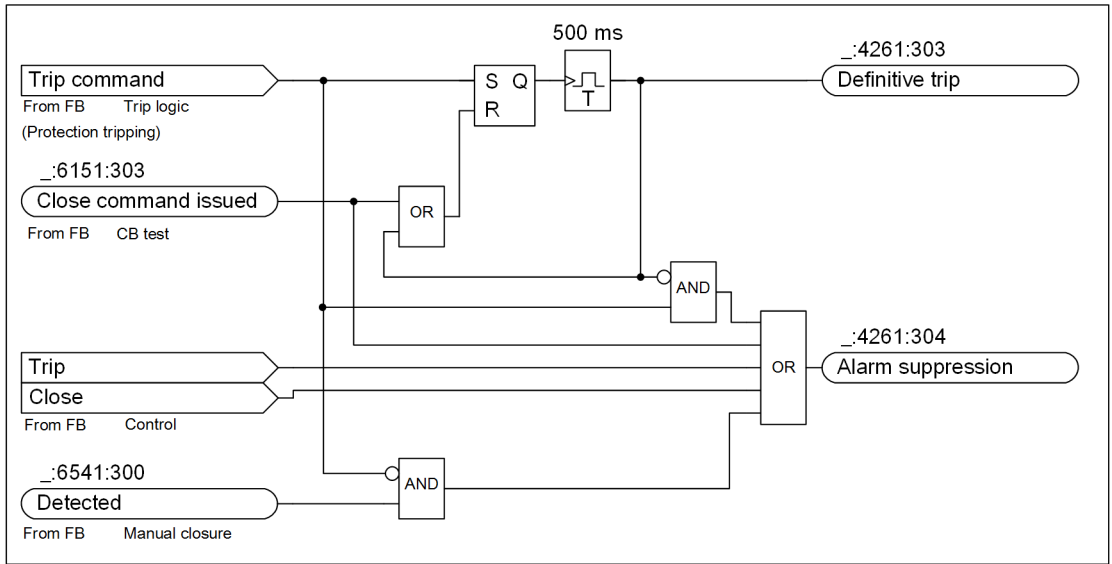

[lo_unterd_4CB_without_1_2_en_US]

Figure 5-127 Definitive Tripping and Circuit-Breaker Tripping Alarm Suppression

5.8.6.5 Tripping and Opening Information

When a trip or opening command is issued, the breaking information shown in the next figure is saved in the fault log.

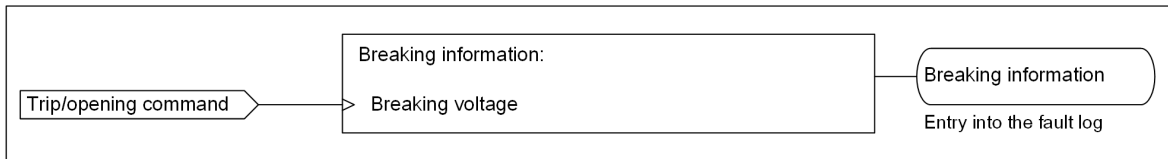

[lo_ausloe_4CB_without_1_1_en_US]

Figure 5-128 Breaking Information

The number of switching cycles is saved for the circuit breaker as the statistics information. All tripping, opening, and closing operations are counted.

The statistics information can be individually set and reset via the device control. It is also possible to reset all values via the binary input signal `>Reset switch statist..`

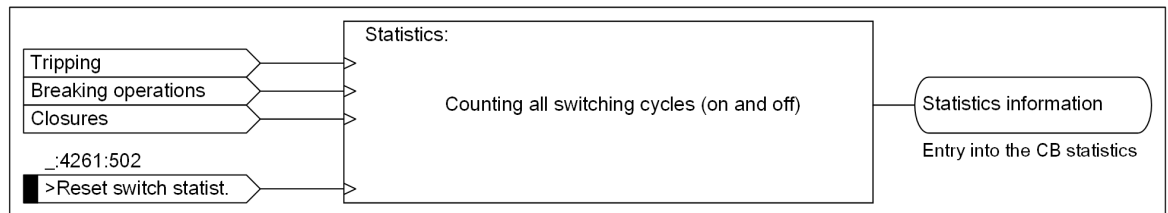

[lo_statistics information CB_4CB_without_1_1_en_US]

Figure 5-129 Statistics Information about the Circuit Breaker

5.8.6.6 Application and Setting Notes

Routings for Activation of the Circuit Breaker

Figure 5-130 shows the necessary routings for the device:

- 3-pole tripping via the protection
- 3-pole opening via the control

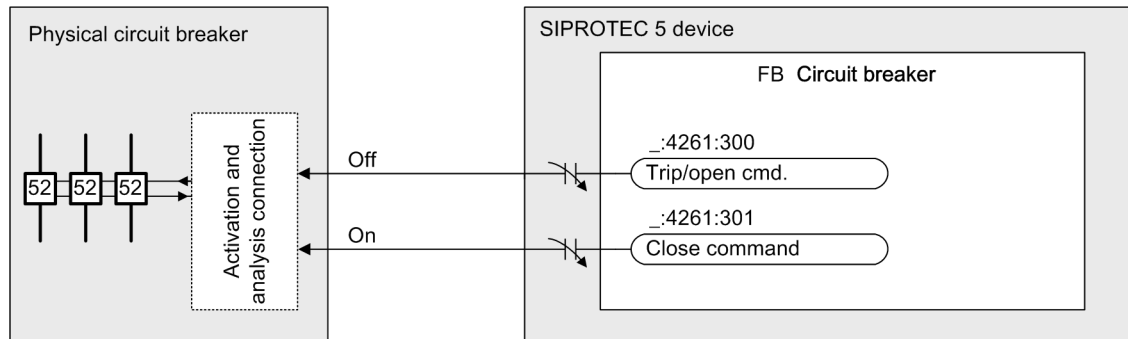

[to_ansteu_2_en_US]

Figure 5-130 Activation of the Circuit Breaker

By routing the **Trip/open cmd.** signals to 1 or 2 binary outputs, you can carry out 1-pole, 1.5-pole, and 2-pole activations of the circuit breaker. You can find a detailed description of this in chapter [9.2.2.3 Connection Variants of the Circuit Breaker](#).

**NOTE**

Do not confuse these 1-pole, 1.5-pole, and 2-pole activations of the circuit breaker with 1-pole or 3-pole tripping of the circuit breaker.

Routing for Analysis of the Circuit-Breaker Switch Position

For certain functions of the device, it is useful to detect the circuit-breaker switch position via its auxiliary contacts. The following shows a number of examples:

- Function block **Circuit-breaker position recognition**
- Function block **Control**

The operating principle of the auxiliary contacts is described in the individual functions.

Siemens recommends detecting the *Circuit breaker is open in 3 poles* and *Circuit breaker is closed in 3 poles* information via auxiliary contacts. This is the optimal configuration for the control functionality. For purely protection applications, it is also sufficient to detect just one of the 2 circuit-breaker switch positions. When used as a protection and control device, Siemens recommends the following analysis of the circuit-breaker switch position:

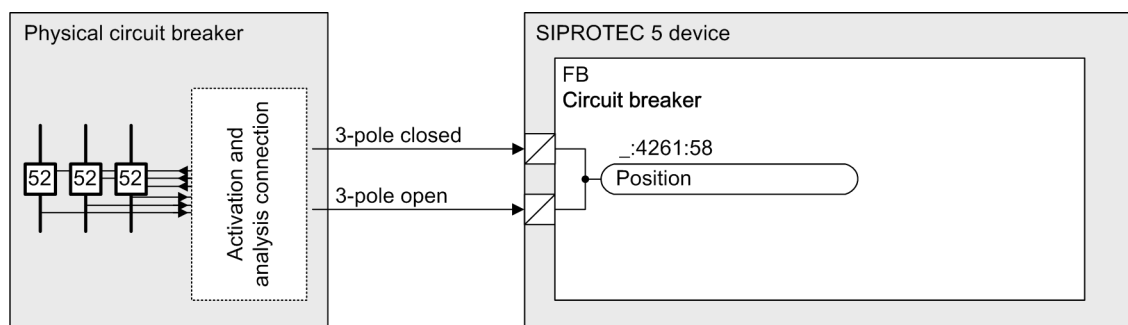

[to_evaluation2_1_en_US]

Figure 5-131 Recommended Analysis of the Circuit-Breaker Switch Position

The following figure shows the recommended routing, in which **OH** stands for **active with voltage**.

Information				Source								
				Binary input								
				Base module								
Signals	Fav	Number	Type	1.1	1.2	1.3	1.4	1.5	1.6	1.7	1.8	
(All)	...	(All)	
Position	☆	201.4261.58	DPC	CH	OH							

[sc_polg3p_1_en_US]

Figure 5-132 Routing for Acquisition of the Circuit-Breaker Switch Position via 2 Auxiliary Contacts

The device can also function without the analysis from the circuit-breaker auxiliary contacts, that is, routing of the auxiliary contacts is not absolutely necessary. However, this is a requirement for the control functions.

Parameter: Output Time

- Default setting (`_:101`) **Output time** = `0.10 s`

The **Output time** parameter acts on the signals for tripping, opening, and closing of the circuit breaker.



CAUTION

Do not set a time that is too short.

If you set a time that is too short, there is a danger that the device contacts will interrupt the control circuit. If this happens, the device contacts will burn out.

- ✧ Set a time that is long enough to ensure that the circuit breaker reliably reaches its final position (**open** or **closed**) after a control operation.

Parameter: Indicat. of breaking values

- Default setting (`_:105`) **Indicat. of breaking values** = `always`

With the parameter **Indicat. of breaking values**, you specify whether the measured values are to be reported if the circuit breaker is opened via the control function.

Parameter Value	Description
<code>always</code>	With this setting, the measured values are reported if the circuit breaker is opened either via the control function or via the trip command of a protection function.
<code>with trip</code>	With this setting, the measured values are only reported if the circuit breaker is opened via the trip command of a protection function.

Measured Values

When a protection function opens the circuit breaker, the following measured values can be stored in the fault log:

- `Break. voltage phs A`
- `Break. voltage phs B`
- `Break. voltage phs C`

Output Signal: Indication Suppression

For this, the alarm activation circuit should be looped via a suitably routed output contact of the device (output signal **Alarm suppression**). In the idle state and when the device is switched off, this contact is always closed. For this, an output contact with a break contact must be routed. The contact opens whenever the output signal **Alarm suppression** becomes active, so that tripping or a switching operation does not cause an alarm.

You can find more detailed information in the logic in [5.7.7.3 Acquisition of Circuit-Breaker Auxiliary Contacts and Further Information](#).

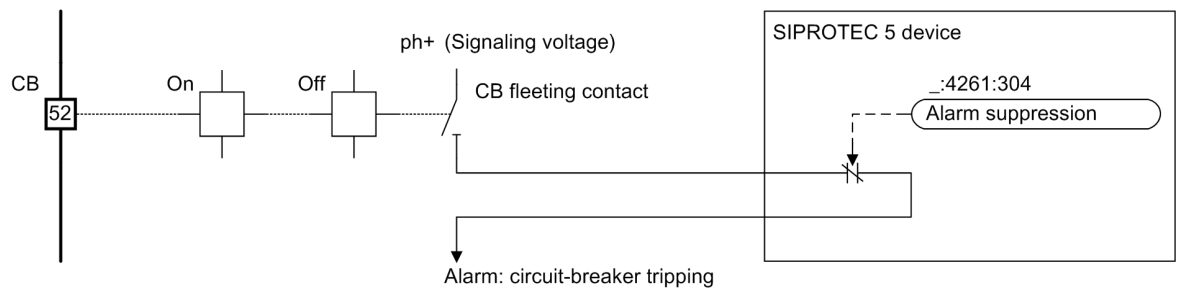

[to_schalt; 2_en_US]

Figure 5-133 Circuit-Breaker Tripping Alarm Suppression

5.8.6.7 Settings

Addr.	Parameter	C	Setting Options	Default Setting
Circuit break.				
_:101	Circuit break.:Output time		0.02 s to 1800.00 s	0.10 s
_:105	Circuit break.:Indicat. of breaking values		<ul style="list-style-type: none"> with trip always 	always

5.8.6.8 Information List

No.	Information	Data Class (Type)	Type
Circuit break.			
_:500	Circuit break.:>Ready	SPS	I
_:501	Circuit break.:>Acquisition blocking	SPS	I
_:502	Circuit break.:>Reset switch statist.	SPS	I
_:504	Circuit break.:>Reset AcqBlk&Subst	SPS	I
_:503	Circuit break.:External health	ENS	I
_:53	Circuit break.:Health	ENS	O
_:58	Circuit break.:Position	DPC	C
_:300	Circuit break.:Trip/open cmd.	SPS	O
_:301	Circuit break.:Close command	SPS	O
_:302	Circuit break.:Command active	SPS	O
_:303	Circuit break.:Definitive trip	SPS	O
_:304	Circuit break.:Alarm suppression	SPS	O
_:306	Circuit break.:Op.ct.	INS	O
_:314	Circuit break.:Break. voltage phs A	MV	O
_:315	Circuit break.:Break. voltage phs B	MV	O
_:316	Circuit break.:Break. voltage phs C	MV	O
_:322	Circuit break.:CB open hours	INS	O

5.8.7 Circuit-Breaker Position Recognition for Protection-Related Auxiliary Functions

5.8.7.1 Overview

This function block calculates the position of the circuit breaker from the evaluation of the auxiliary contacts.

This information is needed in the following protection-related additional functions:

- Trip logic (see [5.8.5.1 Function Description](#))
- Detection of manual closing (see [5.8.8.1 Function Description](#))
- Process monitor (Standard V/I) (see [5.10 Process Monitor](#))

The specified chapters describe the way the protection-related additional functions are processing the information of this function block.

The control does not use this information. The control evaluates the circuit-breaker auxiliary contacts.

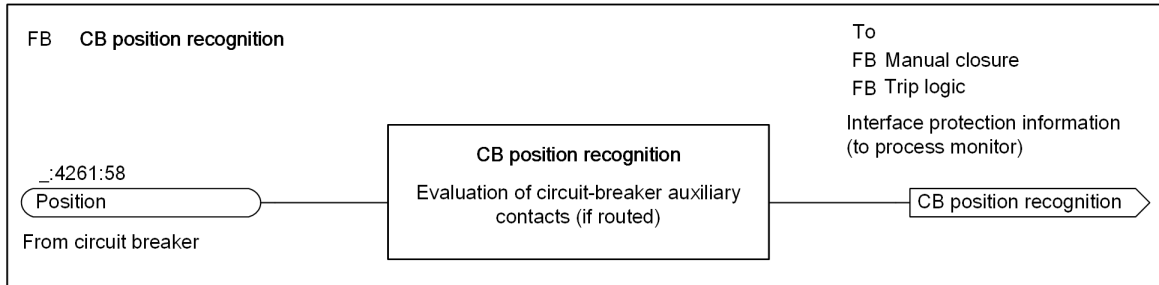

[lo_zust3p_4CB_without_1, 1, en_US]

Figure 5-134 Overview of the Circuit-Breaker Position Recognition

Based on the link between the information from the auxiliary contacts, shown in [Figure 5-118](#), the circuit breaker can assume the following positions. The following table shows the possible circuit-breaker positions:

Circuit-Breaker Position	Description
<i>Open</i>	The circuit-breaker pole is detected unambiguously as <i>open</i> according to both criteria.
<i>Closed</i>	The circuit-breaker pole is detected unambiguously as <i>closed</i> according to both criteria.
<i>Possibly open</i>	This condition occurs if the information is incomplete due to the routing of the auxiliary contacts and the condition can no longer be determined reliably. This uncertain condition is evaluated differently by certain functions.

5.8.8 Detection Manual Closure (for Processor Monitor)

5.8.8.1 Function Description

Detection of Manual Closure (for Process Monitor)

The **Manual closure** function block detects any closure carried out by hand. This information is used in the **Process monitor** functions (within protection function groups).

You can find detailed information in the chapter *Process monitor*.

The following figure shows the logic for manual closure detection.

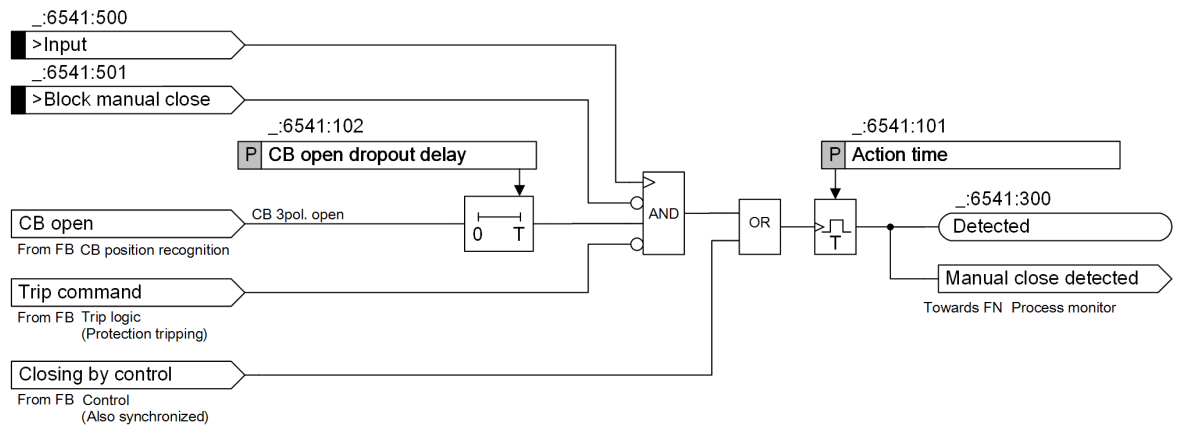

[to_hand_3p_4CB_without_I_1_en_US]

Figure 5-135 Logic for Manual Closure Detection

External Manual Closure

An external manual closure is communicated to the device via the input signal **>Input**. The input signal can also be connected directly to the control circuit of the circuit-breaker closing coil. Detection via the input signal **>Input** is also blocked if the circuit breaker is closed or if a protection trip is active.

Internal Manual Closure

Manual closure is detected in all cases if a close command is transmitted by the internal control function of the device. This is possible because the control carries out plausibility checks itself and is also subject to interlocking.

5.8.8.2 Application and Setting Notes

Input Signals: >Input, >Blocking of Manual Closure

In practice, the input signal **>Input** is connected directly to the control circuit of the circuit-breaker closing coil (see following figure).

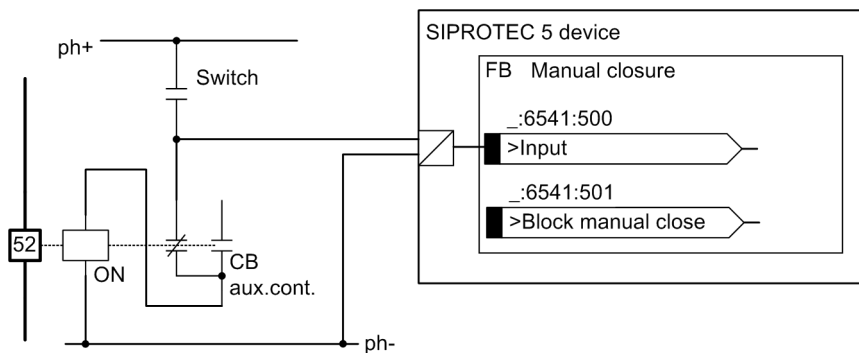

[to_steuer_1_en_US]

Figure 5-136 Connection of the Input Signal to the Control Circuit of the Circuit-Breaker Closing Coil

Every closure of the circuit breaker is recorded in the process.

If external close commands are possible (actuation of the circuit breaker by other devices), which are not intended to promptly detect a manual closure, this can be ensured in 2 ways:

- The input signal is connected in such a way that it is not activated in the event of external close commands.
- The external close command is connected to the blocking input **>Block manual close** for manual closure detection.

Parameter: Action time

- Recommended setting value (`_:101`) **Action time = 0.30 s**

In order to ensure independence from manual activation of the input signal, the detection function is extended for a defined length of time using the parameter **Action time**.

Siemens recommends an action time of **0.30 s**.

Parameter: CB open dropout delay

- Default setting (`_:102`) **CB open dropout delay = 0.00 s**

With the **CB open dropout delay** parameter, you can maintain the effectiveness of internal indication **CB open** for the set time. If the input signal **>Input** becomes active after external delayed manual closure, the indication (`_:300`) **Detected** is output as long as the dropout delay is effective.

5.8.8.3 Settings

Addr.	Parameter	C	Setting Options	Default Setting
Manual close				
<code>_:101</code>	Manual close:Action time		0.01 s to 60.00 s	0.30 s
<code>_:102</code>	Manual close:CB open dropout delay		0.00 s to 60.00 s	0.00 s

5.8.8.4 Information List

No.	Information	Data Class (Type)	Type
Manual close			
<code>_:6541:501</code>	Manual close:>Block manual close	SPS	I
<code>_:6541:500</code>	Manual close:>Input	SPS	I
<code>_:6541:300</code>	Manual close:Detected	SPS	O
<code>_:6541:52</code>	Manual close:Behavior	ENS	O
<code>_:6541:53</code>	Manual close:Health	ENS	O

5.9 Function-Group Recording

5.9.1 Overview

The device has a flash memory in which records can be saved. The recording documents operations within the power system and how devices respond to them. You can read out records from the device and analyze them. Depending on the recorder, the records are available in different file formats (see the following table).

Table 5-15 File Format Used by Individual Recorders

Interface	File Format	FR ¹¹	SSR ¹²	CR ¹³	TR ¹⁴
DIGSI 5	SIPROTEC 5	–	X	X	X
DIGSI 5	COMTRADE	X	–	–	–
IEC 61850	SIPROTEC 5	–	X	–	–
IEC 61850	COMTRADE	X	X	–	–
IEC 61850	PQDIF	–	–	X	X
Browser-based user interface	SIPROTEC 5	–	X	–	–
Browser-based user interface	COMTRADE	X	X	–	–
Browser-based user interface	PQDIF	–	–	X	X
T103	COMTRADE	X	–	–	–
T104	COMTRADE	X	–	–	–
DNP	COMTRADE	X	–	–	–

5.9.2 Structure of the Function Group

The **Recording** function group consists of the following functionalities:

- **General** function block
- **Fault recorder** function
- **Slow-scan recorder** function
- **Continuous recorder** function
- **Trend recorder** function

The following figure shows the structure of the **Recording** function group. The function blocks are described in the following chapters.

¹¹ FR: Protection fault recorder

¹² SSR: Slow-scan recorder

¹³ CR: Continuous recorder

¹⁴ TR: Trend recorder

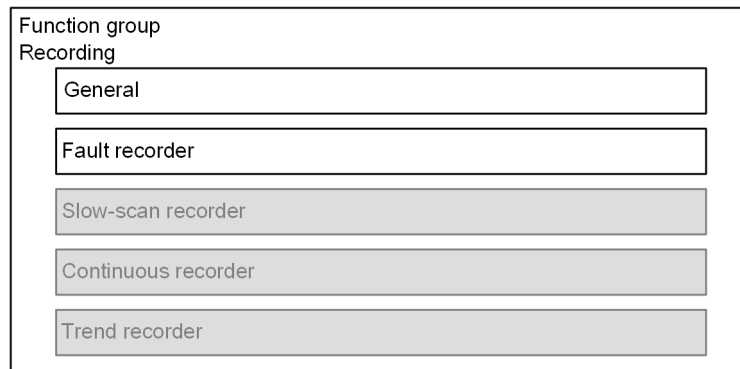

White: Fixed instantiate (unerasable)

Gray: Optional

[dw_fg_recorder, 4, en_US]

Figure 5-137 Structure of the Recording Function Group



NOTE

If you want to use one of the following functions, the device must be equipped with the CP300, CP150, or CP050 CPU printed circuit board assembly:

- Slow-scan recorder
- Continuous recorder
- Trend recorder

The function group **Protection Recording** is a central device function. The recording criterion, measured-value channels, and binary channels to be recorded are functionally preconfigured through the application templates. You can individually adapt the configuration in DIGSI 5 after enabling Recorder Routing functions. For more information on the **Fault recorder** function, refer to **Fault Recording**, starting at [3.5.1 Overview of Functions](#).

For more information on the function group **Recording**, refer to the *SIPROTEC 5 Protection Recording manual* (C53000-H5040-C089).

5.10 Process Monitor

5.10.1 Overview of Functions

All function groups that have functions with dependencies on the state of the protected object contain a process monitor. The process monitor detects the current state of the protected object.

5.10.2 Structure of the Function

The **Process monitor** function is used in the **Standard V/I 3-phase** protection function group.

The **Process monitor** function is provided by the manufacturer with the following function blocks:

- Cold-load pickup detection (optional)
- Current-flow criterion
- Circuit-breaker condition
- Closure detection

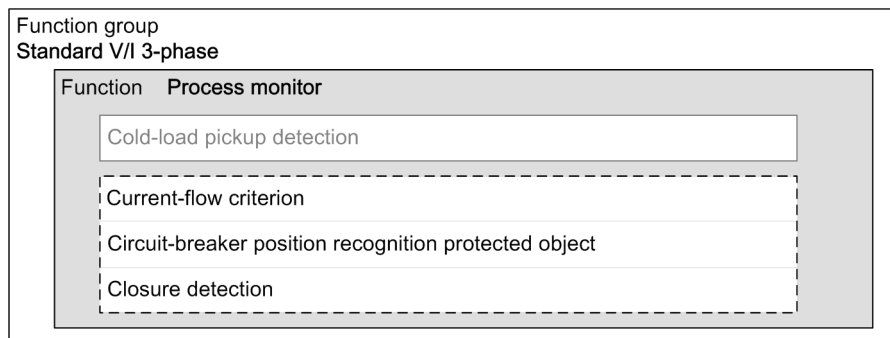

[dx_pro3pt_2_en_US]

Figure 5-138 Structure/Embedding of the Function

You can activate the cold-load pickup detection as needed. All other stages of the process monitor run permanently in the background and are not displayed in DIGSI.

The following figure shows the relationships of the individual function blocks.

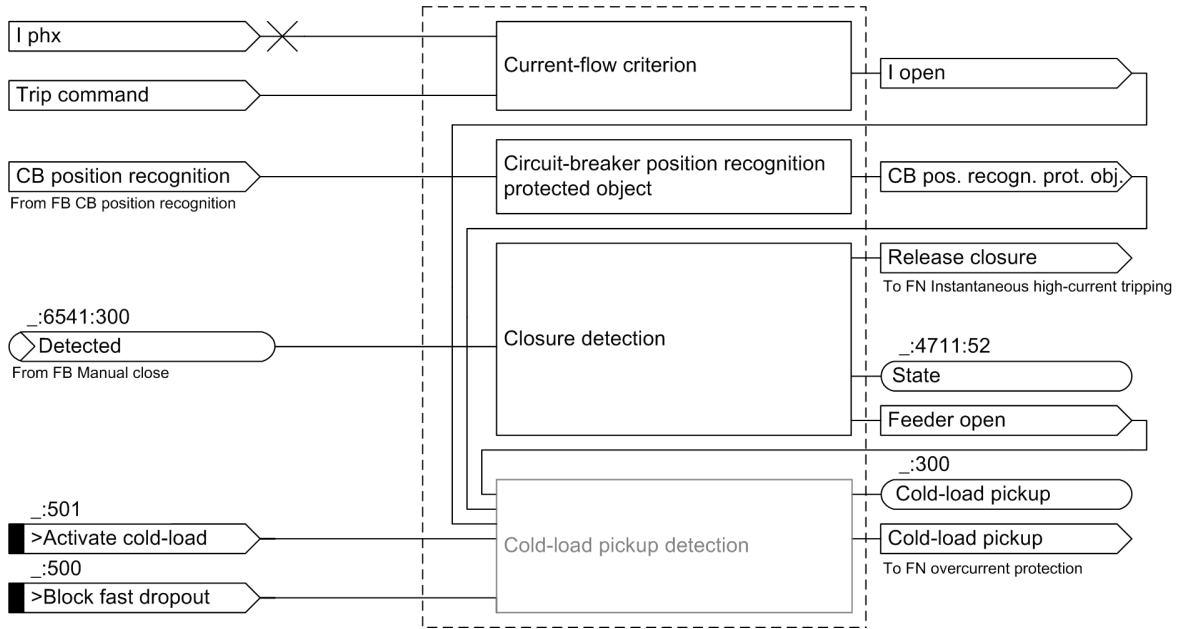

[lo_pro_3pt, 2, en_US]

Figure 5-139 Logic Diagram of the Overall Function Process Monitor

5.10.3 Current-Flow Criterion

Logic

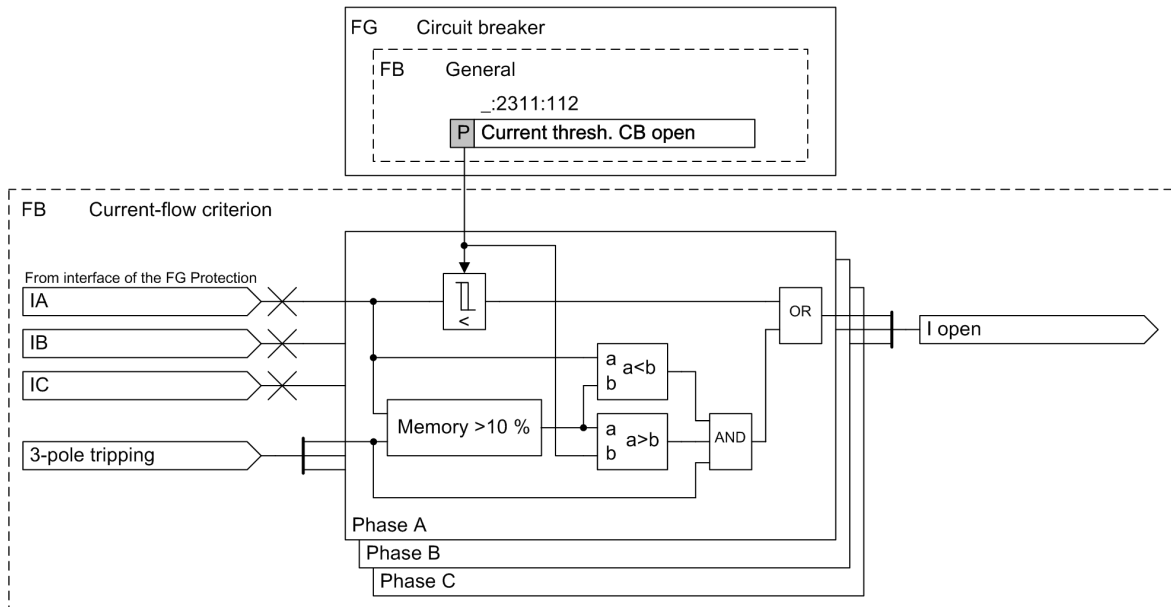

[lo_proikr, 2, en_US]

Figure 5-140 Logic Diagram of the Current-Flow Criterion Function Block

The phase currents are provided via the interface to the protection function group.

The **I open** signal of one phase is generated if one of the following conditions is met:

- A phase current falls below the set threshold of the **Current thresh. CB open** parameter. The hysteresis stabilizes the signal.
- The corresponding phase current, for example, **I A**, falls below 10 % of the phase current when the trip command arrives. If the current does not drop until after a delay due to current transformer influences, an open pole can therefore be detected quickly even after a high-current fault on the line.

With the **Current thresh. CB open** parameter, you define the minimum current as the criterion for a deactivated line. The parameter lies in the **Circuit-breaker** function group. It acts both in the **Circuit-breaker** function group, for example circuit-breaker position recognition, and also for the process monitor in the protection function group.

If a protection function group with integrated process monitor is connected to several **Circuit breaker** FGs, the **Current thresh. CB open** parameter is present in each FG **Circuit breaker**. The smallest setting value of the parameter **Current thresh. CB open** is used.

5.10.4 Application and Setting Notes (Current-Flow Criterion)

Parameter: **Current thresh. CB open**

- Recommended setting value (`_:2311:112`) **Current thresh. CB open** = **0.100 A**

The **Current thresh. CB open** parameter is used to define the threshold for the leakage current as the criterion for a deactivated line.

Set the **Current thresh. CB open** parameter so that the current measured when the feeder is deactivated falls below the value of the **Current thresh. CB open** parameter with certainty. The hysteresis is additionally active if the threshold is exceeded.

If parasitic currents, for example, due to induction, are ruled out when the feeder is deactivated, set the **Current thresh. CB open** parameter sensitively.

Siemens recommends a setting value of **0.100 A**.

5.10.5 Circuit-Breaker Condition for the Protected Object

Logic

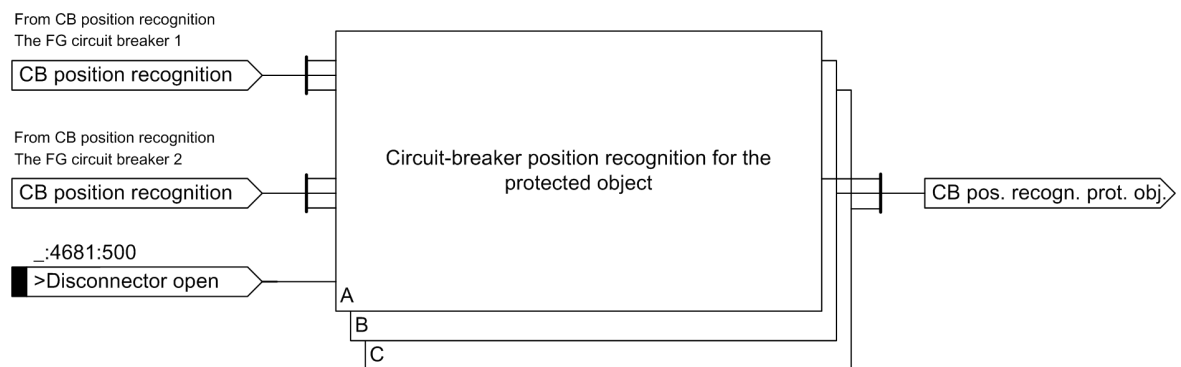

[to_protsz_2_en_US]

Figure 5-141 Logic Diagram of the Circuit-Breaker Condition for the Protected-Object Function Block

The circuit-breaker position recognition in the **Circuit-breaker** (CB) function group provides the circuit-breaker condition by way of the internal signal **CB pos. recogn. prot. obj.**

If a protected object is supplied via 2 circuit breakers (CBs), for example with the 1 1/2 circuit-breaker layout, then the circuit-breaker switch position of the protected object must be determined with the aid of both circuit breakers. In this case, the **Circuit-breaker position recognition for the protected object** function block connects the individual CB states. The connection provides the internal **CB pos. recogn. prot.**

obj. signal to the other function blocks of the process monitor and to other functions, for example, **Trip in the event of weak infeed** and **Echo function for teleprotection method**, within the same function group. If one of the following 2 conditions is met, the *CB pos. recogn. prot. obj.* signal is in the **Open** state:

- All connected circuit breakers signal the **Open** state internally.
- The **>Disconnecter open** input is active.

If the following 2 conditions are met, the *CB pos. recogn. prot. obj.* signal is in the **Closed** state:

- At least one of the connected circuit breakers signals the **Closed** state internally.
- The **>Disconnecter open** input is not active.

5.10.6 Closure Detection

5.10.7 Information List

No.	Information	Data Class (Type)	Type
<i>Closure detec.</i>			
_:4681:500	Closure detec.:>Disconnecter open	SPS	I
_:4681:300	Closure detec.:Closure	SPS	O

5.10.8 Cold-Load Pickup Detection (Optional)

Logic

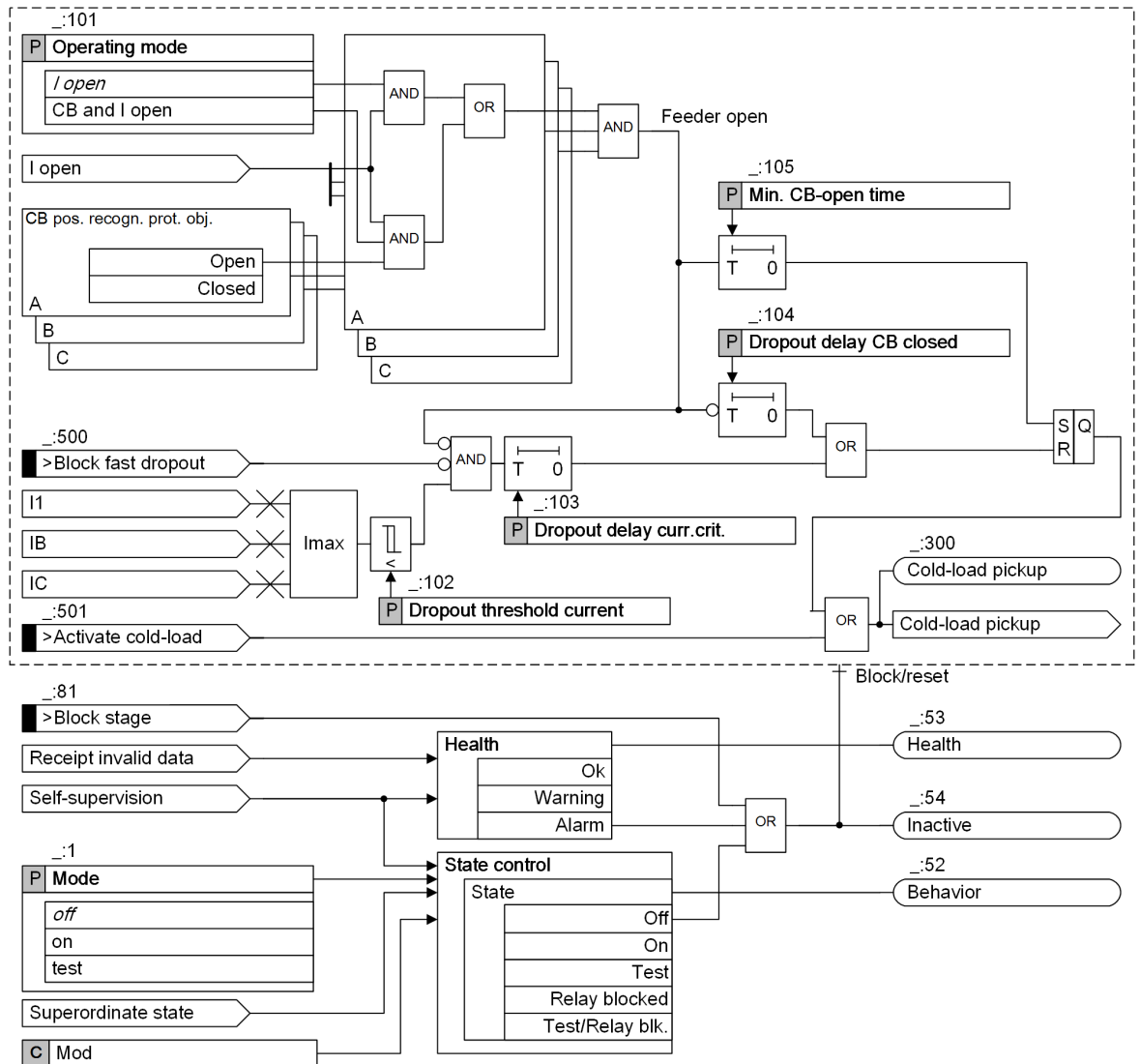

[lo_pro_dis_2_en_US]

Figure 5-142 Logic Diagram of the Cold-Load Pickup Detection Function Block

The **Cold-load pickup detection** function block detects that a specific time has been exceeded after deactivation of the line or protected object. If you want to connect the protected object again, you must note that an increased load-current requirement exists for a limited time after connection. This results from the nature of the load.

The **Cold-load pickup detection** function block ensures that different parameters are used for an adjustable time after connection. For example, for the time of the **Min. CB-open time** parameter, you can increase the threshold value of a protection function or you can select a special characteristic curve.

If the **Cold-load pickup detection** function block detects an open feeder and the set time of the **Min. CB-open time** parameter has expired, the indication **>Activate cold-load** is generated.

With the **>Activate cold-load** indication, you can activate a parameter set of the **Cold-load pickup** function. Via the binary input signal **>Activate cold-load**, you can also activate the **>Activate cold-load** indication directly.

If the **Cold-load pickup detection** function block detects closure and the corresponding load current, it starts the time set in the **Dropout delay CB closed** parameter. The **>Activate cold-load** indication and the activated parameter set are deactivated after this time has elapsed.

If, for the time set in the **Dropout delay curr.crit.** parameter, the maximum phase current falls below the threshold value **Dropout threshold current**, the parameter set for the **Cold-load pickup detection** function block is also deactivated. As a result, if the load current is very low, the action time **Dropout delay curr.crit.** of the **>Activate cold-load** indication can be shortened.

5.10.9 Application and Setting Notes (Cold-Load Pickup Detection)



NOTE

The settings and indications described in this chapter are only available when using the optional **Cold-load pickup detection** function block.

Parameter: Operating mode

- Default setting (**_:101**) **Operating mode = I open**

With the **Operating mode** parameter, you set the criteria with which the Closure-detection function block operates.

Parameter Value	Description
<i>I open</i>	When the Current-flow criterion function block detects a clearing open condition, the decision is made for pickup. For this setting, make sure that the Current thresh. CB open parameter is set lower than the possible load current. If this is not the case, open is detected continuously and each fault current that exceeds the Current thresh. CB open parameter is interpreted as closure.
<i>CB and I open</i>	Closure is detected if one of the following conditions is met: <ul style="list-style-type: none"> • Analysis of the circuit-breaker auxiliary contact detects a clearing open condition in at least one phase. • The current-flow criterion detects a clearing open condition.

Parameter: Dropout threshold current

- Default setting (**_:102**) **Dropout threshold current = 1.00 A**

With the **Dropout threshold current** parameter, you set the threshold at which the output signal **Cold-load pickup** is deactivated when the current in at least one phase falls below this threshold.

Parameter: Dropout delay current criterion

- Default setting (**_:103**) **Dropout delay curr.crit. = 600 s**

With the **Dropout delay curr.crit.** parameter, you set the time for which the actual value must be below the **Dropout threshold current** threshold so that the output signal **Cold-load pickup** can be deactivated prematurely.

Parameter: Dropout delay CB closed

- Default setting (**_:104**) **Dropout delay CB closed = 3600 s**

With the **Dropout delay CB closed** parameter, you set the action time for the dynamic parameter set switching in the event of cold-load pickup detection.

Parameter: Min. CB open time

- Default setting (**_:105**) **Min. CB-open time = 3600 s**

With the **Min. CB-open time** parameter, you set the time after which the dynamic parameter set is activated in the event of **cold-load pickup** when the line is opened.

5.10.10 Settings

Addr.	Parameter	C	Setting Options	Default Setting
<i>Cold-load PU</i>				
_:1	Cold-load PU:Mode		<ul style="list-style-type: none"> • off • on • test 	off
_:101	Cold-load PU:Operating mode		<ul style="list-style-type: none"> • I open • CB and I open 	I open
_:102	Cold-load PU:Dropout threshold current	1 A @ 100 Irated	0.030 A to 10.000 A	1.000 A
		5 A @ 100 Irated	0.15 A to 50.00 A	5.00 A
		1 A @ 50 Irated	0.030 A to 10.000 A	1.000 A
		5 A @ 50 Irated	0.15 A to 50.00 A	5.00 A
		1 A @ 1.6 Irated	0.001 A to 1.600 A	1.000 A
		5 A @ 1.6 Irated	0.005 A to 8.000 A	5.000 A
_:103	Cold-load PU:Dropout delay curr.crit.		1 s to 600 s	600 s
_:104	Cold-load PU:Dropout delay CB closed		1 s to 21600 s	3600 s
_:105	Cold-load PU:Min. CB-open time		0 s to 21600 s	3600 s

5.10.11 Information List

No.	Information	Data Class (Type)	Type
<i>Cold-load PU</i>			
_:81	Cold-load PU:>Block stage	SPS	I
_:500	Cold-load PU:>Block fast dropout	SPS	I
_:501	Cold-load PU:>Activate cold-load	SPS	I
_:54	Cold-load PU:Inactive	SPS	O
_:52	Cold-load PU:Behavior	ENS	O
_:53	Cold-load PU:Health	ENS	O
_:300	Cold-load PU:Cold-load pickup	SPS	O

6 General Protection and Automation Functions

6.1	Power-System Data	323
6.2	Group Indications of Overcurrent Protection Functions	348
6.3	Overcurrent Protection, Phases	350
6.4	Voltage-Dependent Overcurrent Protection, Phases	385
6.5	Overcurrent Protection, Ground	405
6.6	Directional Overcurrent Protection, Phases	436
6.7	Directional Overcurrent Protection, Ground	470
6.8	Inrush-Current and 2nd Harmonic Detection	514
6.9	Instantaneous High-Current Tripping	526
6.10	Instantaneous Tripping at Switch onto Fault	531
6.11	Overcurrent Protection, 1-Phase	534
6.12	Positive-Sequence Overcurrent Protection	560
6.13	Non-Directional Intermittent Ground-Fault Protection	570
6.14	Directional Intermittent Ground-Fault Protection	579
6.15	Sensitive Ground-Fault Detection	591
6.16	Undercurrent Protection	673
6.17	Negative-Sequence Protection	679
6.18	Directional Negative-Sequence Protection	689
6.19	Thermal Overload Protection, 3-Phase - Advanced	699
6.20	Thermal Overload Protection, User-Defined Characteristic Curve	712
6.21	Thermal Overload Protection, 1-Phase	724
6.22	Unbalanced-Load Protection	735
6.23	Overvoltage Protection with 3-Phase Voltage	742
6.24	Overvoltage Protection with Zero-Sequence Voltage/Residual Voltage	755
6.25	Overvoltage Protection with Positive-Sequence Voltage	761
6.26	Overvoltage Protection with Negative-Sequence Voltage	765
6.27	Overvoltage Protection with Any Voltage	772
6.28	Overvoltage Protection with Negative-Sequence Voltage/Positive-Sequence Voltage	778
6.29	Undervoltage Protection with 3-Phase Voltage	785
6.30	Undervoltage Protection with Positive-Sequence Voltage	802
6.31	Undervoltage Protection with Any Voltage	808
6.32	Rate-of-Voltage-Change Protection	815
6.33	Overfrequency Protection	822
6.34	Underfrequency Protection	827

6.35	Underfrequency Load Shedding	832
6.36	Rate of Frequency Change Protection	844
6.37	Vector-Jump Protection	850
6.38	Power Protection (P,Q), 3-Phase	858
6.39	Reverse-Power Protection	867
6.40	Overexcitation Protection	875
6.41	Undervoltage-Controlled Reactive-Power Protection	885
6.42	Circuit-Breaker Failure Protection	894
6.43	Circuit-Breaker Restrike Protection	913
6.44	Restricted Ground-Fault Protection	922
6.45	External Trip Initiation 3-Pole	940
6.46	Automatic Reclosing Function	943
6.47	Fault Locator	997
6.48	Fault Locator Plus	1012
6.49	Temperature Supervision	1026
6.50	Phase-Sequence Switchover	1036
6.51	Current-Jump Detection	1042
6.52	Voltage-Jump Detection	1045
6.53	Voltage Measuring-Point Selection	1049
6.54	Protection and Automation Functions (CEI 0-16 Standard)	1052
6.55	Overvoltage Protection with 3-Phase Voltage (CEI 0-16 Standard)	1053
6.56	Frequency Protection (CEI 0-16 Standard)	1060
6.57	Undervoltage Protection with 3-Phase Voltage (CEI 0-16 Standard)	1077
6.58	PI Trip Logic (CEI 0-16 Standard) in FG Circuit Breaker	1083

6.1 Power-System Data

6.1.1 Overview

The **Power-system data** are provided with each SIPROTEC 5 device and cannot be deleted. You can find them in DIGSI under **Settings** → **Power-system data**.

6.1.2 Structure of the Power-System Data

The **Power-system data** contain the block **General** and the **Measuring points** of the device. The following figure shows the structure of the **Power-system data**:

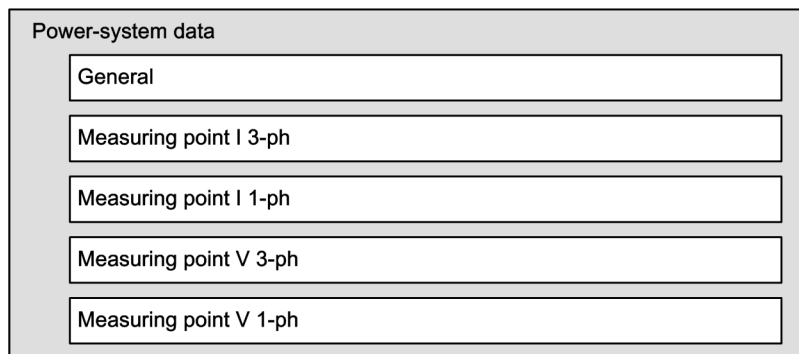

[dw_system data, 2, en_US]

Figure 6-1 Structure of the Power-System Data

In order to adjust its functions to the application, the device requires some data about the power system. The necessary settings can be found in the Power-system data under **General** as well as in the **Measuring points**.



NOTE

You can find information on the supervision-function parameters in [10.3 Supervision of the Secondary System](#).

Type and scope of the required measuring points depend on the application. Possible measuring points are:

- Voltage 3-phase (measuring point V 3-ph)
- Current 3-phase (measuring point I 3-ph)
- Voltage 1-phase (measuring point V 1-ph)
- Current 1-phase (measuring point I 1-ph)

The measuring points have interfaces to the function groups, which require voltage and/or current measured values of the power system.

6.1.3 Application and Setting Notes – General Settings

Parameter: Phase sequence

- Recommended setting value (`_:2311:101`) **Phase sequence= ABC**

The parameter **Phase sequence** is used to set the phase sequence (**ABC**) or (**ACB**). The setting value applies to the entire SIPROTEC 5 device.

Use the **General** function to set the settings in the power-system data.

You can find detailed information about phase-rotation reversal in chapter [6.50.1 Overview of Functions](#).

6.1.4 Application and Setting Notes for Measuring Point Current 3-Phase (I-3ph)

The supervision function settings are also located in the current measuring point. You can find the description of these parameters in [10 Supervision Functions](#).

Parameter: CT connection

- Default setting (`_:8881:115`) **CT connection** = *3-phase + IN-separate*

The parameter **CT connection** shows the connection type of the current transformer for the 3-phase current measuring point. You can find the parameter in the DIGSI 5 project tree under **Name of the device** → **Settings** → **Power-system data** → **Measuring point I-3ph**. You cannot change the connection type of the current transformer in the **Power-system data**.

You can change the connection type of the current transformer only under measuring point routing in DIGSI 5. Under **Name of the device** → **Measuring point routing** → **Current measuring points**, select the desired connection type under Connection type. The following types of connections are possible:

- *3-phase + IN-separate*
- *3-phase + IN*
- *3-phase*
- *3-phase, 2 primary CT*
- *3ph, 2prim.CT + IN-sep*
- *2ph, 2p. CT + IN-sep*

Depending on the connection type selected, you must route the measured values to the terminals of the current measuring point in DIGSI 5. You can find connection examples for current transformers in [A.8 Connection Examples for Current Transformers](#). The connection examples provide assistance when selecting the type of connection.

Parameter: Tracking

- Default setting (`_:8881:127`) **Tracking** = *active*

With the parameter **Tracking**, you specify whether you would like to work with the sampling-frequency tracking function.

Parameter Value	Description
<i>active</i>	If the parameter Tracking = <i>active</i> has been set, the measuring point will be included when determining the sampling frequency. If possible, only the 3-phase measuring points shall be considered. Siemens recommends using the default setting. Note: If the parameter is Tracking = <i>active</i> , the determined sampling frequency applies to all functions in the device not using fixed sampling rates.
<i>inactive</i>	If the channels of the measuring point are not to be considered for determining the sampling frequency, select the setting value <i>inactive</i> .

Parameter: Measuring-point ID

- Default setting (`_:8881:130`) **Measuring-point ID** = *1*

The parameter **Measuring-point ID** is write-protected and displays the ID of the measuring point. If you are using several measuring points, the **Measuring-point ID** is continuously incremented.

Parameter: Rated primary current

- Default setting (`_:8881:101`) **Rated primary current** = *1000 A*

With the parameter **Rated primary current**, you set the active rated primary current of the current transformer.

Parameter: Rated secondary current

- Default setting (`_:8881:102`) **Rated secondary current** = 1 A

With the parameter **Rated secondary current**, you set the active rated secondary current of the current transformer.

Parameter: Current range

- Default setting (`_:8881:117`) **Current range** = 100 x IR

The parameter **Current range** allows you to set the dynamic range for the current input. Retain the default setting for power-system protection applications. The current measuring range **1.6 x IR** applies for the connection type **3-phase + IN-separate** and the sensitive current input or for the measuring inputs.

Parameter: Neutr.point in dir.of ref.obj

- Default setting (`_:8881:116`) **Neutr.point in dir.of ref.obj** = yes

The **Neutr.point in dir.of ref.obj** parameter is used to set the direction of the neutral point of the current transformer (see following figure). Often, the neutral point of the current transformer is determined by the direction of the protected object (for example, in the direction of the line, cable, transformer). For this reason, the default setting of the parameter was defined as **yes**.

When switching the parameter, the direction of the phase currents and of the ground current IN or IN-separate is rotated device-internally.

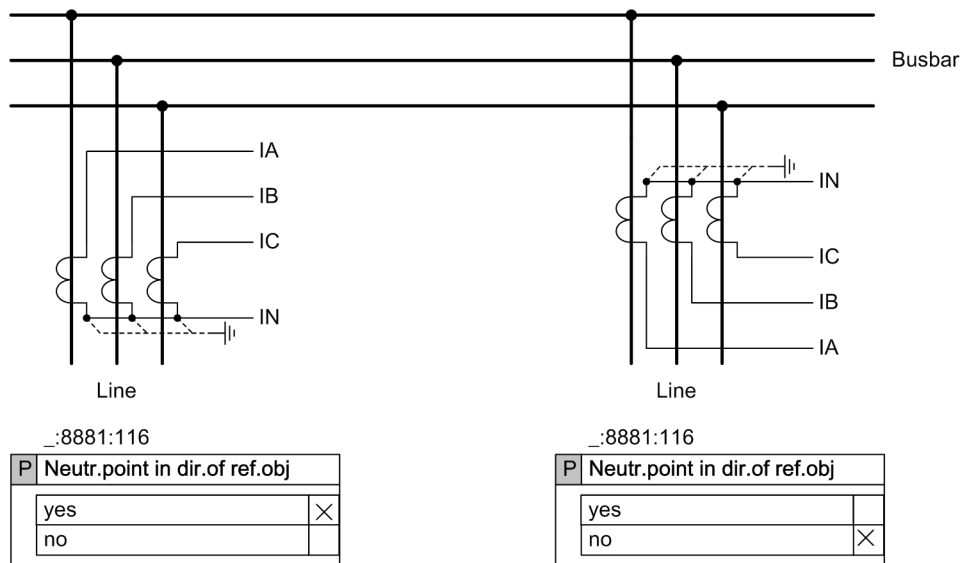

[dw_polstromwdl, 1, en_US]

Figure 6-2 Polarity of Current Transformers

Parameter: Inverted phases

- Default setting (`_:8881:114`) **Inverted phases** = none

The parameter **Inverted phases** is intended for special applications, for example, pumped-storage hydro-power plants (refer to [6.50 Phase-Sequence Switchover](#)). This default setting may be retained for power-system protection applications.

Parameter: Magnitude correction

- Default setting (`_:3841:103`) **Magnitude correction** = 1.000

When using the parameter **Magnitude correction**, you set the magnitude (magnitude correction) for the current input. This allows you to correct the tolerances of the primary current transformer phase-selectively. The magnitude correction may be required for high-precision measurements. Use a comparison measurement to determine the setting value (for example, a high-precision measuring-voltage transformer). If a primary correction is not necessary, retain the default setting.



NOTE

The **Magnitude correction** parameter has nothing to do with the internal adjustment of the input circuit.

6.1.5 Application and Setting Notes for Measuring Point Current 1-Phase (I-1ph)

If you insert a **Measuring point I 1-ph** in DIGSI 5, you must route a current to the measuring point under **Name of the device** → **Measuring-point routing** → **Current measuring points**.

You can only route the current **I_x**.

Parameter: Rated primary current

- Default setting (**_:2311:101**) **Rated primary current = 1000 A**

With the parameter **Rated primary current**, you set the active rated primary current of the current transformer.

Parameter: Rated secondary current

- Default setting (**_:2311:102**) **Rated secondary current = 1 A**

With the parameter **Rated secondary current**, you set the active rated secondary current of the current transformer.

Parameter: Current range

- Default setting (**_:2311:103**) **Current range = 100 x IR**

The parameter **Current range** allows you to set the dynamic range for the current input.

Parameter: Term. 1,3,5,7 in dir. of obj.

- Default setting (**_:2311:116**) **Term. 1,3,5,7 in dir. of obj. = yes**

With the parameter **Term. 1,3,5,7 in dir. of obj.**, you define the direction of the current. If you set the parameter **Term. 1,3,5,7 in dir. of obj. = yes**, the direction of the current to the protected object is defined as *forward*.

Parameter: Tracking

- Default setting (**_:2311:105**) **Tracking = active**

With the parameter **Tracking**, you specify whether you would like to work with the sampling-frequency tracking function.

Parameter Value	Description
active	If the parameter Tracking is active has been set, the measuring point will be included when determining the sampling frequency. Note: If the parameter Tracking is active , the determined sampling frequency applies to all functions in the device not using fixed sampling rates.
inactive	If the channels of the measuring point are not to be considered for determining the sampling frequency, select the setting value inactive .

Parameter: Measuring-point ID

- Default setting (`_:2311:130`) **Measuring-point ID** = 1

The parameter **Measuring-point ID** is write-protected and displays the ID of the measuring point. If you are using several measuring points, the **Measuring-point ID** is continuously incremented.

Parameter: Magnitude correction

- Default setting (`_:3841:103`) **Magnitude correction** = 1.000

With the parameter **Magnitude correction**, you set the amplitude (amplitude correction) for the current input. This allows you to correct the tolerances of the primary current transformer phase-selectively. The magnitude correction can be required for high-precision measurements. Use a comparison measurement to determine the setting value (for example, a high-precision measuring-voltage transformer). If a primary correction is not necessary, retain the default setting.



NOTE

The **Magnitude correction** parameter has nothing to do with the internal adjustment of the input circuit.

6.1.6 Application and Setting Notes for Measuring Point Voltage 3-Phase (V-3ph)

Settings for the supervision functions are also located in the voltage measuring point. You can find the description of these settings in *Supervision functions*.

Parameter: Rated primary voltage

- Default setting (`_:8911:101`) **Rated primary voltage** = 400.000 kV

With the parameter **Rated primary voltage**, you set the primary rated voltage of the voltage transformer.

Parameter: Rated secondary voltage

- Default setting (`_:8911:102`) **Rated secondary voltage** = 100 V

With the parameter **Rated secondary voltage**, you set the secondary rated voltage of the voltage transformer.

Parameter: Matching ratio V_{ph} / V_N

- Default setting (`_:8911:103`) **Matching ratio V_{ph} / V_N** = 1.73

With the parameter **Matching ratio V_{ph} / V_N**, you set the deviation between the calculated zero-sequence voltage and the residual voltage measured directly via a measuring input. The different transmission ratio of the voltage transformers is the cause for the deviation (refer to [Figure 6-3](#)).

The **Matching ratio V_{ph} / V_N** is equal to the ratio $3V_{0\text{ sec}}/V_{N\text{ sec}}$

with

$V_{0\text{ sec}}$ Calculated zero-sequence voltage

$V_{N\text{ sec}}$ Measured residual voltage

The zero-sequence voltage is calculated as phase-to-ground voltages. The residual voltage is measured on the broken-delta winding of the voltage transformer. For 1-phase voltage transformers, the residual voltage is measured in the generator or the transformer neutral point.



NOTE

The measurement residual voltage $V_{N_{sec}}$ is converted to a zero-sequence voltage in the device as follows:

$$V_{0_{sec}} = V_{N_{sec}} \cdot \frac{\text{Matching ratio } V_{ph}/VN}{3}$$

EXAMPLE 1:

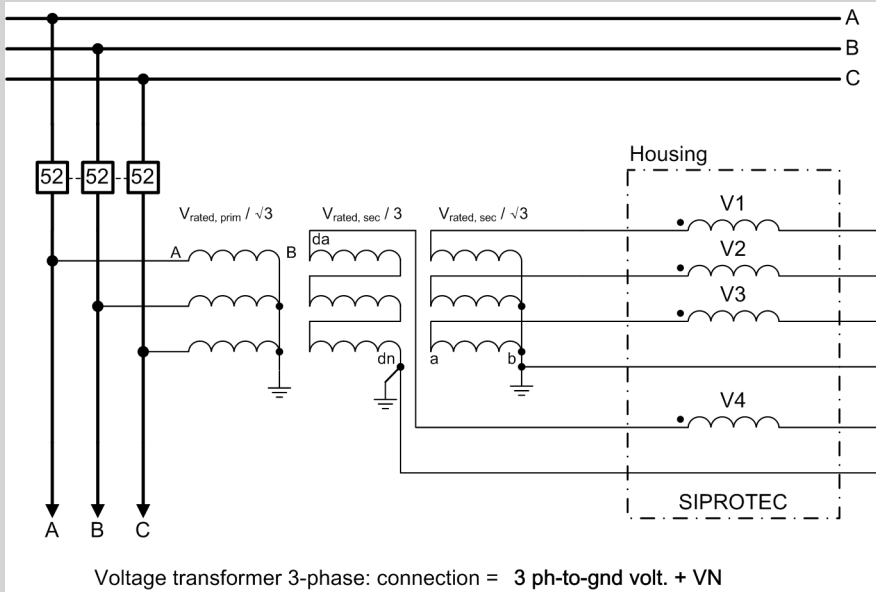

[dw_bsp1uwdl_anpassfaktor_2_en_US]

Figure 6-3 3-Phase Voltage Transformer: Connection = 3 Phase-to-Ground Voltage + VN

When the type of connection for the voltage transformer is **3 ph-to-gnd volt. + VN** (parameter: **VT connection**) and the voltage input V4 is connected to the broken-delta winding of the voltage transformer (da/dn), the **Matching ratio V_{ph} / VN** is as follows:

When changing the neutral point according to [Figure 6-3](#), this results in the following values:

- The calculated secondary zero-sequence voltage $V_{0_{sec}}$ is equal to the secondary phase-to-ground voltage. Expressed as secondary transformer rated voltage, then $V_{rated_{sec}}/\sqrt{3}$.
- The measured residual voltage on the broken-delta winding is the sum of the voltage drops on the 3 sides. Expressed with the side ratio, the result is $V_{N_{sec}} = 3 V_{rated_{sec}}/3$.

Calculate the parameter **Matching ratio V_{ph} / VN** as follows:

$$\text{Matching ratio } \frac{V_{ph}}{VN} = \frac{3 \cdot V_{0_{sec}}}{V_{N_{sec}}} = \frac{3 \cdot \frac{V_{rated_{sec}}}{\sqrt{3}}}{3 \cdot \frac{V_{rated_{sec}}}{3}} = \frac{3}{\sqrt{3}} = \sqrt{3} = 1.73$$

[fo_example_1_2_en_US]

Set **Matching ratio $V_{ph} / VN = 1.73$.**

In **example 1** $V_{rated_{sec}}$, the phase-to-ground voltage and the secondary voltage on the broken-delta winding were identical. If these voltages are different, use the actual numerical values in the calculation.

EXAMPLE 2:

Phase-to-ground voltage $V_{\text{rated sec}} = 100 \text{ V}$
 Broken-delta winding (for example, grounding transformer in generator protection) $V_{\text{rated sec}} = 500 \text{ V}$
 The voltage input of the device is designed for a continuous operation, using 230 V max. Therefore, the voltage on the broken-delta winding (500 V) is reduced to a 5:2 ratio, using an ohmic divider. In order to calculate the matching factor, the secondary voltage of 200 V will be applied.

Calculate the parameter **Matching ratio $V_{\text{ph}} / V_{\text{N}}$** as follows:

$$\text{Matching ratio } \frac{V_{\text{ph}}}{V_{\text{N}}} = \frac{3 \cdot V_{0 \text{ sec}}}{V_{\text{N sec}}} = \frac{3 \cdot \frac{V_{\text{rated sec}}}{\sqrt{3}}}{3 \cdot \frac{V_{\text{rated sec}}}{3}} = \frac{3 \cdot \frac{100 \text{ V}}{\sqrt{3}}}{3 \cdot \frac{200 \text{ V}}{3}} = \frac{3}{2 \cdot \sqrt{3}} = \frac{\sqrt{3}}{2} = 0.866$$

[fo_example_2_1_en_US]

Set **Matching ratio $V_{\text{ph}} / V_{\text{N}} = 0.866$.**

Interpretation of the result:

The zero-sequence voltage calculated from the phase-to-ground voltage is 57.73 V (= 100V/√3). The measured residual voltage is 200 V. The calculated adaptation factor is 0.866. The measured residual voltage is converted to a zero-sequence voltage inside the device:

$$V_{0 \text{ sec}} = V_{\text{N sec}} \cdot \frac{\text{Matching ratio } V_{\text{ph}}/V_{\text{N}}}{3} = 200 \text{ V} \cdot \frac{0.866}{3} = 57.73 \text{ V}$$

[fo_conversion2_2_en_US]



NOTE

During the ground-fault test, the set adaptation factor can be checked by comparing the operational measured values. The operational measured values contain the calculated zero-sequence voltage $V_{0 \text{ sec}}$ and the measured residual voltage $V_{\text{N sec}}$. Proceed with the compilation as follows:

$$\text{Matching ratio. } \frac{V_{\text{ph}}}{V_{\text{N}}} = \frac{3 \cdot V_{0 \text{ sec}}}{V_{\text{N sec}}}$$

The parameter **Matching ratio $V_{\text{ph}} / V_{\text{N}}$** is significant for the following functions:

- Overvoltage protection with zero-sequence voltage/residual voltage
- Measured-value supervision
- Scaling of the faulty and measured values

Parameter: VT connection

- Default setting (`_:8911:104`) **VT connection = 3 ph-to-gnd volt. + VN**

The parameter **VT connection** shows the connection type of the voltage transformer for the 3-phase voltage measuring point. You can find the parameter in the DIGSI 5 project tree under **Name of the device** → **Settings** → **Power-system data** → **Measuring point V 3-phase**. You cannot change the connection type of the voltage transformer in the power-system data.

You can change the connection type of the voltage transformer only under measuring point routing in DIGSI 5. Under **Name of the device** → **Measuring-point routing** → **Voltage measuring points**, select the desired connection type under **Connection type**. The following types of connections are possible:

- **3 ph-to-gnd volt. + VN**
- **3 ph-to-gnd voltages**
- **3 ph-to-ph volt. + VN**

- 3 *ph-to-ph voltages*
- 2 *ph-to-ph volt. + VN*
- 2 *ph-to-ph voltages*
- 2 *ph-to-gnd volt. + VN*
- 2 *ph-to-gnd voltages*

Depending on the connection type selected, you must route the measured values to the terminals of the voltage measuring point in DIGSI 5. You can find connection examples for voltage transformers in [A.9 Connection Examples of Voltage Transformers](#). The connection examples provide assistance when selecting the type of connection.

Parameter: Inverted phases

- Default setting (`_:8911:106`) **Inverted phases = none**

The parameter **Inverted phases** is intended for special applications, for example, pumped-storage hydro-power plants (refer to [6.50 Phase-Sequence Switchover](#)). This default setting can be retained for power-system protection applications.

Parameter: Tracking

- Default setting (`_:8911:111`) **Tracking = active**

The parameter **Tracking** is used to determine whether the measuring channels of this measuring point shall be used to determine the sampling frequency.

The sampling frequency of the device is adjusted to the power frequency. The device selects a measuring channel, through which the sampling frequency is determined. Preferably, this should be a voltage measuring channel. This validity of the signal is monitored (minimum level, frequency range). If these values are invalid, the device switches to another channel (etc.). Once switched to a current channel, the system automatically switches back to this channel if a voltage channel is valid again.

Parameter Value	Description
active	<p>If you set the parameter Tracking = active, the measuring point will be included when determining the sampling frequency. If possible, only the 3-phase measuring points shall be considered.</p> <p>Siemens recommends using the default setting.</p> <p>Note: If the parameter Tracking = active, the determined sampling frequency applies to all functions in the device not using fixed sampling rates.</p> <p>With platform version V07.80 and higher, you can merge measuring points into Frequency tracking groups in SIPROTEC 5 devices. In this case, every frequency tracking group specifies its own sampling frequency. For more information, refer to 3.3 Sampling-Frequency Tracking.</p>
inactive	<p>If the channels of the measuring point are not to be considered for determining the sampling frequency, select the setting value inactive.</p>

Parameter: Measuring-point ID

- Default setting (`_:8911:130`) **Measuring-point ID = 1**

The parameter **Measuring-point ID** is write-protected and displays the ID of the measuring point. If you are using several measuring points, the **Measuring-point ID** is continuously incremented.

With platform version V07.80 and higher, you can merge measuring points into **Frequency tracking groups** in SIPROTEC 5 devices. In this case, every frequency tracking group specifies its own sampling frequency. For more information, refer to [3.3 Sampling-Frequency Tracking](#).

Parameter: Magnitude correction

- Default setting (`_:3811:103`) **Magnitude correction = 1.000**

With the parameter **Magnitude correction**, you adjust the magnitude (magnitude correction) for the voltage input. This allows you to correct the tolerances of the primary current transformer phase-selectively. The magnitude correction may be required for high-precision measurements. Use a comparison measurement to determine the setting value (for example, a high-precision measuring-voltage transformer). If a primary correction is not necessary, retain the default setting.



NOTE

The parameter **Magnitude correction** has nothing to do with the internal adjustment of the input circuit.

6.1.7 Application and Setting Notes for Measuring Point Voltage 1-Phase (V-1ph)

If you insert a **Measuring point V 1-ph** in DIGSI 5, you must route a voltage to the measuring point under **Name of the device** → **Measuring point routing** → **Voltage measuring points**.

You can route the following voltages:

- **V A**
- **V B**
- **V C**
- **V AB**
- **V BC**
- **V CA**
- **Vx**
- **VN broken-delta**¹⁵
- **VN**¹⁶

Parameter: Rated primary voltage

- Default setting (**_:2311:101**) **Rated primary voltage = 400.000 kV**

The **Rated primary voltage** parameter is used to set the primary rated voltage of the voltage transformer.

Parameter: Rated secondary voltage

- Default setting (**_:2311:102**) **Rated secondary voltage = 100 V**

The **Rated secondary voltage** parameter is used to set the secondary rated voltage of the voltage transformer.

Parameter: Matching ratio Vph / VN

- Default setting (**_:2311:108**) **Matching ratio Vph / VN = 1.73**

With the parameter **Matching ratio Vph / VN**, you set the deviation between the calculated zero-sequence voltage and the residual voltage measured directly via a measuring input.

For more detailed information, refer to [6.1.6 Application and Setting Notes for Measuring Point Voltage 3-Phase \(V-3ph\)](#).

¹⁵ If you route this voltage, the protection functions operate with the voltage measured directly at the broken-delta winding of the voltage transformer.

¹⁶ If you route this voltage, the protection functions operate with the neutral-point displacement voltage.



NOTE

The **Matching ratio** V_{ph} / V_N parameter is only visible in the **Measuring point V-1ph** if the voltage **VN broken-delta** has been routed.

Parameter: Tracking

- Default setting (`_:2311:103`) **Tracking = inactive**

The **Tracking** parameter is used to determine whether the measuring channels of this measuring point shall be used to determine the sampling frequency.

The sampling frequency of the device is adjusted to the power frequency. The device selects a measuring channel, through which the sampling frequency is determined. Preferably, this should be a voltage metering channel. The validity of the signal is monitored (minimum level, frequency range). If these values are invalid, the device switches to another channel (etc.). Once switched to a current channel, the system automatically switches back to the voltage channel if a voltage channel is valid again.

Parameter Value	Description
inactive	If the channels of the measuring point are not to be considered for determining the sampling frequency, select the setting value inactive .
active	If the parameter Tracking = active has been set, the measuring point will be included when determining the sampling frequency. Note: If the parameter is Tracking = active , the determined sampling frequency applies to all functions in the device not using fixed sampling rates. Starting from platform version V07.80, you can merge measuring points into Frequency tracking groups in SIPROTEC 5 devices. In this case, every frequency tracking group specifies its own sampling frequency. For more detailed information, refer to 3.3 Sampling-Frequency Tracking .

Parameter: Measuring-point ID

- Default setting (`_:2311:130`) **Measuring-point ID = 1**

The parameter **Measuring-point ID** is write-protected and displays the ID of the measuring point. If you are using several measuring points, the **Measuring-point ID** is continuously incremented.

Starting from platform version V07.80, you can merge measuring points into **Frequency tracking groups** in SIPROTEC 5 devices. In this case, every frequency tracking group specifies its own sampling frequency. For more detailed information, refer to [3.3 Sampling-Frequency Tracking](#).

Parameter: Magnitude correction

- Default setting (`_:3811:103`) **Magnitude correction = 1.000**

When using the **Magnitude correction** parameter, you adjust the magnitude (magnitude correction) for the voltage input. This allows you to correct the tolerances of the primary current transformer phase-selectively. The magnitude correction may be required for high-precision measurements. Use a comparison measurement to determine the setting value (for example, a high-precision measuring-voltage transformer). If a primary correction is not necessary, retain the default setting.



NOTE

The **Magnitude correction** parameter has nothing to do with the internal adjustment of the input circuit.

6.1.8 Disconnection of Measuring Points

6.1.8.1 Overview

Maintenance work or specific operating and switching states of the power system can require disconnection of measuring point. Therefore, it is sometimes necessary to take individual measuring points out of processing, for example, to prevent an unwanted tripping of the Differential protection. With the **Disconnection of measuring points** functionality, you can disconnect the connection of the **Measuring point I-3ph** to a protection function group.

If the measuring point has been disconnected, you can carry out any work without influencing the work of the protection functions that are assigned to the measuring point. Once the measuring point has been disconnected, the Differential protection, for example, does not take the measured values of this measuring point into account anymore for calculating the differential current.

An exception applies for the following protection functions of the FG **Line**:

- Distance Protection with Classic Method
- Distance Protection with Reactance Method (RMD)
- Power-Swing Blocking
- Ground-Fault Protection for High-Resistance Ground Faults in Grounded Systems (67N)
- Measuring-voltage failure detection



NOTE

If one of the current measuring points is disconnected, the mentioned protection functions of the FG **Line** switch to the *Alarm* state and are not active.

There is another exception for the disconnection of measuring points for the FG **Circuit breaker**: If the FG **Circuit breaker** is connected to a disconnected measuring point, the functional measured values are indicated as usual and used by the functions in the FG **Circuit breaker**. That is, the disconnection does not set the functional measured values to 0. If a circuit-breaker failure detection is instantiated in the FG **Circuit breaker**, Siemens recommends blocking the function for current tests.

6.1.8.2 Description

Logic

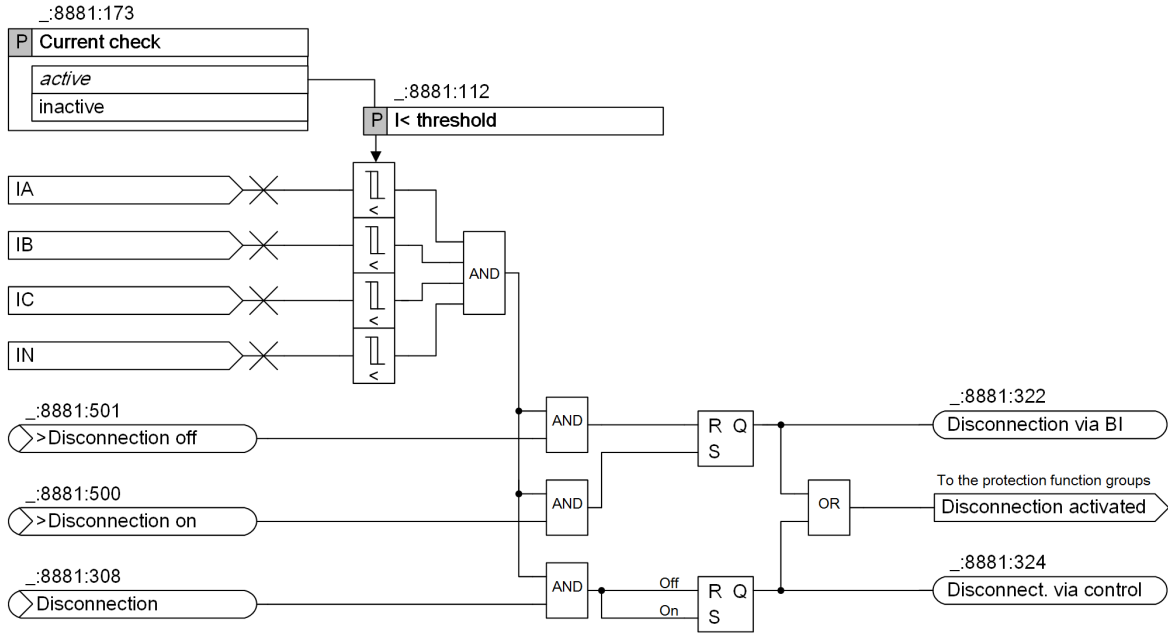

[lo_measuring point isolation, 1, en_US]

Figure 6-4 Logic of the Disconnection of Measuring Point

You can find the signals for the **Disconnection of measuring points** in the Information routing matrix in DIGSI under **Settings** → **Power system** → **Meas.point I-3ph**.

The following signals are available for activating the **Measuring point I-3ph**:

- The binary inputs (*_:8881:500*) *>Disconnection on* and (*_:8881:501*) *>Disconnection off*
- The controllable (*_:8881:308*) *Disconnection*

You can control whether the **Measuring point I-3ph** may only be disconnected if the measured currents fall below the set threshold value. The measuring point can also be disconnected without checking the threshold value. If you want to disconnect the measuring point without threshold-value check, consider that no currents are flowing anymore in the primary plant.

Disconnection messages are also available after a restart of the device. The device stores the disconnection efficacy in NVRAM¹⁷ The last information on disconnection remains available, even if the auxiliary voltage fails. When the auxiliary voltage returns, the device compares the stored state with that of the binary inputs.

6.1.8.3 Application and Setting Notes

Parameter: Current check

- Default setting (*_:8881:173*) **Current check = active**

With the **Current check** parameter, you can set whether you want to compare the RMS values of the phase currents IA, IB, IC and of the measured zero-sequence current IN with a threshold value.

¹⁷ NVRAM = Non-Volatile Random Access Memory; RAM, which does not lose the stored data, even when there is no power.

Parameter Value	Description
active	The RMS values of the phase currents IA, IB, IC and of the measured zero-sequence current IN are compared to the setting value of the parameter I< threshold . The Measuring point I-3ph can only be activated if the current measured values fall below the threshold value.
inactive	The RMS values of the phase currents IA, IB, IC and of the measured zero-sequence current IN are not compared to the setting value of the parameter I< threshold .

Parameter: I< threshold

- Default setting (_:8881:112) **I< threshold = 0.100 A**

With the **I< threshold** parameter, you set the threshold for disconnection of a measuring point. If the current measured values fall below the threshold value, the **Measuring point I-3ph** can be activated.

Set the **I< threshold** parameter so that the measured current will certainly fall below the parameterized value, for example, if the circuit-breaker pole is open. If parasitic currents, for example, due to induction, are not possible with the line/feeder deactivated, you can make a secondary setting of the value with a high degree of sensitivity, to 0.050 A for example. If no special requirements exist, Siemens recommends retaining the setting value of 0.100 A for secondary purposes.

EXAMPLE

Temporary Disconnection of a Connection of a Current Measuring Point to a Protection Function Group, Using the Example of a Line Differential Protection

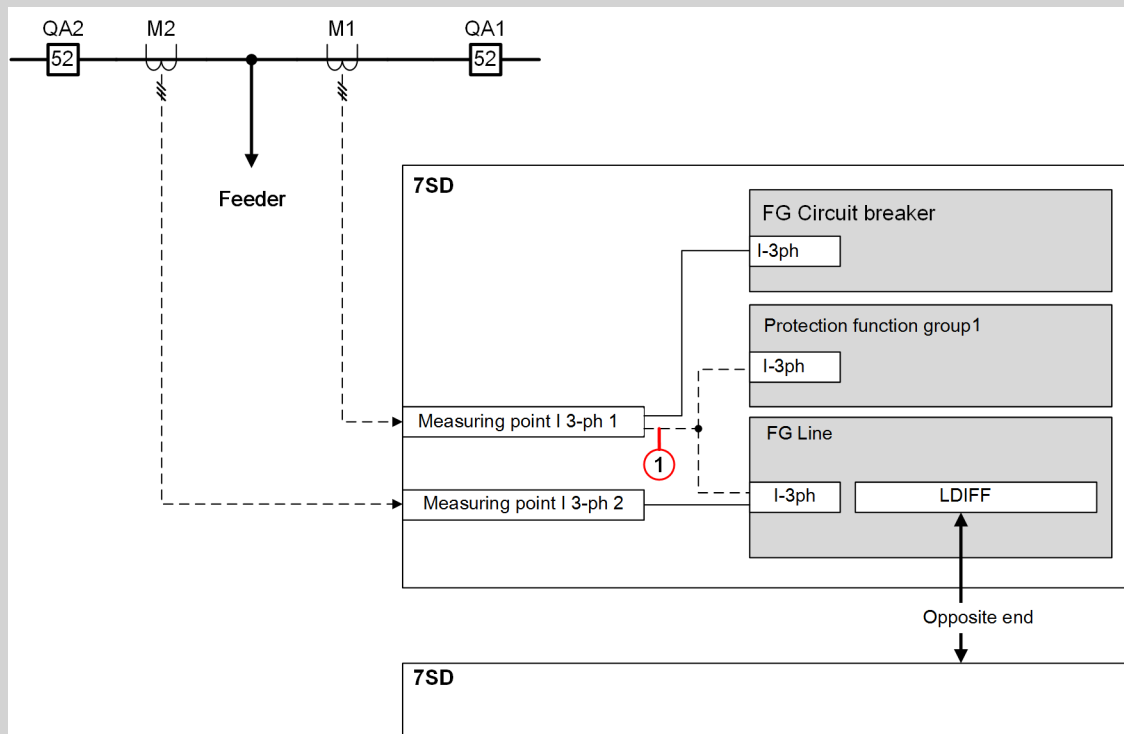

[dw_similar-application_7SD_with_2-MU_1_en_US]

Figure 6-5 Possible Disconnection of Measuring Point for the Line Differential Protection

- (1) Temporary disconnection of the connection to the **Measuring point I-3ph 1** for the **FG Line** and to the **Protection Function Group 1**



NOTE

If you disconnect the **Measuring point I-3ph 1**, you must make sure that no currents flows into the feeder via **M1**. Otherwise, this leads to an unwanted tripping of the **Line differential protection** function.

EXAMPLE

Temporary Disconnection of a Connection of a Current Measuring Point to the Protection Function Group 3-ph Voltage/Current

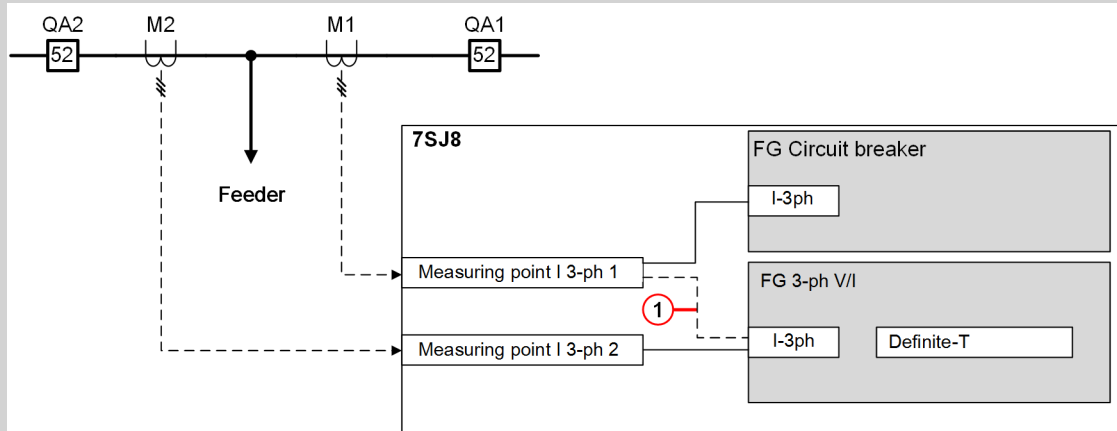

Idw_similar-application_7SJ8_with_2-MU_1_en_US1

Figure 6-6 Possible Disconnection of Measuring Point for the Feeder Protection

- (1) Temporary disconnection of the connection of the **Measuring point I-3ph 1** to the **FG 3-ph voltage/current**

6.1.8.4 Settings

Addr.	Parameter	C	Setting Options	Default Setting
MP disconnection				
_:8881:173	CT 3-phase:Current check		<ul style="list-style-type: none"> • inactive • active 	active
_:8881:112	CT 3-phase:I< threshold	1 A @ 100 Irated	0.030 A to 10.000 A	0.100 A
		5 A @ 100 Irated	0.15 A to 50.00 A	0.50 A
		1 A @ 50 Irated	0.030 A to 10.000 A	0.100 A
		5 A @ 50 Irated	0.15 A to 50.00 A	0.50 A
		1 A @ 1.6 Irated	0.001 A to 1.600 A	0.100 A
		5 A @ 1.6 Irated	0.005 A to 8.000 A	0.500 A

6.1.8.5 Information List

No.	Information	Data Class (Type)	Type
General			
_:8881:500	CT 3-phase:>Disconnection on	SPS	I
_:8881:501	CT 3-phase:>Disconnection off	SPS	I
_:8881:308	CT 3-phase:Disconnection	SPC	C
_:8881:322	CT 3-phase:Disconnection via BI	SPS	O
_:8881:324	CT 3-phase:Disconnect. via control	SPS	O

No.	Information	Data Class (Type)	Type
_:8881:319	CT 3-phase:Phases AB inverted	SPS	O
_:8881:320	CT 3-phase:Phases BC inverted	SPS	O
_:8881:321	CT 3-phase:Phases AC inverted	SPS	O

6.1.9 Settings

General

Addr.	Parameter	C	Setting Options	Default Setting
General				
_:2311:101	General:Phase sequence		<ul style="list-style-type: none"> • ABC • ACB 	ABC

Measuring Point I-3ph

Addr.	Parameter	C	Setting Options	Default Setting
General				
_:8881:115	CT 3-phase:CT connection		<ul style="list-style-type: none"> • not assigned • 3-phase + IN • 3-phase • 3-phase + IN-separate • 3-phase, 2 primary CT • 2ph, 2p. CT + IN-sep 	3-phase + IN
_:8881:127	CT 3-phase:Tracking		<ul style="list-style-type: none"> • inactive • active 	active
_:8881:130	CT 3-phase:Measuring-point ID		0 to 100	0
CT phases				
_:8881:101	CT 3-phase:Rated primary current		1.0 A to 100 000.0 A	1000.0 A
_:8881:102	CT 3-phase:Rated secondary current		<ul style="list-style-type: none"> • 1 A • 5 A 	1 A
_:8881:117	CT 3-phase:Current range		<ul style="list-style-type: none"> • 1.6 x IR • 8 x IR • 20 x IR • 100 x IR • 50 x IR 	100 x IR
_:8881:118	CT 3-phase:Internal CT type		<ul style="list-style-type: none"> • CT protection • CT measurement • CT protection • CT measurement • CT Process bus 	CT protection
_:8881:116	CT 3-phase:Neutr.point in dir.of ref.obj		<ul style="list-style-type: none"> • no • yes 	yes

Addr.	Parameter	C	Setting Options	Default Setting
_.8881:114	CT 3-phase:Inverted phases		<ul style="list-style-type: none"> • none • AC • BC • AB 	none
_.8881:107	CT 3-phase:CT error changeover		1.00 to 10.00	1.00
_.8881:108	CT 3-phase:CT error A		0.5 % to 50.0 %	5.0 %
_.8881:109	CT 3-phase:CT error B		0.5 % to 50.0 %	15.0 %
CT IN				
_.8881:104	CT 3-phase:Rated primary current		1.0 A to 100 000.0 A	1000.0 A
_.8881:105	CT 3-phase:Rated secondary current		<ul style="list-style-type: none"> • 1 A • 5 A 	1 A
_.8881:119	CT 3-phase:Current range		<ul style="list-style-type: none"> • 1.6 x IR • 8 x IR • 20 x IR • 100 x IR • 50 x IR 	100 x IR
_.8881:120	CT 3-phase:Internal CT type		<ul style="list-style-type: none"> • CT protection • CT measurement • CT protection • CT measurement • CT Process bus 	CT protection
CT 1				
_.3841:103	CT 1:Magnitude correction		0.010 to 10.000	1.000
_.3841:117	CT 1:Phase		<ul style="list-style-type: none"> • I A • I B • I C • IN • INsens • Ix 	
CT 2				
_.3842:103	CT 2:Magnitude correction		0.010 to 10.000	1.000
_.3842:117	CT 2:Phase		<ul style="list-style-type: none"> • I A • I B • I C • IN • INsens • Ix 	
CT 3				
_.3843:103	CT 3:Magnitude correction		0.010 to 10.000	1.000

Addr.	Parameter	C	Setting Options	Default Setting
_:3843:117	CT 3:Phase		<ul style="list-style-type: none"> • I A • I B • I C • IN • INsens • Ix 	
CT 4				
_:3844:103	CT 4:Magnitude correction		0.010 to 10.000	1.000
_:3844:117	CT 4:Phase		<ul style="list-style-type: none"> • I A • I B • I C • IN • INsens • Ix 	
Brk.wire det.				
_:5581:1	Brk.wire det.:Mode		<ul style="list-style-type: none"> • off • on • test 	off
_:5581:101	Brk.wire det.:Mode of blocking		<ul style="list-style-type: none"> • blocking • not blocking 	blocking
_:5581:102	Brk.wire det.:Delta value for autoblock		0.004 to 5.000	1.000
Supv. balan. I				
_:2491:1	Supv. balan. I:Mode		<ul style="list-style-type: none"> • off • on • test 	off
_:2491:101	Supv. balan. I:Release threshold	1 A @ 100 Irated	0.030 A to 35.000 A	0.500 A
		5 A @ 100 Irated	0.15 A to 175.00 A	2.50 A
		1 A @ 50 Irated	0.030 A to 35.000 A	0.500 A
		5 A @ 50 Irated	0.15 A to 175.00 A	2.50 A
		1 A @ 1.6 Irated	0.001 A to 1.600 A	0.500 A
		5 A @ 1.6 Irated	0.005 A to 8.000 A	2.500 A
_:2491:102	Supv. balan. I:Threshold min/max		0.10 to 0.95	0.50
_:2491:6	Supv. balan. I:Delay failure indication		0.00 s to 100.00 s	5.00 s
Supv. ph.seq. I				
_:2551:1	Supv. ph.seq.I:Mode		<ul style="list-style-type: none"> • off • on • test 	off
_:2551:6	Supv. ph.seq.I:Delay failure indication		0.00 s to 100.00 s	5.00 s

Addr.	Parameter	C	Setting Options	Default Setting
Supv. sum I				
_:2431:1	Supv. sum I:Mode		<ul style="list-style-type: none"> • off • on • test 	off
_:2431:102	Supv. sum I:Threshold	1 A @ 100 Irated	0.030 A to 10.000 A	0.100 A
		5 A @ 100 Irated	0.15 A to 50.00 A	0.50 A
		1 A @ 50 Irated	0.030 A to 10.000 A	0.100 A
		5 A @ 50 Irated	0.15 A to 50.00 A	0.50 A
		1 A @ 1.6 Irated	0.001 A to 1.600 A	0.100 A
		5 A @ 1.6 Irated	0.005 A to 8.000 A	0.500 A
_:2431:101	Supv. sum I:Slope factor		0.00 to 0.95	0.10
_:2431:6	Supv. sum I:Delay failure indication		0.00 s to 100.00 s	5.00 s
Supv. ADC sum I				
_:2401:1	Supv. ADC sum I:Mode		<ul style="list-style-type: none"> • off • on • test 	off

Measuring Point I-1ph

Addr.	Parameter	C	Setting Options	Default Setting
General				
_:2311:101	General:Rated primary current		1.0 A to 100 000.0 A	1000.0 A
_:2311:102	General:Rated secondary current		<ul style="list-style-type: none"> • 1 A • 5 A 	1 A
_:2311:103	General:Current range		<ul style="list-style-type: none"> • 1.6 x IR • 8 x IR • 20 x IR • 100 x IR • 50 x IR 	100 x IR
_:2311:104	General:Internal CT type		<ul style="list-style-type: none"> • CT protection • CT measurement • CT Process bus 	CT protection
_:2311:116	General:Term. 1,3,5,7 in dir. of obj.		<ul style="list-style-type: none"> • no • yes 	yes
_:2311:105	General:Tracking		<ul style="list-style-type: none"> • inactive • active 	inactive
_:2311:130	General:Measuring-point ID		0 to 100	0

Addr.	Parameter	C	Setting Options	Default Setting
CT 1				
_:3841:103	CT 1:Magnitude correction		0.010 to 10.000	1.000
_:3841:117	CT 1:Phase		<ul style="list-style-type: none"> • I A • I B • I C • IN • INsens • Ix 	

Measuring Point V-3ph

Addr.	Parameter	C	Setting Options	Default Setting
General				
_:8911:101	VT 3-phase:Rated primary voltage		0.100 kV to 1200.000 kV	400.000 kV
_:8911:102	VT 3-phase:Rated secondary voltage		80 V to 230 V	100 V
_:8911:103	VT 3-phase:Matching ratio Vph / VN		0.10 to 9.99	1.73
_:8911:104	VT 3-phase:VT connection		<ul style="list-style-type: none"> • not assigned • 3 ph-to-gnd volt. + VN • 3 ph-to-gnd voltages • 3 ph-to-ph volt. + VN • 3 ph-to-ph voltages 	3 ph-to-gnd volt. + VN
_:8911:106	VT 3-phase:Inverted phases		<ul style="list-style-type: none"> • none • AC • BC • AB 	none
_:8911:111	VT 3-phase:Tracking		<ul style="list-style-type: none"> • inactive • active 	active
_:8911:130	VT 3-phase:Measuring-point ID		0 to 100	0
VT 1				
_:3811:103	VT 1:Magnitude correction		0.010 to 10.000	1.000
_:3811:108	VT 1:Phase		<ul style="list-style-type: none"> • V A • V B • V C • V AB • V BC • V CA • VN • Vx • VCB 	

Addr.	Parameter	C	Setting Options	Default Setting
VT 2				
_:3812:103	VT 2:Magnitude correction		0.010 to 10.000	1.000
_:3812:108	VT 2:Phase		<ul style="list-style-type: none"> • V A • V B • V C • V AB • V BC • V CA • VN • Vx • VCB 	
VT 3				
_:3813:103	VT 3:Magnitude correction		0.010 to 10.000	1.000
_:3813:108	VT 3:Phase		<ul style="list-style-type: none"> • V A • V B • V C • V AB • V BC • V CA • VN • Vx • VCB 	
VT 4				
_:3814:103	VT 4:Magnitude correction		0.010 to 10.000	1.000
_:3814:108	VT 4:Phase		<ul style="list-style-type: none"> • V A • V B • V C • V AB • V BC • V CA • VN • Vx • VCB 	
Supv. balan. V				
_:2521:1	Supv. balan. V:Mode		<ul style="list-style-type: none"> • off • on • test 	off
_:2521:101	Supv. balan. V:Release threshold		0.300 V to 170.000 V	50.000 V
_:2521:102	Supv. balan. V:Threshold min/max		0.58 to 0.95	0.75

Addr.	Parameter	C	Setting Options	Default Setting
_:2521:6	Supv. balan. V:Delay failure indication		0.00 s to 100.00 s	5.00 s
Supv. ph.seq.V				
_:2581:1	Supv. ph.seq.V:Mode		<ul style="list-style-type: none"> • off • on • test 	off
_:2581:6	Supv. ph.seq.V:Delay failure indication		0.00 s to 100.00 s	5.00 s
Supv. sum V				
_:2461:1	Supv. sum V:Mode		<ul style="list-style-type: none"> • off • on • test 	off
_:2461:3	Supv. sum V:Threshold		0.300 V to 170.000 V	25.000 V
_:2461:6	Supv. sum V:Delay failure indication		0.00 s to 100.00 s	5.00 s
VT miniatureCB				
_:2641:101	VT minia- tureCB:Response time		0.00 s to 0.03 s	0.00 s

Measuring Point V-1ph

Addr.	Parameter	C	Setting Options	Default Setting
General				
_:2311:101	General:Rated primary voltage		0.100 kV to 1200.000 kV	400.000 kV
_:2311:102	General:Rated secondary voltage		80 V to 340 V	100 V
_:2311:108	General:Matching ratio V _{ph} / V _N		0.10 to 9.99	1.73
_:2311:103	General:Tracking		<ul style="list-style-type: none"> • inactive • active 	inactive
_:2311:130	General:Measuring-point ID		0 to 100	0
VT 1				
_:3811:103	VT 1:Magnitude correc- tion		0.010 to 10.000	1.000
_:3811:108	VT 1:Phase		<ul style="list-style-type: none"> • V A • V B • V C • V AB • V BC • V CA • V N • V x • VCB • V N broken-delta 	
_:3811:107	VT 1:Sequence number device		1 to 2147483647	2147483647

Addr.	Parameter	C	Setting Options	Default Setting
VT miniatureCB				
_.2641:101	VT miniatureCB:Response time		0.00 s to 0.03 s	0.00 s

6.1.10 Information List

General

No.	Information	Data Class (Type)	Type
General			
_.2311:500	General:>Phs-rotation reversal	SPS	I
_.2311:501	General:>Invert Phases	SPS	I
General			
_.2311:319	General:Phase sequence ABC	SPS	O
_.2311:320	General:Phase sequence ACB	SPS	O
_.2311:321	General:Freq.out of oper.range	SPS	O
_.2311:322	General:f sys	MV	O
_.2311:323	General:f track	MV	O
_.2311:52	General:Behavior	ENS	O
_.2311:53	General:Health	ENS	O

Measuring Point I-3ph

No.	Information	Data Class (Type)	Type
General			
_.8881:319	CT 3-phase:Phases AB inverted	SPS	O
_.8881:320	CT 3-phase:Phases BC inverted	SPS	O
_.8881:321	CT 3-phase:Phases AC inverted	SPS	O
Meas.val.dist			
_.8881:325	CT 3-phase:Meas.point mult.config.	SPS	O
CT 1			
_.3841:300	CT 1:Sampled val. current	SAV	O
CT 2			
_.3842:300	CT 2:Sampled val. current	SAV	O
CT 3			
_.3843:300	CT 3:Sampled val. current	SAV	O
CT 4			
_.3844:300	CT 4:Sampled val. current	SAV	O
Calc.IN			
_.20191:300	Calc.IN:Sampled val. current	SAV	O
Brk.wire det.			
_.5581:82	Brk.wire det.:>Block function	SPS	I
_.5581:54	Brk.wire det.:Inactive	SPS	O
_.5581:52	Brk.wire det.:Behavior	ENS	O
_.5581:53	Brk.wire det.:Health	ENS	O
_.5581:301	Brk.wire det.:Phs A BW suspected	SPS	O
_.5581:302	Brk.wire det.:Phs B BW suspected	SPS	O

No.	Information	Data Class (Type)	Type
_:5581:303	Brk.wire det.:Phs C BW suspected	SPS	O
_:5581:304	Brk.wire det.:Phase A broken wire	SPS	O
_:5581:305	Brk.wire det.:Phase B broken wire	SPS	O
_:5581:306	Brk.wire det.:Phase C broken wire	SPS	O
_:5581:307	Brk.wire det.:Broken wire suspected	SPS	O
_:5581:308	Brk.wire det.:Broken wire confirmed	SPS	O
Supv. balan. I			
_:2491:82	Supv. balan. I:>Block function	SPS	I
_:2491:54	Supv. balan. I:Inactive	SPS	O
_:2491:52	Supv. balan. I:Behavior	ENS	O
_:2491:53	Supv. balan. I:Health	ENS	O
_:2491:71	Supv. balan. I:Failure	SPS	O
Supv. ph.seq. I			
_:2551:82	Supv. ph.seq.I:>Block function	SPS	I
_:2551:54	Supv. ph.seq.I:Inactive	SPS	O
_:2551:52	Supv. ph.seq.I:Behavior	ENS	O
_:2551:53	Supv. ph.seq.I:Health	ENS	O
_:2551:71	Supv. ph.seq.I:Failure	SPS	O
Supv. sum I			
_:2431:82	Supv. sum I:>Block function	SPS	I
_:2431:54	Supv. sum I:Inactive	SPS	O
_:2431:52	Supv. sum I:Behavior	ENS	O
_:2431:53	Supv. sum I:Health	ENS	O
_:2431:71	Supv. sum I:Failure	SPS	O
Supv.ADC sum I			
_:2401:82	Supv.ADC sum I:>Block function	SPS	I
_:2401:54	Supv.ADC sum I:Inactive	SPS	O
_:2401:52	Supv.ADC sum I:Behavior	ENS	O
_:2401:53	Supv.ADC sum I:Health	ENS	O
_:2401:71	Supv.ADC sum I:Failure	SPS	O
Saturat. det.			
_:17731:54	Saturat. det.:Inactive	SPS	O
_:17731:52	Saturat. det.:Behavior	ENS	O
_:17731:53	Saturat. det.:Health	ENS	O

Measuring Point I-1ph

No.	Information	Data Class (Type)	Type
CT 1			
_:3841:300	CT 1:Sampled val. current	SAV	O
_:3841:52	CT 1:Behavior	ENS	O
_:3841:53	CT 1:Health	ENS	O

Measuring Point V-3ph

No.	Information	Data Class (Type)	Type
General			
_.8911:315	VT 3-phase:Phases AB inverted	SPS	O
_.8911:316	VT 3-phase:Phases BC inverted	SPS	O
_.8911:317	VT 3-phase:Phases AC inverted	SPS	O
VT 1			
_.3811:300	VT 1:Sampled val. voltage	SAV	O
_.3811:52	VT 1:Behavior	ENS	O
_.3811:53	VT 1:Health	ENS	O
VT 2			
_.3812:300	VT 2:Sampled val. voltage	SAV	O
_.3812:52	VT 2:Behavior	ENS	O
_.3812:53	VT 2:Health	ENS	O
VT 3			
_.3813:300	VT 3:Sampled val. voltage	SAV	O
_.3813:52	VT 3:Behavior	ENS	O
_.3813:53	VT 3:Health	ENS	O
VT 4			
_.3814:300	VT 4:Sampled val. voltage	SAV	O
_.3814:52	VT 4:Behavior	ENS	O
_.3814:53	VT 4:Health	ENS	O
Supv. balan. V			
_.2521:82	Supv. balan. V:>Block function	SPS	I
_.2521:51	Supv. balan. V:Mode (controllable)	ENC	C
_.2521:54	Supv. balan. V:Inactive	SPS	O
_.2521:52	Supv. balan. V:Behavior	ENS	O
_.2521:53	Supv. balan. V:Health	ENS	O
_.2521:71	Supv. balan. V:Failure	SPS	O
Supv. ph.seq.V			
_.2581:82	Supv. ph.seq.V:>Block function	SPS	I
_.2581:51	Supv. ph.seq.V:Mode (controllable)	ENC	C
_.2581:54	Supv. ph.seq.V:Inactive	SPS	O
_.2581:52	Supv. ph.seq.V:Behavior	ENS	O
_.2581:53	Supv. ph.seq.V:Health	ENS	O
_.2581:71	Supv. ph.seq.V:Failure	SPS	O
Supv. sum V			
_.2461:82	Supv. sum V:>Block function	SPS	I
_.2461:51	Supv. sum V:Mode (controllable)	ENC	C
_.2461:54	Supv. sum V:Inactive	SPS	O
_.2461:52	Supv. sum V:Behavior	ENS	O
_.2461:53	Supv. sum V:Health	ENS	O
_.2461:71	Supv. sum V:Failure	SPS	O
Definite-T 1			
_.2641:500	VT miniatureCB:>Open	SPS	I
_.2641:52	VT miniatureCB:Behavior	ENS	O
_.2641:53	VT miniatureCB:Health	ENS	O

No.	Information	Data Class (Type)	Type
Calc. VN			
_:20221:300	Calc.VN:Sampled val. voltage	SAV	O

Measuring Point V-1ph

No.	Information	Data Class (Type)	Type
VT 1			
_:3811:300	VT 1:Sampled val. voltage	SAV	O
_:3811:52	VT 1:Behavior	ENS	O
_:3811:53	VT 1:Health	ENS	O
Definite-T 1			
_:2641:500	VT miniatureCB:>Open	SPS	I
_:2641:52	VT miniatureCB:Behavior	ENS	O
_:2641:53	VT miniatureCB:Health	ENS	O

6.2 Group Indications of Overcurrent Protection Functions

6.2.1 Description

The function block **Group indications of the overcurrent protection functions** uses the pickup and operate indications of the following functions:

- Overcurrent protection, phases
- Overcurrent protection, ground
- Voltage-dependent overcurrent protection
- Directional overcurrent protection, phases
- Directional overcurrent protection, ground
- Ground-fault protection for high-impedance ground faults in grounded systems
- Instantaneous high-current tripping

The group indications of the overcurrent protection are generated by a logical OR of the stage-selective pickup and operate indications of the functions listed above (see also [Figure 6-7](#)):

- **Pickup**
- **Operate**

The pickup and operate indications are output, where present, with direction information.

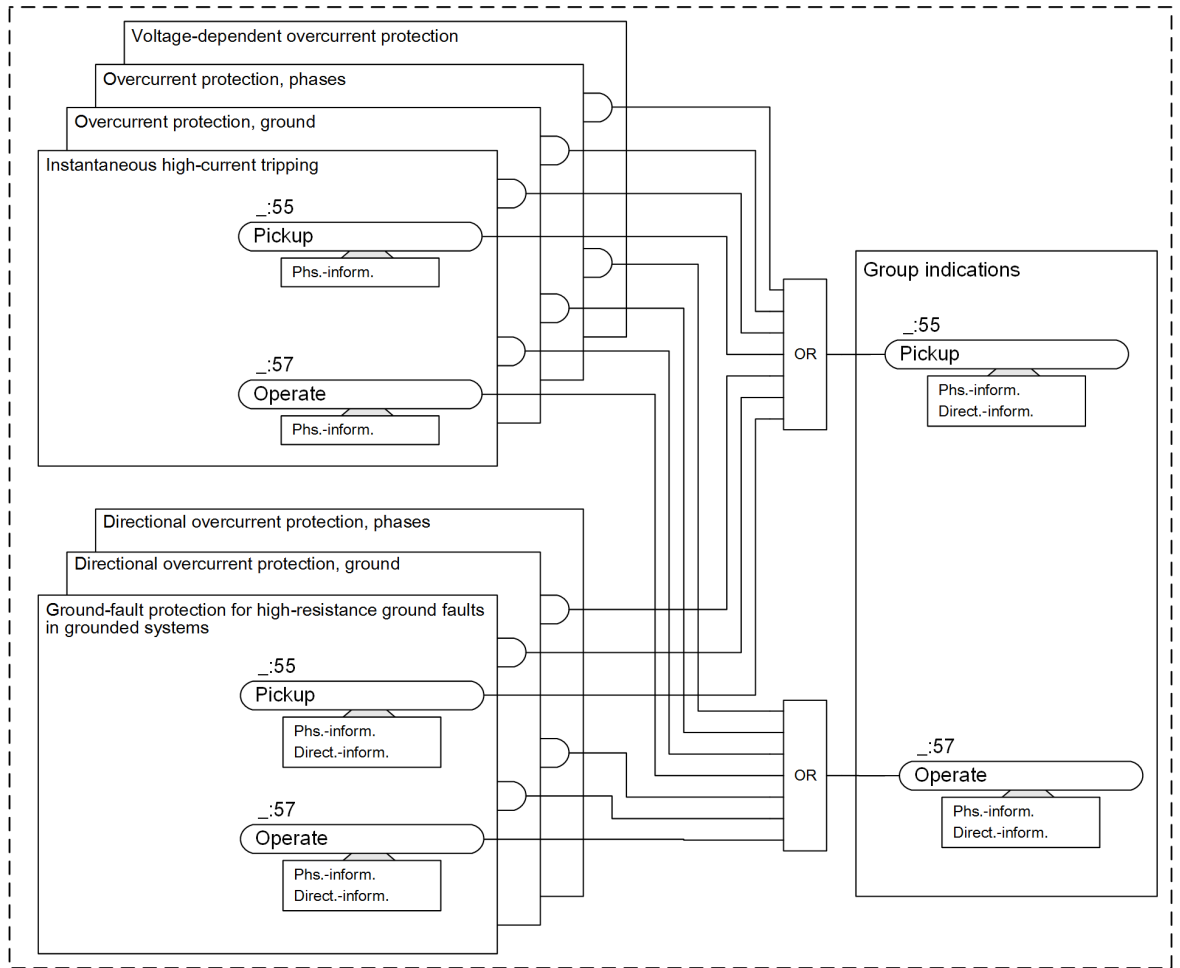

[to_oc_grin, 4, en_US]

Figure 6-7 Logic Diagram of the Overcurrent Protection Group Indications

6.3 Overcurrent Protection, Phases

6.3.1 Overview of Functions

The **Overcurrent protection, phases** function (ANSI 50/51):

- Detects short circuits in electrical equipment
- Can be used as backup or emergency overcurrent protection in addition to the main protection

6.3.2 Structure of the Function

6.3.3 Filter for RMS Value Gain

6.3.3.1 Description

The function block **Filter** can be used to adapt the RMS value for 2 means:

- To gain harmonics in a defined way. Higher harmonics can stress the protected object thermally more than lower harmonics. This is the case for reactors applied in AC filters. In addition, the amplitude attenuation of higher frequencies due to the anti-aliasing filter of the device is automatically compensated by the filter
- To only compensate the amplitude attenuation of higher frequencies due to the anti-aliasing filter

The filter gain (amplitude response) is realized by a 9-order FIR filter.

Logic

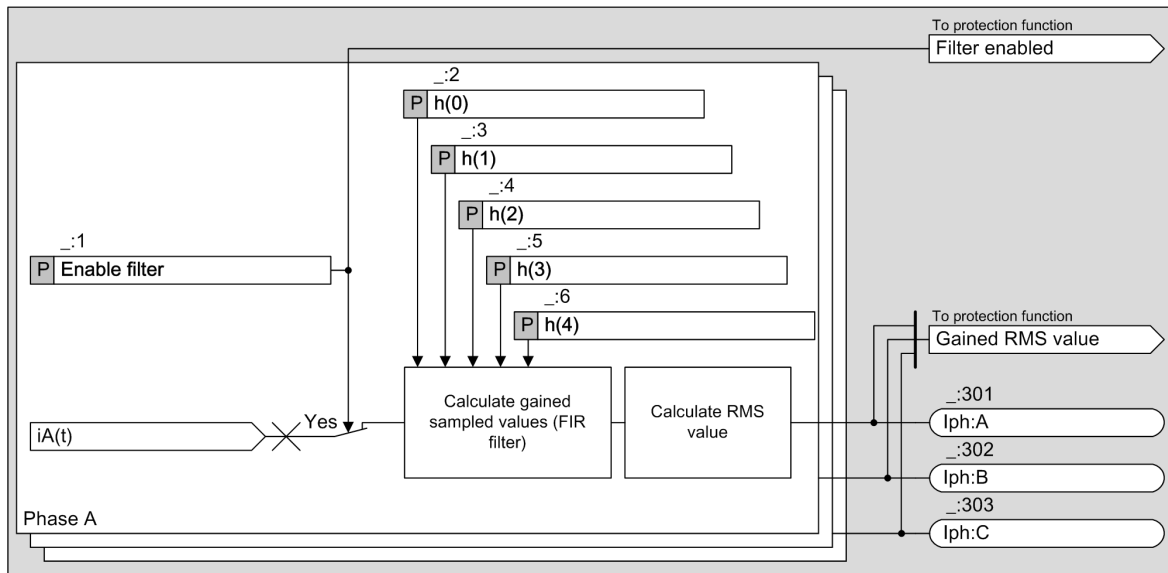

[io_tolp_filter_stage, 1, en_US]

Figure 6-8 Logic Diagram of the Function Block Filter

The FIR filter gains the 8-kHz sampled values according to the set filter coefficients. Afterwards, the RMS value is calculated. The symmetrical 9-order filter coefficients are set via the values of the respective parameters $h(0)$, $h(1)$, $h(2)$, $h(3)$, and $h(4)$.



NOTE

A FIR-filter configuration tool is provided as an auxiliary PC tool. With this PC tool, the coefficients $h(0)$, $h(1)$, $h(2)$, $h(3)$, $h(4)$ of the FIR filter are generated according to the required gain factors (amplitude response).

If you require the tool, contact the local Siemens representative to download it via the Intranet of Siemens Industry Online Support (SIOS). The tool is available on SIOS under **Protection > Engineering tools for protection > Further Tools**.

The gained RMS value is delivered to the protection stages only when the function block **Filter** is instantiated and the parameter **Enable filter** is set as **yes**. Otherwise, the normal RMS value is used.

Functional Measured Values

Values	Description	Primary	Secondary	% Referenced to
Iph:A	Gained RMS measured value of current A	kA	A	Parameter Rated current
Iph:B	Gained RMS measured value of current B	kA	A	Parameter Rated current
Iph:C	Gained RMS measured value of current C	kA	A	Parameter Rated current

You can find the parameter **Rated current** in the **FB General** of function groups where the **Overcurrent protection, phases – advanced** function is used.

If the parameter **Enable filter** is set to **no**, the functional measured values are shown as ---.

6.3.3.2 Application and Setting Notes

Parameter: Enable filter

- Default setting (_:1) **Enable filter** = **no**.

With the parameter **Enable filter**, you set whether the **Filter** is enabled.

Parameter Value	Description
yes	If gained RMS values should be used in one of the protection stages, set parameter Enable filter = yes .
no	If no gained RMS values are needed, set the parameter Enable filter = no .

Parameter: h (0) , h (1) , h (2) , h (3) , h (4)

- Default setting (_:2) **h (0)** = **0.000**
- Default setting (_:3) **h (1)** = **0.000**
- Default setting (_:4) **h (2)** = **0.000**
- Default setting (_:5) **h (3)** = **0.000**
- Default setting (_:6) **h (4)** = **1.000**

With the default value of the coefficients, the filter has no effect and no gain is applied.

If the filter shall be applied to adapt the RMS value calculation to a specific protection object such as a reactor, the reactor manufacturer has to provide the required amplitude response (gain factors) for the reactor. To determine the coefficients $h(0)$ to $h(4)$ for the FIR filter, you must enter the gain factors into the auxiliary PC tool which is available in the SIPROTEC download area. The 5 required coefficients are generated by the tool. They have to be entered manually as settings to configure the filter. The amplitude attenuation of higher frequencies due to the anti aliasing filter of the device is automatically taken into account and compensated by the filter.

To only compensate the attenuation of higher frequencies by the device, set the following coefficients in the filter.

Rated Frequency	Filter Coefficients for Only Compensating the Device Amplitude Attenuation
50 Hz	$h(0) = -0.002$ $h(1) = -0.012$ $h(2) = 0.045$ $h(3) = -0.110$ $h(4) = 1.151$
60 Hz	$h(0) = -0.005$ $h(1) = -0.020$ $h(2) = 0.058$ $h(3) = -0.128$ $h(4) = 1.170$

6.3.3.3 Settings

Addr.	Parameter	C	Setting Options	Default Setting
Filter				
_:1	Filter:Enable filter		<ul style="list-style-type: none"> • no • yes 	no
_:2	Filter:h(0)		-100.000 to 100.000	0.000
_:3	Filter:h(1)		-100.000 to 100.000	0.000
_:4	Filter:h(2)		-100.000 to 100.000	0.000
_:5	Filter:h(3)		-100.000 to 100.000	0.000
_:6	Filter:h(4)		-100.000 to 100.000	1.000

6.3.3.4 Information List

No.	Information	Data Class (Type)	Type
Filter			
_:301	Filter:lph:A	MV	O
_:302	Filter:lph:B	MV	O
_:303	Filter:lph:C	MV	O
_:52	Filter:Behavior	ENS	O
_:53	Filter:Health	ENS	O

6.3.4 Stage with Definite-Time Characteristic Curve

6.3.4.1 Description

Logic of the Basic Stage

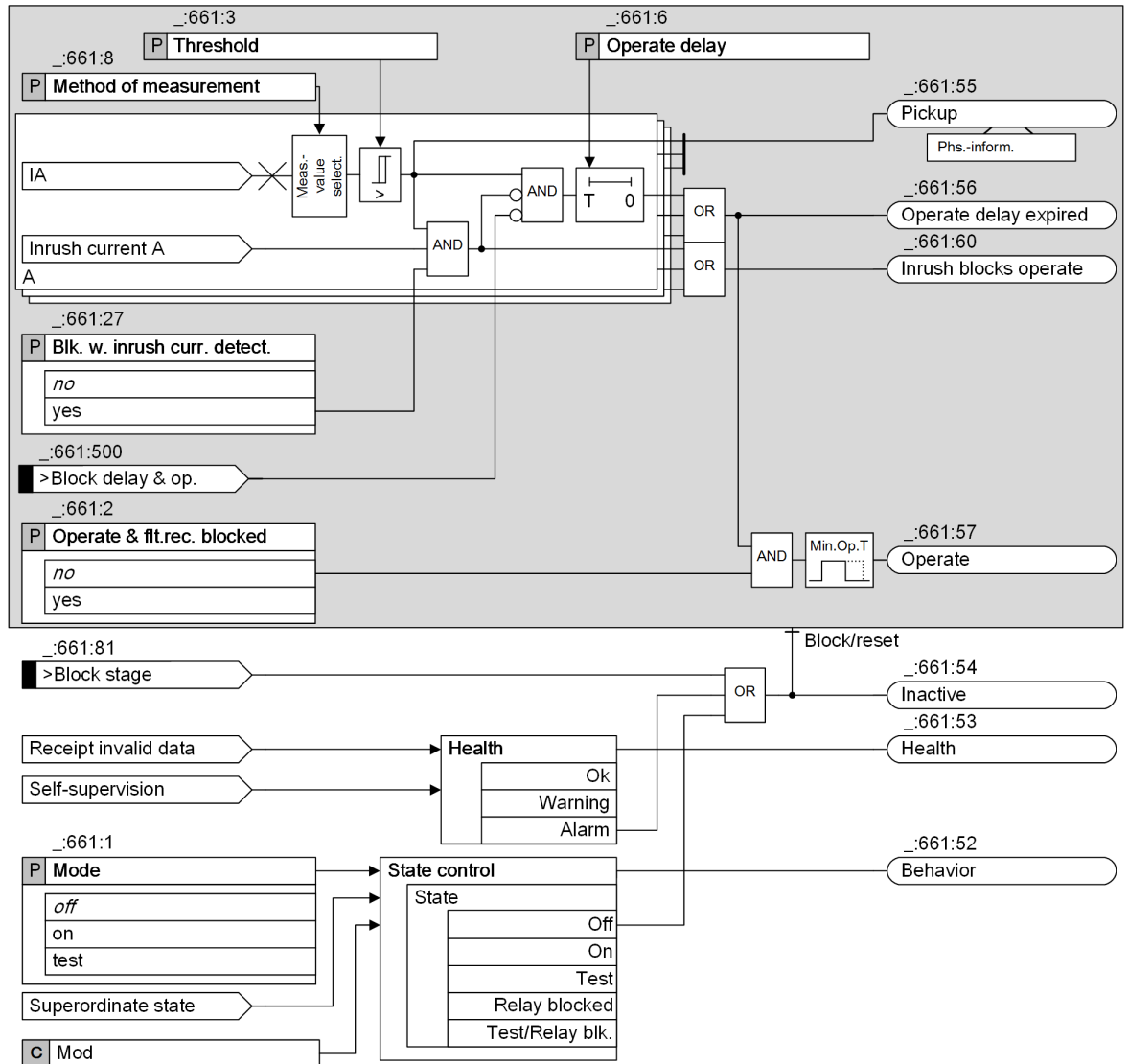

[file_ocrp_3b1_4_en_US]

Figure 6-9 Logic Diagram of the Definite-Time Overcurrent Protection (Phases) – Basic

Logic of the Advanced Stage

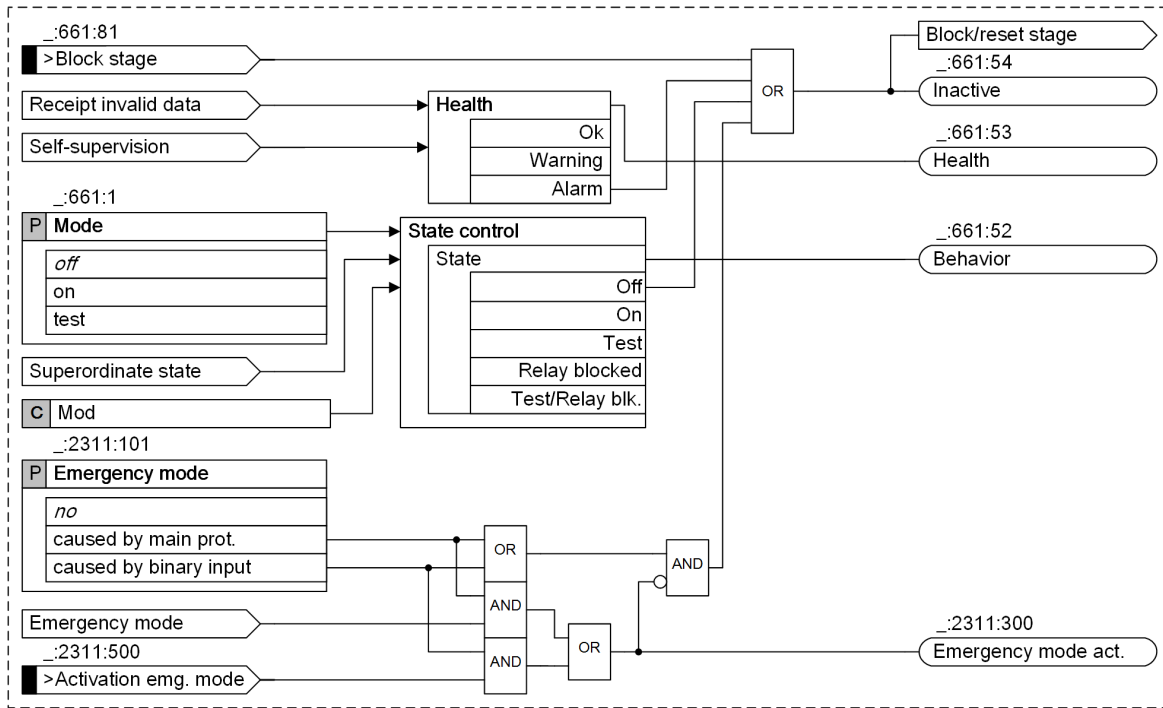

[lo_occup_umz_ad_2_en_US]

Figure 6-10 Logic Diagram of the Stage Control

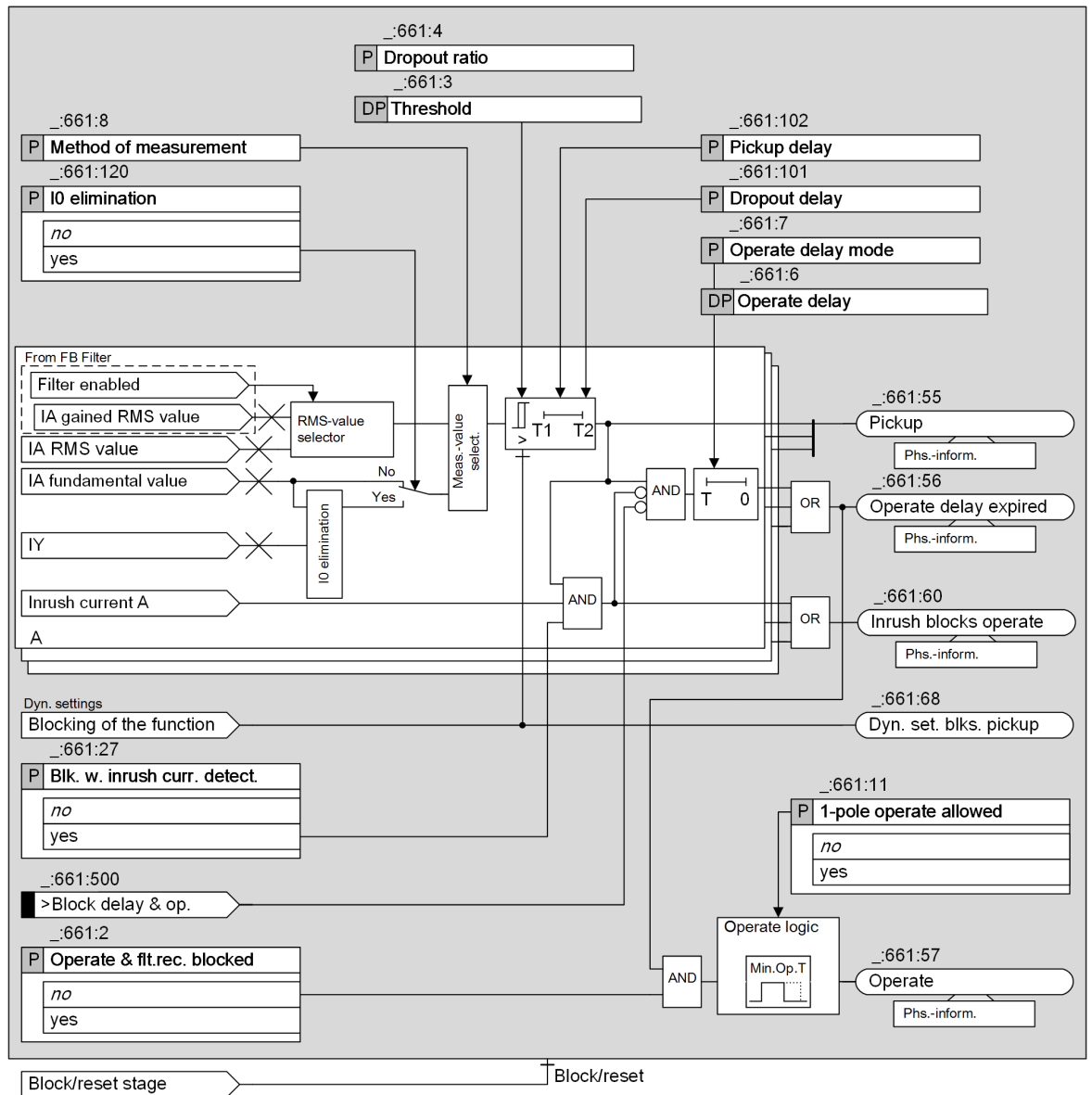

[to_ocp_3p1_5_en_US]

Figure 6-11 Logic Diagram of the Definite-Time Overcurrent Protection (Phases) – Advanced

Emergency mode (Advanced Stage)

You use the **Emergency mode** parameter to define whether the stage operates as emergency overcurrent protection or as backup overcurrent protection. With the setting **Emergency mode = caused by main prot.**, emergency overcurrent protection starts automatically when the main protection fails. This means that the emergency mode replaces the main protection as short-circuit protection. With the appropriate parameterization (**Emergency mode = caused by binary input**), the emergency mode can also be activated from an external source.

If the overcurrent protection is set as backup overcurrent protection (parameter **Emergency mode = no**), it operates independently of the main protection and thus in parallel. Backup overcurrent protection can also serve as sole short-circuit protection when, for example, no voltage transformers are available for an initial startup.

Method of measurement (Basic and Advanced Stage)

You use the **Method of measurement** parameter to define whether the stage uses the *fundamental comp.* or the calculated *RMS value*.

- Measurement of the fundamental component:
This method of measurement processes the sampled current values and filters out the fundamental component numerically.
- Measurement of the RMS value:
This method of measurement determines the current amplitude from the sampled values according to the defining equation of the RMS value. Harmonics are included in the analysis.

RMS-Value Selection (Advanced Stage)

If *RMS value* is selected as the method of measurement, the protection function supports 2 kinds of RMS measurement.

- Normal RMS value
- Gained RMS value from the function block **Filter**

If the function block **Filter** is configured and if you have enabled the filter, the gained RMS value is automatically used.



NOTE

When the function block **Filter** is applied, only one 3-phase current measuring point is allowed to be connected to the 3-phase current interface of the function group.

I0 Elimination (Advanced Stage)

In order to increase the sensitivity for the 2-phase short circuit on the transformer low-voltage side, use the I0 elimination of the phase currents for the overcurrent-protection application on one transformer.

In order to determine the I0 elimination of the phase currents, the transformer neutral point current I_Y must be measured.

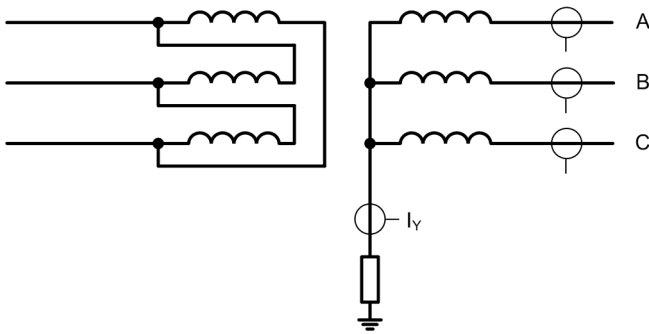

[dw_sgaocp, 1, en_US]

Figure 6-12 I0 Elimination Principle

In case of an I0 elimination, the following calculations result:

$$I_{A\text{-elim.}} = I_A - 1/3 I_Y$$

$$I_{B\text{-elim.}} = I_B - 1/3 I_Y$$

$$I_{C\text{-elim.}} = I_C - 1/3 I_Y$$

The phase current $I_{\text{phx-elim.}}$ is necessary for the following protection process.

If the **Method of measurement** parameter is set to *fundamental comp.*, the I0 elimination is applied.

The currents $I_{\text{phx-elim.}}$ are available as functional values.

Pickup Delay (Advanced Stage)

If the current exceeds the threshold value, the pickup delay is generated. If the threshold remains exceeded during the pickup delay time, the pickup signal is generated.

Dropout Delay (Advanced Stage)

If the current falls below the dropout threshold, the dropout can be delayed for the time specified by the parameter **Dropout delay**. During the dropout delay, the pickup is maintained. Meanwhile, the operate delay continues to run (parameter **Operate delay mode = Running dur. DO-delay**) or is frozen (parameter **Operate delay mode = Frozen dur. DO-delay**). If the operate delay expires while the pickup is still maintained, the stage operates.

Blocking of the Stage (Basic and Advanced Stage)

The following blockings reset the picked up stage completely:

- Via the binary input signal **>Block stage** from an external or internal source
- Via the functionality of the **dynamic settings** (only available in the Advanced function type, see **Influence of other functions via dynamic settings** and [6.3.8.1 Description](#)).

Blocking of the Time Delay (Basic and Advanced Stage)

You can use the binary input signal **>Block delay & op.** to prevent the start of the time delay and thus also the operate signal. A running time delay is reset. The pickup is indicated and the fault logging and recording takes place.

Blocking of the Operate Delay and the Operate Signal via the Device-Internal Inrush-Current Detection Function (Basic and Advanced Stage)

Blocking of the operate delay and the operate signal via the device-internal **Inrush-current detection** function is described in [6.3.7.1 Description](#).

6.3.4.2 Application and Setting Notes

Parameter: Method of measurement

- Default setting (**_:661:8**) **Method of measurement = fundamental comp.**

With the **Method of measurement** parameter, you define whether the stage uses the **fundamental comp.** (standard method) or the calculated **RMS value**.

Parameter Value	Description
fundamental comp.	Select this method of measurement if harmonics or transient current peaks are to be suppressed. Siemens recommends using this method as the standard method.
RMS value	Select this method of measurement if you want the stage to take harmonics into account (for example, at capacitor banks). Consider that aperiodic DC components present in the secondary circuit are measured and can cause an overfunction. For this method of measurement, do not set the threshold value of the stage to less than $0.1 I_{rated,sec}$. If currents from more than one measuring point are added up in the current interface of a function group, the setting value should not be set lower than $0.1 I_{rated,sec}$ multiplied by the number of added currents.

Parameter: Operate delay mode

- Default setting (**_:661:7**) **Operate delay mode = Running dur. DO-delay**

This parameter is not visible in the basic stage.

With the parameter **Operate delay mode**, you specify whether the operate delay continues to run or is frozen during the dropout delay.

This setting is only valid if the parameter **Dropout delay** is not 0.

Parameter Value	Description
<i>Running dur. DO-delay</i>	During the dropout delay, the operate delay continues to run.
<i>Frozen dur. DO-delay</i>	During the dropout delay, the operate delay is frozen. If the current exceeds the threshold value again, the operate delay continues to run.

Parameter: Threshold, Operate delay

- Default setting (`_ :661:3`) **Threshold** = 1.500 A (for the 1st stage)
- Default setting (`_ :661:6`) **Operate delay** = 0.30 s (for the 1st stage)

Set the **Threshold** and **Operate delay** parameters for the specific application.

The following details apply to a 2-stage characteristic curve (1st stage = definite-time overcurrent protection stage and 2nd stage = high-current stage).

1st stage (overcurrent stage):

The setting depends on the maximum occurring operating current. Pickup by overload must be excluded since overcurrent protection operates with short tripping times as short-circuit protection and not as overload protection. Therefore, set the **Threshold** parameter for lines to approx. 10 %, for transformers and motors to approx. 20 % above the maximum load that is expected.

EXAMPLE

Overcurrent-protection stage: 110-kV overhead line, 150 mm² cross-section

Maximum transmittable power

$$P_{max} = 120 \text{ MVA}$$

Correspondingly

$$I_{max} = 630 \text{ A}$$

$$\text{Current transformer} = 600 \text{ A/5 A}$$

$$\text{Safety factor} = 1.1$$

Settings in primary and secondary measurands result in the setting values:

Threshold value 1 st stage (primary)	= 1.1 · 630 A = 693 A
Threshold value 1 st stage (secondary)	= 1.1 · $\frac{630 \text{ A}}{600 \text{ A}} \cdot 5 \text{ A} = 5.8 \text{ A}$

[66_ocp_ph1_2_en_US]

The **Operate delay** to be set is derived from the time-grading schedule that has been prepared for the system. Where overcurrent protection is used in emergency mode, shorter time delays might be reasonable (one grading time above fast tripping), since the emergency mode only operates if the main protection function fails.

2nd Stage (High-Current Stage):

This tripping stage can also be used for current grading. This applies in the case of very long lines with low source impedance or ahead of high reactances (for example, transformers, shunt reactors). Set the **Threshold** parameter to ensure that the stage does not pick up in case of a short circuit at the end of the line.

Set the **Operate delay** parameter to 0 or to a low value.

Siemens recommends that the threshold values be determined with a system analysis. The following example illustrates the principle of grading with a current threshold on a long line.

EXAMPLE

High-current stage: 110-kV overhead line, 150 mm² cross-section

$$s \text{ (length)} = 60 \text{ km}$$

$$Z_L/s = 0.46 \text{ } \Omega/\text{km}$$

$$\text{Ratio of zero-sequence impedance and positive-sequence impedance of the line: } Z_{L0}/Z_{L1} = 4$$

Short-circuit power at the beginning of the line:

$$S_{sc}' = 2.5 \text{ GVA}$$

Ratio of zero-sequence impedance and positive-sequence impedance of the source impedance at the beginning of the line: $Z_{P0}/Z_{P1} = 2$

$$\text{Current transformer} = 600 \text{ A/5 A}$$

Resulting in the following values for the line impedance Z_L and the source impedance Z_p :

$$Z_L = 0.46 \text{ } \Omega/\text{km} \cdot 60\text{km} = 27.6 \text{ } \Omega$$

[fg_0cp_002_1_en_US]

$$Z_p = \frac{110 \text{ kV}^2}{2500 \text{ MVA}} = 4.84 \text{ } \Omega$$

[fg_0cp_003_1_en_US]

The 3-phase short-circuit current at the end of the line is $I_{sc \text{ end}}$:

$$I_{sc \text{ end}} = \frac{1.1 \cdot V_{\text{rated}}}{\sqrt{3} \cdot (Z_p + Z_L)} = \frac{1.1 \cdot 110 \text{ kV}}{\sqrt{3} \cdot (4.84 \text{ } \Omega + 27.6 \text{ } \Omega)} = 2150 \text{ A}$$

[fg_0cp_ph4_1_en_US]

The settings in primary and secondary values result in the following setting values which include a safety margin of 10 %:

$$\text{Threshold value 2}^{\text{nd}} \text{ stage (primary)} = 1.1 \cdot 2150 \text{ A} = 2365 \text{ A}$$

$$\text{Threshold value 2}^{\text{nd}} \text{ stage (secondary)} = 1.1 \cdot \frac{2150 \text{ A}}{600 \text{ A}} \cdot 5 \text{ A} = 19.7 \text{ A}$$

[fg_0cp_004_2_en_US]

If short-circuit currents exceed 2365 A (primary) or 19.7 A (secondary), there is a short circuit on the line to be protected. The overcurrent protection can cut off this short circuit immediately.

Note: The amounts in the calculation example are accurate enough for overhead lines. If the source impedance and line impedance have different angles, you have to use complex numbers to calculate the

Threshold .

Parameter: IO elimination

- Default setting (`_:661:120`) **IO elimination** = *no*

This parameter is not visible in the basic stage.

The IO elimination in phase currents for overcurrent-protection applications can be used in a transformer. This increases the sensitivity for the 2-phase short circuit on the transformer low-voltage side. The following conditions must be fulfilled:

- The transformer neutral point current I_N is measured and is available for the protection function group.
- The parameter **Method of measurement** is set to *fundamental comp.*

With the **IO elimination** parameter, you can switch the IO elimination function on or off.

Parameter: Pickup delay

- Default setting (**_:661:102**) **Pickup delay = 0.00 s**

This parameter is not visible in the basic stage.

For special applications, it is desirable that a short exceeding of the current threshold does not lead to the pickup of the stage and start fault logging and recording. If this stage is used as a thermal overload function, that is considered a special application.

When using the **Pickup delay** parameter, a time interval is defined during which a pickup is not triggered if the current threshold is exceeded.

For all short-circuit protection applications, this value is 0.00 s as a default.

Parameter: Dropout delay

- Default setting (**_:661:101**) **Dropout delay = 0.00 s**

This parameter is not visible in the basic stage.

Siemens recommends using the default setting **0** since the dropout of a protection stage must be done as fast as possible.

You can use the **Dropout delay** parameter $\neq 0$ to obtain a uniform dropout behavior if you use it together with an electromechanical relay. This is required for time grading. The dropout time of the electromechanical relay must be known for this purpose. Subtract the dropout time of your own device (see Technical Data) and set the result.

Parameter: Dropout ratio

- Default setting (**_:661:4**) **Dropout ratio = 0.95**

This parameter is not visible in the basic stage.

The recommended set value of **0.95** is appropriate for most applications.

To achieve high-precision measurements, the setting value of the parameter **Dropout ratio** can be reduced, for example, to **0.98**. If you expect highly fluctuating measurands at the response threshold, you can increase the setting value of the parameter **Dropout ratio**. This avoids chattering of the tripping stage.

Parameter: 1-pole operate allowed

- Default setting (**_:661:11**) **1-pole operate allowed = no**

The parameter must be set for the specific application.

Parameter Value	Description
no	The stage always operates 3-pole.
yes	The stage operates phase-selectively. However, tripping by the device (generated in the trip logic of the Circuit-breaker function group) is always 3-pole because the device does not support phase-selective tripping.

6.3.4.3 Settings

Addr.	Parameter	C	Setting Options	Default Setting
General				
_:2311:101	General:Emergency mode		<ul style="list-style-type: none"> • no • caused by main prot. • caused by binary input 	no
General				
_:661:1	Definite-T 1:Mode		<ul style="list-style-type: none"> • off • on • test 	off

Addr.	Parameter	C	Setting Options	Default Setting
_:661:2	Definite-T 1:Operate & flt.rec. blocked		<ul style="list-style-type: none"> no yes 	no
_:661:11	Definite-T 1:1-pole operate allowed		<ul style="list-style-type: none"> no yes 	no
_:661:26	Definite-T 1:Dynamic settings		<ul style="list-style-type: none"> no yes 	no
_:661:27	Definite-T 1:Blk. w. inrush curr. detect.		<ul style="list-style-type: none"> no yes 	no
_:661:8	Definite-T 1:Method of measurement		<ul style="list-style-type: none"> fundamental comp. RMS value 	fundamental comp.
_:661:120	Definite-T 1:I0 elimination		<ul style="list-style-type: none"> no yes 	no
_:661:3	Definite-T 1:Threshold	1 A @ 100 Irated	0.030 A to 40.000 A	1.500 A
		5 A @ 100 Irated	0.15 A to 200.00 A	7.50 A
		1 A @ 50 Irated	0.030 A to 40.000 A	1.500 A
		5 A @ 50 Irated	0.15 A to 200.00 A	7.50 A
		1 A @ 1.6 Irated	0.001 A to 1.600 A	1.500 A
		5 A @ 1.6 Irated	0.005 A to 8.000 A	7.500 A
_:661:4	Definite-T 1:Dropout ratio		0.90 to 0.99	0.95
_:661:102	Definite-T 1:Pickup delay		0.00 s to 60.00 s	0.00 s
_:661:101	Definite-T 1:Dropout delay		0.00 s to 60.00 s	0.00 s
_:661:6	Definite-T 1:Operate delay		0.00 s to 100.00 s	0.30 s
_:661:7	Definite-T 1:Operate delay mode		<ul style="list-style-type: none"> Running dur. DO-delay Frozen dur. DO-delay 	Running dur. DO-delay
<i>Dyn.s: AR off/n.rdy</i>				
_:661:28	Definite-T 1:Effect. by AR off/n.ready		<ul style="list-style-type: none"> no yes 	no
_:661:35	Definite-T 1:Stage blocked		<ul style="list-style-type: none"> no yes 	no
<i>Dyn.set: AR cycle 1</i>				
_:661:29	Definite-T 1:Effected by AR cycle 1		<ul style="list-style-type: none"> no yes 	no
_:661:36	Definite-T 1:Stage blocked		<ul style="list-style-type: none"> no yes 	no
_:661:14	Definite-T 1:Threshold	1 A @ 100 Irated	0.030 A to 40.000 A	1.500 A
		5 A @ 100 Irated	0.15 A to 200.00 A	7.50 A
		1 A @ 50 Irated	0.030 A to 40.000 A	1.500 A
		5 A @ 50 Irated	0.15 A to 200.00 A	7.50 A
		1 A @ 1.6 Irated	0.001 A to 1.600 A	1.500 A
		5 A @ 1.6 Irated	0.005 A to 8.000 A	7.500 A
_:661:20	Definite-T 1:Operate delay		0.00 s to 100.00 s	0.30 s

Addr.	Parameter	C	Setting Options	Default Setting
<i>Dyn.set: AR cycle 2</i>				
_.661:30	Definite-T 1:Effected by AR cycle 2		<ul style="list-style-type: none"> • no • yes 	no
_.661:37	Definite-T 1:Stage blocked		<ul style="list-style-type: none"> • no • yes 	no
_.661:15	Definite-T 1:Threshold	1 A @ 100 Irated	0.030 A to 40.000 A	1.500 A
		5 A @ 100 Irated	0.15 A to 200.00 A	7.50 A
		1 A @ 50 Irated	0.030 A to 40.000 A	1.500 A
		5 A @ 50 Irated	0.15 A to 200.00 A	7.50 A
		1 A @ 1.6 Irated	0.001 A to 1.600 A	1.500 A
		5 A @ 1.6 Irated	0.005 A to 8.000 A	7.500 A
_.661:21	Definite-T 1:Operate delay		0.00 s to 100.00 s	0.30 s
<i>Dyn.set: AR cycle 3</i>				
_.661:31	Definite-T 1:Effected by AR cycle 3		<ul style="list-style-type: none"> • no • yes 	no
_.661:38	Definite-T 1:Stage blocked		<ul style="list-style-type: none"> • no • yes 	no
_.661:16	Definite-T 1:Threshold	1 A @ 100 Irated	0.030 A to 40.000 A	1.500 A
		5 A @ 100 Irated	0.15 A to 200.00 A	7.50 A
		1 A @ 50 Irated	0.030 A to 40.000 A	1.500 A
		5 A @ 50 Irated	0.15 A to 200.00 A	7.50 A
		1 A @ 1.6 Irated	0.001 A to 1.600 A	1.500 A
		5 A @ 1.6 Irated	0.005 A to 8.000 A	7.500 A
_.661:22	Definite-T 1:Operate delay		0.00 s to 100.00 s	0.30 s
<i>Dyn.s: AR cycle>3</i>				
_.661:32	Definite-T 1:Effected by AR cycle gr. 3		<ul style="list-style-type: none"> • no • yes 	no
_.661:39	Definite-T 1:Stage blocked		<ul style="list-style-type: none"> • no • yes 	no
_.661:17	Definite-T 1:Threshold	1 A @ 100 Irated	0.030 A to 40.000 A	1.500 A
		5 A @ 100 Irated	0.15 A to 200.00 A	7.50 A
		1 A @ 50 Irated	0.030 A to 40.000 A	1.500 A
		5 A @ 50 Irated	0.15 A to 200.00 A	7.50 A
		1 A @ 1.6 Irated	0.001 A to 1.600 A	1.500 A
		5 A @ 1.6 Irated	0.005 A to 8.000 A	7.500 A
_.661:23	Definite-T 1:Operate delay		0.00 s to 100.00 s	0.30 s
<i>Dyn.s: Cold load PU</i>				
_.661:33	Definite-T 1:Effect. b. cold-load pickup		<ul style="list-style-type: none"> • no • yes 	no
_.661:40	Definite-T 1:Stage blocked		<ul style="list-style-type: none"> • no • yes 	no

Addr.	Parameter	C	Setting Options	Default Setting
_:661:18	Definite-T 1:Threshold	1 A @ 100 Irated	0.030 A to 40.000 A	1.500 A
		5 A @ 100 Irated	0.15 A to 200.00 A	7.50 A
		1 A @ 50 Irated	0.030 A to 40.000 A	1.500 A
		5 A @ 50 Irated	0.15 A to 200.00 A	7.50 A
		1 A @ 1.6 Irated	0.001 A to 1.600 A	1.500 A
		5 A @ 1.6 Irated	0.005 A to 8.000 A	7.500 A
_:661:24	Definite-T 1:Operate delay		0.00 s to 100.00 s	0.30 s
<i>Dyn.set: bin.input</i>				
_:661:34	Definite-T 1:Effected by binary input		<ul style="list-style-type: none"> • no • yes 	no
_:661:41	Definite-T 1:Stage blocked		<ul style="list-style-type: none"> • no • yes 	no
_:661:19	Definite-T 1:Threshold	1 A @ 100 Irated	0.030 A to 40.000 A	1.500 A
		5 A @ 100 Irated	0.15 A to 200.00 A	7.50 A
		1 A @ 50 Irated	0.030 A to 40.000 A	1.500 A
		5 A @ 50 Irated	0.15 A to 200.00 A	7.50 A
		1 A @ 1.6 Irated	0.001 A to 1.600 A	1.500 A
		5 A @ 1.6 Irated	0.005 A to 8.000 A	7.500 A
_:661:25	Definite-T 1:Operate delay		0.00 s to 100.00 s	0.30 s

6.3.4.4 Information List

No.	Information	Data Class (Type)	Type
<i>General</i>			
_:2311:500	General:>Activation emg. mode	SPS	I
_:2311:300	General:Emergency mode act.	SPS	O
_:2311:52	General:Behavior	ENS	O
_:2311:53	General:Health	ENS	O
<i>Group indicat.</i>			
_:4501:55	Group indicat.:Pickup	ACD	O
_:4501:57	Group indicat.:Operate	ACT	O
_:4501:52	Group indicat.:Behavior	ENS	O
_:4501:53	Group indicat.:Health	ENS	O
<i>Definite-T 1</i>			
_:661:81	Definite-T 1:>Block stage	SPS	I
_:661:84	Definite-T 1:>Activ. dyn. settings	SPS	I
_:661:500	Definite-T 1:>Block delay & op.	SPS	I
_:661:51	Definite-T 1:Mode (controllable)	ENC	C
_:661:54	Definite-T 1:Inactive	SPS	O
_:661:52	Definite-T 1:Behavior	ENS	O
_:661:53	Definite-T 1:Health	ENS	O
_:661:60	Definite-T 1:Inrush blocks operate	ACT	O
_:661:62	Definite-T 1:Dyn.set. AR cycle1act.	SPS	O
_:661:63	Definite-T 1:Dyn.set. AR cycle2act.	SPS	O
_:661:64	Definite-T 1:Dyn.set. AR cycle3act.	SPS	O

No.	Information	Data Class (Type)	Type
_.661:65	Definite-T 1:Dyn.set. ARcycl.>3act	SPS	O
_.661:66	Definite-T 1:Dyn.set. CLP active	SPS	O
_.661:67	Definite-T 1:Dyn.set. BI active	SPS	O
_.661:68	Definite-T 1:Dyn. set. blks. pickup	SPS	O
_.661:55	Definite-T 1:Pickup	ACD	O
_.661:56	Definite-T 1:Operate delay expired	ACT	O
_.661:57	Definite-T 1:Operate	ACT	O
_.661:302	Definite-T 1:I0el.lph	WYE	O
Definite-T 2			
_.662:81	Definite-T 2:>Block stage	SPS	I
_.662:84	Definite-T 2:>Activ. dyn. settings	SPS	I
_.662:500	Definite-T 2:>Block delay & op.	SPS	I
_.662:51	Definite-T 2:Mode (controllable)	ENC	C
_.662:54	Definite-T 2:Inactive	SPS	O
_.662:52	Definite-T 2:Behavior	ENS	O
_.662:53	Definite-T 2:Health	ENS	O
_.662:60	Definite-T 2:Inrush blocks operate	ACT	O
_.662:62	Definite-T 2:Dyn.set. AR cycle1act.	SPS	O
_.662:63	Definite-T 2:Dyn.set. AR cycle2act.	SPS	O
_.662:64	Definite-T 2:Dyn.set. AR cycle3act.	SPS	O
_.662:65	Definite-T 2:Dyn.set. ARcycl.>3act	SPS	O
_.662:66	Definite-T 2:Dyn.set. CLP active	SPS	O
_.662:67	Definite-T 2:Dyn.set. BI active	SPS	O
_.662:68	Definite-T 2:Dyn. set. blks. pickup	SPS	O
_.662:55	Definite-T 2:Pickup	ACD	O
_.662:56	Definite-T 2:Operate delay expired	ACT	O
_.662:57	Definite-T 2:Operate	ACT	O
_.662:302	Definite-T 2:I0el.lph	WYE	O

6.3.5 Stage with Inverse-Time Characteristic Curve

6.3.5.1 Description

Logic of the Basic Stage

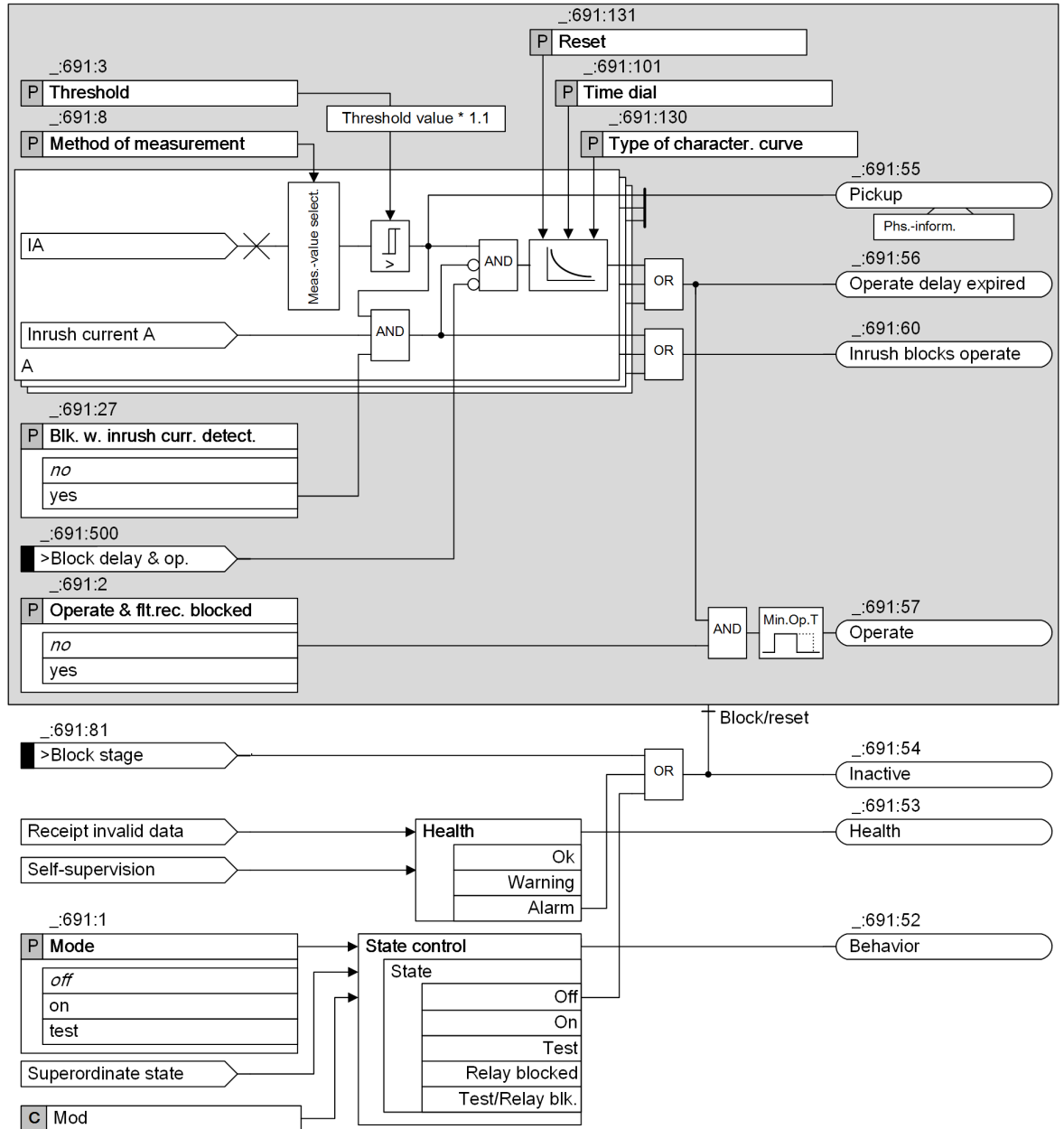

[to_ ocp3b2_3_en_US]

Figure 6-13 Logic Diagram Inverse-Time Overcurrent Protection (Phases) – Basic

Logic of the Advanced Stage

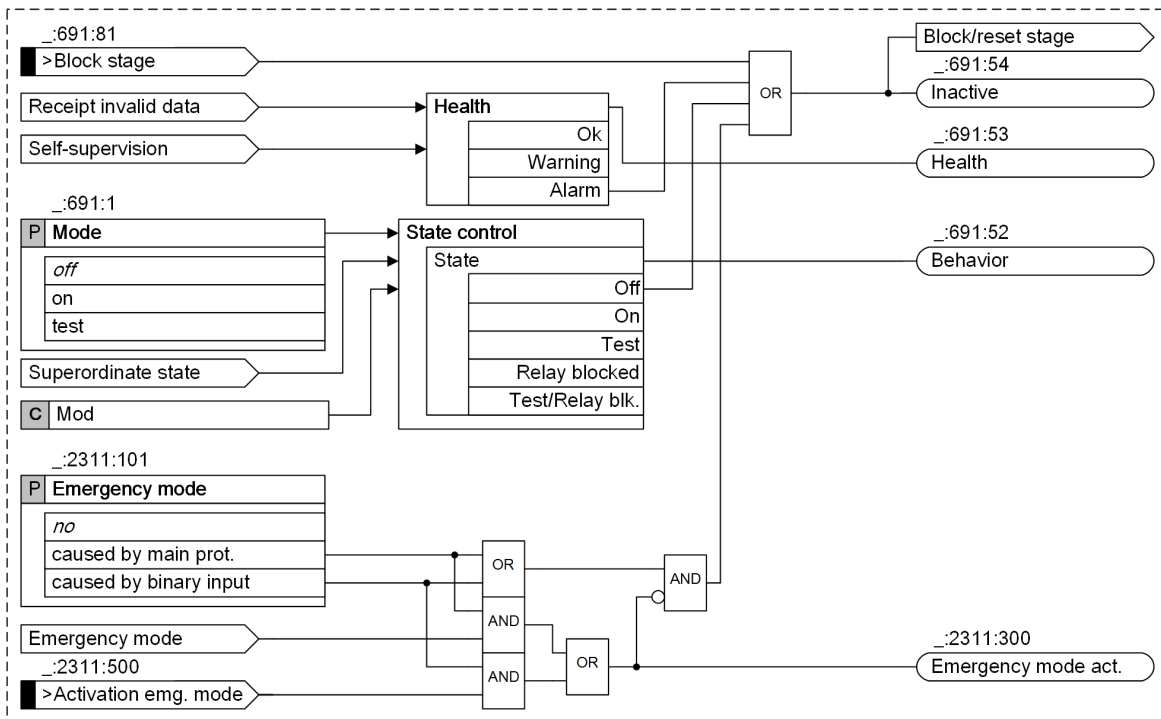

[ilo_ocp_am2_ad_2_en_US]

Figure 6-14 Logic Diagram Stage Control

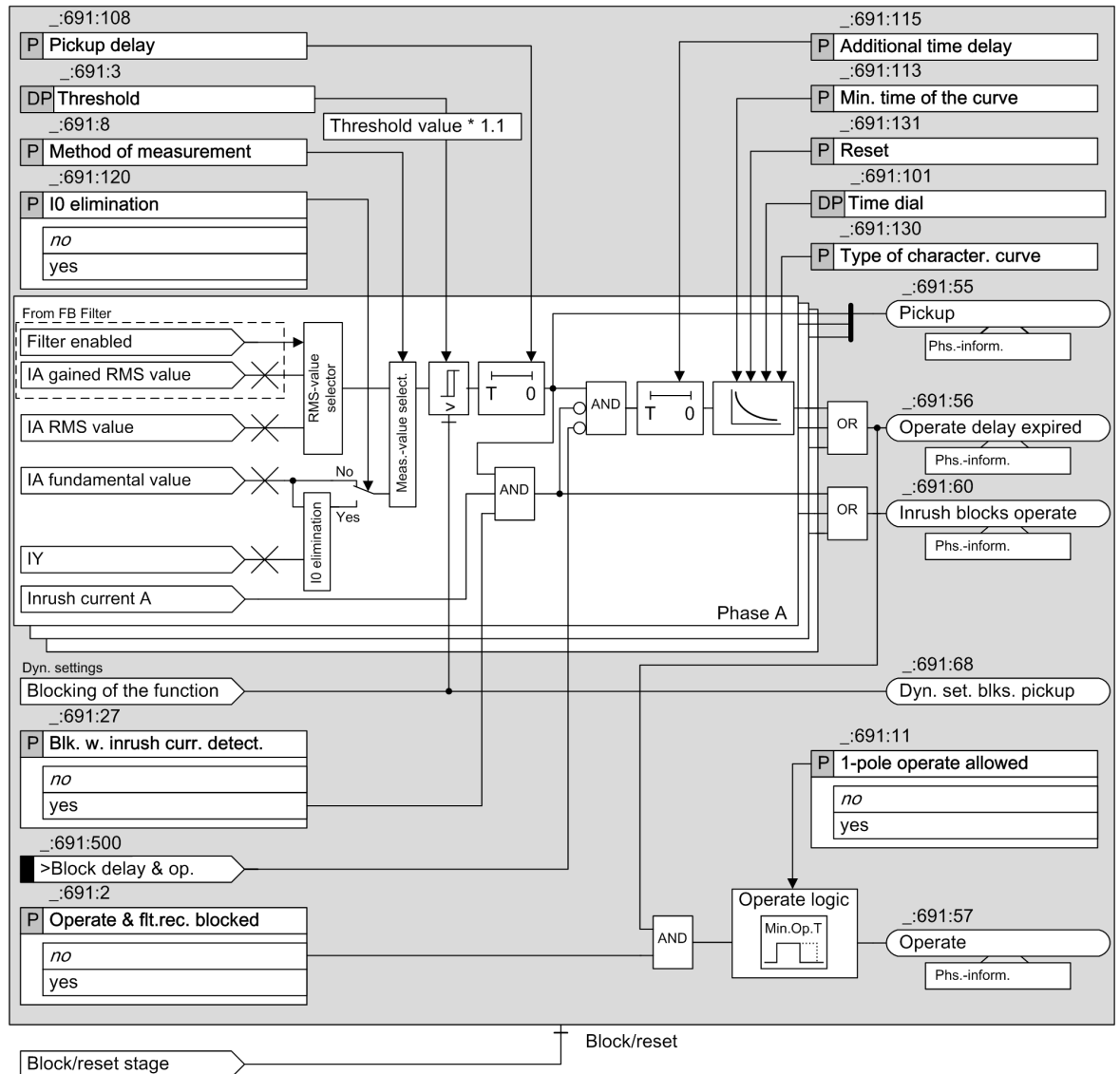

[lo_ocp_3p2_4_en_US]

Figure 6-15 Logic Diagram Inverse-Time Overcurrent Protection (Phases) – Advanced

RMS-Value Selection (Advanced Stage)

If **RMS value** is selected as the method of measurement, the protection function supports 2 kinds of RMS measurement.

- Normal RMS value
- Gained RMS value from the function block **Filter**

If the function block **Filter** is configured and if you have enabled the filter, the gained RMS value is automatically used.



NOTE

When the function block **Filter** is applied, only one 3-phase current measuring point is allowed to be connected to the 3-phase current interface of the function group.

Emergency mode (Advanced Stage)

You use the **Emergency mode** parameter to define whether the stage operates as emergency overcurrent protection or as backup overcurrent protection. With the setting **Emergency mode = *caused by main prot.***, emergency overcurrent protection starts automatically when the main protection fails. This happens, for example, in the case of distance protection when a short circuit occurs in the voltage-transformer secondary circuit, when the voltage-transformer secondary circuit is disconnected or in the case of line differential protection where protection communication is disconnected. This means that the emergency mode replaces the main protection as short-circuit protection. With the appropriate parameterization (**Emergency mode = *caused by binary input***), the emergency mode can also be activated from an external source.

If the overcurrent protection is set as backup overcurrent protection (parameter **Emergency mode = *no***), it operates independently of the main protection and thus in parallel. Backup overcurrent protection can also serve as sole short-circuit protection when, for example, no voltage transformers are available for an initial startup.

Pickup and Dropout Behaviors of the Inverse-Time Characteristic Curve according to IEC and ANSI (Basic and Advanced Stage)

When the input variable exceeds the threshold value by a factor of 1.1, the inverse-time characteristic curve is processed. An integrating method of measurement summarizes the weighted time. The weighted time results from the characteristic curve. For this, the time that is associated with the present current value is determined from the characteristic curve. Once the weighted time exceeds the value 1, the stage operates.

When the measured value falls below the pickup value by a factor of 1.045 ($0.95 \cdot 1.1 \cdot \text{threshold value}$), the dropout is started. The pickup will be indicated as clearing. You can influence the dropout behavior via setting parameters. You can select between instantaneous dropout (totalized time is deleted) or dropout according to the characteristic curve (reduction of totalized time depending on the characteristic curve). The dropout according to characteristic curve (disk emulation) is the same as turning back a rotor disk. The weighted reduction of the time is initiated from 0.9 of the set threshold value.

The characteristic curve and associated formulas are shown in the Technical Data.

Minimum Time of the Curve (Advanced Stage)

With the parameter **Min. time of the curve**, you define a minimum operate delay time. The operate delay time of inverse-time characteristic curve never falls below the minimum operate delay time.

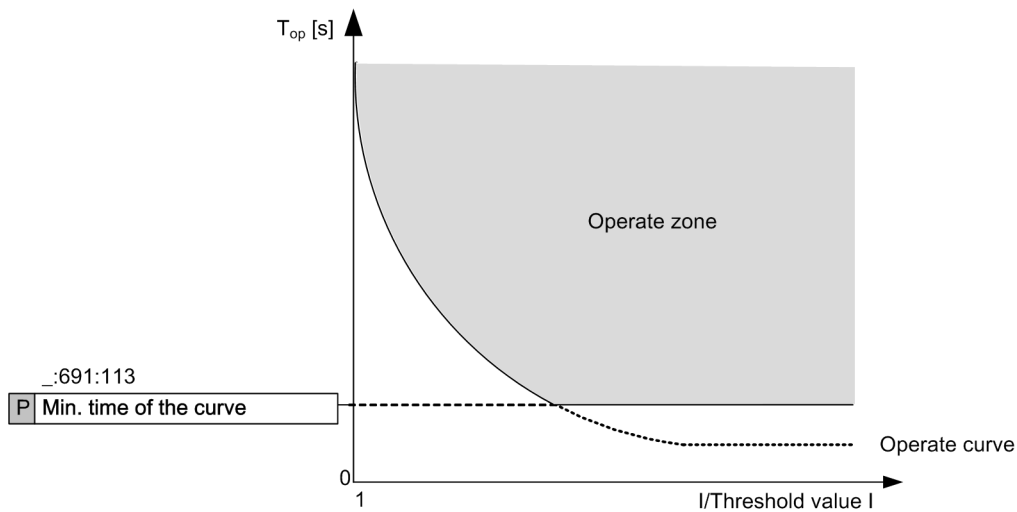

[idw_ocp_3_mi_1_en_US]
 Figure 6-16 Minimum Operating Time of the Curve

Additional Time Delay (Advanced Stage)

With the parameter **Additional time delay**, you define a definite-time delay in addition to the inverse-time delay. With this setting, the whole curve is shifted on the time axis by this additional definite time.

Method of Measurement (Basic and Advanced Stage)

You use the **Method of measurement** parameter to define whether the stage uses the *fundamental comp.* or the calculated *RMS value*.

- Measurement of the fundamental component:
This method of measurement processes the sampled current values and filters out the fundamental component numerically.
- Measurement of the RMS value:
This method of measurement determines the current amplitude from the sampled values according to the defining equation of the RMS value. Harmonics are included in the analysis.

I0 Elimination (Advanced Stage)

In order to increase the sensitivity for the 2-phase short circuit on the transformer low-voltage side, use the I0 elimination of the phase currents for the overcurrent-protection applications on one transformer.

In order to determine the I0 elimination of the phase currents, the transformer neutral point current I_Y must be measured.

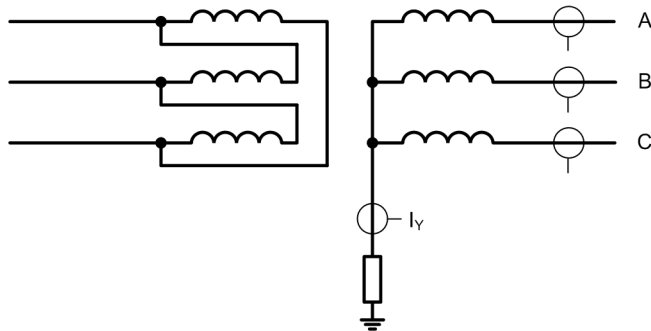

[dw_sgaocp.1.en_US]

Figure 6-17 I0 Elimination Principle

In case of an I0 elimination, the following calculations must be considered:

$$I_{A\text{-elim.}} = I_A - 1/3 I_Y$$

$$I_{B\text{-elim.}} = I_B - 1/3 I_Y$$

$$I_{C\text{-elim.}} = I_C - 1/3 I_Y$$

The phase current $I_{\text{phx-elim.}}$ is necessary for the following protection process.

If the **Method of measurement** parameter is set to *fundamental comp.*, the I0 elimination is operating.

The currents $I_{\text{phx-elim.}}$ are available as functional values.

Pickup Delay (Advanced Stage)

If the current exceeds the threshold value, the pickup delay starts. If the threshold is exceeded during the pickup delay time, the pickup signal is generated.

Blocking of the Stage (Basic and Advanced Stage)

The following blockings reset the picked up stage completely:

- Via the binary input signal **>Block stage** from an external or internal source
- Via the functionality of the **dynamic settings** (only available in the Advanced function type, see **Influence of other functions via dynamic settings** and [6.3.8.1 Description](#)).

Blocking of the Time Delay (Basic and Advanced Stage)

You can use the binary input signal **>Block delay & op.** to prevent the start of the time delay and thus also the operate signal. A running time delay is reset. The pickup is indicated and the fault logging and recording takes place.

Blocking of the Operate Delay and the Operate Signal via the Device-Internal Inrush-Current Detection Function (Basic and Advanced Stage)

Blocking of the operate delay and the operate signal via the device-internal **Inrush-current detection** function is described in [6.3.7.1 Description](#).

6.3.5.2 Application and Setting Notes

Parameter: Method of measurement

- Recommended setting value (**_ :691:8**) **Method of measurement** = *fundamental comp.*

With the **Method of measurement** parameter, you define whether the stage uses the *fundamental comp.* (standard method) or the calculated *RMS value*.

Parameter Value	Description
<i>fundamental comp.</i>	Select this method of measurement if harmonics or transient current peaks are to be suppressed. Siemens recommends using this method as the standard method.
<i>RMS value</i>	Select this method of measurement if you want the stage to take harmonics into account (for example, at capacitor banks). Consider that aperiodic DC components present in the secondary circuit are measured and can cause an overfunction. For this method of measurement, do not set the threshold value of the stage to less than $0.1 I_{rated,sec}$. If currents from more than one measuring point are added up in the current interface of a function group, the setting value should not be set lower than $0.1 I_{rated,sec}$ multiplied by the number of added currents.

Parameter: Type of character. curve

- Default setting (**_ :691:130**) **Type of character. curve** = *IEC normal inverse*

The device offers all the usual inverse-time characteristic curves according to IEC and ANSI. Select the **Type of character. curve** required for your specific application. For more information about the parameter **Type of character. curve**, refer to chapter [14.4.2 Stage with Inverse-Time Characteristic Curve](#).

Parameter: Min. time of the curve

- Default setting (**_ :691:113**) **Min. time of the curve** = *0.00 s*

This parameter is only available in the advanced stage.

With the **Min. time of the curve** parameter, you define a minimum operate delay time. The operate delay time of inverse-time characteristic curve never falls below the minimum operate delay time. If the setting is left on its default value of 0 s, this parameter has no effect on the inverse-time characteristic curve. This parameter is only required for time coordination in recloser schemes. For all other applications, Siemens recommends keeping the default setting of 0 s.



NOTE

If the set value is smaller than the smallest possible time delay of the inverse-time characteristic curve, the parameter has no influence on the delay time.

Parameter: Additional time delay

- Default setting (`_:691:115`) **Additional time delay** = 0.00 s

With the **Additional time delay** parameter, you define a definite-time delay in addition to the inverse-time delay.

If the setting is left on its default value of 0 s, this parameter has no effect on the inverse-time characteristic time.

This parameter is only required for time coordination in recloser schemes. For all other applications, Siemens recommends keeping the default setting of 0 s.

Parameter: Threshold

- Default setting (`_:691:3`) **Threshold** = 1.500 A

Set the **Threshold** and **Type of character. curve** parameters for the specific application.

The setting depends on the maximum occurring operating current. Pickup by overload must be excluded since overcurrent protection operates with short tripping times as short-circuit protection and not as overload protection. Set the **Threshold** parameter for lines to approx. 10 %, for transformers and motors to approx. 20 % above the maximum expected load.

Note that a safety margin is set between pickup value and threshold value. The stage only picks up at approx. 10 % above the **Threshold**.

EXAMPLE

Overcurrent-protection stage: 110-kV overhead line, 150 mm² cross-section

Maximum transmittable power

$$P_{\max} = 120 \text{ MVA}$$

Correspondingly

$$I_{\max} = 630 \text{ A}$$

$$\text{Current transformer} = 600 \text{ A/5 A}$$

Settings in primary and secondary measurands result in the setting values:

$$\text{Threshold value } I > \text{ (primary)} = 630 \text{ A}$$

$$\text{Threshold value } I > \text{ (secondary)} = \frac{630 \text{ A}}{600 \text{ A}} \cdot 5 \text{ A} = 5.25 \text{ A}$$

[fo_ocp_005_2_en_US]

Parameter: I0 elimination

- Default setting (`_:661:120`) **I0 elimination** = no

This parameter is not visible in the basic stage.

The I0 elimination in phase currents for overcurrent-protection applications can be used in a transformer. This increases the sensitivity for the 2-phase short circuit on the low-voltage side of the transformer. The following conditions must be fulfilled:

- The transformer neutral point current I_N is measured and is available for the protection function group.
- The parameter **Method of measurement** is set to *fundamental comp.*.

With the **I0 elimination** setting, you can switch the I0 elimination function on or off.

Parameter: Pickup delay

- Default setting (`_:661:102`) **Pickup delay** = 0.00 s

This parameter is not visible in the basic stage.

For special applications it is desirable if the current threshold is briefly exceeded, that this will not lead to the pickup of the stage and starts fault logging or recording. If this stage is used as a thermal overload function, that is considered a special application.

When using the **Pickup delay** parameter, a time interval is defined during which a pickup is not trigger if the current threshold is exceeded.

For all short-circuit protection applications, this value is 0.00 s and is considered as a default.

Parameter: Time dial

- Default setting (`_:691:101`) **Time dial** = 1.00

With the **Time dial** parameter, you displace the characteristic curve in the time direction.

The set value for the **Time dial** parameter is derived from the time-grading schedule that has been prepared for the electrical power system. Where overcurrent protection is used in emergency mode, shorter time delays might be reasonable (one grading time above fast tripping), since the emergency mode only operates if the main protection function fails.

Where no time grading and therefore no displacement of the characteristic curve is required, leave the parameter **Time dial** at 1 (default setting).

Parameter: Reset

- Default setting (`_:691:131`) **Reset** = *disk emulation*

With the **Reset** parameter, you define whether the stage drops out according to the dropout characteristic curve (in accordance with the behavior of a disk emulation = rotor disk) or instantaneously.

Parameter Value	Description
<i>disk emulation</i>	Select this setting if the device is coordinated with electromechanical devices or other devices which perform a dropout after a disk emulation.
<i>instantaneous</i>	Select this setting if the dropout is not to be performed after disk emulation and an instantaneous dropout is desired instead.

Parameter: 1-pole operate allowed

- Default setting (`_:691:11`) **1-pole operate allowed** = *no*

The parameter must be set for the specific application.

Parameter Value	Description
<i>no</i>	The stage always operates 3-pole.
<i>yes</i>	The stage operates phase-selectively. However, tripping by the device (generated in the trip logic of the Circuit-breaker function group) is always 3-pole because the device does not support phase-selective tripping.

6.3.5.3 Settings

Addr.	Parameter	C	Setting Options	Default Setting
<i>General</i>				
_:2311:101	General:Emergency mode		<ul style="list-style-type: none"> • no • caused by main prot. • caused by binary input 	no
<i>General</i>				
_:691:1	Inverse-T 1:Mode		<ul style="list-style-type: none"> • off • on • test 	off
_:691:2	Inverse-T 1:Operate & flt.rec. blocked		<ul style="list-style-type: none"> • no • yes 	no

Addr.	Parameter	C	Setting Options	Default Setting
_:691:11	Inverse-T 1:1-pole operate allowed		<ul style="list-style-type: none"> no yes 	no
_:691:26	Inverse-T 1:Dynamic settings		<ul style="list-style-type: none"> no yes 	no
_:691:27	Inverse-T 1:Blk. w. inrush curr. detect.		<ul style="list-style-type: none"> no yes 	no
_:691:8	Inverse-T 1:Method of measurement		<ul style="list-style-type: none"> fundamental comp. RMS value 	fundamental comp.
_:691:120	Inverse-T 1:I0 elimination		<ul style="list-style-type: none"> no yes 	no
_:691:3	Inverse-T 1:Threshold	1 A @ 100 Irated	0.030 A to 40.000 A	1.500 A
		5 A @ 100 Irated	0.15 A to 200.00 A	7.50 A
		1 A @ 50 Irated	0.030 A to 40.000 A	1.500 A
		5 A @ 50 Irated	0.15 A to 200.00 A	7.50 A
		1 A @ 1.6 Irated	0.001 A to 1.600 A	1.500 A
		5 A @ 1.6 Irated	0.005 A to 8.000 A	7.500 A
_:691:108	Inverse-T 1:Pickup delay		0.00 s to 60.00 s	0.00 s
_:691:130	Inverse-T 1:Type of character. curve			
_:691:113	Inverse-T 1:Min. time of the curve		0.00 s to 1.00 s	0.00 s
_:691:131	Inverse-T 1:Reset		<ul style="list-style-type: none"> instantaneous disk emulation 	disk emulation
_:691:101	Inverse-T 1:Time dial		0.00 to 15.00	1.00
_:691:115	Inverse-T 1:Additional time delay		0.00 s to 60.00 s	0.00 s
<i>Dyn.s: AR off/n.rdy</i>				
_:691:28	Inverse-T 1:Effect. by AR off/n.ready		<ul style="list-style-type: none"> no yes 	no
_:691:35	Inverse-T 1:Stage blocked		<ul style="list-style-type: none"> no yes 	no
<i>Dyn.set: AR cycle 1</i>				
_:691:29	Inverse-T 1:Effected by AR cycle 1		<ul style="list-style-type: none"> no yes 	no
_:691:36	Inverse-T 1:Stage blocked		<ul style="list-style-type: none"> no yes 	no
_:691:14	Inverse-T 1:Threshold	1 A @ 100 Irated	0.030 A to 40.000 A	1.500 A
		5 A @ 100 Irated	0.15 A to 200.00 A	7.50 A
		1 A @ 50 Irated	0.030 A to 40.000 A	1.500 A
		5 A @ 50 Irated	0.15 A to 200.00 A	7.50 A
		1 A @ 1.6 Irated	0.001 A to 1.600 A	1.500 A
		5 A @ 1.6 Irated	0.005 A to 8.000 A	7.500 A
_:691:102	Inverse-T 1:Time dial		0.00 to 15.00	1.00
<i>Dyn.set: AR cycle 2</i>				
_:691:30	Inverse-T 1:Effected by AR cycle 2		<ul style="list-style-type: none"> no yes 	no

Addr.	Parameter	C	Setting Options	Default Setting
_.691:37	Inverse-T 1:Stage blocked		<ul style="list-style-type: none"> • no • yes 	no
_.691:15	Inverse-T 1:Threshold	1 A @ 100 Irated	0.030 A to 40.000 A	1.500 A
		5 A @ 100 Irated	0.15 A to 200.00 A	7.50 A
		1 A @ 50 Irated	0.030 A to 40.000 A	1.500 A
		5 A @ 50 Irated	0.15 A to 200.00 A	7.50 A
		1 A @ 1.6 Irated	0.001 A to 1.600 A	1.500 A
		5 A @ 1.6 Irated	0.005 A to 8.000 A	7.500 A
_.691:103	Inverse-T 1:Time dial		0.00 to 15.00	1.00
Dyn.set: AR cycle 3				
_.691:31	Inverse-T 1:Effected by AR cycle 3		<ul style="list-style-type: none"> • no • yes 	no
_.691:38	Inverse-T 1:Stage blocked		<ul style="list-style-type: none"> • no • yes 	no
_.691:16	Inverse-T 1:Threshold	1 A @ 100 Irated	0.030 A to 40.000 A	1.500 A
		5 A @ 100 Irated	0.15 A to 200.00 A	7.50 A
		1 A @ 50 Irated	0.030 A to 40.000 A	1.500 A
		5 A @ 50 Irated	0.15 A to 200.00 A	7.50 A
		1 A @ 1.6 Irated	0.001 A to 1.600 A	1.500 A
		5 A @ 1.6 Irated	0.005 A to 8.000 A	7.500 A
_.691:104	Inverse-T 1:Time dial		0.00 to 15.00	1.00
Dyn.s: AR cycle>3				
_.691:32	Inverse-T 1:Effected by AR cycle gr. 3		<ul style="list-style-type: none"> • no • yes 	no
_.691:39	Inverse-T 1:Stage blocked		<ul style="list-style-type: none"> • no • yes 	no
_.691:17	Inverse-T 1:Threshold	1 A @ 100 Irated	0.030 A to 40.000 A	1.500 A
		5 A @ 100 Irated	0.15 A to 200.00 A	7.50 A
		1 A @ 50 Irated	0.030 A to 40.000 A	1.500 A
		5 A @ 50 Irated	0.15 A to 200.00 A	7.50 A
		1 A @ 1.6 Irated	0.001 A to 1.600 A	1.500 A
		5 A @ 1.6 Irated	0.005 A to 8.000 A	7.500 A
_.691:105	Inverse-T 1:Time dial		0.00 to 15.00	1.00
Dyn.s: Cold load PU				
_.691:33	Inverse-T 1:Effect. b. cold-load pickup		<ul style="list-style-type: none"> • no • yes 	no
_.691:40	Inverse-T 1:Stage blocked		<ul style="list-style-type: none"> • no • yes 	no
_.691:18	Inverse-T 1:Threshold	1 A @ 100 Irated	0.030 A to 40.000 A	1.500 A
		5 A @ 100 Irated	0.15 A to 200.00 A	7.50 A
		1 A @ 50 Irated	0.030 A to 40.000 A	1.500 A
		5 A @ 50 Irated	0.15 A to 200.00 A	7.50 A
		1 A @ 1.6 Irated	0.001 A to 1.600 A	1.500 A
		5 A @ 1.6 Irated	0.005 A to 8.000 A	7.500 A
_.691:106	Inverse-T 1:Time dial		0.00 to 15.00	1.00

Addr.	Parameter	C	Setting Options	Default Setting
Dyn.set: bin.input				
_:691:34	Inverse-T 1:Effected by binary input		<ul style="list-style-type: none"> • no • yes 	no
_:691:41	Inverse-T 1:Stage blocked		<ul style="list-style-type: none"> • no • yes 	no
_:691:19	Inverse-T 1:Threshold	1 A @ 100 Irated	0.030 A to 40.000 A	1.500 A
		5 A @ 100 Irated	0.15 A to 200.00 A	7.50 A
		1 A @ 50 Irated	0.030 A to 40.000 A	1.500 A
		5 A @ 50 Irated	0.15 A to 200.00 A	7.50 A
		1 A @ 1.6 Irated	0.001 A to 1.600 A	1.500 A
		5 A @ 1.6 Irated	0.005 A to 8.000 A	7.500 A
_:691:107	Inverse-T 1:Time dial		0.00 to 15.00	1.00

6.3.5.4 Information List

No.	Information	Data Class (Type)	Type
General			
_:2311:500	General:>Activation emg. mode	SPS	I
_:2311:300	General:Emergency mode act.	SPS	O
_:2311:52	General:Behavior	ENS	O
_:2311:53	General:Health	ENS	O
Group indicat.			
_:4501:55	Group indicat.:Pickup	ACD	O
_:4501:57	Group indicat.:Operate	ACT	O
_:4501:52	Group indicat.:Behavior	ENS	O
_:4501:53	Group indicat.:Health	ENS	O
Inverse-T 1			
_:691:81	Inverse-T 1:>Block stage	SPS	I
_:691:84	Inverse-T 1:>Activ. dyn. settings	SPS	I
_:691:500	Inverse-T 1:>Block delay & op.	SPS	I
_:691:51	Inverse-T 1:Mode (controllable)	ENC	C
_:691:54	Inverse-T 1:Inactive	SPS	O
_:691:52	Inverse-T 1:Behavior	ENS	O
_:691:53	Inverse-T 1:Health	ENS	O
_:691:60	Inverse-T 1:Inrush blocks operate	ACT	O
_:691:62	Inverse-T 1:Dyn.set. AR cycle1act.	SPS	O
_:691:63	Inverse-T 1:Dyn.set. AR cycle2act.	SPS	O
_:691:64	Inverse-T 1:Dyn.set. AR cycle3act.	SPS	O
_:691:65	Inverse-T 1:Dyn.set. ARcycl.>3act	SPS	O
_:691:66	Inverse-T 1:Dyn.set. CLP active	SPS	O
_:691:67	Inverse-T 1:Dyn.set. BI active	SPS	O
_:691:68	Inverse-T 1:Dyn. set. blks. pickup	SPS	O
_:691:59	Inverse-T 1:Disk emulation running	SPS	O
_:691:55	Inverse-T 1:Pickup	ACD	O
_:691:56	Inverse-T 1:Operate delay expired	ACT	O
_:691:57	Inverse-T 1:Operate	ACT	O
_:691:302	Inverse-T 1:I0el.lph	WYE	O

6.3.6 Stage with User-Defined Characteristic Curve

6.3.6.1 Description

This stage is only available in the advanced function type.

This stage is structured the same way as the **Inverse-time overcurrent protection – advanced** stage (see chapter 6.3.5.1 *Description*). The only differences are as follows:

- You can define the characteristic curve as desired.
- The pickup and dropout behaviors of this stage are determined by the standard parameter **Threshold** and, if necessary, by an additional parameter **Threshold (absolute)**.

User-Defined Characteristic Curve

With the user-defined characteristic curve, you can define the operate curve point by point using up to 30 value pairs of current and time. The device uses linear interpolation to calculate the characteristic curve from these values. You can also define a dropout characteristic curve if you wish.

Pickup and Dropout Behaviors with the User-Defined Characteristic Curve

When the input variable exceeds the **Threshold** value by 1.1 times, the characteristic curve is processed. An integrating method of measurement totalizes the weighted time. The weighted time results from the characteristic curve. For this, the time that is associated with the present current value is determined from the characteristic curve. Once the weighted time exceeds the value 1, the stage operates.

When the measured value falls short of the pickup value by a factor of 1.045 ($0.95 \times 1.1 \times \text{Threshold}$ value), the dropout is started. The pickup will be indicated as clearing. You can influence the dropout behavior via setting parameters. You can select between instantaneous dropout (totalized time is deleted) or dropout according to the characteristic curve (reduction of totalized time depending on the characteristic curve). The dropout according to characteristic curve (disk emulation) is the same as turning back a rotor disk. The weighted reduction of the time is initiated from 0.9 of the set threshold value.

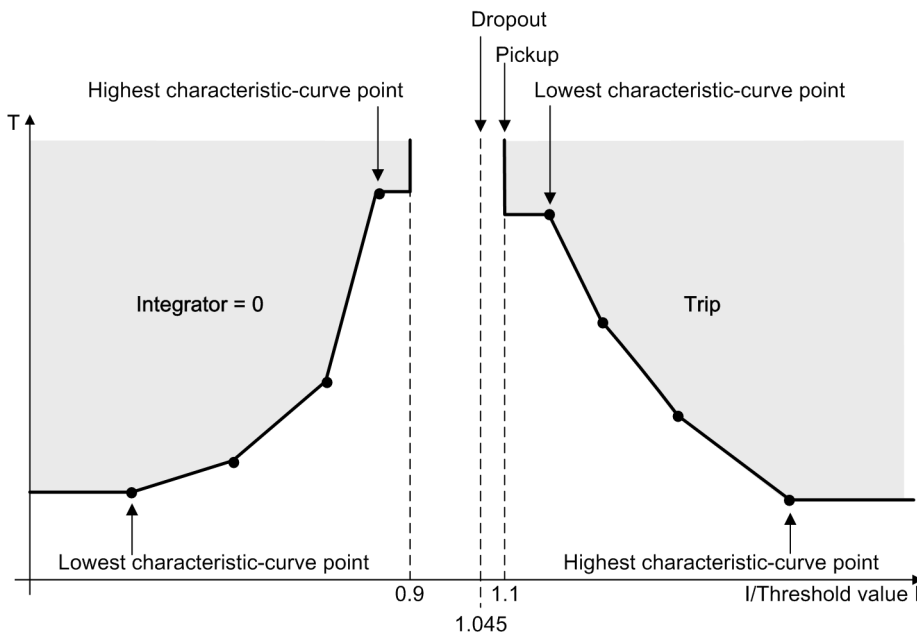

[dw_ocp_ken_02_2_en_US]

Figure 6-18 Pickup Behavior and Dropout Behavior when Using a User-Defined Characteristic Curve



NOTE

The currents that are lower than the current value of the smallest characteristic-curve point do not extend the operate time. The pickup characteristic runs in parallel to the current axis up to the smallest characteristic-curve point. Currents that are larger than the current value of the largest characteristic-curve point do not reduce the operate time. The pickup characteristic runs in parallel to the current axis from the largest characteristic-curve point.

If you want to change the pickup threshold of the stage without changing all points of the characteristic curve, you can use the additional **Threshold (absolute)** parameter.

You can set the **Threshold (absolute)** parameter to be greater than 1.1 times the **Threshold** value. Then the stage behaviors are as follows:

- The stage picks up when the measured current value exceeds the **Threshold (absolute)** value.
- The stage starts dropout when the measured current value falls short of the **Threshold (absolute)** value by 0.95 times.
- For measured current values lower than the **Threshold (absolute)** value, no pickup takes place and consequently the characteristic curve is not processed.

If you set the **Threshold (absolute)** parameter to be less than 1.1 times the **Threshold** value, the pickup and dropout behaviors are not affected by the **Threshold (absolute)** parameter.

6.3.6.2 Application and Setting Notes

This stage is structured the same way as the **Inverse-time overcurrent protection – advanced** stage. The only differences are described in chapter [6.3.6.1 Description](#). This chapter provides only the application and setting notes for setting characteristic curves and for setting the **Threshold (absolute)** parameter. You can find more information on the other parameters of the stage in chapter [6.3.5.2 Application and Setting Notes](#).

Parameter: Current/time value pairs (from the operate curve)

With these settings, you define the characteristic curve. Set a current/time value pair for each characteristic-curve point. The setting depends on the characteristic curve you want to realize.

Set the current value as a multiple of the threshold value. Siemens recommends that you set the **Threshold** parameter to **1.00** in order to obtain a simple relation. You can change the threshold value setting afterwards if you want to shift the characteristic curve.

Set the time value in seconds. The characteristic curve is shifted via the **Time dial** parameter.



NOTE

The value pairs must be entered in continuous order.

Parameter: Time dial

- Default setting (**_:101**) **Time dial = 1**

With the **Time dial** parameter, you displace the characteristic curve in the time direction.

The set value for the **Time dial** parameter is derived from the time-grading schedule that has been prepared for the electrical power system. Where no time grading and therefore no displacement of the characteristic curve is required, leave the **Time dial** parameter at **1**.

Parameter: Reset

- Default setting (**_:110**) **Reset = disk emulation**

With the **Reset** parameter, you define whether the stage drops out according to the dropout characteristic curve (in accordance with the behavior of a disk emulation = rotor disk) or instantaneously.

Parameter Value	Description
<i>disk emulation</i>	In the case of this setting, a dropout characteristic curve has to be set in addition to the operate curve. Select this setting if the device is coordinated with electromechanical devices or other devices which perform a dropout after a disk emulation.
<i>instantaneous</i>	Select this setting if the dropout is not to be performed after disk emulation but an instantaneous dropout is desired.

Parameter: Current/time value pairs (of the dropout characteristic curve)

With these settings, you define the characteristic curve. Set a current/time value pair for each characteristic-curve point. The setting depends on the characteristic curve you want to realize.
 Set the current value as a multiple of the threshold value. Siemens recommends that you set the **Threshold** parameter to **1.00** in order to obtain a simple relation. You can change the threshold value setting afterwards if you want to shift the characteristic curve.
 Set the time value in seconds. The characteristic curve is shifted via the **Time dial** parameter.



NOTE
 The value pairs must be entered in continuous order.

Parameter: 1-pole operate allowed

- Default setting (**_:11**) **1-pole operate allowed = no**

The parameter must be set for the specific application.

Parameter Value	Description
<i>no</i>	The stage always operates 3-pole.
<i>yes</i>	The stage operates phase-selectively. However, tripping by the device (generated in the trip logic of the Circuit-breaker function group) is always 3-pole because the device does not support phase-selective tripping.

Parameter: Threshold (absolute)

- Default setting (**_:113**) **Threshold (absolute) = 0.000 A**

With the **Threshold (absolute)** parameter, you define and change the absolute pickup threshold of the stage without changing all points of the characteristic curve.

The parameter is only used for special applications. With the default setting, this functionality is disabled. You can find more information in [Pickup and Dropout Behaviors with the User-Defined Characteristic Curve, Page 376](#).

6.3.6.3 Settings

Addr.	Parameter	C	Setting Options	Default Setting
<i>General</i>				
_:1	User curve #:Mode		<ul style="list-style-type: none"> • off • on • test 	off
_:2	User curve #:Operate & flt.rec. blocked		<ul style="list-style-type: none"> • no • yes 	no
_:11	User curve #:1-pole operate allowed		<ul style="list-style-type: none"> • no • yes 	no

Addr.	Parameter	C	Setting Options	Default Setting
_:26	User curve #:Dynamic settings		<ul style="list-style-type: none"> no yes 	no
_:27	User curve #:Blk. w. inrush curr. detect.		<ul style="list-style-type: none"> no yes 	no
_:8	User curve #:Method of measurement		<ul style="list-style-type: none"> fundamental comp. RMS value 	fundamental comp.
_:120	User curve #:IO elimination		<ul style="list-style-type: none"> no yes 	no
_:3	User curve #:Threshold	1 A @ 100 Irated	0.030 A to 40.000 A	1.500 A
		5 A @ 100 Irated	0.15 A to 200.00 A	7.50 A
		1 A @ 50 Irated	0.030 A to 40.000 A	1.500 A
		5 A @ 50 Irated	0.15 A to 200.00 A	7.50 A
		1 A @ 1.6 Irated	0.001 A to 1.600 A	1.500 A
		5 A @ 1.6 Irated	0.005 A to 8.000 A	7.500 A
_:113	User curve #:Threshold (absolute)	1 A @ 100 Irated	0.000 A to 40.000 A	0.000 A
		5 A @ 100 Irated	0.00 A to 200.00 A	0.00 A
		1 A @ 50 Irated	0.000 A to 40.000 A	0.000 A
		5 A @ 50 Irated	0.00 A to 200.00 A	0.00 A
		1 A @ 1.6 Irated	0.000 A to 1.600 A	0.000 A
		5 A @ 1.6 Irated	0.000 A to 8.000 A	0.000 A
_:111	User curve #:Pickup delay		0.00 s to 60.00 s	0.00 s
_:110	User curve #:Reset		<ul style="list-style-type: none"> instantaneous disk emulation 	disk emulation
_:101	User curve #:Time dial		0.05 to 15.00	1.00
_:115	User curve #:Additional time delay		0.00 s to 60.00 s	0.00 s
<i>Dyn.s: AR off/n.rdy</i>				
_:28	User curve #:Effect. by AR off/n.ready		<ul style="list-style-type: none"> no yes 	no
_:35	User curve #:Stage blocked		<ul style="list-style-type: none"> no yes 	no
<i>Dyn.set: AR cycle 1</i>				
_:29	User curve #:Effected by AR cycle 1		<ul style="list-style-type: none"> no yes 	no
_:36	User curve #:Stage blocked		<ul style="list-style-type: none"> no yes 	no
_:14	User curve #:Threshold	1 A @ 100 Irated	0.030 A to 40.000 A	1.500 A
		5 A @ 100 Irated	0.15 A to 200.00 A	7.50 A
		1 A @ 50 Irated	0.030 A to 40.000 A	1.500 A
		5 A @ 50 Irated	0.15 A to 200.00 A	7.50 A
		1 A @ 1.6 Irated	0.001 A to 1.600 A	1.500 A
		5 A @ 1.6 Irated	0.005 A to 8.000 A	7.500 A
_:102	User curve #:Time dial		0.05 to 15.00	1.00

Addr.	Parameter	C	Setting Options	Default Setting
Dyn.set: AR cycle 2				
_:30	User curve #:Effected by AR cycle 2		<ul style="list-style-type: none"> • no • yes 	no
_:37	User curve #:Stage blocked		<ul style="list-style-type: none"> • no • yes 	no
_:15	User curve #:Threshold	1 A @ 100 Irated	0.030 A to 40.000 A	1.500 A
		5 A @ 100 Irated	0.15 A to 200.00 A	7.50 A
		1 A @ 50 Irated	0.030 A to 40.000 A	1.500 A
		5 A @ 50 Irated	0.15 A to 200.00 A	7.50 A
		1 A @ 1.6 Irated	0.001 A to 1.600 A	1.500 A
		5 A @ 1.6 Irated	0.005 A to 8.000 A	7.500 A
_:103	User curve #:Time dial		0.05 to 15.00	1.00
Dyn.set: AR cycle 3				
_:31	User curve #:Effected by AR cycle 3		<ul style="list-style-type: none"> • no • yes 	no
_:38	User curve #:Stage blocked		<ul style="list-style-type: none"> • no • yes 	no
_:16	User curve #:Threshold	1 A @ 100 Irated	0.030 A to 40.000 A	1.500 A
		5 A @ 100 Irated	0.15 A to 200.00 A	7.50 A
		1 A @ 50 Irated	0.030 A to 40.000 A	1.500 A
		5 A @ 50 Irated	0.15 A to 200.00 A	7.50 A
		1 A @ 1.6 Irated	0.001 A to 1.600 A	1.500 A
		5 A @ 1.6 Irated	0.005 A to 8.000 A	7.500 A
_:104	User curve #:Time dial		0.05 to 15.00	1.00
Dyn.s: AR cycle>3				
_:32	User curve #:Effected by AR cycle gr. 3		<ul style="list-style-type: none"> • no • yes 	no
_:39	User curve #:Stage blocked		<ul style="list-style-type: none"> • no • yes 	no
_:17	User curve #:Threshold	1 A @ 100 Irated	0.030 A to 40.000 A	1.500 A
		5 A @ 100 Irated	0.15 A to 200.00 A	7.50 A
		1 A @ 50 Irated	0.030 A to 40.000 A	1.500 A
		5 A @ 50 Irated	0.15 A to 200.00 A	7.50 A
		1 A @ 1.6 Irated	0.001 A to 1.600 A	1.500 A
		5 A @ 1.6 Irated	0.005 A to 8.000 A	7.500 A
_:105	User curve #:Time dial		0.05 to 15.00	1.00
Dyn.s: Cold load PU				
_:33	User curve #:Effect. b. cold-load pickup		<ul style="list-style-type: none"> • no • yes 	no
_:40	User curve #:Stage blocked		<ul style="list-style-type: none"> • no • yes 	no

Addr.	Parameter	C	Setting Options	Default Setting
_:18	User curve #:Threshold	1 A @ 100 Irated	0.030 A to 40.000 A	1.500 A
		5 A @ 100 Irated	0.15 A to 200.00 A	7.50 A
		1 A @ 50 Irated	0.030 A to 40.000 A	1.500 A
		5 A @ 50 Irated	0.15 A to 200.00 A	7.50 A
		1 A @ 1.6 Irated	0.001 A to 1.600 A	1.500 A
		5 A @ 1.6 Irated	0.005 A to 8.000 A	7.500 A
_:106	User curve #:Time dial		0.05 to 15.00	1.00
Dyn.set: bin.input				
_:34	User curve #:Effected by binary input		<ul style="list-style-type: none"> • no • yes 	no
_:41	User curve #:Stage blocked		<ul style="list-style-type: none"> • no • yes 	no
_:19	User curve #:Threshold	1 A @ 100 Irated	0.030 A to 40.000 A	1.500 A
		5 A @ 100 Irated	0.15 A to 200.00 A	7.50 A
		1 A @ 50 Irated	0.030 A to 40.000 A	1.500 A
		5 A @ 50 Irated	0.15 A to 200.00 A	7.50 A
		1 A @ 1.6 Irated	0.001 A to 1.600 A	1.500 A
		5 A @ 1.6 Irated	0.005 A to 8.000 A	7.500 A
_:107	User curve #:Time dial		0.05 to 15.00	1.00

6.3.6.4 Information List

No.	Information	Data Class (Type)	Type
User curve #			
_:81	User curve #:>Block stage	SPS	I
_:84	User curve #:>Activ. dyn. settings	SPS	I
_:500	User curve #:>Block delay & op.	SPS	I
_:54	User curve #:Inactive	SPS	O
_:52	User curve #:Behavior	ENS	O
_:53	User curve #:Health	ENS	O
_:60	User curve #:Inrush blocks operate	ACT	O
_:62	User curve #:Dyn.set. AR cycle1act.	SPS	O
_:63	User curve #:Dyn.set. AR cycle2act.	SPS	O
_:64	User curve #:Dyn.set. AR cycle3act.	SPS	O
_:65	User curve #:Dyn.set. ARcycl.>3act	SPS	O
_:66	User curve #:Dyn.set. CLP active	SPS	O
_:67	User curve #:Dyn.set. BI active	SPS	O
_:68	User curve #:Dyn. set. blks. pickup	SPS	O
_:59	User curve #:Disk emulation running	SPS	O
_:55	User curve #:Pickup	ACD	O
_:56	User curve #:Operate delay expired	ACT	O
_:57	User curve #:Operate	ACT	O

6.3.7 Blocking of the Tripping by Device-Internal Inrush-Current Detection

6.3.7.1 Description

The **Blk. w. inrush curr. detect.** parameter allows you to define whether the operate indication of the stage should be blocked when a threshold value is exceeded due to an inrush current. In case of a blocking and fulfilled pickup conditions, the stage picks up. The start of the time delay and the operate indication are blocked. The function indicates this through a corresponding indication. If the blocking drops out and the pickup conditions are still met, the time delay is started. After that time, the stage operates.

The following figure only shows the part of the stage (exemplified by definite-time overcurrent protection stage 1) that illustrates the influence of the blocking. Only if the central function **Inrush-current detection** (see chapter 14.9 *Inrush-Current Detection*) is in effect can the blocking be set.

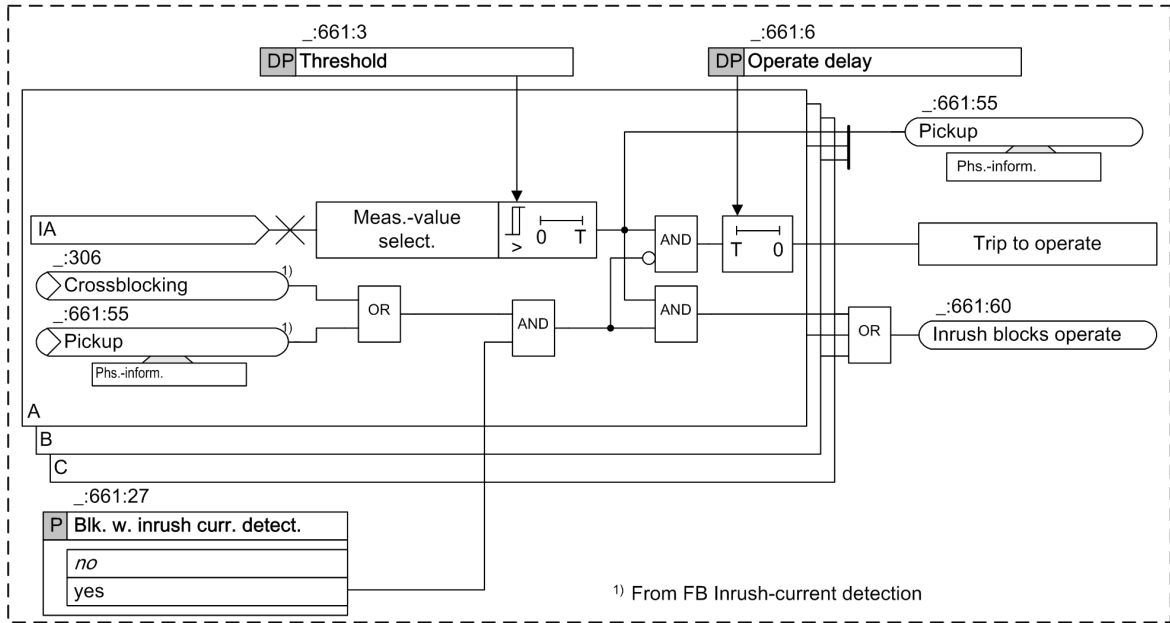

[[lo_occup3pha_1_en_US]

Figure 6-19 Part-Logic Diagram on the Influence of Inrush-Current Detection Exemplified by the 1st Definite-Time Overcurrent Protection Stage

6.3.7.2 Application and Setting Notes

Parameter: **Blk. w. inrush curr. detect.**

- Default setting (`._:661:27`) **Blk. w. inrush curr. detect.** = *no*

Parameter Value	Description
<i>no</i>	<p>The transformer inrush-current detection does not affect the stage.</p> <p>Select this setting in the following cases:</p> <ul style="list-style-type: none"> In cases where the device is not used on transformers. In cases where the device is used on transformers and the threshold value of the stage is set above the maximum inrush current of the transformer. This, for example, applies to the high-current stage that is set such according to the short-circuit voltage V_{sc} of the transformer that it only picks up on faults from the high-voltage side. The transformer inrush current cannot become larger than the maximum transmittable short-circuit current.
<i>yes</i>	<p>When the transformer inrush current detection detects an inrush current that would lead to a tripping of the stage, the start of the time delay and tripping of the stage are blocked.</p> <p>Select this setting if the device is used on transformers and the threshold value of the stage is set below the maximum inrush current of the transformer. This applies to the overcurrent-protection stage, which is used as a backup stage with grading time for faults on the undervoltage side of the transformer.</p>

6.3.8 Influence of Other Functions via Dynamic Settings

6.3.8.1 Description

Link to the Device-Internal Function *Cold-Load Pickup Detection (Advanced Stage)*

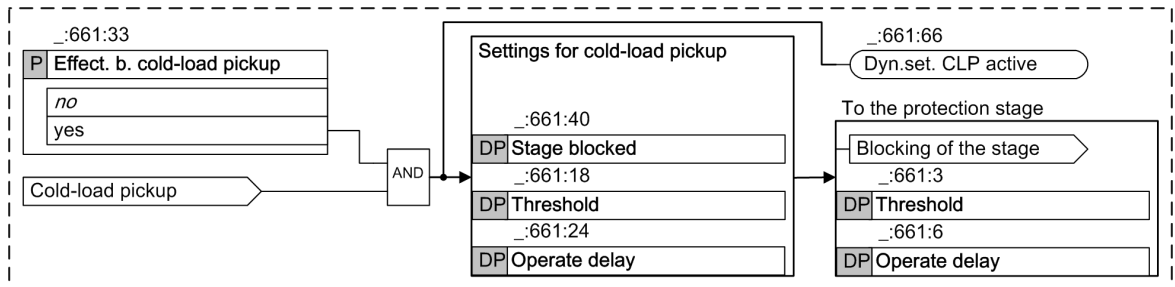

[to_ocp3kal_1_en_US]

Figure 6-20 Influence of the Cold-Load Pickup Detection on the Overcurrent-Protection Stage

In the case of cold-load pickup, you have the option to change the settings for the **Threshold** and **Operate delay** parameters of the protection stage. You can also block the stage. To do so, you must activate the influence of the cold-load pickup. You also have to set the **Threshold** and **Operate delay** or assign settings to **Stage blocked**, which take effect when the signal is active.

The way signals are generated **Cold-load pickup** is described in [5.10.1 Overview of Functions](#).

Link to an External *Function via a Binary Input Signal (Advanced Stage)*

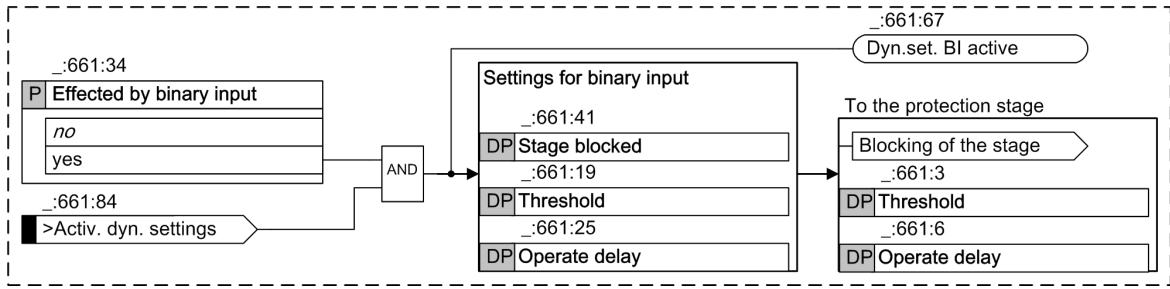

[lo_ocp3bin_1_en_US]

Figure 6-21 Influence of the Binary Input on the Overcurrent-Protection Stage

You can use the binary input signal **>Activ. dyn. settings** to change the settings for the **Threshold** and the **Operate delay** parameters of the protection stage. You can also block the stage. To do so, you must activate the influence of the binary input. You also have to set the **Threshold** and **Operate delay** or assign settings to **Stage blocked**, which take effect when the signal is active.

6.3.8.2 Application and Setting Notes (Advanced Stage)

6.4 Voltage-Dependent Overcurrent Protection, Phases

6.4.1 Overview of Functions

The **Voltage-dependent overcurrent protection** (ANSI 51V) function:

- Detects short circuits affecting electric equipment
- Can be used for special network conditions where the overcurrent pickup level should be decreased depending on the fault voltage
- Can be used for generators where the excitation voltage is derived from the machine terminals and the overcurrent pickup should be kept depending on the fault voltages

6.4.2 Structure of the Function

The **Voltage-dependent overcurrent protection** function is used in protection function groups with 3-phase current and voltage measurement.

The function **Voltage-dependent overcurrent protection** comes with the following factory-set stages:

- Inverse-time overcurrent protection, voltage-dependent stage
- Definite-time overcurrent protection, undervoltage seal-in stage

In this function, the following stages can operate simultaneously:

- A maximum of 2 inverse-time overcurrent protection, voltage-dependent stages
- A maximum of 2 inverse-time overcurrent protection, voltage-released stages
- A maximum of 2 definite-time overcurrent protection, undervoltage seal-in stages
- A maximum of 2 definite-time overcurrent protection, voltage-released undervoltage seal-in stages

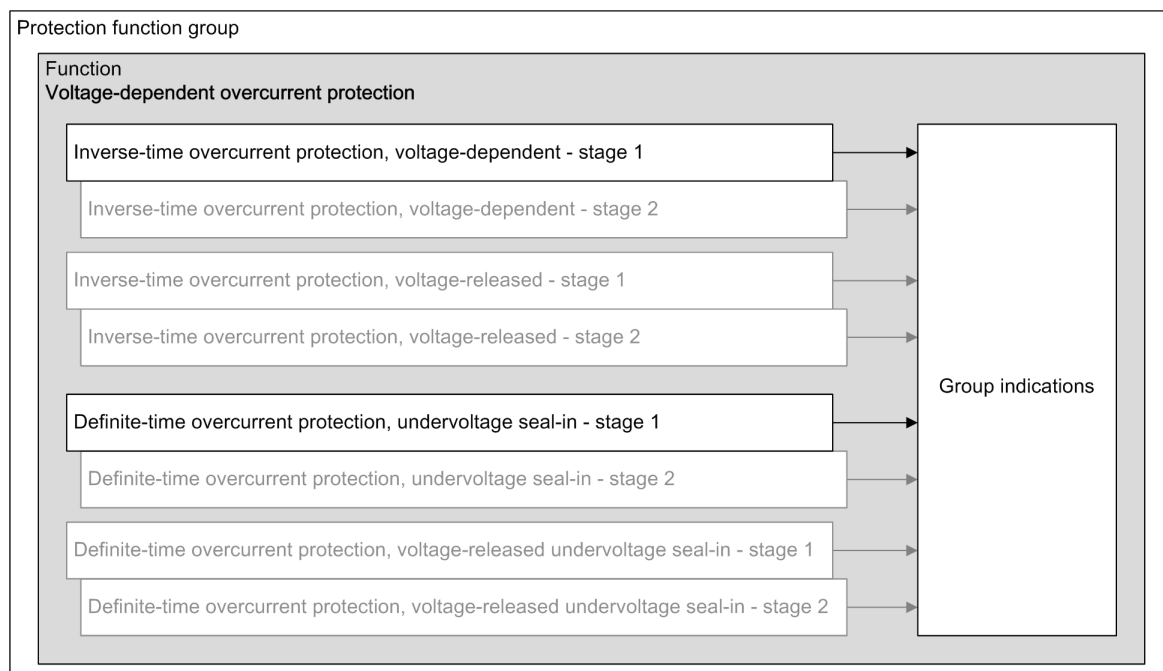

[dw_stuvol_release_3_en_US]

Figure 6-22 Structure/Embedding of the Function

6.4.3 Stage with Inverse-Time Overcurrent Protection, Voltage-Dependent

6.4.3.1 Description

Logic of the Stage

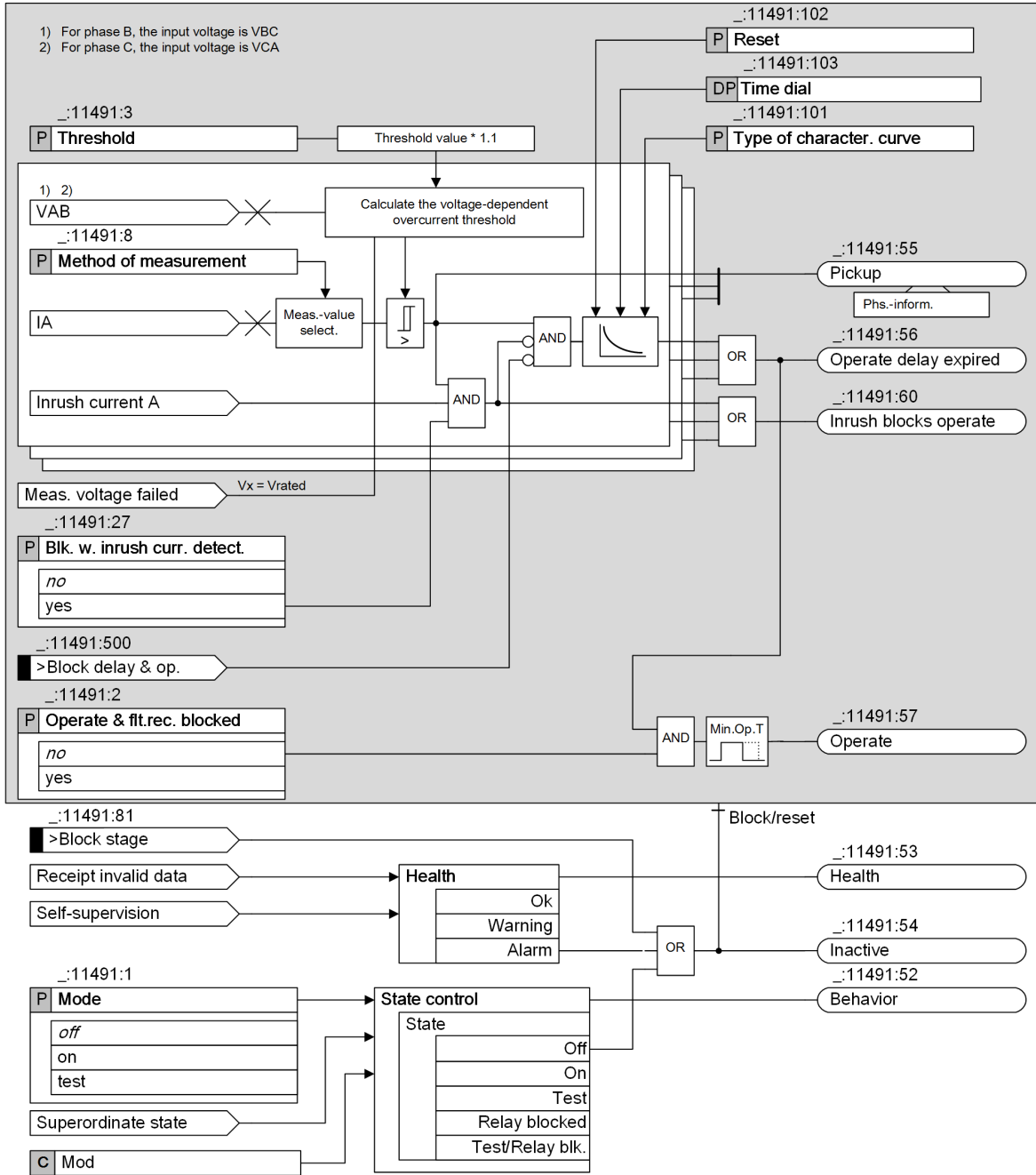

[file_ocp_volt-dependent_3_en_US]

Figure 6-23 Logic Diagram of the Inverse-Time Overcurrent Protection, Voltage-Dependent

Method of Measurement

You use the **Method of measurement** parameter to define whether the stage uses the *fundamental comp.* (standard method) or the calculated *RMS value*.

- Measurement of the fundamental comp.:
This method of measurement processes the sampled current values and filters out the fundamental component numerically.
- Measurement of the RMS value:
This method of measurement determines the current amplitude from the sampled values according to the defining equation of the RMS value. Harmonics are included in the analysis.

Voltage-Dependent Pickup Threshold

The pickup threshold of the overcurrent stage depends on the voltage magnitude. A lower voltage decreases the current pickup value (see [Figure 6-24](#)). In the range between $V/V_{rated} = 1.00$ to 0.25 a linear, directly proportional dependence is realized.

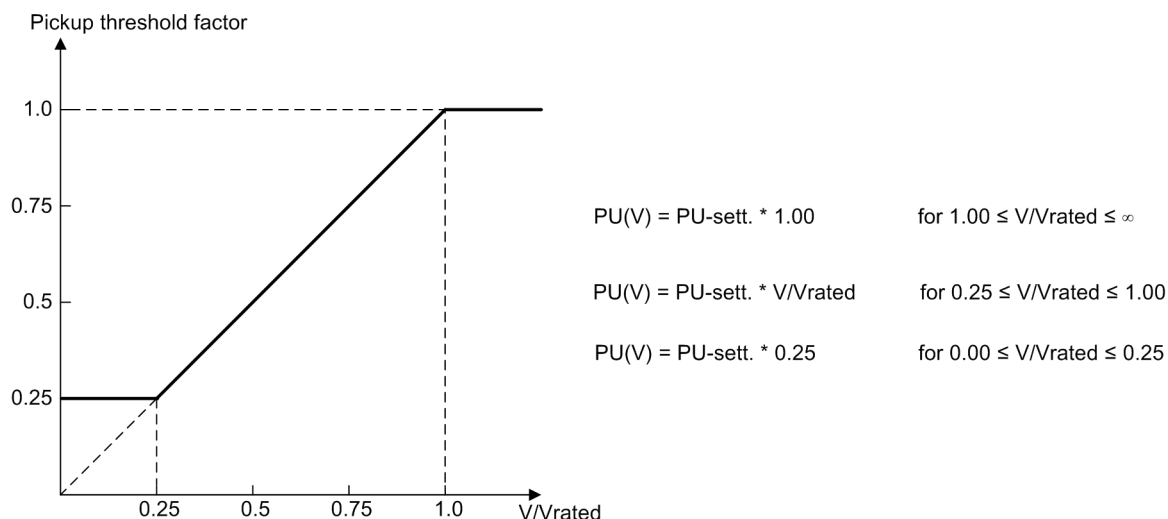

[dw_volpic_1_en_US]

Figure 6-24 Voltage Influence of the Pickup Threshold

With:

- V = Measured phase-to-phase voltage
- V_{rated} = Rated voltage (parameter Rated voltage in the function block General of the protection function group)
- PU sett. = Pickup threshold setting (parameter address: _11491:3)
- PU(V) = Applied pickup threshold according to the voltage influence

The minimum current pickup threshold value is $0.03 * I_{rated}$. This value cannot be decreased any further even not by voltage-dependent pickup threshold factor.

Decreasing the pickup threshold is carried out phase-selectively. The following table shows the assignment of voltages to current-carrying phases.

Table 6-1 Controlling Voltages in Relation to the Fault Current

Current	Controlling Voltage
I_A	V_{AB}
I_B	V_{BC}
I_C	V_{CA}

Pickup and Dropout Behaviors of the Inverse-Time Characteristic Curve According to IEC and ANSI

When the input variable exceeds the threshold value by a factor of 1.1, the inverse-time characteristic curve is processed. An integrating method of measurement summarizes the weighted time. The weighted time results

from the characteristic curve. For this, the time that is associated with the present current value is determined from the characteristic curve. Once the weighted time exceeds the value 1, the stage operates.

When the measured value falls below the pickup value by a factor of 1.045 (0.95 · 1.1 · threshold value), the dropout is started. The pickup will be indicated as clearing. You can influence the dropout behavior via setting parameters. You can select between instantaneous dropout (totalized time is deleted) or dropout according to the characteristic curve (reduction of totalized time depending on the characteristic curve). The dropout according to characteristic curve (disk emulation) is the same as turning back a rotor disk. The weighted reduction of the time is initiated from 0.9 of the set threshold value.

The characteristic curve and associated formulas are shown in the Technical Data.

Influence On the Operate Curve

The current pickup threshold is decreased proportional to the voltage decrease. Consequently, for a constant current I the I/Threshold-value ratio is increased and the operate time is reduced. Compared with the standard curves represented in the **Technical Data**, the operate curve shifts to the left side as the voltage decreases.

Measuring-Voltage Failure Detection

In case of a measuring-voltage failure detection the input voltage value is automatically set to V_{rated} , so that the pickup threshold factor will be 1.

Blocking of the Time Delay

You can use the binary input signal *>Block delay & op.* to prevent the start of the time delay and thus also the operate signal. A running time delay is reset. The pickup is indicated and the fault logging and recording takes place.

Blocking of the Operate Delay and the Operate Signal via the Device-Internal Inrush-Current Detection Function

Blocking of the operate delay and the operate signal via the device-internal **Inrush-current detection** function is described in chapter [6.3.7.1 Description](#).

6.4.3.2 Application and Setting Notes

Parameter: **Blk. w. inrush curr. detect.**

- Default setting (`_:11491:27`) **Blk. w. inrush curr. detect. = no**

Parameter Value	Description
<i>no</i>	The transformer inrush-current detection does not affect the stage. Select this setting in the following cases: <ul style="list-style-type: none"> • In cases where the device is not used on transformers. • In cases where the device is used on transformers and the threshold value of the stage is set above the maximum inrush current of the transformer. This applies, for example, to the high-current stage that is set according to the short-circuit voltage u_k of the transformer in such a way that the stage only picks up on faults from the high-voltage side. The transformer-inrush current cannot become larger than the maximum transmittable short-circuit current.
<i>yes</i>	When the transformer inrush-current detection detects an inrush current that would lead to a tripping of the stage, the start of the time delay and tripping of the stage are blocked. Select this setting if the device is used on transformers and the threshold value of the stage is set below the maximum inrush current of the transformer. This applies to the overcurrent-protection stage, which is used as a backup stage with grading time for faults on the undervoltage side of the transformer.

Parameter: Method of measurement

- Recommended setting value (**_:11491:8**) **Method of measurement** = *fundamental comp.*

With the **Method of measurement** parameter, you define whether the stage uses the *fundamental comp.* (standard method) or the calculated *RMS value*.

Parameter Value	Description
<i>fundamental comp.</i>	Select this method of measurement if harmonics or transient current peaks are to be suppressed. Siemens recommends using this method as the standard method.
<i>RMS value</i>	Select this method of measurement if you want the stage to take harmonics into account (for example, at capacitor banks). Consider that aperiodic DC components present in the secondary circuit are measured and can cause an overfunction. For this method of measurement, do not set the threshold value of the stage to less than $0.1 I_{rated,sec}$. If currents from more than one measuring point are added up in the current interface of a function group, the setting value should not be set lower than $0.1 I_{rated,sec}$ multiplied by the number of added currents.

Parameter: Threshold

- Default setting (**_:11491:3**) **Threshold** = *1.500 A*

The recommended setting value of 1.500 A is suitable for most applications.

Set the **Threshold** and **Type of character. curve** parameters for the specific application.

The setting depends on the maximum occurring operating current. Pickup by overload must be excluded since overcurrent protection operates with short tripping times as short-circuit protection and not as overload protection.

Set the **Threshold** parameter for lines to approx. 10 %, for transformers and motors to approx. 20 % above the maximum expected load.

Note that a safety margin is set between pickup value and threshold value. The stage only picks up at approx. 10 % above the **Threshold**.

Parameter Type of character. curve

- Default setting (**_:11491:101**) **Type of character. curve** = *IEC normal inverse*

The device offers all the usual inverse-time characteristic curves according to IEC and ANSI. Select the **Type of character. curve** required for your specific application.

Parameter: Reset

- Default setting (**_:11491:102**) **Reset** = *disk emulation*

The **Reset** parameter allows you to define whether the stage decreases according to the dropout characteristic curve (behavior of a disk emulation = rotor disc) or instantaneously.

Parameter Value	Description
<i>disk emulation</i>	Select this setting if the device is coordinated with electromechanical devices or other devices which perform a dropout after a disk emulation.
<i>instantaneous</i>	Select this setting if the dropout does not have to be performed after a disk emulation and an instantaneous dropout is desired instead.

Parameter: Time dial

- Default setting (**_:11491:103**) **Time dial** = *1*

You can use the **Time dial** parameter to displace the characteristic curve in the time direction.

The setting value for the **Time dial** parameter is derived from the time-grading chart that has been prepared for the electrical power system.
 Where no time grading and therefore no displacement of the characteristic curve is required, leave the parameter **Time dial** at 1 (default setting).

6.4.3.3 Settings

Addr.	Parameter	C	Setting Options	Default Setting
V-dependent 1				
_:11491:1	V-dependent 1:Mode		<ul style="list-style-type: none"> off on test 	off
_:11491:2	V-dependent 1:Operate & flt.rec. blocked		<ul style="list-style-type: none"> no yes 	no
_:11491:27	V-dependent 1:Blk. w. inrush curr. detect.		<ul style="list-style-type: none"> no yes 	no
_:11491:8	V-dependent 1:Method of measurement		<ul style="list-style-type: none"> fundamental comp. RMS value 	fundamental comp.
_:11491:3	V-dependent 1:Threshold	1 A @ 100 Irated	0.030 A to 35.000 A	1.500 A
		5 A @ 100 Irated	0.15 A to 175.00 A	7.50 A
		1 A @ 50 Irated	0.030 A to 35.000 A	1.500 A
		5 A @ 50 Irated	0.15 A to 175.00 A	7.50 A
		1 A @ 1.6 Irated	0.001 A to 1.600 A	1.500 A
		5 A @ 1.6 Irated	0.005 A to 8.000 A	7.500 A
_:11491:101	V-dependent 1:Type of character. curve			
_:11491:102	V-dependent 1:Reset		<ul style="list-style-type: none"> instantaneous disk emulation 	disk emulation
_:11491:103	V-dependent 1:Time dial		0.05 to 15.00	1.00

6.4.3.4 Information List

No.	Information	Data Class (Type)	Type
Group indicat.			
_:4501:55	Group indicat.:Pickup	ACD	O
_:4501:57	Group indicat.:Operate	ACT	O
_:4501:52	Group indicat.:Behavior	ENS	O
_:4501:53	Group indicat.:Health	ENS	O
V-dependent 1			
_:11491:81	V-dependent 1:>Block stage	SPS	I
_:11491:500	V-dependent 1:>Block delay & op.	SPS	I
_:11491:51	V-dependent 1:Mode (controllable)	ENC	C
_:11491:54	V-dependent 1:Inactive	SPS	O
_:11491:52	V-dependent 1:Behavior	ENS	O
_:11491:53	V-dependent 1:Health	ENS	O
_:11491:60	V-dependent 1:Inrush blocks operate	ACT	O
_:11491:59	V-dependent 1:Disk emulation running	SPS	O
_:11491:55	V-dependent 1:Pickup	ACD	O

No.	Information	Data Class (Type)	Type
_:11491:56	V-dependent 1:Operate delay expired	ACT	O
_:11491:57	V-dependent 1:Operate	ACT	O

6.4.4 Stage with Inverse-Time Overcurrent Protection, Voltage-Released

6.4.4.1 Description

Logic of the Stage

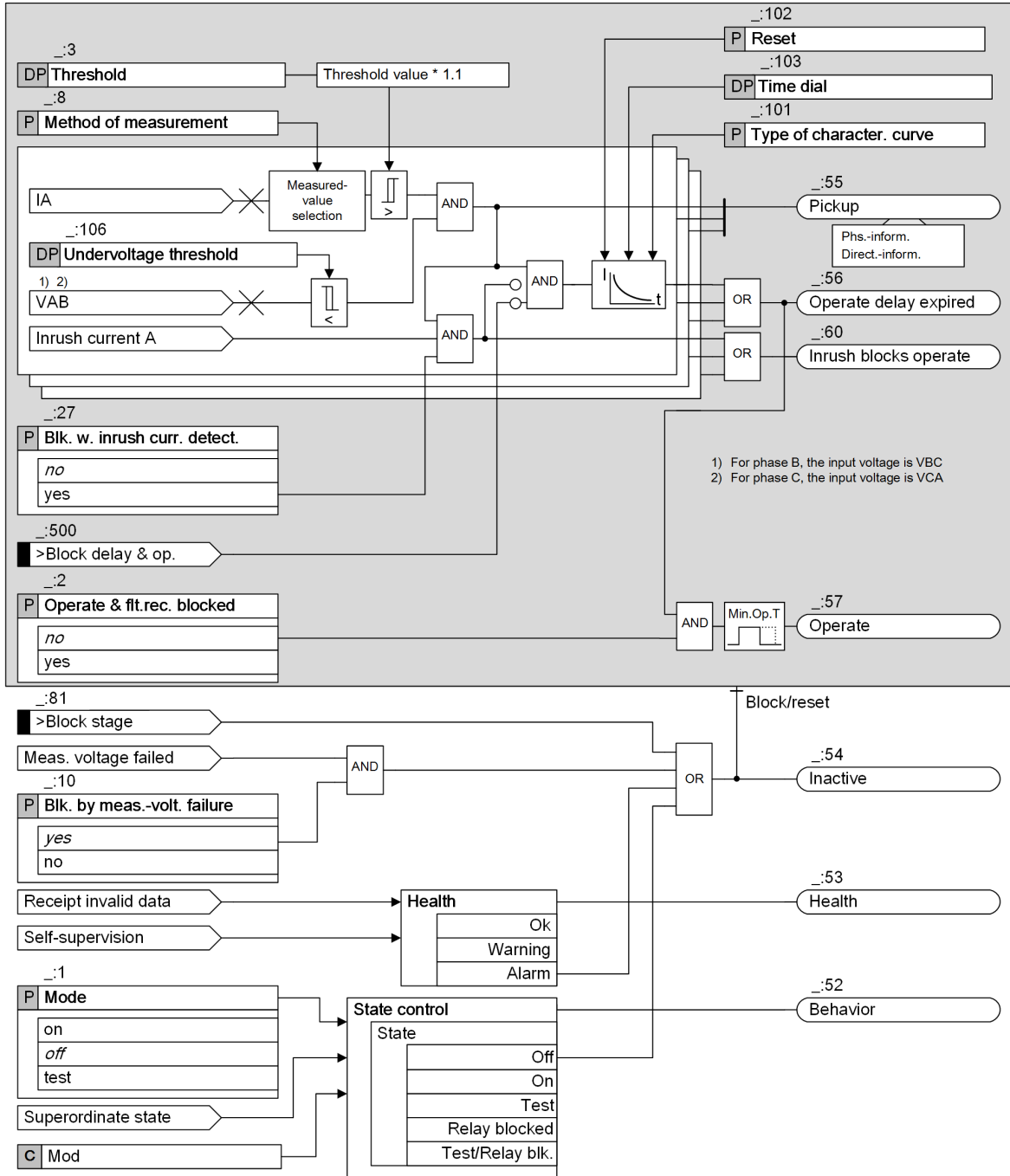

[lo_ocp_volt-release_3_en_US]

Figure 6-25 Logic Diagram of the Inverse-Time Overcurrent Protection, Voltage-Released

This stage is structured in the same way as the Inverse-time overcurrent, voltage-dependent stage. The only differences are the conditions for the pickup and the influence on the operate curve.

Measuring-Element Release

When the controlling voltage drops below the setting **Undervoltage threshold**, the respective measuring element is released.

The release of the measuring elements is carried out phase-selectively. The assignment of voltages to current-carrying phases is shown in [Figure 6-24](#).

Blocking of the Stage with Measuring-Voltage Failure

The stage can be blocked if a measuring-voltage failure occurs. In case of a blocking, the picked up stage is reset. The following blocking options are available for the stage:

- From an internal source upon pickup of the **Measuring-voltage failure detection** function
- From an external source via the binary input signal *>Open* of the function block **Volt.-transf. c. b.**, which links in the tripping of the voltage-transformer circuit breaker

The **Blk. by meas.-volt. failure** parameter can be set so that measuring-voltage failure detection blocks the stage or does not block it.

6.4.4.2 Application and Setting Notes

This stage is structured in the same way as the **Inverse-time overcurrent, voltage-dependent** stage. The only differences are the conditions for the pickup and the influence on the operate curve. This chapter only provides the application and setting notes for the setting **Blk. by meas.-volt. failure** and **Undervoltage threshold**.

Parameter: **Blk. by meas.-volt. failure**

- Recommended setting value (**_:10**) **Blk. by meas.-volt. failure = yes**

You can use the **Blk. by meas.-volt. failure** parameter to control the response of the stage when a measuring-voltage failure is detected.

A measuring-voltage failure can only be detected if one of the following 2 conditions is met:

- The device-internal **Measuring-voltage failure detection** function is configured and switched on.
- The binary input signal *>Open* of the function block **Voltage-transformer circuit breaker** is connected to the voltage-transformer circuit breaker.

Parameter Value	Description
no	The overcurrent-protection stage is not blocked when a measuring-voltage failure is detected.
yes	The overcurrent-protection stage is blocked when a measuring-voltage failure is detected. Siemens recommends using the default setting, as correct operation of the stage cannot be guaranteed if a measuring-voltage failure occurs.

Parameter: **Undervoltage threshold**

- Default setting (**_:104**) **Undervoltage threshold = 75.0 V**

When the controlling voltage is below the set value, the **Inverse-time overcurrent protection** stage is released.

The parameter is set to a value just below the lowest phase-to-phase voltage admissible during operation, for example, from 75 % to 80 % of V_{rated} .

6.4.4.3 Settings

Addr.	Parameter	C	Setting Options	Default Setting
V-release #				
_:1	V-release #:Mode		<ul style="list-style-type: none"> off on test 	off
_:2	V-release #:Operate & flt.rec. blocked		<ul style="list-style-type: none"> no yes 	no
_:10	V-release #:Blk. by meas.-volt. failure		<ul style="list-style-type: none"> no yes 	yes
_:27	V-release #:Blk. w. inrush curr. detect.		<ul style="list-style-type: none"> no yes 	no
_:8	V-release #:Method of measurement		<ul style="list-style-type: none"> fundamental comp. RMS value 	fundamental comp.
_:3	V-release #:Threshold	1 A @ 100 Irated	0.030 A to 35.000 A	1.500 A
		5 A @ 100 Irated	0.15 A to 175.00 A	7.50 A
		1 A @ 50 Irated	0.030 A to 35.000 A	1.500 A
		5 A @ 50 Irated	0.15 A to 175.00 A	7.50 A
		1 A @ 1.6 Irated	0.001 A to 1.600 A	1.500 A
		5 A @ 1.6 Irated	0.005 A to 8.000 A	7.500 A
_:101	V-release #:Type of character. curve		<ul style="list-style-type: none"> ANSI long-time inv. ANSI short-time inv. ANSI extremely inv. ANSI very inverse ANSI normal inverse ANSI moderately inv. ANSI definite inverse IEC normal inverse IEC very inverse IEC extremely inv. IEC long-time inverse 	IEC normal inverse
_:102	V-release #:Reset		<ul style="list-style-type: none"> instantaneous disk emulation 	disk emulation
_:103	V-release #:Time dial		0.05 to 15.00	1.00
_:104	V-release #:Under-voltage threshold		0.300 V to 175.000 V	75.000 V

6.4.4.4 Information List

No.	Information	Data Class (Type)	Type
V-release #			
_:81	V-release #:>Block stage	SPS	I
_:500	V-release #:>Block delay & op.	SPS	I
_:54	V-release #:Inactive	SPS	O
_:52	V-release #:Behavior	ENS	O
_:53	V-release #:Health	ENS	O

No.	Information	Data Class (Type)	Type
_:60	V-release #:Inrush blocks operate	ACT	O
_:59	V-release #:Disk emulation running	SPS	O
_:55	V-release #:Pickup	ACD	O
_:56	V-release #:Operate delay expired	ACT	O
_:57	V-release #:Operate	ACT	O

6.4.5 Stage with Definite-Time Overcurrent Protection, Undervoltage Seal-In

6.4.5.1 Description

Logic of the Stage

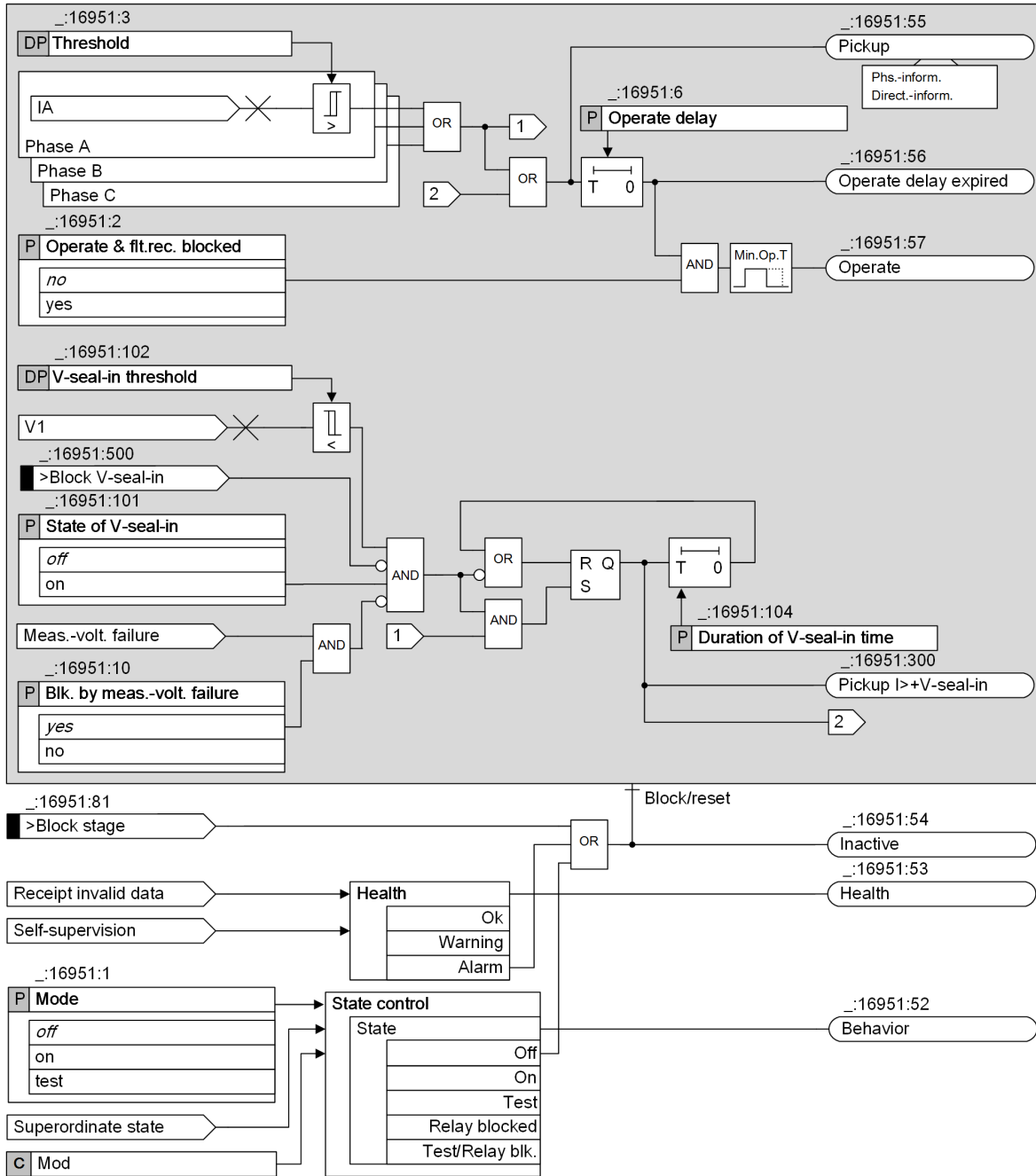

[file_seal-in, 3, en_US]

Figure 6-26 Logic Diagram of the Definite-Time Overcurrent Protection, Undervoltage Seal-in

Undervoltage Seal-In

In generators where the excitation voltage is derived from the machine terminals, the short-circuit current decreases quickly in the event of close-in faults (for example, in a generator or a generator-transformer range). The current decreases to a value below the current threshold within a few seconds because of the

absence of the excitation voltage. To avoid a dropout of the relay, the positive-sequence voltages are used as an additional criterion for detecting a short circuit.

The pickup signal is maintained for a settable seal-in time **Duration of V-seal-in time**, if the positive-sequence voltage falls below a settable threshold **V-seal-in threshold** after an overcurrent pickup, even if the current falls below the threshold again. If the voltage recovers before the seal-in time has elapsed, or if the undervoltage seal-in is blocked via a binary input **>Block V-seal-in**, the signal **Pickup I>V-seal-in** drops out immediately.

You can switch off the undervoltage seal-in via the parameter **State of V-seal-in**.

Blocking of the Undervoltage Seal-in with Measuring-Voltage Failure

The **Undervoltage seal-in** can be blocked if a measuring-voltage failure occurs. In case of a blocking, the pickup signal **Pickup I>V-seal-in** drops out immediately. The following blocking options are available for the **Undervoltage seal-in**:

- From an internal source upon pickup of the **Measuring-voltage failure detection** function.
- From an external source via the binary input signal **>Open** of the function block **VT miniature CB**, which links in the tripping of the voltage-transformer circuit breaker.

The parameter **Blk. by meas.-volt. failure** can be used to control the measuring-voltage failure detection. The **Undervoltage seal-in** remains unaffected if the parameter **Blk. by meas.-volt. failure** is switched off.

6.4.5.2 Application and Setting Notes

Parameter: **Operate &flt.rec. blocked**

- Default setting (**_:16951:2**) **Operate &flt.rec. blocked = no**

With the parameter **Operate &flt.rec. blocked**, you can block the operate indication, the fault recording, and the fault log.

Parameter: **Threshold**

- Default setting (**_:16951:3**) **Threshold = 1.350 A**

The setting is mainly determined by the maximum operating current.

Pickup by overload must be excluded since the protection may trip if a short operate delay time is set. Set the **Threshold** parameter for generators to a value between 20 % and 30 %, for transformers and motors approx. 40 % above the expected peak load.

Parameter: **Operate delay**

- Default setting (**_:16951:6**) **Operate delay = 3.00 s**

The parameter **Operate delay** must be coordinated with the time grading of the network protection to guarantee the selectivity. Practical time delays are between 1 s to 2 s.

Parameter: **Blk. by meas.-volt. failure**

- Default setting (**_:16951:10**) **Blk. by meas.-volt. failure = yes**

With the parameter **Blk. by meas.-volt. failure**, you can activate (**yes**) or deactivate (**no**) the blocking by the **Measuring voltage failure detection** function. The recommended setting is the default setting.

Parameter: **State of V-seal-in**

- Default setting (**_:16951:101**) **State of V-seal-in = off**

With the parameter **State of V-seal-in**, the seal-in functionality can be activated (switched **on**). Siemens recommends this setting if the excitation transformer is connected to the main lead of the generator.

Parameter: V-seal-in threshold

- Default setting (`_:16951:102`) **V-seal-in threshold = 46.2 V**

The **V-seal-in threshold** (positive-sequence voltage) is set to a value below the lowest phase-to-phase voltage admissible during an operation, for example 80 % of the rated voltage of a generator. The positive-sequence voltage is evaluated. The practicable value for a voltage transformer with a rated secondary voltage of 100 V is 46.2 V.

The following table shows an example of a specification:

Threshold	1.4 * I _{rated, Gen}		
Operate delay	3.00 s		
Undervoltage seal-in	0.8 * V _{rated, Gen}		
Duration of V-seal-in time	4.00 s		
Dropout ratio	0.95		
Rated current I _{rated, Gen}	483 A	Rated voltage V _{rated, Gen}	6.3 kV
Rated current I _{rated, VT, prim}	500 A	Rated voltage V _{rated, VT, prim}	6.3 kV
Rated current I _{rated, VT, sec}	1 A	Rated voltage V _{rated, VT, sec}	100 V

The following secondary setting values result from this specification:

$$\text{Threshold} = \frac{1.4 \times I_{\text{rated, Gen}}}{I_{\text{rated, CT, prim}}} \times I_{\text{rated, VT, sec}} = \frac{1.4 \times 483 \text{ A}}{500 \text{ A}} \times 1 \text{ A} = 1.35 \text{ A}$$

[fo_ocp_uvsi_threshold, 1, en_US]

$$\text{Undervoltage seal-in} = \frac{0.8 \times V_{\text{rated, Gen}}}{V_{\text{rated, VT, prim}}} \times \frac{V_{\text{rated, VT, sec}}}{\sqrt{3}} = \frac{0.8 \times 6.3 \text{ kV}}{6.3 \text{ kV}} \times \frac{100 \text{ V}}{\sqrt{3}} = 46.200 \text{ V}$$

[fo_ocp_uvsi_seal-in, 1, en_US]

Parameter: Duration of V-seal-in time

- Default setting (`_:16951:104`) **Duration of V-seal-in time = 4.00 s**

The parameter **Duration of V-seal-in time** limits the pickup seal-in induced by an overcurrent or undervoltage. The value must be set higher than the value of the parameter **Operate delay**. The difference shall be greater than 0.5 s. In the default setting, a difference of 1 s is used.

6.4.5.3 Settings

Addr.	Parameter	C	Setting Options	Default Setting
V-seal-in 1				
<code>_:16951:1</code>	V-seal-in 1:Mode		<ul style="list-style-type: none"> • off • on • test 	off
<code>_:16951:2</code>	V-seal-in 1:Operate & flt.rec. blocked		<ul style="list-style-type: none"> • no • yes 	no
<code>_:16951:3</code>	V-seal-in 1:Threshold	1 A @ 100 I _{rated}	0.030 A to 35.000 A	1.350 A
		5 A @ 100 I _{rated}	0.15 A to 175.00 A	6.75 A
		1 A @ 50 I _{rated}	0.030 A to 35.000 A	1.350 A
		5 A @ 50 I _{rated}	0.15 A to 175.00 A	6.75 A
		1 A @ 1.6 I _{rated}	0.001 A to 1.600 A	1.350 A
		5 A @ 1.6 I _{rated}	0.005 A to 8.000 A	6.750 A
<code>_:16951:6</code>	V-seal-in 1:Operate delay		0.00 s to 60.00 s	3.00 s

Addr.	Parameter	C	Setting Options	Default Setting
_:16951:10	V-seal-in 1:Blk. by meas.-volt. failure		<ul style="list-style-type: none"> • no • yes 	yes
_:16951:101	V-seal-in 1:State of V-seal-in		<ul style="list-style-type: none"> • off • on 	off
_:16951:102	V-seal-in 1:V-seal-in threshold		0.300 V to 175.000 V	46.200 V
_:16951:104	V-seal-in 1:Duration of V-seal-in time		0.10 s to 60.00 s	4.00 s

6.4.5.4 Information List

No.	Information	Data Class (Type)	Type
V-seal-in 1			
_:16951:81	V-seal-in 1:>Block stage	SPS	I
_:16951:500	V-seal-in 1:>Block V-seal-in	SPS	I
_:16951:52	V-seal-in 1:Behavior	ENS	O
_:16951:53	V-seal-in 1:Health	ENS	O
_:16951:54	V-seal-in 1:Inactive	SPS	O
_:16951:55	V-seal-in 1:Pickup	ACD	O
_:16951:300	V-seal-in 1:Pickup I>+V-seal-in	SPS	O
_:16951:56	V-seal-in 1:Operate delay expired	ACT	O
_:16951:57	V-seal-in 1:Operate	ACT	O

6.4.6 Stage with Definite-Time Overcurrent Protection, Voltage-Released Undervoltage Seal-In

6.4.6.1 Description

Logic of the Stage

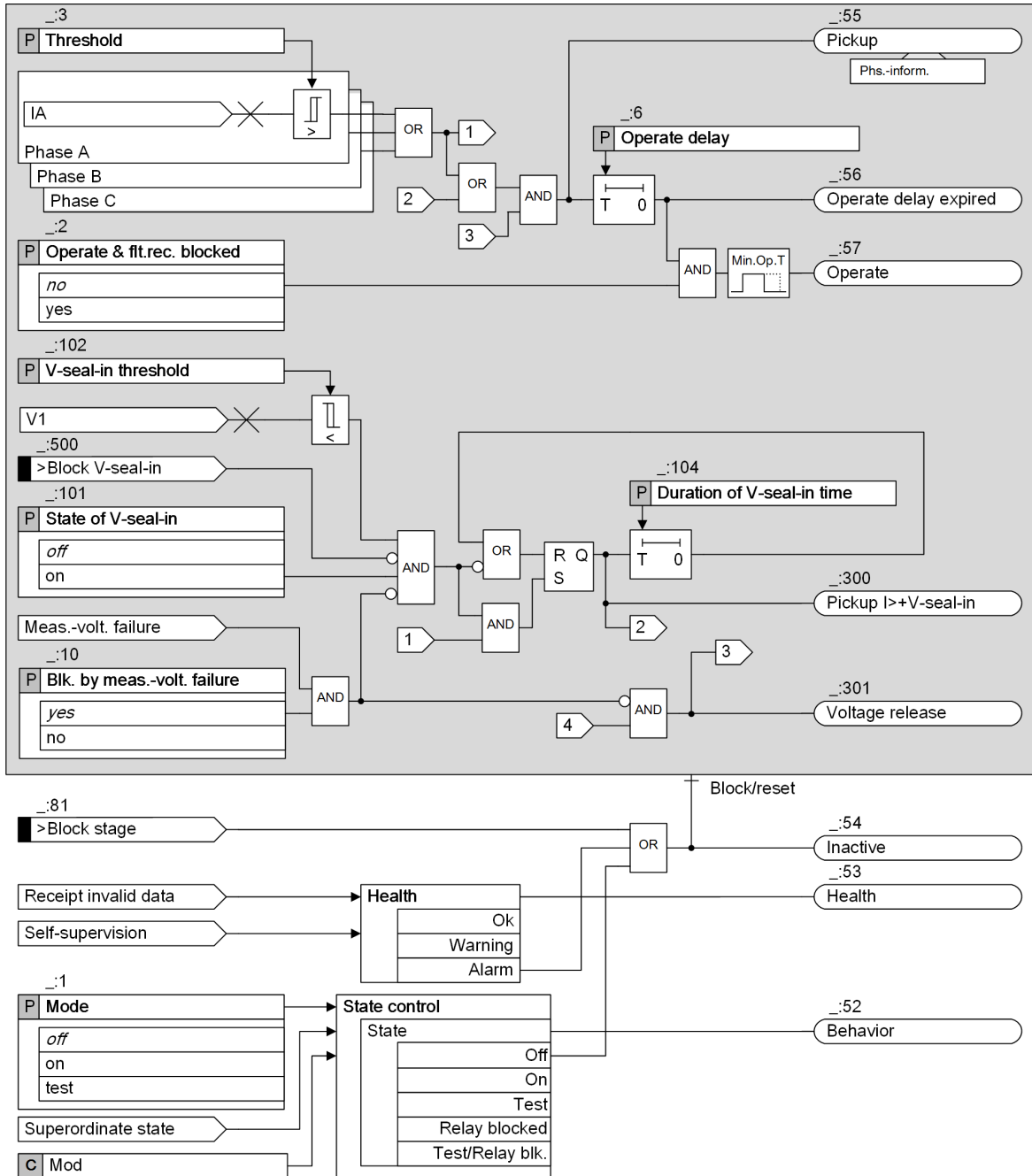

||lo_seal-in_rel_3_en_US|

Figure 6-27 Logic Diagram of the Definite-Time Overcurrent Protection, Voltage-Released Undervoltage Seal-in, Part 1

Signal 4 in the following figure refers to [Figure 6-27](#).

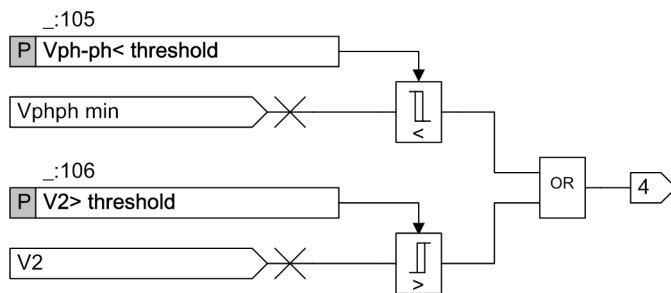

[to_seal-in_rei2, 1, en_US]

Figure 6-28 Logic Diagram of the Definite-Time Overcurrent Protection, Voltage-Released Undervoltage Seal-in, Part 2

Voltage Release

In addition to the current criterion with undervoltage seal-in, a voltage-released logic must be present to issue the indication *Pickup*. The voltage-released logic monitors the negative-sequence voltage and phase-to-phase voltages respectively for detecting unsymmetrical faults and symmetrical faults. With the voltage-released logic, the setting value of the parameter **Threshold** can be reduced in a certain range and the reliability and sensibility of this function can be improved correspondingly.

Undervoltage Seal-In

In generators where the excitation voltage is derived from the machine terminals, the short-circuit current decreases quickly in the event of close-in faults (for example, in a generator or a generator-transformer range). The current decreases to a value below the current threshold within a few seconds because of the absence of the excitation voltage. To avoid a dropout of the relay, the positive-sequence voltages are used as an additional criterion for detecting a short circuit.

The pickup signal is maintained for a settable seal-in time **Duration of V-seal-in time**, if the positive-sequence voltage falls below a settable threshold **V-seal-in threshold** after an overcurrent pickup, even if the current falls below the threshold again. If the voltage recovers before the seal-in time has elapsed, or if the undervoltage seal-in is blocked via a binary input **>Block V-seal-in**, the signal *Pickup I>V-seal-in* drops out immediately.

You can switch off the undervoltage seal-in via the parameter **State of V-seal-in**.

Blocking of the Undervoltage Seal-in with Measuring-Voltage Failure

The **Undervoltage seal-in** can be blocked if a measuring-voltage failure occurs. In case of a blocking, the pickup signal *Pickup I>V-seal-in* drops out immediately. The following blocking options are available for the **Undervoltage seal-in**:

- From an internal source upon pickup of the **Measuring-voltage failure detection** function.
- From an external source via the binary input signal **>Open** of the function block **VT miniature CB**, which links in the tripping of the voltage-transformer circuit breaker.

The parameter **Blk. by meas.-volt. failure** can be used to control the measuring-voltage failure detection. The **Undervoltage seal-in** remains unaffected if the parameter **Blk. by meas.-volt. failure** is switched off.

6.4.6.2 Application and Setting Notes

Parameter: Operate & flt.rec. blocked

- Default setting (_:2) **Operate & flt.rec. blocked** = no

With the parameter **Operate & flt.rec. blocked**, you can block the operate indication, the fault recording, and the fault log.

Parameter: Threshold

- Default setting (_:3) **Threshold = 1.350 A**

The setting is mainly determined by the maximum operating current.

Pickup by overload must be excluded since the protection may trip if a short operate delay time is set. Set the **Threshold** parameter for generators to a value between 20 % and 30 %, for transformers and motors approx. 40 % above the expected peak load.

Parameter: Operate delay

- Default setting (_:6) **Operate delay = 3.00 s**

The parameter **Operate delay** must be coordinated with the time grading of the network protection to guarantee the selectivity. Practical time delays are between 1 s to 2 s.

Parameter: Blk. by meas.-volt. failure

- Default setting (_:10) **Blk. by meas.-volt. failure = yes**

With the parameter **Blk. by meas.-volt. failure**, you can activate (**yes**) or deactivate (**no**) the blocking by the **Measuring voltage failure detection** function. The recommended setting is the default setting.

Parameter: State of V-seal-in

- Default setting (_:101) **State of V-seal-in = off**

With the parameter **State of V-seal-in**, the seal-in functionality can be activated (switched **on**). Siemens recommends this setting if the excitation transformer is connected to the main lead of the generator.

Parameter: V-seal-in threshold

- Default setting (_:102) **V-seal-in threshold = 46.2 V**

The **V-seal-in threshold** (positive-sequence voltage) is set to a value below the lowest phase-to-phase voltage admissible during an operation, for example 80 % of the rated voltage of a generator. The positive-sequence voltage is evaluated. The practicable value for a voltage transformer with a rated secondary voltage of 100 V is 46.2 V.

The following table shows an example of a specification:

Threshold	1.4 * I _{rated, Gen}		
Operate delay	3.00 s		
Undervoltage seal-in	0.8 * V _{rated, Gen}		
Duration of V-seal-in time	4.00 s		
Dropout ratio	0.95		
Rated current I _{rated, Gen}	483 A	Rated voltage V _{rated, Gen}	6.3 kV
Rated current I _{rated, VT, prim}	500 A	Rated voltage V _{rated, VT, prim}	6.3 kV
Rated current I _{rated, VT, sec}	1 A	Rated voltage V _{rated, VT, sec}	100 V

The following secondary setting values result from this specification:

$$\text{Threshold} = \frac{1.4 \times I_{\text{rated, Gen}}}{I_{\text{rated, CT, prim}}} \times I_{\text{rated, VT, sec}} = \frac{1.4 \times 483 \text{ A}}{500 \text{ A}} \times 1 \text{ A} = 1.35 \text{ A}$$

[fo_ocp_uvsi_threshold, 1, en_US]

$$\text{Undervoltage seal - in} = \frac{0.8 \times V_{\text{rated, Gen}}}{V_{\text{rated, VT, prim}}} \times \frac{V_{\text{rated, VT, sec}}}{\sqrt{3}} = \frac{0.8 \times 6.3 \text{ kV}}{6.3 \text{ kV}} \times \frac{100 \text{ V}}{\sqrt{3}} = 46.200 \text{ V}$$

[fo_ocp_uvsi_seal-in, 1, en_US]

Parameter: Duration of V-seal-in time

- Default setting (_:104) **Duration of V-seal-in time = 4.00 s**

The parameter **Duration of V-seal-in time** limits the pickup seal-in induced by an overcurrent or undervoltage. The value must be set higher than the value of the parameter **Operate delay**. The difference shall be greater than 0.5 s. In the default setting, a difference of 1 s is used.

Parameter: Vph-ph< threshold

- Default setting (_:105) **Vph-ph< threshold = 60.000 V**

With the parameter **Vph-ph< threshold**, you can set the threshold at which the output signal *voltage release* is activated when the minimum phase-to-phase voltage falls below this threshold.

Parameter: V2> threshold

- Default setting (_:106) **V2> threshold = 4.600 V**

With the parameter **V2> threshold**, you can set the threshold at which the output signal *voltage release* is issued when V2 exceeds the threshold.

6.4.6.3 Settings

Addr.	Parameter	C	Setting Options	Default Setting
Vseal-in+Vrel#				
_:1	Vseal-in+Vrel#:Mode		<ul style="list-style-type: none"> • off • on • test 	off
_:2	Vseal-in+Vrel#:Operate &flt.rec. blocked		<ul style="list-style-type: none"> • no • yes 	no
_:3	Vseal-in+Vrel#:Threshold	1 A @ 100 Irated	0.030 A to 35.000 A	1.350 A
		5 A @ 100 Irated	0.150 A to 175.000 A	6.750 A
		1 A @ 50 Irated	0.030 A to 35.000 A	1.350 A
		5 A @ 50 Irated	0.150 A to 175.000 A	6.750 A
		1 A @ 1.6 Irated	0.001 A to 1.600 A	1.350 A
		5 A @ 1.6 Irated	0.005 A to 8.000 A	6.750 A
_:6	Vseal-in+Vrel#:Operate delay		0.00 s to 60.00 s	3.00 s
_:10	Vseal-in+Vrel#:Blk. by meas.-volt. failure		<ul style="list-style-type: none"> • no • yes 	yes
_:101	Vseal-in+Vrel#:State of V-seal-in		<ul style="list-style-type: none"> • off • on 	off
_:102	Vseal-in+Vrel#:V-seal-in threshold		0.300 V to 175.000 V	46.200 V
_:104	Vseal-in+Vrel#:Duration of V-seal-in time		0.10 s to 60.00 s	4.00 s
_:105	Vseal-in+Vrel#:Vph-ph< threshold		0.300 V to 175.000 V	60.000 V
_:106	Vseal-in+Vrel#:V2> threshold		0.300 V to 200.000 V	4.600 V

6.4.6.4 Information List

No.	Information	Data Class (Type)	Type
<i>Vseal-in+Vrel#</i>			
_.81	Vseal-in+Vrel#:>Block stage	SPS	I
_.500	Vseal-in+Vrel#:>Block V-seal-in	SPS	I
_.52	Vseal-in+Vrel#:Behavior	ENS	O
_.53	Vseal-in+Vrel#:Health	ENS	O
_.54	Vseal-in+Vrel#:Inactive	SPS	O
_.55	Vseal-in+Vrel#:Pickup	ACD	O
_.300	Vseal-in+Vrel#:Pickup I>+V-seal-in	SPS	O
_.301	Vseal-in+Vrel#:Voltage release	SPS	O
_.56	Vseal-in+Vrel#:Operate delay expired	ACT	O
_.57	Vseal-in+Vrel#:Operate	ACT	O

6.5 Overcurrent Protection, Ground

6.5.1 Overview of Functions

The **Overcurrent protection, ground** function (ANSI 50N/51N):

- Detects short circuits in electrical equipment
- Can be used as backup or emergency overcurrent protection in addition to the main protection

6.5.2 Structure of the Function

6.5.3 General Functionality

6.5.3.1 Description

Measured-Value Selection

The function provides the option to select between the values *IN measured* or *3I0 calculated*.

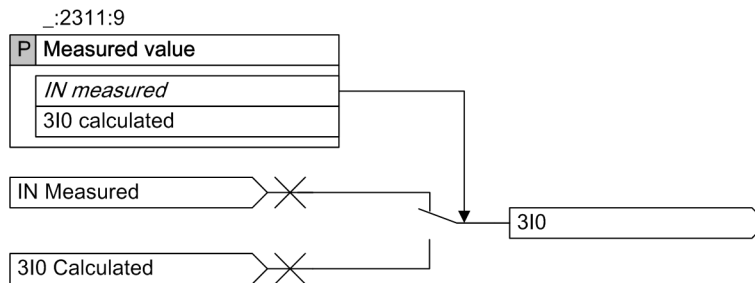

[to_meas_value_02_1_en_US]

Figure 6-29 Logic Diagram of Measured-Value Selection

Both options are only available for the current-transformer connection types **3-phase + IN** and **3-phase + IN-separate**. For other connection types respectively, only one option is possible. If you select an option that is not allowed, an inconsistency message is given.

Depending on the CT secondary rated current, the CT connection type, and the selected setting, the secondary threshold setting range varies according to the following table.

Table 6-2 Threshold Setting Range

Connection Type	Measured Value	CT Terminal Type	Threshold Setting Range (rated I-sec.: ph = 1 A, IN = 1 A)	Threshold Setting Range (rated I-sec.: ph = 1 A, IN = 5 A)	Threshold Setting Range (rated I-sec.: ph = 5 A, IN = 1 A)	Threshold Setting Range (rated I-sec.: ph = 5 A, IN = 5 A)
3ph + IN	3I0 calculated	4 * Protection	0.010 A to 40.000 A	N/A	N/A	0.050 A to 200.00 A
		4 * Measurement	0.001 A to 1.600 A	N/A	N/A	0.002 A to 8.000 A
	IN measured	4 * Protection	0.010 A to 40.000 A	N/A	N/A	0.050 A to 200.00 A
		4 * Measurement	0.001 A to 1.600 A	N/A	N/A	0.002 A to 8.000 A

3ph + IN-separate	3I0 calculated	4 * Protection	0.010 A to 40.000 A	0.010 A to 40.000 A	0.050 A to 200.00 A	0.050 A to 200.00 A
		3 * Protection, 1 * sen.	0.010 A to 40.000 A	0.010 A to 40.000 A	0.050 A to 200.00 A	0.050 A to 200.00 A
		4 * Measurement	0.001 A to 1.600 A	0.001 A to 1.600 A	0.002 A to 8.000 A	0.002 A to 8.000 A
	IN measured	4 * Protection	0.010 A to 40.000 A	0.050 A to 200.00 A	0.010 A to 40.000 A	0.050 A to 200.00 A
		3 * Protection, 1 * sen.	0.001 A to 1.600 A	0.002 A to 8.000 A	0.001 A to 1.600 A	0.002 A to 8.000 A
		4 * Measurement	0.001 A to 1.600 A	0.002 A to 8.000 A	0.001 A to 1.600 A	0.002 A to 8.000 A

6.5.3.2 Application and Setting Notes

Parameter: Measured value

- Recommended setting value **Measured value = IN Measured**

This parameter is not available in the basic function.

Parameter Value	Description
<i>IN Measured</i>	The function operates with the measured ground current IN. This is the recommended setting unless there is a specific reason to use the calculated zero-sequence current 3I0.
<i>3I0 Calculated</i>	The function operates with the calculated zero sequence current 3I0. This setting option can be used when applying a redundant 50N/51N function for safety reasons.

6.5.3.3 Settings

Addr.	Parameter	C	Setting Options	Default Setting
<i>General</i>				
_:2311:9	General:Measured value		<ul style="list-style-type: none"> 3I0 calculated IN measured 	IN measured

6.5.4 Stage with Definite-Time Characteristic Curve

6.5.4.1 Description

Logic of the Basic Stage

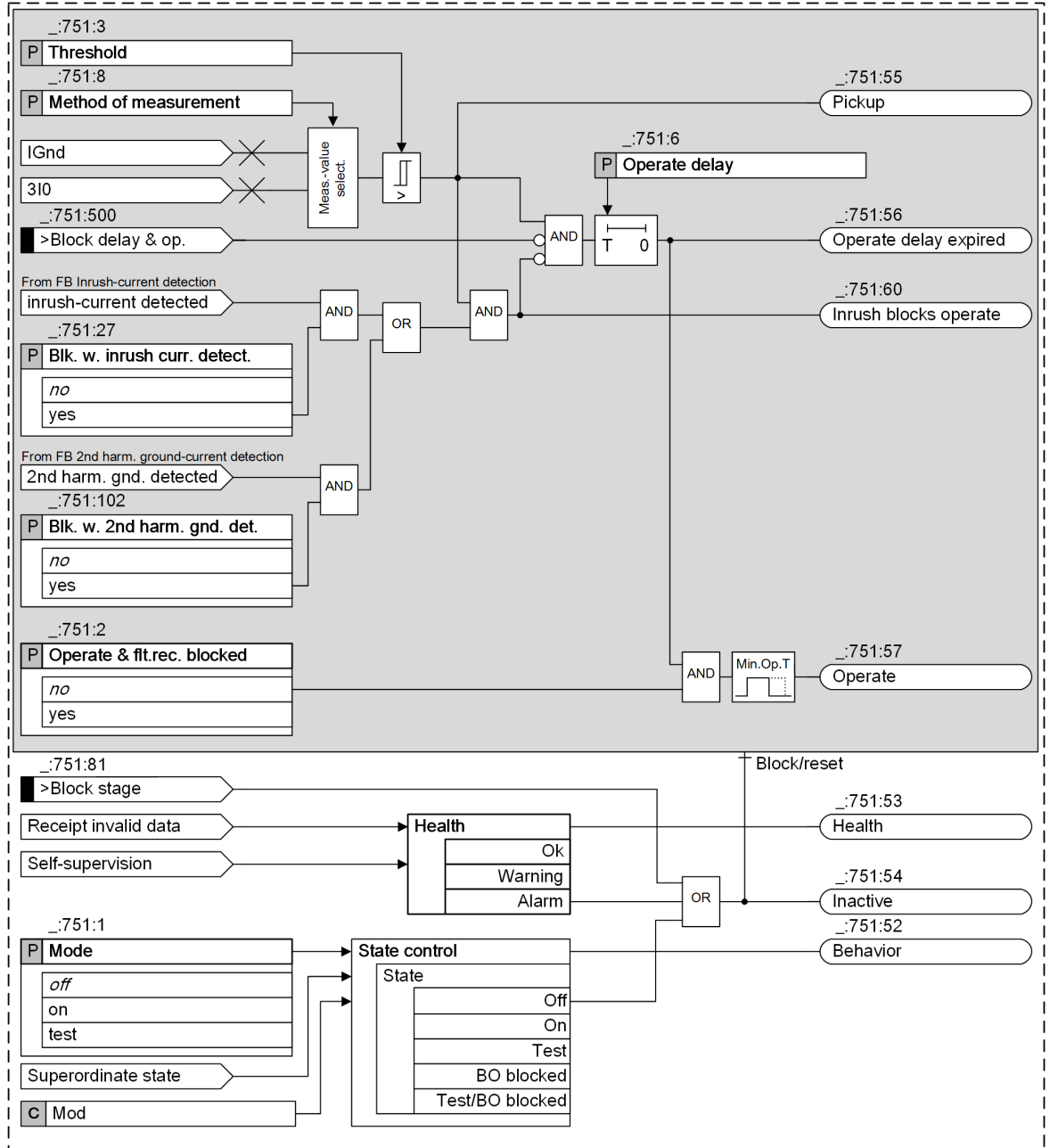

[to_occup_gb1, 4, en_US]

Figure 6-30 Logic Diagram Definite-Time Overcurrent Protection (Ground) – Basic

Logic of the Advanced Stage

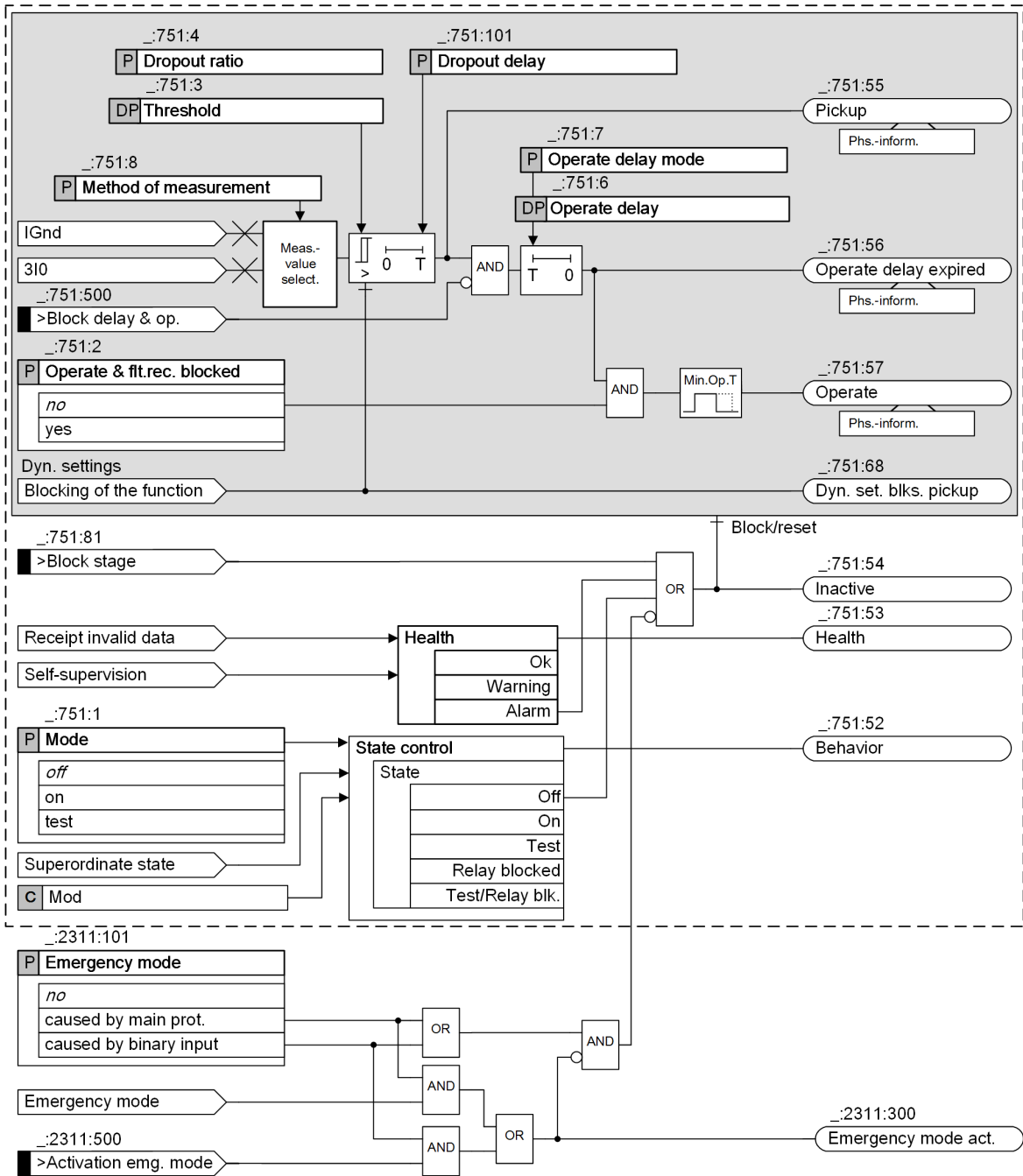

[lo_ocp_gr1_4_en_US]

Figure 6-31 Logic Diagram Definite-Time Overcurrent Protection (Ground) – Advanced

Emergency mode (Advanced Stage)

You use the **Emergency mode** parameter to define whether the stage operates as emergency overcurrent protection or as backup overcurrent protection. With the setting **Emergency mode = caused by main prot.**, emergency overcurrent protection starts automatically when the main protection fails. This happens, for example, in the case of distance protection when a short circuit occurs in the voltage-transformer secondary circuit, when the voltage-transformer secondary circuit is disconnected or in the case of line differential protection where protection communication is disconnected. This means that the emergency mode replaces

the main protection as short-circuit protection. With the appropriate parameterization (**Emergency mode = caused by binary input**), the emergency mode can also be activated from an external source. If the overcurrent protection is set as backup overcurrent protection (parameter **Emergency mode = no**), it operates independently of the main protection and thus in parallel. Backup overcurrent protection can also serve as sole short-circuit protection when, for example, no voltage transformers are available for an initial startup.

Method of Measurement (Basic and Advanced Stage)

You use the **Method of measurement** parameter to define whether the stage uses the *fundamental comp.* or the calculated *RMS value*.

- Measurement of the fundamental component:
This method of measurement processes the sampled current values and filters out the fundamental component numerically.
- Measurement of the RMS value:
This method of measurement determines the current amplitude from the sampled values according to the defining equation of the RMS value. Harmonics are included in the analysis.

Dropout Delay (Advanced Stage)

If the current falls below the dropout threshold, the dropout can be delayed for the time specified by the parameter **Dropout delay**. During the dropout delay, the pickup is maintained. Meanwhile, the operate delay continues to run (parameter **Operate delay mode = Running dur. DO-delay**) or is frozen (parameter **Operate delay mode = Frozen dur. DO-delay**). If the operate delay expires while the pickup is still maintained, the stage operates.

Blocking of the Stage (Basic and Advanced Stage)

The following blockings reset the picked up stage completely:

- Via the binary input signal **>Block stage** from an external or internal source
- Via the functionality of the **dynamic settings** (see **Influence of other functions via dynamic settings** and [6.5.8.1 Description](#)).

Blocking of the Time Delay (Basic and Advanced Stage)

You can use the binary input signal **>Block delay & op.** to prevent the start of the time delay and thus also the operate signal. A running time delay is reset. The pickup is indicated and the fault logging and recording takes place.

Blocking of the Operate Delay and the Operate Signal via the Device-Internal Inrush-Current Detection Function (Basic and Advanced Stage)

Blocking of the operate delay and the operate signal via the device-internal **Inrush-current detection** function is described in [6.5.7.1 Description](#).

6.5.4.2 Application and Setting Notes

Parameter: **Method of measurement**

- Recommended setting value (**_ : 751 : 8**) **Method of measurement = fundamental comp.**

With the **Method of measurement** parameter, you define whether the stage uses the *fundamental comp.* (standard method) or the calculated *RMS value*.

Parameter Value	Description
<i>fundamental comp.</i>	Select this method of measurement if harmonics or transient current peaks are to be suppressed. Siemens recommends using this method as the standard method.
<i>RMS value</i>	Select this method of measurement if you want the stage to take harmonics into account (for example, at capacitor banks). Consider that aperiodic DC components present in the secondary circuit are measured and can cause an overfunction. For this method of measurement, do not set the threshold value of the stage to less than $0.1 I_{rated,sec}$. If currents from more than one measuring point are added up in the current interface of a function group, the setting value should not be set lower than $0.1 I_{rated,sec}$ multiplied by the number of added currents.

Parameter: Operate delay mode

- Default setting (`_:661:7`) **Operate delay mode = Running dur. DO-delay**

This parameter is not visible in the basic stage.

With the parameter **Operate delay mode**, you specify whether the operate delay continues to run or is frozen during the dropout delay.

This setting is only valid if the parameter **Dropout delay** is not 0.

Parameter Value	Description
<i>Running dur. DO-delay</i>	During the dropout delay, the operate delay continues to run.
<i>Frozen dur. DO-delay</i>	During the dropout delay, the operate delay is frozen. If the current exceeds the threshold value again, the operate delay continues to run.

Parameter: Threshold, Operate delay

- Default setting (`_:751:3`) **Threshold = 1.20 A** (for the first stage)
- Default setting (`_:751:6`) **Operate delay = 0.300 s** (for the first stage)

Set the **Threshold** and **Operate delay** parameters for the specific application.

The following details apply to a 2-stage characteristic curve (1st stage = definite-time overcurrent protection stage and 2nd stage = high-current stage).

1st stage (overcurrent stage):

The setting depends on the minimal occurring ground-fault current. This must be determined.

For very small ground-fault currents, Siemens recommends using the **Ground-fault protection against high-resistance ground faults in grounded systems** function.

The **Operate delay** to be set is derived from the time-grading schedule that has been prepared for the system. Where overcurrent protection is used in emergency mode, shorter time delays might be reasonable (one grading time above fast tripping), since the emergency mode only operates if the main protection function fails.

2nd stage (high-current stage):

This tripping stage can also be used for current grading. This applies in the case of very long lines with low source impedance or ahead of high reactances (for example, transformers, shunt reactors). Set the **Threshold** parameter to ensure that the stage does not pick up in case of a short-circuit at the end of the line.

Set the **Operate delay** parameter to 0 or to a low value.

Siemens recommends that the threshold values be determined with a system analysis. The following example illustrates the principle of grading with a current threshold on a long line.

EXAMPLE

High-current stage: 110-kV overhead line, 150 mm² cross-section

s (length) = 60 km

Z_L/s = 0.46 Ω/km

Ratio of zero-sequence impedance and positive-sequence impedance of the line: $Z_{L0}/Z_{L1} = 4$

Short-circuit power at the beginning of the line:

S_{sc}' = 2.5 GVA

Ratio of zero-sequence impedance and positive-sequence impedance of the source impedance at the beginning of the line: $Z_{P0}/Z_{P1} = 2$

Current transformer = 600 A/5 A

Resulting in the following values for the line impedance Z_L and the source impedance Z_p :

$$Z_L = 0.46 \text{ } \Omega/\text{km} \cdot 60\text{km} = 27.6 \text{ } \Omega$$

[fo_ocp_002_1_en_US]

$$Z_p = \frac{110 \text{ kV}^2}{2500 \text{ MVA}} = 4.84 \text{ } \Omega$$

[fo_ocp_003_1_en_US]

The 1-pole short-circuit current at the end of the line is $I_{sc \text{ G end}}$:

$$I_{sc \text{ gnd end}} = \frac{1.1 \cdot V_N \cdot 3}{\sqrt{3} \cdot \left[Z_p \cdot \left(2 + \frac{Z_{P0}}{Z_{P1}} \right) + Z_L \cdot \left(2 + \frac{Z_{L0}}{Z_{L1}} \right) \right]} = \frac{1.1 \cdot 110\text{kV} \cdot 3}{\sqrt{3} \cdot [4.84 \text{ } \Omega \cdot (2 + 2) + 27.6 \text{ } \Omega \cdot (2 + 4)]} = 1133 \text{ A}$$

[fo_ocp_005_1_en_US]

The settings in primary and secondary values result in the following setting values which include a safety margin of 10 %:

$$\text{Threshold value 2nd stage (primary)} = 1.1 \cdot 1133 \text{ A} = 1246.3 \text{ A}$$

$$\text{Threshold value 2nd stage (secondary)} = 1.1 \cdot \frac{1133 \text{ A}}{600 \text{ A}} \cdot 5 \text{ A} = 10.39 \text{ A}$$

[fo_ocp_gr4_3_en_US]

In case of short-circuit currents exceeding 1246 A (primary) or 10.39 A (secondary) there is a short-circuit on the line to be protected. The overcurrent protection can cut off this short circuit immediately.

Note: The amounts in the calculation example are accurate enough for overhead lines. If the source impedance, line impedance and zero-sequence impedance have very different angles, you have use complex numbers to calculate the **Threshold**.

Parameter: Dropout delay

- Recommended setting value (**_ :751:101**) **Dropout delay = 0**

This parameter is not visible in the basic stage.

Siemens recommends using the default setting **0** since the dropout of a protection stage must be done as fast as possible.

You can use the **Dropout delay** parameter $\neq 0$ to obtain a uniform dropout behavior if you use it together with an electromechanical relay. This is required for time grading. The dropout time of the electromechanical relay must be known for this purpose. Subtract the dropout time of your own device (see Technical Data) and set the result.

Parameter: Dropout ratio

- Recommended setting value (**_:751:4**) **Dropout ratio = 0.95**

This parameter is not visible in the basic stage.

The recommended set value of **0.95** is appropriate for most applications.

To achieve high-precision measurements, the setting value of the parameter **Dropout ratio** can be reduced, for example, to **0.98**. If you expect highly fluctuating measurands at the response threshold, you can increase the setting value of the parameter **Dropout ratio**. This avoids chattering of the stage.

6.5.4.3 Settings

Addr.	Parameter	C	Setting Options	Default Setting
General				
_:2311:101	General:Emergency mode		<ul style="list-style-type: none"> no caused by main prot. caused by binary input 	no
_:2311:9	General:Measured value		<ul style="list-style-type: none"> 3I0 calculated IN measured 	IN measured
General				
_:751:1	Definite-T 1:Mode		<ul style="list-style-type: none"> off on test 	off
_:751:2	Definite-T 1:Operate & flt.rec. blocked		<ul style="list-style-type: none"> no yes 	no
_:751:26	Definite-T 1:Dynamic settings		<ul style="list-style-type: none"> no yes 	no
_:751:27	Definite-T 1:Blk. w. inrush curr. detect.		<ul style="list-style-type: none"> no yes 	no
_:751:102	Definite-T 1:Blk. w. 2nd harm. gnd. det.		<ul style="list-style-type: none"> no yes 	no
_:751:8	Definite-T 1:Method of measurement		<ul style="list-style-type: none"> fundamental comp. RMS value 	fundamental comp.
_:751:3	Definite-T 1:Threshold	1 A @ 100 Irated	0.010 A to 40.000 A	1.200 A
		5 A @ 100 Irated	0.05 A to 200.00 A	6.00 A
		1 A @ 50 Irated	0.010 A to 40.000 A	1.200 A
		5 A @ 50 Irated	0.05 A to 200.00 A	6.00 A
		1 A @ 1.6 Irated	0.001 A to 1.600 A	1.200 A
		5 A @ 1.6 Irated	0.002 A to 8.000 A	6.000 A
_:751:4	Definite-T 1:Dropout ratio		0.90 to 0.99	0.95
_:751:101	Definite-T 1:Dropout delay		0.00 s to 60.00 s	0.00 s
_:751:6	Definite-T 1:Operate delay		0.00 s to 60.00 s	0.30 s
_:751:7	Definite-T 1:Operate delay mode		<ul style="list-style-type: none"> Running dur. DO-delay Frozen dur. DO-delay 	Running dur. DO-delay
Dyn. s: AR off/n.rdy				
_:751:28	Definite-T 1:Effect. by AR off/n.ready		<ul style="list-style-type: none"> no yes 	no

Addr.	Parameter	C	Setting Options	Default Setting
_:751:35	Definite-T 1:Stage blocked		<ul style="list-style-type: none"> • no • yes 	no
<i>Dyn.set: AR cycle 1</i>				
_:751:29	Definite-T 1:Effected by AR cycle 1		<ul style="list-style-type: none"> • no • yes 	no
_:751:36	Definite-T 1:Stage blocked		<ul style="list-style-type: none"> • no • yes 	no
_:751:14	Definite-T 1:Threshold	1 A @ 100 Irated	0.010 A to 40.000 A	1.200 A
		5 A @ 100 Irated	0.05 A to 200.00 A	6.00 A
		1 A @ 50 Irated	0.010 A to 40.000 A	1.200 A
		5 A @ 50 Irated	0.05 A to 200.00 A	6.00 A
		1 A @ 1.6 Irated	0.001 A to 1.600 A	1.200 A
		5 A @ 1.6 Irated	0.002 A to 8.000 A	6.000 A
_:751:20	Definite-T 1:Operate delay		0.00 s to 60.00 s	0.30 s
<i>Dyn.set: AR cycle 2</i>				
_:751:30	Definite-T 1:Effected by AR cycle 2		<ul style="list-style-type: none"> • no • yes 	no
_:751:37	Definite-T 1:Stage blocked		<ul style="list-style-type: none"> • no • yes 	no
_:751:15	Definite-T 1:Threshold	1 A @ 100 Irated	0.010 A to 40.000 A	1.200 A
		5 A @ 100 Irated	0.05 A to 200.00 A	6.00 A
		1 A @ 50 Irated	0.010 A to 40.000 A	1.200 A
		5 A @ 50 Irated	0.05 A to 200.00 A	6.00 A
		1 A @ 1.6 Irated	0.001 A to 1.600 A	1.200 A
		5 A @ 1.6 Irated	0.002 A to 8.000 A	6.000 A
_:751:21	Definite-T 1:Operate delay		0.00 s to 60.00 s	0.30 s
<i>Dyn.set: AR cycle 3</i>				
_:751:31	Definite-T 1:Effected by AR cycle 3		<ul style="list-style-type: none"> • no • yes 	no
_:751:38	Definite-T 1:Stage blocked		<ul style="list-style-type: none"> • no • yes 	no
_:751:16	Definite-T 1:Threshold	1 A @ 100 Irated	0.010 A to 40.000 A	1.200 A
		5 A @ 100 Irated	0.05 A to 200.00 A	6.00 A
		1 A @ 50 Irated	0.010 A to 40.000 A	1.200 A
		5 A @ 50 Irated	0.05 A to 200.00 A	6.00 A
		1 A @ 1.6 Irated	0.001 A to 1.600 A	1.200 A
		5 A @ 1.6 Irated	0.002 A to 8.000 A	6.000 A
_:751:22	Definite-T 1:Operate delay		0.00 s to 60.00 s	0.30 s
<i>Dyn.s: AR cycle>3</i>				
_:751:32	Definite-T 1:Effected by AR cycle gr. 3		<ul style="list-style-type: none"> • no • yes 	no
_:751:39	Definite-T 1:Stage blocked		<ul style="list-style-type: none"> • no • yes 	no

Addr.	Parameter	C	Setting Options	Default Setting
_:751:17	Definite-T 1:Threshold	1 A @ 100 Irated	0.010 A to 40.000 A	1.200 A
		5 A @ 100 Irated	0.05 A to 200.00 A	6.00 A
		1 A @ 50 Irated	0.010 A to 40.000 A	1.200 A
		5 A @ 50 Irated	0.05 A to 200.00 A	6.00 A
		1 A @ 1.6 Irated	0.001 A to 1.600 A	1.200 A
		5 A @ 1.6 Irated	0.002 A to 8.000 A	6.000 A
_:751:23	Definite-T 1:Operate delay		0.00 s to 60.00 s	0.30 s
Dyn.s: Cold load PU				
_:751:33	Definite-T 1:Effect. b. cold-load pickup		<ul style="list-style-type: none"> • no • yes 	no
_:751:40	Definite-T 1:Stage blocked		<ul style="list-style-type: none"> • no • yes 	no
_:751:18	Definite-T 1:Threshold	1 A @ 100 Irated	0.010 A to 40.000 A	1.200 A
		5 A @ 100 Irated	0.05 A to 200.00 A	6.00 A
		1 A @ 50 Irated	0.010 A to 40.000 A	1.200 A
		5 A @ 50 Irated	0.05 A to 200.00 A	6.00 A
		1 A @ 1.6 Irated	0.001 A to 1.600 A	1.200 A
		5 A @ 1.6 Irated	0.002 A to 8.000 A	6.000 A
_:751:24	Definite-T 1:Operate delay		0.00 s to 60.00 s	0.30 s
Dyn.set: bin.input				
_:751:34	Definite-T 1:Effected by binary input		<ul style="list-style-type: none"> • no • yes 	no
_:751:41	Definite-T 1:Stage blocked		<ul style="list-style-type: none"> • no • yes 	no
_:751:19	Definite-T 1:Threshold	1 A @ 100 Irated	0.010 A to 40.000 A	1.200 A
		5 A @ 100 Irated	0.05 A to 200.00 A	6.00 A
		1 A @ 50 Irated	0.010 A to 40.000 A	1.200 A
		5 A @ 50 Irated	0.05 A to 200.00 A	6.00 A
		1 A @ 1.6 Irated	0.001 A to 1.600 A	1.200 A
		5 A @ 1.6 Irated	0.002 A to 8.000 A	6.000 A
_:751:25	Definite-T 1:Operate delay		0.00 s to 60.00 s	0.30 s
General				
_:752:1	Definite-T 2:Mode		<ul style="list-style-type: none"> • off • on • test 	off
_:752:2	Definite-T 2:Operate & flt.rec. blocked		<ul style="list-style-type: none"> • no • yes 	no
_:752:26	Definite-T 2:Dynamic settings		<ul style="list-style-type: none"> • no • yes 	no
_:752:27	Definite-T 2:Blk. w. inrush curr. detect.		<ul style="list-style-type: none"> • no • yes 	no
_:752:102	Definite-T 2:Blk. w. 2nd harm. gnd. det.		<ul style="list-style-type: none"> • no • yes 	no

Addr.	Parameter	C	Setting Options	Default Setting
_:752:8	Definite-T 2:Method of measurement		<ul style="list-style-type: none"> fundamental comp. RMS value 	fundamental comp.
_:752:3	Definite-T 2:Threshold	1 A @ 100 Irated	0.010 A to 40.000 A	1.200 A
		5 A @ 100 Irated	0.05 A to 200.00 A	6.00 A
		1 A @ 50 Irated	0.010 A to 40.000 A	1.200 A
		5 A @ 50 Irated	0.05 A to 200.00 A	6.00 A
		1 A @ 1.6 Irated	0.001 A to 1.600 A	1.200 A
		5 A @ 1.6 Irated	0.002 A to 8.000 A	6.000 A
_:752:4	Definite-T 2:Dropout ratio		0.90 to 0.99	0.95
_:752:101	Definite-T 2:Dropout delay		0.00 s to 60.00 s	0.00 s
_:752:6	Definite-T 2:Operate delay		0.00 s to 60.00 s	0.30 s
_:752:7	Definite-T 2:Operate delay mode		<ul style="list-style-type: none"> Running dur. DO-delay Frozen dur. DO-delay 	Running dur. DO-delay
<i>Dyn.s: AR off/n.rdy</i>				
_:752:28	Definite-T 2:Effect. by AR off/n.ready		<ul style="list-style-type: none"> no yes 	no
_:752:35	Definite-T 2:Stage blocked		<ul style="list-style-type: none"> no yes 	no
<i>Dyn.set: AR cycle 1</i>				
_:752:29	Definite-T 2:Effected by AR cycle 1		<ul style="list-style-type: none"> no yes 	no
_:752:36	Definite-T 2:Stage blocked		<ul style="list-style-type: none"> no yes 	no
_:752:14	Definite-T 2:Threshold	1 A @ 100 Irated	0.010 A to 40.000 A	1.200 A
		5 A @ 100 Irated	0.05 A to 200.00 A	6.00 A
		1 A @ 50 Irated	0.010 A to 40.000 A	1.200 A
		5 A @ 50 Irated	0.05 A to 200.00 A	6.00 A
		1 A @ 1.6 Irated	0.001 A to 1.600 A	1.200 A
		5 A @ 1.6 Irated	0.002 A to 8.000 A	6.000 A
_:752:20	Definite-T 2:Operate delay		0.00 s to 60.00 s	0.30 s
<i>Dyn.set: AR cycle 2</i>				
_:752:30	Definite-T 2:Effected by AR cycle 2		<ul style="list-style-type: none"> no yes 	no
_:752:37	Definite-T 2:Stage blocked		<ul style="list-style-type: none"> no yes 	no
_:752:15	Definite-T 2:Threshold	1 A @ 100 Irated	0.010 A to 40.000 A	1.200 A
		5 A @ 100 Irated	0.05 A to 200.00 A	6.00 A
		1 A @ 50 Irated	0.010 A to 40.000 A	1.200 A
		5 A @ 50 Irated	0.05 A to 200.00 A	6.00 A
		1 A @ 1.6 Irated	0.001 A to 1.600 A	1.200 A
		5 A @ 1.6 Irated	0.002 A to 8.000 A	6.000 A
_:752:21	Definite-T 2:Operate delay		0.00 s to 60.00 s	0.30 s

Addr.	Parameter	C	Setting Options	Default Setting
Dyn.set: AR cycle 3				
_:752:31	Definite-T 2:Effected by AR cycle 3		<ul style="list-style-type: none"> • no • yes 	no
_:752:38	Definite-T 2:Stage blocked		<ul style="list-style-type: none"> • no • yes 	no
_:752:16	Definite-T 2:Threshold	1 A @ 100 Irated	0.010 A to 40.000 A	1.200 A
		5 A @ 100 Irated	0.05 A to 200.00 A	6.00 A
		1 A @ 50 Irated	0.010 A to 40.000 A	1.200 A
		5 A @ 50 Irated	0.05 A to 200.00 A	6.00 A
		1 A @ 1.6 Irated	0.001 A to 1.600 A	1.200 A
		5 A @ 1.6 Irated	0.002 A to 8.000 A	6.000 A
_:752:22	Definite-T 2:Operate delay		0.00 s to 60.00 s	0.30 s
Dyn.s: AR cycle>3				
_:752:32	Definite-T 2:Effected by AR cycle gr. 3		<ul style="list-style-type: none"> • no • yes 	no
_:752:39	Definite-T 2:Stage blocked		<ul style="list-style-type: none"> • no • yes 	no
_:752:17	Definite-T 2:Threshold	1 A @ 100 Irated	0.010 A to 40.000 A	1.200 A
		5 A @ 100 Irated	0.05 A to 200.00 A	6.00 A
		1 A @ 50 Irated	0.010 A to 40.000 A	1.200 A
		5 A @ 50 Irated	0.05 A to 200.00 A	6.00 A
		1 A @ 1.6 Irated	0.001 A to 1.600 A	1.200 A
		5 A @ 1.6 Irated	0.002 A to 8.000 A	6.000 A
_:752:23	Definite-T 2:Operate delay		0.00 s to 60.00 s	0.30 s
Dyn.s: Cold load PU				
_:752:33	Definite-T 2:Effect. b. cold-load pickup		<ul style="list-style-type: none"> • no • yes 	no
_:752:40	Definite-T 2:Stage blocked		<ul style="list-style-type: none"> • no • yes 	no
_:752:18	Definite-T 2:Threshold	1 A @ 100 Irated	0.010 A to 40.000 A	1.200 A
		5 A @ 100 Irated	0.05 A to 200.00 A	6.00 A
		1 A @ 50 Irated	0.010 A to 40.000 A	1.200 A
		5 A @ 50 Irated	0.05 A to 200.00 A	6.00 A
		1 A @ 1.6 Irated	0.001 A to 1.600 A	1.200 A
		5 A @ 1.6 Irated	0.002 A to 8.000 A	6.000 A
_:752:24	Definite-T 2:Operate delay		0.00 s to 60.00 s	0.30 s
Dyn.set: bin.input				
_:752:34	Definite-T 2:Effected by binary input		<ul style="list-style-type: none"> • no • yes 	no
_:752:41	Definite-T 2:Stage blocked		<ul style="list-style-type: none"> • no • yes 	no

Addr.	Parameter	C	Setting Options	Default Setting
_:752:19	Definite-T 2:Threshold	1 A @ 100 Irated	0.010 A to 40.000 A	1.200 A
		5 A @ 100 Irated	0.05 A to 200.00 A	6.00 A
		1 A @ 50 Irated	0.010 A to 40.000 A	1.200 A
		5 A @ 50 Irated	0.05 A to 200.00 A	6.00 A
		1 A @ 1.6 Irated	0.001 A to 1.600 A	1.200 A
		5 A @ 1.6 Irated	0.002 A to 8.000 A	6.000 A
_:752:25	Definite-T 2:Operate delay		0.00 s to 60.00 s	0.30 s

6.5.4.4 Information List

No.	Information	Data Class (Type)	Type
General			
_:2311:500	General:>Activation emg. mode	SPS	I
_:2311:300	General:Emergency mode act.	SPS	O
_:2311:52	General:Behavior	ENS	O
_:2311:53	General:Health	ENS	O
Group indicat.			
_:4501:55	Group indicat.:Pickup	ACD	O
_:4501:57	Group indicat.:Operate	ACT	O
_:4501:52	Group indicat.:Behavior	ENS	O
_:4501:53	Group indicat.:Health	ENS	O
Definite-T 1			
_:751:81	Definite-T 1:>Block stage	SPS	I
_:751:84	Definite-T 1:>Activ. dyn. settings	SPS	I
_:751:500	Definite-T 1:>Block delay & op.	SPS	I
_:751:51	Definite-T 1:Mode (controllable)	ENC	C
_:751:54	Definite-T 1:Inactive	SPS	O
_:751:52	Definite-T 1:Behavior	ENS	O
_:751:53	Definite-T 1:Health	ENS	O
_:751:60	Definite-T 1:Inrush blocks operate	ACT	O
_:751:62	Definite-T 1:Dyn.set. AR cycle1act.	SPS	O
_:751:63	Definite-T 1:Dyn.set. AR cycle2act.	SPS	O
_:751:64	Definite-T 1:Dyn.set. AR cycle3act.	SPS	O
_:751:65	Definite-T 1:Dyn.set. ARcycl.>3act	SPS	O
_:751:66	Definite-T 1:Dyn.set. CLP active	SPS	O
_:751:67	Definite-T 1:Dyn.set. BI active	SPS	O
_:751:68	Definite-T 1:Dyn. set. blks. pickup	SPS	O
_:751:55	Definite-T 1:Pickup	ACD	O
_:751:56	Definite-T 1:Operate delay expired	ACT	O
_:751:57	Definite-T 1:Operate	ACT	O

6.5.5 Stage with Inverse-Time Characteristic Curve

6.5.5.1 Description

Logic of the Basic Stage

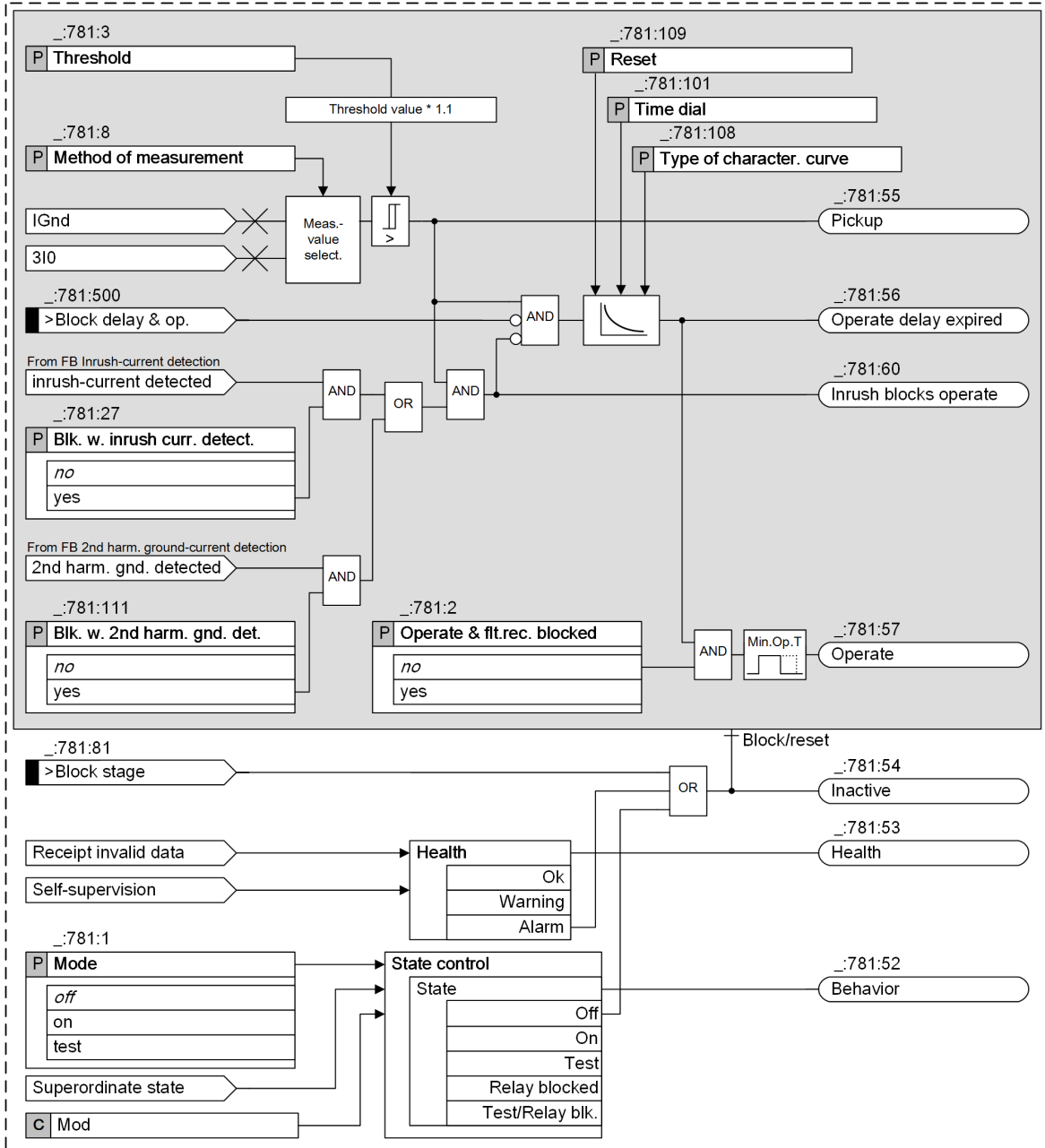

[no_occupr2_6_en_US]

Figure 6-32 Logic Diagram Inverse-Time Overcurrent Protection (Ground) – Basic

Logic of the Advanced Stage

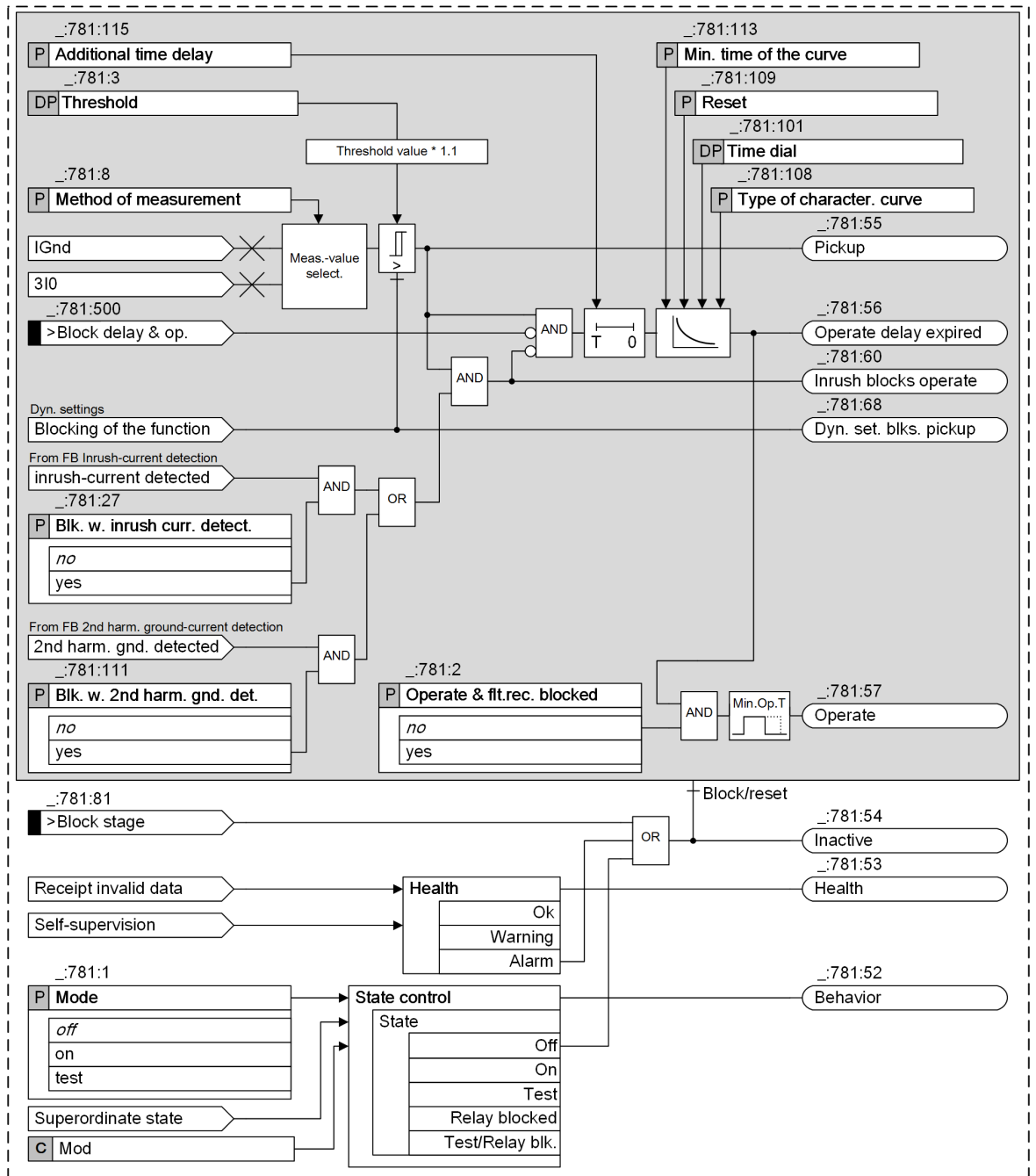

[to_ocr_0n2_5_en_US]

Figure 6-33 Logic Diagram Inverse-Time Overcurrent Protection (Ground) – Advanced

Emergency mode (Advanced Stage)

You use the **Emergency mode** parameter to define whether the stage operates as emergency overcurrent protection or as backup overcurrent protection. With the setting **Emergency mode = caused by main prot.**, emergency overcurrent protection starts automatically when the main protection is **caused by main prot.**, for example, in the case of distance protection when a short circuit occurs in the voltage-transformer secondary circuit, when the voltage-transformer secondary circuit is disconnected or in the case of line differential protection where protection communication is disconnected. This means that the emergency mode replaces

the main protection as short-circuit protection. With the appropriate parameterization (**Emergency mode = caused by binary input**), the emergency mode can also be activated from an external source. If the overcurrent protection is set as backup overcurrent protection (parameter **Emergency mode = no**), it operates independently of the main protection and thus in parallel. Backup overcurrent protection can also serve as sole short-circuit protection when, for example, no voltage transformers are available for an initial startup.

Pickup and Dropout Behaviors of the Inverse-Time Characteristic Curve According to IEC and ANSI (Basic and Advanced Stage)

When the input variable exceeds the threshold value by a factor of 1.1, the inverse-time characteristic curve is processed. An integrating method of measurement summarizes the weighted time. The weighted time results from the characteristic curve. For this, the time that is associated with the present current value is determined from the characteristic curve. Once the weighted time exceeds the value 1, the stage operates. When the measured value falls below the pickup value by a factor of 1.045 ($0.95 \cdot 1.1 \cdot \text{threshold value}$), the dropout is started. The pickup will be indicated as clearing. You can influence the dropout behavior via setting parameters. You can select between instantaneous dropout (totalized time is deleted) or dropout according to the characteristic curve (reduction of totalized time depending on the characteristic curve). The dropout according to characteristic curve (disk emulation) is the same as turning back a rotor disk. The weighted reduction of the time is initiated from 0.9 of the set threshold value. The characteristic curve and associated formulas are shown in the Technical Data.

Minimum Time of the Curve (Advanced Stage)

With the parameter **Min. time of the curve**, you define the minimum operate delay time. The operate delay time of inverse-time characteristic curve never falls below the minimum operate delay time.

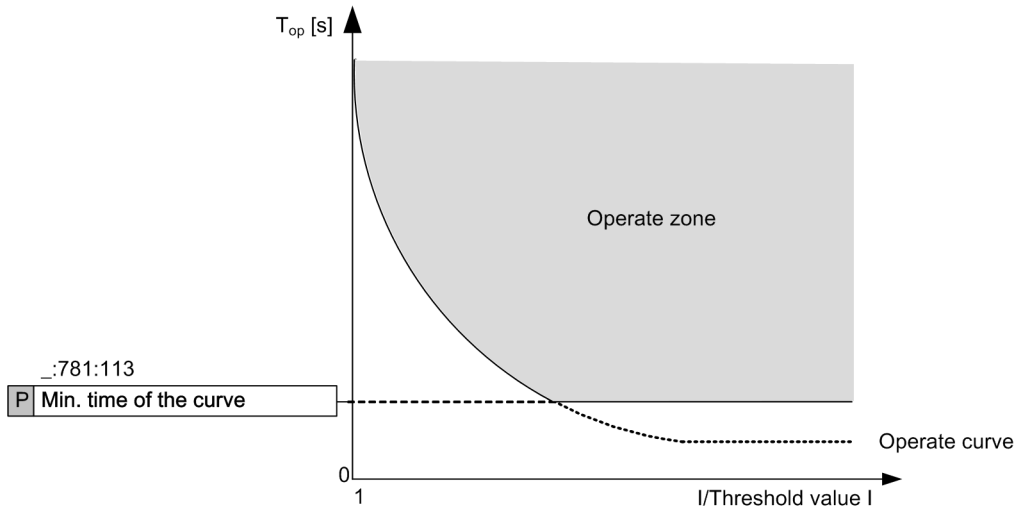

[dw_ocp_gr3_mi_1_en_US]
 Figure 6-34 Minimum Operating Time of the Curve

Additional Time Delay (Advanced Stage)

With the parameter **Additional time delay**, you define a definite-time delay in addition to the inverse-time delay. With this setting, the whole curve is shifted on the time axis by this additional definite time.

Method of Measurement (Basic and Advanced Stage)

You use the **Method of measurement** parameter to define whether the stage uses the *fundamental comp.* or the calculated *RMS value*.

- Measurement of the fundamental component:
This method of measurement processes the sampled current values and filters out the fundamental component numerically.
- Measurement of the RMS value:
This method of measurement determines the current amplitude from the sampled values according to the defining equation of the RMS value. Harmonics are included in the analysis.

Blocking of the Stage (Basic and Advanced Stage)

The following blockings reset the picked up stage completely:

- Via the binary input signal **>Block stage** from an external or internal source
- Via the functionality of the **dynamic settings** (see **Influence of other functions via dynamic settings** and [6.5.8.1 Description](#)).

Blocking of the Time Delay (Basic and Advanced Stage)

You can use the binary input signal **>Block delay & op.** to prevent the start of the time delay and thus also the operate signal. A running time delay is reset. The pickup is indicated and the fault logging and recording takes place.

Blocking of the Operate Delay and the Operate Signal via the Device-Internal Inrush-Current Detection Function (Basic and Advanced Stage)

Blocking of the operate delay and the operate signal via the device-internal **Inrush-current detection** function is described in [6.5.7.1 Description](#).

Influence of Other Functions via Dynamic Settings (Advanced Stage)

If available in the device, the following functions can influence the overcurrent-protection stages:

- Automatic reclosing
- Binary input signal

The influence of these functions via dynamic settings is described in [6.5.8.1 Description](#).

6.5.5.2 Application and Setting Notes

Parameter: **Method of measurement**

- Recommended setting value (**_:781:8**) **Method of measurement** = *fundamental comp.*

With the **Method of measurement** parameter, you define whether the stage uses the *fundamental comp.* (standard method) or the calculated *RMS value*.

Parameter Value	Description
<i>fundamental comp.</i>	Select this method of measurement if harmonics or transient current peaks are to be suppressed. Siemens recommends using this method as the standard method.
<i>RMS value</i>	Select this method of measurement if you want the stage to take harmonics into account (for example, at capacitor banks). Consider that aperiodic DC components present in the secondary circuit are measured and can cause an overfunction. For this method of measurement, do not set the threshold value of the stage to less than $0.1 I_{rated,sec}$. If currents from more than one measuring point are added up in the current interface of a function group, the setting value should not be set lower than $0.1 I_{rated,sec}$ multiplied by the number of added currents.

Parameter: Type of character. curve

- Default setting (`_:781:108`) **Type of character. curve** = *IEC normal inverse*
- The device offers all the usual inverse-time characteristic curves according to IEC and ANSI. Select the **Type of character. curve** required for your specific application. For more information about the parameter **Type of character. curve**, refer to chapter [14.6.2 Stage with Inverse-Time Characteristic Curve](#).

Parameter: Min. time of the curve

- Default setting (`_:781:113`) **Min. time of the curve** = *0.00 s*
- This parameter is only available in the advanced stage.
- With the **Min. time of the curve** parameter, you define a minimum operate delay time. The operate delay time of inverse-time characteristic curve never falls below the minimum operate delay time. If the setting is left on its default value of 0 s, this parameter has no effect on the inverse-time characteristic curve. This parameter is only required for time coordination in recloser schemes. For all other applications, Siemens recommends keeping the default setting of 0 s.



NOTE

If the set value is smaller than the smallest possible time delay of the inverse-time characteristic curve, the parameter has no influence on the delay time.

Parameter: Additional time delay

- Recommended setting value (`_:781:115`) **Additional time delay** = *0.00 s*
- With the **Additional time delay** parameter, you define a definite-time delay in addition to the inverse-time delay.
- If the setting is left on its default value of 0 s, this parameter has no effect on the inverse-time characteristic curve.
- This parameter is only required for time coordination in recloser schemes. For all other applications, Siemens recommend keeping the default setting of 0 s.

Parameter: Threshold

- Default setting (`_:781:3`) **Threshold** = *1.20 A*
- The setting depends on the minimal occurring ground-fault current. This must be determined.

Parameter: Time dial

- Default setting (`_:781:101`) **Time dial** = *1*
- With the **Time dial** parameter, you displace the characteristic curve in the time direction.

The set value for the **Time dial** parameter is derived from the time-grading schedule that has been prepared for the electrical power system. Where overcurrent protection is used in emergency mode, shorter time delays might be reasonable (one grading time above fast tripping), since the emergency mode only operates if the main protection function fails.

Where no time grading and therefore no displacement of the characteristic curve is required, leave the **Time dial** parameter at **1**.

Parameter: Reset

- Default setting (**_:781:109**) **Reset = disk emulation**

With the **Reset** parameter, you define whether the stage drops out according to the dropout characteristic curve (in accordance with the behavior of a disk emulation = rotor disk) or instantaneously.

Parameter Value	Description
<i>disk emulation</i>	Select this setting if the device is coordinated with electromechanical devices or other devices which perform a dropout after a disk emulation.
<i>instantaneous</i>	Select this setting if the dropout is not to be performed after disk emulation and an instantaneous dropout is desired instead.

6.5.5.3 Settings

Addr.	Parameter	C	Setting Options	Default Setting
General				
_:2311:101	General:Emergency mode		<ul style="list-style-type: none"> • no • caused by main prot. • caused by binary input 	no
_:2311:9	General:Measured value		<ul style="list-style-type: none"> • 3I0 calculated • IN measured 	IN measured
General				
_:781:1	Inverse-T 1:Mode		<ul style="list-style-type: none"> • off • on • test 	off
_:781:2	Inverse-T 1:Operate &flt.rec. blocked		<ul style="list-style-type: none"> • no • yes 	no
_:781:26	Inverse-T 1:Dynamic settings		<ul style="list-style-type: none"> • no • yes 	no
_:781:27	Inverse-T 1:Blk. w. inrush curr. detect.		<ul style="list-style-type: none"> • no • yes 	no
_:781:111	Inverse-T 1:Blk. w. 2nd harm. gnd. det.		<ul style="list-style-type: none"> • no • yes 	no
_:781:8	Inverse-T 1:Method of measurement		<ul style="list-style-type: none"> • fundamental comp. • RMS value 	fundamental comp.
_:781:3	Inverse-T 1:Threshold	1 A @ 100 Irated	0.010 A to 40.000 A	1.200 A
		5 A @ 100 Irated	0.05 A to 200.00 A	6.00 A
		1 A @ 50 Irated	0.010 A to 40.000 A	1.200 A
		5 A @ 50 Irated	0.05 A to 200.00 A	6.00 A
		1 A @ 1.6 Irated	0.001 A to 1.600 A	1.200 A
		5 A @ 1.6 Irated	0.002 A to 8.000 A	6.000 A
_:781:108	Inverse-T 1:Type of character. curve			

Addr.	Parameter	C	Setting Options	Default Setting
_:781:113	Inverse-T 1:Min. time of the curve		0.00 s to 1.00 s	0.00 s
_:781:109	Inverse-T 1:Reset		<ul style="list-style-type: none"> • instantaneous • disk emulation 	disk emulation
_:781:101	Inverse-T 1:Time dial		0.00 to 15.00	1.00
_:781:115	Inverse-T 1:Additional time delay		0.00 s to 60.00 s	0.00 s
<i>Dyn.s: AR off/n.rdy</i>				
_:781:28	Inverse-T 1:Effect. by AR off/n.ready		<ul style="list-style-type: none"> • no • yes 	no
_:781:35	Inverse-T 1:Stage blocked		<ul style="list-style-type: none"> • no • yes 	no
<i>Dyn.set: AR cycle 1</i>				
_:781:29	Inverse-T 1:Effected by AR cycle 1		<ul style="list-style-type: none"> • no • yes 	no
_:781:36	Inverse-T 1:Stage blocked		<ul style="list-style-type: none"> • no • yes 	no
_:781:14	Inverse-T 1:Threshold	1 A @ 100 Irated	0.010 A to 40.000 A	1.200 A
		5 A @ 100 Irated	0.05 A to 200.00 A	6.00 A
		1 A @ 50 Irated	0.010 A to 40.000 A	1.200 A
		5 A @ 50 Irated	0.05 A to 200.00 A	6.00 A
		1 A @ 1.6 Irated	0.001 A to 1.600 A	1.200 A
		5 A @ 1.6 Irated	0.002 A to 8.000 A	6.000 A
_:781:102	Inverse-T 1:Time dial		0.00 to 15.00	1.00
<i>Dyn.set: AR cycle 2</i>				
_:781:30	Inverse-T 1:Effected by AR cycle 2		<ul style="list-style-type: none"> • no • yes 	no
_:781:37	Inverse-T 1:Stage blocked		<ul style="list-style-type: none"> • no • yes 	no
_:781:15	Inverse-T 1:Threshold	1 A @ 100 Irated	0.010 A to 40.000 A	1.200 A
		5 A @ 100 Irated	0.05 A to 200.00 A	6.00 A
		1 A @ 50 Irated	0.010 A to 40.000 A	1.200 A
		5 A @ 50 Irated	0.05 A to 200.00 A	6.00 A
		1 A @ 1.6 Irated	0.001 A to 1.600 A	1.200 A
		5 A @ 1.6 Irated	0.002 A to 8.000 A	6.000 A
_:781:103	Inverse-T 1:Time dial		0.00 to 15.00	1.00
<i>Dyn.set: AR cycle 3</i>				
_:781:31	Inverse-T 1:Effected by AR cycle 3		<ul style="list-style-type: none"> • no • yes 	no
_:781:38	Inverse-T 1:Stage blocked		<ul style="list-style-type: none"> • no • yes 	no

Addr.	Parameter	C	Setting Options	Default Setting
_:781:16	Inverse-T 1:Threshold	1 A @ 100 Irated	0.010 A to 40.000 A	1.200 A
		5 A @ 100 Irated	0.05 A to 200.00 A	6.00 A
		1 A @ 50 Irated	0.010 A to 40.000 A	1.200 A
		5 A @ 50 Irated	0.05 A to 200.00 A	6.00 A
		1 A @ 1.6 Irated	0.001 A to 1.600 A	1.200 A
		5 A @ 1.6 Irated	0.002 A to 8.000 A	6.000 A
_:781:104	Inverse-T 1:Time dial		0.00 to 15.00	1.00
Dyn.s: AR cycle>3				
_:781:32	Inverse-T 1:Effected by AR cycle gr. 3		<ul style="list-style-type: none"> • no • yes 	no
_:781:39	Inverse-T 1:Stage blocked		<ul style="list-style-type: none"> • no • yes 	no
_:781:17	Inverse-T 1:Threshold	1 A @ 100 Irated	0.010 A to 40.000 A	1.200 A
		5 A @ 100 Irated	0.05 A to 200.00 A	6.00 A
		1 A @ 50 Irated	0.010 A to 40.000 A	1.200 A
		5 A @ 50 Irated	0.05 A to 200.00 A	6.00 A
		1 A @ 1.6 Irated	0.001 A to 1.600 A	1.200 A
		5 A @ 1.6 Irated	0.002 A to 8.000 A	6.000 A
_:781:105	Inverse-T 1:Time dial		0.00 to 15.00	1.00
Dyn.s: Cold load PU				
_:781:33	Inverse-T 1:Effect. b. cold-load pickup		<ul style="list-style-type: none"> • no • yes 	no
_:781:40	Inverse-T 1:Stage blocked		<ul style="list-style-type: none"> • no • yes 	no
_:781:18	Inverse-T 1:Threshold	1 A @ 100 Irated	0.010 A to 40.000 A	1.200 A
		5 A @ 100 Irated	0.05 A to 200.00 A	6.00 A
		1 A @ 50 Irated	0.010 A to 40.000 A	1.200 A
		5 A @ 50 Irated	0.05 A to 200.00 A	6.00 A
		1 A @ 1.6 Irated	0.001 A to 1.600 A	1.200 A
		5 A @ 1.6 Irated	0.002 A to 8.000 A	6.000 A
_:781:106	Inverse-T 1:Time dial		0.00 to 15.00	1.00
Dyn.set: bin.input				
_:781:34	Inverse-T 1:Effected by binary input		<ul style="list-style-type: none"> • no • yes 	no
_:781:41	Inverse-T 1:Stage blocked		<ul style="list-style-type: none"> • no • yes 	no
_:781:19	Inverse-T 1:Threshold	1 A @ 100 Irated	0.010 A to 40.000 A	1.200 A
		5 A @ 100 Irated	0.05 A to 200.00 A	6.00 A
		1 A @ 50 Irated	0.010 A to 40.000 A	1.200 A
		5 A @ 50 Irated	0.05 A to 200.00 A	6.00 A
		1 A @ 1.6 Irated	0.001 A to 1.600 A	1.200 A
		5 A @ 1.6 Irated	0.002 A to 8.000 A	6.000 A
_:781:107	Inverse-T 1:Time dial		0.00 to 15.00	1.00

6.5.5.4 Information List

No.	Information	Data Class (Type)	Type
General			
_:2311:500	General:>Activation emg. mode	SPS	I
_:2311:300	General:Emergency mode act.	SPS	O
_:2311:52	General:Behavior	ENS	O
_:2311:53	General:Health	ENS	O
Group indicat.			
_:4501:55	Group indicat.:Pickup	ACD	O
_:4501:57	Group indicat.:Operate	ACT	O
_:4501:52	Group indicat.:Behavior	ENS	O
_:4501:53	Group indicat.:Health	ENS	O
Inverse-T 1			
_:781:81	Inverse-T 1:>Block stage	SPS	I
_:781:84	Inverse-T 1:>Activ. dyn. settings	SPS	I
_:781:500	Inverse-T 1:>Block delay & op.	SPS	I
_:781:51	Inverse-T 1:Mode (controllable)	ENC	C
_:781:54	Inverse-T 1:Inactive	SPS	O
_:781:52	Inverse-T 1:Behavior	ENS	O
_:781:53	Inverse-T 1:Health	ENS	O
_:781:60	Inverse-T 1:Inrush blocks operate	ACT	O
_:781:62	Inverse-T 1:Dyn.set. AR cycle1 act.	SPS	O
_:781:63	Inverse-T 1:Dyn.set. AR cycle2act.	SPS	O
_:781:64	Inverse-T 1:Dyn.set. AR cycle3act.	SPS	O
_:781:65	Inverse-T 1:Dyn.set. ARcycl.>3act	SPS	O
_:781:66	Inverse-T 1:Dyn.set. CLP active	SPS	O
_:781:67	Inverse-T 1:Dyn.set. BI active	SPS	O
_:781:68	Inverse-T 1:Dyn. set. blks. pickup	SPS	O
_:781:59	Inverse-T 1:Disk emulation running	SPS	O
_:781:55	Inverse-T 1:Pickup	ACD	O
_:781:56	Inverse-T 1:Operate delay expired	ACT	O
_:781:57	Inverse-T 1:Operate	ACT	O

6.5.6 Stage with User-Defined Characteristic Curve

6.5.6.1 Description

This stage is only available in the advanced function type.

This stage is structured the same way as the **Inverse-time overcurrent protection – advanced** stage (see chapter [6.5.5.1 Description](#)). The only differences are as follows:

- You can define the characteristic curve as desired.
- The pickup and dropout behaviors of this stage are determined by the standard parameter **Threshold** and, if necessary, by an additional parameter **Threshold (absolute)**.

User-Defined Characteristic Curve

With the user-defined characteristic curve, you can define the operate curve point by point using up to 30 value pairs of current and time. The device uses linear interpolation to calculate the characteristic curve from these values. You can also define a dropout characteristic curve if you wish.

Pickup and Dropout Behaviors with the User-Defined Characteristic Curve

When the input variable exceeds the **Threshold** value by 1.1 times, the characteristic curve is processed. An integrating method of measurement totalizes the weighted time. The weighted time results from the characteristic curve. For this, the time that is associated with the present current value is determined from the characteristic curve. Once the weighted time exceeds the value 1, the stage operates.

When the measured value falls short of the pickup value by a factor of 1.045 ($0.95 \times 1.1 \times \mathbf{Threshold}$ value), the dropout is started. The pickup will be indicated as clearing. You can influence the dropout behavior via setting parameters. You can select between instantaneous dropout (totalized time is deleted) or dropout according to the characteristic curve (reduction of totalized time depending on the characteristic curve). The dropout according to characteristic curve (disk emulation) is the same as turning back a rotor disk. The weighted reduction of the time is initiated from 0.9 of the set threshold value.

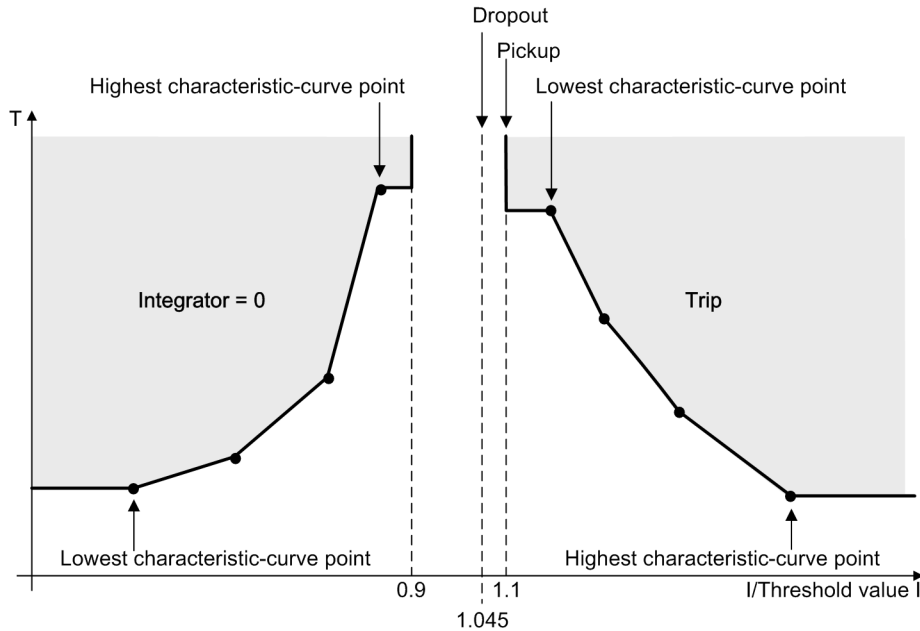

[dw_ocp_ken_02_2_en_US]

Figure 6-35 Pickup Behavior and Dropout Behavior when Using a User-Defined Characteristic Curve



NOTE

The currents that are lower than the current value of the smallest characteristic-curve point do not extend the operate time. The pickup characteristic runs in parallel to the current axis up to the smallest characteristic-curve point. Currents that are larger than the current value of the largest characteristic-curve point do not reduce the operate time. The pickup characteristic runs in parallel to the current axis from the largest characteristic-curve point.

If you want to change the pickup threshold of the stage without changing all points of the characteristic curve, you can use the additional **Threshold (absolute)** parameter.

You can set the **Threshold (absolute)** parameter to be greater than 1.1 times the **Threshold** value. Then the stage behaviors are as follows:

- The stage picks up when the measured current value exceeds the **Threshold (absolute)** value.
- The stage starts dropout when the measured current value falls short of the **Threshold (absolute)** value by 0.95 times.
- For measured current values lower than the **Threshold (absolute)** value, no pickup takes place and consequently the characteristic curve is not processed.

If you set the **Threshold (absolute)** parameter to be less than 1.1 times the **Threshold** value, the pickup and dropout behaviors are not affected by the **Threshold (absolute)** parameter.

6.5.6.2 Application and Setting Notes

This stage is structured the same way as the **Inverse-time overcurrent protection – advanced** stage. The only differences are described in chapter [6.5.6.1 Description](#). This chapter provides only the application and setting notes for setting characteristic curves and for setting the **Threshold (absolute)** parameter. You can find more information on the other parameters of the stage in chapter [6.5.5.2 Application and Setting Notes](#).

Parameter: Current/time value pairs (from the operate curve)

With these settings, you define the characteristic curve. Set a current/time value pair for each characteristic-curve point. The setting depends on the characteristic curve you want to realize.

Set the current value as a multiple of the threshold value. Siemens recommends that you set the **Threshold** parameter to **1.00** in order to obtain a simple relation. You can change the threshold value setting afterwards if you want to shift the characteristic curve.

Set the time value in seconds. The characteristic curve is shifted via the **Time dial** parameter.



NOTE

The value pairs must be entered in continuous order.

Parameter: Time dial

- Default setting (`_:101`) **Time dial = 1**

With the **Time dial** parameter, you displace the characteristic curve in the time direction.

The set value for the **Time dial** parameter is derived from the time-grading schedule that has been prepared for the electrical power system. Where no time grading and therefore no displacement of the characteristic curve is required, leave the **Time dial** parameter at **1**.

Parameter: Reset

- Default setting (`_:110`) **Reset = disk emulation**

With the **Reset** parameter, you define whether the stage drops out according to the dropout characteristic curve (in accordance with the behavior of a disk emulation = rotor disk) or instantaneously.

Parameter Value	Description
<i>disk emulation</i>	In the case of this setting, a dropout characteristic curve has to be set in addition to the operate curve. Select this setting if the device is coordinated with electromechanical devices or other devices which perform a dropout after a disk emulation.
<i>instantaneous</i>	Select this setting if the dropout is not to be performed after disk emulation but an instantaneous dropout is desired.

Parameter: Current/time value pairs (of the dropout characteristic curve)

With these settings, you define the characteristic curve. Set a current/time value pair for each characteristic-curve point. The setting depends on the characteristic curve you want to realize.

Set the current value as a multiple of the threshold value. Siemens recommends that you set the **Threshold** parameter to **1.00** in order to obtain a simple relation. You can change the threshold value setting afterwards if you want to shift the characteristic curve.

Set the time value in seconds. The characteristic curve is shifted via the **Time dial** parameter.



NOTE

The value pairs must be entered in continuous order.

Parameter: Threshold (absolute)

- Default setting (**_:113**) **Threshold (absolute) = 0.000 A**

With the **Threshold (absolute)** parameter, you define and change the absolute pickup threshold of the stage without changing all points of the characteristic curve.

The parameter is only used for special applications. With the default setting, this functionality is disabled. You can find more information in [Pickup and Dropout Behaviors with the User-Defined Characteristic Curve](#), Page 427.

6.5.6.3 Settings

Addr.	Parameter	C	Setting Options	Default Setting
General				
_:1	User curve #:Mode		<ul style="list-style-type: none"> • off • on • test 	off
_:2	User curve #:Operate &flt.rec. blocked		<ul style="list-style-type: none"> • no • yes 	no
_:26	User curve #:Dynamic settings		<ul style="list-style-type: none"> • no • yes 	no
_:27	User curve #:Blk. w. inrush curr. detect.		<ul style="list-style-type: none"> • no • yes 	no
_:111	User curve #:Blk. w. 2nd harm. gnd. det.		<ul style="list-style-type: none"> • no • yes 	no
_:8	User curve #:Method of measurement		<ul style="list-style-type: none"> • fundamental comp. • RMS value 	fundamental comp.
_:3	User curve #:Threshold	1 A @ 100 Irated	0.010 A to 40.000 A	1.200 A
		5 A @ 100 Irated	0.05 A to 200.00 A	6.00 A
		1 A @ 50 Irated	0.010 A to 40.000 A	1.200 A
		5 A @ 50 Irated	0.05 A to 200.00 A	6.00 A
		1 A @ 1.6 Irated	0.001 A to 1.600 A	1.200 A
		5 A @ 1.6 Irated	0.002 A to 8.000 A	6.000 A
_:113	User curve #:Threshold (absolute)	1 A @ 100 Irated	0.000 A to 40.000 A	0.000 A
		5 A @ 100 Irated	0.00 A to 200.00 A	0.00 A
		1 A @ 50 Irated	0.000 A to 40.000 A	0.000 A
		5 A @ 50 Irated	0.00 A to 200.00 A	0.00 A
		1 A @ 1.6 Irated	0.000 A to 1.600 A	0.000 A
		5 A @ 1.6 Irated	0.000 A to 8.000 A	0.000 A
_:110	User curve #:Reset		<ul style="list-style-type: none"> • instantaneous • disk emulation 	disk emulation
_:101	User curve #:Time dial		0.05 to 15.00	1.00
_:115	User curve #:Additional time delay		0.00 s to 60.00 s	0.00 s
Dyn.s: AR off/n.rdy				
_:28	User curve #:Effect. by AR off/n.ready		<ul style="list-style-type: none"> • no • yes 	no
_:35	User curve #:Stage blocked		<ul style="list-style-type: none"> • no • yes 	no

Addr.	Parameter	C	Setting Options	Default Setting
Dyn.set: AR cycle 1				
_:29	User curve #:Effected by AR cycle 1		<ul style="list-style-type: none"> • no • yes 	no
_:36	User curve #:Stage blocked		<ul style="list-style-type: none"> • no • yes 	no
_:14	User curve #:Threshold	1 A @ 100 Irated	0.010 A to 40.000 A	1.200 A
		5 A @ 100 Irated	0.05 A to 200.00 A	6.00 A
		1 A @ 50 Irated	0.010 A to 40.000 A	1.200 A
		5 A @ 50 Irated	0.05 A to 200.00 A	6.00 A
		1 A @ 1.6 Irated	0.001 A to 1.600 A	1.200 A
		5 A @ 1.6 Irated	0.002 A to 8.000 A	6.000 A
_:102	User curve #:Time dial		0.05 to 15.00	1.00
Dyn.set: AR cycle 2				
_:30	User curve #:Effected by AR cycle 2		<ul style="list-style-type: none"> • no • yes 	no
_:37	User curve #:Stage blocked		<ul style="list-style-type: none"> • no • yes 	no
_:15	User curve #:Threshold	1 A @ 100 Irated	0.010 A to 40.000 A	1.200 A
		5 A @ 100 Irated	0.05 A to 200.00 A	6.00 A
		1 A @ 50 Irated	0.010 A to 40.000 A	1.200 A
		5 A @ 50 Irated	0.05 A to 200.00 A	6.00 A
		1 A @ 1.6 Irated	0.001 A to 1.600 A	1.200 A
		5 A @ 1.6 Irated	0.002 A to 8.000 A	6.000 A
_:103	User curve #:Time dial		0.05 to 15.00	1.00
Dyn.set: AR cycle 3				
_:31	User curve #:Effected by AR cycle 3		<ul style="list-style-type: none"> • no • yes 	no
_:38	User curve #:Stage blocked		<ul style="list-style-type: none"> • no • yes 	no
_:16	User curve #:Threshold	1 A @ 100 Irated	0.010 A to 40.000 A	1.200 A
		5 A @ 100 Irated	0.05 A to 200.00 A	6.00 A
		1 A @ 50 Irated	0.010 A to 40.000 A	1.200 A
		5 A @ 50 Irated	0.05 A to 200.00 A	6.00 A
		1 A @ 1.6 Irated	0.001 A to 1.600 A	1.200 A
		5 A @ 1.6 Irated	0.002 A to 8.000 A	6.000 A
_:104	User curve #:Time dial		0.05 to 15.00	1.00
Dyn.s: AR cycle>3				
_:32	User curve #:Effected by AR cycle gr. 3		<ul style="list-style-type: none"> • no • yes 	no
_:39	User curve #:Stage blocked		<ul style="list-style-type: none"> • no • yes 	no

Addr.	Parameter	C	Setting Options	Default Setting
_:17	User curve #:Threshold	1 A @ 100 Irated	0.010 A to 40.000 A	1.200 A
		5 A @ 100 Irated	0.05 A to 200.00 A	6.00 A
		1 A @ 50 Irated	0.010 A to 40.000 A	1.200 A
		5 A @ 50 Irated	0.05 A to 200.00 A	6.00 A
		1 A @ 1.6 Irated	0.001 A to 1.600 A	1.200 A
		5 A @ 1.6 Irated	0.002 A to 8.000 A	6.000 A
_:105	User curve #:Time dial		0.05 to 15.00	1.00
Dyn.s: Cold load PU				
_:33	User curve #:Effect. b. cold-load pickup		<ul style="list-style-type: none"> • no • yes 	no
_:40	User curve #:Stage blocked		<ul style="list-style-type: none"> • no • yes 	no
_:18	User curve #:Threshold	1 A @ 100 Irated	0.010 A to 40.000 A	1.200 A
		5 A @ 100 Irated	0.05 A to 200.00 A	6.00 A
		1 A @ 50 Irated	0.010 A to 40.000 A	1.200 A
		5 A @ 50 Irated	0.05 A to 200.00 A	6.00 A
		1 A @ 1.6 Irated	0.001 A to 1.600 A	1.200 A
		5 A @ 1.6 Irated	0.002 A to 8.000 A	6.000 A
_:106	User curve #:Time dial		0.05 to 15.00	1.00
Dyn.set: bin.input				
_:34	User curve #:Effected by binary input		<ul style="list-style-type: none"> • no • yes 	no
_:41	User curve #:Stage blocked		<ul style="list-style-type: none"> • no • yes 	no
_:19	User curve #:Threshold	1 A @ 100 Irated	0.010 A to 40.000 A	1.200 A
		5 A @ 100 Irated	0.05 A to 200.00 A	6.00 A
		1 A @ 50 Irated	0.010 A to 40.000 A	1.200 A
		5 A @ 50 Irated	0.05 A to 200.00 A	6.00 A
		1 A @ 1.6 Irated	0.001 A to 1.600 A	1.200 A
		5 A @ 1.6 Irated	0.002 A to 8.000 A	6.000 A
_:107	User curve #:Time dial		0.05 to 15.00	1.00

6.5.6.4 Information List

No.	Information	Data Class (Type)	Type
User curve #			
_:81	User curve #:>Block stage	SPS	I
_:84	User curve #:>Activ. dyn. settings	SPS	I
_:500	User curve #:>Block delay & op.	SPS	I
_:54	User curve #:Inactive	SPS	O
_:52	User curve #:Behavior	ENS	O
_:53	User curve #:Health	ENS	O
_:60	User curve #:Inrush blocks operate	ACT	O
_:62	User curve #:Dyn.set. AR cycle1act.	SPS	O
_:63	User curve #:Dyn.set. AR cycle2act.	SPS	O
_:64	User curve #:Dyn.set. AR cycle3act.	SPS	O

No.	Information	Data Class (Type)	Type
_:65	User curve #:Dyn.set. ARcycl.>3act	SPS	O
_:66	User curve #:Dyn.set. CLP active	SPS	O
_:67	User curve #:Dyn.set. BI active	SPS	O
_:68	User curve #:Dyn. set. blks. pickup	SPS	O
_:59	User curve #:Disk emulation running	SPS	O
_:55	User curve #:Pickup	ACD	O
_:56	User curve #:Operate delay expired	ACT	O
_:57	User curve #:Operate	ACT	O

6.5.7 Blocking of the Tripping by Device-Internal Inrush-Current Detection

6.5.7.1 Description

The **Blk. w. inrush curr. detect.** parameter allows you to define whether the operate indication of the stage should be blocked when a threshold value is exceeded due to an inrush current. In case of a blocking and fulfilled pickup conditions, the stage picks up. The start of the time delay and the operate indication are blocked. The function indicates this through a corresponding indication. If the blocking drops out and the pickup conditions are still met, the time delay is started. After that time, the stage operates.

The **Blk. w. 2nd harm. gnd. det.** parameter allows you to define whether the operate indication of the stage should be blocked when the detected 2nd harmonic component of the ground current exceeds a threshold value. In case of a blocking and fulfilled pickup conditions, the stage picks up. The start of the time delay and the operate indication are blocked. The function indicates this through a corresponding indication. If the blocking drops out and the pickup conditions are still met, the time delay is started. After that time, the stage operates.

The following figure only shows the part of the stage (exemplified by definite-time overcurrent protection stage 1) that illustrates the influence of the inrush-current detection. Only if the central function **Inrush-current detection** (see section [14.9 Inrush-Current Detection](#)) is in effect can the blocking be set.

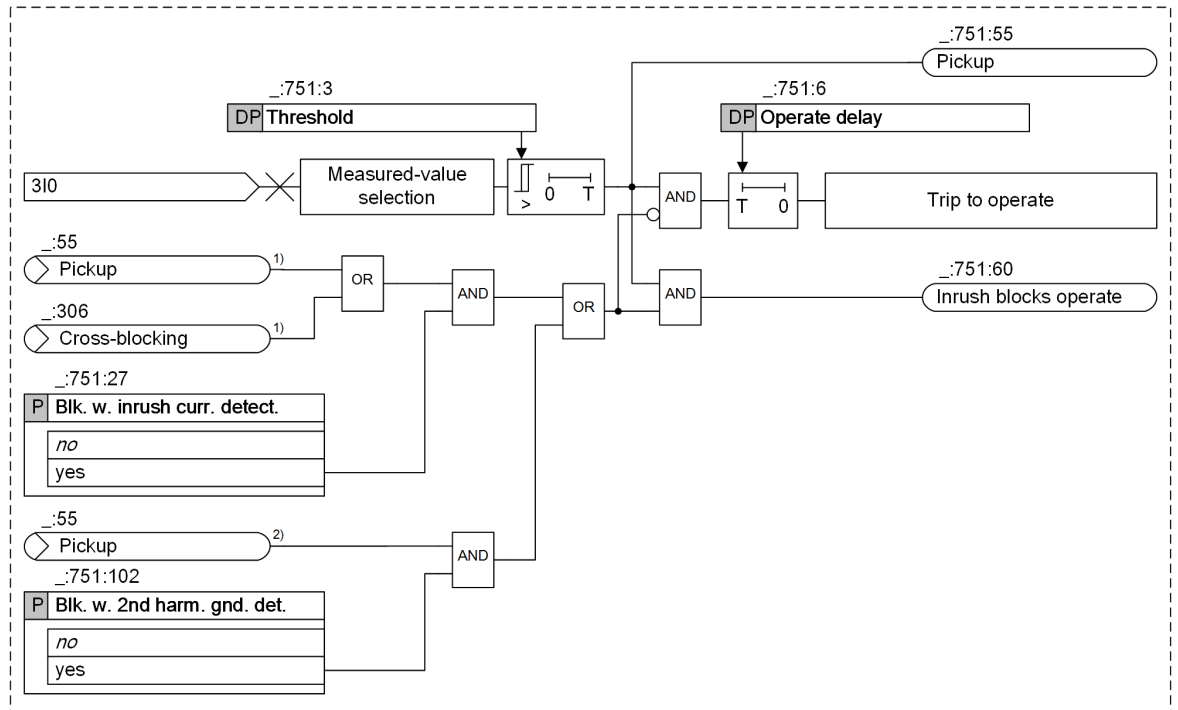

[to_ ocp_grd_2_en_US]

Figure 6-36 Part-Logic Diagram on the Influence of Inrush-Current Detection Exemplified by the 1st Definite-Time Overcurrent Protection Stage

- (1) From FB **Inrush-current detection**
- (2) From FB **2nd harmonic ground-current detection**

6.5.7.2 Application and Setting Notes

Parameter: **Blk. w. inrush curr. detect.**

- Default setting (_:751:27) **Blk. w. inrush curr. detect. = no**

Parameter Value	Description
no	<p>The transformer inrush-current detection does not affect the stage. Select this setting in the following cases:</p> <ul style="list-style-type: none"> • In cases where the device is not used on transformers. • In cases where the device is used on transformers and the threshold value of the stage is set above the maximum inrush current of the transformer. This, for example, applies to the high-current stage that is set such according to the short-circuit voltage V_{sc} of the transformer that it only picks up on faults from the high-voltage side. The transformer inrush current cannot become larger than the maximum transmittable short-circuit current.
yes	<p>When the transformer inrush-current detection detects an inrush current that would lead to a tripping of the stage, the start of the time delay and tripping of the stage are blocked. Select this setting if the device is used on transformers and the threshold value of the stage is set below the maximum inrush current of the transformer. This applies to the overcurrent-protection stage, which is used as a backup stage with grading time for faults on the undervoltage side of the transformer.</p>

Parameter: **Blk. w. 2nd harm. gnd. det.**

- Default setting (`_:751:102`) **Blk. w. 2nd harm. gnd. det. = no**

Parameter Value	Description
no	If no 3I0/IIN current flow due to CT saturation with a level above the pickup threshold is expected, select this setting.
yes	If 3I0/IIN current flow due to CT saturation with a level above the pickup threshold is expected, the blocking must be activated. This provides stability for the following conditions: <ul style="list-style-type: none"> • CT saturation without inrush current since a saturated signal also contains 2nd-harmonic content • Phase inrush current that leads to CT saturation and therefore causes 2nd-harmonic inrush current being present also in the parasitic 3I0 current

6.5.8 Influence of Other Functions via Dynamic Settings

6.5.8.1 Description

Link to the Device-Internal Function *Cold-Load Pickup Detection (Advanced Stage)*

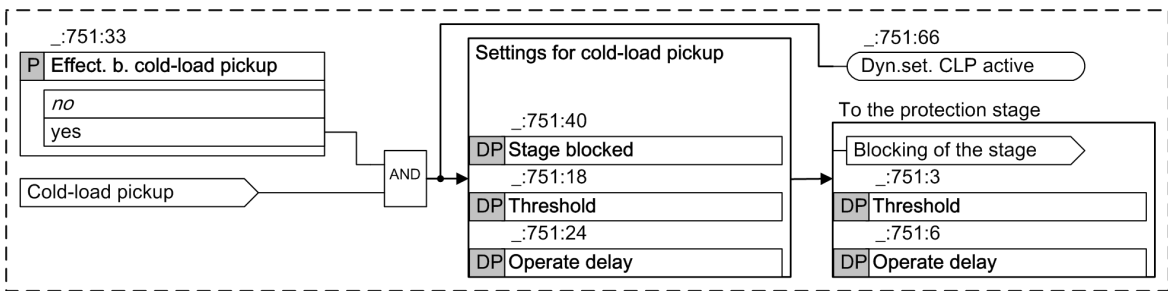

[ilo_occup_kal_gnd_1_en_US]

Figure 6-37 Influence of the Cold-Load Pickup Detection on the Overcurrent-Protection Stage

You have the option of changing the settings for the **Threshold** and the **Operate delay** of the protection stage for a cold-load pickup. You can also block the stage. To do so, you must activate the influence of the cold-load pickup. You also have to set the **Threshold** and **Operate delay** or assign settings to **Stage blocked**, which take effect when the signal is active.

The way signals are generated **Cold-load pickup** is described in chapter [5.10.8 Cold-Load Pickup Detection \(Optional\)](#).

Link to an External *Function via a Binary Input Signal (Advanced Stage)*

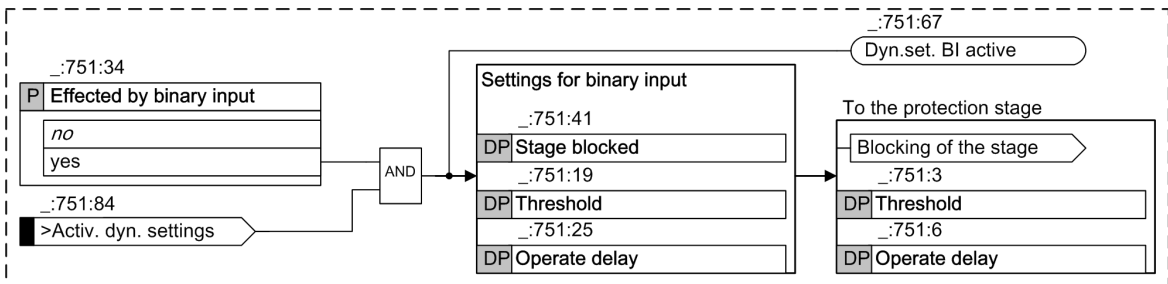

[ilo_occup_bin_gnd_1_en_US]

Figure 6-38 Influence of the Binary Input on the Overcurrent-Protection Stage

You can use the binary input signal **>Activ. dyn. settings** to change the settings for the **Threshold** and the **Operate delay** of the protection stage. You can also block the stage. To do so, you must activate the influence of the binary input. You also have to set the **Threshold** and **Operate delay** or assign settings to **Stage blocked**, which take effect when the signal is active.

6.5.8.2 Application and Setting Notes (Advanced Stage)

6.6 Directional Overcurrent Protection, Phases

6.6.1 Overview of Functions

The **Directional overcurrent protection, phases** function (ANSI 67):

- Detects short circuits at electrical equipment
- Can be used as backup or emergency overcurrent protection in addition to the main protection
- Ensures selective fault detection for parallel lines or transformers with infeed at one end
- Ensures selective fault detection in cable runs with infeed at both ends or in lines connected to form ring topologies

6.6.2 Structure of the Function

6.6.3 Stage Control

6.6.3.1 Description

Logic

The following figure represents the stage control. It applies to all types of stages.

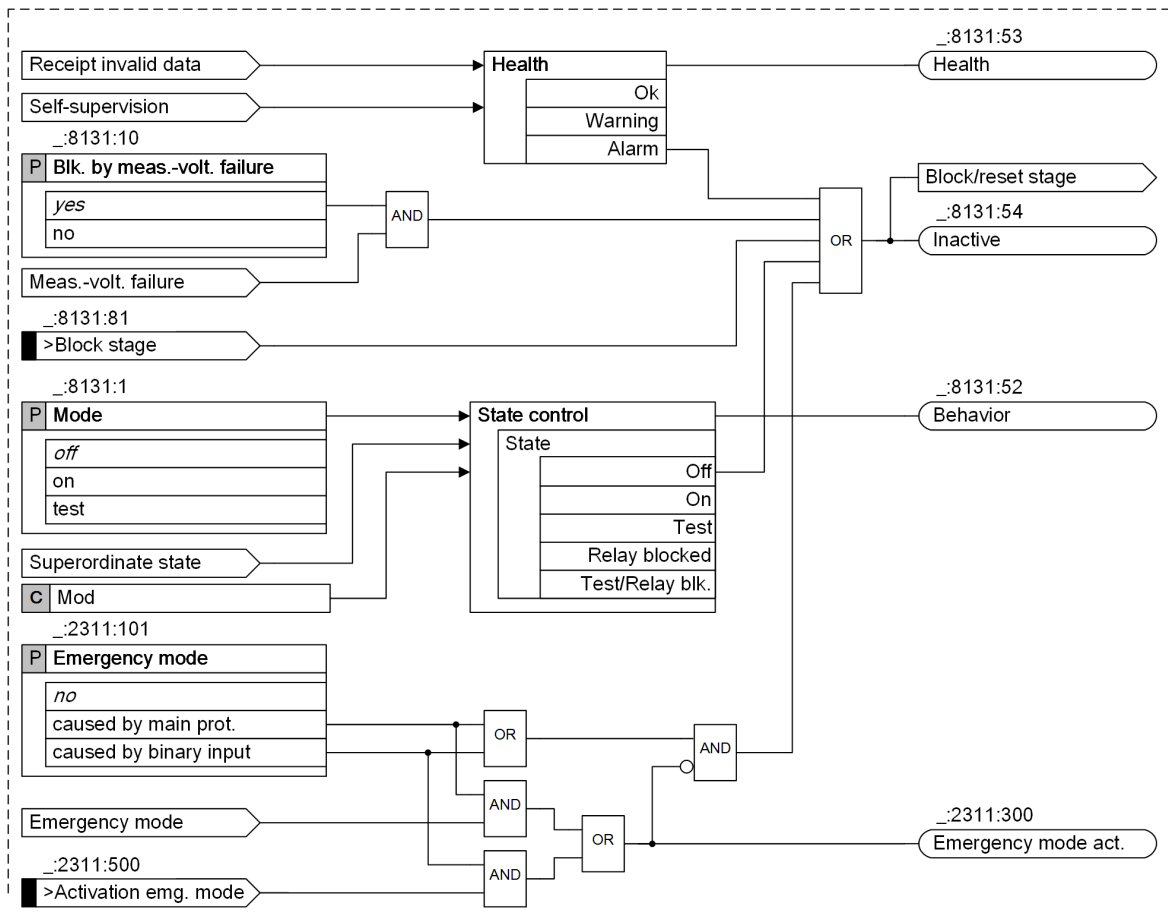

[no_dhcp_32_2_en_US]

Figure 6-39 Stage-Control Logic Diagram

Emergency Mode (Advanced Stage)

You use the **Emergency mode** parameter to define whether the stage operates as emergency overcurrent protection or as backup overcurrent protection. With the setting **Emergency mode = caused by main prot.**, emergency overcurrent protection starts automatically when the main protection fails. With the appropriate parameterization (**Emergency mode = caused by binary input**), the emergency mode can also be activated from an external source.

If the overcurrent protection is set as backup overcurrent protection (parameter **Emergency mode = no**), it operates independently of the main protection and thus in parallel.

Blocking of the Stage with Measuring-Voltage Failure (Basic and Advanced Stage)

The stage can be blocked if a measuring-voltage failure occurs. In the event of blocking, the picked up stage will be reset. The following blocking options are available for the stage:

- From inside on pickup of the **Measuring-voltage failure detection** function (see chapter [10.3.2.1 Overview of Functions](#))
- From an external source via the binary input signal **>Open** of the function block **Volt.-transf. c. b.**, which links in the tripping of the voltage-transformer circuit breaker

The **Blk. by meas.-volt. failure** parameter can be set so that measuring-voltage failure detection blocks the stage or does not block it.

6.6.3.2 Application and Setting Notes

Parameter: Blk. by meas.-volt. failure

- Recommended setting value (**_:8131:10**) **Blk. by meas.-volt. failure = yes**

You use the **Blk. by meas.-volt. failure** parameter to control the behavior of the stage when a measuring-voltage failure is detected.

A measuring-voltage failure can only be detected if one of the following two conditions is met:

- The device-internal supervision function **Measuring-voltage failure detection** is configured and switched on.
- The binary input signal **>Open** of the function block **VTCTB** is connected to the voltage-transformer circuit breaker (see chapter [10.3.4.1 Overview of Functions](#)).

Parameter Value	Description
yes	The directional overcurrent-protection stage is blocked. Siemens recommends that you retain the default setting, as correct direction determination cannot be guaranteed if a measuring-voltage failure occurs.
no	The directional overcurrent-protection stage is not blocked.

6.6.4 Stage with Definite-Time Characteristic Curve

6.6.4.1 Description

Logic of the Basic Stage

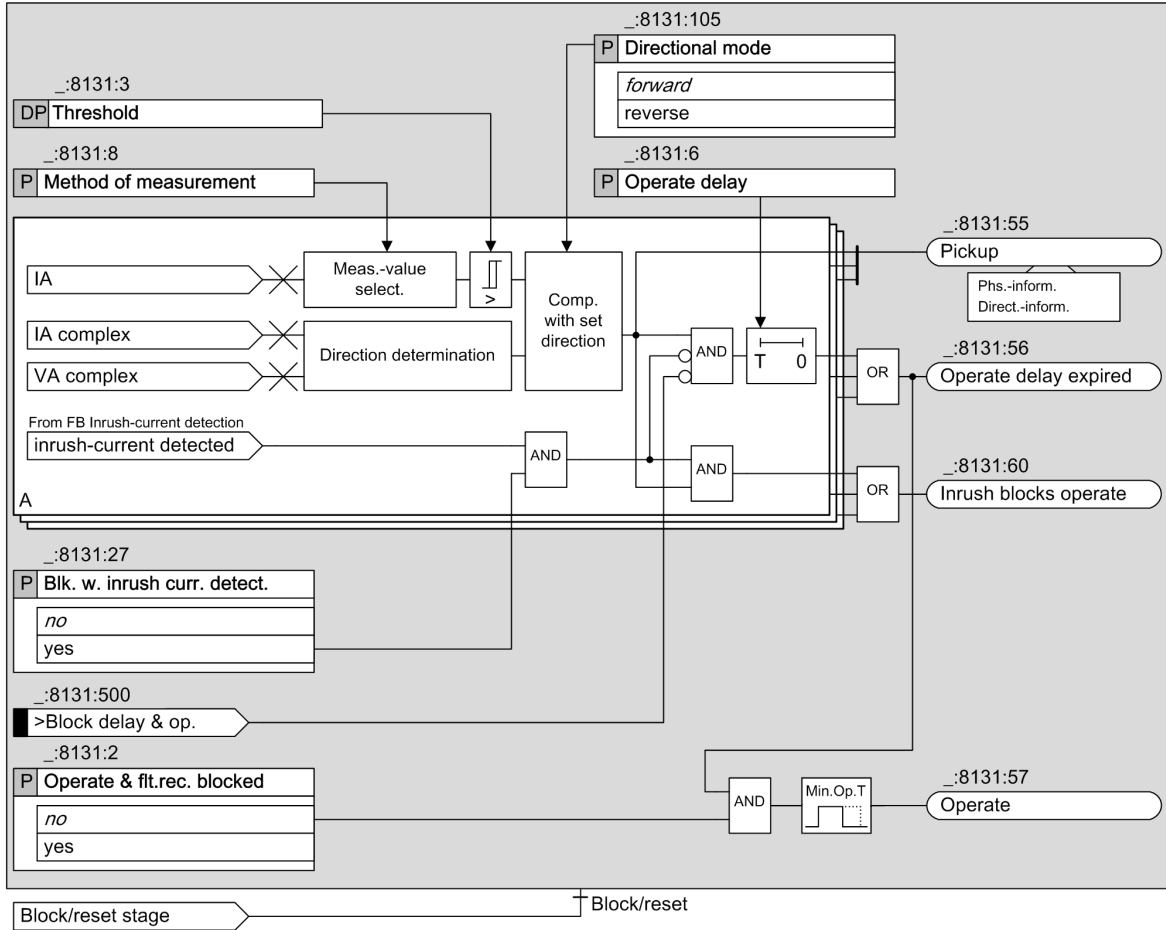

[la_doc66b, 2, en_US]

Figure 6-40 Logic Diagram of the Directional, Definite-Time Overcurrent Protection, Phases - Basic

Logic of the Advanced Stage

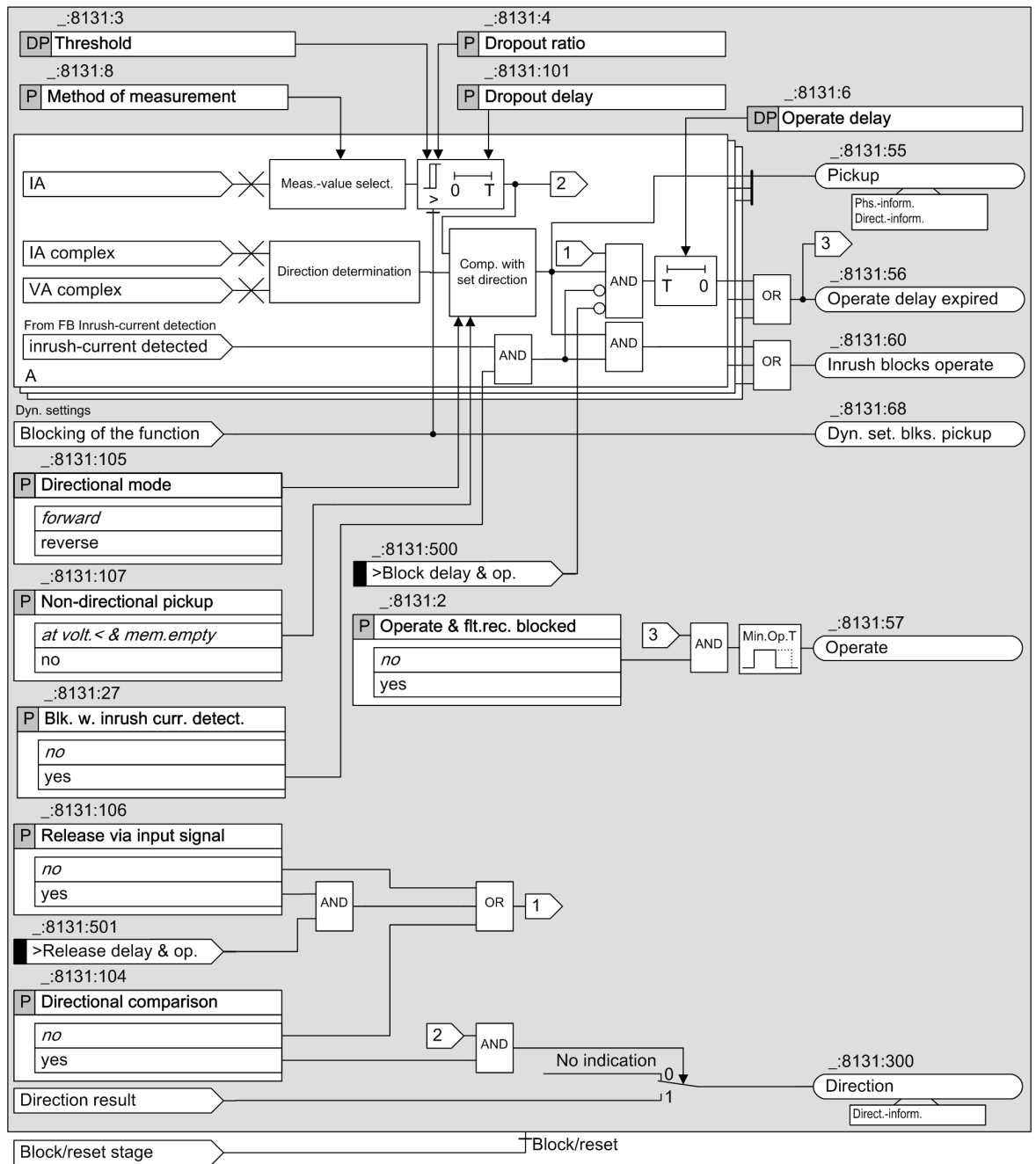

[to_docp_31_1_en_US]

Figure 6-41 Logic Diagram of the Directional, Definite-Time Overcurrent Protection, Phases - Advanced

Directional Mode (Basic and Advanced Stage)

You use the **Directional mode** parameter to define whether the stage works in a forward or reverse direction.

Direction determination itself works across stages (see section [6.6.7.1 Description](#)).

Non-Directional Pickup, Voltage Memory (Basic and Advanced Stage)

If a 3-phase close-up fault occurs, all 3 phase-to-ground voltages drop to almost 0. If this happens, direction determination can fall back on a voltage memory (see chapter [6.6.7.1 Description](#)). If no voltage

measurements which can be used to determine the direction are available in the voltage memory, the basic stage generally picks up without direction determination, that is non-directionally. For the advanced stage, the response can be defined via the **Non-directional pickup** parameter. With the **at volt.< & mem.empty** setting, the function picks up in such a situation without direction determination. With the **no** setting, the function does not pick up.

Directional Comparison Protection (Advanced Stage)

The stage can be used for directional comparison protection. This is set using the **Directional comparison** parameter. With the **yes** setting, the function uses the threshold-value violation to determine the direction (forward or reverse) and reports the indication **Direction**. The direction indicated is independent of the directional mode set for the stage.

The **Release via input signal** setting and the **>Release delay & op.** input signal are available with directional comparison protection. If the **Release via input signal** parameter is set to **yes**, the start of the time delay, and therefore the tripping of the stage, are only enabled if the **>Release delay & op.** input signal is active.

Method of Measurement (Basic and Advanced Stage)

You use the **Method of measurement** parameter to define whether the stage uses the **fundamental comp.** or the calculated **RMS value**.

- Measurement of the fundamental component:
This method of measurement processes the sampled current values and filters out the fundamental component numerically.
- Measurement of the RMS value:
This method of measurement determines the current amplitude from the sampled values according to the defining equation of the RMS value. Harmonics are included in the analysis.

Dropout Delay (Advanced Stage)

If the value falls below the dropout threshold, the dropout can be delayed. The pickup is maintained for the specified time. The tripping delay continues to run. If the time delay expires while the pickup is still maintained, the stage operates.

Blocking of the Stage (Basic and Advanced Stage)

The following blockings reset the picked up stage completely:

- Externally or internally via the binary input signal **>Block stage** (see chapter [6.6.3.1 Description](#))
- Measuring-voltage failure (see chapter [6.6.3.1 Description](#))
- Via the dynamic settings function (only provided in the Advanced function type, see chapter **Influence of other functions via dynamic settings** and chapter [6.3.8.1 Description](#))

Blocking of the Time Delay (Basic and Advanced Stage)

You can use the binary input signal **>Block delay & op.** to prevent the start of the time delay and thus also the operate signal. A running time delay is reset. The pickup is indicated and the fault logging and recording takes place.

Blocking of the Operate Delay and the Operate Signal via the Device-Internal Inrush-Current Detection Function (Basic and Advanced Stage)

Blocking of the operate delay and the operate signal via the device-internal **Inrush-current detection** function is described in chapter [6.3.7.1 Description](#) .

6.6.4.2 Application and Setting Notes

Parameter: Directional mode

- Default setting (`_:8131:105`) **Directional mode** = *forward*

You use the **Directional mode** parameter to define the directional mode of the stage.

Parameter Value	Description
<i>forward</i>	Select this setting if the stage is to work in a forward direction (in the direction of the line).
<i>reverse</i>	Select this setting if the stage is to work in a reverse direction (in the direction of the busbar).

Parameter: Method of measurement

- Recommended setting value (`_:8131:8`) **Method of measurement** = *fundamental comp.*

With the **Method of measurement** parameter, you define whether the stage uses the *fundamental comp.* (standard method) or the calculated **RMS value**.

Parameter Value	Description
<i>fundamental comp.</i>	Select this method of measurement if harmonics or transient current peaks are to be suppressed. Siemens recommends using this method as the standard method.
RMS value	Select this method of measurement if you want the stage to take harmonics into account (for example, at capacitor banks). Consider that aperiodic DC components present in the secondary circuit are measured and can cause an overfunction. For this method of measurement, do not set the threshold value of the stage to less than $0.1 I_{rated,sec}$. If currents from more than one measuring point are added up in the current interface of a function group, the setting value should not be set lower than $0.1 I_{rated,sec}$ multiplied by the number of added currents.

Parameter: Directional comparison, Release via input signal

- Default setting (`_:8131:104`) **Directional comparison** = *no*
- Default setting (`_:8131:106`) **Release via input signal** = *no*

These 2 parameters are not visible in the basic stage.

You use these parameters to define whether the stage is to be used for directional comparison protection. Directional comparison protection is performed via the **Direction** and **>Release delay & op.** signals.

Parameter Value	Description
<i>no</i>	The stage is not used for directional comparison protection.
yes	If the Directional comparison parameter is set to yes , the Release via input signal parameter, the Direction output signal, and the >Release delay & op. input signal become available. If the Release via input signal parameter is set to yes , the start of the time delay, and therefore also the operate signal of the stage, are only enabled if the >Release delay & op. input signal is active. The >Release delay & op. input signal must be connected to the release information from the opposite end (forward information from the Direction output signal); see also the application example in 6.6.10 Application Notes for Directional Comparison Protection .

Parameter: Non-directional pickup

- Recommended setting value (`_:8131:107`) **Non-directional pickup = at volt.< & mem.empty**

This parameter is not visible in the basic stage.

Parameter Value	Description
at volt.< & mem.empty	Select this setting if the stage is to pick up in a non-directional manner if the voltage memory is empty and determining of direction has to be performed at low voltages (3-phase close-up fault). An empty voltage memory may exist, for example, if there is a voltage transformer at the line end and the circuit breaker (CB) trips. Siemens recommends using the default setting.
no	Select this setting if determining of direction is required under all circumstances, that is, even in the event of pickup on a 3-phase close-up fault.

Parameter: Threshold

- Default setting (`_:8131:3`) **Threshold = 1.50 A** (for the first stage)

The same considerations apply to setting the threshold value as for non-directional overcurrent protection. For further information, refer to section [6.3.4.2 Application and Setting Notes](#).

Parameter: Operate delay

- Default setting (`_:8131:6`) **Operate delay = 0.300 s** (for the 1st stage)

The Operate delay to be set is derived from the time-grading schedule that has been prepared for the system. Where overcurrent protection is used in emergency mode, shorter time delays might be reasonable (one grading time above fast tripping), since the emergency mode only operates if the main protection function fails.

Typical examples of grading times are provided in [6.6.9 Application Notes for Parallel Lines](#) and [6.6.10 Application Notes for Directional Comparison Protection](#).

Parameter: Dropout ratio

- Recommended setting value (`_:8131:4`) **Dropout ratio = 0.95**

This parameter is not visible in the basic stage.

The recommended set value of 0.95 is appropriate for most applications.

For high-precision measurements, the setting value of the **Dropout ratio** parameter can be reduced, for example to 0.98. If you expect heavily fluctuating measurands at the response threshold, you can increase the setting value of the **Dropout ratio** parameter. This avoids chattering of the tripping stage.

Parameter: Dropout delay

- Recommended setting value (`_:8131:101`) **Dropout delay = 0 s**

This parameter is not visible in the basic stage.

Siemens recommends using this setting value, since the dropout of a protection stage must be performed as fast as possible.

You can use the **Dropout delay** parameter $\neq 0$ s to obtain a uniform dropout behavior if you use it together with an electromechanical relay. This is required for time grading. The dropout time of the electromechanical relay must be known for this purpose. Subtract the dropout time of your own device (see Technical Data) and set the result.

6.6.4.3 Settings

Addr.	Parameter	C	Setting Options	Default Setting
General				
_:2311:101	General:Emergency mode		<ul style="list-style-type: none"> no caused by main prot. caused by binary input 	no
_:2311:102	General:Rotation angle of ref. volt.		-180 ° to 180 °	45 °
General				
_:8131:1	Definite-T 1:Mode		<ul style="list-style-type: none"> off on test 	off
_:8131:2	Definite-T 1:Operate & flt.rec. blocked		<ul style="list-style-type: none"> no yes 	no
_:8131:105	Definite-T 1:Directional mode		<ul style="list-style-type: none"> forward reverse 	forward
_:8131:8	Definite-T 1:Method of measurement		<ul style="list-style-type: none"> fundamental comp. RMS value 	fundamental comp.
_:8131:107	Definite-T 1:Non-directional pickup		<ul style="list-style-type: none"> no at volt.< & mem.empty 	at volt.< & mem.empty
_:8131:104	Definite-T 1:Directional comparison		<ul style="list-style-type: none"> no yes 	no
_:8131:106	Definite-T 1:Release via input signal		<ul style="list-style-type: none"> no yes 	no
_:8131:10	Definite-T 1:Blk. by meas.-volt. failure		<ul style="list-style-type: none"> no yes 	yes
_:8131:26	Definite-T 1:Dynamic settings		<ul style="list-style-type: none"> no yes 	no
_:8131:27	Definite-T 1:Blk. w. inrush curr. detect.		<ul style="list-style-type: none"> no yes 	no
_:8131:3	Definite-T 1:Threshold	1 A @ 100 Irated	0.030 A to 40.000 A	1.500 A
		5 A @ 100 Irated	0.15 A to 200.00 A	7.50 A
		1 A @ 50 Irated	0.030 A to 40.000 A	1.500 A
		5 A @ 50 Irated	0.15 A to 200.00 A	7.50 A
		1 A @ 1.6 Irated	0.001 A to 1.600 A	1.500 A
		5 A @ 1.6 Irated	0.005 A to 8.000 A	7.500 A
_:8131:4	Definite-T 1:Dropout ratio		0.90 to 0.99	0.95
_:8131:101	Definite-T 1:Dropout delay		0.00 s to 60.00 s	0.00 s
_:8131:6	Definite-T 1:Operate delay		0.00 s to 60.00 s	0.30 s
Dyn. s: AR off/n.rdy				
_:8131:28	Definite-T 1:Effect. by AR off/n.ready		<ul style="list-style-type: none"> no yes 	no
_:8131:35	Definite-T 1:Stage blocked		<ul style="list-style-type: none"> no yes 	no

Addr.	Parameter	C	Setting Options	Default Setting
Dyn.set: AR cycle 1				
_:8131:29	Definite-T 1:Effected by AR cycle 1		<ul style="list-style-type: none"> • no • yes 	no
_:8131:36	Definite-T 1:Stage blocked		<ul style="list-style-type: none"> • no • yes 	no
_:8131:14	Definite-T 1:Threshold	1 A @ 100 Irated	0.030 A to 40.000 A	1.500 A
		5 A @ 100 Irated	0.15 A to 200.00 A	7.50 A
		1 A @ 50 Irated	0.030 A to 40.000 A	1.500 A
		5 A @ 50 Irated	0.15 A to 200.00 A	7.50 A
		1 A @ 1.6 Irated	0.001 A to 1.600 A	1.500 A
		5 A @ 1.6 Irated	0.005 A to 8.000 A	7.500 A
_:8131:20	Definite-T 1:Operate delay		0.00 s to 60.00 s	0.30 s
Dyn.set: AR cycle 2				
_:8131:30	Definite-T 1:Effected by AR cycle 2		<ul style="list-style-type: none"> • no • yes 	no
_:8131:37	Definite-T 1:Stage blocked		<ul style="list-style-type: none"> • no • yes 	no
_:8131:15	Definite-T 1:Threshold	1 A @ 100 Irated	0.030 A to 40.000 A	1.500 A
		5 A @ 100 Irated	0.15 A to 200.00 A	7.50 A
		1 A @ 50 Irated	0.030 A to 40.000 A	1.500 A
		5 A @ 50 Irated	0.15 A to 200.00 A	7.50 A
		1 A @ 1.6 Irated	0.001 A to 1.600 A	1.500 A
		5 A @ 1.6 Irated	0.005 A to 8.000 A	7.500 A
_:8131:21	Definite-T 1:Operate delay		0.00 s to 60.00 s	0.30 s
Dyn.set: AR cycle 3				
_:8131:31	Definite-T 1:Effected by AR cycle 3		<ul style="list-style-type: none"> • no • yes 	no
_:8131:38	Definite-T 1:Stage blocked		<ul style="list-style-type: none"> • no • yes 	no
_:8131:16	Definite-T 1:Threshold	1 A @ 100 Irated	0.030 A to 40.000 A	1.500 A
		5 A @ 100 Irated	0.15 A to 200.00 A	7.50 A
		1 A @ 50 Irated	0.030 A to 40.000 A	1.500 A
		5 A @ 50 Irated	0.15 A to 200.00 A	7.50 A
		1 A @ 1.6 Irated	0.001 A to 1.600 A	1.500 A
		5 A @ 1.6 Irated	0.005 A to 8.000 A	7.500 A
_:8131:22	Definite-T 1:Operate delay		0.00 s to 60.00 s	0.30 s
Dyn.s: AR cycle>3				
_:8131:32	Definite-T 1:Effected by AR cycle gr. 3		<ul style="list-style-type: none"> • no • yes 	no
_:8131:39	Definite-T 1:Stage blocked		<ul style="list-style-type: none"> • no • yes 	no

Addr.	Parameter	C	Setting Options	Default Setting
_:8131:17	Definite-T 1:Threshold	1 A @ 100 Irated	0.030 A to 40.000 A	1.500 A
		5 A @ 100 Irated	0.15 A to 200.00 A	7.50 A
		1 A @ 50 Irated	0.030 A to 40.000 A	1.500 A
		5 A @ 50 Irated	0.15 A to 200.00 A	7.50 A
		1 A @ 1.6 Irated	0.001 A to 1.600 A	1.500 A
		5 A @ 1.6 Irated	0.005 A to 8.000 A	7.500 A
_:8131:23	Definite-T 1:Operate delay		0.00 s to 60.00 s	0.30 s
<i>Dyn.s: Cold load PU</i>				
_:8131:33	Definite-T 1:Effect. b. cold-load pickup		<ul style="list-style-type: none"> • no • yes 	no
_:8131:40	Definite-T 1:Stage blocked		<ul style="list-style-type: none"> • no • yes 	no
_:8131:18	Definite-T 1:Threshold	1 A @ 100 Irated	0.030 A to 40.000 A	1.500 A
		5 A @ 100 Irated	0.15 A to 200.00 A	7.50 A
		1 A @ 50 Irated	0.030 A to 40.000 A	1.500 A
		5 A @ 50 Irated	0.15 A to 200.00 A	7.50 A
		1 A @ 1.6 Irated	0.001 A to 1.600 A	1.500 A
		5 A @ 1.6 Irated	0.005 A to 8.000 A	7.500 A
_:8131:24	Definite-T 1:Operate delay		0.00 s to 60.00 s	0.30 s
<i>Dyn.set: bin.input</i>				
_:8131:34	Definite-T 1:Effected by binary input		<ul style="list-style-type: none"> • no • yes 	no
_:8131:41	Definite-T 1:Stage blocked		<ul style="list-style-type: none"> • no • yes 	no
_:8131:19	Definite-T 1:Threshold	1 A @ 100 Irated	0.030 A to 40.000 A	1.500 A
		5 A @ 100 Irated	0.15 A to 200.00 A	7.50 A
		1 A @ 50 Irated	0.030 A to 40.000 A	1.500 A
		5 A @ 50 Irated	0.15 A to 200.00 A	7.50 A
		1 A @ 1.6 Irated	0.001 A to 1.600 A	1.500 A
		5 A @ 1.6 Irated	0.005 A to 8.000 A	7.500 A
_:8131:25	Definite-T 1:Operate delay		0.00 s to 60.00 s	0.30 s
<i>General</i>				
_:8132:1	Definite-T 2:Mode		<ul style="list-style-type: none"> • off • on • test 	off
_:8132:2	Definite-T 2:Operate & flt.rec. blocked		<ul style="list-style-type: none"> • no • yes 	no
_:8132:105	Definite-T 2:Directional mode		<ul style="list-style-type: none"> • forward • reverse 	forward
_:8132:8	Definite-T 2:Method of measurement		<ul style="list-style-type: none"> • fundamental comp. • RMS value 	fundamental comp.
_:8132:107	Definite-T 2:Non-directional pickup		<ul style="list-style-type: none"> • no • at volt.< & mem.empty 	at volt.< & mem.empty

Addr.	Parameter	C	Setting Options	Default Setting
_:8132:104	Definite-T 2:Directional comparison		<ul style="list-style-type: none"> • no • yes 	no
_:8132:106	Definite-T 2:Release via input signal		<ul style="list-style-type: none"> • no • yes 	no
_:8132:10	Definite-T 2:Blk. by meas.-volt. failure		<ul style="list-style-type: none"> • no • yes 	yes
_:8132:26	Definite-T 2:Dynamic settings		<ul style="list-style-type: none"> • no • yes 	no
_:8132:27	Definite-T 2:Blk. w. inrush curr. detect.		<ul style="list-style-type: none"> • no • yes 	no
_:8132:3	Definite-T 2:Threshold	1 A @ 100 Irated	0.030 A to 40.000 A	2.000 A
		5 A @ 100 Irated	0.15 A to 200.00 A	10.00 A
		1 A @ 50 Irated	0.030 A to 40.000 A	2.000 A
		5 A @ 50 Irated	0.15 A to 200.00 A	10.00 A
		1 A @ 1.6 Irated	0.001 A to 1.600 A	2.000 A
		5 A @ 1.6 Irated	0.005 A to 8.000 A	10.000 A
_:8132:4	Definite-T 2:Dropout ratio		0.90 to 0.99	0.95
_:8132:101	Definite-T 2:Dropout delay		0.00 s to 60.00 s	0.00 s
_:8132:6	Definite-T 2:Operate delay		0.00 s to 60.00 s	0.10 s
Dyn. s: AR off/n.rdy				
_:8132:28	Definite-T 2:Effect. by AR off/n.ready		<ul style="list-style-type: none"> • no • yes 	no
_:8132:35	Definite-T 2:Stage blocked		<ul style="list-style-type: none"> • no • yes 	no
Dyn.set: AR cycle 1				
_:8132:29	Definite-T 2:Effected by AR cycle 1		<ul style="list-style-type: none"> • no • yes 	no
_:8132:36	Definite-T 2:Stage blocked		<ul style="list-style-type: none"> • no • yes 	no
_:8132:14	Definite-T 2:Threshold	1 A @ 100 Irated	0.030 A to 40.000 A	2.000 A
		5 A @ 100 Irated	0.15 A to 200.00 A	10.00 A
		1 A @ 50 Irated	0.030 A to 40.000 A	2.000 A
		5 A @ 50 Irated	0.15 A to 200.00 A	10.00 A
		1 A @ 1.6 Irated	0.001 A to 1.600 A	2.000 A
		5 A @ 1.6 Irated	0.005 A to 8.000 A	10.000 A
_:8132:20	Definite-T 2:Operate delay		0.00 s to 60.00 s	0.10 s
Dyn.set: AR cycle 2				
_:8132:30	Definite-T 2:Effected by AR cycle 2		<ul style="list-style-type: none"> • no • yes 	no
_:8132:37	Definite-T 2:Stage blocked		<ul style="list-style-type: none"> • no • yes 	no

Addr.	Parameter	C	Setting Options	Default Setting
_:8132:15	Definite-T 2:Threshold	1 A @ 100 Irated	0.030 A to 40.000 A	2.000 A
		5 A @ 100 Irated	0.15 A to 200.00 A	10.00 A
		1 A @ 50 Irated	0.030 A to 40.000 A	2.000 A
		5 A @ 50 Irated	0.15 A to 200.00 A	10.00 A
		1 A @ 1.6 Irated	0.001 A to 1.600 A	2.000 A
		5 A @ 1.6 Irated	0.005 A to 8.000 A	10.000 A
_:8132:21	Definite-T 2:Operate delay		0.00 s to 60.00 s	0.10 s
<i>Dyn.set: AR cycle 3</i>				
_:8132:31	Definite-T 2:Effected by AR cycle 3		<ul style="list-style-type: none"> • no • yes 	no
_:8132:38	Definite-T 2:Stage blocked		<ul style="list-style-type: none"> • no • yes 	no
_:8132:16	Definite-T 2:Threshold	1 A @ 100 Irated	0.030 A to 40.000 A	2.000 A
		5 A @ 100 Irated	0.15 A to 200.00 A	10.00 A
		1 A @ 50 Irated	0.030 A to 40.000 A	2.000 A
		5 A @ 50 Irated	0.15 A to 200.00 A	10.00 A
		1 A @ 1.6 Irated	0.001 A to 1.600 A	2.000 A
		5 A @ 1.6 Irated	0.005 A to 8.000 A	10.000 A
_:8132:22	Definite-T 2:Operate delay		0.00 s to 60.00 s	0.10 s
<i>Dyn.s: AR cycle>3</i>				
_:8132:32	Definite-T 2:Effected by AR cycle gr. 3		<ul style="list-style-type: none"> • no • yes 	no
_:8132:39	Definite-T 2:Stage blocked		<ul style="list-style-type: none"> • no • yes 	no
_:8132:17	Definite-T 2:Threshold	1 A @ 100 Irated	0.030 A to 40.000 A	2.000 A
		5 A @ 100 Irated	0.15 A to 200.00 A	10.00 A
		1 A @ 50 Irated	0.030 A to 40.000 A	2.000 A
		5 A @ 50 Irated	0.15 A to 200.00 A	10.00 A
		1 A @ 1.6 Irated	0.001 A to 1.600 A	2.000 A
		5 A @ 1.6 Irated	0.005 A to 8.000 A	10.000 A
_:8132:23	Definite-T 2:Operate delay		0.00 s to 60.00 s	0.10 s
<i>Dyn.s: Cold load PU</i>				
_:8132:33	Definite-T 2:Effect. b. cold-load pickup		<ul style="list-style-type: none"> • no • yes 	no
_:8132:40	Definite-T 2:Stage blocked		<ul style="list-style-type: none"> • no • yes 	no
_:8132:18	Definite-T 2:Threshold	1 A @ 100 Irated	0.030 A to 40.000 A	2.000 A
		5 A @ 100 Irated	0.15 A to 200.00 A	10.00 A
		1 A @ 50 Irated	0.030 A to 40.000 A	2.000 A
		5 A @ 50 Irated	0.15 A to 200.00 A	10.00 A
		1 A @ 1.6 Irated	0.001 A to 1.600 A	2.000 A
		5 A @ 1.6 Irated	0.005 A to 8.000 A	10.000 A
_:8132:24	Definite-T 2:Operate delay		0.00 s to 60.00 s	0.10 s

Addr.	Parameter	C	Setting Options	Default Setting
Dyn.set: bin.input				
_:8132:34	Definite-T 2:Effected by binary input		<ul style="list-style-type: none"> no yes 	no
_:8132:41	Definite-T 2:Stage blocked		<ul style="list-style-type: none"> no yes 	no
_:8132:19	Definite-T 2:Threshold	1 A @ 100 Irated	0.030 A to 40.000 A	2.000 A
		5 A @ 100 Irated	0.15 A to 200.00 A	10.00 A
		1 A @ 50 Irated	0.030 A to 40.000 A	2.000 A
		5 A @ 50 Irated	0.15 A to 200.00 A	10.00 A
		1 A @ 1.6 Irated	0.001 A to 1.600 A	2.000 A
		5 A @ 1.6 Irated	0.005 A to 8.000 A	10.000 A
_:8132:25	Definite-T 2:Operate delay		0.00 s to 60.00 s	0.10 s

6.6.4.4 Information List

No.	Information	Data Class (Type)	Type
General			
_:2311:500	General:>Activation emg. mode	SPS	I
_:2311:501	General:>Test of direction	SPS	I
_:2311:300	General:Emergency mode act.	SPS	O
_:2311:301	General:Test direction	ACD	O
_:2311:52	General:Behavior	ENS	O
_:2311:53	General:Health	ENS	O
Group indicat.			
_:4501:55	Group indicat.:Pickup	ACD	O
_:4501:57	Group indicat.:Operate	ACT	O
_:4501:52	Group indicat.:Behavior	ENS	O
_:4501:53	Group indicat.:Health	ENS	O
Definite-T 1			
_:8131:81	Definite-T 1:>Block stage	SPS	I
_:8131:501	Definite-T 1:>Release delay & op.	SPS	I
_:8131:84	Definite-T 1:>Activ. dyn. settings	SPS	I
_:8131:500	Definite-T 1:>Block delay & op.	SPS	I
_:8131:51	Definite-T 1:Mode (controllable)	ENC	C
_:8131:54	Definite-T 1:Inactive	SPS	O
_:8131:52	Definite-T 1:Behavior	ENS	O
_:8131:53	Definite-T 1:Health	ENS	O
_:8131:60	Definite-T 1:Inrush blocks operate	ACT	O
_:8131:62	Definite-T 1:Dyn.set. AR cycle1act.	SPS	O
_:8131:63	Definite-T 1:Dyn.set. AR cycle2act.	SPS	O
_:8131:64	Definite-T 1:Dyn.set. AR cycle3act.	SPS	O
_:8131:65	Definite-T 1:Dyn.set. ARcycl.>3act	SPS	O
_:8131:66	Definite-T 1:Dyn.set. CLP active	SPS	O
_:8131:67	Definite-T 1:Dyn.set. BI active	SPS	O
_:8131:68	Definite-T 1:Dyn. set. blks. pickup	SPS	O
_:8131:55	Definite-T 1:Pickup	ACD	O

No.	Information	Data Class (Type)	Type
_:8131:300	Definite-T 1:Direction	ACD	O
_:8131:56	Definite-T 1:Operate delay expired	ACT	O
_:8131:57	Definite-T 1:Operate	ACT	O
Definite-T 2			
_:8132:81	Definite-T 2:>Block stage	SPS	I
_:8132:501	Definite-T 2:>Release delay & op.	SPS	I
_:8132:84	Definite-T 2:>Activ. dyn. settings	SPS	I
_:8132:500	Definite-T 2:>Block delay & op.	SPS	I
_:8132:54	Definite-T 2:Inactive	SPS	O
_:8132:52	Definite-T 2:Behavior	ENS	O
_:8132:53	Definite-T 2:Health	ENS	O
_:8132:60	Definite-T 2:Inrush blocks operate	ACT	O
_:8132:62	Definite-T 2:Dyn.set. AR cycle1act.	SPS	O
_:8132:63	Definite-T 2:Dyn.set. AR cycle2act.	SPS	O
_:8132:64	Definite-T 2:Dyn.set. AR cycle3act.	SPS	O
_:8132:65	Definite-T 2:Dyn.set. ARcycl.>3act	SPS	O
_:8132:66	Definite-T 2:Dyn.set. CLP active	SPS	O
_:8132:67	Definite-T 2:Dyn.set. BI active	SPS	O
_:8132:68	Definite-T 2:Dyn. set. blks. pickup	SPS	O
_:8132:55	Definite-T 2:Pickup	ACD	O
_:8132:300	Definite-T 2:Direction	ACD	O
_:8132:56	Definite-T 2:Operate delay expired	ACT	O
_:8132:57	Definite-T 2:Operate	ACT	O

6.6.5 Stage with Inverse-Time Characteristic Curve

6.6.5.1 Description

Logic of the Basic Stage

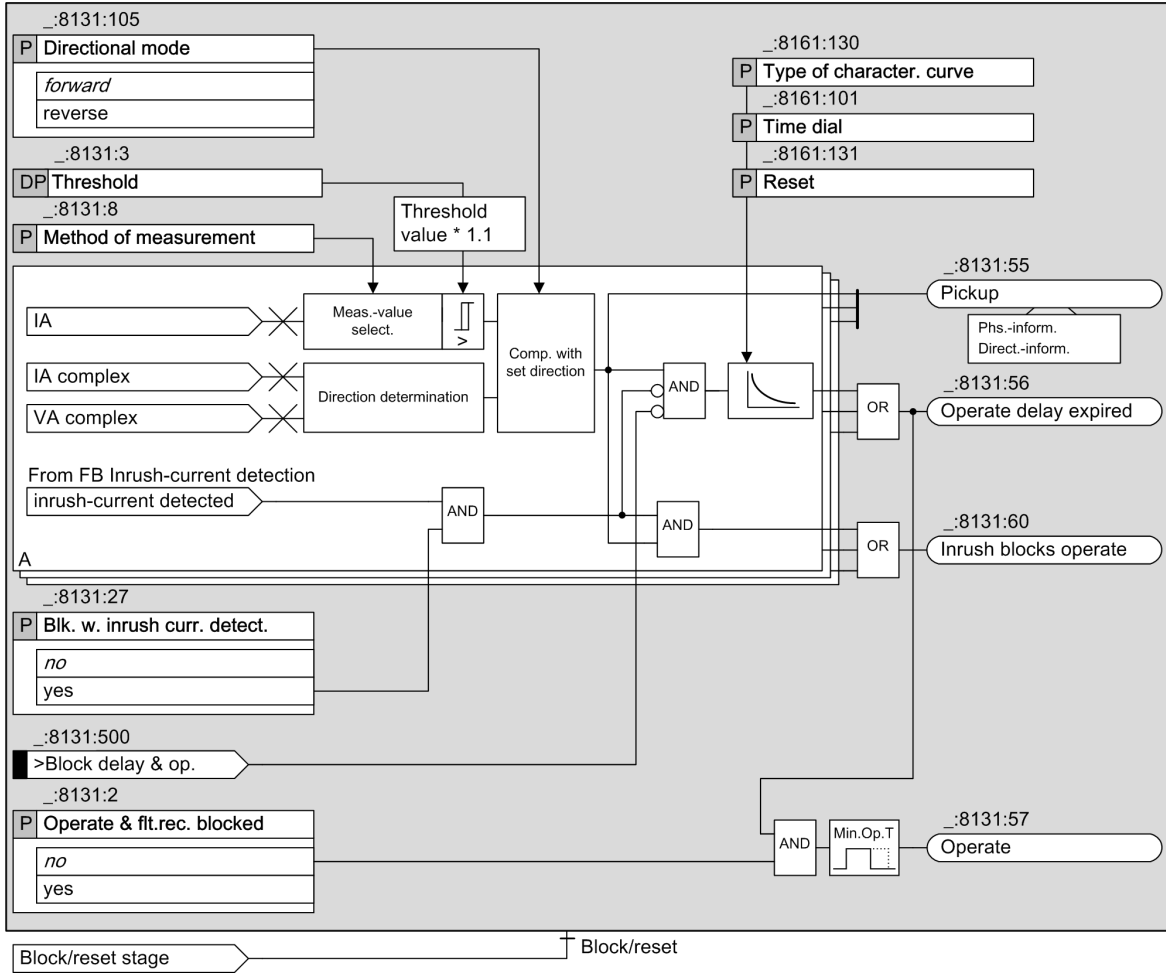

[lo_doc6b, 2, en_US]

Figure 6-42 Logic Diagram of the Directional, Inverse-Time Overcurrent Protection, Phases - Basic

Logic of the Advanced Stage

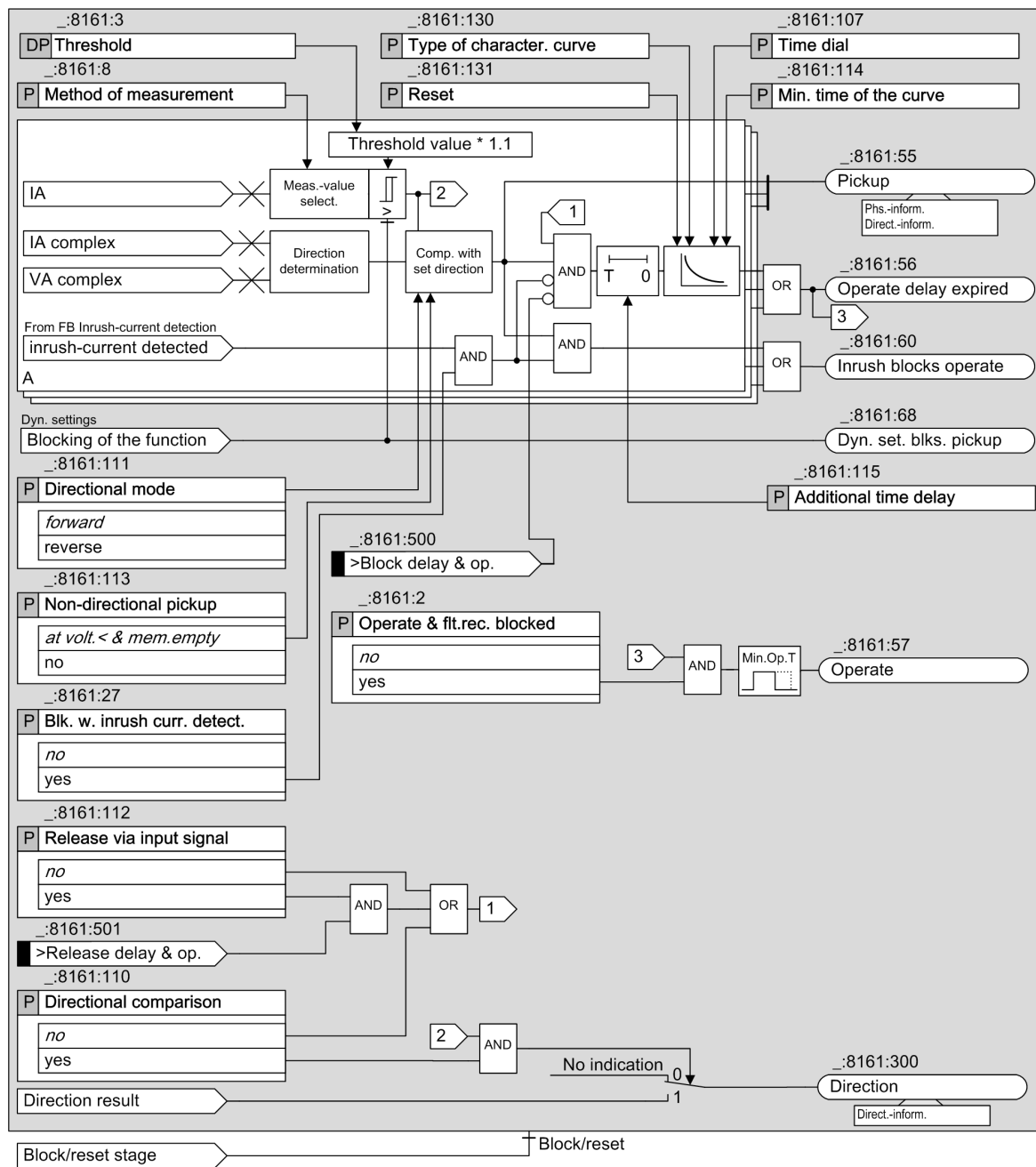

[to_docp_33_2_en_US]

Figure 6-43 Logic Diagram of the Directional, Inverse-Time Overcurrent Protection, Phases - Advanced

Directional Mode (Basic and Advanced Stage)

You use the **Directional mode** parameter to define whether the stage works in a forward or reverse direction.

The direction determination works across stages (see chapter [6.6.7.1 Description](#)).

Non-Directional Pickup, Voltage Memory (Basic and Advanced Stage)

If a 3-phase close-up fault occurs, all 3 phase-to-ground voltages drop to almost 0. If this happens, direction determination can fall back on a voltage memory (see chapter [6.6.7.1 Description](#)). If no voltage measurements which can be used to determine the direction are available in the voltage memory, the basic

stage generally picks up without direction determination, that is non-directionally. For the advanced stage, the response can be defined via the **Non-directional pickup** parameter. With the **at volt.< & mem. empty** setting, the function picks up in such a situation without direction determination. With the **no** setting, the function does not pick up.

Directional Comparison Protection (Advanced Stage)

The stage can be used for directional comparison protection. This is set using the **Directional comparison** parameter. With the **yes** setting, the function uses the threshold-value violation to determine the direction (forward or reverse) and reports the indication **Direction**. The direction indicated is independent of the directional mode set for the stage.

The **Release via input signal** setting and the **>Release delay & op.** input signal are available with directional comparison protection. If the **Release via input signal** parameter is set to **yes**, the start of the time delay, and therefore the tripping of the stage, are only enabled if the **>Release delay & op.** input signal is active.

Pickup and Dropout Behaviors of the Inverse-Time Characteristic Curve According to IEC and ANSI (Basic and Advanced Stage)

When the input variable exceeds the threshold value by a factor of 1.1, the inverse-time characteristic curve is processed. An integrating method of measurement summarizes the weighted time. The weighted time results from the characteristic curve. For this, the time that is associated with the present current value is determined from the characteristic curve. Once the weighted time exceeds the value 1, the stage operates.

When the measured value falls below the pickup value by a factor of 1.045 (0.95 · 1.1 · threshold value), the dropout is started. The pickup will be indicated as clearing. You can influence the dropout behavior via setting parameters. You can select between instantaneous dropout (totalized time is deleted) or dropout according to the characteristic curve (reduction of totalized time depending on the characteristic curve). The dropout according to characteristic curve (disk emulation) is the same as turning back a rotor disk. The weighted reduction of the time is initiated from 0.9 of the set threshold value.

The characteristic curve and associated formulas are shown in the Technical Data.

Minimum Time of the Curve (Advanced Stage)

With the parameter **Min. time of the curve**, you define a minimum operate delay time. The operate delay time of inverse-time characteristic curve never falls below the minimum operate delay time.

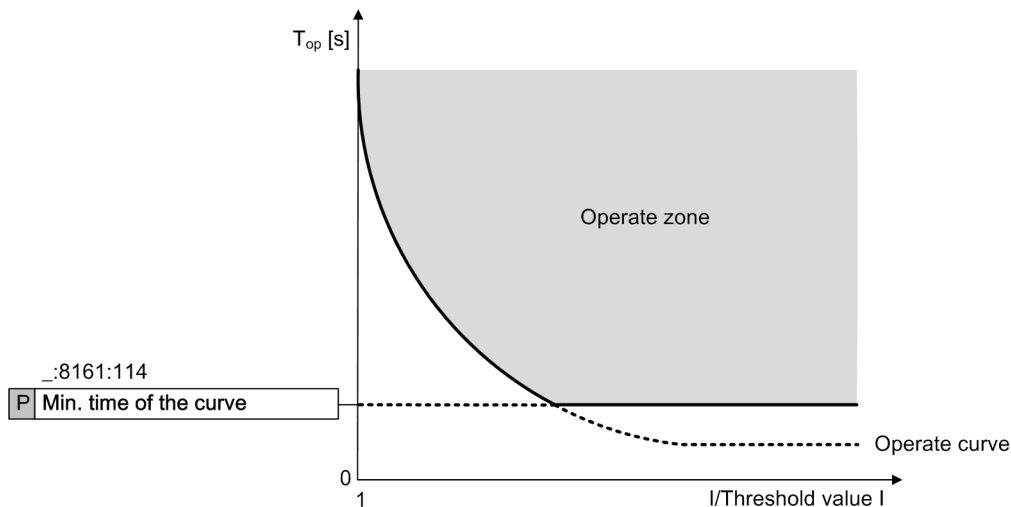

[idw_docp_01_1_en_US]
 Figure 6-44 Minimum Operating Time of the Curve

Additional Time Delay (Advanced Stage)

With the parameter **Additional time delay**, you define a definite-time delay in addition to the inverse-time delay. With this setting, the whole curve is shifted on the time axis by this additional definite time.

Blocking of the Stage (Basic and Advanced Stage)

The following blockings reset the picked up stage completely:

- Externally or internally via the binary input signal **>Block stage** (see chapter [6.6.3.1 Description](#))
- Measuring-voltage failure (see chapter [6.6.3.1 Description](#))
- Via the functionality of the **dynamic settings** (only in the advanced function type, see subtitle **Influence of other functions via dynamic settings** and chapter [6.3.8.1 Description](#)).

Blocking of the Time Delay (Basic and Advanced Stage)

You can use the binary input signal **>Block delay & op.** to prevent the start of the time delay and thus also the operate signal. A running time delay is reset. The pickup is indicated and a fault record is opened.

Blocking of the Operate Delay and the Operate Signal via the Device-Internal Inrush-Current Detection Function (Basic and Advanced Stage)

Blocking of the operate delay and the operate signal via the device-internal **Inrush-current detection** function is described in chapter [6.3.7.1 Description](#) .

6.6.5.2 Application and Setting Notes

Parameter: Directional mode

- Default setting (**_ :8161:111**) **Directional mode** = *forward*

You use the **Directional mode** parameter to define the directional mode of the stage.

Parameter Value	Description
<i>forward</i>	Select this setting if the stage is to work in a forward direction (in the direction of the line).
<i>reverse</i>	Select this setting if the stage is to work in a reverse direction (in the direction of the busbar).

Parameter: Method of measurement

- Recommended setting value (**_ :8161:8**) **Method of measurement** = *fundamental comp.*

With the **Method of measurement** parameter, you define whether the stage uses the *fundamental comp.* (standard method) or the calculated **RMS value**.

Parameter Value	Description
<i>fundamental comp.</i>	Select this method of measurement if harmonics or transient current peaks are to be suppressed. Siemens recommends using this method as the standard method.
RMS value	Select this method of measurement if you want the stage to take harmonics into account (for example, at capacitor banks). Consider that aperiodic DC components present in the secondary circuit are measured and can cause an overfunction. For this method of measurement, do not set the threshold value of the stage to less than $0.1 I_{rated,sec}$. If currents from more than one measuring point are added up in the current interface of a function group, the setting value should not be set lower than $0.1 I_{rated,sec}$ multiplied by the number of added currents.

Parameter: Directional comparison, Release via input signal

- Default setting (`_ :8161:110`) **Directional comparison** = *no*
- Default setting (`_ :8161:112`) **Release via input signal** = *no*

These 2 parameters are not visible in the basic stage.

You use these parameters to define whether the stage is to be used for directional comparison protection. Directional comparison protection is performed via the **Direction** and **>Release delay & op.** signals.

Parameter Value	Description
<i>no</i>	The stage is not used for directional comparison protection.
<i>yes</i>	If the Directional comparison parameter is set to <i>yes</i> , the Release via input signal parameter, the Direction output signal, and the >Release delay & op. input signal become available. If the Release via input signal parameter is set to <i>yes</i> , the start of the time delay, and therefore also the operate signal of the stage, are only enabled if the >Release delay & op. input signal is active. The >Release delay & op. input signal must be connected to the release information from the opposite end (forward information from the Direction output signal); see also the application example in 6.6.10 Application Notes for Directional Comparison Protection .

Parameter: Non-directional pickup

- Recommended setting value (`_ :8161:113`) **Non-directional pickup** = *at volt.< & mem.empty*

This parameter is not visible in the basic stage.

Parameter Value	Description
<i>at volt.< & mem.empty</i>	Select this setting if the stage is to pick up in a non-directional manner if the voltage memory is empty and determining of direction has to be performed at low voltages (3-phase close-up fault). An empty voltage memory may exist, for example, if there is a voltage transformer at the line end and the CB trips. Siemens recommends using the default setting.
<i>no</i>	Select this setting if determining of direction is required under all circumstances, that is, even in the event of pickup on a 3-phase close-up fault.

Parameter: Type of character. curve

- Default setting (`_ :8161:130`) **Type of character. curve** = *IEC normal inverse*

The device offers all the usual inverse-time characteristic curves according to IEC and ANSI. Select the **Type of character. curve** required for your specific application.

Parameter: Min. time of the curve

- Default setting (`_ :8161:114`) **Min. time of the curve** = *0.00 s*

This parameter is only available in the advanced stage.

With the parameter **Min. time of the curve**, you define a minimum operate delay time. The operate delay time of inverse-time characteristic curve never falls below the minimum operate delay time. If the setting is left on its default value of 0 s, this parameter has no effect on the inverse-time characteristic curve.

This parameter is only required for time coordination in recloser schemes. For all other applications, Siemens recommends keeping the default setting of 0 s.



NOTE

If the set value is smaller than the smallest possible time delay of the inverse-time characteristic curve, the parameter has no influence on the delay time.

Parameter: Additional time delay

- Default setting (`_:8161:115`) **Additional time delay** = 0.00 s

With the parameter **Additional time delay**, you define a definite-time delay in addition to the inverse-time delay.

If the setting is left on its default value of 0 s, this parameter has no effect on the inverse-time characteristic curve.

This parameter is only required for time coordination in recloser schemes. For all other applications, Siemens recommends keeping the default setting of 0 s.

Parameter: Threshold

- Default setting (`_:8161:3`) **Threshold** = 1.50 A

The same considerations apply to setting the threshold value as for non-directional overcurrent protection. Therefore, refer to [6.3.5.2 Application and Setting Notes](#) for further information.

Parameter: Time dial

- Default setting (`_:8161:101`) **Time dial** = 1

Use the **Time dial** parameter to displace the characteristic curve in the time direction.

The set value for the **Time dial** parameter is derived from the time-grading chart that has been prepared for the electrical power system. Where overcurrent protection is used in emergency mode, shorter time delays might be reasonable (one grading time above fast tripping), since the emergency mode only operates if the main protection function fails.

Where no time grading and therefore no displacement of the characteristic curve is required, leave the **Time dial** parameter at 1 (default setting).

Parameter: Reset

- Default setting (`_:8161:131`) **Reset** = *disk emulation*

You use the **Reset** parameter to define whether the stage drops out according to the dropout characteristic curve (in accordance with the behavior of a disk emulation = rotor disk) or instantaneously.

Parameter Value	Description
<i>disk emulation</i>	Select this setting if the device is coordinated with electromechanical devices or other devices which perform a dropout after a disk emulation.
<i>instantaneous</i>	Use this setting if the dropout is not to be performed after disk emulation and an instantaneous dropout is desired instead.

6.6.5.3 Settings

Addr.	Parameter	C	Setting Options	Default Setting
<i>General</i>				
_:2311:101	General:Emergency mode		<ul style="list-style-type: none"> • no • caused by main prot. • caused by binary input 	no
_:2311:102	General:Rotation angle of ref. volt.		-180 ° to 180 °	45 °

Addr.	Parameter	C	Setting Options	Default Setting
General				
_.8341:1	Inverse-T 1:Mode		<ul style="list-style-type: none"> • off • on • test 	off
_.8341:2	Inverse-T 1:Operate & flt.rec. blocked		<ul style="list-style-type: none"> • no • yes 	no
_.8341:111	Inverse-T 1:Directional mode		<ul style="list-style-type: none"> • forward • reverse 	forward
_.8341:11	Inverse-T 1:1-pole operate allowed		<ul style="list-style-type: none"> • no • yes 	no
_.8341:8	Inverse-T 1:Method of measurement		<ul style="list-style-type: none"> • fundamental comp. • RMS value 	fundamental comp.
_.8341:113	Inverse-T 1:Non-directional pickup		<ul style="list-style-type: none"> • no • at volt.< & mem.empty 	at volt.< & mem.empty
_.8341:110	Inverse-T 1:Directional comparison		<ul style="list-style-type: none"> • no • yes 	no
_.8341:112	Inverse-T 1:Release via input signal		<ul style="list-style-type: none"> • no • yes 	no
_.8341:10	Inverse-T 1:Blk. by meas.-volt. failure		<ul style="list-style-type: none"> • no • yes 	yes
_.8341:26	Inverse-T 1:Dynamic settings		<ul style="list-style-type: none"> • no • yes 	no
_.8341:27	Inverse-T 1:Blk. w. inrush curr. detect.		<ul style="list-style-type: none"> • no • yes 	no
_.8341:3	Inverse-T 1:Threshold	1 A @ 100 Irated	0.030 A to 40.000 A	1.500 A
		5 A @ 100 Irated	0.15 A to 200.00 A	7.50 A
		1 A @ 50 Irated	0.030 A to 40.000 A	1.500 A
		5 A @ 50 Irated	0.15 A to 200.00 A	7.50 A
		1 A @ 1.6 Irated	0.001 A to 1.600 A	1.500 A
		5 A @ 1.6 Irated	0.005 A to 8.000 A	7.500 A
_.8341:130	Inverse-T 1:Type of character. curve			
_.8341:114	Inverse-T 1:Min. time of the curve		0.00 s to 1.00 s	0.00 s
_.8341:131	Inverse-T 1:Reset		<ul style="list-style-type: none"> • instantaneous • disk emulation 	disk emulation
_.8341:101	Inverse-T 1:Time dial		0.05 to 15.00	1.00
_.8341:115	Inverse-T 1:Additional time delay		0.00 s to 60.00 s	0.00 s
Dyn. s: AR off/n.rdy				
_.8341:28	Inverse-T 1:Effect. by AR off/n.ready		<ul style="list-style-type: none"> • no • yes 	no
_.8341:35	Inverse-T 1:Stage blocked		<ul style="list-style-type: none"> • no • yes 	no

Addr.	Parameter	C	Setting Options	Default Setting
Dyn.set: AR cycle 1				
_:8341:29	Inverse-T 1:Effected by AR cycle 1		<ul style="list-style-type: none"> • no • yes 	no
_:8341:36	Inverse-T 1:Stage blocked		<ul style="list-style-type: none"> • no • yes 	no
_:8341:14	Inverse-T 1:Threshold	1 A @ 100 Irated	0.030 A to 40.000 A	1.500 A
		5 A @ 100 Irated	0.15 A to 200.00 A	7.50 A
		1 A @ 50 Irated	0.030 A to 40.000 A	1.500 A
		5 A @ 50 Irated	0.15 A to 200.00 A	7.50 A
		1 A @ 1.6 Irated	0.001 A to 1.600 A	1.500 A
		5 A @ 1.6 Irated	0.005 A to 8.000 A	7.500 A
_:8341:102	Inverse-T 1:Time dial		0.05 to 15.00	1.00
Dyn.set: AR cycle 2				
_:8341:30	Inverse-T 1:Effected by AR cycle 2		<ul style="list-style-type: none"> • no • yes 	no
_:8341:37	Inverse-T 1:Stage blocked		<ul style="list-style-type: none"> • no • yes 	no
_:8341:15	Inverse-T 1:Threshold	1 A @ 100 Irated	0.030 A to 40.000 A	1.500 A
		5 A @ 100 Irated	0.15 A to 200.00 A	7.50 A
		1 A @ 50 Irated	0.030 A to 40.000 A	1.500 A
		5 A @ 50 Irated	0.15 A to 200.00 A	7.50 A
		1 A @ 1.6 Irated	0.001 A to 1.600 A	1.500 A
		5 A @ 1.6 Irated	0.005 A to 8.000 A	7.500 A
_:8341:103	Inverse-T 1:Time dial		0.05 to 15.00	1.00
Dyn.set: AR cycle 3				
_:8341:31	Inverse-T 1:Effected by AR cycle 3		<ul style="list-style-type: none"> • no • yes 	no
_:8341:38	Inverse-T 1:Stage blocked		<ul style="list-style-type: none"> • no • yes 	no
_:8341:16	Inverse-T 1:Threshold	1 A @ 100 Irated	0.030 A to 40.000 A	1.500 A
		5 A @ 100 Irated	0.15 A to 200.00 A	7.50 A
		1 A @ 50 Irated	0.030 A to 40.000 A	1.500 A
		5 A @ 50 Irated	0.15 A to 200.00 A	7.50 A
		1 A @ 1.6 Irated	0.001 A to 1.600 A	1.500 A
		5 A @ 1.6 Irated	0.005 A to 8.000 A	7.500 A
_:8341:104	Inverse-T 1:Time dial		0.05 to 15.00	1.00
Dyn.s: AR cycle>3				
_:8341:32	Inverse-T 1:Effected by AR cycle gr. 3		<ul style="list-style-type: none"> • no • yes 	no
_:8341:39	Inverse-T 1:Stage blocked		<ul style="list-style-type: none"> • no • yes 	no

Addr.	Parameter	C	Setting Options	Default Setting
_8341:17	Inverse-T 1:Threshold	1 A @ 100 Irated	0.030 A to 40.000 A	1.500 A
		5 A @ 100 Irated	0.15 A to 200.00 A	7.50 A
		1 A @ 50 Irated	0.030 A to 40.000 A	1.500 A
		5 A @ 50 Irated	0.15 A to 200.00 A	7.50 A
		1 A @ 1.6 Irated	0.001 A to 1.600 A	1.500 A
		5 A @ 1.6 Irated	0.005 A to 8.000 A	7.500 A
_8341:105	Inverse-T 1:Time dial		0.05 to 15.00	1.00
Dyn.s: Cold load PU				
_8341:33	Inverse-T 1:Effect. b. cold-load pickup		<ul style="list-style-type: none"> • no • yes 	no
_8341:40	Inverse-T 1:Stage blocked		<ul style="list-style-type: none"> • no • yes 	no
_8341:18	Inverse-T 1:Threshold	1 A @ 100 Irated	0.030 A to 40.000 A	1.500 A
		5 A @ 100 Irated	0.15 A to 200.00 A	7.50 A
		1 A @ 50 Irated	0.030 A to 40.000 A	1.500 A
		5 A @ 50 Irated	0.15 A to 200.00 A	7.50 A
		1 A @ 1.6 Irated	0.001 A to 1.600 A	1.500 A
		5 A @ 1.6 Irated	0.005 A to 8.000 A	7.500 A
_8341:106	Inverse-T 1:Time dial		0.05 to 15.00	1.00
Dyn.set: bin.input				
_8341:34	Inverse-T 1:Effected by binary input		<ul style="list-style-type: none"> • no • yes 	no
_8341:41	Inverse-T 1:Stage blocked		<ul style="list-style-type: none"> • no • yes 	no
_8341:19	Inverse-T 1:Threshold	1 A @ 100 Irated	0.030 A to 40.000 A	1.500 A
		5 A @ 100 Irated	0.15 A to 200.00 A	7.50 A
		1 A @ 50 Irated	0.030 A to 40.000 A	1.500 A
		5 A @ 50 Irated	0.15 A to 200.00 A	7.50 A
		1 A @ 1.6 Irated	0.001 A to 1.600 A	1.500 A
		5 A @ 1.6 Irated	0.005 A to 8.000 A	7.500 A
_8341:107	Inverse-T 1:Time dial		0.05 to 15.00	1.00

6.6.5.4 Information List

No.	Information	Data Class (Type)	Type
General			
_2311:500	General:>Activation emg. mode	SPS	I
_2311:501	General:>Test of direction	SPS	I
_2311:300	General:Emergency mode act.	SPS	O
_2311:301	General:Test direction	ACD	O
_2311:52	General:Behavior	ENS	O
_2311:53	General:Health	ENS	O
Group indicat.			
_4501:55	Group indicat.:Pickup	ACD	O
_4501:57	Group indicat.:Operate	ACT	O
_4501:52	Group indicat.:Behavior	ENS	O

No.	Information	Data Class (Type)	Type
_:4501:53	Group indicat.:Health	ENS	O
Inverse-T 1			
_:8161:81	Inverse-T 1:>Block stage	SPS	I
_:8161:501	Inverse-T 1:>Release delay & op.	SPS	I
_:8161:84	Inverse-T 1:>Activ. dyn. settings	SPS	I
_:8161:500	Inverse-T 1:>Block delay & op.	SPS	I
_:8161:51	Inverse-T 1:Mode (controllable)	ENC	C
_:8161:54	Inverse-T 1:Inactive	SPS	O
_:8161:52	Inverse-T 1:Behavior	ENS	O
_:8161:53	Inverse-T 1:Health	ENS	O
_:8161:60	Inverse-T 1:Inrush blocks operate	ACT	O
_:8161:62	Inverse-T 1:Dyn.set. AR cycle1act.	SPS	O
_:8161:63	Inverse-T 1:Dyn.set. AR cycle2act.	SPS	O
_:8161:64	Inverse-T 1:Dyn.set. AR cycle3act.	SPS	O
_:8161:65	Inverse-T 1:Dyn.set. ARcycl.>3act	SPS	O
_:8161:66	Inverse-T 1:Dyn.set. CLP active	SPS	O
_:8161:67	Inverse-T 1:Dyn.set. BI active	SPS	O
_:8161:68	Inverse-T 1:Dyn. set. blks. pickup	SPS	O
_:8161:59	Inverse-T 1:Disk emulation running	SPS	O
_:8161:55	Inverse-T 1:Pickup	ACD	O
_:8161:300	Inverse-T 1:Direction	ACD	O
_:8161:56	Inverse-T 1:Operate delay expired	ACT	O
_:8161:57	Inverse-T 1:Operate	ACT	O

6.6.6 Stage with User-Defined Characteristic Curve

6.6.6.1 Description

The structure of this stage is identical to that of the advanced stage with directional inverse-time characteristic curve ([6.6.4.1 Description](#)). The only difference is that you can define the characteristic curve as desired.

User-Defined Characteristic Curve

With the directional, user-defined characteristic curve, you can define the operate curve point by point using up to 30 value pairs of current and time. The device uses linear interpolation to calculate the characteristic curve from these values. You can also define a dropout characteristic curve if you wish.

Pickup and Dropout Behaviors with User-Defined Characteristic Curve

When the input variable exceeds the threshold value by 1.1 times, the characteristic curve is processed. An integrating method of measurement totalizes the weighted time. The weighted time results from the characteristic curve. For this, the time that is associated with the present current value is determined from the characteristic curve. Once the weighted time exceeds the value 1, the stage operates.

When the measured value falls short of the pickup value by a factor of 1.045 ($0.95 \times 1.1 \times$ threshold value), the dropout is started. The pickup will be indicated as clearing. You can influence the dropout behavior via setting parameters. You can select between instantaneous dropout (totalized time is deleted) or dropout according to the characteristic curve (reduction of totalized time depending on the characteristic curve). The dropout according to characteristic curve (disk emulation) is the same as turning back a rotor disk. The weighted reduction of the time is initiated from 0.9 of the set threshold value.

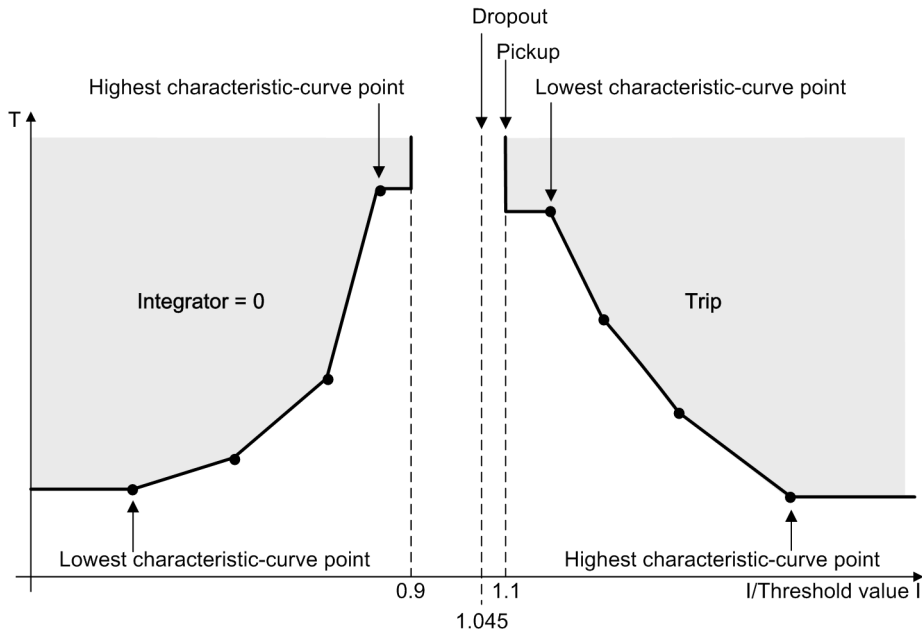

[dw_ocp_ken_02_2_en_US]

Figure 6-45 Pickup and Dropout Behaviors when Using a Directional User-Defined Characteristic Curve



NOTE

Note that the currents that are lower than the current value of the smallest characteristic-curve point do not extend the operate time. The pickup characteristic runs in parallel to the current axis up to the smallest characteristic-curve point. Currents that are larger than the current value of the largest characteristic-curve point do not reduce the operate time. The pickup characteristic runs in parallel to the current axis from the largest characteristic-curve point.

6.6.6.2 Application and Setting Notes

This stage is structured in the same way as the stage with a directional inverse-time characteristic curve. The only difference is that you can define the characteristic curve as desired. This chapter only provides application and setting notes for setting characteristic curves.

Parameter: Current/time value pairs (from the operate curve)

Use these settings to define the characteristic curve. Set a current/time value pair for each characteristic-curve point. The setting depends on the characteristic curve you want to realize.

Set the current value as a multiple of the threshold value. Siemens recommends that you set the **Threshold** parameter to **1.00** in order to obtain a simple relation. You can change the threshold value setting afterwards if you want to displace the characteristic curve.

Set the time value in seconds. The characteristic curve is displaced using the **Time dial** parameter.



NOTE

The value pairs must be entered in continuous order.

Parameter: Time dial

- Default setting (**_:101**) **Time dial = 1**

Use the **Time dial** parameter to displace the characteristic curve in the time direction.

The set value for the **Time dial** parameter is derived from the time-grading chart that has been prepared for the electrical power system. Where no time grading and therefore no displacement of the characteristic curve is required, leave the **Time dial** parameter set to **1**.

Parameter: Reset

- Default setting (**_:115**) **Reset = disk emulation**

You use the **Reset** parameter to define whether the stage drops out according to the dropout characteristic curve (in accordance with the behavior of a disk emulation = rotor disk) or instantaneously.

Parameter Value	Description
<i>disk emulation</i>	In the case of this setting, a dropout characteristic curve has to be set in addition to the operate curve. Select this setting if the device is coordinated with electromechanical devices or other devices which perform a dropout after a disk emulation.
<i>instantaneous</i>	Use this setting if the dropout is not to be performed after disk emulation and an instantaneous dropout is desired instead.

Parameter: Current/time value pairs (of the dropout characteristic curve)

Use these settings to define the characteristic curve. Set a current/time value pair for each characteristic-curve point. The setting depends on the characteristic curve you want to realize.

Set the current value as a multiple of the threshold value. Siemens recommends that you set the **Threshold** parameter to **1.00** in order to obtain a simple relation. You can change the threshold value setting afterwards if you want to displace the characteristic curve.

Set the time value in seconds. The characteristic curve is displaced using the **Time dial** parameter.



NOTE

The value pairs must be entered in continuous order.

6.6.6.3 Settings

Addr.	Parameter	C	Setting Options	Default Setting
<i>General</i>				
_:1	User curve #:Mode		<ul style="list-style-type: none"> • off • on • test 	off
_:2	User curve #:Operate &flt.rec. blocked		<ul style="list-style-type: none"> • no • yes 	no
_:110	User curve #:Directional mode		<ul style="list-style-type: none"> • forward • reverse 	forward
_:8	User curve #:Method of measurement		<ul style="list-style-type: none"> • fundamental comp. • RMS value 	fundamental comp.
_:112	User curve #:Non-directional pickup		<ul style="list-style-type: none"> • no • at volt.< & mem.empty 	at volt.< & mem.empty
_:109	User curve #:Directional comparison		<ul style="list-style-type: none"> • no • yes 	no
_:111	User curve #:Release via input signal		<ul style="list-style-type: none"> • no • yes 	no
_:10	User curve #:Blk. by meas.-volt. failure		<ul style="list-style-type: none"> • no • yes 	yes

Addr.	Parameter	C	Setting Options	Default Setting
_:26	User curve #:Dynamic settings		<ul style="list-style-type: none"> no yes 	no
_:27	User curve #:Blk. w. inrush curr. detect.		<ul style="list-style-type: none"> no yes 	no
_:3	User curve #:Threshold	1 A @ 100 Irated	0.030 A to 40.000 A	1.500 A
		5 A @ 100 Irated	0.15 A to 200.00 A	7.50 A
		1 A @ 50 Irated	0.030 A to 40.000 A	1.500 A
		5 A @ 50 Irated	0.15 A to 200.00 A	7.50 A
		1 A @ 1.6 Irated	0.001 A to 1.600 A	1.500 A
		5 A @ 1.6 Irated	0.005 A to 8.000 A	7.500 A
_:115	User curve #:Reset		<ul style="list-style-type: none"> instantaneous disk emulation 	disk emulation
_:101	User curve #:Time dial		0.05 to 15.00	1.00
<i>Dyn.s: AR off/n.rdy</i>				
_:28	User curve #:Effect. by AR off/n.ready		<ul style="list-style-type: none"> no yes 	no
_:35	User curve #:Stage blocked		<ul style="list-style-type: none"> no yes 	no
<i>Dyn.set: AR cycle 1</i>				
_:29	User curve #:Effected by AR cycle 1		<ul style="list-style-type: none"> no yes 	no
_:36	User curve #:Stage blocked		<ul style="list-style-type: none"> no yes 	no
_:14	User curve #:Threshold	1 A @ 100 Irated	0.030 A to 40.000 A	1.500 A
		5 A @ 100 Irated	0.15 A to 200.00 A	7.50 A
		1 A @ 50 Irated	0.030 A to 40.000 A	1.500 A
		5 A @ 50 Irated	0.15 A to 200.00 A	7.50 A
		1 A @ 1.6 Irated	0.001 A to 1.600 A	1.500 A
		5 A @ 1.6 Irated	0.005 A to 8.000 A	7.500 A
_:102	User curve #:Time dial		0.05 to 15.00	1.00
<i>Dyn.set: AR cycle 2</i>				
_:30	User curve #:Effected by AR cycle 2		<ul style="list-style-type: none"> no yes 	no
_:37	User curve #:Stage blocked		<ul style="list-style-type: none"> no yes 	no
_:15	User curve #:Threshold	1 A @ 100 Irated	0.030 A to 40.000 A	1.500 A
		5 A @ 100 Irated	0.15 A to 200.00 A	7.50 A
		1 A @ 50 Irated	0.030 A to 40.000 A	1.500 A
		5 A @ 50 Irated	0.15 A to 200.00 A	7.50 A
		1 A @ 1.6 Irated	0.001 A to 1.600 A	1.500 A
		5 A @ 1.6 Irated	0.005 A to 8.000 A	7.500 A
_:103	User curve #:Time dial		0.05 to 15.00	1.00
<i>Dyn.set: AR cycle 3</i>				
_:31	User curve #:Effected by AR cycle 3		<ul style="list-style-type: none"> no yes 	no

Addr.	Parameter	C	Setting Options	Default Setting
_:38	User curve #:Stage blocked		<ul style="list-style-type: none"> • no • yes 	no
_:16	User curve #:Threshold	1 A @ 100 Irated	0.030 A to 40.000 A	1.500 A
		5 A @ 100 Irated	0.15 A to 200.00 A	7.50 A
		1 A @ 50 Irated	0.030 A to 40.000 A	1.500 A
		5 A @ 50 Irated	0.15 A to 200.00 A	7.50 A
		1 A @ 1.6 Irated	0.001 A to 1.600 A	1.500 A
		5 A @ 1.6 Irated	0.005 A to 8.000 A	7.500 A
_:104	User curve #:Time dial		0.05 to 15.00	1.00
Dyn.s: AR cycle>3				
_:32	User curve #:Effected by AR cycle gr. 3		<ul style="list-style-type: none"> • no • yes 	no
_:39	User curve #:Stage blocked		<ul style="list-style-type: none"> • no • yes 	no
_:17	User curve #:Threshold	1 A @ 100 Irated	0.030 A to 40.000 A	1.500 A
		5 A @ 100 Irated	0.15 A to 200.00 A	7.50 A
		1 A @ 50 Irated	0.030 A to 40.000 A	1.500 A
		5 A @ 50 Irated	0.15 A to 200.00 A	7.50 A
		1 A @ 1.6 Irated	0.001 A to 1.600 A	1.500 A
		5 A @ 1.6 Irated	0.005 A to 8.000 A	7.500 A
_:105	User curve #:Time dial		0.05 to 15.00	1.00
Dyn.s: Cold load PU				
_:33	User curve #:Effect. b. cold-load pickup		<ul style="list-style-type: none"> • no • yes 	no
_:40	User curve #:Stage blocked		<ul style="list-style-type: none"> • no • yes 	no
_:18	User curve #:Threshold	1 A @ 100 Irated	0.030 A to 40.000 A	1.500 A
		5 A @ 100 Irated	0.15 A to 200.00 A	7.50 A
		1 A @ 50 Irated	0.030 A to 40.000 A	1.500 A
		5 A @ 50 Irated	0.15 A to 200.00 A	7.50 A
		1 A @ 1.6 Irated	0.001 A to 1.600 A	1.500 A
		5 A @ 1.6 Irated	0.005 A to 8.000 A	7.500 A
_:106	User curve #:Time dial		0.05 to 15.00	1.00
Dyn.set: bin.input				
_:34	User curve #:Effected by binary input		<ul style="list-style-type: none"> • no • yes 	no
_:41	User curve #:Stage blocked		<ul style="list-style-type: none"> • no • yes 	no
_:19	User curve #:Threshold	1 A @ 100 Irated	0.030 A to 40.000 A	1.500 A
		5 A @ 100 Irated	0.15 A to 200.00 A	7.50 A
		1 A @ 50 Irated	0.030 A to 40.000 A	1.500 A
		5 A @ 50 Irated	0.15 A to 200.00 A	7.50 A
		1 A @ 1.6 Irated	0.001 A to 1.600 A	1.500 A
		5 A @ 1.6 Irated	0.005 A to 8.000 A	7.500 A
_:107	User curve #:Time dial		0.05 to 15.00	1.00

6.6.6.4 Information List

No.	Information	Data Class (Type)	Type
<i>User curve #</i>			
_.81	User curve #:>Block stage	SPS	I
_.501	User curve #:>Release delay & op.	SPS	I
_.84	User curve #:>Activ. dyn. settings	SPS	I
_.500	User curve #:>Block delay & op.	SPS	I
_.54	User curve #:Inactive	SPS	O
_.52	User curve #:Behavior	ENS	O
_.53	User curve #:Health	ENS	O
_.60	User curve #:Inrush blocks operate	ACT	O
_.62	User curve #:Dyn.set. AR cycle1act.	SPS	O
_.63	User curve #:Dyn.set. AR cycle2act.	SPS	O
_.64	User curve #:Dyn.set. AR cycle3act.	SPS	O
_.65	User curve #:Dyn.set. ARcycl.>3act	SPS	O
_.66	User curve #:Dyn.set. CLP active	SPS	O
_.67	User curve #:Dyn.set. BI active	SPS	O
_.68	User curve #:Dyn. set. blks. pickup	SPS	O
_.59	User curve #:Disk emulation running	SPS	O
_.55	User curve #:Pickup	ACD	O
_.309	User curve #:Direction	ACD	O
_.56	User curve #:Operate delay expired	ACT	O
_.57	User curve #:Operate	ACT	O

6.6.7 Direction Determination

6.6.7.1 Description

General

Every phase has a separate direction-measuring element. If the threshold value in a phase is exceeded, the direction determination is started for this phase. If there are multiphase short circuits, all measuring elements involved perform direction determination independently. If one of the determined directions matches the set direction, the stage picks up (see descriptions of the stage logic).

The direction is determined by calculating the phase angle between the short-circuit current and a reference voltage.

Measurands for Direction Determining

The directional measuring element uses the short-circuit current of the phase concerned and the cross-polarized phase-to-phase voltage (as the reference voltage) to determine the direction. This means that the direction can still be determined unambiguously and correctly, even if the short-circuit voltages collapse completely when a 1-phase or 2-phase fault occurs (close-up fault).

The phase-to-phase voltages are calculated when phase-to-ground voltages are connected.

The cross-polarized voltage (reference voltage) is vertical in relation to the short-circuit voltages for 1-phase-to-ground faults (Figure 6-46, left). For 2-phase short circuits, the position of the reference voltages changes up to 30°, depending on the extent to which the short-circuit voltages collapse (Figure 6-46, right).

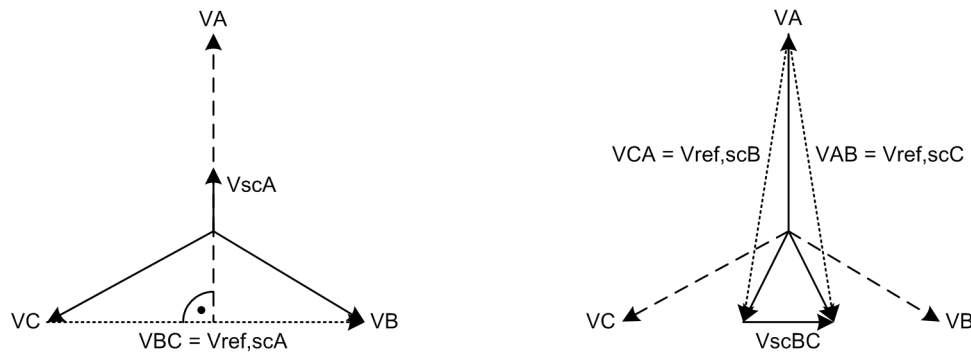

[dwt_docp_02_1_en_US]

Figure 6-46 Cross-Polarized Voltages for Direction Determination

The following table shows how measurands are assigned for direction-determination purposes in the event of different types of fault.

Table 6-3 Measurands for Direction Determining

Threshold-Value Exceeding	Measuring Element							
	A		B		C		Ground	
	Current	Voltage	Current	Voltage	Current	Voltage	Current	Voltage
A	I_A	V_{BC}	–	–	–	–	–	–
B	–	–	I_B	V_{CA}	–	–	–	–
C	–	–	–	–	I_C	V_{AB}	–	–
Gnd	–	–	–	–	–	–	I_r	V_0
A, Gnd	–	V_{BC}	–	–	–	–	I_r	V_0
B, Gnd	–	–	I_B	V_{CA}	–	–	I_r	V_0
C, Gnd	–	–	–	–	I_C	V_{AB}	I_r	V_0
A, B	I_A	V_{BC}	I_B	V_{CA}	–	–	–	–
B, C	–	–	I_B	V_{CA}	I_C	V_{AB}	–	–
A, C	I_A	V_{BC}	–	–	I_C	V_{AB}	–	–
A, B, Gnd	I_A	V_{BC}	I_B	V_{CA}	–	–	I_r	V_0
B, C, Gnd	–	–	I_B	V_{CA}	I_C	V_{AB}	I_r	V_0
A, C, Gnd	I_A	V_{BC}	–	–	I_C	V_{AB}	I_r	V_0
A, B, C	I_A	V_{BC}	I_B	V_{CA}	I_C	V_{AB}	–	–
A, B, C, Gnd	I_A	V_{BC}	I_B	V_{CA}	I_C	V_{AB}	I_r	V_0

Voltage Memory

Saved voltages are used if, when a 3-pole close-up fault occurs, the measuring voltages are not sufficient for reliable direction determination. Insofar as and as long as no sufficient measuring voltage is available after the storage time (2 s) has elapsed, the detected direction is retained. If the memory does not contain any voltages (when closing onto a short circuit, for example), the behavior of the stage is defined using the **Non-directional pickup** parameter.

Direction Determination

As mentioned in the **General** section, the direction is determined by calculating the phase angle between short-circuit current and reference voltage. To take different system conditions and applications into account, the reference voltage can be rotated through an adjustable angle (**Rotation angle of ref. volt.** parameter). This moves the vector of the rotated reference voltage close to the vector of the short-circuit

current. Consequently, the result of direction determination is as reliable as possible. *Figure 6-47* illustrates the relationship based on a 1-phase ground fault in phase A. The short-circuit current I_{scA} lags the short-circuit voltage by the short-circuit angle φ_{sc} . The reference voltage, in this case V_{BC} for measuring element A, is rotated positively (counterclockwise) by the setting value of the **Rotation angle of ref. volt.** parameter. In the scenario illustrated here, the rotation is $+45^\circ$.

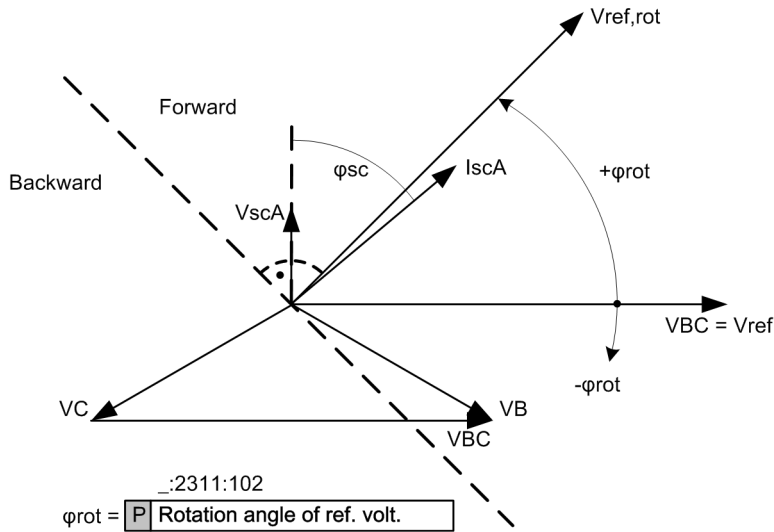

[dw_docp_33, 2, en_US]

Figure 6-47 Rotation of the Reference Voltage, Phase-Measuring Element

The rotated reference voltage defines the forward and reverse range, as shown in *Figure 6-48*. The forward range is calculated as $\pm 88^\circ$ around the rotated reference voltage $V_{ref,rot}$. If the short-circuit current vector is located in this range, the device decides on the forward direction. In the mirrored range, the device decides on the backward direction. In the intermediate range, the direction is undetermined.

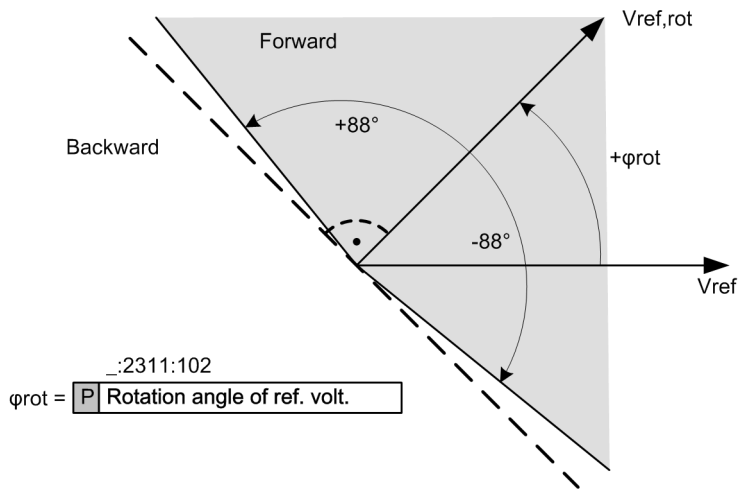

[dw_docp_34, 2, en_US]

Figure 6-48 Forward Characteristic of the Directional Function, Phase-Measuring Element

Direction Determination for Test Purposes

If you activate the binary input signal **>Test of direction**, the direction is determined and indicated even without the current threshold being exceeded in one of the stages. The direction can be determined as soon as current and voltage are greater than approx. 7 % of their secondary rated values.

6.6.7.2 Application and Setting Notes

Parameter: **Rotation angle of ref. volt.**

- Default setting (`_:2311:102`) **Rotation angle of ref. volt.** = 45°

The directional characteristic, that is, the position of the **forward** and **reverse** ranges, is set with the **Rotation angle of ref. volt.** parameter. The short-circuit angle is typically to be found in a range from 30° to 60° inductive. Therefore, in most cases, the default setting of $+45^\circ$ can be retained to position the reference voltage, as it ensures a reliable directional result.

Some example settings for special applications appear in the following ([Table 6-4](#)). Please note that for phase-to-ground faults (PG faults), the reference voltage (fault-free voltage) is vertical in relation to the short-circuit voltage. This results in the following setting for the rotation angle:

Rotation angle of ref. volt. = $90 - \varphi_{sh}$ phase-measuring elements (PG faults)

Please also note that for phase-to-phase faults, the reference voltage is rotated between 0° (distant fault) and 30° (close-up fault) dependent upon the collapse of the faulted voltage (see [Figure 6-47](#)). You can take this into account with an average value of 15° .

Rotation angle of ref. volt. = $90 - \varphi_{sh} - 15^\circ$ phase-measuring elements (PP faults)

Table 6-4 Example settings

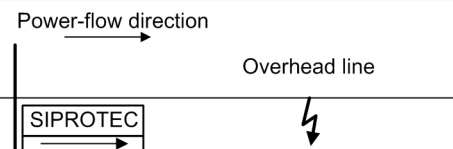
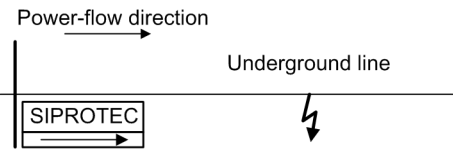
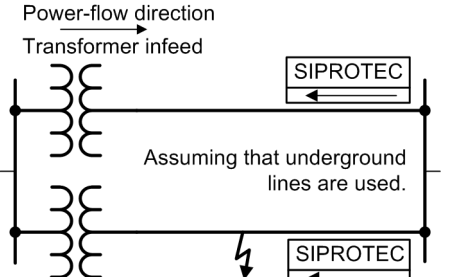
Application	φ_{sh} typical	Setting Rotation angle of ref. volt.
 <p>Power-flow direction Overhead line SIPROTEC</p>	60°	Range 30° to 0° for PP faults Selected: 15°
 <p>Power-flow direction Underground line SIPROTEC</p>	30°	Range 60° to 30° for PP faults Selected: 45°
 <p>Power-flow direction Transformer infeed Assuming that underground lines are used. SIPROTEC</p>	30°	Range 60° to 30° for PP faults Selected: 45°

Input signal: **>Test of direction**

If you activate the binary input signal **>Test of direction**, the direction is determined and indicated even without the current threshold being exceeded in one of the stages. This provides an easy means of checking the direction during commissioning, without changing the threshold values of the stages.

6.6.8 Influence of Other Functions via Dynamic Settings

The influence of these functions via dynamic settings is described in chapter [6.3.8.1 Description](#) and chapter [6.3.8.2 Application and Setting Notes \(Advanced Stage\)](#).

6.6.9 Application Notes for Parallel Lines

Parallel Lines or Transformers

In parallel lines or transformers with infeed at one end (see [Figure 6-49](#)), if there is no directional measuring element, a fault on feeder T1 will also trip the other feeder T2. In contrast, a directional measuring element in the devices on busbar B prevents the tripping of the circuit breaker in the parallel feeder. Therefore, in [Figure 6-49](#), directional overcurrent protection is used in the places marked with direction arrows. Please note that the forward direction of the protection device represents the direction towards the object to be protected. This does not have to be the same as the power direction of normal power flow.

Set time grading in opposition to the power flow with increasing time. As load can only flow in one direction, you can set the directional devices without time delay.

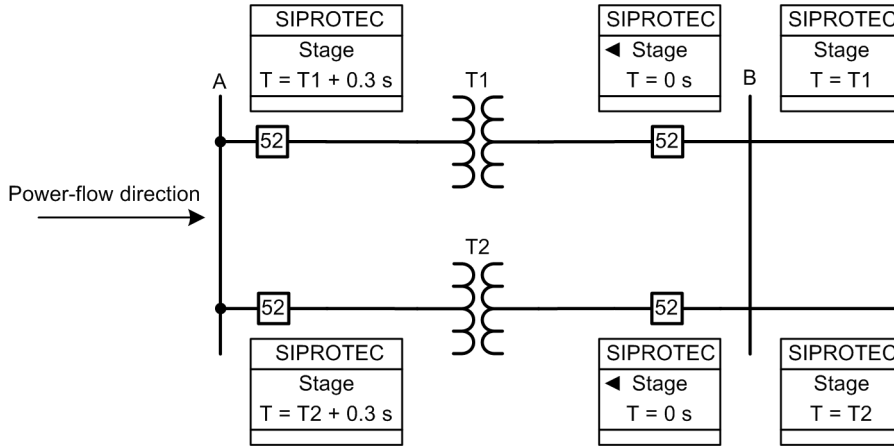

[idw_docp_05_1_en_US]

Figure 6-49 Parallel Line with Transformers

Legend for [Figure 6-49](#)

- Stage ►: Directional stage, **forward** direction set
- Stage: Non-directional stage
- T: Grading time

6.6.10 Application Notes for Directional Comparison Protection

The direction determination of directional overcurrent protection can be used to implement directional comparison protection for cable runs with infeed at both ends. Directional comparison protection is used for the selective isolation of a faulted line section (for example, subsections of closed rings). Sections are isolated in fast time, that is, they do not suffer the disadvantage of long grading times.

This technique requires that directional information can be exchanged between the individual protection stations. You can implement this information exchange using IEC 61850 GOOSE or with pilot wires for signal transmission via an auxiliary voltage loop.

Protection Principle

The protection principle is shown in [Figure 6-50](#). 2 devices (one at the start of the line and the other at the end of the line) work together in each line section. The information **fault in forward direction** is transferred between them. A directional definite-time overcurrent protection level is in operation in both devices in the forward direction (1st level). However, this level is not enabled in the idle state. The level is only released when the information **fault in forward direction** is received from the opposite end. If the enabled level also defines the fault in the forward direction, the fault must be on this line section and the level trips immediately. As this protection principle works with an enable procedure (and not with a blocking procedure), there is no need to delay the level.

A second directional definite-time overcurrent protection stage with standard time grading works in parallel with the first stage as a selective backup stage. This ensures full selectivity of protection in the following situations:

- Infeed at one end or weak infeed at one end: In this case, no release signal is generated.
- Failure of the communication route: In this case, the release signal is not transmitted.

To provide selective protection in fast time for busbars between the line sections also, you can combine this protection principle with the principle of reverse interlocking. This principle is not discussed in further detail in this document.

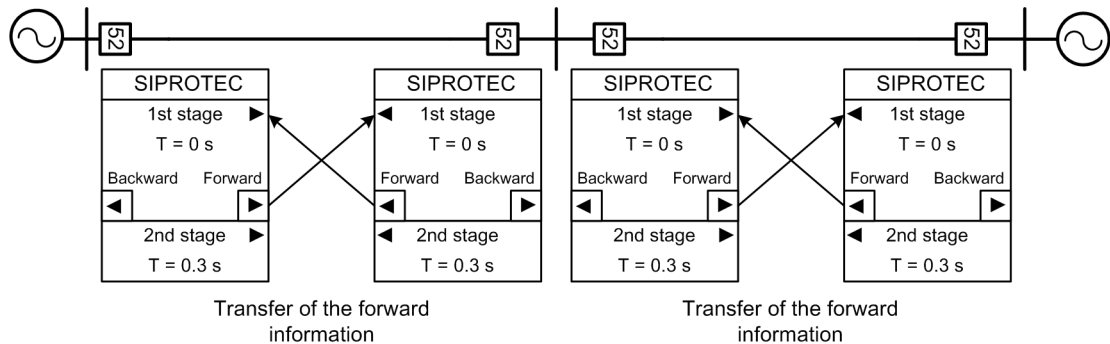

[dsw_docp_07_2_en_US]

Figure 6-50 Selectivity through Directional Comparison Protection

Legend for [Figure 6-50](#)

- Stage ▶: Stage is set in the **forward** direction; stage 1 is instantaneous, stage 2 is graded
- ▶, ◀: If a threshold value is exceeded, the stage indicates the direction (forward or reverse)

If you are using a communication channel, the protocol-transmission methods detect if the channel is interrupted. If you are using pilot wires, Siemens recommends an operation based on a closed-circuit connection. The device uses a CFC chart to check and indicate if the binary input is dead for an unexpectedly long period. In contrast with the blocking procedure, overfunction is not possible if communication is lost. Therefore, a loss of communication is not critical where this procedure is concerned, although it must be detected and indicated.

Directional comparison protection can also be implemented as a blocking procedure. This procedure works under all system switching states, i.e. also with infeed at one end (or weak infeed). However, to use it you must delay the stage (typically by 100 ms) so that the blocking signal is received in time under all circumstances. It is also essential that you monitor the communication channel to avoid overfunction in the event of failure followed by a system incident.

Configuration of the Stage, CFC Chart

To configure the stage, proceed as follows:

- The **Directional mode** parameter of both stages must be set to **forward**
- The **Directional comparison** and **Release via input signal** parameters of the first stage must be set to **yes**. This is so that the first stage is only released if the **>Release delay & op.** input signal is active. Furthermore, the direction is indicated if a threshold value is exceeded.
- The first stage can be set without a time delay. The second stage has to be graded
- The information **forward** from the **Direction** signal in the first stage must be transmitted to the opposite end. The routing is determined by the type of transmission
- A CFC chart has to be implemented at the receive end to link the received (**forward** information) and release signals, dependent upon the type of transmission.

6.7 Directional Overcurrent Protection, Ground

6.7.1 Overview of Functions

The **Directional overcurrent protection, ground** function (ANSI 67N):

- Detects short circuits to ground affecting electric equipment
- Ensures selective ground-fault detection for parallel lines or transformers with infeed at one end
- Ensures selective ground-fault detection in cable runs with infeed at both ends or in lines connected to form ring topologies

6.7.2 Structure of the Function

The **Directional overcurrent protection, ground** function can be used in protection function groups which provide zero-sequence current and zero-sequence voltage measurements. 2 function types are offered:

- **Directional overcurrent protection, ground – advanced** (67N Dir.OC-gnd-A)
- **Directional overcurrent protection, ground – basic** (67N Dir.OC-gnd-B)

The basic function type shall be used for standard applications. The advanced function type provides more functionalities and is intended for more sophisticated applications.

Both function types are preconfigured by the manufacturer with 2 **Definite-time overcurrent protection** stages and 1 **Inverse-time overcurrent protection** stage.

In the advanced function type **Directional overcurrent protection, ground – advanced**, the following stages can operate simultaneously:

- A maximum of 4 **Definite-time overcurrent protection – advanced** stages
- 1 **Inverse-time overcurrent protection – advanced** stage
- 1 **Logarithmic inverse-time overcurrent protection** stage
- 1 **Logarithmic inverse time with knee-point overcurrent protection** stage
- 1 **User-defined characteristic curve overcurrent protection** stage

In the basic function type **Directional overcurrent protection, ground – basic**, the following stages can operate simultaneously:

- A maximum of 4 **Definite-time overcurrent protection – basic** stages
- 1 **Inverse-time overcurrent protection – basic** stage

Referring to [Figure 6-51](#) and [Figure 6-52](#), the stages not preconfigured are shown in gray. Apart from the operate-delay characteristic curve, the stages are similar in structure.

The general functionality includes the direction determination and the measured-value selection (only advanced function). They take place on the functional level and have a uniform effect on the stages (see [Figure 6-51](#) and chapter [6.5.3 General Functionality](#)). This ensures that all stages of the function receive the same measured current value and the same direction result. Each stage can be set to work in forward or reverse direction.

The group indication output logic generates the following group indications for the protection function by the logic OR from the stage-selective indications:

- Pickup
- Operate

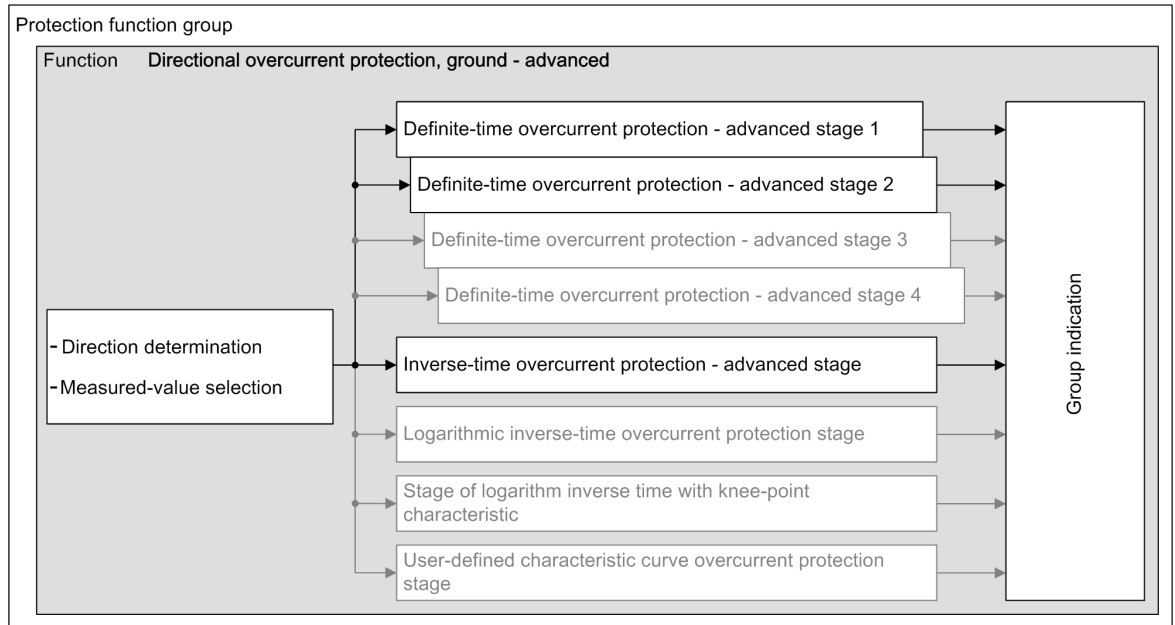

[dw_rdirad, 3, en_US]

Figure 6-51 Structure/Embedding of the Function Directional Overcurrent Protection, Ground – Advanced

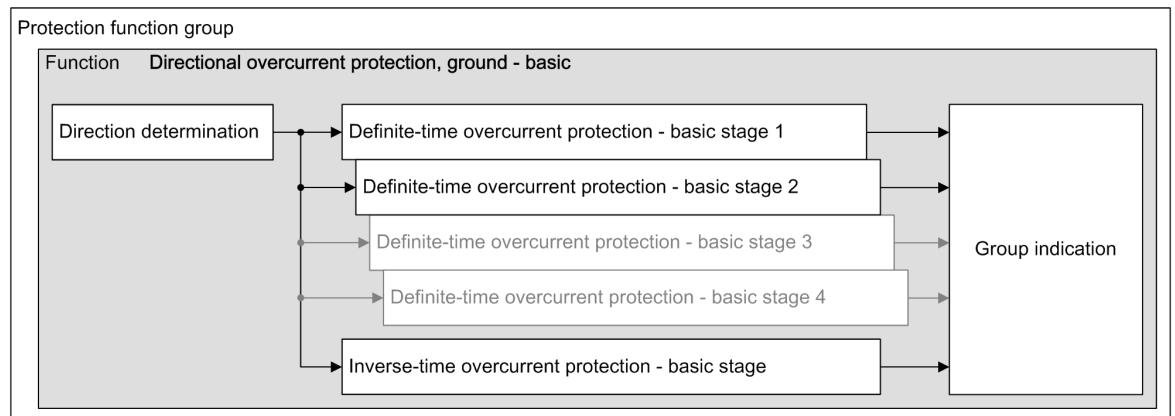

[dw_rdirba, 2, en_US]

Figure 6-52 Structure/Embedding of the Function Directional Overcurrent Protection, Ground – Basic

If the following listed device-internal functions are present in the device, these functions can influence the pickup values and operate delays of the stages or block the stages. The stage can also be affected by an external source via a binary input signal.

- Automatic reclosing (AREC)
- Cold-load pickup detection
- Binary input signal

If the device is equipped with the **Inrush-current detection** function, the stages can be stabilized against operate due to transformer-inrush currents.

6.7.3 General Functionality

6.7.3.1 Measured-Value Selection

Logic

The function provides the option to select between the values *IN measured* or *3I0 calculated*.

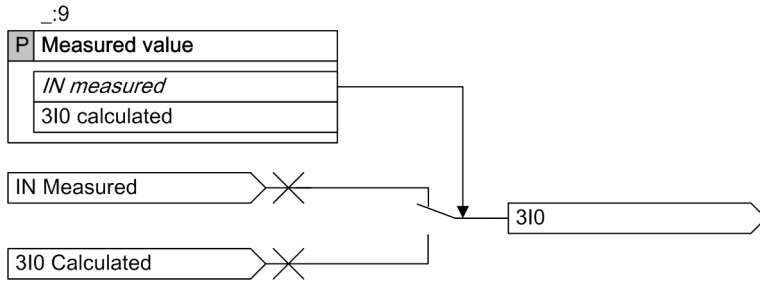

[!o_meas_value, 1, en_US]

Figure 6-53 Logic Diagram of Measured-Value Selection

Both options are only available for the current-transformer connection types **3-phase + IN** and **3-phase + IN-separate**. For other connection types respectively, only one option is possible. If you select an option that is not allowed, an inconsistency message is given.

Depending on the CT secondary rated current, the CT connection type, and the selected setting, the secondary threshold setting range varies according to the following table.

Table 6-5 Threshold Setting Range

Connection Type	Measured Value	CT Terminal Type	Threshold Setting Range (rated I-sec.: ph = 1 A, IN = 1 A)	Threshold Setting Range (rated I-sec.: ph = 1 A, IN = 5 A)	Threshold Setting Range (rated I-sec.: ph = 5 A, IN = 1 A)	Threshold Setting Range (rated I-sec.: ph = 5 A, IN = 5 A)
3ph + IN	3I0 calculated	4 * Protection	0.030 A to 40.000 A	N/A	N/A	0.15 A to 200.00 A
		4 * Measurement	0.001 A to 1.600 A	N/A	N/A	0.005 A to 8.000 A
	IN measured	4 * Protection	0.030 A to 40.000 A	N/A	N/A	0.15 A to 200.00 A
		4 * Measurement	0.001 A to 1.600 A	N/A	N/A	0.005 A to 8.000 A
3ph + IN-separate	3I0 calculated	4 * Protection	0.030 A to 40.000 A	0.030 A to 40.000 A	0.15 A to 200.00 A	0.15 A to 200.00 A
		3 * Protection, 1 * sen.	0.030 A to 40.000 A	0.030 A to 40.000 A	0.15 A to 200.00 A	0.15 A to 200.00 A
		4 * Measurement	0.001 A to 1.600 A	0.001 A to 1.600 A	0.005 A to 8.000 A	0.005 A to 8.000 A
	IN measured	4 * Protection	0.030 A to 40.000 A	0.15 A to 200.00 A	0.030 A to 40.000 A	0.15 A to 200.00 A
		3 * Protection, 1 * sen.	0.001 A to 1.600 A	0.005 A to 8.000 A	0.001 A to 1.600 A	0.005 A to 8.000 A
		4 * Measurement	0.001 A to 1.600 A	0.005 A to 8.000 A	0.001 A to 1.600 A	0.005 A to 8.000 A

6.7.3.2 Direction Determination

Logic of Direction Determination

The following figure represents the logic of the direction determination. It applies to all types of stages.

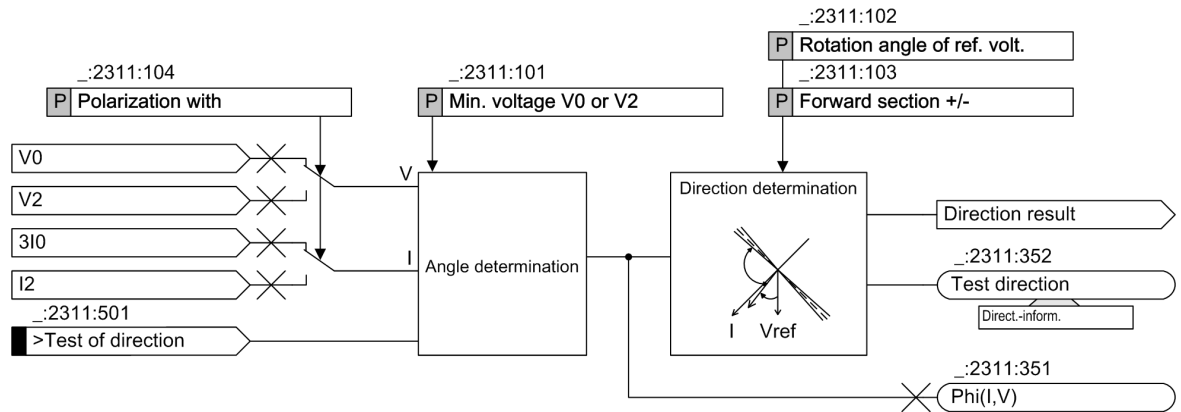

[to_dirdet, 1, en_US]

Figure 6-54 Logic Diagram of Direction Determination

Measurand for the Direction Determination

With the parameter **Direct. determination with** you define whether the direction determination is calculated with the zero-sequence components 3I0 and V0 or with the negative-sequence components I2 and V2, which are present during faults in the network.

The angle between $I_N (= -3I_0)$ and V_0 (respectively $-I_2$ and V_2) in case of using the negative-sequence components is available as a functional measured value. This value is only present during faults in the network.

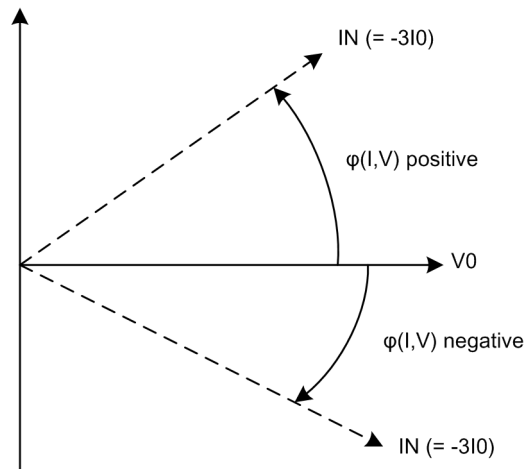

[dw_UI_kern, 1, en_US]

Figure 6-55 Measured-Value Definition

Start of the Direction Determination

If the zero-sequence current 3I0 exceeds the pickup threshold of a stage and the selected voltage (V0 or V2) exceeds the parameter **Min. voltage V0 or V2** as well, the direction determination is started.

Direction Determination with Zero-Sequence Values

The direction is determined by calculating the phase angle between the short-circuit current $-3I_0$ and the rotated reference voltage $V_{ref, rot}$. Contrary to the **Directional overcurrent protection, phase** function, which works with the healthy voltage as reference voltage, the fault voltage V_0 itself is the reference voltage for the **Directional overcurrent protection, ground** function. To take different system conditions and applications

into account, the reference voltage V_0 can be rotated through an adjustable angle (parameter **Rotation angle of ref. volt.**). This moves the vector of the rotated reference voltage close to the vector of the short-circuit current $-3I_0$. Consequently, the result of direction determination is as reliable as possible. [Figure 6-56](#) illustrates the relationship based on a 1-phase-to-ground fault in phase A. The fault current has a phase displacement of 180° to the fault current I_{scA} and lags the fault voltage by the fault angle φ_{sc} . The reference voltage V_0 is rotated by φ_{prot} which is -45° .

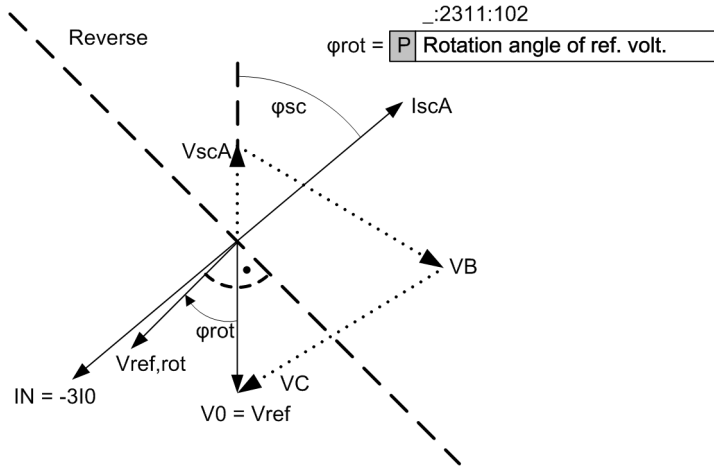

[ldw_r0reze, 2, en_US]
 Figure 6-56 Rotation of the Reference Voltage, Directional Overcurrent Protection, Ground Function with Zero-Sequence Values

The rotated reference voltage $V_{ref,rot}$ and the parameter **Forward section +/-** define the forward and reverse ranges, see [Figure 6-57](#). The forward range is calculated as $\pm \Delta\varphi^\circ$ around the rotated reference voltage $V_{ref,rot}$. $\Delta\varphi$ is set with the parameter **Forward section +/-**. If the short-circuit current vector $-3I_0$ is located in this range, the device decides on the forward direction. In the mirrored range, the device decides on the reverse direction. In the intermediate range, the direction is undetermined.

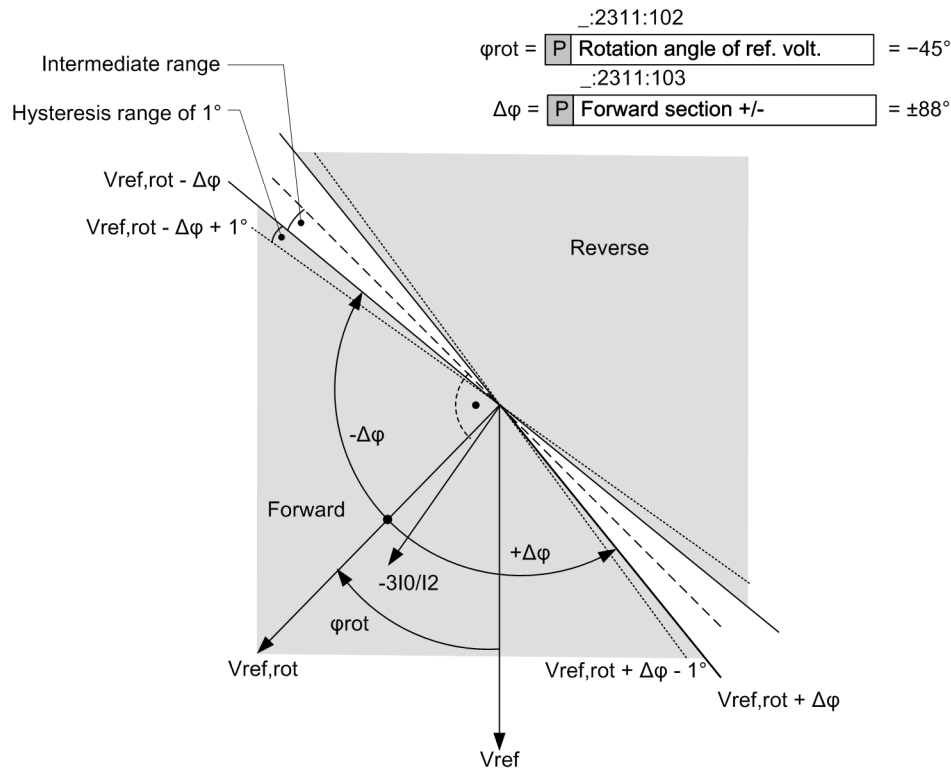

[dsw_forrev, 2, en, US]

Figure 6-57 Forward/Reverse Characteristic of the Directional Overcurrent Protection, Ground Function

Direction Determination with Negative-Sequence Values

The method works in the same way as for zero-sequence values. Instead of $3I_0$ and V_0 , the negative-sequence values I_2 and V_2 are used for determining the direction.

Direction Determination for Test Purposes

If you activate the binary input signal *>Test of direction*, the direction is determined and indicated even without the current threshold being exceeded in one of the stages. The direction can be determined as soon as the zero-sequence current $3I_0$ and the zero-sequence voltage V_0 exceeds approx. 7 % of the secondary rated values of phase current and voltage.

6.7.3.3 Application and Setting Notes

Parameter: Measured value

- Recommended setting value ($_ : 9$) **Measured value = IN Measured**

This parameter is not available in the basic function.

Parameter Value	Description
<i>IN Measured</i>	The function operates with the measured ground current I_N . This is the recommended setting unless there is a specific reason to use the calculated zero-sequence current $3I_0$.
<i>3I0 Calculated</i>	The function operates with the calculated zero-sequence current $3I_0$. This setting option can be used when applying a redundant 50N/51N function for safety reasons.

Parameter: Min. voltage V0 or V2

- Recommended setting value ($_ : 2311 : 101$) **Min. voltage V0 or V2 = 2 V**

This parameter is not available in the basic function. The basic function uses a fixed value of 2 V.
 You use the **Min. voltage V0 or V2** parameter to define the minimum zero-sequence voltage or negative-sequence voltage for the direction determination. The minimum voltage must be set greater than the maximum operational unbalance plus the voltage-transformer measuring errors.
 As the measuring error of the individual voltage transformer is not added up, the critical measuring-error influence is the unbalance of the primary system.
 Siemens recommends observing the operational zero-sequence voltage V0 of the protected object (for example, the line) via the operational measured values of the device and providing the maximum value with a certainty of 50 %.

EXAMPLE

Maximum operational measured value of zero-sequence voltage V0 = 0.5 Vsec
Min. voltage V0 or V2 = 1.5 · 0.5 V = 0.75 Vsec

If you have no information about maximum operational unbalance, Siemens recommends using the default setting.

Parameter: Rotation angle of ref. volt. / Forward section +/-

- Recommended setting value (_:2311:102) **Rotation angle of ref. volt.** = -45°
- Recommended setting value (_:2311:103) **Forward section +/-** = 88°

The parameter **Forward section +/-** is not available in the basic function. The basic function uses a fixed value of 88°.

The direction characteristic, that is, the area of the forward and reverse ranges, is set with the **Rotation angle of ref. volt.** and the **Forward section +/-** parameters. The short-circuit angle is typically to be found in a range from -30° to -60° inductively. Therefore, in most cases, the default setting of -45° can be retained to position the reference voltage, as it ensures a reliable directional result.

Some example settings for special applications appear below [Table 6-6](#). Note that for 1-phase-to-ground faults (PG faults), the reference voltage is the zero-sequence voltage V0. This results in the following setting for the rotation angle:

Rotation angle of ref. volt. = -φk ground-measuring elements (PG faults)

Table 6-6 Example Settings

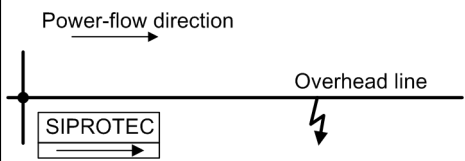
Application	φk Typical	Setting
	60°	Rotation angle of ref. volt. -60°

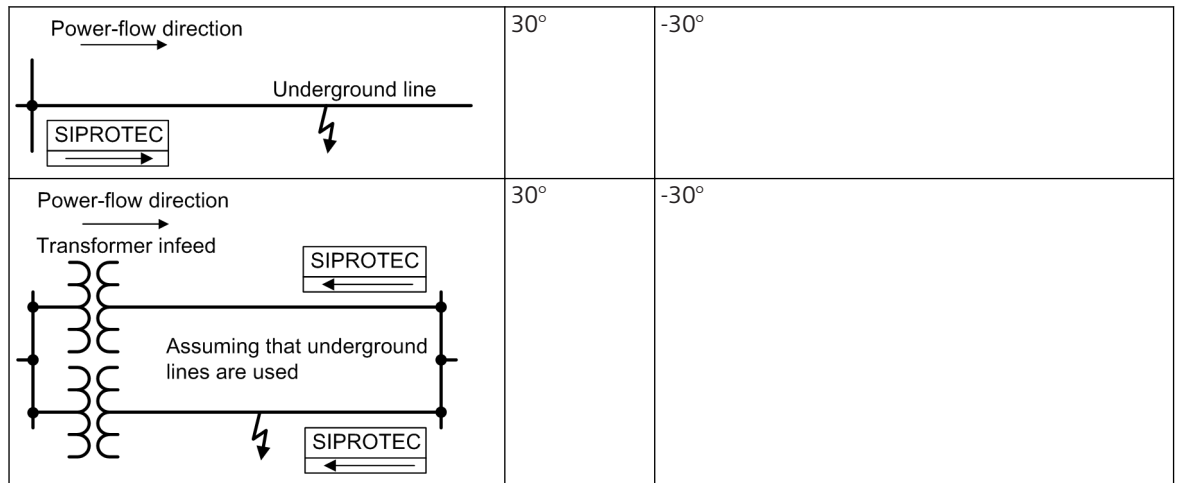

Parameter: Direct. determination with

- Recommended setting value (_:2311:104) **Direct. determination with = zero sequence**

This parameter is not available in the basic function. The basic function uses always zero-sequence components for the direction determination.

You use the parameter **Direct. determination with** to select the values for the direction determination.

Parameter Value	Description
zero sequence	Select zero sequence to determine the direction via the zero-sequence components V0 and 3I0. Siemens recommends using the zero-sequence components for the direction determination.
negative sequence	Select negative sequence to determine the direction via the negative-sequence components V2 and I2. The negative-sequence system can be used in case of danger that the zero-sequence voltage is too small due to unfavorable zero-sequence impedance conditions or that a parallel line influences the zero-sequence system.

Input Signal: >Test of direction

If you activate the binary input signal **>Test of direction**, the direction is determined and indicated even without the current threshold being exceeded in one of the stages. This provides an easy means of checking the direction during commissioning, without changing the threshold values of the stages.

6.7.3.4 Settings

Addr.	Parameter	C	Setting Options	Default Setting
General				
_:2311:9	General:Measured value		<ul style="list-style-type: none"> 3I0 calculated IN measured 	IN measured
_:2311:101	General:Min. voltage V0 or V2		0.150 V to 20.000 V	2.000 V
_:2311:102	General:Rotation angle of ref. volt.		-180 ° to 180 °	-45 °

Addr.	Parameter	C	Setting Options	Default Setting
_:2311:103	General:Forward section +/-		0 ° to 90 °	88 °
_:2311:104	General:Direct. determination with		<ul style="list-style-type: none"> • zero sequence • negative sequence 	zero sequence

6.7.3.5 Information List

No.	Information	Data Class (Type)	Type
General			
_:2311:501	General:>Test of direction	SPS	I
_:2311:352	General:Test direction	ACD	O
_:2311:351	General:Phi(I,V)	MV	O
_:2311:52	General:Behavior	ENS	O
_:2311:53	General:Health	ENS	O

6.7.4 Stage Control

6.7.4.1 Description

Logic

The following figure represents the stage control. It applies to all types of stages.

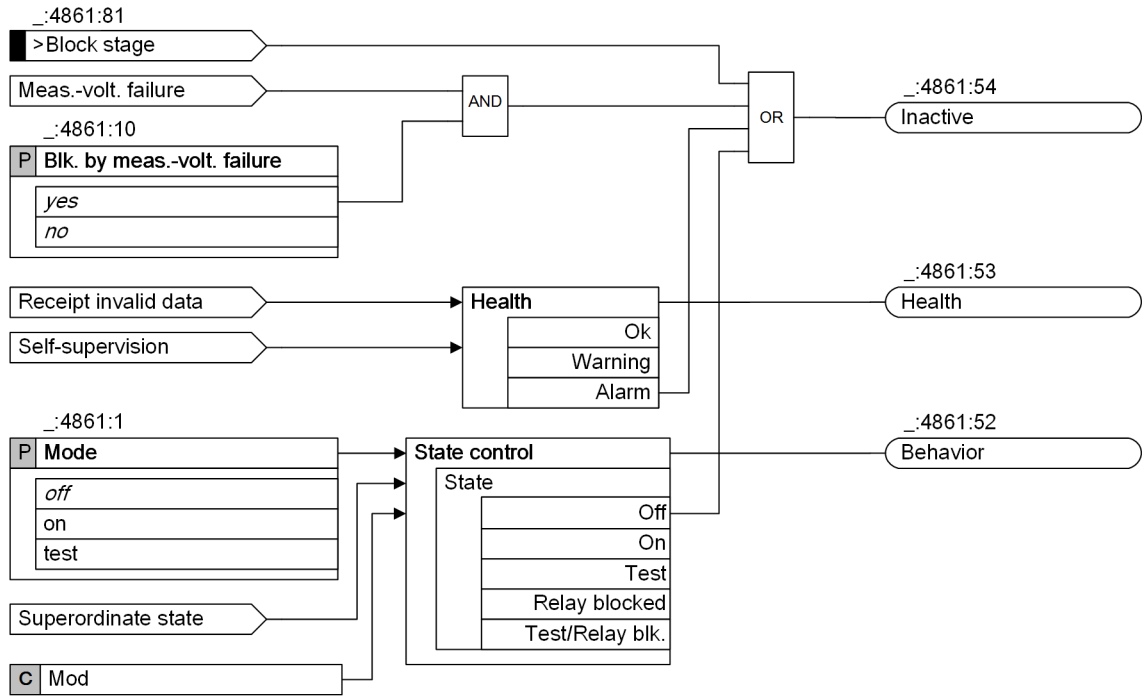

Figure 6-58 Logic Diagram of the Stage Control

Blocking of Stage in Case of Measuring-Voltage Failure

The stages can be blocked if a measuring-voltage failure occurs. In the event of blocking, the picked up stage will be reset. The following blocking options are available for the stage:

- From an internal source on the pickup of the **Measuring-voltage failure detection** function
- From an external source via the binary input signal *>Open* of the function block **Voltage-transformer circuit breaker**, which links to the trip of the voltage-transformer circuit breaker

The **Blk. by meas.-volt. failure** parameter can be set to either block or not block the stage when the **Measuring-voltage failure detection** function picks up.

6.7.4.2 Application and Setting Notes

Parameter: **Blk. by meas.-volt. failure**

- Recommended setting value (`_:4861:10`) **Blk. by meas.-volt. failure = yes**

You can use the **Blk. by meas.-volt. failure** parameter to control the response of the stage when a measuring-voltage failure is detected.

A measuring-voltage failure can only be detected if one of the following 2 conditions is met:

- The device-internal **Measuring-voltage failure detection** function is configured and switched on.
- The binary input signal *>Open* of the function block **Voltage-transformer circuit breaker** is connected to the voltage-transformer circuit breaker.

Parameter Value	Description
<i>yes</i>	The directional overcurrent-protection stage is blocked when a measuring-voltage failure is detected. Siemens recommends using the default setting, as correct direction determination cannot be guaranteed if a measuring-voltage failure occurs.
<i>no</i>	The directional overcurrent-protection stage is not blocked when a measuring-voltage failure is detected.

6.7.5 Stage with Definite-Time Characteristic Curve

6.7.5.1 Description

Logic of the Basic Stage

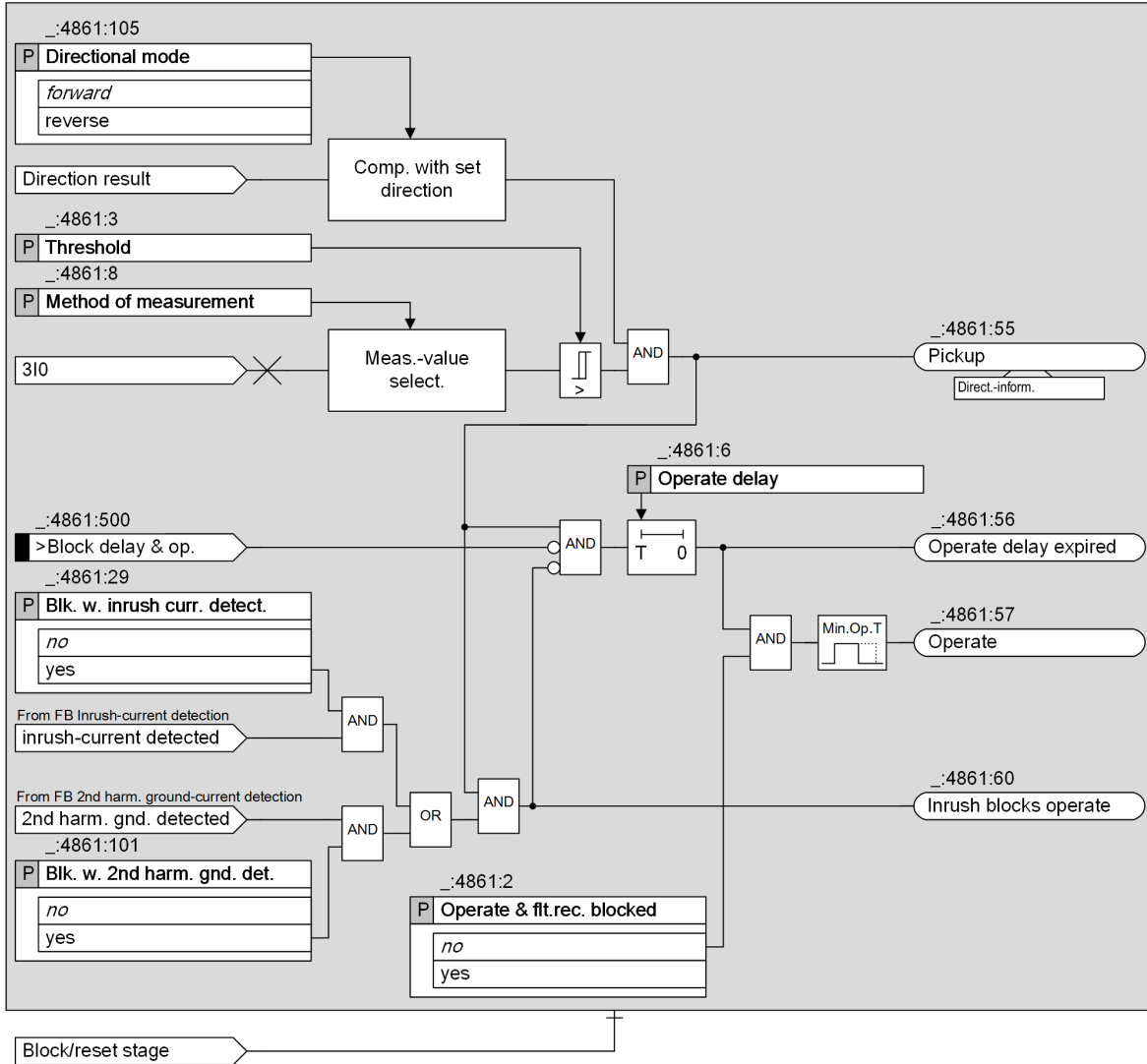

[lo_dirovb, 2, en_US]

Figure 6-59 Logic Diagram of the Directional Definite-Time Overcurrent Protection, Ground – Basic

Logic of the Advanced Stage

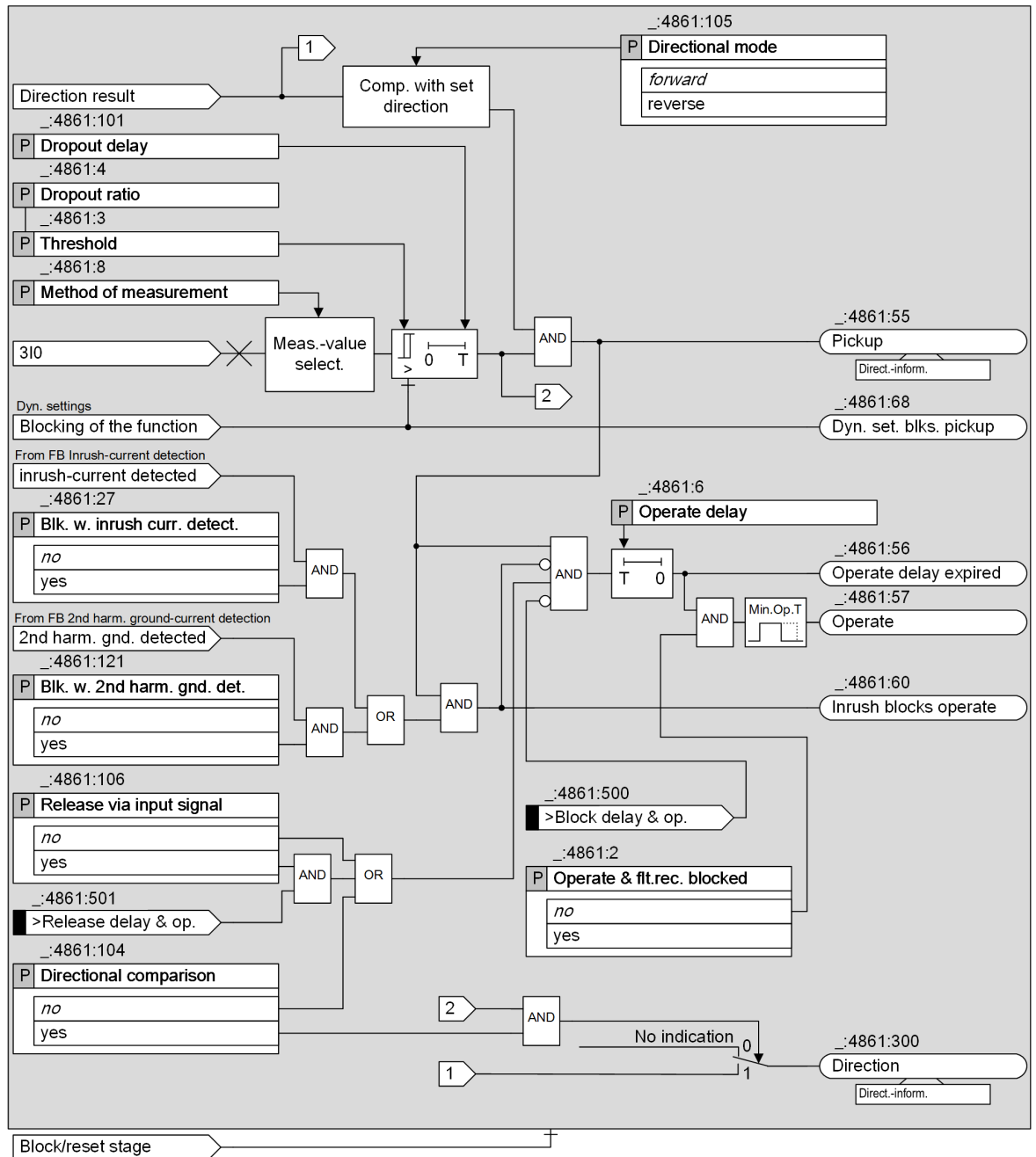

[to_dirova_1_en_US]

Figure 6-60 Logic Diagram of the Directional Definite-Time Overcurrent Protection, Ground – Advanced

Measurand (Basic and Advanced Stage)

The function uses the zero-sequence current (3I0) as a criterion for the ground fault.

Depending on the parameter setting connection type of the **Measuring point I-3ph**, the zero-sequence current is measured or calculated. Depending on the applied CT terminal type, the 3I0 **Threshold** range varies according to the following table.

Table 6-7 Threshold Setting Range

Connection Type of the Measuring Point	Ground Current	CT Terminal Type	Threshold Setting Range (Secondary)
I-3ph			
3-phase	Calculated	4 * Protection	0.030 A to 40.000 A
		3 * Protection, 1 * sensitive	0.030 A to 40.000 A
		4 * Measurement	0.001 A to 1.600 A
x + IN x + IN-separate	Measured	4 * Protection	0.030 A to 40.000 A
		3 * Protection, 1 * sensitive	0.001 A to 1.600 A
		4 * Measurement	0.001 A to 1.600 A

Method of Measurement (Basic and Advanced Stage)

You use the **Method of measurement** parameter to define whether the stage uses the *fundamental comp.* (standard method) or the calculated *RMS value*.

- Measurement of the fundamental component:
This measuring procedure processes the sampled current values and filters out the fundamental components numerically.
- Measurement of the RMS value:
This measuring procedure determines the current amplitude from the sampled values according to the defining equation of the RMS value. Harmonics are included in the analysis.

Directional Mode (Basic and Advanced Stage)

You can use the **Directional mode** parameter to define whether the stage works in a forward or reverse direction.

The direction determination works across all stages (see chapter [6.7.3.2 Direction Determination](#)).

Blocking of the Stage (Basic and Advanced Stage)

The following blockings reset the picked up stage completely:

- Externally or internally via the binary input signal *>Block stage* (see chapter [6.7.4.1 Description](#))
- Measuring-voltage failure (see chapter [6.7.4.1 Description](#))
- Via the dynamic settings functionality (only available in the advanced function type, see **Influence of Other Functions via Dynamic Settings** and chapter [6.7.10 Influence of Other Functions via Dynamic Settings](#))

Blocking of the Operate Delay (Basic and Advanced Stage)

You can use the binary input signal *>Block delay & op.* to prevent the start of the operate delay and thus also the generation of the operate signal. A running operate delay is reset. The pickup is indicated. Fault logging and fault recording take place.

Blocking of the Operate Delay and Operate Signal via the Device-Internal Inrush-Current Detection Function (Basic and Advanced Stage)

Blocking of the operate delay and the operate signal via the device-internal **Inrush-current detection** function is described in chapter [6.5.7.1 Description](#)

Dropout Delay (Advanced Stage)

In case of undershooting of the dropout threshold, the dropout can be delayed. The pickup is maintained for the specified time. The operate delay continues to run. If the operate delay expires while the pickup is still maintained, the stage operates.

Directional Comparison Protection (Advanced Stage)

The stage can be used for directional comparison protection. This is set using the **Directional comparison** parameter. With the **yes** setting, the direction indication *Direction* is released and the direction (forward or reverse) is determined, if the current exceeds the threshold of the stage. The direction indicated is independent of the directional mode set for the stage.

The **Release via input signal** parameter and the *>Release delay & op.* input signal are available with directional comparison protection. If the **Release via input signal** parameter is set to **yes**, the start of the operate delay, and therefore the operate signal of the stage, are only enabled when the *>Release delay & op.* input signal is active.

Influence of Other Functions via Dynamic Settings (Advanced Stage)

If available in the device, the following functions can exert an influence on the overcurrent-protection stage:

- Automatic reclosing
- Cold-load pickup detection
- Binary input signal

The influence of these functions via dynamic settings is described in chapter [6.7.10 Influence of Other Functions via Dynamic Settings](#).

6.7.5.2 Application and Setting Notes

Parameter: Directional mode

- Default setting (**_:4861:105**) **Directional mode** = *forward*

You can use the **Directional mode** parameter to define the directional mode of the stage.

Parameter Value	Description
<i>forward</i>	Select this setting if the stage is to work in forward direction (in the direction of the line).
<i>reverse</i>	Select this setting if the stage is to work in reverse direction (in the direction of the busbar).

Parameter: Method of measurement

- Recommended setting value (**_:4861:8**) **Method of measurement** = *fundamental comp.*

With the **Method of measurement** parameter, you define whether the stage uses the *fundamental comp.* (standard method) or the calculated *RMS value*.

Parameter Value	Description
<i>fundamental comp.</i>	Select this method of measurement if harmonics or transient current peaks are to be suppressed. Siemens recommends using this method as the standard method.
<i>RMS value</i>	Select this method of measurement if you want the stage to take harmonics into account (for example, at capacitor banks). Consider that aperiodic DC components present in the secondary circuit are measured and can cause an overfunction. For this method of measurement, do not set the threshold value of the stage to less than $0.1 I_{rated,sec}$. If currents from more than one measuring point are added up in the current interface of a function group, the setting value should not be set lower than $0.1 I_{rated,sec}$ multiplied by the number of added currents.

Parameter: Directional comparison, Release via input signal

- Default setting (`_:4861:104`) **Directional comparison** = *no*
- Default setting (`_:4861:106`) **Release via input signal** = *no*

The parameters **Directional comparison** and **Release via input signal** are not visible for the basic stage.

You can use these settings to define whether the stage is to be used for directional comparison protection. Directional comparison protection is performed via the *Direction* and *>Release delay & op.* signals.

Parameter Value	Description
<i>no</i>	The stage is not used for directional comparison protection.
<i>yes</i>	<p>If the Directional comparison parameter is set to <i>yes</i>, the Release via input signal parameter, the <i>Direction</i> output signal, and the <i>>Release delay & op.</i> input signal become available.</p> <p>If the Release via input signal parameter is set to <i>yes</i>, the starts of the operate delay and operate signal are only enabled when the <i>>Release delay & op.</i> input signal is active. The <i>>Release delay & op.</i> input signal must be connected to the enable information from the opposite end (forward information from the <i>Direction</i> output signal).</p> <p>See also the application example in 6.6.10 Application Notes for Directional Comparison Protection</p>

Parameter: Dynamic settings

- Default setting (`_:4861:26`) **Dynamic settings** = *no*

This parameter is not visible for the basic stage.

Parameter Value	Description
<i>no</i>	The influence on the overcurrent-protection stage by device-internal or external functions is not necessary.
<i>yes</i>	<p>If a device-internal function (Automatic reclosing or Cold-load pickup detection) or an external function should affect the overcurrent-protection stage (such as change the setting of the threshold value or operate delay, blocking of the stage), the setting must be changed to <i>yes</i>.</p> <p>This makes the configuration parameters affected by Auto reclosing/Cold-load PU/Binary input as well as the dynamic settings Threshold, Operate delay, and Stage blocked of the stage visible and enables the settings to be set for the specific influence.</p>

For further setting notes, refer to [6.5.8.2 Application and Setting Notes \(Advanced Stage\)](#) of the function **Overcurrent Protection, Ground**.

Parameter: Blk. w. inrush curr. detect.

- Default setting (`_:4861:27`) **Blk. w. inrush curr. detect.** = *no*

Parameter Value	Description
no	The transformer inrush-current detection does not affect the stage. Select this setting in the following cases: <ul style="list-style-type: none"> • In cases where the device is not used on transformers. • In cases where the device is used on transformers and the threshold value of the stage is set above the maximum inrush current of the transformer. This applies, for example, to the high-current stage that is set according to the short-circuit voltage V_{sc} of the transformer in such a way that the stage only picks up on faults from the high-voltage side. The transformer inrush current cannot become larger than the maximum transmittable short-circuit current.
yes	When the transformer inrush-current detection detects an inrush current that would lead to an operate of the stage, the start of the operate delay and operate of the stage are blocked. Select this setting if the device is used on transformers and the threshold value of the stage is set below the maximum inrush current of the transformer. This applies to the overcurrent-protection stage, which is used as a backup stage with grading time for faults on the undervoltage side of the transformer.

Parameter: Threshold

- Default setting (**_:4861:3**) **Threshold = 1.20 A**

For setting the threshold value, the same considerations apply as for the non-directional overcurrent protection function.

For further information, refer to [6.5.4.2 Application and Setting Notes](#).

Parameter: Dropout ratio

- Recommended setting value (**_:4861:4**) **Dropout ratio = 0.95**

This parameter is not visible for the basic stage.

The recommended setting value of **0.95** is appropriate for most applications.

For high-precision measurements, the setting value of the **Dropout ratio** parameter can be reduced, for example to 0.98. If you expect highly fluctuating measurands at the pickup threshold, you can increase the setting value of the **Dropout ratio** parameter. This avoids chattering of the stage.

Parameter: Dropout delay

- Recommended setting value (**_:4861:101**) **Dropout delay = 0 s**

This parameter is not visible for the basic stage.

Siemens recommends using the dropout delay of 0 s, since the dropout of a protection stage must be performed as fast as possible.

You can use the **Dropout delay** parameter $\neq 0$ s to obtain a uniform dropout behavior if you use it together with an electromechanical relay. This is required for time grading. The dropout time of the electromechanical relay must be known for this purpose. Subtract the dropout time of your own device (see Technical data) and set the result.

Parameter: Operate delay

- Default setting (**_:4861:6**) **Operate delay = 0.300 s** (for the 1st stage)

The **Operate delay** to be set is derived from the time-grading chart that has been prepared for the system.

Typical examples of grading times are provided in sections [6.6.9 Application Notes for Parallel Lines](#) and [6.6.10 Application Notes for Directional Comparison Protection](#).

6.7.5.3 Settings

6.7.5.4 Information List

No.	Information	Data Class (Type)	Type
General			
_:2311:501	General:>Test of direction	SPS	I
_:2311:352	General:Test direction	ACD	O
_:2311:351	General:Phi(I,V)	MV	O
Group indicat.			
_:4501:55	Group indicat.:Pickup	ACD	O
_:4501:57	Group indicat.:Operate	ACT	O
Definite-T 1			
_:4861:81	Definite-T 1:>Block stage	SPS	I
_:4861:501	Definite-T 1:>Release delay & op.	SPS	I
_:4861:84	Definite-T 1:>Activ. dyn. settings	SPS	I
_:4861:500	Definite-T 1:>Block delay & op.	SPS	I
_:4861:54	Definite-T 1:Inactive	SPS	O
_:4861:52	Definite-T 1:Behavior	ENS	O
_:4861:53	Definite-T 1:Health	ENS	O
_:4861:60	Definite-T 1:Inrush blocks operate	SPS	O
_:4861:62	Definite-T 1:Dyn.set. AR cycle1act.	SPS	O
_:4861:63	Definite-T 1:Dyn.set. AR cycle2act.	SPS	O
_:4861:64	Definite-T 1:Dyn.set. AR cycle3act.	SPS	O
_:4861:65	Definite-T 1:Dyn.set. ARcycl.>3act	SPS	O
_:4861:66	Definite-T 1:Dyn.set. CLP active	SPS	O
_:4861:67	Definite-T 1:Dyn.set. BI active	SPS	O
_:4861:68	Definite-T 1:Dyn. set. blks. pickup	SPS	O
_:4861:55	Definite-T 1:Pickup	ACD	O
_:4861:300	Definite-T 1:Direction	ACD	O
_:4861:56	Definite-T 1:Operate delay expired	ACT	O
_:4861:57	Definite-T 1:Operate	ACT	O

6.7.6 Stage with Inverse-Time Characteristic Curve

6.7.6.1 Description

Logic of the Basic Stage

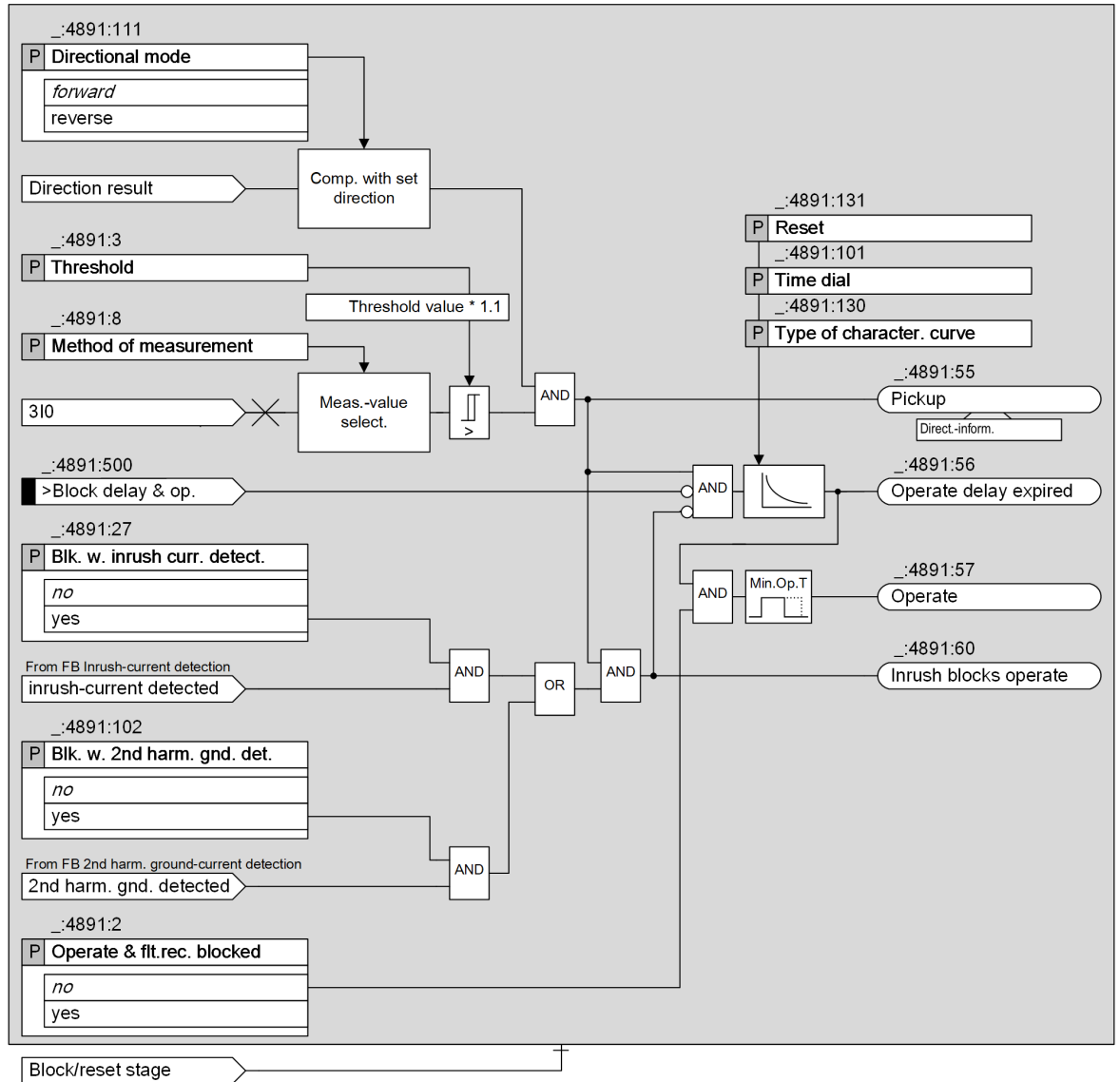

[to_dinrvb, 3, en_US]

Figure 6-61 Logic Diagram of the Directional Inverse-Time Overcurrent Protection, Ground – Basic

Logic of the Advanced Stage

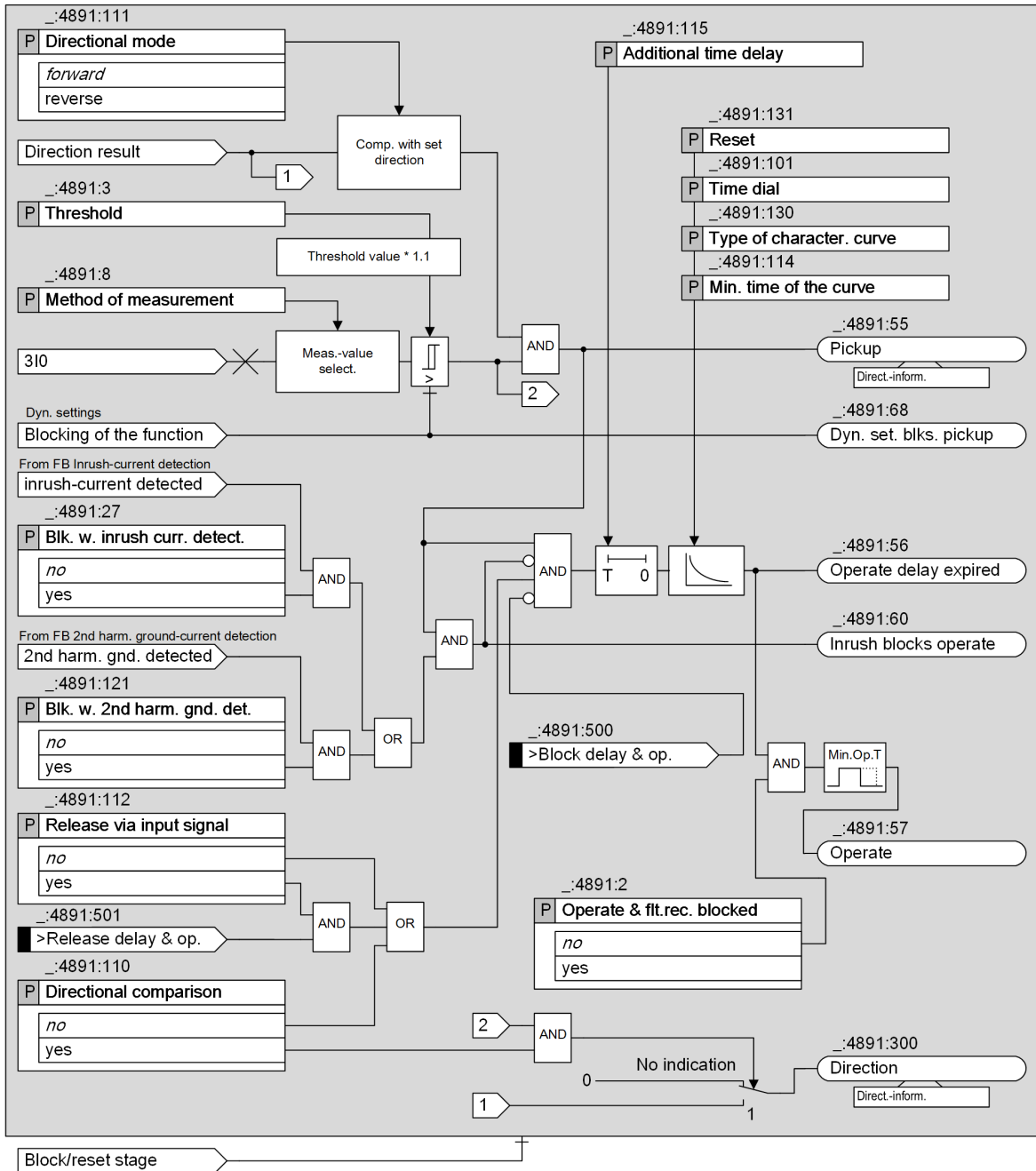

Figure 6-62 Logic Diagram of the Directional Inverse-Time Overcurrent Protection, Ground – Advanced

Measurand (Basic and Advanced Stage)

The function uses the zero-sequence current (3I0) as a criterion for the ground fault. Depending on the parameter setting connection type of the **Measuring point I-3ph**, the zero-sequence current is measured or calculated. Depending on the applied CT terminal type, the 3I0 **Threshold** range varies according to the following table.

Table 6-8 Threshold Setting Range

Connection Type of the Measuring Point I-3ph	Ground Current	CT Terminal Type	Threshold Setting Range (Secondary)
3-phase	Calculated	4 * Protection	0.030 A to 40.000 A
		3 * Protection, 1 * sensitive	0.030 A to 40.000 A
		4 * Measurement	0.001 A to 1.600 A
x + IN x + IN-separate	Measured	4 * Protection	0.030 A to 40.000 A
		3 * Protection, 1 * sensitive	0.001 A to 1.600 A
		4 * Measurement	0.001 A to 1.600 A

Method of Measurement (Basic and Advanced Stage)

You use the **Method of measurement** parameter to define whether the stage uses the standard method (*fundamental comp.*) or the calculated **RMS value**.

- Measurement of the fundamental component:
This measuring procedure processes the sampled current values and filters out the fundamental components numerically.
- Measurement of the RMS value:
This measuring procedure determines the current amplitude from the sampled values according to the defining equation of the RMS value. Harmonics are included in the analysis.

Directional Mode (Basic and Advanced Stage)

You can use the **Directional mode** parameter to define whether the stage works in a forward or reverse direction.

The direction determination works across all stages (see [6.7.3.2 Direction Determination](#)).

Pickup and Dropout Behaviors of the Inverse-Time Characteristic Curve According to IEC and ANSI (Basic and Advanced Stage)

When the input variable exceeds the threshold value by a factor of 1.1, the inverse-time characteristic curve is processed. An integrating method of measurement summarizes the weighted time. The weighted time results from the characteristic curve. For this, the time that is associated with the present current value is determined from the characteristic curve. Once the weighted time exceeds the value 1, the stage operates.

When the measured value falls below the pickup value by a factor of 1.045 ($0.95 \cdot 1.1 \cdot \text{threshold value}$), the dropout is started. The pickup will be indicated as clearing. You can influence the dropout behavior via setting parameters. You can select between instantaneous dropout (totalized time is deleted) or dropout according to the characteristic curve (reduction of totalized time depending on the characteristic curve). The dropout according to characteristic curve (disk emulation) is the same as turning back a rotor disk. The weighted reduction of the time is initiated from 0.9 of the set threshold value.

The characteristic curve and associated formulas are shown in the Technical Data.

Minimum Time of the Curve (Advanced Stage)

With the parameter **Min. time of the curve**, you define a minimum operate delay time. The operate delay time of inverse-time characteristic curve never falls below the minimum operate delay time.

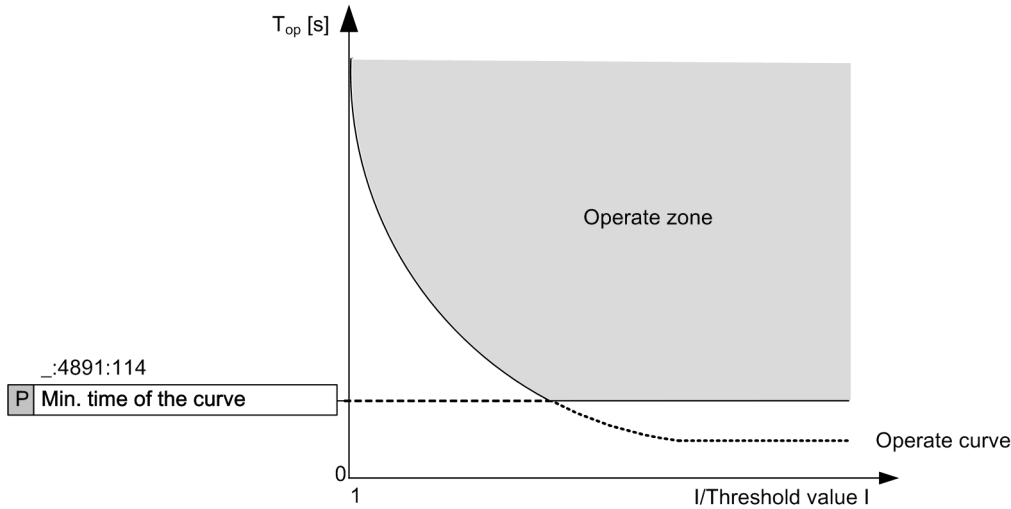

[dw_min_time_1_en_US]
 Figure 6-63 Minimum Operating Time of the Curve

Additional Time Delay (Advanced Stage)

With the parameter **Additional time delay**, you define a definite-time delay in addition to the inverse-time delay. With this setting, the whole curve is shifted on the time axis by this additional definite time.

Blocking of the Stage (Basic and Advanced Stage)

The following blockings reset the picked up stage completely:

- Externally or internally via the binary input signal **>Block stage** (see [6.7.4.1 Description](#))
- Measuring-voltage failure (see [6.7.4.1 Description](#))
- Via the dynamic settings functionality (only available in the advanced function type, see **Influence of Other Functions via Dynamic Settings** and [6.7.10 Influence of Other Functions via Dynamic Settings](#))

Blocking of the Operate Delay (Basic and Advanced Stage)

You can use the binary input signal **>Block delay & op.** to prevent the start of the operate delay and thus also the generation of the operate signal. A running operate delay is reset. The pickup is indicated. Fault logging and fault recording take place.

Blocking of the Operate Delay and Operate Signal via the Device-Internal Inrush-Current Detection Function (Basic and Advanced Stage)

Blocking of the operate delay and the operate signal via the device-internal **Inrush-current detection** function is described in [Blocking of the Tripping by Device-Internal Inrush-Current Detection](#). For more information, refer to [6.5.7.1 Description](#).

Directional Comparison Protection (Advanced Stage)

The stage can be used for directional comparison protection. This is set using the **Directional comparison** parameter. With the **yes** setting, the direction indication *Direction* is released and the direction (forward or reverse) is determined, if the current exceeds the threshold of the stage. The direction indicated is independent of the directional mode set for the stage.

The **Release via input signal** parameter and the **>Release delay & op.** input signal are available with directional comparison protection. If the **Release via input signal** parameter is set to **yes**, the start of the operate delay, and therefore the operate signal of the stage, are only enabled when the **>Release delay & op.** input signal is active.

Influence of Other Functions via Dynamic Settings (Advanced Stage)

If available in the device, the following functions can exert an influence on the overcurrent-protection stage:

- Automatic reclosing
- Cold-load pickup detection
- Binary input signal

The influence of these functions via dynamic settings is described in [6.7.10 Influence of Other Functions via Dynamic Settings](#).

6.7.6.2 Application and Setting Notes

Parameter: Directional mode

- Default setting (`_:4891:111`) **Directional mode** = *forward*

You can use the **Directional mode** parameter to define the directional mode of the stage.

Parameter Value	Description
<i>forward</i>	Select this setting if the stage is to work in forward direction (in the direction of the line).
<i>reverse</i>	Select this setting if the stage is to work in reverse direction (in the direction of the busbar).

Parameter: Method of measurement

- Recommended setting value (`_:4891:8`) **Method of measurement** = *fundamental comp.*

With the **Method of measurement** parameter, you define whether the stage uses the *fundamental comp.* (standard method) or the calculated *RMS value*.

Parameter Value	Description
<i>fundamental comp.</i>	Select this method of measurement if harmonics or transient current peaks are to be suppressed. Siemens recommends using this method as the standard method.
<i>RMS value</i>	Select this method of measurement if you want the stage to take harmonics into account (for example, at capacitor banks). Consider that aperiodic DC components present in the secondary circuit are measured and can cause an overfunction. For this method of measurement, do not set the threshold value of the stage to less than $0.1 I_{rated,sec}$. If currents from more than one measuring point are added up in the current interface of a function group, the setting value should not be set lower than $0.1 I_{rated,sec}$ multiplied by the number of added currents.

Parameter: Directional comparison, Release via input signal

- Default setting (`_:4891:110`) **Directional comparison** = *no*
- Default setting (`_:4891:112`) **Release via input signal** = *no*

The parameters **Directional comparison** and **Release via input signal** are not visible for the basic stage.

You can use these settings to define whether the stage is to be used for directional comparison protection. Directional comparison protection is performed via the *Direction* and *>Release delay & op.* signals.

Parameter Value	Description
<i>no</i>	The stage is not used for directional comparison protection.
<i>yes</i>	<p>If the Directional comparison parameter is set to yes, the Release via input signal parameter, the <i>Direction</i> output signal, and the <i>>Release delay & op.</i> input signal become available.</p> <p>If the Release via input signal parameter is set to yes, the starts of the operate delay and operate signal are only enabled when the <i>>Release delay & op.</i> input signal is active. The <i>>Release delay & op.</i> input signal must be connected to the release information from the opposite end (forward information from the <i>Direction</i> output signal).</p> <p>See also the application example in chapter 6.6.10 Application Notes for Directional Comparison Protection .</p>

Parameter: Dynamic settings

- Default setting (`_ :4891:26`) **Dynamic settings** = *no*

This parameter is not visible for the basic stage.

Parameter Value	Description
<i>no</i>	The influence on the overcurrent-protection stage by device-internal or external functions is not necessary.
<i>yes</i>	<p>If a device-internal function (Automatic reclosing or Cold-load pickup detection) or an external function should affect the overcurrent-protection stage (such as change the setting of the threshold value or operate delay, blocking of the stage), the setting must be changed to yes.</p> <p>This makes the configuration parameters affected by Auto reclosing/ Cold-load PU/Binary input as well as the dynamic settings Threshold, Time dial, and Stage blocked of the stage visible and enables the settings to be set for the specific influence.</p>

For further setting notes, refer to chapter [6.5.8.2 Application and Setting Notes \(Advanced Stage\)](#) of the function **Overcurrent Protection, Ground**.

Parameter: Blk. w. inrush curr. detect.

- Default setting (`_ :4891:27`) **Blk. w. inrush curr. detect.** = *no*

Parameter Value	Description
no	The transformer inrush-current detection does not affect the stage. Select this setting in the following cases: <ul style="list-style-type: none"> • In cases where the device is not used on transformers. • In cases where the device is used on transformers and the threshold value of the stage is set above the maximum inrush current of the transformer. This applies, for example, to the high-current stage that is set according to the short-circuit voltage V_{sc} of the transformer in such a way that the stage only picks up on faults from the high-voltage side. The transformer inrush current cannot become larger than the maximum transmittable shortcircuit current.
yes	When the transformer inrush-current detection detects an inrush current that would lead to an operate of the stage, the start of the operate delay and operate of the stage are blocked. Select this setting if the device is used on transformers and the threshold value of the stage is set below the maximum inrush current of the transformer. This applies to the overcurrent-protection stage, which is used as a backup stage with grading time for faults on the undervoltage side of the transformer.

Parameter: Min. time of the curve

- Default setting (**_:4891:114**) **Min. time of the curve** = 0.00 s

This parameter is only available in the advanced stage.

With the parameter **Min. time of the curve**, you define a minimum operate delay time. The operate delay time of inverse-time characteristic curve never falls below the minimum operate delay time. If the setting is left on its default value of 0 s, this parameter has no effect on the inverse-time characteristic curve. This parameter is only required for time coordination in recloser schemes. For all other applications, Siemens recommends keeping the default setting of 0 s.



NOTE

If the set value is smaller than the smallest possible time delay of the inverse-time characteristic curve, the parameter has no influence on the delay time.

Parameter: Additional time delay

- Default setting (**_:4891:115**) **Additional time delay** = 0.00 s

With the parameter **Additional time delay**, you define a definite-time delay in addition to the inverse-time delay.

If the setting is left on its default value of 0 s, this parameter has no effect on the inverse-time characteristic curve.

This parameter is only required for time coordination in recloser schemes. For all other applications, Siemens recommend keeping the default setting of 0 s.

Parameter: Threshold

- Default setting (**_:4891:3**) **Threshold** = 1.20 A

The setting depends on the minimal occurring ground-fault current. This must be detected.

Consider that a safety margin is set between pickup value and threshold value. The stage only picks up at approx. 10 % above the **Threshold**.

Parameter: Type of character. curve

- Default setting (`_:4891:130`) **Type of character. curve = IEC normal inverse**

The device offers all the usual inverse-time characteristic curves according to IEC and ANSI. Select the **Type of character. curve** required for your specific application.

Parameter: Time dial

- Default setting (`_:4891:101`) **Time dial = 1**

You can use the **Time dial** parameter to displace the characteristic curve in the time direction.

The setting value for the **Time dial** parameter is derived from the time-grading chart that has been prepared for the electrical power system.

Where no time grading and therefore no displacement of the characteristic curve is required, leave the **Time dial** parameter at **1** (default setting).

Parameter: Reset

- Default setting (`_:4891:131`) **Reset = disk emulation**

You can use the **Reset** parameter setting to define whether the stage decreases according to the dropout characteristic curve (in accordance with the behavior of a disk emulation = rotor disk) or instantaneously.

Parameter Value	Description
<i>disk emulation</i>	Select this setting if the device is coordinated with electromechanical devices or other devices which perform a dropout after a disk emulation.
<i>instantaneous</i>	Select this setting if the dropout does not have to be performed after a disk emulation and an instantaneous dropout is desired instead.

6.7.6.3 Settings

6.7.6.4 Information List

No.	Information	Data Class (Type)	Type
Inverse-T 1			
<code>_:4891:81</code>	Inverse-T 1:>Block stage	SPS	I
<code>_:4891:501</code>	Inverse-T 1:>Release delay & op.	SPS	I
<code>_:4891:84</code>	Inverse-T 1:>Activ. dyn. settings	SPS	I
<code>_:4891:500</code>	Inverse-T 1:>Block delay & op.	SPS	I
<code>_:4891:54</code>	Inverse-T 1:Inactive	SPS	O
<code>_:4891:52</code>	Inverse-T 1:Behavior	ENS	O
<code>_:4891:53</code>	Inverse-T 1:Health	ENS	O
<code>_:4891:60</code>	Inverse-T 1:Inrush blocks operate	SPS	O
<code>_:4891:62</code>	Inverse-T 1:Dyn.set. AR cycle1 act.	SPS	O
<code>_:4891:63</code>	Inverse-T 1:Dyn.set. AR cycle2 act.	SPS	O
<code>_:4891:64</code>	Inverse-T 1:Dyn.set. AR cycle3 act.	SPS	O
<code>_:4891:65</code>	Inverse-T 1:Dyn.set. AR cycl.>3 act	SPS	O
<code>_:4891:66</code>	Inverse-T 1:Dyn.set. CLP active	SPS	O
<code>_:4891:67</code>	Inverse-T 1:Dyn.set. BI active	SPS	O
<code>_:4891:68</code>	Inverse-T 1:Dyn. set. blks. pickup	SPS	O
<code>_:4891:59</code>	Inverse-T 1:Disk emulation running	SPS	O
<code>_:4891:55</code>	Inverse-T 1:Pickup	ACD	O
<code>_:4891:300</code>	Inverse-T 1:Direction	ACD	O

No.	Information	Data Class (Type)	Type
_:4891:56	Inverse-T 1:Operate delay expired	ACT	O
_:4891:57	Inverse-T 1:Operate	ACT	O

6.7.7 Stage with Inverse-Time Overcurrent Protection with Logarithmic-Inverse Characteristic Curve

6.7.7.1 Description

Logic of the Stage

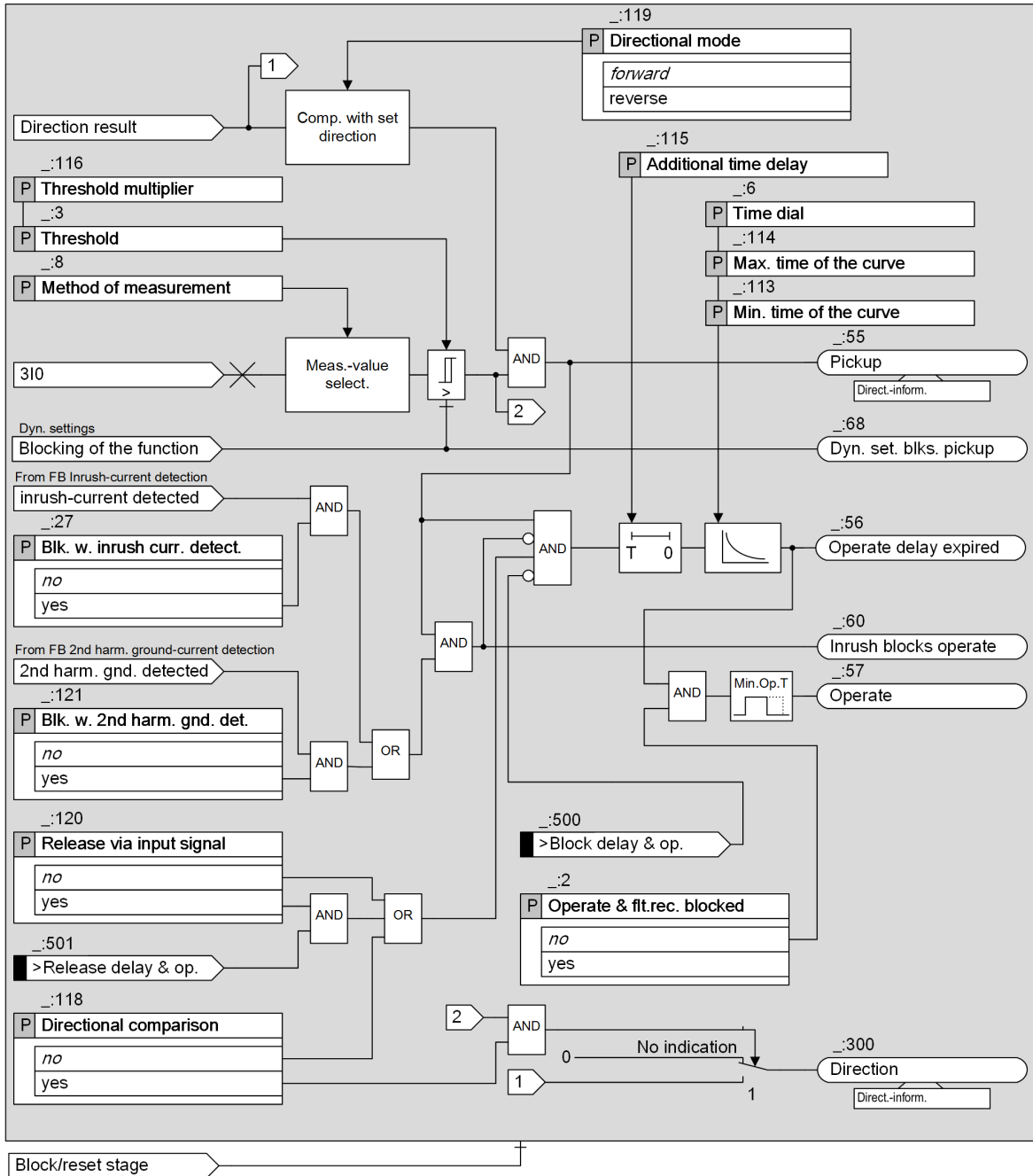

[to_diloin_4_en_US]

Figure 6-64 Logic Diagram of the Directional Logarithmic Inverse-Time Overcurrent Protection, Ground

Apart from the operate curve, this type of stage is identical to the **Inverse-time overcurrent protection – advanced** stage (see chapter [6.7.6.1 Description](#)).

This section will only discuss the nature of the operate curve. For further functionality, refer to chapter [6.7.6.1 Description](#).

Operate Curve

If the function picks up, the logarithmic inverse-time characteristic curve is processed. A time value T_{op} is calculated for every input value exceeding 95 % of the pickup value. An integrator accumulates the value $1/T_{op}$. If the accumulated integral reaches the fixed value 1, the stage operates.

The curve used to calculate the time value T_{op} is shown in the following figure. The **Threshold multiplier** parameter defines the beginning of the characteristic curve. The **Max. time of the curve** determines the initial value of the characteristic curve. The **Time dial** parameter changes the slope of the characteristic curve. At high currents, the **Min. time of the curve** parameter indicates the lower time limit.

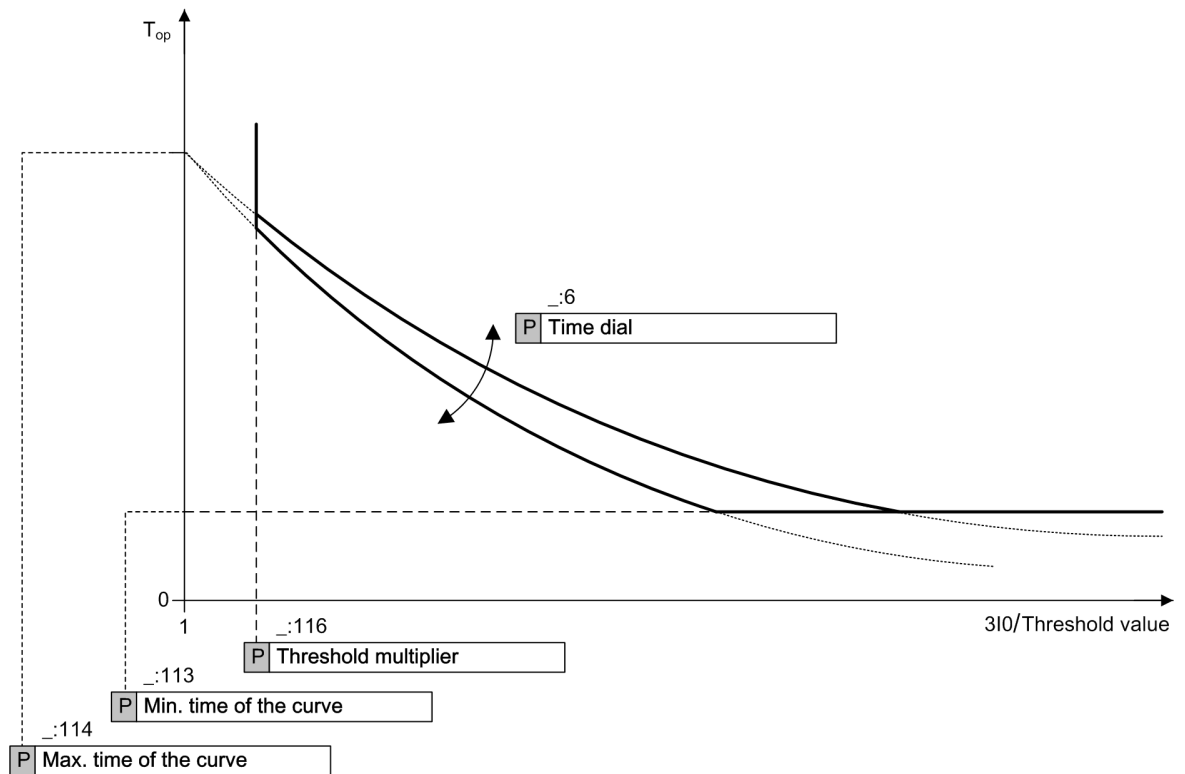

[dwx_loginv, 3, en_US]

Figure 6-65 Operate Curve of Logarithmic Inverse-Time Characteristic

The time to operate is calculated with the following formula:

$$T_{op} = T_{max} - T_d \ln \left(\frac{310}{I_{thresh} \times I_{mul}} \right)$$

[fo_mula_01, 1, en_US]

Where

T_{max}	Maximum time of the curve (parameter Max. time of the curve)
T_d	Time dial (parameter Time dial)
T_{op}	Operate time
310	Measured zero-sequence current

I_{thresh}	Threshold value (parameter Threshold)
I_{mul}	Threshold multiplier (parameter Threshold multiplier)

If the calculated time is less than T_{min} (parameter **Min. time of the curve**), T_{min} is used.

6.7.7.2 Application and Setting Notes

Apart from the operate curve, this type of stage is identical to the ground-fault protection type with inverse-time delay according to IEC and ANSI (advanced function type) (see [6.7.6.1 Description](#)).

This section only discusses the nature of the operate curve. For further functionality, refer to chapter [6.7.6.2 Application and Setting Notes](#).

Stage Type Selection

If the operate delay is to be dependent on the current level according to a logarithmic characteristic curve, select this stage type.

Dynamic Settings: **Threshold**

- Default setting (**_:3**) **Threshold = 1.20 A**

Define the pickup value corresponding to the application. In doing so, for time-graded stages, the settings of the superordinate and of the subordinate stages in the time-grading chart must be taken into consideration.

Parameter: **Threshold multiplier**

- Default setting (**_:116**) **Threshold multiplier = 1.1**

You can use the **Threshold multiplier** parameter to define the beginning of the characteristic curve on the current axis (in relation to the threshold value).

General information cannot be provided. Define the value corresponding to the application.

EXAMPLE

Threshold (Secondary current)	$I_{\text{thresh}} = 1.2 \text{ A}$
Threshold multiplier	$I_{\text{mul}} = 1.1$
Pickup value (Secondary current)	$I_{\text{PU}} = 1.2 \text{ A} \times 1.1 = 1.32 \text{ A}$

Dynamic Settings: **Time dial**

- Default setting (**_:6**) **Time dial = 1.250 s**

You can use the **Time dial** parameter to change the slope of the characteristic curve.

General information cannot be provided. Define the value corresponding to the application.

Parameter: **Max. time of the curve**

- Default setting (**_:114**) **Max. time of the curve = 5.800 s**

The parameter **Max. time of the curve** determines the initial value of the characteristic curve (for $3I_0 = \text{Threshold}$).

General information cannot be provided. Define the value corresponding to the application.

Parameter: **Min. time of the curve**

- Default setting (**_:113**) **Min. time of the curve = 1.200 s**

The parameter **Min. time of the curve** determines the lower time limit (at high currents).

General information cannot be provided. Define the value corresponding to the application.

Parameter: Additional time delay

- Recommended setting value (_:115) **Additional time delay = 0 s**

You can set an additional current-independent time delay. This additional delay is intended for special applications.

Siemens recommends setting this time to 0 s so that it has no effect.

6.7.7.3 Settings

Addr.	Parameter	C	Setting Options	Default Setting
<i>General</i>				
_:1	Log.-inv.-T #:Mode		<ul style="list-style-type: none"> • off • on • test 	off
_:2	Log.-inv.-T #:Operate & flt.rec. blocked		<ul style="list-style-type: none"> • no • yes 	no
_:119	Log.-inv.-T #:Directional mode		<ul style="list-style-type: none"> • forward • reverse 	forward
_:8	Log.-inv.-T #:Method of measurement		<ul style="list-style-type: none"> • fundamental comp. • RMS value 	fundamental comp.
_:118	Log.-inv.-T #:Directional comparison		<ul style="list-style-type: none"> • no • yes 	no
_:120	Log.-inv.-T #:Release via input signal		<ul style="list-style-type: none"> • no • yes 	no
_:10	Log.-inv.-T #:Blk. by meas.-volt. failure		<ul style="list-style-type: none"> • no • yes 	yes
_:26	Log.-inv.-T #:Dynamic settings		<ul style="list-style-type: none"> • no • yes 	no
_:27	Log.-inv.-T #:Blk. w. inrush curr. detect.		<ul style="list-style-type: none"> • no • yes 	no
_:121	Log.-inv.-T #:Blk. w. 2nd harm. gnd. det.		<ul style="list-style-type: none"> • no • yes 	no
_:3	Log.-inv.-T #:Threshold	1 A @ 100 Irated	0.030 A to 40.000 A	1.200 A
		5 A @ 100 Irated	0.15 A to 200.00 A	6.00 A
		1 A @ 50 Irated	0.030 A to 40.000 A	1.200 A
		5 A @ 50 Irated	0.15 A to 200.00 A	6.00 A
		1 A @ 1.6 Irated	0.001 A to 1.600 A	1.200 A
		5 A @ 1.6 Irated	0.005 A to 8.000 A	6.000 A
_:6	Log.-inv.-T #:Time dial		0.000 s to 60.000 s	1.250 s
_:113	Log.-inv.-T #:Min. time of the curve		0.000 s to 60.000 s	1.200 s
_:114	Log.-inv.-T #:Max. time of the curve		0.000 s to 60.000 s	5.800 s
_:116	Log.-inv.-T #:Threshold multiplier		1.00 to 4.00	1.10
_:115	Log.-inv.-T #:Additional time delay		0.000 s to 60.000 s	0.000 s

Addr.	Parameter	C	Setting Options	Default Setting
Dyn.s: AR off/n.rdy				
_.28	Log.-inv.-T #:Effect. by AR off/n.ready		<ul style="list-style-type: none"> • no • yes 	no
_.35	Log.-inv.-T #:Stage blocked		<ul style="list-style-type: none"> • no • yes 	no
Dyn.set: AR cycle 1				
_.29	Log.-inv.-T #:Effected by AR cycle 1		<ul style="list-style-type: none"> • no • yes 	no
_.36	Log.-inv.-T #:Stage blocked		<ul style="list-style-type: none"> • no • yes 	no
_.14	Log.-inv.-T #:Threshold	1 A @ 100 Irated	0.030 A to 40.000 A	1.200 A
		5 A @ 100 Irated	0.15 A to 200.00 A	6.00 A
		1 A @ 50 Irated	0.030 A to 40.000 A	1.200 A
		5 A @ 50 Irated	0.15 A to 200.00 A	6.00 A
		1 A @ 1.6 Irated	0.001 A to 1.600 A	1.200 A
		5 A @ 1.6 Irated	0.005 A to 8.000 A	6.000 A
_.107	Log.-inv.-T #:Time dial		0.000 s to 60.000 s	1.250 s
Dyn.set: AR cycle 2				
_.30	Log.-inv.-T #:Effected by AR cycle 2		<ul style="list-style-type: none"> • no • yes 	no
_.37	Log.-inv.-T #:Stage blocked		<ul style="list-style-type: none"> • no • yes 	no
_.15	Log.-inv.-T #:Threshold	1 A @ 100 Irated	0.030 A to 40.000 A	1.200 A
		5 A @ 100 Irated	0.15 A to 200.00 A	6.00 A
		1 A @ 50 Irated	0.030 A to 40.000 A	1.200 A
		5 A @ 50 Irated	0.15 A to 200.00 A	6.00 A
		1 A @ 1.6 Irated	0.001 A to 1.600 A	1.200 A
		5 A @ 1.6 Irated	0.005 A to 8.000 A	6.000 A
_.108	Log.-inv.-T #:Time dial		0.000 s to 60.000 s	1.250 s
Dyn.set: AR cycle 3				
_.31	Log.-inv.-T #:Effected by AR cycle 3		<ul style="list-style-type: none"> • no • yes 	no
_.38	Log.-inv.-T #:Stage blocked		<ul style="list-style-type: none"> • no • yes 	no
_.16	Log.-inv.-T #:Threshold	1 A @ 100 Irated	0.030 A to 40.000 A	1.200 A
		5 A @ 100 Irated	0.15 A to 200.00 A	6.00 A
		1 A @ 50 Irated	0.030 A to 40.000 A	1.200 A
		5 A @ 50 Irated	0.15 A to 200.00 A	6.00 A
		1 A @ 1.6 Irated	0.001 A to 1.600 A	1.200 A
		5 A @ 1.6 Irated	0.005 A to 8.000 A	6.000 A
_.109	Log.-inv.-T #:Time dial		0.000 s to 60.000 s	1.250 s
Dyn.s: AR cycle>3				
_.32	Log.-inv.-T #:Effected by AR cycle gr. 3		<ul style="list-style-type: none"> • no • yes 	no
_.39	Log.-inv.-T #:Stage blocked		<ul style="list-style-type: none"> • no • yes 	no

Addr.	Parameter	C	Setting Options	Default Setting
_:17	Log.-inv.-T #:Threshold	1 A @ 100 Irated	0.030 A to 40.000 A	1.200 A
		5 A @ 100 Irated	0.15 A to 200.00 A	6.00 A
		1 A @ 50 Irated	0.030 A to 40.000 A	1.200 A
		5 A @ 50 Irated	0.15 A to 200.00 A	6.00 A
		1 A @ 1.6 Irated	0.001 A to 1.600 A	1.200 A
		5 A @ 1.6 Irated	0.005 A to 8.000 A	6.000 A
_:110	Log.-inv.-T #:Time dial		0.000 s to 60.000 s	1.250 s
Dyn.s: Cold load PU				
_:33	Log.-inv.-T #:Effect. b. cold-load pickup		<ul style="list-style-type: none"> • no • yes 	no
_:40	Log.-inv.-T #:Stage blocked		<ul style="list-style-type: none"> • no • yes 	no
_:18	Log.-inv.-T #:Threshold	1 A @ 100 Irated	0.030 A to 40.000 A	1.200 A
		5 A @ 100 Irated	0.15 A to 200.00 A	6.00 A
		1 A @ 50 Irated	0.030 A to 40.000 A	1.200 A
		5 A @ 50 Irated	0.15 A to 200.00 A	6.00 A
		1 A @ 1.6 Irated	0.001 A to 1.600 A	1.200 A
		5 A @ 1.6 Irated	0.005 A to 8.000 A	6.000 A
_:111	Log.-inv.-T #:Time dial		0.000 s to 60.000 s	1.250 s
Dyn.set: bin.input				
_:34	Log.-inv.-T #:Effected by binary input		<ul style="list-style-type: none"> • no • yes 	no
_:41	Log.-inv.-T #:Stage blocked		<ul style="list-style-type: none"> • no • yes 	no
_:19	Log.-inv.-T #:Threshold	1 A @ 100 Irated	0.030 A to 40.000 A	1.200 A
		5 A @ 100 Irated	0.15 A to 200.00 A	6.00 A
		1 A @ 50 Irated	0.030 A to 40.000 A	1.200 A
		5 A @ 50 Irated	0.15 A to 200.00 A	6.00 A
		1 A @ 1.6 Irated	0.001 A to 1.600 A	1.200 A
		5 A @ 1.6 Irated	0.005 A to 8.000 A	6.000 A
_:112	Log.-inv.-T #:Time dial		0.000 s to 60.000 s	1.250 s

6.7.7.4 Information List

No.	Information	Data Class (Type)	Type
Log.-inv.-T #			
_:81	Log.-inv.-T #:>Block stage		I
_:501	Log.-inv.-T #:>Release delay & op.		I
_:84	Log.-inv.-T #:>Activ. dyn. settings		I
_:500	Log.-inv.-T #:>Block delay & op.		I
_:54	Log.-inv.-T #:Inactive		O
_:52	Log.-inv.-T #:Behavior		O
_:53	Log.-inv.-T #:Health		O
_:60	Log.-inv.-T #:Inrush blocks operate		O
_:62	Log.-inv.-T #:Dyn.set. AR cycle1act.		O
_:63	Log.-inv.-T #:Dyn.set. AR cycle2act.		O

No.	Information	Data Class (Type)	Type
_:64	Log.-inv.-T #:Dyn.set. AR cycle3act.		0
_:65	Log.-inv.-T #:Dyn.set. ARcycl.>3act		0
_:66	Log.-inv.-T #:Dyn.set. CLP active		0
_:67	Log.-inv.-T #:Dyn.set. BI active		0
_:68	Log.-inv.-T #:Dyn. set. blks. pickup		0
_:55	Log.-inv.-T #:Pickup		0
_:300	Log.-inv.-T #:Direction		0
_:56	Log.-inv.-T #:Operate delay expired		0
_:57	Log.-inv.-T #:Operate		0

6.7.8 Stage with Knee-Point Characteristic Curve

6.7.8.1 Description

Logic of the Stage

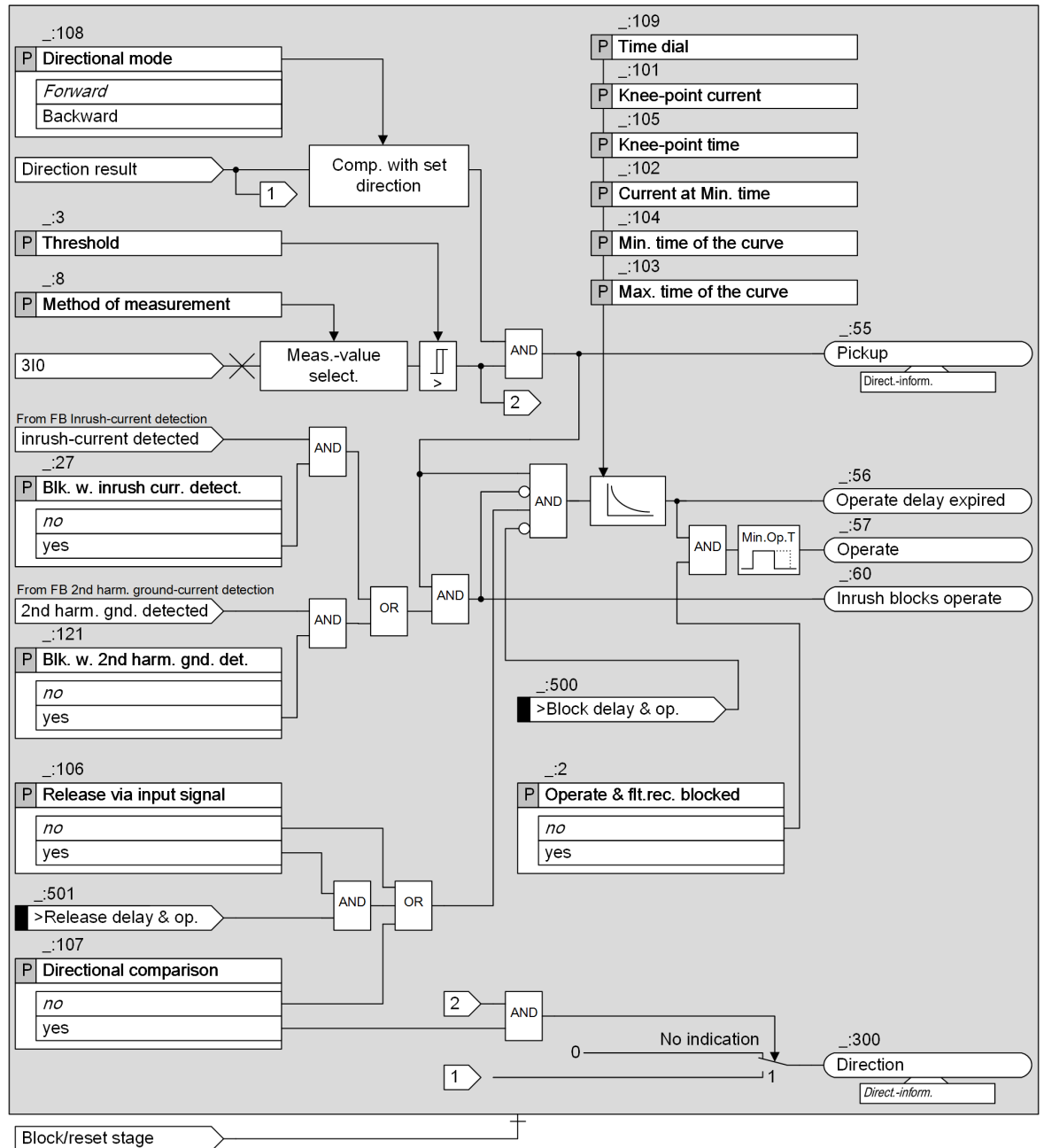

[to_dilokn, 4, en_US]

Figure 6-66 Logic Diagram of the Directional Logarithmic Inverse Time with Knee-Point Overcurrent Protection, Ground

Apart from the operate curve, this type of stage is almost identical to the **Inverse-time overcurrent protection – advanced** stage (see chapter [6.7.6.1 Description](#)). The only difference is that the dynamic settings change functionality is not available.

This section only discusses the nature of the operate curve. For further functionality, refer to chapter [6.7.6.1 Description](#).

Operate Curve

If the function picks up, the logarithmic inverse-time characteristic curve is processed. A time value T_{op} is calculated for every input value exceeding 95 % of the threshold value. An integrator accumulates the value $1/T_{op}$. If the accumulated integral reaches the fixed value 1, the stage operates.

The curve used to calculate the time value T_{op} is shown in the following graphic. The curve is composed of 2 sections with different slopes. 7 parameters are used to define the logarithmic inverse time with knee-point characteristic curve. The parameter **Max. time of the curve** determines the initial time value of the characteristic curve, and relates to the 3I0 **Threshold** value. The transition point is defined by parameter **Knee-point current** and parameter **Knee-point time**. The parameter **Min. time of the curve** indicates the lower time limit, and parameter **Current at Min. time** determines the current value at **Min. time of the curve**. The parameter **Time dial** servers as a time factor to the operate time.

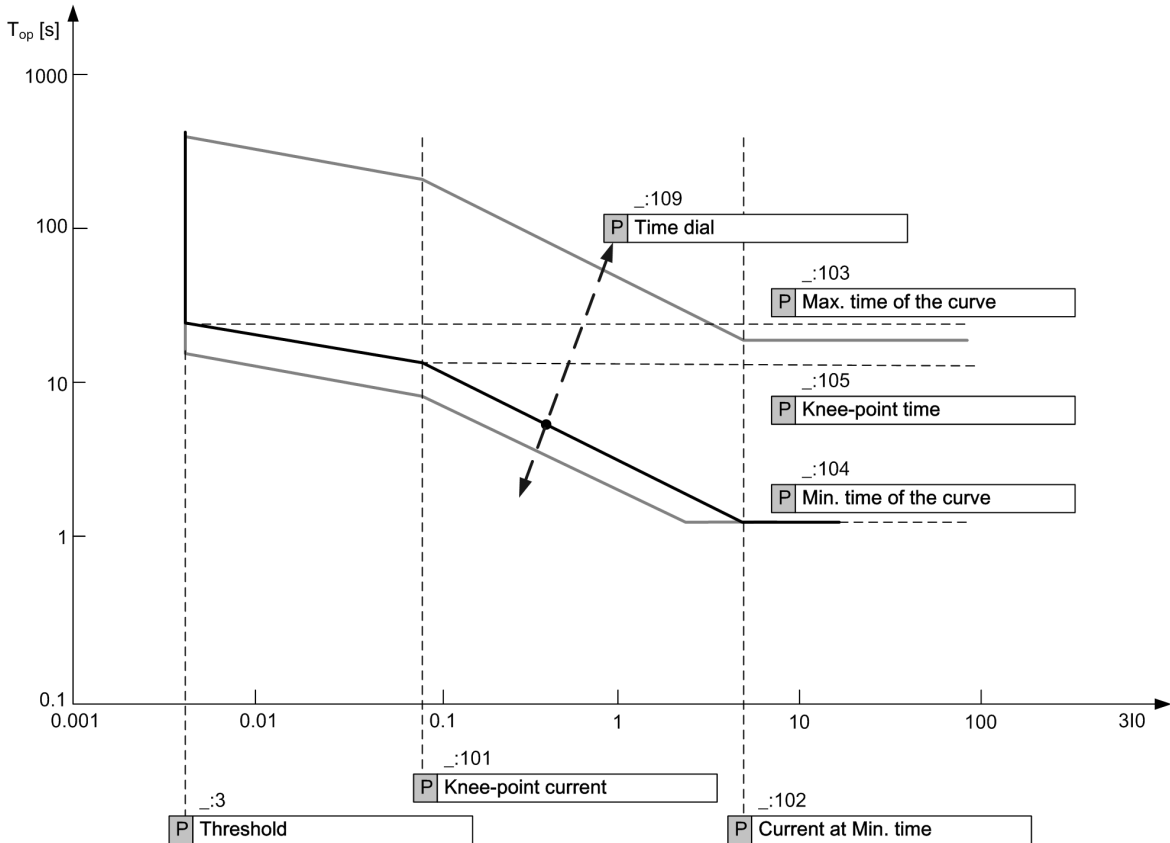

Figure 6-67 Operate Curve of the Logarithmic Inverse Time with Knee-Point Characteristic (In the Example of **Threshold = 0.004 A**)

6.7.8.2 Application and Setting Notes

Apart from the operate curve, this type of stage is almost identical to the **Inverse-time overcurrent protection – advanced** stage (see chapter [6.7.6.1 Description](#)). The only difference is that the dynamic settings change functionality is not available.

This section only discusses the nature of the operate curve. For further functionality, refer to chapter [6.7.6.2 Application and Setting Notes](#).

Parameter: **Threshold**

- Default setting (**_:3**) **Threshold = 1.20 A**

You can use the **Threshold** parameter to define the pickup value of the stage corresponding to the specific application.

Parameter: Time dial

- Default setting (`_:6`) **Time dial** = 0.2

You can use the **Time dial** parameter to displace the operate curve in the time direction.
General information cannot be provided. Define the value corresponding to the application.

Parameter: Knee-point

- Default setting (`_:101`) **Knee-point current** = 1.300 A
- Default setting (`_:105`) **Knee-point time** = 23.60 s

You use the **Knee-point current** parameter and the **Knee-point time** parameter to define the knee-point of the operate curve.
General information cannot be provided. Define the values corresponding to the application.

Parameter: Minimum Time of the Operate Curve

- Default setting (`_:104`) **Min. time of the curve** = 0.80 s
- Default setting (`_:102`) **Current at Min. time** = 1.500 A

Via the parameters **Min. time of the curve** and **Current at Min. time**, the point of the operate curve is defined where higher currents do no longer cause shorter operate times.
General information cannot be provided. Define the value corresponding to the application.

Parameter: Maximum Time of the Operate Curve

- Default setting (`_:103`) **Max. time of the curve** = 93.00 s

You can use the parameter **Max. time of the curve** to determine the initial value of the operate curve (for 3I0 = **Threshold**).
General information cannot be provided. Define the value corresponding to the application.

6.7.8.3 Settings

Addr.	Parameter	C	Setting Options	Default Setting
<i>General</i>				
<code>_:1</code>	Log.inv.T KP #:Mode		<ul style="list-style-type: none"> • off • on • test 	off
<code>_:2</code>	Log.inv.T KP #:Operate &flt.rec. blocked		<ul style="list-style-type: none"> • no • yes 	no
<code>_:108</code>	Log.inv.T KP #:Directional mode		<ul style="list-style-type: none"> • forward • reverse 	forward
<code>_:8</code>	Log.inv.T KP #:Method of measurement		<ul style="list-style-type: none"> • fundamental comp. • RMS value 	fundamental comp.
<code>_:107</code>	Log.inv.T KP #:Directional comparison		<ul style="list-style-type: none"> • no • yes 	no
<code>_:106</code>	Log.inv.T KP #:Release via input signal		<ul style="list-style-type: none"> • no • yes 	no
<code>_:10</code>	Log.inv.T KP #:Blk. by meas.-volt. failure		<ul style="list-style-type: none"> • no • yes 	yes
<code>_:27</code>	Log.inv.T KP #:Blk. w. inrush curr. detect.		<ul style="list-style-type: none"> • no • yes 	no

Addr.	Parameter	C	Setting Options	Default Setting
_:121	Log.inv.T KP #:Blk. w. 2nd harm. gnd. det.		<ul style="list-style-type: none"> no yes 	no
_:3	Log.inv.T KP #:Threshold	1 A @ 100 Irated	0.030 A to 40.000 A	1.200 A
		5 A @ 100 Irated	0.15 A to 200.00 A	6.00 A
		1 A @ 50 Irated	0.030 A to 40.000 A	1.200 A
		5 A @ 50 Irated	0.15 A to 200.00 A	6.00 A
		1 A @ 1.6 Irated	0.001 A to 1.600 A	1.200 A
		5 A @ 1.6 Irated	0.005 A to 8.000 A	6.000 A
_:109	Log.inv.T KP #:Time dial		0.05 to 1.50	0.20
_:101	Log.inv.T KP #:Knee-point current	1 A @ 100 Irated	0.030 A to 40.000 A	1.300 A
		5 A @ 100 Irated	0.15 A to 200.00 A	6.50 A
		1 A @ 50 Irated	0.030 A to 40.000 A	1.300 A
		5 A @ 50 Irated	0.15 A to 200.00 A	6.50 A
		1 A @ 1.6 Irated	0.001 A to 1.600 A	1.300 A
		5 A @ 1.6 Irated	0.005 A to 8.000 A	6.500 A
_:105	Log.inv.T KP #:Knee-point time		0.00 s to 100.00 s	23.60 s
_:102	Log.inv.T KP #:Current at Min. time	1 A @ 100 Irated	0.030 A to 40.000 A	1.500 A
		5 A @ 100 Irated	0.15 A to 200.00 A	7.50 A
		1 A @ 50 Irated	0.030 A to 40.000 A	1.500 A
		5 A @ 50 Irated	0.15 A to 200.00 A	7.50 A
		1 A @ 1.6 Irated	0.001 A to 1.600 A	1.500 A
		5 A @ 1.6 Irated	0.005 A to 8.000 A	7.500 A
_:104	Log.inv.T KP #:Min. time of the curve		0.00 s to 30.00 s	0.80 s
_:103	Log.inv.T KP #:Max. time of the curve		0.00 s to 200.00 s	93.00 s

6.7.8.4 Information List

No.	Information	Data Class (Type)	Type
Stage #			
_:81	Log.inv.T KP #:>Block stage	SPS	I
_:501	Log.inv.T KP #:>Release delay & op.	SPS	I
_:500	Log.inv.T KP #:>Block delay & op.	SPS	I
_:54	Log.inv.T KP #:Inactive	SPS	O
_:52	Log.inv.T KP #:Behavior	ENS	O
_:53	Log.inv.T KP #:Health	ENS	O
_:60	Log.inv.T KP #:Inrush blocks operate	SPS	O
_:55	Log.inv.T KP #:Pickup	ACD	O
_:300	Log.inv.T KP #:Direction	ACD	O
_:56	Log.inv.T KP #:Operate delay expired	ACT	O
_:57	Log.inv.T KP #:Operate	ACT	O

6.7.9 Stage with User-Defined Characteristic Curve

6.7.9.1 Description

Logic of the Stage

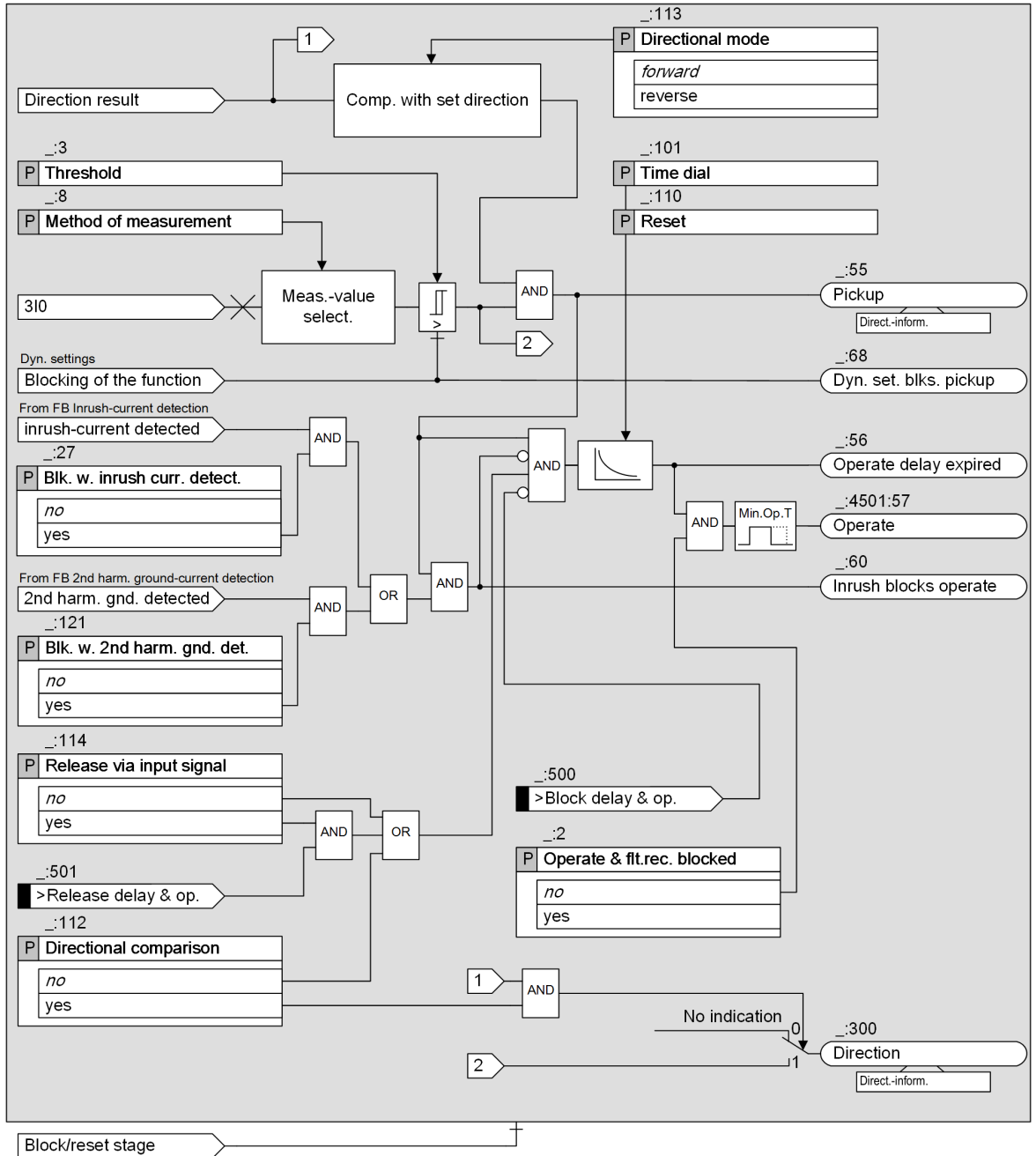

[to_dirusr, 2, en_US]

Figure 6-68 Logic Diagram of the Directional User-Defined Characteristic Curve Overcurrent Protection, Ground

This stage is structured in the same way as the **Inverse-time overcurrent protection – advanced** stage (see chapter [6.7.6.1 Description](#)). The only difference is that you can define the characteristic curve.

This section only discusses the nature of the operate curve. For further functionality, refer to chapter [6.7.6.1 Description](#).

User-Defined Characteristic Curve

With the directional, user-defined characteristic curve, you can define the operate curve point by point using up to 30 value pairs of current and time. The device uses linear interpolation to calculate the characteristic curve from these values. You can also define a dropout characteristic curve if you wish.

Pickup and Dropout Behaviors with User-Defined Characteristic Curves

When the input variable exceeds the threshold value by 1.1 times, the characteristic curve is processed. An integrating method of measurement totalizes the weighted time. The weighted time results from the characteristic curve. For this, the time that is associated with the present current value is determined from the characteristic curve. Once the weighted time exceeds the value 1, the stage operates.

When the measured value falls short of the threshold value by a factor of 1.045 ($0.95 \times 1.1 \times$ threshold value), the dropout is started. The pickup will be indicated as outgoing. You can influence the dropout behavior via setting parameters. You can select between instantaneous dropout (totalized time is deleted) or dropout according to the characteristic curve (reduction of totalized time depending on the characteristic curve). The dropout according to characteristic curve (disk emulation) is the same as turning back a rotor disk. The weighted reduction of the time is started from 0.9 of the set threshold value.

The following figure shows the pickup behavior and dropout behavior when a directional user-defined characteristic curve is used.

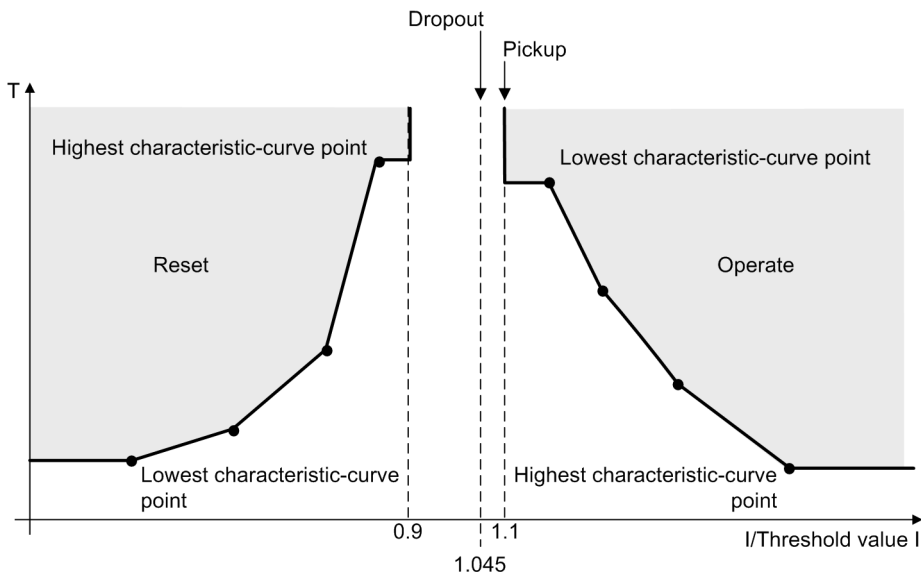

[dsw_pidrbe, 1, en_US]

Figure 6-69 Pickup and Dropout Behaviors when Using a User-Defined Characteristic Curve



NOTE

Note that the currents that are lower than the current value of the smallest characteristic-curve point do not extend the operate time. The pickup characteristic runs in parallel to the current axis up to the smallest characteristic-curve point. Currents that are larger than the current value of the largest characteristic-curve point do not reduce the operate time. The pickup characteristic runs in parallel to the current axis from the largest characteristic-curve point.

6.7.9.2 Application and Setting Notes

This stage is structured in the same way as the **Inverse-time overcurrent protection – advanced** stage. The only difference is that you can define the characteristic curve as required. This section only provides application and setting notes for setting the characteristic curves. For guidance on the other parameters of the stage, see chapter [6.7.6.2 Application and Setting Notes](#).

Parameter: Current/time value pairs (of the Operate Curve)

Use these settings to define the characteristic curve. Set a current/time value pair for each characteristic-curve point. The setting follows the characteristic curve you want to realize.

Set the current value as a multiple of the threshold value. Siemens recommends that you set the **Threshold** parameter to **1.00** in order to obtain a simple relation. You can change the threshold setting afterwards if you want to displace the characteristic curve.

Specify the time value in seconds. The characteristic curve is displaced using the **Time dial** parameter.



NOTE

The value pairs must be entered in continuous order.

Parameter: Time dial

- Default setting (**_:101**) **Time dial = 1**

You can use the **Time dial** parameter to displace the characteristic curve in the time direction.

The setting value for the **Time dial** parameter is derived from the time-grading chart that has been prepared for the system. Where no grading and therefore no displacement of the characteristic curve is required, leave the **Time dial** set to **1**.

Parameter: Reset

- Default setting (**_:110**) **Reset = disk emulation**

The **Reset** parameter is used to define whether the stage drops out according to the dropout characteristic curve (behavior of a disk emulation = rotor disk) or instantaneously.

Parameter Value	Description
<i>disk emulation</i>	Both operate curve and a dropout characteristic curve have to be specified with this setting. Use this setting if the device is coordinated with electromechanical devices or other devices performing dropout after disk emulation.
<i>instantaneous</i>	Use this setting if the dropout is not to be performed after disk emulation, that is, if instantaneous dropout is required.

Parameter: Current/time value pairs (of the Dropout Curve)

Use these settings to define the characteristic curve. Set a current/time value pair for each characteristic-curve point. The setting is determined by the characteristic curve you want to achieve.

Set the current value as a multiple of the threshold value. Siemens recommends that you set the **Threshold** parameter to **1.00** in order to obtain a simple relation. You can change the threshold setting afterwards if you want to displace the characteristic curve.

Specify the time value in seconds. The characteristic curve is displaced using the **Time dial** parameter.



NOTE

The value pairs must be entered in continuous order.

6.7.9.3 Settings

Addr.	Parameter	C	Setting Options	Default Setting
<i>General</i>				
_:1	User curve #:Mode		<ul style="list-style-type: none"> • off • on • test 	off

Addr.	Parameter	C	Setting Options	Default Setting
_:2	User curve #:Operate & flt.rec. blocked		<ul style="list-style-type: none"> no yes 	no
_:113	User curve #:Directional mode		<ul style="list-style-type: none"> forward reverse 	forward
_:8	User curve #:Method of measurement		<ul style="list-style-type: none"> fundamental comp. RMS value 	fundamental comp.
_:112	User curve #:Directional comparison		<ul style="list-style-type: none"> no yes 	no
_:114	User curve #:Release via input signal		<ul style="list-style-type: none"> no yes 	no
_:10	User curve #:Blk. by meas.-volt. failure		<ul style="list-style-type: none"> no yes 	yes
_:26	User curve #:Dynamic settings		<ul style="list-style-type: none"> no yes 	no
_:27	User curve #:Blk. w. inrush curr. detect.		<ul style="list-style-type: none"> no yes 	no
_:121	User curve #:Blk. w. 2nd harm. gnd. det.		<ul style="list-style-type: none"> no yes 	no
_:3	User curve #:Threshold	1 A @ 100 Irated	0.030 A to 40.000 A	1.200 A
		5 A @ 100 Irated	0.15 A to 200.00 A	6.00 A
		1 A @ 50 Irated	0.030 A to 40.000 A	1.200 A
		5 A @ 50 Irated	0.15 A to 200.00 A	6.00 A
		1 A @ 1.6 Irated	0.001 A to 1.600 A	1.200 A
		5 A @ 1.6 Irated	0.005 A to 8.000 A	6.000 A
_:110	User curve #:Reset		<ul style="list-style-type: none"> instantaneous disk emulation 	disk emulation
_:101	User curve #:Time dial		0.05 to 15.00	1.00
Dyn.s: AR off/n.rdy				
_:28	User curve #:Effect. by AR off/n.ready		<ul style="list-style-type: none"> no yes 	no
_:35	User curve #:Stage blocked		<ul style="list-style-type: none"> no yes 	no
Dyn.set: AR cycle 1				
_:29	User curve #:Effected by AR cycle 1		<ul style="list-style-type: none"> no yes 	no
_:36	User curve #:Stage blocked		<ul style="list-style-type: none"> no yes 	no
_:14	User curve #:Threshold	1 A @ 100 Irated	0.030 A to 40.000 A	1.200 A
		5 A @ 100 Irated	0.15 A to 200.00 A	6.00 A
		1 A @ 50 Irated	0.030 A to 40.000 A	1.200 A
		5 A @ 50 Irated	0.15 A to 200.00 A	6.00 A
		1 A @ 1.6 Irated	0.001 A to 1.600 A	1.200 A
		5 A @ 1.6 Irated	0.005 A to 8.000 A	6.000 A
_:102	User curve #:Time dial		0.05 to 15.00	1.00

Addr.	Parameter	C	Setting Options	Default Setting
Dyn.set: AR cycle 2				
_:30	User curve #:Effected by AR cycle 2		<ul style="list-style-type: none"> • no • yes 	no
_:37	User curve #:Stage blocked		<ul style="list-style-type: none"> • no • yes 	no
_:15	User curve #:Threshold	1 A @ 100 Irated	0.030 A to 40.000 A	1.200 A
		5 A @ 100 Irated	0.15 A to 200.00 A	6.00 A
		1 A @ 50 Irated	0.030 A to 40.000 A	1.200 A
		5 A @ 50 Irated	0.15 A to 200.00 A	6.00 A
		1 A @ 1.6 Irated	0.001 A to 1.600 A	1.200 A
		5 A @ 1.6 Irated	0.005 A to 8.000 A	6.000 A
_:103	User curve #:Time dial		0.05 to 15.00	1.00
Dyn.set: AR cycle 3				
_:31	User curve #:Effected by AR cycle 3		<ul style="list-style-type: none"> • no • yes 	no
_:38	User curve #:Stage blocked		<ul style="list-style-type: none"> • no • yes 	no
_:16	User curve #:Threshold	1 A @ 100 Irated	0.030 A to 40.000 A	1.200 A
		5 A @ 100 Irated	0.15 A to 200.00 A	6.00 A
		1 A @ 50 Irated	0.030 A to 40.000 A	1.200 A
		5 A @ 50 Irated	0.15 A to 200.00 A	6.00 A
		1 A @ 1.6 Irated	0.001 A to 1.600 A	1.200 A
		5 A @ 1.6 Irated	0.005 A to 8.000 A	6.000 A
_:104	User curve #:Time dial		0.05 to 15.00	1.00
Dyn.s: AR cycle>3				
_:32	User curve #:Effected by AR cycle gr. 3		<ul style="list-style-type: none"> • no • yes 	no
_:39	User curve #:Stage blocked		<ul style="list-style-type: none"> • no • yes 	no
_:17	User curve #:Threshold	1 A @ 100 Irated	0.030 A to 40.000 A	1.200 A
		5 A @ 100 Irated	0.15 A to 200.00 A	6.00 A
		1 A @ 50 Irated	0.030 A to 40.000 A	1.200 A
		5 A @ 50 Irated	0.15 A to 200.00 A	6.00 A
		1 A @ 1.6 Irated	0.001 A to 1.600 A	1.200 A
		5 A @ 1.6 Irated	0.005 A to 8.000 A	6.000 A
_:105	User curve #:Time dial		0.05 to 15.00	1.00
Dyn.s: Cold load PU				
_:33	User curve #:Effect. b. cold-load pickup		<ul style="list-style-type: none"> • no • yes 	no
_:40	User curve #:Stage blocked		<ul style="list-style-type: none"> • no • yes 	no

Addr.	Parameter	C	Setting Options	Default Setting
_:18	User curve #:Threshold	1 A @ 100 Irated	0.030 A to 40.000 A	1.200 A
		5 A @ 100 Irated	0.15 A to 200.00 A	6.00 A
		1 A @ 50 Irated	0.030 A to 40.000 A	1.200 A
		5 A @ 50 Irated	0.15 A to 200.00 A	6.00 A
		1 A @ 1.6 Irated	0.001 A to 1.600 A	1.200 A
		5 A @ 1.6 Irated	0.005 A to 8.000 A	6.000 A
_:106	User curve #:Time dial		0.05 to 15.00	1.00
Dyn.set: bin.input				
_:34	User curve #:Effected by binary input		<ul style="list-style-type: none"> • no • yes 	no
_:41	User curve #:Stage blocked		<ul style="list-style-type: none"> • no • yes 	no
_:19	User curve #:Threshold	1 A @ 100 Irated	0.030 A to 40.000 A	1.200 A
		5 A @ 100 Irated	0.15 A to 200.00 A	6.00 A
		1 A @ 50 Irated	0.030 A to 40.000 A	1.200 A
		5 A @ 50 Irated	0.15 A to 200.00 A	6.00 A
		1 A @ 1.6 Irated	0.001 A to 1.600 A	1.200 A
		5 A @ 1.6 Irated	0.005 A to 8.000 A	6.000 A
_:107	User curve #:Time dial		0.05 to 15.00	1.00

6.7.9.4 Information List

No.	Information	Data Class (Type)	Type
User curve #			
_:81	User curve #:>Block stage	SPS	I
_:501	User curve #:>Release delay & op.	SPS	I
_:84	User curve #:>Activ. dyn. settings	SPS	I
_:500	User curve #:>Block delay & op.	SPS	I
_:54	User curve #:Inactive	SPS	O
_:52	User curve #:Behavior	ENS	O
_:53	User curve #:Health	ENS	O
_:60	User curve #:Inrush blocks operate	SPS	O
_:62	User curve #:Dyn.set. AR cycle1act.	SPS	O
_:63	User curve #:Dyn.set. AR cycle2act.	SPS	O
_:64	User curve #:Dyn.set. AR cycle3act.	SPS	O
_:65	User curve #:Dyn.set. ARcycl.>3act	SPS	O
_:66	User curve #:Dyn.set. CLP active	SPS	O
_:67	User curve #:Dyn.set. BI active	SPS	O
_:68	User curve #:Dyn. set. blks. pickup	SPS	O
_:59	User curve #:Disk emulation running	SPS	O
_:55	User curve #:Pickup	ACD	O
_:300	User curve #:Direction	ACD	O
_:56	User curve #:Operate delay expired	ACT	O
_:57	User curve #:Operate	ACT	O

6.7.10 Influence of Other Functions via Dynamic Settings

[6.5.8.1 Description](#) and [6.5.8.2 Application and Setting Notes \(Advanced Stage\)](#) describe the influence of other functions on dynamic settings.

6.8 Inrush-Current and 2nd Harmonic Detection

6.8.1 Inrush-Current Detection

6.8.1.1 Overview of Functions

The function **Inrush-current detection**

- Recognizes an inrush process on transformers
- Generates a blocking signal for protection functions that protect the transformer (protected object) or for protection functions that are affected in undesirable ways when transformers are switched on
- Allows a sensitive setting of the protection functions

6.8.1.2 Structure of the Function

The function **Inrush-current detection** is not an individual protection function. In the connection process of a transformer, it transmits a blocking signal to other protection functions. For this reason, the inrush-current detection must be in the same function group as the functions that are to be blocked.

The following figure shows the embedding of the function. The setting parameter **Blk. w. inrush curr. detect.** establishes the connection between inrush-current detection and the functions that are to be blocked. If the parameter is set to **yes**, the connection is effective.

A jump detection or the threshold value exceeding of the functions to be blocked is used as trigger signal for synchronization of the internal measurement methods.

The jump detection reacts to changes in the current. The threshold value exceeding is recognized due to an internal pickup of the protection function that is to be blocked.

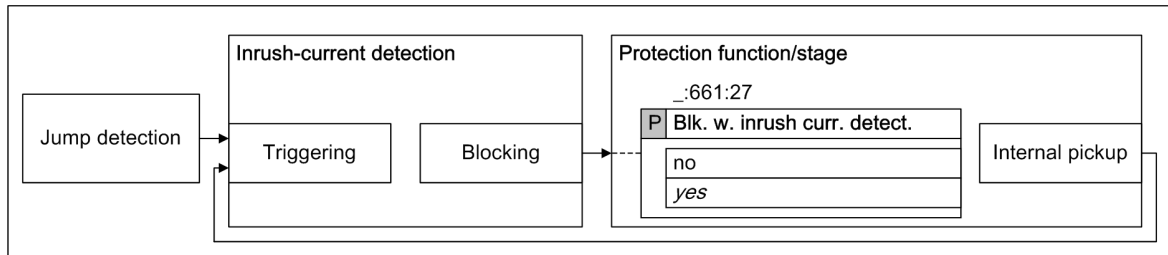

[idw_insh01, 1, en_US]

Figure 6-70 Structure/Embedding of the Function

6.8.1.3 Function Description

The function **Inrush-current detection** analyzes the trigger signal of the jump detection or the threshold-value violation of the function to be blocked in a start logic and synchronizes the method of measurement. In order to securely record the inrush processes, the function uses the methods of measurement **Harmonic Analysis** and the **CWA method** (current wave shape analysis). Both methods work in parallel and link the results with a logical OR.

If you wish to work with only one process, deactivate the other method by way of the parameters **Blocking with 2. harmonic** or **Blocking with CWA**.

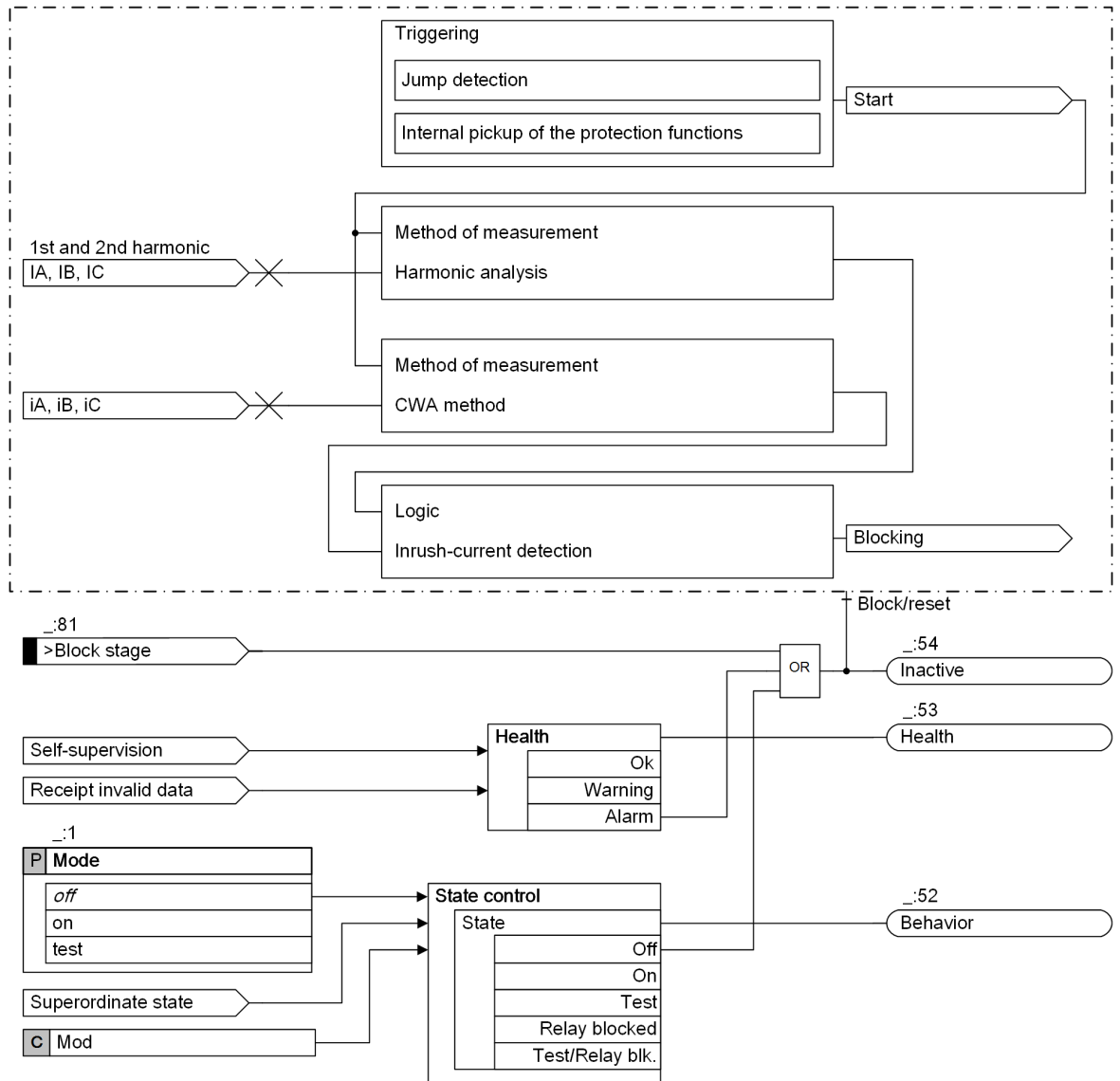

[to_inru_02_3_en_US]

Figure 6-71 Basic Structure of the Inrush-Current Detection

Harmonic Analysis

For this method of measurement, the content of the 2nd harmonic and the fundamental component (1st harmonic) are determined for each of the phase currents I_A , I_B , and I_C and the quotient $I_{2nd\ harm} / I_{1st\ harm}$ is formed from this. If this quotient exceeds the set threshold value, a phase-selective signal is issued. If 75 % of the set threshold value is exceeded, this leads to a pickup reset (dropout ratio = 0.75).

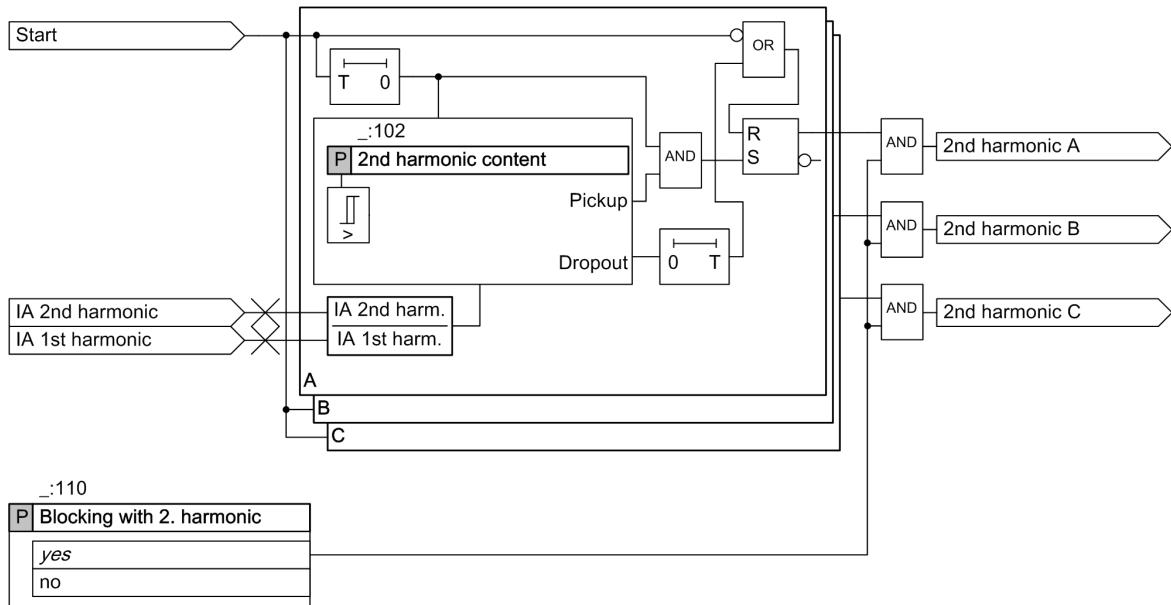

[file_inrush_10_1_en_US]
 Figure 6-72 Logic of the Harmonic Analysis Function (T = 1 Period)

CWA Method (Current Wave Shape Analysis)

The CWA method executes a wave shape analysis of the phase currents IA, IB, and IC. If all 3 phase currents show flat areas at the same point in time, the inrush-current detection signal will be issued. This signal applies for all 3 phases simultaneously. The following figure shows a typical inrush-current characteristic, with the simultaneously occurring flat areas clearly recognizable.

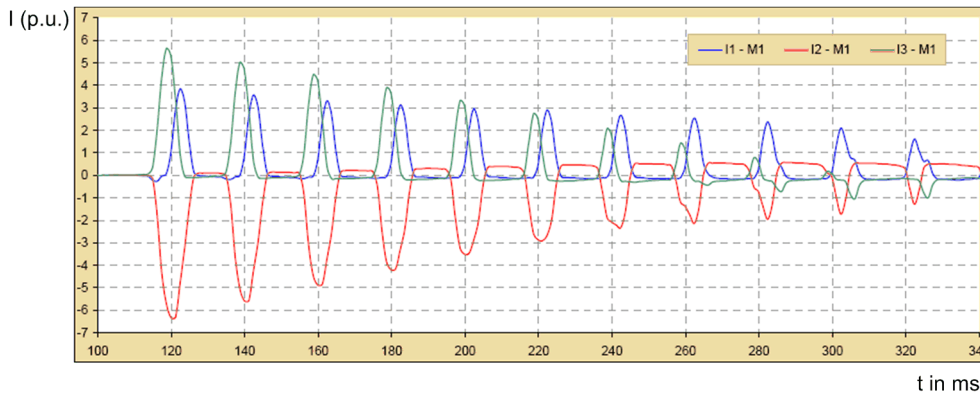

[dvw_inrush_03_1_en_US]
 Figure 6-73 Inrush-Current Characteristic

The following figure shows the logic diagram of the CWA method. From the present fundamental-component current (1st harmonic), the threshold value for identification of the flat areas is derived via an internal factor.

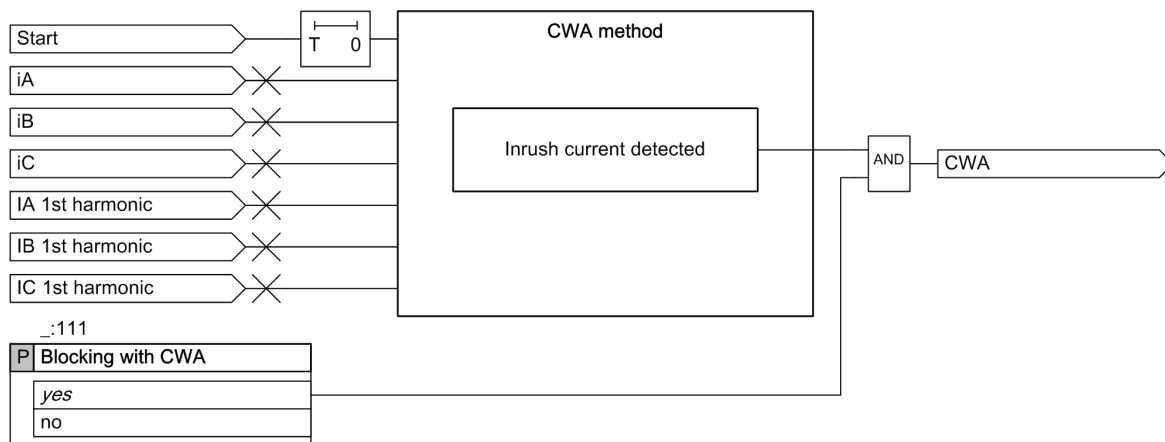

[to_inrush_05_1_en_US]

Figure 6-74 Logic of the CWA-Method Function (T = 1 Period)

Logic of the Inrush-Current Detection

The following logic diagram shows the link of the 2 methods of measurement **Harmonic Analysis** and **CWA method**.

The crossblock function influences the **Harmonic Analysis** process. If you have set the parameter **Cross-blocking** to **yes**, you will receive a blocking indication in the event of threshold-value violation for all 3 phase currents and the measured or calculated zero-sequence current ($I_{2nd\ harm} / I_{1st\ harm}$). The crossblock function works via a timer. Set parameters for time depending on the expected duration factor via the parameter **Cross-blocking time**.

If the phase current exceeds the maximum permissible current **Operat.-range limit I_{max}**, the inrush-current detection will be blocked.

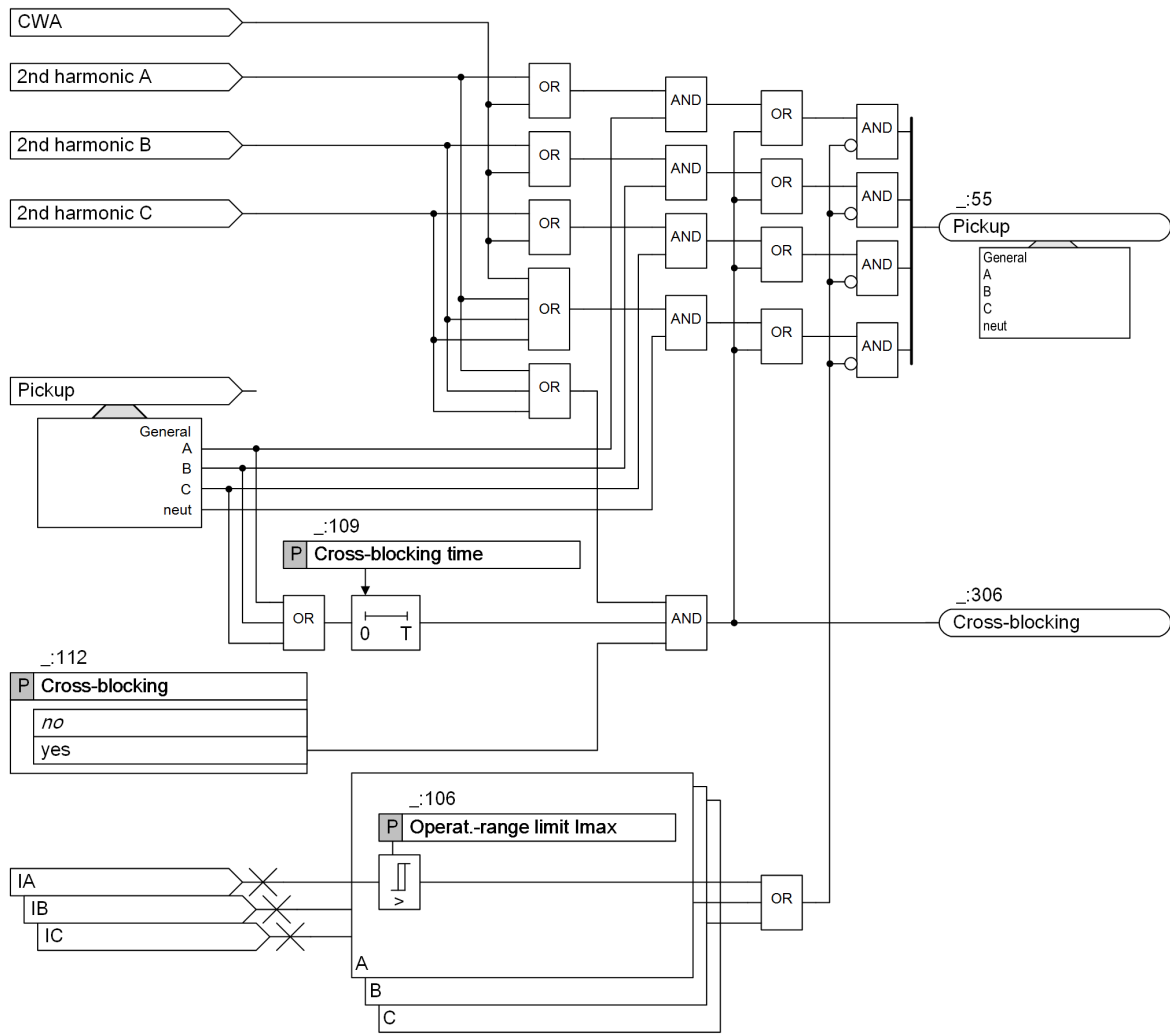

[lo_inrush_12_2_en_US]
 Figure 6-75 Logic Diagram of the Inrush-Current Detection

6.8.1.4 Application and Setting Notes

Parameter: Operat.-range limit I_{max}

- Recommended setting value (**:106**) **Operat.-range limit I_{max} = 7.5 A**
 With the parameter **Operat.-range limit I_{max}**, you can specify at which current the inrush-current detection is blocked internally. Set the value to be greater than the RMS value of the maximum inrush current of the transformer. A practicable value is 7.5 times the transformer rated current.

Parameter: Blocking with CWA

- Recommended setting value = (**:111**) **Blocking with CWA = yes**

Parameter Value	Description
yes	CWA process activated.
no	CWA process deactivated.

Parameter: Blocking with 2. harmonic

- Recommended setting value (**:110**) **Blocking with 2. harmonic = yes**

Parameter Value	Description
<i>yes</i>	Harmonic analysis process activated.
<i>no</i>	Harmonic analysis process deactivated.



NOTE

Make sure that at least one process is activated. Siemens recommends retaining the advised setting values.

Parameter: 2nd harmonic content

- Recommended setting value (`_:102`) **2nd harmonic content = 15 %**
With the parameter **2nd harmonic content**, you can specify the pickup value of the harmonic analysis function. The setting value of 15 % is practicable for most transformers.

Parameter: Cross-blocking

- Recommended setting value (`_:112`) **Cross-blocking = no**

Parameter Value	Description
<i>no</i>	Through the CWA process working in parallel in the inrush-current detection, the function is not activated as standard.
<i>yes</i>	If a subfunction of the inrush-current detection is identified in the course of the closure trials during commissioning, set the parameter Cross-blocking to yes .

Parameter: Cross-blocking time

- Default setting (`_:109`) **Cross-blocking time = 0.06 s**
You define the duration of this blocking with the **Cross-blocking time** parameter. The default setting of **0.06 s** (about 3 periods) has proven practicable. Set the time as short as possible and check the value during the closure trials. The parameter **Cross-blocking time** is inactive at **Cross-blocking = no**.

Parameter: Start flt.rec

- Default setting (`_:114`) **Start flt.rec = yes**
With the **Start flt.rec** parameter, you determine whether a fault record should be started upon pickup of the inrush-current detection. The following settings are possible:

Parameter Value	Description
<i>no</i>	No fault recording starts with pickup.
<i>yes</i>	The fault recording starts with pickup. When the protection function is blocked by the inrush-current detection, a fault recording is started nevertheless.

6.8.1.5 Settings

Addr.	Parameter	C	Setting Options	Default Setting
<i>Inrush detect.</i>				
<code>_:1</code>	Inrush detect.:Mode		<ul style="list-style-type: none"> off on test 	on

Addr.	Parameter	C	Setting Options	Default Setting
_:106	Inrush detect.:Operat.-range limit I _{max}	1 A @ 100 I _{rated}	0.030 A to 35.000 A	7.500 A
		5 A @ 100 I _{rated}	0.15 A to 175.00 A	37.50 A
		1 A @ 50 I _{rated}	0.030 A to 35.000 A	7.500 A
		5 A @ 50 I _{rated}	0.15 A to 175.00 A	37.50 A
		1 A @ 1.6 I _{rated}	0.001 A to 1.600 A	7.500 A
		5 A @ 1.6 I _{rated}	0.005 A to 8.000 A	37.500 A
_:111	Inrush detect.:Blocking with CWA		<ul style="list-style-type: none"> • no • yes 	yes
_:110	Inrush detect.:Blocking with 2. harmonic		<ul style="list-style-type: none"> • no • yes 	yes
_:102	Inrush detect.:2nd harmonic content		10 % to 45 %	15 %
_:112	Inrush detect.:Cross-blocking		<ul style="list-style-type: none"> • no • yes 	no
_:109	Inrush detect.:Cross-blocking time		0.03 s to 200.00 s	0.06 s
_:114	Inrush detect.:Start flt.rec		<ul style="list-style-type: none"> • no • yes 	yes

6.8.1.6 Information List

No.	Information	Data Class (Type)	Type
<i>Inrush detect.</i>			
_:81	Inrush detect.:>Block stage	SPS	I
_:54	Inrush detect.:Inactive	SPS	O
_:52	Inrush detect.:Behavior	ENS	O
_:53	Inrush detect.:Health	ENS	O
_:300	Inrush detect.:2.harmonic phase A	SPS	O
_:301	Inrush detect.:2.harmonic phase B	SPS	O
_:302	Inrush detect.:2.harmonic phase C	SPS	O
_:305	Inrush detect.:CWA	SPS	O
_:306	Inrush detect.:Cross-blocking	SPS	O
_:55	Inrush detect.:Pickup	ACD	O

6.8.2 2nd Harmonic Ground Detection

6.8.2.1 Overview of Functions

The **2nd harmonic to ground detection** function:

- Detects the content of 2nd harmonics in the neutral-point phase current **IN** or in the calculated zero-sequence current **3I0**.
- Generates a blocking signal for protection functions that use the neutral-point phase current **IN** or the calculated zero-sequence current **3I0** as a measured value
- Allows a sensitive setting of the protection functions

The following protection functions analyze the blocking signal:

- Overcurrent protection, ground
- Directional sensitive ground-fault detection
- Non-directional sensitive ground-fault detection

6.8.2.2 Structure of the Function

The **2nd harmonic ground detection** function is not an autonomous protection function. In the connection process of a transformer, it sends a blocking signal to other protection functions. For this reason, the **2nd harmonic ground detection** function must be in the same function group as the functions that are to be blocked.

6.8.2.3 Function Description

Logic

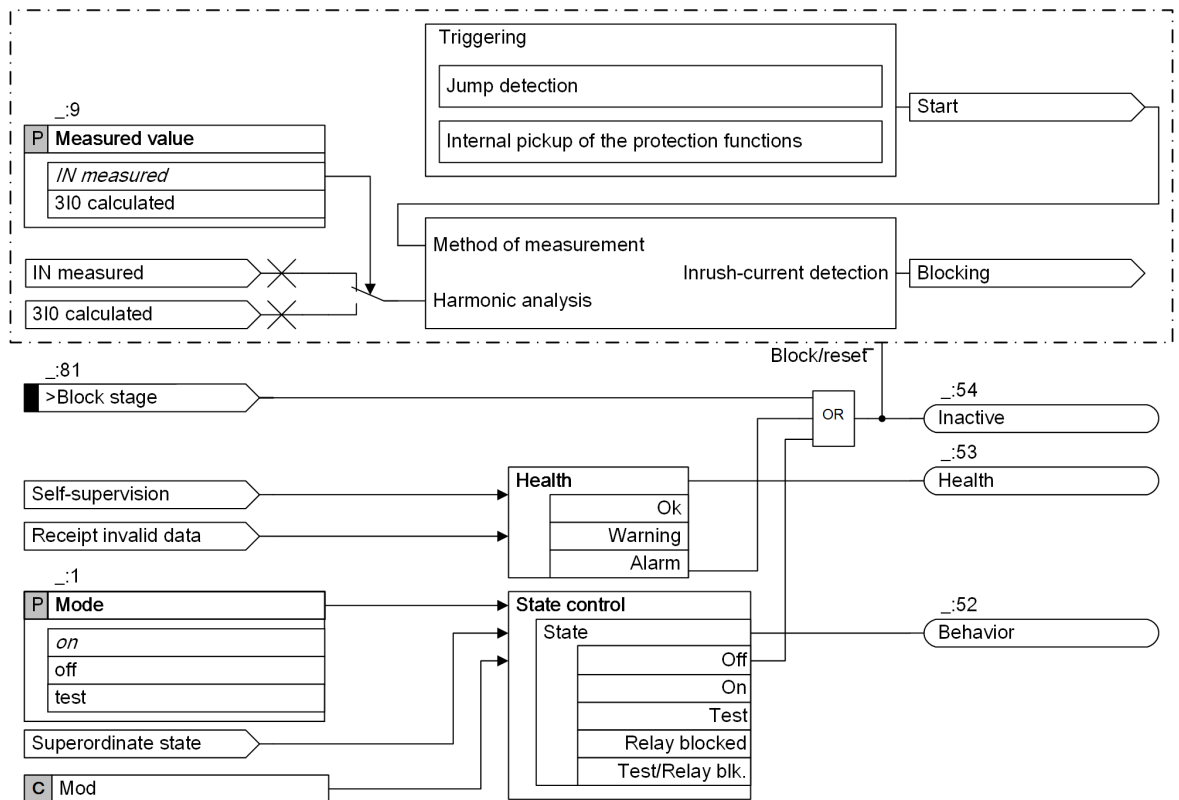

[to_2harm_detec_gnd_2_en_US]

Figure 6-76 Logic of 2nd Harmonic Detection Ground

Harmonic Analysis

For this method of measurement, the content of the 2nd harmonic and the fundamental component (1st harmonic) is determined for the neutral-point phase current I_N or the calculated zero-sequence current $3I_0$ and the quotient $I_{2nd\ harm}/I_{1st\ harm}$ is formed from this. If this quotient exceeds the set threshold value, a blocking signal is issued.



NOTE

During a transformer saturation, the high content of the 2nd harmonic in the ground current must not lead to a pickup of the function.



NOTE

If the ground current is measured in case of a sensitive transformer and the measured value exceeds the saturation threshold of $1.6 \cdot I_N$, the function switches to the calculated 3I0 value.

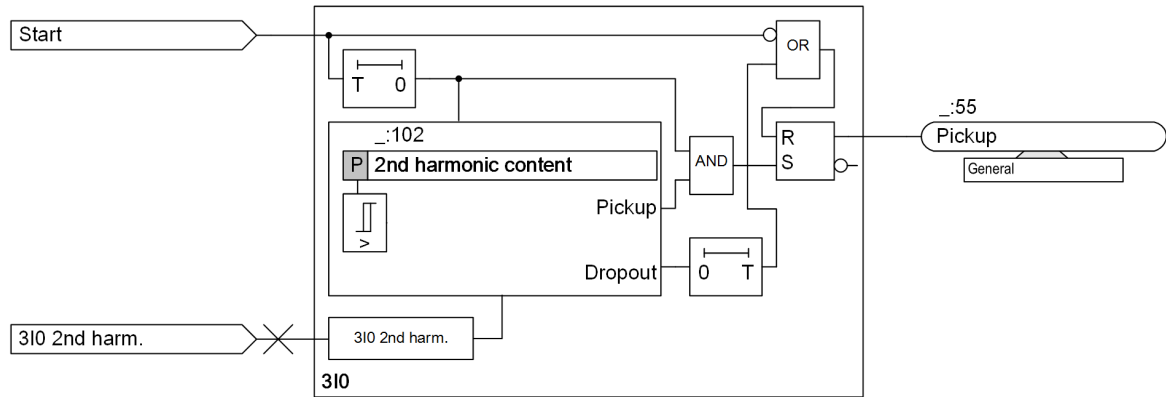

[lo_harmon-analyse, 1, en_US]

Figure 6-77 Logic of the Harmonic Analysis Function

6.8.2.4 Application and Setting Notes

Parameter: Measured value

- Default setting = (._:9) **Measured value = I_N measured**

Parameter Value	Description
<i>I_N measured</i>	The function evaluates the measured neutral-point phase current I_N .
<i>3I0 calculated</i>	The function evaluates the calculated zero-sequence current 3I0 .

Parameter: 2nd harmonic content

- Default setting (._:102) **2nd harmonic content = 15 %**

With the parameter **2nd harmonic content**, you can specify the percentage content of the 2nd harmonic in *I_N measured* or in *3I0 calculated* at which the inrush-current detection is blocked internally.

6.8.2.5 Settings

Addr.	Parameter	C	Setting Options	Default Setting
2.hrm.det.gnd				
._:1	2.hrm.det.gnd:Mode		<ul style="list-style-type: none"> • off • on • test 	on
._:9	2.hrm.det.gnd:Measured value		<ul style="list-style-type: none"> • 3I0 calculated • I_N measured 	I_N measured
._:102	2.hrm.det.gnd:2nd harmonic content		10 % to 45 %	15 %

6.8.2.6 Information List

No.	Information	Data Class (Type)	Type
2.hrm.det.gnd			
._:81	2.hrm.det.gnd:>Block stage	SPS	I

No.	Information	Data Class (Type)	Type
_:51	2.hrm.det. gnd:Mode (controllable)	ENC	C
_:54	2.hrm.det. gnd:Inactive	SPS	O
_:52	2.hrm.det. gnd:Behavior	ENS	O
_:53	2.hrm.det. gnd:Health	ENS	O
_:55	2.hrm.det. gnd:Pickup	ACD	O

6.8.3 2nd Harmonic Detection 1-Phase

6.8.3.1 Overview of Functions

The **2nd harmonic detection 1-phase** function:

- Detects the content of 2nd harmonics of a 1-phase current
- Generates a blocking signal for protection functions that use this 1-phase current as a measured value
- Allows a sensitive setting of the protection functions

The following protection functions analyze the blocking signal:

- Overcurrent protection, 1-phase

6.8.3.2 Structure of the Function

The function **2nd harmonic detection 1-phase** is not an autonomous protection function. In the connection process of a transformer, it sends a blocking signal to other protection functions. For this reason, the function **2nd harmonic detection 1-phase** must be instantiated in the same function group as the function **Inrush-current detection** and the functions that are to be blocked.

If the function **2nd harmonic detection 1-phase** and the functions to be blocked are not instantiated in the same function group, you must interconnect the protection function groups. Interconnect the protection function groups in the DIGSI 5 **Project tree > Function-group connections > Protection-FG <-> Protection-FG**.

6.8.3.3 Function Description

Logic

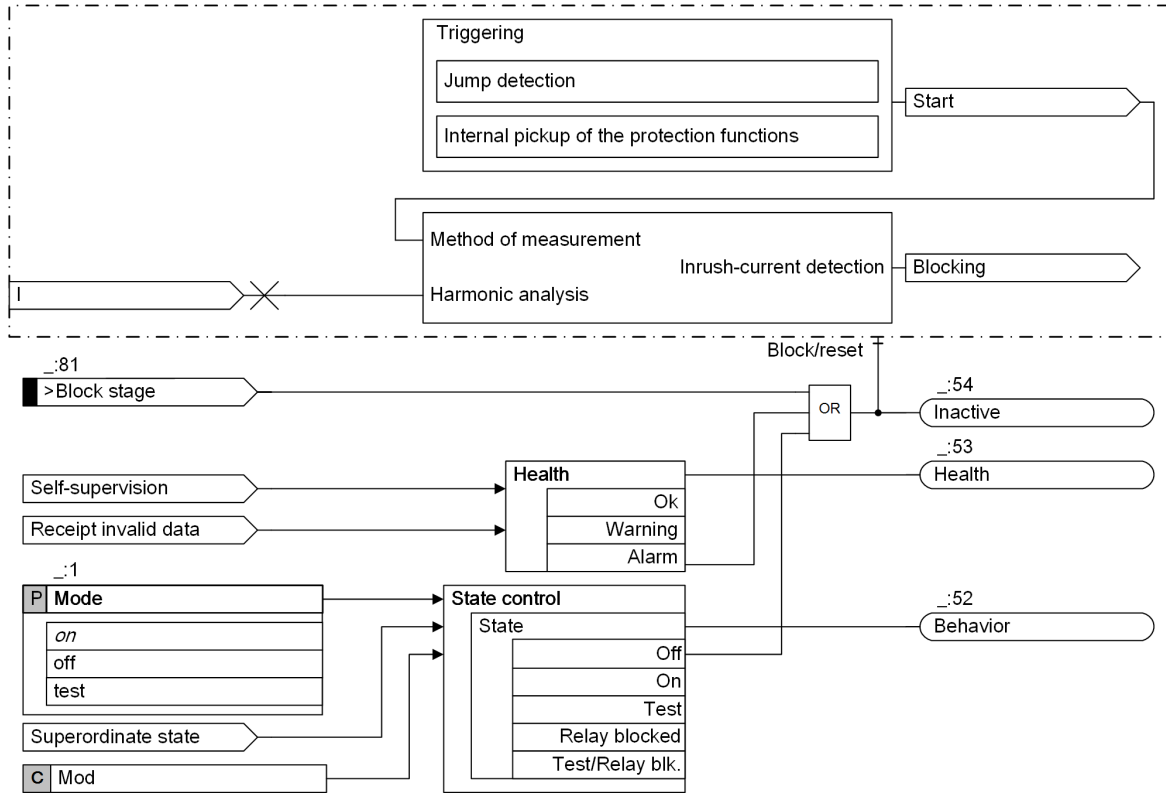

[lo_2harm_detec_1ph_2_en_US]

Figure 6-78 Logic of 2nd Harmonic Detection 1-Phase

Harmonic Analysis

For this method of measurement, the content of the 2nd harmonic and the fundamental component (1st harmonic) is determined for the 1-phase current and the quotient $I_{2nd\ harm}/I_{1st\ harm}$ is formed from this. If this quotient exceeds the set threshold value, a blocking signal is issued.



NOTE

During a transformer saturation, the high content of the 2nd harmonic in the 1-phase current must not lead to a pickup of the function.

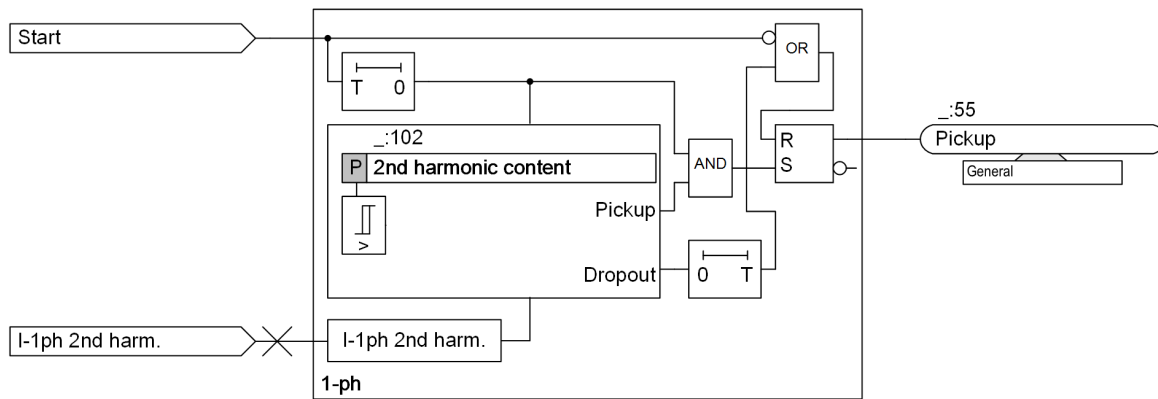

[to_harmon-analyse_1ph_1_en_US]

Figure 6-79 Logic of the Harmonic Analysis Function

6.8.3.4 Application and Setting Notes

Parameter: 2nd harmonic content

- Default setting (._:102) 2nd harmonic content = 15 %

With the parameter **2nd harmonic content**, you can specify the percentage content of the 2nd harmonic at which the inrush-current detection is blocked internally.

6.8.3.5 Settings

Addr.	Parameter	C	Setting Options	Default Setting
2.hrm.det. 1ph				
._:1	2.hrm.det. 1ph:Mode		<ul style="list-style-type: none"> • off • on • test 	on
._:102	2.hrm.det. 1ph:2nd harmonic content		10 % to 45 %	15 %

6.8.3.6 Information List

No.	Information	Data Class (Type)	Type
2.hrm.det. 1ph			
._:81	2.hrm.det. 1ph:>Block stage	SPS	I
._:51	2.hrm.det. 1ph:Mode (controllable)	ENC	C
._:54	2.hrm.det. 1ph:Inactive	SPS	O
._:52	2.hrm.det. 1ph:Behavior	ENS	O
._:53	2.hrm.det. 1ph:Health	ENS	O
._:55	2.hrm.det. 1ph:Pickup	ACD	O

6.9 Instantaneous High-Current Tripping

6.9.1 Overview of Functions

The function **Instantaneous high-current tripping** (ANSI 50) has the following tasks:

- Instantaneous tripping when switching onto an existing fault, for example, if a grounding switch is closed.
- Instantaneous disconnection of high currents above the highest overcurrent-protection stage.
- The function works independently of other functions.

6.9.2 Structure of the Function

The **Instantaneous high-current tripping** function works with the standard release procedure.

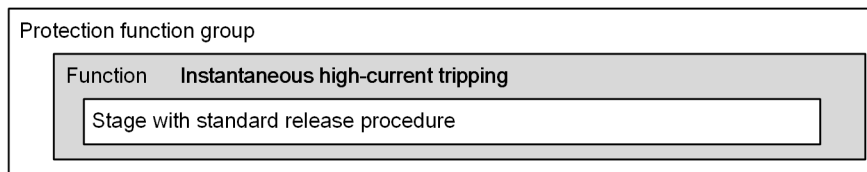

[dw_ihc_standard, 1, en_US]

Figure 6-80 Structure/Embedding of the Function

6.9.3 Standard Release Procedure

Logic

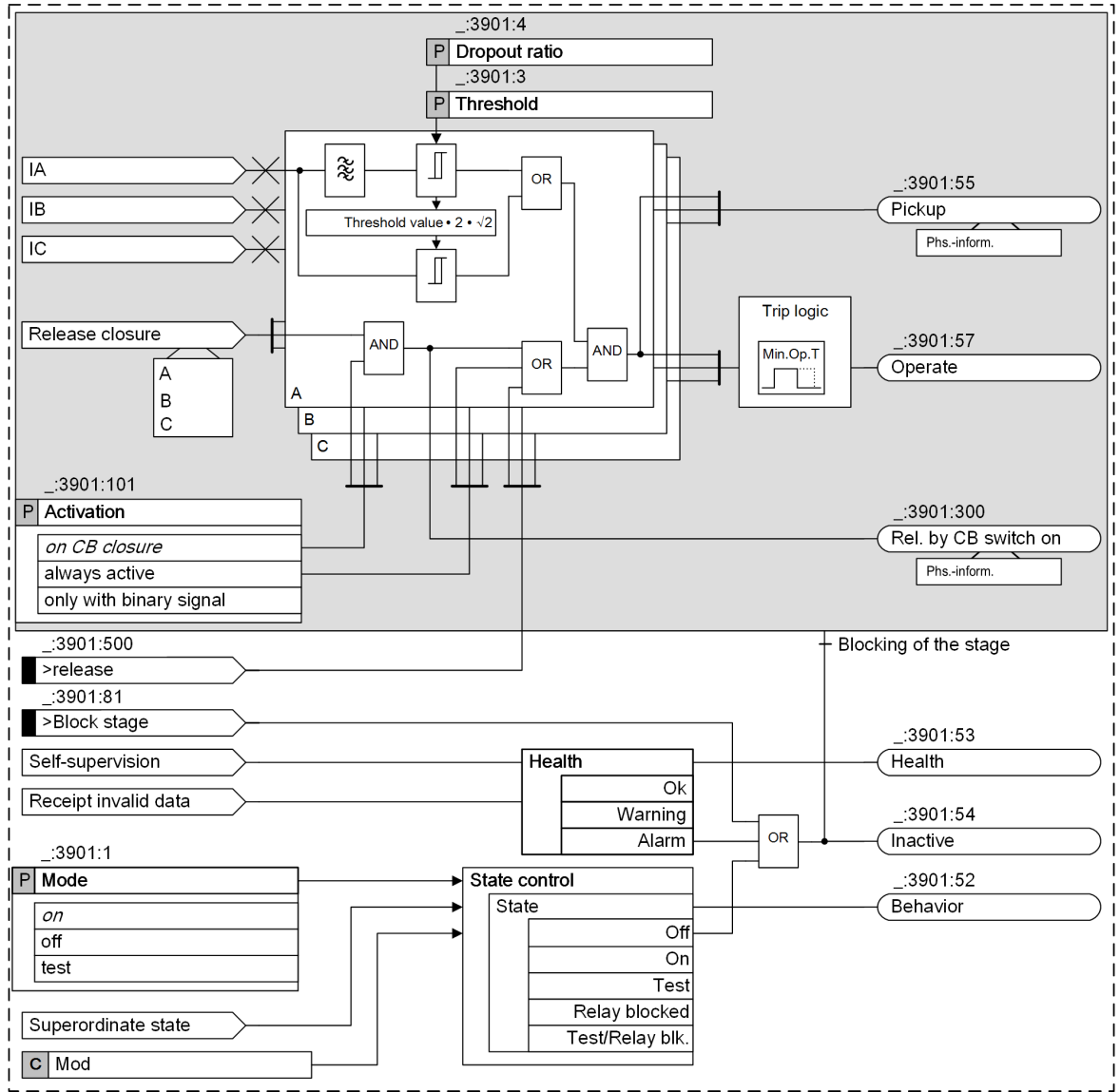

[to_hlore3, 3, en_US]

Figure 6-81 Logic Diagram of Instantaneous High-Current Tripping with Standard Release Method

Activation

Using the **Activation** parameter, you set the conditions under which the stage is released.

- on CB closure**
 With this procedure, the stage is released only if the circuit breaker is about to be closed (the CB is open) or if the circuit breaker is being closed or the binary input signal *>release* is active. The way the *Rel. by CB switch on* signal is generated is described in chapter 5.7.8 *Circuit-Breaker Position Recognition for Protection-Related Auxiliary Functions*.
- always active**
 The stage is always released and is thus independent of the closing of the circuit breaker switch and of the binary input signal *>release*.

- **only with binary signal**
 The stage is released only if the binary input signal *>release* is active.

Method of Measurement, Threshold Value

The stage works with 2 different methods of measurement:

- Measurement of the fundamental component:
 This method of measurement processes the sampled current values and filters out the fundamental component numerically. A DC component is thus eliminated. The RMS value of the fundamental component is compared with the set threshold value.
- Evaluation of the unfiltered measurand:
 The stage also works with unfiltered sampled values. Thus, very short operate times are possible. The current sampling values are compared with the threshold value of $2 \cdot \sqrt{2}$ of the preset threshold value.

6.9.4 Application and Setting Notes

Parameter: Activation

- Default setting (`_:3901:101`) **Activation = on CB closure**

With the parameter **Activation**, you define the conditions under which the stage is released.

Parameter Value	Description
<i>on CB closure</i>	Select this setting to activate the stage only when the circuit breaker is closed.
<i>always active</i>	Select this setting to release the stage statically.
<i>only with binary signal</i>	Select this setting to release the stage via an external signal.

Parameter: Threshold

- Default setting (`_:3901:3`) **Threshold = 10.0 A** for $I_{rated} = 1 A$ or **50.0 A** for $I_{rated} = 5 A$

The stage works independently of the position of the remote circuit breakers. For this reason, set the **Threshold** so that the fault current flowing through does not trigger the stage. Thus, use this stage only if current grading over the protected object is possible, that is, for transformers, shunt reactors or long lines with low source impedance. In other cases, deactivate the stage.

EXAMPLE

Calculation example for current grading of a 110-kV overhead line measuring 150 mm²

s (length) = 100 km;

$R_1/s = 0.21 \Omega/km$;

$X_1/s = 0.43 \Omega/km$

Since the stage is non-directional, the calculation must consider the maximum short-circuit power at the start of the line or at the opposite end:

$S_{sc}'' = 3.5$ GVA (subtransient, because the function can respond to the 1st peak value)

Current transformer: 600 A/5 A

The line impedance Z_L and the minimum source impedance Z_S are calculated on this basis:

Line impedance Z_L and Source impedance Z_S : $Z_1/s = \sqrt{0.21^2 + 0.43^2} \Omega/km = 0.479 \Omega/km$
 $Z_L = 0.479 \Omega/km \cdot 100 km = 47.9 \Omega$
 $Z_S = \frac{110 kV^2}{3500 MVA} = 3.46 \Omega$

[fo_gchzv_1_en_US]

The maximum 3-phase short-circuit current I''_{sc} flowing through is (at a source voltage of $1.1 V_N$):

$$I''_{sc} = \frac{1.1 \cdot V_{net}}{\sqrt{3} \cdot (Z_S + Z_L)} + \frac{1.1 \cdot 110 \text{ kV}}{\sqrt{3} \cdot (3.46 \Omega + 47.9 \Omega)} = 1360 \text{ A}$$

[fo_glchik, 1, en_US]

With a safety margin of 10 %, the following setting value results:

- **Threshold value (primary)** = $1.1 \cdot 1360 \text{ A} = 1496 \text{ A}$
- **Threshold value (secondary)** = $1.1 \cdot \frac{1360 \text{ A}}{600 \text{ A}} \cdot 5 \text{ A} = 12.5 \text{ A}$

[fo_glmste, 1, en_US]

If short-circuit currents exceed 1496 A (primary) or 12.5 A (secondary), there is a short circuit on the line to be protected. It can be disconnected immediately.



NOTE

The calculation was performed with absolute values, which is accurate enough for overhead lines. A complex calculation is required only if the source impedance and the line impedance have extremely different angles.

Parameter: Dropout ratio

- Recommended setting value (`_:3901:4`) **Dropout ratio** = **0.90**

The recommended setting value of **0.90** is sufficient for many applications. To obtain high-precision measurements, the **Dropout ratio** can be reduced. If you expect highly fluctuating measurands at the pickup threshold, you can increase the setting value of the parameter **Dropout ratio**. This avoids chattering of the tripping stage.

6.9.5 Settings

Addr.	Parameter	C	Setting Options	Default Setting
<i>Standard 1</i>				
_:3901:1	Standard 1:Mode		<ul style="list-style-type: none"> • off • on • test 	on
_:3901:101	Standard 1:Activation		<ul style="list-style-type: none"> • on CB closure • only with binary signal • always active 	on CB closure
_:3901:3	Standard 1:Threshold	1 A @ 100 Irated	0.030 A to 35.000 A	10.000 A
		5 A @ 100 Irated	0.15 A to 175.00 A	50.00 A
		1 A @ 50 Irated	0.030 A to 35.000 A	10.000 A
		5 A @ 50 Irated	0.15 A to 175.00 A	50.00 A
		1 A @ 1.6 Irated	0.001 A to 1.600 A	10.000 A
		5 A @ 1.6 Irated	0.005 A to 8.000 A	50.000 A
_:3901:4	Standard 1:Dropout ratio		0.50 to 0.90	0.90

6.9.6 Information List

No.	Information	Data Class (Type)	Type
Group indicat.			
_:4501:55	Group indicat.:Pickup	ACD	O
_:4501:57	Group indicat.:Operate	ACT	O
_:4501:52	Group indicat.:Behavior	ENS	O
_:4501:53	Group indicat.:Health	ENS	O
Standard 1			
_:3901:500	Standard 1:>release	SPS	I
_:3901:81	Standard 1:>Block stage	SPS	I
_:3901:51	Standard 1:Mode (controllable)	ENC	C
_:3901:54	Standard 1:Inactive	SPS	O
_:3901:52	Standard 1:Behavior	ENS	O
_:3901:53	Standard 1:Health	ENS	O
_:3901:300	Standard 1:Rel. by CB switch on	ACT	O
_:3901:55	Standard 1:Pickup	ACD	O
_:3901:57	Standard 1:Operate	ACT	O

6.10 Instantaneous Tripping at Switch onto Fault

6.10.1 Overview of Functions

The **Instantaneous tripping at switch onto fault** function serves for immediate tripping when switching onto a fault.

The function does not have its own measurement and must be linked to another protection function with the pickup (measurement).

6.10.2 Structure of the Function

The function **Instantaneous tripping at switch onto fault** can be used in . The function is preconfigured with 1 stage. A maximum of 2 tripping stages can be operated simultaneously within the function. The tripping stages have an identical structure.

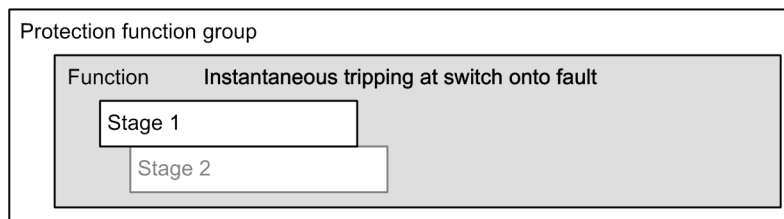

[dw_strsto, 1, en, US]

Figure 6-82 Structure/Embedding of the Function

6.10.3 Stage Description

Logic of the Stage

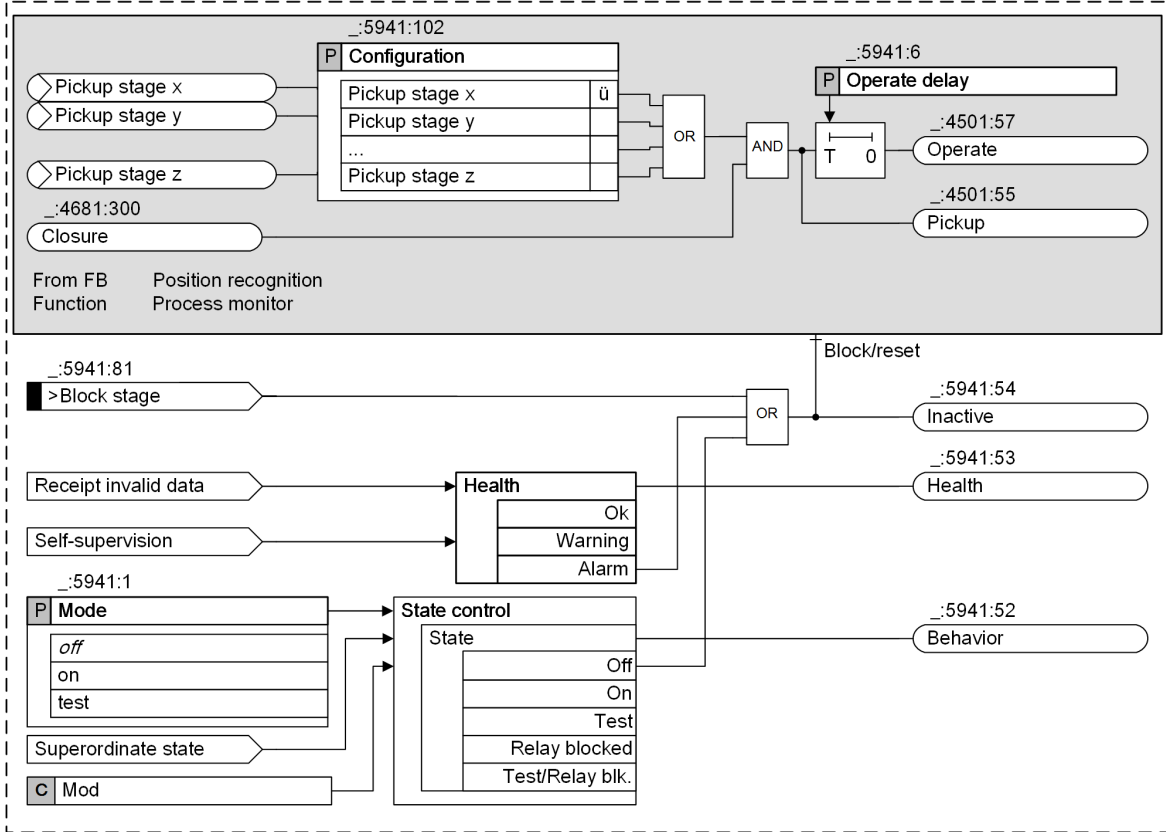

Figure 6-83 Logic Diagram of the Stage Instantaneous Tripping at Switch onto Fault

Connection of the Stage

The stage is intended to initiate instantaneous tripping when switching onto a fault. To do this, the stage must be connected to one or more pickups from protection functions or protection stages, for example, to pickup of an overcurrent-protection stage. That is, the stage of the **Instantaneous tripping at switch onto fault** function does not have its own measuring function but requires the pickup of another protection function or protection stage to pick up.

The stage is active only if switching is pending or executed (refer to [6.3 Overcurrent Protection, Phases](#)).



NOTE

If a protection stage picks up and tripping is blocked by the **Inrush-current detection** function, the **Instantaneous tripping at switch onto fault** function does not pick up. In this case there is no fault recording either.

Despite this, if a fault recording is necessary, you can activate it with the parameter (`_:114`) **Start f1t.rec** of the **Inrush-current detection** function (refer to [6.8.1 Inrush-Current Detection](#)).

6.10.4 Application and Setting Notes

Parameter: Operate delay

- Recommended setting value (`_:5941:6`) **Operate delay** = 0.00 s

When switching onto a fault, the tripping should usually be instantaneous. The tripping delay is therefore set to 0.

6.10.5 Settings

Addr.	Parameter	C	Setting Options	Default Setting
Stage 1				
_:5941:1	Stage 1:Mode		<ul style="list-style-type: none"> • off • on • test 	off
_:5941:2	Stage 1:Operate & flt.rec. blocked		<ul style="list-style-type: none"> • no • yes 	no
_:5941:6	Stage 1:Operate delay		0.00 s to 60.00 s	0.00 s
_:5941:102	Stage 1:Configuration		Setting options depend on configuration	

6.10.6 Information List

No.	Information	Data Class (Type)	Type
Group indicat.			
_:4501:55	Group indicat.:Pickup	ACD	O
_:4501:57	Group indicat.:Operate	ACT	O
_:4501:52	Group indicat.:Behavior	ENS	O
_:4501:53	Group indicat.:Health	ENS	O
Stage 1			
_:5941:81	Stage 1:>Block stage	SPS	I
_:5941:51	Stage 1:Mode (controllable)	ENC	C
_:5941:54	Stage 1:Inactive	SPS	O
_:5941:52	Stage 1:Behavior	ENS	O
_:5941:53	Stage 1:Health	ENS	O
_:5941:55	Stage 1:Pickup	ACD	O
_:5941:57	Stage 1:Operate	ACT	O

6.11 Overcurrent Protection, 1-Phase

6.11.1 Function Overview

The **Overcurrent protection, 1-phase** function (ANSI 50N/51N):

- Detects and monitors the current measured in a transformer neutral point grounding
- Can operate as sensitive tank leakage protection
- Detects and monitors the circulating current between the neutral points of 2 capacitor banks
- Switches off high-current faults instantaneously

6.11.2 Structure of the Function

The **Overcurrent protection, 1-phase** function is used in protection function groups with 1-phase current measurement. 2 function types are available:

- **Overcurrent protection, 1-phase – advanced** (50N/51N OC-1ph-A)
- **Overcurrent protection, 1-phase – basic** (50N/51N OC-1ph-B)

The function type Basic is provided for standard applications. The function type Advanced offers more functionality and is provided for more complex applications.

Both function types are pre-configured by the manufacturer with 2 **Definite-time overcurrent protection** stages and with 1 **Inverse-time overcurrent protection** stage.

In the function type **Overcurrent protection, 1-phase – advanced** the following stages can be operated simultaneously:

- Maximum of 3 stages **Definite-time overcurrent protection** (UMZ)
- 1 stage **Inverse-time overcurrent protection** (AMZ)
- 1 stage **Logarithmic inverse-time overcurrent protection**
- 1 stage **User-defined characteristic curve overcurrent protection**
- 1 **Fast stage**

In the function type **Overcurrent protection, 1-phase – basic**, the following stages can operate simultaneously:

- Maximum of 3 stages **Definite-time overcurrent protection**
- 1 stage **Inverse-time overcurrent protection**

The non-preconfigured stages in [Figure 6-84](#) and [Figure 6-85](#) are shown in gray. Apart from the operate-delay characteristic curve, the **Definite-time overcurrent protection** stage, the **Inverse-time overcurrent protection** stage, the **Logarithmic inverse-time overcurrent protection** stage, and the **User-defined characteristic curve-time overcurrent protection** stage are structured identically.

The **Fast stage** uses a fast tripping algorithm. It is therefore suited in particular for sensitive ground-fault detection according to the high-impedance principle.

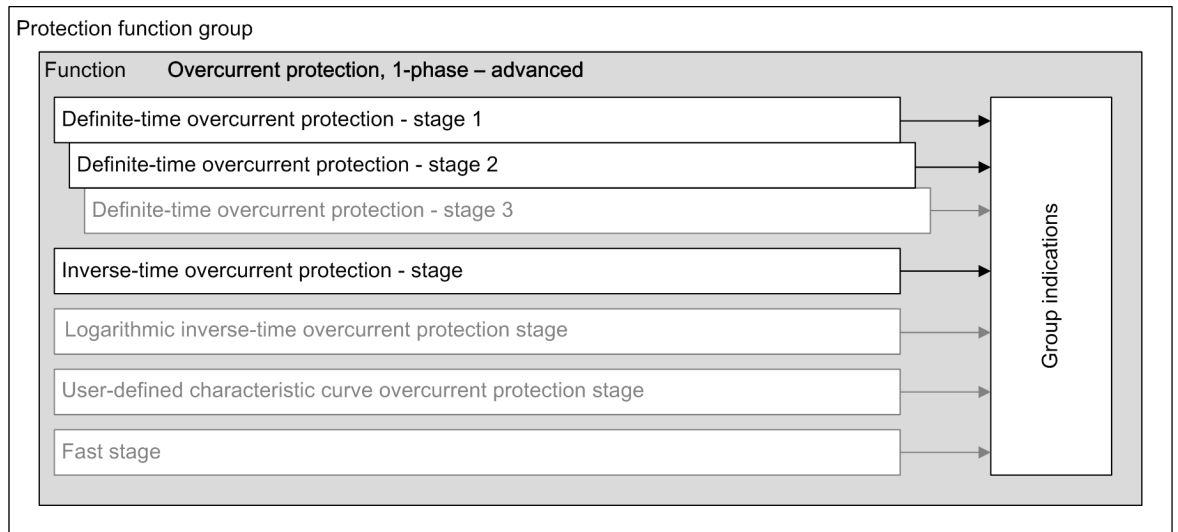

[dw_ocp_1pa_4_en_US]

Figure 6-84 Structure/Embedding the Function Overcurrent Protection, 1-Phase – Advanced

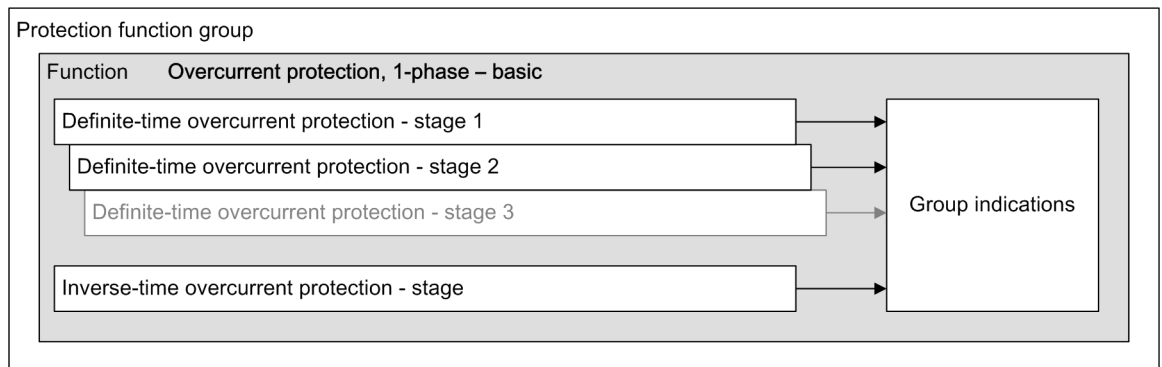

[dw_ocp_1pb_3_en_US]

Figure 6-85 Structure/Embedding the Function Overcurrent Protection, 1-Phase – Basic

If the device is equipped with the **Inrush-current detection** function, you can stabilize the stages against issuing of the operate indication due to transformer inrush-currents.

6.11.3 Stage with Definite-Time Characteristic Curve

6.11.3.1 Description

Logic of a Stage

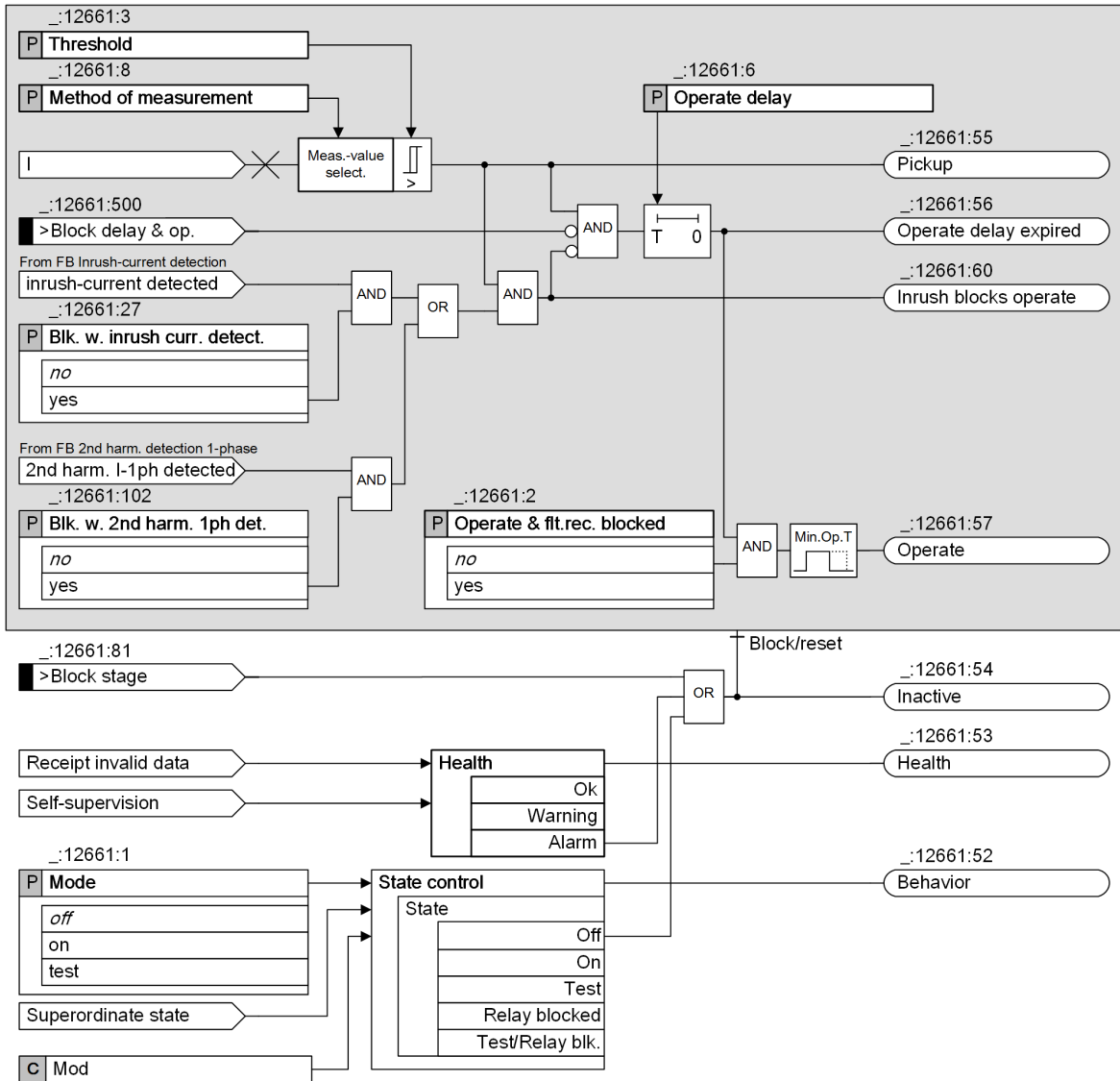

[to_inv_bcp_3_en_US]

Figure 6-86 Logic Diagram of the Definite-Time Overcurrent Protection, 1-Phase

Method of measurement

You use the **Method of measurement** parameter to define whether the stage uses the *fundamental comp.* or the calculated *RMS value*.

- Measurement of the fundamental component:
 This method of measurement processes the sampled current values and filters out the fundamental component numerically.
- Measurement of the RMS value:
 This method of measurement determines the current amplitude from the sampled values according to the defining equation of the RMS value. Harmonics are included in the analysis.

Blocking of the Stage

The picked up stage can reset completely via the binary input signal *>Block stage*.

Blocking of the Time Delay

You can use the binary input signal *>Block delay & op.* to prevent the start of the time delay and thus also tripping. A running time delay is reset. The pickup is reported and a fault is opened.

Blocking of the Tripping by Device-Internal Inrush-Current Detection

Blocking of the operate delay and the operate signal via the device-internal **Inrush-current detection** function is described in chapter [6.3.7 Blocking of the Tripping by Device-Internal Inrush-Current Detection](#).

6.11.3.2 Application and Setting Notes

Parameter: Method of measurement

- Recommended setting value (`_:12661:8`) **Method of measurement** = *fundamental comp.*

With the **Method of measurement** parameter, you define whether the stage uses the *fundamental comp.* (standard method) or the calculated *RMS value*.

Parameter Value	Description
<i>fundamental comp.</i>	Select this method of measurement if harmonics or transient current peaks are to be suppressed. Siemens recommends using this method as the standard method.
<i>RMS value</i>	Select this method of measurement if you want the stage to take harmonics into account (for example, at capacitor banks). Consider that aperiodic DC components present in the secondary circuit are measured and can cause an overfunction. For this method of measurement, do not set the threshold value of the stage to less than $0.1 I_{rated,sec}$. If currents from more than one measuring point are added up in the current interface of a function group, the setting value should not be set lower than $0.1 I_{rated,sec}$ multiplied by the number of added currents.

Parameter: Threshold, Operate delay

- Default setting (`_:12661:3`) **Threshold** = *1.200 A* (for the first stage)
- Default setting (`_:12661:6`) **Operate delay** = *0.300 s* (for the first stage)

Set the **Threshold** and **Operate delay** parameters for the specific application.

6.11.3.3 Settings

Addr.	Parameter	C	Setting Options	Default Setting
<i>Definite-T 1</i>				
<code>_:12661:1</code>	Definite-T 1:Mode		<ul style="list-style-type: none"> off on test 	off
<code>_:12661:2</code>	Definite-T 1:Operate &flt.rec. blocked		<ul style="list-style-type: none"> no yes 	no
<code>_:12661:27</code>	Definite-T 1:Blk. w.inrush curr. detect.		<ul style="list-style-type: none"> no yes 	no
<code>_:12661:102</code>	Definite-T 1:Blk. w. 2nd harm. 1ph det.		<ul style="list-style-type: none"> no yes 	no

Addr.	Parameter	C	Setting Options	Default Setting
_:12661:8	Definite-T 1:Method of measurement		<ul style="list-style-type: none"> fundamental comp. RMS value 	fundamental comp.
_:12661:3	Definite-T 1:Threshold	1 A @ 100 Irated	0.010 A to 35.000 A	1.200 A
		5 A @ 100 Irated	0.05 A to 175.00 A	6.00 A
		1 A @ 50 Irated	0.010 A to 35.000 A	1.200 A
		5 A @ 50 Irated	0.05 A to 175.00 A	6.00 A
		1 A @ 1.6 Irated	0.001 A to 1.600 A	1.200 A
		5 A @ 1.6 Irated	0.002 A to 8.000 A	6.000 A
_:12661:6	Definite-T 1:Operate delay		0.00 s to 60.00 s	0.30 s

6.11.3.4 Information List

No.	Information	Data Class (Type)	Type
Group indicat.			
_:4501:55	Group indicat.:Pickup	ACD	O
_:4501:57	Group indicat.:Operate	ACT	O
_:4501:52	Group indicat.:Behavior	ENS	O
_:4501:53	Group indicat.:Health	ENS	O
Definite-T 1			
_:12661:81	Definite-T 1:>Block stage	SPS	I
_:12661:500	Definite-T 1:>Block delay & op.	SPS	I
_:12661:51	Definite-T 1:Mode (controllable)	ENC	C
_:12661:54	Definite-T 1:Inactive	SPS	O
_:12661:52	Definite-T 1:Behavior	ENS	O
_:12661:53	Definite-T 1:Health	ENS	O
_:12661:60	Definite-T 1:Inrush blocks operate	ACT	O
_:12661:55	Definite-T 1:Pickup	ACD	O
_:12661:56	Definite-T 1:Operate delay expired	ACT	O
_:12661:57	Definite-T 1:Operate	ACT	O
Definite-T 2			
_:12662:81	Definite-T 2:>Block stage	SPS	I
_:12662:500	Definite-T 2:>Block delay & op.	SPS	I
_:12662:51	Definite-T 2:Mode (controllable)	ENC	C
_:12662:54	Definite-T 2:Inactive	SPS	O
_:12662:52	Definite-T 2:Behavior	ENS	O
_:12662:53	Definite-T 2:Health	ENS	O
_:12662:60	Definite-T 2:Inrush blocks operate	ACT	O
_:12662:55	Definite-T 2:Pickup	ACD	O
_:12662:56	Definite-T 2:Operate delay expired	ACT	O
_:12662:57	Definite-T 2:Operate	ACT	O

6.11.4 Stage with Inverse-Time Characteristic Curve

6.11.4.1 Description

Logic of the Stage

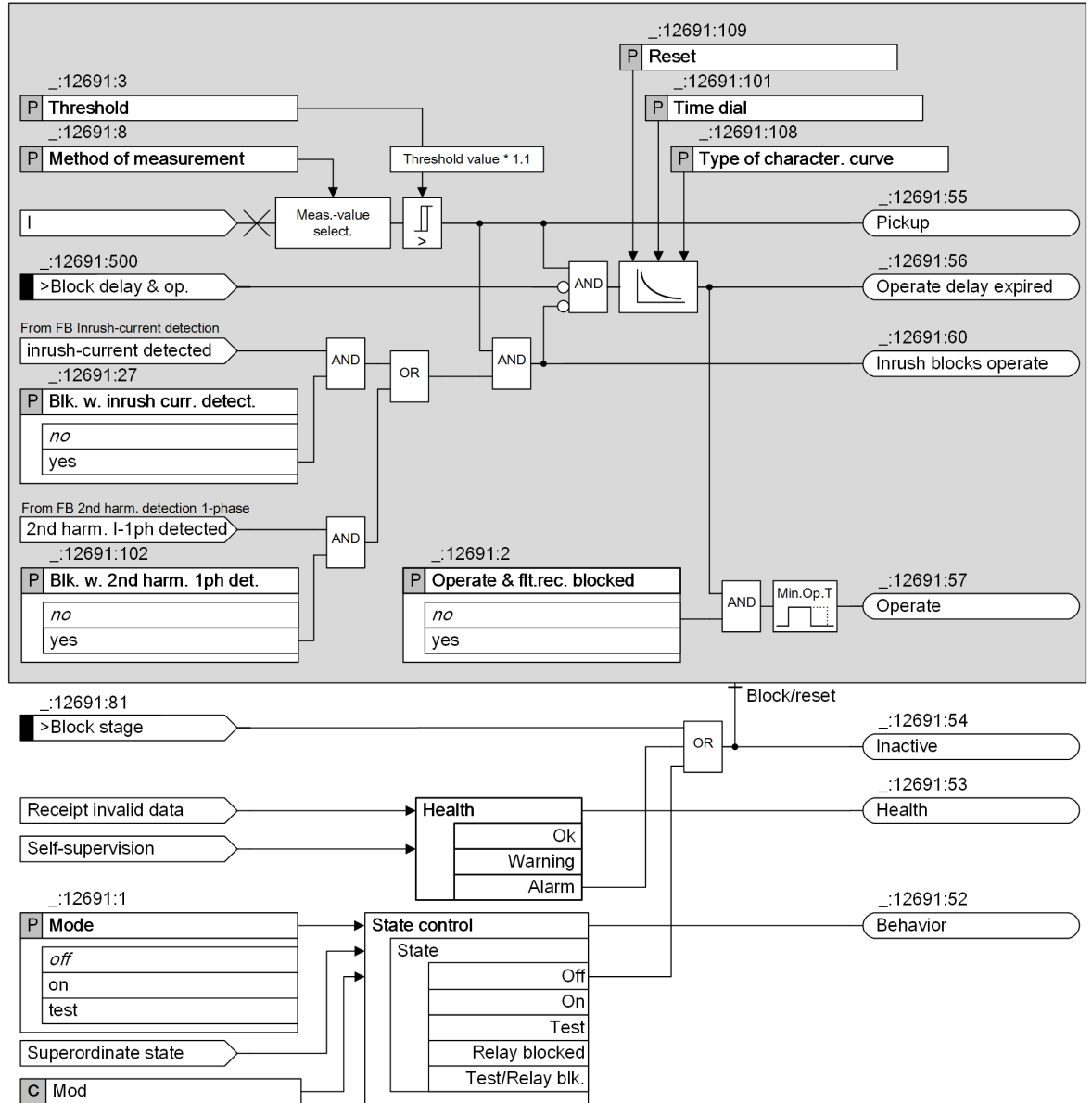

[to_def_ocp_3_en_US]

Figure 6-87 Logic Diagram of the Inverse-Time Overcurrent Protection (1-Phase)

Pickup and Dropout Behaviors of the Inverse-Time Characteristic Curve According to IEC and ANSI

When the input variable exceeds the threshold value by a factor of 1.1, the inverse-time characteristic curve is processed. An integrating method of measurement summarizes the weighted time. The weighted time results from the characteristic curve. For this, the time that is associated with the present current value is determined from the characteristic curve. Once the weighted time exceeds the value 1, the stage operates.

When the measured value falls below the pickup value by a factor of 1.045 ($0.95 \cdot 1.1 \cdot \text{threshold value}$), the dropout is started. The pickup will be indicated as clearing. You can influence the dropout behavior via setting parameters. You can select between instantaneous dropout (totalized time is deleted) or dropout according to the characteristic curve (reduction of totalized time depending on the characteristic curve). The dropout

according to characteristic curve (disk emulation) is the same as turning back a rotor disk. The weighted reduction of the time is initiated from 0.9 of the set threshold value.
 The characteristic curve and associated formulas are shown in the Technical Data.

Method of Measurement

You use the **Method of measurement** parameter to define whether the stage uses the *fundamental comp.* or the calculated *RMS value*.

- Measurement of the fundamental component:
 This method of measurement processes the sampled current values and filters out the fundamental component numerically.
- Measurement of the RMS value:
 This method of measurement determines the current amplitude from the sampled values according to the defining equation of the RMS value. Harmonics are included in the analysis.

Blocking of the Stage

The picked up stage can reset completely via the binary input signal *>Block stage*.

Blocking of the Time Delay

You can use the binary input signal *>Block delay & op.* to prevent the start of the time delay and thus also tripping. A running time delay is reset. The pickup is reported and a fault is opened.

Blocking of the Tripping by Device-Internal Inrush-Current Detection

Blocking of the operate delay and the operate signal via the device-internal **Inrush-current detection** function is described in chapter [6.3.7 Blocking of the Tripping by Device-Internal Inrush-Current Detection](#).

6.11.4.2 Application and Setting Notes

Parameter: Method of measurement

- Recommended setting value (`_:12691:8`) **Method of measurement** = *fundamental comp.*

With the **Method of measurement** parameter, you define whether the stage uses the *fundamental comp.* (standard method) or the calculated *RMS value*.

Parameter Value	Description
<i>fundamental comp.</i>	Select this method of measurement if harmonics or transient current peaks are to be suppressed. Siemens recommends using this method as the standard method.
<i>RMS value</i>	Select this method of measurement if you want the stage to take harmonics into account (for example, at capacitor banks). Consider that aperiodic DC components present in the secondary circuit are measured and can cause an overfunction. For this method of measurement, do not set the threshold value of the stage to less than $0.1 I_{rated,sec}$. If currents from more than one measuring point are added up in the current interface of a function group, the setting value should not be set lower than $0.1 I_{rated,sec}$ multiplied by the number of added currents.

Parameter: Type of character. curve

- Default setting (`_:12691:108`) **Type of character. curve** = *IEC normal inverse*

The device offers all the usual inverse-time characteristic curves according to IEC and ANSI. Select the **Type of character. curve** required for your specific application.

Parameter: Threshold

- Default setting (`_:12691:3`) **Threshold = 1.200 A**

Set the **Threshold** and **Type of character. curve** parameters for the specific application.

Note that a safety margin is set between pickup value and threshold value. The stage only picks up at approx. 10 % above the **Threshold**.

Parameter: Time dial

- Default setting (`_:12691:101`) **Time dial = 1**

Use the **Time dial** parameter to displace the characteristic curve in the time direction.

Where no time grading and therefore no displacement of the characteristic curve is required, leave the parameter **Time dial** at **1** (default setting).

Parameter: Reset

- Default setting (`_:12691:109`) **Reset = disk emulation**

You use the **Reset** parameter to define whether the stage drops out according to the dropout characteristic curve (in accordance with the behavior of a disk emulation = rotor disk) or instantaneously.

Parameter Value	Description
<i>disk emulation</i>	Select this setting if the device is coordinated with electromechanical devices or other devices which perform a dropout after a disk emulation.
<i>instantaneous</i>	Use this setting if the dropout is not to be performed after disk emulation and an instantaneous dropout is desired instead.

6.11.4.3 Settings

Addr.	Parameter	C	Setting Options	Default Setting
Inverse-T 1				
<code>_:12691:1</code>	Inverse-T 1:Mode		<ul style="list-style-type: none"> • off • on • test 	off
<code>_:12691:2</code>	Inverse-T 1:Operate & flt.rec. blocked		<ul style="list-style-type: none"> • no • yes 	no
<code>_:12691:27</code>	Inverse-T 1:Blk. w. inrush curr. detect.		<ul style="list-style-type: none"> • no • yes 	no
<code>_:12691:102</code>	Inverse-T 1:Blk. w. 2nd harm. 1ph det.		<ul style="list-style-type: none"> • no • yes 	no
<code>_:12691:8</code>	Inverse-T 1:Method of measurement		<ul style="list-style-type: none"> • fundamental comp. • RMS value 	fundamental comp.
<code>_:12691:3</code>	Inverse-T 1:Threshold	1 A @ 100 Irated	0.010 A to 35.000 A	1.200 A
		5 A @ 100 Irated	0.05 A to 175.00 A	6.00 A
		1 A @ 50 Irated	0.010 A to 35.000 A	1.200 A
		5 A @ 50 Irated	0.05 A to 175.00 A	6.00 A
		1 A @ 1.6 Irated	0.001 A to 1.600 A	1.200 A
		5 A @ 1.6 Irated	0.002 A to 8.000 A	6.000 A

Addr.	Parameter	C	Setting Options	Default Setting
_:12691:108	Inverse-T 1:Type of character. curve		<ul style="list-style-type: none"> • ANSI long-time inv. • ANSI short-time inv. • ANSI extremely inv. • ANSI very inverse • ANSI normal inverse • ANSI moderately inv. • ANSI definite inverse • IEC normal inverse • IEC very inverse • IEC extremely inv. • IEC long-time inverse 	IEC normal inverse
_:12691:109	Inverse-T 1:Reset		<ul style="list-style-type: none"> • instantaneous • disk emulation 	disk emulation
_:12691:101	Inverse-T 1:Time dial		0.05 to 15.00	1.00

6.11.4.4 Information List

No.	Information	Data Class (Type)	Type
Group indicat.			
_:4501:55	Group indicat.:Pickup	ACD	O
_:4501:57	Group indicat.:Operate	ACT	O
_:4501:52	Group indicat.:Behavior	ENS	O
_:4501:53	Group indicat.:Health	ENS	O
Inverse-T 1			
_:12691:81	Inverse-T 1:>Block stage	SPS	I
_:12691:500	Inverse-T 1:>Block delay & op.	SPS	I
_:12691:51	Inverse-T 1:Mode (controllable)	ENC	C
_:12691:54	Inverse-T 1:Inactive	SPS	O
_:12691:52	Inverse-T 1:Behavior	ENS	O
_:12691:53	Inverse-T 1:Health	ENS	O
_:12691:60	Inverse-T 1:Inrush blocks operate	ACT	O
_:12691:59	Inverse-T 1:Disk emulation running	SPS	O
_:12691:55	Inverse-T 1:Pickup	ACD	O
_:12691:56	Inverse-T 1:Operate delay expired	ACT	O
_:12691:57	Inverse-T 1:Operate	ACT	O

6.11.5 Stage with Inverse-Time Overcurrent Protection with Logarithmic-Inverse Characteristic Curve

6.11.5.1 Description

Logic of the Stage

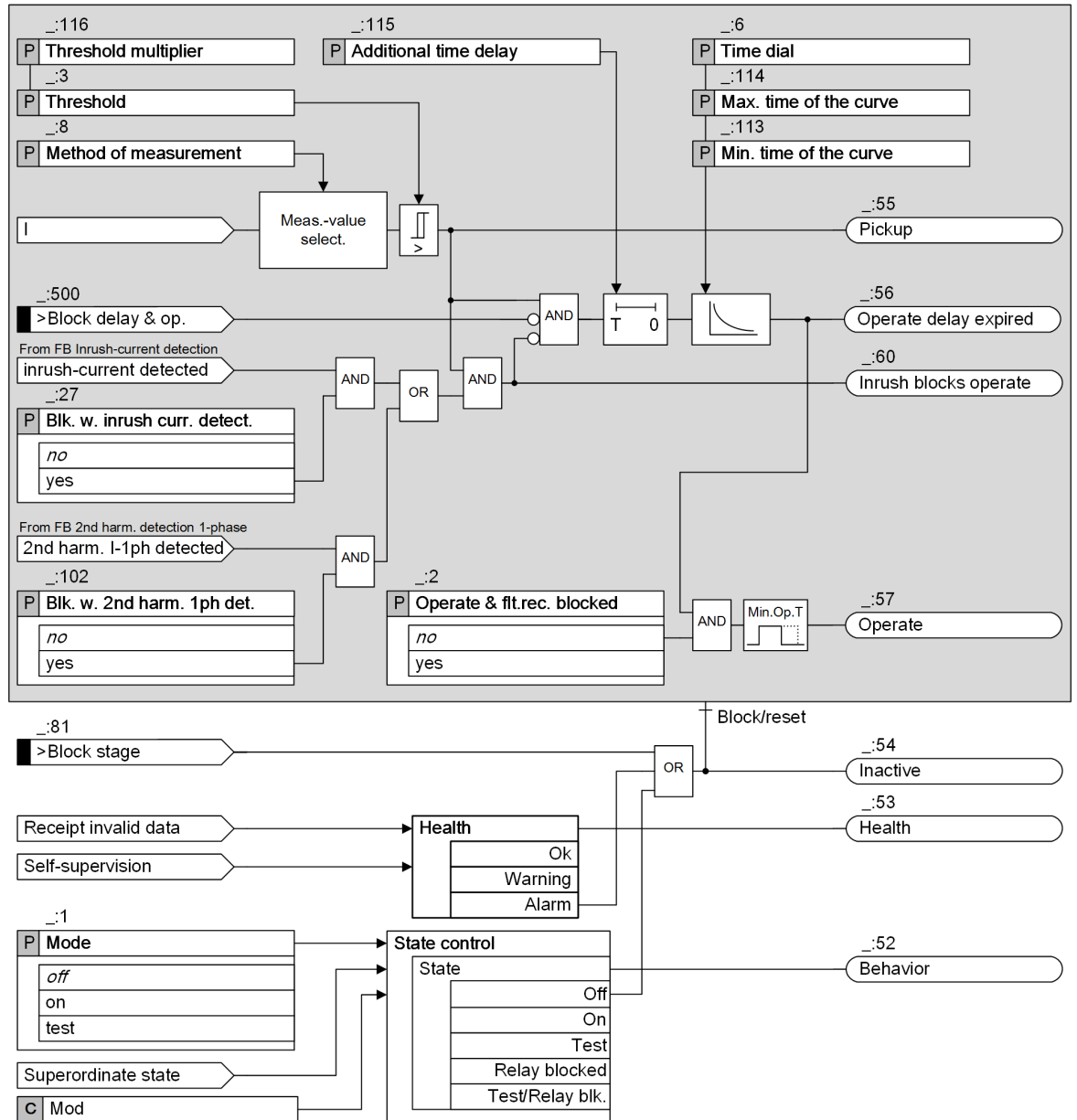

[to_ocp 1phase logarithmic, 3, en_US]

Figure 6-88 Logic Diagram of the Logarithmic Inverse-Time Overcurrent Protection (1-Phase)

Apart from the operate curve, this type of stage is identical to the **Inverse-time overcurrent protection** stage (see chapter [6.11.4.1 Description](#)).

This section will only discuss the nature of the operate curve. For further functionality, refer to chapter [6.11.4.1 Description](#) .

Operate Curve

If the function picks up, the logarithmic inverse-time characteristic curve is processed. A time value T_{op} is calculated for every input value exceeding 95 % of the pickup value. An integrator accumulates the value $1/T_{op}$. If the accumulated integral reaches the fixed value 1, the stage operates.

The curve used to calculate the time value T_{op} is shown in the following figure. The **Threshold multiplier** parameter defines the beginning of the characteristic curve. The **Max. time of the curve** determines the initial value of the characteristic curve. The **Time dial** parameter changes the slope of the characteristic curve. At high currents, the **Min. time of the curve** parameter indicates the lower time limit.

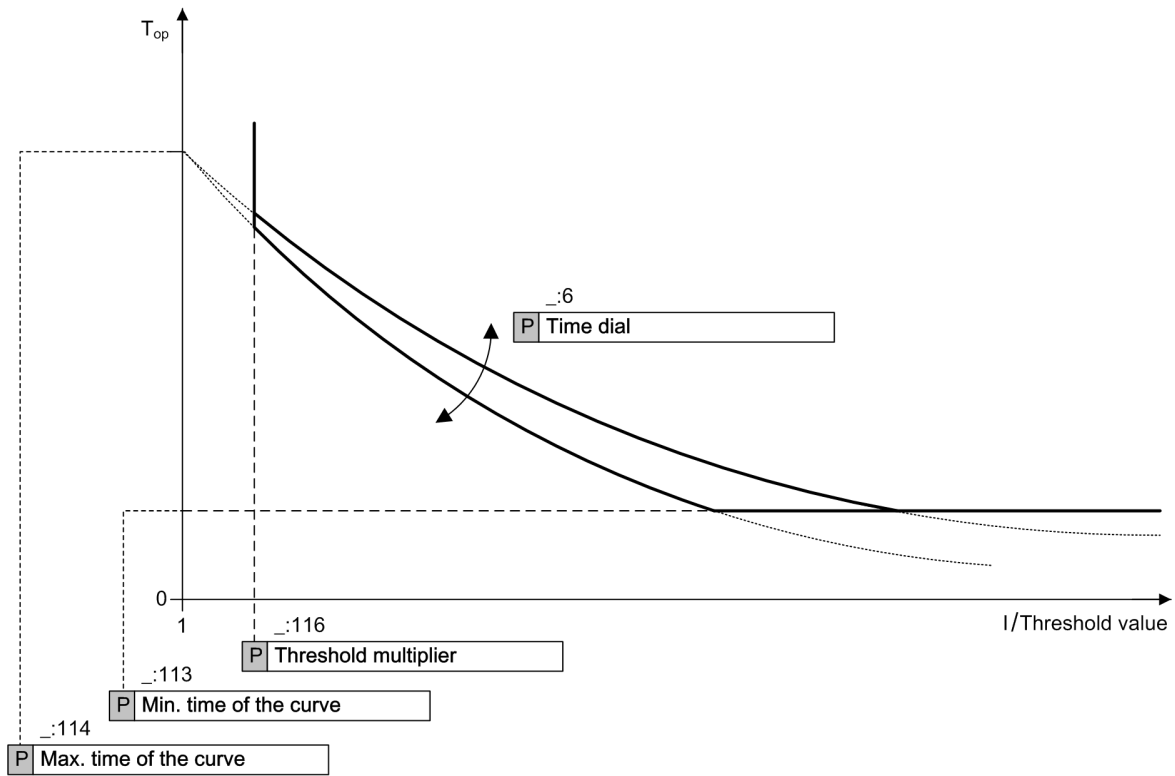

[dw_ocp 1phase logarithmic, 1, en_US]

Figure 6-89 Operate Curve of Logarithmic Inverse-Time Characteristic

The time to operate is calculated with the following formula:

$$T_{op} = T_{max} - T_d \ln\left(\frac{I}{I_{thresh} \cdot I_{mul}}\right)$$

[fo_ocp 1phase logarithmic, 1, en_US]

Where

- T_{max} Maximum time of the curve (parameter **Max. time of the curve**)
- T_d Time dial (parameter **Time dial**)
- T_{op} Operate time
- I 1-phase current
- I_{thresh} Threshold value (parameter **Threshold**)
- I_{mul} Threshold multiplier (parameter **Threshold multiplier**)

If the calculated time is less than T_{min} (parameter **Min. time of the curve**), T_{min} is used.

6.11.5.2 Application and Setting Notes

Apart from the operate curve, this type of stage is identical to the ground-fault protection type with inverse-time delay according to IEC and ANSI (see chapter [6.11.4.1 Description](#)).

This section only discusses the nature of the operate curve. For further functionality, refer to chapter [6.11.4.2 Application and Setting Notes](#).

Stage Type Selection

If the operate delay is to be dependent on the current level according to a logarithmic characteristic curve, select this stage type.

Parameter: **Threshold**

- Default setting (**_:3**) **Threshold** = 1.20 A

With the parameter **Threshold**, you define the pickup value corresponding to the application. In doing so, for the time-graded stages, the setting for the superordinate and subordinate stages must be taken into account in the grading chart.

Parameter: **Threshold multiplier**

- Default setting (**_:116**) **Threshold multiplier** = 1.1

With the parameter **Threshold multiplier**, you define the beginning of the characteristic curve on the current axis (in relation to the threshold value).

General information cannot be provided. Define the value corresponding to the application.

EXAMPLE

Threshold (Secondary current)	$I_{\text{thresh}} = 1.2 \text{ A}$
Threshold multiplier	$I_{\text{mul}} = 1.1$
Pickup value (Secondary current)	$I_{\text{PU}} = 1.2 \text{ A} \times 1.1 = 1.32 \text{ A}$

Parameter: **Time dial**

- Default setting (**_:6**) **Time dial** = 1.250 s

With the parameter **Time dial**, you change the slope of the characteristic curve.

General information cannot be provided. Define the value corresponding to the application.

Parameter: **Max. time of the curve**

- Default setting (**_:114**) **Max. time of the curve** = 5.800 s

The parameter **Max. time of the curve** determines the initial value of the characteristic curve (for $I = \text{Threshold}$).

General information cannot be provided. Define the value corresponding to the application.

Parameter: **Min. time of the curve**

- Default setting (**_:113**) **Min. time of the curve** = 1.200 s

The parameter **Min. time of the curve** determines the lower time limit (at high currents).

General information cannot be provided. Define the value corresponding to the application.

Parameter: **Additional time delay**

- Default setting (**_:115**) **Additional time delay** = 0 s

With the parameter **Additional time delay**, you set an additional current-independent time delay. This additional delay is intended for special applications.
 Siemens recommends setting this time to **0 s** so that it has no effect.

6.11.5.3 Settings

Addr.	Parameter	C	Setting Options	Default Setting
Log. -inv. -T #				
_:1	Log.-inv.-T #:Mode		<ul style="list-style-type: none"> off on test 	off
_:2	Log.-inv.-T #:Operate & flt.rec. blocked		<ul style="list-style-type: none"> no yes 	no
_:27	Log.-inv.-T #:Blk. w. inrush curr. detect.		<ul style="list-style-type: none"> no yes 	no
_:102	Log.-inv.-T #:Blk. w. 2nd harm. 1ph det.		<ul style="list-style-type: none"> no yes 	no
_:8	Log.-inv.-T #:Method of measurement		<ul style="list-style-type: none"> fundamental comp. RMS value 	fundamental comp.
_:3	Log.-inv.-T #:Threshold	1 A @ 100 Irated	0.010 A to 35.000 A	1.200 A
		5 A @ 100 Irated	0.05 A to 175.00 A	6.00 A
		1 A @ 50 Irated	0.010 A to 35.000 A	1.200 A
		5 A @ 50 Irated	0.05 A to 175.00 A	6.00 A
		1 A @ 1.6 Irated	0.001 A to 1.600 A	1.200 A
		5 A @ 1.6 Irated	0.002 A to 8.000 A	6.000 A
_:6	Log.-inv.-T #:Time dial		0.000 s to 60.000 s	1.250 s
_:113	Log.-inv.-T #:Min. time of the curve		0.000 s to 60.000 s	1.200 s
_:114	Log.-inv.-T #:Max. time of the curve		0.000 s to 60.000 s	5.800 s
_:116	Log.-inv.-T #:Threshold multiplier		1.00 to 4.00	1.10
_:115	Log.-inv.-T #:Additional time delay		0.000 s to 60.000 s	0.000 s

6.11.5.4 Information List

No.	Information	Data Class (Type)	Type
Log. -inv. -T #			
_:81	Log.-inv.-T #:>Block stage	SPS	I
_:500	Log.-inv.-T #:>Block delay & op.	SPS	I
_:54	Log.-inv.-T #:Inactive	SPS	O
_:52	Log.-inv.-T #:Behavior	ENS	O
_:53	Log.-inv.-T #:Health	ENS	O
_:60	Log.-inv.-T #:Inrush blocks operate	ACT	O
_:55	Log.-inv.-T #:Pickup	ACD	O
_:56	Log.-inv.-T #:Operate delay expired	ACT	O
_:57	Log.-inv.-T #:Operate	ACT	O

6.11.6 Stage with User-Defined Characteristic Curve

6.11.6.1 Description

The **User-defined characteristic curve overcurrent protection** stage is only available in the advanced function type.

This stage is structured the same way as the stage with the inverse-time characteristic curve. The only difference is that you can define the characteristic curve as desired.

User-Defined Characteristic Curve

With the user-defined characteristic curve, you can define the operate curve point by point using up to 30 value pairs of current and time. The device uses linear interpolation to calculate the characteristic curve from these values. You can also define a dropout characteristic curve if you wish.

Pickup and Dropout Behaviors with the User-Defined Characteristic Curve

When the input variable exceeds the threshold value by 1.1 times, the characteristic curve is processed.

An integrating method of measurement totalizes the weighted time. The weighted time results from the characteristic curve. For this, the time that is associated with the present current value is determined from the characteristic curve. Once the weighted time exceeds the value 1, the stage operates.

When the measured value falls short of the pickup value by a factor of 1.045 ($0.95 \times 1.1 \times \text{threshold value}$), the dropout is started. The pickup will be indicated as clearing. You can influence the dropout behavior via setting parameters. You can select between instantaneous dropout (totalized time is deleted) or dropout according to the characteristic curve (reduction of totalized time depending on the characteristic curve).

The dropout according to characteristic curve (disk emulation) is the same as turning back a rotor disk. The weighted reduction of the time is initiated from 0.9 of the set threshold value.

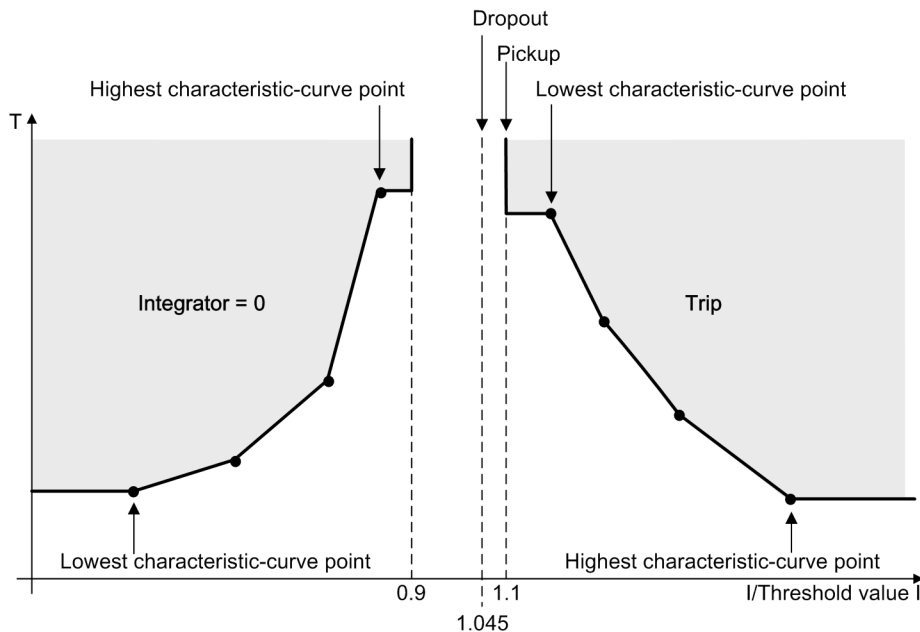

[dw_ocp_ken_02_2_en_US]

Figure 6-90 Pickup Behavior and Dropout Behavior when Using a User-Defined Characteristic Curve



NOTE

Note that the currents that are lower than the current value of the smallest characteristic-curve point do not extend the operate time. The pickup characteristic runs in parallel to the current axis up to the smallest characteristic-curve point. Currents that are larger than the current value of the largest characteristic-curve point do not reduce the operate time. The pickup characteristic runs in parallel to the current axis from the largest characteristic-curve point.

6.11.6.2 Application and Setting Notes

This stage is structured the same way as the stage with the inverse-time characteristic curve. The only difference is that you can define the characteristic curve as desired. This chapter only provides application and setting notes for setting characteristic curves.

Parameter: Current/time value pairs (from the operate curve)

Use these settings to define the characteristic curve. Set a current/time value pair for each characteristic-curve point. The setting depends on the characteristic curve you want to realize.

Set the current value as a multiple of the threshold value. Siemens recommends that you set the **Threshold** parameter to **1.00** in order to obtain a simple relation. You can change the threshold value setting afterwards if you want to displace the characteristic curve.

Set the time value in seconds. The characteristic curve is displaced using the **Time dial** parameter.



NOTE

The value pairs must be entered in continuous order.

Parameter: Time dial

- Default setting (**_:101**) **Time dial = 1**

Use the **Time dial** parameter to displace the characteristic curve in the time direction.

Where no time grading and therefore no displacement of the characteristic curve is required, leave the **Time dial** parameter at **1**.

Parameter: Reset

- Default setting **Reset = disk emulation**

You use the **Reset** parameter to define whether the stage drops out according to the dropout characteristic curve (in accordance with the behavior of a disk emulation = rotor disk) or instantaneously.

Parameter Value	Description
<i>disk emulation</i>	In the case of this setting, a dropout characteristic curve has to be set in addition to the operate curve. Select this setting if the device is coordinated with electromechanical devices or other devices which perform a dropout after a disk emulation.
<i>instantaneous</i>	Use this setting if the dropout is not to be performed after disk emulation and an instantaneous dropout is desired instead.

Parameter: Current/time value pairs (of the dropout characteristic curve)

Use these settings to define the characteristic curve. Set a current/time value pair for each characteristic-curve point. The setting depends on the characteristic curve you want to realize.

Set the current value as a multiple of the threshold value. Siemens recommends that you set the **Threshold** parameter to **1.00** in order to obtain a simple relation. You can change the threshold value setting afterwards if you want to displace the characteristic curve.

Set the time value in seconds. The characteristic curve is displaced using the **Time dial** parameter.



NOTE

The value pairs must be entered in continuous order.

6.11.6.3 Settings

Addr.	Parameter	C	Setting Options	Default Setting
General				
_:1	User curve #:Mode		<ul style="list-style-type: none"> • off • on • test 	off
_:2	User curve #:Operate & flt.rec. blocked		<ul style="list-style-type: none"> • no • yes 	no
_:27	User curve #:Blk. w. inrush curr. detect.		<ul style="list-style-type: none"> • no • yes 	no
_:102	User curve #:Blk. w. 2nd harm. 1ph det.		<ul style="list-style-type: none"> • no • yes 	no
_:8	User curve #:Method of measurement		<ul style="list-style-type: none"> • fundamental comp. • RMS value 	fundamental comp.
_:3	User curve #:Threshold	1 A @ 100 Irated	0.010 A to 35.000 A	1.200 A
		5 A @ 100 Irated	0.05 A to 175.00 A	6.00 A
_:110	User curve #:Reset		<ul style="list-style-type: none"> • instantaneous • disk emulation 	disk emulation
_:101	User curve #:Time dial		0.05 to 15.00	1.00

6.11.6.4 Information List

No.	Information	Data Class (Type)	Type
User curve #			
_:81	User curve #:>Block stage	SPS	I
_:500	User curve #:>Block delay & op.	SPS	I
_:54	User curve #:Inactive	SPS	O
_:52	User curve #:Behavior	ENS	O
_:53	User curve #:Health	ENS	O
_:60	User curve #:Inrush blocks operate	ACT	O
_:59	User curve #:Disk emulation running	SPS	O
_:55	User curve #:Pickup	ACD	O
_:56	User curve #:Operate delay expired	ACT	O
_:57	User curve #:Operate	ACT	O

6.11.7 Fast Stage

6.11.7.1 Description

Logic of a Stage

The fast stage is only available in function type Advanced.

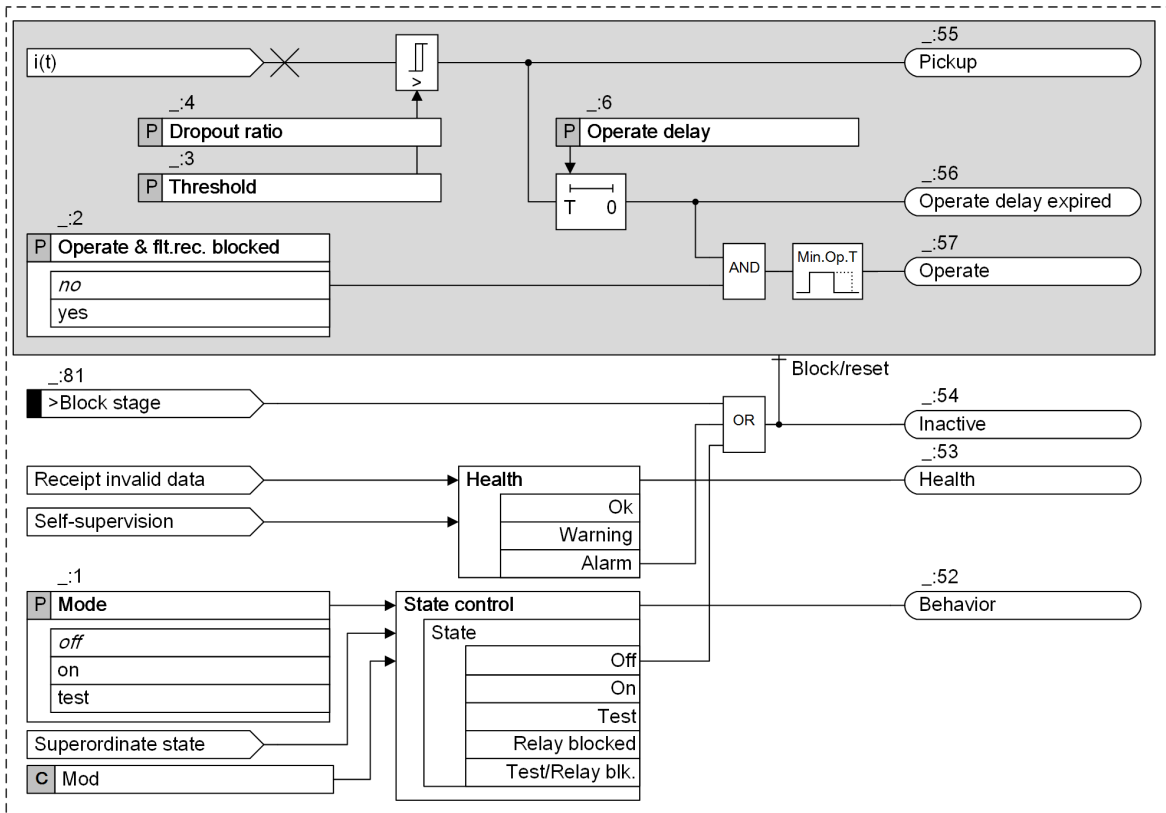

[file_occup_1phs_3_en_US]

Figure 6-91 Logic Diagram of the Fast Stage, 1-Phase

Method of Measurement, Pickup and Dropout Behaviors of the Fast Stage

This stage evaluates the unfiltered measurands. Thus, very short response times are possible. When the absolute values of 2 consecutive sampled values of the last half period exceed the **Threshold**, the stage picks up. When all sampled values of the previous period are less than the dropout threshold, the stage drops out.

Blocking of the Stage

The picked up stage can reset completely via the binary input signal *>Block stage*.

6.11.7.2 Application and Setting Notes

Parameter: **Threshold, Operate delay**

- Default setting (:3) **Threshold** = 10.00 A
- Default setting (:6) **Operate delay** = 0.00 s

Set the **Threshold** and **Operate delay** parameters for the specific application.

Ensure that the sampled values are compared directly without an additional factor with the set threshold value.

Parameter: **Dropout ratio**

- Recommended setting value (:4) **Dropout ratio** = 0.90

The recommended setting value of 0.90 is sufficient for many applications. To obtain high-precision measurements, the **Dropout ratio** can be reduced. If you expect highly fluctuating measurands at the pickup threshold, you can increase the **Dropout ratio** setting. This avoids chattering of the tripping stage.

6.11.7.3 Settings

Addr.	Parameter	C	Setting Options	Default Setting
Fast stage #				
_:1	Fast stage #:Mode		<ul style="list-style-type: none"> • off • on • test 	off
_:2	Fast stage #:Operate & flt.rec. blocked		<ul style="list-style-type: none"> • no • yes 	no
_:3	Fast stage #:Threshold	1 A @ 100 Irated	0.030 A to 35.000 A	10.000 A
		5 A @ 100 Irated	0.15 A to 175.00 A	50.00 A
		1 A @ 50 Irated	0.030 A to 35.000 A	10.000 A
		5 A @ 50 Irated	0.15 A to 175.00 A	50.00 A
		1 A @ 1.6 Irated	0.001 A to 1.600 A	10.000 A
		5 A @ 1.6 Irated	0.005 A to 8.000 A	50.000 A
_:4	Fast stage #:Dropout ratio		0.90 to 0.99	0.90
_:6	Fast stage #:Operate delay		0.00 s to 60.00 s	0.00 s

6.11.7.4 Information List

No.	Information	Data Class (Type)	Type
Fast stage #			
_:81	Fast stage #:>Block stage	SPS	I
_:54	Fast stage #:Inactive	SPS	O
_:52	Fast stage #:Behavior	ENS	O
_:53	Fast stage #:Health	ENS	O
_:55	Fast stage #:Pickup	ACD	O
_:56	Fast stage #:Operate delay expired	ACT	O
_:57	Fast stage #:Operate	ACT	O

6.11.8 Blocking of the Tripping by Device-Internal Inrush-Current Detection

6.11.8.1 Description

The **Blk. w. inrush curr. detect.** parameter allows you to define whether the operate indication of the stage should be blocked when a threshold value is exceeded due to an inrush current. In case of a blocking and fulfilled pickup conditions, the stage picks up. The start of the time delay and the operate indication are blocked. The function indicates this through a corresponding indication. If the blocking drops out and the pickup conditions are still met, the time delay is started. After that time, the stage operates.

The **Blk. w. 2nd harm. 1ph det.** parameter allows you to define whether the operate indication of the stage should be blocked when the detected 2nd harmonic component of the 1-phase current exceeds a threshold value. In case of a blocking and fulfilled pickup conditions, the stage picks up. The start of the time delay and the operate indication are blocked. The function indicates this through a corresponding indication. If the blocking drops out and the pickup conditions are still met, the time delay is started. After that time, the stage operates.

The following figure only shows the part of the stage (exemplified by definite-time overcurrent protection stage 1) that illustrates the influence of the inrush-current detection. Only if the central function **Inrush-current detection** (see section [14.9 Inrush-Current Detection](#)) is in effect can the blocking be set.

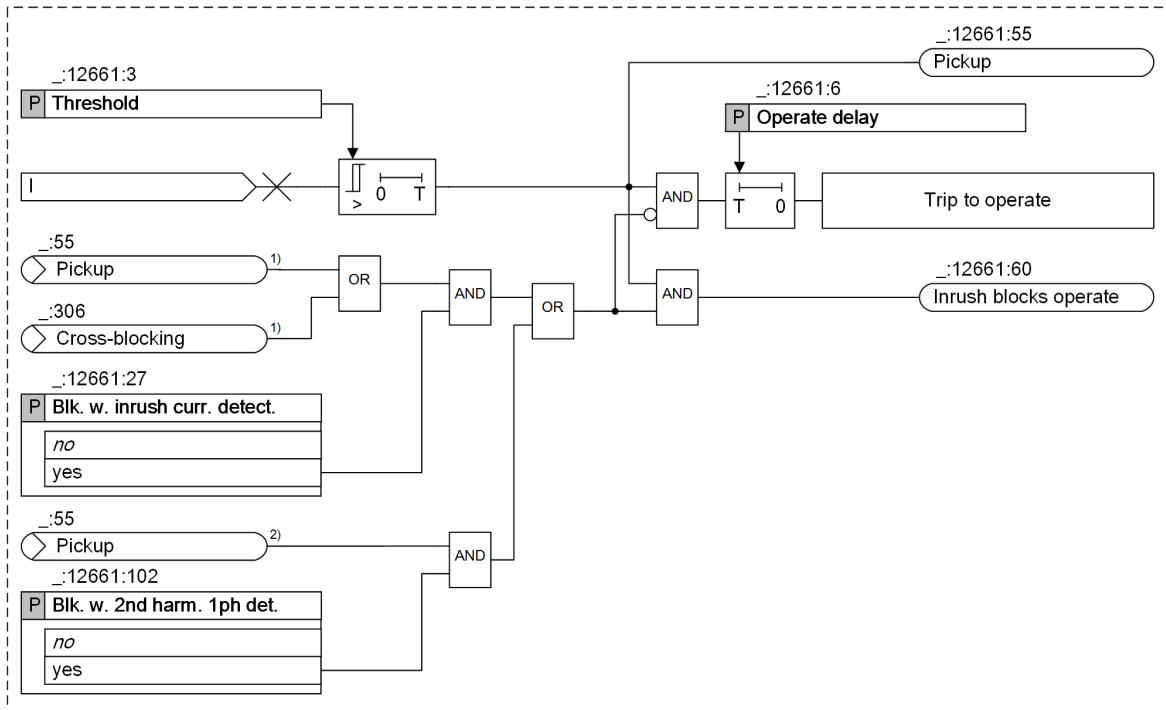

[lo_blk_by_inrush_ocp_1phase.1_en_US]

Figure 6-92 Part-Logic Diagram on the Influence of Inrush-Current Detection Exemplified by the 1st Definite-Time Overcurrent Protection Stage

- (1) From FB **Inrush-current detection**
- (2) From FB **2nd harmonic detection 1-phase**

6.11.8.2 Application and Setting Notes

Parameter: **Blk. w. inrush curr. detect.**

- Default setting (_:12661:27) **Blk. w. inrush curr. detect. = no**

Parameter Value	Description
no	The transformer inrush-current detection does not affect the stage. Select this setting in the following cases: <ul style="list-style-type: none"> • In cases where the device is not used on transformers. • In cases where the device is used on transformers and the threshold value of the stage is set above the maximum inrush current of the transformer. This, for example, applies to the high-current stage that is set such according to the short-circuit voltage V_{sc} of the transformer that it only picks up on faults from the high-voltage side. The transformer inrush current cannot become larger than the maximum transmittable short-circuit current.
yes	When the transformer inrush-current detection detects an inrush current that would lead to a tripping of the stage, the start of the time delay and tripping of the stage are blocked. Select this setting if the device is used on transformers and the threshold value of the stage is set below the maximum inrush current of the transformer. This applies to the overcurrent-protection stage, which is used as a backup stage with grading time for faults on the undervoltage side of the transformer.

Parameter: Blk. w. 2nd harm. 1ph det.

- Default setting (_:12661:102) Blk. w. 2nd harm. 1ph det. = *no*

Parameter Value	Description
<i>no</i>	If no 1-phase current flow due to CT saturation with a level above the pickup threshold is expected, select this setting.
<i>yes</i>	If 1-phase current flow due to CT saturation with a level above the pickup threshold is expected, the blocking must be activated. This provides stability for the following conditions: <ul style="list-style-type: none"> • CT saturation without inrush current since a saturated signal also contains 2nd-harmonic content • Phase inrush current that leads to CT saturation and therefore causes 2nd-harmonic inrush current being present also in the parasitic 1-phase current

6.11.9 Application Example: High-Impedance Restricted Ground-Fault Protection

6.11.9.1 Description

With the high-impedance method, all current transformers operate in parallel at the limits of the protection range on a common, relatively high-impedance resistor R, the voltage of which is measured.

The current transformers must be of the same type of construction and have at least one core of their own for the High-impedance restricted ground-fault protection. Furthermore, they must have the same transfer ratio and approximately the same knee-point voltage.

The high-impedance principle is especially suited for ground-fault detection in grounded networks at transformers, generators, motors, and shunt reactors.

The left part of [Figure 6-93](#) shows an application example for a grounded transformer winding or a grounded motor/generator. The example at the right shows an ungrounded transformer winding or an ungrounded motor/generator. In this example, it is assumed that the network is grounded at a different point.

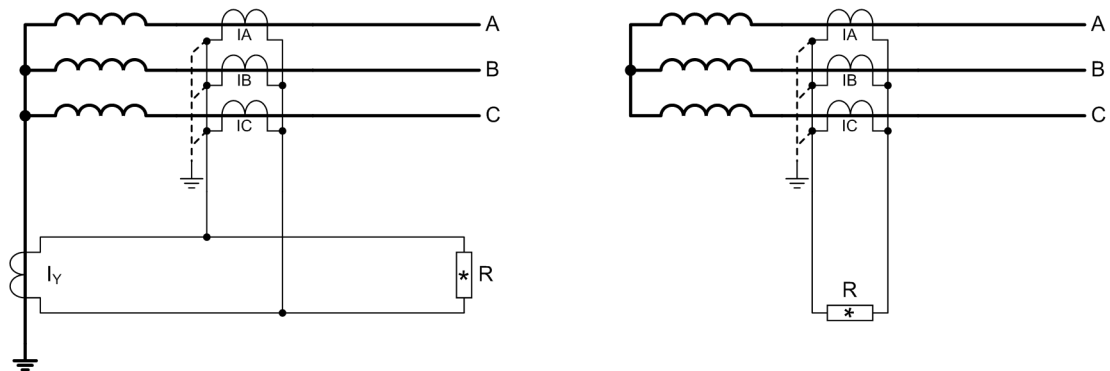

[dw_himpef, 2, en_US]

Figure 6-93 Restricted Ground-Fault Protection According to the High-Impedance Principle

Function of the High-Impedance Principle

The high-impedance principle is explained using the example of a grounded transformer winding.

In normal state, no residual currents flow, that is, in the transformer neutral point $I_N = 0$ and in the phases $3I_0 = I_A + I_B + I_C = 0$.

With an external ground fault (on the left in [Figure 6-94](#)), the short-circuit current of which is fed via a grounded neutral point, the same current flows in the transformer neutral point and in the phases. The respective secondary currents (with the same transfer ratio of all current transformers) draw each other off. They are connected in series. At the resistor R, only a little voltage arises, which results from the internal resistances of the transformers and those of the transformer connection lines. Even if a current transformer is

briefly saturated, it becomes a low-impedance during the time of the saturation and forms a low-impedance shunt to the high-impedance resistor R. The high resistance of the resistor thus has a stabilizing effect (so-called resistor stabilization).

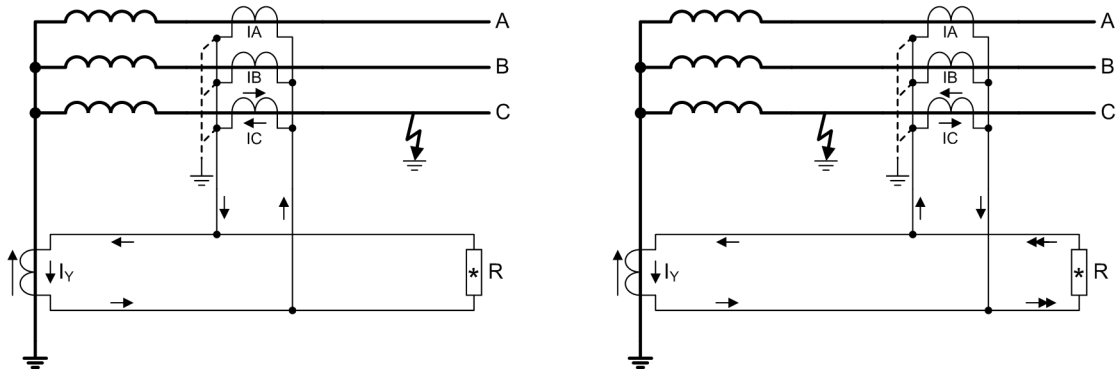

[dw_grlimp, 2, en_US]

Figure 6-94 Principle of the Restricted Ground-Fault Protection According to the High-Impedance Principle

With a ground-fault in the protection range (on the right in [Figure 6-94](#)), a neutral-point current I_y flows in any case. The magnitude of the residual current in the phase currents depends on the grounding conditions in the rest of the network. A secondary current corresponding to the entire short-circuit current attempts to flow via the resistor R. But since this resistor is high-impedance, a high voltage arises there which causes the saturation of the current transformers. The effective voltage at the resistor therefore corresponds approximately to the knee-point voltage of the current transformers.

The resistor R is thus dimensioned in such a way that even the smallest ground-fault current to be detected leads to a secondary voltage that corresponds to half of the knee-point voltage of the current transformers (see chapter 2.5.4).

Further information can be found at *Sensitivity view for high-impedance ground-fault differential protection* in chapter [6.11.9.2 Application and Setting Notes](#).

High-Impedance Restricted Ground-Fault Protection with a SIPROTEC 5 Device

Use the I4 measuring input of the SIPROTEC 5 device for the high-impedance restricted ground-fault protection. This input for this application is to be executed as a sensitive measuring input. Since this is a current input, the current is detected by this resistor instead of the voltage at the resistor R.

[Figure 6-95](#) shows the connection diagram. The protection device is connected in series with the resistor R and thus measures its current.

The varistor V limits the voltage in case of an internal fault. The varistor cuts the high instantaneous voltage peaks in the case of transformer saturation. Simultaneously, a smoothing of the voltage arises without any relevant reduction of the average value.

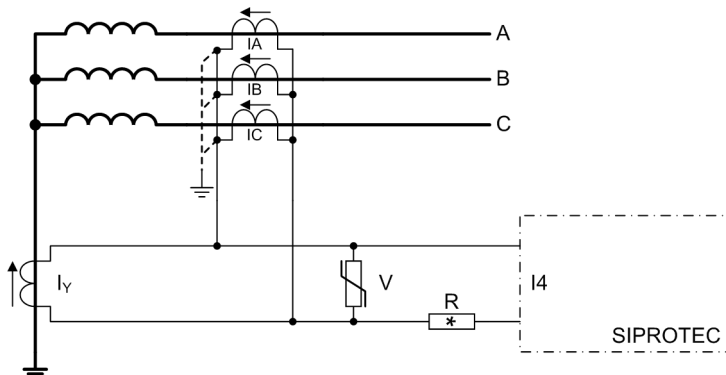

[dw_anedif, 2, en_US]

Figure 6-95 Connection Diagram of the Restricted Ground-Fault Protection According to the High-Impedance Principle

As a protection against overvoltages, it is important that you connect the device directly at the grounded side of the current transformer. The high voltage at the resistor is thus kept away from the device.

In a similar manner, the high-impedance restricted ground-fault protection for generators, motors, and shunt reactors is used. With auto transformers, you must connect the upper-voltage side and low-voltage side current transformers and neutral-point transformer in parallel.

The method can be realized for each protected object. As busbar protection, the device, for example, is connected via the resistor to the parallel connection of the transformers of all feeders.

6.11.9.2 Application and Setting Notes

A prerequisite for the application of the high-impedance restricted ground-fault protection is that neutral-point current detection is possible on the station side (see example in [Figure 6-95](#)). Furthermore, a sensitive input transformer must be available at device input I4. Set the pickup value for current at input I4 with the function **Overcurrent protection, 1-phase**.

Observe the interaction between current-transformer characteristic curve, external resistor R, and the voltage at R for the overall function of the high-impedance restricted ground-fault protection. Notes on this follow.

Current Transformer Data for High-Impedance Restricted Ground-Fault Protection

All affected current transformers must have the same ratio and approximately the same knee-point voltage. This is normally the case when the current transformers are of the same type and have the same rated data. You can calculate the knee-point voltage from the rated data as follows:

$$V_{KP} = \left(R_i + \frac{P_{rated}}{I_{rated}^2} \right) \cdot n \cdot I_{rated}$$

[fo_ukniep, 1, en_US]

V_{KP}	Knee-point voltage
R_i	Internal resistance of the current transformer
P_{rated}	Rated power of the current transformer
I_{rated}	Secondary rated current of the current transformer
n	Rated overcurrent factor

Rated current, rated power, and overcurrent factor are found on the name plate of the transformer.

EXAMPLE

Current transformer with the following data on the name plate: 800/5; 5P10; 30 VA
You can read the following transformer data with this data:

I_{rated}	= 5 A (out of 800/5)
n	= 10 (out of 5P10)
P_{rated}	= 30 VA

The internal resistance is frequently to be found in the test report of the transformer. If it is not known, it can be approximately determined by a direct current measurement at the secondary winding.

EXAMPLE

Calculation of the knee-point voltage
Current transformer 800/5; 5P10; 30 VA with $R_i = 0.3 \Omega$

$$V_{KP} = \left(R_i + \frac{P_{rated}}{I_{rated}^2} \right) \cdot n \cdot I_{rated} = \left(0.3 \Omega + \frac{30 \text{ VA}}{(5 \text{ A})^2} \right) \cdot 10 \cdot 5 \text{ A} = 75 \text{ V}$$

[fo_ukp5aw, 1, en_US]

Current transformer 800/1; 5P10; 30 VA with $R_i = 5 \Omega$

$$V_{KP} = \left(R_i + \frac{P_{rated}}{I_{rated}^2} \right) \cdot n \cdot I_{rated} = \left(5 \Omega + \frac{30 \text{ VA}}{(1 \text{ A})^2} \right) \cdot 10 \cdot 1 \text{ A} = 350 \text{ V}$$

[fo_ukp1aw, 1, en_US]

Besides the current-transformer data, the resistance of the longest connection line between transformer and device must be known.

Stability Consideration for High-Impedance Restricted Ground-Fault Protection

The stability condition is based on the simplified assumption that one current transformer is completely saturated and the others transfer their partial currents proportionately in the case of an external fault. This is theoretically the worst case. A safety margin is automatically provided, since, in practice, even the saturated transformer still delivers some current.

Figure 6-96 shows an equivalent circuit of this simplification. CT1 and CT2 are assumed to be ideal transformers with their internal resistances R_{i1} and R_{i2} . R_a are the core resistances of the connection lines between transformer and resistance R; they are used doubled (forward line and return line). R_{a2} is the resistance of the longest connection line.

CT1 transmits the current I_1 . CT2 is assumed to be saturated. This is indicated by the dotted short-circuit line. The transformer thus represents a low-impedance shunt by its saturation.

A further prerequisite is $R \gg (2R_{a2} + R_{i2})$.

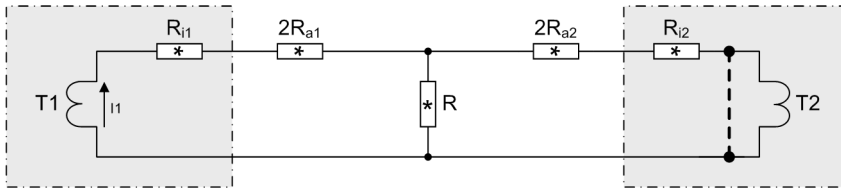

[idw_vebhd1, 2, en_US]

Figure 6-96 Simplified Connection Diagram of a Layout for High-Impedance Restricted Ground-Fault Protection

The voltage at R is, then,

$$V_R = I_1 \cdot (2R_{a2} + R_{i2})$$

A further assumption is that the pickup value of the SIPROTEC 5 device corresponds to half of the knee-point voltage of the current transformers. In the edge case,

$$V_R = V_{KP}/2$$

The stability limit I_{SL} results, which means the through fault current up to which the arrangement remains stable:

$$I_{SL} = \frac{V_{KP} / 2}{2 \cdot R_{a2} + R_{i2}}$$

[fo_istabl, 1, en_US]

EXAMPLE

For the 5 A transformer as above with $V_{KP} = 75 \text{ V}$ and $R_i = 0.3 \Omega$

Longest connection line = 22 m with 4 mm² cross-section; that corresponds to $R_a = 0.1 \Omega$

$$I_{SL} = \frac{V_{KP} / 2}{2 \cdot R_{a2} + R_{i2}} = \frac{37.5 \text{ V}}{2 \cdot 0.1 \Omega + 0.3 \Omega} = 75 \text{ A}$$

[fo_id5aw, 1, en_US]

In the example, the stability limit is $15 \times$ rated current or 12 kA primary.

For the 1 A transformer as above with $V_{KP} = 350$ V and $R_i = 5 \Omega$

Longest connection line = 107 m with 2.5 mm^2 cross-section; that corresponds to $R_a = 0.75 \Omega$

$$I_{SL} = \frac{V_{KP}/2}{2 \cdot R_{a2} + R_{i2}} = \frac{175 \text{ V}}{2 \cdot 0.75 \Omega + 5 \Omega} = 27 \text{ A}$$

[fo_sl1aw, 1, en_US]

In the example, the stability limit is $27 \times$ rated current or 21.6 kA primary.

Sensitivity Consideration for High-Impedance Restricted Ground-Fault Protection

The voltage present at the set of current transformers is supplied to the protection device via a series resistor R as proportional current for evaluation. For dimensioning of the resistor, the following must be taken into account:

The high-impedance restricted ground-fault protection should pick up at approximately half of the knee-point voltage of the current transformers. From this, you can calculate the resistor R.

Since the device measures the current through the resistor, the resistor and measuring input of the device must be connected in series. Since the resistor still should be high-impedance (aforementioned condition $R \gg 2R_{a2} + R_{i2}$), the inherent resistance of the measuring input can be neglected. The resistance results thus from the pickup current I_{pick} and half of the knee-point voltage:

$$R = \frac{V_{KP}/2}{I_{pick}}$$

[fo_beracr, 1, en_US]

EXAMPLE

For the 5 A transformer as above

Desired pickup value $I_{pick} = 0.1$ A (corresponds to 16 A primary)

$$R = \frac{V_{KP}/2}{I_{pick}} = \frac{75 \text{ V}/2}{0.1 \text{ A}} = 375 \Omega$$

[fo_ber5aw, 1, en_US]

For the 1 A transformer as above

Desired pickup value $I_{pick} = 0.05$ A (corresponds to 40 A primary)

$$R = \frac{V_{KP}/2}{I_{pick}} = \frac{350 \text{ V}/2}{0.05 \text{ A}} = 3500 \Omega$$

[fo_ber1aw, 1, en_US]

The series resistor R must be designed for a minimum continuous load $P_{continuous}$.

$$P_{continuous} \geq \frac{(V_{KP}/2)^2}{R} = \frac{37.5^2}{375} = 3.75 \text{ W} \quad \text{at the 5-A-transformer}$$

[fo_pdau5a, 1, en_US]

$$P_{continuous} \geq \frac{(V_{KP}/2)^2}{R} = \frac{175^2}{3500} = 8.75 \text{ W} \quad \text{at the 1-A-transformer}$$

[fo_pdau1a, 1, en_US]

Further, the series resistor R must be designed for a fault current lasting approximately 0.5 s. This time is usually sufficient for fault clearing through backup protection.

The thermal stress of the series resistor depends on the voltage $V_{RMS,stab}$ that is present during an internal fault. It is calculated according to the following equations:

$$V_{RMS,rest} = 1.3 \cdot \sqrt[4]{V_{KP}^3 \cdot R \cdot I_{K,max,int}} = 1.3 \cdot \sqrt[4]{75^3 \cdot 375 \cdot 250} = 579.7 \text{ V} \quad \text{at the 5-A-transformer}$$

[fo_usta5a, 1, en_US]

$$V_{RMS,rest} = 1.3 \cdot \sqrt[4]{V_{KP}^3 \cdot R \cdot I_{K,max,int}} = 1.3 \cdot \sqrt[4]{350^3 \cdot 3500 \cdot 50} = 2151.6 \text{ V} \quad \text{at the 1-A-transformer}$$

[fo_usta1a, 1, en_US]

$I_{K,max,int}$ corresponds to the maximum fault current here in the case of an internal fault.
 5-A current transformer 800/5 with 40 kA primary corresponds to $I_{K,max,int} = 250$ A secondary.
 1-A current transformer 800/1 with 40 kA primary corresponds to $I_{K,max,int} = 50$ A secondary.
 This results in a temporary load for the series resistor over 0.5 s of:

$$P_{0.5s} = \frac{V_{RMS,rest}^2}{R} = \frac{579.7^2}{375} = 896 \text{ W} \quad \text{at the 5-A-transformer}$$

[fo_p055a, 1, en_US]

$$P_{0.5s} = \frac{V_{RMS,rest}^2}{R} = \frac{2151.6^2}{3500} = 1322.7 \text{ W} \quad \text{at the 1-A-transformer}$$

[fo_p051a, 1, en_US]

Observe that with the selection of a higher pickup value I_{pick} , the resistor value must be lowered and therefore the dissipation rises sharply.

The varistor (see following figure) must be sized such that it remains high impedance up to the knee-point voltage, for example:

- Approx. 100 V with 5 A transformer
- Approx. 500 V with 1 A transformer

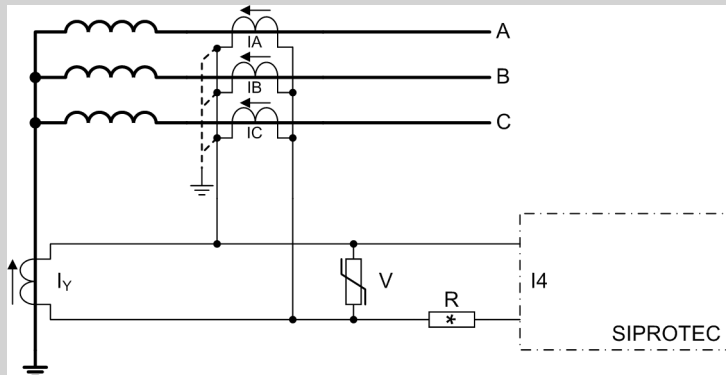

[dw_anedif, 2, en_US]

Figure 6-97 Connection Diagram of the Restricted Ground-Fault Protection According to the High-Impedance Principle

Even with unfavorable wiring, the maximum occurring voltage peaks do not exceed 2 kV for safety reasons. When for performance reasons, several varistors must be connected in parallel, give preference to types with flat characteristic curves, in order to avoid an unbalanced load. Siemens therefore recommends the following types by METROSIL:

- 600A/S1/S256 ($k = 450, \beta = 0.25$)
- 600A/S1/S1088 ($k = 900, \beta = 0.25$)

In the example, set the pickup value of the first Definite-time overcurrent protection stage (setting **Threshold**) to 0.1 A for 5-A transformers or 0.05 A for 1-A transformers. No further protection stages are needed. Delete these or switch them off. Set the **Operate delay** setting to 0 s.

If several current transformers are connected in series, for example, with use as busbar protection with several feeders, the magnetization currents of the transformers switched in parallel can no longer be neglected. In this case, add up the magnetization currents at half of the knee-point voltage (corresponds to the set **Threshold**). These magnetization currents reduce the current through the resistor R. Thus, the actual pickup value is correspondingly higher.

6.11.10 Application Example: Tank Leakage Protection

6.11.10.1 Description

Tank leakage protection records short-circuits to ground – including high-impedance ones – between a phase and the tank of a transformer. The tank is thus insulated, or at least grounded with high impedance. The tank must be connected with a line to ground. The current that flows through this line is fed to the protection device. If a short-circuit to ground occurs in a tank, a fault current (tank current) flows to substation ground via the ground connection.

The function **Overcurrent protection, 1-phase** detects the tank current. If the tank current exceeds the set **Threshold**, the function **Overcurrent protection, 1-phase** generates an operate indication. Depending on the set **Operate delay**, the transformer is tripped immediately or time-delayed on all sides.

For tank protection, a sensitive, 1-phase current measuring input is used.

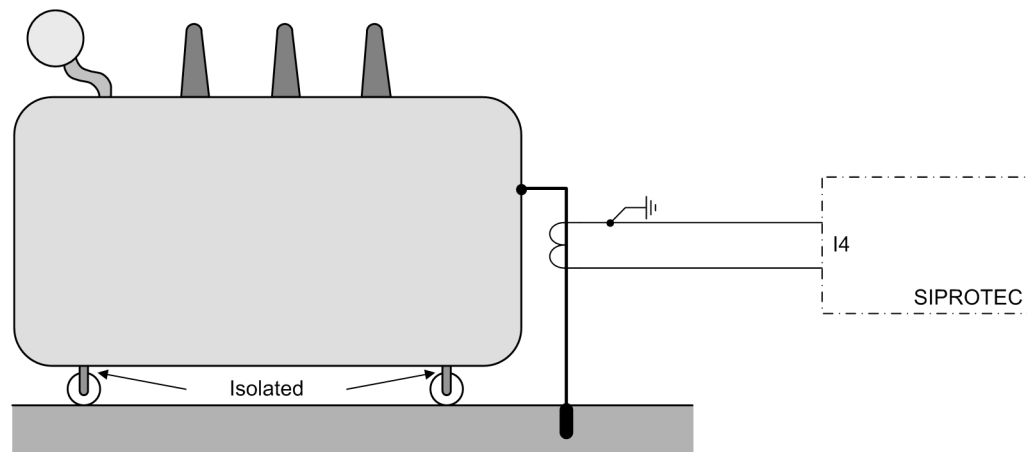

[dw_prkess, 2, en_US]

Figure 6-98 Tank-Control Principle

6.11.10.2 Application and Setting Notes

A prerequisite for the application of tank protection is the availability of a sensitive input transformer at device input I4.

If you connect **Measuring point I 1-ph** with the function group **Voltage-current 1-phase**, the function **Overcurrent protection, 1-phase** works with the 1-phase current connected to input I4.

Use only the first definite-time overcurrent protection stage of function **Overcurrent protection, 1-phase**. The **Threshold** setting is used to set the pickup value. No further protection stages are needed. Delete these or switch them off. Set the **Operate delay** setting to 0 s.

6.12 Positive-Sequence Overcurrent Protection

6.12.1 Overview of Functions

The **Positive-sequence overcurrent protection** function (ANSI 50/51):

- Detects short circuits in electric equipment
- Can be applied when the zero-sequence current or negative-sequence current should not influence the tripping, for example, on the tertiary delta winding of an auto transformer

You can find a typical application scenario in the chapter [6.12.3.2 Application and Setting Notes](#).

6.12.2 Structure of the Function

The **Positive-sequence overcurrent protection** function is used in protection function groups with 3-phase current measurement.

The function comes factory-set with 2 **Definite-time positive-sequence overcurrent protection** stages.

The following stages can be operated simultaneously within the function:

- 3 stages **Definite-time positive-sequence overcurrent protection**
- 2 stages **Inverse-time positive-sequence overcurrent protection**

Stages that are not preconfigured are shown in gray in the following figure. Apart from the tripping delay characteristic, the stages are identical in structure.

The group-indication output logic generates the following group indications of the protection function by the logical OR of the stage-selective indications:

- **Pickup**
- **Operate**

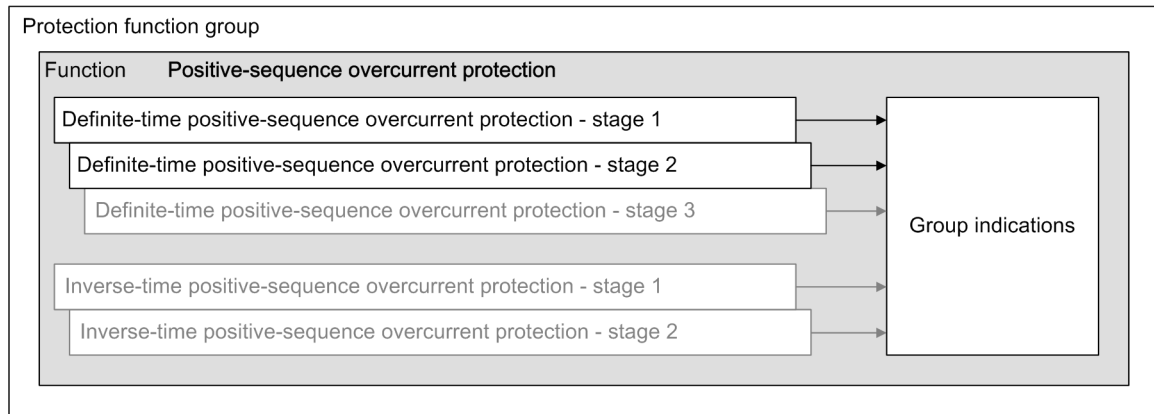

[dw_PSP_structure_1_en_US]

Figure 6-99 Structure/Embedding of the Function

If the device is equipped with an **Inrush-current detection** function, the stages can be stabilized against tripping due to transformer-inrush currents.

6.12.3 Stage with Definite-Time Characteristic Curve

6.12.3.1 Description

Logic

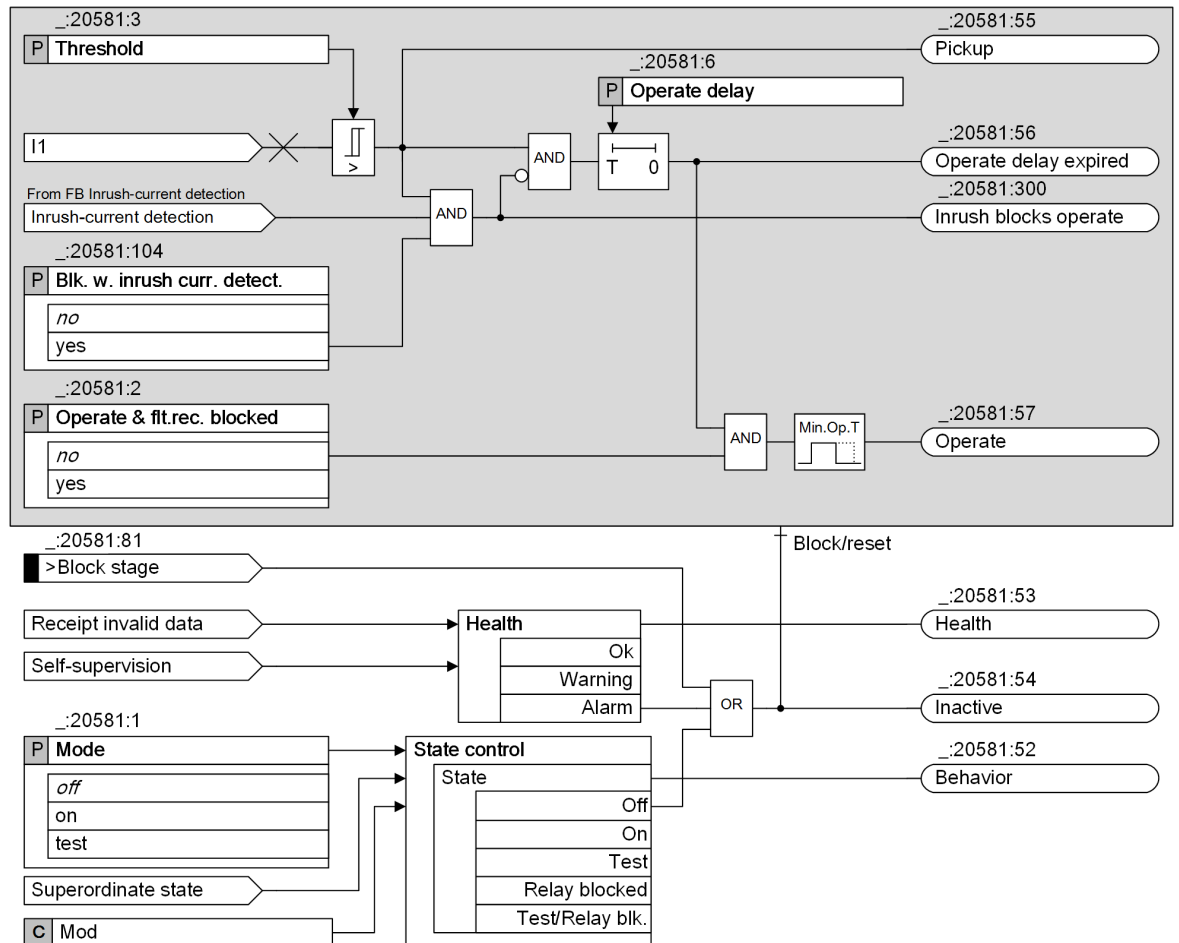

[to_PSP_definite_2_en_US]

Figure 6-100 Logic Diagram of the Stage Definite-Time Positive-Sequence Overcurrent Protection

Method of Measurement

The fundamental phasors are calculated from the 3-phase phase currents. Based on this, the positive-sequence current is calculated.

Blocking of the Stage

You can block the stage externally or internally via the binary input signal **>Block stage**. In the event of blocking, the picked up stage is reset.

Blocking of Tripping via the Device-Internal Inrush-Current Detection Function

If the device is equipped with the additional **Inrush-current detection** function, the stages can be stabilized against tripping due to transformer inrush currents.

With the **Blk. w. inrush curr. detect.** parameter, you can define whether tripping of the stage should be blocked when a threshold value is exceeded due to an inrush current. In case of a blocking, the stage picks up. The start of the time delay and tripping are however blocked. The stage signals this by way of a corresponding indication. If the blocking drops out and the threshold value of the stage is still exceeded, the tripping delay (time delay) is started. After that time, the stage operates.

6.12.3.2 Application and Setting Notes

Application Example

The **Positive-sequence overcurrent protection** function is applied to the tertiary delta winding of the auto transformer as shown in the following figure.

Short circuits on the delta winding must be detected. The stage should be as sensitive as possible but must not pick up in case of faults in the circuits connected to the low-voltage side of the auxiliary transformer. A single **Positive-sequence overcurrent protection** stage without time delay is applied and is connected with the CTs marked in the following figure. When the stage operates, both the high-voltage and low-voltage sides of the auto transformer will trip.

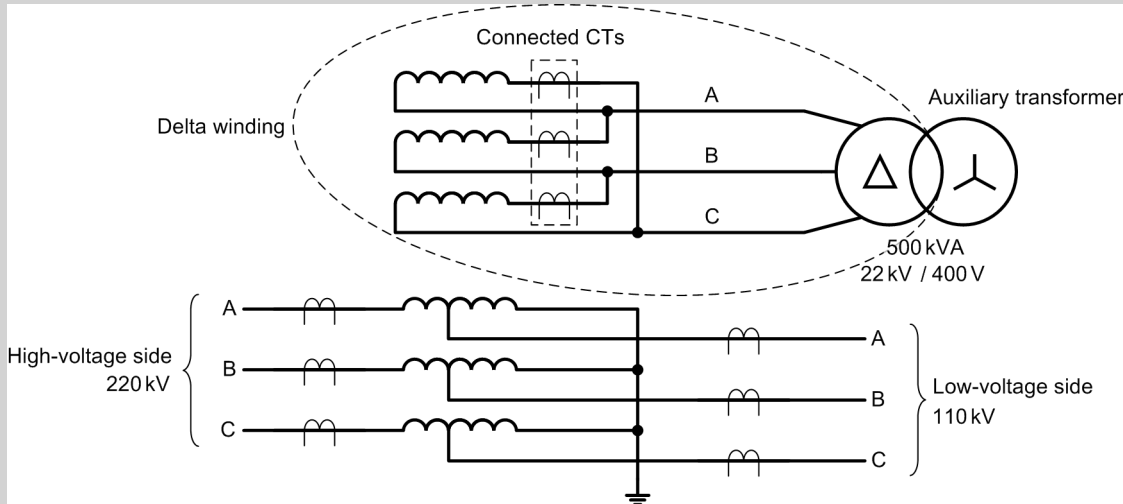

Figure 6-101 Auto Transformer with Tertiary Delta Winding

During ground faults on the high-voltage side (220 kV) or low-voltage side (110 kV) of the auto transformer, large currents circulate in the delta winding. This circulating current is a pure zero-sequence current. The protection function applied to the delta winding must not respond to this zero-sequence current. For this purpose, the **Positive-sequence overcurrent protection** function is applied.

In this application example, there is no circuit breaker on the delta winding, and the load on the delta winding is directly connected via the 500-kVA auxiliary transformer.

The application data in this application example is as follows:

Application Data	Value
Rated apparent power of the auto transformer	300 MVA
Rated apparent power of the auxiliary transformer ($S_{rated, aux}$)	500 kVA
Short-circuit voltage of the auxiliary transformer (u_{k-aux})	12 %
Rated apparent power of the delta winding	30 MVA
Rated voltage of the delta winding ($V_{rated, delta}$)	22 kV
Connected load on the delta winding	500 kVA
Current transformer ratio in the delta winding ($Ratio_i$)	800 A/1 A

Generally, for the delta winding, the short-circuit current is substantially larger than the rated current, and the expected maximum load current is substantially smaller than the rated current. Therefore, you only need to consider the short-circuit current when determining the pickup threshold of the **Positive-sequence overcurrent protection** function.

As there is no circuit breaker between the delta winding and the connected auxiliary transformer, the pickup threshold of the **Positive-sequence overcurrent protection** function is graded against the maximum short-circuit current due to a short circuit on the low-voltage (400 V) side of the auxiliary transformer. The

maximum fault current for a fault on the low-voltage side of the auxiliary transformer must therefore be determined to establish the pickup threshold.

To determine the pickup threshold (setting of the **Threshold** parameter) of the stage, the following calculations must be carried out:

- Maximum short-circuit current ($I_{SC, \max}$) on the high-voltage side of the auxiliary transformer due to a short circuit on the low-voltage (400 V) side

$$I_{SC, \max} = \frac{S_{\text{rated, aux}} \cdot 100}{V_{\text{rated, delta}} \cdot \sqrt{3} \cdot u_{k\text{-aux}}} = \frac{500 \text{ kVA} \cdot 100}{22 \text{ kV} \cdot \sqrt{3} \cdot 12 \%} = 109 \text{ A}$$

[fo_max_fault_current_1_en_US]

- Primary-current pickup threshold ($I_{1, \text{stage1, prim}}$)
In this example, a safety margin (k_s) of 200 % is applied.

$$I_{1, \text{stage1, prim}} = \frac{I_{SC, \max} \cdot k_s}{\sqrt{3}} = \frac{109 \text{ A} \cdot 2}{\sqrt{3}} = 126 \text{ A}$$

[fo_prim_threshold_1_en_US]

- Secondary-current pickup threshold ($I_{1, \text{stage1, sec}}$), which is the setting of the **Threshold** parameter

$$I_{1, \text{stage1, sec}} = I_{1, \text{stage1, prim}} \cdot \frac{1}{\text{Ratio}_1} = 126 \text{ A} \cdot \frac{1 \text{ A}}{800 \text{ A}} = 0.16 \text{ A}$$

[fo_sec_threshold_1_en_US]

Parameter: **Threshold, Operate delay**

- Default setting (`_:20581:3`) **Threshold** = **1.200 A** (for the 1st stage)
- Default setting (`_:20581:6`) **Operate delay** = **0.50 s** (for the 1st stage)

Set the **Threshold** and **Operate delay** parameters for the specific application.

As time coordination with other protection functions is not required, you can set the **Operate delay** parameter to a rather small value of **0.03 s**.

Parameter: **Blk. w. inrush curr. detect.**

- Default setting (`_:20581:104`) **Blk. w. inrush curr. detect.** = **no**

With the **Blk. w. inrush curr. detect.** parameter, you stabilize the stage against tripping due to transformer-inrush currents. If transformers are parts of the protection zones, set this parameter to **yes**.

When the pickup threshold is set to 2 times the maximum short-circuit current, the threshold value should be above the current flowing during an inrush to the auxiliary transformer. Consequently, the setting of the **Blk. w. inrush curr. detect.** can remain **no**. For more sensitive pickup thresholds, the **Blk. w. inrush curr. detect.** should be set to **yes**.

Parameter: **Operate & flt.rec. blocked**

- Default setting (`_:20581:2`) **Operate & flt.rec. blocked** = **no**

With the **Operate & flt.rec. blocked** parameter, you block the operate indication, the fault recording, and the fault log.

6.12.3.3 Settings

Addr.	Parameter	C	Setting Options	Default Setting
Definite-T 1				
_:20581:1	Definite-T 1:Mode		<ul style="list-style-type: none"> • off • on • test 	off
_:20581:2	Definite-T 1:Operate & flt.rec. blocked		<ul style="list-style-type: none"> • no • yes 	no
_:20581:3	Definite-T 1:Threshold	1 A @ 100 Irated	0.030 A to 35.000 A	1.200 A
		5 A @ 100 Irated	0.15 A to 175.00 A	6.00 A
		1 A @ 50 Irated	0.030 A to 35.000 A	1.200 A
		5 A @ 50 Irated	0.15 A to 175.00 A	6.00 A
		1 A @ 1.6 Irated	0.001 A to 1.600 A	1.200 A
		5 A @ 1.6 Irated	0.005 A to 8.000 A	6.000 A
_:20581:104	Definite-T 1:Blk. w. inrush curr. detect.		<ul style="list-style-type: none"> • no • yes 	no
_:20581:6	Definite-T 1:Operate delay		0.00 s to 60.00 s	0.50 s
Definite-T 2				
_:20582:1	Definite-T 2:Mode		<ul style="list-style-type: none"> • off • on • test 	off
_:20582:2	Definite-T 2:Operate & flt.rec. blocked		<ul style="list-style-type: none"> • no • yes 	no
_:20582:3	Definite-T 2:Threshold	1 A @ 100 Irated	0.030 A to 35.000 A	1.500 A
		5 A @ 100 Irated	0.15 A to 175.00 A	7.50 A
		1 A @ 50 Irated	0.030 A to 35.000 A	1.500 A
		5 A @ 50 Irated	0.15 A to 175.00 A	7.50 A
		1 A @ 1.6 Irated	0.001 A to 1.600 A	1.500 A
		5 A @ 1.6 Irated	0.005 A to 8.000 A	7.500 A
_:20582:104	Definite-T 2:Blk. w. inrush curr. detect.		<ul style="list-style-type: none"> • no • yes 	no
_:20582:6	Definite-T 2:Operate delay		0.00 s to 60.00 s	0.50 s

6.12.3.4 Information List

No.	Information	Data Class (Type)	Type
Group indicat.			
_:4501:55	Group indicat.:Pickup	ACD	O
_:4501:57	Group indicat.:Operate	ACT	O
_:4501:52	Group indicat.:Behavior	ENS	O
_:4501:53	Group indicat.:Health	ENS	O
Definite-T 1			
_:20581:81	Definite-T 1:>Block stage	SPS	I
_:20581:51	Definite-T 1:Mode (controllable)	ENC	C
_:20581:52	Definite-T 1:Behavior	ENS	O

No.	Information	Data Class (Type)	Type
_:20581:53	Definite-T 1:Health	ENS	O
_:20581:54	Definite-T 1:Inactive	SPS	O
_:20581:56	Definite-T 1:Operate delay expired	ACT	O
_:20581:300	Definite-T 1:Inrush blocks operate	ACT	O
_:20581:55	Definite-T 1:Pickup	ACD	O
_:20581:57	Definite-T 1:Operate	ACT	O
<i>Definite-T 2</i>			
_:20582:81	Definite-T 2:>Block stage	SPS	I
_:20582:51	Definite-T 2:Mode (controllable)	ENC	C
_:20582:52	Definite-T 2:Behavior	ENS	O
_:20582:53	Definite-T 2:Health	ENS	O
_:20582:54	Definite-T 2:Inactive	SPS	O
_:20582:56	Definite-T 2:Operate delay expired	ACT	O
_:20582:300	Definite-T 2:Inrush blocks operate	ACT	O
_:20582:55	Definite-T 2:Pickup	ACD	O
_:20582:57	Definite-T 2:Operate	ACT	O

6.12.4 Stage with Inverse-Time Characteristic Curve

6.12.4.1 Description

Logic

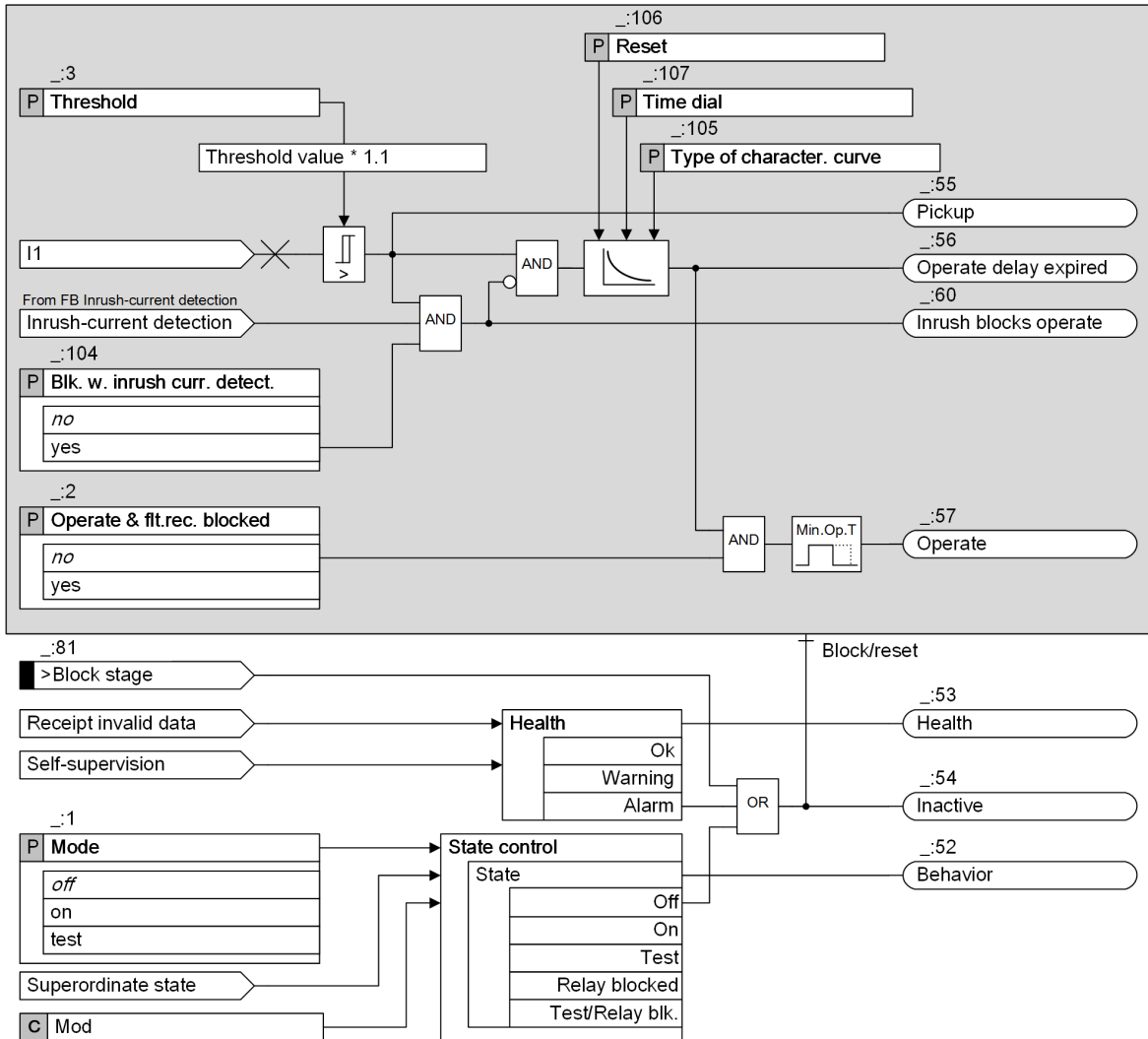

[!o_PSP_Inverse_2_en_US]

Figure 6-102 Logic Diagram of the Inverse-Time Positive-Sequence Overcurrent Protection

Method of Measurement

The fundamental phasors are calculated from the 3-phase phase currents. Based on this, the positive-sequence current is calculated.

Pickup and Dropout Behaviors of the Inverse-Time Characteristic Curve According to IEC and ANSI

When the input variable exceeds the threshold value by a factor of 1.1, the inverse-time characteristic curve is processed. An integrating method of measurement summarizes the weighted time. The weighted time results from the characteristic curve. For this, the time that is associated with the present current value is determined from the characteristic curve. Once the weighted time exceeds the value 1, the stage operates.

When the measured value falls below the pickup value by a factor of 1.045 (0.95 · 1.1 · threshold value), the dropout is started. The pickup will be indicated as clearing. You can influence the dropout behavior via setting parameters. You can select between instantaneous dropout (totalized time is deleted) or dropout according

to the characteristic curve (reduction of totalized time depending on the characteristic curve). The dropout according to characteristic curve (disk emulation) is the same as turning back a rotor disk. The weighted reduction of the time is initiated from 0.9 of the set threshold value.

The characteristic curve and associated formulas are shown in the Technical Data.

Blocking of the Stage

You can block the stage externally or internally via the binary input signal **>Block stage**. In the event of blocking, the picked up stage is reset.

Blocking of the Tripping by Device-Internal Inrush-Current Detection

The **Blk. w. inrush curr. detect.** parameter allows you to define whether the operate indication of the stage should be blocked when a threshold value is exceeded due to an inrush current. In case of a blocking and fulfilled pickup conditions, the stage picks up. The start of the time delay and the operate indication are blocked. The function indicates this through a corresponding indication. If the blocking drops out and the pickup conditions are still met, the time delay is started. After that time, the stage operates.

6.12.4.2 Application and Setting Notes

Parameter: **Type of character. curve**

- Default setting (**_:105**) **Type of character. curve** = *IEC normal inverse*

The device offers all the usual inverse-time characteristic curves according to IEC and ANSI. Select the **Type of character. curve** required for your specific application. For more information about the parameter **Type of character. curve**, refer to chapter [14.16.2 Stage with Inverse-Time Characteristic Curve](#).

Parameter: **Threshold**

- Default setting (**_:3**) **Threshold** = *1.200 A*

Set the **Threshold** and **Type of character. curve** parameters for the specific application.

Note that a safety margin is set between the pickup value and the threshold value. The stage only picks up at approx. 10 % above the **Threshold**.

Parameter: **Time dial**

- Default setting (**_:107**) **Time dial** = *1.00*

With the **Time dial** parameter, you displace the characteristic curve in the time direction.

The set value for the **Time dial** parameter is derived from the time-grading schedule that has been prepared for the electrical power system.

Where no time grading and therefore no displacement of the characteristic curve is required, leave the parameter **Time dial** at *1.00* (default setting).

Parameter: **Reset**

- Default setting (**_:106**) **Reset** = *disk emulation*

With the **Reset** parameter, you define whether the stage drops out according to the dropout characteristic curve (in accordance with the behavior of a disk emulation = rotor disk) or instantaneously.

Parameter Value	Description
<i>disk emulation</i>	Select this setting if the device is coordinated with electromechanical devices or other devices which perform a dropout after a disk emulation.
<i>instantaneous</i>	Select this setting if the dropout is not to be performed after disk emulation and an instantaneous dropout is desired instead.

Parameter: **Blk. w. inrush curr. detect.**

- Default setting (**_:104**) **Blk. w. inrush curr. detect.** = *no*

With the **Blk. w. inrush curr. detect.** parameter, you stabilize the stage against tripping due to transformer-inrush currents. If transformers are parts of the protection zones, set this parameter to **yes**.

6.12.4.3 Settings

Addr.	Parameter	C	Setting Options	Default Setting
Inverse-T #				
_:1	Inverse-T #:Mode		<ul style="list-style-type: none"> off on test 	off
_:2	Inverse-T #:Operate & flt.rec. blocked		<ul style="list-style-type: none"> no yes 	no
_:3	Inverse-T #:Threshold	1 A @ 100 Irated	0.030 A to 35.000 A	1.200 A
		5 A @ 100 Irated	0.15 A to 175.00 A	6.00 A
		1 A @ 50 Irated	0.030 A to 35.000 A	1.200 A
		5 A @ 50 Irated	0.15 A to 175.00 A	6.00 A
		1 A @ 1.6 Irated	0.001 A to 1.600 A	1.200 A
		5 A @ 1.6 Irated	0.005 A to 8.000 A	6.000 A
_:104	Inverse-T #:Blk. w. inrush curr. detect.		<ul style="list-style-type: none"> no yes 	no
_:105	Inverse-T #:Type of character. curve		<ul style="list-style-type: none"> ANSI long-time inv. ANSI short-time inv. ANSI extremely inv. ANSI very inverse ANSI normal inverse ANSI moderately inv. ANSI definite inverse IEC normal inverse IEC very inverse IEC extremely inv. IEC long-time inverse 	IEC normal inverse
_:106	Inverse-T #:Reset		<ul style="list-style-type: none"> instantaneous disk emulation 	disk emulation
_:107	Inverse-T #:Time dial		0.05 to 15.00	1.00

6.12.4.4 Information List

No.	Information	Data Class (Type)	Type
Inverse-T #			
_:81	Inverse-T #:>Block stage	SPS	I
_:52	Inverse-T #:Behavior	ENS	O
_:53	Inverse-T #:Health	ENS	O
_:54	Inverse-T #:Inactive	SPS	O
_:56	Inverse-T #:Operate delay expired	ACT	O
_:60	Inverse-T #:Inrush blocks operate	ACT	O
_:59	Inverse-T #:Disk emulation running	SPS	O

No.	Information	Data Class (Type)	Type
_:55	Inverse-T #:Pickup	ACD	O
_:57	Inverse-T #:Operate	ACT	O

6.13 Non-Directional Intermittent Ground-Fault Protection

6.13.1 Overview of Functions

A typical characteristic of intermittent ground faults is that they often extinguish automatically and strike again after some time. The fault duration can last between a few milliseconds and many seconds. Thus, such faults are not detected at all or not selectively by the ordinary overcurrent protection. If pulse durations are extremely short, not all protection devices in a short-circuit path can pick up. Thus, selective tripping is not ensured.

Due to the time delay of the overcurrent protection function, such faults are too short to initiate switching off the faulted cable. The short-circuit protection can clear such ground faults selectively only if the ground faults have become permanent.

But such intermittent ground faults already bear the risk of damaging the equipment thermally. This is why SIPROTEC 5 devices feature a protection function that is able to detect such intermittent ground faults and accumulates their duration. If the sum reaches a configurable value within a certain time, the limit of the thermal rating has been reached. If intermittent ground faults are distributed over a long period or if the ground fault disappears and does not restrike after some time, the equipment under load is expected to cool down. Tripping is not necessary in this case.

The function **Non-directional intermittent ground-fault protection** is used to protect against intermittent ground faults which occur, for example, in cables due to poor insulation or water ingress in cable joints.

6.13.2 Structure of the Function

The function **Non-directional intermittent ground-fault protection** can be used in protection function groups with current measurement. The function comes factory-set with 1 stage, and a maximum of 2 stages can be operated simultaneously. The non-preconfigured stages are shown in gray in the following figure.

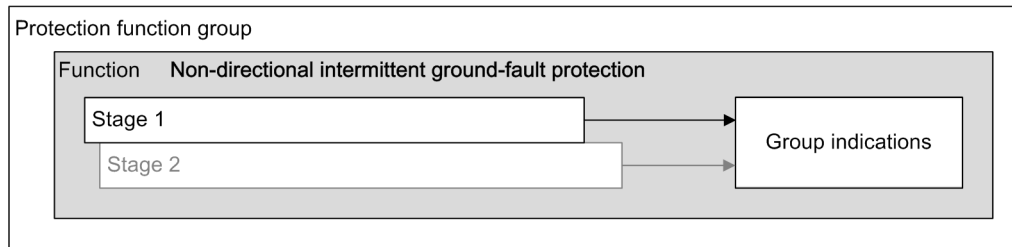

[dsw_int_GFP_1_en_US]

Figure 6-103 Structure/Embedding of the Function

6.13.3 Stage Description

Logic

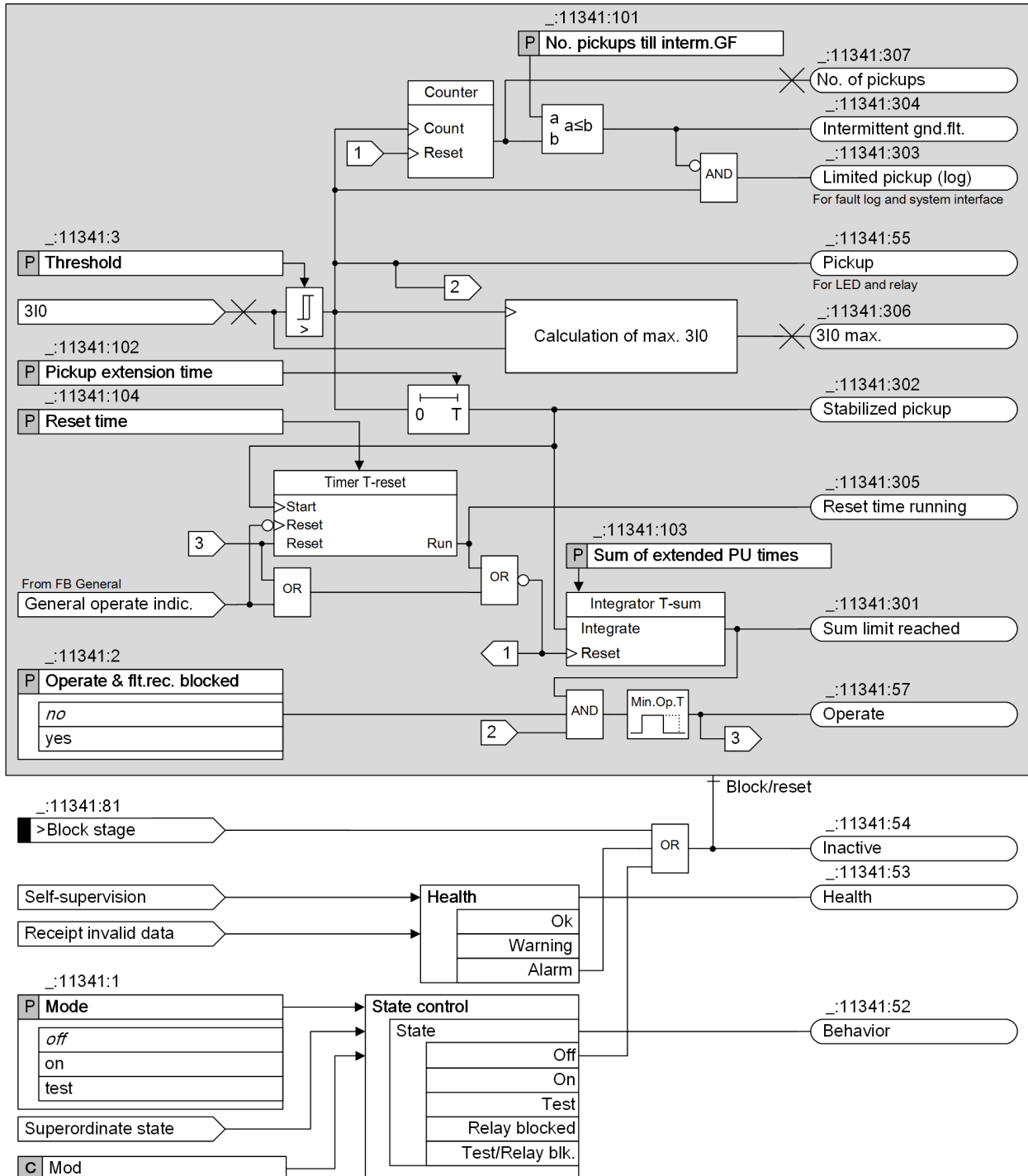

[to: Intron, 2, en, US]

Figure 6-104 Logic of the Non-Directional Intermittent Ground-Fault Protection

Measured Value 3I0

The intermittent ground-fault current 3I0 can either be measured via the standard ground-current input IN or via the sensitive ground-current input I_{NS} . It can also be calculated from the sum of the 3-phase currents. The current value and its setting range depend on the parameter **Connection type** of the measuring point I-3ph.

Table 6-9 Threshold Setting Range with Different Connection Types

Connection Type of the Measuring Point I-3ph	Current Threshold 3I0/IN	CT Terminal Type	Setting Range Threshold Value (Secondary) ¹⁸
3-phase	Calculated 3I0 ¹⁹	4 x Protection	0.030 A to 35.000 A
		3 x Protection, 1 x sensitive	0.030 A to 35.000 A
		4 x Measurement	0.001 A to 1.600 A
3-phase + IN 3-phase + IN-separate	Measured IN ²⁰	4 x Protection	0.030 A to 35.000 A
		4 x Measurement	0.001 A to 1.600 A
	Measured IN and calculated 3I0 when IN > 1.6 A	3 x Protection, 1 x sensitive	0.001 A to 35.000 A

Method of Measurement

The stage calculates the RMS value of 3I0 since this value takes into account the higher-order harmonics components and the direct component (DC). Both components contribute to the thermal load.

Maximum 3I0 of the Fault

The stage records the maximum RMS value of 3I0 during the intermittent ground fault. The statistical value *3I0 max.* is a percentage value calculated through dividing the primary maximum RMS value by the rated current value of the protected object. With the coming operate signal, this value is logged via the information *3I0 max..*

Pickup and Intermittent Ground-Fault Indication

When 3I0 exceeds the threshold value, the pickup signals *Pickup* and *Limited pickup (log)* are issued. The stage generates the signal *Stabilized pickup* by extending the *Pickup* for a defined time (parameter **Pickup extension time**).

The stage counts the signals *Pickup*. If the counted number reaches the configured **No. pickups till interm.GF**, the signal *Intermittent gnd.flt.* is issued. The signal *Limited pickup (log)* is not issued anymore after the issue of the signal *Intermittent gnd.flt..*

¹⁸ These values apply for a secondary rated current of 1 A. The values need to be multiplied by 5 when the secondary rated current is 5 A.

¹⁹ If the connection type is without IN, such as 3-phase, the current threshold value is a calculated 3I0 value.

²⁰ If the connection type is with IN, such as 3-phase + IN, the current threshold value is a measured IN value.

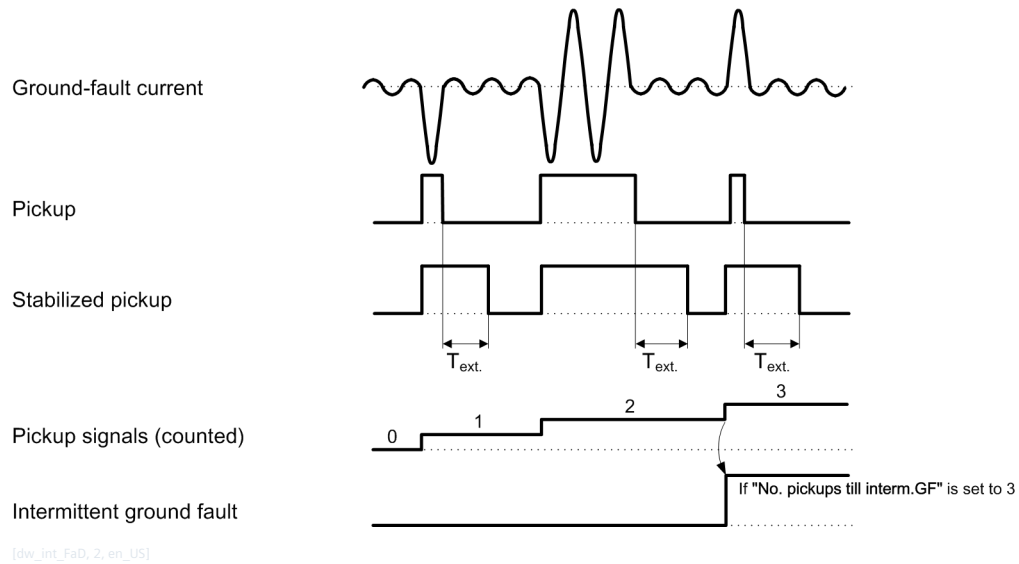

Figure 6-105 Fault Detection of the Intermittent Ground-Fault Protection

$T_{ext.}$ Defined time for extending the signal *Pickup*

Number of Pickups

The stage counts the number of signals *Pickup* during the intermittent ground fault. With the operate of the stage this number is logged via the information *No. of pickups*.

Accumulation of the Intermittent Ground-Fault Current and Issuing the Operate Signal

An intermittent ground fault can result in thermal stress on the protected equipment. The magnitude and the duration of the ground-fault current are decisive for the thermal stress. In order to calculate the thermal stress, the stage sums up the duration of the stabilized pickups with a sum of times. If the integration value reaches the predefined **Sum of extended PU times**, the limit of the thermal load is reached. The stage issues the signal *Sum limit reached* and operates when the signal *Pickup* is active.

Reset Timer for the Definition of the Interval between Independent Ground Faults

If there is a large interval between independent ground faults or if ground fault extinguishes and does not restrike again within a larger time, the stressed equipment can cool down. In this case, an operation is not necessary. The interval between ground faults is monitored with the reset timer. If a ground fault occurs, the **Timer T-reset** with its setting **Reset time** is launched simultaneously with **Integrator T-sum**. Unlike the integrator, each new ground fault restarts the reset timer with its initial value. If **Timer T-reset** expires, that is, no new ground fault was detected during that period, all memories and the stage logics are reset. **Timer T-reset** thus determines the time during which the next ground fault must occur to be processed yet as intermittent ground fault in connection with the previous fault. A ground fault that occurs later is considered as a new fault event.

Reset Conditions

Under one of the following 2 conditions, **Timer T-reset** is reset.

- The Intermittent ground-fault protection stage operates.
- The general operate indication is going.

Under one of the following conditions, **Integrator T-sum** and **Counter** are reset and the whole stage is reset and returns to its idle state.

- **Timer T-reset** expires without an operate signal of this stage or another function was issued.
- The operate signal of the intermittent ground-fault protection stage is going.
- The general operate indication is going without the operate signal of the intermittent ground-fault protection stage issued.

Fault Log and Fault Recording

You can select between the ground-fault log without fault recording or the normal fault log with fault recording. If you set the parameter **Operate & flt.rec. blocked** to **yes**, the operate of the stage and fault recording are blocked and the information automatically appears in the ground-fault log. Otherwise, the operate and fault recording are not blocked and the information appears in the normal fault log.

Start & Stop of Fault Recording, Fault Logging, and General Pickup

The signal *stabilized pickup* initiates the fault recording, fault logging, and the general pickup of the function group. The fault recording starts according to the pre-trigger time before the signal *stabilized pickup* rises.

With the reset condition of this stage, the fault recording, fault logging, and the general pickup of the function group are terminated.

Influence on Other Functions to Avoid a Burst of Signals

Intermittent ground faults may cause other functions, based on overcurrent measurement, to pick up, which may result in a burst of signals. In order to avoid an overflow of the fault log, a special mechanism is applied to the signals of these functions after detection of an intermittent ground fault (signal *Intermittent gnd. flt.*).

The special mechanism is applied for the following listed functions and other functions are not influenced:

- Overcurrent protection, phases
- Overcurrent protection, ground
- Directional overcurrent protection, phases
- Directional overcurrent protection, ground
- Overcurrent protection, 1-phase
- Negative-sequence protection with definite-time characteristic curve
- Directional negative-sequence protection with definite-time delay
- Directional overcurrent-protection stage with cos phi or sin phi measurement
- Directional overcurrent-protection stage with 3I0-phi (V,I) measurement
- Sensitive ground-current protection with 3I0

If a function picks up, normally its output signals are sent directly to the information targets, for example, the pickup signal is written to the fault log. To avoid overflow of logs due to intermittent ground faults, a special log buffer mechanism is used. If one of the preceding functions or stages picks up after an intermittent ground fault has been detected (signal *Intermittent gnd. flt.* has been issued), its output signals are processed as shown in the following 2 tables.

Table 6-10 Processing of the Signal Status Changes

Processing of Signal Status Changes	Description
Special buffering mechanism	The status changes of signals are written to a special buffer. This buffer can store the latest change for each signal. With the pickup signal as example, if one of the preceding protection functions or stages picks up during an active signal <i>Intermittent gnd. flt.</i> , the pickup signal is not written in the fault log anymore unless one of the preceding functions operates. After the operation, the buffered signals are written to the information target with the original time stamp. This measure ensures that a pickup signal, although delayed, is always signaled in association with each operate command.
Discard	The signal status changes are discarded.
Pass through	The signal is forwarded to the information target without restriction. Special buffering does not apply for specific information targets as protection measure, for example, reverse interlocking, need these signals for proper operation.

Table 6-11 Information Target with Different Processing of Signal Status Changes

Information Target	Processing of Signal Status Changes
Processing of Signal Status Changes Operational log Fault log Ground-fault log User-defined log	Special buffering mechanism
Communication interface IEC 61850-8-1 Client/Server IEC 60870-5-103/104 DNP V3.0	Special buffering mechanism
Automatic reclosing function	Discard
Circuit-breaker failure protection	Discard
Group indications	Discard ⁽¹⁾
IEC 61850-8-1 GOOSE	Pass through
CFC	Pass through
LEDs	Pass through
Binary output	Pass through
Fault recorder	Pass through

(1) Note for reverse-interlocking applications: To ensure that the interlocking signal is not discarded during an intermittent ground fault, Siemens recommends using the individual pickup signals of the function stages instead of the group indications for reverse-interlocking applications in combination with the intermittent ground-fault protection function.

6.13.4 Application and Setting Notes

No Start of the Automatic Reclosing Function

Automatic reclosing is not an effective measure against intermittent ground faults as the protection function only operates after repeated detection of a fault or after the integration value reaches the predefined **Sum of**

extended PU times. Besides this, its basic design is to prevent thermal overload. For these reasons, the intermittent ground-fault protection function is not intended to start the automatic reclosing function.

Rooting of Pickup Signals

The signal *Pickup* is supposed to be routed to LED and relay. The signal *Limited pickup (log)* is only reported to the fault log and communication interface before the signal *Intermittent gnd.flt.* is issued. This scheme prevents a burst of messages.



NOTE

To avoid a burst of messages, do not route the signal *Pickup* to the operational log and fault log.

Parameter: **Threshold**

- Default setting (`_:11341:3`) **Threshold** = 1.00 A

With the parameter **Threshold**, you set the threshold value of the ground current 3I0, measured as RMS value.

A rather sensitive setting is possible to respond also to short ground faults since the pickup time shortens as the ground-fault current increases.

Parameter: **No. pickups till interm.GF**

- Default setting (`_:11341:101`) **No. pickups till interm.GF** = 3

With the parameter **No. pickups till interm.GF**, you set the number of counted *Pickup* signals after which the ground fault is considered as intermittent.

Parameter: **Pickup extension time**

- Default setting (`_:11341:102`) **Pickup extension time** = 0.10 s

You can get a stabilized pickup signal with the parameter **Pickup extension time**. This stabilization is especially important for the coordination with existing static or electromechanical overcurrent protections.

Parameter: **Sum of extended PU times**

- Default setting (`_:11341:103`) **Sum of extended PU times** = 20 s

With the parameter **Sum of extended PU times**, you set the threshold value for the integrator. If the integration reaches **Sum of extended PU times**, the stage operates if the pickup state is present.

This **Sum of extended PU times** represents one of the 4 selectivity criteria (pickup threshold, pickup extension time, reset time, and integrator threshold value) for coordination of the relays on adjacent feeders. It is comparable to the time grading of the overcurrent protection. The protection in the radial system which is closest to the intermittent fault and picks up, has the shortest summation time **Sum of extended PU times**.

Parameter: **Reset time**

- Default setting (`_:11341:104`) **Reset time** = 300 s

With the parameter **Reset time**, you can define the maximum interval between 2 adjacent ground faults. If the interval is larger than the **Reset time**, the counter and integrator are reset.

The parameter **Reset time** must be much higher than the operate value of the **Sum of extended PU times**.



NOTE

Siemens recommends setting the parameter **Reset time** to a value not lower than 40 ms. A too low value will lead to a risk that the intermittent ground-fault protection function never picks up.

Parameter: Operate & flt.rec. blocked

- Default setting (`_:11341:2`) **Operate & flt.rec. blocked** = no

You can block the operate indication, the fault recording, and the fault log with the parameter **Operate & flt.rec. blocked**. In this case, a ground-fault log is created instead of the fault log.

EXAMPLE

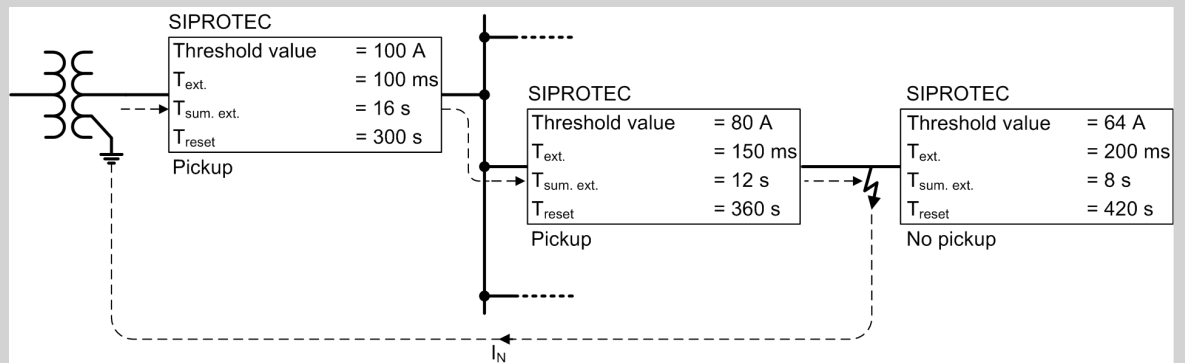

[TIEsht, 1, en, US]

Figure 6-106 Example of Selectivity Criteria of the Intermittent Ground-Fault Protection

6.13.5 Settings

Addr.	Parameter	C	Setting Options	Default Setting
Stage 1				
_:11341:1	Stage 1:Mode		<ul style="list-style-type: none"> • off • on • test 	off
_:11341:2	Stage 1:Operate & flt.rec. blocked		<ul style="list-style-type: none"> • no • yes 	no
_:11341:3	Stage 1:Threshold	1 A @ 100 Irated	0.030 A to 35.000 A	1.000 A
		5 A @ 100 Irated	0.15 A to 175.00 A	5.00 A
		1 A @ 50 Irated	0.030 A to 35.000 A	1.000 A
		5 A @ 50 Irated	0.15 A to 175.00 A	5.00 A
		1 A @ 1.6 Irated	0.001 A to 1.600 A	1.000 A
		5 A @ 1.6 Irated	0.005 A to 8.000 A	5.000 A
_:11341:101	Stage 1:No. pickups till interm.GF		2 to 10	3
_:11341:102	Stage 1:Pickup extension time		0.00 s to 10.00 s	0.10 s
_:11341:103	Stage 1:Sum of extended PU times		0.00 s to 180.00 s	20.00 s
_:11341:104	Stage 1:Reset time		0.00 s to 600.00 s	300.00 s

6.13.6 Information List

No.	Information	Data Class (Type)	Type
Group indicat.			
_:4501:55	Group indicat.:Pickup	ACD	O
_:4501:57	Group indicat.:Operate	ACT	O
_:4501:52	Group indicat.:Behavior	ENS	O
_:4501:53	Group indicat.:Health	ENS	O
Stage 1			
_:11341:81	Stage 1:>Block stage	SPS	I
_:11341:51	Stage 1:Mode (controllable)	ENC	C
_:11341:54	Stage 1:Inactive	SPS	O
_:11341:52	Stage 1:Behavior	ENS	O
_:11341:53	Stage 1:Health	ENS	O
_:11341:55	Stage 1:Pickup	ACD	O
_:11341:302	Stage 1:Stabilized pickup	ACD	O
_:11341:303	Stage 1:Limited pickup (log)	ACD	O
_:11341:304	Stage 1:Intermittent gnd.flt.	SPS	O
_:11341:301	Stage 1:Sum limit reached	SPS	O
_:11341:305	Stage 1:Reset time running	SPS	O
_:11341:57	Stage 1:Operate	ACT	O
_:11341:306	Stage 1:3I0 max.	MV	O
_:11341:307	Stage 1:No. of pickups	MV	O

6.14 Directional Intermittent Ground-Fault Protection

6.14.1 Overview of Functions

The function **Directional intermittent ground-fault protection**:

- Detects the intermittent ground faults in grounded, compensated, or isolated cable systems selectively
- Can be operated in 2 different modes:
 - Operate only by counting directional ground-current pulses
 - Operate by integration of the fault current in combination with a directional criterion by counting directional ground-current pulses

The intermittent ground faults in cable systems are frequently caused by weak insulation or water ingress in cable joints. The ground faults are characterized by the following properties:

- Intermittent ground faults show very short high ground-current pulses (up to several hundred amperes) with a duration of less than 1 ms.
- Intermittent ground faults are self-extinguishing and reignite within one half period up to several periods, depending on the power-system conditions and the fault type.
- Intermittent ground faults can persist over longer periods (several seconds to minutes) and develop to static ground faults.

6.14.2 Structure of the Function

The function **Directional intermittent ground-fault protection** can be used in protection function groups with current and voltage measurement. The function is preconfigured by the manufacturer with 1 stage, and a maximum of 2 stages can be operated simultaneously.

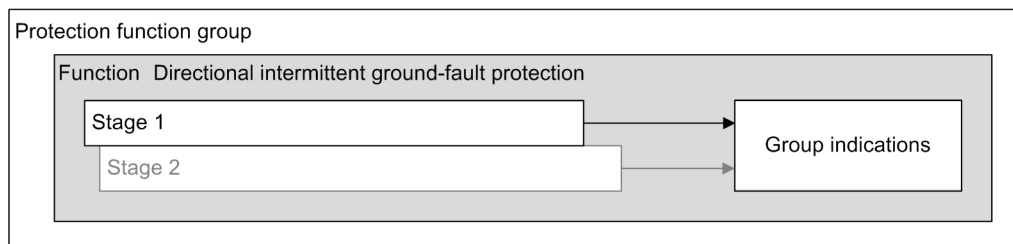

[dw_structure_dirl_GFP, 1, en_US]

Figure 6-107 Structure/Embedding of the Function

6.14.3 Stage Description

Overview

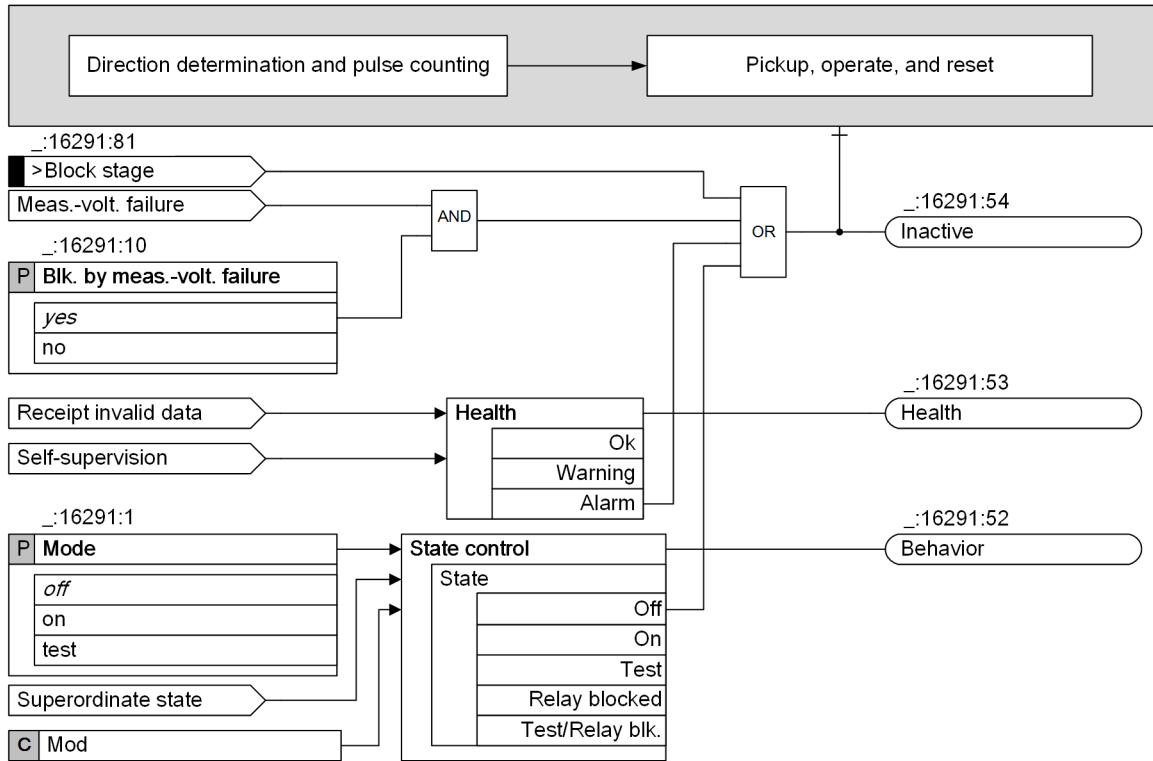

[lg_overview_2_en_US]

Figure 6-108 Logic of the Directional Intermittent Ground-Fault Protection

Blocking of the Stage with Measuring-Voltage Failure

The stage can be blocked if a measuring-voltage failure occurs. In the event of blocking, the picked up stage will be reset. The following blocking options are available for the stage:

- From an internal source upon pickup of the **Measuring-voltage failure detection** function
- From an external source via the binary input signal *>Open* of the function block **Volt.-transf. c. b.**, which links in the tripping of the voltage-transformer circuit breaker

The **Blk. by meas.-volt. failure** parameter can be set so that the measuring-voltage failure detection blocks the stage or does not block it.

Logic for Direction Determination and Pulse Counting

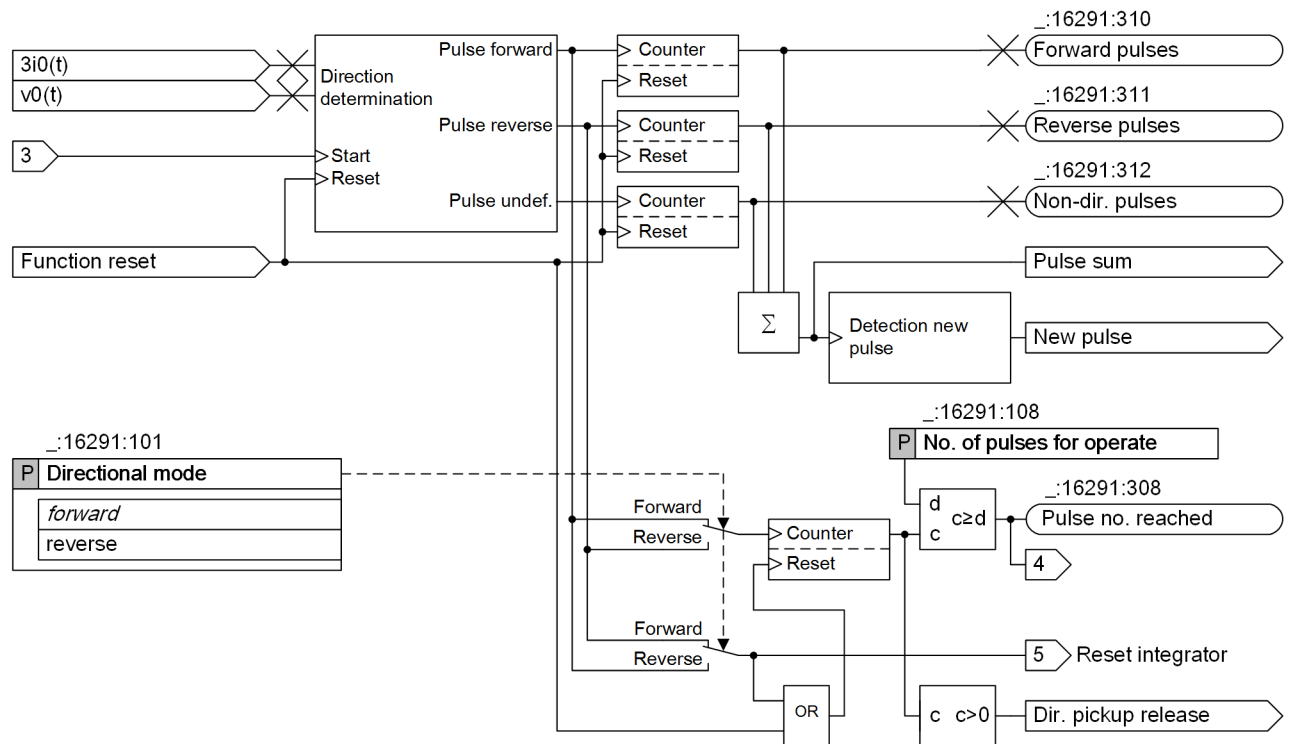

[to_int_dir1.3.en_US]

Figure 6-109 Logic Diagram of Direction Determination and Pulse Counting

(1) The input signal 3 is from [Figure 6-110](#).

Measurement Values for Direction Determination

The function **Directional intermittent ground-fault protection** determines the direction of the ground-current pulse by comparing the maximum $3I_0$ and the VN changing trend of the ground-current pulse.

The zero-sequence voltage $v_0(t)$ can either be measured via the voltage input VN or can be calculated from the sum of 3 phase-to-ground voltages. The measured value depends on the parameter **Connection type** of the measuring point V-3ph.

The intermittent ground-fault current $3I_0(t)$ can either be measured via the ground-current input IN or via the sensitive ground-current input I_{NS} . It can also be calculated from the sum of the 3 phase currents. The current value and its setting range depend on the parameter **Connection type** of the measuring point I-3ph.

Table 6-12 Threshold Setting Range with Different Connection Types

Connection Type of the Measuring Point I-3ph	Current Threshold $3I_0/IN$	CT Terminal Type	Threshold Setting Range (Secondary) ²¹
3-phase	Calculated $3I_0$ ²²	4 x Protection	0.030 A to 35.000 A
		3 x Protection, 1 x sensitive	0.030 A to 35.000 A
		4 x Measurement	0.001 A to 1.600 A

²¹ These values apply for a secondary rated current of 1 A. The values need to be multiplied by 5 when the secondary rated current is 5 A.

²² If the connection type is without IN, such as 3-phase, the current threshold value is a calculated $3I_0$ value.

Connection Type of the Measuring Point I-3ph	Current Threshold 3I0/IN	CT Terminal Type	Threshold Setting Range (Secondary) ²¹
3-phase + IN 3-phase + IN-separate	Measured IN ²³	4 x Protection	0.030 A to 35.000 A
		4 x Measurement	0.001 A to 1.600 A
	Measured IN and calculated 3I0 when IN > 1.6 A	3 x Protection, 1 x sensitive	0.001 A to 35.000 A

Direction Determination and Pulse Counting

When the RMS value of 3I0 exceeds the set threshold value (signal no. 3 in *Figure 6-109*), the direction determination process is started and is continuously carried out until the function resets. At first, the current pulse (current peak) detection takes place. If a current pulse is detected, the direction determination for this pulse is carried out.

The direction is determined by the maximum 3I0 and the VN changing trend of the ground-current pulse. The plus or minus sign of the maximum 3I0 is compared to the plus or minus sign of the VN changing trend, resulting in the directional decision **forward** or **reverse**. If the VN changing trend is smaller than $0.03 V_{rated}$ or if the maximum 3I0 is smaller than $0.1 I_{rated}$, the direction is undefined.

During the ongoing intermittent ground fault, the directional results for all current pulses are counted.

Directional Mode and Directional Pulse Counter Criterion

The parameter **Directional mode** defines whether the function operates in **forward** or in **reverse** direction. The pulses in the specified direction are counted. If the pulse counter reaches the threshold value set in the parameter **No. of pulses for operate**, the signal *Pulse no. reached* is issued. Depending on the operating mode (**Counter** or **Integrator and counter**) of the function, the signal can immediately cause the operate of the function (**Counter** mode) or it is processed as directional release criteria (**Integrator and counter** operating mode). Refer to the further description in the following sections.

The directional pulse counter is reset when a different direction than the set **Directional mode** is detected. An undefined direction result does not reset the counter.

Operating Mode

2 different functional operating modes are available: **Counter** and **Integrator and counter**. You can select the different operating modes using the parameter **Operating mode**.

- Operating mode **Counter**:
 Many ground-current pulses of intermittent ground faults can result in a damage of the protected object. In this mode, the criterion for operate is only the number of directional current pulses. This is similar to the SIPROTEC 4 implementation.
- Operating mode **Integrator and counter**:
 An intermittent ground fault can result in thermal stress on the protected object. The magnitude and the duration of the ground-current pulses are decisive for the thermal stress. In order to calculate the thermal stress, the stage sums up the duration of the stabilized pickups with an integrator. If the integration value reaches the threshold value, one criterion for the operate is fulfilled. The 2nd criterion for the operate is the ground-fault direction. The ground-fault direction is determined by counting the directional ground-current pulses.

²¹ These values apply for a secondary rated current of 1 A. The values need to be multiplied by 5 when the secondary rated current is 5 A.

²³ If the connection type is with IN, such as 3-phase + IN, the current threshold value is a measured IN value.

Pickup, Operate, and Reset logic for the Counter Mode

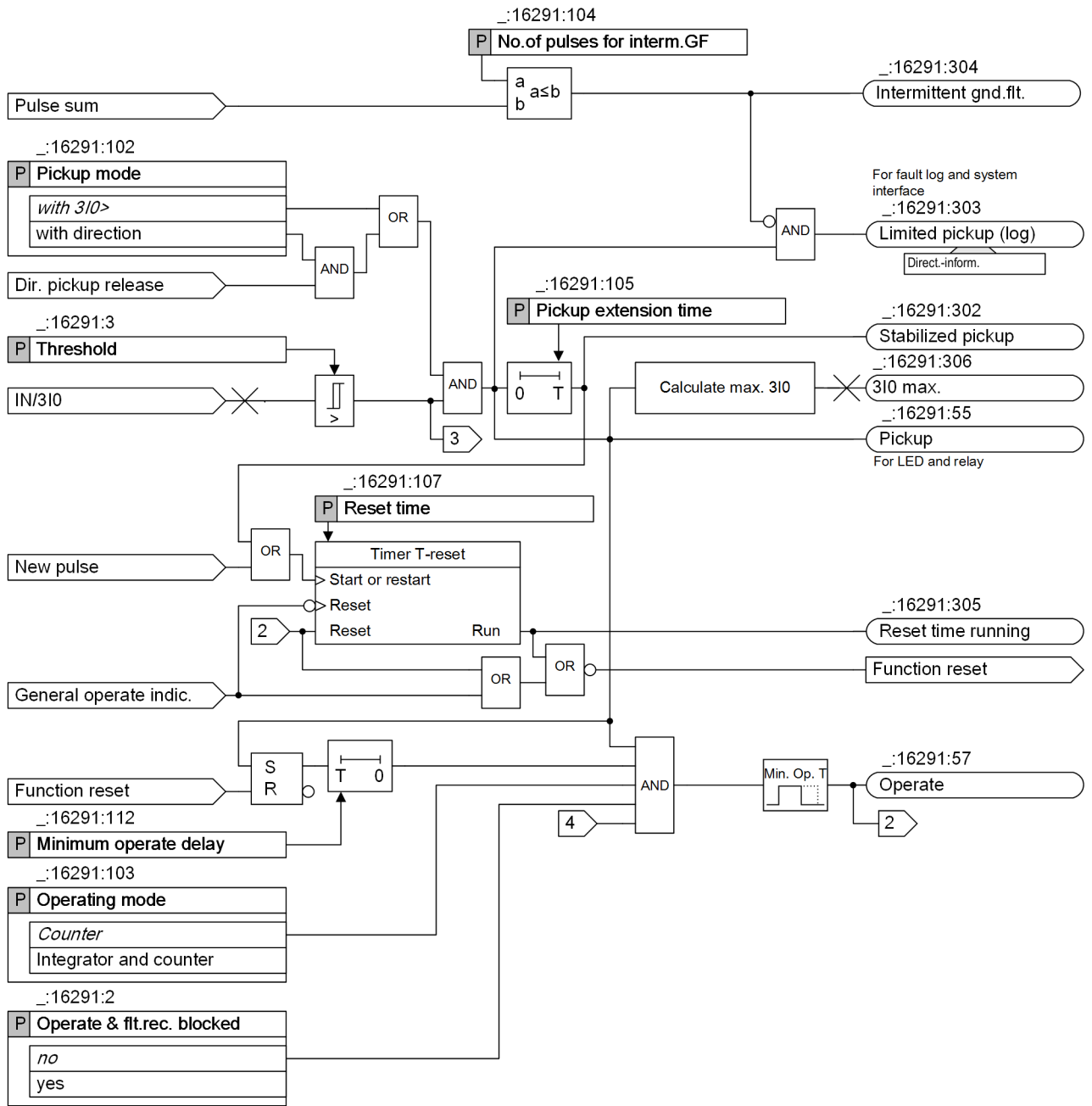

[to_int_dir2, 4, en_US]

Figure 6-110 Pickup, Operate, and Reset Logic in Operating Mode Counter

(1) The internal signal 4 is from [Figure 6-109](#).

Pickup, Operate, and Reset logic for the Integrator and Counter Mode

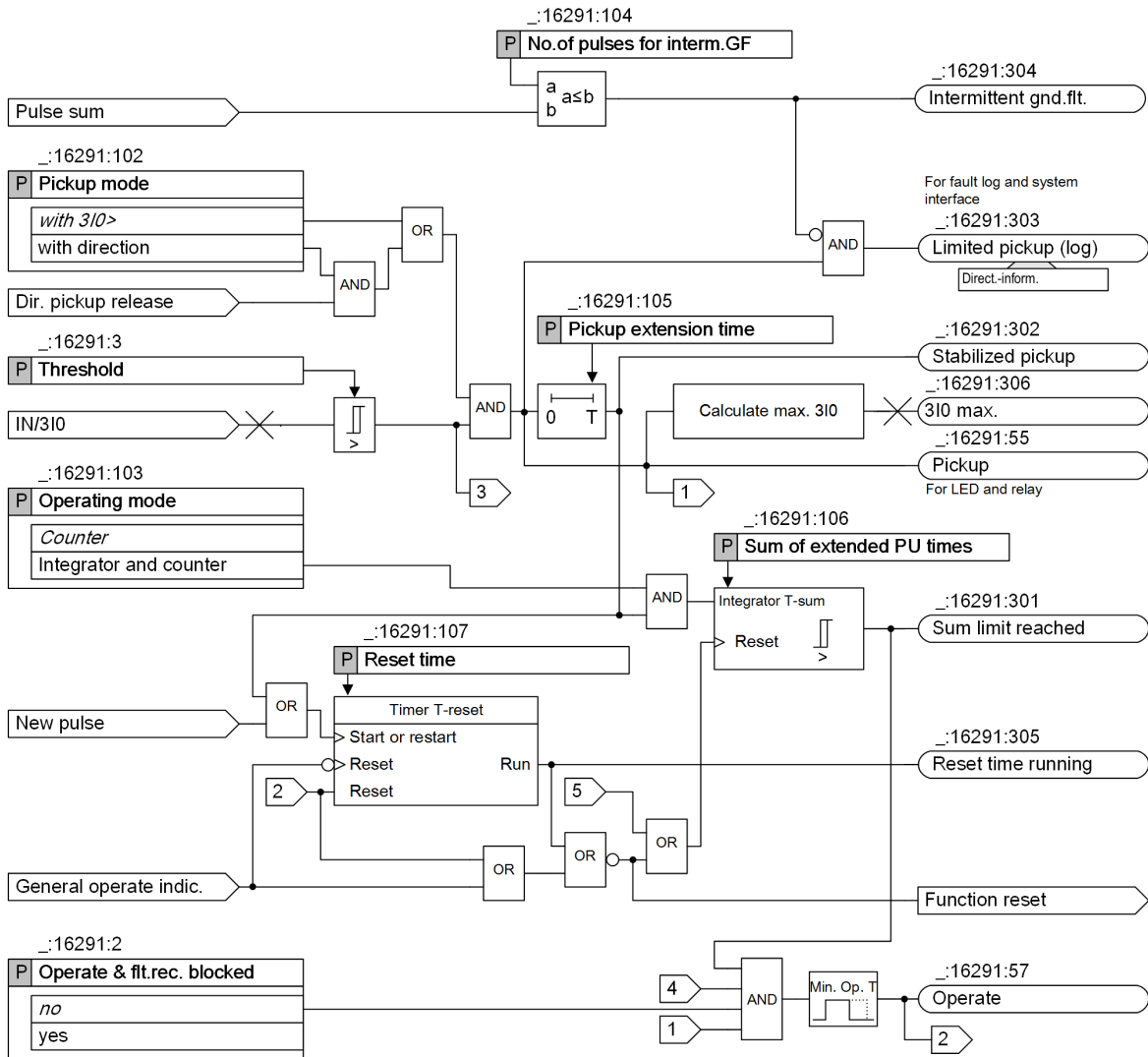

[file_int_dir3, 5, en_US]

Figure 6-111 Pickup, Operate, and Reset Logic in Operating Mode Integrator and Counter

(1) The internal signal 4 and 5 are from [Figure 6-109](#).

Measurement Value for Pickup and Integration

The stage calculates the RMS value of 3I0 since this value takes into account the higher-order harmonic components and the direct component (DC). Both components contribute to the thermal load.

Pickup, Limited Pickup, and Stabilized Pickup

Whenever 3I0 exceeds **Threshold**, the stage issues the signal *Pickup*. The signal is intended to be applied for LED and relay output.
Stabilized pickup is formed by prolonging the pickup indication by a settable time **Pickup extension time**. This stabilization is especially important for the coordination with the existing static or electromechanical overcurrent protection.
 The *Limited pickup (log)* signal is intended to be applied for logging and communication interface. The *Limited pickup (log)* signal will be entered in the fault log and reported via the system interface unless the *Intermittent gnd. flt.* indication is given. This behavior prevents a burst of indications.

Intermittent Ground-Fault Indication

The stage counts the 3I0 pulses. If the sum of forward pulse counts, reverse counts, and directional undefined counts is equal to or greater than **No. of pulses for interm.GF**, the signal *Intermittent gnd.flt.* is issued.

If the signal *Intermittent gnd.flt.* is issued, the pickup indications of some protection functions will be restraint to avoid an indication burst during an intermittent ground fault.

Operate

The conditions for issuing the signal *Operate* depend on the operating mode.

Operating Mode	Conditions for Issuing the Operate Signal
<i>Counter</i>	<ul style="list-style-type: none"> The current-pulse counter reached the No. of pulses for operate, which is signaled via the <i>Pulse no. reached</i> indication. The timer Minimum operate delay expired. The timer is started with the first pickup and is reset when the function resets. The pickup is active, which is signaled via the <i>Pickup</i> indication.
<i>Integrator and counter</i>	<ul style="list-style-type: none"> The 3I0 current integration value reaches the predefined Sum of extended PU times, which is signaled via the <i>Sum limit reached</i> indication. The current-pulse counter reached the No. of pulses for operate, which is signaled via the <i>Pulse no. reached</i> indication. The pickup is active, which is signaled via the <i>Pickup</i> indication.

When an opposite current pulse against the setting **Directional mode** is detected, the **Integrator T-sum** and the **Counter** are reset.

Reset Time for the Definition of the Interval between Independent Ground Faults

If there is a long interval between independent ground faults or if the ground fault extinguishes and does not restrike again within a long time, the function must not operate. The interval between ground faults is monitored with the reset time. If a ground fault occurs, the **Timer T-reset** with the setting **Reset time** and the **Integrator T-sum** are launched simultaneously. Unlike the integrator, each new ground-current pulse restarts the reset time with its initial value. If the **Timer T-reset** expires, that is, no new ground fault was detected during that period, all memories and the stage logics are reset. The **Timer T-reset** thus determines the time during which the next ground fault must occur to be processed yet as intermittent ground fault in connection with the previous fault. A ground fault that occurs later is considered as a new ground-fault event.

Reset Conditions

Under one of the following 2 conditions, **Timer T-reset** is reset:

- The intermittent ground-fault protection stage operates.
- The general operate indication is going.

Under one of the following conditions, **Integrator T-sum** and **Counter** are reset and the whole stage is reset and returns to its idle state:

- The **Timer T-reset** expires without an operate signal of this stage or another function was issued.
- The operate signal of the intermittent ground-fault protection stage is going.
- The general operate indication is going without the operate signal of the intermittent ground-fault protection stage issued.

Maximum Value 3I0 of the Ground Fault

The stage records the maximum RMS value of 3I0 during the intermittent ground fault. The statistic value *3I0 max.* is a percentage value calculated through dividing the primary maximum RMS value by the rated current value of the protected object. If the function resets or operates, this value is logged via the signal *3I0 max.*

Fault Log and Fault Recording

You can select between the ground-fault log without fault recording or the normal fault log with fault recording. If you set the parameter **Operate & flt.rec. blocked** to **yes**, the operate of the stage and fault recording are blocked and the information automatically appears in the ground-fault log. Otherwise, the operate and fault recording are not blocked and the information appears in the normal fault log.

Start and Stop of Fault Recording, Fault Logging, and General Pickup

The *Stabilized pickup* signal initiates fault recording, fault logging, and the general pickup of the function group. The fault recording starts according to the pre-trigger time before the *Stabilized pickup* signal rises.

With the reset condition of this stage, the fault recording, fault logging, and the general pickup of the function group are terminated.

Influence on Other Functions to Avoid a Burst of Indications

In this case, the function uses the same mechanism as the **Non-directional intermittent ground-fault protection**. For more information, refer to chapter [Influence on Other Functions to Avoid a Burst of Signals](#), Page 574.

6.14.4 Application and Setting Notes

No Start of the Automatic Reclosing Function

Automatic reclosing is not an effective measure against intermittent ground faults. For this reason, the function **Directional intermittent ground-fault protection** is not intended to start the Automatic reclosing function.

Routing of Pickup Signals

The signal *Pickup* is supposed to be routed to an LED and a relay. The signal *Limited pickup (log)* is only reported to the fault log and communication interface until the signal *Intermittent gnd.flt.* is issued. This scheme prevents a burst of indications.



NOTE

To avoid a burst of indications, do not route the signal *Pickup* to the operational log and to the fault log.

Parameter: **Threshold**

- Default setting (`_:16291:3`) **Threshold** = *1.00 A*

With the parameter **Threshold**, you set the threshold value of the ground current 3I0, measured as RMS value.

A rather sensitive setting is possible to respond also to short ground faults since the pickup time shortens as the ground-fault current increases.

Parameter: **Directional mode**

- Default setting (`_:16291:101`) **Directional mode** = *forward*

With the parameter **Directional mode**, you define if the function operates in *forward* or in *reverse* direction.

Parameter: **Pickup mode**

- Default setting (`_:16291:102`) **Pickup mode** = *with 3I0*

With the parameter **Pickup mode**, you define under which conditions pickup is detected and fault logging and recording start:

- When the parameter **Pickup mode** is set to **with 3I0>**, the signal *Pickup* is released without considering the ground fault direction. The signal *Pickup* is issued once the IN/3I0 exceeds the threshold value.
- When the parameter **Pickup mode** is set to **with direction**, the signal *Pickup* is issued when at least one pulse direction is the same as the direction specified by the set value of parameter **Directional mode**.

Parameter: Operating mode

- Default setting (**_:16291:103**) **Operating mode = Counter**

With the parameter **Operating mode**, you define if the function operates in **Counter** or in **Integrator and counter** mode.

Operating Mode	Application and Setting Notes
Counter	The number of directional pulses is the determining operate criterion. This is a simple method which is similar to the implementation in the 7SJ SIPROTEC 4 devices. Siemens recommends using this method if no time grading or only simple time grading between protection devices (time grading of only 2 or 3 devices) is required. Time grading is then carried out by increasing the parameter value No. of pulses for operate towards the infeed.
Integrator and counter	The integrator and the counter are the determining operate criteria while the counter criterion is only used for the direction determination. The integrator works in the same way as for the non-directional intermittent ground fault function. This allows the same time-grading principles as for the non-directional intermittent ground fault function. Refer to this function for more description.

Parameter: No. of pulses for interm. GF

- Default setting (**_:16291:104**) **No. of pulses for interm. GF = 3**

With the parameter **No. of pulses for interm. GF**, you set the total number of pulse counts (**forward**, **reverse** and **non-dir. pulses**) at which the ground fault is considered to be intermittent. Siemens recommends using the default setting.

Parameter: Pickup extension time

- Default setting (**_:16291:105**) **Pickup extension time = 0.10 s**

With the parameter **Pickup extension time**, you get a prolonged and thus stabilized pickup signal. This stabilization is especially important for the coordination with existing static or electromechanical overcurrent protections.

Parameter: No. of pulses for operate

- Default setting (**_:16291:108**) **No. of pulses for operate = 5**

The pulses in the specified direction from **Directional mode** are counted. If the pulse counter reaches the set value of the parameter **No. of pulses for operate**, the directional counter criterion is fulfilled.

The setting of parameter **No. of pulses for operate** depends on the **Operating mode**.

Operating Mode	Application and Setting Notes
<i>Counter</i>	The number of directional pulses is the determining operate criterion. Thus do not set the value for parameter No. of pulses for operate too small. Consider that a permanent intermittent ground fault will cause many current pulses. If no time-grading considerations are required, Siemens recommends using a value in the range of 10 to 20.
<i>Integrator and counter</i>	The integrator and the counter are the determining operate criteria while the counter criterion is only used for the direction determination. The value for parameter No. of pulses for operate to fulfill the directional criterion can be set to a rather small value in the range of 3 to 5.

Parameter: Sum of extended PU times

- Default setting (`_:16291:106`) **Sum of extended PU times = 20.00 s**

This parameter is only relevant in the operating mode *Integrator and counter*.

With the parameter **Sum of extended PU times**, you set the threshold value for the integrator. If the integration reaches **Sum of extended PU times**, the stage operates if the signal *Pulse no. reached* and the pickup state is present.

The parameter **Sum of extended PU times** represents one of the 5 selectivity criteria (ground-fault direction, pickup threshold, pickup extension time, reset time, and integrator threshold value) for coordination of the relays on subordinate devices. It is comparable to the time grading of the overcurrent protection.

The **Sum of extended PU times** has the shortest summation time in the radial system for the device that is closest to the intermittent ground fault and that picks up.

Parameter: Reset time

- Default setting (`_:16291:107`) **Reset time = 300 s**

With the parameter **Reset time**, you can define the maximum interval between 2 adjacent ground faults. If the interval is larger than the **Reset time**, the counter and integrator are reset.

The parameter **Reset time** must be much higher than the operate value of the **Sum of extended PU times**.



NOTE

Siemens recommends setting the parameter **Reset time** to a value not lower than 40 ms. A too low value will lead to a risk that the intermittent ground-fault protection function never picks up.

Parameter: Operate & flt.rec. blocked

- Default setting (`_:16291:2`) **Operate & flt.rec. blocked = no**

With the parameter **Operate & flt.rec. blocked**, you can block the operate indication, the fault recording, and the fault log. In this case, a ground-fault log is created instead of the fault log.

Parameter: Minimum operate delay

- Default setting (`_:16291:112`) **Minimum operate delay = 0.00 s**

This parameter is only relevant in the operating mode *Counter*.

The parameter **Minimum operate delay** is used to avoid too fast tripping in case of frequent restriking (for example, restriking occurs every 30 ms).

6.14.5 Settings

Addr.	Parameter	C	Setting Options	Default Setting
Stage 1				
_:16291:1	Stage 1:Mode		<ul style="list-style-type: none"> off on test 	off
_:16291:2	Stage 1:Operate & flt.rec. blocked		<ul style="list-style-type: none"> no yes 	no
_:16291:10	Stage 1:Blk. by meas.-volt. failure		<ul style="list-style-type: none"> no yes 	yes
_:16291:101	Stage 1:Directional mode		<ul style="list-style-type: none"> forward reverse 	forward
_:16291:102	Stage 1:Pickup mode		<ul style="list-style-type: none"> with 3I0> with direction 	with 3I0>
_:16291:103	Stage 1:Operating mode		<ul style="list-style-type: none"> Counter Integrator and counter 	Counter
_:16291:3	Stage 1:Threshold	1 A @ 100 Irated	0.030 A to 35.000 A	1.000 A
		5 A @ 100 Irated	0.15 A to 175.00 A	5.00 A
		1 A @ 50 Irated	0.030 A to 35.000 A	1.000 A
		5 A @ 50 Irated	0.15 A to 175.00 A	5.00 A
		1 A @ 1.6 Irated	0.001 A to 1.600 A	1.000 A
		5 A @ 1.6 Irated	0.005 A to 8.000 A	5.000 A
_:16291:105	Stage 1:Pickup extension time		0.00 s to 10.00 s	0.10 s
_:16291:104	Stage 1:No.of pulses for interm.GF		2 to 10	3
_:16291:106	Stage 1:Sum of extended PU times		0.00 s to 180.00 s	20.00 s
_:16291:107	Stage 1:Reset time		0.00 s to 600.00 s	300.00 s
_:16291:108	Stage 1:No. of pulses for operate		2 to 100	5
_:16291:112	Stage 1:Minimum operate delay		0.00 s to 60.00 s	0.00 s

6.14.6 Information List

No.	Information	Data Class (Type)	Type
Group indicat.			
_:4501:55	Group indicat.:Pickup	ACD	O
_:4501:57	Group indicat.:Operate	ACT	O
_:4501:52	Group indicat.:Behavior	ENS	O
_:4501:53	Group indicat.:Health	ENS	O
Stage 1			
_:16291:81	Stage 1:>Block stage	SPS	I
_:16291:51	Stage 1:Mode (controllable)	ENC	C
_:16291:54	Stage 1:Inactive	SPS	O

No.	Information	Data Class (Type)	Type
_:16291:52	Stage 1:Behavior	ENS	0
_:16291:53	Stage 1:Health	ENS	0
_:16291:55	Stage 1:Pickup	ACD	0
_:16291:302	Stage 1:Stabilized pickup	ACD	0
_:16291:303	Stage 1:Limited pickup (log)	ACD	0
_:16291:304	Stage 1:Intermittent gnd.flt.	SPS	0
_:16291:301	Stage 1:Sum limit reached	SPS	0
_:16291:308	Stage 1:Pulse no. reached	SPS	0
_:16291:305	Stage 1:Reset time running	SPS	0
_:16291:57	Stage 1:Operate	ACT	0
_:16291:306	Stage 1:3I0 max.	MV	0
_:16291:310	Stage 1:Forward pulses	MV	0
_:16291:311	Stage 1:Reverse pulses	MV	0
_:16291:312	Stage 1:Non-dir. pulses	MV	0

6.15 Sensitive Ground-Fault Detection

6.15.1 Overview of Functions

2 functions are available for ground-fault detection: a directional one and a non-directional one.

The **Directional sensitive ground-fault detection** (ANSI 67Ns) serves:

- For directional detection of permanent ground faults in isolated or resonant-grounded systems
- For directional detection of fast extinguishing transient ground faults in isolated or resonant-grounded systems
- For determination of the faulty phase
- For detection of high-impedance ground faults in effectively (solidly) or low-impedance (semi-solidly) grounded systems

The **Non-directional sensitive ground-fault detection** (ANSI 51Ns) serves:

- For ground-fault detection in isolated or resonant-grounded systems
- For detection of high-impedance ground faults in effectively (solidly) or low-impedance (semi-solidly) grounded systems

6.15.2 Structure of the Function

Directional Sensitive Ground-Fault Detection

The **Directional sensitive ground-fault detection** function can be used in protection function groups that make current and voltage zero-sequence systems (3I0 and V0) available. The function comes factory-set with a non-directional **V0> stage with zero-sequence voltage/residual voltage**, a directional **3I0> stage with $\cos \varphi$ or $\sin \varphi$ measurement**, a directional **transient ground-fault stage**, and an **intermittent ground-fault blocking stage**.

The following stages can be operated simultaneously within the function:

- 2 non-directional **V0> stages with zero-sequence voltage/residual voltage**
- 4 directional **3I0> stages with $\cos \varphi$ or $\sin \varphi$ measurement**
- 2 directional **transient ground-fault stages**
- 4 directional **3I0> stages with $\varphi(V0, 3I0)$ measurement**
- 4 directional **Y0> stages with G0 or B0 measurement** (admittance method)
- 4 directional **stages with phasor measurement of a harmonic**
- 4 non-directional **3I0> stages**
- 2 non-directional **Y0> stages**
- 2 non-directional **pulse-pattern detection stages**
- 1 **intermittent ground-fault blocking stage**

The general functionality works across stages on the function level.

The group-indications output logic generates the following group indications of the entire function by the logical OR from the stage-selective indications:

- Pickup
- Operate indication

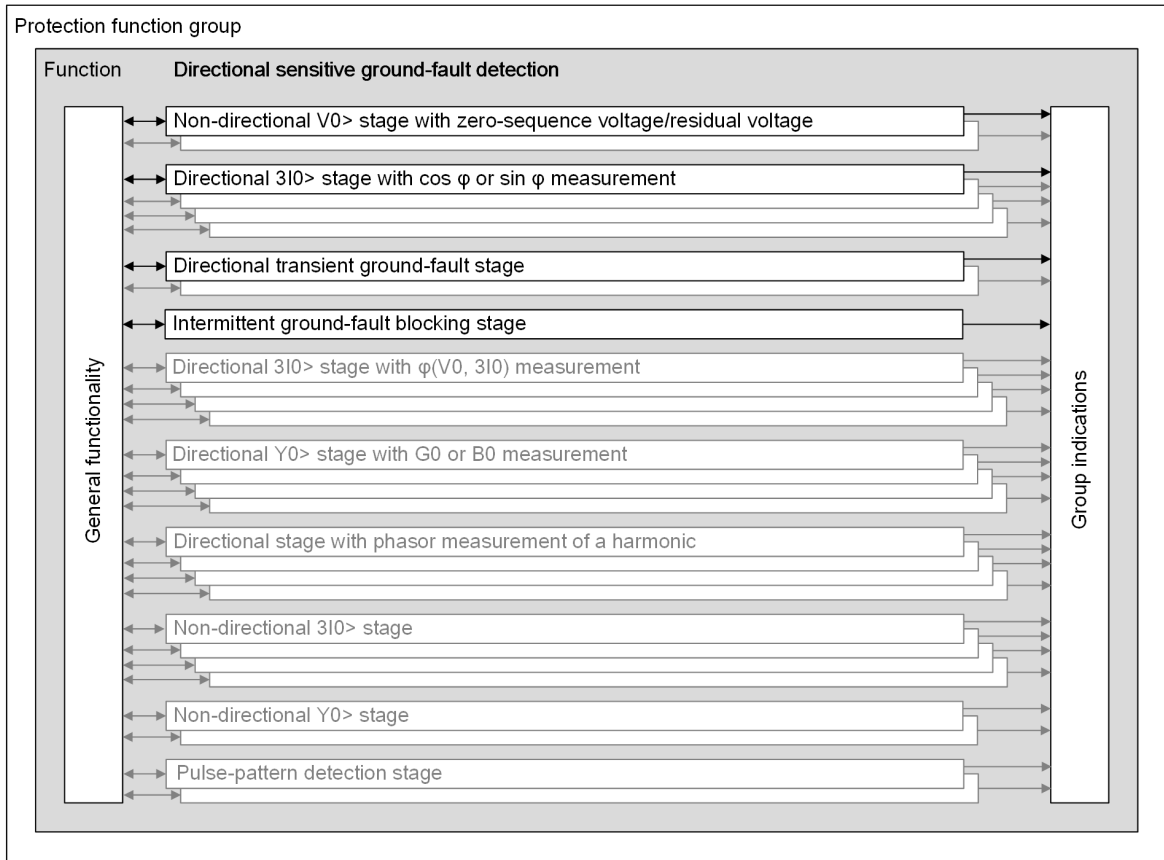

[dw_str_GFP, 6, en_US]

Figure 6-112 Structure/Embedding of the Directional Function in Protection Function Groups

Non-Directional Sensitive Ground-Fault Detection

The **Non-directional sensitive ground-fault detection** function can be used in protection function groups that only make the zero-sequence system (3I0) available. The function comes factory-set with a non-directional **3I0> stage**.

The following stages can be operated simultaneously within the function:

- 4 non-directional **3I0> stages**
- 2 non-directional **Y0> stages**
- 4 non-directional **3I0> harmonic stages**
- 2 non-directional **pulse-pattern detection stages**

The general functionality works across stages on the function level.

The group-indications output logic generates the following group indications of the entire function by the logical OR from the stage-selective indications:

- Pickup
- Operate indication

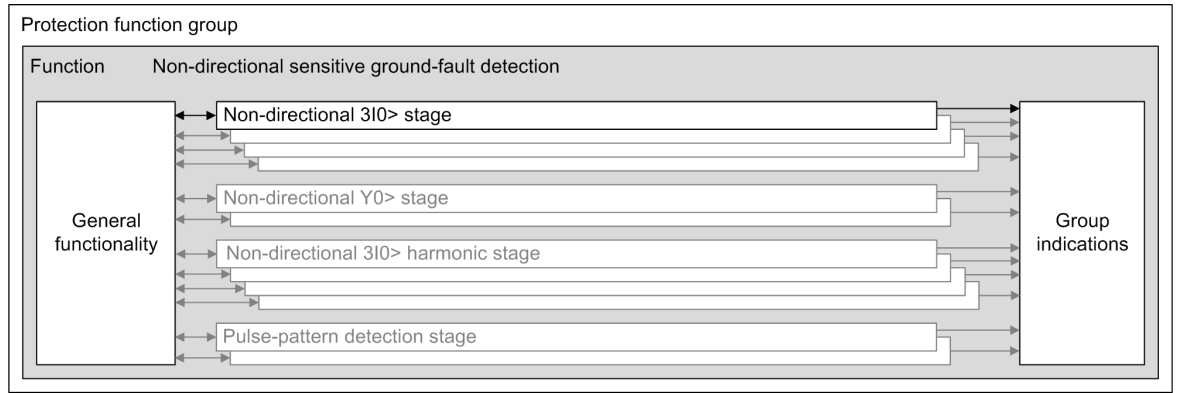

[dw_SGFP_u4, 5, en_US]

Figure 6-113 Structure/Embedding of the Non-Directional Function in Protection Function Groups

6.15.3 General Functionality

6.15.3.1 Description

Logic

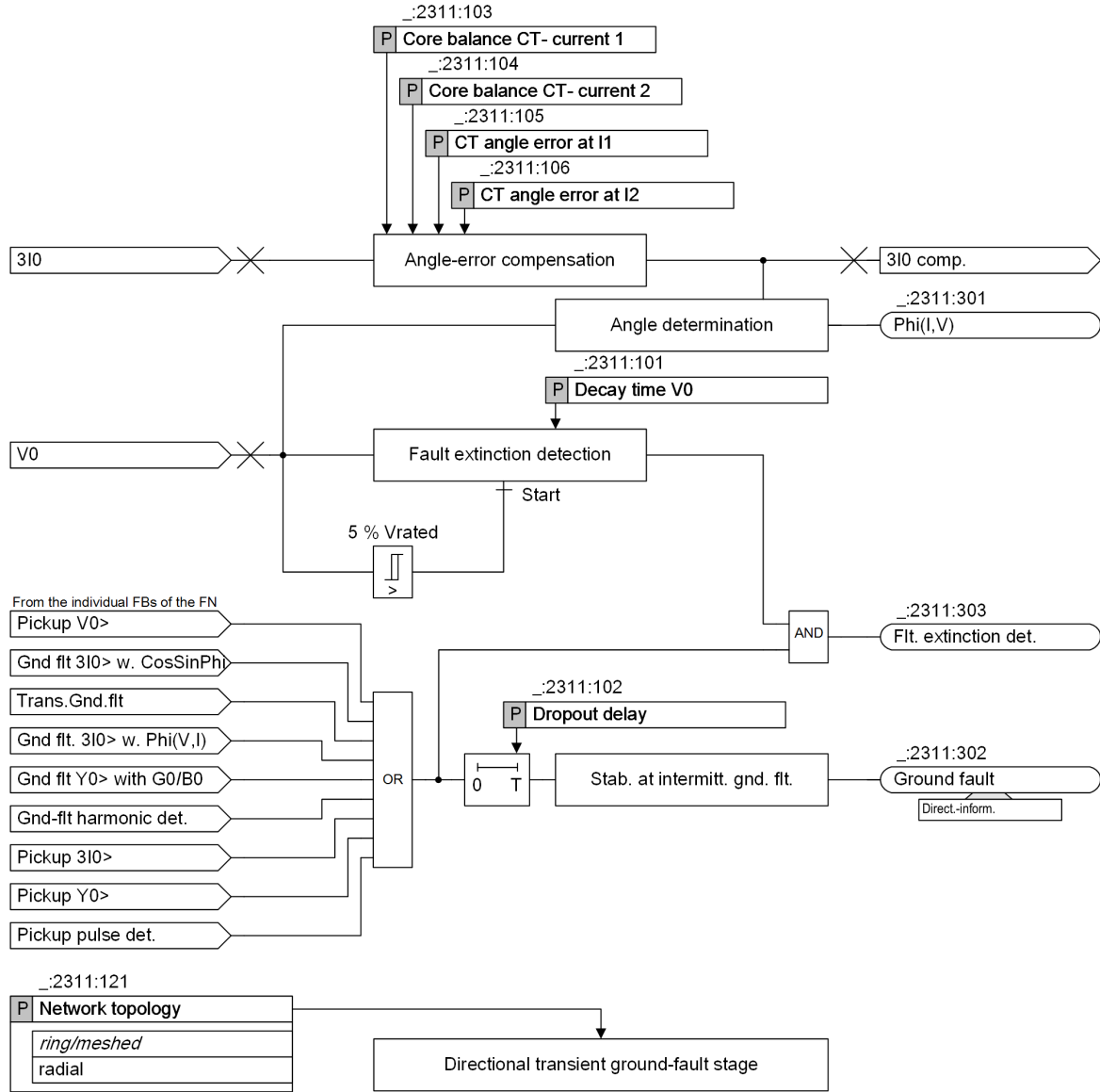

[lo_gfp ger, 8, en_US]

Figure 6-114 Logic Diagram of the Cross-Stage Functionality of the Directional Function

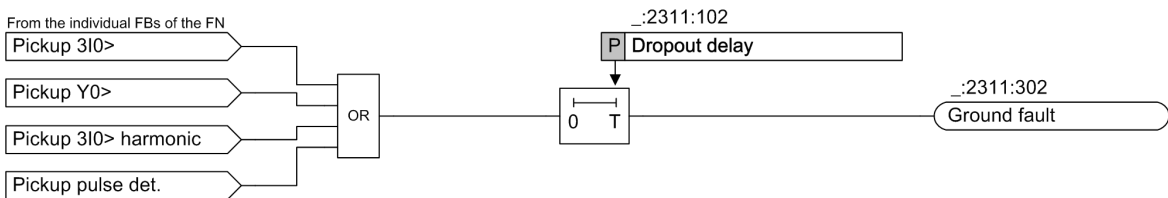

[lo_gfp non, 6, en_US]

Figure 6-115 Logic Diagram of the Cross-Stage Functionality of the Non-Directional Function

Operational Measured Value $\varphi(I,V)$

The function block calculates the angle between I_N and V_0 and makes the angle available as function measured value $\varphi(I, V)$.

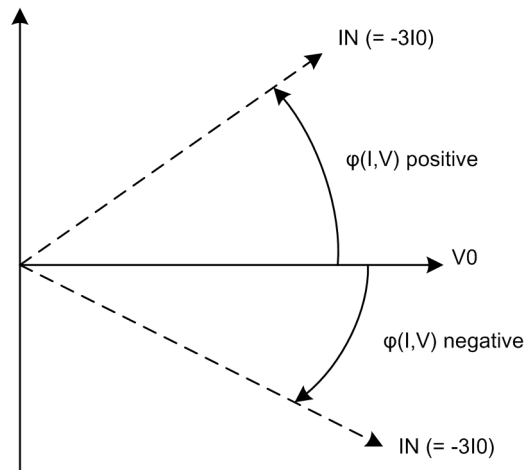

[dw_ph_1_N_U0, 1, en_US]

Figure 6-116 Sign Definition for the Measured Value

Network Topology

The parameter **Network topology** parameter is only used in the **Directional transient ground-fault** stage. With this parameter, the algorithm of the directional transient ground-fault stage adopts its processing of an operational 3I0.

Fault-Extinction Detection

The extinction of the fault is characterized by the fact that the zero-sequence voltage subsides. Depending on the system conditions and fault characteristics, this process can last several 100 ms. If a continuously falling zero-sequence voltage is detected during the set time **Decay time V0**, then the fault is considered extinguished. The signal *Flt. extinction det.* is issued.

Thus, the possibility exists, for example, to block the stage **3I0>** with $\cos \varphi$ or $\sin \varphi$ measurement directly after the fault extinction, in order to avoid an overfunction during the subsiding process with a very sensitive setting of the stage.

Angle-Error Compensation

The high reactive power factor in the arc-suppression-coil-ground system and the unavoidable air-gap of the core balance current transformer often make necessary a compensation of the angle error of the core balance current transformer. Using the characteristic shown in the following figure, the device approaches the angle error of the core balance current transformer with sufficient precision.

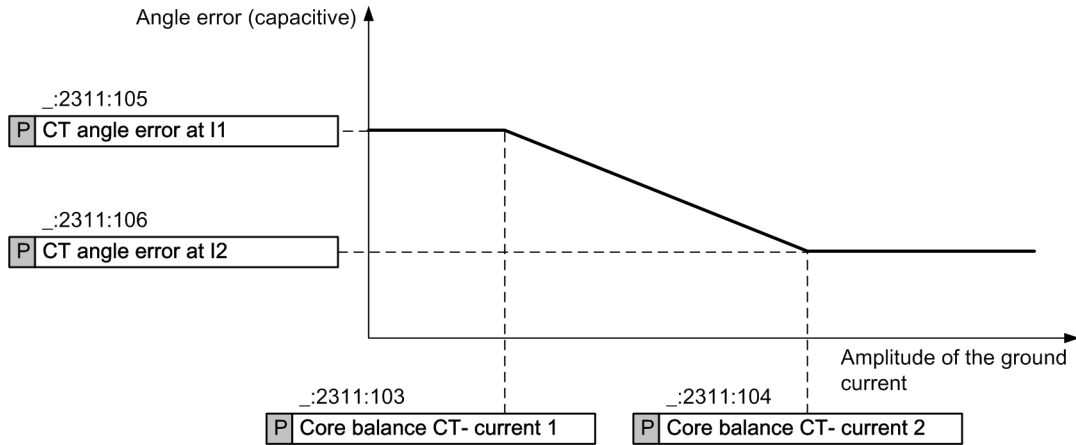

[dw_erdwdl_1_en_US]

Figure 6-117 Correction of the Transmission Characteristic Curve of a Core Balance Current Transformer

Ground-Fault Indication, Stabilization at Intermittent Ground Fault

The indication *Ground fault* indicates the ground fault and manages the ground-fault log (see [Ground-Fault Log, Page 596](#)). The corresponding information of the stages used is accessed for the generation of this indication.

The indication *Ground fault* contains the direction information, independent of the parameterized working direction of a stage. The indication is thus suited for transfer to a station.

To avoid a flood of indications in case of an intermittent ground fault, a maximum of 30 status changes of this indication is logged per ground fault. An intermittent ground fault must be treated as one ground fault so that the stabilization can take action. This is ensured with the parameter **Dropout delay**, by the dropout of the indication *Ground fault* being delayed. If the next ignition of the ground fault takes place during the dropout delay, the indication does not drop out and the log remains open.



NOTE

The *Ground fault* indication in the general stage must be routed into the ground-fault log. If not, you can meet a flood of ground-fault logs when an intermittent ground fault occurs.

Ground-Fault Log

Ground faults can be recorded in a designated buffer, the ground-fault log. As long as the **Operate & flt.rec. blocked** parameter is set to **yes**, all indications routed into the ground-fault log are written in the ground-fault log.

The criterion for opening the ground-fault log is the raising of any indication which is routed to the ground-fault log, for example, the indication *Ground fault*. The criterion for closing is the clearing of all routed indications.

Related Topics

You can find general notes on the ground-fault login chapter **Indications** under [3.1.5.5 Ground-Fault Log](#).

Value Indications in Log and Real-Time Functional Values

If the value indications listed in [Table 6-13](#) can be calculated, they are written into the log (ground-fault log or fault log) at the time of the 1st raising ground-fault indication and the 1st operate indication of any stage.

The function also provides some real-time functional values, as described in [Table 6-13](#).

Table 6-13 Value Indications in Log and Real-Time Functional Values

Value Indication in Log	Real-Time Functional Value	Description
IN	–	Neutral-point current IN
IN active	IN act.	Active component IN
IN reactive	IN react.	Reactive component IN
V0	–	Zero-sequence voltage V0
Phi(IN, V0)	Phi(I,V)	Angle between IN and V0 Refer to <i>Operational Measured Value $\varphi(I,V)$</i> , Page 595.

If the ground current is measured via a sensitive input and the measured value exceeds the measuring range of $1.6 \cdot I_{rated}$, the function switches from the measured IN value to the calculated 3I0 value and the 3I0 values are displayed.

Group-Indication Blocking

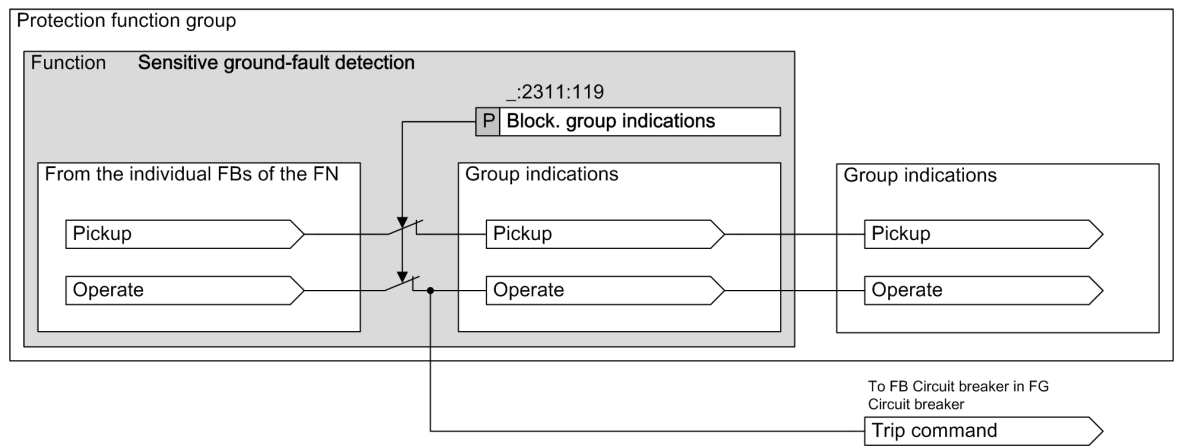

[to_SGFP block group ind., 1, en_US]

Figure 6-118 Logic Diagram of the Group-Indication Blocking of the Directional and Non-Directional Functions

By setting the **Block. group indications** parameter to **yes**, the following indications are blocked:

- The group indications of the function and the corresponding group indications of the function group
- The trip command from the function **Sensitive ground-fault detection** to the **FB Circuit breaker**

Fault recording and logging are not affected by the setting.

6.15.3.2 Application and Setting Notes

Indication: *Ground fault*

To indicate the ground fault and its direction via the protocol, Siemens recommends using the indication (**_:2311:302**) *Ground fault*. The indication contains the direction information, independent of the parameterized working direction of a stage. And this indication is also stabilized against a flood of indications in case of an intermittent ground fault.

Parameter: **Decay time V0**

- Recommended setting value (**_:2311:101**) **Decay time V0 = 0.10 s**

With the **Decay time V0** parameter, you specify the time slot for the detection of a fault extinction. If V0 continuously falls within this time, fault extinction is detected and the indication *Flt. extinction det.* is issued.

Siemens recommends using the default setting.

Parameter: Dropout delay

- Recommended setting value (`_:2311:102`) **Dropout delay = 1.00 s**

To avoid chattering of the indication *Ground fault* during an intermittent ground fault and thus a frequent opening and closing of the ground-fault log, the dropout of the indication *Ground fault* (and thus the closing of the log) can be delayed by the **Dropout delay**.

Siemens recommends using the default setting.

Using the default setting ensures that no flood of indications arises in case of an intermittent ground fault for the indication *Ground fault*. The intermittent ground fault is then treated as a ground fault, and the stabilization of the indication *Ground fault* can thus take action.

Angle-Error Compensation of the Core Balance Current Transformer

- Default setting (`_:2311:103`) **Core balance CT- current 1 = 0.050 A**
- Default setting (`_:2311:104`) **Core balance CT- current 2 = 1.000 A**
- Default setting (`_:2311:105`) **CT angle error at I1 = 0.0°**
- Default setting (`_:2311:106`) **CT angle error at I2 = 0.0°**

The high reactive-power factor in the arc-suppression-coil-ground system and the unavoidable air gap of the core balance current transformer often make necessary a compensation of the angle error of the core balance current transformer. For the burden actually connected, the maximum angle error **CT angle error at I1** and the corresponding secondary current **Core balance CT- current 1** as well as a further operating point **CT angle error at I2/Core balance CT- current 2** are entered, from which point the angle error no longer changes appreciably.

In the isolated or grounded system, angle compensation is not necessary.

Parameter: Block. group indications

- Default setting (`_:2311:119`) **Block. group indications = no**

The **Block. group indications** parameter supports in applying the **Sensitive ground-fault detection** function as a supervision function. If you set this parameter to **yes**, the following indications are blocked:

- The group indications of the function and the corresponding group indications of the function group are blocked.
 Consequently, the group-indications of the function group are then related to short-circuit protection functions and can be forwarded to a station controller in the meaning of short-circuit protection.
- The trip command from the **Directional sensitive ground-fault detection** function to the **FB Circuit breaker** is blocked.

Fault recording and logging are not affected by the setting.

Parameter: Network topology

- Default setting (`_:2311:121`) **Network topology = ring/meshed**

This parameter is only used in the **Directional transient ground-fault** stage.

With the **Network topology** parameter, you set the network topology with reference to the network section to be protected by the individual device.

Network Topology	Description
<i>ring/meshed</i>	The device is applied in a meshed system or a closed feeder ring.
<i>radial</i>	The device is applied in a single feeder with radial topology. This setting has to be also selected if parallel feeders are closed rings, as long as the own feeder is single.

6.15.3.3 Settings

Directional sensitive ground-fault detection

Addr.	Parameter	C	Setting Options	Default Setting
General				
_:2311:121	General:Network topology		<ul style="list-style-type: none"> ring/meshed radial 	ring/meshed
_:2311:101	General:Decay time V0		0.03 s to 0.20 s	0.10 s
_:2311:102	General:Dropout delay		0.00 s to 60.00 s	1.00 s
_:2311:103	General:Core balance CT- current 1	1 A @ 100 Irated	0.030 A to 35.000 A	0.050 A
		5 A @ 100 Irated	0.15 A to 175.00 A	0.25 A
		1 A @ 50 Irated	0.030 A to 35.000 A	0.050 A
		5 A @ 50 Irated	0.15 A to 175.00 A	0.25 A
		1 A @ 1.6 Irated	0.001 A to 1.600 A	0.050 A
		5 A @ 1.6 Irated	0.005 A to 8.000 A	0.250 A
_:2311:104	General:Core balance CT- current 2	1 A @ 100 Irated	0.030 A to 35.000 A	1.000 A
		5 A @ 100 Irated	0.15 A to 175.00 A	5.00 A
		1 A @ 50 Irated	0.030 A to 35.000 A	1.000 A
		5 A @ 50 Irated	0.15 A to 175.00 A	5.00 A
		1 A @ 1.6 Irated	0.001 A to 1.600 A	1.000 A
		5 A @ 1.6 Irated	0.005 A to 8.000 A	5.000 A
_:2311:105	General:CT angle error at I1		0.0° to 5.0°	0.0°
_:2311:106	General:CT angle error at I2		0.0° to 5.0°	0.0°
_:2311:119	General:Block. group indications		<ul style="list-style-type: none"> no yes 	no

Non-directional sensitive ground-fault detection

Addr.	Parameter	C	Setting Options	Default Setting
General				
_:2311:102	General:Dropout delay		0.00 s to 60.00 s	1.00 s
_:2311:119	General:Block. group indications		<ul style="list-style-type: none"> no yes 	no

6.15.3.4 Information List

Directional sensitive ground-fault detection

No.	Information	Data Class (Type)	Type
General			
_:2311:302	General:Ground fault	ACD	O
_:2311:303	General:Flt. extinction det.	SPS	O
_:2311:309	General:Pos. measuring window	SPS	O
_:2311:301	General:Phi(I,V)	MV	O
_:2311:306	General:IN	MV	O
_:2311:307	General:V0	MV	O
_:2311:311	General:IN act.	MV	O

No.	Information	Data Class (Type)	Type
_:2311:312	General:IN react.	MV	0
_:2311:52	General:Behavior	ENS	0
_:2311:53	General:Health	ENS	0

Non-directional sensitive ground-fault detection

No.	Information	Data Class (Type)	Type
General			
_:2311:302	General:Ground fault	ACD	0
_:2311:52	General:Behavior	ENS	0
_:2311:53	General:Health	ENS	0

6.15.4 Directional 3I0 Stage with Cos φ or Sin φ Measurement

6.15.4.1 Description

Logic

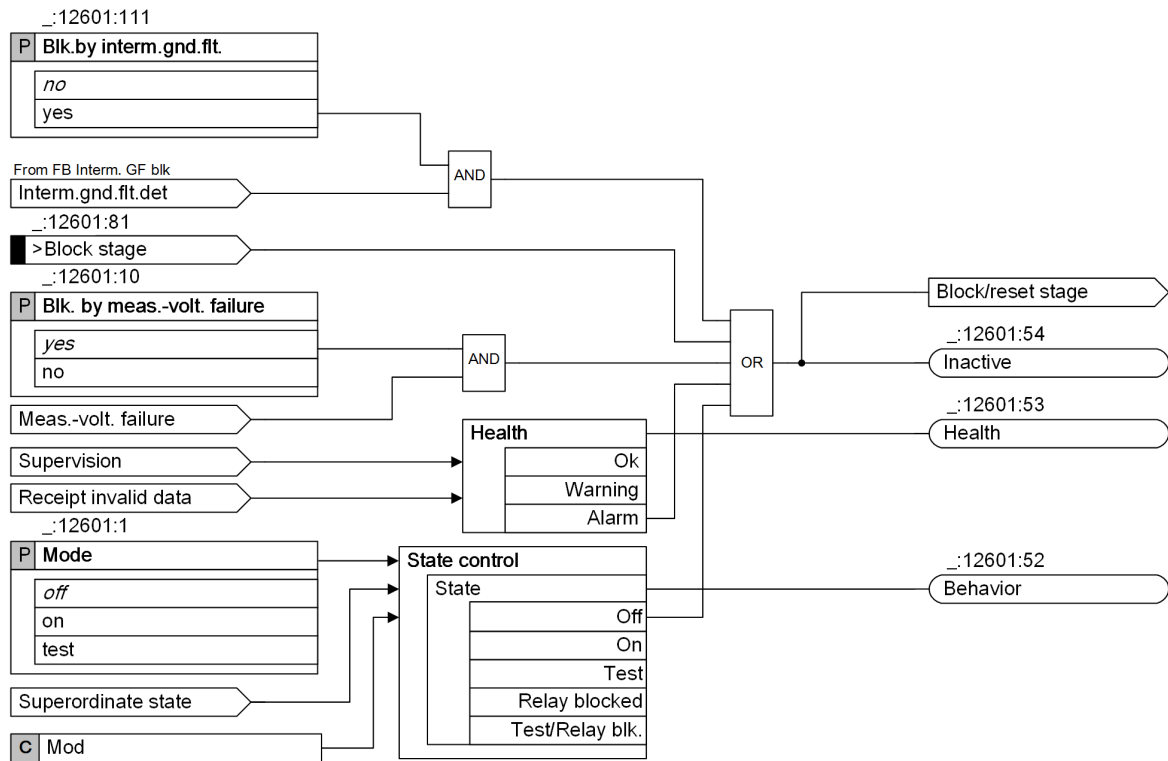
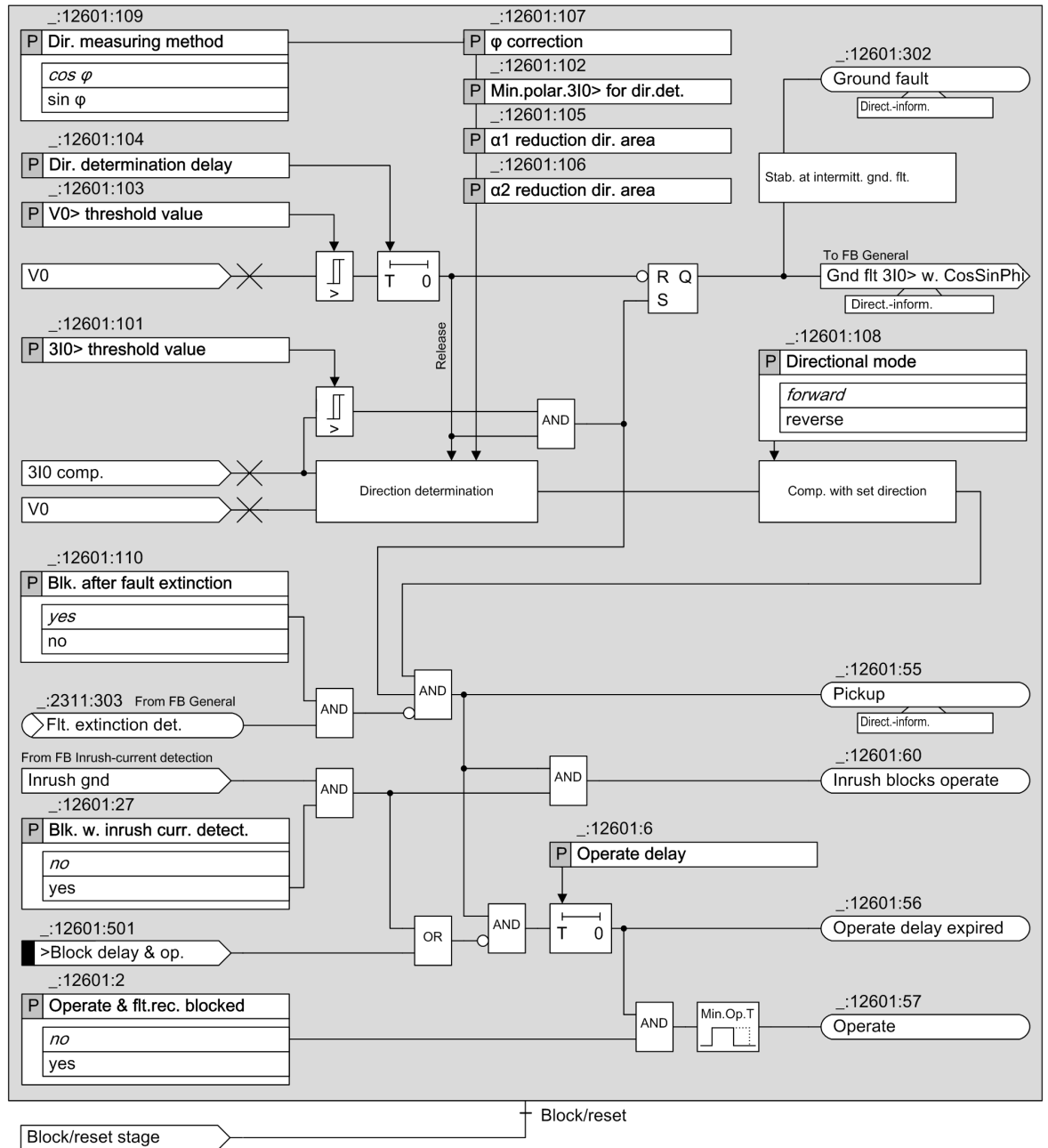

Figure 6-119 Logic Diagram of the Stage Control



[to_gfp_3i0f.5.en_US]

Figure 6-120 Logic Diagram of the Directional 3I0 Stage with Cos φ or Sin φ Measurement

Measured Value V0, Method of Measurement

The device can measure the residual voltage at the broken-delta winding. The measured voltage V_N is converted to a value with reference to the zero-sequence voltage V_0 . If the residual voltage is not available to the device as a measurand, the zero-sequence voltage V_0 is calculated from the measured phase-to-ground voltages V_A , V_B , and V_C using the defining equation.

This method of measurement processes the sampled voltage values and filters out the fundamental component numerically.

Measured Value 3I0, Method of Measurement

The function usually evaluates the sensitively measured ground current 3I0 via a core balance current transformer. Since the linearity range of the sensitive measuring input ends at approx. 1.6 A, for larger secondary

ground currents, the function switches to the 3I0 current calculated from the phase currents. This results in a very large linearity and settings range.

Depending on the setting of the **Connection type** parameter of the measuring point **I-3ph** as well as the current terminal block used, the following different linearity and settings ranges result in addition to the common application:

Connection Type of the Measuring Point I-3ph	Current Threshold 3I0/IN	Current Terminal Block	3I0 Threshold Value Settings Range (Secondary) ²⁴
3-phase	Calculated 3I0 ²⁵	4 × protection	0.030 A to 35.000 A
		3 × protection, 1 × sensitive	0.030 A to 35.000 A
		4 × measurement	0.001 A to 1.600 A
3-phase + IN 3-phase + IN-separate	Measured IN ²⁶	4 × protection	0.030 A to 35.000 A
		4 × measurement	0.001 A to 1.600 A
2ph, 2p. CT + 2 IN-sep	Measured IN and calculated 3I0 when IN > 1.6 A	3 × protection, 1 × sensitive	0.001 A to 35.000 A
3ph, 2prim. CT + IN-sep 2ph, 2p. CT + IN-sep	Measured IN	4 × protection	0.030 A to 35.000 A
		4 × measurement	0.001 A to 1.600 A
		3 × protection, 1 × sensitive	0.001 A to 1.600 A

With the use of the function within a 1-phase function group and therefore at a 1-phase measuring point **I-1ph**, the following different linearity and settings ranges result:

Measuring Point I-1ph	Current Threshold	Current Terminal Block	3I0 Threshold Value Settings Range (Secondary) ²⁷
	Measured	Sensitive	0.001 A to 1.600 A
		Protection	0.030 A to 35.000 A

The method of measurement processes the sampled current values and filters out the fundamental component numerically.

The methods of measurement are characterized by high accuracy and by insensitivity to harmonics, especially the 3rd and 5th harmonics frequently present in the ground-fault (residual) current.

Ground-Fault Detection, Pickup

If the absolute value of the ground current 3I0 exceeds the threshold value **3I0 > threshold value** and the absolute value of the zero-sequence voltage V0 exceeds the threshold value **V0 > threshold value**, the stage recognizes the ground fault. The direction determination (see the next paragraph) is started when the V0 threshold value is exceeded. The direction result is indicated via the *Ground fault* signal (in the **General** function block). If the direction result equals the parameterized direction (parameter **Directional mode**), the stage picks up.

Direction Determination

Exceeding the threshold values by the zero-sequence voltage V0 is a criterion for the ground fault. The direction determination can be delayed from the occurrence of the zero-sequence voltage with the **Dir. determination delay** parameter to achieve steady-state measurands. The result from the direction determination is only valid if the absolute value of the ground current 3I0 has also exceeded its threshold value.

²⁴ These values apply for a secondary rated current of 1 A. For a secondary rated current of 5 A, the values must be multiplied by 5.

²⁵ If the connection type is without IN, such as 3-phase, the current threshold value is a calculated 3I0 value.

²⁶ If the connection type is with IN, such as 3-phase + IN, the current threshold value is a measured IN value.

²⁷ These values apply for a secondary rated current of 1 A. For a secondary rated current of 5 A, the values must be multiplied by 5.

The following figure shows an example of the direction determination in the complex phasor diagram for the $\cos\phi$ direction measurement method with a correction value of the direction straight lines from 0 (parameter ϕ **correction**). The example is suitable for the determination of the ground-fault direction in an arc-suppression-coil-ground system where the variable $3I_0 \cdot \cos\phi$ is decisive for the direction determination.

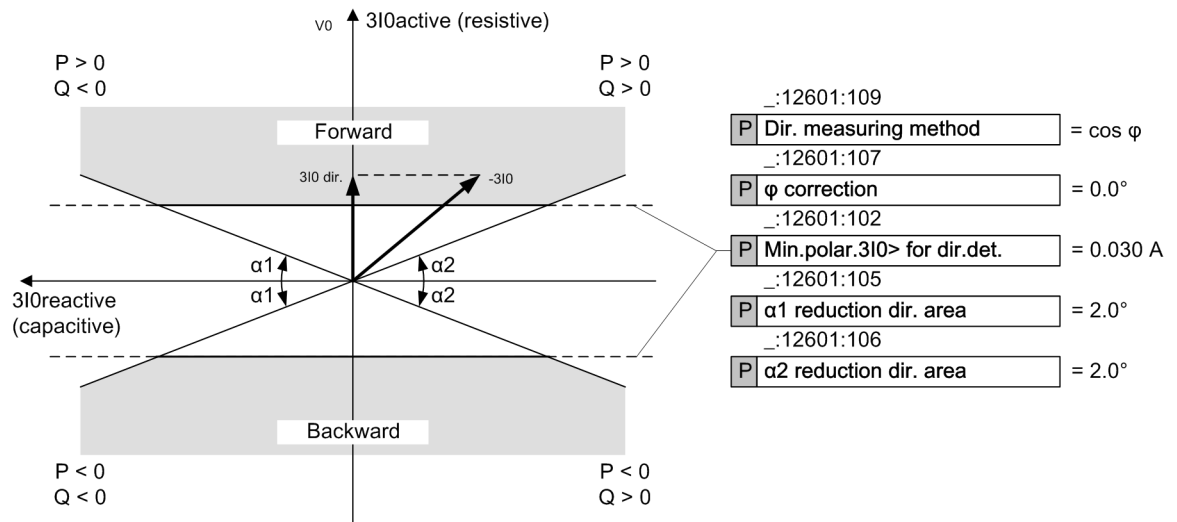

[dir_cospfi_3_en_US]

Figure 6-121 Direction-Characteristic Curve with Cos ϕ Measurement

The zero-sequence voltage V_0 is basically the reference value for the real axis. The axis of symmetry of the direction-characteristic curve coincides with the $3I_0$ reactive axis for this example. For the direction determination, basically the portion of the current vertical to the set direction-characteristic curve (= axis of symmetry) is decisive ($3I_0$ dir.). In this example, this is the active portion $3I_0$ active of the current $3I_0$. The current $3I_0$ dir. (here = $3I_0$ active) is calculated and compared with the setting value **Min.polar.3I0> for dir.det.**. If the current $3I_0$ dir. exceeds the positive setting value, the direction is forward. If the current $3I_0$ dir. exceeds the negative setting value, the direction is backward. In the range in between, the direction is undetermined. With the **α_1 reduction dir. area** and **α_2 reduction dir. area** parameters, you can limit the forward and backward ranges as shown in the figure. With this, the direction determination is secured in case of high currents in the direction of the axis of symmetry.

The symmetry axis can be turned via a correction angle ϕ **correction** parameter) in a range of $\pm 45^\circ$. Through this, it is possible, for example, to attain the greatest sensitivity in grounded systems in the resistive-inductive range with a -45° turn. In the case of electric machines in busbar connection on the isolated system, the greatest sensitivity in the resistive-capacitive range can be attained with a rotation of $+45^\circ$.

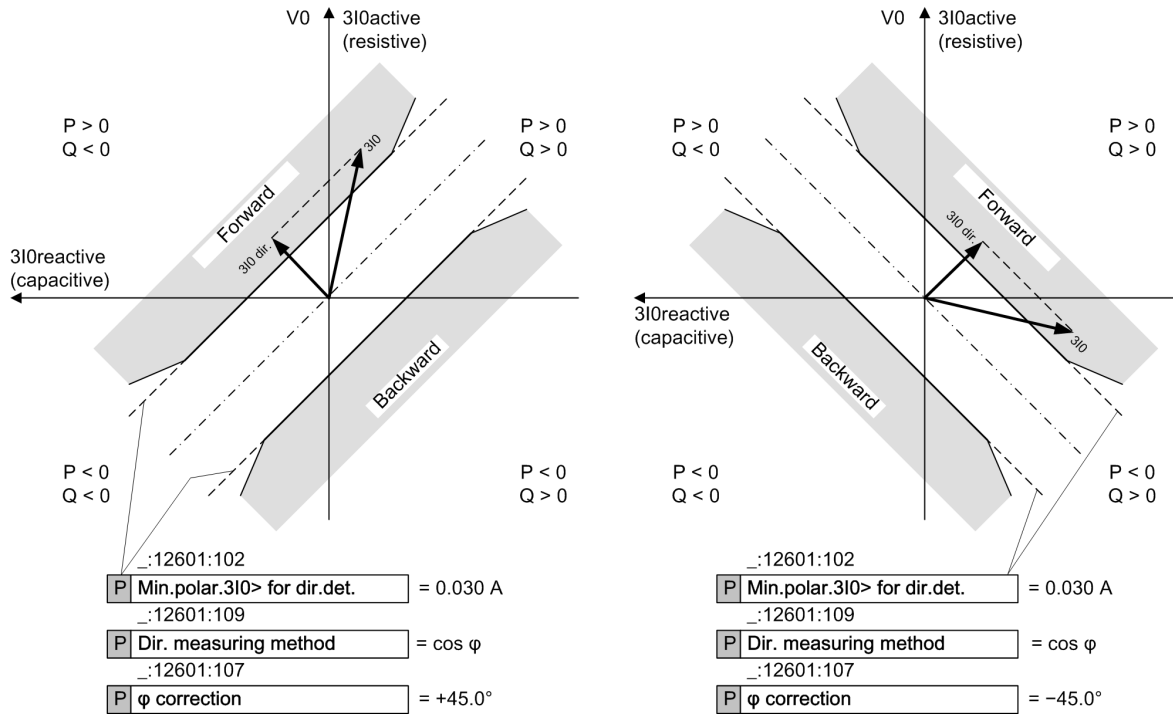

[idw_phicor, 2, en_US]

Figure 6-122 Turning the Direction-Characteristic Curves with $\cos \varphi$ Measurement with Angle Correction

If you set the **Dir. measuring method** parameter to $\sin \varphi$ and the **φ correction** parameter to 0 , the symmetry axis of the direction-characteristic curve coincides with the $3I_{0\text{active}}$ axis and the V_0 axis. Since the portion of the current vertical to the direction-characteristic curve (= axis of symmetry) is decisive ($3I_{0\text{dir.}}$), here, the current $3I_{0\text{reactive}}$ is included in the direction determination. If the current $3I_{0\text{dir.}}$ (here = $3I_{0\text{reactive}}$) exceeds the negative setting value **Min.polar.3I0> for dir.det.**, the direction is forward. If the current $3I_{0\text{dir.}}$ exceeds the positive setting value, the direction is backward. In the range in between, the direction is undetermined.

This direction measurement thus is appropriate for the determination of ground-fault direction in isolated systems.

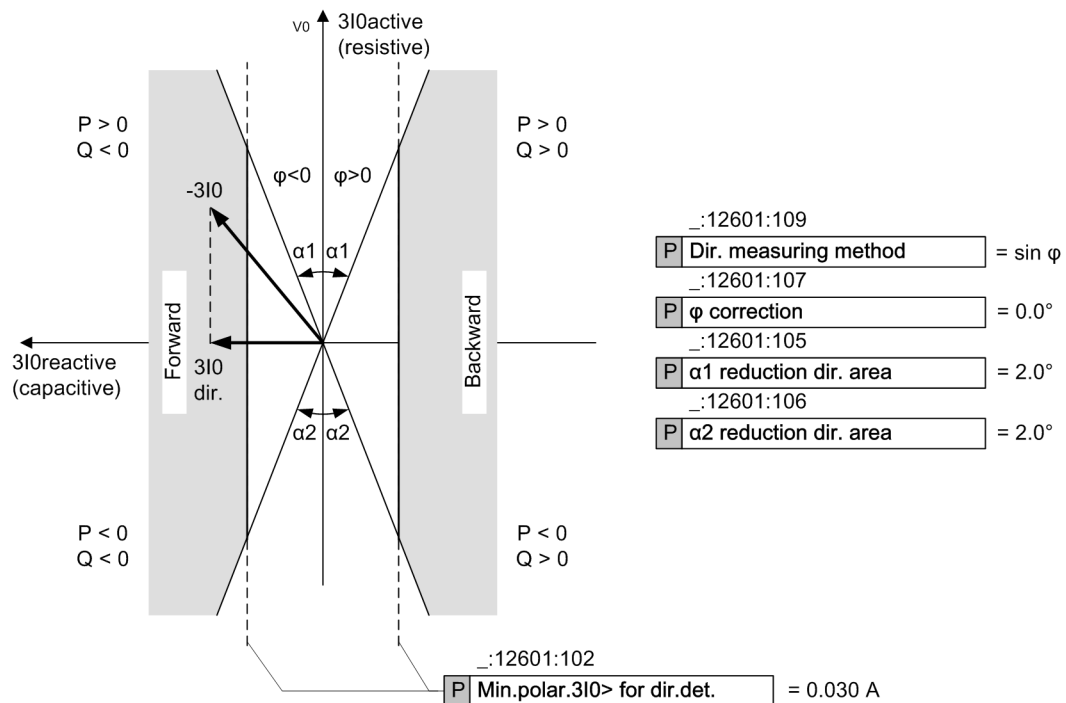

[dw_sin_phi, 4, en_US]

Figure 6-123 Direction-Characteristic Curve with Sin ϕ Measurement

Blocking the Stage via Binary Input Signal

You can block the stage externally or internally via the binary input signal $>Block$ stage. In the event of blocking, the picked up stage will be reset.

Blocking the Stage in Case of Measuring-Voltage Failure

The stage can be blocked if a measuring-voltage failure occurs. In the event of blocking, the picked up stage will be reset.

The following blocking options are available for the stage:

- From inside on pickup of the **Measuring-voltage failure detection** function
- From an external source via the binary input signal $>Open$ of the function block **Voltage-transformer circuit breaker**, which links in the tripping of the voltage-transformer circuit breaker.

The **Blk. by meas.-volt. failure** parameter can be set so that Measuring-voltage failure detection blocks the stage or does not block it.

Blocking the Stage in Case of an Intermittent Ground Fault

In case of an intermittent ground fault, the stage can be blocked upon receiving the internal signal **Interm.gnd.fl.t.det** from the **Intermittent ground-fault blocking** stage. In the event of blocking, the picked-up stage will be reset.

After the release of the blocking, the timer **Dir. determination delay** is newly started and must expire before a new ground fault or pickup is annunciated.

With the **Blk. by interm.gnd.fl.t.** parameter, you can enable or disable the blocking of the stage in case of an intermittent ground fault.

Blocking the Pickup with Detection of the Fault Extinction

Using the evaluation of the instantaneous value developing of the zero-sequence voltage, the fault extinction can be recognized faster than via the dropout of the V_0 fundamental-component value under the pickup value. The pickup of the stage is blocked with the fast detection of the fault extinction. With this, the pickups

are avoided due to the decay procedure in the zero-sequence system after the fault extinction. With the **Blk. after fault extinction** parameter, you enable or disable this accelerated detection of the fault extinction.

Blocking the Time Delay

You can use the binary input signal *>Block delay & op.* to prevent the start of the time delay and thus also the operate indication. A running time delay is reset. The pickup is indicated and a fault record is opened.

Blocking of the Tripping by Device-Internal Inrush-Current Detection

The **Blk. w. inrush curr. detect.** parameter allows you to define whether the operate indication of the stage should be blocked when a threshold value is exceeded due to an inrush current. In case of a blocking and fulfilled pickup conditions, the stage picks up. The start of the time delay and the operate indication are blocked. The function indicates this through a corresponding indication. If the blocking drops out and the pickup conditions are still met, the time delay is started. After that time, the stage operates.

6.15.4.2 Application and Setting Notes

Parameter: Operate & flt.rec. blocked

- Default setting (`_ :12601:2`) **Operate & flt.rec. blocked = no**
- You can block the operate indication, the fault recording, and the fault log with the **Operate & flt.rec. blocked** parameter. In this case, a ground-fault log is created instead of the fault log.

Parameter: Blk. by meas.-volt. failure

- Recommended setting value (`_ :12601:10`) **Blk. by meas.-volt. failure = yes**
- You use the **Blk. by meas.-volt. failure** parameter to control the behavior of the stage when a measuring-voltage failure is detected.
- A measuring-voltage failure can only be detected if one of the following 2 conditions is met:
- The device-internal supervision function **Measuring-voltage failure detection** is configured and enabled.
 - The binary input signal *>Open* of the function block **Voltage-transformer circuit breaker** is connected to the voltage-transformer circuit breaker.

Parameter Value	Description
<i>yes</i>	The protection stage is blocked (= default setting). If V0 is calculated from the phase-to-ground voltages, Siemens recommends using the blocking.
<i>no</i>	The protection stage is not blocked. If V0 is obtained from the VN measurement of a broken-delta winding, Siemens recommends not using the blocking.

Parameter: Blk. w. inrush curr. detect.

- Recommended setting value (`_ :12601:27`) **Blk. w. inrush curr. detect. = no**
- With the **Blk. w. inrush curr. detect.** parameter, you specify whether the operate is blocked during detection of an inrush current.
- Siemens recommends disabling the blocking. The fundamental component of the zero-sequence voltage is a reliable criterion for the ground fault and remains unaffected by a switching-on procedure.

Parameter: Blk.by interm.gnd.flt.

- Default setting (`_ :12601:111`) **Blk.by interm.gnd.flt. = no**
- With the **Blk.by interm.gnd.flt.** parameter, you specify whether the stage is blocked upon receiving an internal signal *Interm.gnd.flt.det* from the **Intermittent ground-fault blocking** stage.

During intermittent ground faults, stages designed for detecting permanent ground faults (based on continuous RMS measurement) tend to generate a flood of signals and probably even temporary wrong directional information. This can be avoided by blocking these stages in case of an intermittent ground fault.

If intermittent ground faults in your network are probable, Siemens recommends enabling the blocking.

Parameter: Blk. after fault extinction

- Recommended setting value (`_:12601:110`) **Blk. after fault extinction = yes**

If the **Blk. after fault extinction** parameter is set to **yes**, the pickup is blocked after detection of the fault extinction. With this, the pickups are avoided due to the decay procedure in the zero-sequence system after the fault extinction. Siemens recommends using the default setting.

Parameter: Directional mode

- Default setting (`_:12601:108`) **Directional mode = forward**

When a fault is detected, the selection of the parameter **Directional mode** defines whether the pickup of the stage occurs in forward or backward direction.

Parameter: Dir. measuring method, φ correction, Min.polar.3I0> for dir.det., 3I0> threshold value

- Default setting (`_:12601:109`) **Dir. measuring method = cos φ**
- Default setting (`_:12601:107`) **φ correction = 0.0°**
- Default setting (`_:12601:102`) **Min.polar.3I0> for dir.det. = 0.030 A**
- Default setting (`_:12601:101`) **3I0> threshold value = 0.050 A**

These parameters are used to define the direction characteristic of the stage. The direction characteristic to use is dependent on the neutral-point treatment of the system.

Note that, for the direction determination, basically only a portion of the current vertical to the set direction-characteristic curve (3I0dir.) is decisive, refer to [6.15.4.1 Description](#). This portion of the current is compared to the threshold value **Min.polar.3I0> for dir.det.**. In contrast, the absolute value of the current 3I0 is compared with the **3I0> threshold value** parameter.

System Type/ Neutral-Point Treatment	Description
Arc-suppression coil grounded	<p>In the arc-suppression-coil-ground system, the watt-metric residual current $3I_0 \cdot \cos \varphi$ of the arc-suppression coil is decisive for the direction determination.</p> <p>To evaluate the watt-metric residual current, set the parameters as follows:</p> <ul style="list-style-type: none"> • Dir. measuring method = $\cos \varphi$ • φ correction = 0.0° <p>The direction determination for a ground fault is made more difficult in that a much larger capacitive or inductive reactive current is superimposed on the small watt-metric residual current. Therefore, depending on the system configuration and the fault evaluation, the total ground current supplied to the device can vary considerably in its values regarding the magnitude and the phase angle. However, the device should only evaluate the active component of the ground-fault current.</p> <p>This requires extremely high accuracy, particularly regarding the phase-angle measurement of all the instrument transformers. Furthermore, the device must not be set to operate too sensitively. A reliable direction measurement can only be expected with connection to a core balance current transformer. For the setting of the Min.polar.3I0> for dir.det. parameter, the rule of thumb is: Set the pickup value only to half of the expected measuring current as only the watt-metric residual current can be put into use.</p> <p>The 3I0> threshold value parameter can also be set to half of the expected measuring current, whereby here the entire zero-sequence current can be put to use.</p>
Isolated	<p>In the isolated system, the capacitive ground reactive current $3I_0 \cdot \sin \varphi$ is decisive for the direction determination.</p> <p>To evaluate the capacitive ground reactive current, set the parameters as follows:</p> <ul style="list-style-type: none"> • Dir. measuring method = $\sin \varphi$ • φ correction = 0.0° <p>In an isolated system, the capacitive ground-fault currents of the entire electrically connected system flow through the measuring point in case of a ground fault. The ground current of the faulty feeder is compensated in the measuring point. As the pickup value of the Min.polar.3I0> for dir.det. and 3I0> threshold value parameters, select about half of this capacitive ground-fault current flowing via the measuring point.</p>
Resistance-Grounded	<p>In the resistance-grounded system, the ohmic-inductive ground-fault current is decisive for the direction determination.</p> <p>To evaluate this short-circuit current, set the parameters as follows:</p> <ul style="list-style-type: none"> • Dir. measuring method = $\cos \varphi$ • φ correction = -45.0° <p>Set the Min.polar.3I0> for dir.det. and 3I0> threshold value parameters to a value below the minimum ground-fault current to be expected.</p>

Parameter: α_1 reduction dir. area, α_2 reduction dir. area

- Recommended setting value (**_:12601:105**) **α_1 reduction dir. area** = 2°
- Recommended setting value (**_:12601:106**) **α_2 reduction dir. area** = 2°

With the **α_1 reduction dir. area** and **α_2 reduction dir. area** parameters, you specify the angle for the limitation of the direction range. Siemens recommends using the default setting of 2° .

In an arc-suppression-coil-ground system in feeders with a very large reactive current, it can be practical to set a somewhat larger angle α_1 to avoid a false pickup based on transformer and algorithm tolerances.

Parameter: V0> threshold value

- Default setting (`_:12601:103`) **V0> threshold value = 30.000 V**

The **V0> threshold value** parameter allows you to set the zero-sequence voltage sensitivity of the stage. Set the threshold value smaller than the minimum absolute value of the zero-sequence voltage V0 that must still be detected.

Parameter: Dir. determination delay

- Default setting (`_:12601:104`) **Dir. determination delay = 0.00 s**

The start of the ground fault normally shows a significant transient behavior. This can lead to an incorrect direction decision. The direction determination can be delayed from the occurrence of the zero-sequence voltage with the **Dir. determination delay** parameter to achieve steady-state measurands. The duration of the transient cycle is determined from the system conditions and the respective fault characteristics. If you have no knowledge of a suitable time delay, Siemens recommends keeping the default setting.

Parameter: Operate delay

- Default setting (`_:12601:6`) **Operate delay = 2.0 s**

The **Operate delay** parameter determines the time during which the pickup conditions must be met to issue the operate indication. The operate indication is issued when this time expires.

6.15.4.3 Settings

Addr.	Parameter	C	Setting Options	Default Setting
3I0> cos/sinφ1				
<code>_:12601:1</code>	3I0> cos/sinφ1:Mode		<ul style="list-style-type: none"> • off • on • test 	off
<code>_:12601:2</code>	3I0> cos/sinφ1:Operate & ft.rec. blocked		<ul style="list-style-type: none"> • no • yes 	no
<code>_:12601:10</code>	3I0> cos/sinφ1:Blk. by meas.-volt. failure		<ul style="list-style-type: none"> • no • yes 	yes
<code>_:12601:111</code>	3I0> cos/sinφ1:Blk.by interm.gnd.ft.		<ul style="list-style-type: none"> • no • yes 	no
<code>_:12601:27</code>	3I0> cos/sinφ1:Blk. w. inrush curr. detect.		<ul style="list-style-type: none"> • no • yes 	no
<code>_:12601:110</code>	3I0> cos/sinφ1:Blk. after fault extinction		<ul style="list-style-type: none"> • no • yes 	yes
<code>_:12601:108</code>	3I0> cos/sinφ1:Directional mode		<ul style="list-style-type: none"> • forward • reverse 	forward
<code>_:12601:109</code>	3I0> cos/sinφ1:Dir. measuring method		<ul style="list-style-type: none"> • cos φ • sin φ 	cos φ
<code>_:12601:107</code>	3I0> cos/sinφ1:φ correction		-45° to 45°	0°
<code>_:12601:102</code>	3I0> cos/sinφ1:Min.polar.3I0> for dir.det.	1 A @ 100 Irated	0.030 A to 35.000 A	0.030 A
		5 A @ 100 Irated	0.15 A to 175.00 A	0.15 A
		1 A @ 50 Irated	0.030 A to 35.000 A	0.030 A
		5 A @ 50 Irated	0.15 A to 175.00 A	0.15 A
		1 A @ 1.6 Irated	0.001 A to 35.000 A	0.030 A
		5 A @ 1.6 Irated	0.005 A to 35.000 A	0.150 A

Addr.	Parameter	C	Setting Options	Default Setting
_:12601:105	3I0> cos/sinφ1:α1 reduction dir. area		1° to 15°	2°
_:12601:106	3I0> cos/sinφ1:α2 reduction dir. area		1° to 15°	2°
_:12601:101	3I0> cos/sinφ1:3I0> threshold value	1 A @ 100 Irated	0.030 A to 35.000 A	0.050 A
		5 A @ 100 Irated	0.15 A to 175.00 A	0.25 A
		1 A @ 50 Irated	0.030 A to 35.000 A	0.050 A
		5 A @ 50 Irated	0.15 A to 175.00 A	0.25 A
		1 A @ 1.6 Irated	0.001 A to 35.000 A	0.050 A
		5 A @ 1.6 Irated	0.005 A to 35.000 A	0.250 A
_:12601:103	3I0> cos/sinφ1:V0> threshold value		0.300 V to 200.000 V	30.000 V
_:12601:104	3I0> cos/sinφ1:Dir. determination delay		0.00 s to 60.00 s	0.10 s
_:12601:6	3I0> cos/sinφ1:Operate delay		0.00 s to 60.00 s	2.00 s

6.15.4.4 Information List

No.	Information	Data Class (Type)	Type
<i>3I0> cos/sinφ1</i>			
_:12601:81	3I0> cos/sinφ1:>Block stage	SPS	I
_:12601:501	3I0> cos/sinφ1:>Block delay & op.	SPS	I
_:12601:54	3I0> cos/sinφ1:Inactive	SPS	O
_:12601:52	3I0> cos/sinφ1:Behavior	ENS	O
_:12601:53	3I0> cos/sinφ1:Health	ENS	O
_:12601:60	3I0> cos/sinφ1:Inrush blocks operate	ACT	O
_:12601:302	3I0> cos/sinφ1:Ground fault	ACD	O
_:12601:55	3I0> cos/sinφ1:Pickup	ACD	O
_:12601:56	3I0> cos/sinφ1:Operate delay expired	ACT	O
_:12601:57	3I0> cos/sinφ1:Operate	ACT	O

6.15.5 Directional Transient Ground-Fault Stage

6.15.5.1 Description

Overview

Ground faults occurring in arc-suppression-coil-ground systems often extinguish a short time after the ignition, mostly within a few milliseconds. Such transient occurrences are called transient ground faults. In order to detect the ground-fault direction, based on these transient occurrences, a special method of measurement is required that can also capture high frequencies. Conventional methods based on phasor calculations are not suitable. Even for ground faults lasting for a short time, usually, a high-frequency charging process occurs in healthy phases. The transient charging process is evaluated by an energy-integrating method to determine the ground-fault direction. This method ensures high sensitivity and positive stability against parasitic signals in the zero-sequence system.

Since permanent ground faults also start with the transient charging process in healthy phases, those errors will be detected as well.

This stage is most suitable for the use in closed loops or meshed systems. Operational, circulating zero-sequence currents are eliminated and therefore, cannot affect the directional result.

Stage-Control Logic

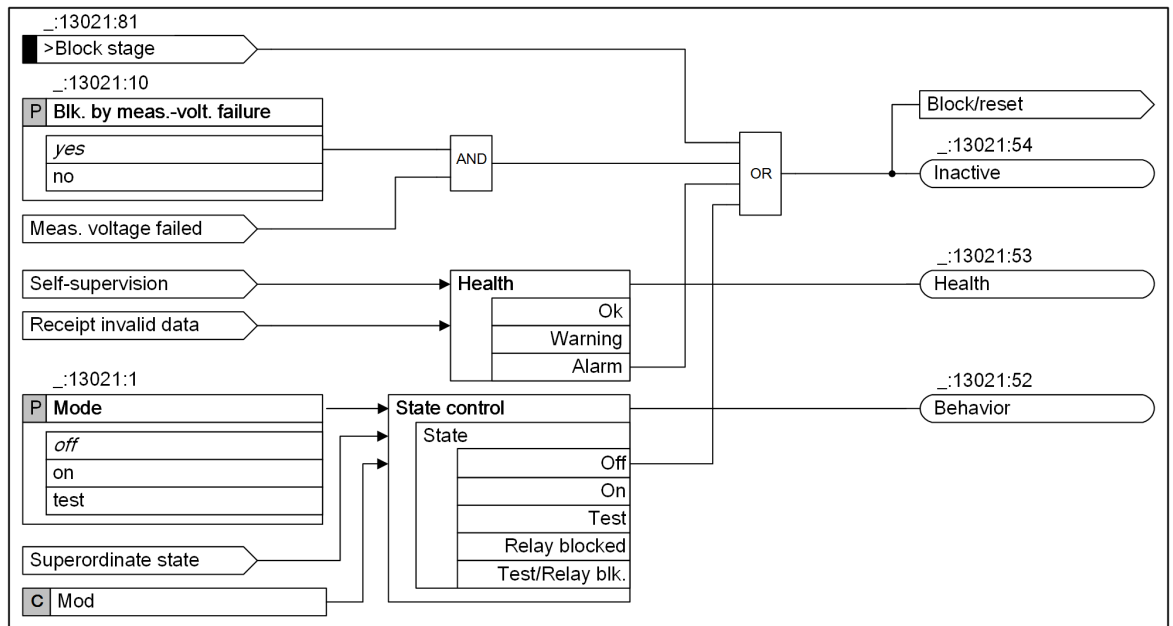

[to: stu_wis, 3, en, US]

Figure 6-124 Logic Diagram of the Stage Control

Blocking the Stage via Binary Input Signal

You can block the stage externally or internally via the binary input signal *>Block stage*. In the event of blocking, the picked up stage will be reset.

Blocking the Stage in Case of Measuring-Voltage Failure

The stage can be blocked if a measuring-voltage failure occurs. In the event of blocking, the picked up stage will be reset. The following blocking options are available for the stage:

- From inside on pickup of the **Measuring-voltage failure detection** function
- From an external source via the binary input signal *>Open* of the function block **Volt.-transf. c. b.**, which links in the tripping of the voltage-transformer circuit breaker.

The **Blk. by meas.-volt. failure** parameter can be set so that **measuring-voltage failure detection** blocks the stage or not.

Logic of the Transient Ground-Fault Functionality

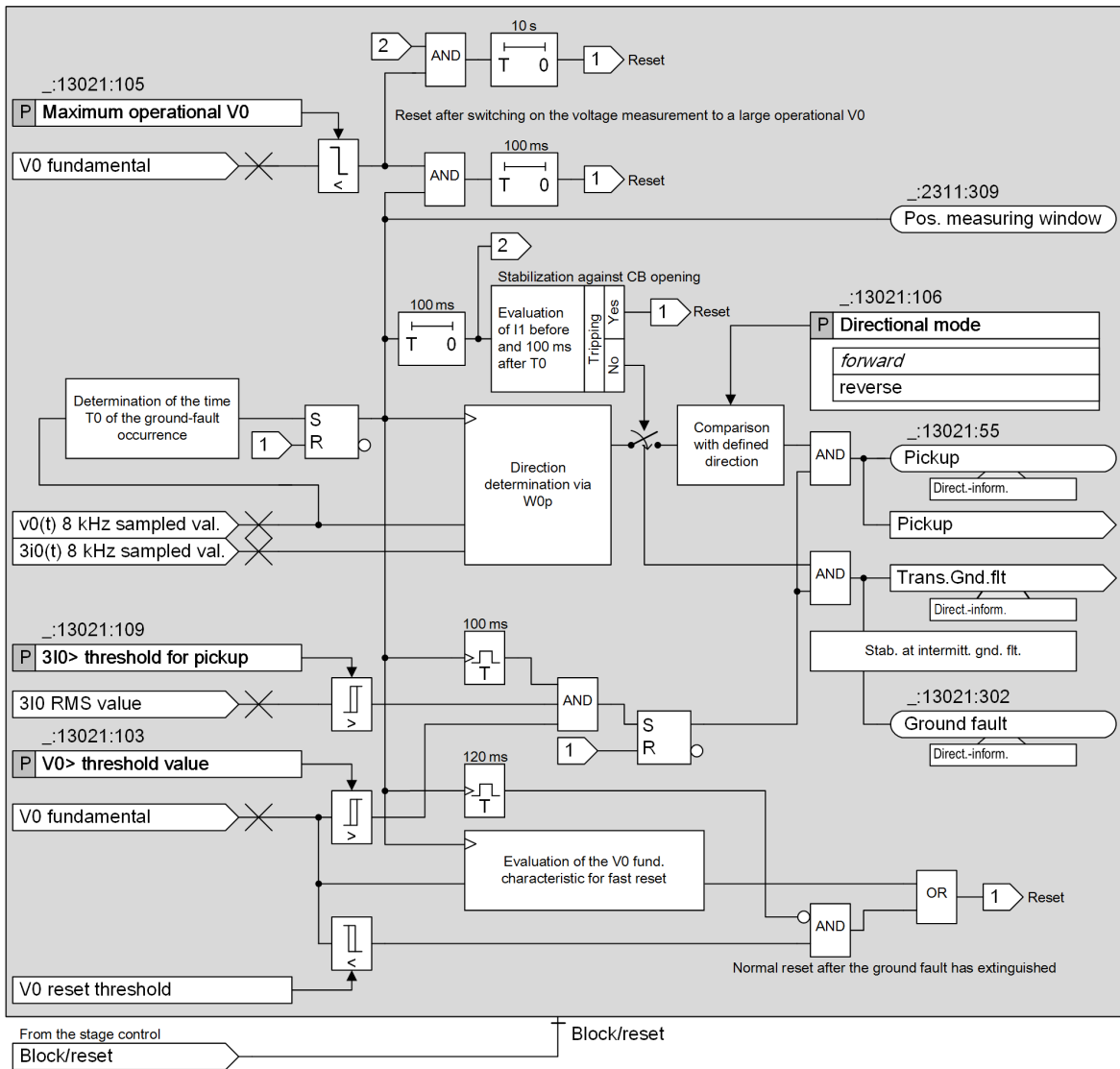

Figure 6-125 Logic Diagram of the Directional Transient Ground-Fault Stage

Measured Values, Method of Measurement

The zero-sequence voltage and zero-sequence current are measured directly or calculated from the phase variables. When measuring directly, the following is detected:

- Zero-sequence voltage on the broken-delta winding
- Zero-sequence current via Holmgreen connection or via core balance current transformer

The voltage measured on the broken-delta winding will be converted to the zero-sequence voltage V_0 .

The instantaneous values of the zero-sequence voltage $v_0(t)$ that are sampled at a high frequency (8 kHz) serve to determine the point in time of the ground fault occurrence T_0 .

The instantaneous values of the zero-sequence voltage $v_0(t)$ and the ground current $3i_0(t)$, which are sampled at a high frequency (8 kHz), are the basis for direction determination.

The fundamental-component values of the zero-sequence voltage V_0 serve to release the directional result and the pickup as well as a criterion for the stabilization against switching operations.

The positive-sequence system (if it exists as a measured value) serves as an additional criterion for the stabilization against switching operations.

The fundamental-component value of V_0 and the true RMS value of I_0 will be used for the pickup and the optional trip logic.

Operational, meaning circulating zero-sequence currents, can occur in closed loops or meshed systems. This type of zero-sequence current is also present in case of a failure and can falsify the directional result. Therefore, an operational zero-sequence current is eliminated.

Determining the Time of the Ground-Fault Ignition

The algorithm uses the evaluation of the instantaneous values of the zero-sequence voltage to verify continuously whether a ground fault occurred. This takes place regardless of whether the set threshold value for V_0 is exceeded. If a ground fault occurs, the measuring window for determining the direction is positioned and the direction determination is performed. The position of the measuring window is logged via the indication *Pos. measuring window* (in FB **General**). The precise identification of the time T_0 at which the ground fault occurs is decisive for the correct direction determination.

Determination of Direction, Method of Measurement

The active energy of the zero-sequence system is calculated for the direction determination. Once the ground-fault occurrence has been detected, the active energy will be calculated across approximately 1 cycle frequency. If the active energy of the zero-sequence system is negative, a forward fault is present; otherwise it is a backward fault.

Directional Ground-Fault Signal, Pickup

Determining the time of the ground-fault ignition and the direction is always done with maximum sensitivity. With the parameters **$V_0 > \text{threshold value}$** and **$I_0 > \text{threshold for pickup}$** , you define the sensitivity for the indication of the direction and the pickup of the stage.

If both of the following conditions are met, the direction result will be reported:

- The fundamental-component value of the zero-sequence voltage V_0 exceeds the **$V_0 > \text{threshold value}$** within 100 ms after detecting the ground-fault ignition.
- The true RMS value of the zero-sequence current I_0 exceeds the **$I_0 > \text{threshold for pickup}$** .

In this way, high-impedance ground faults are also reported in which the zero-sequence system values rise only slowly, and, for this reason, the occurrence of the ground fault is detected noticeably earlier than the exceedance of the parameterized threshold value.

The direction result will be reported to the function via the (*_:2311:302*) *Ground fault* of the function block **General information**. This indication is reported irrespective of the parameterized direction of the function.

If the determined direction corresponds with the parameterized direction (parameter **Directional mode**), a pickup occurs.

Reset of the Algorithm

To allow a new directional measurement, the algorithm needs to be reset. The normal reset takes place when all the following conditions are met:

- The fundamental component of the zero-sequence voltage V_0 drops below the V_0 reset threshold. This reset threshold is a small device-internal V_0 threshold. It is also depending on an operational V_0 and is thus a dynamic threshold. The threshold value is 2.0 V secondary without dynamic influence.
- The duration of 120 ms after T_0 has expired.

Stabilization against Switching Operations

Switching operations in the system to be protected can cause transient signals in the zero-sequence system. The stage is stabilized against possible overfunction due to switching operations.

The following mechanisms are applied:

- The fundamental-component value of the zero-sequence voltage V_0 is usually only marginal influenced by switching operations and is thus a good criterion for distinguishing the ground fault from a switching operation. The condition that the fundamental-component value must exceed the **$V_0 >$ threshold value** for reporting the direction result effectively suppresses the influence of switching operations.

For rare cases in which high zero-sequence voltages occur over longer time ranges after switching off the feeder or line, a criterion based on the positive-sequence current is also effective. This criterion compares the positive-sequence current before and after the transient event and thus detects a disconnection. In case of disconnection, the direction result is not reported.

Through stabilization mechanisms, the direction result is reported 100 ms after the ground-fault ignition. Thus a pickup occurs with a 100-ms delay.

If the stage is used in a 1-phase function group, the additional criterion via the positive-sequence current is not effective.
- The function detects transient ground faults using the zero-sequence voltage. In systems with operational zero-sequence voltages, if the measuring voltage is switched on, the function can internally be started. If the fundamental-component value of the zero-sequence voltage does not exceed the threshold of the **Maximum operational V_0** parameter in a time slot of 100 ms after the function start, the function is reset internally. For an unexpected case where the function is started due to a switching transient event, a further reset criterion exists to ensure that the function does not permanently remain in the start condition. After the time of 100 ms, if the fundamental-component value is continuously less than the **Maximum operational V_0** threshold for 10 s, the function is reset as well.

Trip Logic

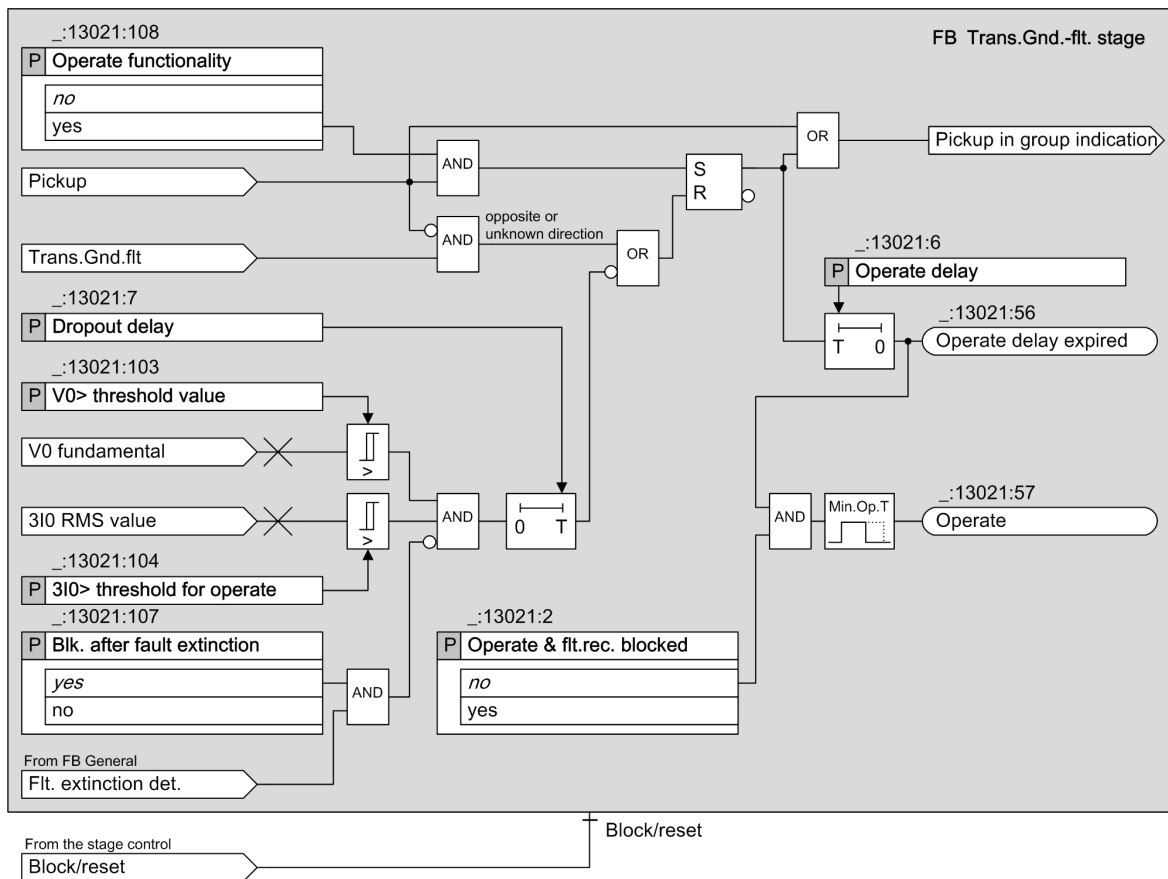

[to_auswis, 4, en_US]

Figure 6-126 Trip Logic Diagram

In many applications, the transient ground-fault stage is used only to indicate the direction. In this case, the trip logic is not required and remains disabled. However, this stage can also be used to trip a permanent ground fault. For this, you enable the optional trip logic with the **Operate functionality** parameter. If the fundamental-component value of V0 and the true RMS value of 3I0 exceed the set threshold values, the tripping delay (**Operate delay** parameter) starts with the pickup. If the parameter **Operate & flt.rec. blocked** is set to **no**, the stage operates when the tripping delay expires.

An intermittent ground fault has the characteristics of periodical extinction and reignition within one half period up to several periods. You can find more information in chapter [6.14.1 Overview of Functions](#). Due to the tripping delay and the too short fault durations (contact to ground), reliable tripping is not possible. To ensure reliable tripping under such conditions, the parameter **Dropout delay** can be used. When the fault extinguishes, the fundamental-component value of V0 and the true RMS value of 3I0 drop below the threshold values. A dropout can be delayed for a time specified with the **Dropout delay** parameter. The tripping delay continues to run. If the time delay expires within the dropout delay, the stage operates. You can set the **Dropout delay** according to the application. The default setting is 0 s. The setting of the dropout delay does not affect the direction determination. When the fault reignites, a new direction determination takes place if the function has dropped out before. If the determined direction is opposite to the parameterized direction or is unknown, the tripping delay is reset immediately.

Blocking the Tripping Delay with Detection of the Fault Extinction

Using the evaluation of the instantaneous value cycle of the zero-sequence voltage, the fault extinction of the ground fault can be detected faster than via the dropout of the V0 fundamental-component value under the pickup value. The fast detection of the fault extinction (see function block **General information**) blocks the tripping delay after the dropout delay expires. With the parameter **Blk. after fault extinction**, this accelerated blocking mechanism can be enabled or disabled.

6.15.5.2 Application and Setting Notes

Parameter: **Operate functionality**

- Default setting (`_:13021:108`) **Operate functionality** = **no**

If the transient ground-fault stage is used only to indicate the direction, this optional trip logic is not required and remains disabled. If the transient ground-fault stage is used to trip permanent faults as well, this optional trip logic must be enabled. Pickup of the stage will initiate the tripping delay.

Parameter: **Operate & flt.rec. blocked**

- Default setting (`_:13021:2`) **Operate & flt.rec. blocked** = **no**

You can block the operate indication, the fault recording, and the fault log with the **Operate & flt.rec. blocked** parameter. In this case, a ground-fault log is created instead of the fault log.

Parameter: **Blk. by meas.-volt. failure**

- Recommended setting value (`_:13021:10`) **Blk. by meas.-volt. failure** = **yes**

You use the **Blk. by meas.-volt. failure** parameter to control the behavior of the stage when a measuring-voltage failure is detected.

A measuring-voltage failure can only be detected if one of the following 2 conditions is met:

- The device-internal supervision function **Measuring-voltage failure detection** is configured and enabled.
- The binary input signal *>Open* of the function block **Voltage-transformer circuit breaker** is connected to the voltage-transformer circuit breaker.

Parameter Value	Description
yes	The protection stage is blocked (= default setting). If V0 is calculated from the phase-to-ground voltages, Siemens recommends using the blocking.
no	The protection stage is not blocked. If V0 is obtained from the VN measurement of a broken-delta winding, Siemens recommends not using the blocking.

Parameter:Blk. after fault extinction

- Recommended setting value (_:13021:107) **Blk. after fault extinction = yes**

If the **Blk. after fault extinction** parameter is set to **yes**, the tripping delay is reset after the detection of the fault extinction. Therefore, if the tripping delay is set for a short time, the possibility of an overfunction is avoided. The reason for an overfunction is a slower attenuation in the zero-sequence system following the fault extinction. Siemens recommends keeping this default setting if the stage is used for tripping.

To protect against intermittent ground faults, the stage uses the parameter **Dropout delay** to delay a dropout due to fault extinction. If you are using the stage for protection against intermittent ground faults, disable the blocking.

Parameter:Directional mode

- Default setting (_:13021:106) **Directional mode = forward**

When a fault is detected, the selection of the parameter **Directional mode** defines whether the pickup of the stage occurs in forward or backward direction.

Parameter:V0> threshold value

- Default setting (_:13021:103) **V0> threshold value = 15.000 V**

With the parameter **V0> threshold value**, you define the sensitivity for the indication of the direction and the pickup of the stage.

Note that the sensitivity of the direction determination itself is not influenced. The direction determination always works with maximum sensitivity.

If high-resistive ground faults must also be reported, very sensitive settings are possible, for example, **V0> threshold value = 5 V**secondary.

Parameter:Maximum operational V0

- Recommended setting value (_:13021:105) **Maximum operational V0 = 3.000 V**

With the parameter **Maximum operational V0**, you define the maximum operational zero-sequence voltage V0. If the fundamental-component value of the zero-sequence voltage V0 does not exceed the parameter **Maximum operational V0** in a time slot of 100 ms after the function has started, the stage is reset.

The setting is made with reference to the zero-sequence voltage V0 according to its definition.

Network Structure	Description
Radial network	In radial networks, operational zero-sequence voltages are rather small. Siemens recommends using the default value of 3.000 V.
Ring network, meshed network	<p>Greater operational zero-sequence voltages can occur in ring or meshed networks.</p> <p>The secondary operational zero-sequence voltages can be determined by reading the residual voltage $V_{N\text{sec}}$ or the zero-sequence voltage $V_{0\text{sec}}$ under the symmetrical components from the device or via DIGSI.</p> <p>In case you read the secondary residual voltage $V_{N\text{sec}}$, you convert it to $V_{0\text{sec}}$ with the Matching ratio V_{ph} / V_N parameter. For more information, see also 6.1.6 Application and Setting Notes for Measuring Point Voltage 3-Phase (V-3ph).</p> <p>If $V_{0\text{sec}}$ is greater than 2.5 V, the value of Maximum operational V_0 shall be increased to $V_{0\text{sec}} \cdot 1.2$.</p> <p>Example: $V_{N\text{sec}} = 5.000 \text{ V}$ Matching ratio $V_{ph} / V_N = \sqrt{3}$ $V_{0\text{sec}} = 5.000 \text{ V} \cdot \sqrt{3} / 3 = 2.887 \text{ V}$ Maximum operational $V_0 = 2.887 \text{ V} \cdot 1.2 = 3.464 \text{ V}$</p> <p>In most cases, the operational zero-sequence voltages are smaller than 2.500 V. Siemens recommends using the default value of 3.000 V.</p>

Parameter: 3I0> threshold for pickup

- Default setting (`_:13021:109`) **3I0> threshold for pickup = 0.000 A**

With the parameter **3I0> threshold for pickup**, you define the sensitivity for the indication of the direction and the pickup of the stage.

In ring or meshed systems, you can use this parameter to reduce the number of ground-fault reporting devices. The parameter needs to be set according to the user experience on the specific network. For radial systems, normally you can keep the default value of 0 A which sets this parameter to inactive.

Parameter: 3I0> threshold for operate

- Default setting (`_:13021:104`) **3I0> threshold for operate = 0.030 A**

The setting is significant only for optional trip logic for switching off permanent ground faults. Select the setting such that the static ground-fault current exceeds the threshold value. You can disable this criterion by setting the value to 0 A.

Parameter: Dropout delay

- Default setting (`_:13021:7`) **Dropout delay = 0.00 s**

The parameter **Dropout delay** allows you to use the function also as a protection against intermittent ground faults. With the parameter **Dropout delay**, the dropout of the pickup state after fault extinction is delayed or held until the next ignition. Thus, the operate delay can go on and trip the fault.

Set the time to a value within which the new ignition can still be assigned to the previous fault. Typical values are in a range between several hundred milliseconds and a few seconds.

Parameter: Operate delay

- Default setting (`_:13021:6`) **Operate delay = 0.50 s**

The **Operate delay** parameter determines the time during which the pickup conditions must be met to issue the operate indication. The operate indication is issued when this time expires.

The setting of the **Operate delay** depends on the specific application. Ensure that the pickup is delayed by 100 ms regarding the time of the ground-fault ignition.

6.15.5.3 Settings

Addr.	Parameter	C	Setting Options	Default Setting
Trans.Gnd.flt1				
_:13021:1	Trans.Gnd.flt1:Mode		<ul style="list-style-type: none"> • off • on • test 	off
_:13021:2	Trans.Gnd.flt1:Operate & flt.rec. blocked		<ul style="list-style-type: none"> • no • yes 	no
_:13021:10	Trans.Gnd.flt1:Blk. by meas.-volt. failure		<ul style="list-style-type: none"> • no • yes 	yes
_:13021:107	Trans.Gnd.flt1:Blk. after fault extinction		<ul style="list-style-type: none"> • no • yes 	yes
_:13021:108	Trans.Gnd.flt1:Operate functionality		<ul style="list-style-type: none"> • no • yes 	no
_:13021:106	Trans.Gnd.flt1:Directional mode		<ul style="list-style-type: none"> • forward • reverse 	forward
_:13021:103	Trans.Gnd.flt1:V0> threshold value		0.300 V to 200.000 V	15.000 V
_:13021:105	Trans.Gnd.flt1:Maximum operational V0		0.300 V to 200.000 V	3.000 V
_:13021:109	Trans.Gnd.flt1:3I0> threshold for pickup	1 A @ 100 Irated	0.000 A to 35.000 A	0.000 A
		5 A @ 100 Irated	0.00 A to 175.00 A	0.00 A
		1 A @ 50 Irated	0.000 A to 35.000 A	0.000 A
		5 A @ 50 Irated	0.00 A to 175.00 A	0.00 A
		1 A @ 1.6 Irated	0.000 A to 1.600 A	0.000 A
		5 A @ 1.6 Irated	0.000 A to 8.000 A	0.000 A
_:13021:104	Trans.Gnd.flt1:3I0> threshold for operate	1 A @ 100 Irated	0.000 A to 35.000 A	0.030 A
		5 A @ 100 Irated	0.00 A to 175.00 A	0.15 A
		1 A @ 50 Irated	0.000 A to 35.000 A	0.030 A
		5 A @ 50 Irated	0.00 A to 175.00 A	0.15 A
		1 A @ 1.6 Irated	0.000 A to 1.600 A	0.030 A
		5 A @ 1.6 Irated	0.000 A to 8.000 A	0.150 A
_:13021:6	Trans.Gnd.flt1:Operate delay		0.00 s to 60.00 s	0.50 s
_:13021:7	Trans.Gnd.flt1:Dropout delay		0.00 s to 60.00 s	0.00 s

6.15.5.4 Information List

No.	Information	Data Class (Type)	Type
Trans.Gnd.flt1			
_:13021:81	Trans.Gnd.flt1:>Block stage	SPS	I
_:13021:54	Trans.Gnd.flt1:Inactive	SPS	O
_:13021:52	Trans.Gnd.flt1:Behavior	ENS	O
_:13021:53	Trans.Gnd.flt1:Health	ENS	O
_:13021:302	Trans.Gnd.flt1:Ground fault	ACD	O
_:13021:55	Trans.Gnd.flt1:Pickup	ACD	O

No.	Information	Data Class (Type)	Type
_:13021:56	Trans.Gnd.flt1:Operate delay expired	ACT	O
_:13021:57	Trans.Gnd.flt1:Operate	ACT	O

6.15.6 Directional 3I0 Stage with ϕ (V0,3I0) Measurement

6.15.6.1 Description

Logic

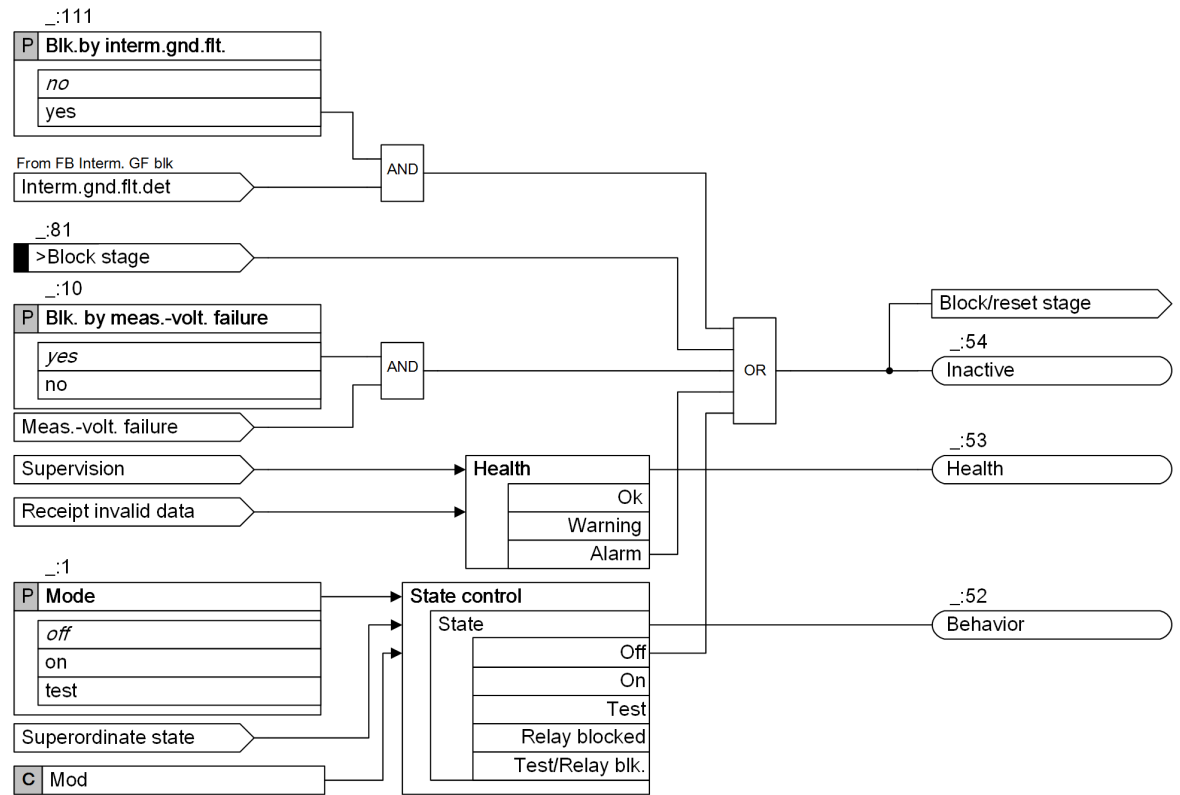

[to_gfp_pvi_3_en_US]

Figure 6-127 Logic Diagram of the Stage Control

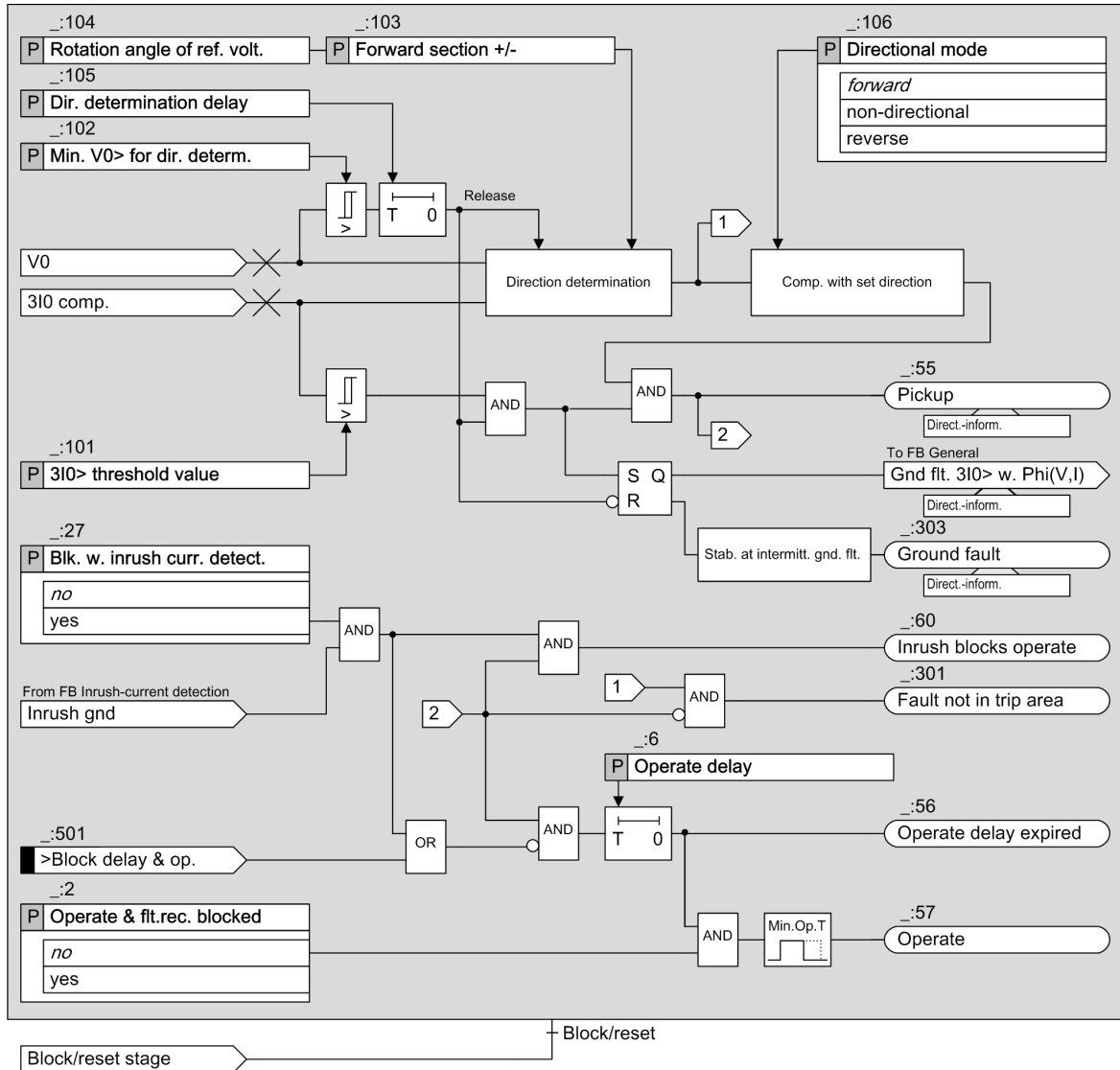

[Ilo_dir sensGFP 3I0 phi V1, 1, en_US]

Figure 6-128 Logic Diagram of the Directional 3I0 Stage with ϕ (V0,3I0) Measurement

Measured Value V0, Method of Measurement

The device can measure the residual voltage at the broken-delta winding. The measured voltage is converted to a value with reference to the zero-sequence voltage V0. If the residual voltage is not available to the device as a measurand, the zero-sequence voltage V0 is calculated from the measured phase-to-ground voltages VA, VB, and VC using the defining equation.

This method of measurement processes the sampled voltage values and filters out the fundamental component numerically.

Measured Value 3I0, Method of Measurement

The function usually evaluates the sensitively measured ground current 3I0 via a core balance current transformer. Since the linearity range of the sensitive measuring input ends at approx. 1.6 A, for larger secondary ground currents, the function switches to the 3I0 current calculated from the phase currents. This results in a very large linearity and settings range.

The method of measurement processes the sampled current values and filters out the fundamental component numerically.

Depending on the connection type of the measuring point and on the current terminal blocks used, different linearity and setting ranges result. You can find more information in chapter [Measured Value 3I0, Method of Measurement, Page 601](#).

Ground-Fault Detection, Pickup

If the absolute value of the ground current 3I0 vector exceeds the threshold value **3I0> threshold value** and the absolute value of the zero-sequence voltage V0 vector exceeds the threshold value **Min. V0> for dir. determ.**, the stage detects the ground fault. The direction determination (see in the following paragraph) is started when the zero-sequence voltage exceeds the threshold. The result from the direction determination is only valid if the absolute value of the ground current 3I0 vector has also exceeded its threshold value. The direction result is indicated via the *Ground fault* signal (in the **General** function block).

As long as the direction result equals the parameterization direction (parameter **Directional mode**), the stage picks up.

Direction Determination

Exceeding the threshold values by the zero-sequence voltage V0 is a criterion for the ground fault. The direction determination can be delayed from the occurrence of the zero-sequence voltage with the **Dir. determination delay** parameter to achieve steady-state measurands.

The direction is determined via the determination of the phase angle between the angle-error compensated ground current 3I0com. and the rotated zero-sequence voltage V0, indicated in the following as reference voltage $V_{ref,rot}$. To take different system conditions and applications into account, the reference voltage can be rotated through an adjustable angle (**Rotation angle of ref. volt.** parameter). This moves the vector of the rotated reference voltage close to the vector ground current -3I0com. Consequently, the result of direction determination is as reliable as possible.

The rotated reference voltage $V_{ref,rot}$ and the **Forward section +/-** parameter define the forward and reverse area. The forward area results as range $\pm \Delta\phi$ around the rotated reference voltage $V_{ref,rot}$. The value $\pm \Delta\phi$ is set with the **Forward section +/-** parameter. The remaining area besides the forward area is the reverse area. Between the forward and reverse area, a hysteresis is defined, refer to [Figure 6-129](#).

$\varphi_{rot} =$ **Rotation angle of ref. volt.** = -45°
 $\Delta\varphi =$ **Forward section +/-** = 88°
 Directional mode = Forward

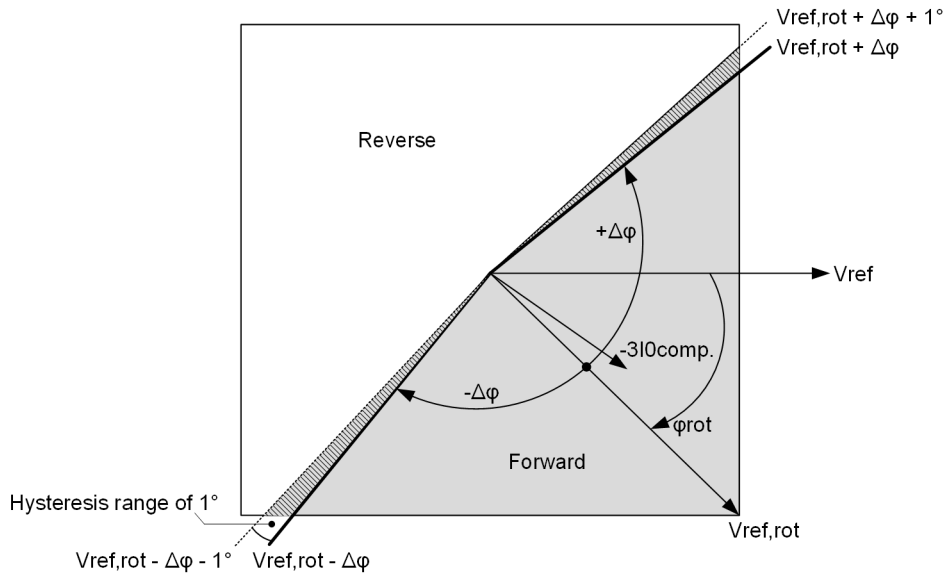

[dsw_dirrot, 1, en, US]

Figure 6-129 Directional Characteristic in Forward Mode

Blocking the Stage via Binary Input Signal

You can block the stage externally or internally via the binary input signal `>Block stage`. In the event of blocking, the picked up stage will be reset.

Blocking the Stage in Case of Measuring-Voltage Failure

The stage can be blocked if a measuring-voltage failure occurs. In the event of blocking, the picked up stage will be reset.

The following blocking options are available for the stage:

- From inside on pickup of the **Measuring-voltage failure detection** function
- From an external source via the binary input signal `>open` of the function block **Voltage-transformer circuit breaker**, which links in the tripping of the voltage-transformer circuit breaker.

The `Blk. by meas.-volt. failure` parameter can be set so that **measuring-voltage failure detection** blocks the stage or not.

Blocking the Stage in Case of an Intermittent Ground Fault

In case of an intermittent ground fault, the stage can be blocked upon receiving the internal signal `Interm.gnd.flt.det` from the **Intermittent ground-fault blocking** stage. In the event of blocking, the picked-up stage will be reset.

After the release of the blocking, the timer `Dir. determination delay` is newly started and must expire before a new ground fault or pickup is annunciated.

With the `Blk.by interm.gnd.flt.` parameter, you can enable or disable the blocking of the stage in case of an intermittent ground fault.

Blocking the Time Delay

You can use the binary input signal *>Block delay & op.* to prevent the start of the time delay and thus also the operate indication. A running time delay is reset. The pickup is indicated and a fault record is opened.

Blocking of the Tripping by Device-Internal Inrush-Current Detection

The **Blk. w. inrush curr. detect.** parameter allows you to define whether the operate indication of the stage should be blocked when a threshold value is exceeded due to an inrush current. In case of a blocking and fulfilled pickup conditions, the stage picks up. The start of the time delay and the operate indication are blocked. The function indicates this through a corresponding indication. If the blocking drops out and the pickup conditions are still met, the time delay is started. After that time, the stage operates.

6.15.6.2 Application and Setting Notes

Parameter: **Operate & flt.rec. blocked**

- Default setting (`_:2`) **Operate & flt.rec. blocked = no**

You can block the operate indication, the fault recording, and the fault log with the **Operate & flt.rec. blocked** parameter. In this case, a ground-fault log is created instead of the fault log.

Parameter: **Blk. by meas.-volt. failure**

- Recommended setting value (`_:10`) **Blk. by meas.-volt. failure = yes**

You use the **Blk. by meas.-volt. failure** parameter to control the behavior of the stage when a measuring-voltage failure is detected.

A measuring-voltage failure can only be detected if one of the following 2 conditions is met:

- The device-internal supervision function **Measuring-voltage failure detection** is configured and enabled.
- The binary input signal *>open* of the function block **Voltage-transformer circuit breaker** is connected to the voltage-transformer circuit breaker.

Parameter Value	Description
yes	The protection stage is blocked (= default setting). If V0 is calculated from the phase-to-ground voltages, Siemens recommends using the blocking.
no	The protection stage is not blocked. If V0 is obtained from the VN measurement of a broken-delta winding, Siemens recommends not using the blocking.

Parameter: **Blk. w. inrush curr. detect.**

- Recommended setting value (`_:27`) **Blk. w. inrush curr. detect. = no**

With the **Blk. w. inrush curr. detect.** parameter, you specify whether the operate is blocked during detection of an inrush current.

Siemens recommends disabling the blocking. The fundamental component of the zero-sequence voltage is a reliable criterion for the ground fault and remains unaffected by a switching-on procedure.

Parameter: **Blk.by interm.gnd.flt.**

- Default setting (`_:111`) **Blk.by interm.gnd.flt. = no**

With the **Blk.by interm.gnd.flt.** parameter, you specify whether the stage is blocked upon receiving an internal signal *Interm.gnd.flt.det* from the **Intermittent ground-fault blocking** stage.

During intermittent ground faults, stages designed for detecting permanent ground faults (based on continuous RMS measurement) tend to generate a flood of signals and probably even temporary wrong directional information. This can be avoided by blocking these stages in case of an intermittent ground fault.

If intermittent ground faults in your network are probable, Siemens recommends enabling the blocking.

Parameter: Directional mode

- Default setting (`_:106`) **Directional mode** = *forward*

When a fault is detected, the selection of the parameter **Directional mode** defines whether the pickup of the stage occurs in forward or reverse direction.

When the parameter **Directional mode** is set as *non-directional*, the direction determination is not considered. The pickup condition depends only on the absolute values **3I0** and **V0** and the respective thresholds. The forward direction is the direction towards the motor.

Parameter: Rotation angle of ref. volt., Forward section +/-

- Default setting (`_:104`) **Rotation angle of ref. volt.** = -45°
- Default setting (`_:103`) **Forward section +/-** = 88°

With the **Rotation angle of ref. volt.** and **Forward section +/-** parameters, you set the direction characteristic, that is, the areas of forward and reverse. With this, you set the direction characteristic according to the system conditions and the neutral-point treatment.

Typical settings for the **Rotation angle of ref. volt.** parameter are:

- Arc-suppression-coil-ground system: 0°
- Isolated system: $+45^\circ$ to $+90^\circ$
- Grounded system: -45°

The **Forward section +/-** parameter can normally be left at its default setting. A reduction of the forward area by a few degrees is practical, for example, in an arc-suppression-coil-ground system with long cable feeders, that generate high capacitive fault currents.



NOTE

In isolated networks, the setting is near $+90^\circ$.

The generator protection is also an isolated system. However, to take into account the loading resistor in the busbar connection of the generator, the setting is near $+45^\circ$.

Parameter: Min. V0> for dir. determ.

- Default setting (`_:102`) **Min. V0> for dir. determ.** = 2.000 V

With the **Min. V0> for dir. determ.** parameter, you determine the minimum voltage **V0** necessary for the release of the direction determination that must be attained within the time delay **Dir. determination delay**.

Parameter: 3I0> threshold value

- Default setting (`_:101`) **3I0> threshold value** = 0.050 A

The **3I0> threshold value** parameter allows you to set the ground-current sensitivity of the stage. Set the threshold value lower than the minimum absolute value of the ground-fault current **3I0** that must still be detected.

Parameter: Dir. determination delay

- Default setting (`_:105`) **Dir. determination delay** = 0.10 s

The start of the ground fault normally shows a significant transient behavior. This can lead to an incorrect direction decision. The direction determination can be delayed from the occurrence of the zero-sequence voltage with the **Dir. determination delay** parameter to achieve steady-state measurands. The duration of the transient cycle is determined from the system conditions and the respective fault characteristics. If you have no knowledge of a suitable time delay, Siemens recommends keeping the default setting.

Parameter: Operate delay

- Default setting (_:6) **Operate delay = 0.50 s**

The **Operate delay** parameter determines the time during which the pickup conditions must be met to issue the operate indication. The operate indication is issued when this time expires.

6.15.6.3 Settings

Addr.	Parameter	C	Setting Options	Default Setting
3I0> φ(VI) #				
_:1	3I0> φ(VI) #:Mode		<ul style="list-style-type: none"> • off • on • test 	off
_:2	3I0> φ(VI) #:Operate &flt.rec. blocked		<ul style="list-style-type: none"> • no • yes 	no
_:10	3I0> φ(VI) #:Blk. by meas.-volt. failure		<ul style="list-style-type: none"> • no • yes 	yes
_:111	3I0> φ(VI) #:Blk.by interm.gnd.flt.		<ul style="list-style-type: none"> • no • yes 	no
_:27	3I0> φ(VI) #:Blk. w. inrush curr. detect.		<ul style="list-style-type: none"> • no • yes 	no
_:106	3I0> φ(VI) #:Directional mode		<ul style="list-style-type: none"> • non-directional • forward • reverse 	forward
_:104	3I0> φ(VI) #:Rotation angle of ref. volt.		-180° to 180°	-45°
_:103	3I0> φ(VI) #:Forward section +/-		0° to 180°	88°
_:102	3I0> φ(VI) #:Min. V0> for dir. determ.		0.300 V to 200.000 V	2.000 V
_:101	3I0> φ(VI) #:3I0> threshold value	1 A @ 100 Irated	0.030 A to 35.000 A	0.050 A
		5 A @ 100 Irated	0.15 A to 175.00 A	0.25 A
		1 A @ 50 Irated	0.030 A to 35.000 A	0.050 A
		5 A @ 50 Irated	0.15 A to 175.00 A	0.25 A
		1 A @ 1.6 Irated	0.001 A to 35.000 A	0.050 A
		5 A @ 1.6 Irated	0.005 A to 35.000 A	0.250 A
_:105	3I0> φ(VI) #:Dir. determination delay		0.00 s to 60.00 s	0.10 s
_:6	3I0> φ(VI) #:Operate delay		0.00 s to 100.00 s	0.50 s

6.15.6.4 Information List

No.	Information	Data Class (Type)	Type
3I0> φ(VI) #			
_:81	3I0> φ(VI) #:>Block stage	SPS	I
_:501	3I0> φ(VI) #:>Block delay & op.	SPS	I
_:54	3I0> φ(VI) #:Inactive	SPS	O
_:52	3I0> φ(VI) #:Behavior	ENS	O

No.	Information	Data Class (Type)	Type
_.53	3I0> φ(VI) #:Health	ENS	O
_.301	3I0> φ(VI) #:Fault not in trip area	SPS	O
_.60	3I0> φ(VI) #:Inrush blocks operate	ACT	O
_.303	3I0> φ(VI) #:Ground fault	ACD	O
_.55	3I0> φ(VI) #:Pickup	ACD	O
_.56	3I0> φ(VI) #:Operate delay expired	ACT	O
_.57	3I0> φ(VI) #:Operate	ACT	O

6.15.7 Directional Y0 Stage with G0 or B0 Measurement

6.15.7.1 Description

Logic

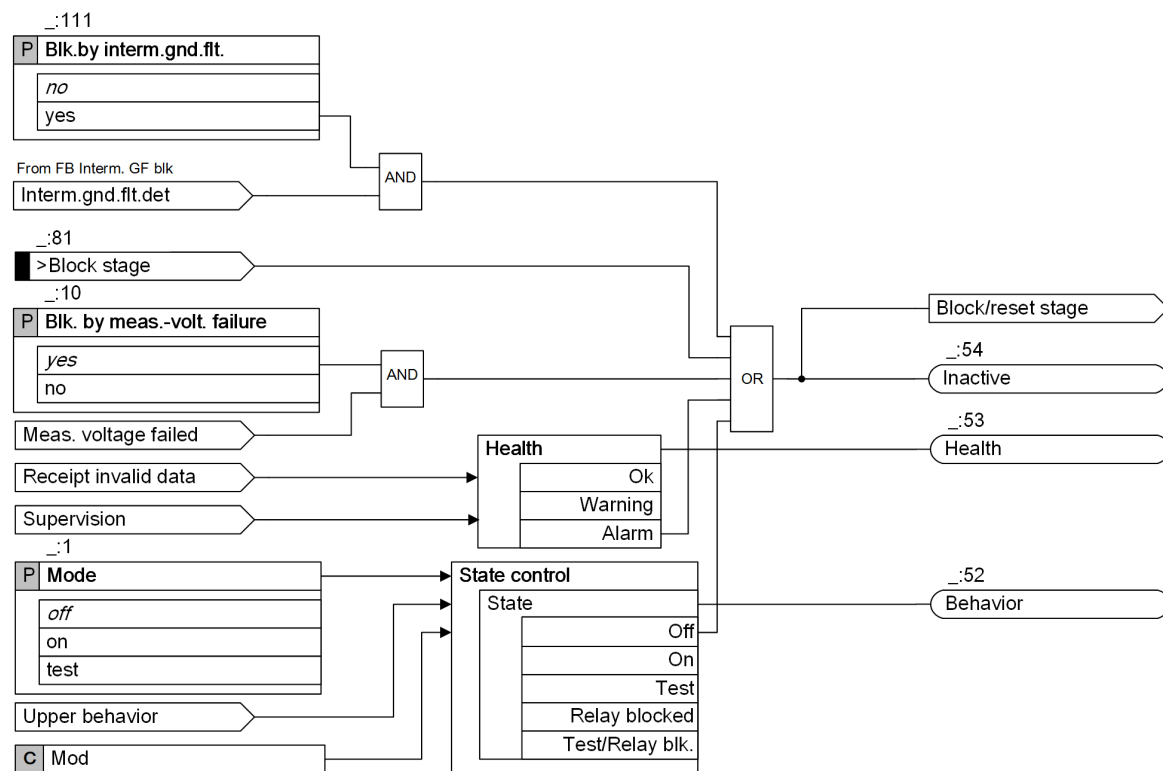

[!o_stage_control_Y0G0B0_3_en_US]

Figure 6-130 Logic Diagram of the Stage Control

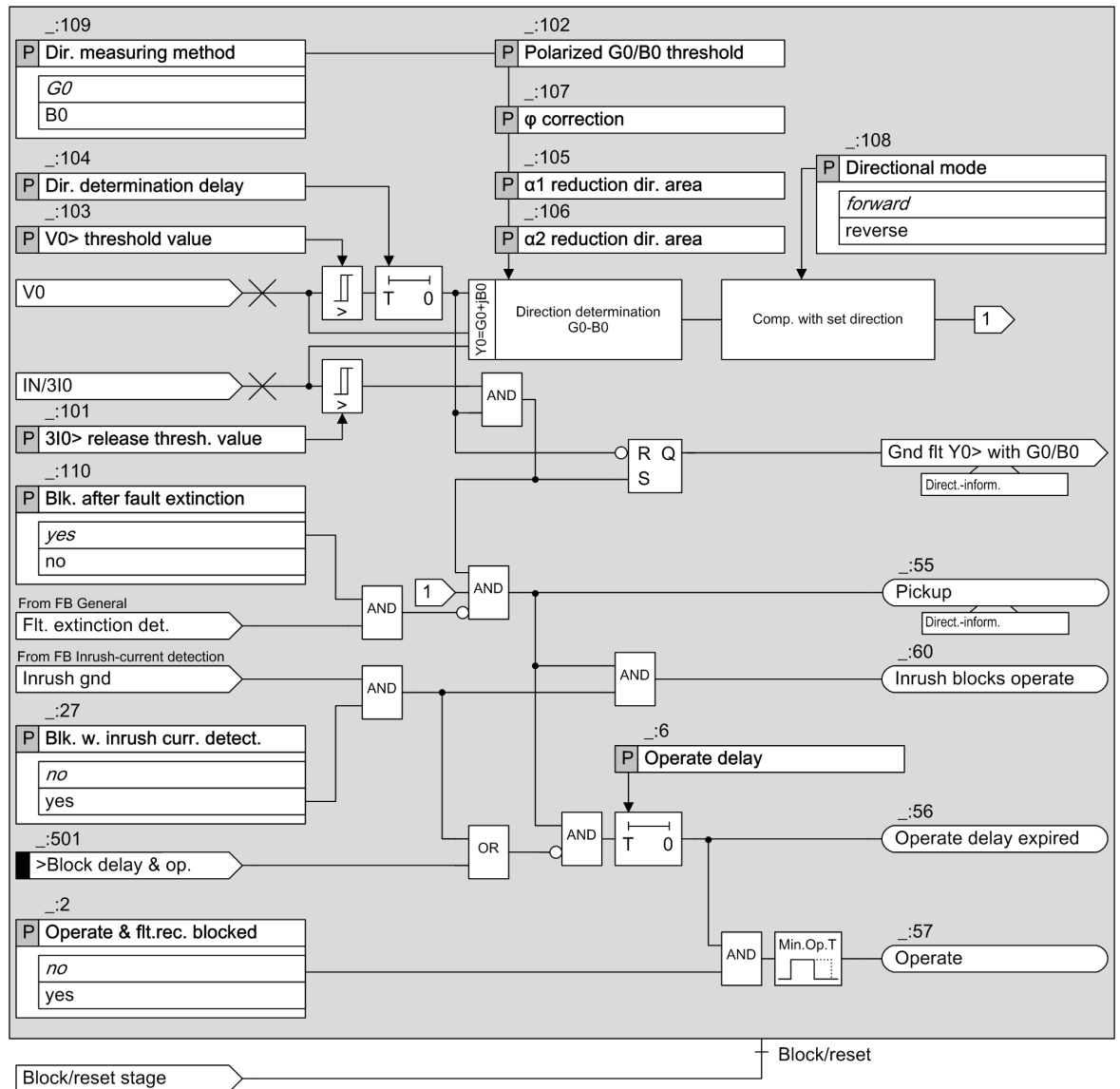

[file_Y0_G0_B0_6_en_US]

Figure 6-131 Logic Diagram of the Directional Y0 Stage with G0 or B0 Measurement

Measured Value V0, Method of Measurement

The device can measure the residual voltage at the broken-delta winding. The measured voltage VN is converted to a value with reference to the zero-sequence voltage V0. If the residual voltage is not available to the device as a measurand, the zero-sequence voltage V0 is calculated from the measured phase-to-ground voltages VA, VB, and VC using the definition equation.

The method of measurement processes the sampled voltage values and filters out the fundamental component numerically.

Measured Value 3I0, Method of Measurement

The function usually evaluates the ground current 3I0 sensitively measured via a core balance current transformer. Since the linearity range of the sensitive measuring input ends at approx. 1.6 A, for larger secondary ground currents, the function switches to the 3I0 calculated from the phase currents. This results in a very large linearity and settings range.

The method of measurement processes the sampled current values and filters out the fundamental component numerically. The methods of measurement are characterized by high accuracy and by insensitivity to harmonics, especially the 3rd and 5th harmonics frequently present in the ground-fault (residual) current.

Depending on the connection type of the measuring point as well as the current terminal blocks used, different linearity and setting ranges result. You can find more information in section *Measured Value 3I0, Method of Measurement, Page 601*.

Y0, G0, B0

The fundamental-component values of V0 and 3I0 are used to calculate the admittance $Y0 = G0 + jB0$. You can choose to use G0 or B0 to determine the direction.

Ground-Fault Detection, Pickup

If the absolute value of the ground current 3I0 exceeds the threshold value **3I0 > release thresh. value** and the absolute value of the zero-sequence voltage V0 exceeds the threshold value **V0 > threshold value**, the stage recognizes the ground fault. The calculation of G0 or B0 is started with exceeding the threshold values and then, the direction determination (see the following) is performed. The direction result is indicated via the *Ground fault* signal (in the **General** function block). If the direction result equals the parameterized direction (parameter **Directional mode**), the stage picks up.

Direction Determination

Exceeding the threshold values by the zero-sequence voltage V0 is a criterion for the ground fault. The direction determination can be delayed from the occurrence of the zero-sequence voltage with the **Dir. determination delay** parameter to achieve steady-state measurands. The result from the direction determination is only valid if the absolute value of the ground current 3I0 has also exceeded its release threshold value.

The following figure shows an example of the direction determination in the complex phasor diagram for the G0 direction measurement method with a correction value of the direction straight line from 0 (Parameter **φ correction**). The example is suitable for the determination of the ground-fault direction in an arc-suppression-coil-ground system where the value G0 is decisive for the direction determination.

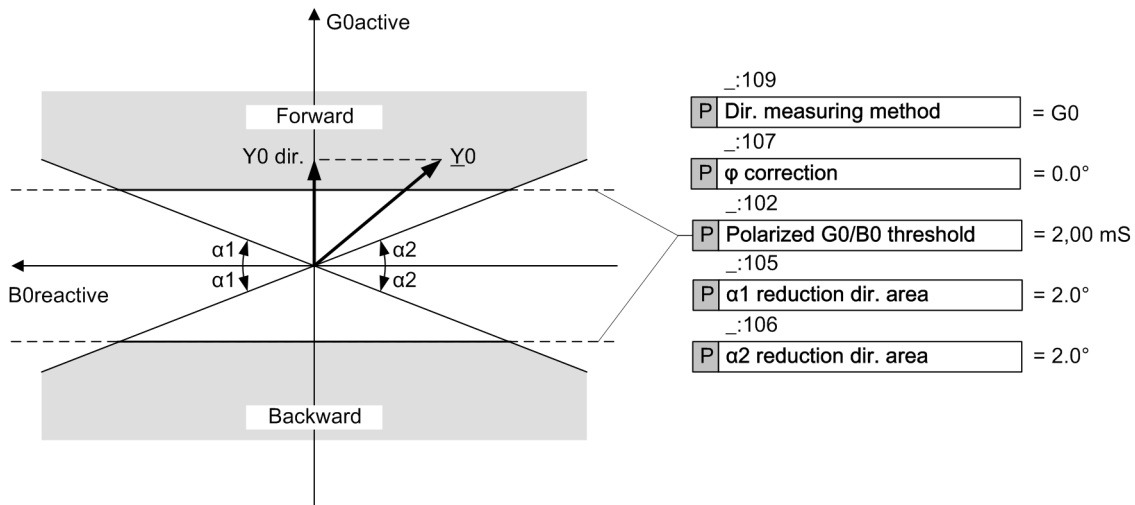

[dw_Y0_dir.1_en_US]
 Figure 6-132 Direction-Characteristic Curve for the G0 Measurement

The zero-sequence voltage V0 is generally the reference value for the real axis and is identical to the G0 axis. The axis of symmetry of the direction-characteristic curve coincides with the B0 (reactive) axis for this example. For the direction determination, the component of the admittance perpendicular to the set direction-characteristic curve (= axis of symmetry) is decisive G0dir (=Y0dir). In this example, this is the active component **G0active** of the admittance Y0. The conductance G0dir. (here = G0active) is calculated and compared with the setting value **Polarized G0/B0 threshold**. If the conductance G0dir. exceeds the positive setting value, the direction is forward. If the conductance G0dir. exceeds the negative setting value, the direction is backward. In the range in between, the direction is undetermined.

With the **$\alpha 1$ reduction dir. area** and **$\alpha 2$ reduction dir. area** parameters, you can limit the forward and backward ranges as shown in *Figure 6-133*. With this, the direction determination is secured in case of high currents in the direction of the axis of symmetry.

The symmetry axis can be turned via a correction angle (**φ correction** parameter) in a range of $\pm 45^\circ$. Through this, it is possible, for example, to attain the greatest sensitivity in grounded systems in the resistive-inductive range with a -45° turn. In the case of electric machines in busbar connection on the isolated system, the greatest sensitivity in the resistive-capacitive range can be attained with a turn of $+45^\circ$ (see following figure).

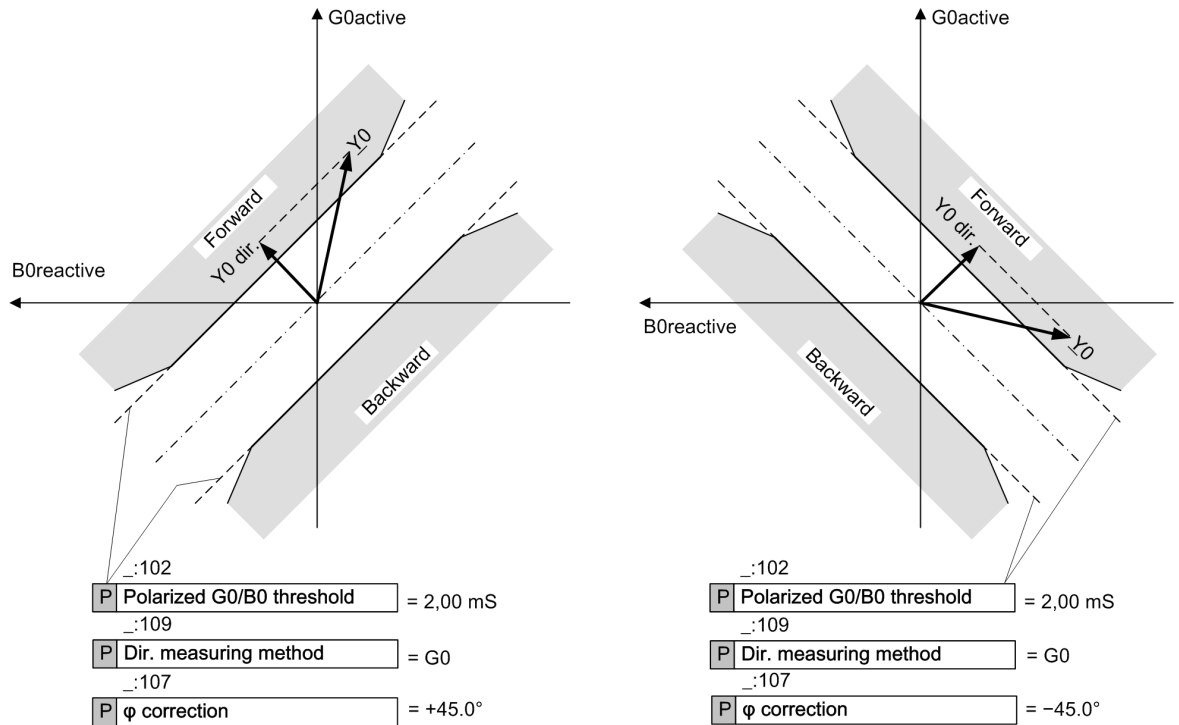

[dw_Y0_meas, 1, en_US]

Figure 6-133 Turning the Direction-Characteristic Curves with G0 Measurement with Angle Correction

If you set the **Dir. measuring method** parameter to B0 and the **φ correction** parameter to 0, the axis of symmetry of the direction-characteristic curve coincides with the G0 and V0 axes. Since the component of the admittance Y0 perpendicular to the direction-characteristic curve (= axis of symmetry) is decisive (B0dir. (=Y0dir.)), here, the susceptance B0 (reactive) is used in the direction determination. If the susceptance B0dir. (B0reactive) exceeds the negative setting value **Polarized G0/B0 threshold**, the direction is forward. If the susceptance B0dir. exceeds the positive setting value, the direction is backward. In the range in between, the direction is undetermined.

This direction measurement thus is appropriate for the determination of ground-fault direction in isolated systems.

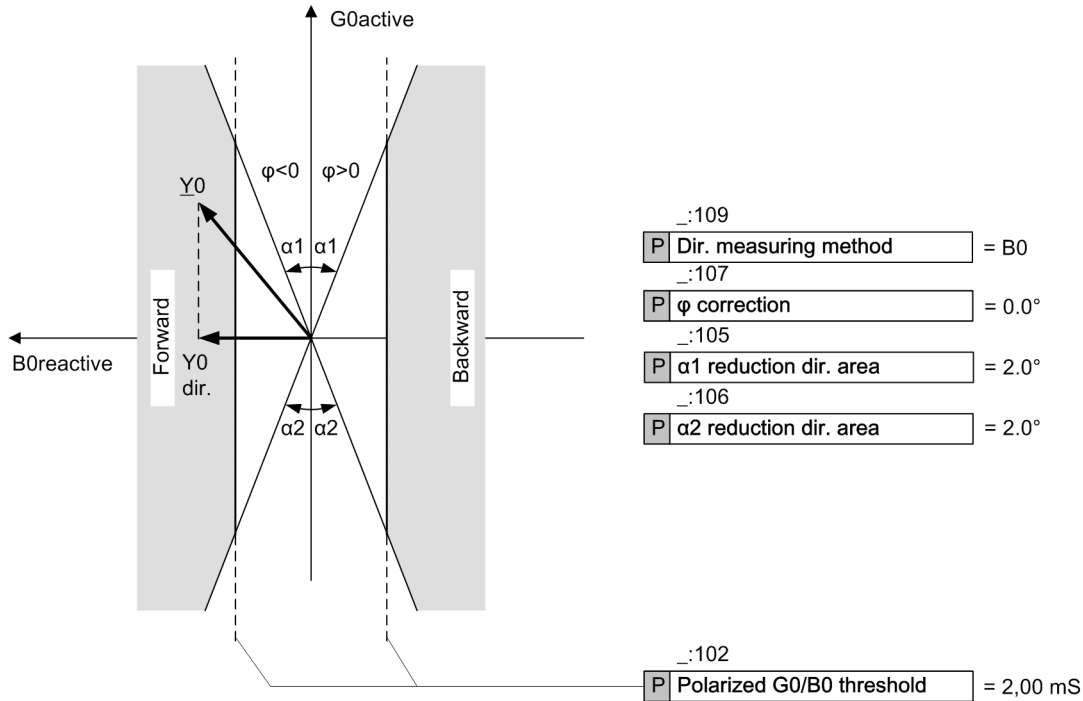

[dw_sl_co_Y0_1_en_US]
 Figure 6-134 Direction-Characteristic Curve for the B0 Measurement

Blocking the Stage via Binary Input Signal

You can block the stage externally or internally via the binary input signal `>Block stage`. In the event of blocking, the picked up stage will be reset.

Blocking the Stage in Case of Measuring-Voltage Failure

The stage can be blocked if a measuring-voltage failure occurs. In the event of blocking, the picked up stage will be reset.

The following blocking options are available for the stage:

- From inside on pickup of the **Measuring-voltage failure detection** function
- From an external source via the binary input signal `>open` of the function block **Voltage-transformer circuit breaker**, which links in the tripping of the voltage-transformer circuit breaker.

The `Blk. by meas.-volt. failure` parameter can be set so that Measuring-voltage failure detection blocks the stage or does not block it.

Blocking the Stage in Case of an Intermittent Ground Fault

In case of an intermittent ground fault, the stage can be blocked upon receiving the internal signal `Interm.gnd.flt.det` from the **Intermittent ground-fault blocking** stage. In the event of blocking, the picked-up stage will be reset.

After the release of the blocking, the timer `Dir. determination delay` is newly started and must expire before a new ground fault or pickup is annunciated.

With the `Blk.by interm.gnd.flt.` parameter, you can enable or disable the blocking of the stage in case of an intermittent ground fault.

Blocking the Pickup with Detection of the Fault Extinction

Using the evaluation of the instantaneous value developing of the zero-sequence voltage, the fault extinction can be recognized faster than via the dropout of the V0 fundamental-component value under the pickup value. The pickup of the stage is blocked with the fast detection of the fault extinction. With this, the pickups

are avoided due to the decay procedure in the zero-sequence system after the fault extinction. With the **Blk. after fault extinction** parameter, you enable or disable this accelerated detection of the fault extinction.

Blocking of the Time Delay

You can use the binary input signal *>Block delay & op.* to prevent the start of the time delay and thus also the operate indication. A running time delay is reset. The pickup is indicated and a fault record is opened.

Blocking of the Tripping by Device-Internal Inrush-Current Detection

The **Blk. w. inrush curr. detect.** parameter allows you to define whether the operate indication of the stage should be blocked when a threshold value is exceeded due to an inrush current. In case of a blocking and fulfilled pickup conditions, the stage picks up. The start of the time delay and the operate indication are blocked. The function indicates this through a corresponding indication. If the blocking drops out and the pickup conditions are still met, the time delay is started. After that time, the stage operates.

6.15.7.2 Application and Setting Notes

Parameter: **Blk. by meas.-volt. failure**

- Recommended setting value (_:10) **Blk. by meas.-volt. failure = yes**

You use the **Blk. by meas.-volt. failure** parameter to control the behavior of the stage when a measuring-voltage failure is detected.

A measuring-voltage failure can only be detected if one of the following 2 conditions is met:

- The device-internal supervision function **Measuring-voltage failure detection** is configured and enabled.
- The binary input signal *>open* of the function block **Voltage-transformer circuit breaker** is connected to the voltage-transformer circuit breaker.

Parameter Value	Description
yes	The protection stage is blocked (= default setting). If V0 is calculated from the phase-to-ground voltages, Siemens recommends using the blocking.
no	The protection stage is not blocked. If V0 is obtained from the VN measurement of a broken-delta winding, Siemens recommends not using the blocking.

Parameter: **Blk. w. inrush curr. detect.**

- Recommended setting value (_:27) **Blk. w. inrush curr. detect. = no**

With the **Blk. w. inrush curr. detect.** parameter, you specify whether the operate is blocked during detection of an inrush current.

Siemens recommends disabling the blocking. The fundamental component of the zero-sequence voltage is a reliable criterion for the ground fault and remains untouched by a switching-on procedure.

Parameter: **Blk.by interm.gnd.flt.**

- Default setting (_:111) **Blk.by interm.gnd.flt. = no**

With the **Blk.by interm.gnd.flt.** parameter, you specify whether the stage is blocked upon receiving an internal signal *Interm.gnd.flt.det* from the **Intermittent ground-fault blocking** stage.

During intermittent ground faults, stages designed for detecting permanent ground faults (based on continuous RMS measurement) tend to generate a flood of signals and probably even temporary wrong directional information. This can be avoided by blocking these stages in case of an intermittent ground fault.

If intermittent ground faults in your network are probable, Siemens recommends enabling the blocking.

Parameter: Blk. after fault extinction

- Recommended setting value (_:110) **Blk. after fault extinction = yes**

If the **Blk. after fault extinction** parameter is set to **yes**, the pickup is blocked after detection of the fault extinction. With this, the pickups are avoided due to the decay procedure in the zero-sequence system after the fault extinction. Siemens recommends using the default setting.

Parameter: Directional mode

- Default setting (_:108) **Directional mode = forward**

When a fault is detected, the selection of the parameter **Directional mode** defines whether the pickup of the stage occurs in forward or backward direction.

Parameter: Dir. measuring method, φ correction, Polarized G0/B0 threshold, 3I0> release thresh. value

- Default setting (_:109) **Dir. measuring method = G0**
- Default setting (_:107) **φ correction = 0.0°**
- Default setting (_:102) **Polarized G0/B0 threshold = 2.00 mS**
- Default setting (_:101) **3I0> release thresh. value = 0.002 A**

These parameters are used to define the direction characteristic of the stage. The direction characteristic to use is dependent on the neutral-point treatment of the system.

Note that, for the direction determination, basically only the component of the admittance perpendicular to the set direction-characteristic curve is decisive, see also [6.15.7.1 Description](#). This admittance component is compared to the threshold value **Polarized G0/B0 threshold**. In contrast, the absolute value of the current 3I0 is compared with the **3I0> release thresh. value** parameter.

System Type/ Neutral-Point Treat- ment	Description
Grounded	<p>In the arc-suppression-coil-ground system, the watt-metric residual current $3I_0 \cdot \cos \varphi$ of the arc-suppression coil is decisive for the direction determination.</p> <p>To evaluate the watt-metric residual current, set the parameters as follows:</p> <ul style="list-style-type: none"> • Dir. measuring method = G0 • φ correction = 0.0° <p>The direction determination for a ground fault is made more difficult in that a much larger reactive current of capacitive or inductive character is superimposed on the small watt-metric residual current. Therefore, depending on the system configuration and the fault evaluation, the total ground current supplied to the device can vary considerably in its values regarding the magnitude and the phase angle. However, the device should only evaluate the active component of the ground-fault current.</p> <p>This requires extremely high accuracy, particularly regarding the phase-angle measurement of all the instrument transformers. Furthermore, the device must not be set to operate too sensitively. A reliable direction measurement can only be expected with connection to a core balance current transformer. For the setting of the Polarized G0/B0 threshold parameter, the following formula applies:</p> $G0 > k_s \frac{I_{0\text{active}}}{\sqrt{3}V_{\text{rated}}} + I_{0\text{min}} > V0 >$ <p>where:</p> <p>k_s: Safety margin, $k_s = 1.2$ (cable networks), $k_s = 2.0$ (overhead lines)</p> <p>$I_{0\text{active}}$: Active component of the ground-fault current (watt-metric residual current) of the protected line</p> <p>V_{rated}: Secondary rated voltage in the healthy case</p> <p>$I_{0\text{min}}$: Min. ground current in the healthy case, 5 mA to 10 mA (core balance current transformer), 50 mA to 100 mA (Holmgreen transformer)</p> <p>$V0 >$: Pickup threshold of the residual voltage $\approx 0.1\sqrt{3}V_{\text{rated}}$</p> <p>If a parallel resistor R_p is used on the arc-suppression coil, the threshold value $G0$ must also be smaller than:</p> $G0 \leq \frac{1}{k_s} \frac{I_{Rp}}{\sqrt{3}V_{\text{rated}}}$ <p>where:</p> <p>k_s: Safety margin ≥ 1.5</p> <p>I_{Rp}: Secondary rated current of the parallel resistor</p> <p>V_{rated}: Secondary rated voltage in the healthy case</p> <p>The 3I0> release thresh. value parameter can be set to half of the expected measuring current and here, the entire zero-sequence current can be put to use.</p>
Isolated	<p>In the isolated system, the capacitive ground reactive current $3I_0 \cdot \sin \varphi$ is decisive for the direction determination.</p> <p>To evaluate the capacitive ground reactive current, set the parameters as follows:</p> <ul style="list-style-type: none"> • Dir. measuring method = B0 • φ correction = 0.0° <p>In isolated systems, a ground fault allows the capacitive ground-fault currents of the entire electrically connected system, except for the ground current in the faulty cable itself, to flow through the measuring point as the latter flows directly away from the</p>

System Type/ Neutral-Point Treat- ment	Description
	<p>fault location (that is, not via the measuring point). The following formula can be used to determine the pickup value of the Polarized G0/B0 threshold parameter.</p> $B0 \geq \frac{I_{0min}}{V0 >}$ <p>where: I_{0min}: Ground current in the healthy case $V0 >$: Pickup threshold of the residual voltage $\approx 0.02\sqrt{3}V_{rated}$ In healthy operation, $B0 \leq 0$. For the 3I0 > release thresh. value parameter, select around half of this capacitive ground-fault current flowing via the measuring point.</p>
Resistance-Grounded	<p>In the resistance-grounded system, the ohmic-inductive ground-fault current is decisive for the direction determination. To evaluate this short-circuit current, set the parameters as follows:</p> <ul style="list-style-type: none"> • Dir. measuring method = G0 • φ correction = -45.0° <p>For the setting of the Polarized G0/B0 threshold parameter, the rule of thumb is: Set the pickup value according to the following formula where only the active ground-fault current can be put into use.</p> $G0 > k_s \frac{I_{0active}}{\sqrt{3}V_{rated}} + \frac{I_{0min}}{V0 >}$ <p>where: k_s: Safety margin, $k_s = 1.2$ (cable networks), $k_s = 2.0$ (overhead lines) $I_{0active}$: Active component of the ground-fault current of the protected line V_{rated}: Secondary rated voltage in the healthy case I_{0min}: Min. ground current in the healthy case, 5 mA to 10 mA (core balance current transformer), 50 mA to 100 mA (Holmgreen transformer) $V0 >$: Pickup threshold of the residual voltage $\approx 0.02\sqrt{3}V_{rated}$ The 3I0 > release thresh. value parameter must be set to a value below the minimum expected ground-fault current.</p>

Parameter: $\alpha 1$ reduction dir. area, $\alpha 2$ reduction dir. area

- Recommended setting value (`_:105`) **$\alpha 1$ reduction dir. area = 2°**
- Recommended setting value (`_:106`) **$\alpha 2$ reduction dir. area = 2°**

With the **$\alpha 1$ reduction dir. area** and **$\alpha 2$ reduction dir. area** parameters, you specify the angle for the limitation of the direction range. Siemens recommends using the default setting of 2° .

In an arc-suppression-coil-ground system in feeders with a very large reactive current, it can be practical to set a somewhat larger angle $\alpha 1$ to avoid a false pickup based on transformer and algorithm tolerances.

Parameter: $V0 >$ threshold value

- Default setting (`_:103`) **$V0 >$ threshold value = 30.000 V**

The **$V0 >$ threshold value** parameter allows you to set the zero-sequence voltage sensitivity of the stage. The threshold value must be smaller than the minimum amount of the zero-sequence voltage $V0$ which must still be detected.

Parameter: Dir. determination delay

- Default setting (_:104) **Dir. determination delay** = 0.10 s

The start of the ground fault normally indicates a significant transient behavior. This can lead to an incorrect direction decision. The direction determination can be delayed for this reason from the occurrence of the zero-sequence voltage with the **Dir. determination delay** parameter to achieve steady-state measurements. The duration of the transient cycle is determined from the system conditions and the respective fault characteristics. If you have no knowledge of a suitable time delay, Siemens recommends keeping the default setting.

Parameter: Operate delay

- Default setting (_:6) **Operate delay** = 2.0 s

The **Operate delay** parameter determines the time during which the pickup conditions must be met to issue the operate indication. The operate indication is issued when this time expires.

6.15.7.3 Settings

Addr.	Parameter	C	Setting Options	Default Setting
Y0> G0/BO #				
_:1	Y0> G0/BO #:Mode		<ul style="list-style-type: none"> • off • on • test 	off
_:2	Y0> G0/BO #:Operate &flt.rec. blocked		<ul style="list-style-type: none"> • no • yes 	no
_:10	Y0> G0/BO #:Blk. by meas.-volt. failure		<ul style="list-style-type: none"> • no • yes 	yes
_:111	Y0> G0/BO #:Blk.by interm.gnd.flt.		<ul style="list-style-type: none"> • no • yes 	no
_:27	Y0> G0/BO #:Blk. w. inrush curr. detect.		<ul style="list-style-type: none"> • no • yes 	no
_:110	Y0> G0/BO #:Blk. after fault extinction		<ul style="list-style-type: none"> • no • yes 	yes
_:108	Y0> G0/BO #:Directional mode		<ul style="list-style-type: none"> • forward • reverse 	forward
_:109	Y0> G0/BO #:Dir. measuring method		<ul style="list-style-type: none"> • G0 • B0 	G0
_:107	Y0> G0/BO #:φ correction		-45° to 45°	0°
_:102	Y0> G0/BO #:Polarized G0/BO threshold		0.10 mS to 100.00 mS	2.00 mS
_:105	Y0> G0/BO #:α1 reduction dir. area		1° to 15°	2°
_:106	Y0> G0/BO #:α2 reduction dir. area		1° to 15°	2°
_:101	Y0> G0/BO #:3I0> release thresh. value	1 A @ 100 Irated 5 A @ 100 Irated 1 A @ 50 Irated 5 A @ 50 Irated 1 A @ 1.6 Irated 5 A @ 1.6 Irated	0.030 A to 35.000 A 0.15 A to 175.00 A 0.030 A to 35.000 A 0.15 A to 175.00 A 0.001 A to 35.000 A 0.005 A to 35.000 A	0.030 A 0.15 A 0.030 A 0.15 A 0.030 A 0.150 A

Addr.	Parameter	C	Setting Options	Default Setting
_:103	Y0> G0/B0 #:V0> threshold value		0.300 V to 200.000 V	30.000 V
_:104	Y0> G0/B0 #:Dir. determination delay		0.00 s to 60.00 s	0.10 s
_:6	Y0> G0/B0 #:Operate delay		0.00 s to 60.00 s	2.00 s

6.15.7.4 Information List

No.	Information	Data Class (Type)	Type
Y0> G0/B0 #			
_:81	Y0> G0/B0 #:>Block stage	SPS	I
_:501	Y0> G0/B0 #:>Block delay & op.	SPS	I
_:54	Y0> G0/B0 #:Inactive	SPS	O
_:52	Y0> G0/B0 #:Behavior	ENS	O
_:53	Y0> G0/B0 #:Health	ENS	O
_:60	Y0> G0/B0 #:Inrush blocks operate	ACT	O
_:55	Y0> G0/B0 #:Pickup	ACD	O
_:56	Y0> G0/B0 #:Operate delay expired	ACT	O
_:57	Y0> G0/B0 #:Operate	ACT	O

6.15.8 Directional Stage with Phasor Measurement of a Harmonic

6.15.8.1 Description

The **Directional stage with phasor measurement of a harmonic** is based on a continuous measuring direction-determination method. The stage determines the direction via the 3rd, 5th, or 7th harmonic phasors of the zero-sequence voltage V0 and current 3I0.

Logic

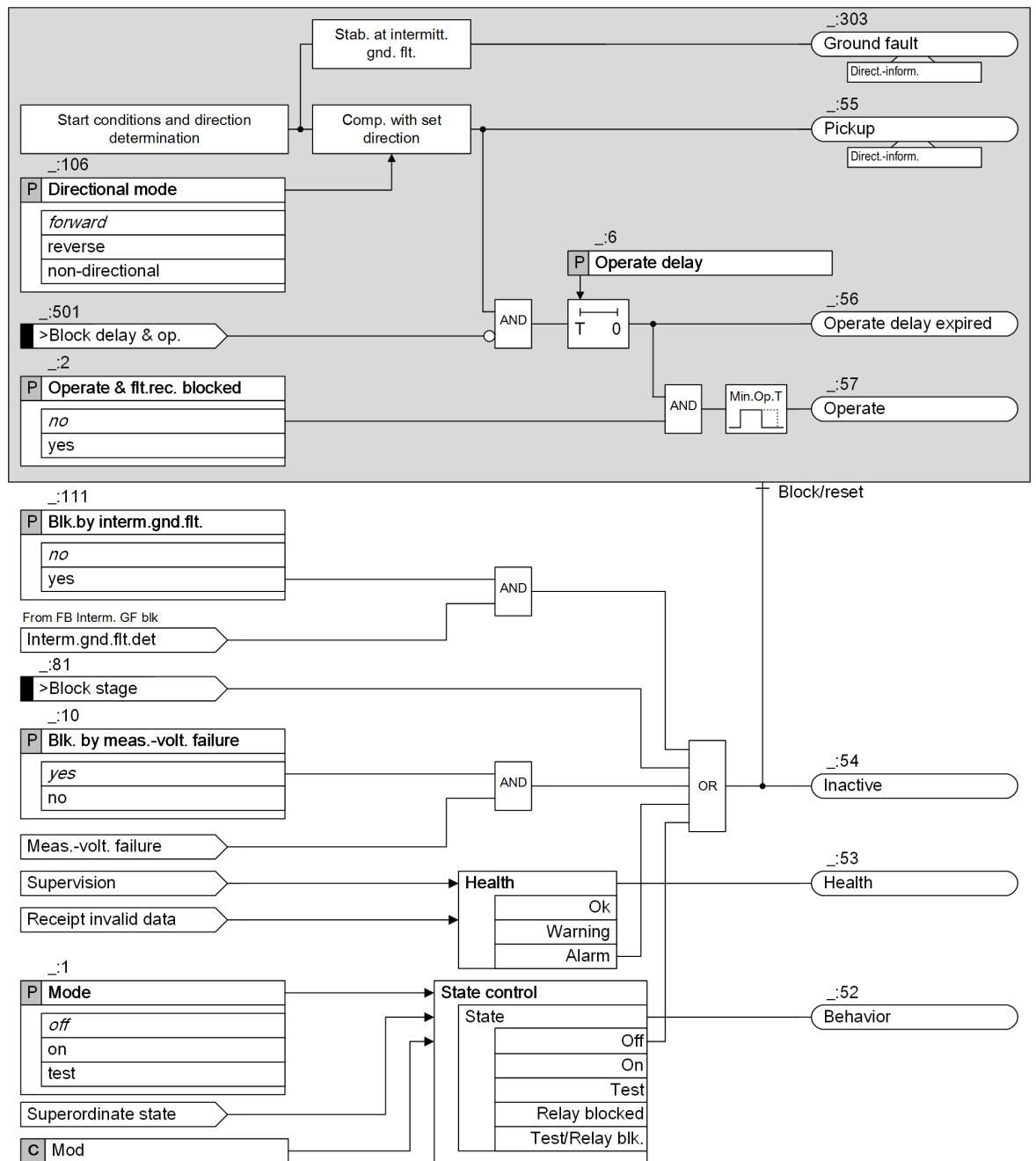

[to_sensGFP V0 dir harmonic, 3, en_US]

Figure 6-135 Logic Diagram of the Directional Stage with Phasor Measurement of a Harmonic

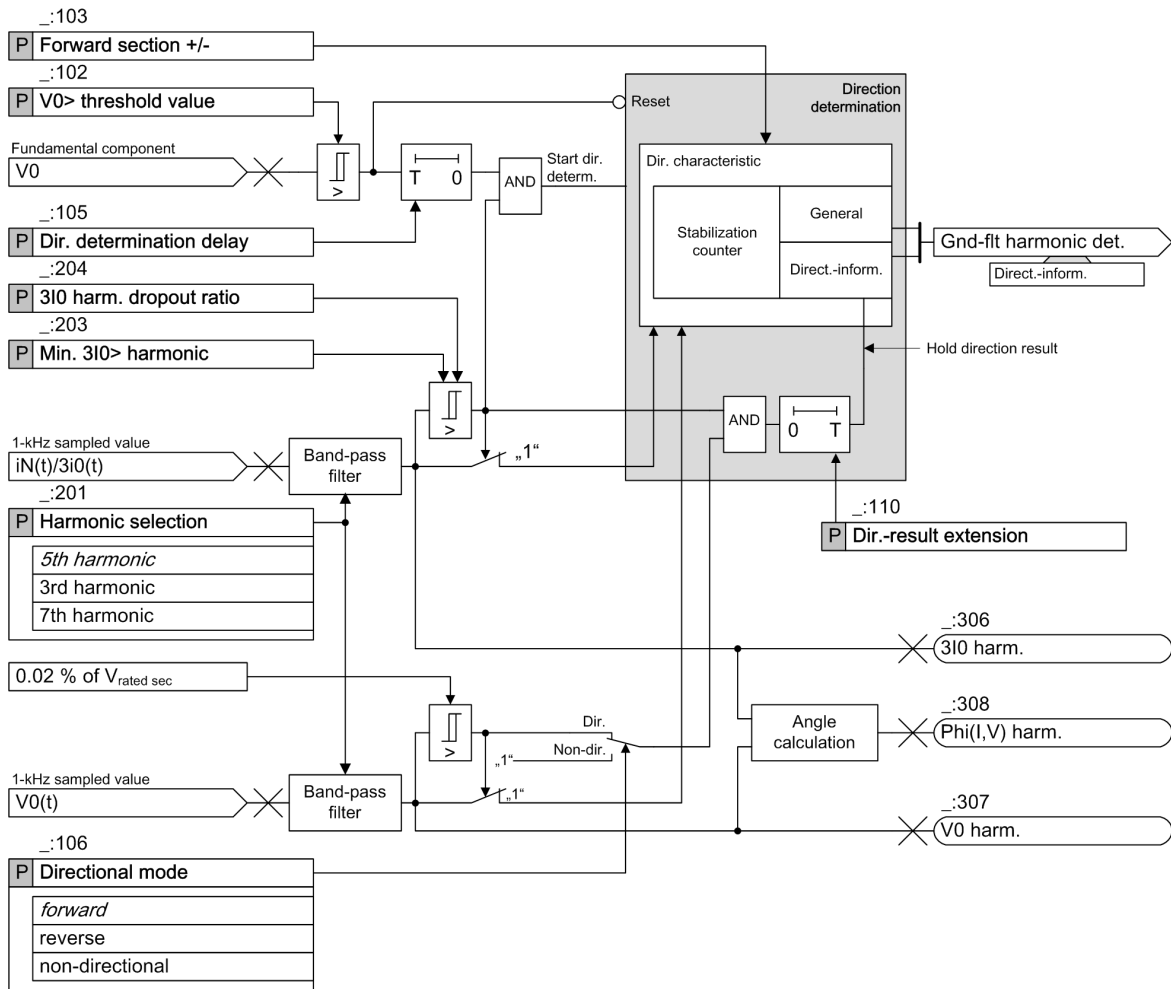

[/io_start condition and dir. determ. 1, en_US]

Figure 6-136 Logic Diagram of the Start Conditions and of the Direction Determination

Measured Values, Methods of Measurement

The device can measure the residual voltage at the broken-delta winding. The measured voltage is converted to a value with reference to the zero-sequence voltage V_0 . If the residual voltage is not available to the device as a measurand, the zero-sequence voltage V_0 is calculated from the measured phase-to-ground voltages V_A , V_B , and V_C using the defining equation.

For the measured value $3I_0$ and the method of measurement, you can find more information in section [Measured Value \$3I_0\$, Method of Measurement, Page 601](#).

The function uses the fundamental-component value of V_0 and the 3rd, 5th, or 7th harmonic phasor of V_0 and $3I_0$ for direction determination. The specific harmonic phasor to be used is determined by the **Harmonic selection** setting.

Ground-Fault Detection, Pickup

If the fundamental-component value of the zero-sequence voltage V_0 exceeds the threshold **$V_0 >$ threshold value**, the stage detects the ground fault and the timer **Dir. determination delay** starts. If the following 2 conditions are met, the ground-fault signaling and direction determination start:

- The fundamental-component value of the zero-sequence voltage V_0 keeps exceeding the threshold **$V_0 >$ threshold value** during the period of the timer **Dir. determination delay**.
- The absolute value of the zero-sequence harmonic current $3I_0$ harm. exceeds the threshold **Min. $3I_0 >$ harmonic** when the timer **Dir. determination delay** expires.

To carry out the direction determination, the following condition must also be met in addition to the preceding 2 conditions:

The zero-sequence harmonic voltage $V_{0\text{harm}}$ must exceed the threshold which is 0.02 % of the secondary rated voltage of the voltage transformer. If this condition is not met, the direction result is **unknown**.

The direction result is indicated via the *Ground fault* signal.

The stage pickup depends on the direction result and on the **Directional mode** parameter:

- If the **Directional mode** parameter is set as *forward* or *reverse*, the stage picks up when the direction result equals the parameterized direction, and the *Pickup* is signaled with the determined direction.
- If the **Directional mode** parameter is set as *non-directional*, the stage picks up regardless of the direction result, and the *Pickup* is signaled with the **unknown** information.

Direction Determination

With the **Harmonic selection** parameter, you can select the 3rd, 5th, or 7th harmonic phasor for direction determination. The direction is determined via the calculation of the phase angle between the following values:

- Zero-sequence harmonic current $3I_{0\text{harm}}$.
- Rotated zero-sequence harmonic voltage $V_{0\text{harm}}$, indicated in the following as reference voltage $V_{\text{ref,rot}}$.

The reference voltage is rotated by the angle $+90^\circ$ in relation to V_0 . This provides the maximum security for the direction determination assuming that $3I_{0\text{harm}}$ is a reactive current.

The rotated reference voltage $V_{\text{ref,rot}}$ and the **Forward section +/-** parameter define the forward and reverse area. For details, refer to [Figure 6-137](#).

The areas in the following figure are as follows:

- The forward area results as range $\pm \Delta\phi$ around the rotated reference voltage $V_{\text{ref,rot}}$. You can set the value $\pm \Delta\phi$ with the **Forward section +/-** parameter. If the vector of the secondary ground current $-3I_{0\text{harm}}$ lies within this area, the direction result is forward.
- The mirror area of the forward area is the reverse area. If the vector of the secondary ground current $-3I_{0\text{harm}}$ lies within this area, the direction result is reverse.
- In the intermediate range, the direction is **unknown**.

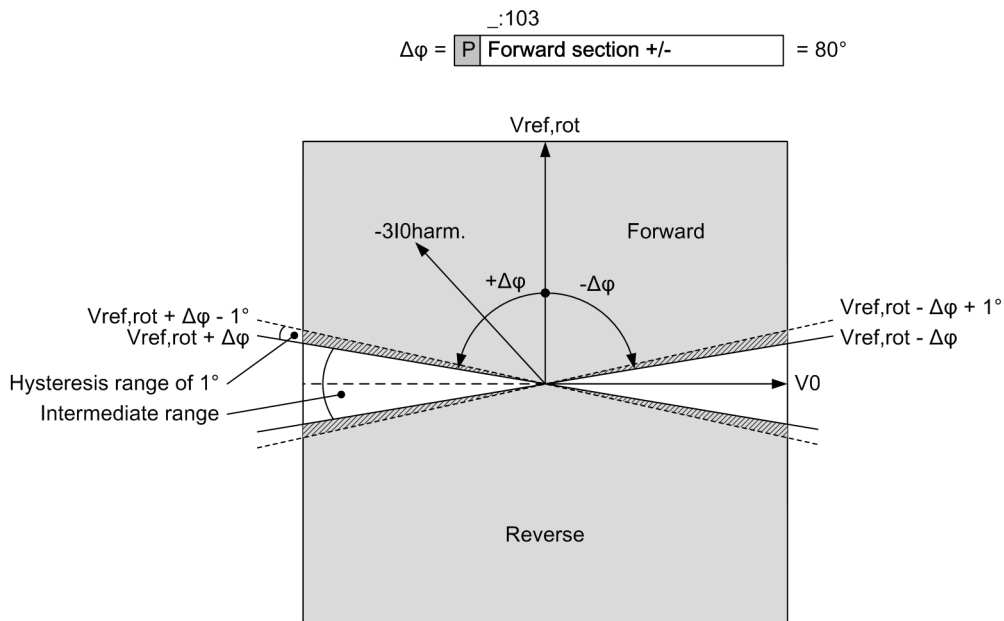

[dw_sensGFP_V0_dir_harmonic, 1, en_US]

Figure 6-137 Direction Characteristic

Stabilization Counter

To determine a reliable direction result, the function uses a stabilization counter. For indicating a direction result, the determined direction must be stable for 4 successive measuring cycles. The cycle time is 10 ms.

Direction-Result Extension

With the timer **Dir.-result extension**, you can extend the last determined direction result if the conditions for a further direction determination are no longer met. The last direction result is held until the conditions for a further direction determination are met again (timer is reset) or until the timer expires. The behavior of the direction-result extension varies according to the setting of the **Directional mode** parameter:

- **Directional mode = forward or reverse**
As soon as the zero-sequence harmonic current $3I_{0harm.}$ or the zero-sequence harmonic voltage $V_{0harm.}$ falls below its respective dropout value, the timer **Dir.-result extension** starts. If the direction result equals the setting of the **Directional mode** parameter, the last *Pickup* signal is also extended.
If both $3I_{0harm.}$ and $V_{0harm.}$ exceed their thresholds again, the timer **Dir.-result extension** is reset immediately and the direction determination is carried out again.
- **Directional mode = non-directional**
As soon as the zero-sequence harmonic current $3I_{0harm.}$ falls below its dropout value, the timer **Dir.-result extension** starts.
In this directional mode, the *Pickup* is signaled only with the direction information *unknown* regardless of the actual direction that is indicated via the *Ground fault* signal. Therefore, the *Pickup* signal with the *unknown* information is extended.
If $3I_{0harm.}$ exceeds its threshold again, the timer **Dir.-result extension** is reset immediately and the direction determination is carried out again.

Measured Value Display

After the timer **Dir. determination delay** expires and the V_0 fundamental-component value keeps exceeding the **$V_0 >$ threshold value**, the following measured values are issued:

- *V_0 harm.*
- *$3I_0$ harm.*
- *$\Phi(I, V)$ harm.*

These measured values are displayed as --- if $3I_{0harm.}$ or $V_{0harm.}$ is smaller than 0.005 % of the rated secondary current or voltage.

Blocking the Stage via Binary Input Signal

You can block the stage externally or internally via the binary input signal **$>Block$ stage**. In the event of blocking, the picked up stage will be reset.

Blocking the Stage in Case of Measuring-Voltage Failure

The stage can be blocked if a measuring-voltage failure occurs. In the event of blocking, the picked up stage will be reset.

The following blocking options are available for the stage:

- From inside on pickup of the **Measuring-voltage failure detection** function
- From an external source via the binary input signal **$>Open$** of the function block **Voltage-transformer circuit breaker**, which links in the tripping of the voltage-transformer circuit breaker

The **Blk. by meas.-volt. failure** parameter can be set so that the **Measuring-voltage failure detection** blocks the stage or not.

Blocking the Stage in Case of an Intermittent Ground Fault

In case of an intermittent ground fault, the stage can be blocked upon receiving the internal signal *Interm.gnd.flt.det* from the **Intermittent ground-fault blocking** stage. In the event of blocking, the picked-up stage will be reset.

After the release of the blocking, the timer **Dir. determination delay** is newly started and must expire before a new ground fault or pickup is annunciated.

With the **Blk.by interm.gnd.flt.** parameter, you can enable or disable the blocking of the stage in case of an intermittent ground fault.

6.15.8.2 Application and Setting Notes

Parameter: **V0> threshold value**

- Default setting (**_:102**) **V0> threshold value = 20.000 V**

The **V0> threshold value** parameter allows you to set the zero-sequence (fundamental) voltage sensitivity of the stage. Set the threshold value smaller than the minimum absolute value of the zero-sequence voltage **V0** that must still be detected. Typical values are in the range of 15 V to 25 V.

Parameter: **Dir. determination delay**

- Default setting (**_:105**) **Dir. determination delay = 0.00 s**

The start of the ground fault normally shows a significant transient behavior. This can lead to an incorrect direction decision. The direction determination can be delayed from the occurrence of the zero-sequence voltage with the **Dir. determination delay** parameter to achieve steady-state measurands. The duration of the transient cycle is determined from the system conditions and the respective fault characteristics. If you have no knowledge of a suitable time delay, Siemens recommends keeping the default setting.

Parameter: **Forward section +/-**

- Default setting (**_:103**) **Forward section +/- = 80°**

With the **Forward section +/-** parameter, you set the direction characteristic, that is, the forward and reverse areas.

The **Forward section +/-** parameter can normally be left at its default setting. With reducing the forward area, you can provide more security for the direction result, but on the other hand, you increase the probability of an underfunction.

Parameter: **Dir.-result extension**

- Default setting (**_:110**) **Dir.-result extension = 5.00 s**

With the **Dir.-result extension** parameter, you define the time for extending the last determined direction result if the conditions for further direction determination are no longer met.

This timer can be used to generate a stable direction indication under fluctuating zero-sequence harmonics. A stable direction indication again can be required for the implementation of a prioritization schema between different parallel working detection methods (stages).

Parameter: **Harmonic selection**

- Default setting (**_:201**) **Harmonic selection = 5th harmonic**

With the **Harmonic selection** parameter, you select to use the 3rd, 5th, or 7th harmonic phasor of the zero-sequence voltage **V0** and of the zero-sequence current **3I0** for direction determination.

Parameter: **Min. 3I0> harmonic**

- Default setting (**_:203**) **Min. 3I0> harmonic = 0.030 A**

With the **Min. 3I0> harmonic** parameter, you define the threshold value of the zero-sequence harmonic current **3I0harm.** for detecting the ground fault and for starting direction determination. For more information, see also [Ground-Fault Detection, Pickup, Page 638](#).

This parameter needs to be set according to the experience from the specific network. This requires the analysis of permanent ground faults from the network. If such information is unavailable, Siemens recommends a rather low setting in the area of 5 mA to 10 mA secondary.

Parameter: 3I0 harm. dropout ratio

- Default setting (`_:204`) **3I0 harm. dropout ratio** = *0.60*

With the **3I0 harm. dropout ratio** parameter, you define the dropout threshold for the **Min. 3I0> harmonic** parameter.

Lowering this dropout threshold enlarges the range and the period of direction determination under fluctuating zero-sequence harmonics. Siemens recommends using the default setting.

Parameter: Directional mode

- Default setting (`_:106`) **Directional mode** = *forward*

With the **Directional mode** parameter, you define for which direction result the function generates the pickup state:

- If the **Directional mode** parameter is set as *forward* or *reverse*, the stage picks up when the direction result equals the parameterized direction, and the *Pickup* is signaled with the determined direction.
- If the **Directional mode** parameter is set as *non-directional*, the stage picks up regardless of the direction result, and the *Pickup* is signaled with the **unknown** information.

Parameter: Operate delay

- Default setting (`_:6`) **Operate delay** = *1.00 s*

The **Operate delay** parameter determines the time during which the pickup conditions must be met to issue the operate indication. The operate indication is issued when this time expires.



NOTE

When both the **Operate delay** and the **Dir.-result extension** are applied, the **Operate delay** should usually be set to a considerably greater value than the **Dir.-result extension**. If the **Operate delay** is less than the **Dir.-result extension**, the function will operate for each fault regardless of the fault duration, as long as the fault direction equals the set direction.

Parameter: Operate & flt.rec. blocked

- Default setting (`_:2`) **Operate & flt.rec. blocked** = *no*

With the **Operate & flt.rec. blocked** parameter, you block the operate indication, the fault recording, and the fault log. In this case, a ground-fault log is created instead of the fault log.

Parameter: Blk. by meas.-volt. failure

- Default setting (`_:10`) **Blk. by meas.-volt. failure** = *yes*

You use the **Blk. by meas.-volt. failure** parameter to control the behavior of the stage when a measuring-voltage failure is detected.

A measuring-voltage failure can only be detected if one of the following 2 conditions is met:

- The device-internal supervision function **Measuring-voltage failure detection** is configured and enabled.
- The binary input signal *>open* of the function block **Voltage-transformer circuit breaker** is connected to the voltage-transformer circuit breaker.

Parameter Value	Description
yes	The protection stage is blocked (= default setting). If V0 is calculated from the phase-to-ground voltages, Siemens recommends using the blocking.
no	The protection stage is not blocked. If V0 is obtained from the VN measurement of a broken-delta winding, Siemens recommends not using the blocking.

Parameter: Blk.by interm.gnd.flt.

- Default setting (`_:111`) **Blk.by interm.gnd.flt.** = *no*

With the **Blk.by interm.gnd.flt.** parameter, you specify whether the stage is blocked upon receiving an internal signal *Interm.gnd.Flt.det* from the **Intermittent ground-fault blocking** stage.

During intermittent ground faults, stages designed for detecting permanent ground faults (based on continuous RMS measurement) tend to generate a flood of signals and probably even temporary wrong directional information. This can be avoided by blocking these stages in case of an intermittent ground fault.

If intermittent ground faults in your network are probable, Siemens recommends enabling the blocking.

6.15.8.3 Settings

Addr.	Parameter	C	Setting Options	Default Setting
V0>dir.harm.#				
<code>_:1</code>	V0>dir.harm.#:Mode		<ul style="list-style-type: none"> • off • on • test 	off
<code>_:2</code>	V0>dir.harm.#:Operate & flt.rec. blocked		<ul style="list-style-type: none"> • no • yes 	no
<code>_:10</code>	V0>dir.harm.#:Blk. by meas.-volt. failure		<ul style="list-style-type: none"> • no • yes 	yes
<code>_:111</code>	V0>dir.harm.#:Blk.by interm.gnd.flt.		<ul style="list-style-type: none"> • no • yes 	no
<code>_:106</code>	V0>dir.harm.#:Directional mode		<ul style="list-style-type: none"> • non-directional • forward • reverse 	forward
<code>_:103</code>	V0>dir.harm.#:Forward section +/-		0° to 90°	80°
<code>_:102</code>	V0>dir.harm.#:V0> threshold value		0.300 V to 200.000 V	20.000 V
<code>_:201</code>	V0>dir.harm.#:Harmonic selection		<ul style="list-style-type: none"> • 3rd harmonic • 5th harmonic • 7th harmonic 	5th harmonic

Addr.	Parameter	C	Setting Options	Default Setting
_:203	V0>dir.harm.#:Min. 3I0> harmonic	1 A @ 100 Irated	0.030 A to 35.000 A	0.030 A
		5 A @ 100 Irated	0.15 A to 175.00 A	0.15 A
		1 A @ 50 Irated	0.030 A to 35.000 A	0.030 A
		5 A @ 50 Irated	0.15 A to 175.00 A	0.15 A
		1 A @ 1.6 Irated	0.001 A to 35.000 A	0.030 A
		5 A @ 1.6 Irated	0.005 A to 35.000 A	0.150 A
_:204	V0>dir.harm.#:3I0 harm. dropout ratio		0.10 to 0.95	0.60
_:110	V0>dir.harm.#:Dir.-result extension		0.00 s to 60.00 s	5.00 s
_:105	V0>dir.harm.#:Dir. determination delay		0.00 s to 60.00 s	0.00 s
_:6	V0>dir.harm.#:Operate delay		0.00 s to 60.00 s	1.00 s

6.15.8.4 Information List

No.	Information	Data Class (Type)	Type
V0>dir.harm.#			
_:81	V0>dir.harm.#:>Block stage	SPS	I
_:501	V0>dir.harm.#:>Block delay & op.	SPS	I
_:54	V0>dir.harm.#:Inactive	SPS	O
_:52	V0>dir.harm.#:Behavior	ENS	O
_:53	V0>dir.harm.#:Health	ENS	O
_:303	V0>dir.harm.#:Ground fault	ACD	O
_:55	V0>dir.harm.#:Pickup	ACD	O
_:56	V0>dir.harm.#:Operate delay expired	ACT	O
_:57	V0>dir.harm.#:Operate	ACT	O
_:308	V0>dir.harm.#:Phi(I,V) harm.	MV	O
_:307	V0>dir.harm.#:V0 harm.	MV	O
_:306	V0>dir.harm.#:3I0 harm.	MV	O

6.15.9 Non-Directional V0 Stage with Zero-Sequence Voltage/Residual Voltage

6.15.9.1 Description

Logic

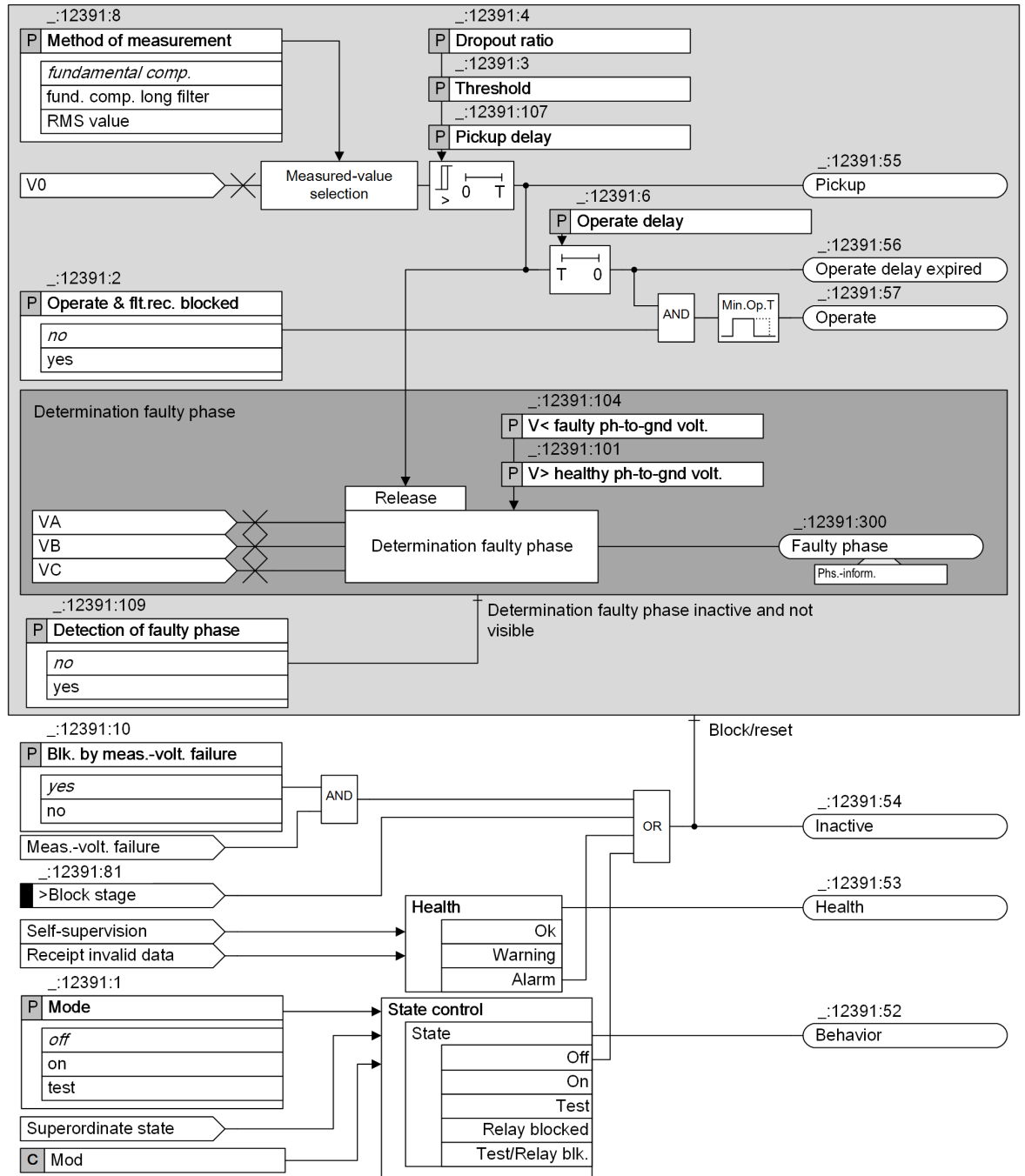

[to_gfps v0_5_en_US]

Figure 6-138 Logic Diagram of the Non-Directional V0 Stage with Zero-Sequence Voltage/Residual Voltage

Measured Value, Method of Measurement

The device can measure the residual voltage at the broken-delta winding. The measured voltage V_N is converted to a value with reference to the zero-sequence voltage V_0 . If the residual voltage is not available

to the device as a measurand, the zero-sequence voltage V_0 is calculated from the measured phase-to-ground voltages V_A , V_B , and V_C using the defining equation.

Use the **Method of measurement** parameter to select the relevant method of measurement, depending on the application:

- Measurement of the fundamental component (standard filter):
This method of measurement processes the sampled voltage values and filters out the fundamental component numerically.
- Measurement of the RMS value (true RMS):
This method of measurement determines the voltage amplitude from the sampled values according to the defining equation of the RMS value.
- Measurement of the fundamental component over 2 cycle filters with triangular window:
This method of measurement processes the sampled voltage values and filters out the fundamental component numerically. The extended filter length compared to the standard filter and the use of the triangular window results in a particularly strong attenuation of harmonics and transient faults. The extended filter length causes the pickup time to increase slightly compared to the standard filter (see [14.19.7 Non-Directional \$V_0\$ Stage with Zero-Sequence Voltage/Residual Voltage](#)).

Pickup, Dropout

The stage compares the **Threshold** with the zero-sequence voltage V_0 . The **Pickup delay** parameter allows you to delay the pickup of the stage depending on the residual voltage.

With the **Dropout ratio** parameter, you can define the ratio of the dropout value to the **Threshold**.

Determination of the Faulty Phase

With the **Detection of faulty phase** parameter, you can enable or disable the determination of the ground-fault phase. Determining is released when the stage picks up. If 2 phases exceed the threshold value **V > healthy ph-to-gnd volt.** and one phase falls below the threshold value **V < faulty ph-to-gnd volt.**, the last phase is determined to be faulty and is signaled as such.

Blocking the Stage

In the event of blocking, the picked up stage will be reset. The following blocking options are available for the stage:

- Via the binary input signal **>Block stage** from an external or internal source
- From inside on pickup of the **measuring-voltage failure detection** function. The **Blk. by meas.-volt. failure** parameter can be set so that measuring-voltage failure detection blocks the stage or does not block it.
- From an external source via the binary input signal **>open** of the function block **Voltage-transformer circuit breaker**, which links in the tripping of the voltage-transformer circuit breaker. The **Blk. by meas.-volt. failure** parameter can be set so that measuring-voltage failure detection blocks the stage or not.

6.15.9.2 Application and Setting Notes

Parameter: Method of measurement

- Recommended setting value (**_:12391:8**) **Method of measurement = fundamental comp.**

The **Method of measurement** parameter allows you to define whether the function works with the fundamental component or the calculated RMS value.

Parameter Value	Description
<i>fundamental comp.</i>	This method of measurement suppresses the harmonics or transient voltage peaks. Siemens recommends using this setting as the standard method.
<i>RMS value</i>	Select this method of measurement if you want the stage to take harmonics into account (for example at capacitor banks).
<i>fund. comp. long filter</i>	To implement particularly strong damping of harmonics and transient faults, select this method of measurement. At 2 periods, the length of the filter is longer than that of the standard filter. Note that in this case the pickup time of the stage increases slightly (see 14.19.7 Non-Directional V0 Stage with Zero-Sequence Voltage/Residual Voltage).

Parameter: Pickup delay

- Recommended setting value (`_:12391:107`) **Pickup delay = 0 ms**

The **Pickup delay** parameter allows you to delay the analysis of the measurand (to generate the pickup) depending on the occurrence of the residual voltage. A pickup delay can be necessary if high transients are anticipated after fault inception due to high line and ground capacitances.

Siemens recommends using the default setting **Pickup delay = 0 ms**.

Parameter: Threshold

- Default setting (`_:12391:3`) **Threshold = 30 V**

The threshold value of the function is set as the zero-sequence voltage V_0 . The device calculates the zero-sequence voltage V_0 either from the residual voltage measured via the broken-delta winding or from the 3 phase-to-ground voltages.

The setting value depends on the system grounding:

- Since virtually the full residual voltage occurs during ground faults in isolated or arc-suppression-coil-grounded systems, the setting value is uncritical there. Siemens recommends setting the value between 20 V and 40 V. A higher sensitivity (= lower threshold value) can be necessary for high fault resistances.
- Siemens recommends setting a more sensitive (smaller) value in grounded systems. This value must be higher than the maximum residual voltage anticipated during operation caused by system unbalances.

EXAMPLE

For an isolated system

The residual voltage is measured via the broken-delta winding:

- If the ground fault is fully unbalanced, a residual voltage of 100 V is present at the device terminals.
- The threshold value should be set so that the stage picks up on 50 % of the full residual voltage.
- At full residual voltage, the zero-sequence voltage is $100 \text{ V}/\sqrt{3} = 57.7 \text{ V}$
Setting value: $0.5 \cdot 57.7 \text{ V} = 28.9 \text{ V} \approx 30 \text{ V}$

Parameter: Dropout ratio

- Recommended setting value (`_:12391:4`) **Dropout ratio = 0.95**

The recommended setting value of **0.95** is appropriate for most applications. To achieve high measurement precision, the dropout ratio can be reduced to 0.98, for example.

Parameter: Operate delay

- Default setting (`_:12391:6`) **Operate delay = 3.00 s**

The **Operate delay** allows you to prevent transient residual voltages from initiating a trip. The setting depends on the specific application.

Parameter: Blk. by meas.-volt. failure

- Recommended setting value (`_:12391:10`) **Blk. by meas.-volt. failure = yes**

You use the **Blk. by meas.-volt. failure** parameter to control the behavior of the stage when a measuring-voltage failure is detected.

A measuring-voltage failure can only be detected if one of the following 2 conditions is met:

- The device-internal supervision function **Measuring-voltage failure detection** is configured and enabled.
- The binary input signal *>Open* of the function block **Voltage-transformer circuit breaker** is connected to the voltage-transformer circuit breaker.

Parameter Value	Description
<i>yes</i>	The protection stage is blocked (= default setting). If V_0 is calculated from the phase-to-ground voltages, Siemens recommends using the blocking.
<i>no</i>	The protection stage is not blocked. If V_0 is obtained from the VN measurement of a broken-delta winding, Siemens recommends not using the blocking.

Parameter: Detection of faulty phase

- Default setting (`_:12391:109`) **Detection of faulty phase = no**

The **Detection of faulty phase** parameter controls how the stage responds to determine which phase is affected by the ground fault.

Parameter Value	Description
<i>no</i>	The phase affected by the ground fault is not determined. Select the default setting if you do not want to use the stage to detect ground faults, for example for applications in grounded systems.
<i>yes</i>	After a pickup by the residual voltage, the device tries to determine which phase is affected by the ground fault. Select this setting for applications in isolated or arc-suppression-coil-grounded systems.

Parameter: V< faulty ph-to-gnd volt.

- Default setting (`_:12391:104`) **V< faulty ph-to-gnd volt. = 30 V**

Set the threshold value for determining which phase is affected by the ground fault in the **V< faulty ph-to-gnd volt.** parameter. The setting value is a phase-to-ground quantity.

The set value must be smaller than the minimum phase-to-ground voltage occurring during operation. Siemens recommends using the default setting **V< faulty ph-to-gnd volt. = 30 V**.

Parameter: V> healthy ph-to-gnd volt.

- Default setting (`_:12391:101`) **V> healthy ph-to-gnd volt. = 70 V**

Set the threshold value for the 2 healthy phases in the **V> healthy ph-to-gnd volt.** parameter. The setting value is a phase-to-ground measurand.

The set value must be above the maximum phase-to-ground voltage occurring during operation, but below the minimum phase-to-phase voltage present during operation. At $V_{rated} = 100\text{ V}$, the value has to be set to 70 V, for example. Siemens recommends using the default setting **V> healthy ph-to-gnd volt. = 70 V**.

Operation as Supervision Function

If you want the stage to have a reporting effect only, the generation of the operate indication and fault logging can be disabled via the **Operate & flt.rec. blocked** parameter.

6.15.9.3 Settings

Addr.	Parameter	C	Setting Options	Default Setting
V0> 1				
_:12391:1	V0> 1:Mode		<ul style="list-style-type: none"> • off • on • test 	off
_:12391:2	V0> 1:Operate & flt.rec. blocked		<ul style="list-style-type: none"> • no • yes 	no
_:12391:10	V0> 1:Blk. by meas.-volt. failure		<ul style="list-style-type: none"> • no • yes 	yes
_:12391:109	V0> 1:Detection of faulty phase		<ul style="list-style-type: none"> • no • yes 	no
_:12391:8	V0> 1:Method of measurement		<ul style="list-style-type: none"> • fundamental comp. • fund. comp. long filter • RMS value 	fundamental comp.
_:12391:3	V0> 1:Threshold		0.300 V to 200.000 V	30.000 V
_:12391:4	V0> 1:Dropout ratio		0.90 to 0.99	0.95
_:12391:107	V0> 1:Pickup delay		0.00 s to 60.00 s	0.00 s
_:12391:6	V0> 1:Operate delay		0.00 s to 100.00 s	3.00 s
_:12391:101	V0> 1:V> healthy ph-to-gnd volt.		0.300 V to 200.000 V	70.000 V
_:12391:104	V0> 1:V< faulty ph-to-gnd volt.		0.300 V to 200.000 V	30.000 V

6.15.9.4 Information List

No.	Information	Data Class (Type)	Type
V0> 1			
_:12391:81	V0> 1:>Block stage	SPS	I
_:12391:54	V0> 1:Inactive	SPS	O
_:12391:52	V0> 1:Behavior	ENS	O
_:12391:53	V0> 1:Health	ENS	O
_:12391:300	V0> 1:Faulty phase	ACT	O
_:12391:55	V0> 1:Pickup	ACD	O
_:12391:56	V0> 1:Operate delay expired	ACT	O
_:12391:57	V0> 1:Operate	ACT	O

6.15.10 Non-Directional 3I0 Stage

6.15.10.1 Description

In the **Directional sensitive ground-fault detection** function, the **Non-directional 3I0 stage** also works on demand.

Logic

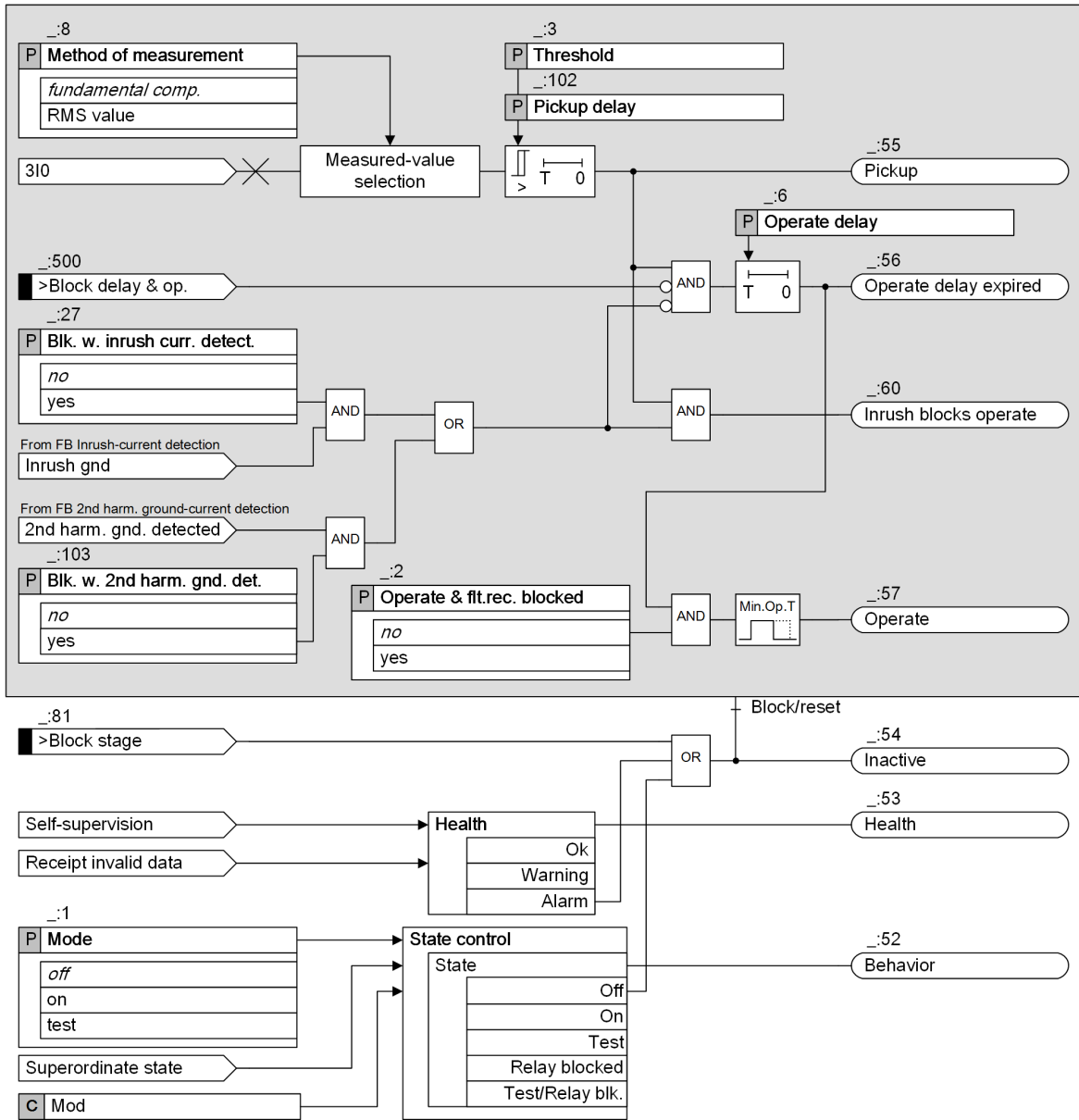

[!o_sensitive ground-current protection 3I0, 3, en_US]

Figure 6-139 Logic Diagram of the Non-Directional 3I0 Stage

Measured Value 3I0

The function usually evaluates the sensitively measured ground current 3I0 via a core balance current transformer. Since the linearity range of the sensitive measuring input ends at approx. 1.6 A, for larger secondary ground currents, the function switches to the 3I0 current calculated from the phase currents. This results in a very large linearity and settings range.

Depending on the connection type of the measuring point as well as the current terminal blocks used, different linearity and setting ranges result. You can find more information in section [Measured Value 3I0, Method of Measurement](#), Page 601.

Method of Measurement

You use the **Method of measurement** parameter to define whether the stage uses the *fundamental comp.* or the calculated *RMS value*.

- Measurement of the fundamental component:
This method of measurement processes the sampled current values and filters out the fundamental component numerically.
- Measurement of the RMS value:
This method of measurement determines the current amplitude from the sampled values according to the defining equation of the RMS value. Harmonics are included in the analysis.

Blocking the Stage via Binary Input Signal

You can block the stage externally or internally via the binary input signal *>Block stage*. In the event of blocking, the picked up stage will be reset.

Blocking the Time Delay

You can use the binary input signal *>Block delay & op.* to prevent the start of the time delay and thus also the operate indication. A running time delay is reset. The pickup is indicated and a fault record is opened.

Blocking of the Tripping by Device-Internal Inrush-Current Detection

The **Blk. w. inrush curr. detect.** parameter allows you to define whether the operate indication of the stage should be blocked when a threshold value is exceeded due to an inrush current. In case of a blocking and fulfilled pickup conditions, the stage picks up. The start of the time delay and the operate indication are blocked. The function indicates this through a corresponding indication. If the blocking drops out and the pickup conditions are still met, the time delay is started. After that time, the stage operates.

The **Blk. w. 2nd harm. gnd. det.** parameter allows you to define whether the operate indication of the stage should be blocked when the detected 2nd harmonic component of the ground current exceeds a threshold value. In case of a blocking and fulfilled pickup conditions, the stage picks up. The start of the time delay and the operate indication are blocked. The function indicates this through a corresponding indication. If the blocking drops out and the pickup conditions are still met, the time delay is started. After that time, the stage operates.

6.15.10.2 Application and Setting Notes

Parameter: **Blk. w. inrush curr. detect.**

- Default setting (`_:27`) **Blk. w. inrush curr. detect. = no**

With the **Blk. w. inrush curr. detect.** parameter, you determine whether the tripping is blocked during the detection of an inrush current.

Parameter: **Blk. w. 2nd harm. gnd. det.**

- Default setting (`_:103`) **Blk. w. 2nd harm. gnd. det. = no**

Parameter Value	Description
<i>no</i>	If no 3I0/IN current flow due to CT saturation with a level above the pickup threshold is expected, select this setting.
<i>yes</i>	If 3I0/IN current flow due to CT saturation with a level above the pickup threshold is expected, the blocking must be activated. This provides stability for the following conditions: <ul style="list-style-type: none"> • CT saturation without inrush current since a saturated signal also contains 2nd-harmonic content • Phase inrush current that leads to CT saturation and therefore causes 2nd-harmonic inrush current being present also in the parasitic 3I0 current

Parameter: Method of measurement

- Recommended setting value (**_:8**) **Method of measurement** = *fundamental comp.*

With the **Method of measurement** parameter, you define whether the stage uses the *fundamental comp.* (standard method) or the calculated *RMS value*.

Parameter Value	Description
<i>fundamental comp.</i>	Select this method of measurement if harmonics or transient current peaks are to be suppressed. Siemens recommends using this method as the standard method.
<i>RMS value</i>	Select this method of measurement if you want the stage to take harmonics into account (for example, at capacitor banks). Consider that aperiodic DC components present in the secondary circuit are measured and can cause an overfunction. For this method of measurement, do not set the threshold value of the stage to less than $0.1 I_{rated,sec}$. If currents from more than one measuring point are added up in the current interface of a function group, the setting value should not be set lower than $0.1 I_{rated,sec}$ multiplied by the number of added currents.

Parameter: Threshold

- Default setting (**_:3**) **Threshold** = *0.050 A*

The **Threshold** parameter allows you to set the threshold value of the ground current 3I0.

Parameter: Pickup delay

- Default setting (**_:102**) **Pickup delay** = *0.00 s*

With the parameter **Pickup delay** you set whether pickup of the stage is to be delayed or not. If the transient cycle of the ground fault occurrence should not be evaluated, set a delay of 100 ms, for example.

Parameter: Operate delay

- Default setting (**_:6**) **Operate delay** = *0.30 s*

The **Operate delay** parameter determines the time during which the pickup conditions must be met to issue the operate indication. The operate indication is issued when this time expires.

6.15.10.3 Settings

Addr.	Parameter	C	Setting Options	Default Setting
3I0> #				
_:1	3I0> #:Mode		<ul style="list-style-type: none"> • off • on • test 	off
_:2	3I0> #:Operate & flt.rec. blocked		<ul style="list-style-type: none"> • no • yes 	no
_:27	3I0> #:Blk. w. inrush curr. detect.		<ul style="list-style-type: none"> • no • yes 	no
_:103	3I0> #:Blk. w. 2nd harm. gnd. det.		<ul style="list-style-type: none"> • no • yes 	no
_:8	3I0> #:Method of measurement		<ul style="list-style-type: none"> • fundamental comp. • RMS value 	fundamental comp.
_:3	3I0> #:Threshold	1 A @ 100 Irated	0.030 A to 35.000 A	0.050 A
		5 A @ 100 Irated	0.15 A to 175.00 A	0.25 A
		1 A @ 50 Irated	0.030 A to 35.000 A	0.050 A
		5 A @ 50 Irated	0.15 A to 175.00 A	0.25 A
		1 A @ 1.6 Irated	0.001 A to 35.000 A	0.050 A
		5 A @ 1.6 Irated	0.005 A to 35.000 A	0.250 A
_:102	3I0> #:Pickup delay		0.00 s to 60.00 s	0.00 s
_:6	3I0> #:Operate delay		0.00 s to 100.00 s	0.30 s

6.15.10.4 Information List

No.	Information	Data Class (Type)	Type
3I0> #			
_:81	3I0> #:>Block stage	SPS	I
_:500	3I0> #:>Block delay & op.	SPS	I
_:54	3I0> #:Inactive	SPS	O
_:52	3I0> #:Behavior	ENS	O
_:53	3I0> #:Health	ENS	O
_:60	3I0> #:Inrush blocks operate	ACT	O
_:55	3I0> #:Pickup	ACD	O
_:56	3I0> #:Operate delay expired	ACT	O
_:57	3I0> #:Operate	ACT	O

6.15.11 Non-Directional Y0 Stage

6.15.11.1 Description

In the **Directional sensitive ground-fault detection** function, the **Non-directional Y0 stage** also works on demand.

Logic

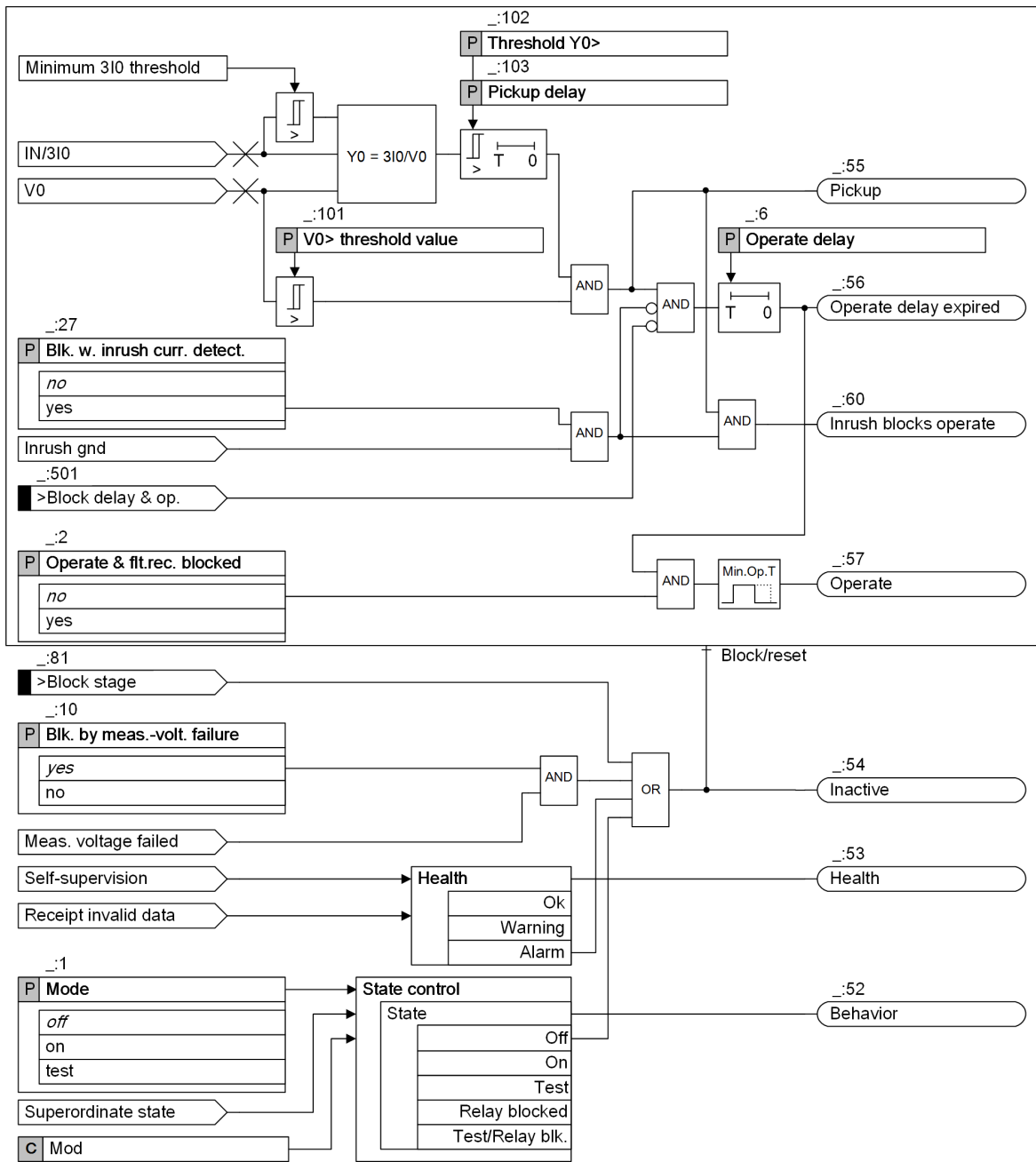

[lo_gfp_sy_0_3_en_US]

Figure 6-140 Logic Diagram of the Non-Directional Y0 Stage

Measured Value V0, Method of Measurement

The device can measure the residual voltage at the broken-delta winding. The measured voltage VN is converted to a value with reference to the zero-sequence voltage V0. If the residual voltage is not available, the device calculates the zero-sequence voltage V0 from the measured phase-to-ground voltages VA, VB, and VC using the defining equation.

The method of measurement processes the sampled voltage values and filters out the fundamental component numerically.

Measured Value 3I0, Method of Measurement

The function usually evaluates the sensitively measured ground current 3I0 via a core balance current transformer. Since the linearity range of the sensitive measuring input ends at approx. 1.6 A, for larger secondary ground currents, the function switches to the 3I0 current calculated from the phase currents. This results in a very large linearity and settings range.

The method of measurement processes the sampled current values and filters out the fundamental component numerically.

Depending on the connection type of the measuring point as well as the current terminal blocks used, different linearity and setting ranges result. You can find more information in section [Measured Value 3I0, Method of Measurement](#), Page 601.

Y0

The fundamental-component values of V0 and 3I0 are used to calculate the admittance Y0 through the formula $Y0 = 3I0/V0$. This stage uses Y0 as a condition to recognize the ground fault.

Minimum 3I0 Threshold

To start the Y0 calculation, the IN/3I0 value must exceed a minimum 3I0 threshold. For protection-class current transformers, the threshold value is 30 mA ($I_{rated, sec} = 1$ A) or 150 mA ($I_{rated, sec} = 5$ A). For sensitive current transformers, the threshold value is 1 mA ($I_{rated, sec} = 1$ A) or 5 mA ($I_{rated, sec} = 5$ A).

Ground-Fault Detection, Pickup

If the absolute value of the zero-sequence voltage V0 exceeds the threshold value **V0 > threshold value** and Y0 exceeds the threshold value **Threshold Y0 >**, the stage recognizes the ground fault. If the threshold values remain exceeded during the **Pickup delay**, the stage picks up.

Blocking the Stage via Binary Input Signal

Blocking of the stage is possible externally or internally via the binary input signal **>Block stage**. In the event of blocking, the picked up stage will be reset.

Blocking the Stage in Case of Measuring-Voltage Failure

The stage can be blocked if a measuring-voltage failure occurs. In the event of blocking, the picked up stage will be reset.

The following blocking options are available for the stage:

- From inside on pick up of the **Measuring-voltage failure detection** function
- From an external source via the binary input signal **>open** of the function block **Voltage-transformer circuit breaker**, which links in the tripping of the voltage-transformer circuit breaker.

The **Blk. by meas.-volt. failure** parameter can be set so that measuring-voltage failure detection blocks the stage or does not block it.

Blocking of the Time Delay

You can use the binary input signal **>Block delay & op.** to prevent the start of the time delay and thus also the operate indication. A running time delay is reset. The pickup is indicated and a fault record is opened.

Blocking of the Tripping by Device-Internal Inrush-Current Detection

The **Blk. w. inrush curr. detect.** parameter allows you to define whether the operate indication of the stage should be blocked when a threshold value is exceeded due to an inrush current. In case of a blocking and fulfilled pickup conditions, the stage picks up. The start of the time delay and the operate indication are blocked. The function indicates this through a corresponding indication. If the blocking drops out and the pickup conditions are still met, the time delay is started. After that time, the stage operates.

6.15.11.2 Application and Setting Notes

Parameter: Operate & flt.rec. blocked

- Default setting (`_:2`) **Operate & flt.rec. blocked** = *no*

You can block the operate indication, the fault recording, and the fault log with the **Operate & flt.rec. blocked** parameter. In this case, a ground-fault log is created instead of the fault log.

Parameter: Blk. by meas.-volt. failure

- Recommended setting value (`_:10`) **Blk. by meas.-volt. failure** = *yes*

You use the **Blk. by meas.-volt. failure** parameter to control the behavior of the stage when a measuring-voltage failure is detected.

A measuring-voltage failure can only be detected if one of the following 2 conditions is met:

- The device-internal supervision function **Measuring-voltage failure detection** is configured and enabled.
- The binary input signal *>Open* of the function block **Voltage-transformer circuit breaker** is connected to the voltage-transformer circuit breaker.

Parameter Value	Description
<i>yes</i>	The protection stage is blocked (= default setting). If V0 is calculated from the phase-to-ground voltages, Siemens recommends using the blocking.
<i>no</i>	The protection stage is not blocked. If V0 is obtained from the VN measurement of a broken-delta winding, Siemens recommends not using the blocking.

Parameter: Blk. w. inrush curr. detect.

- Default setting (`_:27`) **Blk. w. inrush curr. detect.** = *no*

With the **Blk. w. inrush curr. detect.** parameter, you determine whether the operate is blocked during the detection of an inrush current.

Parameter: V0> threshold value

- Default setting (`_:101`) **V0> threshold value** = *5.000 V*

The **V0> threshold value** parameter allows you to set the zero-sequence voltage sensitivity of the stage. The threshold value must be smaller than the minimum amount of the zero-sequence voltage V0 which must still be detected.

Parameter: Threshold Y0>

- Default setting (`_:102`) **Threshold Y0>** = *2.00 mS*

With the parameter **Threshold Y0>**, you set the threshold value of the ground admittance Y0. If the ground admittance for the setting value is unknown, you can assume the following relation:

$$Y0 > k_s \frac{I_{c,line}}{3V_{ph-gnd}} + \frac{3I_{0min}}{V0>}$$

[fo_se_g_f_Y0_2_en_US]

- k_s Factor, takes into account the ohmic components of the current (1.2 for overhead lines, 1.0 to 1.05 for cable systems)
- $I_{c,line}$ Secondary capacitive ground-fault current for the protected line
- V_{ph-gnd} Secondary phase-to-ground voltage in the healthy case

$3I_{0min}$	Secondary ground current in the healthy case (resulting from transformer error), 5 mA to 10 mA (core balance current transformer), 50 mA to 100 mA (Holmgreen transformer)
V0>	Secondary pickup threshold of the residual voltage

Parameter: Pickup delay

- Default setting (`_:103`) **Pickup delay** = 0.00 s

With the parameter **Pickup delay**, you set whether pickup of the stage is to be delayed or not. If the transient cycle of the ground fault occurrence should not be evaluated, set a delay of 100 ms, for example.

Parameter: Operate delay

- Default setting (`_:6`) **Operate delay** = 0.30 s

The **Operate delay** parameter determines the time during which the pickup conditions must be met to issue the operate indication. The operate indication is issued when this time expires.

6.15.11.3 Settings

Addr.	Parameter	C	Setting Options	Default Setting
Y0> #				
<code>_:1</code>	Y0> #:Mode		<ul style="list-style-type: none"> • off • on • test 	off
<code>_:2</code>	Y0> #:Operate & flt.rec. blocked		<ul style="list-style-type: none"> • no • yes 	no
<code>_:10</code>	Y0> #:Blk. by meas.-volt. failure		<ul style="list-style-type: none"> • no • yes 	yes
<code>_:27</code>	Y0> #:Blk. w. inrush curr. detect.		<ul style="list-style-type: none"> • no • yes 	no
<code>_:101</code>	Y0> #:V0> threshold value		0.300 V to 200.000 V	5.000 V
<code>_:102</code>	Y0> #:Threshold Y0>		0.10 mS to 100.00 mS	2.00 mS
<code>_:103</code>	Y0> #:Pickup delay		0.00 s to 60.00 s	0.00 s
<code>_:6</code>	Y0> #:Operate delay		0.00 s to 60.00 s	0.30 s

6.15.11.4 Information List

No.	Information	Data Class (Type)	Type
Y0> #			
<code>_:81</code>	Y0> #:>Block stage	SPS	I
<code>_:501</code>	Y0> #:>Block delay & op.	SPS	I
<code>_:54</code>	Y0> #:Inactive	SPS	O
<code>_:52</code>	Y0> #:Behavior	ENS	O
<code>_:53</code>	Y0> #:Health	ENS	O
<code>_:60</code>	Y0> #:Inrush blocks operate	ACT	O
<code>_:55</code>	Y0> #:Pickup	ACD	O
<code>_:56</code>	Y0> #:Operate delay expired	ACT	O
<code>_:57</code>	Y0> #:Operate	ACT	O

6.15.12 Non-Directional 3I0 Harmonic Stage

6.15.12.1 Description

The **Non-directional 3I0 harmonic stage** detects ground faults via the 3rd, 5th, or 7th harmonic component of the zero-sequence current 3I0.

Logic

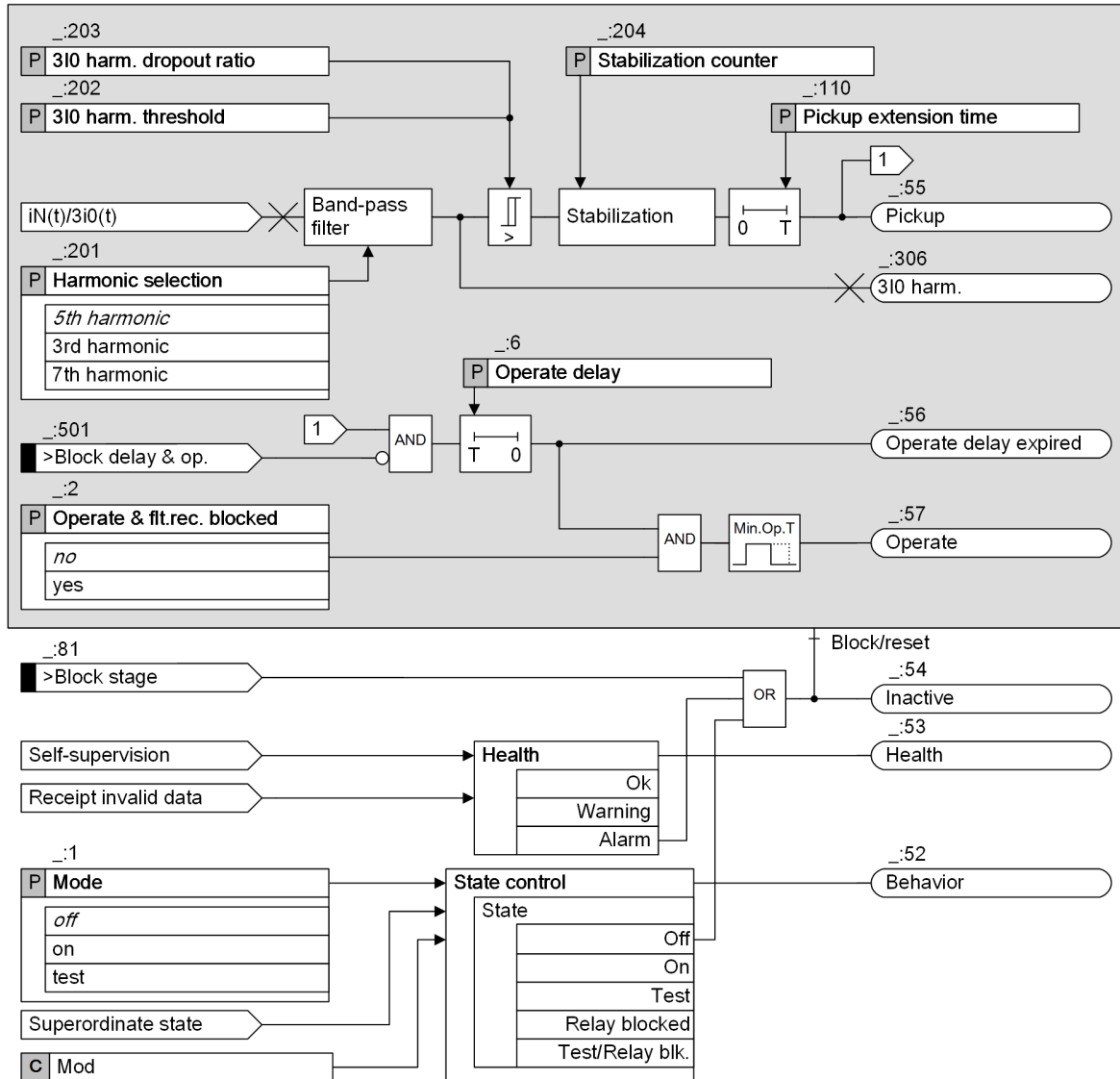

[file_3i0_harmonic_2_en_US]

Figure 6-141 Logic Diagram of the Non-Directional 3I0 Harmonic Stage

Measured Value 3I0, Method of Measurement

The function usually evaluates the sensitively measured ground current 3I0 via a core balance current transformer. Since the linearity range of the sensitive measuring input ends at approx. 1.6 A, for larger secondary ground currents, the function switches to the 3I0 current calculated from the phase currents. This results in a very large linearity and settings range.

Depending on the connection type of the measuring point and on the current terminal blocks used, different linearity and setting ranges result. You can find more information in chapter [6.15.4.1 Description](#).

The function uses the 3rd, 5th, or 7th harmonic component of the ground current 3I0 for detecting the ground fault. The specific harmonic component to be used is determined by the **Harmonic selection** setting.

Stabilization, Pickup

To avoid a wrong pickup in case of transient current peaks, the function uses the **Stabilization counter** parameter. If the magnitude of the zero-sequence harmonic current 3I0harm. exceeds the **3I0 harm. threshold**, the stabilization counter starts. If the 3I0harm. current keeps exceeding the **3I0 harm. threshold** for a specified number of measuring cycles, the stage picks up. You can define the specified number via the **Stabilization counter** parameter.

Pickup Extension

Considering the discontinuity of the 3I0harm. current, the *Pickup* signal does not drop out immediately after the 3I0harm. current falls below the **3I0 harm. threshold**.

When the 3I0harm. current falls below the **3I0 harm. threshold**, the timer **Pickup extension time** starts to hold the *Pickup* signal until the timer expires. The timer resets after the 3I0harm. current exceeds the **3I0 harm. threshold** again during the extension time.

Blocking the Stage via Binary Input Signal

You can block the stage externally or internally via the binary input signal *>Block stage*. In the event of blocking, the picked up stage will be reset.

Blocking the Time Delay

You can use the binary input signal *>Block delay & op.* to prevent the start of the time delay and thus also the operate signal. A running time delay is reset. The pickup is indicated. Fault logging and fault recording take place.

Functional Measured Values

Values	Description	Primary	Secondary	% Referenced to
3I0 harm.	3rd, 5th, or 7th harmonic component of the ground current	A	A	Parameter Rated current

You can find the parameter **Rated current** in the **FB General** of the function group where the **Sensitive ground-fault detection** function is used. If the 3I0harm. current is smaller than 0.005 % of the rated secondary current, the functional measured value is displayed as ---.

6.15.12.2 Application and Setting Notes

Parameter: **Harmonic selection**

- Default setting (`_:201`) **Harmonic selection** = *5th harmonic*

With the **Harmonic selection** parameter, you select to use the 3rd, 5th, or 7th harmonic component of the zero-sequence current 3I0 for detecting the ground fault.

Parameter: **3I0 harm. threshold**

- Default setting (`_:202`) **3I0 harm. threshold** = *0.030 A*

With the **3I0 harm. threshold** parameter, you define the threshold value of the zero-sequence harmonic current 3I0harm. for detecting the ground fault.

This parameter needs to be set according to the experience from the specific network. The experience requires the analysis of permanent ground faults from the network. If such information is unavailable, Siemens recommends a rather low setting between 5 mA and 10 mA secondary.

Parameter: Stabilization counter

- Default setting (`_:204`) **Stabilization counter = 4**

With the **Stabilization counter** parameter, you define the number of measuring cycles in which the 3I0harm. current must keep exceeding the **3I0 harm. threshold** to meet the pickup condition. With this setting, you can optimize the pickup-condition reliability versus the pickup time.

For example, the **Stabilization counter** value is 4. Then, if the 3I0harm. current exceeds the **3I0 harm. threshold** and keeps exceeding the threshold for 4 measuring cycles, the stage picks up. The measuring cycle time is half of the network period. For 50 Hz, the cycle time is 10 ms. To avoid a false pickup due to CB switching operations, Siemens recommends using the default setting.

Parameter: 3I0 harm. dropout ratio

- Default setting (`_:203`) **3I0 harm. dropout ratio = 0.60**

With the **3I0 harm. dropout ratio** parameter, you define the dropout threshold for the **3I0 harm. threshold** parameter. Siemens recommends using the default setting.

Parameter: Pickup extension time

- Default setting (`_:110`) **Pickup extension time = 0.00 s**

With the **Pickup extension time** parameter, you define the time for extending the *Pickup* signal if the zero-sequence harmonic current 3I0harm. falls below the **3I0 harm. threshold**.

This extension time can be used to generate a stable pickup indication under fluctuating zero-sequence harmonics.

Parameter: Operate delay

- Default setting (`_:6`) **Operate delay = 1.00 s**

With the **Operate delay** parameter, you determine the time during which the pickup conditions must be met to issue the operate indication. The operate indication is issued when this time expires.

Parameter: Operate & flt.rec. blocked

- Default setting (`_:2`) **Operate & flt.rec. blocked = no**

With the **Operate & flt.rec. blocked** parameter, you block the operate indication, the fault recording, and the fault log. In this case, a ground-fault log is created instead of the fault log.

6.15.12.3 Settings

Addr.	Parameter	C	Setting Options	Default Setting
3I0> harmonic#				
<code>_:1</code>	3I0> harmonic#:Mode		<ul style="list-style-type: none"> • off • on • test 	off
<code>_:2</code>	3I0> harmonic#:Operate & flt.rec. blocked		<ul style="list-style-type: none"> • no • yes 	no
<code>_:201</code>	3I0> harmonic#:Harmonic selection		<ul style="list-style-type: none"> • 3rd harmonic • 5th harmonic • 7th harmonic 	5th harmonic

Addr.	Parameter	C	Setting Options	Default Setting
_:202	3I0> harmonic#:3I0 harm. threshold	1 A @ 100 Irated	0.030 A to 35.000 A	0.030 A
		5 A @ 100 Irated	0.15 A to 175.00 A	0.15 A
		1 A @ 50 Irated	0.030 A to 35.000 A	0.030 A
		5 A @ 50 Irated	0.15 A to 175.00 A	0.15 A
		1 A @ 1.6 Irated	0.001 A to 35.000 A	0.030 A
		5 A @ 1.6 Irated	0.005 A to 35.000 A	0.150 A
_:203	3I0> harmonic#:3I0 harm. dropout ratio		0.10 to 0.95	0.60
_:204	3I0> harmonic#:Stabili- zation counter		1 to 10	4
_:110	3I0> harmonic#:Pickup extension time		0.00 s to 60.00 s	0.00 s
_:6	3I0> harmonic#:Operate delay		0.00 s to 60.00 s	1.00 s

6.15.12.4 Information List

No.	Information	Data Class (Type)	Type
<i>3I0> harmonic#</i>			
_:81	3I0> harmonic#:>Block stage	SPS	I
_:501	3I0> harmonic#:>Block delay & op.	SPS	I
_:54	3I0> harmonic#:Inactive	SPS	O
_:52	3I0> harmonic#:Behavior	ENS	O
_:53	3I0> harmonic#:Health	ENS	O
_:55	3I0> harmonic#:Pickup	ACD	O
_:56	3I0> harmonic#:Operate delay expired	ACT	O
_:57	3I0> harmonic#:Operate	ACT	O
_:306	3I0> harmonic#:3I0 harm.	MV	O

6.15.13 Pulse-Pattern Detection Stage

6.15.13.1 Description

Overview

The **Pulse-pattern detection** stage detects a faulty feeder during a permanent ground fault in overcompensated systems. This method is not reliably applicable to undercompensated systems.

The following figure shows a simplified network that applies the pulse-pattern detection method.

The pulse pattern in the ground current 3I0 is generated by switching on and off a capacitor in parallel to the arc-suppression coil:

- When the capacitor is switched on, an additional capacitive ground current is generated and the 3I0 compensation changes.
- When the capacitor is switched off, the additional capacitive ground current is vanished and the 3I0 compensation returns to the normal state.

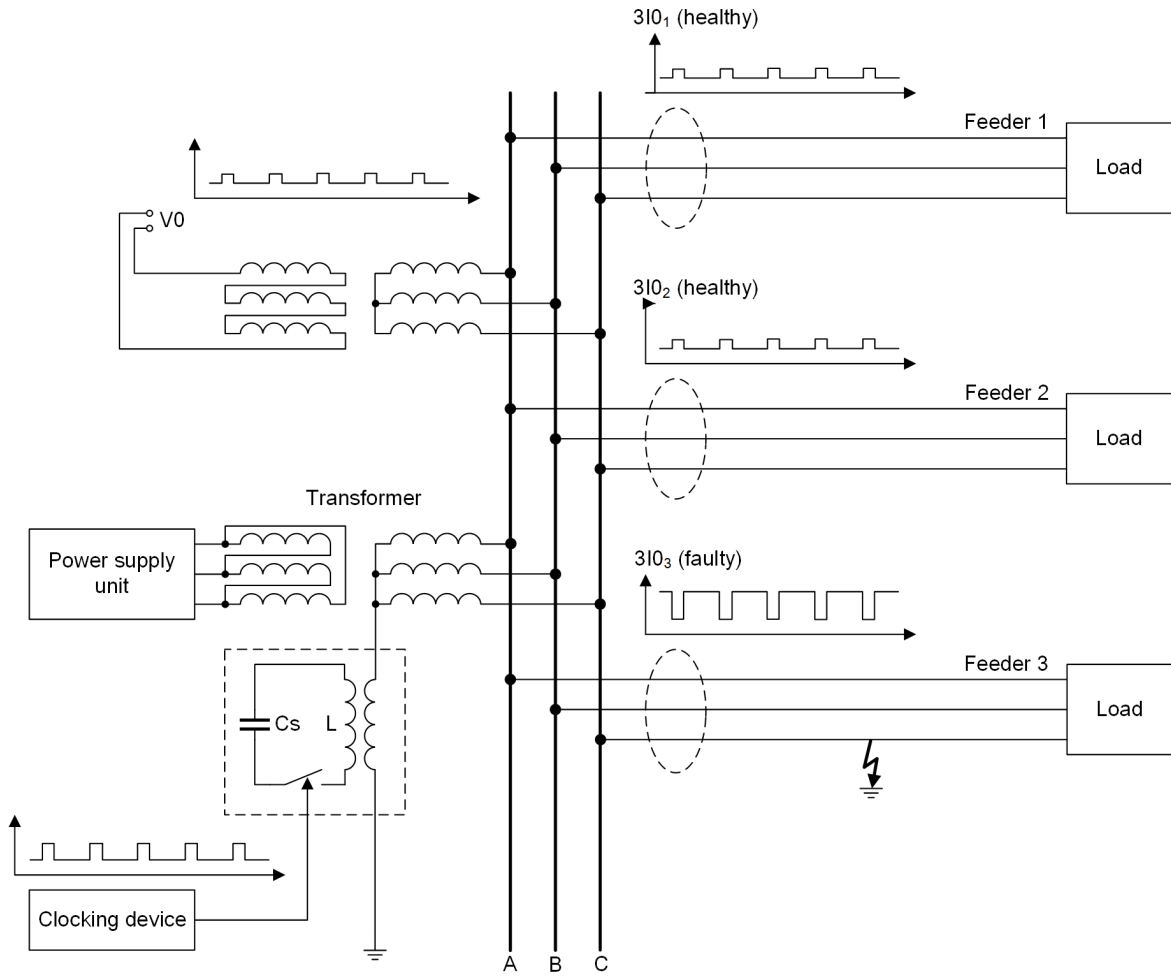

[dw_pulse detection network, 2, en_US]
 Figure 6-142 Network that Uses the Pulse-Pattern Detection

Cs Capacitance of the switched capacitor
 L Inductance of the arc-suppression coil

Pulse Pattern during a Ground Fault

The following figure shows the 3I0 pulse pattern in an overcompensated system for a low-impedance ground fault and a high-impedance ground fault.

- For low-impedance ground faults, the 3I0 pulse pattern exists only in the faulty feeder.
- For high-impedance ground faults, the pulse pattern is also present in the healthy feeders with lower amplitude but in phase opposition to the faulty feeder.

Applying a different switch-on/switch-off duration allows distinguishing between faulty and healthy feeders in case of high-impedance ground faults.

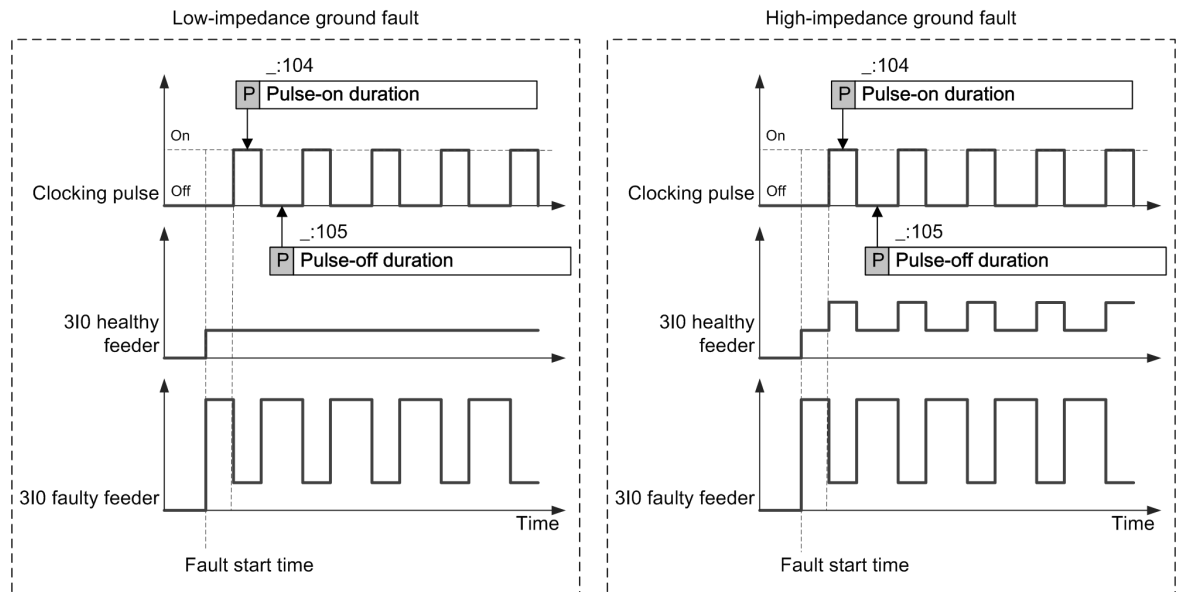

[dw_pulse pattern in overcompensation network, 1, en_US]

Figure 6-143 Current Pulse Pattern in the Overcompensated System

For the faulty feeder, the current pulse pattern is as follows:

- When the clocking pulse is on, the capacitor is switched on, the zero-sequence current 3I₀ in the faulty feeder is reduced, and the corresponding current pulse pattern is off.
- When the clocking pulse is off, the capacitor is switched off, 3I₀ in the faulty feeder is increased, and the current pulse pattern is on.

Clocking Pulse	Capacitor	3I ₀ in the Faulty Feeder	Current Pulse Pattern of the Faulty Feeder
On	On	Reduced	Off
Off	Off	Increased	On

Logic

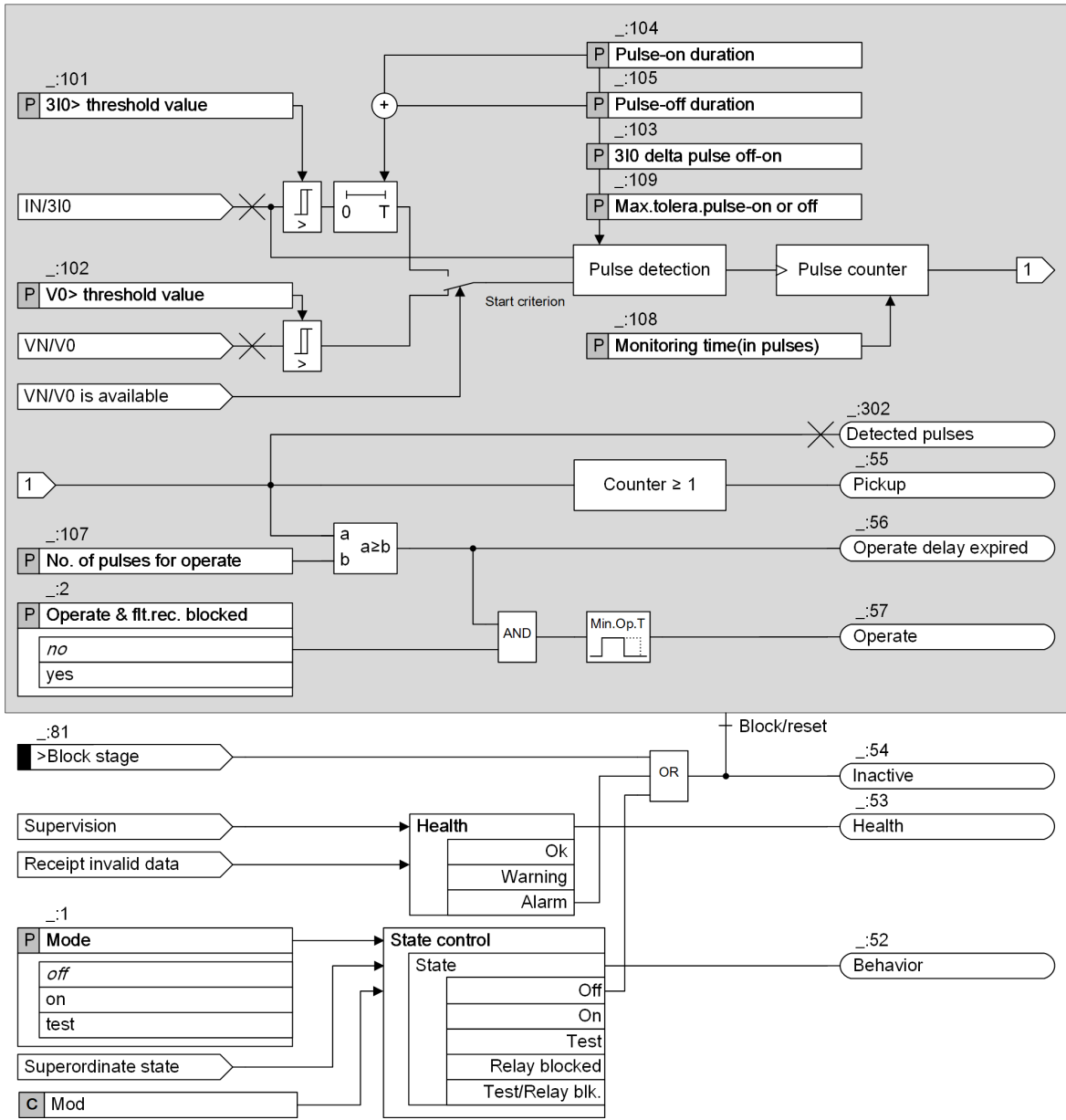

[file_sensGFP_pulse_detection_3_en_US]

Figure 6-144 Logic Diagram of the Pulse-Pattern Detection Stage

Measured Value V0, Method of Measurement

The device can measure the residual voltage at the broken-delta winding. The measured voltage VN is converted to a value with reference to the zero-sequence voltage V0. If the residual voltage is not available to the device as a measurand, the zero-sequence voltage V0 is calculated from the measured phase-to-ground voltages V_A , V_B , and V_C using the defining equation.

This method of measurement processes the sampled voltage values and filters out the fundamental component numerically.

Measured Value 3I0, Method of Measurement

The function usually evaluates the ground current 3I0 sensitively measured via a core balance current transformer. Since the linearity range of the sensitive measuring input ends at approx. 1.6 A, for larger secondary

ground currents, the function switches to the 3I0 calculated from the phase currents. This results in a very large linearity and settings range.

The method of measurement processes the sampled current values and filters out the fundamental component numerically.

Depending on the connection type of the measuring point as well as the current terminal blocks used, different linearity and setting ranges result. You can find more information in [Measured Value 3I0, Method of Measurement](#), Page 601.

Pulse Detection, Pulse Counter

For this stage, voltage routing is optional and current routing is mandatory.

- If VN or V0 is available, the voltage is the only criterion for starting the pulse-detection logic. When the fundamental-component value of V0 exceeds the **V0 > threshold value**, the pulse-detection logic is started.
- If VN or V0 is not available, the current is the only criterion for starting the pulse-detection logic. When the fundamental-component value of the zero-sequence current 3I0 exceeds the **3I0 > threshold value**, the pulse-detection logic is started.

If the measured current pulse-off duration equals to the value of the **Pulse-on duration** parameter and the measured current pulse-on duration equals to the value of the **Pulse-off duration** parameter, a valid pulse is detected.

After the first valid pulse is detected, the pulse counter is started to count the number of pulses continuously until the stage resets.

Pickup, Operate

After the first valid pulse is detected, the stage picks up.

If the number of detected pulses within the pulse monitoring time reaches the setting of the **No. of pulses for operate** parameter, the stage operates. The pulse monitoring time is calculated via the following formula:

Pulse monitoring time = Value **Monitoring time (in pulses)** · (Value **Pulse-on duration** + Value **Pulse-off duration**)

For example, the value of the **No. of pulses for operate** parameter is 3, and the value of the **Monitoring time (in pulses)** is 5. Then the pickup and operate time diagram is as follows:

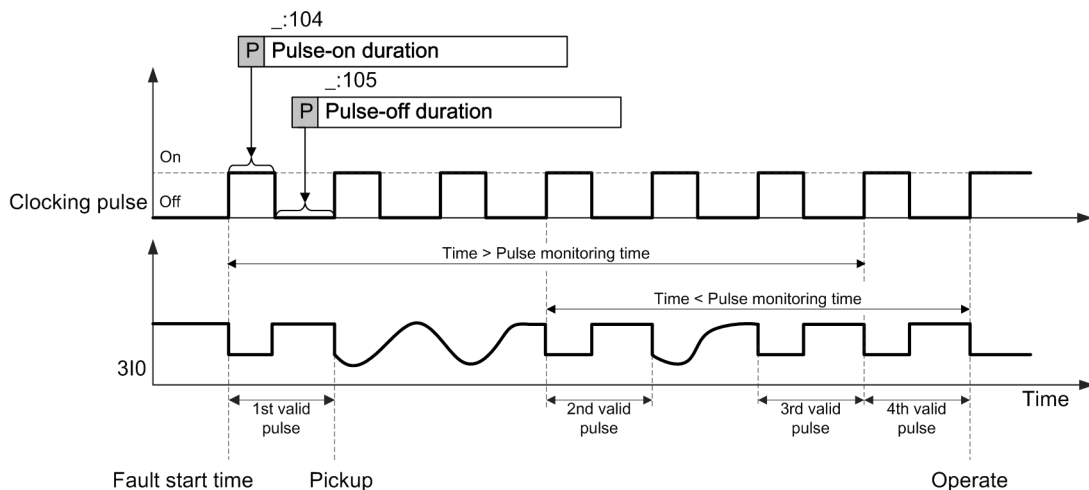

[dw_pulse pickup and operate, 1, en_US]

Figure 6-145 Pickup and Operate Time

- After the 3rd valid pulse is detected, the stage does not operate because the time between the 1st and the 3rd valid pulses is greater than the pulse monitoring time which is 5 clocking pulses.
- After the 4th valid pulse is detected, the stage operates because the time between the 2nd and the 4th valid pulses is within the pulse monitoring time which is 5 clocking pulses.

Dropout Delay

Switching on the capacitor usually causes 3I0 to decrease in the faulty feeder. This must not cause the stage to drop out. For that reason, a dropout delay is active for the sum of the **Pulse-on duration** and **Pulse-off duration** values.

Detected Pulses of the Ground Fault

The stage records the total number of detected pulses during the permanent ground fault. If the function resets or the operate condition is met, this number is issued via the signal *Detected pulses*.

Blocking the Stage via Binary Input Signal

You can block the stage externally or internally via the binary input signal *>Block stage*. In the event of blocking, the picked up stage will be reset.

6.15.13.2 Application and Setting Notes

Parameter: **V0> threshold value**

- Default setting (`_:102`) **V0> threshold value = 30.000 V**

The **V0> threshold value** parameter allows you to set the zero-sequence (fundamental) voltage sensitivity of the stage. Set the threshold value smaller than the minimum absolute value of the zero-sequence voltage V0 that must still be detected.

If VN or V0 is not available, the **V0> threshold value** parameter is hidden and the **3I0> threshold value** parameter is visible and used.

Parameter: **3I0> threshold value**

- Default setting (`_:101`) **3I0> threshold value = 0.200 A**

If VN or V0 is not available, the **3I0> threshold value** parameter is visible and used.

The **3I0> threshold value** parameter allows you to set the zero-sequence (fundamental) current sensitivity of the stage. Set the threshold value smaller than the minimum absolute value of the zero-sequence current 3I0 that must still be detected.

Parameter: **Pulse-on duration, Pulse-off duration**

- Default setting (`_:104`) **Pulse-on duration = 1.00 s**
- Default setting (`_:105`) **Pulse-off duration = 1.50 s**

With the **Pulse-on duration** and **Pulse-off duration** parameters, you define the switch-on and switch-off duration of the capacitor.

These values must be set according to the operation of the clocking device that determines the switch-on and switch-off duration of the capacitor. If you set these 2 parameters to the same or similar values, there is a risk of failure because the stage cannot distinguish the healthy and faulty feeders by only evaluating the ground current during a high-impedance ground fault.

Parameter: **Max.tolera.pulse-on or off**

- Default setting (`_:109`) **Max.tolera.pulse-on or off = 0.15 s**

With the **Max.tolera.pulse-on or off** parameter, you define the tolerance for the measured pulse-on/pulse-off duration. The tolerance is the maximum deviation from the set values for the **Pulse-on duration** and **Pulse-off duration** parameters.

The recommended setting for this parameter is the maximum tolerance of the clocking device plus 40 ms (tolerance of the SIPROTEC 5 device). For the tolerance of the clocking device, you have to consider the tolerances of the pulse-on and pulse-off durations individually and select the larger tolerance of both.

EXAMPLE

Clocking device:

Set pulse-on duration for the clocking device	1.00 s
Max. tolerance pulse-on duration of the clocking device	70 ms
Set pulse-off duration for the clocking device	1.50 s
Max. tolerance pulse-off duration of the clocking device	110 ms
Larger tolerance of both	110 ms

Tolerance to be set:

Tolerance of the SIPROTEC 5 device	40 ms
Total tolerance to be set	110 ms + 40 ms = 150 ms

Consequently, you must set the respective device settings as:

- **Pulse-on duration** = 1.00 s
- **Pulse-off duration** = 1.50 s
- **Max.tolera.pulse-on or off** = 0.15 s

The following figure shows the measured pulse durations which are within the maximum stated tolerances of the example.

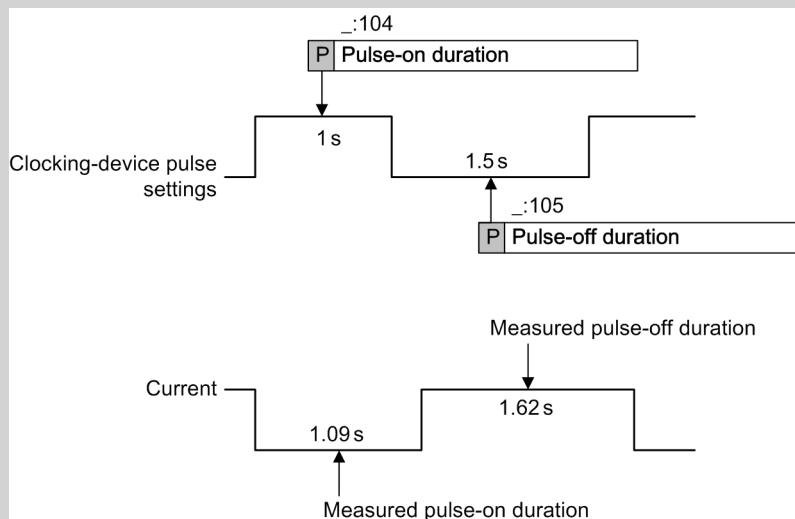

[dw_tolerance_1_en_US]

If you have no information about the tolerance of the clocking device, you can carry out a test recording while the clocking device is in operation. From the test recording, you can read the inaccuracy of the pulse-on/ pulse-off durations. Add a safety margin of 20 ms on the read inaccuracy and consider this as the maximum tolerance of the clocking device. For the setting, add another 40 ms for the tolerance of the SIPROTEC 5 device.

Parameter: 3I0 delta pulse off-on

- Default setting (_:103) **3I0 delta pulse off-on** = 10 %

With the **3I0 delta pulse off-on** parameter, you define the minimum percentage value of the ground-current delta between the capacitor switched-on and capacitor switched-off states to detect the pulse pattern. That is, to detect the pulse pattern, the following condition must be met:

$$\frac{3I0_{\text{switched-off}} - 3I0_{\text{switched-on}}}{3I0_{\text{switched-off}}} \cdot 100 \% \geq 3I0 \text{ delta pulse off-on}$$

[fo_delta_ratio, 1, en_US]

To prevent minor current fluctuations from leading to a maloperation of the function, the setting of the **3I0 delta pulse off-on** parameter cannot be less than 2 %.

The setting of the **3I0 delta pulse off-on** parameter can be calculated with the following formula:

$$3I0 \text{ delta pulse off-on} = \frac{K_f C_s}{\frac{1}{\omega^2 L} - 3(C_{0\Sigma} - C_{0i})} \cdot 100 \%$$

[fo_3I0_delta_pulse_off-on, 1, en_US]

Where

- K_f Safety factor
Siemens recommends applying the factor 0.6 to also detect high-impedance ground faults.
- C_s Capacitance of the switched capacitor
- ω Angular frequency, which equals to $2\pi f$, where f is the power frequency
- L Inductance of the arc-suppression coil
- $C_{0\Sigma}$ Zero-sequence capacitance of the whole network
- C_{0i} Zero-sequence capacitance of the protected feeder

EXAMPLE

- K_f 0.6
- C_s $1.1 \cdot 10^{-6}$ F
- ω 314 rad/s
- L 0.577 H
- $C_{0\Sigma}$ $5.4297 \cdot 10^{-6}$ F
- C_{0i} $1.5502 \cdot 10^{-6}$ F

Then the setting of the **3I0 delta pulse off-on** parameter is calculated as follows:

$$3I0 \text{ delta pulse off-on} = \frac{0.6 \cdot 1.1 \cdot 10^{-6}}{\frac{1}{314^2 \cdot 0.577} - 3(5.4297 \cdot 10^{-6} - 1.5502 \cdot 10^{-6})} \cdot 100 \% = 11 \%$$

[fo_delta_calculate, 1, en_US]

If the network information for the setting calculation is not available, Siemens recommends using the default setting of **10 %**.

Parameter: No. of pulses for operate, Monitoring time (in pulses)

- Default setting (**_:107**) **No. of pulses for operate = 3**
- Default setting (**_:108**) **Monitoring time (in pulses) = 5**

With the **No. of pulses for operate** parameter, you determine the number of pulses to be detected within the pulse monitoring time, so that the stage operates.

With the **Monitoring time (in pulses)** parameter, you define the pulse monitoring time, which is calculated via the following formula:

Pulse monitoring time = Value **Monitoring time(in pulses)** · (Value **Pulse-on duration** + Value **Pulse-off duration**)

6.15.13.3 Settings

Addr.	Parameter	C	Setting Options	Default Setting
<i>Pulse detect.#</i>				
_:1	Pulse detect.#:Mode		<ul style="list-style-type: none"> • off • on • test 	off
_:2	Pulse detect.#:Operate & flt.rec. blocked		<ul style="list-style-type: none"> • no • yes 	no
_:102	Pulse detect.#:V0> threshold value		0.300 V to 200.000 V	30.000 V
_:101	Pulse detect.#:3I0> threshold value	1 A @ 100 Irated	0.030 A to 35.000 A	0.200 A
		5 A @ 100 Irated	0.15 A to 175.00 A	1.00 A
		1 A @ 50 Irated	0.030 A to 35.000 A	0.200 A
		5 A @ 50 Irated	0.15 A to 175.00 A	1.00 A
		1 A @ 1.6 Irated	0.001 A to 35.000 A	0.200 A
		5 A @ 1.6 Irated	0.005 A to 35.000 A	1.000 A
_:103	Pulse detect.#:3I0 delta pulse off-on		2 % to 50 %	10 %
_:104	Pulse detect.#:Pulse-on duration		0.20 s to 10.00 s	1.00 s
_:105	Pulse detect.#:Pulse-off duration		0.20 s to 10.00 s	1.50 s
_:109	Pulse detect.#:Max.tolera.pulse-on or off		0.02 s to 2.00 s	0.15 s
_:107	Pulse detect.#:No. of pulses for operate		2 to 100	3
_:108	Pulse detect.#:Monitoring time(in pulses)		2 to 100	5

6.15.13.4 Information List

No.	Information	Data Class (Type)	Type
<i>Pulse detect.#</i>			
_:81	Pulse detect.#:>Block stage	SPS	I
_:54	Pulse detect.#:Inactive	SPS	O
_:52	Pulse detect.#:Behavior	ENS	O
_:53	Pulse detect.#:Health	ENS	O
_:302	Pulse detect.#:Detected pulses	MV	O
_:55	Pulse detect.#:Pickup	ACD	O
_:56	Pulse detect.#:Operate delay expired	ACT	O
_:57	Pulse detect.#:Operate	ACT	O

6.15.14 Intermittent Ground-Fault Blocking Stage

6.15.14.1 Description

Most functions designed for the detection of permanent ground faults may show a disadvantageous behavior in case of intermittent ground faults. An example of these functions is the **3I0> stage with cos φ or sin φ measurement**. In case of an intermittent ground fault, these functions may cause a flood of information due to continuously exceeding and dropping below thresholds. Also short-term wrong directional results are possible due to the nature of the intermittent signals. To avoid this disadvantage, these functions should be blocked in case of intermittent grounds faults.

The **Intermittent ground-fault blocking** stage detects and classifies a ground fault as intermittent and sends a blocking signal to the following stages:

- Directional **3I0> stage with cos φ or sin φ measurement**
- Directional **3I0> stage with φ(V0, 3I0) measurement**
- Directional **Y0> stage with G0 or B0 measurement**
- Directional **stage with phasor measurement of a harmonic**

Logic

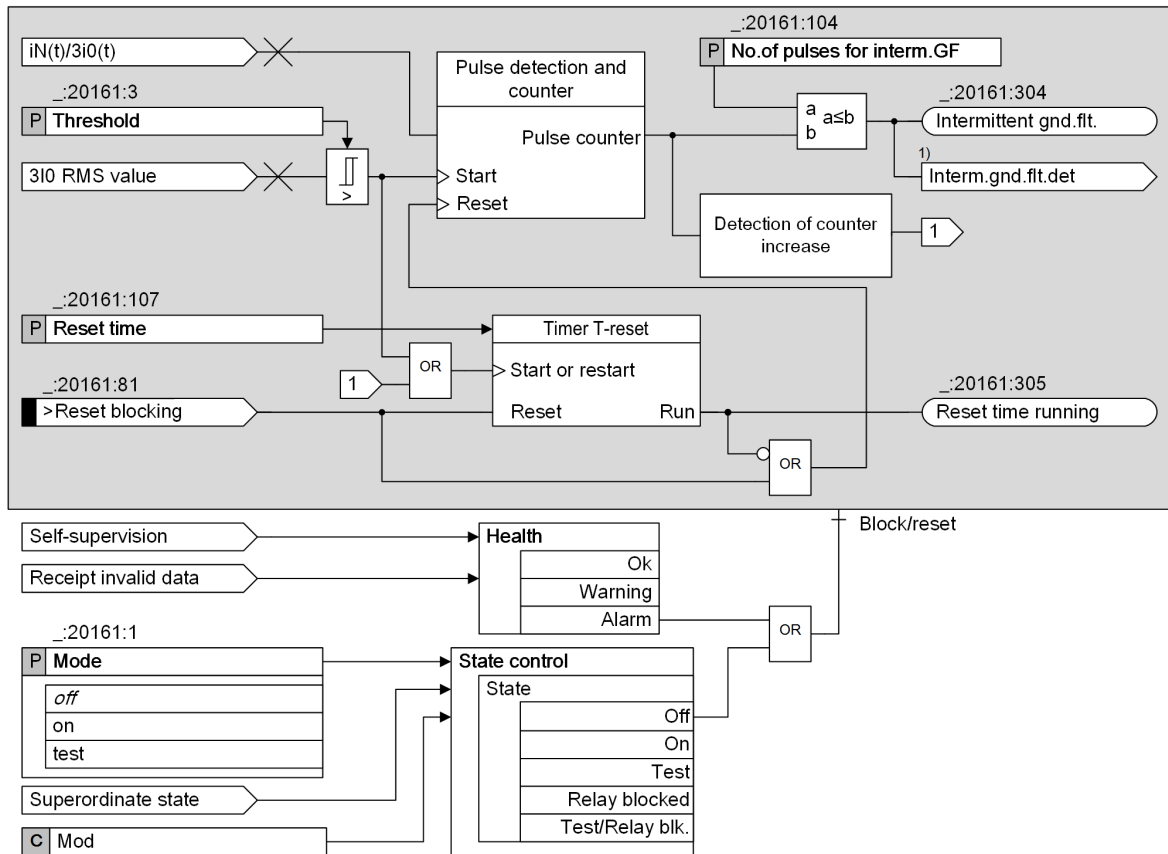

Figure 6-146 Logic Diagram of the Intermittent Ground-Fault Blocking Stage

(1) This signal is sent to the protection stages described in the preceding sections.

Measured Value 3I0

The algorithm evaluates the true RMS value of the ground current to ensure that ground-current pulses are considered.

You can find more information about possible connection types and measuring angles in chapter [Measured Value 3I0, Method of Measurement, Page 601](#).

Pulse Counting and Intermittent Ground-Fault Indication

If the true RMS value of 3I0 exceeds the **Threshold** value, the current-pulse (current-peak) detection takes place. During the ongoing intermittent ground fault, all current pulses are counted.

If the pulse count reaches the threshold value set in the parameter **No. of pulses for interm.GF**, the signal *Intermittent gnd. flt.* is issued. At once, the internal signal *Interm.gnd. flt. det* is sent to the following stages:

- Directional 3I0> stage with $\cos \varphi$ or $\sin \varphi$ measurement
- Directional 3I0> stage with $\varphi(V0, 3I0)$ measurement
- Directional stage with phasor measurement of a harmonic
- Directional Y0> stage with G0 or B0 measurement

If the **Blk. by interm.gnd.flt.** parameter in one of these stages is set to **yes**, the stage is blocked.

Reset Time for the Definition of the Interval between Independent Ground Faults

If there is a large interval between independent ground faults or if the ground fault extinguishes and does not restrike within a large time, an intermittent ground fault can be considered as definitely disappeared.

The interval between ground faults is monitored with the reset time. If a ground fault occurs, the **Timer T-reset** with the setting **Reset time** is launched. Each new ground-current pulse restarts the **Reset time** with its initial value. If the **Timer T-reset** expires, that is, if no new ground fault was detected during that period, all memories and the stage logics are reset.

The **Timer T-reset** thus determines the time during which the next ground fault must occur to be processed yet as an intermittent ground fault in connection with the previous fault. A ground fault that occurs later is considered as a new ground-fault event.

Start and Reset Conditions of the Timer T-reset

The **Timer T-reset** is started if one of the following conditions is fulfilled:

- The true RMS value of 3I0 exceeds the **Threshold** value.
- A new pulse is detected. That is, with each new pulse, the timer starts again with its initial value.

The **Timer T-reset** can be reset via the binary input signal *>Reset blocking*.

Reset Conditions of the Counter and the Protection-Stage Blocking

The whole stage, including the counter and protection-stage blocking signal, is reset if one of the following conditions is fulfilled:

- The **Timer T-reset** expires.
- The binary input signal *>Reset blocking* is activated.

6.15.14.2 Application and Setting Notes

Parameter: **Threshold**

- Default setting (**_ :20161:3**) **Threshold** = 1.000 A

With the parameter **Threshold**, you set the intermittent ground-fault pickup threshold. This setting must be coordinated with the applied protection stage for detecting a permanent ground fault, which shall be blocked for an intermittent fault, for example, the **3I0> stage with $\cos \varphi$ or $\sin \varphi$ measurement**.

The parameter **Threshold** must be set to the same value as the respective **3I0> threshold value** of the protection stage. For example, in case of the **3I0> stage with $\cos \varphi$ or $\sin \varphi$ measurement**, the value from the parameter (**_ :12601:101**) **3I0> threshold value** must be applied for the parameter **Threshold**. It is not required to set a lower value than the respective **3I0> threshold value** of the protection stage.

If the **3I0> threshold value** of the protection stage is set to a higher value than the setting range for the parameter **Threshold**, set the maximum setting value for the parameter **Threshold**.

Parameter: No. of pulses for interm. GF

- Default setting (`_:20161:104`) **No. of pulses for interm. GF = 3**

With the parameter **No. of pulses for interm. GF**, you set the total number of pulse counts at which the ground fault is considered to be intermittent. Siemens recommends using the default setting.

Parameter: Reset time

- Default setting (`_:20161:107`) **Reset time = 5.00 s**

With the parameter **Reset time**, you define the minimum time between 2 adjacent ground faults/impulses. If the time is larger than the **Reset time**, the intermittent ground fault is considered as disappeared. This can mean that the ground fault has disappeared or that the intermittent ground fault has changed to a static ground fault. The function resets and a blocking is cleared. Siemens recommends using the default setting.

6.15.14.3 Settings

Addr.	Parameter	C	Setting Options	Default Setting
Blk. interm. GF				
<code>_:20161:1</code>	Blk.interm.GF:Mode		<ul style="list-style-type: none"> • off • on • test 	off
<code>_:20161:3</code>	Blk.interm.GF:Threshold	1 A @ 100 Irated	0.030 A to 35.000 A	1.000 A
		5 A @ 100 Irated	0.15 A to 175.00 A	5.00 A
		1 A @ 50 Irated	0.030 A to 35.000 A	1.000 A
		5 A @ 50 Irated	0.15 A to 175.00 A	5.00 A
		1 A @ 1.6 Irated	0.001 A to 1.600 A	1.000 A
		5 A @ 1.6 Irated	0.005 A to 8.000 A	5.000 A
<code>_:20161:104</code>	Blk.interm.GF:No. of pulses for interm. GF		2 to 50	3
<code>_:20161:107</code>	Blk.interm.GF:Reset time		1.00 s to 600.00 s	5.00 s

6.15.14.4 Information List

No.	Information	Data Class (Type)	Type
Blk. interm. GF			
<code>_:20161:81</code>	Blk.interm.GF:>Reset blocking	SPS	I
<code>_:20161:304</code>	Blk.interm.GF:Intermittent gnd.flt.	SPS	O
<code>_:20161:305</code>	Blk.interm.GF:Reset time running	SPS	O

6.16 Undercurrent Protection

6.16.1 Overview of Functions

The **Undercurrent protection** function (ANSI 37):

- Detects the going current in a feeder after the opening of the infeed circuit breaker
- Detects the loss of loads
- Detects and protects pumps from running idle

6.16.2 Structure of the Function

The **Undercurrent protection** function is used in protection function groups with current measurement. The **Undercurrent protection** function comes with 1 protection stage preconfigured at the factory. A maximum of 2 protection stages can be operated simultaneously in this function. The protection stages are structured identically.

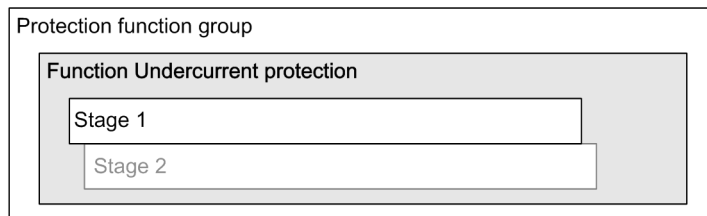

[to_stuundcu, 2, en_US]

Figure 6-147 Structure/Embedding of the Function

6.16.3 Stage Description

Logic of the Stage

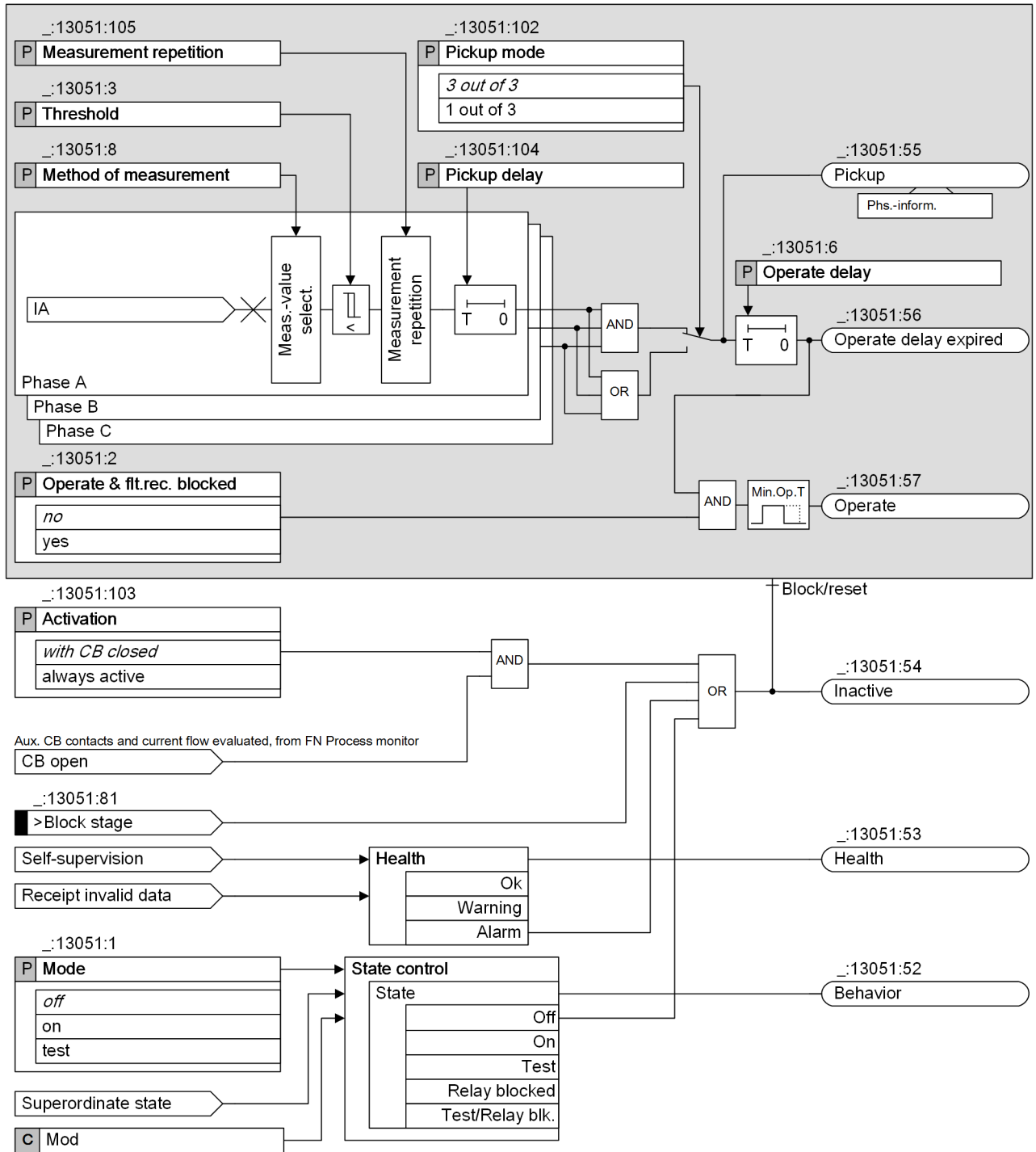

[ilo_UCP-3pol_4_en_US]

Figure 6-148 Logic Diagram of the Undercurrent Protection

Method of Measurement

You use the parameter **Method of measurement** to define whether the stage uses the *fundamental comp.* (standard method) or the calculated *RMS value*.

- Measurement of the fundamental comp.:
This measurement method processes the sampled current values and numerically filters out the fundamental component.
- Measurement of the parameter value RMS value:
This measurement method determines the current amplitude from the sampled values according to the definition equation of the RMS value. Harmonics are included in the analysis.

Measurement Repetition

To enable the pickup stabilization, you set the parameter **Measurement repetition** to a value other than 0. Then, if the input current keeps below the **Threshold** for a specified number (**Measurement repetition** value) of successive measuring cycles, the stage picks up. For 50 Hz, the measuring cycle time is 5 ms (**Method of measurement = fundamental comp.**) or 10 ms (**Method of measurement = RMS value**).

If you set this parameter to 0 (default value), the stabilization is not applied. The pickup signal is issued immediately after the input current falls below the parameter **Threshold**.

Pickup Mode

The parameter **Pickup mode** defines whether the protection stage picks up if all 3 measuring elements detect the undercurrent condition (**3 out of 3**) or if only 1 measuring element has to detect the undercurrent condition (**1 out of 3**).

Blocking the Stage

When blocked, the picked-up protection stage will drop out. Blocking the stage is possible externally or internally via the binary input signal *>Block stage*.

Activation and Blocking of the Stage Depending On the Circuit-Breaker Condition

With the parameter **Activation**, you define if the stage **Undercurrent protection** is always active or only active if the circuit breaker is indicating **closed**.

If the parameter **Activation** is set to *with CB closed* and the local circuit breaker is not **closed**, the function **Undercurrent protection** is blocked and no pickup is generated.

The circuit-breaker position is detected as **closed** if one of the following conditions is met:

- The binary inputs are connected to the auxiliary contacts of the circuit breaker. The circuit-breaker switch position is detected as **closed** via the related binary inputs of the indication *Position*. This is also true under the condition that no phase current is flowing.
- The current-flow criterion indicates that the circuit breaker is **closed**. This is also true under the condition that the auxiliary contacts indicate the circuit breaker as **open**.

Behavior on Leaving the Operating Range

The sampling frequency tracking makes a wide frequency operating range possible. If the stage has picked up before leaving the frequency operating range, the pickup is maintained. The signal **Pickup** is reset when a blocking condition becomes active.

6.16.4 Application and Setting Notes

Parameter: Activation

- Default setting (`_:13051:103`) **Activation = with CB closed**

Parameter Value	Description
<i>with CB closed</i>	The Undercurrent protection is active only when the circuit-breaker position is detected as closed . A precondition is, that the Position indication is routed to binary inputs to obtain the CB position information via the CB auxiliary contacts. If this is not the case, the function will always be inactive.
<i>always active</i>	The Undercurrent protection stage is always active independent of the position of the circuit breaker.

Parameter: Method of measurement

- Recommended setting value (`_:13051:8`) **Method of measurement** = *fundamental comp.*

With the **Method of measurement** parameter, you define whether the stage uses the *fundamental comp.* (standard method) or the calculated *RMS value*.

Parameter Value	Description
<i>fundamental comp.</i>	Select this method of measurement if harmonics or transient current peaks are to be suppressed. Siemens recommends using this method as the standard method.
<i>RMS value</i>	Select this method of measurement if you want the stage to take harmonics into account (for example, at capacitor banks). Consider that aperiodic DC components present in the secondary circuit are measured and can cause an overfunction. For this method of measurement, do not set the threshold value of the stage to less than $0.1 I_{rated,sec}$. If currents from more than one measuring point are added up in the current interface of a function group, the setting value should not be set lower than $0.1 I_{rated,sec}$ multiplied by the number of added currents.

Parameter: Pickup mode

- Default setting (`_:13051:102`) **Pickup mode** = *3 out of 3*

Use the **Pickup mode** parameter to define whether the protection stage picks up if all 3 measuring elements detect the undercurrent condition (*3 out of 3*) or if only 1 measuring element has to detect the undercurrent condition (*1 out of 3*).

Parameter: Pickup delay

- Default setting (`_:13051:104`) **Pickup delay** = *0.00 s*

For special applications, it could be desirable that a short falling below the current threshold does not lead to the pickup of the stage and to the start of fault logging and recording.

With the **Pickup delay** parameter, you define a time interval during which a pickup is not triggered if the current falls below the threshold.

Parameter: Threshold

- Default setting (`_:13051:3`) **Threshold** = *0.050 A*

Specify the **Threshold** (pickup threshold) for the specific application.

Parameter: Measurement repetition

- Default setting (`_:13051:105`) **Measurement repetition** = *0*

For special applications, it could be desirable that a short falling of the input current below the pickup value does not lead to the pickup of the stage, which starts fault logging and recording. This is achieved by setting the parameter **Measurement repetition** to a value other than 0.

For example, if you set this parameter to **2**, the pickup signal is issued when the current keeps being below the **Threshold** for 2 additional measuring cycles. For 50 Hz, the measuring cycle time is 5 ms (**Method of measurement = fundamental comp.**) or 10 ms (**Method of measurement = RMS value**).

Parameter: Operate delay

- Default setting (**_:13051:6 Operate delay = 0.05 s**)

Operate delay must be set according to the specific application. No general application notes can be given.

6.16.5 Settings

Addr.	Parameter	C	Setting Options	Default Setting
Stage 1				
_:13051:1	Stage 1:Mode		<ul style="list-style-type: none"> • off • on • test 	off
_:13051:2	Stage 1:Operate & flt.rec. blocked		<ul style="list-style-type: none"> • no • yes 	no
_:13051:103	Stage 1:Activation		<ul style="list-style-type: none"> • always active • with CB closed 	with CB closed
_:13051:8	Stage 1:Method of measurement		<ul style="list-style-type: none"> • fundamental comp. • RMS value 	fundamental comp.
_:13051:105	Stage 1:Measurement repetition		0 to 10	0
_:13051:102	Stage 1:Pickup mode		<ul style="list-style-type: none"> • 1 out of 3 • 3 out of 3 	3 out of 3
_:13051:3	Stage 1:Threshold	1 A @ 100 Irated	0.030 A to 35.000 A	0.050 A
		5 A @ 100 Irated	0.15 A to 175.00 A	0.25 A
		1 A @ 1.6 Irated	0.001 A to 1.600 A	0.050 A
		5 A @ 1.6 Irated	0.005 A to 8.000 A	0.250 A
_:13051:104	Stage 1:Pickup delay		0.00 s to 60.00 s	0.00 s
_:13051:6	Stage 1:Operate delay		0.00 s to 60.00 s	0.50 s

6.16.6 Information List

No.	Information	Data Class (Type)	Type
Group indicat.			
_:4501:55	Group indicat.:Pickup	ACD	O
_:4501:57	Group indicat.:Operate	ACT	O
_:4501:52	Group indicat.:Behavior	ENS	O
_:4501:53	Group indicat.:Health	ENS	O
Stage 1			
_:13051:81	Stage 1:>Block stage	SPS	I
_:13051:51	Stage 1:Mode (controllable)	ENC	C
_:13051:54	Stage 1:Inactive	SPS	O
_:13051:52	Stage 1:Behavior	ENS	O
_:13051:53	Stage 1:Health	ENS	O

No.	Information	Data Class (Type)	Type
_:13051:55	Stage 1:Pickup	ACD	O
_:13051:56	Stage 1:Operate delay expired	ACT	O
_:13051:57	Stage 1:Operate	ACT	O

6.17 Negative-Sequence Protection

6.17.1 Overview of Functions

The function **Negative-sequence protection** (ANSI 46):

- Detects 1-phase or 2-phase short circuits in the electrical power system with clearly increased sensitivity compared to the classical overcurrent protection
- Protects electric machines during excessive unbalanced load
- Reports unbalanced load conditions in the electricity supply system
- Detects phase interruptions in the primary system
- Locates short circuits or inversions in the connections to the current transformers

6.17.2 Structure of the Function

The **Negative-sequence protection** function is used in protection function groups with current measurement.

The function is preconfigured by the manufacturer with 2 **Definite-time negative-sequence protection** stages.

In the function **Negative-sequence protection**, the following stages can be operated simultaneously:

- 3 stages **Definite-time negative-sequence protection**
- 2 stages **Inverse-time negative-sequence protection**

The stages have an identical structure. Stages that are not preconfigured are shown in gray in the following figure.

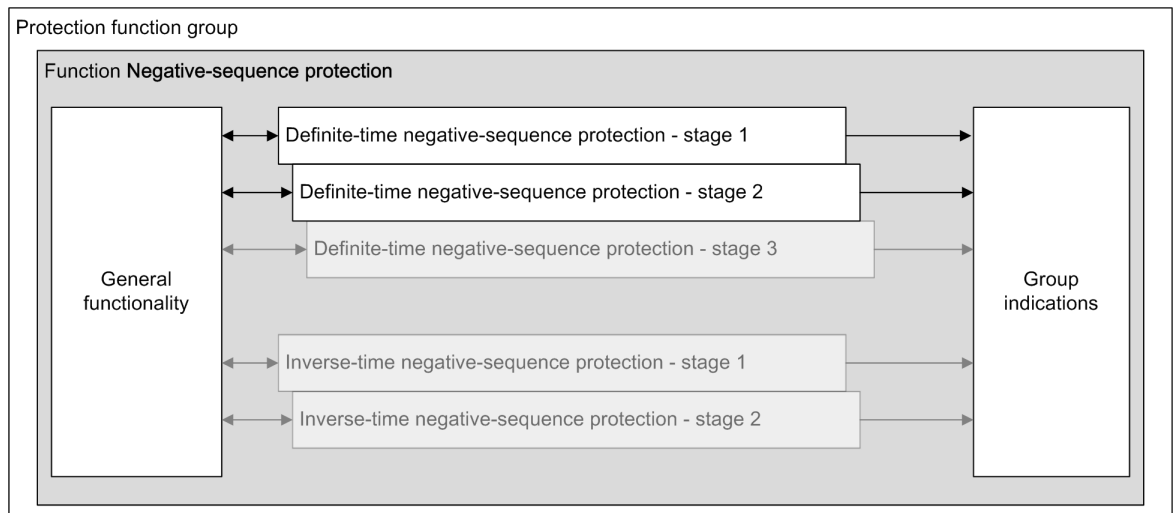

[dw_nsp_str, 3, en_US]

Figure 6-149 Structure/Embedding of the Function

If the device is equipped with the **Inrush-current detection** function, the stages can be stabilized against operate due to transformer-inrush currents.

6.17.3 General Functionality

6.17.3.1 Description

Logic

The following figure represents the logic of the general functionality which applies across all configured stages. It contains:

- Selection of the reference value
- Current-release criterion

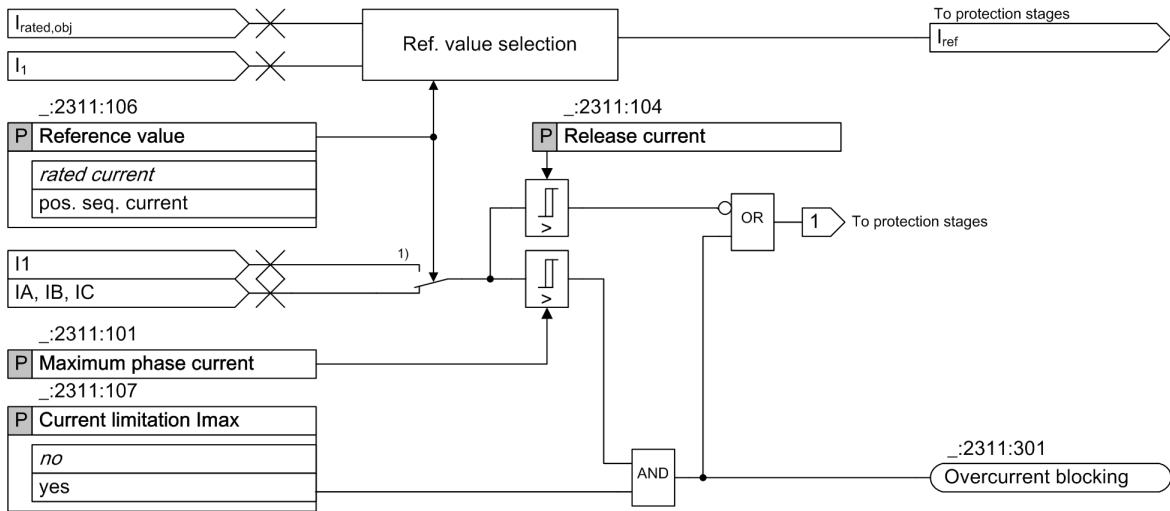

[!o_general_functionality_01_1_en_US]

Figure 6-150 Logic Diagram of the General Functionality

- (1) Switchover to I_1 with (:2311:106) **Reference value = pos. seq. current**

Reference Value

With the parameter **Reference value**, the negative-sequence current I_2 is normalized to the rated object current $I_{rated,obj}$ or to the positive-sequence current I_1 . When I_2 is normalized to I_1 , the sensitivity of the function for low short-circuit currents is increased.

Current Limitation and Maximum Phase Current

With the parameters **Current limitation I_{max}** and **Maximum phase current**, you restrict the operating range of the function. When the limiting is activated, pickup of the stages is blocked as soon as the maximum phase-current threshold value is exceeded. For more information, refer to the stage description.

Release Current

The threshold value of the **Release current** serves to release the negative-sequence protection.

6.17.3.2 Application and Setting Notes

Parameter: Reference value

- Default setting (:2311:106) **Reference value = rated current**

With the parameter **Reference value**, you define the normalization of the negative-sequence current I_2 to the rated object current $I_{rated,obj}$ ($I_2/I_{rated,obj}$) or to the positive-sequence current I_1 (I_2/I_1).

Parameter Value	Description
$I_2/I_{\text{rated, obj}}$	The negative-sequence current is referred to the rated current of the protected object. This is a preferred normalization for electrical machines, because the permissible limiting values are indicated exclusively referred to the machine rated current. You can also use this normalization for other applications.
I_2/I_1	The normalization of the negative-sequence system to the positive-sequence system yields a higher sensitivity. Use this normalization when detecting interruptions in the primary system.

Set the parameter depending on the application.

Parameter: Current limitation I_{max} , Maximum phase current

- Default setting (`_:2311:107`) **Current limitation $I_{\text{max}} = no$**
- Recommended setting value (`_:2311:101`) **Maximum phase current = 10.0 A at 1 A**

If the protection function needs a maximum current limitation, set the value of the **Current limitation I_{max}** parameter from *no* to *yes*. With the parameter **Maximum phase current**, you set the upper limit of the phase current. CT saturation will cause negative-sequence current in the secondary system. To avoid overfunction due to the CT saturation, a suitable phase-current limit value is 10 times of the rated protection-object current.

Parameter: Release current

- Recommended setting value (`_:2311:104`) **Release current = 0.05 A at 1 A**

For the safe calculation of negative-sequence currents, the current in at least one phase must be greater than 5 % of the secondary rated device current. For a 1-A device, the value of **Release current** is 0.05 A (0.25 A for a 5-A device).

6.17.4 Stage with Definite-Time Characteristic Curve

6.17.4.1 Stage Description

Logic of a Stage

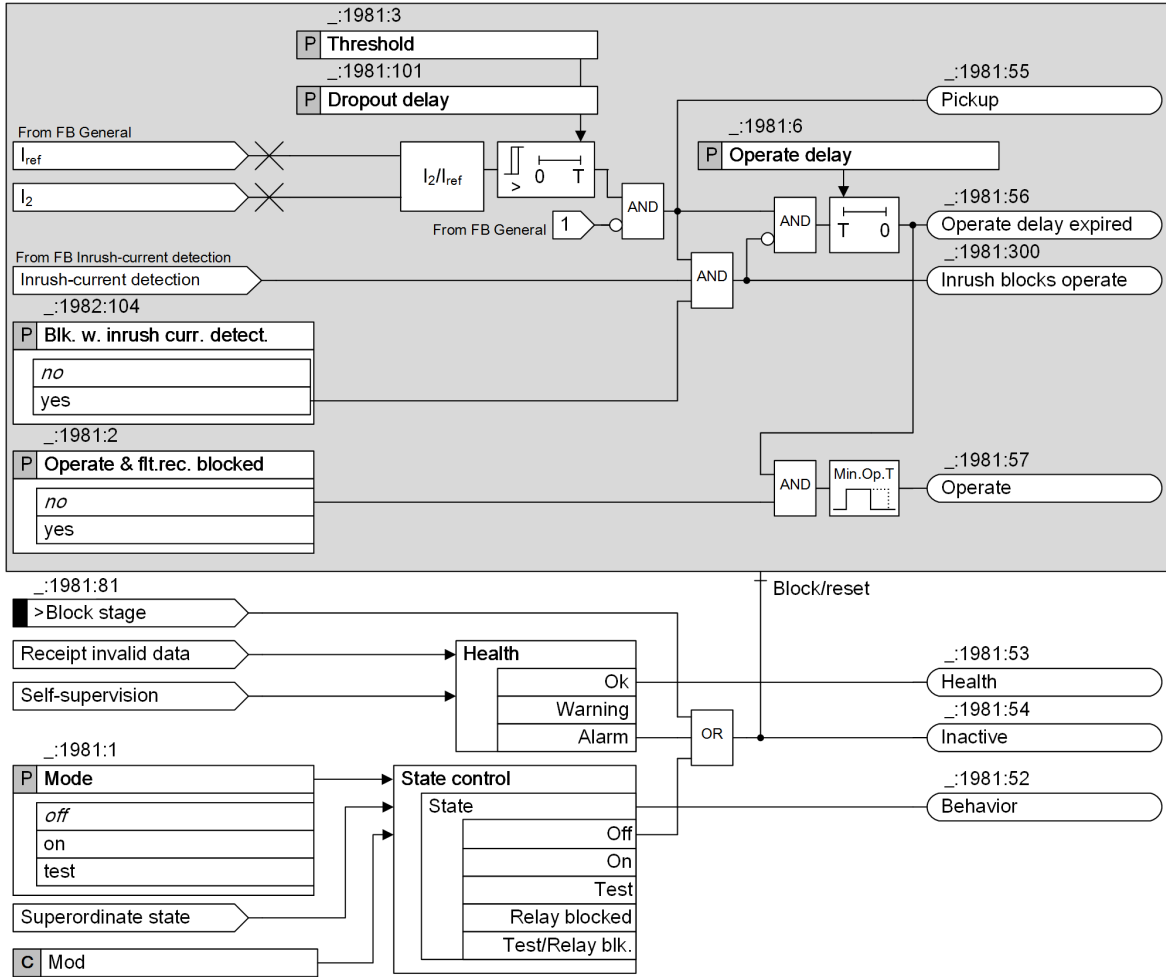

Figure 6-151 Logic Diagram of the Stage Negative-Sequence Protection with Definite-Time Characteristic Curve

Method of Measurement

The fundamental phasors are calculated from the 3-phase phase currents. Based on this, the negative-sequence system and the positive-sequence system are calculated. Following this, the negative-sequence current is normalized to the reference current. The selection of the reference current is made in the **FB General**.

Blocking of the Stage

When blocked, the picked-up stage will drop out. Blocking the stage is possible externally or internally via the binary input signal **>Block stage**.

Blocking of the Tripping by Device-Internal Inrush-Current Detection

The **Blk. w. inrush curr. detect.** parameter allows you to define whether the operate indication of the stage should be blocked when a threshold value is exceeded due to an inrush current. In case of a blocking

and fulfilled pickup conditions, the stage picks up. The start of the time delay and the operate indication are blocked. The function indicates this through a corresponding indication. If the blocking drops out and the pickup conditions are still met, the time delay is started. After that time, the stage operates.

6.17.4.2 Application and Setting Notes

Parameter: **Threshold**

- Recommended setting value (`_:1981:3`) **Threshold** = 10 %

The setting of the parameter **Threshold** depends on the respective application. A threshold value of 10 % is a practicable value for fault indications of electrical machines.

Parameter: **Operate delay**

- Recommended setting value (`_:1981:6`) **Operate delay** = 1500 ms

The setting of the **Operate delay** depends on the application. Observe the time grading in the power-system protection and do not set the time for monitoring too short. The default setting is practicable. For motors, the time depends on the permissible time period for the set unbalanced load.

Parameter: **Blk. w. inrush curr. detect.**

- Default setting (`_:1981:104`) **Blk. w. inrush curr. detect.** = no

With the parameter **Blk. w. inrush curr. detect.**, the stage can be stabilized against tripping on transformer-inrush currents. If transformers are parts of the protection zones, set this parameter to **yes**.

6.17.4.3 Settings

Addr.	Parameter	C	Setting Options	Default Setting
General				
<code>_:2311:106</code>	General:Reference value		<ul style="list-style-type: none"> pos. seq. current rated current 	rated current
<code>_:2311:107</code>	General:Current limitation I _{max}		<ul style="list-style-type: none"> no yes 	no
<code>_:2311:101</code>	General:Maximum phase current	1 A @ 100 Irated	0.030 A to 35.000 A	10.000 A
		5 A @ 100 Irated	0.15 A to 175.00 A	50.00 A
		1 A @ 50 Irated	0.030 A to 35.000 A	10.000 A
		5 A @ 50 Irated	0.15 A to 175.00 A	50.00 A
		1 A @ 1.6 Irated	0.001 A to 1.600 A	10.000 A
		5 A @ 1.6 Irated	0.005 A to 8.000 A	50.000 A
<code>_:2311:104</code>	General:Release current	1 A @ 100 Irated	0.030 A to 10.000 A	0.050 A
		5 A @ 100 Irated	0.15 A to 50.00 A	0.25 A
		1 A @ 50 Irated	0.030 A to 10.000 A	0.050 A
		5 A @ 50 Irated	0.15 A to 50.00 A	0.25 A
		1 A @ 1.6 Irated	0.001 A to 1.600 A	0.050 A
		5 A @ 1.6 Irated	0.005 A to 8.000 A	0.250 A
Definite-T 1				
<code>_:1981:1</code>	Definite-T 1:Mode		<ul style="list-style-type: none"> off on test 	off
<code>_:1981:2</code>	Definite-T 1:Operate & flt.rec. blocked		<ul style="list-style-type: none"> no yes 	no
<code>_:1981:3</code>	Definite-T 1:Threshold		5.0 % to 999.9 %	10.0 %

Addr.	Parameter	C	Setting Options	Default Setting
_:1981:4	Definite-T 1:Dropout ratio		0.40 to 0.99	0.95
_:1981:104	Definite-T 1:Blk. w. inrush curr. detect.		<ul style="list-style-type: none"> • no • yes 	no
_:1981:101	Definite-T 1:Dropout delay		0.00 s to 60.00 s	0.00 s
_:1981:6	Definite-T 1:Operate delay		0.00 s to 60.00 s	1.50 s
Definite-T 2				
_:1982:1	Definite-T 2:Mode		<ul style="list-style-type: none"> • off • on • test 	off
_:1982:2	Definite-T 2:Operate & flt.rec. blocked		<ul style="list-style-type: none"> • no • yes 	no
_:1982:3	Definite-T 2:Threshold		5.0 % to 999.9 %	65.0 %
_:1982:4	Definite-T 2:Dropout ratio		0.40 to 0.99	0.95
_:1982:104	Definite-T 2:Blk. w. inrush curr. detect.		<ul style="list-style-type: none"> • no • yes 	no
_:1982:101	Definite-T 2:Dropout delay		0.00 s to 60.00 s	0.00 s
_:1982:6	Definite-T 2:Operate delay		0.00 s to 60.00 s	0.50 s

6.17.4.4 Information List

No.	Information	Data Class (Type)	Type
General			
_:2311:301	General:Overcurrent blocking	SPS	O
_:2311:52	General:Behavior	ENS	O
_:2311:53	General:Health	ENS	O
Group indicat.			
_:4501:55	Group indicat.:Pickup	ACD	O
_:4501:57	Group indicat.:Operate	ACT	O
_:4501:52	Group indicat.:Behavior	ENS	O
_:4501:53	Group indicat.:Health	ENS	O
Definite-T 1			
_:1981:81	Definite-T 1:>Block stage	SPS	I
_:1981:51	Definite-T 1:Mode (controllable)	ENC	C
_:1981:52	Definite-T 1:Behavior	ENS	O
_:1981:53	Definite-T 1:Health	ENS	O
_:1981:54	Definite-T 1:Inactive	SPS	O
_:1981:56	Definite-T 1:Operate delay expired	ACT	O
_:1981:300	Definite-T 1:Inrush blocks operate	ACT	O
_:1981:55	Definite-T 1:Pickup	ACD	O
_:1981:57	Definite-T 1:Operate	ACT	O

No.	Information	Data Class (Type)	Type
<i>Definite-T 2</i>			
_:1982:81	Definite-T 2:>Block stage	SPS	I
_:1982:51	Definite-T 2:Mode (controllable)	ENC	C
_:1982:52	Definite-T 2:Behavior	ENS	O
_:1982:53	Definite-T 2:Health	ENS	O
_:1982:54	Definite-T 2:Inactive	SPS	O
_:1982:56	Definite-T 2:Operate delay expired	ACT	O
_:1982:300	Definite-T 2:Inrush blocks operate	ACT	O
_:1982:55	Definite-T 2:Pickup	ACD	O
_:1982:57	Definite-T 2:Operate	ACT	O

6.17.5 Stage with Inverse-Time Characteristic Curve

6.17.5.1 Description

Logic of a Stage

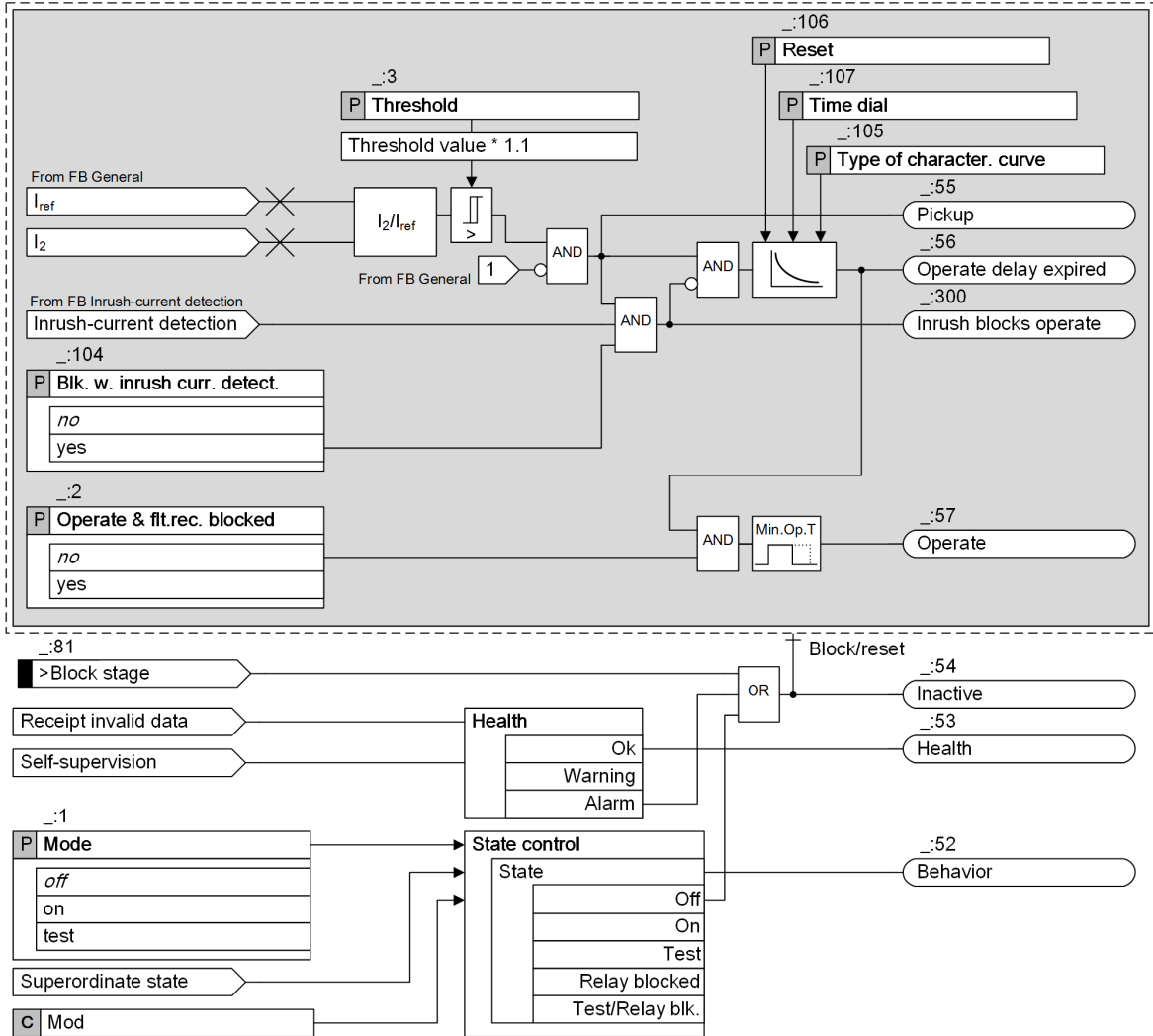

[lo_nsp_inverse_2_en_US]

Figure 6-152 Logic Diagram of the Negative-Sequence Protection with Inverse-Time Characteristic Curve

Method of Measurement

The fundamental phasors are calculated from the 3-phase phase currents. Based on this, the negative-sequence system and the positive-sequence system are calculated. Following this, the negative-sequence current is normalized to the reference current. The selection of the reference current is made in the **FB General**.

Pickup and Dropout Behaviors of the Inverse-Time Characteristic Curve According to IEC and ANSI

When the input variable exceeds the threshold value by a factor of 1.1, the inverse-time characteristic curve is processed. An integrating method of measurement summarizes the weighted time. The weighted time results from the characteristic curve. For this, the time that is associated with the present current value is determined from the characteristic curve. Once the weighted time exceeds the value 1, the stage operates.

When the measured value falls below the pickup value by a factor of 1.045 ($0.95 \cdot 1.1 \cdot \text{threshold value}$), the dropout is started. The pickup will be indicated as clearing. You can influence the dropout behavior via setting

parameters. You can select between instantaneous dropout (totalized time is deleted) or dropout according to the characteristic curve (reduction of totalized time depending on the characteristic curve). The dropout according to characteristic curve (disk emulation) is the same as turning back a rotor disk. The weighted reduction of the time is initiated from 0.9 of the set threshold value.

The characteristic curve and associated formulas are shown in the Technical Data.

Blocking of the Stage

When blocked, the picked-up protection stage will drop out.

Blocking the stage is possible externally or internally via the binary input signal **>Block stage**.

Blocking of the Tripping by Device-Internal Inrush-Current Detection

The **Blk. w. inrush curr. detect.** parameter allows you to define whether the operate indication of the stage should be blocked when a threshold value is exceeded due to an inrush current. In case of a blocking and fulfilled pickup conditions, the stage picks up. The start of the time delay and the operate indication are blocked. The function indicates this through a corresponding indication. If the blocking drops out and the pickup conditions are still met, the time delay is started. After that time, the stage operates.

6.17.5.2 Application and Settings Notes

Parameter: **Type of character. curve**

- Default setting (**_:105**) **Type of character. curve** = *IEC normal inverse*

The device offers all the usual inverse-time characteristic curves according to IEC and ANSI. Select the **Type of character. curve** required for your specific application. For more information about the parameter **Type of character. curve**, refer to chapter [14.21.2 Stage with Inverse-Time Characteristic Curve](#).

Parameter: **Threshold**

- Recommended setting value (**_:3**) **Threshold** = *10.0 %*

The setting of the parameter **Threshold** depends on the respective application. A threshold value of 10 % is a practicable value for fault detection for different applications.

Parameter: **Time dial**

- Recommended setting value (**_:107**) **Time dial** = *1.00*

With the parameter **Time dial**, you displace the characteristic curve in the time direction.

The set value for the parameter **Time dial** is derived from the time-grading schedule that has been prepared for the electrical power system.

Where no time grading and therefore no displacement of the characteristic curve is required, leave the **Time dial** parameter at 1.00 (default setting).

Parameter: **Reset**

- Default setting (**_:106**) **Reset** = *disk emulation*

With the parameter **Reset**, you define whether the stage drops out according to the dropout characteristic curve (in accordance with the behavior of a disk emulation = rotor disk) or instantaneously.

Parameter Value	Description
<i>disk emulation</i>	Select this setting if the device is coordinated with electromechanical devices or other devices which perform a dropout after a disk emulation.
<i>instantaneous</i>	Use this setting if the dropout is not to be performed after disk emulation and an instantaneous dropout is desired instead.

Parameter: **Blk. w. inrush curr. detect.**

- Default setting (**_:104**) **Blk. w. inrush curr. detect.** = *no*

With the parameter **Blk. w. inrush curr. detect.**, the stage can be stabilized against tripping on transformer-inrush currents. If transformers are parts of the protection zones, set this parameter to **yes**.

6.17.5.3 Settings

Addr.	Parameter	C	Setting Options	Default Setting
<i>Inverse-T #</i>				
_:1	Inverse-T #:Mode		<ul style="list-style-type: none"> • off • on • test 	off
_:2	Inverse-T #:Operate & flt.rec. blocked		<ul style="list-style-type: none"> • no • yes 	no
_:3	Inverse-T #:Threshold		5.0 % to 999.9 %	10.0 %
_:104	Inverse-T #:Blk. w. inrush curr. detect.		<ul style="list-style-type: none"> • no • yes 	no
_:105	Inverse-T #:Type of character. curve			
_:106	Inverse-T #:Reset		<ul style="list-style-type: none"> • instantaneous • disk emulation 	disk emulation
_:107	Inverse-T #:Time dial		0.05 to 15.00	1.00

6.17.5.4 Information List

No.	Information	Data Class (Type)	Type
<i>Inverse-T #</i>			
_:81	Inverse-T #:>Block stage	SPS	I
_:52	Inverse-T #:Behavior	ENS	O
_:53	Inverse-T #:Health	ENS	O
_:54	Inverse-T #:Inactive	SPS	O
_:56	Inverse-T #:Operate delay expired	ACT	O
_:300	Inverse-T #:Inrush blocks operate	ACT	O
_:59	Inverse-T #:Disk emulation running	SPS	O
_:55	Inverse-T #:Pickup	ACD	O
_:57	Inverse-T #:Operate	ACT	O

6.18 Directional Negative-Sequence Protection

6.18.1 Overview of Functions

The function **Directional negative-sequence protection with current-independent time delay** (ANSI 46) serves as the backup short-circuit protection for unbalanced faults.

With the negative-sequence system, various supervision and protection tasks can be realized, for example:

- Recording of 1 or 2-phase short circuits in the system with a higher sensitivity than in classic overcurrent protection. The pickup value can be set under the rated object current.
- Recording of phase conductor interruptions in the primary system and in the current-transformer secondary circuits
- Location of short circuits or reversals in the connections to the current transformers
- Indication of unbalanced states in the energy system
- Protection of electrical machines following unbalanced loads that are caused by unbalanced voltages or conductor interruptions (for example, through a defective fuse)

6.18.2 Structure of the Function

The **Directional negative-sequence protection with definite time delay** function can be used in protection function groups with 3-phase current and voltage measurement.

The function comes factory-set with 1 stage. A maximum of 6 tripping stages can be operated simultaneously in the function.

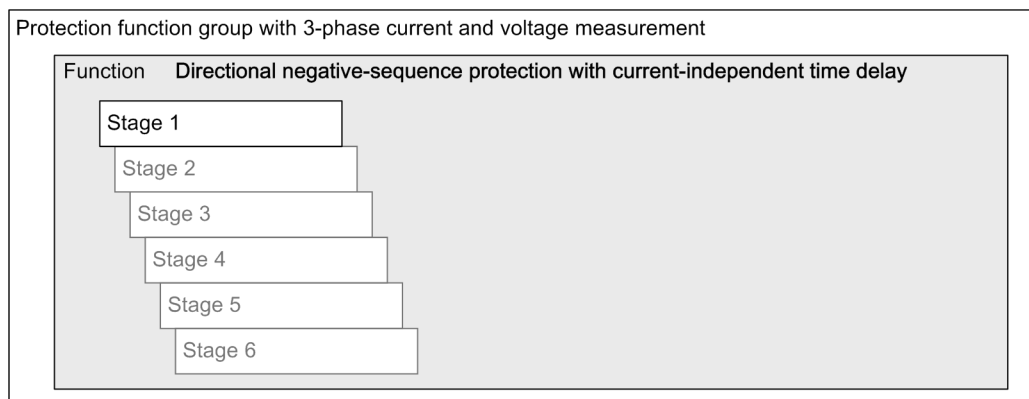

[dw_nsp_dir_1_en_US]

Figure 6-153 Structure/Embedding of the Function

If the device is equipped with the **Inrush-current detection** function, the tripping stages can be stabilized against tripping due to transformer-inrush currents.

6.18.3 Function Description

Stage Control

The following figure shows a stage control. It is available separately for each stage.

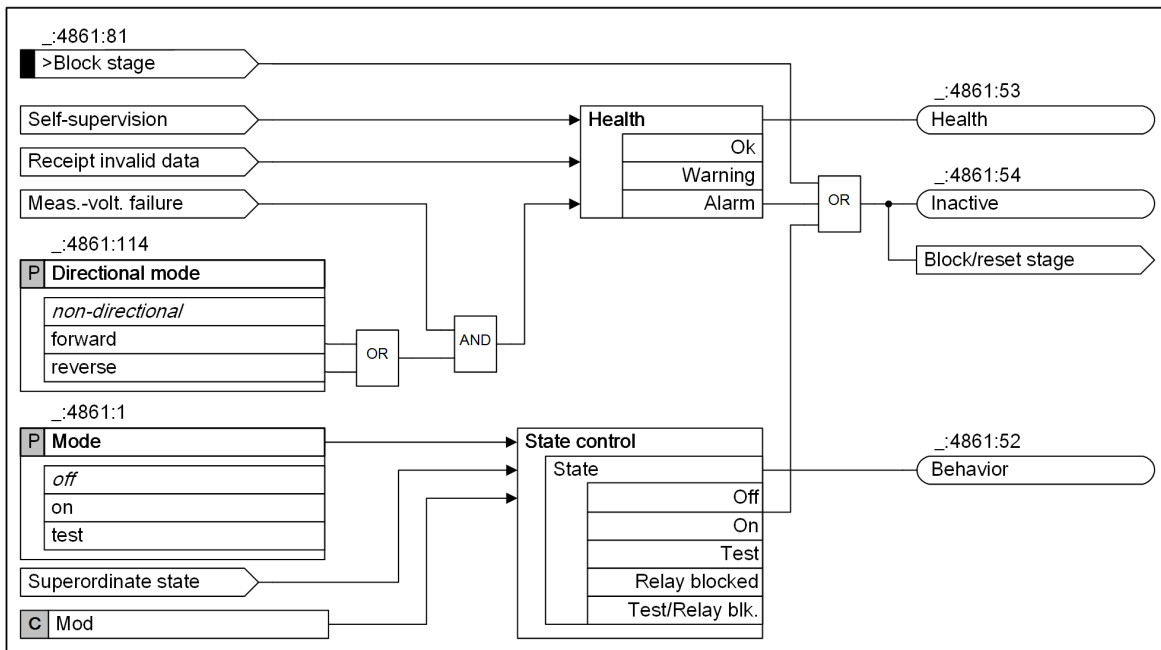

[lo_stersp, 2, en_US]

Figure 6-154 Stage Control of the Directional Negative-Sequence Protection

In addition to the generally valid stage control, the stage is blocked in the event of a measuring-voltage failure, provided the stage is working directionally.

Logic of the Stage

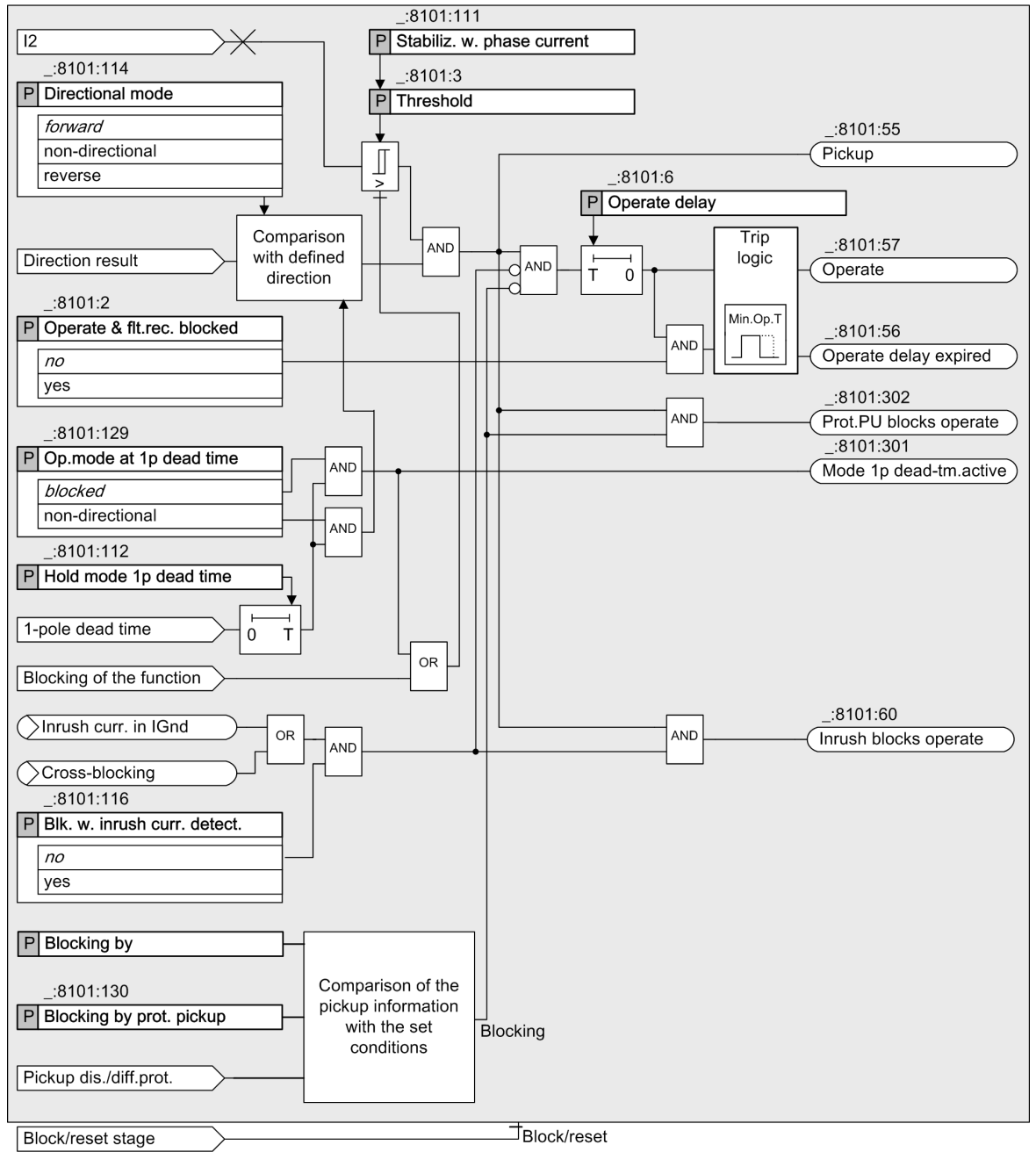

[to_nsp_dir, 1, en_US]

Figure 6-155 Logic Diagram of the Function Directional Negative-Sequence System Protection with Current-Independent Time Delay

Measurand

The negative-sequence current I_2 is used as a measurand. From the 3-phase currents, the fundamental phasors are determined via a 1-cycle filter and, corresponding with the definition equation of the symmetrical components, the negative-sequence system is calculated from this.

Functioning

The stage picks up if the negative-sequence system current exceeds the set threshold value and the parameterized direction agrees with the measured direction. The pickup drops out if the negative-sequence system current falls below 95 % of the set threshold.

Stabilization with Phase Current

Unbalance in operation and unbalanced transformer ratios can lead to spurious pickups and incorrect tripping. In order to avoid this, the directional negative-sequence system stage is stabilized with the phase currents. The threshold value increases with rising phase currents (see next image).

You can change the stabilization factor (= gradient) via the **Stabiliz. w. phase current** parameter.

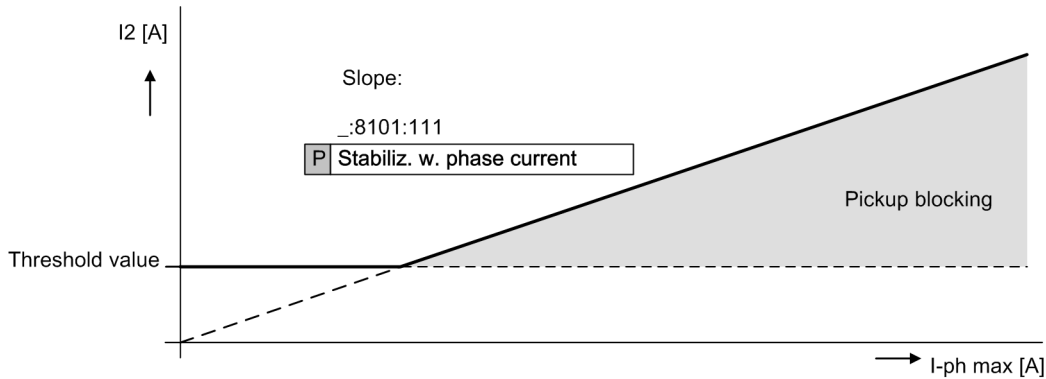

[ldw_stabil_1_en_US]

Figure 6-156 Stabilization with Phase Currents

Direction Determination

The direction determination takes place with the negative-sequence system measurements I_2 and V_2 .

The forward and reverse region is defined through the parameters **Angle forward α** and **Angle forward β** (see next figure). The reference for the 2 angles that must be set is the positive real axis. The angles are positively defined in a mathematical sense (counter-clockwise). The region between the limit angle α and the limit angle β - counted from the former in a positive direction - is the forward region. The remaining region is the reverse region.

For determining of the direction, the function places the measuring current I_2 on the real axis. If the phasor of the negative-sequence system voltage V_2 is located within the defined forward region, the function determines the direction as *forward*. In the other case, the function determines the direction as *reverse*.

The requirement for determining the direction is that the adjustable minimum variables have been exceeded for the negative-sequence system current and negative-sequence system voltage (parameters **Min. neg. - seq. current I_2** and **Min. neg.-seq. voltage V_2**).

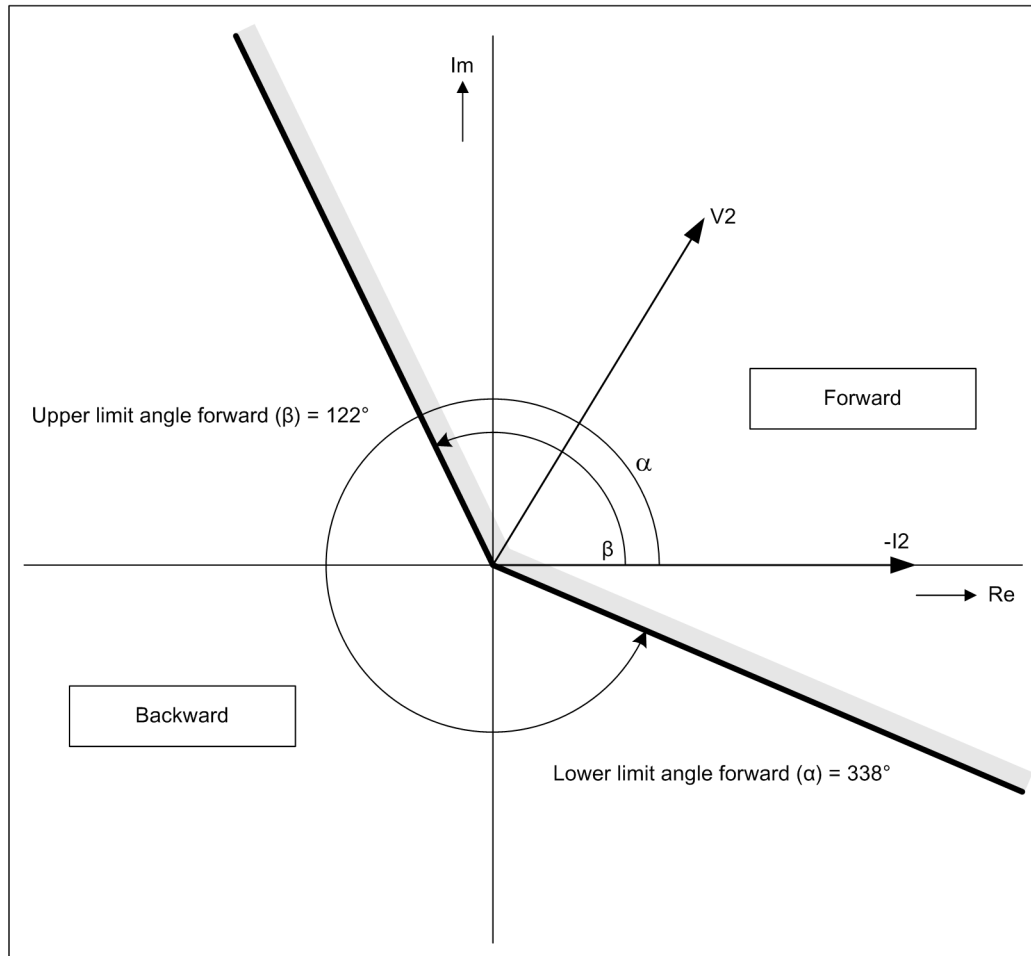

[dw_phasor, 1, en_US]

Figure 6-157 Phasor Diagram for Direction Determination with Negative-Sequence System Values

If the device determines a fault in the voltage-transformer secondary circuit (through the binary input *voltage transformer circuit-breaker dropout* or through **measuring-voltage failure detection**), direction determination will be disabled and every directionally set stage will be blocked. Non-directionally set stages become active again if there are faults in the voltage-transformer secondary circuit.

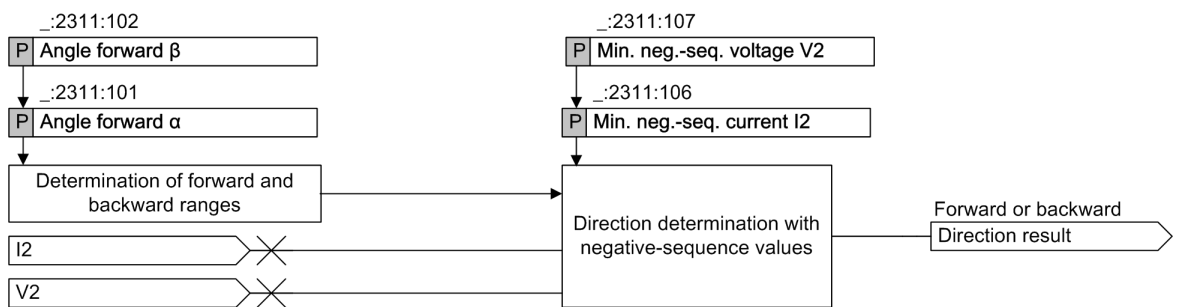

[lo_richtu, 1, en_US]

Figure 6-158 Logic of Direction Determination

Directional Mode

You use the **Directional mode** parameter to define whether the stage works in a forward or reverse direction. Non-directional operation is also possible.

Operating Mode upon 1-Pole Interruption

With the parameter **Op.mode at 1p dead time**, you determine if the stage is blocked during a 1-pole dead time, or if it works in a non-directional manner, even if it is set for directional operation. When the 1-pole dead time is complete, the corresponding device-internal signal is extended by the time of the parameter **Hold mode 1p dead time**.



NOTE

The **Op.mode at 1p dead time** parameter is only available in devices with 1-/3-pole tripping. In devices with 3-pole tripping, this setting does not apply.

Blocking the Tripping by Pickup of the Main Protection Functions

The pickup and type of pickup for the main protection functions can block the tripping of the stage. You can perform this setting via 2 parameters:

- **Blocking by**
This setting is used to select the zone or stage at which blocking is to occur in the event of pickup.
- **Blocking by prot. pickup**
The pickup type at which the blocking is to occur is defined with this parameter. The blocking can occur at any pickup or only at 1-pole or only at multipole pickups.
This parameter is also used to set that no blocking should occur when the main protection has picked up.

Blocking of Tripping via the Device-Internal Inrush-Current Detection Function

If the device is equipped with the additional **Inrush-current detection** function, the stages can be stabilized against tripping due to transformer inrush currents.

With the **Blk. w. inrush curr. detect.** parameter, you can define whether tripping of the stage should be blocked when a threshold value is exceeded due to an inrush current. In case of a blocking, the stage picks up. The start of the time delay and tripping are however blocked. The stage signals this by way of a corresponding indication. If the blocking drops out and the threshold value of the stage is still exceeded, the tripping delay (time delay) is started. After that time, the stage operates.

6.18.4 Application and Setting Notes for Direction Determination

Parameter: Limit Angle Region Forward

- Recommended setting value (**_:2311:101**) **Angle forward $\alpha = 338^\circ$**
- Recommended setting value (**_:2311:102**) **Angle forward $\beta = 122^\circ$**

With the parameters **Angle forward α** and **Angle forward β** , you can change the location of the directional characteristic curve.

Siemens recommends using the defaults, because the function with these settings reliably determines the direction.

Parameter: Minimum Negative-Sequence System Variables V2 and I2

- Default setting (**_:2311:107**) **Min. neg.-seq. voltage V2 = 0.7 V**
- Default setting (**_:2311:106**) **Min. neg.-seq. current I2 = 0.05 A**

With the parameters **Min. neg.-seq. voltage V2** and **Min. neg.-seq. current I2**, you can specify the minimum negative-sequence system values for direction determination with V2 and I2. The set limiting values must not be exceeded by operational unbalances.

6.18.5 Application and Setting Notes for Stages

Parameter: Directional mode

- Default setting (`_:8101:114`) **Directional mode** = *forward*

You use the **Directional mode** parameter to define the directional mode of the stage.

Parameter Value	Description
<i>non-directional</i>	If the stage is to work in the forward and reverse direction (in the direction of the line and busbar), then select this setting. The stage will work with this setting even if no direction measurement is possible, for example due to insufficient polarization voltage (or none at all), or due to failure of the measuring voltage.
<i>forward</i>	Select these settings if the stage is only to work in a forward direction (in direction of the line).
<i>reverse</i>	Select this setting if the level is only to work in the reverse direction (in the direction of the busbar).

Parameter: Blk. w. inrush curr. detect.

If the device is equipped with the additional **Inrush-current detection** function, the stages can be stabilized against tripping due to transformer inrush currents.

- Default setting (`_:8101:116`) **Blk. w. inrush curr. detect.** = *no*

Parameter Value	Description
<i>no</i>	The transformer inrush current detection does not affect the stage. Select this setting in the following cases: 1) In cases where the device is not used on transformers. 2) In cases where the device is used on transformers and the threshold value of the stage is set above the maximum inrush current of the transformer.
<i>yes</i>	When the transformer inrush current detection detects an inrush current that can lead to a tripping of the stage, the start of the time delay and tripping of the stage are blocked. Select this setting if the device is used on transformers and the threshold value of the stage is set below the maximum inrush current of the transformer.

Parameter: Blocking by the main Protection

- Recommended setting value (`_:8101:140`) **Blocking by** =

If you wish to give selective fault clarification through the main protection function precedence over tripping through the directional negative-sequence protection, you can define this via the 2 parameters **Blocking by** and **Blocking by prot. pickup**. The **Blocking by** parameter is used to select the zones or tripping stages of the main protection function(s), upon whose pickup the negative-sequence protection is to be blocked.

Parameter: Blocking by prot. pickup

- Default setting (`_:8101:130`) **Blocking by prot. pickup** = *every pickup*

The **Blocking by prot. pickup** parameter can be used to define the type of pickup, which leads to the blocking.

Parameter Value	Description
<i>every pickup</i>	Blocking at every pickup
<i>1-phase pickup</i>	Blocking only at 1-pole pickup

Parameter Value	Description
<i>multi-phase pickup</i>	Blocking only at multipole pickup
<i>no pickup</i>	If the pickup of the main protection function should not lead to blocking of the negative-sequence protection, select this setting.

Parameter: Op.mode at 1p dead time

- Default setting (`_:8101:129`) **Op.mode at 1p dead time = blocked**

The **Op.mode at 1p dead time** parameter is used to define the behavior of the stage in the event of a 1-pole interruption.

Parameter Value	Description
<i>blocked</i>	The energy-transmission system is unbalanced in the 1-pole dead time. A mode-dependent negative-sequence system results from this, which can lead to an undesired pickup of the directional negative-sequence protection. That is why blocking with this setting makes sense if the pickup threshold of the stage is lower than/equal to the maximum mode-dependent negative-sequence current in the 1-pole dead time.
<i>non-directional</i>	If the directional negative-sequence protection is to continue to work in the 1-pole dead time, select this setting. The directional measurement works in a non-directional manner, because a reliable direction dead time measurement is not possible due to load current in the zero and negative-sequence system with the circuit breaker open on one pole. Set the pickup threshold of the stage higher than the maximum mode-dependent negative-sequence current in the 1-pole dead time.



NOTE

The **Op.mode at 1p dead time** parameter is only available in devices with 1-/3-pole tripping. In devices with 3-pole tripping, this setting does not apply.

Parameter: Hold mode 1-p dead time

- Default setting (`_:8101:112`) **Hold mode 1p dead time = 0.040 s**

The parameter **Hold mode 1p dead time** is used to define the time by which the device-internal signal for the 1-pole interruption is extended after the end of the 1-pole interruption.

At all line ends, there is no simultaneous switch-in after a 1-pole dead time. Thus, the parameterized operating mode for a 1-pole dead time must be retained for a certain time after the switch-in (end of the 1-pole dead time) until the other end or ends have securely switched in. The time to be set here corresponds to the maximum time between the switch-in of the 1st circuit breaker and the switch-in of the last circuit breaker at all ends of the feeder after a 1-pole dead time.



NOTE

The **Hold mode 1p dead time** parameter is only available in devices with 1-/3-pole tripping. In devices with 3-pole tripping, this setting does not apply.

Parameter: Stabiliz. w. phase current

- Recommended setting value (`_:8101:111`) **Stabiliz. w. phase current = 10 %**

In order to avoid unwanted pickups and tripping, the negative-sequence system current stage is stabilized with the phase currents.

More information can be found in chapter [6.18.3 Function Description](#).

The threshold value increases as the phase currents increase.

You can change the stabilization factor (= gradient) via the **Stabiliz. w. phase current** parameter.

Siemens recommends a default setting of 10 % under normal operations.

Parameter: Threshold

- Default setting (**_:8101:3**) **Threshold = 1.5 A**

Define the pickup value corresponding to the application. In doing so, for the time-graded stages, the setting for the superordinate and subordinate stages must be taken into account in the grading chart.

With a very sensitive setting, you must make sure that the negative-sequence system current does not lead to undesired response of the stage due to unbalance (for example non-twisted line).

Parameter: Operate delay

- Default setting (**_:8101:6**) **Operate delay = 0.30 s**

The tripping delay (time delay) to be set is derived from the time-grading schedule that has been prepared for the system.

When selecting the current and time setting, pay attention to whether the stage must work dependent on the direction.

6.18.6 Settings

Addr.	Parameter	C	Setting Options	Default Setting
General				
_:2311:101	General:Angle forward α		0 ° to 360 °	338 °
_:2311:102	General:Angle forward β		0 ° to 360 °	122 °
_:2311:107	General:Min. neg.-seq. voltage V2		0.150 V to 34.000 V	1.213 V
_:2311:106	General:Min. neg.-seq. current I2	1 A @ 100 Irated	0.030 A to 10.000 A	0.050 A
		5 A @ 100 Irated	0.15 A to 50.00 A	0.25 A
		1 A @ 50 Irated	0.030 A to 10.000 A	0.050 A
		5 A @ 50 Irated	0.15 A to 50.00 A	0.25 A
		1 A @ 1.6 Irated	0.001 A to 1.600 A	0.050 A
		5 A @ 1.6 Irated	0.005 A to 8.000 A	0.250 A
Definite-T 1				
_:8101:1	Definite-T 1:Mode		<ul style="list-style-type: none"> • off • on • test 	off
_:8101:2	Definite-T 1:Operate &flt.rec. blocked		<ul style="list-style-type: none"> • no • yes 	no
_:8101:114	Definite-T 1:Directional mode		<ul style="list-style-type: none"> • non-directional • forward • reverse 	forward
_:8101:111	Definite-T 1:Stabiliz. w. phase current		0 % to 30 %	10 %
_:8101:3	Definite-T 1:Threshold	1 A @ 100 Irated	0.030 A to 35.000 A	1.500 A
		5 A @ 100 Irated	0.15 A to 175.00 A	7.50 A
		1 A @ 50 Irated	0.030 A to 35.000 A	1.500 A
		5 A @ 50 Irated	0.15 A to 175.00 A	7.50 A
		1 A @ 1.6 Irated	0.001 A to 1.600 A	1.500 A
		5 A @ 1.6 Irated	0.005 A to 8.000 A	7.500 A

Addr.	Parameter	C	Setting Options	Default Setting
_:8101:6	Definite-T 1:Operate delay		0.00 s to 60.00 s	0.30 s
_:8101:116	Definite-T 1:Blk. w. inrush curr. detect.		<ul style="list-style-type: none"> • no • yes 	no
_:8101:130	Definite-T 1:Blocking by prot. pickup		<ul style="list-style-type: none"> • every pickup • 1-phase pickup • multi-phase pickup • no pickup 	every pickup
_:8101:129	Definite-T 1:Op.mode at 1p dead time		<ul style="list-style-type: none"> • blocked • non-directional 	blocked
_:8101:112	Definite-T 1:Hold mode 1p dead time		0.000 s to 60.000 s	0.040 s
_:8101:140	Definite-T 1:Blocking by		Setting options depend on configuration	

6.18.7 Information List

No.	Information	Data Class (Type)	Type
General			
_:2311:500	General:>Test of direction	SPS	I
_:2311:300	General:Test direction	ACD	O
_:2311:52	General:Behavior	ENS	O
_:2311:53	General:Health	ENS	O
Group indicat.			
_:4501:55	Group indicat.:Pickup	ACD	O
_:4501:57	Group indicat.:Operate	ACT	O
_:4501:52	Group indicat.:Behavior	ENS	O
_:4501:53	Group indicat.:Health	ENS	O
Definite-T 1			
_:8101:81	Definite-T 1:>Block stage	SPS	I
_:8101:51	Definite-T 1:Mode (controllable)	ENC	C
_:8101:54	Definite-T 1:Inactive	SPS	O
_:8101:52	Definite-T 1:Behavior	ENS	O
_:8101:53	Definite-T 1:Health	ENS	O
_:8101:60	Definite-T 1:Inrush blocks operate	ACT	O
_:8101:302	Definite-T 1:Prot.PU blocks operate	SPS	O
_:8101:301	Definite-T 1:Mode 1p dead-tm.active	SPS	O
_:8101:55	Definite-T 1:Pickup	ACD	O
_:8101:56	Definite-T 1:Operate delay expired	ACT	O
_:8101:57	Definite-T 1:Operate	ACT	O

6.19 Thermal Overload Protection, 3-Phase - Advanced

6.19.1 Overview of Functions

The **Thermal overload protection, 3-phase – advanced** function (ANSI 49) is used to:

- Protect the equipment (motors, generators, transformers, capacitors, overhead lines, and cables) against thermal overloads
- Monitor the thermal state of motors, generators, transformers, capacitors, overhead lines, and cables

6.19.2 Structure of the Function

The **Thermal overload protection, 3-phase – advanced** function is used in protection function groups with current measurement.

The function is preconfigured by the manufacturer with 1 **Thermal overload protection, 3-phase – advanced** stage.

The non-preconfigured function block **Filter** can optionally be applied to gain the RMS value used by the **Thermal overload protection, 3-phase – advanced** stage.

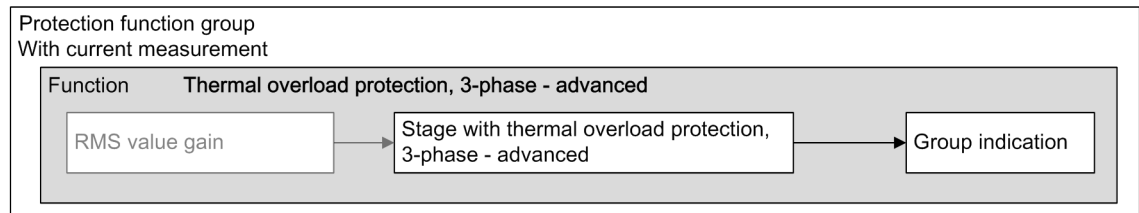

[dw_TOLP_with_filter_stage_2_en_US]

Figure 6-159 Structure/Embedding of the Function

6.19.3 Filter for RMS Value Gain

6.19.3.1 Description

The function block **Filter** can be used to adapt the RMS value for 2 means:

- To gain harmonics in a defined way. Higher harmonics can stress the protected object thermally more than lower harmonics. This is the case for reactors applied in AC filters. In addition, the amplitude attenuation of higher frequencies due to the anti-aliasing filter of the device is automatically compensated by the filter
- To only compensate the amplitude attenuation of higher frequencies by the device (due to the anti-aliasing filter)

The filter gain (amplitude response) is realized by a 9-order FIR filter.

Logic

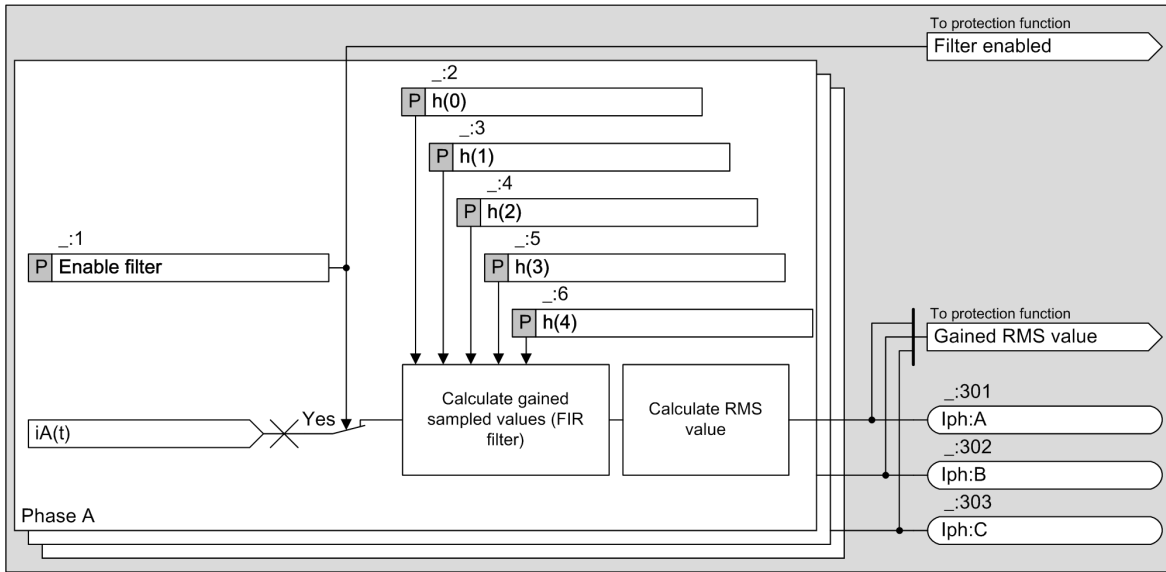

[!o_tolp_filter_stage, 1, en_US]

Figure 6-160 Logic Diagram of the Function Block Filter

The FIR filter gains the 8-kHz sampled values according to the set filter coefficients. Afterwards the RMS value is calculated. The symmetrical 9-order filter coefficients are set via the respective parameters **h (0)** , **h (1)** , **h (2)** , **h (3)** and **h (4)** .



NOTE

A FIR-filter configuration tool is provided as an auxiliary PC tool. With this PC tool, the coefficients **h(0)** , **h(1)** , **h(2)** , **h(3)** , **h(4)** of the FIR filter are generated according to the required gain factors (amplitude response). The tool can be obtained from the SIPROTEC download area. For more information about the tool, refer to the tool help function.

The gained RMS value is delivered to the protection stages only when the function block **Filter** is instantiated and the parameter **Enable filter** is set as **yes** . Otherwise, the normal RMS value is used.

Functional Measured Values

Values	Description	Primary	Secondary	% Referenced to
Iph:A	Filtered RMS measured value of current A	kA	A	Parameter Rated current
Iph:B	Filtered RMS measured value of current B	kA	A	Parameter Rated current
Iph:C	Filtered RMS measured value of current C	kA	A	Parameter Rated current

You can find the parameter **Rated current** in the **FB General** of function groups where the **Thermal overload protection, 3-phase - advanced** function is used.

If the parameter **Enable filter** is set to **no**, the function values are shown as ---.

6.19.3.2 Application and Setting Notes

Parameter: **Enable filter**

- Default setting (_:1) **Enable filter** = **no**.

With the parameter **Enable filter**, you set whether the **Filter** is enabled.

Parameter Value	Description
<i>yes</i>	If gained RMS values should be used in one of the protection stages, set parameter Enable filter = <i>yes</i> .
<i>no</i>	If no gained RMS values are needed, set the parameter Enable filter = <i>no</i> .

Parameter: h (0) , h (1) , h (2) , h (3) , h (4)

- Default setting (**_:2**) **h (0)** = 0.000
- Default setting (**_:3**) **h (1)** = 0.000
- Default setting (**_:4**) **h (2)** = 0.000
- Default setting (**_:5**) **h (3)** = 0.000
- Default setting (**_:6**) **h (4)** = 1.000

With the default value of the coefficients, the filter has no effect and no gain is applied.

If the filter shall be applied to adapt the RMS value calculation to a specific protection object such as a reactor, the reactor manufacturer has to provide the required amplitude response (gain factors) for the reactor. To determine the coefficients h(0) to h(4) for the FIR filter, you must enter the gain factors into the auxiliary PC tool which is available in the SIPROTEC download area. The 5 required coefficients are generated by the tool. They have to be entered manually as settings to configure the filter. The amplitude attenuation of higher frequencies due to the anti aliasing filter of the device is automatically taken into account and compensated by the filter.

To only compensate the attenuation of higher frequencies by the device, set the following coefficients in the filter.

Rated Frequency	Filter Coefficients for Only Compensating the Device Amplitude Attenuation
50 Hz	h(0) = -0.002 h(1) = -0.012 h(2) = 0.045 h(3) = -0.110 h(4) = 1.151
60 Hz	h(0) = -0.005 h(1) = -0.020 h(2) = 0.058 h(3) = -0.128 h(4) = 1.170

6.19.3.3 Settings

Addr.	Parameter	C	Setting Options	Default Setting
Filter				
_:1	Filter:Enable filter		<ul style="list-style-type: none"> • no • yes 	no
_:2	Filter:h(0)		-100.000 to 100.000	0.000
_:3	Filter:h(1)		-100.000 to 100.000	0.000
_:4	Filter:h(2)		-100.000 to 100.000	0.000
_:5	Filter:h(3)		-100.000 to 100.000	0.000
_:6	Filter:h(4)		-100.000 to 100.000	1.000

6.19.3.4 Information List

No.	Information	Data Class (Type)	Type
<i>Filter</i>			
_:301	Filter:Iph:A	MV	O
_:302	Filter:Iph:B	MV	O
_:303	Filter:Iph:C	MV	O
_:52	Filter:Behavior	ENS	O
_:53	Filter:Health	ENS	O

6.19.4 Stage with Thermal Overload Protection, 3-Phase - Advanced

6.19.4.1 Description

Logic

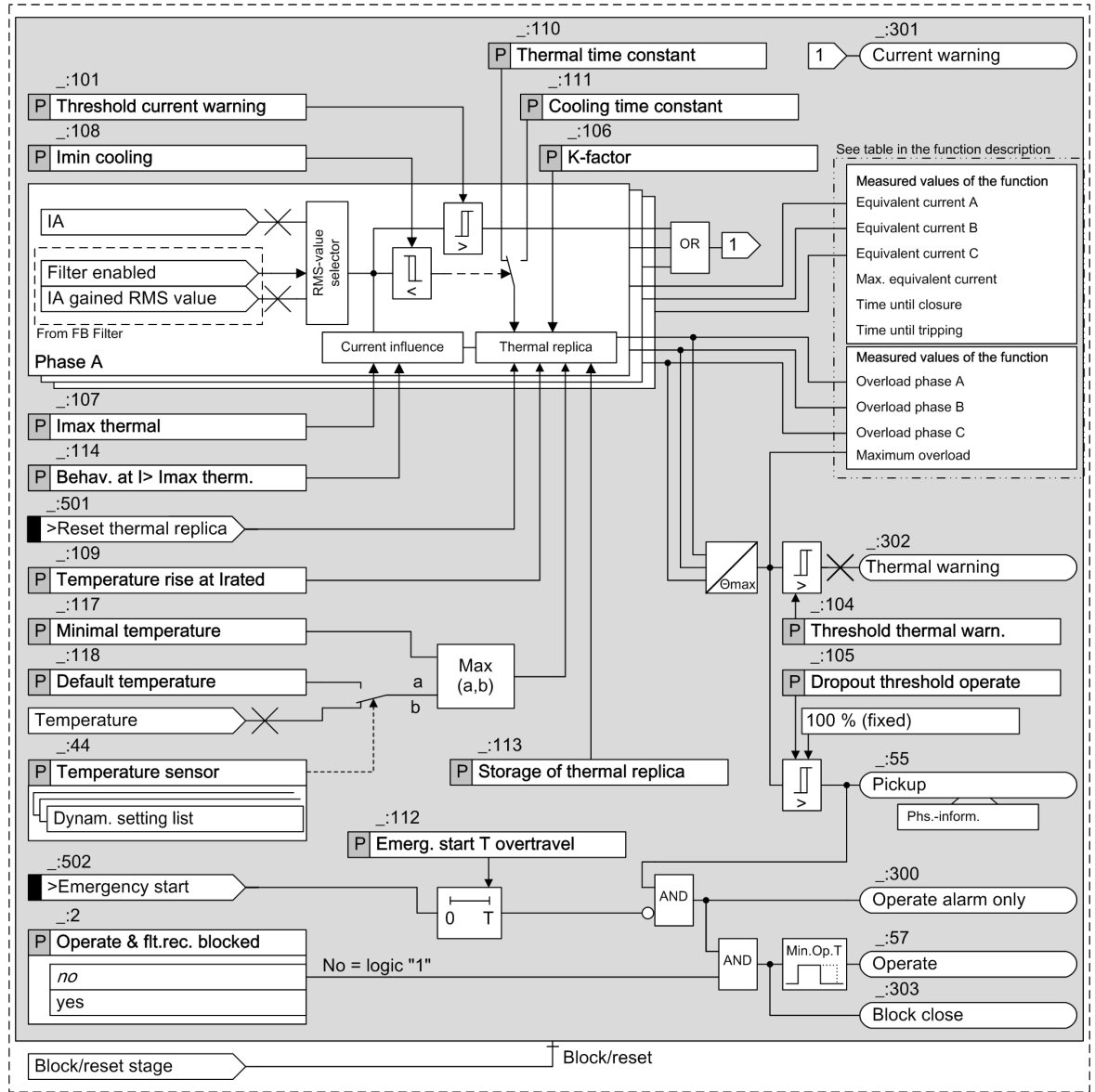

[to_top_with_filter_stage_2_en_US]

Figure 6-161 Logic Diagram of the Thermal Overload Protection, 3-Phase - Advanced Stage

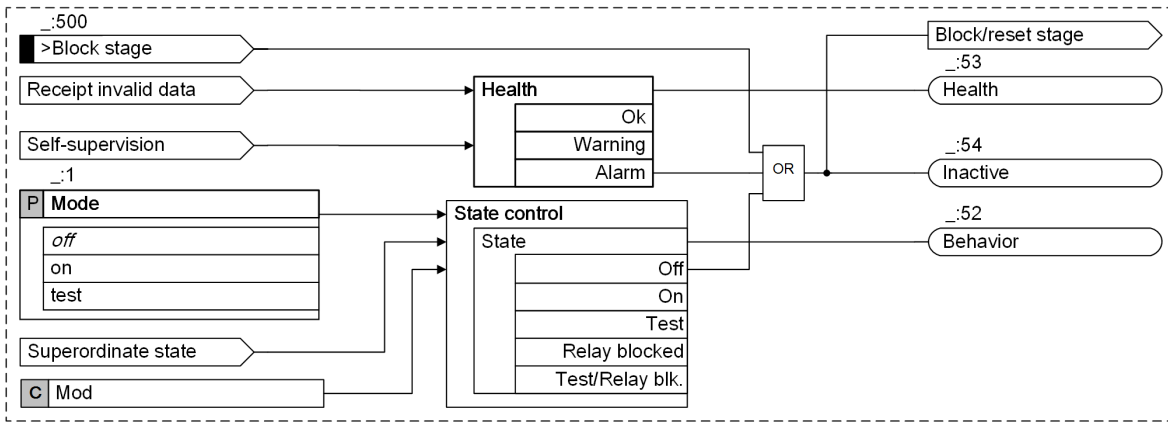

[fo_stage_control_TOLP, 2, en_US]

Figure 6-162 Logic Diagram of the Stage Control

RMS-Value Selection

The protection function supports 2 kinds of RMS measurement:

- Normal RMS value
- Gained RMS value from the function block **Filter**

The gained RMS value is automatically used if the function block **Filter** is configured and the filter has been enabled.



NOTE

When the function block **Filter** is applied, only one current measuring point I-3ph is allowed to be connected to the 3-phase current interface of the function group.

Thermal Replica

The protection function calculates the overtemperature from the phase currents based on a thermal single-body model according to the thermal differential equation with

$$I_{p.u.}^2 = \tau_{th} \frac{d\theta}{dt} + \theta - \theta_{Amb}$$

[fo_diffgl-170914, 2, en_US]

With the following standardization:

$$I_{p.u.} = \frac{I}{I_{max}} = \frac{I}{K \cdot I_{rated, obj.}} \quad \theta = \frac{\vartheta}{\vartheta_{max}} = \frac{\vartheta}{K^2 \cdot \Delta\vartheta_{rated, obj.}}$$

$$\tau_{th} = R_{th} \cdot C_{th} \quad \vartheta_{Amb} = \frac{\vartheta_{Amb} - 40 \text{ }^\circ\text{C}}{\vartheta_{max}} = \frac{\vartheta_{Amb} - 40 \text{ }^\circ\text{C}}{K^2 \cdot \Delta\vartheta_{rated, obj.}}$$

[fo_normie_01, 3, en_US]

Θ	Current overtemperature, in relation to the final temperature at a maximum permissible phase current $k I_{rated, obj}$
Θ_{Amb}	Standardized ambient temperature, where ϑ_{Amb} describes the coupled ambient temperature. The coupled ambient temperature ϑ_{Amb} can be the measured ambient temperature or the ambient temperature preset using the Default temperature parameter.
$\Delta \vartheta_{rated, obj}$	Overtemperature of the protected object set at rated current

τ_{th}	Thermal time constant (temperature rise/cooling) of the protected object
k	This factor indicates the maximum continuous permissible phase current. The factor refers to the rated current of the protected object ($k = I_{max}/I_{rated, obj}$)
$I_{rated, obj}$	Rated current of the protected object

At the same time, $I_{rated, obj}$ is the rated current of the assigned protected object side:

- In the case of transformers, the rated current of the winding to be protected, which the device calculates from the set rated apparent power and rated voltage, is decisive.
- The uncontrolled winding forms the basis in the case of transformers with voltage control
- In the case of generators, motors and reactors, the rated current, which the device calculates from the set rated apparent power and rated voltage, is decisive.
- In the case of lines, nodes and busbars, the rated current of the protected object is set directly

In a steady state, the solution to the thermal differential equation is an e-function whose asymptote represents the final overtemperature Θ_{end} . The time constant τ_{th} determines the rise. After reaching an initial adjustable overtemperature threshold Θ_{warn} (**Threshold thermal warn.**), a warning indication is given. If the overtemperature limit Θ_{off} (tripping overtemperature) is exceeded, an operate indication is immediately issued and the equipment disconnected from the power supply. This threshold is specified at 100 % and corresponds to the final temperature set at a flowing permissible continuous current (I_{max}).

Figure 6-163 shows the temperature rise at different overload currents and the supervision thresholds.

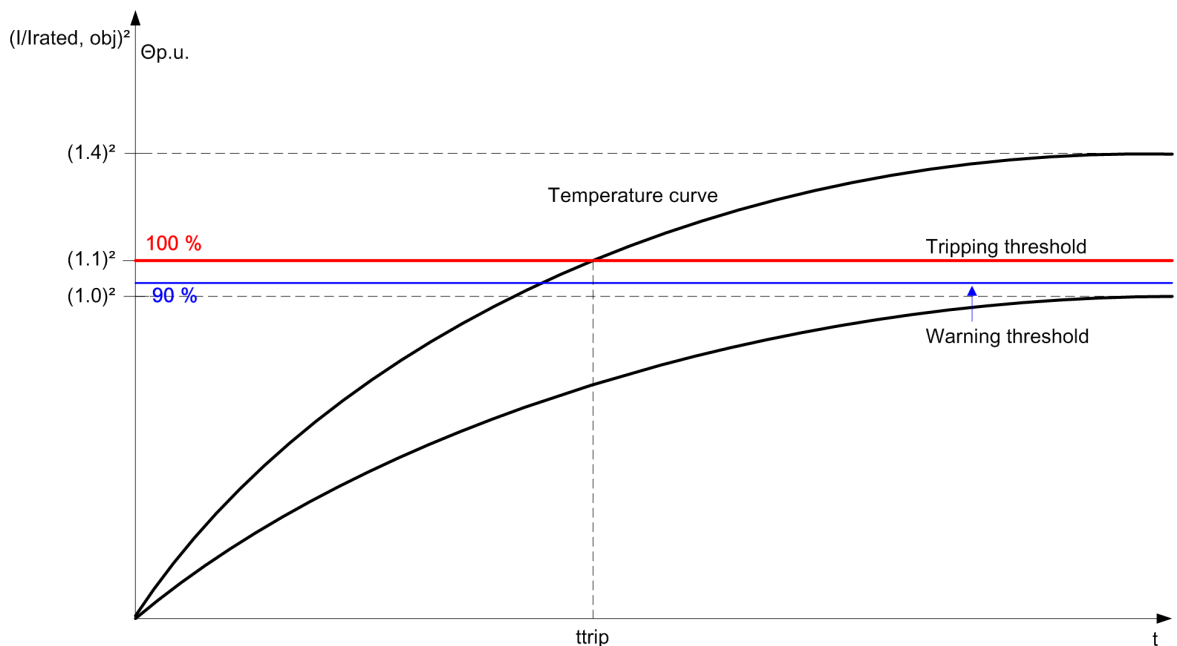

[dw_temp_ve.1_en_US]

Figure 6-163 Temperature History for Different Overload Currents (**K-factor** = 1.1)

The overtemperature is calculated separately for each phase. The current overtemperature can be obtained from the operational measured values. It is shown in percent. An indication of 100 % means that the thermal threshold has been reached. The maximum overtemperature of the phases is regarded as the tripping temperature. This means that the highest of the 3 phase currents is always assumed.

The analysis of the RMS values of the currents over a broad frequency band also includes the harmonic components. These harmonic components contribute to the temperature rise of the equipment.

If the flowing current falls below an adjustable minimum current **I_{min cooling}**, the **Cooling time constant** is activated.

Operate Curve

If the ambient temperature is not measured and set to 40°C, you can get the operate curve as following:

$$t = \tau_{th} \cdot \ln \frac{\left(\frac{I}{k \cdot I_{rated,obj}} \right)^2 - \left(\frac{I_{preload}}{k \cdot I_{rated,obj}} \right)^2}{\left(\frac{I}{k \cdot I_{rated,obj}} \right)^2 - 1}$$

[fo_austos, 1, en_US]

t	Operate time
τ_{th}	Time constant
I	Measured load current
$I_{preload}$	Preload current
k	Setting factor according to VDE 0435 part 3011 or IEC 60255-149 (K factor)
$I_{rated,obj}$	Rated current of the protected object

Ambient Temperature

This function takes the ambient temperature into consideration. The reference temperature of the thermal model is 40 °C.

Compared to the reference temperature, a different ambient temperature leads to different results.

- The ambient temperature is smaller than the reference temperature.
 If the ambient temperature is smaller than the reference temperature, the thermal limit increases. This means that the persistent maximum permissible current increases and results in a higher actual K factor.
- The ambient temperature is larger than the reference temperature.
 If the ambient temperature is larger than the reference temperature, the thermal limit decreases. This means that the persistent maximum permissible current decreases and results in a lower actual K factor.

The ambient temperature can be measured with an RTD (Resistance Temperature Detector) element and can influence the thermal limit dynamically. Alternatively, a higher or lower ambient temperature can be considered statically with the parameter **Default temperature**, which results in a lower or higher actual K factor compared to the parameter that corresponds to an ambient temperature of 40 °C.

So, the parameter **Default temperature** is a fixed value to describe the ambient temperature if no sensor is connected or it is the value to be considered if the temperature sensor is defective. The parameter **Minimal temperature** parameter limits the coupled ambient temperature. If the measured ambient temperature is lower than the minimum temperature, the minimum temperature is processed in the thermal model.

To calculate the actual K factor depending on the ambient temperature, the value of the parameter **Temperature rise at Irated** is required.

The ambient temperature is measured by an external RTD unit and provided by the functions **RTD unit Ether**, or **RTD unit serial** of the function group **Analog unit**. When using the parameter **Temperature sensor**, the respective temperature sensor can be selected.

If the temperature measurement is faulty, for example, due to an open circuit between the device and the RTD unit, the health state of the function **Thermal overload protection, 3-phase – advanced** changes to *warning*. In this case, the process continues with either the temperature measured last or the value set under the parameter **Default temperature**, depending on which value is higher.

Current Influence

The thermal replica based on the single-body model applies with limitations to high overcurrent situations (short circuits, motor startup currents). To avoid an overfunction of the overload protection, the thermal replica must be influenced for overcurrents (exceeding $I_{threshold}$). You can select between 2 strategies for this:

- Freezing of the thermal memory
- Limitation of the input current for the thermal replica to the set current. The temperature rise is thereby **retarded** at high currents.

Warning Thresholds

The thermal warning threshold issues a warning indication before the tripping threshold (tripping temperature) is reached. In this way, for example, a load can be reduced in sufficient time and a disconnection avoided. At a normal **K-factor** of **1.1**, a thermal memory value of 83 % sets in at continuously flowing rated current.

Apart from the thermal warning threshold, the overload protection also has a current-warning threshold. This current-warning threshold can signal an overload current in sufficient time before the overtemperature value has reached the warning or tripping threshold.

Dropout of Tripping

Once the thermal memory has fallen below the setting value of the **Dropout threshold operate**, the trip command is canceled upon tripping. In contrast, the current-warning threshold and the thermal warning threshold are reduced at a fixed dropout threshold (see Technical Data).

Behavior in the Event of Auxiliary-Voltage Failure

The behavior of the thermal replica can be controlled upon auxiliary-voltage failure via the setting parameter **Storage of thermal replica**. You can save the thermal state for a time of 500 min. Once the supply voltage returns, the thermal replica continues to function with the saved thermal state.

If the thermal replica is not saved, it will be reset to 0 upon failure of the auxiliary voltage.

Resetting the Thermal Map

You can reset the thermal memory via the binary input indication **>Reset thermal replica**. The thermal memory will then have a 0 value. A reparameterization will also lead to resetting the thermal memory.

Emergency Start

Depending on the operating conditions, tripping can be blocked or closure enabled despite the permissible thermal limits being exceeded. Upon activation of the binary input signal **>Emergency start**, tripping is blocked and closure enabled. This does not affect the state of the thermal memory. After the input **>Emergency start** disappears, the blocking remains in effect for the set **Emerg. start T overtravel**.

Blocking the Function

Blocking will cause a picked up function to be reset. The tripping function can be blocked externally or internally by the binary input signal **>Block stage**.

All indications then drop out and the thermal memory is set to the value 0.

Blocking Closure

The signal **Block close** can be used to prevent closure of the protected object at a high thermal load. The signal is set if the tripping overtemperature is exceeded, and canceled if the temperature falls below the dropout threshold.

Functional Measured Values

Values	Description	Primary	Secondary	% Referenced to
(_:601:305) Time until trip	Expected time until tripping	s	s	s
(_:601:304) Time until close	Time until close release	s	s	s
(_:601:306) Overload phase A	Thermal measured values of the phases	%	%	Tripping temperature
(_:601:307) Overload phase B				
(_:601:308) Overload phase C				

Values	Description	Primary	Secondary	% Referenced to
(_:601:309) Overload maximum	Thermal measured value of the overload protection	%	%	Tripping temperature
(_:601:310) Equival. current phs A	Current measured value which serves as basis for the overload measured value	A	A	Rated operating current of the primary values
(_:601:311) Equival. current phs B				
(_:601:312) Equival. current phs C				
(_:601:313) Equival. current max.	Maximum current measured value which serves as basis for the overload measured value	A	A	Rated operating current of the primary values

6.19.4.2 Application and Setting Notes

Parameter: Threshold current warning

- Default setting (_:101) **Threshold current warning** = 1.000 A at $I_{rated} = 1$ A
- Set the threshold to the maximum permissible continuous current ($I_{max, perm}$). This results in the same setting value as for the **K-factor**.

Parameter: Threshold thermal warn.

- Default setting (_:104) **Threshold thermal warn.** = 90 %
- The default setting can be left at a **K-factor**, of 1.1, as the thermal memory results for 83 % at continuously flowing rated current. The calculation uses the rule of three: 100 % corresponds to $(K\text{-factor})^2$ and x % corresponds to 1^2 .

$$\frac{\Theta}{\Theta_{off}} = \frac{100 \%}{k^2} = 83 \%$$

[fo_warmsc, 2, en_US]

At a **K-factor** of 1.05, the thermal memory for rated current is already 91 % filled. Increase the **Threshold thermal warn.** to 95 %.

Parameter: Dropout threshold operate

- Default setting (_:105) **Dropout threshold operate** = 90 %
- The **Dropout threshold operate** parameter is used to drop out pickup and tripping when the value drops below this threshold. A setting on the order of magnitude of the warning threshold is recommended. You can select a lower setting value for special applications, desired additional cooling or longer blocking of closing.
- Note that the calculation of the operational measured value **Time until close** refers to this value.

Parameter: Temperature rise at Irated

- Default setting (_:109) **Temperature rise at Irated** = 70 K
- Consider this parameter only if the ambient temperature is not 40 °C or if you use a sensor for the measurement of the ambient temperature.
- At an ambient temperature of 40 °C, if the equipment operates continuously with the rated current, the temperature rise is 70 K. Here, the rated current refers to the protected object. You can find the temperature value in the technical data of the equipment or measure it. If you use a temperature sensor when measuring at the rated current, deduct the actual ambient temperature or the coolant temperature from the measured value.

When selecting the setting value, you can also use the specified temperature class for orientation. Usually, you will find the overtemperature expressed in Kelvin (K), which can be accepted as is. If the absolute temperature is given, the ambient temperature must be deducted. As a rule, this is 40 °C.

The overtemperature at maximum permissible current (ϑ_{max}) and the **Temperature rise at Irated** ($\vartheta_{rated, obj.}$) can be converted by using the following formula:

$$k^2 = \left(\frac{\Delta\vartheta_{max}}{\Delta\vartheta_{rated, obj.}} \right)$$

[fo_web_for_irated, 3, en_US]

EXAMPLE:

Temperature class **B** for continuous operation: permissible overtemperature = 80 K

From this, a temperature for I_{rated} of 120 °C (80 K + 40 °C) can be derived when using a temperature sensor for the measurement.

Temperature class **F** as thermal limiting value: permissible overtemperature = 105 K.

From this, a maximum temperature of 145 °C (105 K + 40 °C) derives.

From these values, the K factor can be derived:

$$k^2 = \frac{\Delta\vartheta_{max, Obj.}}{\Delta\vartheta_{rated, Obj.}} = \frac{105 \text{ K}}{80 \text{ K}} = 1.31 \quad \rightarrow \quad k = 1.146$$

[fo_bsp_kfaktor, 3, en_US]

If you select a setting value of 1.1 for the **K-factor**, your selection can be considered as conservative.



NOTE

For electrical machines, the limits can vary depending on the type of coolant.

Consult the machine manufacturer to agree on a setting value for the overtemperature.

Parameter: Storage of thermal replica

- Default setting (`_:113`) **Storage of thermal replica = no**

If a continuous auxiliary voltage for the bay units is ensured, the bay default setting can be retained.

Parameter: Temperature sensor

- Default setting (`_:44`) **Temperature sensor = none**

With the **Temperature sensor** parameter, you determine which temperature sensor to use to detect the ambient temperature.

A temperature sensor is used to measure the ambient temperature of the protected object and to feed it to the device via an RTD unit (RTD = Resistance Temperature Detector). The function **Thermal overload protection, 3-phase – Advanced** receives the measured temperature value via the functions **RTD unit Ether** or **RTD unit Serial** from the function group **Analog units**.

Parameter: Default temperature

- Default setting (`_:118`) **Default temperature = 40 °C**

The **Default temperature** defines the ambient temperature under the following conditions:

- No temperature sensor for measuring the ambient temperature is connected.
- The temperature measurement is faulty and the last measured temperature value is less than the **Default temperature**.

The actual K factor which defines the thermal limit of the function **Thermal overload protection, 3-phase – Advanced** is influenced by the parameter **Default temperature**. For the default value **40 °C**, the persistent maximum permissible current equals to K times the $I_{rated, motor}$. A lower or higher **Default temperature** results in a higher or lower actual K factor. Siemens recommends using the default setting.

Parameter: Minimal temperature

- Default setting (**_:117**) **Minimal temperature** = **-20 °C**

If the measured ambient temperature drops below the set value, the set value is assumed as the ambient temperature. If the overload protection works with a prespecified outside temperature, and this temperature drops below the value set in the **Minimal temperature** parameter, the **Minimal temperature** is also used.

6.19.4.3 Settings

Addr.	Parameter	C	Setting Options	Default Setting
49 Th.overl. #				
_:1	49 Th.overl. #:Mode		<ul style="list-style-type: none"> • off • on • test 	off
_:2	49 Th.overl. #:Operate &flt.rec. blocked		<ul style="list-style-type: none"> • no • yes 	no
_:101	49 Th.overl. #:Threshold current warning	1 A @ 100 Irated	0.030 A to 35.000 A	1.000 A
		5 A @ 100 Irated	0.15 A to 175.00 A	5.00 A
		1 A @ 50 Irated	0.030 A to 35.000 A	1.000 A
		5 A @ 50 Irated	0.15 A to 175.00 A	5.00 A
		1 A @ 1.6 Irated	0.001 A to 1.600 A	1.000 A
		5 A @ 1.6 Irated	0.005 A to 8.000 A	5.000 A
_:104	49 Th.overl. #:Threshold thermal warn.		50 % to 100 %	90 %
_:105	49 Th.overl. #:Dropout threshold operate		50 % to 99 %	90 %
_:112	49 Th.overl. #:Emerg. start T overtravel		0 s to 15000 s	300 s
_:106	49 Th.overl. #:K-factor		0.10 to 4.00	1.10
_:110	49 Th.overl. #:Thermal time constant		10 s to 60000 s	900 s
_:111	49 Th.overl. #:Cooling time constant		10 s to 60000 s	3600 s
_:107	49 Th.overl. #:Imax thermal	1 A @ 100 Irated	0.030 A to 10.000 A	2.500 A
		5 A @ 100 Irated	0.15 A to 50.00 A	12.50 A
		1 A @ 50 Irated	0.030 A to 10.000 A	2.500 A
		5 A @ 50 Irated	0.15 A to 50.00 A	12.50 A
		1 A @ 1.6 Irated	0.001 A to 1.600 A	2.500 A
		5 A @ 1.6 Irated	0.005 A to 8.000 A	12.500 A
_:108	49 Th.overl. #:Imin cooling	1 A @ 100 Irated	0.000 A to 10.000 A	0.500 A
		5 A @ 100 Irated	0.00 A to 50.00 A	2.50 A
		1 A @ 50 Irated	0.000 A to 10.000 A	0.500 A
		5 A @ 50 Irated	0.00 A to 50.00 A	2.50 A
		1 A @ 1.6 Irated	0.000 A to 1.600 A	0.500 A
		5 A @ 1.6 Irated	0.000 A to 8.000 A	2.500 A

Addr.	Parameter	C	Setting Options	Default Setting
_:109	49 Th.overl. #:Temperature rise at Irated		40 K to 200 K	70 K
_:113	49 Th.overl. #:Storage of thermal replica		<ul style="list-style-type: none"> • no • yes 	no
_:114	49 Th.overl. #:Behav. at I > I _{max} therm.		<ul style="list-style-type: none"> • current limiting • freeze therm. rep. 	current limiting
_:118	49 Th.overl. #:Default temperature		-55°C to 55°C	40°C
_:117	49 Th.overl. #:Minimal temperature		-55°C to 40°C	-20°C
_:44	49 Th.overl. #:Temperature sensor		Setting options depend on configuration	

6.19.4.4 Information List

No.	Information	Data Class (Type)	Type
49 Th.overl. #			
_:500	49 Th.overl. #:>Block stage	SPS	I
_:501	49 Th.overl. #:>Reset thermal replica	SPS	I
_:51	49 Th.overl. #:Mode (controllable)	ENC	C
_:54	49 Th.overl. #:Inactive	SPS	O
_:52	49 Th.overl. #:Behavior	ENS	O
_:53	49 Th.overl. #:Health	ENS	O
_:301	49 Th.overl. #:Current warning	SPS	O
_:302	49 Th.overl. #:Thermal warning	SPS	O
_:303	49 Th.overl. #:Block close	SPS	O
_:55	49 Th.overl. #:Pickup	ACD	O
_:300	49 Th.overl. #:Operate alarm only	ACT	O
_:57	49 Th.overl. #:Operate	ACT	O
_:304	49 Th.overl. #:Time until close	MV	O
_:305	49 Th.overl. #:Time until trip	MV	O
_:306	49 Th.overl. #:Overload	MV	O
_:310	49 Th.overl. #:Equival. current	MV	O

6.20 Thermal Overload Protection, User-Defined Characteristic Curve

6.20.1 Overview of Functions

The **Thermal overload protection, user-defined characteristic curve** function (ANSI 49) is used to:

- Protect the equipment (motors, generators, and transformers) against thermal overloads
- Realize a manufacturer specific overload characteristic curve for specific equipment, for example, shunt reactors
- Monitor the thermal state of motors, generators, and transformers

6.20.2 Structure of the Function

The **Thermal overload protection, user-defined characteristic curve** function is used in protection function groups with 3-phase current measurement.

The function comes factory-set with 1 **Thermal overload protection, user-defined characteristic curve** stage.

The non-preconfigured function block **Filter** can optionally be applied to gain the RMS value used by the **Thermal overload protection, user-defined characteristic curve** stage.

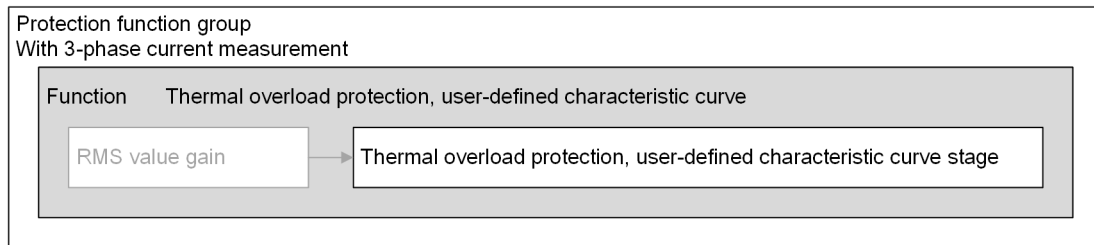

[dw_TOLP_user_curve_str, 2, en_US]

Figure 6-164 Structure/Embedding of the Function

6.20.3 Function Description

Filter for RMS Value Gain

You can find more information about the function block **Filter** in chapter [6.3.3 Filter for RMS Value Gain](#).

Logic

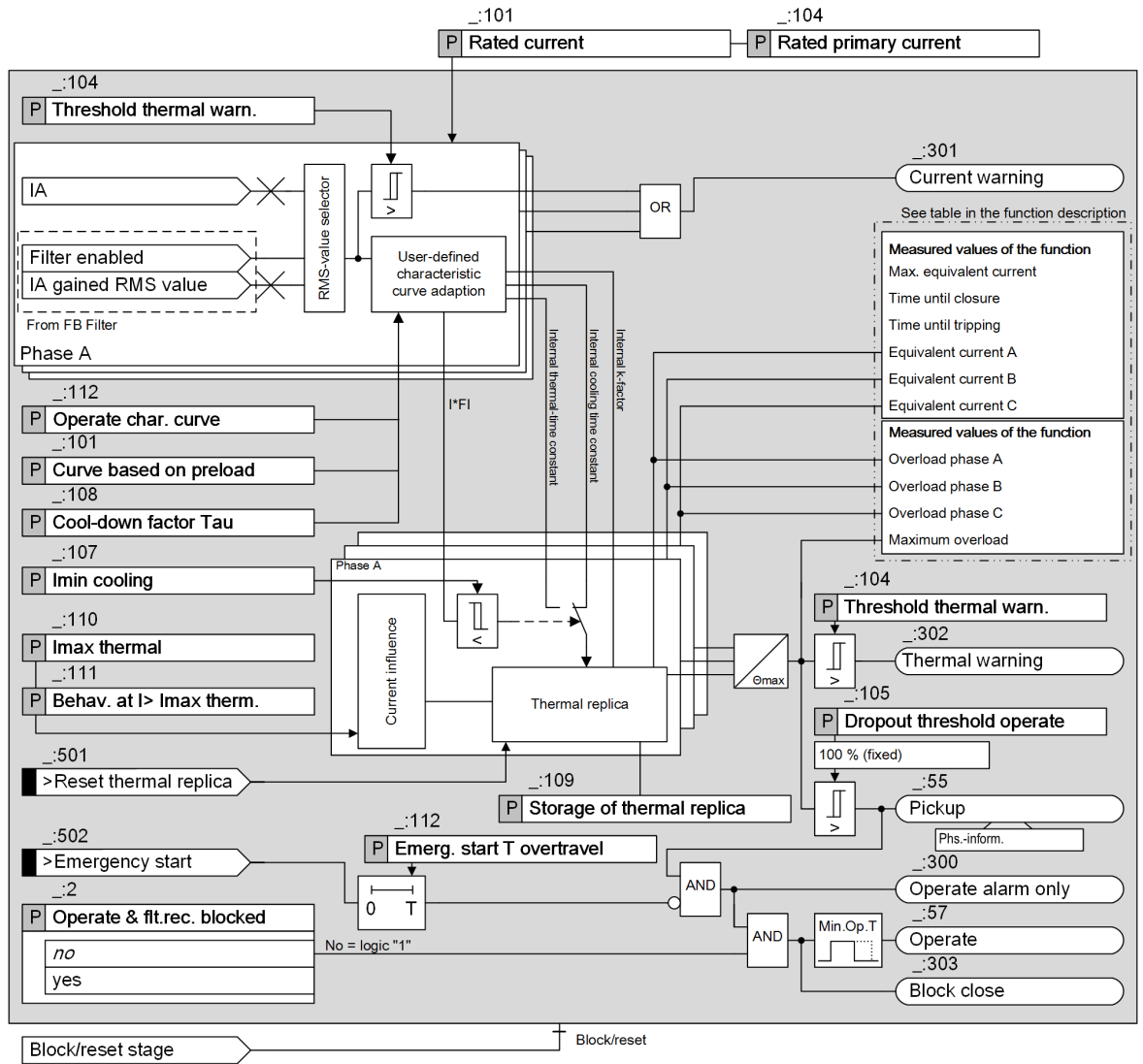

[to_tolp_user_curve_stage_2_en_US]

Figure 6-165 Logic Diagram of the Thermal Overload Protection, User-Defined Characteristic Curve Function

- (1) The (:101) **Rated current** parameter is from the protected object.
- (2) The (:104) **Rated primary current** parameter is from the used current transformer.

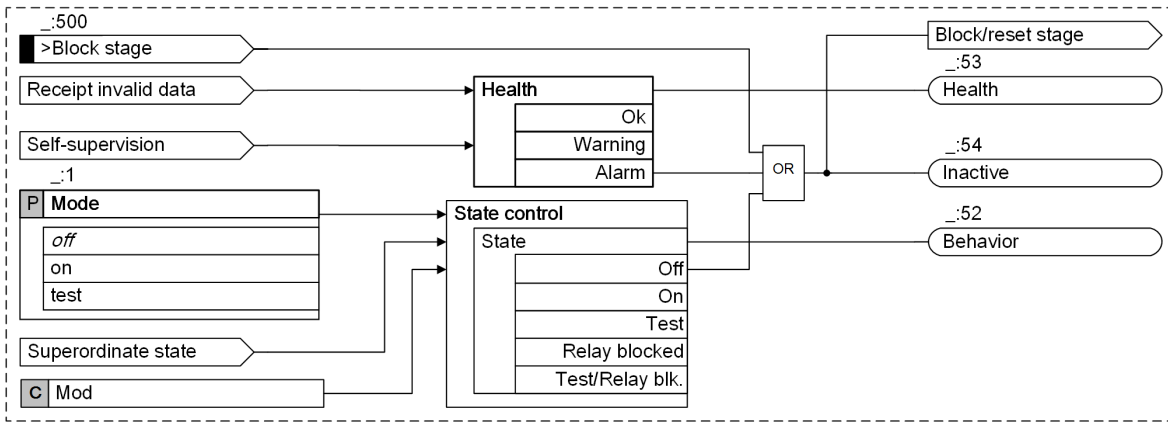

[No_stage_control_TOLP, 2, en_US]

Figure 6-166 Logic Diagram of the Stage Control

RMS-Value Selection

The protection function supports 2 kinds of RMS measurement:

- Normal RMS value
- Gained RMS value from the function block **Filter**

The gained RMS value is automatically used if the function block **Filter** is configured and the filter has been enabled.



NOTE

When the function block **Filter** is applied, only one current measuring point I-3ph is allowed to be connected to the 3-phase current interface of the function group.

User-Defined Characteristic Curve

For specific equipment (for example, shunt reactors and transformers) or for special applications, the manufacturer specifies an overload characteristic curve. This curve cannot be described accurately with a single-body model so that deviations can occur. The following figure shows an example of a predefined overload characteristic curve and 2 standard characteristic curves based on the single-body model.

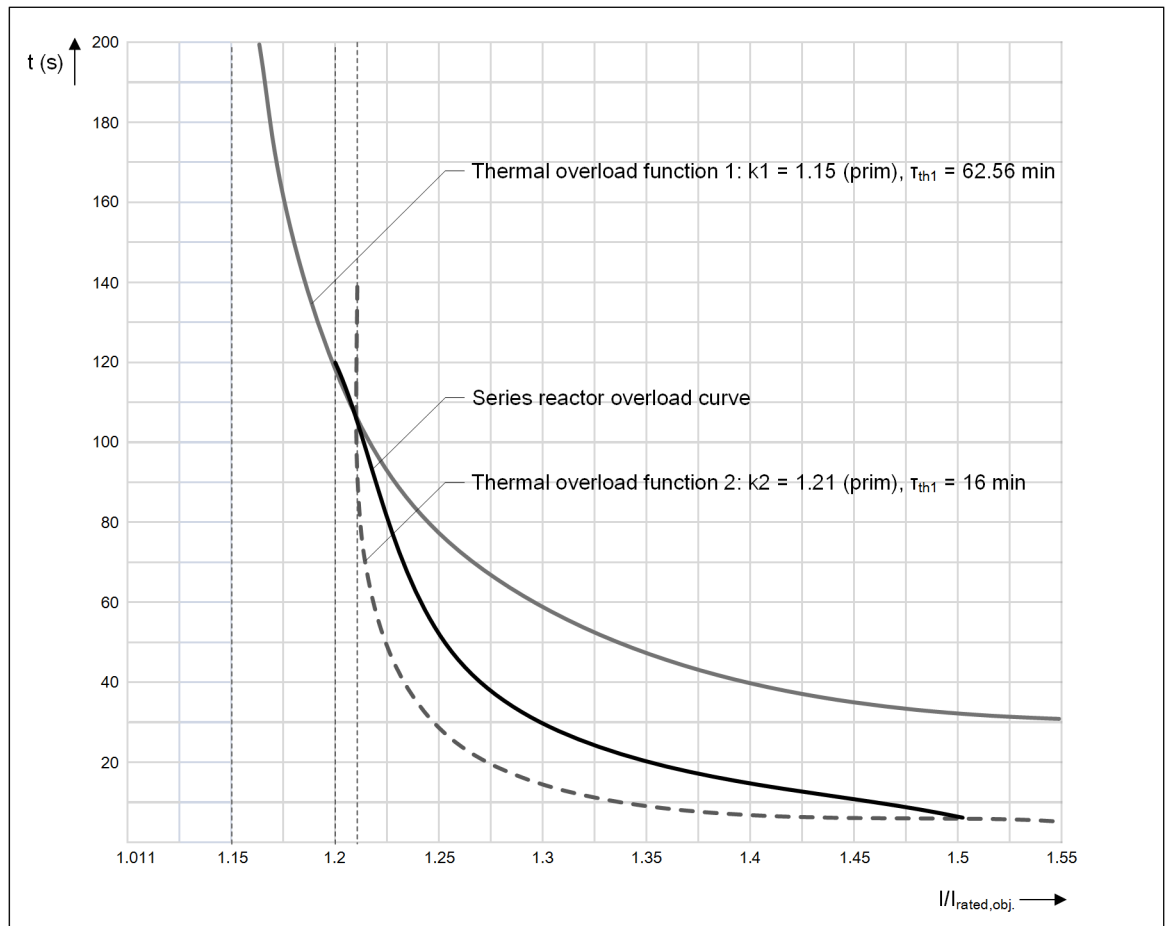

[dw_TOLP_user_curve_characteristic, 2, en_US]

Figure 6-167 User-Defined Characteristic Curve with Replica of Standard Characteristics

The calculation is identical to the realization of the standard **Thermal overload protection, 3-phase - advanced** function. You can find more information in the function description **Thermal overload protection, 3-phase - advanced** starting from chapter [6.19.1 Overview of Functions](#).

The main deviations are as follows:

- The thermal characteristic is set with a flexible characteristic ($t_{\text{trip}} = f(I/I_{\text{rated,obj}})$).
 - The first point of the characteristic curve is important and is used to calculate the internal k-Factor. To meet the applications with a minimum internal k-Factor value of 1.001, the minimum $I/I_{\text{rated,obj}}$ value of 1.011 can be set as the first point of the characteristic curve.
 - The point at $I/I_{\text{rated,obj}} = 1.5$ is used to calculate the internal thermal time constant. If there is no point at $I/I_{\text{rated,obj}} = 1.5$, the point which is the closest to $I/I_{\text{rated,obj}} = 1.5$ from $I/I_{\text{rated,obj}} = 1.1$ is used to calculate the internal thermal time.
 - The points are set according to the maximum permissible load current.
- The **Curve based on preload** parameter describes for which thermal preload the user-defined characteristic curve is valid. Normally, such a curve is given for protected objects under rated load.
- The **Cool-down factor Tau** parameter is used for the determination of the cooling time constant. The set factor is multiplied with the internal calculated time constant.
- The thermal model is based on a constant ambient temperature of 40 °C. It cannot be corrected via the external measurement.

Thermal Replica

The protection function calculates the overtemperature from the phase currents on the basis of a thermal single-body model according to the thermal differential equation with

$$I_{p.u.}^2 = \tau_{th} \frac{d\theta}{dt} + \theta$$

[fo_tolp_diffgl, 1, en_US]

With the following standardization:

$$I_{p.u.} = \frac{I}{I_{max}} = \frac{I}{K \cdot I_{rated, obj}} \quad \theta = \frac{\vartheta}{\vartheta_{max}} = \frac{\vartheta}{K^2 \cdot \Delta\vartheta_{rated, obj}}$$

$$\tau_{th} = R_{th} \cdot C_{th}$$

[fo_tolp_normie, 1, en_US]

Θ	Current overtemperature, in relation to the final temperature at a maximum permissible phase current $k I_{rated, obj}$
$\Delta \vartheta_{rated, obj}$	Overtemperature of the protected object set at rated current
τ_{th}	Thermal time constant (temperature rise/cooling) of the protected object. The value is calculated internally.
K	This factor indicates the maximum continuous permissible phase current. The factor refers to the rated current of the protected object ($K = I_{max} / I_{rated, obj}$) and is calculated internally.
$I_{rated, obj}$	Rated current of the protected object

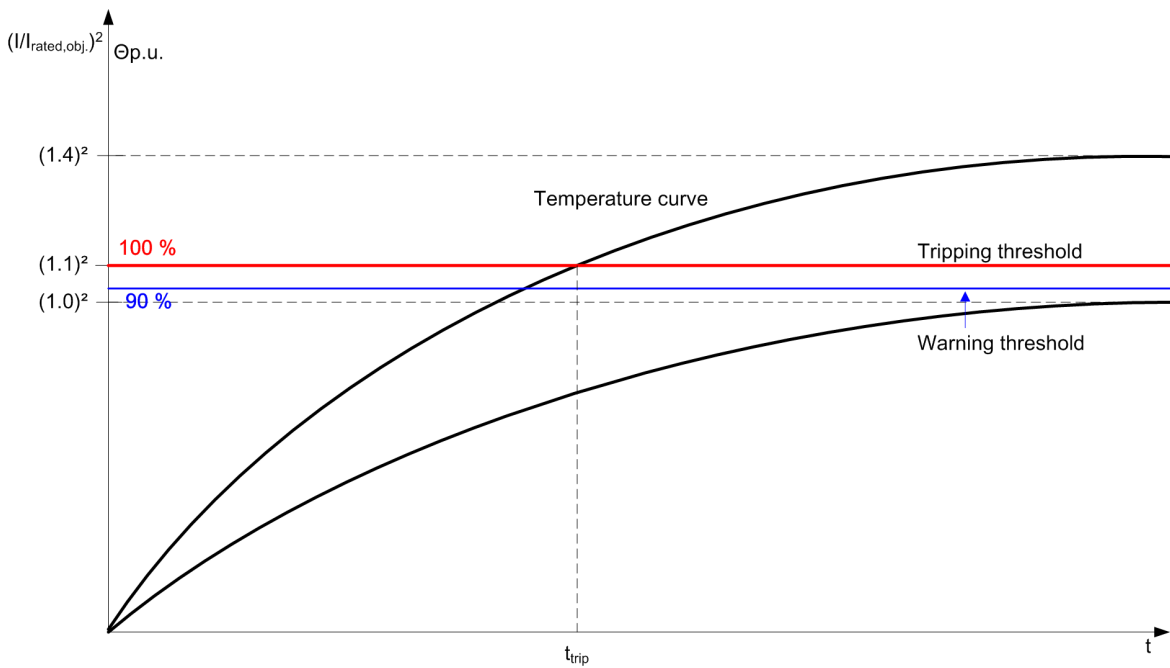

[dw_TOLP_temperature, 1, en_US]

Figure 6-168 Temperature History for Different Overload Currents (**K-factor = 1.1**)

The overtemperature is calculated separately for each phase. The current overtemperature can be obtained from the operational measured values. It is shown in percent. An indication of 100 % means that the thermal threshold has been reached. The maximum overtemperature of the phases is regarded as the tripping temperature. This means that the highest of the 3 phase currents is always assumed.

The analysis of the RMS values of the currents over a broad frequency band also includes the harmonic components. These harmonic components contribute to the temperature rise of the equipment.

Current Influence

The thermal replica based on the single-body model applies only with limitations to high overcurrent situations (short circuits, motor startup currents). To avoid an overfunction of the overload protection, the thermal replica must be influenced in case of overcurrents (exceeding $I_{\text{threshold}}$). You can select between 2 strategies for this:

- Freezing of the thermal memory
- Limitation of the input current for the thermal replica to the set current. The temperature rise is thereby **retarded** at high currents.

Warning Thresholds

The thermal warning threshold issues a warning indication before the tripping threshold (tripping temperature) is reached. In this way, for example, a load can be reduced in sufficient time and a disconnection can be avoided. If the first setting value of the user-defined characteristic curve is set to 1.1 of the rated current, a thermal memory value of 83 % is set to the continuously flowing rated current.

Apart from the thermal warning threshold, the overload protection also has a current-warning threshold. This current-warning threshold can signal an overload current in sufficient time before the overtemperature value has reached the warning or tripping threshold.

Dropout of Tripping

Once the thermal memory has fallen below the setting value of the **Dropout threshold operate**, the trip command is cancelled upon tripping. In contrast, the current-warning threshold and the thermal warning threshold are reduced at a fixed dropout threshold (see Technical Data).

Behavior in the Event of Auxiliary-Voltage Failure

The behavior of the thermal replica can be controlled upon auxiliary-voltage failure via the setting parameter **Storage of thermal replica**. You can save the thermal state for a time of 500 min. Once the supply voltage returns, the thermal replica continues to function with the saved thermal state.

If the thermal replica is not saved, it will be reset to 0 upon failure of the auxiliary voltage.

Resetting the Thermal Memory

You can reset the thermal memory via the binary input indication **>Reset thermal replica**. The thermal memory will then have a 0 value.

Emergency Start

Depending on the operating conditions, tripping can be blocked or closure enabled despite the permissible thermal limits being exceeded. Upon activation of the binary input signal **>Emergency start**, tripping is blocked and closure enabled. This does not affect the state of the thermal memory. After the input **>Emergency start** disappears, the blocking remains in effect for the set **Emerg. start T overtravel**.

Blocking the Function

Blocking will cause a picked up function to be reset. The tripping function can be blocked externally or internally by the binary input signal **>Block stage**.

All indications then drop out and the thermal memory is not calculated.

Blocking Closure

The signal **Block close** can be used to prevent closure of the protected object at a high thermal load. The signal is set if the tripping overtemperature is exceeded, and cancelled if the temperature falls below the dropout threshold.

Functional Measured Values

Values	Description	Primary	Secondary	% Referenced to
(_:601:305) Time until trip	Expected time until tripping	s	s	s
(_:601:304) Time until close	Time until close release	s	s	s
(_:601:306) Overload phase A	Thermal measured values of the phases	%	%	Tripping temperature
(_:601:307) Overload phase B				
(_:601:308) Overload phase C				
(_:601:309) Overload maximum	Thermal measured value of the overload protection	%	%	Tripping temperature
(_:601:310) Equival. current phs A	Current measured value which serves as basis for the overload measured value	A	A	Rated operating current of the primary values
(_:601:311) Equival. current phs B				
(_:601:312) Equival. current phs C				
(_:601:313) Equival. current max.	Maximum current measured value which serves as basis for the overload measured value	A	A	Rated operating current of the primary values

6.20.4 Application and Setting Notes

Motors and generators as well as transformers are at risk from long-lasting overloads. You can adapt the given overload characteristic curve to the user-defined characteristic curve with the **Thermal overload protection, user-defined characteristic curve** function. You can find the predefined characteristic curve in the chapter [14.24 Thermal Overload Protection, User-Defined Characteristic Curve](#).

When setting the parameters, consider the following:

- The settings for the used current transformer (primary values and secondary values) must be set correctly in the power system.
- The rated values for the protected object must be correct in the used function group.

Parameter: Threshold current warning

- Recommended setting value (_:101) **Threshold current warning** = 1.1 A at $I_{rated} = 1 A$

Set the threshold to the maximum permissible continuous current ($I_{max, perm}$). This results in the same setting value as for the first value of the user-defined characteristic curve.

Parameter: Threshold thermal warn.

- Recommended setting value (_:104) **Threshold thermal warn.** = 90 %

If the first value of the user-defined characteristic curve is 1.1 of the rated current, the default setting can be left. The thermal memory results for 83 % at continuously flowing rated object current.

If the first value of the user-defined characteristic curve is 1.05 of the rated object current, the thermal memory for rated current is already 91 % filled. Increase the **Threshold thermal warn.** to 95 %.

Parameter: Dropout threshold operate

- Recommended setting value (_:105) **Dropout threshold operate** = 90 %

The **Dropout threshold operate** parameter is used to drop out pickup and tripping when the value drops below this threshold. A setting on the order of magnitude of the warning threshold is recommended. You can select a lower setting value for special applications, desired additional cooling or longer blocking of closing.

Note that the calculation of the operational measured value **Time until close** refers to this value.

Parameter: Emerg. start T overtravel

- Default setting (`_:112`) **Emerg. start T overtravel** = 300 s

The **Emerg. start T overtravel** parameter is used to set the time for which blocking of the tripping has to remain active after an outgoing binary input signal **>Emergency start**. With an outgoing input signal, the load on the protected object is removed. The emergency start T-overtravel must be set long enough to allow the thermal memory to fall below the dropout threshold after cooling. Select a time on the order of magnitude of the **Cooling time constant**. In the example, 5 min (300 s) have been assumed.

Parameter: Imax thermal

- Recommended setting value (`_:107`) **Imax thermal** = 2.5 A at $I_{rated} = 1$ A

The **Imax thermal** parameter allows you to set the threshold current for the **Behav. at I > Imax therm.** parameter. If you calculate with relatively long start times for motors (longer than 25 s), the current limiting must be reduced to $2 I_{rated, obj}$.

Parameter: Imin cooling

- Recommended setting value (`_:108`) **Imin cooling** = 0.5 A at $I_{rated} = 1$ A

When defining the minimum current **Imin cooling**, you can use the no-load current for orientation. If no data is available, set $0.5 I_{rated, obj}$. If the current falls below this value, the internal thermal time constant τ automatically switches to the internal cooling time constant with the **Cool-down factor Tau** parameter.

Parameter: Storage of thermal replica

- Recommended setting value (`_:113`) **Storage of thermal replica** = no

If a continuous auxiliary voltage for the bay units is ensured, the default setting can be retained.

Parameter: Behav. at I > Imax therm.

- Recommended setting value (`_:114`) **Behav. at I > Imax therm.** = *current limiting*

The **Behav. at I > Imax therm.** parameter is used to select the process by which the function reacts to short-circuit currents. To prevent premature tripping of the overload protection at low time constants, high preloading and high short-circuit currents, the thermal replica can be modified. As overcurrent due to a starting of the motor also leads to a certain heating of the stator winding, limiting the input current is recommended for machines.

Parameter Value	Description
<i>current limiting</i>	The input currents are limited to the value set in the Imax thermal parameter. If the measured current exceeds the set current value, the limited current value is supplied to the thermal replica. An advisable current threshold is approx. 2 to $2.5 I_{rated, obj}$.
<i>freeze therm. rep.</i>	If input currents exceed the Imax thermal parameter, the thermal replica will be frozen for the time the parameter is exceeded.

Parameter: Curve based on preload

- Default value (`_:101`) **Curve based on preload** = 100 %

The **Curve based on preload** parameter is used for a certain load case. In most cases, it applies for an operation under rated conditions. For that, it is assumed that rated current is flowing permanently. This is referred to as warm condition. In this case, the default setting 100 % is applied.

Thus, the thermal behavior is also correct for different preloads.

For cases without preload or cold condition, set the parameter to 0 %.

Parameter: Cool-down factor Tau

- Default value (`_:108`) **Cool-down factor Tau = 7.0**

If the current becomes lower than the setting value of the **Imin cooling** parameter, you can set the **Cool-down factor Tau** parameter to calculate the internal cooling time constant.

Parameter: Operate char. curve

- Default value **Operate char. curve = 1.1 p.u., 600.00 s**

With the **Operate char. curve** parameter, you define the characteristic curve in a tabular form with ordered normalized current values and associated normalized time values.

When setting the parameter, consider the following:

- Set the current value as per-unit value with the rated current of the protected object as reference.
- Set the time value in seconds.
- Enter the values in continuous order.

EXAMPLE

With the following 12 points, you can get a user-defined characteristic curve as shown in the following figure.

Table 6-14 User-Defined Points

I / I_{obj}	t (s)
1.16	120.00
1.21	96.00
1.25	76.00
1.28	62.00
1.35	48.00
1.42	37.50
1.48	33.50
1.58	27.50
1.84	20.50
2.09	14.00
2.25	9.85
8.00	9.85

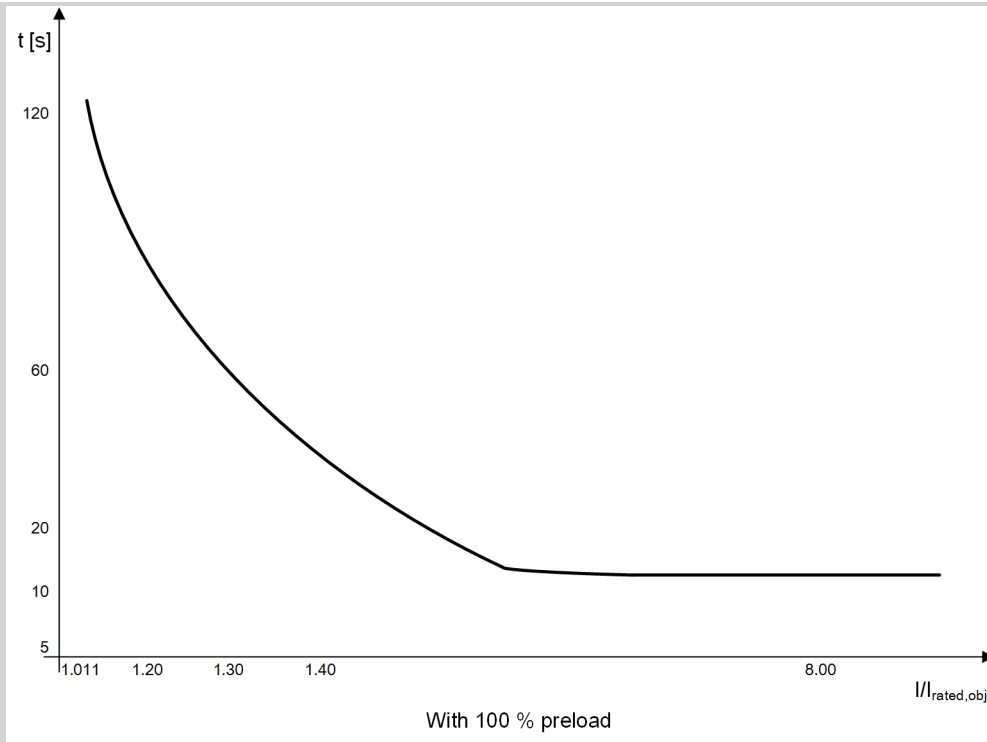

[dw_TOLP_predefined curve_2_en_US]

Figure 6-169 Example of the User-Defined Characteristic Curve

6.20.5 Settings

Addr.	Parameter	C	Setting Options	Default Setting
General				
_:1	User charact. #:Mode		<ul style="list-style-type: none"> • off • on • test 	off
_:2	User charact. #:Operate & fkt.rec. blocked		<ul style="list-style-type: none"> • no • yes 	no
_:102	User charact. #:Threshold current warning	1 A @ 100 I _{rated}	0.030 A to 35.000 A	1.000 A
		5 A @ 100 I _{rated}	0.15 A to 175.00 A	5.00 A
		1 A @ 50 I _{rated}	0.030 A to 35.000 A	1.000 A
		5 A @ 50 I _{rated}	0.15 A to 175.00 A	5.00 A
		1 A @ 1.6 I _{rated}	0.001 A to 1.600 A	1.000 A
		5 A @ 1.6 I _{rated}	0.005 A to 8.000 A	5.000 A
_:104	User charact. #:Threshold thermal warn.		50 % to 100 %	90 %
_:105	User charact. #:Dropout threshold operate		50 % to 99 %	90 %
_:106	User charact. #:Emerg. start T overtravel		0 s to 15000 s	300 s

Addr.	Parameter	C	Setting Options	Default Setting
_:107	User charact.#:Imin cooling	1 A @ 100 Irated	0.000 A to 10.000 A	0.500 A
		5 A @ 100 Irated	0.00 A to 50.00 A	2.50 A
		1 A @ 50 Irated	0.000 A to 10.000 A	0.500 A
		5 A @ 50 Irated	0.00 A to 50.00 A	2.50 A
		1 A @ 1.6 Irated	0.000 A to 1.600 A	0.500 A
		5 A @ 1.6 Irated	0.000 A to 8.000 A	2.500 A
_:108	User charact.#:Cool-down factor Tau		0.5 to 20.0	7.0
_:109	User charact.#:Storage of thermal replica		<ul style="list-style-type: none"> no yes 	no
_:110	User charact.#:Imax thermal	1 A @ 100 Irated	0.030 A to 35.000 A	2.500 A
		5 A @ 100 Irated	0.15 A to 175.00 A	12.50 A
		1 A @ 50 Irated	0.030 A to 35.000 A	2.500 A
		5 A @ 50 Irated	0.15 A to 175.00 A	12.50 A
		1 A @ 1.6 Irated	0.001 A to 1.600 A	2.500 A
		5 A @ 1.6 Irated	0.005 A to 8.000 A	12.500 A
_:111	User charact.#:Behav. at I> Imax therm.		<ul style="list-style-type: none"> current limiting freeze therm. rep. 	current limiting
_:112	User charact.#:Operate char. curve		Setting options depend on configuration	1.1 p.u., 600 s
_:101	User charact.#:Curve based on preload		0 % to 100 %	100 %

6.20.6 Information List

No.	Information	Data Class (Type)	Type
<i>User charact. #</i>			
_:81	User charact.#:>Block stage	SPS	I
_:500	User charact.#:>Reset thermal replica	SPS	I
_:501	User charact.#:>Emergency start	SPS	I
_:51	User charact.#:Mode (controllable)	ENC	C
_:54	User charact.#:Inactive	SPS	O
_:52	User charact.#:Behavior	ENS	O
_:53	User charact.#:Health	ENS	O
_:300	User charact.#:Current warning	SPS	O
_:301	User charact.#:Thermal warning	SPS	O
_:302	User charact.#:Block close	SPS	O
_:55	User charact.#:Pickup	ACD	O
_:303	User charact.#:Operate alarm only	ACT	O
_:57	User charact.#:Operate	ACT	O
_:304	User charact.#:Time until close	MV	O
_:305	User charact.#:Time until trip	MV	O
_:306	User charact.#:Overload phase A	MV	O
_:307	User charact.#:Overload phase B	MV	O
_:308	User charact.#:Overload phase C	MV	O
_:309	User charact.#:Overload maximum	MV	O

No.	Information	Data Class (Type)	Type
_:310	User charact. #: Equival. current phs A	MV	O
_:311	User charact. #: Equival. current phs B	MV	O
_:312	User charact. #: Equival. current phs C	MV	O
_:313	User charact. #: Equival. current max.	MV	O

6.21 Thermal Overload Protection, 1-Phase

6.21.1 Overview of Functions

The **Thermal overload protection 1-phase** function (ANSI 49) is used to:

- Protect the equipment (reactors or resistors in the neutral point of a transformer) from thermal overload

6.21.2 Structure of the Function

The **Thermal overload protection 1-phase** function is used in 1-phase protection function groups with current measurement.

The **Thermal overload protection, 1-phase** function is steplessly preconfigured.

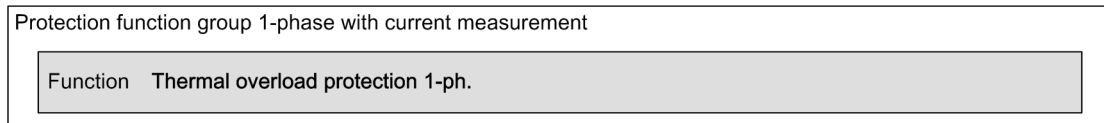

[dw_tolp1p_2_en_US]

Figure 6-170 Structure/Embedding of the Function

6.21.3 Function Description

Logic

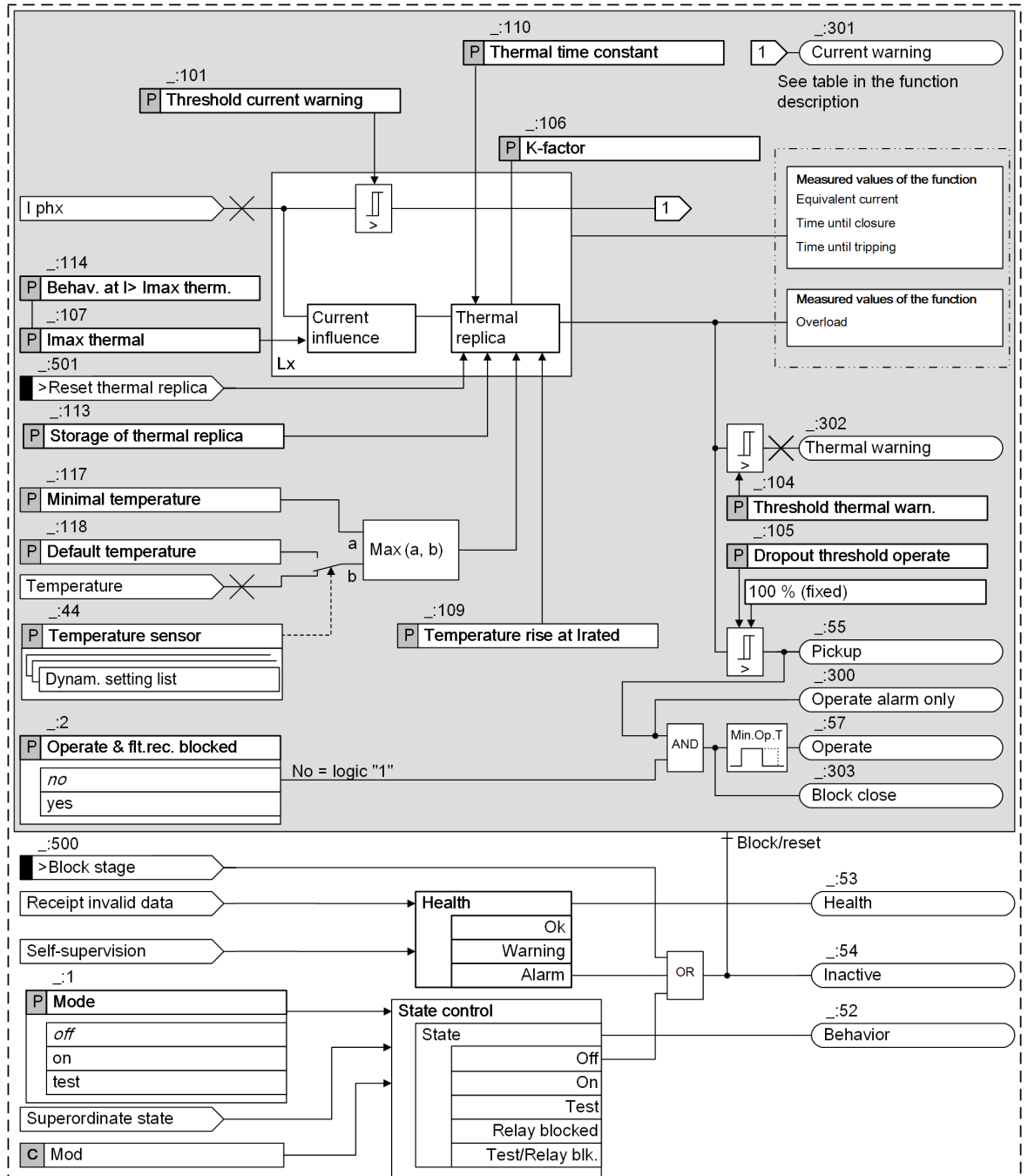

Figure 6-171 Logic Diagram of the Thermal Overload Protection Function

Thermal Replica

The protection function calculates the overtemperature from the current flowing in the protected object (for example, reactor or resistance in the transformer neutral point) on the basis of a thermal single-body model according to the thermal differential equation with

$$I_{p.u.}^2 = \tau_{th} \frac{d\Theta}{dt} + \Theta - \Theta_V$$

[fo_diffgl, 2, en_US]

With the following standardization:

$$I_{p.u.} = \frac{I}{I_{max}} = \frac{I}{k \cdot I_{rated,obj.}} \quad \Theta = \frac{\vartheta}{\vartheta_{max}} = \frac{\vartheta}{k^2 \cdot \Delta\vartheta_{rated,obj.}}$$

$$\tau_{th} = R_{th} \cdot C_{th} \quad \Theta_V = \frac{\vartheta_{Amb} - 40 \text{ °C}}{\vartheta_{max}} = \frac{\vartheta_{Amb} - 40 \text{ °C}}{k^2 \cdot \Delta\vartheta_{rated,obj.}}$$

[fo_normie, 2, en_US]

Θ	Current overtemperature, in relation to the final temperature at a maximum permissible current $k I_{rated,obj}$
Θ_V	Standardized ambient temperature, where ϑ_{Amb} describes the coupled ambient temperature. The coupled ambient temperature ϑ_{Amb} can be the measured ambient temperature or the ambient temperature preset using the Default temperature parameter.
$\Delta \vartheta_{rated,obj}$	Overtemperature of the protected object set at rated current
τ_{th}	Thermal time constant (temperature rise/cooling) of the protected object
k	This factor indicates the maximum continuous permissible phase current. The factor refers to the rated current of the protected object ($k = I_{max}/I_{rated,obj}$)
$I_{rated,obj}$	Rated current of the protected object

At the same time, $I_{rated,obj}$ is the rated current of the protected object.

In a steady state, the solution to the thermal differential equation is an e-function whose asymptote represents the final overtemperature Θ_{end} . The time constant τ_{th} determines the rise. After reaching an initial adjustable overtemperature threshold Θ_{warn} (**Threshold thermal warn.**), a warning indication is given.

If the overtemperature limit Θ_{off} (tripping overtemperature) is exceeded, an operate indication is immediately issued and the equipment disconnected from the power supply. This threshold is specified at 100 % and corresponds to the final temperature set at a flowing permissible continuous current (I_{max}).

Figure 6-172 shows the temperature rise at different overload currents and the supervision thresholds.

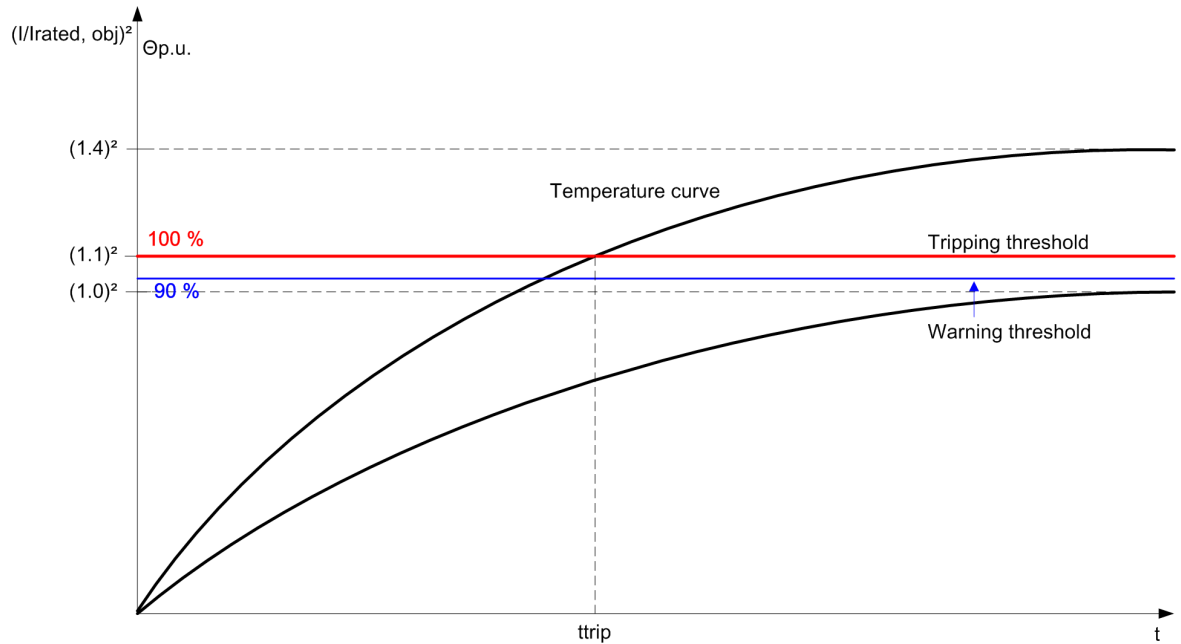

[dw_temp_ve, 1, en_US]

Figure 6-172 Temperature History for Different Overload Currents (κ -factor = 1.1)

The current overtemperature can be obtained from the operational measured values. It is shown in percent. An indication of 100 % means that the thermal tripping threshold has been reached.

The analysis of the RMS value of the current over a broad frequency band also includes the harmonic components. These harmonic components contribute to the temperature rise of the equipment.

Operate Curve

If the ambient temperature is not measured and set to 40°C, you get the following operate curve:

$$t = \tau_{th} \cdot \ln \frac{\left(\frac{I}{k \cdot I_{rated,obj}} \right)^2 - \left(\frac{I_{preload}}{k \cdot I_{rated,obj}} \right)^2}{\left(\frac{I}{k \cdot I_{rated,obj}} \right)^2 - 1}$$

[fo_auslos, 1, en_US]

t	Operate time
τ_{th}	Time constant
I	Measured load current
$I_{preload}$	Preload current
k	Setting factor according to VDE 0435 part 3011 or IEC 60255-149 (K factor)
$I_{rated,obj}$	Rated current of the protected object

Ambient Temperature

This function can take the ambient temperature into consideration. The reference temperature of the thermal model is 40 °C. If the ambient temperature drops below the reference temperature, the thermal limit increases. The equipment can be stressed more. If the ambient temperature is higher, the conditions change.

The **Default temperature** parameter can be used to fix or measure the ambient temperature. The **Minimal temperature** parameter limits the coupled ambient temperature. If the measured ambient temperature is lower than the minimum temperature, the minimum temperature is processed in the thermal model.

The ambient temperature refers to the overtemperature of the protected object, which sets itself at the rated current (parameter **Temperature rise at Irated**).

The measured ambient temperature is measured by an external RTD unit (RTD = Resistance Temperature Detector) and provided by the functions **RTD unit Ether**. or **RTD unit serial** of the function group **Analog unit**. When using the **Temperature sensor** parameter, the respective temperature sensor can be selected. If the temperature measurement is disrupted, for example, due to an open circuit between the device and the RTD unit, the health state of the **Thermal overload protection, 1-phase** function changes to *warning*. In this case, the process continues with either the temperature measured last or the value set under the **Default temperature** parameter, whichever value is the highest.

Current Influence

The thermal replica based on the single-body model applies with limitations to high overcurrent situations (short circuits). To avoid an overfunction of the overload protection, the thermal replica must be influenced for overcurrents (exceeding I_{limit}). You can select between 2 strategies for this:

- Freezing of the thermal memory
- Limitation of the input current for the thermal replica to the set current. The temperature rise is thereby **retarded** at high currents.

Warning Thresholds

The thermal warning threshold issues a warning indication before the tripping threshold (tripping temperature) is reached. In this way, for example, a load can be reduced in sufficient time and a disconnection avoided. At a normal **K-factor** of **1.1**, a thermal memory value of 83 % sets in at continuously flowing rated current.

Apart from the thermal warning threshold, the overload protection also has a current-warning threshold. This current-warning threshold can signal an overload current in sufficient time before the overtemperature value has reached the warning or tripping threshold.

Dropout of Tripping

Once the thermal memory has fallen below the setting value of the **Dropout threshold operate**, the trip command is cancelled upon tripping. In contrast, the current-warning threshold and the thermal warning threshold are reduced at a fixed dropout threshold (see technical data).

Behavior in the Event of Auxiliary-Voltage Failure

The behavior of the thermal replica can be controlled upon auxiliary-voltage failure via the **Storage of thermal replica** parameter. You can save the thermal state for a down time of 500 min. If the supply voltage returns, the thermal replica continues to function with the saved thermal state.

If the thermal replica is not saved, it will be reset to 0 upon failure of the auxiliary voltage.

Resetting the Thermal Map

You can reset the thermal memory via the binary input indication **>Reset thermal replica**. The thermal memory will then have a 0 value. A reparameterization will also lead to resetting the thermal memory.

Blocking the Function

Blocking will cause a picked up function to be reset. The function can be blocked externally or internally by the binary input signal **>Block stage**.

All indications then drop out and the thermal memory is set to the value 0.

Blocking Closure

The signal **Block close** can be used to prevent closure of the protected object at a high thermal load. The signal is set if the tripping overtemperature is exceeded, and cancelled if the temperature falls below the dropout threshold.

Functional Measured Values

Measured Value	Description
(_:310) Equival. current	Besides the thermal measured values in percent, the equivalent current is also issued as a thermal current-measured value (A or kA). The current equivalent is the primary current, which corresponds to the thermal measured value in percent, assuming steady-state conditions.
(_:304) Time until close	The Time until close is the expected time until it is possible for the protected object for reclosure. The calculation of this value is based on the assumption of constant currents. The thermal replica has then fallen below the setting value of the dropout threshold.
(_:305) Time until trip	The Time until trip is the expected time until tripping (100 % value exceeded) occurs. The calculation of this value is based on the assumption of constant currents.
(_:306) Overload	The value Overload indicates the current temperature of the protected object in percent. Tripping occurs if 100 % is exceeded.

6.21.4 Application and Setting Notes

Parameter: Threshold current warning

- Recommended setting value (_:101) **Threshold current warning** = 1.1 A for $I_{\text{rated}} = 1 \text{ A}$

Set the threshold to the maximum permissible continuous current ($I_{\text{max, perm}}$). This results in the same setting value as for **K-factor**.

Parameter: Threshold thermal warn.

- Recommended setting value (_:104) **Threshold thermal warn.** = 90 %

The default setting can be left at a **K-factor** of 1.1, because the thermal memory sets itself to 83 % at continuously flowing rated current. The calculation uses the rule of three: 100 % corresponds to $(\text{K-factor})^2$ and x % corresponds to 1^2 .

$$\frac{\Theta}{\Theta_{\text{off}}} = \frac{100 \%}{k^2} = 83 \%$$

[to_warnsc, 2, en_US]

At a **K-factor** of 1.05, the thermal memory for rated current is 91 % filled. Increase the **Threshold thermal warn.** to 95 %.

Parameter: Dropout threshold operate

- Recommended setting value (_:105) **Dropout threshold operate** = 90 %

The **Dropout threshold operate** parameter is used to cancel pickup and tripping when the value drops below this threshold. A setting on the order of magnitude of the warning threshold is recommended. You can select a lower setting value for special applications, desired additional cooling, or longer blocking of switching on.

The calculation of the operational measured value **Time until close** refers to this value.

Parameter: K-factor

- Recommended setting value (_:106) **K-factor** = 1.1

The **K-factor** parameter is used to describe the limiting value for the maximum permissible continuous load. The rated current $I_{\text{rated, obj}}$ of the protected object (for example, resistance) is the basic current for overload sensing.

You can determine **K-factor** on the basis of the thermally permissible continuous current $I_{\text{max, perm}}$:

$$K\text{-factor} = \frac{I_{\text{max,perm.}}}{I_{\text{rated,obj.}}}$$

[fo_tolp_kf_2_en_US]



NOTE

The thermally permissible continuous current for the protected object is known from relevant tables or from the specifications of the manufacturer!

Siemens recommends using the default value as it is a typical value for many applications.

Parameter: Thermal time constant

- Default value (_:110) **Thermal time constant = 900 s (15 min)**

The **Thermal time constant** parameter is used to define the operate curve of the stage. If no time constant is given, you can derive it from other values.

EXAMPLE

Protection of a current-limiting resistance

Rated current of the resistance: $I_{\text{rated}} = 100 \text{ A}$

Values for the overload capability:

- $1.1 I_{\text{rated}}$ permanent (k-Factor = 1.1; $k = 1.1$)
- $1.5 I_{\text{rated}}$ for 20 s for charge by cold

The following time constant results from these assumed values:

$$\tau_{\text{th}} = t \times \left[\ln \frac{\left(\frac{I}{k \times I_{\text{rated,obj}}} \right)^2}{\left(\frac{I}{k \times I_{\text{rated,obj}}} \right)^2 - 1} \right]^{-1} = 20 \text{ s} \times \left[\ln \frac{\left(\frac{1.5}{1.1} \right)^2}{\left(\frac{1.5}{1.1} \right)^2 - 1} \right]^{-1} = 20 \text{ s} \times \left[\ln \frac{1.86}{0.86} \right]^{-1} \approx 26 \text{ s}$$

[fo_time_constance_1_en_US]

For **Thermal time constant**, set 26 s.

The following time-dependent characteristic results from the data. In case of a current increase to $1.5 I_{\text{rated}}$, the tripping occurs in 20 s.

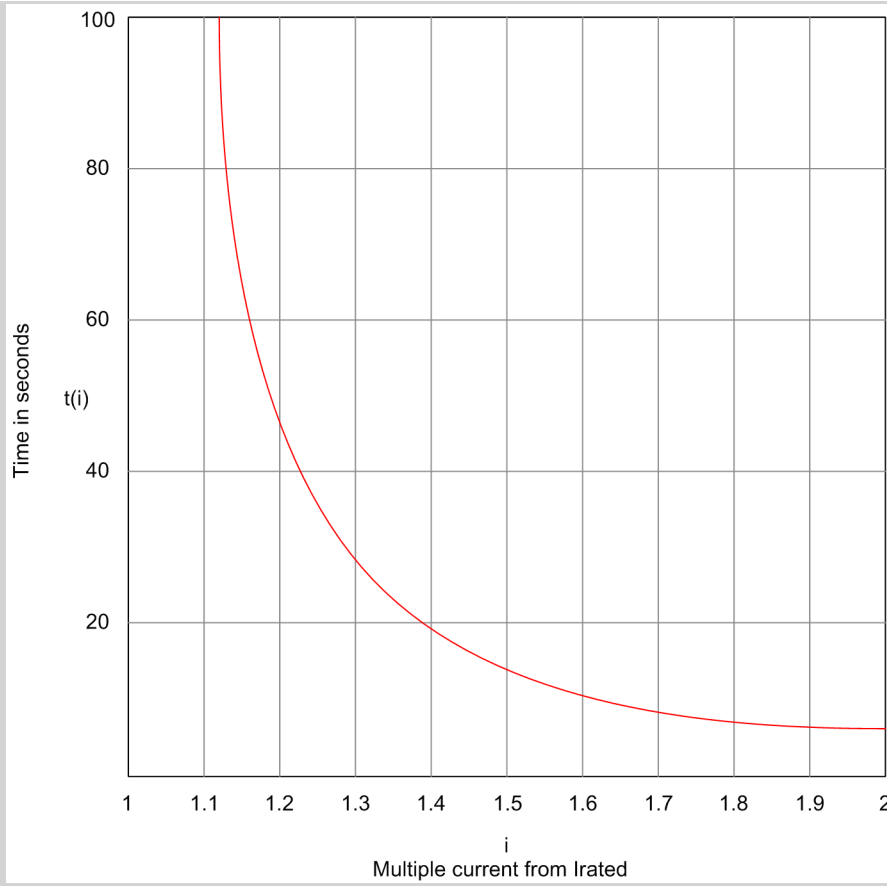

[dw_time-dependent, 1, en_US]

Parameter: I_{max thermal}

- Recommended setting value (**_:107**) **I_{max thermal} = 2.5 A** for $I_{rated} = 1 A$

The **I_{max thermal}** parameter allows you to set the threshold current for the **Behav. at I > I_{max thermal}** parameter. The selected current threshold of $2.5 I_{rated, obj}$ is a practicable value.

Parameter: Temperature rise at Irated

- Default setting (**_:109**) **Temperature rise at Irated = 70 K**



NOTE

For an application as a 1-phase overload protection, the ambient temperature measured via the temperature sensor is not taken into account. Therefore, the setting has no influence. You can keep the default setting. If you take into account the temperature, note the following descriptions.

Set the overtemperature as the value that is the result if the equipment is continuously operated with the rated current and at an ambient temperature of 40 °C. Here, the rated current refers to the protected object. You can find the temperature value in the Technical data of the equipment or you can measure the value. If you use a temperature sensor when measuring at the rated current, deduct the actual ambient temperature or the coolant temperature from the measured value.

When selecting the setting value, you can also use the specified temperature class for orientation. Usually, you will find the overtemperature expressed in Kelvin (K), which can be accepted as is. If the absolute temperature is given, the ambient temperature must be deducted. As a rule, this is 40 °C.

The overtemperature (**Δ_{max}**) at maximum permissible current and the **Temperature rise at Irated (Δ_{rated, obj.})** can be converted by using the following formula:

$$k^2 = \left(\frac{\Delta\theta_{\max}}{\Delta\theta_{\text{rated, obj.}}} \right)$$

[fo_ueb_for_rated, 3, en_US]

EXAMPLE:

Temperature class **B** for continuous operation: permissible overtemperature = 80 K
 From this, a temperature for I_{rated} of 120 °C (80 K + 40 °C) can be derived when using a measuring element for the measurement.

Temperature class **F** as thermal limiting value: permissible overtemperature = 105 K.

From this, a maximum temperature of 145 °C (105 K + 40 °C) derives.

From these values, the magnitude of the K factor can also be derived.

$$k^2 = \frac{\Delta\theta_{\max, \text{Obj.}}}{\Delta\theta_{\text{rated, Obj.}}} = \frac{105 \text{ K}}{80 \text{ K}} = 1.31 \quad \rightarrow \quad k = 1.146$$

[fo_bsp_kfaktor, 3, en_US]

If selecting a setting value of 1.1 for the **K-factor**, your selection can be considered as conservative.

Parameter: Storage of thermal replica

- Recommended setting value (**_:113**) **Storage of thermal replica = no**

If a continuous auxiliary voltage of the bay units is ensured, the default setting can be retained.

Parameter: Behav. at I > I_{max} therm.

- Recommended setting value (**_:114**) **Behav. at I > I_{max} therm. = current limiting**

The **Behav. at I > I_{max} therm.** parameter is used to select the process by which the function reacts to short-circuit currents. To prevent premature tripping of the overload protection at low time constants, high preloading and high short-circuit currents, the thermal replica can be modified.

The default setting has been selected compatible with SIPROTEC 4 devices. If you wish to take further temperature rise into consideration, the **current limiting** procedure is recommended.

Parameter Value	Description
current limiting	The input current is limited to the value set in the I_{max} therm parameter. If the measured current exceeds the set current value, the limited current value is supplied to the thermal replica. An advisable current threshold is approx. 2 to 2.5 $I_{\text{rated, obj.}}$
freeze therm. rep.	If the input current exceeds the I_{max} therm parameter, the thermal replica will be frozen for the time the parameter is exceeded. This parameter value is provided to enable compatibility with older products!

Parameter: Temperature sensor

- Default setting (**_:44**) **Temperature sensor = none**

Use the **Temperature sensor** parameter to determine which temperature sensor to use to detect the ambient temperature.

A temperature sensor is used to measure the ambient temperature of the protected object and to feed it to the device via an RTD unit (RTD = Resistance Temperature Detector). The function **Thermal overload protection** receives the measured temperature value via the functions **RTD unit Ether.** or **RTD unit Serial** from the function group **Analog units**.

Parameter: Default temperature

- Recommended setting value (**_:118**) **Default temperature = 40 °C**

Under the following conditions, the **Default temperature** will be set as ambient temperature:

- A temperature sensor for measuring the ambient temperature is not connected.
- The temperature measurement is interrupted and the measured temperature value is less than the **Default temperature**.

Siemens recommends using the default setting.

Parameter: Minimal temperature

- Default setting (**_:117**) **Minimal temperature** = -20 °C

If the measured ambient temperature drops below the preset value, the set value will be assumed as the ambient temperature. If the overload protection works with a prespecified outside temperature, and this temperature drops below the value set in the **Minimal temperature** parameter, the **Minimal temperature** can also be used.

6.21.5 Settings

Addr.	Parameter	C	Setting Options	Default Setting
49 Th.overl. #				
_:1	49 Th.overl. #:Mode		<ul style="list-style-type: none"> • off • on • test 	off
_:2	49 Th.overl. #:Operate &flt.rec. blocked		<ul style="list-style-type: none"> • no • yes 	no
_:101	49 Th.overl. #:Threshold current warning	1 A @ 100 Irated	0.030 A to 35.000 A	1.000 A
		5 A @ 100 Irated	0.15 A to 175.00 A	5.00 A
		1 A @ 50 Irated	0.030 A to 35.000 A	1.000 A
		5 A @ 50 Irated	0.15 A to 175.00 A	5.00 A
		1 A @ 1.6 Irated	0.001 A to 1.600 A	1.000 A
		5 A @ 1.6 Irated	0.005 A to 8.000 A	5.000 A
_:104	49 Th.overl. #:Threshold thermal warn.		50 % to 100 %	90 %
_:105	49 Th.overl. #:Dropout threshold operate		50 % to 99 %	90 %
_:106	49 Th.overl. #:K-factor		0.10 to 4.00	1.10
_:110	49 Th.overl. #:Thermal time constant		10 s to 60000 s	900 s
_:107	49 Th.overl. #:Imax thermal	1 A @ 100 Irated	0.030 A to 10.000 A	2.500 A
		5 A @ 100 Irated	0.15 A to 50.00 A	12.50 A
		1 A @ 50 Irated	0.030 A to 10.000 A	2.500 A
		5 A @ 50 Irated	0.15 A to 50.00 A	12.50 A
		1 A @ 1.6 Irated	0.001 A to 1.600 A	2.500 A
		5 A @ 1.6 Irated	0.005 A to 8.000 A	12.500 A
_:109	49 Th.overl. #:Temperature rise at Irated		40 K to 200 K	70 K
_:113	49 Th.overl. #:Storage of thermal replica		<ul style="list-style-type: none"> • no • yes 	no
_:114	49 Th.overl. #:Behav. at l> Imax therm.		<ul style="list-style-type: none"> • current limiting • freeze therm. rep. 	current limiting

Addr.	Parameter	C	Setting Options	Default Setting
_:118	49 Th.overl. #:Default temperature		-55°C to 55°C	40°C
_:117	49 Th.overl. #:Minimal temperature		-55°C to 40°C	-20°C
_:44	49 Th.overl. #:Temperature sensor		Setting options depend on configuration	

6.21.6 Information List

No.	Information	Data Class (Type)	Type
49 Th.overl. #			
_:500	49 Th.overl. #:>Block stage	SPS	I
_:501	49 Th.overl. #:>Reset thermal replica	SPS	I
_:51	49 Th.overl. #:Mode (controllable)	ENC	C
_:54	49 Th.overl. #:Inactive	SPS	O
_:52	49 Th.overl. #:Behavior	ENS	O
_:53	49 Th.overl. #:Health	ENS	O
_:301	49 Th.overl. #:Current warning	SPS	O
_:302	49 Th.overl. #:Thermal warning	SPS	O
_:303	49 Th.overl. #:Block close	SPS	O
_:55	49 Th.overl. #:Pickup	ACD	O
_:300	49 Th.overl. #:Operate alarm only	ACT	O
_:57	49 Th.overl. #:Operate	ACT	O
_:304	49 Th.overl. #:Time until close	MV	O
_:305	49 Th.overl. #:Time until trip	MV	O
_:306	49 Th.overl. #:Overload	MV	O
_:310	49 Th.overl. #:Equival. current	MV	O

6.22 Unbalanced-Load Protection

6.22.1 Overview of Functions

The **Unbalanced-load protection** function detects unbalanced loads or line interruptions of electrical machines (generators and motors). Unbalanced loads create a counter-rotating magnetic field at double frequency in the rotor. The skin effect leads to local overheating on the surface of the rotor bars in the transition between the slot wedges and the winding bundles. Another effect of unbalanced loads is the overheating of the damper winding.

6.22.2 Structure of the Function

The **Unbalanced-load protection** function is used in the protection function group. The **Unbalanced-load protection** function is preconfigured with 1 stage. A maximum of 2 stages can operate simultaneously in the function.

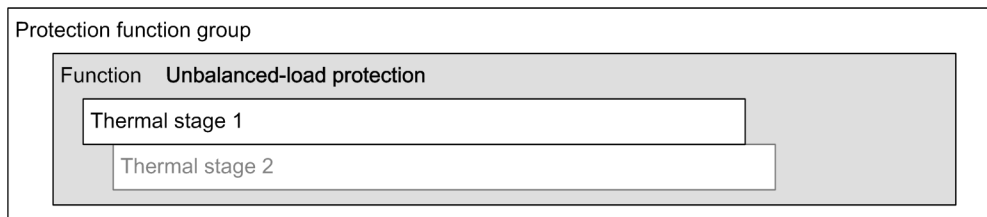

[dw_unbla, 1, en_US]

Figure 6-173 Structure/Embedding of the Function

6.22.3 Function Description

Logic of the Stage

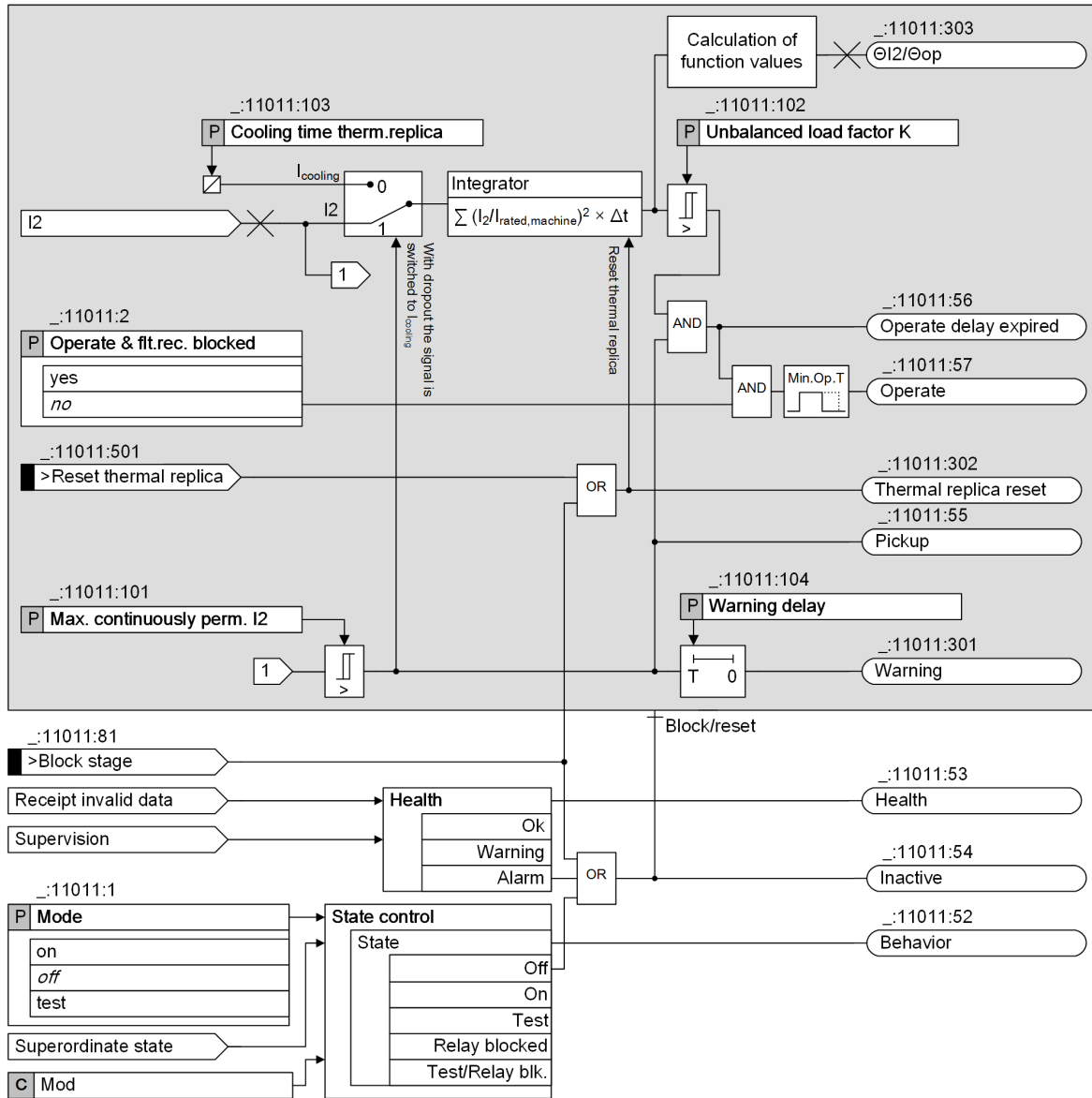

[io_unbala-load, 3, en_US]

Figure 6-174 Logic Diagram of the Unbalanced-Load Protection Function

Method of Measurement

The stage uses the negative-sequence current I_2 as a measurand. The negative-sequence current is calculated from the measured 3-phase currents according to the defining equation of symmetrical components.

Warning Stage

If the negative-sequence current I_2 continuously exceeds the parameter **Max. continuously perm. I_2** , the **warning** indication is given after expiry of a set time **Warning delay**.

Thermal Characteristic Stage

The machine manufacturers indicate the permissible unbalanced load using the following formula:

$$t_{I_2 \text{ Perm}} = \frac{K}{(I_2 / I_{\text{rated, machine}})^2}$$

[fo_rbanl, 1, en_US]

With:

$t_{I_2 \text{ Perm}}$	Permissible time of the negative-sequence current
K	Unbalanced-load factor of the machine (parameter Unbalanced load factor K)
$I_2 / I_{\text{rated, machine}}$	Actual unbalanced-load current as a per unit value (negative-sequence current/rated current of the machine)

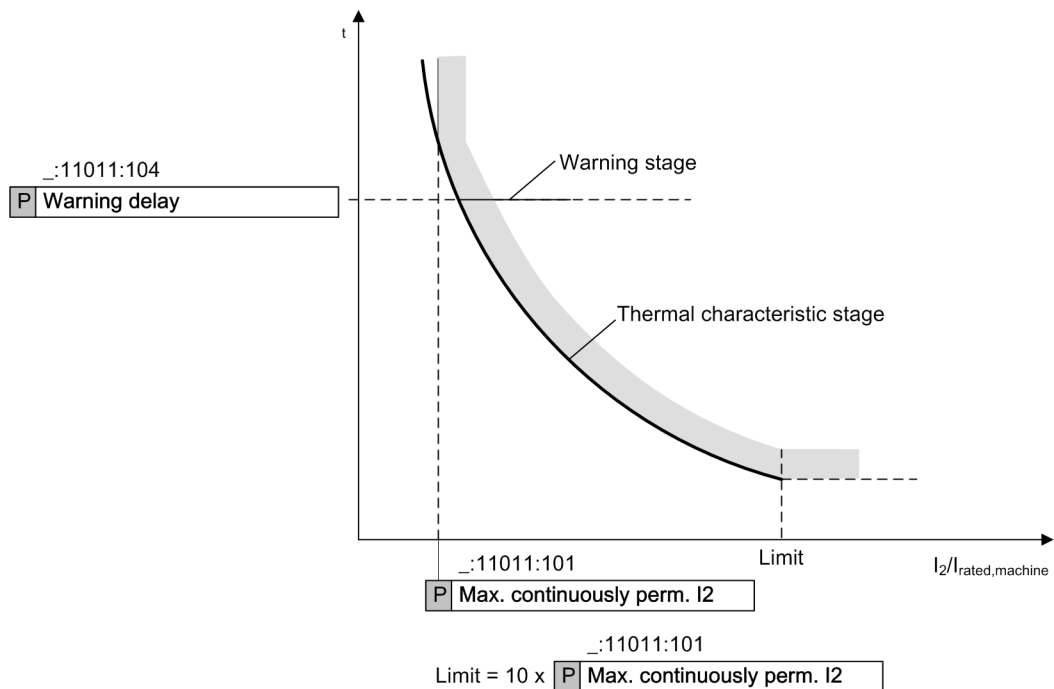

[dw_umbalo, 2, en_US]

Figure 6-175 Operate Curve of the Unbalanced-Load Protection

The parameter **Unbalanced load factor K** depends on the machine. It also represents the time in seconds during which the machine can be loaded with a 100 % unbalanced load. This factor is typical in a range from 5 s to 40 s. The heating of the protected object starts to calculate as soon as the negative-sequence current I_2 exceeds the parameter **Max. continuously perm. I2**. The operate time is calculated from the flowing negative-sequence current I_2 with an integrating method of measurement depending on the thermal characteristic. As soon as the integrate result reaches the parameter **Unbalanced load factor K**, the thermal characteristic stage operates.

Limitation of Operate Curve

To avoid an overfunction of the thermal characteristic stage in the situation of unbalanced short circuits (for example, 2-phase short circuit), the input current I_2 is restricted to an upper limit. The limiting value is 10 times of **Max. continuously perm. I2**. If I_2 exceeds the limit, the operate time of the function is constant.

In addition, the thermal memory is limited to 200 % of **Unbalanced load factor K**. The limitation avoids a too long cooling after a delayed short-circuit tripping (for example, of external power-system faults).

Cooling Time Thermal Replica

The thermal replica starts to cool down as soon as the negative-sequence current I_2 is lower than **Max. continuously perm. I2**. The thermal replica decreases according to the parameter **Cooling time therm.replica**. The parameter **Cooling time therm.replica** is the time required by the thermal replica to cool down from 100 % to 0 %. If the parameter **Cooling time therm.replica** is set to 0, the thermal replica is reset immediately.

The parameter **Cooling time therm.replica** depends on the construction type of the machine, especially of the damper winding. Preloading is considered when unbalanced loading occurs again during the cooling time. The protection device thus operates in a shorter time.

Functional Measured Values

The following formula is used to calculate the functional measured value $\Theta I2/\Theta op$:

$$\Theta I2/\Theta op = \frac{\sum_0^t (I_2/I_{rated,machine})^2 \cdot \Delta t}{K} \cdot 100 \%$$

[fo_runbl2, 1, en_US]

With

$\Theta I2/\Theta op$	Functional measured value indicating the thermal replica of the unbalanced load
$\sum_0^t (I_2/I_{rated,machine})^2 \cdot \Delta t$	Integrating method of measurement of the thermal replica of the negative-sequence system
K	Unbalanced-load factor of the machine (parameter Unbalanced load factor K)
$I_2/I_{rated,machine}$	Unbalanced-load as a per unit value (negative-sequence current/rated current of the machine)

If the functional measured value reaches 100 %, the operate of the function is initiated.

6.22.4 Application and Setting Notes

The function is used in the applications of machines. You can get the necessary settings from the technical data of the synchronous generators and motors. The setting example is applied for a generator application.

Parameter: **Max. continuously perm. I2, Warning delay**

- Default setting (`_:11011:101`) **Max. continuously perm. I2 = 10.0 %**
- Default setting (`_:11011:104`) **Warning delay = 15 s**

If the negative-sequence current I_2 exceeds **Max. continuously perm. I2**, the stage picks up and a warning indication is given after the set time delay **Warning delay**.

The parameter **Max. continuously perm. I2** is given in percentage of the rated current of the protected object.

The setting value of the parameter **Max. continuously perm. I2** depends on following parts:

- Design of the machine (salient pole or non-salient pole rotor synchronous machine)
- Cooling system (directly or indirectly cooled)
- Size of the machine

Depending on the standards IEEE C50.12 and IEC 60034-1, the parameter is given in the range between 5 % and 12 %. To set the parameter **Max. continuously perm. I2**, technical data of the machine

is required. The technical data of the machine is provided in the Technical Data Sheet of the machine manufacturer.

EXAMPLE

The following example shows the setting of the parameter **Max. continuously perm. I₂**. The value 10 % is selected in the example.

To avoid issuing the *warning* indication too fast, Siemens recommends a longer delay. Setting the parameter **Warning delay** in the range of 10 s to 20 s is practicable. 15 s is selected in the example.

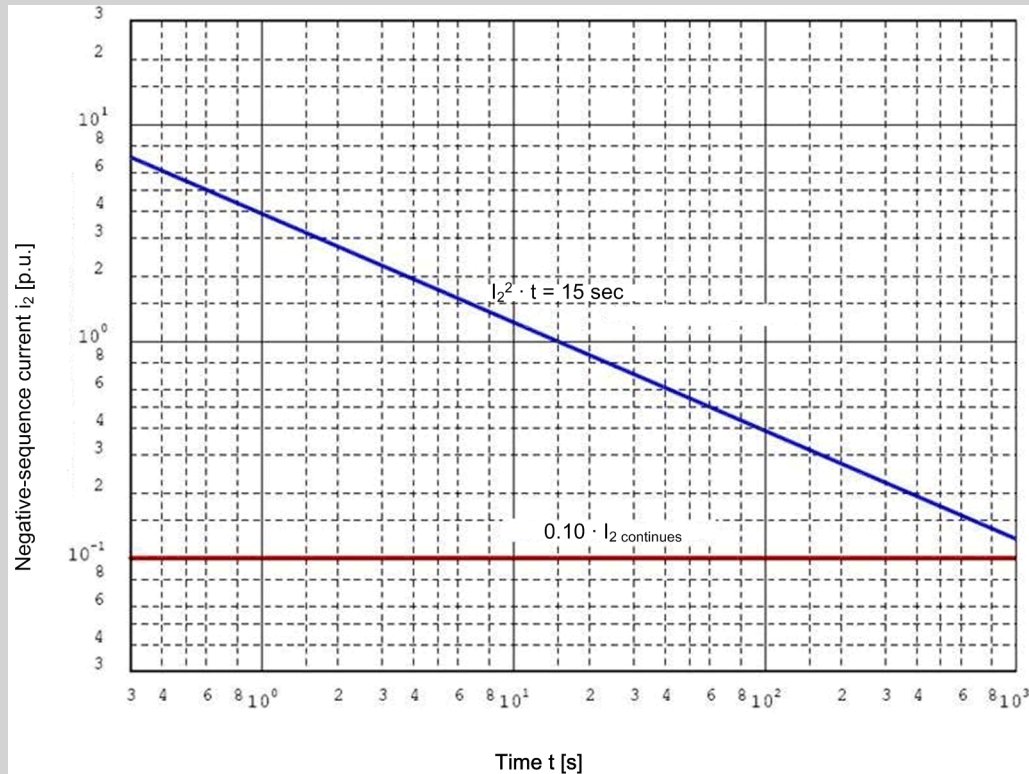

[dw_unbloc_1_en_US]

Figure 6-176 Example of an Unbalanced-Load Characteristic Specified by the Machine Manufacturer

Parameter: Unbalanced load factor K

- Default setting (`_:11011:102`) **Unbalanced load factor K = 15 s**

Unbalanced load factor K can be derived from the unbalanced-load characteristic according to [Figure 6-176](#). You can read the time corresponding to **Unbalanced load factor K** at the point $I_2 / I_{\text{rated, machine}} = 1$. In the example, this is the p.u. value 10⁰ which corresponds to a time of 15 s. As the example shows, the time is often written directly on the characteristic curve.

Parameter: Cooling time therm.replica

- Default setting (`_:11011:103`) **Cooling time therm.replica = 1500 s**

The parameter **Cooling time therm.replica** establishes the time required by the protected object to cool down the thermal replica to the initial value. If the machine manufacturer does not provide this information, the setting value of **Cooling time therm.replica** can be calculated from the setting values of **Unbalanced load factor K** and **Max. continuously perm. I₂** by the formula in the following example.

EXAMPLE

$$\text{Cooling time therm. replica} = \frac{\text{Unbalanced load factor K}}{(\text{Max. continuously perm. } I_2)^2}$$

[fo_rhala2_02_1_en_US]

- Max. continuously perm. I_2 = 10.0 % (corresponds to 0.1)
- Unbalanced load factor K = 15 s
- Cooling time therm. replica = 1500 s

6.22.5 Settings

Addr.	Parameter	C	Setting Options	Default Setting
Therm. Stage 1				
_:11011:1	Therm. Stage 1:Mode		<ul style="list-style-type: none"> • off • on • test 	off
_:11011:2	Therm. Stage 1:Operate &flt.rec. blocked		<ul style="list-style-type: none"> • no • yes 	no
_:11011:101	Therm. Stage 1:Max. continuously perm. I_2		3.0 % to 30.0 %	10.0 %
_:11011:102	Therm. Stage 1:Unbalanced load factor K		1.0 s to 100.0 s	15.0 s
_:11011:103	Therm. Stage 1:Cooling time therm.replica		0 s to 50000 s	1500 s
_:11011:104	Therm. Stage 1:Warning delay		0.0 s to 60.0 s;∞	15.0 s

6.22.6 Information List

No.	Information	Data Class (Type)	Type
Group indicat.			
_:4501:55	Group indicat.:Pickup	ACD	O
_:4501:57	Group indicat.:Operate	ACT	O
_:4501:52	Group indicat.:Behavior	ENS	O
_:4501:53	Group indicat.:Health	ENS	O
Therm. Stage 1			
_:11011:81	Therm. Stage 1:>Block stage	SPS	I
_:11011:501	Therm. Stage 1:>Reset thermal replica	SPS	I
_:11011:51	Therm. Stage 1:Mode (controllable)	ENC	C
_:11011:53	Therm. Stage 1:Health	ENS	O
_:11011:54	Therm. Stage 1:Inactive	SPS	O
_:11011:52	Therm. Stage 1:Behavior	ENS	O
_:11011:302	Therm. Stage 1:Thermal replica reset	SPS	O
_:11011:301	Therm. Stage 1:Warning	ACD	O
_:11011:55	Therm. Stage 1:Pickup	ACD	O
_:11011:56	Therm. Stage 1:Operate delay expired	ACT	O

No.	Information	Data Class (Type)	Type
_:11011:57	Therm. Stage 1:Operate	ACT	O
_:11011:303	Therm. Stage 1:ΘI2/Θop	MV	O

6.23 Overvoltage Protection with 3-Phase Voltage

6.23.1 Overview of Functions

The function **Overvoltage protection with 3-phase voltage** (ANSI 59) is used to:

- Monitor the permissible voltage range
- Protect equipment (for example, plant components, machines, etc.) against damages caused by over-voltage
- Decouple systems (for example, wind power supply)

Abnormally high voltages in power systems are caused by voltage controller failure at the transformer or on long transmission lines under low-load conditions.

When using common-mode reactors in the protected power system, the device must shut down the line quickly if the reactors fail (for example, due to fault clearance). The insulation is endangered by the over-voltage condition.

Overvoltages at capacitor banks can be caused by resonances with line or transformer inductances.

In power plants increased voltage levels can be due to one of these factors:

- Incorrect operation when controlling the excitation system manually
- Failure of the automatic voltage controller
- After full load shedding of a generator
- Generators which are disconnected from the network or in island mode

6.23.2 Structure of the Function

The **Overvoltage protection with 3-phase voltage** function is used in protection function groups with voltage measurement.

The **Overvoltage protection with 3-phase voltage** function comes factory-set with 2 **Definite-time over-voltage protection** stages. In this function, the following stages can operate simultaneously:

- 3 stages **Definite-time overvoltage protection**
- 2 stages **Inverse-time overvoltage protection**

Stages that are not preconfigured are shown in gray in the following figure.

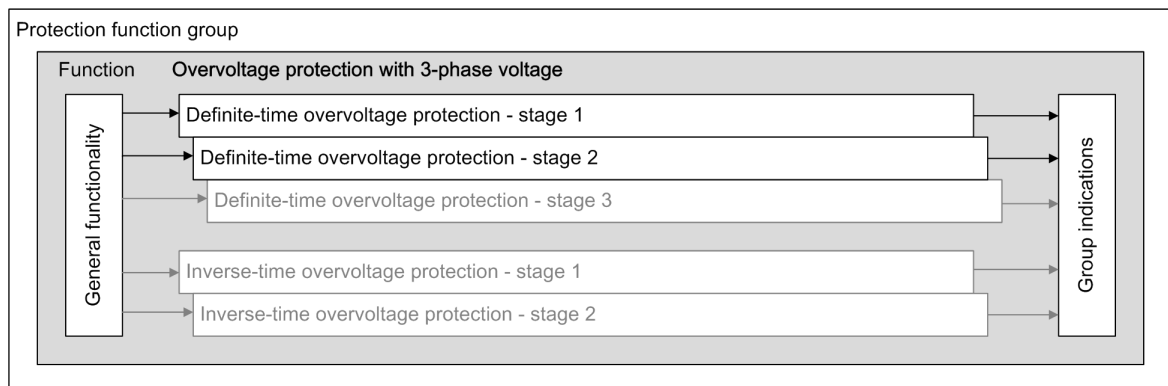

[dw_3-phase_ovp_5_en_US]

Figure 6-177 Structure/Embedding of the Function

6.23.3 Stage with Definite-Time Characteristic Curve

6.23.3.1 Description

Logic of the Stage

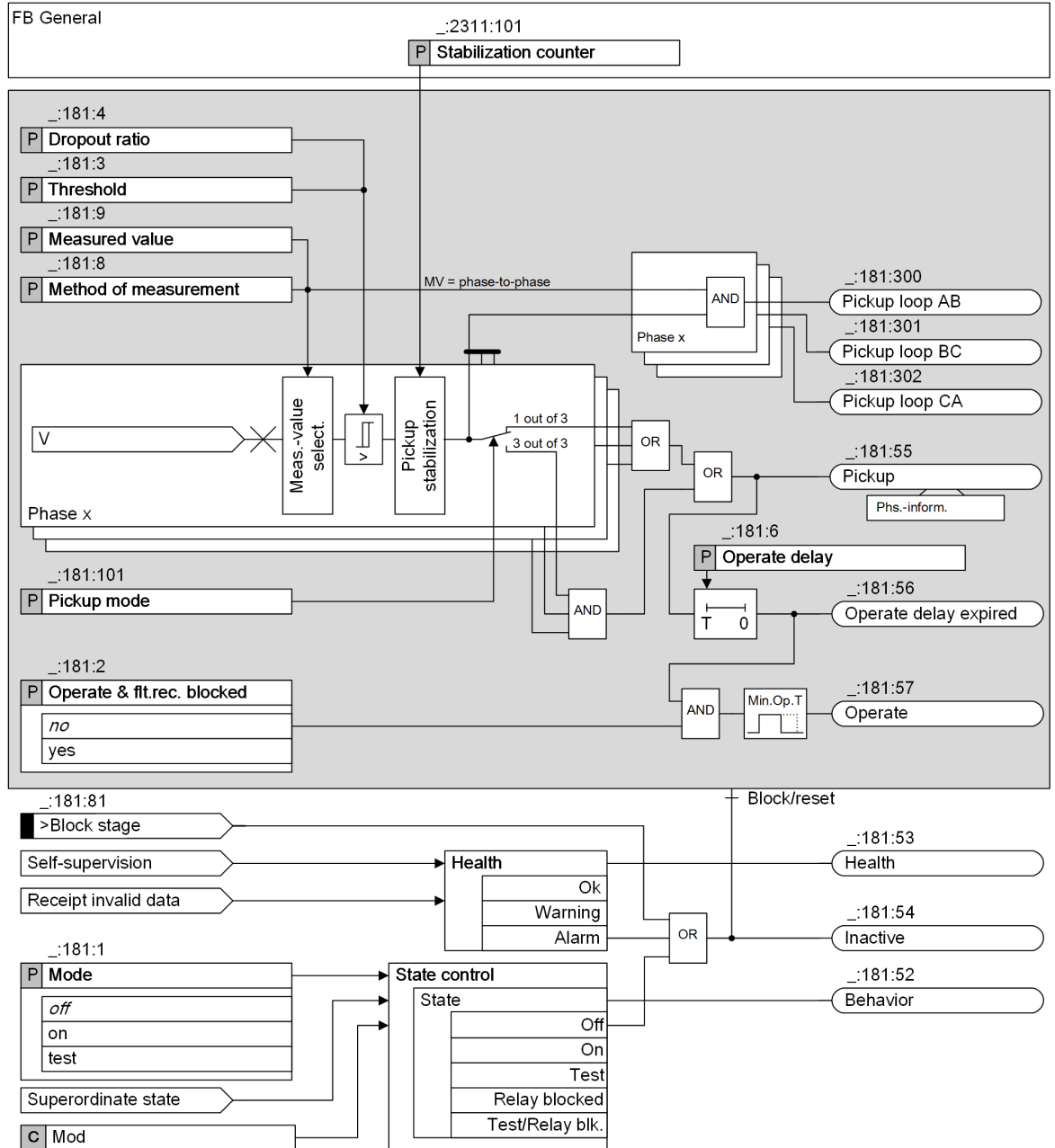

[to_3phas_1_5_en_US]

Figure 6-178 Logic Diagram of the Definite-Time Overvoltage Protection with 3-Phase Voltage

Method of Measurement

Use the **Method of measurement** parameter to define whether the stage uses the *fundamental comp.* or the *RMS value*.

- Measurement *fundamental comp.*:
 This method of measurement processes the sampled voltage values and filters out the fundamental component numerically.
- Measurement *RMS value*:
 This method of measurement determines the voltage amplitude from the sampled values according to the defining equation of the RMS value. Harmonics are included in the analysis.

Pickup Stabilization

To enable the pickup stabilization, you set the **Stabilization counter** parameter to a value other than zero. Then, if the input voltage keeps exceeding the **Threshold** for a specified number ($1 + \text{Stabilization counter}$ value) of successive measuring cycles, the stage picks up. For 50 Hz, the measuring cycle time is 10 ms.

If you set this parameter to 0 (default value), the stabilization is not applied. The pickup signal is issued immediately after the input voltage exceeds the **Threshold**.

Pickup Mode

The **Pickup mode** parameter defines whether the protection stage picks up if all 3 measuring elements detect the overvoltage condition (*3 out of 3*) or if only 1 measuring element detects the overvoltage condition (*1 out of 3*).

Measured Value

Use the **Measured value** parameter to define whether the tripping stage analyzes the phase-to-phase voltages V_{AB} , V_{BC} , and V_{CA} , or the phase-to-ground voltages V_A , V_B , and V_C .

If the measured value is set to phase-to-phase, the function reports those measuring elements that have picked up.

Blocking the Stage

In the event of blocking, the picked up stage will be reset. Blocking is possible externally or internally via the binary input signal *>Block stage*.

6.23.3.2 Application and Setting Notes

Parameter: Method of measurement

- Recommended setting value (`_:181:8`) **Method of measurement** = *fundamental comp.*

With the **Method of measurement** parameter, you define whether the stage uses the fundamental component (standard method = default setting) or the calculated RMS value.

Parameter Value	Description
<i>fundamental comp.</i>	Select this method of measurement to suppress harmonics or transient voltage peaks. Siemens recommends this method of measurement as the default setting.
<i>RMS value</i>	Select this method of measurement if you want the stage to take harmonics into account (for example, at capacitor banks). Do not set the threshold value of the stage under 10 V for this method of measurement.

Parameter: Measured value

- Default setting (`_:181:9`) **Measured value** = *phase-to-phase*

With the **Measured value** parameter, you define whether the stage monitors the phase-to-phase voltages V_{AB} , V_{BC} , and V_{CA} or the phase-to-ground voltages V_A , V_B , and V_C .

Parameter Value	Description
<i>phase-to-phase</i>	If you want to monitor the voltage range, keep <i>phase-to-phase</i> as the default setting. In this case, the function will not pick up on ground faults. Siemens recommends the measured value <i>phase-to-phase</i> as the default setting.
<i>phase-to-ground</i>	Select the <i>phase-to-ground</i> setting if you want to detect voltage unbalances and overvoltage conditions caused by ground faults.

Parameter: Threshold

- Default setting (`_:181:3`) **Threshold** = 110 V

Depending on the **Measured value**, the **Threshold** is set either as phase-to-phase quantity or as phase-to-ground quantity. The default setting assumes that the voltage range is monitored on long-distance transmission lines under low-load conditions.

Specify the **Threshold** (pickup threshold) for the specific application.

Parameter: Stabilization counter

- Default setting (`_:2311:101`) **Stabilization counter** = 0

You can configure the **Stabilization counter** parameter in the function block **General**.

For special applications, it could be desirable that a short exceeding of the input voltage above the pickup value does not lead to the pickup of the stage, which starts fault logging and recording. This is achieved by setting the **Stabilization counter** parameter to a value other than zero.

For example, if you set this parameter to **1**, the pickup signal is issued when the voltage keeps exceeding the **Threshold** for 2 successive measuring cycles. For 50 Hz, the measuring cycle time is 10 ms.

Parameter: Operate delay

- Default setting (`_:181:6`) **Operate delay** = 3 s

The **Operate delay** must be set for the specific application.

Parameter: Dropout ratio

- Recommended setting value (`_:181:4`) **Dropout ratio** = 0.95

The recommended set value of **0.95** is appropriate for most applications. To achieve high measurement precision, the **Dropout ratio** can be reduced, to 0.98, for example.

Parameter: Pickup mode

- Recommended setting value (`_:181:101`) **Pickup mode** = 1 out of 3

With the **Pickup mode** parameter, you define whether the protection stage picks up if all 3 measuring elements detect the overvoltage condition (**3 out of 3**) or if only 1 measuring element detects the overvoltage condition (**1 out of 3**).

Parameter Value	Description
1 out of 3	Select the setting for protection applications or for monitoring the voltage range. Siemens recommends 1 out of 3 as the default setting. This reflects how the function behaved in previous generations (SIPROTEC 4, SIPROTEC 3).
3 out of 3	Select this setting when using the stage to disconnect from the power system (in the case of wind farms, for example).

Operation as Supervision Function

If you want the stage to have a reporting effect only, generation of the operate indication and fault logging can be disabled via the **Operate & flt.rec. blocked** parameter.

EXAMPLE

Example for 2-stage overvoltage protection

The example describes the possible settings for a 2-stage overvoltage protection function. We will look at the settings of the parameters **Threshold** and **Operate delay**.

- 1. Stage:
 To detect stationary overvoltages, set the threshold value of the first overvoltage-protection element at least 10 % above the max. stationary phase-to-phase voltage anticipated during normal operation. When setting the parameter **Measured value** to phase-to-phase voltage and a secondary rated voltage of 100 V, the secondary setting value of the first overvoltage-protection element is calculated as follows:

Threshold value: 10 % above V_{rated}

$$V_{threshold, sec} = 1.1 V_{rated, sec} = 1.1 \times 100 V = 110 V$$

This requires that the primary rated voltages of protected object and voltage transformer are identical. If they are different, you have to adjust the pickup value.

For the **Operate delay** set a value of 3 s.

- 2. Stage:
 The second overvoltage-protection stage is intended for high overvoltages with short duration. A high pickup value is selected here, for example, 1.5 times the rated voltage. A time delay setting of 0.1 s to 0.2 s is sufficient then.

Stage	Setting Values	
	Threshold value	Time delay
1	$1.1 V_{rated}$	3 s
2	$1.5 V_{rated}$	0.1 s to 0.2 s

6.23.3.3 Settings

Addr.	Parameter	C	Setting Options	Default Setting
General				
_:2311:101	General:Stabilization counter		0 to 10	0
Definite-T 1				
_:181:1	Definite-T 1:Mode		<ul style="list-style-type: none"> off on test 	off
_:181:2	Definite-T 1:Operate & flt.rec. blocked		<ul style="list-style-type: none"> no yes 	no
_:181:9	Definite-T 1:Measured value		<ul style="list-style-type: none"> phase-to-ground phase-to-phase 	phase-to-phase
_:181:8	Definite-T 1:Method of measurement		<ul style="list-style-type: none"> fundamental comp. RMS value 	fundamental comp.
_:181:101	Definite-T 1:Pickup mode		<ul style="list-style-type: none"> 1 out of 3 3 out of 3 	1 out of 3
_:181:3	Definite-T 1:Threshold		0.300 V to 340.000 V	110.000 V

Addr.	Parameter	C	Setting Options	Default Setting
_:181:4	Definite-T 1:Dropout ratio		0.90 to 0.99	0.95
_:181:6	Definite-T 1:Operate delay		0.00 s to 300.00 s	3.00 s
Definite-T 2				
_:182:1	Definite-T 2:Mode		<ul style="list-style-type: none"> • off • on • test 	off
_:182:2	Definite-T 2:Operate & flt.rec. blocked		<ul style="list-style-type: none"> • no • yes 	no
_:182:9	Definite-T 2:Measured value		<ul style="list-style-type: none"> • phase-to-ground • phase-to-phase 	phase-to-phase
_:182:8	Definite-T 2:Method of measurement		<ul style="list-style-type: none"> • fundamental comp. • RMS value 	fundamental comp.
_:182:101	Definite-T 2:Pickup mode		<ul style="list-style-type: none"> • 1 out of 3 • 3 out of 3 	1 out of 3
_:182:3	Definite-T 2:Threshold		0.300 V to 340.000 V	130.000 V
_:182:4	Definite-T 2:Dropout ratio		0.90 to 0.99	0.95
_:182:6	Definite-T 2:Operate delay		0.00 s to 300.00 s	0.50 s

6.23.3.4 Information List

No.	Information	Data Class (Type)	Type
Group indicat.			
_:4501:55	Group indicat.:Pickup	ACD	O
_:4501:57	Group indicat.:Operate	ACT	O
_:4501:52	Group indicat.:Behavior	ENS	O
_:4501:53	Group indicat.:Health	ENS	O
Definite-T 1			
_:181:81	Definite-T 1:>Block stage	SPS	I
_:181:51	Definite-T 1:Mode (controllable)	ENC	C
_:181:54	Definite-T 1:Inactive	SPS	O
_:181:52	Definite-T 1:Behavior	ENS	O
_:181:53	Definite-T 1:Health	ENS	O
_:181:55	Definite-T 1:Pickup	ACD	O
_:181:300	Definite-T 1:Pickup loop AB	SPS	O
_:181:301	Definite-T 1:Pickup loop BC	SPS	O
_:181:302	Definite-T 1:Pickup loop CA	SPS	O
_:181:56	Definite-T 1:Operate delay expired	ACT	O
_:181:57	Definite-T 1:Operate	ACT	O
Definite-T 2			
_:182:81	Definite-T 2:>Block stage	SPS	I
_:182:51	Definite-T 2:Mode (controllable)	ENC	C
_:182:54	Definite-T 2:Inactive	SPS	O
_:182:52	Definite-T 2:Behavior	ENS	O

No.	Information	Data Class (Type)	Type
_:182:53	Definite-T 2:Health	ENS	O
_:182:55	Definite-T 2:Pickup	ACD	O
_:182:300	Definite-T 2:Pickup loop AB	SPS	O
_:182:301	Definite-T 2:Pickup loop BC	SPS	O
_:182:302	Definite-T 2:Pickup loop CA	SPS	O
_:182:56	Definite-T 2:Operate delay expired	ACT	O
_:182:57	Definite-T 2:Operate	ACT	O

6.23.4 Stage with Inverse-Time Characteristic Curve

6.23.4.1 Description

Logic of the Stage

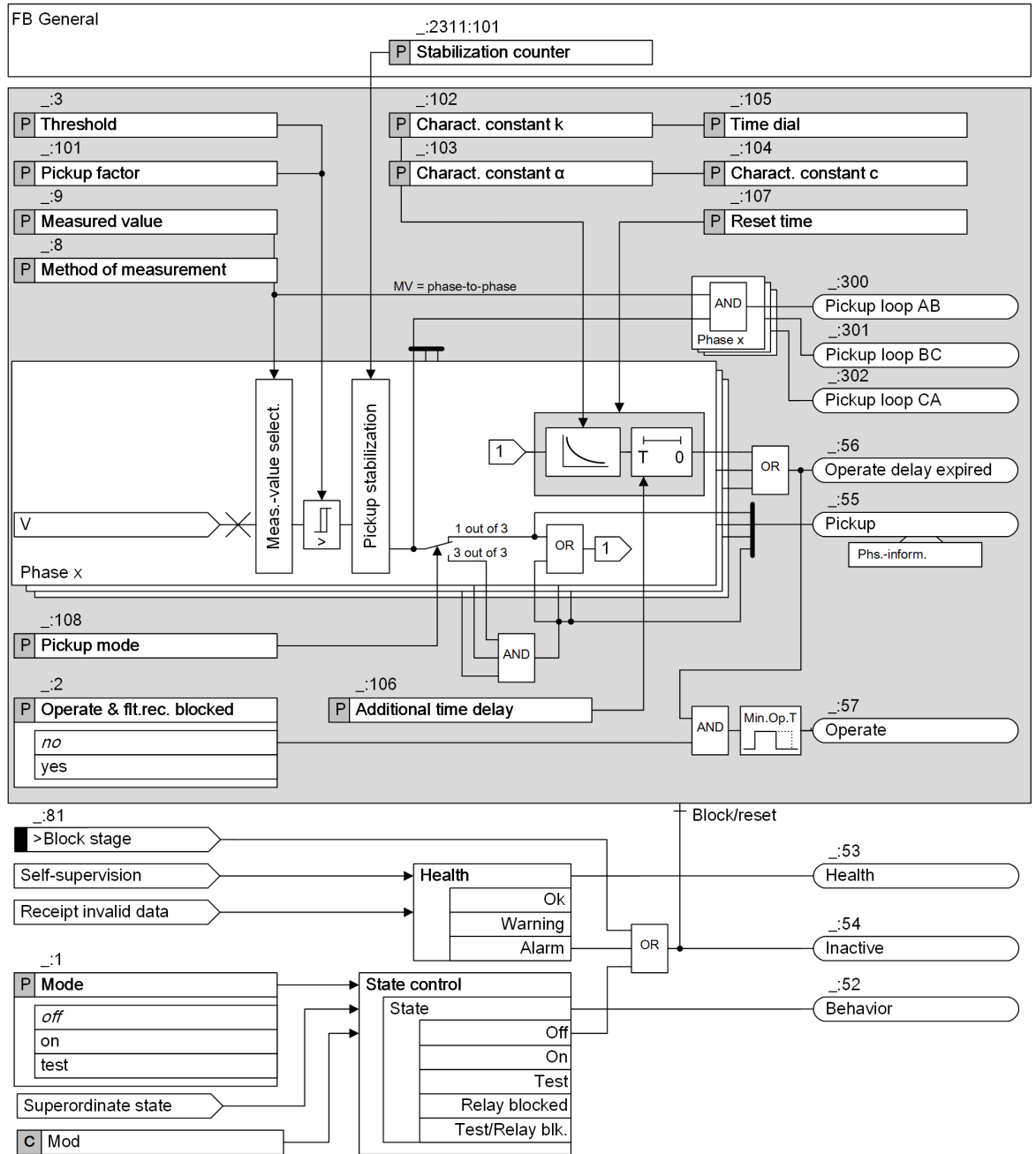

[to_3ph_inv_4_en_US]

Figure 6-179 Logic Diagram of the Inverse-Time Overvoltage Protection with 3-Phase Voltage

Method of Measurement

Use the **Method of measurement** parameter to define whether the stage uses the *fundamental comp.* or the *RMS value* .

- Measurement *fundamental comp.* :
This method of measurement processes the sampled voltage values and filters out the fundamental component numerically.
- Measurement *RMS value* :
This method of measurement determines the voltage amplitude from the sampled values according to the defining equation of the RMS value. Harmonics are included in the analysis.

Pickup Stabilization

To enable the pickup stabilization, you set the **Stabilization counter** parameter to a value other than zero. Then, if the input voltage keeps exceeding the pickup value for a specified number (1 + **Stabilization counter** value) of successive measuring cycles, the stage picks up. For 50 Hz, the measuring cycle time is 10 ms.

If you set this parameter to 0 (default value), the stabilization is not applied. The pickup signal is issued immediately after the input voltage exceeds the pickup value.

Pickup Mode

With the **Pickup mode** parameter, you define whether the protection stage picks up if all 3 measuring elements detect the overvoltage condition (*3 out of 3*) or if only 1 measuring element detects the overvoltage condition (*1 out of 3*).

Measured Value

Use the **Measured value** parameter to define whether the stage analyzes the phase-to-phase voltages V_{AB} , V_{BC} , and V_{CA} , or the phase-to-ground voltages V_A , V_B , and V_C .

If the measured value is set to phase-to-phase, the function reports those measuring elements that have picked up.

Pickup and Operate Curve

When the input voltage exceeds the threshold value by a settable value **Pickup factor** , the stage picks up and the inverse-time characteristic curve is processed. Operate delay starts. The operate delay is the sum of inverse-time delay and additional time delay.

$$T_{op} = T_{inv} + T_{add}$$

Where

T_{op} Operate delay

T_{inv} Inverse-time delay

T_{add} Additional time delay (parameter **Additional time delay**)

After pickup, the time value T_{inv} is calculated for every input voltage that exceeds the threshold. An integrator accumulates the value $1/T_{inv}$. Once the accumulated integral reaches the fixed value 1, the inverse-time delay expires. The additional time delay T_{add} starts. The stage operates after the additional time delay expires.

The inverse-time characteristic is shown in the following figure.

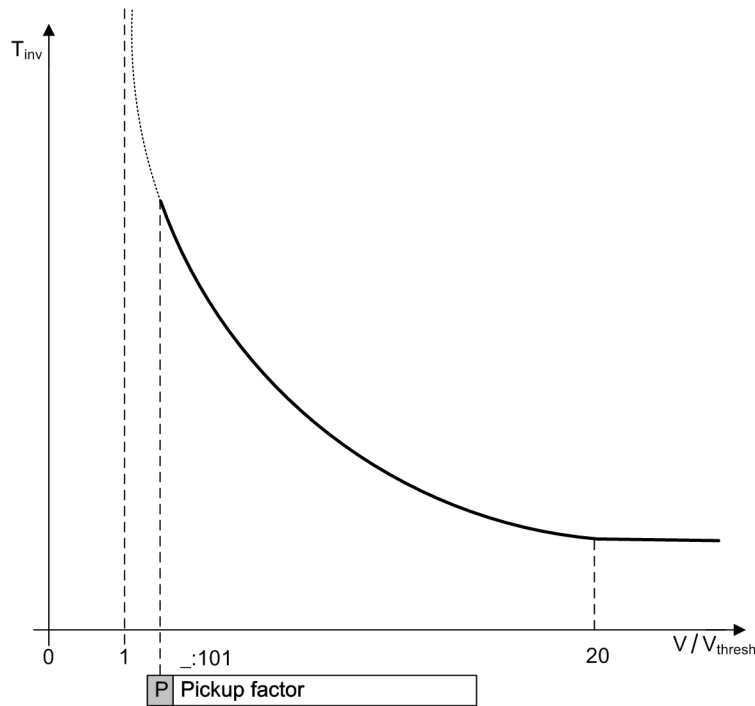

[dw_ovp_inv, 2, en_US]

Figure 6-180 Operate Curve of Inverse-Time Characteristic

The inverse-time delay is calculated with the following formula:

$$T_{inv} = T_p \left(\frac{k}{\left(\frac{V}{V_{thresh}} \right)^\alpha - 1} + c \right) [s]$$

Where

- T_{inv} Inverse-time delay
- T_p Time multiplier (parameter **Time dial**)
- V Measured voltage
- V_{thresh} Threshold value (parameter **Threshold**)
- k Curve constant k (parameter **Charact. constant k**)
- α Curve constant α (parameter **Charact. constant α**)
- c Curve constant c (parameter **Charact. constant c**)

When V/V_{thresh} is equal to or greater than 20, the inverse-time delay does not decrease any further.

Dropout Behavior

When the voltage falls below the dropout threshold ($0.95 \times \text{pickup factor} \times \text{threshold value}$), the pickup signal is going and the dropout is started. You can define the dropout behavior via parameter **Reset time** . Instantaneous reset takes place by setting **Reset time** to 0 s. A delayed reset takes place by setting the desired delay time.

During the **Reset time** (> 0 s), the elapsed operate delay is frozen. If the pickup value is exceeded again within this period, the stage operates when the rest of operate delay expires.

Blocking the Stage

In the event of blocking, the picked up stage will be reset. Blocking is possible externally or internally via the binary input signal *>Block stage* .

6.23.4.2 Application and Setting Notes

Parameter: Method of measurement

- Recommended setting value (**_:8**) **Method of measurement** = *fundamental comp.*

With the **Method of measurement** parameter, you define whether the tripping stage uses the fundamental component (standard method = default setting) or the calculated RMS value.

Parameter Value	Description
<i>fundamental comp.</i>	Select this method of measurement to suppress harmonics or transient voltage peaks. Siemens recommends this method of measurement as the default setting.
<i>RMS value</i>	Select this method of measurement if you want the stage to take harmonics into account (for example, at capacitor banks). Do not set the threshold value of the tripping stage under 10 V for this method of measurement.

Parameter: Measured value

- Default setting (**_:9**) **Measured value** = *phase-to-phase*

With the **Measured value** parameter, you define whether the tripping stage monitors the phase-to-phase voltages V_{AB} , V_{BC} , and V_{CA} or the phase-to-ground voltages V_A , V_B , and V_C .

Parameter Value	Description
<i>phase-to-phase</i>	If you want to monitor the voltage range, keep <i>phase-to-phase</i> as the default setting. In this case, the function will not pick up on ground faults. Siemens recommends the measured value <i>phase-to-phase</i> as the default setting.
<i>phase-to-ground</i>	Select the <i>phase-to-ground</i> setting if you want to detect voltage unbalances and overvoltage conditions caused by ground faults.

Parameter: Threshold, Pickup factor

- Default setting (**_:3**) **Threshold** = *110.000 V*
- Default setting (**_:101**) **Pickup factor** = *1.10*

The stage picks up when the measured voltage value exceeds the pickup value **Threshold** × **Pickup factor**.

Depending on the **Measured value**, the **Threshold** is set either as phase-to-phase quantity or as phase-to-ground quantity.

With the **Pickup factor** parameter, you modify the pickup value. To avoid a long-time operate delay after pickup when the measured value is slightly over the threshold, Siemens recommends using the default setting.

Specify the **Threshold** (pickup threshold) and **Pickup factor** for the specific application.

Parameter: Stabilization counter

- Default setting (**_:2311:101**) **Stabilization counter** = *0*

You can configure the **Stabilization counter** parameter in the function block **General**.

For special applications, it could be desirable that a short exceeding of the input voltage above the pickup value does not lead to the pickup of the stage, which starts fault logging and recording. This is achieved by setting the **Stabilization counter** parameter to a value other than zero.

For example, if you set this parameter to **1**, the pickup signal is issued when the voltage keeps exceeding the pickup value for 2 successive measuring cycles. For 50 Hz, the measuring cycle time is 10 ms.

Parameter: Pickup mode

- Recommended setting value (`_:182:101`) **Pickup mode = 1 out of 3**

With the **Pickup mode** parameter, you define whether the protection stage picks up if all 3 measuring elements detect the overvoltage condition (**3 out of 3**) or if only 1 measuring element detects the overvoltage condition (**1 out of 3**).

Parameter Value	Description
1 out of 3	Select the setting for protection applications or for monitoring the voltage range. Siemens recommends 1 out of 3 as the default setting. This reflects how the function behaved in previous generations (SIPROTEC 4, SIPROTEC 3).
3 out of 3	Select this setting when using the stage to disconnect from the power system (in the case of wind farms, for example).

Parameter: Charact. constant k, Charact. constant α , Charact. constant c

- Default setting (`_:102`) **Charact. constant k = 1.00**
- Default setting (`_:103`) **Charact. constant α = 1.000**
- Default setting (`_:104`) **Charact. constant c = 0.000**

With the parameters **Charact. constant k**, **Charact. constant α** , and **Charact. constant c**, you define the required inverse-time characteristic curve.

Parameter: Time dial

- Default setting (`_:105`) **Time dial = 1.00**

With the **Time dial** parameter, you displace the characteristic curve in the time direction.

As usually, there is no time grading for voltage protection and therefore no displacement of the characteristic curve, Siemens recommends leaving the **Time dial** parameter at **1.00** (default setting).

Parameter: Additional time delay

- Default setting (`_:106`) **Additional time delay = 0.00 s**

With the **Additional time delay** parameter, you define a definite-time delay in addition to the inverse-time delay.

If the setting is left on its default value of 0 s, only the inverse-time delay is operative.

Parameter: Reset time

- Default setting (`_:107`) **Reset time = 0.00 s**

With the **Reset time** parameter, you define the reset time delay which is started when the voltage falls below the dropout threshold. Set the parameter **Reset time** to 0 s when instantaneous reset is desired.

Under network conditions of intermittent faults or faults which occur in rapid succession, Siemens recommends setting the **Reset time** to an appropriate value (> 0 s) to ensure the operation. Otherwise Siemens recommends keeping the default value to ensure a fast reset of the function.

6.23.4.3 Settings

Addr.	Parameter	C	Setting Options	Default Setting
Inverse-T #				
_:1	Inverse-T #:Mode		<ul style="list-style-type: none"> off on test 	off
_:2	Inverse-T #:Operate & flt.rec. blocked		<ul style="list-style-type: none"> no yes 	no
_:9	Inverse-T #:Measured value		<ul style="list-style-type: none"> phase-to-ground phase-to-phase 	phase-to-phase
_:8	Inverse-T #:Method of measurement		<ul style="list-style-type: none"> fundamental comp. RMS value 	fundamental comp.
_:108	Inverse-T #:Pickup mode		<ul style="list-style-type: none"> 1 out of 3 3 out of 3 	1 out of 3
_:3	Inverse-T #:Threshold		0.300 V to 340.000 V	110.000 V
_:101	Inverse-T #:Pickup factor		1.00 to 1.20	1.10
_:102	Inverse-T #:Charact. constant k		0.00 to 300.00	1.00
_:103	Inverse-T #:Charact. constant α		0.010 to 5.000	1.000
_:104	Inverse-T #:Charact. constant c		0.000 to 5.000	0.000
_:105	Inverse-T #:Time dial		0.05 to 15.00	1.00
_:106	Inverse-T #:Additional time delay		0.00 s to 60.00 s	0.00 s
_:107	Inverse-T #:Reset time		0.00 s to 60.00 s	0.00 s

6.23.4.4 Information List

No.	Information	Data Class (Type)	Type
Inverse-T #			
_:81	Inverse-T #:>Block stage	SPS	I
_:54	Inverse-T #:Inactive	SPS	O
_:52	Inverse-T #:Behavior	ENS	O
_:53	Inverse-T #:Health	ENS	O
_:55	Inverse-T #:Pickup	ACD	O
_:300	Inverse-T #:Pickup loop AB	SPS	O
_:301	Inverse-T #:Pickup loop BC	SPS	O
_:302	Inverse-T #:Pickup loop CA	SPS	O
_:56	Inverse-T #:Operate delay expired	ACT	O
_:57	Inverse-T #:Operate	ACT	O

6.24 Overvoltage Protection with Zero-Sequence Voltage/Residual Voltage

6.24.1 Overview of Functions

The function **Overvoltage protection with zero-sequence voltage/residual voltage** (ANSI 59N):

- Detects ground faults in isolated or arc-suppression-coil-grounded systems
- Determines the phase affected by the ground fault
- Works with electrical machines to detect ground faults in the stator winding

6.24.2 Structure of the Function

The function **Overvoltage protection with zero-sequence voltage/residual voltage** is used in protection function groups with voltage measurement.

The function **Overvoltage protection with zero-sequence voltage/residual voltage** comes factory-set with 1 stage **Definite-time overvoltage protection**. In this function, the following stages can operate simultaneously:

- 3 stages **Definite-time overvoltage protection**
- 2 stages **Inverse-time overvoltage protection**

Stages that are not preconfigured are shown in gray in the following figure.

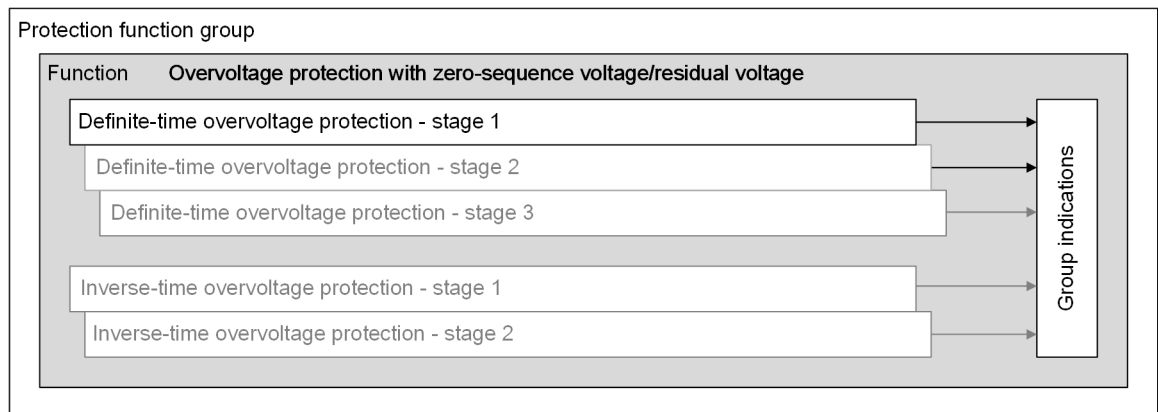

[dwr_u0_ovps, 3, en_US]

Figure 6-181 Structure/Embedding of the Function

6.24.3 Stage Description

Logic of the Stage

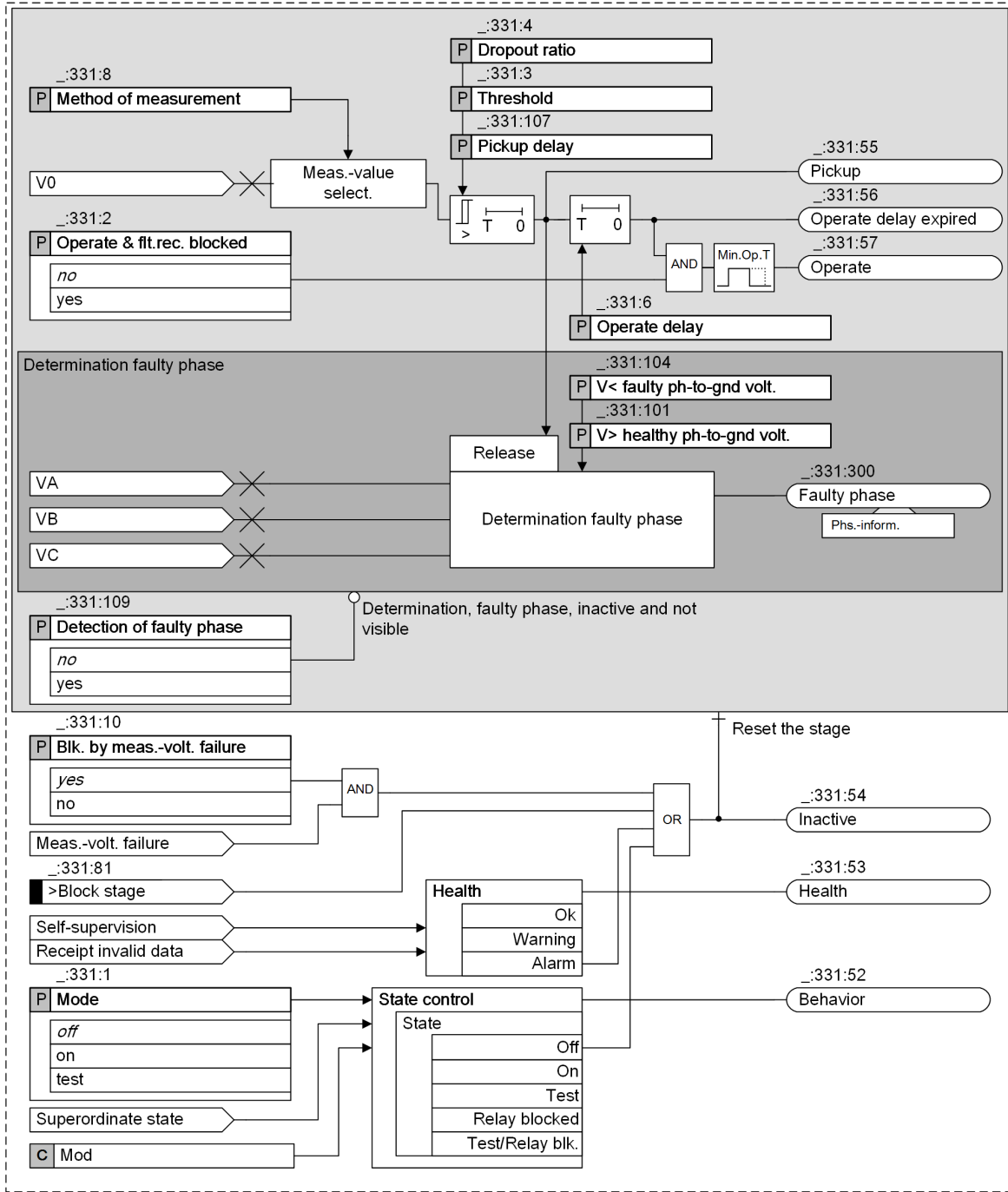

Figure 6-182 Logic Diagram of the Definite-Time Overvoltage Protection with Zero-Sequence Voltage/Residual Voltage

Measured Value, Method of Measurement

The device measures the residual voltage at the broken-delta winding. The measured voltage is converted to the zero-sequence voltage V_0 . If the residual voltage is not available to the device as a measurand, the

zero-sequence voltage V_0 is calculated from the measured phase-to-ground voltages V_A , V_B , and V_C using the defining equation.

With the parameter **Method of measurement**, you select the relevant method of measurement, depending on the application:

- **fundamental comp.** (standard filter):
This method of measurement processes the sampled voltage values and filters out the fundamental component numerically.
- **RMS value** (true RMS):
This method of measurement determines the voltage amplitude from the sampled values according to the defining equation of the RMS value.
- **fund. comp. long filter** (fundamental component over 2 cycle filters with triangular window):
This method of measurement processes the sampled voltage values and filters out the fundamental component numerically. The extended filter length compared to the standard filter and the use of the triangular window results in a particularly strong attenuation of harmonics and transient faults. The extended filter length causes the pickup time to increase slightly compared to the standard filter (refer to the technical data in [14.30 Overvoltage Protection with Zero-Sequence Voltage/Residual Voltage](#)).

Pickup, Dropout

The stage compares the **Threshold** with the zero-sequence voltage V_0 . The parameter **Pickup delay** allows you to delay the pickup of the stage depending on the residual voltage.

With the parameter **Dropout ratio**, you can define the ratio of the dropout value to the **Threshold**.

Determination of the Faulty Phase

You can use the parameter **Detection of faulty phase** to enable or disable the determination of the phase affected by the ground fault. Determining is released when the stage picks up. If 2 phases exceed the threshold value **V > healthy ph-to-gnd volt.** and 1 phase falls below the threshold value **V < faulty ph-to-gnd volt.**, the last phase is considered to be affected by the ground fault and is signaled as such.

Blocking the Stage

6.24.4 Application and Setting Notes

Parameter: Method of measurement

- Default setting (`_:331:8`) **Method of measurement** = *fundamental comp.*

With the parameter **Method of measurement**, you define whether the function works with the fundamental component or the calculated RMS value.

Parameter Value	Description
<i>fundamental comp.</i>	This method of measurement suppresses the harmonics or transient voltage peaks. Siemens recommends using this setting as the standard method.
<i>RMS value</i>	Select this method of measurement if you want the stage to take harmonics into account (for example, at capacitor banks). Do not set the threshold value of the tripping stage under 10 V for this method of measurement.
<i>fund. comp. long filter</i>	To implement a particularly strong attenuation of harmonics and transient faults, select this method of measurement. With this method, the length of the filter is longer than that of the standard filter. Note: In this case, the pickup time of the stage increases slightly (refer to the technical data in 14.30 Overvoltage Protection with Zero-Sequence Voltage/Residual Voltage).

Parameter: Pickup delay

- Recommended setting value (`_:331:107`) **Pickup delay** = *0.00 ms*

The **Pickup delay** parameter allows you to delay the analysis of the measurand (to generate the pickup) depending on the occurrence of the residual voltage. A pickup delay can be necessary if high transients are anticipated after fault inception due to high line and ground capacitances.

Siemens recommends using the default setting **Pickup delay** = *0.00 ms*.

Parameter: Threshold

- Default setting (`_:331:3`) **Threshold** = *30.000 V²⁸*

The threshold value of the function is set as the zero-sequence voltage V_0 . The device calculates the zero-sequence voltage V_0 either from the residual voltage measured via the broken-delta winding or from the 3 phase-to-ground voltages.

The setting value depends on the system grounding:

- Since virtually the full residual voltage occurs during ground faults in isolated or arc-suppression-coil-grounded systems, the setting value is uncritical there. It should range between 20 V and 40 V. A higher sensitivity (= lower threshold value) can be necessary for high fault resistances.
- You should select a more sensitive (smaller) value in a grounded system. This value must be higher than the maximum residual voltage anticipated during operation caused by system unbalances.

EXAMPLE**For an isolated system**

The residual voltage is measured via the broken-delta winding:

- If the ground fault is fully unbalanced, a residual voltage of 100 V is present at the device terminals.
- The threshold value should be set so that the stage picks up on 50 % of the full residual voltage.
- At full residual voltage, the zero-sequence voltage is $100 \text{ V}/\sqrt{3} = 57.7 \text{ V}$
Setting value: $0.5 \cdot 57.7 \text{ V} = 28.9 \text{ V} \approx 30 \text{ V}$

Parameter: Dropout ratio

- Recommended setting value (`_:331:4`) **Dropout ratio** = *0.95*

The recommended set value of *0.95* is appropriate for most applications. The dropout ratio can be reduced for example, to 0.98 to achieve a high measurement precision.

Parameter: Operate delay

- Default setting (`_:331:6`) **Operate delay** = *3.00 s*

The **Operate delay** allows you to prevent transient residual voltages from initiating a trip. The setting depends on the specific application.

Parameter: Blk. by meas.-volt. failure

- Default setting (`_:331:10`) **Blk. by meas.-volt. failure** = *yes*

With the parameter **Blk. by meas.-volt. failure**, you control the behavior of the stage when a measuring-voltage failure is detected.

²⁸ The specific setting limits depend on the transformer data and transformer connections set.

A measuring-voltage failure can only be detected if one of the following 2 conditions is met:

- The device-internal supervision function **Measuring-voltage failure detection** is configured and switched on.
- The binary input signal **>Open** of the function block **Voltage-transformer circuit breaker** is connected to the voltage-transformer circuit breaker (refer to [10.3.4.1 Overview of Functions](#)).

Parameter Value	Description
<i>yes</i>	The protection stage is blocked (= default setting). Siemens recommends using the default setting.
<i>no</i>	The protection stage is not blocked.

Parameter: Detection of faulty phase

- Default setting (`_:331:109`) **Detection of faulty phase** = *no*

With the parameter **Detection of faulty phase**, you control how the stage responds to determine which phase is affected by the ground fault.

Parameter Value	Description
<i>no</i>	The phase affected by the ground fault is not determined. Select the default setting if you do not want to use the stage to detect ground faults, for example, for applications in grounded systems.
<i>yes</i>	After a pickup by the residual voltage, the device tries to determine which phase is affected by the ground fault. Select this setting for applications in isolated or arc-suppression-coil-grounded systems.

Parameter: V< faulty ph-to-gnd volt.

- Default setting (`_:331:104`) **V< faulty ph-to-gnd volt.** = *40.000 V*²⁹

With the parameter **V< faulty ph-to-gnd volt.**, you set the threshold value for determining which phase is affected by the ground fault. The setting value is a phase-to-ground quantity.

The setting value must be smaller than the minimum phase-to-ground voltage occurring during operation. Siemens recommends using the default setting of *40.000 V*.

Parameter: V> healthy ph-to-gnd volt.

- Default setting (`_:331:101`) **V> healthy ph-to-gnd volt.** = *75.000 V*²⁹

With the parameter **V> healthy ph-to-gnd volt.**, you set the threshold value for the 2 healthy phases. The setting value is a phase-to-ground quantity.

The setting value must be greater than the maximum phase-to-ground voltage occurring during operation, but smaller than the minimum phase-to-phase voltage occurring during operation. At $V_{\text{rated}} = 100 \text{ V}$, set the value, for example, to *75.000 V*. Siemens recommends using the default setting of *75.000 V*.

Operation as Supervision Function

If you want the stage to have a reporting effect only, you can set the parameter **Operate & flt.rec. blocked** to disable the generation of the operate indication and fault logging.

²⁹ The specific setting limits depend on the transformer data and transformer connections set.

6.24.5 Settings

Addr.	Parameter	C	Setting Options	Default Setting
Definite-T 1				
_.331:1	Definite-T 1:Mode		<ul style="list-style-type: none"> • off • on • test 	off
_.331:2	Definite-T 1:Operate & flt.rec. blocked		<ul style="list-style-type: none"> • no • yes 	no
_.331:10	Definite-T 1:Blk. by meas.-volt. failure		<ul style="list-style-type: none"> • no • yes 	yes
_.331:109	Definite-T 1:Detection of faulty phase		<ul style="list-style-type: none"> • no • yes 	no
_.331:8	Definite-T 1:Method of measurement		<ul style="list-style-type: none"> • fundamental comp. • fund. comp. long filter • RMS value 	fundamental comp.
_.331:3	Definite-T 1:Threshold		0.300 V to 200.000 V	30.000 V
_.331:4	Definite-T 1:Dropout ratio		0.90 to 0.99	0.95
_.331:107	Definite-T 1:Pickup delay		0.00 s to 320.00 s	0.00 s
_.331:6	Definite-T 1:Operate delay		0.00 s to 60.00 s	3.00 s
_.331:101	Definite-T 1:V> healthy ph-to-gnd volt.		0.300 V to 200.000 V	75.000 V
_.331:104	Definite-T 1:V< faulty ph-to-gnd volt.		0.300 V to 200.000 V	40.000 V

6.24.6 Information List

No.	Information	Data Class (Type)	Type
Group indicat.			
_.4501:55	Group indicat.:Pickup	ACD	O
_.4501:57	Group indicat.:Operate	ACT	O
_.4501:52	Group indicat.:Behavior	ENS	O
_.4501:53	Group indicat.:Health	ENS	O
Definite-T 1			
_.331:81	Definite-T 1:>Block stage	SPS	I
_.331:51	Definite-T 1:Mode (controllable)	ENC	C
_.331:54	Definite-T 1:Inactive	SPS	O
_.331:52	Definite-T 1:Behavior	ENS	O
_.331:53	Definite-T 1:Health	ENS	O
_.331:300	Definite-T 1:Faulty phase	ACT	O
_.331:55	Definite-T 1:Pickup	ACD	O
_.331:56	Definite-T 1:Operate delay expired	ACT	O
_.331:57	Definite-T 1:Operate	ACT	O

6.25 Overvoltage Protection with Positive-Sequence Voltage

6.25.1 Overview of Functions

The function **Overvoltage protection with positive-sequence voltage** (ANSI 59) is used to:

- Detect symmetric stationary overvoltages
- Supervise the voltage range if the positive-sequence voltage is the decisive quantity

Unbalanced overvoltages, for example, caused by ground faults and unbalanced faults, are not detected due to the evaluation of the positive-sequence voltage.

6.25.2 Structure of the Function

The **Overvoltage protection with positive-sequence voltage** function is used in protection function groups, which are based on voltage measurement.

The function **Overvoltage protection with positive-sequence voltage** comes factory-set with 2 stages. A maximum of 3 tripping stages can be operated simultaneously in the function. The tripping stages have an identical structure.

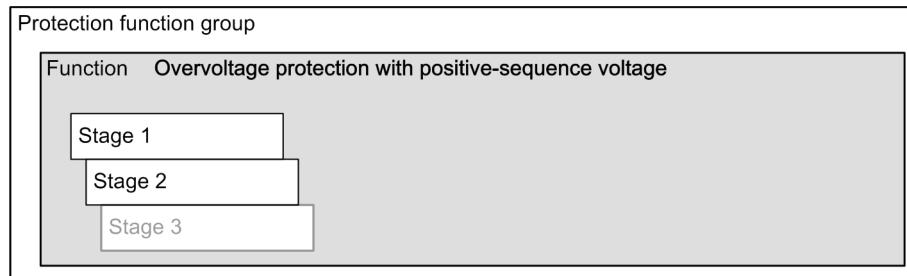

[dw_ovp_u1s_1_en_US]

Figure 6-183 Structure/Embedding of the Function

6.25.3 Stage Description

Logic of a Stage

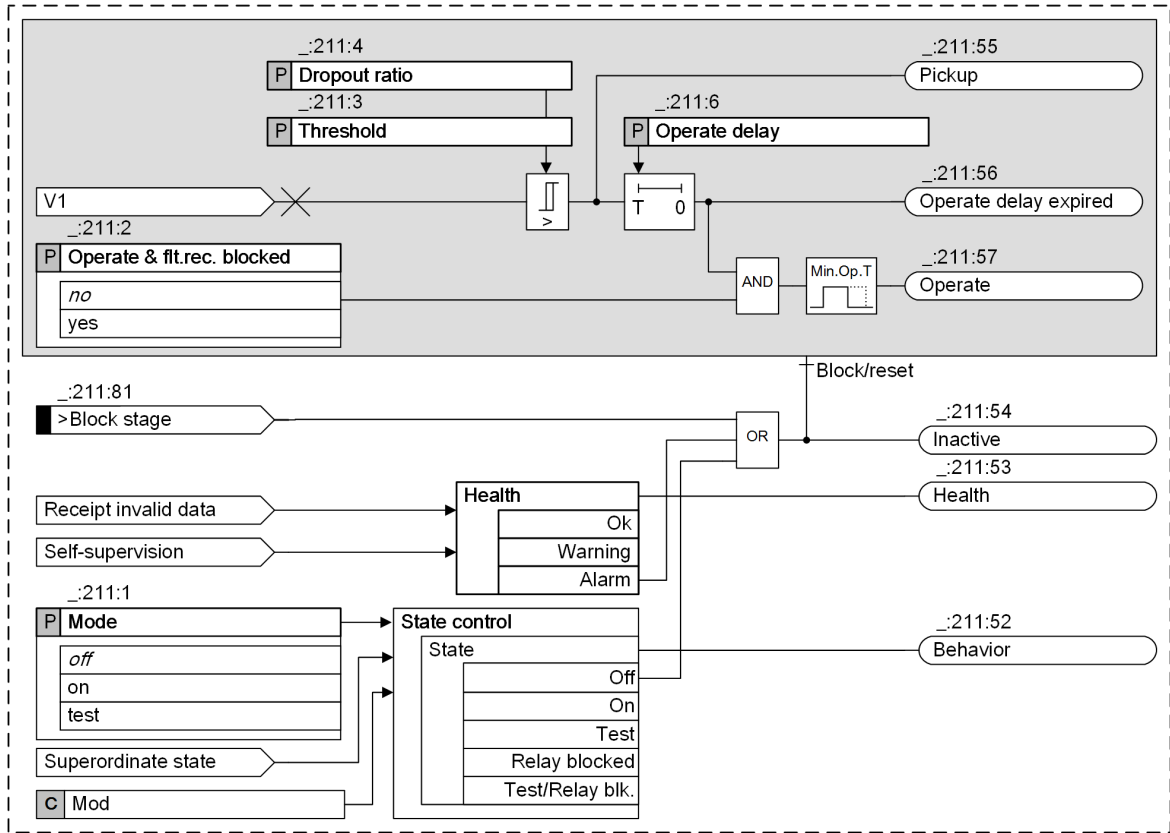

[to_govpu1_2_en_US]

Figure 6-184 Logic Diagram of a Stage: Overvoltage Protection with Positive-Sequence Voltage

Method of Measurement

The stage uses the positive-sequence voltage. The positive-sequence voltage is calculated from the measured phase-to-ground voltages according to the defining equation.

Blocking the Stage

In the event of blocking, the picked up stage will be reset. Blocking is possible externally or internally via the binary input signal **>Block stage**.

6.25.4 Application and Setting Notes

Parameter: Threshold

- Default setting (_:211:3) **Threshold = 65 V**

The Threshold is set according to the definition of the positive-sequence system. Specify the Threshold (pickup threshold) for the specific application.

Parameter: Operate delay

- Default (_:211:6) **Operate delay = 3 s**

The **Operate delay** must be set for the specific application.

Parameter: Dropout ratio

- Recommended setting value (`_:211:4`) **Dropout ratio** = 0.95

The default value of 0.95 is appropriate for most applications. To achieve high measurement precision, the **Dropout ratio** can be reduced, to 0.98, for example.

General Notes

If the overvoltage is high, the first stage can trip with a short time delay. If overvoltages are lower, the second stage can either only signal the threshold value violation (see *Operation as monitoring function*) or trip with a longer delay to allow the voltage controller to regulate the voltage back into the nominal range.

Operation as Supervision Function

If you want the tripping stage to have a reporting effect only, generation of the operate indication and fault logging can be disabled via the **Operate & flt.rec. blocked** parameter.

6.25.5 Settings

Addr.	Parameter	C	Setting Options	Default Setting
Stage 1				
_:211:1	Stage 1:Mode		<ul style="list-style-type: none"> off on test 	off
_:211:2	Stage 1:Operate & flt.rec. blocked		<ul style="list-style-type: none"> no yes 	no
_:211:3	Stage 1:Threshold		0.300 V to 200.000 V	65.000 V
_:211:4	Stage 1:Dropout ratio		0.90 to 0.99	0.95
_:211:6	Stage 1:Operate delay		0.00 s to 60.00 s	3.00 s
Stage 2				
_:212:1	Stage 2:Mode		<ul style="list-style-type: none"> off on test 	off
_:212:2	Stage 2:Operate & flt.rec. blocked		<ul style="list-style-type: none"> no yes 	no
_:212:3	Stage 2:Threshold		0.300 V to 200.000 V	75.000 V
_:212:4	Stage 2:Dropout ratio		0.90 to 0.99	0.95
_:212:6	Stage 2:Operate delay		0.00 s to 60.00 s	0.50 s

6.25.6 Information List

No.	Information	Data Class (Type)	Type
Group indicat.			
_:4501:55	Group indicat.:Pickup	ACD	O
_:4501:57	Group indicat.:Operate	ACT	O
_:4501:52	Group indicat.:Behavior	ENS	O
_:4501:53	Group indicat.:Health	ENS	O
Stage 1			
_:211:81	Stage 1:>Block stage	SPS	I

No.	Information	Data Class (Type)	Type
_:211:51	Stage 1:Mode (controllable)	ENC	C
_:211:54	Stage 1:Inactive	SPS	O
_:211:52	Stage 1:Behavior	ENS	O
_:211:53	Stage 1:Health	ENS	O
_:211:55	Stage 1:Pickup	ACD	O
_:211:56	Stage 1:Operate delay expired	ACT	O
_:211:57	Stage 1:Operate	ACT	O
Stage 2			
_:212:81	Stage 2:>Block stage	SPS	I
_:212:51	Stage 2:Mode (controllable)	ENC	C
_:212:54	Stage 2:Inactive	SPS	O
_:212:52	Stage 2:Behavior	ENS	O
_:212:53	Stage 2:Health	ENS	O
_:212:55	Stage 2:Pickup	ACD	O
_:212:56	Stage 2:Operate delay expired	ACT	O
_:212:57	Stage 2:Operate	ACT	O

6.26 Overvoltage Protection with Negative-Sequence Voltage

6.26.1 Overview of Functions

The function **Overvoltage protection with negative-sequence voltage** (ANSI 47) is used to:

- Monitor the power system and electric machines for voltage unbalances
- Establish a release criterion of overcurrent protection for unbalanced faults

Voltage unbalances can be caused by various factors:

- The most common cause is unbalanced load, caused by different consumers in the individual phases, for example.
- Voltage unbalance can also be caused by phase failure, for example due to a tripped 1-phase fuse, a broken conductor, etc.
- Other causes can include faults in the primary system, for example, at the transformer or in installations for reactive-power compensation.

6.26.2 Structure of the Function

The **Overvoltage protection with negative-sequence voltage** function is used in protection function groups, which are based on voltage measurement.

The **Overvoltage protection with negative-sequence voltage** function comes factory-set with 2 stages.

A maximum of 3 stages can be operated simultaneously in the function.

The stages have an identical structure.

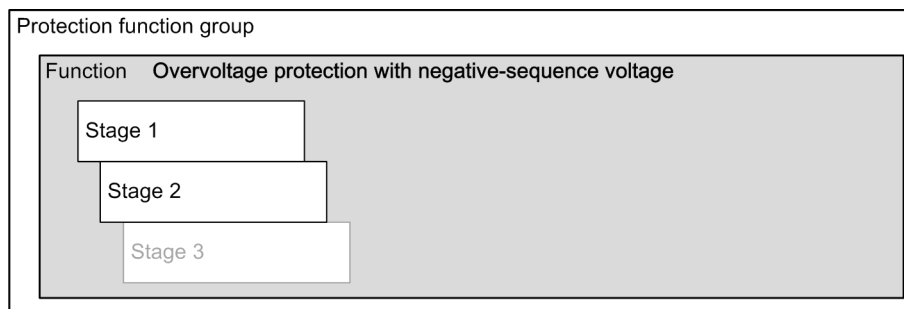

[dw_u2ovps_ext_2_en_US]

Figure 6-185 Structure/Embedding of the Function

6.26.3 General Functionality

6.26.3.1 Description

Logic

The following figure represents the logic of the average-value calculation of the negative-sequence voltage. The average value is forwarded to all subordinate stages.

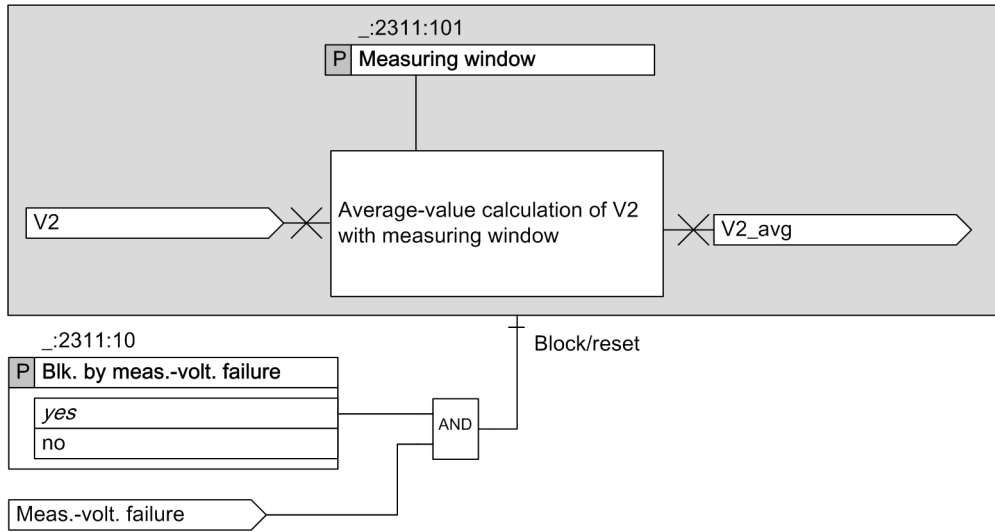

Figure 6-186 Logic Diagram of the General Functionality

Measurand

The average value of negative-sequence voltage is determined by a settable time interval (parameter: **Measuring window**). With the parameter **Measuring window**, you can adapt this function to all power-system conditions.

You can set the parameter **Measuring window** with a large value to get a more accurate calculated result, which leads to a longer pickup time however.

Blocking the Function with Measuring-Voltage Failure Detection

In case of blocking, the picked up function is reset. The following blocking options is available for the function:

- From inside on pick up of the **Measuring-voltage failure detection** function (see section [10.3.2.1 Overview of Functions](#)).
- From an external source via the binary input signal *>Open* of the function block **Volt.-transf. c. b.**, which links in the tripping of the voltage-transformer circuit breaker.

The parameter **Blk. by meas.-volt. failure** can be set so that the measuring-voltage failure detection blocks the function or does not block it.

6.26.3.2 Application and Setting Notes

Parameter: Measuring window

- Default setting (**._:2311:101**) **Measuring window = 1 cycle**
 With the parameter **Measuring window**, you can optimize the measuring accuracy or the pickup time of this function.
 For sensitive settings of the parameter **Threshold**, for example, lower than 10 % of the rated voltage, Siemens recommends using a higher number of cycles. Siemens recommends **10 cycles**, and in this case, the pickup time is increased.
 For further information, refer to chapter [14.32 Overvoltage Protection with Negative-Sequence Voltage](#).

Parameter: Blk. by meas.-volt. failure

- Recommended setting value (**._:2311:10**) **Blk. by meas.-volt. failure = yes**
 You use the **Blk. by meas.-volt. failure** parameter to control the behavior of the function when a measuring-voltage failure is detected.

A measuring-voltage failure can only be detected if one of the following 2 conditions is met:

- The device-internal supervision function **Measuring-voltage failure detection** is configured and switched on.
- The binary input signal **>Open** of the function block **VTCB** is connected to the voltage-transformer circuit breaker (see chapter [10.3.4.1 Overview of Functions](#)).

Parameter Value	Description
<i>yes</i>	The protection function is blocked (= default setting). Siemens recommends using the default setting.
<i>no</i>	The protection function is not blocked.

6.26.3.3 Settings

Addr.	Parameter	C	Setting Options	Default Setting
<i>General</i>				
_:2311:10	General:Blk. by meas.-volt. failure		<ul style="list-style-type: none"> • no • yes 	yes
_:2311:101	General:Measuring window		1 cycles to 10 cycles	1 cycles

6.26.3.4 Information List

No.	Information	Data Class (Type)	Type
<i>General</i>			
_:2311:301	General:V2 average	MV	O
_:2311:52	General:Behavior	ENS	O
_:2311:53	General:Health	ENS	O

6.26.4 Stage with Negative-Sequence Voltage

6.26.4.1 Description

Logic of a Stage

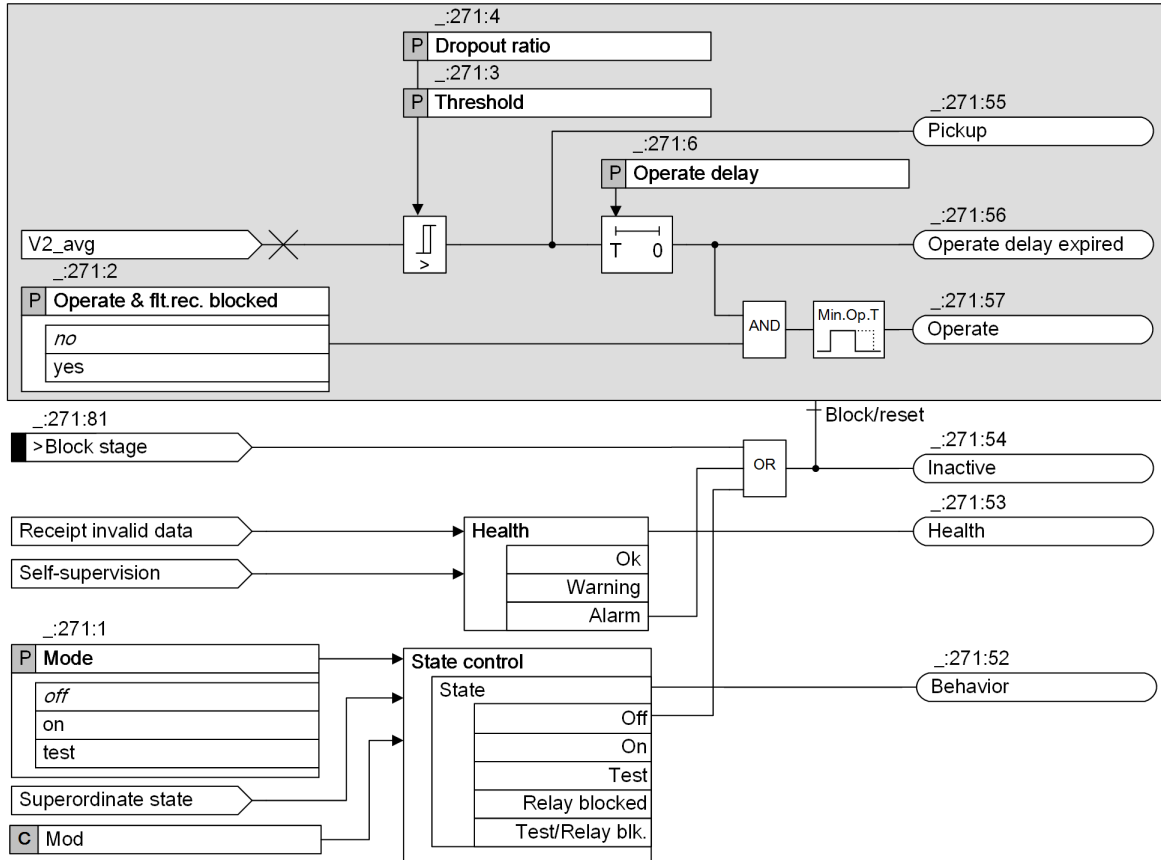

[10_ovp_v2_3pol_4_en_US]

Figure 6-187 Logic Diagram of the Stage: Overvoltage Protection with Negative-Sequence Voltage

Method of Measurement

The stage uses the average value of the negative-sequence voltage, which is calculated from the function block **General Functionality**. For more information, refer to chapter [6.26.3.1 Description](#).

Blocking the Stage

In case of blocking, the picked up function is reset. The following blocking option is available for the function:

- From an external or internal source via the binary input signal *>Block stage*

6.26.4.2 Application and Setting Notes

Parameter: Threshold

- Default setting (_:271:3) **Threshold** = 5.800 V

The parameter **Threshold** is set according to the definition of the negative-sequence system.

Specify the **Threshold** (pickup threshold) for the specific application.

The secondary voltage of the voltage transformer can be used if the voltage transformer is adapted to the rated voltage. The value of the 10 % negative-sequence voltage at a 100 V rated secondary voltage is:

$$100 \text{ V} / 1.73 * 0.1 = 5.77 \text{ V}$$

Parameter: Dropout ratio

- Default setting (`_:271:4`) **Dropout ratio** = 0.95

The default setting of 0.95 is appropriate for most applications.

You can decrease the dropout ratio to avoid chattering of the stage if the threshold value is low. For example, for the stage with a 2 % setting, you can use a dropout ratio of 0.90.

Parameter: Operate delay

- Default setting (`_:271:6`) **Operate delay** = 3.00 s

Specify the **Operate delay** for the specific application. 3.00 s is a practicable value.

For a higher threshold value, a shorter tripping delay is required.

Operation as Supervision Function

If you want the stage to have a reporting effect only, generation of the operate indication and fault logging can be disabled via the `Operate & flt.rec. blocked` parameter.

Example 1:

Releasing an overcurrent protection stage for unbalanced faults

The following section describes how to set the function to release an **Overcurrent-protection** stage when unbalanced faults occur. Set the **Overcurrent-protection** stage only slightly higher than the load current, that is very sensitive. To prevent the **Overcurrent-protection** stage from picking up inadvertently, the **Overcurrent-protection** stage is released when the **Negative-sequence voltage** stage picks up. The **Overcurrent-protection** stage remains blocked as long as the **Negative-sequence voltage** stage has not picked up.

[Figure 6-188](#) shows the voltage phasors during a 2-phase local fault between phases B and C. The phase-to-phase voltage V_{BC} is virtually 0.

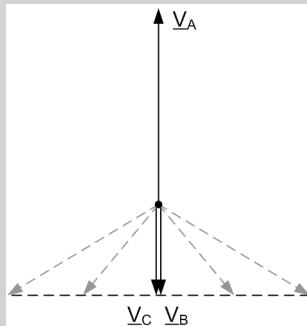

[dw_ua_zelig_1_en_US]

Figure 6-188 Voltage Phasors during a 2-Phase Local Fault

A 2-phase local fault generates a relatively large negative-sequence voltage of up to 50 % referred to the phase-to-ground voltage. The portion of the negative-sequence decreases in case of a remote fault. The lower setting limit results from the possible unbalance at full load. If you assume for example 5 % negative-sequence voltage, the pickup value must be higher. A setting value of 10 % warrants sufficient stability during unbalanced operating states and sufficient sensitivity to release the **Overcurrent-protection** stage when a fault occurs.

For a secondary rated voltage of 100 V, set the following secondary threshold value:

$$V_{2_{\text{sec}}} = \frac{V_{\text{rated}} 100 \text{ V}}{\sqrt{3}} \times 10 \% = \frac{100 \text{ V}}{\sqrt{3}} \times 0.1 \approx 5.8 \text{ V}$$

[f6_ovp_v2_secondary.threshold_1_en_US]

You can keep the default setting of 0.95 for the dropout ratio. This avoids chattering of the stage.

Set the **Negative-sequence voltage** stage so that it does not generate a fault when it picks up and does not initiate tripping. The **Overcurrent-protection** stage generates a fault indication. The pickup of the **Negative-sequence voltage** stage is used as the release criterion because the **Short-circuit** function must be released immediately when the **Negative-sequence voltage** stage has picked up. The time delay is thus not relevant and can be left at the default setting.

You implement the release of the **Overcurrent-protection** stage using a logic block chart. An inverter links the pickup of the **Negative-sequence voltage** stage with the **Overcurrent-protection** stage blocking.

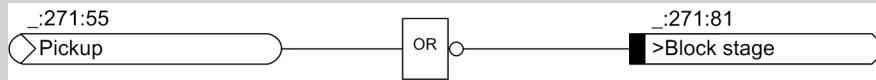

[!o_invert, 1, en_US]

Figure 6-189 Linking the Pickup of the Negative-Sequence Voltage Stage

Stage	Setting Values		
	Secondary Threshold Value	Time Delay	Dropout Ratio
1	5.800 V	3.00 s	0.95

The second stage is not needed. It is deleted or remains off.

Example 2:

A negative-sequence voltage in the auxiliary system of the power plant causes negative-sequence currents on motors. This leads to a thermal overload of the rotors. The following estimation can be used as a basis: 1 % negative-sequence voltage can lead to approximately 5 % or 6 % negative-sequence current.

A negative-sequence voltage can be caused by a broken conductor on the high-voltage side. If a negative-sequence voltage occurs, this can, for example, initiate a switching of the infeed in order to prevent a protection trip of an unbalanced-load protection of the motors.

Siemens recommends using multiple stages for a better grading, whereby a sensitive setting of the threshold permits an increased tripping delay.

For a reference, only 2 stages are discussed.

The first stage has a pickup threshold of 10 % with a time delay of 1.5 s. The second stage has a pickup threshold of 3 % with a time delay of 8 s, see [Table 6-15](#). Further, it is assumed that the voltage transformer is well adapted to the rated voltage.

$$V2_{sec} = \frac{100 \text{ V}}{1.73} \times \frac{V2 [\%]}{100\%}$$

[!fo_ovp_v2_secondary_threshold2, 1, en_US]

Table 6-15 Recommended Settings

Stage	Threshold	Operate Delay
Stage 1	5.800 V	1.50 s
Stage 2	1.730 V	8.00 s

6.26.4.3 Settings

Addr.	Parameter	C	Setting Options	Default Setting
Stage 1				
_:271:1	Stage 1:Mode		<ul style="list-style-type: none"> • off • on • test 	off
_:271:2	Stage 1:Operate & flt.rec. blocked		<ul style="list-style-type: none"> • no • yes 	no

Addr.	Parameter	C	Setting Options	Default Setting
_:271:3	Stage 1:Threshold		0.300 V to 200.000 V	5.800 V
_:271:4	Stage 1:Dropout ratio		0.90 to 0.99	0.95
_:271:6	Stage 1:Operate delay		0.00 s to 60.00 s	3.00 s
Stage 2				
_:272:1	Stage 2:Mode		<ul style="list-style-type: none"> • off • on • test 	off
_:272:2	Stage 2:Operate & flt.rec. blocked		<ul style="list-style-type: none"> • no • yes 	no
_:272:3	Stage 2:Threshold		0.300 V to 200.000 V	9.000 V
_:272:4	Stage 2:Dropout ratio		0.90 to 0.99	0.95
_:272:6	Stage 2:Operate delay		0.00 s to 60.00 s	0.50 s

6.26.4.4 Information List

No.	Information	Data Class (Type)	Type
General			
_:2311:301	General:V2 average	MV	O
_:2311:52	General:Behavior	ENS	O
_:2311:53	General:Health	ENS	O
Group indicat.			
_:4501:55	Group indicat.:Pickup	ACD	O
_:4501:57	Group indicat.:Operate	ACT	O
_:4501:52	Group indicat.:Behavior	ENS	O
_:4501:53	Group indicat.:Health	ENS	O
Stage 1			
_:271:81	Stage 1:>Block stage	SPS	I
_:271:51	Stage 1:Mode (controllable)	ENC	C
_:271:54	Stage 1:Inactive	SPS	O
_:271:52	Stage 1:Behavior	ENS	O
_:271:53	Stage 1:Health	ENS	O
_:271:55	Stage 1:Pickup	ACD	O
_:271:56	Stage 1:Operate delay expired	ACT	O
_:271:57	Stage 1:Operate	ACT	O
Stage 2			
_:272:81	Stage 2:>Block stage	SPS	I
_:272:51	Stage 2:Mode (controllable)	ENC	C
_:272:54	Stage 2:Inactive	SPS	O
_:272:52	Stage 2:Behavior	ENS	O
_:272:53	Stage 2:Health	ENS	O
_:272:55	Stage 2:Pickup	ACD	O
_:272:56	Stage 2:Operate delay expired	ACT	O
_:272:57	Stage 2:Operate	ACT	O

6.27 Overvoltage Protection with Any Voltage

6.27.1 Overview of Functions

The function **Overvoltage protection with any voltage** (ANSI 59) detects any 1-phase overvoltages and is intended for special applications.

6.27.2 Structure of the Function

The **Overvoltage protection with any voltage** function is used in protection function groups, which are based on voltage measurement.

The function **Overvoltage protection with any voltage** comes factory-set with 2 stages. A maximum of 3 tripping stages can be operated simultaneously in the function. The tripping stages have an identical structure.

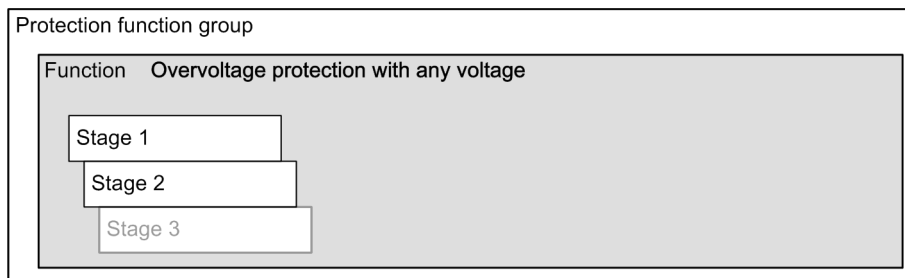

[dw_ovp_uxs_1_en_US]

Figure 6-190 Structure/Embedding of the Function

6.27.3 Stage Description

Logic of a Stage

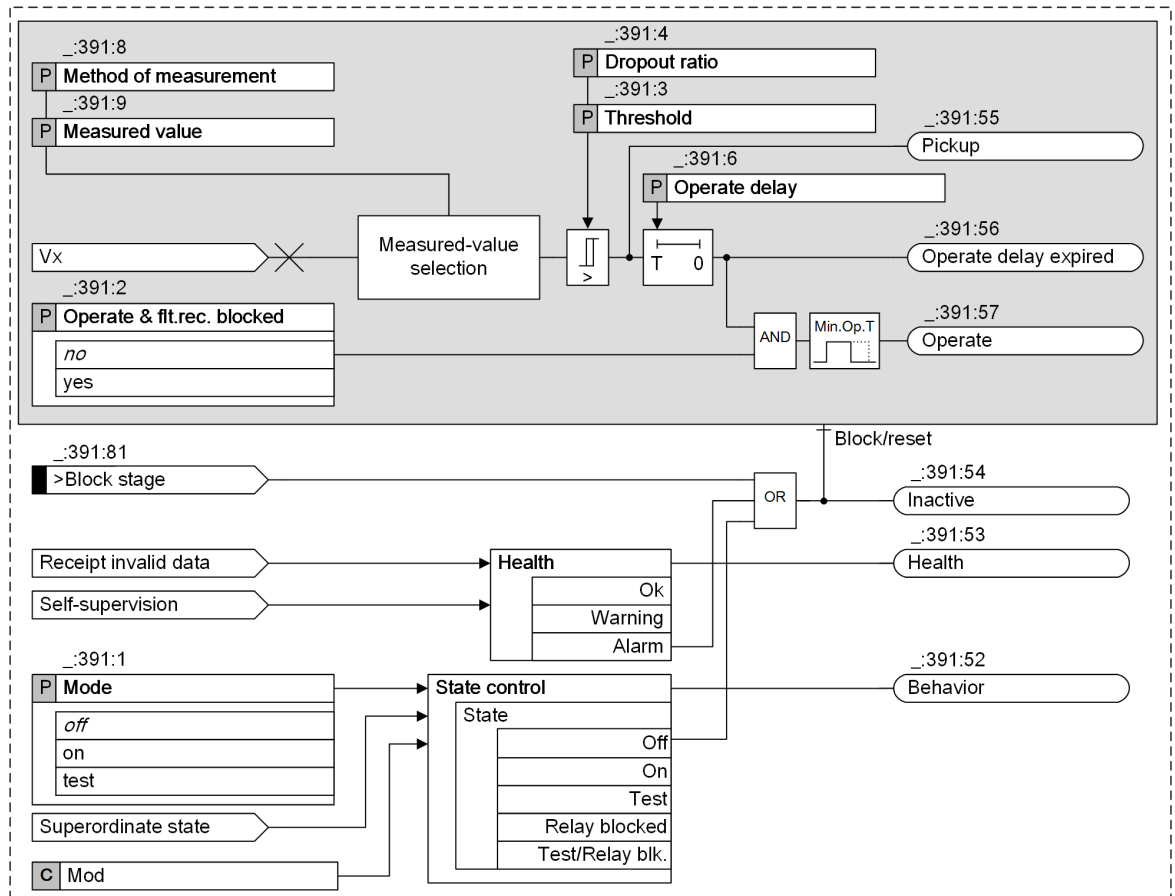

[file:ovp_vx_any-volt_2_en_US]

Figure 6-191 Logic Diagram of a Stage: Overvoltage Protection with Any Voltage



NOTE

If the function **Overvoltage protection with any voltage** is used in a 1-phase function group, the parameter **Measured value** is not visible.

Method of Measurement

The **Method of measurement** parameter allows you to define whether the function works with the fundamental component or the calculated RMS value.

- Measurement of the **fundamental comp.:**
This method of measurement processes the sampled voltage values and filters out the fundamental component numerically.
- Measurement of the parameter value **RMS value:**
This method of measurement determines the voltage amplitude from the sampled values according to the defining equation of the RMS value. Harmonics are included in the analysis.

Measured Value

The parameter **Measured value** allows you to select whether the stage uses a measured (directly connected) voltage or a calculated phase-to-phase voltage.

If the function **Overvoltage protection with any voltage** is used in a 1-phase function group, the parameter **Measured value** is not visible.

Blocking the Stage

In the event of blocking, the picked up stage will be reset. Blocking is possible externally or internally via the binary input signal *>Block stage*.

6.27.4 Application and Setting Notes

Parameter: Method of measurement

- Recommended setting value (`_:391:8`) **Method of measurement = *fundamental comp.***

Use the **Method of measurement** parameter to define whether the tripping stage uses the fundamental component (standard method = default setting) or the calculated RMS value.

Parameter Value	Description
<i>fundamental comp.</i>	Select this method of measurement to suppress harmonics or transient voltage peaks. Siemens recommends this method of measurement as the default setting.
<i>RMS value</i>	Select this method of measurement if you want the stage to take harmonics into account (for example at capacitor banks). Do not set the threshold value of the tripping stage under 10 V for this method of measurement.

Parameter: Measured value

- Default setting (`_:391:9`) **Measured value = *VA measured***

The **Measured value** parameter is used to specify which voltage is monitored by the stage.

The scope of setting options depends on the connection type for the voltage transformers and the routing of the measured values to the terminals of the voltage measuring point. You can find connection examples for voltage transformers in the *Appendix*.

The following setting options can be available:

- Measured phase-to-ground voltage V_A (*VA measured*)
- Measured phase-to-ground voltage V_B (*VB measured*)
- Measured phase-to-ground voltage V_C (*VC measured*)
- Measured phase-to-phase voltage V_{AB} (*VAB measured*)
- Measured phase-to-phase voltage V_{BC} (*VBC measured*)
- Measured phase-to-phase voltage V_{CA} (*VCA measured*)
- Calculated phase-to-phase voltage V_{AB} (*VAB calculated*)
- Calculated phase-to-phase voltage V_{BC} (*VBC calculated*)
- Calculated phase-to-phase voltage V_{CA} (*VCA calculated*)
- Calculated voltage V_0 (*V0 calculated*)

The selection depends on the corresponding application.



NOTE

From V7.30 on, the value **VN measured** is no longer provided. If you have selected this value in earlier versions, you can use either the following methods instead after upgrading the configuration to V7.30 or a later version:

- Select the value **V0 calculated** for the **Measured value** parameter in the function **Overvoltage protection with any voltage**.
- Use the function **Overvoltage protection with zero-sequence voltage/residual voltage**.

If the function **Overvoltage protection with any voltage** is used in a 1-phase function group, the parameter **Measured value** is not visible.

Parameter: Threshold

- Default setting (**_:391:3**) **Threshold = 110 V**

Specify the **Threshold** (pickup threshold) for the specific application.

Depending on the measured value, the **Threshold** is set either as **Measured voltage** or as **Phase-to-phase** quantity.



NOTE

If the function is used in a **Voltage-current 1-phase** function group connected to the 1-phase voltage measuring point with the voltage type **VN broken-delta**, you set the threshold value based on the equivalent zero-sequence voltage.

Calculate the equivalent zero-sequence voltage $V_{0 \text{ equiv. sec}}$ from the measured voltage $V_{N \text{ sec}}$ with the following formula:

$$\frac{V_{0 \text{ equiv. sec}}}{V_{N \text{ sec}}} = \frac{\text{Matching ratio } V_{ph}/V_N}{3}$$

For more information about the parameter **Matching ratio Vph / VN**, refer to [6.1.6 Application and Setting Notes for Measuring Point Voltage 3-Phase \(V-3ph\)](#).

Parameter: Operate delay

- Default setting (**_:391:6**) **Operate delay = 3 s**

The **Operate delay** must be set for the specific application.

Parameter: Dropout ratio

- Recommended setting value (**_:391:4**) **Dropout ratio = 0.95**

The recommended set value of **0.95** is appropriate for most applications. To achieve high measurement precision, the **Dropout ratio** can be reduced, to 0.98, for example.

Operation as Supervision Function

If you want the tripping stage to have a reporting effect only, generation of the operate indication and fault logging can be disabled via the **Operate & flt.rec. blocked** parameter.

6.27.5 Settings

Addr.	Parameter	C	Setting Options	Default Setting
Stage 1				
_:391:1	Stage 1:Mode		<ul style="list-style-type: none"> • off • on • test 	off
_:391:2	Stage 1:Operate & flt.rec. blocked		<ul style="list-style-type: none"> • no • yes 	no
_:391:9	Stage 1:Measured value		<ul style="list-style-type: none"> • VA measured • VB measured • VC measured • VAB calculated • VBC calculated • VCA calculated • V0 calculated 	VA measured
_:391:8	Stage 1:Method of measurement		<ul style="list-style-type: none"> • fundamental comp. • RMS value 	fundamental comp.
_:391:3	Stage 1:Threshold		0.300 V to 340.000 V	110.000 V
_:391:4	Stage 1:Dropout ratio		0.90 to 0.99	0.95
_:391:6	Stage 1:Operate delay		0.00 s to 60.00 s	3.00 s
Stage 2				
_:392:1	Stage 2:Mode		<ul style="list-style-type: none"> • off • on • test 	off
_:392:2	Stage 2:Operate & flt.rec. blocked		<ul style="list-style-type: none"> • no • yes 	no
_:392:9	Stage 2:Measured value		<ul style="list-style-type: none"> • VA measured • VB measured • VC measured • VAB measured • VBC measured • VCA measured • VAB calculated • VBC calculated • VCA calculated • V0 calculated 	VA measured
_:392:8	Stage 2:Method of measurement		<ul style="list-style-type: none"> • fundamental comp. • RMS value 	fundamental comp.
_:392:3	Stage 2:Threshold		0.300 V to 340.000 V	130.000 V
_:392:4	Stage 2:Dropout ratio		0.90 to 0.99	0.95
_:392:6	Stage 2:Operate delay		0.00 s to 60.00 s	0.50 s

6.27.6 Information List

No.	Information	Data Class (Type)	Type
Group indicat.			
_:4501:55	Group indicat.:Pickup	ACD	O
_:4501:57	Group indicat.:Operate	ACT	O
_:4501:52	Group indicat.:Behavior	ENS	O
_:4501:53	Group indicat.:Health	ENS	O
Stage 1			
_:391:81	Stage 1:>Block stage	SPS	I
_:391:51	Stage 1:Mode (controllable)	ENC	C
_:391:54	Stage 1:Inactive	SPS	O
_:391:52	Stage 1:Behavior	ENS	O
_:391:53	Stage 1:Health	ENS	O
_:391:55	Stage 1:Pickup	ACD	O
_:391:56	Stage 1:Operate delay expired	ACT	O
_:391:57	Stage 1:Operate	ACT	O
Stage 2			
_:392:81	Stage 2:>Block stage	SPS	I
_:392:51	Stage 2:Mode (controllable)	ENC	C
_:392:54	Stage 2:Inactive	SPS	O
_:392:52	Stage 2:Behavior	ENS	O
_:392:53	Stage 2:Health	ENS	O
_:392:55	Stage 2:Pickup	ACD	O
_:392:56	Stage 2:Operate delay expired	ACT	O
_:392:57	Stage 2:Operate	ACT	O

6.28 Overvoltage Protection with Negative-Sequence Voltage/Positive-Sequence Voltage

6.28.1 Overview of Functions

The function **Overvoltage protection with negative-sequence voltage/positive-sequence voltage** is used to:

- Monitor the power system and electric machines for voltage unbalances
- Establish a release criterion of overcurrent protection for unbalanced faults

Voltage unbalances can be caused by various factors:

- The most common cause is unbalanced load, caused by different consumers in the individual phases, for example.
- Voltage unbalance can also be caused by phase failure, for example due to a tripped 1-phase fuse, a broken conductor, etc.
- Other causes can include faults in the primary system, for example, at the transformer or in installations for reactive-power compensation.

6.28.2 Structure of the Function

The **Overvoltage protection with negative-sequence voltage/positive-sequence voltage** function is used in protection function groups, which are based on voltage measurement.

The **Overvoltage protection with negative-sequence voltage/positive-sequence voltage** function comes factory-set with 2 stages. A maximum of 3 stages can be operated simultaneously in the function. The stages have an identical structure.

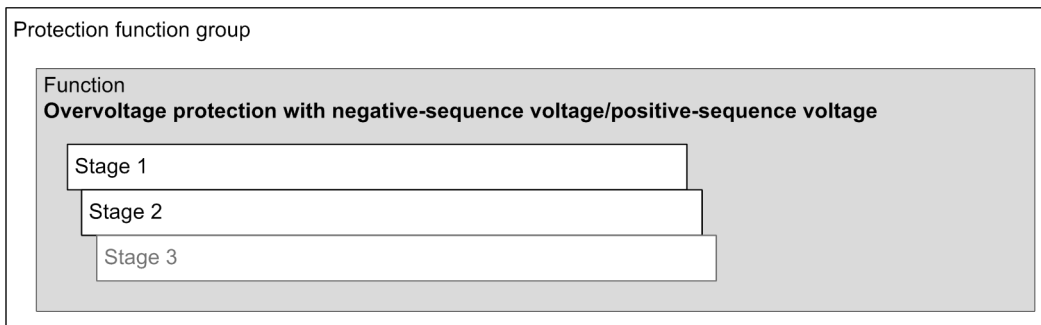

[lo_structure_V2_V1_2_en_US]

Figure 6-192 Structure/Embedding of the Function

6.28.3 General Functionality

6.28.3.1 Description

Logic

The following figure represents the logic of the average-value calculation of the ratio of negative-sequence voltage to positive-sequence voltage. The average value is forwarded to all subordinate stages.

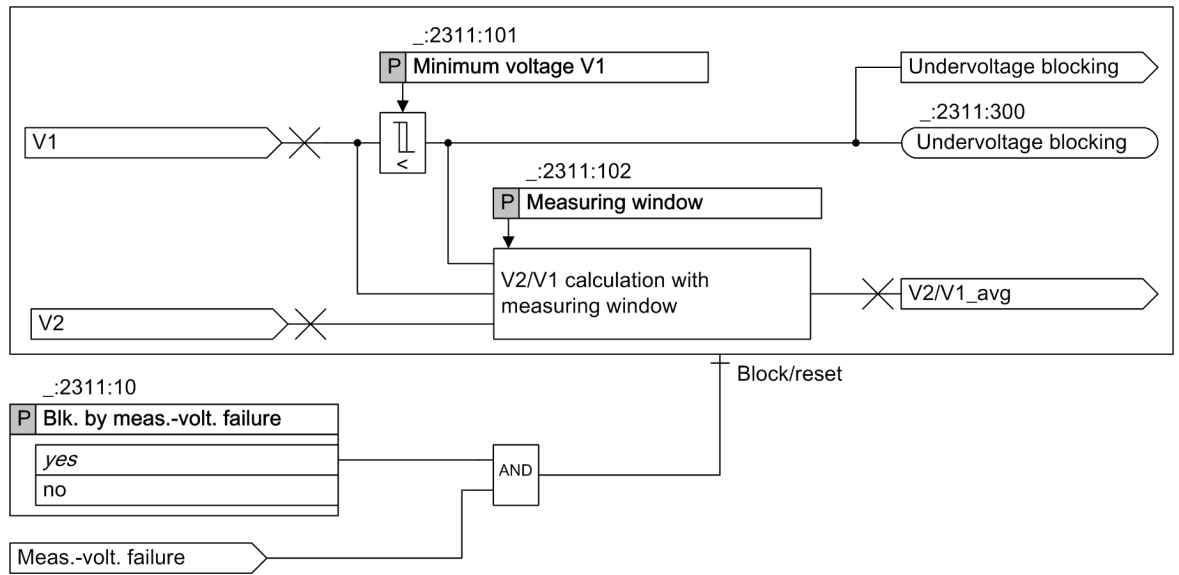

[to_V2-to-V1_FB general, 1, en_US]

Figure 6-193 Logic Diagram of the General Functionality

Measurand

The average value of the ratio of negative-sequence voltage to positive-sequence voltage is determined by a settable time interval (parameter: **Measuring window**). With the parameter **Measuring window**, you can adapt this function to all power-system conditions.

You can set the parameter **Measuring window** with a large value to get a more accurate calculated result, which leads to a longer pickup time however.

Blocking the Function with Measuring-Voltage Failure Detection

In case of blocking, the picked up function is reset. The following blocking options is available for the function:

- From inside on pick up of the **Measuring-voltage failure detection** function (see section [10.3.2.1 Overview of Functions](#)).
- From an external source via the binary input signal *>Open* of the function block **Volt.-transf. c. b.**, which links in the tripping of the voltage-transformer circuit breaker.

The parameter **Blk. by meas.-volt. failure** can be set so that the measuring-voltage failure detection blocks the function or does not block it.

6.28.3.2 Application and Setting Notes

Parameter: Measuring window

- Default setting (_:2311:102) **Measuring window** = 1 cycle

With the parameter **Measuring window**, you can optimize the measuring accuracy or the pickup time of this function.

For sensitive settings of the parameter **Threshold**, for example, lower than 10 % of the rated voltage, Siemens recommends using a higher number of cycles. Siemens recommends **10 cycles**, and in this case, the pickup time is increased.

For further information, refer to chapter [14.35 Overvoltage Protection with Negative-Sequence Voltage/Positive-Sequence Voltage](#).

Parameter: Blk. by meas.-volt. failure

- Recommended setting value (_:2311:10) **Blk. by meas.-volt. failure** = yes

You use the **Blk. by meas.-volt. failure** parameter to control the behavior of the function when a measuring-voltage failure is detected.

A measuring-voltage failure can only be detected if one of the following 2 conditions is met:

- The device-internal supervision function **Measuring-voltage failure detection** is configured and switched on.
- The binary input signal **>Open** of the function block **vTCB** is connected to the voltage-transformer circuit breaker (see chapter [10.3.4.1 Overview of Functions](#)).

Parameter Value	Description
yes	The protection function is blocked (= default setting). Siemens recommends using the default setting.
no	The protection function is not blocked.

6.28.3.3 Settings

Addr.	Parameter	C	Setting Options	Default Setting
General				
_:2311:10	General:Blk. by meas.-volt. failure		<ul style="list-style-type: none"> • no • yes 	yes
_:2311:102	General:Measuring window		1 cycles to 10 cycles	1 cycles
_:2311:101	General:Minimum voltage V1		0.300 V to 60.000 V	5.000 V

6.28.3.4 Information List

No.	Information	Data Class (Type)	Type
General			
_:2311:300	General:Undervoltage blocking	SPS	0
_:2311:301	General:V2/V1	MV	0
_:2311:52	General:Behavior	ENS	0
_:2311:53	General:Health	ENS	0

6.28.4 Stage with Negative-Sequence Voltage/Positive-Sequence Voltage

6.28.4.1 Description

Logic of a Stage

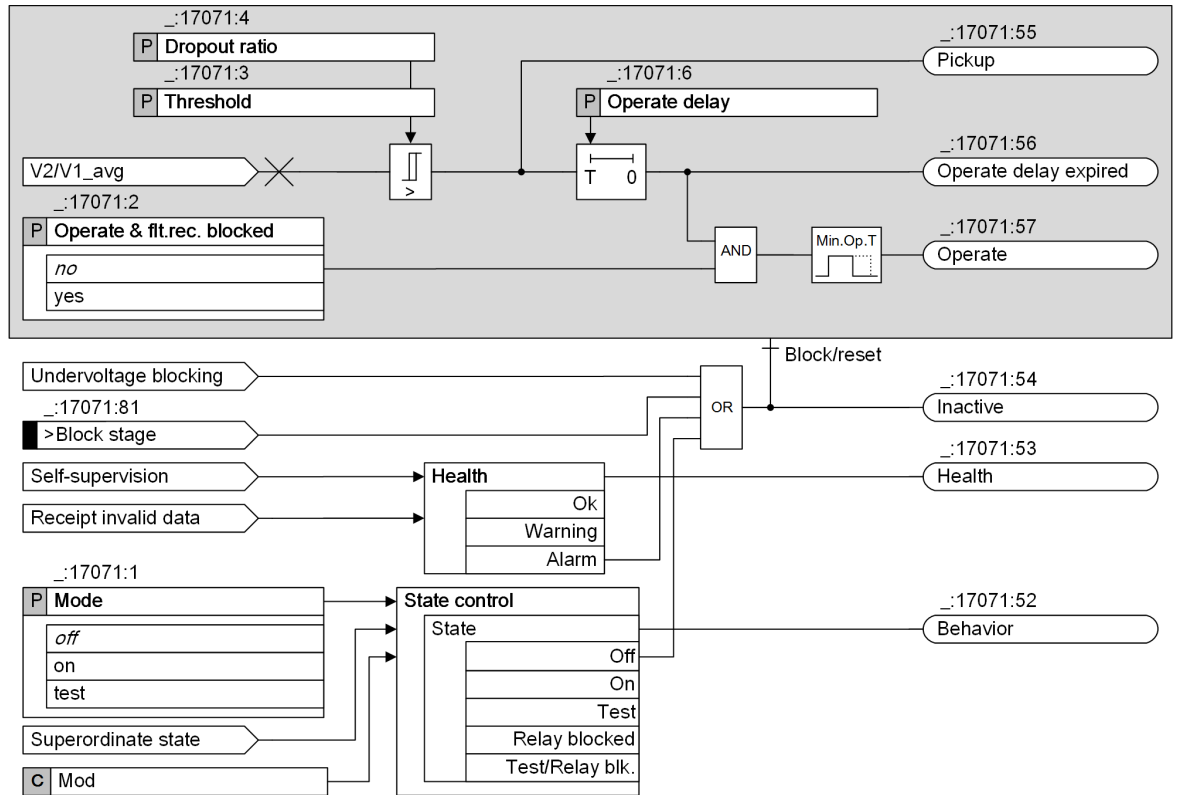

[to_V2_V1_Prov, 2, en_US]

Figure 6-194 Logic Diagram of the Stage: Overvoltage Protection with Negative-Sequence Voltage/Positive-Sequence Voltage

Method of Measurement

The stage uses the average value of the negative-sequence voltage/positive-sequence voltage, which is calculated from the function block **General Functionality**. For more information, refer to chapter [6.28.3.1 Description](#).

Blocking the Stage

In case of blocking, the picked up function is reset. The following blocking option is available for the function:

- From an external or internal source via the binary input signal *>Block stage*

6.28.4.2 Application and Setting Notes

Parameter: Threshold

- Default setting (`_:17071:3`) **Threshold** = 10.00 %

The parameter **Threshold** is set in percentage according to the definition of the symmetrical components. It is the ratio of the negative-sequence voltage to positive-sequence voltage.

Specify the **Threshold** (pickup threshold) for the specific application.

In the application with a lower threshold setting of about 2.00 %, there is a risk of an overfunction due to the measuring errors with small values as well as an influence via disturbances.

Parameter: Dropout ratio

- Default setting (`_:17071:4`) **Dropout ratio** = 0.95

The default setting of 0.95 is appropriate for most applications if a higher threshold is used.

You can decrease the dropout ratio to avoid chattering of the stage if the threshold value is low. For example, for the stage with a 2 % setting, you can use a dropout ratio of 0.90.

Parameter: Operate delay

- Default setting (`_:17071:6`) **Operate delay** = 3.00 s

Specify the **Operate delay** for the specific application. When using the sensitive setting of the threshold value that is described in this chapter, the function can be delayed by 3.00 s.

For a higher threshold value, a shorter tripping delay is required.

Operation as Supervision Function

If you want the stage to have a reporting effect only, generation of the operate indication and fault logging can be disabled via the `Operate & flt.rec. blocked` parameter.

Example 1:

Releasing an overcurrent protection stage for unbalanced faults

The following section describes how to set the function to release an **Overcurrent-protection** stage when unbalanced faults occur. Set the **Overcurrent-protection** stage only slightly higher than the load current, that is very sensitive. To prevent the **Overcurrent-protection** stage from picking up inadvertently, the **Overcurrent-protection** stage is released when the **Negative-sequence voltage** stage picks up. The **Overcurrent-protection** stage remains blocked as long as the **Negative-sequence voltage** stage has not picked up.

Figure 6-195 shows the voltage phasors during a 2-phase local fault between phases B and C. The phase-to-phase voltage V_{BC} is virtually 0.

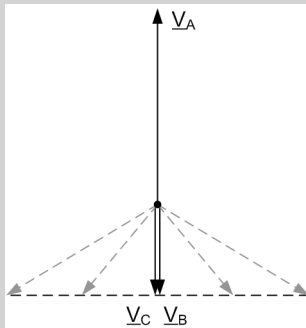

[dw_ua_zeig_1_en_US]

Figure 6-195 Voltage Phasors during a 2-Phase Local Fault

A 2-phase local fault generates a relatively large negative-sequence voltage of up to 100 % referred to the positive-sequence voltage. The portion of the negative-sequence decreases in case of a remote fault. The lower setting limit results from the possible unbalance at full load. If you assume for example 5 % of the negative-sequence voltage to positive-sequence voltage, the pickup value must be higher. A setting value of 10 % warrants sufficient stability during unbalanced operating states and sufficient sensitivity to release the **Overcurrent-protection** stage when a fault occurs.

You can keep the default setting of 0.95 for the dropout ratio. This avoids chattering of the stage.

Set the **Negative-sequence voltage** stage so that it does not generate a fault when it picks up and does not initiate tripping. The **Overcurrent-protection** stage generates a fault indication. The pickup of the **Negative-sequence voltage** stage is used as the release criterion because the **Short-circuit** function must be released immediately when the **Negative-sequence voltage** stage has picked up. The time delay is thus not relevant and can be left at the default setting.

You implement the release of the **Overcurrent-protection** stage using a logic block chart. An inverter links the pickup of the **Negative-sequence voltage** stage with the **Overcurrent-protection** stage blocking.

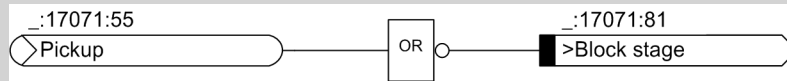

[lo_pickup v2, 1, en_US]

Figure 6-196 Linking the Pickup of the Negative-Sequence Voltage Stage

Stage	Setting Values		
	Percentage of the Negative-Sequence Voltage to Positive-Sequence Voltage	Time Delay	Dropout Ratio
1	10.00 %	3.00 s	0.95

The second stage is not needed. It is deleted or remains off.

Example 2:

A negative-sequence voltage in the auxiliary system of the power plant causes negative-sequence currents on motors. This leads to a thermal overload of the rotors. The following estimation can be used as a basis: 1 % negative-sequence voltage can lead to approximately 5 % or 6 % negative-sequence current.

A negative-sequence voltage can be caused by a broken conductor on the high-voltage side. If a negative-sequence voltage occurs, this can, for example, initiate a switching of the infeed in order to prevent a protection trip of an unbalanced-load protection of the motors.

Siemens recommends using multiple stages for a better grading, whereby a sensitive setting of the threshold permits an increased tripping delay.

For a reference, only 2 stages are discussed.

The first stage has a pickup threshold of 10 % with a time delay of 1.5 s. The second stage has a pickup threshold of 3 % with a time delay of 8 s, see [Table 6-16](#).

Table 6-16 Recommended Settings

Stage	Threshold	Operate Delay
Stage 1	10.00 %	1.50 s
Stage 2	3.00 %	8.00 s

6.28.4.3 Settings

Addr.	Parameter	C	Setting Options	Default Setting
Stage 1				
_:17071:1	Stage 1:Mode		<ul style="list-style-type: none"> • off • on • test 	off
_:17071:2	Stage 1:Operate &flt.rec. blocked		<ul style="list-style-type: none"> • no • yes 	no
_:17071:3	Stage 1:Threshold		0.50 % to 100.00 %	10.00 %
_:17071:4	Stage 1:Dropout ratio		0.90 to 0.99	0.95
_:17071:6	Stage 1:Operate delay		0.00 s to 60.00 s	3.00 s
Stage 2				
_:17072:1	Stage 2:Mode		<ul style="list-style-type: none"> • off • on • test 	off

Addr.	Parameter	C	Setting Options	Default Setting
_:17072:2	Stage 2:Operate & flt.rec. blocked		<ul style="list-style-type: none"> • no • yes 	no
_:17072:3	Stage 2:Threshold		0.50 % to 100.00 %	15.00 %
_:17072:4	Stage 2:Dropout ratio		0.90 to 0.99	0.95
_:17072:6	Stage 2:Operate delay		0.00 s to 60.00 s	0.50 s

6.28.4.4 Information List

No.	Information	Data Class (Type)	Type
Stage 1			
_:17071:81	Stage 1:>Block stage	SPS	I
_:17071:54	Stage 1:Inactive	SPS	O
_:17071:52	Stage 1:Behavior	ENS	O
_:17071:53	Stage 1:Health	ENS	O
_:17071:55	Stage 1:Pickup	ACD	O
_:17071:56	Stage 1:Operate delay expired	ACT	O
_:17071:57	Stage 1:Operate	ACT	O
Stage 2			
_:17072:81	Stage 2:>Block stage	SPS	I
_:17072:54	Stage 2:Inactive	SPS	O
_:17072:52	Stage 2:Behavior	ENS	O
_:17072:53	Stage 2:Health	ENS	O
_:17072:55	Stage 2:Pickup	ACD	O
_:17072:56	Stage 2:Operate delay expired	ACT	O
_:17072:57	Stage 2:Operate	ACT	O

6.29 Undervoltage Protection with 3-Phase Voltage

6.29.1 Overview of Functions

The function **Undervoltage protection with 3-phase voltage** (ANSI 27):

- Monitors the permissible voltage range
- Protects equipment (for example, plant components and machines) against damages caused by undervoltage
- Handles disconnection or load shedding tasks in a system

6.29.2 Structure of the Function

The function **Undervoltage protection with 3-phase voltage** is used in protection function groups with voltage measurement.

The function **Undervoltage protection with 3-phase voltage** comes factory-set with 2 **Definite-time undervoltage protection** stages.

In the function **Undervoltage protection with 3-phase voltage**, the following stages can be operated simultaneously:

- 3 stages **Definite-time undervoltage protection**
- 2 stages **Inverse-time undervoltage protection**

Stages that are not preconfigured are shown in gray in the following figure.

The protection function is structured such that one current-flow criterion can act on all undervoltage protection stages (see [Figure 6-197](#)). If the protection function group used has no current measurement, you can only set the current-flow criterion as **fulfilled** via the corresponding binary input signal.

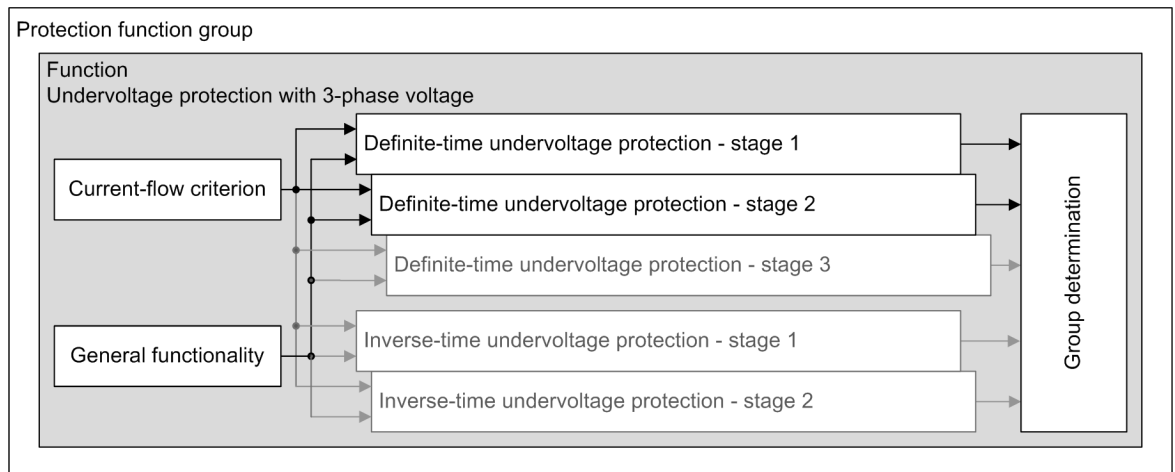

[dw_stru_3p_5_en_US]

Figure 6-197 Structure/Embedding of the Function

6.29.3 Stage with Definite-Time Characteristic Curve

6.29.3.1 Description

Logic of the Stage

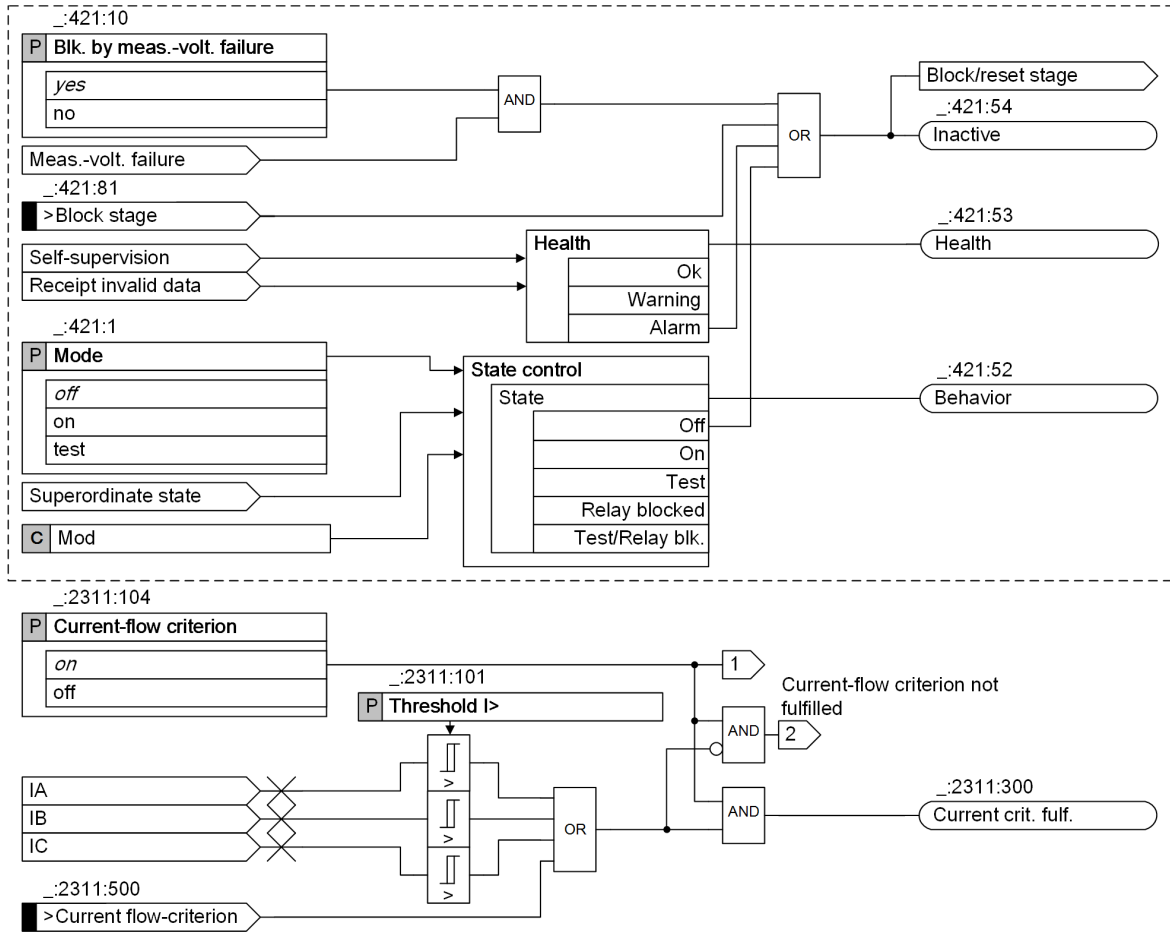

[lo_uvp_3phs_stage-control_4_en_US]

Figure 6-198 Logic Diagram Stage Control

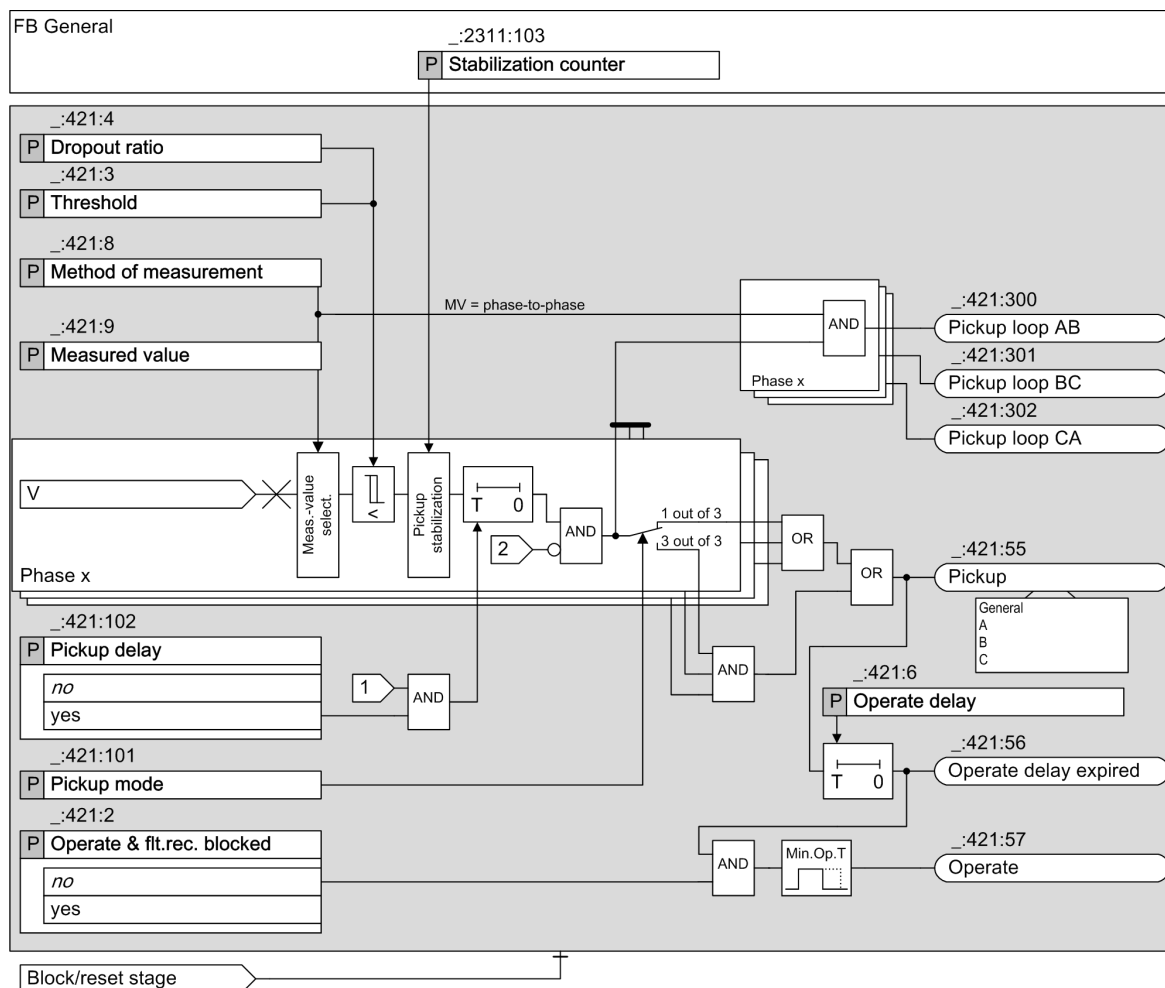

[to_uvp_3ph_3_en_US]

Figure 6-199 Logic Diagram of the Definite-Time Undervoltage Protection with 3-Phase Voltage

Method of Measurement

With the **Method of measurement** parameter, you select the relevant method of measurement, depending on the application.

- **Measurement fundamental component:**
This method of measurement processes the sampled voltage values and filters out the fundamental component numerically.
- **Measurement RMS value:**
This method of measurement determines the voltage amplitude from the sampled values according to the defining equation of the RMS value. Harmonics are included in the analysis.

Measured Value

With the **Measured value** parameter, you define whether the stage analyzes the phase-to-phase voltages $V_{AB'}$, $V_{BC'}$ and $V_{CA'}$, or the phase-to-ground voltages $V_{A'}$, $V_{B'}$ and $V_{C'}$.

If the measured value is set to phase-to-phase, the function reports those measuring elements that have picked up.

Pickup Stabilization

To enable the pickup stabilization, you set the **Stabilization counter** parameter to a value other than 0. Then, if the input voltage keeps being below the **Threshold** for a specified number ($1 + \text{Stabilization}$

counter value) of successive measuring cycles, the stage picks up. For 50 Hz, the measuring cycle time is 10 ms.

If you set this parameter to 0 (default value), the stabilization is not applied. The pickup signal is issued after the input voltage falls below the threshold value.

Pickup Mode

With the **Pickup mode** parameter, you define whether the stage picks up when there is a lower threshold-value violation in one measuring element (*1 out of 3*) or when there is a lower threshold-value violation in all 3 measuring elements (*3 out of 3*).

Pickup Delay

The **Pickup delay** parameter is only available and of relevance if you are using the current-flow criterion of the function (parameter **Current-flow criterion = on**).

If the circuit breaker opens when the current-flow criterion is being used, the undervoltage detection and current-flow dropout functions conflict with one another. Depending on the threshold value settings for undervoltage detection and current-flow criterion, it is possible that the undervoltage is detected before the current-flow criterion has dropped out. In this case, the stage picks up briefly. Use the **Pickup delay** parameter to prevent the stage from briefly picking up in this way when the circuit breaker opens. This is achieved by delaying the pickup by approximately 40 ms.

Current-Flow Criterion

The undervoltage protection stages work optionally with a current-flow criterion. The **Current-flow criterion** works across all tripping stages.

When the **Current-flow criterion** parameter is activated, the undervoltage protection stages only pick up if a settable minimum current (**Threshold I>**) is exceeded. A current below the minimum current blocks the stages.

The current-flow criterion can also be set to **fulfilled** with the binary input signal **>Current flow-criterion**. The function reports when the current-flow criterion is fulfilled.

[Figure 6-199](#) illustrates the influence of the current-flow criterion.



NOTE

If the (**_:2311:104**) **Current-flow criterion** parameter is deactivated, the device picks up immediately if a missing measuring voltage is detected while the undervoltage protection is active. The parameter setting can be changed even when the device has picked up.

Blocking the Stage

In the event of blocking, the picked-up stage will be reset. The following blocking options are available for the stage:

- Via the binary input signal **>Block stage** from an external or internal source
- From inside on pickup of the **Measuring-voltage failure detection** function (see [10.3.2.1 Overview of Functions](#)). The **Blk. by meas.-volt. failure** parameter can be set so that measuring-voltage failure detection blocks the stage or does not block it.
- From an external source via the binary input signal **>Open** of the function block **Volt.-transf. c. b.**, which links in the tripping of the voltage-transformer circuit breaker. The **Blk. by meas.-volt. failure** parameter can be set so that measuring-voltage failure detection blocks the stage or does not block it.

6.29.3.2 Application and Setting Notes

Parameter: Method of measurement

- Recommended setting value (**_:421:8**) **Method of measurement = fundamental comp.**

With the **Method of measurement** parameter, you define whether the stage uses the fundamental component (standard method = default setting) or the calculated RMS value.

Parameter Value	Description
<i>fundamental comp.</i>	Select this method of measurement to suppress harmonics or transient voltage peaks. Siemens recommends using this parameter value as the default setting.
<i>RMS value</i>	Select this method of measurement if you want the stage to take harmonics into account (for example at capacitor banks). Do not set the threshold value of the stage under 10 V for this method of measurement.

Parameter: Measured value

- Recommended setting value (**_:421:9**) **Measured value = phase-to-phase**

With the **Measured value** parameter, you define whether the stage monitors the phase-to-phase voltages $V_{AB'}$, $V_{BC'}$, and $V_{CA'}$, or the phase-to-ground voltages $V_{A'}$, $V_{B'}$, and $V_{C'}$. Parameter Value

Parameter Value	Description
<i>phase-to-phase</i>	If you want to detect voltage dips caused by multiphase short circuits, or generally monitor the voltage range, keep phase-to-phase as the default setting. The function will not pick up on ground faults. Siemens recommends the measured value <i>phase-to-phase</i> as the default setting.
<i>phase-to-ground</i>	Select the <i>phase-to-ground</i> setting if you want to detect voltage unbalances or overvoltage conditions caused by ground faults.

Parameter: Threshold

- Default setting (**_:421:3**) **Threshold = 80 V**

The **Threshold** is set in accordance with the **Measured value** as either a *phase-to-phase* or *phase-to-ground* variable.

Specify the **Threshold** (pickup threshold) for the specific application.

For the default setting, the lower limit of the voltage range to be monitored is assumed to be 80 % of the rated voltage of the protected object.

EXAMPLE:

Rated voltage of the protected object:

$$V_{\text{rated, obj.}} = 10 \text{ kV}$$

Voltage transformer:

$$\text{Ratio}_V = \frac{10 \text{ kV} / \sqrt{3}}{100 \text{ V} / \sqrt{3}}$$

Threshold value:

$$80 \% \text{ of } V_{\text{rated, obj.}}$$

The secondary setting value is calculated as follows:

$$V_{\text{Threshold value, sec}} = \frac{0.8 \cdot V_{\text{rated, obj.}}}{\text{Ratio}_V} = \frac{0.8 \cdot 10 \text{ kV} \cdot 100 \text{ V}}{10 \text{ kV}} = 80 \text{ V}$$

[To schw_lw_2_en_US]

Parameter: Stabilization counter

- Default setting (**_:2311:103**) **Stabilization counter = 0**

You can configure the **Stabilization counter** parameter in the function block **General**.

For special applications, it could be desirable that a short falling of the input voltage below the pickup value does not lead to the pickup of the stage, which starts fault logging and recording. This is achieved by setting the **Stabilization counter** parameter to a value other than zero.

For example, if you set this parameter to **1**, the pickup signal is issued when the voltage keeps being below the **Threshold** for 2 successive measuring cycles. For 50 Hz, the measuring cycle time is 10 ms.

Parameter: Pickup mode

- Recommended setting value (**_:421:101**) **Pickup mode = 1 out of 3**

With the **Pickup mode** parameter, you specify whether the stage picks up when there is a lower threshold-value violation in one measuring element (**1 out of 3**) or when there is a lower threshold-value violation in all 3 measuring elements (**3 out of 3**).

Parameter Value	Description
1 out of 3	Use this setting for protection applications or for monitoring the voltage range. Siemens recommends 1 out of 3 as the default setting. This reflects how the function behaved in previous generations (SIPROTEC 4, SIPROTEC 3).
3 out of 3	Select this setting when using the stage to disconnect from the power system (in the case of wind farms, for example).

Parameter: Pickup delay

- Default setting (**_:421:102**) **Pickup delay = no**

The **Pickup delay** parameter is only available if you are using the current-flow criterion of the function (parameter **Current-flow criterion = on**). If the current-flow criterion is deactivated, no pickup delay is required.

With the **Pickup delay** parameter, you set whether pickup of the stage is to be delayed by approximately 40 ms or not. The delay avoids possible brief pickup of the stage when the circuit breaker opens.

When applied in parallel, the pickup delay and the delay through pickup stabilization add up.

Parameter Value	Description
no	Use this setting if you definitely do not want stage pickup to be subject to a time delay in the event of a fault. This setting results in pickup and, where applicable, tripping being performed as quickly as possible. Note that switching procedures (opening of the CB) can result in brief pickup of the stage, depending on the threshold-value settings for under-voltage pickup and the current-flow criterion. To prevent unwanted tripping, you must set a minimum tripping delay of 50 ms.
yes	Use this setting when switching procedures (opening of the CB) are not permitted to result in stage pickup. Note that pickup is delayed by approximately 40 ms. This delay is added to the operate time.

Parameter: Operate delay

- Default (**_:421:6**) **Operate delay = 3 s**

The **Operate delay** must be set for the specific application.

Parameter: Dropout ratio

- Recommended setting value (**_:421:4**) **Dropout ratio = 1.05**

The recommended setting value of **1.05** is appropriate for most applications. To achieve high-precision measurements, the **Dropout ratio** can be reduced (to 1.02, for example).

Parameter: Blk. by meas.-volt. failure

- Default setting (**_:421:10**) **Blk. by meas.-volt. failure = yes**

With the **Blk. by meas.-volt. failure** parameter, you control the behavior of the stage when a measuring-voltage failure is detected.

A measuring-voltage failure can only be detected if one of the following two conditions is met:

- The device-internal supervision function **Measuring-voltage failure detection** is configured and switched on.
- The binary input signal **>Open** of the function block **VTCB** is connected to the voltage-transformer circuit breaker (see [10.3.4.1 Overview of Functions](#)).

Parameter Value	Description
yes	The protection stage is blocked (= default setting). Siemens recommends using the default setting.
no	The protection stage is not blocked.

6.29.3.3 Settings

Addr.	Parameter	C	Setting Options	Default Setting
General				
_:2311:104	General:Current-flow criterion		<ul style="list-style-type: none"> • off • on 	on
_:2311:101	General:Threshold I>	1 A @ 100 Irated	0.030 A to 10.000 A	0.050 A
		5 A @ 100 Irated	0.15 A to 50.00 A	0.25 A
		1 A @ 50 Irated	0.030 A to 10.000 A	0.050 A
		5 A @ 50 Irated	0.15 A to 50.00 A	0.25 A
		1 A @ 1.6 Irated	0.001 A to 1.600 A	0.050 A
		5 A @ 1.6 Irated	0.005 A to 8.000 A	0.250 A
_:2311:103	General:Stabilization counter		0 to 10	0
Definite-T 1				
_:421:1	Definite-T 1:Mode		<ul style="list-style-type: none"> • off • on • test 	off
_:421:2	Definite-T 1:Operate &flt.rec. blocked		<ul style="list-style-type: none"> • no • yes 	no
_:421:10	Definite-T 1:Blk. by meas.-volt. failure		<ul style="list-style-type: none"> • no • yes 	yes
_:421:9	Definite-T 1:Measured value		<ul style="list-style-type: none"> • phase-to-ground • phase-to-phase 	phase-to-phase
_:421:8	Definite-T 1:Method of measurement		<ul style="list-style-type: none"> • fundamental comp. • RMS value 	fundamental comp.
_:421:101	Definite-T 1:Pickup mode		<ul style="list-style-type: none"> • 1 out of 3 • 3 out of 3 	1 out of 3
_:421:102	Definite-T 1:Pickup delay		<ul style="list-style-type: none"> • no • yes 	no
_:421:3	Definite-T 1:Threshold		0.300 V to 175.000 V	80.000 V
_:421:4	Definite-T 1:Dropout ratio		1.01 to 1.20	1.05
_:421:6	Definite-T 1:Operate delay		0.00 s to 300.00 s	3.00 s

Addr.	Parameter	C	Setting Options	Default Setting
Definite-T 2				
_:422:1	Definite-T 2:Mode		<ul style="list-style-type: none"> • off • on • test 	off
_:422:2	Definite-T 2:Operate & flt.rec. blocked		<ul style="list-style-type: none"> • no • yes 	no
_:422:10	Definite-T 2:Blk. by meas.-volt. failure		<ul style="list-style-type: none"> • no • yes 	yes
_:422:9	Definite-T 2:Measured value		<ul style="list-style-type: none"> • phase-to-ground • phase-to-phase 	phase-to-phase
_:422:8	Definite-T 2:Method of measurement		<ul style="list-style-type: none"> • fundamental comp. • RMS value 	fundamental comp.
_:422:101	Definite-T 2:Pickup mode		<ul style="list-style-type: none"> • 1 out of 3 • 3 out of 3 	1 out of 3
_:422:102	Definite-T 2:Pickup delay		<ul style="list-style-type: none"> • no • yes 	no
_:422:3	Definite-T 2:Threshold		0.300 V to 175.000 V	65.000 V
_:422:4	Definite-T 2:Dropout ratio		1.01 to 1.20	1.05
_:422:6	Definite-T 2:Operate delay		0.00 s to 300.00 s	0.50 s

6.29.3.4 Information List

No.	Information	Data Class (Type)	Type
General			
_:2311:500	General:>Current flow-criterion	SPS	I
_:2311:300	General:Current crit. fulf.	SPS	O
_:2311:52	General:Behavior	ENS	O
_:2311:53	General:Health	ENS	O
Group indicat.			
_:4501:55	Group indicat.:Pickup	ACD	O
_:4501:57	Group indicat.:Operate	ACT	O
_:4501:52	Group indicat.:Behavior	ENS	O
_:4501:53	Group indicat.:Health	ENS	O
Definite-T 1			
_:421:81	Definite-T 1:>Block stage	SPS	I
_:421:51	Definite-T 1:Mode (controllable)	ENC	C
_:421:54	Definite-T 1:Inactive	SPS	O
_:421:52	Definite-T 1:Behavior	ENS	O
_:421:53	Definite-T 1:Health	ENS	O
_:421:55	Definite-T 1:Pickup	ACD	O
_:421:300	Definite-T 1:Pickup loop AB	SPS	O
_:421:301	Definite-T 1:Pickup loop BC	SPS	O
_:421:302	Definite-T 1:Pickup loop CA	SPS	O
_:421:56	Definite-T 1:Operate delay expired	ACT	O

No.	Information	Data Class (Type)	Type
_:421:57	Definite-T 1:Operate	ACT	O
<i>Definite-T 2</i>			
_:422:81	Definite-T 2:>Block stage	SPS	I
_:422:51	Definite-T 2:Mode (controllable)	ENC	C
_:422:54	Definite-T 2:Inactive	SPS	O
_:422:52	Definite-T 2:Behavior	ENS	O
_:422:53	Definite-T 2:Health	ENS	O
_:422:55	Definite-T 2:Pickup	ACD	O
_:422:300	Definite-T 2:Pickup loop AB	SPS	O
_:422:301	Definite-T 2:Pickup loop BC	SPS	O
_:422:302	Definite-T 2:Pickup loop CA	SPS	O
_:422:56	Definite-T 2:Operate delay expired	ACT	O
_:422:57	Definite-T 2:Operate	ACT	O

6.29.4 Stage with Inverse-Time Characteristic Curve

6.29.4.1 Description

Logic of the Stage

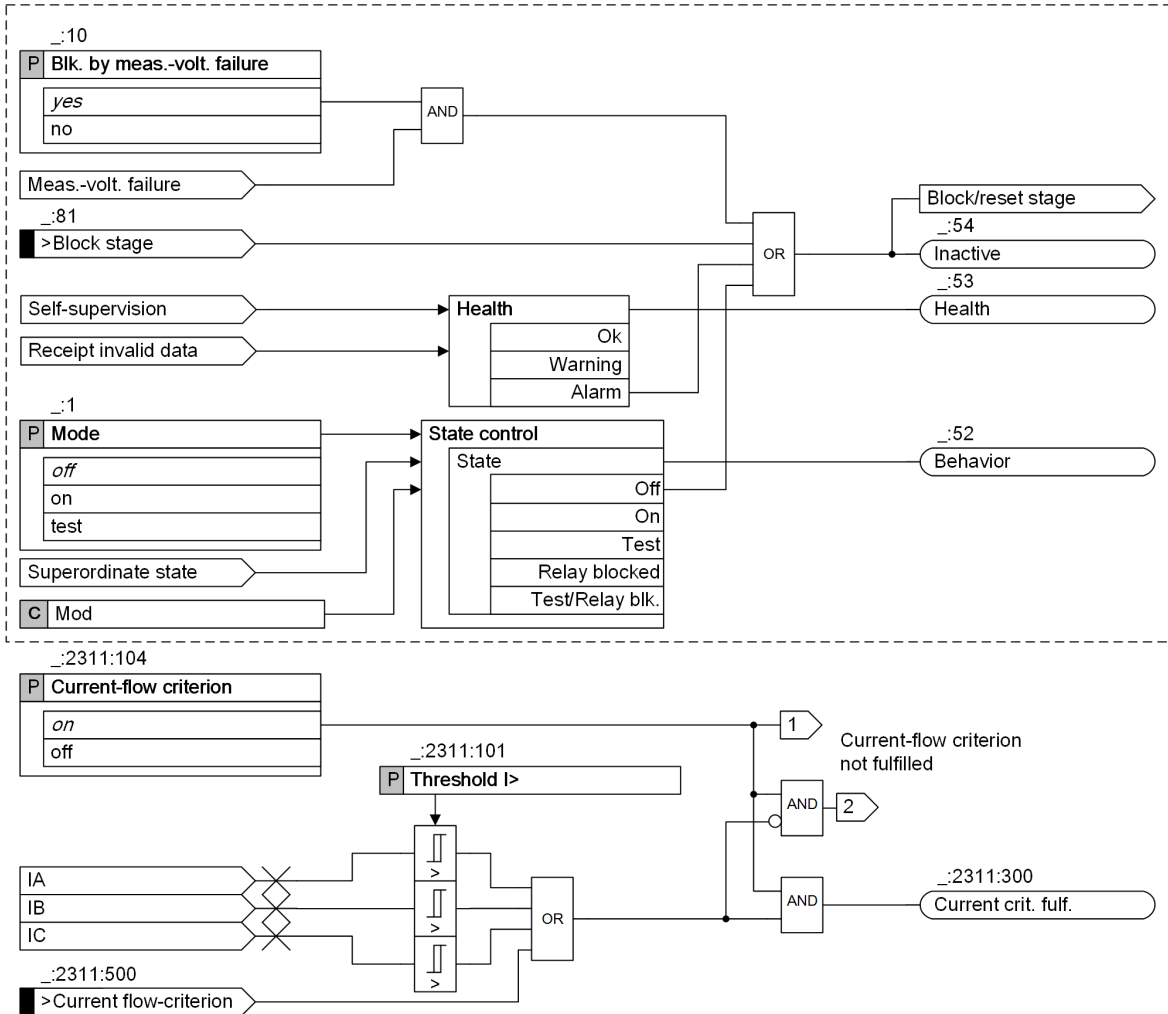

[!o_UVP3ph_in_stage control, 4, en_US]

Figure 6-200 Logic Diagram of the Stage Control

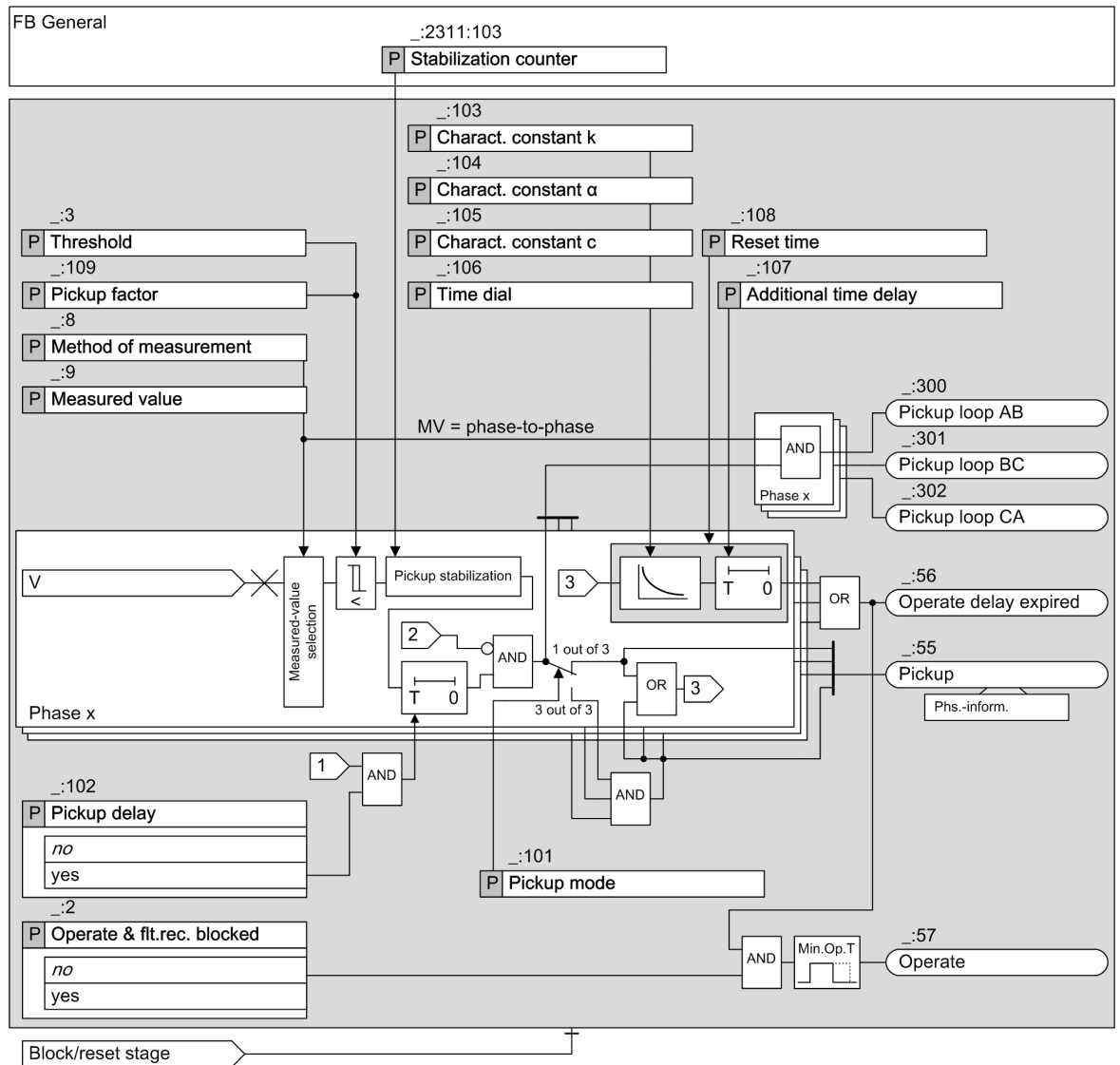

[to_UVP3ph_in_5_en_US]

Figure 6-201 Logic Diagram of the Inverse-Time Undervoltage Protection with 3-Phase Voltage

Method of Measurement

With the **Method of measurement** parameter, you define whether the stage uses the **fundamental comp.** or the **RMS value**.

- Measurement **fundamental comp.**:
This method of measurement processes the sampled voltage values and filters out the fundamental component numerically.
- Measurement **RMS value**:
This method of measurement determines the voltage amplitude from the sampled values according to the defining equation of the RMS value. Harmonics are included in the analysis.

Measured Value

With the **Measured value** parameter, you define whether the stage analyzes the phase-to-phase voltages V_{AB} , V_{BC} , and V_{CA} , or the phase-to-ground voltages $V_{A'}$, $V_{B'}$, and $V_{C'}$.

If the measured value is set to phase-to-phase, the function reports those measuring elements that have picked up.

Pickup Stabilization

To enable the pickup stabilization, you set the **Stabilization counter** parameter to a value other than zero. Then, if the input voltage keeps being below the pickup value for a specified number ($1 + \text{Stabilization counter}$ value) of successive measuring cycles, the stage picks up. For 50 Hz, the measuring cycle time is 10 ms.

If you set this parameter to 0 (default value), the stabilization is not applied. The pickup signal is issued after the input voltage falls below the pickup value.

Pickup Mode

With the **Pickup mode** parameter, you define whether the stage picks up when there is a lower threshold-value violation in one measuring element (**1 out of 3**) or when there is a lower threshold-value violation in all 3 measuring elements (**3 out of 3**).

Pickup and Operate Curve

When the input voltage falls below the threshold value by a settable value **Pickup factor**, the stage picks up and the inverse-time characteristic curve is processed. The operate delay starts. The operate delay is the sum of inverse-time delay and additional time delay.

$$T_{op} = T_{Inv} + T_{add}$$

Where:

T_{op}	Operate delay
T_{Inv}	Inverse-time delay
T_{add}	Additional time delay (Parameter Additional time delay)

After pickup the time value T_{Inv} is calculated for every input voltage less than the dropout value. An integrator accumulates the value $1/T_{Inv}$. Once the accumulated integral reaches the fixed value 1, the inverse-time delay expires. The stage operates after the additional time delay.

The inverse-time delay is calculated with the following formula:

$$T_{Inv} = T_p \left(\frac{k}{1 - \left(\frac{V}{V_{Thresh}} \right)^\alpha} + c \right) [s]$$

[fo_uvp_3ph_inverse, 2, en_US]

Where

T_{Inv}	Inverse-time delay
T_p	Time multiplier (Parameter Time dial)
V	Measured undervoltage
V_{Thresh}	Threshold value (Parameter Threshold)
k	Curve constant k (Parameter Character. constant k)
α	Curve constant α (Parameter Character. constant α)
c	Curve constant c (Parameter Character. constant c)

The inverse-time characteristic is shown in the following figure:

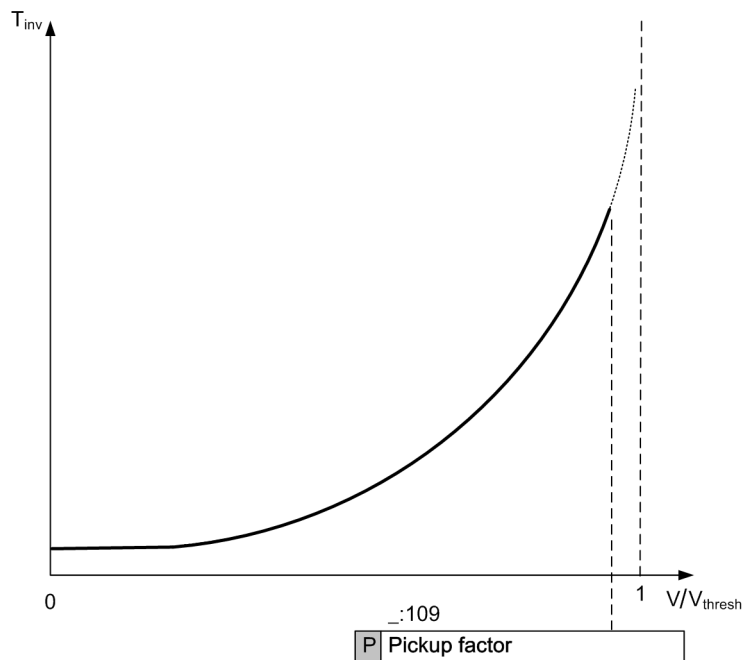

[dw_uvp_3ph_inverse, 1, en_US]

Figure 6-202 Inverse-Time Characteristics for Undervoltage Protection

Pickup Delay

The **Pickup delay** parameter is only available and of relevance if you are using the current-flow criterion of the function (parameter **Current-flow criterion = on**).

If the circuit breaker opens when the current-flow criterion is being used, the undervoltage detection and current-flow dropout functions conflict with one another. Depending on the threshold value settings for undervoltage detection and current-flow criterion, it is possible that the undervoltage is detected before the current-flow criterion has dropped out. In this case, the stage picks up briefly. Use the **Pickup delay** parameter to prevent the stage from briefly picking up in this way when the circuit breaker opens. This is achieved by delaying the pickup by approximately 40 ms.

Dropout Behavior

When the voltage exceeds the dropout value ($1.05 \times \text{pickup factor} \times \text{threshold value}$), the pickup signal is going and the dropout is started. You can define the dropout behavior via parameter **Reset time**. Instantaneous reset takes place by setting **Reset time** to 0 s. A delayed reset takes place by setting the desired delay time.

During the Reset time (> 0 s), the elapsed operate delay is frozen. If the stage picks up again within this period, the stage operates when the rest of operate delay expires.

Current-Flow Criterion

The undervoltage protection stages work optionally with a current-flow criterion. The **Current-flow criterion** works across all tripping stages.

When the **Current-flow criterion** parameter is activated, the undervoltage-protection stages only pick up if a settable minimum current (**Threshold I**) is exceeded. A current below the minimum current blocks the stages.

The current-flow criterion can also be set to **fulfilled** with the binary input signal **>Current flow-criterion**. The function reports when the current-flow criterion is fulfilled.

[Figure 6-201](#) illustrates the influence of the current-flow criterion.



NOTE

If the (`_:2311:104`) **Current-flow criterion** parameter is deactivated, the device picks up immediately if a missing measuring voltage is detected while the undervoltage protection is active. The parameter setting can be changed even when the device has picked up.

Blocking the Stage

In the event of blocking, the picked-up stage is reset. The following blocking options are available for the stage:

- Via the binary input signal `>Block stage` from an external or internal source
- From inside on pickup of the **Measuring-voltage failure detection** function (see [10.3.2.1 Overview of Functions](#)). The `Blk. by meas.-volt. failure` parameter can be set so that measuring-voltage failure detection blocks the stage or does not block it.
- From an external source via the binary input signal `>Open` of the function block `Volt.-transf. c. b.`, which links in the tripping of the voltage-transformer circuit breaker. The `Blk. by meas.-volt. failure` parameter can be set so that measuring-voltage failure detection blocks the stage or does not block it.

6.29.4.2 Application and Setting Notes

Parameter: Method of measurement

- Recommended setting value (`_:8`) **Method of measurement** = *fundamental comp.*

With the **Method of measurement** parameter, you define whether the stage uses the fundamental component (standard method = default setting) or the calculated RMS value.

Parameter Value	Description
<i>fundamental comp.</i>	Select this method of measurement to suppress harmonics or transient voltage peaks. Siemens recommends using this parameter value as the default setting.
<i>RMS value</i>	Select this method of measurement if you want the stage to take harmonics into account (for example, at capacitor banks). Do not set the threshold value of the stage under 10 V for this method of measurement.

Parameter: Measured value

- Recommended setting value (`_:9`) **Measured value** = *phase-to-phase*

With the **Measured value** parameter, you define whether the stage monitors the phase-to-phase voltages V_{AB} , V_{BC} , and V_{CA} , or the phase-to-ground voltages $V_{A'}$, $V_{B'}$, and $V_{C'}$.

Parameter Value	Description
<i>phase-to-phase</i>	If you want to detect voltage dips caused by multiphase short circuits, or generally monitor the voltage range, keep phase-to-phase as the default setting. The function will not pick up on ground faults. Siemens recommends the measured value <i>phase-to-phase</i> as the default setting.
<i>phase-to-ground</i>	Select the <i>phase-to-ground</i> setting if you want to detect voltage unbalances or overvoltage conditions caused by ground faults.

Parameter: Threshold, Pickup factor

- Default setting (`_:3`) **Threshold** = *80.000 V*
- Default setting (`_:109`) **Pickup factor** = *0.90*

The stage picks up when the measured voltage value falls below the pickup value **Threshold** × **Pickup factor**.

Depending on the **Measured value**, the **Threshold** is set either as **phase-to-phase** quantity or as **phase-to-ground** quantity.

With the **Pickup factor** parameter, you modify the pickup value. To avoid a long operate delay time after pickup, Siemens recommends using the default value of **Pickup factor**.

Specify the **Threshold** (pickup threshold) and **Pickup factor** for the specific application.

Parameter: Stabilization counter

- Default setting (**_:2311:103**) **Stabilization counter** = 0

You can configure the **Stabilization counter** parameter in the function block **General**.

For special applications, it could be desirable that a short falling of the input voltage below the pickup value does not lead to the pickup of the stage, which starts fault logging and recording. This is achieved by setting the **Stabilization counter** parameter to a value other than zero.

For example, if you set this parameter to **1**, the pickup signal is issued when the voltage keeps being below the pickup value for 2 successive measuring cycles. For 50 Hz, the measuring cycle time is 10 ms.

Parameter: Pickup mode

- Recommended setting value (**_:101**) **Pickup mode** = 1 out of 3

With the **Pickup mode** parameter, you specify whether the stage picks up when there is a lower threshold-value violation in one measuring element (**1 out of 3**) or when there is a lower threshold-value violation in all 3 measuring elements (**3 out of 3**).

Parameter Value	Description
1 out of 3	Use this setting for protection applications or for monitoring the voltage range. Siemens recommends 1 out of 3 as the default setting. This reflects how the function behaved in previous generations (SIPROTEC 4, SIPROTEC 3).
3 out of 3	Select this setting when using the stage to disconnect from the power system (in the case of wind farms, for example).

Parameter: Pickup delay

- Default setting (**_:102**) **Pickup delay** = no

The **Pickup delay** parameter is only available if you are using the current-flow criterion of the function (parameter **Current-flow criterion** = on). If the current-flow criterion is deactivated, no pickup delay is required.

With the **Pickup delay** parameter, you set whether pickup of the stage is to be delayed by approximately 40 ms or not. The delay avoids possible brief pickup of the stage when the circuit breaker opens.

When applied in parallel, the pickup delay and the delay through pickup stabilization add up.

Parameter Value	Description
no	Use this setting if you definitely do not want stage pickup to be subject to a time delay in the event of a fault. This setting results in pickup and, where applicable, tripping being performed as quickly as possible. Note that switching procedures (opening of the CB) can result in brief pickup of the stage, depending on the threshold-value settings for under-voltage pickup and the current-flow criterion. To prevent unwanted tripping, you must set a minimum tripping delay of 50 ms.
yes	Use this setting when switching procedures (opening of the CB) are not permitted to result in stage pickup. Note that pickup is delayed by approximately 40 ms. This delay is added to the operate time.

Parameter: Charact. constant k, Charact. constant α , Charact. constant c

- Default setting (_:103) **Charact. constant k = 1.00**
- Default setting (_:104) **Charact. constant α = 1.000**
- Default setting (_:105) **Charact. constant c = 0.000**

With the **Charact. constant k**, **Charact. constant α** , and **Charact. constant c** parameters, you define the required inverse-time characteristic.

Parameter: Time dial

- Default setting (_:106) **Time dial = 1.00**

With the **Time dial** parameter, you displace the characteristic curve in the time direction.

As usually, there is no time grading for voltage protection and therefore no displacement of the characteristic curve, Siemens recommends leaving the **Time dial** parameter at **1.00** (default setting).

Parameter: Reset time

- Default setting (_:108) **Reset time = 0.00 s**

With the **Reset time** parameter, you define the reset time delay which is started when the voltage exceeds the dropout value. Set the parameter **Reset time** to 0 s when instantaneous reset is desired.

Under network conditions of intermittent faults or faults which occur in rapid succession, Siemens recommends setting the **Reset time** to an appropriate value > 0 s to ensure the operation. Otherwise, Siemens recommends keeping the default value to ensure a fast reset of the function.

Parameter: Additional time delay

- Default setting (_:107) **Additional time delay = 0.00 s**

With the **Additional time delay** parameter, you define a definite-time delay in addition to the inverse-time delay.

If the setting is left on its default value of 0 s, only the inverse-time delay is operative.

Parameter: Blk. by meas.-volt. failure

- Default setting (_:10) **Blk. by meas.-volt. failure = yes**

With the **Blk. by meas.-volt. failure** parameter, you control the behavior of the stage when a measuring-voltage failure is detected.

A measuring-voltage failure can only be detected if one of the following 2 conditions is met:

- The device-internal supervision function **Measuring-voltage failure detection** is configured and switched on.
- The binary input signal **>Open** of the function block **VTCB** is connected to the voltage-transformer circuit breaker (see [10.3.4.1 Overview of Functions](#)).

Parameter Value	Description
yes	The protection stage is blocked (= default setting). Siemens recommends using the default setting.
no	The protection stage is not blocked.

6.29.4.3 Settings

Addr.	Parameter	C	Setting Options	Default Setting
Inverse-T #				
_:1	Inverse-T #:Mode		<ul style="list-style-type: none"> • off • on • test 	off
_:2	Inverse-T #:Operate & flt.rec. blocked		<ul style="list-style-type: none"> • no • yes 	no
_:10	Inverse-T #:Blk. by meas.-volt. failure		<ul style="list-style-type: none"> • no • yes 	yes
_:9	Inverse-T #:Measured value		<ul style="list-style-type: none"> • phase-to-ground • phase-to-phase 	phase-to-phase
_:8	Inverse-T #:Method of measurement		<ul style="list-style-type: none"> • fundamental comp. • RMS value 	fundamental comp.
_:101	Inverse-T #:Pickup mode		<ul style="list-style-type: none"> • 1 out of 3 • 3 out of 3 	1 out of 3
_:102	Inverse-T #:Pickup delay		<ul style="list-style-type: none"> • no • yes 	no
_:3	Inverse-T #:Threshold		0.300 V to 175.000 V	80.000 V
_:109	Inverse-T #:Pickup factor		0.80 to 1.00	0.90
_:103	Inverse-T #:Charact. constant k		0.00 to 300.00	1.00
_:104	Inverse-T #:Charact. constant α		0.010 to 5.000	1.000
_:105	Inverse-T #:Charact. constant c		0.000 to 5.000	0.000
_:106	Inverse-T #:Time dial		0.05 to 15.00	1.00
_:107	Inverse-T #:Additional time delay		0.00 s to 60.00 s	0.00 s
_:108	Inverse-T #:Reset time		0.00 s to 60.00 s	0.00 s

6.29.4.4 Information List

No.	Information	Data Class (Type)	Type
Inverse-T #			
_:81	Inverse-T #:>Block stage	SPS	I
_:54	Inverse-T #:Inactive	SPS	O
_:52	Inverse-T #:Behavior	ENS	O
_:53	Inverse-T #:Health	ENS	O
_:55	Inverse-T #:Pickup	ACD	O
_:300	Inverse-T #:Pickup loop AB	SPS	O
_:301	Inverse-T #:Pickup loop BC	SPS	O
_:302	Inverse-T #:Pickup loop CA	SPS	O
_:56	Inverse-T #:Operate delay expired	ACT	O
_:57	Inverse-T #:Operate	ACT	O

6.30 Undervoltage Protection with Positive-Sequence Voltage

6.30.1 Overview of Functions

The **Undervoltage protection with positive-sequence voltage** function (ANSI 27):

- Monitors the permissible voltage range
- Protects equipment (for example, plant components and machines) from damages caused by undervoltage
- Protects motors and generators from inadmissible operating states and a possible loss of stability in the event of voltage dips

2-phase short circuits or ground faults lead to an unbalanced voltage collapse. In comparison to three 1-phase measuring systems, such events have no noticeable impact on the positive-sequence voltage. This makes this function particularly suitable for the assessment of stability problems.

6.30.2 Structure of the Function

The **Undervoltage protection with positive-sequence voltage** function is used in protection function groups, which are based on voltage measurement.

The **Undervoltage protection with positive-sequence voltage** function comes factory-set with 2 tripping stages. A maximum of 3 tripping stages can be operated simultaneously in the function. The tripping stages have an identical structure.

The protection function is structured such that one current-flow criterion can act on all undervoltage protection stages (see [Figure 6-203](#)). If the protection function group used has no current measurement, you can only set the current-flow criterion as **fulfilled** via the corresponding binary input signal.

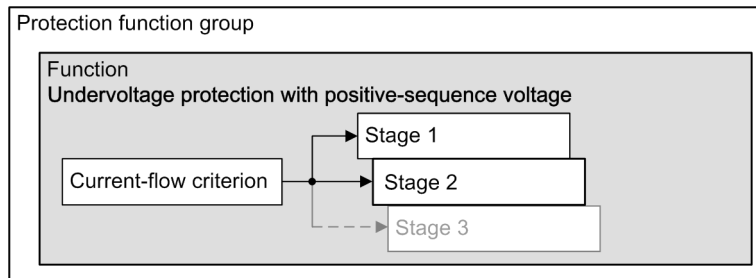

[dw_stuvu1, 3, en_US]

Figure 6-203 Structure/Embedding of the Function

6.30.3 Stage Description

Logic of the Stage

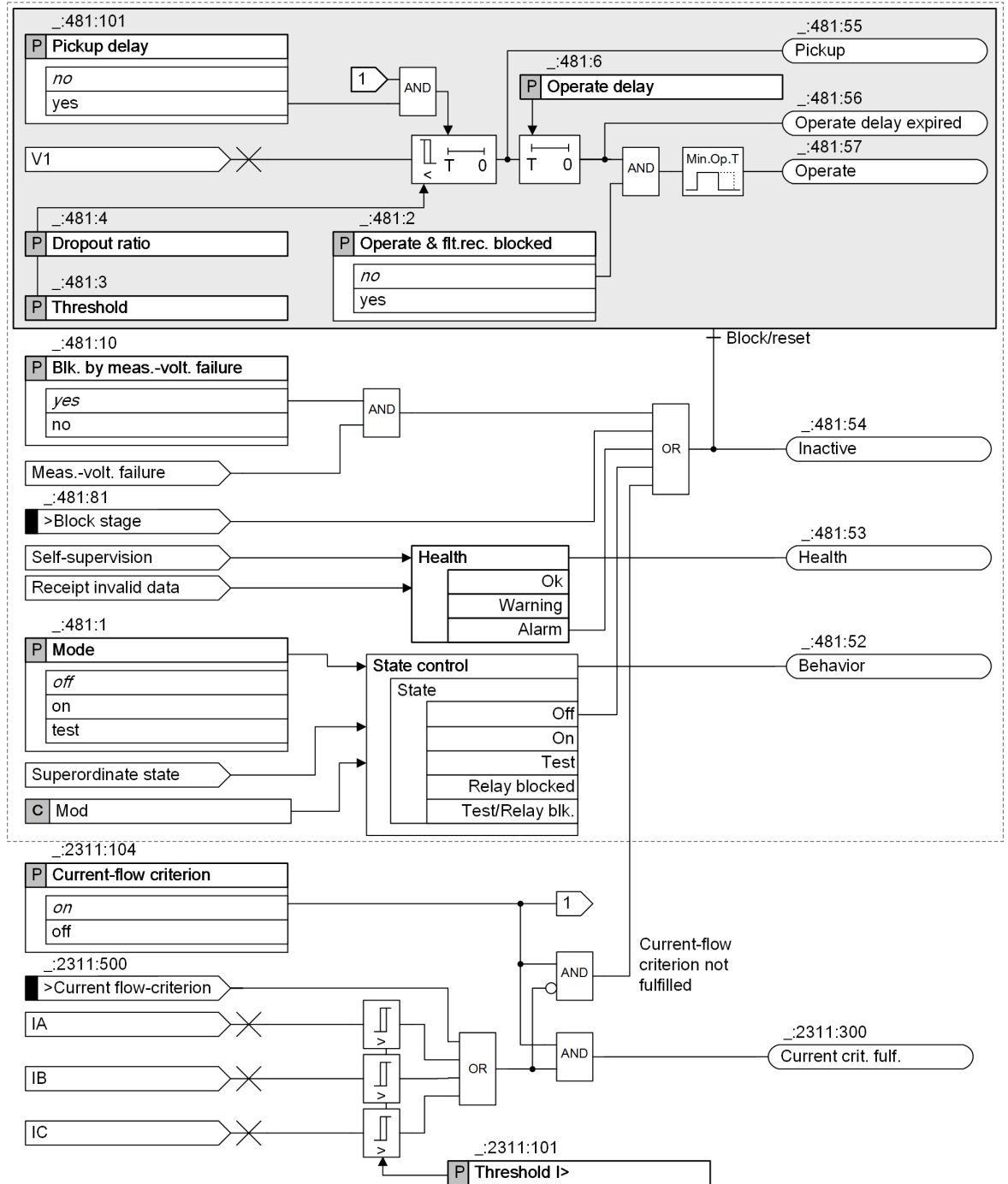

[to_uvP_3pol-V1_2_en_US]

Figure 6-204 Logic Diagram of the Stage Undervoltage Protection with Positive-Sequence Voltage

Method of Measurement

The stage uses the positive-sequence voltage. The positive-sequence voltage is calculated from the measured phase-to-ground voltages according to the defining equation.

Pickup Delay

The **Pickup delay** parameter is only available and of relevance if you are using the current-flow criterion of the function (parameter **Current-flow criterion = on**).

If the circuit breaker opens when the current-flow criterion is being used, the undervoltage detection and current-flow dropout functions conflict with one another. Depending on the threshold value settings for undervoltage detection and current-flow criterion, it is possible that the undervoltage is detected before the current-flow criterion has dropped out. In this case, the tripping stage picks up briefly. Use the **Pickup delay** parameter to prevent the tripping stage from briefly picking up in this way when the circuit breaker opens. This is achieved by delaying pickup by approximately 40 ms.

Current-Flow Criterion

The undervoltage-protection stages work optionally with a current-flow criterion. The current-flow criterion works across all stages.

When the **Current-flow criterion** parameter is switched on, the undervoltage protection stages only pick up if a settable minimum current (**Threshold I>**) is exceeded in at least one phase. A current below the minimum current blocks the tripping stages.

The current-flow criterion can also be set to **fulfilled** via the binary input signal **>Current flow-criterion**. The function reports when the current-flow criterion is fulfilled.

[Figure 6-204](#) illustrates the influence of the current-flow criterion.



NOTE

If the **Current-flow criterion** parameter is switched off, the device picks up immediately if a missing measuring voltage is detected while the undervoltage protection is active. The parameter setting can be changed even when the device has picked up.

Blocking the Stage

In the event of blocking, the picked up stage will be reset. The following blocking options are available for the stage:

- Via the binary input signal **>Block stage** from an external or internal source
- From inside on pickup of the **Measuring-voltage failure detection** function (see chapter [10.3.2.1 Overview of Functions](#)). The **Blk. by meas.-volt. failure** parameter can be set to either block or not block the tripping stage when the measuring-voltage failure detection picks up.
- From an external source via the binary input signal **>Open** of the function block **Volt.-transf. c. b.**, which links in the tripping of the voltage-transformer circuit breaker. The **Blk. by meas.-volt. failure** parameter can be set so that measuring-voltage failure detection blocks the stage or does not block it.

6.30.4 Application and Setting Notes

Parameter: Threshold

- Default setting (**_:481:3**) **Threshold = 46 V**

Specify the **Threshold** (pickup threshold) for the specific application. For the default setting, the lower limit of the voltage range to be monitored is assumed to be 80 % of the rated voltage of the protected object.

Parameter: Pickup delay

- Default setting (**_:481:101**) **Pickup delay = no**

The **Pickup delay** parameter is only available if you are using the current-flow criterion of the function (parameter **Current-flow criterion = on**). If the current-flow criterion is deactivated, no pickup delay is required.

With the parameter **Pickup delay** you set whether pickup of the stage is to be delayed by approximately 40 ms or not. The delay avoids possible brief pickup of the stage when the circuit breaker opens.

Parameter Value	Description
no	Use this setting if you definitely do not want tripping-stage pickup to be subject to a time delay in the event of a fault. This setting results in pickup and, where applicable, tripping being performed as quickly as possible. Note that switching procedures (opening of the CB) can result in brief pickup of the tripping stage, depending on the threshold-value settings for undervoltage pickup and the current-flow criterion. To prevent unwanted tripping, you must set a minimum tripping delay of 50 ms.
yes	Use this setting when switching procedures (opening of the CB) are not permitted to result in tripping-stage pickup. Note that pickup is delayed by approximately 40 ms. This delay is added to the operate time.

Parameter: Operate delay

- Default setting (**_:481:6**) **Operate delay = 3 s**

The **Operate delay** must be set for the specific application.

Parameter: Dropout ratio

- Recommended setting value (**_:481:4**) **Dropout ratio = 1.05**

The recommended setting value of 1.05 is sufficient for many applications. To obtain extremely accurate indications, the **Dropout ratio** can be reduced.

Parameter: Blk. by meas.-volt. failure

- Default setting (**_:481:10**) **Blk. by meas.-volt. failure = yes**

You use the **Blk. by meas.-volt. failure** parameter to control the behavior of the stage when a measuring-voltage failure is detected.

A measuring-voltage failure can only be detected if one of the following 2 conditions is met:

- The device-internal supervision function **Measuring-voltage failure detection** is configured and switched on.
- The binary input signal **>Open** of the function block **VT**CB is connected to the voltage-transformer circuit breaker (see chapter [10.3.4.1 Overview of Functions](#)).

Parameter Value	Description
yes	The protection stage is blocked (= default setting). Siemens recommends using the default setting.
no	The protection stage is not blocked.

Parameter: Current-flow criterion

- Recommended setting value (**_:2311:104**) **Current-flow criterion = on**

Depending on the system, the voltage transformers can be located on the supply or the output side. These 2 possible voltage transformer locations induce a different behavior of the function after tripping and opening of the circuit breaker:

- If they are located on the supply side, the voltage still exists.
- If they are located on the output side, the voltage does not exist.

Parameter Value	Description
<i>on</i>	If the voltage transformers are located on the output side, you can use the current-flow criterion to make the pickup drops out when the current falls below a minimum value (parameter Threshold I> value I>).
<i>off</i>	In the case of undervoltage, the pickup of the undervoltage-protection stage persists when the current-flow criterion is not used.

Parameter: Threshold I>

- Recommended setting value (`_:2311:101`) **Threshold I> = 0.05 A**

The **Threshold I>** parameter makes it possible to detect when the circuit breaker is closed. Siemens recommends setting the **Threshold I>** parameter to 5% of the rated current. With a secondary rated transformer current of 1 A, the secondary setting value for **Threshold I>** would be 0.05 A.

If the sensitivity of the **Threshold I>** parameter is set too high, compensation processes in the secondary circuit of the current transformer extend the dropout time when breaking extremely high currents. To speed up dropout, increase the default setting.

Operation as Supervision Function

If you want the tripping stage to have a reporting effect only, generation of the operate indication and fault logging can be disabled via the **Operate & flt.rec. blocked** parameter.

6.30.5 Settings

Addr.	Parameter	C	Setting Options	Default Setting
<i>General</i>				
_:2311:104	General:Current-flow criterion		<ul style="list-style-type: none"> • off • on 	on
_:2311:101	General:Threshold I>	1 A @ 100 Irated	0.030 A to 10.000 A	0.050 A
		5 A @ 100 Irated	0.15 A to 50.00 A	0.25 A
		1 A @ 50 Irated	0.030 A to 10.000 A	0.050 A
		5 A @ 50 Irated	0.15 A to 50.00 A	0.25 A
		1 A @ 1.6 Irated	0.001 A to 1.600 A	0.050 A
		5 A @ 1.6 Irated	0.005 A to 8.000 A	0.250 A
<i>Stage 1</i>				
_:481:1	Stage 1:Mode		<ul style="list-style-type: none"> • off • on • test 	off
_:481:2	Stage 1:Operate & flt.rec. blocked		<ul style="list-style-type: none"> • no • yes 	no
_:481:10	Stage 1:Blk. by meas.-volt. failure		<ul style="list-style-type: none"> • no • yes 	yes
_:481:101	Stage 1:Pickup delay		<ul style="list-style-type: none"> • no • yes 	no
_:481:3	Stage 1:Threshold		0.300 V to 200.000V	46.000V
_:481:4	Stage 1:Dropout ratio		1.01 to 1.20	1.05
_:481:6	Stage 1:Operate delay		0.00 s to 60.00 s	3.00 s

Addr.	Parameter	C	Setting Options	Default Setting
Stage 2				
_:482:1	Stage 2:Mode		<ul style="list-style-type: none"> • off • on • test 	off
_:482:2	Stage 2:Operate & flt.rec. blocked		<ul style="list-style-type: none"> • no • yes 	no
_:482:10	Stage 2:Blk. by meas.-volt. failure		<ul style="list-style-type: none"> • no • yes 	yes
_:482:101	Stage 2:Pickup delay		<ul style="list-style-type: none"> • no • yes 	no
_:482:3	Stage 2:Threshold		0.300 V to 200.000 V	40.000V
_:482:4	Stage 2:Dropout ratio		1.01 to 1.20	1.05
_:482:6	Stage 2:Operate delay		0.00 s to 60.00 s	0.50 s

6.30.6 Information List

No.	Information	Data Class (Type)	Type
General			
_:2311:500	General:>Current flow-criterion	SPS	I
_:2311:300	General:Current crit. fulf.	SPS	O
_:2311:52	General:Behavior	ENS	O
_:2311:53	General:Health	ENS	O
Group indicat.			
_:4501:55	Group indicat.:Pickup	ACD	O
_:4501:57	Group indicat.:Operate	ACT	O
_:4501:52	Group indicat.:Behavior	ENS	O
_:4501:53	Group indicat.:Health	ENS	O
Stage 1			
_:481:81	Stage 1:>Block stage	SPS	I
_:481:51	Stage 1:Mode (controllable)	ENC	C
_:481:54	Stage 1:Inactive	SPS	O
_:481:52	Stage 1:Behavior	ENS	O
_:481:53	Stage 1:Health	ENS	O
_:481:55	Stage 1:Pickup	ACD	O
_:481:56	Stage 1:Operate delay expired	ACT	O
_:481:57	Stage 1:Operate	ACT	O
Stage 2			
_:482:81	Stage 2:>Block stage	SPS	I
_:482:51	Stage 2:Mode (controllable)	ENC	C
_:482:54	Stage 2:Inactive	SPS	O
_:482:52	Stage 2:Behavior	ENS	O
_:482:53	Stage 2:Health	ENS	O
_:482:55	Stage 2:Pickup	ACD	O
_:482:56	Stage 2:Operate delay expired	ACT	O
_:482:57	Stage 2:Operate	ACT	O

6.31 Undervoltage Protection with Any Voltage

6.31.1 Overview of Functions

The function **Undervoltage protection with any voltage** (ANSI 27) detects any 1-phase undervoltage and is intended for special applications.

6.31.2 Structure of the Function

The **Undervoltage protection with any voltage** function is used in protection function groups, which are based on voltage measurement.

The function **Undervoltage protection with any voltage** comes factory-set with 2 stages. A maximum of 3 tripping stages can be operated simultaneously in the function. The tripping stages have an identical structure.

The protection function is structured such that one current-flow criterion can act on all undervoltage protection stages (see [Figure 6-205](#)).

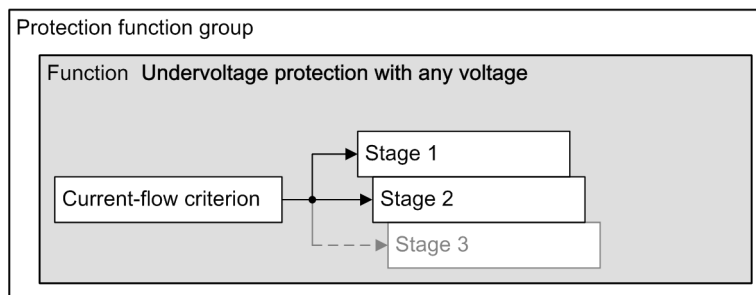

[dw_stuvux, 1, en_US]

Figure 6-205 Structure/Embedding of the Function

6.31.3 Stage Description

Logic of a Stage

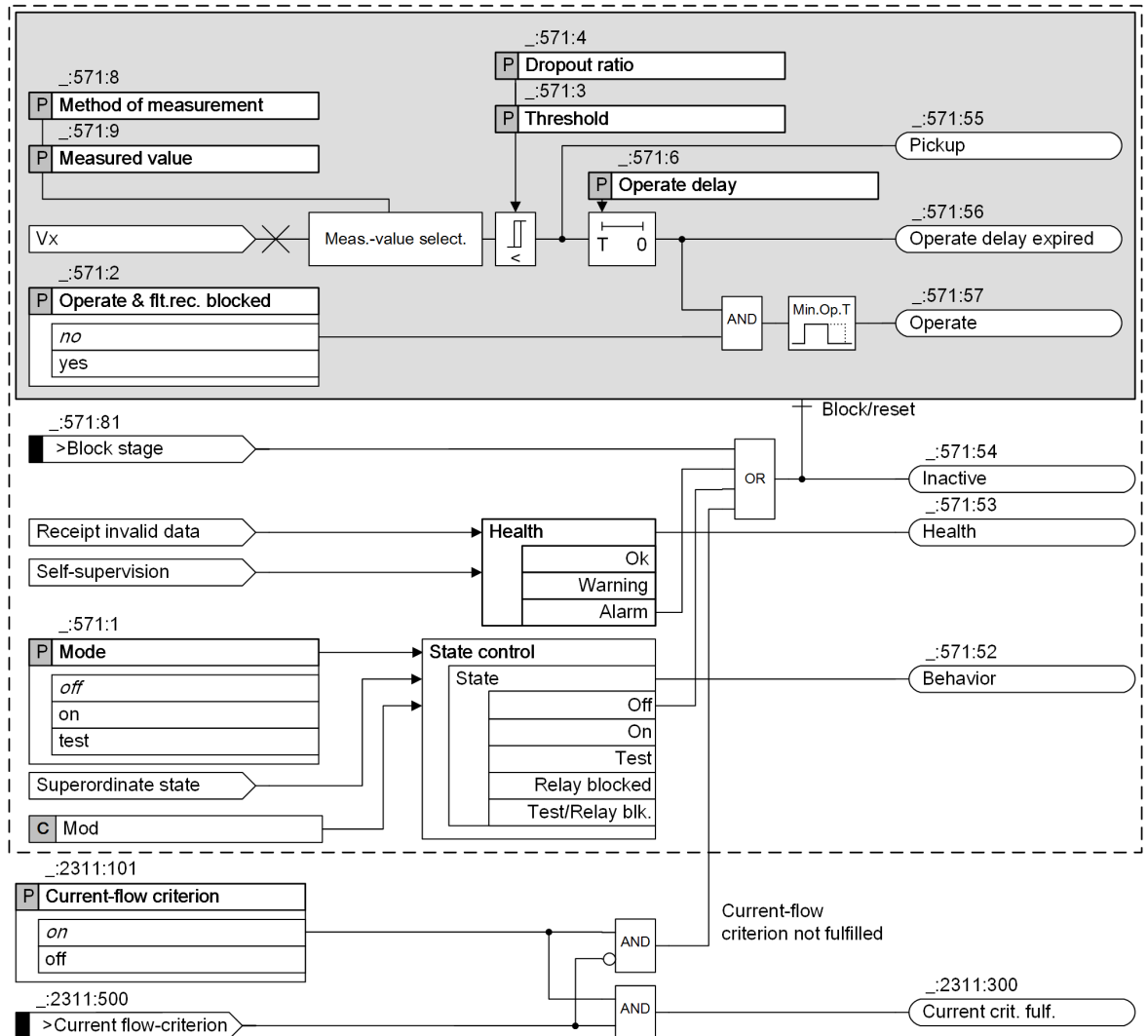

[to: uvp_Vx_any-volt_2_en_US]

Figure 6-206 Logic Diagram of a Stage: Undervoltage Protection with Any Voltage



NOTE

If the function **Undervoltage protection with any voltage** is used in a 1-phase function group, the parameter **Measured value** is not visible.

Method of Measurement

The **Method of measurement** parameter allows you to define whether the function works with the fundamental component or the calculated RMS value.

- **Measurement of the fundamental component:**
This method of measurement processes the sampled voltage values and filters out the fundamental component numerically.

- Measurement of the RMS value:
 This method of measurement determines the voltage amplitude from the sampled values according to the defining equation of the RMS value. Harmonics are included in the analysis.

Measured Value

The parameter **Measured value** allows you to select whether the stage uses a measured (directly connected) voltage or a calculated phase-to-phase voltage.
 If the function **Undervoltage protection with any voltage** is used in a 1-phase function group, the parameter **Measured value** is not visible.

Current-Flow Criterion

The undervoltage-protection stages work optionally with a current-flow criterion. The current-flow criterion works across all stages.

When the **Current-flow criterion** parameter is switched on, the undervoltage protection stages only pick up when the current-flow criterion has been set to **fulfilled** via the binary input signal **>Current flow-criterion**. The function reports when the current-flow criterion is fulfilled.

Figure 6-206 illustrates the influence of the current-flow criterion.



NOTE

If the (**_:2311:101**) **Current-flow criterion** parameter is deactivated, the device picks up immediately if a missing measuring voltage is detected while the undervoltage protection is active. The parameter setting can be changed even when the device has picked up.

Blocking the Stage

In the event of blocking, the picked up stage will be reset. Blocking the stage is possible externally or internally via the binary input signal **>Block stage**.

6.31.4 Application and Setting Notes

Parameter: Method of measurement

- Recommended setting value (**_:571:8**) **Method of measurement = fundamental comp.**

Use the **Method of measurement** parameter to define whether the tripping stage uses the fundamental component (standard method = default setting) or the calculated RMS value.

Parameter Value	Description
<i>fundamental comp.</i>	Select this method of measurement to suppress harmonics or transient voltage peaks. Siemens recommends using this parameter value as the default setting.
<i>RMS value</i>	Select this method of measurement if you want the stage to take harmonics into account (for example at capacitor banks). Do not set the threshold value of the tripping stage under 10 V for this method of measurement.

Parameter: Measured value

- Default setting (**_:571:9**) **Measured value = VA measured**

The **Measured value** parameter is used to specify which voltage is monitored by the stage.
 The scope of setting options depends on the connection type for the voltage transformers and the routing of the measured values to the terminals of the voltage measuring point. You can find connection examples for voltage transformers in the *Appendix*.

The following setting options can be available:

- Measured phase-to-ground voltage V_A (**VA measured**)
- Measured phase-to-ground voltage V_B (**VB measured**)
- Measured phase-to-ground voltage V_C (**VC measured**)
- Measured phase-to-phase voltage V_{AB} (**VAB measured**)
- Measured phase-to-phase voltage V_{BC} (**VBC measured**)
- Measured phase-to-phase voltage V_{CA} (**VCA measured**)
- Calculated phase-to-phase voltage V_{AB} (**VAB calculated**)
- Calculated phase-to-phase voltage V_{BC} (**VBC calculated**)
- Calculated phase-to-phase voltage V_{CA} (**VCA calculated**)
- Calculated voltage V_0 (**V0 calculated**)

The selection depends on the corresponding application.



NOTE

From V7.30 on, the value **VN measured** is no longer provided. If you have selected this value in earlier versions, you can select the value **V0 calculated** instead after upgrading the configuration to V7.30 or a later version.

If the function **Undervoltage protection with any voltage** is used in a 1-phase function group, the parameter **Measured value** is not visible.

Parameter: Threshold

- Default setting (**_:571:3**) **Threshold = 80 V**

Specify the **Threshold** (pickup threshold) for the specific application.

Depending on the **Measured value**, the **Threshold** is set either as **measured voltage** or as a **phase-to-phase** variable.



NOTE

If the function is used in a **Voltage-current 1-phase** function group connected to the 1-phase voltage measuring point with the voltage type **VN broken-delta**, you set the threshold value based on the equivalent zero-sequence voltage.

Calculate the equivalent zero-sequence voltage $V_{0 \text{ equiv. sec}}$ from the measured voltage $V_{N \text{ sec}}$ with the following formula:

$$\frac{V_{0 \text{ equiv. sec}}}{V_{N \text{ sec}}} = \frac{\text{Matching ratio } V_{ph}/V_N}{3}$$

For more information about the parameter **Matching ratio V_{ph} / V_N** , refer to [6.1.6 Application and Setting Notes for Measuring Point Voltage 3-Phase \(V-3ph\)](#).

Parameter: Operate delay

- Default setting (**_:571:6**) **Operate delay = 3 s**

The **Operate delay** must be set for the specific application.

Parameter: Dropout ratio

- Recommended setting value (**_:571:4**) **Dropout ratio = 1.05**

The recommended set value of **1.05** is appropriate for most applications. To achieve high measurement precision, the **Dropout ratio** can be reduced to 1.02, for example.

Parameter: Current-flow criterion

- Recommended setting value (**_:2311:101**) **Current-flow criterion = on**

Parameter Value	Description
<i>on</i>	Because of the application, it makes sense that the stage is only active (that is, not blocked) when a certain current flow is present (see note).
<i>off</i>	Current flow monitoring does not make sense for the application.



NOTE

Because of the flexible setting options of the voltage measurand, the function itself does not determine the current associated with the voltage. A suitable current-flow monitoring function must be created by the user with the Continuous Function Chart (CFC), and connected to the binary input signal **>Current flow-criterion**.

Operation as Supervision Function

If you want the tripping stage to have a reporting effect only, generation of the operate indication and fault logging can be disabled via the **Operate & flt.rec. blocked** parameter.

6.31.5 Settings

Addr.	Parameter	C	Setting Options	Default Setting
<i>General</i>				
_:2311:101	General:Current-flow criterion		<ul style="list-style-type: none"> off on 	on
<i>Stage 1</i>				
_:571:1	Stage 1:Mode		<ul style="list-style-type: none"> off on test 	off
_:571:2	Stage 1:Operate & flt.rec. blocked		<ul style="list-style-type: none"> no yes 	no
_:571:9	Stage 1:Measured value		<ul style="list-style-type: none"> VA measured VB measured VC measured VAB measured VBC measured VCA measured VAB calculated VBC calculated VCA calculated VO calculated 	VA measured
_:571:8	Stage 1:Method of measurement		<ul style="list-style-type: none"> fundamental comp. RMS value 	fundamental comp.
_:571:3	Stage 1:Threshold		0.300 V to 340.000 V	80.000 V
_:571:4	Stage 1:Dropout ratio		1.01 to 1.20	1.05

Addr.	Parameter	C	Setting Options	Default Setting
_:571:6	Stage 1:Operate delay		0.00 s to 60.00 s	3.00 s
Stage 2				
_:572:1	Stage 2:Mode		<ul style="list-style-type: none"> • off • on • test 	off
_:572:2	Stage 2:Operate & flt.rec. blocked		<ul style="list-style-type: none"> • no • yes 	no
_:572:9	Stage 2:Measured value		<ul style="list-style-type: none"> • VA measured • VB measured • VC measured • VAB measured • VBC measured • VCA measured • VAB calculated • VBC calculated • VCA calculated • V0 calculated 	VA measured
_:572:8	Stage 2:Method of measurement		<ul style="list-style-type: none"> • fundamental comp. • RMS value 	fundamental comp.
_:572:3	Stage 2:Threshold		0.300 V to 340.000 V	65.000 V
_:572:4	Stage 2:Dropout ratio		1.01 to 1.20	1.05
_:572:6	Stage 2:Operate delay		0.00 s to 60.00 s	0.50 s

6.31.6 Information List

No.	Information	Data Class (Type)	Type
General			
_:2311:500	General:>Current flow-criterion	SPS	I
_:2311:300	General:Current crit. fulf.	SPS	O
_:2311:52	General:Behavior	ENS	O
_:2311:53	General:Health	ENS	O
Group indicat.			
_:4501:55	Group indicat.:Pickup	ACD	O
_:4501:57	Group indicat.:Operate	ACT	O
_:4501:52	Group indicat.:Behavior	ENS	O
_:4501:53	Group indicat.:Health	ENS	O
Stage 1			
_:571:81	Stage 1:>Block stage	SPS	I
_:571:51	Stage 1:Mode (controllable)	ENC	C
_:571:54	Stage 1:Inactive	SPS	O
_:571:52	Stage 1:Behavior	ENS	O
_:571:53	Stage 1:Health	ENS	O
_:571:55	Stage 1:Pickup	ACD	O
_:571:56	Stage 1:Operate delay expired	ACT	O

No.	Information	Data Class (Type)	Type
_.571:57	Stage 1:Operate	ACT	O
Stage 2			
_.572:81	Stage 2:>Block stage	SPS	I
_.572:51	Stage 2:Mode (controllable)	ENC	C
_.572:54	Stage 2:Inactive	SPS	O
_.572:52	Stage 2:Behavior	ENS	O
_.572:53	Stage 2:Health	ENS	O
_.572:55	Stage 2:Pickup	ACD	O
_.572:56	Stage 2:Operate delay expired	ACT	O
_.572:57	Stage 2:Operate	ACT	O

6.32 Rate-of-Voltage-Change Protection

6.32.1 Overview of Functions

In a power system, in addition to short circuits, there are other situations which also cause voltage changes. For example, too high loads can reduce the voltage level at the end of the line, or too high power production can cause a voltage-level increase.

The function **Rate-of-voltage-change protection** can be used to:

- Prevent the system from not secure states caused by unbalance between the generated and consumed active power
- Detect a network island state
- Advanced load-shedding applications
- Detect a rather fast voltage change related to a fault in the power system

6.32.2 Structure of the Function

The function **Rate-of-voltage-change protection** can be used in protection function groups with 3-phase voltage measurement.

2 stage types are available:

- **dV/dt rising**
- **dV/dt falling**

The function **Rate-of-voltage-change protection** comes factory-set with 1 **dV/dt rising** stage and 1 **dV/dt falling** stage. A maximum of 5 **dV/dt rising** stages and 5 **dV/dt falling** stages can be operated simultaneously within the function. Both stage types are similar in structure.

The general functionality works across stages on the function level.

The group-indication output logic generates the following group indications of the protection function by the logical OR of the stage-selective indications:

- Pickup
- Operate

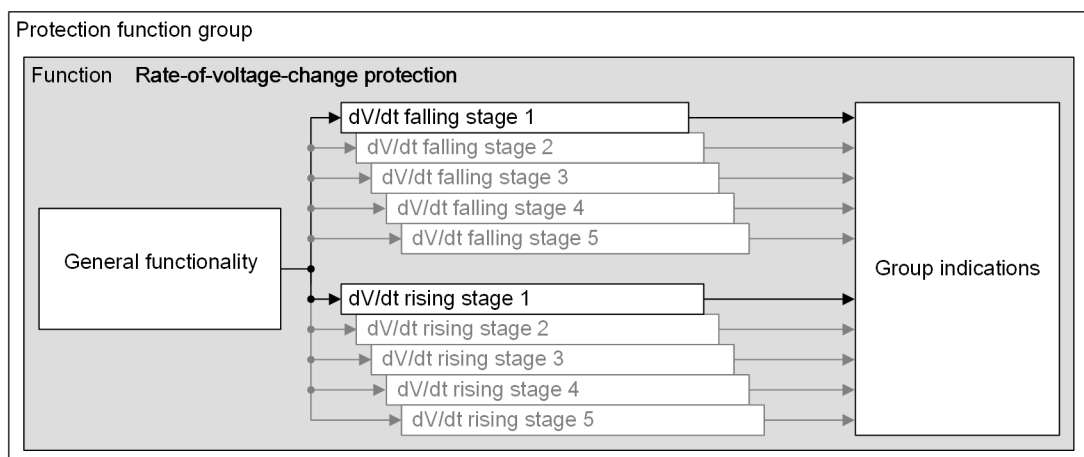

[dw_dVdt structure, 1, en_US]

Figure 6-207 Structure/Embedding of the Function

6.32.3 General Functionality

6.32.3.1 Description

Logic

The following figure shows the dV/dt calculation logic. It applies to all configured stages.

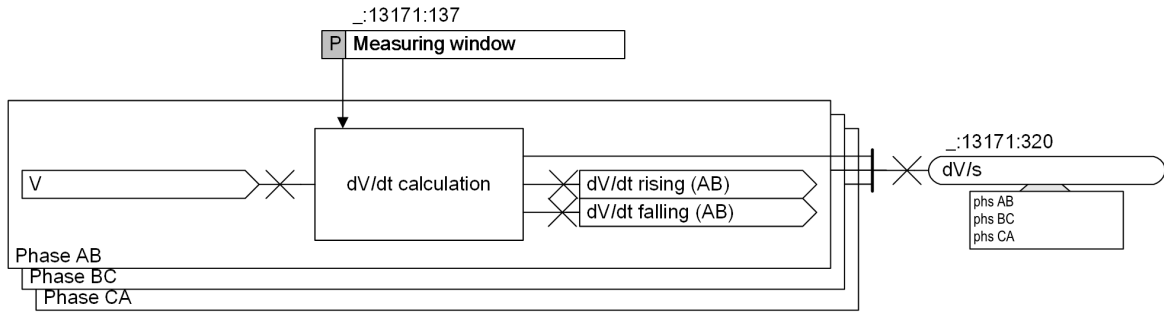

[lo_dvdt_general_1_en_US]

Figure 6-208 Logic Diagram of the General Functionality

dV/dt Calculation

The measured phase-to-phase voltages are used for calculating the rate of voltage change.

The measuring-window interval is used for calculating the dV/dt mean value for further processing. A larger measuring window increases the accuracy of the dV/dt mean value while simultaneously increasing the pickup time.

The ratio between the voltage difference and the time difference reflects the voltage change which can be positive or negative.

Functional Measured Value

Value	Description
dV/s	Calculated mean voltage change per second

6.32.3.2 Application and Setting Notes

Parameter: Measuring window

- Default setting (`_:13171:137`) **Measuring window = 5 periods**

With the **Measuring window** parameter, you optimize the measuring accuracy or the pickup time of the function. If the measuring window increases, the measuring accuracy increases while the pickup time increases as well. You can find more information about the pickup time and measuring accuracy in the technical data in chapter [14.39 Rate-of-Voltage-Change Protection](#).

If you do not have specific requirements for an especially short pickup time, Siemens recommends using the default setting. The default setting is a reasonable compromise between the measuring accuracy and the pickup time. If the measuring window is smaller than 5 periods, the accuracy of the calculated dV/dt value is affected.

6.32.4 Stage Description

6.32.4.1 Description

Logic of the Stage

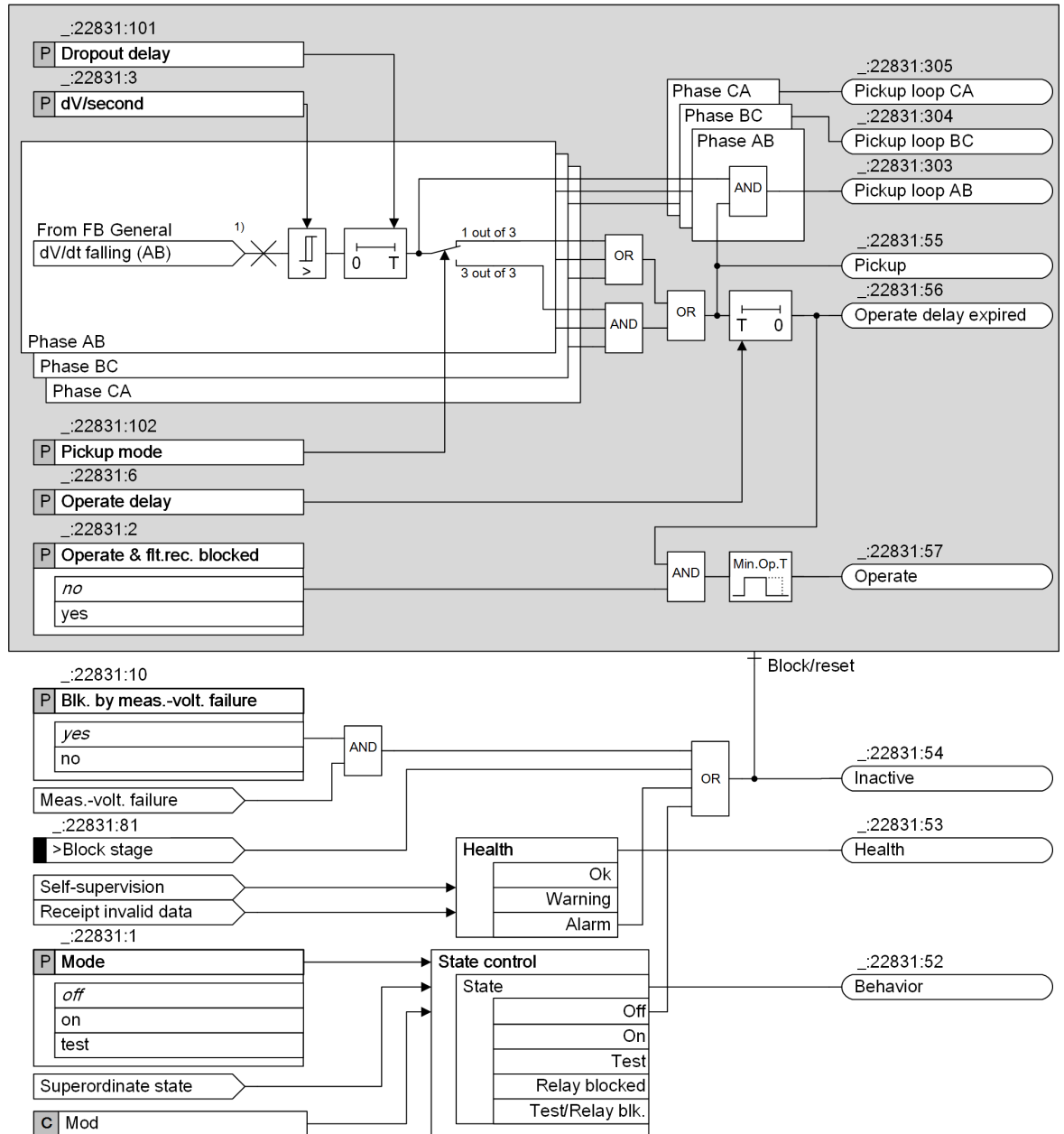

[to_dvdt_stage_1_en_US]

Figure 6-209 Logic Diagram of the dV/dt Falling Stage

(1) For the stage type **dV/dt rising**, the value **dV/dt rising (AB)** is used.

Voltage Change

The stage **dV/dt falling** is used to detect a system-voltage decrease and the stage **dV/dt rising** is used to detect a system-voltage increase.

You set the threshold value **dV/second** as the absolute voltage change per second. You define the voltage-change direction via the stage type.

Pickup Mode

The **Pickup mode** parameter defines whether the stage picks up if all 3 measuring elements detect the voltage-change condition (**3 out of 3**) or if only 1 measuring element detects the voltage-change condition (**1 out of 3**).

Dropout Delay

If the dV/dt value falls below the dropout threshold, the dropout of the stage can be delayed. The pickup is maintained for the specified time. The operate delay continues to run. If the operate delay expires while the pickup is still maintained, the stage operates.

Blocking the Stage via Binary Input Signal

You can block the stage externally or internally via the binary input signal **>Block stage**. In the event of blocking, the picked up stage will be reset.

Blocking the Stage in Case of Measuring-Voltage Failure

The stage can be blocked if a measuring-voltage failure occurs. In the event of blocking, the picked up stage will be reset. The following blocking options are available for the stage:

- From inside on pickup of the **Measuring-voltage failure detection** function
- From an external source via the binary input signal **>Open** of the function block **Voltage-transformer circuit breaker**, which links in the tripping of the voltage-transformer circuit breaker.

The **Blk. by meas.-volt. failure** parameter can be set so that **Measuring-voltage failure detection** blocks the stage or not.

6.32.4.2 Application and Setting Notes

Parameter: **dV/second**

- Default setting (**_:22831:3**) **dV/second = 20.000 V**

With the **dV/second** parameter, you determine the pickup value of the stage. The pickup value depends on the application.

For the load-shedding application, it is necessary to detect faster rates of voltage change in the range from 20 V to 30 V per second.

For an island-state detection of the network, the pickup value can be set much lower in the range of 1 V per second or less.

Parameter: **Dropout delay**

- Default setting (**_:22831:101**) **Dropout delay = 0.00 s**

The **Dropout delay** parameter maintains the pickup even if the measured value drops temporarily below the threshold value. A delay is required for very low pickup values to prevent a chattering of the function.

Parameter: **Operate delay**

- Default setting (**_:22831:6**) **Operate delay = 3.00 s**

You can use the **Operate delay** parameter to avoid overfunction due to disturbing influences (for example, switching operations). If the protection function is supposed to respond immediately, set the **Operate delay** to 0.00 s.

Parameter: **Pickup mode**

- Default setting (**_:22831:102**) **Pickup mode = 1 out of 3**

With the **Pickup mode** parameter, you define whether the protection stage picks up if all 3 measuring elements detect the voltage falling/rising condition (**3 out of 3**) or if only 1 measuring element detects the voltage falling/rising condition (**1 out of 3**).

Parameter Value	Description
1 out of 3	Select the setting for protection applications or for monitoring the voltage range. This setting reflects how the function operated in previous generations (SIPROTEC 4).
3 out of 3	Select this setting when using the stage to disconnect from the power system (for example in the case of wind farms).

Operation as Supervision Function

If you want the stage to have a reporting effect only, generation of the operate indication and fault logging can be disabled via the **Operate & flt.rec. blocked** parameter.

Parameter: **Blk. by meas.-volt. failure**

- Default setting (`_:22831:10`) **Blk. by meas.-volt. failure = yes**

You use the **Blk. by meas.-volt. failure** parameter to control the behavior of the stage when a measuring-voltage failure is detected.

A measuring-voltage failure can only be detected if one of the following 2 conditions is met:

- The device-internal supervision function **Measuring-voltage failure detection** is configured and enabled.
- The binary input signal **>open** of the function block **Voltage-transformer circuit breaker** is connected to the voltage-transformer circuit breaker.

Parameter Value	Description
yes	The protection stage is blocked (= default setting). Siemens recommends using the default setting.
no	The protection stage is not blocked.

6.32.5 Settings

Addr.	Parameter	C	Setting Options	Default Setting
General				
_:13171:137	General:Measuring window		2 periods to 50 periods	5 periods
dV/dt falling1				
_:22831:1	dV/dt falling1:Mode		<ul style="list-style-type: none"> • off • on • test 	off
_:22831:2	dV/dt falling1:Operate & flt.rec. blocked		<ul style="list-style-type: none"> • no • yes 	no
_:22831:10	dV/dt falling1:Blk. by meas.-volt. failure		<ul style="list-style-type: none"> • no • yes 	yes
_:22831:102	dV/dt falling1:Pickup mode		<ul style="list-style-type: none"> • 1 out of 3 • 3 out of 3 	1 out of 3
_:22831:3	dV/dt falling1:dV/second		0.500 V to 200.000 V	20.000 V
_:22831:6	dV/dt falling1:Operate delay		0.00 s to 60.00 s	3.00 s

Addr.	Parameter	C	Setting Options	Default Setting
_:22831:101	dV/dt falling1:Dropout delay		0.00 s to 60.00 s	0.00 s
<i>dV/dt rising 1</i>				
_:22801:1	dV/dt rising 1:Mode		<ul style="list-style-type: none"> • off • on • test 	off
_:22801:2	dV/dt rising 1:Operate & flt.rec. blocked		<ul style="list-style-type: none"> • no • yes 	no
_:22801:10	dV/dt rising 1:Blk. by meas.-volt. failure		<ul style="list-style-type: none"> • no • yes 	yes
_:22801:102	dV/dt rising 1:Pickup mode		<ul style="list-style-type: none"> • 1 out of 3 • 3 out of 3 	1 out of 3
_:22801:3	dV/dt rising 1:dV/second		0.500 V to 200.000 V	20.000 V
_:22801:6	dV/dt rising 1:Operate delay		0.00 s to 60.00 s	3.00 s
_:22801:101	dV/dt rising 1:Dropout delay		0.00 s to 60.00 s	0.00 s

6.32.6 Information List

No.	Information	Data Class (Type)	Type
<i>General</i>			
_:13171:320	General:dV/s	DEL	O
_:13171:52	General:Behavior	ENS	O
_:13171:53	General:Operate	ENS	O
<i>Group indicat.</i>			
_:4501:55	Group indicat.:Pickup	ACD	O
_:4501:57	Group indicat.:Operate	ACT	O
_:4501:52	Group indicat.:Behavior	ENS	O
_:4501:53	Group indicat.:Health	ENS	O
<i>dV/dt falling1</i>			
_:22831:81	dV/dt falling1:>Block stage	SPS	I
_:22831:51	dV/dt falling1:Mode (controllable)	ENC	C
_:22831:54	dV/dt falling1:Inactive	SPS	O
_:22831:52	dV/dt falling1:Behavior	ENS	O
_:22831:53	dV/dt falling1:Health	ENS	O
_:22831:55	dV/dt falling1:Pickup	ACD	O
_:22831:303	dV/dt falling1:Pickup loop AB	SPS	O
_:22831:304	dV/dt falling1:Pickup loop BC	SPS	O
_:22831:305	dV/dt falling1:Pickup loop CA	SPS	O
_:22831:56	dV/dt falling1:Operate delay expired	ACT	O
_:22831:57	dV/dt falling1:Operate	ACT	O
<i>dV/dt rising 1</i>			
_:22801:81	dV/dt rising 1:>Block stage	SPS	I
_:22801:51	dV/dt rising 1:Mode (controllable)	ENC	C
_:22801:54	dV/dt rising 1:Inactive	SPS	O

No.	Information	Data Class (Type)	Type
_:22801:52	dV/dt rising 1:Behavior	ENS	O
_:22801:53	dV/dt rising 1:Health	ENS	O
_:22801:55	dV/dt rising 1:Pickup	ACD	O
_:22801:303	dV/dt rising 1:Pickup loop AB	SPS	O
_:22801:304	dV/dt rising 1:Pickup loop BC	SPS	O
_:22801:305	dV/dt rising 1:Pickup loop CA	SPS	O
_:22801:56	dV/dt rising 1:Operate delay expired	ACT	O
_:22801:57	dV/dt rising 1:Operate	ACT	O

6.33 Overfrequency Protection

6.33.1 Overview of Functions

The **Overfrequency protection** function (ANSI 81O):

- Detect overfrequencies in electrical power systems or machines
- Monitor the frequency band and output failure indications
- Disconnect generating units when the power frequency is critical
- Provide additional turbine protection if the speed limiter fails

Frequency deviations are caused by an unbalance between the active power generated and consumed. Overfrequency is caused by load shedding (island network), power system disconnection or disturbances of the frequency controller. Overfrequency implies a risk of self excitation of machines which are connected to long lines without load.

Overfrequency protection is available in two functional configurations (selectable from the DIGSI functions library). The functional configurations differ in the frequency measurement method they use.

6.33.2 Structure of the Function

The **Overfrequency protection** function is used in protection function groups, which are based on voltage measurement.

The overfrequency protection function comes with 2 factory-set stages. A maximum of 3 tripping stages can be operated simultaneously in the function. The tripping stages have an identical structure.

The parameters **Dropout differential** and **Minimum voltage** are set for all stages.

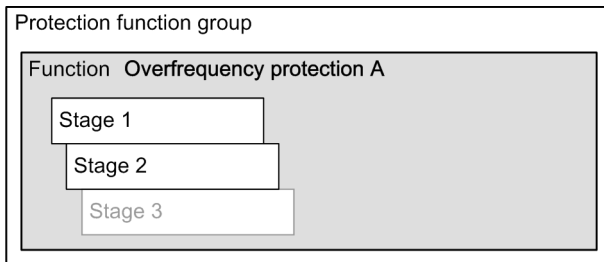

[dw_stofop_1, en_US]

Figure 6-210 Structure/Embedding of the Function

6.33.3 Overfrequency-Protection Stage

Logic of a Stage

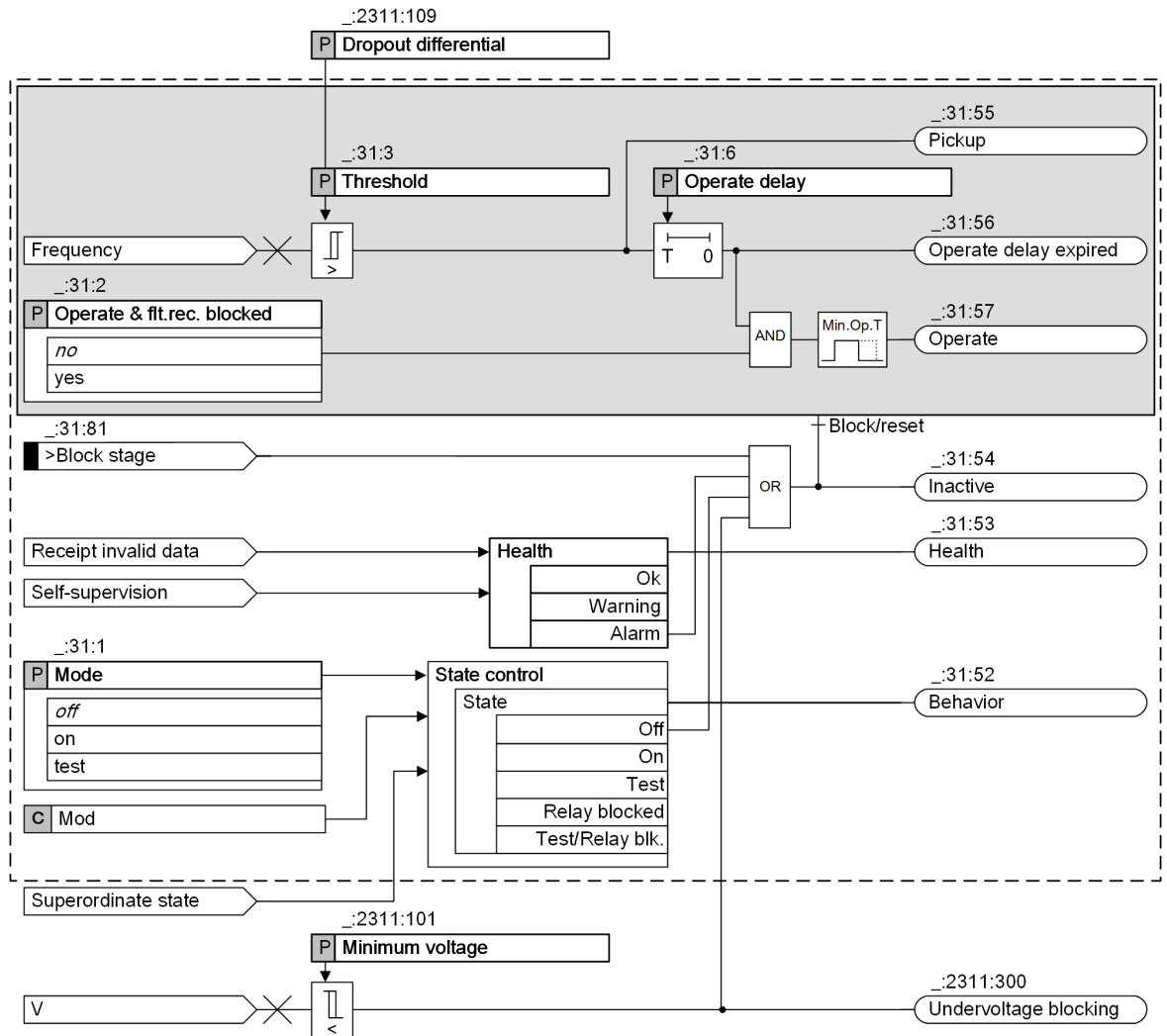

[to_stofqp, 2_en_US]

Figure 6-211 Logic Diagram of the Overfrequency-Protection Stage

Frequency-Measurement Method

Underfrequency protection is available in 2 functional configurations. These work with different frequency-measurement methods. You select the frequency-measurement method in dependence of the application.

- Angle-difference method (method A):
The angle-difference method determines the phasor of the positive-sequence voltage in multiphase systems. In the case of 1-phase connection, it always processes the phasor of the connected voltage. Since the change of angle of the voltage phasor over a given time interval is proportional to the frequency change, the current frequency can be derived from it.
- Filtering method (method B):
The filtering method processes the instantaneous voltage values and determines the current frequency using a suitable combination of filters. The frequency-protection function selects automatically the largest voltage as the measurand. In a multiphase connection, the phase-to-phase voltage is always the largest. If in a multiphase connection the selected voltage is no longer available, the function changes over automatically to the next maximum voltage. The function can even operate with just one voltage.

Both methods of measurement are characterized by a high measuring accuracy combined with a short response time. Disturbance values such as harmonics, high frequency disturbances, phase-angle jumps during switching operations and compensation processes due to power swings are effectively suppressed.



NOTE

The angle difference method (method A) requires the sampling-frequency tracking.
 If you use the angle difference method as method of measurement, ensure that sampling-frequency tracking is active (see [3.3.2 Sampling-Frequency Tracking](#)).

Functional Measured Value

The angle-difference method provides the following measured value:

Measured Value	Description
f	Frequency calculated with the angle-difference method

Behavior on Leaving the Operating Range

The sampling-frequency tracking makes a wide frequency operating range possible. If the stage has picked up before leaving the frequency operating range and the measuring voltage is higher than the set minimum voltage, the pickup is maintained. A dropout of the pickup is only possible by means of a blocking.

Blocking the Stage

In the event of blocking, a picked-up stage will be reset. The following blocking options are available for the stage:

- Externally or internally via the logical binary input *>Block stage*
- Internally when the voltage drops below the **Minimum voltage**

6.33.4 Application and Setting Notes

Parameter: Minimum voltage

- Recommended setting value (`_:2311:101`) **Minimum voltage = 37.500 V**

For the **Undervoltage blocking**, Siemens recommends 65 % of the rated voltage of the protected object as the setting value.

Calculate the secondary or primary setting value with the phase-to-ground voltage, that is, $V_{rated}/\sqrt{3}$.

For $V_{rated} = 100$ V secondary, the setting value of the **Minimum voltage** is calculated as follows:

$$\text{Minimum voltage} = 0.65 \cdot V_{rated} = 0.65 \cdot \frac{100 \text{ V}}{\sqrt{3}} = 37.500 \text{ V}$$

[fo_minimal voltage A, 1, en_US]

In the angle-difference method, the setting value relates to the positive-sequence system.



NOTE

If in DIGSI you switch over the settings view of the parameters to **Percent**, the phase-to-phase value of the rated voltage is the reference value for the **Minimum voltage** in both methods of measurement.

6.33.5 Settings

Addr.	Parameter	C	Setting Options	Default Setting
General				
_:2311:101	General:Minimum voltage		3.000 V to 175.000 V	37.500 V
_:2311:109	General:Dropout differential		20 mHz to 2000 mHz	20 mHz
Stage 1				
_:31:1	Stage 1:Mode		<ul style="list-style-type: none"> • off • on • test 	off
_:31:2	Stage 1:Operate & flt.rec. blocked		<ul style="list-style-type: none"> • no • yes 	no
_:31:3	Stage 1:Threshold	Overfrequency A	40.00 Hz to 90.00 Hz	51.50 Hz
		Overfrequency B	40.00 Hz to 70.00 Hz	
_:31:6	Stage 1:Operate delay		0.00 s to 600.00 s	10.00 s
Stage 2				
_:32:1	Stage 2:Mode		<ul style="list-style-type: none"> • off • on • test 	off
_:32:2	Stage 2:Operate & flt.rec. blocked		<ul style="list-style-type: none"> • no • yes 	no
_:32:3	Stage 2:Threshold	Overfrequency A	40.00 Hz to 90.00 Hz	54.00 Hz
		Overfrequency B	40.00 Hz to 70.00 Hz	
_:32:6	Stage 2:Operate delay		0.00 s to 600.00 s	5.00 s

6.33.6 Information List

No.	Information	Data Class (Type)	Type
General			
_:2311:300	General:Undervoltage blocking	SPS	O
_:2311:301	General:f	MV	O
Group indicat.			
_:4501:55	Group indicat.:Pickup	ACD	O
_:4501:57	Group indicat.:Operate	ACT	O
Stage 1			
_:31:81	Stage 1:>Block stage	SPS	I
_:31:54	Stage 1:Inactive	SPS	O
_:31:52	Stage 1:Behavior	ENS	O
_:31:53	Stage 1:Health	ENS	O
_:31:55	Stage 1:Pickup	ACD	O
_:31:56	Stage 1:Operate delay expired	ACT	O
_:31:57	Stage 1:Operate	ACT	O
Stage 2			
_:32:81	Stage 2:>Block stage	SPS	I

No.	Information	Data Class (Type)	Type
_:32:54	Stage 2:Inactive	SPS	O
_:32:52	Stage 2:Behavior	ENS	O
_:32:53	Stage 2:Health	ENS	O
_:32:55	Stage 2:Pickup	ACD	O
_:32:56	Stage 2:Operate delay expired	ACT	O
_:32:57	Stage 2:Operate	ACT	O

6.34 Underfrequency Protection

6.34.1 Overview of Functions

The **Underfrequency protection** function (ANSI 81U) is used to:

- Detect underfrequencies in electrical power systems or machines
- Monitor the frequency band and output failure indications
- Decouple power systems
- Load shedding to ensure power system stability and protect motors
- Disconnect generating units when the power system frequency is critical (for example, $f < 0.95 f_{\text{rated}}$)

Frequency deviations are caused by an unbalance between the active power generated and consumed. Underfrequency is caused by an increase of the consumers' active power demand or by a decrease of the power generated. These conditions occur in the case of power system disconnection, generator failure, or disturbances of the power and frequency controller.

Underfrequency protection is available in 2 functional configurations (selectable from the DIGSI functions library). The functional configurations differ in the frequency measurement method they use.

6.34.2 Structure of the Function

The **Underfrequency protection** function is used in protection function groups, which are based on voltage measurement.

The **Underfrequency protection** function comes with 3 factory-set stages. A maximum of 5 tripping stages can be operated simultaneously in the function. The tripping stages have an identical structure.

The parameters **Dropout differential** and **Minimum voltage** are set for all stages.

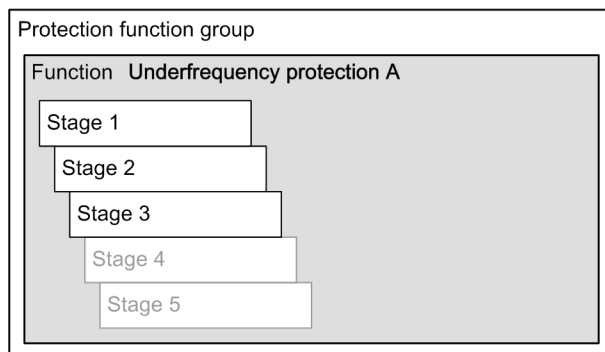

[dw_stufqp, 1, en, US]

Figure 6-212 Structure/Embedding of the Function

6.34.3 Underfrequency-Protection Stage

Logic of a Stage

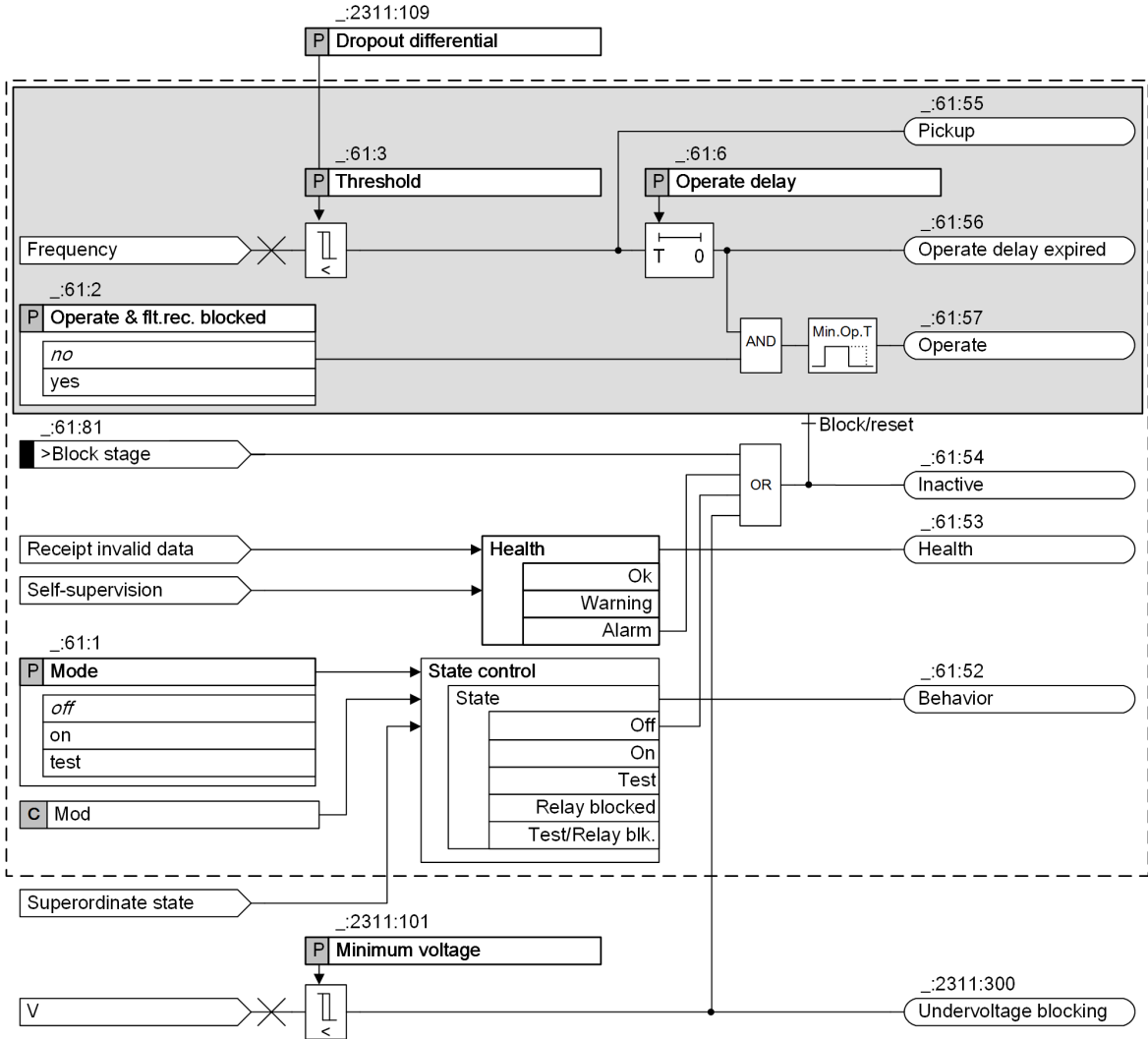

[io_stuf_gp.3.en_US]

Figure 6-213 Logic Diagram of the Underfrequency-Protection Stage

Frequency-Measurement Method

Underfrequency protection is available in 2 functional configurations. These work with different frequency-measurement methods. You select the frequency-measurement method in dependence of the application.

- Angle-difference method (method A):
 The angle-difference method determines the phasor of the positive-sequence voltage in multiphase systems. In the case of 1-phase connection, it always processes the phasor of the connected voltage. Since the change of angle of the voltage phasor over a given time interval is proportional to the frequency change, the current frequency can be derived from it.
- Filtering method (method B):
 The filtering method processes the instantaneous voltage values and determines the current frequency using a suitable combination of filters. The frequency-protection function selects automatically the largest voltage as the measurand. In a multiphase connection, the phase-to-phase voltage is always the largest. If in a multiphase connection the selected voltage is no longer available, the function changes over automatically to the next maximum voltage. The function can even operate with just one voltage.

Both methods of measurement are characterized by a high measuring accuracy combined with a short response time. Disturbance values such as harmonics, high frequency disturbances, phase-angle jumps during switching operations and compensation processes due to power swings are effectively suppressed.



NOTE

The angle difference method (method A) requires the sampling-frequency tracking. If you use the angle difference method as method of measurement, ensure that sampling-frequency tracking is active (see [3.3.2 Sampling-Frequency Tracking](#)).

Behavior on Leaving the Operating Range

Sampling-frequency tracking makes an additional frequency operating range possible. If the stage has picked up before leaving the frequency operating range and the measuring voltage is higher than the set minimum voltage, the pickup is maintained. A dropout of the pickup is only possible by means of a blocking.

Blocking the Stage

In the event of blocking, a picked-up stage will be reset. The following blocking options are available for the stage:

- Via the binary input signal *>Block stage* from an external or internal source
- Internally when the voltage drops below the **Minimum voltage**

6.34.4 Application and Setting Notes

Parameter: Minimum voltage

- Recommended setting value (`_:2311:101`) **Minimum voltage = 37.500 V**

For the **Undervoltage blocking**, Siemens recommends 65 % of the rated voltage of the protected object as the setting value.

Calculate the secondary or primary setting value with the phase-to-ground voltage, that is, $V_{rated}/\sqrt{3}$.

For $V_{rated} = 100$ V secondary, the setting value of the **Minimum voltage** is calculated as follows:

$$\text{Minimum voltage} = 0.65 \cdot V_{rated} = 0.65 \cdot \frac{100 \text{ V}}{\sqrt{3}} = 37.500 \text{ V}$$

[fo_minimal voltage A, 1, en_US]

In the angle-difference method, the setting value relates to the positive-sequence system.



NOTE

If in DIGSI you switch over the settings view of the parameters to **Percent**, the phase-to-phase value of the rated voltage is the reference value for the **Minimum voltage** in both methods of measurement.

6.34.5 Settings

Addr.	Parameter	C	Setting Options	Default Setting
General				
_:2311:101	General:Minimum voltage		3.000 V to 175.000 V	37.500 V
_:2311:109	General:Dropout differential		20 mHz to 2000 mHz	20 mHz

Addr.	Parameter	C	Setting Options	Default Setting
Stage 1				
_.61:1	Stage 1:Mode		<ul style="list-style-type: none"> • off • on • test 	off
_.61:2	Stage 1:Operate & flt.rec. blocked		<ul style="list-style-type: none"> • no • yes 	no
_.61:3	Stage 1:Threshold		30.00 Hz to 70.00 Hz	49.80 Hz
_.61:6	Stage 1:Operate delay		0.00 s to 600.00 s	10.00 s
Stage 2				
_.62:1	Stage 2:Mode		<ul style="list-style-type: none"> • off • on • test 	off
_.62:2	Stage 2:Operate & flt.rec. blocked		<ul style="list-style-type: none"> • no • yes 	no
_.62:3	Stage 2:Threshold		30.00 Hz to 70.00 Hz	47.50 Hz
_.62:6	Stage 2:Operate delay		0.00 s to 600.00 s	10.00 s
Stage 3				
_.63:1	Stage 3:Mode		<ul style="list-style-type: none"> • off • on • test 	off
_.63:2	Stage 3:Operate & flt.rec. blocked		<ul style="list-style-type: none"> • no • yes 	no
_.63:3	Stage 3:Threshold		30.00 Hz to 70.00 Hz	47.00 Hz
_.63:6	Stage 3:Operate delay		0.00 s to 600.00 s	10.00 s

6.34.6 Information List

No.	Information	Data Class (Type)	Type
General			
_.2311:300	General:Undervoltage blocking	SPS	O
_.2311:52	General:Behavior	ENS	O
_.2311:53	General:Operate	ENS	O
Group indicat.			
_.4501:55	Group indicat.:Pickup	ACD	O
_.4501:57	Group indicat.:Operate	ACT	O
_.4501:52	Group indicat.:Behavior	ENS	O
_.4501:53	Group indicat.:Health	ENS	O
Stage 1			
_.61:81	Stage 1:>Block stage	SPS	I
_.61:51	Stage 1:Mode (controllable)	ENC	C
_.61:54	Stage 1:Inactive	SPS	O
_.61:52	Stage 1:Behavior	ENS	O
_.61:53	Stage 1:Health	ENS	O
_.61:55	Stage 1:Pickup	ACD	O
_.61:56	Stage 1:Operate delay expired	ACT	O

No.	Information	Data Class (Type)	Type
_:61:57	Stage 1:Operate	ACT	O
Stage 2			
_:62:81	Stage 2:>Block stage	SPS	I
_:62:51	Stage 2:Mode (controllable)	ENC	C
_:62:54	Stage 2:Inactive	SPS	O
_:62:52	Stage 2:Behavior	ENS	O
_:62:53	Stage 2:Health	ENS	O
_:62:55	Stage 2:Pickup	ACD	O
_:62:56	Stage 2:Operate delay expired	ACT	O
_:62:57	Stage 2:Operate	ACT	O
Stage 3			
_:63:81	Stage 3:>Block stage	SPS	I
_:63:51	Stage 3:Mode (controllable)	ENC	C
_:63:54	Stage 3:Inactive	SPS	O
_:63:52	Stage 3:Behavior	ENS	O
_:63:53	Stage 3:Health	ENS	O
_:63:55	Stage 3:Pickup	ACD	O
_:63:56	Stage 3:Operate delay expired	ACT	O
_:63:57	Stage 3:Operate	ACT	O

6.35 Underfrequency Load Shedding

6.35.1 Overview of Functions

The **Underfrequency load shedding** function:

- Detects underfrequencies in the electrical power systems
- Switches off the medium-voltage busbar or feeders that consume active power to stabilize the frequency
- Maintains operations for the medium-voltage busbar or feeders that generate active power

6.35.2 Structure of the Function

The **Underfrequency load shedding** function can be used in the **Voltage/Current 3-phase** function group and in the **Line** function group.

The **Underfrequency load shedding** function comes factory-set with 8 stages. A maximum of 12 stages can be operated simultaneously within the function. These stages are identical in structure.

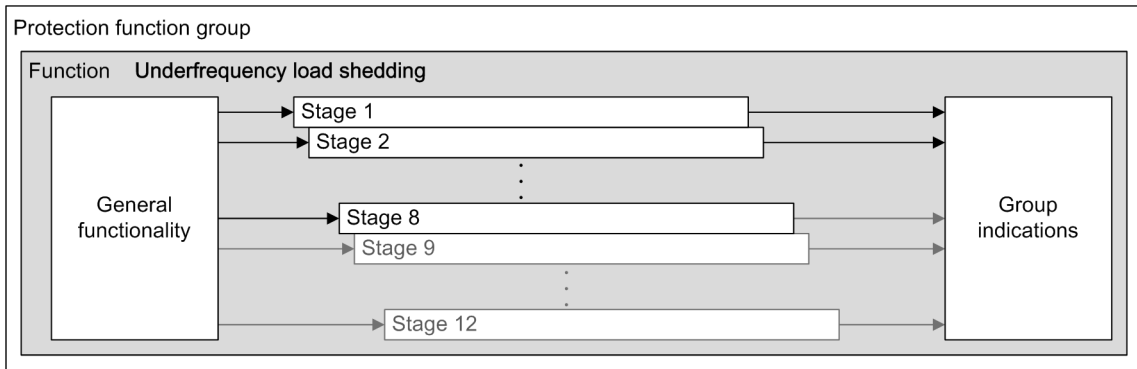

[dw_load shedding_structure_1_en_US]

Figure 6-214 Structure/Embedding of the Function

6.35.3 General Functionality

6.35.3.1 Description

Logic

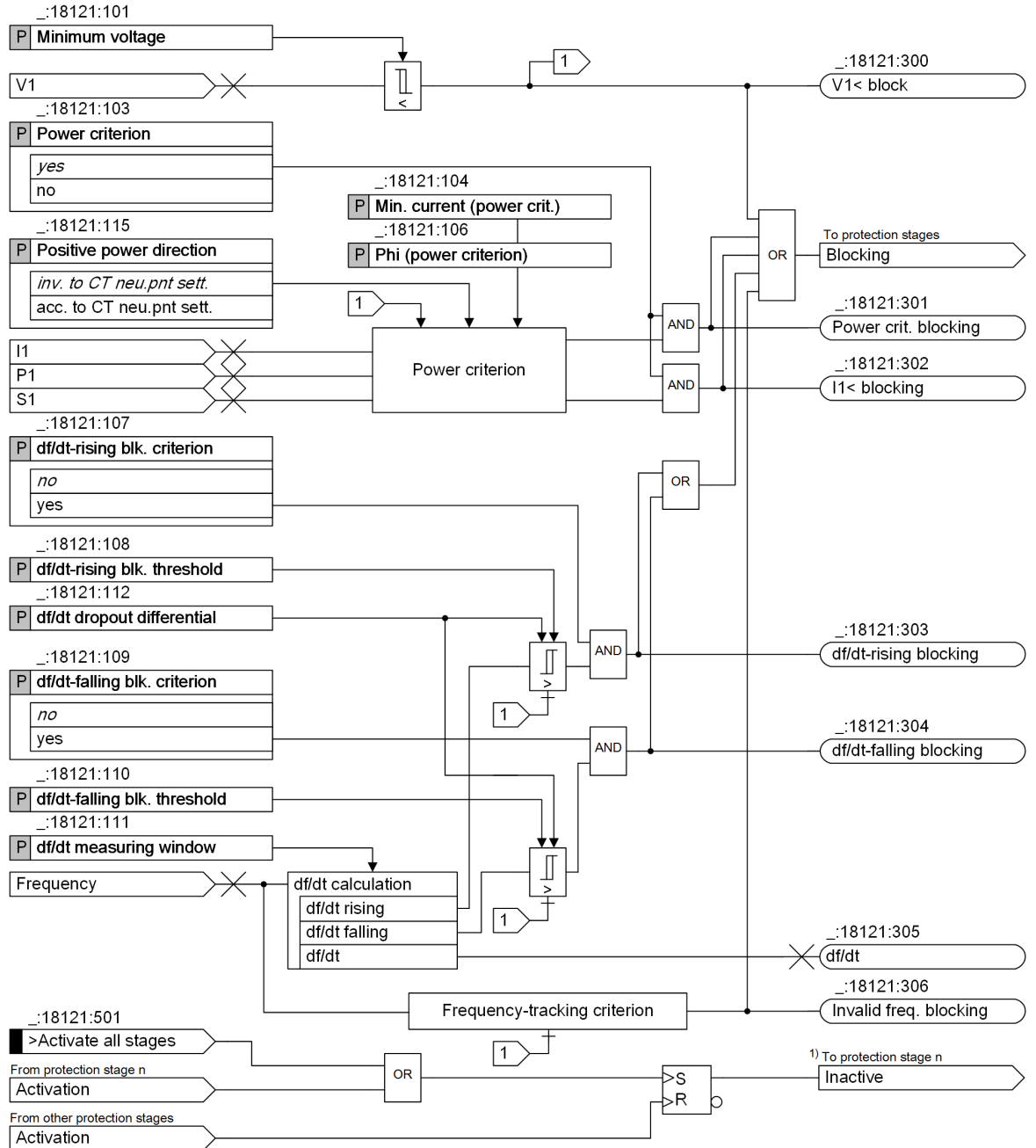

[to_UFLS_general functionality, 2, en_US]

Figure 6-215 Logic Diagram of the General Functionality

(1) n means the number of the protection stage.

Measurands

The general functionality requires the following input measurands:

- Positive-sequence voltage V1
- Positive-sequence current I1
- Positive-sequence system apparent power S1
- Positive-sequence system active power P1
- Frequency

S1 and P1 are both calculated from V1 and I1. The frequency is calculated from V1.

The frequency and the frequency change rate df/dt are calculated via the angle difference algorithm. For more information, see [6.33.3 Overfrequency-Protection Stage](#).

Undervoltage Blocking

The frequency of the **Underfrequency load shedding** function is calculated from the positive-sequence voltage V1. In order to obtain a reliable and accurate frequency calculation result, the magnitude of V1 is monitored. If the magnitude of V1 is smaller than the **Minimum voltage**, all the protection stages are blocked and the *V1 < block* indication is issued.

Power Criterion

If a feeder delivers active power towards the busbar, or if the medium-voltage busbar delivers active power to the high-voltage busbar, it is meaningless to switch off this feeder or the medium-voltage busbar during the load-shedding process. The power criterion determines the power-flow direction and includes this information as a blocking criterion into the load-shedding decision of all protection stages.

The parameter **Positive power direction** defines the positive active-power flow direction of the function in relation to the standard forward direction of the protection functionality. For more information, see [6.35.3.2 Application and Setting Notes](#).

In the following figures, if the power flow is located in the release area which is marked in gray, the protection stages are released. In the remaining area, the protection stages are blocked.

The release area is configured via the following parameters:

- The parameter **Phi (power criterion)** defines the area which limits the range of the power angle.
- The parameter **Min. current (power crit.)** defines the minimum positive-sequence current that must be present to calculate the active power in a reliable way. In the following figures, the minimum current is indicated as the circle whose center is the origin of the coordinates.

The power criterion is checked only when the following 2 conditions are fulfilled:

- The positive-sequence current I1 exceeds the threshold **Min. current (power crit.)**, that is, I1 is out of the circle in the following figures.
- The undervoltage blocking is not fulfilled, that is, the magnitude of V1 is not smaller than the **Minimum voltage**.

The dashed lines in the figures show the dropout characteristics. The dropout differential of the power angle is 1° .

The symbol ϕ in the following figures represents the setting value of the parameter **Phi (power criterion)**.

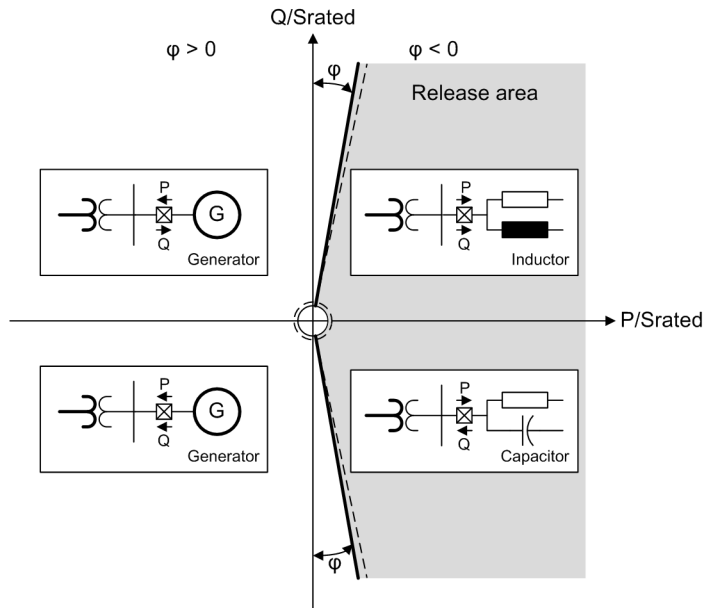

[dw_load_shedding_power_crit=0, 1, en_US]

Figure 6-216 Power-Criterion Checking at Φ (power criterion) ≤ 0

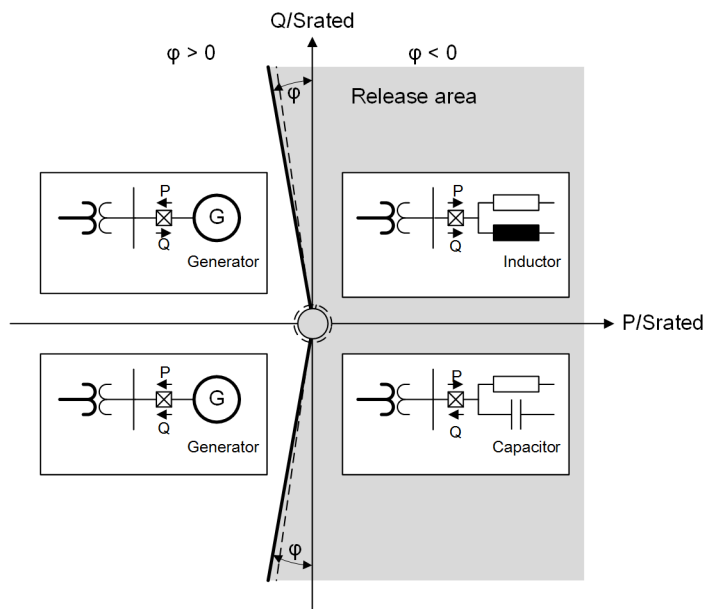

[dw_load_shedding_power_crit=0, 2, en_US]

Figure 6-217 Power-Criterion Checking at Φ (power criterion) > 0 (according to VDE-AR-N 4142:2020-04)

The power criterion contains the check of the current criterion and of the power-angle criterion. You can determine whether to check the power criterion or not by setting the **Power criterion** parameter. The power criterion is carried out only when the **Power criterion** parameter is set to **yes**. The working method of the current criterion and of the power-angle criterion differ at Φ (power criterion) ≤ 0 and Φ (power criterion) > 0 .

For **Phi (power criterion) ≤ 0**, the power criterion is checked as follows:

- When the positive-sequence current I1 falls below the **Min. current (power crit.)**, the current criterion is not fulfilled and the *I1 < blocking* indication is issued. Therefore, all the protection stages are blocked and the power-angle criterion is not considered.
- When I1 exceeds the **Min. current (power crit.)** and the power angle is out of the release area, the *Power crit. blocking* indication is issued and all the protection stages are blocked.

For **Phi (power criterion) > 0**, the power criterion is checked as follows:

- When I1 falls below the **Min. current (power crit.)**, all the protection stages are released and the power-angle criterion is not considered.
- When I1 exceeds the **Min. current (power crit.)** and the power angle is out of the release area, the *Power crit. blocking* indication is issued and all the protection stages are blocked.

df/dt Blocking

If the change rate of df/dt is too high, the **Underfrequency load shedding** function may not be applicable anymore.

The df/dt blocking comprises the df/dt-rising blocking and the df/dt-falling blocking.

The df/dt-rising criterion and the df/dt-falling criterion can be individually switched on or off. These 2 df/dt criteria are operative only when the magnitude of the positive-sequence voltage V1 is greater than the **Minimum voltage**:

- The df/dt-rising blocking takes place when the df/dt-rising value exceeds the setting value of the parameter **df/dt-rising blk. threshold**. It is signaled via the indication *df/dt-rising blocking*.
- The df/dt-falling blocking takes place when the df/dt-falling value exceeds the setting value of the parameter **df/dt-falling blk. threshold**. It is signaled via the indication *df/dt-falling blocking*.

Frequency-Tracking Criterion

The frequency-tracking criterion is only checked when no undervoltage blocking is given.

The frequency of the **Underfrequency load shedding** function is calculated via the angle difference algorithm, which requires the sampling-frequency tracking to be active (see [3.3.2 Sampling-Frequency Tracking](#)). If the sampling-frequency tracking is inactive, all the protection stages are blocked and the signal *Invalid freq. blocking* is issued.

Activating/Deactivating Protection Stages

The mechanism of exclusive stage activation is described in [Exclusive Stage Activation, Page 840](#).

Functional Measured Value

Value	Description
df/dt	Calculated rate of frequency change

6.35.3.2 Application and Setting Notes

Parameter: **Minimum voltage**

- Default setting (**_ :18121:101**) **Minimum voltage** = 0.700 p.u.

If the magnitude of V1 is smaller than the **Minimum voltage**, all protection stages are blocked.

The **Minimum voltage** parameter is set as a per-unit value related to the rated voltage of the connected voltage measuring point. Siemens recommends using the default setting.

Parameter: **Positive power direction**

- Default setting (**_ :18121:115**) **Positive power direction** = *inv. to CT neu.pnt sett.*

With the **Positive power direction** parameter, you define the positive active-power flow direction of the function in relation to the standard forward direction of the protection functionality.

The following figure shows 2 application scenarios of protection devices with the **Underfrequency load shedding** function.

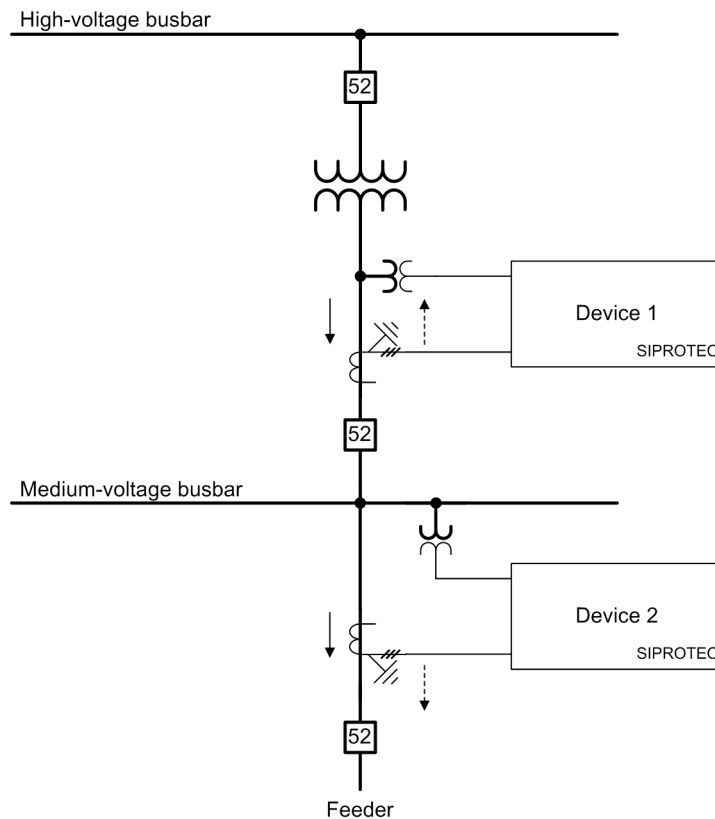

[dw_UFLS_positive power direction, 1, en_US]

Figure 6-218 Application Scenarios

Dotted arrow: Standard forward direction of the protection functionality

Solid arrow: Positive active-power flow direction

The standard forward direction of the protection functionality is from the busbar to the protected object which is the transformer for device 1 or the feeder for device 2. The standard forward direction of the protection functionality is configured via the (`_:8881:116`) **Neutr.point in dir.of ref.obj** parameter of the measuring point I-3ph (see chapter [6.1.4 Application and Setting Notes for Measuring Point Current 3-Phase \(I-3ph\)](#)). For the load-shedding function, the positive active-power flow direction can differ from the standard forward direction of the protection functionality, such as for device 1. To adapt the function to this condition, the **Positive power direction** parameter is used. With the **Positive power direction** parameter, you can set the positive active-power flow direction either to the same as or to the inverse of the standard forward direction.

- For device 1, set the **Positive power direction** parameter to `inv. to CT neu.pnt sett..`. Then, the positive active-power flow direction of the power criterion is opposite to the standard forward direction of the protection functionality. Consequently, the **Underfrequency load shedding** function sheds the medium-voltage busbar when the positive power-flow direction is from the high-voltage busbar to the medium-voltage busbar.
- For device 2, set the **Positive power direction** parameter to `acc. to CT neu.pnt sett..`. Then, the positive active-power flow direction of the power criterion is the same as the standard forward direction of the protection functionality. Consequently, the **Underfrequency load shedding** function sheds the feeder when the positive power-flow direction is from the medium-voltage busbar to the feeder.

Parameter: Power criterion, Phi (power criterion), Min. current (power crit.)

- Default setting (`_:18121:103`) **Power criterion** = *yes*
- Default setting (`_:18121:106`) **Phi (power criterion)** = -5°
- Default setting (`_:18121:104`) **Min. current (power crit.)** = *0.050 p.u.*

The power criterion evaluates the power-flow direction as a blocking criterion for the protection stages.

- With the **Power criterion** parameter, you configure whether to apply the power criterion or not. If a feeder can deliver active power towards the busbar, or if the medium-voltage busbar can deliver active power to the high-voltage busbar, Siemens recommends using the power criterion to exclude the feeder or the medium-voltage busbar from being shed under this condition. If a feeder or the medium-voltage busbar is always consuming active power, the power criterion is not required.
- With the **Phi (power criterion)** parameter, you decide whether the protection stage is blocked or released in the case of low active-power flow. If the active-power flow is low, the determined active power-flow direction is not always reliable.
For **Phi (power criterion)** ≤ 0 , the protection stage is released for a clear forward active power-flow direction. If the active power-flow direction is not reliable, the protection stages are blocked. For **Phi (power criterion)** > 0 , the behavior is the contrary.
The **Phi (power criterion)** parameter can be set depending on your philosophy.
- With the **Min. current (power crit.)** parameter, you set the minimum positive-sequence current threshold to achieve a reliable active-power criterion result. The **Min. current (power crit.)** parameter is set as a per-unit value related to the rated current of the connected current measuring point. Siemens recommends using the default setting.

Parameter: df/dt-rising blk. criterion, df/dt-rising blk. threshold, df/dt-falling blk. criterion, df/dt-falling blk. threshold

- Default setting (`_:18121:107`) **df/dt-rising blk. criterion** = *no*
- Default setting (`_:18121:108`) **df/dt-rising blk. threshold** = *1.0 Hz/s*
- Default setting (`_:18121:109`) **df/dt-falling blk. criterion** = *no*
- Default setting (`_:18121:110`) **df/dt-falling blk. threshold** = *3.0 Hz/s*

If the change rate of df/dt is too high, the **Underfrequency load shedding** function may not be applicable anymore.

With the parameters **df/dt-rising blk. criterion** and **df/dt-falling blk. criterion**, you determine whether to check the df/dt-rising blocking and the df/dt-falling blocking.

With the parameters **df/dt-rising blk. threshold** and **df/dt-falling blk. threshold**, you set the threshold rates of df/dt-rising and df/dt-falling.

Parameter: df/dt measuring window

- Default setting (`_:18121:111`) **df/dt measuring window** = *5 periods*

With the **df/dt measuring window** parameter, you optimize the measuring accuracy or the pickup time of the function.

The default setting provides the maximum measuring accuracy. If you do not have specific requirements for a decreased pickup time, Siemens recommends using the default setting.

For a non-sensitive setting (high threshold value), you can set the **df/dt measuring window** parameter to a value which is smaller than *5 periods*.

Parameter: df/dt dropout differential

- Default setting (`_:18121:112`) **df/dt dropout differential** = *0.1 Hz/s*

With the **df/dt dropout differential** parameter, you define the dropout threshold of the parameters **df/dt-rising blk. threshold** and **df/dt-falling blk. threshold**.

The default setting is a reasonable value. Siemens recommends using the default setting.

6.35.4 Stage Description

6.35.4.1 Description

Logic of the Stage

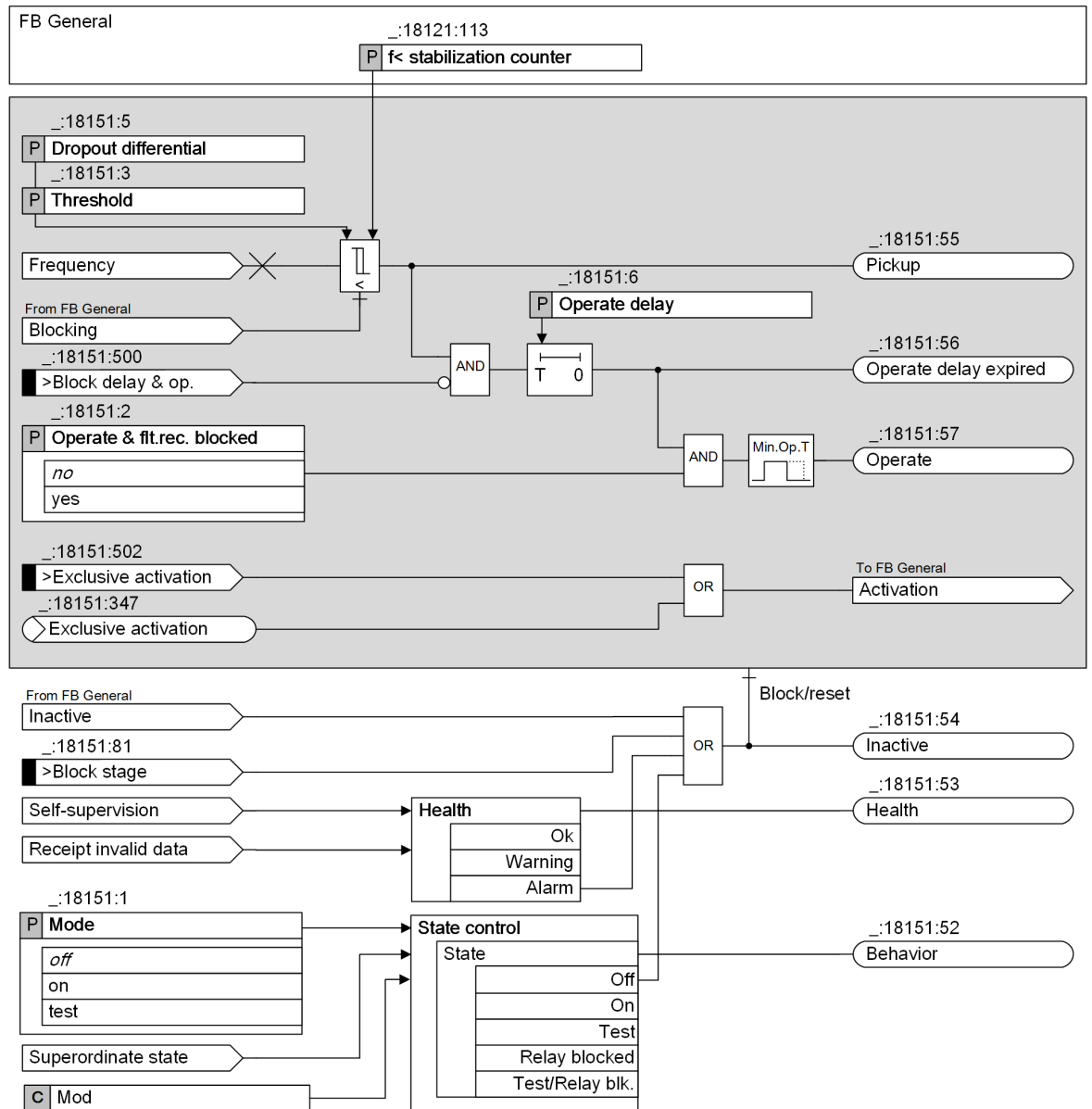

[to_load shedding_stage, 2, en_US]

Figure 6-219 Logic Diagram of the Underfrequency Load Shedding Stage

Pickup and Operate

If the following 3 conditions are all fulfilled, a **Pickup** indication is issued:

- The frequency value drops below the **Threshold**.
- The **Blocking** input from the function block **General** is inactive.
- The preceding 2 conditions are fulfilled during the configured number of frequency measurement cycles (cycle time = 10 ms). You can set the number with the parameter **f< stabilization counter**.

If the **Pickup** signal is maintained during the **Operate delay** time, an **Operate** indication is issued.

Exclusive Stage Activation

A load-shedding schema defines in which order feeders (power consumers) are disconnected. To not discriminate power consumers, this order is changed regularly. The mechanism of exclusive stage activation supports this order change efficiently.

Even though multiple protection stages are instantiated and their **Mode** parameters are set to *on*, you can only activate one stage at a time via the exclusive stage activation in an **Underfrequency load shedding** function.

The exclusive stage activation comprises the following input signals:

- The SPS signal *>Exclusive activation* which is offered in the protection stage.
- The SPC signal *Exclusive activation* which is offered in the protection stage.
This SPC signal allows the exclusive stage activation from a station controller.
- The SPS signal *>Activate all stages* which is offered in the function block **General**.

The protection stage which receives the newest SPS signal *>Exclusive activation* or SPC signal *Exclusive activation* remains active and all other stages are deactivated. If 2 or more protection stages simultaneously receive the SPS signals *>Exclusive activation* and/or the SPC signals *Exclusive activation*, only the protection stage with the largest stage number is activated.

If the SPS signal *>Activate all stages* is activated, the exclusive stage activation is reset, that is, all protection stages whose **Mode** parameters are set to *on* become active again.

After a normal device restart (reset), the statuses of the protection stages which were influenced by the SPS signal *>Exclusive activation* or the SPC signal *Exclusive activation* are still maintained.

After an initial startup, the exclusive stage activation is reset.

EXAMPLE

Configured protection stages:	Protection stages 1 to 8
Protection stages whose Mode parameters are set to <i>on</i> :	Protection stages 1 to 8

The following cases occur in sequence:

- **Case 1:**
Scenario: In the protection stage 1, the SPS signal *>Exclusive activation* or the SPC signal *Exclusive activation* is activated.
Result: The protection stage 1 remains active and stages 2 to 8 are deactivated.
- **Case 2:**
Scenario: In the protection stage 2, the SPS signal *>Exclusive activation* or the SPC signal *Exclusive activation* is activated.
Result: The protection stage 2 is activated, the stage 1 is deactivated, and stages 3 to 8 remain deactivated.
- **Case 3:**
Scenario: The SPS signal *>Activate all stages* is activated.
Result: The protection stages 1 to 8 are activated.

- **Case 4:**
Scenario: In the protection stages 2 to 4, the SPS signal *>Exclusive activation* or the SPC signal *Exclusive activation* is activated simultaneously.
Result: The protection stage 4 is activated and the other stages are deactivated.
- **Case 5:**
Scenario: A normal device restart (reset) occurs.
Result: After the device restart, the protection stage 4 remains activated and the other stages remain deactivated.

Blocking the Stage

In the event of blocking, the picked up stage will be reset. The following blocking options are available for the stage:

- Via the binary input signal *>Block stage* from an external or internal source
- Via the *Inactive* input from the function block **General**

Behavior on Leaving the Operating Range

The sampling frequency tracking makes a wide frequency-operating range possible. If the stage has picked up before leaving the frequency-operating range, the pickup is maintained. The **Pickup** signal is reset when a blocking condition becomes active.

6.35.4.2 Application and Setting Notes

Parameter: **Threshold**

- Default setting (`_:18151:3`) **Threshold** = **49.00 Hz** for $f_{\text{rated}} = 50 \text{ Hz}$

With the **Threshold** parameter, you define the underfrequency pickup value of the stage. The specific value depends on the application and the total number of the stages applied in parallel.

Parameter: **Operate delay**

- Default setting (`_:18151:6`) **Operate delay** = **0.10 s**

Set the **Operate delay** parameter for the specific application.

Parameter: **Dropout differential**

- Default setting (`_:18151:5`) **Dropout differential** = **20 mHz**

With the **Dropout differential** parameter, you define the dropout threshold. For example, if you set the **Threshold** to 49.00 Hz and the dropout differential to 20 mHz, the stage drops out at 49.02 Hz.

Due to the high-precision frequency measurement, the setting value can remain at the default value of 20 mHz.

Parameter: **Operate & flt.rec. blocked**

- Default setting (`_:18151:2`) **Operate & flt.rec. blocked** = **no**

With the **Operate & flt.rec. blocked** parameter, you can block the operate indication, the fault recording, and the fault log.

Parameter: **f< stabilization counter**

- Default setting (`_:18121:113`) **f< stabilization counter** = **6**

You can configure the **f< stabilization counter** parameter in the function block **General**.

With the **f< stabilization counter** parameter, you set the number of measurement cycles in which the measured frequency value must be lower than the frequency threshold to meet the pickup condition. With this setting, you can optimize the pickup-condition reliability versus the pickup time.

The measuring cycle time is 10 ms. With the default setting of **6**, the pickup time is the sum of the inherent frequency measuring time (approx. 10 ms to 30 ms) plus the 6 times measuring repetition of 60 ms, which is 70 ms to 90 ms in total.

In order to avoid a wrong pickup in case of a phase jump, Siemens recommends setting the value of the **f< stabilization counter** parameter not below 5.

6.35.5 Settings

Addr.	Parameter	C	Setting Options	Default Setting
General				
_:18121:101	General:Minimum voltage		0.300 p.u. to 0.900 p.u.	0.700 p.u.
_:18121:103	General:Power criterion		<ul style="list-style-type: none"> • no • yes 	yes
_:18121:104	General:Min. current (power crit.)		0.020 p.u. to 0.200 p.u.	0.050 p.u.
_:18121:115	General:Positive power direction		<ul style="list-style-type: none"> • inv. to CT neu.pnt sett. • acc. to CT neu.pnt sett. 	inv. to CT neu.pnt sett.
_:18121:106	General:Phi (power criterion)		-30° to 30°	-5°
_:18121:107	General:df/dt-rising blk. criterion		<ul style="list-style-type: none"> • no • yes 	no
_:18121:108	General:df/dt-rising blk. threshold		0.1 Hz/s to 20.0 Hz/s	1.0 Hz/s
_:18121:109	General:df/dt-falling blk. criterion		<ul style="list-style-type: none"> • no • yes 	no
_:18121:110	General:df/dt-falling blk. threshold		0.1 Hz/s to 20.0 Hz/s	3.0 Hz/s
_:18121:111	General:df/dt measuring window		2 periods to 5 periods	5 periods
_:18121:112	General:df/dt dropout differential		0.02 Hz/s to 0.99 Hz/s	0.10 Hz/s
_:18121:113	General:f< stabilization counter		1 to 20	6
Stage 1				
_:18151:1	Stage 1:Mode		<ul style="list-style-type: none"> • off • on • test 	off
_:18151:2	Stage 1:Operate & flt.rec. blocked		<ul style="list-style-type: none"> • no • yes 	no
_:18151:3	Stage 1:Threshold		40.00 Hz to 70.00 Hz	49.00 Hz
_:18151:5	Stage 1:Dropout differential		20 mHz to 2000 mHz	20 mHz
_:18151:6	Stage 1:Operate delay		0.00 s to 60.00 s	0.10 s

6.35.6 Information List

No.	Information	Data Class (Type)	Type
General			
_:18121:501	General:>Activate all stages	SPS	I
_:18121:300	General:V1< block	SPS	O
_:18121:306	General:Invalid freq. blocking	SPS	O
_:18121:301	General:Power crit. blocking	SPS	O
_:18121:302	General:I1< blocking	SPS	O
_:18121:303	General:df/dt-rising blocking	SPS	O
_:18121:304	General:df/dt-falling blocking	SPS	O
_:18121:305	General:df/dt	MV	O
_:18121:52	General:Behavior	ENS	O
_:18121:53	General:Operate	ENS	O
Group indicat.			
_:4501:55	Group indicat.:Pickup	ACD	O
_:4501:57	Group indicat.:Operate	ACT	O
_:4501:52	Group indicat.:Behavior	ENS	O
_:4501:53	Group indicat.:Health	ENS	O
Stage 1			
_:18151:81	Stage 1:>Block stage	SPS	I
_:18151:500	Stage 1:>Block delay & op.	SPS	I
_:18151:502	Stage 1:>Exclusive activation	SPS	I
_:18151:347	Stage 1:Exclusive activation	SPC	C
_:18151:51	Stage 1:Mode (controllable)	ENC	C
_:18151:54	Stage 1:Inactive	SPS	O
_:18151:52	Stage 1:Behavior	ENS	O
_:18151:53	Stage 1:Health	ENS	O
_:18151:55	Stage 1:Pickup	ACD	O
_:18151:56	Stage 1:Operate delay expired	ACT	O
_:18151:57	Stage 1:Operate	ACT	O

6.36 Rate of Frequency Change Protection

6.36.1 Overview of Functions

The function **Rate of frequency change protection** is used to:

- Detect a frequency change quickly
- Prevent the system from not secure states caused by unbalance between the generated and consumed active power
- Network decoupling
- Load shedding

6.36.2 Structure of the Function

The function **Rate of frequency change protection** can be used in protection function groups containing a 3-phase voltage measurement.

2 function block types are available:

- **df/dt rising**
- **df/dt falling**

The function **Rate of frequency change protection** is preconfigured by the manufacturer with 1 df/dt rising stage and 1 df/dt falling stage. A maximum of 5 df/dt rising stages and 5 df/dt falling stages can operate simultaneously within the function. Both of the function block types are similar in structure.

Undervoltage check and df/dt calculation are general functionalities and take place on the function level. All stages use these general functionalities.

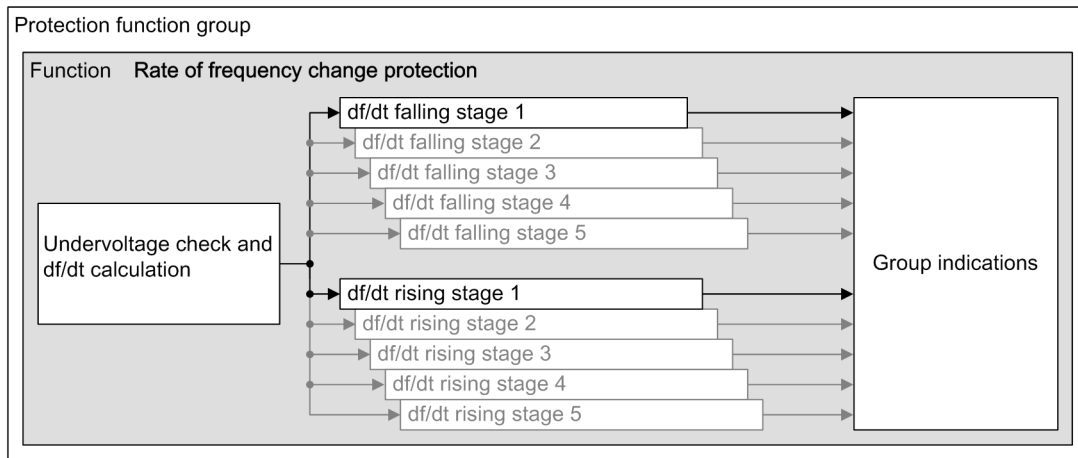

[dw_dfat 01, 1, en_US]

Figure 6-220 Structure/Embedding of the Function

6.36.3 General Functions (Undervoltage Test, df/dt Calculation)

6.36.3.1 Description

Logic

The following figure represents the logic of undervoltage check and df/dt calculation. It applies to all types of stages.

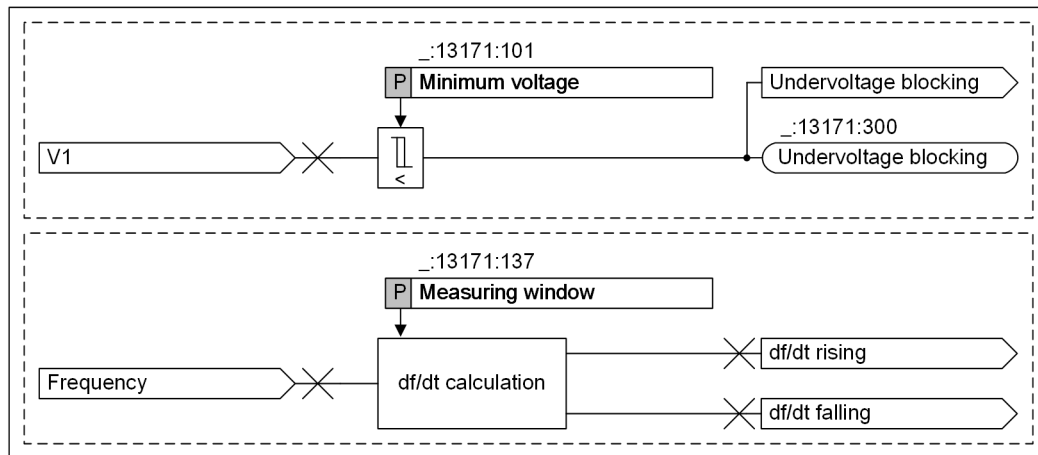

[to_dfdtgf_2_en_US]

Figure 6-221 Logic Diagram of General Functionality

Measurand

This function uses the frequency calculated via the angle difference algorithm.

For more information, refer to chapter [6.33.3 Overfrequency-Protection Stage](#).

The frequency difference is calculated over a settable time interval (default setting: 5 periods).

The ratio between the frequency difference and the time difference reflects the frequency change which can be positive or negative.

A stabilization counter works to avoid overfunction. This counter is increased if the set threshold value is exceeded. If the value drops below the threshold value, the counter is reset immediately. The counter is set to 8 internally and is activated at each half system cycle.

Undervoltage Blocking

If the measuring voltage drops below the **Minimum voltage**, the **Rate of frequency change protection** is blocked because precise frequency values cannot be calculated anymore.

Functional Measured Value

Value	Description
df/dt	Calculated rate of frequency change

6.36.3.2 Application and Setting Notes

Parameter: **Minimum voltage**

- Recommended setting value (**_:13171:101**) **Minimum voltage** = **37.500 V**

For the **Undervoltage blocking**, 65 % of the rated voltage of the protected object is recommended.

The method of measurement uses the phasor of the positive-sequence voltage. When determining the setting value, keep in mind that the absolute value of the sound positive-sequence voltage is equal to the absolute value of the phase-to-ground voltage. The default setting is referred to this value.

Parameter: **Measuring window**

- Default setting (**_:13171:137**) **Measuring window** = **5 periods**

You can use the **Measuring window** parameter to optimize the measuring accuracy or the pickup time of the function. For information regarding pickup time and measuring accuracy, refer to the technical data.

The default setting provides maximum measuring accuracy. If you do not have specific requirements for a decreased pickup time, Siemens recommends using the default setting.

The default setting is a reasonable compromise between measuring accuracy and pickup time. For a non-sensitive setting (high threshold value), you can set the parameter **Measuring window** to a smaller value.

6.36.4 Stage Description

6.36.4.1 Description

Logic of the Stage

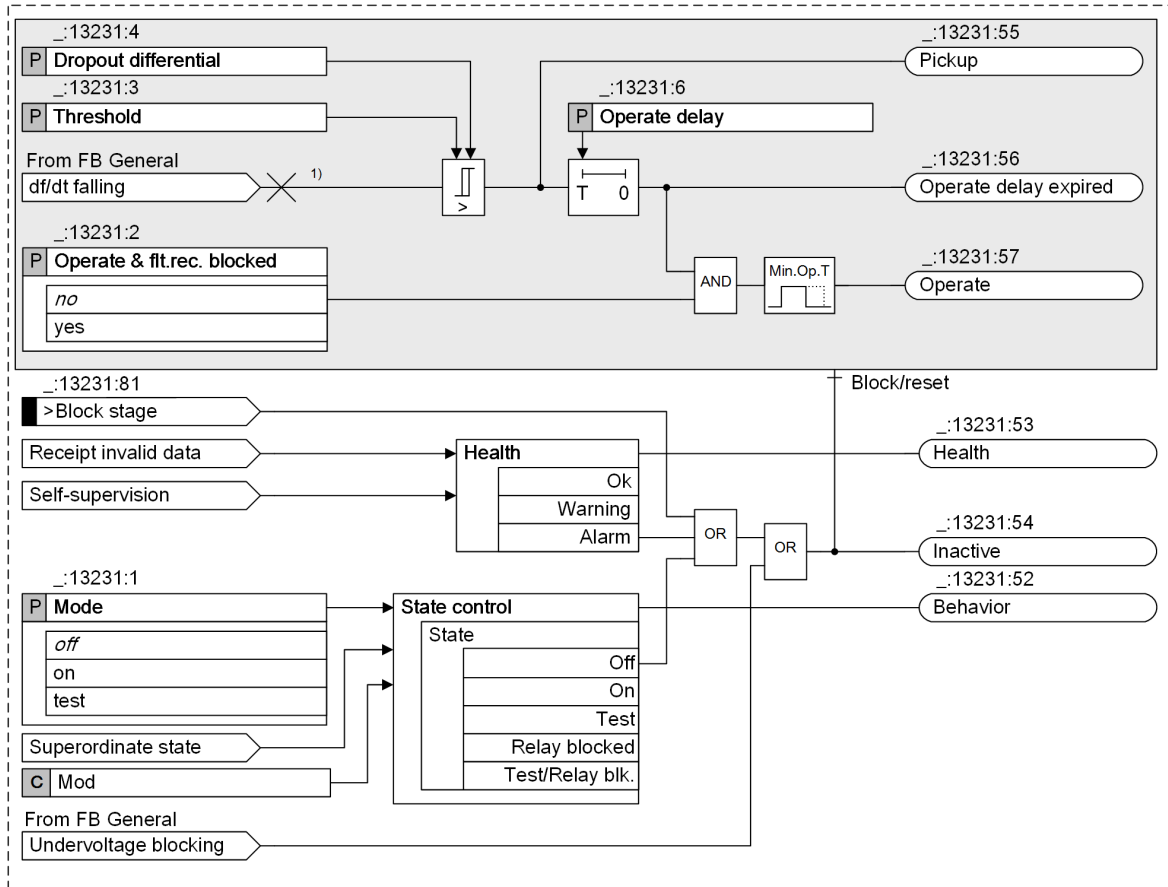

[lo_dfdt_st_2_en_US]

Figure 6-222 Logic Diagram of Rate of Frequency Change Protection

(1) For the stage type **df/dt rising**, the value **df/dt rising** is used.

Frequency Rising/Falling

The stage **df/dt falling** is used to detect frequency falling and the stage **df/dt rising** is used to detect frequency rising.

You set the threshold value as an absolute value. You define the frequency-change direction via the selected stage type.

Blocking of the Stage

The following blockings reset the picked up stage completely:

- Via the binary input signal **>Block stage**
- Via the undervoltage blocking when the voltage drops below the **Minimum voltage**

6.36.4.2 Application and Setting Notes

Parameter: **Threshold**

- Default setting (`_:13231:3`) **Threshold** = 3.000 Hz/s

The pickup value depends on the application and is determined by power-system conditions. In most cases, a network analysis will be necessary. A sudden disconnection of loads leads to a surplus of active power. The frequency rises and causes a positive frequency change. On the other hand, a failure of generators leads to a deficit of active power. The frequency drops and results in a negative frequency change.

The following relations can be used as an example for estimation. They apply for the change rate at the beginning of a frequency change (approximate 1 s).

$$\frac{df}{dt} = -\frac{f_{\text{rated}}}{2H} \cdot \frac{\Delta P}{S_{\text{rated}}}$$

Where:

f_{rated}	Rated frequency
ΔP	Active power change $\Delta P = P_{\text{Consumption}} - P_{\text{Generation}}$
S_{rated}	Rated apparent power of the machines
H	Inertia constant

Typical data for H:

For hydro generators (salient-pole machines)	H = 1.5 s to 6 s
For turbine-driven generators (non-salient pole rotors)	H = 2 s to 10 s
For industrial turbine-driven generators	H = 3 s to 4 s

EXAMPLE

$f_{\text{rated}} = 50 \text{ Hz}$
 $H = 3 \text{ s}$
 Case 1: $\Delta P/S_{\text{rated}} = 0.12$
 Case 2: $\Delta P/S_{\text{rated}} = 0.48$
 Case 1: $df/dt = -1 \text{ Hz/s}$
 Case 2: $df/dt = -4 \text{ Hz/s}$

Parameter: **Operate delay**

- Default setting (`_:13231:6`) **Operate delay** = 1.00 s

You can use the **Operate delay** parameter to avoid overfunction due to disturbing influences (for example, switching operations). If the protection function is supposed to respond quickly, set the **Operate delay** parameter to 0 s.

For monitoring small changes (< 1 Hz/s), a small time delay is useful to avoid overfunctioning.

Parameter: **Dropout differential**

- Recommended setting value (`_:13231:4`) **Dropout differential** = 0.10 Hz/s

You can use the **Dropout differential** parameter to define the dropout value. The recommended value is 0.10 Hz/s.



NOTE

In case of power-system incidents, especially in case of transmission incidents and influence of voltage-stabilizing measures via power-electronic components (reactive-power compensation through SVC), the magnitude and the phase angle of the voltage can change. Sensitive settings can lead to overfunction. Therefore, it is reasonable to block the **Rate of Frequency Change Protection** if other protection functions, for example, residual voltage or negative-sequence voltage, pick up. To do this, use the blocking input *>Block stage* and connect it via CFC.

6.36.5 Settings

Addr.	Parameter	C	Setting Options	Default Setting
General				
_:13171:101	General:Minimum voltage		3.000 V to 175.000 V	37.500 V
_:13171:137	General:Measuring window		2 periods to 5 periods	5 periods
df/dt falling1				
_:13231:1	df/dt falling1:Mode		<ul style="list-style-type: none"> • off • on • test 	off
_:13231:2	df/dt falling1:Operate &flt.rec. blocked		<ul style="list-style-type: none"> • no • yes 	no
_:13231:3	df/dt falling1:Threshold		0.100 Hz/s to 20.000 Hz/s	3.000 Hz/s
_:13231:4	df/dt falling1:Dropout differential		0.02 Hz/s to 0.99 Hz/s	0.10 Hz/s
_:13231:6	df/dt falling1:Operate delay		0.00 s to 60.00 s	1.00 s
df/dt rising1				
_:13201:1	df/dt rising1:Mode		<ul style="list-style-type: none"> • off • on • test 	off
_:13201:2	df/dt rising1:Operate &flt.rec. blocked		<ul style="list-style-type: none"> • no • yes 	no
_:13201:3	df/dt rising1:Threshold		0.100 Hz/s to 20.000 Hz/s	3.000 Hz/s
_:13201:4	df/dt rising1:Dropout differential		0.02 Hz/s to 0.99 Hz/s	0.10 Hz/s
_:13201:6	df/dt rising1:Operate delay		0.00 s to 60.00 s	1.00 s

6.36.6 Information List

No.	Information	Data Class (Type)	Type
General			
_:13171:300	General:Undervoltage blocking	SPS	0
_:13171:301	General:df/dt	MV	0
_:13171:52	General:Behavior	ENS	0
_:13171:53	General:Health	ENS	0

No.	Information	Data Class (Type)	Type
<i>Group indicat.</i>			
_:4501:55	Group indicat.:Pickup	ACD	O
_:4501:57	Group indicat.:Operate	ACT	O
_:4501:52	Group indicat.:Behavior	ENS	O
_:4501:53	Group indicat.:Health	ENS	O
<i>df/dt falling1</i>			
_:13231:81	df/dt falling1:>Block stage	SPS	I
_:13231:54	df/dt falling1:Inactive	SPS	O
_:13231:52	df/dt falling1:Behavior	ENS	O
_:13231:53	df/dt falling1:Health	ENS	O
_:13231:55	df/dt falling1:Pickup	ACD	O
_:13231:56	df/dt falling1:Operate delay expired	ACT	O
_:13231:57	df/dt falling1:Operate	ACT	O
<i>df/dt rising1</i>			
_:13201:81	df/dt rising1:>Block stage	SPS	I
_:13201:54	df/dt rising1:Inactive	SPS	O
_:13201:52	df/dt rising1:Behavior	ENS	O
_:13201:53	df/dt rising1:Health	ENS	O
_:13201:55	df/dt rising1:Pickup	ACD	O
_:13201:56	df/dt rising1:Operate delay expired	ACT	O
_:13201:57	df/dt rising1:Operate	ACT	O

6.37 Vector-Jump Protection

6.37.1 Overview of Functions

The **Vector-jump protection** function:

- Is used for network decoupling of the power generating unit in case of a load loss
- Evaluates the phase-angle jump of the voltage phasors

6.37.2 Structure of the Function

The **Vector-jump protection** function can be used in the following function groups:

- Voltage-current 3-phase
- Voltage 3-phase

The **Vector-jump protection** function comes factory-set with a $\Delta\phi$ stage.

The following stages can operate simultaneously within the function:

- 1 $\Delta\phi$ stage
- 1 $I1 < \text{Release}$ stage

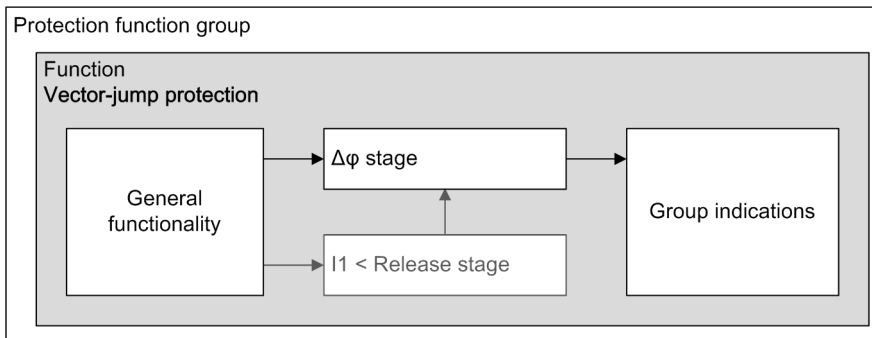

[dw_VJP_structure, 1, en_US]

Figure 6-223 Structure/Embedding of the Function

6.37.3 General Functionality

6.37.3.1 Description

Basic Principle of Vector-Jump Protection

The following 2 figures show the basic principle of the function **Vector-jump protection**.

The following figure shows the voltage vector of the steady state condition. The load current causes a voltage drop between the internal voltage V_p and the generator terminal voltage V .

If the load is switched off, the following situations occur:

- The current is reduced.
- A smaller voltage drop is caused.

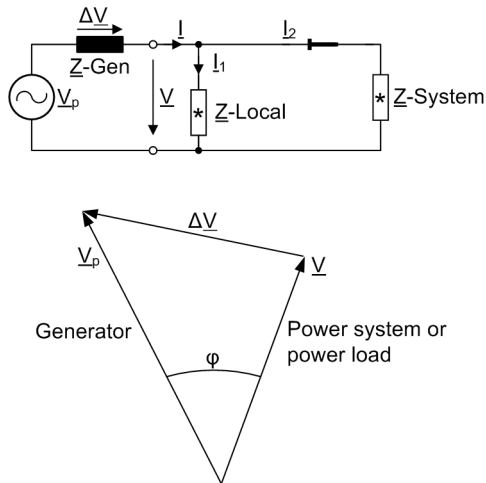

[dw_load loss, 1, en_US]

Figure 6-224 Voltage Vector of the Steady State

The following figure shows the situations after the load is switched off:

- The terminal voltage V changes to V' .
- An additional phase-angle jump occurs.

A phase-angle jump occurs with load loss and is the evaluation criterion for the function **Vector-jump protection**. If the phase-angle differential exceeds a set threshold, the generator circuit breaker or the circuit breaker of the system switch opens. Therefore, the generator unit can be protected against unacceptable stress.

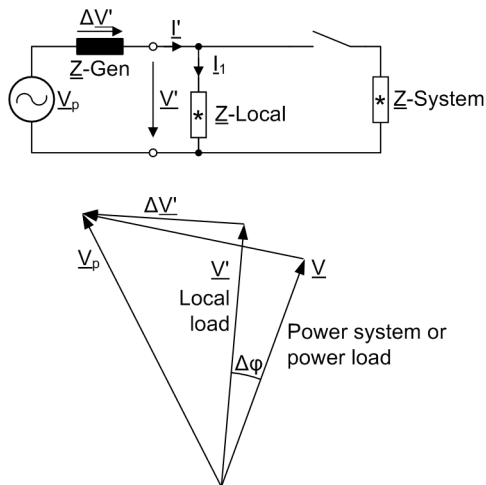

[dw_vector change, 1, en_US]

Figure 6-225 Vector Change after the Load Shedding

Table 6-17 Vector Description

Vector	Description
\underline{V}_p	Vector of the generator internal voltage (rotor voltage)
\underline{V}	Vector of the generator terminal voltage
$\underline{\Delta V}$	Vector of the voltage differential
\underline{V}'	Vector of the terminal voltage after the load shedding
$\underline{\Delta V}'$	Vector of the voltage differential after the load shedding

The following measures are applied to avoid unwanted tripping:

- Correction of steady-state deviations from rated frequency
- Frequency operating range limited to $f_{rated} \pm 3$ Hz
- High measuring accuracy by using frequency-tracked measured values and evaluation of the positive-sequence phasor
- Enabling the minimum voltage for the function **Vector-jump protection**
- Blocking the function when the primary voltage is switched on or off as switching can lead to a phase-angle jump

Logic

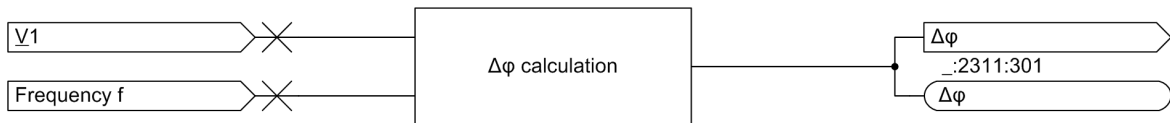

[lo_VJP_general_1, en_US]

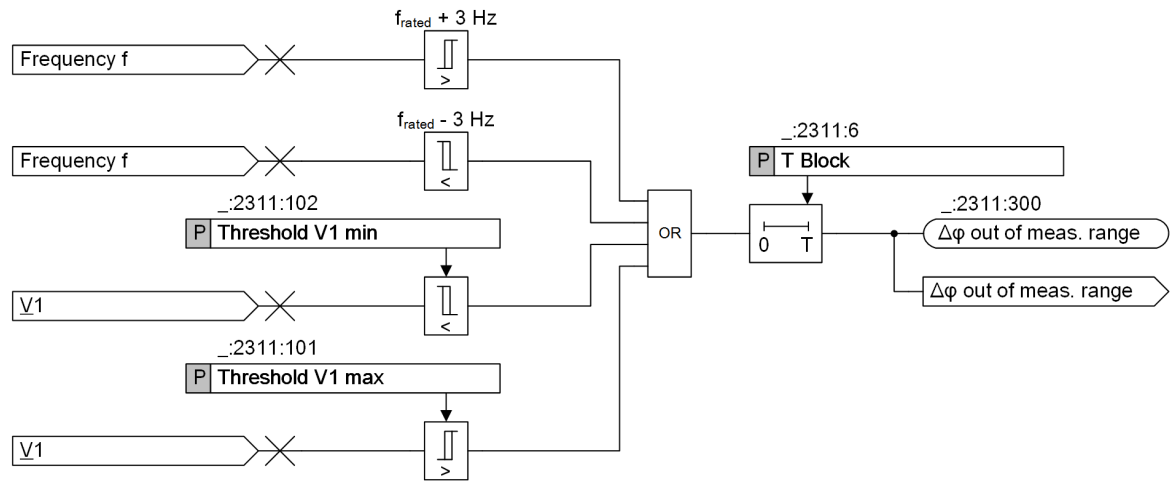

[lo_VJP_general_2, 2, en_US]

Figure 6-226 Logic Diagram of the General Functionality

Phase-Angle Calculation

The phase-angle differential is calculated at different time intervals ($t-T$, $t-2T$, $t-3T^{30}$) from the vector of the positive-sequence voltage via a delta-interval measurement. With the current measured power frequency, the measuring errors of the angle measurement caused by frequency deviations are compensated.

Range

If the measured frequency or voltage is below the set threshold, the function **Vector-jump protection** is blocked.

The voltage and frequency bands have the following limits:

- The threshold of the voltage band is configurable.
- The frequency band ranges is fixed from $f_{rated} - 3$ Hz to $f_{rated} + 3$ Hz.

³⁰ T = period or cycle time of the power system

Measurand

The general functionality calculates the phase-angle displacement $\Delta\phi$ and sends it to the $\Delta\phi$ stage. $\Delta\phi$ is used for comparison with the parameter **Threshold $\Delta\phi$** . $\Delta\phi$ is displayed in the functional measured value and can be routed in a fault record and displayed in the fault log.

The functional measured values of $\Delta\phi$ in HMI are displayed differently in the following situations:

- If the function **Vector-jump protection** is inactive, the function value of $\Delta\phi$ is displayed as "---"
- If the function **Vector-jump protection** is active and has not picked up, the functional measured value of $\Delta\phi$ is displayed as 0.0°
- If the function **Vector-jump protection** is active and has picked up, the functional measured value of $\Delta\phi$ is displayed as a calculated value (for example, 12.0°) and remains unchanged until the next pickup of the function **Vector-jump protection**.

6.37.3.2 Application and Setting Notes

Parameter: **Threshold V1 min**

- Default setting (`_:2311:102`) **Threshold V1 min** = 46.189 V

With the parameter **Threshold V1 min**, you can define the minimum threshold of the voltage band.

The setting value is closed to the allowed lower limit of the voltage band. The default setting is 80 % of the rated positive-sequence voltage. The value of the rated positive-sequence voltage is $100 V/\sqrt{3}$.

Parameter: **Threshold V1 max**

- Default setting (`_:2311:101`) **Threshold V1 max** = 75.058 V

With the parameter **Threshold V1 max**, you can define the maximum threshold of the voltage band.

The setting value is closed to the allowed higher limit of the voltage band. The default setting is 130 % of the rated positive-sequence voltage. The value of the rated positive-sequence voltage is $100 V/\sqrt{3}$.

Parameter: **T Block**

- Default setting (`_:2311:6`) **T Block** = 0.10 s

With the parameter **T Block**, you set the dropout delay of the $\Delta\phi$ stage.

When voltages are connected or disconnected, the overfunction can be avoided with the timer **T Block**.

Siemens recommends to use the default setting of the parameter **T Block**. Keep in mind that the parameter **T Block** has always to be set to 2 cycles more than the measuring window for vector-jump measurement.

6.37.3.3 Settings

Addr.	Parameter	C	Setting Options	Default Setting
General				
<code>_:2311:102</code>	General:Threshold V1 min		0.300 V to 175.000 V	46.189 V
<code>_:2311:101</code>	General:Threshold V1 max		0.300 V to 175.000 V	75.058 V
<code>_:2311:6</code>	General:T Block		0.00 s to 60.00 s	0.10 s

6.37.3.4 Information List

No.	Information	Data Class (Type)	Type
General			
<code>_:2311:301</code>	General: $\Delta\phi$	MV	O
<code>_:2311:300</code>	General: $\Delta\phi$ out of meas. range	SPS	O

No.	Information	Data Class (Type)	Type
_:2311:52	General:Behavior	ENS	O
_:2311:53	General:Health	ENS	O

6.37.4 Δφ Stage

6.37.4.1 Description

Logic

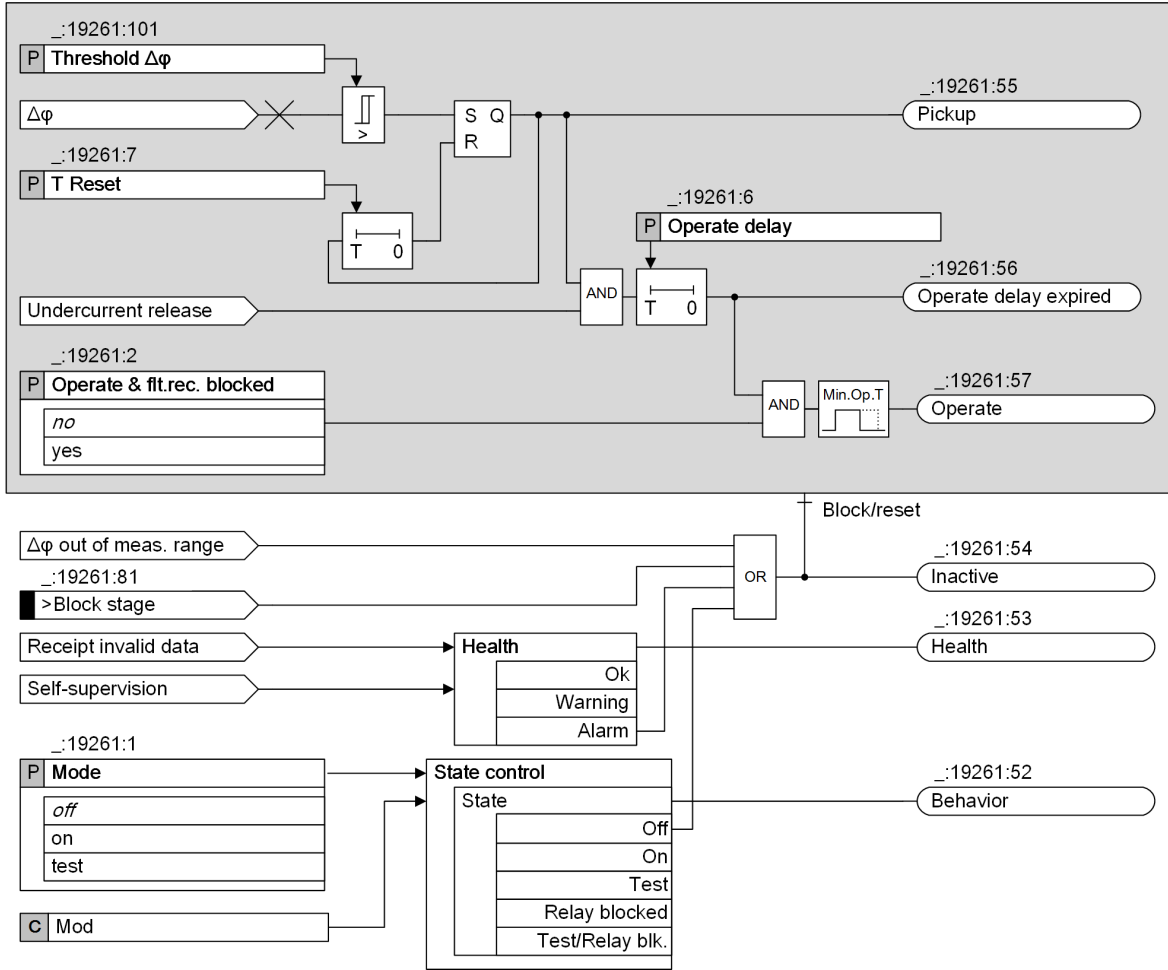

[[lo_delta_phi_stage_2_en_US]]

Figure 6-227 Logic Diagram of the Δφ Stage

In the logic diagram, the I1 < Release stage is instantiated. You can find more information in chapter [6.37.5.1 Description](#).

If the I1 < Release stage is not instantiated, the AND operation has no influence. The *Operate* indication is issued under the following conditions:

- The parameter **Operate & flt.rec. blocked** is set to *no*.
- The operate delay expires.
- The phase-angle differential exceeds the parameter **Threshold Δφ**.

Measurand

The $\Delta\phi$ stage gets the measured value $\Delta\phi$ from the general functionality.

Pickup

The $\Delta\phi$ stage compares the value of the vector jump $\Delta\phi$ with the **Threshold $\Delta\phi$** .

If the value of the **Threshold $\Delta\phi$** is exceeded, the pickup delay starts.

The vector jump $\Delta\phi$ is stored in an RS flip-flop. Trippings can be delayed by the associated time delay.

Blocking the Stage

In the event of blocking, the picked up stage will be reset. The following blocking options are available for the stage:

- The parameter **Mode** is in the state *off*.
- The binary input signal *>Block stage* is active.
- The signal *$\Delta\phi$ out of meas. range* is active.

6.37.4.2 Application and Setting Notes

Parameter: **Operate & flt.rec. blocked**

- Default setting (`_:19261:2`) **Operate & flt.rec. blocked** = *no*

With the parameter **Operate & flt.rec. blocked**, you can block the operate indication, the fault recording, and the fault log. If you want the stage to have a warning indication only, set the parameter **Operate & flt.rec. blocked** to *yes*.

Parameter: **Threshold $\Delta\phi$**

- Default setting (`_:19261:101`) **Threshold $\Delta\phi$** = 10°

With the parameter **Threshold $\Delta\phi$** , you can set the pickup value of the $\Delta\phi$ stage.

The parameter value to be set for the vector jump depends on the supply and load conditions. Load changes cause a jump of the voltage vector. The value to be set must be established in accordance with the particular power system. An estimation can be done based on the system equivalent circuit in [Figure 6-225](#). A network calculation considering the relevant source and load situations will be more precise.

If the setting for the parameter **Threshold $\Delta\phi$** is too sensitive, every time loads are connected or disconnected, the protection function performs a network decoupling. Therefore, if no other calculated value is applicable to the setting of this parameter, Siemens recommends using the default setting.

Parameter: **Operate delay**

- Default setting (`_:19261:6`) **Operate delay** = 0.00 s

With the parameter **Operate delay**, you can set the operate delay of the $\Delta\phi$ stage. For the tripping stage, set the operate delay between 0.00 s and 60.00 s .

Siemens recommends the default setting.

The following requirements can necessitate a change of the parameter **Operate delay** with respect to the default setting:

- The operate indication should be transmitted with delay to a programmable logic.
- There shall be enough time for an external blocking to take effect.

Parameter: **T Reset**

- Default setting **T Reset** = 5.00 s

With the parameter **T Reset**, you can set the reset time for the *Pickup* indication stored in the RS flip-flop. When the timer **T Reset** expires, the protection function is reset automatically.

The reset time meets the following conditions:

- The reset time depends on the decoupling requirements
- The reset time must expire before the circuit breaker is reclosed

6.37.4.3 Settings

Addr.	Parameter	C	Setting Options	Default Setting
Stage Δφ 1				
_:19261:1	Stage Δφ 1:Mode		<ul style="list-style-type: none"> • off • on • test 	off
_:19261:2	Stage Δφ 1:Operate & flt.rec. blocked		<ul style="list-style-type: none"> • no • yes 	no
_:19261:101	Stage Δφ 1:Threshold Δφ		2.0° to 30.0°	10.0°
_:19261:6	Stage Δφ 1:Operate delay		0.00 s to 60.00 s	0.00 s
_:19261:7	Stage Δφ 1:T Reset		0.00 s to 60.00 s	5.00 s

6.37.4.4 Information List

No.	Information	Data Class (Type)	Type
Stage Δφ 1			
_:19261:81	Stage Δφ 1:>Block stage	SPS	I
_:19261:54	Stage Δφ 1:Inactive	SPS	O
_:19261:52	Stage Δφ 1:Behavior	ENS	O
_:19261:53	Stage Δφ 1:Health	ENS	O
_:19261:55	Stage Δφ 1:Pickup	ACD	O
_:19261:56	Stage Δφ 1:Operate delay expired	ACT	O
_:19261:57	Stage Δφ 1:Operate	ACT	O

6.37.5 I1 < Release Stage

6.37.5.1 Description

Logic

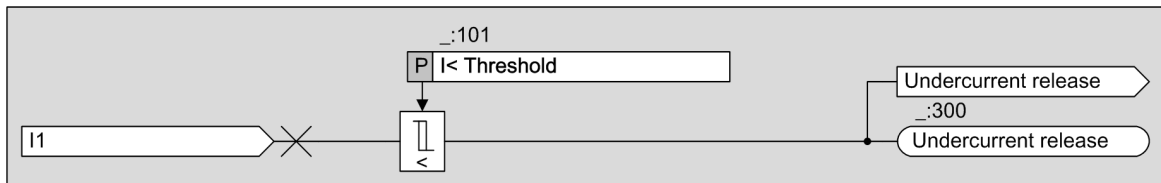

Figure 6-228 Logic Diagram of the I1 < Release Stage

The **I1 < Release** stage is an optional stage and is used to reduce the risk of overfunction. The indication *Undercurrent release* is an additional safety criterion to avoid an unexpected trip. It indicates a load loss of the connected line to the system and the phase-angle criterion is released. If any load in the network is switched on or off, an unexpected trip can occur.

If the **I1 < Release** stage is not instantiated, the **Δφ** stage works without current-flow criterion. You can find more information in chapter [6.37.4.1 Description](#).

If the positive-sequence current falls below the parameter **I< Threshold**, the message *Undercurrent release* is issued and is forwarded to the **Δφ** stage.

6.37.5.2 Application and Setting Notes

Parameter: **I< Threshold**

- Default setting (**_:101**) **I< Threshold** = 0.100 A

With the parameter **I< Threshold**, you can set the pickup value of the **I < Release** stage corresponding to the specific application. Consider that the current measuring point must be on the line side. The parameter **I< Threshold** depends on the load situation.

6.37.5.3 Settings

Addr.	Parameter	C	Setting Options	Default Setting
I1 < Release #				
_:101	I1 < Release #:I< Threshold	1 A @ 100 Irated	0.030 A to 35.000 A	0.100 A
		5 A @ 100 Irated	0.15 A to 175.00 A	0.50 A
		1 A @ 50 Irated	0.030 A to 35.000 A	0.100 A
		5 A @ 50 Irated	0.15 A to 175.00 A	0.50 A
		1 A @ 1.6 Irated	0.001 A to 1.600 A	0.100 A
		5 A @ 1.6 Irated	0.005 A to 8.000 A	0.500 A

6.37.5.4 Information List

No.	Information	Data Class (Type)	Type
I1 < Release #			
_:300	I1 < Release #:Undercurrent release	SPS	O

6.38 Power Protection (P,Q), 3-Phase

6.38.1 Overview of Functions

The 3-phase power protection (P, Q) function (ANSI 32) is used to:

- Detect whether the active or reactive power rises above or drops below a set threshold
- Monitor agreed power limits and output warning indications
- Detect both active and reactive power feedback in the power systems or on electric machines
- Detect machines (motors, generators) running without load and output an indication to shut them down.
- Be integrated into any automation solution, for example, to monitor very specific power limits (further logical processing in CFC)

6.38.2 Structure of the Function

The 3-phase power protection (P, Q) function can be integrated in function groups, which provide measured voltages and currents of the 3-phases for calculation of the power.

The 3-phase power protection (P,Q) function comes with one factory-set stage each for the active and the reactive power. The following stages are preconfigured:

- Power P>
- Power Q>
- Power P<
- Power Q<

A maximum of 4 active power stages and 4 reactive power stages can be operated simultaneously in the function. The tripping stages have an identical structure.

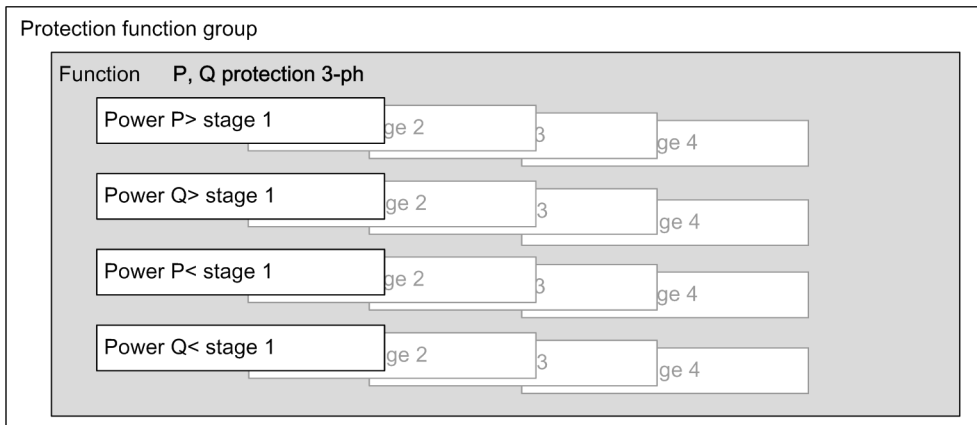

[idw_GFP 3-phase structure, 2, en_US]

Figure 6-229 Structure/Embedding of the Function

Logical Combination of Output Signals

The operate indications of the active and reactive power stage(s) can be logically combined in CFC. When an operate indication is present in both the active and the reactive power stage, an alarm indication is generated.

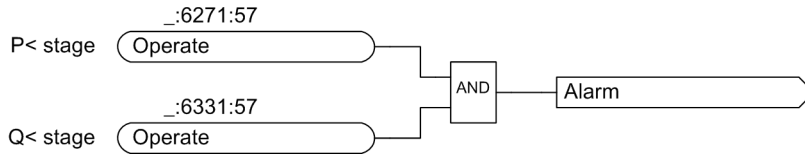

[to_GPP operate indication logical comb, 2, en_US]

Figure 6-230 Logical Combination of Operate Indications in CFC

6.38.3 Active Power Stage

Logic of a Stage

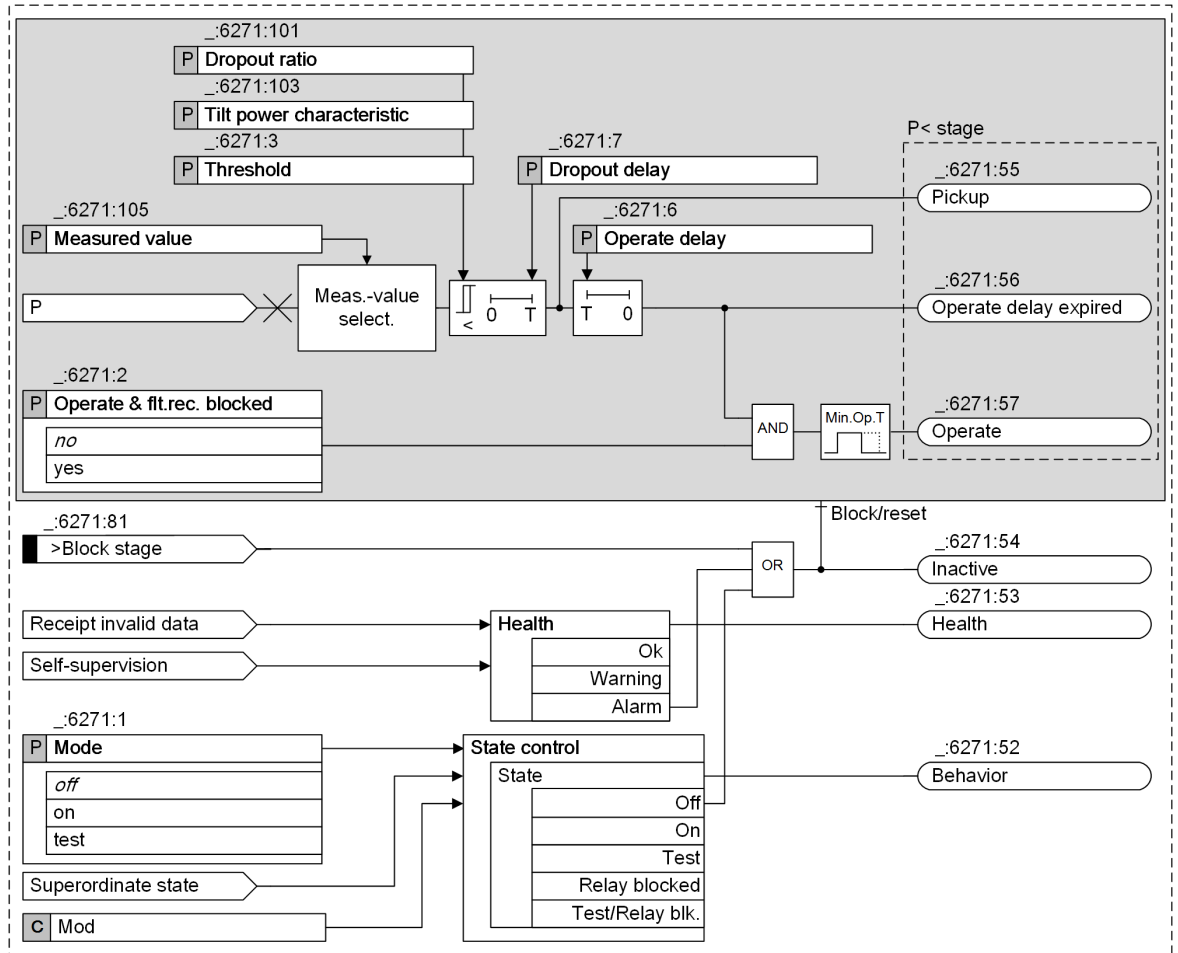

[to_3-phase active power, 3, en_US]

Figure 6-231 Logic Diagram of the Active Power Stage (Stage Type: Power P<)

Measured Value

The **Measured value** parameter is used to specify which measured power value is analyzed by the tripping stage. Possible settings are *positive seq. power* and the phase-selective powers *power of phase A*, *power of phase B* or *power of phase C*.

Pickup Characteristic

With the stage type you specify if the stage work as a **greater stage** (stage type: **Power P>**) or as a **smaller stage** (stage type: **Power P<**).

The **Threshold** parameter is used to define the pickup threshold of the stage. The **Tilt power characteristic** parameter is used to define the tilt of the pickup characteristic. The figure below shows the definition of the signs.

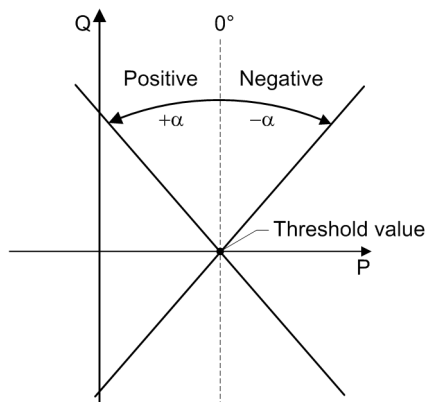

[dw_tilt-power active power, 2, en_US]

Figure 6-232 Tilt-Power Characteristic

Pickup

The stage compares the selected power value with the set **Threshold**. Depending on the stage type (**Power P>** or **Power P<**) being above or falling below the threshold value will lead to a pickup.

Dropout Delay

A delay can be set for the dropout when the measured value falls below the dropout threshold. The pickup is maintained for the specified time. The time delay of the tripping (parameter **Operate delay**) continues to run. Once the **Operate delay** has elapsed, the stage trips.

Blocking the Stage

In the event of blocking, a picked-up stage is reset. The following blocking options are available for the stage:

- Internally or externally via the binary input signal *>Block stage*
- The frequency is less than or equal to 10 Hz.

6.38.4 Reactive Power Stage

Logic of a Stage

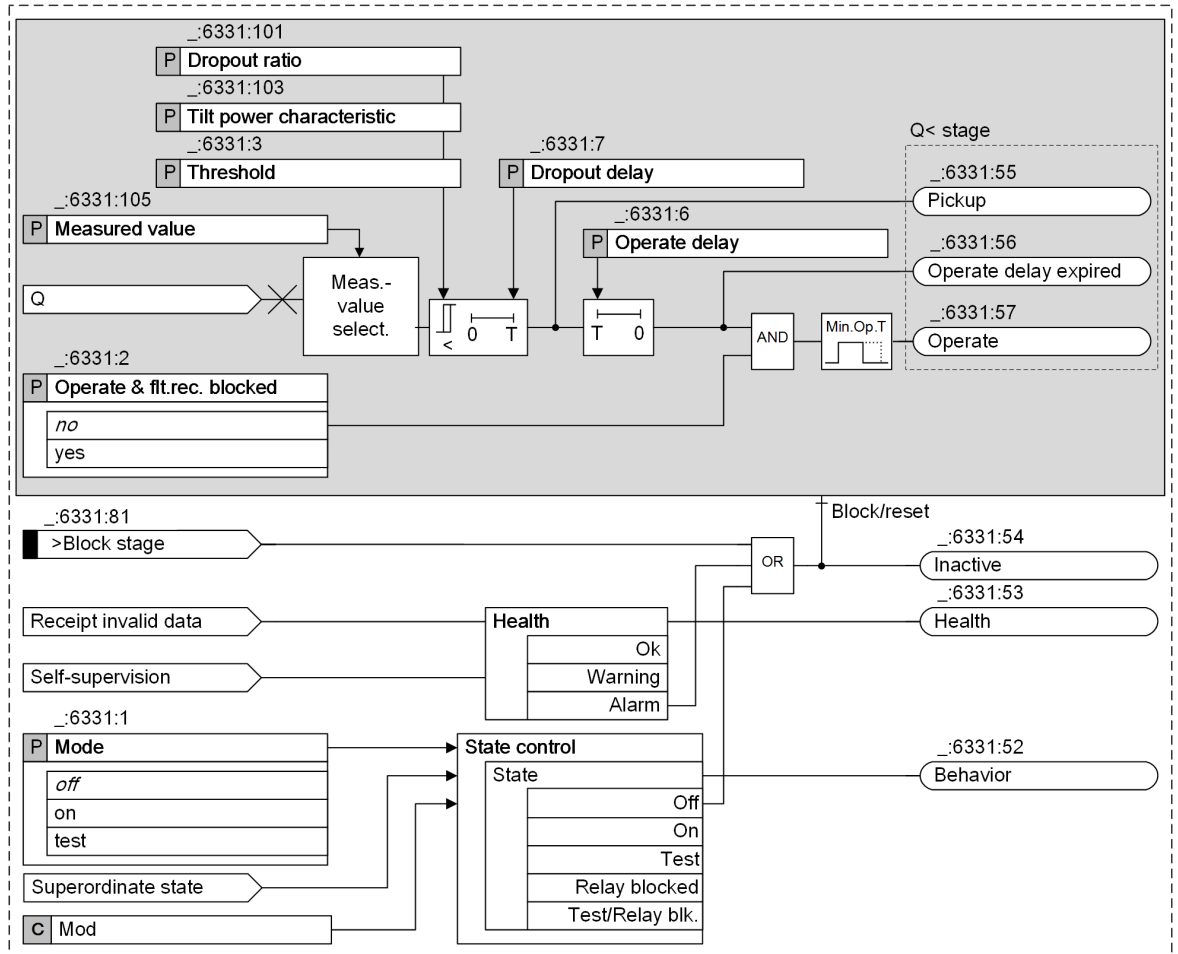

[to_3phase reactive power_3_en_US]

Figure 6-233 Logic Diagram of the Reactive Power Stage (Stage Type: Power Q<)

Measured Value

The **Measured value** parameter is used to specify which measured power value is processed by the tripping stage. Possible settings are *positive seq. power* and the phase-selective powers *power of phase A*, *power of phase B* or *power of phase C*.

Pickup Characteristic

With the stage type you specify if the stage work as a **greater stage** (stage type: **Power Q>**) or as a **smaller stage** (stage type: **Power Q<**).

The **Threshold** parameter is used to define the pickup threshold of the stage. The **Tilt power characteristic** parameter is used to define the tilt of the pickup characteristic. The figure below shows the definition of the signs.

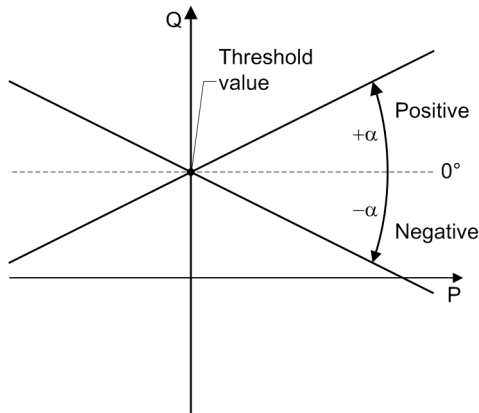

[dw_tilt-power reactive power, 2, en_US]

Figure 6-234 Tilt-Power Characteristic

Pickup

The stage compares the selected power value with the set **Threshold**. Depending on the stage type (**Power Q>** or **Power Q<**) being above or falling below the threshold value will lead to a pickup.

Dropout Delay

A delay can be set for the dropout when the measured value falls below the dropout threshold. The pickup is maintained for the specified time. The time delay of the tripping (parameter **Operate delay**) continues to run. Once the **Operate delay** has elapsed, the stage trips.

Blocking the Stage

In the event of blocking, the picked up stage will be reset. Blocking the stage is possible externally or internally via the binary input signal **>Block stage**.

6.38.5 Application Example

6.38.6 Setting Notes for the Active Power Stage

Stage Type

In the following example, a drop of the active power below a threshold is to be monitored. In the **3-phase circuit breaker (P, Q)** function, work with the stage type **Power P<**.

Parameter: Measured value

- Recommended setting value (**_:6271:105**) **Measured value = positive seq. power**

The **Measured value** parameter is used to specify which measured power value is evaluated. For 3-phase measurement, Siemens recommends to evaluate the positive-sequence system power.



NOTE

If you use several settings groups, consider the following:

- The threshold of a stage must have the same sign in all settings groups.
- Switching from a positive threshold to a negative threshold or vice versa is not allowed. As a result, DIGSI reports an inconsistency.
- If you want to change the sign of the threshold of a stage in an additional settings group, instantiate a new stage and enable it. If the new stage should not be effective in another settings group, disable the stage there.

Parameter: Dropout ratio

- Recommended setting value (`_:6271:101`) **Dropout ratio = 1.05**

A hysteresis of 5 % is sufficient for most applications. The setting value for the **lower stage** is therefore 1.05.

6.38.7 Setting Notes for the Reactive Power Stage

Parameter: Measured value

- Recommended setting value (`_:6331:105`) **Measured value = positive seq. power**

The **Measured value** parameter is used to specify which measured power value is evaluated. For 3-phase measurement, Siemens recommends to evaluate the positive-sequence system power.



NOTE

If you use several settings groups, consider the following:

- The threshold value of a stage must have the same sign in all settings groups.
- Switching from a positive threshold value to a negative threshold value or vice versa is not allowed. As a result, DIGSI reports an inconsistency.
- If you want to change the sign of the threshold value of a stage in an additional settings group, instantiate a new stage and enable it. If the new stage should not be effective in another settings group, disable the stage there.

Parameter: Dropout ratio

- Recommended setting value (`_:6331:101`) **Dropout ratio = 0.95**

A hysteresis of 5 % is sufficient for most applications. The setting value for the **lower stage** is therefore 0.95.

6.38.8 Settings

Addr.	Parameter	C	Setting Options	Default Setting
<i>Power P> 1</i>				
_:6241:1	Power P> 1:Mode		<ul style="list-style-type: none"> • off • on • test 	off
_:6241:2	Power P> 1:Operate & flt.rec. blocked		<ul style="list-style-type: none"> • no • yes 	no

Addr.	Parameter	C	Setting Options	Default Setting
_.6241:104	Power P> 1:Measured value		<ul style="list-style-type: none"> power of phase A power of phase B power of phase C positive seq. power 	positive seq. power
_.6241:3	Power P> 1:Threshold		-200.0 % to -1.0 % 1.0 % to 200.0 %	80.0 %
_.6241:101	Power P> 1:Dropout ratio		0.90 to 0.99	0.95
_.6241:103	Power P> 1:Tilt power characteristic		-89.0 ° to 89.0 °	0.0 °
_.6241:7	Power P> 1:Dropout delay		0.00 s to 60.00 s	0.00 s
_.6241:6	Power P> 1:Operate delay		0.00 s to 60.00 s	1.00 s
Power P< 1				
_.6271:1	Power P< 1:Mode		<ul style="list-style-type: none"> off on test 	off
_.6271:2	Power P< 1:Operate & flt.rec. blocked		<ul style="list-style-type: none"> no yes 	no
_.6271:105	Power P< 1:Measured value		<ul style="list-style-type: none"> power of phase A power of phase B power of phase C positive seq. power 	positive seq. power
_.6271:3	Power P< 1:Threshold		-200.0 % to -1.0 % 1.0 % to 200.0 %	5.0 %
_.6271:101	Power P< 1:Dropout ratio		1.01 to 1.10	1.05
_.6271:103	Power P< 1:Tilt power characteristic		-89.0 ° to 89.0 °	0.0 °
_.6271:7	Power P< 1:Dropout delay		0.00 s to 60.00 s	0.00 s
_.6271:6	Power P< 1:Operate delay		0.00 s to 60.00 s	1.00 s
Power Q> 1				
_.6301:1	Power Q> 1:Mode		<ul style="list-style-type: none"> off on test 	off
_.6301:2	Power Q> 1:Operate & flt.rec. blocked		<ul style="list-style-type: none"> no yes 	no
_.6301:105	Power Q> 1:Measured value		<ul style="list-style-type: none"> power of phase A power of phase B power of phase C positive seq. power 	positive seq. power
_.6301:3	Power Q> 1:Threshold		-200.0 % to -1.0 % 1.0 % to 200.0 %	70.0 %
_.6301:101	Power Q> 1:Dropout ratio		0.90 to 0.99	0.95
_.6301:103	Power Q> 1:Tilt power characteristic		-89.0 ° to 89.0 °	0.0 °
_.6301:7	Power Q> 1:Dropout delay		0.00 s to 60.00 s	0.00 s
_.6301:6	Power Q> 1:Operate delay		0.00 s to 60.00 s	1.00 s

Addr.	Parameter	C	Setting Options	Default Setting
Power Q< 1				
_:6331:1	Power Q< 1:Mode		<ul style="list-style-type: none"> • off • on • test 	off
_:6331:2	Power Q< 1:Operate & flt.rec. blocked		<ul style="list-style-type: none"> • no • yes 	no
_:6331:105	Power Q< 1:Measured value		<ul style="list-style-type: none"> • power of phase A • power of phase B • power of phase C • positive seq. power 	positive seq. power
_:6331:3	Power Q< 1:Threshold		-200.0 % to -1.0 % 1.0 % to 200.0 %	-30.0 %
_:6331:101	Power Q< 1:Dropout ratio		0.90 to 0.99	0.95
_:6331:103	Power Q< 1:Tilt power characteristic		-89.0 ° to 89.0 °	0.0 °
_:6331:7	Power Q< 1:Dropout delay		0.00 s to 60.00 s	0.00 s
_:6331:6	Power Q< 1:Operate delay		0.00 s to 60.00 s	1.00 s

6.38.9 Information List

No.	Information	Data Class (Type)	Type
Power P> 1			
_:6241:81	Power P> 1:>Block stage	SPS	I
_:6241:54	Power P> 1:Inactive	SPS	O
_:6241:52	Power P> 1:Behavior	ENS	O
_:6241:53	Power P> 1:Health	ENS	O
_:6241:55	Power P> 1:Pickup	ACD	O
_:6241:56	Power P> 1:Operate delay expired	ACT	O
_:6241:57	Power P> 1:Operate	ACT	O
Power P< 1			
_:6271:81	Power P< 1:>Block stage	SPS	I
_:6271:54	Power P< 1:Inactive	SPS	O
_:6271:52	Power P< 1:Behavior	ENS	O
_:6271:53	Power P< 1:Health	ENS	O
_:6271:55	Power P< 1:Pickup	ACD	O
_:6271:56	Power P< 1:Operate delay expired	ACT	O
_:6271:57	Power P< 1:Operate	ACT	O
Power Q> 1			
_:6301:81	Power Q> 1:>Block stage	SPS	I
_:6301:54	Power Q> 1:Inactive	SPS	O
_:6301:52	Power Q> 1:Behavior	ENS	O
_:6301:53	Power Q> 1:Health	ENS	O
_:6301:55	Power Q> 1:Pickup	ACD	O
_:6301:56	Power Q> 1:Operate delay expired	ACT	O
_:6301:57	Power Q> 1:Operate	ACT	O

No.	Information	Data Class (Type)	Type
<i>Power Q< 1</i>			
_.6331:81	Power Q< 1:>Block stage	SPS	I
_.6331:54	Power Q< 1:Inactive	SPS	O
_.6331:52	Power Q< 1:Behavior	ENS	O
_.6331:53	Power Q< 1:Health	ENS	O
_.6331:55	Power Q< 1:Pickup	ACD	O
_.6331:56	Power Q< 1:Operate delay expired	ACT	O
_.6331:57	Power Q< 1:Operate	ACT	O

6.39 Reverse-Power Protection

6.39.1 Overview of Functions

The **Reverse-power protection** function (ANSI 32R):

- Monitors the motor operation of generators and thus detects driving-power failure
- Prevents endangering the turbine (e.g. the turbine-blade damage due to overheating) by opening the circuit breaker of the system
- Protects a turbo-generator set

For the generator, there is a danger that the turbo-generator set accelerates and reaches overspeed in case of an incorrect residual-steam passage (quick-stop valves defective) after the circuit breaker has opened. Consequently, disconnecting the system (opening the circuit breaker of the system) shall only occur after reverse power (active-power consumption) has been detected.

6.39.2 Structure of the Function

The **Reverse-power protection** function comes factory-set with 1 stage. A maximum of 2 stages can be operated simultaneously within the function.

In all function groups, the function works with a 3-phase voltage and current interface. Depending on the current transformer used, this is the **Voltage/current 3-phase** function group or the **Generator stator** function group.

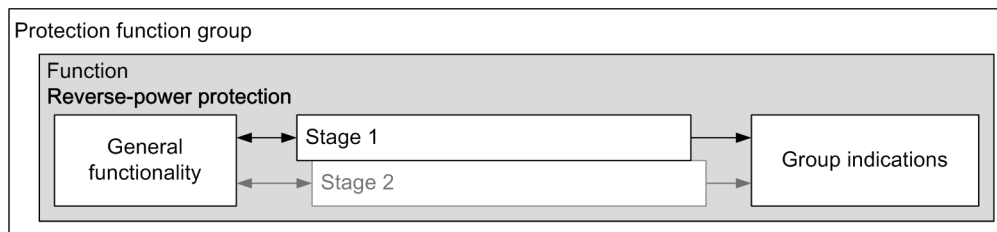

[dw_rpp_structure, 3, en_US]

Figure 6-235 Structure/Embedding of the Function

6.39.3 General Functionality

6.39.3.1 Description

Logic of the Function

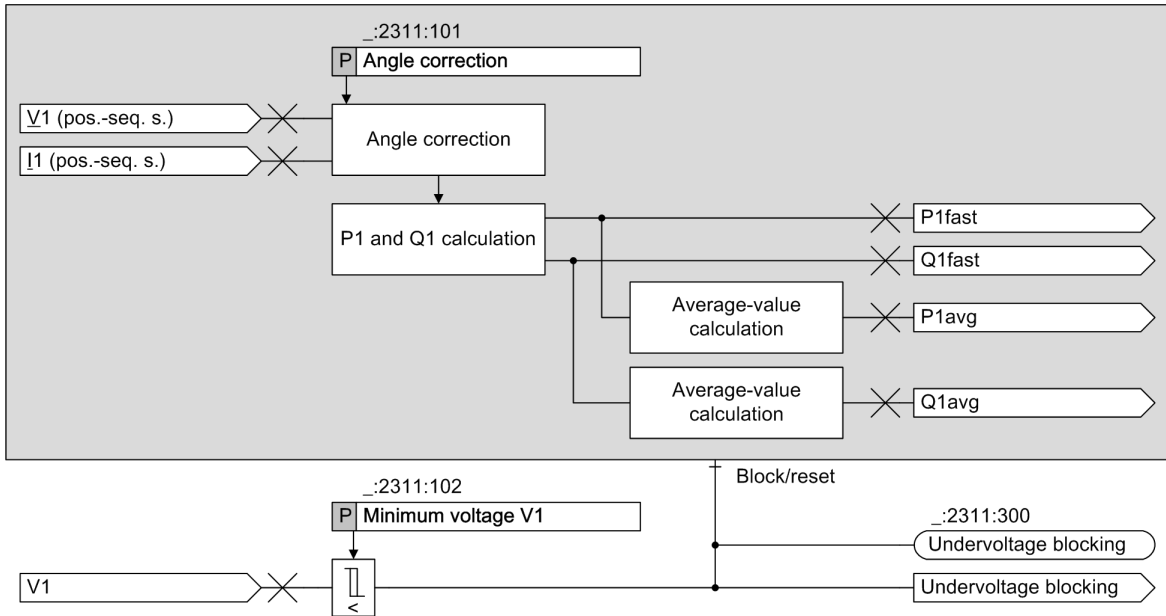

[io_RPP general functionality, 2, en_US]

Figure 6-236 Logic Diagram of the Cross-Stage Functionality

Calculating the Reverse Power

The reverse-power protection calculates the active power from the symmetrical components of the fundamental components of the voltages and currents. It generates the average value of the active power over a fixed number of cycles. Since positive-sequence variables are used for evaluation, the reverse power is determined independently of unbalance in currents or voltages. The frequency-tracking sampled values are used for calculation. The determined reverse power corresponds to the load on the driving-power side. The calculated active-power value corresponds to the total active power.

Taking the phase-displacement angle of the voltage and current transformers into account, the function calculates the exact active power even with a high apparent power and a small $\cos \varphi$. A constant correction angle φ_{corr} makes correction possible. The influence of the current-transformer angle error is predominant here. Determine this constant correction angle when you commission the protection device in the plant and adjust it as specified in the table (see [Table 13-1](#)).

Power Calculation and Angle Correction

To satisfy the high measuring-accuracy requirements, the power measured value is additionally averaged over 16 cycles before it is supplied to the protection function. The active power is calculated from the symmetrical-component vectors of voltage V_1 and current I_1 . The total power is evaluated as power. The complex apparent power results from the following relationship. The real component is the active power:

$$\underline{S} = 3\underline{V}_1 \cdot \underline{I}_1^* = 3V_1 e^{j\varphi_V} \cdot I_1 e^{-j\varphi_I} = 3V_1 I_1 e^{j(\varphi_V - \varphi_I)}$$

$$P = 3V_1 I_1 \cos(\varphi_V - \varphi_I)$$

The angle error between voltage transformer and current transformer has a strong influence on the measuring accuracy. With the parameter (`_:2311:101`) **Angle correction**, you can correct the angle error. The following 2 methods are possible here:

- Determine the angle error from the transformer test report data. Ask the transformer manufacturer for these values when you order the transformer.
- While the generator is connected to the power system, measure to determine the angle error (see chapter [13.15.2 Primary Test](#)).

The influence on the power-system voltage makes it very difficult to test high-power generators with a measurement while the generator is connected to the power system. In this case, you must determine the angle error from the transformer test report data (see chapter [6.39.3.2 Application and Setting Notes](#)). Alternatively, you can use instrument transformers with small angle errors. This is ensured with class 0.2 instrument transformers (voltage and current). The following equation describes the influence of the angle error:

$$P = 3V_1 I_1 \cos(\varphi_V + \varphi_{V,F} - (\varphi_I + \varphi_{I,F})) = 3V_1 I_1 \cos(\varphi_U - \varphi_I + (\varphi_{V,F} - \varphi_{I,F}))$$

The angle error to be corrected results as:

$$\phi_{\text{Corr}} = \varphi_{V,F} - \varphi_{I,F}$$

To rotate in the correct direction, the correction angle is considered with inverted sign inside the unit.

Functional Measured Values

You can use the following functional measured values to check the behavior of the protection function and to support commissioning. The total power is represented as the measured value.

Measured Value	Description	
P1fast	Positive-sequence system active power calculated per cycle	Angle correction influences the measured value
Q1fast	Positive-sequence system reactive power calculated per cycle	Angle correction influences the measured value
P1avg	Positive-sequence system active power calculated from P1fast over 16 cycles	Input value for Reverse-power protection
Q1avg	Positive-sequence system reactive power calculated from Q1fast over 16 cycles	–

6.39.3.2 Application and Setting Notes

In the general functionality, you can adjust the parameter (`_:2311:101`) **Angle correction**. The parameter results from the angle error of the primary transformer. In SIPROTEC 5, the input transformers are calibrated so that the angle error is negligible. You can assume an error of $< 0.1^\circ$. There is no difference between a protection input and an instrument-transformer input.



NOTE

If you use class 0.2 instrument transformers on the primary side to avoid the influence of the angle, you can connect a protection device with a protection current transformer without any problems. Class 0.2 voltage transformers have a maximum admissible angle error of 10 min (0.17°). The angle error of a class 0.2 measuring current transformer at rated current is approximately 10 min, at $0.2 I_{\text{rated}} = 15$ min, and at $0.05 I_{\text{rated}} = 30$ min.

Parameter: Angle correction

- Default setting (`_:2311:101`) **Angle correction** = 0°

To determine the correction angle via measurement with the primary system, follow the instructions in chapter [13.15.2 Primary Test](#).

You can use the method that is explained in the following section to derive the necessary correction angle from the transformer measuring reports.

Example

This example uses a class 0.2 voltage transformer with a rated burden of 45 VA. The following data was taken from the measuring report.

Table 6-18 For Phase A

V/Vn	S _b = S _{br}		S _b = S _{br} /4	
	ε _v [%]	δ _v [min]	ε _v [%]	δ _v [min]
0.8	-0.14	0.31	0.16	-0.34
1	-0.15	0.43	0.15	-0.24
1.2	-0.16	0.68	0.14	-0.06

The values resulting for the phases B and C are almost identical.

Furthermore, a termination with a rated burden (other measuring devices are still connected) is assumed so that an angle error of +0.43 min (rated-voltage value) is used as the calculation variable.

A current transformer of type 5PR is used here. This current transformer features a gap that limits the remanence to 10 %. However, this gap results in larger angle errors. The following tables show excerpts from the test reports.

Table 6-19 Phase A

I/I _n [%]	S _b = S _{br} (cos β = 0.8)	
	ε _i [%]	δ _i [min]
100	0.314	46.40

Table 6-20 Phase B

I/I _n [%]	S _b = S _{br} (cos β = 0.8)	
	ε _i [%]	δ _i [min]
100	0.247	35.10

Table 6-21 Phase C

I/I _n [%]	S _b = S _{br} (cos β = 0.8)	
	ε _i [%]	δ _i [min]
100	0.702	41.10

Since the positive-sequence system power is evaluated in the device, take the sign into account when you add the angle errors per phase, and divide the result by 3.

The following value results in this example:

$$\delta_i [\text{min}] = \frac{1}{3} (\delta_{i,A} + \delta_{i,B} + \delta_{i,C}) = \frac{1}{3} (46.40 + 35.10 + 41.10) = 40.87 \text{ min}$$

The resulting correction angle is:

$$\varphi_{\text{corr}} [\text{min}] = \varphi_{V,F} - \varphi_{I,F} = 0.43 \text{ min} - 40.87 \text{ min} = -40.44 \text{ min}$$

$$\varphi_{\text{corr}} [^\circ] = \frac{\varphi_{\text{corr}}[\text{min}]}{60} \cdot 1^\circ = \frac{-40.44}{60} \cdot 1^\circ = -0.674^\circ$$

Set the parameter (`_ :2311:101`) **Angle correction** = `-0.67°`.

Parameter: Minimum voltage V1

- Default setting (_:2311:102) **Minimum voltage V1** = 5.000 V

With the parameter **Minimum voltage V1**, you can limit the operating range of the reverse-power protection. If the positive-sequence voltage falls below the set value, the reverse-power protection is deactivated. If no other restrictions are known, Siemens recommends using the default setting.

6.39.3.3 Settings

Addr.	Parameter	C	Setting Options	Default Setting
<i>General</i>				
_:2311:101	General:Angle correction		-10.00 ° to 10.00 °	0.00 °
_:2311:102	General:Minimum voltage V1		0.300 V to 60.000 V	5.000 V

6.39.3.4 Information List

No.	Information	Data Class (Type)	Type
<i>General</i>			
_:2311:300	General:Undervoltage blocking	SPS	O
_:2311:301	General:P1avg	MV	O
_:2311:302	General:Q1avg	MV	O
_:2311:303	General:P1fast	MV	O
_:2311:304	General:Q1fast	MV	O
_:2311:52	General:Behavior	ENS	O
_:2311:53	General:Health	ENS	O

6.39.4 Stage Description

6.39.4.1 Description

Logic of the Stage

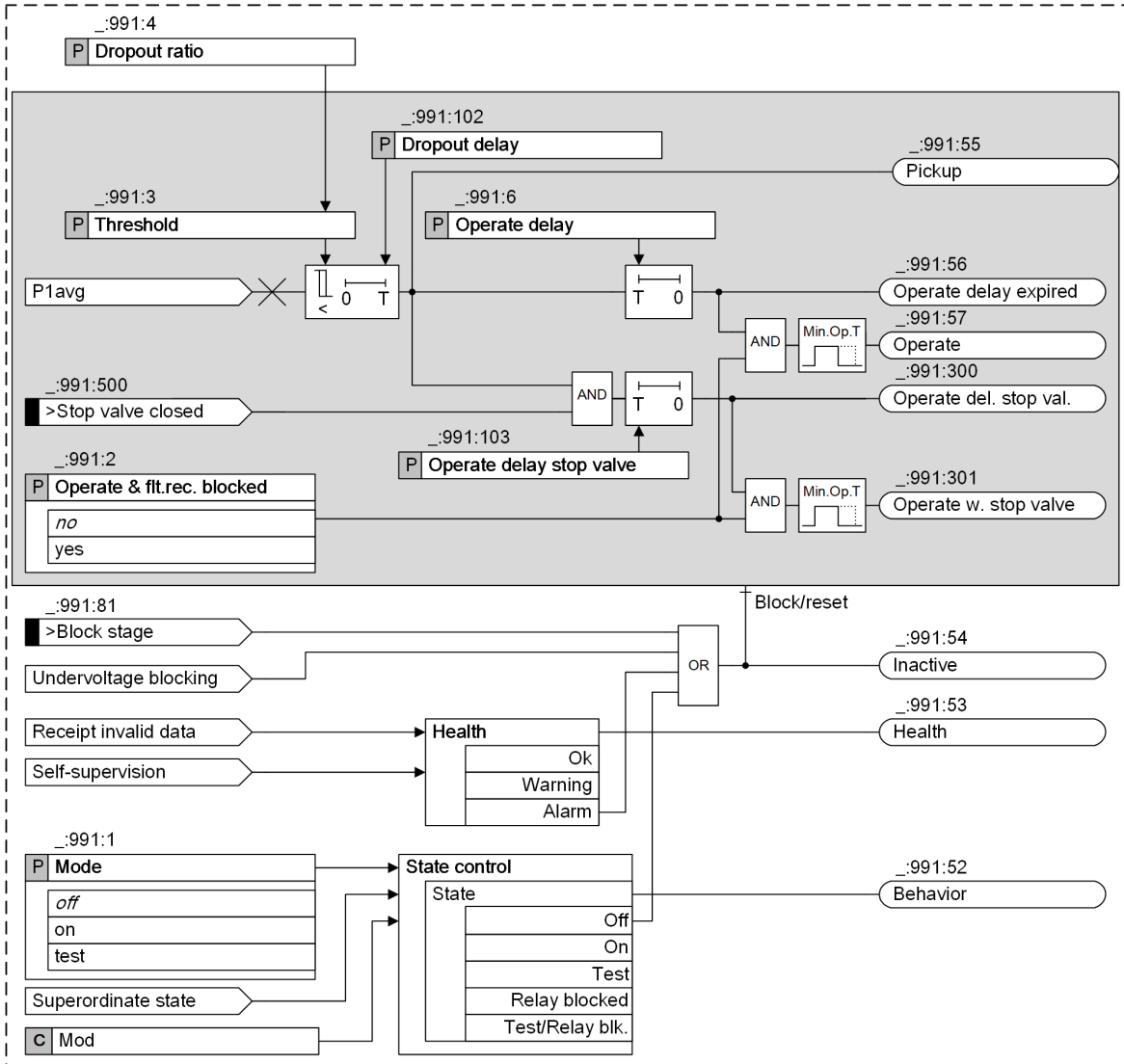

[io_RPP stage_4_en_US]

Figure 6-237 Logic Diagram of the Reverse-Power Protection Stage

Trip Command

To bridge brief power consumption during synchronization or during power swings caused by system incidents, tripping (shutdown of the generator via reverse power) is delayed by a settable time (for example, 10 s).

A brief delay is enough when the quick-stop valve is closed. Couple the position of the quick-stop valve via the binary input signal **>Stop valve closed** . When quick stop is tripped, the short Operate delay thus becomes effective.

Blocking the Stage

In the event of blocking, the picked up stage will be reset. Blocking of the stage is possible externally or internally via the binary input signal **>Block stage** .

6.39.4.2 Application and Setting Notes

If reverse power occurs in a power plant, the turbo-generator set must be disconnected from the electrical power system. Operating the turbine without the minimum steam flow (cooling effect) is dangerous. For a gas turbine cogeneration unit, the motor load can also be too great for the electrical power system.

Parameter: **Threshold**

- Recommended setting value (**_:991:3**) **Threshold** = **-1.00** %

The friction losses that have to be overcome mainly determine the active power consumed by a turbo-generator set. Depending on the plant, the consumed active power is of the following ranges:

Steam turbines	$P_{\text{reverse}}/S_{\text{rated}} = 1.00\% \text{ to } 3.00\%$
Diesel drives	$P_{\text{reverse}}/S_{\text{rated}} > 5.00\%$
Gas turbines	$P_{\text{reverse}}/S_{\text{rated}} = \text{up to } 30.00\%$

You can measure the reverse power of the turbo-generator set yourself in a primary test by using the protection function. Set the setting value P_{reverse} for example, to 0.5 times the value of the measured reverse power. This power is shown additionally in the functional measured values in the **Reverse-power protection** function (**P1avg**). For large machines with very small reverse power, you must use the angle-error correction option of the current and voltage transformers.



NOTE

In the current-input selection, you can select protection current transformers or instrument transformers on the device side. Since the transformers are calibrated at the factory, there are hardly any differences between the transformers for the **Reverse-power protection** function. You can thus always select device inputs with a protection current transformer.

In contrast, a primary current transformer significantly influences the measuring accuracy via its angle error. The angle error of a class 0.2 instrument transformer is significantly smaller than the angle error of a class 5P protection current transformer. A separate function group is necessary for the connection to an instrument transformer. Use a **Voltage/current 3-phase** function group and load the **Reverse-power protection** function from the library.

Do not connect the **Reverse-power protection** function to a linear core-type transformer (for example, a TPZ type), as these transformers have a large angle error (for example, approx. 180 min).

6.39.4.3 Settings

Addr.	Parameter	C	Setting Options	Default Setting
Stage 1				
_:991:1	Stage 1:Mode		<ul style="list-style-type: none"> off on test 	off
_:991:2	Stage 1:Operate & flt.rec. blocked		<ul style="list-style-type: none"> no yes 	no
_:991:3	Stage 1:Threshold		-30.00 % to -0.30 %	-1.00 %
_:991:4	Stage 1:Dropout ratio		0.40 to 0.99	0.60
_:991:102	Stage 1:Dropout delay		0.00 s to 60.00 s	0.00 s
_:991:6	Stage 1:Operate delay		0.00 s to 60.00 s	10.00 s
_:991:103	Stage 1:Operate delay stop valve		0.00 s to 60.00 s	1.00 s

6.39.4.4 Information List

No.	Information	Data Class (Type)	Type
Group indicat.			
_:4501:55	Group indicat.:Pickup	ACD	O
_:4501:57	Group indicat.:Operate	ACT	O
Stage 1			
_:991:81	Stage 1:>Block stage	SPS	I
_:991:500	Stage 1:>Stop valve closed	SPS	I
_:991:54	Stage 1:Inactive	SPS	O
_:991:52	Stage 1:Behavior	ENS	O
_:991:53	Stage 1:Health	ENS	O
_:991:55	Stage 1:Pickup	ACD	O
_:991:56	Stage 1:Operate delay expired	ACT	O
_:991:57	Stage 1:Operate	ACT	O
_:991:300	Stage 1:Operate del. stop val.	ACT	O
_:991:301	Stage 1:Operate w. stop valve	ACT	O

6.40 Overexcitation Protection

6.40.1 Overview of Functions

The **Overexcitation protection** (ANSI 24) is used for detecting high induction values in generators and transformers. It protects the equipment from excessive thermal loads.

The induction is recorded indirectly by analyzing the V/f ratio (also referred to as Volt per Hertz protection). Overvoltage leads to excessive magnetizing currents, while underfrequency leads to higher losses when resetting the magnetization.

If the power system is disconnected and the voltage and frequency control function in the remaining system does not react quickly or the power imbalance is excessive, there is a risk of overexcitation.

6.40.2 Structure of the Function

The **Overexcitation protection** function is used within protection function groups that have a 3-phase voltage input. The function comes with the following factory-set stages:

- Thermal stage adjustable with a user-defined characteristic curve
- Definite-time stage which can be delayed using a time component

Within this function, the following maximum number of stages can be operated simultaneously: one stage with a user-defined characteristic curve and 2 definite-time stages.

The group-indication output logic (see following figure) uses the logical OR function from the stage-selective indications to generate the following group indications of the entire **Overexcitation protection** function:

- Pickup
- Operate Indication

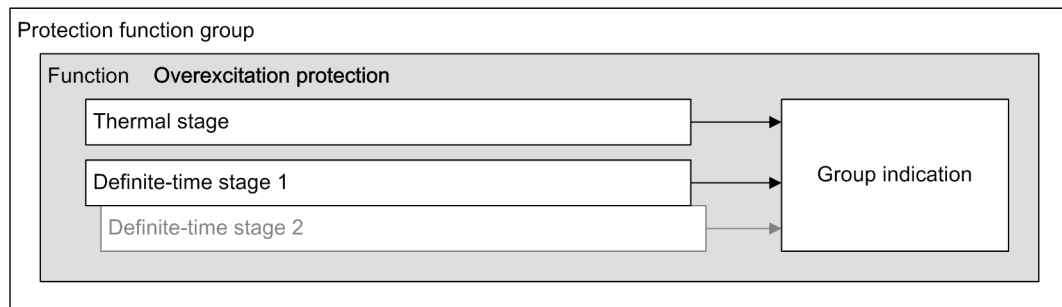

[dw_ovexuf_3_en_US]

Figure 6-238 Structure/Embedding of the Function

Function Measured Value

Measured Value	Description
(_:2311:322) V/f	Value calculated by the voltage and the frequency

6.40.3 Stage with Dependent Characteristic Curve (Thermal Stage)

6.40.3.1 Function Description

Logic

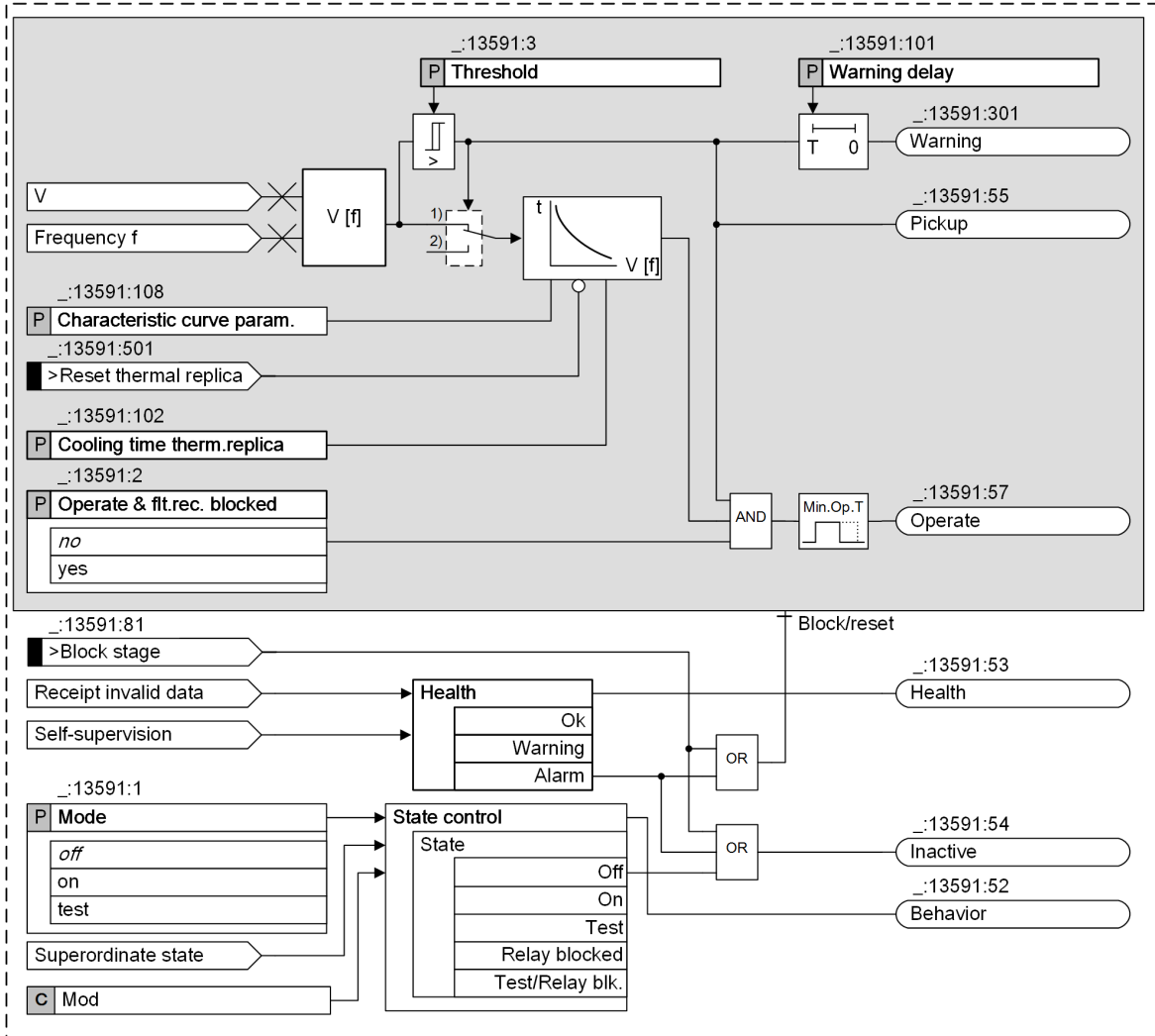

[lo_therm-char_V-f_2_en_US]

Figure 6-239 Logic of the Overexcitation Protection with Thermal Characteristic Curve

- (1) Heating
- (2) Cooling

V/f Method of Measurement

The input values of the protection function are the continuously measured voltage and the frequency. The phase-to-phase voltage is used to process the voltage. The angle difference method (see [6.33 Overfrequency Protection](#)) is used to determine the frequency. Both values form the V/f ratio. In order to arrive at an absolute value, standardized data is applied.

Thus, the ratio is derived from:

$$\frac{V/V_{rated,obj.}}{f/f_{rated}}$$

[fo_verufn_1_en_US]

with

V	Measured voltage (maximum phase-to-phase voltage)
$V_{\text{rated, obj.}}$	Adjusted rated voltage of the protected object
f	Measured frequency
f_{rated}	Adjusted rated frequency

Based on the definition above, the protection function refers exclusively to primary values of the protected object. A deviation between the primary rated voltage of the voltage transformer and the protected object is corrected automatically.



NOTE

This fact must be considered during a secondary test.
More information can be found in chapter [13.16 Functional Test for Overexcitation Protection](#).

The function compares the calculated value of the measured V/f ratio with the threshold value and the user-defined thermal characteristic curve.

Depending on the characteristic curve, a **thermal** trip signal is triggered after a pre-determined duration.

Characteristic Curve

You can freely configure the thermal characteristic curve with the user-defined values. This provides a flexible adjustment to the specified characteristics of the protected object. If the set threshold value (parameter (`_:13591:3`) **Threshold**) is exceeded, the evaluation of the characteristic curve is initiated. Exceeding the threshold value triggers an indication (`(_:13591:55) Pickup`). In addition, a definite-time stage may be used to generate a delayed indication output as (`(_:13591:301) warning`).

The pickup is used to start the integration process (weighted counting) of the thermal characteristic curve. If the time as a factor of V/f is reached, the pickup is triggered. Based on the replica of the thermal behavior, the trigger value is always 100 % (see [Thermal Behavior, Page 878](#)).

If the value drops below the pickup threshold, the trip command is rescinded and the **internal counter** of the parameterized cooling time (parameter (`_:13591:102`) **Cooling time therm.replica**) is reduced.

The dropout threshold of the pickup threshold is fixed to $0.98 * \text{Threshold}$.

The thermal characteristic curve can be set through a maximum of 30 overexcitation value pairs V/f (referring to the rated values) and the operate time t can be set. The default characteristic curve refers to a standard transformer.

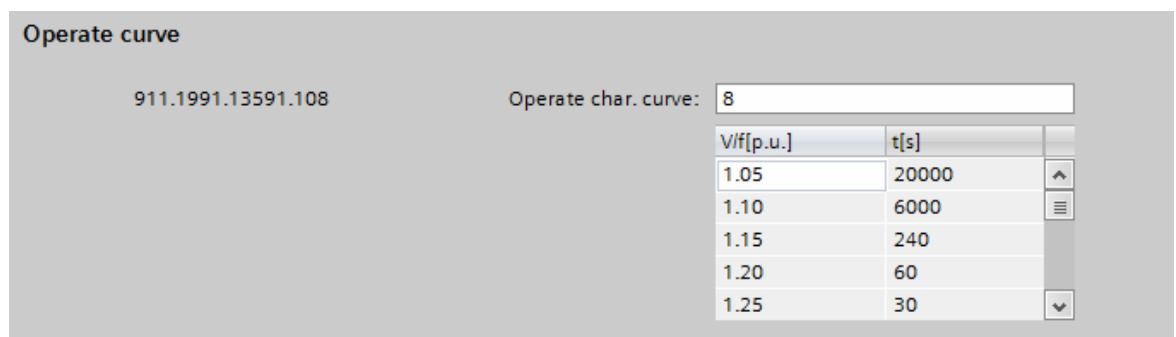

[sc_aulskn_1_en_US]

Figure 6-240 Data Sheet for Adjustment of Thermal Characteristic Curve

The parameter **Threshold** (pickup threshold) affects the evaluation of the characteristic curve as follows:
If the **Threshold** is smaller than the first characteristic pair, the set time will be extended (see [Figure 6-241](#)).

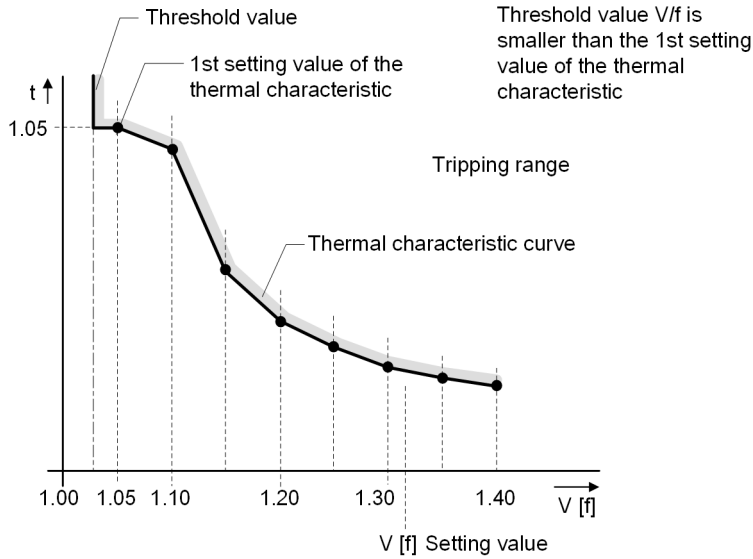

[dw_ovexak_1_en_US]
 Figure 6-241 Tripping Zone of the Thermal Characteristic Curve (I)

If the **Threshold** is greater, then a cutoff occurs (see [Figure 6-242](#)).

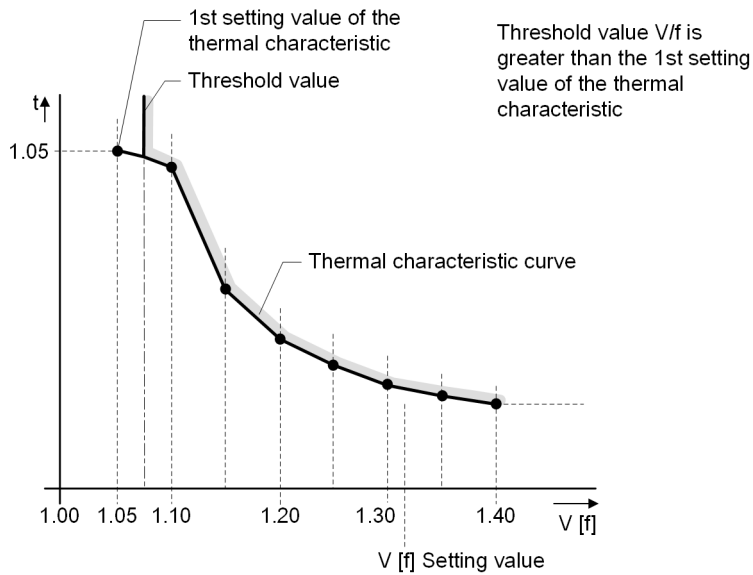

[dw_ovexab_1_en_US]
 Figure 6-242 Tripping Zone of the Thermal Characteristic Curve (II)

Warning Threshold

If the **Threshold** is exceeded, the time delay (parameter (`_:13591:101`) **Warning delay**) is started. If the time delay has elapsed, the indication (`(_:13591:301)` *warning*) will be displayed.

Thermal Behavior

The time derived from the characteristic curve and associated with the V/f value is set to 100 %. With each function call, the time will be increased according to the respective weighted invocation interval. If the 100 % value is exceeded, tripping is initiated. If the V/f value is changed, the associated time from the characteristic curve is added as a new 100 % value.

In order to prevent excessive cooling times, the thermal storage has been limited internally to 150 %. The *fill level* of the thermal storage will be provided as functional measured value.

Measured Value	Description
(_:13591:321) v/f th.	Thermal tripping of the overexcitation protection. If the value reaches 100 %, the tripping occurs.

Cooling Time

If the value drops below the threshold value (_:13591:3) **Threshold**), tripping of the thermal characteristic curve (dependent characteristic curve) is reverted. However, the parameterized cooling time (**Cooling time therm.replica**) reduces the thermal storage (counter content) to 0. This parameter is defined as time. It is required by the thermal replica in order to cool down from 100 % to 0 %.

Resetting the Thermal Map

The binary input indication (_:13591:501) *>Reset thermal replica* can be applied to reset the thermal replica. The thermal replica will then have a value of 0. A reparameterization will also lead to resetting the thermal replica.

Blocking the Stage

The function can be blocked externally or internally by the binary input signal (_:13591:81) *>Block stage*. Blocking will cause a picked up function to be reset.

6.40.3.2 Application and Setting Notes

Thermal overloads extended over a longer period will jeopardize electric equipment, for example, synchronous motors, generators, or transformers and may cause damage. When using the thermal, user-defined characteristic curve, the overexcitation protection is ideally suited for adjusting the specified limits of the protection equipment.

The following provides the recommended settings:



NOTE

One requirement for the correct mode of operation of the function is based on the proper setting of the power-system data.

You can find more detailed information on this in [6.1 Power-System Data](#).

For additional setting recommendations, verify the following parameter in the power-system data:

- Adjusted rated frequency
- Adjusted rated voltage of the protected object
- Adjusted rated voltage of the voltage transformer of the applicable measuring point

Parameter: Threshold Value

- Default setting (_:13591:3) **Threshold** = 1.10
The **Threshold** parameter is used to describe the value for the permissible continuous overexcitation. The default value is a practical value used for transformers. The value may be less for generator applications. These values can be found in the manufacturer's information.

Parameter: Time Delayed Warning

- Default setting (_:13591:101) **Warning delay** = 10.00 s
When using the **Warning delay** parameter, the time can be determined by which the warning indication of the stage should be delayed after the pickup. This time delay depends on the specific application. This time must clearly exceed the reaction time of the regulators. 10 seconds is a feasible value.

Parameter: Cooling Time Therm. Replica

- Default setting (`_:13591:102`) `Cooling time therm.replica = 3600 s`

The `Cooling time therm.replica` parameter is used to define the cooling characteristics of the thermal replica. If concrete specifications are not given, the default value can be retained.

Parameter: V/f/time value pairs (operate curve)

With this parameter, the number of potting points along the thermal operate curve are defined. This is required for the calculation. The number of points defines the accuracy of the image of the specified characteristic curve. Adjust the value individually.

Set a V/f/time value pair for each characteristic-curve point. The setting depends on the characteristic curve you want to realize. The default settings refer to a Siemens standard transformer.



NOTE

The value pairs must be entered in continuous order.



NOTE

Note that the V/f values that are lower than the V/f values of the smallest characteristic-curve point do not extend the operate time. Up to the smallest characteristic-curve point, the characteristic curves runs parallel to the V/f axis. V/f values that are larger than the V/f value of the largest characteristic-curve point do not reduce the operate time. From the largest characteristic-curve point, the pickup characteristic runs parallel to the V/f axis (see [Characteristic Curve, Page 877](#)).

6.40.3.3 Settings

Addr.	Parameter	C	Setting Options	Default Setting
Definite-T 1				
<code>_:13621:1</code>	Definite-T 1:Mode		<ul style="list-style-type: none"> • off • on • test 	off
<code>_:13621:2</code>	Definite-T 1:Operate & flt.rec. blocked		<ul style="list-style-type: none"> • no • yes 	no
<code>_:13621:3</code>	Definite-T 1:Threshold		1.00 to 1.40	1.40
<code>_:13621:6</code>	Definite-T 1:Operate delay		0.00 s to 60.00 s	1.00 s
General				
<code>_:13591:1</code>	Therm.charact.:Mode		<ul style="list-style-type: none"> • off • on • test 	off
<code>_:13591:2</code>	Therm.charact.:Operate & flt.rec. blocked		<ul style="list-style-type: none"> • no • yes 	no
<code>_:13591:3</code>	Therm.charact.:Threshold		1.00 to 1.20	1.10
<code>_:13591:101</code>	Therm.charact.:Warning delay		0.00 s to 60.00 s	10.00 s
<code>_:13591:102</code>	Therm.charact.:Cooling time therm.replica		0 s to 100000 s	3600 s

6.40.3.4 Information List

No.	Information	Data Class (Type)	Type
General			
_:2311:322	General:V/f	MV	O
Group indicat.			
_:4501:55	Group indicat.:Pickup	ACD	O
_:4501:57	Group indicat.:Operate	ACT	O
_:4501:52	Group indicat.:Behavior	ENS	O
_:4501:53	Group indicat.:Health	ENS	O
Definite-T 1			
_:13621:81	Definite-T 1:>Block stage	SPS	I
_:13621:51	Definite-T 1:Mode (controllable)	ENC	C
_:13621:54	Definite-T 1:Inactive	SPS	O
_:13621:52	Definite-T 1:Behavior	ENS	O
_:13621:53	Definite-T 1:Health	ENS	O
_:13621:55	Definite-T 1:Pickup	ACD	O
_:13621:56	Definite-T 1:Operate delay expired	ACT	O
_:13621:57	Definite-T 1:Operate	ACT	O
Therm. charact.			
_:13591:81	Therm.charact.:>Block stage	SPS	I
_:13591:501	Therm.charact.:>Reset thermal replica	SPS	I
_:13591:51	Therm.charact.:Mode (controllable)	ENC	C
_:13591:54	Therm.charact.:Inactive	SPS	O
_:13591:52	Therm.charact.:Behavior	ENS	O
_:13591:53	Therm.charact.:Health	ENS	O
_:13591:55	Therm.charact.:Pickup	ACD	O
_:13591:301	Therm.charact.:Warning	ACT	O
_:13591:57	Therm.charact.:Operate	ACT	O
_:13591:321	Therm.charact.:V/f th.	MV	O

6.40.4 Stage with Independent Characteristic Curve

6.40.4.1 Function Description

Logic

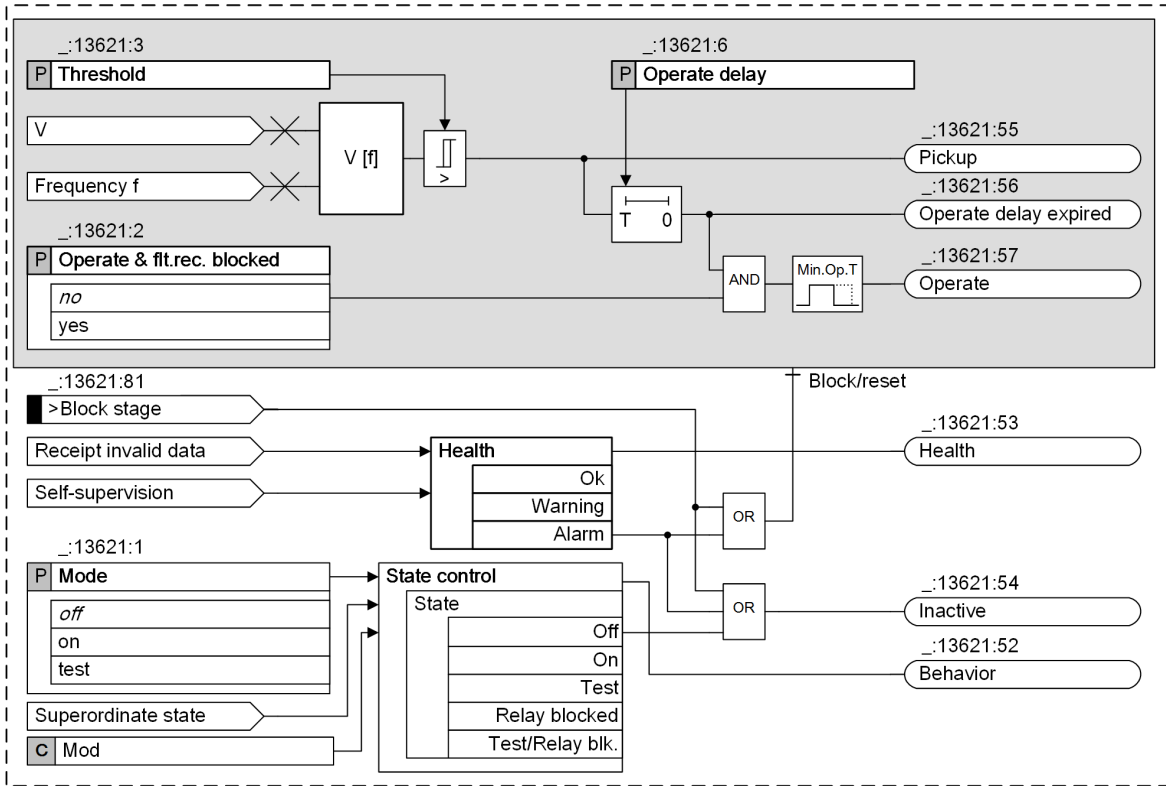

[do_dtchuf, 2, en, US]

Figure 6-243 Logic of the Overexcitation Protection with Independent Characteristic Curve (Definite-Time Stage)

Method of Measurement

This stage also evaluates the V/f value that is identical to the input value of the thermal stage. For measurement-relevant details, see also [6.40.3 Stage with Dependent Characteristic Curve \(Thermal Stage\)](#).

Operating Principle of the Definite-Time Stage

The stage comprises a threshold value and a time-delay stage. If the V/f value is greater than the set threshold value (`_:13621:3` **Threshold**), then the stage is tripped after an adjustable time delay has elapsed. You can set the time delay with the parameter (`_:13621:6`) **Operate delay**. The dropout ratio for the **Threshold** is fixed to 98 %.

6.40.4.2 Application and Setting Notes

The definite-time stage can be applied when fast tripping is required in the presence of high V/f values. In this case, the stage acts superimposed on the thermal, dependent stage.

Parameter: Threshold Value

- Default setting (`_:13621:3`) **Threshold** = 1.40
 The **Threshold** parameter is used to describe the overexcitation value that causes the tripping function. The default value matches a feasible upper limit.

Parameter: Tripping delay

- Default setting (**_:13621:6**) **Operate delay = 1.00 s**
The **Operate delay** parameter is used to determine the time by which the stage is delayed after the pickup. This time delay depends on the specific application. The default value is practical for the application described in the previous chapter.

6.40.4.3 Settings

Addr.	Parameter	C	Setting Options	Default Setting
Definite-T 1				
_:13621:1	Definite-T 1:Mode		<ul style="list-style-type: none"> • off • on • test 	off
_:13621:2	Definite-T 1:Operate & flt.rec. blocked		<ul style="list-style-type: none"> • no • yes 	no
_:13621:3	Definite-T 1:Threshold		1.00 to 1.40	1.40
_:13621:6	Definite-T 1:Operate delay		0.00 s to 60.00 s	1.00 s
Therm. charact.				
_:13591:1	Therm.charact.:Mode		<ul style="list-style-type: none"> • off • on • test 	off
_:13591:2	Therm.charact.:Operate & flt.rec. blocked		<ul style="list-style-type: none"> • no • yes 	no
_:13591:3	Therm.charact.:Threshold		1.00 to 1.20	1.10
_:13591:101	Therm.charact.:Warning delay		0.00 s to 60.00 s	10.00 s
_:13591:102	Therm.charact.:Cooling time therm.replica		0 s to 100 000 s	3600 s

6.40.4.4 Information List

No.	Information	Data Class (Type)	Type
General			
_:2311:322	General:V/f	MV	O
Group indicat.			
_:4501:55	Group indicat.:Pickup	ACD	O
_:4501:57	Group indicat.:Operate	ACT	O
df/dt falling1			
_:13621:81	Definite-T 1:>Block stage	SPS	I
_:13621:54	Definite-T 1:Inactive	SPS	O
_:13621:52	Definite-T 1:Behavior	ENS	O
_:13621:53	Definite-T 1:Health	ENS	O
_:13621:55	Definite-T 1:Pickup	ACD	O
_:13621:56	Definite-T 1:Operate delay expired	ACT	O
_:13621:57	Definite-T 1:Operate	ACT	O
Therm. charact.			
_:13591:81	Therm.charact.:>Block stage	SPS	I

No.	Information	Data Class (Type)	Type
_:13591:501	Therm.character.:>Reset thermal replica	SPS	I
_:13591:54	Therm.character.:Inactive	SPS	O
_:13591:52	Therm.character.:Behavior	ENS	O
_:13591:53	Therm.character.:Health	ENS	O
_:13591:55	Therm.character.:Pickup	ACD	O
_:13591:301	Therm.character.:Warning	ACT	O
_:13591:57	Therm.character.:Operate	ACT	O
_:13591:321	Therm.character.:V/f th.	MV	O

6.41 Undervoltage-Controlled Reactive-Power Protection

6.41.1 Overview of Functions

The **Undervoltage-controlled reactive-power protection** function (ANSI 27/Q):

- Detects critical power-system situations, mainly in case of regenerative generation
- Prevents a voltage collapse in power system by disconnecting the power-generation facility from the main power systems
- Ensures reconnection under stable power-system conditions

6.41.2 Structure of the Function

The **Undervoltage-controlled reactive-power protection** function can be used in protection function groups containing 3-phase voltage and current measurement. Depending on the device, it is preconfigured by the manufacturer with 1 **Protection stage** and 1 **Reclosure stage**. A maximum of 2 **Protection stages** and 1 **Reclosure stage** can operate simultaneously within the function.

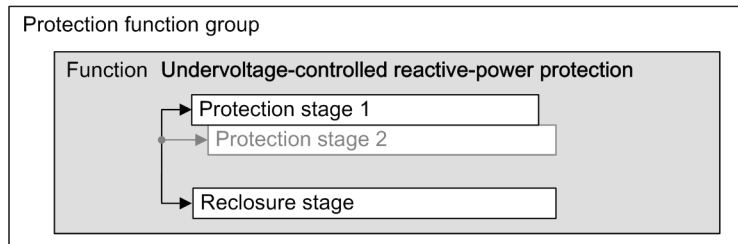

[dw_qvprot, 1, en_US]

Figure 6-244 Structure/Embedding of the Function

6.41.3 Protection Stage

6.41.3.1 Description

Logic of the Stage

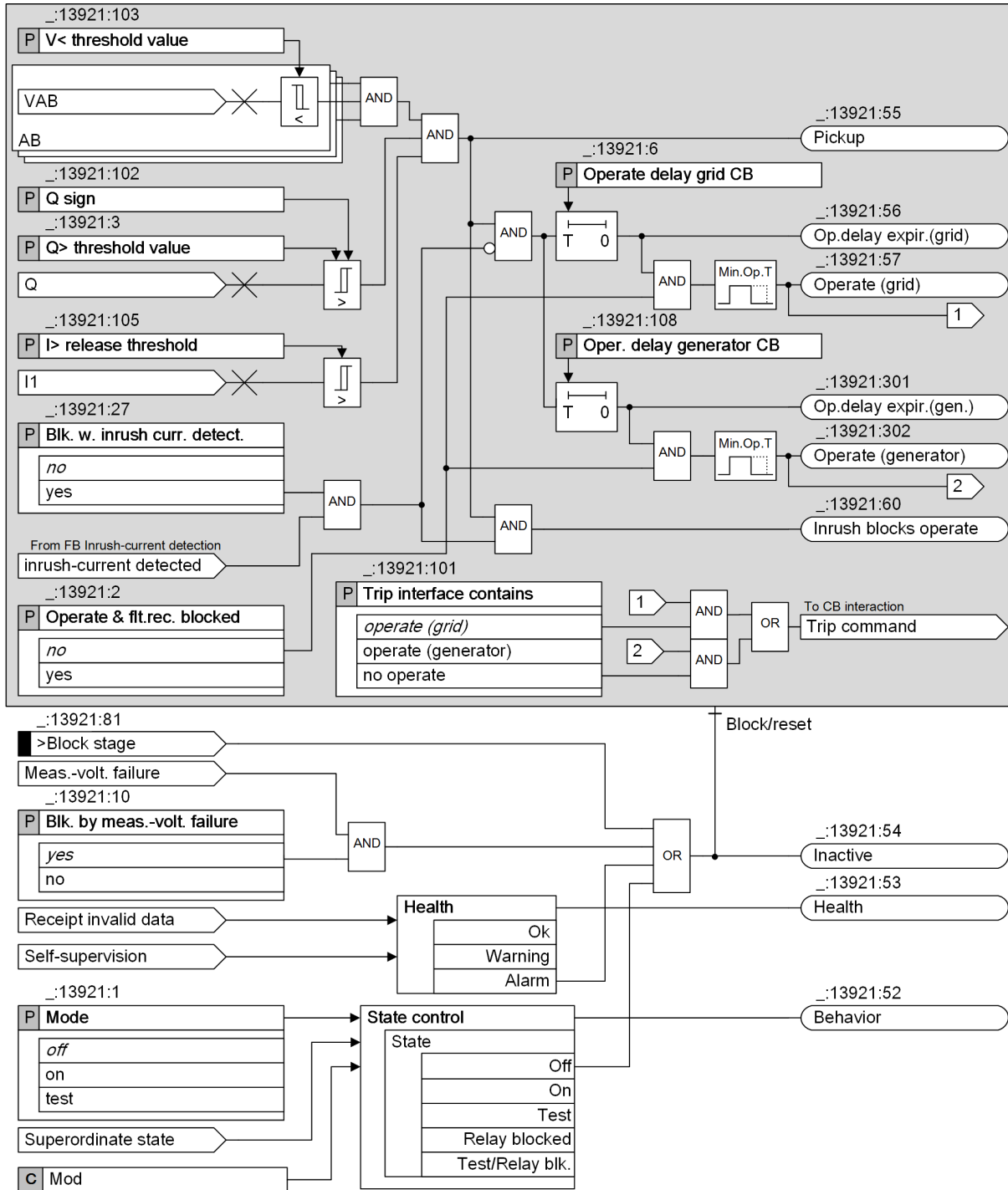

[lo_qvprst, 2, en_US]

Figure 6-245 Logic Diagram of the Protection Stage of the Undervoltage-Controlled Reactive-Power Protection

Measurand

To detect critical power-system situations, the **Undervoltage-controlled reactive-power protection** function uses the fundamental values of the phase-to-phase voltages, the positive-sequence current, and the reactive power.

Q-Measurement Direction

The default directions of the positive reactive-power flow Q and the forward direction of the short-circuit protection are identical, in the direction of the protected object. Via parameter **Q sign**, the direction of the positive reactive-power flow Q can be changed by inverting the sign of the reactive power Q.

Pickup

The protection stage picks up under the following conditions:

- All 3 phase-to-phase voltages are below the parameterized threshold value.
- The positive-sequence current I_1 is above the parameterized threshold value.
- The power-generation facility requires more than the parameterized reactive power (Q is above the parameterized threshold value).

Trip Interface

The stage provides 2 operate signals, the *Operate (generator)* and the *Operate (grid)*. Depending on the parameter **Trip interface contains**, one or none of them will be forwarded to the trip interface of the circuit-breaker interaction.

Blocking of the Stage

The following blockings reset the picked up stage completely:

- Externally or internally via the binary input signal *>Block stage*
- Measuring-voltage failure

Blocking of the Operate Delay and Operate Signal via the Device-Internal Inrush-Current Detection Function

The **Blk. w. inrush curr. detect.** parameter permits you to define whether the operate delay should be blocked by a threshold-value violation due to an inrush current.

For further information about device-internal **Inrush-current detection** function, refer to chapter [6.3.7.1 Description](#) .

6.41.3.2 Application and Setting Notes

Parameter: **Blk. by meas.-volt. failure**

- Recommended setting value (`_:13921:10`) **Blk. by meas.-volt. failure = yes**

You use the **Blk. by meas.-volt. failure** parameter to control the response of the stage when a measuring-voltage failure is detected.

A measuring-voltage failure can only be detected if one of the following 2 conditions is met:

- The device-internal **Measuring-voltage failure detection** function is configured and switched on.
- The binary input signal *>Open* of the function block **Voltage-transformer circuit breaker** is connected to the voltage-transformer circuit breaker.

Parameter Value	Description
yes	The Protection stage is blocked when a measuring-voltage failure is detected. Siemens recommends using the default setting, as there is no assurance that the Protection stage will function correctly if the measuring voltage fails.
no	The Protection stage is not blocked when a measuring-voltage failure is detected.

Parameter: Blk. w. inrush curr. detect.

- Default setting (`_:13921:27`) **Blk. w. inrush curr. detect. = no**
- You use the **Blk. w. inrush curr. detect.** parameter to determine whether the operate delay and operate signal are blocked during the detection of an inrush current.

Parameter: I> release threshold

- Recommended setting value (`_:13921:105`) **I> release threshold = 0.100 A**
- You use the **I> release threshold** parameter to define a precondition that the stage can pick up. The default setting is at 10 % of the rated current. Siemens recommends using the default setting.

Parameter: V< threshold value

- Recommended setting value (`_:13921:103`) **V< threshold value = 85.000 V**
- You use the **V< threshold value** parameter to define one of the 2 pickup criteria. If all 3 phase-to-phase voltages drop below the parameterized undervoltage threshold value, the pickup criterion is fulfilled. The setting should be set below the lower value of the permissible voltage range, according to the national transmission code. In Germany, the recommended undervoltage threshold is 85 % of the rated voltage. Therefore Siemens recommends using the default setting.

Parameter: Q> threshold value

- Default setting (`_:13921:3`) **Q> threshold value = 5 %**
- You use the **Q> threshold value** parameter to define the second of the 2 pickup criteria. If the positive reactive power exceeds the parameterized **Q> threshold value**, the pickup criterion is fulfilled. In the following example, the pickup takes place if Q exceeds 5 % of the power-supply system rated power.

EXAMPLE

The following example is given for settings in secondary values.
 Rated voltage: $V_{\text{rated, sec}} = 100 \text{ V}$
 Rated current: $I_{\text{rated, sec}} = 1 \text{ A}$
 Threshold value: 5 % of the power-supply system rated power
 You can calculate the setting value as follows:

$$Q_{\text{threshold}} = 100 \text{ V} \cdot 1 \text{ A} \cdot \sqrt{3} \cdot 0.05 = 8.7 \text{ VAR}$$

[file:gwprot_1_en_US]

Parameter: Operate delay

- Default setting (`_:13921:6`) **Operate delay grid CB = 1.50 s**
 - Default setting (`_:13921:108`) **Oper. delay generator CB = 0.50 s**
- You can set the **Operate delay grid CB** for the circuit breaker at the power-supply system connection point, or set the **Oper. delay generator CB** for the circuit breaker of the facility, for example, the generator.

The time of the **Operate delay grid CB** should always be set longer than the time of the **Oper. delay generator CB**.

Parameter: Trip interface contains

- Default setting (`_:13921:101`) **Trip interface contains = operate (grid)**

The stage provides 2 operate signals, the *Operate (generator)* and the *Operate (grid)*.

You use the **Trip interface contains** parameter to define whether one or none of them will be forwarded to the trip interface of the circuit-breaker interaction. The selected operate signal will trip the circuit breaker that has been connected to the protection function group.

The setting depends on the specific application.

Parameter: Q sign

- Default setting (`_:13921:102`) **Q sign = not reversed**

The default directions of the positive reactive-power flow Q and the forward direction of the short-circuit protection are identical, in the direction of the main protected object (for example, a feeder). You use the **Q sign** parameter to reverse the sign and therefore the direction of the reactive-power flow Q. This reversal may be required for specific application, where the main protected object (for example, a line towards the main power systems) is in different direction to the power-generation facility.

Parameter Value	Description
<i>not reversed</i>	The protected object is in the same direction as the power-generation facility.
<i>reversed</i>	The protected object is not in the same direction as the power-generation facility.

6.41.3.3 Settings

Addr.	Parameter	C	Setting Options	Default Setting
Prot. stage 1				
<code>_:13921:1</code>	Prot. stage 1:Mode		<ul style="list-style-type: none"> • off • on • test 	off
<code>_:13921:2</code>	Prot. stage 1:Operate & flt.rec. blocked		<ul style="list-style-type: none"> • no • yes 	no
<code>_:13921:10</code>	Prot. stage 1:Blk. by meas.-volt. failure		<ul style="list-style-type: none"> • no • yes 	yes
<code>_:13921:27</code>	Prot. stage 1:Blk. w. inrush curr. detect.		<ul style="list-style-type: none"> • no • yes 	no
<code>_:13921:101</code>	Prot. stage 1:Trip interface contains		<ul style="list-style-type: none"> • no operate • operate (generator) • operate (grid) 	operate (grid)
<code>_:13921:102</code>	Prot. stage 1:Q sign		<ul style="list-style-type: none"> • not reversed • reversed 	not reversed
<code>_:13921:3</code>	Prot. stage 1:Q> threshold value		1.00 % to 200.00 %	5.00 %
<code>_:13921:103</code>	Prot. stage 1:V< threshold value		3.000 V to 175.000 V	85.000 V

Addr.	Parameter	C	Setting Options	Default Setting
_:13921:105	Prot. stage 1:l> release threshold	1 A @ 100 Irated	0.030 A to 10.000 A	0.100 A
		5 A @ 100 Irated	0.15 A to 50.00 A	0.50 A
		1 A @ 50 Irated	0.030 A to 10.000 A	0.100 A
		5 A @ 50 Irated	0.15 A to 50.00 A	0.50 A
		1 A @ 1.6 Irated	0.001 A to 1.600 A	0.100 A
		5 A @ 1.6 Irated	0.005 A to 8.000 A	0.500 A
_:13921:108	Prot. stage 1:Oper. delay generator CB		0.00 s to 60.00 s	0.50 s
_:13921:6	Prot. stage 1:Operate delay grid CB		0.00 s to 60.00 s	1.50 s

6.41.3.4 Information List

No.	Information	Data Class (Type)	Type
Group indicat.			
_:4501:55	Group indicat.:Pickup	ACD	O
_:4501:57	Group indicat.:Operate	ACT	O
_:4501:52	Group indicat.:Behavior	ENS	O
_:4501:53	Group indicat.:Health	ENS	O
Prot. stage 1			
_:13921:81	Prot. stage 1:>Block stage	SPS	I
_:13921:51	Prot. stage 1:Mode (controllable)	ENC	C
_:13921:54	Prot. stage 1:Inactive	SPS	O
_:13921:52	Prot. stage 1:Behavior	ENS	O
_:13921:53	Prot. stage 1:Health	ENS	O
_:13921:60	Prot. stage 1:Inrush blocks operate	ACT	O
_:13921:55	Prot. stage 1:Pickup	ACD	O
_:13921:301	Prot. stage 1:Op.delay expir.(gen.)	ACT	O
_:13921:302	Prot. stage 1:Operate (generator)	ACT	O
_:13921:56	Prot. stage 1:Op.delay expir.(grid)	ACT	O
_:13921:57	Prot. stage 1:Operate (grid)	ACT	O

6.41.4 Reclosure Stage

6.41.4.1 Description

Logic of the Stage

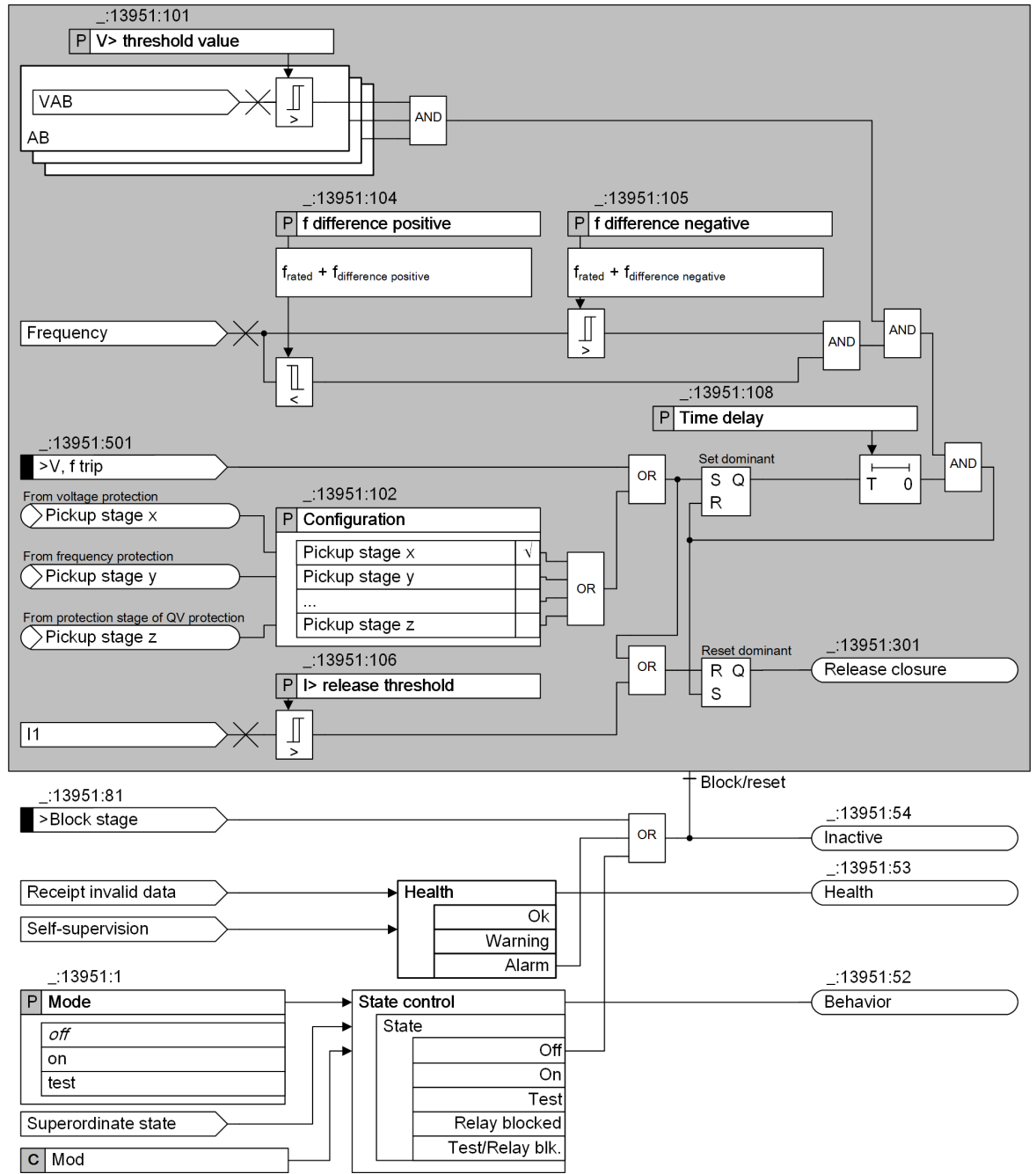

[to: gvclst_4_en_US]

Figure 6-246 Logic Diagram of Reclosure Stage in Undervoltage-Controlled Reactive-Power Protection

Measurand

The stage works with fundamental values of voltage and current.

Release for Reconnecting

The release for reconnecting the power-generation facility is given under the following conditions:

- All 3 phase-to-phase voltages are above the threshold value.
- The power frequency is within a specified range.
- The reclosure time delay, started by the operate of specific protection functions, has elapsed. The time delay is started by the first operate signal of the protection stages configured via the **Configuration** parameter. All protection stages of the voltage protection, the frequency protection, and the QV protection are available for configuration.

External Start of Reclosure Time Delay

Reclosure time delay can be started via the binary input signal $>V, f \text{ trip}$, which can be connected to external voltage and frequency protection trip signals.

Blocking of the Stage

The stage can be blocked via the binary input signal $>Block \text{ stage}$.

6.41.4.2 Application and Setting Notes

Parameter: Configuration

- Default setting ($_ : 13951 : 102$) **Configuration = no stage**

You use the **Configuration** parameter to define which operate signal of specific protection functions starts the release time delay of the **Reclosure stage**:

- Overfrequency protection
- Underfrequency protection
- Overvoltage protection
- Undervoltage protection
- Protection stage of undervoltage-controlled reactive-power protection

When the protection stage of undervoltage-controlled reactive-power protection is selected, only the signal *Operate (generator)* can start the release time delay of this stage. The signal *Operate (grid)* cannot start the release time delay.

The configuration depends on the specific application.

Parameter: I> release threshold

- Recommended setting value ($_ : 13951 : 106$) **I> release threshold = 0.100 A**

You use the **I> release threshold** parameter to define a precondition that the stage can work.

The default setting is at 10 % of the rated current. Siemens recommends using the default setting.

Parameter: V> threshold value

- Recommended setting value ($_ : 13951 : 101$) **V> threshold value = 95.000 V**

You use the **V> threshold value** parameter to set one of the 2 release criteria. The setting should be set above the lower value of the allowed voltage range, according to the national transmission code. In Germany, the recommended overvoltage threshold is 95 % of the rated voltage. Therefore Siemens recommends using the default setting.

Parameter: Frequency range

- Recommended setting value ($_ : 13951 : 104$) **f difference positive = 0.05 Hz**
- Recommended setting value ($_ : 13951 : 105$) **f difference negative = -2.50 Hz**

You use these 2 parameters to define the admitted frequency deviation from the rated frequency. **f difference positive** defines the upper frequency range limit. **f difference negative** defines the lower frequency range limit.

Siemens recommends using the default settings, which reflect common practice in Germany. Other national transmission codes may require a slightly different range.

Parameter: Time delay

- Default setting (**_:13951:108**) **Time delay = 0.00 s**

You use the **Time delay** parameter to specify the minimum time delay for releasing the reconnection of the power-generation facility after tripping by protection.

The setting depends on the specific application.

6.41.4.3 Settings

Addr.	Parameter	C	Setting Options	Default Setting
Reclos. stage				
_:13951:1	Reclos. stage:Mode		<ul style="list-style-type: none"> • off • on • test 	off
_:13951:101	Reclos. stage:V> threshold value		3.000 V to 340.000 V	95.000 V
_:13951:104	Reclos. stage:f difference positive		0.01 Hz to 5.00 Hz	0.05 Hz
_:13951:105	Reclos. stage:f difference negative		-5.00 Hz to -0.01 Hz	-2.50 Hz
_:13951:106	Reclos. stage:l> release threshold	1 A @ 100 Irated	0.030 A to 10.000 A	0.100 A
		5 A @ 100 Irated	0.15 A to 50.00 A	0.50 A
		1 A @ 50 Irated	0.030 A to 10.000 A	0.100 A
		5 A @ 50 Irated	0.15 A to 50.00 A	0.50 A
		1 A @ 1.6 Irated	0.001 A to 1.600 A	0.100 A
		5 A @ 1.6 Irated	0.005 A to 8.000 A	0.500 A
_:13951:108	Reclos. stage:Time delay		0.00 s to 3600.00 s	0.00 s
_:13951:102	Reclos. stage:Configura-tion		Setting options depend on configuration	

6.41.4.4 Information List

No.	Information	Data Class (Type)	Type
Reclos. stage			
_:13951:81	Reclos. stage:>Block stage	SPS	I
_:13951:501	Reclos. stage:>V, f trip	SPS	I
_:13951:54	Reclos. stage:Inactive	SPS	O
_:13951:52	Reclos. stage:Behavior	ENS	O
_:13951:53	Reclos. stage:Health	ENS	O
_:13951:301	Reclos. stage:Release closure	ACT	O

6.42 Circuit-Breaker Failure Protection

6.42.1 Overview of Functions

The **Circuit-breaker failure protection** function (ANSI 50BF) monitors the tripping of the associated circuit-breaker (CB) and generates a backup trip signal if the circuit-breaker fails.

Starting with version V7.50, the previous function **CB failure** has been replaced with the new Circuit-breaker failure protection with an adaptive algorithm **Adaptive CB failure protection**. In this way, you achieve a faster, more reliable detection of the opening of the circuit breaker in the event of complex signal histories. The 2 functions are identical, with the exception of a slightly increased processor load, in terms of setting options, logic and indications. Siemens recommends using the adaptive circuit-breaker failure protection and avoiding mixing the protection types in one device. You can find additional information on the processor load in DIGSI for each device under **Device information** in the **Resource consumption** tab.

6.42.2 Structure of the Function

The function **Circuit-breaker failure protection (CBFP)** can be used in the **Circuit-breaker** function group.

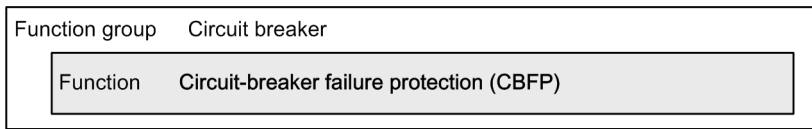

[dw_srbfp_1_en_US]

Figure 6-247 Structure/Embedding of the Function

[Figure 6-248](#) shows the functionalities and the function control of the function.

The start is initiated by the device-internal protection function or by an external protection. Along with the start, the current-flow criterion or the circuit-breaker auxiliary contact criterion is used to check whether the circuit breaker is closed. If the circuit breaker is closed, the function picks up and starts the time delay. During the time delay, the system continuously checks whether the circuit breaker has opened. If this is the case, the function drops out. If the circuit breaker is not opened, the function trips upon expiration of the time delay. The following description elaborates on the detailed functionality of the individual function blocks.

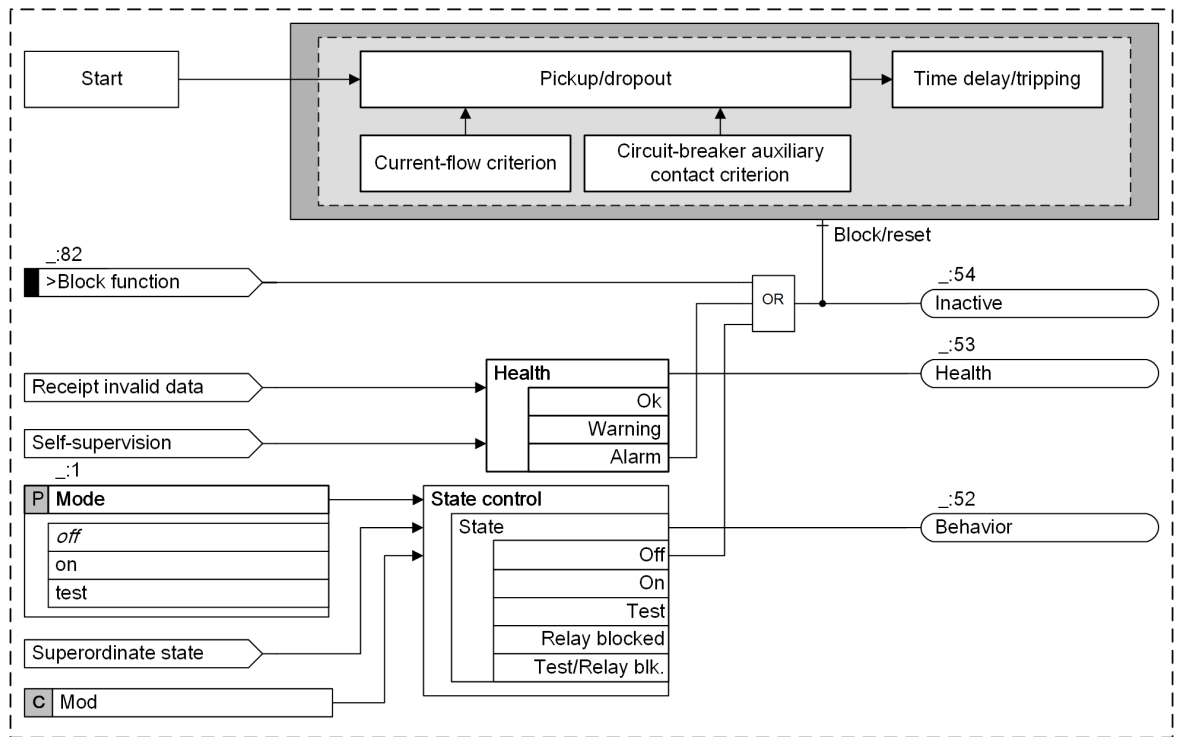

[to_svs_bfp_3_en_US]
Figure 6-248 Function Logic Overview

6.42.3 Function Description

The circuit-breaker failure protection function is started by device-internal protection functions and/or externally (via a binary input or an interface, such as GOOSE). [Figure 6-249](#) and [Figure 6-250](#) show the functionality.

Internal Start

By default, each device-internal protection stage that must control the local circuit breaker starts the circuit-breaker failure protection. The function is started by the tripping of the protection stage. In the default setting, the starting signal **Internal start** (see [Figure 6-249](#)) is held when the pickup signal has a falling edge or the protection function has tripped. The Circuit-breaker failure protection function can in this case only drop out if the circuit breaker is detected to be open. This is detected using the current flow or circuit-breaker auxiliary contact criterion. If necessary, the Circuit-breaker failure protection function can also drop out when the pickup signal has a falling edge or the protection function trips (internal starting signal is not held). You can use routing to determine whether individual protection stages or protection functions are used as a starting source or whether the start is only supposed to be external.

The internal starting sources are routed in the protection function groups via the entry **Circuit-breaker interaction** (for this, see

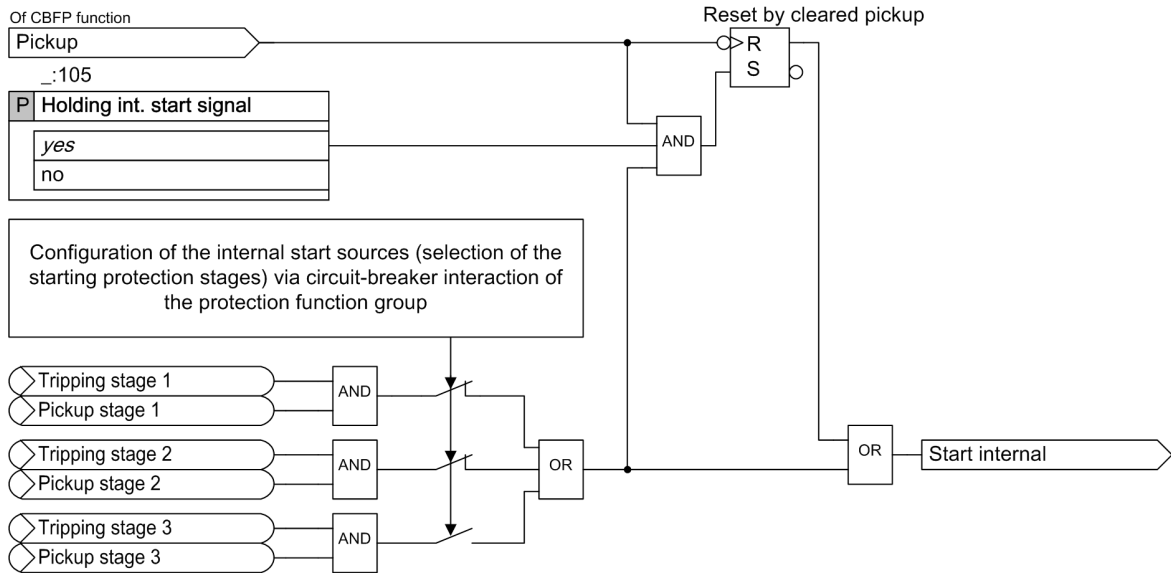

[lo_anwint, 2, en_US]
 Figure 6-249 Internal Start of the Circuit-Breaker Failure Protection Function

External Start

The parameter **Start via binary input** is used to set whether the external start is initiated by a 1-channel or 2-channel signal. The required routing of the input signals is compared with the setting. If a routing is missing, an error message is generated. The Health signal changes to the state *warning*.

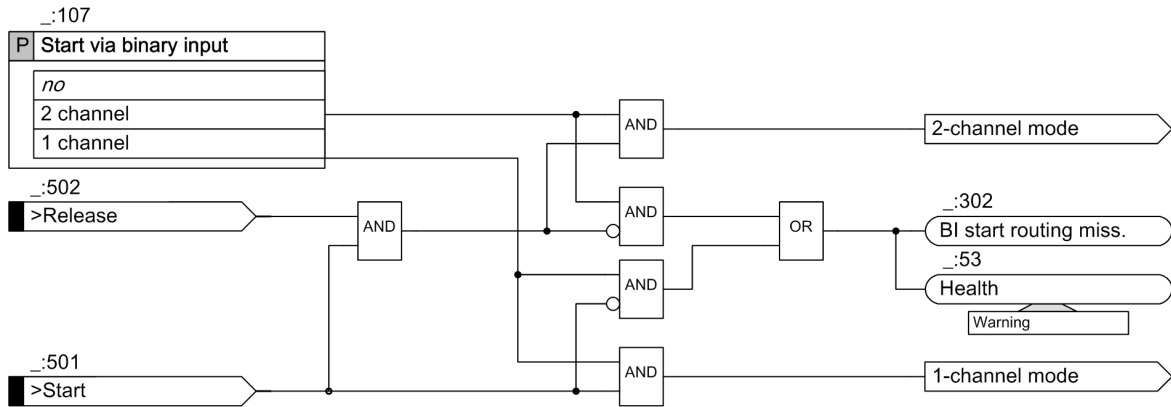

[lo_anwext, 1, en_US]
 Figure 6-250 Configuration of the External Start of the Circuit-Breaker Failure Protection Function

In 1-channel operation, the start is initiated with the binary input signal **>Start** only. In 2-channel operation, the binary input signal **>Release** must also be activated to initiate the start. In the default setting, the starting signal **External start** drops out immediately when the input signals have a falling edge (see [Figure 6-251](#)). If necessary, the starting signal can be held. In this case the start remains active when the binary input signals have a falling edge.

The input signals are monitored to avoid an unwanted pickup of the function. If either of the signals **>Start** or **>Release** is active for more than the set supervision time of the corresponding signal without the function being picked up, an error in the binary input circuit is assumed. The corresponding signal is blocked to exclude an external pickup of the function. An indication to this effect is output, and the Health signal changes to the state *warning*. The blocking is reset as soon as the binary input signal drops out.

Supervision is disabled in the following cases:

- On pickup of the Circuit-breaker failure protection function (only in the case of an external start). This prevents an unwanted pickup of the supervision if the external protection that starts the Circuit-breaker failure protection function uses a lockout functionality. When the starting signal drops out, supervision is enabled again.
- As long as the function or the device is in **test mode**. This allows to check the function without the supervision blocking the function.

If the signal **>Start** is active and no release signal is present after elapse of a settable supervision time for the starting signal, the pickup is blocked and an indication to this effect is output. The Health signal changes to the state Warning. The blocking is reset with the dropout of the starting signal.

The binary input signals only take effect if the binary inputs are activated for at least 10 ms (SW filter, see [Figure 6-251](#)).

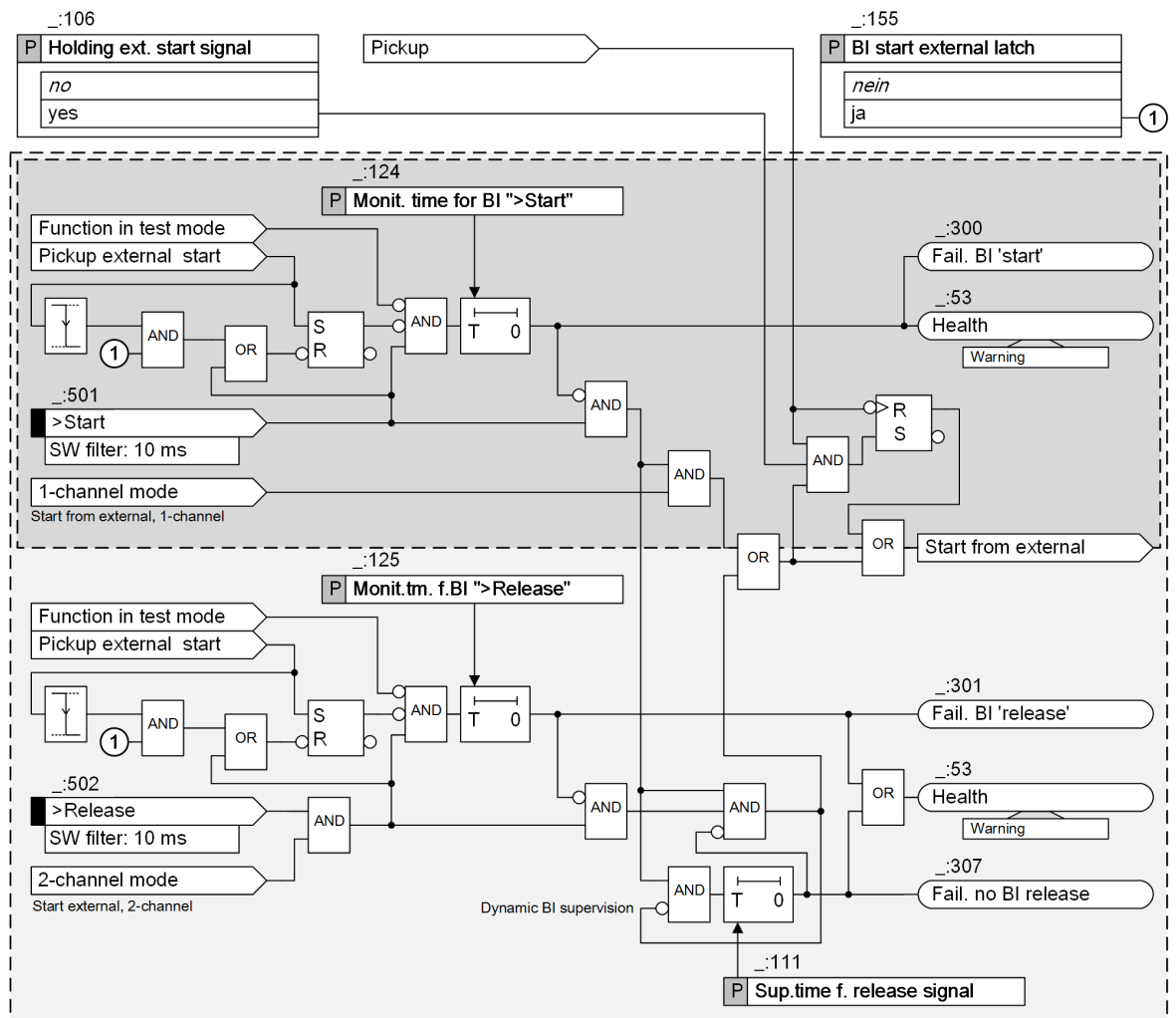

[to_ext_3_en_US]

Figure 6-251 External Start of the Circuit-Breaker Failure Protection Function, Logic

Current-Flow Criterion

The current-flow criterion is the primary criterion for determining the circuit-breaker switch position. A circuit-breaker pole is supposed to be closed, and the current-flow criterion fulfilled, as soon as one of the phase currents exceeds the phase-current threshold value, and at the same time a plausibility current exceeds the associated threshold value. The plausibility current can be either a 2nd phase current (to compare with the threshold value for phase currents) or the zero-sequence or negative-sequence current (to compare with

the sensitive threshold value). The additional evaluation of the plausibility current increases the safety of a criterion.

If you are using the transformer connection type **3-phase, 2prim.trans.**, the ground current is neither measured nor calculated. The plausibility check via the ground current is therefore not possible. The setting **Direct release** via the ground current does not lead to a pickup of the circuit-breaker failure protection. In the case of ground faults, the sensitive threshold value can be dynamically applied to the phase currents as well. The current-flow criterion is in this case fulfilled when the currents exceed the sensitive threshold value. The phase-current threshold value is then ineffective. The binary signal **>Threshold sensitive** is used for the switchover.

If you set the parameter **3I0 criterion** to **Direct release**, you block the plausibility check of the zero-sequence current. In this way a pickup can only be achieved by way of this current. The **Threshold 3I0 dir. release** parameter is used to set the threshold value to be exceeded.

If you set the parameter **I2 criterion** to **Direct release**, you also switch off the plausibility check of the negative-sequence current. The **Threshold I2 dir. release** parameter is used to set the threshold value to be exceeded.

If you set the parameter **I2 criterion** to **Direct release**, a plausibility check is performed via the phase currents with $1/3 * \text{Threshold I2 dir. release}$.

The measuring algorithm is optimized for fast dropout when the value drops below the threshold value.

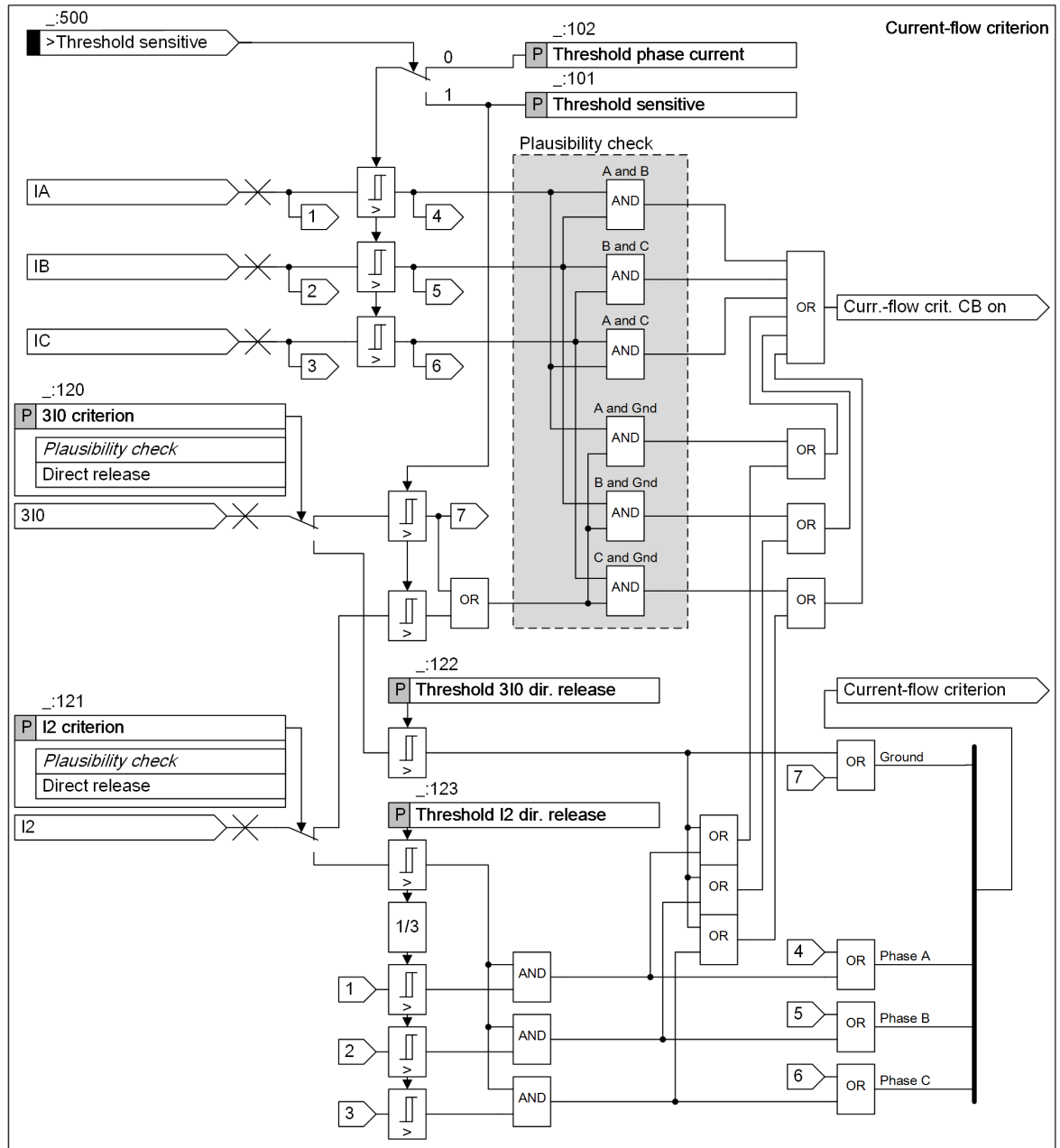

[fo_current1, 4, en_US]

Figure 6-252 Current-Flow Criterion

Circuit-Breaker Auxiliary Contact Criterion

Settings allow you to specify whether the circuit-breaker auxiliary contacts are permitted for determining the circuit-breaker switch position.

The double-point indication **3-pole position** (from the function block **Circuit-breaker**) is used to determine whether all 3 poles of the circuit breaker are closed. If the double-point indication is not routed, the output is an error message. Furthermore, the Health signal changes to the state *warning*.

The detection of a static disturbed position (not an intermediate position) has the effect that the circuit-breaker auxiliary contact criterion is not used (the internal signal **Aux.co.crit. : CB Clsd** is disabled).

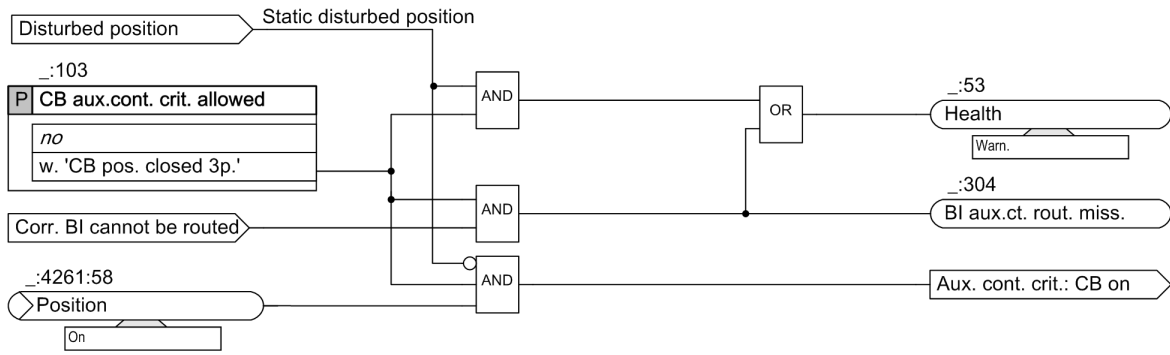

[lo_criter, 1, en_US]

Figure 6-253 Circuit-Breaker Auxiliary Contact Criterion

Pickup/Dropout

After the start, a check is performed whether the circuit breaker is closed. The current-flow criterion and the circuit-breaker auxiliary contact criterion are available for this purpose.

Even if the circuit-breaker auxiliary contact criterion is permitted, preference is given to the fulfilled current-flow criterion because the current-flow criterion is the most reliable criterion for detecting whether the circuit breaker is closed. This means that the circuit breaker is deemed to be closed if it is closed according to the current-flow criterion but at the same time open according to the circuit-breaker auxiliary contact criterion.

If no current is flowing at the start time, the function can only pick up on the basis of the circuit-breaker auxiliary contact criterion. For this purpose, the circuit-breaker auxiliary contacts must be permitted as criterion. When the current begins to flow after the start, the function switches over to the current-flow criterion.

If the circuit breaker is detected as closed and the starting condition is present, the function picks up.

The pickup starts a time delay (see Delay/Tripping). While the delay is running, the system checks continuously whether the circuit breaker has opened. In the default setting, the opening of the circuit breaker is checked on the basis of the currently valid criterion, which is normally the current-flow criterion because it is preferred. If until expiration of the time delay, no current flow above the set threshold values has been detected, the circuit-breaker auxiliary contact criterion becomes effective.

The function has also a setting in which dropout is only possible if both criteria in parallel detect the circuit breaker to be open (dropout with auxiliary contact and current-flow criterion).

In the default setting, the internal starting signal is held (see Figure 6-249 and Figure 6-251). This means that dropout is controlled solely by the current or the circuit-breaker auxiliary contact criterion. If dropout is also to occur on the falling edge of the starting signal (that is, when the pickup signal has a falling edge or the protection function trips), holding of the start signal must be disabled.

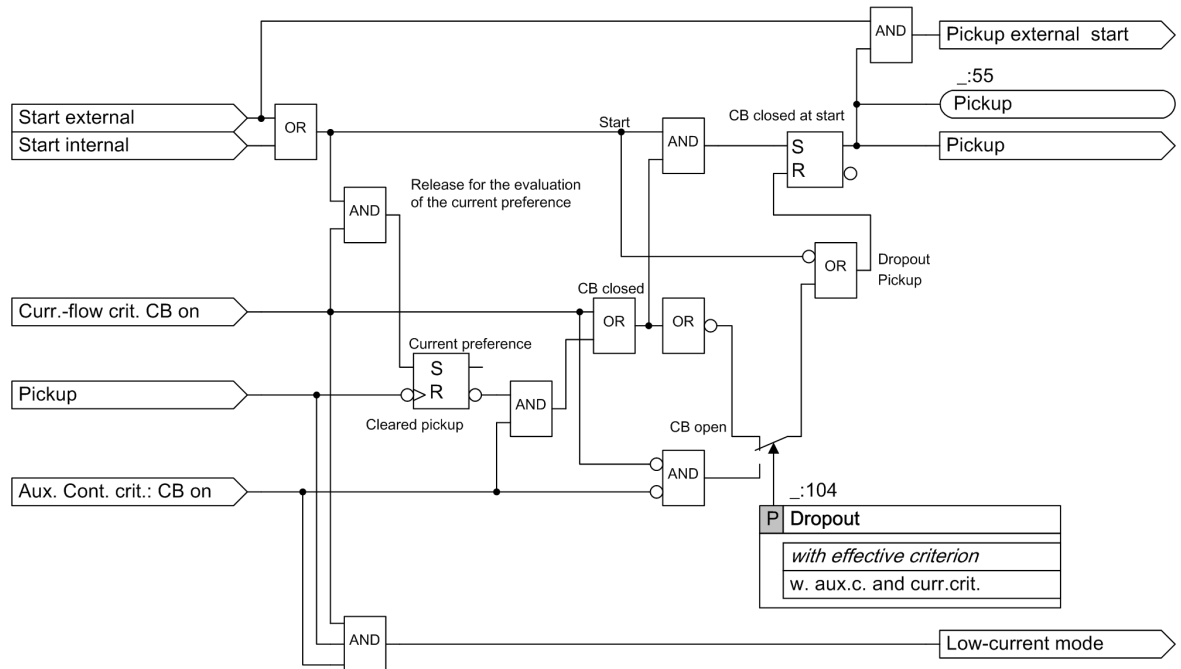

[to_pickup1_4_en_US]

Figure 6-254 Pickup/Dropout of the Circuit-Breaker Failure Protection Function

Delay/Tripping

In a first step, tripping at the local circuit breaker can be repeated. Tripping is repeated after expiration of the settable delay T1. If the local CB was not yet tripped, for example, in the event of an external start of the circuit-breaker failure protection, the trip logic of the circuit breaker itself is activated when the time delay T1 elapses.

Time delay T2 (backup tripping) can commence in parallel either with the start of time T1 or after expiration of time T1.

If time delay T2 expires without a dropout of the function, a circuit-breaker failure is assumed and the backup tripping signal **Tripping T2** is output.

If the **>CB defect** input signal is valid, any repetition of the trip signal is suppressed, and the backup tripping signal T2 is generated immediately (without delay). The binary input of the **>CB defect** input signal must be activated for at least 20 ms before the signal becomes valid.

With help of the **CB failure pole** indication, you can determine the phase currents that are above the threshold value at the tripping time T2.

The **Minimum operate time** parameter defines the minimum duration for tripping the function. In contrast to other protection functions, the parameter is set within its own function. As a result, the setting is independent of the identically named global parameter that is set in the **Device settings**.

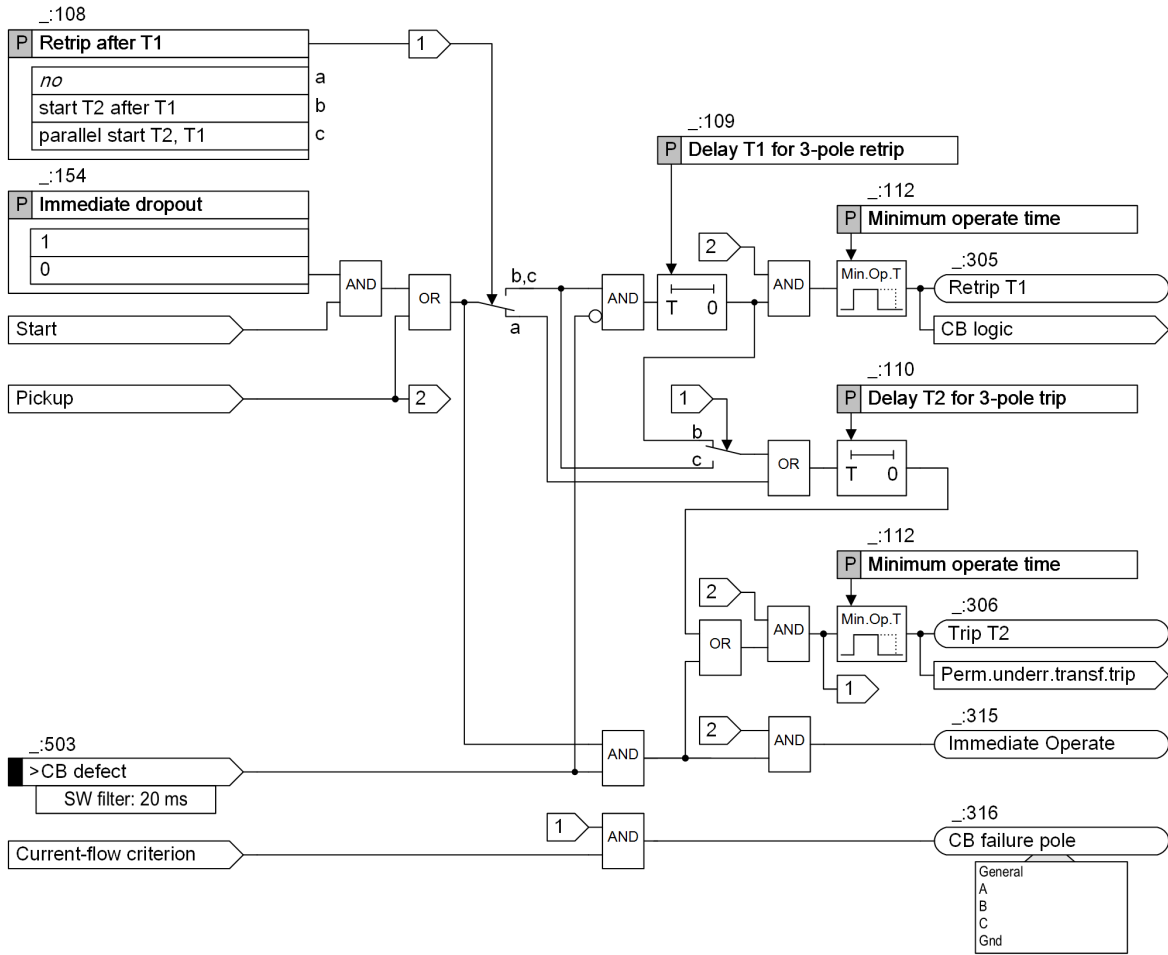

[lo_bbp-verza-3ph_6_en_US]

Figure 6-255 Delay/Tripping of the Circuit-Breaker Failure Protection Function

With the parameter **Immediate dropout**, you determine whether the circuit-breaker switch position is checked continuously or on expiration of the T1 and T2 time delays. If the circuit-breaker switch position is checked once the time delays have expired, the function picks up using Start.

6.42.4 Application and Setting Notes

Figure 6-256 gives an overview of the functions involved in an external start of the CBFP function. In the case of an internal start, there is no external protection device and the protection functionality is located in the CBFP device.

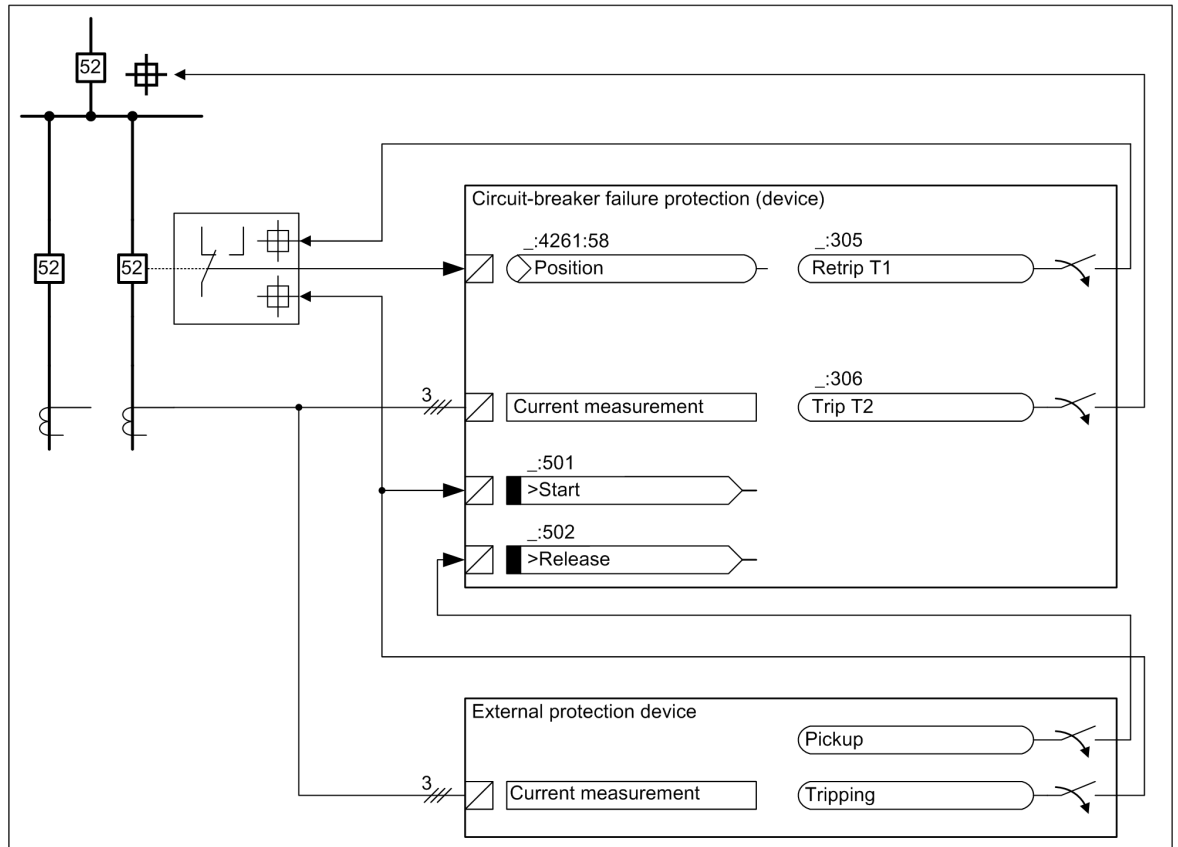

[to_extpol_2_en_US]

Figure 6-256 Circuit-Breaker Failure Protection with External Start, Tripping Repetition, and 3-Pole Tripping (T2)

Routing: Configuration of Internal Starting Sources (Internal Protection Function)

Configuration of the internal starting sources takes place in the protection function groups via the **Circuit-breaker interaction** entry ().

By default, the function can be started by any tripping of the internal protection functions that control the local circuit breaker. Depending on the specific application, it can be necessary to exclude certain device-internal protection functions from starting the CBF. For instance, busbar disconnection following a local circuit-breaker failure may be undesirable in the case of load-shedding applications or ground faults in isolated/resonant-grounded systems.

Where a start exclusively from external source is required, all internal protection functions must be routed so that they are excluded as a starting source.

Parameter: Start via binary input

- Default setting (_:107) **Start via binary input = no**

Parameter Value	Description
<i>no</i>	If no external start is intended, the parameter is set to <i>no</i> .
<i>2 channel</i>	2-channel start is used if there is a danger that the circuit-breaker failure protection causes a tripping due to a faulty activation of the start binary input. This is the case in the following situations: a) The CBFP pickup value (threshold value) is set to less than the load current. b) There can be operating conditions under which the current flow is higher than the pickup value. To avoid a possible overfunction, Siemens recommends using the 2-channel start.
<i>1 channel</i>	The 1-channel start must be used where only one control circuit of a binary input is available for starting the CBFP.

Input Signals: >Start, >Release

The start and release input signals have a filtering time of **10 ms** as default setting. If a transient control signal to the binary inputs is to be expected due to the design of the external binary-input control circuits and due to environmental conditions, the filtering time can be extended. This delays the start of the CBFP function.

Input Signals	Description
>Start	The start input signal is linked with the tripping of the external protection device (<i>Figure 6-256</i>).
>Release	The release input signal is normally linked with the pickup of the external protection device (<i>Figure 6-256</i>). Another common configuration is the parallel wiring of the external trip initiation to both binary inputs (start and release).

Parameter: Supervision time f. release signal

- Default setting (`_:111`) **Sup.time f. release signal = 0.06 s**

The setting depends on the external function which generates the release signal. If the pickup or tripping of the external protection is used as release signal, the default setting can be kept. If it is ensured that the release signal is always present before the start signal, the time can be set to 0.

Parameter: Holding internal start signal

- Recommended setting value (`_:105`) **Holding int. start signal = yes**

Parameter Value	Description
<i>yes</i>	In the case of an internal start, the start signal is hold. The dropout of the CBFP depends exclusively on the determination of the circuit-breaker position. This setting must be selected if it is not ensured that all 3 poles of the CB have opened when the pickup signal of the protection function has a falling edge. Siemens recommends using this method as the standard method.
<i>no</i>	Holding of the start signal can be disabled if it is ensured by the application that the CB has reliably opened when the start signal has a falling edge, or if the CBFP is explicitly required to drop out when the start signal has a falling edge.

EXAMPLE

Holding Internal Start Signal (Setting Value: yes)

In the event of a 2-pole fault, only one contact of the CB opens. The fault current is thus reduced, and the starting phase short-circuit protection drops out.

Parameter: Holding external start signal

- Recommended setting value (_:106) **Holding ext. start signal = no**

Parameter Value	Description
no	The CBFP drops out when the external start signal has a falling edge. This setting prevents the CBFP from generating a tripping signal when an unwanted pulse is received at the binary input and the current flow is high enough. Siemens recommends using this method as the standard method.
yes	You can hold the start signal if it is not ensured that the circuit breaker is open when the external start signal has a falling edge.

EXAMPLE

Holding External Start Signal (Setting Value: Yes)

The function is started from the opposite end via an auxiliary device for command transmission. This device generates only a signal pulse.



NOTE

Siemens would like to point out that, with a hold signal, the CBFP generates a trip signal each time a starting pulse is received and the current flow is high enough. Remember this particularly in the case of an external start.

Parameters: Threshold phase current/Threshold sensitive

- Recommended setting value (_:102) **Threshold phase current = approx. $0.50 I_{sc, min}$**
- Recommended setting value (_:101) **Threshold sensitive = approx. $0.50 I_{sc, min}$**

In order to ensure that the disconnection of the fault is promptly detected and the function can drop out quickly, Siemens recommends setting both thresholds to half the minimum short-circuit current ($I_{sc, min}$).

If – depending on the neutral-point treatment and/or load conditions – ground faults lead to relatively low fault currents, a sensitive setting of the parameter **Threshold sensitive** must be selected according to the rule ($0.5 I_{sc, min}$). There can also be values which are noticeably below the rated or load current.

Input Signal: >Threshold sensitive

In order to ensure that the function picks up reliably in all switch positions of the power system (examples: opposite end of line open, switching onto a ground fault), the setting of the parameter **Threshold sensitive** can be applied dynamically to all currents - including phase currents – in the presence of ground faults. For this purpose, the binary signal **>Threshold sensitive** must be activated. This can be done via a device-internal function for ground-fault detection (if provided in the device), for example, using **Overvoltage protection with zero-sequence voltage**. In this case, the pickup of the V0> function must be linked with the binary signal. Alternatively, the signal can be coupled from a separate device for sensitive ground-fault detection via a binary input.

Parameter: Circuit-breaker auxiliary-contact criterion allowed for protection

- Recommended setting value (_:103) **CB aux.cont. crit. allowed = no**

Parameter Value	Description
<i>no</i>	If sufficient current flow is ensured under all conditions with the CB closed, Siemens recommends not to permit the auxiliary contacts as a further criterion for determining the CB position, because measurement based on the current flow is the most reliable criterion.
<i>w. 'CB pos. closed 3p.'</i>	The auxiliary contacts are permitted as a further criterion in applications (see the following examples) where the current is no reliable criterion for determining the circuit-breaker position.

Parameter: 3I0 criterion

- Recommended setting value (_:120) **3I0 criterion = Plausibility check**

Parameter Value	Description
<i>Plausibility check</i>	The ground current is only used to check the plausibility of the phase currents. The value set under the parameter Threshold sensitive is used as the threshold for the ground current.
<i>Direct release</i>	The current-flow criterion can be fulfilled only by the ground current without the phase currents exceeding their set threshold value. The value set under the parameter Threshold 3I0 dir. release is used in this case as the threshold for the ground current.

If you have set the **Threshold phase current** to be larger than the maximum load current, overfunction because of a false start is impossible. To ensure **Circuit-breaker failure protection** for smaller ground faults even with this setting, you can select **3I0 criterion** to be *Direct release* and **Threshold 3I0 dir. release** to be appropriately smaller than **Threshold phase current**.

Parameter: I2 criterion

- Recommended setting value (_:121) **I2 criterion = Plausibility check**

Parameter Value	Description
<i>Plausibility check</i>	The negative-sequence current is only used to check the plausibility of the phase currents. The value set under the parameter Threshold sensitive is used as the threshold for the negative-sequence current.
<i>Direct release</i>	If a phase current exceeds 1/3 of the Threshold I2 dir. release , the current-flow criterion can be fulfilled only by the negative-sequence current without the phase currents exceeding their set threshold value. The threshold for the negative-sequence current uses the value set in the Threshold I2 dir. release parameter in this case.

If you have set the **Threshold phase current** to be larger than the maximum load current, overfunction because of a false start is impossible. To have Circuit-breaker failure protection function for smaller unbalanced faults even with this setting, you can select **I2 criterion** to be *Direct release* and **Threshold 3I0 dir. release** to be appropriately smaller than **Threshold phase current**.

Parameter: Threshold 3I0 dir. release

Recommended setting value (_:122) **Threshold 3I0 dir. release = approx. 0.5 I_{sc_min}**

This parameter is effective only if the **3I0 criterion** parameter is set to *Direct release*. Siemens recommends setting the threshold to half the minimum short-circuit current ($I_{sc_{min}}$) to ensure that the disconnection of the fault is promptly detected and the function can drop out quickly.

Parameter: Threshold I2 dir. release

Recommended setting value (_:123) **Threshold I2 dir. release = approx. 0.5 I2_{min}**

This parameter is effective only if the **I2 criterion** parameter is set to **Direct release**. Siemens recommends setting the parameter to half the permissible negative-sequence current (I2_{min}) to achieve a fast fault clearing in the event of an undesired negative-sequence system component.

Parameters: Monit. time for BI ">Start"/Monit.tm. f.BI ">Release"

- Default setting (_:124) **Monit. time for BI ">Start" = 15 s**
- Default setting (_:125) **Monit.tm. f.BI ">Release" = 15 s**

With these parameters, you set the monitoring time of the binary inputs **>Start/>Release**. If the **Circuit-breaker failure protection** does not pick up during this monitoring time, a failure in the binary-input circuit is assumed. Siemens recommends retaining the default setting of 15 s.

EXAMPLES

Applications which Require you to Permit the Circuit-Breaker Auxiliary-Contact Criterion:

- Tripping of the high and low-voltage side CB on the transformer. If only one of the 2 CBs trips, there is no more current flow.
- Tripping of protection functions whose tripping decision is not based on a current measurement in combination with voltage or frequency protection functions
- Injection of the tripping signal from Buchholz protection

Parameter: Dropout

- Recommended setting value (_:104) **Dropout = with effective criterion**

The parameter **Dropout** is available if the circuit-breaker auxiliary contact criterion is permitted (see parameter **CB aux.cont. crit. allowed**).

Parameter Value	Description
<i>with effective criterion</i>	Siemens recommends keeping the default setting, because it prefers the current as a reliable criterion for detection of an open CB and thus for dropout of the CBF function.
<i>w. aux.c. and curr.crit.</i>	Select this setting for applications on transformers or generators (see the preceding examples) in which the current flow is such that the current is no longer a reliable criterion for detecting the opening of the CB.

Parameter: Retrip

- Default setting (_:108) **Retrip after T1 = no**

Parameter Value	Description
<i>no</i>	Where no redundant CB control is provided, a repetition of the trip signal to the local CB is not required.
<i>start T2 after T1</i>	Where a redundant CB control (2nd trip coil with 2 trip circuits) is provided, a repetition of the trip signal to the local CB makes sense. Siemens recommends the setting <i>start T2 after T1</i> because it provides a clear chronological separation of the processes for trip repeat and backup tripping. Remember here that the overall fault-clearance time in case of a failure of the local CB is the sum of T1 and T2.
<i>parallel start T2, T1</i>	As an alternative to the setting <i>start T2 after T1</i> , the user can start T2 and T1 in parallel.

Parameter: Delay T1 for 3-pole retrip

- Default setting (`_:109`) **Delay T1 for 3-pole retrip = 0.05 s**

The parameter is visible only when retripping is set.

The setting depends on the user's philosophy.

The following settings make sense:

- If the minimum fault-clearing time has top priority, Siemens recommends setting the time to 0. This setting causes initiation of the retrip immediately upon the start. The drawback is that a defect of the 1st trip circuit is not detected.
- With a small time delay of, for instance, 50 ms, the defect of the 1st trip circuit can be detected based on the evaluation of the fault record.
- With a long time delay, which reliably ensures the dropout of the CBFP with the CB open, the rising edge indication of the trip repeat **Retrip T1** is a sure signal for a fault in the 1st trip circuit. The following example shows how this time is determined.

EXAMPLE

Determining the T1 Time that Reliably Ensures the Dropout of the CBFP with the CB Open:

Time of binary device output (when tripping is caused by device-internal protection)	5 ms
CB inherent time up to current interruption	2 periods (assumed rated frequency = 50 Hz)
Dropout time of CBFP function	1 period
Subtotal	65 ms
Security	Factor 2
Total (time T1)	130 ms

Parameter: Delay T2 for 3-pole trip

- Default setting (`_:110`) **Delay T2 for 3-pole trip = 0.13 s**

This setting has to ensure that after opening of the local CB the function drops out reliably and that backup tripping is avoided under all circumstances. The setting depends on the parameter **Retrip after T1**.

If T2 is started after T1, there is no need to consider the time T1 for the setting of T2.

EXAMPLE

Determining the T2 Time that Reliably Ensures the Dropout of the CBFP with the CB Open:

Time of binary device output (when tripping is caused by device-internal protection)	5 ms
CB inherent time up to current interruption	2 periods (assumed rated frequency = 50 Hz)
Dropout time of CBFP function	1 period
Subtotal	65 ms
Security	Factor 2
Total (time T2)	130 ms

If T1 and T2 are started in parallel, take into account the time T1 for the setting of T2.

EXAMPLE

Simultaneous Start of T2 and T1

Time for a reliable dropout after the local CB has opened	130 ms
Setting of T1	50 ms
Total (= T2)	180 ms

Parameter: Minimum operate time

- Default setting (_:112) **Minimum operate time = -**

The **Minimum operate time** parameter is used to set the minimum duration for tripping the function.



CAUTION

Too short setting times for the minimum tripping duration

If you set a time that is too short for tripping, there is a risk (dropout of the function without the current-flow criterion) that the device contacts will interrupt the control loop. If this happens, the device contacts will burn out.

- ✧ Set a minimum time period that is long enough to ensure that the circuit breaker reliably reaches the end position **Open** after a control operation.

Input Signal: >CB defect

The input signal **>CB defect** has a default filtering time of 20 ms. This filtering time prevents the input signal from becoming effective in the case of a transient activation of the physical binary input, which can be caused by the pressure change when the CB opens.

This time can be set to 0 if such a transient pickup of the physical binary input can be excluded due to the CB design.

Output Signal: Retrip T1

If only 1 control circuit is available for the local circuit breaker, the output signal does not necessarily have to be routed because the signal also controls the circuit-breaker trip logic.

If a 2nd control circuit is present, the **Retrip T1** output signal must be routed to the associated binary output.

Output Signal: Trip T2

For operational handling of the adjacent circuit breakers, the backup tripping (indication **Trip T2**) must be routed to a binary output; and if necessary, to an interface (intertripping to opposite end).

Parameter: CBFP interact. with dBBP

- Default setting (_:153) **CBFP interact. with dBBP = No**

If you use a merging unit as the bay unit of the distributed busbar protection, the **CBFP interact. with dBBP** parameter becomes visible after the successful central-unit update in the merging unit.

Parameter Value	Description
no	With this parameter, you specify that this function operates independently from the distributed busbar protection.
yes	With this parameter, the function will work with the distributed busbar protection.

Parameter: Immediate dropout

- Recommended setting (_:154) **Immediate dropout** =

Parameter Value	Description
<input checked="" type="checkbox"/>	The criteria are checked continuously and the circuit-breaker failure protection drops out immediately once the criteria have no longer been met. Siemens recommends keeping this setting.
<input type="checkbox"/>	This setting is used to take alternating load cases into account in the event of a fault, for example when using a breaker-and-a-half layout. The time delays and function pickup are actuated separately using a starter. The criteria for determining a closed circuit breaker are only checked once the time delays have expired. Select the monitoring times for the binary inputs > <i>Start</i> and > <i>Release</i> in such a way that supervision for these inputs does not respond prior to achieving the current or circuit-breaker auxiliary-contact criterion.

Parameter: BI start external latch

- Default setting (_:155) **BI start external latch** =

Parameter Value	Description
<input checked="" type="checkbox"/>	In the case of buffered sources (for example lock-out mechanism after tripping) the start binary signal is latched externally after the protection trip. This means that the binary-input supervision remains inactive until the binary-input source has been reset. Supervision is only activated after this has taken place.
<input type="checkbox"/>	In the case of sources that are not buffered for an external start, the expectation is that they will drop out once the circuit-breaker failure protection has picked up. If this is not the case, the binary input may fail. This is why this setting results in binary-input supervision being reactivated once the Circuit-breaker failure protection function drops out.

6.42.5 Settings

Addr.	Parameter	C	Setting Options	Default Setting
50BF Ad.CBF #				
_:1	50BF Ad.CBF #:Mode		<ul style="list-style-type: none"> off on test 	on
_:105	50BF Ad.CBF #:Holding int. start signal		<ul style="list-style-type: none"> no yes 	yes
_:107	50BF Ad.CBF #:Start via binary input		<ul style="list-style-type: none"> no 2 channel 1 channel 	no
_:106	50BF Ad.CBF #:Holding ext. start signal		<ul style="list-style-type: none"> no yes 	no
_:111	50BF Ad.CBF #:Sup.time f. release signal		0.00 s to 1.00 s	0.06 s
_:103	50BF Ad.CBF #:CB aux.cont. crit. allowed		<ul style="list-style-type: none"> no w. 'CB pos. closed 3p.' 	no

Addr.	Parameter	C	Setting Options	Default Setting
_:104	50BF Ad.CBF #:Dropout		<ul style="list-style-type: none"> with effective criterion w. aux.c. and curr.crit. 	with effective criterion
_:108	50BF Ad.CBF #:Retrip after T1		<ul style="list-style-type: none"> no start T2 after T1 parallel start T2, T1 	no
_:102	50BF Ad.CBF #:Threshold phase current	1 A @ 100 Irated	0.030 A to 35.000 A	0.500 A
		5 A @ 100 Irated	0.15 A to 175.00 A	2.50 A
		1 A @ 50 Irated	0.030 A to 35.000 A	0.500 A
		5 A @ 50 Irated	0.15 A to 175.00 A	2.50 A
		1 A @ 1.6 Irated	0.001 A to 1.600 A	0.500 A
		5 A @ 1.6 Irated	0.005 A to 8.000 A	2.500 A
_:101	50BF Ad.CBF #:Threshold sensitive	1 A @ 100 Irated	0.030 A to 35.000 A	0.250 A
		5 A @ 100 Irated	0.15 A to 175.00 A	1.25 A
		1 A @ 50 Irated	0.030 A to 35.000 A	0.250 A
		5 A @ 50 Irated	0.15 A to 175.00 A	1.25 A
		1 A @ 1.6 Irated	0.001 A to 1.600 A	0.250 A
		5 A @ 1.6 Irated	0.005 A to 8.000 A	1.250 A
_:109	50BF Ad.CBF #:Delay T1 for 3-pole retrip		0.000 s to 60.000 s	0.050 s
_:110	50BF Ad.CBF #:Delay T2 for 3-pole trip		0.050 s to 60.000 s	0.130 s
_:112	50BF Ad.CBF #:Minimum operate time		0.00 s to 60.00 s	0.10 s
_:120	50BF Ad.CBF #:3I0 criterion		<ul style="list-style-type: none"> Direct release Plausibility check 	Plausibility check
_:121	50BF Ad.CBF #:I2 criterion		<ul style="list-style-type: none"> Direct release Plausibility check 	Plausibility check
_:122	50BF Ad.CBF #:Threshold 3I0 dir. release	1 A @ 100 Irated	0.030 A to 35.000 A	0.250 A
		5 A @ 100 Irated	0.15 A to 175.00 A	1.25 A
		1 A @ 50 Irated	0.030 A to 35.000 A	0.250 A
		5 A @ 50 Irated	0.15 A to 175.00 A	1.25 A
		1 A @ 1.6 Irated	0.001 A to 1.600 A	0.250 A
		5 A @ 1.6 Irated	0.005 A to 8.000 A	1.250 A
_:123	50BF Ad.CBF #:Threshold I2 dir. release	1 A @ 100 Irated	0.030 A to 35.000 A	0.250 A
		5 A @ 100 Irated	0.15 A to 175.00 A	1.25 A
		1 A @ 50 Irated	0.030 A to 35.000 A	0.250 A
		5 A @ 50 Irated	0.15 A to 175.00 A	1.25 A
		1 A @ 1.6 Irated	0.001 A to 1.600 A	0.250 A
		5 A @ 1.6 Irated	0.005 A to 8.000 A	1.250 A
_:124	50BF Ad.CBF #:Monit. time for BI ">Start"		0.05 s to 60.00 s	15.00 s
_:125	50BF Ad.CBF #:Monit.tm. f.BI ">Release"		0.05 s to 60.00 s	15.00 s

Addr.	Parameter	C	Setting Options	Default Setting
_:154	50BF Ad.CBF #:Immediate dropout		<ul style="list-style-type: none"> • 0 • 1 	true
_:155	50BF Ad.CBF #:BI start external latch		<ul style="list-style-type: none"> • 0 • 1 	true

Table 6-22 Starting with V8.40, the Merging Units Have the Following Enhancement that is Especially Intended for Use with the Distributed Busbar Protection and Evaluated there:

Addr.	Parameter	C	Setting Options	Default Setting
50BF Ad.CBF #				
_:153	50BF Ad.CBF #:CBFP interact. with dBBP		<ul style="list-style-type: none"> • no • yes 	no

6.42.6 Information List

No.	Information	Data Class (Type)	Type
50BF Ad.CBF #			
_:501	50BF Ad.CBF #:>Start	SPS	I
_:502	50BF Ad.CBF #:>Release	SPS	I
_:82	50BF Ad.CBF #:>Block function	SPS	I
_:503	50BF Ad.CBF #:>CB defect	SPS	I
_:500	50BF Ad.CBF #:>Threshold sensitive	SPS	I
_:54	50BF Ad.CBF #:Inactive	SPS	O
_:52	50BF Ad.CBF #:Behavior	ENS	O
_:53	50BF Ad.CBF #:Health	ENS	O
_:55	50BF Ad.CBF #:Pickup	ACD	O
_:305	50BF Ad.CBF #:Retrip T1	ACT	O
_:306	50BF Ad.CBF #:Trip T2	ACT	O
_:302	50BF Ad.CBF #:BI start routing miss.	SPS	O
_:304	50BF Ad.CBF #:BI aux.ct. rout. miss.	SPS	O
_:300	50BF Ad.CBF #:Fail. BI 'start'	SPS	O
_:307	50BF Ad.CBF #:Fail. no BI release	SPS	O
_:301	50BF Ad.CBF #:Fail. BI 'release'	SPS	O
_:315	50BF Ad.CBF #:Immediate Operate	SPS	O
_:316	50BF Ad.CBF #:CB failure pole	ACD	O

6.43 Circuit-Breaker Restrike Protection

6.43.1 Overview of Function

The **Circuit-breaker restrike protection** function:

- Monitors the circuit breaker against restriking, for example, caused by an overvoltage over the circuit-breaker poles after switching off a capacitor bank
- Generates a backup operate signal in case of a circuit-breaker restriking

6.43.2 Structure of the Function

The **Circuit-breaker restrike protection** function is used in the **Circuit-breaker** function group. A maximum of 2 functions can operate simultaneously within the function group.

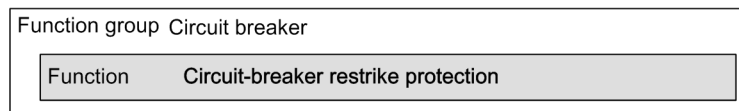

[lo_strestrike, 2, en_US]

Figure 6-257 Structure/Embedding of the Function

The function logic is grouped into the parts shown in [Figure 6-258](#). In the following chapter, these logic parts are described in detail.

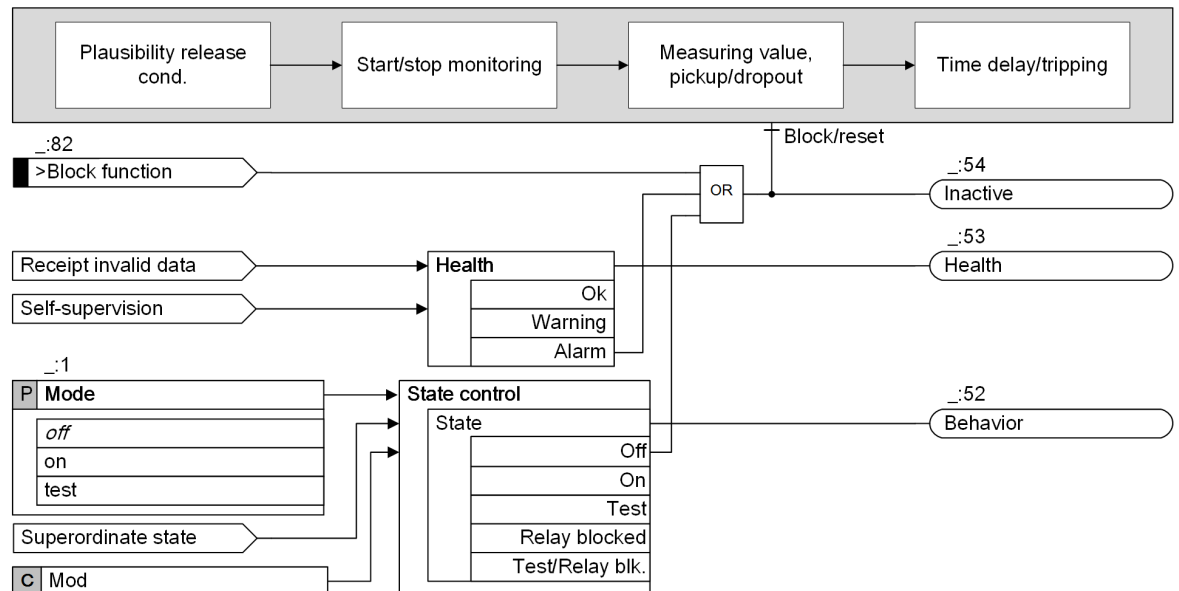

[lo_respro, 2, en_US]

Figure 6-258 Logic Overview of the Function

6.43.3 Function Description

Plausibility Release

The function **Circuit-breaker restrike protection** issues a trip command to a superordinated circuit breaker, usually the infeed circuit breaker of a busbar. Overfunction of this protection can cause extreme problems for the whole application.

The logic of plausibility release strongly reduces the risk of a false start of the function by adding an extra release criteria for a function start.
 Each criterion can be switched on or off individually.

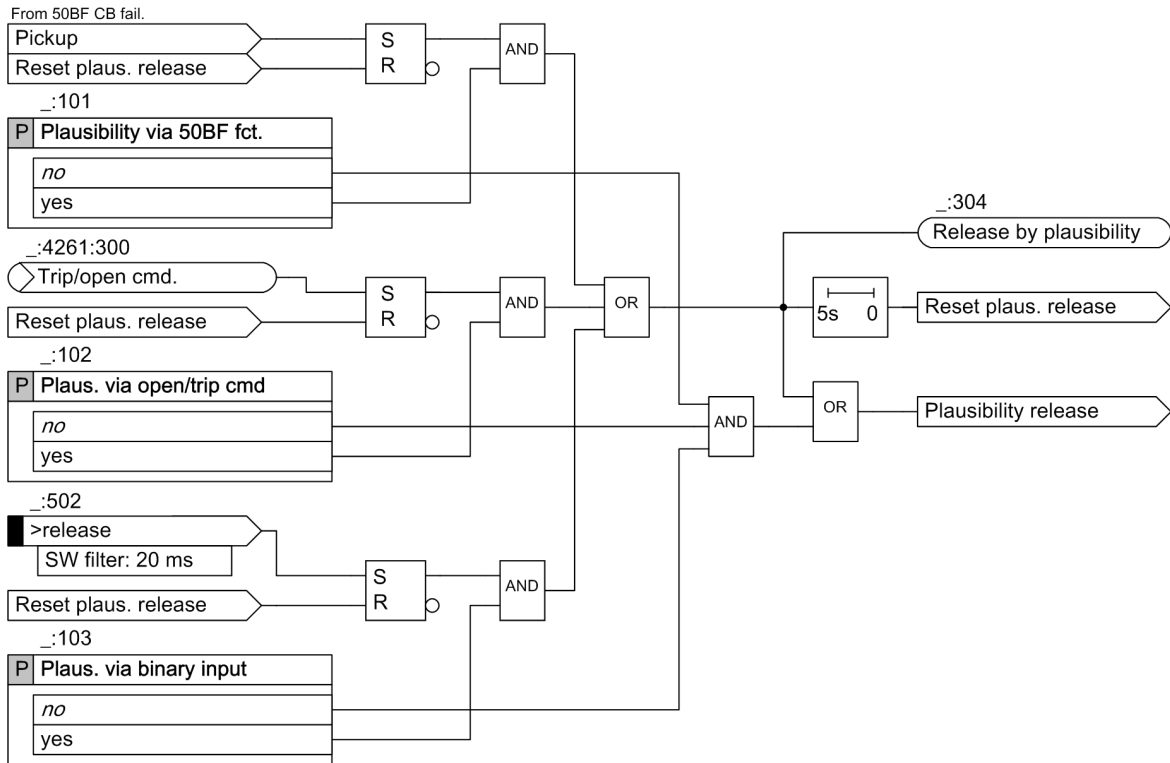

[io_paus. 1. en_US]

Figure 6-259 Logic Diagram for the Plausibility Release of the Circuit-Breaker Restrike Protection

The plausibility-release logic checks the following conditions:

- When the parameter **Plausibility via 50BF fct.** is set to **yes**, the pickup signal of the **Circuit-breaker failure protection** is monitored. The plausibility release is given if the **Circuit-breaker failure protection** has picked up.
- When the parameter **Plaus. via open/trip cmd** is set to **yes**, the trip/open command is monitored. The plausibility release is given if the trip/open command has been generated.
- When the parameter **Plaus. via binary input** is set to **yes**, the **>release** signal is monitored. The plausibility release is given if the **>release** signal has been received.

If one of the conditions is fulfilled, the plausibility release is given for 5 s. The 5-s timer ensures that the release criterion and start condition relate to the same circuit-breaker opening/tripping process.

If all the 3 plausibility settings are set to **no**, the start/stop-monitoring logic considers the release as fulfilled.

For safety reasons, the input signal **>release** has a preset software filtering time of 20 ms.

Start/Stop Monitoring

Via the start/stop monitoring logic, the monitoring duration of the current signal regarding restriking is determined.

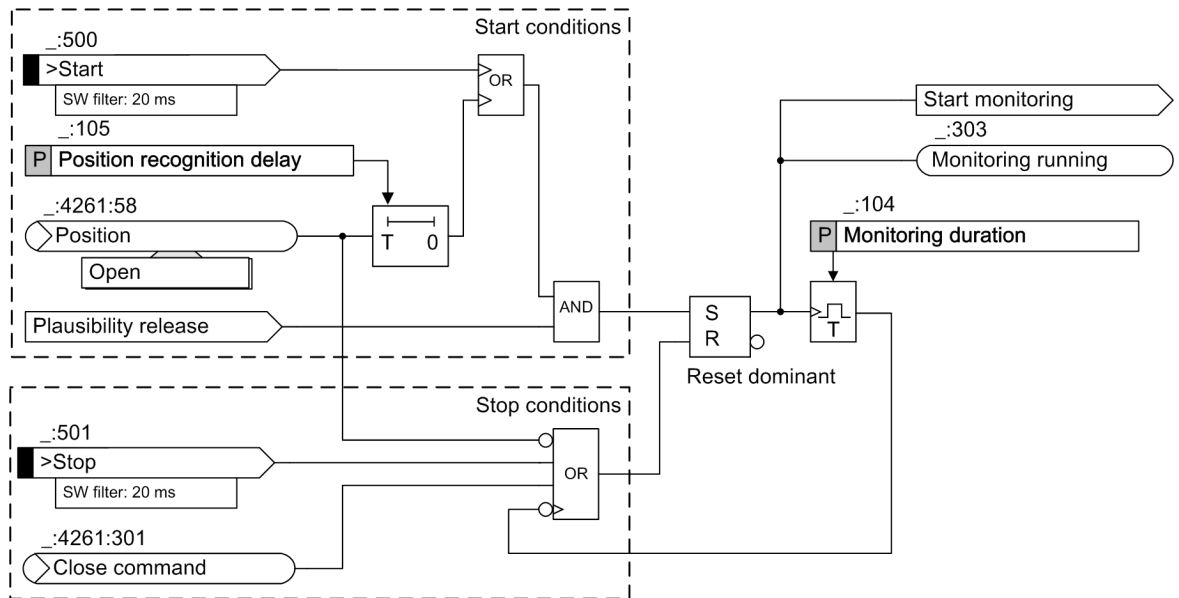

[to_starstop_2_en_US]

Figure 6-260 Logic Diagram for Start/Stop Monitoring of the Circuit-Breaker Restrike Protection

The monitoring is started if one of the following conditions is met:

- The circuit-breaker position is detected as **open** via the circuit-breaker auxiliary contacts during the time set with the parameter **Position recognition delay**.
The **Position recognition delay** time is used for safety means to ensure that the circuit breaker is definitely open when the monitoring starts. This parameter allows to adapt this start criterion to all kinds of auxiliary-contact configurations.
- The binary input signal **>Start** is activated.

For safety reasons, the input signal has a preset software filtering time of 20 ms.

In addition to the active start criterion, the plausibility release (refer to the [Plausibility Release, Page 913](#)) must be present to start the monitoring duration.

With the fulfilled start condition, the **Monitoring duration** timer is started. This timer defines how long the current signal is monitored regarding restriking. If the time expires, the monitoring is terminated.

The monitoring is also terminated immediately if one of the following conditions is met:

- The circuit-breaker position is detected no longer as **open**.
- A close command is given by the device.
- The binary input signal **>Stop** is activated.
For safety reasons, the input signal has a preset software filtering time of 20 ms.

Measuring Value, Pickup/Dropout

During the **Monitoring duration**, the current signal is monitored phase-selectively regarding restriking. As a measuring value, the fundamental component of the current is used.

- On one hand, current peaks are damped but still detected reliably by the fundamental-component value.
- On the other hand, a DC (Direct Current) component is suppressed. A DC component can occur after switching off the circuit breaker.

Thus, the fundamental-component value is a good choice for a reliable restrike detection.

If any phase current exceeds the set current threshold value, the function picks up. The coming pickup indicates the first restrike current pulse. With the pickup, the operate delay timers are started, see also the following description [Delay/Tripping, Page 916](#).

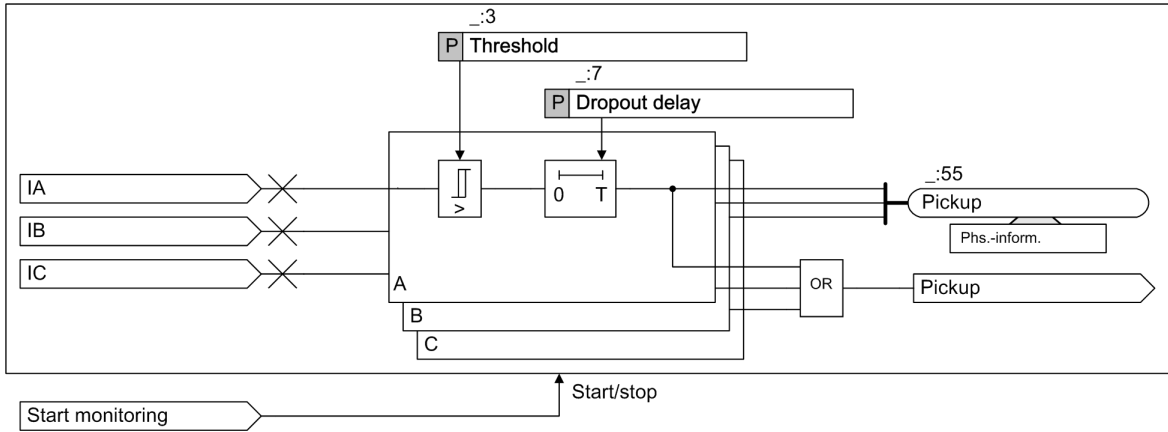

Figure 6-261 Logic Diagram for Measuring Value, Pickup/Dropout of the Circuit-Breaker Restrike Protection

If restriking occurs, the current signal drops below the current threshold if the time between restriking pulses is long enough. In this case, the operate delay must not be reset. During the dropout delay, the pickup is extended to ensure that the operate delay timers are not reset. However, if the dropout delay time expires (no new current peak occurred), the function drops out and the operate delay timers are reset.

Delay/Tripping

In the first step, tripping of the local circuit breaker can be repeated. Tripping is repeated after expiration of the settable delay T1. The retrip on the local circuit breaker is as a safety mechanism as well. In the event of a wrong start and pickup, only the local circuit breaker is opened instead of the superordinated circuit breaker. Time delay T2 (backup tripping) can start in parallel either with the start of time T1 or after expiration of time T1.

If time delay T2 expires, circuit-breaker restriking takes place and the backup-tripping signal *Trip T2* is generated.

If the *>CB defect* input signal is valid, any repetition of the trip signal is suppressed and the backup-tripping signal *Trip T2* is generated immediately (without delay). For safety reasons, a default software filter time of 20 ms is preset (configurable in DIGSI) for the binary input signal *>CB defect*.

The **Minimum operate time** parameter defines the minimum duration for the trip command of the function. In contrast to other protection functions, the parameter is set within its own function. As a result, the setting is independent of the identically named comprehensive parameter that is set in the **Device settings**.

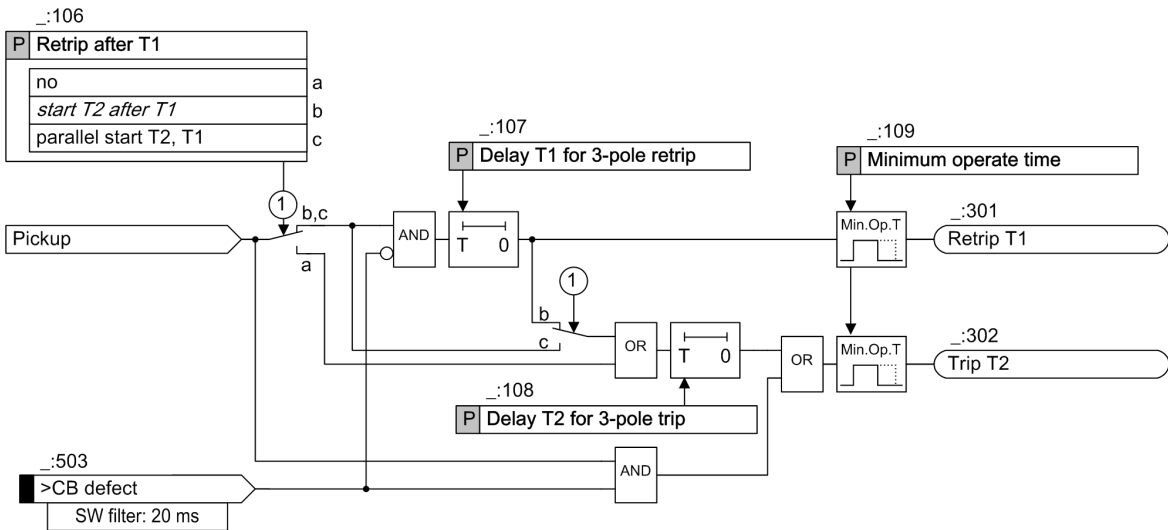

Figure 6-262 Logic Diagram for Delay/Tripping of the Circuit-Breaker Restrike Protection

6.43.4 Application and Setting Notes

Parameter: Switch On or Off Additional Plausibility Release Criteria

- Default setting (_:101) **Plausibility via 50BF fct. = no**
- Default setting (_:102) **Plaus. via open/trip cmd = no**
- Default setting (_:103) **Plaus. via binary input = no**

When using the plausibility release, the start condition and the release condition instead of only the start condition must be present to start the current monitoring regarding restriking. Since the current threshold value is set below the operating current, a false start would directly cause tripping. Thus, the plausibility release strongly reduces the risk that a falsely given start criterion leads to a wrong tripping of the superordinated circuit breaker.

3 different release criteria are available. You can use one or more than one or none of them. The selection depends on the application.



NOTE

When using release criteria, it must be ensured that the criteria are given under all the conditions where the **Circuit-breaker restrike protection** shall be started. If you choose no release criteria, the release is permanently given.

- **Open/trip command by the device**

Use this criterion in case that all control or trip commands are given by the protection device.



NOTE

Opening the circuit breaker manually without using the device will not release the start of the **Circuit-breaker restrike protection**.

- **Pickup of the Circuit-breaker failure protection**

Use this criterion if the **Circuit-breaker restrike protection** should only be started in case that the **Circuit-breaker failure protection** was started (picked up) before.



NOTE

Opening the circuit breaker by control or manually will not trigger the **Circuit-breaker failure protection**. Consequently the **Circuit-breaker restrike protection** cannot be released either.

- **Binary input signal**

Use this option if neither of the above 2 release criteria fit the application and you want to define your own release criterion.

Input signals: **>Start**, **>release**, **>Stop**

Input Signals	Description
>Start	This input signal allows to start the monitoring, for example, via protocol commands from a master (by use of a CFC chart) or by other specific conditions.
>release	This input signal allows to define specific release conditions by use of a CFC chart. Also refer to Parameter: Switch On or Off Additional Plausibility Release Criteria , Page 917.
>Stop	This input signal allows to stop the monitoring, for example, via protocol commands from a master (by use of a CFC chart) or by other specific conditions.

The input signals *>Start* , *>release* , and *>Stop* have a filtering time of *20 ms* as default setting. If a transient spurious signal to the binary inputs is expected due to the design of the external binary-input control circuits and environmental conditions, the filtering time can be extended.

Parameter: Position recognition delay

- Default setting (`_:105`) **Position recognition delay** = *0.02 s*

With the parameter **Position recognition delay**, you define how long the circuit breaker must be detected as **open** (via the circuit-breaker auxiliary contacts) before the monitoring time is started. This definition is a safety feature to ensure that the monitoring is not started too early. For example, in case that due to a non-standard auxiliary-contacts configuration, the circuit-breaker is already detected as **open** while current flow is still present.

The setting depends on the circuit-breaker auxiliary-contacts configuration. If it can be ensured that the auxiliary contacts announce the circuit breaker as **open** after the current flow is interrupted, the time can be set to zero.

Parameter: Monitoring duration

- Default setting (`_:104`) **Monitoring duration** = *200.00 s*

With the parameter **Monitoring duration**, you define how long the current signal is monitored regarding restriking after the circuit breaker has been opened.

With ongoing discharging of the capacitor bank, the probability of restriking is decreasing. There is no need to set the monitoring time longer than the discharging time. Siemens recommends setting the monitoring time in the range of $0.5 \cdot \text{discharging time}$ to $1 \cdot \text{discharging time}$.

Parameter: Threshold

- Default setting (`_:3`) **Threshold** = *0.250 A*

After opening of the circuit breaker, the phase currents are compared with the threshold value. If no restriking takes place, the current is zero. Consequently the threshold for detecting restriking can be set much smaller than the operating current. A typical value is 25 % of the operating current.

With a threshold below the operating current, a falsely-given start directly cause tripping. For minimizing this risk, Siemens recommends applying a release criterion additionally. Refer to [Parameter: Switch On or Off Additional Plausibility Release Criteria](#) , Page 917.

Parameter: Dropout delay

- Default setting (`_:7`) **Dropout delay** = *0.05 s*

The parameter **Dropout delay** ensures that a short dropping below the current threshold does not cause the operate delay timers to be reset.

Since restriking is normally a periodical effect, the dropout delay can be set to a rather small time. Siemens recommends applying the default value of 50 ms.

Input signal: >CB defect

The input signal *>CB defect* has a preset filtering time of 20 ms. This filtering time prevents the input signal from becoming effective in the case of a transient activation of the physical binary input, which can be caused by the pressure change when the circuit breaker opens.

This time can be set to 0 if such a transient response of the physical binary input can be excluded due to the circuit-breaker design.

Parameter: Retrip after T1

- Default setting (`_:106`) **Retrip after T1** = *start T2 after T1*

Parameter Value	Description
<i>start T2 after T1</i>	The retrip on the local circuit breaker is a safety mechanism to avoid false tripping of the superordinated circuit breaker. With generating a retrip, only the local circuit breaker is tripped in the event of a false start. Afterwards the Circuit-breaker restrike protection function drops out during the T2 delay time. Siemens recommends applying a retrip on the local circuit breaker. Siemens also recommends applying the parameter value <i>start T2 after T1</i> . The parameter value provides a clear chronological separation of the processes for trip repeat and backup tripping. Remember that the overall fault-clearance time in case of circuit-breaker restriking is the sum of T1 and T2.
<i>no</i>	No retrip is given
<i>parallel start T2, T1</i>	As an alternative to the setting <i>parallel start T2, T1</i> the customer can start T2 and T1 in parallel.

Parameter: Delay T1 for 3-pole retrip

- Default setting (_:109) **Delay T1 for 3-pole retrip** = 0.00 s

The parameter is visible only when the parameter **Retrip after T1** is set to *start T2 after T1* or *parallel start T2, T1*.

The retrip on the local circuit breaker is as a safety mechanism to avoid false tripping of the superordinated circuit breaker. In the event of a false start, only the local circuit breaker is tripped by the retrip. Afterwards the **Circuit-breaker restrike protection** function will drop out during the T2 delay time.

Siemens recommends applying a retrip on the local circuit breaker. Since the retrip is a safety mechanism, it can be given without a delay time. Siemens recommends setting the delay time to 0 s.

Parameter: Delay T2 for 3-pole trip

- Default setting (_:110) **Delay T2 for 3-pole trip** = 0.15 s

This parameter defines the duration of restriking after the backup tripping is sent. The following should be considered:

- When using the retrip functionality, this delay time must ensure a safe function dropout after giving the retrip on the local circuit breaker.

Siemens recommends applying a delay time of 150 ms which is the default setting.

Parameter: Minimum operate time

- Default setting (_:109) **Minimum operate time** = 0.15 s

The **Minimum operate time** parameter is used to set the minimum duration for the trip command of the function.



CAUTION

Do not set a time that is too short.

If you set a time that is too short, there is a danger (dropout of the function without the current-flow criterion) that the device contacts interrupt the control circuit. If this happens, the device contacts burn out.

- ◇ Set a duration that is long enough to ensure that the circuit breaker reliably reaches its final position (**open**) after a control operation.

Output signal: *Retrip T1*

The output signal *Retrip T1* must be routed to a binary output.

If only one control circuit is available for the local circuit breaker, the output signal must be routed to the binary output to which the general circuit breaker trip command (command *Position*) is routed.

If a second control circuit is present, the *Retrip T1* output signal can be routed to the associated binary output.

Output signal: *Trip T2*

In order to trip the adjacent circuit breakers, the backup tripping (indication *Trip T2*) must be routed to a binary output and if necessary, to an interface (intertripping to the opposite end). Thus, the circuit breaker on the opposite end can be tripped without delay.

6.43.5 Settings

Addr.	Parameter	C	Setting Options	Default Setting
<i>Restrike prt. #</i>				
_:1	Restrike prt. #:Mode		<ul style="list-style-type: none"> • off • on • test 	off
_:101	Restrike prt. #:Plausibility via 50BF fct.		<ul style="list-style-type: none"> • no • yes 	no
_:102	Restrike prt. #:Plaus. via open/trip cmd		<ul style="list-style-type: none"> • no • yes 	no
_:103	Restrike prt. #:Plaus. via binary input		<ul style="list-style-type: none"> • no • yes 	no
_:106	Restrike prt. #:Retrip after T1		<ul style="list-style-type: none"> • no • start T2 after T1 • parallel start T2, T1 	start T2 after T1
_:104	Restrike prt. #:Monitoring duration		1.00 s to 600.00 s	200.00 s
_:105	Restrike prt. #:Position recognition delay		0.00 s to 60.00 s	0.02 s
_:3	Restrike prt. #:Threshold	1 A @ 100 Irated	0.030 A to 35.000 A	0.250 A
		5 A @ 100 Irated	0.15 A to 175.00 A	1.25 A
		1 A @ 50 Irated	0.030 A to 35.000 A	0.250 A
		5 A @ 50 Irated	0.15 A to 175.00 A	1.25 A
		1 A @ 1.6 Irated	0.001 A to 1.600 A	0.250 A
		5 A @ 1.6 Irated	0.005 A to 8.000 A	1.250 A
_:7	Restrike prt. #:Dropout delay		0.00 s to 60.00 s	0.05 s
_:107	Restrike prt. #:Delay T1 for 3-pole retrip		0.00 s to 60.00 s	0.00 s
_:108	Restrike prt. #:Delay T2 for 3-pole trip		0.05 s to 60.00 s	0.15 s
_:109	Restrike prt. #:Minimum operate time		0.00 s to 60.00 s	0.15 s

6.43.6 Information List

No.	Information	Data Class (Type)	Type
<i>Restrike prt.#</i>			
_:500	Restrike prt.#:>Start	SPS	I
_:501	Restrike prt.#:>Stop	SPS	I
_:502	Restrike prt.#:>release	SPS	I
_:82	Restrike prt.#:>Block function	SPS	I
_:503	Restrike prt.#:>CB defect	SPS	I
_:54	Restrike prt.#:Inactive	SPS	O
_:52	Restrike prt.#:Behavior	ENS	O
_:53	Restrike prt.#:Health	ENS	O
_:304	Restrike prt.#:Release by plausibility	SPS	O
_:303	Restrike prt.#:Monitoring running	SPS	O
_:55	Restrike prt.#:Pickup	ACD	O
_:301	Restrike prt.#:Retrip T1	ACT	O
_:302	Restrike prt.#:Trip T2	ACT	O

6.44 Restricted Ground-Fault Protection

6.44.1 Overview of Functions

The **Restricted ground-fault protection** function (ANSI 87N, REF):

- Detects ground faults in transformers, shunt reactors, neutral reactors, or rotating machinery in which the neutral point is grounded.
- Has high sensitivity to ground faults near the neutral point.
- Is supplemental main protection to longitudinal differential protection.
- Protects grounding transformers in the protection range. It is required that a current transformer be used in the case of neutral point feed, that is, between neutral point and grounding conductor. The neutral point transformer and the phase current transformer define the protection range.
- Automatically adapts itself to the highest-amperage side with auto transformers, and thereby prevents overfunction in the event of external ground faults.

6.44.2 Structure of the Function

The function **Restricted ground-fault protection** is used in the protection function group **Standard UI**. The function depends upon application in the corresponding application template preconfigured by the manufacturer or can be copied during the engineering into the corresponding function group.

The function **Restricted ground-fault protection** is stepless.

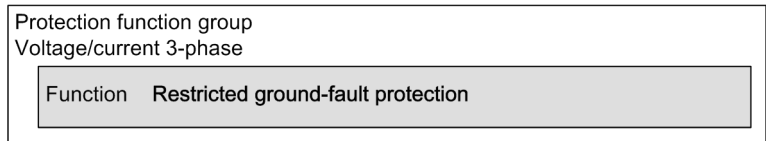

[dw_stru_pt_2_en_US]

Figure 6-263 Structure/Embedding of the Function

6.44.3 Function Description

Logic of the Function

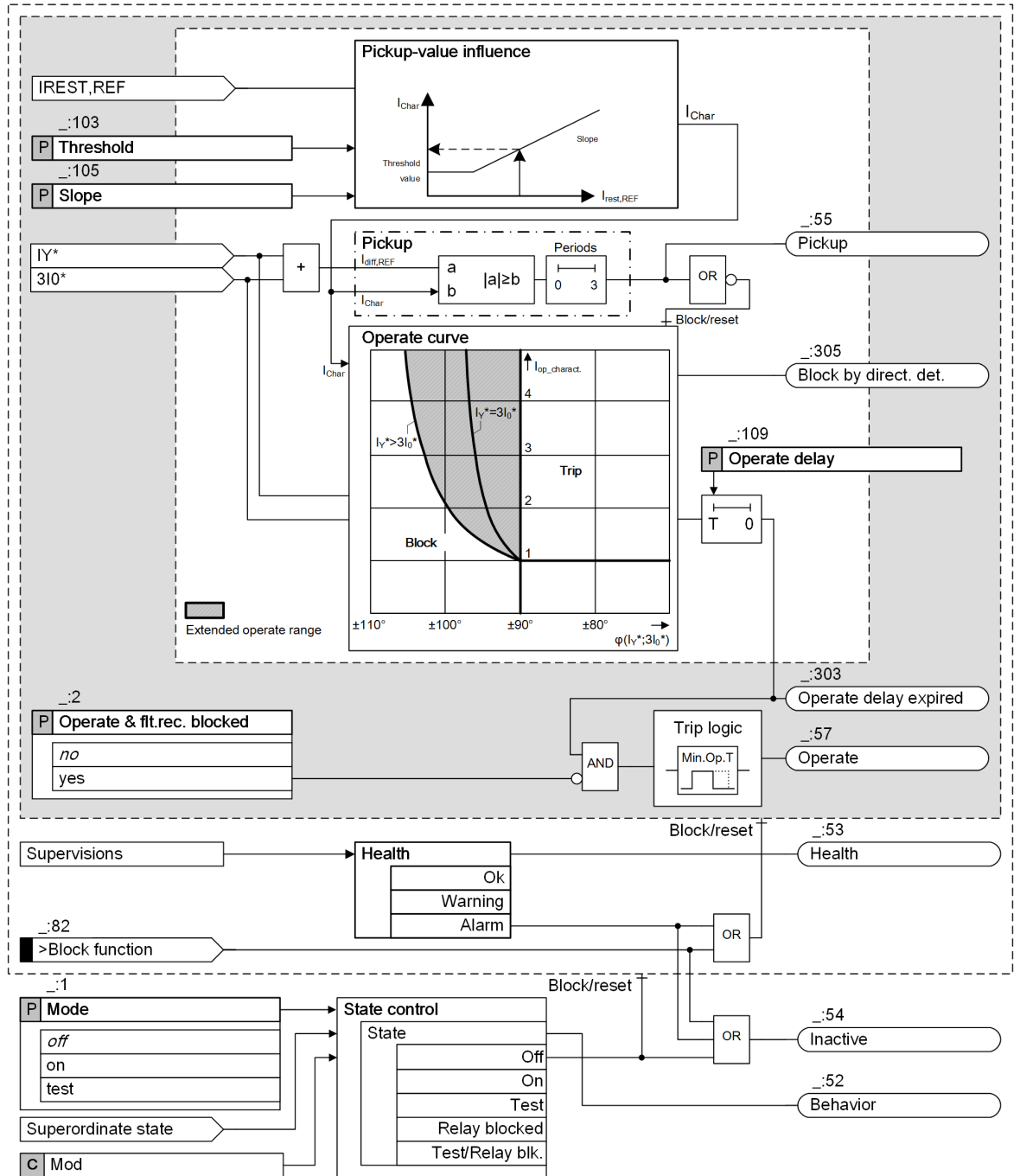

[to_refkt, 4, en_US]

Figure 6-264 Logic Diagram of the Restricted Ground-Fault Protection Function

The protection function processes the neutral-point current I_Y^* and the zero-sequence current $3I_0$ calculated from the phase currents (see following figure). The amount-adapted (compensated) currents are described by the * symbol. They are normalized to the rated object current of the respective side. The protection range extends exclusively over the transformer winding, including current transformer.

In case of an internal ground fault, the zero-sequence currents flow to the fault location. With an external ground fault, the fault current inverts itself in the phase current transformers. In this way, the direction of current flow serves as the decisive criterion for an internal fault.

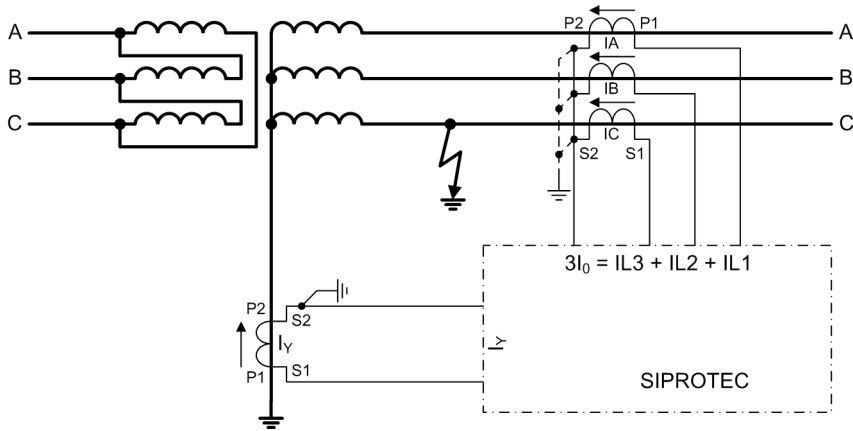

[dw_grdpri_2_en_US]

Figure 6-265 Basic Principle of the Function



NOTE

Consider the polarity of the current transformers. It must be set in accordance with the connection type. Connect the neutral point to the 3-pole measuring points on the device side using the even-numbered terminals.

The protection function operates in 3 steps according to the logic diagram [Figure 6-264](#):

- Effect of pickup value:
Increasing the set pickup threshold using the restraint current. This prevents overfunction in the event of high-current external ground faults.
- Pickup:
If the calculated current $I_{Diff,REF}$ exceeds the adapted pickup threshold, pickup starts.
- Operate curve based on phase-angle difference:
The angle difference between the neutral-point current (I_Y^*) and the calculated zero-sequence current ($3I_0^*$) in the operate curve is taken into consideration to differentiate between internal and external faults.

Effect of Pickup Value

The restraint current ($I_{Rest,REF}$) is calculated from the measured currents. The reference arrows are defined as positive when pointing to the protected object (see [Figure 6-265](#)). Consider that the neutral-point current (I_Y) detected using the 1-phase measuring point is displayed as positive in the fault record and in the DIGSI 5 Test Suite if the current flows from the protected object to ground.



NOTE

The following calculation applies to the configurations with one current measuring point for the side. In a special case of 2 current measuring points per side, the calculation of the restraint current must be performed in greater detail.

$$I_Y^* = k_{yx} \cdot 3I_Y$$

$$3I_0^* = k_{sx} \cdot (I_A + I_B + I_C)$$

with

$k_{yx} = I_{N,transformerY} / I_{N,side}$ with the secondary current measured in the neutral point (Y)

$k_{sx} = I_{N,transformerS} / I_{N,side}$ with the secondary current measured on the transformer side (S)

$$I_{Diff,REF} = |I_Y^* + 3I_0^*|$$

$I_{Rest,REF} = |I_Y^*| + |I_A^*| + |I_B^*| + |I_C^*|$ with all currents normalized to the rated object current

where:

I_Y	Measured zero-sequence current at neutral point
k_{yx}	Factor for magnitude adaptation (neutral point)
k_{sx}	Factor for magnitude adaptation (side)
$I_{N,transformer}$	Primary transformer rated current
$I_{N,side}$	Primary rated current of the transformer side (rated object current)
$I_{Diff,REF}$	Differential current
$I_{Rest,REF}$	Restraint current

Using the calculated restraint current, a current I_{Char} which represents the pickup value for the tripping is determined from the characteristic curve (Figure 6-266). In this way, the protection function is stabilized in the event of external, multiphase ground faults, for example, a 2-pole ground fault. This means that the protection function becomes less sensitive.

If the **Slope = 0** is set here (as an exception), the set **Threshold** of the operate curve is passed regardless of the restraint current.

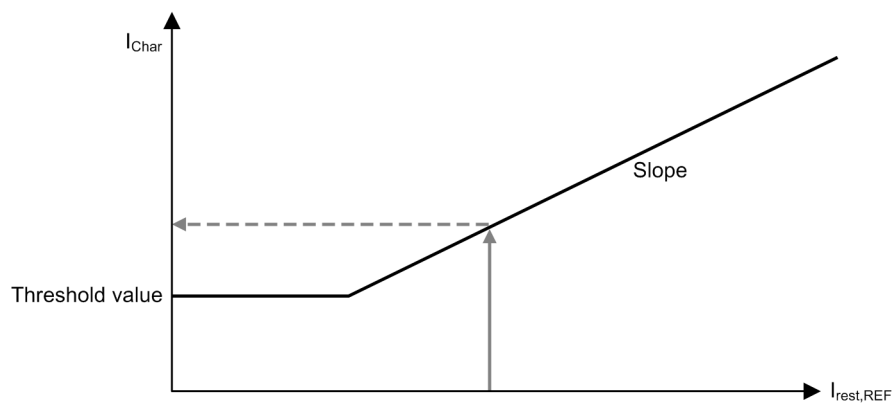

[dw_stab_ke, 2, en_US]

Figure 6-266 Stabilized Characteristic Curve

The ratio between the neutral-point current and the value for the current I_{Char} determined from Figure 6-266 is observed in the operate curve.

$$I_{op_charact} = \frac{|I_Y^*|}{I_{Char}}$$

[fo_trip current, 1, en_US]

Pickup

If the $I_{Diff,REF}$ calculated differential current exceeds the calculated current I_{Char} (see Figure 6-264), pickup occurs and the internal processing is enabled. The pickup is indicated.

Operate Curve Based on Phase-Angle Difference

The operate curve represented in the following figure consists of 2 parts. In the right part of the characteristic curve (angle magnitude $\leq 90^\circ$), you will find the case of an **internal ground fault**. Under ideal conditions, the angle between the evaluated currents ($\angle(I_Y^*, 3I_0^*)$) equals 0 in the event of an internal fault. In the right section of the characteristic curve (internal fault), the trip threshold for the current $I_{op_charact}$ is >1 .

If the measured current on the transformer side yields only a very small $3I_0^*$ amount, there is no sense in determining the angle difference. If, in the event of an internal fault, a small $3I_0^*$ current simulates an angle error due to a measuring error, the **extended operate range** allows reliable tripping with an angle difference of $>90^\circ$.

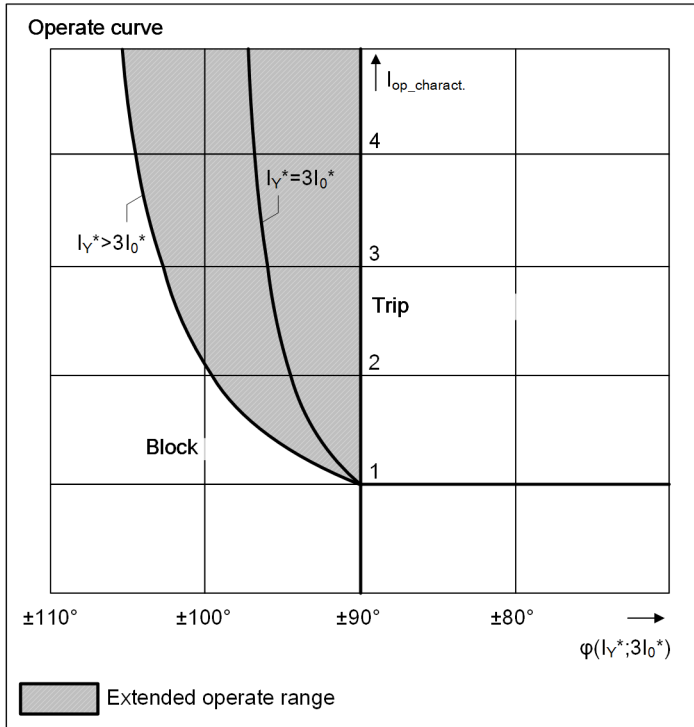

[dw_ausken, 3_en_US]
 Figure 6-267 Operate Curve Depending on the Phase Angle



NOTE

The characteristic curve shown in [Figure 6-267](#) shows the limit of the tripping range with the angle criterion. The **extended operate range** is shown symbolically for 2 conditions:

- Condition 1: $|I_Y^*| = |3I_0^*|$
- Condition 2: $|I_Y^*| = 3 \cdot |3I_0^*|$

The characteristic curve $|I_Y^*| = |3I_0^*|$ is the angle limit of the extended operate range for this condition.

In the event of an external fault with $|I_Y^*| = |3I_0^*|$, the phase angle is between I_Y^* and $3I_0^* \approx 180^\circ$.

If a measuring error now changes the angle and this angle error is $<80^\circ$, unwanted tripping does not occur. In [Figure 6-267](#), that is the section to the left of 100° .

If, for example, the ratio is $|I_Y^*| \gg |3I_0^*|$, tripping is theoretically not possible for an angle difference of 180° . This is the case if no fault current is flowing on the transformer side and the current $3I_0^*$ results from a measuring error. With the **extended operate range**, internal faults are cleared in a secured way.

In case of an **external ground fault**, the zero-sequence current calculated from the phase currents reverses by 180° . The phase angle between the zero-sequence currents thus ($\angle(I_Y^*, 3I_0^*)$) equals $\pm 180^\circ$. They are located in the left part of the operate curve and detect a clearly increased tripping limit.

As specified in [Figure 6-267](#), the characteristic-curve limit with regard to the angle specification on the x-axis depends on the ratio $|I_Y^*|$ to $|3I_0^*|$. If the amounts differ, the characteristic curve shifts.

The current $I_{Angle,REF}$ for the **Angle decision** is determined from the following subtraction and summation:

$$I_{Angle,REF} = |I_Y^* - 3I_0^*| - |I_Y^* + 3I_0^*|$$

The resulting current $I_{Angle,REF}$ results from the respective fault conditions, which are illustrated in the following figure. With an internal fault (angle difference $\approx 0^\circ$) a value results for $I_{Angle,REF}$ that has a negative sign. The sign remains negative, even when angle errors occur. The amount of $I_{Angle,REF}$ decreases.

With an external short circuit ($\approx 180^\circ$), the value of $I_{Angle,REF}$ becomes positive. The current $I_{Angle,REF}$ remains positive, even if an angle error occurs. The amount also decreases.

The following figure shows this for $I_{Angle,REF} = (-Term) - (+Term)$.

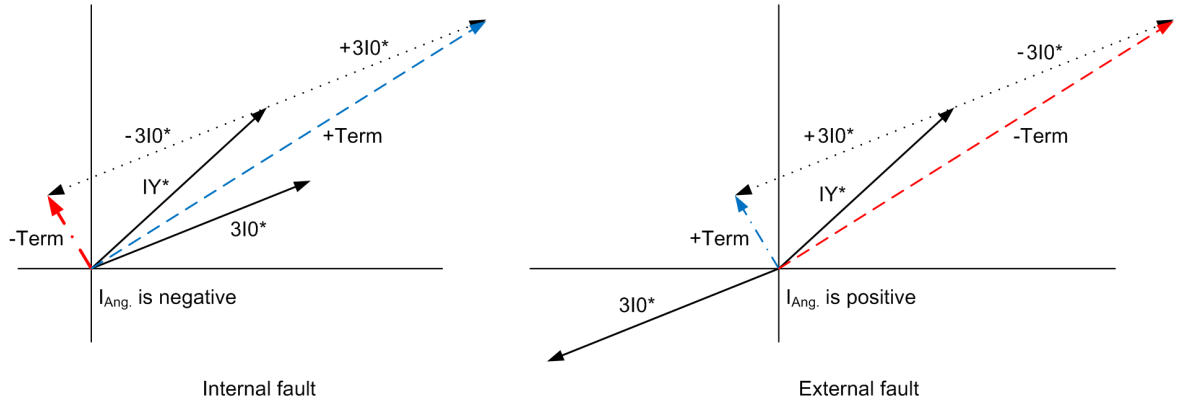

[dvw_angle-decision_for_external-faults, 1, en_US]

Figure 6-268 Angle Decision in Internal and External Faults

For tripping to occur, the neutral-point current I_{LY}^* must reach the value $I_{REF,Trip}$.

The following table shows the relationship between angle magnitude $\phi(I_{LY}^*, 3I_{L0}^*)$, angle dimension $I_{Angle,REF}$ and trip variable $I_{REF,Trip}$

Angle Magnitude $\phi(I_{LY}^*, 3I_{L0}^*)$	Angle Dimension $I_{Angle,REF}$	Trip Variable $I_{REF,Trip}$	Comments
$0^\circ < \phi \leq 90^\circ$	$I_{Angle,REF} = 0$	$I_{REF,Trip} = I_{LY}^* $	Internal fault
$90^\circ < \phi < 180^\circ$	$I_{Angle,REF} > 0$	$I_{REF,Trip} = \max(0, I_{LY}^* - k_{REF} I_{Angle,REF})$	Normal operation or external fault

where:

k_{REF} Factor (permanently set to 4.05657)
With this value, the limit angle at $|I_{LY}^*| = |3I_{L0}^*|$ is precisely 100° . No tripping is possible from this angle on.

The following figure shows an example of the effect on the **extended operate** by the different ratio I_Y^* to $3I_0^*$ ($I_{rest,REF}$ is not considered in the representation).

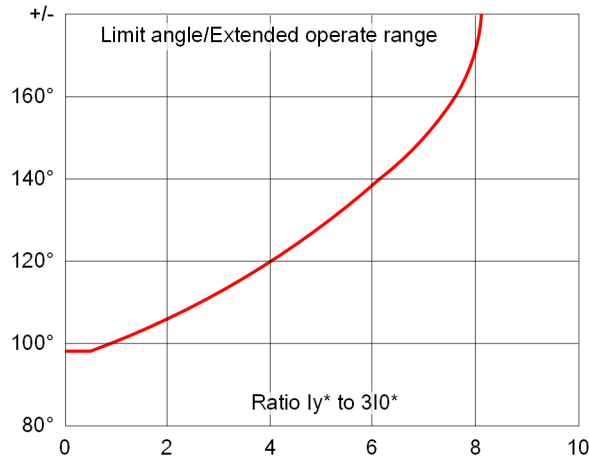

[idw_angle_trip_relationship_1_en_US]

Figure 6-269 Ratio I_Y^* to $3I_0^*$

Tripping is possible for each angle from a ratio of I_Y^* to $3I_0^*$ > 8.2.

Functional Measured Values

Measured Value	Description
(_:306) I REF,operate	Operate quantity of the restricted ground-fault protection from the angle criterion and can be displayed in the fault record
(_:307) I Angle,REF	Stabilizing value (angle) of the restricted ground-fault protection from the angle criterion and can be displayed in the fault record
(_:311) I REF,Trip operate	Operate quantity of the restricted ground-fault protection when OFF; will be issued in the log
(_:312) I angle,REF operate	Stabilizing value of the restricted ground-fault protection when OFF; will be issued in the log
(_:301) I diff.	Differential current; can be displayed in the fault record
(_:302) I restr.	Restraint current; can be displayed in the fault record

You can find the measured values for the **Restricted ground-fault protection** under the following device menu items:

- Main menu → Measurements → function → Function values → 87N REF

6.44.4 Application and Setting Notes



NOTE

You can determine the setting limits for the threshold values as follows (the adaption is done automatically and a setting is only possible within the permissible range):

Lower limit:

$$\text{Threshold value} \geq \max \{ 0.05 I/I_{\text{rated},S}; 0.05 I/I_{\text{rated},S} * I_{\text{prim transf. max}} / I_{\text{rated, protected object}} \}$$

Upper limit:

$$\text{Threshold value} \leq \min \{ 2.00 I/I_{\text{rated},S}; 100.00 I/I_{\text{rated},S} * I_{\text{prim transf. max}} / I_{\text{rated, protected object}} \}$$

The value $0.05 I/I_{\text{rated},S}$ is the minimum possible setting value and $2.00 I/I_{\text{rated},S}$ the maximum possible. $I_{\text{prim,transf. max}}$ is the largest transformer current and $I_{\text{rated,protected object}}$ the protected object rated current (reference current) $100.00 I/I_{\text{rated},S}$ is the upper measurement limit.

The adaptation of the setting limits is done automatically. In addition, a setting is prevented outside of these limits.

In the following, typical applications are described for the restricted ground-fault protection.

Protection of a Solidly Grounded Star Winding (Y Side)

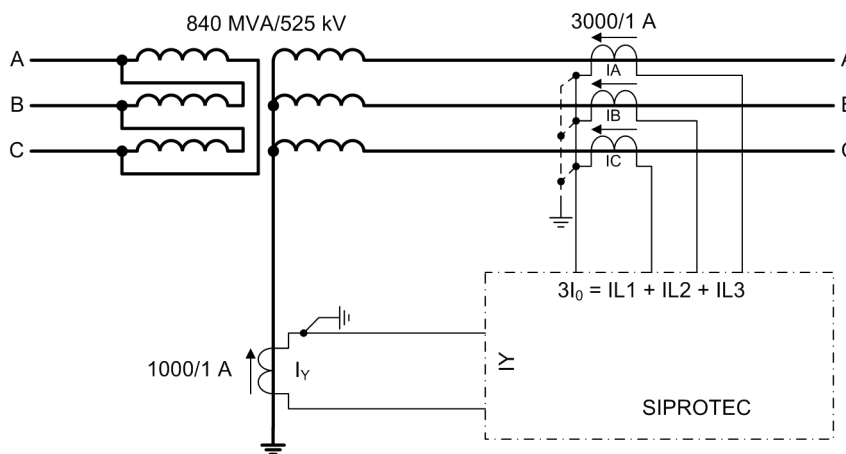

[dw_anster, 3, en_US]

Figure 6-270 Application Star Side

This application is a standard application. Here the phase currents of one side and the neutral-point current are processed. The function is located in the **Transformer Side** function group.

The following figure shows the structural division of the function. The restricted ground-fault protection gets its measurands from the current transformers, which are connected to the **Transformer side** function group. The neutral-point current is guided via the **Transformer neutral point** function group to the **Transformer side** function group. The current I_Y measured at the neutral point is inverted by 180° in the fault record (COMTRADE). This is due to the fact that, for a Holmgreen connection, the summation current flows via the terminal with an even connection number, and for a 1-phase connection, it flows via the terminal with an uneven connection number. To be compatible with SIPROTEC 4 (including reference arrow definition of the restricted ground-fault protection), in addition to the magnitude scaling of the neutral-point current, a rotation of the polarity (phase rotation by 180°) is also carried out in the function group **Transformer neutral point**.



NOTE

The fault record indicates the analog traces according to the connection. For this reason, the neutral-point current is shown rotated by 180° in comparison to SIPROTEC 4. This is due to the fact that, for a Holmgreen connection, the summation current flows via the terminal with an even connection number, and for a 1-phase connection, it flows via the terminal with an uneven connection number.

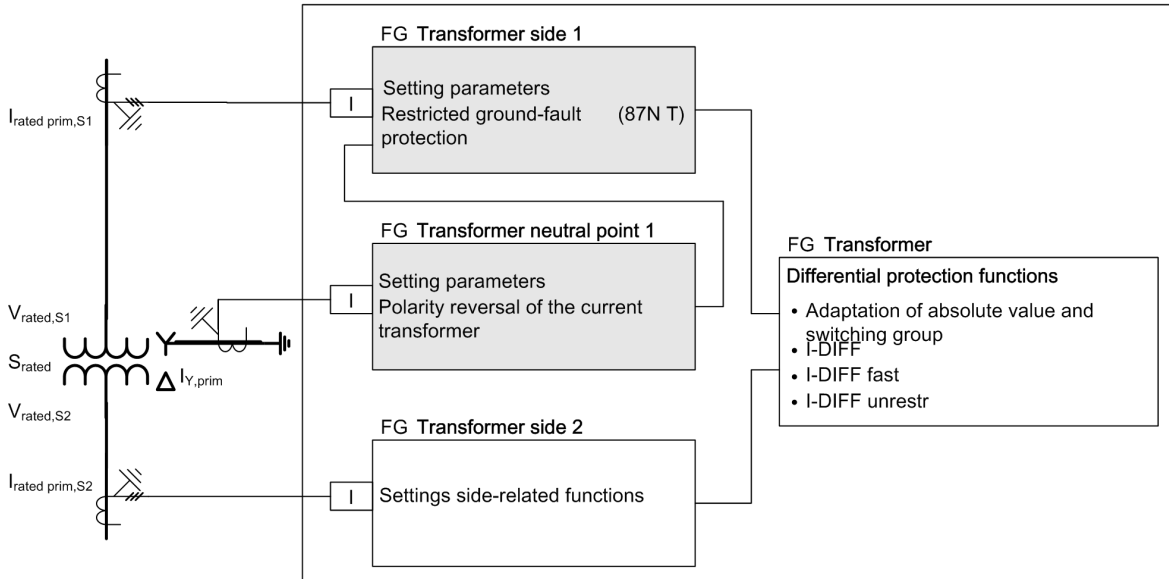

[dsw_2wtyde_3_en_US]

Figure 6-271 Function Group Structure of the Restricted Ground-Fault Protection

Explanations on the Connection and Current-Direction Definition

Uniform reference arrows and transformer burdens are defined for the SIPROTEC 5 device series. These agreements also apply to the transformer protection devices. The special handling of the neutral-point current described previously is a result of this.

Due to the current definition, the current in the direction of the protected object is always positive. For the 3-phase current-transformer connection, the representation in [Figure 6-272](#) and [Figure 6-273](#) applies. For a Holmgreen connection, the summation current is always generated with the neutral point at the terminals with even numbers. If a separate I_N is detected ([Figure 6-273](#)), for example, with a core balance current transformer, the current I_4 must have the same directional mode as in [Figure 6-272](#) with Holmgreen. The protected object is located to the right or left of the transformer set. The polarity in case of a 3-phase transformer connection is set with the neutral point (in the direction of the protected object or not). The following basic connections result from this.

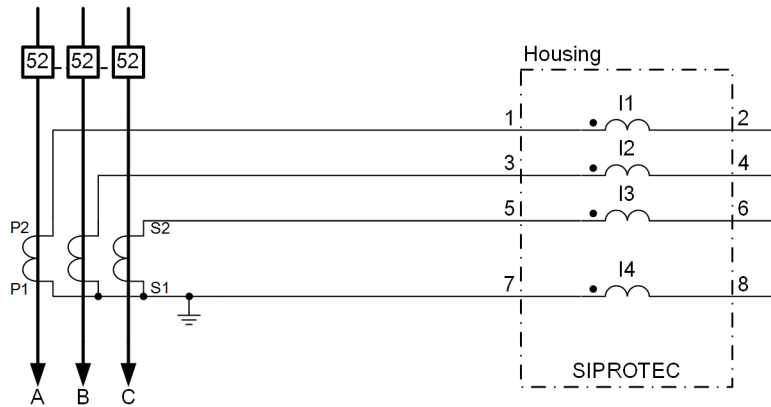

Current transformer 3-phase: connection = 3-phase + IN

[6_phase_2_4_en_US]

Figure 6-272 Current-Transformer Connection (1) According to Definition

or

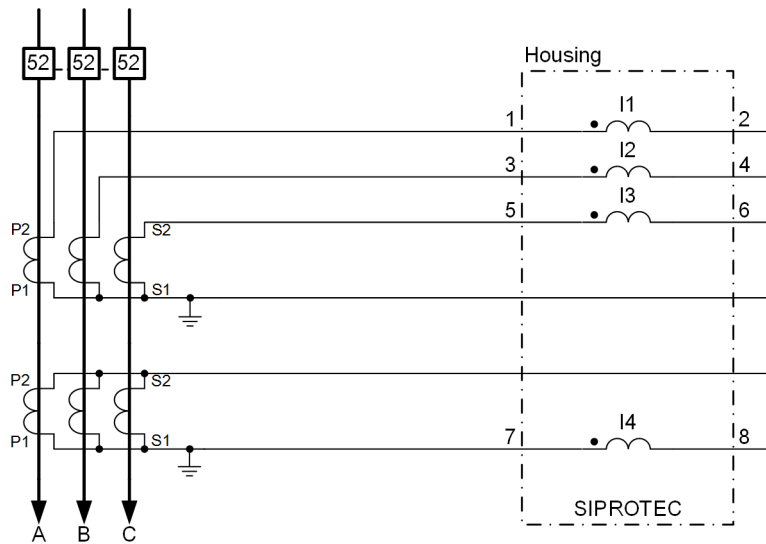

Current transformer 3-phase: connection = 3-phase + IN-separate

[tileite4-260313-01.tif_4_en_US]

Figure 6-273 Current-Transformer Connection (2) According to Definition

The following connection is defined for the transformer according to [Figure 6-274](#). The current flow for an external ground fault is entered at the same time. It is recognized that the secondary currents each flow from the device. From this, a differential current ($I_{\text{Diff, REF}} = |I_Y + I_{-A} + I_B + I_C| = |-I_4 - I_3|$) results, according to the reference arrow definition for the restricted ground-fault protection (positive to the protected object) with an external ground fault. To prevent that, the neutral-point current is rotated in the **Transformer neutral-point** function group. It follows that: $I_{\text{Diff, REF}} = |I_4 - I_3| = 0$.

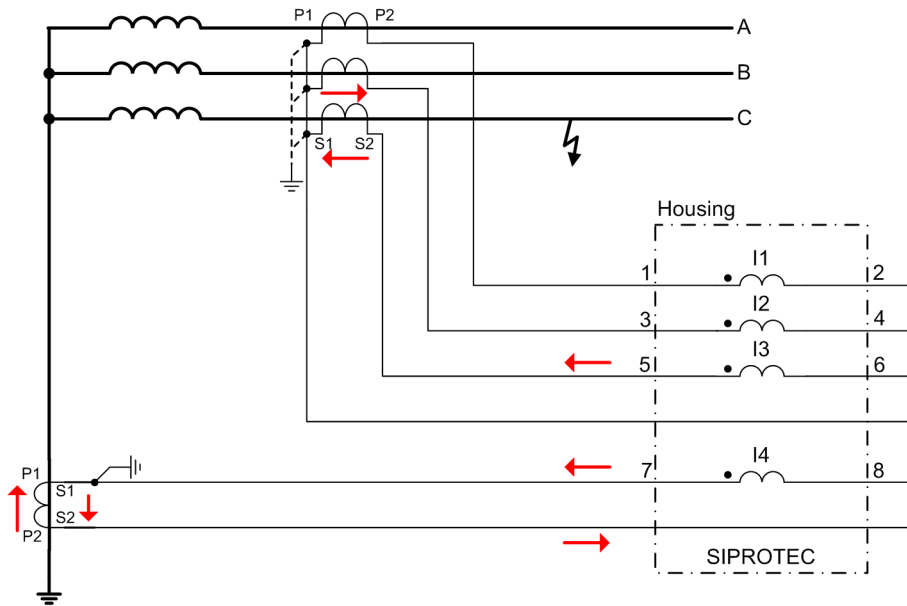

Current transformer 3-phase: connection = 3-phase

Current transformer 1-phase: connection = IN

[dw_stwnas, 2, en_US]

Figure 6-274 Current-Transformer Connection on the Transformer

The setting of the 1-phase measuring point based on the definition is carried out as follows:

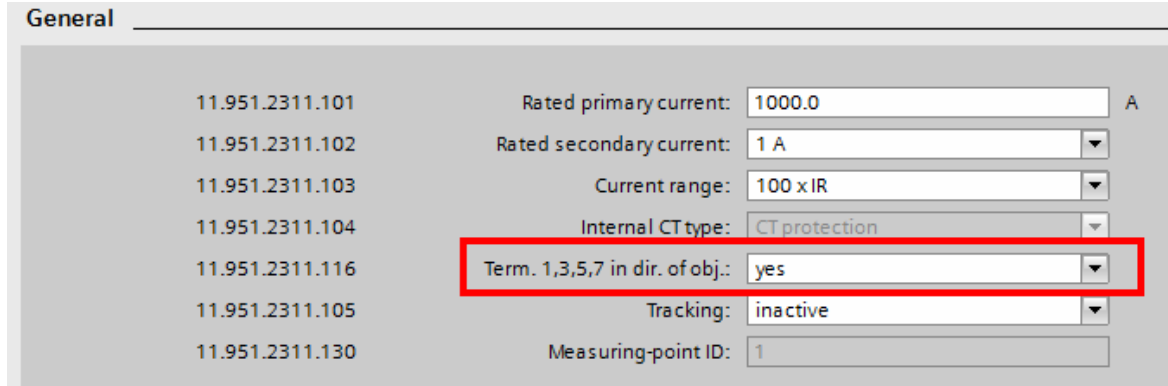

[scedsail-200214-01, 1, en_US]

Figure 6-275 DIGSI 5 Setting

The point in [Figure 6-274](#) describes the polarity of the current transformer. At the same time, the current terminal is designed so that this side is fed out on an odd number terminal point. Since in the SIPROTEC 5 system each current transformer can be assigned a 1-phase measuring point, the odd number terminal points are named in the setting parameters. According to [Figure 6-274](#), the setting must be **yes**.

- Default setting (`_:115`) **terminal 1,3,5,7 in dir.obj.= yes**

The polarity of the 3-phase transformer connection is always configured on the side of the terminals with even numbers for orientation of the neutral point.

Threshold Value

The following view can be used to derive the threshold value. The transformer is supplied, for example, via the delta winding and a 1-pole ground fault occurs on the star side.



NOTE

For estimation of the short-circuit current, note that the inductance changes quadratically with the winding and linearly with the voltage.

The right part in the following figure represents the fault current as a function of the fault location. The fault current curve I_{F1} shows that the longitudinal differential protection with faults near the neutral point has sensitivity problems due to the sinking current. On the other hand, the neutral-point current I_{F2} is sufficiently large. There is therefore no need to set the **Threshold** (current through the neutral point transformer) to sensitive.

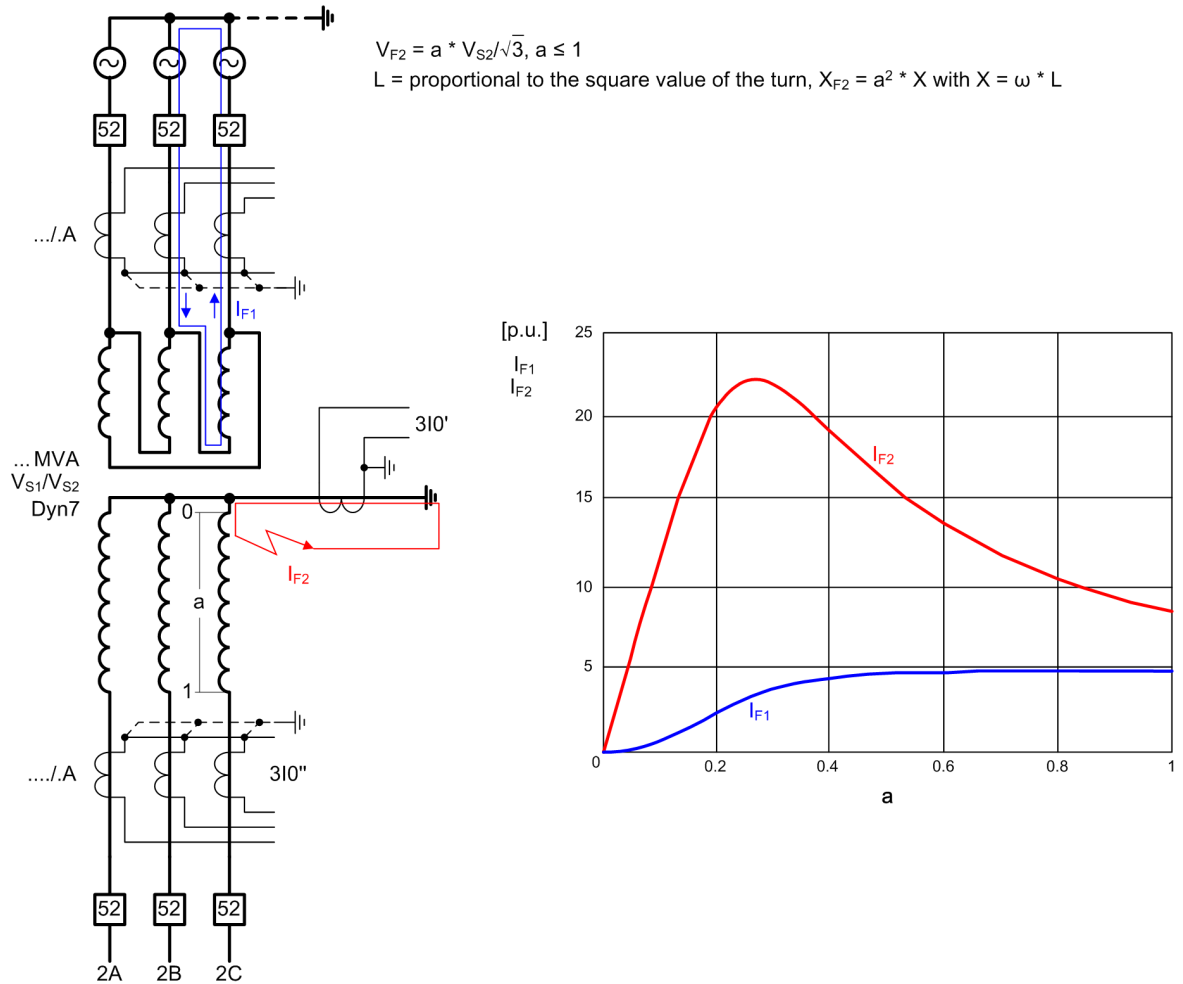

[dw_f1pole, 2, en_US]

Figure 6-276 Principal Fault Current Curves with a 1-Pole Ground Fault

- Recommended setting value (_:103) **Threshold = 0.2 I/I_{rated}, S**

The previously mentioned setting limits must be maintained during the setting process (refer to the following example):

$$\text{Threshold value} \geq 0.05 I/I_{\text{rated}}, S \cdot \frac{I_{\text{CT max,prim}}}{I_{\text{rated,side}}}$$

[fo_schwe1, 1, en_US]

The following lower limiting value results from the data from [Figure 6-270](#):

$$\text{Threshold value} \geq 0.05 I/I_{\text{rated},S} \cdot \frac{3000A}{924A} = 0.162 I/I_{\text{rated},S}$$

$$\text{with } I_{\text{object,side}} = \frac{S_{\text{rated}}}{\sqrt{3} V_{\text{rated}}} = \frac{840\text{MVA}}{\sqrt{3} 525\text{kV}} = 924A$$

[fo_schwe2, 1, en_US]

The recommended setting value of $0.2 I/I_{\text{rated},S}$ lies above it.

- Recommended setting value (_:105) **Slope = 0.07**

You can stabilize the protection function with external multiphase short-circuits to ground with the parameter **Slope**. To determine the setting value, no pickup value increase can occur up to the rated current. After this, the gradient must be active. To derive the gradient, it is assumed that continuation of the straight line must go through the coordinate origin (see [Figure 6-277](#)). Determine the intersection from the threshold value and the restraint current at rated current. Calculate the gradient as follows:

$$I_{\text{rest,REF}} = |I_0^*| + |I_A| + |I_B| + |I_C| = 0 + 3 I/I_{\text{rated},S} = 3 I/I_{\text{rated},S}$$

$$\text{Slope} = \frac{\text{Threshold value}}{I_{\text{rest,REF}}} = \frac{0.2 I/I_{\text{rated},S}}{3 I/I_{\text{rated},S}} = 0.07$$

[fo_stbref, 2, en_US]

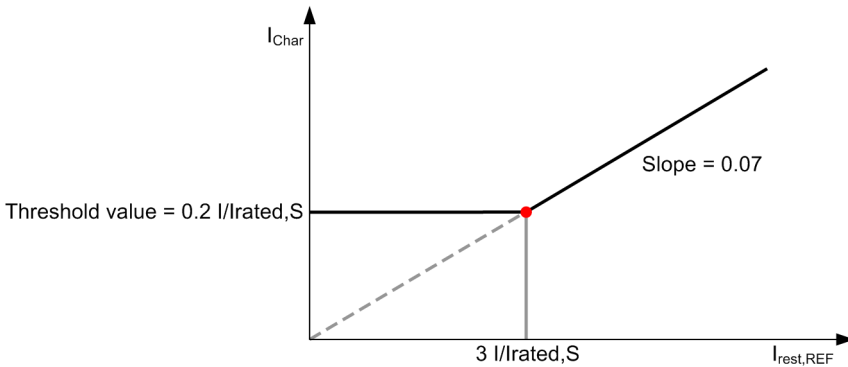

[dw_steiga, 3, en_US]

Figure 6-277 Derivation of the Setting Value for the Gradient

Protection of a Resistance-Grounded Star Winding (Y Side)

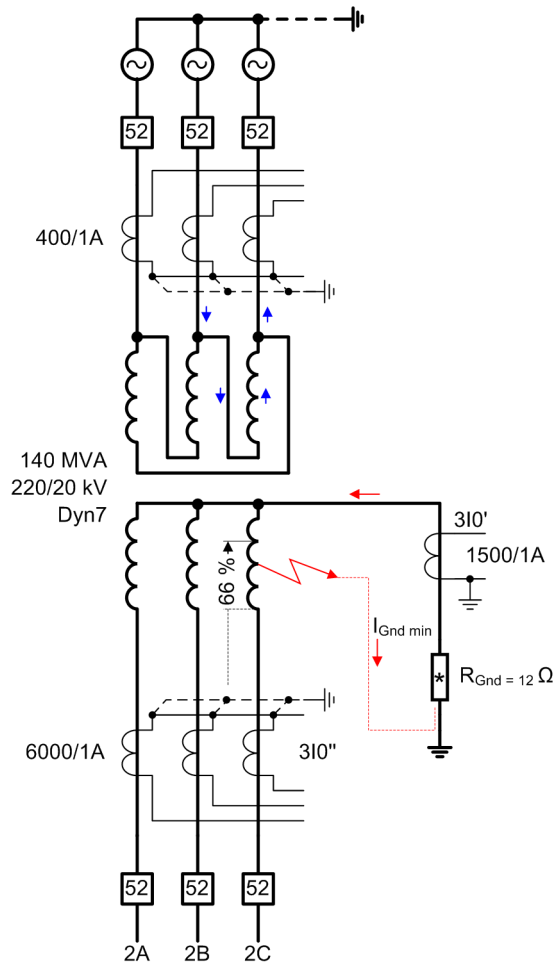

[dw_ref_spa, 1, en_US]

Figure 6-278 Application with Resistance-Grounded Neutral Point

The pickup values can be derived from the example data in [Figure 6-278](#). As side rated value, the following results:

$$140 \text{ MVA} / (\sqrt{3} \cdot 20 \text{ kV}) = 4042 \text{ A}$$

The following threshold value results as lower limit:

$$\text{Threshold value} \geq 0.05 I/I_{\text{rated},S} \cdot \frac{6000 \text{ A}}{4042 \text{ A}} = 0.07422 I/I_{\text{rated},S}$$

$$\text{with } I_{\text{object,side}} = \frac{S_{\text{rated}}}{\sqrt{3} \cdot V_{\text{rated}}} = \frac{840 \text{ MVA}}{\sqrt{3} \cdot 525 \text{ kV}} = 924 \text{ A}$$

[fo_schwe3, 1, en_US]

So that the function is responsive, select a setting value of 0.08 I/I_{rated,S}.

- Recommended setting value (_ :103) **Threshold = 0.08 I/I_{rated,S}**

As slope, the following results:

$$\text{Slope} = \frac{\text{Threshold value}}{I_{\text{rest,REF}}} = \frac{0.08 I/I_{\text{rated},S}}{3 I/I_{\text{rated},S}} \approx 0.03$$

[fo_steig1, 2, en_US]

- Recommended setting value (**_ :105**) **Slope = 0.03**

Because of the grounding resistance R_E reduced protection range results. This can be estimated as follows: The grounding resistance is much larger than the winding reactance, thus the following maximum ground current results:

$$I_{\text{gnd max}} = 20 \text{ kV} / (\sqrt{3} \cdot 12 \Omega) = 962 \text{ A}$$

You can determine the minimum tripping current from the setting value:

$$I_{\text{gnd min}} = \text{side rated current} \cdot \text{threshold value} = 4042 \text{ A} \cdot 0.08 = 323 \text{ A}$$

Thus, the following protection range results:

$$\text{Protection range} = 1 - \frac{I_{\text{gnd min}}}{I_{\text{gnd max}}} = 1 - \frac{323 \text{ A}}{962 \text{ A}} = 0.664$$

[fo_schwe4, 1, en_US]

The attainable protection range amounts to approx. 66.4 %. In order to capture ground faults near the neutral point, it is also recommended to connect a sensitive ground current protection to the neutral point transformer. You must coordinate its operate time with the line protection.



NOTE

Ensure that the protection range further limits itself with larger neutral-point resistances, or the restricted ground-fault protection can no longer be used.

Protection with Neutral Reactors on the Delta Side

To produce ground currents on the delta side of a transformer, neutral reactors (zigzag reactors) are used. A resistance for ground current limitation can also be present. In this case, the resistance is much greater than the reactor and delta reactance of the transformer. The following figure shows a typical implementation. The restricted ground-fault protection works between output-sided phase current transformers and the current transformer in the neutral point of the neutral reactor.

In the example, the fault current curve with the ground fault in a delta winding is also represented. The fault location at which the lowest fault current flows can also be seen. This current influences the protection setting set close.

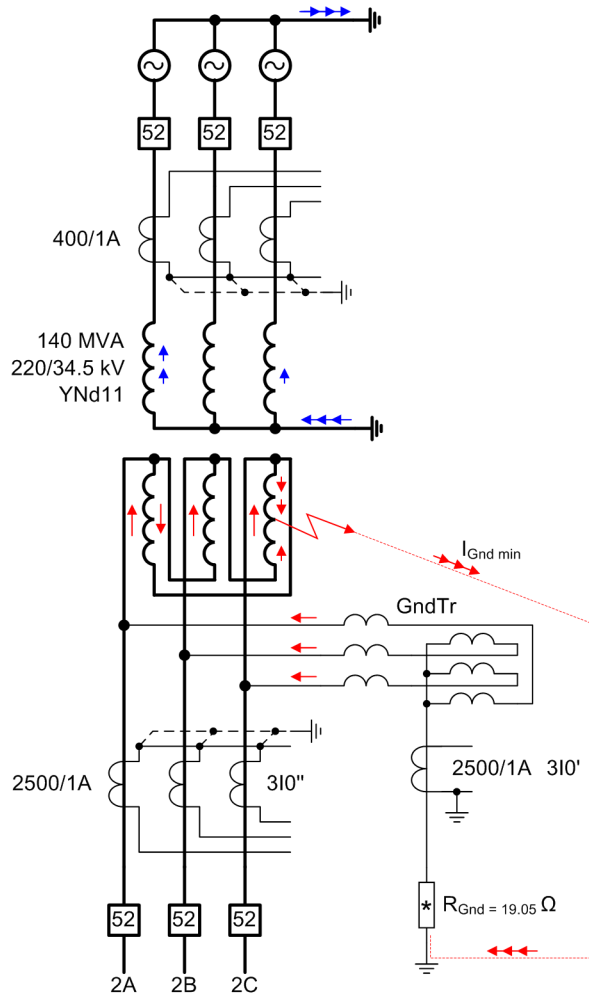

[dw_strpkt, 1, en_US]

Figure 6-279 Application with Neutral Reactor

As side rated value, the following results:

$$140 \text{ MVA} / (\sqrt{3} \cdot 34.5 \text{ kV}) = 2343 \text{ A}$$

You can thus define the lower limit for the threshold value:

$$\text{Threshold value} \geq 0.05 \text{ I/I}_{\text{rated,S}} \cdot \frac{2500 \text{ A}}{2343 \text{ A}} = 0.06 \text{ I/I}_{\text{rated,S}}$$

[fo_schwe5, 1, en_US]

If the fault is in the middle of the winding, as shown in [Figure 6-279](#), the minimum ground current will arise.

The driving voltage is:

$$V_{\text{gnd min}} = V_{\text{rated,S2}} / (2 \sqrt{3}) = 34.5 \text{ kV} / (2 \sqrt{3}) = 9.96 \text{ kV}$$

The following minimum ground current results:

$$I_{\text{gnd min}} = V_{\text{gnd min}} / R_{\text{gnd}} = 9.96 \text{ kV} / 19.05 \Omega = 523 \text{ A}$$

With reference to the side rated current, the relationship is:

$$I_{\text{gnd min}} / I_{\text{rated,S}} = 523 \text{ A} / 2343 \text{ A} = 0.223$$

With a safety margin of 2, $0.223/2 = 0.1115$ is the result. Select this value as threshold value (rounded: $0.12 \text{ I/I}_{\text{rated,S}}$).

- Recommended setting value (_:103) **Threshold = 0.12 I/I_{rated,S}**

As slope, the following results:

$$\text{Slope} = \frac{\text{Threshold value}}{I_{\text{rest,REF}}} = \frac{0.12 I/I_{\text{rated,S}}}{3 I/I_{\text{rated,S}}} \approx 0.04$$

[fo_steig2, 2, en_US]

- Recommended setting value (_:105) **Slope = 0.04**

Protection of a Shunt Reactor

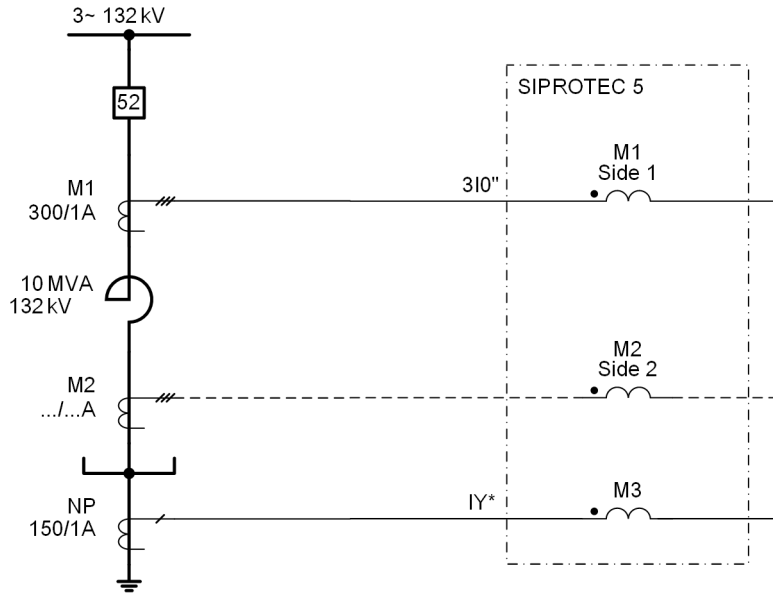

[dw_anquer, 2, en_US]

Figure 6-280 Application with Neutral Reactor

As side rated value, the following results:

$$10 \text{ MVA} / (\sqrt{3} \cdot 132 \text{ kV}) = 43.7 \text{ A}$$

You can thus define the lower limit for the threshold value:

$$\text{Threshold value} \geq 0.05 I/I_{\text{rated,S}} \cdot \frac{300 \text{ A}}{43.7 \text{ A}} = 0.343 I/I_{\text{rated,S}}$$

[fo_schwe6, 1, en_US]

Select 0.35 I/I_{rated,S} as threshold value.

- Recommended setting value (_:103) **Threshold = 0.35 I/I_{rated,S}**

There are no fault currents which could potentially lead to a current-transformer saturation flowing through the protection range of the shunt reactor. The characteristic curve therefore does not require an increased value for stabilization (parameter (_:11041:100) **Slope 1**). You can set the operate curve very flat since there are no transient faults due to magnetization, transformer tap changers, or transformer faults. Siemens recommends a minimum slope of 0.05.

- Recommended setting value (_:105) **Slope = 0.05**

6.44.5 Settings

6.44.6 Information List

No.	Information	Data Class (Type)	Type
87N REF #			
_:82	87N REF #:>Block function	SPS	I
_:54	87N REF #:Inactive	SPS	O
_:52	87N REF #:Behavior	ENS	O
_:53	87N REF #:Health	ENS	O
_:55	87N REF #:Pickup	ACD	O
_:57	87N REF #:Operate	ACT	O
_:303	87N REF #:Operate delay expired	ACT	O
_:305	87N REF #:Block by direct. det.	SPS	O
_:306	87N REF #:I REF,operate	MV	O
_:307	87N REF #:I Angle,REF	MV	O
_:311	87N REF #:I REF,Trip operate	MV	O
_:312	87N REF #:I angle,REF operate	MV	O
_:301	87N REF #:I diff.	MV	O
_:302	87N REF #:I restr.	MV	O

6.45 External Trip Initiation 3-Pole

6.45.1 Overview of Functions

The **External trip initiation** function:

- Processes any signals from external protection or supervision devices
- Enables the integration of any signals from external protection equipment in the indication and tripping processing, for example from transient ground-fault relays or Buchholz protection
- Enables direct tripping of the circuit breaker in conjunction with busbar-protection applications
- Enables direct tripping of the circuit breaker in the case of circuit-breaker failure at the other line end

6.45.2 Structure of the Function

The function **External trip initiation** includes one stage. You can instantiate the **External trip initiation** function in DIGSI 5 multiple times.

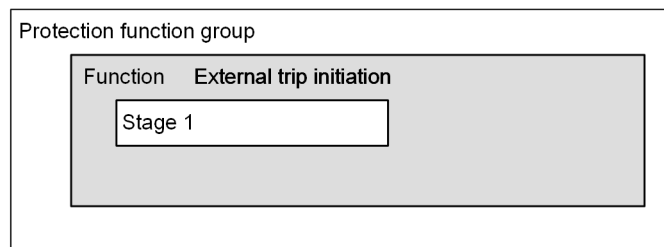

[dw_strext, 2, en, US]

Figure 6-281 Structure/Embedding of the Function

6.45.3 Stage Description

Logic of the Stage

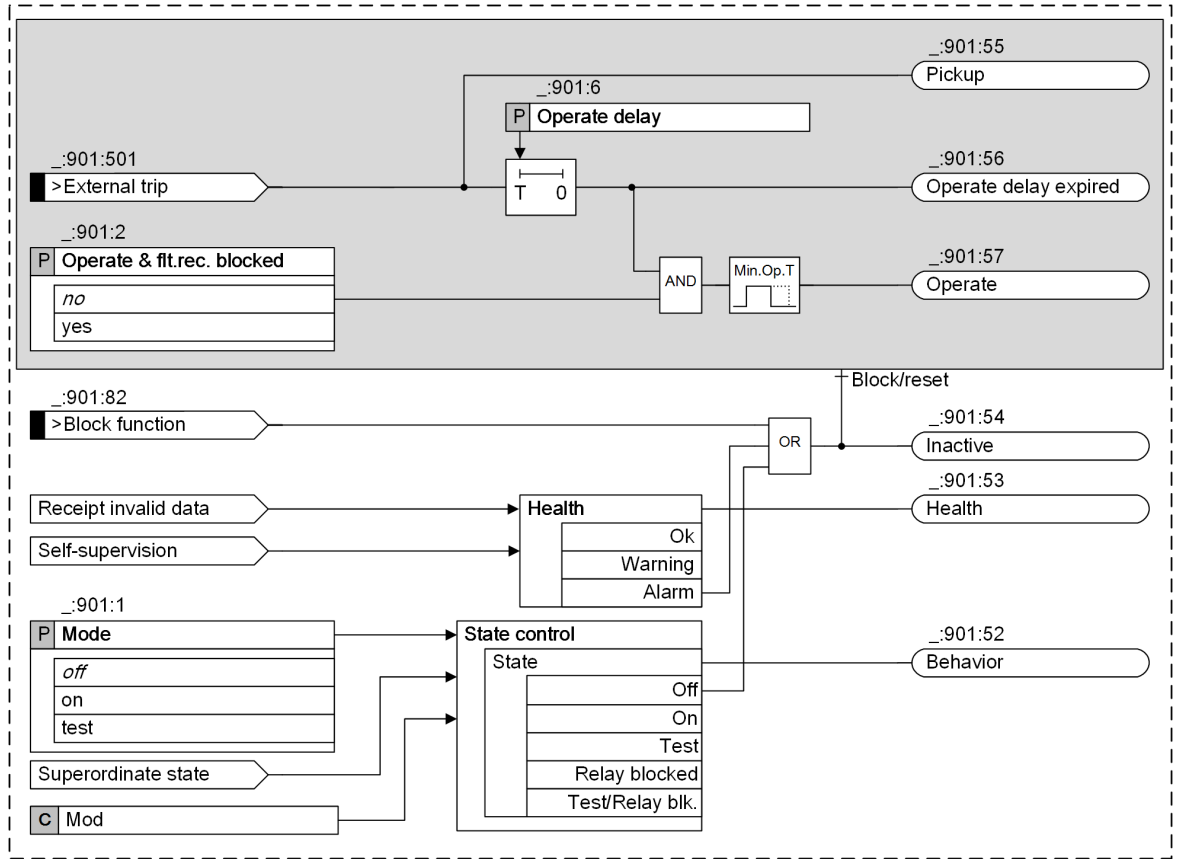

[lo_ext-trip-initiation, 3_en_US]

Figure 6-282 Logic Diagram for the External Trip-Initiation Stage

Binary Input Signal >External Trip

The binary input signal **>External trip** starts the **Pickup** and the **Operate delay**.

Blocking the Stage

The stage can be switched to ineffective via a number of signals. If the stage is in the pickup state at the time of blocking, it will be immediately reset. However, the operate indication remains stopped for the minimum operating time (**_:102**) **Minimum operate time**.

6.45.4 Application and Setting Notes

6.45.5 Settings

Addr.	Parameter	C	Setting Options	Default Setting
<i>Stage 1</i>				
_:901:1	Stage 1:Mode		<ul style="list-style-type: none"> • off • on • test 	on

Addr.	Parameter	C	Setting Options	Default Setting
_:901:2	Stage 1:Operate & flt.rec. blocked		<ul style="list-style-type: none"> • no • yes 	no
_:901:6	Stage 1:Operate delay		0.00 s to 60.00 s	0.00 s

6.45.6 Information List

No.	Information	Data Class (Type)	Type
Stage 1			
_:901:82	Stage 1:>Block function	SPS	I
_:901:501	Stage 1:>External trip	SPS	I
_:901:54	Stage 1:Inactive	SPS	O
_:901:52	Stage 1:Behavior	ENS	O
_:901:53	Stage 1:Health	ENS	O
_:901:55	Stage 1:Pickup	ACD	O
_:901:56	Stage 1:Operate delay expired	ACT	O
_:901:57	Stage 1:Operate	ACT	O

6.46 Automatic Reclosing Function

6.46.1 Overview of Functions

The Automatic reclosing function (ANSI 79/RREC)

- Automatically closes overhead lines after arc short-circuits
- Is only permissible for overhead lines, because only the possibility of self-activated extinguishing of an arc short-circuit exists here
- Can be controlled by integrated protection functions and by external protection devices
- The automatic reclosing can be controlled via an external automatic reclosing function via binary input signals.

The automatic reclosing function (AREC) takes over automatic reclosing after a switch off via a short-circuit protection. The following figure shows an example for the normal procedure with a two-time automatic reclosing where the 2nd automatic reclosing attempt is successful.

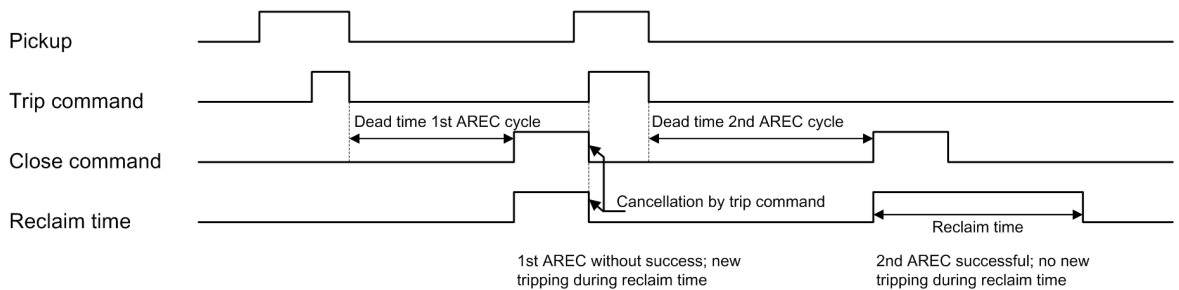

[dw_2awewz_1_en_US]

Figure 6-283 Process Diagram of a Two-Time Reclosing with Action Time (2nd AREC Successful)

The integrated Automatic reclosing function allows up to 8 reclosing attempts. Each of the 8 disruption cycles can work with different parameters.

The following figure shows an example for normal procedure with a two-time automatic reclosing after disconnection via the internal overload protection. The 2nd automatic reclosing attempt is successful.

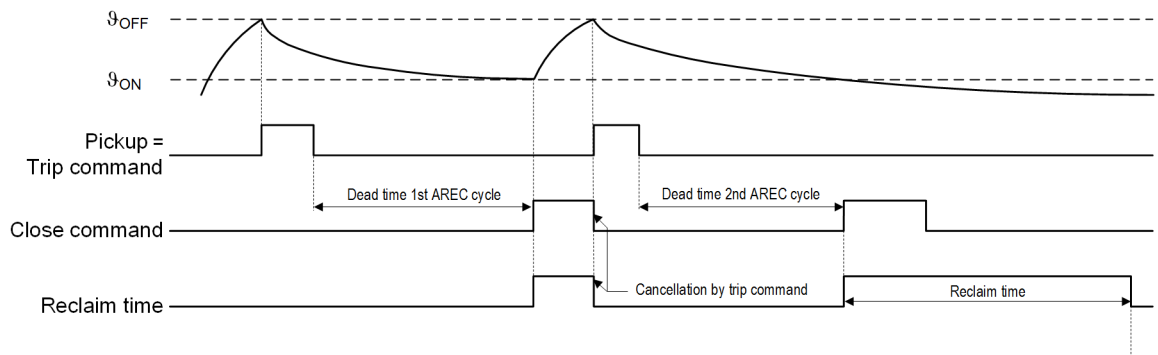

[dw_ablaufdiagramm_2-AWE-nach Abschalt-Thermo_1_en_US]

Figure 6-284 Process Diagram of a Two-Time Reclosing after Disconnection via Overload Protection

The integrated Automatic reclosing function allows up to 8 reclosing attempts here as well. In contrast to disconnection through the short-circuit protection, each of the 8 disruption cycles can work with its own parameters that are the same for all cycles.

6.46.2 Structure of the Function

The Automatic reclosing function is used in function groups for circuit breakers. In a function group for circuit breakers, one of the 3 types of functions illustrated in the following figures can be used. The Automatic reclosing function has a central function control.

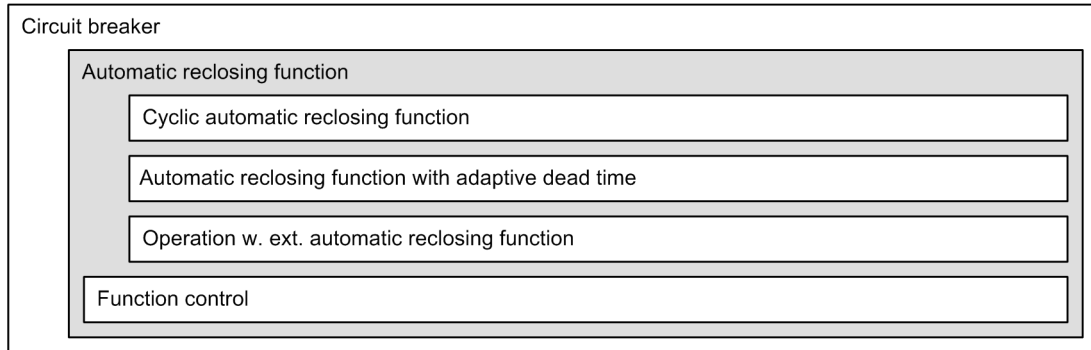

[dw_fkt_awe, 1, en_US]

Figure 6-285 Structure/Embedding of the Function

Cyclic Automatic Reclosing Function

The Cyclic automatic reclosing function ([Figure 6-286](#)) allows up to 8 reclosing attempts. Here each disruption cycle can work with different settings.

For the Cyclic automatic reclosing function, 1 cycle is preset. The preset cycle cannot be deleted. You can add and delete additional cycles from the function library in DIGSI 5.

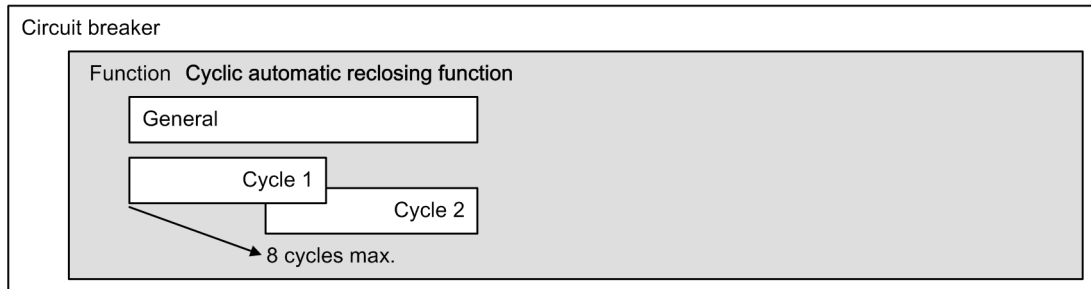

[dw_zyk_awe, 1, en_US]

Figure 6-286 Structure/Embedding of the Cyclic Automatic Reclosing Function

Automatic Reclosing Function with Adaptive Dead Time

The Automatic reclosing function with adaptive dead time (ADT) works without set disruption cycles ([Figure 6-287](#)). The requirement for the usage of ADT is that voltage transformers on the line-side are connected or there is a possibility for the transmission of a close command to a remote line end. With the ADT, the Automatic reclosing function decides independently if and when an automatic reclosing is reasonable and permissible and when it is not. The criteria is the phase-to-ground voltage, which is switched through after reclosing from the opposite line end. The Automatic reclosing function with ADT occurs as soon as it is known that the line from the opposite end has been placed back under voltage.

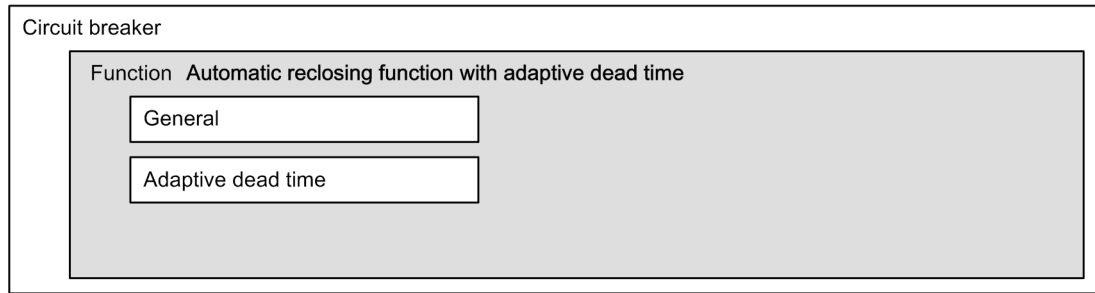

[dw_aveasp, 1, en_US]

Figure 6-287 Structure/Embedding of the Automatic Reclosing Function With Adaptive Dead Time (ADT)

Operation with External Automatic Reclosing Function

If an external reclosing device operates together with the SIPROTEC protection device, use the function type **Operation with external automatic reclosing function** (Figure 6-288). The function only provides binary inputs for the influence of the protection functions in the SIPROTEC protection device. The external reclosing device delivers the close command. The SIPROTEC protection functions then provide for the trip commands.

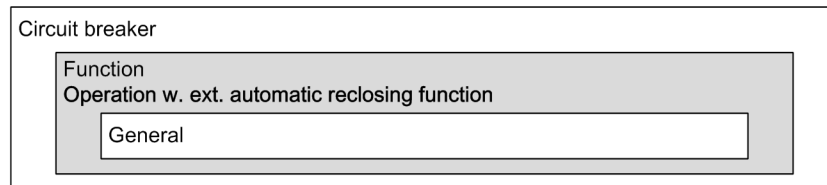

[dw_extawe, 1, en_US]

Figure 6-288 Structure/Embedding of the Operating Function With External Automatic Reclosing Function

Function Control

The Automatic reclosing function contains a central function control, see the following figure. You can find detailed information on the function control in the chapter **Function/Stage Control**.

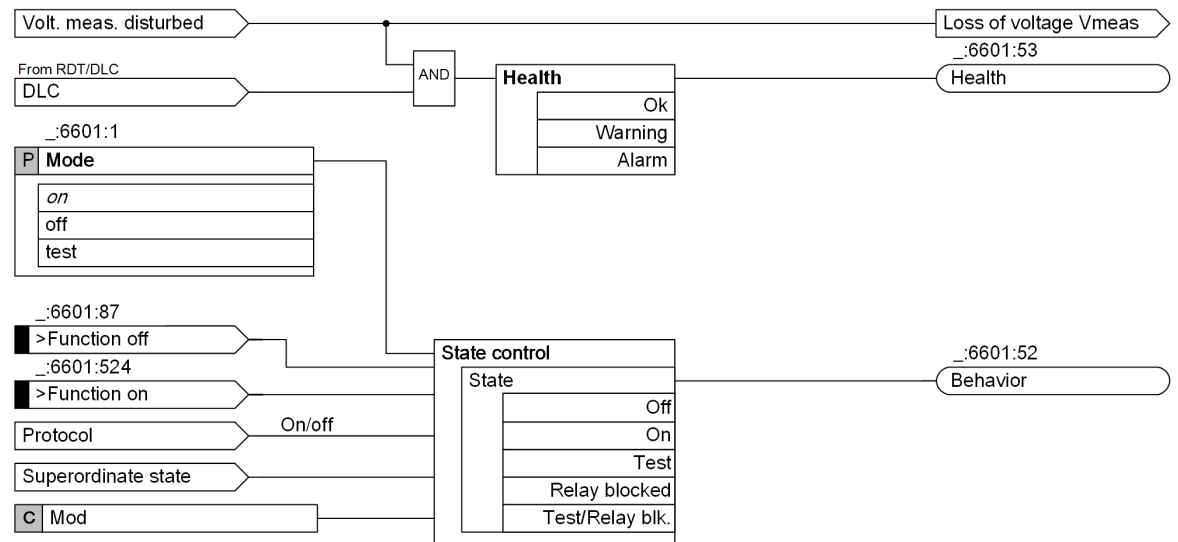

[fo_arc_fkt, 2, en_US]

Figure 6-289 Function Control for the Automatic Reclosing Function

6.46.3 Cooperation of the Automatic Reclosing Function and Protection Functions

The Automatic reclosing function (AREC) can be influenced by the protection functions in the following way:

- The AREC is started through pickup indications and operate indications by the selected protection functions or protection stages. The start depends on the set operating mode for the AREC.
- Individual protection functions or protection stages can be configured so that their operate indication blocks the AREC. If such a blocking exists, the AREC cannot be started. If the AREC is already started, the blocking will lead to the cancellation of the AREC.

The automatic reclosing device can thus have an influence on the effects of the protection functions. The following influence possibilities exist:

- The AREC provides signals that can be used by protection functions for the blocking or release of special stages or zones. An example is the release of overreaching zones with distance protection.

The configuration of the interaction between internal protection functions and automatic reclosing functions can be set separately for each protection function, see [Figure 6-290](#).

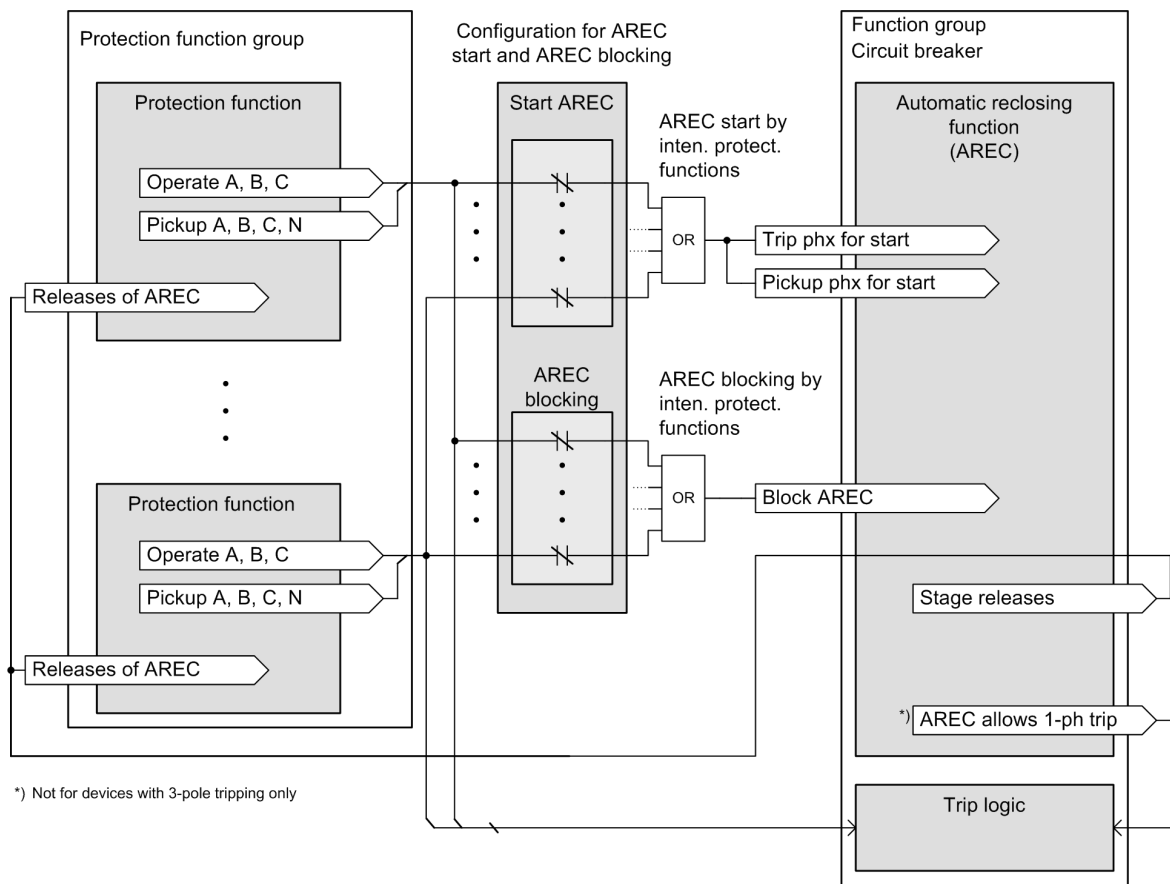

[lo_awsig, 1, en_US]

Figure 6-290 Signals between Protection Functions and Automatic Reclosing Functions

The configuration occurs in a matrix view in DIGSI, see the following figure.

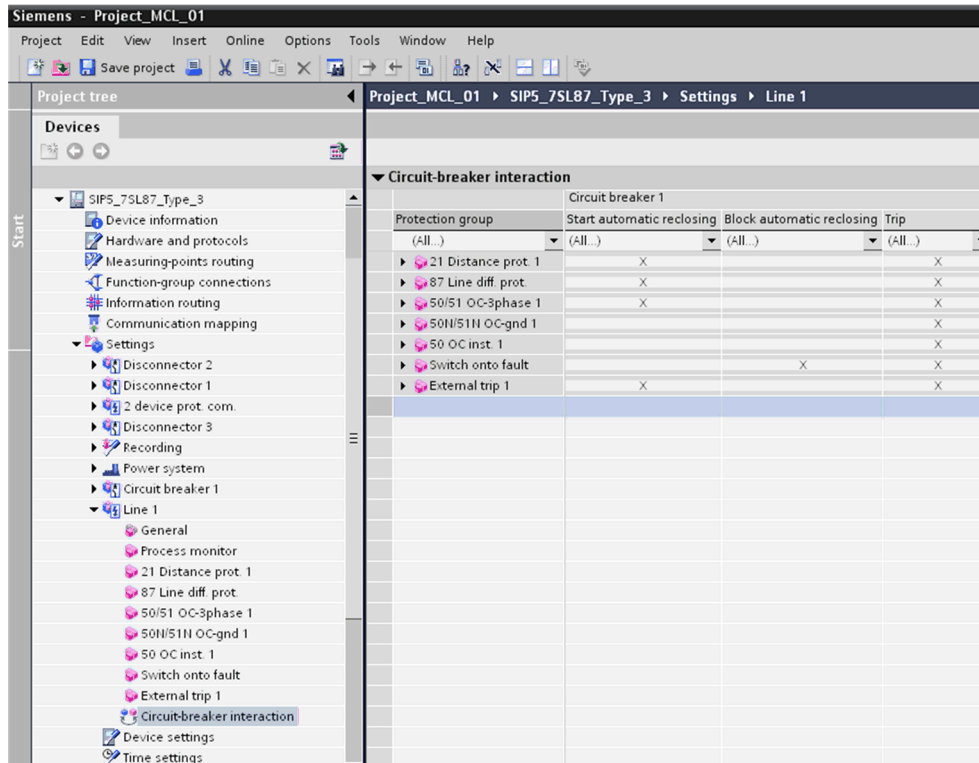

[scdigsi-080311-01.tif, 1, en_US]

Figure 6-291 Configuration of the Protection Functions for Starting and Blocking the Automatic Reclosing Function in DIGSI 5

If a protection function or the stage of a protection function is connected with the AREC through the matrix, this means that the respective pickup and operate indications are forwarded to the AREC.

The links can be conducted separately

- For starting the automatic reclosing function and
- For the blocking of the automatic reclosing function

The Automatic reclosing function also has the corresponding binary inputs and binary outputs through which the external protection devices can be connected to the internal Automatic reclosing function.

6.46.4 Cyclic Automatic Reclosing Function

6.46.4.1 Operating Modes for Cyclic Automatic Reclosing Function

For the cyclic automatic reclosing function, there are 4 operating modes, from which one can be selected for the parameterization (parameter (_ :6601:101) **79 operating mode**).

The selection of the operating mode is dependent on the tripping behavior of the protection functions and the circuit breaker.

For applications with 3-pole tripping, all 4 operating modes are available.

- Operating mode 1: *with op., with act. time*
- Operating mode 2: *w.pickup, w. action time*
- Operating mode 3: *with op., w/o act. time*
- Operating mode 4: *w.pickup, w/o act. time*

Operating Mode 1: with op., with act. time

The operating mode *with op., with act. time* allows different automatic reclosing cycles depending on the tripping type and operate time of the protection function(s). With this operating mode, the automatic reclosing must be started with the operate indications. Additionally, the general pickup must also be considered.

With raising general pickup, the action times of the configured automatic reclosing cycles start. The general pickup is in this connection the group indication of all internal protection functions configured for starting the automatic reclosing and the external binary input for general pickup *>Gen. pickup for start*.

Through the time between the raising general pickup and clearing operate indication, the automatic reclosing cycle to be started will be determined. Here for multiple automatic reclosing cycles, the sequence of the expiring automatic reclosing cycles is not fixed, like the operating modes without action time.

The following example in [Figure 6-292](#) shows a tripping that comes after expiration of the action time of cycle 1, but still before the expiration of the action times from cycle 2 and cycle 3. Cycle 2 is now active.

Within the following reclaim time, there will be another pickup and tripping. Since cycle 2 is already complete, these and all lower cycles are no longer able to expire. The 2nd operate indication comes during the running action time of cycle 3. Thus, cycle 3 is now active.

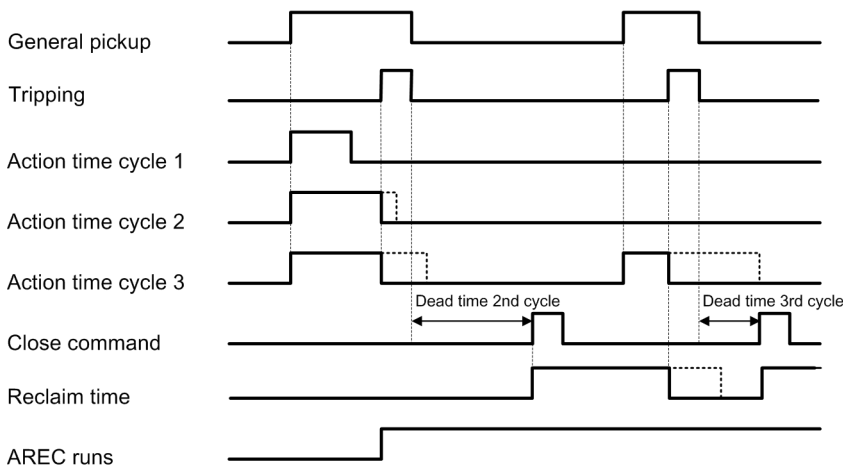

[idw_arce1d_1_en_US]

Figure 6-292 Operating-Mode Signal Examples: With Tripping/With Action Time

Through the action time, there is a direct influence on the dead time behavior of the automatic reclosing function. With faults with short operate times, other dead times can be realized than for removed faults with longer tripping time. With faults with short operate time, an automatic reclosing is executed, with removed faults this does not occur with longer operate time. The operating mode *with op., with act. time* allows for different automatic reclosing cycles depending on the operate time of the protection function(s).

Operating Mode 2: w.pickup, w. action time

The operating mode *w.pickup, w. action time* allows different automatic reclosing cycles depending on the operate time and type of fault. It is only suitable and applicable for applications with 3-pole tripping.

With this operating mode, the automatic reclosing must be started with the operate indications from the protection functions. Additionally, the pickup sample from the conductor pickups and the general pickup are considered:

- With 1-phase pickup, the automatic reclosing cycles set for 1-phase dead times are activated. 1-phase pickup includes both pickup samples **phase-to-ground** and **only grounding**.
- With 2-phase pickup, the automatic reclosing cycles set for 2-phase dead times are activated.
- With 3-phase pickup, the automatic reclosing cycles set for 3-phase dead times are activated.

With each automatic reclosing cycle, it is checked to see if it is a 1-phase, 2-phase or 3-phase pickup.

With raising general pickup, the action times of the configured automatic reclosing cycles start. The general pickup is in this connection the group indication of all internal protection functions configured for starting the automatic reclosing and the external binary input for general pickup *>Gen. pickup for start*.

Through the time between the raising general pickup and raising trip command, the automatic reclosing cycle to be started will be determined. Here for multiple automatic reclosing cycles, the sequence of the expiring automatic reclosing cycles is not fixed, like the operating modes without action time.

The following example shows a tripping that comes after expiration of the action time of cycle 1, but still before the expiration of the action times from cycle 2 and cycle 3. Since it is a 2-phase pickup, cycle 2 is active with the dead-time setting for 2-phase faults.

After reclosing, there will be another, this time 3-phase, pickup and tripping within the following reclaim time. Since cycle 2 is already complete, these and all lower cycles are no longer able to expire. The trip command comes during the current action time of cycle 3. Thus, cycle 3 is active, with the dead time setting for 3-phase faults.

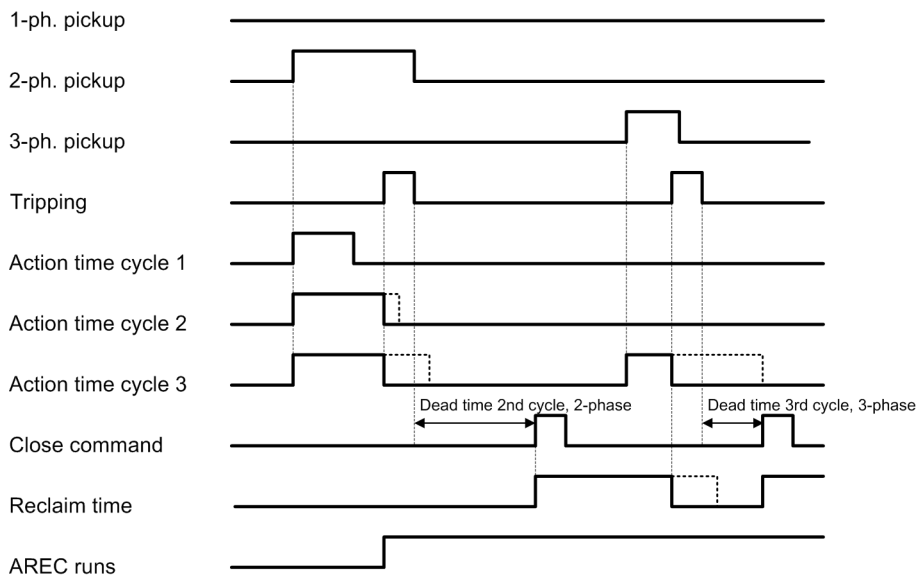

[dw_arcbm2, 1, en_US]

Figure 6-293 Operating-Mode Signal Examples: With Pickup/With Action Time

Operating Mode 3: with op., w/o act. time

With the operating mode *with op., w/o act. time*, the respective dead time is started after each trip command. The pickups are not considered. If more than one automatic reclosing cycle is configured, the sequence of the expiring automatic reclosing cycles is identical with the cycle number (1, 2, and 3.).

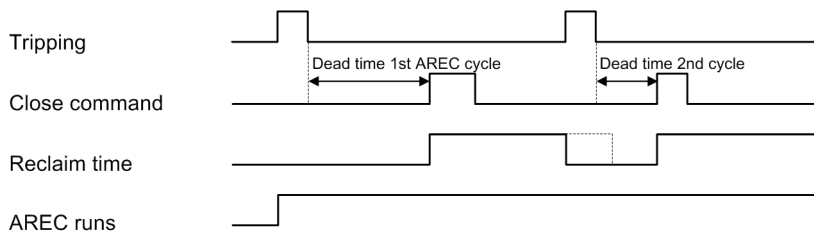

[dw_aweb3d, 1, en_US]

Figure 6-294 Operating-Mode Signal Examples: With Tripping/Without Action Time

Operating Mode 4: w.pickup, w/o act. time

With the operating mode *w.pickup, w/o act. time*, the automatic reclosing must be started with the operate indications from the protection functions. It is only suitable and applicable for applications with 3-pole tripping.

The start of the dead time occurs after each trip command. Additionally, the pickup sample from the conductor pickups is considered:

- With 1-phase pickup, the automatic reclosing cycles set for 1-phase dead times are activated. 1-phase pickup includes both pickup samples **phase-to-ground** and **only grounding**.
- With 2-phase pickup, the automatic reclosing cycles set for 2-phase dead times are activated.
- With 3-phase pickup, the automatic reclosing cycles set for 3-phase dead times are activated.

With each automatic reclosing cycle, it is checked to see if it is a 1-phase, 2-phase or 3-phase pickup. If more than one automatic reclosing cycle is configured, the sequence of the expiring automatic reclosing cycles is identical with the cycle number (1, 2, 3, etc.).

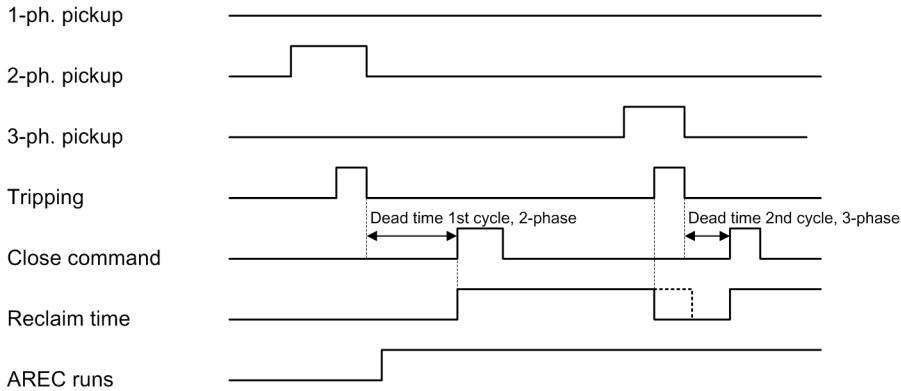

[idw_arcbst4, 1, en_US]

Figure 6-295 Operating-Mode Signal Examples: With Pickup/Without Action Time

6.46.4.2 Structure of the Cyclic Automatic Reclosing Function

In [Figure 6-296](#), the functional structure of the cyclic automatic reclosing function is illustrated as a block diagram. The figure displays the important signals, coming from outside of the cyclic automatic reclosing function, and the most important signals between the individual function blocks.

The automatic reclosing function works as a state machine. From the idle state **AREC ready**, the automatic reclosing function gets through the tripping or pickup indications of the protection functions to the **Dead time** state. After expiration of the dead time, the subsequent state is reached with the closing indication. The reclaim time is also started together with the closing indication. If the reclaim time can expire without further operate or pickup indications, the automatic reclosing is successful and the automatic reclosing function turns back to idle state.

If the automatic reclosing function is restarted during the current reclaim time, there will be either a dynamic blocking or other reclosing cycles will be executed. If other reclosing cycles are possible, there will be a dead time start and the described process starts again.

After the end of a dynamic blocking, the automatic reclosing function switches back to idle state or goes into the state **Static Blocking** if the blocking condition is permanently present. In the following sections, the individual function blocks are described in detail.

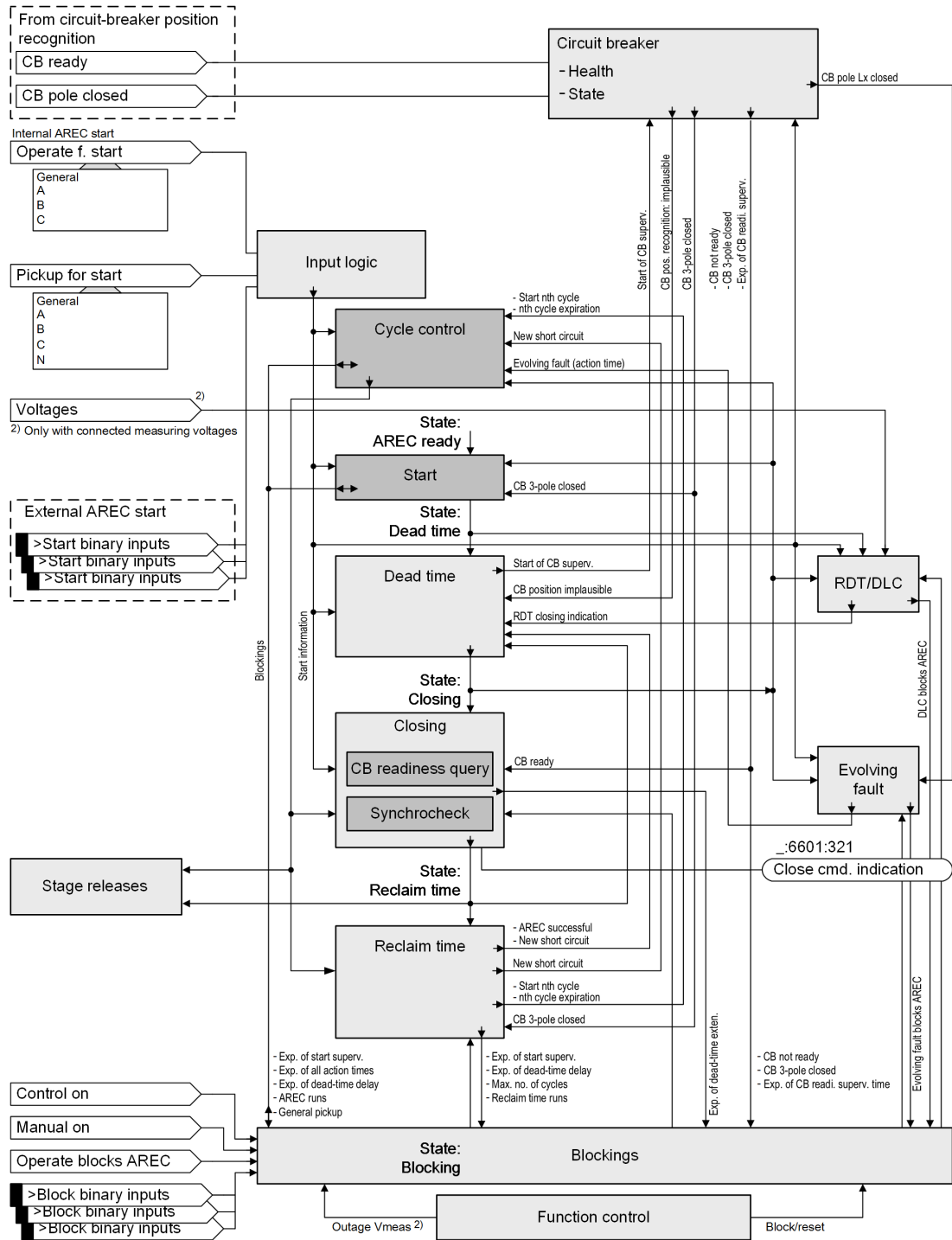

[to_zyk_aws_2_en_US]
Figure 6-296 Cyclic Automatic Reclosing: Block Diagram of Automatic Reclosing

6.46.4.3 Input Logic for Operating Modes with Tripping

The operate indications are used as starting signals. For operating modes **with action time**, the start of the action time(s) occurs with the pickup messages. During all operating modes, the pickup indications are also required during the processing of faults and for supervision during the reclaim time.

Applications with 3-Pole Tripping

For applications with only 3-pole tripping options, the internal operate indications are always 3-pole. For external starts, there is a binary input, which signalizes a 3-pole tripping of the external protection device. The outputs of the input logic signalize that the reclosing start has occurred through a 3-pole operate indication.

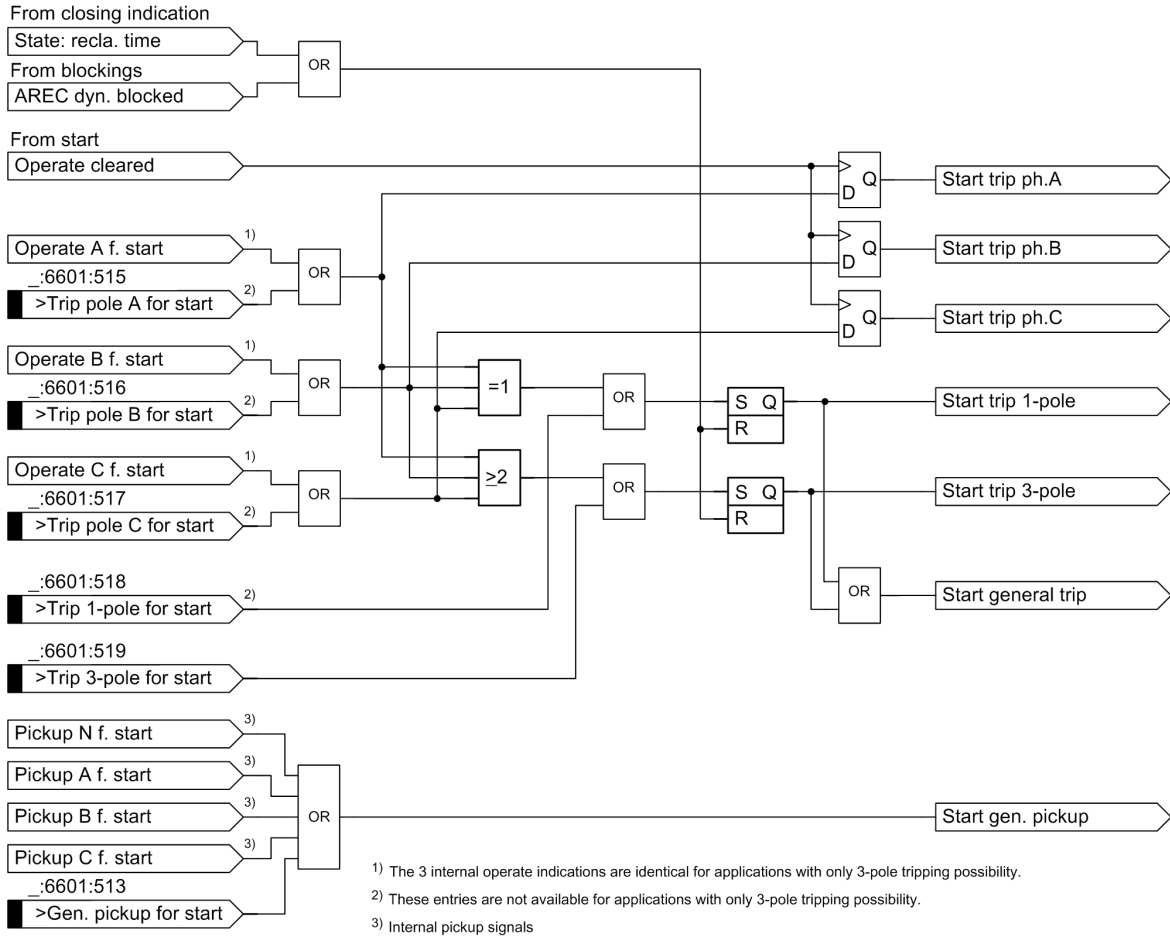

Figure 6-297 Input Logic for Operating Modes: With Tripping

6.46.4.4 Input Logic for Operating Modes with Pickup

The operate indications and the pickup indications are used as starting signals. The internal pickup indications are processed selective to the phase. Through binary inputs, the pickup information can also be coupled by external protection devices (>Pickup A for start, >Pickup B for start and >Pickup C for start). Optionally, the pickup information can be externally captured as a pickup sample, thus, as a 1-phase, 2-phase and 3-phase pickup.

The outputs of the input logic signalize if the automatic reclosing start occurs through a 1-phase, 2-phase, or 3-phase pickup:

- On **Start with 3-phase pickup**, it is recognized if all 3 phases were picked up in the period from the first raising pickup indication up to the last clearing outgoing pickup indication.
- On **Start with 2-phase pickup**, it is recognized if all 2 phases were picked up in the period from the first raising pickup indication up to the last clearing pickup indication and at no time 3 phases.
- On **Start with 1-phase pickup**, it is recognized if only 1 phase was picked up in the period from the first raising pickup indication up to the last clearing pickup indication.

For operating modes **with action time**, the start of the action time(s) occurs with the pickup indications. During operating modes **with pickup**, the pickup indications affect the selection of the dead times. During all operating modes, the pickup indications are also required during the processing of faults and for supervision during the reclaim time.

The automatic reclosing operating modes **with pickup** are only ideal for applications with 3-pole tripping. Therefore, the outputs of the input logic always signal 3-pole operate indications.

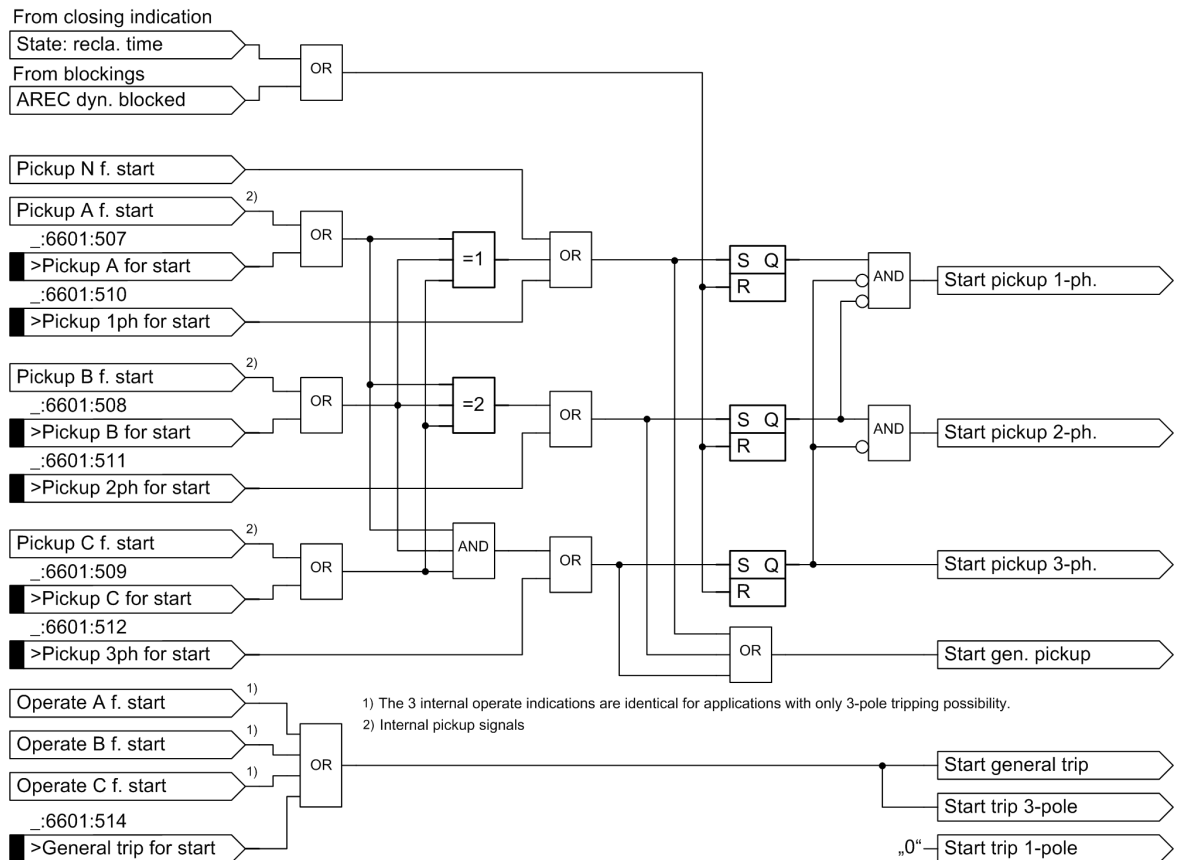

Figure 6-298 Input Logic for Operating Modes: With Pickup

6.46.4.5 Start

In the **Start** function block, the automatic reclosing function is switched from the idle state **AREC ready** to the state **Dead time**, see [Figure 6-299](#). The length of the starting signals is controlled with a supervision time.

Start-Signal Supervision Time

The start-signal supervision stops the automatic reclosing if the short circuit is not switched off within the normal time; for example, in the case of a circuit-breaker failure.

With the first raising operate indication, the start-signal supervision time is initiated, parameter **start signal supervis. time**. The time is stopped as soon as no operate indication is active.

The automatic reclosing function is blocked if there is an expiration of the start-signal supervision time through a long operate indication. The blocking lasts until the operate indication dropout, extended by a further 0.5 s.

Transition to the Dead-Time State

The transition of the automatic reclosing function to the **dead-time** state occurs for:

- Clearing operate indications if none of the signal inputs for operate indications are active
- or if the circuit breaker can no longer be recognized as 3-pole closed
- and the start-signal supervision time is not expired

Additionally, the following conditions must be fulfilled:

- The circuit breaker signals the readiness for automatic reclosing typically through a binary input. If the circuit breaker is not ready, the automatic reclosing function can be statically blocked. In this situation, the automatic closing function is not in idle state **automatic closing function ready**. The control of the circuit-breaker readiness is optional and can be turned off through settings, see also [6.46.4.16 Circuit-Breaker Readiness and Circuit-Breaker Position](#) and [6.46.4.17 Blockings](#).
- The circuit breaker must be closed before the 3-pole trip command. This condition is not considered if the circuit-breaker auxiliary contacts are not connected to the protection device.

You can delay the transition to the **dead time** state through the binary input *>Dead time start delay*. As long the corresponding binary signal is present, the dead time of the automatic reclosing function will not be started. The maximum duration of this binary signal is monitored through a time stage that can be set, parameter **Max. dead-time delay**. Upon expiration of this time stage, that is, if the binary signal is present longer than permitted, the automatic reclosing function will be blocked until the dropout of the binary signal, additionally extended by another 0.5 s, see also [6.46.4.17 Blockings](#).

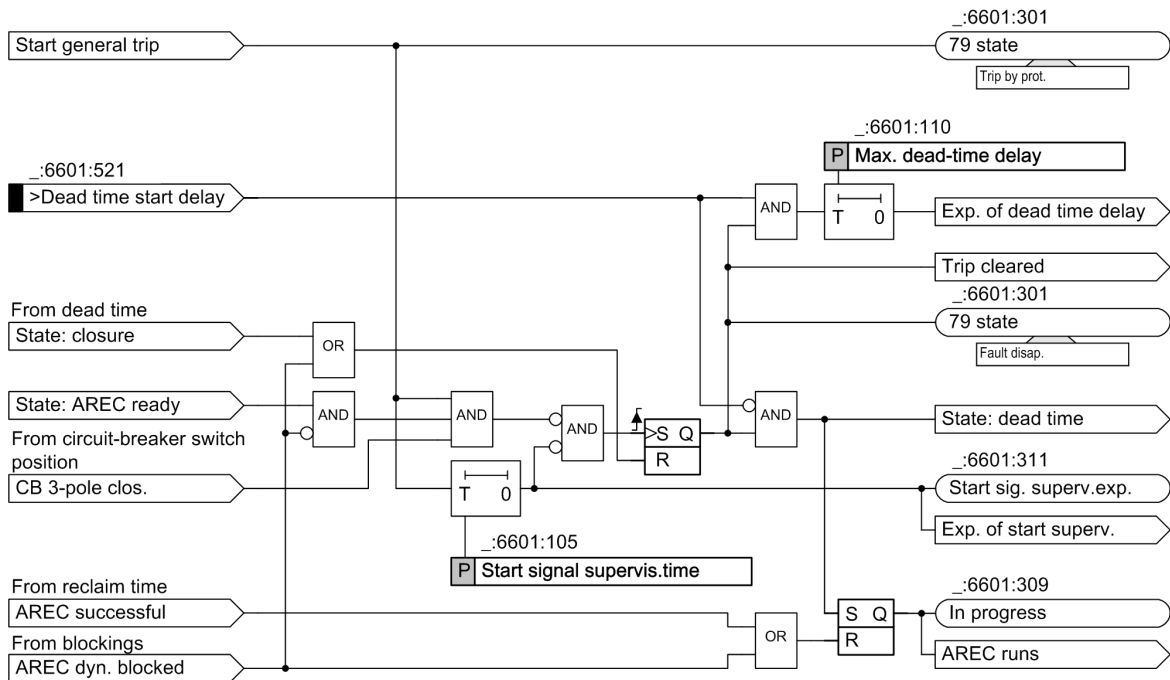

[do_gistar_1_en_US]
 Figure 6-299 Logic for Function Block Start

6.46.4.6 Cycle Control with Operating Mode 1: With Tripping/With Action Time

The cycle control checks the readiness for each automatic reclosing cycle and controls the process of the action time(s). In [Figure 6-300](#), the cycle control is illustrated.

Cycle Availability

The cycle availability is influenced through the parameterization of the dead time and through a binary input. In this way, setting the parameter **Dead time aft. 3-pole trip to invalid** avoids an automatic reclosing after 3-pole tripping. Correspondingly, there is no automatic reclosing function if the **Dead time**

aft. 1-pole trip³¹ is set to *invalid*. If both dead times are set to *invalid*, the respective automatic reclosing cycle will be completely blocked. With the binary input *>Block 79 cycle*, you can block the associated automatic reclosing cycle.

For applications with 1-pole tripping, the cycle control provides a signal, based on which the protection functions can recognize that the automatic reclosing function only occurs after 1-pole tripping (*AR only after 1p. trip*). The release or switch over of special protection stages only occurs for types of faults that lead to 1-pole tripping.

Action Time

If the automatic reclosing function is in the idle state **automatic reclosing function ready**, an incoming general pickup will affect the start of the action time. This applies for the reclosing function cycles that are released through the parameter **Start from idle state allow**. and not blocked.

During one of the started action times, the corresponding reclosing cycle is blocked and the reclosing cycle is assigned the next highest cycle number, whose action time is running and is not blocked.

With raising trip commands, the action times are stopped and reset. The process state of the action times existing at this moment determines the automatic reclosing cycle that should be started.

If all initiated action times expire without capturing a tripping, the automatic reclosing function does not take place. However, if a tripping function is initiated after expiry of the action time, the automatic closing function is blocked for 3 seconds. A new start of the reclosing function is only possible if the general pickup is no longer active.

³¹ is not available for devices with only 3-pole tripping

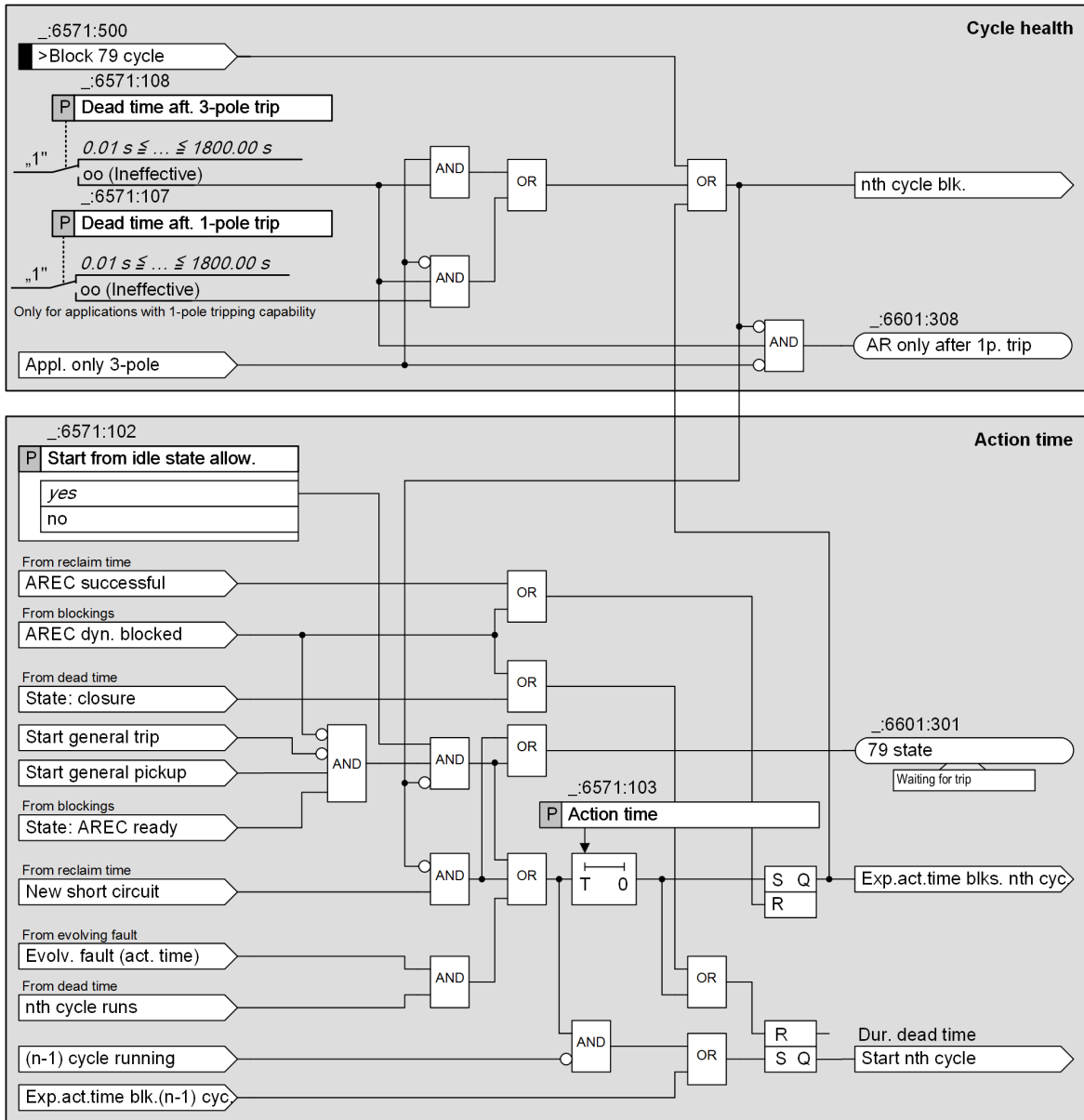

[to_auswir, 2, en_US]

Figure 6-300 Cycle Control with Operating Mode: With Tripping/With Action Time

6.46.4.7 Cycle Control with Operating Mode 2: With Pickup/With Action Time

The cycle control checks the readiness for each automatic reclosing cycle and controls the process of the action time(s). In [Figure 6-301](#), the cycle control is illustrated.

Cycle Availability

The cycle availability is influenced through the parameterization of the dead time and through a binary input. In this way, setting the parameter **Dead time aft. 1ph. pickup** to *invalid* avoids an automatic reclosing after 3-pole tripping due to 1-phase short circuits. This also applies to **Dead time aft. 2ph. pickup** and **Dead time aft. 3ph. pickup**. If all 3 dead times are set to *invalid*, the respective automatic reclosing cycle will be completely blocked. With the binary input **>Block 79 cycle**, you can block the associated automatic reclosing cycle.

Action Time

If the automatic reclosing function is in the idle state **automatic reclosing function ready**, an incoming general pickup will affect the start of the action time. This applies for the reclosing function cycles that are released through the parameter **Start from idle state allow**. and not blocked.

During one of the started action times, the corresponding reclosing cycle is blocked and the reclosing cycle is assigned the next highest cycle number, whose action time is running and is not blocked.

With raising trip commands, the action times are stopped and reset. The process state of the action times existing at this moment determines the automatic reclosing cycle that should be started.

If all initiated action times expire without capturing a tripping, the automatic reclosing function does not take place. However, if a tripping function is initiated after expiry of the action time, the automatic closing function is blocked for 3 seconds. A new start of the reclosing function is only possible if the general pickup is no longer active.

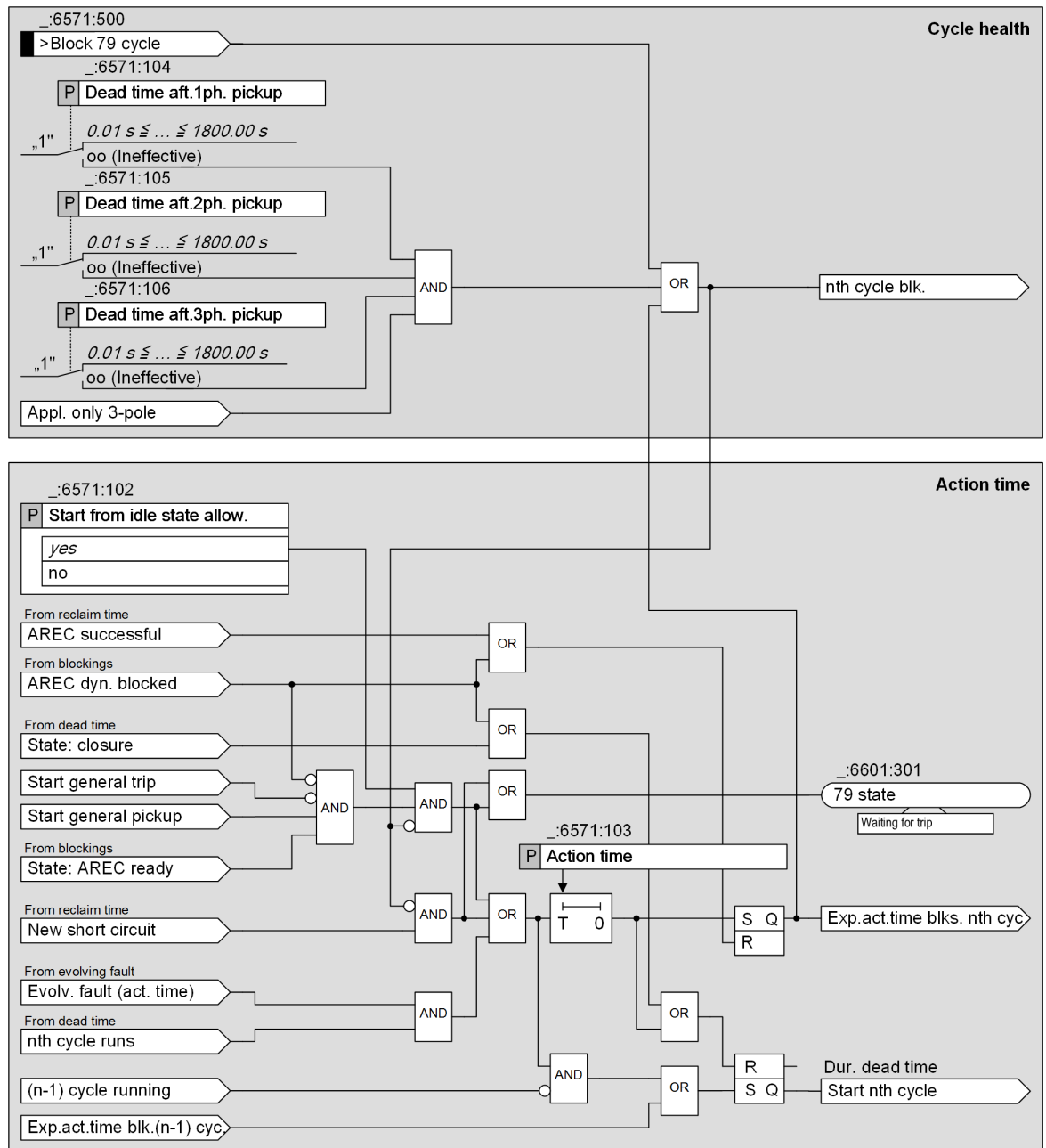

[to_anwir_2_en_US]

Figure 6-301 Cycle Control with Operating Mode: With Pickup/With Action Time

6.46.4.8 Cycle Control with Operating Mode 3: With Tripping/Without Action Time

The cycle control checks the availability for each automatic reclosing cycle. In [Figure 6-302](#), the cycle control for the 1st automatic reclosing cycle and other reclosing cycles is illustrated. The further automatic reclosing cycles are generally described with the cycle number *n* and apply for all other configured automatic reclosing cycles.

The cycle availability is influenced through the parameterization of the dead time and through a binary input. In this way, setting the parameter **Dead time aft. 3-pole trip** to *invalid* avoids an automatic reclosing after 3-pole tripping. Correspondingly, there is no automatic reclosing function after 1-pole tripping if the **Dead time aft. 1-pole trip**³² is set to *invalid*. If both dead times are set to *invalid*, the respective automatic reclosing cycle will be completely blocked. With the binary input *>Block 79 cycle*, you can block the associated automatic reclosing cycle.

For applications with 1-pole tripping, the cycle control provides a signal, based on which the protection functions can recognize that the automatic reclosing function only occurs after 1-pole tripping (*AR only after 1p. trip*). The release or switch over of special protection stages only occurs for types of faults that lead to 1-pole tripping.

³² not available for devices with only 3-pole tripping

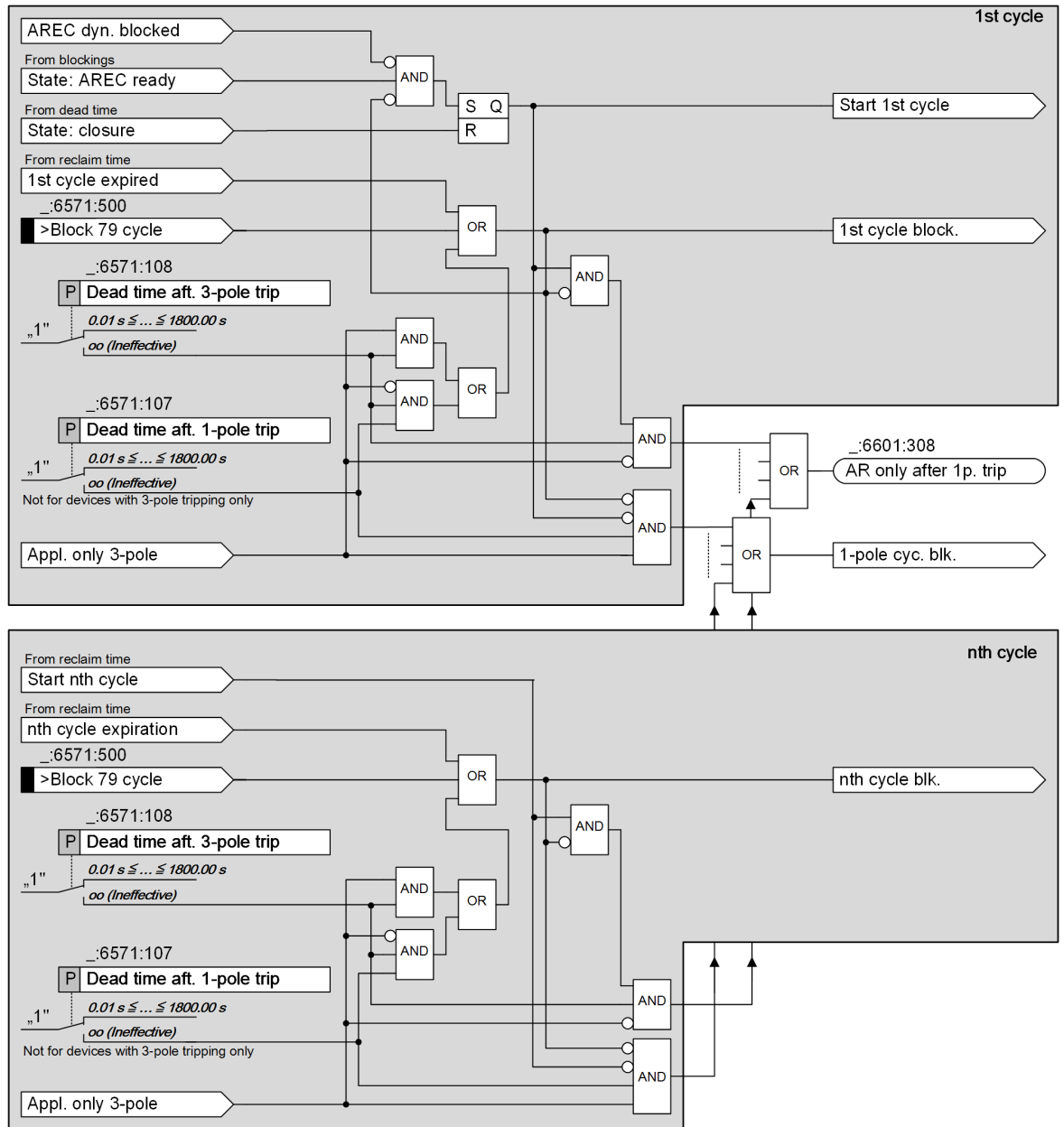

[to_aubrkw, 2, en_US]

Figure 6-302 Cycle Control with Operating Mode: With Tripping/Without Action Time

6.46.4.9 Cycle Control with Operating Mode 4: With Pickup/Without Action Time

The cycle control checks the availability for each automatic reclosing cycle. In [Figure 6-303](#), the cycle control for the 1st automatic reclosing cycle and other reclosing cycles is illustrated. The further automatic reclosing cycles are generally described with the cycle number n and apply for all other configured automatic reclosing cycles.

The cycle availability is influenced through the parameterization of the dead time and through a binary input. In this way, setting the parameter **Dead time aft. 1ph. pickup** to *invalid* avoids an automatic reclosing after 3-pole tripping due to 1-phase short circuits. This also applies to **Dead time aft. 2ph. pickup** and **Dead time aft. 3ph. pickup**. If all 3 dead times are set to *invalid*, the respective automatic reclosing cycle will be completely blocked. With the binary input **>Block 79 cycle**, you can block the associated automatic reclosing cycle.

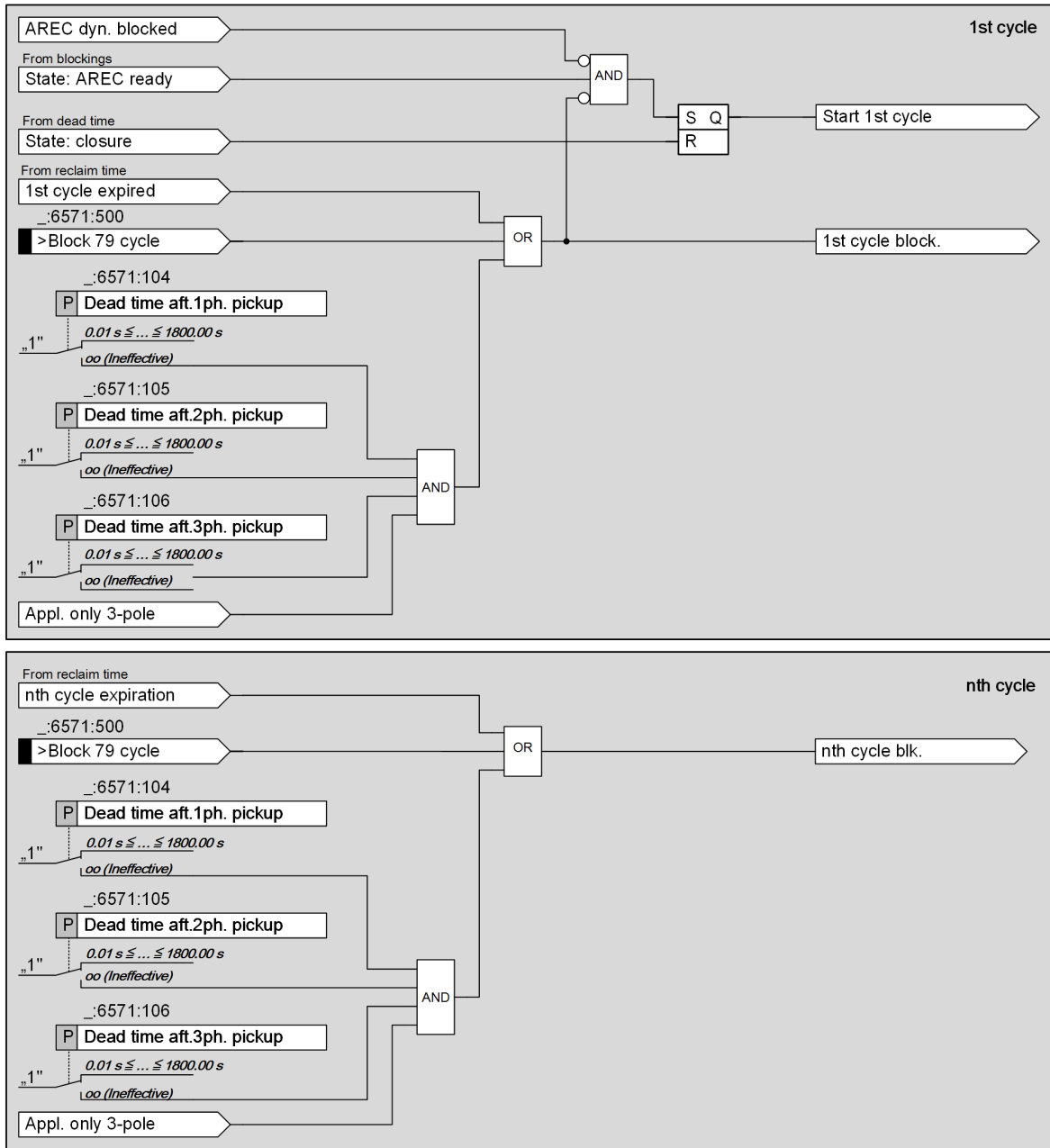

[file_anowrk_2_en_US]

Figure 6-303 Cycle Control with Operating Mode: With Pickup/Without Action Time

6.46.4.10 Stage Release

The function block **Stage release** creates output indications for the release or switching over of special stages for protection functions (stage release in the 1st cycle or stage release in the n. cycle). Examples of this are the release of overreaching zones with distance protection and the dynamic adjustment of time delays or threshold values with overcurrent protection.

Figure 6-304 shows the stage release for the 1st automatic reclosing cycle. With available automatic reclosing functions, the tripping stage release typically occurs up to the expiration of the dead time.

In this state the cycle number is 1. If the automatic reclosing cycle is only set for 1-phase³³, the stage release will be reset to the beginning of the 1-phase dead time. This is necessary, since every additional evolving fault

³³ not for devices with only 3-phase tripping

that occurs within the dead time causes a 3-pole cut-off, and subsequently, the automatic reclosing function can no longer take place.

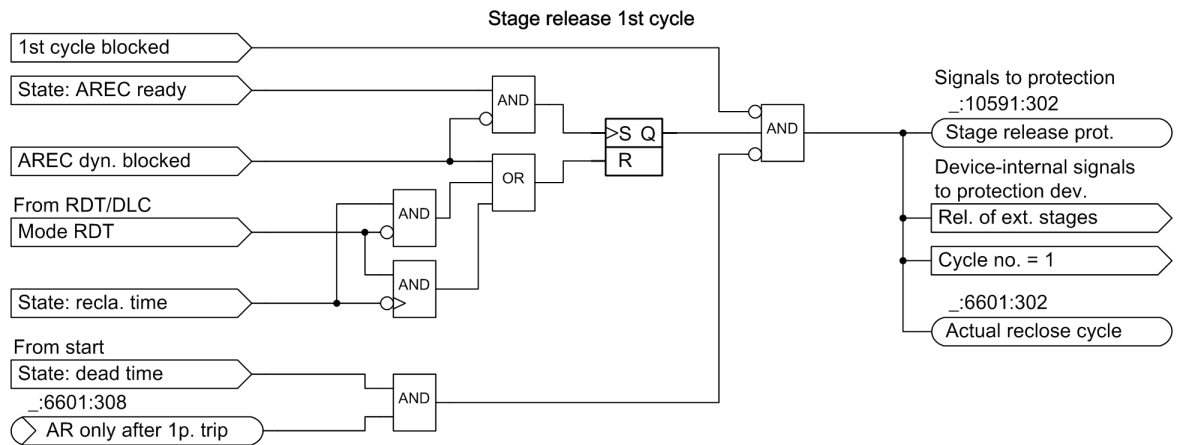

[to_1aweck_1_en_US]

Figure 6-304 Stage Release for Protection Functions in the 1st Automatic Reclosing Cycle

The tripping stage release for higher automatic reclosing cycles is set to the beginning of the reclaim time for rising edge close commands. Simultaneously, the cycle number is increased. The reset condition is identical to the condition for the 1st automatic reclosing cycle. If the reduced dead time (RDT) mode is selected and no additional reduced dead time occurs, the release will be maintained for the 2nd cycle, since it can be assumed that the opposite end of the line is still open-circuited.

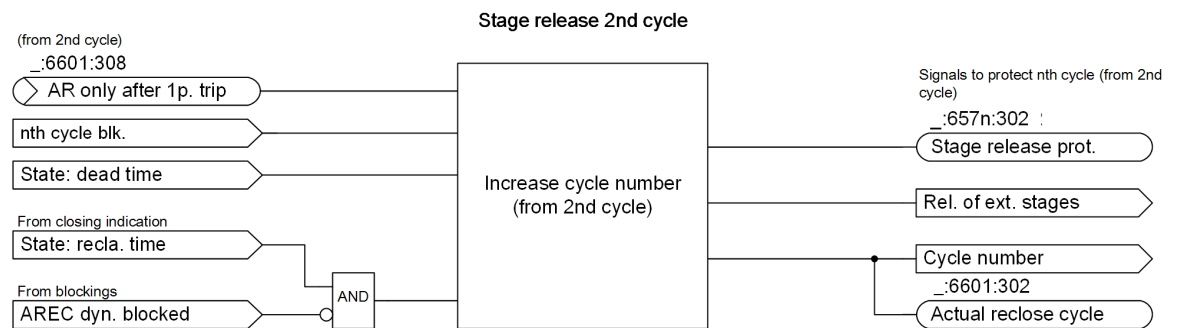

[to_2aweck_2_en_US]

Figure 6-305 Stage Release for Protection Functions Starting With the 2nd Automatic Reclosing Cycle

6.46.4.11 Dead Time for Operating Modes with Tripping

In the **Dead time** function block, that dead time which corresponds with the previous trip command is started. After expiration of the dead time, the automatic reclosing function changes to the status **Switch on**. [Figure 6-306](#) shows the dead time logic.

There are the following time stages that can be set differently:

- Dead time after 3-pole tripping
- Dead time after 1-pole tripping (only available for applications with 1-pole tripping)
- Dead time after evolving fault

Setting the parameter **Dead time aft. 3-pole trip** to ∞ (= invalid) avoids an automatic reclosing after 3-pole tripping. Likewise, after 1-pole tripping there is no automatic reclosing if the **Dead time aft. 1-pole trip** is set to ∞ (= invalid).

As soon as an evolving fault is recognized (see [6.46.4.13 Evolving-Fault Detection During the Dead Time](#)), switching to an automatic reclosing cycle for 3-pole interruption occurs. With the 3-pole cut-off of the evolving fault, a separate adjustable dead time for the evolving fault begins. The total dead time is composed

of the part of the dead time that expired until the evolving fault was stopped for the 1st disruption plus the dead time for the evolving fault.

3-Pole Coupling of the Circuit Breaker with 1-Pole Tripping and Implausible Circuit-Breaker Position

With applications with 1-pole tripping, during the dead time there is a plausibility check between the assigned trip command and the current flow in the open conductor. If the circuit-breaker auxiliary contacts are connected pole-selectively, the plausibility check also occurs with the circuit-breaker auxiliary contacts. For more information see [6.46.4.16 Circuit-Breaker Readiness and Circuit-Breaker Position](#).

The plausibility check determines whether the circuit-breaker poles that have not been switched off after a 1-pole trip command remain closed.

For an implausible circuit-breaker position, a 3-pole coupling of the trip command for the circuit breaker is executed, provided the coupling of the trip command is permitted through the parameter (parameter **3-pole operate by 79**). After this 3-pole tripping, if set and not blocked, more 3-pole automatic reclosing cycles may follow.

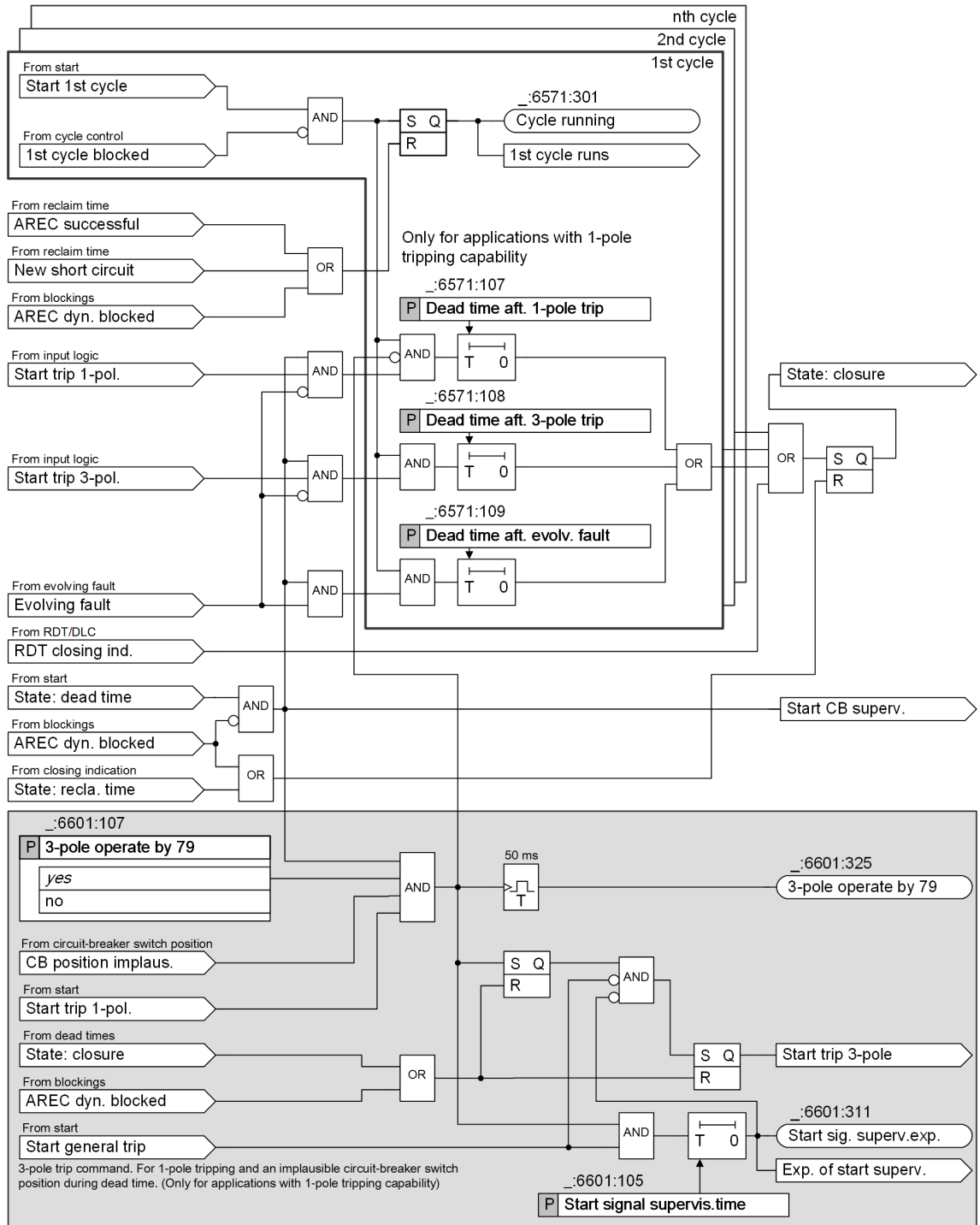

[to_pauaul, 3, en, US]

Figure 6-306 Cyclic Automatic Reclosing Function – Logic of the Dead Time for the Operating Modes: With Tripping

6.46.4.12 Dead Time for Operating Modes with Pickup

In the **Dead time** function block, the dead time corresponding to the type of short circuit that led to the trip command is started. The automatic reclosing operating modes **with pickup** are only suitable for applications with 3-pole tripping. After expiration of the dead time, the automatic reclosing function changes to the status **Switch on**. [Figure 6-307](#) shows the dead time logic.

There are 4 time stages that can be set differently:

- Dead time after 1-phase short circuits
- Dead time after 2-phase short circuits
- Dead time after 3-phase short circuits
- Dead time for evolving faults

In this way, setting the parameter **Dead time aft.1ph. pickup** to *invalid* avoids an automatic reclosing after 3-pole tripping due to 1-phase short circuits. This also applies to **Dead time aft.2ph. pickup** and **Dead time aft.3ph. pickup**.

As soon as an evolving fault is recognized (see chapter 6.46.4.13 *Evolving-Fault Detection During the Dead Time*), a separate dead time for faults begins with the stopping of the fault. The total dead time is composed of the part of the dead time that expired until the evolving fault was stopped plus the dead time for the evolving fault. With the setting of the **Dead time aft. evolv. fault** to *invalid*, no other automatic reclosing cycle is executed after tripping due to evolving faults. The tripping through evolving faults is then finished.

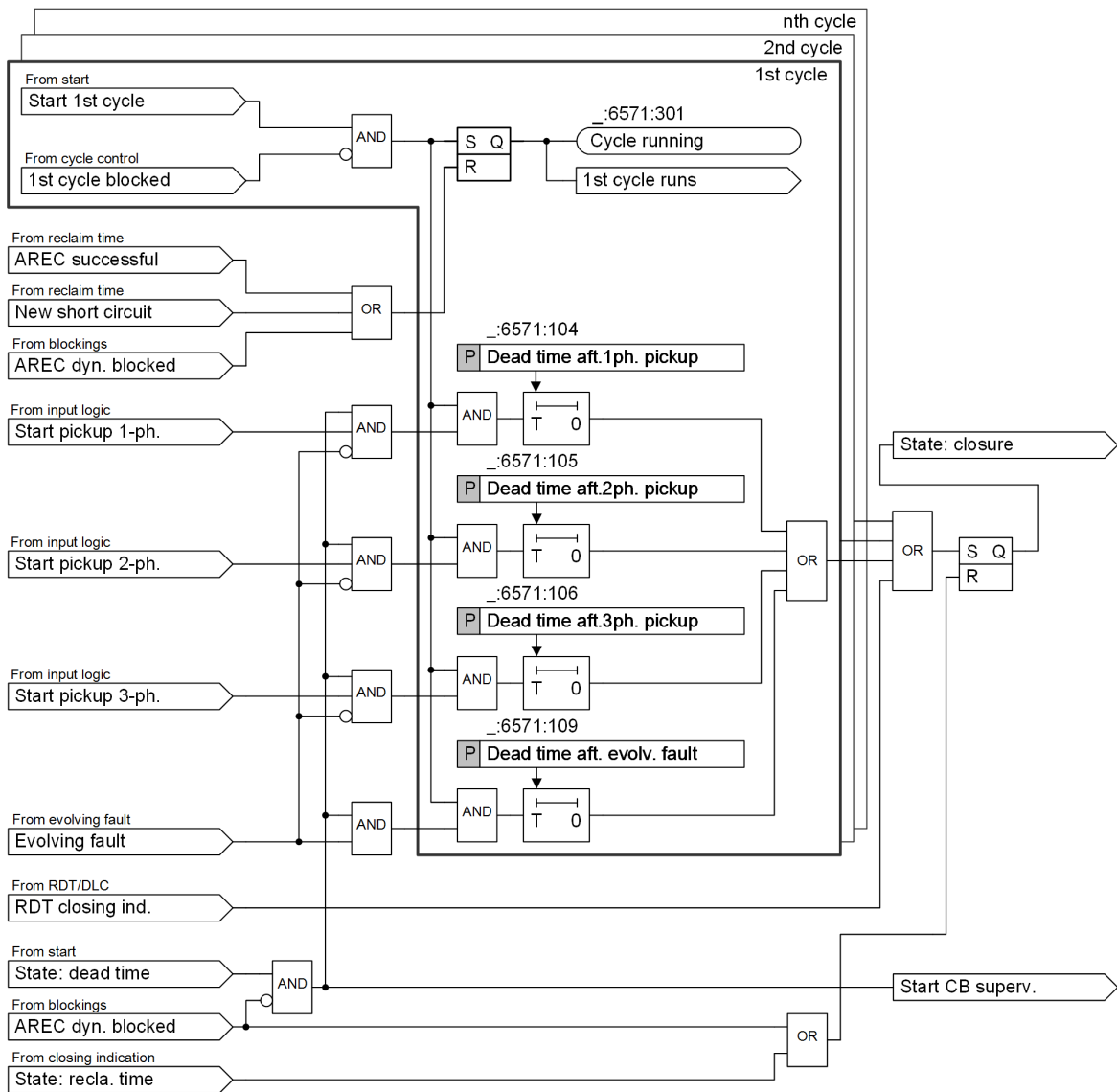

[lo_paware, 2, en_US]

Figure 6-307 Cyclic Automatic Reclosing Function – Logic of the Dead Time for the Operating Modes: With Pickup

6.46.4.13 Evolving-Fault Detection During the Dead Time

Evolving faults are short circuits, which occur after switching off a short circuit during dead time. This may be the case during 1-pole tripping and there is a short circuit in the non-switched conductors after this.

After 3-pole tripping there may also be evolving faults if the line is fed through a second (non-3-pole) opened circuit breaker, for example, for systems with a 1 1/2 circuit breaker layout.

The evolving-fault detection is divided into components:

- Detection of evolving faults
- Evolving-faults processing
- 3-pole coupling of a circuit breaker during evolving faults

The procedure during evolving faults is illustrated in [Figure 6-308](#).

Detection of Evolving Faults

For the detection of an evolving fault, the following criteria can be selected through parameters:

- Parameter **Evolving-fault detection = with trip**
For this setting, **any tripping** during the dead time leads to evolving-fault detection. At **any tripping** it is decided if an internal protection function is tripped or if the tripping is signaled through a binary input. Thus, it does not matter if the tripping-protection function is configured for the start of the Automatic reclosing function or not.
- Parameter **Evolving-fault detection = with pickup**
Evolving faults are detected if during the dead time a protection function configured for the Automatic reclosing function start is picked up or if an external pickup is recognized through a binary input.
- Binary input **>Evolving fault start**
The evolving-fault detection can also be introduced through a binary input without an internal protection pickup being available.

Reaction to Evolving Faults

After a recognized evolving fault, the Automatic reclosing function can be influenced in 2 ways.

- Parameter **Response to evolv. faults = blocks 79**
As soon as an evolving fault is recognized, the reclosing function will be blocked. There are no other reclosing attempts and the Automatic reclosing function is blocked until the pickup and operate indications causing the evolving fault disappear.
- Parameter **Response to evolv. faults = strt. evol.flt.dead time**
As soon as an evolving fault is recognized, an automatic reclosing cycle for 3-pole interruption is switched to. The Automatic reclosing function does not allow any 1-pole tripping until the fault is solved or there is a final switch off; thus, every following trip command will be 3-pole. When the evolving fault is fixed, the separate dead time for faults will start, see also chapter **Dead time**. The further process is as by 3-pole cycles.

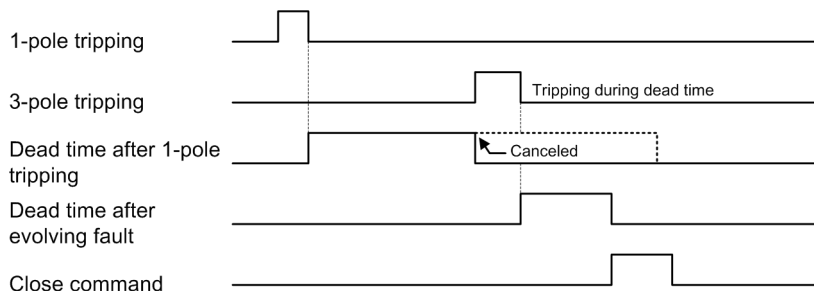

[dwr_bspffe_1_en_US]

Figure 6-308 Cyclic Automatic Reclosing Function - Example for an Evolving Fault

For tripping through evolving faults, the entire dead time consists of the part of the dead time expired until disconnecting the evolving fault for the 1-pole interruption plus the dead time for the fault together, see [Figure 6-309](#).

The dead time for evolving faults is started with the return of the operate indication or with the opening of all 3 circuit-breaker poles, provided the circuit-breaker auxiliary contacts are connected.

3-Pole Tripping of the Circuit Breaker for Automatic Reclosing Function Blocking through Evolving Faults in a 1-Pole Dead Time

If due to an evolving fault there is a blocking of the Automatic reclosing function in the 1-pole dead time without a protection function submitting a 3-pole trip command, for example, during an evolving-fault detection with pickup, the Automatic reclosing function can create a 3-pole trip command. Thus, the circuit breaker will have 3-pole tripping in which the blocking of the Automatic reclosing function will occur.

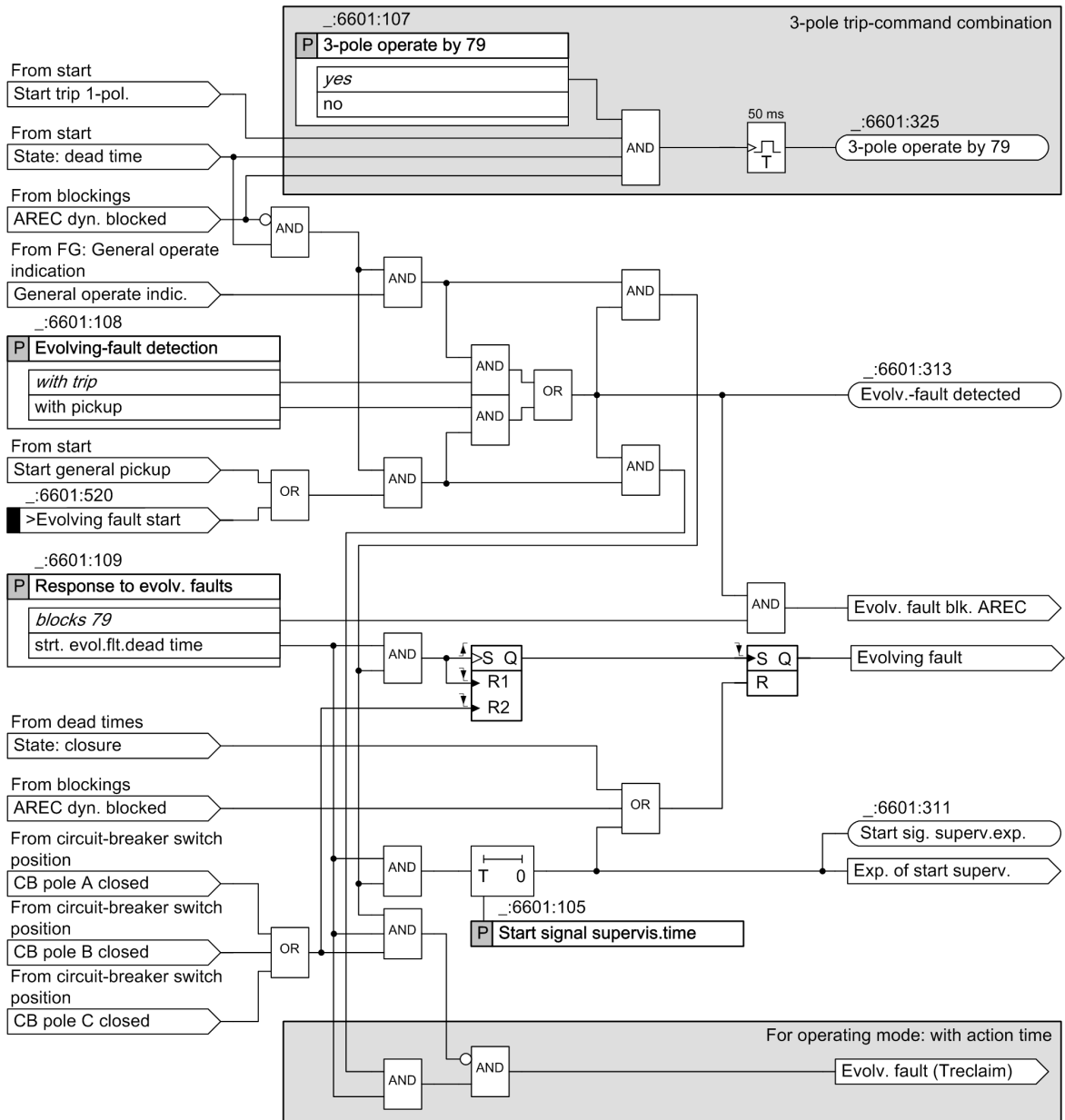

[10_fofeer, 1, en_US]

Figure 6-309 Cyclic Automatic Reclosing Function - Logic of Evolving-Fault Detection

6.46.4.14 Closing Indication and Close Command

After the expiration of the dead time, the Automatic reclosing function is in the **closing** state. The **closing** state can depend on the following influences, see [Figure 6-310](#):

- Through a synchrocheck if the circuit breaker was opened during the 3-pole dead time
- Through the readiness of the circuit breaker signaled through the binary input
- Through a binary input for delaying the close command (*>Delay close cmd.*)

The *Close cmd. indication* is a requirement to issue the actual close command to the circuit breaker. The mentioned criteria must not be fulfilled directly after expiration of the dead time. If a dead-time prolongation is set, the mentioned criteria will be checked during the prolongation time. With the release of the closing indication, the Automatic reclosing function switches to the **reclaim time** state.

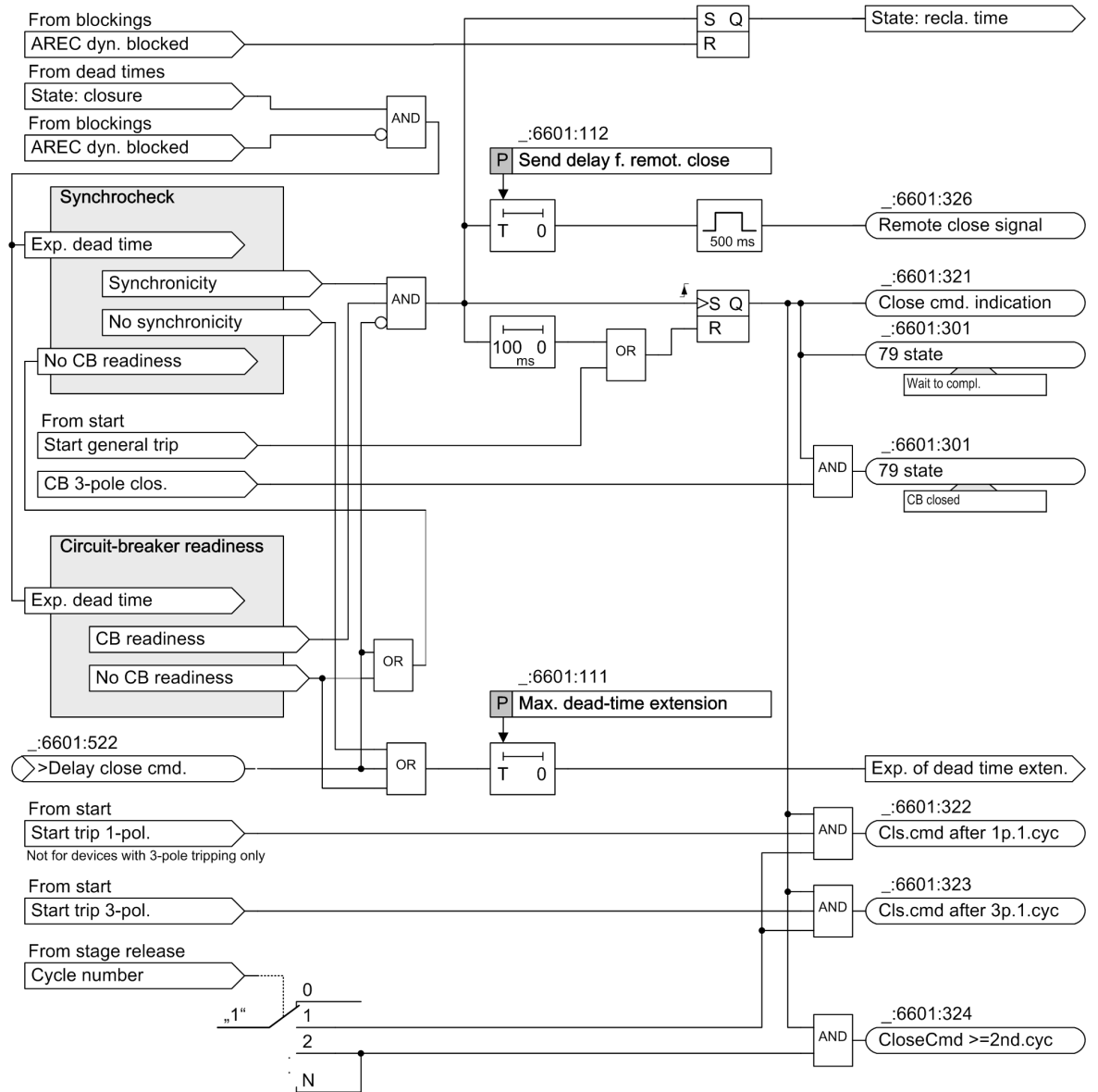

[to_einsha, 1, en_US]

Figure 6-310 Cyclic Automatic Reclosing: Logic for the Closing Indication

Testing the Circuit-Breaker Readiness Directly before Closing

For each of the configured automatic reclosing cycles, you can set whether a circuit-breaker readiness test is to be carried out directly before closing (parameter **CB ready check bef.close**, [Figure 6-311](#)). Independently of this, a circuit-breaker readiness test can be carried out before the start of the 1st automatic reclosing cycle; see [6.46.4.5 Start](#) and [6.46.4.16 Circuit-Breaker Readiness and Circuit-Breaker Position](#).

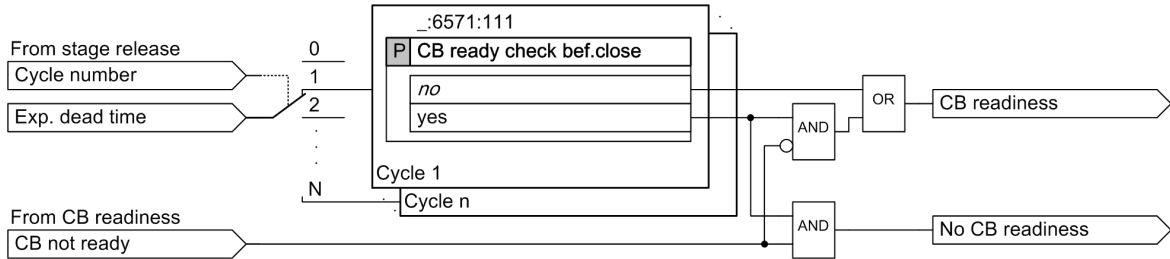

[lo_is_voel, 1, en_US]

Figure 6-311 Cyclic Reclosing Function: Logic for the Query of the Circuit-Breaker Readiness Directly before Closing

Synchrocheck

For each of the configured automatic reclosing cycles, you can set whether a synchrocheck is to be carried out, and which functionality is to be used here; see [Figure 6-312](#). You can only use the internal synchrocheck if the device is connected to a voltage transformer.

Alternatively, you can also connect an external device with synchrocheck through a binary input.

The measuring request for the synchrocheck is placed if the optional test of the circuit-breaker readiness was positive. The measuring request for the synchrocheck exists until the synchrocheck assigns the allowance for the closure. If the allowance is not given within the set maximum dead time extension, the closure will be cancelled through the blocking of the Automatic reclosing function. The minimum duration of the measuring request is 50 ms.

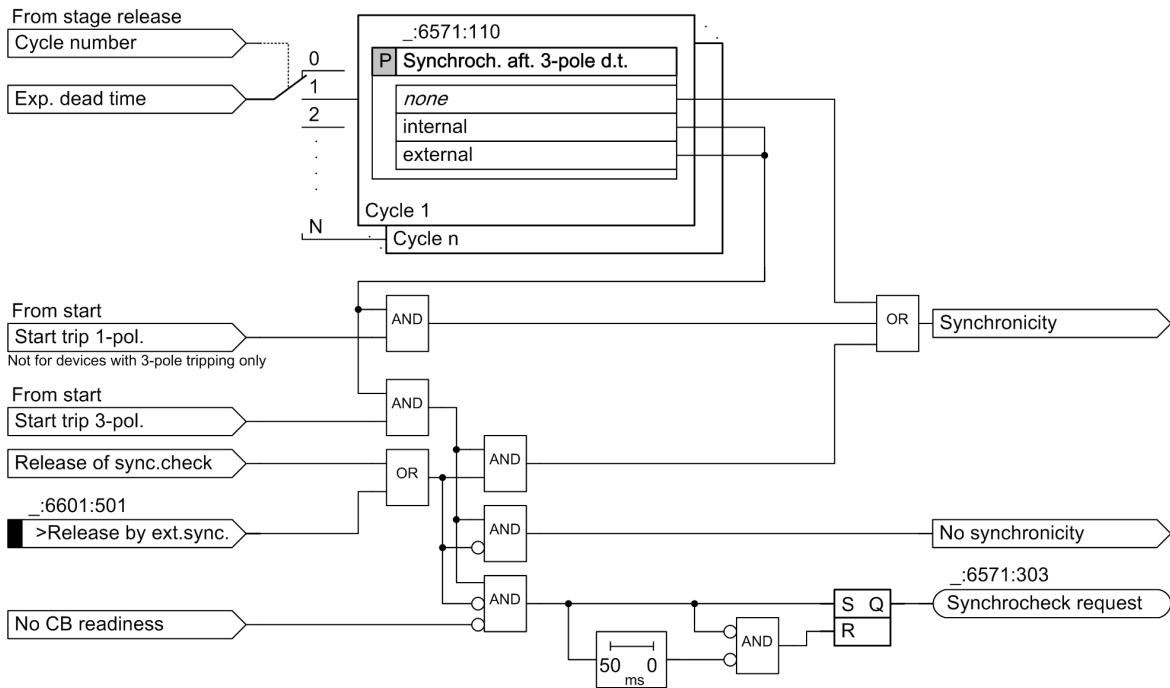

[lo_syncro, 1, en_US]

Figure 6-312 Cyclic Reclosing Function: Logic for the Query of the Synchronism

Close Command

As soon as the test of the circuit-breaker readiness and the synchrocheck deliver a positive result, the closing indication will be created. It will be assigned for 100 ms. The actual close command is not created by the Automatic reclosing function, but rather from the circuit-breaker function block outside of the Automatic reclosing function. Here the set maximum duration of the close command is also considered.

In addition to the closing indication, additional indications will be created that describe the type of closure. These include:

- Close command after 1-pole tripping in the 1st cycle (*cls.cmd after 1p.1.cyc*)
- Close command after 3-pole tripping in the 1st cycle (*cls.cmd after 3p.1.cyc*)
- Close command after 1-pole or 3-pole tripping starting with the 2nd cycle (*CloseCmd >=2nd.cyc*)

Generation of the Signal Remote close signal

The cyclic automatic reclosing function can generate the information *Remote close signal*. This information can be transferred to the protection device as a binary signal on the line to be protected on the opposite end and processed by the AREC function there in the operating mode **Adaptive dead time (ADT)**.

The information *Remote close signal* is generated by the closing logic. It can be delayed by a set time over the local close indication. With this delay, you can make sure that information is only set if the automatic reclosing was successful and there was no further tripping. The pulse duration of the inter-close signal has a fixed length of 500 ms.

6.46.4.15 Reclaim Time

With the assignment of the close command, the automatic reclosing function goes into the **reclaim time** state. During this time, it is decided if the current reclosing cycle was successful or not.

- If during the reclaim time no further tripping occurs, the currently running automatic reclosing cycle, and thus the entire automatic reclosing, was successful.
- If during the reclaim time another tripping occurred, the currently running automatic reclosing cycle was not successful. If other AREC cycles are permitted, one of these cycles will be used to continue the process. If, in contrast, the currently executed cycle was the last permissible cycle, the automatic reclosing process will end and be reported as unsuccessful.

In both cases, the automatic reclosing function switches back to the idle state **automatic reclosing function ready**.

Short Circuits during Running Reclaim Time

A trip command that occurs during a reclaim time leads to a cancellation of the reclaim time. If further AREC cycles are allowed, the regulation of the next cycle depends on whether the automatic reclosing function is executed in an operating mode **without action times** or **with action times**, see [Figure 6-313](#).

- For operating modes **with action time**, the action times of all higher cycles are started with the beginning of the new general pickup if these are not blocked. The cycle with the lowest cycle number is selected, whose action time is not yet expired with the incoming operate indication. If no further cycles are possible or if the action times of all possible cycles are expired before the trip indication, there will be no further reclosing.
- For the operating modes **without action time**, the cycle following the current cycle will always be selected in the set cycle. If this is blocked, the cycle following this one will be selected, etc. If no higher cycles exist or if they are all blocked, there will be no further automatic reclosing.

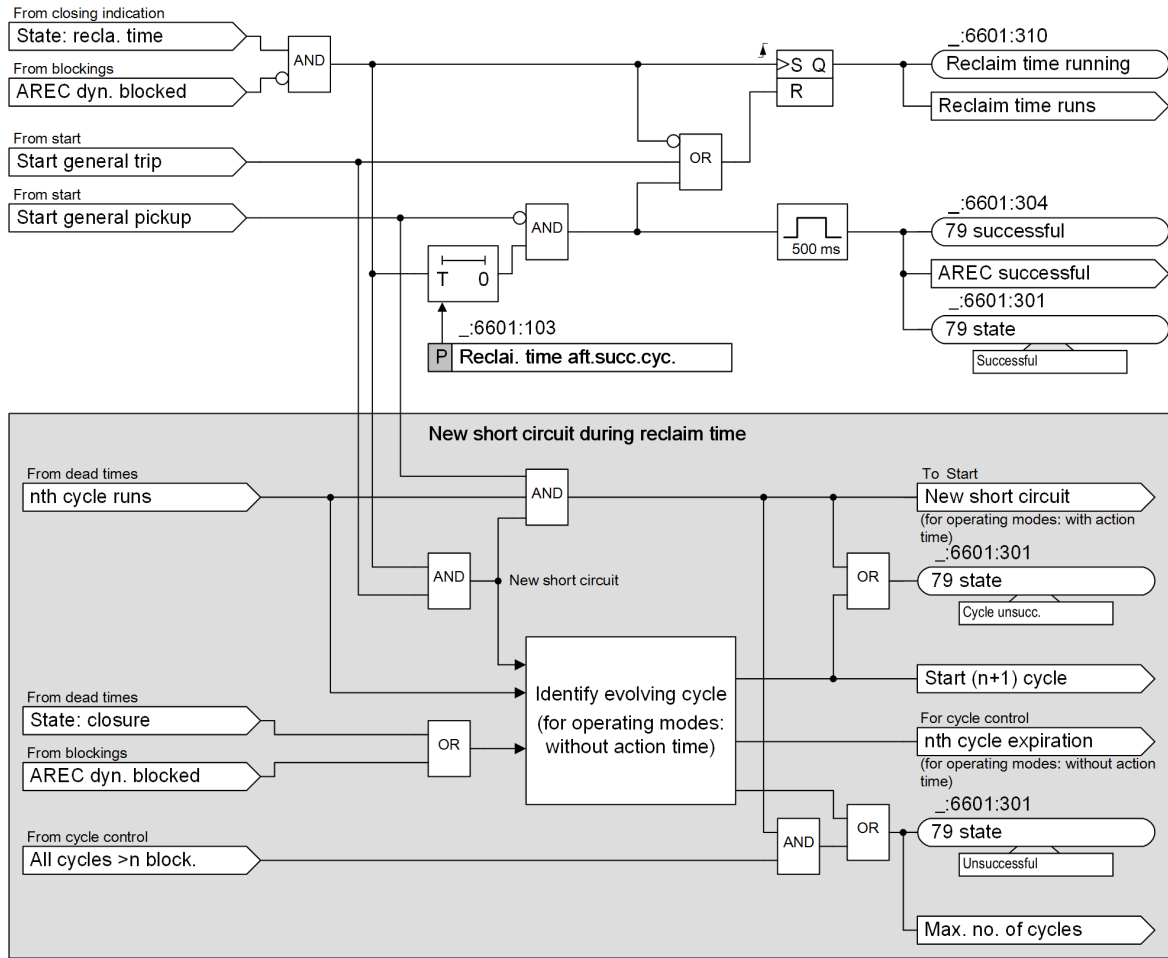

Figure 6-313 Cyclic Automatic Reclosing: Logic for the Reclaim Time

After unsuccessful automatic reclosing with thermal automatic reclosing function, the corresponding, next-higher cycle is started.

6.46.4.16 Circuit-Breaker Readiness and Circuit-Breaker Position

The Automatic reclosing function needs circuit-breaker readiness for the following purposes, see [Figure 6-314](#):

- Recognition of the circuit-breaker readiness before starting:
 In idle state of the Automatic reclosing function, an unavailable circuit breaker leads to the blocking of the Automatic reclosing function. This monitoring is optional and must be switched off through settings if the readiness signal is not available for the protection device.
- Analysis of the circuit-breaker readiness directly before the close command:
 For each of the configured automatic reclosing cycles, it can be set whether the circuit-breaker readiness is a requirement for the assignment of the close command. This monitoring is also optional.

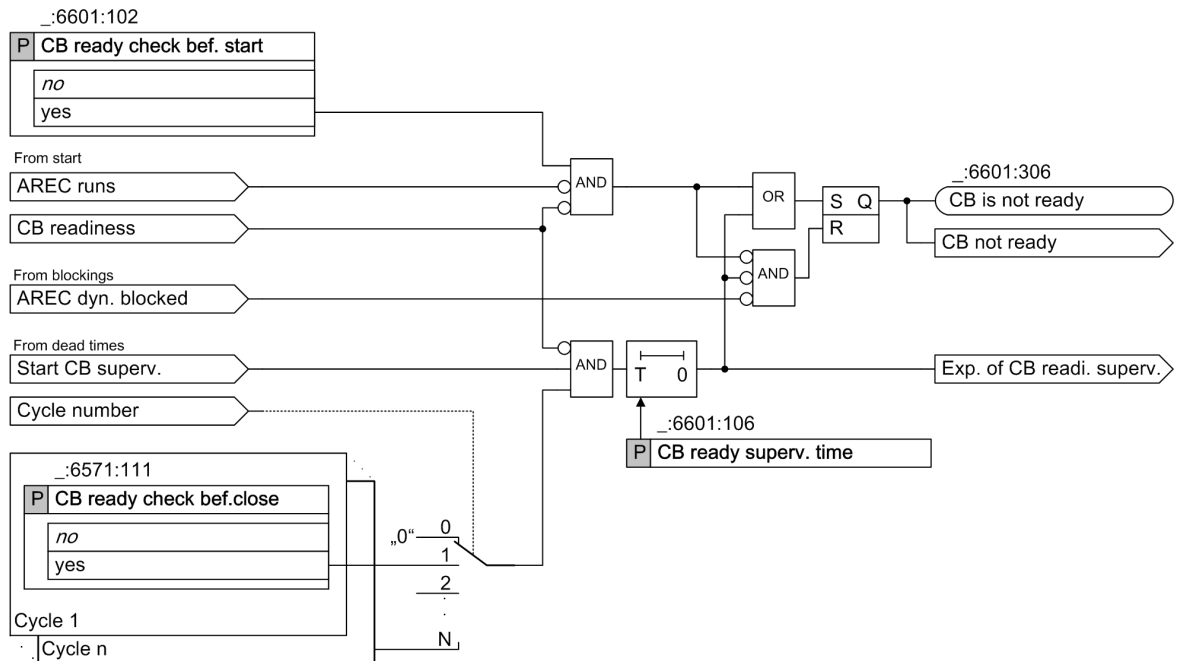

(no_kbere, 1, en_US)

Figure 6-314 Cyclic Automatic Reclosing: Logic for the Circuit-Breaker Readiness

With the thermal automatic reclosing function the setting value of the parameter **CB ready check bef. close** applies to all cycles.

The Automatic reclosing function uses the circuit-breaker position information for the following purposes (see [Figure 6-315](#)):

- **Detection of a non-closed circuit breaker before the start:**
When the Automatic reclosing function is in idle state, a not 3-pole closed circuit breaker leads to the blocking of the Automatic reclosing function; see also [6.46.4.17 Blockings](#). This monitoring is not needed if the auxiliary-contact signals are unavailable.
- **Detection of the reaction of the circuit breaker after a trip command:**
The Automatic reclosing function dead time is started immediately with the opening of the circuit breaker if the circuit-breaker auxiliary contacts are connected. Here a decision is made regarding the opening of the circuit breaker if the circuit breaker is no longer closed as 3-pole.
An exception is the reaction to an evolving fault. As the circuit breaker already has 1 pole open before the occurrence of an evolving fault, the dead time is started if the circuit breaker is detected as having 3 poles open.
If the circuit-breaker auxiliary contacts are not connected, the Automatic reclosing function dead time will start with the dropout of the operate indication.
- **After a 1-pole tripping, a check is done during the dead time to determine whether the circuit-breaker poles that were not switched off remain closed. The circuit-breaker position recognition is delivered from the central circuit-breaker position recognition of the Circuit-breaker function group.**
For an implausible circuit-breaker position, a 3-pole coupling of the trip command for the circuit breaker is executed, provided the settings allow this. After this 3-pole tripping, further 3-pole automatic reclosing cycles can follow, provided they are parameterized accordingly and not blocked; see also [6.46.4.11 Dead Time for Operating Modes with Tripping](#).

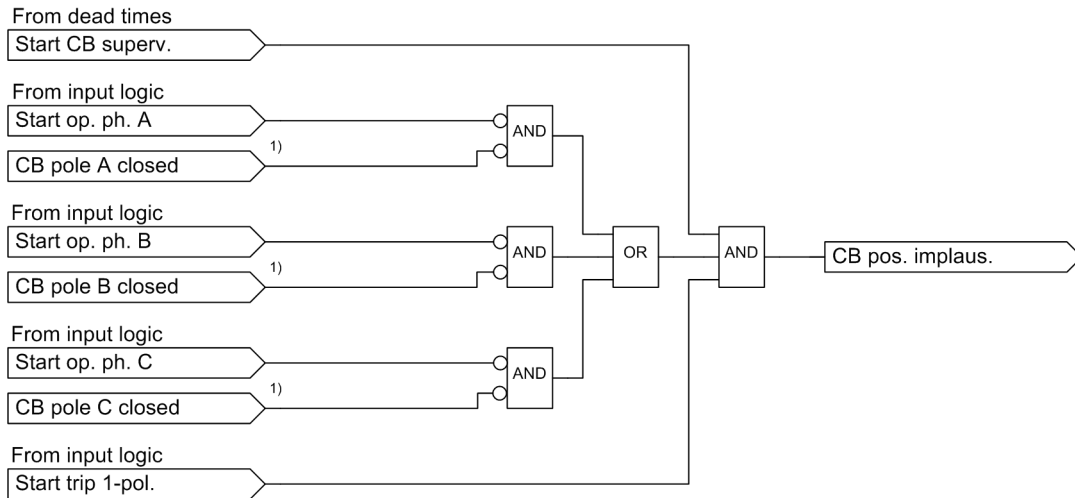

¹⁾ From circuit-breaker position recognition

[lo_isuebe, 1, en_US]

Figure 6-315 Cyclic Automatic Reclosing: Logic for Circuit-Breaker Position and Supervision

6.46.4.17 Blockings

The Automatic reclosing function differentiates between 2 types of blockings, see [Figure 6-316](#):

- Static blocking
- Dynamic blocking

Static Blocking

The Automatic reclosing function is *statically blocked* if the function is switched on, but is not ready for reclosing and also cannot be started as long as this blocking is present. The static blocking is signaled with the indication *Inactive*.

The following conditions lead to the static blocking:

Condition	Indication
Manual closing of the circuit breaker, recognition through binary input or internal device control. The blocking is temporary, the duration can be set with the parameter Block. time aft. man.close.	Inactive
Circuit breaker not available for automatic reclosing function, recognition through binary input. This cause can be switched on or off through the parameter CB ready check bef.close.	Inactive

Condition	Indication
Circuit breaker not closed for 3-pole, recognition through binary input. This criteria is used if the circuit-breaker auxiliary contacts are connected.	Inactive
No reclosing cycle possible Recognition due to the following causes: <ul style="list-style-type: none"> • Automatic reclosing cycle is not set. • Automatic reclosing cycles are set, but all are blocked, for example, via binary input. • No device-internal function and binary input have been configured for starting the automatic reclosing function. • With operating modes with tripping: <ul style="list-style-type: none"> – both 1-pole and 3-pole cycles are blocked via binary inputs • With operating modes with pickup: <ul style="list-style-type: none"> – 1-phase, 2-phase and 3-phase automatic reclosing cycles are blocked via binary inputs. • With operating modes without action time: <ul style="list-style-type: none"> – the first automatic reclosing cycle is blocked via binary input. • With the dead-line check functionality: <ul style="list-style-type: none"> – if the voltage measurement is not available or is disrupted. 	Inactive

Dynamic Blocking

The automatic reclosing function is *dynamically blocked* if a blocking condition occurs while an automatic reclosing function is already running. The dynamic blocking is signaled with the indication *Not ready*.

After the occurrence of a dynamic blocking, it is checked at intervals of 0.5 s to see if the blocking can be removed. If the blocking condition remains or if a different blocking condition occurs in the meantime, the blocking will remain. If, in contrast, the cause of the blocking disappears, the dynamic blocking will be removed if no general pickup or no tripping configured for the automatic reclosing function start is available.

A separate indication for logging exists for each individual blocking cause.

The following conditions lead to the dynamic blocking:

Condition	Indication
<p>If no reclosing cycle fitting the fault type is released:</p> <ul style="list-style-type: none"> • With operating modes with tripping: If a 1-pole or 3-pole operate indication occurs at the automatic reclosing function start input, however, the automatic reclosing function does not start in accordance with the parameterization for this type of tripping, the respective dead time will be set to invalid. • With operating modes with pickup: If a 1-phase, 2-phase or 3-phase pickup indication occurs during the automatic reclosing function starting process, but the automatic reclosing function may not be started in accordance with the parameterization for this type of pickup. 	<p><i>Not ready</i> <i>Block. by no cycle</i></p>
<p>If a protection function configured to block the automatic reclosing function operates.</p>	<p><i>Not ready</i> <i>Block. by protection</i></p>
<p>If the maximum set waiting time for the delay of the start of the dead time through the binary input expires without the binary input <i>>Dead time start delay</i> becoming inactive during this period of time.</p>	<p><i>Not ready</i> <i>Blk.by max. d.t. delay</i></p>
<p>If the synchrocheck is set and the synchronism conditions after the expiration of the maximum dead-time extension are not fulfilled before the assignment of the close command.</p>	<p><i>Not ready</i> <i>Blk.by max.d.t. expiry</i></p>
<p>If the query of the circuit-breaker readiness is switched on directly before the close command through the parameter and the maximum dead-time extension expires.</p>	<p><i>Not ready</i> <i>Blk.by CB ready sup.</i></p>
<p>If the closing indication is delayed through the binary input <i>>Delay close cmd.</i> for so long until the maximum dead time extension is exceeded before the assignment of the close command</p>	<p><i>Not ready</i> <i>Blk.by max.d.t. expiry</i></p>
<p>If an evolving fault occurs and the parameter Response to evolv. faults is set to blocks 79</p>	<p><i>Not ready</i> <i>Blk. by evolving fault</i></p>
<p>If the start-signal supervision time for the operate indication starting from the automatic reclosing function or the starting binary input expires. In this case, a circuit-breaker failure is assumed.</p>	<p><i>Not ready</i> <i>Blk.by strtsig.superv.</i></p>
<p>If after the start of the automatic reclosing function a dead time is already running and a blocking binary input is active, with the following binary inputs: <i>>Blk. 1-pole AR, >Blk. 3-pole AR, >Blk. with 1-ph pickup, >Blk. with 2-ph pickup, >Blk. with 3-ph pickup</i></p>	<p><i>Not ready</i> <i>Block. by binary input</i></p>
<p>If the maximum number of automatic reclosing attempts is reached and there is a trip command within the reclaim time</p>	<p><i>Not ready</i> <i>Block. by max. cycles</i></p>
<p>With operating modes with action time: If the action times of all released automatic reclosing cycles expire without a trip command</p>	<p><i>Not ready</i> <i>Blk.by action time exp</i></p>

Condition	Indication
For applications with voltage measurement and switched on functionality with dead-line check : If during the dead time the required voltage criteria is not fulfilled	<i>Not ready</i> <i>Blk.by dead-line check</i>
For applications with voltage measurement and switched on functionality with dead-line check : If during a running automatic reclosing cycle a failure of the measuring voltage is determined. After the completion of the automatic reclosing cycle, the dynamic blocking becomes static blocking if there is a continued failure of the measuring voltage.	<i>Not ready</i> <i>Blk.by loss of voltage</i>

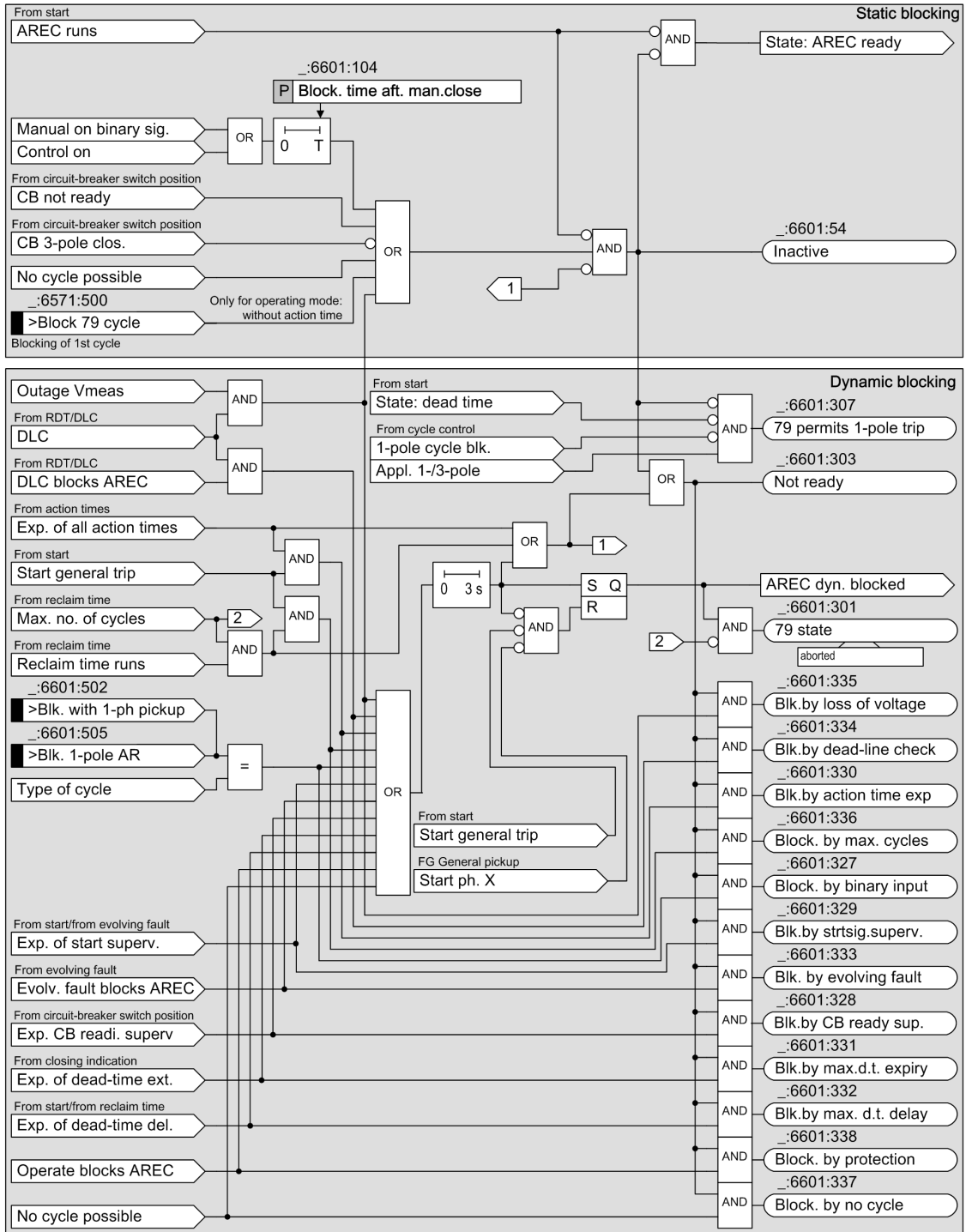

Figure 6-316 Cyclic Automatic Reclosing: Blocking Logic in the Example for a 1-Pole Cycle (Static and Dynamic Blocking)

6.46.4.18 Dead-Line Checking (DLC) and Reduced Dead Time (RDT)

The additional functions **Dead-line check (DLC)** and **Reduced dead time (RDT)**, are only possible for applications with a voltage-transformer connection. Another requirement is that the voltage of the line being switched on can be correctly measured with an open circuit breaker. This is only possible if the voltage transformer is aligned on the line-side - seen from the circuit breaker.

Both additional functions DLC and RDT are mutually exclusive, because the DLC checks if the value falls below a voltage threshold, while the RDT checks if the value exceeds the voltage threshold.
The respectively selected additional function runs in the automatic reclosing state **dead time**.

Reduced Dead Time (RDT)

With the **Reduced dead time**, a close command can be assigned before the expiration of the set dead times if the line to switch on is recognized as fault-free through the measurement of the line voltage.

The voltage measurement occurs with the 3 phase-to-phase-voltages.

In systems with a grounded neutral point, the 3 phase-to-ground voltages are additionally observed.

In systems with compensated or with isolated neutral points, the largest 2 of the 3 phase-to-ground voltages are additionally considered. Through this, a RDT can also be executed with 1-phase ground connections.

For the approval of the close command with RDT, the following conditions apply:

- The automatic reclosing function is in the state **dead time**.
- Each measured voltage is above the set threshold values **Volt. thres.f. live line/bus**
The phase-to-phase voltages are divided by $\sqrt{3}$ prior to comparing the threshold value. Thus, the phase-to-ground voltage $U_N\sqrt{3}$ applies as the reference size for the parameterization.
- Exceeding the threshold is fulfilled for the set duration **Voltage supervision time**.

Dead-Line Check (DLC)

If after switching off a short-circuit the voltage on the switched off line does not disappear, the automatic reclosing function can be avoided with the **dead-line check (DLC)**.

The voltage measurement occurs with the 3 phase-to-ground voltages.

For the release of the close command with DLC, the following conditions apply:

- The automatic reclosing function is in the state **dead time**.
- All measured voltages for the set duration **Voltage supervision time** are below the set threshold **Volt. thres.f. live line/bus**.
- The set dead time is expired.

As soon as the voltages fall below the threshold value for the set duration, the allowance for automatic reclosing with DLC is assigned. This also applies if the values are not below the voltage threshold until the expiration of the set dead time. In this way, an automatic reclosing is executed if the automatic reclosing function is first switched to at the end of the protected line and thus, the line is exposed to voltage again.

The automatic reclosing function is blocked by the DLC under the following conditions:

- The automatic reclosing function is in the **Closure** state, the dead time has expired
- All measured voltages were not simultaneously below the set threshold values **Volt. thres. f. dead line/bus** for the set duration **Voltage supervision time** during the dead time.

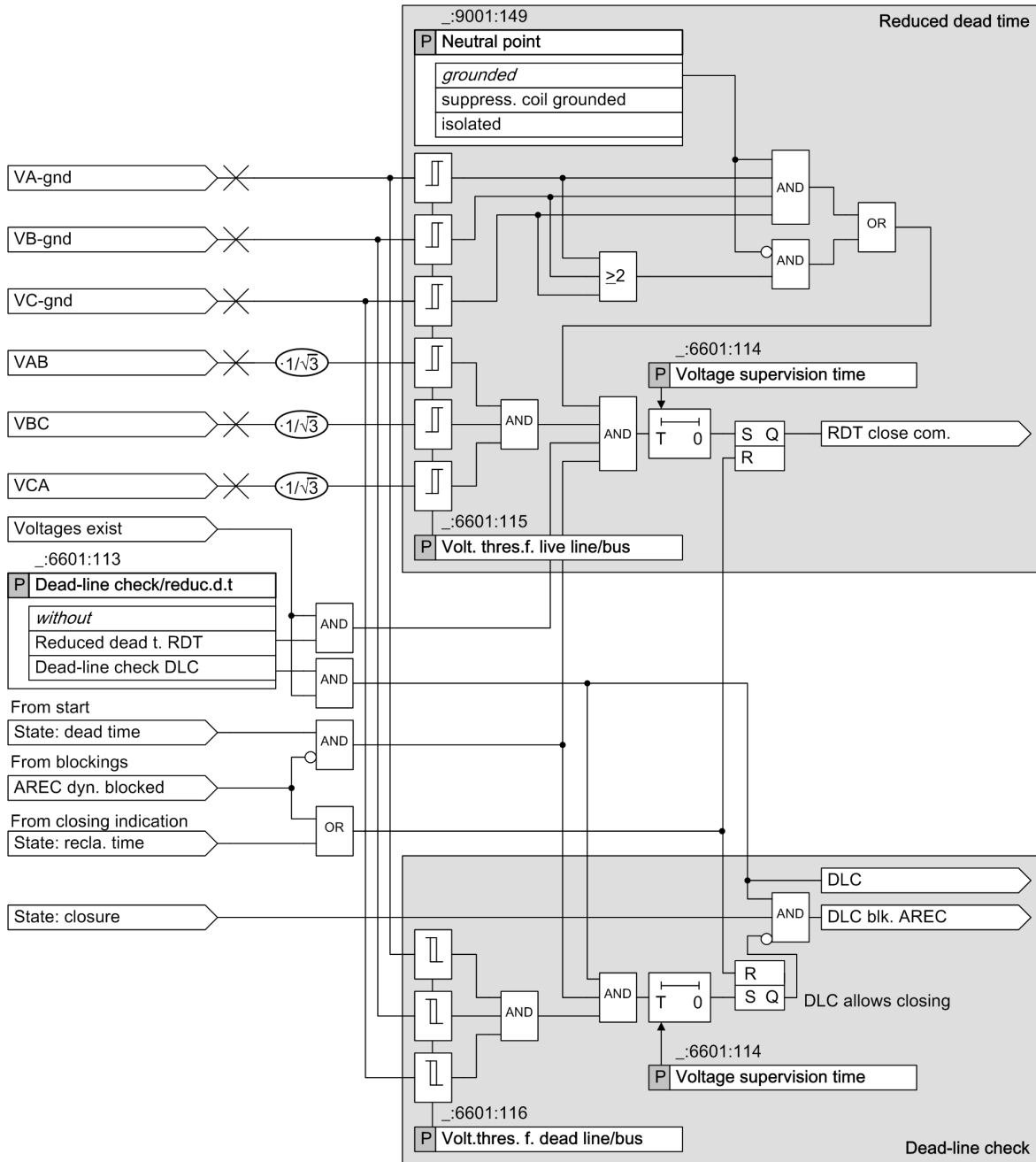

[io_vrkarc, 1, en_US]

Figure 6-317 Cyclic Reclosing Function: Logic for the Functions of Reduced Dead Time and Dead-Line Check

6.46.4.19 Settings

Addr.	Parameter	C	Setting Options	Default Setting
General				
_:6601:1	General:Mode		<ul style="list-style-type: none"> • off • on • test 	on

Addr.	Parameter	C	Setting Options	Default Setting
_:6601:101	General:79 operating mode		<ul style="list-style-type: none"> with op., w/o act. time with op., with act. time w.pickup, w/o act. time w.pickup, w. action time 	with op., with act. time
_:6601:102	General:CB ready check bef. start		<ul style="list-style-type: none"> no yes 	no
_:6601:103	General:Reclai. time aft.succ.cyc.		0.50 s to 300.00 s	3.00 s
_:6601:104	General:Block. time aft. man.close		0.00 s to 300.00 s	1.00 s
_:6601:105	General:Start signal supervis.time		0.01 s to 300.00 s	0.13 s
_:6601:106	General:CB ready superv. time		0.01 s to 300.00 s	3.00 s
_:6601:107	General:3-pole operate by 79		<ul style="list-style-type: none"> no yes 	yes
_:6601:108	General:Evolving-fault detection		<ul style="list-style-type: none"> with trip with pickup 	with trip
_:6601:109	General:Response to evolv. faults		<ul style="list-style-type: none"> strt. evol.flt.dead time blocks 79 	blocks 79
_:6601:110	General:Max. dead-time delay		0.01 s to 300.00 s	0.50 s
_:6601:111	General:Max. dead-time extension		0.00 s to 300.00 s; ∞	1.20 s
_:6601:112	General:Send delay f. remot. close		0.00 s to 300.00 s; ∞	∞
DLC, RDT				
_:6601:113	General:Dead-line check/reduc.d.t		<ul style="list-style-type: none"> without Reduced dead t. RDT Dead-line check DLC 	without
_:6601:114	General:Voltage supervision time		0.10 s to 30.00 s	0.10 s
_:6601:115	General:Volt. thres.f. live line/bus		0.300 V to 340.000 V	48.000 V
_:6601:116	General:Volt.thres. f. dead line/bus		0.300 V to 340.000 V	30.000 V
Cycle 1				
_:6571:102	Cycle 1:Start from idle state allow.		<ul style="list-style-type: none"> no yes 	yes
_:6571:103	Cycle 1:Action time		0.00 s to 300.00 s; ∞	0.20 s
_:6571:108	Cycle 1:Dead time aft. 3-pole trip		0.00 s to 1800.00 s; ∞	0.50 s
_:6571:107	Cycle 1:Dead time aft. 1-pole trip		0.00 s to 1800.00 s; ∞	1.20 s
_:6571:104	Cycle 1:Dead time aft.1ph. pickup		0.00 s to 1800.00 s; ∞	1.20 s
_:6571:105	Cycle 1:Dead time aft.2ph. pickup		0.00 s to 1800.00 s; ∞	1.20 s

Addr.	Parameter	C	Setting Options	Default Setting
_.6571:106	Cycle 1:Dead time aft.3ph. pickup		0.00 s to 1800.00 s; ∞	0.50 s
_.6571:109	Cycle 1:Dead time aft. evolv. fault		0.01 s to 1800.00 s	1.20 s
_.6571:111	Cycle 1:CB ready check bef.close		<ul style="list-style-type: none"> • no • yes 	no
_.6571:110	Cycle 1:Synchroch. aft. 3-pole d.t.		<ul style="list-style-type: none"> • none • internal • external 	none
_.6571:112	Cycle 1:Intern. synchro-check with		Setting options depend on configuration	

6.46.4.20 Information List

No.	Information	Data Class (Type)	Type
General			
_.6601:51	General:Mode (controllable)	ENC	C
_.6601:87	General:>Function off	SPS	I
_.6601:524	General:>Function on	SPS	I
_.6601:347	General:Function on	SPC	C
_.6601:82	General:>Block function	SPS	I
_.6601:501	General:>Release by ext.sync.	SPS	I
_.6601:502	General:>Blk. with 1-ph pickup	SPS	I
_.6601:503	General:>Blk. with 2-ph pickup	SPS	I
_.6601:504	General:>Blk. with 3-ph pickup	SPS	I
_.6601:505	General:>Blk. 1-pole AR	SPS	I
_.6601:506	General:>Blk. 3-pole AR	SPS	I
_.6601:507	General:>Pickup A for start	SPS	I
_.6601:508	General:>Pickup B for start	SPS	I
_.6601:509	General:>Pickup C for start	SPS	I
_.6601:510	General:>Pickup 1ph for start	SPS	I
_.6601:511	General:>Pickup 2ph for start	SPS	I
_.6601:512	General:>Pickup 3ph for start	SPS	I
_.6601:513	General:>Gen. pickup for start	SPS	I
_.6601:514	General:>General trip for start	SPS	I
_.6601:515	General:>Trip pole A for start	SPS	I
_.6601:516	General:>Trip pole B for start	SPS	I
_.6601:517	General:>Trip pole C for start	SPS	I
_.6601:518	General:>Trip 1-pole for start	SPS	I
_.6601:519	General:>Trip 3-pole for start	SPS	I
_.6601:520	General:>Evolving fault start	SPS	I
_.6601:521	General:>Dead time start delay	SPS	I
_.6601:522	General:>Delay close cmd.	SPS	I
_.6601:52	General:Behavior	ENS	O
_.6601:53	General:Health	ENS	O
_.6601:54	General:Inactive	SPS	O
_.6601:301	General:79 state	ENS	O

No.	Information	Data Class (Type)	Type
_:6601:302	General:Actual reclose cycle	INS	O
_:6601:303	General:Not ready	SPS	O
_:6601:304	General:79 successful	SPS	O
_:6601:305	General:CB ready superv.expir	SPS	O
_:6601:306	General:CB is not ready	SPS	O
_:6601:307	General:79 permits 1-pole trip	SPS	O
_:6601:308	General:AR only after 1p. trip	SPS	O
_:6601:309	General:In progress	SPS	O
_:6601:310	General:Reclaim time running	SPS	O
_:6601:311	General:Start sig. superv.exp.	SPS	O
_:6601:313	General:Evolv.-fault detected	SPS	O
_:6601:314	General:RDT CloseCmd indicat.	SPS	O
_:6601:315	General:Dead t. aft.1pole trip	SPS	O
_:6601:316	General:Dead t. aft.3pole trip	SPS	O
_:6601:317	General:Dead t. aft.1ph pickup	SPS	O
_:6601:318	General:Dead t. aft.2ph pickup	SPS	O
_:6601:319	General:Dead t. aft.3ph pickup	SPS	O
_:6601:320	General:Dead t. aft.evolv.flt.	SPS	O
_:6601:321	General:Close cmd. indication	ACT	O
_:6601:322	General:Cls.cmd after 1p.1.cyc	SPS	O
_:6601:323	General:Cls.cmd after 3p.1.cyc	SPS	O
_:6601:324	General:CloseCmd >=2nd.cyc	SPS	O
_:6601:325	General:3-pole operate by 79	SPS	O
_:6601:326	General:Remote close signal	SPS	O
_:6601:327	General:Block. by binary input	SPS	O
_:6601:328	General:Blk.by CB ready sup.	SPS	O
_:6601:329	General:Blk.by strtsig.superv.	SPS	O
_:6601:330	General:Blk.by action time exp	SPS	O
_:6601:331	General:Blk.by max.d.t. expiry	SPS	O
_:6601:332	General:Blk.by max. d.t. delay	SPS	O
_:6601:333	General:Blk. by evolving fault	SPS	O
_:6601:337	General:Block. by no cycle	SPS	O
_:6601:338	General:Block. by protection	SPS	O
_:6601:334	General:Blk.by dead-line check	SPS	O
_:6601:335	General:Blk.by loss of voltage	SPS	O
_:6601:336	General:Block. by max. cycles	SPS	O
_:6601:339	General:Cyc1 1p AR	INS	O
_:6601:340	General:Cyc1 3p AR	INS	O
_:6601:341	General:Cyc2+ 1p AR	INS	O
_:6601:342	General:Cyc2+ 3p AR	INS	O
Cycle 1			
_:6571:51	Cycle 1:Mode (controllable)	ENC	C
_:6571:500	Cycle 1:>Block 79 cycle	SPS	I
_:6571:52	Cycle 1:Behavior	ENS	O
_:6571:53	Cycle 1:Health	ENS	O
_:6571:301	Cycle 1:Cycle running	SPS	O

No.	Information	Data Class (Type)	Type
_:6571:302	Cycle 1:Stage release prot.	SPS	O
_:6571:303	Cycle 1:Synchrocheck request	SPS	O

6.46.5 Automatic Reclosing Function with Adaptive Dead Time (ADT)

6.46.5.1 Description

Description

It is also possible to set the dead times only at one line end and to configure the adaptive dead time at the other end or ends. The requirements for this is that the voltage transformer aligned on the line side or a possibility to transfer a close command to a remote line end exists.

Figure 6-318 shows an example with a voltage measurement. It is assumed that device I works with defined dead times, while the adaptive dead time is configured in device II. It is important that the line is at least fed from busbar A, so from the side with the defined dead times.

With the adaptive dead time, the automatic reclosing function at the line end II decides independently if and when a reclosing is reasonable and permissible and when it is not. The criteria is the voltage of the line at the end II, which is switched through after reclosing from end I. The reclosing at end II occurs, as soon as it exists, so that the line from end I is set back under voltage. Basically, all phase-to-phase and phase-to-ground voltages are monitored.

With an implied short-circuit, the lines at the positions I, II, and III in the example are switched off. Position I is switched on again after the dead time set there. At position III the reduced dead time (RDT) can be executed with the appropriate configuration (see chapter) if an infeed is also available on busbar B.

If the short circuit has been cleared after successful reclosing, the line A-B from the busbar A will be set under voltage through the position I. Device II recognizes this voltage and switches on to warrant adequate voltage measurement time after a short delay The system incident is thus successfully cleared.

If the short circuit is not cleared after closure at position I, I will be switched to the fault again. At line end II, now no healthy voltage will appear. The device here recognizes this and does not close again.

With multiple reclosing, the process may repeat if the reclosing is unsuccessful until one of the reclosings is successful or a final disconnection occurs.

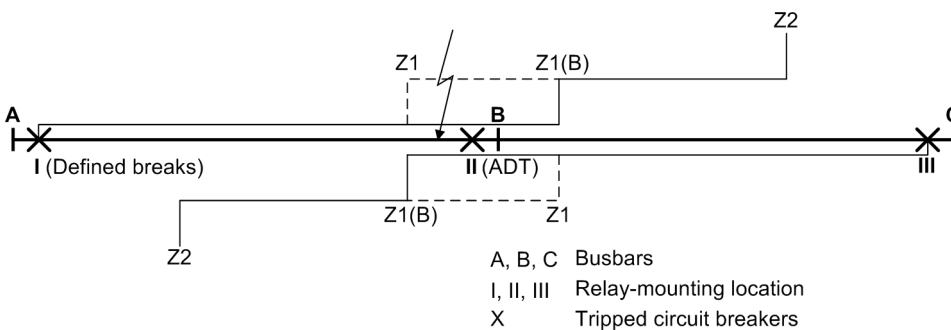

[dw_arcasp, 1, en_US]

Figure 6-318 Example for Adaptive Dead Time (ADT)

As the example shows, the adaptive dead time brings along the following advantages:

- The circuit breaker at position II does not switch off again with a remaining fault and is protected through this.
- With non-selective tripping by overreach at position III, no further disruption cycles may occur here because the short-circuit path via busbar B and the position II remains disrupted even with multiple reclosing.
- At position I, with multiple reclosing and even with a final tripping, an overlapping is allowed, because the line at position II remains open and thus, no actual overreaching can occur at position I.

The adaptive dead time also contains the reduced dead time (RDT), because the criteria are the same. A special setting of the reduced dead time (RDT) is unnecessary if the automatic reclosing function is used with adaptive dead time (ADT).

6.46.5.2 Settings

Addr.	Parameter	C	Setting Options	Default Setting
General				
_:6601:1	General:Mode		<ul style="list-style-type: none"> • off • on • test 	on
_:6601:101	General:79 operating mode		<ul style="list-style-type: none"> • with op., w/o act. time • with op., with act. time • w.pickup, w/o act. time • w.pickup, w. action time 	with op., with act. time
_:6601:102	General:CB ready check bef. start		<ul style="list-style-type: none"> • no • yes 	no
_:6601:103	General:Reclai. time aft.succ.cyc.		0.50 s to 300.00 s	3.00 s
_:6601:104	General:Block. time aft. man.close		0.00 s to 300.00 s	1.00 s
_:6601:105	General:Start signal supervis.time		0.01 s to 300.00 s	0.13 s
_:6601:106	General:CB ready superv. time		0.01 s to 300.00 s	3.00 s
_:6601:107	General:3-pole operate by 79		<ul style="list-style-type: none"> • no • yes 	yes
_:6601:111	General:Max. dead-time extension		0.00 s to 300.00 s; ∞	1.20 s
_:6601:114	General:Voltage supervision time		0.10 s to 30.00 s	0.10 s
_:6601:115	General:Volt. thres.f. live line/bus		0.300 V to 340.000 V	48.000 V
ADT				
_:6631:101	ADT:1-pole trip allowed		<ul style="list-style-type: none"> • no • yes 	no
_:6631:104	ADT:Action time		0.00 s to 300.00 s; ∞	0.20 s
_:6631:105	ADT:Maximum dead time		0.50 s to 3000.00 s	5.00 s
_:6631:102	ADT:CB ready check bef.close		<ul style="list-style-type: none"> • no • yes 	no
_:6631:103	ADT:Synchroch. aft. 3-pole d.t.		<ul style="list-style-type: none"> • none • internal • external 	none
_:6631:106	ADT:Intern. synchrocheck with		Setting options depend on configuration	

6.46.5.3 Information List

No.	Information	Data Class (Type)	Type
General			
_.6601:51	General:Mode (controllable)	ENC	C
_.6601:87	General:>Function off	SPS	I
_.6601:524	General:>Function on	SPS	I
_.6601:347	General:Function on	SPC	C
_.6601:82	General:>Block function	SPS	I
_.6601:501	General:>Release by ext.sync.	SPS	I
_.6601:502	General:>Blk. with 1-ph pickup	SPS	I
_.6601:503	General:>Blk. with 2-ph pickup	SPS	I
_.6601:504	General:>Blk. with 3-ph pickup	SPS	I
_.6601:505	General:>Blk. 1-pole AR	SPS	I
_.6601:506	General:>Blk. 3-pole AR	SPS	I
_.6601:507	General:>Pickup A for start	SPS	I
_.6601:508	General:>Pickup B for start	SPS	I
_.6601:509	General:>Pickup C for start	SPS	I
_.6601:510	General:>Pickup 1ph for start	SPS	I
_.6601:511	General:>Pickup 2ph for start	SPS	I
_.6601:512	General:>Pickup 3ph for start	SPS	I
_.6601:513	General:>Gen. pickup for start	SPS	I
_.6601:514	General:>General trip for start	SPS	I
_.6601:515	General:>Trip pole A for start	SPS	I
_.6601:516	General:>Trip pole B for start	SPS	I
_.6601:517	General:>Trip pole C for start	SPS	I
_.6601:518	General:>Trip 1-pole for start	SPS	I
_.6601:519	General:>Trip 3-pole for start	SPS	I
_.6601:522	General:>Delay close cmd.	SPS	I
_.6601:52	General:Behavior	ENS	O
_.6601:53	General:Health	ENS	O
_.6601:54	General:Inactive	SPS	O
_.6601:301	General:79 state	ENS	O
_.6601:302	General:Actual reclose cycle	INS	O
_.6601:303	General:Not ready	SPS	O
_.6601:304	General:79 successful	SPS	O
_.6601:305	General:CB ready superv.expir	SPS	O
_.6601:306	General:CB is not ready	SPS	O
_.6601:307	General:79 permits 1-pole trip	SPS	O
_.6601:308	General:AR only after 1p. trip	SPS	O
_.6601:309	General:In progress	SPS	O
_.6601:310	General:Reclaim time running	SPS	O
_.6601:311	General:Start sig. superv.exp.	SPS	O
_.6601:312	General:Max. dead time expired	SPS	O
_.6601:315	General:Dead t. aft. 1pole trip	SPS	O
_.6601:316	General:Dead t. aft. 3pole trip	SPS	O
_.6601:317	General:Dead t. aft. 1ph pickup	SPS	O
_.6601:318	General:Dead t. aft. 2ph pickup	SPS	O

No.	Information	Data Class (Type)	Type
_:6601:319	General:Dead t. aft.3ph pickup	SPS	O
_:6601:321	General:Close cmd. indication	ACT	O
_:6601:322	General:Cls.cmd after 1p.1.cyc	SPS	O
_:6601:323	General:Cls.cmd after 3p.1.cyc	SPS	O
_:6601:325	General:3-pole operate by 79	SPS	O
_:6601:327	General:Block. by binary input	SPS	O
_:6601:328	General:Blk.by CB ready sup.	SPS	O
_:6601:329	General:Blk.by strtsig.superv.	SPS	O
_:6601:330	General:Blk.by action time exp	SPS	O
_:6601:331	General:Blk.by max.d.t. expiry	SPS	O
_:6601:337	General:Block. by no cycle	SPS	O
_:6601:338	General:Block. by protection	SPS	O
_:6601:335	General:Blk.by loss of voltage	SPS	O
_:6601:336	General:Block. by max. cycles	SPS	O
_:6601:339	General:Cyc1 1p AR	INS	O
_:6601:340	General:Cyc1 3p AR	INS	O
ADT			
_:6631:51	ADT:Mode (controllable)	ENC	C
_:6631:501	ADT:>Remote close signal	SPS	I
_:6631:52	ADT:Behavior	ENS	O
_:6631:53	ADT:Health	ENS	O
_:6631:301	ADT:ADT is running	SPS	O
_:6631:302	ADT:Stage release prot.	SPS	O
_:6631:303	ADT:Synchrocheck request	SPS	O

6.46.6 Cooperation with External Automatic Reclosing Function

6.46.6.1 Description

The operation of an external reclosing device with the SIPROTEC protection device occurs through the function mode **Operation with external automatic reclosing function**. In this function mode, the SIPROTEC protection functions create the trip command and the external reclosing device creates the close command.

The following figure shows the interaction of an external reclosing device with the functions of the SIPROTEC 5 device.

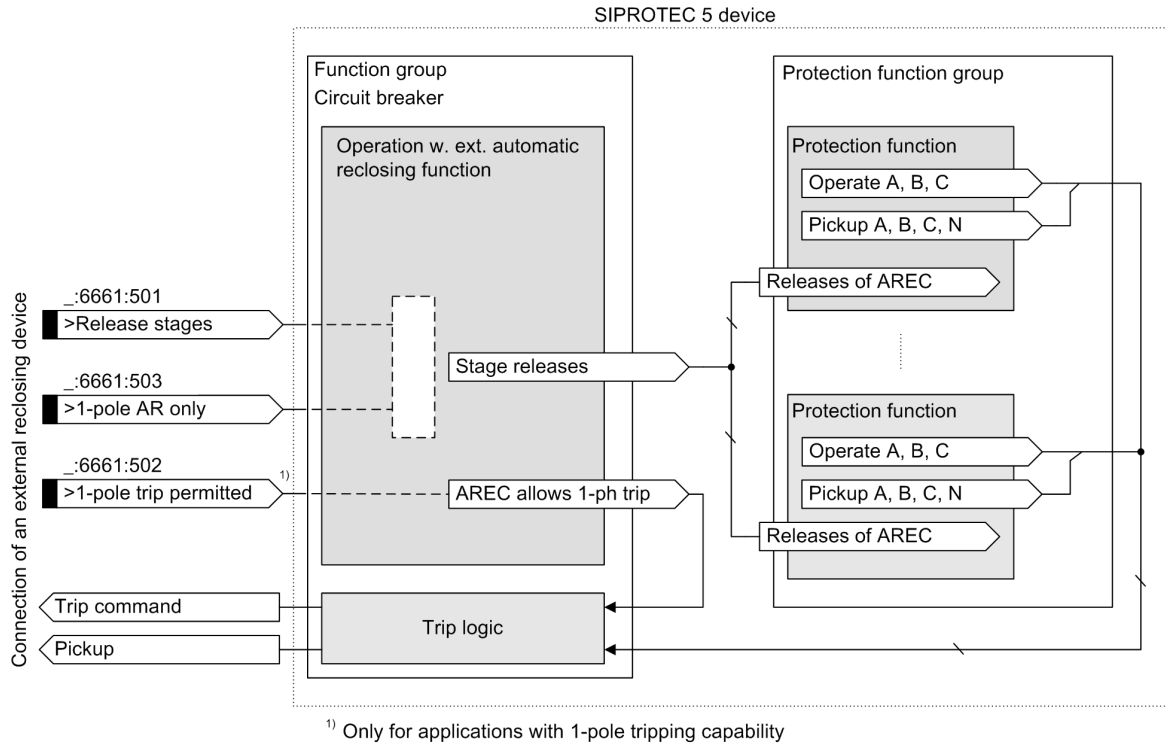

[file_aware_ext_1_en_US]

Figure 6-319 Connection of an External Automatic Reclosing Function

There are no setting parameters for operation with external automatic reclosing functions. The function provides exclusively the following described binary inputs. The external reclosing device can thus have an influence on the effects of the internal protection functions.

The following connection possibilities exist:

- From the external reclosing function, the signal *>Release stages* can be coupled so that the protection functions use special stages or zones for release. An example is the release of an overreaching zone with a distance protection or the non-delayed tripping of an overcurrent protection stage in the 1st reclosing cycle.
- For applications with 1-pole tripping, the external reclosing can provide the signal *>1-pole trip permitted*, based on which the protection functions can switch off the 1-pole circuit breaker.
- For applications with reclosing functions only with 1-pole faults and stage or zone releases through the reclosing function can the signal *>1-pole AR only* be connected. The protection functions use this information to allow the stage or zone release only affect 1-pole faults.

6.46.6.2 Information List

No.	Information	Data Class (Type)	Type
Ext			
_:6661:51	Ext:Mode (controllable)		C
_:6661:501	Ext:>Release stages		I
_:6661:502	Ext:>1-pole trip permitted		I
_:6661:503	Ext:>1-pole AR only		I
_:6661:52	Ext:Behavior		O
_:6661:53	Ext:Health		O
_:6661:54	Ext:Inactive		O

6.46.7 Application and Setting Notes for General Settings

For the Automatic reclosing function, 3 function specifications are available in the function library of the device. In each function group **Circuit breaker**, one function specification of the Automatic reclosing function can be used.

Configure one of the 3 following function specifications:

- Cyclic Automatic reclosing function
- Automatic reclosing function with adaptive dead time (ADT)
- Operation with external Automatic reclosing function

Starting the Automatic Reclosing Function

The configuration of the interaction between internal protection functions and the Automatic reclosing function can be set separately for each protection function. The configuration occurs in a matrix view in DIGSI. The Automatic reclosing function also has the corresponding binary inputs and binary outputs through which the external protection devices can be connected to the internal Automatic reclosing function.

Configure the starting and blocking condition for the Automatic reclosing function at the position shown in [Figure 6-320](#) in DIGSI (shown here using the example of the protection function group **Line**) or route the corresponding binary inputs.

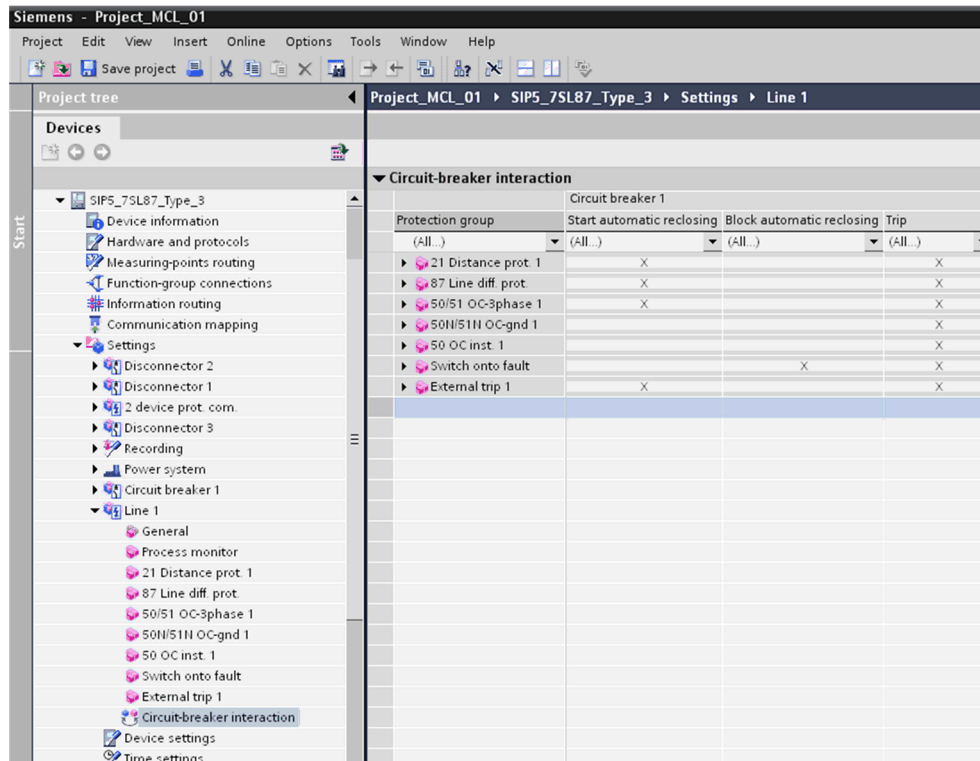

[sdcigsia-080311-01.tif, 1_en_US]

Figure 6-320 Configuration of the Protection Functions for Starting and Blocking the Automatic Reclosing Function in DIGSI

General Settings

If you use the function specification **Cyclic automatic reclosing function** or **Automatic reclosing function with adaptive dead time (ASP)**, set the following settings under **General**.

For the function specification **Operation with external automatic reclosing function** there are no settings. The control occurs exclusively through binary inputs and binary outputs.

Parameter: 79 operating mode

- Default setting (`_:6601:101`) **79 operating mode = with op., with act. time**

With the parameter **79 operating mode**, you determine which start criterion the Automatic reclosing function operates with.

Parameter Value	Description
<i>with op., with act. time</i>	The Automatic reclosing function cycles are dependent on the operate time of the protection function(s). The start occurs with all protection function(s) or protection stages that are configured through the Automatic reclosing function start matrix. Siemens generally recommends this setting for applications with 1/3-pole tripping and for applications with 3-pole tripping if a single dead time, independent of the type of connection working, is required in the Automatic reclosing function cycle. You can find detailed information in 6.46.4.1 Operating Modes for Cyclic Automatic Reclosing Function, Operating mode 1 .
<i>w.pickup, w. action time</i>	The Automatic reclosing function cycles are dependent on the operate time of the protection function(s) and the type of fault. The start occurs with all protection function(s) or protection stages that are configured through the Automatic reclosing function start matrix. For applications with 3-pole tripping and dead time dependent on the circuit type, Siemens recommends this setting. You can find detailed information in 6.46.4.1 Operating Modes for Cyclic Automatic Reclosing Function, in Operating mode 2 .
<i>with op., w/o act. time</i>	Each operate indication starts the Automatic reclosing function. The start occurs with all protection function(s) or protection stages that are configured through the Automatic reclosing function start matrix. The Automatic reclosing function start must be configured so that it only occurs from the protection stages/zones for which an Automatic reclosing should occur after tripping. You can find detailed information in 6.46.4.1 Operating Modes for Cyclic Automatic Reclosing Function, Operating mode 3 .
<i>w.pickup, w/o act. time</i>	Each operate indication starts the Automatic reclosing function. The Automatic reclosing function cycles are dependent on the type of fault. The start occurs with all protection function(s) or protection stages that are configured through the Automatic reclosing function start matrix. The Automatic reclosing function start must be configured so that it only occurs from the protection stages/zones for which an Automatic reclosing should occur after tripping. You can find detailed information in 6.46.4.1 Operating Modes for Cyclic Automatic Reclosing Function, Operating mode 4 .

Parameter: CB ready check bef. start

- Default setting (`_:6601:102`) **CB ready check bef. start = no**

With the parameter **CB ready check bef. start**, you determine whether the circuit-breaker readiness has been checked **before the start** of the Automatic reclosing function.

Additionally or alternatively, it is possible to check the readiness of the circuit breaker after the expiration of the dead time, directly before the assignment of the close command. Another parameter described in [6.46.8 Application and Setting Notes for 1 Cycle of the Cyclic Automatic Reclosing Function](#) exists for this function.

Parameter Value	Description
yes	The Automatic reclosing function checks the readiness of the circuit breaker for a switching cycle, consisting of a tripping-reclosing-switching. If the circuit breaker is ready - signaled through a binary input - the startup of the Automatic reclosing function can occur. If the circuit breaker is not ready, the Automatic reclosing function reports the static blocking. Siemens recommends using this setting. Note: The default setting of this parameter does not correspond to the recommended setting value for operation. The Automatic reclosing function would otherwise be blocked with a non-available circuit breaker-ready-signal. Set the parameter as recommended.
no	The readiness of the circuit breaker is not checked before starting the Automatic reclosing function. The test also does not occur if the readiness signal from the circuit breaker is connected to a binary input on the device.

Parameter: Reclai. time aft.succ.cyc.

- Default setting (`_:6601:103`) **Reclai. time aft.succ.cyc. = 3.00 s**

With the parameter **Reclai. time aft.succ.cyc.**, you define the time in which it is decided whether or not the currently running automatic reclosing cycle was successful. You can find detailed information on the function of the reclaim time in [6.46.4.15 Reclaim Time](#).

The default setting for the reclaim time can be frequently maintained. In areas prone to thunderstorms or gales, a shorter reclaim time is advisable in order to reduce the danger of final disconnection due to lightning strikes or cable rollovers in rapid succession.

Select a long reclaim time if there is no possibility for circuit-breaker supervision with multiple automatic reclosing, for example, due to missing auxiliary contacts or lacking circuit-breaker-ready-information. In that case the reclaim time must be longer than circuit-breaker recovery time.

Parameter: Block. time aft. man.close

- Default setting (`_:6601:104`) **Block. time aft. man.close = 1.00 s**

With the parameter **Block. time aft. man.close**, you determine the length of time for which the automatic reclosing is to be blocked after manual activation.

Set the time so that the circuit breaker can be safely switched on and off during connection to a short circuit without the Automatic reclosing function being automatically closed.

Parameter: Start signal supervis.time

- Default setting (`_:6601:105`) **Start signal supervis.time = 0.25 s**

With the parameter **Start signal supervis.time**, you set the maximum time after which a circuit breaker must open after a trip command. If the time expires, a failure of the circuit breaker is assumed and the Automatic reclosing function is dynamically blocked.

For detailed information about the start supervision time function, refer to [6.46.4.5 Start](#).



NOTE

With the use of an internal or external circuit-breaker failure protection at the same line branch, observe the following:

- The start supervision time should be the same as the circuit-breaker failure protection time delay. With this, you can make sure that in the case of a circuit-breaker failure followed by the tripping of the busbar, no Automatic reclosing will be executed.
(Note: An exception to this recommendation is described below.)
- During a 1-pole trip command repeat caused by the circuit-breaker failure protection, the start supervision time must be longer than the delay time for the 1-pole trip command repeat + the **Minimum operate time** set in the circuit-breaker failure protection. With this, it can be ensured that the trip command is not connected before the 1-pole trip command repeat through the circuit-breaker failure protection from the coupling of the trip command of the 3-pole automatic reclosing function.
- The start supervision time must be longer than the time delay for the tripping of the busbar if a 1-pole trip command for the line branch should not be coupled by the Automatic reclosing function or the circuit-breaker failure protection 3-pole before the circuit-breaker failure protection can trip the busbar. With this case, the Automatic reclosing function must be blocked with the trip command for the busbar. This helps to avoid an Automatic reclosing function being executed after the tripping of the busbar for the line branch. The blocking of the Automatic reclosing function can occur with a CFC link to the binary input *>Block function*.

Parameter: CB ready superv. time

The setting of this parameter is significant only if one of the cycle-specific parameters **CB ready check bef. close** is set to **yes**. Otherwise, this parameter has no effect.

- Default setting (`_:6601:106`) **CB ready superv. time = 3.00 s**

With the parameter **CB ready superv. time**, you can determine the maximum time after which the circuit breaker must be ready for reclosing after tripping.

Set the time somewhat longer than the regeneration time of the circuit breaker after an OFF-ON-OFF cycle.

You can find detailed information on this function in [6.46.4.16 Circuit-Breaker Readiness and Circuit-Breaker Position](#) and [6.46.4.14 Closing Indication and Close Command](#).

Parameter: 3-pole operate by 79

This parameter is irrelevant and cannot be set if the circuit breaker is configured exclusively for 3-pole tripping.

- Recommended setting value (`_:6601:107`) **3-pole operate by 79 = yes**

With the parameter **3-pole operate by 79**, you determine whether the Automatic reclosing function generates a 3-pole operate indication for the 3-pole coupling of the circuit-breaker poles, if required.

Parameter Value	Description
<i>yes</i>	<p>The Automatic reclosing function can create a 3-pole operate indication under the following conditions:</p> <ul style="list-style-type: none"> • With the blocking of the Automatic reclosing function in the 1-pole dead time, for example, through an evolving fault or external blocking • If an Automatic reclosing function start is signaled with 2-pole tripping, for example by external binary inputs • In operating modes with tripping, if a 1-pole operate indication is generated and the Automatic reclosing function does not allow for 1-pole cycles according to its parameterization. • If, during a 1-pole Automatic reclosing function cycle, the supervision of the circuit-breaker pole recognizes an implausible condition. <p>Siemens recommends using this setting.</p>
<i>no</i>	The Automatic reclosing function does not create 3-pole tripping.

You can find detailed information on this function in [6.46.4.11 Dead Time for Operating Modes with Tripping](#), [6.46.4.16 Circuit-Breaker Readiness and Circuit-Breaker Position](#) and [6.46.4.13 Evolving-Fault Detection During the Dead Time](#).

Parameter: Evolving-fault detection

This parameter is not important and cannot be set if you use the ADT function (Automatic reclosing function with adaptive dead time).

- Default setting (`_:6601:108`) **Evolving-fault detection = with trip**

With the parameter **Evolving-fault detection**, you determine which criterion is used to detect an evolving fault. The actual effect of the detected evolving fault on the Automatic reclosing function can be set with the parameter described below **Response to evolv. faults**.

Evolving faults are short circuits, which occur after switching off a short circuit during dead time.

For detailed information on evolving-fault detection, refer to [6.46.4.13 Evolving-Fault Detection During the Dead Time](#).

Parameter Value	Description
<i>with trip</i>	<p>Evolving faults are recognized if an operate indication occurs during the dead time. Thus, it does not matter if the tripping-protection function is configured for the start of the Automatic reclosing function or not.</p> <p>The pickup of a protection function without an operate indication does not lead to evolving-fault detection.</p>
<i>with pickup</i>	<p>Evolving faults are detected if during the dead time a protection function configured for the Automatic reclosing function start is picked up or if an external pickup is detected through a binary input.</p>

For applications with 1-/3-pole tripping, Siemens recommends the setting **with trip**, if the system is sufficiently meshed.

If several individual lines in a series form an overall transmission path, the setting **with pickup** may be more suitable. With this setting, you can prevent 2 lines following each other from switching to 1-pole in different conductors during evolving faults. The consequence of this fault would be the remainder of a single conductor in the dead time for the overall transmission path. This is particularly important if power plants are coupled through the overall transmission path.

Parameter: Response to evolv. faults

This parameter is not important and cannot be set if you use the ADT function (Automatic reclosing function with adaptive dead time).

- Default setting (`_:6601:109`) **Response to evolv. faults = blocks 79**

With the parameter **Response to evol. faults**, you determine how the Automatic reclosing function reacts to detected evolving faults.

You can find detailed information about the Automatic reclosing function for faults in [6.46.4.13 Evolving-Fault Detection During the Dead Time](#).

Parameter Value	Description
blocks 79	The Automatic reclosing function is immediately blocked until the disconnection of the fault. In case of blockings due to evolving faults during 1-pole dead times, you can force a 3-pole coupling of the trip command through the Automatic reclosing function if you set the parameter 3-pole operate by 79 to yes .
strt. evol.flt.dead time	After the 3-pole trip command, to clarify that the evolving fault has been issued, the Automatic reclosing function starts a new 3-pole AREC cycle with the set Dead time aft. evol. fault .

Parameter: Max. dead-time delay

This parameter is not important and cannot be set if you use the ADT function (Automatic reclosing function with adaptive dead time).

- Default setting (**_:6601:110**) **Max. dead-time delay = 0.5 s**

With the parameter **Max. dead-time delay**, you determine the maximum time by which the start of the dead time may be delayed before the automatic reclosing is dynamically blocked.

The delay to the start of the dead time can be set with the binary input **>Dead time start delay**.

For detailed information on the functionality, refer to [6.46.4.5 Start](#).

Parameter: Max. dead-time extension

- Default setting (**_:6601:111**) **Max. dead-time extension = 1.2 s**

With the parameter **Max. dead-time extension**, you determine the maximum time by which the dead time may be delayed before the automatic reclosing is dynamically blocked.

With the setting **oo (ineffective)**, the extension is unlimited.

An extension of the dead time can be required under the following conditions:

- Waiting for the readiness of the circuit breaker
- Query of a synchronous test
- Delay through binary input in order, for example, to give the leading Automatic reclosing function priority in a system with 1 1/2 circuit breaker layout.

Remember that longer dead times after 3-pole disconnection are only permissible if no stability problems occur or if a synchronous test occurs before the reclosing.

For detailed information on the functionality, refer to [6.46.4.14 Closing Indication and Close Command](#).

Parameter: Voltage supervision time

This parameter is only important if you use the subfunctions RDT, DLC, or the ADT function. If you do not use any of these functions, the setting value of this parameter is free to select.

- Default setting (**_:6601:114**) **Voltage supervision time = 0.1 s**

With the parameter **Voltage supervision time**, you determine the measuring time that is available as a criterion for a voltage decision. It should be longer than all transient oscillations through switching operations. For the subfunctions **Reduced dead time (RDT)** and **Automatic reclosing with adaptive dead time (ASP)**, this measuring time applies for the determination of the exceedance of a voltage threshold. For the subfunction **Dead-line check**, the undercutting of a voltage threshold is checked.

Siemens recommends the setting 0.10 s.

For detailed information on the functionality, refer to the following parameters, as well as to [6.46.4.18 Dead-Line Checking \(DLC\) and Reduced Dead Time \(RDT\)](#) and [6.46.5.1 Description](#).

Parameter: Volt. thres.f. live line/bus

This parameter is relevant only if you use the subfunction **RDT** or the function **ADT**. If you do not use any of these functions, the setting value of this parameter is free to select.

- Default setting (`_:6601:115`) **Volt. thres.f. live line/bus = 48 V**

With the parameter **Volt. thres.f. live line/bus**, you define the limit voltage above which the line is to be considered healthy. It must be lower than the lowest expected operating voltage. The phase-to-ground voltage applies as the reference value.

For detailed information on the functionality, refer to the following parameters, as well as to [6.46.4.18 Dead-Line Checking \(DLC\) and Reduced Dead Time \(RDT\)](#) and [6.46.5.1 Description](#).

Parameter: Dead-line check/reduc.d.t

This parameter is not important and cannot be set if you use the ADT function (Automatic reclosing function with adaptive dead time).

- Default setting (`_:6601:113`) **Dead-line check/reduc.d.t = without**

With the parameter **Dead-line check/reduc.d.t**, you determine whether the AREC is to operate with one of the additional functions **Dead-line check DLC** or **Reduced dead t. RDT**.

Parameter Value	Description
<i>without</i>	The Automatic reclosing function occurs after the expiration of the parameterized dead times. Dead-line check or RDT are not activated.
<i>Reduced dead t. RDT</i>	The Automatic reclosing function works with a reduced dead time (RDT).
<i>Dead-line check DLC</i>	The Automatic reclosing functions works with dead-line check. The closing indication is only assigned if the line was really de-energized during the dead time.

For detailed information on the functionality, refer to [6.46.4.18 Dead-Line Checking \(DLC\) and Reduced Dead Time \(RDT\)](#).



NOTE

Use RDT or dead-line check only if the voltages of the line can be correctly measured with an open circuit breaker. This is only possible if the voltage transformer is aligned on the line-side - seen from the circuit breaker.

Parameter: Volt.thres. f. dead line/bus

This parameter is only important if you use the Dead-line check subfunction. If you do not use any of this subfunction, the setting value of this parameter is free to select.

- Default setting (`_:6601:116`) **Volt.thres. f. dead line/bus = 30 V**

With the parameter **Volt.thres. f. dead line/bus**, you define the limit voltage below which the line is to be considered secure due to being de-energized – that is, switched off. The threshold value is used by the Dead-line check subfunction (dead-line check). The reference value is the phase-to-ground voltage.

For detailed information on the functionality, refer to [6.46.4.18 Dead-Line Checking \(DLC\) and Reduced Dead Time \(RDT\)](#).

Parameter: Send delay f. remot. close

With the parameter **Send delay f. remot. close**, you determine the time after automatic reclosing after which the information is sent for remote closing.

- Default setting (`_:6601:112`) **Send delay f. remot. close = ∞ (ineffective)**

The transmission delay prevents the device operating in the adaptive dead time mode on the opposite end from closing unnecessarily if the local reclosing function remains unsuccessful. Conversely, it should be borne in mind that the line is not available for power transmission until the opposite end is also closed. In order to take system stability into consideration, the **Send delay f. remot. close** must therefore be added to the dead time.

For detailed information on the functionality, refer to [6.46.4.14 Closing Indication and Close Command](#).

6.46.8 Application and Setting Notes for 1 Cycle of the Cyclic Automatic Reclosing Function

For the function of the cyclic automatic reclosing function, 1 cycle is preset. The preset cycle cannot be deleted. You can add and delete more cycles from the function library in **DIGSI 5**.

Parameter: Start from idle state allow.

This parameter is only important and can be set if you use the automatic reclosing function in an operating mode **with action time**.

- Default setting (`_:6571:102`) **Start from idle state allow. = yes**

With the parameter **Start from idle state allow.** you can determine whether the action time of this automatic reclosing cycle is started, if the automatic reclosing function is in idle state during with incoming general pickup. Please set the parameter always to **yes**, if the automatic reclosing function is configured for only 1 cycle. If several cycles are configured, you can control the effectiveness of the automatic reclosing cycles with this parameter and various action times.

Detailed information about the functionality can be found in Chapters [6.46.4.6 Cycle Control with Operating Mode 1: With Tripping/With Action Time](#) and [6.46.4.7 Cycle Control with Operating Mode 2: With Pickup/With Action Time](#).

Parameter: Action time

This parameter is only important and can be set if you use the automatic reclosing function in an operating mode **with action time**.

- Default setting (`_:6571:103`) **Action time = 0.2 s**

With this parameter **Action time** you can determine, within which time frame the trip command must appear, in order to start the automatic reclosing function. If the trip command occurs only after the action time has expired, automatic reclosing does not occur within the active automatic reclosing cycle.

You can find detailed information about the functionality in

Chapters [6.46.4.6 Cycle Control with Operating Mode 1: With Tripping/With Action Time](#) and [6.46.4.7 Cycle Control with Operating Mode 2: With Pickup/With Action Time](#).

Parameter: Dead time aft. 3-pole trip

This parameter is only important and can be set if you use the automatic reclosing function in an operating mode **with tripping**.

- Default setting (`_:6571:108`) **Dead time aft. 3-pole trip = 0.5 s**

With this parameter **Dead time aft. 3-pole trip**, you can determine after which dead time the automatic reclosing function will be executed. After a 3-pole trip of the circuit breaker, the system stability is priority. Since the switched off line cannot develop synchronizing forces, only a short dead time is permitted in most cases. The usual duration is 0.3 s to 0.6 s. A longer period can be tolerated if a synchrocheck is carried out prior to reclosing. Longer 3-pole dead times are also possible in radial systems.

Parameter: Dead time aft.1ph. pickup, Dead time aft.2ph. pickup, Dead time aft.3ph. pickup

This parameter is only important and can be set if you use the automatic reclosing function in an operating mode **with pickup**.

- Default setting (`_:6571:104`) **Dead time aft.1ph. pickup** = 1.2 s
- Default setting (`_:6571:105`) **Dead time aft.2ph. pickup** = 1.2 s
- Default setting (`_:6571:106`) **Dead time aft.3ph. pickup** = 0.5 s

With the 3 dead-time parameters, you can determine after which dead time the automatic reclosing function will be executed. Please set the times as desired for the respective type of short circuit.

- The parameter **Dead time aft.1ph. pickup** applies to dead times after 1-phase short circuits and the following protection tripping: A, B, C, or A-Gnd, B-Gnd, C-Gnd
- The parameter **Dead time aft.2ph. pickup** applies to dead times after 2-phase short circuits and the following protection tripping: A-B, B-C, C-A, or A-B-gnd, B-C-gnd, C-A-gnd
- The parameter **Dead time aft.3ph. pickup** applies to dead times after 3-phase short circuits and the following protection tripping: A-B-C or A-B-C-Gnd



NOTE

If you would like to avoid automatic reclosing during individual short-circuit types, please set the respective dead times to `oo` (*invalid*).

Example:

After 1-phase short-circuits, the automatic reclosing function should occur after 1.2 s. The automatic reclosing function should not occur for 2-phase and 3-phase short circuits.

For this application, the parameters should be set as follows:

- **Dead time aft.1ph. pickup** = 1.2 s
- **Dead time aft.2ph. pickup** = `oo` (*invalid*)
- **Dead time aft.3ph. pickup** = `oo` (*invalid*)

Parameter: Dead time aft. evolv. fault

These parameters are only significant if the parameter (`_:6601:109`) **Response to evolv. faults** is set to `strt. evol.flt.dead time`.

- Default setting (`_:6571:109`) **Dead time aft. evolv. fault** = 1.2 s

With the parameter **Dead time aft. evolv. fault**, you can determine after which dead time the automatic reclosing function should be executed, if based on an evolving fault during the current dead time, a 3-pole trip has occurred. For this 3-pole dead time, stability concerns for the system are also important. Often, this dead time as well as the parameter (`_:6571:108`) **Dead time aft. 3-pole trip** can be set.

Detailed information about the function during evolving faults during dead time are described in Chapter [6.46.4.13 Evolving-Fault Detection During the Dead Time](#).

Parameter: CB ready check bef.close

- Default setting (`_:6571:111`) **CB ready check bef.close** = `no`

With the parameter **CB ready check bef.close** you can determine if after the expiration of the dead time (meaning, directly prior to assigning the close command) readiness of the circuit breaker should be queried.

Parameter Value	Description
<i>no</i>	With the setting <i>no</i> , the automatic reclosing function does not check again the readiness of the circuit breaker prior to assigning the close demand. Siemens recommends this setting, if it is sufficient to check the readiness of the circuit breaker for the entire switching cycle once before the start of a reclosing function, consisting of tripping-reclosing-tripping. The setting for checking the readiness of the circuit breaker prior to the start of the automatic reclosing function is done using the parameter (_:6601:102) CB ready check bef. start .
<i>yes</i>	With the setting <i>yes</i> , the dead time can be extended if after the expiration of the dead time the circuit breaker is not ready for the next ON-OFF cycle. The maximum delay of the dead time can be set with the parameter (_:6601:111) Max. dead-time extension . Siemens recommends this setting, if it can be assumed that the circuit breaker becomes available to switch on the reclosing function only after an additional waiting period.

Detailed information about the function can be found in Chapters [6.46.4.16 Circuit-Breaker Readiness and Circuit-Breaker Position](#) and [6.46.4.14 Closing Indication and Close Command](#).

Parameter: Synchroch. aft. 3-pole d.t.

- Default setting (**_:6571:110**) **Synchroch. aft. 3-pole d.t.** = *none*

With the parameter **Synchroch. aft. 3-pole d.t.** you can determine if a synchrocheck must be carried out for the configured automatic reclosing cycle.

If during a 3-pole interruption in the system stability problems may be a concern, the synchrocheck should be carried out. If only 1-pole reclosure cycles are possible or stability problems are not to be expected during the 3-pole dead time, for example, due to a highly intermeshed system or radial system, please select the parameter *none* .

Parameter Value	Description
<i>none</i>	During the automatic reclosing cycle a synchrocheck is not executed.
<i>internal</i>	In the configured automatic reclosing cycle, a synchrocheck is executed after a 3-pole dead time prior to the close command of the circuit breaker. For the synchrocheck a synchrocheck stage of the internal synchronization function is used, which is contained in the same function group as the circuit breaker and the automatic reclosing function. The selection of the synchrocheck stage that is used in the automatic reclosing cycle occurs through the following described parameter Internal synchrocheck .
<i>external</i>	In the configured automatic reclosing cycle, a synchrocheck is executed after a 3-pole dead time prior to the close command of the circuit breaker. An external synchrocheck device initiates the synchrocheck. The external synchrocheck device is connected with the binary signals <i>Synchrocheck request</i> and <i>>Release by ext.sync.</i> . Detailed information about the function can be found in Chapter 6.46.4.14 Closing Indication and Close Command under the section Synchrocheck .

Parameter: Internal Synchrocheck

These parameters are only significant if the previously described parameter (**_:6571:110**) **Synchroch. aft. 3-pole d.t.** is set to *internal* .

With the parameter **Internal Synchrocheck**, you can determine which function block of the synchronization function for the automatic reclosing function is used after a 3-pole dead time. This selection is only possible for function blocks of the synchronization function, and which are included in the same circuit-breaker function group as the automatic reclosing function. The setting options of the parameter will be generated dynamically, according to the actual parameterization.

6.47 Fault Locator

6.47.1 Overview of Functions

The **Fault locator** function is used to determine the distance to the fault location. Quick determination of fault location and the associated rapid troubleshooting increase the availability of the line for the power transmission in the electrical power system. Fault-location determination is based on the determination of the reactance of the short-circuited measuring loops.

6.47.2 Structure of the Function

The function **Fault locator** can be used in protection function groups with 3-phase current and voltage measurement.

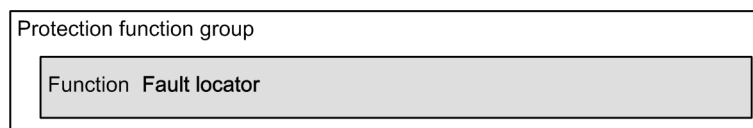

[dw_stbafo, 1, en_US]

Figure 6-321 Structure/Embedding of the Function

The fault location is calculated based on the line parameter. The fault-location determination is always carried out **with going pickup** of the short-circuit protection. There is an option to limit the fault-location determination to cases with tripping (setting value for parameter **Start = with operate**).

The fault locator can be started as follows:

- Via the phase-segregated binary inputs *>Fault detected phs A*, *>Fault detected phs B*, *>Fault detected phs C*, and *>Fault detected gnd*.
- Via the differential protection
- Via the distance protection
- Via the directional overcurrent protection, phases or ground
- Via the overcurrent protection, phases or ground
- Via the non-phase segregated binary input *>Flt. det. w/o phs.&gnd*.

If multiple protection functions are operating in parallel, the fault locator is only started by the protection-function pickup with the highest priority. The functions are listed in decreasing priority.

The **Fault locator** function only works with the following current and voltage-transformer connection types (see parameter value).

Parameter	Parameter Value
CT connection	<ul style="list-style-type: none"> • <i>3-phase + IN-separate</i> • <i>3-phase + IN</i> • <i>3-phase</i> • <i>2ph, 2p. CT + 2 IN-sep</i>
VT connection	<ul style="list-style-type: none"> • <i>3 ph-to-gnd volt. + VN</i> • <i>3 ph-to-gnd voltages</i>



NOTE

The **Fault locator** function does not work with all possible current and voltage transformer connection types. An error message is displayed in DIGSI 5 if the **Fault locator** function cannot work with the set connection types. In this case check the current and voltage transformer connection type. You will find the **CT connection** or **VT connection** parameters in DIGSI 5 under **Power system** → **Meas.point I-3ph** or **Power system** → **Meas.point V-3ph**.

6.47.3 Function Description

Starting Conditions

Each protection function that can start the fault locator also provides the **fault locator** with information on the pickup and tripping times. If multiple protection functions pick up at the same time, the **fault locator** is started only by the function with the highest priority. The pickup pattern for the other protection functions is discarded.

The fault locator uses the pickup and tripping information for the protection function being started to form its own measurand memory for the following calculations. Depending on the pickup duration of the protection function, the measurand memory is positioned such that it contains pre-fault processes, short-circuit processes, and switch-off processes. If the pickup lasts for a longer time, only the short-circuit processes and switch-off processes are recorded by the measurand memory. The fault-location determination always starts only after the dropout of the pickup.

Fault-location determination is also possible via the starting condition *with going pickup*, if the protection device only picks up and does not trigger. Fault-location determination is then performed via the starting condition *with operate* only if the protection device has reported the tripping and the pickup has dropped out.

Alternatively, the **fault locator** can be started via one or more binary inputs. If the phase-segregated indications *>Fault detected phs A*, *>Fault detected phs B*, *>Fault detected phs C*, and *>Fault detected gnd.* are routed in the DIGSI 5 information routing, the **fault locator** interprets the binary inputs as a phase-segregated external protection function and treats them with the highest priority.



NOTE

The phase-segregated start of the fault locator is only possible if you have routed all 4 indications in the DIGSI 5 information routing.

When routing the binary input *>Flt. det. w/o phs.&gnd.*, the binary input is interpreted as a non-segregated external protection function and is treated with the lowest priority. The fault locator starts when the binary input drops out.

When the parameter *with operate* is set and the **fault locator** is started via the binary input, the fault-location determination is started only when a device-internal protection function generates an operate indication, or when the binary input *>Fault locator start* is activated in addition to the above mentioned binary inputs.

Fault locator		21.8671		*	*	*	*
>Fault detected phs A	21.8671.501	SPS	H				
>Fault detected phs B	21.8671.502	SPS		H			
>Fault detected phs C	21.8671.503	SPS			H		
>Fault detected gnd.	21.8671.504	SPS					H
>Flt. det. w/o phs.&gnd.	21.8671.505	SPS					
>Fault locator start	21.8671.506	SPS					

[sc_rout_BE, 1, en_US]

Figure 6-322 Routing Matrix for the Triggering of the Fault Locator via Binary Input

Determining Fault Location

The recorded sampled values of the short-circuit currents and voltages are transferred to an internal measurand memory. The pickup indications are used to determine the short-circuited loops. The measurand memory is searched for an optimal measurement window. The largest possible measurement window is selected. If possible, the measurement window is positioned at the end of the short-circuit process. This means that the transient response and the ring down have the least possible impact on the measuring result.

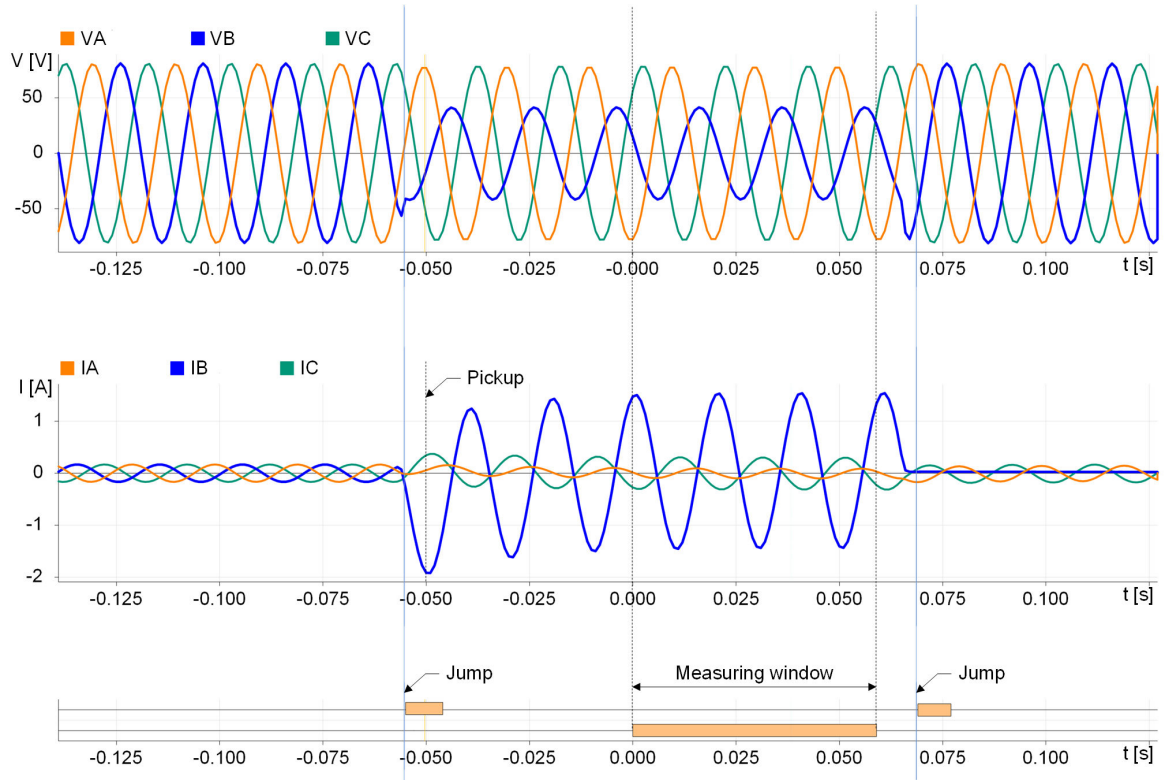

[dw_sigra_flo, 1, en_US]

Figure 6-323 Determining the Measurement Window

The impedances of the short-circuit loops are calculated of the measurement-window data. If there are multiple short-circuited loops, a selection process is used to select a loop and the results are then issued. If it is not possible to determine a sufficient data window with usable measured values or a plausible short-circuited loop, the indication *FLO invalid* signals the invalid measuring result.

Output of the Fault Location

The following results for the fault location are output:

- The fault reactance X in Ω primary
- The fault resistance R in Ω primary
- The fault distance d of the line proportional to the reactance in kilometers or miles, converted on the basis of the parameterized reactance per unit length of the line
- The fault distance d as a percentage of the line length, calculated on the basis of the parameterized reactance per unit length and the parameterized line length
- The selected fault loop for calculation of the fault location



NOTE

The indication of distance in kilometers, miles, or percent is applicable only for homogeneous line sections. If the line comprises parts which exhibit different reactances per unit of length (for example, overhead-line-cable sections), you can then analyze the reactance determined from the fault location for separate calculation of the fault distance.

Impedance-Based Fault Location

The determination of the fault distance is based on the evaluation of the imaginary part of the calculated short-circuit impedance. The fault distance is determined by dividing the calculated reactance X with the parameterizable reactance per unit length (parameter **X per length unit**). Both the impedance up to the fault location and the fault distance are issued by the fault locator.

An impedance measuring element is available for each of the 6 possible short-circuit loops A-gnd, B-gnd, C-gnd, A-B, B-C, C-A. The loop to be measured is selected depending on the fault type.

For 2-phase short circuits with grounding, the phase-to-phase loop is preferred for fault location. For 3-phase short circuits, the average reactance, determined from the reactance of the 3 phase-to-phase loops is used.

A 2-phase short circuit B-C, for example, is used for the calculation of the phase-to-phase loop.

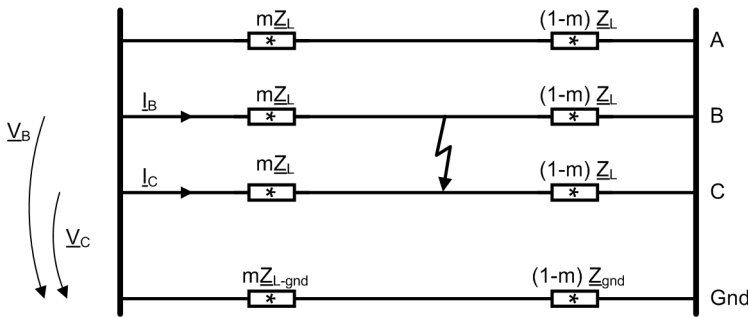

[dww_ilschleife_flo_1_en_US]

Figure 6-324 Short Circuit of a Phase-to-Phase Loop

The loop equation for the calculation of the short-circuit impedance of the phase-to-phase loop B-C is:

$$I_A \cdot m \cdot Z_L - I_B \cdot m \cdot Z_L = V_A - V_B$$

[fo_L2-L3_schl_1_en_US]

With:

- V_B, V_C Short-circuit voltage phasor for phases B and C
- I_B, I_C Short-circuit current phasor phases B and C
- m Proportionate distance to the fault
- $mZ_L = m \cdot (R_L + jX_L)$ Line impedance up to fault location

The line impedance is calculated as follows:

$$R = \frac{R_{gnd}(V_A - V_B) \cdot R_{gnd}(I_A - I_B) + \text{Im}(V_A - V_B) \cdot \text{Im}(I_A - I_B)}{[R_{gnd}(I_A - I_B)]^2 + [\text{Im}(I_A - I_B)]^2}$$

[fo_R_L2-L3_schl_1_en_US]

$$X = \frac{\text{Im}(V_A - V_B) \cdot R_{gnd}(I_A - I_B) - R_{gnd}(V_A - V_B) \cdot \text{Im}(I_A - I_B)}{[R_{gnd}(I_A - I_B)]^2 + [\text{Im}(I_A - I_B)]^2}$$

[fo_X_L2-L3_schl_1_en_US]

In case of a phase-to-ground short circuit, for example, A-gnd, for the calculation of a phase-to-ground loop, it must be considered that the impedance of the ground-return path does not match the impedance of the phases.

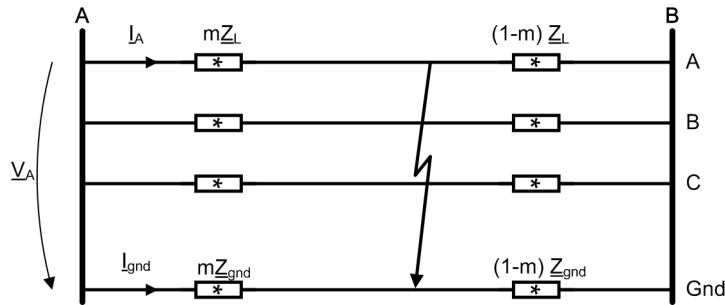

[dw_leschleife_flo_1_en_US]

Figure 6-325 Short Circuit of a Phase-to-Ground Loop

In case of A-gnd short circuit, the phase-to-ground voltage \underline{V}_A , the phase current \underline{I}_A and the ground current $\underline{I}_{\text{gnd}}$ are measured.

$$\underline{V}_A = \underline{I}_A \cdot m \cdot (R_L + jX_L) - \underline{I}_{\text{gnd}} \cdot m \cdot (k_r \cdot R_L + jk_x X_L)$$

[fo_L1-E_schl_1_en_US]

The impedance at the fault location is calculated as:

$$R = \frac{\text{Rgnd}(\underline{V}_A) \cdot \text{Rgnd}(\underline{I}_x) + \text{Im}(\underline{V}_A) \cdot \text{Im}(\underline{I}_x)}{\text{Rgnd}(\underline{I}_R) \cdot \text{Rgnd}(\underline{I}_x) + \text{Im}(\underline{I}_R) \cdot \text{Im}(\underline{I}_x)}$$

[fo_R_L1-E_schl_1_en_US]

and

$$X = \frac{\text{Im}(\underline{V}_A) \cdot \text{Rgnd}(\underline{I}_R) - \text{Rgnd}(\underline{V}_A) \cdot \text{Im}(\underline{I}_R)}{\text{Rgnd}(\underline{I}_R) \cdot \text{Rgnd}(\underline{I}_x) + \text{Im}(\underline{I}_R) \cdot \text{Im}(\underline{I}_x)}$$

[fo_X_L1-E_schl_1_en_US]

With:

\underline{V}_A	Short-circuit voltage phasor
\underline{I}_A	Short-circuit current phasor phase A
$\underline{I}_{\text{gnd}}$	Ground-fault current phasor
$\underline{I}_R = \underline{I}_A - k_r \cdot \underline{I}_{\text{gnd}}$	Auxiliary quantity
$\underline{I}_x = \underline{I}_A - k_x \cdot \underline{I}_{\text{gnd}}$	Auxiliary quantity

The factors $k_r = R_{\text{gnd}}/R_{\text{ph}}$ and $k_x = X_{\text{gnd}}/X_{\text{ph}}$ depend only on the line constants and not on the distance to the fault.

Measured-Value Correction at Load Current on Lines Fed on Both Sides

In the case of faults on lines fed on both sides and with load transport and contact resistance (see [Figure 6-326](#)), the fault voltage \underline{V}_A is influenced not only by the voltage source on side A, but also by the voltage source on side B if both voltage sources feed to the fault location. Without special measures, this leads to measuring errors in the impedance, since the current portion \underline{I}_B cannot be recorded at measuring point A. For long and highly loaded lines, this measuring error in the X portion of the fault impedance can be considerable. This X component is critical for the distance calculation.

The X component can be corrected when using load compensation. When using load compensation, the calculated R component comprises the combination of the fault resistance to be determined and the resistance of the line up to the fault location. This form of impedance calculation corresponds to the distance-protection

measurement protocol using the reactance method. The load compensation impacts both the 1-pole short circuit and the 2-pole short circuit. You can activate and deactivate the load compensation via the parameter **Load compensation**. If the distance protection operates with the reactance method, Siemens recommends switching on the load compensation for the fault locator too.

The following figure serves as an example of the description of the impedance calculation:

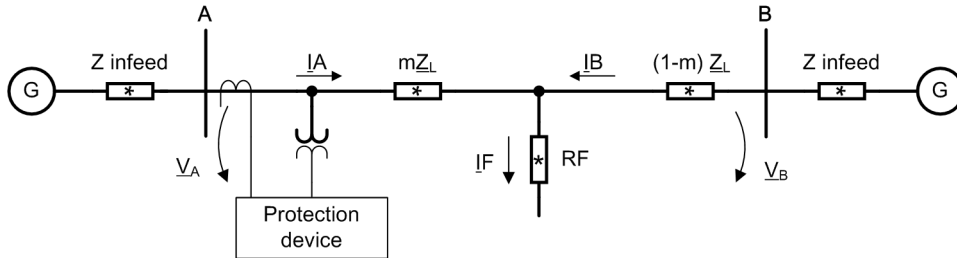

[dw_ueb_impedanzber_2_en_US]

Figure 6-326 Fault Currents and Voltages of a Line Fed on Both Sides (1-Pole Display)

A	Measuring point
V_A, V_B	Voltage source
I_A, I_B	Partial fault currents
I_F	Total fault current
V_A	Fault voltage at measuring point A
R_F	Common fault resistance
$Z_L, (1-m) Z_L$	Fault impedances
Z_A, Z_B	Source impedances
m	Proportionate distance to the fault

Impedance Calculation for Phase-to-Ground Loops

For calculation of a phase-to-ground loop, it must be considered that the impedance of the ground-return path generally does not match the impedance of the phases. This is the case, for example, for an A-gnd short circuit.

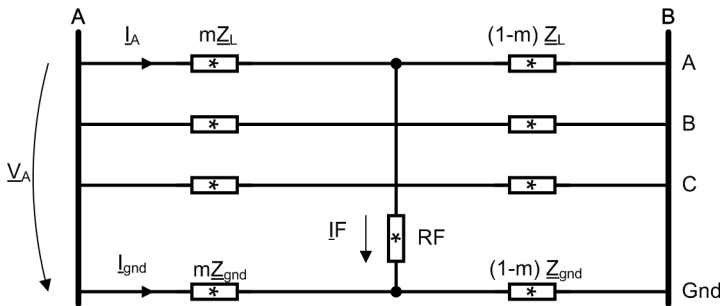

[dw_feschleife_rmd_2_en_US]

Figure 6-327 Short Circuit of a Phase-to-Ground Loop

The loop equation for calculating the impedance is:

$$V_A = m \cdot Z_L \cdot (I_A - k_0 \cdot I_{Gnd}) + R_F \cdot I_F$$

[fo_schl_le_ohne_icomp_3_en_US]

The loop equation is extended with the equivalent current $I_{Subst.}$ on both sides and converted according to the impedance.

$$m \cdot |Z_L| = \frac{\operatorname{Im}\{V_A \cdot [I_{\text{Subst.}} \cdot e^{j\delta_{\text{comp}}}]^*\}}{\operatorname{Im}\{Z_L / |Z_L| \cdot (I_A - k_0 \cdot I_{\text{Gnd}}) \cdot [I_{\text{Subst.}} \cdot e^{j\delta_{\text{comp}}}]^*\}}$$

[fo_schl le mit icomp, 4, en_US]

The following applies:

$$X = m \cdot |Z_L| \cdot \sin\varphi$$

[fo_x_impber, 1, en_US]

The reactance **X** of the phase-to-ground loop is calculated as follows:

$$X = \frac{\operatorname{Im}\{V_A \cdot [I_{\text{Subst.}} \cdot e^{j\delta_{\text{comp}}}]^*\}}{\operatorname{Im}\{Z_L / |Z_L| \cdot (I_A - k_0 \cdot I_{\text{Gnd}}) \cdot [I_{\text{Subst.}} \cdot e^{j\delta_{\text{comp}}}]^*\}} \cdot \sin\varphi$$

[fo_xf_impber, 2, en_US]

With:

A	Measuring point
V_A	Fault voltage at measuring point A (phase-to-ground voltage)
I_A, I_{Gnd}	Partial fault currents
I_F	Total fault current
RF	Common fault resistance
Z_L, Z_B	Line impedance
m	Proportionate distance to the fault
$I_{\text{Subst.}}$	Equivalent current
k_0	Ground-fault factor
δ_{Comp}	Compensation angle

You can select the equivalent current $I_{\text{Subst.}}$ such that the impact of the fault current I_B is compensated at the fault resistance R_F . This prevents the measuring error in the reactance.

The resulting measuring error in RF can be compensated only partially.

RF is calculated as follows:

$$R = \frac{\operatorname{Im}\{V_A \cdot [Z_L \cdot (I_A - k_0 \cdot I_{\text{Gnd}})]^*\}}{\operatorname{Im}\{I_F \cdot [Z_L \cdot (I_A - k_0 \cdot I_{\text{Gnd}})]^*\}} + X \cdot \operatorname{ctg}(\varphi)$$

[fo_rf_impber, 4, en_US]

The protection device cannot measure the fault current I_F directly. Therefore, either $3I_0$ or $3I_2$ is used as an equivalent for I_F . In order to achieve the best result, the procedure uses the larger one of the 2 equivalent currents. If the angles of the source impedances and the line impedance are not equal, you can compensate the inhomogeneity using the compensation angles.

The compensation angles δ_{comp} depend on the network conditions and can be calculated for the zero and negative-sequence system using the following formulas:

$$\delta_{\text{comp},0} = \arg\left(\frac{Z_{A,0} + Z_{B,0} + Z_{L,0}}{(1-m)Z_{L,0} + Z_{B,0}}\right)$$

[fo_kompwi_nullsys_impber, 1, en_US]

$$\delta_{\text{comp},2} = \arg\left(\frac{Z_{A,2} + Z_{B,2} + Z_{L,2}}{(1-m)Z_{L,2} + Z_{B,2}}\right)$$

[fo_kompwi_gegensys_impber, 1, en_US]

With:

- $Z_{A,0}, Z_{B,0}$ Source impedances in zero-sequence system
- $Z_{L,0}$ Line impedance in zero-sequence system
- m Proportionate distance to the fault
- $\delta_{comp,0}$ Compensation angle in zero-sequence system
- $Z_{A,2}, Z_{B,2}$ Source impedances in negative-sequence system
- $Z_{L,2}$ Line impedance in negative-sequence system
- $\delta_{comp,2}$ Compensation angle in negative-sequence system

Impedance Calculation for Phase-to-Phase Loops

A 2-phase short circuit B-C is assumed as an example for the calculation:

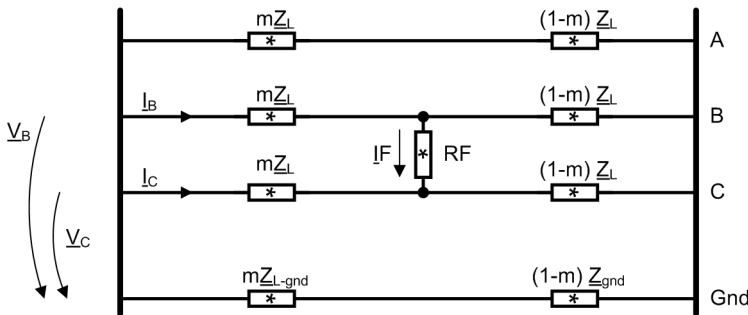

[dw_itschleife_rmd, 3, en_US]

Figure 6-328 Short Circuit of a Phase-to-Phase Loop

The loop equation for the calculation of the phase-to-phase loop is:

$$V_{BC} = m \cdot Z_L \cdot (I_B - I_C) + R_F \cdot I_F$$

[fo_schl_II_ohne_icomp, 2, en_US]

Thus, X is calculated as follows:

$$X = \frac{\text{Im}\{V_{BC} \cdot [I_{subst} \cdot e^{j\delta_{comp}}]^*\}}{\text{Im}\{Z_L / |Z_L| \cdot (I_B - I_C) \cdot [I_{subst} \cdot e^{j\delta_{comp}}]^*\}} \cdot \sin\varphi$$

[fo_xf_impber_II_schl, 2, en_US]

Whereby the following applies for the B-C loop: $I_{subst} = (\underline{a} - \underline{a}^2) \cdot I_2$ and $\underline{a} = e^{j120^\circ}$.

The rotation of the negative-sequence system, which is dependent on the fault loop, performs the fault-locator algorithm internally.

R_F is calculated as follows:

$$R = \frac{\text{Im}\{V_{BC} \cdot [Z_L \cdot (I_B - I_C)]^*\}}{\text{Im}\{2 \cdot I_{subst} \cdot [Z_L \cdot (I_B - I_C)]^*\}} + X \cdot \text{ctg}(\varphi)$$

[fo_rf_impber_II_schl, 4, en_US]

Measured-Value Correction for Parallel Lines

For ground faults on double lines, the values determined for the impedance calculation are influenced by the coupling of the ground impedances of both line systems. Without special measures, this leads to measuring errors in the impedance-calculation result. The device is therefore equipped with parallel-line compensation. This parallel-line compensation considers the ground current of the parallel line in the line equation and thereby compensates the coupling influence, similar to the determination of the distance in distance protection. To this end, you must connect the ground current of the parallel line to the device and configure it. The parallel-line compensation only provides correct values for 1-phase short circuits on the line to be protected.

Compensation is not possible for faults located externally, including those on the parallel line, and does not improve the measured values.

You can activate and deactivate the parallel-line compensation with the parameter **Parallel-line compensat...** Furthermore, the parallel-line compensation is only released, if the ratio between the calculated ground current I_{gnd} of the particular line and the ground current of the parallel line I_{gndP} is above the parameterized threshold **Gnd.curr.ratio (MutComp)**.

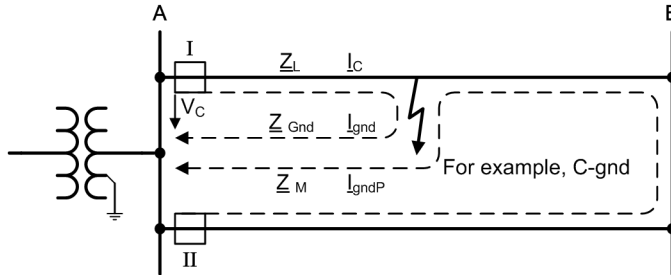

[dw_parkomp_L3-E, 1, en_US]

Figure 6-329 Ground Fault on a Double Line

The impact of the parallel-line compensation is calculated as follows:

Calculation without load-current compensation:

$$\underline{V}_C = \underline{I}_C \cdot m \cdot \underline{Z}_L - \underline{I}_{\text{gnd}} \cdot m \cdot \underline{Z}_{\text{gnd}} - \underline{I}_{\text{gndP}} \cdot m \cdot \underline{Z}_{0M}/3$$

[fo_parkomp1, 1, en_US]

$$\underline{V}_C = \underline{I}_C \cdot m \cdot (R_L + jX_L) - \underline{I}_{\text{gnd}} \cdot m \cdot (k_r \cdot R_L + jk_x \cdot X_L) - \underline{I}_{\text{gndP}} \cdot m \cdot (k_{mR} \cdot R_L + jk_{mX} \cdot X_L)$$

[fo_parkomp2, 1, en_US]

I_{gndP} is the ground current of the parallel line. The ratios $k_{mR} = R_{0M}/3R_{\text{ph}}$ and $k_{mX} = X_{0M}/3X_{\text{ph}}$ are line constants that result from the geometry of the double line and the suitability of the grounding.

Calculation with load-current compensation:

$$\underline{V}_C = \underline{I}_C \cdot m \cdot \underline{Z}_L - \underline{I}_{\text{gnd}} \cdot m \cdot \underline{Z}_{\text{gnd}} - \underline{I}_{\text{gndP}} \cdot m \cdot \underline{Z}_{0M}/3 + R_F \cdot \underline{I}_F$$

[fo_parkomp1_rmd, 1, en_US]

$$\underline{V}_C = m \cdot \underline{Z}_L (\underline{I}_C - \underline{I}_{\text{gnd}} \cdot \underline{k}_0 - \underline{I}_{\text{gndP}} \cdot \underline{k}_{0M}) + R_F \cdot \underline{I}_F$$

[fo_parkomp2_rmd, 1, en_US]

The factor $\underline{k}_{0M} = \underline{Z}_{0M}/(3\underline{Z}_{\text{ph}})$ is a line constant that results from the geometry of the double line and the suitability of the grounding.

With:

\underline{Z}_{0M}	Coupling impedance in zero-sequence system
R_{0M}	Coupling resistance in zero-sequence system
X_{0M}	Coupling reactance in zero-sequence system
\underline{k}_{0M}	Coupling factor in zero-sequence system

6.47.4 Application and Setting Notes

The function requires the following key line data to calculate fault distance:

- Reactance per unit length of the line per kilometer or per mile
- Line length for the correct output of the fault distance as a percentage of the line length
- Residual-compensation factors in the setting format **Kr** and **Kx** or **K0** and **Angle (K0)**.

Parameter: Start

- Recommended setting value (`_:101`) **Start = with going pickup**

The **Start** parameter is used to define the criterion for starting the fault location.

Parameter Value	Description
<i>with going pickup</i>	If a pickup signal of the protection functions designated for the start has dropped out, the fault-location determination starts.
<i>with operate</i>	If one of the protection functions designated for start has reported the tripping and the pickup has dropped out, the fault-location determination starts.

As an alternative, the fault locator can be started using external binary input.

Parameter: Parallel-Line Compensation

- Default setting (`_:102`) **Parallel-line compensat. = no**

The parameter **Parallel-line compensat.** is only visible if the ground current of the parallel line is connected to the **Line** function group.

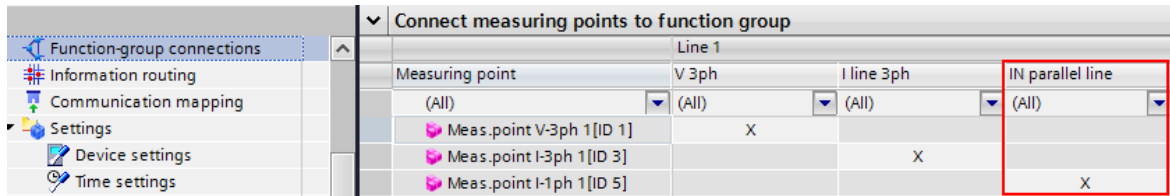

[scParkomp, 1, en_US]
 Figure 6-330 Routing in DIGSI

If you wish to apply the parallel-line compensation for double lines, set the **Parallel-line compensat.** parameter to **yes**.

Parameter Value	Description
<i>no</i>	The parallel-line compensation does not become effective with this setting.
<i>yes</i>	The parallel-line compensation becomes effective with this setting.

The following conditions have to be fulfilled so that the parallel-line compensation functions:

- Connect the ground current of the parallel line in the correct polarity to an additional current input.
- Set the input used for the parallel current in the correct ratio to the phase currents for the power-system data.

The parallel-line compensation is carried out only if the ground current of the line to be protected (I_{gnd}) is greater than the ground current of the parallel line (I_{gndp}) evaluated with the parameter **Gnd.curr.ratio (MutComp)**.

Siemens recommends keeping the default setting **Gnd.curr.ratio (MutComp) = 85 %**. In highly unbalanced system conditions and if the coupling factor is very small (X_M/X_L less than 0.4), a smaller value may be advisable.

- Set the coupling impedances to the parallel system for the line data.

Parameter: Load Compensation

- Default setting (`_:103`) **Load compensation** = *no*

With the **Load compensation** parameter, you can correct measuring errors for 1-phase and 2-phase short circuits on lines fed on both sides.

Parameter Value	Description
<i>no</i>	The load compensation does not become effective with this setting.
<i>yes</i>	The load compensation becomes effective with this setting. If you use the load compensation, the following parameters are relevant and are shown automatically: <ul style="list-style-type: none"> • (<code>_:104</code>) Substitute for IF • (<code>_:106</code>) Comp. angle zero seq. • (<code>_:107</code>) Comp. angle neg. seq.

Parameter: Substitute for IF

- Default setting (`_:104`) **Substitute for IF** = $3I_0$

The parameter **Substitute for IF** is only visible and relevant if you use the load compensation.

With the **Substitute for IF** parameter, for ground-impedance loops, you define which substitute value to use at the fault location for the fault current I_F that cannot be measured due to the fault resistance.

First, calculate the compensation angles for the zero-sequence system and the negative-sequence system. Set the parameter **Substitute for IF** according to the smaller compensation angle. The smaller compensation angle indicates that the associated system (zero-sequence or negative-sequence system) is more homogeneous and that the fault current can be approximated in a better way through the fault resistance at the fault location.

Parameter: Compensation Angle for Zero-Sequence System/Negative-Sequence System

- Default setting (`_:106`) **Comp. angle zero seq.** = 0.00°
- Default setting (`_:107`) **Comp. angle neg. seq.** = 0.00°

The parameters **Comp. angle zero seq.** and **Comp. angle neg. seq.** are only visible and relevant if you use the load compensation.

If you have determined an angle difference between the measured $3I_0$ or $3I_2$ and I_F based on network model tests or calculations, you can compensate this with the parameters **Comp. angle zero seq.** or parameter **Comp. angle neg. seq.**.

A setting of the compensation angle deviating from 0 is only relevant for non-homogeneous systems.

With the **Comp. angle zero seq.** parameter, you compensate the angle difference between the $3I_0$ calculated by the device and the fault current I_F .

With the **Comp. angle neg. seq.** parameter, you compensate the angle difference between the $3I_2$ calculated by the device and the fault current I_F .



NOTE

If you use the **Fault locator** function in the **Line** function group, the function operates with the line parameters of the function group.

If you use the **Fault locator** function in the **Voltage/current 3-phase** function group, you must enter the following line parameters in the **Voltage/current 3-phase** function group.

Parameter: X per length unit

- Default setting (`_:113`) **X per length unit** = $0.0525 \Omega/km$

With the **X per length unit** parameter, you set the reactance per unit length for the line to be protected. You set the **X per length unit** parameter as a relative value in Ω/km or Ω/miles .

Parameter: Line length

- Default setting (`_:114`) **Line length** = 60 km

With the **Line length** parameter, you can set the length of the line to be protected as a unit of length in km or miles.

Parameter: Line angle

- Default setting (`_:108`) **Line angle** = 85.00°

Calculate the setting value for the parameter **Line angle** from the line constants for the line to be protected as follows:

$$\tan \varphi = \frac{X_L}{R_L} \quad \text{or} \quad \varphi = \arctan \left(\frac{X_L}{R_L} \right)$$

[fo_lwinkl_1_en_US]

where:

- R_L Resistance of the line to be protected
- X_L Reactance of the line to be protected

EXAMPLE

110-kV overhead line, 150 mm² with the data

$$R'_1 = 0.19 \Omega/\text{km}$$

$$X'_1 = 0.42 \Omega/\text{km}$$

You calculate the setting value for the line angle as follows:

$$\tan \varphi = \frac{X_L}{R_L} = \frac{X'_1}{R'_1} = \frac{0.42 \Omega/\text{km}}{0.19 \Omega/\text{km}} = 2.21$$

[fo_tan_phi_1_en_US]

$$\arctan(2.21) = 65.7^\circ$$

[fo_arctan_phi_1_en_US]

Parameter: Kr and Kx

- Default setting (`_:104`) **Kr** = 1.00
- Default setting (`_:105`) **Kx** = 1.00

The **Kr** and **Kx** parameters are used to set the residual compensation factors as scalar values. The **Kr** and **Kx** parameters are relevant for the **Fault locator** function.

Calculate the setting values for the parameters **Kr** and **Kx** from the line data as follows:

Resistance ratio	Reactance ratio
$K_r = \frac{R_{\text{gnd}}}{R_L} = \frac{1}{3} \cdot \left(\frac{R_0}{R_1} - 1 \right)$	$K_x = \frac{X_{\text{gnd}}}{X_L} = \frac{1}{3} \cdot \left(\frac{X_0}{X_1} - 1 \right)$

where:

R_0	Zero-sequence system resistance of the line
X_0	Zero-sequence system reactance of the line
R_1	Positive-sequence system resistance of the line
X_1	Positive-sequence system reactance of the line

This data can either be used for the entire line or as length-related values, since the quotients are length-independent. You can calculate the data both from the primary values and from the secondary values.

EXAMPLE

110-kV overhead line, 150 mm² with the data:

R_1/s	0.19 Ω/km positive-sequence system resistance
X_1/s	0.42 Ω/km positive-sequence system reactance
R_0/s	0.53 Ω/km zero-sequence system resistance
X_0/s	1.19 Ω/km zero-sequence system reactance
s	Line length

You receive the following setting values for the parameters **K_r** and **K_x**:

$$K_r = \frac{R_{Gnd}}{R_L} = \frac{1}{3} \cdot \left(\frac{R_0}{R_1} - 1 \right) = \frac{1}{3} \cdot \left(\frac{0.53 \text{ Ω/km}}{0.19 \text{ Ω/km}} - 1 \right) = 0.60$$

[fo_kr_1_en_US]

$$K_x = \frac{X_{Gnd}}{X_L} = \frac{1}{3} \cdot \left(\frac{X_0}{X_1} - 1 \right) = \frac{1}{3} \cdot \left(\frac{1.19 \text{ Ω/km}}{0.42 \text{ Ω/km}} - 1 \right) = 0.61$$

[fo_kx_1_en_US]

Parameter: **K0** and Angle (**K0**)

- Default setting **K0** = 1.000
- Default setting **Angle (K0)** = 0.00°



NOTE

The visibility of the **K0** and **Angle (K0)** parameters depends on the selected setting format of the residual compensation factors. The parameters **K0** and **Angle (K0)** are only visible if you have set the parameter **Set. format residu. comp.** = **K0** for the device. The **Set. format residu. comp.** parameter can be found in the DIGSI 5 project tree under **Name of the device** → **Parameter** → **Device settings**.

The **K0** and **Angle (K0)** parameters are used to set the complex grounding-resistance factor.

Make sure that the line angle is set correctly because the device needs the line angle for calculation of the compensation components from the **K0** factor. The complex grounding-resistance factor is defined by the value and the angle. You can calculate the complex grounding-resistance factor from the line data as follows:

$$K_0 = \left| \frac{Z_{Gnd}}{Z_L} \right| = \left| \frac{1}{3} \cdot \left(\frac{Z_0}{Z_1} - 1 \right) \right|$$

[fo_K01_1_en_US]

where:

Z_0	(Complex) zero-sequence impedance
Z_1	(Complex) positive-sequence impedance

This data can either be used for the entire line or as length-related values, since the quotients are length-independent. You can calculate the data both from the primary values and from the secondary values. For overhead lines, you can use the values for the calculation because the angles of the zero-sequence system and the positive-sequence system differ only slightly. For cables, however, significant angular differences can occur, as the following example illustrates.

EXAMPLE

110-kV single-conductor liquid-filled cable 3 · 185 mm² Cu with the data:

- Z_1/s 0.408 · e^{j73°} Ω/km positive-sequence impedance
- Z_0/s 0.632 · e^{j18.4°} Ω/km zero-sequence impedance
- s Line length

The values for calculation of the grounding-resistance factor K_0 are:

$$\frac{Z_0}{Z_1} = \frac{0.632}{0.408} \cdot e^{j(18.4^\circ - 73^\circ)} = 1.55 \cdot e^{-j54.6^\circ} = 1.55 \cdot (0.579 - j 0.815) = 0.898 - j 1.263$$

[fo_1_k0_1_en_US]

$$k_0 = \left| \frac{1}{3} \cdot \left(\frac{Z_0}{Z_1} - 1 \right) \right| = \left| \frac{1}{3} \cdot (0.898 - j 1.263 - 1) \right| = \left| \frac{1}{3} \cdot (-0.102 - j 1.263) \right|$$

[fo_2_k0_1_en_US]

The setting value of the parameter K_0 is calculated from:

$$k_0 = \left| \frac{1}{3} \cdot \sqrt{(-0.102^2) + (-1.263^2)} \right| = 0.42$$

[fo_3_k0_1_en_US]

When determining the angle, take note of the quadrant of the result. The following table lists the quadrants and the angle range obtained from the operational signs of the real and imaginary parts of K_0 .

Real Part	Imaginary Part	tan Phi (K0)	Quadrant/Range	Calculation Method
+	+	+	I 0° to 90°	arc tan (Im / Re)
+	-	-	IV -90° to 0°	-arc tan (Im / Re)
-	-	+	III -90° to -180°	arc tan (Im / Re) - 180°
-	+	-	II +90° to +180°	-arc tan (Im / Re) +180°

In this example, the following setting value for the **Angle (K0)** parameter is obtained:

$$\varphi(K_0) = \arctan \left(\frac{1.263}{0.102} \right) - 180^\circ = -94.6^\circ$$

[fo_phi_k0_1_en_US]

6.47.5 Settings

Addr.	Parameter	C	Setting Options	Default Setting
<i>Fault locator</i>				
_:1	Fault locator:Mode		<ul style="list-style-type: none"> • off • on • test 	off

Addr.	Parameter	C	Setting Options	Default Setting
_:101	Fault locator:Start		<ul style="list-style-type: none"> with operate with going pickup 	with going pickup
_:103	Fault locator:Load compensation		<ul style="list-style-type: none"> no yes 	no
_:113	Fault locator:X per length unit	1 A	0.0001 Ω/km to 9.5000 Ω/km	Ω/km
		5 A	0.0000 Ω/km to 1.9000 Ω/km	0.0000 Ω/km
_:114	Fault locator:Line length		0.10 km to 1000.00 km	60.00 km
_:108	Fault locator:Line angle		10.00 ° to 89.00 °	85.00 °
_:104	Fault locator:Kr		-0.33 to 11.00	1.00
_:105	Fault locator:Kx		-0.33 to 11.00	1.00
_:118	Fault locator:K0		0.000 to 11.000	1.000
_:150	Fault locator:Angle (K0)		-180.00 ° to 180.00 °	0.00 °

6.47.6 Information List

No.	Information	Data Class (Type)	Type
<i>Fault locator</i>			
_:54	Fault locator:Inactive	SPS	O
_:52	Fault locator:Behavior	ENS	O
_:53	Fault locator:Health	ENS	O
_:302	Fault locator:Fault resistance prim.	MV	O
_:303	Fault locator:Fault reactance prim.	MV	O
_:308	Fault locator:Fault resistance sec.	MV	O
_:309	Fault locator:Fault reactance sec.	MV	O
_:304	Fault locator:Fault distance	MV	O
_:305	Fault locator:Fault distance in %	MV	O
_:306	Fault locator:Fault loop	ENS	O
_:307	Fault locator:FLO invalid	ENS	O

6.48 Fault Locator Plus

6.48.1 Overview of Functions

The **Fault locator plus** function

- Is used for 2-sided measurement of the distance to the fault location
- Also reliably detects the fault location with 2-sided infeed, faults with ground involvement and with fault resistances
- Can be used for fault-location determination with non-homogeneous lines

The **Fault locator plus** function calculates the fault location with the measured values of both line ends. For the transmission of the measured values between the line ends, a communication connection must be present via the protection interface.

If 2-sided fault-location determination is not possible, alternatively, the 1-sided method is used with a calculation of the reactance of the short-circuited measurement loops.



NOTE

With SIPROTEC 5 Compact, the Fault locator plus function can be used to determine the fault location for inhomogeneous lines with up to 9 line sections.

The 2-sided fault location is not supported because the SIPROTEC 5 Compact does not have a protection interface.

Fast fault-location determination and the associated fast fault clearance increase the availability of the line for power transmission in the electrical power system.

6.48.2 Structure of the Function

The **Fault locator plus** function can be used in protection function groups with 3-phase current and voltage measurement.

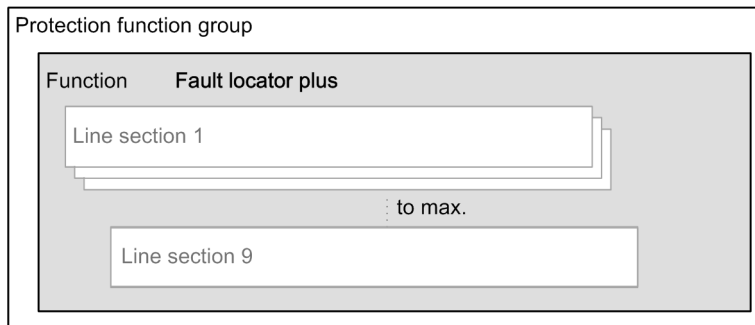

[dwst fo_double, 1, en_US]

Figure 6-331 Structure/Embedding of the Function

The fault location is calculated based on the line parameters. Fault-location determination is always carried out **with going pickup** of the short-circuit protection. There is an option to limit fault-location determination to cases with tripping (setting the value for the parameter **Start = with operate**).

For inhomogeneous lines, such as overhead line/cable sections, you can set parameters for separate line sections with dedicated line data. You can instantiate a maximum of 9 line sections.

For 2-sided fault-location determination, the measured values of both line ends must be available at each line end. For this purpose, a SIPROTEC 5 device must be installed with a protection interface at each end of the area to be protected. The devices exchange their measurands via protection interface. The measurands are encrypted in digital telegrams and transmitted via protection communication. The current and voltage transformers selectively delimit the protection range.

2-sided fault-location determination is not possible with the function **Fault locator plus** under the following conditions, for example:

- The fault is not located on the line.
- The devices at the line ends do not have a protection interface.
- Protection communication is disrupted.
- With a 1-sided infeed, a metallic fault occurs.



NOTE

If 2-sided fault-location determination is not possible, the function **Fault locator plus** alternatively works with the 1-sided method for fault-location determination.

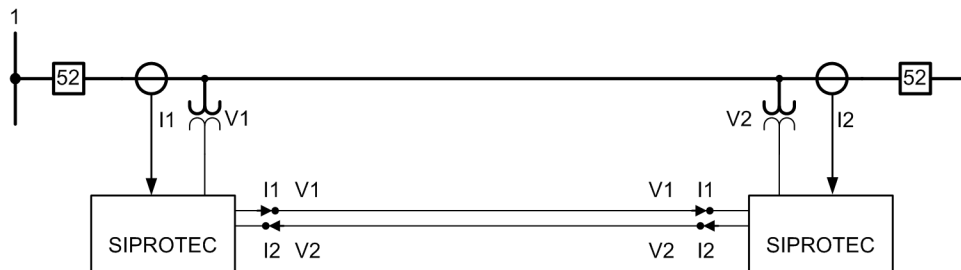

[dw_example_WS.1_en_US]

Figure 6-332 Data Exchange for 2 Devices, Each With Protection Communication

Fault locator plus can be started as follows:

- Via the phase-segregated binary inputs *>Fault detected phs A*, *>Fault detected phs B*, *>Fault detected phs C*, and *>Fault detected gnd*.
- Via differential protection
- Via distance protection
- Via directional overcurrent protection, phases or ground
- Via overcurrent protection, phases or ground
- Via the non-phase-segregated binary input *>Flt. det. w/o phs.&gnd*.

If multiple protection functions are operating in parallel, the fault locator is only started by the function pickup with the highest priority. The functions are listed in decreasing priority.

Connection Types of the Current and Voltage Transformers



NOTE

The function **Fault locator plus** does not work with all possible current and voltage transformer connection types.

An error message is displayed in DIGSI 5 if the function cannot work with the set connection type. In this case, check the current and voltage transformer connection type.

You can find the **CT connection** or **VT connection** settings in DIGSI 5 under **Power system** → **Meas.point I-3ph** or **System data** → **Meas.point V-3ph**.

The **Fault locator plus** function only works with the following current and voltage transformer connection types (see parameter value).

Parameter	Parameter Value
CT connection	<ul style="list-style-type: none"> • 3-phase + IN-separate • 3-phase + IN • 3-phase
VT connection	<ul style="list-style-type: none"> • 3 ph-to-gnd volt. + VN • 3 ph-to-gnd voltages

6.48.3 Function Description

Starting Conditions

Each protection function that can start the fault locator also provides **Fault locator plus** with information on the pickup and tripping times. If multiple protection functions pick up at the same time, **Fault locator plus** is started only by the function with the highest priority.

The fault locator uses the pickup and tripping information for the protection function being started to form its own measurand memory for the following calculations. Depending on the pickup duration of the protection function, the measurand memory is positioned such that it contains pre-fault processes, short-circuit processes, and switch-off processes. If the pickup lasts for a longer time, only the short-circuit processes and switch-off processes are recorded by the measurand memory. The fault-location determination always starts only after the dropout of the pickup.

Fault-location determination is also possible via the starting condition *with going pickup*, if the protection device only picks up and does not trigger. Fault-location determination is then performed via the starting condition *with operate* only if the protection device has reported the tripping and the pickup has dropped out.

Alternatively, the **Fault locator** can be started via one or more binary inputs. If the phase-segregated indications *>Fault detected phs A*, *>Fault detected phs B*, *>Fault detected phs C*, and *>Fault detected gnd.* are routed in the DIGSI 5 information routing, the **Fault locator** interprets the binary inputs as a phase-segregated external protection function and treats them with the highest priority.



NOTE

The phase-segregated start of the fault locator will only be possible if you have routed all 4 indications in the DIGSI 5 information routing.

When routing the binary input *>Flt. det. w/o phs.&gnd.*, the binary input is interpreted as a non-segregated external protection function and is treated with the lowest priority. The fault locator starts when the binary input drops out.

When the parameter *with operate* is set and the **Fault locator** is started via the binary input, the fault-location determination is started only when a device-internal protection function generates an operate indication, or when the binary *>Fault locator start* input is activated in addition to the above mentioned binary inputs.

▼ Fault locator plus	21.1611		*	*	*	*
▼ General	21.1611.2311		*	*	*	*
◆ >Block function	21.1611.2311.81	SPS				
◆ >Fault detected phs A	21.1611.2311.501	SPS	H			
◆ >Fault detected phs B	21.1611.2311.502	SPS		H		
◆ >Fault detected phs C	21.1611.2311.503	SPS			H	
◆ >Fault detected gnd.	21.1611.2311.504	SPS				H
◆ >Flt. det. w/o phs.&gnd.	21.1611.2311.505	SPS				
◆ >Fault locator start	21.1611.2311.506	SPS				

[sCrang_FOplus_1_en_US]

Figure 6-333 Routing Matrix for the Triggering of the Fault Locator via Binary Input

Definition of the Line Sections

For inhomogeneous lines, for example, cable/overhead line sections, you can define several line sections and set the line parameters separately for each line section.



NOTE

If you have an inhomogeneous line with several line sections, you must enter the line sections in the device at the opposite end back-to-front. The function checks the correct parameter configuration and issues the inconsistency indication (`_:2311:310) Line sect. setting err.` in the case of a fault.

EXAMPLE:

The line between line ends **A** and **B** consists of the line sections Cable **A** – overhead line – Cable **B**. Consider the following with the parameter configuration of the function:

- Instantiate each of 3 line ends in the device at line end **A** and at line end **B** and enter the line data for each section.
- Ensure that you enter the data for the line sections in device **B** back-to-front to device **A**.

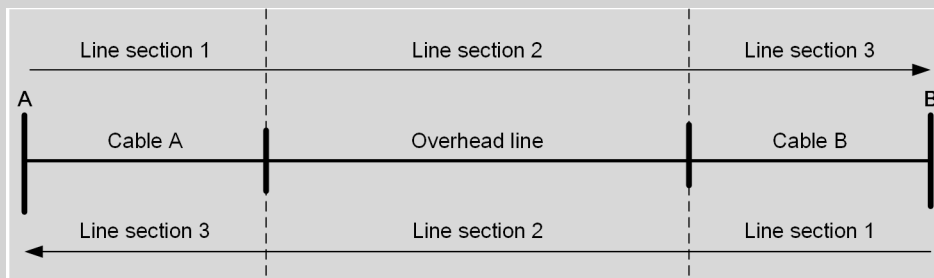

[dw def line sections, 1, en, US]

Figure 6-334 Line with 3 Line Sections

Installation Site	Definition of Line Sections
Device A	Define the line sections on device A as follows: <ul style="list-style-type: none"> • Line section 1: Line data from cable A • Line section 2: Line data from the overhead line • Line section 3: Line data from cable B
Device B	Define the line sections on device B as follows: <ul style="list-style-type: none"> • Line section 1: Line data from cable B • Line section 2: Line data from the overhead line • Line section 3: Line data from cable A

You can rename the instantiated line sections.

Algorithm for 2-Sided Fault-Location Determination

For an unbranched line with known current and known voltage on the line ends, the voltage can be calculated at any position x of the line. The algorithm calculates the voltage of both sides of the line. At the fault location itself, the voltage calculated from both line ends must correspond. If both voltage curves are displayed graphically, their intersection is the position of the fault location d_{FL} . [Figure 6-335](#) illustrates the basic principle of 2-sided fault-location determination. The algorithm calculates the voltage curves with the measured data of the protection devices of both line ends **A** and **B**. The voltage curve is not linear and is calculated as follows with the telegraph equation:

$$\underline{V}_d(d) = \cosh(\underline{\gamma} \cdot d) \cdot \underline{V} - \underline{Z} \cdot \sinh(\underline{\gamma} \cdot d) \cdot I$$

[fo telegraph equation line, 1, en_US]

with

$$\underline{\gamma} = j\omega \cdot \sqrt{L' \cdot C'} \quad \text{Wave propagation constant}$$

$$\underline{Z} = j\omega \sqrt{\frac{L'}{C'}} \quad \text{Wave impedance}$$

d Distance

\underline{V}, I Measured values on the line ends

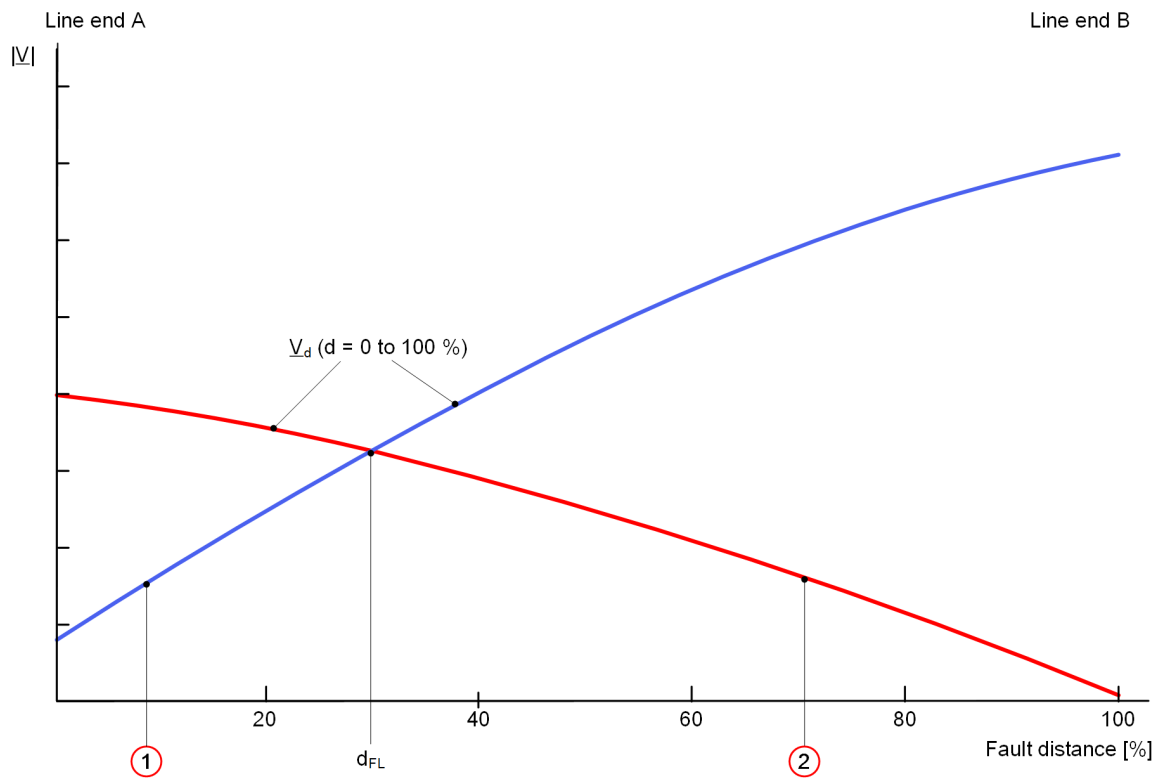

[dvw fault locator voltage char, 1, en_US]

Figure 6-335 Voltage Curve, Calculated from Both Sides of the Line

with:

- 1 Voltage curve calculated with the measured values at line end A
- 2 Voltage curve calculated with the measured values at line end B
- d_{FL} Fault location

The algorithm of the 2-sided fault-location determination offers the following advantages compared to the 1-sided method:

- Correct fault-location determination is also possible with power flow, 2-sided infeed and high fault resistances.
- The algorithm is independent from the zero-sequence system and therefore also from its influencing variables, such as inductive couplings of parallel lines.
- An imprecise setting of the residual impedance compensation factors has no influence on the precision of the fault location.

Output of the Fault Location

The following results for the fault location are issued:

- The fault resistance in Ω primary and secondary
- The fault transfer resistance in Ω primary and secondary
This value is only issued, if 2-sided fault-location determination is possible.
- The fault reactance up to the fault location in Ω primary and secondary
- The fault distance d in km or miles
- The fault distance d in percentage of the line length
- The number of the line section, in which the fault was localized
- The selected fault loop for calculation of the fault location

The indication of distance in kilometers, miles, or percent is also applicable only for inhomogeneous line sections (for example, overhead line cable routes). If you have defined several line sections for an inhomogeneous line, the **Fault locator plus** function issues the number of the faulty line section.



NOTE

If 2-sided fault-location determination is not possible by the **Fault locator plus** function, the function works automatically with the algorithm for the 1-sided fault-location determination. You can find the description for the 1-sided fault locator in [6.47.1 Overview of Functions](#).

6.48.4 Application and Setting Notes

The following line data are relevant for the 2-sided fault-location determination:

- Reactance per unit length of the line per kilometer or per mile
- Line length for the correct output of the fault distance as a percentage of the line length

The following parameters are only relevant for the 1-sided fault-location determination:

- **Parallel-line compensat.**
- **Gnd.curr.ratio (MutComp)**
- **Load compensation**
- The residual compensation factors in the setting format **Kr** and **Kx** or **K0** and **Angle (K0)**.



NOTE

Parallel-line compensation and load compensation are only possible with homogeneous lines. If you define more than one line section and set the parameter **Parallel-line compensat.** or **Load compensation = yes**, DIGSI reports an inconsistency.

Parameter: Start

- Recommended setting value (**_:2311:101**) **Start = with going pickup**

With the parameter **Start**, you define the criterion for starting the fault location.

Parameter Value	Description
<i>with going pickup</i>	If a pickup signal of the protection functions designated for the startup has dropped out, fault-location determination starts.
<i>with operate</i>	If one of the protection functions designated for startup has reported the tripping and the pickup has dropped out, fault-location determination starts.

As an alternative, the fault locator can be started using an external binary input.

Parameter: Parallel-line compensat.

- Default setting (`_:2311:102`) **Parallel-line compensat.** = *no*

The parameter **Parallel-line compensat.** is only visible when the ground current of the parallel line is connected to the **Line** function group.

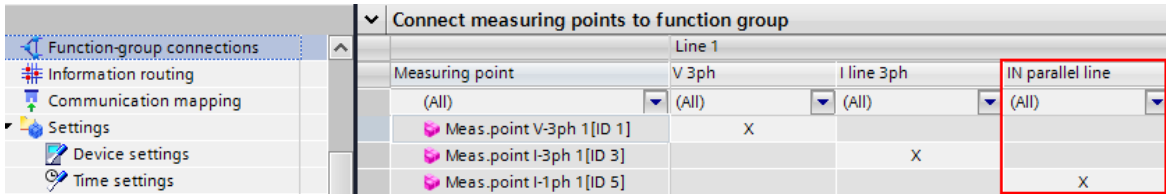

[scParkomp, 1, en_US]

Figure 6-336 Routing in DIGSI

This parameter is only relevant for 1-sided fault-location determination.

If you wish to apply the parallel-line compensation for double lines, set the **Parallel-line compensat.** parameter to *yes*.

Parameter Value	Description
<i>no</i>	The parallel-line compensation is not effective with this setting.
<i>yes</i>	The parallel-line compensation is effective with this setting.

The following conditions have to be fulfilled so that the parallel-line compensation functions:

- Connect the ground current of the parallel line in the correct polarity to an additional current input.
- Set the input used for the parallel current in the correct ratio to the phase currents for the power-system data.

Parallel-line compensation is only carried out if the ground current of the line to be protected (I_{gnd}) is greater than the ground current of the parallel line (I_{gndP}) evaluated with the parameter **Gnd.curr.ratio (MutComp)**.

Siemens recommends keeping the default setting **Gnd.curr.ratio (MutComp)** = 85 %. In highly unbalanced system conditions and if the coupling factor is very small (X_M/X_L less than 0.4), a smaller value may be advisable.

- Set the coupling impedances to the parallel system correctly for the line data.

Parameter: Gnd.curr.ratio(MutComp)

- Recommended setting value (`_:2311:109`) **Gnd.curr.ratio (MutComp)** = 85 %

This parameter is only relevant for the 1-sided fault-location determination.

With the **Gnd.curr.ratio (MutComp)** parameter, you define the ground-current balance for parallel-line compensation. This parameter is important for parallel-line compensation in the event of ground faults outside of the line to be protected.

For the ground-current balance of the distance protection, the setting value indicates the current ratio I_{gnd}/I_{gndP} for the protection device at installation site II.

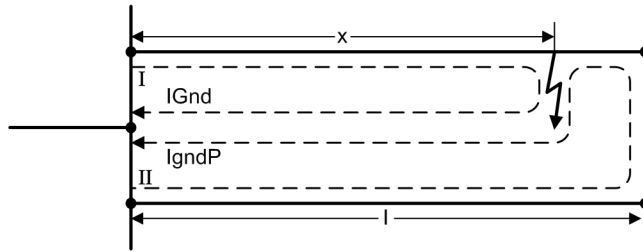

[dwparkomnw-161013, 1, en_US]
Figure 6-337 Radius of Parallel-Line Compensation at II

Parallel-line compensation is only carried out if the ground current of the line to be protected (I_{gnd}) is greater than the ground current of the parallel line (I_{gndP}) evaluated with the parameter **Gnd.curr.ratio (MutComp)**.

Siemens recommends keeping the default setting **Gnd.curr.ratio (MutComp) = 85 %**. In highly unbalanced system conditions and if the coupling factor is very small (X_M/X_L less than 0.4), a smaller value may be advisable.

Parameter: Load compensation

- Default setting (`_:2311:103`) **Load compensation = no**

This parameter is only relevant for 1-sided fault-location determination.

With the parameter **Load compensation**, you correct measuring errors for 1-phase short circuits on lines fed on both sides. This is the case for overhead lines without grounding cable or with unfavorable grounding conditions of the towers, if high contact resistances can occur in the event of 1-phase short circuits.

Parameter Value	Description
<i>no</i>	The load compensation is not effective with this setting.
<i>yes</i>	The load compensation is effective with this setting. If you operate using load compensation, the following parameters are relevant and are shown automatically: <ul style="list-style-type: none"> • Substitute for IF • Comp. angle zero seq. • Comp. angle neg. seq.

Parameter: Substitute for IF

- Default setting (`_:2311:104`) **Substitute for IF = 3I0**

The parameter **Substitute for IF** is only visible and relevant if you operate using load compensation. With the parameter **Substitute for IF**, you define which substitute value can be used in ground-impedance loops for the unmeasurable fault current I_F and replace it with the fault resistance at the fault location. First, calculate the compensation angle for the zero-sequence system and the negative-sequence system. Set the parameter **Substitute for IF** for the relatively smaller compensation angle. The relatively smaller compensation angle indicates that the associated system (zero-sequence and negative-sequence system) is more homogeneous and the fault current can be approximated better through the fault resistance at the fault location.

Parameter: Compensation Angle for Zero-Sequence System/Negative-Sequence System

- Default setting (`_:2311:106`) **Comp. angle zero seq. = 0.00°**
- Default setting (`_:2311:107`) **Comp. angle neg. seq. = 0.00°**

The parameters **Comp. angle zero seq.** and **Comp. angle neg. seq.** are only visible and relevant if you operate using load compensation.

If, based on network model tests or calculations, an angle difference between the measured $3I_0$ or $3I_2$ and I_F was determined, this can be compensated for with the parameter **Comp. angle zero seq.** or the parameter **Comp. angle neg. seq.**.

A setting of the compensation angle deviating from 0 is only relevant for non-homogeneous systems.

When using the **Comp. angle zero seq.** parameter, the angle difference between the $3I_0$ calculated by the device and the fault current I_F is being compensated.

When using the **Comp. angle neg. seq.** parameter, the angle difference between the $3I_2$ calculated by the device and the fault current I_F is being compensated.



NOTE

For non-homogeneous lines, for example, cable/overhead line routes, you can define several line sections and set the line parameters separately for each line section.

You can find further information on the line parameters in [6.47.4 Application and Setting Notes](#).

Parameter: C1 per length unit

- Default setting (`_:16921:112`) **C1 per length unit** = 0.010 $\mu\text{F}/\text{km}$

With the **C1 per length unit** parameter, you specify the capacitance per unit length in the positive-sequence system for the line to be protected. You set the **C1 per length unit** parameter as a relative value in $\mu\text{F}/\text{km}$ or $\mu\text{F}/\text{miles}$. The capacitance per unit length in the positive-sequence system is identical to the operating capacitance c_b' .

Parameter: C0 per length unit

- Default setting (`_:16921:148`) **C0 per length unit** = 0.010 $\mu\text{F}/\text{km}$

With the **C0 per length unit** parameter, you specify the capacitance per unit length in the zero-sequence system for the line to be protected. You set the **C0 per length unit** parameter as a relative value in $\mu\text{F}/\text{km}$ or $\mu\text{F}/\text{miles}$. The capacitance per unit length in the zero-sequence system is identical to the ground capacitance c_{gd}' .

Parameter: X per length unit

- Default setting (`_:16921:113`) **X per length unit** = 0.0525 Ω/km

With the **X per length unit** parameter, you set the reactance per unit length for the line to be protected. You set the **X per length unit** parameter as a relative value in Ω/km or Ω/miles .

Parameter: Line length

- Default setting (`_:16921:114`) **Line length** = 60 km

With the **Line length** parameter, you can set the length of the line to be protected as a unit of length in km or miles.

Parameter: Line angle

- Default setting (`_:16921:108`) **Line angle** = 85.00°

Calculate the setting value for the parameter **Line angle** from the line constants for the line to be protected as follows:

$$\tan \varphi = \frac{X_L}{R_L} \quad \text{or} \quad \varphi = \arctan \left(\frac{X_L}{R_L} \right)$$

[fo_winkl, 1, en_US]

where:

R_L Resistance of the line to be protected
 X_L Reactance of the line to be protected

EXAMPLE

110 kV overhead line 150 mm² with the data

$$R'_1 = 0.19 \Omega/\text{km}$$

$$X'_1 = 0.42 \Omega/\text{km}$$

You calculate the setting value for the line angle as follows:

$$\tan \varphi = \frac{X_L}{R_L} = \frac{X'_1}{R'_1} = \frac{0.42 \Omega/\text{km}}{0.19 \Omega/\text{km}} = 2.21$$

[fo_tan_phi_1_en_US]

$$\arctan(2.21) = 65.7^\circ$$

[fo_arctan_phi_1_en_US]

Parameter: Kr and Kx

- Default setting (_:16921:104) $K_r = 1.00$
- Default setting (_:16921:105) $K_x = 1.00$

The K_r and K_x parameters are used to set the residual compensation factors as scalar values. The K_r and K_x parameters are relevant for the **Fault locator** function.

Calculate the setting values for the parameters K_r and K_x from the line data as follows:

Resistance ratio

Reactance ratio

$$K_r = \frac{R_{\text{gnd}}}{R_L} = \frac{1}{3} \cdot \left(\frac{R_0}{R_1} - 1 \right)$$

$$K_x = \frac{X_{\text{gnd}}}{X_L} = \frac{1}{3} \cdot \left(\frac{X_0}{X_1} - 1 \right)$$

where:

R_0 Zero-sequence system resistance of the line
 X_0 Zero-sequence system reactance of the line
 R_1 Positive-sequence system resistance of the line
 X_1 Positive-sequence system reactance of the line

This data can either be used for the entire line or as length-related values, since the quotients are length-independent. You can calculate the data both from the primary values and from the secondary values.

EXAMPLE

110-kV overhead line 150 mm² with the data:

R_1/s 0.19 Ω/km positive-sequence system resistance
 X_1/s 0.42 Ω/km positive-sequence system reactance
 R_0/s 0.53 Ω/km zero-sequence system resistance
 X_0/s 1.19 Ω/km zero-sequence system reactance
 s Line length

You receive the following setting values for the parameters K_r and K_x :

$$k_r = \frac{R_{Gnd}}{R_L} = \frac{1}{3} \cdot \left(\frac{R_0}{R_1} - 1 \right) = \frac{1}{3} \cdot \left(\frac{0.53 \Omega/km}{0.19 \Omega/km} - 1 \right) = 0.60$$

[fo_kr_1_en_US]

$$k_x = \frac{X_{Gnd}}{X_L} = \frac{1}{3} \cdot \left(\frac{X_0}{X_1} - 1 \right) = \frac{1}{3} \cdot \left(\frac{1.19 \Omega/km}{0.42 \Omega/km} - 1 \right) = 0.61$$

[fo_kx_1_en_US]

Parameter: K0 and Angle (K0)

- Default setting (_:16921:118) **K0** = 1.000
- Default setting (_:16921:150) **Angle (K0)** = 0.00°



NOTE

The visibility of the **K0** and **Angle (K0)** parameters depends on the selected setting format of the residual compensation factors. The parameters **K0** and **Angle (K0)** are only visible if you have set the parameter **Set. format residu. comp.** = **K0** for the device. You can find the parameter **Set. format residu. comp.** in the DIGSI 5 project tree under **Name of the device** → **Settings** → **Device settings**.

The **K0** and **Angle (K0)** parameters are used to set the complex grounding-resistance factor.

Make sure that the line angle is set correctly because the device needs the line angle for calculation of the compensation components from the K0 factor. The complex grounding-resistance factor is defined by the absolute value and the angle. You can calculate the complex grounding-resistance factor from the line data as follows:

$$K_0 = \left| \frac{Z_{Gnd}}{Z_L} \right| = \left| \frac{1}{3} \cdot \left(\frac{Z_0}{Z_1} - 1 \right) \right|$$

[fo_K01_1_en_US]

where:

Z_0 (Complex) zero-sequence impedance

Z_1 (Complex) positive-sequence impedance

This data can either be used for the entire line or as length-related values, since the quotients are length-independent. You can calculate the data both from the primary values and from the secondary values.

For overhead lines, you can use the values for the calculation because the angles of the zero-sequence system and the positive-sequence system differ only slightly. For cables, however, significant angular differences can occur, as the following example illustrates.

EXAMPLE

110-kV single-conductor liquid-filled cable 3 · 185 mm² Cu with the data:

Z_1/s 0.408 · e^{j73°} Ω/km positive-sequence impedance

Z_0/s 0.632 · e^{j18.4°} Ω/km zero-sequence impedance

s Line length

The values for calculation of the grounding-resistance factor **K0** are:

$$\frac{Z_0}{Z_1} = \frac{0.632}{0.408} \cdot e^{j(18.4° - 73°)} = 1.55 \cdot e^{-j54.6°} = 1.55 \cdot (0.579 - j 0.815) = 0.898 - j 1.263$$

[fo_1_k0_1_en_US]

$$k_0 = \left| \frac{1}{3} \cdot \left(\frac{Z_0}{Z_1} - 1 \right) \right| = \left| \frac{1}{3} \cdot (0.898 - j 1.263 - 1) \right| = \left| \frac{1}{3} \cdot (-0.102 - j 1.263) \right|$$

[fo_2_k0_1_en_US]

The setting value of the parameter **K0** is calculated from:

$$k_0 = \frac{1}{3} \cdot \sqrt{(-0.102)^2 + (-1.263)^2} = 0.42$$

[fo_3_k0_1_en_US]

When determining the angle, take note of the quadrant of the result. The following table lists the quadrants and the angle range obtained from the operational signs of the real and imaginary parts of **K0**.

Real Part	Imaginary Part	tan Phi (K0)	Quadrant/Range	Calculation Method
+	+	+	I	0° to 90° arc tan (Im / Re)
+	-	-	IV	-90° to 0° -arc tan (Im / Re)
-	-	+	III	-90° to -180° arc tan (Im / Re) - 180°
-	+	-	II	+90° to +180° -arc tan (Im / Re) + 180°

In this example, the following setting value for the **Angle (K0)** parameter is obtained:

$$\varphi(K_0) = \arctan \left(\frac{1.263}{0.102} \right) - 180^\circ = -94.6^\circ$$

[fo_phi_k0_1_en_US]

Parameter: Blocking of the auto. recl.

- Default setting (**_:16921:120**) **Blocking of the auto. recl. = no**

With the parameter **Blocking of the auto. recl.**, with inhomogeneous lines, you can block the **Automatic reclosing** function for faults on individual line sections, for example, on cable sections.



NOTE

The parameter **Blocking of the auto. recl.** is only visible, if you have instantiated the function block **Blk by FtLc. #** in the **Automatic reclosing** function.

You can find the function block **Blk by FtLc. #** in the DIGSI 5 library in the **FG Circuit breaker → Automatic reclosing function → Blocking by fault locator**.

Parameter Value	Description
no	The Fault locator plus function has no impact on the Automatic reclosing function.
yes	The Fault locator plus function blocks the Automatic reclosing function. The blocking only functions if the function block (FB) Blk by FtLc. # is instantiated in the Automatic reclosing function. The parameter (_:102) Min. dead time of blocking is in the FB. Set the parameter Min. dead time of blocking to the smallest dead time of all instantiated AREC cycles.

6.48.5 Settings

Addr.	Parameter	C	Setting Options	Default Setting
Control				
_:2311:1	General:Mode		<ul style="list-style-type: none"> off on test 	off
_:2311:101	General:Start		<ul style="list-style-type: none"> with operate with going pickup 	with going pickup
Compensation				
_:2311:102	General:Parallel-line compensat.		<ul style="list-style-type: none"> no yes 	no
_:2311:109	General:Gnd.curr.ratio(MutComp)		50 % to 95 %	85 %
_:2311:103	General:Load compensa- tion		<ul style="list-style-type: none"> no yes 	no
_:2311:104	General:Substitute for IF		<ul style="list-style-type: none"> 312 310 	310
_:2311:106	General:Comp. angle zero seq.		-40.00 ° to 40.00 °	0.00 °
_:2311:107	General:Comp. angle neg. seq.		-40.00 ° to 40.00 °	0.00 °
Line data 1				
_:16921:112	Line section 1:C1 per length unit	1 A	0.000 µF/km to 100000.000 µF/km	0.010 µF/km
		5 A	0.000 µF/km to 500000.000 µF/km	0.050 µF/km
_:16921:148	Line section 1:C0 per length unit	1 A	0.000 µF/km to 100000.000 µF/km	0.010 µF/km
		5 A	0.000 µF/km to 500000.000 µF/km	0.050 µF/km
_:16921:113	Line section 1:X per length unit	1 A	0.0005 Ω/km to 9.5000 Ω/km	0.0525 Ω/km
		5 A	0.0001 Ω/km to 1.9000 Ω/km	0.0105 Ω/km
_:16921:114	Line section 1:Line length		0.10 km to 1000.00 km	60.00 km
_:16921:108	Line section 1:Line angle		10.00 ° to 89.00 °	85.00 °
_:16921:104	Line section 1:Kr		-0.33 to 11.00	1.00
_:16921:105	Line section 1:Kx		-0.33 to 11.00	1.00
_:16921:118	Line section 1:K0		0.000 to 11.000	1.000
_:16921:150	Line section 1:Angle (K0)		-180.00 ° to 180.00 °	1.00 °
_:16921:106	Line section 1:KmR		0.00 to 8.00	1.00
_:16921:107	Line section 1:KmX		0.00 to 8.00	1.00
_:16921:124	Line section 1:Km0		0.000 to 8.000	1.000
_:16921:125	Line section 1:Angle (Km0)		-180.00 ° to 180.00 °	0.00 °
_:16921:120	Line section 1:Blocking of the auto. recl.		<ul style="list-style-type: none"> no yes 	no

Settings in the AWE

Addr.	Parameter	C	Setting Options	Default Setting
Blk by FtLc. #				
_:102	Blk by FtLc. #:Min. dead time of blocking		0.00 s to 1800.00 s	0.50 s

6.48.6 Information List

No.	Information	Data Class (Type)	Type
General			
_:2311:81	General:>Block function	SPS	I
_:2311:501	General:>Fault detected phs A	SPS	I
_:2311:502	General:>Fault detected phs B	SPS	I
_:2311:503	General:>Fault detected phs C	SPS	I
_:2311:504	General:>Fault detected gnd.	SPS	I
_:2311:505	General:>Flt. det. w/o phs.&gnd.	SPS	I
_:2311:506	General:>Fault locator start	SPS	I
_:2311:52	General:Behavior	ENS	O
_:2311:53	General:Health	ENS	O
_:2311:54	General:Inactive	SPS	O
_:2311:302	General:Fault resistance prim.	MV	O
_:2311:321	General:Fault trans. resis. prim.	MV	O
_:2311:303	General:Fault reactance prim.	MV	O
_:2311:308	General:Fault resistance sec.	MV	O
_:2311:322	General:Fault trans. resis. sec.	MV	O
_:2311:309	General:Fault reactance sec.	MV	O
_:2311:304	General:Fault distance	MV	O
_:2311:305	General:Fault distance in %	MV	O
_:2311:306	General:Fault loop	ENS	O
_:2311:307	General:State	ENS	O
_:2311:310	General:Line sect. setting err.	SPS	O
Line section 1			
_:16921:52	Line section 1:Behavior	ENS	O
_:16921:53	Line section 1:Health	ENS	O
_:16921:301	Line section 1:Fault on section	SPS	O

6.49 Temperature Supervision

6.49.1 Overview of Functions

The **Temperature supervision** function checks the thermal state of:

- Motors
- Generators
- Transformers

In rotating machines, it also checks bearing temperatures for a limit violation.

The temperatures are measured at various locations of the protected object using temperature sensors (RTD = Resistance Temperature Detector) and are sent to the device via one or more RTD units.

The **Temperature supervision** function receives its measured temperature values via the **RTD unit Ether.** or **RTD unit serial** functions from the **Analog units** function group.

6.49.2 Structure of the Function

The Temperature supervision function can work in all protection function groups. A maximum of 48 temperature supervision locations can operate simultaneously in the **Temperature supervision function** function. Each temperature supervision location has 2 threshold stages.

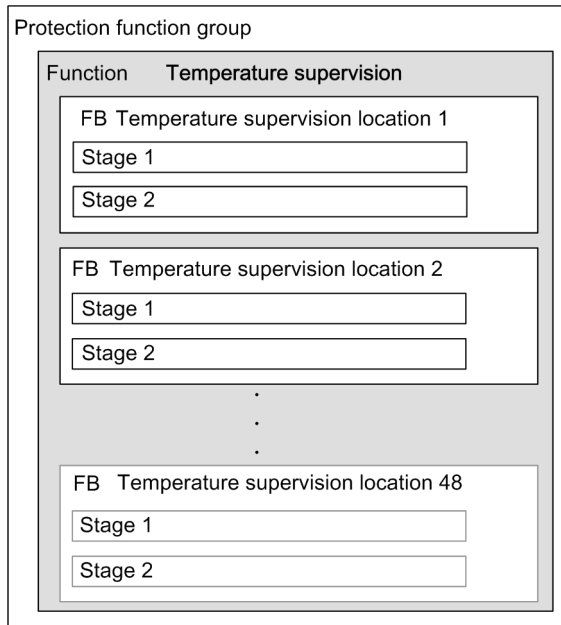

[dw_str_tmp_1_en_US]

Figure 6-338 Structure/Embedding of the Function

6.49.3 Function Description

Logic

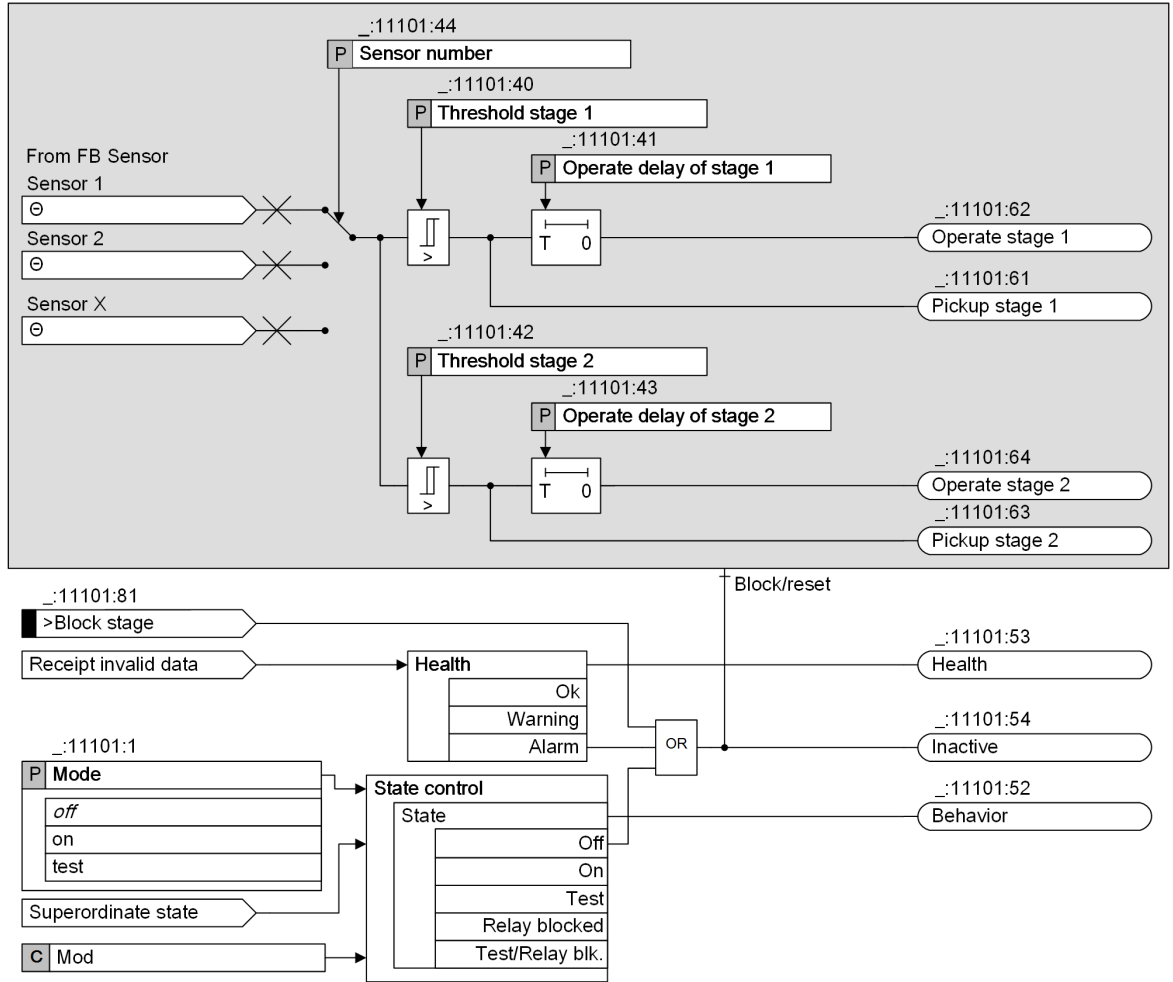

[to_temp_supervision, 3, en_US]

Figure 6-339 Logic Diagram for a Temperature Supervision Location

The **Temperature supervision location** function block (**Location FB**) receives a measured temperature value in °C or °F as an input variable delivered from the temperature sensor function blocks of the **Analog units** function group. The **Sensor number** parameter is used to select the temperature sensor.

2 threshold value decisions can be performed for each measuring point. If the measured temperature value is greater than or equal to the set threshold values, the stages generate a pickup indication independent of one another and, after a set tripping time delay, an operate indication.

The indications from the supervision locations remain available for further processing.



NOTE

The pickup of the stages does not result in fault logging. The operate indications of the stages do not go into the trip logic of the device.

6.49.4 Application and Setting Notes

If you use an external RTD unit, connect the RTD unit via an interface (Ethernet or serial) to the SIPROTEC 5 Compact device. Observe the setting notes for configuration of the interfaces in chapter *Analog Transformer Function Group Type* under [5.6.6.3 Communication with an RTD Unit](#).

Parameter: **Sensor location**

- Default setting (`_:11101:46`) **Sensor location = Other**

You inform the device of the sensor installation location using the **Sensor location** parameter. *Oil*, *Ambient*, *Turn*, *Bearing* and *Other* are available for selection. The selection is not evaluated in the device, it only serves an informational purpose in the medium in which the temperature measurement takes place.

Parameter: **Sensor number**

- Default setting (`_:11101:44`) **sensor number = no function block selected**

With the **sensor number** parameter, you assign a specific sensor whose temperature is to be monitored to the **Location** function block. You perform the assignment in DIGSI using a list box that contains all connected RTD units and their sensors.

Parameter: **Threshold stage 1**

- Default setting (`_:11101:40`) **Threshold stage 1 = 100 °C**

With the **Threshold stage 1** parameter you establish the temperature value whose exceedance causes a pickup of the 1st tripping stage.

Parameter: **Operate delay of stage 1**

- Default setting (`_:11101:41`) **Operate delay of stage 1 = 5 s**

With the **Operate delay of stage 1** parameter you establish the time the operate indication of the 1st tripping stage should be delayed after the pickup. This time delay depends on the specific application. If you set the time delay to ∞ the operate indication is blocked.

Parameter: **Threshold stage 2**

- Default setting (`_:11101:42`) **Threshold stage 2 = 120 °C**

With the **Threshold stage 2** parameter you establish the temperature value whose exceedance causes a pickup of the 2nd tripping stage.

Parameter: **Operate delay of stage 2**

- Default setting (`_:11101:43`) **Operate delay of stage 2 = 0 s**

With the **Operate delay of stage 2** parameter you establish the time the operate indication of the 2nd tripping stage should be delayed after the pickup. This time delay depends on the specific application. If you set the time delay to ∞ the operate indication is blocked.

Temperature Unit

Temperature Unit To change the display and evaluation of measured temperature values from °C to °F, adapt the DIGSI user default settings accordingly (see [5.6.6.5 Temperature Sensor](#)).

6.49.5 Settings

Addr.	Parameter	C	Setting Options	Default Setting
Point 1				
_:11101:46	Point 1:Sensor location		<ul style="list-style-type: none"> • Oil • Ambient • Turn • Bearing • Other 	Other
_:11101:1	Point 1:Mode		<ul style="list-style-type: none"> • off • on • test 	off
_:11101:40	Point 1:Threshold stage 1		-50°C to 250°C	100°C
_:11101:41	Point 1:Operate delay of stage 1		0 s to 60 s; ∞	5 s
_:11101:42	Point 1:Threshold stage 2		-50°C to 250°C	120°C
_:11101:43	Point 1:Operate delay of stage 2		0 s to 60 s; ∞	0 s
_:11101:44	Point 1:Sensor		Setting options depend on configuration	
Point 2				
_:11102:46	Point 2:Sensor location		<ul style="list-style-type: none"> • Oil • Ambient • Turn • Bearing • Other 	Other
_:11102:1	Point 2:Mode		<ul style="list-style-type: none"> • off • on • test 	off
_:11102:40	Point 2:Threshold stage 1		-50°C to 250°C	100°C
_:11102:41	Point 2:Operate delay of stage 1		0 s to 60 s; ∞	5 s
_:11102:42	Point 2:Threshold stage 2		-50°C to 250°C	120°C
_:11102:43	Point 2:Operate delay of stage 2		0 s to 60 s; ∞	0 s
_:11102:44	Point 2:Sensor		Setting options depend on configuration	
Point 3				
_:11103:46	Point 3:Sensor location		<ul style="list-style-type: none"> • Oil • Ambient • Turn • Bearing • Other 	Other
_:11103:1	Point 3:Mode		<ul style="list-style-type: none"> • off • on • test 	off
_:11103:40	Point 3:Threshold stage 1		-50°C to 250°C	100°C

Addr.	Parameter	C	Setting Options	Default Setting
_:11103:41	Point 3:Operate delay of stage 1		0 s to 60 s; ∞	5 s
_:11103:42	Point 3:Threshold stage 2		-50°C to 250°C	120°C
_:11103:43	Point 3:Operate delay of stage 2		0 s to 60 s; ∞	0 s
_:11103:44	Point 3:Sensor		Setting options depend on configuration	
Point 4				
_:11104:46	Point 4:Sensor location		<ul style="list-style-type: none"> • Oil • Ambient • Turn • Bearing • Other 	Other
_:11104:1	Point 4:Mode		<ul style="list-style-type: none"> • off • on • test 	off
_:11104:40	Point 4:Threshold stage 1		-50°C to 250°C	100°C
_:11104:41	Point 4:Operate delay of stage 1		0 s to 60 s; ∞	5 s
_:11104:42	Point 4:Threshold stage 2		-50°C to 250°C	120°C
_:11104:43	Point 4:Operate delay of stage 2		0 s to 60 s; ∞	0 s
_:11104:44	Point 4:Sensor		Setting options depend on configuration	
Point 5				
_:11105:46	Point 5:Sensor location		<ul style="list-style-type: none"> • Oil • Ambient • Turn • Bearing • Other 	Other
_:11105:1	Point 5:Mode		<ul style="list-style-type: none"> • off • on • test 	off
_:11105:40	Point 5:Threshold stage 1		-50°C to 250°C	100°C
_:11105:41	Point 5:Operate delay of stage 1		0 s to 60 s; ∞	5 s
_:11105:42	Point 5:Threshold stage 2		-50°C to 250°C	120°C
_:11105:43	Point 5:Operate delay of stage 2		0 s to 60 s; ∞	0 s
_:11105:44	Point 5:Sensor		Setting options depend on configuration	
Point 6				
_:11106:46	Point 6:Sensor location		<ul style="list-style-type: none"> • Oil • Ambient • Turn • Bearing • Other 	Other

Addr.	Parameter	C	Setting Options	Default Setting
_:11106:1	Point 6:Mode		<ul style="list-style-type: none"> • off • on • test 	off
_:11106:40	Point 6:Threshold stage 1		-50°C to 250°C	100°C
_:11106:41	Point 6:Operate delay of stage 1		0 s to 60 s; ∞	5 s
_:11106:42	Point 6:Threshold stage 2		-50°C to 250°C	120°C
_:11106:43	Point 6:Operate delay of stage 2		0 s to 60 s; ∞	0 s
_:11106:44	Point 6:Sensor		Setting options depend on configuration	
Point 7				
_:11107:46	Point 7:Sensor location		<ul style="list-style-type: none"> • Oil • Ambient • Turn • Bearing • Other 	Other
_:11107:1	Point 7:Mode		<ul style="list-style-type: none"> • off • on • test 	off
_:11107:40	Point 7:Threshold stage 1		-50°C to 250°C	100°C
_:11107:41	Point 7:Operate delay of stage 1		0 s to 60 s; ∞	5 s
_:11107:42	Point 7:Threshold stage 2		-50°C to 250°C	120°C
_:11107:43	Point 7:Operate delay of stage 2		0 s to 60 s; ∞	0 s
_:11107:44	Point 7:Sensor		Setting options depend on configuration	
Point 8				
_:11108:46	Point 8:Sensor location		<ul style="list-style-type: none"> • Oil • Ambient • Turn • Bearing • Other 	Other
_:11108:1	Point 8:Mode		<ul style="list-style-type: none"> • off • on • test 	off
_:11108:40	Point 8:Threshold stage 1		-50°C to 250°C	100°C
_:11108:41	Point 8:Operate delay of stage 1		0 s to 60 s; ∞	5 s
_:11108:42	Point 8:Threshold stage 2		-50°C to 250°C	120°C
_:11108:43	Point 8:Operate delay of stage 2		0 s to 60 s; ∞	0 s
_:11108:44	Point 8:Sensor		Setting options depend on configuration	

Addr.	Parameter	C	Setting Options	Default Setting
Point 9				
_:11109:46	Point 9:Sensor location		<ul style="list-style-type: none"> • Oil • Ambient • Turn • Bearing • Other 	Other
_:11109:1	Point 9:Mode		<ul style="list-style-type: none"> • off • on • test 	off
_:11109:40	Point 9:Threshold stage 1		-50°C to 250°C	100°C
_:11109:41	Point 9:Operate delay of stage 1		0 s to 60 s; ∞	5 s
_:11109:42	Point 9:Threshold stage 2		-50°C to 250°C	120°C
_:11109:43	Point 9:Operate delay of stage 2		0 s to 60 s; ∞	0 s
_:11109:44	Point 9:Sensor		Setting options depend on configuration	
Point 10				
_:11110:46	Point 10:Sensor location		<ul style="list-style-type: none"> • Oil • Ambient • Turn • Bearing • Other 	Other
_:11110:1	Point 10:Mode		<ul style="list-style-type: none"> • off • on • test 	off
_:11110:40	Point 10:Threshold stage 1		-50°C to 250°C	100°C
_:11110:41	Point 10:Operate delay of stage 1		0 s to 60 s; ∞	5 s
_:11110:42	Point 10:Threshold stage 2		-50°C to 250°C	120°C
_:11110:43	Point 10:Operate delay of stage 2		0 s to 60 s; ∞	0 s
_:11110:44	Point 10:Sensor		Setting options depend on configuration	
Point 11				
_:11111:46	Point 11:Sensor location		<ul style="list-style-type: none"> • Oil • Ambient • Turn • Bearing • Other 	Other
_:11111:1	Point 11:Mode		<ul style="list-style-type: none"> • off • on • test 	off
_:11111:40	Point 11:Threshold stage 1		-50°C to 250°C	100°C
_:11111:41	Point 11:Operate delay of stage 1		0 s to 60 s; ∞	5 s

Addr.	Parameter	C	Setting Options	Default Setting
_:11111:42	Point 11:Threshold stage 2		-50°C to 250°C	120°C
_:11111:43	Point 11:Operate delay of stage 2		0 s to 60 s; ∞	0 s
_:11111:44	Point 11:Sensor		Setting options depend on configuration	
Point 12				
_:11112:46	Point 12:Sensor location		<ul style="list-style-type: none"> • Oil • Ambient • Turn • Bearing • Other 	Other
_:11112:1	Point 12:Mode		<ul style="list-style-type: none"> • off • on • test 	off
_:11112:40	Point 12:Threshold stage 1		-50°C to 250°C	100°C
_:11112:41	Point 12:Operate delay of stage 1		0 s to 60 s; ∞	5 s
_:11112:42	Point 12:Threshold stage 2		-50°C to 250°C	120°C
_:11112:43	Point 12:Operate delay of stage 2		0 s to 60 s; ∞	0 s
_:11112:44	Point 12:Sensor		Setting options depend on configuration	

6.49.6 Information List

No.	Information	Data Class (Type)	Type
Point 1			
_:11101:81	Point 1:>Block stage	SPS	I
_:11101:54	Point 1:Inactive	SPS	O
_:11101:52	Point 1:Behavior	ENS	O
_:11101:53	Point 1:Health	ENS	O
_:11101:61	Point 1:Pickup stage 1	SPS	O
_:11101:62	Point 1:Operate stage 1	SPS	O
_:11101:63	Point 1:Pickup stage 2	SPS	O
_:11101:64	Point 1:Operate stage 2	SPS	O
Point 2			
_:11102:81	Point 2:>Block stage	SPS	I
_:11102:54	Point 2:Inactive	SPS	O
_:11102:52	Point 2:Behavior	ENS	O
_:11102:53	Point 2:Health	ENS	O
_:11102:61	Point 2:Pickup stage 1	SPS	O
_:11102:62	Point 2:Operate stage 1	SPS	O
_:11102:63	Point 2:Pickup stage 2	SPS	O
_:11102:64	Point 2:Operate stage 2	SPS	O
Point 3			
_:11103:81	Point 3:>Block stage	SPS	I

No.	Information	Data Class (Type)	Type
_:11103:54	Point 3:Inactive	SPS	0
_:11103:52	Point 3:Behavior	ENS	0
_:11103:53	Point 3:Health	ENS	0
_:11103:61	Point 3:Pickup stage 1	SPS	0
_:11103:62	Point 3:Operate stage 1	SPS	0
_:11103:63	Point 3:Pickup stage 2	SPS	0
_:11103:64	Point 3:Operate stage 2	SPS	0
Point 4			
_:11104:81	Point 4:>Block stage	SPS	I
_:11104:54	Point 4:Inactive	SPS	0
_:11104:52	Point 4:Behavior	ENS	0
_:11104:53	Point 4:Health	ENS	0
_:11104:61	Point 4:Pickup stage 1	SPS	0
_:11104:62	Point 4:Operate stage 1	SPS	0
_:11104:63	Point 4:Pickup stage 2	SPS	0
_:11104:64	Point 4:Operate stage 2	SPS	0
Point 5			
_:11105:81	Point 5:>Block stage	SPS	I
_:11105:54	Point 5:Inactive	SPS	0
_:11105:52	Point 5:Behavior	ENS	0
_:11105:53	Point 5:Health	ENS	0
_:11105:61	Point 5:Pickup stage 1	SPS	0
_:11105:62	Point 5:Operate stage 1	SPS	0
_:11105:63	Point 5:Pickup stage 2	SPS	0
_:11105:64	Point 5:Operate stage 2	SPS	0
Point 6			
_:11106:81	Point 6:>Block stage	SPS	I
_:11106:54	Point 6:Inactive	SPS	0
_:11106:52	Point 6:Behavior	ENS	0
_:11106:53	Point 6:Health	ENS	0
_:11106:61	Point 6:Pickup stage 1	SPS	0
_:11106:62	Point 6:Operate stage 1	SPS	0
_:11106:63	Point 6:Pickup stage 2	SPS	0
_:11106:64	Point 6:Operate stage 2	SPS	0
Point 7			
_:11107:81	Point 7:>Block stage	SPS	I
_:11107:54	Point 7:Inactive	SPS	0
_:11107:52	Point 7:Behavior	ENS	0
_:11107:53	Point 7:Health	ENS	0
_:11107:61	Point 7:Pickup stage 1	SPS	0
_:11107:62	Point 7:Operate stage 1	SPS	0
_:11107:63	Point 7:Pickup stage 2	SPS	0
_:11107:64	Point 7:Operate stage 2	SPS	0
Point 8			
_:11108:81	Point 8:>Block stage	SPS	I
_:11108:54	Point 8:Inactive	SPS	0

No.	Information	Data Class (Type)	Type
_:11108:52	Point 8:Behavior	ENS	O
_:11108:53	Point 8:Health	ENS	O
_:11108:61	Point 8:Pickup stage 1	SPS	O
_:11108:62	Point 8:Operate stage 1	SPS	O
_:11108:63	Point 8:Pickup stage 2	SPS	O
_:11108:64	Point 8:Operate stage 2	SPS	O
Point 9			
_:11109:81	Point 9:>Block stage	SPS	I
_:11109:54	Point 9:Inactive	SPS	O
_:11109:52	Point 9:Behavior	ENS	O
_:11109:53	Point 9:Health	ENS	O
_:11109:61	Point 9:Pickup stage 1	SPS	O
_:11109:62	Point 9:Operate stage 1	SPS	O
_:11109:63	Point 9:Pickup stage 2	SPS	O
_:11109:64	Point 9:Operate stage 2	SPS	O
Point 10			
_:11110:81	Point 10:>Block stage	SPS	I
_:11110:54	Point 10:Inactive	SPS	O
_:11110:52	Point 10:Behavior	ENS	O
_:11110:53	Point 10:Health	ENS	O
_:11110:61	Point 10:Pickup stage 1	SPS	O
_:11110:62	Point 10:Operate stage 1	SPS	O
_:11110:63	Point 10:Pickup stage 2	SPS	O
_:11110:64	Point 10:Operate stage 2	SPS	O
Point 11			
_:11111:81	Point 11:>Block stage	SPS	I
_:11111:54	Point 11:Inactive	SPS	O
_:11111:52	Point 11:Behavior	ENS	O
_:11111:53	Point 11:Health	ENS	O
_:11111:61	Point 11:Pickup stage 1	SPS	O
_:11111:62	Point 11:Operate stage 1	SPS	O
_:11111:63	Point 11:Pickup stage 2	SPS	O
_:11111:64	Point 11:Operate stage 2	SPS	O
Point 12			
_:11112:81	Point 12:>Block stage	SPS	I
_:11112:54	Point 12:Inactive	SPS	O
_:11112:52	Point 12:Behavior	ENS	O
_:11112:53	Point 12:Health	ENS	O
_:11112:61	Point 12:Pickup stage 1	SPS	O
_:11112:62	Point 12:Operate stage 1	SPS	O
_:11112:63	Point 12:Pickup stage 2	SPS	O
_:11112:64	Point 12:Operate stage 2	SPS	O

6.50 Phase-Sequence Switchover

6.50.1 Overview of Functions

The **Phase-sequence reversal** function enables correct execution of the protection of the device and supervision functions, independently of the phase sequence of the phases in a system or system section.

The phase sequence is set via parameters. You can select between the phase sequences **ABC** or **ACB**.

Binary inputs also provide the option of switching over the phase sequence with respect to the parameter setting. For example, in pumped-storage hydropower plants with motor or motor/generator operation you temporarily change the direction of rotation by changing over the phase sequence.

The phase sequence has an effect on calculation of the positive-sequence system and negative-sequence system values and on calculation of phase-to-phase values. A phase-rotation reversal therefore has an effect on all protection and supervision functions that use these values.

You can change the phase sequence in 2 ways via binary inputs.

- Change over the phase sequence for the entire device.
In doing so, all 3-phase measuring points are switched over. All analog inputs are therefore affected (for example current and voltage inputs simultaneously).
- Change over the phase sequence per measuring point.
In doing so, only the activated measuring points are switched over. The other measuring points remain unaffected.

6.50.2 Structure of the Function

The **Phase-sequence switchover** function is integrated in the **Power-system data**. You will find the signals in the DIGSI 5 project tree under **Name of the device** → **Settings**. There you will find the parameter for setting the phase sequence and the binary inputs via which you can influence a change in the phase sequence.

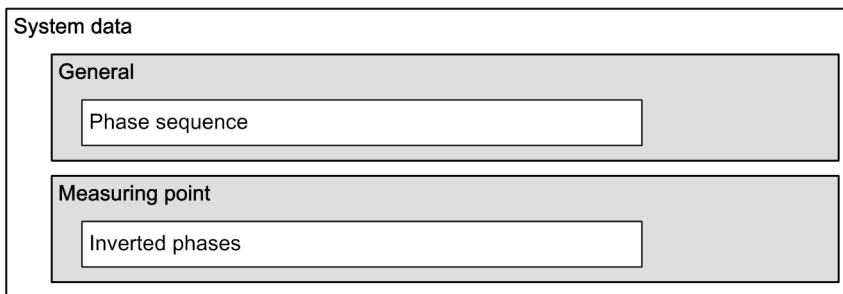

[dsw_ph_rein_1_en_US]

Figure 6-340 Structure/Embedding of the Function

6.50.3 Function Description

General

The phase sequence of the system is set in the device via the **Phase sequence** parameter. You will find the signals in the DIGSI 5 project tree under **Name of the device** → **Settings** → **Power-system data** → **General**. There are 3 methods to change the phase sequence for different operational requirements.

- Changing the phase sequence via the setting parameter.
 - **Note:** With version V7.50 and higher, this setting parameter is a reset parameter. If the parameter is changed and transmitted to the device, the device performs a startup. The parameter change affects all 3-phase measuring points. If the device is in operation and if measurands are present at the measuring points, perform a parameter change carefully since this affects all measuring points.

- With the binary signal *>Phs-rotation reversal*, you change over the phase sequence of all measuring points.
- With the binary signal *>Invert Phases*, you change over the phase sequence per measuring point. The **Inverted phases** parameter available for each measuring point is used to set which phases at the measuring point must be swapped. The parameter can be found at each 3-phase measuring point.

The 2 binary-signal mechanisms are explained separately below.

Switchover of the Phase Sequence of All Measuring Points

The direction of rotation of the currents and voltages depends on the phase sequence. The following drawing shows the vector definitions for the 2 phase sequences.

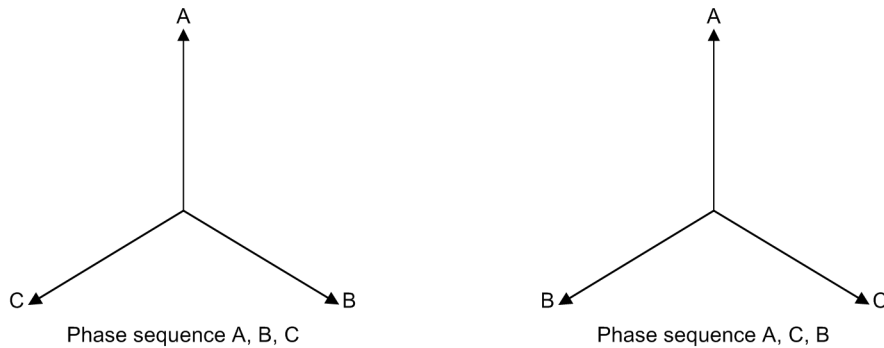

[dw_ph_rdrf_1_en_US]

Figure 6-341 Vector with Different Phase Sequences

The phase sequence of a system or a system section is defined when parameterizing via the **Phase sequence** parameter. The setting parameter acts on all measuring points.

The operationally induced switchover between the phase sequence **ABC** and the phase sequence **ACB** is initiated via the binary input *>Phs-rotation reversal*. This switches over the phase sequence simultaneously at all 3-phase measuring points.

The following image shows a logic diagram for determining the current phase assignment and switchover. The indications shown on the right show the present phase sequence. If the phase sequence is set via the **Phase sequence** parameter to **ABC**, activation of the binary input will result in a switchover to the phase sequence **ACB**.



NOTE

The switchover of the phase sequence is only authorized for a time at which no measured values are pending. The switchover command must be present for at least 200 ms. The change of phase sequence is only permissible when the machine is at standstill. If the current and voltage values of all 3-phase measuring points are below 5 % of the rated variables, this is recognized as machine standstill.

A renewed machine standstill must be detected for a resetting of the phase sequence to the set preferred position.

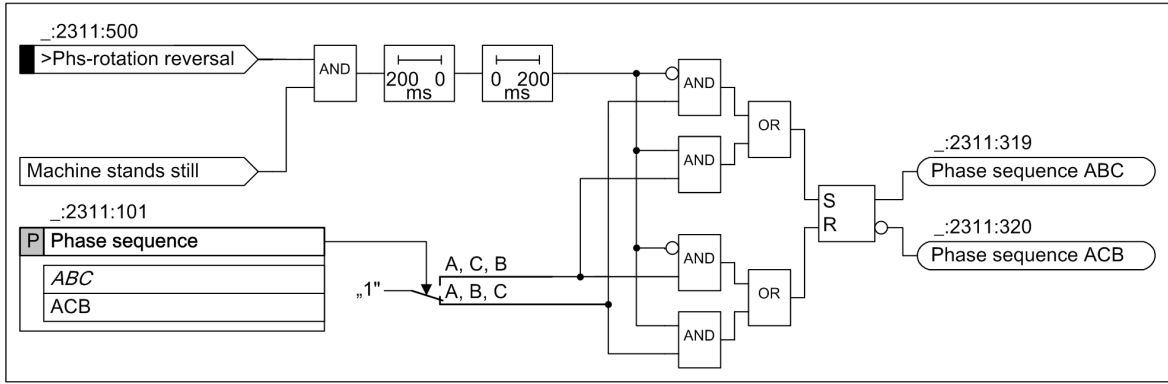

[ldw_phrrpsys1, 2, en_US]
 Figure 6-342 Phase Sequence Switchover

Changing Over the Phase Sequence per Measuring Point

A switchover of the phase sequence per measuring point can also be necessary for operational reasons. This switchover enables proper behavior of the protection equipment, for example at the transition from generator operation to motor operation (pump operation).

The following example shows an application in a pumped storage plant. The switchover of the phase sequence (change in rotational direction) realizes the transition there from generator operation to motor operation. Which phases and measuring points are changed over depends on the conditions in the system.

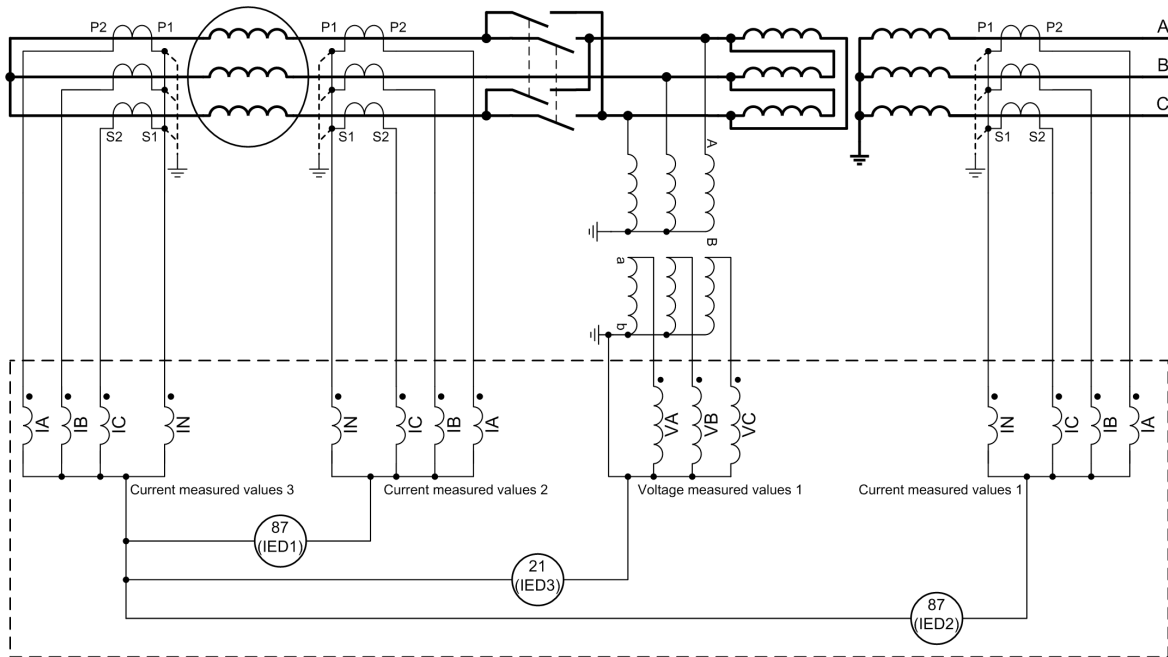

[ldw_phrrapp, 2, en_US]
 Figure 6-343 Application Example for Phase-Rotation Reversal in a Pump Station

The example shows 2 differential protection devices (IED1 and IED2) and an impedance protection (IED3) with the connected measuring points.

The phase sequence is insignificant for the differential protection of IED1, as the protected object is not affected by the switchover option of the phase sequence.

The phase sequence is also relevant to the differential protection of IED2, as the protected object extends beyond the switchover option.

The phase sequence is also relevant to the impedance protection (IED3). Depending on the switch position, the voltage measured values 1 and the current measured values 3 have a different phase sequence.

The phase sequence of the system is set in the device via the **Phase sequence** parameter for generator operation. The **Inverted phases** parameter is used to set which phase is swapped for the relevant measuring point. The swap is communicated to the measuring point via the binary input signal **>Invert Phases**. The changed phase sequence is then included for calculation of the measurands at the measuring point.

In accordance with [Figure 6-343](#) the phase sequence is set to **ABC**. A is swapped with C in motor operation. The **Inverted phases** parameter must be set to **AC** for the measuring points of current measured values 2 and current measured values 3. As a result, the phase assignment for the differential protection IED2 and the impedance protection IED3 is correct. The positive-sequence and negative-sequence current is calculated correctly.

The following logic diagram shows the principle for determining the present phase assignment and measured variables with the example of currents.

The switchover of the phase sequence is only authorized for a time at which no measured values are pending at the selected measuring points. The switchover command must be present for at least 200 ms. The change in the phase sequence is only implemented if the measurands at the measuring points that are to be switched are under 5 % of the rated variables. If the currents of the measuring points of current measured values 2 and current measured values 3 of the example fall below 5 % of their rated variables, the switchover is released and the set phases are switched with active binary input.

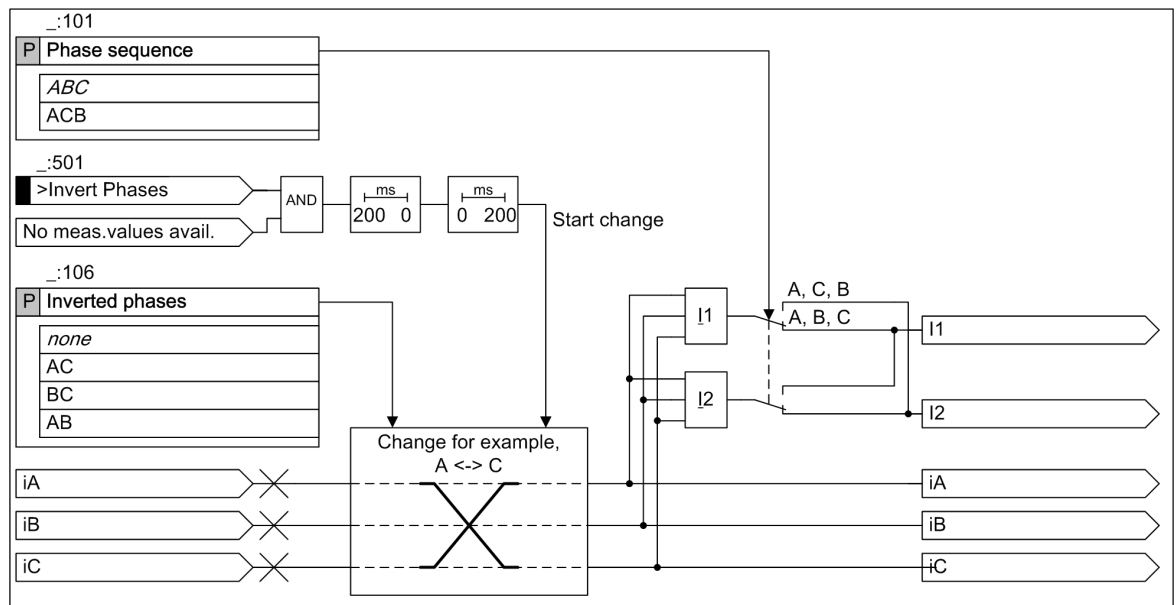

[to_phrgph_1_en_US]

Figure 6-344 Measured Values for Changed-Over Phases

6.50.4 Application and Setting Notes

Parameter: Phase sequence

- Default setting (**_:101**) **Phase sequence** = **ABC**

ABC	Phase sequence A, B, C
ACB	Phase sequence A, C, B

Parameter: Inverted phases

- Default setting (**_:106**) **Inverted phases** = **none**

none	No phase exchange
AC	Phase A changed over with phase C

BC	Phase B changed over with phase C
AB	Phase C changed over with phase B



NOTE

If you change the setting value of the parameter **Inverted phases**, consider the following:
 The device can take the new setting value only if the binary input signal **>Invert Phases** is not active.

Input signal: >Phs-rotation reversal

The **>Phs-rotation reversal** binary input is used to switch between the **ABC** phase sequence and the **ACB** phase sequence. The switchover direction depends on the setting of the **Phase sequence** parameter. In doing so, the phase sequence of all 3-phase measuring points is changed. Changing of the phase-rotation reversal via the binary input is only possible if no measurands (< 5 % of the rated variables) are present at all 3-phase measuring points.

Input signal: >Invert Phases

The binary input **>Invert Phases** is used to activate the setting of the parameter **Inverted phases**. In doing so, the phase sequence of the selected measuring point is changed. Changing of the phase sequence via the binary input is only possible if no measurand (< 5 % of the rated variables) is present at the respective 3-phase measuring point.

6.50.5 Settings

Addr.	Parameter	C	Setting Options	Default Setting
General				
_:101	General:Phase sequence		<ul style="list-style-type: none"> • ABC • ACB 	ABC
General				
_:101	VT 3-phase:Rated primary voltage		0.10 kV to 1200.00 kV	400.00 kV
_:102	VT 3-phase:Rated secondary voltage		80 V to 230 V	100 V
_:103	VT 3-phase:Matching ratio V _{ph} / V _N		0.10 to 9.99	1.73
_:104	VT 3-phase:VT connection		<ul style="list-style-type: none"> • 3 ph-to-gnd volt. + V_N • 3 ph-to-gnd voltages • 3 ph-to-ph volt. + V_N • 3 ph-to-ph voltages 	3 ph-to-gnd volt. + V _N
_:106	VT 3-phase:Inverted phases		<ul style="list-style-type: none"> • none • AC • BC • AB 	none
_:111	VT 3-phase:Tracking		<ul style="list-style-type: none"> • inactive • active 	active
_:107	VT 3-phase:Measuring-point ID		0 to 100	0

6.50.6 Information List

No.	Information	Data Class (Type)	Type
General			
_:500	General:>Phs-rotation reversal	SPS	I
_:501	General:>Invert Phases	SPS	I
General			
_:319	General:Phase sequence ABC	SPS	O
_:320	General:Phase sequence ACB	SPS	O
_:321	General:Freq.out of oper.range	SPS	O
_:322	General:f sys	MV	O
_:323	General:f track	MV	O
General			
_:315	VT 3-phase:Phases AB inverted	SPS	O
_:316	VT 3-phase:Phases BC inverted	SPS	O
_:317	VT 3-phase:Phases AC inverted	SPS	O

6.51 Current-Jump Detection

6.51.1 Overview of Functions

The **Current jump detection** function has the following tasks:

- Detection of jumps in the phase or zero-sequence current (ΔI)
- Generation of an indication when the measurands change by more than a configured threshold value from one system period to the next.

The function for detecting jumps in the phase or zero-sequence current is an additional function used for indication purposes or for further processing in user-specific CFC logics. Pick up of the function therefore neither opens a separate fault in the fault log nor generates an operate indication.

6.51.2 Structure of the Function

The **Current-jump detection** function is used in protection function groups based on current measurement. It can be instantiated multiple times.

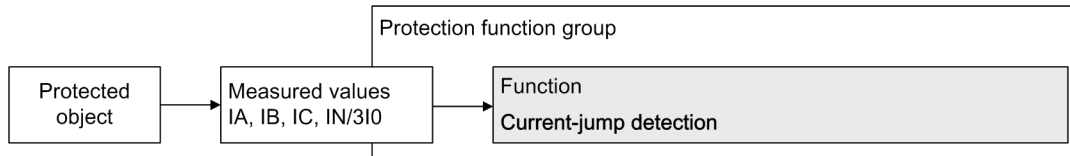

[idw_struki_1_en_US]

Figure 6-345 Structure/Embedding of the Function

6.51.3 Function Description

Current-jump detection operates directly with the sampled values without numeric filtering. This provides very short response times to sudden changes in the current. The method used is not sensitive to slow changes of amplitude or frequency.

Using a configurable selection of measured values, you can select from 3 line currents or the residual current. Current-jump detection is phase-selective for the line current A, B and C.

The difference from the previous sampled value of the first system cycle is calculated for each sampled value. The rectified average is then determined for a $\frac{1}{2}$ system cycle from this differential signal $\Delta i(t)$. The rectified average for sinusoidal measurands is then converted to a RMS value ΔI by subsequent multiplication by 1.11. The resultant measurand ΔI is then compared with the threshold value.

If the parameter (`_:101`) **Threshold** is exceeded, the output indication *Jump* is generated. If you have selected the phase currents for measurement, the output indication data type used includes the separate phase information. If you have selected the residual current for measurement, the output indication data type used includes the NI information. If the current-jump detection responds (ΔI_{Limit}), the general information is generated in the output indication in all cases.

Dropout occurs with a dynamically increased threshold value (ΔI_{Limit}) in accordance with the logic in [Figure 6-346](#). Dynamic increase of the dropout threshold value achieves optimally short dropout times.

The output indication *Pulse* is formed with the configurable timer (`_:102`) **Minimum pulse length**. As a consequence, this output indication has a consistent minimum size. If you activate the binary input *>Pulse extension*, you can prolong the pulse duration even further. If the binary input *>Pulse extension* has been activated, the indication *Pulse* drops off when the configured time has elapsed and the falling edge of the binary input is detected.

Logic

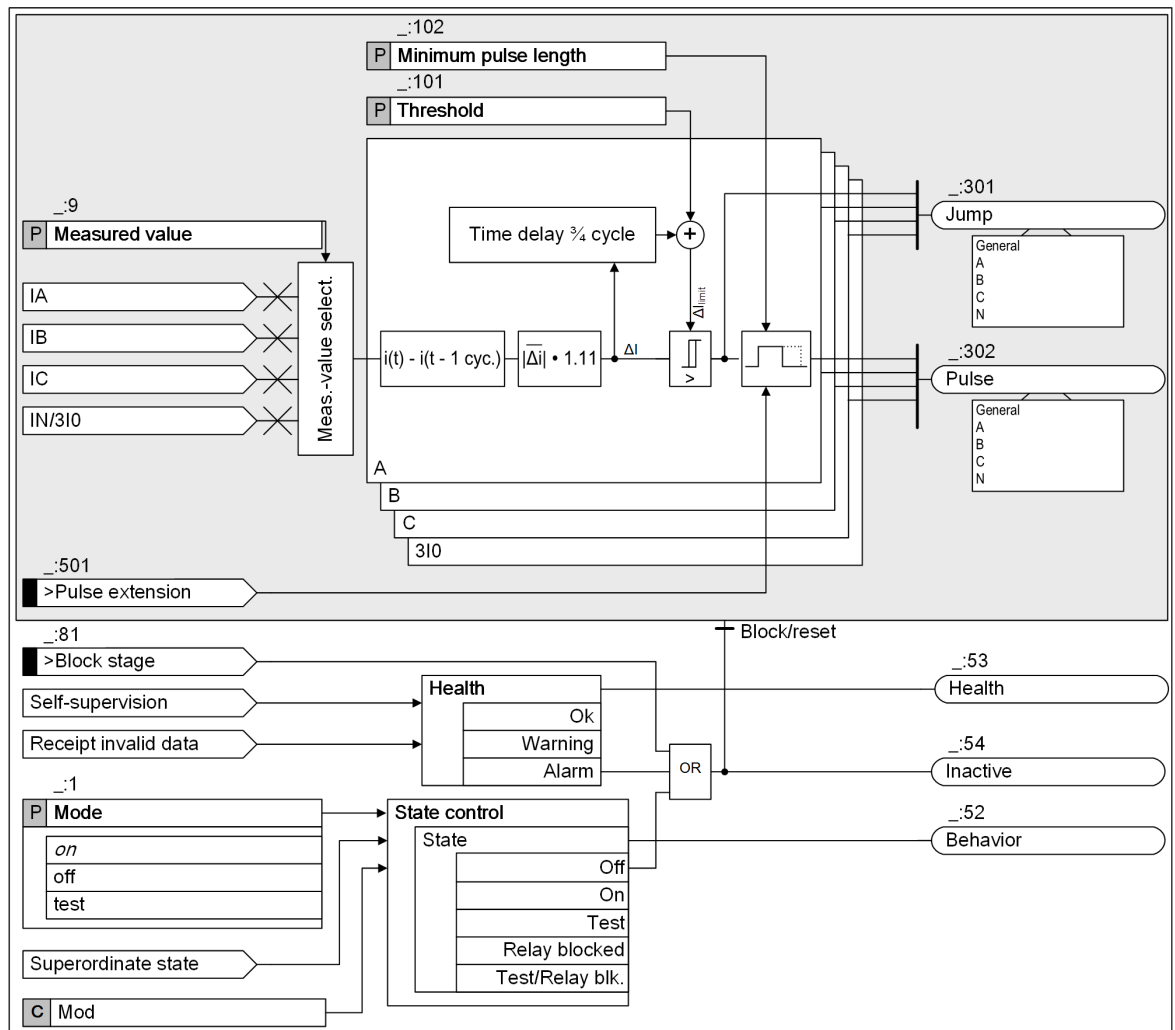

[file_jump_i1_2_en_US]

Figure 6-346 Current-Jump Detection Logic

6.51.4 Application and Setting Notes

Parameter: Measured value

- Default setting (P:9) **Measured value** = *phase currents*

With the parameter **Measured value**, you set whether the line current(s) or the residual current is to be used for jump detection.

Parameter Value	Description
<i>phase currents</i>	The tripping stage evaluates the line currents IA, IB, and IC phase-selectively to detect a jump.
<i>zero-sequence current</i>	The tripping stage evaluates the residual current IN/310 to detect a jump.

Parameter: Threshold

- Default setting (P:101) **Threshold** = 0.10 A for $I_{rated} = 1A$ or 0.50 A for $I_{rated} = 5A$

With the parameter **Threshold**, you set the threshold value for the measurand which, when exceeded, generates the output indication *Jump*.

Parameter: Minimum pulse length

- Default setting (**_:102**) **Minimum pulse length = 0.10 s**

With the parameter **Minimum pulse length**, you specify a consistent minimum size for the output indication *Pulse*.

6.51.5 Settings

Addr.	Parameter	C	Setting Options	Default Setting
<i>I-jump det. #</i>				
_:1	I-jump det. #:Mode		<ul style="list-style-type: none"> • off • on • test 	off
_:9	I-jump det. #:Measured value		<ul style="list-style-type: none"> • phase currents • zero-sequence current 	phase currents
_:101	I-jump det. #:Threshold	1 A @ 100 Irated	0.030 A to 35.000 A	0.100 A
		5 A @ 100 Irated	0.15 A to 175.00 A	0.50 A
		1 A @ 50 Irated	0.030 A to 35.000 A	0.100 A
		5 A @ 50 Irated	0.15 A to 175.00 A	0.50 A
		1 A @ 1.6 Irated	0.001 A to 1.600 A	0.100 A
		5 A @ 1.6 Irated	0.005 A to 8.000 A	0.500 A
_:102	I-jump det. #:Minimum pulse length		0.01 s to 60.00 s	0.10 s

6.51.6 Information List

No.	Information	Data Class (Type)	Type
<i>I-jump det. #</i>			
_:81	I-jump det. #:>Block stage	SPS	I
_:501	I-jump det. #:>Pulse extension	SPS	I
_:54	I-jump det. #:Inactive	SPS	O
_:52	I-jump det. #:Behavior	ENS	O
_:53	I-jump det. #:Health	ENS	O
_:301	I-jump det. #:Jump	ACT	O
_:302	I-jump det. #:Pulse	ACT	O

6.52 Voltage-Jump Detection

6.52.1 Overview of Functions

The **Voltage-jump detection** function has the following tasks:

- Recognition of jumps in the phase or zero-sequence voltage (ΔV)
- Generation of an indication when the measurands change by more than a configured threshold value from one system cycle to the next.

The function for detecting jumps in the phase or zero-sequence voltage is an additional function used for indication purposes or for further processing in user-specific CFC logics. Pick up of the function therefore neither opens a separate fault in the fault log nor generates an operate indication.

6.52.2 Structure of the Function

The **Voltage-jump detection** function is used in protection function groups based on voltage measurement. It can be instantiated multiple times.

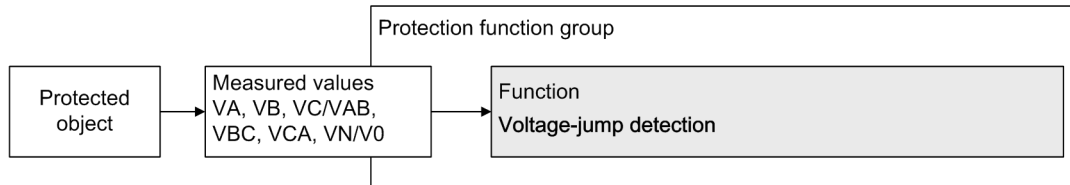

[doc_struku, 1, en, US]

Figure 6-347 Structure/Embedding of the Function

6.52.3 Function Description

Voltage-jump detection operates directly with the sampled values without numeric filtering. This provides very short response times to sudden changes in the voltage. The method used is not sensitive to slow changes of amplitude or frequency.

By using a configurable selection of measured values, you can select from phase-to-ground voltages, phase-to-phase voltages or the zero-sequence voltage. Voltage-jump detection is phase-selective.

The difference from the previous sampled value of a system cycle is calculated for each sampled value. The rectified average is then determined for a $\frac{1}{2}$ system cycle from this differential signal $\Delta v(t)$. The rectified average for sinusoidal measurands is then converted to a RMS value ΔV by subsequent multiplication by 1.11. The resultant measurand ΔV is then compared with the threshold value.

If the parameter (**_:101**) **Threshold** is exceeded, the output indication *Jump* is generated. If the measured value is set to phase-to-phase, the sudden change in voltage is signaled selectively for the individual measuring elements that have picked up (*Jump VAB*, *Jump VBC* or *Jump VCA*). If you have selected the phase-to-phase or phase-to-ground voltages for measurement, the output indication data type used includes the separate phase information. If you have selected the zero-sequence voltage for measurement, the output indication data type used includes the N information. If the voltage-jump detection responds (ΔV_{Limit}), the general information is generated in the output indication in all cases.

Dropout occurs with a dynamically increased threshold value ΔU_{Limit} in accordance with the information in [Figure 6-348](#). Dynamic increase of the dropout threshold value achieves optimally short dropout times.

A timing element is added to the indication *Jump*. The element generates a pulse from this. The length of this pulse can be set using the parameter (**_:102**) **Minimum pulse length**. This gives the output indication *Pulse* a reliable minimum size. If you activate the binary input *>Pulse extension*, you can prolong the pulse duration even further. If the binary input *>Pulse extension* has been activated, the indication *Pulse* drops off when the configured time has elapsed and the falling edge of the binary input

is detected. If the measured value is set to phase-to-phase, the pulse duration is signaled selectively for the individual measuring elements that have picked up (*Pulse VAB*, *Pulse VBC* or *Pulse VCA*).

Logic

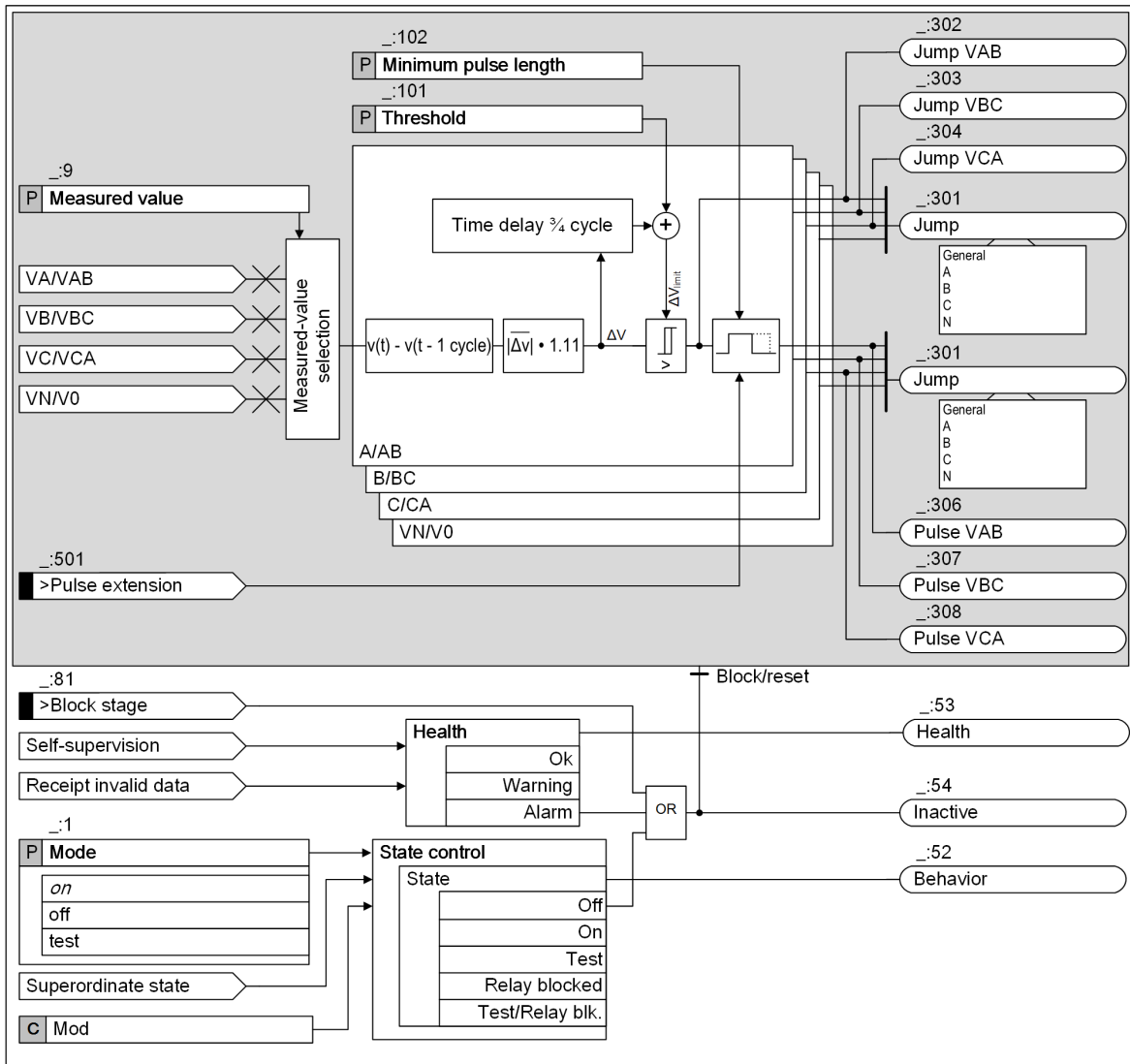

[to_jump_uu_3_en_US]

Figure 6-348 Voltage-Jump Detection Logic

6.52.4 Application and Setting Notes

Parameter: **Measured value**

- Default setting ($_ :9$) **Measured value** = *phase-to-ground*

With the parameter **Measured value**, you specify which measured values of voltage are to be used for determining the voltage jumps.

Parameter Value	Description
<i>phase-to-ground</i>	The tripping stage evaluates the phase-to-ground voltages VA, VB and VC.
<i>phase-to-phase</i>	The tripping stage evaluates the phase-to-phase voltages VAB, VBC and VCA.
<i>zero-sequence voltage</i>	The tripping stage evaluates the zero-sequence voltage VN/V0.

Parameter: Threshold

- Default setting (_:101) **Threshold** = 5.000 V

With the parameter **Threshold** , you set the threshold value for the measurand which, when exceeded, generates the output indication *Jump* .

Parameter: Minimum pulse length

- Default setting (_:102) **Minimum pulse length** = 0.10 s

With the parameter **Minimum pulse length** , you specify a consistent minimum size for the output indication *Pulse* .

6.52.5 Settings

Addr.	Parameter	C	Setting Options	Default Setting
<i>V-jump det. #</i>				
_:1	V-jump det. #:Mode		<ul style="list-style-type: none"> • off • on • test 	off
_:9	V-jump det. #:Measured value		<ul style="list-style-type: none"> • phase-to-ground • phase-to-phase • zero-sequence voltage 	phase-to-ground
_:101	V-jump det. #:Threshold		0.300 V to 340.000 V	5.000 V
_:102	V-jump det. #:Minimum pulse length		0.01 s to 60.00 s	0.10 s

6.52.6 Information List

No.	Information	Data Class (Type)	Type
<i>V-jump det. #</i>			
_:81	V-jump det. #:>Block stage	SPS	I
_:501	V-jump det. #:>Pulse extension	SPS	I
_:54	V-jump det. #:Inactive	SPS	O
_:52	V-jump det. #:Behavior	ENS	O
_:53	V-jump det. #:Health	ENS	O
_:301	V-jump det. #:Jump	ACT	O
_:302	V-jump det. #:Jump VAB	SPS	O
_:303	V-jump det. #:Jump VBC	SPS	O
_:304	V-jump det. #:Jump VCA	SPS	O
_:305	V-jump det. #:Pulse	ACT	O

No.	Information	Data Class (Type)	Type
_:306	V-jump det. #:Pulse VAB	SPS	0
_:307	V-jump det. #:Pulse VBC	SPS	0
_:308	V-jump det. #:Pulse VCA	SPS	0

6.53 Voltage Measuring-Point Selection

6.53.1 Overview of Functions

The function block **Voltage measuring-point selection** can:

- Provide the ability to switchover the voltage measuring points to be applied, if various voltage measuring points are connected to the voltage interface of the function group
- Select the correct voltage based on the switch position of the plant

If more than one voltage measuring points are connected to the same voltage interface of the function group, use the **Voltage measuring-point selection** function block in the function group to select the correct voltage based on the switch position of the plant.

The **Voltage measuring-point selection** is a common functionality for the function groups of the protected objects.

6.53.2 Function Description

The **Voltage measuring-point selection** function block realizes the selection of 1-phase voltage measuring points or of 3-phase voltage measuring points by a logic block chart. The logic block chart controls the input *>MP-ID selection* depending on the switch positions of disconnectors.

Example

[Figure 6-349](#) shows an example of voltage measuring points selection for the function group **Capacitor bank** in a double busbar application.

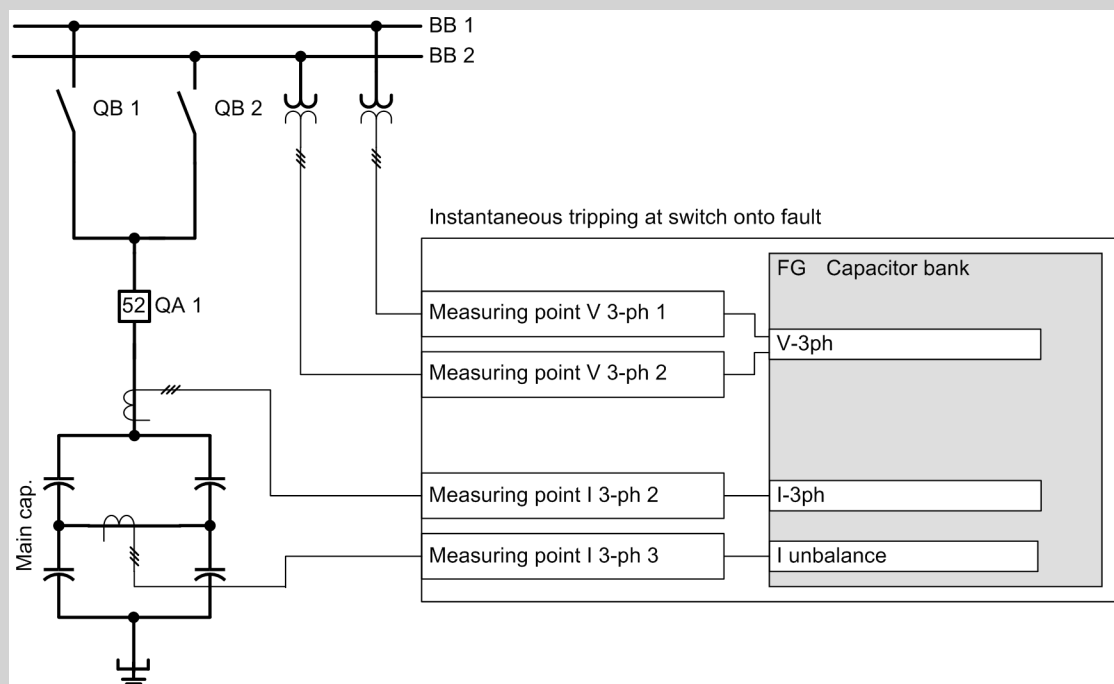

[dw_busbar_double_2_en_US]

Figure 6-349 Double Busbar with Capacitor Bank

Connecting Measuring Points to Capacitor Bank Function Group

[Figure 6-350](#) shows the connection of the function group **Capacitor bank** with several measuring points in DIGSI. The ID of each measuring point appears in the bracket after the name.

Connect measuring points to function group								
Measuring point	Circuit breaker 1			Capacitor bank 1				
	V 3ph	I 3ph	V 3ph cap. tap	V unbalance	I unbalance	I 3ph RLC		
(All)	(All)	(All)	(All)	(All)	(All)	(All)	(All)	(All)
Meas. point I-3ph 1 [ID 1]		X						
Meas. point V-3ph 1 [ID 2]	X							
Meas. point V-3ph 2 [ID 3]	X							
Meas. point I-1ph 1 [ID 4]						X		

[sc_connection_1_en_US]

Figure 6-350 Connecting the Measuring Points with the Capacitor Bank Function Group

There are consistency checks that validate the connections of voltage measuring points to the function group:

- The connection type must be identical for all measuring points connected to the same interface of the function group.
- The rated voltage (primary and secondary) must be identical for all measuring points connected to the same interface.
- If more than 1 measuring point is connected to one voltage interface, a function block must be added to enable the selection of the voltage measuring points.

6.53.3 Application and Setting Notes

CFC Control

The voltage measuring point is selected by logic block chart on basis of the measuring point IDs. If more than one measuring point is connected to the interface of the function group, instantiate the function block **Voltage measuring-point selection** from the library in the corresponding function group.

In order to ensure the correct measuring-point connection for the function group, a logic block chart has to define the actual valid IDs for the input *>MP-ID selection* of the function block.

The following logic block chart implementation is based on the example given in [Figure 6-349](#).

If the Disconnector 1 (QB1) is closed and no matter what the position the Disconnector 2 (QB2) is, the value 2 is the output of CFC block **mux_d_1** and transferred to the input *>MP-ID selection*. Then, the **Meas.point V-3ph** with ID 2 is selected as the reference voltage. Similarly, the **Meas.point V-3ph** with ID 3 is selected as the reference voltage if the Disconnector 1 (QB1) is not closed (open or in intermediate position) while Disconnector 2 (QB2) is closed.

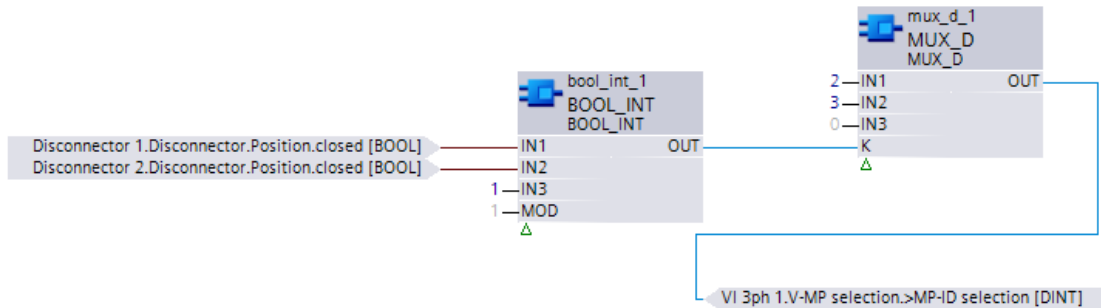

[sc_lo-cfcVP_1_en_US]

Figure 6-351 Logic Block Chart: Voltage Selection Using Measuring Point ID

However, the disconnectors might be both open or in a transient state. In this case, the input IN3 of the block **bool_int_1** becomes true, the value 0 is used as the ID for voltage selection input (*>MP-ID selection*). If ID 0 is selected, then all voltage values of the respective function-group interface are set to 0 V immediately. An alarm indication *selection invalid* is issued and the indication *Health* is issued as *OK*. In case you want to supply the function group with voltage values under the condition that both disconnectors are open or in transient state from one or the other busbar, you can alter the CFC chart respectively.



NOTE

An invalid measuring-point selection (ID < 0 or an ID of a unconnected measuring point) for input *>MP-ID selection* results in the following:

- The voltage measured values are displayed as **failure**.
- The validity of the voltage measured values is set to **invalid**.
- The indication *Health* is set to **Alarm**.
- The indication *selection invalid* becomes true.

6.53.4 Information List

No.	Information	Data Class (Type)	Type
<i>V-MP selection</i>			
_:501	V-MP selection:>MP-ID selection	INS	I
_:53	V-MP selection:Health	ENS	O
_:301	V-MP selection:Selection invalid	SPS	O

6.54 Protection and Automation Functions (CEI 0-16 Standard)

6.54.1 Introduction

CEI 0-16 is an Italian technical standard for the connection to the MV distribution network. In the CEI 0-16 standard, interface protection (PI) includes protection functions used to monitor frequency and voltage parameters of the distribution network. Interface protection (PI) is required in generation plants connected to the distribution network. Interface protection (PI) aims to disconnect the generation plant in case of faults in the MV distribution network.

For further details, refer to the CEI 0-16 standard. The following figure shows the application.

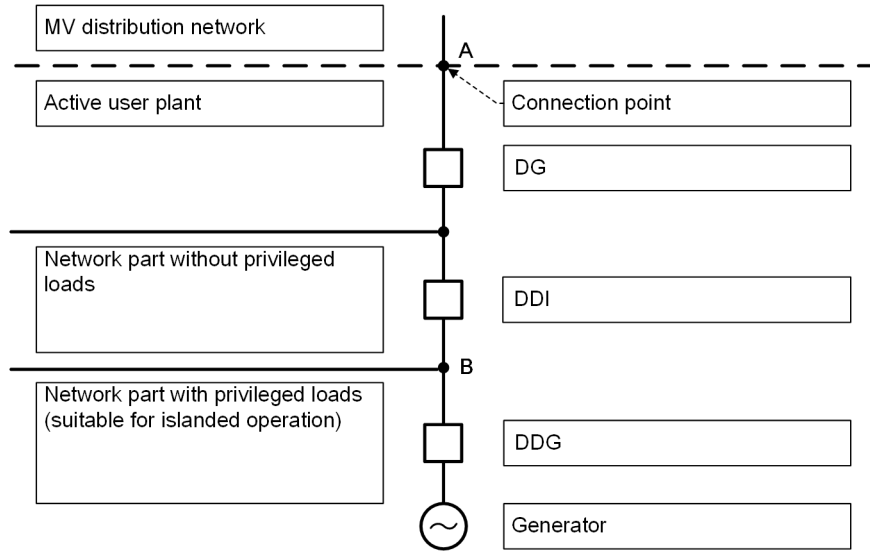

[dw_primary main wiring_CEI, 1, en_US]

Term in CEI 0-16 Standard	Stands for	Description
DG	General switching device	A switching device whose opening (controlled by the general protection system) ensures the separation of the entire system of the user from the distribution network.
DDI	Interface device	One (or more) switching device whose opening (controlled by the protection system) ensures the separation of the production plant from the network, allowing the production plant itself to feed the privileged loads in the island operation.
DDG	Generator device	A switching device whose opening (controlled by the protection system) determines the separation of the generating unit.

In the preceding figure, DG, DDI, and DDG are circuit breakers. In some applications, DG and DDI are possibly combined into one circuit breaker. In case of faults, the interface protection (PI) trips the DDI.

SIPROTEC 5 supports the following protection functions for interface protection (PI):

- **Overvoltage protection with 3-phase voltage (CEI 0-16 standard)**
- **Undervoltage protection with 3-phase voltage (CEI 0-16 standard)**
- **Frequency protection (CEI 0-16 standard)**

The following chapters describe these functions.

6.55 Overvoltage Protection with 3-Phase Voltage (CEI 0-16 Standard)

6.55.1 Structure of the Function

The function **Overvoltage protection with 3-phase voltage (CEI 0-16 standard)** can be used in the following function groups with 3-phase voltage measurement:

- Function group **Voltage/current 3-phase**
- Function group **Voltage 3-phase**
- Function group **Line**

The function **Overvoltage protection with 3-phase voltage (CEI 0-16 standard)** comes factory-set with 1 stage **Definite-time overvoltage protection, 10-min RMS value** and 1 stage **Definite-time overvoltage protection, fundamental component**. The following stages can be operated simultaneously within the function:

- 2 stages **Definite-time overvoltage protection, 10-min RMS value**
- 2 stages **Definite-time overvoltage protection, fundamental component**

Stages that are not preconfigured are shown in gray in the following figure.

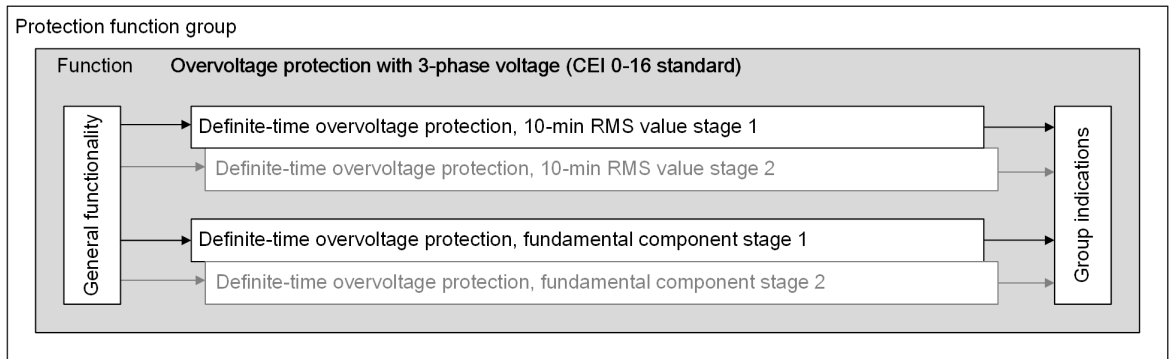

[dw_OVP_CEI_3-phase_1_en_US]

Figure 6-352 Structure/Embedding of the Function

6.55.2 General Functionality

6.55.2.1 Description

Logic

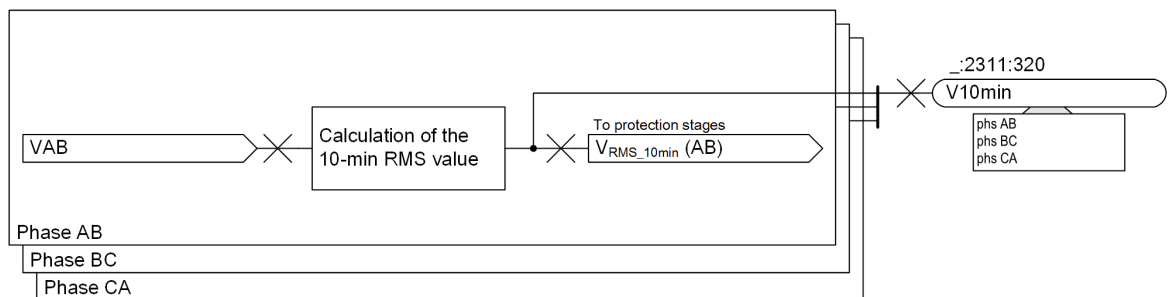

[to_OVP_CEI_FB_General_1_en_US]

Figure 6-353 Logic Diagram of the General Functionality

The general functionality calculates the RMS values of the phase-to-phase voltage of the past 10 min (30 000 cycles for 50 Hz), according to the requirement of the CEI 0-16 standard. The calculated result V_{RMS_10min} is forwarded to the protection stages and is updated every 3 s.

Functional Measured Value

Measured Value	Description
V10min	Calculated RMS values of the phase-to-phase voltage of the past 10 min.

6.55.3 Stage with Definite-Time Characteristic Curve, 10-Min RMS Value

6.55.3.1 Description

Logic of the Stage

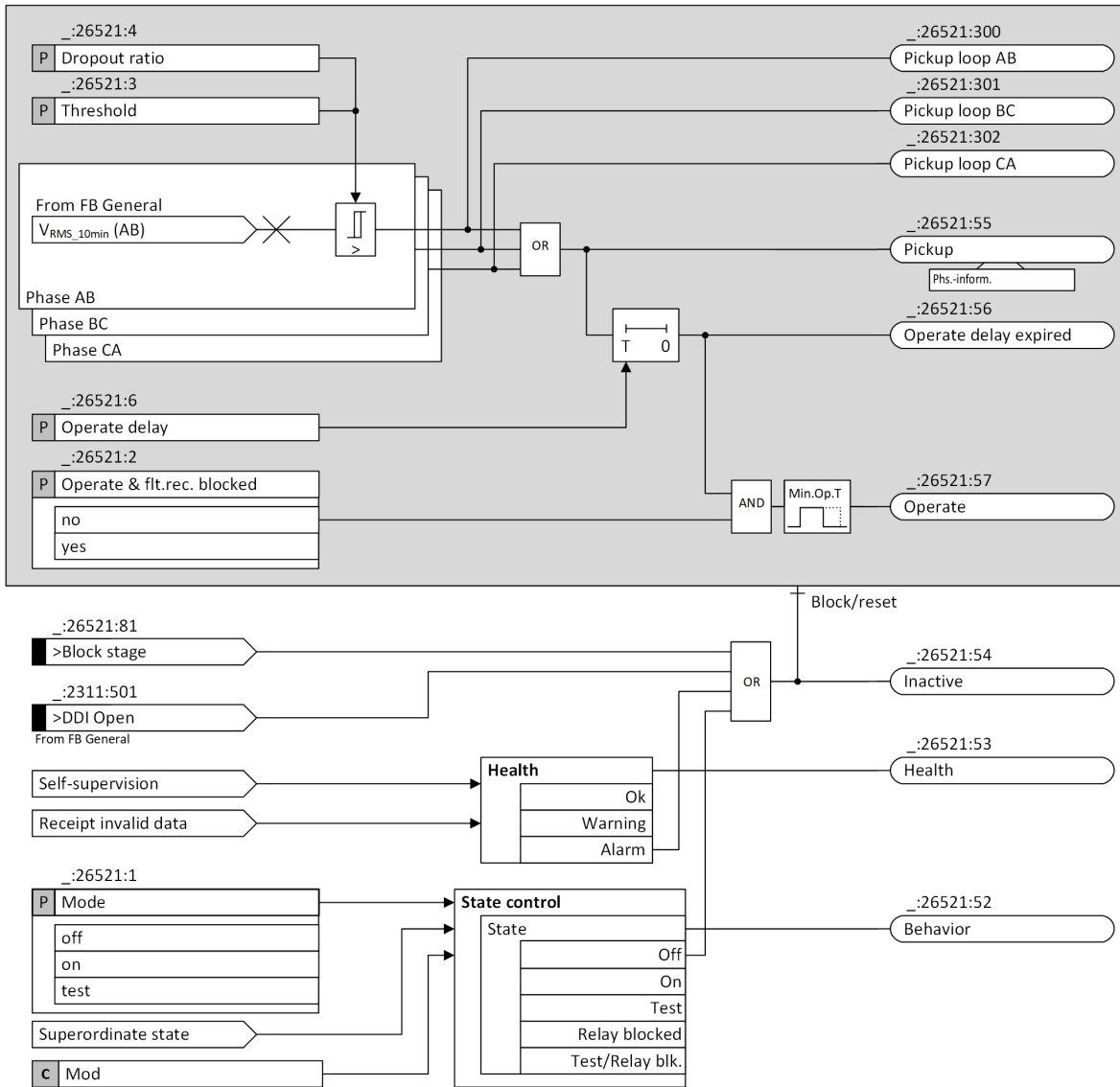

[!o_stage_OVP_CEI_10MinRMS_1_en_US]

Figure 6-354 Logic Diagram of the Stage with Definite-Time Characteristic Curve, 10-Min RMS Value

Measurand

The stage obtains the 10-min RMS value of the phase-to-phase voltage from the FB **General**.

Pickup, Operate, Dropout

The stage compares the 10-min RMS value with the threshold value (specified by the parameter **Threshold**). If the 10-min RMS value exceeds threshold value, the pickup signal is issued.

Once the pickup signal is issued, the operate delay (specified by the parameter **Operate delay**) starts. After the expiration of the operate delay, the operate signal is issued.

With the parameter **Dropout ratio**, you can define the ratio of the dropout threshold to the value of the parameter **Threshold**.

Blocking the Stage

In the event of blocking, the picked up stage is reset. The following blocking options are available for the stage:

- Externally or internally via the binary input signal *>Block stage*
- Internally via the binary input signal *>DDI Open* (defined in the CEI 0-16 standard) from the general functionality

6.55.3.2 Application and Setting Notes

Parameter: **Threshold**

- Default setting (**_:26521:3**) **Threshold** = 110.000 V

In the CEI 0-16 standard, the default setting of 110.000 V is recommended. Siemens recommends using the default setting.

Parameter: **Dropout ratio**

- Recommended setting value (**_:26521:4**) **Dropout ratio** = 0.95

The recommended setting value of 0.95 is appropriate for most applications. To achieve high-precision measurements, the **Dropout ratio** can be reduced, to 0.98, for example.

Parameter: **Operate delay**

- Default setting (**_:26521:6**) **Operate delay** = 3.00 s

The parameter **Operate delay** determines the time during which the pickup conditions must be met to issue the operate indication. The operate indication is issued when this time expires.

In the CEI 0-16 standard, the operate delay is a fixed value of 3.00 s. Siemens recommends using the default setting.

Operation as Supervision Function

If you want the stage to have a reporting effect only, you can set the parameter **Operate & flt.rec. blocked** to disable the generation of the operate indication and fault logging.

6.55.4 Stage with Definite-Time Characteristic Curve, Fundamental Component

6.55.4.1 Description

Logic of the Stage

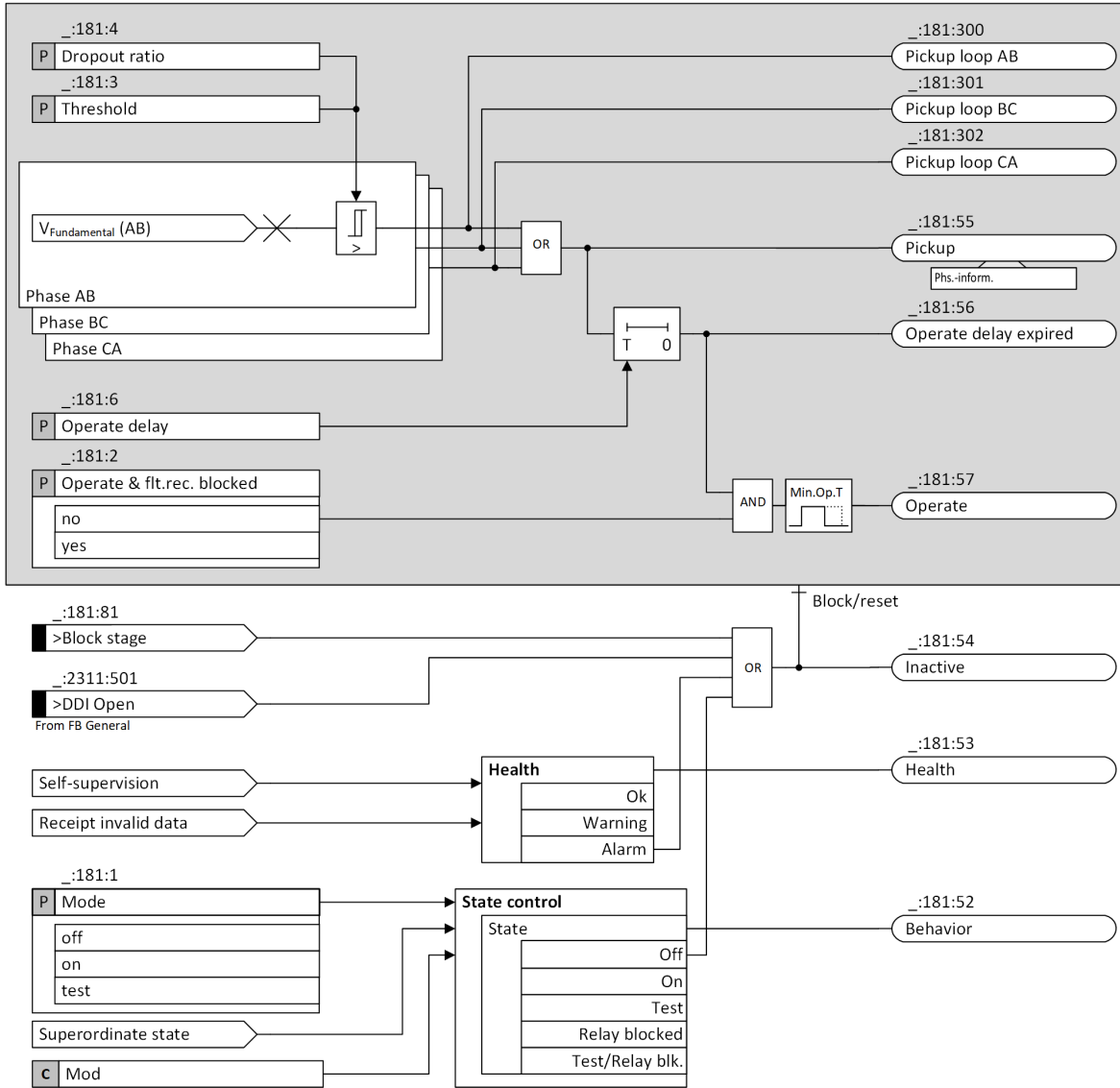

[no_stage_OVP_CEI_Fund, 1, en_US]

Figure 6-355 Logic Diagram of the Stage with Definite-Time Characteristic Curve, Fundamental Component

Measurand

The stage processes the sampled values of the phase-to-phase voltage and filters out the fundamental component numerically.

Pickup, Operate, Dropout

The stage compares the fundamental-component value of the phase-to-phase voltage with the threshold value (specified by the parameter **Threshold**). If the fundamental-component value exceeds the threshold value, the pickup signal is issued.

Once the pickup signal is issued, the operate delay (specified by the parameter **Operate delay**) starts. After the expiration of the operate delay, the operate signal is issued.

With the parameter **Dropout ratio**, you can define the ratio of the dropout threshold to the value of the parameter **Threshold**.

Blocking the Stage

In the event of blocking, the picked up stage is reset. The following blocking options are available for the stage:

- Externally or internally via the binary input signal *>Block stage*
- Internally via the binary input signal *>DDI Open* (defined in the CEI 0-16 standard) from the general functionality

6.55.4.2 Application and Setting Notes

Parameter: **Threshold**

- Default setting (**_:181:3**) **Threshold** = 120.000 V

In the CEI 0-16 standard, the default setting of 120.000 V is recommended. Siemens recommends using the default setting.

Parameter: **Dropout ratio**

- Default setting (**_:181:4**) **Dropout ratio** = 0.95

The default setting of 0.95 is appropriate for most applications. To achieve high-precision measurements, the **Dropout ratio** can be reduced, to 0.98, for example.

Parameter: **Operate delay**

- Default setting (**_:181:6**) **Operate delay** = 0.57 s

Based on the CEI 0-16 standard, the recorded time between the start of overvoltage and the instant when the trip contact of the function changes the state represents the tripping time. It means that the tripping time contains the following times:

- The function pickup time
- The time from pickup to operate
- The trip-contact close time

In the CEI 0-16 standard, the default setting of the trip time is 0.60 s.

The parameter **Operate delay** determines the time from pickup to operate. Therefore, the default setting of the parameter **Operate delay** is 0.57 s, that is, 0.60 s minus the function pickup time and the trip-contact close time which is around 30 ms.

Operation as Supervision Function

If you want the stage to have a reporting effect only, you can set the parameter **Operate & flt.rec. blocked** to disable the generation of the operate indication and fault logging.

6.55.5 Settings

Addr.	Parameter	C	Setting Options	Default Setting
<i>Def-T-CEI 1</i>				
_:26521:1	Def-T-CEI 1:Mode		<ul style="list-style-type: none"> • off • on • test 	off

Addr.	Parameter	C	Setting Options	Default Setting
_:26521:2	Def-T-CEI 1:Operate & flt.rec. blocked		<ul style="list-style-type: none"> no yes 	no
_:26521:3	Def-T-CEI 1:Threshold		0.300 V to 340.000 V	110.000 V
_:26521:4	Def-T-CEI 1:Dropout ratio		0.90 to 0.99	0.95
_:26521:6	Def-T-CEI 1:Operate delay		0.00 s to 300.00 s	3.00 s
Definite-T 1				
_:181:1	Definite-T 1:Mode		<ul style="list-style-type: none"> off on test 	off
_:181:2	Definite-T 1:Operate & flt.rec. blocked		<ul style="list-style-type: none"> no yes 	no
_:181:3	Definite-T 1:Threshold		0.300 V to 340.000 V	120.000 V
_:181:4	Definite-T 1:Dropout ratio		0.90 to 0.99	0.95
_:181:6	Definite-T 1:Operate delay		0.00 s to 300.00 s	0.57 s

6.55.6 Information List

No.	Information	Data Class (Type)	Type
General			
_:2311:501	General:>DDI Open	SPS	I
_:2311:320	General:V10min	DEL	O
_:2311:52	General:Behavior	ENS	O
_:2311:53	General:Operate	ENS	O
Group indicat.			
_:4501:55	Group indicat.:Pickup	ACD	O
_:4501:57	Group indicat.:Operate	ACT	O
_:4501:52	Group indicat.:Behavior	ENS	O
_:4501:53	Group indicat.:Health	ENS	O
Def-T-CEI 1			
_:26521:81	Def-T-CEI 1:>Block stage	SPS	I
_:26521:51	Def-T-CEI 1:Mode (controllable)	ENC	C
_:26521:54	Def-T-CEI 1:Inactive	SPS	O
_:26521:52	Def-T-CEI 1:Behavior	ENS	O
_:26521:53	Def-T-CEI 1:Health	ENS	O
_:26521:55	Def-T-CEI 1:Pickup	ACD	O
_:26521:300	Def-T-CEI 1:Pickup loop AB	SPS	O
_:26521:301	Def-T-CEI 1:Pickup loop BC	SPS	O
_:26521:302	Def-T-CEI 1:Pickup loop CA	SPS	O
_:26521:56	Def-T-CEI 1:Operate delay expired	ACT	O
_:26521:57	Def-T-CEI 1:Operate	ACT	O
Definite-T 1			
_:181:81	Definite-T 1:>Block stage	SPS	I
_:181:51	Definite-T 1:Mode (controllable)	ENC	C

No.	Information	Data Class (Type)	Type
_:181:54	Definite-T 1:Inactive	SPS	O
_:181:52	Definite-T 1:Behavior	ENS	O
_:181:53	Definite-T 1:Health	ENS	O
_:181:55	Definite-T 1:Pickup	ACD	O
_:181:300	Definite-T 1:Pickup loop AB	SPS	O
_:181:301	Definite-T 1:Pickup loop BC	SPS	O
_:181:302	Definite-T 1:Pickup loop CA	SPS	O
_:181:56	Definite-T 1:Operate delay expired	ACT	O
_:181:57	Definite-T 1:Operate	ACT	O

6.56 Frequency Protection (CEI 0-16 Standard)

6.56.1 Structure of the Function

The function **Frequency protection (CEI 0-16 standard)** can be used in the following function groups with 3-phase voltage measurement:

- Function group **Voltage/current 3-phase**
- Function group **Voltage 3-phase**
- Function group **Line**

The function **Frequency protection (CEI 0-16 standard)** comes factory-set with the following stages:

- 1 stage **Overvoltage protection with zero-sequence voltage/residual voltage**
- 1 stage **Overfrequency protection S1**
- 1 stage **Overfrequency protection S2**
- 1 stage **Underfrequency protection S1**
- 1 stage **Underfrequency protection S2**

The following stages can be operated simultaneously within the function:

- 2 stages **Overvoltage protection with zero-sequence voltage/residual voltage**
- 2 stages **Overfrequency protection S1**
- 2 stages **Overfrequency protection S2**
- 2 stages **Underfrequency protection S1**
- 2 stages **Underfrequency protection S2**

Stages that are not preconfigured are shown in gray in the following figure.

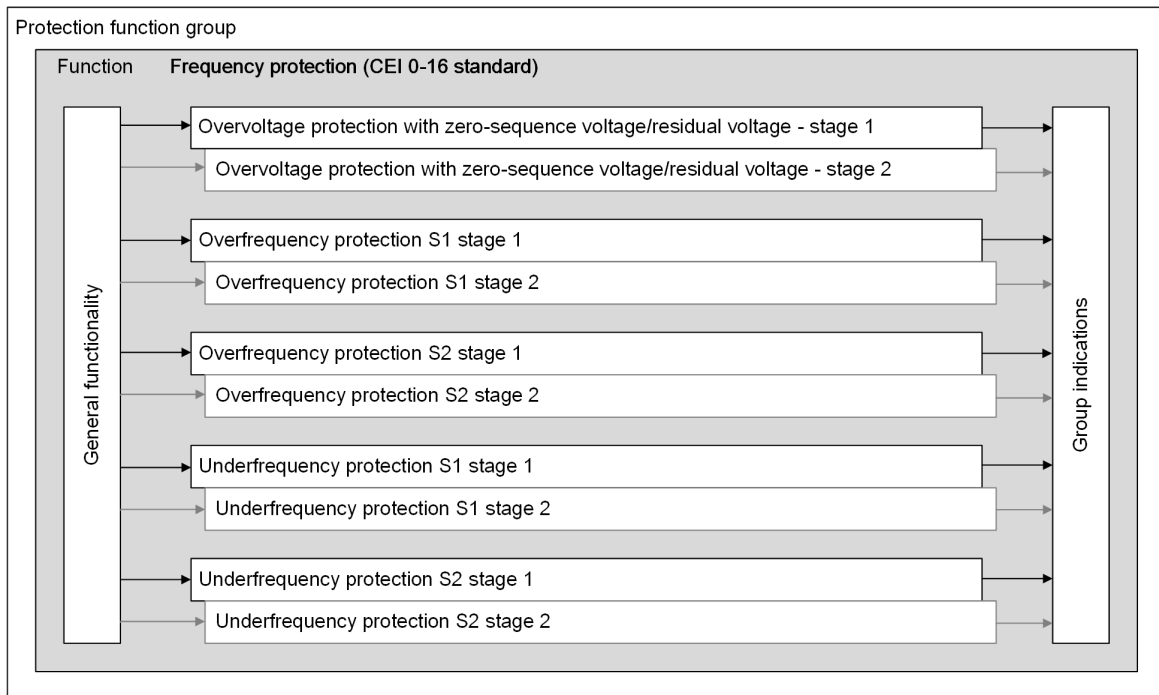

[dw_Freq.Prot_CEI_1_en_US]

Figure 6-356 Structure/Embedding of the Function

6.56.2 General Functionality

6.56.2.1 Description

The general functionality contains 3 logic parts:

- Voltmetric unblocking
- Undervoltage blocking
- Acceleration

Voltmetric Unblocking

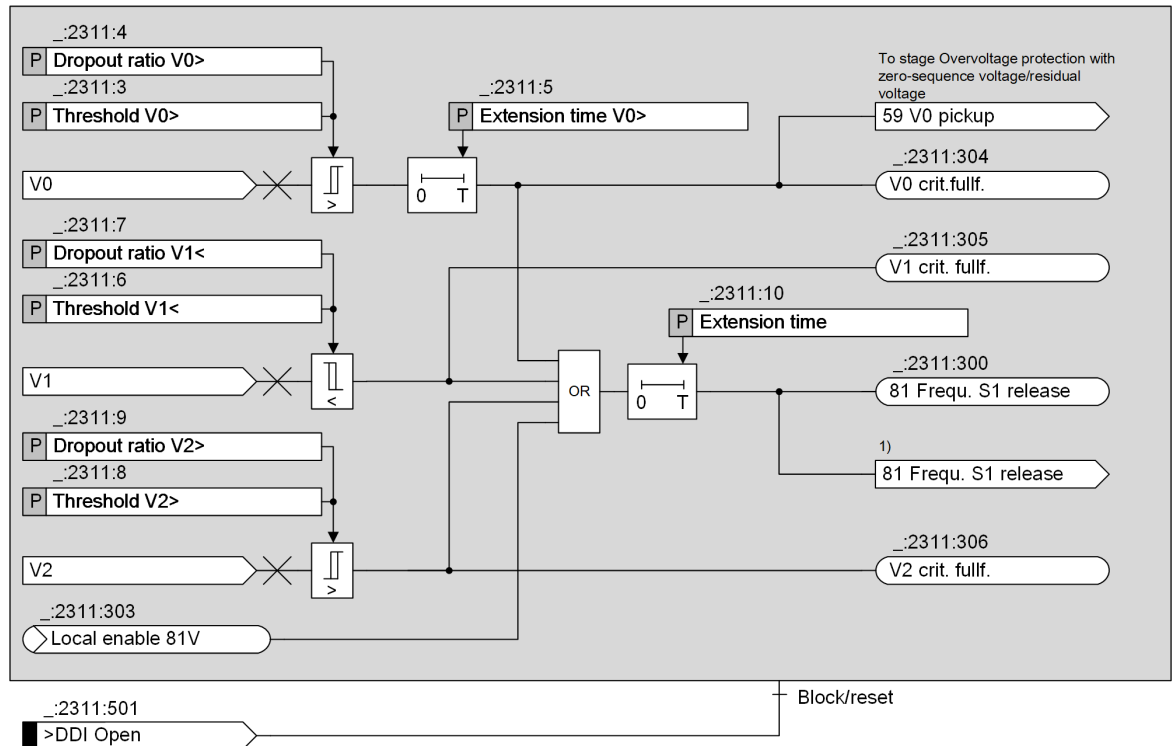

[to_Freq.Prot_Voltmetric_unblock_1_en_US]

Figure 6-357 Logic Diagram of the Voltmetric Unblocking

- (1) The internal signal *81 Freq. S1 release* is sent to the stages **Overfrequency protection S1** and **Underfrequency protection S1**.

The voltmetric unblocking logic releases the following stages:

- Frequency-protection S1 stages, that is, **Overfrequency protection S1** and **Underfrequency protection S1**
If the voltmetric unblocking conditions are not fulfilled, the stages are internally blocked.
- Stage **Overvoltage protection with zero-sequence voltage/residual voltage**
If the V0 condition is fulfilled, the stage picks up.

The voltmetric unblocking logic compares the following voltage components with settable thresholds and decides whether to issue the signals *81 Freq. S1 release*, *V0 crit. fullf.*, *V1 crit. fullf.*, and *V2 crit. fullf.*:

- Zero-sequence component (V0)
- Positive-sequence component (V1)
- Negative-sequence component (V2)

Meanwhile, a local control command *Local enable 81V* can also trigger the signal *81 Frequ. S1 release*. The command can be switched to *on* or *off* by the communication control command or the control menu for different operating modes:

- If the command *Local enable 81V* is in the state *off*, the frequency-protection S1 stages are blocked, except in the case of the intervention of the voltmetric unblocking.
- If the command *Local enable 81V* is in the state *on*, the frequency-protection S1 stages are released and the signal *81 Frequ. S1 release* is issued, regardless of the intervention of the voltmetric unblocking.

If the signal *81 Frequ. S1 release* is issued (that is, the voltmetric unblocking conditions are fulfilled), an internal signal *81 Frequ. S1 release* is sent to the frequency-protection S1 stages to release the stages.

If the signal *V0 crit. fullf.* is issued (that is, the V0 condition is fulfilled), an internal signal *59 V0 pickup* is sent to the stage **Overvoltage protection with zero-sequence voltage/residual voltage** to pick up the stage.

The voltmetric unblocking logic can be reset using the binary input signal *>DDI Open*.

Undervoltage Blocking

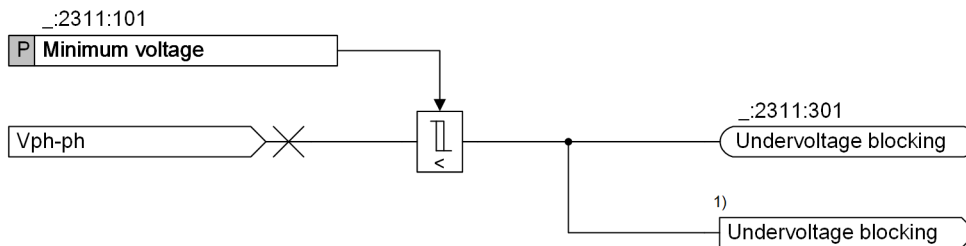

[Ilo_Freq.Prot_Undervolt_block_1_en_US]

Figure 6-358 Logic Diagram of the Undervoltage Blocking

- (1) The internal signal *Undervoltage blocking* is sent to the stages **Overfrequency protection S1**, **Overfrequency protection S2**, **Underfrequency protection S1**, and **Underfrequency protection S2**.

The frequency value to be used in each frequency-protection stage is calculated from each phase-to-phase voltage on 3 phases.

The undervoltage blocking logic is used to avoid a wrong calculated frequency value.

If the phase-to-phase voltage falls below the threshold **Minimum voltage**, a signal *Undervoltage blocking* is issued. In this condition, all the frequency-protection stages are blocked.

The dropout ratio of the undervoltage blocking is fixed at 1.05.

Acceleration

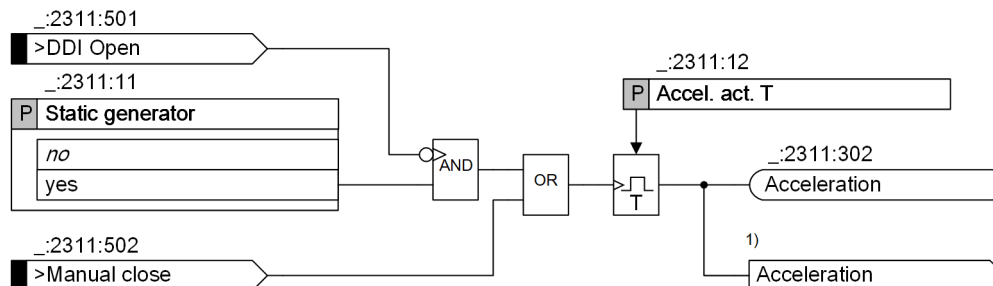

[Ilo_Freq.Prot_Acceleration_1_en_US]

Figure 6-359 Logic Diagram of the Acceleration

- (1) The internal signal *Acceleration* is sent to the stages **Overfrequency protection S2**, **Underfrequency protection S2**, and **Overvoltage protection with zero-sequence voltage/residual voltage**.

The acceleration logic is used to reduce the operate time of the following stages:

- **Overvoltage protection with zero-sequence voltage/residual voltage**
- **Overfrequency protection S2**
- **Underfrequency protection S2**

The preceding stages can be accelerated in either of the following ways:

- Issue of the signal *>Manual close*
If according to the CEI 0-16 standard, the transformers or transducers dedicated to the measurement of the residual voltage (phase-to-ground transducers or broken-delta winding of voltage transformers) are installed downstream of the DDI (interface device) at the generator side, the preceding stages are accelerated upon the intentional close (manual, automatic, with remote control, etc.) of the DDI, that is, upon the issue of the signal *>Manual close*.
- Removal of the signal *>DDI Open*
If according to the CEI 0-16 standard, the transformers or transducers for voltage or frequency measurement are installed downstream of the DDI (interface device) at the generator side, all the PI functions are blocked by the signal *>DDI Open*.
For the static generators or the asynchronous non-self-excited generators, at the closure of the DDI, the preceding mentioned stages can be accelerated by the removal of the signal *>DDI Open*. To do so, the parameter **Static generator** must be set to **yes**.
For other generators, the parameter **Static generator** is set to **no**, and the preceding mentioned stages are not accelerated by the signal *>DDI Open*.

For detailed applications, refer to [Application Example of the Acceleration Logic, Page 1065](#).

6.56.2.2 Application and Setting Notes

Voltage-Transformer Connection Types

As the zero-sequence voltage (V0) is necessary for the function **Frequency protection (CEI 0-16 standard)**, the function can be used in the following voltage-transformer connection types with V0:

- 3 ph-to-gnd volt. + VN
- 3 ph-to-gnd voltages
- 3 ph-to-ph volt. + VN
- 2 ph-to-ph volt. + VN

In the voltage-transformer connection types **3 ph-to-ph voltages** and **2 ph-to-ph voltages** without V0, the function cannot be used.

Parameter: Threshold V0>, Dropout ratio V0>, Extension time V0>

- Default setting (`_:2311:3`) **Threshold V0> = 5.000 V**
- Default setting (`_:2311:4`) **Dropout ratio V0> = 0.96**
- Default setting (`_:2311:5`) **Extension time V0> = 0.20 s**

With these parameters, you specify the voltmetric unblocking condition for the zero-sequence component (V0) of voltage as well as the pickup condition of the stage **Overvoltage protection with zero-sequence voltage/residual voltage**.

With the parameter **Extension time V0>**, you get a prolonged and therefore stabilized pickup signal of the stage **Overvoltage protection with zero-sequence voltage/residual voltage**. This parameter is used in case of an intermittent arc or when a fault is cleared, to avoid repetitive pickups and dropouts of the stage.

Siemens recommends using the default setting.

Parameter: Threshold V1<, Dropout ratio V1<

- Default setting (_:2311:6) **Threshold V1< = 40.416 V**
- Default setting (_:2311:7) **Dropout ratio V1< = 1.04**

With these parameters, you specify the voltmetric unblocking condition for the positive-sequence component (V1) of voltage.

Siemens recommends using the default setting.

Parameter: Threshold V2>, Dropout ratio V2>

- Default setting (_:2311:8) **Threshold V2> = 8.661 V**
- Default setting (_:2311:9) **Dropout ratio V2> = 0.95**

With these parameters, you specify the voltmetric unblocking condition for the negative-sequence component (V2) of voltage.

Siemens recommends using the default setting.

Parameter: Extension time

- Default setting (_:2311:10) **Extension time = 30.00 s**

With the parameter **Extension time**, you get a prolonged and therefore stabilized voltmetric-unblocking signal *81 Frequ. S1 release*.

Parameter: Minimum voltage

- Default setting (_:2311:101) **Minimum voltage = 20.000 V**

With the parameter **Minimum voltage**, you specify the voltage threshold value below which all the frequency-protection stages are blocked.

Set this parameter to a phase-to-phase voltage value.

Parameter: Static generator

- Default setting (_:2311:11) **Static generator = no**

With the parameter **Static generator**, you specify the type of the generator.

For the static or asynchronous non-self-excited generator, set the parameter to **yes**. For other generator types, set the parameter to **no**.

Parameter: Accel. act. T

- Default setting (_:2311:12) **Accel. act. T = 30.00 s**

With the parameter **Accel. act. T**, you specify the time range during which the operate of the following stages is accelerated:

- **Overvoltage protection with zero-sequence voltage/residual voltage**
- **Overfrequency protection S2**
- **Underfrequency protection S2**

The default setting of **30.00 s** is appropriate because it should be possible to wait for a reclose cycle in the network.

If you set this parameter to **0.00 s**, the acceleration logic is not active and the parameter **Operate delay** of the preceding 3 stages takes effect.

Application Example of the Acceleration Logic

Voltage transformers can be either connected upstream or downstream of the DDI (interface device). If inductive voltage transformers are used, only a phase-to-phase voltage connection is allowed to measure the phase-to-phase voltages and frequencies. According to the CEI 0-16 standard, the phase-to-ground voltage must be measured only with a broken-delta winding. With reference to the position of the voltage transformer, to comply with the CEI 0-16 standard, some parameters and signals must be used. The following provides examples.

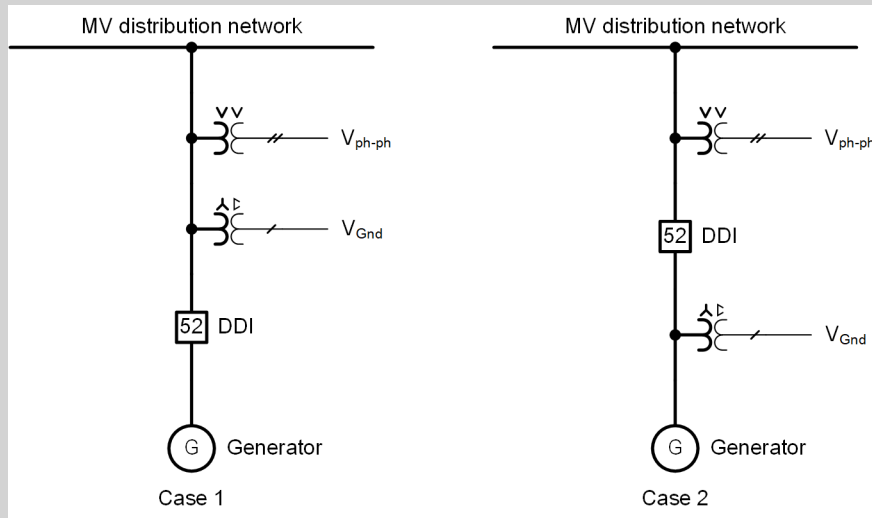

[dw_acceleration_example_1_1_en_US]

Figure 6-360 Application Example of Voltage-Transformer Positions: Case 1 and Case 2

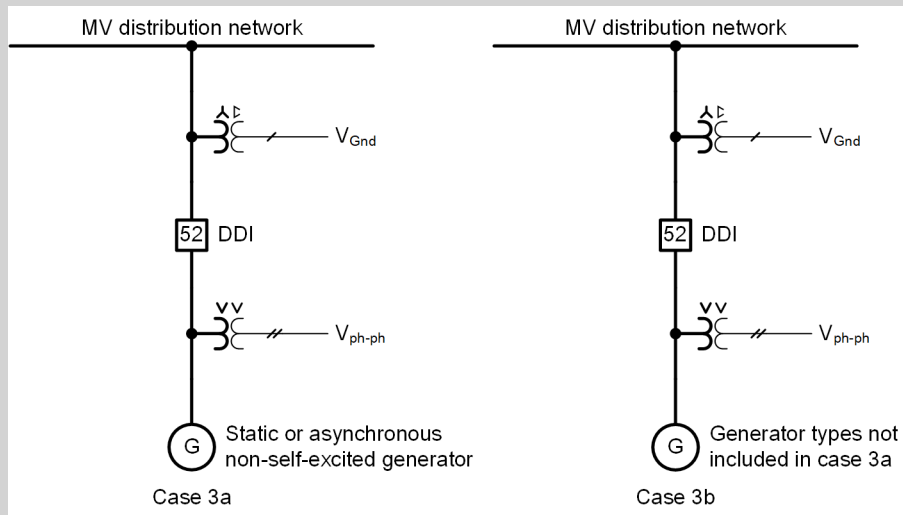

[dw_acceleration_example_2_1_en_US]

Figure 6-361 Application Example of Voltage-Transformer Positions: Case 3

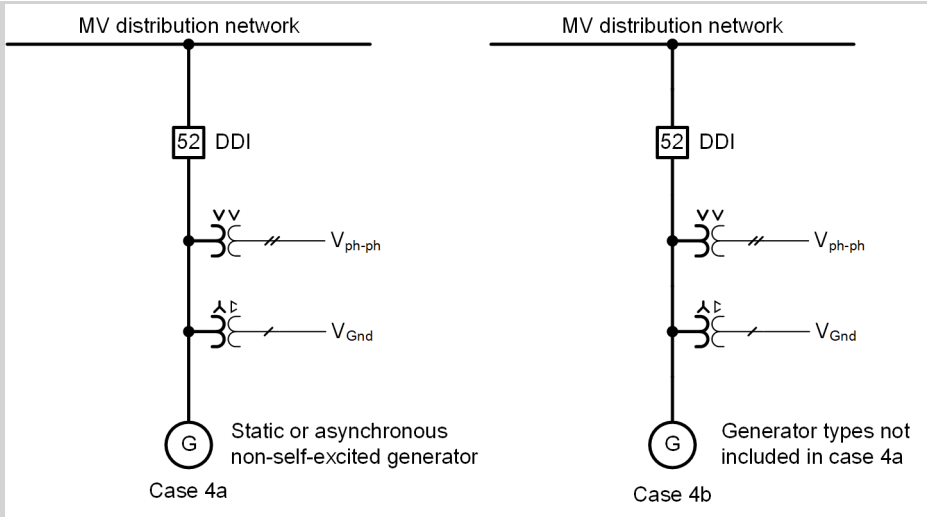

[dsw_acceleration_example_3_1_en_US]

Figure 6-362 Application Example of Voltage-Transformer Positions: Case 4

For different voltage-transformer positions in the preceding cases, the usage of the following signals and parameters is different according to the CEI 0-16 standard:

- Signal *>DDI Open*: indicates the state of the DDI.
- Signal *>Manual Close*: indicates the intentional closing command of the DDI.
- Parameter **Static generator**: specifies the type of the generator. For the static or asynchronous non-self-excited generator, the value of this parameter is **yes**. For other generator types, the value of this parameter is **no**.

The following table describes the usage of the preceding signals and parameters in the cases.

Table 6-23 Usage of the Signals and Parameters in Different Cases

Case	Use the Signal <i>>DDI Open</i>	Use the Signal <i>>Manual Close</i>	Set the Parameter Static generator
Case 1	No	No	Set to no
Case 2	No	Yes	Set to no
Case 3a	Yes	No	Set to yes
Case 3b	Yes	No	Set to no
Case 4a	Yes	Yes	Set to yes
Case 4b	Yes	Yes	Set to no

6.56.3 Overvoltage-Protection Stage with Zero-Sequence Voltage/Residual Voltage

6.56.3.1 Description

Logic of the Stage

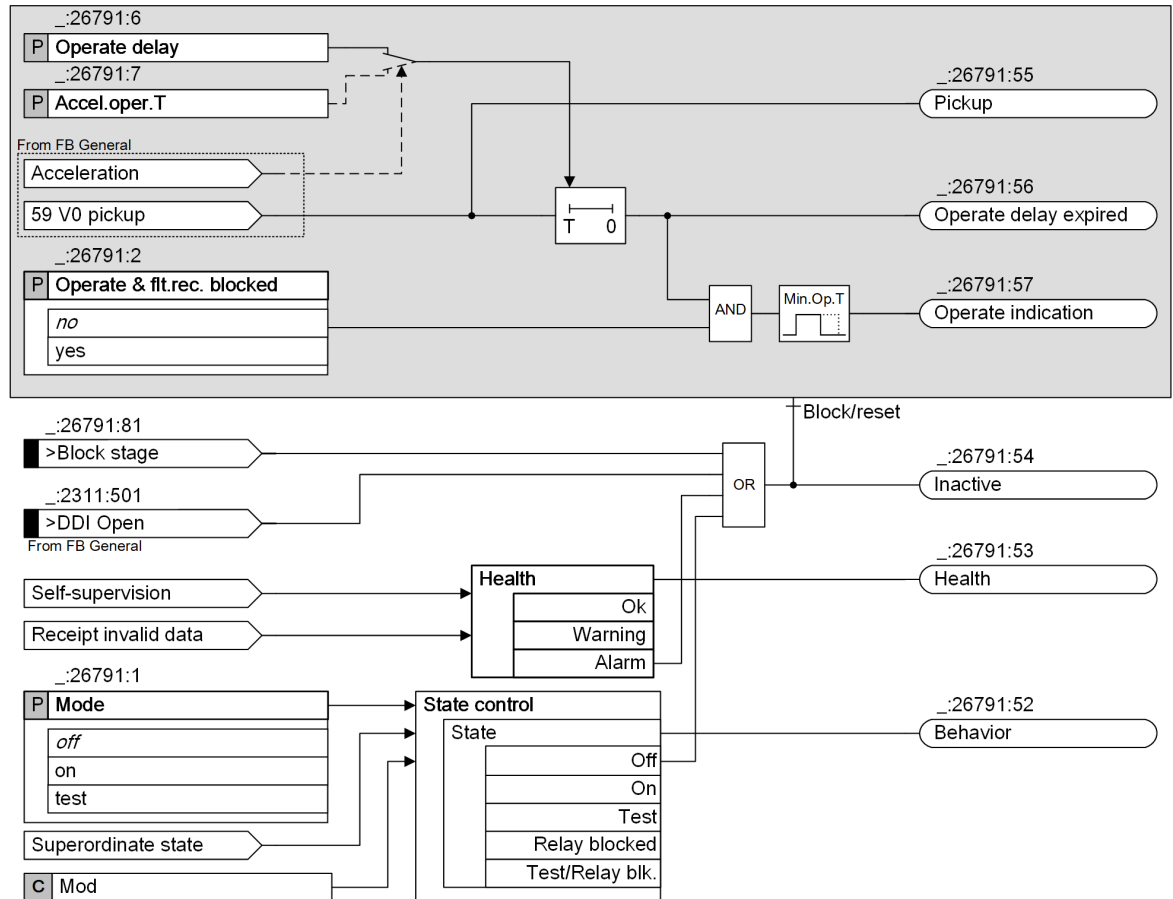

[ilo_Freq.Prot_V0_1_en_US]

Figure 6-363 Logic Diagram of the Overvoltage-Protection Stage with Zero-Sequence Voltage/Residual Voltage

Pickup and Operate

If the stage receives the internal signal *59 V0 pickup* from the general functionality, the pickup signal is issued.

Once the pickup signal is issued, the operate delay starts. If the stage receives the internal signal *Acceleration* from the general functionality, the parameter `Accel.oper.T` takes effect as the operate delay. Otherwise, the parameter `Operate delay` takes effect as the operate delay.

After the expiration of the operate delay, the operate signal is issued.

Blocking the Stage

In the event of blocking, the picked up stage is reset. The following blocking options are available for the stage:

- Externally or internally via the binary input signal `>Block stage`
- Internally via the binary input signal `>DDI Open` (defined in the CEI 0-16 standard) from the general functionality

6.56.3.2 Application and Setting Notes

Parameter: **Operate delay**

- Default setting (`_:26791:6`) **Operate delay** = *24.97 s*

Based on the CEI 0-16 standard, the recorded time between the start of overvoltage and the instant when the trip contact of the function changes the state represents the tripping time. It means that the tripping time contains the following times:

- The function pickup time
- The time from pickup to operate
- The trip-contact close time

In the CEI 0-16 standard, the default setting of the tripping time is 25.00 s.

The parameter **Operate delay** determines the time from pickup to operate. Therefore, the default setting of the parameter **Operate delay** is *24.97 s*, that is, 25.00 s minus the function pickup time and the trip-contact close time which is around 30 ms.

Parameter: **Accel.oper.T**

- Default setting (`_:26791:7`) **Accel.oper.T** = *0.17 s*

If the acceleration is active, the parameter **Accel.oper.T** takes effect instead of the parameter **Operate delay** to reduce the operate delay.

Operation as Supervision Function

If you want the stage to have a reporting effect only, you can set the parameter **Operate &flt.rec.blocked** to disable the generation of the operate indication and fault logging.

6.56.4 Frequency Protection S1 Stages

6.56.4.1 Description

Logic of the Stage

The logic of the stage **Overfrequency protection S1** is the same as that of the stage **Underfrequency protection S1**. The following figure shows the logic of the stage **Overfrequency protection S1** as an example.

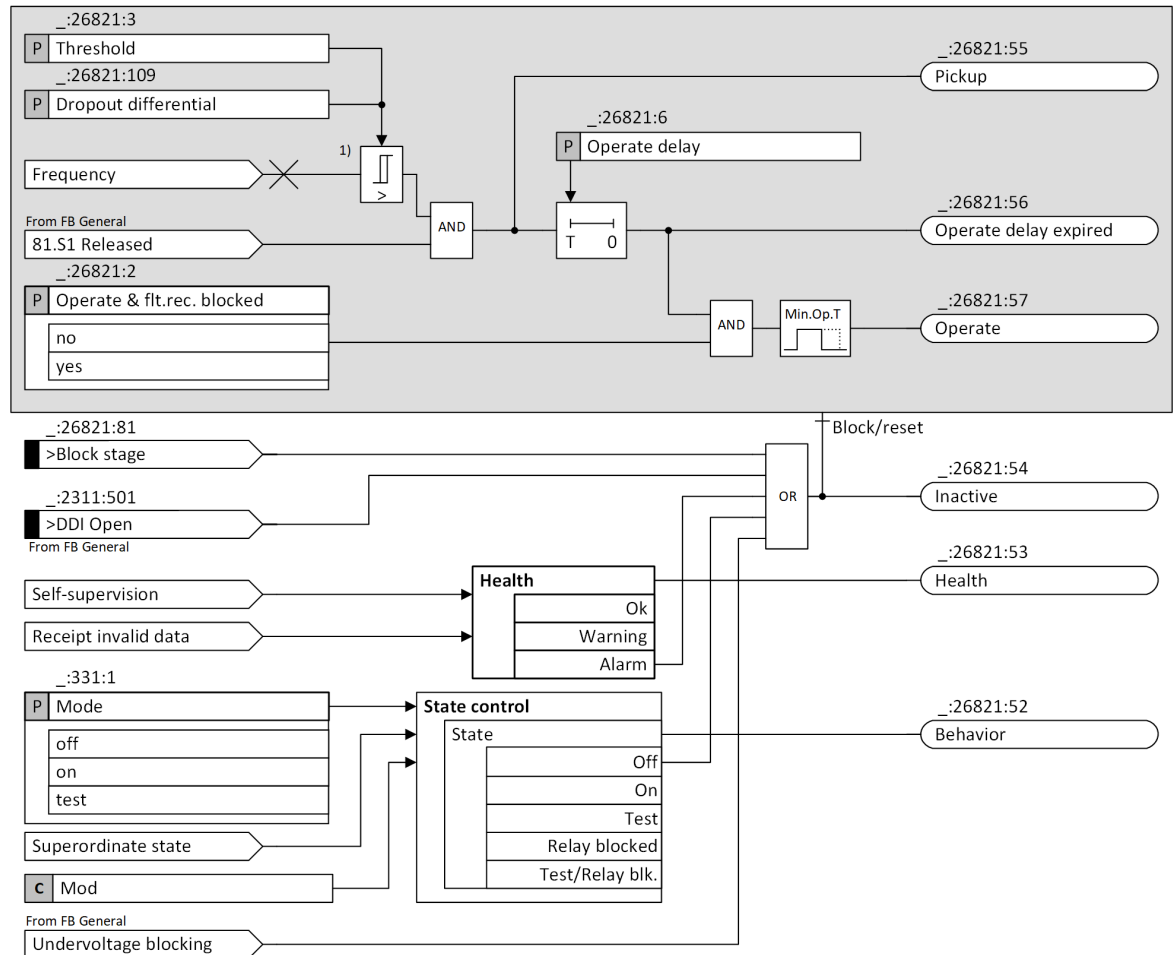

[to_FreqProt_S1_1_en_US]

Figure 6-364 Logic Diagram of the Stage Overfrequency-Protection S1

(1) For the stage **Underfrequency protection S1**, the symbol is:



Frequency-Measurement Method

The angle-difference method is used for frequency measurement. This method determines the phasor of the positive-sequence voltage in multiphase systems. Since the change of angle of the voltage phasor over a given time interval is proportional to the frequency change, the current frequency can be derived from it.

Pickup and Operate

If both of the following conditions are fulfilled, the pickup signal is issued:

- The stage receives the internal signal *81 Frequ. S1 release* from the general functionality.
- For the stage **Overfrequency protection S1**, the frequency value exceeds the **Threshold**. For the stage **Underfrequency protection S1**, the frequency value falls below the **Threshold**.

Once the pickup signal is issued, the operate delay (specified by the parameter **Operate delay**) starts. After the expiration of the operate delay, the operate signal is issued.

Behavior on Leaving the Operating Range

The sampling-frequency tracking makes a wide frequency operating range possible. If the stage has picked up before leaving the frequency operating range and the measuring voltage is higher than the set minimum voltage, the pickup is maintained. A dropout of the pickup is only possible by means of a blocking.

Blocking the Stage

In the event of blocking, the picked up stage is reset. The following blocking options are available for the stage:

- Externally or internally via the binary input signal *>Block stage*
- Internally via the binary input signal *>DDI Open* (defined in the CEI 0-16 standard) from the general functionality
- Internally when the phase-to-phase voltage falls below the threshold **Minimum voltage**

6.56.4.2 Application and Setting Notes

Parameter: **Threshold**

- Default setting (`_:26821:3`) **Threshold = 50.20 Hz** for $f_{rated} = 50$ Hz (for the stage **Overfrequency protection S1**)
- Default setting (`_:26881:3`) **Threshold = 49.80 Hz** for $f_{rated} = 50$ Hz (for the stage **Underfrequency protection S1**)

In the CEI 0-16 standard, the default setting of this parameter is recommended. Siemens recommends using the default setting.

Parameter: **Operate delay**

- Default setting (`_:26821:6`) **Operate delay = 0.07 s**

Based on the CEI 0-16 standard, the recorded time between the instant of the frequency deviation and the instant when the trip contact of the function changes the state represents the tripping time. It means that the tripping time contains the following times:

- The function pickup time
- The time from pickup to operate
- The trip-contact close time

In the CEI 0-16 standard, the default setting of the tripping time is 0.15 s.

The parameter **Operate delay** determines the time from pickup to operate. Therefore, the default setting of the parameter **Operate delay** is **0.07 s**, that is, 0.15 s minus the function pickup time and the trip-contact close time which is around 80 ms.

Parameter: **Dropout differential**

- Default setting (`_:26821:109`) **Dropout differential = 20 mHz**

Due to the high-precision frequency measurement, the recommended setting value for the **Dropout differential** can remain at 20 mHz. If you wish a subsequent dropout of the tripping stage in your application, then increase the setting value of the dropout differential. For example, if the pickup value (parameter **Threshold**) of the tripping stage is set to **50.20 Hz** (for the stage **Overfrequency protection S1**) or to **49.80 Hz** (for the stage **Underfrequency protection S1**) and the **Dropout differential** to **100 mHz**, the stage drops out at 50.10 Hz (for the stage **Overfrequency protection S1**) or at 49.90 Hz (for the stage **Underfrequency protection S1**).

6.56.5 Frequency Protection S2 Stages

6.56.5.1 Description

Logic of the Stage

The logic of the stage **Overfrequency protection S2** is the same as that of the stage **Underfrequency protection S2**. The following figure shows the logic of the stage **Overfrequency protection S2** as an example.

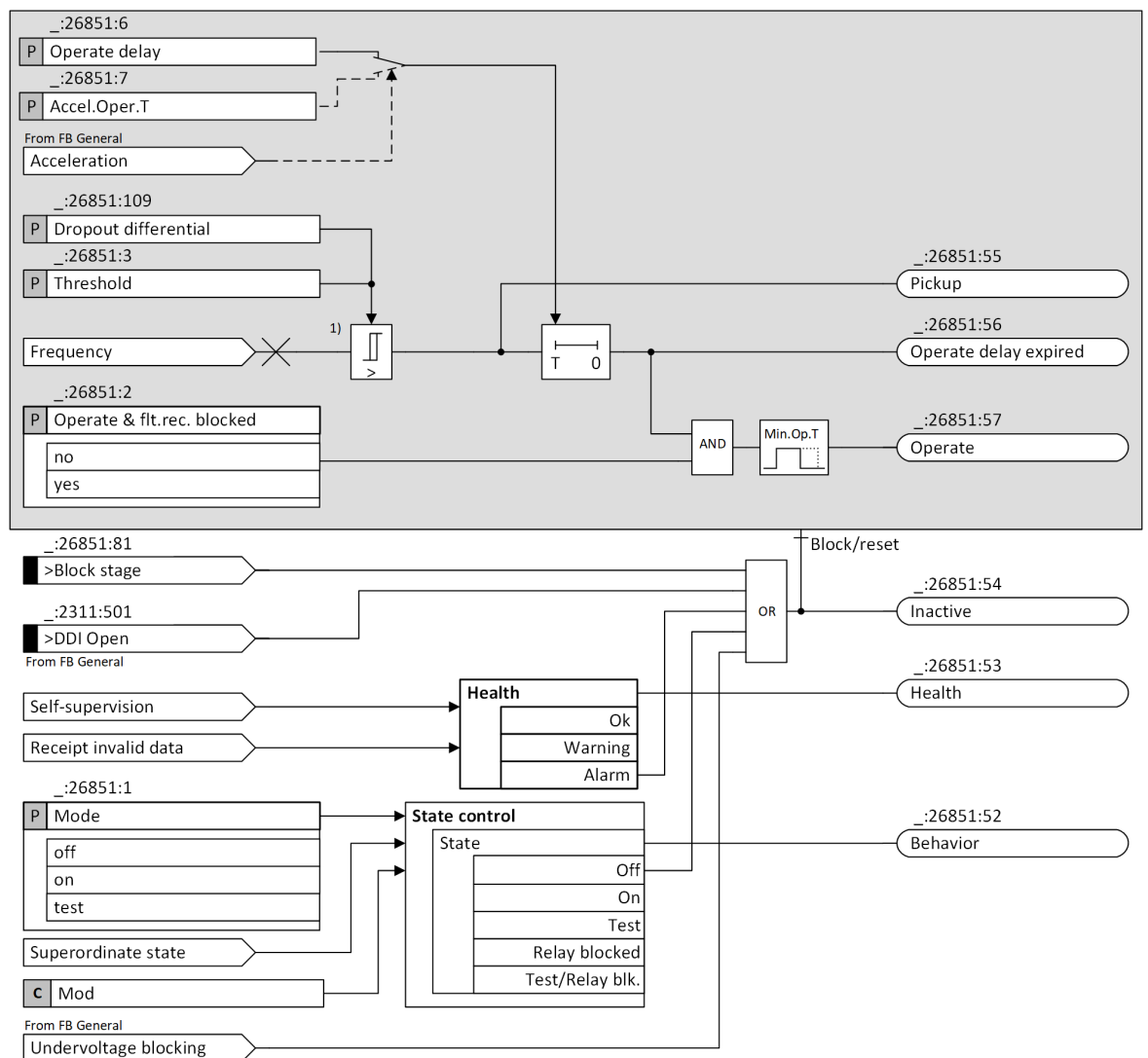

[Io_Freq.Prot_S2_1_en_US]

Figure 6-365 Logic Diagram of the Stage Overfrequency-Protection S2

(1) For the stage **Underfrequency protection S2**, the symbol is:



Frequency-Measurement Method

The angle-difference method is used for frequency measurement. This method determines the phasor of the positive-sequence voltage in multiphase systems. Since the change of angle of the voltage phasor over a given time interval is proportional to the frequency change, the current frequency can be derived from it.

Pickup and Operate

For the stage **Overfrequency protection S2**, if the frequency value exceeds the **Threshold**, the pickup signal is issued.

For the stage **Underfrequency protection S2**, if the frequency value falls below the **Threshold**, the pickup signal is issued.

Once the pickup signal is issued, the operate delay starts. If the stage receives the internal signal *Acceleration* from the general functionality, the parameter **Accel.oper.T** takes effect as the operate delay. Otherwise, the parameter **Operate delay** takes effect as the operate delay.

After the expiration of the operate delay, the operate signal is issued.

Behavior on Leaving the Operating Range

The sampling-frequency tracking makes a wide frequency operating range possible. If the stage has picked up before leaving the frequency operating range and the measuring voltage is higher than the set minimum voltage, the pickup is maintained. A dropout of the pickup is only possible by means of a blocking.

Blocking the Stage

In the event of blocking, the picked up stage is reset. The following blocking options are available for the stage:

- Externally or internally via the binary input signal *>Block stage*
- Internally via the binary input signal *>DDI Open* (defined in the CEI 0-16 standard) from the general functionality
- Internally when the phase-to-phase voltage falls below the threshold **Minimum voltage**

6.56.5.2 Application and Setting Notes

Parameter: **Threshold**

- Default setting (**_:26851:3**) **Threshold = 51.50 Hz** for $f_{rated} = 50$ Hz (for the stage **Overfrequency protection S2**)
- Default setting (**_:26911:3**) **Threshold = 47.50 Hz** for $f_{rated} = 50$ Hz (for the stage **Underfrequency protection S2**)

In the CEI 0-16 standard, the default setting of this parameter is recommended. Siemens recommends using the default setting.

Parameter: **Operate delay**

- Default setting (**_:26851:6**) **Operate delay = 0.92 s** (for the stage **Overfrequency protection S2**)
- Default setting (**_:26911:6**) **Operate delay = 3.92 s** (for the stage **Underfrequency protection S2**)

Based on the CEI 0-16 standard, the recorded time between the instant of the frequency deviation and the instant when the trip contact of the function changes the state represents the tripping time. It means that the tripping time contains the following times:

- The function pickup time
- The time from pickup to operate
- The trip-contact close time

In the CEI 0-16 standard, the default setting of the trip time is 1.00 s for the stage **Overfrequency protection S2** and 4.00 s for the stage **Underfrequency protection S2**.

The parameter **Operate delay** determines the time from pickup to operate. Therefore, the default setting of the parameter **Operate delay** is 0.92 s for the stage **Overfrequency protection S2** and 3.92 s for the stage **Underfrequency protection S2**, that is, 1.00 s for the stage **Overfrequency protection S2** or 4.00 s for the stage **Underfrequency protection S2** minus the function pickup time and the trip-contact close time which is around 80 ms.

Parameter: `Accel.oper.T`

- Default setting (`_:26851:7`) **`Accel.oper.T`** = 0.12 s

If the acceleration is active, the parameter **`Accel.oper.T`** takes effect instead of the parameter **`Operate delay`** to reduce the operate delay.

Parameter: `Dropout differential`

- Recommended setting value **`Dropout differential`** = 20 mHz

Due to the high-precision frequency measurement, the recommended setting value for the **`Dropout differential`** can remain at 20 mHz. If you wish a subsequent dropout of the tripping stage in your application, then increase the setting value of the dropout differential. For example, if the pickup value (parameter **`Threshold`**) of the tripping stage is set to 51.50 Hz (for the stage **Overfrequency protection S2**) or to 47.50 Hz (for the stage **Underfrequency protection S2**) and the **`Dropout differential`** to 100 mHz, the stage drops out at 51.40 Hz (for the stage **Overfrequency protection S1**) or at 47.60 Hz (for the stage **Underfrequency protection S1**).

Operation as Supervision Function

If you want the stage to have a reporting effect only, you can set the parameter **`Operate & flt.rec.blocked`** to disable the generation of the operate indication and fault logging.

6.56.6 Settings

Addr.	Parameter	C	Setting Options	Default Setting
<i>Voltmetric unblock</i>				
<code>_:2311:3</code>	General:Threshold V0>		0.300 V to 200.000 V	5.000 V
<code>_:2311:4</code>	General:Dropout ratio V0>		0.90 to 0.99	0.96
<code>_:2311:5</code>	General:Extension time V0>		0.00 s to 0.20 s	0.20 s
<code>_:2311:6</code>	General:Threshold V1<		0.300 V to 200.000 V	40.416 V
<code>_:2311:7</code>	General:Dropout ratio V1<		1.01 to 1.20	1.04
<code>_:2311:8</code>	General:Threshold V2>		0.300 V to 200.000 V	8.661 V
<code>_:2311:9</code>	General:Dropout ratio V2>		0.90 to 0.99	0.95
<code>_:2311:10</code>	General:Extension time		1.00 s to 240.00 s	30.00 s

Addr.	Parameter	C	Setting Options	Default Setting
Undervoltage block				
_:2311:101	General:Minimum voltage		3.000 V to 175.000 V	20.000 V
Acceleration				
_:2311:11	General:Static generator		<ul style="list-style-type: none"> • no • yes 	no
_:2311:12	General:Accel. act. T		0.00 s to 60.00 s	30.00 s
59 V0 CEI 1				
_:26791:1	59 V0 CEI 1:Mode		<ul style="list-style-type: none"> • off • on • test 	off
_:26791:2	59 V0 CEI 1:Operate &flt.rec. blocked		<ul style="list-style-type: none"> • no • yes 	no
_:26791:6	59 V0 CEI 1:Operate delay		0.00 s to 300.00 s	24.97 s
_:26791:7	59 V0 CEI 1:Accel.oper.T		0.00 s to 5.00 s	0.17 s
OverF.S1 CEI 1				
_:26821:1	OverF.S1 CEI 1:Mode		<ul style="list-style-type: none"> • off • on • test 	off
_:26821:2	OverF.S1 CEI 1:Operate &flt.rec. blocked		<ul style="list-style-type: none"> • no • yes 	no
_:26821:3	OverF.S1 CEI 1:Threshold		40.00 Hz to 90.00 Hz	50.20 Hz
_:26821:6	OverF.S1 CEI 1:Operate delay		0.00 s to 600.00 s	0.07 s
_:26821:109	OverF.S1 CEI 1:Dropout differential		20 mHz to 2000 mHz	20 mHz
OverF.S2 CEI 1				
_:26851:1	OverF.S2 CEI 1:Mode		<ul style="list-style-type: none"> • off • on • test 	off
_:26851:2	OverF.S2 CEI 1:Operate &flt.rec. blocked		<ul style="list-style-type: none"> • no • yes 	no
_:26851:3	OverF.S2 CEI 1:Threshold		40.00 Hz to 90.00 Hz	51.50 Hz
_:26851:6	OverF.S2 CEI 1:Operate delay		0.00 s to 600.00 s	0.92 s
_:26851:7	OverF.S2 CEI 1:Accel.oper.T		0.00 s to 5.00 s	0.12 s
_:26851:109	OverF.S2 CEI 1:Dropout differential		20 mHz to 2000 mHz	20 mHz
Und.F.S1 CEI 1				
_:26881:1	Und.F.S1 CEI 1:Mode		<ul style="list-style-type: none"> • off • on • test 	off

Addr.	Parameter	C	Setting Options	Default Setting
_:26881:2	Und.F.S1 CEI 1:Operate & flt.rec. blocked		<ul style="list-style-type: none"> • no • yes 	no
_:26881:3	Und.F.S1 CEI 1:Threshold		30.00 Hz to 70.00 Hz	49.80 Hz
_:26881:6	Und.F.S1 CEI 1:Operate delay		0.00 s to 600.00 s	0.07 s
_:26881:109	Und.F.S1 CEI 1:Dropout differential		20 mHz to 2000 mHz	20 mHz
Und. F. S2 CEI 1				
_:26911:1	Und.F.S2 CEI 1:Mode		<ul style="list-style-type: none"> • off • on • test 	off
_:26911:2	Und.F.S2 CEI 1:Operate & flt.rec. blocked		<ul style="list-style-type: none"> • no • yes 	no
_:26911:3	Und.F.S2 CEI 1:Threshold		30.00 Hz to 70.00 Hz	47.50 Hz
_:26911:6	Und.F.S2 CEI 1:Operate delay		0.00 s to 600.00 s	3.92 s
_:26911:7	Und.F.S2 CEI 1:Accel.oper.T		0.00 s to 5.00 s	0.12 s
_:26911:109	Und.F.S2 CEI 1:Dropout differential		20 mHz to 2000 mHz	20 mHz

6.56.7 Information List

No.	Information	Data Class (Type)	Type
General			
_:2311:501	General:>DDI Open	SPS	I
_:2311:502	General:>Manual close	SPS	I
_:2311:303	General:Local enable 81V	SPC	C
_:2311:304	General:V0 crit. fullf.	SPS	O
_:2311:305	General:V1 crit. fullf.	SPS	O
_:2311:306	General:V2 crit. fullf.	SPS	O
_:2311:300	General:81 Frequ. S1 release	SPS	O
_:2311:301	General:Undervoltage blocking	SPS	O
_:2311:302	General:Acceleration	SPS	O
_:2311:307	General:f	MV	O
_:2311:52	General:Behavior	ENS	O
_:2311:53	General:Operate	ENS	O
Group indicat.			
_:4501:55	Group indicat.:Pickup	ACD	O
_:4501:57	Group indicat.:Operate	ACT	O
_:4501:52	Group indicat.:Behavior	ENS	O
_:4501:53	Group indicat.:Health	ENS	O
59 V0 CEI 1			
_:26791:81	59 V0 CEI 1:>Block stage	SPS	I
_:26791:51	59 V0 CEI 1:Mode (controllable)	ENC	C

No.	Information	Data Class (Type)	Type
_:26791:54	59 V0 CEI 1:Inactive	SPS	O
_:26791:52	59 V0 CEI 1:Behavior	ENS	O
_:26791:53	59 V0 CEI 1:Health	ENS	O
_:26791:55	59 V0 CEI 1:Pickup	ACD	O
_:26791:56	59 V0 CEI 1:Operate delay expired	ACT	O
_:26791:57	59 V0 CEI 1:Operate	ACT	O
OverF.S1 CEI 1			
_:26821:81	OverF.S1 CEI 1:>Block stage	SPS	I
_:26821:51	OverF.S1 CEI 1:Mode (controllable)	ENC	C
_:26821:54	OverF.S1 CEI 1:Inactive	SPS	O
_:26821:52	OverF.S1 CEI 1:Behavior	ENS	O
_:26821:53	OverF.S1 CEI 1:Health	ENS	O
_:26821:55	OverF.S1 CEI 1:Pickup	ACD	O
_:26821:56	OverF.S1 CEI 1:Operate delay expired	ACT	O
_:26821:57	OverF.S1 CEI 1:Operate	ACT	O
OverF.S2 CEI 1			
_:26851:81	OverF.S2 CEI 1:>Block stage	SPS	I
_:26851:51	OverF.S2 CEI 1:Mode (controllable)	ENC	C
_:26851:54	OverF.S2 CEI 1:Inactive	SPS	O
_:26851:52	OverF.S2 CEI 1:Behavior	ENS	O
_:26851:53	OverF.S2 CEI 1:Health	ENS	O
_:26851:55	OverF.S2 CEI 1:Pickup	ACD	O
_:26851:56	OverF.S2 CEI 1:Operate delay expired	ACT	O
_:26851:57	OverF.S2 CEI 1:Operate	ACT	O
Und.F.S1 CEI 1			
_:26881:81	Und.F.S1 CEI 1:>Block stage	SPS	I
_:26881:51	Und.F.S1 CEI 1:Mode (controllable)	ENC	C
_:26881:54	Und.F.S1 CEI 1:Inactive	SPS	O
_:26881:52	Und.F.S1 CEI 1:Behavior	ENS	O
_:26881:53	Und.F.S1 CEI 1:Health	ENS	O
_:26881:55	Und.F.S1 CEI 1:Pickup	ACD	O
_:26881:56	Und.F.S1 CEI 1:Operate delay expired	ACT	O
_:26881:57	Und.F.S1 CEI 1:Operate	ACT	O
Und.F.S2 CEI 1			
_:26911:81	Und.F.S2 CEI 1:>Block stage	SPS	I
_:26911:51	Und.F.S2 CEI 1:Mode (controllable)	ENC	C
_:26911:54	Und.F.S2 CEI 1:Inactive	SPS	O
_:26911:52	Und.F.S2 CEI 1:Behavior	ENS	O
_:26911:53	Und.F.S2 CEI 1:Health	ENS	O
_:26911:55	Und.F.S2 CEI 1:Pickup	ACD	O
_:26911:56	Und.F.S2 CEI 1:Operate delay expired	ACT	O
_:26911:57	Und.F.S2 CEI 1:Operate	ACT	O

6.57 Undervoltage Protection with 3-Phase Voltage (CEI 0-16 Standard)

6.57.1 Structure of the Function

The function **Undervoltage protection with 3-phase voltage (CEI 0-16 standard)** can be used in the following function groups with 3-phase voltage measurement:

- Function group **Voltage/current 3-phase**
- Function group **Voltage 3-phase**
- Function group **Line**

The function **Undervoltage protection with 3-phase voltage (CEI 0-16 standard)** comes factory-set with 2 stages **Definite-time undervoltage protection**, and a maximum of 2 stages can be operated simultaneously within the function.

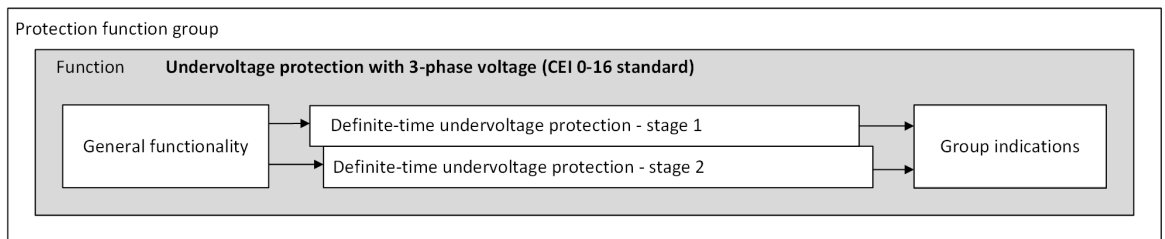

[dw_UVP_CEI_1_en_US]

Figure 6-366 Structure/Embedding of the Function

6.57.2 General Functionality

6.57.2.1 Description

Logic

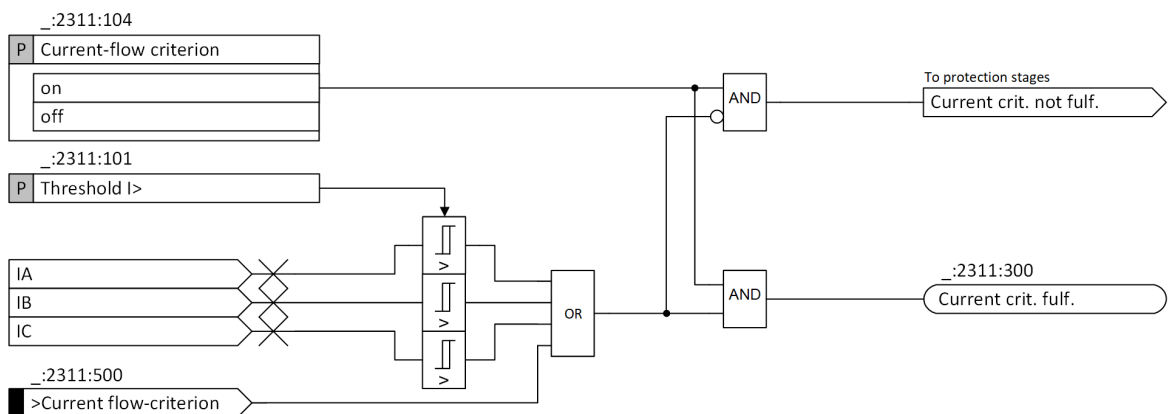

[fo_UVP_CEI_FB General_1_en_US]

Figure 6-367 Logic Diagram of the General Functionality

Current-Flow Criterion

The undervoltage-protection stages work optionally with a current-flow criterion. The parameter **Current-flow criterion** works across all tripping stages.

When the parameter **Current-flow criterion** is activated, the undervoltage-protection stages only pick up if a settable minimum current (**Threshold I>**) is exceeded. A current below the minimum current blocks the stages.

The current-flow criterion can also be set to **fulfilled** with the binary input signal **Current-flow criterion**. The function reports when the current-flow criterion is fulfilled.



NOTE

If the parameter **Current-flow criterion** is deactivated, the device picks up immediately if a missing measuring voltage is detected while the undervoltage protection is active. The parameter setting can be changed even when the device has picked up.

6.57.2.2 Application and Setting Notes

Parameter: Current-flow criterion

- Default setting (`_:2311:104`) **Current-flow criterion** = *on*

Depending on the system, the voltage transformers are arranged on either the supply side or the junction side. These 2 possible voltage-transformer locations induce a different behavior of the function after tripping and opening of the circuit breaker:

- If they are located on the supply side, the voltage still exists.
- If they are located on the junction side, the voltage does not exist.

Parameter Value	Description
<i>on</i>	If the voltage transformers are located on the junction side, you can use the current-flow criterion to make the pickup drop out when the current falls below a minimum value (parameter Threshold I>).
<i>off</i>	In the case of undervoltage, the pickup of the undervoltage-protection stage persists when the current-flow criterion is not used.

Parameter: Threshold I>

- Default setting (`_:2311:101`) **Threshold I>** = *0.050 A*

If the function is instantiated in the function group **Voltage 3-phase**, this parameter is invisible.

The parameter **Threshold I>** makes it possible to detect when the circuit breaker is closed. Siemens recommends setting the parameter **Threshold I>** to 5 % of the rated current. With a secondary rated transformer current of 1 A, the secondary setting value for **Threshold I>** is 0.05 A.

If the sensitivity of the parameter **Threshold I>** is set too high, compensation processes in the secondary circuit of the current transformer extend the dropout time when breaking extremely high currents. To speed up the dropout, increase the default setting.

6.57.3 Stage with Definite-Time Characteristic Curve

6.57.3.1 Description

Logic of the Stage

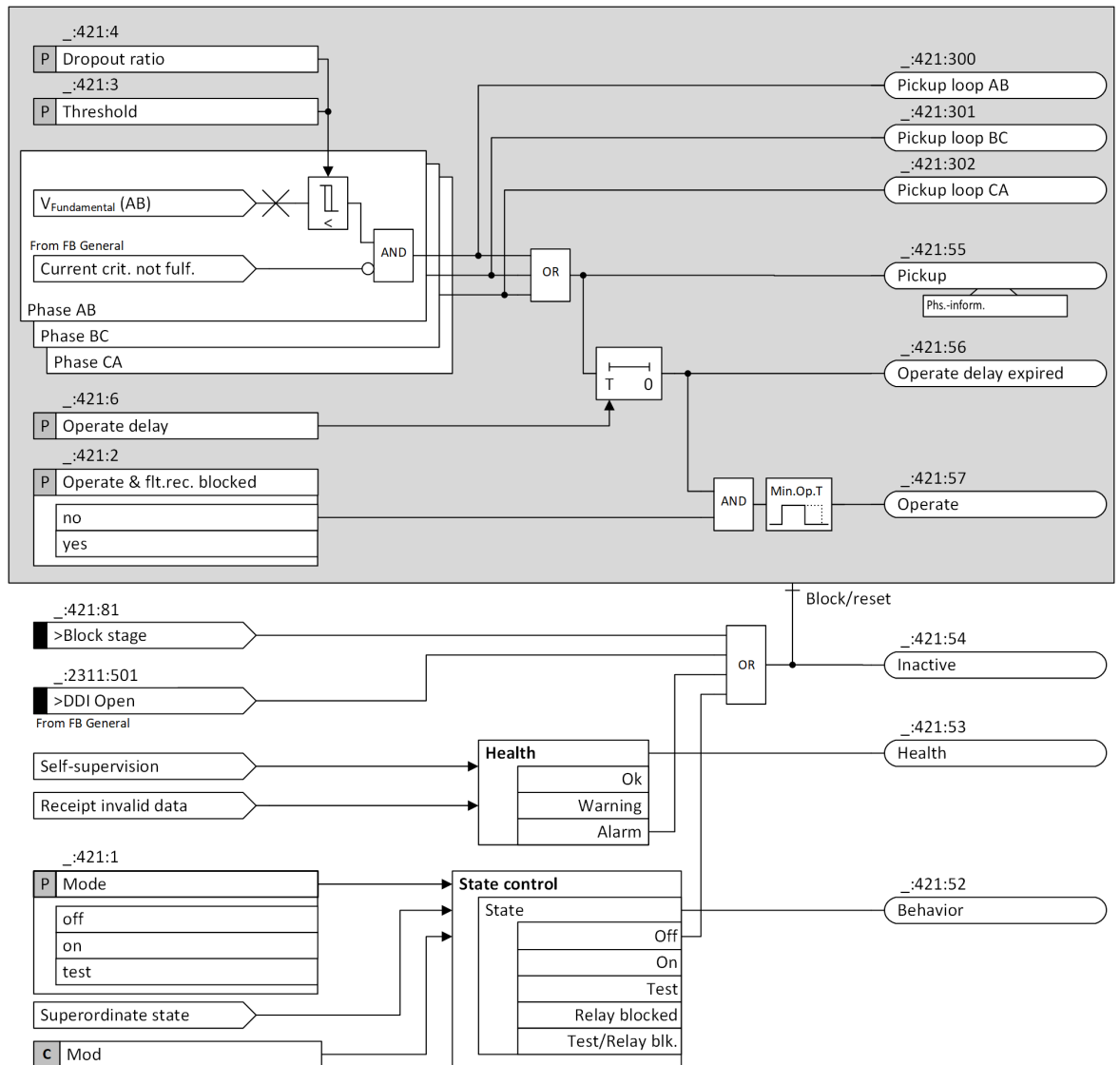

[to_stage_UVP_CEI_Fund_1_en_US]

Figure 6-368 Logic Diagram of the Stage with Definite-Time Characteristic Curve, Fundamental Component

Measurand

The stage processes the sampled values of the phase-to-phase voltage and filters out the fundamental component numerically.

Pickup, Operate, Dropout

If both the following conditions are fulfilled, the pickup signal is issued:

- If the parameter **Current-flow criterion** is activated, the current-flow criterion is fulfilled.
If the parameter **Current-flow criterion** is deactivated, this condition is not valid.
For details, refer to the section [Current-Flow Criterion, Page 1077](#) in the general functionality.
- The fundamental-component value of the phase-to-phase voltage falls below the threshold value (specified by the parameter **Threshold**).

Once the pickup signal is issued, the operate delay (specified by the parameter **Operate delay**) starts. After the expiration of the operate delay, the operate signal is issued.

With the parameter **Dropout ratio**, you can define the ratio of the dropout threshold to the value of the parameter **Threshold**.

Blocking the Stage

In the event of blocking, the picked up stage is reset. The following blocking options are available for the stage:

- Externally or internally via the binary input signal *>Block stage*
- Internally via the binary input signal *>DDI Open* (defined in the CEI 0-16 standard) from the general functionality

6.57.3.2 Application and Setting Notes

Parameter: **Threshold**

- Default setting (**_:421:3**) **Threshold** = *85.000 V* (for the 1st stage)
- Default setting (**_:422:3**) **Threshold** = *30.000 V* (for the 2nd stage)

In the CEI 0-16 standard, the default setting of this parameter is recommended. Siemens recommends using the default setting.

Parameter: **Dropout ratio**

- Default setting (**_:421:4**) **Dropout ratio** = *1.04*

The default setting *1.04* is appropriate for most applications. To achieve high-precision measurements, the **Dropout ratio** can be reduced, to 0.98, for example.

Parameter: **Operate delay**

- Default setting (**_:421:6**) **Operate delay** = *1.47 s* (for the 1st stage)
- Default setting (**_:422:6**) **Operate delay** = *0.17 s* (for the 2nd stage)

Based on the CEI 0-16 standard, the recorded time between the start of overvoltage and the instant when the trip contact of the function changes the state represents the tripping time. It means that the tripping time contains the following times:

- The function pickup time
- The time from pickup to operate
- The trip-contact close time

In the CEI 0-16 standard, the default setting of the trip time is 1.50 s for the 1st stage and 0.20 s for the 2nd stage.

The parameter **Operate delay** determines the time from pickup to operate. Therefore, the default setting of the parameter **Operate delay** is *1.47 s* for the 1st stage and *0.17 s* for the 2nd stage, that is, 1.50 s for the 1st stage and 0.20 s for the 2nd stage minus the function pickup time and the trip-contact close time which is around 30 ms.

Operation as Supervision Function

If you want the stage to have a reporting effect only, you can set the parameter **Operate & flt.rec. blocked** to disable the generation of the operate indication and fault logging.

6.57.4 Settings

Addr.	Parameter	C	Setting Options	Default Setting
General				
_:2311:104	General:Current-flow criterion		<ul style="list-style-type: none"> • off • on 	on
_:2311:101	General:Threshold I>	1 A @ 100 Irated	0.030 A to 10.000 A	0.050 A
		5 A @ 100 Irated	0.15 A to 50.00 A	0.25 A
		1 A @ 50 Irated	0.030 A to 10.000 A	0.050 A
		5 A @ 50 Irated	0.15 A to 50.00 A	0.25 A
		1 A @ 1.6 Irated	0.001 A to 1.600 A	0.050 A
		5 A @ 1.6 Irated	0.005 A to 8.000 A	0.250 A
Definite-T 1				
_:421:1	Definite-T 1:Mode		<ul style="list-style-type: none"> • off • on • test 	off
_:421:2	Definite-T 1:Operate & flt.rec. blocked		<ul style="list-style-type: none"> • no • yes 	no
_:421:3	Definite-T 1:Threshold		0.300 V to 175.000 V	85.000 V
_:421:4	Definite-T 1:Dropout ratio		1.01 to 1.20	1.04
_:421:6	Definite-T 1:Operate delay		0.00 s to 300.00 s	1.47 s
Definite-T 2				
_:422:1	Definite-T 2:Mode		<ul style="list-style-type: none"> • off • on • test 	off
_:422:2	Definite-T 2:Operate & flt.rec. blocked		<ul style="list-style-type: none"> • no • yes 	no
_:422:3	Definite-T 2:Threshold		0.300 V to 175.000 V	30.000 V
_:422:4	Definite-T 2:Dropout ratio		1.01 to 1.20	1.04
_:422:6	Definite-T 2:Operate delay		0.00 s to 300.00 s	0.17 s

6.57.5 Information List

No.	Information	Data Class (Type)	Type
General			
_:2311:500	General:>Current flow-criterion	SPS	I
_:2311:501	General:>DDI Open	SPS	I
_:2311:300	General:Current crit. fulf.	SPS	O

No.	Information	Data Class (Type)	Type
_:2311:52	General:Behavior	ENS	O
_:2311:53	General:Health	ENS	O
Group indicat.			
_:4501:55	Group indicat.:Pickup	ACD	O
_:4501:57	Group indicat.:Operate	ACT	O
_:4501:52	Group indicat.:Behavior	ENS	O
_:4501:53	Group indicat.:Health	ENS	O
Definite-T 1			
_:421:81	Definite-T 1:>Block stage	SPS	I
_:421:51	Definite-T 1:Mode (controllable)	ENC	C
_:421:54	Definite-T 1:Inactive	SPS	O
_:421:52	Definite-T 1:Behavior	ENS	O
_:421:53	Definite-T 1:Health	ENS	O
_:421:55	Definite-T 1:Pickup	ACD	O
_:421:300	Definite-T 1:Pickup loop AB	SPS	O
_:421:301	Definite-T 1:Pickup loop BC	SPS	O
_:421:302	Definite-T 1:Pickup loop CA	SPS	O
_:421:56	Definite-T 1:Operate delay expired	ACT	O
_:421:57	Definite-T 1:Operate	ACT	O
Definite-T 2			
_:422:81	Definite-T 2:>Block stage	SPS	I
_:422:51	Definite-T 2:Mode (controllable)	ENC	C
_:422:54	Definite-T 2:Inactive	SPS	O
_:422:52	Definite-T 2:Behavior	ENS	O
_:422:53	Definite-T 2:Health	ENS	O
_:422:55	Definite-T 2:Pickup	ACD	O
_:422:300	Definite-T 2:Pickup loop AB	SPS	O
_:422:301	Definite-T 2:Pickup loop BC	SPS	O
_:422:302	Definite-T 2:Pickup loop CA	SPS	O
_:422:56	Definite-T 2:Operate delay expired	ACT	O
_:422:57	Definite-T 2:Operate	ACT	O

6.58 PI Trip Logic (CEI 0-16 Standard) in FG Circuit Breaker

6.58.1 Description

The function block **PI trip** is located in the function group **Circuit breaker** for 3-pole tripping to realize the PI trip logic. After instantiation of the function block **PI trip**, a new column **PI Trip** is available in the Editor **Circuit-breaker interaction**, as shown in the following figure.

Circuit breaker 1		
	Trip logic	PI Trip
Protection group	Trip	PI Trip
(All) ▼	(All) ▼	(All) ▼
▼ 27 Undervolt. CEI 1	X	X
Definite-T 1	X	X
Definite-T 2	X	X
▼ 59 Overvolt. CEI 1	X	X
DefT-CEI 1	X	X
Definite-T 1	X	X
▼ 81 Freq.prot. CEI 1	X	X
59 V0 CEI 1	X	X
OverF.S1 CEI 1	X	X
OverF.S2 CEI 1	X	X
Und.F.S1 CEI 1	X	X
Und.F.S2 CEI 1	X	X

[sc_CBinteraction_CEI_1_en_US]

Figure 6-369 Column **PI Trip** in the Editor **Circuit-breaker interaction**

The PI protection functions according to the CEI 0-16 standard are prerouted to the PI trip. If you want to use the PI trip logic for other protection functions, you can manually route them in the Editor **Circuit-breaker interaction**.

The PI trip logic issues the signal *PI trip*, which is a normal close signal.

Logic

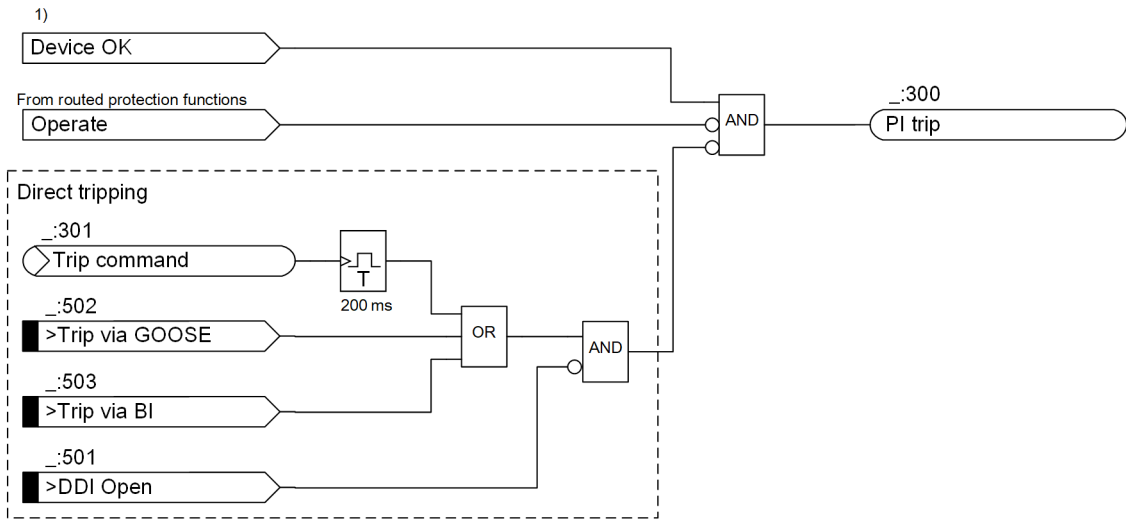

[lo_PI_Trip, 1, en_US]

Figure 6-370 Logic Diagram of the PI Trip

(1) The protection device is running normally.

Direct Tripping

In the CEI 0-16 standard, the direct tripping is possible in the following ways:

- Tripping via a communication command (signal *Trip command*)
 The signal *Trip command* becomes inactive after a short delay of 200 ms.
- Tripping via a GOOSE message (signal *>Trip via GOOSE*) using IEC 61850
- Tripping via a binary-input signal (signal *>Trip via BI*)

All the preceding signals can be blocked by the binary-input signal *>DDI Open*.

Issue of the Signal *PI trip*

The signal *PI trip* is issued when the following conditions are met:

- The protection device is running normally (in the process mode or simulation mode).
- No protection function that is routed to the PI trip operates.
- The direct tripping logic is not fulfilled.

6.58.2 Information List

No.	Information	Data Class (Type)	Type
PI Trip			
._:501	PI Trip:>DDI Open	SPS	I
._:502	PI Trip:>Trip via GOOSE	SPS	I
._:503	PI Trip:>Trip via BI	SPS	I
._:301	PI Trip:Trip command	SPC	C
._:300	PI Trip:PI trip	SPS	O

7 Motor-Protection Functions

7.1	Motor-Starting Time Supervision	1086
7.2	Motor Restart Inhibit	1096
7.3	Load-Jam Protection Motor	1108
7.4	Thermal Overload Protection, Rotor	1114

7.1 Motor-Starting Time Supervision

7.1.1 Overview of Functions

The **Motor-starting time supervision** (ANSI 48) function protects motors against too long starting operations thus supplementing the **Thermal overload protection rotor** described in chapter [7.4.1 Overview of Functions](#). In particular, rotor-critical high-voltage motors can exceed their thermal limits quickly, when multiple starting attempts occur in a short period.

Followed are examples which can prolong the duration of starting attempts:

- Excessive voltage surges during motor starting
- Excessive load moments
- Locked-rotor states

If the durations of starting attempts are prolonged to a degree which can damage the motor, the function initiates an operate signal.

7.1.2 Structure of the Function

The **Motor-starting time supervision** function is used in the protection-function group **Motor**.

The **Motor-starting time supervision** function is pre-configured with 1 inverse-time characteristic curve stage. The function can operate a maximum of 1 inverse-time characteristic curve stage and 2 user-defined characteristic curve stages simultaneously.

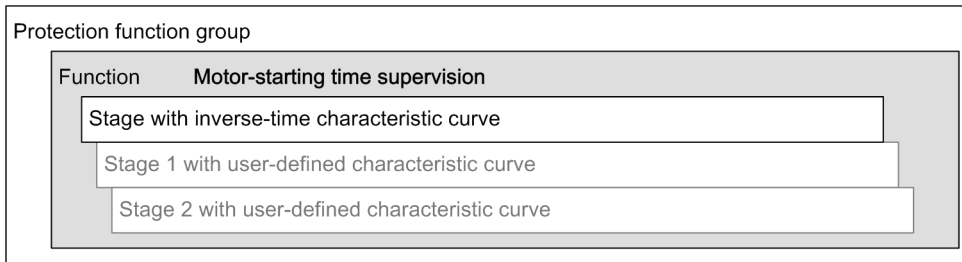

[dw_structure_02_1_en_US]

Figure 7-1 Structure/Embedding of the Function

7.1.3 Stage with Inverse-Time Characteristic Curve

7.1.3.1 Description

Logic of the Stage

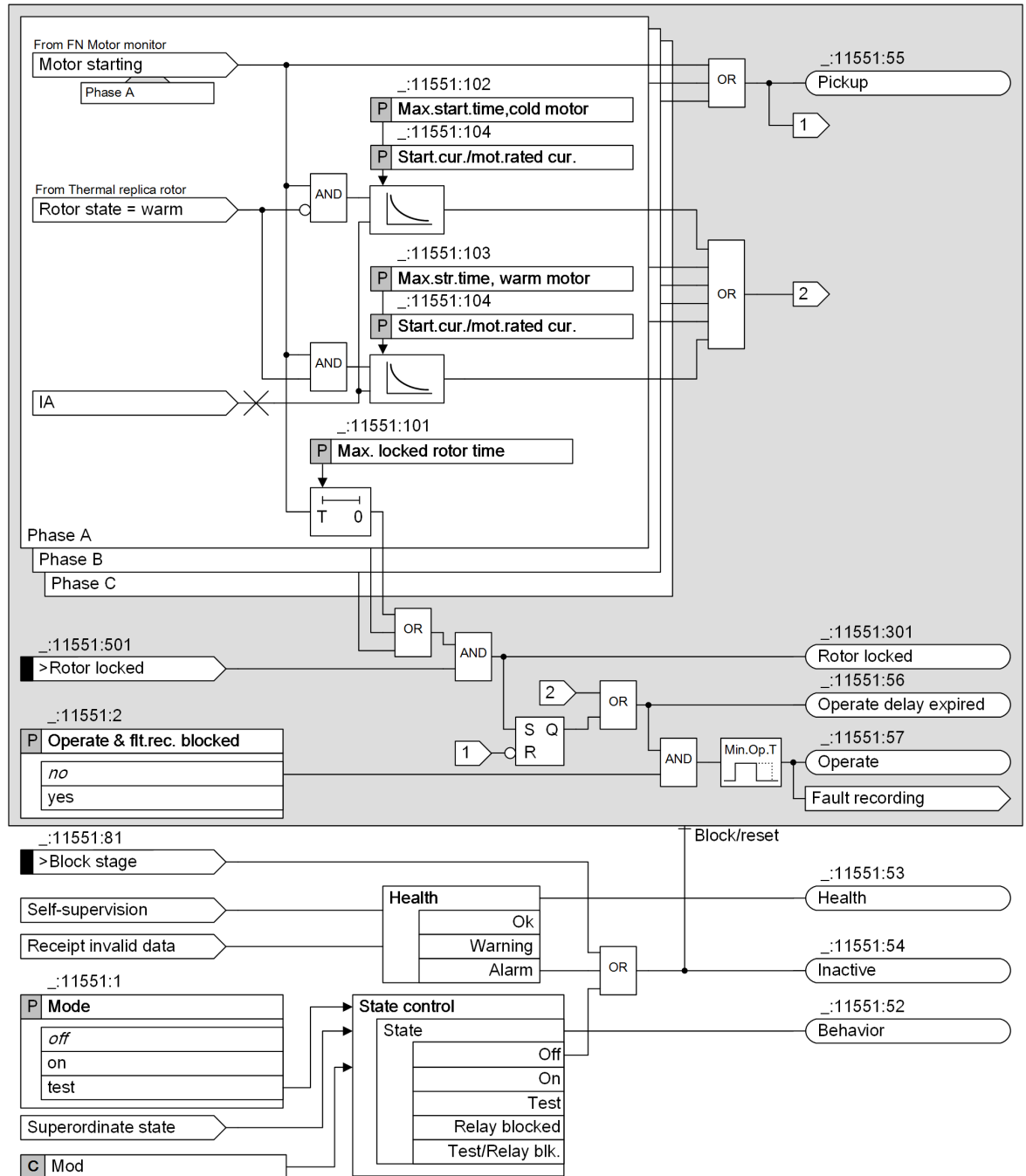

[to_mot_inv, 4, en_US]

Figure 7-2 Logic Diagram of Motor-Starting Time Supervision with Inverse-Time Characteristic Curve

Characteristic Curve Types

The stage consists of 1 thermal characteristic curve and 1 definite-time characteristic curve (**Locked-Rotor Time**). The thermal characteristic curve differentiates between cold rotor state and warm rotor state.

Measurand

The calculated fundamental components of phase-current values are used as measurands.

Motor Starting, Pickup, Fault Recording, and Dropout Behavior

The device-internal signal **Motor starting** is detected in the **Motor monitor** function (for further description, see chapter 5.4.5.1 *Overview of Functions*).

The signal starting initiates the **Motor-starting time supervision** function phase-selectively. The stage picks up and all timers are started.

The pickup of the function does not trigger the general pickup, fault recording, or fault logging, as motor starting is a normal operation. Fault recording and fault logging are started with the operate signal.

If the signal **Motor starting** becomes inactive, the stage drops out immediately with all indications dropping out. Fault recording and fault logging are terminated.

Thermal Characteristic Curve

The thermal characteristic curve operates when the rotor is not locked. You can calculate the appropriate operate time using following formula. The thermal characteristic curve includes 2 curves with different rated starting times. The 2 curves are applied for cold rotor state and warm rotor state respectively (see *Figure 7-3*).

$$t_{operate} = \left(\frac{I_{starting,param.}}{I} \right)^2 \cdot T_{starting,param.}$$

[fo_ope_star_parameter, 1, en_US]

With

- $t_{operate}$ Operate time at current flow I
- $I_{starting,param.}$ Per-unit value of rated starting current of the motor with motor rated current as reference (parameter **Start.cur./mot.rated cur.**)
- I Measured-value current in per unit with motor rated current as reference
- $T_{starting,param.}$ Operate time at rated starting current $I_{starting,param.}$ (parameter **Max.start.time,cold motor** or **Max.str.time, warm motor**).

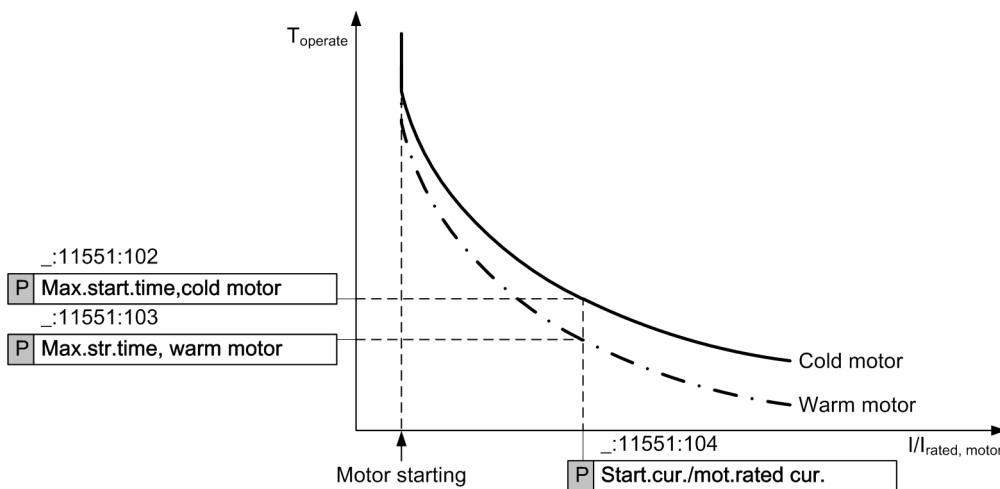

[ldw_therms_03, 1, en_US]

Figure 7-3 Thermal Characteristic Curve with Starting Current

Definite-Time Characteristic (Locked-Rotor Time)

A locked rotor leads to a loss of ventilation, and therefore to a reduced thermal rating of the motor. If the rotor is locked, the **Motor-starting time supervision** is able to operate faster.

If the rotor is locked and if motor-starting time exceeds the maximum allowable locked-rotor time **Max. locked rotor time**, the stage operates.

The stage can detect a locked-rotor state via a binary input `>Rotor Locked`. An external speed monitor provides the binary input.

Integral Method

The function uses the time integral of the measured current. This integral represents the current-time area based on the actual current flowing during motor starting. The measurement is done per phase.

The result of the integration is compared with a calculated threshold value. The calculated threshold value is derived from the current-time area below the characteristic curve corresponding to the actual current.

If the result of integration exceeds the calculated threshold value, the stage operates.

Cold and Warm Rotor States, Switching of Starting Times of the Thermal Characteristic Curve

The device-internal signal **Rotor state** indicates whether the motor is in cold or warm rotor state. The signal is detected in **Thermal replica rotor** function block (for detailed description, see chapter [5.4.6.1 Overview of Functions](#)).

The motor manufacturer provides motor-starting time characteristic curves for both cold and warm rotor states (see [Figure 7-3](#)). The stage can automatically perform a switching of the thermal characteristic curve by the signal **Rotor state**. If the signal **Rotor state** indicates a switching from cold rotor state to warm rotor state, or in opposite direction, the thermal characteristic curve changes accordingly.

The switching of the thermal characteristic curve does not reset the integral result. The integral method proceeds continually when the rotor state changes.

7.1.3.2 Application and Setting Notes

Parameter: `Max.start.time, cold motor`; `Max.str.time, warm motor`; `Start.cur./mot.rated cur.`

- Default setting (`_:11551:102`) `Max.start.time, cold motor = 10.0 s`
- Default setting (`_:11551:103`) `Max.str.time, warm motor = 10.0 s`
- Default setting (`_:11551:104`) `Start.cur./mot.rated cur. = 4.90`

Use the 3 parameters to define the thermal characteristic curve. The `Max.start.time, cold motor` parameter defines the rated starting time for the cold rotor state. The `Max.str.time, warm motor` parameter defines the rated starting time for the warm rotor state. The `Start.cur./mot.rated cur.` parameter defines the rated starting-current values under normal operation. The parameter `Start.cur./mot.rated cur.` is given in per unit with the motor rated current as reference.

For setting the function correctly, technical data from the motor is required. The technical data is usually provided in the technical data sheet of the motor manufacturer. Please refer to the following example.

EXAMPLE

The following data and diagrams are excerpted from the technical data sheet of a 2 MV 3-phase induction motor with squirrel cage rotor, relevant for determining the function settings.

The motor rated current is given as a value in the data sheet:

Motor rated current $I_{\text{rated,motor}} = 430 \text{ A}$

The starting current is obtained from the starting-data diagram, which shows the starting current in dependency to the motor speed:

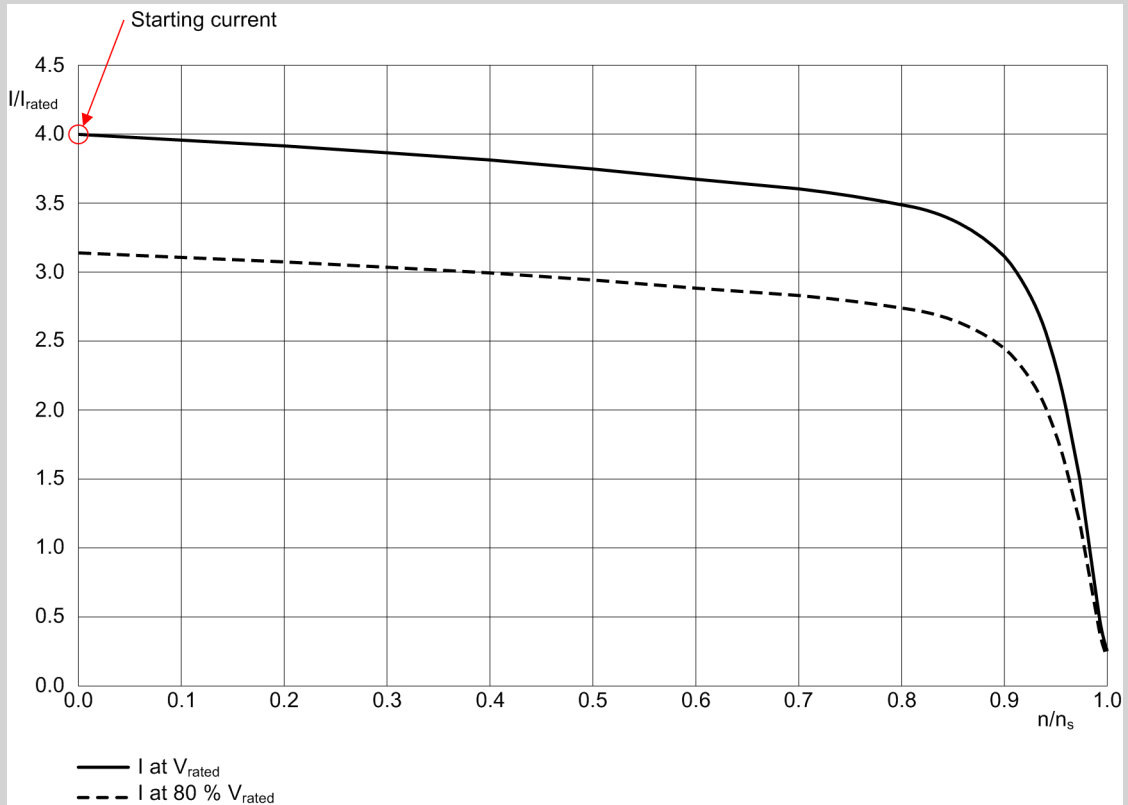

[dlw_start_03_1_en_US]

Figure 7-4 Starting-Data Diagram

Starting current $I_{starting} = 4 * I_{rated,motor}$

As the starting current is given in per unit of the motor rated current, the parameter **Start.cur./mot.rated cur.** can be set directly:

Start.cur./mot.rated cur. = 4

The motor-starting time is given as a value in the data sheet:

Starting time at V_{rated} 44.0 s

Starting time at 80 % V_{rated} 77.0 s

If the rotor is locked while trying to start the motor, the locked-rotor time defines the maximum allowed time that will not cause thermally damage of the motor. This time is either a given data-sheet value or obtained from the thermal-limit curve, as shown in the following:

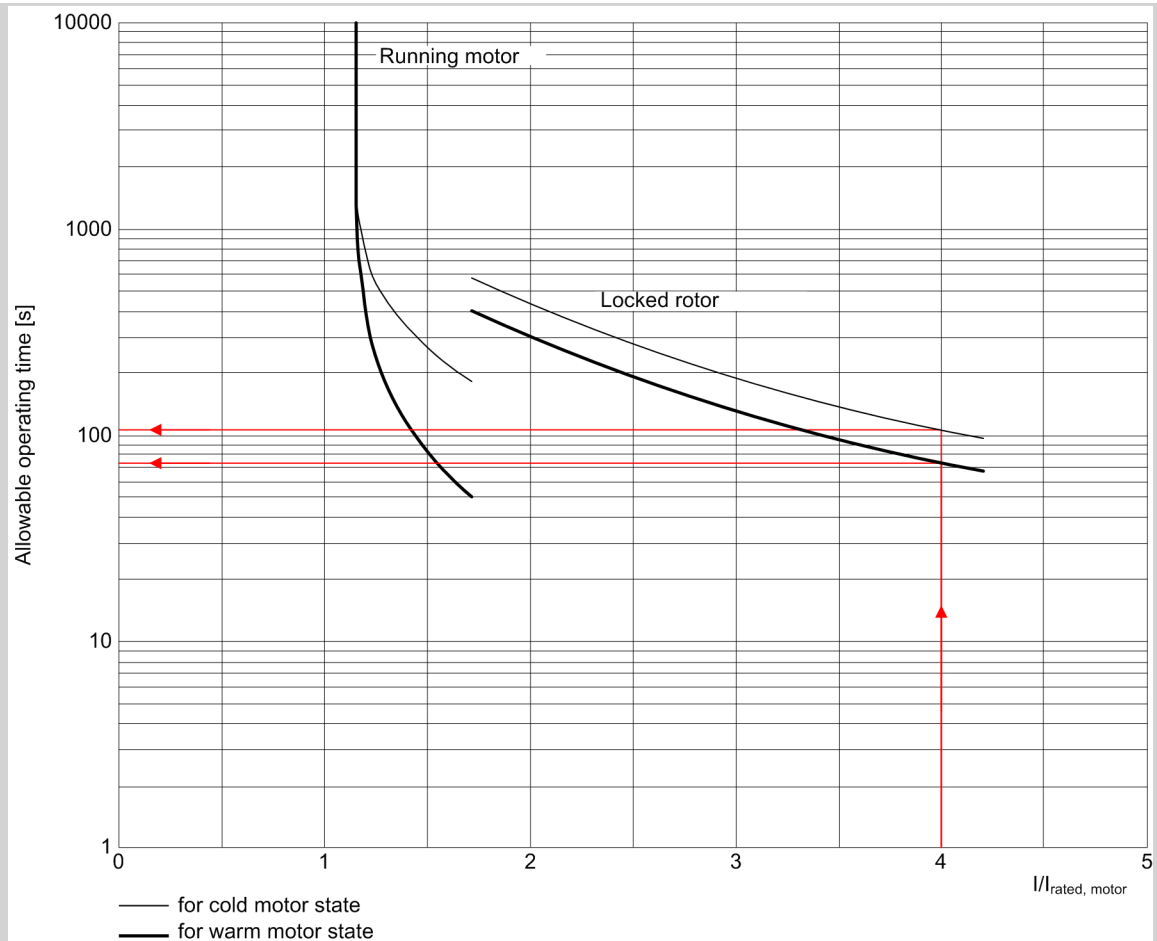

[dw_thermi_1_en_US]

Figure 7-5 Thermal-Limit Curve

Locked-rotor time (thermal limit), cold motor	110 s
Locked-rotor time (thermal limit), warm motor	75 s

Siemens recommends the following consideration for the parameters **Max.str.time, warm motor** and **Max.start.time, cold motor**:

The given starting time (44 s) has to be compared to the locked-rotor time for a warm start (75 s). Due to an adequate safety margin between 44 s and 75 s, select a setting a bit below the locked-rotor time, for example, 70 s.

Max.str.time, warm motor = 70 s

For the motor in the example (with a starting time of 44 s and a locked-rotor time of 75 s for the warm motor), a differentiation between cold motor and warm motor is not required. Therefore the parameter **Max.start.time, cold motor** is set to the same value:

Max.start.time, cold motor = 70 s

If the locked-rotor time for the warm motor is lower and in the range of the starting time, a differentiation between cold motor and warm motor should take place.

Also for a reduced primary voltage, for example, 80 % of V_{rated} , the starting time is usually given in the data sheet:

Starting time at 80 % V_{rated}	77.0 s
-----------------------------------	--------

The starting time in this case is longer than the time for rated voltage. For a reduced voltage, the starting current is also reduced almost linearly. The inverse thermal characteristic curve adapts very well to such

starting conditions with reduced voltage. As a consequence, no specific configuration measures are required for a reduced primary voltage.

Parameter: Max. locked rotor time

- Default setting (_:11551:101) **Max. locked rotor time = 2.0 s**

Usually the locked-rotor time is longer than the starting time (also refer to the preceding example). Therefore the **Max. locked rotor time** parameter is normally not required. The default can be kept, since the setting only becomes active when using the associated binary input signal.

The parameter can be used for special locked-rotor state. If short operate times (shorter than the starting time) are required for a locked-rotor state, use the parameter. In this case, the locked-rotor state must be detected by an external device (for example, a tacho-generator) and signaled to the device with the binary input signal *>Rotor locked*.

7.1.3.3 Settings

Addr.	Parameter	C	Setting Options	Default Setting
Inverse-T 1				
_:11551:1	Inverse-T 1:Mode		<ul style="list-style-type: none"> • off • on • test 	off
_:11551:2	Inverse-T 1:Operate & flt.rec. blocked		<ul style="list-style-type: none"> • no • yes 	no
_:11551:101	Inverse-T 1:Max. locked rotor time		0.5 s to 180.0 s	2.0 s
_:11551:104	Inverse-T 1:Start.cur./mot.rated cur.		1.00 I/IrObj to 20.00 I/IrObj	4.90 I/IrObj
_:11551:102	Inverse-T 1:Max.start.time,cold motor		1.0 s to 180.0 s	10.0 s
_:11551:103	Inverse-T 1:Max.str.time,warm motor		0.5 s to 180.0 s	10.0 s

7.1.3.4 Information List

No.	Information	Data Class (Type)	Type
Group indicat.			
_:4501:55	Group indicat.:Pickup	ACD	O
_:4501:57	Group indicat.:Operate	ACT	O
_:4501:52	Group indicat.:Behavior	ENS	O
_:4501:53	Group indicat.:Health	ENS	O
Inverse-T 1			
_:11551:81	Inverse-T 1:>Block stage	SPS	I
_:11551:501	Inverse-T 1:>Rotor locked	SPS	I
_:11551:51	Inverse-T 1:Mode (controllable)	ENC	C
_:11551:54	Inverse-T 1:Inactive	SPS	O
_:11551:52	Inverse-T 1:Behavior	ENS	O
_:11551:53	Inverse-T 1:Health	ENS	O
_:11551:301	Inverse-T 1:Rotor locked	SPS	O
_:11551:55	Inverse-T 1:Pickup	ACD	O

No.	Information	Data Class (Type)	Type
_:11551:57	Inverse-T 1:Operate	ACT	O
_:11551:56	Inverse-T 1:Operate delay expired	ACT	O

7.1.4 Stage with User-Defined Characteristic Curve

7.1.4.1 Description

The stage has the same structure as the stage with inverse-time characteristic curve (see chapter [7.1.3.1 Description](#)), except the following differences:

- You can define the characteristic curve as desired.
- The cold rotor state and warm rotor state have no influence on the stage.

Logic of the Stage

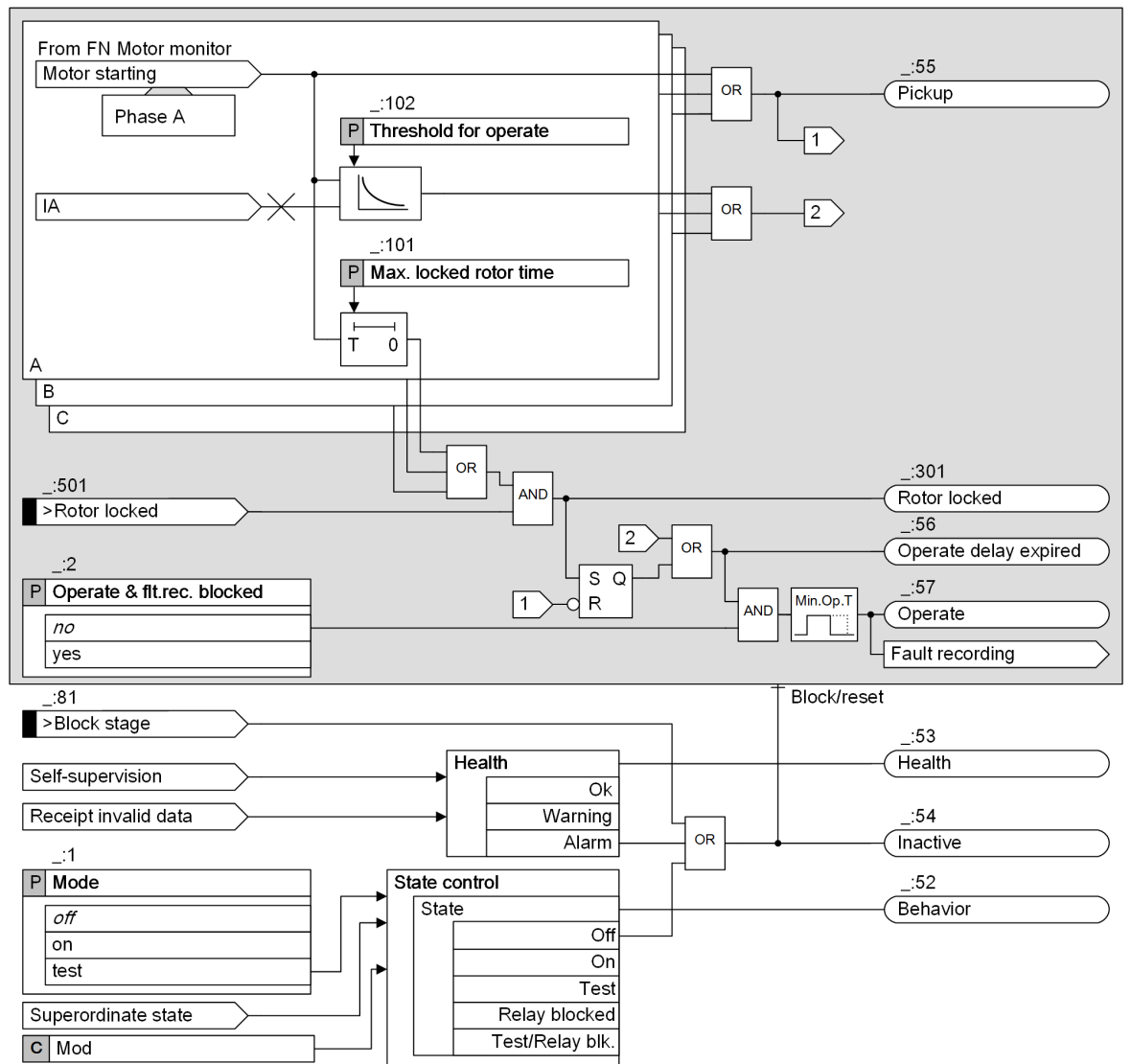

[to_mot_use, 3, en_US]

Figure 7-6 Logic Diagram of Motor-Starting Time Supervision with User-Defined Characteristic Curve

User-Defined Characteristic Curve

You can define the characteristic curve point by point using up to 30 current/time value pairs. The algorithm uses linear interpolation to calculate the characteristic from these values.

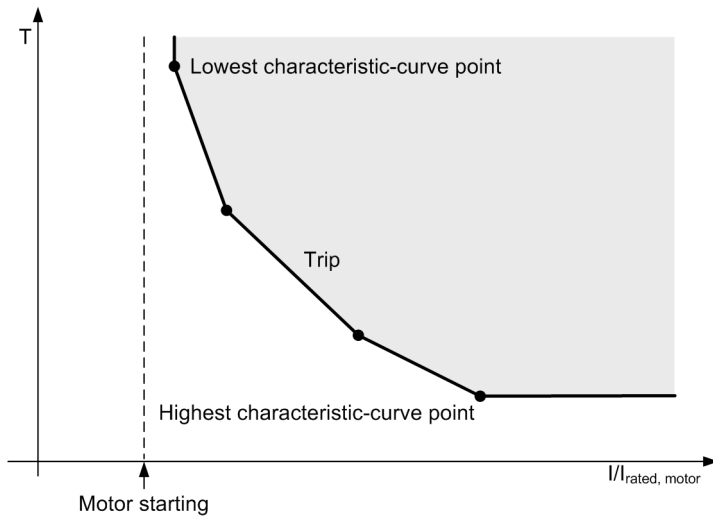

[dw_therms_1_en_US]

Figure 7-7 Example of User-Defined Characteristic Curve



NOTE

Currents that are lower than the current value of the smallest characteristic-curve extend the operate time to infinite.

Currents that are larger than the current value of the largest characteristic-curve point do not reduce the operate time. The pickup characteristic runs in parallel to the current axis from the largest characteristic-curve point.

Motor Starting, Pickup, Fault Recording, and Dropout Behavior

The device-internal signal **Motor starting** is detected in the **Motor monitor** function (for further description, see chapter [5.4.5.1 Overview of Functions](#)).

The signal **Motor starting** initiates the **Motor-starting time supervision** function phase-selectively. The stage picks up and all timers are started.

The pickup of the function does not trigger the general pickup, fault recording, or fault logging, as motor starting is a normal operation. Fault recording and fault logging are started with the operate signal.

If the signal **Motor starting** becomes inactive, the stage drops out immediately with all indications dropping out. Fault recording and fault logging are terminated.

7.1.4.2 Application and Setting Notes

The section only provides application and setting notes for the parameters which define the characteristic curve. For other parameters of the stage, see section [7.1.3.2 Application and Setting Notes](#).

Parameter: Current/time value pairs (of the Operate Curve)

Use **Current/time value pairs** parameter to define the course of the characteristic curve. Set a current/time value pair for each characteristic-curve point. The parameter depends on the characteristic you want to realize.

Set the current value in per-unit value with motor rated current as reference. Set the time value in seconds.



NOTE

Enter the values in continuous order.

7.1.4.3 Settings

Addr.	Parameter	C	Setting Options	Default Setting
General				
_:1	User curve #:Mode		<ul style="list-style-type: none"> • off • on • test 	off
_:2	User curve #:Operate & flt.rec. blocked		<ul style="list-style-type: none"> • no • yes 	no
_:101	User curve #:Max. locked rotor time		0.5 s to 180.0 s	2.0 s

7.1.4.4 Information List

No.	Information	Data Class (Type)	Type
User curve #			
_:81	User curve #:>Block stage	SPS	I
_:501	User curve #:>Rotor locked	SPS	I
_:51	User curve #:Mode (controllable)	ENC	C
_:54	User curve #:Inactive	SPS	O
_:52	User curve #:Behavior	ENS	O
_:53	User curve #:Health	ENS	O
_:301	User curve #:Rotor locked	SPS	O
_:55	User curve #:Pickup	ACD	O
_:57	User curve #:Operate	ACT	O
_:56	User curve #:Operate delay expired	ACT	O

7.2 Motor Restart Inhibit

7.2.1 Overview of Functions

The **Motor restart inhibit (ANSI 66)** function:

- Prevents from restarting the motor if the rotor of the motor would exceed the permissible thermal limit due to the start (**Thermal stage**)
- Prevents from multiple starts and stops in a short time interval (**Counter stage**)
- Ensures that a certain amount of time passes between stop and restart of the motor (**Timer stage**)

7.2.2 Structure of the Function

The **Motor restart inhibit** function can be used in specific protection function groups. The **Motor restart inhibit** function is preconfigured by the manufacturer with 1 **Thermal stage** (see [Figure 7-8](#)).

1 **Thermal stage**, 1 **Counter stage** as well as 1 **Timer stage** can operate simultaneously within this function.

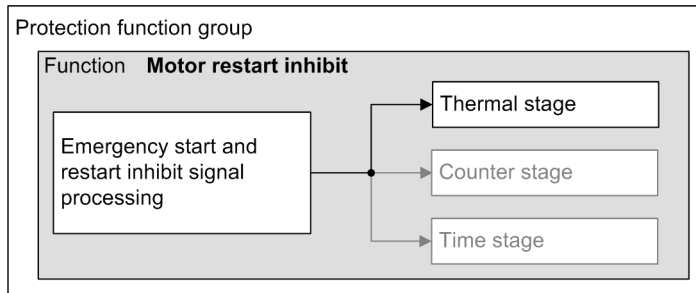

[dw_morein, 1, en_US]

Figure 7-8 Structure/Embedding of the Function

Mode of Operation

The rotor temperature of a motor generally remains well below the maximum permissible temperature during normal operation and also under increased load conditions. However, high starting currents, required during motor start, increase the risk of the rotor being thermally damaged rather than the stator, due to the short thermal constant of the rotor. To avoid that multiple starting attempts provoke tripping of the circuit breaker during motor start, a restart of the motor must be inhibited, if it is apparent that the thermal limit of the rotor will be exceeded during this starting attempt.

7.2.3 Thermal Stage

7.2.3.1 Description

Logic of the Stage

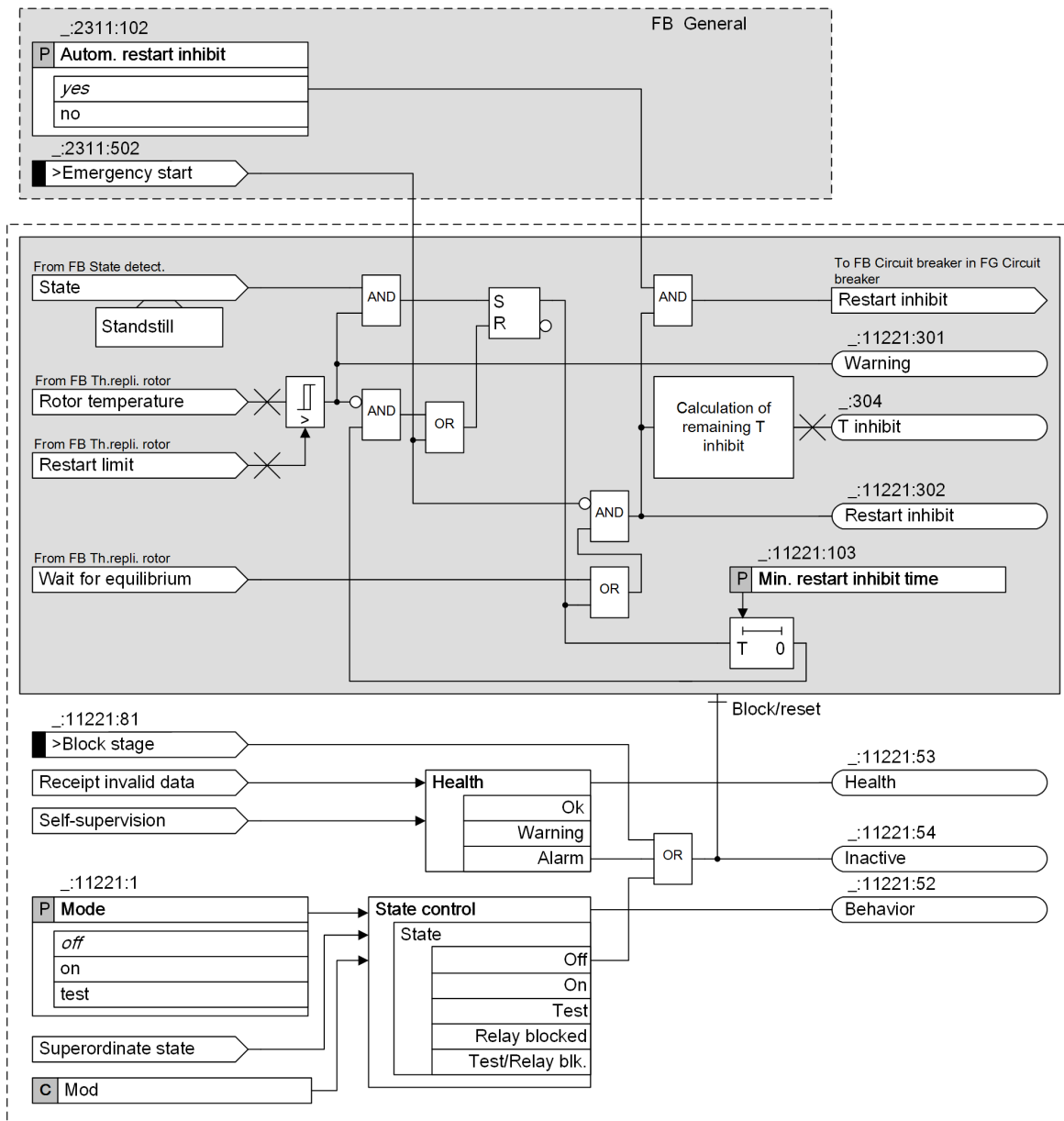

[to_mo_ther, 2, en_US]

Figure 7-9 Logic Diagram of the Thermal Stage

Rotor-Temperature Curve and Relevant Information during Repeated Motor-Starting Attempts

Figure 7-10 shows, as an example, the rotor heating processes, the thermal replica, currents, motor state, and function-block signals during repeated motor-starting attempts (3 starts from cold operating condition).

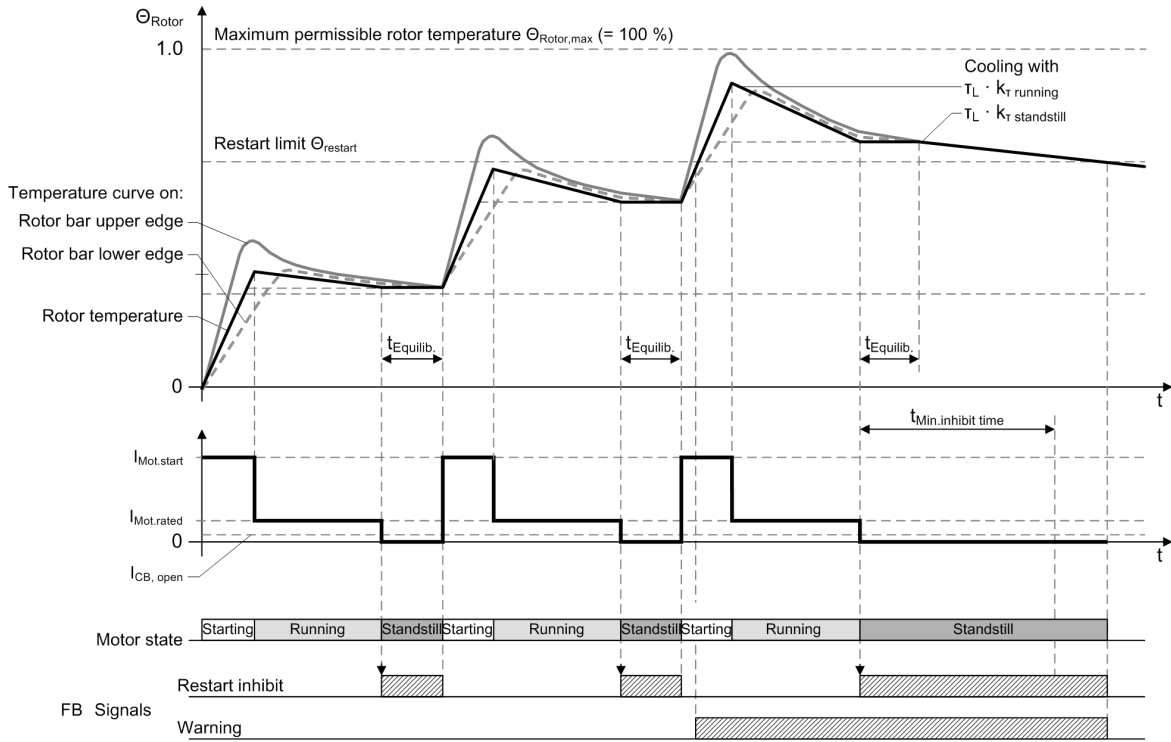

[dsw_prrelo_1_en_US]

Figure 7-10 Rotor-Temperature Curve and Repeated Motor-Starting Attempts

Restart Limit, Rotor Temperature Θ

The restart limit and rotor temperature Θ are calculated and obtained from the function block **Thermal replica rotor**.

For more information, refer to chapter [5.4.6.1 Overview of Functions](#).

Restart Inhibit, Minimum Restart-Inhibit Time

The signal *Restart inhibit* is used to prevent the motor from a further start. Under the following conditions, the signal *Restart inhibit* is issued:

- The motor state changes to *Standstill* and the rotor temperature Θ exceeds the restart limit.
- During the equilibrium time (refer to the following section).

When the rotor temperature Θ exceeds the restart limit and the motor state changes to *Standstill*, the minimum restart-inhibit time (parameter **Min. restart inhibit time**) is started. This time ensures a minimum standstill time of the motor independent of the thermal replica.

If the rotor temperature Θ falls below the restart limit and if the minimum restart-inhibit time has expired, the signal *Restart inhibit* drops out.



NOTE

Unlike the operate signal, the signal *Restart inhibit* does not trigger fault logging or fault recording.

Equilibrium Time

The equilibrium time takes into account the different thermal conditions of the motor parts at the moment of a shutdown. During equilibrium time (represented by the input signal *wait for equilibrium*), the signal *Restart inhibit* is issued and the motor cannot be restarted.

For further information about equilibrium time, see chapter [5.4.6.1 Overview of Functions](#).

Total Restart-Inhibit Time, Remaining Restart-Inhibit Time

The total restart-inhibit time $T_{inhibit,total}$ depends on the following times:

- Equilibrium time $T_{Equil.}$ and thermal cooling time $T_{Therm.}$ (both are obtained from the function block **Thermal replica rotor**).
If the rotor temperature Θ exceeds the restart limit and the motor state changes to *standstill*, the thermal cooling time $T_{Therm.}$ forecasts the time since the rotor temperature Θ starts to decrease until it falls below the restart limit.
For more information, see chapter [5.4.6.1 Overview of Functions](#).
- Minimum restart-inhibit time $T_{Min.inhibit\ time}$ (parameter **Min. restart inhibit time**).

The total restart-inhibit time can also be interpreted as the total waiting time until a further motor restart is possible. The total restart-inhibit time is calculated as follows:

$T_{inhibit,total} = T_{Equil.} + T_{Therm.}$	for rotor temperature $\Theta >$ restart limit, and $T_{Equil.} + T_{Therm.} > T_{Min.inhibit\ time}$
$T_{inhibit,total} = T_{Min.inhibit}$	for rotor temperature $\Theta >$ restart limit, and $T_{Equil.} + T_{Therm.} < T_{Min.inhibit\ time}$
$T_{inhibit,total} = T_{Equil.}$	for rotor temperature $\Theta <$ restart limit

The remaining restart-inhibit time $\tau_{inhibit}$ is available for the user as function value. This is the waiting time until the issued signal *Restart inhibit* drops off.

Processing the Restart Inhibit Signal

The signal *Restart inhibit* is routed to the function block **Circuit breaker** contained in the function group **Circuit breaker**. Once the signal *Restart inhibit* becomes active, the function block **Circuit breaker** issues the *Trip/open cmd.* signal and therefore inhibits the closing of the circuit breaker. Furthermore the signal *Close command* is blocked (see [Figure 7-11](#)).

With means of the parameter **Autom. restart inhibit**, the automatic processing of the *Restart inhibit* signal to the circuit breaker can be disconnected (see [Figure 7-9](#)). This provides the option to connect the *Restart inhibit* signal to a different switch than the circuit breaker.

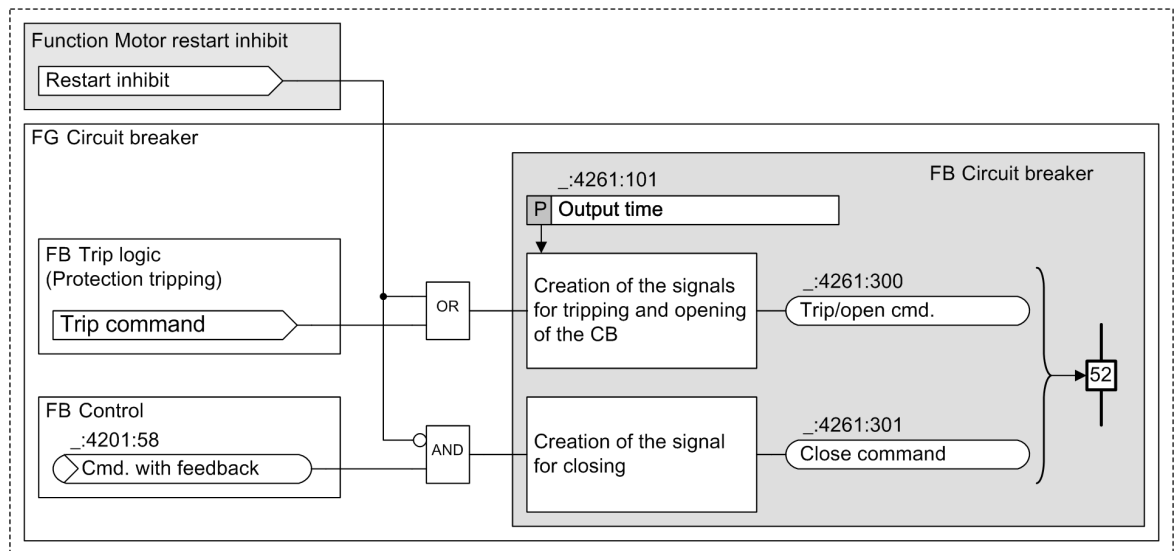

[dw_presi,]_en_US]

Figure 7-11 Processing the Restart Inhibit Signal

Emergency Start

The signal *>Emergency start* of the function block **General** immediately resets the output signal *Restart inhibit* as well as the internal timer. The signal *>Emergency start* works across all stages in the **Motor restart inhibit** function.

7.2.3.2 Application and Setting Notes

Parameters for the Thermal Replica of the Rotor

All parameters related to the thermal replica of the rotor are set in the function block **Thermal replica rotor**. For the application and setting notes and an example, refer to chapter [5.4.6.1 Overview of Functions](#).

Parameter: **Min. restart inhibit time**

- Default setting (`_:11221:103`) **Min. restart inhibit time = 6.0 min**

The **Min. restart inhibit time** parameter defines the minimum duration for the restart-inhibit time. Regardless of thermal replicas, some motor manufacturers require a minimum restart-inhibit time after the maximum number of permissible starting attempts has been exceeded. If available, the value must be taken from the technical data of the motor. In any case, the value should be selected higher than the parameter **Equilibrium time**. If the value is not available from the technical data of the motor, a value can be selected that reflects the thermal cooling time T_{Therm} of the thermal replica (refer to the example given in the description of the function block **Thermal replica rotor** of the function group **Motor**).

Parameter: **Autom. restart inhibit**

- Default setting (`_:2311:102`) **Autom. restart inhibit = yes**

Usually all functions of the **Motor** function group are connected to a circuit breaker. The operate signals of the protection functions and the *Restart inhibit* signal of the **Motor restart inhibit** function are processed automatically. In specific applications, the **Motor restart inhibit** function should inhibit the closing of a different switch rather than the circuit breaker. With means of the parameter **Autom. restart inhibit**, the automatic processing of the signal to the circuit breaker can be disconnected. For further processing, the signal *Restart inhibit* can be routed directly to any binary output.

Signal: *>Emergency Start*

If, for operational or emergency reasons, motor starting that will exceed the maximum permissible rotor temperature, must take place, the motor *Restart inhibit* signal can be terminated via the signal *>Emergency start*, thus allowing a new starting attempt. The thermal rotor profile, however, continues to function and the maximum permissible rotor temperature is exceeded. No motor shutdown is initiated by the **Motor restart inhibit** function, but the calculated overtemperature of the rotor can be observed for risk assessment.

7.2.3.3 Settings

Addr.	Parameter	C	Setting Options	Default Setting
General				
_:2311:102	General:Autom. restart inhibit		<ul style="list-style-type: none"> • no • yes 	yes
Thermal stage				
_:11221:1	Thermal stage:Mode		<ul style="list-style-type: none"> • off • on • test 	off
_:11221:103	Thermal stage:Min. restart inhibit time		0.2 min to 500.0 min	6.0 min

7.2.3.4 Information List

No.	Information	Data Class (Type)	Type
General			
_:2311:502	General:>Emergency start	SPS	I
_:2311:52	General:Behavior	ENS	O
_:2311:53	General:Health	ENS	O
Thermal stage			
_:11221:81	Thermal stage:>Block stage	SPS	I
_:11221:53	Thermal stage:Health	ENS	O
_:11221:54	Thermal stage:Inactive	SPS	O
_:11221:52	Thermal stage:Behavior	ENS	O
_:11221:302	Thermal stage:Restart inhibit	SPS	O
_:11221:301	Thermal stage:Warning	SPS	O
_:11221:304	Thermal stage:T inhibit	INS	O

7.2.4 Counter Stage

7.2.4.1 Description

Logic of the Stage

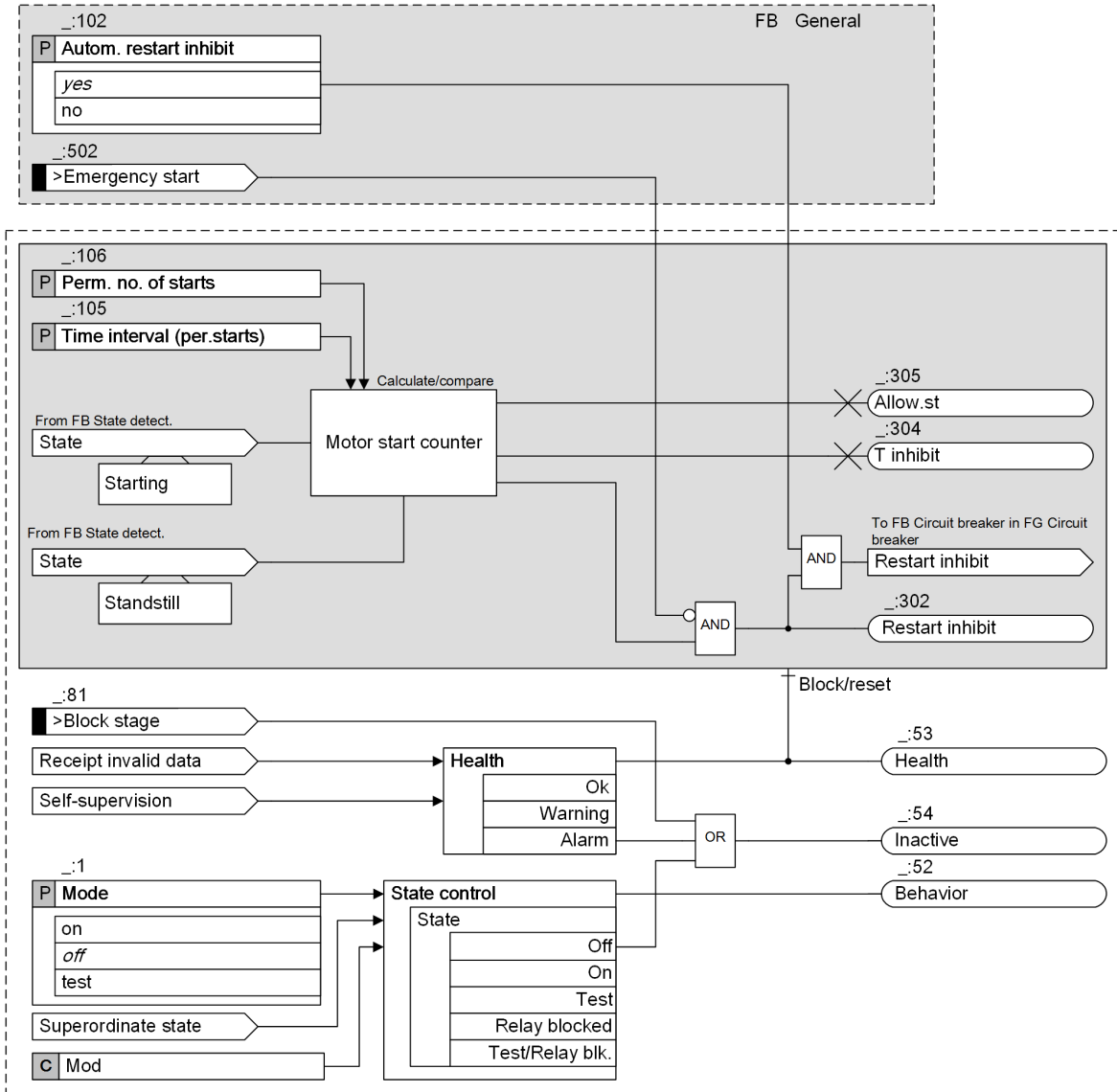

[lo_mocoun_3_en_US]

Figure 7-12 Logic Diagram of the Counter Stage

Restart Inhibit

The signal *Restart inhibit* is used to prevent the motor from a further start. Once the maximum permissible number of starts (parameter **Perm. no. of starts**) within a set time interval (parameter **Time interval (per.starts)**) is reached and the motor state changes to *Standstill*, the *Restart inhibit* signal becomes active.



NOTE

Unlike the operate signal, the signal *Restart inhibit* does not trigger fault logging or fault recording.

Processing the Restart Inhibit Signal

For more information, see the related description in chapter [7.2.3.1 Description](#).

Allowed Starts, Remaining Restart-Inhibit Time

The following function values are available:

- Number of currently allowed starts (value *Allow.st*)
- Remaining restart-inhibit time (value *T inhibit*). This is the waiting time until the issued signal *Restart inhibit* drops off. As long as further restarts are allowed, this value equals 0.

Emergency Start

The *>Emergency start* signal of the function block **General** immediately resets the output signal *Restart inhibit*. However, it does not reset the counter. That is, if the motor is switched off again and the restart inhibit conditions are still fulfilled, the signal *Restart inhibit* is issued again.

7.2.4.2 Application and Setting Notes

Parameter: Perm. no. of starts; Time interval (per.starts)

- Default setting (`_:106`) **Perm. no. of starts** = 3
- Default setting (`_:105`) **Time interval (per.starts)** = 60 min

The **Perm. no. of starts** parameter defines the maximum number of motor starts within a set time interval (parameter **Time interval (per.starts)**).

The values should be taken from the technical data of the motor or they can be subject to general guidelines of the user.

EXAMPLE

The motor is allowed to be started 2 times within a time interval of 60 min. Accordingly the settings are: **Time interval (per.starts)** is set to 60 min, and **Perm. no. of starts** is set to 2.

Assuming that the motor starts as follows:

	Start at	Stop at
First start	0 min	10 min
Second start	17 min	33 min

After 17 min, the number of motor starts reaches the permissible number of motor starts, and with the motor stop after 33 min, the signal *Restart inhibit* becomes active. The remaining restart-inhibit time (*T inhibit*) is obtained by 60 min - 33 min = 27 min, and the number of allowed starts (*Allow.st*) is 0. That is, the signal *Restart inhibit* will remain active for 27 min.

Parameter: Autom. restart inhibit

- Default setting (`_:2311:102`) **Autom. restart inhibit** = yes

For more information, see the related description in chapter [7.2.3.2 Application and Setting Notes](#).

Signal: >Emergency start

If, for operational or emergency reasons, motor starting must take place while the function inhibits the restart of the motor, the *Restart inhibit* signal can be terminated via the signal *>Emergency start*. Thus a new starting attempt is possible. However, it does not reset the counter. That is, if the motor is switched off again and the inhibit conditions are still fulfilled, the signal *Restart inhibit* is issued again.

7.2.4.3 Settings

Addr.	Parameter	C	Setting Options	Default Setting
Counter stage				
_:1	Counter stage:Mode		<ul style="list-style-type: none"> • off • on • test 	off
_:106	Counter stage:Perm. no. of starts		1 to 6	3
_:105	Counter stage:Time interval (per.starts)		20 min to 120 min	60 min

7.2.4.4 Information List

No.	Information	Data Class (Type)	Type
Counter stage			
_:81	Counter stage:>Block stage	SPS	I
_:53	Counter stage:Health	ENS	O
_:54	Counter stage:Inactive	SPS	O
_:52	Counter stage:Behavior	ENS	O
_:302	Counter stage:Restart inhibit	SPS	O
_:304	Counter stage:T inhibit	MV	O
_:305	Counter stage:Allow.st	INS	O

7.2.5 Timer Stage

7.2.5.1 Description

Logic of the Stage

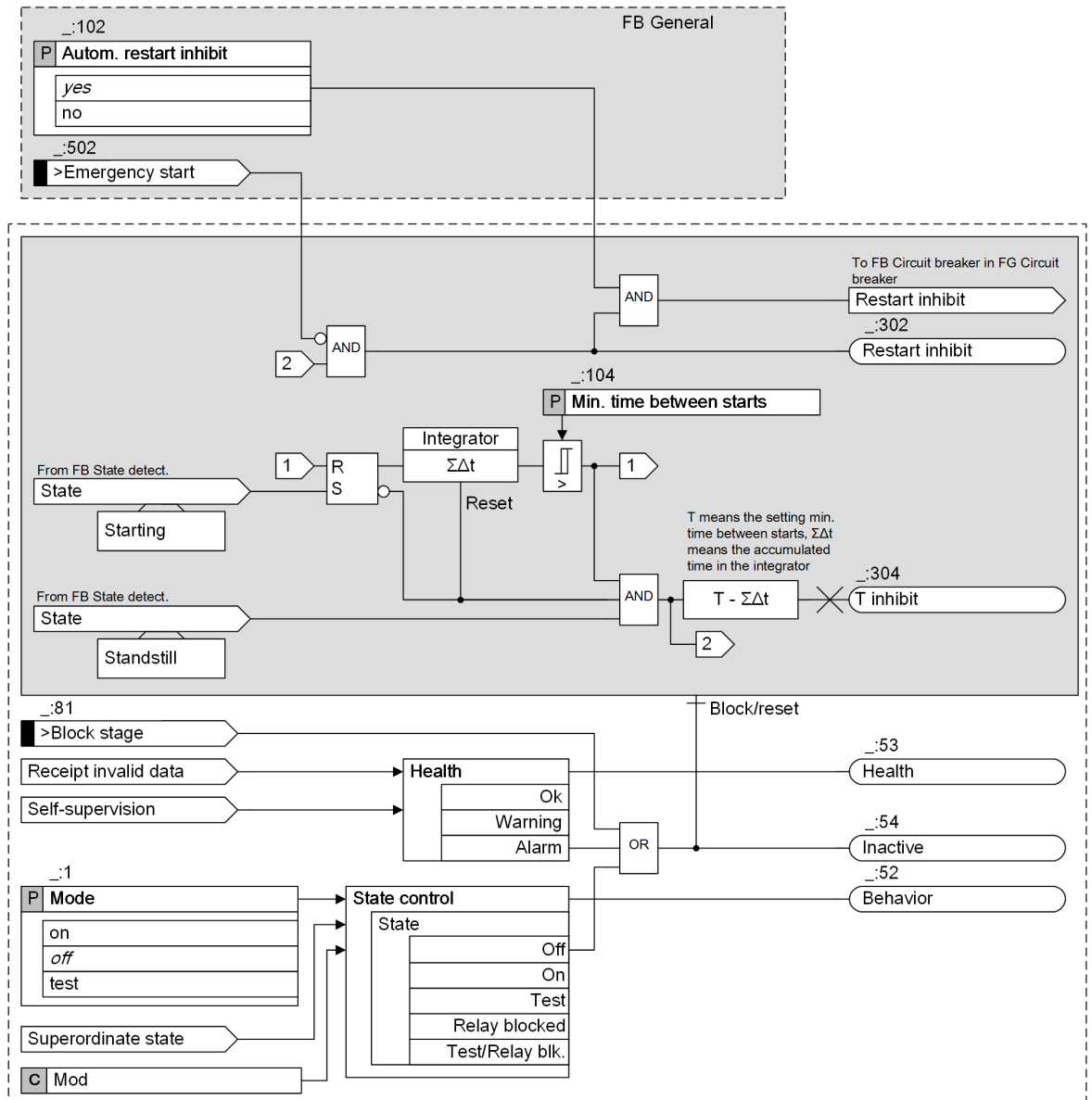

[to_mo_time, 2, en_US]

Figure 7-13 Logic Diagram of the Timer Stage

Restart Inhibit

The signal *Restart inhibit* is used to prevent the motor from a further start. When the motor state changes to *standstill* and the time interval from the most recent start to the motor state change is less than the setting value **Min. time between starts**, the *Restart inhibit* signal becomes active.



NOTE

Unlike the operate signal, the signal *Restart inhibit* does not trigger fault logging or fault recording.

Processing the Restart Inhibit Signal

For more information, see the related description in chapter [7.2.3.1 Description](#).

Remaining Restart-Inhibit Time

The function value of the remaining restart-inhibit time (value $T_{inhibit}$) is the waiting time until an issued signal *Restart inhibit* drops off. As long as further restarts are allowed, this value equals 0.

Emergency Start

The *>Emergency start* signal of the function block **General** immediately resets the output indication *Restart inhibit*. However it does not reset the timer. That is, if the motor is switched off again and the restart inhibit conditions are still fulfilled, the signal *Restart inhibit* is issued again.

7.2.5.2 Application and Setting Notes

Parameter: **Min. time between starts**

- Default setting (`_:104`) **Min. time between starts** = 10 min

The **Min. time between starts** parameter defines the minimum restart-inhibit time between motor starts.

EXAMPLE

The parameter **Min. time between starts** is set to 25 min.

- The motor starts at T = 0 min and stops at T = 12 min. At the moment, the signal *Restart inhibit* becomes active, the remaining restart-inhibit time ($T_{inhibit}$) equals to 25 min - 12 min = 13 min.
- The motor starts at T = 0 min and stops at T = 26 min. At the moment, the time since the first start exceeds the parameter **Min. time between starts**, a further motor start is allowed and no *Restart inhibit* signal is issued.

Parameter: **Autom. restart inhibit**

- Default setting (`_:2311:102`) **Autom. restart inhibit** = yes

For more information, see the related description in chapter [7.2.3.2 Application and Setting Notes](#).

Signal: *>Emergency start*

If, for operational or emergency reasons, motor starting must take place while the function inhibits the restart of the motor, the *Restart inhibit* signal can be terminated via the signal *>Emergency start*. Thus a new starting attempt is possible. However, it does not reset the timer. That is, if the motor is switched off again and the inhibit conditions are still fulfilled, the signal *Restart inhibit* is issued again.

7.2.5.3 Settings

Addr.	Parameter	C	Setting Options	Default Setting
<i>Timer stage</i>				
_:1	Timer stage:Mode		<ul style="list-style-type: none"> • off • on • test 	off
_:104	Timer stage:Min. time between starts		0 min to 120 min	10 min

7.2.5.4 Information List

No.	Information	Data Class (Type)	Type
<i>Timer stage</i>			
_:81	Timer stage:>Block stage	SPS	I
_:53	Timer stage:Health	ENS	O
_:54	Timer stage:Inactive	SPS	O
_:52	Timer stage:Behavior	ENS	O
_:302	Timer stage:Restart inhibit	SPS	O
_:304	Timer stage:T inhibit	MV	O

7.3 Load-Jam Protection Motor

7.3.1 Overview of Functions

The **Load-jam protection** function protects the motor in case of sudden rotor locking or a jump in load increase. A quick motor shutdown avoids or reduces damage to drives, bearings, and other mechanic motor components.

The rotor locking results in a jump in current increase in the phases. The current jump is used by the function as a recognition criterion.

The **Thermal overload protection rotor** function can also pick up as soon as the configured threshold values of the thermal replicas are exceeded. Because of the important stator time constants, this takes much more time. The **Load-jam protection** function, however, is able to detect a locked rotor quicker, thus reducing possible damage to the motor and to the powered equipment.

7.3.2 Structure of the Function

The **Load-jam protection** function can be used in the **Motor** function group. A maximum of 2 **Load-jam protection** functions can operate simultaneously within the function group.

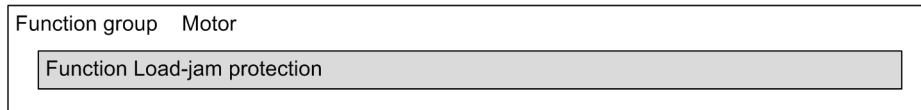

[dw_rfoaja, 2, en_US]

Figure 7-14 Structure/Embedding of the Function

Mode of Operation

[Figure 7-15](#) shows the development of the current and of the torque as a function of the slip of an asynchronous motor. A rated current flows in case of rated load and the rated slip appears. If the load is increased, the current flow also increases and the speed of motor decreases something. The slip increases correspondingly. Above a certain load, however, the motor is no longer able to adjust by increasing the torque. The motor comes to standstill in spite of an increase in current to a multiple of its rated value, as the breakdown torque is exceeded. (see [Figure 7-16](#)). Apart from the thermal heating of the motor, a locked rotor causes substantial mechanical strain on the rotor winding and bearings.

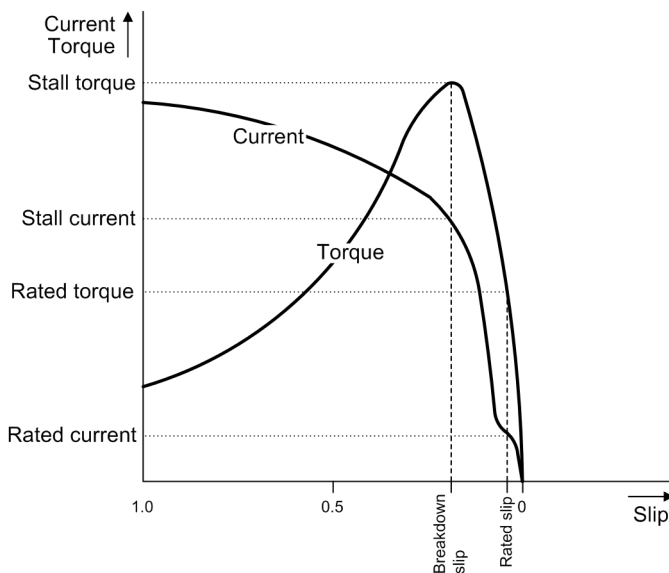

[dw_asysqu, 2, en_US]

Figure 7-15 Typical Characteristic Curve of an Asynchronous Squirrel-Cage Motor

The following figure shows an example of a locked rotor caused by mechanical overload. The current flow increases substantially as soon as the mechanical load approximates the breakdown point.

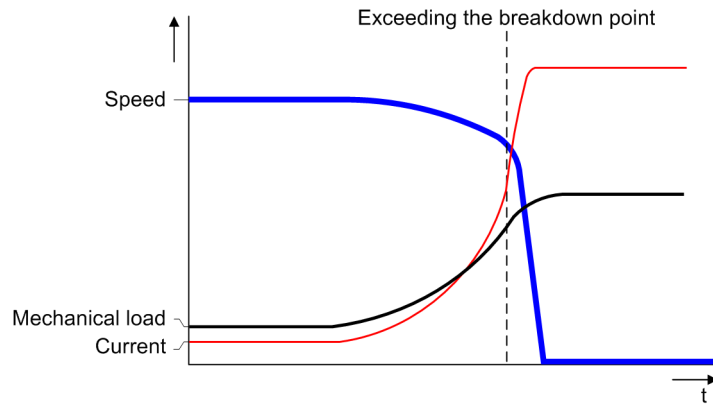

[dwr_exmero_2_en_US]

Figure 7-16 Example of the Time Characteristic Curve for Mechanical Rotor Locking

7.3.3 Stage Description

Logic

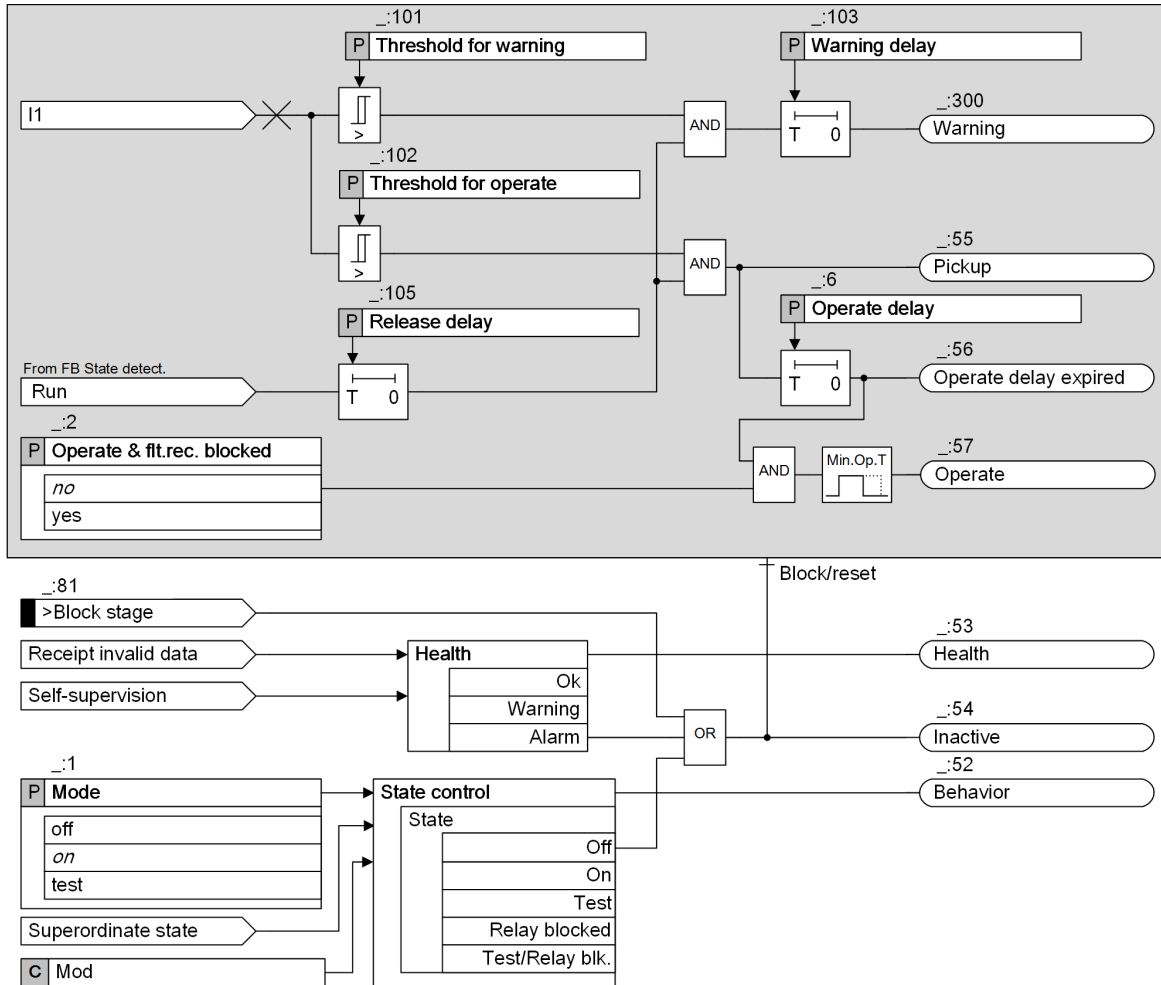

[ilo_load_ja_3_en_US]

Figure 7-17 Logic Diagram of Load-Jam Protection

Release of the Stage

In order to detect the rotor locking, a continuous comparison of the motor current with the parameter **Threshold for operate** takes place. The threshold-value comparison is blocked during the **starting** state. The starting current is usually in a size similar to the occurring current when a rotor is locked.

The **Load-jam protection** function is released if the **running** state has been detected and **Release delay** has been expired.

The **running** state is a device-internal signal detected in the function block **Motor-state detection** of the **Motor monitor** function.

Method of Measurement

The calculated positive-sequence current I_1 calculated from the 3 phase currents is used as measurand.

7.3.4 Application and Setting Notes

Parameter: **Threshold for warning, Warning delay**

- Default setting (`_:101`) **Threshold for warning** = 1.50 A
- Default setting (`_:103`) **Warning delay** = 2.00 s

Parameter: **Threshold for operate, Operate delay**

- Default setting (`_:102`) **Threshold for operate** = 2.00 A
- Default setting (`_:6`) **Operate delay** = 1.00 s

You can configure a warning stage and an operate stage by the previous parameters. The parameter **Threshold for operate** is usually configured to about 2 times of the motor rated current which is usually below the starting current. The **Operate delay** can remain at the default setting of 1 s.

The parameter **Threshold for warning** is naturally configured below the parameter **Threshold for operate** (for example, to approx. 75 % of the operate stage), with a longer time delay (parameter **Warning delay**), for example of 2 s. If the warning stage is not required, the setting value of **Threshold for warning** can be set to the maximum value.

Parameter: **Release delay**

- Default setting (`_:105`) **Release delay** = 5.00 s

The function must be blocked during the *starting* state to avoid overfunctions. Therefore the function is released after detecting the *running* state plus an additional time delay (parameter **Release delay**), to ensure no too early release of the function. Siemens recommends setting **Release delay** to the motor starting time.

EXAMPLE

Motor Protection

[Figure 7-18](#) shows an example of a complete motor-protection characteristic curve. In general, a characteristic curve consists of different protection functions. Each function is responsible for a special motor fault type.

The following protection functions are available:

- **Thermal overload protection rotor**
To avoid overheating of the motor due to inadmissible load
- **Load-jam protection**
To prevent overheating and mechanical damage due to rotor locking
- **Motor-starting time supervision**
To protect the motor against prolonged starting procedures and the consequent thermal overload of the rotor
- **Overcurrent and high-current functions**
To shut down the motor due to electrical faults

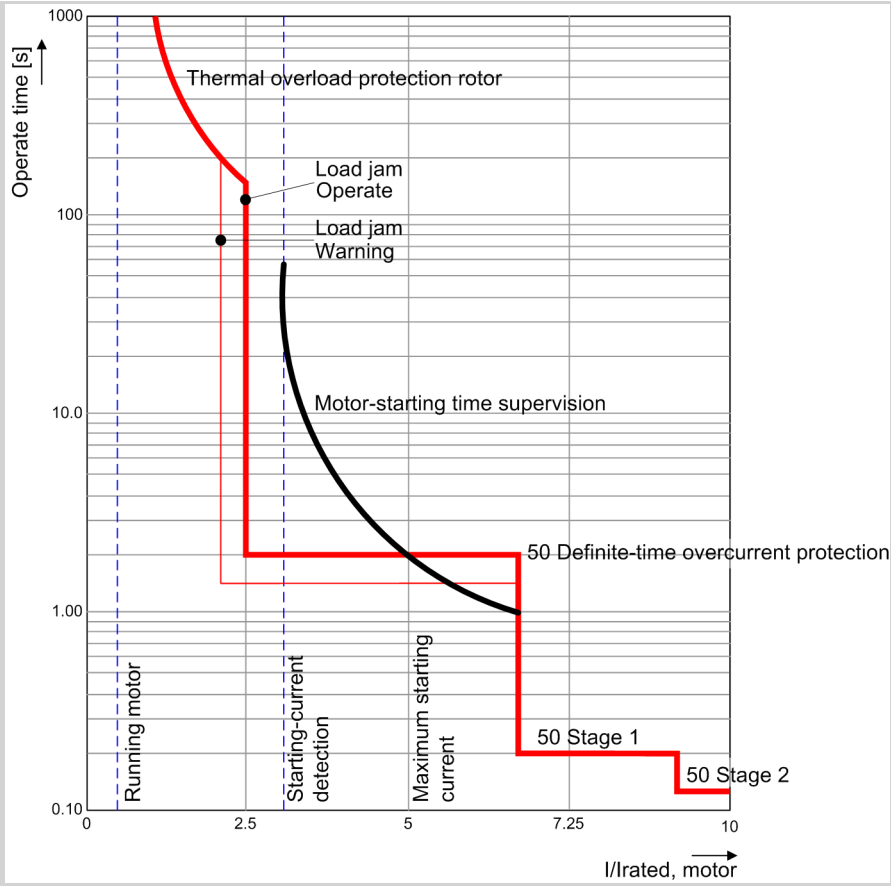

[dw_exmocu_2_en_US]

Figure 7-18 Example of a Complete Motor-Protection Characteristic Curve

EXAMPLE

Motor with the following data:

Rated voltage	$V_{rated,motor} = 6000 \text{ V}$
Rated current	$I_{rated,motor} = 154 \text{ A}$
Max. permissible Starting time (cold)	$T_{start} = 19.0 \text{ s}$
Current transformer	$I_{rated,CTprim} / I_{rated,CTsec} = 300 \text{ A} / 1 \text{ A}$

The setting for the parameter **Threshold for operate** as secondary value is calculated as follows:

$$(2 * 154 \text{ A}) / 300 \text{ A} * 1 \text{ A} = 1,027 \text{ A}$$

The parameter **Operate delay** can remain at the default setting of 1 s.

The parameter **Threshold for warning** is set to 75 % of the operating threshold, that is, 75 % x 1.027 A = 0.77 A.

The parameter **Warning delay** can remain at the default setting of 2 s.

The parameter **Release delay** is set to the motor starting time, which is 19.0 s.

7.3.5 Settings

Addr.	Parameter	C	Setting Options	Default Setting
<i>Load-jam prot.</i>				
_:1	Load-jam prot.:Mode		<ul style="list-style-type: none"> • off • on • test 	off
_:2	Load-jam prot.:Operate & flt.rec. blocked		<ul style="list-style-type: none"> • no • yes 	no
_:101	Load-jam prot.:Threshold for warning	1 A @ 100 Irated	0.030 A to 35.000 A	1.500 A
		5 A @ 100 Irated	0.15 A to 175.00 A	7.50 A
		1 A @ 50 Irated	0.030 A to 35.000 A	1.500 A
		5 A @ 50 Irated	0.15 A to 175.00 A	7.50 A
		1 A @ 1.6 Irated	0.001 A to 1.600 A	1.500 A
		5 A @ 1.6 Irated	0.005 A to 8.000 A	7.500 A
_:103	Load-jam prot.:Warning delay		0.00 s to 600.00 s	2.00 s
_:102	Load-jam prot.:Threshold for operate	1 A @ 100 Irated	0.030 A to 35.000 A	2.000 A
		5 A @ 100 Irated	0.15 A to 175.00 A	10.00 A
		1 A @ 50 Irated	0.030 A to 35.000 A	2.000 A
		5 A @ 50 Irated	0.15 A to 175.00 A	10.00 A
		1 A @ 1.6 Irated	0.001 A to 1.600 A	2.000 A
		5 A @ 1.6 Irated	0.005 A to 8.000 A	10.000 A
_:6	Load-jam prot.:Operate delay		0.00 s to 600.00 s	1.00 s
_:105	Load-jam prot.:Release delay		0.00 s to 600.00 s	5.00 s

7.3.6 Information List

No.	Information	Data Class (Type)	Type
<i>Load-jam prot.</i>			
_:81	Load-jam prot.:>Block stage	SPS	I
_:53	Load-jam prot.:Health	ENS	O
_:54	Load-jam prot.:Inactive	SPS	O
_:52	Load-jam prot.:Behavior	ENS	O
_:55	Load-jam prot.:Pickup	ACD	O
_:300	Load-jam prot.:Warning	ACT	O
_:57	Load-jam prot.:Operate	ACT	O

7.4 Thermal Overload Protection, Rotor

7.4.1 Overview of Functions

The function **Thermal overload protection rotor (ANSI 49R)** is used to protect the rotor of asynchronous motors against thermal overloads. If the rotor temperature exceeds the maximum admissible temperature (which is 100 % rotor overload), an operate or a warning indication occurs.

7.4.2 Structure of the Function

The **Thermal overload protection rotor** function is used in specific protection-function groups. Only one **Thermal overload protection rotor (49R Overl.rot.)** function can be applied within the protection-function group.

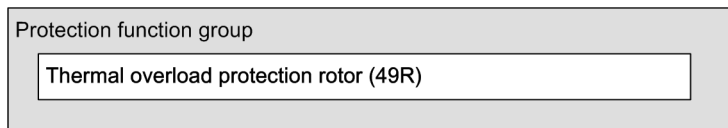

[dw_rtheov, 1, en_US]
 Figure 7-19 Structure/Embedding of the Function

7.4.3 Function Description

Logic of the stage

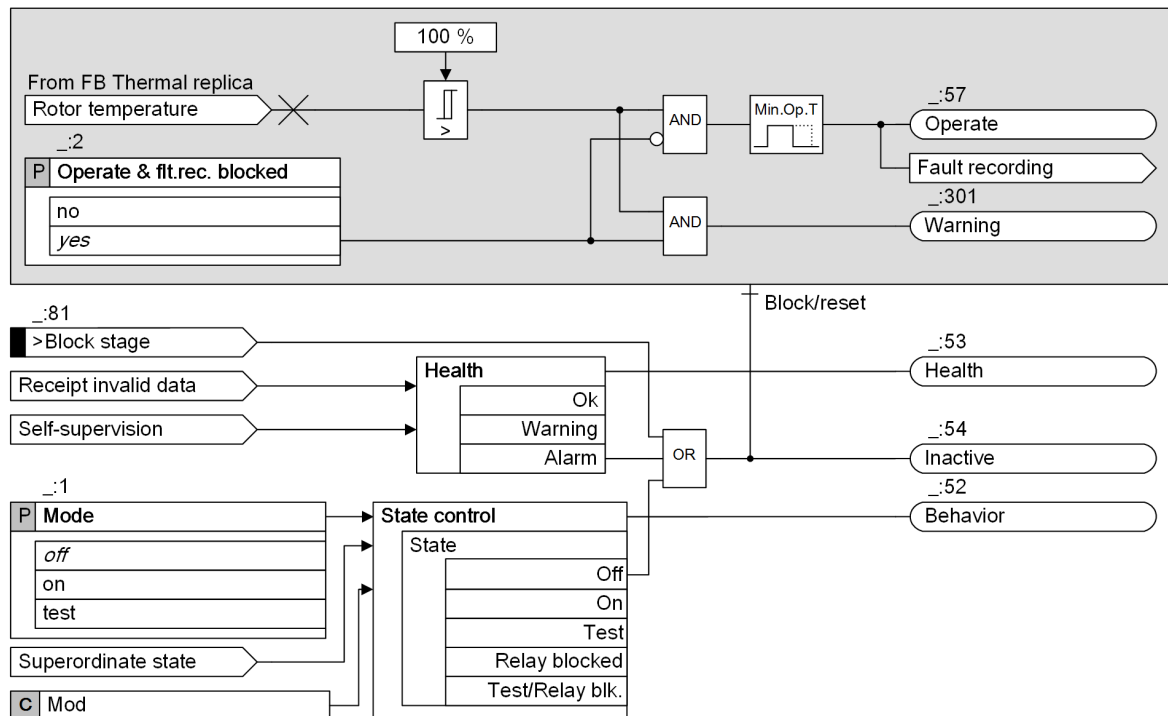

[lo_therm_tolp-rotor, 4, en_US]
 Figure 7-20 Logic Diagram of the Thermal Overload Protection Rotor (49R Overl.rot. Protection)

Rotor Temperature

The **Rotor temperature** comes from the **Thermal replica of the rotor** function block. The **Rotor temperature** is calculated as a percentage value of the maximum allowed thermal load of the rotor.

Mode of Operation and Fault Recording

The threshold value is fixed to 100 %. As soon as the rotor temperature exceeds 100 %, the function operates. Fault recording and fault logging started with the operate signal.

If the parameter **Operate & flt.rec. blocked** is set to **yes**, a warning indication occurs. Fault recording and fault logging do not start.

7.4.4 Application and Setting Notes

Parameter: Operate & flt.rec. blocked

- Default setting = (_:2) **Operate & flt.rec. blocked = yes**

If you want the stage to have a warning indication only, set the **Operate & flt.rec. blocked** parameter to **yes**. Then, the operate indication, fault logging, and fault recording do not start.

7.4.5 Settings

Addr.	Parameter	C	Setting Options	Default Setting
<i>49R Overl.rot.</i>				
_:1	49R Overl.rot.:Mode		<ul style="list-style-type: none"> • off • on • test 	off
_:2	49R Overl.rot.:Operate & flt.rec. blocked		<ul style="list-style-type: none"> • no • yes 	yes

7.4.6 Information List

No.	Information	Data Class (Type)	Type
<i>49R Overl.rot.</i>			
_:81	49R Overl.rot.:>Block stage	SPS	I
_:53	49R Overl.rot.:Health	ENS	O
_:54	49R Overl.rot.:Inactive	SPS	O
_:52	49R Overl.rot.:Behavior	ENS	O
_:57	49R Overl.rot.:Operate	ACT	O
_:301	49R Overl.rot.:Warning	SPS	O

8 Capacitor Bank Protection Functions

8.1	Introduction	1118
8.2	Current-Unbalance Protection for Capacitors, 1-Phase	1119
8.3	Peak Overvoltage Protection for Capacitors	1138

8.1 Introduction

Capacitors and capacitor banks are used for various applications. Examples are:

- Reactive-power compensation for voltage stabilization
- Fast voltage- and reactive-power control
- Filter circuits for the elimination of certain frequencies

Capacitor banks for transmission systems are complex systems customized for the special application. The design depends much on the used switching technology (for example, mechanically or via thyristor). In detail hardly one capacitor bank resembles another. However, a capacitor bank consists always of the same components (C, R, L, and switches). A capacitor bank often consists of several subcomponents which are connected to the capacitor-bank busbar via the circuit breakers.

The modularity of the protection functionality allows to tailor the protection device exactly to the needs of the capacitor bank or the subcomponent of the capacitor bank.

Capacitor banks require the use of extensive protection functionality. The protection consists of standard protection functions and specific capacitor protection functions. The following topics are described in the next chapters:

- Extensions on standard protection functions for optimal utilization in a capacitor bank
- Specific capacitor protection functions
- Application of standard protection functions for specific protection tasks within a capacitor bank

8.2 Current-Unbalance Protection for Capacitors, 1-Phase

8.2.1 Overview of Functions

The **Current-unbalance protection for capacitors, 1-phase** function (ANSI 60C):

- Protects in case of faults in capacitor elements (C-elements) of a double neutral point capacitor bank
- Provides very sensitive supervision of the unbalanced current between the 2 neutral points
- Allows counting individual faulty C-elements

8.2.2 Structure of the Function

The **Current-unbalance protection for capacitors, 1-phase** function is used in the **Capacitor bank** function group. It is preconfigured at the factory with 2 overcurrent-protection stages **I>** and 1 stage of the type **Counter**. A maximum of 3 overcurrent-protection stages and 4 counter stages can be operated simultaneously in the function.

The function is designed so that the **General functionality** (including adjustment) and the **Measuring-point selection** can work across the stages.

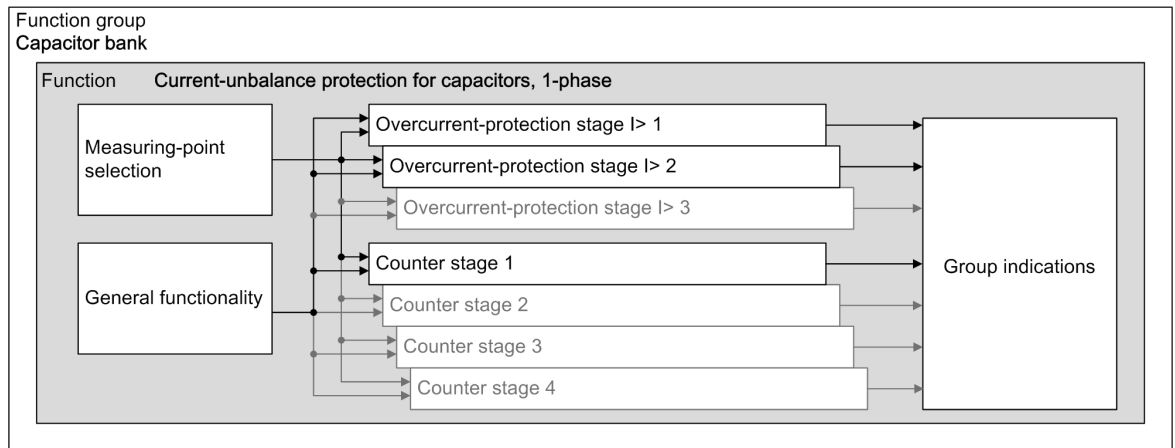

[dw_ocp_i_unb_1ph_3_en_US]

Figure 8-1 Structure/Embedding of the Function

8.2.3 General Functions and Measuring-Point Selection

8.2.3.1 Description

The General functionality is structured in the following functional parts:

- Compensation of the unbalance
- Normalization of the unbalanced current with the current I_c
- Counting faulty C-elements (the stage type **Counter** is used to monitor the counter status)

Logic for Compensation and Normalization

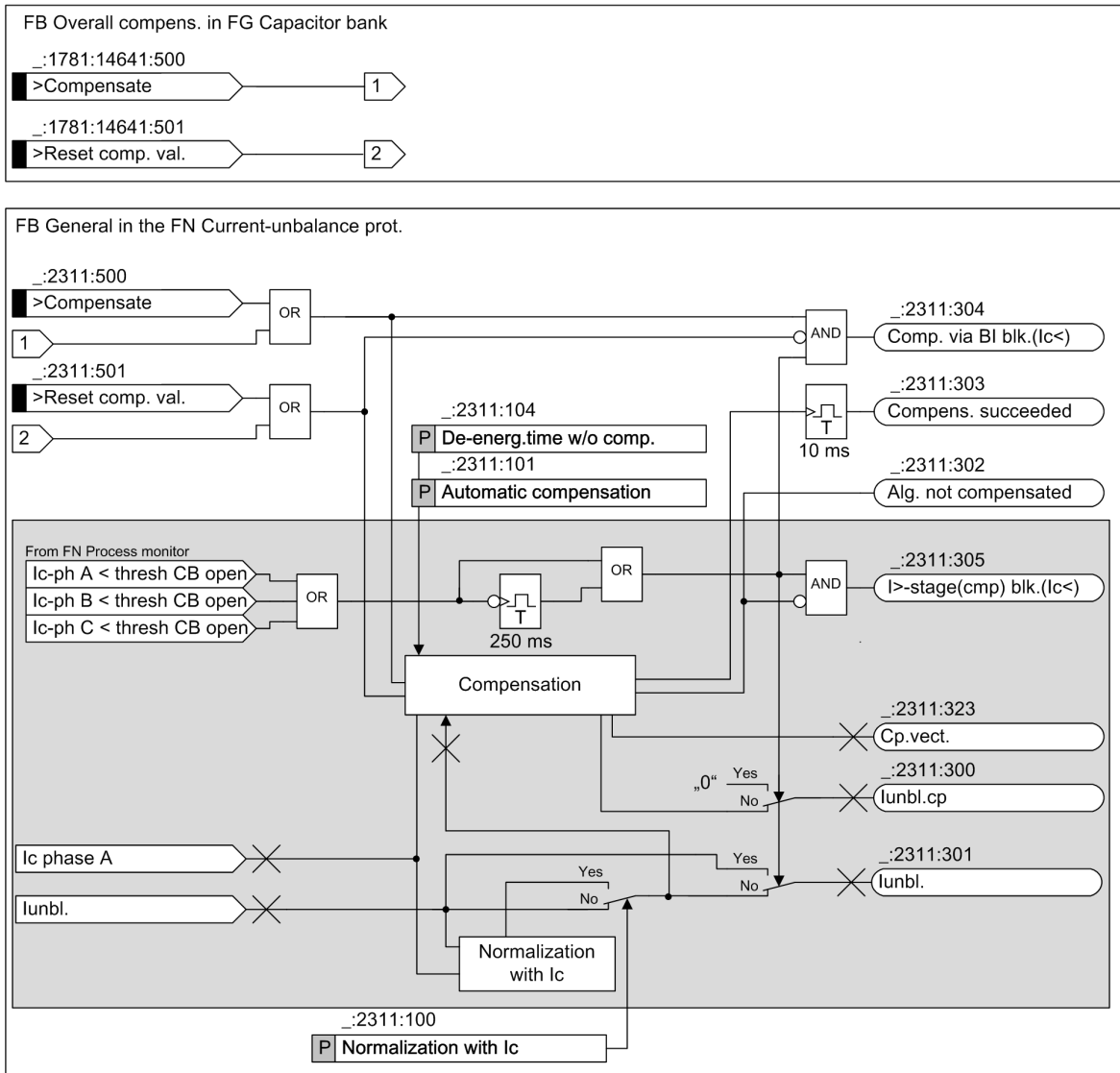

Figure 8-2 Cross-Stage Functionality

Measuring-Point Selection

With the **MP selection** parameter, you can select from a list of measuring points a 1-phase measuring point that is connected to the **I Unbalanced** interface in the **Capacitor bank** function group. The **Current-unbalance protection for capacitors, 1-phase** function processes the 1-phase current that is connected to the measuring point.

For more information, refer to the description of the **Capacitor bank** function group starting from chapter [5.5.1 Overview](#).

Measurands, Method of Measurement

The function receives its measurands via the **I Unbalanced** interface of the **Capacitor bank** function group. The compensated and non-compensated unbalanced currents are provided for the overcurrent-protection stage. Within the protection stage, one of the 2 values is selected in the protection stage via the parameter **Measured value**. Both values are available as functional measured values (see [Figure 8-2](#)).

Configure across the stages whether the unbalanced current must be normalized with the current I_c that flows into the capacitor bank. Phase A component of the current I_c flowing into the capacitor bank is used as the reference for the normalization. You can find more information in this chapter under [Normalization with \$I_c\$](#) , [Page 1122](#).

The method of measurement used processes the sampled unbalanced-current values and filters out the fundamental component numerically. The protection stages evaluate the fundamental component of the unbalanced current.

General Notes on the Compensation

An operational unbalanced current is added to an unbalanced current resulting from faulty capacitor elements. This corrupts the measuring result.

Operational unbalanced currents can result from the following causes:

- Manufacturing tolerances of the capacitor
- Aging of the capacitor
- Environmental influences, for example, temperature

The compensation eliminates operational unbalanced currents by calculation. For this purpose, the phasor of the operational unbalanced current $I_{unbal.,op.}$ is stored at specific times. The stored phasor (compensation phasor), is subtracted from the actually measured unbalanced-current phasor:

$$I_{unbal.,comp.} = I_{unbal.} - I_{unbal.,op.}$$

[fo_compensated_unbalanced, 1, en_US]

The following indications describe the status of the compensation:

Indication	Description
<i>Alg. not compensated</i>	The algorithm is not compensated. The compensated values are not available under the following conditions: <ul style="list-style-type: none"> • After initial startup of the device before any compensation is carried out • After activating the binary input <i>>Reset comp. val.</i> • After change of $I_{rated,obj}$ Protection stages that are working with compensated values are inactive.
<i>Compens. succeeded</i>	This indication is issued (as transient indication with a pulse duration of 10 ms) if the existing unbalance has been compensated manually or automatically. In case of automatic compensation, the signal is issued at each event-based situation where full compensation is carried out.
<i>Comp. via BI blk. (Ic<)</i>	If a manual compensation has been initiated and the current I_c (current flowing into the capacitor bank) at this time is less than the threshold Current threshold CB open , the manual compensation is not executed. This is signaled via the <i>Comp. via BI blk. (Ic<)</i> indication.

2 different methods are available for the compensation:

- Manual compensation via binary input signals
- Automatic compensation

Manual Compensation via Binary Input Signal

If the binary input signal *>Compensate* is activated, the manual compensation starts. This will fully compensate any unbalance that exists at this time. This means, the value $I_{unbal.,comp.}$ will then become 0. You can also use the manual compensation in parallel with the automatic compensation.

For the reliability of manual compensation, the binary input signal *>Compensate* has a preset software filtering time (configurable in DIGSI) of 20 ms.

Automatic Compensation

When using the parameter **Automatic compensation**, this automatic compensation function can be enabled or disabled.

The automatic compensation consists of 2 different mechanisms:

- Event-based compensation of any existing unbalance
This compensation is performed in the following situations:
 - After energizing the capacitor bank or a phase of the bank
 - After counting a faulty C-element
 - After each startup of the device
 - After specific parameter changes:
 - Switching on the automatic compensation
 - Changing the rated current of the capacitor bank

To avoid transient inrush-current effects, the compensation is delayed by 250 ms after energizing has been detected.

Full compensation after bank energization can be avoided in case of only short de-energization by means of parameter **De-energ.time w/o comp.**. If the de-energized duration is less than the setting of parameter **De-energ.time w/o comp.**, the full compensation is not carried out after energizing a phase or the whole bank.

- Cyclic and thus gradual compensation of an existing unbalance in small increments
This permits, for example, the automatic compensation of environmental influences.

Resetting the Compensation

The algorithm can be reset to the non-compensated status. Compensated values are not available in this case. Protection stages that work with compensated values are rendered inactive. The binary input signal **>Reset comp. val.** of the function or function group resets the compensation (see also [Figure 8-2](#)).

For the reliability of manual compensation, the binary input signal **>Reset comp. val.** has a preset software filtering time (configurable in DIGSI) of 20 ms.

Normalization with I_c

The threshold for the unbalanced current is usually set by assuming the rated capacitor current $I_{c, rated}$. The current I_c flowing into the capacitor bank determines the amount of the unbalanced current. A lower I_c also means a lower unbalanced current. If $I_c < I_{c, rated}$, the protection becomes less sensitive. This influence can be compensated via the normalization. Normalization keeps the sensitivity of the protection function constant by normalizing the unbalance value with the current I_c . Phase A component of the current I_c flowing into the capacitor bank is used as the reference for the normalization. When using the parameter **Normalization with I_c** , normalization is enabled or disabled.

I_c Lower than Current Thresh. CB Open

If any phase current of I_c is lower than the threshold **Current thresh. CB open**, the compensated value can no longer be computed with sufficient accuracy. To avoid a malfunction, the compensated unbalanced value $I_{unbal, comp}$ is set to 0 A (see [Figure 8-2](#)). This deactivates the protection stages that work with compensated values.

This condition will be indicated (indication **I>-stage(cmp) blk. (Ic<)**).

In this case, normalization with current I_c will no longer work properly either. Normalization is canceled. This means that the non-normalized value will be used instead of the normalized value (see [Figure 8-2](#)).

Charging/Energizing the Capacitor Bank or a Phase of the Bank

Charging of the bank takes place when the discharged bank is switched on to the network. Charging of a phase can occur in case of network faults. If a phase-to-ground voltage drops to 0 V due to a network fault, the respective phase is discharged and the return of the phase-to-ground voltage (after the fault has been cleared) will charge the phase.

Charging the bank causes inrush currents in the respective phases. To avoid overfunction in case of sensitive threshold settings, the stages using compensated unbalanced values are blocked by setting $I_{unbal,comp}$ to 0 A.

These stages are:

- Counter stage
- $I >$ stage, if set to operate with compensated unbalanced values

The blocking ($I_{unbal,comp}$ set to 0 A) lasts for 250 ms after energizing detection. Afterwards, the calculated $I_{unbal,comp}$ is processed again.

Energizing detection takes place by monitoring the phases currents I_c flowing into the bank. If all 3-phase currents exceed the threshold **Current Thresh. CB Open**, energizing is detected.

Logic for Counting Faulty C-Elements

This part of the General functionality is only important if counter stages are used.

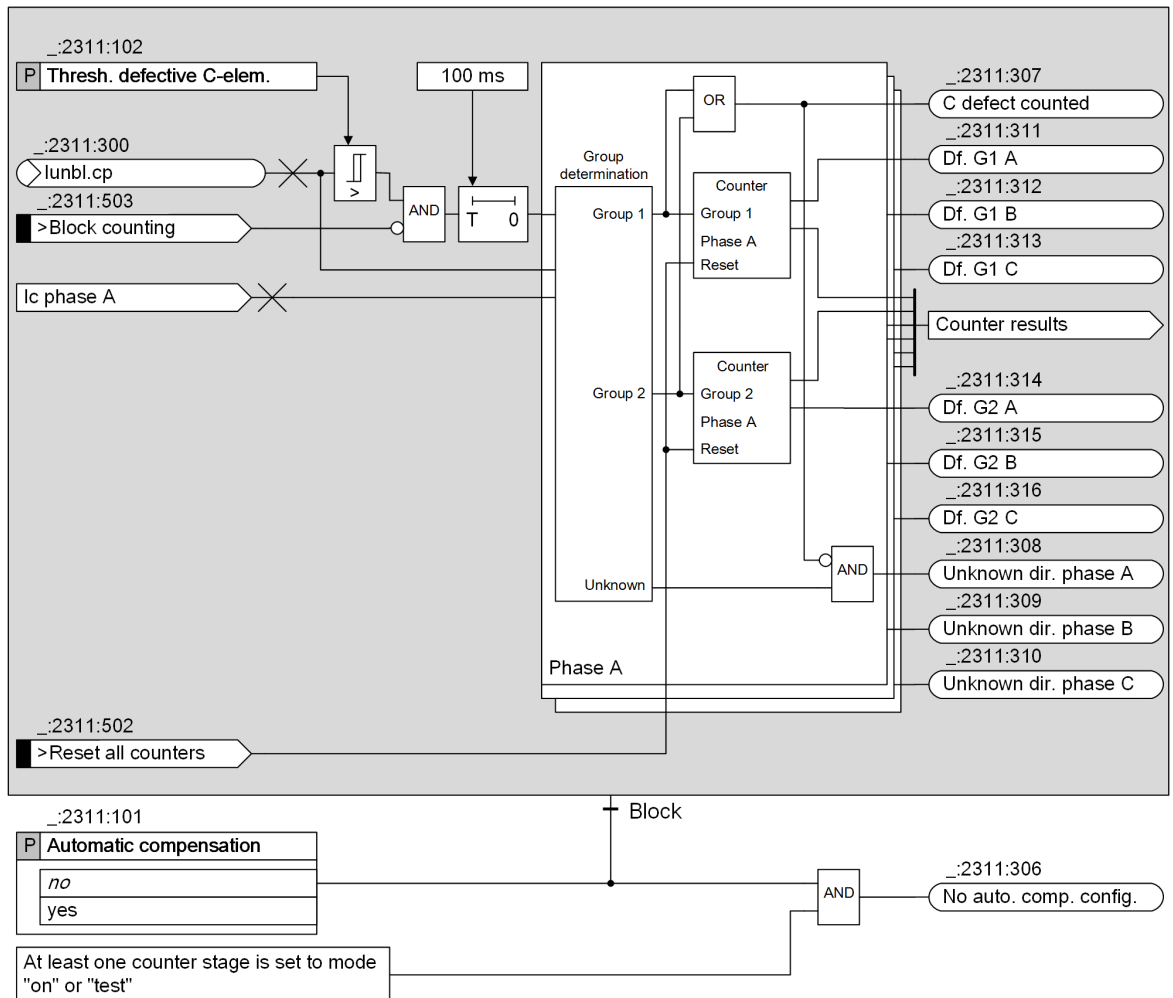

[Ilo_cnt EF_1ph_4_en_US]

Figure 8-3 Counting Faulty C-Elements

Activation/Blocking Counting

If at least one counter stage is enabled, the counting function is active. Furthermore, the counting function works only if the automatic compensation is enabled.

To prevent counting as a consequence of the charging process, the counting function is implicitly blocked for 250 ms by setting $I_{unbal.,comp.}$ to 0 A, after the capacitor energizing has been detected.

If the 3-phase capacitor bank is not fully symmetrical, a bank-external fault (for example, a phase-to-ground fault near the capacitor bank) may lead to the incorrect counting of C-elements for the counter stage. To avoid this situation, the binary input *>Block counting* can be used to block the counting (refer to [Blocking the Counting for Bank-External Faults, Page 1127](#)). The binary input is started by a pickup signal of a (protection) function which is used for detecting a bank-external fault. The binary input *>Block counting* also blocks the cyclic compensation.

Measurands, Counting

The measurand is the 1-phase compensated unbalanced current $I_{unbal.,comp.}$. If a single C-element is faulty, an unbalance occurs between the neutral points of the 2 capacitor banks. This unbalance causes an unbalanced current; this means, a small current jump occurs in the unbalanced current. Set the parameter **Thresh. defective C-elem.**, so that this current jump can be detected (see also [8.2.3.2 Application and Setting Notes](#)). The unbalanced current that was caused by the fault must exceed the threshold for 100 ms before the affected phase and the affected group are determined and counting (incrementing the counter) takes place. The angle reference of the unbalanced-current phasor to the reference current $I_{c,A}$ is used to determine the phase of the faulty C element. Thus, phase-segregated counting is possible. There is one counter for each phase and group. After the counting, the existing unbalance is compensated; this means, the unbalance is reset to 0 A. If the faulty group cannot be determined, the unbalance is also compensated.

Resetting/Setting the Counters

You can reset or set the counters of group 1 and group 2 via:

- On-site operation panel directly on the device
- Online DIGSI connection to the device
- Binary input *>Reset all counters* (only reset of all counters)
- Communication connection with the control center

You can directly set or reset the counters via IEC 61850 by setting the counter values to the desired value. If you want to reset the counters via DNP3, IEC 60870-5-103, Modbus, or IEC 60870-5-104, an additional configuration with CFC is necessary. For more information, refer to chapter [8.2.3.2 Application and Setting Notes](#).

Functional Measured Values

Values	Description	Primary	Secondary	% Referenced to
(_:2311:300) $I_{unbl.cp}$	Compensated unbalanced current $I_{unbal.,comp.}$	kA	A	Parameter Rated primary current
(_:2311:301) $I_{unbl.}$	Non-compensated unbalanced current $I_{unbal.}$	kA	A	Parameter Rated primary current
(_:2311:323) $I_{comp.,vect.}$	Compensation vector $I_{comp.,vect.}$	kA	A	Parameter Rated primary current

You can find the value of the parameter **Rated primary current** of the preceding table in the chapter [6.1.9 Settings](#) according to the specified parameter **MP selection**.

$I_{comp.,vect.}$ is normalized with I_c . The normalization is carried out no matter if the parameter **Normalization with I_c** is set to **yes** or **no**. $I_{comp.,vect.}$ keeps its value unchanged until the next compensation occurs.

$$I_{\text{comp., vect}} = I_{\text{unbal. op.}} \frac{I_{\text{c, rated}}}{I_{\text{c}}}$$

[fo_compensation vector, 1, en_US]

Where:

$I_{\text{unbal. op.}}$ Operational unbalanced current at the moment the compensation is carried out

$I_{\text{c, rated}}$ Rated current of the capacitor bank

I_{c} Current of the capacitor bank at the moment the compensation is carried out

Definition of the Group and Fault Location

If the capacitor is designed as a double neutral-point circuit, the following definition is assumed:

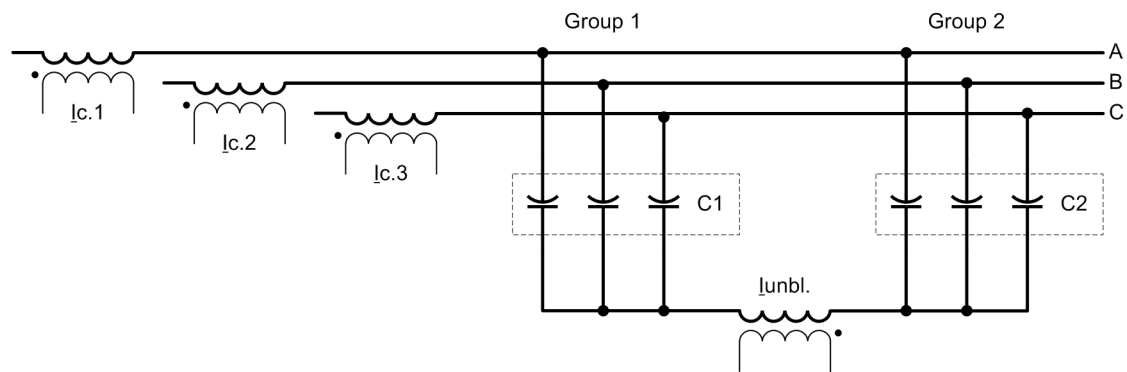

[dw_fehlerortinf_iunsy1ph, 1, en_US]

Figure 8-4 Definition of the Fault-Location Information

The black dot indicates the orientation of the current transformer. For the connection of the current transformer shown in the previous figure, the following definition applies:

- Group 1: C1
- Group 2: C2

To determine the fault location (group 1 or 2) correctly, use the parameter **Capacitor element type** (in FB **General** of the **Capacitor bank** function group) to tell the device whether the elements of the capacitor bank have internal fuses or not.

The angle reference of the unbalanced-current phasor to the reference current I_{c} is used to determine the direction of the unbalanced current and, thus, the affected group is determined. If the direction cannot be determined with confidence, an appropriate indication will be generated.

8.2.3.2 Application and Setting Notes

Parameter: **MP selection**

- Default setting (`_:13501:81`) **MP selection** = *None*

With the **MP selection** parameter, you can select from a list the measuring point that is connected to the **I Unbalanced** interface of the **Capacitor bank** function group.

The setting applies equally to all stages of the function.

In the default setting, a measuring point is not selected. You must select a measuring point. If you do not select a measuring point, an inconsistency is indicated via the read-only parameter **Consistency failure**.

Parameter: **Automatic compensation**

- Default setting (`_:2311:101`) **Automatic compensation** = *no*

The parameter applies equally to all stages of the function that work with compensated measurands.

If no counter stages are applied, Siemens recommends switching the automatic compensation off and use the manual compensation. You can find more information on this recommendation in chapter [8.2.4.2 Application and Setting Notes](#) (setting notes for the operate delay of the I> stage).

If the counter stages are applied, the automatic compensation must be switched on, otherwise the counting function will not work.

Parameter: De-energ.time w/o comp.

- Default setting (`_:2311:104`) **De-energ.time w/o comp.** = 2.00 s

In case of networks faults, the faulty phases are discharged. With the returning voltage after fault clearance, charging takes place. For such conditions, Siemens recommends that no automatic full compensation takes place in the affected phases. Otherwise, C-element defects occurring in this period (for example, because of discharging stress due to network-fault inception) will not be detected.

With the parameter **De-energ.time w/o comp.**, you define the duration of short de-energization after which no automatic compensation takes place. The parameter must be set to a value larger than the slowest fault clearing time in your network plus a safety margin.

If the setting is set to 0 s, an automatic full compensation is carried out after each energizing detection.

Parameter: Normalization with I_c

- Default setting (`_:2311:100`) **Normalization with I_c** = no

This parameter applies equally to all stages of the function.

Parameter Value	Description
no	Select this setting if you can safely assume that I _c will not change for operational reasons or if you do not desire normalization of the unbalanced current with I _c . Consider that the protection sensitivity will decrease with decreasing I _c .
yes	Select this setting if you want to keep the sensitivity of the protection stages constant during changes of I _c .

Parameter: Thresh. defective C-elem.

- Default setting (`_:2311:102`) **Thresh. defective C-elem.** = 0.030 A

Set the parameter **Thresh. defective C-elem.** to ensure that the jump in the unbalanced current caused by the faulty C-element is detected. Information about occurring unbalanced current as a consequence of single faulty C-elements will be provided by the manufacturer of the capacitor bank. Siemens recommends setting the threshold value to approx. 75 % of the unbalanced current that occurs after the fault of the 1st C-element.

Example 1: Information about the Unbalanced Current Available from the Manufacturer of the Capacitor Bank

Table 8-1 Unbalanced Current, Depending on the Number of Faulty C-Elements

Number of Faulty C-Elements	Primary Unbalanced Current
0	0.00 A
1	0.71 A
2	1.47 A
3	2.29 A
...	...

Assumed current transformer ratio: 10 A/1 A

Primary unbalanced current if 1st C-element fails: 0.71 A

Secondary unbalanced current if 1st C-element fails: 0.071 A

Secondary setting value: $0.75 \cdot 0.071 \text{ A} = 0.053 \text{ A}$



NOTE

Use sensitive device current inputs in order to apply secondary thresholds of < 30 mA.

Blocking the Counting for Bank-External Faults

To avoid the incorrect counting of C-elements for the counter stage due to a bank-external fault, Siemens recommends using the binary input *>Block counting* to block the counting by a pickup signal of a (protection) function, which is applied to detect the bank-external fault.

Siemens recommends using the function **Overvoltage protection with negative-sequence voltage** or the function **Negative-sequence protection** (based on current measurement) to detect the bank-external fault. The following function chart (CFC) is an example to block the counting by a pickup signal of the function **Overvoltage protection with negative-sequence voltage**.

EXAMPLE

Create a CFC as follows:

- Connect the signal *Pickup* of the function **Overvoltage protection with negative-sequence voltage** as input.
If you use the function **Overvoltage protection with negative-sequence voltage** only for blocking the counting, you must set the parameter **Operate & flt.rec. blocked** of this function to **yes** to block tripping, fault recording, and fault logging of this function.
- Connect the signal *>Block counting* as output.

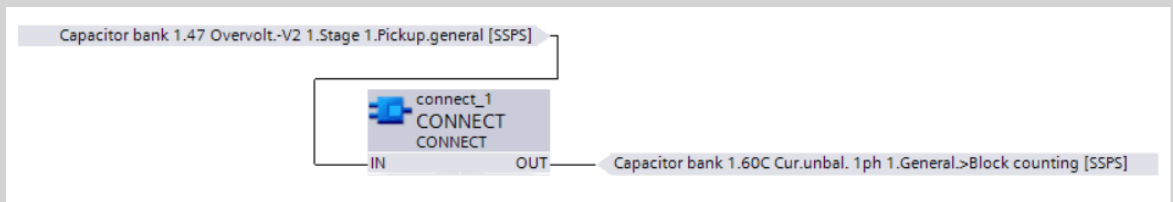

[sc_CFC_blockcounting_1_en_US]

Figure 8-5 CFC for Blocking the Counting

Resetting the Counters via Protocols IEC 60870-5-103, IEC 60870-5-104, DNP3, or Modbus

The following example shows how to use a function chart (CFC) to reset the counters with the protocols IEC 60870-5-103, IEC 60870-5-104, DNP3, or Modbus.

EXAMPLE

- Add a **Marker command (SPC)** signal to the information list.

Signals	Number	Type
(All)	(All)	
60C Cur.unbal. 1ph 1	981.2031	
General	981.2031.2311	
>Compensate	981.2031.2311.500	SPS
>Reset comp. val.	981.2031.2311.501	SPS
>Reset all counters	981.2031.2311.502	SPS
Alg. not compensated	981.2031.2311.302	SPS
Compens. succeeded	981.2031.2311.303	SPS
Comp. via Bl blk.(lc<)	981.2031.2311.304	SPS
l>stage(cmp) blk.(lc<)	981.2031.2311.305	SPS
No auto. comp. config.	981.2031.2311.306	SPS
C defect counted	981.2031.2311.307	SPS
Unknown dir. phase A	981.2031.2311.308	SPS
Unknown dir. phase B	981.2031.2311.309	SPS
Unknown dir. phase C	981.2031.2311.310	SPS
Df. G1 A	981.2031.2311.311	INS
Df. G1 B	981.2031.2311.312	INS
Df. G1 C	981.2031.2311.313	INS
Df. G2 A	981.2031.2311.314	INS
Df. G2 B	981.2031.2311.315	INS
Df. G2 C	981.2031.2311.316	INS
lunbl.cp	981.2031.2311.300	CMV
lunbl.	981.2031.2311.301	CMV
Cp.vect.	981.2031.2311.323	CMV
SPC marker cmd		SPC
Group indicat.	981.2031.4501	
l> 1	981.2031.16231	

[sc_add_spc_signal_1ph_1_en_US]

Figure 8-6 Adding Marker Command (SPC) Signal to Information List

- Set up the following CFC. Connect the SPC signal as input, and the signal *>Reset all counters* as output.

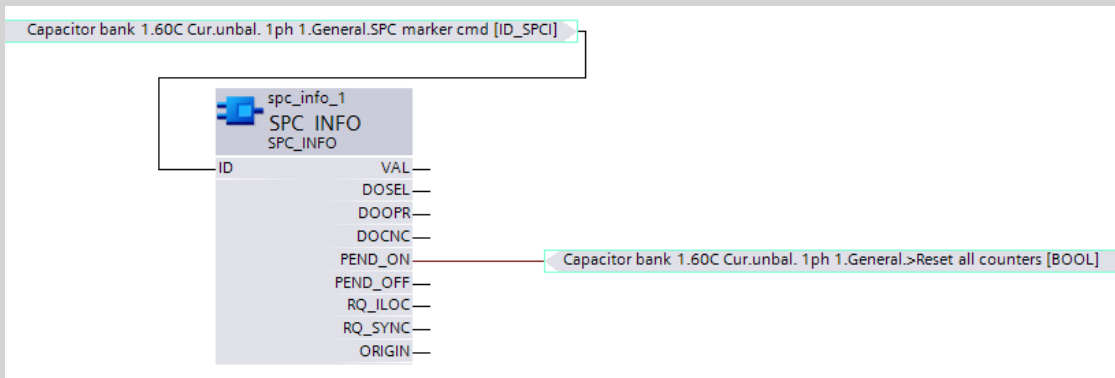

[sc_CFC_60C_1ph_1_en_US]

Figure 8-7 Function Chart (CFC): Activating the Binary Input Signal

- Send a single-point control command from the control center to the SPC signal to activate the signal *>Reset all counters*. Then the counters are reset.

8.2.3.3 Settings

Addr.	Parameter	C	Setting Options	Default Setting
MP selection				
_:13501:100	MP selection:Consistency failure		<ul style="list-style-type: none"> no MP configured no Sensor configured 	no MP configured
_:13501:81	MP selection:MP selection		Setting options depend on configuration	
General				
_:2311:101	General:Automatic compensation		<ul style="list-style-type: none"> no yes 	no
_:2311:100	General:Normalization with Ic		<ul style="list-style-type: none"> no yes 	no
_:2311:102	General:Thresh. defective C-elem.	1 A @ 100 Irated	0.030 A to 35.000 A	0.030 A
		5 A @ 100 Irated	0.15 A to 175.00 A	0.15 A
		1 A @ 50 Irated	0.030 A to 35.000 A	0.030 A
		5 A @ 50 Irated	0.15 A to 175.00 A	0.15 A
		1 A @ 1.6 Irated	0.001 A to 1.600 A	0.030 A
		5 A @ 1.6 Irated	0.005 A to 8.000 A	0.150 A
_:2311:104	General:De-energ.time w/o comp.		0.00 s to 60.00 s	2.00 s

8.2.3.4 Information List

No.	Information	Data Class (Type)	Type
Group indicat.			
_:4501:55	Group indicat.:Pickup	ACD	O
_:4501:57	Group indicat.:Operate	ACT	O
_:4501:52	Group indicat.:Behavior	ENS	O
_:4501:53	Group indicat.:Health	ENS	O
General			
_:2311:500	General:>Compensate	SPS	I
_:2311:501	General:>Reset comp. val.	SPS	I
_:2311:502	General:>Reset all counters	SPS	I
_:2311:503	General:>Block counting	SPS	I
_:2311:302	General:Alg. not compensated	SPS	O
_:2311:303	General:Compens. succeeded	SPS	O
_:2311:304	General:Comp. via BI blk.(Ic<)	SPS	O
_:2311:305	General:I>-stage(cmp) blk.(Ic<)	SPS	O
_:2311:306	General:No auto. comp. config.	SPS	O
_:2311:307	General:C defect counted	SPS	O
_:2311:308	General:Unknown dir. phase A	SPS	O
_:2311:309	General:Unknown dir. phase B	SPS	O
_:2311:310	General:Unknown dir. phase C	SPS	O
_:2311:311	General:Df. G1 A	INS	O
_:2311:312	General:Df. G1 B	INS	O
_:2311:313	General:Df. G1 C	INS	O
_:2311:314	General:Df. G2 A	INS	O
_:2311:315	General:Df. G2 B	INS	O

No.	Information	Data Class (Type)	Type
._:2311:316	General:Df. G2 C	INS	O
._:2311:300	General:lunbl.cp	CMV	O
._:2311:301	General:lunbl.	CMV	O
._:2311:323	General:Cp.vect.	CMV	O
._:2311:52	General:Behavior	ENS	O
._:2311:53	General:Health	ENS	O

8.2.4 Overcurrent-Protection Stage I >

8.2.4.1 Description

Logic of a Stage

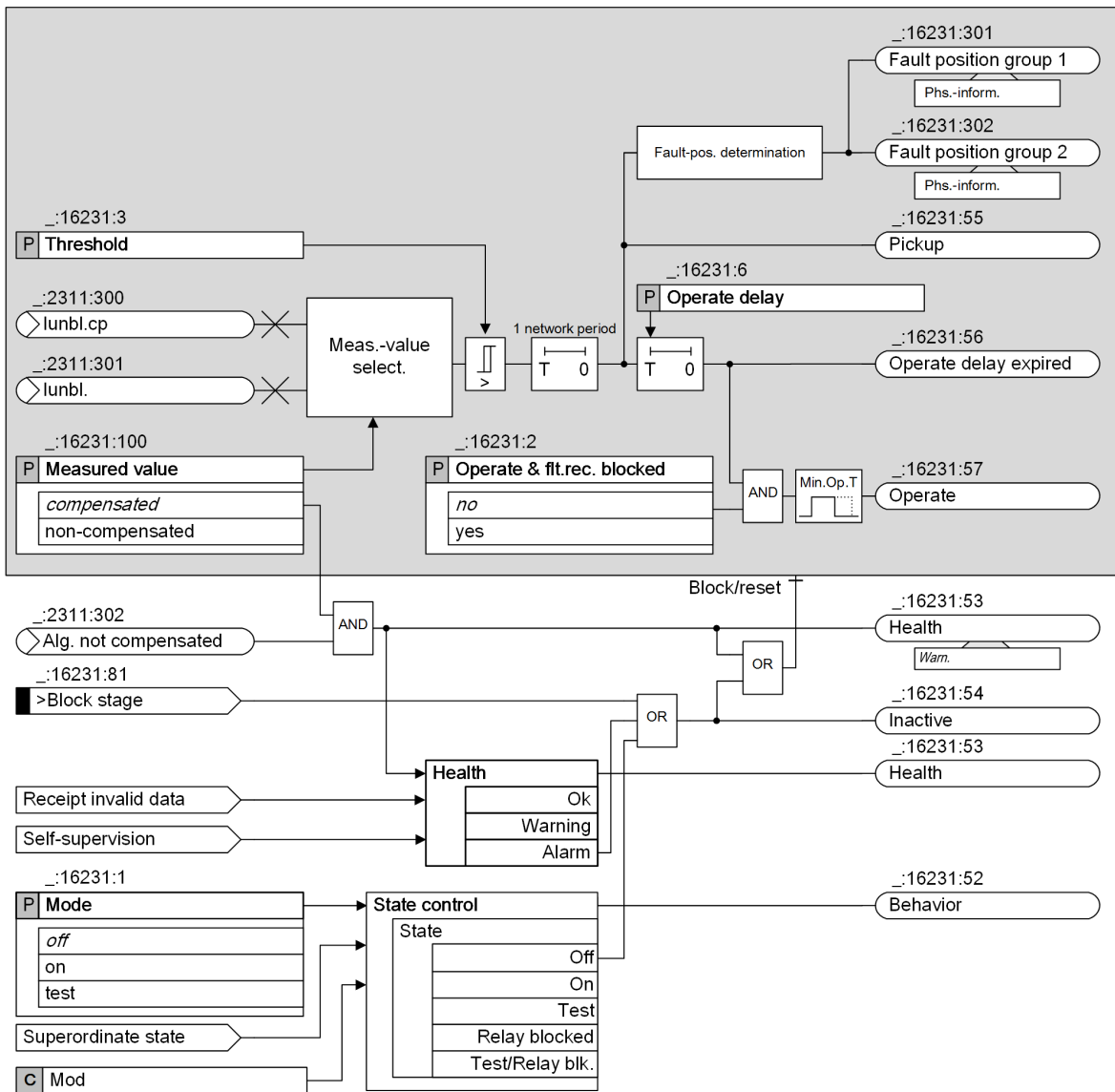

[lo_occup-cap-bank_lunblstu1ph_3_en_US]

Figure 8-8 Logic Diagram of the Overcurrent-Protection Stage I >

Measurands

Within the protection stage, the compensated and the non-compensated unbalanced currents are available. Use parameter **Measured value** to select one of the 2 values. Both values are displayed as measured values of the function at the function stage.

Pickup, Operate Delay

If the selected measurand exceeds the threshold, the pickup delay of 1 network period starts. If the threshold remains exceeded during the pickup delay, the stage picks up. The pickup starts the operate delay, and a fault-location information is issued. More information can be found in this chapter under [Fault-Location Information, Page 1131](#). If the threshold is exceeded during the entire operate delay, the operate indication is issued.

Please note that, when using the compensated measurands as well as the automatic compensation, the currently measured current unbalance (that resulted in the threshold being exceeded) is gradually compensated. This means that even in case of a constantly existing unbalance in the primary system, the compensated measurand becomes gradually lower and may therefore fall below the threshold again at some time. The timing depends on by how much the threshold is exceeded.

For this reason and under those conditions, long time delays must not be set, see also chapter [8.2.4.2 Application and Setting Notes](#).

This effect does not occur if manual compensation or the non-compensated measurand is used.

Blocking While Charging

In order to prevent pickup as a consequence of the charging process, the I> stage is implicitly blocked for 250 ms by setting $I_{unbal,comp}$ to 0 A, after capacitor energizing has been detected. Blocking only takes place if the stage operates with compensated unbalanced values.

Fault-Location Information

When picking up, the stage provides information about the faulty group of the capacitor bank. If the location can be safely determined, the corresponding indication *Fault position group 1* or *Fault position group 2* is issued.

Both indications also contain the information about the faulty phase. If the capacitor is implemented with 2 neutral points, the following definition is assumed:

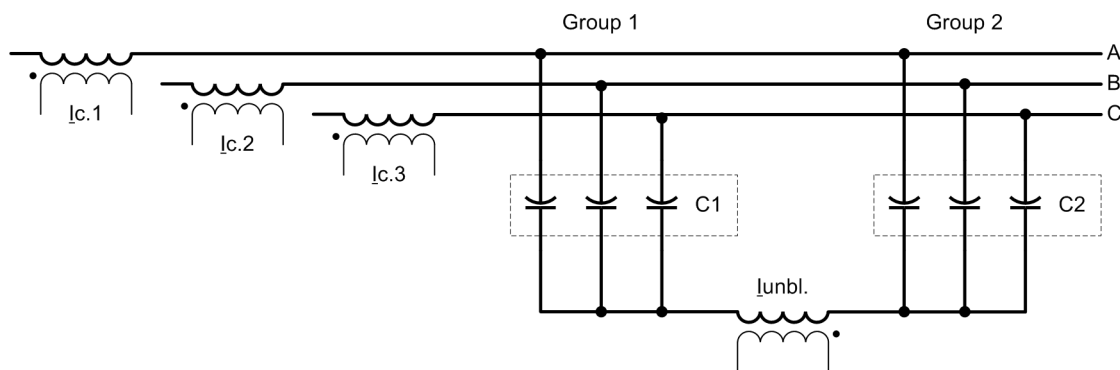

[dw_fehlerortinf_junsi1ph_1_en_US]

Figure 8-9 Definition for the Fault-Location Information

The black dot indicates the orientation of the current transformer. For the connection of the current transformer shown in the previous figure, the following definition applies:

- Group 1: C1
- Group 2: C2

In order to determine the fault location (group 1 or 2) correctly, use the parameter **Capacitor element type** (in FB **General** of the **Capacitor bank** function group) to tell the device whether the elements of the capacitor bank have internal fuses or not.

Non-Compensated Status

If no compensated values are available and the stage has been set to use such values, the stage will be blocked. The readiness of the stage turns to *warning*. This condition will be reported on the function stage (indication *Alg. not compensated*).

8.2.4.2 Application and Setting Notes

Parameter: Measured value

- Default setting (`_:16231:100`) **Measured value** = *compensated*

With this parameter you set the **Measured value** .

Parameter Value	Description
<i>compensated</i>	The stage uses compensated unbalanced values. This means an operational current unbalance will be eliminated. This allows you to increase significantly the sensitivity of the measurement. Note: If any phase current I_c is lower than the threshold Current threshold CB open , the stage is rendered inactive by setting $I_{unbal,comp}$ to 0 A. This condition is held for 250 ms after energizing has been detected in order to avoid a pickup as a consequence of the charging process. Siemens recommends using compensated unbalanced values. In case that automatic compensation is applied, consider the setting notes for the operate delay.
<i>non-compensated</i>	The stage works with non-compensated unbalanced values. This means the measurand may contain an existing operational current unbalance.

Parameter: Threshold

- Default setting (`_:16231:3`) **Threshold** = *1.500 A*

Set the parameter **Threshold** for the specific application.

When using compensated unbalanced values, very sensitive settings are possible. When using non-compensated unbalanced values, the threshold must be higher than the maximum operational unbalanced current.

Parameter: Operate delay

- Default setting (`_:16231:6`) **Operate delay** = *0.30 s* (for the 1st stage)

Set the parameter **Operate delay** for the specific application.



NOTE

If the function has been set to automatic compensation and the stage works with compensated values, the maximum permitted operate delay is 80 ms. If the operate delay is set to longer than 80 ms the automatic compensation might cause dropout of the picked-up stage. This risk does not exist when manual compensation or non-compensated values are used.

8.2.4.3 Settings

Addr.	Parameter	C	Setting Options	Default Setting
<i>I> 1</i>				
<code>_:16231:1</code>	<code>I> 1:Mode</code>		<ul style="list-style-type: none"> • off • on • test 	off
<code>_:16231:2</code>	<code>I> 1:Operate & flt.rec. blocked</code>		<ul style="list-style-type: none"> • no • yes 	no

Addr.	Parameter	C	Setting Options	Default Setting
_:16231:100	I> 1:Measured value		<ul style="list-style-type: none"> compensated non-compensated 	compensated
_:16231:3	I> 1:Threshold	1 A @ 100 Irated	0.030 A to 35.000 A	0.200 A
		5 A @ 100 Irated	0.15 A to 175.00 A	1.00 A
		1 A @ 50 Irated	0.030 A to 35.000 A	0.200 A
		5 A @ 50 Irated	0.15 A to 175.00 A	1.00 A
		1 A @ 1.6 Irated	0.001 A to 1.600 A	0.200 A
		5 A @ 1.6 Irated	0.005 A to 8.000 A	1.000 A
_:16231:6	I> 1:Operate delay		0.00 s to 60.00 s	0.08 s

8.2.4.4 Information List

No.	Information	Data Class (Type)	Type
I> 1			
_:16231:81	I> 1:>Block stage	SPS	I
_:16231:54	I> 1:Inactive	SPS	O
_:16231:52	I> 1:Behavior	ENS	O
_:16231:53	I> 1:Health	ENS	O
_:16231:55	I> 1:Pickup	ACD	O
_:16231:56	I> 1:Operate delay expired	ACT	O
_:16231:57	I> 1:Operate	ACT	O
_:16231:301	I> 1:Fault position group 1	ACT	O
_:16231:302	I> 1:Fault position group 2	ACT	O

8.2.5 Counter Stage

8.2.5.1 Description

Logic of a Stage

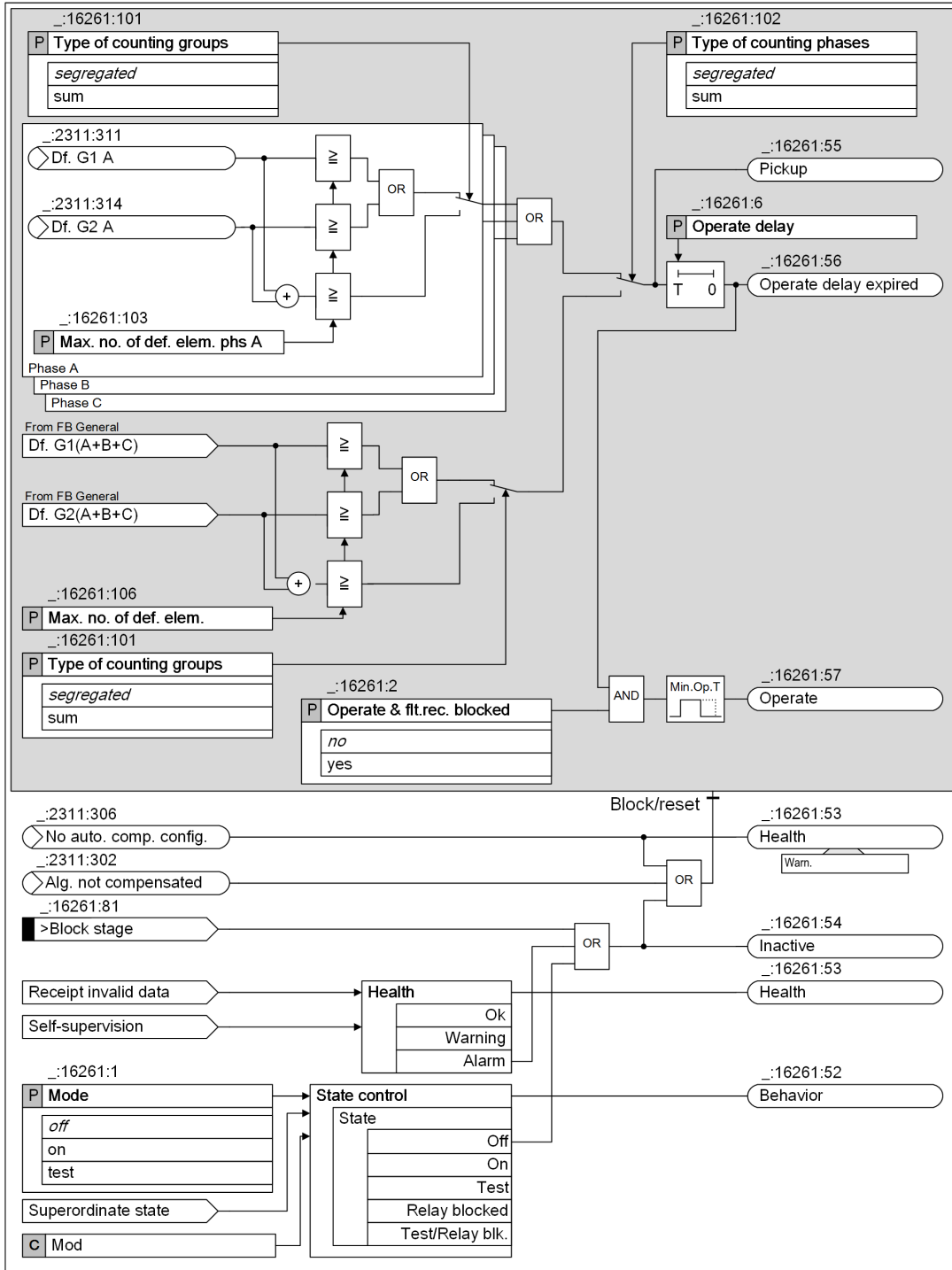

[/o_cnt-stage_1ph_3_en_US]

Figure 8-10 Logic Diagram of the Counter Stage

Measurands/Input Values

The measurand/input values of the counter stage are phase-segregated and group-segregated counter contents that are determined in the **General** FB.

Pickup, Operate Delay

With the parameter **Type of counting phases**, a selection is made whether the supervision function occurs in a phase-segregated way or with the sum value of the phases. With the parameter **Type of counting groups**, a selection is made whether the supervision function occurs in a group-segregated way or with the sum value of both groups. If a counter reaches the set threshold, the stage picks up. The pickup starts the time delay. If the time delay has elapsed, the operate indication will be issued.

Automatic Compensation

If the automatic compensation function is enabled, the counter stage is working. If this is not the case, the readiness status of the stage changes to the state *warning*.

8.2.5.2 Application and Setting Notes

General Notes

- The setting notes for the current-threshold value for counting faulty C-elements are provided in chapter [8.2.3.2 Application and Setting Notes](#) as you must set this parameter across all stages.
- In order to react quickly to the simultaneous fault of many C-elements, always use an overcurrent-protection stage I> with a short operate delay (< 100 ms) in addition to the counter stage. This is necessary as the counter function counts each current jump only once, regardless of its height.

Parameter: Type of counting groups

- Default setting (`_:16261:101`) **Type of counting groups** = *segregated*

With the parameter **Type of counting groups**, you specify whether the group-segregated counter status or the sum value of both group counters are compared to the threshold.

Parameter: Type of counting phases

- Default setting (`_:16261:102`) **Type of counting phases** = *segregated*

With the parameter **Type of counting phases**, you specify whether the supervision function occurs in a phase-segregated way or with the sum value of the phases.

Parameter: Maximum Number of Faulty Elements, Operate delay

- Default setting (`_:16261:103`) **Max. no. of def. elem. phs A** = 10
- Default setting (`_:16261:104`) **Max. no. of def. elem. phs B** = 10
- Default setting (`_:16261:105`) **Max. no. of def. elem. phs C** = 10
- Default setting (`_:16261:106`) **Max. no. of def. elem.** = 10
- Default setting (`_:16261:6`) **Operate delay** = 0.00 s

Set the parameters for the specific application.

It is possible to configure several stages for different tasks:

- Reporting only (with or without fault record)

Use this stage to report 1 or 2 faulty C-elements. To do this, set the parameters **Max. no. of def. elem. phs A**, **Max. no. of def. elem. phs B**, **Max. no. of def. elem. phs C**, or **Max. no. of def. elem.** to a small value (1 or 2). The parameter **Operate delay** can be set to 0. If you would like to prevent the operate (tripping) and fault logging (fault log and fault record), set the parameter **Operate & flt.rec. blocked** to **yes**.

If you would like to prevent only the operate (tripping) and the fault logging must occur, remove this stage from the interface **Trip** to the circuit breaker (see also [5.5.2 Structure of the Function Group Interfaces with Circuit-Breaker Function Group](#)).
- Indication with delayed operate

Use this stage to report in case of some faulty C-elements and to set a relatively long time delay of the operate, for example, 2 hours. During this time, the fault of the C-elements can be clarified. If it is possible to find a solution, the counter status can be reset manually. This way, the stage drops out. If a solution cannot be found within 2 hours, the stage trips and disconnects the capacitor bank.
- Immediate operate

The stage is used to initiate the operate immediately after a larger number of C-elements became faulty.

8.2.5.3 Settings

Addr.	Parameter	C	Setting Options	Default Setting
Counter 1				
_:16261:1	Counter 1:Mode		<ul style="list-style-type: none"> off on test 	off
_:16261:2	Counter 1:Operate & flt.rec. blocked		<ul style="list-style-type: none"> no yes 	no
_:16261:101	Counter 1:Type of counting groups		<ul style="list-style-type: none"> segregated sum 	segregated
_:16261:102	Counter 1:Type of counting phases		<ul style="list-style-type: none"> segregated sum 	segregated
_:16261:103	Counter 1:Max. no. of def. elem. phs A		1 to 1000	10
_:16261:104	Counter 1:Max. no. of def. elem. phs B		1 to 1000	10
_:16261:105	Counter 1:Max. no. of def. elem. phs C		1 to 1000	10
_:16261:106	Counter 1:Max. no. of def. elem.		1 to 1000	10
_:16261:6	Counter 1:Operate delay		0.00 s to 10000.00 s	0.00 s

8.2.5.4 Information List

No.	Information	Data Class (Type)	Type
Counter 1			
_:16261:81	Counter 1:>Block stage	SPS	I
_:16261:54	Counter 1:Inactive	SPS	O
_:16261:52	Counter 1:Behavior	ENS	O
_:16261:53	Counter 1:Health	ENS	O
_:16261:55	Counter 1:Pickup	ACD	O

No.	Information	Data Class (Type)	Type
_:16261:56	Counter 1:Operate delay expired	ACT	O
_:16261:57	Counter 1:Operate	ACT	O

8.3 Peak Overvoltage Protection for Capacitors

8.3.1 Overview of Functions

The **Peak overvoltage protection for capacitors (ANSI 59C)** function protects capacitors against:

- Peak overvoltages that stress the dielectric medium in the capacitor causing accelerated aging
- Peak overvoltages that in extreme cases can destroy the dielectric medium in the capacitor

8.3.2 Structure of the Function

The **Peak overvoltage protection for capacitors** function can be applied in the **Capacitor bank** function group.

3 types of stages are available:

- Stage with inverse-time characteristic curve according to IEC and IEEE Standards
- Stage with definite-time characteristic curve
- Stage with user-defined characteristic curve

The function is preconfigured at the factory with a stage having an inverse-time characteristic curve and a stage having a definite-time characteristic curve.

Within the function, the following maximum number of stages can be operated simultaneously:

- 1 stage with an inverse-time characteristic curve
- 4 stages with a definite-time characteristic curve
- 1 stage with a user-defined characteristic curve

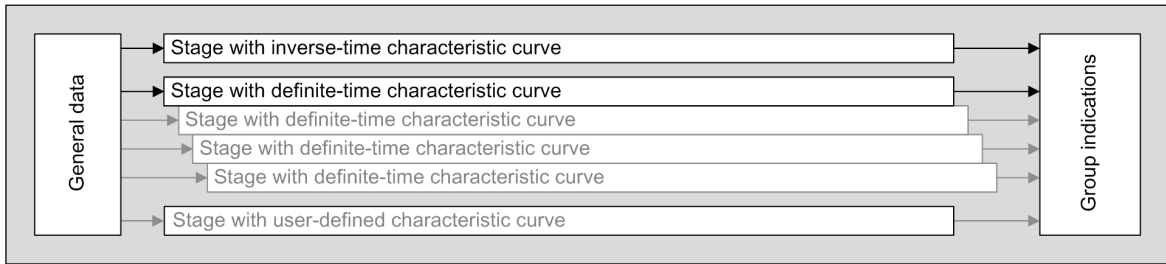

[dw_strpea, 3, en_US]

Figure 8-11 Structure/Embedding of the Function

8.3.3 Stage with Inverse-Time Characteristic Curve

8.3.3.1 Description

Logic of the Stage

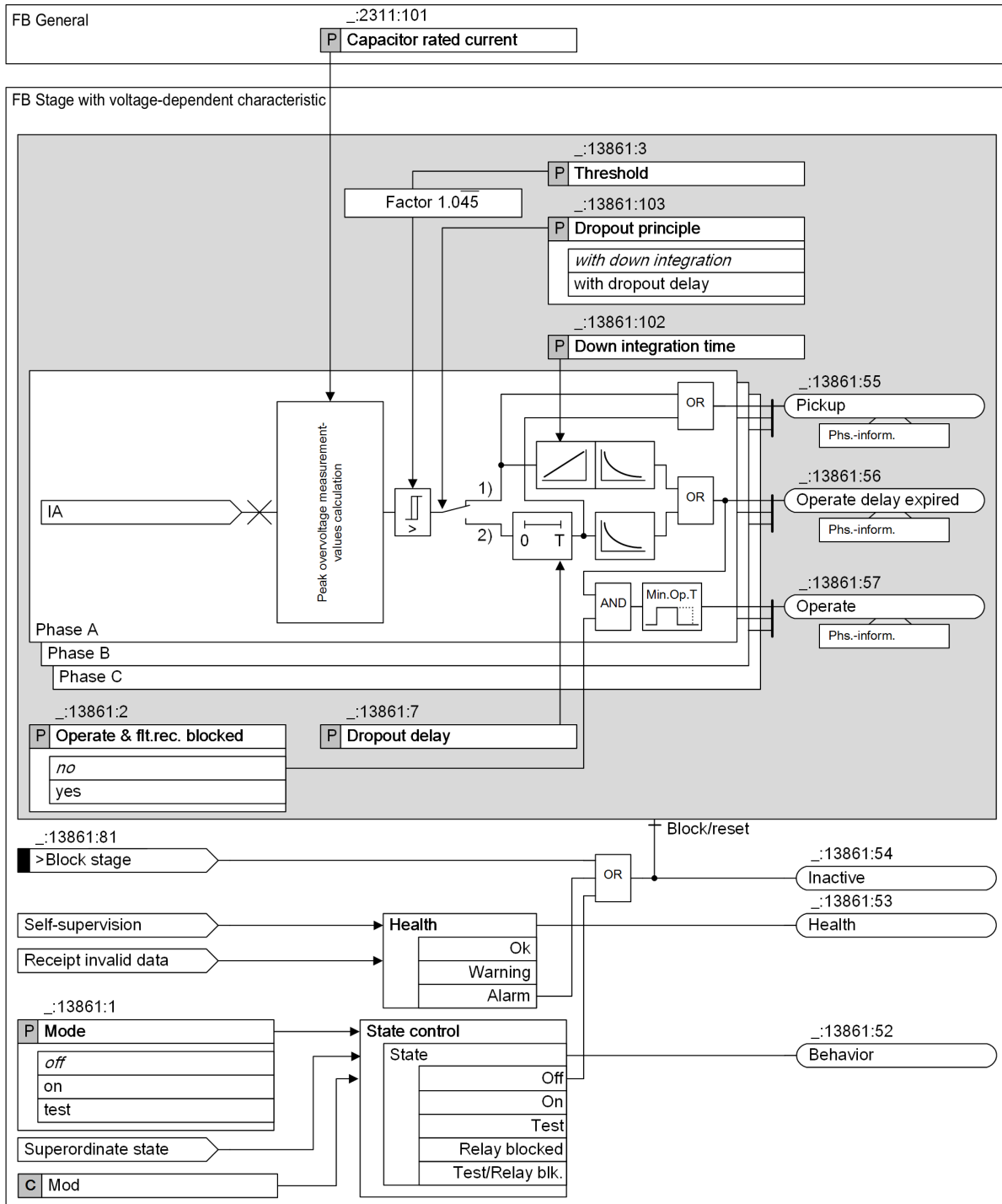

[to_peainv, 3, en_US]

Figure 8-12 Logic Diagram of the Stage with Inverse-Time Characteristic Curve

- (1) With down integration time
- (2) With dropout delay

Measurand, Method of Measurement

The function calculates the peak voltage in a phase-segregated way from the fundamental component and superimposed harmonics. Integration of the phase currents then yields the voltage. This approach captures the higher harmonics considerably better since they are transferred better by current transformers than by voltage transformers.

The peak voltage determined is then set with reference to the rated voltage of the capacitor. The resulting measurand is $\hat{U}/V_{C-rated}(t)$. The threshold value for the stage is thus set as a referenced quantity.

The phase-selective peak overvoltages $\hat{U}/V_{C-rated}(t)$ are available as measured values for display or further processing.

Frequency Restriction

If the frequency deviates from the rated frequency for more than 3 Hz, the peak-voltage calculation becomes less accurate. Due to this situation, the calculation is blocked under this condition and the functional measured values *vpeakA*, *vpeakB*, and *vpeakC* are shown as "---" (not calculated). The definite-time and inverse-time stages of peak overvoltage protection do not operate. In this condition, the signal *Freq. oper. range left* is issued.

Pickup, Tripping, and Dropout Behavior with the Inverse-Time Characteristic Curve

If the measurand $\hat{U}/V_{C-rated}(t)$ exceeds 1.045 times the set threshold value (for example, $1.045 \times 1.1 \approx 1.15$), pickup occurs and the inverse-time characteristic curve is then followed. For each input value that exceeds the pickup value ($1.045 \times$ threshold value), the time value T_{trip} is calculated. An integrator accumulates the value $1/T_{trip}$. When the accumulated integral reaches the fixed value of 1, the stage trips.

If the measurand falls below 1.045 times the set threshold value (pickup value), processing of the characteristic (accumulation of the time values) stops. In the hysteresis region between the pickup value and dropout value (95 % of the pickup value, for example, $0.95 \times 1.15 = 1.0925$), the integral value remains unchanged. The stage, however, remains in the picked-up state.

Use the parameter **Dropout principle** to select the method for the dropout of the stage:

- **Method with down integration time:**
If the measurand falls below the dropout threshold, the pickup drops out immediately. If the value drops below the pickup threshold, the internal integral value that depends on the selected **Down integration time** is slowly reduced. The **Down integration time** defines the duration in order to reduce the internal integral value linear from 100 % to 0 %. The internal integral value is limited to 100 % and is reached with the tripping function.
- **Method with dropout delay:**
If the measurand falls below the dropout threshold, the pickup drops not out immediately. The pickup remains for the duration of the set **Dropout delay**. The integral value remains frozen during this time. If the pickup value is not exceeded again during this time, a dropout occurs and the integral value is reset to 0. If the pickup value is exceeded during this time again, the integrator continues with the integration of frozen values. The pickup remains active and the **Dropout delay** is reset.

Inverse-Time Characteristic Curve

The characteristic curve is defined by the Standards IEC 60871-1:2014 and IEEE Std 1036-2020, see [Figure 8-13](#).

The points on the characteristic curve defined in the standards result from a threshold setting of 1.1. Threshold values differing from this value shift the characteristic as shown in [Figure 8-13](#).

Straight-line segments are implemented between the defined points on semi-logarithmic coordinates.

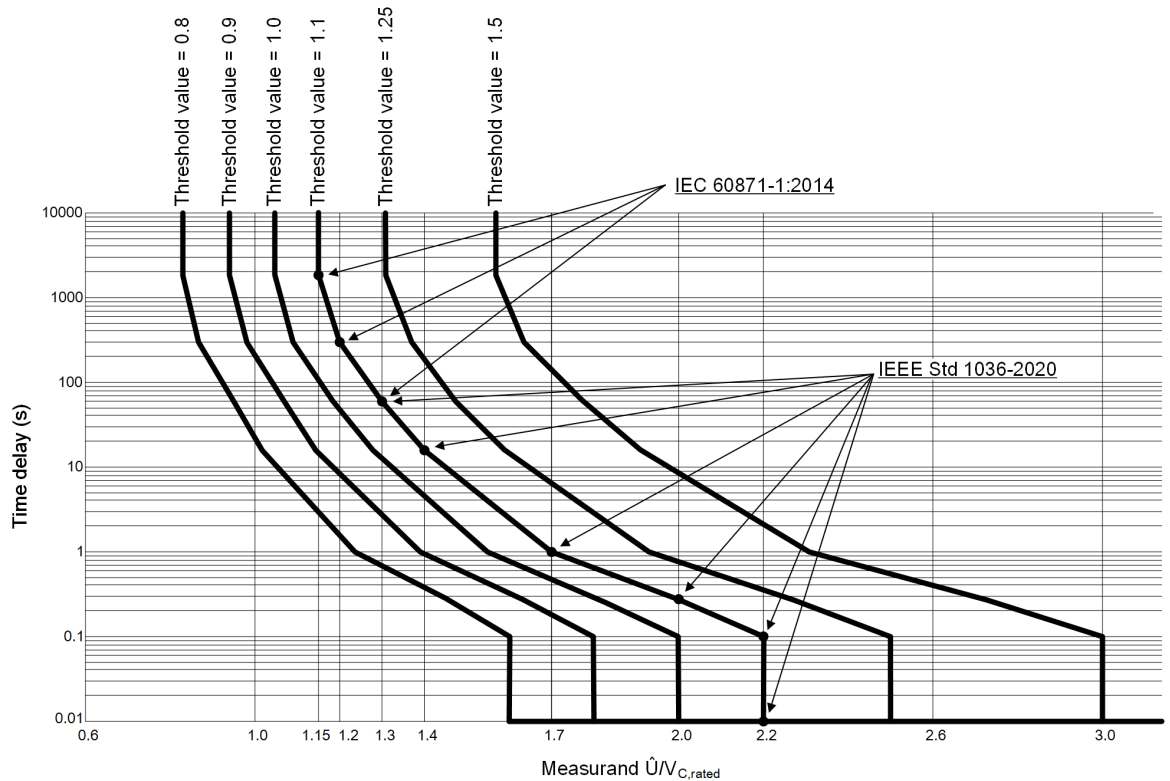

[dw_pecinv, 3_en_US]

Figure 8-13 Inverse-Time Characteristic Curve

Phase-Segregated Operate Indications

In contrast to what normally occurs in a 3-phase protection device, the function generates phase-segregated operate indications. These indications are needed for supervision applications.

Functional Measured Values

Values	Description	Primary	Secondary	% Referenced to
(_:2311:301) VpeakA	Peak voltage phase A	kV	V	Parameter Capacitor reference volt./√3
(_:2311:302) VpeakB	Peak voltage phase B	kV	V	Parameter Capacitor reference volt./√3
(_:2311:303) VpeakC	Peak voltage phase C	kV	V	Parameter Capacitor reference volt./√3

You can find the parameter **Capacitor reference volt.** of the preceding table in the function block **General** of the function group **Capacitor bank**.

8.3.3.2 Application and Setting Notes

Parameter: Capacitor rated current

- Default setting (_:2311:101) **Capacitor rated current** = 1000.0 A

With the **Capacitor rated current** parameter, you set the primary rated current $I_{C, \text{rated}}$ of the capacitor or the capacitor bank.

Keep in mind that the rated current of the capacitor considers harmonics in addition to the fundamental component.

The rated current $I_{C-rated}$ is determined from the rated capacity and the rated voltage across the bank. Both values are listed in the Technical Data for the capacitor. Take note of the following:

- The rated voltage for the capacitor also takes harmonics into account. This is not the rated voltage of the system.
- The rated voltage to be used is the voltage applied across the capacitor; depending on the application, this can be a phase-to-phase or phase-to-ground voltage.

Example: Determining the Capacitor Rated Current for a Capacitor in a Star Connection

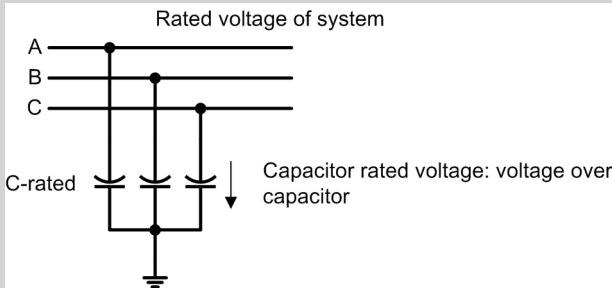

Figure 8-14 Capacitor in Star Connection

Rated voltage of the system	220 kV
Rated capacity per phase	5.233 μF
Capacitor rated voltage $V_{C-rated}$	192.30 kVrms
Rated frequency f	50 Hz

$$I_{C-rated} = \omega C \times U_{C-rated} = 2\pi f \times C \times U_{C-rated} = 2 \pi 50 \times 5.233 \cdot 10^{-6} \times 192.3 \cdot 10^3 \text{ [Hz} \times \text{F} \times \text{U}] = 316.1 \text{ [A]}$$

Parameter: Threshold

- Default setting (`_:13861:3`) **Threshold = 1.10**

The peak voltage determined is then set with reference to the rated voltage of the capacitor. The threshold value is thus set as a referenced quantity.

The points on the characteristic curve defined in the Standards IEC 60871-1:2014 and IEEE Std 1036-2020 result from a threshold setting of **1.10** (see [Figure 8-13](#)). Threshold values differing from this shift the characteristic as shown in [Figure 8-13](#).

Siemens recommends using the default setting.

Parameter: Dropout principle

- Default setting (`_:13861:103`) **Dropout principle = with down integration**

Use the parameter **Dropout principle** to select the method for the dropout of the stage:

Parameter Value	Description
with down integration	If the measurand for the dropout threshold falls below the limit, the pickup drops out immediately. If the value drops below the pickup threshold, the internal integral value that depends on the selected down integration time is reduced from 100 % to 0 %
with dropout delay	If the measurand falls below the dropout threshold, the measurand remains active for the duration of the preset dropout delay. The integral value remains frozen during this time.

Parameter: Down integration time

- Default setting (`_:13861:102`) **Down integration time = 3.00 min**

Use the parameter **Down integration time** in order to determine the duration until the internal integration value is linearly reduced from 100 % to 0 %.

For example, if the integration value is 52 %, a duration of 52 % × down integration time is required until the integration value 0 % is reached. When using this parameter, the preloading of a capacitor can be considered and therefore released quicker.

If you are knowledgeable about recovery time of stressed capacitors, they can be considered with this parameter.

Parameter: Dropout delay

- Default setting (`_:13861:7`) **Dropout delay = 1.00 s**

The parameter **Dropout delay** can be used to prevent resetting of the integral value in the event that the measured value briefly falls below the dropout threshold.

8.3.3.3 Settings

Addr.	Parameter	C	Setting Options	Default Setting
General				
<code>_:2311:101</code>	General:Capacitor rated current		1.0 A to 100000.0 A	1000.0 A
Inverse-T 1				
<code>_:13861:1</code>	Inverse-T 1:Mode		<ul style="list-style-type: none"> • off • on • test 	off
<code>_:13861:2</code>	Inverse-T 1:Operate & flt.rec. blocked		<ul style="list-style-type: none"> • no • yes 	no
<code>_:13861:103</code>	Inverse-T 1:Dropout principle		<ul style="list-style-type: none"> • with dropout delay • with down integration 	with down integration
<code>_:13861:3</code>	Inverse-T 1:Threshold		0.80 p.u. to 3.00 p.u.	1.10 p.u.
<code>_:13861:102</code>	Inverse-T 1:Down integration time		1 min to 1500 min	3 min
<code>_:13861:7</code>	Inverse-T 1:Dropout delay		0.00 s to 3600.00 s	1.00 s

8.3.3.4 Information List

No.	Information	Data Class (Type)	Type
General			
<code>_:2311:301</code>	General:VpeakA	MV	O
<code>_:2311:302</code>	General:VpeakB	MV	O
<code>_:2311:303</code>	General:VpeakC	MV	O
<code>_:2311:304</code>	General:Freq. oper. range left	SPS	O
<code>_:2311:52</code>	General:Behavior	ENS	O
<code>_:2311:53</code>	General:Health	ENS	O
Group indicat.			
<code>_:4501:55</code>	Group indicat.:Pickup	ACD	O
<code>_:4501:57</code>	Group indicat.:Operate	ACT	O
<code>_:4501:52</code>	Group indicat.:Behavior	ENS	O

No.	Information	Data Class (Type)	Type
_:4501:53	Group indicat.:Health	ENS	O
<i>Inverse-T 1</i>			
_:13861:81	Inverse-T 1:>Block stage	SPS	I
_:13861:51	Inverse-T 1:Mode (controllable)	ENC	C
_:13861:54	Inverse-T 1:Inactive	SPS	O
_:13861:52	Inverse-T 1:Behavior	ENS	O
_:13861:53	Inverse-T 1:Health	ENS	O
_:13861:55	Inverse-T 1:Pickup	ACD	O
_:13861:301	Inverse-T 1:Down integr. running	SPS	O
_:13861:56	Inverse-T 1:Operate delay expired	ACT	O
_:13861:57	Inverse-T 1:Operate	ACT	O

8.3.4 Stage with Definite-Time Characteristic Curve

8.3.4.1 Description

Logic of the Stage

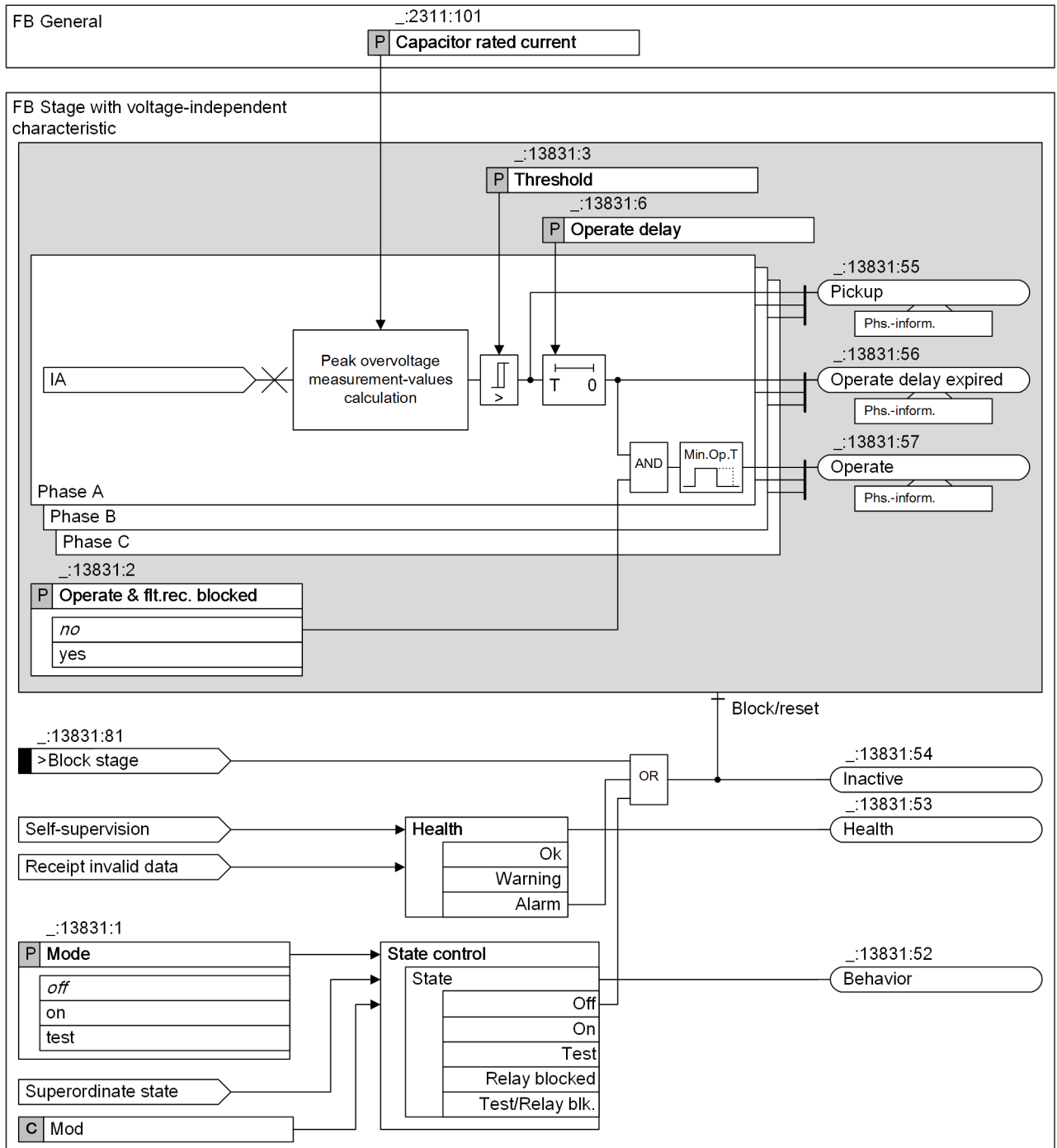

[to_peadef, 2, en_US]

Figure 8-15 Logic Diagram of the Stage with Definite-Time Characteristic Curve

Measurand, Method of Measurement

The function calculates the peak voltage in a phase-segregated way from the fundamental component and superimposed harmonics. Integration of the phase currents then yields the voltage. This approach captures the higher harmonics considerably better since they are transferred better by current transformers than by voltage transformers.

The peak voltage determined is then set with reference to the rated voltage of the capacitor. The resulting measurand is $\hat{U}/V_{C\text{-rated}}(t)$. The threshold value for the stage is thus set as a referenced quantity.

The phase-selective peak overvoltages $\hat{U}/V_{C\text{-rated}}(t)$ are available as measured values for display or further processing.

Frequency Restriction

If the frequency deviates from the rated frequency for more than 3 Hz, the peak-voltage calculation becomes less accurate. Due to this situation, the calculation is blocked under this condition and the functional measured values *vpeakA*, *vpeakB*, and *vpeakC* are shown as "---" (not calculated). The definite-time and inverse-time stages of peak overvoltage protection do not operate. In this condition, the signal *Freq. oper. range left* is issued.

Pickup, Tripping and Dropout Behavior with the Definite-Time Characteristic Curve

If the measurand $\hat{U}/V_{C\text{-rated}}(t)$ exceeds the set threshold value, pickup occurs and the tripping delay starts. If the measurand remains above the dropout value (95 % of the threshold value) during the tripping delay, the stage trips.

Phase-Segregated Operate Indications

In contrast to what normally occurs in a 3-phase protection device, the function generates phase-segregated operate indications. These indications are needed for supervision applications.

Functional Measured Values

For the detailed information of the functional measured values, refer to [Functional Measured Values, Page 1141](#).

8.3.4.2 Application and Setting Notes

Parameter: Capacitor rated current

- Default setting (`_ :2311:101`) **Capacitor rated current** = 1000.0 A

You can find the setting notes for the parameter **Capacitor rated current** under [Parameter: Capacitor rated current, Page 1141](#).

Parameter: Threshold

- Default setting (`_ :13831:3`) **Threshold** = 1.10

The peak voltage determined is then set with reference to the rated voltage of the capacitor. The **Threshold** is thus set as a referenced quantity.

The setting depends on the application of the stage. If this stage is intended to operate as a warning stage, a very sensitive setting of approx. 1.05 can be selected. If the stage is used for instantaneous tripping in addition to the stage with inverse-time characteristic curve, Siemens recommends a setting of ≥ 3.00 .

Parameter: Operate delay

- Default setting (`_ :13831:6`) **Operate delay** = 3.00 s

The setting depends on the application of the stage. If this stage is intended to operate as a warning stage, the time delay can be selected in a range of seconds. If the stage is used for instantaneous tripping in addition to the stage with inverse-time characteristic curve, the **Operate delay** can be set to 0.00 s.

8.3.4.3 Settings

Addr.	Parameter	C	Setting Options	Default Setting
General				
_:2311:101	General:Capacitor rated current		1.0 A to 100000.0 A	1000.0 A
Definite-T 1				
_:13831:1	Definite-T 1:Mode		<ul style="list-style-type: none"> • off • on • test 	off
_:13831:2	Definite-T 1:Operate & flt.rec. blocked		<ul style="list-style-type: none"> • no • yes 	no
_:13831:3	Definite-T 1:Threshold		0.80 p.u. to 10.00 p.u.	5.00 p.u.
_:13831:6	Definite-T 1:Operate delay		0.01 s to 3600.00 s	0.03 s

8.3.4.4 Information List

No.	Information	Data Class (Type)	Type
General			
_:2311:301	General:VpeakA	MV	O
_:2311:302	General:VpeakB	MV	O
_:2311:303	General:VpeakC	MV	O
_:2311:304	General:Freq. oper. range left	SPS	O
_:2311:52	General:Behavior	ENS	O
_:2311:53	General:Health	ENS	O
Group indicat.			
_:4501:55	Group indicat.:Pickup	ACD	O
_:4501:57	Group indicat.:Operate	ACT	O
_:4501:52	Group indicat.:Behavior	ENS	O
_:4501:53	Group indicat.:Health	ENS	O
Definite-T 1			
_:13831:81	Definite-T 1:>Block stage	SPS	I
_:13831:51	Definite-T 1:Mode (controllable)	ENC	C
_:13831:54	Definite-T 1:Inactive	SPS	O
_:13831:52	Definite-T 1:Behavior	ENS	O
_:13831:53	Definite-T 1:Health	ENS	O
_:13831:55	Definite-T 1:Pickup	ACD	O
_:13831:56	Definite-T 1:Operate delay expired	ACT	O
_:13831:57	Definite-T 1:Operate	ACT	O

8.3.5 Stage with User-Defined Characteristic Curve

8.3.5.1 Description

This stage is structured the same way as the stage with a **voltage-dependent** characteristic (see chapter [8.3.3.1 Description](#)). The only difference is that you can define the characteristic curve as desired. This means that you can also define a dropout characteristic curve. This makes the **dropout delay** parameter superfluous and unneeded.

User-Defined Characteristic Curve

With the user-defined characteristic curve, you can define the operate curve point by point using up to 30 value pairs of voltage and time. The device uses linear interpolation to calculate the characteristic curve from these values. You can also define a dropout characteristic curve if you wish.

Pickup and Dropout Behavior with the User-Defined Characteristic Curve

If the measurand $\hat{U}/V_{C-rated}(t)$ exceeds the threshold value, the characteristic is followed. An integrating method of measurement summarizes the weighted time. The weighted time results from the characteristic curve. This means that the time associated with the present measured value is determined from the characteristic curve. Once the weighted time exceeds the value 1, the stage operates.

If the measured value falls below 95 % of the set threshold value, the dropout is initiated. The pickup will be indicated as clearing. The weighted time results from the dropout characteristic curve. The integral value is reduced until it reaches 0.

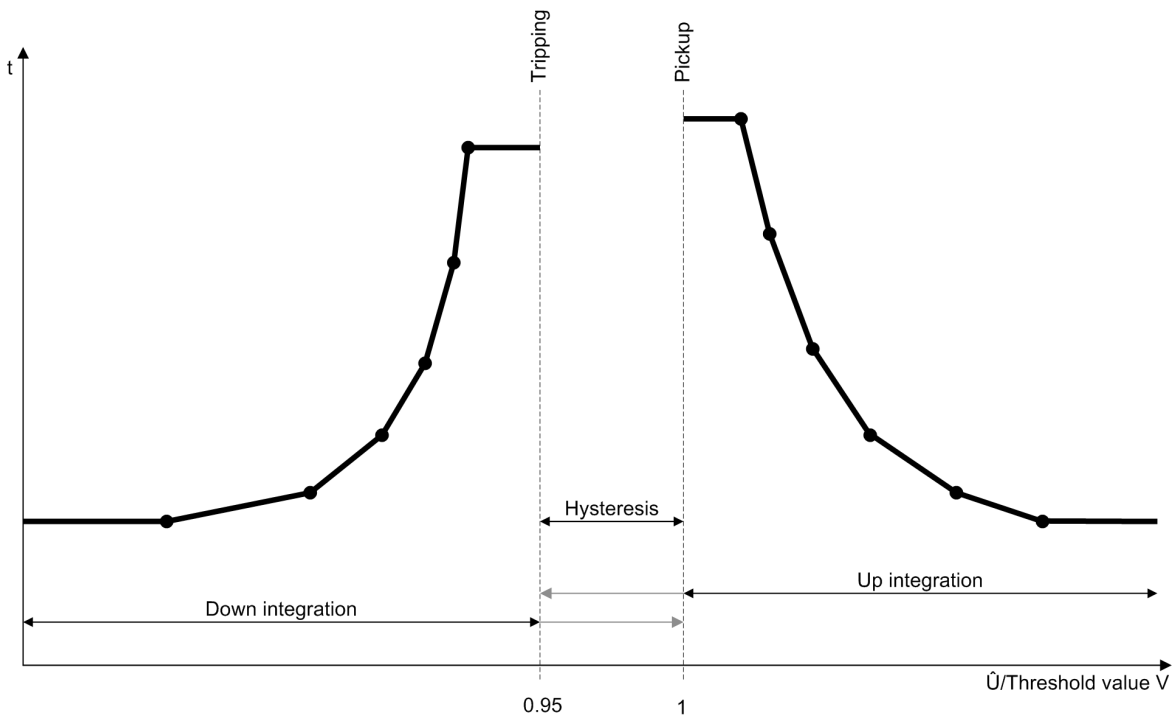

[dw_pecuse_2_en_US]

Figure 8-16 Pickup Behavior and Dropout Behavior when Using a User-Defined Characteristic Curve

8.3.5.2 Application and Setting Notes

This stage is structured the same way as the stage with an **inverse-time** characteristic (see chapter [8.3.3.2 Application and Setting Notes](#)). The only difference is that you can define the characteristic curve as desired. This chapter provides only application and setting notes for setting characteristic curves.

Parameter: Voltage/Time Value Pairs (from the Operate Curve)

Use these settings to define the characteristic curve. Set a voltage/time value pair for each point on the characteristic curve. The setting depends on the characteristic curve you want to realize.

Set the voltage to a multiple of the threshold value. In order to obtain a simple relation, Siemens recommends setting the **Threshold** parameter to **1.00**. You can change the threshold value setting afterwards if you want to shift the characteristic curve.

Set the time value in seconds. The characteristic curve is shifted via the **Time dial** parameter.

Set the number of value pairs to be used with DIGSI. You can define a maximum of 30 value pairs.



NOTE

The value pairs must be entered in continuous order.

Parameter: Time dial

- Default setting (`_:101`) **Time dial** = 1

Use the **Time dial** parameter to displace the characteristic curve in the time direction.

Where no time grading of tripping and thus no shifting of the characteristic curve is required, leave the parameter **Time dial** at 1.

Parameter: Voltage/Time Value Pairs (from the Dropout Characteristic Curve)

Use these settings to define the characteristic curve. Set a voltage/time value pair for each point on the characteristic curve. The setting depends on the characteristic curve you want to realize.

Set the voltage to a multiple of the threshold value. Siemens recommends setting the **Threshold** parameter to **1.00** in order to obtain a simple relation. You can change the threshold value afterwards if you want to shift the characteristic curve.

Set the time value in seconds. The characteristic curve is shifted via the **Time dial** parameter.

Set the number of value pairs to be used with DIGSI. You can define a maximum of 30 value pairs.



NOTE

The value pairs must be entered in continuous order.

8.3.5.3 Settings

Addr.	Parameter	C	Setting Options	Default Setting
<i>General</i>				
<code>_:1</code>	User curve #:Mode		<ul style="list-style-type: none"> • off • on • test 	off
<code>_:2</code>	User curve #:Operate & flt.rec. blocked		<ul style="list-style-type: none"> • no • yes 	no
<code>_:3</code>	User curve #:Threshold		0.80 p.u. to 3.00 p.u.	1.10 p.u.
<code>_:101</code>	User curve #:Time dial		0.05 to 15.00	1.00

8.3.5.4 Information List

No.	Information	Data Class (Type)	Type
<i>User curve #</i>			
<code>_:81</code>	User curve #:>Block stage	SPS	I
<code>_:54</code>	User curve #:Inactive	SPS	O
<code>_:52</code>	User curve #:Behavior	ENS	O
<code>_:53</code>	User curve #:Health	ENS	O
<code>_:55</code>	User curve #:Pickup	ACD	O
<code>_:56</code>	User curve #:Operate delay expired	ACT	O
<code>_:57</code>	User curve #:Operate	ACT	O
<code>_:301</code>	User curve #:Down integr. running	SPS	O

9 Control Functions

9.1	Introduction	1152
9.2	Switching Devices	1155
9.3	Control Functionality	1178
9.4	Synchronization Function	1202
9.5	Switching Sequences	1267
9.6	User-Defined Function Block [Control]	1274
9.7	CFC-Chart Settings	1279
9.8	Tap Changers	1281
9.9	Point-on-Wave Switching	1293

9.1 Introduction

9.1.1 Overview

The SIPROTEC 5 series of devices offers powerful command processing capability as well as additional functions that are needed when serving as bay controllers for the substation automation technology or when providing combi-protection. The object model for the devices is based on the IEC 61850 standard, making the SIPROTEC 5 series of devices ideally suited for use in systems employing the IEC 61850 communication protocol. In view of the function blocks necessary for the control functions, other logs are also used.

9.1.2 Concept of Controllables

The concept of so-called controllables is based on the data model described in IEC 61850. Controllables are objects that can be controlled, such as a switch with feedback. The model of a transformer tap changer, for example, contains controllables. The controllables are identifiable by their last letter **C** of the data type (for example, DPC = Double Point Controllable/Double Command with feedback or BSC = Binary-Controlled Step Position Indication / transformer tap command with feedback).

Information			Source			
			Binary input			
			Basismodul			
Signals	Number	Type	1.1	1.2	1.3	1.4
(All) ▾	(All) ▾
▼ Circuit break.	202.4261		*	*		
◆ >Ready	202.4261.500	SPS				
◆ >Acquisition blocking	202.4261.501	SPS				
◆ >Reset switch statist.	202.4261.502	SPS				
◆ >Reset AcqBlk&Subst	202.4261.504	SPS				
▶ ◆ External health	202.4261.503	ENS				
▶ ◆ Health	202.4261.53	ENS				
▼ Position	202.4261.58	DPC	OH	CH		
◆ not selected		SPS				
◆ open		SPS				
◆ closed		SPS				
◆ intermediate posi...		SPS				
◆ disturbed position		SPS				
◆ acquisition blk. ac...		SPS				
◆ manual update ac...		SPS				
◆ Trip/open cmd.	202.4261.300	SPS				
◆ Close command	202.4261.301	SPS				
◆ Command active	202.4261.302	SPS				
◆ Definitive trip	202.4261.303	SPS				
◆ Alarm suppression	202.4261.304	SPS				
◆ Op.ct.	202.4261.306	INS				
Break-current phs A	202.4261.311	MV				
Break-current phs B	202.4261.312	MV				
Break-current phs C	202.4261.313	MV				
Break. voltage phs A	202.4261.314	MV				
Break. voltage phs B	202.4261.315	MV				
Break. voltage phs C	202.4261.316	MV				

[sc_control, 1, en_US]

- (1) Position (connect with binary inputs)
- (2) Signalization of the current condition
- (3) Command output (connect with relay)

The trip, opening, and the close commands are connected to the relays. For the trip command, a choice between saved and unsaved output is possible. The position is connected with 2 binary inputs (double-point indication). In addition, signals are available that display the current state of the switch (**not selected**, **off**, **on**, **intermediate position**, **disturbed position**). These signals can be queried in CFC, for example, in order to build interlocking conditions.

Control Models

You can set the operating mode of the controllables by selecting the control model.

4 different control models are available:

- Direct without feedback monitoring (**direct w. normal secur.**)
- With reservation (SBO)³⁴ without feedback monitoring (**SBO w. normal secur.**)
- Direct with feedback monitoring (**direct w. enh. security**)
- With SBO with feedback monitoring (**SBO w. enh. security**)

The next figure shows the command sources, command types, and control models.

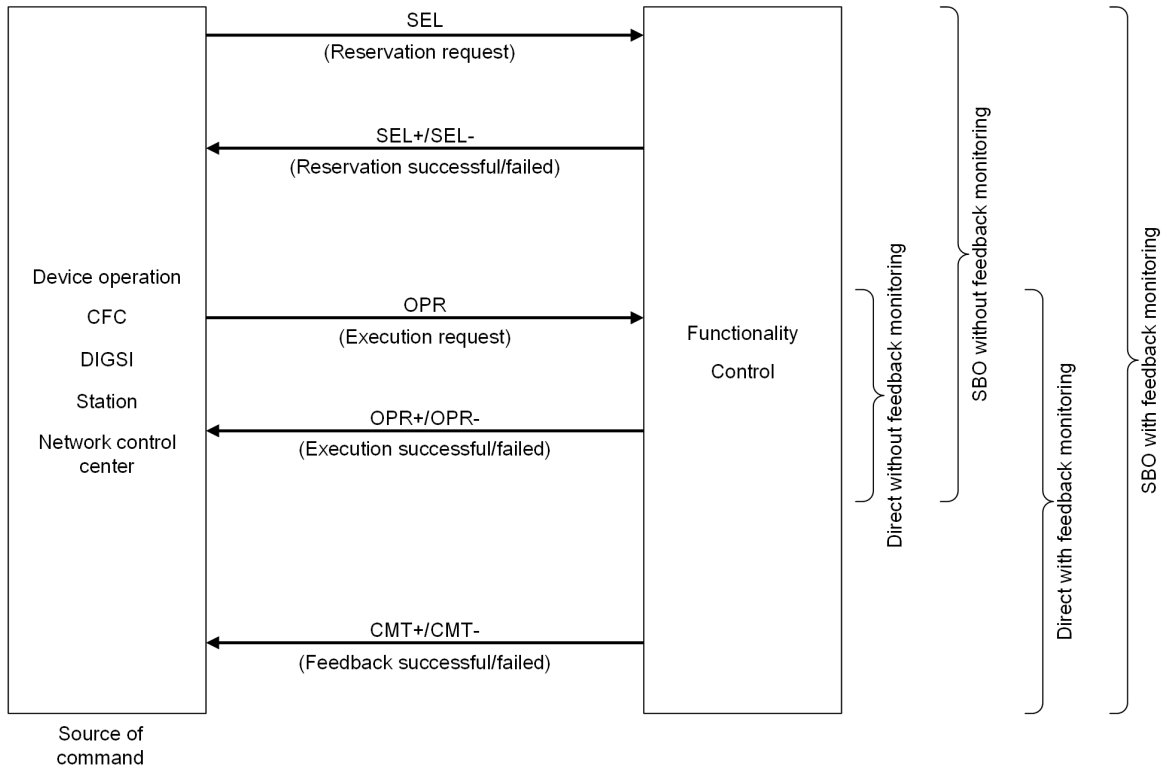

[dw_steuer, 2, en_US]

Figure 9-1 Command Sources, Command Types, and Control Models

The figure shows the control models (right) with the respective control mechanisms (center). The standard control model for a switching command in an IEC 61850 compliant system is **SBO with feedback monitoring (SBO w. enh. security)**. This control model is the default setting for newly created switching devices.

³⁴ SBO: Select Before Operate

9.2 Switching Devices

9.2.1 General Overview

You can find the following switching devices in the DIGSI 5 library in the function groups **Circuit breaker** and **Switching devices** (see following figures).

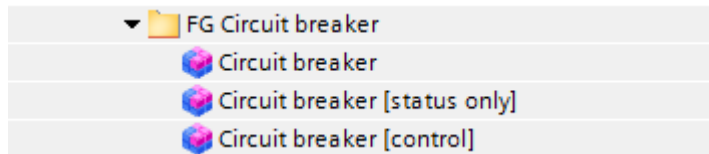

[sc_cb_ausw, 1, en_US]

Figure 9-2 Selecting the Circuit-Breaker Switching Device Using the DIGSI Circuit-Breaker Function Group Menu

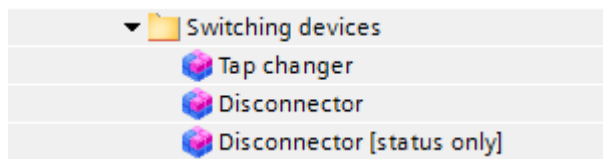

[scswausw, 1, en_US]

Figure 9-3 Selecting the Remaining Switching Devices Using the DIGSI Switching-Devices Menu

9.2.2 Switching Device Circuit Breaker

9.2.2.1 Structure of the Circuit-Breaker Switching Device

This chapter describes the control properties of the **Circuit-breaker** switching device.

The **Circuit-breaker** switching device contains the following function blocks that are needed for control:

- Function block **Circuit breaker**
- Function block **Control**
- Function block **Interlocking**

This corresponds to the logical nodes XCBR, CSWI, and CILO in IEC 61850.

In the case of protection devices or combined protection and control devices, additional functions can be contained in the **Circuit-breaker** switching device, for example, **Synchrocheck**, the **Automatic reclosing (AREC)**, the **Trip logic**, or **Manual On function**. However, these are not relevant for the control function. You can find the description of these functions in the chapter *Protection and Automatic Functions*. In addition, other functions can be initialized. You can find the description of these functions in the chapter *Protection Functions*.

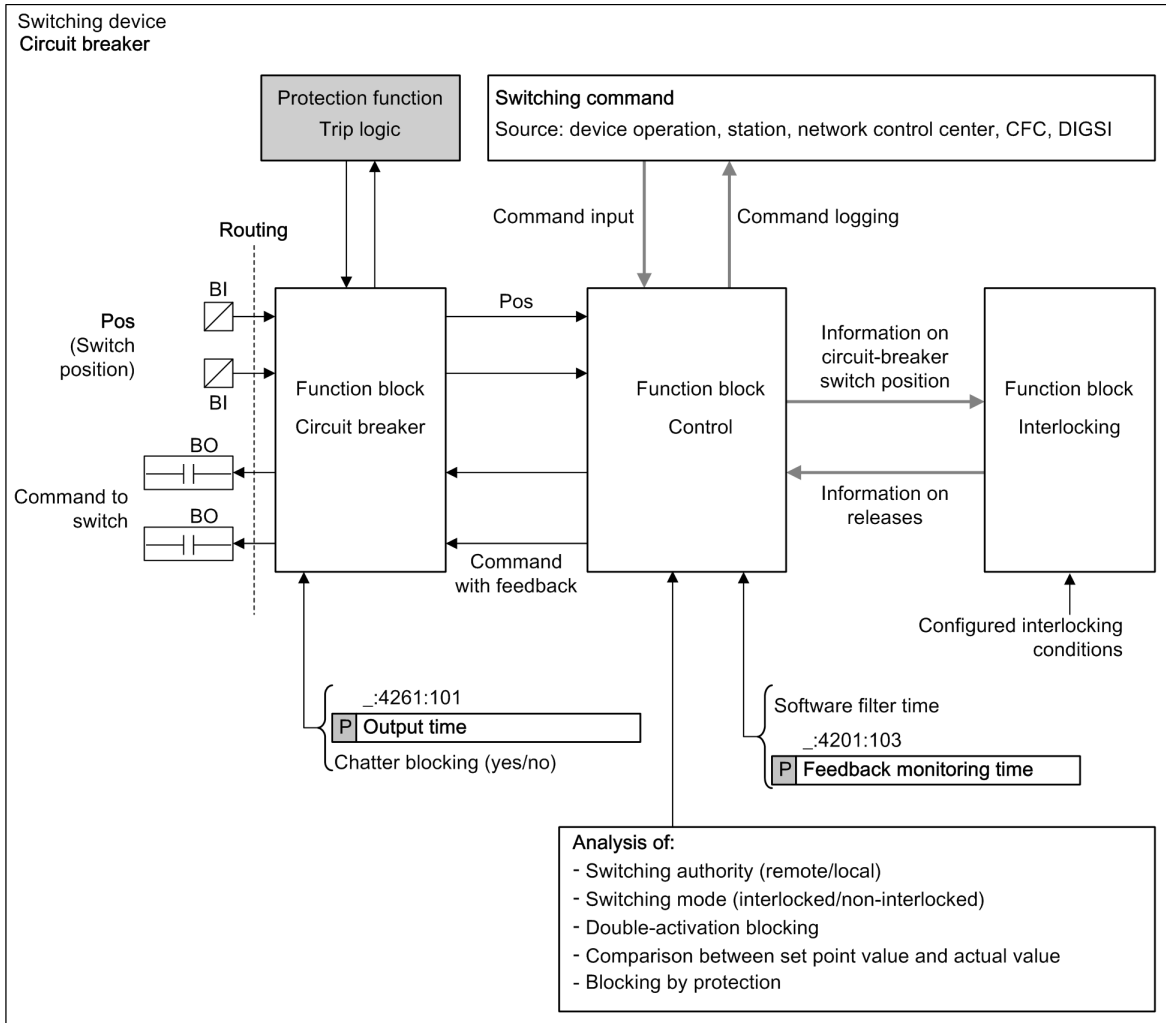

[dw_breake, 1, en_US]

Figure 9-4 Control Function Blocks of the Circuit-Breaker Switching Device

The circuit breaker in DIGSI 5 is linked with the binary inputs that acquire the switch position via information routing. The circuit breaker in DIGSI 5 is also linked with the binary outputs that issue the switching commands.

Function Blocks of the Circuit Breaker

Table 9-1 Function Blocks of the Circuit-Breaker Function Group

Function Block	Description	Parameter	Function
Circuit breaker	The Circuit-breaker function block in the SIPROTEC 5 device represents the physical switch.	Output time	The circuit breaker forms the switch position from the positions of the binary inputs and also outputs the command via the binary outputs.
Control	Command processing	Control model SBO time-out Feedback monitoring time Check switching authority Check if pos. is reached Check double activat. blk. Check blk. by protection	Command check, communication with the command source and with the function block Circuit breaker
Interlocking	Switchgear interlocking protection	Interlocking condition (deposited in CFC)	The functionality Interlocking generates the releases for switchgear interlocking protection.

For the setting values of the parameter, refer to [9.2.2.2 Application and Setting Notes](#).

Additional Setting Options of the Circuit-Breaker Switching Element

The setting options of the circuit breaker are assigned to the function blocks on the basis of their relevance. Additional setting options of the circuit breakers that cannot be directly assigned to one of the 3 function blocks are nevertheless available:

Table 9-2 Setting Options of the Controllable **Cmd. with feedback** in the Function Block **Control** of the Circuit Breaker.

Properties	Function	To Be Found in
Software filtering time	Software filtering time for position detection	Position of the function block Control ³⁵
Retrigger filter (yes/no)	Switching retriggering of the filtering time on/off by changing the position	Position of the function block Control ³⁵
Message time before filtering (yes/no)	Consideration of the hardware filtering time for position-detection time stamp	Position of the function block Control ³⁵
Suppress intermediate position (yes/no)	When activated, only the intermediate position is suppressed by the duration of the software filtering time.	Position of the function block Control ³⁵

³⁵ First click **Position** and then click the **Details** key in the **Properties** window (below).

Properties	Function	To Be Found in
Treatment of spontaneous position changes (Gen. Software Filt./Spont. Software Filt.)	If you select the General software filter setting, the general settings for software filtering of spontaneous position changes and for position changes caused by a switching command apply. By selecting Spontaneous software filter , a separate filtering is activated for spontaneous position changes.	Position of the function block Control ³⁵
Spontaneous software filtering time	Software filtering time for spontaneous position changes	Position of the function block Control ³⁵
Spontaneous retrigger filter (yes/no)	Switching on/off retriggering of the filtering time by spontaneous position change	Position of the function block Control ³⁵
Spontaneous indication timestamp before filtering (yes/no)	Consideration of the hardware filtering time for position-detection time stamp in case of a spontaneous change	Position of the function block Control ³⁵
Inhibit intermediate position for a spontaneous chng. (yes/no)	When activated, only the spontaneous change to the intermediate position is suppressed by the duration of the software filtering time.	Position of the function block Control ³⁵

Table 9-3 Setting Options of the Controllable **Position** in the Circuit-Breaker Function Block (Chatter Blocking)

Properties	Function	To Be Found in
Chatter blocking (yes/no)	Switching chatter blocking on/off	Position of the function block Circuit breaker ³⁵

Table 9-4 Additional Settings in the Device Settings Having Effects on the Circuit Breaker

Properties	Function	To Be Found in
Number of permissible status changes	Chatter-blocking setting value: Once for the entire device	Device settings (to be found under Settings)
Chatter test time		
Number of chatter tests		
Chatter idle time		
Chatter check time		

The inputs and outputs as well as the setting options of the function blocks **Circuit breaker** and **Control** are described in the next section (refer to [9.2.2.3 Connection Variants of the Circuit Breaker](#)).

Interlocking

The function block **Interlocking** generates the releases for switchgear interlocking protection. The actual interlocking conditions are deposited in CFC. For more information on this, refer to the general chapter [9.3.1 Command Checks and Switchgear Interlocking Protection](#).

9.2.2.2 Application and Setting Notes

Circuit Breaker

The Circuit-breaker function block in the SIPROTEC 5 device represents the physical switch device. The task of the circuit breaker is to replicate the switch position from the status of the binary inputs.

The following figure shows the logical inputs and outputs of the **Circuit-breaker** function block.

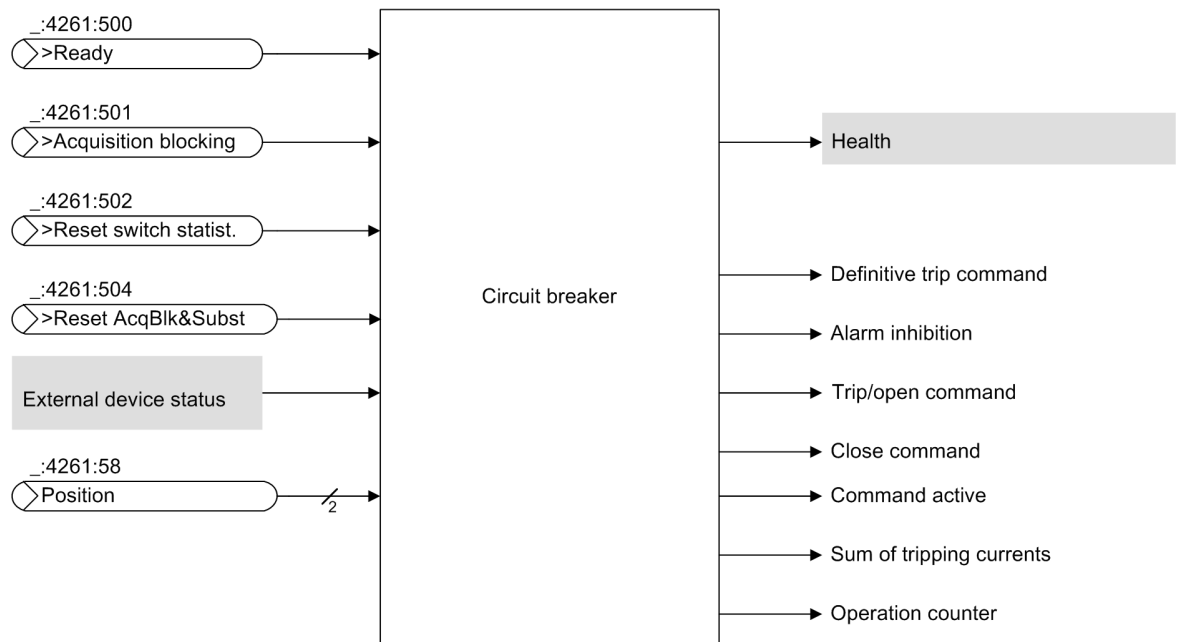

[dw_func_is_2_en_US]

Figure 9-5 Logical Inputs and Outputs of the Circuit-Breaker Function Blocks

[Table 9-5](#) and [Table 9-6](#) list the inputs and outputs with a description of their function and type. For inputs, the effect of **Quality = invalid** on the value of the signal is described.

EXAMPLE

If the signal **>Ready** has the **Quality = invalid**, then the value is set to **cleared**. In problematic operating states, the circuit breaker should signal that it is not ready for an **Off-On-Off cycle**.

Table 9-5 Inputs of the Circuit-Breaker Function Block

Signal Name	Description	Type	Default Value if Signal Quality = invalid
>Ready	The signal >Ready indicates that the OFF-ON-OFF cycle is possible with the circuit breaker. This signal is used for the AREC standby status.	SPS	Going
>Acquisition blocking	The binary input activates acquisition blocking. You can also set this binary input with an external toggle switch.	SPS	Unchanged
>Reset AcqBlk&Subst	Acquisition blocking and the substitution of the circuit breaker are reset with this input. If the input is activated, setting the acquisition blocking and the substitution is blocked.	SPS	Unchanged
>Reset switch statist.	Among other things, the binary input sets the operation counter for the switch to the value 0.	SPS	Unchanged

Signal Name	Description	Type	Default Value if Signal Quality = invalid
External health	The binary input External health reflects the circuit-breaker status (EHealth). This input will be set by the CFC using the BUILD_ENS block. In turn, BUILD_ENS can query binary inputs that represent the conditions <i>OK</i> , <i>Warning</i> , or <i>Alarm</i> (as a result of the function Trip-circuit supervision).	ENS	Unchanged
Position	The signal Position can be used to read the circuit-breaker position with double-point indication.	DPC	Unchanged

If the quality of the input signal assumes the status **Quality = invalid**, then the standby status (EHealth) of the **Circuit-breaker** function block is set to *warning*.

Table 9-6 Outputs of the Circuit-Breaker Function Block

Signal Name	Description	Type
Definitive trip	Protection has finally been tripped.	SPS
Alarm suppression	The signaling contact for external alarm inhibition is suppressed during the runtime of automatic reclosing (optional) as well as during the command output of switching commands.	SPS
Op.ct.	The information counts the number of switching cycles of the circuit breaker.	INS
Trip/open cmd.	This logic output is responsible for the command output Off .	SPS
Close command	This logic output is responsible for the command output On .	SPS
Command active	The binary output Command active is responsible for signaling a running command (relay active or selected switching device (SEL)).	SPS
CB open hours	The statistical value counts the hours the circuit breaker is open.	INS
Operating hours	The statistical value counts the hours where at least one phase current is greater than the Current thresh. CB open parameter.	INS

Control

It is the task of the controls to execute command checks and establish communication between the command source and the circuit breaker. Using the control settings, you specify how the commands are to be processed (see also chapter [9.3.1 Command Checks and Switchgear Interlocking Protection](#)).

Through the function SBO (Select Before Operate, reservation³⁶), the switching device is reserved prior to the actual switching operation, thus it remains locked for additional commands. Feedback monitoring provides information about the initiator of the command while the command is in process, that means, informing whether or not the command was implemented successfully. These 2 options can be selected individually in the selection of the control model, so that 4 combinations in total are available (see the following table).

The control makes the following settings available (see next table).

Parameters	Default Setting	Possible Parameter Values
(_:4201:101) Control model	<i>SBO w. enh. security</i> ³⁷	<i>direct w. normal secur.</i> <i>SBO w. normal secur.</i> <i>direct w. enh. security</i> <i>SBO w. enh. security</i>
(_:4201:102) SBO time-out	<i>30.00 s</i>	0.01 s to 1800 s (Increment: 0.01 s)

³⁶ In the IEC 61850 standard, reservation is described as **Select before Operate (SBO)**.

³⁷ This default setting is the standard control model for a switching command in an IEC 61850-compliant system.

Parameters	Default Setting	Possible Parameter Values
(_:4201:103) Feedback monitoring time	1.00 s	0.01 s to 1800 s (Increment: 0.01 s)
(_:4201:104) Check switching authority	yes	no yes advanced
(_:4201:105) Check if pos. is reached	yes	no yes
(_:4201:106) Check double activat. blk.	yes	no yes
(_:4201:107) Check blk. by protection	yes	no yes

The following figure shows the logical inputs and outputs of the **Control** function block.

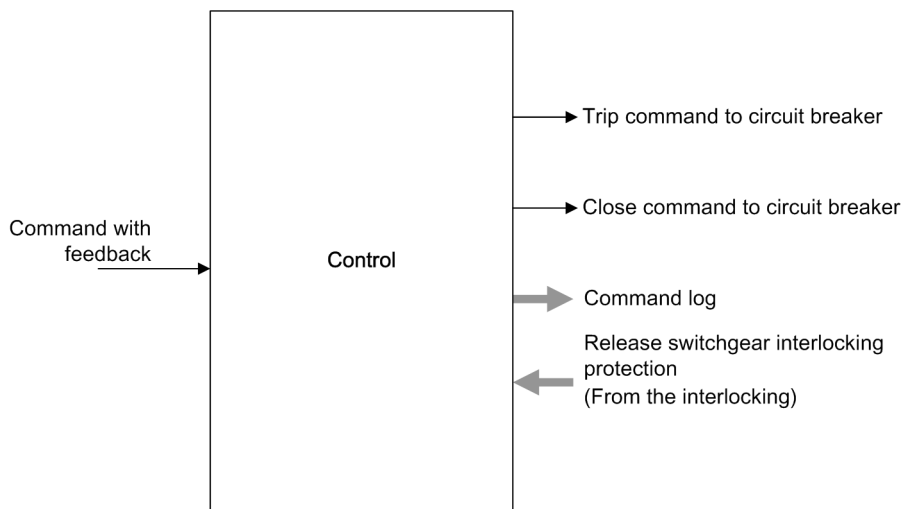

[dw_steue1, 1, en_US]

Figure 9-6 Logical Inputs and Outputs of the Control Function Block

Table 9-7 Control Function Block Input and Output

Signal Name	Description	Type	Value if Signal Quality=Invalid
Cmd. with feedback	With the Cmd. with feedback signal, the circuit-breaker position is accepted via the double-point indication of the Circuit-breaker function block and the command is issued.	Controllable (DPC) Unchanged	Unchanged

In the information routing of DIGSI 5, you may select a function key as a possible command source. In addition, it is displayed here if the command is activated by CFC. The logging is routed here.

9.2.2.3 Connection Variants of the Circuit Breaker

For each switching device, you can establish the number of poles (for example, 1-pole, 1.5-pole or 2-pole) that are switched with or without feedback. This results in the necessary amount of information to be processed, thus establishing the command type.

Whether the circuit breaker is triggered 1-, 1.5-, or 2-pole, depends on the design of the auxiliary and control-voltage system. In most cases, the activation of the opening coil of the circuit breaker is 1-pole.

Table 9-8 Meaning of the Abbreviations of the Connection Variants

Abbreviation	Meaning of the Abbreviation of the Connection Variants
BO	Binary output
L+; L-	Control voltage
A	Trip command
Gnd	Close command

Table 9-9 Meaning of the Abbreviations in DIGSI

Abbreviation	Description of the Input in DIGSI
V	Unsaved trip command Click the right mouse button and enter V .
X	Close Command Click the right mouse button and enter X for the respective binary output.
OH	The switching-device feedback is in the position OFF , if there is voltage present at the routed binary input (H). Click the right mouse button and enter OH .
OL	The switching-device feedback is in the position OFF , if there is no voltage present at the routed binary input (L). Click the right mouse button and enter OL .
CH	The switching-device feedback is in the position ON , if there is voltage present at the routed binary input (H). Click the right mouse button and enter CH .
CL	The switching-device feedback is in the position ON , if there is no voltage present at the routed binary input (H). Click the right mouse button and enter CL .
TL	Trip command stored Click the right mouse button and enter TL .

Connection Variant: 3-Pole Circuit Breaker

This is the standard type for the control function. All 3 individual poles of the circuit breaker are triggered together by a double command.

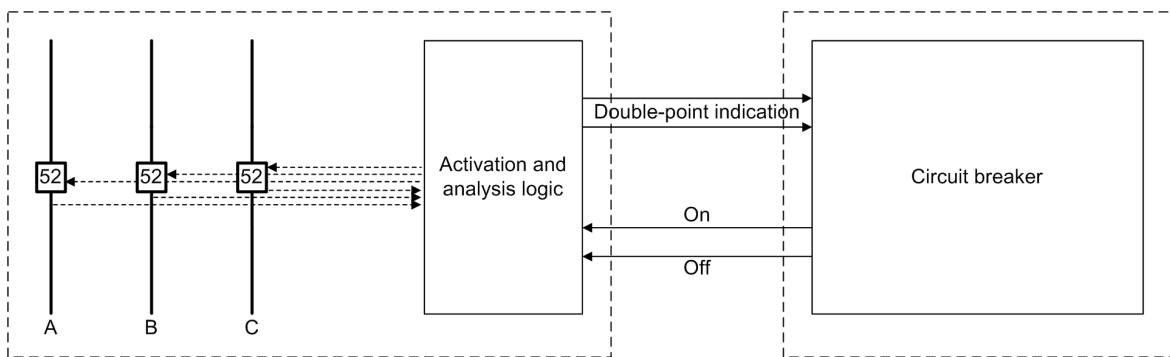

[idw_3-pole_ls_1_en_US]
 Figure 9-7 3-Pole Circuit Breaker

Acquisition of the Circuit-Breaker Position

The binary inputs for feedback of the switch position are routed as shown in the previous figure (see also see [5.7.7.3 Acquisition of Circuit-Breaker Auxiliary Contacts and Further Information](#)).

Information			Source			
			Binary input			
			Base module			
Signals	Number	Type	1.1	1.2	1.3	1.4
(All) ▾	(All) ▾
▶ Line 1	21					
▼ Circuit breaker 1	301		*	*	*	*
▶ Trip logic	301.5341					
▼ Circuit break.	301.4261		*	*	*	*
▶ >Ready	301.4261.500	SPS				
▶ >Acquisition blocking	301.4261.501	SPS				
▶ >Reset switch statist.	301.4261.502	SPS				
▶ >Reset AcqBlk&Subst	301.4261.504	SPS				
▶ External health	301.4261.503	ENS				
▶ Health	301.4261.53	ENS				
▶ Position 3-pole	301.4261.58	DPC	OH			
▶ Position 1-pole phsA	301.4261.459	DPC		CH		
▶ Position 1-pole phsB	301.4261.460	DPC			CH	
▶ Position 1-pole phsC	301.4261.461	DPC				CH
▶ Trip/open cmd. 3-pole	301.4261.300	SPS				
▶ Trip only pole A	301.4261.401	SPS				
▶ Trip only pole B	301.4261.402	SPS				
▶ Trip only pole C	301.4261.403	SPS				
▶ Close command	301.4261.301	SPS				

[sc_rang_1p_cb_HK, 1, en_US]

Figure 9-8 Routing of the 1-Pole in DIGSI

You can find the meaning of abbreviations in [Table 9-8](#) and [Table 9-9](#).

The indication **Command active** can also be routed to a binary output. This binary output is always active if either a close or trip command is pending, or the switching device was selected by the command control.

9.2.2.4 Settings

Addr.	Parameter	C	Setting Options	Default Setting
<i>Ref. for %-values</i>				
_:2311:101	General:Rated normal current		0.20 A to 100000.00 A	1000.00 A
_:2311:102	General:Rated voltage		0.10 kV to 1200.00 kV	400.00 kV
<i>Breaker settings</i>				
_:2311:112	General:Current thresh. CB open	1 A @ 100 Irated	0.030 A to 10.000 A	0.100 A
		5 A @ 100 Irated	0.15 A to 50.00 A	0.50 A
		1 A @ 50 Irated	0.030 A to 10.000 A	0.100 A
		5 A @ 50 Irated	0.15 A to 50.00 A	0.50 A
		1 A @ 1.6 Irated	0.001 A to 1.600 A	0.100 A
		5 A @ 1.6 Irated	0.005 A to 8.000 A	0.500 A
_:2311:136	General:Op. mode BFP		<ul style="list-style-type: none"> unbalancing l> query 	unbalancing

Addr.	Parameter	C	Setting Options	Default Setting
Trip logic				
_:5341:103	Trip logic:Reset of trip command		<ul style="list-style-type: none"> with I< with I< & aux.contact with dropout 	with I<
Circuit break.				
_:4261:101	Circuit break.:Output time		0.02 s to 1800.00 s	0.10 s
_:4261:105	Circuit break.:Indicat. of breaking values		<ul style="list-style-type: none"> with trip always 	always
Manual close				
_:6541:101	Manual close:Action time		0.01 s to 60.00 s	0.30 s
_:6541:102	Manual close:CB open dropout delay		0.00 s to 60.00 s	0.00 s
Control				
_:4201:101	Control:Control model		<ul style="list-style-type: none"> status only direct w. normal secur. SBO w. normal secur. direct w. enh. security SBO w. enh. security 	SBO w. enh. security
_:4201:102	Control:SBO time-out		0.01 s to 1800.00 s	30.00 s
_:4201:103	Control:Feedback monitoring time		0.01 s to 1800.00 s	1.00 s
_:4201:104	Control:Check switching authority		<ul style="list-style-type: none"> no yes advanced 	yes
_:4201:105	Control:Check if pos. is reached		<ul style="list-style-type: none"> no yes 	yes
_:4201:106	Control:Check double activat. blk.		<ul style="list-style-type: none"> no yes 	yes
_:4201:107	Control:Check blk. by protection		<ul style="list-style-type: none"> no yes 	yes
Switching authority				
_:4201:151	Control:Swi.dev. related sw.auth.		<ul style="list-style-type: none"> 0 1 	false
_:4201:152	Control:Specific sw. authorities		<ul style="list-style-type: none"> 0 1 	true
_:4201:115	Control:Specific sw.auth. valid for		<ul style="list-style-type: none"> station station/remote remote 	station/remote
_:4201:153	Control:Num. of specific sw.auth.		2 to 5	2
_:4201:155	Control:Ident. sw.auth. 1		Freely editable text	

Addr.	Parameter	C	Setting Options	Default Setting
_:4201:156	Control:Ident. sw.auth. 2		Freely editable text	
_:4201:157	Control:Ident. sw.auth. 3		Freely editable text	
_:4201:158	Control:Ident. sw.auth. 4		Freely editable text	
_:4201:159	Control:Ident. sw.auth. 5		Freely editable text	
_:4201:154	Control:Multiple specific sw.auth.		<ul style="list-style-type: none"> • 0 • 1 	false
CB test				
_:6151:101	CB test:Dead time		0.00 s to 60.00 s	0.10 s
_:6151:102	CB test:Trip only		<ul style="list-style-type: none"> • 0 • 1 	false
_:6151:103	CB test:Consider current criterion		<ul style="list-style-type: none"> • 0 • 1 	false
_:6151:104	CB test:Current threshold	1 A @ 100 Irated	0.030 A to 10.000 A	0.100 A
		5 A @ 100 Irated	0.15 A to 50.00 A	0.50 A
		1 A @ 50 Irated	0.030 A to 10.000 A	0.100 A
		5 A @ 50 Irated	0.15 A to 50.00 A	0.50 A
		1 A @ 1.6 Irated	0.001 A to 1.600 A	0.100 A
		5 A @ 1.6 Irated	0.005 A to 8.000 A	0.500 A

9.2.2.5 Information List

No.	Information	Data Class (Type)	Type
Trip logic			
_:5341:300	Trip logic:Trip indication	ACT	O
_:5341:58	Trip logic:Trip ind.:Busbar diff.prt.	ACT	O
_:5341:59	Trip logic:Trip ind.:Busbar BFP	ACT	O
_:5341:60	Trip logic:Trip ind.:Busbar ext.trip	ACT	O
_:5341:52	Trip logic:Behavior	ENS	O
_:5341:53	Trip logic:Health	ENS	O
Circuit break.			
_:4261:500	Circuit break.:>Ready	SPS	I
_:4261:501	Circuit break.:>Acquisition blocking	SPS	I
_:4261:502	Circuit break.:>Reset switch statist.	SPS	I
_:4261:504	Circuit break.:>Reset AcqBlk&Subst	SPS	I
_:4261:505	Circuit break.:>Trip release BBP	SPS	I
_:4261:503	Circuit break.:External health	ENS	I
_:4261:52	Circuit break.:Behavior	ENS	O
_:4261:53	Circuit break.:Health	ENS	O
_:4261:58	Circuit break.:Position 3-pole	DPC	C
_:4261:300	Circuit break.:Trip/open cmd. 3-pole	SPS	O
_:4261:301	Circuit break.:Close command	SPS	O
_:4261:410	Circuit break.:Open cmd. 1-pole phsA	SPS	O
_:4261:411	Circuit break.:Open cmd. 1-pole phsB	SPS	O

No.	Information	Data Class (Type)	Type
_:4261:412	Circuit break.:Open cmd. 1-pole phsC	SPS	O
_:4261:413	Circuit break.:Close cmd. 1-pole phsA	SPS	O
_:4261:414	Circuit break.:Close cmd. 1-pole phsB	SPS	O
_:4261:415	Circuit break.:Close cmd. 1-pole phsC	SPS	O
_:4261:302	Circuit break.:Command active	SPS	O
_:4261:303	Circuit break.:Definitive trip	SPS	O
_:4261:304	Circuit break.:Alarm suppression	SPS	O
_:4261:416	Circuit break.:PoW capability	ENS	O
_:4261:326	Circuit break.:BBP trip relays blocked	SPS	O
_:4261:327	Circuit break.:no release of trip cmd	SPS	O
_:4261:306	Circuit break.:Op.ct.	INS	O
_:4261:307	Circuit break.:ΣI Brk.	BCR	O
_:4261:308	Circuit break.:ΣIA Brk.	BCR	O
_:4261:309	Circuit break.:ΣIB Brk.	BCR	O
_:4261:310	Circuit break.:ΣIC Brk.	BCR	O
_:4261:311	Circuit break.:Break.-current phs A	MV	O
_:4261:312	Circuit break.:Break.-current phs B	MV	O
_:4261:313	Circuit break.:Break.-current phs C	MV	O
_:4261:317	Circuit break.:Break. current 3I0/IN	MV	O
_:4261:314	Circuit break.:Break. voltage phs A	MV	O
_:4261:315	Circuit break.:Break. voltage phs B	MV	O
_:4261:316	Circuit break.:Break. voltage phs C	MV	O
_:4261:322	Circuit break.:CB open hours	INS	O
_:4261:323	Circuit break.:Operating hours	INS	O
Manual close			
_:6541:501	Manual close:>Block manual close	SPS	I
_:6541:500	Manual close:>Input	SPS	I
_:6541:300	Manual close:Detected	SPS	O
_:6541:52	Manual close:Behavior	ENS	O
_:6541:53	Manual close:Health	ENS	O
Reset LED Group			
_:13381:500	Reset LED Group:>LED reset	SPS	I
_:13381:320	Reset LED Group:LED have been reset	SPS	O
_:13381:52	Reset LED Group:Behavior	ENS	O
_:13381:53	Reset LED Group:Health	ENS	O
Control			
_:4201:503	Control:>Sw. authority local	SPS	I
_:4201:504	Control:>Sw. authority remote	SPS	I
_:4201:505	Control:>Sw. mode interlocked	SPS	I
_:4201:506	Control:>Sw. mode non-interl.	SPS	I
_:4201:52	Control:Behavior	ENS	O
_:4201:53	Control:Health	ENS	O
_:4201:58	Control:Cmd. with feedback	DPC	C
_:4201:302	Control:Switching auth. station	SPC	C
_:4201:308	Control:Enable sw. auth. 1	SPC	C
_:4201:309	Control:Enable sw. auth. 2	SPC	C

No.	Information	Data Class (Type)	Type
_:4201:310	Control:Enable sw. auth. 3	SPC	C
_:4201:311	Control:Enable sw. auth. 4	SPC	C
_:4201:312	Control:Enable sw. auth. 5	SPC	C
_:4201:313	Control:Switching authority	ENS	O
_:4201:314	Control:Switching mode	ENS	O
Interlocking			
_:4231:500	Interlocking:>Enable opening	SPS	I
_:4231:501	Interlocking:>Enable closing	SPS	I
_:4231:502	Interlocking:>Enable opening(fixed)	SPS	I
_:4231:503	Interlocking:>Enable closing (fixed)	SPS	I
_:4231:52	Interlocking:Behavior	ENS	O
_:4231:53	Interlocking:Health	ENS	O
CB test			
_:6151:52	CB test:Behavior	ENS	O
_:6151:53	CB test:Health	ENS	O
_:6151:301	CB test:Test execution	ENS	O
_:6151:302	CB test:Trip command issued	ENS	O
_:6151:303	CB test:Close command issued	ENS	O
_:6151:304	CB test:Test canceled	ENS	O
_:6151:311	CB test:3-pole open-close	SPC	C

9.2.3 Disconnecter Switching Device

9.2.3.1 Structure of the Disconnecter Switching Device

Like the circuit breaker, the **Disconnecter** switching device contains the following 3 function blocks:

- Function block **Disconnecter**
- Function block **Control**
- Function block **Interlocking**

This corresponds to the logical nodes XSWI, CSWI, and CILO in IEC 61850.



NOTE

In contrast to the **Circuit-breaker** switching device, the **Disconnecter** switching device cannot contain any additional functions because protection functions or synchronization can have no effect on the disconnecter.

Function Blocks of the Disconnecter

Table 9-10 Function Blocks of the Disconnecter Function Group

Function Block	Description	Parameter	Function
Disconnector	The disconnector represents the physical switch in the SIPROTEC 5 device.	Maximum output time Seal-in time Switching-device type	The disconnector replicates the switch position from the status of the binary inputs and also transmits the command via the binary outputs.
Control	Command processing	Control model SBO time-out Feedback monitoring time Check switching authority Check if pos. is reached Check double activat. blk.	Command checks, communication with the command source and with the function block Disconnecter
Interlocking	Switchgear interlocking protection	Interlocking condition (deposited in CFC)	The Interlocking functionality generates the releases for switchgear interlocking protection.

You can find the setting values of the parameter in [9.2.3.2 Application and Setting Notes](#).

Additional Settings of Disconnecter Switching Element

The settings of the disconnector are assigned to the function blocks on the basis of their relevance. Additional disconnector settings that cannot be directly assigned to one of the 3 function blocks and are identical to the circuit-breaker settings are available:

Table 9-11 Setting Options of the Controllable **Command with Feedback** in the **Control** Function Block of the Circuit Breaker

Characteristics	Function	To Be Found in
Software filtering time	Software filtering time for position detection	Position of the Control ⁽¹⁾ function block
Retrigger filter (yes/no)	Switching retriggering of the filtering time on/off by changing the position	Position of the Control ⁽¹⁾ function block
Message time before filtering (yes/no)	Consideration of the hardware filtering time for position-detection time stamp	Position of the Control ⁽¹⁾ function block
Suppress intermediate position (yes/no)	When activated, only the intermediate position is suppressed by the duration of the software filtering time.	Position of the Control ⁽¹⁾ function block

Characteristics	Function	To Be Found in
Spontaneous position changes filtered by (Gen. Software Filt./Spont. Software Filt.)	If the General software filter setting is selected, the general settings for software filtering of spontaneous position changes and for position changes caused by a switching command apply. By selecting Spontaneous software filter , a separate filtering is activated for spontaneous position changes.	Position of the Control ⁽¹⁾ function block
Spontaneous software filter time	Software filtering time for spontaneous position changes	Position of the Control ⁽¹⁾ function block
Spontaneous retrigger filter (yes/no)	Switching on/off retriggering of the filtering time by spontaneous position change	Position of the Control ⁽¹⁾ function block
Spontaneous indication timestamp before filtering (yes/no)	Consideration of the hardware filtering time for position-detection time stamp in case of a spontaneous change	Position of the Control ⁽¹⁾ function block
Spontaneous suppress intermediate position (yes/no)	When activated, only the spontaneous change to the intermediate position is suppressed by the duration of the software filtering time.	Position of the Control ⁽¹⁾ function block

(1) First click **Position** and then click the **Details** button in the **Properties** window (below).

Table 9-12 Setting Options of the Controllable **Position** in the Disconnecter Function Block (Chatter Blocking)

Characteristics	Function	To Be Found in
Chatter blocking (yes/no)	Switching chatter blocking on/off	Position of the Disconnecter ⁽¹⁾ function block

(1) First click **Position** and then click the **Details** button in the **Properties** window (below).

Table 9-13 Additional Settings in the Device Settings with Effects on the Disconnecter

Characteristics	Function	To Be Found in
Number of permissible state changes	Chatter-blocking setting value: Once for the entire device	Device settings (to be found under Settings)
Chatter test time		
Number of chatter tests		
Chatter dead time		
Chatter test time		

The inputs and outputs as well as the setting options of the **Disconnecter switch** function block are described in [9.2.3.3 Trigger Variants of the Disconnecter](#). The **Control** function block is described identically as the **Circuit-breaker** function block, with the exception that the command check blocking is available through protection only with the circuit breaker.

You can find more information on this in [9.2.2.2 Application and Setting Notes](#).

Interlocking

The **Interlocking** function block generates the releases for switchgear interlocking protection. The actual interlocking conditions are deposited in CFC. For more information on this, see the general chapter [9.3.1 Command Checks and Switchgear Interlocking Protection](#).

9.2.3.2 Application and Setting Notes

Disconnecter

The disconnector represents the physical switch in the SIPROTEC 5 device. The task of the disconnector is to replicate the switch position from the status of the binary inputs.

The **Disconnecter** function block is linked automatically via the information matrix with the binary inputs that register the switch position and with the binary outputs that issue the switching commands.

The **Disconnecter** function block makes the following settings available (see next table).

Parameters	Default Setting	Possible Parameter Values
<p>(_:5401:101) Maximum output time The Maximum output time specifies the duration of the output pulse created by the switching command.</p>	<i>10.00 s</i>	0.02 s to 1800 s (Increment: 0.01 s)
<p>(_:5401:102) Seal-in time If the target actuating position is not yet attained although feedback has already been received, the output time is extended by the Seal-in time. The Seal-in time is relevant for equipment that sends feedback before the switching operation is completely performed. The Seal-in time is only considered for control models with feedback monitoring.</p>	<i>0.00 s</i>	0 s to 60 s
<p>(_:5401:103) Switching-device type The Switching-device type specifies the type of the switching device.</p>	<i>disconnector</i>	<i>switch-disconnector</i> <i>disconnector</i> <i>grounding switch</i> <i>fast grounding switch</i>



NOTE

The parameter **Switching-device type** is effective only on the IEC 61850 interface. This parameter is used to set the disconnector switching device type for communication via IEC 61850. It is a mandatory data object in the IEC 61850 standard.

The following figure shows the logical inputs and outputs of the **Disconnecter** function block.

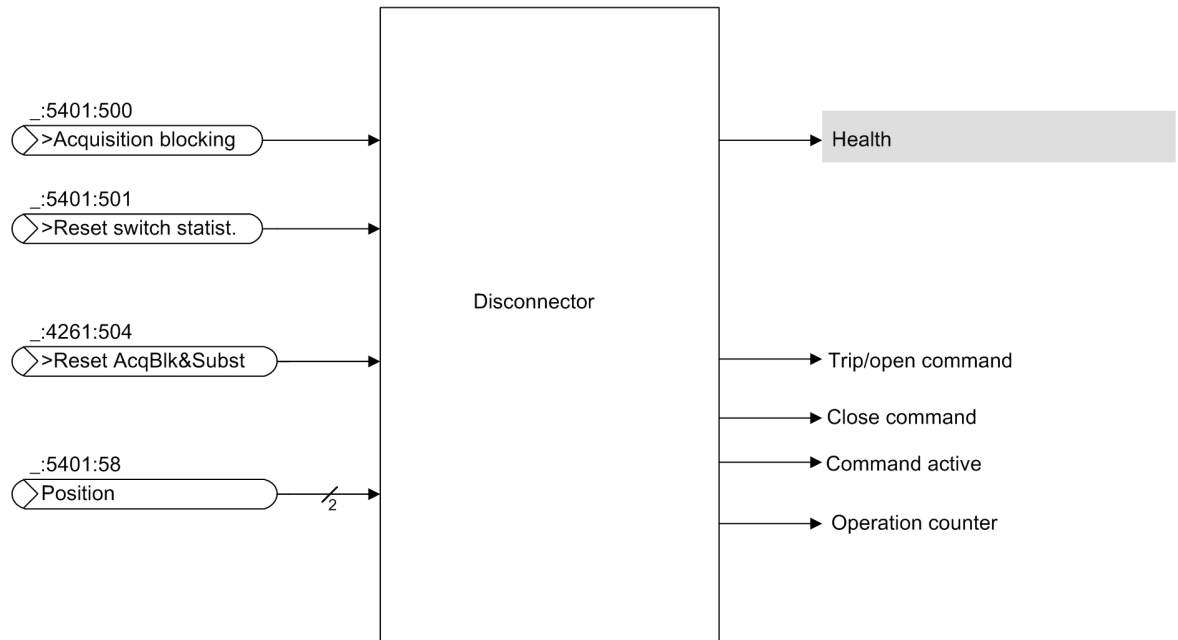

[dw_out_inp, 2, en_US]

Figure 9-9 Logical Inputs and Outputs of the Disconnecter Function Block

Table 9-14 and Table 9-15 list the inputs and outputs with a description of their function and type. For inputs, the effect of **Quality = invalid** on the value of the signal is described.

Table 9-14 Inputs of the Disconnecter Function Block

Signal Name	Description	Type	Value if Signal Quality=Invalid
>Acquisition blocking	The binary input activates acquisition blocking. You can also set this binary input with an external toggle switch.	SPS	Unchanged
>Reset AcqBlk&Subst	Acquisition blocking and the substitution of the circuit breaker are reset with this input. If the input is activated, setting of the acquisition blocking and of the substitution is blocked.	SPS	Unchanged
>Reset switch statist.	The binary input sets the operation counter for the switch to the value 0.	SPS	Unchanged
Position	The binary input Position can be used to read the disconnecter position with double-point indication.	DPC	Unchanged

If the quality of the input signal assumes the status **Quality = invalid**, then the standby status (Health) of the **Disconnecter** function block is set to *warning*.

Table 9-15 Outputs of the Disconnecter Function Block

Signal Name	Description	Type
Open command	This binary output is responsible for the command output Off .	SPS
Close command	This binary output is responsible for the command output On .	SPS

Signal Name	Description	Type
Command active	The binary output Command active is a running command for the signalization (command active or selected switching device). During Command active either an On or Off command is active.	SPS
Op.ct.	The information counts the number of disconnecter switching cycles.	INS

Control

It is the task of the controls to execute command checks and establish communication between the command source and the disconnecter. Using the control settings, you specify how the commands are to be processed (see also chapter [9.3.1 Command Checks and Switchgear Interlocking Protection](#)).

Through the function SBO (Select Before Operate, reservation³⁸), the switching device is reserved prior to the actual switching operation, thus it remains locked for additional commands. Feedback monitoring provides information about the initiator of the command while the command is in process, that means, informing whether or not the command was implemented successfully. These two options can be selected individually in the selection of the control model, so that 4 combinations in total are available (see the following table).

The control makes the following settings available (see next table).

Parameters	Default Setting	Possible Parameter Values
(_:4201:101) Control model	<i>SBO w. enh. security</i> ³⁹	<i>direct w. normal secur.</i> <i>SBO w. normal secur.</i> <i>direct w. enh. security</i> <i>SBO w. enh. security</i>
(_:4201:102) SBO time-out	<i>30.00 s</i>	-
(_:4201:103) Feedback monitoring time	<i>10.00 s</i>	-
(_:4201:104) Check switching authority	<i>yes</i>	<i>no</i> <i>yes</i> <i>advanced</i>
(_:4201:105) Check if pos. is reached	<i>yes</i>	<i>no</i> <i>yes</i>
(_:4201:106) Check double activat. blk.	<i>yes</i>	<i>no</i> <i>yes</i>

9.2.3.3 Trigger Variants of the Disconnecter

The activation types are identical to those for the circuit breaker. The meaning of abbreviations can be found in [9.2.2.3 Connection Variants of the Circuit Breaker](#) and [9.2.2.3 Connection Variants of the Circuit Breaker](#).

Whether the disconnecter is triggered for 1-, 1.5-, or 2-phases depends on the design of the auxiliary and control voltage system.

³⁸ In the IEC 61850 standard, Reservation is described as **Select before Operate (SBO)**.

³⁹ This default setting is the standard control model for a switching command in an IEC 61850-compliant system.

1-Pole Triggering

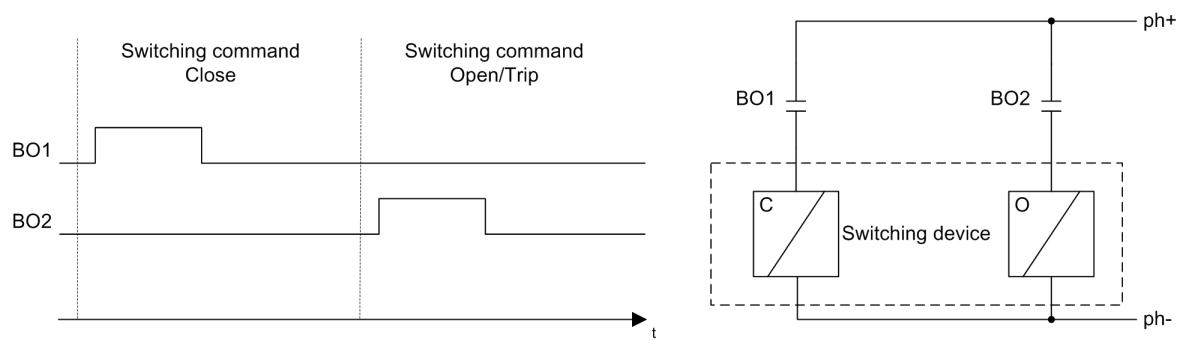

[dw_1ptren_1_en_US]

Figure 9-10 1-Pole Triggering

Information			▼ S	► Destination			
				► Binary output			
				► Basismodul			
Signals	Number	Type	1.1	1.2	1.3	1.4	
(All)			
▼ Disconnecter 1	601		*	*			
▼ Disconnecter	601.5401		*	*			
▶ >Acquisition blocking	601.5401.500	SPS					
▶ >Reset switch statist.	601.5401.501	SPS					
▶ >Reset AcqBlk&Subst	601.5401.504	SPS					
▶ Health	601.5401.53	ENS					
▶ Position	601.5401.58	DPC					
▶ Open command	601.5401.300	SPS		X			
▶ Close command	601.5401.301	SPS	X				

[sclangtrenn1p_1_en_US]

Figure 9-11 1-Pole Triggering, Routing in DIGSI

You can select the contacts for *On* and *Off* as desired. They need not necessarily be next to one another.

1.5-Pole Triggering

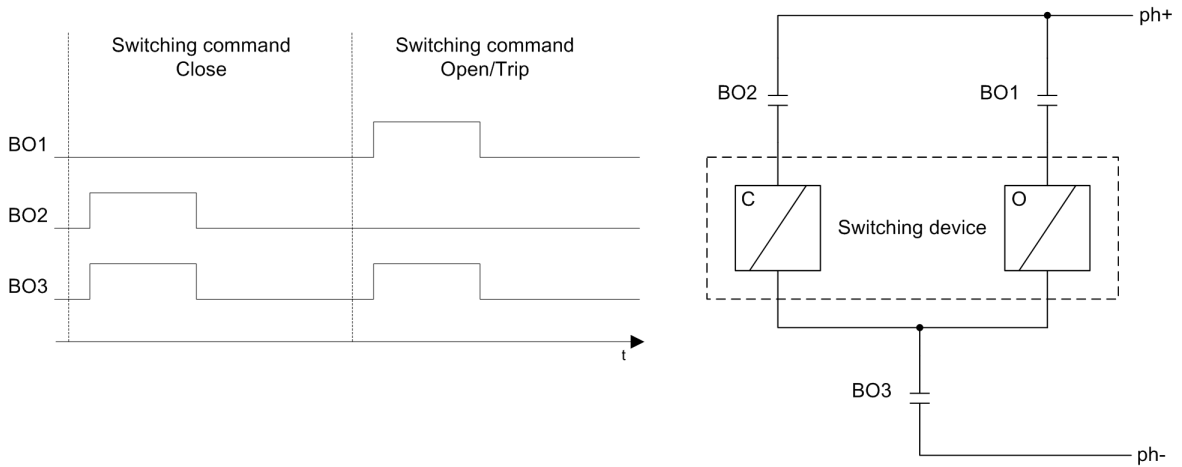

[dw_5-pole, 1, en_US]

Figure 9-12 1.5-Pole Triggering

Information			S			
			Destination			
			Binary output			
			Basismodul			
			1.1	1.2	1.3	1.4
Signals	Number	Type				
Disconnector 1			*	*	*	
Disconnector	601.5401		*	*	*	
>Acquisition blocking	601.5401.500	SPS				
>Reset switch statist.	601.5401.501	SPS				
>Reset AcqBlk&Subst	601.5401.504	SPS				
Health	601.5401.53	ENS				
Position	601.5401.58	DPC				
Open command	601.5401.300	SPS	X		X	
Close command	601.5401.301	SPS		X	X	

[scrangtrenn15p, 1, en_US]

Figure 9-13 1.5-Pole Triggering, Routing in DIGSI

2-Pole Triggering

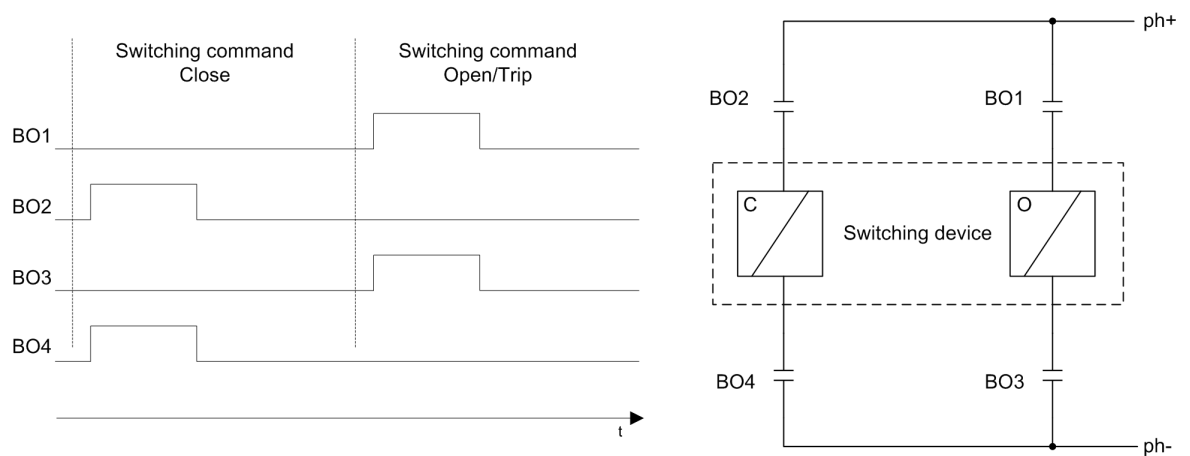

[dw_2-pole-open_1_en_US]

Figure 9-14 2-Pole Triggering

Information			S			
			Destination			
			Binary output			
			Basismodul			
Signals	Number	Type	1.1	1.2	1.3	1.4
(All)		
Disconnector 1	601		*	*	*	*
Disconnector	601.5401		*	*	*	*
>Acquisition blocking	601.5401.500	SPS				
>Reset switch statist.	601.5401.501	SPS				
>Reset AcqBlk&Subst	601.5401.504	SPS				
Health	601.5401.53	ENS				
Position	601.5401.58	DPC				
Open command	601.5401.300	SPS	X		X	
Close command	601.5401.301	SPS		X		X

[scrangtrenn2b_1_en_US]

Figure 9-15 2-Pole Triggering, Routing in DIGSI

The feedback is routed via the position with the disconnector.

9.2.3.4 Settings

Addr.	Parameter	C	Setting Options	Default Setting
Control				
_:4201:101	Control:Control model		<ul style="list-style-type: none"> status only direct w. normal secur. SBO w. normal secur. direct w. enh. security SBO w. enh. security 	SBO w. enh. security
_:4201:102	Control:SBO time-out		0.01 s to 1800.00 s	30.00 s
_:4201:103	Control:Feedback monitoring time		0.01 s to 1800.00 s	10.00 s

Addr.	Parameter	C	Setting Options	Default Setting
_:4201:104	Control:Check switching authority		<ul style="list-style-type: none"> no yes 	yes
_:4201:105	Control:Check if pos. is reached		<ul style="list-style-type: none"> no yes 	yes
_:4201:106	Control:Check double activat. blk.		<ul style="list-style-type: none"> no yes 	yes
Disconnecter				
_:5401:101	Disconnecter:Maximum output time		0.01 s to 1800.00 s	10.00 s
_:5401:102	Disconnecter:Seal-in time		0.00 s to 60.00 s	0.00 s
_:5401:103	Disconnecter:Switching-device type		<ul style="list-style-type: none"> switch-disconnector disconnecter grounding switch fast grounding switch 	disconnecter

9.2.3.5 Information List

No.	Information	Data Class (Type)	Type
Control			
_:4201:503	Control:>Sw. authority local	SPS	I
_:4201:504	Control:>Sw. authority remote	SPS	I
_:4201:505	Control:>Sw. mode interlocked	SPS	I
_:4201:506	Control:>Sw. mode non-interl.	SPS	I
_:4201:52	Control:Behavior	ENS	O
_:4201:53	Control:Health	ENS	O
_:4201:58	Control:Cmd. with feedback	DPC	C
_:4201:302	Control:Switching auth. station	SPC	C
_:4201:308	Control:Enable sw. auth. 1	SPC	C
_:4201:309	Control:Enable sw. auth. 2	SPC	C
_:4201:310	Control:Enable sw. auth. 3	SPC	C
_:4201:311	Control:Enable sw. auth. 4	SPC	C
_:4201:312	Control:Enable sw. auth. 5	SPC	C
_:4201:313	Control:Switching authority	ENS	O
_:4201:314	Control:Switching mode	ENS	O
Interlocking			
_:4231:500	Interlocking:>Enable opening	SPS	I
_:4231:501	Interlocking:>Enable closing	SPS	I
_:4231:502	Interlocking:>Enable opening(fixed)	SPS	I
_:4231:503	Interlocking:>Enable closing (fixed)	SPS	I
_:4231:52	Interlocking:Behavior	ENS	O
_:4231:53	Interlocking:Health	ENS	O
Disconnecter			
_:5401:500	Disconnecter:>Acquisition blocking	SPS	I
_:5401:501	Disconnecter:>Reset switch statist.	SPS	I
_:5401:504	Disconnecter:>Reset AcqBlk&Subst	SPS	I
_:5401:52	Disconnecter:Behavior	ENS	O

No.	Information	Data Class (Type)	Type
_:5401:53	Disconnecter:Health	ENS	O
_:5401:58	Disconnecter:Position	DPC	C
_:5401:300	Disconnecter:Open command	SPS	O
_:5401:301	Disconnecter:Close command	SPS	O
_:5401:302	Disconnecter:Command active	SPS	O
_:5401:305	Disconnecter:Op.ct.	INS	O

9.3 Control Functionality

9.3.1 Command Checks and Switchgear Interlocking Protection

Before switching commands can be issued by the SIPROTEC 5 device, several steps are used to check the command:

- Switching mode (interlocked/non-interlocked)
- Switching authority (local/DIGSI/station/remote)
- Switching direction (set=actual)
- Bay interlocking and substation interlocking
- 1-out-of-n check (double-activation blocking)
- Blocking by protection function

Confirmation IDs (with Inactive RBAC)

SIPROTEC 5 devices can operate using role-based access control (RBAC). If RBAC is active in the device, the authorizations to execute various actions are linked directly to the role concept.

If RBAC is inactive in the device, various actions are secured using the **confirmation IDs**. The following **confirmation IDs** from the **Safety** menu apply to the control functions:

Enter confirmation ID			
Active	Scope of operation	Action	Description
<input checked="" type="checkbox"/>	Settings	Change...	Allows changing the settings and device mode, loading the firmware, setting the counters, deleting logs.
<input type="checkbox"/>	Fct.Key/PB operation		Allows operating via function keys and push-buttons only with entering the confirmation ID for "Setting".
<input checked="" type="checkbox"/>	Switching	Change...	Allows switching operations
<input checked="" type="checkbox"/>	Switch./interl.check	Change...	Allow switching operations. Interlocking checks can be switched on and off.
<input checked="" type="checkbox"/>	Switch./switch.auth.	Change...	Allows switching operations. The switching authority can be changed.

[sc_conf_2_en_US]

Figure 9-16 Confirmation IDs in DIGSI 5: Settings Menu

The following table identifies the meanings of the confirmation IDs:

Table 9-16 Relevant Confirmation IDs for Controls

Confirmation ID	Meaning	Description
Setting	Changing settings	The confirmation ID is requested before the device parameters can be changed.
Operation (function keys)	Process data access via function buttons	Access to process data is possible with the help of push-buttons and function buttons. The confirmation ID of Set/operation is requested.
Switching	General release for control of switching devices	The confirmation ID is usually not needed for bay controllers. In the case of protection devices, this confirmation ID can be used to safeguard control of switching devices.

Confirmation ID	Meaning	Description
Switch./interl.check	Switching non-interlocked	Switching mode: Release for switching without querying the interlocking conditions (S1 operation). The fixed interlocking conditions (for example, >Enable opening(fixed) and >Enable closing(fixed)) are still queried if this is set in the parameters. The confirmation ID is queried only for devices without a key switch; otherwise it is replaced with the key switch position.
Switch./switch.auth.	Release for switching authority Local	The confirmation ID is queried only for devices without a key switch; otherwise it is replaced with the key switch position.

The confirmation IDs are preset with the following values:

- Setting 222222
- Switching 333333
- Switch./interl.check 444444
- Switch./switch.auth. 666666

If you have configured a device with key switches, the confirmation IDs for non-interlocked switching and switching authority are not displayed or editable in DIGSI; the function is handled by the position of the key switch.

To increase security, change these codes with DIGSI.

Switching Mode (Interlocked/Non-Interlocked)

The switching mode determines whether or not the switchgear interlocking that has been configured in the CFC is checked before the command is output.

You can change the switching mode with the key switch **S1** (interlocking off/normal). For devices without a key switch, you can change the switching mode with a corresponding menu item on the display (after input of a confirmation ID). You can also set the switching mode for switching commands from the sources DIGSI, station or remote.



DANGER

If the switching mode = non-interlocked, the switchgear interlocking protection is shut off.

Erroneous switching operations can lead to severe or fatal injuries.

- ◇ Ensure manually that all checks have been implemented.

In addition, you can set the switching mode directly with a binary input or CFC. Use the **General** function block (see next figure).

Signals	Fav	Number	Type
(All) ... (All) ...			
▼ General		91	
◆ >SG choice bit 1	☆	91.500	SPS
◆ >SG choice bit 2	☆	91.501	SPS
◆ >SG choice bit 3	☆	91.502	SPS
◆ >Sw. authority local	☆	91.503	SPS
◆ >Sw. authority remote	☆	91.504	SPS
◆ >Sw. mode interlocked	☆	91.505	SPS
◆ >Sw. mode non-interl.	☆	91.506	SPS
🔑 Switching auth. station	☆	91.308	SPC
▼ ◆ Switching authority	☆	91.311	ENS
◆ local			SPS
◆ DIGSI			SPS
◆ station			SPS
◆ remote			SPS
▼ ◆ Switching mode	☆	91.312	ENS
◆ interlocked			SPS
◆ non-interlocked			SPS
▼ ◆ Sw.authority key/set	☆	91.309	ENS
◆ local			SPS
◆ remote			SPS
▼ ◆ Sw.mode key/set	☆	91.310	ENS
◆ interlocked			SPS
◆ non-interlocked			SPS

[sc_moscha, 1, en_US]

Figure 9-17 Switching Mode in Function Block General

The following table shows the effects of changing the switching mode to use command checks.

Table 9-17 Relationship Between Switching Mode and Command Checks

Command Check	Switching Mode	
	Interlocked	Non-Interlocked
Switching authority	Checked	Checked
Switching direction (set=actual)	Checked	Checked
Fixed interlocking conditions	Checked	Checked
Interlocking conditions	Checked	Not checked
1-out-of-n check (double-activation blocking)	Checked	Not checked
Blocking by protection function	Checked	Not checked

Switching Authority

The switching authority determines which command source is allowed. The following command sources are possible:

- Local:**
 A switching command from the local control (cause-of-error source **Local**) is possible only if the switching authority is set to **Local** and the device is capable of on-site operation. Setting the switching authority to **Local** is typically accomplished with and the function key **0** (Local/Remote). In this case, commands from all other sources are rejected. If the switching authority is set to **Local**, the setting cannot be changed **remotely**. The switching authority **Local** is indicated by the flashing indication **Switching authority:Local** in the upper section of the device display. The indication is displayed on all pages.

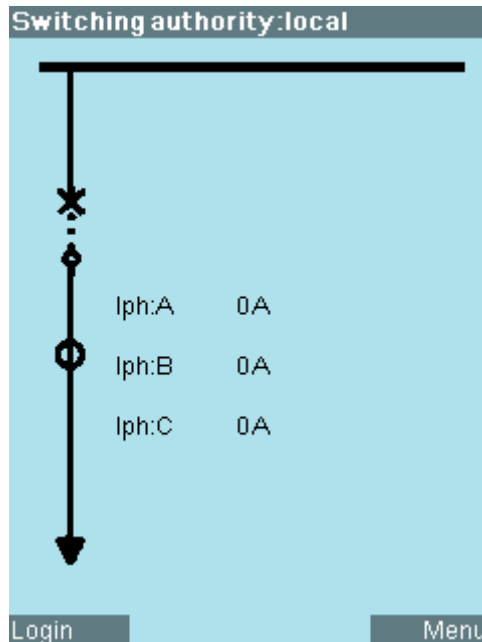

[sc_swit_authority_local_1_en_US]

Figure 9-18 Display of the Switching Authority

- DIGSI:**
 A switching command from DIGSI (connected via USB or Ethernet, cause-of-error source **Maintenance**) is accepted only if the switching authority in the device is set to **Remote**. Once DIGSI has signed on the device for command output, no commands from other command sources or a different DIGSI PC will be executed.
- Station:**
 This switching authority level can be activated via a parameter in the **General** function block. A switching command from the station level (cause-of-error source **Station** or **Automatic station**) is accepted if the switching authority is set to **Remote** and the controllable **Station switching authority** is set. This is accomplished by a command from the substation automation technology. Switching commands from the device or from outside the station (cause-of-error source **Local**, **Remote** or **Automatic remote**) are rejected.
 Full support of the switching-authority level is assured only when using the IEC 61850 protocol.
- Remote:**
 This switching authority level stands from remote control directly from the network control center or (if the switching authority level **Station** is not activated) generally for **Remote** control. The cause-of-error source is **Automatic remote**. Commands from this level are accepted if the switching authority is set to **Remote** and the controllable **Station switching authority** is not set. Switching commands from the device or from the station (cause-of-error source **Local**, **Station** or **Automatic station**) are rejected.

Signals	Fav	Number	Type
(All) ... (All) ...			
▼ General		91	
◆ >SG choice bit 1	☆	91.500	SPS
◆ >SG choice bit 2	☆	91.501	SPS
◆ >SG choice bit 3	☆	91.502	SPS
◆ >Sw. authority local	☆	91.503	SPS
◆ >Sw. authority remote	☆	91.504	SPS
◆ >Sw. mode interlocked	☆	91.505	SPS
◆ >Sw. mode non-interl.	☆	91.506	SPS
🔑 Switching auth. station	☆	91.308	SPC
▼ ◆ Switching authority	☆	91.311	ENS
◆ local			SPS
◆ DIGSI			SPS
◆ station			SPS
◆ remote			SPS
▼ ◆ Switching mode	☆	91.312	ENS
◆ interlocked			SPS
◆ non-interlocked			SPS
▼ ◆ Sw.authority key/set	☆	91.309	ENS
◆ local			SPS
◆ remote			SPS
▼ ◆ Sw.mode key/set	☆	91.310	ENS
◆ interlocked			SPS
◆ non-interlocked			SPS

[sc_moscha, 1, en_US]

Figure 9-19 Display of Switching Authority and Switching Mode in Information Routing (in Function Block General)

Sw. authority key/set and **Sw.mode key/set** indicate the current state of the key switch or parameter for switching authority or switching mode and provide this information for further processing in the CFC. In the CFC, for example, it is possible to set up an automatic routine to ensure that the switching authority is automatically set to **Local** when the key switch is set to **non-interlocked**.

The following table shows the dependency of the switching mode on the key-switch position and the switching authority. In the case of switching commands from **Remote**, the information on whether switching is to be made to locked or unlocked is also sent. For this reason, the position of the key switch is irrelevant for the switching mode in these cases. The information in the table assumes that, in the case of **remote** switching commands or those from the **station**, the switching mode is **interlocked** in each case.

Table 9-18 Dependency of the Switching Mode on the Key-Switch Position and Switching Authority

Key Switch for Switching Mode	Switching Authority		
	Local	Remote	Station
Interlocked	Interlocked	Interlocked	Interlocked
Not interlocked	Non-interlocked	Interlocked	Interlocked

The signals shown in [Figure 9-19](#) in DIGSI 5 information routing have the following relationship:

- In terms of switching authority and switching mode, the respective key switch position serves as the input signal and the input signals in the matrix.
- The state of the switching authority and switching mode is indicated by corresponding output signals.
- The **Switching authority** and **Switching mode** functions link the input signals and in this way establish the output signals (see [Figure 9-20](#) and [Figure 9-21](#)).

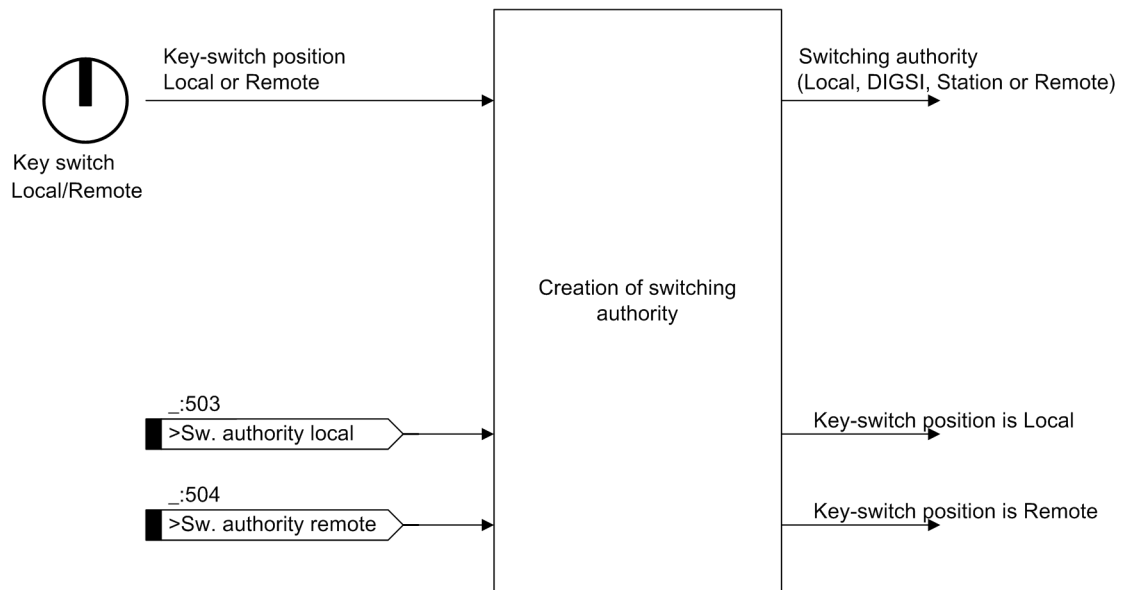

[dw_authority, 1, en_US]

Figure 9-20 Establishing Switching Authority

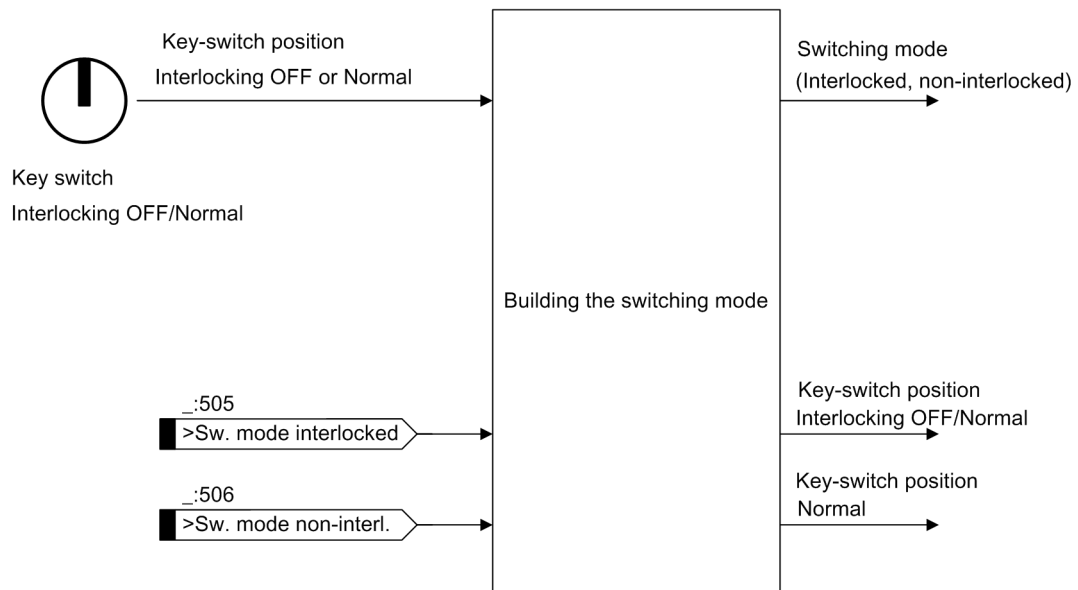

[dw_modsch, 1, en_US]

Figure 9-21 Establishing Switching Mode

In the case of both functions, the input signals overwrite the state of the key switch. This allows external inputs to also set the switching authority or switching mode, if desired (for instance, by querying an external key switch).

The following additional settings are available for the switching authority:

- **Enable sw.auth. station** (defined in IEC 61850 Edition 2):
 If you would like to use this switching authority, set the check mark **General/Control**.
- **Multiple sw.auth. levels:**
 This option permits switching commands from several command sources in the device if the switching authority **Remote** is selected. Subsequently, a distinction between these command sources can also be made. You can find more details in the following table. Activate this option by setting the check mark **General/Control**.
- **Specific sw. authorities:**
 You can enable additional options for the switching authority check. You can find more information about these options in [Specific Switching Authority, Page 1185](#). By default, these are not used.
- **Show int.lck.cond. on HMI:**
 You can activate the parameter to show the status of interlocking conditions in the device. For additional information refer to [Specific Switching Authority, Page 1185](#). By default, this parameter is inactive.

General

Device

91.101	Rated frequency:	50 Hz	
91.102	Minimum operate time:	0.00 s	
91.115	Set. format residu. comp.:	Kr, Kx	
91.138	Block monitoring dir.:	off	

Chatter blocking

91.123	No. permis.state changes:	0	
91.127	Initial test time:	1 s	
91.124	No. of chatter tests:	0	
91.125	Chatter idle time:	1 min	
91.137	Subsequent test time:	2 s	

Measurements

91.111	Energy restore interval:	10 min	
91.112	Energy restore time:	none	
91.120	Energy restore:	latest value	
91.121	Energy restore by A.time:	<input type="checkbox"/>	
91.104	Average calc. interval:	60 min	
91.105	Average update interval:	60 min	
91.106	Average synchroniz. time:	hh:00	

Control

91.118	Enable sw.auth. station:	<input type="checkbox"/>	
91.119	Multiple sw.auth. levels:	<input type="checkbox"/>	
91.152	Specific sw. authorities:	<input type="checkbox"/>	
91.166	Shows interlock.cond. HMI:	<input type="checkbox"/>	

[sc_akt_hoh, 2, en_US]

Figure 9-22 How to Activate the Station Switching Authority and to Enable Several Switching-Authority Levels

Table 9-19 Effect on Switching Authority when Several Switching-Authority Levels Are Enabled with/without Activation of the Station Switching Authority

Release Several Switching Authority Levels	Switching Authority in the Device	Status of DIGSI in the Device	Station Switching Authority Activated	State of the Station Switching Authority	Resulting Switching Authority
No	Local	–	–	–	Local
	Remote	Signed on	–	–	DIGSI
		Not signed on	No	–	Station and remote
			Yes	Set	Station
				Not set	Remote
Yes	Local	–	–	–	Local
	Remote	Signed on	–	–	DIGSI
		Not signed on	No	–	Local and station and remote
			Yes	Set	Local and station
				Not set	Local and station and remote

The following table shows the result of the switching-authority check, based on the set switching authority and the cause of the command. This overview represents a simplified normal case (no multiple command sources when using Station and Remote).

Table 9-20 Result of a Switching-Authority Check

Cause Source	Switching Authority			
	Local	DIGSI	Station	Remote
Local	Release	Blocked	Blocked	Blocked
Station	Blocked	Blocked	Release	Blocked
Remote	Blocked	Blocked	Blocked	Release
Local automatic operation	Release	Release	Release	Release
Station automatic operation	Blocked	Blocked	Release	Blocked
Remote automatic operation	Blocked	Blocked	Blocked	Release
DIGSI	Blocked	Release	Blocked	Blocked

Specific Switching Authority

Special switching authorities can be configured as extension of the switching-authority check. This makes it possible to differentiate the **Remote** command sources at the bay level. Switching authority can be routed to or revoked from different control centers that can, for example, belong to different companies. Thus, precisely one of these command sources can switch at a certain time. This function is based on extending the switching-authority check by verifying the identifier of the command source (field **Originator/orident** of switching command). In order to turn on the function, go to **General/Control** and set the check mark for the parameter **Specific sw. authorities**. More settings for the configuration of the identifiers and the behavior of the function as well as additional signals appear (see [Figure 9-24](#)). In order to permit an additional command source to switch, you must activate this specific switching authority. In order to do this, set the controllable **Enable sw. auth. 1** to **Enable sw. auth. 5**.

General			
Device			
91.101	Rated frequency:	50 Hz	
91.102	Minimum operate time:	0.00 s	
91.115	Set. format residu. comp.:	Kr, Kx	
91.138	Block monitoring dir.:	off	
Chatter blocking			
91.123	No. permis.state changes:	0	
91.127	Initial test time:	1 s	
91.124	No. of chatter tests:	0	
91.125	Chatter idle time:	1 min	
91.137	Subsequent test time:	2 s	
Measurements			
91.111	Energy restore interval:	10 min	
91.112	Energy restore time:	none	
91.120	Energy restore:	latest value	
91.121	Energy restore by A.time:	<input type="checkbox"/>	
91.104	Average calc. interval:	60 min	
91.105	Average update interval:	60 min	
91.106	Average synchroniz. time:	hh:00	
Control			
91.118	Enable sw.auth. station:	<input type="checkbox"/>	
91.119	Multiple sw.auth. levels:	<input type="checkbox"/>	
91.152	Specific sw. authorities:	<input checked="" type="checkbox"/>	
91.153	Specific sw.auth. valid for:	station/remote	
91.154	Num. of specific sw.auth.:	2	
91.156	Ident. sw.auth. 1:	ID1	
91.157	Ident. sw.auth. 2:	ID2	
91.155	Multiple specific sw.auth.:	<input type="checkbox"/>	
91.166	Shows interlock.cond. HMI:	<input type="checkbox"/>	

[sc_act additional options sw authority, 4, en_US]

Figure 9-23 Activating Additional Options of the Switching Authority

The additional parameters allow you to set the following options:

- **Specific sw.auth. valid for** (for *station/remote*, only *remote* or only *station*):
 With this parameter, you determine for which command source the extended switching-authority check is used.

Table 9-21 Result Derived from the Combination of the Parameter Value **Specific sw.auth. valid for** and the Level of the Command Source (Field **Originator/orCat** of the Switching Command)

Command Source	Specific sw.auth. valid for		
	<i>station</i>	<i>station/remote</i>	<i>remote</i>
Local, local automatic	No check	No check	No check
Station, station automatic	Check	Check	No check

Command Source	Specific sw.auth. valid for		
	station	station/remote	remote
Remote, remote automatic	No check	Check	Check
DIGSI	No check	No check	No check

- Num. of specific sw.auth.:**
 With this parameter, you determine how many specific switching authorities are available. This determines the number of parameters **Identifier switching authority** as well as the controllable **Active. Sw. auth.**
- Identifier switching authority 1 to Identifier switching authority 5:**
 The number of names that appear corresponds to the number set in the previous parameter. You can select the names as you wish, 1 to 64 characters are allowed. The command check verifies whether these titles correspond with those sent by the command source. This applies to the switching commands as well as to the activation of a specific switching authority. The requirement for this is the system interface IEC 61850. The field **Originator/orident** is used.
- Multiple specific sw.auth.** ensures the simultaneous validity of the various command sources. The following table shows how to determine the resulting specific switching authority when activating the command sources of Remote or Station. If this parameter is activated, all parameterized command sources get permissible automatically (see last row in the table) and they cannot be deactivated via the controllable **Enable sw. auth. 1** to **Enable sw. auth. 5**. Otherwise, the enabled command source with the lowest number has always the highest priority and prevails against the other numbers.

Table 9-22 Determining Switching Authority if Multiple Command Sources Are Available

Multiple specific sw.auth.	Enable sw. auth. 1	Enable sw. auth. 2	Enable sw. auth. 3	Enable sw. auth. 4	Enable sw. auth. 5	Resulting Specific Switching Authority
No	On	*	*	*	*	Switch. auth. 1
No	Off	On	*	*	*	Switch. auth. 2
No	Off	Off	On	*	*	Switch. auth. 3
No	Off	Off	Off	On	*	Switch. auth. 4
No	Off	Off	Off	Off	On	Switch. auth. 5
No	Off	Off	Off	Off	Off	None
Yes	On	On	On	On	On	All

The * symbol in the previous table refers to any value.

Switching auth. station	91.308	SPC			
▼ Enable sw. auth. 1	91.324	SPC			
◆ off		SPS			
◆ on		SPS			
▼ Enable sw. auth. 2	91.325	SPC			
◆ off		SPS			
◆ on		SPS			
▼ ◆ Switching authority	91.311	ENS			
◆ local		SPS			
◆ DIGSI		SPS			
◆ station		SPS			
◆ remote		SPS			
▼ ◆ Switching mode	91.312	ENS			
◆ interlocked		SPS			
◆ non-interlocked		SPS			
▼ ◆ Sw.authority key/set	91.309	ENS			
◆ local		SPS			
◆ remote		SPS			
▼ ◆ Sw.mode key/set	91.310	ENS			
◆ interlocked		SPS			
◆ non-interlocked		SPS			

[sc_sw authority and mode in info routing, 1, en_US]

Figure 9-24 Display of Switching Authority and Switching Mode in the Information Routing (in Function Block General), Example of 2 Activated Remote Switching Authorities

Individual Switching Authority and Switching Mode for the Switching Devices

In a standard case, the functionalities switching authority, switching mode, and specific switching authority as described in the previous sections, are applicable to the entire bay unit and, therefore, are valid for all switching devices that are controlled by this bay unit. In addition, you can configure an individual switching authority and specific switching authority as well as individual switching modes for single switching devices. Therefore, individual switching devices can accept various switching authorities and switching modes simultaneously.

This is offered for the following function groups and function blocks:

- **Circuit-breaker** function group
- **Disconnecter** function group
- **Transformer tap changer** function group
- **Switching sequence** function block

This allows to select individual settings for each switching device. This is useful if, for example, switching devices of different utilities are managed within a single bay.

In order to activate this option, go to the function block **Control** of a switching device and set the parameter **Check switching authority** to **advanced**. An additional table containing initially 2 parameters is displayed.

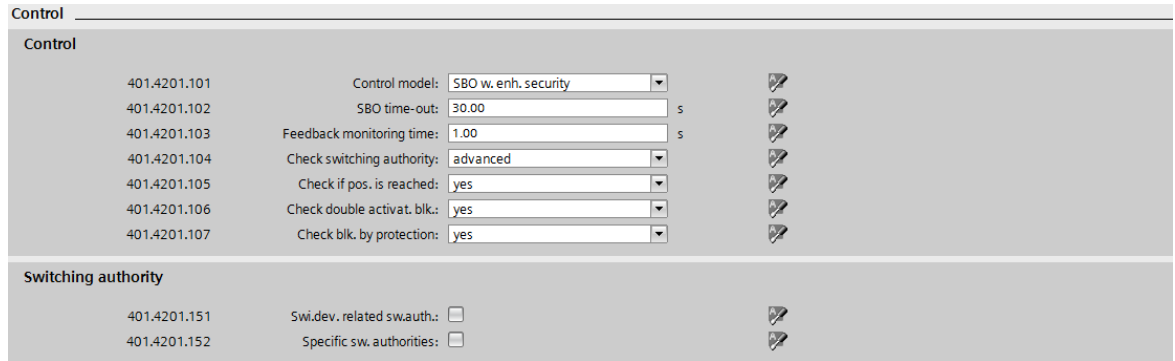

[sc_add parameters sw authority sw device, 1, en_US]

Figure 9-25 Additional Parameters for Switching Authorities in the Parameters of a Switching Device

When activating the parameter **Swi.dev. related sw.auth.**, an individual switching authority as well as an individual switching mode for this switching device are configured. Additional signals are displayed in the **Control** function block of the corresponding switching device.

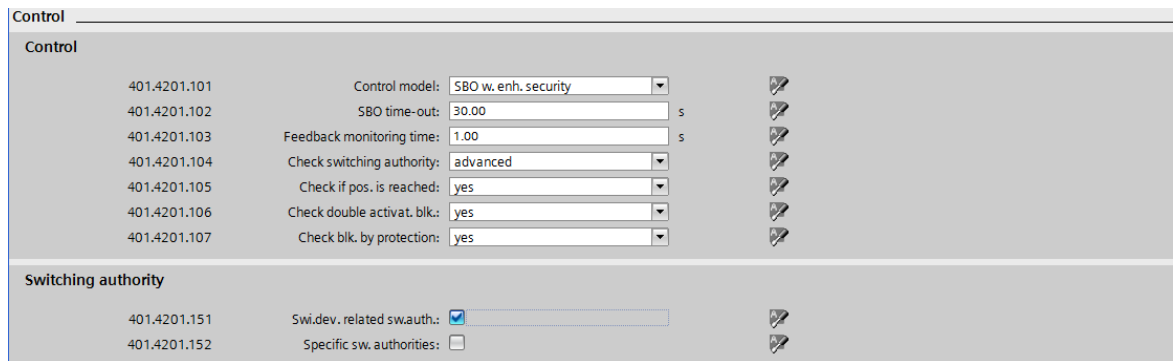

[sc_extended parameters sw authority sw device, 1, en_US]

Figure 9-26 Expanded Parameters for the Switching Authority in the Switching Device

Control	401.4201		
>Sw. authority local	401.4201.503	SPS	
>Sw. authority remote	401.4201.504	SPS	
>Sw. mode interlocke	401.4201.505	SPS	
>Sw. mode non-interl.	401.4201.506	SPS	
Health	401.4201.53	ENS	
ok		SPS	
warning		SPS	
alarm		SPS	
Cmd. with feedback	401.4201.58	DPC	
Switching auth. station	401.4201.302	SPC	
Switching authority	401.4201.313	ENS	
local		SPS	
DIGSI		SPS	
station		SPS	
remote		SPS	
Switching mode	401.4201.314	ENS	
interlocked		SPS	
non-interlocked		SPS	

[sc_switching auth sw mode changeable, 1, en_US]

Figure 9-27 Individually Modifiable Switching Authority and Switching Mode for Switching Devices

The new input signals that are displayed allow you to set the individual switching authority and switching mode for the switching devices. For this switching device, these inputs overwrite the central switching

authority and the switching mode. The outputs *Switching authority* and *Switching mode* indicate the states only for this switching device.

When activating **Specific sw. authorities**, an individual specific switching authority for this switching device is configured. Additional parameters are displayed.

[sc_parameters FB control all additional options, 1, en_US]

Figure 9-28 Parameters of the FB Control with All Additional Options

The functionality of the specific switching authority for the individual switching device and the significance of the additional parameters is identical to the operating mode of the central specific switching authority. Additional signals are displayed in the **Control** function block.

Control	202.4201		
Health	202.4201.53	ENS	
Cmd. with feedback	202.4201.58	DPC	
Switching auth. stati...	202.4201.302	SPC	
Enable sw. auth. 1	202.4201.308	SPC	
off		SPS	
on		SPS	
Enable sw. auth. 2	202.4201.309	SPC	
off		SPS	
on		SPS	

[sc_specific sw authority changeable per sw device, 1, en_US]

Figure 9-29 Specific Switching Authority, Modifiable for Each Switching Device

Switching Direction (Set = Actual)

With this check, you avoid switching a switching device into a state that has already been achieved. For instance, before a trip command is issued to a circuit breaker, its current position is determined. If this circuit breaker is already in the **OFF** position, no command is issued. This is logged accordingly.

Switchgear Interlocking Protection

Switchgear interlocking protection means avoiding maloperation by checking the bay and substation interlocking and thus preventing equipment damage and personal injury. The interlocking conditions are always system-specific and for this reason are stored as CFC charts in the devices.

SIPROTEC 5 devices recognize 2 different types of interlocking conditions:

- Normal interlocking conditions:
 These can be revoked by changing the switching mode to **non-interlocked**.

- Non-revocable (fixed) interlocking conditions:
These are still checked even if the switching mode is set to **non-interlocked**.
Application: Replacing mechanical interlocking, for example, that prevent actuation of a medium-voltage switch.

Each of the 2 categories has 2 release signals (for the *On* and *Off* switching directions) that represent the result of the interlocking plan, so that interlocking is in effect during the command check (see the figure below). The default setting for all release signals is **TRUE**, so that no switchgear interlocking checks take place if no CFC charts have been prepared.

Information			Source									
			▶ Binary input									
			▶ Base module									
Signals	Number	Type	1.1	1.2	1.3	1.4	1.5	1.6	1.7	1.8		
(All) ▼	(All) ▼	
▼ Circuit breaker 1	201											
▶ Trip logic	201.5341											
▶ Circuit break.	201.4261											
▶ Manual close	201.6541											
▶ Control	201.4201											
▼ Interlocking	201.4231											
▶ >Enable opening	201.4231.500	SPS										
▶ >Enable closing	201.4231.501	SPS										
▶ >Enable opening (fixed)	201.4231.502	SPS										
▶ >Enable closing (fixed)	201.4231.503	SPS										
▶ Health	201.4231.53	ENS										

[sc_verrie, 1, en_US]

Figure 9-30 Interlocking Signals in Function Block Interlocking

By default, the status of interlocking conditions is not visible in the device, see the following figure.

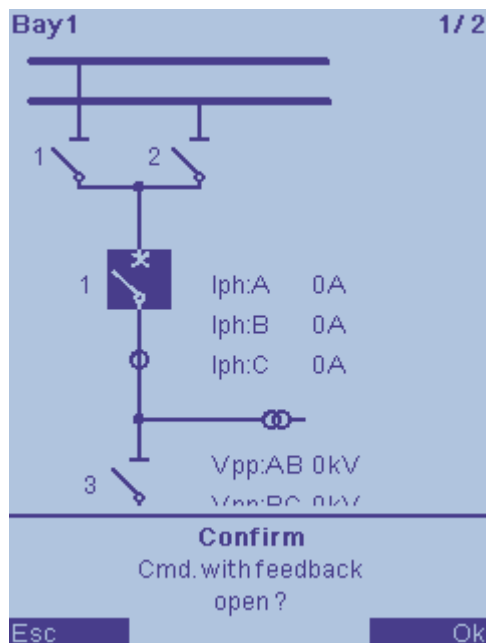

[sc_HMI_WO_Position, 1, en_US]

Figure 9-31 The Status of Interlocking Conditions is not Visible in the Control Display

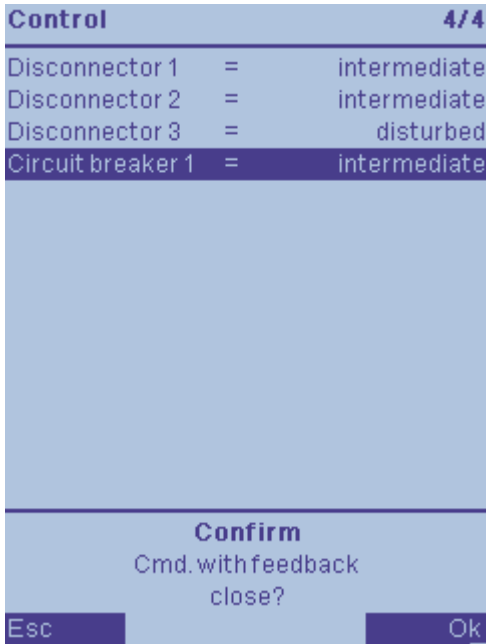

[sc_HMI_WO_Position2, 1, en_US]

Figure 9-32 The Status of Interlocking Conditions is not Visible in the Control Menu

But, if you activate the parameter **Show int.lck.cond. on HMI** by navigating to **Settings > Device settings > General > Control** in DIGSI 5, you can get the status of interlocking conditions in the device.

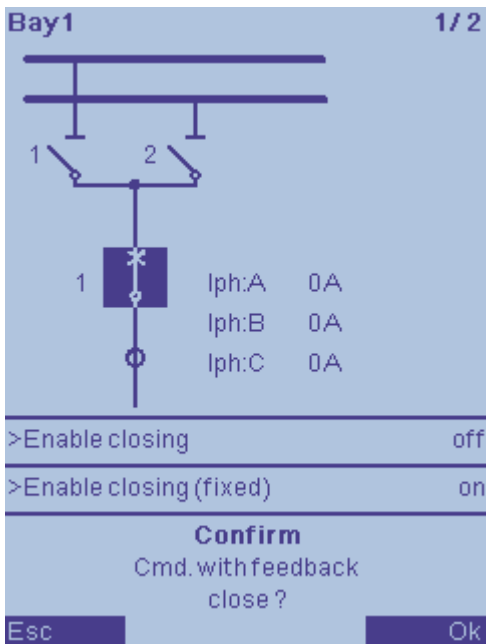

[sc_HMI_W_Position, 1, en_US]

Figure 9-33 The Status of Interlocking Conditions is Visible in the Control Display

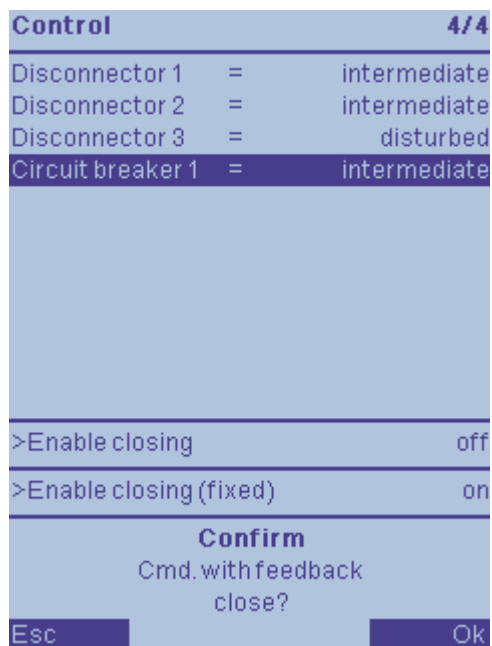

[sc_HMI_W_Position2, 1, en_US]

Figure 9-34 The Status of Interlocking Conditions is Visible in the Control Menu

EXAMPLE

For Interlocking

For the making direction of the circuit breaker QA in bay E01 (see the figure below), it is necessary to check whether the disconnectors QB1, QB2, and QB9 are in the defined position, that is, either **On** or **OFF**. Opening the circuit breaker QA should be possible at any time.

The interlocking equations are: $QA_On = ((QB1 = On) \text{ or } (QB1 = Off)) \text{ and } ((QB2 = On) \text{ or } (QB2 = Off)) \text{ and } ((QB9 = On) \text{ or } (QB9 = Off))$. There is no condition for opening.

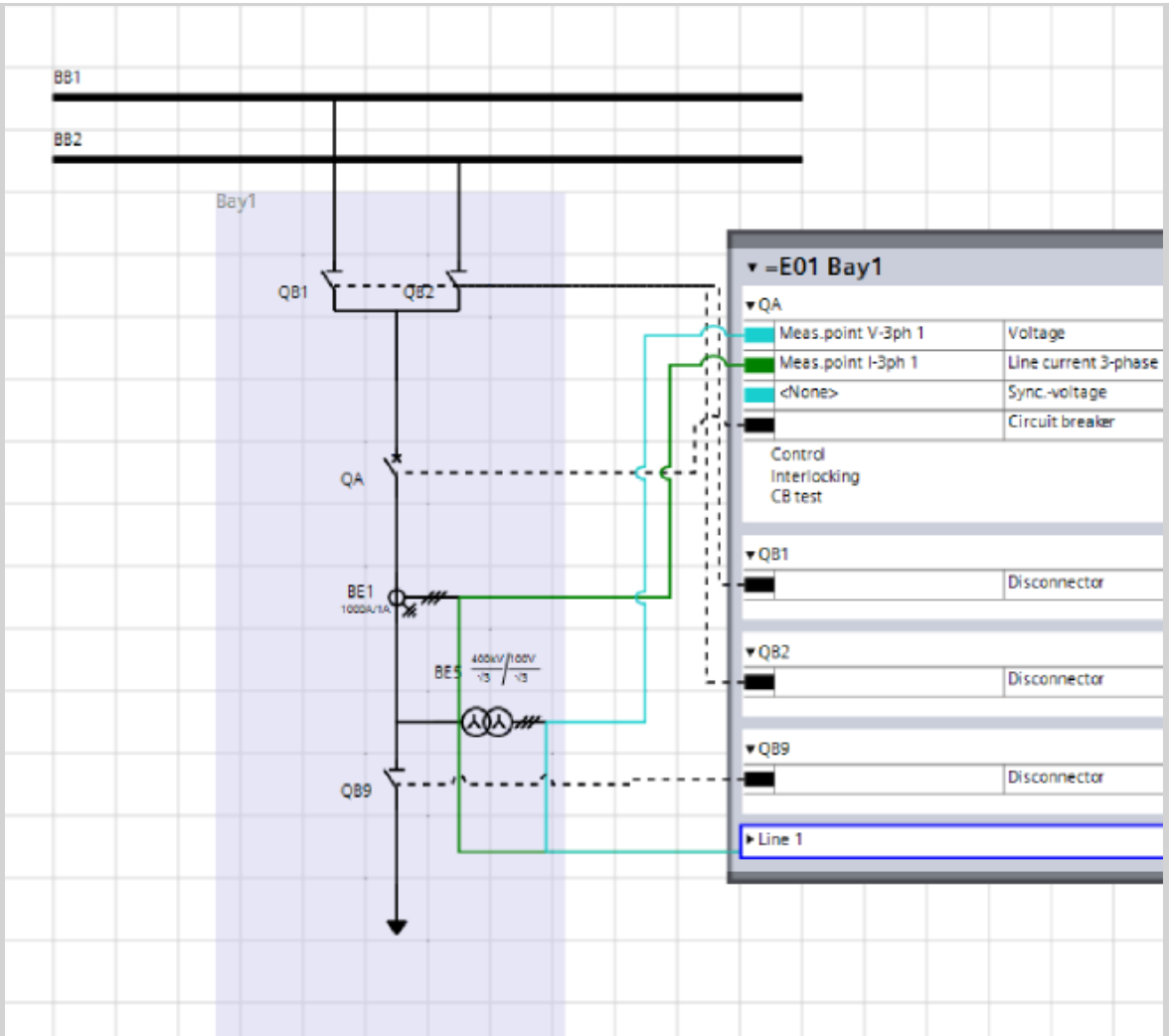

Figure 9-35 Feeder Bay for a Double Busbar System

The CFC chart that is required to implement the interlocking equation is shown in the next figure.

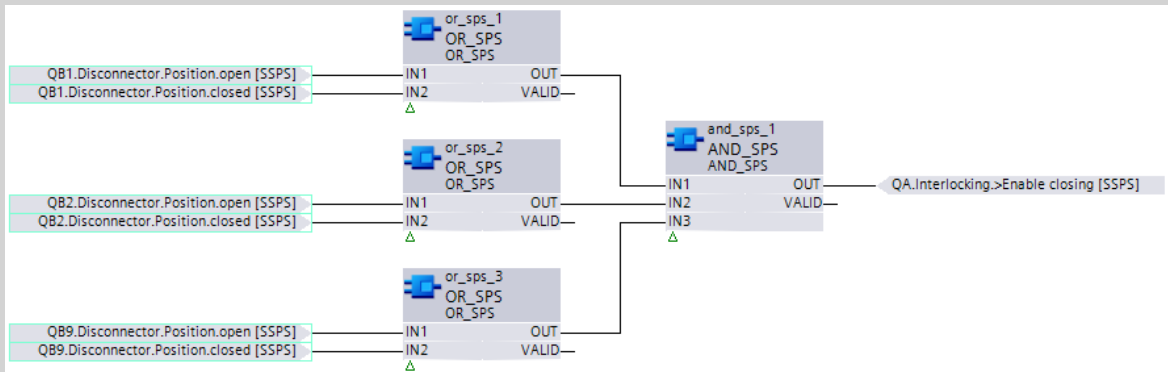

Figure 9-36 Interlocking Chart for Bay Interlocking

Since the **Disconnector** function block provides the defined position *On* or *Off*, the exclusive OR gate XOR is not necessary for the linkage. A simple OR suffices.

As can be seen in the CFC chart, the result of the check is connected to the **>Release on signal** in the **Interlocking** function block in the **Circuit breaker QA** function group (see [Figure 9-36](#)).

EXAMPLE

For System Interlocking

This example considers the feeder = E01 from the previous example (bay interlocking) and additionally the coupler bay = E02 (see the figure below).

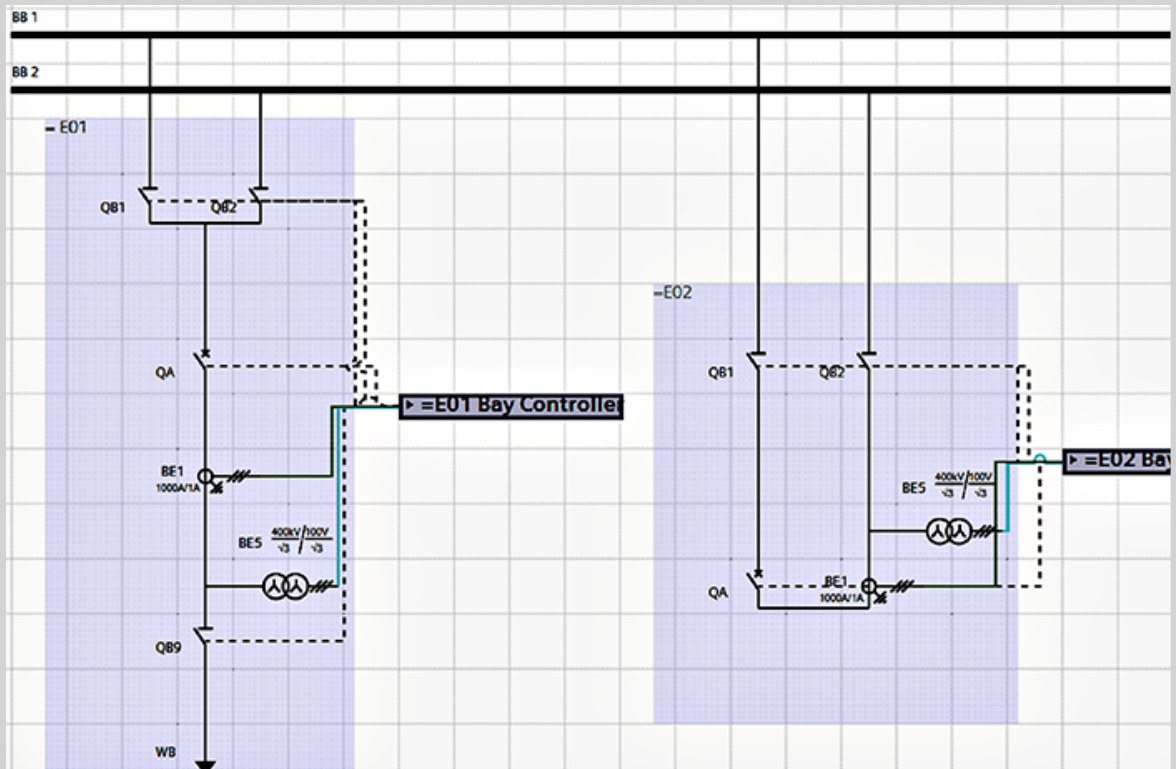

[sc_system, 1, en_US]

Figure 9-37 System with Feeder and Coupler Bays

The circuit breaker QA in coupler bay = E02 will be considered next. As the multibay interlocking condition, you must provide the bus-coupler circuit-breaker command block at the end:

If the 2 busbars in bay = E01 are connected, that is, if the 2 disconnectors QB1 and QB2 in bay = E01 are closed, the circuit breaker QA in bay = E02 is not allowed to be switched off. Accordingly, bay = E01 in the CFC of the device generates the indication *Bus coupler closed* from the positions of the switches QB1 and QB2 and, using IEC 61850-GOOSE, transmits it to bay = E02 in the device. You must then store the following interlocking condition in bay = E02:

QA_Off = NOT (= E01/Bus coupler closed)

In the CFC chart for the bus coupler device = E02, you must create the following CFC chart (see the figure below).

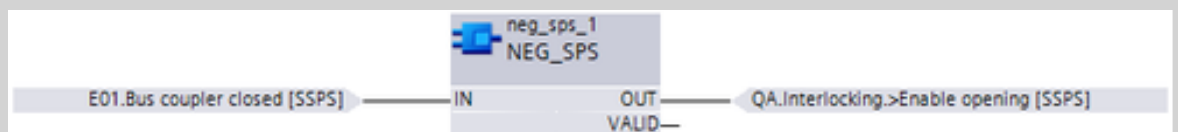

[sc_planve, 1, en_US]

Figure 9-38 Interlocking Chart for System Interlocking

1-Out-of-n Check (Double-Activation Blocking)

The double-activation blocking prevents 2 commands from being executed in the device simultaneously. You can set the device-internal check for each switching device as a parameter in the **Control** function block. The default setting is **Yes**, that is, double-activation blocking is active (see the figure below).

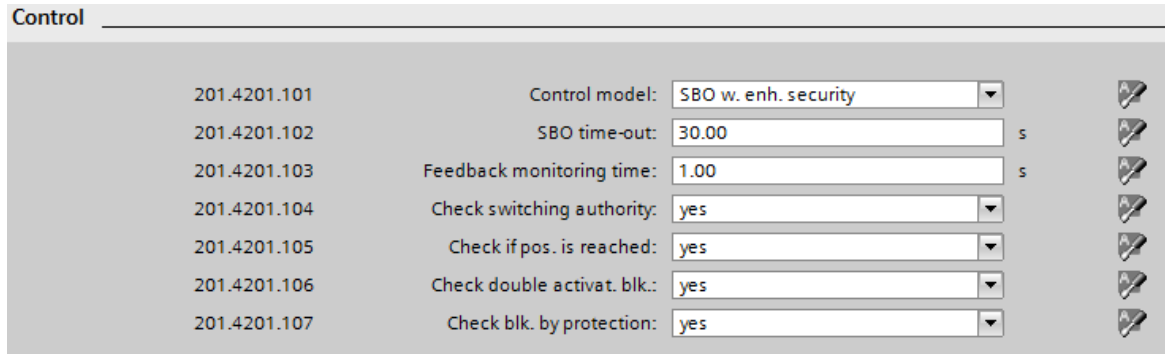

[sc_double, 1, en_US]

Figure 9-39 Activating the Double-Activation Blocking

With SIPROTEC 5, it is also possible to achieve multibay double-activation blocking. In this case, send the signal **not selected** to other devices for analysis using IEC 61850-GOOSE. This signal is available under **Position** in every **Circuit breaker** or **Disconnecter** function block in the switching device function groups (see figure below).

▼	Circuit breaker 1	201	
▶	Trip logic	201.5341	
▼	Circuit break.	201.4261	
◆	>Ready	201.4261.500	SPS
◆	>Acquisition blocking	201.4261.501	SPS
◆	>Reset switch statist.	201.4261.502	SPS
◆	>Reset AcqBlk&Subst	201.4261.504	SPS
▶	External health	201.4261.503	ENS
▶	Health	201.4261.53	ENS
▼	Position	201.4261.58	DPC
◆	not selected		SPS
◆	open		SPS
◆	closed		SPS
◆	intermediate position		SPS
◆	disturbed position		SPS
◆	acquisition blk. active		SPS
◆	manual update active		SPS

[sc_notselected, 1, en_US]

Figure 9-40 Signal *not selected* in the Circuit-Breaker Function Block

The signal is then queried in the CFC interlocking conditions for the associated switching devices and is used to generate the release signal (for example, **>Release on**).

9.3.2 Command Logging

All commands in the sequence are logged. The command log contains:

- Date and time
- Name of the switching device (or function group)
- Reason for the transmission (SEL = Selected, OPR = Operate, CMT = Command execution end, SPN = Spontaneous)
- Status or switching direction

EXAMPLE

The following example illustrates control of a disconnector QB1 for various cases.

- Successful command output
- Interrupted command
- Command interrupted by switchgear interlocking
- Command ended due to missing feedback
- Spontaneous change of switch position without command output

[Figure 9-41](#) to [Figure 9-47](#) indicate command logging for various scenarios of the standard control model SBO with feedback monitoring.

Operational log		1/6
07.04.2011	14:12:48.060	
Disconnector 1		
Control:Cmd. with feedback		
		SEL+ open
07.04.2011	14:12:49.834	
Disconnector 1		
Disconnector:Open command		
		on
07.04.2011	14:12:49.834	
Disconnector 1		
Control:Cmd. with feedback		
		OPR+ open
07.04.2011	14:12:50.390	
Disconnector 1		
Control:Cmd. with feedback		
		intermediate position
07.04.2011	14:12:57.129	
Delete		

[sc_poscas_1_en_US]

Figure 9-41 Positive Case (Display 1)

Operational log		3/6
07.04.2011	14:12:49.834	
Disconnecter 1		
Control:Cmd. with feedback		
		OPR+ open
07.04.2011	14:12:50.390	
Disconnecter 1		
Control:Cmd. with feedback		
		intermediate position
07.04.2011	14:12:57.129	
Disconnecter 1		
Disconnecter:Open command		
		off
07.04.2011	14:12:57.129	
Disconnecter 1		
Control:Cmd. with feedback		
		CMT+ open
*****End*****		
Delete		

[sc_posca2, en_US]

Figure 9-42 Positive Case (Display 2)

Operational log		1/2
07.04.2011	14:14:26.594	
Disconnecter 1		
Control:Cmd. with feedback		
		SEL+ close
07.04.2011	14:14:38.014	
Disconnecter 1		
Control:Cmd. with feedback		
		CNC+ close
*****End*****		
Delete		

[sc_poscan, 1, en_US]

Figure 9-43 Positive Case with Command Cancellation

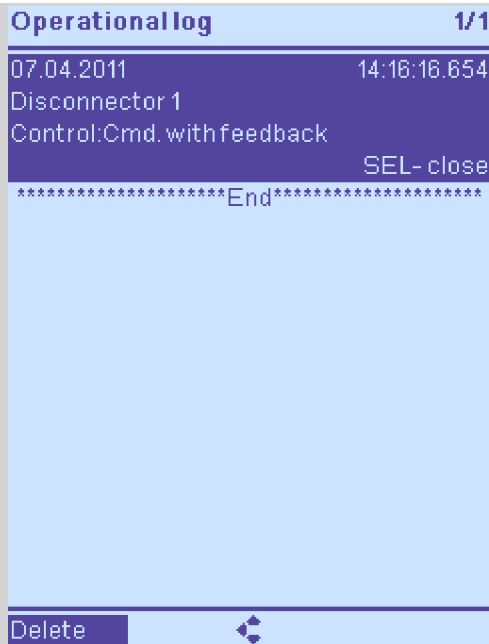

[sc_negint, 1, en_US]

Figure 9-44 Negative Case (Blocked by Switchgear Interlocking)

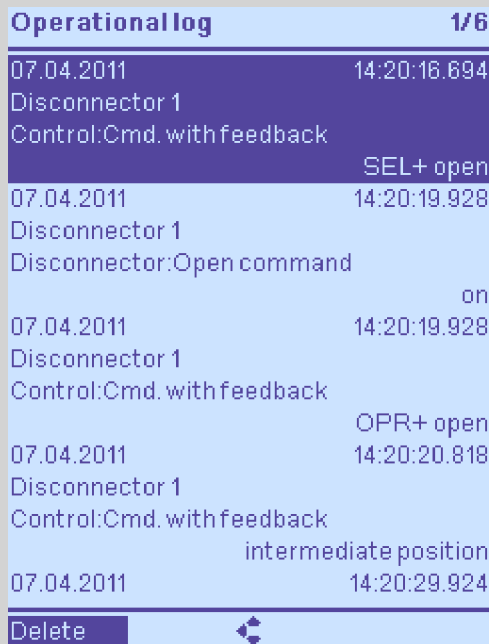

[sc_negim, 1, en_US]

Figure 9-45 Negative Case (Expiration of Feedback Supervision Time) (Display 1)

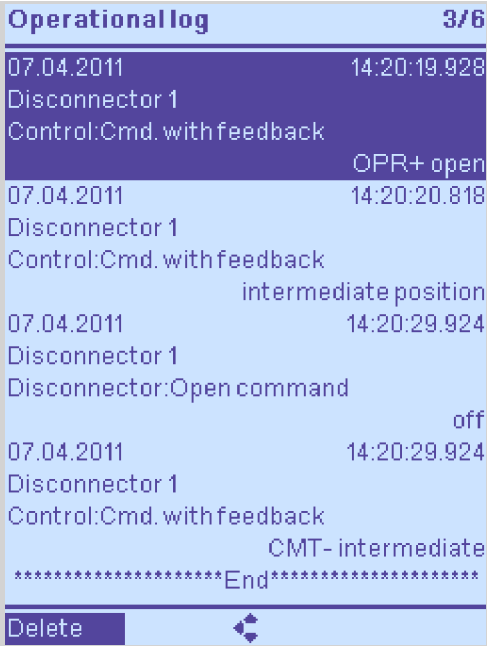

[sc_negt2_1_en_US]
 Figure 9-46 Negative Case (Expiration of Feedback Supervision Time) (Display 2)

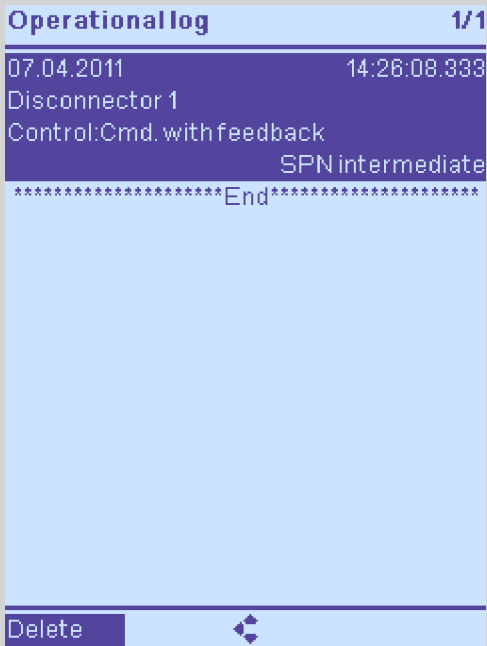

[sc_sponta_1_en_US]
 Figure 9-47 Spontaneous Status Change

Depending on the transmission reason, the desired control value or the actual state value of the controllable and the switching device can be contained in the log. The following table shows the relationship.

Table 9-23 Relationship between the Reason for Transmission and the Value Logged

Reason for Transmission	Value
Selected (SEL)	Desired value
Operate (OPR)	Desired value

Reason for Transmission	Value
Command cancellation (CNC)	Desired value
Command execution and termination (CMT)	Actual value
Spontaneous change (SPN)	Actual value

9.3.3 Settings

Addr.	Parameter	C	Setting Options	Default Setting
<i>Control</i>				
_:101	Control:Control model		<ul style="list-style-type: none"> • status only • direct w. normal secur. • SBO w. normal secur. • direct w. enh. security • SBO w. enh. security 	SBO w. enh. security
_:102	Control:SBO time-out		0.01 s to 1800.00 s	30.00 s
_:103	Control:Feedback monitoring time		0.01 s to 1800.00 s	1.00 s
_:104	Control:Check switching authority		<ul style="list-style-type: none"> • no • yes 	yes
_:105	Control:Check if pos. is reached		<ul style="list-style-type: none"> • no • yes 	yes
_:106	Control:Check double activat. blk.		<ul style="list-style-type: none"> • no • yes 	yes
_:107	Control:Check blk. by protection		<ul style="list-style-type: none"> • no • yes 	yes

9.3.4 Information List

No.	Information	Data Class (Type)	Type
<i>Control</i>			
_:53	Control:Health	ENS	O
_:58	Control:Cmd. with feedback	DPC	C

9.4 Synchronization Function

9.4.1 Overview of Functions

The 1-channel **Synchronization function** (ANSI 25) checks whether the activation is permissible without a risk to the stability of the system when interconnecting 2 parts of an electrical power system.

Typical applications are as follows:

- Synchronization of a line and a busbar
- Synchronization of 2 busbars via a cross-coupling
- Synchronization of a generator and a busbar

A power transformer between the 2 measuring points can also be taken into consideration.

The following operating modes are covered:

- Synchrocheck
- Switching synchronous power systems
- Switching asynchronous power systems
- Switching to dead line/busbar

9.4.2 Structure of the Function

The function **Synchronization** is used in the function group **Circuit-breaker**.

The following stage types can be used within the function:

- Synchrocheck stage
- Synchronous/asynchronous stage

The stage types **Synchrocheck** and **Synchronous/Asynchronous (Sychr./Asycr.)** are preconfigured at the factory.

In addition, the stage type **Extended delta-f options** are available in the function library. This has not been preconfigured.

You can operate a maximum of 2 stages of the stage type **Synchrocheck** or 6 stages of the **Synchronous/asynchronous** in parallel.

As soon as the function is available in the device, the functional measured values are calculated and displayed.

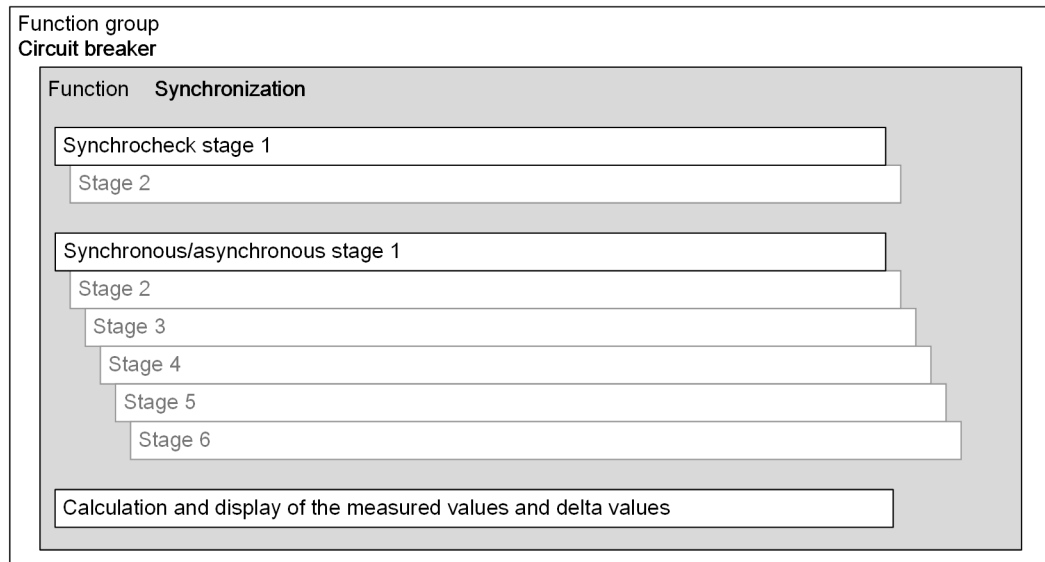

[dw_synfn1-01_2_en_US]

Figure 9-48 Structure/Embedding of the Function

9.4.3 Connection and Definition

Connection

You can find examples for the synchronization of line and busbar in the following 2 figures. [Figure 9-50](#) shows an example for the synchronization of 2 busbars via bus coupler.

The synchronization function uses 2 voltages to check the connecting conditions: a voltage of the reference side 1 (V1) as well as a voltage to be used as a reference on side 2 (V2). The reference voltage of side 1 is designated in the synchronization function as V1⁴⁰.

This is always the voltage of the measuring point that is connected to the **Sync. voltage 1** interface of the Circuit-breaker function group. The voltage to be set as reference is designated with V2⁴⁰. This is always the voltage of the measuring point that is connected to the **Sync. voltage 2** interface of the **Circuit-breaker** function group. The assignment of the measuring points to the interfaces of the **Circuit-breaker** function group can be configured, see .

The selection of the voltages used for the synchronization depends on the device connection to the primary system:

- Connection of the primary system via 4 voltage inputs and hence use of a 1-phase and a 3-phase measuring point ([Figure 9-49](#) and [Figure 9-50](#)):
The voltage connected to the 1-phase measuring point is definitive here. If, for example, this is the phase-to-ground voltage V_A , the voltage V_A is also used by the other side of the 3-phase measuring point.

You can connect both the phase-to-ground voltages and the phase-to-phase voltages to the device. The possible interface connections are listed in the Appendix.

⁴⁰ Do not confuse the designations V1 and V2 with the numbering of the voltage inputs V1 to V4 ([Figure 9-49](#)) .

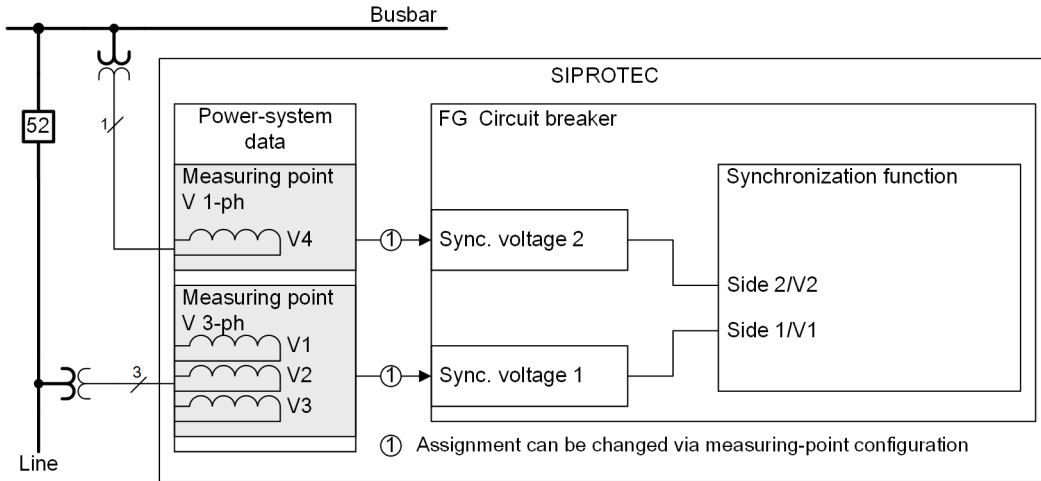

[dw_syms01-01, 2, en_US]

Figure 9-49 Synchronization of Line and Busbar, Connection via 4 Voltage Inputs

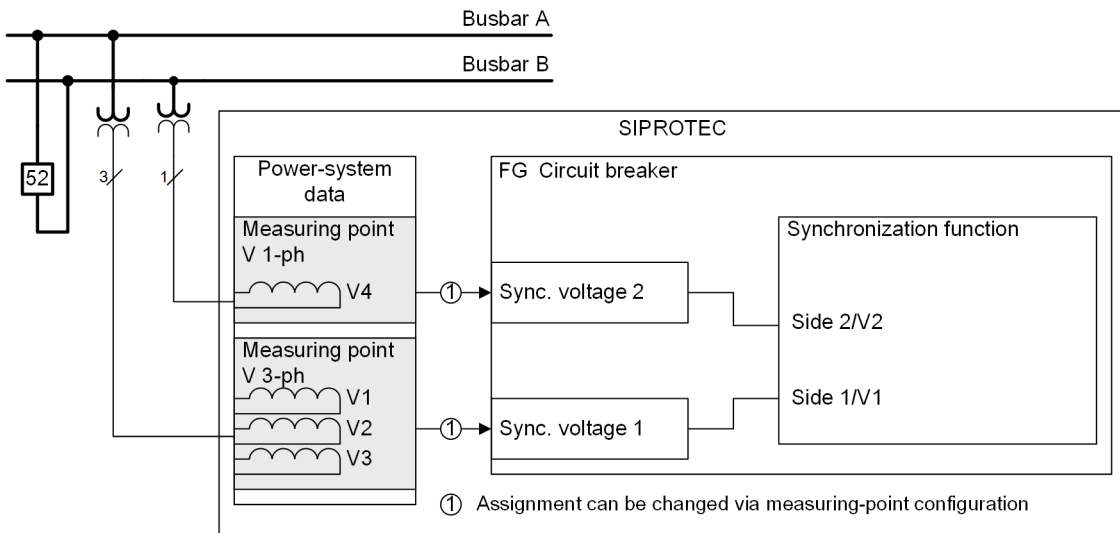

[dw_syms03-01, 2, en_US]

Figure 9-50 Synchronization of 2 Busbars via Cross-Coupling, Connection via 4 Voltage Inputs

Definition of the Variables

The definition of the variables is important for understanding the following implementation. The reference side 1 indicates the function with 1. This yields the reference values voltageV1, frequencyf1, and phase angle α_1 . The side to be synchronized indicates the function with 2. The electrical variables of side 2 are then the voltageV2, frequencyf2, and phase angle α_2 .

When forming the differential variables, the function is oriented to the definition of the absolute measuring error ($\Delta x = \text{measured value} - \text{real value}$). The reference value and hence the real value is side 1. This results in the following calculation specifications:

Differential voltage $dV = V_2 - V_1$

A positive sign means that the voltage V2 is greater than the voltage V1. In other cases, the sign is negative.

Differential frequency $df = f_2 - f_1$

A positive result means that according to the example from [Figure 9-49](#) the busbar frequency is greater than the line frequency.

Phase-angle difference $d\alpha = \alpha_2 - \alpha_1$

The representation is limited to $\pm 180^\circ$. A positive result means that $\alpha 2$ **leads** by a maximum of 180° . In the case of a negative value, $\alpha 2$ **lags** by a maximum of 180° . *Figure 9-51* shows the circumstances. The phase angle $\alpha 1$ was added to the zero axis as a reference system.

If asynchronous systems are present and the frequency $f 2$ is greater than $f 1$, the angle $d\alpha$ then changes from the negative value to 0 and then to the positive value. As shown in *Figure 9-51*, the direction of rotation is counterclockwise (mathematically positive). At $f 2 < f 1$, the direction of rotation is clockwise.

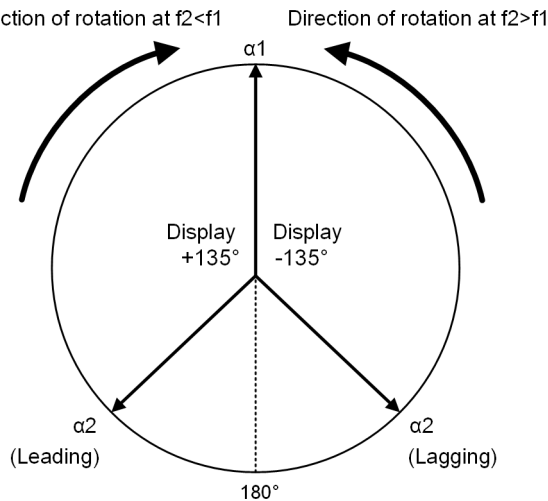

[dw_syp_04_2_en_US]

Figure 9-51 Phase-Angle Difference Representation $d\alpha$

Only positive values are permissible for the setting parameters. Inequalities are used to characterize the setting parameters uniquely. The representation is explained with the example of differential voltage. 2 setting values are necessary to allow unbalanced settings.

The inequality $V 2 > V 1$ yields a positive value for dV . The associated parameter is **Max. voltage diff. $V 2 > V 1$** . For the 2nd setting parameter **Max. voltage diff. $V 2 < V 1$** , the inequality $V 2 < V 1$ applies. It corresponds to a negative dV .

The procedure is the same for the differential frequency and differential phase angle.

9.4.4 General Functionality

9.4.4.1 Description

Overview of a Synchronization Stage (Sync Stage)

A synchronization stage can be integrated in the following blocks (see *Figure 9-52*):

- Stage control with mode, state control, standby, and blocking (description in this chapter)
- Supervision (description in this chapter)
- Functional sequence for issuing the closing release (see *9.4.5 Sequence of Functions*)

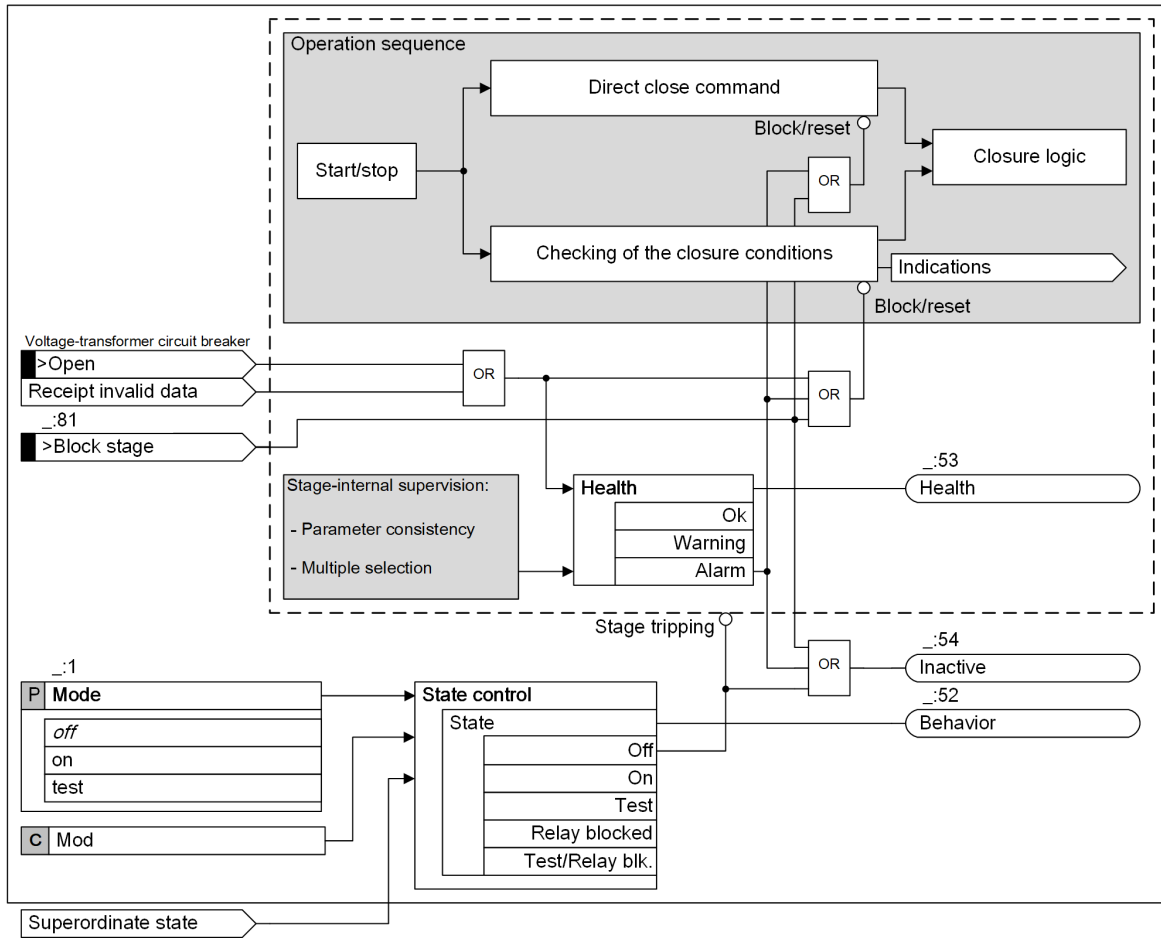

[ilo_syn001-01, 6, en_US]

Figure 9-52 Overview of the Stage Logic

Stage Control

The normal stage control is used for a synchronization stage (see [Figure 9-52](#)).

Note the following special features:

- For control via IEC 61850, a parameterized function Synchrocheck is only executed if the service parameter **Synchrocheck** is set to **true**. The function control also provides the service parameter **Interlock-Check**. If the service parameter **Synchrocheck** is set to **false**, switching is not synchronized. Siemens recommends checking the desired behavior for control from remote via IEC 61850 before the commissioning.
- As soon as there is a synchronization function available in the device, the measured values are calculated and displayed. One stage must be activated for calculating all Delta settings. It is not necessary to start the stage for this purpose.
- If all synchronization stages are deactivated within the function, closure via the control will no longer be possible, as none of the stages can generate a closing release. If the synchronization function is deleted, the circuit breaker is no longer regarded as subject to compulsory synchronization. In this case, it is possible to activate via the control without synchronization.
- If more than one synchronization stage is activated, the **>Selection** signal must be active for exactly one stage, so that it can be activated via the controls.

You can block the entire synchronization stage via the binary signal **>Block stage**. A started process is completed and the entire stage reset after blocking. The stage must be restarted to initiate a new switching

procedure. The blocking only affects the test process for the closing conditions. The measured values are still calculated and displayed.

Operating Range

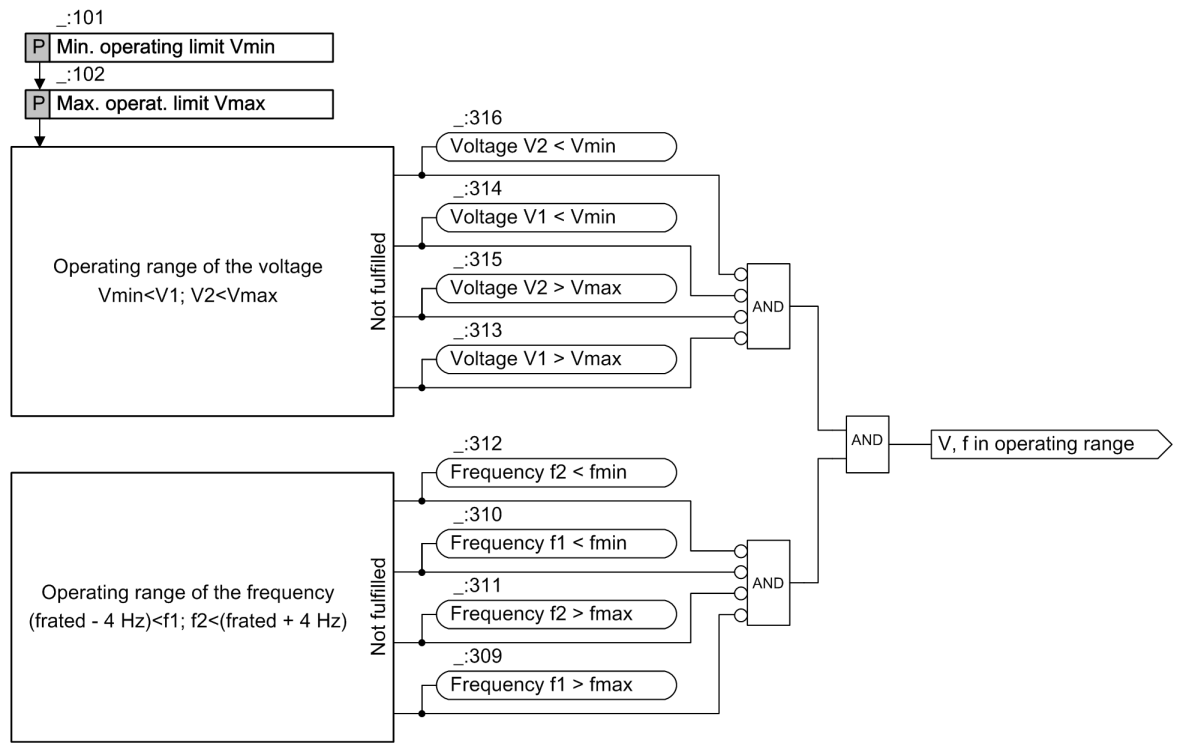

[to_syn002-01_2_en_US]

Figure 9-53 Logic of the Operating Ranges

The operating range of the synchronization function is defined by the configurable voltage limits **Min. operating limit Vmin** and **Max. operat. limit Vmax**, as well as by the specified frequency band $f_{rated} \pm 4$ Hz.

If one or both voltages are outside the permitted operating range when the measurement is started or a voltage leaves the range, this is displayed via corresponding indications **Frequency f1 > fmax**, **Frequency f1 < fmin**, **Voltage V1 > Vmax**, **Voltage V1 < Vmin**, etc. The closing conditions are then not checked.

Supervision

The supervisions listed below are executed in a function-specific manner. If one of the supervisions picks up, the indication *Health* goes to **Warning**. The stage is indicated as **Inactive**. A closing release or direct close command is not possible in this case.

- For consistency of settings of specific parameters
Definite threshold-value settings are checked after a parameter change. If there is an inconsistency, the error message **Setting error** is issued.
- For multiple selection of the stage at the start time of the synchronization
If there is a simultaneous selection of multiple closed synchronization stages at the start time, the error message **Multiple selection** is issued.

Measuring-Voltage Failure

If a voltage-transformer fault (measuring-voltage failure) is recorded via the binary input signal **>Open** of one of the voltage-measuring points, then the closing conditions of the synchronization stage are no longer

tested. This means that a release of the closure based on the measurement is no longer possible. The readiness of the stage turns to **Warning**. Direct close command is still possible.
 The device-internal supervision function measuring-voltage failure detection (Fuse Failure Monitor) does not have any effect on the synchronization stage.

Functional Measured Values

The functional measured values for the Synchronization function are displayed in their own primary, secondary, and percentage measured value windows. Voltage measurements are always displayed as ph-ph voltages, even if the associated measuring point records phase-to-ground voltages. The functional measured values are determined and displayed as soon as the device is functional. The difference values are calculated as soon as the stage is activated.

Table 9-24 Protection-Specific Values of the Synchronization

Values		Primary	Secondary	% Referenced to
V ₁	Reference voltage V ₁	kV	V	Rated operating voltage of the primary values
V ₂	Voltage to be synchronized V ₂	kV	V	Rated operating voltage of the primary values
f ₁	Frequency of the voltage V ₁	Hz	Hz	Rated frequency
f ₂	Frequency of the voltage V ₂	Hz	Hz	Rated frequency
dV	Voltage difference V ₂ -V ₁	kV	V	-
df	Frequency difference f ₂ -f ₁	Hz	Hz	-
da	Angle difference α ₂ -α ₁	°	-	-

Multiple Synchronization Points

The synchronization function can only be used within a Circuit-breaker function group. It always operates on the circuit breaker that is linked to the Circuit-breaker function group. The reference to the circuit breaker is therefore unique. If you wish to switch several circuit breakers (synchronization points) with the device, you must create several Circuit-breaker function groups.

Different Synchronization Conditions per Synchronization Point

Within the synchronization function, you can operate maximum 2 stages of the stage type **Synchrocheck** and maximum 6 stages of the type **Synchronous/asynchronous** in parallel. All setting parameters for a synchronization point are included in each synchronization stage.
 If you have to synchronize with different synchronization conditions (parameter settings), several synchronization stages are used for a synchronization point/circuit breaker. In this case, you must define which of the synchronization stages is currently active via the binary signal **>Selection** (synchronization stage x). The closing conditions are checked if the respective stage is activated via the **>Selection** binary signal and the stage is activated.
 The fault indication **Multiple selection** is issued upon simultaneous selection of different synchronization stages. If several synchronization stages are activated and the input signal **>Selection** (synchronization stage x) is missing at the starting time, a valid selection is awaited during the supervision time **Max. durat. sync. process**. If this does not come, the process is terminated.

Different Voltage-Transformer Ratios from Both Sides of the Electrical Power System

The synchronization function automatically takes different transformation ratios of the voltage measuring points into account on both sides of the power system. Set the parameter **Voltage adjustment** in the synchronization function for the following cases:

- Without a power transformer between the voltage measuring points of the circuit breaker to be synchronized, if the rated primary voltages are different on both sides of the electrical power system.
- With a power transformer between the voltage measuring points of the circuit breaker to be synchronized, if the transfer ratios of the rated primary voltages on the voltage transformer are different on both sides of the electrical power system.

For more information about the parameter **Voltage adjustment**, refer to [9.4.4.2 Application and Setting Notes, Parameter: Voltage adjustment, Page 1212](#).

Synchronization via a Transformer

There are systems in which a power transformer is located between the voltage measuring points of the circuit breaker to be synchronized. The device automatically considers the different voltage stages by setting the rated primary voltages of the power transformer from 2 sides of the electrical power system. A phase displacement must be taken into account based on the transformer vector group via the parameter **Angle adjust. (transform.)**.

The parameter is defined as $-\Delta\alpha = -(\alpha_2 - \alpha_1)$.

To calculate the delta variables $\Delta\alpha$ and ΔU , the voltage of side 2 is converted to that of side 1 using the settings of the 2 parameters **Angle adjust. (transform.)** and **Voltage adjustment**.

The displayed voltage V_2 in the device display is the voltage from the power-transformer side, which is close to the point to be synchronized, and not the measured voltage of the voltage transformer of side 2.

For more information, refer to [9.4.4.2 Application and Setting Notes](#).

Different Connection Types on Both Sides

If both the measuring points used by the synchronization functions record different voltages of the 3-phase system, the calculation of the phase-angle difference is automatically considered.

EXAMPLE:

The 1-phase measuring point connected with **Sync-voltage 1** records the phase-to-phase voltage V_{AB} . The 1-phase measuring point connected with **Sync-voltage 2** records V_A . In this case the phase angle between V_{AB} and V_A takes into consideration the delta variable $\Delta\alpha$ during calculation.

This automation guarantees that several voltage sources can be switched between during running operation, each of which records different voltages.

9.4.4.2 Application and Setting Notes

Stage-Type Selection

The following 2 types of stages are available:

Stage Type	Application
Synchrocheck stage	Select this type of stage to issue, for example, an additional release during a manual reclosing for safety reasons. With this type, the variables ΔV , Δf , and $\Delta\alpha$ are checked before connecting the 2 parts of the power system.
Synchronous/asynchronous stage	Select this type of stage if it is necessary to differentiate between synchronous and asynchronous systems, depending on the switch position. If galvanically coupled systems are switched in parallel, synchronous systems are present. A typical characteristic of synchronous systems is equality of frequency ($\Delta f \approx 0$). In this state, the conditions $\Delta\alpha$ and ΔV are checked. If the systems are galvanically isolated, asynchronous systems can be present. At the same time, compliance with the voltage difference ΔV and frequency difference Δf conditions is checked. The time of the direct close command is calculated taking into account the angle difference $\Delta\alpha$ and the make time of the circuit breaker. The time of the direct close command is calculated such that the voltages are equal at the moment the circuit-breaker poles come into contact ($\Delta V \approx 0$, $\Delta\alpha \approx 0$).

Configuration of the Voltages V1 (Reference Side) and V2

The voltages V1 and V2 are established via the connection of the measuring points to the interface of the function groups (refer to chapter 9.4.3 *Connection and Definition*). The measuring point connected to the interface **Voltage** is the reference side 1 with the reference voltage V1. The measuring point connected to the interface **Sync. voltage** is the side 2 with V2. The definition of the Delta parameters that can be derived from this is also described in chapter 9.4.3 *Connection and Definition*.

Parameter: Min. operating limit Vmin, Max. operat. limit Vmax

- Recommended setting value (`_:5071:101`) **Min. operating limit Vmin = 90 V**
- Recommended setting value (`_:5071:102`) **Max. operat. limit Vmax = 110 V**

The values define the voltage operating range of the synchronization stage. A normal setting is approx. $\pm 10\%$ of the rated voltage.



NOTE

All voltages connected according to the parameterized measuring-point connection type are subjected to the appropriate Vmin/Vmax test. Therefore, connected phase-to-ground voltages are multiplied by $\sqrt{3}$, since the threshold values must be set with reference to the rated voltage (phase-to-phase voltage).

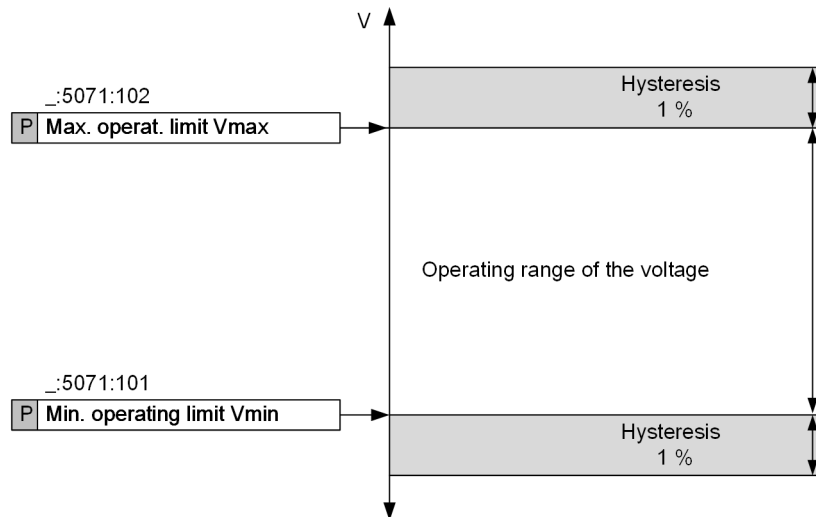

[fo_hyster-01, 2, en_US]

If the Synchronization function is started within the hysteresis, no switching is performed as a result of the minimum and maximum operating limit (parameters **Min. operating limit Vmin** and **Max. operat. limit Vmax**). If the Synchronization function is started within the voltage operating range and the voltage exceeds the minimum or maximum operating limit during the synchronization process, selecting can occur in the area of the hysteresis.

Parameter: Max.durat. sync.process

- Default setting (._:5071:110) **Max.durat. sync.process = 30 s**

The parameterized conditions must be fulfilled within this time. If the conditions are not fulfilled, no further closing release takes place and the synchronization stage is stopped. If this time is set to ∞, conditions are checked until they are fulfilled. This is also the default setting. Observe the operating conditions when defining the time limitation. This must be defined specifically for each system. If 0 or 0.01 s is set, then all conditions are checked once at the starting time. Thereafter the process is stopped immediately.

If the closure release is assigned, the synchronization is terminated. If the synchrocheck is to continuously display the switching conditions, without issuing a direct close command at synchronization, proceed as follows:

EXAMPLE:

For Continuous Checking of the Switching Conditions without Issuing a Direct Close Command

With the aid of the following CFC chart you can set the input *>Block stage* of the corresponding synchrocheck stage permanently:

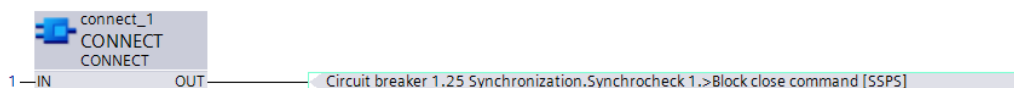

[sc_sync_CFC, 3, en_US]

If you route the indication *All sync. conditio. OK* to the corresponding binary output, you receive a separate release of the closure for an external synchronization unit.

Information			Sc Destination						
			Binary output						
			Base module						
Signals	Number	Type	1.1	1.2	1.3	1.4	1.5	1.6	
(All) ▼	(All) ▼	(All) ▼	
Mode (controllable)	201.1151.5071.51	ENC							
Inactive	201.1151.5071.54	SPS							
▶ Behavior	201.1151.5071.52	ENS							
▶ Health	201.1151.5071.53	ENS							
In progress	201.1151.5071....	SPS							
Release close cmd.	201.1151.5071....	SPS							
All sync. conditio. OK	201.1151.5071....	SPS	U						
Voltage difference OK	201.1151.5071....	SPS							
Angle difference OK	201.1151.5071....	SPS							
Frequency diff. OK	201.1151.5071....	SPS							
Cond. V1<V2> fulfilled	201.1151.5071....	SPS							

[sc_sync_routing, 2, en_US]

If you wish to permanently report each occasion on which synchronization conditions are reached following the start of synchronization, you set the parameter **Max.durat. sync.process** to ∞.

Synchrocheck 1

General

201.1151.5071.1	Mode:	<input type="text" value="off"/>	▼
201.1151.5071.101	Min. operating limit Vmin:	<input type="text" value="0"/>	V
201.1151.5071.102	Max. operat. limit Vmax:	<input type="text" value="0"/>	V
201.1151.5071.110	Max.durat. sync.process:	<input type="text" value="oo"/>	s
201.1151.5071.108	Direct close command:	<input type="text" value="no"/>	▼
201.1151.5071.126	Voltage adjustment:	<input type="text" value="1.000"/>	

[sc_sync_setting, 2, en_US]

Parameter: Voltage adjustment

- Default setting (_:5071:126) **Voltage adjustment** = 1.00

The parameter can be used for correction of amplitude errors, for example, due to indirect measurement (for example, transformer tap changer).

To apply a transformer between measuring points, the **Voltage adjustment** parameter is not needed. The transformer ratios are set for the measuring points and the function will take them into account automatically.

To apply a transformer between the voltage measuring points, the transformer ratio does not have to be taken into account. When you set the parameter **Voltage adjustment**, the transformer ratio is automatically taken into account. In the following, you can find 2 examples for the setting of the parameter **Voltage adjustment**:

Example 1:

In the electrical power system, no power transformer exists between the voltage measuring points of the circuit breaker to be synchronized. The rated primary voltages of 2 sides of the electrical power system are different.

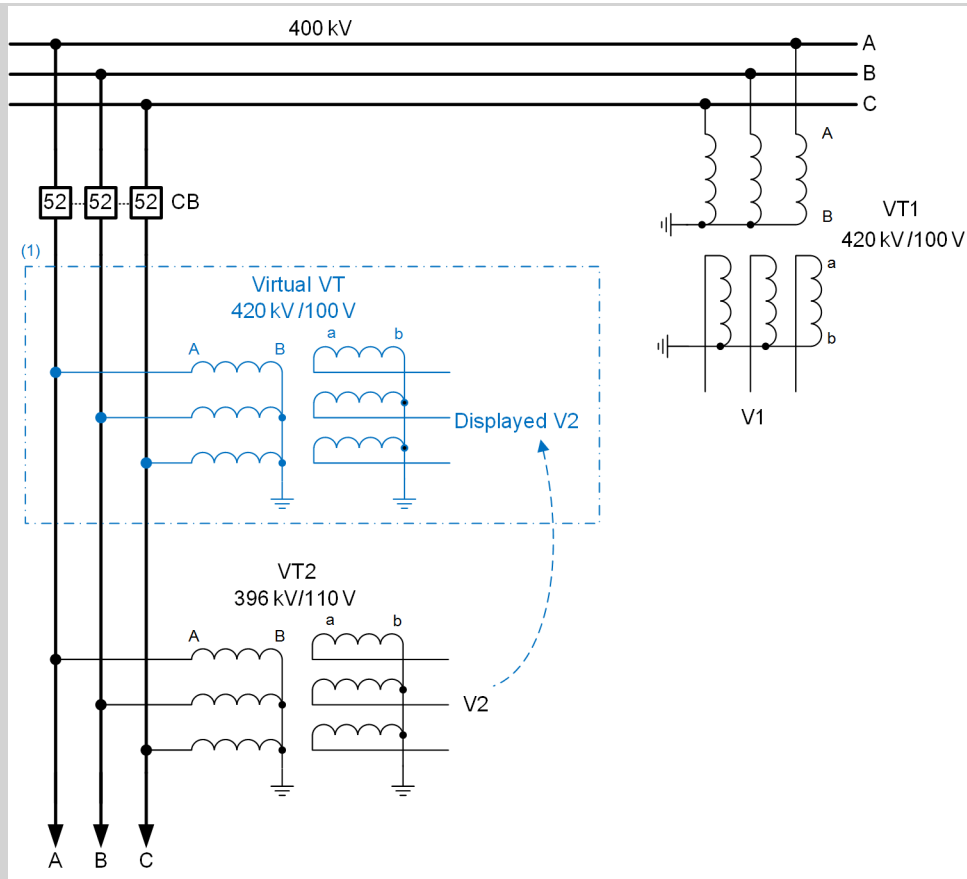

[dw_example w.o. power transformer, 1, en_US]

Figure 9-54 Example: the Electrical Power System without a Power Transformer

- (1) The virtual VT does not exist in the primary voltage system. It is just a virtual voltage transformer to show the displayed V2 on the device display. The virtual VT has the same transformer ratio as VT1.

The displayed V2 is a processed voltage from VT2.

$$\text{Voltage adjustment} = \frac{V2_{\text{rated prim.}}}{V1_{\text{rated prim.}}} = \frac{396 \text{ kV}}{420 \text{ kV}} \approx 0.94$$

[fo_ex1_V adjustment, 1, en_US]

With:

$V2_{\text{rated prim.}}$	Rated primary voltage of VT2
$V1_{\text{rated prim.}}$	Rated primary voltage of VT1

For this example, the displayed voltage V2 on the device display is from the virtual VT, not from VT2.

The primary voltages, secondary voltages, and percentage values of the measured values are shown in the following table.

Table 9-25 Primary Voltage, Secondary Voltage, and Percentage Value

Measured Value	Primary Voltage	Secondary Voltage	Percentage Value
V1	400 kV	$\frac{400 \text{ kV}}{420 \text{ kV}/100 \text{ V}} \approx 95.238 \text{ V}$	$\frac{400 \text{ kV}}{420 \text{ kV}} \cdot 100 \% \approx 95.238 \%$
V2	400 kV	$\frac{400 \text{ kV}}{396 \text{ kV}/110 \text{ V}} \approx 111.111 \text{ V}$	$\frac{400 \text{ kV}}{396 \text{ kV}} \cdot 100 \% \approx 101.01 \%$
Displayed V2	400 kV	$\frac{400 \text{ kV}}{420 \text{ kV}/100 \text{ V}} \approx 95.238 \text{ V}$	$\frac{400 \text{ kV}}{420 \text{ kV}} \cdot 100 \% \approx 95.238 \%$

Example 2:

In the electrical power system, a power transformer is located between the voltage measuring points of the circuit breaker to be synchronized. The power transformer ratio differs from the ratio between the rated primary voltages of the voltage transformers of 2 sides of the electrical power system.

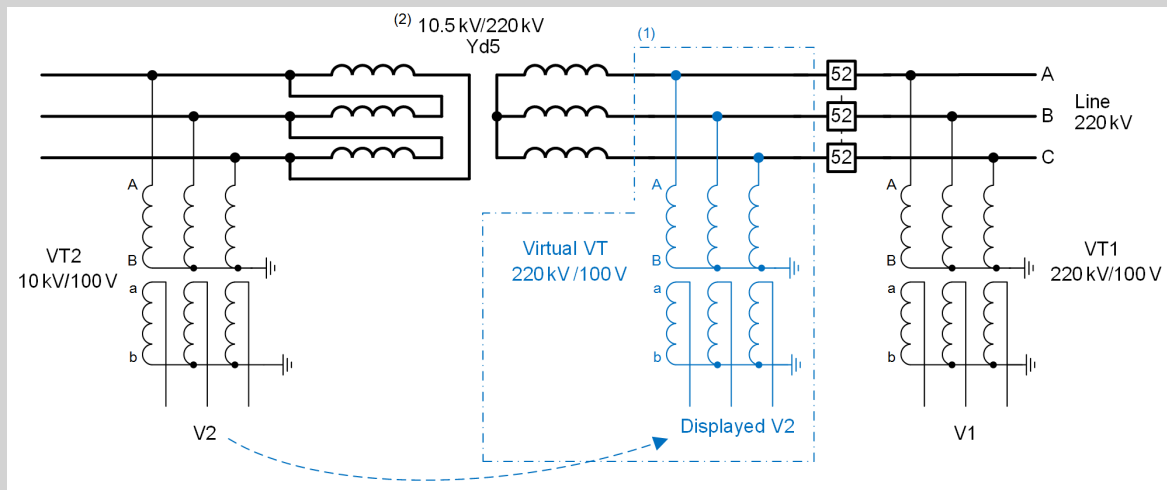

[diw_example_w_power transformer_1_en_US]

Figure 9-55 Example: the Electrical Power System with a Power Transformer

- (1) The virtual VT does not exist in the primary voltage system. It is just a virtual voltage transformer to show the displayed V2 on the device display. The virtual VT has the same transformer ratio as VT1.
 The displayed V2 is a processed voltage from VT2.
- (2) This ratio is not the rated transformer ratio on the transformer name plate. This ratio is an actual ratio which considers the tap-changer scenarios when the **Tap changer** function is not used in the device. The rated transformer ratio is 220 kV/10 kV.

$$\text{Voltage adjustment} = \frac{V2_{\text{rated prim.}}}{V1_{\text{rated prim.}}} \cdot R_{\text{PT}} = \frac{10 \text{ kV}}{220 \text{ kV}} \cdot \frac{220 \text{ kV}}{10.5 \text{ kV}} \approx 0.95$$

[fo_ex2_v adjustment_1_en_US]

With:

- $V2_{\text{rated prim.}}$ Rated primary voltage of VT2
- $V1_{\text{rated prim.}}$ Rated primary voltage of VT1
- R_{PT} Transformer ratio of the power transformer

For this example, the displayed voltage V2 on the device display is from the virtual VT, not from VT2. The primary voltages, secondary voltages, and percentage values of the measured values are shown in the following table.

Table 9-26 Primary Voltage, Secondary Voltage, and Percentage Value

Measured Value	Primary Voltage	Secondary Voltage	Percentage Value
V1	220 kV	$\frac{220 \text{ kV}}{220 \text{ kV}/110 \text{ V}} = 110 \text{ V}$	$\frac{220 \text{ kV}}{220 \text{ kV}} \cdot 100 \% = 100 \%$
V2	10.5 kV	$\frac{10.5 \text{ kV}}{10 \text{ kV}/100 \text{ V}} = 105 \text{ V}$	$\frac{10.5 \text{ kV}}{10 \text{ kV}} \cdot 100 \% = 105 \%$
Displayed V2	220 kV	$\frac{220 \text{ kV}}{220 \text{ kV}/110 \text{ V}} = 110 \text{ V}$	$\frac{220 \text{ kV}}{220 \text{ kV}} \cdot 100 \% = 100 \%$

Parameter: Angle adjust. (transform.)

- Default setting (`_:2311:127`) **Angle adjust. (transform.)** = 0°

The parameter can be applied under the following conditions:

- 1. Phase-angle rotation by power transformer between the measuring points
- 2. Correction of phase-angle errors

1. Phase-angle rotation by power transformer between the measuring points:

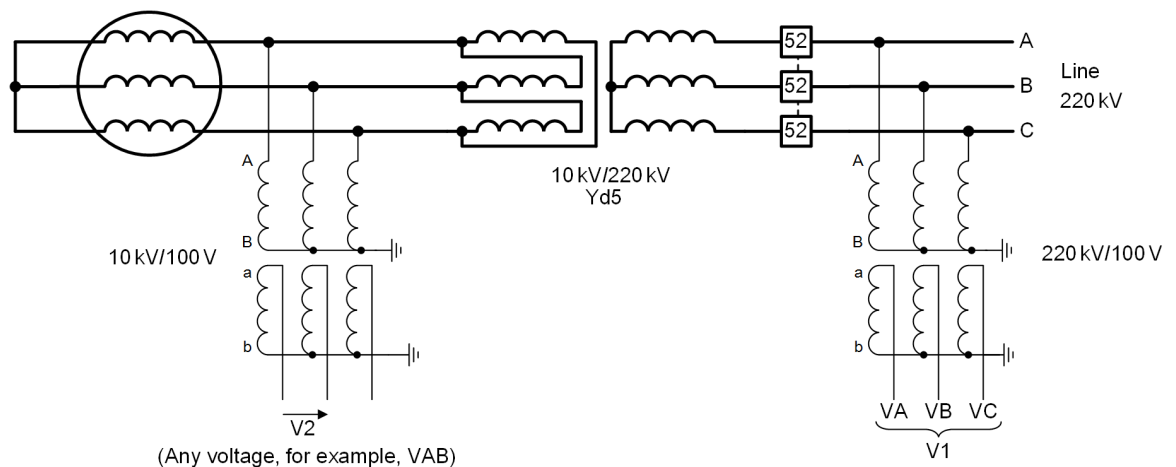

Setting values: `_:126`
P Voltage adjustment = 1.00
`_:2311:127`
P Angle adjust. (transform.) = 150°

[dw_transformer between the measuring points, 2, en_US]

Figure 9-56 Transformer between the Measuring Points

If there is a power transformer between the voltage transformers of the circuit breaker to be synchronized, you then have to correct the phase-angle rotation for a vector group deviating from 0. Figure 9-56 shows such an application. The **Angle adjust. (transform.)** parameter is used to save the phase-angle rotation.

The transformer vector group is defined from the upper-voltage side to the undervoltage side. If the reference voltage transformer V1 is connected on the upper-voltage side of the transformer (as in Figure 9-56), enter the phase-angle rotation directly according to the vector group. A vector-group figure of 5, for example, means an angular rotation of $5 \cdot 30^\circ = 150^\circ$. Set this value for the **Angle adjust. (transform.)** parameter.

If the voltage connection V1 is on the undervoltage side due to the system, you then have to apply the extension angle with 360°. A transformer with vector group 5 yields an angular adjustment of $360^\circ - (5 \cdot 30^\circ) = 210^\circ$.

2. Correction of phase-angle errors:

You can correct a phase-angle error between the voltage transformers in increments. Ascertain a possible correction value during commissioning.

Parameter: CB make time

- Default setting (`_:5041:113`) **CB make time = 0.060 s**

If you are to interconnect under asynchronous system conditions with the device as well, the make time of the circuit breaker must be taken into account. The device uses this to calculate the time of the direct close command, so that the voltages are in phase at the moment of closure of the switch poles. Note that apart from the operating time of the switch, this also includes the pickup time of an auxiliary relay that may be upstream. You can determine the make time using the protection device (see commissioning notes in [13.13 Primary and Secondary Testing of the Synchronization Function](#)).

This parameter only occurs for the stage type **Synchronous/asynchronous**.

9.4.4.3 Settings

Addr.	Parameter	C	Setting Options	Default Setting
General				
_:2311:127	General:Angle adjust. (transform.)		-179.0 ° to 180.0 °	0.0 °
General				
_:5071:1	Synchrocheck 1:Mode		<ul style="list-style-type: none"> • off • on • test 	off
_:5071:101	Synchrocheck 1:Min. operating limit Vmin		0.300 V to 340.000 V	90.000 V
_:5071:102	Synchrocheck 1:Max. operat. limit Vmax		0.300 V to 340.000 V	110.000 V
_:5071:110	Synchrocheck 1:Max.durat. sync.process		0.00 s to 3600.00 s; ∞	30.00 s
_:5071:108	Synchrocheck 1:Direct close command		<ul style="list-style-type: none"> • no • yes 	no
_:5071:126	Synchrocheck 1:Voltage adjustment		0.500 to 2.000	1.000
General				
_:5041:1	Sychr./Asyacr.1:Mode		<ul style="list-style-type: none"> • off • on • test 	off
_:5041:101	Sychr./Asyacr.1:Min. operating limit Vmin		0.300 V to 340.000 V	90.000 V
_:5041:102	Sychr./Asyacr.1:Max. operat. limit Vmax		0.300 V to 340.000 V	110.000 V
_:5041:110	Sychr./Asyacr.1:Max.durat. sync.process		0.00 s to 3600.00 s; ∞	30.00 s
_:5041:108	Sychr./Asyacr.1:Direct close command		<ul style="list-style-type: none"> • no • yes 	no
_:5041:126	Sychr./Asyacr.1:Voltage adjustment		0.500 to 2.000	1.000

9.4.5 Sequence of Functions

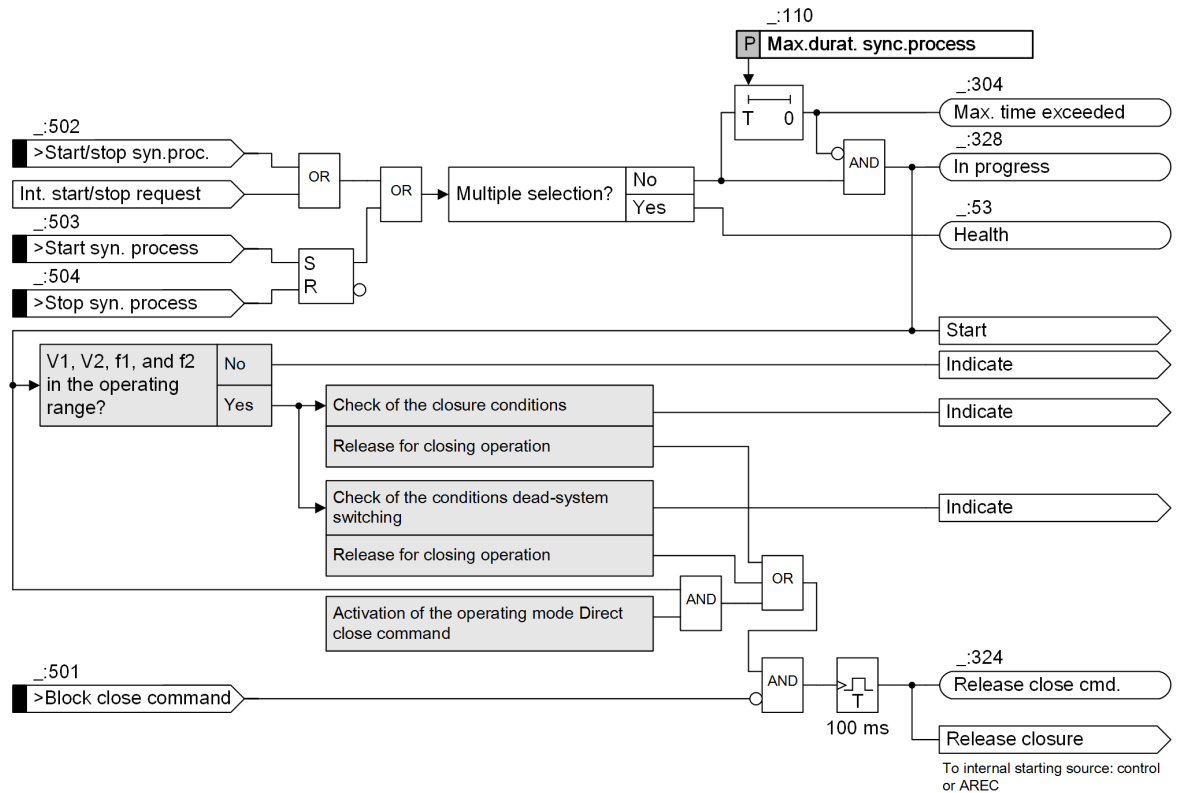

[to_synf01_01_6_en_US]

Figure 9-57 Sequence of Functions

Start

The synchronization stage must be started to check the closing conditions. The synchronization stage can be started device-internally by the control or externally via binary input signals (see [9.4.12 Interaction with Control and External Triggering](#)).

At the start, the system checks whether there is a multiple selection of the synchronization stage (see [Supervision](#) in [9.4.4.1 Description](#)). If this is the case, the process is terminated. After a successful start, the indication **In progress** is cleared and the supervision time for the maximum duration of the synchronization process (parameter **Max.durat. sync.process**) is started. The system also checks whether the voltages and frequencies are in the operating range (see [9.4.4.1 Description](#)). If this is not the case, the closing conditions are not checked.

Checking the Closing Conditions, Closure

After starting, the parameterized closing conditions are checked, depending on the selected operating mode (see [9.4.7.1 Description](#) to [9.4.11 Direct Close Command](#)). Every condition fulfilled is explicitly indicated here. Conditions not fulfilled are also indicated. If all conditions are fulfilled, the synchronization stage sets the indication **All sync. conditio. OK**. The indication is active until all conditions are fulfilled. The further behavior for issuing the release for closing depends on the type of the stage (see [9.4.6.1 Description](#) and [9.4.7.1 Description](#)). The release is signaled via the **Release close cmd.** indication. This indication is active for 100 ms. With an internal start, the control performs the actual closure, depending on the internal starting source.

Switching to Dead Line/Busbar

If operating modes for switching to dead parts of an electrical power system are configured, the associated conditions are also checked after the start (see [9.4.10.1 Description](#)). The fulfilled conditions are signaled. An

adjustable supervision time starts after the closure conditions are fulfilled (parameter **Supervision time**). If the conditions remain valid until expiry of the time, the function gives the release for closure after expiry of the time.

Direct Close Command

If the **Direct close command** operation is active, the function instantaneously initiates the release for closure after the successful start (see chapter [9.4.11 Direct Close Command](#)). A combination of direct close command with other release conditions is not advisable, as these conditions are bypassed by the direct close command.

End of the Process

If the function is started via the device-internal control, these functions also terminate the synchronization process upon closure. The process is terminated via the corresponding binary signals in case of external starting.

If the supervision time (**Max.durat. sync.process** parameter) has expired, the process is also completed and the indication **Max. time exceeded** is issued. A renewed synchronization is only possible if the stage is restarted.

Blocking Closure

You can use the input signal *>Block close command* to block the release signal for the closure (signal **Release close cmd.**) as well as the closure itself. The measurement continues to operate during the blocking. If the blocking is revoked and the release conditions are still fulfilled, the release is given for closure.

9.4.6 Stage Synchrocheck

9.4.6.1 Description

Checking Closing Conditions

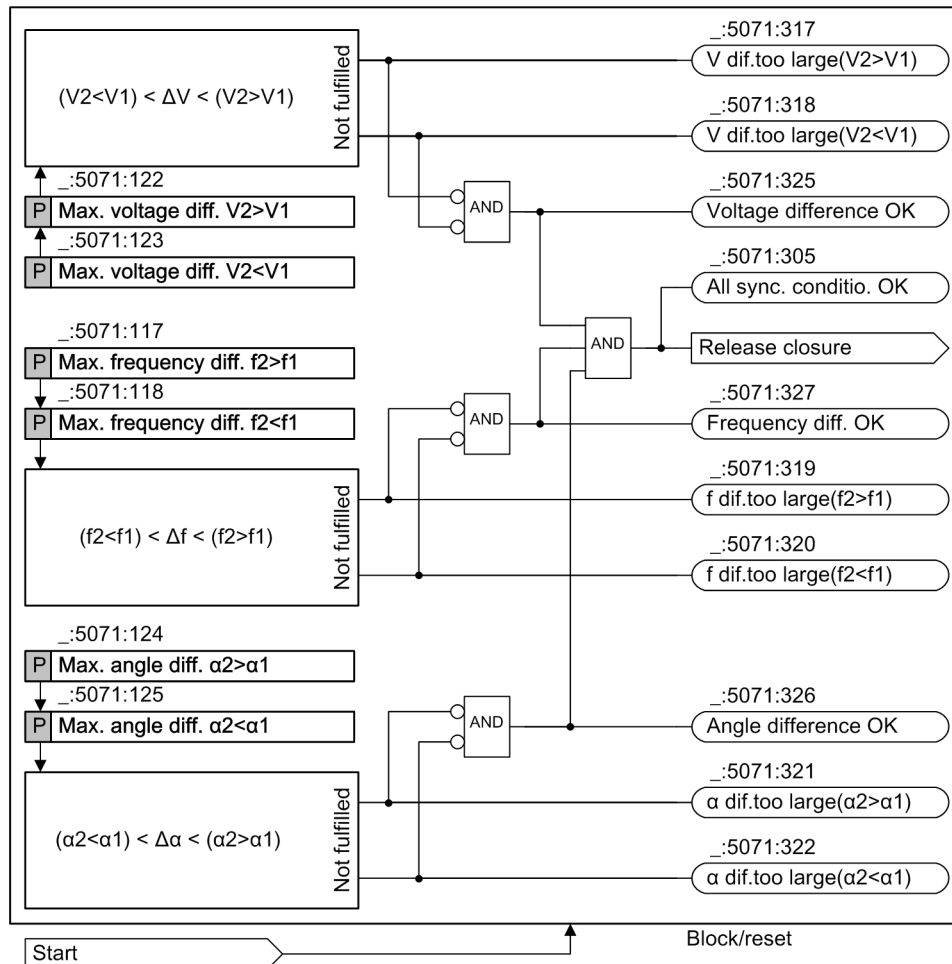

[to_synche-01, 2, en_US]

Figure 9-58 Closing Conditions for the Synchrocheck Function

With this operating mode, the values ΔV , Δf , and $\Delta \alpha$ are checked before connecting the 2 parts of the electrical power system. The indication **All sync. conditio. OK** signals that the setting values (conditions) have been reached and that the release for closure has been given (see **Checking the Closing Conditions, Closure** in [9.4.5 Sequence of Functions](#)).

Every fulfilled condition is signaled individually via the indications **Voltage difference OK**, **Frequency diff. OK**, and **Angle difference OK**.

If a condition is not fulfilled, detailed information on why the condition is not fulfilled is provided via indications. If the differential voltage is outside the setting limits, for example, the indication **V dif. too large ($V2 < V1$)** is issued. The indication indirectly contains information that the voltage $V2$ has to be increased for a successful synchronization.

With the **Expanded delta-f options** stage type configured and an activated ($_ :140$) **Limit dfdiff/dt for sync. op** parameter, the frequency difference rate of change is also checked. If the permissible frequency change rate (parameter ($_ :141$) **Max. value dfdiff/dt syn**) is exceeded, the indication ($_ :329$) **dfdift/dt too large** is issued.

Continuous Supervision

With the parameter **Continuous supervision** selected, even if there is no start command for the signal *start*, the device can continuously monitor the voltage difference, frequency difference, and angle difference of the circuit breaker. Meanwhile, the indications *in progress*, *release close command*, and *max. duration time expired* are not issued.

If you want to release the close command, a start command for the signal *start* is necessary.

If you keep the default setting, then the stage **Synchrocheck** runs as normal.

9.4.6.2 Application and Setting Notes

Parameter: Sync. operating mode

- Default setting **Sync. operating mode = on**

With the parameter **Sync. operating mode**, you can switch the operating mode of the synchronization condition *on* or *off*. The operating mode is activated in the default setting.

Parameter: Maximum Differential Values of Voltage, Frequency and Angle

- Default setting (**_:5071:122**) **Max. voltage diff. $V2 > V1 = 5.0\text{ V}$**
- Default setting (**_:5071:123**) **Max. voltage diff. $V2 < V1 = 5.0\text{ V}$**
- Default setting (**_:5071:117**) **Max. frequency diff. $f2 > f1 = 0.10\text{ Hz}$**
- Default setting (**_:5071:118**) **Max. frequency diff. $f2 < f1 = 0.10\text{ Hz}$**
- Default setting (**_:5071:124**) **Max. angle diff. $\alpha2 > \alpha1 = 10^\circ$**
- Default setting (**_:5071:125**) **Max. angle diff. $\alpha2 < \alpha1 = 10^\circ$**

2 parameters are available for the differential values voltage, frequency, and angle. Unbalanced closing ranges can be set with this, if required.

The permissible differential values must ensure that no protection tripping or damage occurs in the system owing to compensation processes (circulating current) and power swings after interconnection of the parts of the power system. The settings must not be configured too closely on the other side so that necessary closures are not blocked.

Typical differential values are selected in the default setting. Depending on the system, the settings must be checked and adjusted, if necessary.

9.4.6.3 Settings

Addr.	Parameter	C	Setting Options	Default Setting
General				
_:1	Synchrocheck #:Mode		<ul style="list-style-type: none"> • off • on • test 	off
_:113	Synchrocheck #:Continuous supervision		<ul style="list-style-type: none"> • false • true 	false
_:101	Synchrocheck #:Min. operating limit Vmin		0.300 V to 340.000 V	90.000 V
_:102	Synchrocheck #:Max. operat. limit Vmax		0.300 V to 340.000 V	110.000 V
_:110	Synchrocheck #:Max.durat. sync.process		0.00 s to 3600.00 s; ∞	30.00 s
_:108	Synchrocheck #:Direct close command		<ul style="list-style-type: none"> • no • yes 	no

Addr.	Parameter	C	Setting Options	Default Setting
_:126	Synchrocheck #:Voltage adjustment		0.500 to 2.000	1.000
De-en.gized switch.				
_:105	Synchrocheck #:Close cmd. at V1< & V2>		<ul style="list-style-type: none"> • no • yes 	no
_:106	Synchrocheck #:Close cmd. at V1> & V2<		<ul style="list-style-type: none"> • no • yes 	no
_:107	Synchrocheck #:Close cmd. at V1< & V2<		<ul style="list-style-type: none"> • no • yes 	no
_:103	Synchrocheck #:V1, V2 without voltage		0.300 V to 170.000 V	5.000 V
_:104	Synchrocheck #:V1, V2 with voltage		0.300 V to 340.000 V	80.000 V
_:109	Synchrocheck #:Supervision time		0.00 s to 60.00 s	0.10 s
Synchr. conditions				
_:115	Synchrocheck #:Sync. operating mode		<ul style="list-style-type: none"> • off • on 	on
_:122	Synchrocheck #:Max. voltage diff. V2>V1		0.000 V to 170.000 V	5.000 V
_:123	Synchrocheck #:Max. voltage diff. V2<V1		0.000 V to 170.000 V	5.000 V
_:117	Synchrocheck #:Max. frequency diff. f2>f1		0.000 Hz to 2.000 Hz	0.100 Hz
_:118	Synchrocheck #:Max. frequency diff. f2<f1		0.000 Hz to 2.000 Hz	0.100 Hz
_:124	Synchrocheck #:Max. angle diff. α2>α1		0° to 90°	10°
_:125	Synchrocheck #:Max. angle diff. α2<α1		0° to 90°	10°

9.4.6.4 Information List

No.	Information	Data Class (Type)	Type
Synchrocheck #			
_:81	Synchrocheck #:>Block stage	SPS	I
_:500	Synchrocheck #:>Selection	SPS	I
_:502	Synchrocheck #:>Start/stop syn.proc.	SPS	I
_:503	Synchrocheck #:>Start syn. process	SPS	I
_:504	Synchrocheck #:>Stop syn. process	SPS	I
_:506	Synchrocheck #:>Op. mode 'V1<V2>'	SPS	I
_:505	Synchrocheck #:>Op. mode 'V1>V2<'	SPS	I
_:507	Synchrocheck #:>Op. mode 'V1<V2<'	SPS	I
_:508	Synchrocheck #:>Op. mode 'dir.cls.cmd'	SPS	I
_:501	Synchrocheck #:>Block close command	SPS	I
_:51	Synchrocheck #:Mode (controllable)	ENC	C
_:54	Synchrocheck #:Inactive	SPS	O
_:52	Synchrocheck #:Behavior	ENS	O

No.	Information	Data Class (Type)	Type
_.53	Synchrocheck #:Health	ENS	0
_.328	Synchrocheck #:In progress	SPS	0
_.324	Synchrocheck #:Release close cmd.	SPS	0
_.305	Synchrocheck #:All sync. conditio. OK	SPS	0
_.325	Synchrocheck #:Voltage difference OK	SPS	0
_.326	Synchrocheck #:Angle difference OK	SPS	0
_.327	Synchrocheck #:Frequency diff. OK	SPS	0
_.307	Synchrocheck #:Cond. V1<V2> fulfilled	SPS	0
_.306	Synchrocheck #:Cond. V1>V2< fulfilled	SPS	0
_.308	Synchrocheck #:Cond. V1<V2< fulfilled	SPS	0
_.309	Synchrocheck #:Frequency f1 > fmax	SPS	0
_.310	Synchrocheck #:Frequency f1 < fmin	SPS	0
_.311	Synchrocheck #:Frequency f2 > fmax	SPS	0
_.312	Synchrocheck #:Frequency f2 < fmin	SPS	0
_.313	Synchrocheck #:Voltage V1 > Vmax	SPS	0
_.314	Synchrocheck #:Voltage V1 < Vmin	SPS	0
_.315	Synchrocheck #:Voltage V2 > Vmax	SPS	0
_.316	Synchrocheck #:Voltage V2 < Vmin	SPS	0
_.317	Synchrocheck #:V dif.too large(V2>V1)	SPS	0
_.318	Synchrocheck #:V dif.too large(V2<V1)	SPS	0
_.319	Synchrocheck #:f dif.too large(f2>f1)	SPS	0
_.320	Synchrocheck #:f dif.too large(f2<f1)	SPS	0
_.329	Synchrocheck #:dfdiff/dt too large	SPS	0
_.321	Synchrocheck #:α dif.too large(α2>α1)	SPS	0
_.322	Synchrocheck #:α dif.too large(α2<α1)	SPS	0
_.304	Synchrocheck #:Max. time exceeded	SPS	0
_.323	Synchrocheck #:Setting error	SPS	0

9.4.7 Stage Synchronous/Asynchronous

9.4.7.1 Description

A distinction according to synchronous and asynchronous systems can be made with this type of stage.

If galvanically coupled systems are switched in parallel, synchronous systems are present. A typical characteristic for synchronous systems is equality of frequency ($\Delta f \approx 0$). If the frequency difference falls below the setting value of the **f-threshold ASYN<->SYN** parameter, synchronous systems are to be assumed. If the frequency difference exceeds the setting value of the **f-threshold ASYN<->SYN** parameter, asynchronous systems are to be assumed. This status occurs in galvanically isolated systems, for example.

Both states have their own operating mode with its own closing conditions. Both operating modes can be switched on and off separately (parameter **Sync. operating mode** and **Async. operating mode**). The following combinations result from this:

Sync. operating mode	Async. operating mode	Functionality
on	on	If the frequency difference is below the set threshold value f-threshold ASYN<->SYN , the operating mode synchronous is active. In other cases, the operating mode asynchronous is active.

<i>off</i>	<i>on</i>	Regardless of the frequency difference and the threshold value f-threshold ASYN->SYN , the operating mode is exclusively active asynchronously.
<i>on</i>	<i>off</i>	If the frequency difference is below the set threshold value f-threshold ASYN->SYN , the operating mode synchronous is active. In other cases, the stage is inactive, that is, a switching release cannot be issued.
<i>off</i>	<i>off</i>	Both operating modes are deactivated. No activation release can be given via these operating modes either.

Checking the Closing Conditions in Synchronous Systems

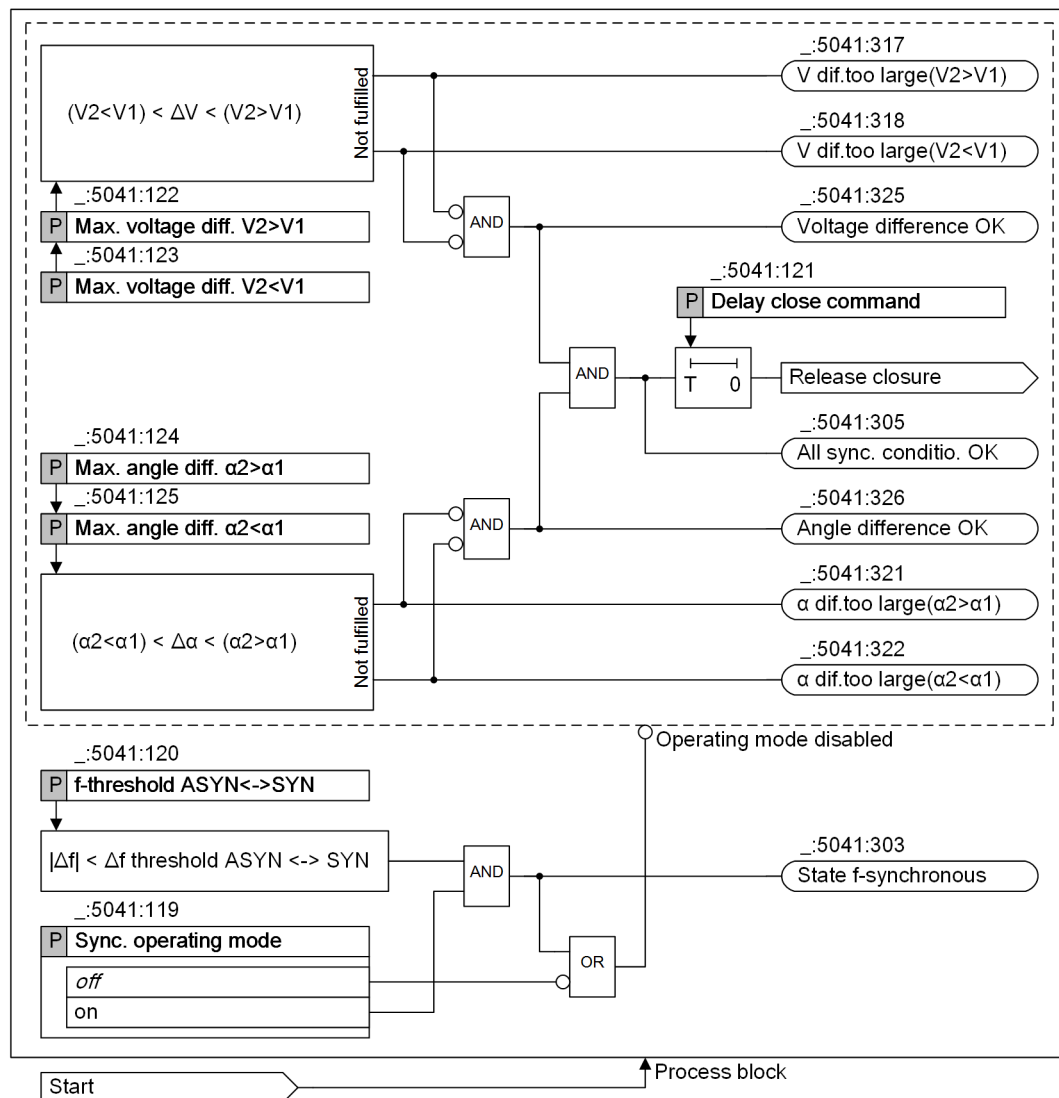

[to_synsyn-01_3_en_US]

Figure 9-59 Closing Conditions when Switching Synchronous Systems

The frequency difference is very low in the synchronous systems operating mode. It is below the threshold value **f-threshold ASYN->SYN**. The status is signaled via the **State f-synchronous** indication.

The parameters ΔV and $\Delta\alpha$ are checked for issuing an activation release (see [Figure 9-60](#)). The indication **All sync. conditio. OK** signals that both setting values (conditions) are reached. If the conditions remain fulfilled over the set time delay (parameter **Delay close command**), the release for closing is given (see also [9.4.6.1 Description](#)).

Every condition fulfilled is signaled individually via the indications **Voltage difference OK** and **Angle difference OK**.

If a condition is not fulfilled, detailed information on why the condition is not fulfilled is provided via indications. If the differential voltage is outside the setting limits, for example, the indication **V dif. too large (V2<V1)** is issued. The indication indirectly contains information that the voltage V2 has to be increased for a successful synchronization.

With the **Expanded delta-f options** stage type configured and an activated (**_:142**) **Limit dfdiff/dt for asyn. op** parameter, the frequency difference rate of change is also checked. If the permissible frequency change rate (parameter (**_:143**) **Max. value dfdiff/dt asyn**) is exceeded, the indication (**_:329**) **dfdiff/dt too large** is generated.

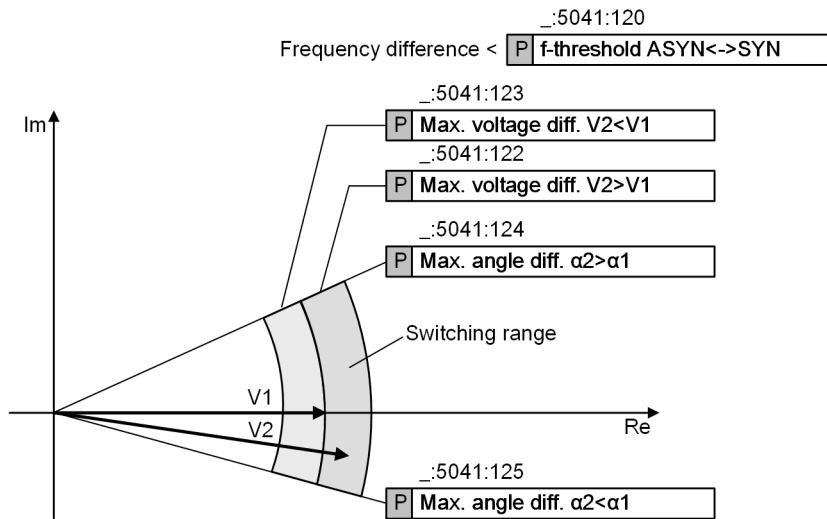

[lo_synzus-01, 2, en_US]

Figure 9-60 Connecting Under Synchronous System Conditions

Checking Closing Conditions in Asynchronous Systems

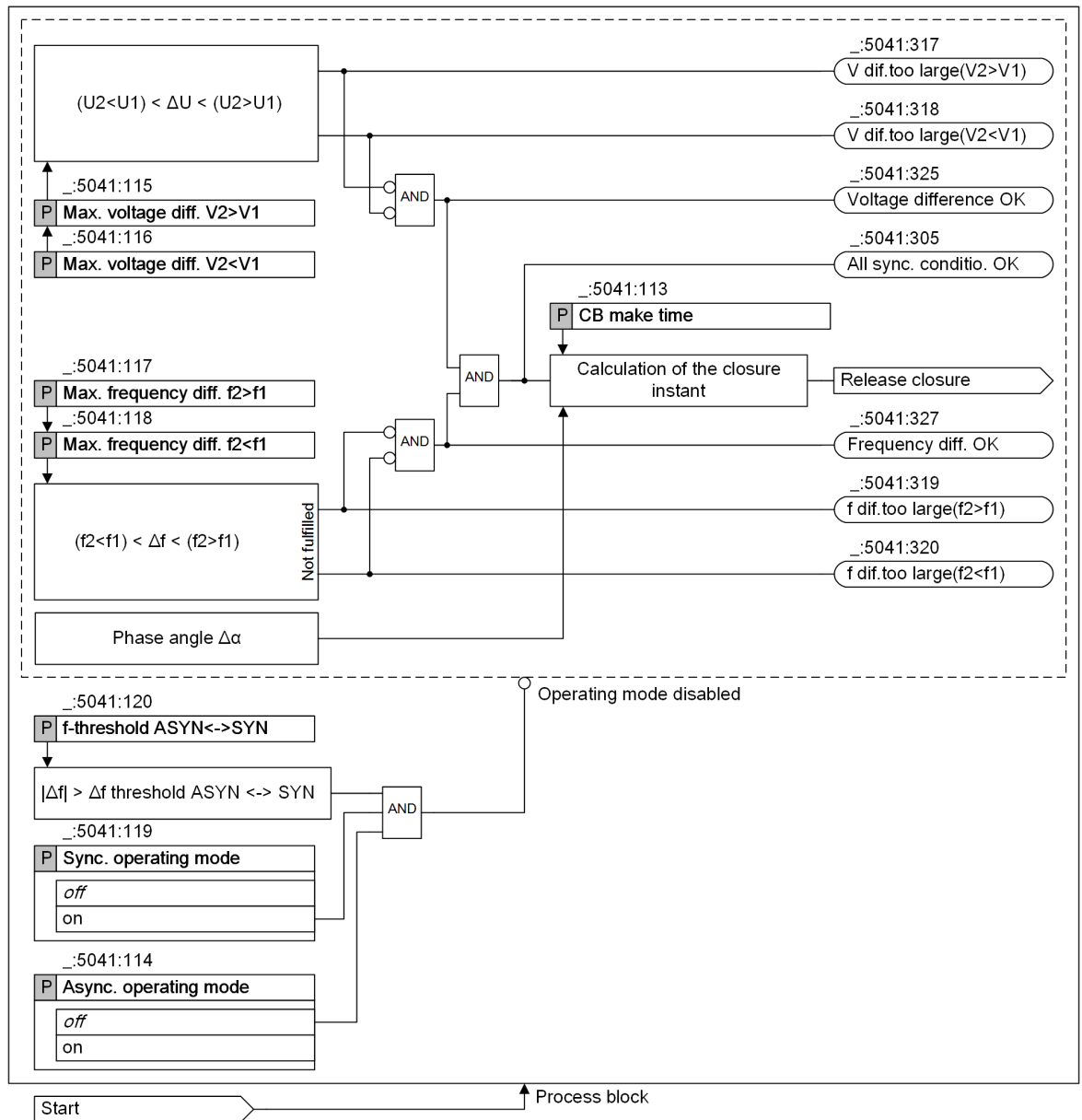

[to_synasy-01_4_en_US]

Figure 9-61 Closing Conditions when Switching Asynchronous Systems

In this operating mode, compliance with the voltage difference ΔV and frequency difference Δf conditions is checked. The function calculates the time point of the close command taking into account the angular difference $\Delta\alpha$ and the make time of the circuit breaker. This is calculated so that the voltage phasors are equal at the moment of pole contact by the circuit breaker ($\Delta V \approx 0$, $\Delta\alpha \approx 0$).

Ranges in the Voltage-Frequency Diagram (V-f Diagram)

Figure 9-62 shows the setting parameters for synchronous and asynchronous conditions in the V-f diagram. The frequency band is very narrow owing to the functional principle in the case of synchronous systems.

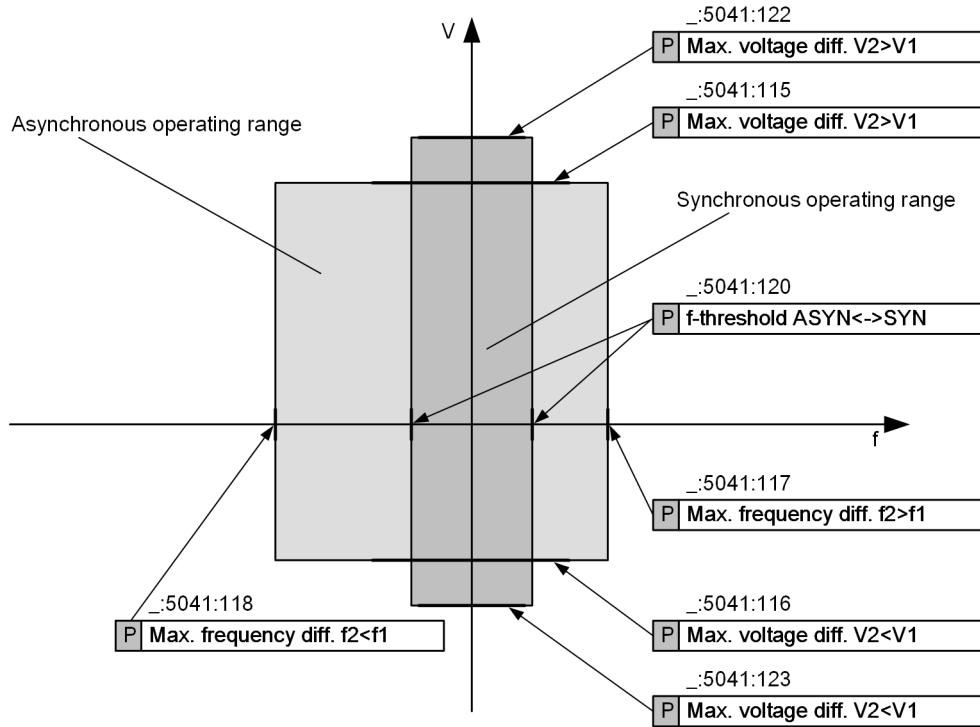

[lo_synarb-01, 2, en_US]

Figure 9-62 Operating Range under Synchronous and Asynchronous Conditions for Voltage (V) and Frequency (f)

Continuous Supervision

With the parameter **Continuous supervision** activated, even if there is no start command for the signal *start*, the device can continuously monitor the synchronous condition of the circuit breaker. Meanwhile, the indications *in progress*, *release close command*, and *max. duration time expired* are not issued.

If you want to release the close command, a start command for the signal *start* is necessary.

If you keep the default setting, then the stage **Synchronous/Asynchronous** runs as normal.

9.4.7.2 Application and Setting Notes

Parameter: Synchronous operating mode, Asynchronous operating mode

- Default setting (`_:5041:119`) **Sync. operating mode = on**
- Default setting (`_:5041:114`) **Async. operating mode = on**

The operating modes of the stages can be activated or deactivated via the parameters. The operating modes are deactivated in the default setting for safety reasons.

The following combination options are possible:

Sync. operating mode	Async. operating mode	Description
<i>on</i>	<i>on</i>	If the frequency difference is below the set threshold value f-threshold ASYN<->SYN , the operating mode synchronous is active. In other cases, the operating mode asynchronous is active. If you wish to interconnect galvanically isolated systems, then select this operating mode.
<i>off</i>	<i>on</i>	Regardless of the frequency difference and the threshold value f-threshold ASYN<->SYN , the asynchronous operating mode is exclusively active. The make time of the circuit breaker is always taken into account for determining the connecting point. Select this operating mode if you wish to activate machines, for example generators or asynchronous motors. However, if synchronous conditions with a low Δf are present, a close command is generated in this operating mode without a kick pulse.
<i>on</i>	<i>off</i>	Use this operating mode for galvanically connected systems. Closure is only possible with synchronous systems (with low Δf).
<i>off</i>	<i>off</i>	Both operating modes are deactivated. No closing release can therefore be given via this operating mode. This configuration is only advisable for special applications. Select this operating mode if you only wish to switch, for example de-energized parts of the power system.

Parameter for asynchronous operation: Max. voltage diff. of voltage and frequency

- Default setting (_:5041:115) **Max. voltage diff. $V_2 > V_1 = 2.0 V$**
- Default setting (_:5041:116) **Max. voltage diff. $V_2 < V_1 = 2.0 V$**
- Default setting (_:5041:117) **Max. frequency diff. $f_2 > f_1 = 0.10 Hz$**
- Default setting (_:5041:118) **Max. frequency diff. $f_2 < f_1 = 0.10 Hz$**

For more information, see **Parameter for synchronous operation**.

Parameter for synchronous operation: Maximum voltage diff. of voltage and angle

- Default setting (_:5041:122) **Max. voltage diff. $V_2 > V_1 = 5.0 V$**
- Default setting (_:5041:123) **Max. voltage diff. $V_2 < V_1 = 5.0 V$**
- Default setting (_:5041:124) **Max. angle diff. $\alpha_2 > \alpha_1 = 10^\circ$**
- Default setting (_:5041:125) **Max. angle diff. $\alpha_2 < \alpha_1 = 10^\circ$**

2 parameters are available for the differential values voltage, frequency, and angle. Unbalanced closing ranges can be set with this, if required.

The permissible differential values must ensure that no protection tripping or damage occurs in the system owing to compensation processes (circulating current) and power swings after interconnection of the parts of the power system. The settings must not be configured too closely on the other side so that necessary closures are not blocked.

Typical differential values are selected in the default setting. Depending on the system, the settings must be checked and adjusted, if necessary.

Parameter: Switchover between synchronous and asynchronous operation

- Recommended setting value (_:5041:120) **f-threshold ASYN<->SYN = 0.01 Hz**

This parameter is used to set the frequency difference for switching over between synchronous and asynchronous operation.

Siemens recommends using the default setting of **0.01 Hz**.

9.4.7.3 Settings

Addr.	Parameter	C	Setting Options	Default Setting
General				
_:1	Sychr./Asydr. #:Mode		<ul style="list-style-type: none"> off on test 	off
_:127	Sychr./Asydr. #:Continuous supervision		<ul style="list-style-type: none"> false true 	false
_:101	Sychr./Asydr. #:Min. operating limit Vmin		0.300 V to 340.000 V	90.000 V
_:102	Sychr./Asydr. #:Max. operat. limit Vmax		0.300 V to 340.000 V	110.000 V
_:110	Sychr./Asydr. #:Max.durat. sync.process		0.00 s to 3600.00 s; ∞	30.00 s
_:108	Sychr./Asydr. #:Direct close command		<ul style="list-style-type: none"> no yes 	no
_:126	Sychr./Asydr. #:Voltage adjustment		0.500 to 2.000	1.000
De-en.gized switch.				
_:105	Sychr./Asydr. #:Close cmd. at V1< & V2>		<ul style="list-style-type: none"> no yes 	no
_:106	Sychr./Asydr. #:Close cmd. at V1> & V2<		<ul style="list-style-type: none"> no yes 	no
_:107	Sychr./Asydr. #:Close cmd. at V1< & V2<		<ul style="list-style-type: none"> no yes 	no
_:103	Sychr./Asydr. #:V1, V2 without voltage		0.300 V to 170.000 V	5.000 V
_:104	Sychr./Asydr. #:V1, V2 with voltage		0.300 V to 340.000 V	80.000 V
_:109	Sychr./Asydr. #:Supervision time		0.00 s to 60.00 s	0.10 s
Asynchr. op.mode				
_:114	Sychr./Asydr. #:Async. operating mode		<ul style="list-style-type: none"> off on 	on
_:113	Sychr./Asydr. #:CB make time		0.010 s to 0.600 s	0.060 s
_:115	Sychr./Asydr. #:Max. voltage diff. V2>V1		0.000 V to 170.000 V	5.000 V
_:116	Sychr./Asydr. #:Max. voltage diff. V2<V1		0.000 V to 170.000 V	5.000 V
_:117	Sychr./Asydr. #:Max. frequency diff. f2>f1		0.000 Hz to 4.000 Hz	0.100 Hz

Addr.	Parameter	C	Setting Options	Default Setting
_:118	Sychr./Asycr. #:Max. frequency diff. $f_2 < f_1$		0.000 Hz to 4.000 Hz	0.100 Hz
Sychr. op. mode				
_:119	Sychr./Asycr. #:Sync. operating mode		<ul style="list-style-type: none"> • off • on 	on
_:120	Sychr./Asycr. #:f-threshold ASYN<->SYN		0.010 Hz to 0.200 Hz	0.010 Hz
_:122	Sychr./Asycr. #:Max. voltage diff. $V_2 > V_1$		0.000 V to 170.000 V	5.000 V
_:123	Sychr./Asycr. #:Max. voltage diff. $V_2 < V_1$		0.000 V to 170.000 V	5.000 V
_:124	Sychr./Asycr. #:Max. angle diff. $\alpha_2 > \alpha_1$		0° to 90°	10°
_:125	Sychr./Asycr. #:Max. angle diff. $\alpha_2 < \alpha_1$		0° to 90°	10°
_:121	Sychr./Asycr. #:Delay close command		0.00 s to 60.00 s	0.00 s

9.4.7.4 Information List

No.	Information	Data Class (Type)	Type
Sychr. /Asycr. #			
_:81	Sychr./Asycr. #:>Block stage	SPS	I
_:500	Sychr./Asycr. #:>Selection	SPS	I
_:502	Sychr./Asycr. #:>Start/stop syn.proc.	SPS	I
_:503	Sychr./Asycr. #:>Start syn. process	SPS	I
_:504	Sychr./Asycr. #:>Stop syn. process	SPS	I
_:506	Sychr./Asycr. #:>Op. mode 'V1<V2>'	SPS	I
_:505	Sychr./Asycr. #:>Op. mode 'V1>V2<'	SPS	I
_:507	Sychr./Asycr. #:>Op. mode 'V1<V2<'	SPS	I
_:508	Sychr./Asycr. #:>Op. mode 'dir.cls.cmd'	SPS	I
_:501	Sychr./Asycr. #:>Block close command	SPS	I
_:51	Sychr./Asycr. #:Mode (controllable)	ENC	C
_:54	Sychr./Asycr. #:Inactive	SPS	O
_:52	Sychr./Asycr. #:Behavior	ENS	O
_:53	Sychr./Asycr. #:Health	ENS	O
_:328	Sychr./Asycr. #:In progress	SPS	O
_:324	Sychr./Asycr. #:Release close cmd.	SPS	O
_:305	Sychr./Asycr. #:All sync. conditio. OK	SPS	O
_:303	Sychr./Asycr. #:State f-synchronous	SPS	O
_:325	Sychr./Asycr. #:Voltage difference OK	SPS	O
_:326	Sychr./Asycr. #:Angle difference OK	SPS	O
_:327	Sychr./Asycr. #:Frequency diff. OK	SPS	O
_:307	Sychr./Asycr. #:Cond. $V_1 < V_2 >$ fulfilled	SPS	O
_:306	Sychr./Asycr. #:Cond. $V_1 > V_2 <$ fulfilled	SPS	O
_:308	Sychr./Asycr. #:Cond. $V_1 < V_2 <$ fulfilled	SPS	O
_:309	Sychr./Asycr. #:Frequency $f_1 > f_{max}$	SPS	O
_:310	Sychr./Asycr. #:Frequency $f_1 < f_{min}$	SPS	O

No.	Information	Data Class (Type)	Type
_:311	Sychr./Asycr.#:Frequency f2 > fmax	SPS	0
_:312	Sychr./Asycr.#:Frequency f2 < fmin	SPS	0
_:313	Sychr./Asycr.#:Voltage V1 > Vmax	SPS	0
_:314	Sychr./Asycr.#:Voltage V1 < Vmin	SPS	0
_:315	Sychr./Asycr.#:Voltage V2 > Vmax	SPS	0
_:316	Sychr./Asycr.#:Voltage V2 < Vmin	SPS	0
_:317	Sychr./Asycr.#:V dif.too large(V2>V1)	SPS	0
_:318	Sychr./Asycr.#:V dif.too large(V2<V1)	SPS	0
_:319	Sychr./Asycr.#:f dif.too large(f2>f1)	SPS	0
_:320	Sychr./Asycr.#:f dif.too large(f2<f1)	SPS	0
_:329	Sychr./Asycr.#:dfdif/dt too large	SPS	0
_:321	Sychr./Asycr.#:α dif.too large(α2>α1)	SPS	0
_:322	Sychr./Asycr.#:α dif.too large(α2<α1)	SPS	0
_:304	Sychr./Asycr.#:Max. time exceeded	SPS	0
_:323	Sychr./Asycr.#:Setting error	SPS	0

9.4.8 Stage Synchronous/Asynchronous with Balancing Commands

9.4.8.1 Description

With this stage type, a distinction between synchronous and asynchronous systems can be made.

Additionally, the stage provides the balancing commands for adjustment of the voltage and frequency (speed) to the target conditions. The stage is used for automatic synchronization of generators. The stage has the functionality of a 1-channel parallel switching function.

If galvanically coupled systems are switched in parallel, synchronous systems are present. A typical feature for synchronous systems is equality of frequency ($\Delta f \approx 0$). If the frequency difference falls below the setting value of the parameter **f-threshold ASYN->SYN**, synchronous systems are to be assumed. If the frequency difference exceeds the setting value of the parameter **f-threshold ASYN->SYN**, asynchronous systems are to be assumed. This status occurs in galvanically separated systems, for example.

Both states have their own operating mode with their own closing conditions. You can switch both operating modes on and off separately (parameters **Sync. operating mode** and **Async. operating mode**). The following combinations result from this:

Sync. operating mode	Async. operating mode	Functionality
<i>on</i>	<i>on</i>	If the frequency difference is below the set threshold value f-threshold ASYN->SYN , the synchronous operating mode is active. In other cases, the asynchronous operating mode is active.
<i>off</i>	<i>on</i>	Regardless of the frequency difference and the threshold value f-threshold ASYN->SYN , the asynchronous operating mode is exclusively active.
<i>on</i>	<i>off</i>	If the frequency difference is below the set threshold value f-threshold ASYN->SYN , the synchronous operating mode is active. In other cases, the stage is inactive, that is, a switching release cannot be issued.
<i>off</i>	<i>off</i>	Both operating modes are deactivated. No closure release can be given via these operating modes either.

Checking Closing Conditions of Synchronous Systems

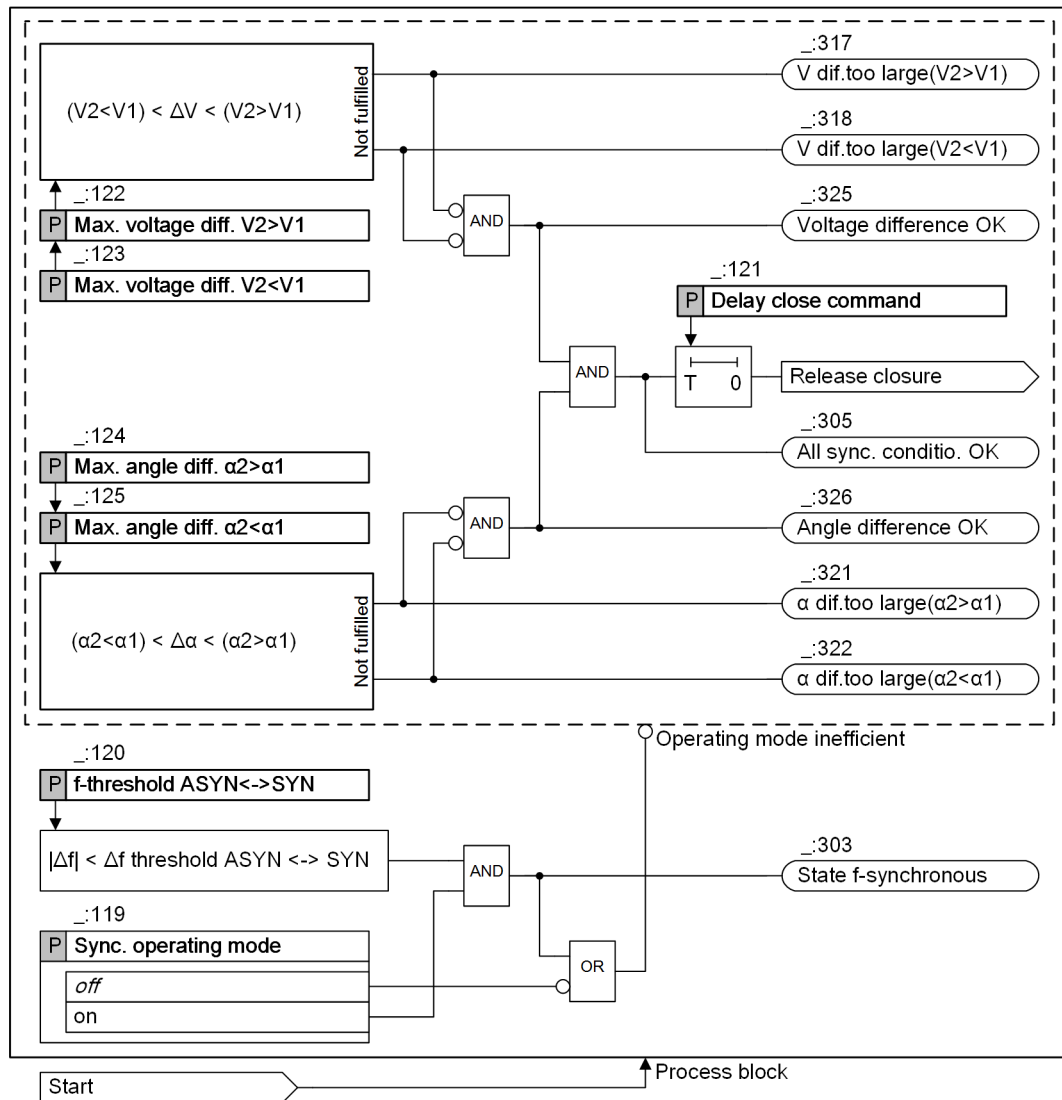

Figure 9-63 Closing Conditions when Switching Synchronous Systems

The frequency difference is very low in the synchronous systems operating mode. It is below the threshold value **f-threshold ASYN<->SYN**. The status is signaled via the indication **State f-synchronous**.

The parameters ΔV and $\Delta\alpha$ are checked for issuing a closure release (see [Figure 9-64](#)). The indication **All sync. conditio. OK** signals that both setting values (conditions) are reached. If the conditions remain fulfilled over the set time delay (parameter **Delay close command**), the release for closing is issued (see also chapter [9.4.6.1 Description](#)).

Every fulfilled condition is signaled individually via the indications **Voltage difference OK** and **Angle difference OK**.

If a condition is not fulfilled, detailed information on why the condition is not fulfilled is provided via indications. If, for example, the differential voltage is outside the setting limits, the indication **V dif. too large (V2>V1)** is issued. The indication indirectly contains information that the voltage V2 must be reduced for successful synchronization.

If the stage type **Expanded delta-f options** is configured and the parameter (._:142) **Limit dfdiff/dt for asyn. op** is activated, the rate of change of the differential frequency is also checked. If the permissible frequency change rate (parameter (._:143) **Max. value dfdiff/dt asyn**) is exceeded, the indication (._:329) **dfdiff/dt too large** is generated.

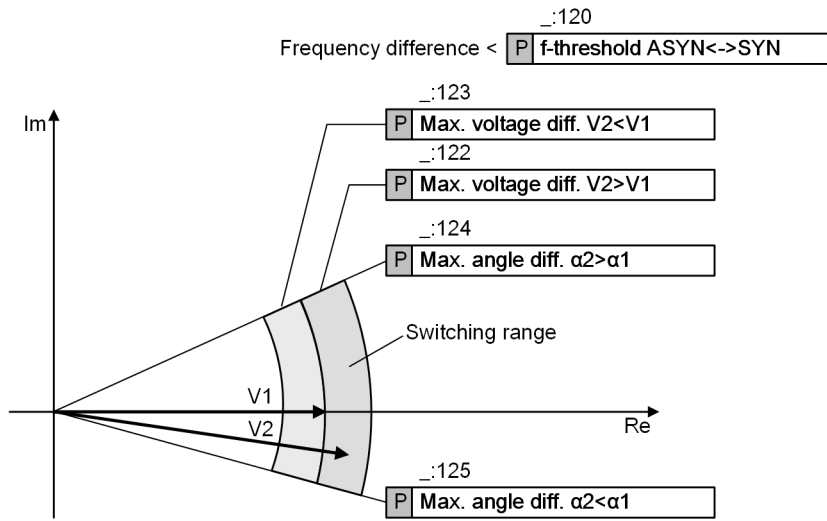

[lo_synzus_adj_comm, 2, en_US]

Figure 9-64 Connecting Under Synchronous System Conditions

Checking Closing Conditions of Asynchronous Systems

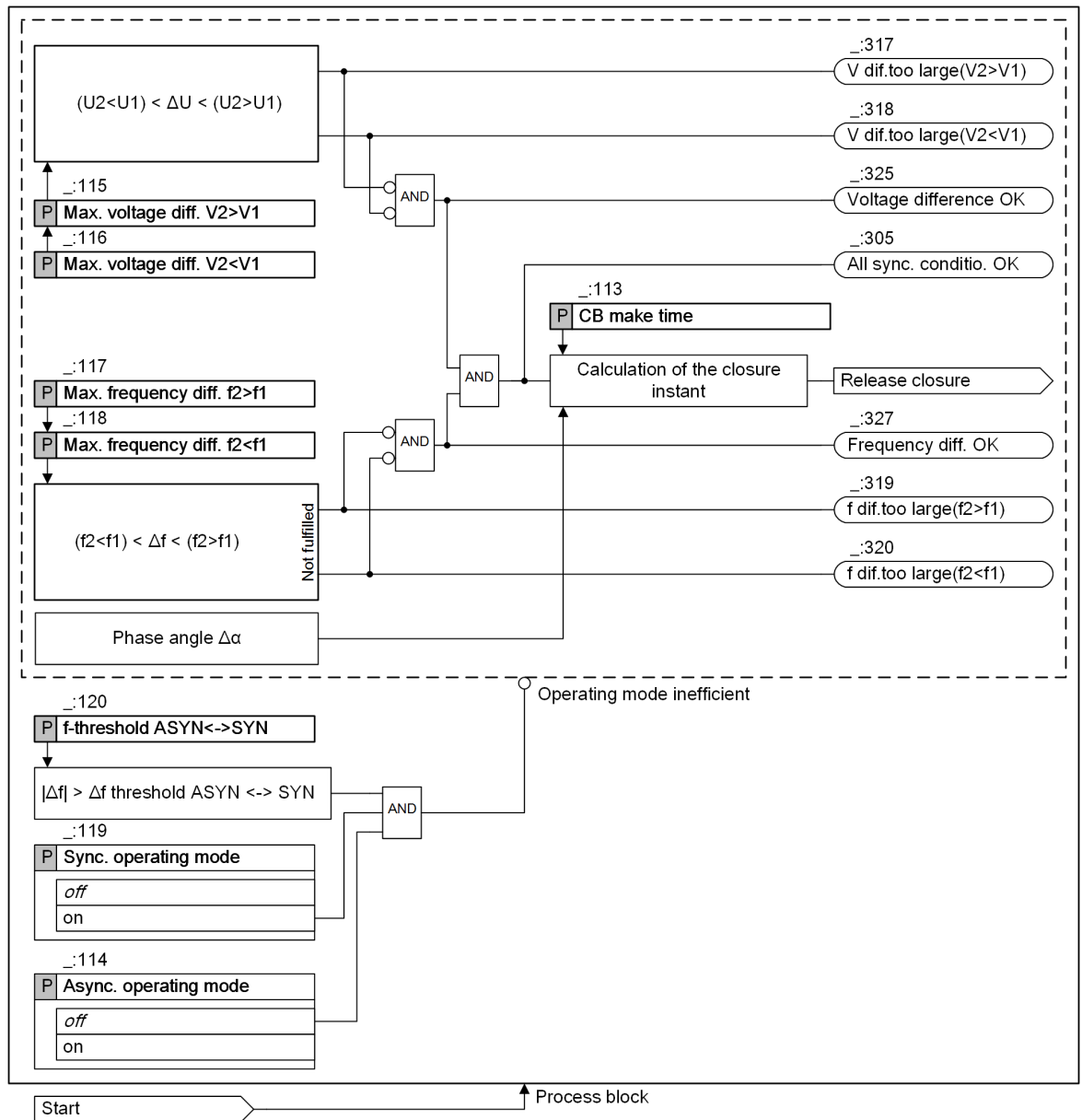

[to_synasy_sd]_comm_2_en_US]

Figure 9-65 Closing Conditions when Switching Asynchronous Systems

In this operating mode, compliance with the voltage difference ΔU and frequency difference Δf conditions is checked. The function calculates the time of the close command taking into account the angle difference $\Delta\alpha$ and the make time of the circuit breaker. This is calculated in such a way that the voltage phasors are equal at the moment of closing the circuit-breaker poles ($\Delta U \approx 0$, $\Delta\alpha \approx 0$).

Ranges in the Voltage-Frequency Diagram (V-f Diagram)

The following figure shows the setting parameters for synchronous and asynchronous conditions in the V-f diagram. For synchronous systems, the frequency band is very narrow owing to the functional principle.

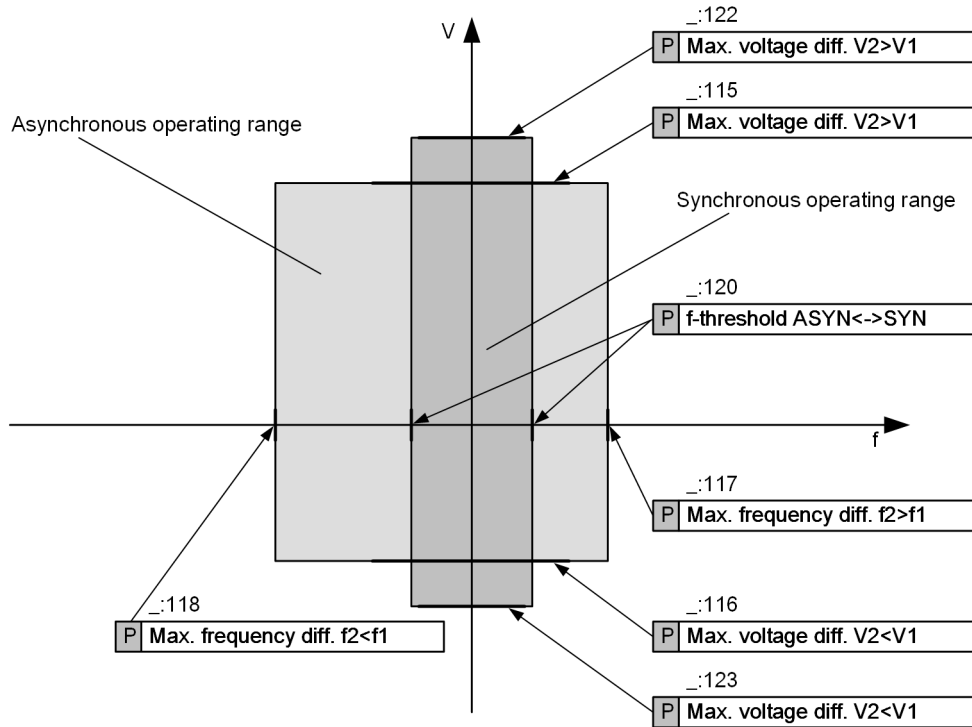

[lo_synarb_adj_comm_2_en_US]

Figure 9-66 Operating Range under Synchronous and Asynchronous Conditions for Voltage (V) and Frequency (f)

Balancing Commands for Voltage and Frequency

The stage has 2 separate blocks, split according to balancing commands for the voltage and the frequency. The balancing pulses for increasing or decreasing the voltage and the frequency are generated in each block. The following values affect the pulse width of the balancing command:

- Current measured values for differential voltage
- Current measured values for differential frequency
- Set gradients dV/dt and df/dt

In addition, the minimum pulse duration (**T V pulse min**, **T f pulse min**) and the maximum pulse duration (**T V pulse max**, **T f pulse max**) are defined. The minimum pulse duration allows for a safe reaction of the controllers while the maximum pulse duration prevents an overreaction, that is an exceedance of the desired target value. A settable dead time intercepts transient states.

The balancing commands are active once the synchronization function has been started.

Balancing Commands for Voltage

The parameters **Max. voltage diff. V2>V1** and **Max. voltage diff. V2<V1** are used to determine the voltage range that defines the admissible voltage difference for asynchronous parallel switching. The middle of the voltage range is defined as the set point value for the balancing commands.

The parameters **T V pulse min** and **T V pulse max** define the minimum and maximum duration of the balancing pulse.

The parameter **dV per second** defines the speed for the set point value change of the voltage control. The functionality uses the measured current voltage difference and the setting value of the parameter to determine the actuating time. The following equation applies:

$$t_{\text{act}} = \frac{dV_{\text{Measured value}}}{dV/dt} = \frac{dV_{\text{Measured value}}}{dV \text{ per second}}$$

[fo_voltage-adjusting-command, 2, en_US]

with:

$dV_{\text{Measured value}}$ Measured differential voltage
dV per second Parameter for default speed of set point value change

The following figure shows the effect of the functionality. When the voltage range limits fall short by approximately 1/8 of the voltage range, the stage no longer issues any voltage balancing commands.

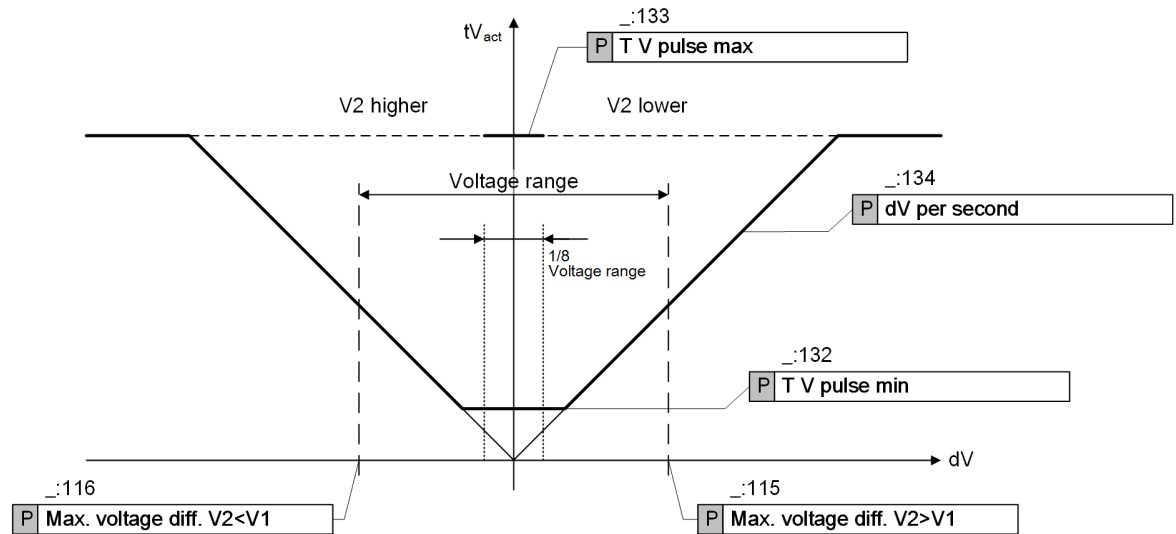

[dw_build_voltage-adjusting-com, 2, en_US]

Figure 9-67 Generation of Balancing Commands for Voltage

Balancing Commands for Frequency

The parameters **Max. frequency diff. f2>f1** and **Max. frequency diff. f2<f1** are used to determine the frequency band that defines the admissible frequency difference for asynchronous parallel switching. The set point value for the balancing commands is not the middle of the frequency band, but the value defined with the parameter **Δf set point for balancing**. If you specify a positive value, the generators are supersynchronously switched in parallel to the network and can immediately transmit active power to the network.

The parameters **T f pulse min** and **T f pulse max** define the minimum and maximum duration of the balancing pulse. The parameter **df/dt of the controller** defines the speed for the set point value change of the frequency control. The functionality uses the measured current frequency difference and the setting value of the parameter to determine the actuating time. The following equation applies:

$$t_{\text{act}} = \frac{df_{\text{Measured value}} - \Delta f_{\text{Set point value}}}{df/dt} = \frac{df_{\text{Measured value}} - \Delta f_{\text{set point for balancing}}}{df/dt \text{ of the controller}}$$

[fo_frequency-adjusting-command, 2, en_US]

with:

$df_{\text{Measured value}}$ Measured differential frequency
 Δf set point for balancing Parameter for default set point value for the frequency balancing commands
 df/dt of the controller Parameter for default speed of set point value change

The following figure shows the effect of the functionality.

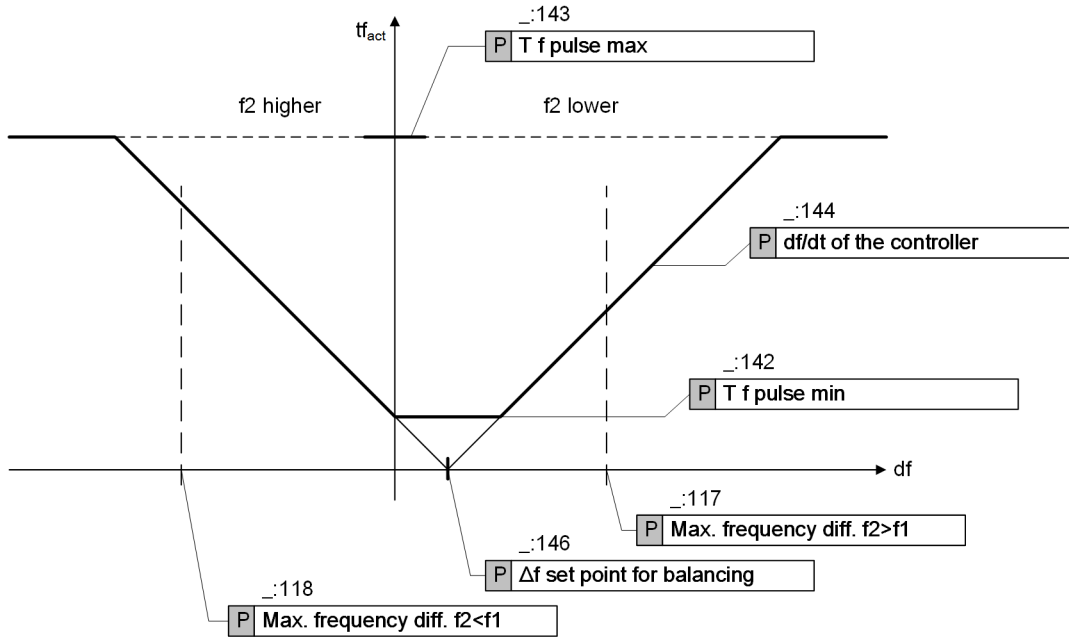

[dw_build_frequency-adjusting-com, 2, en_US]
 Figure 9-68 Generation of Balancing Commands for Frequency

If the speed (frequency) was adjusted in such a way that the differential frequency $df \approx 0$, the voltage phasors of V1 and V2 are practically standing still. This can result in an angle difference that does not allow any switching. A certain frequency difference is required for safe switching. A kick pulse is emitted to attain this state. With the parameter **Release for the kick pulse**, you can control the generation of a kick pulse. A kick pulse is only emitted if the frequency difference falls below the setting value for the parameter **f-threshold ASYN<->SYN**. You can find the parameter **f-threshold ASYN<->SYN** in the entry block **Synchr. op.mode**. The actuating time of the kick pulse is defined with the parameter **Δf for the kick pulse**. The following equation applies:

$$t_{\text{act}} = \frac{\Delta f \text{ for the kick pulse}}{df/dt \text{ of the controller}}$$

[fo_frequency-adjusting-command_01, 2, en_US]

with:

t_{act} Pulse duration
 Δf for the kick pulse Parameter for default set point value for the kick pulse
 df/dt of the controller Parameter for adapting the balancing commands to the controller

The following figure shows the overall effect of the balancing commands:

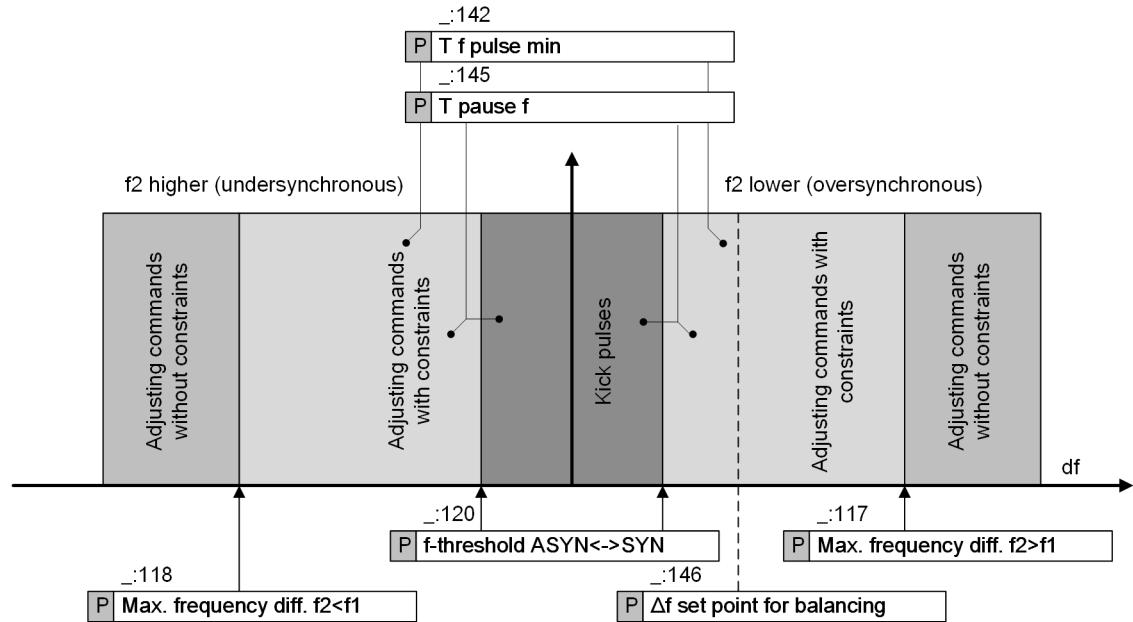

[dw_kick-pulse_freq-adj-com, 2_en_US]

Figure 9-69 Kick Pulse and Frequency Adjustment Ranges

Stabilization and Supervision Actions

The parameter **Smoothing** causes a smoothing of the relevant measuring signal (dV and df) via a recursive filter. The smoothing of the signals prevents wrong balancing commands from being issued to control the voltage and frequency in case of a strong fluctuation of the signals. The smoothing has a low-pass behavior corresponding to a delay element of the 1st order (for PT1 behavior, see also [Figure 9-75](#)).

When the voltage and the frequency are adjusted simultaneously, you must ensure that the admissible overexcitation limit for the generator is not exceeded. The overexcitation is determined by monitoring the $(V/V_{rated})/(f/f_{rated})$ ratio and compared to the admissible threshold value (parameter $(V/V_{rated})/(f/f_{rated})$). When the threshold value is exceeded, a voltage balancing command is issued. In this way, the generator returns to the admissible operating range. The maximum admissible voltage threshold ($V_{2_{max}}$) for V_2 is determined using the overexcitation parameter and the f_2/f_{rated} ratio.

A generator can only be synchronized with a system when there is a certain amount of slip. The frequency difference is a measure for the slip within the functionality. A practically constant frequency difference is assumed when determining the switching point. When adjusting the frequency, take care that no frequency balancing commands are issued near a potential switching point. When the frequency is in the admissible band (parameters **Max. frequency diff. $f_2 > f_1$** and **Max. frequency diff. $f_2 < f_1$** ; see also [Figure 9-69](#)), the currently determined angle difference of the voltage (α) is used to calculate the speed of change ($d\alpha/dt$). This can be used to calculate the remaining time up to the synchronized point ($\alpha \rightarrow 0$) continuously. If the determined time reaches the value for the parameter **T close without balancing** or falls below it, a frequency balancing command will no longer be issued and any active frequency adjustment will be discontinued.

9.4.8.2 Application and Setting Notes

Use the **Synchronous/asynchronous stage type with balancing commands (Syn./Asy.bal.)** for synchronizing generators automatically.

You can find the **Syn./Asy.bal.** stage in the DIGSI 5 library under **FG Circuit Breaker → Synchronization → Function extensions**.

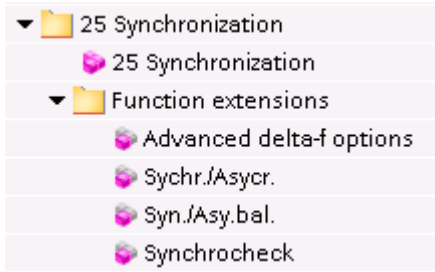

[sc_FB_Adjcomm, 2, en_US]

Figure 9-70 Extract from the DIGSI Library

Delete the stages of the synchronization function that are not used.

Routing the Voltage Transformers to the Measuring Points



NOTE

Ensure that the transformer connections available in the specific application are routed to the correct measuring point!

You can find the routing in the DIGSI 5 project tree under **Function-group connections** → **Connect measuring points to function group**.

- Route the system-side transformer connections in the FG **Circuit breaker** to the input **V Sync 1**.
- Route the generator-side transformer connections in the FG **Circuit breaker** to the input **V Sync 2**.

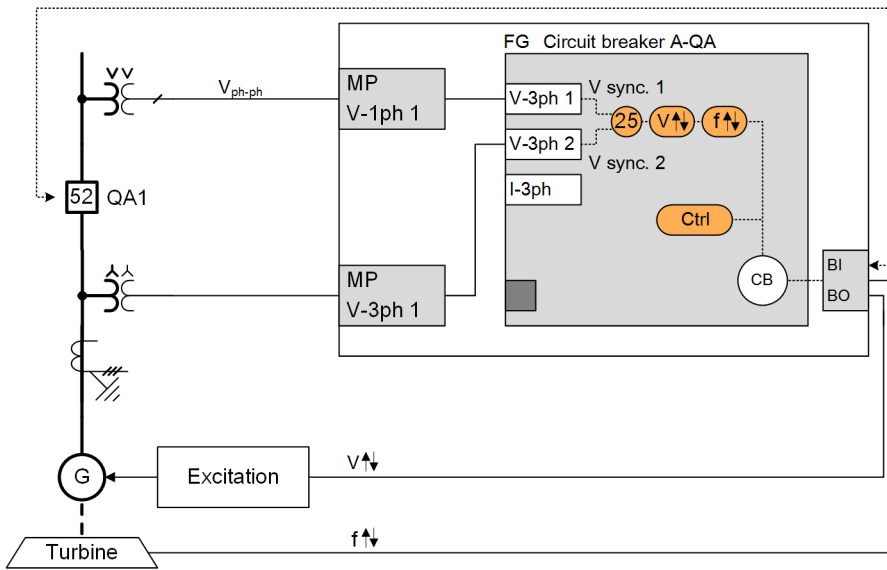

[dw_dim_3ph_and_1ph-voltage-trans, 2, en_US]

Figure 9-71 Connection of a 3-Phase and a 1-Phase Voltage Transformer (Phase-to-Phase Voltage)

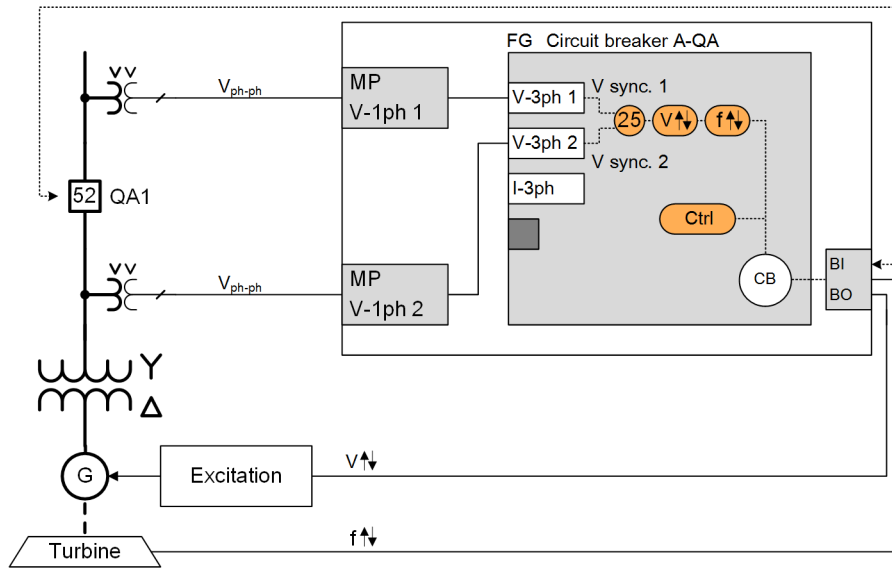

[dw_dim_two_1ph-voltage-trans, 2, en_US]

Figure 9-72 Connection of Two 1-Phase Voltage Transformers (Phase-to-Phase Voltage)

If you have routed the voltage transformers to the measuring points, set the corresponding transformer data in the **System data**.

In the **FG Circuit breaker**, under **General**, set the rated voltage that is used as a reference for percentage-value scaling.

Siemens recommends routing the functional measured values into the fault record in addition to the logical signals. Route at least the functional measured values ($_ : 2311 : 300$) dV , ($_ : 2311 : 301$) df , and ($_ : 2311 : 302$) da into the fault record. This allows you to document the commissioning and subsequently the quality of synchronization.

The asynchronous operating mode defines the automatic synchronization of generators. For this reason, the parameters for this operating mode are described in the following sections.

You can find the basic parameters in DIGSI 5 for the **Syn./Asy.bal.** stage in the **General** block. The default settings for the parameters are typical values. You can use the default settings if the transformer has a secondary rated voltage of 100 V.

Syn./Asy.bal.1	
General	
201.1151.18061.1	Mode: <input type="text" value="off"/>
201.1151.18061.101	Min. operating limit Vmin: <input type="text" value="90.000"/> V
201.1151.18061.102	Max. operat. limit Vmax: <input type="text" value="110.000"/> V
201.1151.18061.110	Max.durat. sync.process: <input type="text" value="30.00"/> s
201.1151.18061.108	Direct close command: <input type="text" value="no"/>
201.1151.18061.126	Voltage adjustment: <input type="text" value="1.000"/>

[sc_FBO_adj_comm, 2, en_US]

Figure 9-73 **General** Block for **Syn./Asy.Bal.** Stage in the DIGSI Setting Sheet

If you want to switch the generator to a dead busbar (black start), Siemens recommends keeping the default values and controlling the release via the binary input signal ($_ : 506$) $>Op. mode 'V1<V2>'$.

The preset voltage ranges $V1 < 5$ V (dead busbar) and $V2 > 80$ V (live generator) are tested only once the binary input signal ($_ : 506$) $>Op. mode 'V1<V2>'$ is active. Siemens recommends this procedure.

If you set the parameter ($_ : 105$) **Close cmd. at $V1 < V2 > = yes$** , on the other hand, the voltage ranges are tested automatically once synchronization has started. The condition $V1 < 5$ V is met if the voltage is really 0 V or in case of an interruption.

In case of an interruption, the current voltage state of the busbar is unknown and there is a risk of wrong synchronization. In this case, you can increase safety with the following measures:

- The operational crew deliberately releases synchronization.
- Alternatively, you can control release via a redundant 2nd channel. If $V1 < 5\text{ V}$ (dead busbar), the binary input signal (`_:506`) *>op. mode 'V1<V2'* is active.

De-en.gized switch.		
201.1151.18061.105	Close cmd. at V1< & V2>:	no
201.1151.18061.106	Close cmd. at V1> & V2<:	no
201.1151.18061.107	Close cmd. at V1< & V2<:	no
201.1151.18061.103	V1, V2 without voltage:	5.000 V
201.1151.18061.104	V1, V2 with voltage:	80.000 V
201.1151.18061.109	Supervision time:	0.10 s

[sc_FB_spglos_sch_2_en_US]

Figure 9-74 De-en.gized Switch. Block for Syn./Asy.Bal. Stage in the DIGSI Setting Sheet



NOTE

In the black-start application, a 3-phase voltage connection provides the advantage that all voltages are monitored. This increases the safety of this application.

Parameters: Sync. operating mode, Async. operating mode

- Default setting (`_:119`) **Sync. operating mode** = *off*
- Default setting (`_:114`) **Async. operating mode** = *off*

With these parameters, you can switch the operating mode of the stage on or off individually. The operating modes are deactivated in the default setting for safety reasons. Set the parameter **Async. operating mode** to *on*.

You can find possible combinations of operating modes in chapter [9.4.7.2 Application and Setting Notes](#).

Parameter for Asynchronous Operation: Maximum Differential Values for Voltage and Frequency

- Default setting (`_:113`) **CB make time** = *0.060 s*
- Default setting (`_:115`) **Max. voltage diff. V2>V1** = *2.0 V*
- Default setting (`_:116`) **Max. voltage diff. V2<V1** = *2.0 V*
- Default setting (`_:117`) **Max. frequency diff. f2>f1** = *0.10 Hz*
- Default setting (`_:118`) **Max. frequency diff. f2<f1** = *0.10 Hz*

The default settings are typical values you can use to synchronize generators. For example, if you only want to connect to the network supersynchronously, set the parameter (`_:118`) **Max. frequency diff. f2<f1** = 0 Hz.

With the parameter (`_:113`) **CB make time**, you set the make time of the closing circuit (circuit-breaker operating time + times of auxiliary relay, where applicable). You must measure this time during commissioning.

Parameter: f-threshold ASYN<->SYN

- Recommended setting value (`_:120`) **f-threshold ASYN<->SYN** = *0.01 Hz*

With the parameter **f-threshold ASYN<->SYN**, you set the frequency difference for switching over between synchronous and asynchronous operation. You can find this parameter in the **Synchr. op.mode** block.

Siemens recommends keeping the default setting value of *0.01 Hz*.

This parameter is also taken into account when the kick pulse has been activated (see [Figure 9-69](#)).

Parameters for Balancing Commands used to Control the Voltage

The following parameters are used as balancing commands to control the voltage:

- (_:131) **Balancing voltage V2**
- (_:132) **T V pulse min**
- (_:133) **T V pulse max**
- (_:134) **dV per second**
- (_:135) **T pause V**
- (_:136) **Smoothing**
- (_:137) **(V/Vrated) / (f/frated)**

Parameter: Balancing voltage V2

- Default setting (_:131) **Balancing voltage V2 = off**

With the parameter **Balancing voltage V2**, you specify whether you wish to issue balancing commands for the voltage V2 on the generator side or not. If you wish to issue balancing commands for the voltage, 2 alternatives are available for voltage control.

Parameter Value	Description
<i>off</i>	If you select this setting value, no balancing commands are issued for the voltage V2 on the generator side.
<i>transformer tap</i>	If you select this setting value, the balancing commands are issued to the voltage controller. The balancing commands control the voltage via the tap changer on the transformer with the pulse duration T V pulse max .
<i>balancing pulses</i>	If you select this setting value, balancing commands are issued for the voltage V2 to the voltage controller of the generator.

Parameter: T V pulse min

- Default setting (_:132) **T V pulse min = 0.10 s**

With the parameter **T V pulse min**, you set the minimum time of the control pulse. It corresponds to the minimum time to which the voltage controller responds. Set the parameter **T V pulse min** to this limiting value. The default setting is a practicable value.

Parameter: T V pulse max

- Default setting (_:133) **T V pulse max = 1.00 s**

With the parameter **T V pulse max**, you set the maximum time of the control pulse. The default setting is a practicable value. This allows you to avoid overadjustment of the voltage in case of major voltage differences.

Parameter: dV per second

- Default setting (_:134) **dV per second = 2.00 V**

With the parameter **dV per second**, you adjust the balancing commands to the controller. You can thus correctly define the set point value. The duration of the control pulse is derived from the measured differential voltage and from the setting value of the parameter. The default setting is a practicable value. Use the following equation to estimate the actuating time.

$$tV_{act} = \frac{dV_{Measured\ value}}{dV/dt} = \frac{dV_{Measured\ value}}{dV\ per\ second}$$

[fo_voltage-adjusting-command, 2_en_US]

with:

$dV_{\text{Measured value}}$
dV per second

Measured differential voltage
Parameter for specifying the speed of set point value change

EXAMPLE:

The following values apply to the example:

Measured differential voltage $dV = 4 \text{ V}$
Parameter setting value **dV per second = 2 V**

Use the following equation to estimate the duration of the balancing pulse:

$$t_{\text{act}} = \frac{dV_{\text{Measured value}}}{dV/dt} = \frac{4 \text{ V}}{2 \text{ V/s}} = 2 \text{ s}$$

[fo_du-dt_2v-s_2_en_US]

The calculated duration of the setting pulse is 2 s. The setting value of the parameter (**_:133**) **T V pulse max** limits the maximum duration of the setting pulse to 1 s. In this case, the value of 1 s applies.

Parameter: T pause V

- Default setting (**_:135**) **T pause V = 5.00 s**

With the parameter **T pause V**, you set the dead time between the balancing commands. This allows the controller or generator to respond to the control pulse. Determine the final setting value during commissioning.

Parameter: Smoothing

- Default setting (**_:136**) **Smoothing = 1**

The parameter **Smoothing** is used for additional smoothing of the dV voltage measured values.

If the measured differential voltage dV fluctuates during commissioning, increase the default setting. The smoothing has low-pass behavior (PT1 behavior).

[Figure 9-75](#) allows you to estimate the effect of the setting value of the parameter. The following figure shows the step response. The longer the delay, the greater the smoothing effect.

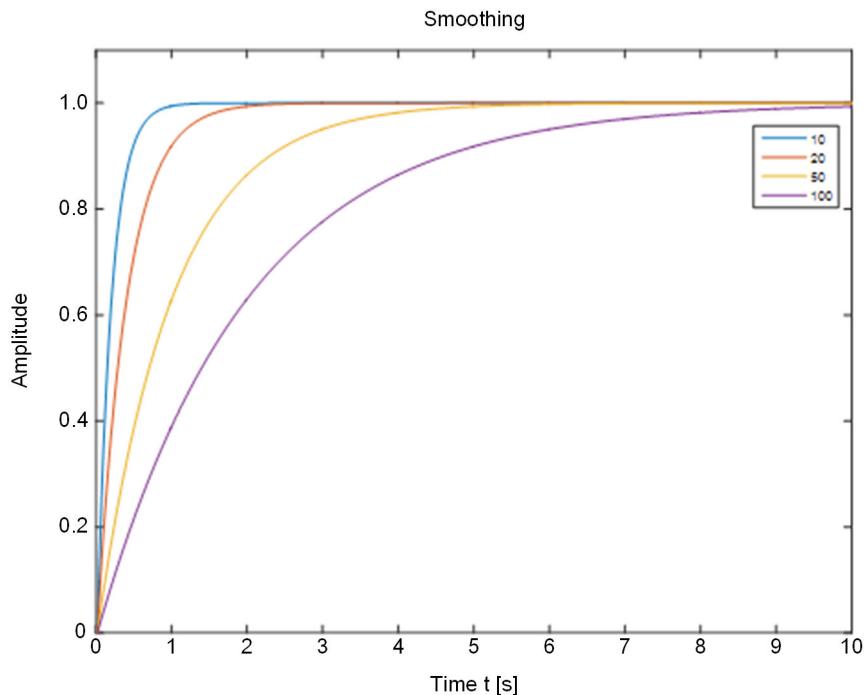

[dw_characteristic-adjusting-com, 2, en_US]

Figure 9-75 Effect of Smoothing Depending on the Set Parameter

Parameter: $(V/V_{rated})/(f/f_{rated})$

- Default setting (`_:137`) $(V/V_{rated}) / (f/f_{rated}) = 1.10$

With the parameter $(V/V_{rated}) / (f/f_{rated})$, you specify the overexcitation threshold.

The default setting is a typical value. Note that the thresholds refer to primary voltages. You can also easily calculate with secondary values, as the voltage transformers are usually exactly adjusted to the rated voltage of the plant. In case of deviations, you must correct the default setting.

EXAMPLE:

Permissible value $(V/V_{rated})/(f/f_{rated})$	1.1
Primary rated voltage of the generator	$V_{prim} = 10.5 \text{ kV}$
Primary voltage of the voltage transformer	$V_{prim, trans.} = 10 \text{ kV}$

This results in the following secondary setting value:

$$(V/V_{rated})/(f/f_{rated}) = \frac{V}{f} \cdot \frac{V_{prim}}{V_{prim,trans.}} = 1.1 \frac{10.5 \text{ kV}}{10 \text{ kV}} = 1.15$$

[fo_v-rated_the_generator, 2, en_US]

Parameters for Balancing Commands used to Control the Frequency

The following parameters are used as balancing commands to control the frequency:

- **Balancing frequency f_2**
- **T f pulse min**
- **T f pulse max**
- **df/dt of the controller**

- **T pause f**
- **Δf set point for balancing**
- **Smoothing**
- **T close without balancing**
- **Release for the kick pulse**
- **Δf for the kick pulse**
- **Stabilization**

Parameter: Balancing frequency f2

- Default setting (**_:141**) **Balancing frequency f2 = off**

With the parameter **Balancing frequency f2**, you specify whether you wish to issue balancing commands for the frequency f2 on the generator side or not.

Parameter Value	Description
<i>off</i>	If you select this setting value, no balancing commands are issued for the frequency f2 on the generator side.
<i>balancing pulses</i>	If you select this setting value, balancing commands are issued for the frequency f2 on the generator side.

Parameter: T f pulse min

- Default setting (**_:142**) **T f pulse min = 0.10 s**

With the parameter **T f pulse min**, you set the minimum time of the control pulse. It corresponds to the minimum time to which the frequency controller responds. Set the time to this limiting value. The default setting is a practicable value.

Parameter: T f pulse max

- Default setting (**_:143**) **T f pulse max = 1.00 s**

With the parameter **T f pulse max**, you set the maximum time of the control pulse. The default setting is a practicable value. This allows you to avoid overadjustment of the speed in case of major frequency differences.

Parameter: df/dt of the controller

- Default setting (**_:144**) **df/dt of the controller = 1.00 Hz/s**

With the parameter **df/dt of the controller**, you adjust the balancing commands to the controller. This allows the set point value to be specified correctly. The control pulse is derived from the measured differential frequency, the setting value of the parameter **df/dt of the controller**, and the set point value **Δf set point for balancing**. The default setting is a practicable value.

Use the following equation to estimate the duration of the balancing pulse:

$$t_{\text{act}} = \frac{df_{\text{Measured value}} - \Delta f_{\text{Set point value}}}{df/dt} = \frac{df_{\text{Measured value}} - \Delta f_{\text{set point for balancing}}}{df/dt \text{ of the controller}}$$

[fo_frequency-adjusting-command, 2, en_US]

with:

- df_{Measured value}** Measured differential frequency
- Δf set point for balancing** Parameter for specifying the set point value for the frequency balancing commands
- df/dt of the controller** Parameter for specifying the speed of set point value change

Parameter: T pause f

- Default setting (`_:145`) **T pause f** = 10.00 s

With the parameter **T pause f**, you set the dead time between the balancing commands. This allows the controller and the generator to respond to the control pulse. Determine the final setting value during commissioning.

Parameter: Δf set point for balancing

- Default setting (`_:146`) **Δf set point for balancing** = 0.04 Hz

With the parameter **Δf set point for balancing**, you define the set point value for the frequency adjustment. The default setting is a practicable value.

EXAMPLE:

Measured differential frequency $df = 0.5 \text{ Hz}$

Parameter setting value **df/dt of the controller** = 1 Hz/s

Set point value **Δf set point for balancing** = 0.04 Hz

Use the following equation to calculate the duration of the balancing pulse:

$$t_{\text{act}} = \frac{df_{\text{Measured value}} - \Delta f_{\text{Set point value}}}{df/dt} = \frac{0.5 \text{ Hz} - 0.04 \text{ Hz}}{1 \text{ Hz/s}} = 0.46 \text{ s}$$

[fo_df-dt_145a_2_en_US]

Parameter: Smoothing

- Default setting (`_:147`) **Smoothing** = 1

The parameter **Smoothing** is used for additional smoothing of the df frequency measured values. If the measured differential frequency df fluctuates during commissioning, increase the default setting. For hydropower plants, in particular, the generator speed may fluctuate, necessitating corresponding adjustment.

Smoothing results in proportional transmission behavior with a delay of the 1st order (PT1 behavior).

[Figure 9-75](#) allows you to estimate the effect of the setting value of the parameter.

Parameter: T close without balancing

- Default setting (`_:148`) **T close without balancing** = 5.00 s

With the parameter **T close without balancing**, you set the time within which no balancing commands are to be issued. This avoids having the frequency change at the moment of switching. The time is thus the remaining duration up to a possible switching. The parameter **T close without balancing** is active if the frequency difference is within the set band (see [Figure 9-69](#)).

Proceed as follows to estimate the time:

Use the set frequency difference to calculate the period duration. The phasors are in phase opposition after half of that time. Do not adjust the frequency within the range from approximately 120° to a maximum of 180° before switching.

EXAMPLE:

The set frequency band in the example is $df = 0.1 \text{ Hz}$.

At this threshold, the period duration is as follows:

$$T_{df} = \frac{1}{df} = \frac{1}{0.1 \text{ Hz}} = 10 \text{ s}$$

[fo_Tdf_2_en_US]

Assuming a constant differential frequency of 0.1 Hz, α changes by 360° in 10 s.

The rule of three may be used to estimate the minimum dead time as follows:

$$360^\circ = 10 \text{ s}$$

$$120^\circ = t_{\min}$$

$$t_{\min} = \frac{120^\circ \cdot 10 \text{ s}}{360^\circ} = 3.33 \text{ s}$$

[fo_frequenzband_2_en_US]

Set the parameter **T close without balancing** to a higher value, as in a practical case, the current differential frequency is less than 0.1 Hz (for example, set point value 0.04 s).

At a differential frequency of 0.04 Hz, a 360° rotation takes 25 s and this leads to a minimum dead time of approximately 8 s.

The example shows that the default setting of 5.00 s is a practicable value.

Parameter: Release for the kick pulse

- Default setting (**_:149**) **Release for the kick pulse = off**

With the parameter **Release for the kick pulse**, you can activate the kick pulse.

If you need a kick pulse for your application, change the default setting.

Parameter: Δf for the kick pulse

- Default setting (**_:150**) **Δf for the kick pulse = 0.04 Hz**

With the parameter **Δf for the kick pulse**, you define the set point value for the kick pulse. The pulse duration is derived from this.

Set the parameter **Δf for the kick pulse** to the same value as the parameter **Δf set point for balancing**.

The setting value of 0.04 Hz leads to the following duration for the kick pulse:

$$t_{\text{act}} = \frac{\Delta f \text{ for the kick pulse}}{df/dt \text{ of the controller}} = \frac{0.04 \text{ Hz}}{1 \text{ Hz/s}} = 0.04 \text{ s}$$

[fo_frequency-adjusting-command_02_2_en_US]

If the controller does not respond to this brief pulse ($t_{\text{act}} < t_{\text{pulse min}}$), the minimum pulse **T f pulse min** applies.

Parameter: Stabilization

- Default setting (**_:151**) **Stabilization = no**

If the dead time is too short, the parameter **Stabilization** results in a faster compensation of the speed controller.

Parameter Value	Description
no	The default setting no is a practicable value for typical synchronization applications.
yes	If the dead time is short, the transition process has not yet been completed after a control pulse for the frequency. The frequency can fluctuate around its set point value. If you set the parameter Stabilization = yes , the transient status is attenuated by canceling the control pulse or by issuing a control pulse in the reverse direction in time. Siemens only recommends this setting value if you wish to achieve fast synchronization by means of short dead times or for special applications.

9.4.8.3 Settings

Addr.	Parameter	C	Setting Options	Default Setting
General				
_:1	Syn./Asy.bal.#:Mode		<ul style="list-style-type: none"> • off • on • test 	off
_:101	Syn./Asy.bal.#:Min. operating limit Vmin		0.300 V to 340.000 V	90.000 V
_:102	Syn./Asy.bal.#:Max. operat. limit Vmax		0.300 V to 340.000 V	110.000 V
_:110	Syn./Asy.bal.#:Max.durat. sync.process		0.00 s to 3600.00 s; ∞	30.00 s
_:108	Syn./Asy.bal.#:Direct close command		<ul style="list-style-type: none"> • no • yes 	no
_:126	Syn./Asy.bal.#:Voltage adjustment		0.500 to 2.000	1.000
De-en.gized switch.				
_:105	Syn./Asy.bal.#:Close cmd. at V1< & V2>		<ul style="list-style-type: none"> • no • yes 	no
_:106	Syn./Asy.bal.#:Close cmd. at V1> & V2<		<ul style="list-style-type: none"> • no • yes 	no
_:107	Syn./Asy.bal.#:Close cmd. at V1< & V2<		<ul style="list-style-type: none"> • no • yes 	no
_:103	Syn./Asy.bal.#:V1, V2 without voltage		0.300 V to 170.000 V	5.000 V
_:104	Syn./Asy.bal.#:V1, V2 with voltage		0.300 V to 340.000 V	80.000 V
_:109	Syn./Asy.bal.#:Supervision time		0.00 s to 60.00 s	0.10 s
Asynchr. op.mode				
_:114	Syn./Asy.bal.#:Async. operating mode		<ul style="list-style-type: none"> • off • on 	off
_:113	Syn./Asy.bal.#:CB make time		0.010 s to 0.600 s	0.060 s
_:115	Syn./Asy.bal.#:Max. voltage diff. V2>V1		0.000 V to 170.000 V	2.000 V
_:116	Syn./Asy.bal.#:Max. voltage diff. V2<V1		0.000 V to 170.000 V	2.000 V
_:117	Syn./Asy.bal.#:Max. frequency diff. f2>f1		0.000 Hz to 4.000 Hz	0.100 Hz
_:118	Syn./Asy.bal.#:Max. frequency diff. f2<f1		0.000 Hz to 4.000 Hz	0.100 Hz
Synchr. op.mode				
_:119	Syn./Asy.bal.#:Sync. operating mode		<ul style="list-style-type: none"> • off • on 	off
_:120	Syn./Asy.bal.#:f-threshold ASYN<->SYN		0.010 Hz to 0.200 Hz	0.010 Hz

Addr.	Parameter	C	Setting Options	Default Setting
_:122	Syn./Asy.bal.#:Max. voltage diff. $V_2 > V_1$		0.000 V to 170.000 V	2.000 V
_:123	Syn./Asy.bal.#:Max. voltage diff. $V_2 < V_1$		0.000 V to 170.000 V	2.000 V
_:124	Syn./Asy.bal.#:Max. angle diff. $\alpha_2 > \alpha_1$		0 ° to 90 °	10 °
_:125	Syn./Asy.bal.#:Max. angle diff. $\alpha_2 < \alpha_1$		0 ° to 90 °	10 °
_:121	Syn./Asy.bal.#:Delay close command		0.00 s to 60.00 s	0.00 s
Balancing V				
_:131	Syn./Asy.bal.#:Balancing voltage V2		<ul style="list-style-type: none"> • off • transformer tap • balancing pulses 	off
_:132	Syn./Asy.bal.#:T V pulse min		0.01 s to 1.00 s	0.10 s
_:133	Syn./Asy.bal.#:T V pulse max		0.01 s to 60.00 s	1.00 s
_:134	Syn./Asy.bal.#:dV per second		0.100 V to 50.000 V	2.000 V
_:135	Syn./Asy.bal.#:T pause V		0.10 s to 60.00 s	5.00 s
_:136	Syn./Asy.bal.#:Smoothing		1 to 100	1
:137	Syn./Asy.bal.#: $(V/V{rated}) / (f/f_{rated})$		1.00 to 1.40	1.10
Balancing f				
_:141	Syn./Asy.bal.#:Balancing frequency f2		<ul style="list-style-type: none"> • off • balancing pulses 	off
_:142	Syn./Asy.bal.#:T f pulse min		0.01 s to 1.00 s	0.10 s
_:143	Syn./Asy.bal.#:T f pulse max		0.01 s to 60.00 s	1.00 s
_:144	Syn./Asy.bal.#:df/dt of the controller		0.05 Hz/s to 5.00 Hz/s	1.00 Hz/s
_:145	Syn./Asy.bal.#:T pause f		0.10 s to 60.00 s	10.00 s
_:146	Syn./Asy.bal.#:Δf set point for balancing		-1.00 Hz to 1.00 Hz	0.04 Hz
_:147	Syn./Asy.bal.#:Smoothing		1 to 100	1
_:148	Syn./Asy.bal.#:T close without balancing		1.00 s to 100.00 s	5.00 s
_:149	Syn./Asy.bal.#:Release for the kick pulse		<ul style="list-style-type: none"> • off • on 	off
_:150	Syn./Asy.bal.#:Δf for the kick pulse		-1.00 Hz to 1.00 Hz	0.04 Hz
_:151	Syn./Asy.bal.#:Stabilization		<ul style="list-style-type: none"> • no • yes 	no

9.4.8.4 Information List

No.	Information	Data Class (Type)	Type
Syn./Asy.bal.#			
_:81	Syn./Asy.bal.#:>Block stage	SPS	I
_:500	Syn./Asy.bal.#:>Selection	SPS	I
_:502	Syn./Asy.bal.#:>Start/stop syn.proc.	SPS	I
_:503	Syn./Asy.bal.#:>Start syn. process	SPS	I
_:504	Syn./Asy.bal.#:>Stop syn. process	SPS	I
_:506	Syn./Asy.bal.#:>Op. mode 'V1<V2>'	SPS	I
_:505	Syn./Asy.bal.#:>Op. mode 'V1>V2<'	SPS	I
_:507	Syn./Asy.bal.#:>Op. mode 'V1<V2<'	SPS	I
_:508	Syn./Asy.bal.#:>Op. mode 'dir.cls.cmd'	SPS	I
_:501	Syn./Asy.bal.#:>Block close command	SPS	I
_:511	Syn./Asy.bal.#:>Block balancing	SPS	I
_:513	Syn./Asy.bal.#:>Block V2 balancing	SPS	I
_:514	Syn./Asy.bal.#:>Block f2 balancing	SPS	I
_:51	Syn./Asy.bal.#:Mode (controllable)	ENC	C
_:54	Syn./Asy.bal.#:Inactive	SPS	O
_:52	Syn./Asy.bal.#:Behavior	ENS	O
_:53	Syn./Asy.bal.#:Health	ENS	O
_:328	Syn./Asy.bal.#:In progress	SPS	O
_:324	Syn./Asy.bal.#:Release close cmd.	SPS	O
_:305	Syn./Asy.bal.#:All sync. conditio. OK	SPS	O
_:303	Syn./Asy.bal.#:State f-synchronous	SPS	O
_:325	Syn./Asy.bal.#:Voltage difference OK	SPS	O
_:326	Syn./Asy.bal.#:Angle difference OK	SPS	O
_:327	Syn./Asy.bal.#:Frequency diff. OK	SPS	O
_:307	Syn./Asy.bal.#:Cond. V1<V2> fulfilled	SPS	O
_:306	Syn./Asy.bal.#:Cond. V1>V2< fulfilled	SPS	O
_:308	Syn./Asy.bal.#:Cond. V1<V2< fulfilled	SPS	O
_:309	Syn./Asy.bal.#:Frequency f1 > fmax	SPS	O
_:310	Syn./Asy.bal.#:Frequency f1 < fmin	SPS	O
_:311	Syn./Asy.bal.#:Frequency f2 > fmax	SPS	O
_:312	Syn./Asy.bal.#:Frequency f2 < fmin	SPS	O
_:313	Syn./Asy.bal.#:Voltage V1 > Vmax	SPS	O
_:314	Syn./Asy.bal.#:Voltage V1 < Vmin	SPS	O
_:315	Syn./Asy.bal.#:Voltage V2 > Vmax	SPS	O
_:316	Syn./Asy.bal.#:Voltage V2 < Vmin	SPS	O
_:317	Syn./Asy.bal.#:V dif.too large(V2>V1)	SPS	O
_:318	Syn./Asy.bal.#:V dif.too large(V2<V1)	SPS	O
_:319	Syn./Asy.bal.#:f dif.too large(f2>f1)	SPS	O
_:320	Syn./Asy.bal.#:f dif.too large(f2<f1)	SPS	O
_:329	Syn./Asy.bal.#:dfdiff/dt too large	SPS	O
_:321	Syn./Asy.bal.#:α dif.too large(α2>α1)	SPS	O
_:322	Syn./Asy.bal.#:α dif.too large(α2<α1)	SPS	O
_:304	Syn./Asy.bal.#:Max. time exceeded	SPS	O
_:323	Syn./Asy.bal.#:Setting error	SPS	O

No.	Information	Data Class (Type)	Type
_:332	Syn./Asy.bal.#:V2 control pulse higher	SPS	0
_:331	Syn./Asy.bal.#:V2 control pulse lower	SPS	0
_:334	Syn./Asy.bal.#:f2 control pulse higher	SPS	0
_:333	Syn./Asy.bal.#:f2 control pulse lower	SPS	0

9.4.9 Expanded Checks (df/dt and Smoothing of Oscillations)

When configuring the function block **Expanded delta-f options**, you can expand the synchronization checks to include the following aspects:

- Limitation of the frequency change rate
 With this option, you can define additional upper limits for the rate of permissible frequency difference change. The release checks for both stage types take these additional upper limits into consideration. Both activation (parameters (_:140) **Limit dfdiff/dt for sync. op** and (_:142) **Limit dfdiff/dt for asyn. op**) and the upper limits (parameters (_:141) **Max. value dfdiff/dt syn** and (_:143) **Max. value dfdiff/dt asyn**) for the frequency change rate are adjustable selectively for synchronous and asynchronous conditions. Both stage types consider the frequency change rate when issuing the release for switching and indicate when the rate is exceeded.
 If you also activate the option to compensate for low-frequency oscillations (parameter (_:150) **Suppr. frequ. oscillations**), the frequency change rate is stabilized in the presence of such oscillations. Stabilization is in effect for asynchronous as well as synchronous operating modes.

- Compensation for low-frequency oscillations
If you activate this option (parameter (`_:150`) **Suppr. frequ. oscillations**), low-frequency oscillations, for example, as a consequence of power swings in the range of 0.8 Hz to 1.6 Hz, are detected and smoothed. This stabilizes the release checks in the presence of frequently changing violations of upper and lower limits for the specified frequency threshold values. The option affects the frequency check of the stage type **Synchrocheck** and the synchronous operating mode of the stage type **Synchronous/Asynchronous**. It does not affect the asynchronous operating mode.

In the example of the following figure, the synchrocheck function would initiate energization, if the allowed frequency difference was set to 10 MHz without the parameter **Suppr. frequ. oscillations** as soon as the frequency f_2 enters the 10-MHz band. If the parameter **Suppr. frequ. oscillations** is activated, energization is not initiated, since the average value of f_2 is outside the band.

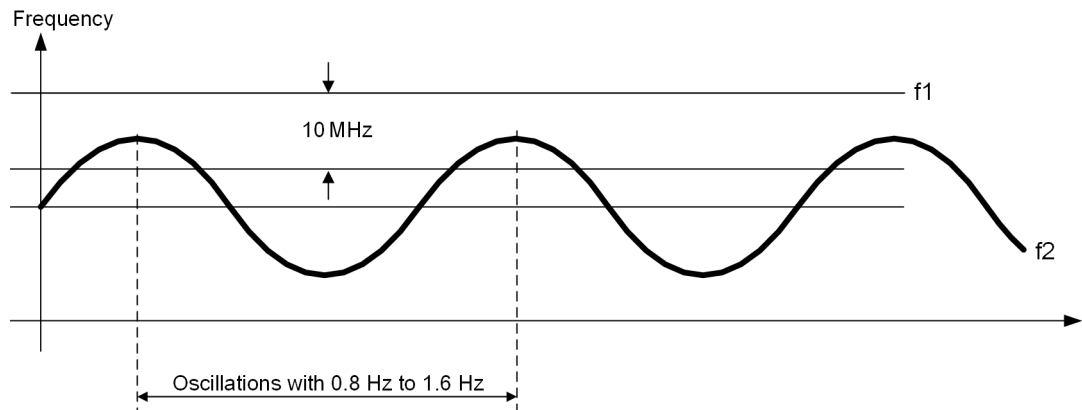

[dw_synfre-01, 2, en_US]

Figure 9-76 Example: Frequency Difference between the Constant Frequency f_1 and the Sinusoidal Oscillating Frequency f_2

With this option active, the range of function measured values is expanded by the smoothed frequency. Release of switching in synchronous networks occurs after one second at the earliest. This time is needed to smooth the frequency measured values.

The actual frequency can be larger or smaller than the smoothed value at any instant. The parameter **Max. diff. "f threshold"** makes it possible to limit the increase in instantaneous frequency value in relation to the respective frequency threshold value.

9.4.10 Closing at De-Energized Line/Busbar

9.4.10.1 Description

If at least one of 2 parts of an electrical power system is de-energized, the parts of the electrical power system can be connected together via the following operating modes.

If the measured voltage is less than the threshold **V1, V2 without voltage**, the zero potential of the part of the electrical power system is detected. In this case, all phases are compared to the parameter **V1, V2 without voltage**. The energized side must be in the defined operating range with respect to voltage and frequency (see chapter [9.4.4.1 Description](#)) and all phases must exceed the threshold **V1, V2 with voltage**.

The following additional closing conditions can be selected, which are then applied next to the closing conditions for the synchronism:

Settings	Description
Close cmd. at V1> & V2<	Closing release under the condition that the part V ₁ of the power system is energized and the part of the electrical power system U ₂ is de-energized.
Close cmd. at V1< & V2>	Closing release under the condition that the part V ₁ of the power system is de-energized and the part of the electrical power system U ₂ is energized.
Close cmd. at V1< & V2<	Closing release provided mains adapters V ₁ and V ₂ are de-energized.

Each of these conditions can be made effective individually via parameters or binary input. You can also set parameters for combinations, for example a release for closure, if **Close cmd. at V1> & V2<** or **Close cmd. at V1< & V2>** has been fulfilled.

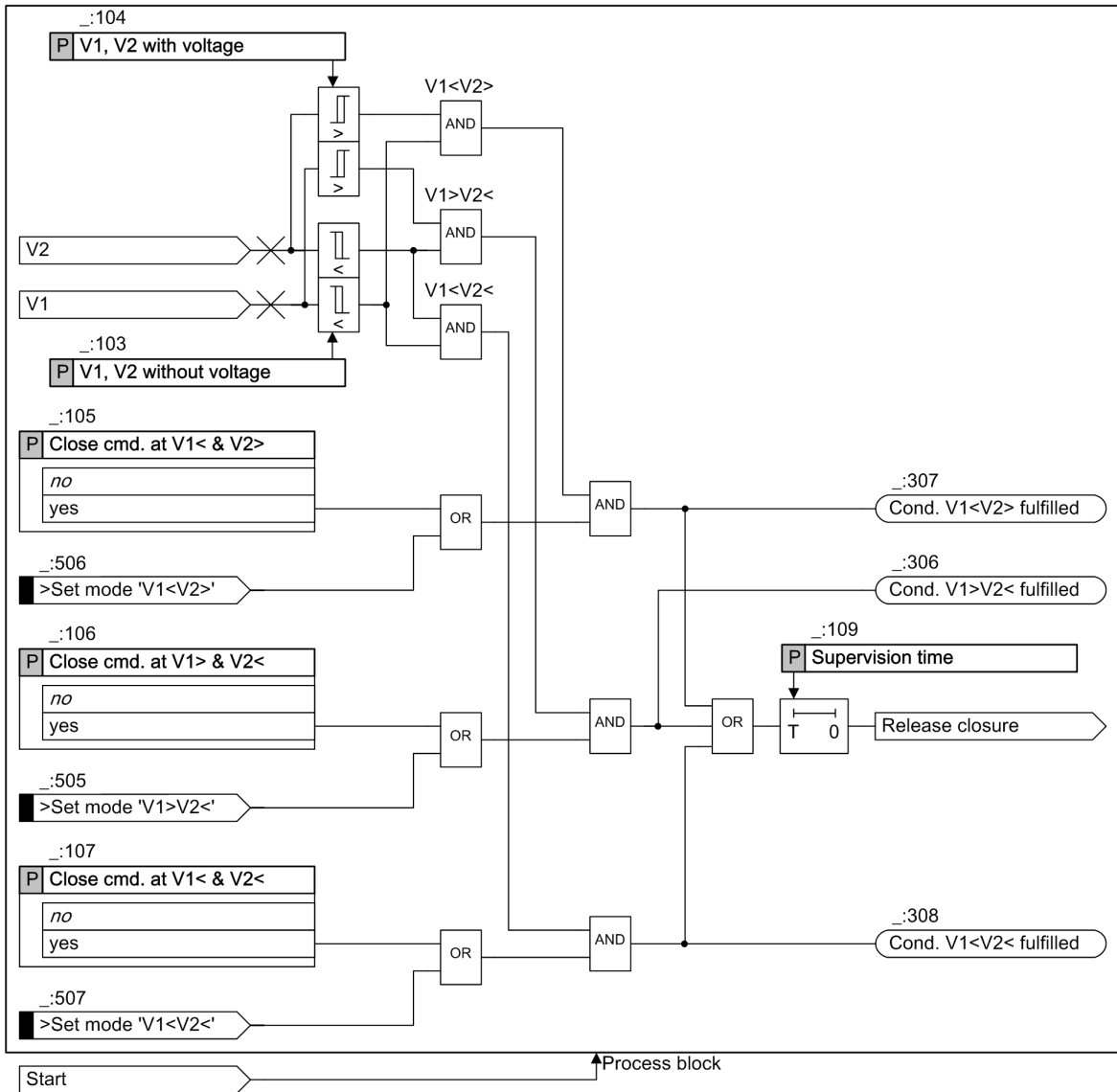

Figure 9-77 Release Conditions for Switching to De-Energized Line/Busbar

The indications **Cond. V1>V2< fulfilled**, **Cond. V1<V2> fulfilled** and **Cond. V1<V2< fulfilled** indicate that the relevant conditions are fulfilled.

If the following 2 conditions are met, these indications refresh automatically:

- You set the parameter **Sync. operating mode** to *on*.
- You select the parameter **Continuous supervision**.

You can use the **Supervision time** parameter to set a supervision time for which the closing conditions must at least be fulfilled with de-energized connection, before closing is allowed.

9.4.10.2 Application and Setting Notes

If at least one of 2 parts of an electrical power system is de-energized, the parts of the electrical power system can be connected together via the following operating modes. The above potential release conditions are independent of one another and can also be combined.



NOTE

For reasons of safety, the releases have been deactivated in the default setting and are therefore at *no*. Even if you wish to apply one of these operating modes, Siemens recommends leaving the setting at *no* for reasons of safety. Set the operating mode only dynamically via the assigned binary input signal (for example **>Operating mode 'U1>U2<'**) (see also [Figure 9-77](#)). This prevents one of these operating modes from being incorrectly activated statically thereby resulting in an incorrect switching.

Parameter: Close cmd. at V1< & V2>

- Recommended setting value (`_:5071:105`) **Close cmd. at V1< & V2> = no**

Settings	Description
<i>no</i>	No release for closing is possible via this operating mode.
<i>yes</i>	If part V1 of the power system is de-energized and part V2 of the power system is energized, the release for closure is given upon starting the synchronization stage after the supervision time has passed. The setting depends on the operational requirements. Note the above information.

Parameter: Close cmd. at V1> & V2<

- Recommended setting value (`_:5071:106`) **Close cmd. at V1> & V2< = no**

Settings	Description
<i>no</i>	No release for closing is possible via this operating mode.
<i>yes</i>	If part V1 of the power system is energized and part V2 of the power system is de-energized, the release for closure is given upon starting the synchronization stage after the supervision time has passed. The setting depends on the operational requirements. Note the above information.

Parameter: Close cmd. at V1< & V2<

- Recommended setting value (`_:5071:107`) **Close cmd. at V1< & V2< = no**

Settings	Description
<i>no</i>	No release for closing is possible via this operating mode.
<i>yes</i>	If the parts V1 and V2 of the power system are de-energized, the release for closure is given upon starting the synchronization stage after the supervision time has passed. The setting depends on the operational requirements. Note the above information.

Parameter: V1, V2 with voltage

- Recommended setting value (`_:5071:104`) **V1, V2 with voltage = 80 V**

The setting value indicates the voltage above which a part of the power system (feeder or busbar) can be regarded as activated with certainty.

You must set the value below the minimum expected operational undervoltage. Siemens therefore recommends a setting value of approx. 80 % of the rated voltage. All voltages connected according to the parameterized measuring-point connection type are subjected to the appropriate Vmin/Vmax test.

Parameter: V1, V2 without voltage

- Recommended setting value (`_:5071:103`) **V1, V2 without voltage = 5 V**

The setting value indicates the voltage below which a part of the power system (feeder or busbar) can be regarded as deactivated with certainty.

Siemens recommends a setting value of approx. 5 % of the rated voltage for this. All voltages connected according to the parameterized measuring-point connection type are subjected to the appropriate Vmin/Vmax test.

Parameter: Supervision time

- Recommended setting value (`_:5071:109`) **Supervision time = 0.1 s**

The parameter defines a supervision time for which the above additional closing conditions have to be at least fulfilled at de-energized switching, before the release for closing is given. In order to include transient phenomena, Siemens recommends a value of *0.1 s*.

Parameter: Direct close command

- Recommended setting value (`_:5071:108`) **Direct close command = no**

In this operating mode, the function initiates a closing release without any testing upon start of the synchronization stage. The closure occurs immediately.



NOTE

For safety reasons, Siemens recommends leaving the setting at *no*. If a direct close command is necessary, Siemens recommends only using this operating mode dynamically via the binary input signal `>Op. mode 'dir.cls.cmd'` (see also [Figure 9-79](#)). This prevents this operating mode from being incorrectly activated statically thereby resulting in an incorrect switching.

9.4.11 Direct Close Command

You can activate the operating mode direct close command statically via the **Direct close command** parameter or dynamically with the binary input signal `>Op. mode 'dir.cls.cmd'` (see [Figure 9-78](#)).

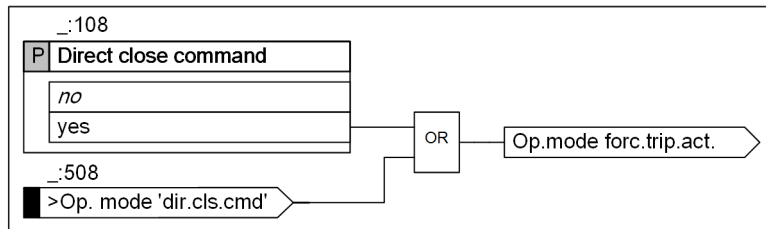

[lo_syndir_01_2_en_US]

Figure 9-78 Activation of the Operating Mode Direct Close Command

The operating mode **Direct close command** function initiates a closure release without any testing upon start of the synchronization stage. The closure occurs immediately.

The combination **Direct close command** with other operating modes is not recommended, as the other operating mode is bypassed.

If the synchronization function is defective (standby of the sync stage = alarm or warning), a direct close command is executed or not executed, depending on the type of fault (see also supervisions in chapter [9.4.4.1 Description](#)).

9.4.12 Interaction with Control and External Triggering

With Control

The control and synchronization functions are always located in a **Circuit-breaker** function group. The control and also the synchronization function always operate with the circuit breaker, which is linked to the function group **Circuit breaker**.

As soon as the synchronization function is in the **Circuit-breaker** function group, the circuit breaker is subject to compulsory synchronization. If all synchronization stages are deactivated, the circuit breaker cannot be activated via the control, as no release can be generated for the closure. The circuit breaker is no longer subject to compulsory synchronization after deletion of the synchronization function. Closure without synchronization is then possible via the control.

If closure is to be synchronized via the control, the control automatically generates an internal signal which starts the synchronization function. The functional sequence is described in chapter [9.4.5 Sequence of Functions](#). After fulfilling all closing conditions, the synchronization sends a release signal to the control, which closes the circuit breaker and then stops and synchronization function.

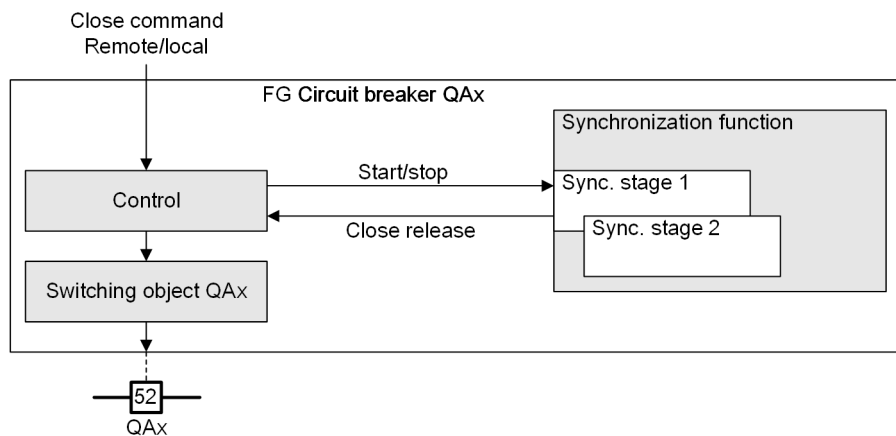

[lo_synaw1-01, 3, en_US]

Figure 9-79 Interaction of the Control with the Synchronization Function

With External Control

You have the option of controlling the synchronization function externally via binary input signals. This can be done as follows:

- Edge-controlled
- Via the signals **>Start syn. process** and **>Stop syn. process**
- State-controlled via the signal **>Start/stop syn.proc.** (see also [9.4.5 Sequence of Functions](#)).

The start is followed by the functional sequence (see [9.4.5 Sequence of Functions](#)). If the conditions are fulfilled, the output signal **Release close cmd.** is output. The switched object QAx of the function group **Circuit breaker** is not closed. The output signal **Release close cmd.** must be explicitly routed to the binary output in order to close the circuit breaker.

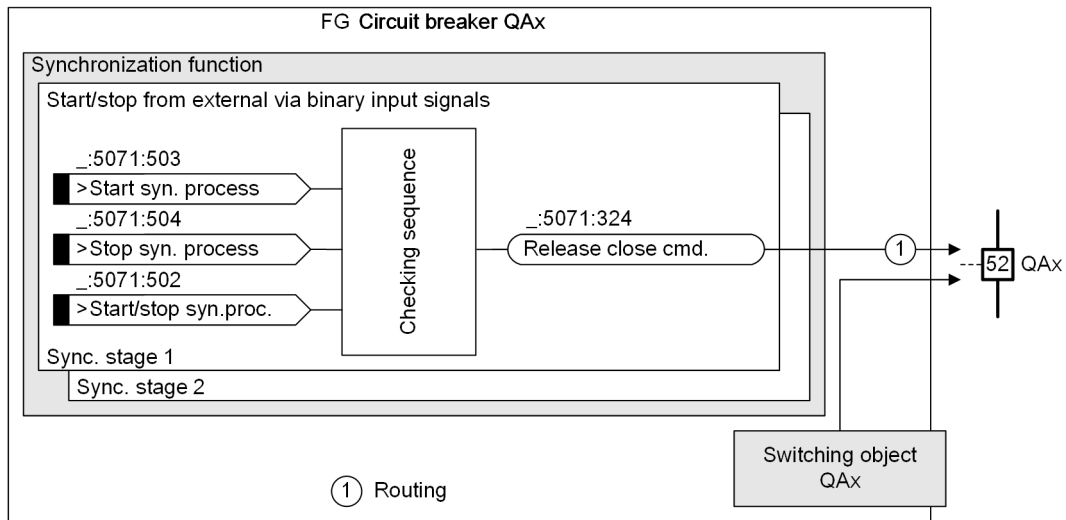

[ilo_synaw3-01_3_en_US]

Figure 9-80 Interaction of the Synchronization Function with External Control

9.4.13 External Synchronization

9.4.13.1 Description

The purpose of the **External synchronization** function is to control an external synchronization device.

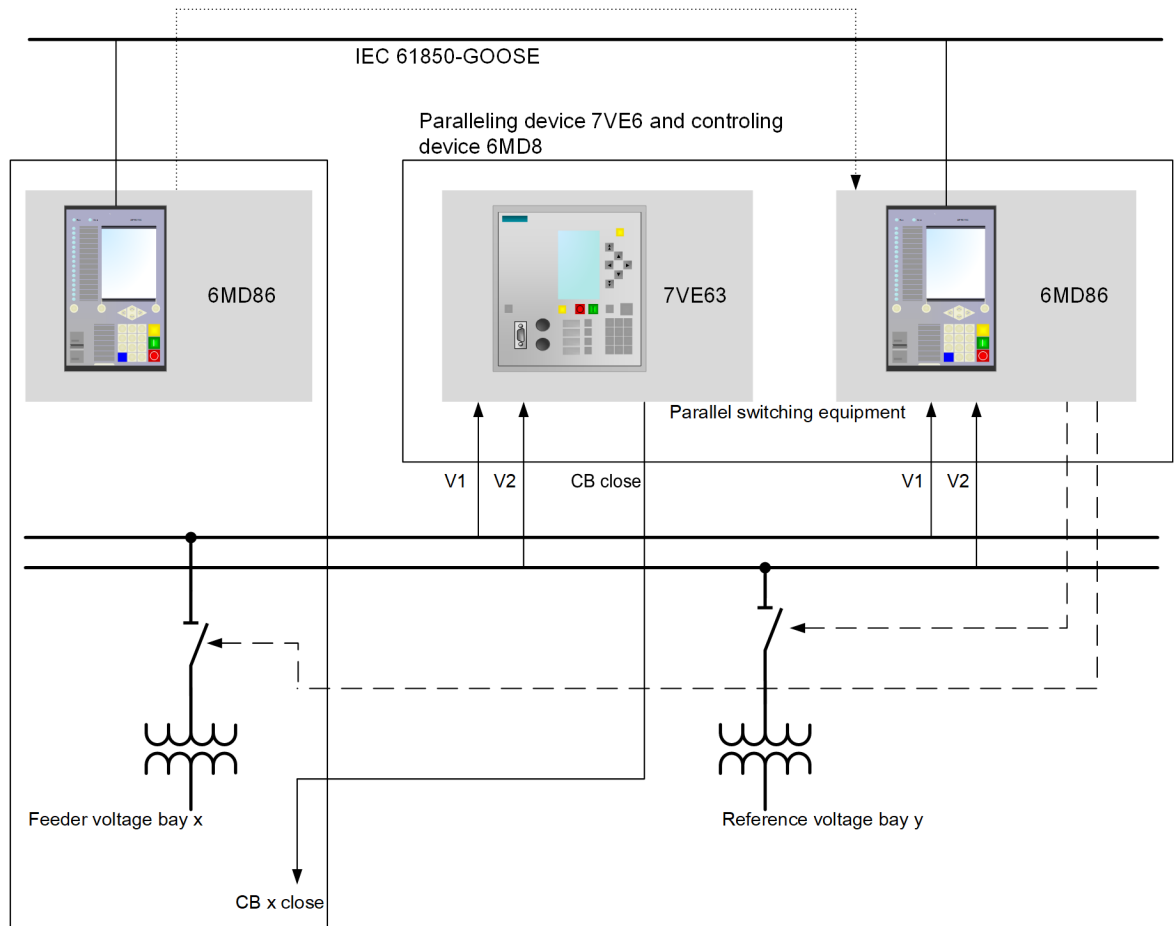

[dw_ctrl_ext_sync_device, 3, en_US]

Figure 9-81 Triggering an External Synchronization Device

The bay controller in bay x should switch the circuit breaker in bay x in synchrony. The synchronization check is carried out in the central paralleling device 7VE6. In addition to the paralleling device, another central bay controller ensures the switching of the correct measuring voltages and the routing of the CB close command from the 7VE6 to the correct circuit breaker in bay x. The bay controller x provides the information to the central bay controller via IEC61850-GOOSE.

The **External synchronization** is designed as a function block which can be used in the Circuit-breaker function group. The additional **External synchronization** function block integrates the external synchronization into command processing, so that the corresponding feedback can be forwarded to the command source.

If a circuit-breaker close command with a synchronization requirement is present, the external synchronization device is started. After successfully checking the synchronization conditions, the close command is issued from the external synchronization device to the circuit breaker. If a circuit-breaker close command without synchronization requirement is present, the circuit-breaker close command is issued directly from the **Circuit-breaker** function group to the circuit breaker. Also, each circuit-breaker trip command is issued directly to the circuit breaker.

In case of a failure of the external synchronization device, you can also close the circuit breaker directly without considering the synchronization conditions.

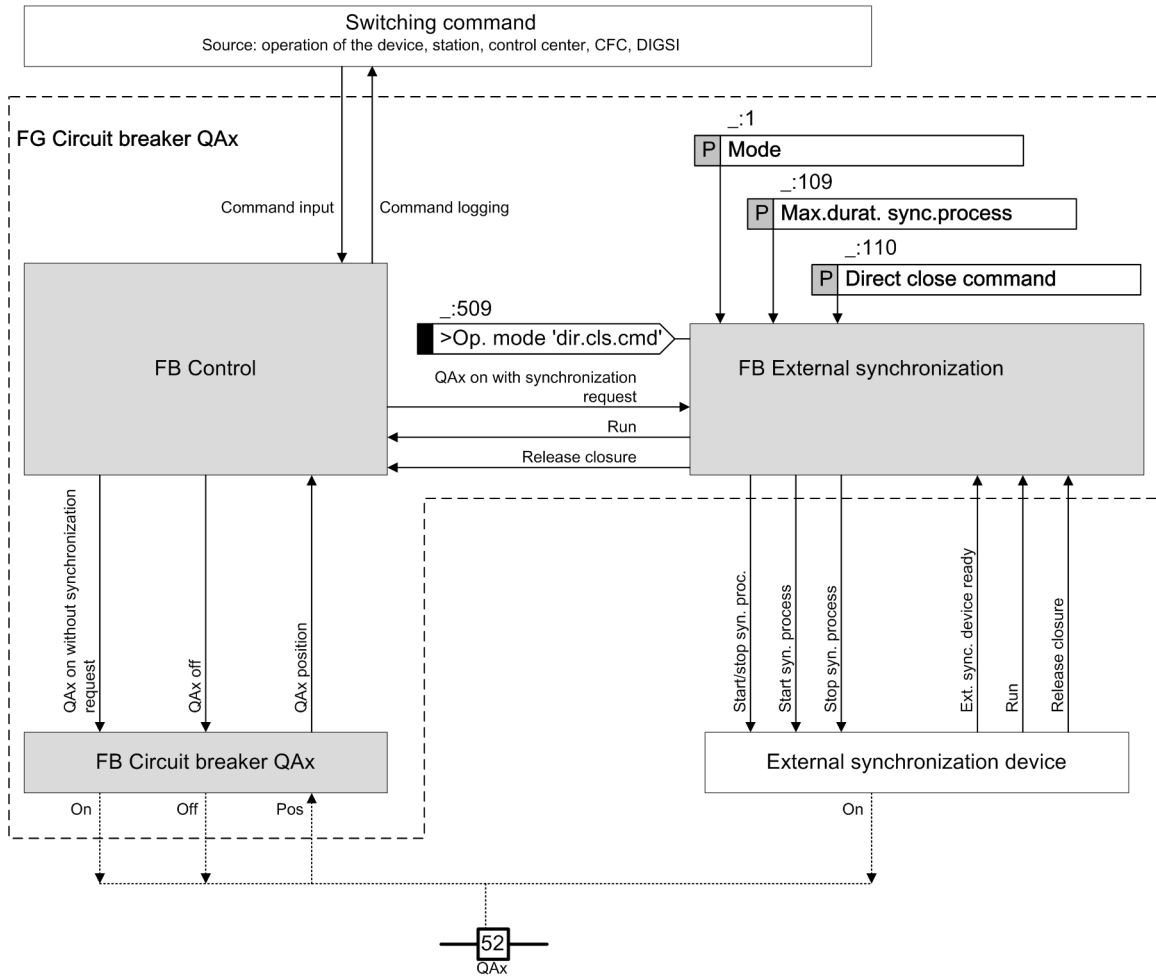

[dw_extsyn-02, 1, en_US]
 Figure 9-82 Interaction between Control and External Synchronization

Parameterization with DIGSI

In the DIGSI library, the function is visible inside the **Circuit-breaker** function group as the **External synchronization** function block. You can instantiate the function block in the **Circuit-breaker** function group and the **Circuit-breaker (control)** function group. You can instantiate only 1 **External synchronization** function block within these function groups at a time.

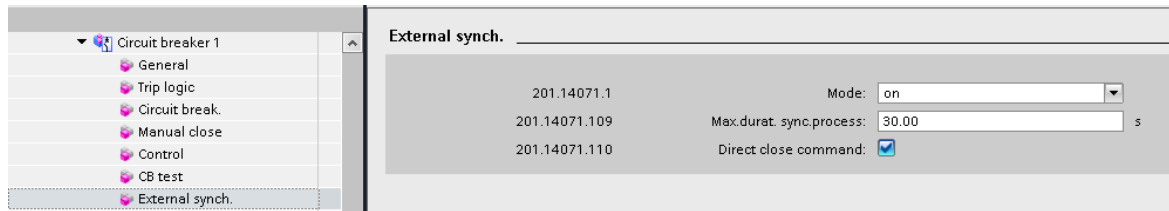

[scextsyn-041116-01, 1, en_US]
 Figure 9-83 Instantiating the **External Synchronization** Function Block in the **Circuit-Breaker** Function Group

It is not possible to jointly instantiate the **External synchronization** function block with the **25 synchronization** function in the same **Circuit-breaker** function group.

Notes for Optional Input Interconnections

You have the option of connecting the input signals *>Close cmd. released* and *>In progress*. If you omit these interconnections, observe the following instructions:

Input *>Close cmd. released*:

If you do not interconnect the input signal *>Close cmd. released* the execution of a circuit-breaker close command with synchronization requirement is confirmed directly (execution successful: OPR+), as soon as the output signal *Start syn. process* is set. In this case, the (`_:109`) **Max.durat. sync.process** setting has no meaning. If you use a control model with feedback monitoring, consider that the feedback monitoring will start immediately when the *Start syn. process* signal is tripped. The (`_:4201:103`) **Feedback monitoring time** setting must therefore be set higher than the maximum synchronization time of the external synchronization device plus the circuit-breaker make time. If *>Close cmd. released* is not routed, the output *Start/stop syn. proc.* is not set.

Input *>In progress*:

The interconnection of the input signal *>In progress* is intended to check whether the synchronization device has received the *Start syn. process* signal. If you do not interconnect this input signal and the external synchronization device rejects a start command, the negative acknowledgment of the circuit-breaker close command does not occur until the maximum synchronization time (parameter (`_:109`) **Max.durat. sync.process**) has expired.

Input *>Op. mode 'dir.cls.cmd'*:

In case of a failure of the external synchronization device, you can also close the circuit breaker directly without considering the synchronization conditions. To do this, activate the input signal *>Op. mode 'dir.cls.cmd'* or the parameter (`_:110`) **Direct close command**. The close command is then issued directly by the bay controller.

9.4.13.2 Application and Setting Notes (External Synchronization)

Parameter: **Mode**

- Default setting (`_:1`) **Mode** = *on*

With the **Mode** parameter, you switch the external synchronization function on or off. If you set the **Mode** parameter to *off*, a circuit-breaker close command with synchronization requirement is rejected.

Parameter: **Max.durat. sync.process**

- Default setting (`_:109`) **Max.durat. sync.process** = *30 s*

The **Max.durat. sync.process** parameter defines the maximum synchronization time. The time starts when the **External synchronization** function block sends a close command to the external synchronization device. The command must be executed within this time. If the close command is not executed within this time, the **External synchronization** function block sends a command to cancel closing to the external synchronization device.

Parameter: **Direct close command**

- Default setting (`_:110`) **Direct close command** = *no*

In case of a failure of the external synchronization device the **Direct close command** parameter is used to close the circuit breaker directly without considering the synchronization conditions. If the parameter is activated a close command with synchronization requirement will not be transmitted to the external synchronization device, but directly carried out by the bay controller.

9.4.13.3 Settings

Addr.	Parameter	C	Setting Options	Default Setting
General				
_:1	Syn./Asy.bal.#:Mode		<ul style="list-style-type: none"> • off • on • test 	off
_:101	Syn./Asy.bal.#:Min. operating limit Vmin		0.300 V to 340.000 V	90.000 V
_:102	Syn./Asy.bal.#:Max. operat. limit Vmax		0.300 V to 340.000 V	110.000 V
_:110	Syn./Asy.bal.#:Max.durat. sync.process		0.00 s to 3600.00 s; ∞	30.00 s
_:108	Syn./Asy.bal.#:Direct close command		<ul style="list-style-type: none"> • no • yes 	no
_:126	Syn./Asy.bal.#:Voltage adjustment		0.500 to 2.000	1.000
De-en.gized switch.				
_:105	Syn./Asy.bal.#:Close cmd. at V1< & V2>		<ul style="list-style-type: none"> • no • yes 	no
_:106	Syn./Asy.bal.#:Close cmd. at V1> & V2<		<ul style="list-style-type: none"> • no • yes 	no
_:107	Syn./Asy.bal.#:Close cmd. at V1< & V2<		<ul style="list-style-type: none"> • no • yes 	no
_:103	Syn./Asy.bal.#:V1, V2 without voltage		0.300 V to 170.000 V	5.000 V
_:104	Syn./Asy.bal.#:V1, V2 with voltage		0.300 V to 340.000 V	80.000 V
_:109	Syn./Asy.bal.#:Supervision time		0.00 s to 60.00 s	0.10 s
Asynchr. op.mode				
_:114	Syn./Asy.bal.#:Async. operating mode		<ul style="list-style-type: none"> • off • on 	off
_:113	Syn./Asy.bal.#:CB make time		0.010 s to 0.600 s	0.060 s
_:115	Syn./Asy.bal.#:Max. voltage diff. V2>V1		0.000 V to 170.000 V	2.000 V
_:116	Syn./Asy.bal.#:Max. voltage diff. V2<V1		0.000 V to 170.000 V	2.000 V
_:117	Syn./Asy.bal.#:Max. frequency diff. f2>f1		0.000 Hz to 4.000 Hz	0.100 Hz
_:118	Syn./Asy.bal.#:Max. frequency diff. f2<f1		0.000 Hz to 4.000 Hz	0.100 Hz
Synchr. op.mode				
_:119	Syn./Asy.bal.#:Sync. operating mode		<ul style="list-style-type: none"> • off • on 	off
_:120	Syn./Asy.bal.#:f-threshold ASYN<->SYN		0.010 Hz to 0.200 Hz	0.010 Hz

Addr.	Parameter	C	Setting Options	Default Setting
_:122	Syn./Asy.bal.#:Max. voltage diff. $V_2 > V_1$		0.000 V to 170.000 V	2.000 V
_:123	Syn./Asy.bal.#:Max. voltage diff. $V_2 < V_1$		0.000 V to 170.000 V	2.000 V
_:124	Syn./Asy.bal.#:Max. angle diff. $\alpha_2 > \alpha_1$		0 ° to 90 °	10 °
_:125	Syn./Asy.bal.#:Max. angle diff. $\alpha_2 < \alpha_1$		0 ° to 90 °	10 °
_:121	Syn./Asy.bal.#:Delay close command		0.00 s to 60.00 s	0.00 s
Balancing V				
_:131	Syn./Asy.bal.#:Balancing voltage V2		<ul style="list-style-type: none"> • off • transformer tap • balancing pulses 	off
_:132	Syn./Asy.bal.#:T V pulse min		0.01 s to 1.00 s	0.10 s
_:133	Syn./Asy.bal.#:T V pulse max		0.01 s to 60.00 s	1.00 s
_:134	Syn./Asy.bal.#:dV per second		0V/sto0 V/s	0 V/s
_:135	Syn./Asy.bal.#:T pause V		0.10 s to 60.00 s	5.00 s
_:136	Syn./Asy.bal.#:Smoothing		1 to 100	1
_:137	Syn./Asy.bal.#: (V/Vrated)/(f/frated)		1.00 to 1.40	1.10
Balancing f				
_:141	Syn./Asy.bal.#:Balancing frequency f2		<ul style="list-style-type: none"> • off • balancing pulses 	off
_:142	Syn./Asy.bal.#:T f pulse min		0.01 s to 1.00 s	0.10 s
_:143	Syn./Asy.bal.#:T f pulse max		0.01 s to 60.00 s	1.00 s
_:144	Syn./Asy.bal.#:df/dt of the controller		0.05 Hz/s to 5.00 Hz/s	1.00 Hz/s
_:145	Syn./Asy.bal.#:T pause f		0.10 s to 60.00 s	5.00 s
_:146	Syn./Asy.bal.#:Δf set point for balancing		-1.00 Hz to 1.00 Hz	0.04 Hz
_:147	Syn./Asy.bal.#:Smoothing		1 to 100	1
_:148	Syn./Asy.bal.#:T close without balancing		1.00 s to 100.00 s	5.00 s
_:149	Syn./Asy.bal.#:Release for the kick pulse		<ul style="list-style-type: none"> • off • on 	off
_:150	Syn./Asy.bal.#:Δf for the kick pulse		-1.00 Hz to 1.00 Hz	0.04 Hz
_:151	Syn./Asy.bal.#:Stabilization		0 to 1000	0

Addr.	Parameter	C	Setting Options	Default Setting
External sync.				
_:1	External sync.:Mode		<ul style="list-style-type: none"> off on test 	on
_:109	External sync.:Max.durat. sync.process		0.00 s to 3600.00 s; ∞	30.00 s
_:110	External sync.:Direct close command		<ul style="list-style-type: none"> 0 1 	false

9.4.13.4 Information List

No.	Information	Data Class (Type)	Type
External sync.			
_:506	External sync.:>Synch. device ready	SPS	I
_:508	External sync.:>In progress	SPS	I
_:507	External sync.:>Close cmd. released	SPS	I
_:509	External sync.:>Op. mode 'dir.cls.cmd'	SPS	I
_:52	External sync.:Behavior	ENS	O
_:54	External sync.:Health	ENS	O
_:55	External sync.:Start syn. process	SPS	O
_:56	External sync.:Stop syn. process	SPS	O
_:57	External sync.:Start/stop syn. proc.	SPS	O

9.4.14 Settings

Addr.	Parameter	C	Setting Options	Default Setting
General				
_:2311:127	General:Angle adjust. (transform.)		-179.0 ° to 180.0 °	0.0 °
General				
_:5071:1	Synchrocheck 1:Mode		<ul style="list-style-type: none"> off on test 	off
_:5071:113	Synchrocheck 1:Continuous supervision		<ul style="list-style-type: none"> false true 	false
_:5071:101	Synchrocheck 1:Min. operating limit Vmin		0.300 V to 340.000 V	90.000 V
_:5071:102	Synchrocheck 1:Max. operat. limit Vmax		0.300 V to 340.000 V	110.000 V
_:5071:110	Synchrocheck 1:Max.durat. sync.process		0.00 s to 3600.00 s; ∞	30.00 s
_:5071:108	Synchrocheck 1:Direct close command		<ul style="list-style-type: none"> no yes 	no
_:5071:126	Synchrocheck 1:Voltage adjustment		0.500 to 2.000	1.000

Addr.	Parameter	C	Setting Options	Default Setting
De-en.gized switch.				
_:5071:105	Synchrocheck 1:Close cmd. at V1< & V2>		<ul style="list-style-type: none"> • no • yes 	no
_:5071:106	Synchrocheck 1:Close cmd. at V1> & V2<		<ul style="list-style-type: none"> • no • yes 	no
_:5071:107	Synchrocheck 1:Close cmd. at V1< & V2<		<ul style="list-style-type: none"> • no • yes 	no
_:5071:103	Synchrocheck 1:V1, V2 without voltage		0.300 V to 170.000 V	5.000 V
_:5071:104	Synchrocheck 1:V1, V2 with voltage		0.300 V to 340.000 V	80.000 V
_:5071:109	Synchrocheck 1:Supervision time		0.00 s to 60.00 s	0.10 s
Synchr. conditions				
_:5071:115	Synchrocheck 1:Sync. operating mode		<ul style="list-style-type: none"> • off • on 	on
_:5071:122	Synchrocheck 1:Max. voltage diff. V2>V1		0.000 V to 170.000 V	5.000 V
_:5071:123	Synchrocheck 1:Max. voltage diff. V2<V1		0.000 V to 170.000 V	5.000 V
_:5071:117	Synchrocheck 1:Max. frequency diff. f2>f1		0.000 Hz to 2.000 Hz	0.100 Hz
_:5071:118	Synchrocheck 1:Max. frequency diff. f2<f1		0.000 Hz to 2.000 Hz	0.100 Hz
_:5071:124	Synchrocheck 1:Max. angle diff. α2>α1		0° to 90°	10°
_:5071:125	Synchrocheck 1:Max. angle diff. α2<α1		0° to 90°	10°
General				
_:5041:1	Sychr./Asychr.1:Mode		<ul style="list-style-type: none"> • off • on • test 	off
_:5041:127	Sychr./Asychr.1:Continuous supervision		<ul style="list-style-type: none"> • false • true 	false
_:5041:101	Sychr./Asychr.1:Min. operating limit Vmin		0.300 V to 340.000 V	90.000 V
_:5041:102	Sychr./Asychr.1:Max. operat. limit Vmax		0.300 V to 340.000 V	110.000 V
_:5041:110	Sychr./Asychr.1:Max.durat. sync.process		0.00 s to 3600.00 s; ∞	30.00 s
_:5041:108	Sychr./Asychr.1:Direct close command		<ul style="list-style-type: none"> • no • yes 	no
_:5041:126	Sychr./Asychr.1:Voltage adjustment		0.500 to 2.000	1.000
De-en.gized switch.				
_:5041:105	Sychr./Asychr.1:Close cmd. at V1< & V2>		<ul style="list-style-type: none"> • no • yes 	no

Addr.	Parameter	C	Setting Options	Default Setting
_.5041:106	Sychr./Asydr.1:Close cmd. at V1> & V2<		<ul style="list-style-type: none"> no yes 	no
_.5041:107	Sychr./Asydr.1:Close cmd. at V1< & V2<		<ul style="list-style-type: none"> no yes 	no
_.5041:103	Sychr./Asydr.1:V1, V2 without voltage		0.300 V to 170.000 V	5.000 V
_.5041:104	Sychr./Asydr.1:V1, V2 with voltage		0.300 V to 340.000 V	80.000 V
_.5041:109	Sychr./Asydr.1:Supervision time		0.00 s to 60.00 s	0.10 s
Asynchr. op.mode				
_.5041:114	Sychr./Asydr.1:Async. operating mode		<ul style="list-style-type: none"> off on 	on
_.5041:113	Sychr./Asydr.1:CB make time		0.010 s to 0.600 s	0.060 s
_.5041:115	Sychr./Asydr.1:Max. voltage diff. V2>V1		0.000 V to 170.000 V	5.000 V
_.5041:116	Sychr./Asydr.1:Max. voltage diff. V2<V1		0.000 V to 170.000 V	5.000 V
_.5041:117	Sychr./Asydr.1:Max. frequency diff. f2>f1		0.000 Hz to 4.000 Hz	0.100 Hz
_.5041:118	Sychr./Asydr.1:Max. frequency diff. f2<f1		0.000 Hz to 4.000 Hz	0.100 Hz
Synchr. op.mode				
_.5041:119	Sychr./Asydr.1:Sync. operating mode		<ul style="list-style-type: none"> off on 	on
_.5041:120	Sychr./Asydr.1:f-threshold ASYN<->SYN		0.010 Hz to 0.200 Hz	0.010 Hz
_.5041:122	Sychr./Asydr.1:Max. voltage diff. V2>V1		0.000 V to 170.000 V	5.000 V
_.5041:123	Sychr./Asydr.1:Max. voltage diff. V2<V1		0.000 V to 170.000 V	5.000 V
_.5041:124	Sychr./Asydr.1:Max. angle diff. $\alpha_2 > \alpha_1$		0 ° to 90 °	10 °
_.5041:125	Sychr./Asydr.1:Max. angle diff. $\alpha_2 < \alpha_1$		0 ° to 90 °	10 °
_.5041:121	Sychr./Asydr.1:Delay close command		0.00 s to 60.00 s	0.00 s

9.4.15 Information List

No.	Information	Data Class (Type)	Type
Measurements			
_.2311:303	General:Multiple selection	SPS	O
_.2311:304	General:Blocked no V selected	SPS	O
_.2311:329	General:V1	MV	O
_.2311:330	General:f1	MV	O
_.2311:331	General:V2	MV	O

No.	Information	Data Class (Type)	Type
_:2311:332	General:f2	MV	O
_:2311:300	General:dV	MV	O
_:2311:301	General:df	MV	O
_:2311:302	General:da	MV	O
_:2311:52	General:Behavior	ENS	O
_:2311:53	General:Health	ENS	O
Synchrocheck 1			
_:5071:81	Synchrocheck 1:>Block stage	SPS	I
_:5071:500	Synchrocheck 1:>Selection	SPS	I
_:5071:502	Synchrocheck 1:>Start/stop syn.proc.	SPS	I
_:5071:503	Synchrocheck 1:>Start syn. process	SPS	I
_:5071:504	Synchrocheck 1:>Stop syn. process	SPS	I
_:5071:506	Synchrocheck 1:>Op. mode 'V1<V2>'	SPS	I
_:5071:505	Synchrocheck 1:>Op. mode 'V1>V2<'	SPS	I
_:5071:507	Synchrocheck 1:>Op. mode 'V1<V2<'	SPS	I
_:5071:508	Synchrocheck 1:>Op. mode 'dir.cls.cmd'	SPS	I
_:5071:501	Synchrocheck 1:>Block close command	SPS	I
_:5071:51	Synchrocheck 1:Mode (controllable)	ENC	C
_:5071:54	Synchrocheck 1:Inactive	SPS	O
_:5071:52	Synchrocheck 1:Behavior	ENS	O
_:5071:53	Synchrocheck 1:Health	ENS	O
_:5071:328	Synchrocheck 1:In progress	SPS	O
_:5071:324	Synchrocheck 1:Release close cmd.	SPS	O
_:5071:305	Synchrocheck 1:All sync. conditio. OK	SPS	O
_:5071:325	Synchrocheck 1:Voltage difference OK	SPS	O
_:5071:326	Synchrocheck 1:Angle difference OK	SPS	O
_:5071:327	Synchrocheck 1:Frequency diff. OK	SPS	O
_:5071:307	Synchrocheck 1:Cond. V1<V2> fulfilled	SPS	O
_:5071:306	Synchrocheck 1:Cond. V1>V2< fulfilled	SPS	O
_:5071:308	Synchrocheck 1:Cond. V1<V2< fulfilled	SPS	O
_:5071:309	Synchrocheck 1:Frequency f1 > fmax	SPS	O
_:5071:310	Synchrocheck 1:Frequency f1 < fmin	SPS	O
_:5071:311	Synchrocheck 1:Frequency f2 > fmax	SPS	O
_:5071:312	Synchrocheck 1:Frequency f2 < fmin	SPS	O
_:5071:313	Synchrocheck 1:Voltage V1 > Vmax	SPS	O
_:5071:314	Synchrocheck 1:Voltage V1 < Vmin	SPS	O
_:5071:315	Synchrocheck 1:Voltage V2 > Vmax	SPS	O
_:5071:316	Synchrocheck 1:Voltage V2 < Vmin	SPS	O
_:5071:317	Synchrocheck 1:V dif.too large(V2>V1)	SPS	O
_:5071:318	Synchrocheck 1:V dif.too large(V2<V1)	SPS	O
_:5071:319	Synchrocheck 1:f dif.too large(f2>f1)	SPS	O
_:5071:320	Synchrocheck 1:f dif.too large(f2<f1)	SPS	O
_:5071:321	Synchrocheck 1:a dif.too large(a2>a1)	SPS	O
_:5071:322	Synchrocheck 1:a dif.too large(a2<a1)	SPS	O
_:5071:304	Synchrocheck 1:Max. time exceeded	SPS	O
_:5071:323	Synchrocheck 1:Setting error	SPS	O

No.	Information	Data Class (Type)	Type
Sychr. /Asycr. 1			
_.5041:81	Sychr./Asycr.1:>Block stage	SPS	I
_.5041:500	Sychr./Asycr.1:>Selection	SPS	I
_.5041:502	Sychr./Asycr.1:>Start/stop syn.proc.	SPS	I
_.5041:503	Sychr./Asycr.1:>Start syn. process	SPS	I
_.5041:504	Sychr./Asycr.1:>Stop syn. process	SPS	I
_.5041:506	Sychr./Asycr.1:>Op. mode 'V1<V2>'	SPS	I
_.5041:505	Sychr./Asycr.1:>Op. mode 'V1>V2<'	SPS	I
_.5041:507	Sychr./Asycr.1:>Op. mode 'V1<V2<'	SPS	I
_.5041:508	Sychr./Asycr.1:>Op. mode 'dir.cls.cmd'	SPS	I
_.5041:501	Sychr./Asycr.1:>Block close command	SPS	I
_.5041:51	Sychr./Asycr.1:Mode (controllable)	ENC	C
_.5041:54	Sychr./Asycr.1:Inactive	SPS	O
_.5041:52	Sychr./Asycr.1:Behavior	ENS	O
_.5041:53	Sychr./Asycr.1:Health	ENS	O
_.5041:328	Sychr./Asycr.1:In progress	SPS	O
_.5041:324	Sychr./Asycr.1:Release close cmd.	SPS	O
_.5041:305	Sychr./Asycr.1:All sync. conditio. OK	SPS	O
_.5041:303	Sychr./Asycr.1:State f-synchronous	SPS	O
_.5041:325	Sychr./Asycr.1:Voltage difference OK	SPS	O
_.5041:326	Sychr./Asycr.1:Angle difference OK	SPS	O
_.5041:327	Sychr./Asycr.1:Frequency diff. OK	SPS	O
_.5041:307	Sychr./Asycr.1:Cond. V1<V2> fulfilled	SPS	O
_.5041:306	Sychr./Asycr.1:Cond. V1>V2< fulfilled	SPS	O
_.5041:308	Sychr./Asycr.1:Cond. V1<V2< fulfilled	SPS	O
_.5041:309	Sychr./Asycr.1:Frequency f1 > fmax	SPS	O
_.5041:310	Sychr./Asycr.1:Frequency f1 < fmin	SPS	O
_.5041:311	Sychr./Asycr.1:Frequency f2 > fmax	SPS	O
_.5041:312	Sychr./Asycr.1:Frequency f2 < fmin	SPS	O
_.5041:313	Sychr./Asycr.1:Voltage V1 > Vmax	SPS	O
_.5041:314	Sychr./Asycr.1:Voltage V1 < Vmin	SPS	O
_.5041:315	Sychr./Asycr.1:Voltage V2 > Vmax	SPS	O
_.5041:316	Sychr./Asycr.1:Voltage V2 < Vmin	SPS	O
_.5041:317	Sychr./Asycr.1:V dif.too large(V2>V1)	SPS	O
_.5041:318	Sychr./Asycr.1:V dif.too large(V2<V1)	SPS	O
_.5041:319	Sychr./Asycr.1:f dif.too large(f2>f1)	SPS	O
_.5041:320	Sychr./Asycr.1:f dif.too large(f2<f1)	SPS	O
_.5041:321	Sychr./Asycr.1:α dif.too large(α2>α1)	SPS	O
_.5041:322	Sychr./Asycr.1:α dif.too large(α2<α1)	SPS	O
_.5041:304	Sychr./Asycr.1:Max. time exceeded	SPS	O
_.5041:323	Sychr./Asycr.1:Setting error	SPS	O

9.5 Switching Sequences

9.5.1 Overview of Functions

Switching sequences may be running inside the device that switch the switchgear automatically in a prespecified sequence.

A switching sequence consists of a special function block **Switching sequence** (Swi. seq.) from the DIGSI 5 Library and the project-specific list of the switching commands that are generated in the CFC.

9.5.2 Function Description

The function block **Switching sequence** is located in folder **User-defined functions** in the DIGSI 5 Library.

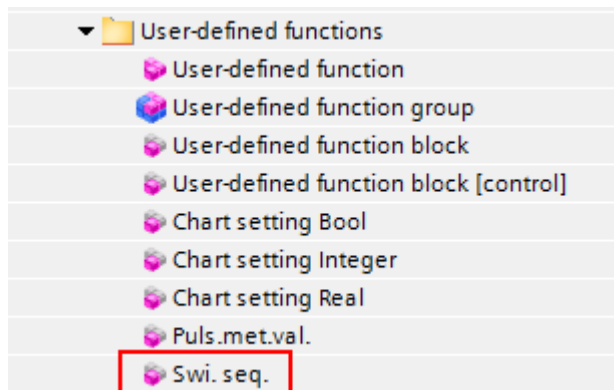

[sc_udeffb, 1, en_US]

Figure 9-84 Function Block **Switching Sequence** in the Library

These function blocks can be used in the information matrix on the highest level (level of the function groups) or in a user-defined function group.

One **Switching sequence** function block is used per switching sequence. The function block is the interface for controlling and monitoring the condition of the CFC switching sequence. The task of the function block is to verify the relative conditions for control commands, for example, switching authority, interlocking conditions, etc. You can connect the signals of the function block with the CFC chart. They start and stop the switching sequence and provide data about the status of the switching sequence (see [Figure 9-85](#)). The CFC chart is used to activate the switching device that must be switched. The CFC blocks define, among other things, the switching devices that must be switched.

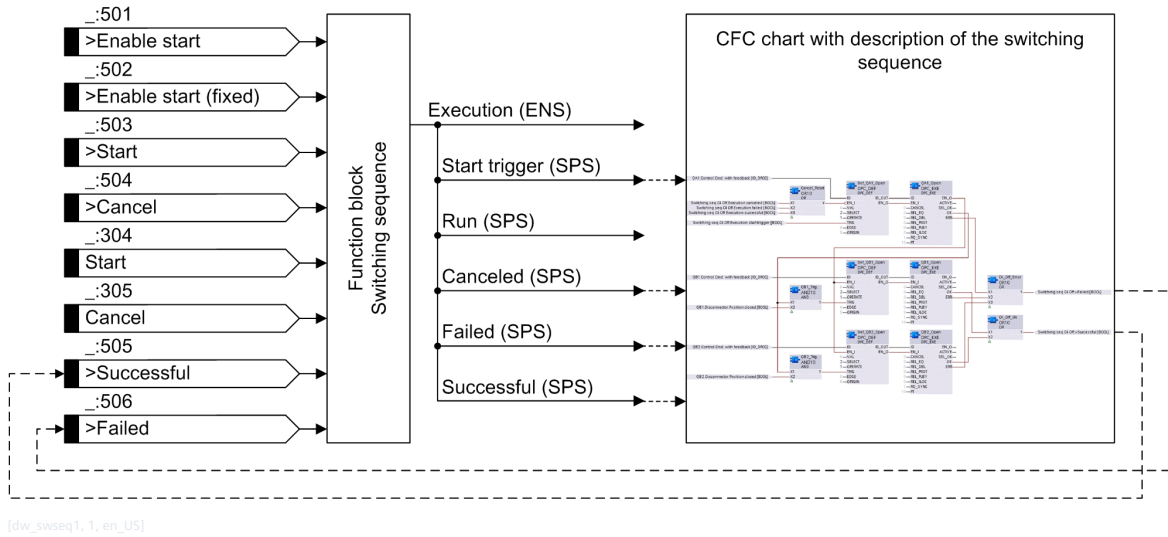

[dsw_swseq1_1_en_US]
 Figure 9-85 Switching Sequence Function Block

Starting and Canceling a Switching Sequence

One of the following methods can be used to start a switching sequence:

- On-site operation: menu or display page
- Input *>Start* during rising edge, for example, via binary input
- Controllable *Start* for the start via a communication protocol, for example, IEC 61850
- Input *>Start* via a function key
- Controllable *Start* via a function key

One of the following methods can be used to cancel a switching sequence:

- On-site operation: menu or display page
- Input *>Cancel* during rising edge, for example, via binary input
- Controllable *Cancel* for the cancelation via a communication protocol, for example, IEC 61850
- Input *>Cancel* via a function key
- Controllable *Cancel* via a function key

On-Site Operation

If at least one **Switching sequence** function block is used in the device, a new **Switching sequences** entry is shown in the first line of the **Control** menu. If this menu item is selected, an overview of all switching sequences and the current status will be displayed (see [Figure 9-86](#), example with 2 switching sequences). You can start or cancel the switching sequences from this menu.

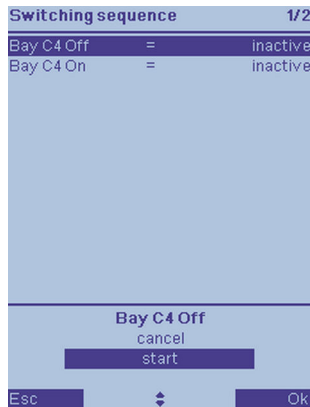
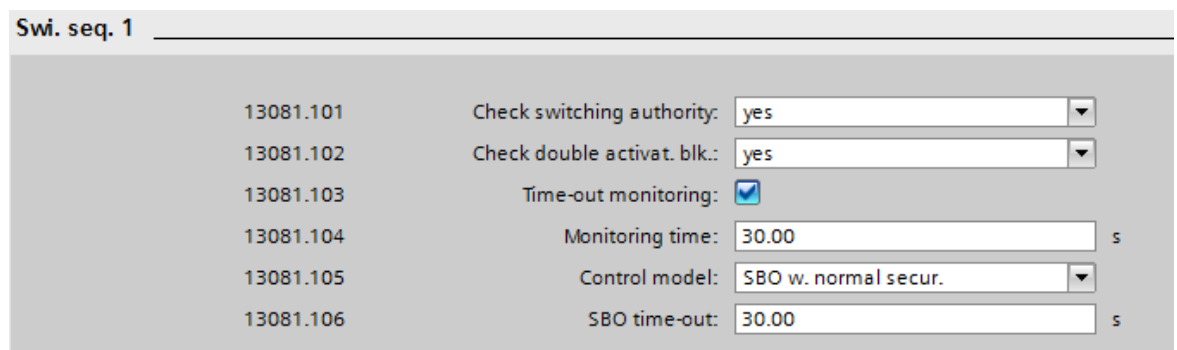

Figure 9-86
Overview of the Switching Sequences on the Device Display

9.5.3 Application and Setting Notes

The function block offers similar settings to the **Control** function block of a circuit breaker or disconnecter (see chapter [9.2.1 General Overview](#)).



[sc_ccs4pa, 1, en_US]
Figure 9-87 Settings of the **Switching Sequence** Function Block

Parameter: Check switching authority

- Default setting (`_:101`) **Check switching authority** = **yes**

With the **Check switching authority** parameter, you can determine whether the switching authority should be checked before the execution of the switching sequence.

Parameter: Check double activat. blk.

- Default setting (`_:102`) **Check double activat. blk.** = **yes**

With the **Check double activat. blk.** parameter, you can determine whether the double activation of switching devices should be checked. The setting value **yes** indicates that a switching sequence will be started only if no switching commands for a circuit breaker and disconnecter are active, provided that double-activation blocking was activated for those switching devices.

Parameter: Time-out monitoring

With the **Time-out monitoring** parameter, you can determine whether the feedback from the process should be evaluated. The feedback is gathered via the inputs *>Successful* and *>Failed*.

Parameter: Monitoring time

- Default setting (`_:104`) **Monitoring time** = **30.00 s**

With the **Monitoring time** parameter, you can determine the duration of the monitoring time.

Parameter: Control model

- Default setting (`_:105`) **Control model** = *SBO w. normal secur.*

With the **Control model** parameter, you select between *direct w. normal secur.* or *SBO w. normal secur.* to start the switching sequence.

It is not possible to set a control model for cancelation of the switching sequence. The control model *direct w. normal secur.* is always used to cancel the function.

Information

The **Switching sequence** function block provides the following data:

▼ Swi. seq. 1	13081	
▶ >Enable start	13081.501	SPS
▶ >Enable start (fixed)	13081.502	SPS
▶ >Start	13081.503	SPS
▶ >Cancel	13081.504	SPS
▶ >Successful	13081.505	SPS
▶ >Failed	13081.506	SPS
▶ Health	13081.53	ENS
▼ Execution	13081.302	ENS
▶ start trigger		SPS
▶ running		SPS
▶ canceled		SPS
▶ failed		SPS
▶ successful		SPS
▶ Start	13081.304	SPC
▶ Cancel	13081.305	SPC
▶ Switching auth. station	13081.303	SPC

[sc_info1, 1, en_US]

Figure 9-88 Data Provided by the **Switching Sequence** Function Block

In the **Switching sequence** function block, the interlocking is analog to the **Interlocking** function block and it is possible to use it in the switching sequence:

- *>Enable start*: Connection to interlocking conditions (CFC) for the start of the entire switching sequence. Not in effect in the **non-interlocked** switching mode.
- *>Enable start (fixed)*: Non-revocable interlocking conditions for the start of the entire switching sequence. In effect regardless of the switching mode.

If the time-out monitoring is activated (parameter **Time-out monitoring**), the process feedback must take place via the inputs *>Successful* and *>Failed*. If the last switching command of the switching sequence was executed successfully, the input *>Successful* usually is set. To do this, connect the feedback of the last switching command from the CFC with this input of the function block during the device parameterization.

If a switching command fails, this feedback can be captured by the input *>Failed*. The active switching sequence will be ended immediately and does not have to wait for a time-out.

The indication *Execution* signals the current state of the switching sequence. The events *running*, *canceled*, *failed*, and *successful* are generated only while the time-out monitoring is activated. The event *Start Trigger* is used to start the switching sequence in the CFC chart.

Example for a Switching Sequence with CFC

The following figure shows a single-line diagram for a substation with 4 bays: Busbar grounding, infeed, bus-coupler circuit-breaker, and feeder bay.

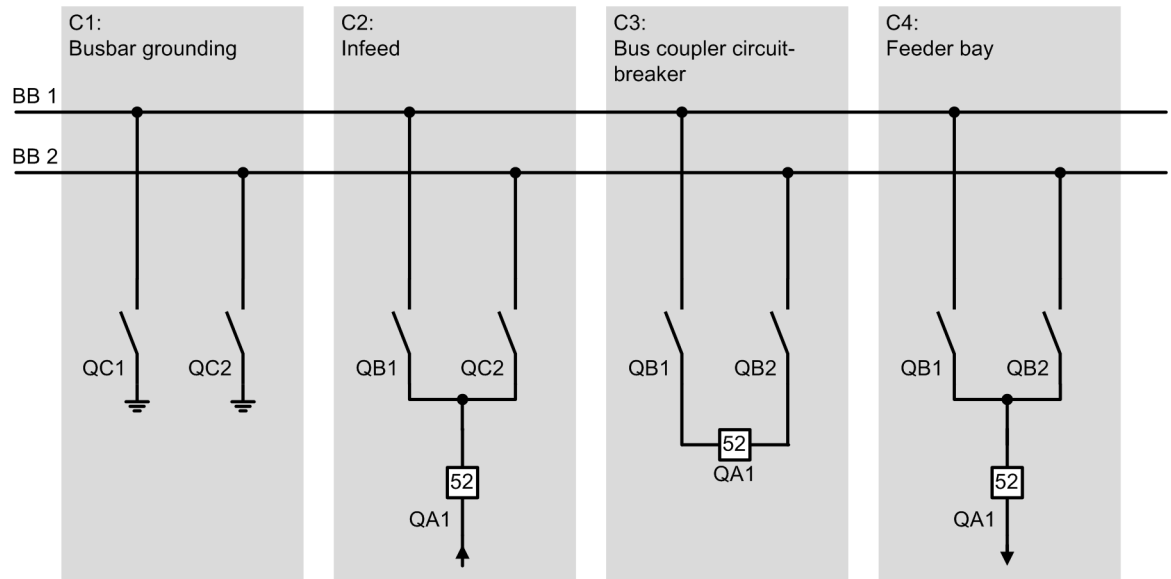

[dw_bspunt, 1, en_US]

Figure 9-89 Example of a Substation

The switching sequence **C4 Off** (Figure 9-90) should switch off feeder bay C4. The circuit breaker is opened; followed by opening of one of the 2 busbar disconnectors.

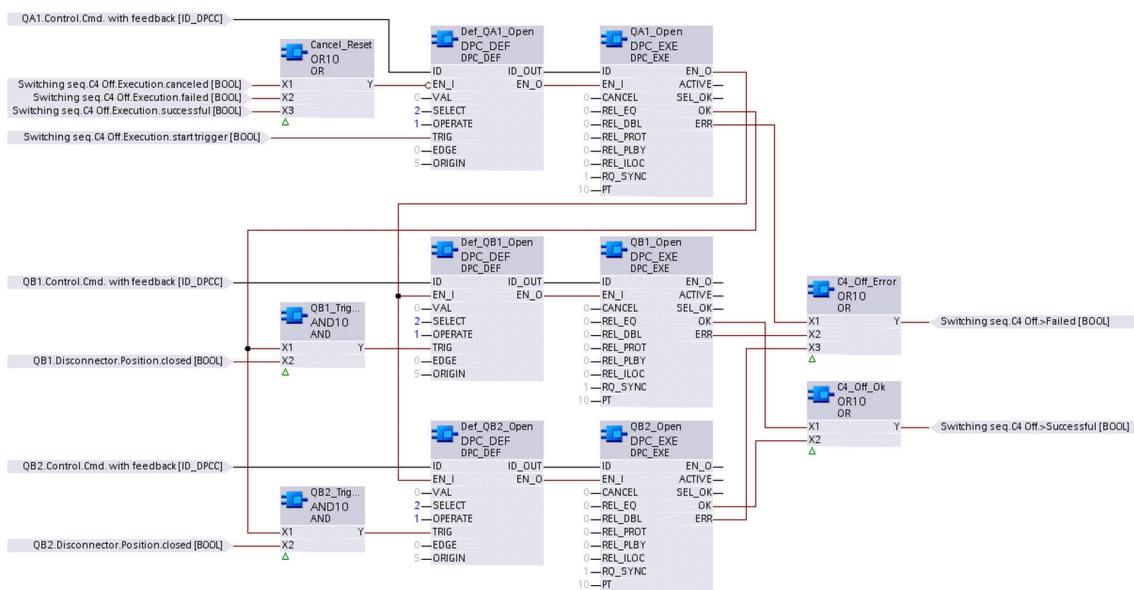

[sc_ssc4as, 1, en_US]

Figure 9-90 CFC Switching Sequence C4 Off

Command Execution

As described in section *Starting and Canceling a Switching Sequence, Page 1268*, the display page or the **Control** menu can be used to start the switching sequence. The *Start Trigger* signal for indication *Execution* is used to recognize the start and initiates the switching sequence by pickup of **TRIG** in the DPC-DEF building block of circuit breaker QA1. Building blocks DPC-DEF and DPC-EXE are always used in pairs. The DEF building block controls the type and nature of the command

- **VAL** = Switching direction (0 = Off, 1 = On)
- **SELECT** = Select switching device (2 = Select with a value suitable for the preset control model *SBO w. enh. security*)
- **OPERATE** = Switch switching device (1 = Switching device is switched on or off)

Using the connected DPC-EXE building block, the command checks can be deactivated (**REL_...**). In the application example, all inputs are set to 0 and therefore, all checks are activated.

After the open command of circuit breaker QA1 is acknowledged via the auxiliary contacts, the **OK** output of the CFC block DPC_EXE becomes active and triggers the next switching object. With the input **PT** the signal for the **OK** output is time-delayed (in the example by 10 ms) and creates a dead time between individual switching commands and the switching sequence. This dead time is important for the updating of the interlocking conditions.

If QB1 is closed, QB1 will be opened. If QB2 is closed, QB2 will be opened. In order to implement this logic, the **OK** output signal of QA1 is linked with the respective positions of circuit breakers QB1 and QB2 via the logical AND function. This signal serves as a trigger for the trip command of QB1 or QB2.

Because in this example the time-out monitoring is activated, the feedback about the successful or unsuccessful execution of the switching sequence must be parameterized. The **Switching sequence** function block provides the inputs *>Successful* and *>Failed*. In order to acknowledge the entire switching sequence positively, the OR operation of the **OK** outputs for the disconnectors QB1 and QB2 is sufficient. The feedback of all failed executions takes place via the OR operation of all **ERR** outputs of the switching devices. The benefit of such assessment is the fact that, in case of a failure, waiting for the time-out is not necessary, but the active switching sequence can be ended immediately.

In this example, the use of the **EN_I** input of building block DPC-DEF fulfills 2 tasks:

- Cancellation of the entire switching sequence
- Resetting of the outputs **OK** and **ERR** on building block DPC-EXE

By linking all **EN_I** inputs and **EN_O** outputs of building blocks DPC-DEF and DPC-EXE, the execution of the switching sequence can be controlled centrally since the value is transmitted between the building blocks. Only if input **EN_I** on the DPC-EXE is set to 1, a switching command is issued. If the input drops back to 0 while a command is being processed, this command will be canceled. With this behavior, cancellation of an entire switching sequence can be achieved. As recognition of a cancellation, the *cancelled* signal of the indication *Execution* is used in the CFC chart and connected with the input **EN_I** of the first switching device, in this example, with the DPC-DEF building block of circuit breaker QA1.

Since the **OK** and **ERR** outputs of the DPC-EXE building block maintain their value until execution of the next command, it is necessary to reset the continuous output after each execution of the switching sequence for correct execution of the entire CFC switching sequence multiple times. In this case, the use of the **EN_I** input is also helpful. In the input drops back to 0, the **OK** and **ERR** outputs are also reset to 0. The triggers for ending the switching sequence are the events *failed* and *successful*. For this reason, in the above example, the signals *failed* and *successful* of the indication *Execution* were connected with **EN_I** of the DPC-DEF building block.

9.5.4 Settings

Addr.	Parameter	C	Setting Options	Default Setting
<i>Swi. seq. #</i>				
_:101	Swi. seq. #:Check switching authority		<ul style="list-style-type: none"> • no • yes • advanced 	yes
_:102	Swi. seq. #:Check double activat. blk.		<ul style="list-style-type: none"> • no • yes 	yes
_:103	Swi. seq. #:Time-out monitoring		<ul style="list-style-type: none"> • 0 • 1 	true
_:104	Swi. seq. #:Monitoring time		0.02 s to 3600.00 s	30.00 s
_:105	Swi. seq. #:Control model		<ul style="list-style-type: none"> • direct w. normal secur. • SBO w. normal secur. 	SBO w. normal secur.
_:106	Swi. seq. #:SBO time-out		0.01 s to 1800.00 s	30.00 s
<i>Switching authority</i>				
_:151	Swi. seq. #:Swi.dev. related sw.auth.		<ul style="list-style-type: none"> • 0 • 1 	false
_:152	Swi. seq. #:Specific sw. authorities		<ul style="list-style-type: none"> • 0 • 1 	true
_:115	Swi. seq. #:Specific sw.auth. valid for		<ul style="list-style-type: none"> • station • station/remote • remote 	station/remote
_:153	Swi. seq. #:Num. of specific sw.auth.		2 to 5	2
_:154	Swi. seq. #:Multiple specific sw.auth.		<ul style="list-style-type: none"> • 0 • 1 	false

9.5.5 Information List

No.	Information	Data Class (Type)	Type
<i>Swi. seq. #</i>			
_:501	Swi. seq. #:>Enable start	SPS	I
_:502	Swi. seq. #:>Enable start (fixed)	SPS	I
_:503	Swi. seq. #:>Start	SPS	I
_:504	Swi. seq. #:>Cancel	SPS	I
_:505	Swi. seq. #:>Successful	SPS	I
_:506	Swi. seq. #:>Failed	SPS	I
_:53	Swi. seq. #:Health	ENS	O
_:302	Swi. seq. #:Execution	ENS	O
_:304	Swi. seq. #:Start	SPC	C
_:305	Swi. seq. #:Cancel	SPC	C

9.6 User-Defined Function Block [Control]

9.6.1 Overview of Functions

The **User-defined function block [control]** allows the switching-authority check of a control command, the check of whether the position has been reached, a double-activation blocking, and the definition of interlocking conditions for user-defined controllables.

9.6.2 Function Description

The **User-defined function block [control]** is located in the folder **User-defined functions** in the DIGSI 5 Library.

You can instantiate the user-defined function blocks on the top level (in parallel to other function groups) as well as within function groups and functions.

The task of the function block is to check the switching authority and the interlocking conditions for the user-defined control commands instantiated within it. For these control commands, the function block checks whether the required switch position is equal to the current switch position (actual/set point comparison). If you activate the double-activation blocking, commands from switching objects and user-defined control signals will be rejected as long as a command is still being performed for one of the other switching objects for which double-activation blocking has also been set.

With the binary release signals, you can determine a switchgear interlocking protection for all the user-defined control signals instantiated in the function block. Unlike the switching devices (circuit breaker, disconnecter), there is only one release input here, since there is only one switching direction for the signal types INC and APC. The signal types DPC, SPC, and BSC have 2 switching directions, but still only one release input. This release input can be operated based on the result of a logic created in the CFC, or can be directly connected to a binary input or a variable. If the input **>Enable** is activated, the switching command can be performed. If it is not activated, the switching command is rejected, with the reason *Interlocking violation*.

This applies in a similar way to the input **>Enable (fixed)**, although with this input, the interlocking cannot be revoked by key switch S1 or an *unLocked* switching authority.

The following table shows the reaction of the function to the assignment of its inputs.

Input >Enable	Input >Enable (fixed)	Effect on control command
1	0	Rejected
0	1	Successful if device mode = <i>unLocked</i> Rejected if device mode = <i>Locked</i>
1	1	Successful
0	0	Rejected



NOTE

The default setting for the state of the inputs is **1**, that is, the switching commands are not locked.

You can instantiate every user-defined signal (for example, SPS, DPC, INC) in the function block and route the corresponding indications (see following figure).

Information			Source					
			Binary input		Basismodul			
Signals	Number	Type	1.1	1.2	1.3	1.4	2.1	2.2
(All)	(All)
U-def.FB ctl.1	851.15931				*	*		
>Enable	851.15931.501	SPS						
>Enable (fixed)	851.15931.502	SPS						
Mode (controllable)	851.15931.51	ENC						
Behavior	851.15931.52	ENS						
Health	851.15931.53	ENS						
Switching auth. station	851.15931.302	SPC						
BSC		BSC						
APC		APC						
SPC		SPC			H			
DPC		DPC				CH		
INC		INC						

[sc_user_01, 1, en_US]

Figure 9-91 Information Routing with Inserted User-Defined Function Block [Control]: Process Indications and Some Single-Point Indications

9.6.3 Application and Setting Notes

The function block contains the parameters (`_:104`) **Check switching authority**, (`_:105`) **Check if pos. is reached**, (`_:106`) **Check double activat. blk.**, and (`_:150`) **Check swi.auth. for Mode**. The parameter settings **Check switching authority** and **Check if pos. is reached** affect all controllables instantiated in the function block. Other signal types are not affected by these parameters and objects.

On the other hand, the parameter setting **Check swi.auth. for Mode** affects the controllable **Mode (controllable)** of the function block.

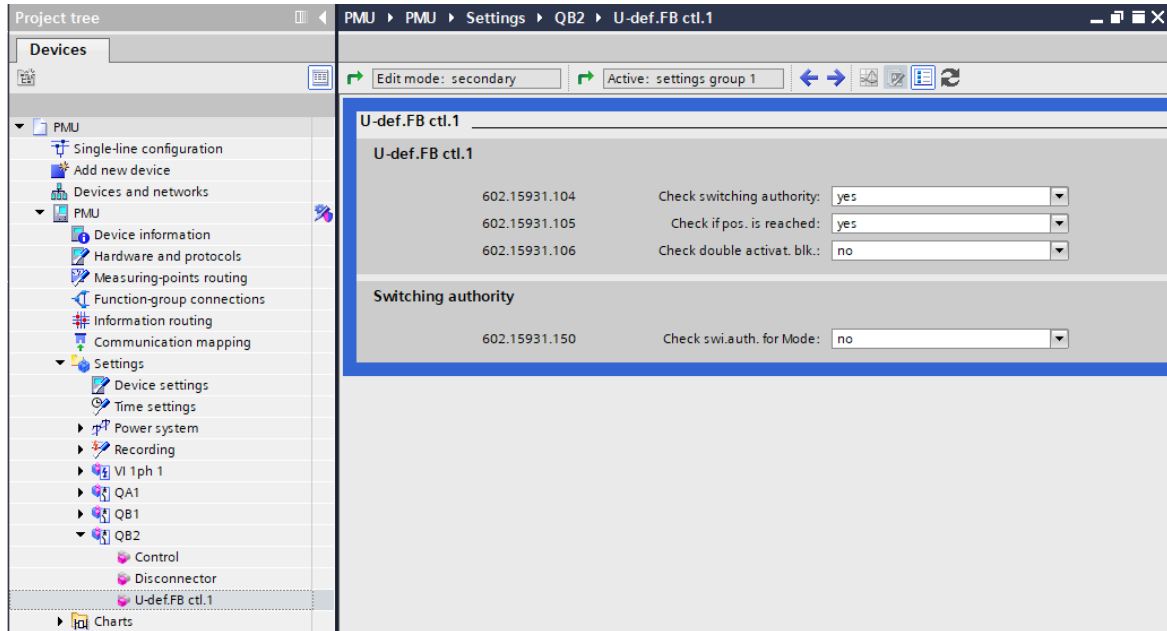

[sc_user_02_1_en_US]

Figure 9-92 Parameterization Options of the User-Defined Function Block [Control]

Parameter: Check switching authority

- Default setting (_:104) **Check switching authority = yes**

With the **Check switching authority** parameter, you determine whether the command source of switching commands must be checked (see chapter [9.3.1 Command Checks and Switchgear Interlocking Protection](#)).

Parameter: Check if pos. is reached

- Default setting (_:105) **Check if pos. is reached = yes**

With the **Check if pos. is reached** parameter, you check at a switching command whether the switching direction equals the current position.

Parameter: Check double activat. blk.

- Default setting (_:106) **Check double activat. blk. = no**

With the **Check double activat. blk.** parameter, you check whether commands from switching objects and user-defined control signals should be rejected, as long as a command is still being executed for one of the other objects.

Parameter: Check swi.auth. for Mode

- Default setting (_:150) **Check swi.auth. for Mode = no**

With the **Check swi.auth. for Mode** parameter, you specify whether the switching authority for the command source must be checked when switching the controllable **Mode (controllable)** to the mode **On**, **Off**, or **Test**. If you set the parameter **Check swi.auth. for Mode** to **yes**, the switching command is only executed with the appropriate switching authority (see chapter [9.3.1 Command Checks and Switchgear Interlocking Protection](#)).

9.6.4 Settings

Addr.	Parameter	C	Setting Options	Default Setting
<i>U-def.FB ctl.#</i>				
_:104	U-def.FB ctl.#:Check switching authority		<ul style="list-style-type: none"> • no • yes • advanced 	yes
_:105	U-def.FB ctl.#:Check if pos. is reached		<ul style="list-style-type: none"> • no • yes 	yes
_:106	U-def.FB ctl.#:Check double activat. blk.		<ul style="list-style-type: none"> • no • yes 	no
<i>Switching authority</i>				
_:150	U-def.FB ctl.#:Check swi.auth. for Mode		<ul style="list-style-type: none"> • no • yes 	no
_:151	U-def.FB ctl.#:Swi.dev. related sw.auth.		<ul style="list-style-type: none"> • 0 • 1 	false
_:152	U-def.FB ctl.#:Specific sw. authorities		<ul style="list-style-type: none"> • 0 • 1 	true
_:115	U-def.FB ctl.#:Specific sw.auth. valid for		<ul style="list-style-type: none"> • station • station/remote • remote 	station/remote
_:153	U-def.FB ctl.#:Num. of specific sw.auth.		2 to 5	2
_:155	U-def.FB ctl.#:Ident. sw.auth. 1		Freely editable text	
_:156	U-def.FB ctl.#:Ident. sw.auth. 2		Freely editable text	
_:157	U-def.FB ctl.#:Ident. sw.auth. 3		Freely editable text	
_:158	U-def.FB ctl.#:Ident. sw.auth. 4		Freely editable text	
_:159	U-def.FB ctl.#:Ident. sw.auth. 5		Freely editable text	
_:154	U-def.FB ctl.#:Multiple specific sw.auth.		<ul style="list-style-type: none"> • 0 • 1 	false

9.6.5 Information List

No.	Information	Data Class (Type)	Type
<i>U-def.FB ctl.#</i>			
_:501	U-def.FB ctl.#:>Enable	SPS	I
_:502	U-def.FB ctl.#:>Enable (fixed)	SPS	I
_:503	U-def.FB ctl.#:>Sw. authority local	SPS	I
_:504	U-def.FB ctl.#:>Sw. authority remote	SPS	I
_:505	U-def.FB ctl.#:>Sw. mode interlocked	SPS	I
_:506	U-def.FB ctl.#:>Sw. mode non-interl.	SPS	I
_:51	U-def.FB ctl.#:Mode (controllable)	ENC	C

No.	Information	Data Class (Type)	Type
_.52	U-def.FB ctl. #:Behavior	ENS	O
_.53	U-def.FB ctl. #:Health	ENS	O
_.302	U-def.FB ctl. #:Switching auth. station	SPC	C
_.308	U-def.FB ctl. #:Enable sw. auth. 1	SPC	C
_.309	U-def.FB ctl. #:Enable sw. auth. 2	SPC	C
_.310	U-def.FB ctl. #:Enable sw. auth. 3	SPC	C
_.311	U-def.FB ctl. #:Enable sw. auth. 4	SPC	C
_.312	U-def.FB ctl. #:Enable sw. auth. 5	SPC	C
_.313	U-def.FB ctl. #:Switching authority	ENS	O
_.314	U-def.FB ctl. #:Switching mode	ENS	O

9.7 CFC-Chart Settings

9.7.1 Overview of Functions

If you want to process a parameter in a CFC chart and this parameter is to be changeable during runtime using DIGSI or HMI, you can use the function blocks **CFC chart of Boolean parameters**, the **CFC chart of integer parameters** and the **CFC chart of floating-point parameters**. Instantiate the appropriate function block depending on the parameter value needed (logical, integer, or floating point). In this way, the current value of the parameter can then be used in the CFC chart at runtime.

9.7.2 Function Description

You can find the CFC-chart parameters **Chrt sett.Bool**, **Chart setting Int**, and **Chrt sett.real** in the DIGSI library in the **User-defined functions** folder. Drag and drop the desired function block into a function group or a function. Set the appropriate parameter value of the function block in DIGSI using the parameter editor or via HMI under the **Settings** menu item. You can then use the parameter as an input signal in CFC charts.

With **Exp. options**, you define the range and the unit of the value. This prevents users from entering incorrect setting values.



NOTE

The user-defined function groups and the user-defined functions can be used to group the CFC-chart parameters. You can rename for the function block and change the parameter value in the DIGSI Information routing matrix to suit your specific application.

Signals	Number	Type
(All)	(All)	...
▶ QB6	603	
▶ E:ETH-BA-2EL	102	
▼ User-defFG1	851	
▶ Reset LED Group	851.13381	
▼ Chart setting Bool	851.15901	
◆ Setting value	851.15901....	SPS
▼ Chart setting Int	851.15871	
◆ Setting value	851.15871....	INS
▼ Chart setting Real	851.15841	
◆ Setting value	851.15841....	MV

[sc_cfc_param, 1, en_US]

Figure 9-93 CFC-Chart Parameters within Information Routing

9.7.3 Application and Setting Notes

Parameter: Chrt sett.Bool

- Default setting **Chrt sett.Bool = False**

You can use the parameter **Chrt sett.Bool** in a CFC chart as an input signal with a Boolean value. This input value can then be changed during the runtime of the CFC chart.

Parameter: Chart setting Int

- Default setting **Chart setting Int = 10**

You can use the parameter **Chart setting Int** in a CFC chart as an input signal with an integer value. This input value can then be changed during the runtime of the CFC chart.

Parameter: Chrt sett.real

- Default setting **Chrt sett.real = 100.000**

You can use the parameter **Chrt sett.real** in a CFC chart as an input signal with a floating-point number. This input value can then be changed during the runtime of the CFC chart.

9.7.4 Settings

Addr.	Parameter	C	Setting Options	Default Setting
Chrt sett.Bool				
_:105	Chrt sett.Bool:Value		<ul style="list-style-type: none"> • 0 • 1 	false

Addr.	Parameter	C	Setting Options	Default Setting
Chart setting Int				
_:105	Chart setting Int:Value		-2147483648 to 2147483647	10

Addr.	Parameter	C	Setting Options	Default Setting
Chrt sett.real				
_:105	Chrt sett.real:Value		-10000000000.000 % to 10000000000.000 %	100.000 %

9.7.5 Information List

No.	Information	Data Class (Type)	Type
Chrt sett.Bool			
_:305	Chrt sett.Bool:Setting value	SPS	O

No.	Information	Data Class (Type)	Type
Chart setting Int			
_:305	Chart setting Int:Setting value	INS	O

No.	Information	Data Class (Type)	Type
Chrt sett.real			
_:305	Chrt sett.real:Setting value	MV	O

9.8 Tap Changers

9.8.1 Function Description

With the device control function, you can change a transformer tap by moving it higher or lower and monitor the proper execution of the adjusting commands.

The function has built-in comprehensive options for measuring the tap changer position as well as supervision and monitoring functions. The supervision and monitoring functions are used to check the voltage and supply information about the tap position for adaptive matching of the transformer differential protection

The following options are provided for control:

- Direct user commands via the device keypad or routed binary inputs
- User-defined conditions via the CFC

If the tap changer reaches the end positions, the control function issues the (*_:301*) *End higher pos. reached* or (*_:302*) *End lower pos. reached* indication.

The transformer tap controller is controlled by the function group **Tap changer**, which you can select from the DIGSI library (group **Switching devices**).

Tap changer 1	161		*	*	*	*
Tap changer	161.5461		*	*	*	*
>Acquisition blocking	161.5461.500	SPS				
>Enable	161.5461.501	SPS				
>Reset AcqBlk&Subst	161.5461.504	SPS				
Health	161.5461.53	ENS				
End higher pos.reached	161.5461.301	SPS				
End lower pos.reached	161.5461.302	SPS				
Position	161.5461.308	BSC	X	X	X	X
acquisition blk. active		SPS				
manual update active		SPS				
Higher command	161.5461.305	SPS				
Lower command	161.5461.306	SPS				
Command active	161.5461.307	SPS				
Motor sup. time expired	161.5461.309	SPS				
Trigger motor prot. sw.	161.5461.310	SPS				
Position failure	161.5461.311	SPS				
Op.ct.	161.5461.312	INS				
Reset failure	161.5461.319	SPC				
Switching auth. station	161.5461.317	SPC				

[sc_tssdig_1_en_US]

Figure 9-94 Tap Changer Functionality in the DIGSI Information Matrix

The central element is the Controllable **Position** of type BSC (Binary Controlled Step Position Information, based on IEC 61850). You connect this Controllable in the matrix to the desired number of binary inputs that indicate the current tap position.

For more information, refer to [9.8.2 Application and Setting Notes](#).

The **Position** Controllable also contains parameters. If you wish to change the settings, you must select the Controllable in the DIGSI information matrix and change the settings by way of the Properties dialog. The taps are controlled via the commands **Higher command** and **Lower command**, each of which must be connected to one binary output.

Example

The following 2 figures show a CFC chart as an example for transformer tap control with the routing of the function keys for stepping up or stepping down.

Information			Source							
			Function keys							
			Basismodul							
Signals	Number	Type	1	2	3	4	5	6	7	8
(All)	(All)
▶ General	162.2311									
▼ Tap changer	162.13981		*	*						
▶ >Acquisition blocking	162.13981....	SPS								
▶ >Enable	162.13981....	SPS								
▶ Health	162.13981.53	ENS								
▶ End higher pos.reach...	162.13981....	SPS								
▶ End lower pos.reached	162.13981....	SPS								
▶ Position	162.13981....	BSC								
▶ Higher command	162.13981....	SPS								
▶ Lower command	162.13981....	SPS								
▶ Command active	162.13981....	SPS								
▶ Motor sup. time expir...	162.13981....	SPS								
▶ Trigger motor prot. sw.	162.13981....	SPS								
▶ Position failure	162.13981....	SPS								
▶ Op.ct.	162.13981....	INS								
▶ Reset failure	162.13981....	SPC								
▶ Motor activ		SPS								
▶ User_def_higher		SPS	P							
▶ User_def_lower		SPS		P						
▼ 90v v.Contn.r.zw	162.14011									
▶ >Block	162.14011.81	SPS								
▶ >Reset min./max.	162.14011.85	SPS								
▶ Health	162.14011.53	ENS								
▶ Inactive	162.14011.54	SPS								
▶ Behavior	162.14011.52	ENS								
▶ End Higher pos. Auto	162.14011....	SPS								
▶ End Lower pos. Auto	162.14011....	SPS								
▶ Cmd. with feedback	162.14011....	BSC								
▶ Block auto	162.14011....	SPC								
▶ Operating mode	162.14011....	SPC								
▶ Bandwidth >	162.14011....	SPS								

[schlued-280316-01, 2, en, US]

Figure 9-95 Routing of the Function Keys and CFC Signals

To use the function keys, you create 2 user-defined single-point indications (SPS). These are used for the function keys (for example, <F1>, Higher function key and <F2>, Lower function key) and as the input signals for the appropriate CFC blocks. In addition, you must use the controllable **Cmd. with feedback** for the CFC chart and set the control model to *direct w. enh. security*.

You can select the control direction using the following values at the **Val** input of the **BSC_DEF** building block:

- 1 means **step up**
- 0 means **step down**

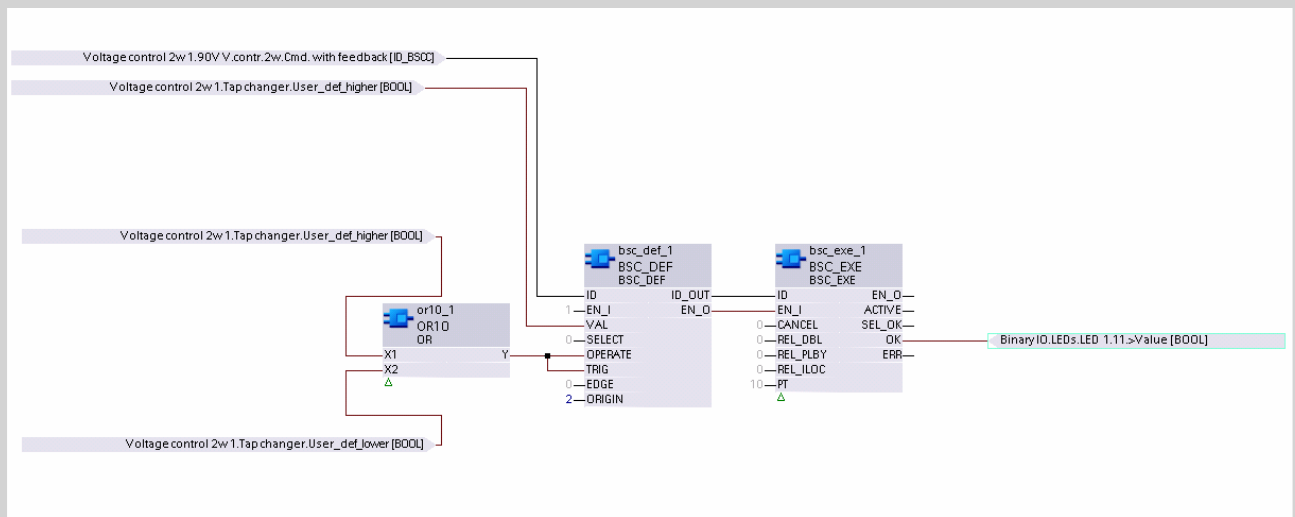

sc_bivctw_3_en_US

Figure 9-96 CFC Chart

Pressing the function keys to step up or down incrementally can be displayed using this simple CFC chart.

Motor Supervision Time

The runtime of the motor-drive mechanism can be monitored from the device. This function is used to identify failures of the motor-drive mechanism during the switching procedure and to trip actions if necessary. To use the **Motor supervision time**, you must route the motor sliding contact (most significant binary input) and set the proper motor runtime.

The motor sliding contact is active until the tap changer has reached the new position. This time is compared to the **Motor supervision time**. If the new tap position is not reached within the motor runtime, the *Motor sup. time expired* indication is set. The *Trigger motor prot. sw.* indication with which the motor can be switched off is output for a duration of 1.5 s.

Adjusting-Command Supervision

Adjusting-command supervision is used for checking the proper operation of the tap-changer mechanism. The **Tap changer** function calculates the next logical tap position as a result of the higher/lower tap command. The time of position detection is determined as a function of the availability of the motor sliding contact. After resetting the active motor sliding contact, the **Tap changer** function reads the new tap position value. If the value for the calculated tap position could not be received within the parameterized time **Motor supervision time**, the error message *Position failure* is output.

The following position errors of the tap changer are taken into consideration during this:

- Invalid tap position: The tap position is outside the predefined range of **minimum value** and **maximum value**
- Adjusting command in the wrong direction (for example, if a higher tap was commanded and the tap changer responds with a lower position and vice versa)
- No operation of the tap changer (for example, if the tap-changer motor is defective or the position indication is not functioning)
- Illogical tap-change operation (for example, if no logical tap position following the previous position is indicated)

The value of 0 during an unexpected interruption of the auxiliary voltage represents a special case. An invalid tap-changer position without a corresponding adjusting command is signaled in the **Position** controllable only as an invalid tap position.

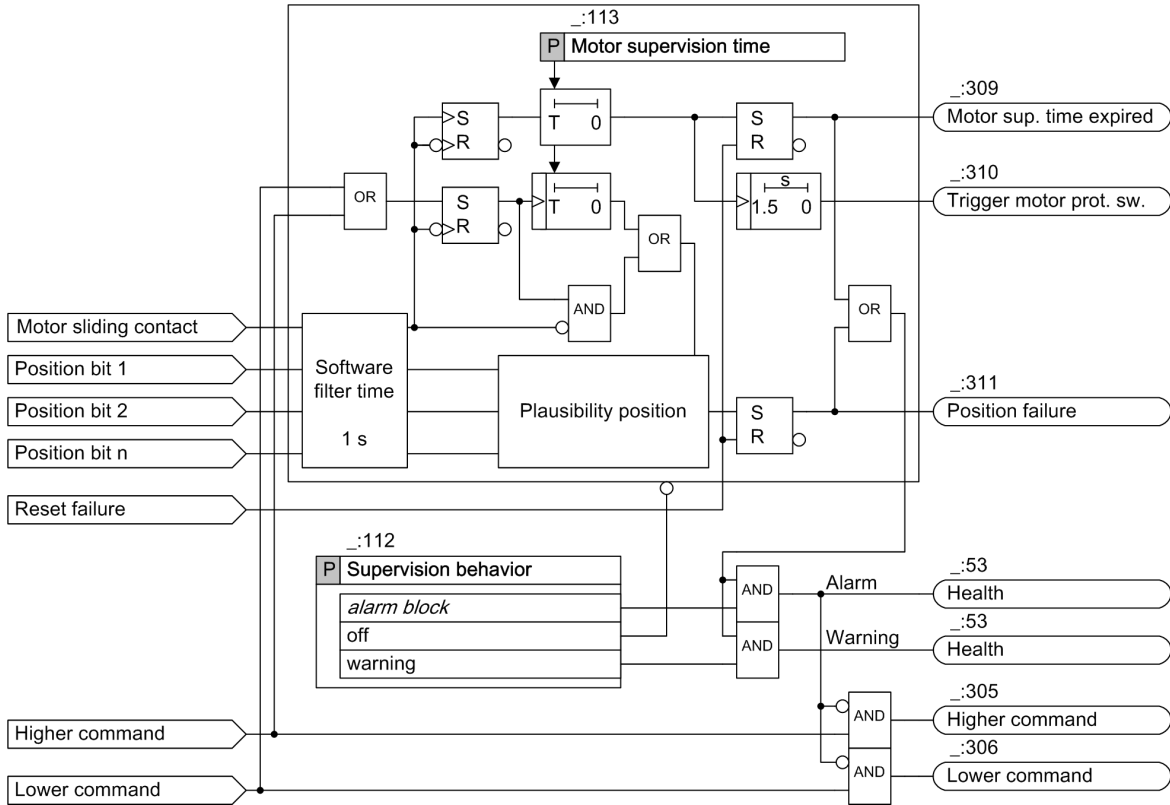

[lio_tcmoue_3_en_US]

Figure 9-97 Position and Motor Supervision Logic

The user-defined signals **Higher command** and **Lower command** are provided via a CFC chart (refer to [9.8.1 Function Description](#)).

Supervision Behavior

Depending on the setting of the **Supervision behavior** parameter, the function reaches a health state of **Alarm** or **Warning**. You can set the parameter **Supervision behavior** to *off*, *alarm block* or *warning*.

In the **alarm block** mode, the function is set to the health state **Alarm**. All tap-changer commands are blocked.

In the **warning** mode, the function is set to the health state **Warning**. Executing tap-changer commands is still possible.

You can manually reset the health state of **alarm block** or **warning** using the controllable **Reset errors** (Main menu → Device functions → Reset functions → Tap changer). As an alternative to this, you can also switch off the supervision function and then switch it on again.

Operating Counter

The device counts the number of successfully completed adjusting commands with the *Op. Ct.* switching cycle counting value. The counting and memory levels are protected against an auxiliary-voltage failure. The switching cycle counting value can be set to 0 or to any other starting value.

You can access the statistical values via the operation panel on the device (measured values/statistics), via DIGSI, or using various communication protocols.

9.8.2 Application and Setting Notes

Parameters of the Tap Changer Function Group

Tap changer			
Control			
161.5461.104	Check switching authority:	yes	
161.5461.108	Control model:	SBO w. enh. security	
161.5461.109	SBO time-out:	30.00	s
161.5461.110	Feedback monitoring time:	10.00	s
Tap changer			
161.5461.111	Maximum output time:	1.50	s
161.5461.112	Supervision behavior:	alarm block	
161.5461.113	Motor supervision time:	10	s
161.5461.116	Highest tap changer pos.:	Lowest voltage tap	
161.5461.114	Lowest tap position:	1	
161.5461.115	Highest tap position:	15	

[scstuslt-100713-01.tif, 2, en_US]

Figure 9-98 Parameters of the Tap Changer



NOTE

If run positions, this means internal tap changer positions without voltage changes, are available, the following must be observed:

If these tap changer positions contain a suffix a and c or + and -, and additional switching pulses are not required, adjust the parameter for the feedback and motor supervision time to the actual motor runtime when passing through a run position. Siemens recommends parameterization with capturing of the motor sliding contact.

Parameter: Check switching authority

- Default setting (`_:104`) **Check switching authority = yes**

With the **Check switching authority** parameter, you specify whether the switching authority (on site, remote) is checked in the case of an adjusting command (see also chapter [9.3.1 Command Checks and Switchgear Interlocking Protection](#)).

Parameter: Control model

- Default setting (`_:108`) **Control model = SBO w. enh. security**

Use the **Control model** parameter to specify the control model according to IEC 61850-7-2. The following selection options are available:

- *direct w. normal secur.*
- *SBO w. normal secur.*
- *direct w. enh. security*
- *SBO w. enh. security*
- *status only*

Parameter: SBO time-out

- Default setting (_:109) **SBO time-out = 30 s**

With this setting, you specify the time for detecting the time-out of the SBO command. The range of values extends from 0.01 s to 1800.00 s. This is the time that can elapse between command acceptance and command execution (command model as per IEC 61850-7-2).

Parameter: Feedback monitoring time

- Default setting (_:110) **Feedback monitoring time = 10 s**

Reaching a new tap position after the switching command is monitored. If a new tap position is not reached, you specify with this setting the time when the command is canceled. The range of values extends from 0.01 s to 1800.00 s.

Parameter: Maximum output time

- Default setting (_:111) **Maximum output time = 1.50 s**

This parameter specifies the maximum output time. The range of values extends from 0.01 s to 1800.00 s. For activating motors to change the tap position, a time of 1.50 s is practical.

Parameter: Supervision behavior

- Default setting (_:112) **Supervision behavior = alarm block**

You can select whether the supervision is switched off (*off*) or if only a warning is indicated (*warning*). With the *alarm block* setting, an alarm indication is generated and the function is blocked.

Parameter: Motor supervision time

- Default setting (_:113) **Motor supervision time = 10 s**

After the motor supervision time has elapsed, the indication *Motor sup. time expired* is displayed. You can find additional information in [9.8.1 Function Description](#). The range of values extends from 5 s to 100 s.

Parameter: Highest tap changer pos.

- Default setting (_:116) **Highest tap changer pos. = Lowest voltage tap**

With the **Highest tap changer pos.** parameter, you specify whether the lowest or highest voltage is present at the highest tap changer position.

Additional Settings (Properties Dialog Position)

Additional settings are assigned to the controllable *Position*. To display and adjust the settings, select *Position* in the DIGSI information matrix and select the Properties dialog. To do this, click the **Properties** tab.

Details

Name:

Original name:

General

Minimum value:

Maximum value:

Tap-display offset:

Number of bits for tap code:

Number of tap positions:

Tap-coding type:

Moving contact (highest binary input):

Software filter

Software filter time: ms

Retrigger filter:

Indication timestamp before filtering:

Chatter blocking

Chatter blocking:

[sc_deegts, 1, en_US]

Figure 9-99 Properties Dialog

Parameter: Minimum value

- Default setting **Minimum value** = 1

Parameter: Maximum value

- Default setting **Maximum value** = 15

The parameters **Minimum value** and **Maximum value** are initially calculated by DIGSI 5 on the basis of the tap coding, the **Number of tap positions** and the **Tap-display offset**. They represent the allowed control area of the position value. Positions outside this area are defined as invalid. This control area can be further restricted within the initially set physical range (see **Number of tap positions** and **Tap-display offset**).

Parameter: Tap-display offset

- Default setting **Tap-display offset** = 0

If you want to move the height of the displayed value in a positive or the negative direction with respect to the height of the actual value, enter the value for this in the **Tap-display offset** field.

Parameter: Number of bits f. tap code

- Default setting **Number of bits f. tap code** = 4

With the **Number of bits f. tap code** parameter, you set the number of bits you need for encoding the transformer taps. The number is dependent on the selected **Encoding** and on the **Moving contact**. For example, you need 3 bits for 7 binary-encoded transformer taps. The range of values extends from 2 to 32.

Parameter: Number of tap positions

- Default setting **Number of tap positions = 15**

With the **Number of tap positions** parameter, you set the number of transformer taps. The range of values extends from 2 to 127. The output of the tap position is limited from -63 to +63. If the number of taps is > 63, set the **Tap-display offset** parameter so that the output of the tap position is within the range of -63 to +63.

Parameter: Tap-coding type

- Default setting **Tap-coding type = binary**

In the **Tap-coding type** list box, select the interpretation type of the indication pending at the binary input. You can select from the following options:

- *binary*
- *1-of-n*
- *BCD*
- *table*
- *BCD signed*
- *gray*

The tap changer position can also be routed via a GOOSE signal (BSC) or a 20-mA measuring transducer input. You can find more information on this in the document **Measuring the transformer tap changer using an analog measuring transducer input in SIPROTEC 5** in the Download area under *SIPROTEC 5 and DIGSI 5 downloads* → *SIPROTEC 5 General* → *Application Notes* → *Control*.

A selection of tap-coding types is described in greater detail using examples in the following text.

Routing of the Binary Inputs (Tap-Coding Type binary)

The following table shows the routing of 3 binary inputs (BI 1 to BI 3) with 4 transformer tap positions designated 3 to 6. BI4 is the moving contact. The encoding is in **binary**.

Table 9-27 Routing of the Binary Inputs (Tap-Coding Type binary)

	Example					
	BI1	BI2	BI3	BI4	BI5	BI6
Tap changer	X	X	X	X	–	–
Meaning	Bit 1	Bit 2	Bit 3	Moving contact	–	–
Tap = 1	1	0	0		–	–

With 3 binary inputs, a maximum of $2^3 - 1 = 7$ tap positions can be mapped in binary code. If all routed binary inputs indicate 0, this is interpreted as a connection error and is reported by Position --- or **-64** with quality **invalid**. The representation of transformer taps should start with the metered value 3. You must configure the information properties as follows for the example:

Tap-coding type:	binary
Number of tap positions:	7
Number of bits f. tap code:	4
Tap-display offset:	2
Moving contact (highest binary input):	Yes

The 3 binary inputs must be numbered sequentially, for example, BI 1, BI 2, BI 3, and BI 4 for the moving contact.

Routing of the Binary Inputs (Tap-Coding Type BCD)

The following table shows the routing of 6 binary inputs (BI 1 to BI 6) with 39 transformer tap positions designated 1 to 39. The encoding is in **BCD**. BI 7 is the moving contact.

Table 9-28 Routing of the Binary Inputs (Tap-Coding Type BCD)

	Example						
	BI1	BI2	BI3	BI4	BI5	BI6	BI7
Tap changer	X	X	X	X	X	X	X
Meaning	BCD 1	BCD 2	BCD 4	BCD 8	BCD 10	BCD 20	Moving contact
Tap = 21	1	0	0	0	0	1	–

With 6 binary inputs, a maximum of 39 tap positions can be mapped with the tap-coding type of BCD. This yields the number of tap positions from 1 to 39. If all routed binary inputs indicate 0, this is detected as tap 0. The 7 binary inputs must be numbered sequentially, for example, BI 1, BI 2, BI 3, BI 4, BI 5, BI 6, and BI 7 for the moving contact.

Tap-coding type:	BCD
Number of tap positions:	39
Number of bits f. tap code:	7
Tap-display offset:	0
Moving contact (highest binary input):	Yes

Individual Tap-Coding Type (table)

With the **table** parameter setting, you can specify an individual **Tap-coding type**.

In the **Representation of encoding** section, select the number system in which your code table entries will take place, alternatively:

- **Binary (2 characters)**
- **Octal (8 characters)**
- **Decimal (10 characters)**
- **Hexadecimal (16 characters)**

The selected option is valid for all inputs in the **Encoding** column.

If you change the number system and there are already entries in this column, these will be converted to the new number system. The selection area becomes visible as soon as you have selected the setting **table** in the **Tap-coding type** list box.

Code table

Code table:

Level	Encod..
1	000001
2	000010
3	000011
4	000100
5	000101
6	000110
7	000111
8	001000
9	001001

Representation of encoding:

Binary (2) Octal (8)
 Decimal (10) Hexadecimal (16)

Figure 9-100 Code Table for the Tap-Coding Type table



NOTE
If the binary inputs used for encoding are all inactive, this indicates an invalid tap position (regardless of the display offset). For an invalid tap position, the display shows the position --- or -64 with quality **invalid**, exception BCD signed, see [Routing of the Binary Inputs \(Tap-Coding Type BCD signed\), Page 1290](#).

Enter the encoding for the tap in the **Encoding** column in the **Code table**. Enter the value according to the number system previously selected. Select the desired number of taps and number of bits for tap coding. Taps with the same encoding and taps with 0 coding are not permitted.

Routing of the Binary Inputs (Tap-Coding Type BCD signed)

The following table shows the routing of 3 binary inputs (BI 1 to BI -3) with 7 transformer tap positions designated 3 to 3. The encoding uses **BCD signed**.

Table 9-29 Routing of the Binary Inputs (Tap-Coding Type BCD signed)

	Example					
	BI1	BI2	BI3	BI4	BI5	BI6
Tap changer	X	X	X	–	–	–
Meaning	BCD 1	BCD 2	Sign	–	–	–
Tap = 1	1	0	1	–	–	–

Using 3 binary inputs, a maximum of 7 tap positions can be mapped with the tap coding type of BCD signed. This yields the number of tap positions from -3 to 3. If all routed binary inputs indicate 0, this is recognized as tap 0. The 3 binary inputs must be numbered sequentially.

Tap-coding type:	BCD signed
Number of tap positions:	7
Number of bits f. tap code:	3
Tap-display offset:	0
Moving contact (highest binary input):	No

Routing the Tap Position to Binary Outputs

For the output of the adjusting commands, route the information **step up** and **step down** on one relay each, see following figure.

Information			Source										Destination			
			Binary input										Function keys			
			Base module										CFC			
			Base module										Binary output			
Signals	Number	Type	1.1	1.2	1.3	1.4	1.5	1.6	1.7	1.8	2.1	2.2	2.3	1.1	1.2	1.3
(All)	(All)	(All)
Tap changer 1	161		*	*	*	*								*	*	
Tap changer	161.5461		*	*	*	*								*	*	
>Acquisition blocking	161.5461.500	SPS														
>Enable	161.5461.501	SPS														
>Reset AcqBlk&Subst	161.5461.504	SPS														
Health	161.5461.53	ENS														
End higher pos.reach...	161.5461.301	SPS														
End lower pos.reached	161.5461.302	SPS														
Position	161.5461.308	BSC	X	X	X	X										
Higher command	161.5461.305	SPS												X		
Lower command	161.5461.306	SPS													X	
Command active	161.5461.307	SPS														X
Motor sup. time expir...	161.5461.309	SPS														
Trigger motor prot. sw.	161.5461.310	SPS														
Position failure	161.5461.311	SPS														
Op.ct.	161.5461.312	INS														
Reset failure	161.5461.319	SPC														
Switching auth. station	161.5461.317	SPC														

[sc_trass7, 1, en_US]

Figure 9-101 Routing the Tap Setting Commands

Parameter: Moving contact (highest binary input)

- Default setting **Moving contact (highest binary input) = no**

If the tap position is only to be recognized as valid and implemented when the motor sliding contact signals that it has reached the taps, then activate the **Moving contact (highest binary input)** option. If this parameter is set, the new position is only labeled with an * when the moving contact drops out.

Parameter: Software filter time

- Default setting **Software filter time = 1000 ms**

With this parameter, you set the **Software filter time** for capturing the tap position. The range of values extends from 0 ms to 100 000 ms. Within this time, brief changes on the binary inputs are suppressed.

Parameter: Retrigger filter

- Default setting **Retrigger filter = Yes**

With this parameter, you switch retriggering of the filtering time by a position change on or off.

Parameter: Indication timestamp before filtering

- Default setting **Indication timestamp before filtering = no**

With this parameter, you specify whether the hardware filtering time is accounted for in the time stamp of position capture.

Parameter: Chatter blocking

- Default setting **Chatter blocking = no**

With this parameter, you switch **Chatter blocking** on or off.

9.8.3 Settings

Addr.	Parameter	C	Setting Options	Default Setting
Tap changer				
_:104	Tap changer:Check switching authority		<ul style="list-style-type: none"> no yes 	yes
_:108	Tap changer:Control model		<ul style="list-style-type: none"> status only direct w. normal secur. SBO w. normal secur. direct w. enh. security SBO w. enh. security 	SBO w. enh. security
_:109	Tap changer:SBO time-out		0.01 s to 1800.00 s	30.00 s
_:110	Tap changer:Feedback monitoring time		0.01 s to 1800.00 s	10.00 s
Tap changer				
_:111	Tap changer:Maximum output time		0.02 s to 1800.00 s	1.50 s
_:112	Tap changer:Supervision behavior		<ul style="list-style-type: none"> off warning alarm block 	alarm block
_:113	Tap changer:Motor supervision time		5 s to 100 s	10 s

9.8.4 Information List

No.	Information	Data Class (Type)	Type
Tap changer			
_:500	Tap changer:>Acquisition blocking	SPS	I
_:501	Tap changer:>Enable	SPS	I
_:53	Tap changer:Health	ENS	O
_:301	Tap changer:End higher pos.reached	SPS	O
_:302	Tap changer:End lower pos.reached	SPS	O
_:308	Tap changer:Position	BSC	C
_:305	Tap changer:Higher command	SPS	O
_:306	Tap changer:Lower command	SPS	O
_:307	Tap changer:Command active	SPS	O
_:309	Tap changer:Motor sup. time expired	SPS	O
_:310	Tap changer:Trigger motor prot. sw.	SPS	O
_:311	Tap changer:Position failure	SPS	O
_:312	Tap changer:Op.ct.	INS	O
_:319	Tap changer:Reset failure	SPC	C

9.9 Point-on-Wave Switching

The **Point-on-wave switching** function in SIPROTEC 5 is used to reduce increased electrodynamic and dielectric loads which are caused by non-optimal switching of circuit breakers in the network. In extreme cases, these loads reduce the reliability and life of the equipment installed in the network or lead to unnecessary opening operations by the protection device. To avoid effects such as overvoltages and inrush currents, this function can control the closing and opening instants of circuit breakers.

Table 9-30 Avoided Effects in Different Load Types

Load Type	Switching Operation	Avoided Effect
Inductive load: Transformer, reactance coil	Opening	Restriking, overvoltage
	Closing	Inrush current
Capacitive load: Capacitor bank, unloaded lines/cables, filter	Opening	Restriking, overvoltage
	Closing	Overvoltage, inrush current

The **Point-on-wave switching** function is always started via a control command, either from the device internal control or from an external control function. Protection functions generally directly trip the circuit breaker and have no interaction with the **Point-on-wave switching** function.

You can find more information about this function in the *Point-on-Wave Switching Function Manual*.

10 Supervision Functions

10.1	Overview	1296
10.2	Resource-Consumption Supervision	1297
10.3	Supervision of the Secondary System	1301
10.4	Supervision of the Device Hardware	1358
10.5	Supervision of Device Firmware	1363
10.6	Supervision of Hardware Configuration	1364
10.7	Supervision of Communication Connections	1365
10.8	Error Responses and Corrective Measures	1366
10.9	Group Indications	1374

10.1 Overview

SIPROTEC 5 devices are equipped with an extensive and integrated supervision concept. Continuous supervision:

- Ensures the availability of the technology used
- Avoids subfunction and overfunction of the device
- Protects persons and primary technical devices
- Offers effective assistance during commissioning and testing

The following areas are monitored:

- Supervision the resource consumption of the application
- Supervision of the secondary system, including the external auxiliary power supply
- Supervision of device hardware
- Supervision of device firmware
- Supervision of hardware configuration
- Supervision of communication connections

When the supervision functions pick up, that will be displayed and also indicated. Error responses are defined for the device. The error responses are grouped in defect severities.

The supervision functions work selectively. When the supervision functions pick up - as far as possible - only the affected parts of the hardware and firmware are blocked. If this is not possible, the device goes out of operation into a secure state (fallback mode). In addition to safety, this warrants a high degree of availability.

10.2 Resource-Consumption Supervision

10.2.1 Load Model

SIPROTEC 5 Compact devices are freely configurable. A load model is integrated in DIGSI 5. The load model prevents you from overloading the device with an excessively large application.

The load model shows the device utilization and the response times for device functions. If it determines that an application created is likely to overload the device, DIGSI prevents the application from being loaded into the device.

In this rare case, you must then reduce the application in order to be able to load it into the device.

The load model can be found in the DIGSI 5 project tree under **Name of the device** → **Device information**. In the operating range, select the **Resource consumption** setting sheet. The following figure shows an example of the view of the load model in DIGSI 5:

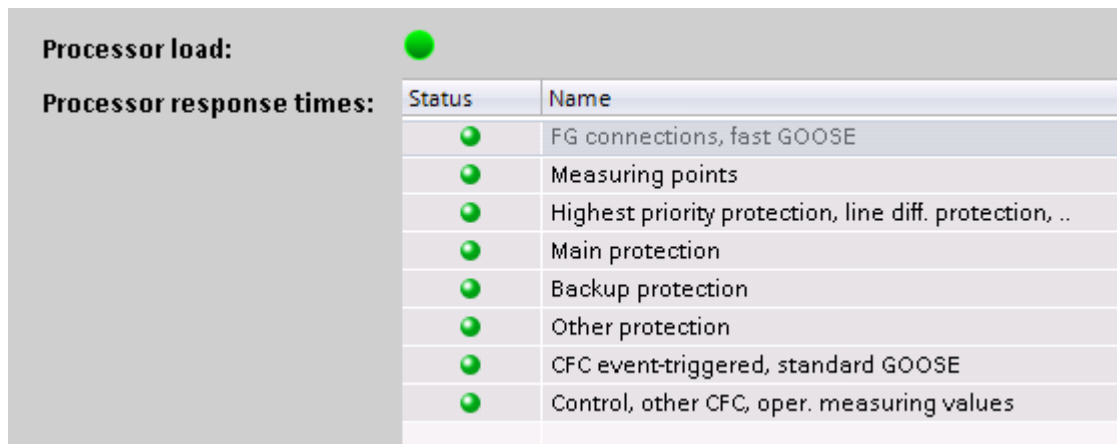

[sc_lastmo_01_1_en_US]

Figure 10-1 Visualization of the Load Model in DIGSI

A green total display for the processor response time indicates that the device is not overloaded by the present application. On the other hand, if you see a red exclamation mark, the planned application is overloading the device.

The list below the total display shows the individual functional areas. These areas combine functions with the same real-time requirements. A green display in front of an area (see [Figure 10-1](#)) indicates that the response times of the functions grouped in this area can be maintained. A red exclamation mark indicates that functions may have longer response times than specified in the Technical data for the device. In such a case, loading of the application into the device is blocked.

The following table provides an overview of the functional areas and the most important influencing quantities on device utilization:

If the load model displays a warning, bear in mind the following general instructions:

The areas named in the table are listed in descending order of real-time requirements. If a warning appears to the effect that the guaranteed response times may be exceeded in an area, you can return to the permitted area by taking the following measures:

- Reduce the functional scope in the marked area (red exclamation mark)
- Reduce the functional scope in another area with higher real-time requirements

When you have reduced the application, check the display in resource consumption! If a function or stage has been switched off, it will continue to represent a load for the area. If you do not need the function or stage, delete it rather than switching it off.

Use the general **Circuit-breaker** function group only in the following cases:

- Interaction with a protection-function group is essential.
That is to say, operate indications of protection functions cause the circuit breaker assigned to the **Circuit-breaker** function group to be switched off.
- You want to use functions such as the automatic reclosing function or circuit-breaker failure protection in the **Circuit-breaker** function group.

10.2.2 Function Points

When you order a SIPROTEC 5 Compact device, you are also ordering a function-points account for use of additional functions.

The following figure illustrates consumption of function points in the current application with respect to the existing function-points account.

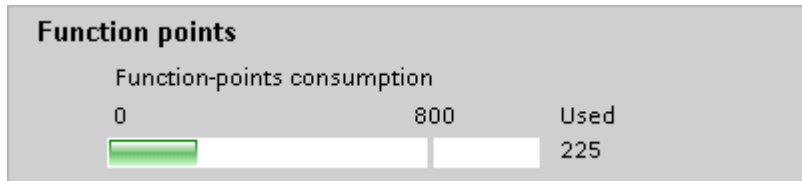

[sc_fpunkt_en_US]

Figure 10-2 Resource Overview: Function-Points Consumption

The remaining white bar shows the function points that have not yet been used up by your configuration. The number of function points available in a device depends on the device purchase order. You can also order function points subsequently, and so increase the function-points account for the device.



NOTE

Find out the function-points requirement for the desired application before ordering the device. For this, you can use the device configurator. Alternatively, you create the license file with the required point credits ad hoc using the SIPROTEC function point manager (refer to [2.2 Application Templates/Adaptation of Functional Scope](#)).

10.2.3 CFC Resources

Task Levels of the CFC Function

A CFC chart, and thus the configured CFC function, runs in the SIPROTEC 5 device on exactly one of the 4 task levels. The individual task levels differ, on the one hand, in the priority of processing tasks and, on the other, in the cyclic or event-triggered processing of the CFC charts.

You can select between the following task levels:

Task Level	Description
High priority Event-triggered	Use the High priority Event-triggered task level for time-critical tasks, for example, if a signal should block a protection function within 2 ms to 3 ms. Functions on this task level are processed in an event-triggered way with the highest priority. Each change to a logical input signal is immediately processed. Processing can interrupt the execution of protection functions and functions on the Event-Triggered task level.
Event-triggered	Use the Event-triggered task level preferably for logic functions that need not be executed with highest priority. Each change to a logical input signal is immediately processed. Protection functions or functions on the High priority Event-triggered task level can disrupt processing. Functions on the Event-triggered task level are typically processed within a maximum of 5 ms in all devices. For busbar protection or line protection, the functions on the Event-triggered task level are processed within a maximum of 10 ms.
Low priority Cyclic-triggered	Use the Low priority Cyclic-triggered task level for processing measured values. Functions on this task level are processed cyclically every 500 ms.
Low priority Event-triggered	Use the Low priority Event-triggered task level preferably for logic functions that should be executed with lower priority than functions in the Event-triggered task level. If the available ticks of the Event-triggered task level shown in the following figure are sufficient for the required CFC functionality, you do not need to use the Low priority Event-triggered task level.

All CFC function blocks can be assigned to all the task levels. There are no device-specific function blocks. If enough ticks are available, all CFC charts can be created in the same task level. A tick is the measure of the performance requirement of CFC blocks.

The number of available ticks for each task is calculated depending on the created device configuration. This calculation is based on the previously described load model. In this process, it is recommended to create all selected functions and objects first followed by configuration of the CFC charts so that a realistic information about the remaining system capacitance for CFC charts is available. Significantly exceeding the typical response time is prevented by the load model by limiting the number of CFC function blocks in the corresponding task level via the number of ticks available.

The typical response times for CFC tasks are listed in the Technical Data.

The following figure shows an example of the CFC chart capacitances in DIGSI calculated by the load model. The ticks available for each task are shown here. The green bars represent the ticks used in the task levels. You reach this dialog with the following call: Device → Device information → Resource consumption.

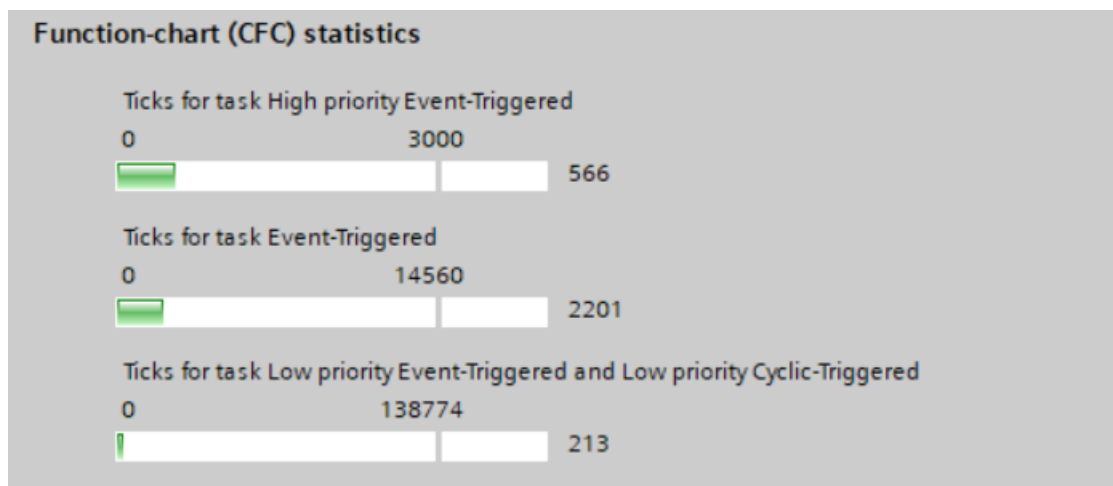

[sc_cfc-statistic, 2, en_US]

Figure 10-3 CFC Statistics



NOTE

High priority Event-triggered CFC charts have the highest priority and are processed before all other tasks. At this level, a considerable smaller number of ticks are available than at all other tasks. It is recommended to configure only very-high-priority logic functions at this task and to configure the other logic functions in any other level.



NOTE

Empty CFC charts also consume system resources. Empty charts that are not required any more should be deleted.

10.3 Supervision of the Secondary System

10.3.1 Overview

The secondary circuits establish a connection to the power system from the point of view of the device. The measuring-input circuits (currents, voltages) as well as the command circuits to the circuit breakers are monitored for the correct function of the device. The connection to the station battery is ensured with the supervision of the external auxiliary voltage. The secondary system has the following supervision systems:

Measuring circuits (voltage):

- Measuring-voltage failure
- Voltage-transformer circuit breaker
- Voltage balance
- Voltage sum
- Voltage rotating field

Measuring circuits (current):

- Broken conductor of the current circuits
- Current balance
- Current sum
- Current rotating field

Trip Circuits

When the supervisions listed in the previous section pick up, corresponding warning indications are output. Some supervisions lead directly to the blocking of affected protection functions or to the marking of measuring points that have become invalid, so that affected protection functions can go into a secure state.

A detailed description of the supervision mechanisms and their error responses can be found in the respective function descriptions.

External Auxiliary Voltage

The supervision of the external auxiliary voltage is described in Error Responses and Corrective Measures starting with [10.8.1 Overview](#).

10.3.2 Measuring-Voltage Failure

10.3.2.1 Overview of Functions

The **Measuring-voltage failure detection** function monitors the voltage transformer secondary circuits:

- Non-connected transformers
- Pickup of the voltage transformer circuit breaker (in the event of short circuits in the secondary circuit)
- Broken conductor in one or more measuring loops

All these events cause a voltage of 0 in the voltage transformer secondary circuits which can lead to failures of the protection functions.

Each of the following protection functions has the parameter **Blk. by meas.-volt. failure**. Using the setting value of the parameter, you can specify whether the protection functions react to a measuring-voltage failure or not (block/not block).

- Directional Overcurrent Protection, Phases
- Overvoltage Protection with Negative-Sequence Voltage

- Overvoltage Protection with Zero-Sequence Voltage/Residual Voltage
- Undervoltage Protection with 3-Phase Voltage
- Overvoltage Protection with Positive-Sequence Voltage

The following protection functions are automatically blocked in the case of a measuring-voltage failure:

- Directional Negative-Sequence Protection
- Ground-Fault Protection for High-Resistance Ground Faults in Grounded Systems

10.3.2.2 Structure of the Function

The function is part of protection function groups which are connected with a 3-phase voltage and current measuring point.

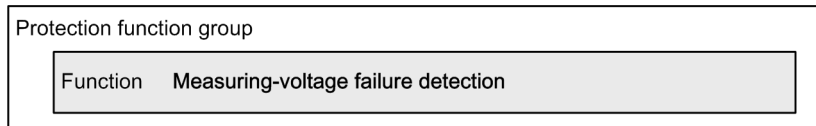

[idw_strfm, 1, en_US]

Figure 10-4 Structure/Embedding of the Function

The function is broken down into 3 subfunctions (see Figure 10-5):

- Supervision for unbalanced measuring-voltage failure
- Supervision for 3-phase measuring-voltage failure
- Supervision for switching onto a 3-phase measuring-voltage failure

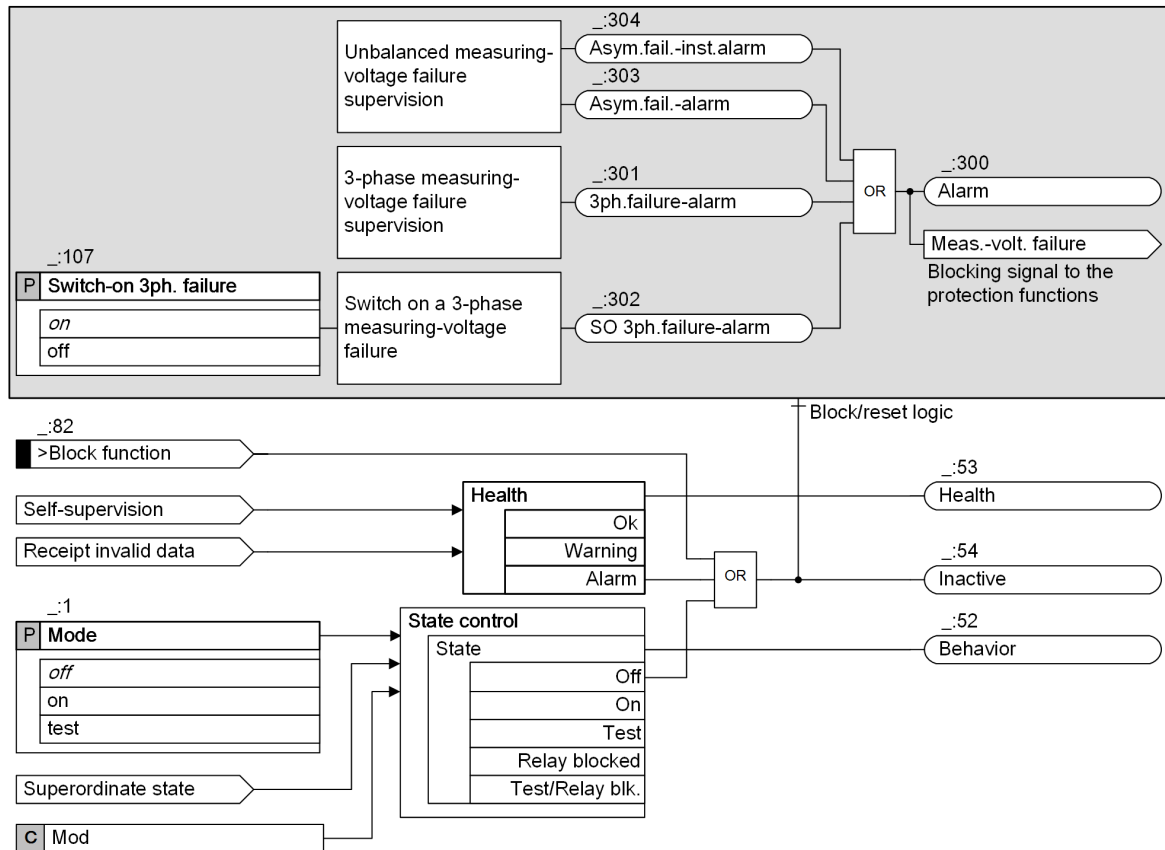

[lo_ffm-3p_zusamm, 3, en_US]

Figure 10-5 Breakdown of the Measuring-Voltage Failure Detection Function

Each subfunction creates its own monitoring indication. The function summarizes these indications via the group indication **Alarm**.
The response to the detection of a measuring-voltage failure is explained in the specific protection-function descriptions.

10.3.2.3 Unbalanced Measuring-Voltage Failure

Logic

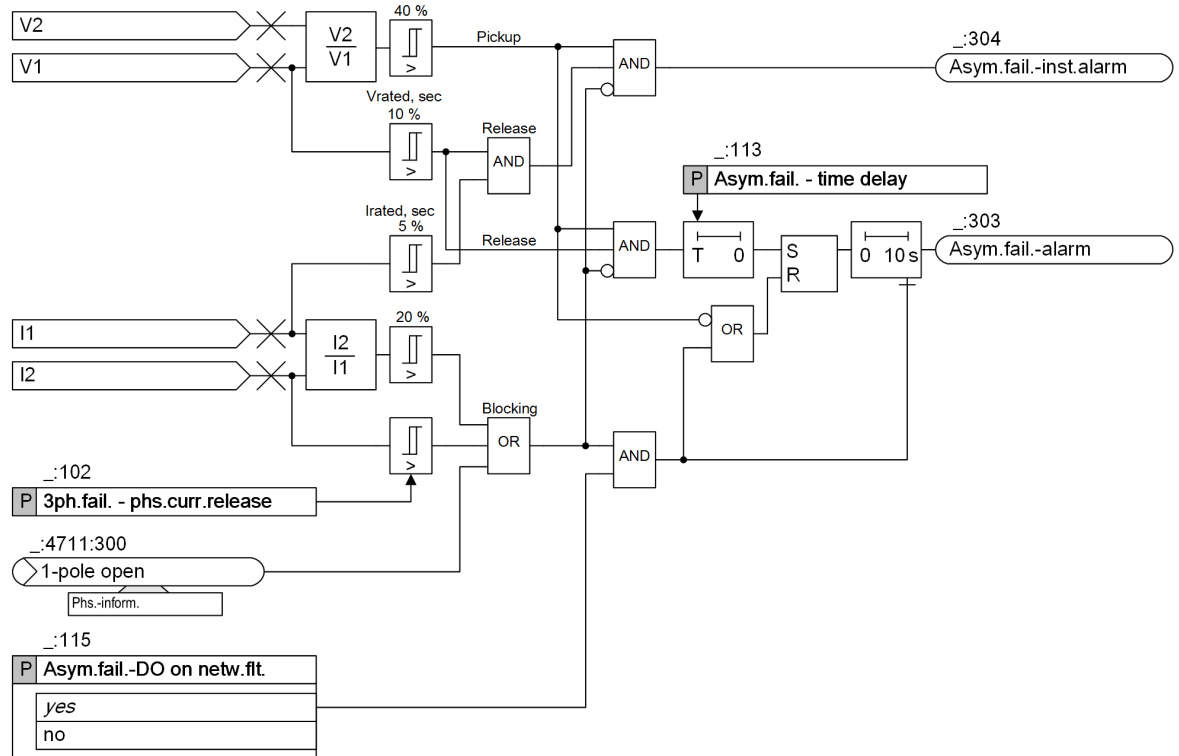

[to_oppode, 5, en_US]

Figure 10-6 Logic Diagram Unbalanced Measuring-Voltage Failure Detection

The criterion for detection of an unbalanced measuring-voltage failure is the voltage unbalance. This unbalance is determined based on the ratio between negative and positive-sequence voltage. If the threshold value is exceeded and the monitoring is released and not blocked, the monitoring picks up (see [Figure 10-6](#)). The indication *Asym.fail.-inst.alarm* is output.

The monitoring is released as soon as a certain minimum voltage is exceeded. This prevents a spurious response in the presence of low voltage measurands or a measurand of 0 (for example, circuit breaker open). Instantaneous monitoring also requires the presence of a minimum current. This prevents a spurious instantaneous pick up of the monitoring in the presence of a weak infeed (current < 10 % of rated current) combined with a power-system incident.

If the voltage unbalance is blocked by unbalanced faults in the primary system, the supervision is blocked. The device detects an unbalanced fault based on the ratio between negative-sequence and positive-sequence current.

Delay/Seal-In

In the presence of a weak infeed (current < 10 % of rated current), certain protection functions require more time for detection of a system incident. For this purpose, monitoring can be delayed using the parameter **Asym.fail. - time delay**.

If a system incident is detected during the time delay, the supervision drops off. This is because the function assumes that the unbalance - and consequently the pickup of the supervision - is due to the system incident.

After the time delay has elapsed, it definitely assumes a measuring-voltage failure. Monitoring seals in and the *Asym.fail.-alarm* indication is output. The dropout does not happen until the voltage unbalance has disappeared after a seal-in time of 10 s. In the presence of 3-pole close-in faults outside the protection zone, this seal-in time prevents the monitoring from dropping off too quickly and thus releasing the protection functions.

The sealing-in function can be deactivated using the *Asym.fail.-DO on netw.flt.* parameter. As soon as a system incident is detected, the monitoring drops off instantaneously.

10.3.2.4 3-Phase Measuring-Voltage Failure

Logic

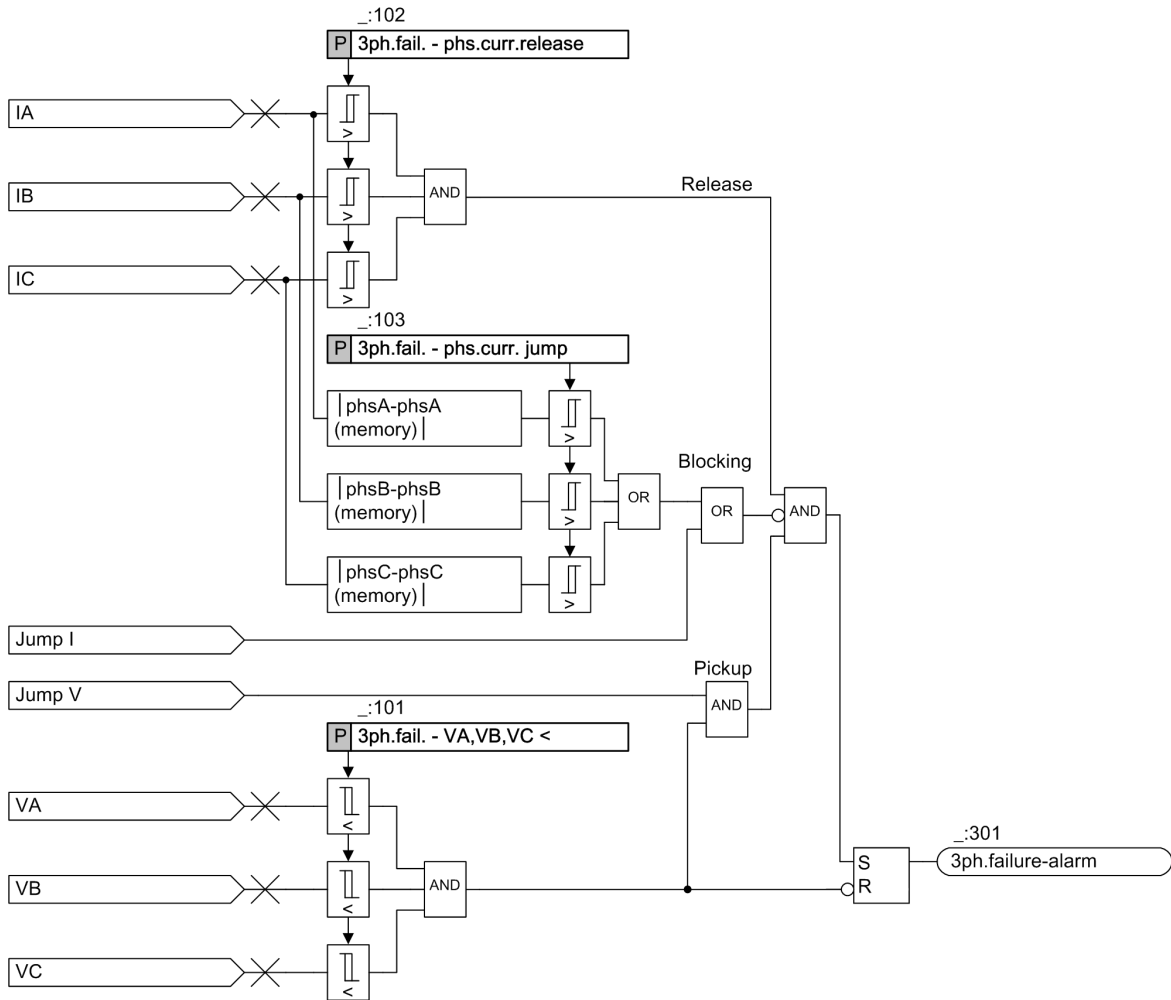

Figure 10-7 Logic Diagram 3-Phase Measuring-Voltage Failure

Balanced Fault – VA, VB, VC <

A 3-phase measuring-voltage failure is detected if the following criteria are fulfilled simultaneously:

- All 3 phase-to-ground voltages drop below the threshold value *3ph.fail. - VA,VB,VC <*
- A jump of the voltage (signal *Jump V*)

If these criteria are fulfilled and the monitoring is released and not blocked, the *3ph.failure-alarm* indication is output. When the voltage returns (even as 1-phase), the monitoring drops out.

If the device incorporates the distance-protection function, the device checks the input threshold value *3ph.fail. - phs.curr.release* against the minimum current setting of the distance protection for

plausibility. The threshold value `3ph.fail. - phs.curr.release` must be set to less than or equal to the release current of the distance protection.

Blocking in the Case of a System Incident

In the case of a 3-phase system incident, supervision must be blocked. The device detects a 3-phase system incident with a jump in the current. This change is detected via the internal signal `Jump I` or when the change in current of a phase current exceeds the threshold value `3ph.fail. - phs.curr.jump`. The change in current of phase currents is formed from the difference between the present current phasor and the current phasor of the previous period. This allows to take into account a jump of the current phase.



NOTE

If a voltage-transformer circuit breaker is installed in the secondary circuit of the voltage transformers, its position is communicated to the device via a binary input (see chapter [10.3.4.1 Overview of Functions](#)).

10.3.2.5 Switching onto a 3-Phase Measuring-Voltage Failure, Low Load

Logic

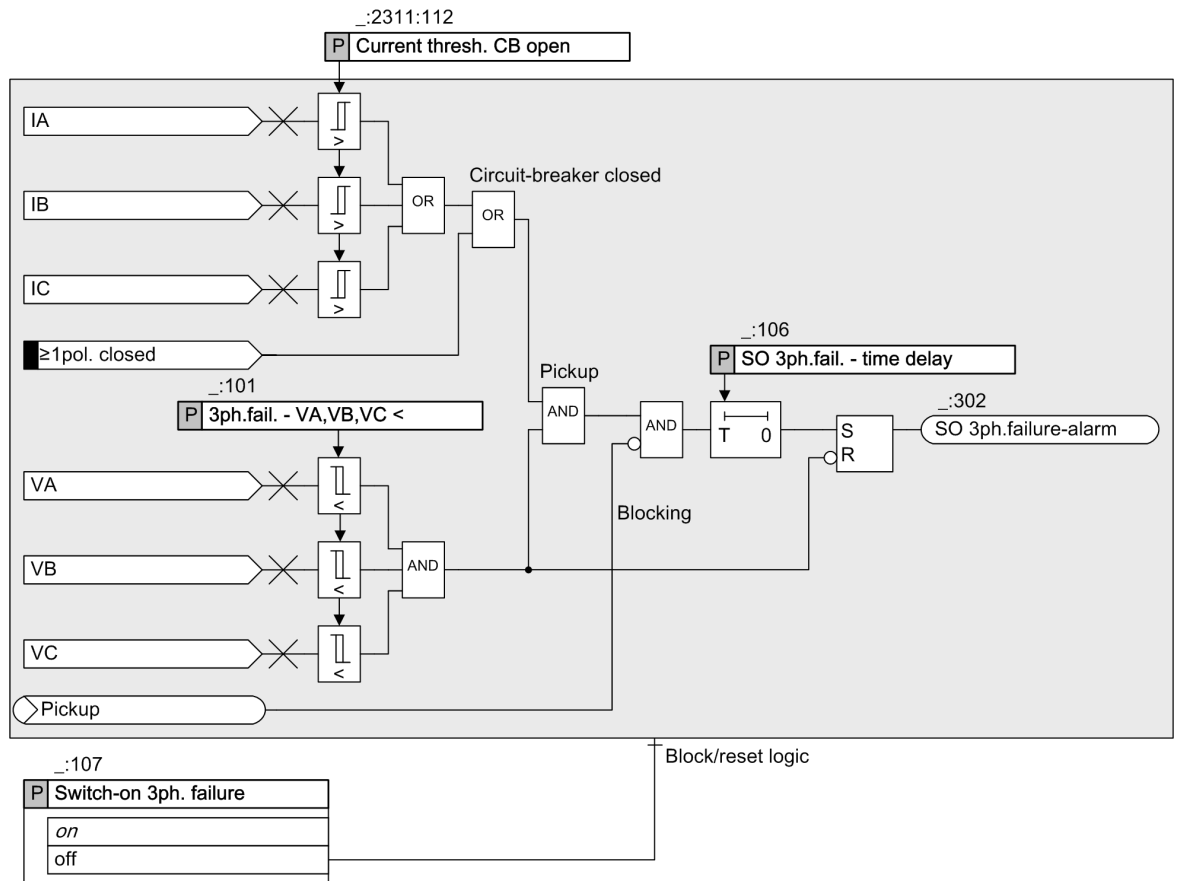

[to_zuscha.1_en-US]

Figure 10-8 Logic Diagram Switching to 3-Phase Measuring-Voltage Failure

Switching onto a 3-phase measuring-voltage failure is detected if the following criteria are fulfilled simultaneously:

- All 3 phase-to-ground voltages have dropped below the threshold value **3ph.fail. - VA,VB,VC <**.
 - The circuit breaker is detected to be in closed position. The detection takes place either via the phase currents or via the **≥1-pole closed** signal, which is generated via the circuit-breaker auxiliary contacts.
- For more detailed information, refer to [5.10.5 Circuit-Breaker Condition for the Protected Object](#).

A voltage jump – such as in a 3-phase measuring-voltage failure with closed circuit breaker (refer to [10.3.2.4 3-Phase Measuring-Voltage Failure](#)) – does not occur in the case of switching to a 3-phase measuring-voltage failure. If the monitoring is not blocked, the time delay **SO 3ph.fail. - time delay** is started. After the time has elapsed, the indication **SO 3ph.failure-alarm** is displayed. A dropout of the monitoring is only possible by a recovery of the voltage.

The supervision is blocked as soon as a pickup of a protection function is detected within a protection function group and the time delay of the supervision has not yet elapsed.

This subfunction also covers the situation of a low load with 3-phase measuring-voltage failure and closed circuit breaker, because the circuit-breaker position is also determined from the circuit-breaker auxiliary contacts. The subfunction for detecting a 3-phase measuring-voltage failure (refer to [10.3.2.4 3-Phase Measuring-Voltage Failure](#)) is not released in this situation, for example, because the current flow is too low.

This subfunction can be switched on or off separately using the **Switch-on 3ph. failure** parameter.

10.3.2.6 Application and Setting Notes

Parameter: **Asym.fail. - time delay**

- Recommended setting value (**_:113**) **Asym.fail. - time delay = 10.00 s**

The **Asym.fail. - time delay** parameter allows you to set the time during which a system incident detected after the occurrence of the unbalance resets the monitoring. This setting is important in the case of weak infeed (current < 10 % of rated current) in order to give certain protection functions (such as distance protection) more time for detecting system incidents. As long as the time delay runs, it is assumed that the unbalance is due to a system incident.

As soon as the time has elapsed, the supervision assumes a measuring-voltage failure and seals in.

Siemens recommends using the default setting.

If you want the seal-in function to operate sooner or at once, you can reduce the time.

Parameter: **Asym.fail.-DO on netw.flt.**

- Recommended setting value (**_:115**) **Asym.fail.-DO on netw.flt. = No**

Parameter Value	Description
no	After elapse of the time delay the supervision function seals in. Even if the system incident criterion is fulfilled, the protection functions concerned will remain blocked. This avoids an unselective tripping of the protection functions due to an absence of the measuring voltage in the case of an unbalanced system incident. This is the default setting.
yes	The seal-in function is switched off. The supervision drops out immediately when a system incident is detected. With this setting, the unbalanced measuring-voltage failure is only reported, and in the event of a double failure (measuring-voltage failure and system incident in parallel), unselective tripping is preferred.

Parameter: **3ph.fail. - VA,VB,VC <**

- Recommended setting value (**_:101**) **3ph.fail. - VA,VB,VC <= 5 V**

The **3ph.fail. - VA,VB,VC <** parameter allows you to set the pickup value of the monitoring.

Siemens recommends using the default setting.

If you expect major disturbances acting upon the voltage inputs, you can increase this value. Increasing the values makes the supervision more sensitive to 3-phase system incidents.

Parameter: 3ph.fail. - phs.curr. jump

- Recommended setting value (`_:103`) **3ph.fail. - phs.curr. jump** = 0.1 A for $I_{rated} = 1$ A or 0.5 A for $I_{rated} = 5$ A

The **3ph.fail. - phs.curr. jump** parameter is used to set the differential current between the present current phasor and the stored phasor (from the previous period). If the value is exceeded, the function detects a system incident and blocks the monitoring.

Siemens recommends using the default setting.

Parameter: SO 3ph.fail. - time delay

- Recommended setting value (`_:106`) **SO 3ph.fail. - time delay** = 3.00 s

The **SO 3ph.fail. - time delay** parameter allows you to set the delay of the monitoring.

Siemens recommends using the default setting.



NOTE

Adapt the **SO 3ph.fail. - time delay** parameter to the inherent time of protection functions which are intended to block the monitoring function.

Note that with parameter values 0 s blocking of the monitoring function via a protection stimulation will not be possible any more.

Parameter: Operating mode

This parameter (`_:4711:101`) **Operating mode** and its settings are described in chapter *Process monitor*. For more information, refer to the chapters starting at [5.10.1 Overview of Functions](#).

Parameter: Switch-on 3ph. failure

- Recommended setting value (`_:107`) **Switch-on 3ph. failure** = on

Parameter Value	Description
<i>on</i>	The subfunction Switching to a 3-phase measuring-voltage failure is active. In the case of low loads, the subfunction for detection of a 3-phase measuring-voltage failure is not released, for example, because the current flow is too low. In this situation, the subfunction Switching to a 3-phase measuring-voltage failure can perform the monitoring task. Siemens recommends switching that subfunction on.
<i>off</i>	With the setting <i>off</i> the subfunction Switching to a 3-phase measuring-voltage failure is not active.

10.3.2.7 Settings

Addr.	Parameter	C	Setting Options	Default Setting
<i>Mes.v.fail.det</i>				
<code>_:1</code>	Mes.v.fail.det:Mode		<ul style="list-style-type: none"> off on test 	on
<code>_:115</code>	Mes.v.fail.det:Asym.fail.-DO on netw.flt.		<ul style="list-style-type: none"> no yes 	yes

Addr.	Parameter	C	Setting Options	Default Setting
_:113	Mes.v.fail.det:Asym.fail. - time delay		0.00 s to 30.00 s	10.00 s
_:102	Mes.v.fail.det:3ph.fail. - phs.curr.release	1 A @ 100 Irated	0.030 A to 35.000 A	0.100 A
		5 A @ 100 Irated	0.15 A to 175.00 A	0.50 A
		1 A @ 50 Irated	0.030 A to 35.000 A	0.100 A
		5 A @ 50 Irated	0.15 A to 175.00 A	0.50 A
		1 A @ 1.6 Irated	0.001 A to 1.600 A	0.100 A
		5 A @ 1.6 Irated	0.005 A to 8.000 A	0.500 A
_:103	Mes.v.fail.det:3ph.fail. - phs.curr. jump	1 A @ 100 Irated	0.030 A to 35.000 A	0.100 A
		5 A @ 100 Irated	0.15 A to 175.00 A	0.50 A
		1 A @ 50 Irated	0.030 A to 35.000 A	0.100 A
		5 A @ 50 Irated	0.15 A to 175.00 A	0.50 A
		1 A @ 1.6 Irated	0.001 A to 1.600 A	0.100 A
		5 A @ 1.6 Irated	0.005 A to 8.000 A	0.500 A
_:101	Mes.v.fail.det:3ph.fail. - VA,VB,VC <		0.300 V to 340.000 V	5.000 V
_:107	Mes.v.fail.det:Switch-on 3ph. failure		<ul style="list-style-type: none"> • off • on 	on
_:106	Mes.v.fail.det:SO 3ph.fail. - time delay		0.01 s to 30.00 s	3.00 s
_:114	Mes.v.fail.det:Asym.fail.- dropout delay		10.00 s to 10.00 s	10.00 s

10.3.2.8 Information List

No.	Information	Data Class (Type)	Type
<i>Mes.v.fail.det</i>			
_:82	Mes.v.fail.det:>Block function	SPS	I
_:54	Mes.v.fail.det:Inactive	SPS	O
_:52	Mes.v.fail.det:Behavior	ENS	O
_:53	Mes.v.fail.det:Health	ENS	O
_:300	Mes.v.fail.det:Alarm	SPS	O
_:304	Mes.v.fail.det:Asym.fail.-inst.alarm	SPS	O
_:303	Mes.v.fail.det:Asym.fail.-alarm	SPS	O
_:301	Mes.v.fail.det:3ph.failure-alarm	SPS	O
_:302	Mes.v.fail.det:SO 3ph.failure-alarm	SPS	O

10.3.3 Signaling-Voltage Supervision

10.3.3.1 Overview of Functions

Signaling-voltage supervision is used to evaluate the validity of binary signals connected to the SIPROTEC device via binary inputs. For this purpose, one binary input is used to monitor the signaling voltage. If the signaling voltage fails, the associated binary signals are marked as invalid and a **Signaling-voltage malfunction** indication is issued.

Several signaling-voltage supervision groups can be created in one SIPROTEC device. Each of these groups monitors an adjustable area with binary inputs.

10.3.3.2 Structure of the Function

The **Signaling-voltage supervision** function group contains, besides the general functionality, one preinstantiated **Supervision group** stage. The **Supervision group** stage can be instantiated in DIGSI 5 multiple times.

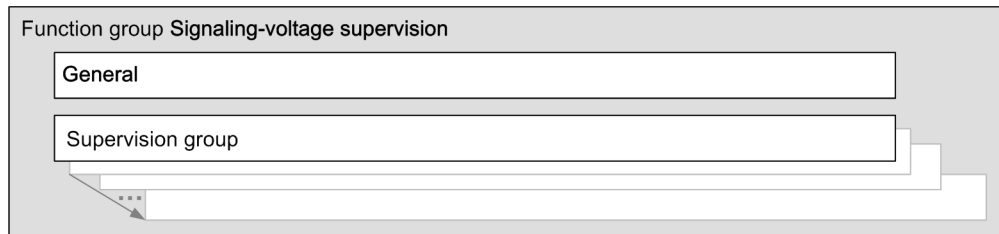

[dw_ivsstr, 1, en_US]

Figure 10-9 Structure/Embedding of the Function Group

10.3.3.3 Function Description

You can instantiate the **Signaling-voltage supervision** function group in the Global DIGSI 5 library. It contains 1 pre-instantiated **Superv. Grp.** function block (see the following figure). You can instantiate a maximum of 25 supervision groups.

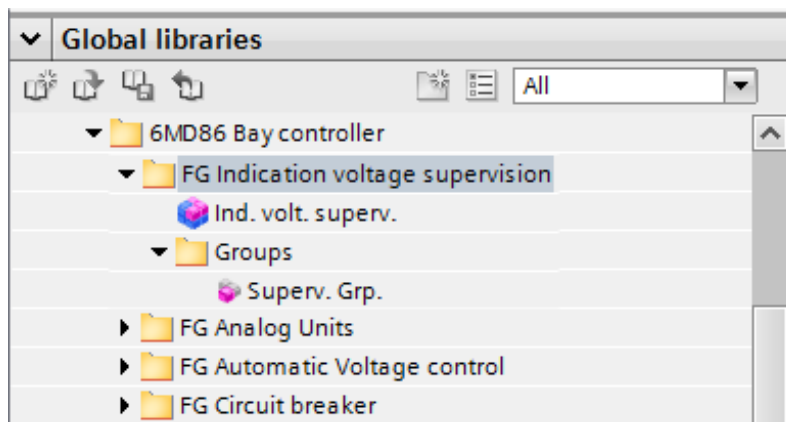

[sc_ivslib, 1, en_US]

Figure 10-10 Entry in the Global Library

Following the instantiation of the function group in the DIGSI project tree, it appears in the information routing of DIGSI (see the following figure). The status indications of the supervision groups can be routed here, for example, to existing binary outputs and/or logs.

Information			▼ S	► Destination				
				► Binary output				
				► Basismodul				
Signals	Number	Type		1.1	1.2	1.3	1.4	1.5
(All) ▼	(All) ▼	... ▼	▼
▼ Ind. volt. superv.	163			*				
▼ Superv. Grp.1	163.15031			*				
▶ Behavior	163.15031.52	ENS						
▶ Ind. volt. Disturbed	163.15031.55	SPS		U				

[sc_ivsrou, 1, en_US]

Figure 10-11 Information Routing

Set the binary input used for signaling-voltage supervision within one input/output module using the setting option (see the following figure). This binary input monitors the presence of the signaling voltage. If the

signaling voltage fails, this sets the quality attribute for all other binary inputs of the parameterized input/output module to *invalid*. The signal status of each of these binary inputs is frozen with its last valid value prior to the occurrence of the fault. The quality attribute of the binary inputs for other input/output modules are not taken into consideration by this.

If the signaling voltage again exceeds the binary threshold, the quality attribute of the binary inputs is reset to *valid*.

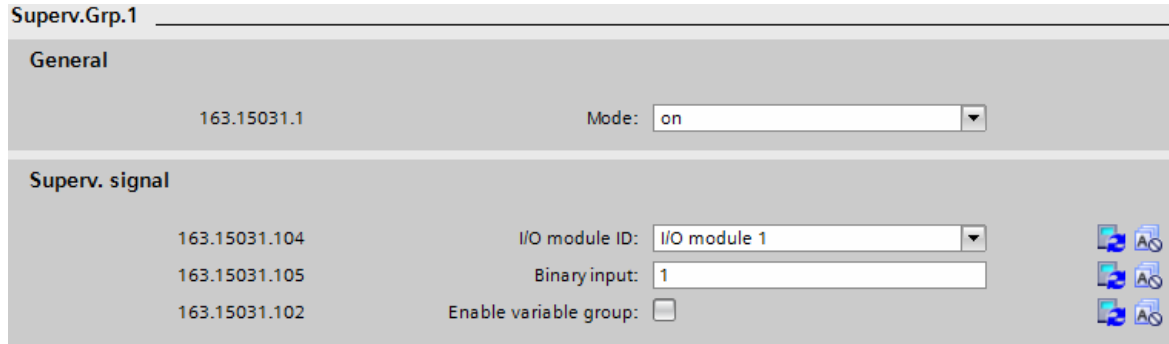

[sc_ivsgrp, 2, en_US]

Figure 10-12 Parameterization Menu of the Supervision Group (I)



NOTE

Each status change of the monitored binary inputs is delayed by 3 ms.

You can also combine binary inputs across modules in one **Superv. Grp.** function block and define any binary input within this group for supervision of the signaling voltage. For this purpose, place a check mark at the parameter (**_:102**) **Enable variable group** when configuring the supervision group. This extends the parameterization menu by the sections **Supervis. grp. start** and **Supervis. grp. end** (see the following figure).

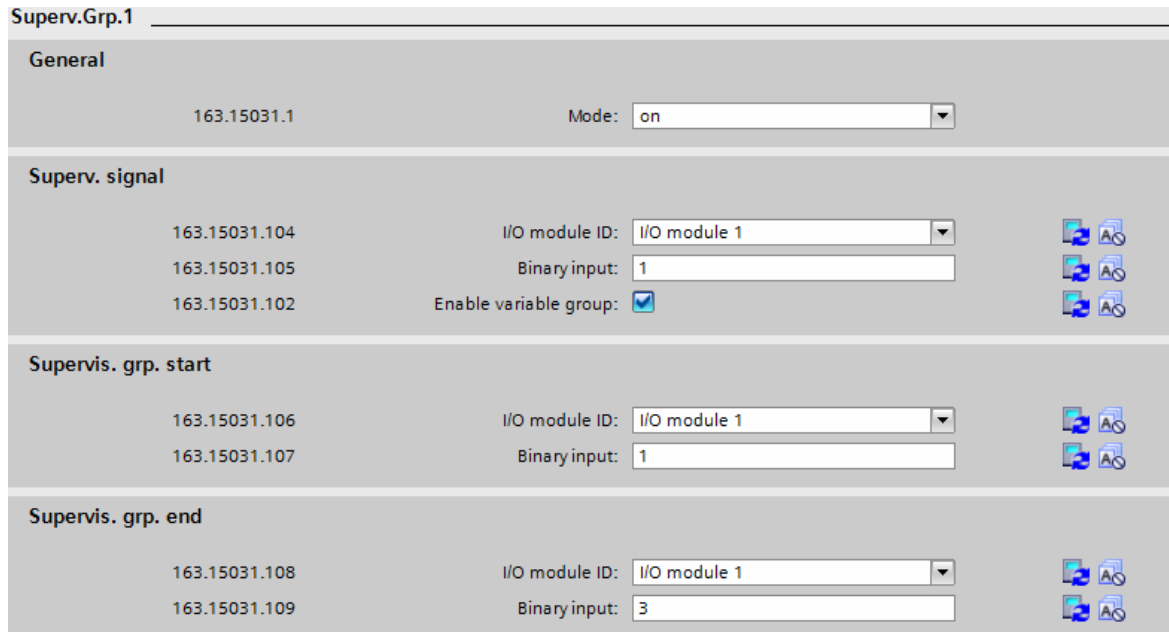

[sc_gruppe_de, 2, en_US]

Figure 10-13 Parameterization Menu of the Supervision Group (II)

There, for example, you are able to combine 1 to n different binary inputs into one supervision group. When doing so, the binary inputs on the input/output modules assignable to a supervision group must be related logically. With 3 input/output modules, for example, this allows only consecutive binary inputs to be grouped on the modules 1 and 2 or 2 and 3, but no binary inputs on modules 1 and 3. The binary inputs used for supervision can be located on any input/output module within the group defined in this manner.

If you have to monitor several binary inputs that, for example, work with different signaling voltages from different sources, then you can also instantiate and configure several **Superv. Grp.** function blocks within the **Signaling-voltage supervision** function group accordingly.

Within different supervision groups, only those consecutive binary inputs that are not already assigned to another supervision group can be grouped. The overlapping of binary inputs in different supervision groups is not permitted.

Error parameters are displayed to you by inconsistency indications in DIGSI.

Example

There are 4 input/output modules available.

Binary inputs of input/output modules 1 and 2 are already combined in supervision group 1. The 2 last binary inputs on module 2 are not included in the grouping.

In supervision group 2, only these 2 binary inputs of the input/output module 2 not used in supervision group 1 as well as further consecutive binary inputs of the input/output modules 3 and 4 can be combined.

10.3.3.4 Application and Setting Notes

Parameter (General): **Mode**

- Default setting (**_:1**) **Mode** = *on*

With the **Mode** parameter, you specify whether you want to activate, deactivate, or test the supervision of the signaling voltage for the appropriate group. If you put the group into test mode, the *Sig. volt. disturbed* indication is given a test flag.

Parameter (Supervision Signal): **I/O module ID**

- Default setting (**_:104**) **I/O module ID** = *I/O module 1*

Using the **I/O module ID** parameter, you specify the I/O module for which you want to activate supervision of the signaling voltage. Counting of the I/O modules starts in increasing order with the binary inputs of the base module. The binary inputs of the PS201 power-supply module permanently installed in the base module count as the 2nd I/O module followed by additional I/O modules (3 to n) on expansion boards of the device.

Parameter (Supervision Signal): **Binary input**

- Default setting (**_:105**) **Binary input** = *1*

Using the **Binary input** parameter, you specify the binary input responsible for the supervision of the signaling voltage for the parameterized I/O module. The quality attribute of all other binary inputs for this module are set to **valid** or **invalid** depending on the presence of the signaling voltage at the parameterized binary input.

Parameter (Supervision Signal): **Enable variable group**

- Default setting (**_:102**) **Enable variable group** = *untrue*

You can activate the parameter **Enable variable group** by placing the checkmark. If you have not set the check mark (default setting), only these 2 parameters are available for the configuration of the supervision signal. If you have set the check mark, the parameter menu is extended by the areas **Start supervision group** and **End supervision group**. You can then use that to carry out the grouping of binary inputs for supervision groups explained in the function description.

Parameter (Start Supervision Group): I/O module ID

- Default setting (`_:106`) **I/O module ID** = *I/O module 1*

Parameter **I/O module ID** is used to define the first I/O module that you want to assign to a supervision group. As the counting of the I/O module starts in ascending order with the binary inputs of the base module, this is the module with the lowest counter number that you can use for carrying out a grouping.

Parameter (Start Supervision Group): Binary input

- Default setting (`_:107`) **Binary input** = *1*

Parameter **Binary input** is used to define the lowest binary input for the first I/O module (see (`_:106`) **I/O module ID**) that you want to assign to a supervision group.

Parameter (End Supervision Group): I/O module ID

- Default setting (`_:108`) **I/O module ID** = *I/O module 1*

Parameter **I/O module ID** is used to define the last I/O module that you want to assign to a supervision group. As the counting of the I/O module starts in ascending order with the binary inputs of the base module, this is the module with the highest counter number that you can use for carrying out a grouping.

Parameter (End Supervision Group): Binary input

- Default setting (`_:109`) **Binary input** = *1*

Parameter **Binary input** is used to define the highest binary input for the last I/O module (see (`_:108`) **I/O module ID**) that you want to assign to a supervision group.

10.3.3.5 Settings

Addr.	Parameter	C	Setting Options	Default Setting
<i>General</i>				
<code>_:1</code>	Superv.Grp.#:Mode		<ul style="list-style-type: none"> • off • on • test 	on
<i>Superv. signal</i>				
<code>_:104</code>	Superv.Grp.#:I/O module ID		<ul style="list-style-type: none"> • I/O module 1 • I/O module 2 • I/O module 3 • I/O module 4 • I/O module 5 • I/O module 6 • I/O module 7 • I/O module 8 • I/O module 9 • I/O module 10 • I/O module 11 • I/O module 12 • I/O module 13 • I/O module 14 • I/O module 15 	I/O module 1
<code>_:105</code>	Superv.Grp.#:Binary input		1 to 256	1

Addr.	Parameter	C	Setting Options	Default Setting
_:102	Superv.Grp.#:Enable variable group		<ul style="list-style-type: none"> • 0 • 1 	false
<i>Supervis. grp. start</i>				
_:106	Superv.Grp.#:I/O module ID		<ul style="list-style-type: none"> • I/O module 1 • I/O module 2 • I/O module 3 • I/O module 4 • I/O module 5 • I/O module 6 • I/O module 7 • I/O module 8 • I/O module 9 • I/O module 10 • I/O module 11 • I/O module 12 • I/O module 13 • I/O module 14 • I/O module 15 	I/O module 1
_:107	Superv.Grp.#:Binary input		1 to 256	1
<i>Supervis. grp. end</i>				
_:108	Superv.Grp.#:I/O module ID		<ul style="list-style-type: none"> • I/O module 1 • I/O module 2 • I/O module 3 • I/O module 4 • I/O module 5 • I/O module 6 • I/O module 7 • I/O module 8 • I/O module 9 • I/O module 10 • I/O module 11 • I/O module 12 • I/O module 13 • I/O module 14 • I/O module 15 	I/O module 1
_:109	Superv.Grp.#:Binary input		1 to 256	1

10.3.3.6 Information List

No.	Information	Data Class (Type)	Type
<i>Superv. Grp. 1</i>			
_:15031:52	Superv.Grp.1:Behavior	ENS	O

No.	Information	Data Class (Type)	Type
_:15031:54	Superv.Grp.1:Health	ENS	0
_:15031:55	Superv.Grp.1:Sig. volt. disturbed	SPS	0

10.3.4 Voltage-Transformer Circuit Breaker

10.3.4.1 Overview of Functions

The function **Voltage-transformer circuit breaker** detects the tripping of the voltage-transformer circuit breaker due to short circuits in the voltage-transformer secondary circuits.

The **Voltage-transformer circuit breaker** function works independently of **Measuring-voltage failure detection** and should be used – if possible – in parallel to it.

The tripping of the voltage-transformer circuit breaker impacts the quality of the recorded measured-value data (refer to [3.4 Processing Quality Attributes](#)).

The following protection functions are automatically blocked if the voltage-transformer circuit breaker trips:

- Distance protection
- Directional negative-sequence protection
- Ground-fault protection for high-resistive faults in grounded systems

For the following functions the reaction (block/not block) can be set within the function in cases of a tripping of the voltage-transformer circuit breaker:

- Directional overcurrent protection, phases
- Overvoltage protection with negative-sequence voltage
- Overvoltage protection with zero-sequence voltage/residual voltage
- Undervoltage protection with 3-phase voltage
- Undervoltage protection with positive-sequence voltage



NOTE

If the voltage signal is generated using the optional Merging unit function, the quality of the voltage signal is sent as *invalid* in the sampled value stream, depending on the status of the voltage-transformer circuit breaker. For more information about configuring the voltage-transformer circuit breaker function for devices with merging unit and process-bus client, refer to the *Process Bus manual*.

10.3.4.2 Structure of the Function

The [Figure 10-14](#) shows the position of the function in the device. Every voltage measuring point contains the **Voltage-transformer circuit breaker** function.

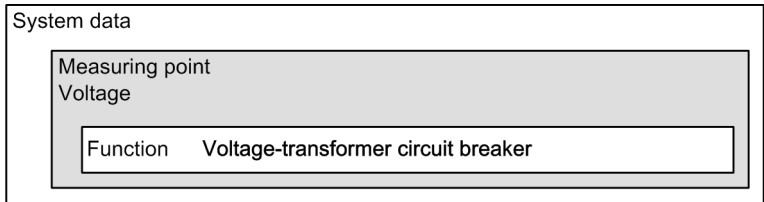

[dw_mcbstr, 1, en_US]

Figure 10-14 Structure/Embedding of the Function

10.3.4.3 Function Description

The tripping of the voltage-transformer circuit breaker is captured via the binary input signal **>Open**. With an active input signal the information about the measuring-voltage failure is relayed to the affected func-

tions (see [10.3.4.1 Overview of Functions](#)). The response to the detection of a measuring-voltage failure is explained in the specific protection-function descriptions.

Response Time of the Voltage-Transformer Circuit Breaker

The response time of the voltage-transformer circuit breaker can be slower than the pickup time of the distance protection. This bears the risk of an overfunction. The response time is communicated to the device with the **Response time** parameter. For a timely detection of the tripping of the voltage-transformer circuit breaker, the pickup of the distance protection is delayed by that response time.

10.3.4.4 Application and Setting Notes

The function is always active and need not be switched on.

Input Signal: >Open

- Input signal: (`_:500`) >Open

The input signal >Open must be connected to the tripping of the voltage-transformer circuit breaker. As a rule, this occurs via the routing to a binary input.

Parameter: Response time of the voltage-transformer circuit breaker

- Recommended setting value (`_:101`) **Response time = 0 ms**

When the voltage-transformer circuit breaker drops out, the device must block the distance protection immediately to prevent an unwanted tripping of the distance protection due to the absence of the measuring voltage while the load current is flowing.

The blocking must be faster than the 1st stage of the distance protection. This requires an extremely short response time of the miniature circuit breaker (≤ 4 ms at 50 Hz, ≤ 3 ms at 60 Hz rated frequency). If the circuit-breaker auxiliary contact does not fulfill this requirement, you have to set the response time accordingly.

10.3.4.5 Settings

Addr.	Parameter	C	Setting Options	Default Setting
<i>VT miniatureCB</i>				
<code>_:101</code>	VT miniatureCB:Response time		0.00 s to 0.03 s	0.00 s

10.3.4.6 Information List

No.	Information	Data Class (Type)	Type
<i>Definite-T #</i>			
<code>_:500</code>	VT miniatureCB:>Open	SPS	I

10.3.5 Voltage-Balance Supervision

10.3.5.1 Overview of Functions

In healthy system operation, a certain balance between voltages can be assumed.

The **Voltage-balance supervision** function detects the following errors:

- Unbalance of phase-to-phase voltages in the secondary circuit
- Connection errors during commissioning or short circuits and interruptions in the secondary circuit

The voltage measurement is based on the RMS values of the fundamental component.

10.3.5.2 Structure of the Function

The **Voltage-balance supervision** function is located in the **Power-system data** of each 3-phase voltage measuring point.

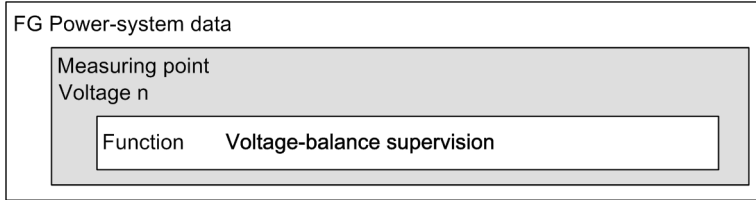

[dw_strusy, 2, en_US]

Figure 10-15 Structure/Embedding of the Function

10.3.5.3 Function Description

The voltage balance is checked by a magnitude supervision function. This function relates the smallest phase-to-phase voltage to the largest phase-to-phase voltage. Unbalance is detected if $|V_{min}| / |V_{max}| < \text{Threshold min/max}$, as long as $V_{max} > \text{Release threshold}$

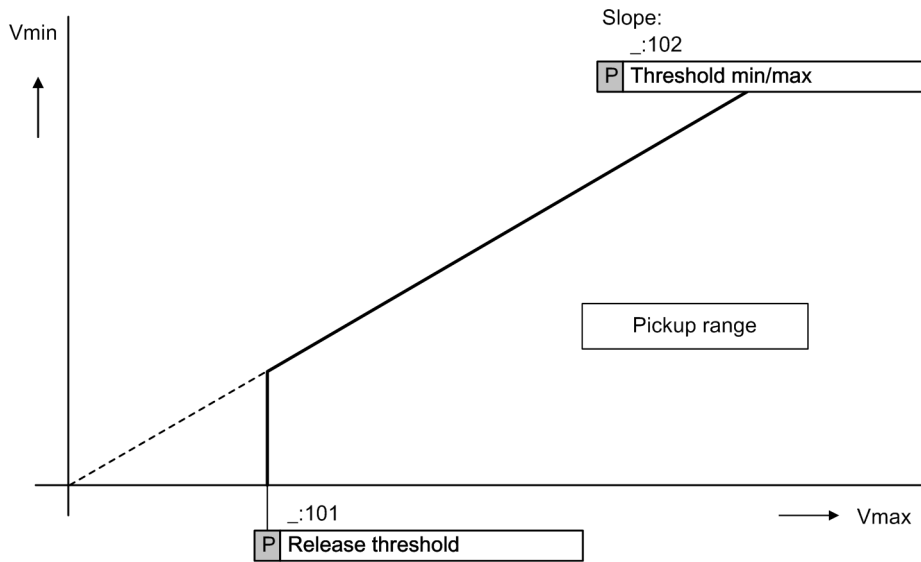

[lo_kenuns, 1, en_US]

Figure 10-16 Characteristic of the Voltage-Balance Supervision

Logic

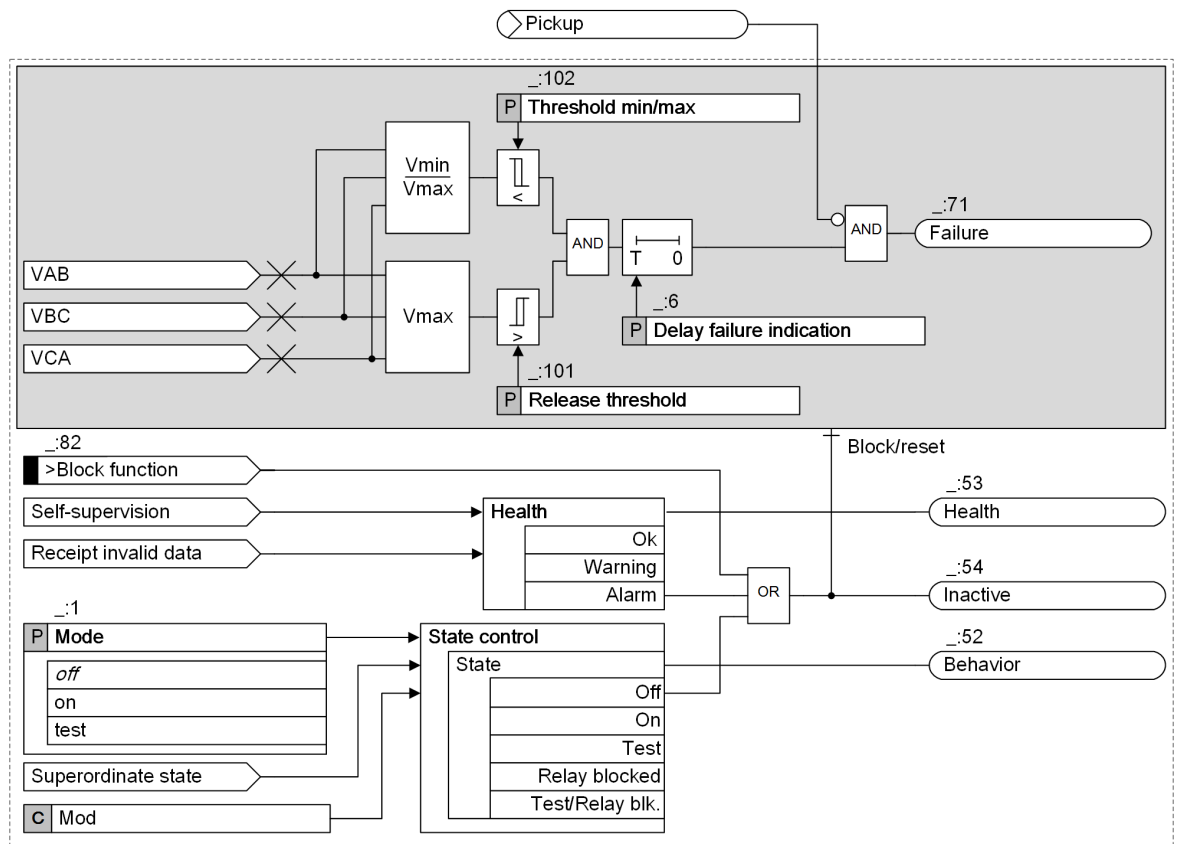

[to_sp_asym, 5, en_US]

Figure 10-17 Logic Diagram of the Voltage-Balance Supervision

The **Threshold min/max** parameter is the criterion by which a phase-to-phase voltage unbalance is measured. The device calculates the ratio between the minimum (V_{min}) and the maximum (V_{max}) phase-to-phase voltage.

Enter the lower limit of the maximum phase-to-phase voltage (V_{max}) with the parameter **Release threshold**. This specifies the lower limit of the operating range of this function.

Delay failure indication

If it falls below the balance factor **Threshold min/max** and at the same time the maximum phase-to-phase voltage exceeds the **Release threshold**, the delay of the failure indication (parameter: **Delay failure indication**) starts. If both conditions persist during this time, the indication **Failure** is generated.

Blocking the Function

The following blockings reset the picked up function completely:

- Externally or internally via the binary input signal *>Block function*
- A protection pickup
The pickup signal of a protection function blocks the *Failure* indication.

10.3.5.4 Application and Setting Notes

Parameter: Threshold min/max

- Recommended setting value (`_:102`) **Threshold min/max = 0.75**

The **Threshold min/max** parameter is used to set the ratio between the minimum (V_{\min}) and the maximum (V_{\max}) phase-to-phase voltage. Siemens recommends using the default setting.

Parameter: Release threshold

- Recommended setting value (**_:101**) **Release threshold = 50 V**

With the **Release threshold** parameter you set the lower limit of the maximum phase-to-phase voltage (V_{\max}). Siemens recommends using the default setting.

Parameter: Delay failure indication

- Recommended setting value (**_:6**) **Delay failure indication = 5.00 s**

Set the **Delay failure indication** parameter so that overfunctions due to disturbing influences (such as switching operations) are avoided. Siemens recommends using the default setting.

10.3.5.5 Settings

Addr.	Parameter	C	Setting Options	Default Setting
<i>Supv. balan. V</i>				
_:1	Supv. balan. V:Mode		<ul style="list-style-type: none"> off on test 	off
_:101	Supv. balan. V:Release threshold		0.300 V to 170.000 V	50.000 V
_:102	Supv. balan. V:Threshold min/max		0.58 to 0.95	0.75
_:6	Supv. balan. V:Delay failure indication		0.00 sto 100.00 s	5.00 s

10.3.5.6 Information List

No.	Information	Data Class (Type)	Type
<i>Supv. balan. V</i>			
_:82	Supv. balan. V:>Block function	SPS	I
_:54	Supv. balan. V:Inactive	SPS	O
_:52	Supv. balan. V:Behavior	ENS	O
_:53	Supv. balan. V:Health	ENS	O
_:71	Supv. balan. V:Failure	SPS	O

10.3.6 Voltage-Sum Supervision

10.3.6.1 Overview of Functions

In healthy system operation, the sum of all voltages at one measuring point must be approximately 0. The **Voltage-sum supervision** monitors the sum of all voltages of one measuring point in the secondary circuit. It detects connection errors during commissioning or short circuits and interruptions in the secondary circuit. For summation of the voltages, the 3 phase-to-ground voltages and the residual voltage (da-dn - voltage of an open-circuited delta winding) are required.

The voltage measurement is based on the RMS values of the fundamental component.



NOTE

For the **Voltage-sum supervision**, the externally generated residual voltage must be connected to the 4th voltage measuring input.
For the **Voltage-sum supervision** to work correctly, the **Matching ratio Vph / VN** parameter must be set accordingly.

10.3.6.2 Structure of the Function

The **Voltage-sum supervision** function is located in the **Power-system data** function group of each 3-phase voltage measuring point.

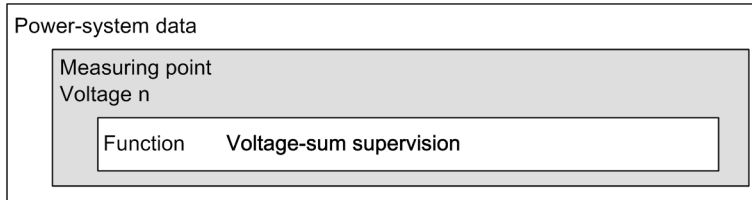

[dw_strvss_2_en_US]

Figure 10-18 Structure/Embedding of the Function

10.3.6.3 Function Description

The voltage sum is generated by addition of the voltage phasors. Errors in the voltage circuits are detected if $VF = |\underline{VA} + \underline{VB} + \underline{VC} - V_{ph}/V_N \cdot \underline{VN}| > \text{Threshold}$, where V_{ph}/V_N forms the **Matching ratio Vph / VN** parameter.

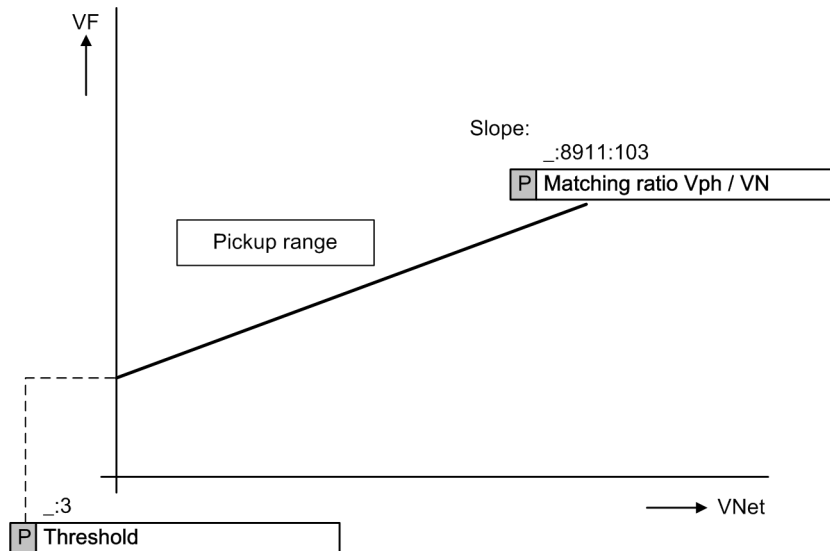

[lo_kenvss-01.tif_1_en_US]

Figure 10-19 Characteristic of the Voltage-Sum Supervision

Logic

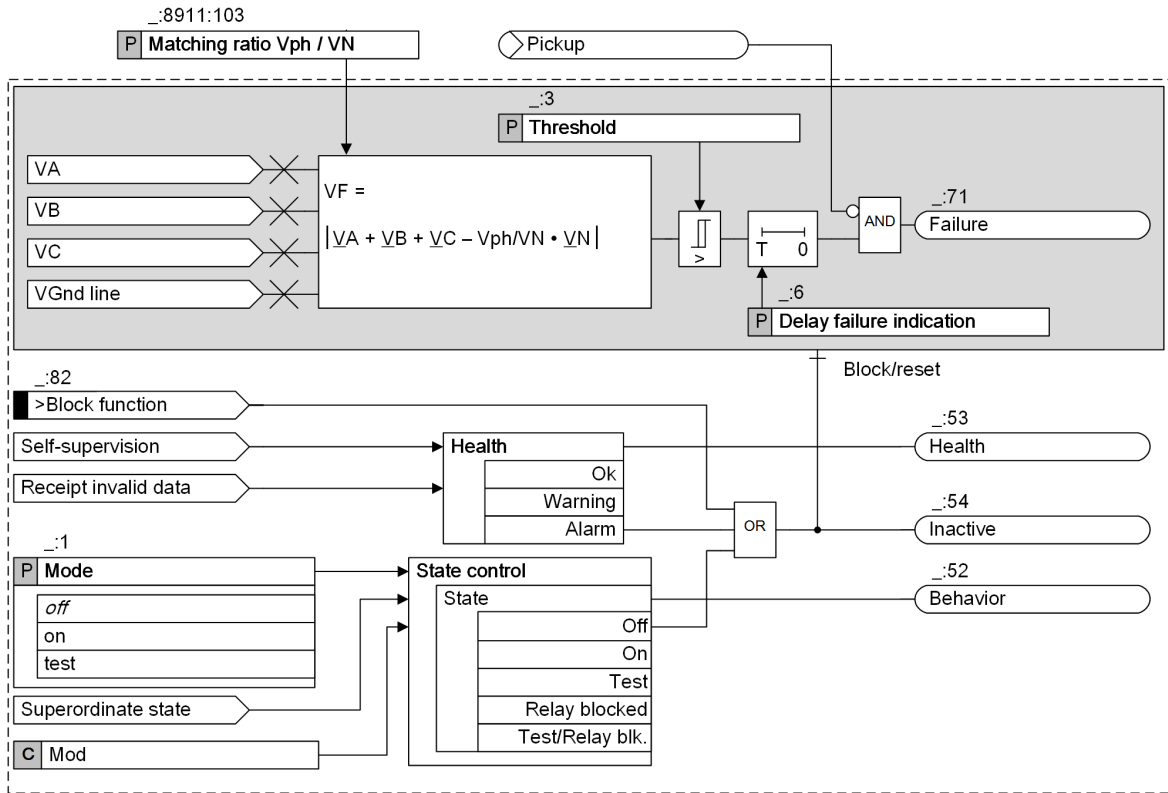

[ilo_volt-sum-supervision, 5, en_US]

Figure 10-20 Logic Diagram of the Voltage-Sum Supervision

The device measures the phase-to-ground voltage and the ground voltage of the lines to be protected. The sum of the 4 voltages must be 0.

Threshold

If the calculated fault voltage (V_f) exceeds the **Threshold** the parameter **Delay failure indication** triggers the indication **Failure**.

The device calculates the fault voltage (V_f) with the formula:

$$V_f = |V_A + V_B + V_C - V_{ph}/U_N \cdot U_N|$$

where V_{ph}/U_N forms the **Matching ratio V_{ph} / V_N** parameter.

The **Matching ratio V_{ph} / V_N** parameter takes into account the differing transformation ratios between the residual voltage input and the phase-voltage inputs.

You can find more information in this respect in chapter [10.3.6.1 Overview of Functions](#)).

Delay failure indication

When the threshold value for the delay of the failure indication (parameter: **Delay failure indication**) is exceeded, the indication **Failure** is generated.

Blocking the Function

The following blockings reset the picked up function completely:

- Externally or internally via the binary input signal **>Block function**
- A protection pickup
 The pickup signal of a protection function blocks the **Failure** indication.

10.3.6.4 Application and Setting Notes

Parameter: Threshold

- Recommended setting value (_:3) **Threshold = 25 V**

The **Threshold** parameter is used to set the voltage which the device uses to recognize the calculated fault voltage (V_F) as a failure of the voltage sums. Siemens recommends using the default setting.

Parameter: Delay failure indication

- Recommended setting value (_:6) **Delay failure indication = 5.00 s**

Set the **Delay failure indication** parameter so that overfunctions due to disturbing influences (such as switching operations) are avoided. Siemens recommends using the default setting.

10.3.6.5 Settings

Addr.	Parameter	C	Setting Options	Default Setting
<i>Supv. sum V</i>				
_:1	Supv. sum V:Mode		<ul style="list-style-type: none"> off on test 	off
_:3	Supv. sum V:Threshold		0.300 V to 170.000 V	43.300 V
_:6	Supv. sum V:Delay failure indication		0.00 sto 100.00 s	5.00 s

10.3.6.6 Information List

No.	Information	Data Class (Type)	Type
<i>Supv. sum V</i>			
_:82	Supv. sum V:>Block function	SPS	I
_:54	Supv. sum V:Inactive	SPS	O
_:52	Supv. sum V:Behavior	ENS	O
_:53	Supv. sum V:Health	ENS	O
_:71	Supv. sum V:Failure	SPS	O

10.3.7 Voltage Phase-Rotation Supervision

10.3.7.1 Overview of Functions

The **Voltage phase-rotation supervision** function monitors the phase sequence of the secondary-circuit voltages by monitoring the sequence of the zero crossings (with same sign) of the voltages. This enables the device to detect connections that were inverted during commissioning. The criterion for the check is the setting of the **Phase sequence** parameter.

10.3.7.2 Structure of the Function

The **Voltage phase-rotation supervision** function is located in the **Power-system data** of each 3-phase voltage measuring point.

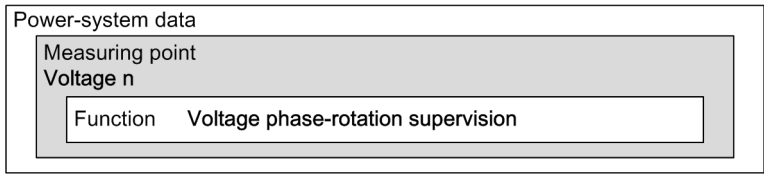

[dw_strvrs, 3, en_US]
 Figure 10-21 Structure/Embedding of the Function

10.3.7.3 Function Description

Logic

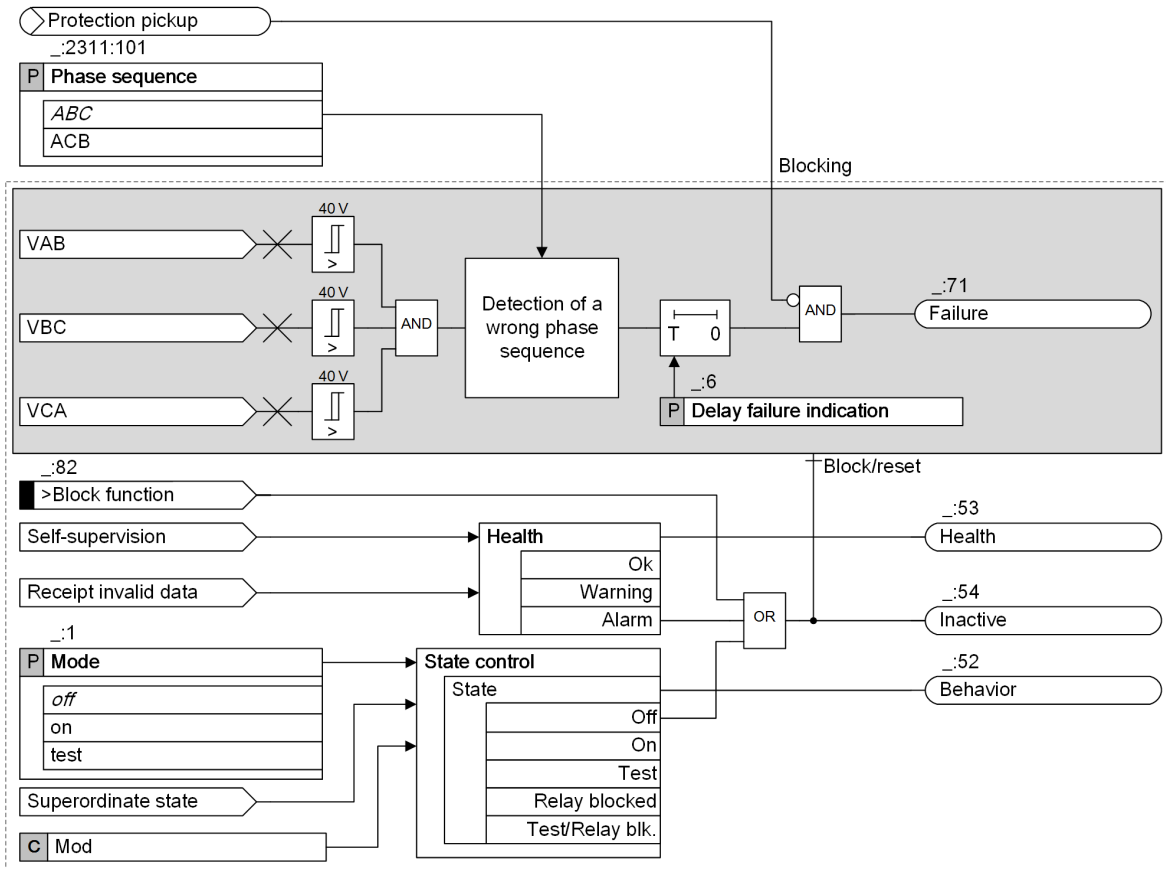

[lo_volt-phas-rotation-supervision, 5, en_US]
 Figure 10-22 Logic Diagram of the Voltage Phase-Rotation Supervision

The phase rotation is important for protection functions which process phase, loop, and directional information. You can set the phase sequence with the **Phase sequence** parameter in the function block **General** of the power-system data (see chapter 6.1 *Power-System Data*).

To supervise the phase rotation, the device compares the measured phase sequence with the set phase sequence. For abnormal phase sequences, the indication *Failure* is generated.

The connection of the voltages to the device does not depend on the selected phase sequence. The connection diagrams are shown in chapter A *Appendix*.

Release Condition

The supervision of the voltage phase rotation is carried out when all measured phase-to-phase voltages are greater than 40 V.

Blocking of the Function

The following blockings reset the function completely:

- Via the binary input signal *>Block function* from an external or internal source
- Via a protection pickup
The pickup signal from a protection function blocks the indication *Failure*.

Delay failure indication

When the device detects an inverted phase-rotation direction for the duration of the **Delay failure indication**, the indication *Failure* is generated.

10.3.7.4 Application and Setting Notes

Parameter: Delay failure indication

- Recommended setting value (_:6) **Delay failure indication = 5.00 s**

Set the **Delay failure indication** parameter so that overfunctions due to disturbing influences (such as switching operations) are avoided. Siemens recommends using the default setting.

10.3.7.5 Settings

Addr.	Parameter	C	Setting Options	Default Setting
<i>Supv. ph.seq.V</i>				
_:1	Supv. ph.seq.V:Mode		<ul style="list-style-type: none"> • off • on • test 	off
_:6	Supv. ph.seq.V:Delay failure indication		0.00 s to 100.00 s	5.00 s

10.3.7.6 Information List

No.	Information	Data Class (Type)	Type
<i>Supv. ph.seq.V</i>			
_:82	Supv. ph.seq.V:>Block function	SPS	I
_:54	Supv. ph.seq.V:Inactive	SPS	O
_:52	Supv. ph.seq.V:Behavior	ENS	O
_:53	Supv. ph.seq.V:Health	ENS	O
_:71	Supv. ph.seq.V:Failure	SPS	O

10.3.8 Voltage-Comparison Supervision

10.3.8.1 Overview of Functions

The **Voltage-comparison supervision** function (ANSI 60):

- Monitors the voltage-transformer circuits by comparing the voltages from 2 voltage transformers
If failures in the voltage circuits are detected, voltage-related protection functions can be blocked.
- Requires the connection of 2 voltage measuring points to the voltage interface of the function group
You can take one of the voltages as the reference voltage and then the other becomes the main voltage.
The reference voltage is used for comparison.



NOTE

The voltage selection for the protection function in the FGs works independent of the status of the **Voltage-comparison supervision** function.

10.3.8.2 Structure of the Function

The **Voltage-comparison supervision** function can be used in the following function groups:

- Generator stator
- Generator side
- Voltage-current 3-phase (VI 3ph)
- Transformer side
- Auto transformer autoside (Auto trf. autoside)

The **Voltage-comparison supervision** function supports only 1 stage. The stage is preconfigured at the factory.

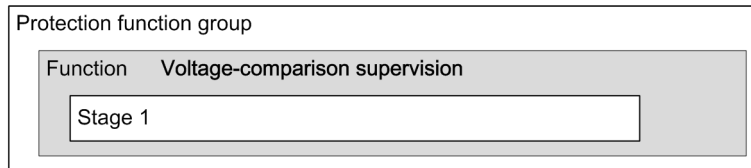

[dw_structure_VBP_1_en_US]

Figure 10-23 Structure/Embedding of the Function

10.3.8.3 Description

Function Application

The following figure shows an application example.

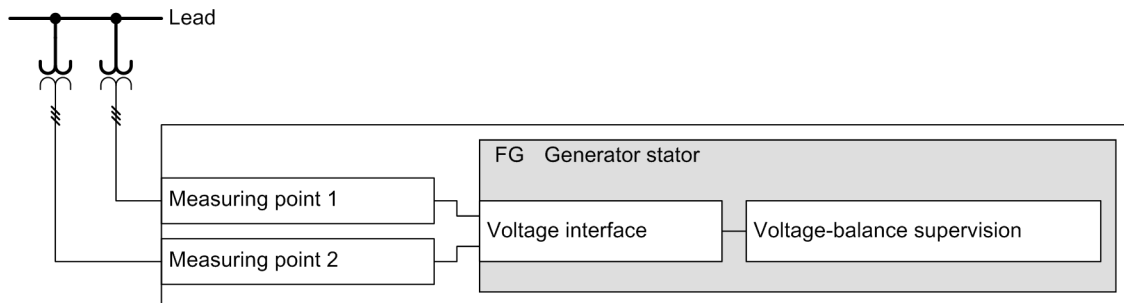

[dw_VBP application_1_en_US]

Figure 10-24 Application Example

Connecting Measuring Points to a Function Group

The following figure shows the connection of the function group **Generator stator** with several measuring points in DIGSI. The ID of each measuring point appears in the brackets after the name.

Connect measuring points to function group			
Measuring point	Generator stator		
	V 3ph	I 3ph	
(All)	(All)	(All)	
Meas.point I-3ph 1[ID 1]		X	
Meas.point V-3ph 1[ID 2]	X		
Meas.point V-3ph 2[ID 3]	X		

[sc_VBStoFG_1_en_US]

Figure 10-25 Connecting the Measuring Points to the Generator Stator Function Group

There are consistency checks that validate the connections of voltage measuring points to the function group:

- The connection type must be identical for all measuring points connected to the same interface of the function group.
- The rated voltage (primary and secondary) must be identical for all measuring points connected to the same interface.
- 2 voltage measuring points must be connected to one voltage interface.
- Either the **Voltage-comparison supervision** function or the **Voltage measuring-point selection** function must be instantiated. They must not be instantiated at the same time.

About the **Voltage measuring-point selection** function, you can find more information in chapter [6.53 Voltage Measuring-Point Selection](#).

Voltage Selection

2 voltage measuring points are connected to a voltage interface of a function group. In the **Voltage-comparison supervision** function, you can set one of the voltages as the reference voltage via the parameter **Reference voltage**, and the other voltage becomes the main voltage.

- The reference voltage is used for voltage comparison.
- The main voltage is used for all voltage-related functions in the FGs that contain the **Voltage-comparison supervision** function.

If the main voltage transformer is disconnected, the **Voltage-comparison supervision** function issues the blocking signal *Meas. -volt failure*. The signal is transmitted to all voltage-related protection functions which are used in the same FGs as the **Voltage-comparison supervision**.

Logic of the Stage

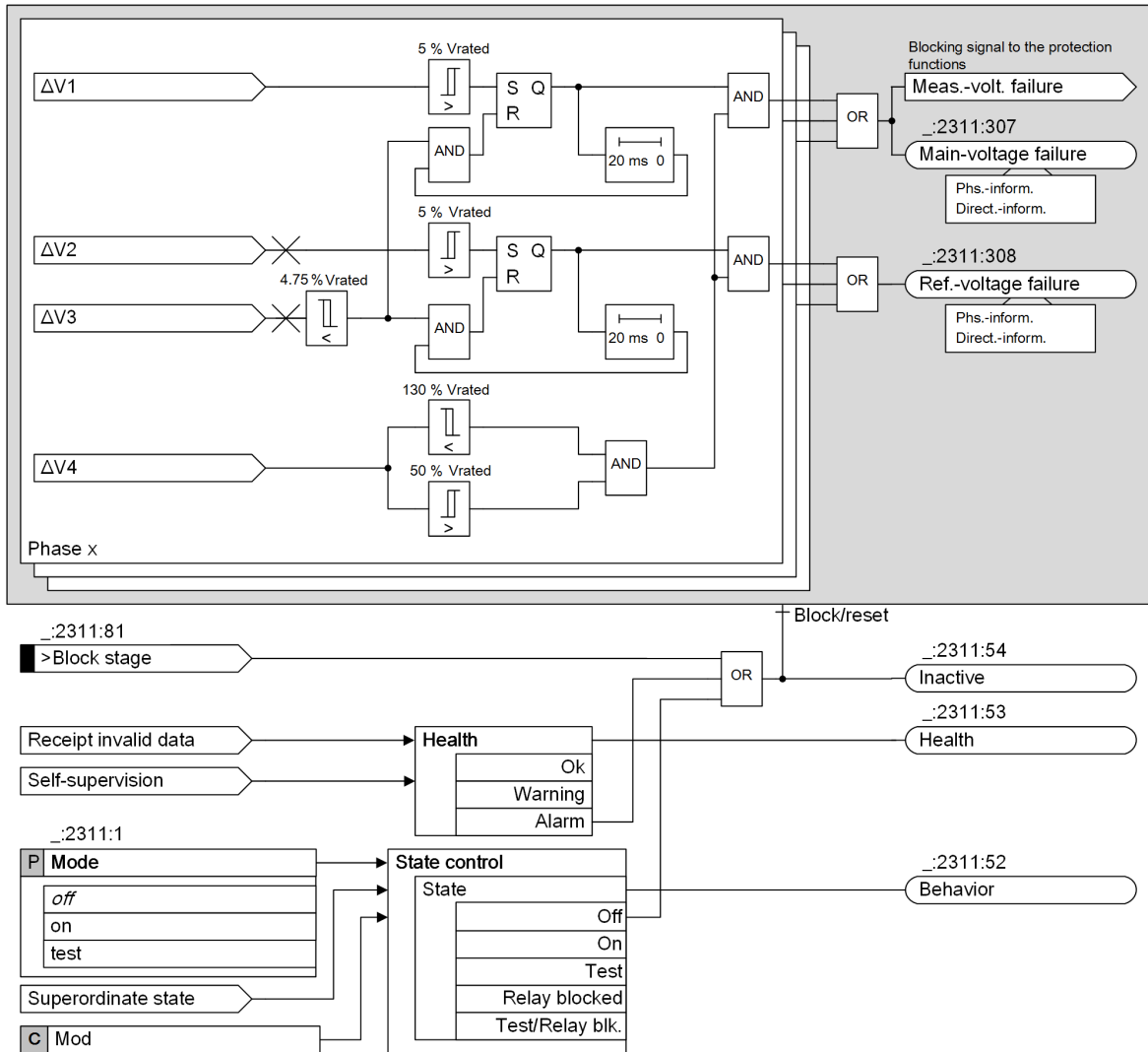

[!o_stage VBP_3_en_US]

Figure 10-26 Logic Diagram of the Supervision Stage

The voltage inputs in the preceding figure are calculated with the following equations:

$$\Delta V1 = |v(n)_{ref.}| - |v(n)_{main}|$$

$$\Delta V2 = |v(n)_{main}| - |v(n)_{ref.}|$$

$$\Delta V3 = |V_{ref.} - V_{main}|$$

$$\Delta V4 = \text{Max.}(V1_{ref.}, V1_{main})$$

The following table shows the description of the voltages.

Table 10-1 Voltage Description

Voltages	Description
$v(n)_{ref.}$	Sampled value of the reference voltage
$v(n)_{main}$	Sampled value of the main voltage
$V_{ref.}$	Fundamental value of the reference voltage
V_{main}	Fundamental value of the main voltage

Voltages	Description
V1 _{ref.}	Positive-sequence value of the reference voltage
V1 _{main}	Positive-sequence value of the main voltage

Pickup

If the voltage difference between each 2 of 3 continuous sampling points is over 8 % V_{rated} of the plant, the supervision stage picks up.

Voltage Supervision

For the **Voltage-comparison supervision** function, the following 2 connection types are allowed:

- Phase-to-ground
The phase-to-ground voltages are used for the voltage-difference comparison.
- Phase-to-phase
The phase-to-phase voltages are used for the voltage-difference comparison.



NOTE

The **2 ph-to-ph volt. + VN** and **2 ph-to-ph voltages** connection types are not allowed.

Voltage-Failure Indication

For different connection types, the indications are different.

- Phase-to-ground
You can get the voltage-failure information from the output signals *Main-voltage failure* and *Ref.-voltage failure*.
- Phase-to-phase
 - If one phase is influenced, the phase information is indicated.
 - If more than one phase is influenced, the phase-to-phase information is indicated.
Take the main voltage transformer for example. You can determine the faulty phase with the following table.

Determination Criteria	Calculated Result		
$(v_{AB(n)ref.} - v_{AB(n)main}) - 8\% V_{rated}$	> 0	> 0	< 0
$(v_{BC(n)ref.} - v_{BC(n)main}) - 8\% V_{rated}$	< 0	> 0	> 0
$(v_{AC(n)ref.} - v_{AC(n)main}) - 8\% V_{rated}$	> 0	< 0	> 0
Failure Information	Phase A is failed.	Phase B is failed.	Phase C is failed.

Release Voltage

If the main positive-sequence voltage or the reference positive-sequence voltage is between 50 % V_{rated} and 130 % V_{rated}, the function is released.

Selection Invalid

An invalid measuring-point selection results in the following:

- The voltage measured values are displayed as **Failure**.
- The validity of the voltage measured values is set to **Invalid**.
- The indication *Health* is set to **Alarm**.
- The indication *Selection invalid* becomes true.

Blocking of the Stage

In the event of blocking, the picked up function is reset. Blocking is possible externally or internally via the binary input signal *>Block stage*.

10.3.8.4 Application and Setting Notes

Parameter: Reference voltage

- Default setting **Reference voltage** = *None*

With the parameter **Reference voltage**, you can set a measured voltage as the reference voltage.



NOTE

You must assign a voltage measuring point to the parameter **Reference voltage**. The assignment influences the voltage-related protection functions which are used in the same FGs as the **Voltage-comparison supervision** function. These voltage-related protection functions use the unassigned voltage measuring point, which is defined as the main voltage in the **Voltage-comparison supervision** function. You can find more information in section [Voltage Selection, Page 1325](#).

EXAMPLE

Meas.point V-3ph 1 and **Meas.point V-3ph 2** are connected to the **Voltage-comparison supervision** function. Then you have 2 more setting options, as shown in the following figure. You must select one of these setting options for the parameter **Reference voltage**.

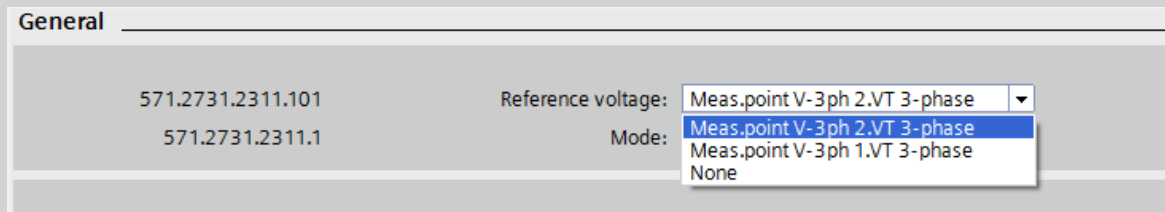

[sc_VBS_ref_voltage_1_en_US]

Parameter: Mode

- Default setting (**_ :2311:1**) **Mode** = *off*

With the parameter **Mode**, you can activate and deactivate the **Voltage-comparison supervision** function. If you switch to **test** mode, the **Voltage-comparison supervision** function is marked as invalid.

10.3.8.5 Settings

Addr.	Parameter	C	Setting Options	Default Setting
VolCmpSup 1				
_:2311:1	General:Mode		<ul style="list-style-type: none"> • off • on • test 	off
_:2311:101	General:Reference voltage		Setting options depend on configuration	None

10.3.8.6 Information List

No.	Information	Data Class (Type)	Type
<i>VolCmpSup 1</i>			
_:2311:81	General:>Block stage	SPS	I
_:2311:501	General:>MP-ID selection	INS	I
_:2311:54	General:Inactive	SPS	O
_:2311:52	General:Behavior	ENS	O
_:2311:53	General:Health	ENS	O
_:2311:307	General:Main-voltage failure	ACD	O
_:2311:308	General:Ref.-voltage failure	ACD	O
_:2311:309	General:Selection invalid	SPS	O

10.3.9 Broken-Wire Detection

10.3.9.1 Overview of Functions

The **Broken-wire detection** detects interruptions in the secondary circuit of the current transformers during steady-state operation. In addition to creating a hazard due to high voltages in the secondary circuit, such interruptions can mimic the presence of differential currents for the differential protection, as caused by short circuits in the protected object. To prevent overfunctions due to faulty current values, the affected protection functions are blocked, for example the Line differential protection and the Distance protection.

An interruption in the secondary circuit of the current transformer cannot always be distinguished from a broken conductor in the primary circuit.

10.3.9.2 Structure of the Function

The **Broken-wire detection** function is located in the power-system data of each 3-phase current measuring point.

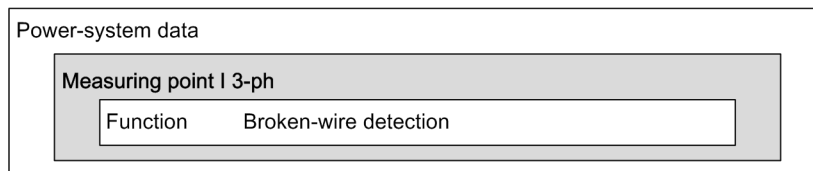

[doc_bwsjsk_3_en_US]

Figure 10-27 Structure/Embedding of the Function

10.3.9.3 Function Description

Broken-Wire Detection

The function **Broken-wire detection** searches for current interruptions at all current measuring points. For this purpose, the instantaneous values of the currents are checked for their plausibility. In addition, further criteria must be met before a wire break can be detected and signaled with assurance.



NOTE

If the function **Broken-wire detection** is activated and the secondary circuits of the current transformers are open, functions such as the differential protection are blocked and do not trip anymore. Hazardous overvoltages can be generated at the open circuit of the current transformer in this condition which are not eliminated because the differential protection is blocked.

Detection:

A wire break initially manifests itself as a sudden decrease of the current below the minimum threshold of $0.06 I_{I_{rated}}$. A plausibility test with the instantaneous values from the previous cycle confirms that the current has fallen below the minimum threshold. If the criteria for a wire break are satisfied, the affected phase is marked with **Broken wire suspected**. The following messages are generated: (*_:301*) *Phs A BW suspected*, (*_:302*) *Phs B BW suspected*, and/or (*_:303*) *Phs C BW suspected*, and (*_:307*) *Broken wire suspected*.

Resetting:

A broken-wire suspicion is reset by phase current flowing again, by a reset criterion of the broken-wire check, by a binary input signal, or by a controllable.

Broken-Wire Check

To prevent unwanted pickup of this monitoring function caused by special operating conditions, for example fault, maintenance, test, etc., the function checks various criteria.

If at least one of the following criteria is met, the broken-wire suspicion is reset including any associated protection blocking.

Local resetting criteria:

- At least one protection function has picked up.
- All circuit breakers assigned to the protection function group are open.
For applications using a 1 1/2 circuit-breaker layout, both circuit breakers must be open.
- A wire break is detected on another phase of a local current measuring point.
- A voltage jump at a local voltage measuring point
- A current jump of the associated zero-sequence current
This reset criterion applies only for **CT connection = 3-phase + IN-separate**.
- A current jump on the same phase of another local current measuring point
- The current in at least one phase is greater than $2.5 I_{I_{rated}}$.

If a broken wire suspicion detected by the broken-wire check is not reset by a reset criterion, the wire break is assured. The messages (*_:304*) *Phase A broken wire*, (*_:305*) *Phase B broken wire*, and/or (*_:306*) *Phase C broken wire*, and (*_:308*) *Broken wire confirmed* are generated and maintained stable for a duration of at least 3 system periods.

Blocking the Protection

The decision to block the protection is performed phase-segregated for each 3-phase current measuring point of the device.

The parameter (*_:5581:101*) **Mode of blocking** controls the blocking behavior:

- **not blocking**
 - Wire break is only signaled.
- **blocking**
 - Each broken-wire suspicion causes the affected protection functions to be blocked.

10.3.9.4 Application and Setting Notes

Parameter: Mode

- Recommended setting value (*_:1*) **Mode = off**

The parameter **Mode** is used to switch the **Broken-wire detection** to **on** or **off** or to activate the state **test**.

Parameter: Mode of blocking

- Recommended setting value (`_:101`) **Mode of blocking = blocking**

With the parameter **Mode of blocking**, you control the behavior when a broken-wire suspicion occurs, refer to [Blocking the Protection, Page 1330](#). Siemens recommends using the default setting. The setting options are **blocking** and **not blocking**.

10.3.9.5 Settings

Addr.	Parameter	C	Setting Options	Default Setting
<i>Brk.wire det.</i>				
<code>_:1</code>	Brk.wire det.:Mode		<ul style="list-style-type: none"> off on test 	off

10.3.9.6 Information List

No.	Information	Data Class (Type)	Type
<i>Brk.wire det.</i>			
<code>_:82</code>	Brk.wire det.:>Block function	SPS	I
<code>_:83</code>	Brk.wire det.:>Reset broken wire	SPS	I
<code>_:55</code>	Brk.wire det.:Reset broken wire	SPC	C
<code>_:54</code>	Brk.wire det.:Inactive	SPS	O
<code>_:52</code>	Brk.wire det.:Behavior	ENS	O
<code>_:53</code>	Brk.wire det.:Health	ENS	O
<code>_:301</code>	Brk.wire det.:Phs A BW suspected	SPS	O
<code>_:302</code>	Brk.wire det.:Phs B BW suspected	SPS	O
<code>_:303</code>	Brk.wire det.:Phs C BW suspected	SPS	O
<code>_:304</code>	Brk.wire det.:Phase A broken wire	SPS	O
<code>_:305</code>	Brk.wire det.:Phase B broken wire	SPS	O
<code>_:306</code>	Brk.wire det.:Phase C broken wire	SPS	O
<code>_:307</code>	Brk.wire det.:Broken wire suspected	SPS	O
<code>_:308</code>	Brk.wire det.:Broken wire confirmed	SPS	O
<code>_:51</code>	Brk.wire det.:Mode (controllable)	ENC	C

10.3.10 Current-Balance Supervision

10.3.10.1 Overview of Functions

In healthy network operation, a certain balance between currents can be assumed.

The **Current-balance supervision** function detects the following errors:

- Unbalance of phase currents in the secondary circuit
- Connection errors during commissioning or short circuits and interruptions in the secondary circuit

The current measurement is based on the RMS values of the fundamental component.

10.3.10.2 Structure of the Function

The **Current-balance supervision** function is located in the **Power-system data** of each 3-phase current measuring point.

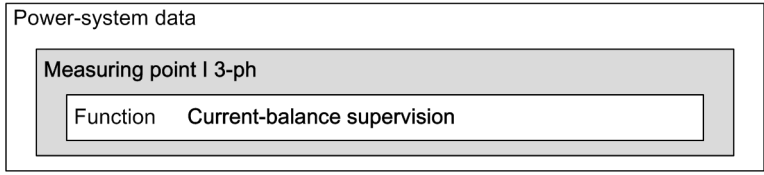

[ldw_str_sym, 3, en_US]

Figure 10-28 Structure/Embedding of the Function

10.3.10.3 Function Description

The current balance is checked by a magnitude monitoring function. This function relates the smallest phase current to the largest phase current. Unbalance is detected if

$$|I_{min}| / |I_{max}| < \text{Threshold min/max}, \text{ as long as } I_{max} > \text{Release threshold}.$$

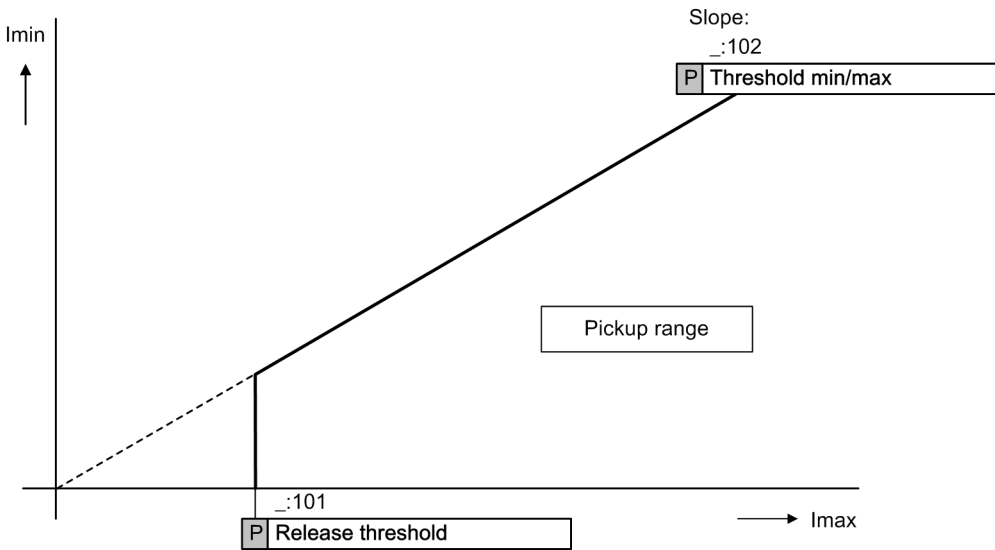

[lo_symmke, 1, en_US]

Figure 10-29 Characteristic of the Current-Balance Supervision

Logic

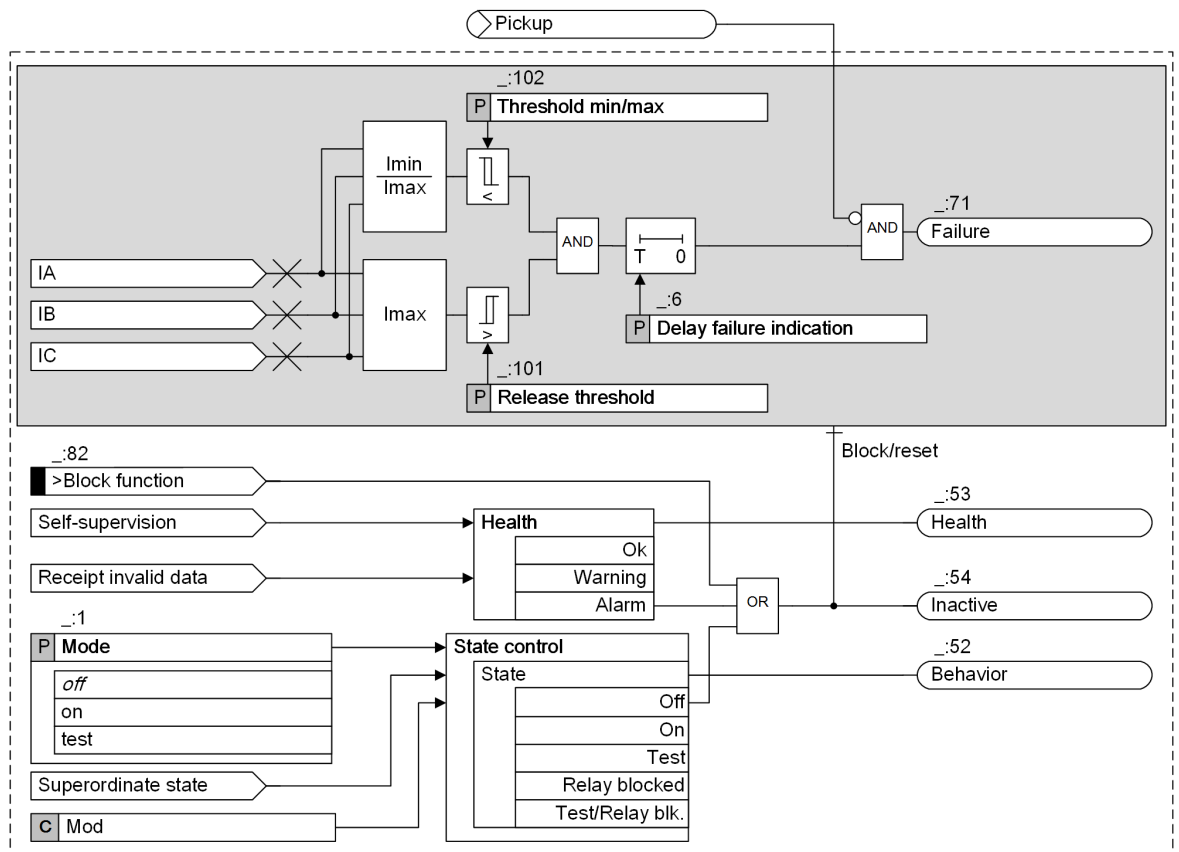

[file:cb_symm, 4, en_US]

Figure 10-30 Logic Diagram of the Current-Balance Supervision

The **Threshold min/max** parameter is the criterion by which unbalance in the phase currents is measured. The device calculates the ratio between the minimum (I_{min}) and the maximum (I_{max}) phase current.

Enter the lower limit of the maximum phase current (I_{max}) with the parameter **Release threshold**. This specifies the lower limit of the operating range of this function.

Delay failure indication

If it falls below the balance factor **Threshold min/max** at the same time as the maximum phase current exceeds the **Release threshold**, the operate delay of the failure indication (parameter **Delay failure indication**) starts. If both conditions persist during this time, the indication **Failure** is generated.

Blocking the Function

The following blockings completely reset the picked up function:

- Externally or internally via the binary input signal *>Block function*
- A protection pickup
The pickup signal of a protection function blocks the indication *Failure*.

10.3.10.4 Application and Setting Notes

Parameter: Threshold min/max

- Recommended setting value (_:102) **Threshold min/max = 0.5**

The **Threshold min/max** parameter is used to set the ratio between the minimum (I_{\min}) and the maximum (I_{\max}) phase current.

Parameter: Release threshold

- Recommended setting value (**_:101**) **Release threshold** = **0.5 A** for $I_{\text{rated}} = 1 \text{ A}$ or **2.5 A** for $I_{\text{rated}} = 5 \text{ A}$

The **Release threshold** parameter is used to set the lower limit of the maximum phase current (I_{\max}).

Parameter: Delay failure indication

- Recommended setting value (**_:6**) **Delay failure indication** = **5.00 s**

Set the **Delay failure indication** parameter so that overfunctions due to disturbing influences (such as switching operations) are avoided.

10.3.10.5 Settings

Addr.	Parameter	C	Setting Options	Default Setting
Supv. balan. I				
_:1	Supv. balan. I:Mode		<ul style="list-style-type: none"> off on test 	off
_:101	Supv. balan. I:Release threshold	1 A @ 100 Irated	0.030 A to 35.000 A	0.500 A
		5 A @ 100 Irated	0.15 A to 175.00 A	2.50 A
		1 A @ 50 Irated	0.030 A to 35.000 A	0.500 A
		5 A @ 50 Irated	0.15 A to 175.00 A	2.50 A
		1 A @ 1.6 Irated	0.001 A to 1.600 A	0.500 A
		5 A @ 1.6 Irated	0.005 A to 8.000 A	2.500 A
_:102	Supv. balan. I:Threshold min/max		0.10 to 0.95	0.50
_:6	Supv. balan. I:Delay failure indication		0.00 s to 100.00 s	5.00 s

10.3.10.6 Information List

No.	Information	Data Class (Type)	Type
Supv. balan. I			
_:82	Supv. balan. I:>Block function	SPS	I
_:54	Supv. balan. I:Inactive	SPS	O
_:52	Supv. balan. I:Behavior	ENS	O
_:53	Supv. balan. I:Health	ENS	O
_:71	Supv. balan. I:Failure	SPS	O

10.3.11 Current-Sum Supervision

10.3.11.1 Overview of Functions

In healthy system operation, the sum of all currents at one measuring point must be approximately 0. The **Current-sum supervision** function monitors the sum of all currents of one measuring point in the secondary circuit. It detects connection errors during commissioning or short circuits and interruptions in the secondary circuit.

For summation of the currents, the device requires the phase currents and the ground current of the current transformer neutral point or of a separate ground-current transformer at this measuring point. Select the following connection variant:

- Current-transformer connections connected to 3 current transformers and the neutral point (see [Figure A-7](#) in the *Attachment*)



NOTE

For current-sum supervision, the ground current of the line to be protected must be connected to the 4th current measurement input (I_N).

10.3.11.2 Structure of the Function

The **Current-sum supervision** function is located in the **Power-system data** of each 3-phase current measurement point.

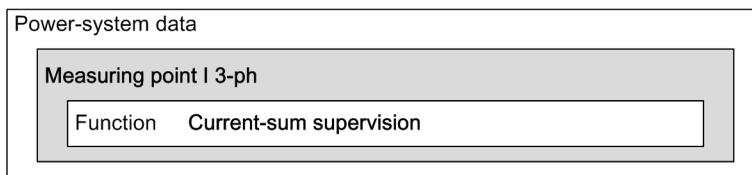

[dw_str_css_3_en_US]

Figure 10-31 Structure/Embedding of the Function

10.3.11.3 Function Description

The current sum is generated by addition of the current phasors. Errors in the current circuits are detected if

$$I_F = |I_A + I_B + I_C + k_I \cdot I_N| > \text{Threshold} + \text{Slope factor} \cdot \sum |I|$$

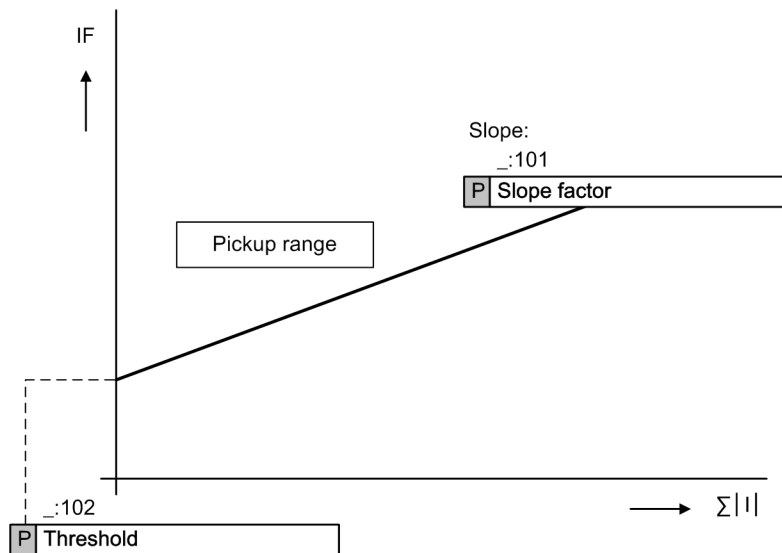

[fo_kensum_1_en_US]

Figure 10-32 Characteristic of the Current-Sum Supervision

Logic

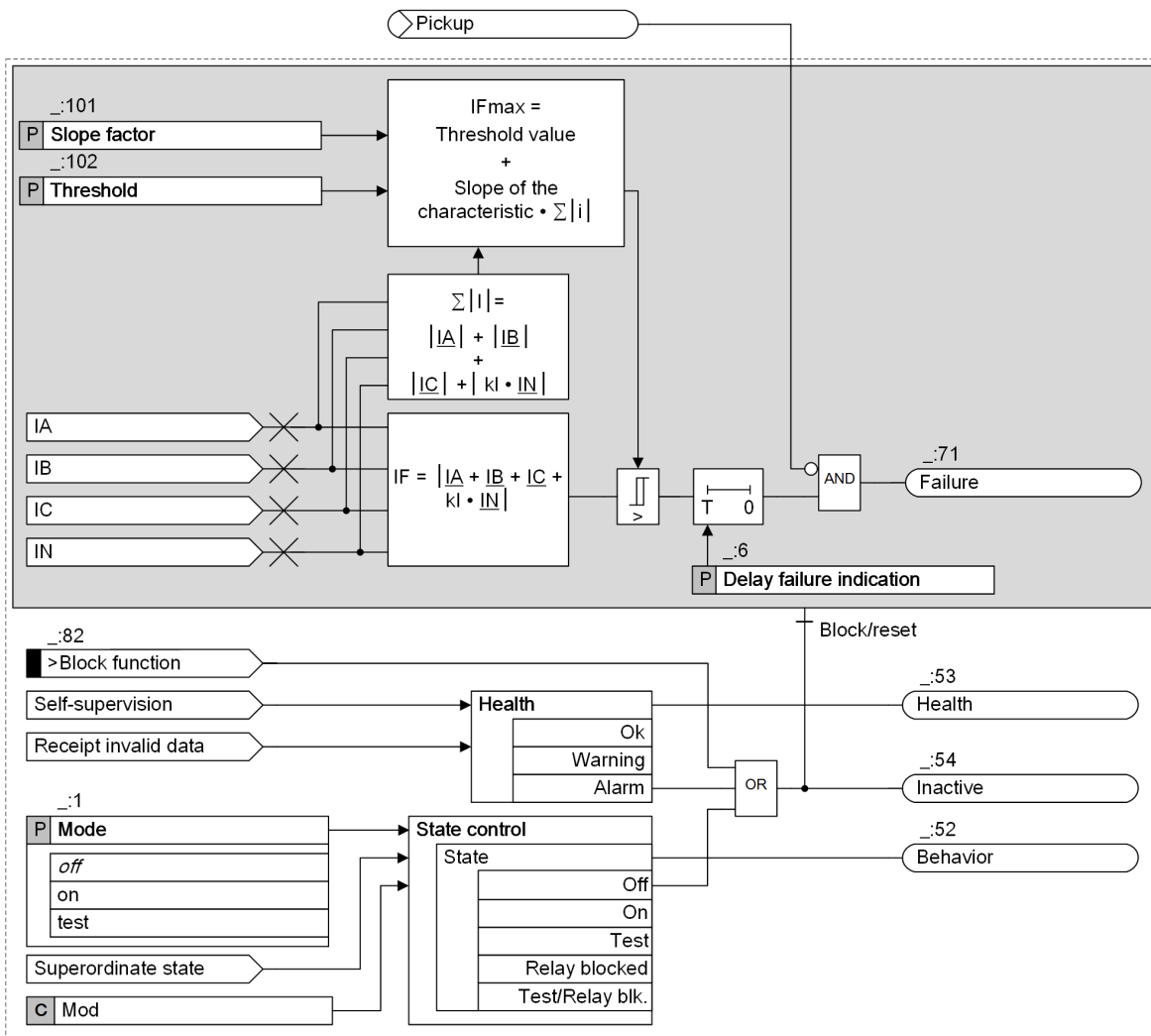

[lo_cs_summ_4_en_US]

Figure 10-33 Logic Diagram of the Current-Sum Supervision

Slope of the Characteristic Curve

The **Slope factor** • $\Sigma |i|$ part takes into account permissible current-proportional transformation errors of the transformer, which can occur in the case of high short-circuit currents.

The **Slope factor** and **Threshold** parameters are used to set the fault-current limit (I_{Fmax}) for the current-sum supervision. The device calculates this fault current limit with the formula:

$$I_{Fmax} = \text{Threshold} + \text{Slope factor} \cdot \Sigma |i|$$

The device uses the current inputs (IA, IB, IC and IN) to calculate:

- The fault current $IF = |IA + IB + IC + k_1 \cdot IN|$
- The maximum current $\Sigma |i| = |IA| + |IB| + |IC| + |k_1 \cdot IN|$

with k_1 taking into account a possible difference from the transformation ratio of a separated ground-current transformer (I_N), for example, cable type current transformer.

- Transformation ratio of zero-sequence current converter: Ratio_N
- Transformation ratio of phase-current converter: Ratio_{ph}

$$k_I = \frac{\text{Ratio}_N}{\text{Ratio}_{ph}}$$

[fo_glchki, 1, en_US]

Threshold

The **Threshold** parameter is the lower limit of the operating range of the **Current-sum supervision** function.

Delay failure indication

When the calculated fault current (I_f) exceeds the calculated fault current limit (I_{Fmax}), the delay of the failure indication (parameter: **Delay failure indication**) starts. If the threshold-value violation persists for that time, the **Failure** indication is generated.

Blocking the Function

The following blockings reset the picked up function completely:

- Externally or internally via the binary input signal *>Block function*
- A protection pickup
The pickup signal of a protection function blocks the *Failure* indication.

10.3.11.4 Application and Setting Notes

Parameter: Slope factor

- Recommended setting value (**_:101**) **Slope factor = 0.1**

The **Slope factor** parameter is used to set the ratio between the minimum (I_{min}) and the maximum (I_{max}) phase current. This function calculates the RMS values.

Parameter: Threshold

- Recommended setting value (**_:102**) **Threshold = 0.1 A** for $I_{rated} = 1 \text{ A}$ or **0.5 A** for $I_{rated} = 5 \text{ A}$

The **Threshold** parameter is used to set the maximum phase current (I_{max}).

Parameter: Delay failure indication

- Recommended setting value (**_:6**) **Delay failure indication = 5.00 s**

Set the **Delay failure indication** parameter so that overfunctions due to disturbing influences (such as switching operations) are avoided.

10.3.11.5 Settings

Addr.	Parameter	C	Setting Options	Default Setting
<i>Supv. sum I</i>				
_:1	Supv. sum I:Mode		<ul style="list-style-type: none"> • off • on • test 	off
_:102	Supv. sum I:Threshold	1 A @ 100 Irated	0.030 A to 10.000 A	0.100 A
		5 A @ 100 Irated	0.15 A to 50.00 A	0.50 A
		1 A @ 50 Irated	0.030 A to 10.000 A	0.100 A
		5 A @ 50 Irated	0.15 A to 50.00 A	0.50 A
		1 A @ 1.6 Irated	0.001 A to 1.600 A	0.100 A
		5 A @ 1.6 Irated	0.005 A to 8.000 A	0.500 A

Addr.	Parameter	C	Setting Options	Default Setting
_:101	Supv. sum I:Slope factor		0.00 to 0.95	0.10
_:6	Supv. sum I:Delay failure indication		0.00 s to 100.00 s	5.00 s

10.3.11.6 Information List

No.	Information	Data Class (Type)	Type
<i>Supv. sum I</i>			
_:82	Supv. sum I:>Block function	SPS	I
_:54	Supv. sum I:Inactive	SPS	O
_:52	Supv. sum I:Behavior	ENS	O
_:53	Supv. sum I:Health	ENS	O
_:71	Supv. sum I:Failure	SPS	O

10.3.12 Current Phase-Rotation Supervision

10.3.12.1 Overview of Functions

The **Current phase-rotation supervision** function monitors the phase sequence of the secondary-circuit currents by monitoring the sequence of the zero crossings (with same sign) of the currents. This enables the device to detect connections that were inverted during commissioning. The criterion for the check is the setting of the **Phase sequence** parameter.

The current measurement is based on the RMS values of the fundamental component.

10.3.12.2 Structure of the Function

The **Current phase-rotation supervision** function is located in the **Power-system data** of each 3-phase current measurement point.

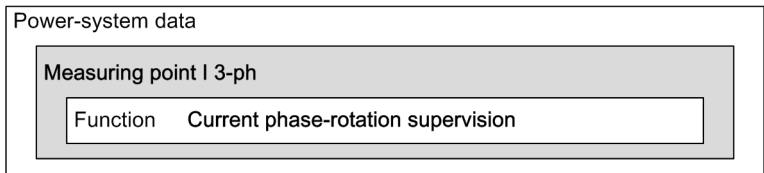

[dw_str_crs_4_en_US]

Figure 10-34 Structure/Embedding of the Function

10.3.12.3 Function Description

Logic

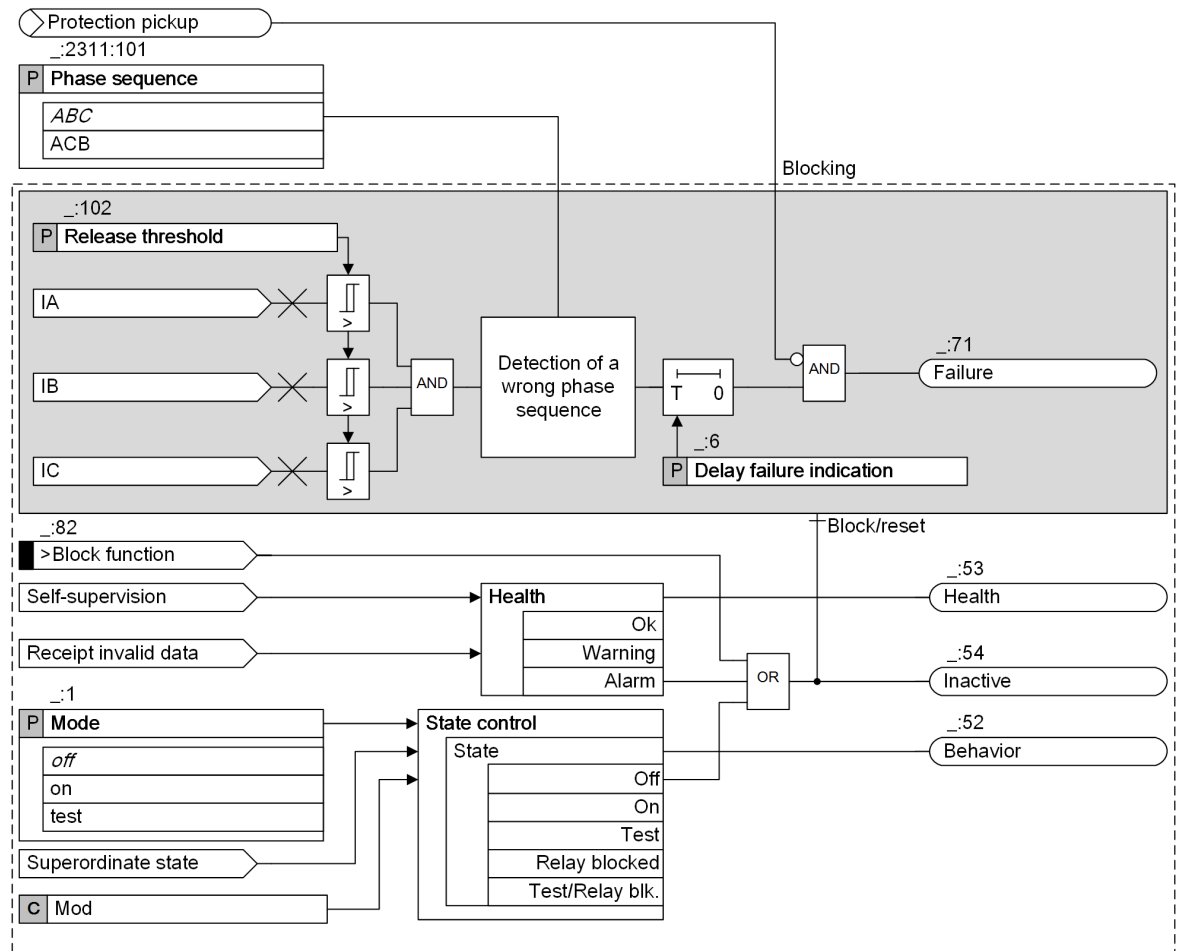

[to_cr_symm, 6, en_US]

Figure 10-35 Logic Diagram of the Current Phase-Rotation Supervision

The phase rotation is important for protection functions which process phase, loop, and directional information. You can set the phase sequence with the **Phase sequence** parameter in the function block **General** of the power-system data (see [6.1 Power-System Data](#)).

To supervise the phase rotation, the device compares the measured phase sequence with the set phase sequence. For abnormal phase sequences, the indication *Failure* is generated.

The connection of the currents to the device does not depend on the selected phase sequence. For connection diagrams see [A Appendix](#).

Release Condition

The supervision of the current phase rotation is carried out when all measured phase currents are greater than the value of the **Release threshold** parameter.

Blocking of the Function

The following blockings reset the function completely:

- Via the binary input signal *>Block function* from an external or internal source
- Via a protection pickup
The pickup signal from a protection function blocks the indication *Failure*.

Delay failure indication

When the device detects an inverted phase sequence for the duration of the **Delay failure indication**, the indication *Failure* is generated.

10.3.12.4 Application and Setting Notes

Parameter: Release threshold

- Default setting (`_:102`) **Release threshold** = **0.500 A** for $I_{rated} = 1\text{ A}$ or **2.50 A** for $I_{rated} = 5\text{ A}$

With the **Release threshold** parameter, you specify the lower limit of the phase current for phase-rotation supervision.

Parameter: Delay failure indication

- Default setting (`_:6`) **Delay failure indication** = **5.00 s**

Set the **Delay failure indication** parameter so that overfunctions due to disturbing influences (such as switching operations) are avoided. Siemens recommends using the default setting.

10.3.12.5 Settings

Addr.	Parameter	C	Setting Options	Default Setting
<i>Supv. ph.seq.I</i>				
<code>_:1</code>	Supv. ph.seq.I:Mode		<ul style="list-style-type: none"> • off • on • test 	off
<code>_:6</code>	Supv. ph.seq.I:Delay failure indication		0.00 s to 100.00 s	5.00 s
<code>_:102</code>	Supv. ph.seq.I:Release threshold	1 A @ 100 I _{rated}	0.030 A to 10.000 A	0.500 A
		5 A @ 100 I _{rated}	0.15 A to 50.00 A	2.50 A
		1 A @ 50 I _{rated}	0.030 A to 10.000 A	0.500 A
		5 A @ 50 I _{rated}	0.15 A to 50.00 A	2.50 A
		1 A @ 1.6 I _{rated}	0.001 A to 1.600 A	0.500 A
		5 A @ 1.6 I _{rated}	0.005 A to 8.000 A	2.500 A

10.3.12.6 Information List

No.	Information	Data Class (Type)	Type
<i>Supv. ph.seq.I</i>			
<code>_:82</code>	Supv. ph.seq.I:>Block function	SPS	I
<code>_:54</code>	Supv. ph.seq.I:Inactive	SPS	O
<code>_:52</code>	Supv. ph.seq.I:Behavior	ENS	O
<code>_:53</code>	Supv. ph.seq.I:Health	ENS	O
<code>_:71</code>	Supv. ph.seq.I:Failure	SPS	O

10.3.13 Trip-Circuit Supervision

10.3.13.1 Overview of Functions

The **Trip-circuit supervision** function recognizes disruptions in the trip circuit. When 2 binary inputs are used, the function recognizes all disruptions in the trip circuit. If only 1 binary input is available, it will not recognize disruptions at the circuit breaker.

The control voltage for the circuit breaker must be greater than the sum of the minimum voltage drops at the binary inputs $V_{Ctrl} > 2 V_{Bmin}$. At least 19 V are required for each binary input. This makes the supervision usable only with a system-side control voltage of > 38 V.

10.3.13.2 Structure of the Function

The trip-circuit supervision is integrated into the **Circuit-breaker** function group. Depending on the number of available binary inputs, it works with 1 or 2 binary inputs.

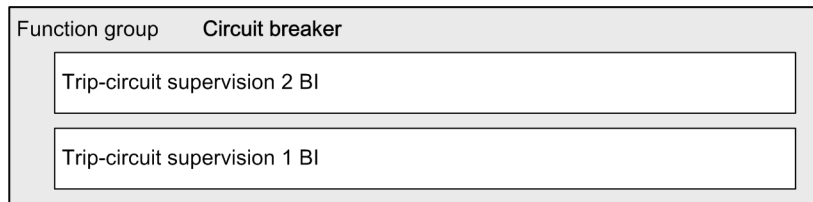

[dw_tcsueb, 1, en_US]

Figure 10-36 Structure/Embedding of the Function

10.3.13.3 Trip-Circuit Supervision with 2 Binary Inputs

In order to recognize disruptions in the trip circuit for each switch position, you need 2 binary inputs. One input is connected parallel to the respective command relay of the protection, the other parallel to the circuit-breaker auxiliary contact.

The following figure shows the principle of the trip-circuit supervision with 2 binary inputs.

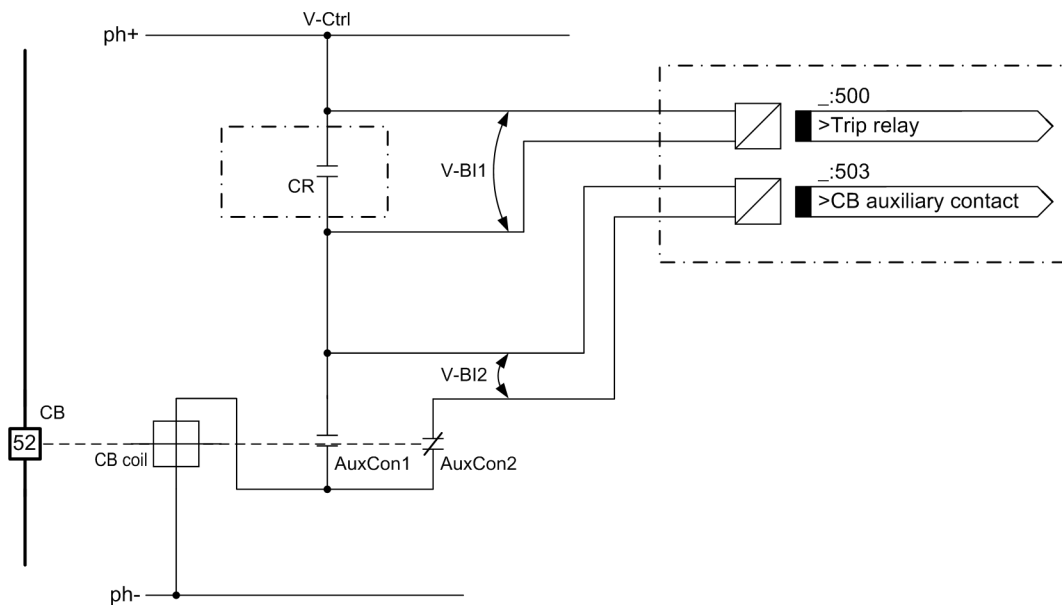

[dw_tcs_2be, 3, en_US]

Figure 10-37 Principle of Trip-Circuit Supervision with 2 Binary Inputs

CR	Command relay
CB	Circuit breaker (open)
CB coil	Circuit-breaker coil
AuxCon1	Circuit-breaker auxiliary contact (make contact)
AuxCon2	Circuit-breaker auxiliary contact (break contact)
V-Ctrl	Control voltage (tripping voltage)
V-BI1	Input voltage for binary input 1
V-BI2	Input voltage for binary input 2

Supervision with 2 binary inputs identifies disruptions in the trip circuit and the outage of the control voltage. It also monitors the reaction of the circuit breaker by way of the position of the circuit-breaker auxiliary contacts.

Depending on the switch position of the command relay and circuit breaker, the binary inputs are either activated (H) or not (L). If both binary inputs are not activated, there is a fault. The fault can be a disruption or a short circuit in the trip circuit, an outage of the battery voltage or a fault in the mechanics of the circuit breaker. With intact trip circuits, this state will occur only briefly while the command relay is closed and the circuit breaker has not yet been opened.

No.	Command Relay (CR)	CB	AuxCon1	AuxCon2	BI 1	BI 2	Dynamic State	Static State
1	Open	ON	Closed	Open	H	L	Normal operation with closed circuit breaker	
2	Open	OFF	Open	Closed	H	H	Normal operation with open circuit breaker	
3	Closed	ON	Closed	Open	L	L	Transmission or fault	Fault
4	Closed	OFF	Open	Closed	L	H	CR successfully activated the circuit breaker	

With the **Alarm delay** parameter, you can set the time delay. After fixing the fault in the trip circuit, the failure indication will automatically expire after the same time.

If the binary input signals *>Trip relay* or *>CB auxiliary contact* are not routed on the binary inputs of the device, then the *Input sig. not routed* indication is generated and the **Trip-circuit supervision** function is ineffective.

The following figure shows the logic diagram of the trip-circuit supervision with 2 binary inputs.

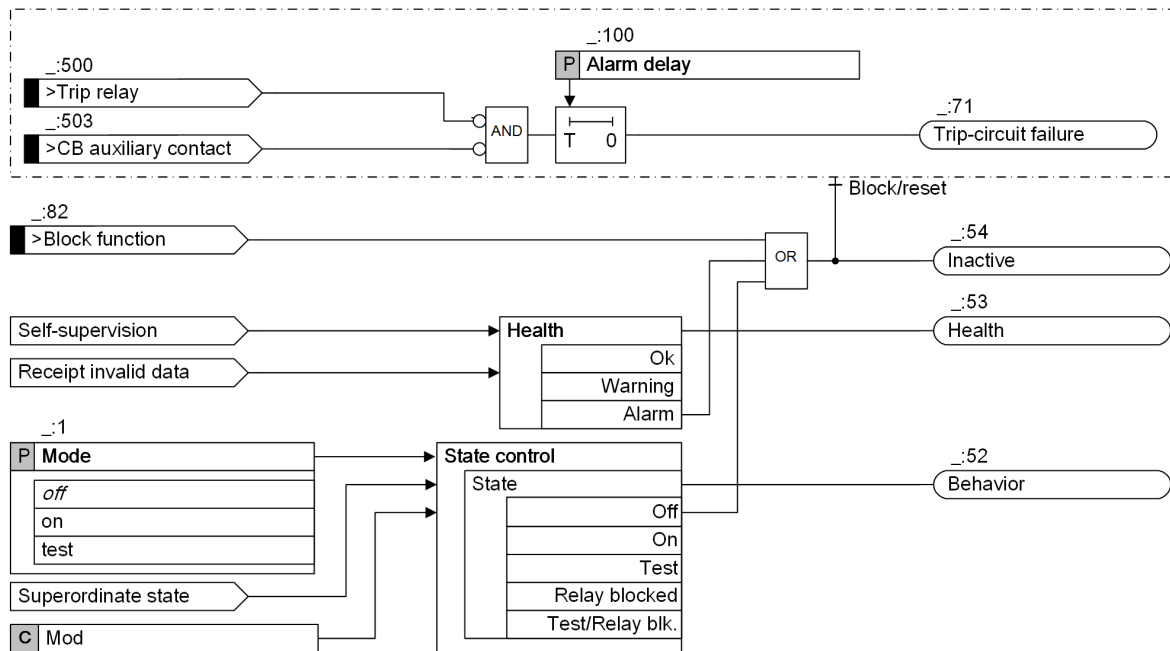

[file_tcs_2ba_2_en_US]

Figure 10-38 Logic Diagram of Trip-Circuit Supervision with 2 Binary Inputs

10.3.13.4 Trip-Circuit Supervision with 1 Binary Input

When using 1 binary input, you will not identify any disruptions on the circuit breaker. The binary input is connected in parallel with the respective command relay of the protection device. The circuit-breaker auxiliary contact is bridged with a high-resistance equivalent resistance R.

The following figure shows the principle of the trip-circuit supervision with 1 binary input.

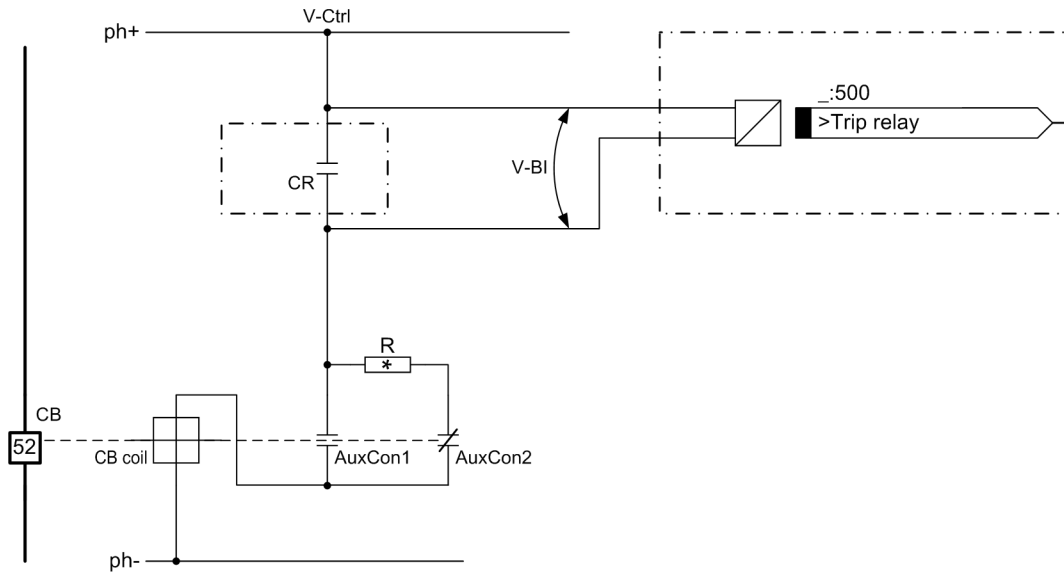

[dw_tcs_1be_3_en_US]

Figure 10-39 Principle of Trip-Circuit Supervision with 1 Binary Input

- CR Command relay
- CB Circuit breaker (open)
- CB coil Circuit-breaker coil
- AuxCon1 Circuit-breaker auxiliary contact (make contact)
- AuxCon2 Circuit-breaker auxiliary contact (break contact)
- V-Ctrl Control voltage (tripping voltage)
- V-BI Input voltage for binary input
- R Equivalent resistance

The supervision with 1 binary input identifies disruptions in the trip circuit and the outage of the control voltage.

In normal operation, the binary input is activated with the command relay open and the trip circuit intact (H). The supervision circuit is closed with the equivalent resistance R or with the auxiliary contact AuxCon1 of the closed circuit breaker. The binary input is not activated while the command relay is closed (L). If the binary input is not activated for a prolonged time, there is a disruption in the trip circuit or the control voltage has failed.

No.	Command Relay	CB	AuxCon1	AuxCon2	BI	Dynamic State	Static State
1	Open	ON	Closed	Open	H	Normal operation with closed circuit breaker	
2	Open	OFF	Open	Closed	H	Normal operation with open circuit breaker	
3	Closed	ON	Closed	Open	L	Transmission or fault	Fault
4	Closed	OFF	Open	Closed	L	CR successfully activated the circuit breaker	

Use the parameter **Blk.by trip/open cmd from** to set the conditions under which the trip-circuit supervision is blocked. The following conditions can cause a blocking of the trip-circuit supervision function:

- The *Trip/open cmd.* of the circuit breaker is activated.
- One of the trip commands of the circuit-breaker failure protection is activated.

As long as the trip-circuit supervision function is blocked, the closed contact of the command relay does not cause a failure indication.

If the command contacts of other devices work in parallel on the trip circuit, the failure indication must be delayed. With the **Alarm delay** parameter, you can set the time delay. After fixing the fault in the trip circuit, the failure indication will automatically expire after the same time.

If the binary input signal *>Trip relay* is not routed to a binary input of the device (**information routing** in DIGSI 5), then the *Input sig. not routed* indication is generated and the **Trip-circuit supervision** function is not in effect.

The following figure shows the logic diagram of the trip-circuit supervision with 1 binary input.

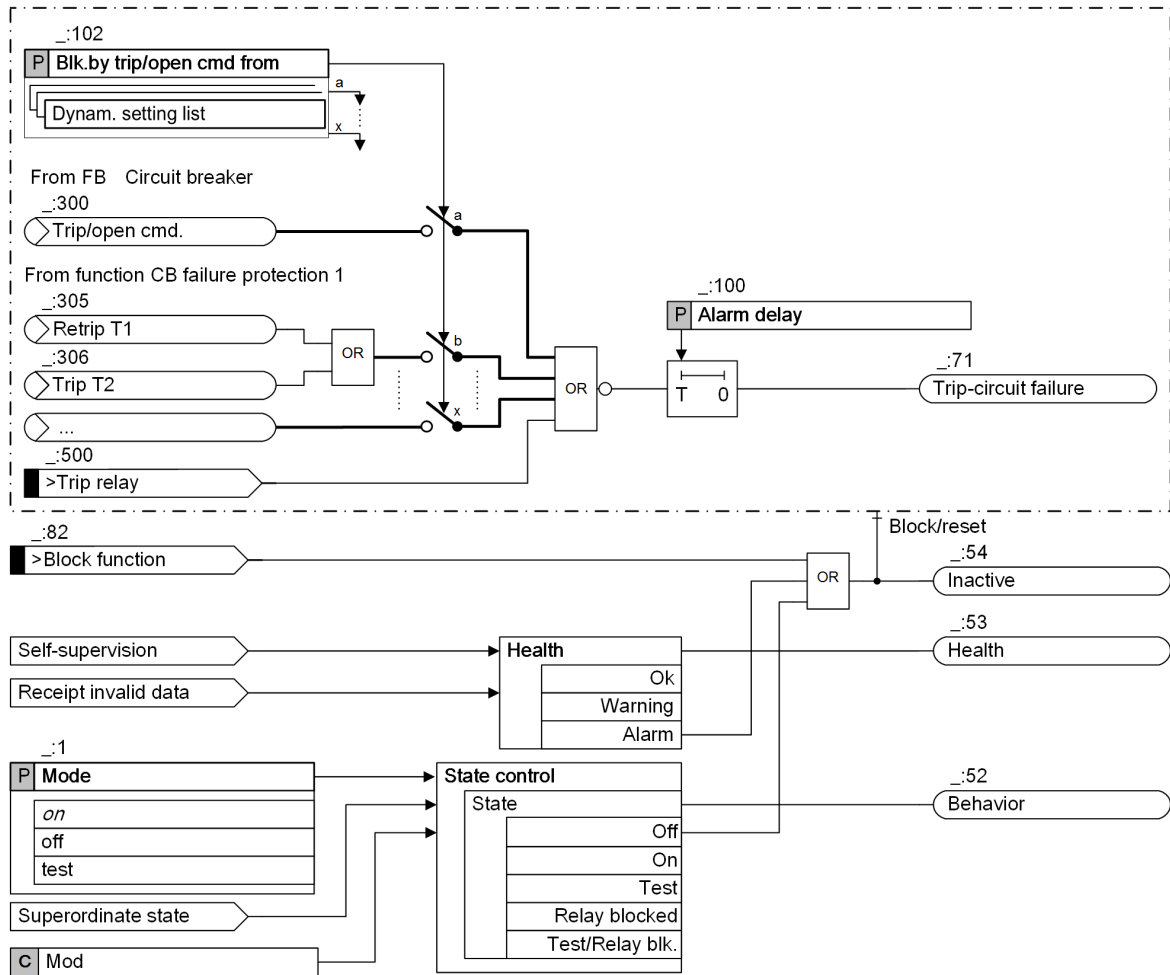

[fo_tcs_1be_2_en_US]

Figure 10-40 Logic Diagram of Trip-Circuit Supervision with 1 Binary Input

Equivalent Resistance R

The equivalent resistance R must be dimensioned such that the circuit-breaker coil is no longer activated when the circuit breaker is open. Simultaneously, the binary input must still be activated when the command relay is open.

In order to ensure the minimum voltage for activating the binary input, R_{max} results in:

$$R_{max} = \left(\frac{V_{Ctrl} - V_{BI\ min}}{I_{BI(High)}} \right) - R_{CBC}$$

[fo_r_max_1_en_US]

So that the circuit-breaker coil does not remain activated, R_{min} results in:

$$R_{\min} = R_{\text{CBC}} \cdot \left(\frac{V_{\text{Ctrl}} - V_{\text{CBC(Low max)}}}{V_{\text{CBC(Low max)}}} \right)$$

[fo_r_min, 1, en_US]

with:

V_{Ctrlst}	Control voltage for the trip circuit
$V_{\text{Bl min}}$	Minimum activate voltage for BI
R_{CBC}	Ohm's resistance of the CB coil
$I_{\text{Bl(High)}}$	Constant current with activated BI
$V_{\text{CBC (Low max)}}$	Maximum voltage at the CB coil that does not lead to a tripping

You can calculate the optimal value for the equivalent resistance R from the 2 values R_{\min} and R_{\max} :

$$R = \frac{R_{\max} + R_{\min}}{2}$$

[fo_r, 1, en_US]

The following applies for the power consumption of the equivalent resistance R:

$$P_R = I^2 \cdot R = \left(\frac{V_{\text{Ctrl}}}{R + R_{\text{CBC}}} \right)^2 \cdot R$$

[fo_pr, 1, en_US]

10.3.13.5 Application and Setting Notes

Parameter: Alarm delay

- Recommended setting value (_:100) **Alarm delay = 2 s** (Trip-circuit supervision with 2 binary inputs)
- Recommended setting value (_:100) **Alarm delay = 300 s** (Trip-circuit supervision with 1 binary input)

With the parameter **Alarm delay**, you can set the time for the delayed output of the indication *Trip-circuit failure*.

For **Trip-circuit supervision with 2 binary inputs**, you set the **Alarm delay** parameter so that the short-term transient states do not cause the function to activate.

For the **Trip-circuit supervision with 1 binary input**, you set the **Alarm delay** so that the longest duration of a trip command is bridged without fail. This ensures that the indication is emitted only if the trip circuit is actually interrupted.

Parameter: Blk.by trip/open cmd from

- Possible settings, application-dependent

The parameter works only with the trip-circuit supervision with 1 binary input.

Use the parameter **Blk.by trip/open cmd from** to set the conditions under which the trip-circuit supervision is blocked. The following conditions can cause a blocking of the trip-circuit supervision function:

- The *Trip/open cmd.* of the circuit breaker is activated.
- One of the trip commands of the circuit-breaker failure protection is activated.
- One of the trip commands of the circuit-breaker reignition protection is activated.

The circuit-breaker failure protection is set to protect a different trip circuit than the local circuit breaker. Using the configuration options of the **Blk.by trip/open cmd from** parameter, multiple trip-circuit supervision functions can be operated in parallel. For instance, a trip-circuit supervision function dedicated to a local

circuit breaker can also be operated parallel to a higher-level circuit breaker upon which the circuit-breaker failure protection acts.

10.3.13.6 Settings

Addr.	Parameter	C	Setting Options	Default Setting
74TC sup. 1BI #				
_:1	74TC sup.1BI #:Mode		<ul style="list-style-type: none"> • off • on • test 	on
_:100	74TC sup.1BI #:Alarm delay		0.50 s to 600.00 s	300.00 s
_:102	74TC sup.1BI #:Blk.by trip/open cmd from		Setting options depend on configuration	
74TC sup. 2BI #				
_:1	74TC sup.2BI #:Mode		<ul style="list-style-type: none"> • off • on • test 	on
_:100	74TC sup.2BI #:Alarm delay		0.50 s to 30.00 s	2.00 s

10.3.13.7 Information List

No.	Information	Data Class (Type)	Type
74TC sup. 1BI #			
_:82	74TC sup.1BI #:>Block function	SPS	I
_:500	74TC sup.1BI #:>Trip relay	SPS	I
_:54	74TC sup.1BI #:Inactive	SPS	O
_:52	74TC sup.1BI #:Behavior	ENS	O
_:53	74TC sup.1BI #:Health	ENS	O
_:71	74TC sup.1BI #:Trip-circuit failure	SPS	O
_:301	74TC sup.1BI #:Input sig. not routed	SPS	O
74TC sup. 2BI #			
_:82	74TC sup.2BI #:>Block function	SPS	I
_:500	74TC sup.2BI #:>Trip relay	SPS	I
_:503	74TC sup.2BI #:>CB auxiliary contact	SPS	I
_:54	74TC sup.2BI #:Inactive	SPS	O
_:52	74TC sup.2BI #:Behavior	ENS	O
_:53	74TC sup.2BI #:Health	ENS	O
_:71	74TC sup.2BI #:Trip-circuit failure	SPS	O
_:301	74TC sup.2BI #:Input sig. not routed	SPS	O

10.3.14 Closing-Circuit Supervision

10.3.14.1 Overview of Functions

The function **Closing-circuit supervision** detects disruptions in the closed circuit of the circuit breaker.

The control voltage for the closed circuit must be greater than the sum of the minimum voltage drops at the binary inputs, that is, $V_{Ctrl} > 2 \cdot V_{high}$ or $V_{Ctrl} > 3 \cdot V_{high}$ depending on the number of available binary inputs .

10.3.14.2 Structure of the Function

The function **Closing-circuit supervision** is integrated into the function group **Circuit breaker**. Depending on the available number of the binary inputs, the function works with 3 binary inputs, 2 binary inputs or 1 binary input.

The following stages can be operated simultaneously in the function group **Circuit breaker**:

- Maximum of 3 stages **Closing-circuit supervision with 3 binary inputs**
- Maximum of 3 stages **Closing-circuit supervision with 2 binary inputs**
- Maximum of 3 stages **Closing-circuit supervision with 1 binary input**

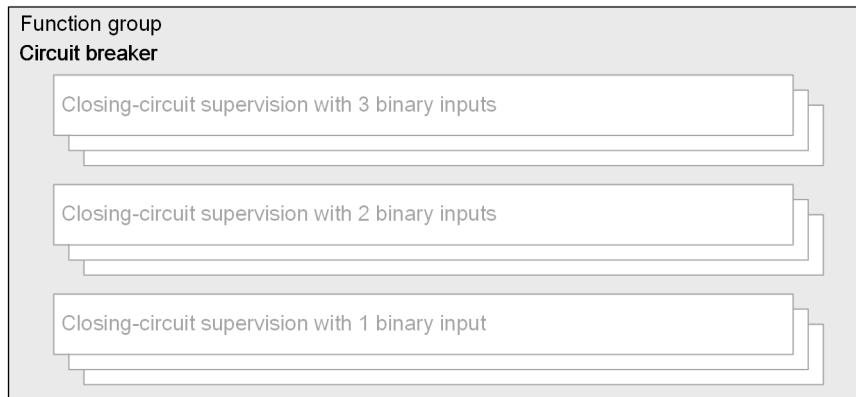

[dw_CCS_structure_3Bl_1_en_US]

Figure 10-41 Structure/Embedding of the Function

10.3.14.3 Closing-Circuit Supervision with 3 Binary Inputs

Precondition

To use the function block **Closing-circuit supervision with 3 binary inputs**, set the control voltage larger than 3 times the voltage of the binary input ($V_{Ctrl} > 3 \cdot V_{high}$).

In the following descriptions, the minimum V_{high} of the binary input is 19 V.

Closing-Circuit Supervision with 3 Binary Inputs

In order to recognize disruptions in the closed circuit for each switch position, you need 3 binary inputs. 2 inputs are connected parallel to the respective command relays of the protection, another is connected parallel to the circuit-breaker auxiliary contact.

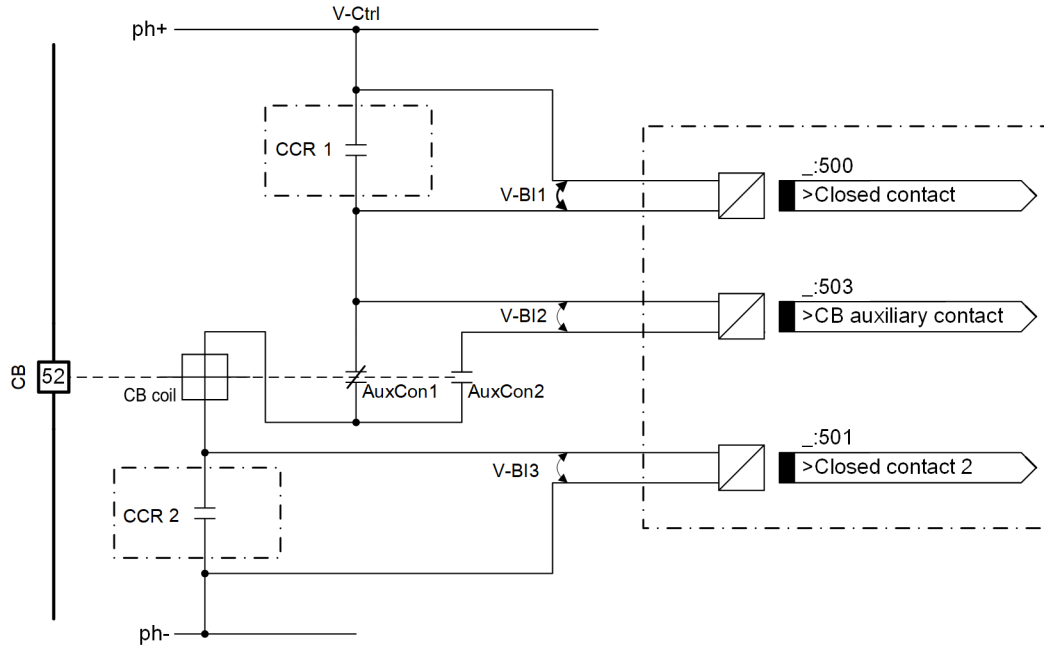

[dw_closed-circuit supervision_3Bis_2_en_US]

Figure 10-42 Principle of the Closing-Circuit Supervision with 3 Binary Inputs

- CCR 1 Closed-command relay 1
- CCR 2 Closed-command relay 2
- CB Circuit breaker (closed)
- CB coil Circuit-breaker coil
- AuxCon1 Circuit-breaker auxiliary contact (closed if the CB is closed)
- AuxCon2 Circuit-breaker auxiliary contact (open if the CB is closed)
- V-Ctrl Control voltage (tripping voltage)
- V-BI1 Input voltage for binary input 1
- V-BI2 Input voltage for binary input 2
- V-BI3 Input voltage for binary input 3

The stage **Closing-circuit supervision with 3 binary inputs** identifies disruptions in the closed circuit and the outage of the control voltage. It also monitors the reaction of the circuit breaker by way of the position of the circuit-breaker auxiliary contacts.

Depending on the switch position of the closed-command relay and the circuit breaker, the binary inputs are either activated (H) or deactivated (L). If both binary inputs are deactivated, a fault occurs. The fault can be a disruption or a short circuit in the closed circuit, a failure of the voltage of the binary inputs or a fault in the mechanics of the circuit breaker. With intact closed circuits, this state occurs only briefly while the command relay is closed and the circuit breaker is not opened.

Closed Command	CB	AuxCon1	AuxCon2	>Closed contact	>Closed contact 2	>CB auxiliary contact	State
No	Closed	Closed	Open	H	H	H	Normal operation with closed circuit breaker
No	Open	Open	Closed	H	H	L	Normal operation with open circuit breaker
Yes	Open	Open	Closed	L	L	L	Transient process
Yes	Closed	Closed	Open	L	L	H	Transient process
No	–	–	–	L	L	–	Fault

Closed Command	CB	AuxCon1	AuxCon2	>Closed contact	>Closed contact 2	>CB auxiliary contact	State
No	–	–	–	H	L	–	Fault
No	–	–	–	L	H	–	Fault

Closing-Circuit Supervision with 2 Binary Inputs and 1 Resistance

In *Figure 10-42*, when the circuit breaker is closed, the binary input *>CB auxiliary contact* is used to form the complete supervision circuit and limit the inductive current. Therefore, the function **Closing-circuit supervision** also works with 2 binary inputs and 1 resistance.

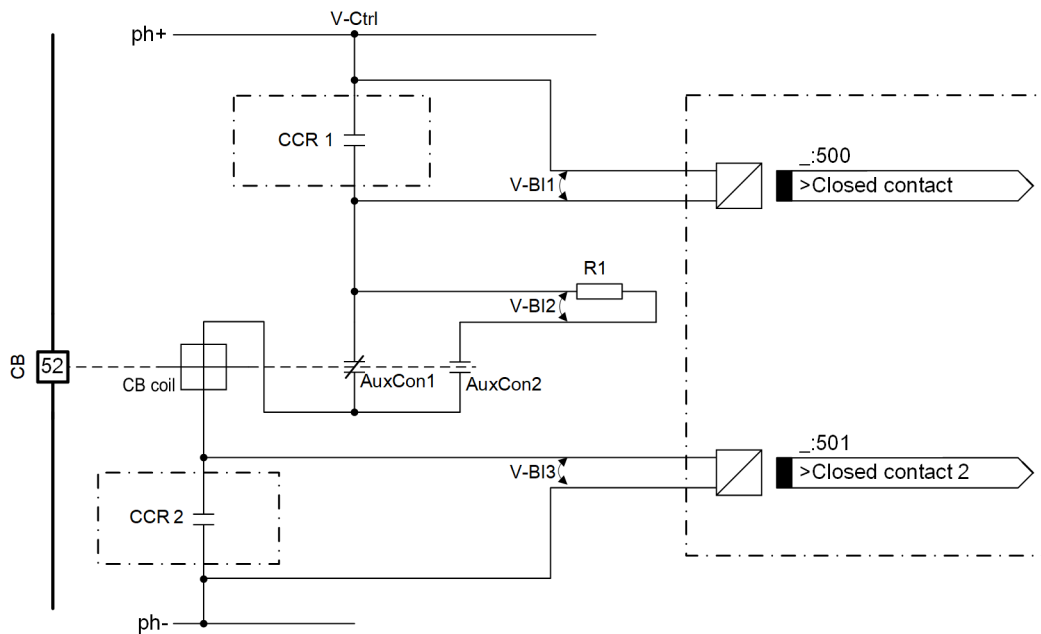

[dw_closed-circuit_supervision_2Bis_2_en_US]

Figure 10-43 Principle of the Closing-Circuit Supervision with 2 Binary Inputs and 1 Resistance

- CCR 1 Closed-command relay 1
- CCR 2 Closed-command relay 2
- CB Circuit breaker (closed)
- CB coil Circuit-breaker coil
- AuxCon1 Circuit-breaker auxiliary contact (closed if the CB is closed)
- AuxCon2 Circuit-breaker auxiliary contact (open if the CB is closed)
- R Equivalent resistance
- V-Ctrl Control voltage (tripping voltage)
- V-BI1 Input voltage for binary input 1
- V-BI2 Input voltage for binary input 2
- V-BI3 Input voltage for binary input 3

Equivalent Resistance R

The equivalent resistance R must be dimensioned in such a way that the circuit-breaker coil is no longer activated when the circuit breaker is open. Simultaneously, the binary input must still be activated when the command relay is open.

In order to ensure the minimum voltage for activating the binary input, R_{max} results in:

$$R_{\max} = \left(\frac{V_{\text{Ctrl}} - 2 \cdot V_{\text{BImin}}}{I_{\text{BI(High)}}} \right) \cdot R_{\text{CBC}}$$

[fo_closed_circuit_supervision_1, 2, en_US]

If there is no closed command, the current flows via the binary inputs. Then the circuit current is limited to 2.5 mA at most. The closed circuit-breaker coil remains activated.

The following formula applies for the power consumption of the equivalent resistance R:

$$P_{\text{R}} = I^2 \times R$$

[fo_closed_circuit_supervision_2, 1, en_US]

In the following examples, you can find the calculation of R under different control voltages.

- **The control voltage is 110 V.**

In the following example, if R_{CBC} is 90 Ω , R_{\max} is calculated as follows:

$$R_{\max} = \left(\frac{V_{\text{Ctrl}} - 2 \cdot V_{\text{BImin}}}{I_{\text{BI(High)}}} \right) \cdot R_{\text{CBC}} = \frac{110 \text{ V} - 2 \cdot 19 \text{ V}}{2.5 \text{ mA}} \cdot 0.09 \text{ k}\Omega = 28.71 \text{ k}\Omega$$

[fo_closed_circuit_supervision_RMax_110V, 2, en_US]

Siemens recommends the resistance R of 18 k Ω , then the calculated maximum power is 0.11 W.

$$P_{\text{R}} = I^2 \times R = \frac{2.5 \text{ mA} \cdot 2.5 \text{ mA} \cdot 18 \text{ k}\Omega}{1000} = 0.11 \text{ W}$$

[fo_closed_circuit_supervision_PR_110V, 1, en_US]

If the closed-command relay is open, the maximum voltage on the circuit-breaker coil and the minimum voltage on each binary input is calculated as follows:

$$V_{\text{CBCmax}} = 1.5 \cdot 0.09 \text{ k}\Omega \cdot 2.5 \text{ mA} = 0.34 \text{ V}$$

[fo_closed_circuit_supervision_Vmax_110V, 3, en_US]

The circuit-breaker coil is not activated.

$$V_{\text{CBCmin}} = [0.8 \cdot V_{\text{CTR}} - I_{\text{BI(High)}} \cdot (1.5 \cdot R_{\text{CBC}} + R)] \cdot 0.5 = [0.8 \cdot 110 \text{ V} - 2.5 \text{ mA} \cdot (1.5 \cdot 0.09 \text{ k}\Omega + 18 \text{ k}\Omega)] \cdot 0.5 = 21.33 \text{ V}$$

[fo_closed_circuit_supervision_Vmin_110V, 3, en_US]

The binary input is activated.

- **The control voltage is 220 V.**

In the following example, if R_{CBC} is 36 Ω , R_{max} is calculated as follows:

$$R_{max} = \left(\frac{V_{Ctrl} - 2 \cdot V_{BImin}}{I_{BI(High)}} \right) - R_{CBC} = \frac{220 \text{ V} - 2 \cdot 19 \text{ V}}{2.5 \text{ mA}} - 0.36 \text{ k}\Omega = 72.44 \text{ k}\Omega$$

[fo_closed_circuit_supervision_RMax_220V_2_en_US]

Siemens recommends the resistance R of 51 k Ω , then the calculated maximum power is 0.32 W.

$$P_R = I^2 \times R = \frac{2.5 \text{ mA} \cdot 2.5 \text{ mA} \cdot 51 \text{ k}\Omega}{1000} = 0.32 \text{ W}$$

[fo_closed_circuit_supervision_PR_220V_1_en_US]

If the closed-command relay is open, the maximum voltage on the circuit-breaker coil and the minimum voltage on each binary input is calculated as follows:

$$V_{CBCmax} = 1.5 \cdot 0.36 \text{ k}\Omega \cdot 2.5 \text{ mA} = 1.35 \text{ V}$$

[fo_closed_circuit_supervision_Vmax_220V_3_en_US]

The circuit-breaker coil is not activated.

$$V_{CBCmin} = [0.8 \cdot V_{CTR} - I_{BI(High)} \cdot (1.5 \cdot R_{CBC} + R)] \cdot 0.5 = [0.8 \cdot 220 \text{ V} - 2.5 \text{ mA} \cdot (1.5 \cdot 0.36 \text{ k}\Omega + 51 \text{ k}\Omega)] \cdot 0.5 = 23.58 \text{ V}$$

[fo_closed_circuit_supervision_Vmin_220V_3_en_US]

The binary input is activated.

Logic

With the parameter **Alarm delay**, you can set the time delay. After fixing the faults in the closed circuit, the failure indication automatically expires after the **Alarm delay** time.

If the binary input signal **>Closed contact** or **>Closed contact 2** is not routed to the binary input of the device (**Information routing** in DIGSI 5), the function **Closing-circuit supervision** does not work.

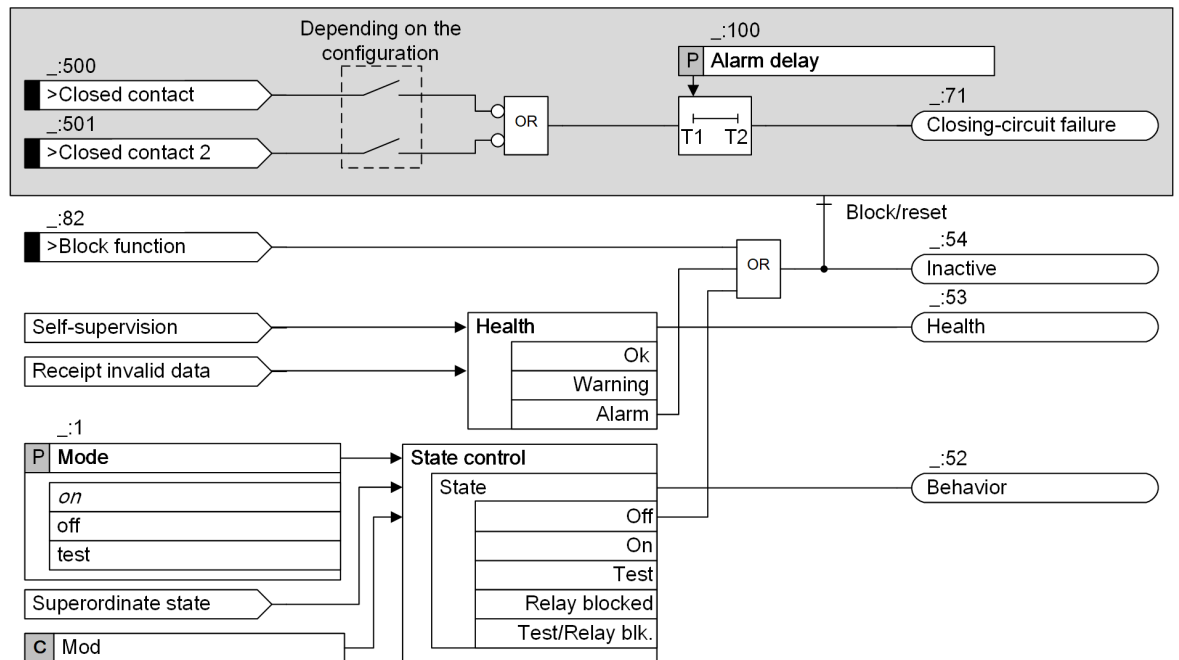

[fo_closed_circuit_supervision_3Bis_4_en_US]

Figure 10-44 Logic Diagram of the Stage Closing-Circuit Supervision with 3 Binary Inputs

The indication *Closing-circuit failure* is generated when the following 2 conditions are met:

- The binary input signal *>Closed contact* or *>Closed contact 2* is deactivated.
- The **Alarm delay** has elapsed.

The indication *Closing-circuit failure* disappears only when the following 2 conditions are met:

- The binary input signals *>Closed contact* and *>Closed contact 2* are activated.
- The **Alarm delay** has elapsed.

10.3.14.4 Closing-Circuit Supervision with 2 Binary Inputs

Principle

In order to detect disruptions in the closed circuit for each switch position, 2 binary inputs are necessary:

- One binary input is connected in parallel to the close-command relay.
- Another binary input is connected in series with the circuit-breaker auxiliary contact.

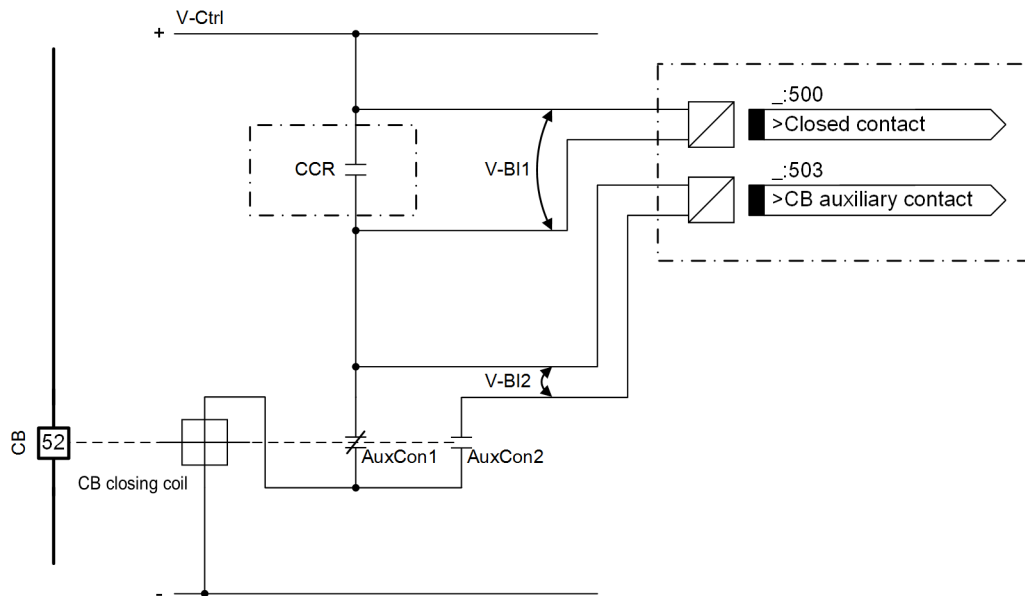

[dlw_CCS_2BI_1_en_US]

Figure 10-45 Principle of the Closing-Circuit Supervision with 2 Binary Inputs

CCR	Close-command relay
CB	Circuit breaker
CB closing coil	Circuit-breaker closing coil
AuxCon1	Circuit-breaker auxiliary contact 1 (open if the CB is closed)
AuxCon2	Circuit-breaker auxiliary contact 2 (closed if the CB is closed)
V-Ctrl	Control voltage for the closed circuit
V-BI1	Input voltage for binary input 1
V-BI2	Input voltage for binary input 2

The stage **Closing-circuit supervision with 2 binary inputs** detects disruptions in the closed circuit. It also monitors the reaction of the circuit breaker via the position of the circuit-breaker auxiliary contacts.

Depending on the switch position of the close-command relay and the circuit breaker, the binary inputs are either activated (H) or deactivated (L). If both binary inputs are deactivated, a fault occurs. The fault can be one of the following conditions:

- A disruption
- An outage of the battery voltage
- An adhesion present on the contact surface of the CCR

The following table shows all the states of the closed circuit:

CCR	CB	AuxCon1	AuxCon2	>Closed contact	>CB auxiliary contact	Dynamic State	Static State
Open	Open	Closed	Open	H	L	Normal operation with an open circuit breaker	
Open	Closed	Open	Closed	H	H	Normal operation with a closed circuit breaker	
Closed	Open	Closed	Open	L	L	Transient	Fault
Closed	Closed	Open	Closed	L	H	Transient, CCR is activated	

Logic

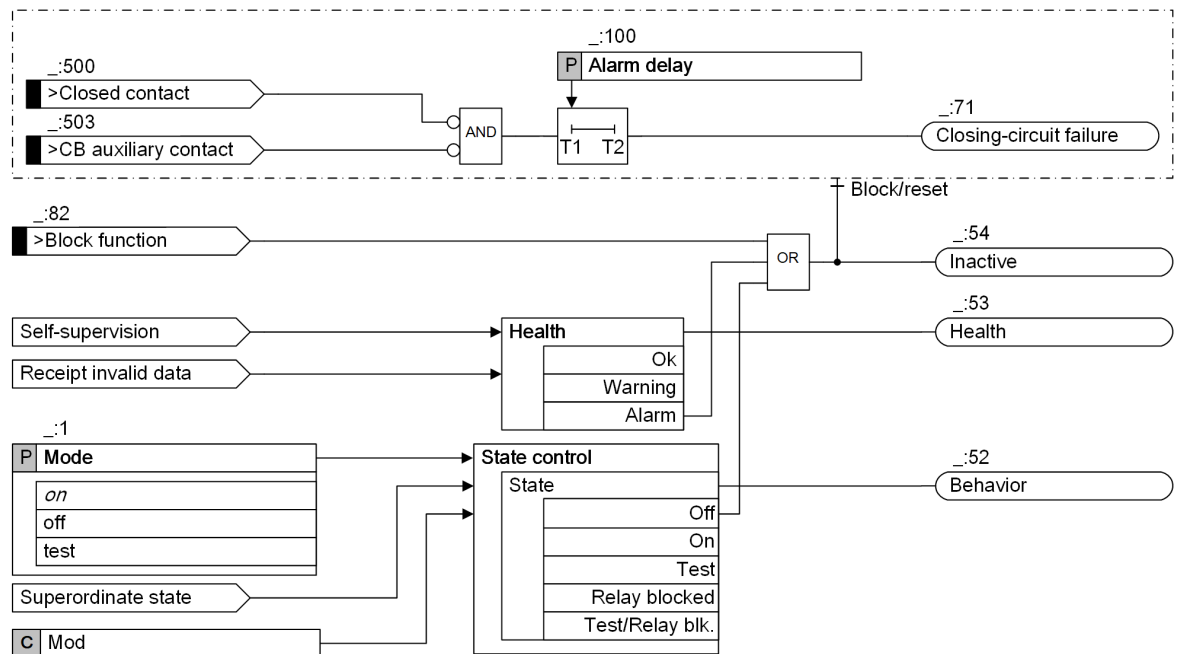

[to_CCS_2Bl_3_en_US]

Figure 10-46 Logic Diagram of the Stage Closing-Circuit Supervision with 2 Binary Inputs

The indication *Closing-circuit failure* is generated when the following 2 conditions are met:

- The binary inputs **>Closed contact** and **>CB auxiliary contact** are both deactivated.
- The **Alarm delay** has elapsed.

10.3.14.5 Closing-Circuit Supervision with 1 Binary Input

Principle

In the stage **Closing-circuit supervision with 1 binary input**, 1 binary input is used to detect the disruption in the closed circuit. The binary input is connected parallel to the close-command relay. The circuit-breaker auxiliary contact is bridged with an equivalent resistance R.

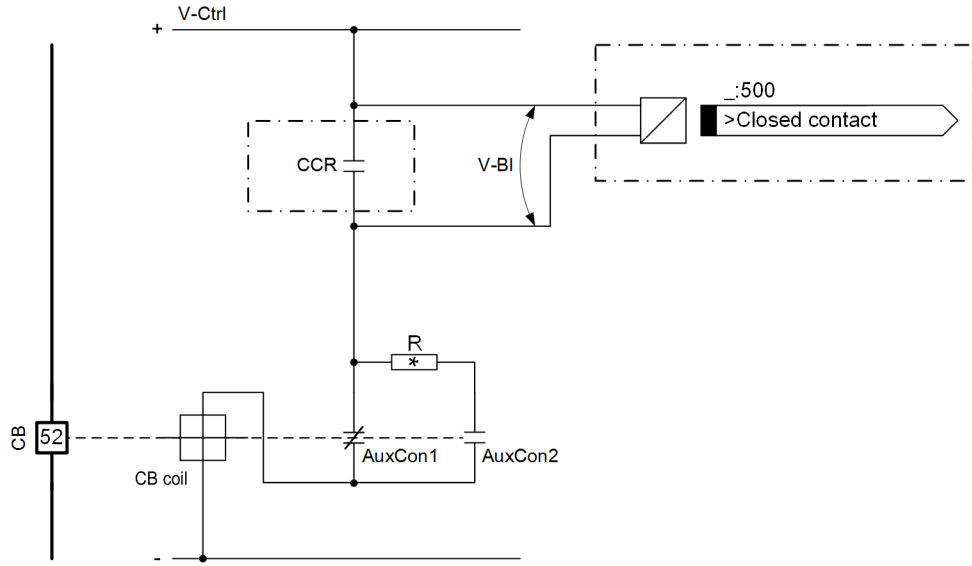

[dw_CCS_1BI_1_en_US]

Figure 10-47 Principle of the Closing-Circuit Supervision with 1 Binary Input

- CCR Close-command relay
- CB Circuit breaker
- CB closing coil Circuit-breaker closing coil
- AuxCon1 Circuit-breaker auxiliary contact 1 (open if the CB is closed)
- AuxCon2 Circuit-breaker auxiliary contact 2 (closed if the CB is closed)
- V-Ctrl Control voltage for the closed circuit
- V-BI Input voltage for binary input
- R Equivalent resistance

Depending on the switch position of the close-command relay, the binary input is either activated (H) or deactivated (L). If the binary input is deactivated, a fault occurs. The fault can be one of the following conditions:

- A disruption
- An outage of the battery voltage
- An adhesion present on the contact surface of the CCR

The following table shows all the states of the closed circuit:

CCR	CB	AuxCon1	AuxCon2	>Closed contact	Dynamic State	Static State
Open	Open	Closed	Open	H	Normal operation with an open circuit breaker	
Open	Closed	Open	Closed	H	Normal operation with a closed circuit breaker	
Closed	Open	Closed	Open	L	Transient	Fault
Closed	Closed	Open	Closed	L	Transient, CCR is activated	

Logic

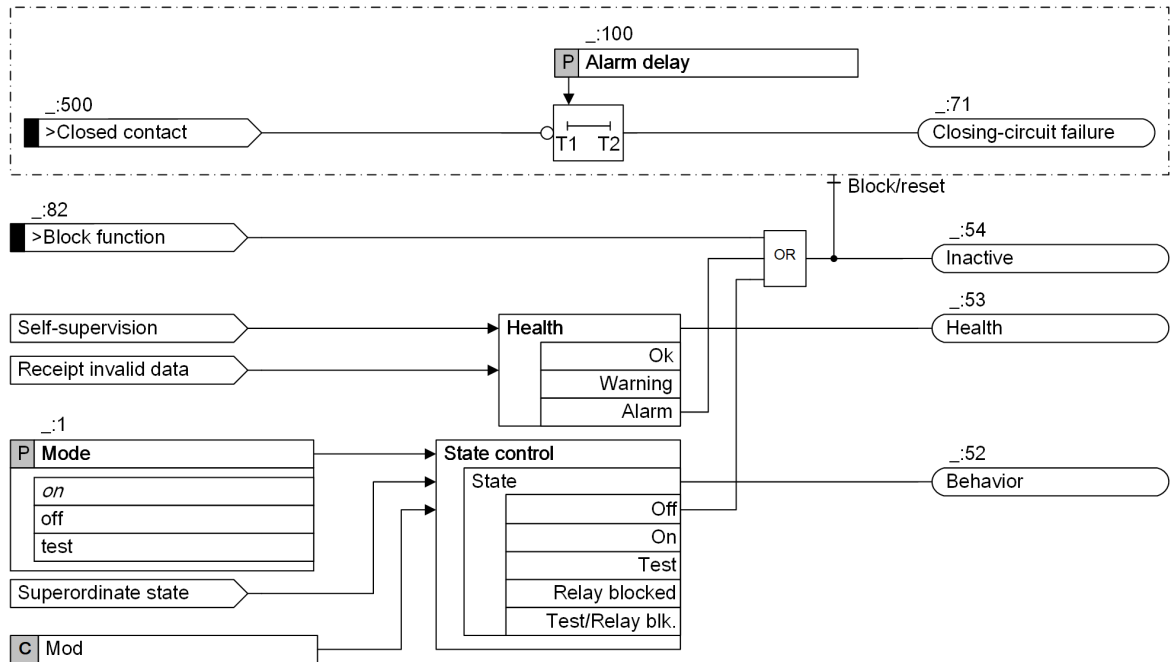

[fo_CCS_1Bl_3_en_US]

Figure 10-48 Logic Diagram of the Stage Closing-Circuit Supervision with 1 Binary Input

The indication *Closing-circuit failure* is generated when the following 2 conditions are met:

- The binary input **>Closed contact** is deactivated.
- The **Alarm delay** has elapsed.

Equivalent Resistance R

The equivalent resistance R must be dimensioned such that the circuit-breaker closing coil is no longer activated when the circuit breaker is open. Simultaneously, the binary input must still be activated when the command relay is open.

In order to ensure the minimum voltage for activating the binary input, R_{\max} results in:

$$R_{\max} = \left(\frac{V_{\text{Ctrl}} - V_{\text{Blmin}}}{I_{\text{Blmax}}} \right) - R_{\text{CBC}}$$

[fo_CCS_general_Rmax_1_en_US]

Because the circuit-breaker closing coil does not remain activated, R_{\min} results in:

$$R_{\min} = R_{\text{CBC}} \cdot \left(\frac{V_{\text{Ctrl}} - V_{\text{CBC(Lowmax)}}}{V_{\text{CBC(Lowmax)}}} \right)$$

[fo_CCS_general_Rmin_1_en_US]

You can calculate the optimal value for the equivalent resistance R from the 2 values R_{\min} and R_{\max} :

$$R = \frac{R_{\max} + R_{\min}}{2}$$

[fo_CCS_general_R_1_en_US]

The following equation applies for the power consumption of the equivalent resistance R:

$$P_R = I^2 \cdot R = \left(\frac{V_{Ctrl}}{R_{CBC} + R} \right)^2 \cdot R$$

[fo_CCS_general_P_1_en_US]

With:

- V_{Ctrl} Control voltage for the closed circuit
- V_{Blmin} The minimum voltage to activate the binary input
- I_{Blmax} The maximum current to activate the binary input
- R_{CBC} The resistance of the circuit-breaker closing coil
- $V_{CBC(Lowmax)}$ The maximum voltage flow through the circuit-breaker closing coil, which does not result in the closing of the circuit breaker

10.3.14.6 Application and Setting Notes

Parameter: Alarm delay

- Default setting ($_ :100$) **Alarm delay** = 2.00 s (Closing-circuit supervision with 3 binary inputs)
- Default setting ($_ :100$) **Alarm delay** = 2.00 s (Closing-circuit supervision with 2 binary inputs)
- Default setting ($_ :100$) **Alarm delay** = 300.00 s (Closing-circuit supervision with 1 binary input)

With the parameter **Alarm delay**, you can set the time for the delayed output of the indication *Closing-circuit failure*.

For the stage **Closing-circuit supervision with 2 binary inputs** or **Closing-circuit supervision with 3 binary inputs**, set the parameter **Alarm delay** so that the short-term transient states do not cause the function to activate.

For the stage **Closing-circuit supervision with 1 binary input**, set the parameter **Alarm delay** so that the longest duration of a close command is bridged without fail. This setting ensures that the function is activated only when the closed circuit is disrupted.

10.3.14.7 Settings

Addr.	Parameter	C	Setting Options	Default Setting
74CC sup. 1BI #				
$_ :1$	74CC sup.1BI #:Mode		<ul style="list-style-type: none"> • off • on • test 	on
$_ :100$	74CC sup.1BI #:Alarm delay		0.50 s to 600.00 s	300.00 s
74CC sup. 2BI #				
$_ :1$	74CC sup.2BI #:Mode		<ul style="list-style-type: none"> • off • on • test 	on
$_ :100$	74CC sup.2BI #:Alarm delay		0.50 s to 30.00 s	2.00 s

Addr.	Parameter	C	Setting Options	Default Setting
74CC sup. 3BI #				
_:1	74CC sup.3BI #:Mode		<ul style="list-style-type: none"> • off • on • test 	on
_:100	74CC sup.3BI #:Alarm delay		0.50 s to 30.00 s	2.00 s

10.3.14.8 Information List

No.	Information	Data Class (Type)	Type
74CC sup. 1BI #			
_:82	74CC sup.1BI #:>Block function	SPS	I
_:500	74CC sup.1BI #:>Closed contact	SPS	I
_:54	74CC sup.1BI #:Inactive	SPS	O
_:52	74CC sup.1BI #:Behavior	ENS	O
_:53	74CC sup.1BI #:Health	ENS	O
_:71	74CC sup.1BI #:Closing-circuit failure	SPS	O
74CC sup. 2BI #			
_:82	74CC sup.2BI #:>Block function	SPS	I
_:500	74CC sup.2BI #:>Closed contact	SPS	I
_:503	74CC sup.2BI #:>CB auxiliary contact	SPS	I
_:54	74CC sup.2BI #:Inactive	SPS	O
_:52	74CC sup.2BI #:Behavior	ENS	O
_:53	74CC sup.2BI #:Health	ENS	O
_:71	74CC sup.2BI #:Closing-circuit failure	SPS	O
74CC sup. 3BI #			
_:82	74CC sup.3BI #:>Block function	SPS	I
_:500	74CC sup.3BI #:>Closed contact	SPS	I
_:503	74CC sup.3BI #:>CB auxiliary contact	SPS	I
_:501	74CC sup.3BI #:>Closed contact 2	SPS	I
_:51	74CC sup.3BI #:Mode (controllable)	ENC	C
_:54	74CC sup.3BI #:Inactive	SPS	O
_:52	74CC sup.3BI #:Behavior	ENS	O
_:53	74CC sup.3BI #:Health	ENS	O
_:71	74CC sup.3BI #:Closing-circuit failure	SPS	O

10.4 Supervision of the Device Hardware

10.4.1 Overview

The correct state of the device hardware is a requirement for the correct functioning of the device. The failure or erroneous function of a hardware component leads to device malfunctions.

The error responses result, depending on type and degree of the error, as follows:

Hardware errors where the device remains in operation.

The error is indicated. The signals/data affected by the failure are marked as **invalid**. In this way, the affected protection functions can go into a secure state. Such errors are, for example:

- Failure integrated Ethernet Interface
- USB interface
- Real-time clock device
- A/D converter (fast current sum)
- Battery voltage
- Faulty or missing compensation values (magnitude/phase)

Failures which can partially be corrected by a restart of the device. The device goes briefly out of operation.

Such errors are, for example:

- Memory error (RAM) in the base module
- Defective module
- Module-connection error (PCB Link)
- Control circuit error binary output
- Outage of an internal auxiliary voltage



NOTE

If the error has not be rectified after 3 unsuccessful attempts, the system automatically recognizes it as a severe device malfunction. The device goes permanently out of operation into a secure state (fallback mode).

Fatal device errors with outage of central components: The device goes permanently out of operation into a secure state (fallback mode).

Such errors are, for example:

- Memory error (flash) in the base module
- CPU/Controller/FPGA error in the base module
- 3 unsuccessful restarts in a row

You can find the detailed description of the error responses in table form at the end of this chapter. You will find corresponding corrective measures there.

Device Operating Hours

The *Device operating hours* statistical value counts the operating hours of the physical device. The starting time and the time in Fallback mode are not considered.

You can neither reset nor change the statistical value.

10.4.2 Analog-Channel Supervision via Fast Current-Sum

10.4.2.1 Overview of Functions

The function **Supervision of the device-internal analog-digital converters** it performs the following tasks:

- Supervision of the correct functioning of the device-internal analog-digital converters, based on the sum of all currents of one measuring point in the secondary circuit.
- Detection of failures in the device-internal measuring circuits (for example, analog-digital converter)
- Blocking of protection and control functions that process the measured values from this current measuring point (for example, differential protection). This avoids an overfunction of the device.

The supervision principle is based on fast current-sum supervision with connection of the neutral-point current to the 4th current measuring input. In order to ensure that even the fast tripping stages of the protection functions can be blocked in time before a spurious pickup, the fast current measurement is based on instantaneous values.

For **Analog-digital converter supervision**, the neutral-point current of the line to be protected must be connected to the 4th current measuring input (I_N). The 4th current measuring input must be routed via the current-transformer neutral point (I_N neutral point) (see next figure).

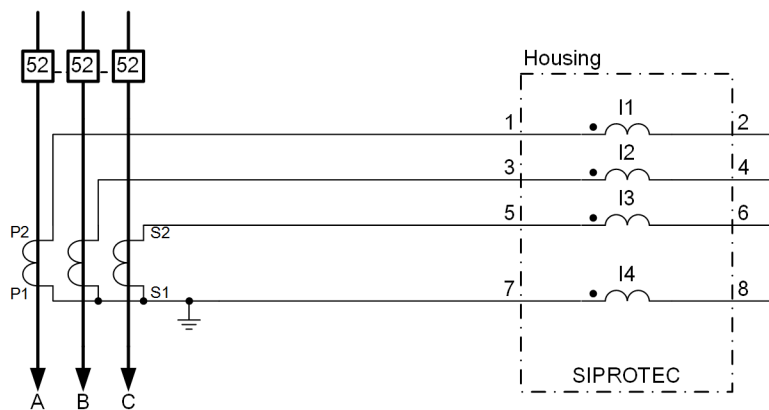

Current transformer 3-phase: connection = **3-phase + IN**

[1]_phase_2_4_en_US

Figure 10-49 Connection to a 3-Phase Current Transformer and Measured Zero-Sequence Current (Current in Common Return Conductor)



NOTE

The analog channel supervision via fast current sum is only available when the 4th current input is a protection-class current transformer. In the DIGSI 5 project tree, under **Device** → **Measuring-point routing**, set the connection type **3-phase + IN** for the current measuring point. When using this function, check the correct connection of the neutral conductor/ground current by supplying an asymmetrical current. Otherwise, a 1-pole or 2-pole fault could result in an unwanted blocking of the protection.

10.4.2.2 Structure of the Function

The **Supervision of the device-internal analog-digital converters** function is located in the **Power-system data** function group of each 3-phase current measuring point.

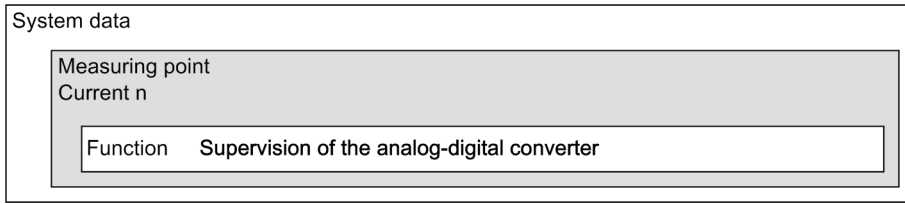

[dw_schstr, 1, en_US]

Figure 10-50 Structure/Embedding of the Function

10.4.2.3 Function Description

Errors in the current circuits are detected if

$$I_F = |i_A + i_B + i_C + i_N| > \text{Threshold value} + \text{Slope of the characteristic 1} \cdot \Sigma |i| \text{ and}$$

$$I_F > \text{Slope of the characteristic 2} \cdot (\Sigma |i| - \text{Base point 2})$$

The device uses the current inputs (iA, iB, iC, and iN) to calculate:

- Fault current $I_F = |i_A + i_B + i_C + i_N|$
- Maximum current $\Sigma |i| = |i_A| + |i_B| + |i_C| + |i_N|$

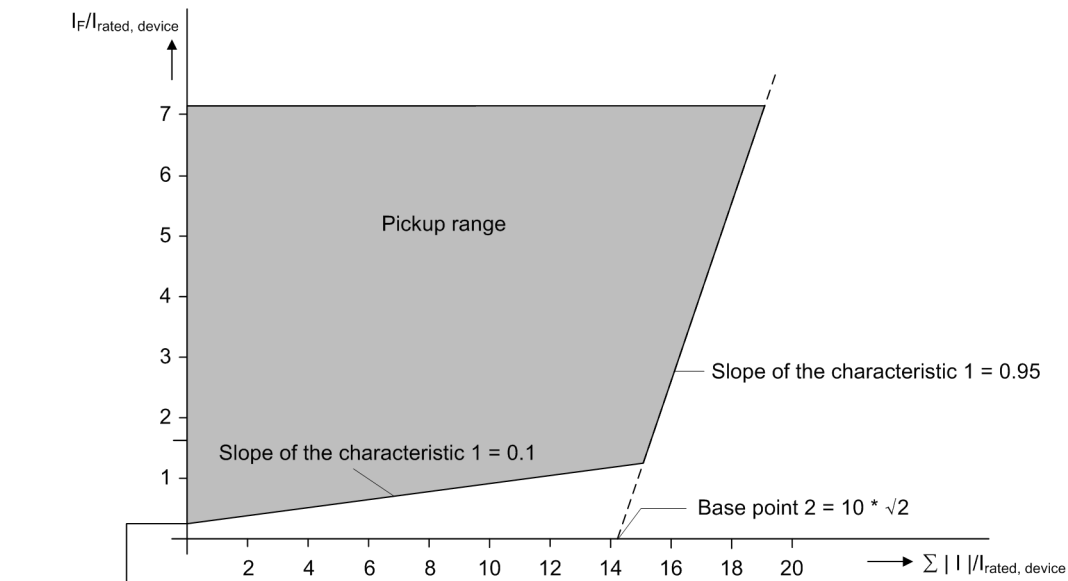

Threshold value 1 = 0.1 * √2

[lo_kenisu, 2, en_US]

Figure 10-51 Characteristic Curve of the Supervision of the Device-Internal Analog-Digital Converters

Logic

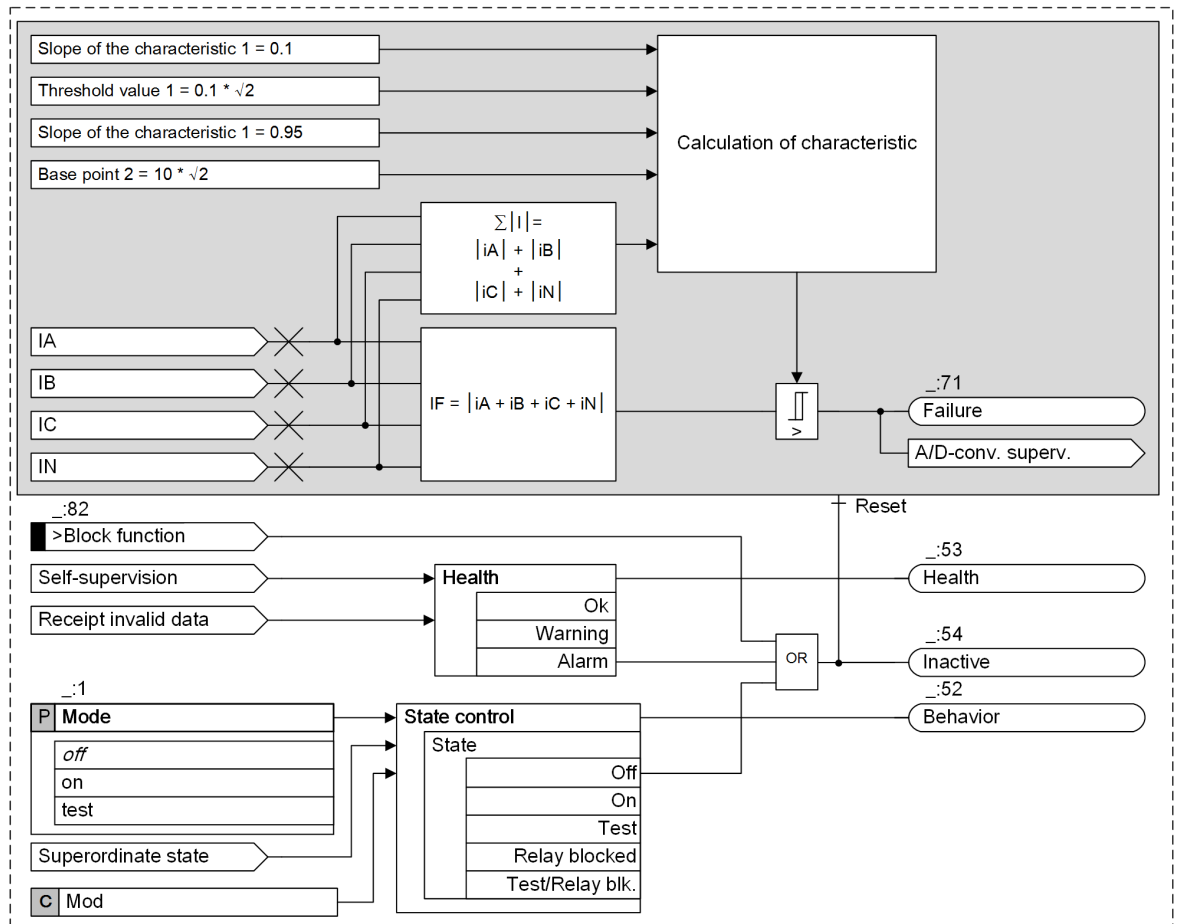

[to_sumsch, 4, en_US]

Figure 10-52 Logic Diagram of the Supervision of the Device-Internal Analog-Digital Converters

When the output signal **A/D converter monit.** is active, certain protection functions are blocked to avoid failures (see [14.70 Analog Channel Supervision via Fast Current Sum](#)).



NOTE

The parameters are set in the device and cannot be changed.
It is not necessary to change the parameters as a function of the application.

Threshold Value

The **threshold value** is the lower limit of the operating range of the **Supervision of the device-internal analog-digital converters** function.

The **threshold value** is permanently set to 10 % of the device rated current.

Slope of the Characteristic 1

The component **Slope of the characteristic 1** $\cdot \Sigma |i|$ accounts for permissible errors of the current input that can occur in the event of slight overcurrents.

The **Slope of the characteristic 1** is permanently set to 0.1.

Slope of the Characteristic 2

The component **Slope of the characteristic 2** accounts for permissible errors of the current input that can occur in the event of large overcurrents (high short-circuit currents).

The **Slope of the characteristic 2** is permanently set to 0.95. The base point of the **Slope of the characteristic 2** is permanently set to 10.

10.5 Supervision of Device Firmware

The device firmware determines essentially the functionality of the device.

The following supervisions ensure the stable function of the device:

- Supervisions of the data and version consistency
- Supervision of the undisturbed sequential activity of the device firmware
- Supervision of the available processor performance

When you start the device, load data via the interfaces and these supervisions of the device firmware will be in effect during the continuous operation. Depending on the type and severity of error, the following error responses will result:

Firmware failures where the device remains in operation.

The error is indicated. The signals/data affected by the failure are marked as **invalid**. In this way, the affected protection functions can go into a secure state. Such errors are, for example, errors in time synchronization (loss and errors).

Failures which can partially be corrected by a restart of the device. The device goes briefly out of operation.

Such errors are, for example:

- Device startup with faulty new parameter set. The old parameter set is still present.
- Overloading of the processor
- Program-sequence error

Fatal firmware error. The device goes permanently out of operation into a secure state (fallback mode).

Such errors are, for example:

- Device startup with faulty new parameter set. No usable parameter set is present.
- Device startup with version error
- CFC-runtime error
- 3 unsuccessful restarts in a row

You can find the detailed description, in table form, of the fault responses at the end of chapter [10.8 Error Responses and Corrective Measures](#). You will find corresponding corrective measures there.

10.6 Supervision of Hardware Configuration

The hardware concept requires adherence to some rules within the product family. Configuration errors show that the hardware configuration saved in the device does not agree with the hardware actually detected. Impermissible components and unallowed combinations must be detected just as missing configured components are.

Depending on the type and severity of error, the following error responses will result: The identified hardware configuration errors are assigned to the defect severities as follows:

Configuration errors for which the device remains in operation.

The failure is indicated. The signals/data affected by the failure are marked as **invalid**. In this way, the affected protection functions can go into a secure state. Such errors are, for example, errors in the IE-converter configuration (normal/sensitive).

Fatal configuration error: The device goes permanently out of operation into a secure state (fallback mode).

Such errors are, for example:

- Defective units

You can find the detailed description of the error responses in table form at the end of this chapter. You will find corresponding corrective measures there. You can resolve configuration errors through another synchronization with DIGSI.

10.7 Supervision of Communication Connections

SIPROTEC 5 Compact devices offer extensive communication options. Beyond the hardware supervision, the transferred data must be monitored with respect to their consistency, failure, or outage.

Supervision

With the supervision of the communication connections, every communication port is monitored selectively.

- Failures are detected and indicated via the operational log. The device remains in operation!
- Additionally, each port is equipped with a separate communication log which displays details of the failures, for example the error rate.

Marking Fault Signals/Data

The signals/data affected by the failure are marked as **invalid**. In this way, the affected protection functions can go into a secure state. In the following, some examples are named:

- GOOSE signals can automatically be set to defined values in case of disturbed IEC 61850 communication.
- Disturbed time-synchronization signals can lead to an automatic change of the source of time synchronization.

You can correct communication failures by checking the external connections .

For further information on error responses, refer to to [10.8.4 Defect Severity 3](#). Corresponding corrective measures are also be described there.

10.8 Error Responses and Corrective Measures

10.8.1 Overview

When device errors occur and the corresponding supervision functions pick up, this is displayed on the device and also indicated. Device errors can lead to corruption of data and signals. These data and signals are marked and tagged as **invalid**, so that affected functions automatically go into a secure state. If the supervision functions pick up, this will lead to defined error responses.

How Do Device Errors Make Themselves Noticeable

In case of a device error the supervision functions of the device pickup. The device responds according to the type and severity of the error. To report an error, supervision functions use outputs on the device and indications.

Run LED (green)	The external auxiliary voltage is present. The device is ready for operation.
Error LED (red)	The device is not ready for operation. The life contact is open.
Life contact	Signaling of device readiness following successful device startup.
Group-warning indication <i>Group warning</i>	The device remains in operation and signals an error via the prerouted LED and the log.
Log of the device	Indications of causes for defects and corrective measures

Determination of Causes for Defects and Corrective Measures

To determine the cause for defect and the corresponding corrective measure, proceed step by step.

- Step 1:** Pick up of supervisions leads to one of the following defect severities in all cases.
- **Defect severity 1:**
Internal or external device error that is reported. The device remains in operation.
 - **Defect severity 2:**
Severe device failure, the device restarts (reset) to correct the cause for defect.
 - **Defect severity 3:**
Severe device failure, the device goes to a safe condition (fallback mode), as the correction of defects cannot be implemented by a restart. In fallback mode, the protection and automated functions are inactive. The device is out of operation.
 - **Defect severity 4:**
Severe device-external failure, the device switches the protection and automatic functions to inactive for safety, but remains in operation. Normally, the user can correct the fault by himself.
- Step 2:** For every defect severity, you will find detailed tables with information about causes for defects, error responses, and corrective measures in the following chapters.

Table 10-2 Error Responses

	Group-Warning Indication Group Warning	Indication in Operational Log	Indication in Device-Diagnosis Log	Indication of the Life Contact	All Protection and Automation Functions are inactive	Device restart (Reset)	Fallback Mode
Defect Severity 1	x	x	x	–	–	–	–
Defect Severity 2	–	–	x	x	During the starting time of the device	x	–
Defect Severity 3	–	–	x	x	x	–	x
Defect Severity 4	–	x	–	x	x	–	–

10.8.2 Defect Severity 1

Defect severity 1 faults allow the continued safe operation of the device. Defect severity 1 faults are indicated. The device remains in operation.

When the supervision functions pick up, corrupted data and signals are marked as **invalid**. In this way, the affected functions can go into a secure state. Whether functions are blocked is decided in the appropriate function itself. For more detailed information, refer to the function descriptions.

Life contact	Remains activated
Red error LED	Is not activated

Log

For every device fault, a corresponding supervision indication is generated. The device records these indications with a real-time stamp in the operational log. In this way they are available for further analyses. If supervisions in the communication interfaces area of the device pick up, there is a separate communication log available for each port. Extended diagnostic indications and measured values are available there. The device-diagnosis log contains expanded fault descriptions. There you also receive recommendations of corresponding corrective measures for each detected device error.

There is further information on handling the logs in [3.1 Indications](#).

Group-Warning Indication Group Warning

As delivered, all monitoring indications of Defect Severity 1 are routed to the signal (`_ : 301`) **Group warning**. In this way, a device error can be indicated with only one indication. The majority of supervision indications are permanently connected to the **Group warning** (**Group warning** column = fixed). However, some supervision indications are routed flexibly to the **Group warning** via a logic block chart (**Group warning** column = CFC). If necessary, the routings via a CFC chart can be taken from the group indication again.

In delivery condition, the **Group warning** is routed to an LED.

The following logic diagram shows the correlation.

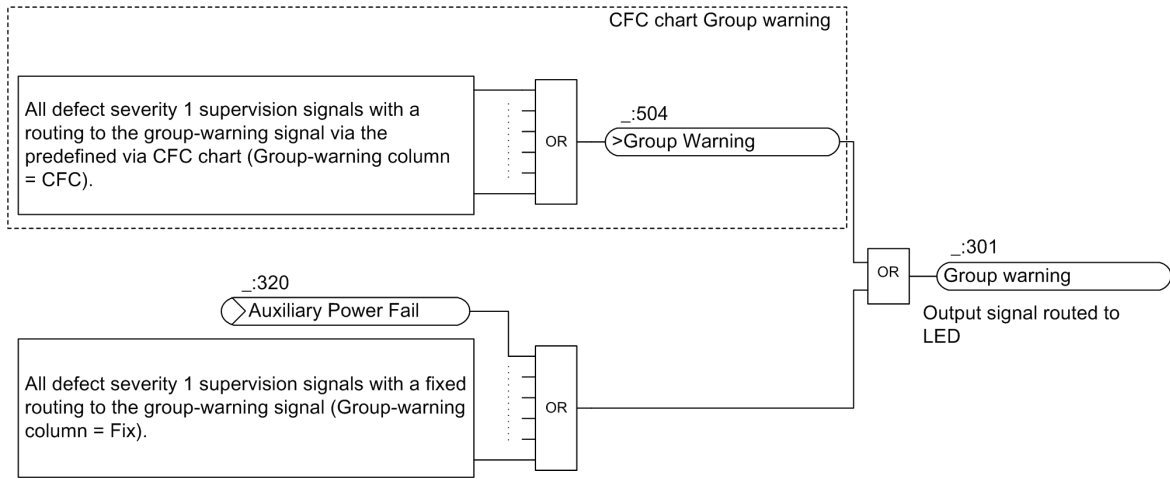

[!o_warning_indication, 1, en_US]

Figure 10-53 Forming the Warning Group Indication Group Warning

Overview of Errors

Indication	Type	Group Warning	Explanation
General:			
(_:53) Health	ENS	CFC	If the Health of an individual function block, for example a protection stage or an individual function, goes to the <i>warning</i> or <i>Alarm</i> state, this state generates up to the general group indication Health (_:53) via the associated function group. Check from the operational log from which function or function block the error originates. In the associated function description, there is additional information as to why the Standby of the function or a function block can change.
(_:53) Health = Warning	SPS		
(_:53) Health = Alarm	SPS		

Indication	Type	Group Warning	Explanation
Device:			
_:320 Auxiliary Power Fail	SPS	Fixed	Fault with the auxiliary power supply: Check the external power supply. This message does not appear if the device has a redundant PS204 power supply module, and is replaced by the messages described below for a device with PS204.
(_:305) Battery failure	SPS		Battery fault: Replace the device battery. To avoid data loss, Siemens recommends replacing the device battery with the device supply voltage switched on. You can find more information on battery disposal in the hardware manual from version V07.80 (order number: C53000-G5040-C002-D).
_:312 Compensation error x	ENS		Calibration error in module x: Contact the Customer Support Center. Quality: Measured values are marked with the quality attribute of <i>questionable</i> (measured value display with ≈).
_:314 Offset error x	ENS		Offset error on module x: If this indication persists after the device start, contact the Customer Support Center. Quality: Measured values are marked with the quality attribute of <i>questionable</i> (measured value display with ≈).
_:306 Clock fail	SPS		Internal time failure <ul style="list-style-type: none"> • Check the time settings first. • Then replace the device battery. • If the fault is not remedied, contact the Customer Support Center. Quality: The internal time is marked with the quality attribute of <i>Clock Failure</i> .
(_:319) Error memory	SPS		Checksum (cyclic redundancy check) error in monitored memory areas of the device

Indication	Type	Group Warning	Explanation
Device with redundant PS204 power supply module:			
_:330 Power sup. Module fail. x	INS	CFC	Internal device error on the power supply module at position x ⁴¹ : <ul style="list-style-type: none"> The device remains in operation because it has a redundant power supply module, provided it is intact. Exchange the defective power supply module so that redundancy is reestablished!
_:331 Power sup. Module OK x	INS		No internal device error in the power supply module at position x ⁴¹ .
_:332 Pow. sup. aux. pow. fail. x	INS		Error in the external auxiliary power supply module at position x ⁴¹ : <ul style="list-style-type: none"> The device remains in operation because it has a redundant power supply module, provided it is intact. Check the auxiliary power supply module.
_:333 Power sup. aux. pow. OK x	INS		The external auxiliary power supply module at position x ⁴¹ is OK.
_:334 Power sup. Module fail. x	SPS	Fixed	At least one power supply module has an internal device error
_:335 Pow. sup. aux. pow. fail. x	SPS	Fixed	At least one power supply module does not have an adequate auxiliary power supply
Handling an alarm:			
(_:504) > Group Warning	SPS	Fixed	Input signal for user-defined generation of group warning
Time sync.:			
(_:305) Time sync. error	SPS	Fixed	Time synchronization error, the timing master is faulty: <ul style="list-style-type: none"> Check the external time source first. Check the external connections. If the fault is not remedied, contact the Customer Support Center. Quality: The internal time is marked with the quality attribute of <i>Clock not synchronized</i> .
Power-system data: meas. point I-3ph:superv. Bal. I: (_:71) Failure	SPS	CFC	Current balance failure (see 10.3.10.1 Overview of Functions)
Power-system data: meas. point I-3ph:superv. Phsseq.I: (_:71) Failure	SPS	CFC	Failure of the current phase-rotation supervision system (see 10.3.12.1 Overview of Functions)
Power-system data: meas. point I-3ph:superv. Sum I (_:71) Failure	SPS	CFC	Failure of the current sum (see 10.3.11.1 Overview of Functions)

⁴¹ x refers to the PCB assembly slot (x=1,2,3,...)

Indication	Type	Group Warning	Explanation
Power-system data: meas. point I-3ph: superv. ADC sum. I: (_:71) Failure	SPS	CFC	<p>Failure of the fast current sum (see 10.4.2.1 Overview of Functions)</p> <p>The failure indication indicates a fault in the analog-digital converter at the power input.</p> <ul style="list-style-type: none"> Check the exterior wiring. If the fault is not remedied, contact the Customer Support Center. <p>Quality: The internally managed current measured values are marked with the <i>invalid</i> quality attribute.</p> <p>Blocking: The protection functions based on current measurement are blocked.</p>
Power-system data: meas. point V-3ph: Volt. Trans. Cir. B: (_:500) >Open	SPS	CFC	<p>Voltage-transformer circuit breaker is open.</p> <p>Blocking: Appropriate functions are either blocked definitely or the blocking can be set individually.</p>
Power-system data: meas. point V-3ph: Superv. of Bal. V: (_:71) Failure	SPS	CFC	<p>Failure of the voltage balance (see 10.3.5.1 Overview of Functions)</p>
Power-system data: meas. point V-3ph: Superv. Phsseq. V: (_:71) Failure	SPS	CFC	<p>Failure of the voltage phase-rotation supervision (see 10.3.7.1 Overview of Functions)</p>
Power-system data: meas. point V-3ph: Superv. of Sum V: (_:71) Failure	SPS	CFC	<p>Failure of the voltage sum (see 10.3.6.1 Overview of Functions)</p>
Device: (_:343) SEU happened	SPS		<p>SEU memory fault:</p> <p>Cosmic radiation can result in a Single Event Upset, which can be detected through bit flips (changes in the status of a bit) in the memory blocks. A reset to reinitialize the memory is initiated. You will find additional explanations on the physical background in a special SEU whitepaper.</p>

10.8.3 Defect Severity 2

Faults of defect severity 2 are fatal device faults that lead to an immediate restart of the device (reset).

This occurs when the device data is corrupted (for example, RAM memory), if a restart prevents restoration of data consistency. The device goes briefly out of operation, a failure is avoided.

Life contact	Is terminated during the restart
Red error LED	Is activated during the restart



NOTE

If the fault of defect severity 2 has not been removed after 3 unsuccessful restarts (reset), the fault is automatically assigned to defect severity 3. The device will automatically turn to the fallback mode.

Log

For every device error with a subsequent restart (reset), only the restart can be detected in the operational log. The actual supervision indication is entered in the device-diagnosis log at the point in time of the fault detection and before the restart. These indications are recorded with a real-time stamp and are thus available for later analyses. The device-diagnosis log contains expanded fault descriptions. There, you also receive recommendations of corresponding corrective measures for each detected device error.

For further information on handling the logs, refer to chapter 3.

Overview of Errors

Number	Device-Diagnosis Log
826	Processor error on the base module: If the fault occurs numerous times, contact the Customer Support Center.
830	FPGA hardware error on the base module: Contact the Customer Support Center.
834	Memory error (short term): Reset initiated.
3823	Program run error: If the fault occurs numerous times, contact the Customer Support Center.
826	CPU overload: If the fault occurs numerous times, contact the Customer Support Center.
11160	SEU memory fault (short term): Reset initiated
Miscellaneous	Internal firmware error: If the fault occurs numerous times, contact the Customer Support Center.

10.8.4 Defect Severity 3

Faults of defect severity 3 are fatal device faults that lead to device immediately going into the fallback mode. The signal (:301) *Physical health* goes to the **Alarm** state. The **Warning** state is not supported for this signal.

Fatal device errors are errors that cannot be resolved by a restart of the device. In this case, contact the Customer Support Center. The device goes permanently out of operation, a failure is avoided. In the fallback mode, minimal operation of the device via the on-site operation panel and DIGSI is possible. In this way, for example, you can still read out information from the device-diagnosis log.

Life contact	Is terminated in the fallback mode
Red error LED	Is activated in the fallback mode

Log

For every device error that immediately leads to entry into the fallback mode, entries from supervision messages and the signal (:301) *Physical health* into the operational log are not possible. The actual supervision indication is entered in the device-diagnosis log at the point in time of the fault detection, that is, before entry into the fallback mode. These indications are recorded with a real-time stamp and are thus available for later analyses. The device-diagnosis log contains expanded fault descriptions. There, you are offered recommendations of corresponding corrective measures for each detected device error.

You can find further information on handling the logs in chapter [3.1 Indications](#).

Overview of Errors

Number	Device-Diagnosis Log
2822	Memory error (continuous) Contact the Customer Support Center.
4729	Device bus error (repeated): <ul style="list-style-type: none"> Contact the Customer Support Center.
4733	Incorrect hardware configuration: Synchronize the hardware configuration of the device with DIGSI.
	Wrong application configuration: Search for the cause in the operational log and load a valid configuration to the device.

Number	Device-Diagnosis Log
3640, 4514	Data-structure error: Contact the Customer Support Center.
956	Firmware-version error: Contact the Customer Support Center.
2013, 2025	Signature error: Contact the Customer Support Center.
	CFC error: In DIGSI, check your CFC chart for the cause.
5050-5061	Binary-output error in module 1 - 12: Contact the Customer Support Center.
5088, 5089	A missing display configuration was established: Synchronize the hardware configuration of the device with DIGSI.

10.8.5 Defect Severity 4 (Group Alarm)

Errors of defect severity 4 are not device failures in the classical meaning. These errors do not affect the device hardware and are not detected or reported by internal device supervision functions. The condition of the defect severity 4 – the group alarm – is set user-specifically by the binary input signal ($_ : 503$) *>Group aAlarm*. If the binary input signal is reset, the device is no longer in the *Group aAlarm* condition and all functions return to the normal operating state.

If the group alarm is generated, the device reacts as follows:

- The group indication ($_ : 300$) *Group aAlarm* is generated and recorded in the operational log.
- The life contact is terminated.
- The red Error LED is activated.
- All protection and automation functions are blocked.
- The device remains in operation, does not carry out any restart (reset), and does not switch to the safe condition (Fallback mode).
- The signals managed internally are marked with the *invalid* quality attribute. Signals managed internally are, for example, measured values, binary input and output signals, GOOSE and CFC signals.

In the delivery condition, every device has the CFC chart **Process mode inactive**, that initiates the Group alarm (see chapter [10.9 Group Indications](#)).

Life contact	Is terminated in case of Group alarm
Red error LED	Is initiated in case of Group alarm

Log

The group indication ($_ : 300$) *Group aAlarm* is recorded in the operational log. Depending on the cause of the initiation, further information can be found in the operational log.

You can find further information on handling the logs in chapter 3.

10.9 Group Indications

The following group indications are available:

- (└:300) *Group alarm*
- (└:301) *Group warning*
- (└:302) *Group indication*

You can find the signals in the DIGSI 5 project tree under **Name of the device** → **Information routing**. In the working area, you can find the signals under **Alarm handling** (see the following figure).

Information			▶ Source
			▶ Binary input
			▶ Basismodul
Signals	Number	Type	1.1 1.2 1.3
(All) ▼	(All) ▼	... ▼	... ▼ ... ▼ ... ▼
▶ General	91		
▶ Device	4171		
▼ Alarm handling	5971		
▶ >Group Alarm	5971.503	SPS	
▶ >Group Warning	5971.504	SPS	
▶ >Group Indication	5971.505	SPS	
▶ Behavior	5971.52	ENS	
▶ Health	5971.53	ENS	
▶ Group alarm	5971.300	SPS	
▶ Group warning	5971.301	SPS	
▶ Group indication	5971.302	SPS	

[sc_gwarrn_1_en_US]

Figure 10-54 Group Monitoring Indication in the DIGSI 5 Information Routing Matrix

Group Indication Group Alarm

The indication (└:300) *Group alarm* is the group indication for defect severity 4 monitoring. This monitoring has a special purpose, as it is set user-specifically by a binary input signal and not by internal device supervision. Nevertheless, the response of the device is serious, such as blocking all protection and automatic functions (refer to [10.8.5 Defect Severity 4 \(Group Alarm\)](#)).

If the binary input signal (└:503) *>Group Alarm* is set, the group indication (└:300) *Group alarm* becomes active. If the binary input signal (└:503) *>Group Alarm* is reset, the signal (└:300) *Group alarm* is also reset and the device returns to the normal operating state.

In the delivery condition, every device has the CFC chart **Process mode inactive** that initiates the *>Group Alarm*. This CFC chart checks whether the device is still accidentally in the simulation or commissioning mode.

You can adapt the CFC chart as needed. You can find the CFC chart in the DIGSI 5 project tree under **Name of the device** → **Charts**.

Group Indication Group Warning

The indication (└:301) *Group warning* is the group indication for defect severity 1 monitoring. Some error messages of defect severity 1 are firmly linked to the signal (└:301) *Group warning*, others are connected flexibly in the device delivery condition via a CFC chart. This assignment is described in chapter [10.8.2 Defect Severity 1](#).

In the delivery condition, every device has the CFC chart **Group warning**, that initiates the *Group warning*.

You can adapt the CFC chart as needed. You can find the CFC chart in the DIGSI 5 project tree under **Name of the device** → **Charts**.

The group-warning indication ($_ :301$) *Group warning* is prerouted to an LED of the base module.

Group Indication

The *Group indication* is exclusively for user-specific purposes. There is no internal device supervision function that activates this indication. If the binary input signal ($_ :505$) *>Group indication* is set, the indication ($_ :302$) *Group indication* becomes active and is recorded in the operational log. This warning indication does not result in blocking a protection function. If the binary input signal is reset, the signal ($_ :302$) *Group indication* drops out. Using a CFC chart, you can define when the binary input signal ($_ :505$) *>Group indication* is to be set.

11 Measured Values, Energy Values, and Supervision of the Primary System

11.1	Overview of Functions	1378
11.2	Structure of the Function	1379
11.3	Operational Measured Values	1380
11.4	Fundamental and Symmetrical Components	1382
11.5	THD and Harmonics	1383
11.6	Average Values	1388
11.7	Minimum/Maximum Values	1391
11.8	Energy Values	1393
11.9	User-Defined Metered Values	1396
11.10	Statistical Values of the Primary System	1400
11.11	Circuit-Breaker Monitoring	1401
11.12	Disconnecter-Switch Monitoring	1458

11.1 Overview of Functions

The measurands are recorded at the measuring points and forwarded to the function groups.

Within the function groups, further measurands are calculated from these measured values, which are required for the functions of this function group. This is how, for example, the electric power is calculated from the voltage and current measurands.

Measuring transducers are an exception as they already form various calculation parameters from the analog current and voltage inputs themselves.

You can find basic instructions for recording and editing process data in [2.1 Embedding of Functions in the Device](#).

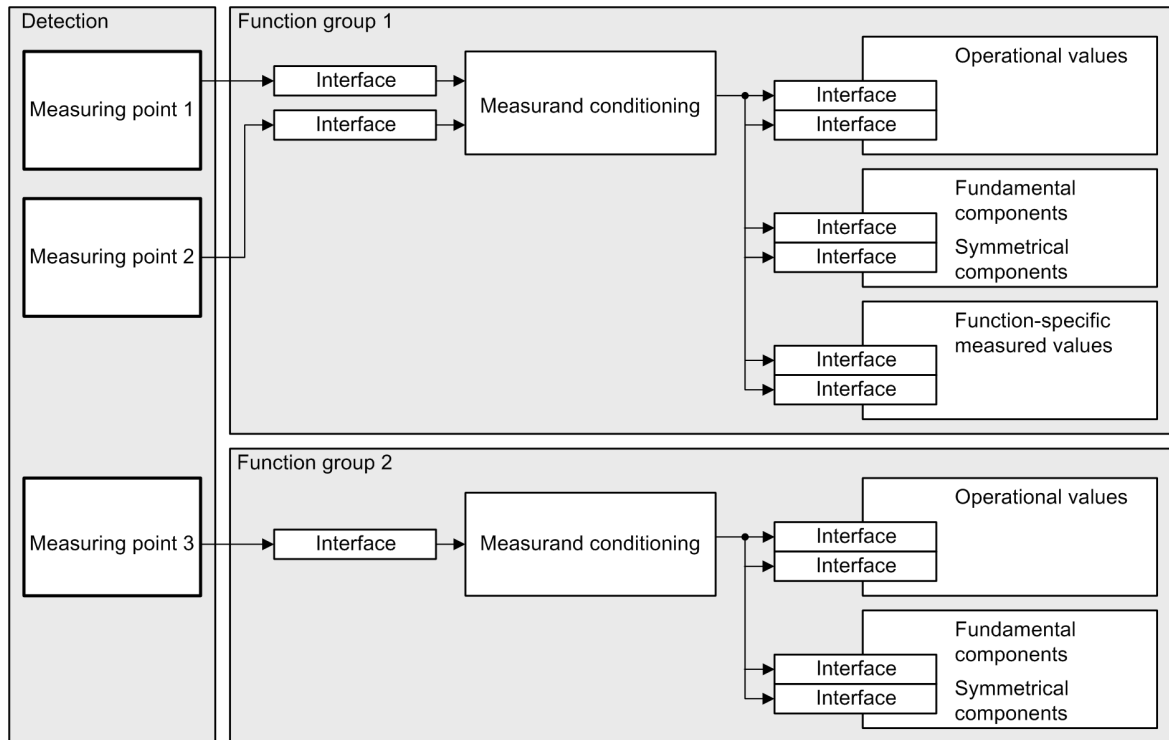

[dw_om_verf_1_en_US]

Figure 11-1 Structure of Measured-Value Acquisition and Processing

For the display, the measured values of a SIPROTEC 5 device are summed up in the following groups:

- Operational measured values
- Fundamental and symmetrical components
- Function-specific measured values
- Minimum values, maximum values, average values
- Energy metered values
- User-defined measured and metered values
- Statistical values

11.2 Structure of the Function

Depending on the interconnection of the function groups, these can contain different measured-value groups. 2 typical function groups are displayed below.

Circuit-Breaker Function Group

The **Circuit-breaker** function group may contain the following measured values:

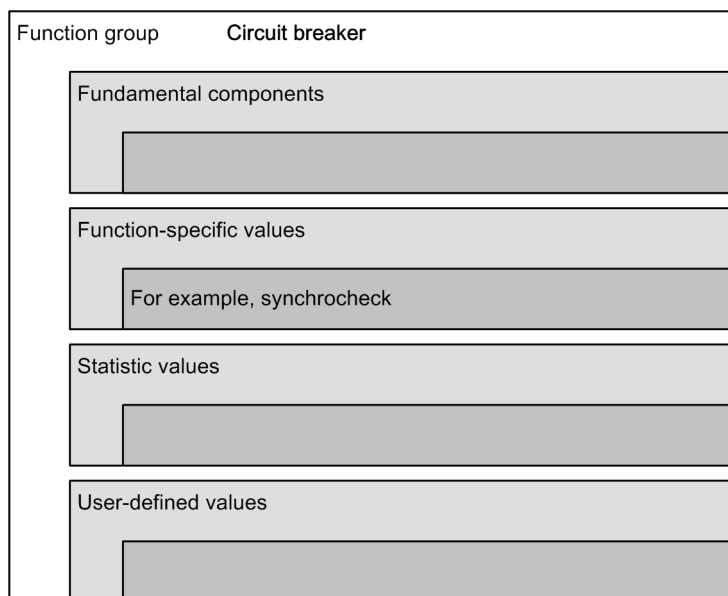

[dw_om_vls1, 1, en_US]

Inversion of Output-Related Measured and Statistical Values

The calculated, directional values in the operational measured values (power, power factor, energy and minimum, maximum, and average values based on these) are normally defined as positive in the direction of the protected object. This requires that the connection polarity for the used measuring points be correctly set (see also parameter (`_:8881:116`) **Neutr.point in dir.of ref.obj** of the measuring point current, 3-phase). It is, however, possible, to set the "forward" direction for the protection functions and the positive direction for the powers, etc., differently, for example, such that the active power consumption (from the line to the busbar) is displayed positively. Then set the option **reversed** in the affected function groups at the parameter **P, Q sign**. With the setting **not reversed** (default setting), the positive direction for the powers etc. corresponds to the "forward" direction for the protection functions.

The affected values are given in detail in the chapters [11.3 Operational Measured Values](#) - [11.10 Statistical Values of the Primary System](#).

11.3 Operational Measured Values

Operational measured values are assigned to different function groups.

The values can be displayed as primary and secondary values and as percentage values. They are updated every 180 ms.

The frequency is calculated using the filter algorithm, which is derived from the voltage or current. The voltage input has higher priority than the current input. If no voltage or current is present, the value contains the last valid frequency. – is displayed on the user interface.

The operational measured values are calculated according to the following definition equations:

RMS values

$$X = \sqrt{\frac{1}{T} \int_t^{t+T} x^2(t) dt}$$

Active power (per phase)

$$P_{phsx} = \frac{1}{T} \int_t^{t+T} v_{phsx}(t) \cdot i_{phsx}(t) dt$$

With $x = 1$ to 3

$v_{phsx}(t)$ – Instantaneous value of the phase voltage, that is, $v_{A'}$, $v_{B'}$, v_C

$i_{phsx}(t)$ – Instantaneous value of the phase current, that is, $i_{A'}$, $i_{B'}$, i_C

Active power (total)

$$P_{total} = \sum_{x=1}^3 P_{phsx}$$

Apparent power (per phase)

$$S_{phsx} = V_{phsx} \cdot I_{phsx}$$

With V_{phsx} – RMS value of the phase-to-ground voltage (true RMS):

$$V_{phsx} = \frac{V}{\sqrt{3}}$$

With $x = A$ to C

I_{phsx} – RMS value of the phase current (true RMS); with $x = A$ to C

Apparent power (total)

$$S_{total} = \sum_{x=1}^3 S_{phsx}$$

Reactive power (per phase)

$$Q_{phsx} = \sum_n V_n \cdot I_n \cdot \sin(\varphi_n)$$

With:

n – Harmonic order (up to $n = 50$)

φ_n – Angle difference between voltage and current of the n th harmonic

Reactive power (total)

$$Q_{total} = \sum_{x=1}^3 Q_{phsx}$$

Power factor

$$\lambda = \frac{|P|}{S}$$

Active factor

$$\cos \varphi = \frac{P}{S}$$

Voltage/Current 3-Phase Function Group

The following table describes the operational measured values of the **Voltage/current 3-Phase** function group.

All protection functions have access to the values.

Table 11-1 Operational Measured Values of the Voltage/Current 3-Phase Function Group

Measured Values		Primary	Secondary	% Referenced to
I_A, I_B, I_C	Phase currents	A	A	Rated operating current of the primary values
3I0	Calculated zero-sequence current	A	A	Rated operating current of the primary values
I_N	Neutral-point phase current	A	A	Rated operating current of the primary values
V_A, V_B, V_C	Phase-to-ground voltages	kV	V	Rated operating voltage of the primary values/ $\sqrt{3}$
V_{AB}, V_{BC}, V_{CA}	Phase-to-phase voltage	kV	V	Rated operating voltage of the primary values
V_0	Calculated zero-sequence voltage	kV	V	Rated operating voltage of the primary values/ $\sqrt{3}$
V_N	Measured neutral-point displacement voltage	kV	V	Rated operating voltage of the primary values/ $\sqrt{3}$
f	Frequency	Hz	Hz	Rated frequency
P	Active power (total power)	MW	–	Active power of the primary values $\sqrt{3} \cdot V_{\text{rated}} \cdot I_{\text{rated}}$
Q	Reactive power (total power)	Mvar	–	Reactive power of the primary values $\sqrt{3} \cdot V_{\text{rated}} \cdot I_{\text{rated}}$
S	Apparent power (total power)	MVA	–	Apparent power of the primary values $\sqrt{3} \cdot V_{\text{rated}} \cdot I_{\text{rated}}$
$\cos \varphi$	Active factor	(abs)	(abs)	100 % corresponds to $\cos \varphi = 1$
P_A, P_B, P_C	Phase-related active power	MW	–	Active power of the phase $V_{\text{rated phsx}} \cdot I_{\text{rated phsx}}$
Q_A, Q_B, Q_C	Phase-related reactive power	Mvar	–	Reactive power of the phase $V_{\text{rated phsx}} \cdot I_{\text{rated phsx}}$
S_A, S_B, S_C	Phase-related apparent power	MVA	–	Apparent power of the phase $V_{\text{rated phsx}} \cdot I_{\text{rated phsx}}$



NOTE

With the parameter **P**, **Q sign** in the function block **General** of the respective function group, the sign of the following measured values can be inverted:

- Active power (total): P total
- Active power (phase-related): P_A, P_B, P_C
- Reactive power (total): Q total
- Reactive power (phase-related): $Q_A, Q_B,$ and Q_C

11.4 Fundamental and Symmetrical Components

The fundamental components are calculated from the frequency-tracked instantaneous values through a Fourier filter (integration interval: one period). The results are phasor values that are described by way of the amount and phase angle.

In accordance with the transformation matrix, the symmetrical components are calculated from the voltage and current phasors. These are also phasor quantities.

Fundamental Components

Table 11-2 Fundamental Components

Values		Primary	Secondary	Phase Angle	% Referenced to
$\underline{V}_A, \underline{V}_B, \underline{V}_C$	Phase-to-ground voltage	kV	V	°	Rated operating voltage of primary values/ $\sqrt{3}$
\underline{V}_N	Measured neutral-point displacement voltage	kV	V	°	Rated operating voltage of primary values/ $\sqrt{3}$
$\underline{V}_{12}, \underline{V}_{23}, \underline{V}_{31}$	Phase-to-phase voltage	kV	V	°	Rated operating voltage of the primary values
$\underline{I}_A, \underline{I}_B, \underline{I}_C$	Phase currents	A	A	°	Rated operating current of the primary values
\underline{I}_N	Neutral-point phase current	A	A	°	Rated operating current of the primary values

Symmetrical Components

Table 11-3 Symmetrical Components

Values		Primary	Secondary	Phase Angle	% Referenced to
\underline{V}_0	Zero-sequence component of the voltage	kV	V	°	Rated operating voltage of primary values/ $\sqrt{3}$
\underline{V}_1	Positive-sequence component of the voltage	kV	V	°	Rated operating voltage of primary values/ $\sqrt{3}$
\underline{V}_2	Negative-sequence component of the voltage	kV	V	°	Rated operating voltage of primary values/ $\sqrt{3}$
\underline{I}_0	Zero-sequence component of the current	A	A	°	Rated operating current of the primary values
\underline{I}_1	Positive-sequence component of the current	A	A	°	Rated operating current of the primary values
\underline{I}_2	Negative-sequence component of the current	A	A	°	Rated operating current of the primary values

11.5 THD and Harmonics

11.5.1 Overview of Functions

At the connection point to the public power system, the allowed total harmonic distortion (THD) is limited according to the power-quality related standards. The function **THD and harmonics** can be used to monitor the THD value.

The function **THD and harmonics** serves for the calculation of the following values:

- THD values of the 3-phase currents and 3-phase voltages
- Aggregated THD values of the 3-phase voltages
If the aggregated THD value exceeds the threshold, a warning is generated.
- Harmonics of the 3-phase currents and 3-phase voltages

The calculated THD values and harmonics are displayed under **Power quality basic > THD and harmonics** of a specific function group in the HMI or via the DIGSI Online-Editor. If routed, the calculated THD values and harmonics are available in the communication protocols and in the fault record. Abnormal values can be logged in the operational or user-defined log if routed.

11.5.2 Structure of the Function

The function **THD and harmonics** can be used in the protection function groups with 3-phase current and voltage measurements and in the protection function group with only 3-phase voltage measurement.

When being used in a function group with 3-phase current and voltage measurements, the function comes factory-set with 1 stage **Current**. The following stages can be operated simultaneously within the function:

- 1 stage **Current**
- 1 stage **Voltage**

When being used in a function group with only 3-phase voltage measurement, the function comes factory-set with 1 stage **Voltage**. Only 1 voltage stage can be operated within the function.

The 2 types of function groups are displayed in the following figure. The stage that is not preconfigured is shown in gray.

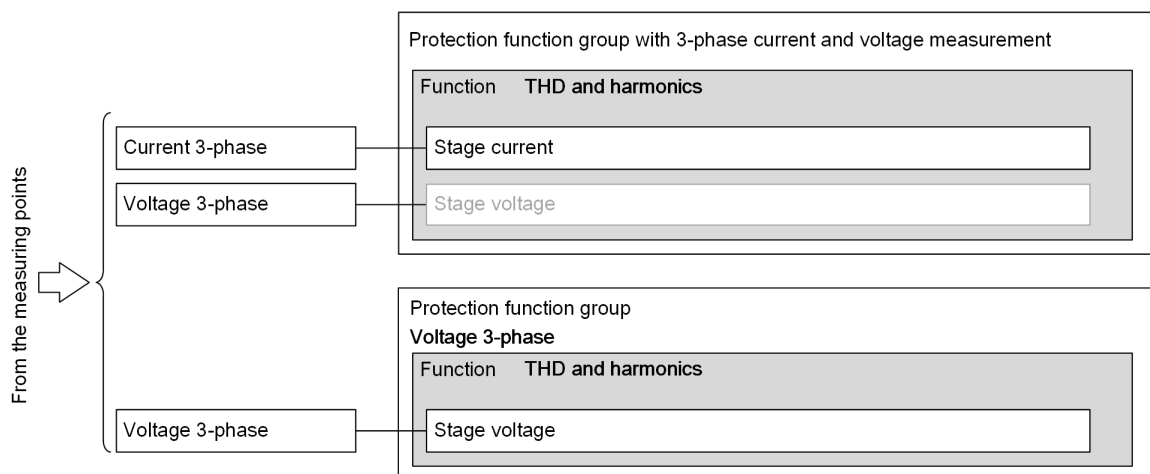

[dw_structure_THD harmonic_3_en_US]

Figure 11-2 Structure/Embedding of the Function

11.5.3 Function Description

The **THD and harmonics** function provides the following stages:

- **Current** stage
The stage calculates and displays the THD values and harmonics for the 3-phase current.
- **Voltage** stage
The stage calculates and displays the THD values and harmonics for the 3-phase voltage.

Calculation of THD Values and Harmonics

For the current and voltage, the calculation formulas of THD values and harmonics are similar. The following uses the voltage as an example.

The THD value is a percentage value calculated as follows:

$$\text{THD} = \frac{\sqrt{\sum_{i=2}^n V_i^2}}{V_s} \cdot 100 \%$$

[fo_THD value, 1, en_US]

Where

- n n = 20
The function supports the THD calculation to the 20th harmonic.
- V_i Harmonic value of order *i*
- V_s Fundamental-component value

The calculated harmonic values are a percentage value that takes the fundamental-component value as reference.

$$\text{Harmonic}_i = \frac{V_i}{V_s} \cdot 100 \%$$

[fo_harmonic ratio, 1, en_US]

Functional Measured Values

For the **Current** stage, the functional measured values are as follows.

Table 11-4 Functional Measured Values of the Current Stage

Measured Value	Description
THD:A	THD values of the 3-phase currents for the phases A, B, and C. The values are percentage values.
THD:B	
THD:C	
H2:A	Harmonic values from the 2nd to 20th harmonics of the 3-phase currents for the phases A, B, and C. The values are percentage values.
H2:B	
H2:C	
...	
H20:A	
H20:B	
H20:C	

For the **Voltage** stage, the functional measured values are divided into 2 submenus: one is for the phase-to-ground voltage and the other is for the phase-to-phase voltage, as shown in [Table 11-5](#) and [Table 11-6](#).

Table 11-5 Functional Measured Values of the Voltage Stage for the Phase-to-Ground Voltage

Measured Value	Description
THD Vph:A THD Vph:B THD Vph:C	THD values of the phase-to-ground voltages for the phases A, B, and C. The values are percentage values.
HPhV2:A HPhV2:B HPhV2:C ... HPhV20:A HPhV20:B HPhV20:C	Harmonic values from the 2nd to 20th harmonics of the phase-to-ground voltages for the phases A, B, and C. The values are percentage values.

Table 11-6 Functional Measured Values of the Voltage Stage for the Phase-to-Phase Voltage

Measured Value	Description
THD Vpp:AB THD Vpp:BC THD Vpp:CA	THD values of the phase-to-phase voltages for the phases AB, BC, and CA. The values are percentage values.
HPPV2:AB HPPV2:BC HPPV2:CA ... HPPV20:AB HPPV20:BC HPPV20:CA	Harmonic values from the 2nd to 20th harmonics of the phase-to-phase voltages for the phases AB, BC, and CA. The values are percentage values.

Frequency Operating Range

The frequency operating range of this function is 0.9 to 1.1 of the rated frequency:

- If the power frequency is in this range, the THD values and harmonics are calculated.
- If the power frequency is out of this range, the THD values and harmonics are shown as --.

Stabilization

For stabilization, THD values and harmonics are set to 0 if one of the following conditions is met:

- **Voltage** stage: The fundamental-component value is smaller than 1 % of the rated voltage.
- **Current** stage: The fundamental-component value is smaller than 1 % of the rated current.

11.5.4 Information List

No.	Information	Data Class (Type)	Type
Current			
_:22081:52	Current:Behavior	ENS	O
_:22081:53	Current:Health	ENS	O
_:22081:301	Current:THD	WYE	O
_:22081:302	Current:H2	WYE	O
_:22081:303	Current:H3	WYE	O
_:22081:304	Current:H4	WYE	O

No.	Information	Data Class (Type)	Type
_:22081:305	Current:H5	WYE	0
_:22081:306	Current:H6	WYE	0
_:22081:307	Current:H7	WYE	0
_:22081:308	Current:H8	WYE	0
_:22081:309	Current:H9	WYE	0
_:22081:310	Current:H10	WYE	0
_:22081:311	Current:H11	WYE	0
_:22081:312	Current:H12	WYE	0
_:22081:313	Current:H13	WYE	0
_:22081:314	Current:H14	WYE	0
_:22081:315	Current:H15	WYE	0
_:22081:316	Current:H16	WYE	0
_:22081:317	Current:H17	WYE	0
_:22081:318	Current:H18	WYE	0
_:22081:319	Current:H19	WYE	0
_:22081:320	Current:H20	WYE	0

No.	Information	Data Class (Type)	Type
Voltage			
_:52	Voltage:Behavior	ENS	0
_:53	Voltage:Health	ENS	0
_:301	Voltage:THD Vph	WYE	0
_:321	Voltage:THD Vpp	DEL	0
_:302	Voltage:HPhV2	WYE	0
_:303	Voltage:HPhV3	WYE	0
_:304	Voltage:HPhV4	WYE	0
_:305	Voltage:HPhV5	WYE	0
_:306	Voltage:HPhV6	WYE	0
_:307	Voltage:HPhV7	WYE	0
_:308	Voltage:HPhV8	WYE	0
_:309	Voltage:HPhV9	WYE	0
_:310	Voltage:HPhV10	WYE	0
_:311	Voltage:HPhV11	WYE	0
_:312	Voltage:HPhV12	WYE	0
_:313	Voltage:HPhV13	WYE	0
_:314	Voltage:HPhV14	WYE	0
_:315	Voltage:HPhV15	WYE	0
_:316	Voltage:HPhV16	WYE	0
_:317	Voltage:HPhV17	WYE	0
_:318	Voltage:HPhV18	WYE	0
_:319	Voltage:HPhV19	WYE	0
_:320	Voltage:HPhV20	WYE	0
_:322	Voltage:HPPV2	DEL	0
_:323	Voltage:HPPV3	DEL	0
_:324	Voltage:HPPV4	DEL	0
_:325	Voltage:HPPV5	DEL	0

No.	Information	Data Class (Type)	Type
_:326	Voltage:HPPV6	DEL	O
_:327	Voltage:HPPV7	DEL	O
_:328	Voltage:HPPV8	DEL	O
_:329	Voltage:HPPV9	DEL	O
_:330	Voltage:HPPV10	DEL	O
_:331	Voltage:HPPV11	DEL	O
_:332	Voltage:HPPV12	DEL	O
_:333	Voltage:HPPV13	DEL	O
_:334	Voltage:HPPV14	DEL	O
_:335	Voltage:HPPV15	DEL	O
_:336	Voltage:HPPV16	DEL	O
_:337	Voltage:HPPV17	DEL	O
_:338	Voltage:HPPV18	DEL	O
_:339	Voltage:HPPV19	DEL	O
_:340	Voltage:HPPV20	DEL	O

11.6 Average Values

11.6.1 Function Description of Average Values

Average values can be formed based on different measurands:

- Operational measured values
- Symmetrical components

Through the settings, you can set how and when the average values are formed. The settings describe:

- Time slot over which the average value is formed
(Parameter: **Average calc. interval**)
- Update interval for the display of the average values
(Parameter: **Average update interval**)
- Synchronization time for establishing the date of commencement updating information, for example, at the top of the hour (hh:00) or at one of the other times (hh:15, hh:30, hh:45).
(Parameter: **Average synchroniz. time**)

Average values are formed through the following measurands:

- Operational measured values except for phase-related ratings
- Amounts of the symmetrical components

You reset the average value formation via the

- Binary input >Reset average value
- DIGSI
- The integrated operation panel



NOTE

With the **P, Q sign** parameter in the function block **General**, the sign of the following measured values of the respective function group can be inverted (see Chapter [11.2 Structure of the Function](#) Structure of the Function, section Inversion of Output-Related Measured and Statistical Values):

- Active power (total): P total
- Reactive power (total): Q total

11.6.2 Application and Setting Notes for Average Values

The average value formation functionality is not preconfigured with the devices in the function group. If you use the functionality, you must load it from the library into the respective function group.

The following settings listed for the calculation of the average values can be set with DIGSI and at the device. You find the setting parameters in DIGSI in the project tree under **Settings > Device settings**.

Parameter: Average calc. interval

- Default setting: (**_:104**) **Average calc. interval = 60 min**

Parameter Value	Description
1 min to 60 min	Time slot for averaging, for example 60 minutes

Parameter: Average update interval

- Default setting: (**_:105**) **Average update interval = 60 min**

Parameter Value	Description
1 min to 60 min	Update interval for displaying the average value, for example 60 minutes

Parameter: Average synchroniz. time

- Default setting: (`_:106`) **Average synchroniz. time** = `hh:00`
The parameter describes the synchronization time for average value formation.

Parameter Value	Description
<code>hh:00</code>	The parameter Average update interval will be effective on the full hour
<code>hh:15</code>	The parameter Average update interval will be effective 15 minutes after the full hour
<code>hh:30</code>	The parameter Average update interval will be effective 30 minutes after the full hour
<code>hh:45</code>	The parameter Average update interval will be effective 45 minutes after the full hour



NOTE

The average value calculation restarts after

- Changing one of the 3 settings for the average-value calculation
- Resetting the device (initial or normal reset)
- Changing the time
- Resetting the average values

The average values are reset immediately. The display changes to "---".

The following examples explain how to set parameters and to make a change.

Average calc. interval = 60 min
Average update interval = 30 min
Average synchroniz. time = `hh:15`.

A new average value is formed every 30 min, at `hh:15` (15 min after the top of the hour) and `hh:45` (15 min before the top of the hour). All measured values obtained during the last 60 min are used for average value formation.

If these settings are changed to `11:03:25`, for instance, the average values are first reset and "---" appears in the display. The 1st average value is then formed at `12:15:00`.

In this example, the **Average synchroniz. time** = `hh:45` acts as described above for = `hh:15`.

Average calc. interval = 60 min
Average update interval = 60 min
Average synchroniz. time = `hh:15`.

A new average value is formed every 60 min at `hh:15` (15 min after the top of the hour). All measured values obtained during the last 60 min are used for average value formation.

If these settings are changed to `11:03:25`, for instance, the average values are first reset and "---" appears in the display. The 1st average value is then formed at `12:15:00`.

Average calc. interval = 5 min
Average update interval = 10 min
Average synchroniz. time = `hh:00`.

11.6 Average Values

A new average value is formed every 10 min at hh:00, hh:10, hh:20, hh:30, hh:40, hh:50. All measured values obtained during the last 5 min are used to form the average value.

If these settings are changed to 11:03:25, for instance, the average values are first reset and "---" appears in the display. The 1st average value is then formed at 11:10:00.

11.7 Minimum/Maximum Values

11.7.1 Function Description of Minimum/Maximum Values

Minimum and maximum values can be formed based on different measured or calculated measurands:

- Operational measured values
- Symmetrical components
- Selected values

You can set which measurand will be used. The measurands for the minimum/maximum formation are loaded from DIGSI.

Calculation and resetting of the minimum and maximum values are controlled through settings. The settings describe the following points:

- Memories of the minimum/maximum values are reset to 0 cyclically or not at all.
(Setting **Min/Max cyclic reset**)
- Point in time when the memories of the minimum/maximum values are reset to 0.
(Setting **Min/Max reset each** and setting **Min/Max reset minute**)
- Point in time at which the cyclical reset procedure of the minimum/maximum values begins (after the parameterization)
(Setting **Min/Max days until start**)

The following figure shows the effect of the settings.

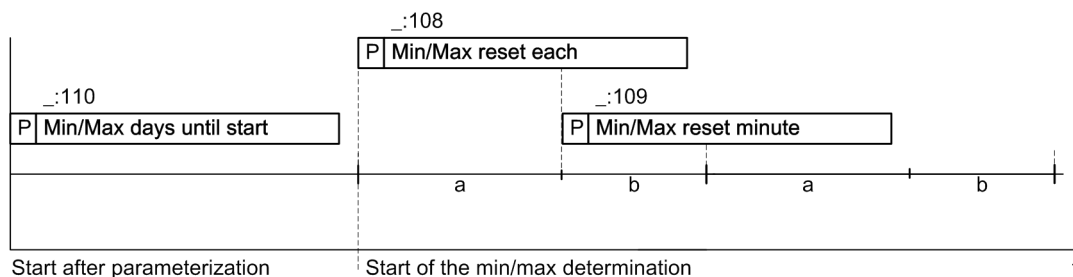

[dw_min_max_1_en_US]

Figure 11-3 Minimum and Maximum-Value Formation

Minimum and maximum values are time-stamped.

Minimum/maximum values are formed through:

- Operational measured values except for phase-related ratings
- Amounts of the symmetrical components
- Average values

The minimum and maximum values are reset on a regular basis or via the

- Binary input >Reset min/max
- DIGSI
- The integrated operation panel



NOTE

With the **P**, **Q sign** parameter in the function block **General**, the sign of the following measured values of the respective function group can be inverted (see Chapter [11.2 Structure of the Function](#) Structure of the Function, section Inversion of Output-Related Measured and Statistical Values):

- Minimum/maximum values of the active and reactive power:
 Min:Ptotal, Max:Ptotal, Min:Qtotal, Max:Qtotal
- Minimum/maximum values of the average values of the active and reactive power:
 AverageMin:Ptotal, AverageMax:Ptotal, AverageMin:Qtotal, AverageMax:Qtotal

11.7.2 Application and Setting Notes for Minimum/Maximum Values

The minimum/maximum values functionality is not preconfigured. If you want to use the functionality, you must load it from the library into the respective function group.

The following settings listed for the calculation of the minimum/maximum values can be set with DIGSI or at the device. You find the setting parameters in DIGSI in the project tree under **Settings > Device settings**.

Parameter: Min/Max cyclic reset

- Default setting: (`_:107`) **Min/Max cyclic reset = yes**

Parameter Value	Description
Yes	Cyclical resetting of the minimum and maximum value memories is activated
No	Cyclical resetting of the minimum and maximum value memories is deactivated None of the following parameters are visible

Parameter: Min/Max reset each

- Default setting: (`_:108`) **Min/Max reset each = 1 day**

Parameter Value	Description
1 day to 365 days	Resetting of the minimum value and the maximum value, cyclically on all specified days, for example each day (1 day)

Parameter: Min/Max reset minute

- Default setting: (`_:109`) **Min/Max reset minute = 0 min**

Parameter Value	Description
0 min to 1439 min	Resetting the minimum value and the maximum value at the specified minute of the day, which is stated in the parameter Min/Max Reset takes place every , for example 0 min 0 min (= 00.00)

Parameter: Min/Max days until start

- Default setting: (`_:110`) **Min/Max days until start = 1 day**

Parameter Value	Description
1 day to 365 days	Indication of when the cyclical reset procedure of the minimum values and maximum values begins, for example in 1 day (after the parameterization)

11.8 Energy Values

11.8.1 Function Description of Energy Values

The device continually determines the values for the active and reactive energy from the power-measured values. It calculates the exported and imported electrical energy. The calculation (summation over time) begins immediately after the device startup. You can read the present energy values on the device display or through DIGSI, delete the energy value (set to 0), or set it to any initial value. After input, the energy-value calculation will continue with the new setting values.

Energy values can be transferred to a control center through an interface. The energy values are converted into energy metered values. Here the following applies:

$$\text{Energy metered value} = \frac{\text{Energy value}}{S_{N,obj}} \cdot 60000 \frac{\text{Pulses}}{\text{h}}$$

[to_omverg_1_en_US]

Through the settings, you set how the metered values are processed. The setting parameters apply for all energy metered values of the device, and do not have a function-group specific effect. You determine the following points:

- Parameter **Energy restore time**

Hour-related point in time; at this point in time, the device will provide a metered value at the communication interface for transmission. After this, it will be transferred in accordance with the selected log.

Note: If the parameter is activated through a time setting, the parameter **Energy restore interval** will be deactivated automatically.
- Parameter **Energy restore interval**

Adjustable period in minutes until the first and every further transfer of the metered value to the communication interface of the device. After this, it will be transferred in accordance with the selected log.

Note: The transfer interval is used alternatively to the transfer time, and deactivates the set transfer time. The display of the device is always up to date.

You will find these parameters in the device settings under **measured values**.

In addition, restoring can be triggered via a routable binary input (>**Restoring**). The rising edge of the binary input leads to restoring, that is, provision of the energy-metered value at the communication interface.

The metered-value memory and the energy values can be set to 0 via a binary input (>**Resetting**) if there is a rising edge.

Note: The binary inputs affect all energy/energy metered values simultaneously.

The following energy values are available:

Energy Values		Primary
Wp+	Active energy, output	kWh, MWh, GWh
Wp-	Active energy, input	kWh, MWh, GWh
Wq+	Reactive energy, output	kvarh, Mvarh, Gvarh
Wq-	Reactive energy, input	kvarh, Mvarh, Gvarh

In compliance with IEC 61850, when individually measured values are missing, the quality of the energy-metered values changes to the state **Questionable**.

This quality state is retained until a new meter content is specified for the energy value by:

- Confirmation of the current meter content via **Set**
- **Setting** a new counter status
- **Resetting** the counter status to 0



NOTE

With the **P**, **Q sign** parameter in the function block **General**, the sign of the following measured values of the respective function group can be inverted (see chapter [11.2 Structure of the Function](#), section on the Inversion of Output-Related Measured and Statistical Values):

- Active energy, output: Wp+
- Active energy, input: Wp-
- Reactive energy, output: Wq+
- Reactive energy, input: Wq-

11.8.2 Application and Setting Notes for Energy Values

The set parameters apply for all electricity meters of the device. You find the setting parameters in DIGSI in the project tree under **Settings > Device settings**.

Parameter: Energy restore interval

- Default setting: (**_:111**) **Energy restore interval = 10 min**

Parameter Value	Description
<i>0 min</i>	Restoring deactivated
<i>60 min</i>	Cyclical restoring after the set time 1 minute to 60 minutes

Note: If the parameter is activated through a time setting, the parameter **Energy restore time** is not in effect and will be deactivated automatically.

Parameter: Energy restore time

- Default setting: (**_:112**) **Energy restore time = none**

Parameter Value	Description
<i>none</i>	Deactivated
<i>hh:00</i>	Restoring on the full hour
<i>hh:15</i>	Restoring 15 minutes after the full hour
<i>hh:30</i>	Restoring 30 minutes after the full hour
<i>hh:45</i>	Restoring 45 minutes after the full hour

Note: If the parameter is activated through a time setting, the parameter **Energy restore interval** is not in effect and will be deactivated automatically.

Parameter: Energy restore

- Default setting: (**_:120**) **Energy restore = latest value**

Parameter Value	Description
<i>latest value</i>	Restoring of the current energy value
<i>delta value</i>	Restoring the difference value between the current energy value and the energy value of the last restoring operation

Parameter: Energy restore by A.time

- Default setting: (**_:121**) **Energy restore by A.time = false**

Parameter Value	Description
False	Restoring deactivated
True	The cyclic restoring after the set time of the parameter (_:111) Energy restore interval will also be synchronized with the system time. Example: Energy restore interval = 30 min; current system time: 12:10 o'clock First restore: 12:30 o'clock; next restore: 13:00 o'clock etc.

Note: When the parameter is activated, the following setting values are possible for the parameter (**_:111**) **Energy restore interval**: 1 min; 2 min; 3 min; 4 min; 5 min; 6 min; 10 min; 12 min; 15 min; 20 min; 30 min; 60 min.

Input Signals: >Restoring and >Resetting

Binary Inputs	Description
>Restoring	The restoring of the metered values is initiated via a binary input.
>Reset	The metered value memory is set to 0 through the binary input.

You route these logical signals in the DIGSI routing matrix. Open the function group, for example, Line, where you created the energy value. There, under the tab **Measured values** you will find the tab **Energy, 3-phase**. In this tab, you will find the logical signals in addition to the measured values.

11.9 User-Defined Metered Values

11.9.1 Function Description of Pulse-Metered Values



NOTE

You can define additional metered values through DIGSI for user-specific applications.

Use pulse meters; then you can define the respective metered values through DIGSI and set parameters for them analogously to the energy values. You can read out the metered values on the display of the device or via DIGSI.

Through settings, you can individually set how each pulse-metered value is processed:

- Parameter **Restore time**
Hour-related point in time when the device will provide a metered value at the communication interface for transmission. After this, the transfer takes place in accordance with the selected protocol.
Note: If the parameter is activated through a time setting, the parameter **Restore interval** will automatically be deactivated.
- Parameter **Restore interval**
Adjustable period in minutes until the first and every further transfer of the metered value to the communication interface of the device. After this, it will be transferred in accordance with the selected log.
Note: If the parameter is activated through a time setting, the parameter **Restore time** will automatically be deactivated.

In addition, restoring can be triggered via a routable binary input (**>Restore trigger**) or via a logical internal binary input. The rising edge of the binary input leads to restoring and thus to provision of the metered value at the communication interface.

The counter pulse of any external/internal pulse generator is connected to the device via a routable binary input (**>Pulse input**). If this does not deliver any plausible values, this can be signaled to the device via another routable binary input (**>External error**).

In compliance with IEC 61850, in the event of an external error, the quality of the pulse-metered value changes to the state **Questionable**. No more pulses are added as long as the external error persists. Once the external fault condition has been cleared, pulses are added again.

The quality of the pulse-metered value remains **Questionable** until a new meter content is specified for the pulse-metered value by:

- Confirmation of the current meter content via **Setting**
- **Setting** a new meter content
- **Resetting** the meter content to 0

- Parameter **Edge trigger**
Through settings, you can select between counting only with a rising edge or with rising and falling edges on the pulse input.

The pulse counter can be reset to 0. You can perform this resetting via the rising edge of a routable binary input (**>Reset**) or via operation on the device.

To display the counting amount at the device display, use DIGSI to set the desired weighting of the counter pulses, the unit of the metered value and a multiplication factor for every pulse generator. You can also assign a user-specific name.

To do this, open the functional area **Pulse-metered value** in DIGSI information routing. (see [Figure 11-4](#)). Select the metered value and enter the settings under **Properties**.

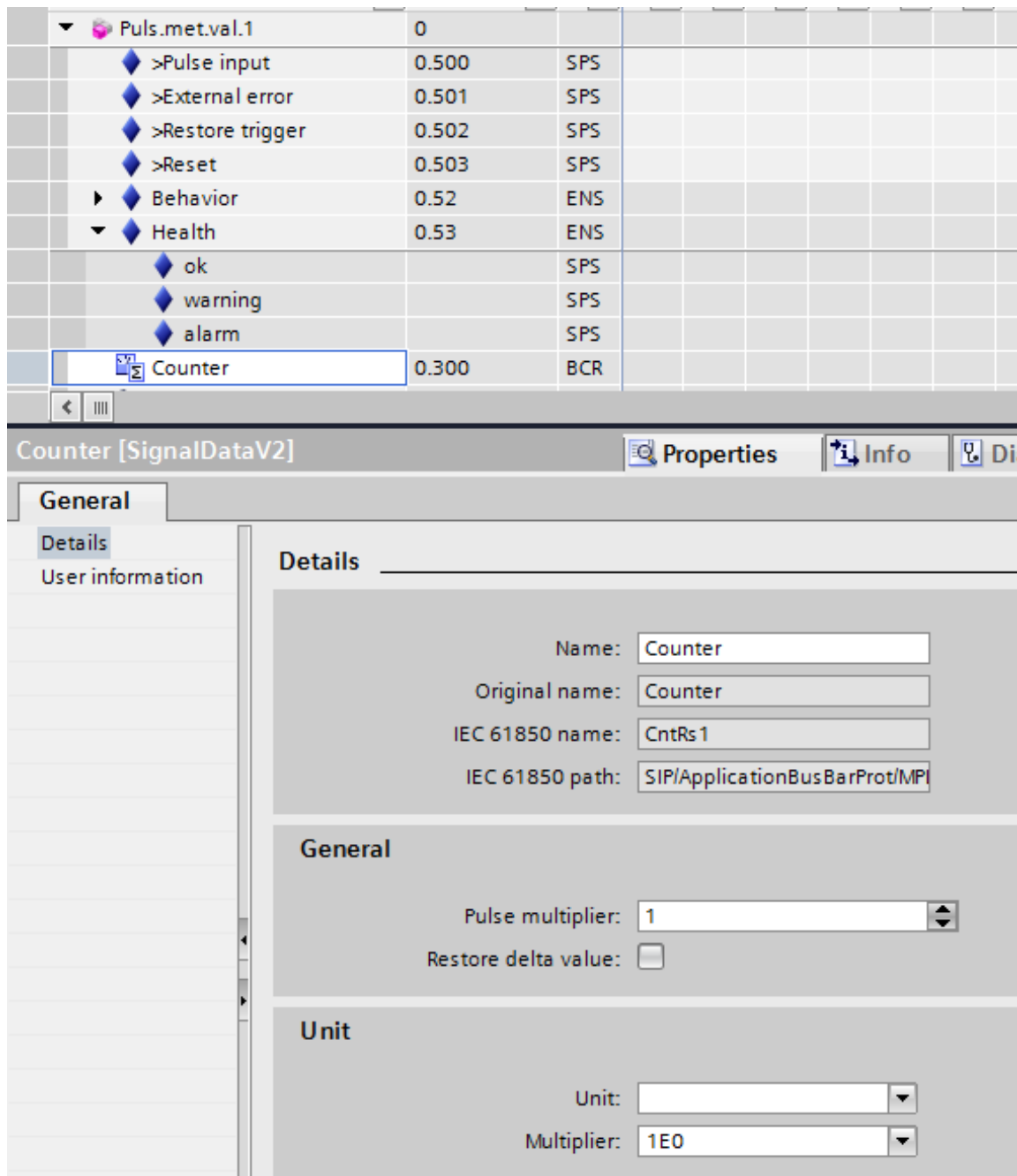

[sc_omvimp, 2, en_US]

Figure 11-4 Setting with DIGSI, General Settings, Pulse-Metered Values

11.9.2 Application and Setting Notes for Pulse-Metered Values

The functionality **Pulse-metered values** is not preconfigured. If you want to use the functionality, you must load it from the library into the respective function group.

The parameters can be set individually for every pulse counter. You will find the setting parameters in DIGSI in the project tree under **Parameter > Function group**. The maximum repetition rate when detecting the pulse-metered values is 50 Hz.

For pulse-metered values, the following described settings and binary inputs are available.

Parameter: Restore time

- Default setting (_:101) **Restore time** = *none*

Parameter Value	Description
<i>none</i>	Deactivated
<i>hh:00</i>	Transfer on the full hour
<i>hh:15</i>	Transfer 15 minutes after the full hour
<i>hh:30</i>	Transfer 30 minutes after the full hour
<i>hh:45</i>	Transfer 45 minutes after the full hour

Note: If the parameter is activated through a time setting, the parameter **Restore interval** is not in effect and will be deactivated automatically.

Parameter: Restore interval

- Default setting (_:102) **Restore interval** = *0 min*

Parameter Value	Description
0 min	Deactivated
1 min to 60 min	Cyclical transfer after the set time 1 minute to 60 minutes

Note: If the parameter is activated through a time setting, the parameter **Restore time** is not in effect and will be deactivated automatically.

Parameter: Edge trigger

- Default setting (_:103) **Edge trigger** = *rising edge*

Parameter Value	Description
<i>rising edge</i>	Counting with rising edge at the pulse input
<i>rising & falling edge</i>	Counting with rising and falling edge at the pulse input

Parameter: Restore by absolute time

- Default setting: (_:104) **Restore by absolute time** = *False*

Parameter Value	Description
<i>False</i>	Deactivated
<i>True</i>	The cyclic restoring of setting Restore interval after the set time is also synchronized with the system time. Example: Restore interval = 30 min; current system time: 12:10 o'clock. First restoring operation: 12:30 o'clock; next restoring operation: 13:00 o'clock, etc.

Input Signals: >Pulse input, >External error, >Restore trigger, >Reset

Binary inputs	Description
>Pulse input	Input for the counting pulses of an external pulse generator
>External error	Indication that the counter pulses of the external pulse generator are faulty. The indication has an effect on the quality identifier of the pulse value.
>Restore trigger	The transfer of the metered values is initiated via a binary input.
>Reset	The rising edge at the binary input resets the pulse counter to 0.

The amount of energy indicated by a pulse generator is to be displayed as a measured value. 1 pulse corresponds to 100 Wh. The pulse weighting, the SI unit, and the factor must be adjusted to one another. Display value = Calculated metered value * Pulse weighting * Factor * SI unit.

If the check box **Restore delta value** is activated, the differential value is transferred at the restore time set via the communication interface. The difference value is formed by subtracting the counter content of the last restoring operation from the current counter content.

You route the logical signal **>Pulse input** to a binary input to which the pulse generator is connected. Set the following values:

Name	Active Power Meter
Pulse weighting	100
Restore differential value	Activated
SI unit	Wh
Factor	1

The factor is used for adaptation to larger units (for instance, 1000 for kWh). It is adjustable in powers of ten (1, 10, 100, 1000, etc.). The following figure shows the signals that can be arranged in the DIGSI information matrix. Open the function group where you created the pulse-metered value, for example, Line 1. There, you will find the function area **Pulse-metered value**. Here you will also find the logical signals next to the metered value. Select the metered value and enter the settings under **Properties**.

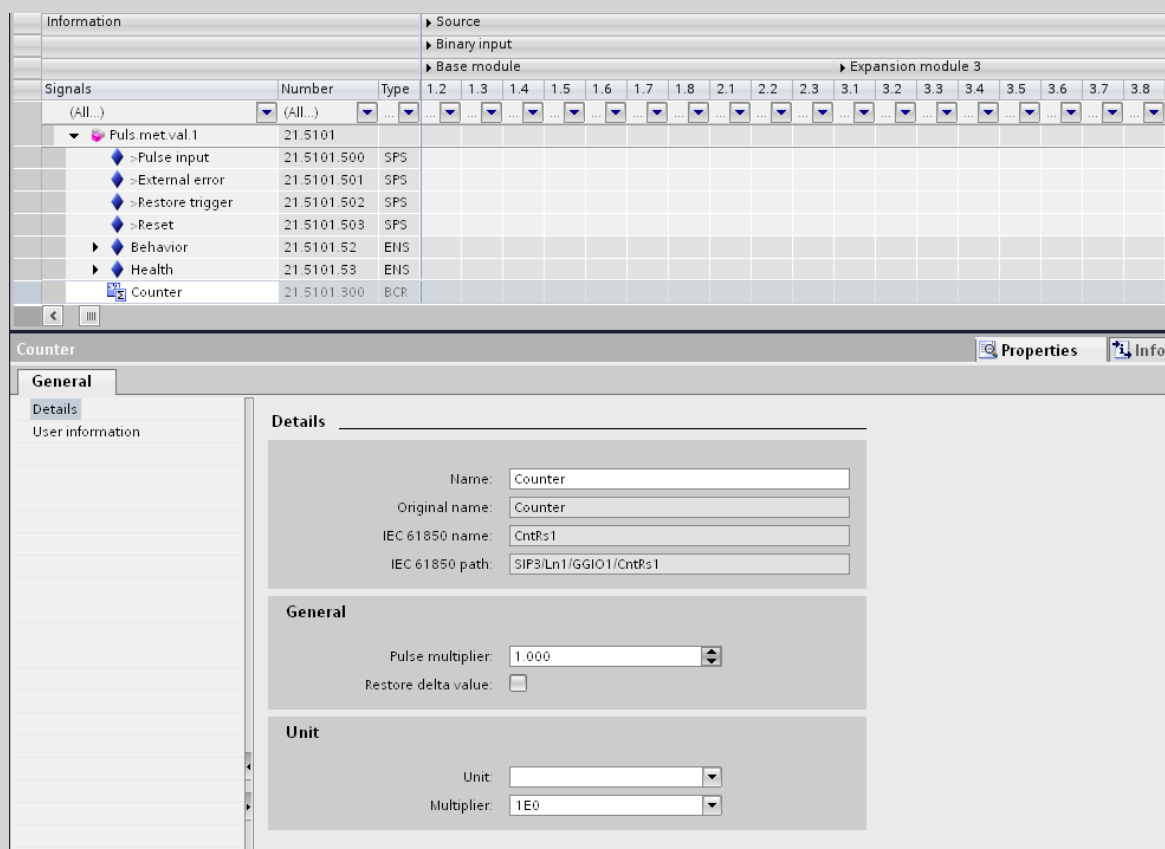

[sc_impzwe, 1, en_US]

Figure 11-5 Setting with DIGSI

11.10 Statistical Values of the Primary System

The device has statistical values for circuit breakers and disconnectors.

The following values are available for each circuit breaker:

- Total number of trippings of the circuit breaker initiated by the device
- Number of trippings of the circuit breaker initiated by the device, separately for each circuit breaker pole (if 1-pole tripping is possible)
- Total sum of primary breaking currents
- Sum of the primary breaking currents, separately for each breaker pole
- Hours with open circuit breaker
- Hours under load

The following values are available for each disconnector switch:

- Total number of switching operations of the disconnector switch initiated by the device
- Number of switching operations of the disconnector switch initiated by the device, separately for each switch pole (if 1-pole switching is possible)

11.11 Circuit-Breaker Monitoring

11.11.1 Overview of Functions

The **Circuit-breaker monitoring** function:

- Detects the abrasion of the circuit breakers phase-selectively
- Allows an adaptation of maintenance intervals for switching contacts of the circuit breakers according to the real abrasion
- Sends a warning signal when the abrasion of the circuit breaker reaches a certain degree
- Allows the supervision of the circuit-breaker make time
- Allows the supervision of the circuit-breaker break time

One of the main advantages of this function is the reduction of maintenance and service costs.

11.11.2 Structure of the Function

The function **Circuit-breaker monitoring** can be used in the function group **Circuit-breaker**.

The function offers 9 independent operating methods with different methods of measurement:

- **ΣI^x -method**
Sum of the breaking-current potentials
- **2P-method**
2 points method for calculating the remaining switching cycles
- **I²t-method**
Sum of all breaking-current square integrals
- **Make time**
Monitoring of the circuit-breaker make time
- **Break time**
Monitoring of the circuit-breaker break time
- **Pole scatter time open**
Supervision of the difference in the switch-off times of the individual phases
- **Pole scatter time close**
Supervision of the difference in the switch-on times of the individual phases
- **Mechanical switching time open**
Supervision of the switching time open detected via the feedback contacts
- **Mechanical switching time close**
Supervision of the switching time close detected via the feedback contacts
- **Operation counter**
Supervision of the number of switching cycles performed

11.11.3 General Functionality

11.11.3.1 Description

Start Criterion for the Function Circuit-Breaker Monitoring

The methods ΣI^x , $2P$ and I^2t are started if one of the following criteria is met:

- The circuit breaker is opened via a command or a protection tripping.
- The binary input signal *>Start calc. for open* is initiated, for example, via an external signal.
- The signal for the closed position of the circuit breaker is going. This signal is built via the circuit-breaker auxiliary-contacts. Thus, a manual opening of the circuit breaker is detected.

The methods **Make time**, **Mechanical switching time close** are started if one of the following criteria is met:

- The circuit breaker is closed via a command.
- The binary input signal *>Start calc. for close* is initiated, for example, via an external signal.

The methods **Break time**, **Mechanical switching time open** and **Pole scatter time open** are started if one of the following criteria is met:

- The circuit breaker is opened via a command.
- The circuit breaker is opened via a protection tripping.
- The binary input signal *>Start calc. for open* is initiated, for example, via an external signal.

Definition of the Times when Opening and Closing the Circuit Breaker

With the parameter **Make time**, you define the point in time when the circuit-breaker poles are closed and the current has reached a constant value.

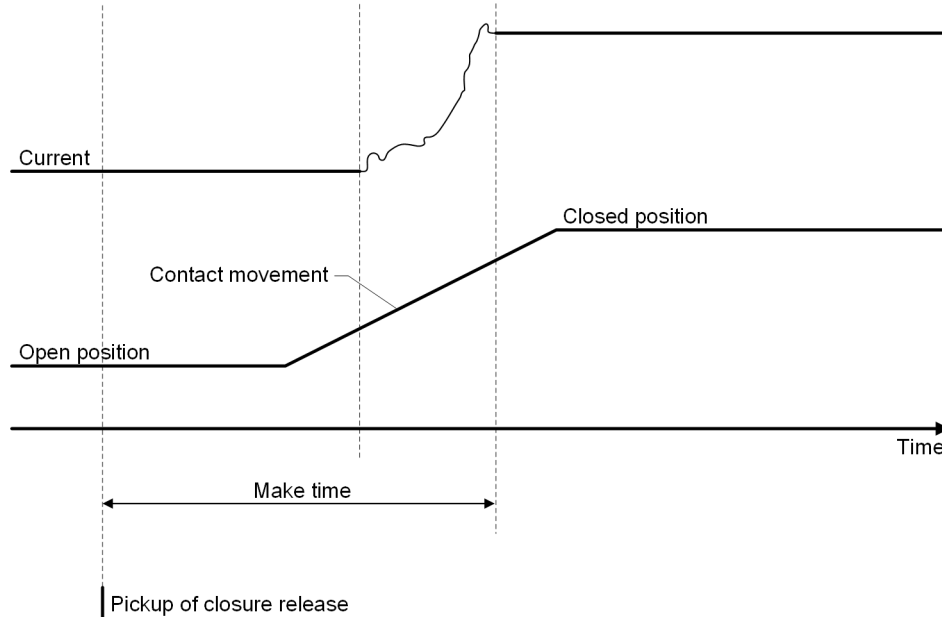

[dw_maketime, 1, en_US]

Figure 11-6 Definition of Make Time

With the parameter **Opening time**, you define the point in time when the circuit-breaker poles begin to open. With the parameter **Break time**, you define the point in time when the circuit-breaker poles are separated and the arc is extinct. The following graphic shows the relation between these 2 points in time of the circuit breaker.

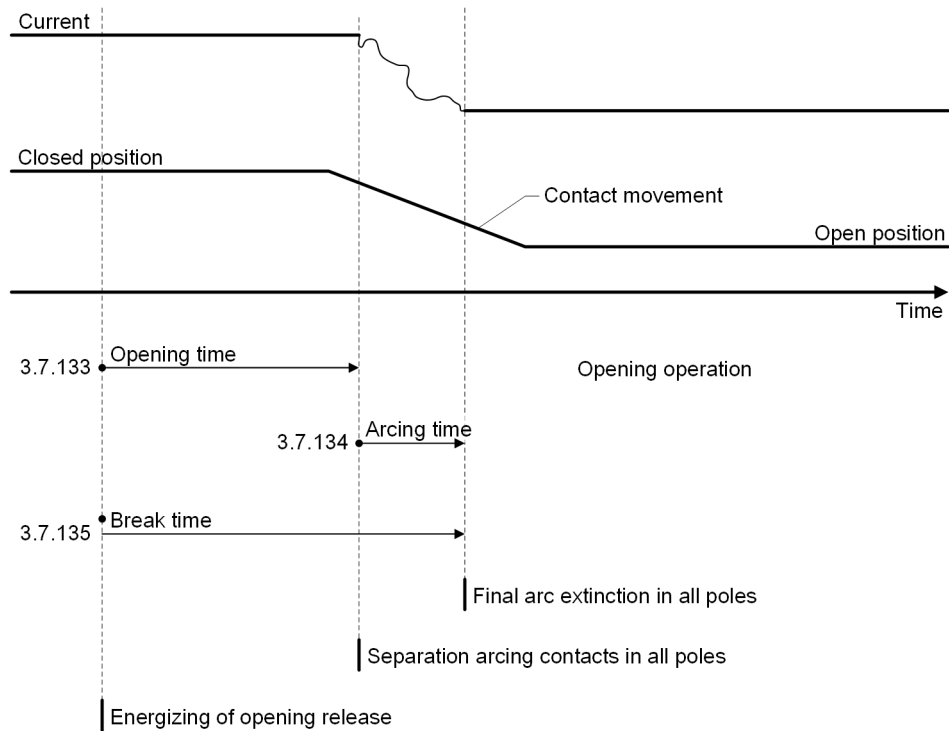

[dw_breaktime, 1, en_US]

Figure 11-7 Circuit-Breaker Times

11.11.3.2 Application and Setting Notes

Parameter: Apply PhaseA config to all

- Default setting (`_:2311:1`) **Apply PhaseA config to all** = *inactive*

If the parameter **Apply PhaseA config to all** is activated, all settings of phase A are adopted for phases B and C.



NOTE

The following parameters apply to one phase. The descriptions apply similarly to the parameters of the remaining phases.

Parameter: Opening time

- Default setting (`_:23971:101`) **Opening time** = *65 ms*

With the parameter **Opening time**, you define the interval between the activation of the shunt release for the circuit breaker and the moment, when the circuit-breaker poles open.

For information on the setting value, refer to the technical data of the used circuit breaker. For further information, refer to [Figure 11-7](#).

Parameter: Break time

- Default setting (`_:23971:102`) **Break time** = *80 ms*

With the parameter **Break time**, you define the interval between the activation of the shunt release for the circuit breaker and the moment, when the arc extincts (and the circuit-breaker poles are open).

For information on the setting value, refer to the technical data of the used circuit breaker. For further information, refer to [Figure 11-7](#).

Parameter: Make time

- Default setting (`_:23971:103`) **Make time** = 80 ms

With the parameter **Make time**, you define the typical time interval between the activation of the closing procedure for the circuit breaker and the point in time when the first current flows.

For information on the setting value, refer to the technical data of the used circuit breaker.

11.11.3.3 Settings

Addr.	Parameter	C	Setting Options	Default Setting
General				
_:2311:1	General:Apply PhaseA config to all		<ul style="list-style-type: none"> • 0 • 1 	False
General				
_:23971:1	Phase A:Mode		<ul style="list-style-type: none"> • off • on • test 	on
_:23971:101	Phase A:Opening time		1 ms to 500 ms	65 ms
_:23971:102	Phase A:Break time		1 ms to 600 ms	80 ms
_:23971:103	Phase A:Make time		1 ms to 600 ms	80 ms
General				
_:24002:1	Phase B:Mode		<ul style="list-style-type: none"> • off • on • test 	on
_:24002:101	Phase B:Opening time		1 ms to 500 ms	65 ms
_:24002:102	Phase B:Break time		1 ms to 600 ms	80 ms
_:24002:103	Phase B:Make time		1 ms to 600 ms	80 ms
General				
_:24033:1	Phase C:Mode		<ul style="list-style-type: none"> • off • on • test 	on
_:24033:101	Phase C:Opening time		1 ms to 500 ms	65 ms
_:24033:102	Phase C:Break time		1 ms to 600 ms	80 ms
_:24033:103	Phase C:Make time		1 ms to 600 ms	80 ms

11.11.3.4 Information List

No.	Information	Data Class (Type)	Type
General			
_:2311:500	General:>Start calc. for open	SPS	I
_:2311:501	General:>Start calc. for close	SPS	I
_:2311:52	General:Behavior	ENS	O
_:2311:53	General:Health	ENS	O

11.11.4 ΣI_x Method

11.11.4.1 Description

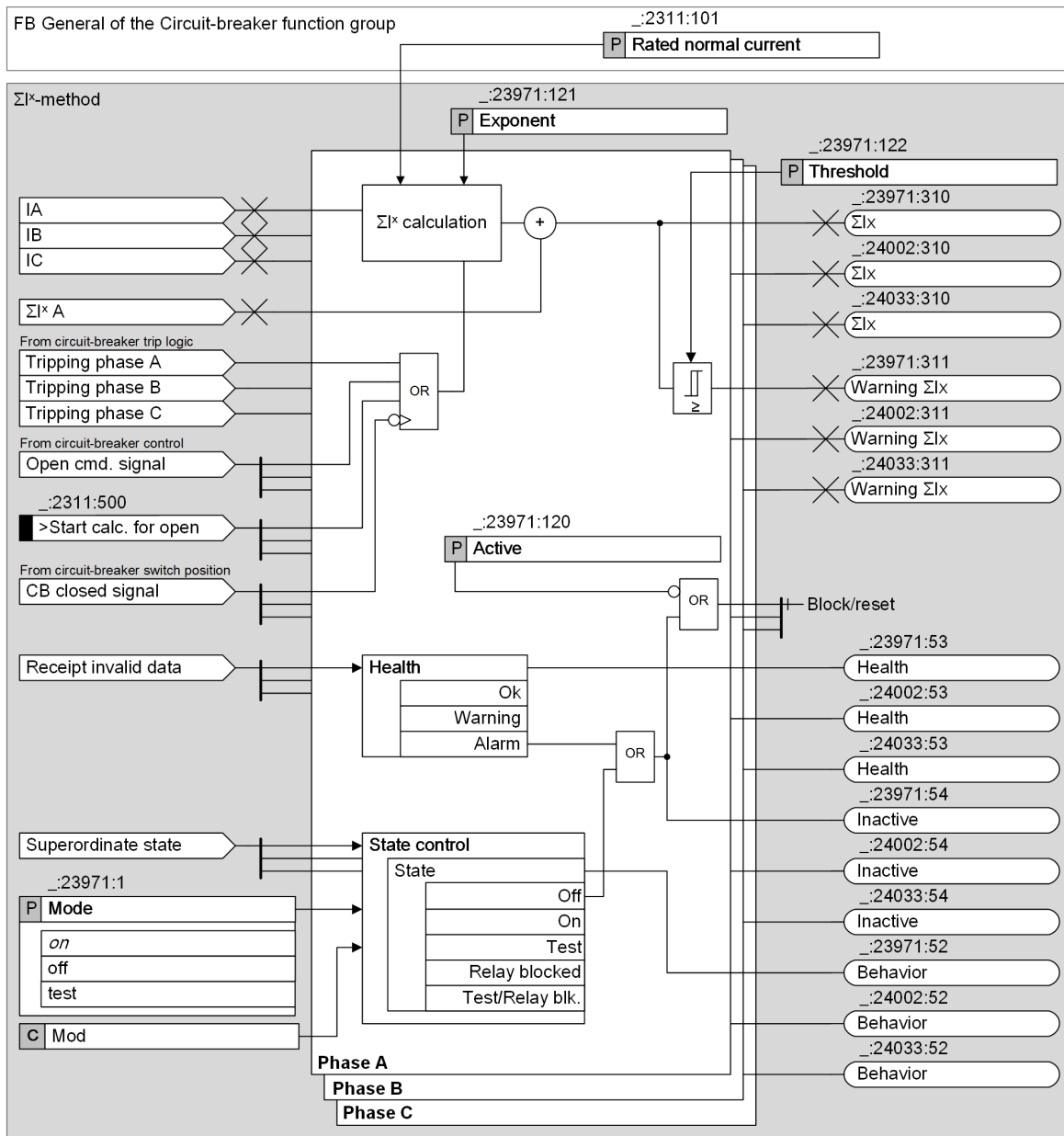

[to_ix-calc, 1, en_US]

Figure 11-8 Logic of the ΣI^x Method

Determination of the Tripping/Opening Current Value

RMS values of the fundamental components are stored for each phase in a buffer during the time between the start criterion and the pole-opening-starts criterion. With the coming pole-opening-starts criterion, the latest value in the buffer is searched for whose value is above the setting of parameter **Current thresh. CB open**. The one period prior value is used as tripping/opening current for further calculation.

If no value within the buffer is above the setting value, this circuit-breaker opening affects only the mechanical lifetime of the circuit breaker and is consequently not considered by this method.

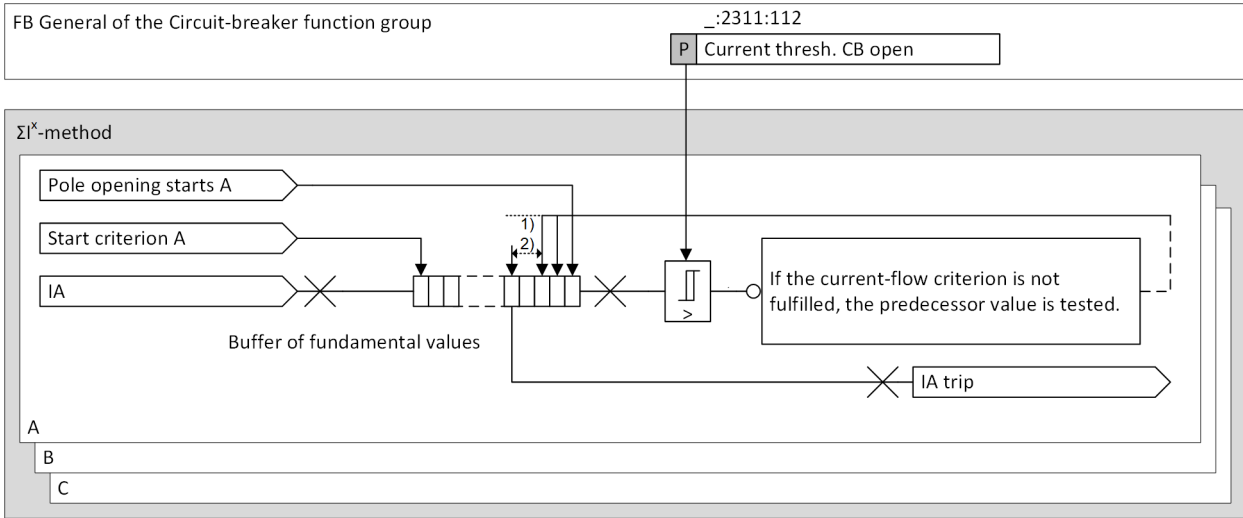

[fo_cb_wixf, 3, en_US]

Figure 11-9 Logic of the Determination of the Tripping Current Value

- (1) Current-flow criterion fulfilled
- (2) 1 period prior value

Calculation of the Wear

If the ΣI^x -method stage receives the logic release signal, the determined tripping current is used in the calculation of wear. The calculation results are then added to the existing statistic values of the ΣI^x method as follows, with phase A as example.

$$\sum I_A^x = \frac{1}{I_{rated}^x} \sum_{q=1}^m I_{A\ trip,q}^x$$

[fo_CB-WI-xA, 1, en_US]

Mit:

- x Parameter exponent
- q No. of circuit-breaker switching cycle
- $I_{A\ trip,q}^x$ Tripping/opening current of phase A to the power of x in the qth circuit-breaker operation
- I_{rated}^x Rated normal current to the power of x
- $\sum I_A^x$ Statistic value of current phase A calculated with the ΣI^x method
- m Total number of switching cycles

The phase-selective ΣI^x value is available as statistical value. You can reset or preset the statistics according to the specific application.

To simplify the interpretation of the sum of the tripping current powers, the values are set in relation to the exponentiated rated normal current I_{rated} of the circuit-breaker (see also setting notes).

Circuit-Breaker Maintenance Warning

If the summated ΣI^x value of any phase is greater than the threshold, a phase-selective warning signal is generated.

11.11.4.2 Application and Setting Notes



NOTE

The following parameters apply to one phase. The descriptions apply similarly to the parameters of the remaining phases.

Parameter: Active

- Default setting (`_:23971:120`) **Active** = *inactive*

With the parameter **Active**, you switch on the method.

Parameter: Exponent

- Default setting (`_:23971:121`) **Exponent** = 2.0

With the parameter **Exponent**, you specify the exponent for the Σ^x method.

A typical value is the default setting of 2. However, due to practical experiences with individual circuit breakers, slightly different values may be requested.

Parameter: Threshold

- Default setting (`_:23971:122`) **Threshold** = 10 000.00

With the parameter **Threshold**, you define the threshold of the statistic value.

The relation of the tripping current powers to the exponentiated rated normal current I_{rated} allows the limiting value of the Σ^x method to correspond to the maximum number of make-break operations. For a circuit breaker, whose contacts have not yet been worn, the maximum number of make-break operations can be entered directly as limiting value.

11.11.4.3 Settings

Addr.	Parameter	C	Setting Options	Default Setting
<i>ΣIx-method</i>				
_:23971:120	Phase A:Active		<ul style="list-style-type: none"> • 0 • 1 	False
_:23971:121	Phase A:Exponent		1.0 to 3.0	2.0
_:23971:122	Phase A:Threshold		0 to 10000000	10000
<i>ΣIx-method</i>				
_:24002:120	Phase B:Active		<ul style="list-style-type: none"> • 0 • 1 	False
_:24002:121	Phase B:Exponent		1.0 to 3.0	2.0
_:24002:122	Phase B:Threshold		0 to 10000000	10000
<i>ΣIx-method</i>				
_:24033:120	Phase C:Active		<ul style="list-style-type: none"> • 0 • 1 	False
_:24033:121	Phase C:Exponent		1.0 to 3.0	2.0
_:24033:122	Phase C:Threshold		0 to 10000000	10000

11.11.4.4 Information List

No.	Information	Data Class (Type)	Type
<i>Phase A</i>			
_:23971:51	Phase A:Mode (controllable)	ENC	C

No.	Information	Data Class (Type)	Type
_:23971:54	Phase A:Inactive	SPS	O
_:23971:52	Phase A:Behavior	ENS	O
_:23971:53	Phase A:Health	ENS	O
_:23971:300	Phase A:2P abrasion remaining	INS	O
_:23971:301	Phase A:2P abrasion cumulated	MV	O
_:23971:302	Phase A:2P abrasion last sw.op.	MV	O
_:23971:303	Phase A:2P abrasion warning	SPS	O
_:23971:304	Phase A:2P abrasion alarm	SPS	O
_:23971:310	Phase A: ΣI_x	BCR	O
_:23971:311	Phase A:Warning ΣI_x	SPS	O
_:23971:320	Phase A: $\Sigma I^2 t$	BCR	O
_:23971:321	Phase A:Warning $\Sigma I^2 t$	SPS	O
_:23971:330	Phase A:Make time	MV	O
_:23971:331	Phase A:Make-time warning	SPS	O
_:23971:332	Phase A:Make-time alarm	SPS	O
_:23971:340	Phase A:Break time	MV	O
_:23971:341	Phase A:Break-time warning	SPS	O
_:23971:342	Phase A:Break-time alarm	SPS	O
_:23971:350	Phase A:Aux.-contact time open	MV	O
_:23971:351	Phase A:Aux.c. time open warn.	SPS	O
_:23971:352	Phase A:Aux.c. time open alarm	SPS	O
_:23971:353	Phase A:Reaction time open	MV	O
_:23971:354	Phase A:React. time open warn.	SPS	O
_:23971:355	Phase A:React. time open alarm	SPS	O
_:23971:356	Phase A:Aux.c. travel time open	MV	O
_:23971:360	Phase A:Aux.-cont. time close	MV	O
_:23971:361	Phase A:Aux.c. time close warn.	SPS	O
_:23971:362	Phase A:Aux.c. time close alarm	SPS	O
_:23971:363	Phase A:Reaction time close	MV	O
_:23971:364	Phase A:React. time close warn.	SPS	O
_:23971:365	Phase A:React. time close alarm	SPS	O
_:23971:366	Phase A:Aux.c. travel time close	MV	O
Phase B			
_:24002:51	Phase B:Mode (controllable)	ENC	C
_:24002:54	Phase B:Inactive	SPS	O
_:24002:52	Phase B:Behavior	ENS	O
_:24002:53	Phase B:Health	ENS	O
_:24002:300	Phase B:2P abrasion remaining	INS	O
_:24002:301	Phase B:2P abrasion cumulated	MV	O
_:24002:302	Phase B:2P abrasion last sw.op.	MV	O
_:24002:303	Phase B:2P abrasion warning	SPS	O
_:24002:304	Phase B:2P abrasion alarm	SPS	O
_:24002:310	Phase B: ΣI_x	BCR	O
_:24002:311	Phase B:Warning ΣI_x	SPS	O
_:24002:320	Phase B: $\Sigma I^2 t$	BCR	O
_:24002:321	Phase B:Warning $\Sigma I^2 t$	SPS	O

No.	Information	Data Class (Type)	Type
_:24002:330	Phase B:Make time	MV	O
_:24002:331	Phase B:Make-time warning	SPS	O
_:24002:332	Phase B:Make-time alarm	SPS	O
_:24002:340	Phase B:Break time	MV	O
_:24002:341	Phase B:Break-time warning	SPS	O
_:24002:342	Phase B:Break-time alarm	SPS	O
_:24002:350	Phase B:Aux.-contact time open	MV	O
_:24002:351	Phase B:Aux.c. time open warn.	SPS	O
_:24002:352	Phase B:Aux.c. time open alarm	SPS	O
_:24002:353	Phase B:Reaction time open	MV	O
_:24002:354	Phase B:React. time open warn.	SPS	O
_:24002:355	Phase B:React. time open alarm	SPS	O
_:24002:356	Phase B:Aux.c. travel time open	MV	O
_:24002:360	Phase B:Aux.-cont. time close	MV	O
_:24002:361	Phase B:Aux.c. time close warn.	SPS	O
_:24002:362	Phase B:Aux.c. time close alarm	SPS	O
_:24002:363	Phase B:Reaction time close	MV	O
_:24002:364	Phase B:React. time close warn.	SPS	O
_:24002:365	Phase B:React. time close alarm	SPS	O
_:24002:366	Phase B:Aux.c. travel time close	MV	O
Phase C			
_:24033:51	Phase C:Mode (controllable)	ENC	C
_:24033:54	Phase C:Inactive	SPS	O
_:24033:52	Phase C:Behavior	ENS	O
_:24033:53	Phase C:Health	ENS	O
_:24033:300	Phase C:2P abrasion remaining	INS	O
_:24033:301	Phase C:2P abrasion cumulated	MV	O
_:24033:302	Phase C:2P abrasion last sw.op.	MV	O
_:24033:303	Phase C:2P abrasion warning	SPS	O
_:24033:304	Phase C:2P abrasion alarm	SPS	O
_:24033:310	Phase C: ΣI_x	BCR	O
_:24033:311	Phase C:Warning ΣI_x	SPS	O
_:24033:320	Phase C: $\Sigma I^2 t$	BCR	O
_:24033:321	Phase C:Warning $\Sigma I^2 t$	SPS	O
_:24033:330	Phase C:Make time	MV	O
_:24033:331	Phase C:Make-time warning	SPS	O
_:24033:332	Phase C:Make-time alarm	SPS	O
_:24033:340	Phase C:Break time	MV	O
_:24033:341	Phase C:Break-time warning	SPS	O
_:24033:342	Phase C:Break-time alarm	SPS	O
_:24033:350	Phase C:Aux.-contact time open	MV	O
_:24033:351	Phase C:Aux.c. time open warn.	SPS	O
_:24033:352	Phase C:Aux.c. time open alarm	SPS	O
_:24033:353	Phase C:Reaction time open	MV	O
_:24033:354	Phase C:React. time open warn.	SPS	O
_:24033:355	Phase C:React. time open alarm	SPS	O

No.	Information	Data Class (Type)	Type
_:24033:356	Phase C:Aux.c. travel time open	MV	O
_:24033:360	Phase C:Aux.-cont. time close	MV	O
_:24033:361	Phase C:Aux.c. time close warn.	SPS	O
_:24033:362	Phase C:Aux.c. time close alarm	SPS	O
_:24033:363	Phase C:Reaction time close	MV	O
_:24033:364	Phase C:React. time close warn.	SPS	O
_:24033:365	Phase C:React. time close alarm	SPS	O
_:24033:366	Phase C:Aux.c. travel time close	MV	O

11.11.5 2P Method

11.11.5.1 Description

Logic of the Stage

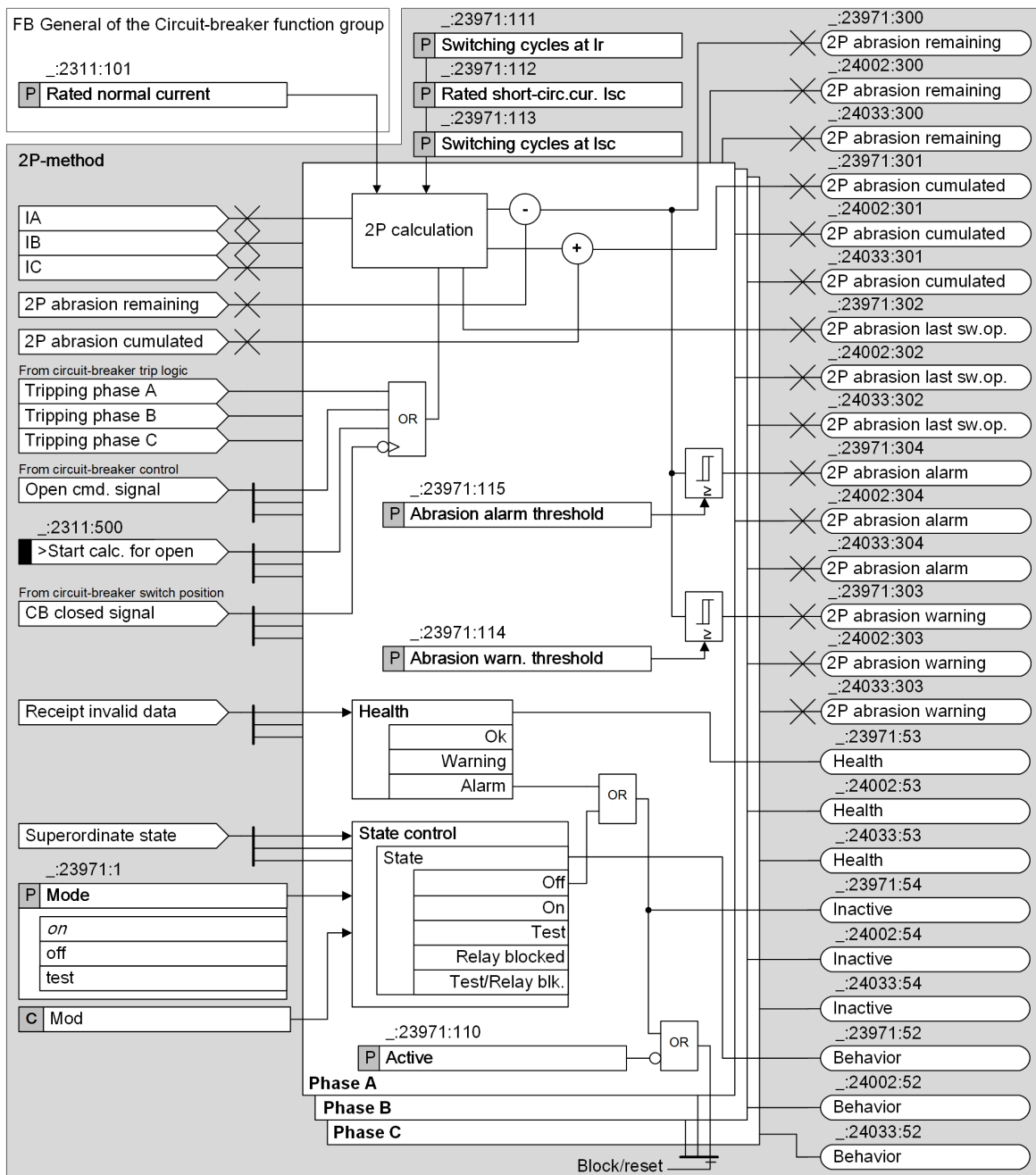

[to_2P-calc, 1, en_US]

Figure 11-10 Logic 2P Method

Calculation of Remaining Switching Cycles

A double-logarithmic diagram provided by the circuit-breaker manufacturer illustrates the relationship of permitted switching cycles and the tripping/opening current, see the following figure. According to the example, this circuit breaker can operate approximately 1000 times at a tripping current of 10 kA.

2 points and their connecting line determine the relationship of switching cycles and tripping current. Point P1 is determined by the number of permitted switching cycles at rated normal current I_{rated} . Point P2 is determined by the maximum number of switching cycles at rated short-circuit breaking current I_{sc} . The 4 associated values can be configured with the parameters **Rated normal current**, **Switching cycles at Ir**, **Rated short-circ. cur. Isc**, and **Switching cycles at Isc**.

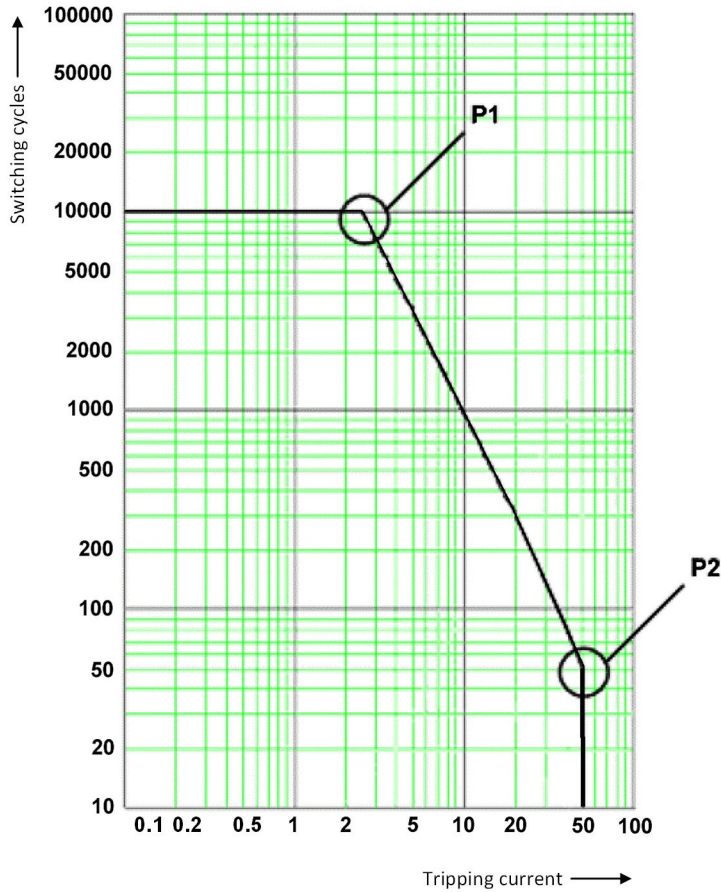

[dw_CB_WOpC, 2, en_US]
 Figure 11-11 Diagram of Switching Cycles for the 2P Method

As shown in the preceding figure, a double-logarithmic diagram, the straight line between P1 and P2 can be expressed by the following exponential function:

$$n = b \left(\frac{I_{rated}}{I_{trip}} \right)^m$$

[fo_CB-W2-P1, 2, en_US]

Where:

- I_{trip} Tripping/opening current
- I_{rated} Rated normal current
- m Slope coefficient
- b Switching cycles at rated normal current
- n Number of switching cycles

The general line equation for the double-logarithmic representation can be derived from the exponential function and leads to the coefficients b and m .



NOTE

Since a slope coefficient of $m < -4$ is technically irrelevant, but could theoretically be the result of incorrect settings, the slope coefficient is limited to -4. If a coefficient is smaller than -4, the exponential function in the switching-cycles diagram is deactivated. The maximum number of switching cycles with I_{sc} is used instead as the calculation result for the current number of switching cycles, as the dashed line with $m = -4.48$ shows in following figure.

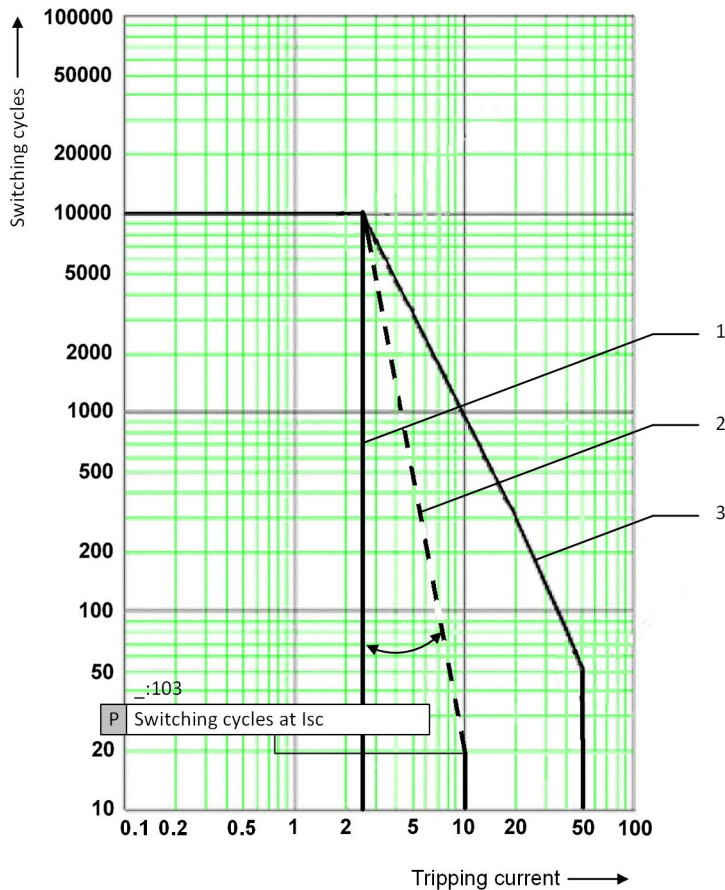

[dw_CB_WSl0, 2, en_US]

Figure 11-12 Value Limitation of Slope Coefficient

- (1) Applied function from $m < -4$
- (2) Parameterized function with $m = -4.48$
- (3) Parameterized function with $m = -1.77$

If the **2P-method** stage receives the logic release signal, the current number of used up switching cycles (in relation to the number of switching cycles at rated normal current) is calculated based on the determined tripping current. This value is subtracted from the the remaining lifetime (switching cycles). The remaining lifetime is available as statistic value. For better understanding, refer to the example below.

You can reset or preset the statistical values according to the specific application. The reset operation changes the statistic values to 0, and not to their default values of 10 000.

The statistic value of the residual switching cycles is calculated according to the following formula:

$$2p \text{ wear rest}_i = 2p \text{ wear rest}_{i-1} - \frac{n_{\text{rated}}}{n_{\text{trip}}}$$

[fo_CB-2P-wear-rest_01, 2, en_US]

Where:

- i No. of latest circuit-breaker switching cycle
- $2p$ wear rest _{i} Residual switching cycles with rated normal current, after the i th switching cycle
- n_{rated} Overall permissible switching cycles at rated normal current
- n_{trip} Overall permissible switching cycles at tripping current I_{trip}
- n_{rated}/n_{trip} Lost switching cycles referring to rated normal current

EXAMPLE

For calculating the residual switching cycles of a circuit breaker, the following is assumed:

P1 (2.5 kA, 10 000)

P2 (50.0 kA, 50)

The circuit breaker has made 100 opening operations with rated normal current, 2 tripping operations with rated short-circuit breaking current, and 3 tripping operations with 10 kA tripping current. Then, the residual switching cycles with rated normal current are:

$$2p \text{ wear rest} = n_{rated} - \left(100 \frac{n_{rated}}{n_{2.5 \text{ kA}}}\right) - \left(2 \frac{n_{rated}}{n_{50 \text{ kA}}}\right) - \left(3 \frac{n_{rated}}{n_{10 \text{ kA}}}\right)$$

$$= 10\,000 - \left(100 \frac{10\,000}{10\,000}\right) - \left(2 \frac{10\,000}{50}\right) - \left(3 \frac{10\,000}{861}\right) = 9465$$

[fo_CB-2P-wear-rest_02_2_en_US]

There are still 9465 possible break operations at rated normal current.

Cumulated Abrasion and Abrasion of the Last Switching Operation

In addition to the remaining switching cycles, the cumulated wear and the wear of the last switching operation is calculated. These are available as percentage values **2P abrasion cumulated** and **2P abrasion last sw.op.**.

Circuit-Breaker Maintenance Warning and Alarm

If the adjustable threshold values are undershot, phase-selective warnings and alarms are generated.

11.11.5.2 Application and Setting Notes



NOTE

The following parameters apply to one phase. The descriptions apply similarly to the parameters of the remaining phases.

Parameter: Active

- Default setting (`_:23971:110`) **Active** = *inactive*

With the parameter **Active**, you switch on the method.

Parameter: Switching cycles at Ir

- Default setting (`_:23971:111`) **Switching cycles at Ir** = *10 000*

With the parameter **Switching cycles at Ir**, you define the number of permitted switching cycles at rated normal current.

You can find the information on the setting value in the technical data of the used circuit breaker.

Parameter: Rated short-circ.cur. Isc

- Default setting (`_:23971:112`) **Rated short-circ.cur. Isc = 25 000 A**

With the parameter **Rated short-circ.cur. Isc**, you define the rated short-circuit breaking current. You can find the information on the setting value in the technical data of the used circuit breaker.

Parameter: Switching cycles at Isc

- Default setting (`_:23971:113`) **Switching cycles at Isc = 50**

With the parameter **Switching cycles at Isc**, you define the number of permitted switching cycles at rated short-circuit breaking current.

You can find the information on the setting value in the technical data of the used circuit breaker.

Parameter: Abrasion warn. threshold

- Default setting (`_:23971:114`) **Abrasion warn. threshold = 1000**

With the parameter **Abrasion warn. threshold**, you define the threshold value for the remaining switching cycles with rated operating current. If the statistical value is below the threshold value, a warning signal is generated.

Parameter: Abrasion alarm threshold

- Default setting (`_:23971:115`) **Abrasion alarm threshold = 500**

With the parameter **Abrasion alarm threshold**, you define the threshold value for the remaining switching cycles with rated operating current. If the statistical value is below the threshold value, an alarm signal is generated.

Example

Here is an example that shows you how to set the threshold parameters. Assuming a circuit breaker with the same technical data as provided in the example for residual switching cycles, 50 breaking operations with rated short-circuit breaking current are permitted.

A warning signal should be issued when the number of possible breaking operations with rated short-circuit breaking current is less than 3. For that condition, you set the threshold value based on the following calculation:

$$3 \cdot \frac{n_{\text{rated}}}{n_{50 \text{ kA}}} = 3 \cdot \frac{10000}{50} = 600$$

[Fr. CB W2-P4, 2, en_US]

11.11.5.3 Settings

Addr.	Parameter	C	Setting Options	Default Setting
2P-method				
<code>_:23971:110</code>	Phase A:Active		<ul style="list-style-type: none"> • 0 • 1 	False
<code>_:23971:111</code>	Phase A:Switching cycles at Ir		100 to 10000000	10000
<code>_:23971:112</code>	Phase A:Rated short-circ.cur. Isc		10 A to 100000 A	25000 A
<code>_:23971:113</code>	Phase A:Switching cycles at Isc		1 to 1000	50
<code>_:23971:114</code>	Phase A:Abrasion warn. threshold		0 to 10000000	100

Addr.	Parameter	C	Setting Options	Default Setting
_:23971:115	Phase A:Abrasion alarm threshold		0 to 10000000	50
2P-method				
_:24002:110	Phase B:Active		<ul style="list-style-type: none"> • 0 • 1 	False
_:24002:111	Phase B:Switching cycles at Ir		100 to 10000000	10000
_:24002:112	Phase B:Rated short-circ.cur. Isc		10 A to 100000 A	25000 A
_:24002:113	Phase B:Switching cycles at Isc		1 to 1000	50
_:24002:114	Phase B:Abrasion warn. threshold		0 to 10000000	100
_:24002:115	Phase B:Abrasion alarm threshold		0 to 10000000	50
2P-method				
_:24033:110	Phase C:Active		<ul style="list-style-type: none"> • 0 • 1 	False
_:24033:111	Phase C:Switching cycles at Ir		100 to 10000000	10000
_:24033:112	Phase C:Rated short-circ.cur. Isc		10 A to 100000 A	25000 A
_:24033:113	Phase C:Switching cycles at Isc		1 to 1000	50
_:24033:114	Phase C:Abrasion warn. threshold		0 to 10000000	100
_:24033:115	Phase C:Abrasion alarm threshold		0 to 10000000	50

11.11.5.4 Information List

No.	Information	Data Class (Type)	Type
Phase A			
_:23971:51	Phase A:Mode (controllable)	ENC	C
_:23971:54	Phase A:Inactive	SPS	O
_:23971:52	Phase A:Behavior	ENS	O
_:23971:53	Phase A:Health	ENS	O
_:23971:300	Phase A:2P abrasion remaining	INS	O
_:23971:301	Phase A:2P abrasion cumulated	MV	O
_:23971:302	Phase A:2P abrasion last sw.op.	MV	O
_:23971:303	Phase A:2P abrasion warning	SPS	O
_:23971:304	Phase A:2P abrasion alarm	SPS	O
_:23971:310	Phase A: ΣI_x	BCR	O
_:23971:311	Phase A:Warning ΣI_x	SPS	O
_:23971:320	Phase A: $\Sigma I^2 t$	BCR	O
_:23971:321	Phase A:Warning $\Sigma I^2 t$	SPS	O
_:23971:330	Phase A:Make time	MV	O
_:23971:331	Phase A:Make-time warning	SPS	O
_:23971:332	Phase A:Make-time alarm	SPS	O

No.	Information	Data Class (Type)	Type
_:23971:340	Phase A:Break time	MV	O
_:23971:341	Phase A:Break-time warning	SPS	O
_:23971:342	Phase A:Break-time alarm	SPS	O
_:23971:350	Phase A:Aux.-contact time open	MV	O
_:23971:351	Phase A:Aux.c. time open warn.	SPS	O
_:23971:352	Phase A:Aux.c. time open alarm	SPS	O
_:23971:353	Phase A:Reaction time open	MV	O
_:23971:354	Phase A:React. time open warn.	SPS	O
_:23971:355	Phase A:React. time open alarm	SPS	O
_:23971:356	Phase A:Aux.c. travel time open	MV	O
_:23971:360	Phase A:Aux.-cont. time close	MV	O
_:23971:361	Phase A:Aux.c. time close warn.	SPS	O
_:23971:362	Phase A:Aux.c. time close alarm	SPS	O
_:23971:363	Phase A:Reaction time close	MV	O
_:23971:364	Phase A:React. time close warn.	SPS	O
_:23971:365	Phase A:React. time close alarm	SPS	O
_:23971:366	Phase A:Aux.c. travel time close	MV	O
Phase B			
_:24002:51	Phase B:Mode (controllable)	ENC	C
_:24002:54	Phase B:Inactive	SPS	O
_:24002:52	Phase B:Behavior	ENS	O
_:24002:53	Phase B:Health	ENS	O
_:24002:300	Phase B:2P abrasion remaining	INS	O
_:24002:301	Phase B:2P abrasion cumulated	MV	O
_:24002:302	Phase B:2P abrasion last sw.op.	MV	O
_:24002:303	Phase B:2P abrasion warning	SPS	O
_:24002:304	Phase B:2P abrasion alarm	SPS	O
_:24002:310	Phase B: ΣI_x	BCR	O
_:24002:311	Phase B:Warning ΣI_x	SPS	O
_:24002:320	Phase B: $\Sigma I^2 t$	BCR	O
_:24002:321	Phase B:Warning $\Sigma I^2 t$	SPS	O
_:24002:330	Phase B:Make time	MV	O
_:24002:331	Phase B:Make-time warning	SPS	O
_:24002:332	Phase B:Make-time alarm	SPS	O
_:24002:340	Phase B:Break time	MV	O
_:24002:341	Phase B:Break-time warning	SPS	O
_:24002:342	Phase B:Break-time alarm	SPS	O
_:24002:350	Phase B:Aux.-contact time open	MV	O
_:24002:351	Phase B:Aux.c. time open warn.	SPS	O
_:24002:352	Phase B:Aux.c. time open alarm	SPS	O
_:24002:353	Phase B:Reaction time open	MV	O
_:24002:354	Phase B:React. time open warn.	SPS	O
_:24002:355	Phase B:React. time open alarm	SPS	O
_:24002:356	Phase B:Aux.c. travel time open	MV	O
_:24002:360	Phase B:Aux.-cont. time close	MV	O
_:24002:361	Phase B:Aux.c. time close warn.	SPS	O

No.	Information	Data Class (Type)	Type
_:24002:362	Phase B:Aux.c. time close alarm	SPS	O
_:24002:363	Phase B:Reaction time close	MV	O
_:24002:364	Phase B:React. time close warn.	SPS	O
_:24002:365	Phase B:React. time close alarm	SPS	O
_:24002:366	Phase B:Aux.c. travel time close	MV	O
Phase C			
_:24033:51	Phase C:Mode (controllable)	ENC	C
_:24033:54	Phase C:Inactive	SPS	O
_:24033:52	Phase C:Behavior	ENS	O
_:24033:53	Phase C:Health	ENS	O
_:24033:300	Phase C:2P abrasion remaining	INS	O
_:24033:301	Phase C:2P abrasion cumulated	MV	O
_:24033:302	Phase C:2P abrasion last sw.op.	MV	O
_:24033:303	Phase C:2P abrasion warning	SPS	O
_:24033:304	Phase C:2P abrasion alarm	SPS	O
_:24033:310	Phase C: ΣI_x	BCR	O
_:24033:311	Phase C:Warning ΣI_x	SPS	O
_:24033:320	Phase C: $\Sigma I^2 t$	BCR	O
_:24033:321	Phase C:Warning $\Sigma I^2 t$	SPS	O
_:24033:330	Phase C:Make time	MV	O
_:24033:331	Phase C:Make-time warning	SPS	O
_:24033:332	Phase C:Make-time alarm	SPS	O
_:24033:340	Phase C:Break time	MV	O
_:24033:341	Phase C:Break-time warning	SPS	O
_:24033:342	Phase C:Break-time alarm	SPS	O
_:24033:350	Phase C:Aux.-contact time open	MV	O
_:24033:351	Phase C:Aux.c. time open warn.	SPS	O
_:24033:352	Phase C:Aux.c. time open alarm	SPS	O
_:24033:353	Phase C:Reaction time open	MV	O
_:24033:354	Phase C:React. time open warn.	SPS	O
_:24033:355	Phase C:React. time open alarm	SPS	O
_:24033:356	Phase C:Aux.c. travel time open	MV	O
_:24033:360	Phase C:Aux.-cont. time close	MV	O
_:24033:361	Phase C:Aux.c. time close warn.	SPS	O
_:24033:362	Phase C:Aux.c. time close alarm	SPS	O
_:24033:363	Phase C:Reaction time close	MV	O
_:24033:364	Phase C:React. time close warn.	SPS	O
_:24033:365	Phase C:React. time close alarm	SPS	O
_:24033:366	Phase C:Aux.c. travel time close	MV	O

11.11.6 I²t Method

11.11.6.1 Description

Logic of the Stage

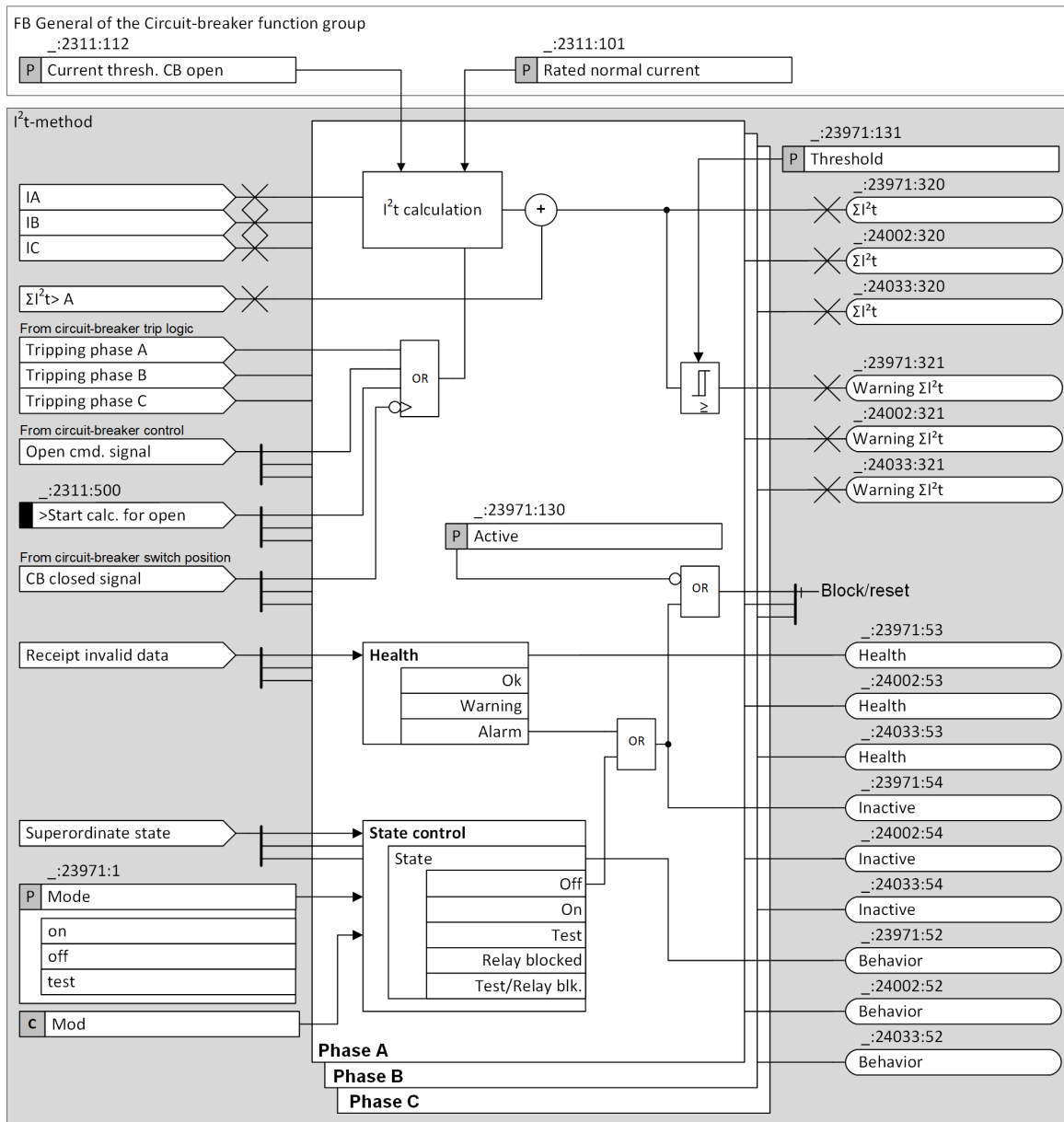

[to_I2t-calc, 2, en, US]

Figure 11-13 Logic of the I²t Method

Calculation of the Wear

The I²t method evaluates the wear of a circuit breaker based on the sampled measuring values of the phase currents during the arc time. The duration of the arc time is defined by the difference between the 2 settings of parameters **Break time** and **Opening time** (see also [Start Criterion for the Function Circuit-Breaker Monitoring, Page 1402](#)). The stage determines the ending point of the arc time by searching backward the zero-crossing point of the phase currents after it receives the logic release signal. Then, the squared fault currents during the arc time are integrated phase-selectively. The integrals are referred to the squared rated normal current of the circuit breaker as shown in the following formula, with phase A as example.

11.11 Circuit-Breaker Monitoring

$$I^2t_{L1} \cdot \frac{1}{I_{rated}^2} = \int_{\text{Start arc time}}^{\text{End arc time}} i_{L1}^2(t) dt$$

[fo_CB-WI-ZT, 2, en_US]

Where:

I_{rated} Rated normal current
 $i_A(t)$ Sampled measured current value of phase A

The calculated squared tripping current integrals are added to the existing statistic values. You can reset or preset the statistic value according to the specific application.

Circuit-Breaker Maintenance Warning

If the statistic value of any phase lies above the threshold, a phase-selective warning signal is generated.

11.11.6.2 Application and Setting Notes

Parameter: Active

- Default setting (`_:23971:130`) **Active** = *inactive*

With the parameter **Active**, you switch on the method.

Parameter: Threshold

- Default setting (`_:24033:131`) **Threshold** = *10 000.00 I/Ir*s*

With the parameter **Threshold**, you specify the maximum permitted integral of squared sampled measured values of the phase currents. The same applies to the threshold values of the other phases.

11.11.6.3 Settings

Addr.	Parameter	C	Setting Options	Default Setting
I2t-method				
_:23971:130	Phase A:Active		<ul style="list-style-type: none"> • 0 • 1 	False
_:23971:131	Phase A:Threshold		0.00 I/Ir*s to 21400000.00 I/Ir*s	10000.00 I/Ir*s
I2t-method				
_:24002:130	Phase B:Active		<ul style="list-style-type: none"> • 0 • 1 	False
_:24002:131	Phase B:Threshold		0.00 I/Ir*s to 21400000.00 I/Ir*s	10000.00 I/Ir*s
I2t-method				
_:24033:130	Phase C:Active		<ul style="list-style-type: none"> • 0 • 1 	False
_:24033:131	Phase C:Threshold		0.00 I/Ir*s to 21400000.00 I/Ir*s	10000.00 I/Ir*s

11.11.6.4 Information List

No.	Information	Data Class (Type)	Type
Phase A			
_:23971:51	Phase A:Mode (controllable)	ENC	C

No.	Information	Data Class (Type)	Type
_:23971:54	Phase A:Inactive	SPS	O
_:23971:52	Phase A:Behavior	ENS	O
_:23971:53	Phase A:Health	ENS	O
_:23971:300	Phase A:2P abrasion remaining	INS	O
_:23971:301	Phase A:2P abrasion cumulated	MV	O
_:23971:302	Phase A:2P abrasion last sw.op.	MV	O
_:23971:303	Phase A:2P abrasion warning	SPS	O
_:23971:304	Phase A:2P abrasion alarm	SPS	O
_:23971:310	Phase A: ΣI_x	BCR	O
_:23971:311	Phase A:Warning ΣI_x	SPS	O
_:23971:320	Phase A: $\Sigma I^2 t$	BCR	O
_:23971:321	Phase A:Warning $\Sigma I^2 t$	SPS	O
_:23971:330	Phase A:Make time	MV	O
_:23971:331	Phase A:Make-time warning	SPS	O
_:23971:332	Phase A:Make-time alarm	SPS	O
_:23971:340	Phase A:Break time	MV	O
_:23971:341	Phase A:Break-time warning	SPS	O
_:23971:342	Phase A:Break-time alarm	SPS	O
_:23971:350	Phase A:Aux.-contact time open	MV	O
_:23971:351	Phase A:Aux.c. time open warn.	SPS	O
_:23971:352	Phase A:Aux.c. time open alarm	SPS	O
_:23971:353	Phase A:Reaction time open	MV	O
_:23971:354	Phase A:React. time open warn.	SPS	O
_:23971:355	Phase A:React. time open alarm	SPS	O
_:23971:356	Phase A:Aux.c. travel time open	MV	O
_:23971:360	Phase A:Aux.-cont. time close	MV	O
_:23971:361	Phase A:Aux.c. time close warn.	SPS	O
_:23971:362	Phase A:Aux.c. time close alarm	SPS	O
_:23971:363	Phase A:Reaction time close	MV	O
_:23971:364	Phase A:React. time close warn.	SPS	O
_:23971:365	Phase A:React. time close alarm	SPS	O
_:23971:366	Phase A:Aux.c. travel time close	MV	O
Phase B			
_:24002:51	Phase B:Mode (controllable)	ENC	C
_:24002:54	Phase B:Inactive	SPS	O
_:24002:52	Phase B:Behavior	ENS	O
_:24002:53	Phase B:Health	ENS	O
_:24002:300	Phase B:2P abrasion remaining	INS	O
_:24002:301	Phase B:2P abrasion cumulated	MV	O
_:24002:302	Phase B:2P abrasion last sw.op.	MV	O
_:24002:303	Phase B:2P abrasion warning	SPS	O
_:24002:304	Phase B:2P abrasion alarm	SPS	O
_:24002:310	Phase B: ΣI_x	BCR	O
_:24002:311	Phase B:Warning ΣI_x	SPS	O
_:24002:320	Phase B: $\Sigma I^2 t$	BCR	O
_:24002:321	Phase B:Warning $\Sigma I^2 t$	SPS	O

No.	Information	Data Class (Type)	Type
_:24002:330	Phase B:Make time	MV	0
_:24002:331	Phase B:Make-time warning	SPS	0
_:24002:332	Phase B:Make-time alarm	SPS	0
_:24002:340	Phase B:Break time	MV	0
_:24002:341	Phase B:Break-time warning	SPS	0
_:24002:342	Phase B:Break-time alarm	SPS	0
_:24002:350	Phase B:Aux.-contact time open	MV	0
_:24002:351	Phase B:Aux.c. time open warn.	SPS	0
_:24002:352	Phase B:Aux.c. time open alarm	SPS	0
_:24002:353	Phase B:Reaction time open	MV	0
_:24002:354	Phase B:React. time open warn.	SPS	0
_:24002:355	Phase B:React. time open alarm	SPS	0
_:24002:356	Phase B:Aux.c. travel time open	MV	0
_:24002:360	Phase B:Aux.-cont. time close	MV	0
_:24002:361	Phase B:Aux.c. time close warn.	SPS	0
_:24002:362	Phase B:Aux.c. time close alarm	SPS	0
_:24002:363	Phase B:Reaction time close	MV	0
_:24002:364	Phase B:React. time close warn.	SPS	0
_:24002:365	Phase B:React. time close alarm	SPS	0
_:24002:366	Phase B:Aux.c. travel time close	MV	0
Phase C			
_:24033:51	Phase C:Mode (controllable)	ENC	C
_:24033:54	Phase C:Inactive	SPS	0
_:24033:52	Phase C:Behavior	ENS	0
_:24033:53	Phase C:Health	ENS	0
_:24033:300	Phase C:2P abrasion remaining	INS	0
_:24033:301	Phase C:2P abrasion cumulated	MV	0
_:24033:302	Phase C:2P abrasion last sw.op.	MV	0
_:24033:303	Phase C:2P abrasion warning	SPS	0
_:24033:304	Phase C:2P abrasion alarm	SPS	0
_:24033:310	Phase C: ΣI_x	BCR	0
_:24033:311	Phase C:Warning ΣI_x	SPS	0
_:24033:320	Phase C: $\Sigma I^2 t$	BCR	0
_:24033:321	Phase C:Warning $\Sigma I^2 t$	SPS	0
_:24033:330	Phase C:Make time	MV	0
_:24033:331	Phase C:Make-time warning	SPS	0
_:24033:332	Phase C:Make-time alarm	SPS	0
_:24033:340	Phase C:Break time	MV	0
_:24033:341	Phase C:Break-time warning	SPS	0
_:24033:342	Phase C:Break-time alarm	SPS	0
_:24033:350	Phase C:Aux.-contact time open	MV	0
_:24033:351	Phase C:Aux.c. time open warn.	SPS	0
_:24033:352	Phase C:Aux.c. time open alarm	SPS	0
_:24033:353	Phase C:Reaction time open	MV	0
_:24033:354	Phase C:React. time open warn.	SPS	0
_:24033:355	Phase C:React. time open alarm	SPS	0

No.	Information	Data Class (Type)	Type
_:24033:356	Phase C:Aux.c. travel time open	MV	O
_:24033:360	Phase C:Aux.-cont. time close	MV	O
_:24033:361	Phase C:Aux.c. time close warn.	SPS	O
_:24033:362	Phase C:Aux.c. time close alarm	SPS	O
_:24033:363	Phase C:Reaction time close	MV	O
_:24033:364	Phase C:React. time close warn.	SPS	O
_:24033:365	Phase C:React. time close alarm	SPS	O
_:24033:366	Phase C:Aux.c. travel time close	MV	O

11.11.7 Make Time

11.11.7.1 Description

Logic of the Stage

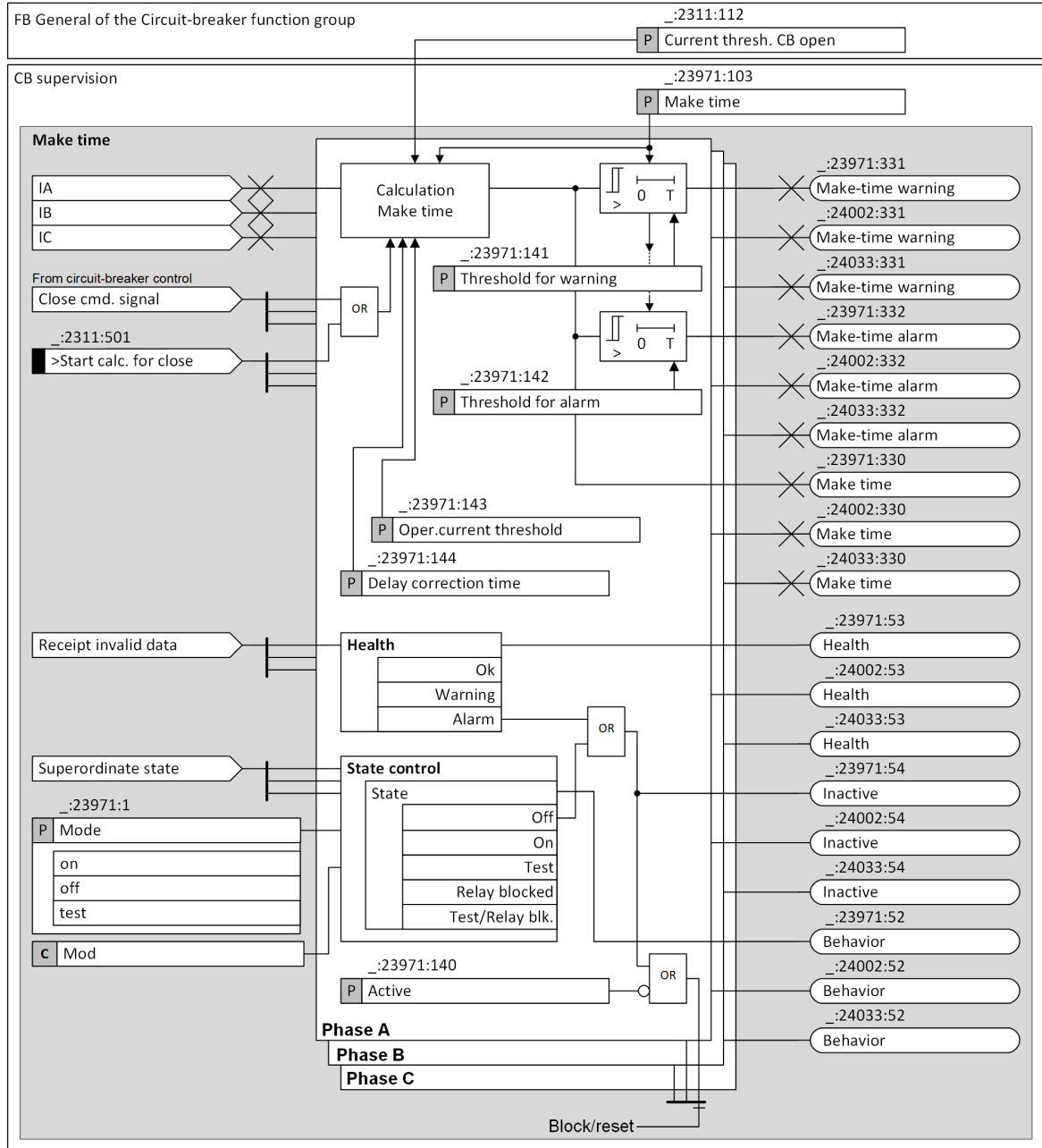

[io_LS-Überwachung_Einschaltzeit_2_en_US]

Figure 11-14 Logic of the Make Time

Operating Mode

The stage for the monitoring of the circuit-breaker make time calculates phase-selectively the time between the circuit-breaker closing command and the point in time when the current exceeds the **Oper. current threshold**. If this threshold has not been exceeded after 2.5 times the value of the parameter **Make time**, the measurement is canceled and the output value *Make time* is set to 0 and marked with the quality invalid.

If one phase of the current has exceeded the parameter **Oper.current threshold** or the parameter **Current thresh. CB open** at the time of the circuit-breaker closing command, the measurement is canceled and the output value *Make time* is marked with the quality invalid.

You can define 2 independent thresholds for the monitoring of the measured make time. When these thresholds are exceeded or undershot, the corresponding outputs *Make-time warning* and *Make-time alarm* are activated for 100 ms. These can be routed in the log.

11.11.7.2 Application and Setting Notes



NOTE

The following parameters apply to one phase. The descriptions apply similarly to the parameters of the remaining phases.

Parameter: Active

- Default setting (`_:23971:140`) **Active** = *inactive*

With the parameter **Active**, you switch on the method.

Parameter: Threshold for warning

- Default setting (`_:23971:141`) **Threshold for warning** = 5 %

With the parameter **Threshold for warning**, you define the percentage the measured value is allowed to exceed or undershot the parameter **Make time** at the output *Make time*, before the output *Make-time warning* is set. The output *Make-time warning* then drops out after 100 ms.

Parameter: Threshold for alarm

- Default setting (`_:23971:142`) **Threshold for alarm** = 10 %

With the parameter **Threshold for alarm**, you define the percentage the measured value is allowed to exceed or undershot the parameter **Make time** at the output *Make time*, before the output *Make-time alarm* is set. The output *Make-time alarm* then drops out after 100 ms.

Parameter: Oper.current threshold

- Default setting (`_:23971:143`) **Oper.current threshold** = 0.100 A

With the parameter **Oper.current threshold**, you define the current threshold. If the measured value exceeds this threshold, the measured value is detected as flowing operating current. As soon as an operating current flows, the end of the time interval *Make time* is detected.

Parameter: Delay correction time

- Default setting (`_:23971:144`) **Delay correction time** = 0.000 s

With the parameter **Delay correction time**, you define a correction value which will be subtracted from the *Make time* during calculation. This allows you to compensate delays caused by the system, for example, relay residual times, if necessary.

11.11.7.3 Settings

Addr.	Parameter	C	Setting Options	Default Setting
<i>Make time</i>				
_:23971:140	Phase A:Active		<ul style="list-style-type: none"> • 0 • 1 	False
_:23971:141	Phase A:Threshold for warning		1 % to 100 %	5 %

Addr.	Parameter	C	Setting Options	Default Setting
_:23971:142	Phase A:Threshold for alarm		1 % to 100 %	10 %
_:23971:143	Phase A:Oper.current threshold	1 A @ 100 Irated	0.030 A to 35.000 A	0.100 A
		5 A @ 100 Irated	0.15 A to 175.00 A	0.50 A
		1 A @ 50 Irated	0.030 A to 35.000 A	0.100 A
		5 A @ 50 Irated	0.15 A to 175.00 A	0.50 A
		1 A @ 1.6 Irated	0.001 A to 1.600 A	0.100 A
		5 A @ 1.6 Irated	0.005 A to 8.000 A	0.500 A
_:23971:144	Phase A:Delay correction time		-50 ms to 50 ms	0 ms
Make time				
_:24002:140	Phase B:Active		<ul style="list-style-type: none"> • 0 • 1 	False
_:24002:141	Phase B:Threshold for warning		1 % to 100 %	5 %
_:24002:142	Phase B:Threshold for alarm		1 % to 100 %	10 %
_:24002:143	Phase B:Oper.current threshold	1 A @ 100 Irated	0.030 A to 35.000 A	0.100 A
		5 A @ 100 Irated	0.15 A to 175.00 A	0.50 A
		1 A @ 50 Irated	0.030 A to 35.000 A	0.100 A
		5 A @ 50 Irated	0.15 A to 175.00 A	0.50 A
		1 A @ 1.6 Irated	0.001 A to 1.600 A	0.100 A
		5 A @ 1.6 Irated	0.005 A to 8.000 A	0.500 A
_:24002:144	Phase B:Delay correction time		-50 ms to 50 ms	0 ms
Make time				
_:24033:140	Phase C:Active		<ul style="list-style-type: none"> • 0 • 1 	False
_:24033:141	Phase C:Threshold for warning		1 % to 100 %	5 %
_:24033:142	Phase C:Threshold for alarm		1 % to 100 %	10 %
_:24033:143	Phase C:Oper.current threshold	1 A @ 100 Irated	0.030 A to 35.000 A	0.100 A
		5 A @ 100 Irated	0.15 A to 175.00 A	0.50 A
		1 A @ 50 Irated	0.030 A to 35.000 A	0.100 A
		5 A @ 50 Irated	0.15 A to 175.00 A	0.50 A
		1 A @ 1.6 Irated	0.001 A to 1.600 A	0.100 A
		5 A @ 1.6 Irated	0.005 A to 8.000 A	0.500 A
_:24033:144	Phase C:Delay correction time		-50 ms to 50 ms	0 ms

11.11.7.4 Information List

No.	Information	Data Class (Type)	Type
Phase A			
_:23971:51	Phase A:Mode (controllable)	ENC	C
_:23971:54	Phase A:Inactive	SPS	O
_:23971:52	Phase A:Behavior	ENS	O

No.	Information	Data Class (Type)	Type
_:23971:53	Phase A:Health	ENS	O
_:23971:300	Phase A:2P abrasion remaining	INS	O
_:23971:301	Phase A:2P abrasion cumulated	MV	O
_:23971:302	Phase A:2P abrasion last sw.op.	MV	O
_:23971:303	Phase A:2P abrasion warning	SPS	O
_:23971:304	Phase A:2P abrasion alarm	SPS	O
_:23971:310	Phase A: ΣI_x	BCR	O
_:23971:311	Phase A:Warning ΣI_x	SPS	O
_:23971:320	Phase A: ΣI^2t	BCR	O
_:23971:321	Phase A:Warning ΣI^2t	SPS	O
_:23971:330	Phase A:Make time	MV	O
_:23971:331	Phase A:Make-time warning	SPS	O
_:23971:332	Phase A:Make-time alarm	SPS	O
_:23971:340	Phase A:Break time	MV	O
_:23971:341	Phase A:Break-time warning	SPS	O
_:23971:342	Phase A:Break-time alarm	SPS	O
_:23971:350	Phase A:Aux.-contact time open	MV	O
_:23971:351	Phase A:Aux.c. time open warn.	SPS	O
_:23971:352	Phase A:Aux.c. time open alarm	SPS	O
_:23971:353	Phase A:Reaction time open	MV	O
_:23971:354	Phase A:React. time open warn.	SPS	O
_:23971:355	Phase A:React. time open alarm	SPS	O
_:23971:356	Phase A:Aux.c. travel time open	MV	O
_:23971:360	Phase A:Aux.-cont. time close	MV	O
_:23971:361	Phase A:Aux.c. time close warn.	SPS	O
_:23971:362	Phase A:Aux.c. time close alarm	SPS	O
_:23971:363	Phase A:Reaction time close	MV	O
_:23971:364	Phase A:React. time close warn.	SPS	O
_:23971:365	Phase A:React. time close alarm	SPS	O
_:23971:366	Phase A:Aux.c. travel time close	MV	O
Phase B			
_:24002:51	Phase B:Mode (controllable)	ENC	C
_:24002:54	Phase B:Inactive	SPS	O
_:24002:52	Phase B:Behavior	ENS	O
_:24002:53	Phase B:Health	ENS	O
_:24002:300	Phase B:2P abrasion remaining	INS	O
_:24002:301	Phase B:2P abrasion cumulated	MV	O
_:24002:302	Phase B:2P abrasion last sw.op.	MV	O
_:24002:303	Phase B:2P abrasion warning	SPS	O
_:24002:304	Phase B:2P abrasion alarm	SPS	O
_:24002:310	Phase B: ΣI_x	BCR	O
_:24002:311	Phase B:Warning ΣI_x	SPS	O
_:24002:320	Phase B: ΣI^2t	BCR	O
_:24002:321	Phase B:Warning ΣI^2t	SPS	O
_:24002:330	Phase B:Make time	MV	O
_:24002:331	Phase B:Make-time warning	SPS	O

No.	Information	Data Class (Type)	Type
_:24002:332	Phase B:Make-time alarm	SPS	0
_:24002:340	Phase B:Break time	MV	0
_:24002:341	Phase B:Break-time warning	SPS	0
_:24002:342	Phase B:Break-time alarm	SPS	0
_:24002:350	Phase B:Aux.-contact time open	MV	0
_:24002:351	Phase B:Aux.c. time open warn.	SPS	0
_:24002:352	Phase B:Aux.c. time open alarm	SPS	0
_:24002:353	Phase B:Reaction time open	MV	0
_:24002:354	Phase B:React. time open warn.	SPS	0
_:24002:355	Phase B:React. time open alarm	SPS	0
_:24002:356	Phase B:Aux.c. travel time open	MV	0
_:24002:360	Phase B:Aux.-cont. time close	MV	0
_:24002:361	Phase B:Aux.c. time close warn.	SPS	0
_:24002:362	Phase B:Aux.c. time close alarm	SPS	0
_:24002:363	Phase B:Reaction time close	MV	0
_:24002:364	Phase B:React. time close warn.	SPS	0
_:24002:365	Phase B:React. time close alarm	SPS	0
_:24002:366	Phase B:Aux.c. travel time close	MV	0
Phase C			
_:24033:51	Phase C:Mode (controllable)	ENC	C
_:24033:54	Phase C:Inactive	SPS	0
_:24033:52	Phase C:Behavior	ENS	0
_:24033:53	Phase C:Health	ENS	0
_:24033:300	Phase C:2P abrasion remaining	INS	0
_:24033:301	Phase C:2P abrasion cumulated	MV	0
_:24033:302	Phase C:2P abrasion last sw.op.	MV	0
_:24033:303	Phase C:2P abrasion warning	SPS	0
_:24033:304	Phase C:2P abrasion alarm	SPS	0
_:24033:310	Phase C: ΣI_x	BCR	0
_:24033:311	Phase C:Warning ΣI_x	SPS	0
_:24033:320	Phase C: $\Sigma I^2 t$	BCR	0
_:24033:321	Phase C:Warning $\Sigma I^2 t$	SPS	0
_:24033:330	Phase C:Make time	MV	0
_:24033:331	Phase C:Make-time warning	SPS	0
_:24033:332	Phase C:Make-time alarm	SPS	0
_:24033:340	Phase C:Break time	MV	0
_:24033:341	Phase C:Break-time warning	SPS	0
_:24033:342	Phase C:Break-time alarm	SPS	0
_:24033:350	Phase C:Aux.-contact time open	MV	0
_:24033:351	Phase C:Aux.c. time open warn.	SPS	0
_:24033:352	Phase C:Aux.c. time open alarm	SPS	0
_:24033:353	Phase C:Reaction time open	MV	0
_:24033:354	Phase C:React. time open warn.	SPS	0
_:24033:355	Phase C:React. time open alarm	SPS	0
_:24033:356	Phase C:Aux.c. travel time open	MV	0
_:24033:360	Phase C:Aux.-cont. time close	MV	0

No.	Information	Data Class (Type)	Type
_:24033:361	Phase C:Aux.c. time close warn.	SPS	O
_:24033:362	Phase C:Aux.c. time close alarm	SPS	O
_:24033:363	Phase C:Reaction time close	MV	O
_:24033:364	Phase C:React. time close warn.	SPS	O
_:24033:365	Phase C:React. time close alarm	SPS	O
_:24033:366	Phase C:Aux.c. travel time close	MV	O

11.11.8 Break Time

11.11.8.1 Description

Logic of the Stage

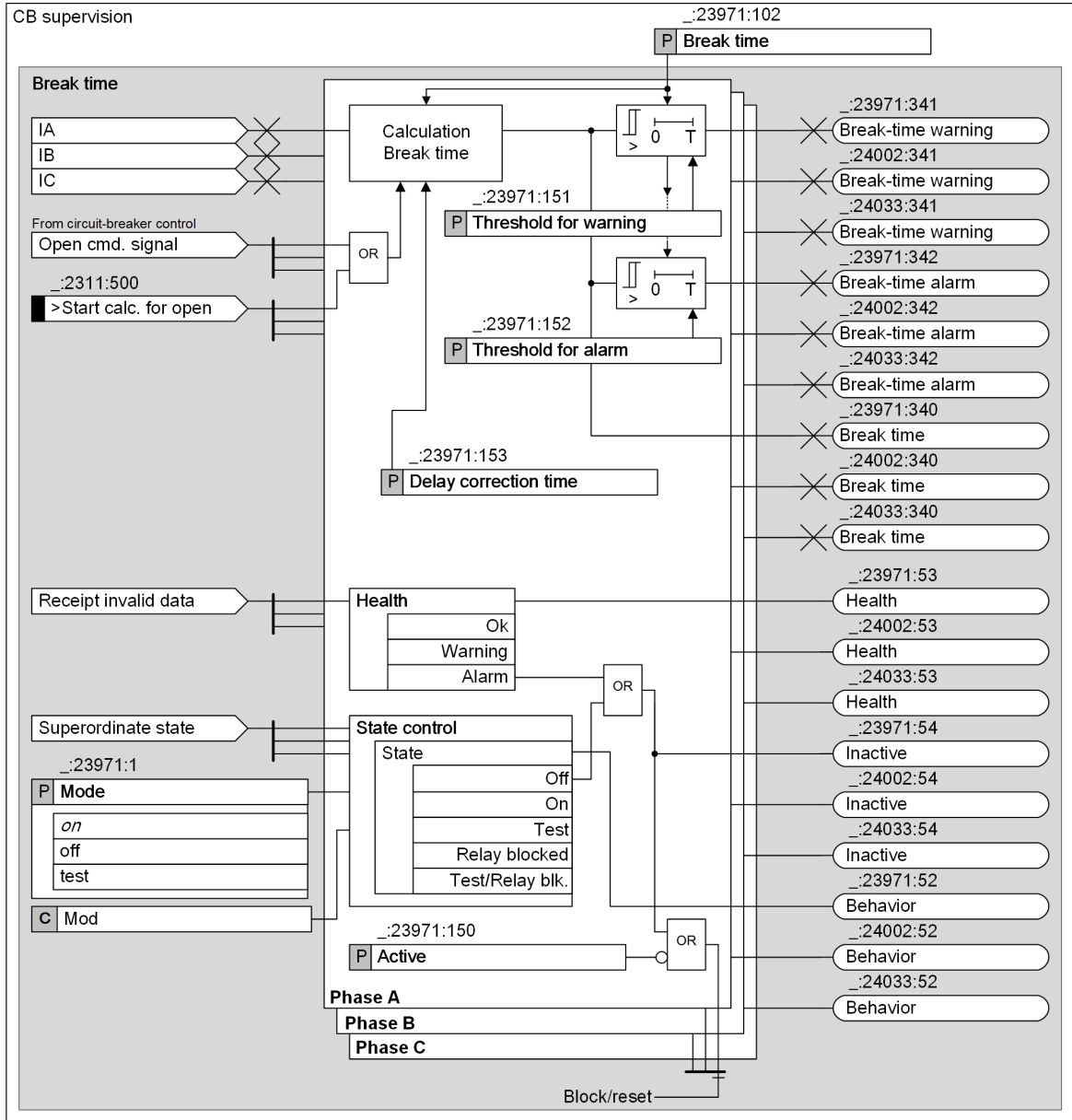

[Ilo_L5-Überwachung_Ausschaltzeit_1_en_US]

Figure 11-15 Logic of the Break Time

Operating Mode

The stage for the monitoring of the circuit-breaker break time calculates phase-selective the time between the circuit-breaker opening command and the point to which no load current flows. In the event of a restrike after the current was lost, the measurement of the break time is extended accordingly. If a current is still measured after 2.5 times of the value parameter **Break time**, the measurement is canceled and the output value **Break time** is set to 0 and marked with the quality invalid.

If no load current is measured at the time of the break time command, the measurement for the relevant phase is canceled and the output value **Break time** is marked with the quality invalid.

You can define 2 independent thresholds for the monitoring of the measured break time. When these thresholds are exceeded or undershot, the corresponding outputs *Break-time warning* and *Break-time alarm* are activated for 100 ms. These can be routed in the log.

11.11.8.2 Application and Setting Notes



NOTE

The following parameters apply to one phase. The descriptions apply similarly to the parameters of the remaining phases.

Parameter: Active

- Default setting (`_:23971:150`) **Active** = *inactive*

With the parameter **Active**, you switch on the method.

Parameter: Threshold for warning

- Default setting (`_:23971:151`) **Threshold for warning** = 5 %

With the parameter **Threshold for warning**, you define the percentage the measured value is allowed to exceed or undershot the parameter **Break time** at the output *Break time*, before the output *Break-time warning* is set. The output *Break-time warning* then drops out after 100 ms.

Parameter: Threshold for alarm

- Default setting (`_:23971:152`) **Threshold for alarm** = 10 %

With the parameter **Threshold for alarm**, you define the percentage the measured value is allowed to exceed or undershot the parameter **Break time** at the output *Break time*, before the output *Break-time alarm* is set. The output *Break-time alarm* then drops out after 100 ms.

Parameter: Delay correction time

- Default setting (`_:23971:153`) **Delay correction time** = 0.000 s

With the parameter **Delay correction time**, you define a correction value which will be subtracted from the *Break time* during calculation. This allows you to compensate delays caused by the system, for example, relay residual times, if necessary.

11.11.8.3 Settings

Addr.	Parameter	C	Setting Options	Default Setting
Break time				
_:23971:150	Phase A:Active		<ul style="list-style-type: none"> • 0 • 1 	False
_:23971:151	Phase A:Threshold for warning		1 % to 100 %	5 %
_:23971:152	Phase A:Threshold for alarm		1 % to 100 %	10 %
_:23971:153	Phase A:Delay correction time		-50 ms to 50 ms	0 ms
Break time				
_:24002:150	Phase B:Active		<ul style="list-style-type: none"> • 0 • 1 	False
_:24002:151	Phase B:Threshold for warning		1 % to 100 %	5 %

Addr.	Parameter	C	Setting Options	Default Setting
_:24002:152	Phase B:Threshold for alarm		1 % to 100 %	10 %
_:24002:153	Phase B:Delay correction time		-50 ms to 50 ms	0 ms
Break time				
_:24033:150	Phase C:Active		<ul style="list-style-type: none"> • 0 • 1 	False
_:24033:151	Phase C:Threshold for warning		1 % to 100 %	5 %
_:24033:152	Phase C:Threshold for alarm		1 % to 100 %	10 %
_:24033:153	Phase C:Delay correction time		-50 ms to 50 ms	0 ms

11.11.8.4 Information List

No.	Information	Data Class (Type)	Type
Phase A			
_:23971:51	Phase A:Mode (controllable)	ENC	C
_:23971:54	Phase A:Inactive	SPS	O
_:23971:52	Phase A:Behavior	ENS	O
_:23971:53	Phase A:Health	ENS	O
_:23971:300	Phase A:2P abrasion remaining	INS	O
_:23971:301	Phase A:2P abrasion cumulated	MV	O
_:23971:302	Phase A:2P abrasion last sw.op.	MV	O
_:23971:303	Phase A:2P abrasion warning	SPS	O
_:23971:304	Phase A:2P abrasion alarm	SPS	O
_:23971:310	Phase A: ΣI_x	BCR	O
_:23971:311	Phase A:Warning ΣI_x	SPS	O
_:23971:320	Phase A: $\Sigma I^2 t$	BCR	O
_:23971:321	Phase A:Warning $\Sigma I^2 t$	SPS	O
_:23971:330	Phase A:Make time	MV	O
_:23971:331	Phase A:Make-time warning	SPS	O
_:23971:332	Phase A:Make-time alarm	SPS	O
_:23971:340	Phase A:Break time	MV	O
_:23971:341	Phase A:Break-time warning	SPS	O
_:23971:342	Phase A:Break-time alarm	SPS	O
_:23971:350	Phase A:Aux.-contact time open	MV	O
_:23971:351	Phase A:Aux.c. time open warn.	SPS	O
_:23971:352	Phase A:Aux.c. time open alarm	SPS	O
_:23971:353	Phase A:Reaction time open	MV	O
_:23971:354	Phase A:React. time open warn.	SPS	O
_:23971:355	Phase A:React. time open alarm	SPS	O
_:23971:356	Phase A:Aux.c. travel time open	MV	O
_:23971:360	Phase A:Aux.-cont. time close	MV	O
_:23971:361	Phase A:Aux.c. time close warn.	SPS	O
_:23971:362	Phase A:Aux.c. time close alarm	SPS	O
_:23971:363	Phase A:Reaction time close	MV	O

No.	Information	Data Class (Type)	Type
_:23971:364	Phase A:React. time close warn.	SPS	O
_:23971:365	Phase A:React. time close alarm	SPS	O
_:23971:366	Phase A:Aux.c. travel time close	MV	O
Phase B			
_:24002:51	Phase B:Mode (controllable)	ENC	C
_:24002:54	Phase B:Inactive	SPS	O
_:24002:52	Phase B:Behavior	ENS	O
_:24002:53	Phase B:Health	ENS	O
_:24002:300	Phase B:2P abrasion remaining	INS	O
_:24002:301	Phase B:2P abrasion cumulated	MV	O
_:24002:302	Phase B:2P abrasion last sw.op.	MV	O
_:24002:303	Phase B:2P abrasion warning	SPS	O
_:24002:304	Phase B:2P abrasion alarm	SPS	O
_:24002:310	Phase B: ΣI_x	BCR	O
_:24002:311	Phase B:Warning ΣI_x	SPS	O
_:24002:320	Phase B: $\Sigma I^2 t$	BCR	O
_:24002:321	Phase B:Warning $\Sigma I^2 t$	SPS	O
_:24002:330	Phase B:Make time	MV	O
_:24002:331	Phase B:Make-time warning	SPS	O
_:24002:332	Phase B:Make-time alarm	SPS	O
_:24002:340	Phase B:Break time	MV	O
_:24002:341	Phase B:Break-time warning	SPS	O
_:24002:342	Phase B:Break-time alarm	SPS	O
_:24002:350	Phase B:Aux.-contact time open	MV	O
_:24002:351	Phase B:Aux.c. time open warn.	SPS	O
_:24002:352	Phase B:Aux.c. time open alarm	SPS	O
_:24002:353	Phase B:Reaction time open	MV	O
_:24002:354	Phase B:React. time open warn.	SPS	O
_:24002:355	Phase B:React. time open alarm	SPS	O
_:24002:356	Phase B:Aux.c. travel time open	MV	O
_:24002:360	Phase B:Aux.-cont. time close	MV	O
_:24002:361	Phase B:Aux.c. time close warn.	SPS	O
_:24002:362	Phase B:Aux.c. time close alarm	SPS	O
_:24002:363	Phase B:Reaction time close	MV	O
_:24002:364	Phase B:React. time close warn.	SPS	O
_:24002:365	Phase B:React. time close alarm	SPS	O
_:24002:366	Phase B:Aux.c. travel time close	MV	O
Phase C			
_:24033:51	Phase C:Mode (controllable)	ENC	C
_:24033:54	Phase C:Inactive	SPS	O
_:24033:52	Phase C:Behavior	ENS	O
_:24033:53	Phase C:Health	ENS	O
_:24033:300	Phase C:2P abrasion remaining	INS	O
_:24033:301	Phase C:2P abrasion cumulated	MV	O
_:24033:302	Phase C:2P abrasion last sw.op.	MV	O
_:24033:303	Phase C:2P abrasion warning	SPS	O

No.	Information	Data Class (Type)	Type
_:24033:304	Phase C:2P abrasion alarm	SPS	0
_:24033:310	Phase C: ΣI_x	BCR	0
_:24033:311	Phase C:Warning ΣI_x	SPS	0
_:24033:320	Phase C: $\Sigma I^2 t$	BCR	0
_:24033:321	Phase C:Warning $\Sigma I^2 t$	SPS	0
_:24033:330	Phase C:Make time	MV	0
_:24033:331	Phase C:Make-time warning	SPS	0
_:24033:332	Phase C:Make-time alarm	SPS	0
_:24033:340	Phase C:Break time	MV	0
_:24033:341	Phase C:Break-time warning	SPS	0
_:24033:342	Phase C:Break-time alarm	SPS	0
_:24033:350	Phase C:Aux.-contact time open	MV	0
_:24033:351	Phase C:Aux.c. time open warn.	SPS	0
_:24033:352	Phase C:Aux.c. time open alarm	SPS	0
_:24033:353	Phase C:Reaction time open	MV	0
_:24033:354	Phase C:React. time open warn.	SPS	0
_:24033:355	Phase C:React. time open alarm	SPS	0
_:24033:356	Phase C:Aux.c. travel time open	MV	0
_:24033:360	Phase C:Aux.-cont. time close	MV	0
_:24033:361	Phase C:Aux.c. time close warn.	SPS	0
_:24033:362	Phase C:Aux.c. time close alarm	SPS	0
_:24033:363	Phase C:Reaction time close	MV	0
_:24033:364	Phase C:React. time close warn.	SPS	0
_:24033:365	Phase C:React. time close alarm	SPS	0
_:24033:366	Phase C:Aux.c. travel time close	MV	0

11.11.9 Pole Scatter Time Open

11.11.9.1 Description

Logic of the Stage

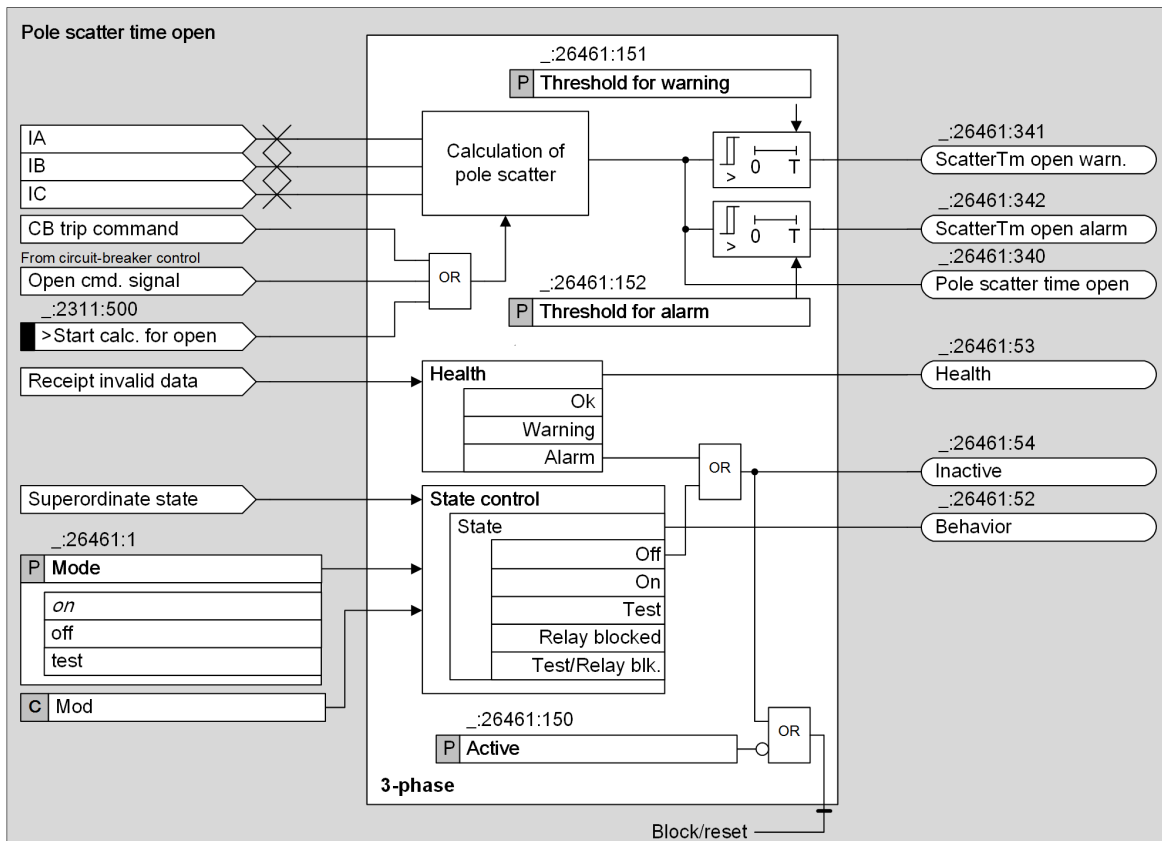

[/o_stage_pole-scatter_open.1.en_US]

Figure 11-16 Logic of the Stage Pole Scatter Time Open

Operating Mode

The time between the extinction of the current of the first phase until the extinction of the last phase current when opening the circuit breaker is the pole scatter time. A greater time difference can lead to conclusions on the circuit-breaker abrasion.

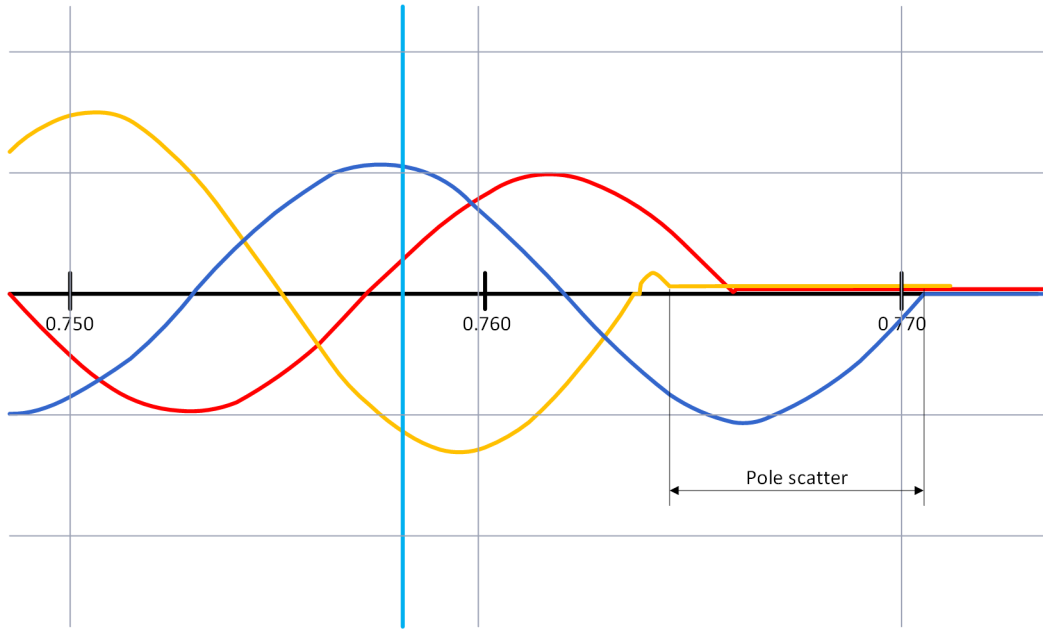

[dw_charact_pole-scatter_2_en_US]

Figure 11-17 Pole Scatter Time

The start criterion can be either the trip command of the circuit breaker or the input signal *>start calc. for open*. You can set 2 independent threshold values for the supervision of the measured pole scatter time. If a threshold value is exceeded, the corresponding output *warning/Alarm* is activated for 100 ms.

11.11.9.2 Application and Setting Notes

Parameter: Threshold for warning

- Default setting (`_:26461:151`) **Threshold for warning = 5 ms**

With the parameter **Threshold for warning**, you define from which measured pole scatter time the output *ScatterTm open warn.* is set. The output *ScatterTm open warn.* drops out after 100 ms.

Parameter: Threshold for alarm

- Default setting (`_:26461:152`) **Threshold for alarm = 10 ms**

With the parameter **Threshold for alarm**, you define from which measured pole scatter time the output *ScatterTm open alarm* is set. The output *ScatterTm open alarm* drops out after 100 ms.

11.11.9.3 Settings

Addr.	Parameter	C	Setting Options	Default Setting
<i>Pole scatter time open</i>				
<code>_:26461:150</code>	3-Phase:Active		<ul style="list-style-type: none"> • 0 • 1 	unwahr
<code>_:26461:151</code>	3-Phase:Threshold for warning		1 ms to 100 ms	5 ms
<code>_:26461:152</code>	3-Phase:Threshold for alarm		1 ms to 100 ms	10 ms

11.11.9.4 Information List

No.	Information	Data Class (Type)	Type
Phase C			
_:24033:51	Phase C:Mode (controllable)	ENC	C
_:24033:54	Phase C:Inactive	SPS	O
_:24033:52	Phase C:Behavior	ENS	O
_:24033:53	Phase C:Health	ENS	O
_:24033:300	Phase C:2P abrasion remaining	INS	O
_:24033:301	Phase C:2P abrasion cumulated	MV	O
_:24033:302	Phase C:2P abrasion last sw.op.	MV	O
_:24033:303	Phase C:2P abrasion warning	SPS	O
_:24033:304	Phase C:2P abrasion alarm	SPS	O
_:24033:310	Phase C: ΣI_x	BCR	O
_:24033:311	Phase C:Warning ΣI_x	SPS	O
_:24033:320	Phase C: $\Sigma I^2 t$	BCR	O
_:24033:321	Phase C:Warning $\Sigma I^2 t$	SPS	O
_:24033:330	Phase C:Make time	MV	O
_:24033:331	Phase C:Make-time warning	SPS	O
_:24033:332	Phase C:Make-time alarm	SPS	O
_:24033:340	Phase C:Break time	MV	O
_:24033:341	Phase C:Break-time warning	SPS	O
_:24033:342	Phase C:Break-time alarm	SPS	O
_:24033:350	Phase C:Aux.-contact time open	MV	O
_:24033:351	Phase C:Aux.c. time open warn.	SPS	O
_:24033:352	Phase C:Aux.c. time open alarm	SPS	O
_:24033:353	Phase C:Reaction time open	MV	O
_:24033:354	Phase C:React. time open warn.	SPS	O
_:24033:355	Phase C:React. time open alarm	SPS	O
_:24033:356	Phase C:Aux.c. travel time open	MV	O
_:24033:360	Phase C:Aux.-cont. time close	MV	O
_:24033:361	Phase C:Aux.c. time close warn.	SPS	O
_:24033:362	Phase C:Aux.c. time close alarm	SPS	O
_:24033:363	Phase C:Reaction time close	MV	O
_:24033:364	Phase C:React. time close warn.	SPS	O
_:24033:365	Phase C:React. time close alarm	SPS	O
_:24033:366	Phase C:Aux.c. travel time close	MV	O

11.11.10 Mechanical Switching Time Open

11.11.10.1 Description

Logic of the Stage

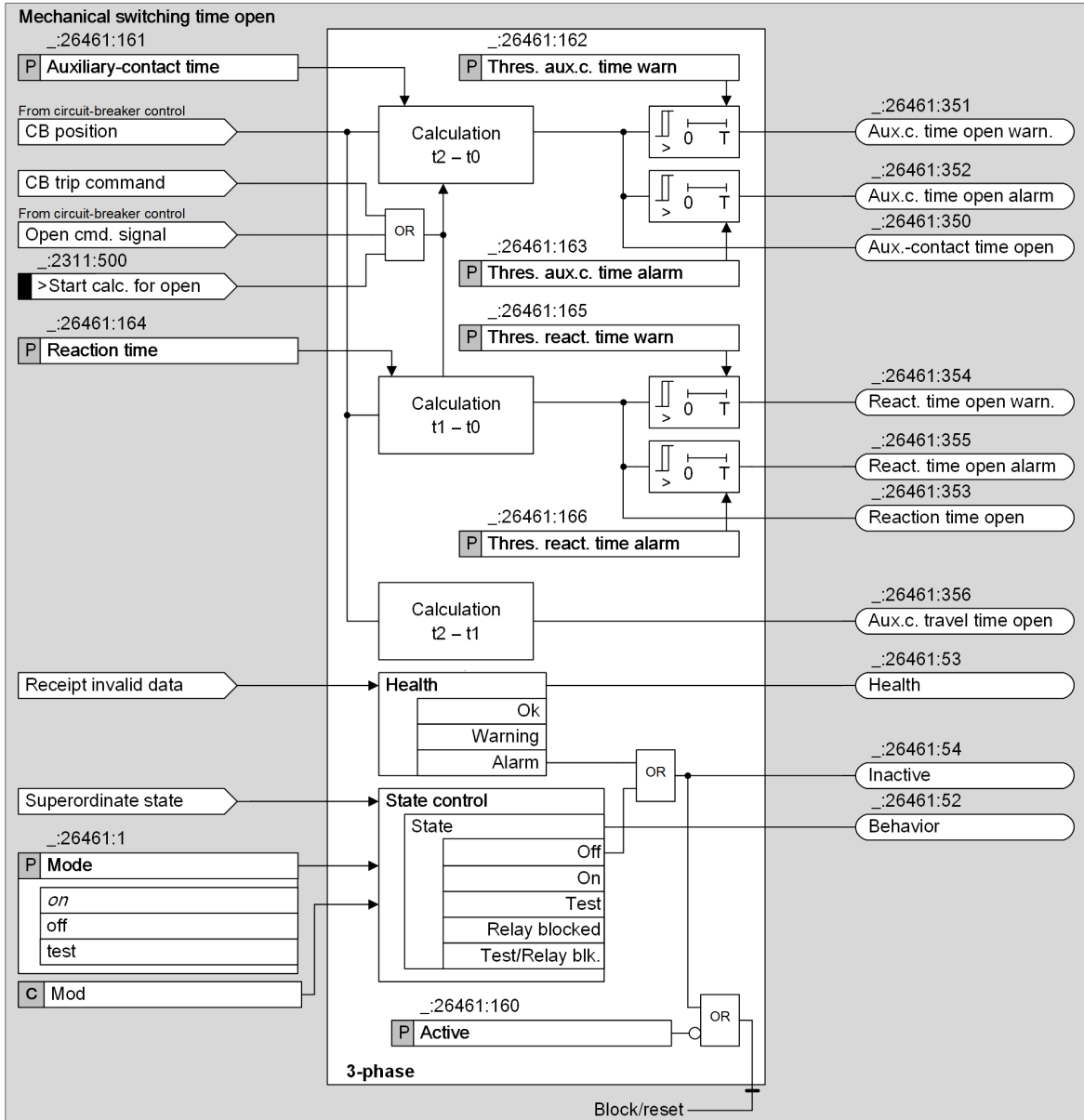

[lo_mechanical_Break-time_3phs_1_en_US]

Figure 11-18 Logic of the Stage Mechanical Switching Time Open for Circuit Breakers 3-Pole

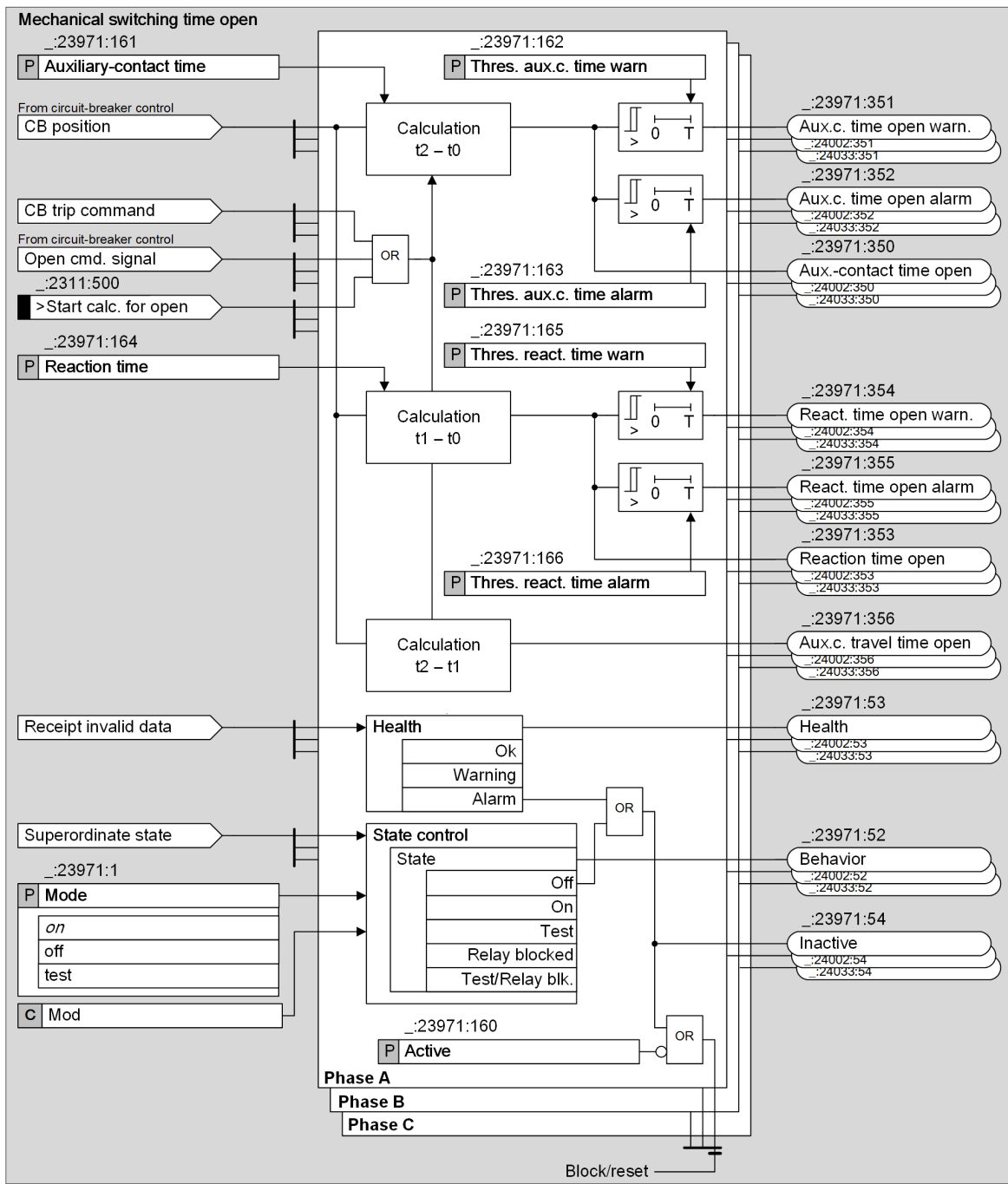

[to_mechanical_Break-time_1phs, 1, en_US]

Figure 11-19 Logic of the Stage Mechanical Switching Time Open for Circuit Breakers 1-Pole

Operating Mode

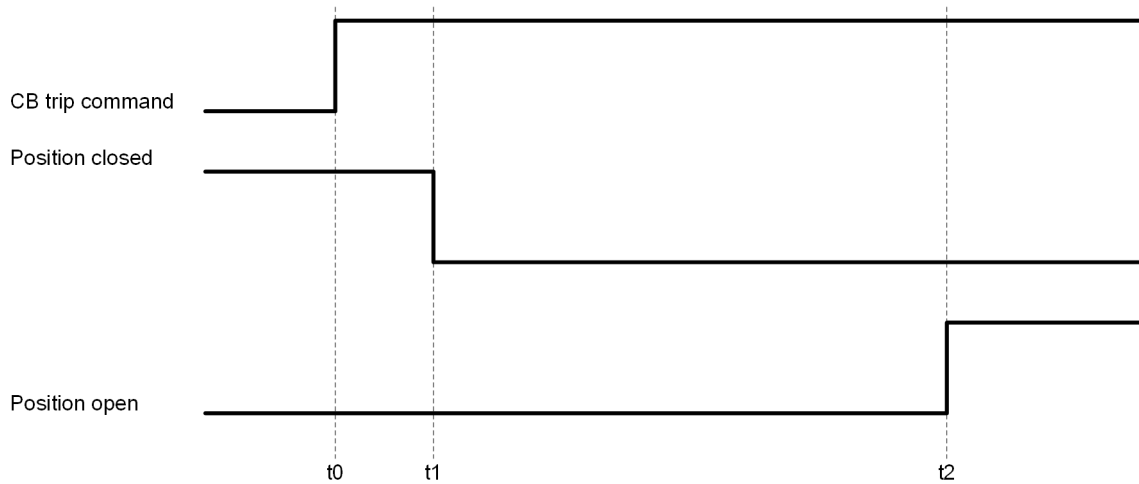

[dw_charact_cb-breaktime, 1, en_US]

- t2 - t0: Auxiliary-contact time opening
- t1 - t0: Response time opening
- t2 - t1: Auxiliary-contact moving time opening

The stage for supervision of the mechanical switching time opening of the circuit breaker measures the time between the starting criterion (t0) and the point in time when the position of the circuit breaker switches to **Intermediate position** (t1). The stage measures the time between the starting criterion (t0) and the point in time when the position of the circuit breaker switches to **Open** (t2). Additionally, it calculates the auxiliary-contact moving time from the intermediate position (t1) until reaching the position **Open** (t2).

The starting criterion can be either the opening command of the circuit breaker, trip from a protection function or the input signal *>Start calc. for open*.

You can set 2 independent threshold values for the supervision of the measured time t1-t0. If a threshold value is exceeded, the corresponding output *warning/Alarm* is activated for 100 ms. You can set 2 independent threshold values for the supervision of the measured time t2-t0. If a threshold value is exceeded, the corresponding output *warning/Alarm* is activated for 100 ms. For t2-t1, only the calculated time is to be indicated. There is no warning or alarm threshold.

If you use a 1-pole circuit breaker, the settings and indications are phase-selective. For 3-pole circuit breakers times cannot be determined phase selective. The settings are done in the section **3-phase**.

A precondition for the monitoring of the mechanical switching times is the routing of the open and closed circuit-breaker position in the function group **Circuit breaker**. If you route only one or no circuit-breaker feedbacks, the function **Mechanical switching time open** cannot work and indicates the status *warning*.

11.11.10.2 Application and Setting Notes



NOTE

The following parameters apply to one phase. The descriptions apply similarly to the parameters of the remaining phases.

Parameter: Auxiliary-contact time

- Default setting (`_:24002:161`) **Auxiliary-contact time** = 35 ms

With the parameter **Auxiliary-contact time**, you define the time period from the circuit-breaker open command until the feedback contacts of the CB indicate **Open**.

Parameter: Thres. aux.c. time warn

- Default setting (`_:24002:162`) **Thres. aux.c. time warn** = 5 ms

With the parameter **Thres. aux.c. time warn**, you define by how many ms the auxiliary-contact time can be exceeded or undershot before the output *Aux.c. time open warn*. is set. The output *Aux.c. time open warn*. drops out after 100 ms.

Parameter: Thres. aux.c. time alarm

- Default setting (`_:24002:163`) **Thres. aux.c. time alarm = 10 ms**

With the parameter **Thres. aux.c. time alarm**, you define by how many ms the auxiliary-contact time can be exceeded or undershot before the output *Aux.c. time open alarm* is set. The output *Aux.c. time open alarm* drops out after 100 ms.

Parameter: Reaction time

- Default setting (`_:24002:164`) **Reaction time = 15 ms**

With the parameter **Reaction time**, you define the time between the circuit-breaker opening command and the indication **Intermediate position** by the feedback contacts of the CB.

Parameter: Thres. react. time warn

- Default setting (`_:24002:165`) **Thres. react. time warn = 3 ms**

With the parameter **Thres. react. time warn**, you define by how many ms the reaction time can be exceeded or undershot before the output *React. time open warn*. is set. The output *React. time open warn*. drops out after 100 ms.

Parameter: Thres. react. time alarm

- Default setting (`_:24002:166`) **Thres. react. time alarm(**`_:24033:166`**) Thres. react. time alarm = 5 ms**

With the parameter **Thres. react. time alarm**, you define by how many ms the reaction time can be exceeded or undershot before the output *React. time open alarm* is set. The *React. time open alarm* drops out after 100 ms.

11.11.10.3 Settings

Addr.	Parameter	C	Setting Options	Default Setting
Mechanical sw. time open				
<code>_:26461:160</code>	3-Phase:Active		<ul style="list-style-type: none"> • 0 • 1 	unwahr
<code>_:26461:161</code>	3-Phase:Auxiliary-contact time		1 ms to 1000 ms	35 ms
<code>_:26461:162</code>	3-Phase:Thres. aux.c. time warn		1 ms to 1000 ms	5 ms
<code>_:26461:163</code>	3-Phase:Thres. aux.c. time alarm		1 ms to 1000 ms	10 ms
<code>_:26461:164</code>	3-Phase:Reaction time		1 ms to 1000 ms	15 ms
<code>_:26461:165</code>	3-Phase:Thres. react. time warn		1 ms to 1000 ms	3 ms
<code>_:26461:166</code>	3-Phase:Thres. react. time alarm		1 ms to 1000 ms	5 ms
Mechanical sw. time open				
<code>_:23971:160</code>	Phase A:Active		<ul style="list-style-type: none"> • 0 • 1 	unwahr
<code>_:23971:161</code>	Phase A:Auxiliary-contact time		1 ms to 1000 ms	35 ms

Addr.	Parameter	C	Setting Options	Default Setting
_:23971:162	Phase A:Thres. aux.c. time warn		1 ms to 1000 ms	5 ms
_:23971:163	Phase A:Thres. aux.c. time alarm		1 ms to 1000 ms	10 ms
_:23971:164	Phase A:Reaction time		1 ms to 1000 ms	15 ms
_:23971:165	Phase A:Thres. react. time warn		1 ms to 1000 ms	3 ms
_:23971:166	Phase A:Thres. react. time alarm		1 ms to 1000 ms	5 ms
Mechanical sw. time open				
_:24002:160	Phase B:Active		<ul style="list-style-type: none"> • 0 • 1 	unwahr
_:24002:161	Phase B:Auxiliary-contact time		1 ms to 1000 ms	35 ms
_:24002:162	Phase B:Thres. aux.c. time warn		1 ms to 1000 ms	5 ms
_:24002:163	Phase B:Thres. aux.c. time alarm		1 ms to 1000 ms	10 ms
_:24002:164	Phase B:Reaction time		1 ms to 1000 ms	15 ms
_:24002:165	Phase B:Thres. react. time warn		1 ms to 1000 ms	3 ms
_:24002:166	Phase B:Thres. react. time alarm		1 ms to 1000 ms	5 ms
Mechanical sw. time open				
_:24033:160	Phase C:Active		<ul style="list-style-type: none"> • 0 • 1 	unwahr
_:24033:161	Phase C:Auxiliary-contact time		1 ms to 1000 ms	35 ms
_:24033:162	Phase C:Thres. aux.c. time warn		1 ms to 1000 ms	5 ms
_:24033:163	Phase C:Thres. aux.c. time alarm		1 ms to 1000 ms	10 ms
_:24033:164	Phase C:Reaction time		1 ms to 1000 ms	15 ms
_:24033:165	Phase C:Thres. react. time warn		1 ms to 1000 ms	3 ms
_:24033:166	Phase C:Thres. react. time alarm		1 ms to 1000 ms	5 ms

11.11.10.4 Information List

No.	Information	Data Class (Type)	Type
General			
_:2311:500	General:>Start calc. for open	SPS	I
_:2311:501	General:>Start calc. for close	SPS	I
_:2311:52	General:Behavior	ENS	O
_:2311:53	General:Health	ENS	O
3-Phase			
_:26461:51	3-Phase:Mode (controllable)	ENC	C
_:26461:54	3-Phase:Inactive	SPS	O

No.	Information	Data Class (Type)	Type
_:26461:52	3-Phase:Behavior	ENS	O
_:26461:53	3-Phase:Health	ENS	O
_:26461:340	3-Phase:Pole scatter time open	MV	O
_:26461:341	3-Phase:ScatterTm open warn.	SPS	O
_:26461:342	3-Phase:ScatterTm open alarm	SPS	O
_:26461:370	3-Phase:Pole scatter time close	MV	O
_:26461:371	3-Phase:ScatterTm close warn.	SPS	O
_:26461:372	3-Phase:ScatterTm close alarm	SPS	O
_:26461:350	3-Phase:Aux.-contact time open	MV	O
_:26461:351	3-Phase:Aux.c. time open warn.	SPS	O
_:26461:352	3-Phase:Aux.c. time open alarm	SPS	O
_:26461:353	3-Phase:Reaction time open	MV	O
_:26461:354	3-Phase:React. time open warn.	SPS	O
_:26461:355	3-Phase:React. time open alarm	SPS	O
_:26461:356	3-Phase:Aux.c. travel time open	MV	O
_:26461:360	3-Phase:Aux.-cont. time close	MV	O
_:26461:361	3-Phase:Aux.c. time close warn.	SPS	O
_:26461:362	3-Phase:Aux.c. time close alarm	SPS	O
_:26461:363	3-Phase:Reaction time close	MV	O
_:26461:364	3-Phase:React. time close warn.	SPS	O
_:26461:365	3-Phase:React. time close alarm	SPS	O
_:26461:366	3-Phase:Aux.c. travel time close	MV	O
Phase A			
_:23971:51	Phase A:Mode (controllable)	ENC	C
_:23971:54	Phase A:Inactive	SPS	O
_:23971:52	Phase A:Behavior	ENS	O
_:23971:53	Phase A:Health	ENS	O
_:23971:300	Phase A:2P abrasion remaining	INS	O
_:23971:301	Phase A:2P abrasion cumulated	MV	O
_:23971:302	Phase A:2P abrasion last sw.op.	MV	O
_:23971:303	Phase A:2P abrasion warning	SPS	O
_:23971:304	Phase A:2P abrasion alarm	SPS	O
_:23971:310	Phase A: ΣI_x	BCR	O
_:23971:311	Phase A:Warning ΣI_x	SPS	O
_:23971:320	Phase A: $\Sigma I^2 t$	BCR	O
_:23971:321	Phase A:Warning $\Sigma I^2 t$	SPS	O
_:23971:330	Phase A:Make time	MV	O
_:23971:331	Phase A:Make-time warning	SPS	O
_:23971:332	Phase A:Make-time alarm	SPS	O
_:23971:340	Phase A:Break time	MV	O
_:23971:341	Phase A:Break-time warning	SPS	O
_:23971:342	Phase A:Break-time alarm	SPS	O
_:23971:350	Phase A:Aux.-contact time open	MV	O
_:23971:351	Phase A:Aux.c. time open warn.	SPS	O
_:23971:352	Phase A:Aux.c. time open alarm	SPS	O
_:23971:353	Phase A:Reaction time open	MV	O

No.	Information	Data Class (Type)	Type
_:23971:354	Phase A:React. time open warn.	SPS	O
_:23971:355	Phase A:React. time open alarm	SPS	O
_:23971:356	Phase A:Aux.c. travel time open	MV	O
_:23971:360	Phase A:Aux.-cont. time close	MV	O
_:23971:361	Phase A:Aux.c. time close warn.	SPS	O
_:23971:362	Phase A:Aux.c. time close alarm	SPS	O
_:23971:363	Phase A:Reaction time close	MV	O
_:23971:364	Phase A:React. time close warn.	SPS	O
_:23971:365	Phase A:React. time close alarm	SPS	O
_:23971:366	Phase A:Aux.c. travel time close	MV	O
Phase B			
_:24002:51	Phase B:Mode (controllable)	ENC	C
_:24002:54	Phase B:Inactive	SPS	O
_:24002:52	Phase B:Behavior	ENS	O
_:24002:53	Phase B:Health	ENS	O
_:24002:300	Phase B:2P abrasion remaining	INS	O
_:24002:301	Phase B:2P abrasion cumulated	MV	O
_:24002:302	Phase B:2P abrasion last sw.op.	MV	O
_:24002:303	Phase B:2P abrasion warning	SPS	O
_:24002:304	Phase B:2P abrasion alarm	SPS	O
_:24002:310	Phase B: ΣI_x	BCR	O
_:24002:311	Phase B:Warning ΣI_x	SPS	O
_:24002:320	Phase B: $\Sigma I^2 t$	BCR	O
_:24002:321	Phase B:Warning $\Sigma I^2 t$	SPS	O
_:24002:330	Phase B:Make time	MV	O
_:24002:331	Phase B:Make-time warning	SPS	O
_:24002:332	Phase B:Make-time alarm	SPS	O
_:24002:340	Phase B:Break time	MV	O
_:24002:341	Phase B:Break-time warning	SPS	O
_:24002:342	Phase B:Break-time alarm	SPS	O
_:24002:350	Phase B:Aux.-contact time open	MV	O
_:24002:351	Phase B:Aux.c. time open warn.	SPS	O
_:24002:352	Phase B:Aux.c. time open alarm	SPS	O
_:24002:353	Phase B:Reaction time open	MV	O
_:24002:354	Phase B:React. time open warn.	SPS	O
_:24002:355	Phase B:React. time open alarm	SPS	O
_:24002:356	Phase B:Aux.c. travel time open	MV	O
_:24002:360	Phase B:Aux.-cont. time close	MV	O
_:24002:361	Phase B:Aux.c. time close warn.	SPS	O
_:24002:362	Phase B:Aux.c. time close alarm	SPS	O
_:24002:363	Phase B:Reaction time close	MV	O
_:24002:364	Phase B:React. time close warn.	SPS	O
_:24002:365	Phase B:React. time close alarm	SPS	O
_:24002:366	Phase B:Aux.c. travel time close	MV	O
Phase C			
_:24033:51	Phase C:Mode (controllable)	ENC	C

No.	Information	Data Class (Type)	Type
_:24033:54	Phase C:Inactive	SPS	O
_:24033:52	Phase C:Behavior	ENS	O
_:24033:53	Phase C:Health	ENS	O
_:24033:300	Phase C:2P abrasion remaining	INS	O
_:24033:301	Phase C:2P abrasion cumulated	MV	O
_:24033:302	Phase C:2P abrasion last sw.op.	MV	O
_:24033:303	Phase C:2P abrasion warning	SPS	O
_:24033:304	Phase C:2P abrasion alarm	SPS	O
_:24033:310	Phase C: ΣI_x	BCR	O
_:24033:311	Phase C:Warning ΣI_x	SPS	O
_:24033:320	Phase C: $\Sigma I^2 t$	BCR	O
_:24033:321	Phase C:Warning $\Sigma I^2 t$	SPS	O
_:24033:330	Phase C:Make time	MV	O
_:24033:331	Phase C:Make-time warning	SPS	O
_:24033:332	Phase C:Make-time alarm	SPS	O
_:24033:340	Phase C:Break time	MV	O
_:24033:341	Phase C:Break-time warning	SPS	O
_:24033:342	Phase C:Break-time alarm	SPS	O
_:24033:350	Phase C:Aux.-contact time open	MV	O
_:24033:351	Phase C:Aux.c. time open warn.	SPS	O
_:24033:352	Phase C:Aux.c. time open alarm	SPS	O
_:24033:353	Phase C:Reaction time open	MV	O
_:24033:354	Phase C:React. time open warn.	SPS	O
_:24033:355	Phase C:React. time open alarm	SPS	O
_:24033:356	Phase C:Aux.c. travel time open	MV	O
_:24033:360	Phase C:Aux.-cont. time close	MV	O
_:24033:361	Phase C:Aux.c. time close warn.	SPS	O
_:24033:362	Phase C:Aux.c. time close alarm	SPS	O
_:24033:363	Phase C:Reaction time close	MV	O
_:24033:364	Phase C:React. time close warn.	SPS	O
_:24033:365	Phase C:React. time close alarm	SPS	O
_:24033:366	Phase C:Aux.c. travel time close	MV	O

11.11.11 Mechanical Switching Time Close

11.11.11.1 Description

Logic of the Stage

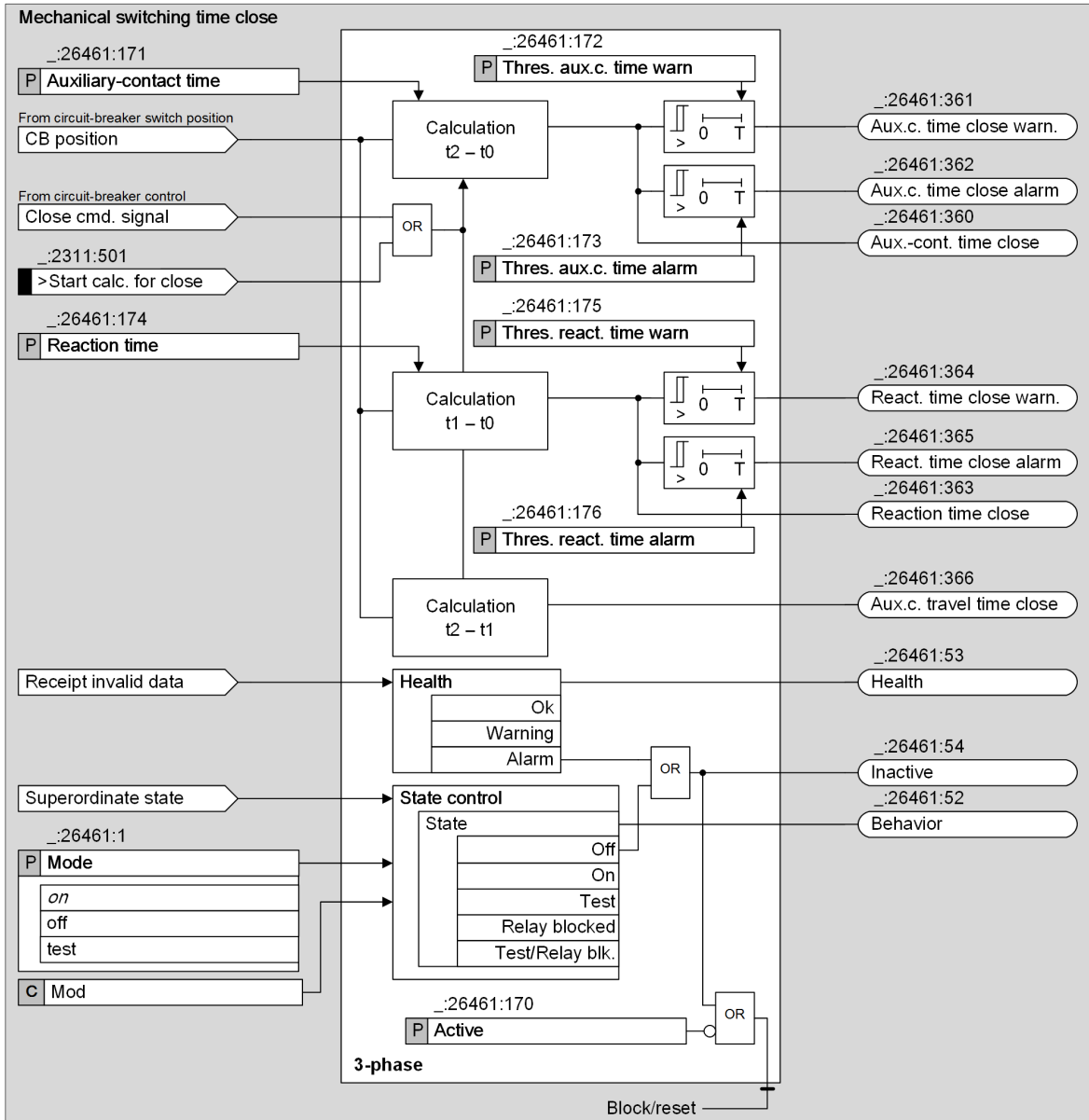

[to_mechanical_Make-time_3phs_1_en_US]

Figure 11-20 Logic of the Stage Mechanical Switching Time Close for Circuit Breakers 3-Pole

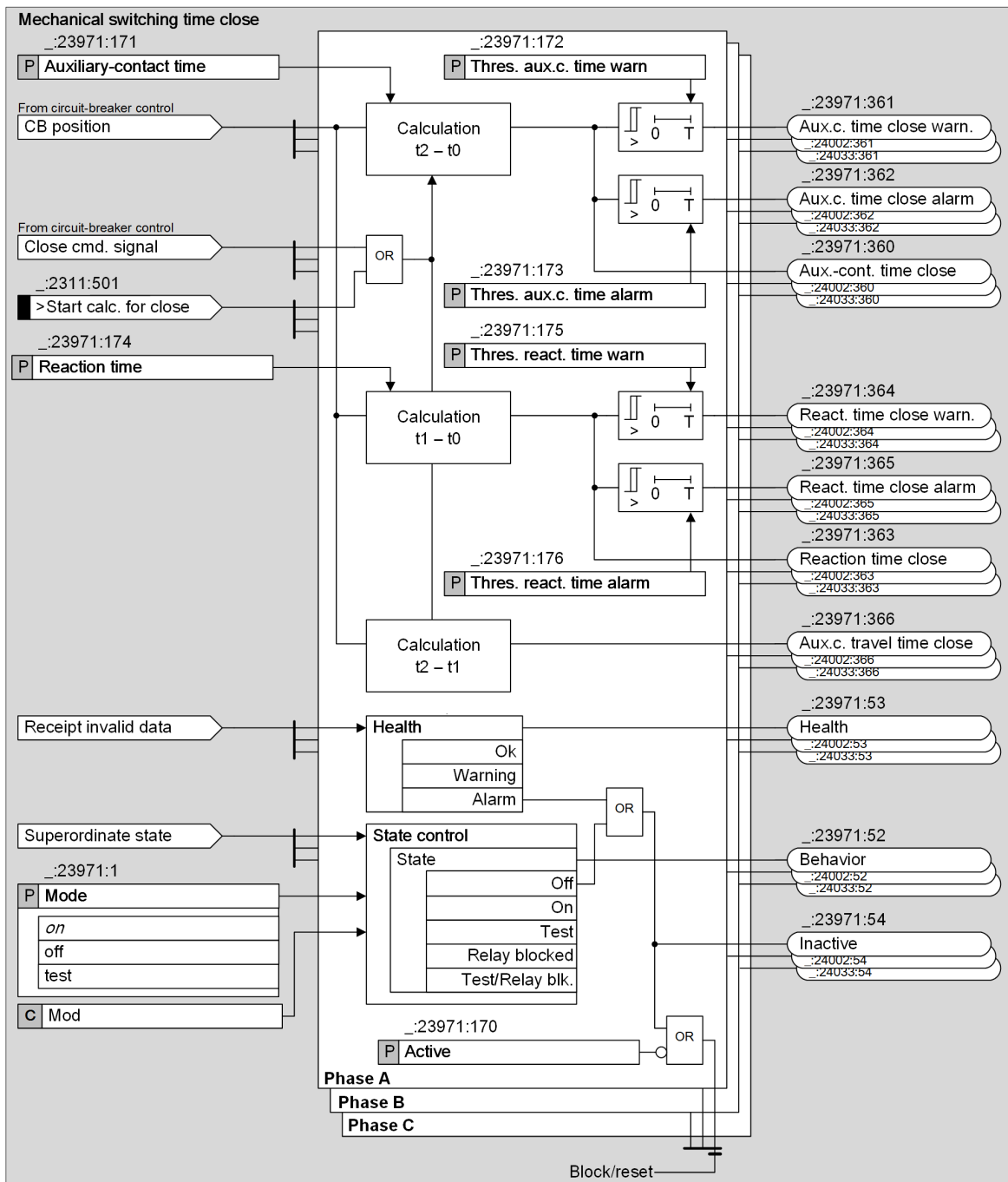

[to_mechanical_Make-time_1phs, 1, en_US]

Figure 11-21 Logic of the Stage Mechanical Switching Time Close for Circuit Breakers 1-Pole

Operating Mode

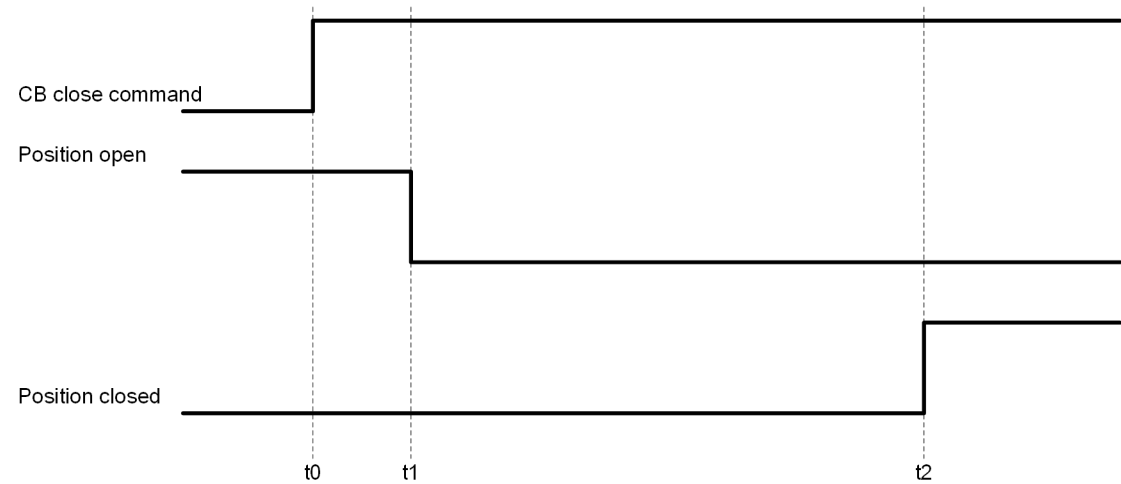

[dw_charact_cb-maketime, 1, en_US]

- t2 - t0: Auxiliary-contact time closing
- t1 - t0: Response time closing
- t2 - t1: Auxiliary-contact moving time closing

The stage for supervision of the mechanical switching time closing of the circuit breaker measures the time between the closing command of the circuit breaker (t0) and the point in time when the position of the circuit breaker switches to **Intermediate position** (t1). The stage measures the time between the close command of the circuit breaker (t0) and the point in time when the position of the circuit breaker switches to **Close** (t2). Additionally, it calculates the auxiliary-contact moving time from the intermediate position (t1) until reaching the position **Close** (t2).

The starting criterion can be either the closing command of the circuit breaker or the input signal *>Start calc. for close*.

You can set 2 independent threshold values for the supervision of the measured time t1-t0. If a threshold value is exceeded, the corresponding output *warning/Alarm* is activated for 100 ms. You can set 2 independent threshold values for the supervision of the measured time t2-t0. If a threshold value is exceeded, the corresponding output *warning/Alarm* is activated for 100 ms. For t2-t1, only the calculated time is to be indicated. There is no warning or alarm threshold.

If you use a 1-pole circuit breaker, the settings and indications are phase-selective. For 3-pole circuit breakers times cannot be determined phase selective. The settings are done in the section **3-phase**.

A precondition for the monitoring of the mechanical switching times is the routing of the open and closed circuit-breaker position in the function group **Circuit breaker**. If you route only one or no circuit-breaker feedbacks, the function **Mechanical switching time close** cannot work and indicates the status *warning*.

11.11.11.2 Application and Setting Notes



NOTE

The following parameters apply to one phase. The descriptions apply similarly to the parameters of the remaining phases.

Parameter: Auxiliary-contact time

- Default setting (`_:23971:171`) **Auxiliary-contact time** = 35 ms

With the parameter **Auxiliary-contact time**, you define the time period from the circuit-breaker close command until the feedback contacts of the CB indicate **Closed**.

Parameter: Thres. aux.c. time warn

- Default setting (`_:23971:172`) **Thres. aux.c. time warn = 5 ms**

With the parameter **Thres. aux.c. time warn**, you define by how many ms the auxiliary-contact time can be exceeded or undershot before the output *Aux.c. time close warn*. is set. The output *Aux.c. time close warn*. drops out after 100 ms.

Parameter: Thres. aux.c. time alarm

- Default setting (`_:23971:173`) **Thres. aux.c. time alarm = 10 ms**

With the parameter **Thres. aux.c. time alarm**, you define by how many ms the auxiliary-contact time can be exceeded or undershot before the output *Aux.c. time close alarm* is set. The output *Aux.c. time close alarm* drops out after 100 ms.

Parameter: Reaction time

- Default setting (`_:23971:174`) **Reaction time = 15 ms**

With the parameter **Reaction time**, you define the time between the circuit-breaker closing command and the indication **Intermediate position** by the feedback contacts of the CB.

Parameter: Thres. react. time warn

- Default setting (`_:23971:175`) **Thres. react. time warn = 3 ms**

With the parameter **Thres. react. time warn**, you define by how many ms the reaction time can be exceeded or undershot before the output *React. time close warn*. is set. The output *React. time close warn*. drops out after 100 ms.

Parameter: Thres. react. time alarm

- Default setting (`_:23971:176`) **Thres. react. time alarm = 5 ms**

With the parameter **Thres. react. time alarm**, you define by how many ms the reaction time can be exceeded or undershot before the output *React. time close alarm* is set. The *React. time close alarm* drops out after 100 ms.

11.11.11.3 Settings

Addr.	Parameter	C	Setting Options	Default Setting
<i>Mechanical sw. time close</i>				
<code>_:26461:170</code>	3-Phase:Active		<ul style="list-style-type: none"> • 0 • 1 	unwahr
<code>_:26461:171</code>	3-Phase:Auxiliary-contact time		1 ms to 1000 ms	35 ms
<code>_:26461:172</code>	3-Phase:Thres. aux.c. time warn		1 ms to 1000 ms	5 ms
<code>_:26461:173</code>	3-Phase:Thres. aux.c. time alarm		1 ms to 1000 ms	10 ms
<code>_:26461:174</code>	3-Phase:Reaction time		1 ms to 1000 ms	15 ms
<code>_:26461:175</code>	3-Phase:Thres. react. time warn		1 ms to 1000 ms	3 ms
<code>_:26461:176</code>	3-Phase:Thres. react. time alarm		1 ms to 1000 ms	5 ms
<i>Mechanical sw. time close</i>				
<code>_:23971:170</code>	Phase A:Active		<ul style="list-style-type: none"> • 0 • 1 	unwahr

Addr.	Parameter	C	Setting Options	Default Setting
_:23971:171	Phase A:Auxiliary-contact time		1 ms to 1000 ms	35 ms
_:23971:172	Phase A:Thres. aux.c. time warn		1 ms to 1000 ms	5 ms
_:23971:173	Phase A:Thres. aux.c. time alarm		1 ms to 1000 ms	10 ms
_:23971:174	Phase A:Reaction time		1 ms to 1000 ms	15 ms
_:23971:175	Phase A:Thres. react. time warn		1 ms to 1000 ms	3 ms
_:23971:176	Phase A:Thres. react. time alarm		1 ms to 1000 ms	5 ms
Mechanical sw. time close				
_:24002:170	Phase B:Active		<ul style="list-style-type: none"> • 0 • 1 	unwahr
_:24002:171	Phase B:Auxiliary-contact time		1 ms to 1000 ms	35 ms
_:24002:172	Phase B:Thres. aux.c. time warn		1 ms to 1000 ms	5 ms
_:24002:173	Phase B:Thres. aux.c. time alarm		1 ms to 1000 ms	10 ms
_:24002:174	Phase B:Reaction time		1 ms to 1000 ms	15 ms
_:24002:175	Phase B:Thres. react. time warn		1 ms to 1000 ms	3 ms
_:24002:176	Phase B:Thres. react. time alarm		1 ms to 1000 ms	5 ms
Mechanical sw. time close				
_:24033:170	Phase C:Active		<ul style="list-style-type: none"> • 0 • 1 	unwahr
_:24033:171	Phase C:Auxiliary-contact time		1 ms to 1000 ms	35 ms
_:24033:172	Phase C:Thres. aux.c. time warn		1 ms to 1000 ms	5 ms
_:24033:173	Phase C:Thres. aux.c. time alarm		1 ms to 1000 ms	10 ms
_:24033:174	Phase C:Reaction time		1 ms to 1000 ms	15 ms
_:24033:175	Phase C:Thres. react. time warn		1 ms to 1000 ms	3 ms
_:24033:176	Phase C:Thres. react. time alarm		1 ms to 1000 ms	5 ms

11.11.11.4 Information List

No.	Information	Data Class (Type)	Type
General			
_:2311:500	General:>Start calc. for open	SPS	I
_:2311:501	General:>Start calc. for close	SPS	I
_:2311:52	General:Behavior	ENS	O
_:2311:53	General:Health	ENS	O

No.	Information	Data Class (Type)	Type
3-Phase			
_:26461:51	3-Phase:Mode (controllable)	ENC	C
_:26461:54	3-Phase:Inactive	SPS	O
_:26461:52	3-Phase:Behavior	ENS	O
_:26461:53	3-Phase:Health	ENS	O
_:26461:340	3-Phase:Pole scatter time open	MV	O
_:26461:341	3-Phase:ScatterTm open warn.	SPS	O
_:26461:342	3-Phase:ScatterTm open alarm	SPS	O
_:26461:370	3-Phase:Pole scatter time close	MV	O
_:26461:371	3-Phase:ScatterTm close warn.	SPS	O
_:26461:372	3-Phase:ScatterTm close alarm	SPS	O
_:26461:350	3-Phase:Aux.-contact time open	MV	O
_:26461:351	3-Phase:Aux.c. time open warn.	SPS	O
_:26461:352	3-Phase:Aux.c. time open alarm	SPS	O
_:26461:353	3-Phase:Reaction time open	MV	O
_:26461:354	3-Phase:React. time open warn.	SPS	O
_:26461:355	3-Phase:React. time open alarm	SPS	O
_:26461:356	3-Phase:Aux.c. travel time open	MV	O
_:26461:360	3-Phase:Aux.-cont. time close	MV	O
_:26461:361	3-Phase:Aux.c. time close warn.	SPS	O
_:26461:362	3-Phase:Aux.c. time close alarm	SPS	O
_:26461:363	3-Phase:Reaction time close	MV	O
_:26461:364	3-Phase:React. time close warn.	SPS	O
_:26461:365	3-Phase:React. time close alarm	SPS	O
_:26461:366	3-Phase:Aux.c. travel time close	MV	O
Phase A			
_:23971:51	Phase A:Mode (controllable)	ENC	C
_:23971:54	Phase A:Inactive	SPS	O
_:23971:52	Phase A:Behavior	ENS	O
_:23971:53	Phase A:Health	ENS	O
_:23971:300	Phase A:2P abrasion remaining	INS	O
_:23971:301	Phase A:2P abrasion cumulated	MV	O
_:23971:302	Phase A:2P abrasion last sw.op.	MV	O
_:23971:303	Phase A:2P abrasion warning	SPS	O
_:23971:304	Phase A:2P abrasion alarm	SPS	O
_:23971:310	Phase A: ΣI_x	BCR	O
_:23971:311	Phase A:Warning ΣI_x	SPS	O
_:23971:320	Phase A: $\Sigma I^2 t$	BCR	O
_:23971:321	Phase A:Warning $\Sigma I^2 t$	SPS	O
_:23971:330	Phase A:Make time	MV	O
_:23971:331	Phase A:Make-time warning	SPS	O
_:23971:332	Phase A:Make-time alarm	SPS	O
_:23971:340	Phase A:Break time	MV	O
_:23971:341	Phase A:Break-time warning	SPS	O
_:23971:342	Phase A:Break-time alarm	SPS	O
_:23971:350	Phase A:Aux.-contact time open	MV	O

No.	Information	Data Class (Type)	Type
_:23971:351	Phase A:Aux.c. time open warn.	SPS	O
_:23971:352	Phase A:Aux.c. time open alarm	SPS	O
_:23971:353	Phase A:Reaction time open	MV	O
_:23971:354	Phase A:React. time open warn.	SPS	O
_:23971:355	Phase A:React. time open alarm	SPS	O
_:23971:356	Phase A:Aux.c. travel time open	MV	O
_:23971:360	Phase A:Aux.-cont. time close	MV	O
_:23971:361	Phase A:Aux.c. time close warn.	SPS	O
_:23971:362	Phase A:Aux.c. time close alarm	SPS	O
_:23971:363	Phase A:Reaction time close	MV	O
_:23971:364	Phase A:React. time close warn.	SPS	O
_:23971:365	Phase A:React. time close alarm	SPS	O
_:23971:366	Phase A:Aux.c. travel time close	MV	O
Phase B			
_:24002:51	Phase B:Mode (controllable)	ENC	C
_:24002:54	Phase B:Inactive	SPS	O
_:24002:52	Phase B:Behavior	ENS	O
_:24002:53	Phase B:Health	ENS	O
_:24002:300	Phase B:2P abrasion remaining	INS	O
_:24002:301	Phase B:2P abrasion cumulated	MV	O
_:24002:302	Phase B:2P abrasion last sw.op.	MV	O
_:24002:303	Phase B:2P abrasion warning	SPS	O
_:24002:304	Phase B:2P abrasion alarm	SPS	O
_:24002:310	Phase B: ΣI_x	BCR	O
_:24002:311	Phase B:Warning ΣI_x	SPS	O
_:24002:320	Phase B: $\Sigma I^2 t$	BCR	O
_:24002:321	Phase B:Warning $\Sigma I^2 t$	SPS	O
_:24002:330	Phase B:Make time	MV	O
_:24002:331	Phase B:Make-time warning	SPS	O
_:24002:332	Phase B:Make-time alarm	SPS	O
_:24002:340	Phase B:Break time	MV	O
_:24002:341	Phase B:Break-time warning	SPS	O
_:24002:342	Phase B:Break-time alarm	SPS	O
_:24002:350	Phase B:Aux.-contact time open	MV	O
_:24002:351	Phase B:Aux.c. time open warn.	SPS	O
_:24002:352	Phase B:Aux.c. time open alarm	SPS	O
_:24002:353	Phase B:Reaction time open	MV	O
_:24002:354	Phase B:React. time open warn.	SPS	O
_:24002:355	Phase B:React. time open alarm	SPS	O
_:24002:356	Phase B:Aux.c. travel time open	MV	O
_:24002:360	Phase B:Aux.-cont. time close	MV	O
_:24002:361	Phase B:Aux.c. time close warn.	SPS	O
_:24002:362	Phase B:Aux.c. time close alarm	SPS	O
_:24002:363	Phase B:Reaction time close	MV	O
_:24002:364	Phase B:React. time close warn.	SPS	O
_:24002:365	Phase B:React. time close alarm	SPS	O

No.	Information	Data Class (Type)	Type
_:24002:366	Phase B:Aux.c. travel time close	MV	O
Phase C			
_:24033:51	Phase C:Mode (controllable)	ENC	C
_:24033:54	Phase C:Inactive	SPS	O
_:24033:52	Phase C:Behavior	ENS	O
_:24033:53	Phase C:Health	ENS	O
_:24033:300	Phase C:2P abrasion remaining	INS	O
_:24033:301	Phase C:2P abrasion cumulated	MV	O
_:24033:302	Phase C:2P abrasion last sw.op.	MV	O
_:24033:303	Phase C:2P abrasion warning	SPS	O
_:24033:304	Phase C:2P abrasion alarm	SPS	O
_:24033:310	Phase C: ΣI_x	BCR	O
_:24033:311	Phase C:Warning ΣI_x	SPS	O
_:24033:320	Phase C: $\Sigma I^2 t$	BCR	O
_:24033:321	Phase C:Warning $\Sigma I^2 t$	SPS	O
_:24033:330	Phase C:Make time	MV	O
_:24033:331	Phase C:Make-time warning	SPS	O
_:24033:332	Phase C:Make-time alarm	SPS	O
_:24033:340	Phase C:Break time	MV	O
_:24033:341	Phase C:Break-time warning	SPS	O
_:24033:342	Phase C:Break-time alarm	SPS	O
_:24033:350	Phase C:Aux.-contact time open	MV	O
_:24033:351	Phase C:Aux.c. time open warn.	SPS	O
_:24033:352	Phase C:Aux.c. time open alarm	SPS	O
_:24033:353	Phase C:Reaction time open	MV	O
_:24033:354	Phase C:React. time open warn.	SPS	O
_:24033:355	Phase C:React. time open alarm	SPS	O
_:24033:356	Phase C:Aux.c. travel time open	MV	O
_:24033:360	Phase C:Aux.-cont. time close	MV	O
_:24033:361	Phase C:Aux.c. time close warn.	SPS	O
_:24033:362	Phase C:Aux.c. time close alarm	SPS	O
_:24033:363	Phase C:Reaction time close	MV	O
_:24033:364	Phase C:React. time close warn.	SPS	O
_:24033:365	Phase C:React. time close alarm	SPS	O
_:24033:366	Phase C:Aux.c. travel time close	MV	O

11.11.12 Operation counter

11.11.12.1 Description

The stage for the supervision of the switching cycles counts the number of switching cycles using the feedback contacts of the circuit breaker.

You can set 2 independent threshold values for the supervision. If a threshold value is exceeded, the corresponding output indication is issued. Use the circuit-breaker statistical values to set and reset the meter. You can also use the input signal *>Reset switch statist.* to reset the meter. You can find the input in the DIGSI 5 Information routing under the FG **Circuit breaker > Circuit break**.

11.11.12.2 Application and Setting Notes



NOTE

The following parameters apply to one phase. The descriptions also apply to the parameters of the other phases.

Parameter: Threshold for warning

- Default setting (`_:26461:151`) **Threshold for warning** = 9500

With the parameter **Threshold for warning**, you specify after how many switching cycles the output indication *Oper.-counter warning* is issued.

Parameter: (`_:26461:152`) Threshold for alarm

- Default setting **Threshold for alarm** = 10 000

With the parameter **Threshold for alarm**, you specify after how many switching cycles the output indication *Oper.-counter alarm* is issued.

11.11.12.3 Settings

Addr.	Parameter	C	Setting Options	Default Setting
Operation counter				
<code>_:26461:190</code>	3-Phase:Active		<ul style="list-style-type: none"> • 0 • 1 	false
<code>_:26461:191</code>	3-Phase:Threshold for warning		0 to 999 999 999	9500
<code>_:26461:192</code>	3-Phase:Threshold for alarm		0 to 999 999 999	10 000

11.11.12.4 Information List

No.	Information	Data Class (Type)	Type
General			
<code>_:2311:500</code>	General:>Start calc. for open	SPS	I
<code>_:2311:501</code>	General:>Start calc. for close	SPS	I
<code>_:2311:52</code>	General:Behavior	ENS	O
<code>_:2311:53</code>	General:Health	ENS	O
3-Phase			
<code>_:26461:51</code>	3-Phase:Mode (controllable)	ENC	C
<code>_:26461:54</code>	3-Phase:Inactive	SPS	O
<code>_:26461:52</code>	3-Phase:Behavior	ENS	O
<code>_:26461:53</code>	3-Phase:Health	ENS	O
<code>_:26461:340</code>	3-Phase:Pole scatter time open	MV	O
<code>_:26461:341</code>	3-Phase:ScatterTm open warn.	SPS	O
<code>_:26461:342</code>	3-Phase:ScatterTm open alarm	SPS	O
<code>_:26461:370</code>	3-Phase:Pole scatter time close	MV	O
<code>_:26461:371</code>	3-Phase:ScatterTm close warn.	SPS	O
<code>_:26461:372</code>	3-Phase:ScatterTm close alarm	SPS	O
<code>_:26461:350</code>	3-Phase:Aux.-contact time open	MV	O
<code>_:26461:351</code>	3-Phase:Aux.c. time open warn.	SPS	O
<code>_:26461:352</code>	3-Phase:Aux.c. time open alarm	SPS	O

No.	Information	Data Class (Type)	Type
_:26461:353	3-Phase:Reaction time open	MV	O
_:26461:354	3-Phase:React. time open warn.	SPS	O
_:26461:355	3-Phase:React. time open alarm	SPS	O
_:26461:356	3-Phase:Aux.c. travel time open	MV	O
_:26461:360	3-Phase:Aux.-cont. time close	MV	O
_:26461:361	3-Phase:Aux.c. time close warn.	SPS	O
_:26461:362	3-Phase:Aux.c. time close alarm	SPS	O
_:26461:363	3-Phase:Reaction time close	MV	O
_:26461:364	3-Phase:React. time close warn.	SPS	O
_:26461:365	3-Phase:React. time close alarm	SPS	O
_:26461:366	3-Phase:Aux.c. travel time close	MV	O
_:26461:380	3-Phase:Operation counter	INS	O
_:26461:381	3-Phase:Oper.-counter warning	SPS	O
_:26461:382	3-Phase:Oper.-counter alarm	SPS	O
Phase A			
_:23971:51	Phase A:Mode (controllable)	ENC	C
_:23971:54	Phase A:Inactive	SPS	O
_:23971:52	Phase A:Behavior	ENS	O
_:23971:53	Phase A:Health	ENS	O
_:23971:300	Phase A:2P abrasion remaining	INS	O
_:23971:301	Phase A:2P abrasion cumulated	MV	O
_:23971:302	Phase A:2P abrasion last sw.op.	MV	O
_:23971:303	Phase A:2P abrasion warning	SPS	O
_:23971:304	Phase A:2P abrasion alarm	SPS	O
_:23971:310	Phase A: ΣI_x	BCR	O
_:23971:311	Phase A:Warning ΣI_x	SPS	O
_:23971:320	Phase A: $\Sigma I^2 t$	BCR	O
_:23971:321	Phase A:Warning $\Sigma I^2 t$	SPS	O
_:23971:330	Phase A:Make time	MV	O
_:23971:331	Phase A:Make-time warning	SPS	O
_:23971:332	Phase A:Make-time alarm	SPS	O
_:23971:340	Phase A:Break time	MV	O
_:23971:341	Phase A:Break-time warning	SPS	O
_:23971:342	Phase A:Break-time alarm	SPS	O
_:23971:350	Phase A:Aux.-contact time open	MV	O
_:23971:351	Phase A:Aux.c. time open warn.	SPS	O
_:23971:352	Phase A:Aux.c. time open alarm	SPS	O
_:23971:353	Phase A:Reaction time open	MV	O
_:23971:354	Phase A:React. time open warn.	SPS	O
_:23971:355	Phase A:React. time open alarm	SPS	O
_:23971:356	Phase A:Aux.c. travel time open	MV	O
_:23971:360	Phase A:Aux.-cont. time close	MV	O
_:23971:361	Phase A:Aux.c. time close warn.	SPS	O
_:23971:362	Phase A:Aux.c. time close alarm	SPS	O
_:23971:363	Phase A:Reaction time close	MV	O
_:23971:364	Phase A:React. time close warn.	SPS	O

No.	Information	Data Class (Type)	Type
_:23971:365	Phase A:React. time close alarm	SPS	O
_:23971:366	Phase A:Aux.c. travel time close	MV	O
_:23971:370	Phase A:Operation counter	INS	O
_:23971:371	Phase A:Oper.-counter warning	SPS	O
_:23971:372	Phase A:Oper.-counter alarm	SPS	O
Phase B			
_:24002:51	Phase B:Mode (controllable)	ENC	C
_:24002:54	Phase B:Inactive	SPS	O
_:24002:52	Phase B:Behavior	ENS	O
_:24002:53	Phase B:Health	ENS	O
_:24002:300	Phase B:2P abrasion remaining	INS	O
_:24002:301	Phase B:2P abrasion cumulated	MV	O
_:24002:302	Phase B:2P abrasion last sw.op.	MV	O
_:24002:303	Phase B:2P abrasion warning	SPS	O
_:24002:304	Phase B:2P abrasion alarm	SPS	O
_:24002:310	Phase B: ΣI_x	BCR	O
_:24002:311	Phase B:Warning ΣI_x	SPS	O
_:24002:320	Phase B: $\Sigma I^2 t$	BCR	O
_:24002:321	Phase B:Warning $\Sigma I^2 t$	SPS	O
_:24002:330	Phase B:Make time	MV	O
_:24002:331	Phase B:Make-time warning	SPS	O
_:24002:332	Phase B:Make-time alarm	SPS	O
_:24002:340	Phase B:Break time	MV	O
_:24002:341	Phase B:Break-time warning	SPS	O
_:24002:342	Phase B:Break-time alarm	SPS	O
_:24002:350	Phase B:Aux.-contact time open	MV	O
_:24002:351	Phase B:Aux.c. time open warn.	SPS	O
_:24002:352	Phase B:Aux.c. time open alarm	SPS	O
_:24002:353	Phase B:Reaction time open	MV	O
_:24002:354	Phase B:React. time open warn.	SPS	O
_:24002:355	Phase B:React. time open alarm	SPS	O
_:24002:356	Phase B:Aux.c. travel time open	MV	O
_:24002:360	Phase B:Aux.-cont. time close	MV	O
_:24002:361	Phase B:Aux.c. time close warn.	SPS	O
_:24002:362	Phase B:Aux.c. time close alarm	SPS	O
_:24002:363	Phase B:Reaction time close	MV	O
_:24002:364	Phase B:React. time close warn.	SPS	O
_:24002:365	Phase B:React. time close alarm	SPS	O
_:24002:366	Phase B:Aux.c. travel time close	MV	O
_:24002:370	Phase B:Operation counter	INS	O
_:24002:371	Phase B:Oper.-counter warning	SPS	O
_:24002:372	Phase B:Oper.-counter alarm	SPS	O
Phase C			
_:24033:51	Phase C:Mode (controllable)	ENC	C
_:24033:54	Phase C:Inactive	SPS	O
_:24033:52	Phase C:Behavior	ENS	O

No.	Information	Data Class (Type)	Type
_:24033:53	Phase C:Health	ENS	O
_:24033:300	Phase C:2P abrasion remaining	INS	O
_:24033:301	Phase C:2P abrasion cumulated	MV	O
_:24033:302	Phase C:2P abrasion last sw.op.	MV	O
_:24033:303	Phase C:2P abrasion warning	SPS	O
_:24033:304	Phase C:2P abrasion alarm	SPS	O
_:24033:310	Phase C:ΣIx	BCR	O
_:24033:311	Phase C:Warning ΣIx	SPS	O
_:24033:320	Phase C:ΣI²t	BCR	O
_:24033:321	Phase C:Warning ΣI²t	SPS	O
_:24033:330	Phase C:Make time	MV	O
_:24033:331	Phase C:Make-time warning	SPS	O
_:24033:332	Phase C:Make-time alarm	SPS	O
_:24033:340	Phase C:Break time	MV	O
_:24033:341	Phase C:Break-time warning	SPS	O
_:24033:342	Phase C:Break-time alarm	SPS	O
_:24033:350	Phase C:Aux.-contact time open	MV	O
_:24033:351	Phase C:Aux.c. time open warn.	SPS	O
_:24033:352	Phase C:Aux.c. time open alarm	SPS	O
_:24033:353	Phase C:Reaction time open	MV	O
_:24033:354	Phase C:React. time open warn.	SPS	O
_:24033:355	Phase C:React. time open alarm	SPS	O
_:24033:356	Phase C:Aux.c. travel time open	MV	O
_:24033:360	Phase C:Aux.-cont. time close	MV	O
_:24033:361	Phase C:Aux.c. time close warn.	SPS	O
_:24033:362	Phase C:Aux.c. time close alarm	SPS	O
_:24033:363	Phase C:Reaction time close	MV	O
_:24033:364	Phase C:React. time close warn.	SPS	O
_:24033:365	Phase C:React. time close alarm	SPS	O
_:24033:366	Phase C:Aux.c. travel time close	MV	O
_:24033:370	Phase C:Operation counter	INS	O
_:24033:371	Phase C:Oper.-counter warning	SPS	O
_:24033:372	Phase C:Oper.-counter alarm	SPS	O

11.12 Disconnecter-Switch Monitoring

11.12.1 Overview of Functions

The function **Disconnecter supervision**:

- Detects and reports temporal changes in the switching procedure of disconnectors

11.12.2 Structure of the Function

The function **Disconnecter supervision** can be used in the function group **Disconnecter**.

The function consists of 2 independent operating procedures:

- **Mechanical switching time open**
Monitoring of the mechanical switching time for the opening operation, detected via the feedback contacts
- **Mechanical switching time close**
Monitoring of the mechanical switching time for the closing operation, detected via the feedback contacts

11.12.3 General Functionality

11.12.3.1 Description

Start Criterion for the Function Disconnecter Supervision

The operating procedure **Mechanical switching time close** is started if one of the following criteria is met:

- The disconnector is closed via a command.
- The binary input signal *>Start calc. for close* is initiated, for example, via an external signal.

The operating procedure **Mechanical switching time open** is started if one of the following criteria is met:

- The disconnector is opened via a command.
- The binary input signal *>Start calc. for open* is initiated, for example, via an external signal.

11.12.3.2 Application and Setting Notes

Parameter: Mode

- Default setting (`_:26671:1`) **Mode** = *on*

With the parameter **Mode**, you can switch the disconnector supervision *on*, *off*, or in *test* mode.

11.12.3.3 Settings

Addr.	Parameter	C	Setting Options	Default Setting
<i>General</i>				
_:26671:1	Discon. monit.:Mode		<ul style="list-style-type: none"> • off • on • test 	on

11.12.3.4 Information List

No.	Information	Data Class (Type)	Type
<i>General</i>			
_:2311:500	General:>Start calc. for open	SPS	I
_:2311:501	General:>Start calc. for close	SPS	I
_:2311:52	General:Behavior	ENS	O
_:2311:53	General:Health	ENS	O

11.12.4 Mechanical Switching Time Open

11.12.4.1 Description

Logic of the Stage

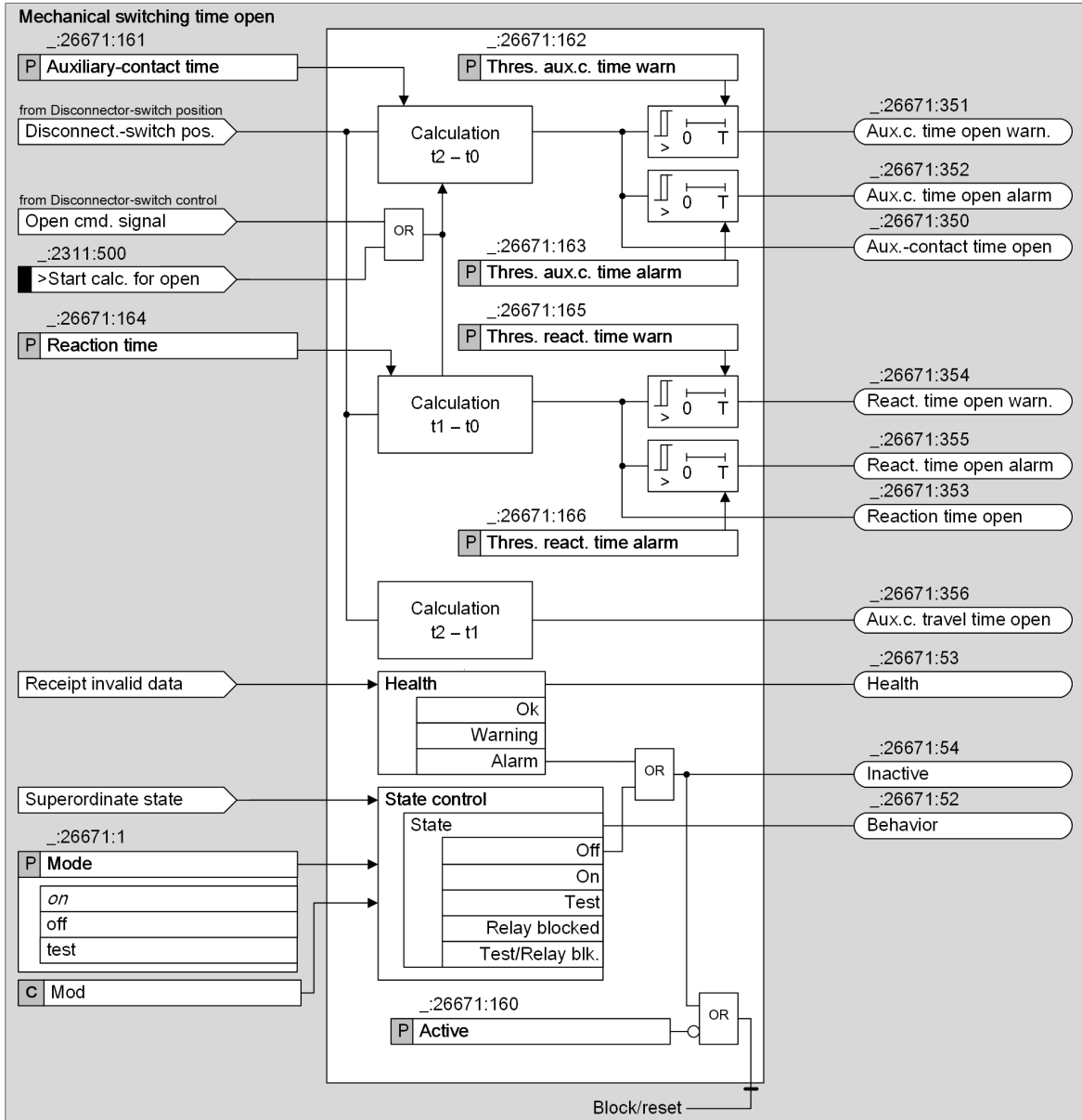

[lo_mechanical_make-time_open_1_en_US]

Figure 11-22 Logic of the Stage Mechanical Switching Time for Disconnecter

Method of Operation



[dw_charact_dcs-maketime_op, 1, en_US]

- 1) $t_2 - t_0$: Auxiliary contact time open operation
- 2) $t_1 - t_0$: Reaction time open operation
- 3) $t_2 - t_1$: Auxiliary contact dead time open operation

The stage for monitoring the **mechanical switching time open** of the disconnector calculates the time between the start criterion (t_0) and the time when the disconnector-switch position changes to the **intermediate position** (t_1). The stage measures the time between the start criterion (t_0) and the time when the disconnector-switch position changes to **open** (t_2). Additionally, the stage calculates the time of the auxiliary contacts between the **intermediate position** (t_1) until the **open** position is reached (t_2).

The start criterion can be either the switching command **open** of the disconnector or the input signal *>Start calc. for open*.

You can define 2 independent threshold values for monitoring the measured time t_1-t_0 . If a threshold value is exceeded, the corresponding output *warning/Alarm* is activated for 100 ms. You can define 2 independent threshold values for monitoring the measured time t_2-t_0 . If a threshold value is exceeded, the corresponding output *warning/Alarm* is activated for 100 ms. For t_2-t_1 , the calculated time must be displayed. There is no warning or alarm threshold.

For monitoring the mechanical switching times, you must route the open and closed disconnector-switch position in the function group **Disconnecter**. If you route only one or no disconnector feedback, the function **Mechanical switching time open** cannot work and issues the state *warning*.

11.12.4.2 Application and Setting Notes

Parameter: Auxiliary-contact time

- Default setting (`_:26671:161`) **Auxiliary-contact time = 10 s**

With the parameter **Auxiliary-contact time**, you can define the duration between the disconnector trip command and the feedback contacts signaling the **open** position.

Parameter: Thres. aux.c. time warn

- Default setting (`_:26671:162`) **Thres. aux.c. time warn = 12 s**

With the parameter **Thres. aux.c. time warn**, you define by how many seconds the auxiliary-contact time may be undercut or exceeded for the output *Aux.c. time open warn*. to be set. The output *Aux.c. time open warn*. drops out after 100 ms.

Parameter: Thres. aux.c. time alarm

- Default setting (`_:26671:163`) **Thres. aux.c. time alarm = 14 s**

With the parameter **Thres. aux.c. time alarm**, you define by how many seconds the auxiliary-contact time may be undercut or exceeded for the output *Aux.c. time open alarm* to be set. The output *Aux.c. time open alarm* drops out after 100 ms.

Parameter: Reaction time

- Default setting (`_:26671:164`) **Reaction time = 2 s**

With the parameter **Reaction time**, you define the duration between the disconnecter trip command and the feedback contacts signaling the **intermediate position**.

Parameter: Thres. react. time warn

- Default setting (`_:26671:165`) **Thres. react. time warn = 2.4 s**

With the parameter **Thres. react. time warn**, you define by how many seconds the reaction time may be undercut or exceeded for the output *React. time open warn*. to be set. The output *React. time open warn*. drops out after 100 ms.

Parameter: Thres. react. time alarm

- Default setting (`_:26671:166`) **Thres. react. time alarm = 2.8 s**

With the parameter **Thres. react. time alarm**, you define by how many seconds the reaction time may be undercut or exceeded for the output *React. time open alarm* to be set. The output *React. time open alarm* drops out after 100 ms.

11.12.4.3 Settings

Addr.	Parameter	C	Setting Options	Default Setting
Mechanical sw. time open				
_:26671:160	Discon. monit.:Active		<ul style="list-style-type: none"> • 0 • 1 	false
_:26671:161	Discon. monit.:Auxiliary-contact time		0.02 s to 1800.00 s	10.00 s
_:26671:162	Discon. monit.:Thres. aux.c. time warn		0.02 s to 1800.00 s	12.00 s
_:26671:163	Discon. monit.:Thres. aux.c. time alarm		0.02 s to 1800.00 s	14.00 s
_:26671:164	Discon. monit.:Reaction time		0.02 s to 1800.00 s	2.00 s
_:26671:165	Discon. monit.:Thres. react. time warn		0.02 s to 1800.00 s	2.40 s
_:26671:166	Discon. monit.:Thres. react. time alarm		0.02 s to 1800.00 s	2.80 s

11.12.4.4 Information List

No.	Information	Data Class (Type)	Type
Discon. monit.			
_:26671:51	Discon. monit.:Mode (controllable)	ENC	C
_:26671:54	Discon. monit.:Inactive	SPS	O
_:26671:52	Discon. monit.:Behavior	ENS	O
_:26671:53	Discon. monit.:Health	ENS	O
_:26671:350	Discon. monit.:Aux.-contact time open	MV	O
_:26671:351	Discon. monit.:Aux.c. time open warn.	SPS	O

No.	Information	Data Class (Type)	Type
_:26671:352	Discon. monit.:Aux.c. time open alarm	SPS	O
_:26671:353	Discon. monit.:Reaction time open	MV	O
_:26671:354	Discon. monit.:React. time open warn.	SPS	O
_:26671:355	Discon. monit.:React. time open alarm	SPS	O
_:26671:356	Discon. monit.:Aux.c. travel time open	MV	O

11.12.5 Mechanical Switching Time Close

11.12.5.1 Description

Logic of the Stage

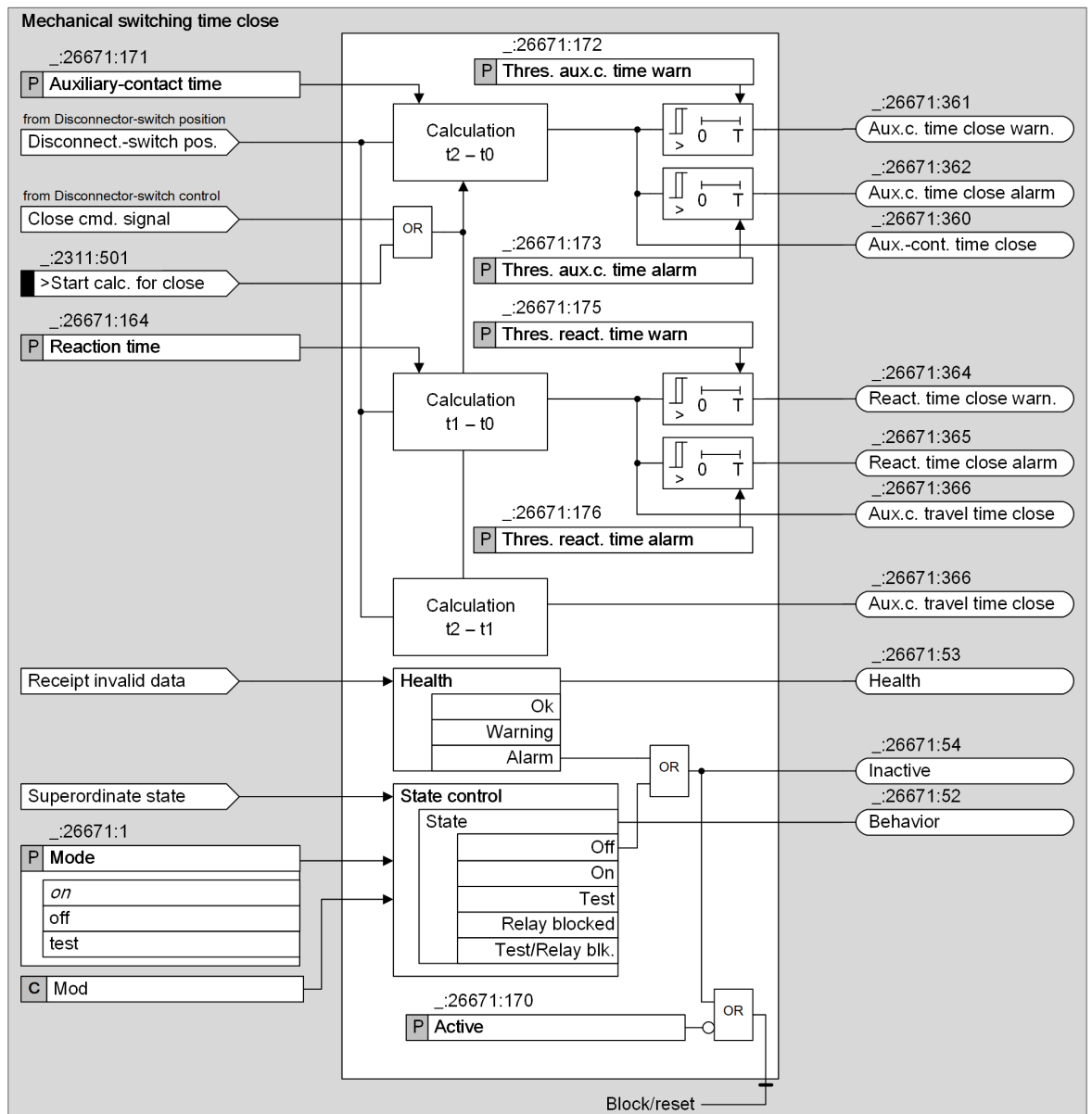

[to_mechanical_break-time_clo, 1, en_US]

Figure 11-23 Logic of the Stage Mechanical Switching Time Close for Disconnecter

Method of Operation

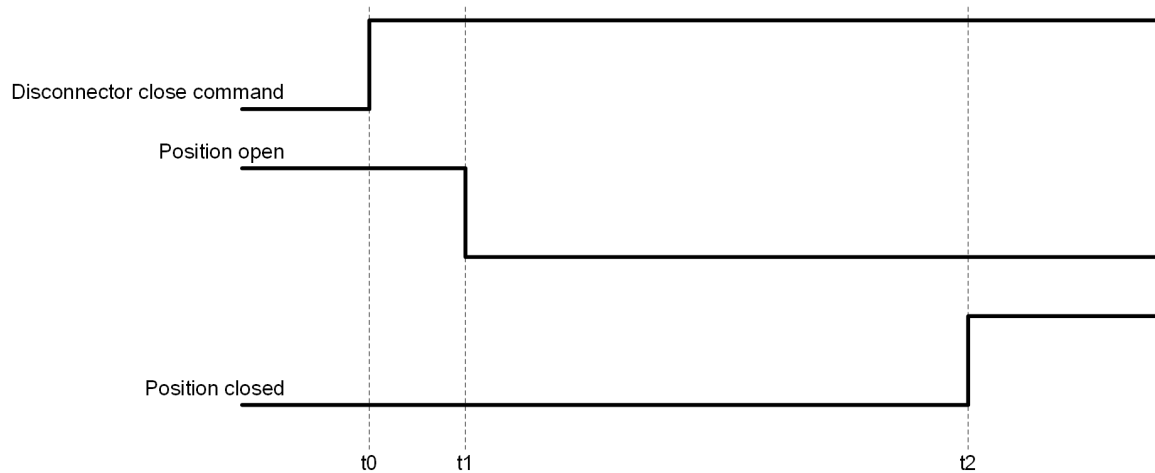

[dw_charact_dcs-breaktime_clo_1_en_US]

- 1) $t2 - t0$: Auxiliary contact time close operation
- 2) $t1 - t0$: Reaction time close operation
- 3) $t2 - t1$: Auxiliary contact dead time close operation

The stage for monitoring the **mechanical switching time close** of the disconnecter measures the time between the disconnecter close command ($t0$) and the time when the disconnecter-switch position changes to the **intermediate position**. The stage measures the time between the disconnecter close command ($t0$) and the time when the disconnecter-switch position changes to **closed** ($t2$). Additionally, the stage calculates the time of the auxiliary contacts between the **intermediate position** ($t1$) until the **closed** position is reached ($t2$).

The start criterion can be either the disconnecter close command or the input signal *>Start calc. for close*.

You can define 2 independent threshold values for monitoring the measured time $t1-t0$. If a threshold value is exceeded, the corresponding output *warning/Alarm* is activated for 100 ms. You can define 2 independent threshold values for monitoring the measured time $t2-t0$. If a threshold value is exceeded, the corresponding output *warning/Alarm* is activated for 100 ms. For $t2-t1$, only the measured time must be reported. There is no warning or alarm threshold.

For monitoring the mechanical switching times, you must route the open and closed disconnecter-switch position in the function group **Disconnecter**. If you route only one or no disconnecter feedback, the function **Mechanical switching time close** cannot work and issues the state *warning*.

11.12.5.2 Application and Setting Notes

Parameter: Auxiliary-contact time

- Default setting (`_:26671:171`) **Auxiliary-contact time = 10 s**

With the parameter **Auxiliary-contact time**, you define the duration between the disconnecter close command and the feedback contacts signaling the **closed** position.

Parameter: Thres. aux.c. time warn

- Default setting (`_:26671:172`) **Thres. aux.c. time warn = 12 s**

With the parameter **Thres. aux.c. time warn**, you define by how many seconds the auxiliary contact time may be undercut or exceeded for the output *Aux.c. time close warn* to be set. The output *Aux.c. time close warn* drops out after 100 ms.

Parameter: Thres. aux.c. time alarm

- Default setting (`_:26671:173`) **Thres. aux.c. time alarm = 14 s**

With the parameter **Thres. aux.c. time alarm**, you define by how many seconds the auxiliary contact time may be undercut or exceeded for the output *Aux.c. time close alarm* to be set. The output *Aux.c. time close alarm* drops out after 100 ms.

Parameter: Reaction time

- Default setting (`_:26671:174`) **Reaction time = 2 s**

With the parameter **Reaction time**, you define the duration between the disconnect close command and the feedback contacts signaling the **intermediate position**.

Parameter: Thres. react. time warn

- Default setting (`_:26671:175`) **Thres. react. time warn = 2.4 s**

With the parameter **Thres. react. time warn**, you define by how many seconds the reaction time may be undercut or exceeded for the output *React. time close warn*. to be set. The output *React. time close warn*. drops out after 100 ms.

Parameter: Thres. react. time alarm

- Default setting (`_:26671:176`) **Thres. react. time alarm = 2.8 s**

With the parameter **Thres. react. time alarm**, you define by how many seconds the reaction time may be undercut or exceeded for the output *React. time close alarm* to be set. The output *React. time close alarm* drops out after 100 ms.

11.12.5.3 Settings

Addr.	Parameter	C	Setting Options	Default Setting
<i>Mechanical sw. time close</i>				
<code>_:26671:170</code>	Discon. monit.:Active		<ul style="list-style-type: none"> • 0 • 1 	false
<code>_:26671:171</code>	Discon. monit.:Auxiliary-contact time		0.02 s to 1800.00 s	10.00 s
<code>_:26671:172</code>	Discon. monit.:Thres. aux.c. time warn		0.02 s to 1800.00 s	12.00 s
<code>_:26671:173</code>	Discon. monit.:Thres. aux.c. time alarm		0.02 s to 1800.00 s	14.00 s
<code>_:26671:174</code>	Discon. monit.:Reaction time		0.02 s to 1800.00 s	2.00 s
<code>_:26671:175</code>	Discon. monit.:Thres. react. time warn		0.02 s to 1800.00 s	2.40 s
<code>_:26671:176</code>	Discon. monit.:Thres. react. time alarm		0.02 s to 1800.00 s	2.80 s

11.12.5.4 Information List

No.	Information	Data Class (Type)	Type
<i>Discon. monit.</i>			
<code>_:26671:51</code>	Discon. monit.:Mode (controllable)	ENC	C
<code>_:26671:54</code>	Discon. monit.:Inactive	SPS	O
<code>_:26671:52</code>	Discon. monit.:Behavior	ENS	O
<code>_:26671:53</code>	Discon. monit.:Health	ENS	O

No.	Information	Data Class (Type)	Type
_:26671:360	Discon. monit.:Aux.-cont. time close	MV	O
_:26671:361	Discon. monit.:Aux.c. time close warn.	SPS	O
_:26671:362	Discon. monit.:Aux.c. time close alarm	SPS	O
_:26671:363	Discon. monit.:Reaction time close	MV	O
_:26671:364	Discon. monit.:React. time close warn.	SPS	O
_:26671:365	Discon. monit.:React. time close alarm	SPS	O
_:26671:366	Discon. monit.:Aux.c. travel time close	MV	O

12 Power Quality – Basic

12.1	Voltage Variation	1468
12.2	Voltage Unbalance	1484
12.3	THD and Harmonics	1497
12.4	Total Demand Distortion	1506

12.1 Voltage Variation

12.1.1 Overview of Functions

The function **Voltage variation** is used for measuring and monitoring short-duration variations of the voltage in distribution and industrial power systems. The power-quality events such as voltage dips, swells, and interruptions in 3-phase systems are detected.

This measuring function provides the RMS value of the voltage for the minimum value in the event of a voltage dip, the lowest residual voltage in the event of an interruption or the highest swell, as well as the duration of the event.

All events can be logged in operational or user-defined logs. They can enable the fault recorder via binary warning indications, and write their values as tracks.

12.1.2 Structure of the Function

The function **Voltage variation** is used in protection function groups with 3-phase voltage measurement. The function comes factory-set with the following stages:

- 1 stage **Dip**
- 1 stage **Swell**
- 1 stage **Interruption**

A maximum of 3 stages **Dip**, 3 stages **Swell**, and 3 stages **Interruption** can be operated simultaneously within the function.

Stages that are not preconfigured are shown in gray in the following figure. The stages are identical in structure.

The measured-value selection is a general functionality and has a uniform effect on the stages (see [Figure 12-1](#) and [12.1.3.1 Description](#)). This ensures that all stages of the function receive the same measured values.

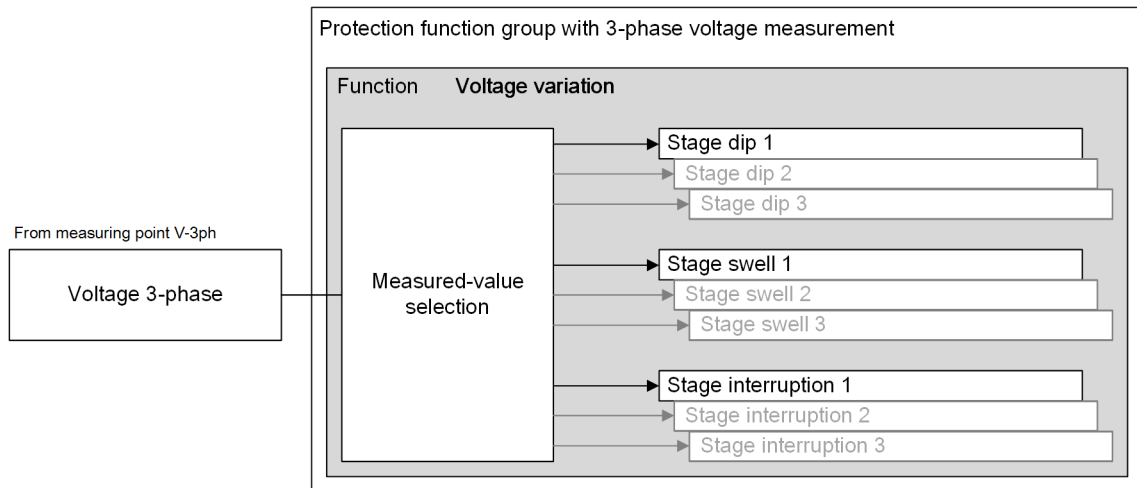

[dw_pq_volt_var_structure, 1, en_US]

Figure 12-1 Structure/Embedding of the Function

12.1.3 General Functionality

12.1.3.1 Description

Measured-Value Selection

The function provides the option to select between the phase-to-phase and phase-to-ground voltage.

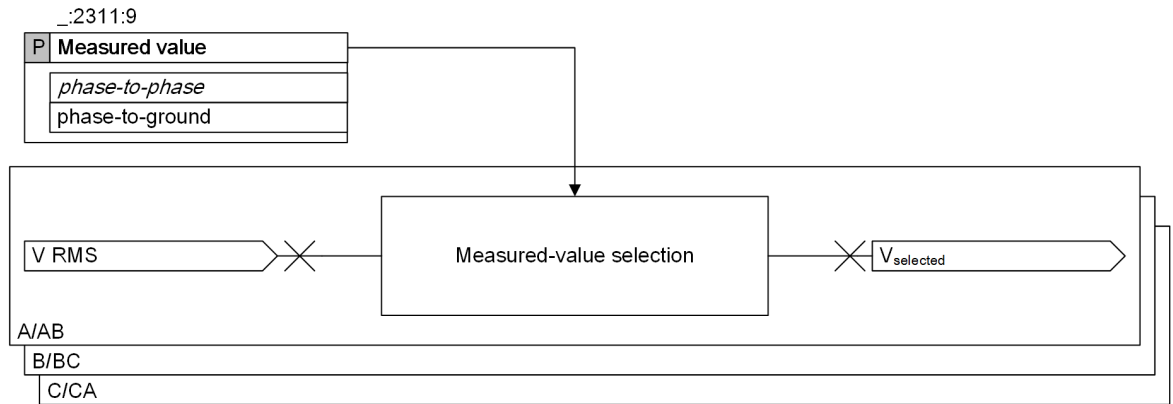

[to_pq_volt_var_general, 1, en_US]

Figure 12-2 Logic Diagram of Measured-Value Selection

The 1-cycle RMS value of the voltage is used in the function.

The setting options of the parameter **Measured value** depend on the connection type of the 3-phase voltage measuring point.

Table 12-1 Setting Options of the Parameter **Measured value**

Connection Type	Setting Options of the Parameter Measured value
3 ph-to-gnd voltages	<ul style="list-style-type: none"> • <i>phase-to-ground</i>
3 ph-to-gnd volt. + VN	<ul style="list-style-type: none"> • <i>phase-to-phase</i>
3 ph-to-ph voltages	<ul style="list-style-type: none"> • <i>phase-to-phase</i> The setting of the parameter is read-only.
3 ph-to-ph volt. + VN	
2 ph-to-ph voltages	
2 ph-to-ph volt. + VN	

12.1.4 Stage Dip

12.1.4.1 Description

The stage **Dip**:

- Detects a voltage dip in the power system and issues a warning signal for any phase
- Logs the dip duration and the minimum residual voltage for any phase when the voltage-dip event disappears
- Counts the number of voltage-dip events

Logic of the Stage

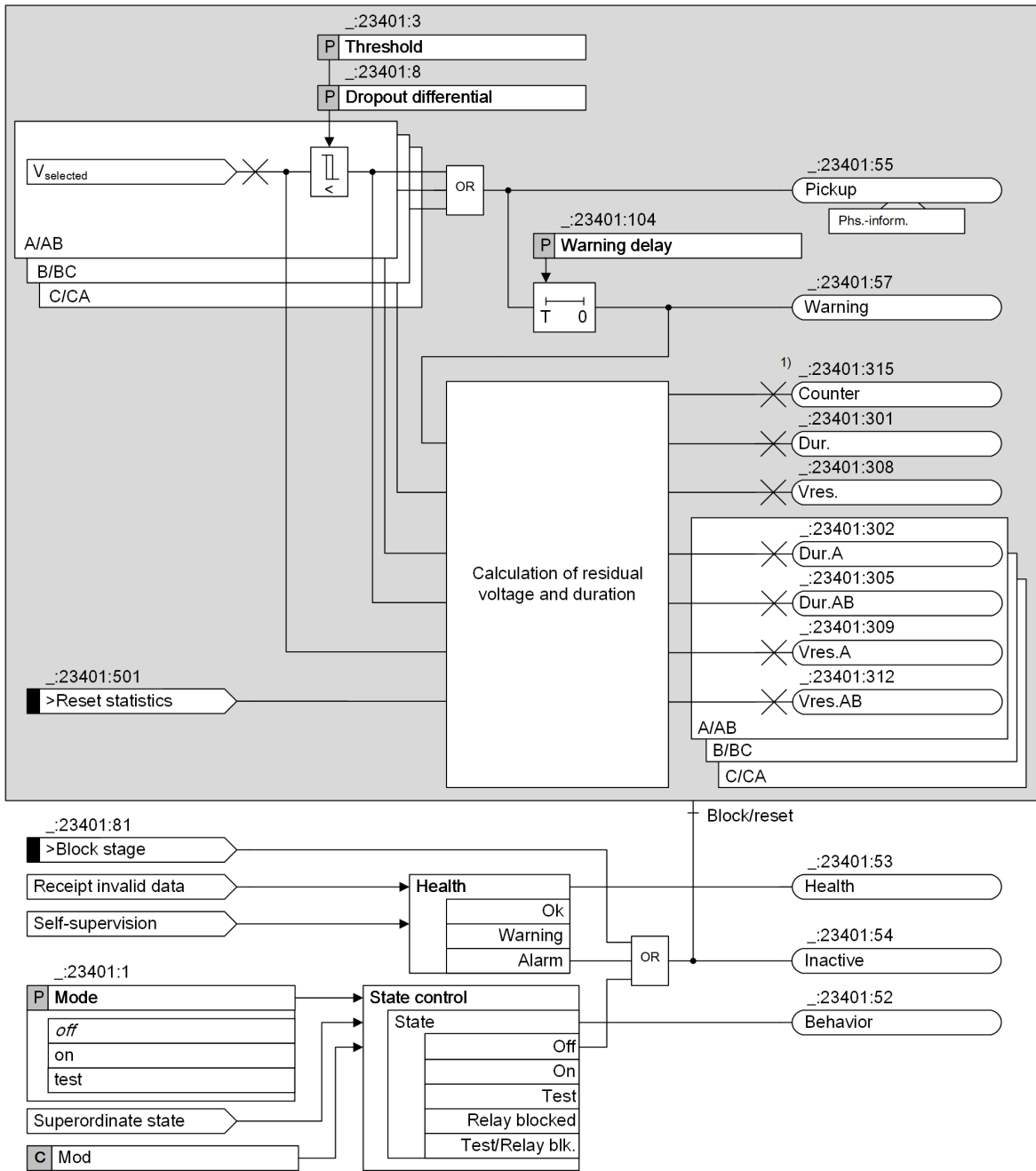

[lo_pq_dip, 1, en_US]

Figure 12-3 Logic Diagram of the Stage Dip

- (1) Counter is a statistical value. It is not reset by the block or reset state of the stage. For more information, refer to [Counter Accumulation, Page 1473](#).

Pickup and Warning

If the voltage falls below the threshold value, a signal *Pickup* is issued. After expiration of the time specified by the parameter **Warning delay**, a signal *warning* is issued.

The phase information of the signal *Pickup* is issued according to the selected measured value:

- The **phase-to-ground** voltage is selected as the measured value:
If a phase-to-ground voltage, for example, VA, falls below the threshold value, the phase information of phase A of the signal *Pickup* is issued.
- The **phase-to-phase** voltage is selected as the measured value:
If a phase-to-phase voltage, for example, VAB, falls below the threshold value, the phase information of phase A and phase B of the signal *Pickup* is issued.

Value Indications

If the signal *warning* is issued, it is regarded as a voltage-dip event. Once the voltage-dip event disappears (the signal *warning* drops out), the following value indications are calculated:

- The durations and residual voltages of this event are calculated and can be logged in the operational or user-defined logs if routed.
- The counter of voltage-dip events is increased by 1.

If, after the pickup, the voltage dip disappears during the time delay, the signal *warning* is not issued and the incident is regarded as a voltage chattering and not as a voltage-dip event. No duration or voltage is calculated and the counter is not increased.

Table 12-2 Value Indications of the Stage Dip

Value	Description	Calculation
Counter	Total number of voltage-dip events This is a statistical value stored in the NVRAM ⁴² .	Refer to Counter Accumulation, Page 1473
Dur.	Calculated phase overall duration of a voltage-dip event	Refer to Duration Calculation, Page 1471
Dur.A Dur.B Dur.C	Durations of a voltage-dip event for the phases A, B, and C These values are only visible when the phase-to-ground voltage is selected.	
Dur.AB Dur.BC Dur.CA	Durations of a voltage-dip event for the phases AB, BC, and CA These values are only visible when the phase-to-phase voltage is selected.	
Vres.	Minimum residual voltage of all phases in a voltage-dip event among the phases A, B, and C or among the phases AB, BC, and CA	
Vres.A Vres.B Vres.C	Minimum residual voltages in a voltage-dip event for the phases A, B, and C These values are only visible when the phase-to-ground voltage is selected.	
Vres.AB Vres.BC Vres.CA	Minimum residual voltages in a voltage-dip event for the phases AB, BC, and CA These values are only visible when the phase-to-phase voltage is selected.	

Duration Calculation

The duration of a voltage-dip or voltage-swell event is defined as the duration between the event start and event end, as shown in [Figure 12-4](#).

⁴² NVRAM = Non-Volatile Random Access Memory; RAM, which does not lose the stored data, even when there is no power.

In the figure, it is assumed as follows:

- The dip threshold is 90 % (specified by the parameter **Threshold** of the stage **Dip**).
- The swell threshold is 110 % (specified by the parameter **Threshold** of the stage **Swell**).
- The hysteresis is 2 % (specified by the parameter **Dropout differential** of the respective stage).
- The warning delay is 0 s (specified by the parameter **Warning delay** of the respective stage).

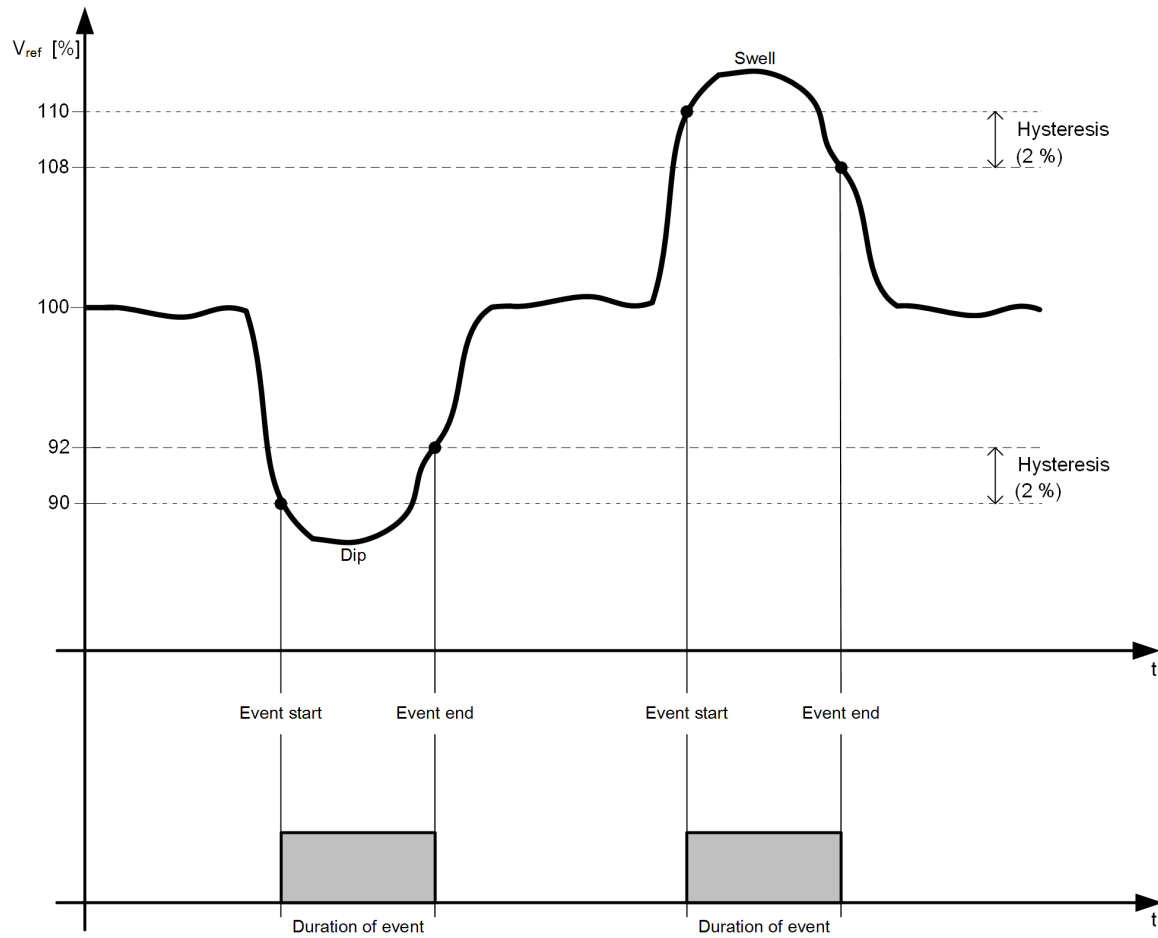

[dw_pq_volt_var_event_duration, 1, en_US]

Figure 12-4 Duration of a Voltage-Dip or Voltage-Swell Event

Where

- Event start The moment when the signal *Pickup* is issued
- Event end The moment when the signal *Pickup* drops out
- V_{ref} [%] The percentage value of the parameter **Rated voltage** (reference voltage) that is set in the function group

Only the durations of picked-up phases as well as the overall duration are calculated and logged. The following figure provides an example of phase-selective duration calculation with the **phase-to-ground** voltage selected as the measured value.

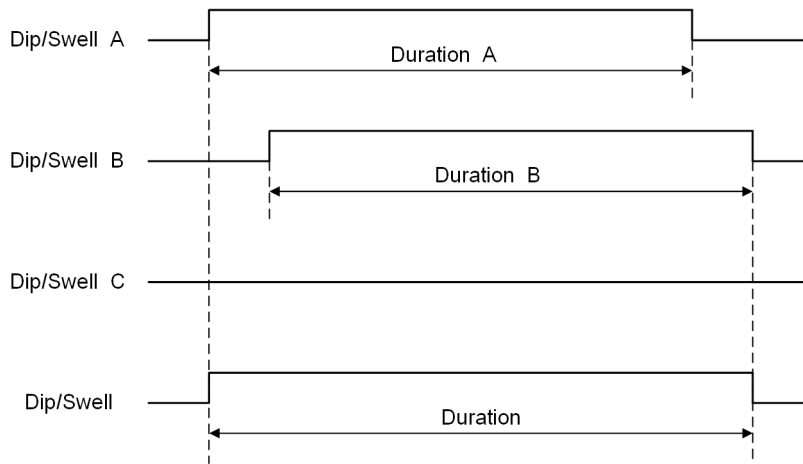

[dw_pq_volt_var_phs-selective_dur, 1, en_US]

Figure 12-5 Example of Phase-Selective and Overall Duration Calculation

In the preceding example, voltage dips or swells occur only in phases A and B. Therefore, durations of phases A and B and the overall duration are calculated and logged. No duration of phase C is calculated or logged.

Residual-Voltage Calculation

Only picked-up phases calculate the minimum values of the residual voltages. If the values are assigned to a log, they are also logged.

Counter Accumulation

The *Counter* value is increased by 1 when the voltage-variation event disappears, as shown in the following figure.

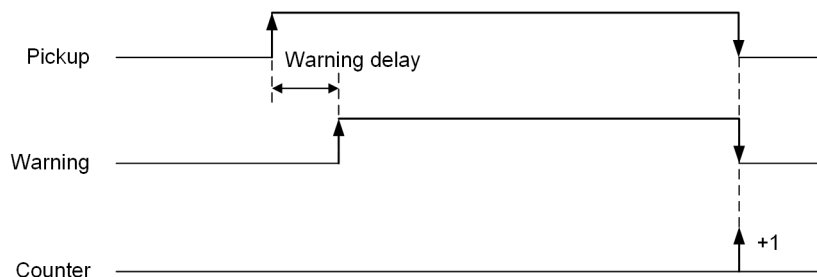

[dw_pq_counter_accum, 1, en_US]

Figure 12-6 Counter Accumulation



NOTE

The counter is accumulated also when the function is in test mode.

The *Counter* value is retained (not reset) in the following scenarios:

- The parameter **Mode** of the stage is set to **off**.
- The signal **>Block stage** is issued.
- Device restart
- Device power-off and power-on (with battery)

The *Counter* value can be reset based on the following possibilities:

- The signal *>Reset statistics* is issued (in condition that the stage is active).
- HMI reset (in condition that the stage is active)
- DIGSI online reset (in condition that the stage is active)
- Device reset (to factory settings)
- Via protocol (in condition that the stage is active)

Blocking of the Stage

You can block the stage externally or internally via the binary input signal *>Block stage*. In the event of blocking, the picked up stage is reset.

12.1.4.2 Application and Setting Notes

Parameter: **Threshold, Dropout differential**

- Default setting (`_:23401:3`) **Threshold** = 90.0 %
- Default setting (`_:23401:8`) **Dropout differential** = 2.0 %

The parameters **Threshold** and **Dropout differential** are percentage values related to the parameter **Rated voltage** (reference voltage) that is set in the function group.

Set the parameters **Threshold** and **Dropout differential** for the specific application.

According to the standard IEC 61000-4-30, the dip threshold is typically in the range of 85 % to 90 % for troubleshooting or statistical applications, and the hysteresis (**Dropout differential**) is typically equal to 2 %.

Parameter: **Warning delay**

- Default setting (`_:23401:104`) **Warning delay** = 0.00 s

If you do not want to log a voltage-dip event that lasts shorter than a specific time duration, for example, 20 ms, you can set the parameter **Warning delay** to 0.02 s.

12.1.4.3 Settings

Addr.	Parameter	C	Setting Options	Default Setting
General				
_:2311:9	General:Measured value		<ul style="list-style-type: none"> • phase-to-ground • phase-to-phase 	phase-to-phase
Dip 1				
_:23401:1	Dip 1:Mode		<ul style="list-style-type: none"> • off • on • test 	off
_:23401:3	Dip 1:Threshold		10.0 % to 100.0 %	90.0 %
_:23401:8	Dip 1:Dropout differential		1.0 % to 10.0 %	2.0 %
_:23401:104	Dip 1:Warning delay		0.00 s to 60.00 s	0.00 s

12.1.4.4 Information List

No.	Information	Data Class (Type)	Type
Dip 1			
_:23401:81	Dip 1:>Block stage	SPS	I

No.	Information	Data Class (Type)	Type
_:23401:501	Dip 1:>Reset statistics	SPS	I
_:23401:51	Dip 1:Mode (controllable)	ENC	C
_:23401:54	Dip 1:Inactive	SPS	O
_:23401:52	Dip 1:Behavior	ENS	O
_:23401:53	Dip 1:Health	ENS	O
_:23401:55	Dip 1:Pickup	ACD	O
_:23401:57	Dip 1:Warning	SPS	O
_:23401:301	Dip 1:Dur.	MV	O
_:23401:302	Dip 1:Dur.A	MV	O
_:23401:303	Dip 1:Dur.B	MV	O
_:23401:304	Dip 1:Dur.C	MV	O
_:23401:305	Dip 1:Dur.AB	MV	O
_:23401:306	Dip 1:Dur.BC	MV	O
_:23401:307	Dip 1:Dur.CA	MV	O
_:23401:308	Dip 1:Vres.	MV	O
_:23401:309	Dip 1:Vres.A	MV	O
_:23401:310	Dip 1:Vres.B	MV	O
_:23401:311	Dip 1:Vres.C	MV	O
_:23401:312	Dip 1:Vres.AB	MV	O
_:23401:313	Dip 1:Vres.BC	MV	O
_:23401:314	Dip 1:Vres.CA	MV	O
_:23401:315	Dip 1:Counter	INS	O

12.1.5 Stage Swell

12.1.5.1 Description

The stage **Swell**:

- Detects a voltage swell in the power system and issues a warning signal for any phase
- Logs the swell duration and the maximum swell voltage for any phase when the voltage-swell event disappears
- Counts the number of voltage-swell events

Logic of the Stage

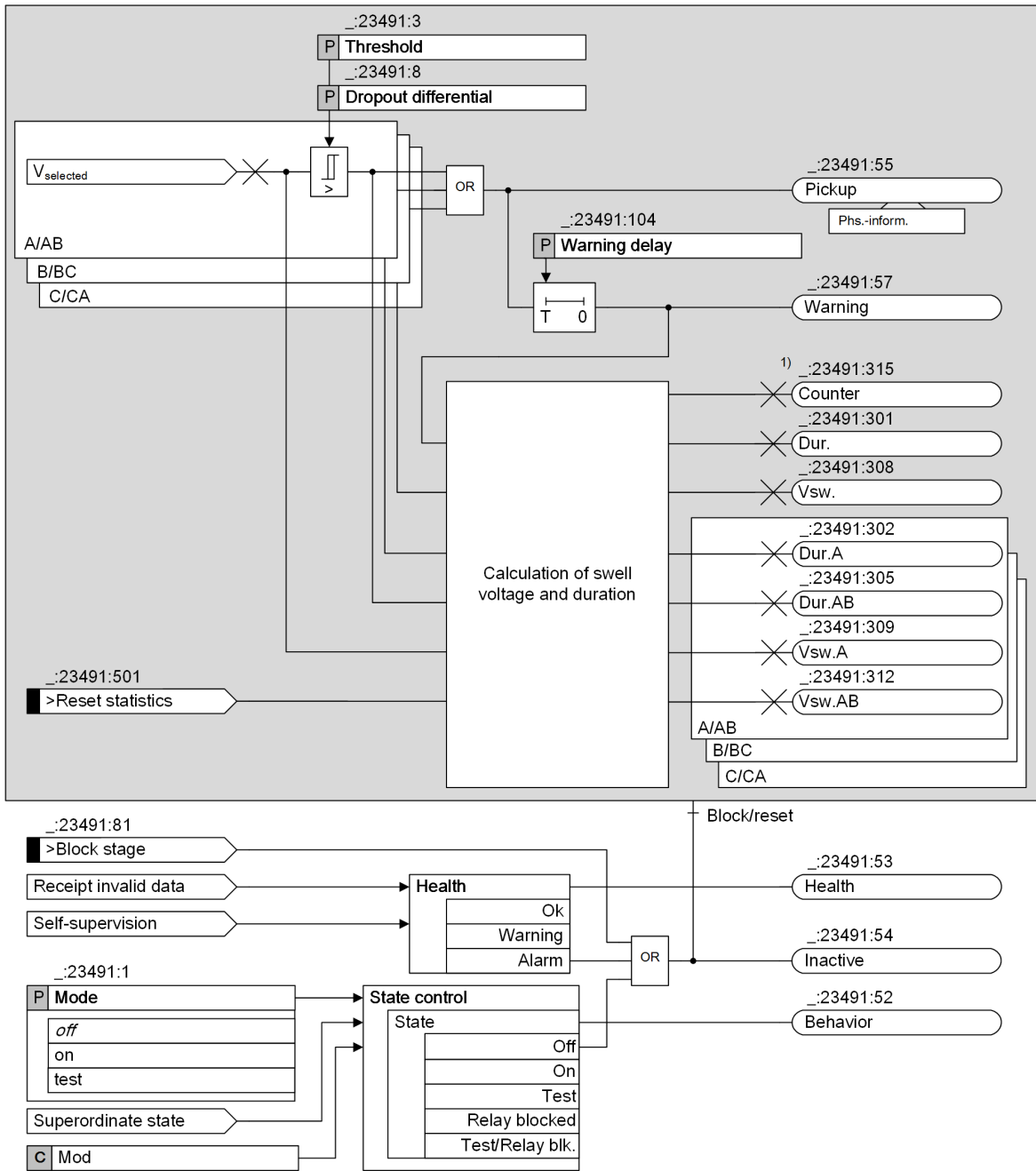

[lo_pq_swell, 1, en_US]

Figure 12-7 Logic Diagram of the Stage Swell

- (1) Counter is a statistical value. It is not reset by the block or reset state of the stage. For more information, refer to [Counter Accumulation, Page 1478](#).

Pickup and Warning

If the voltage exceeds the threshold value, a signal *Pickup* is issued. After expiration of the time specified by the parameter **Warning delay**, a signal *warning* is issued.

The phase information of the signal *Pickup* is issued according to the selected measured value:

- The **phase-to-ground** voltage is selected as the measured value:
If a phase-to-ground voltage, for example, VA, exceeds the threshold value, the phase information of phase A of the signal *Pickup* is issued.
- The **phase-to-phase** voltage is selected as the measured value:
If a phase-to-phase voltage, for example, VAB, exceeds the threshold value, the phase information of phase A and phase B of the signal *Pickup* is issued.

Value Indications

If the signal *warning* is issued, it is regarded as a voltage-swell event. Once the voltage-swell event disappears (the signal *warning* drops out), the following value indications are calculated:

- The durations and swell voltages of this event are calculated and can be logged in the operational or user-defined logs if routed.
- The counter of voltage-swell events is increased by 1.

If, after the pickup, the voltage swell disappears during the time delay, the signal *warning* is not issued and the incident is regarded as a voltage chattering and not as a voltage-swell event. No duration or voltage is calculated and the counter is not increased.

Table 12-3 Value Indications of the Stage Swell

Value	Description	Calculation
Counter	Total number of voltage-swell events This is a statistical value stored in the NVRAM ⁴³ .	Similar to the counter accumulation of the stage Dip , refer to Figure 12-6
Dur.	Calculated phase overall duration of a voltage-swell event	Similar to the duration calculation of the stage Dip , refer to Duration Calculation, Page 1471
Dur.A Dur.B Dur.C	Durations of a voltage-swell event for the phases A, B, and C These values are only visible when the phase-to-ground voltage is selected.	
Dur.AB Dur.BC Dur.CA	Durations of a voltage-swell event for the phases AB, BC, and CA These values are only visible when the phase-to-phase voltage is selected.	
Vsw.	Maximum swell voltage of all phases in a voltage-swell event among the phases A, B, and C or among the phases AB, BC, and CA	
Vsw.A Vsw.B Vsw.C	Maximum swell voltages in a voltage-swell event for the phases A, B, and C These values are only visible when the phase-to-ground voltage is selected.	
Vsw.AB Vsw.BC Vsw.CA	Maximum swell voltages in a voltage-swell event for the phases AB, BC, and CA These values are only visible when the phase-to-phase voltage is selected.	

Duration Calculation

For details, refer to [Duration Calculation, Page 1471](#).

⁴³ NVRAM = Non-Volatile Random Access Memory; RAM, which does not lose the stored data, even when there is no power.

Swell-Voltage Calculation

Only picked-up phases calculate the maximum values of the swells. If the values are assigned to a log, they are also logged.

Counter Accumulation

For details, refer to [Counter Accumulation, Page 1473](#).

Blocking of the Stage

You can block the stage externally or internally via the binary input signal *>Block stage*. In the event of blocking, the picked up stage is reset.

12.1.5.2 Application and Setting Notes

Parameter: Threshold, Dropout differential

- Default setting (_:23491:3) **Threshold** = 110.0 %
- Default setting (_:23491:8) **Dropout differential** = 2.0 %

The parameters **Threshold** and **Dropout differential** are percentage values related to the parameter **Rated voltage** (reference voltage) that is set in the function group.

Set the parameters **Threshold** and **Dropout differential** for the specific application.

According to the standard IEC 61000-4-30, the swell threshold is typically greater than 110 %, and the hysteresis (**Dropout differential**) is typically equal to 2 %.

Parameter: Warning delay

- Default setting (_:23491:104) **Warning delay** = 0.00 s

If you do not want to log a voltage-swell event that lasts shorter than a specific time duration, for example, 20 ms, you can set the parameter **Warning delay** to 0.02 s.

12.1.5.3 Settings

Addr.	Parameter	C	Setting Options	Default Setting
General				
_:2311:9	General:Measured value		<ul style="list-style-type: none"> • phase-to-ground • phase-to-phase 	phase-to-phase
Swell 1				
_:23491:1	Swell 1:Mode		<ul style="list-style-type: none"> • off • on • test 	off
_:23491:3	Swell 1:Threshold		100.0 % to 140.0 %	110.0 %
_:23491:8	Swell 1:Dropout differential		1.0 % to 10.0 %	2.0 %
_:23491:104	Swell 1:Warning delay		0.00 s to 60.00 s	0.00 s

12.1.5.4 Information List

No.	Information	Data Class (Type)	Type
Swell 1			
_:23491:81	Swell 1:>Block stage	SPS	I
_:23491:501	Swell 1:>Reset statistics	SPS	I
_:23491:51	Swell 1:Mode (controllable)	ENC	C

No.	Information	Data Class (Type)	Type
_:23491:54	Swell 1:Inactive	SPS	O
_:23491:52	Swell 1:Behavior	ENS	O
_:23491:53	Swell 1:Health	ENS	O
_:23491:55	Swell 1:Pickup	ACD	O
_:23491:57	Swell 1:Warning	SPS	O
_:23491:301	Swell 1:Dur.	MV	O
_:23491:302	Swell 1:Dur.A	MV	O
_:23491:303	Swell 1:Dur.B	MV	O
_:23491:304	Swell 1:Dur.C	MV	O
_:23491:305	Swell 1:Dur.AB	MV	O
_:23491:306	Swell 1:Dur.BC	MV	O
_:23491:307	Swell 1:Dur.CA	MV	O
_:23491:308	Swell 1:Vsw.	MV	O
_:23491:309	Swell 1:Vsw.A	MV	O
_:23491:310	Swell 1:Vsw.B	MV	O
_:23491:311	Swell 1:Vsw.C	MV	O
_:23491:312	Swell 1:Vsw.AB	MV	O
_:23491:313	Swell 1:Vsw.BC	MV	O
_:23491:314	Swell 1:Vsw.CA	MV	O
_:23491:315	Swell 1:Counter	INS	O

12.1.6 Stage Interruption

12.1.6.1 Description

The stage **Interruption**:

- Detects a voltage interruption in the power system and issues a warning signal
- Logs the interruption duration (not phase-selective) and the minimum residual voltage when the voltage-interruption event disappears
- Counts the number of voltage-interruption events

Logic of the Stage

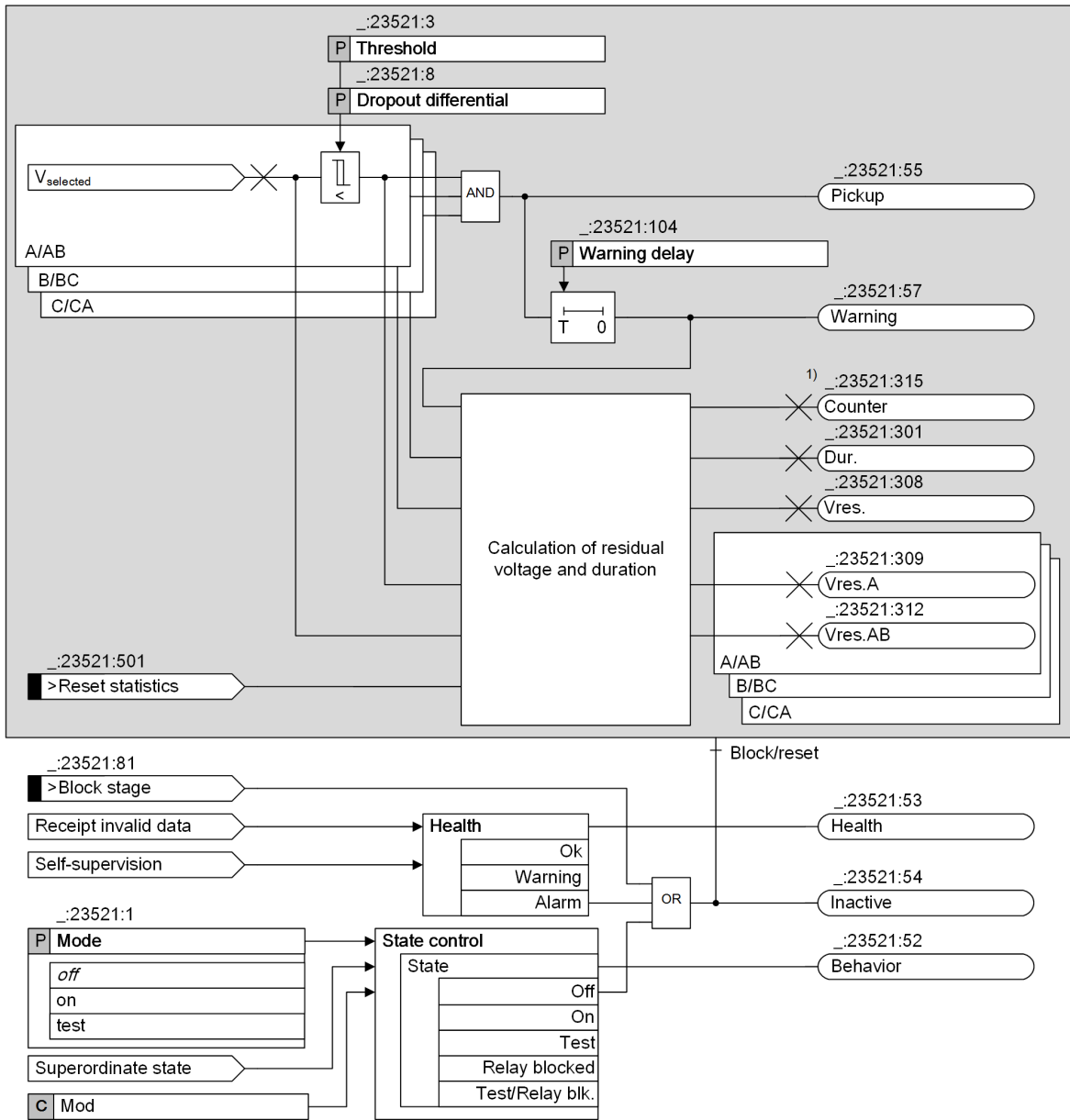

Figure 12-8 Logic Diagram of the Stage Interruption

(1) Counter is a statistical value. It is not reset by the block or reset state of the stage. For more information, refer to [Counter Accumulation, Page 1482](#).

Pickup and Warning

If all 3 voltage measured values fall below the threshold value, a signal *Pickup* is issued. After expiration of the time specified by the parameter **Warning delay**, a signal *Warning* is issued. The following measured-value types can be selected:

- The **phase-to-ground** voltage is selected as the measured value:
 If all the phase-to-ground voltages V_A , V_B , and V_C fall below the threshold value, the signal *Pickup* is issued.

- The **phase-to-phase** voltage is selected as the measured value:
If all the phase-to-phase voltages VAB, VBC, and VCA fall below the threshold value, the signal *Pickup* is issued.

Value Indications

If the signal *warning* is issued, it is regarded as a voltage-interruption event. Once the voltage-interruption event disappears (the signal *warning* drops out), the following value indications are calculated:

- The duration and residual voltages of this event are calculated and can be logged in the operational or user-defined logs if routed.
- The counter of voltage-interruption events is increased by 1.

If, after the pickup, the voltage interruption disappears during the time delay, the signal *warning* is not issued and the incident is regarded as a voltage chattering and not as a voltage-interruption event. No duration or voltage is calculated and the counter is not increased.

Table 12-4 Value Indications of the Stage Interruption

Value	Description	Calculation
Counter	Total number of voltage-interruption events This is a statistical value stored in the NVRAM ⁴⁴ .	Similar to the counter accumulation of the stage Dip, refer to Figure 12-6
Dur.	Calculated phase overall duration of a voltage-interruption event	Refer to Duration Calculation, Page 1481
Vres.	Minimum residual voltage in a voltage-interruption event among the phases A, B, and C or among the phases AB, BC, and CA	These values are percentage values related to the parameter Rated voltage (reference voltage) that is set in the function group refer to Residual-Voltage Calculation, Page 1481 .
Vres.A Vres.B Vres.C	Minimum residual voltages in a voltage-interruption event for the phases A, B, and C These values are only visible when the phase-to-ground voltage is selected.	
Vres.AB Vres.BC Vres.CA	Minimum residual voltages in a voltage-interruption event for the phases AB, BC, and CA These values are only visible when the phase-to-phase voltage is selected.	

Duration Calculation

The duration of a voltage-interruption event is defined as the duration between the event start and event end, which is similar to that of a voltage-dip or voltage-swell event. For more details, refer to [Figure 12-4](#).

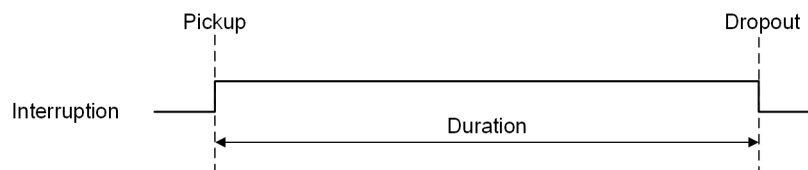

[dw_pq_volt_var_dur_interrupt_1_en_US]

Figure 12-9 Duration Calculation of the Stage Interruption

Residual-Voltage Calculation

The minimum values of the residual voltages of all phases are calculated. If the values are assigned to a log, they are also logged.

⁴⁴ NVRAM = Non-Volatile Random Access Memory; RAM, which does not lose the stored data, even when there is no power.

Counter Accumulation

For details, refer to [Counter Accumulation, Page 1473](#).

Blocking of the Stage

You can block the stage externally or internally via the binary input signal *>Block stage*. In the event of blocking, the picked up stage is reset.

12.1.6.2 Application and Setting Notes

Parameter: **Threshold, Dropout differential**

- Default setting (_:23521:3) **Threshold** = 5.0 %
- Default setting (_:23521:8) **Dropout differential** = 2.0 %

The parameters **Threshold** and **Dropout differential** are percentage values related to the parameter **Rated voltage** (reference voltage) that is set in the function group.

Set the parameters **Threshold** and **Dropout differential** for the specific application.

According to the standard IEC 61000-4-30, the interruption threshold can, for example, be set to 5 % or to 10 %, and the hysteresis (**Dropout differential**) is typically equal to 2 %.

Parameter: **Warning delay**

- Default setting (_:23521:104) **Warning delay** = 0.00 s

If you do not want to log a voltage-interruption event that lasts shorter than a specific time duration, for example, 20 ms, you can set the parameter **Warning delay** to 0.02 s.

12.1.6.3 Settings

Addr.	Parameter	C	Setting Options	Default Setting
General				
_:2311:9	General:Measured value		<ul style="list-style-type: none"> • phase-to-ground • phase-to-phase 	phase-to-phase
Interrup. 1				
_:23521:1	Interrup. 1:Mode		<ul style="list-style-type: none"> • off • on • test 	off
_:23521:3	Interrup. 1:Threshold		1.0 % to 20.0 %	5.0 %
_:23521:8	Interrup. 1:Dropout differential		1.0 % to 10.0 %	2.0 %
_:23521:104	Interrup. 1:Warning delay		0.00 s to 60.00 s	0.00 s

12.1.6.4 Information List

No.	Information	Data Class (Type)	Type
Interrup. 1			
_:23521:81	Interrup. 1:>Block stage	SPS	I
_:23521:501	Interrup. 1:>Reset statistics	SPS	I
_:23521:51	Interrup. 1:Mode (controllable)	ENC	C
_:23521:54	Interrup. 1:Inactive	SPS	O
_:23521:52	Interrup. 1:Behavior	ENS	O
_:23521:53	Interrup. 1:Health	ENS	O

No.	Information	Data Class (Type)	Type
_:23521:55	Interrup. 1:Pickup	ACD	O
_:23521:57	Interrup. 1:Warning	SPS	O
_:23521:301	Interrup. 1:Dur.	MV	O
_:23521:308	Interrup. 1:Vres.	MV	O
_:23521:309	Interrup. 1:Vres.A	MV	O
_:23521:310	Interrup. 1:Vres.B	MV	O
_:23521:311	Interrup. 1:Vres.C	MV	O
_:23521:312	Interrup. 1:Vres.AB	MV	O
_:23521:313	Interrup. 1:Vres.BC	MV	O
_:23521:314	Interrup. 1:Vres.CA	MV	O
_:23521:315	Interrup. 1:Counter	INS	O

12.2 Voltage Unbalance

12.2.1 Overview of Functions

In a 3-phase power system, the voltages are normally balanced, as well as the connected loads. In some cases, however, the balanced conditions can be disturbed due to various influences.

Voltage unbalances can be caused by various factors:

- Unbalanced load, for example, caused by different consumers in the individual phases
- Phase failure, for example, due to a tripped 1-phase fuse or a broken conductor
- Faults in the primary system, for example, at the transformer

The function **Voltage unbalance**:

- Detects the voltage-unbalance conditions in the distribution and industrial power systems.
- Monitors the voltage-unbalance conditions.

In the function **Voltage unbalance**, the following stage types are available:

- **V2/V1**: ratio of the negative-sequence voltage to the positive-sequence voltage
- **V0/V1**: ratio of the zero-sequence voltage to the positive-sequence voltage

All the measured values are displayed under **Power quality basic > Voltage unbalance** of a specific function group in the HMI.

The specific function group in which the function **Voltage unbalance** is instantiated must be connected to the 3-phase voltage measuring point.

12.2.2 Structure of the Function

The function **Voltage unbalance** can be used in the protection function groups with 3-phase voltage measurement.

The function **Voltage unbalance** comes factory-set with a stage **V2/V1**.

The following stages can be operated simultaneously within the function:

- 2 stages **V2/V1**
- 2 stages **V0/V1**

The general functionality works across stages on the function level.

The stages are identical in structure. Stages that are not preconfigured are shown in gray in the following figure.

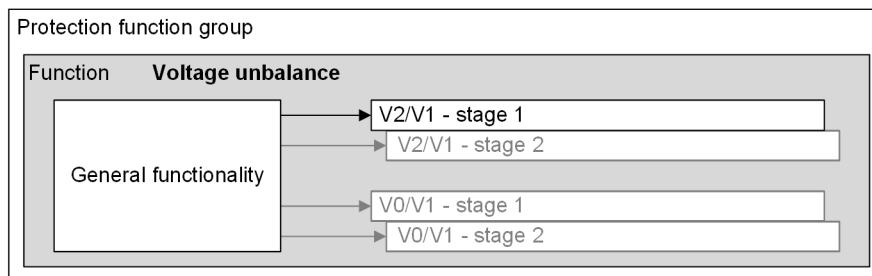

[dw_V_unbalance_structure_1_en_US]

Figure 12-10 Structure/Embedding of the Function

12.2.3 Stage V2/V1

12.2.3.1 Description

Logic of the Stage

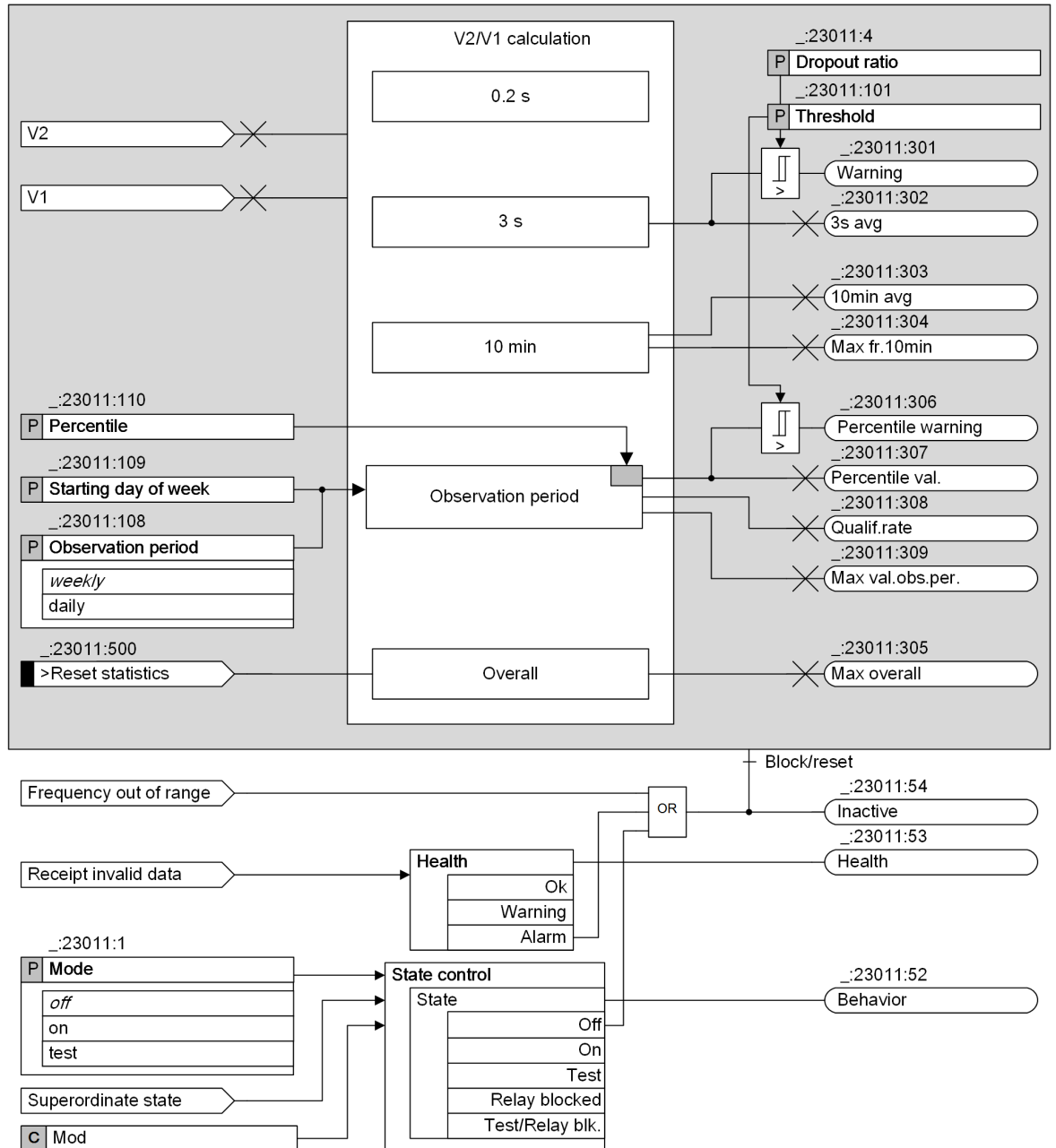

[to_V2_V1, 2, en_US]

Figure 12-11 Logic Diagram of the Stage V2/V1

Measuring Intervals

Measuring Intervals	Description
0.2 s	10 cycles for the 50-Hz system or 12 cycles for the 60-Hz system This interval is the basic measuring interval for this stage. All further measured values are aggregated based on the 0.2-s values.
3 s	150 cycles for the 50-Hz system or 180 cycles for the 60-Hz system This interval is used for the calculation of the 3-s average value.
10 min	The calculation in the 10-min interval is based on the UTC 10-min tick. There is no gap and no overlap between 2 consecutive 10-min intervals. This interval is used for the calculation of the 10-min average value and the maximum 0.2-s value in 10 min.
Observation period	Settable interval of one week or one day
Overall	From the device startup or from the latest reset of statistical values until the current time The maximum value of V2/V1 in overall time is displayed as a statistical value.

Aggregation by the UTC 10-Min Tick

The 10-min average values are aggregated by the UTC 10-min tick according to the standard IEC 61000-4-30. Each 10-min interval begins at a tick.

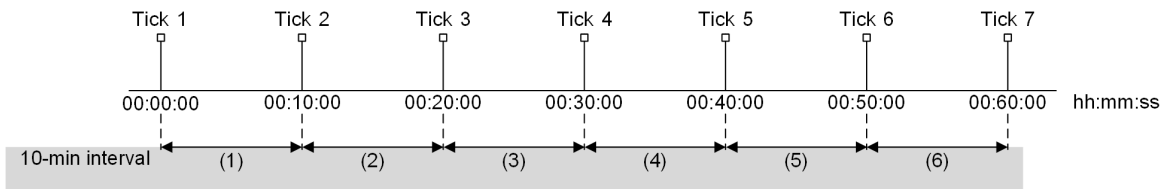

[dw_tick_interval, 1, en_US]

Figure 12-12 Ticks and 10-Min Intervals in an Hour

Warning of the Voltage Unbalance

If the 3-s average value exceeds the threshold value, a voltage-unbalance event occurs and the indication *warning* is generated.

If the 3-s average value is smaller than or equal to the result of the threshold value multiplied by the dropout ratio, the indication *warning* for the voltage unbalance disappears.

Observation

A settable observation period of *weekly* or *daily* is provided. In the observation period, the following measured values are observed to determine the voltage-unbalance conditions.

Table 12-5 Observed Values in the Observation Period

Value	Description
<i>Percentile val.</i>	<p>To locate the value <i>Percentile val.</i>, you must set the parameter Percentile.</p> <p>The following figure shows an example of locating the percentile value: In the figure, all the 10-min average values of V2/V1 in the last observation period are displayed. The parameter Percentile is set to 95 %.</p> <p>Then, the value <i>Percentile val.</i> is determined as the value that 95 % of the 10-min average values in the last observation period are smaller than or equal to.</p>
<i>Qualif.rate</i>	Proportion of the 10-min average values that are smaller than the threshold value in the last observation period
<i>Max val.obs.per.</i>	Maximum 0.2-s value in the last observation period

During the observation period, if the value *Percentile val.* of the 10-min average values exceeds the threshold value, a voltage-unbalance event occurs and the indication *Percentile warning* is generated.

Functional Values

Value	Description
<i>Max overall</i>	Maximum 0.2-s value of V2/V1 from the device startup or from the latest reset of statistical values to the current time
<i>3s avg</i>	Average value of V2/V1 in the last 3-s interval, that is, 150 cycles or 180 cycles
<i>10min avg</i>	Average value of V2/V1 in the last 10-min interval
<i>Max fr.10min</i>	Maximum 0.2-s value of V2/V1 in the last 10-min interval
<i>Percentile val.</i>	<p>The value <i>Percentile val.</i> is the value that, for example, 95 % (default setting of the parameter Percentile) of all 10-min average values in the last observation period are smaller than or equal to.</p> <p>For more information, refer to Observation, Page 1486.</p>
<i>Qualif.rate</i>	Proportion of the 10-min average values that are smaller than the threshold value in the last observation period
<i>Max val.obs.per.</i>	<p>Maximum 0.2-s value in the last observation period</p> <p>This value is refreshed at the end of each observation period.</p>

Value Indications

If the indication *Percentile warning* is generated, routed value indications from the table [Table 12-6](#) can be entered in the log.

Table 12-6 Value Indications

Value	Description
<i>Perc. value abnor.</i>	Percentile value abnormal Percentile in case of a warning (percentile is above limiting value) and possible record It is the same value as <i>Percentile val.</i> from the same observation interval.
<i>Qual. rate abnor.</i>	Quality rate abnormal Quality rate in case of a warning (percentile is above limiting value) and possible record It is the same value as <i>Qualif. rate</i> from the same observation interval.
<i>Max val. obs. per. abnor.</i>	Maximum value observation period abnormal Maximum value of the observation period in case of a warning (percentile is above limiting value) and possible record It is the same value as <i>Max val. obs. per.</i> from the same observation interval.

The value indications can be routed to the following logs:

- Operational log
- User-defined log 1
- User-defined log 2

Resetting the Statistical Value

The statistical value *Max overall* can be reset via the following methods:

- Via the binary input signal *>Reset statistics*
- Via the **Reset** button for the maximum value of statistic in the operation panel of the device
- Via communication protocols
- Via an online DIGSI connection to the device

Influences Caused by the Change of the Device Time

If the device time is changed, the calculated values in the 10-min intervals and in observation periods are influenced. There are 2 cases:

- After the change, the time is still in the time interval of the calculation.
 The calculation is not influenced and continues. The calculated value is refreshed at the end of the time interval.
- After the change, the time is out of the time interval of the calculation.
 The calculation is influenced and is terminated immediately. Meanwhile, the calculated value is refreshed and the calculation of the next time interval is started.

12.2.3.2 Application and Setting Notes

Parameter: **Minimum voltage V1**

- Default setting (`_ :2311:101`) **Minimum voltage V1 = 5.000 V**

You can configure the parameter **Minimum voltage V1** in the function block **General**.

With the parameter **Minimum voltage V1**, you set the minimum value of the positive-sequence voltage V1. The calculation in the stage **V2/V1** or **V0/V1** starts only when V1 exceeds the set **Minimum voltage V1**.

Siemens recommends using the default setting.

Parameter: Threshold

- Default setting (`_:23011:101`) **Threshold** = 2.00 %

With the parameter **Threshold**, you set the threshold value to define the degree of voltage unbalance which is not considered as normal any more. If the average value of V2/V1 exceeds the threshold value, a voltage-unbalance event is detected and the indication *warning* is generated.

According to the standard EN 50160 or IEC TS 62749, Siemens recommends using the default setting.

Parameter: Dropout ratio

- Default setting (`_:23011:4`) **Dropout ratio** = 0.95

With the parameter **Dropout ratio**, you set the dropout ratio for the voltage unbalance. If the average value of V2/V1 is smaller than or equal to the result of the threshold value multiplied by the dropout ratio, the indication *warning* for the voltage unbalance disappears.

Siemens recommends using the default setting.

Parameter: Observation period

- Default setting (`_:23011:108`) **Observation period** = *weekly*

With the parameter **Observation period**, you set the period for the observation.

Parameter Value	Description
<i>weekly</i>	The observation is executed and repeated weekly according to the start day specified by the parameter Starting day of week . After the device startup, the first observation starts immediately and ends at the time 00:00:00 of the first starting day. Then, the observation is repeated weekly.
<i>daily</i>	The observation is executed and repeated every day. After the device startup, the first observation starts immediately and ends at the time 00:00:00 of the next day. Then, the observation is repeated day by day.

Parameter: Starting day of week

- Default setting (`_:23011:109`) **Starting day of week** = *Sunday*

This parameter is effective only when the parameter **Observation period** is set to *weekly*.

With the parameter **Starting day of week**, you set the start day of the weekly observation. The start day can be set to any day of the week. For example, it is Tuesday today and the set start day is *Sunday*, then, the first observation starts from Tuesday to Saturday, and the following observation is executed weekly starting from Sunday.

Parameter: Percentile

- Default setting (`_:23011:110`) **Percentile** = 95 %

With the parameter **Percentile**, you define the range of the 10-min average values that is used to locate the percentile value in the last observation period.

The default setting 95 % is taken as an example. 95 % of the 10-min average values are smaller than or equal to the percentile value in the last observation period.

According to the standard EN 50160 or IEC TS 62749, Siemens recommends using the default setting.

12.2.3.3 Settings

Addr.	Parameter	C	Setting Options	Default Setting
<i>General</i>				
<code>_:2311:101</code>	General:Minimum voltage V1		0.300 V to 60.000 V	5.000 V

Addr.	Parameter	C	Setting Options	Default Setting
V2/V1 stage 1				
_.23011:1	V2/V1 stage 1:Mode		<ul style="list-style-type: none"> • off • on • test 	off
_.23011:101	V2/V1 stage 1:Threshold		0.50 % to 10.00 %	2.00 %
_.23011:4	V2/V1 stage 1:Dropout ratio		0.90 to 0.99	0.95
_.23011:108	V2/V1 stage 1:Observation period		<ul style="list-style-type: none"> • daily • weekly 	weekly
_.23011:109	V2/V1 stage 1:Starting day of week		<ul style="list-style-type: none"> • Sunday • Monday • Tuesday • Wednesday • Thursday • Friday • Saturday 	Sunday
_.23011:110	V2/V1 stage 1:Percentile		80 % to 99 %	95 %

12.2.3.4 Information List

No.	Information	Data Class (Type)	Type
V2/V1 stage 1			
_.23011:500	V2/V1 stage 1:>Reset statistics	SPS	I
_.23011:51	V2/V1 stage 1:Mode (controllable)	ENC	C
_.23011:54	V2/V1 stage 1:Inactive	SPS	O
_.23011:52	V2/V1 stage 1:Behavior	ENS	O
_.23011:53	V2/V1 stage 1:Health	ENS	O
_.23011:301	V2/V1 stage 1:Warning	SPS	O
_.23011:305	V2/V1 stage 1:Max overall	MV	O
_.23011:302	V2/V1 stage 1:3s avg	MV	O
_.23011:303	V2/V1 stage 1:10min avg	MV	O
_.23011:304	V2/V1 stage 1:Max fr.10min	MV	O
_.23011:306	V2/V1 stage 1:Percentile warning	SPS	O
_.23011:307	V2/V1 stage 1:Percentile val.	MV	O
_.23011:308	V2/V1 stage 1:Qualif.rate	MV	O
_.23011:309	V2/V1 stage 1:Max val.obs.per.	MV	O
_.23011:310	V2/V1 stage 1:Perc.value abnor.	MV	O
_.23011:311	V2/V1 stage 1:Qual.rate abnor.	MV	O
_.23011:312	V2/V1 stage 1:Max val.obs.per.abnor.	MV	O

12.2.4 Stage V0/V1

12.2.4.1 Description

Logic of the Stage

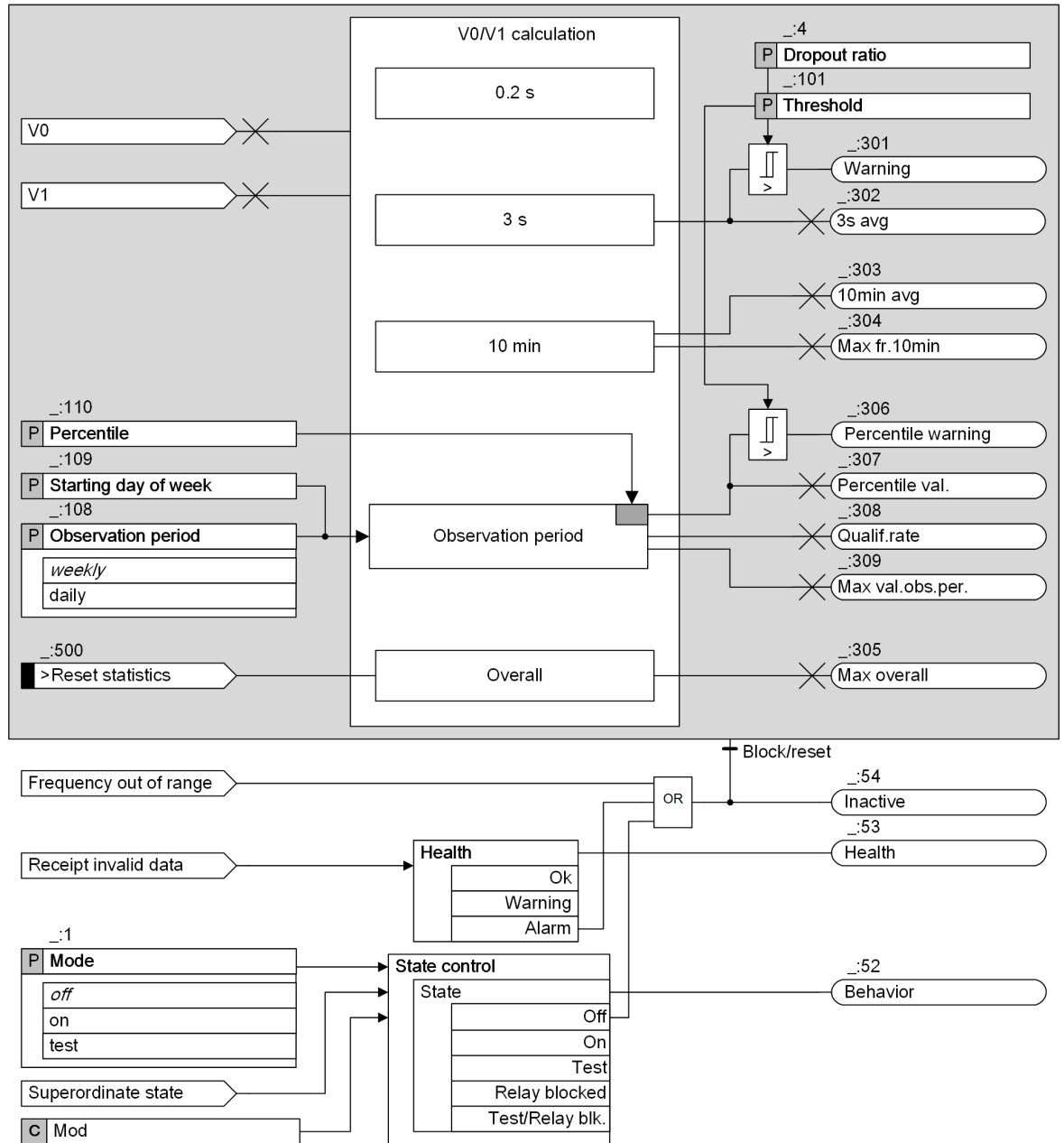

[to_V0_V1, 2, en_US]

Figure 12-13 Logic Diagram of the Stage V0/V1

Measuring Intervals

Measuring Intervals	Description
0.2 s	10 cycles for the 50-Hz system or 12 cycles for the 60-Hz system This interval is the basic measuring interval for this stage. All further measured values are aggregated based on the 0.2-s values.
3 s	150 cycles for the 50-Hz system or 180 cycles for the 60-Hz system This interval is used for the calculation of the 3-s average value.
10 min	The calculation in the 10-min interval is based on the UTC 10-min tick. There is no gap and no overlap between 2 consecutive 10-min intervals. This interval is used for the calculation of the 10-min average value and the maximum 0.2-s value in 10 min.
Observation period	Settable interval of one week or one day
Overall	From the device startup or from the latest reset of statistical values to the current time The maximum value of $V0/V1$ in overall time is displayed as a statistical value.

Aggregation by the UTC 10-Min Tick

For details, refer to [Aggregation by the UTC 10-Min Tick, Page 1486](#).

Warning of the Voltage Unbalance

For details, refer to [Warning of the Voltage Unbalance, Page 1486](#).

Observation

A settable observation period of *weekly* or *daily* is provided. In the observation period, the following measured values are observed to determine the voltage-unbalance conditions.

Table 12-7 Observed Values in the Observation Period

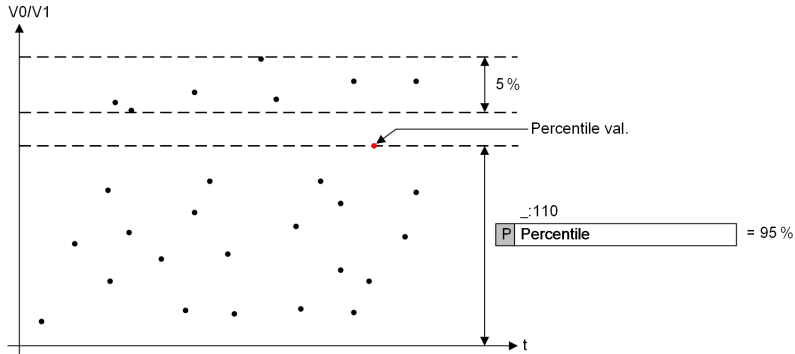
Value	Description
<i>Percentile val.</i>	<p>To locate the value <i>Percentile val.</i>, you must set the parameter Percentile.</p> <p>The following figure shows an example of locating the percentile value: In the figure, all the 10-min average values of V0/V1 in the last observation period are displayed. The parameter Percentile is set to 95 %.</p> <p>Then, the value <i>Percentile val.</i> is determined as the value that 95 % of the 10-min average values in the last observation period are smaller than or equal to.</p> 
<i>Qualif.rate</i>	Proportion of the 10-min average values that are smaller than the threshold value in the last observation period
<i>Max val.obs.per.</i>	Maximum 0.2-s value in the last observation period

During the observation period, if the value *Percentile val.* of the 10-min average values exceeds the threshold value, a voltage-unbalance event occurs and the indication *Percentile warning* is generated.

Functional Values

Value	Description
<i>Max overa11</i>	Maximum 0.2-s value of V0/V1 from the device startup or from the latest reset of statistical values to the current time
<i>3s avg</i>	Average value of V0/V1 in the last 3-s interval, that is, 150 cycles or 180 cycles
<i>10min avg</i>	Average value of V0/V1 in the last 10-min interval
<i>Max fr.10min</i>	Maximum 0.2-s value of V0/V1 in the last 10-min interval
<i>Percentile val.</i>	<p>The value <i>Percentile val.</i> is the value that, for example, 95 % (default setting of the parameter Percentile) of all 10-min average values in the last observation period are smaller than or equal to.</p> <p>For more information, refer to Observation, Page 1492.</p>
<i>Qualif.rate</i>	Proportion of the 10-min average values that are smaller than the threshold value in the last observation period
<i>Max val.obs.per.</i>	<p>Maximum 0.2-s value in the last observation period</p> <p>This value is refreshed at the end of each observation period.</p>

Value Indications

For details, refer to [Value Indications, Page 1487](#).

Resetting the Statistical Value

For details, refer to [Resetting the Statistical Value, Page 1488](#).

Influences Caused by the Change of the Device Time

For details, refer to [Influences Caused by the Change of the Device Time, Page 1488](#).

Connection Type

In the stage **V0/V1**, the following connection types of the voltage transformer are available for the 3-phase voltage measuring point:

- *3 ph-to-gnd volt. + VN*
- *3 ph-to-gnd voltages*
- *3 ph-to-ph volt. + VN*
- *2 ph-to-ph volt. + VN*

The following connection types of the voltage transformer are not available for the 3-phase voltage measuring point. If one of the connection types is connected, DIGSI 5 reports an inconsistency:

- *3 ph-to-ph voltages*
- *2 ph-to-ph voltages*

12.2.4.2 Application and Setting Notes

Parameter: **Threshold**

- Default setting (**_:101**) **Threshold = 2.00 %**

With the parameter **Threshold**, you set the threshold value to define the degree of voltage unbalance which is not considered as normal any more. If the average value of V0/V1 exceeds the threshold value, a voltage-unbalance event is detected and the indication *warning* is generated.

According to the standard EN 50160 or IEC TS 62749, Siemens recommends using the default setting.

Parameter: **Dropout ratio**

- Default setting (**_:4**) **Dropout ratio = 0.95**

With the parameter **Dropout ratio**, you set the dropout ratio for the voltage unbalance. If the average value of V0/V1 is smaller than or equal to the result of the threshold value multiplied by the dropout ratio, the indication *warning* for the voltage unbalance disappears.

Siemens recommends using the default setting.

Parameter: **Observation period**

- Default setting (**_:108**) **Observation period = weekly**

With the parameter **Observation period**, you set the period for the observation.

Parameter Value	Description
<i>weekly</i>	The observation is executed and repeated weekly according to the start day specified by the parameter Starting day of week . After the device startup, the first observation starts immediately and ends at the time 00:00:00 of the first starting day. Then, the observation is repeated weekly.
<i>daily</i>	The observation is executed and repeated every day. After the device startup, the first observation starts immediately and ends at the time 00:00:00 of the next day. Then, the observation is repeated day by day.

Parameter: **Starting day of week**

- Default setting (**_:109**) **Starting day of week = Sunday**

This parameter is effective only when the parameter **Observation period** is set to **weekly**.

With the parameter **Starting day of week**, you set the start day of the weekly observation. The start day can be set to any day of the week. For example, it is Tuesday today and the set start day is **Sunday**, then, the first observation starts from Tuesday to Saturday, and the following observation is executed weekly starting from Sunday.

Parameter: Percentile

- Default setting (**_:110**) **Percentile = 95 %**

With the parameter **Percentile**, you define the range of the 10-min average values that is used to locate the percentile value in the last observation period.

The default setting **95 %** is taken as an example. 95 % of the 10-min average values are smaller than or equal to the percentile value in the last observation period.

According to the standard EN 50160 or IEC TS 62749, Siemens recommends using the default setting.

12.2.4.3 Settings

Addr.	Parameter	C	Setting Options	Default Setting
V0/V1 stage #				
_:1	V0/V1 stage #:Mode		<ul style="list-style-type: none"> • off • on • test 	off
_:101	V0/V1 stage #:Threshold		0.50 % to 10.00 %	2.00 %
_:4	V0/V1 stage #:Dropout ratio		0.90 to 0.99	0.95
_:108	V0/V1 stage #:Observation period		<ul style="list-style-type: none"> • daily • weekly 	weekly
_:109	V0/V1 stage #:Starting day of week		<ul style="list-style-type: none"> • Sunday • Monday • Tuesday • Wednesday • Thursday • Friday • Saturday 	Sunday
_:110	V0/V1 stage #:Percentile		80 % to 99 %	95 %

12.2.4.4 Information List

No.	Information	Data Class (Type)	Type
V0/V1 stage #			
_:500	V0/V1 stage #:>Reset statistics	SPS	I
_:51	V0/V1 stage #:Mode (controllable)	ENC	C
_:54	V0/V1 stage #:Inactive	SPS	O
_:52	V0/V1 stage #:Behavior	ENS	O
_:53	V0/V1 stage #:Health	ENS	O
_:301	V0/V1 stage #:Warning	SPS	O
_:305	V0/V1 stage #:Max overall	MV	O
_:302	V0/V1 stage #:3s avg	MV	O
_:303	V0/V1 stage #:10min avg	MV	O
_:304	V0/V1 stage #:Max fr.10min	MV	O

No.	Information	Data Class (Type)	Type
_:306	V0/V1 stage #:Percentile warning	SPS	O
_:307	V0/V1 stage #:Percentile val.	MV	O
_:308	V0/V1 stage #:Qualif.rate	MV	O
_:309	V0/V1 stage #:Max val.obs.per.	MV	O
_:310	V0/V1 stage #:Perc.value abnor.	MV	O
_:311	V0/V1 stage #:Qual.rate abnor.	MV	O
_:312	V0/V1 stage #:Max val.obs.per.abnor.	MV	O

12.3 THD and Harmonics

12.3.1 Overview of Functions

At the connection point to the public power system, the allowed total harmonic distortion (THD) is limited according to the power-quality related standards. The function **THD and harmonics** can be used to monitor the THD value.

The function **THD and harmonics** serves for the calculation of the following values:

- THD values of the 3-phase currents and 3-phase voltages
- Aggregated THD values of the 3-phase voltages
If the aggregated THD value exceeds the threshold, a warning is generated.
- Harmonics of the 3-phase currents and 3-phase voltages

The calculated THD values and harmonics are displayed under **Power quality basic > THD and harmonics** of a specific function group in the HMI or via the DIGSI Online-Editor. If routed, the calculated THD values and harmonics are available in the communication protocols and in the fault record. Abnormal values can be logged in the operational or user-defined log if routed.

12.3.2 Structure of the Function

The function **THD and harmonics** can be used in the protection function groups with 3-phase current and voltage measurements and in the protection function group with only 3-phase voltage measurement.

When being used in a function group with 3-phase current and voltage measurements, the function comes factory-set with 1 stage **Current**. The following stages can be operated simultaneously within the function:

- 1 stage **Current**
- 1 stage **Voltage**

When being used in a function group with only 3-phase voltage measurement, the function comes factory-set with 1 stage **Voltage**. Only 1 voltage stage can be operated within the function.

The 2 types of function groups are displayed in the following figure. The stage that is not preconfigured is shown in gray.

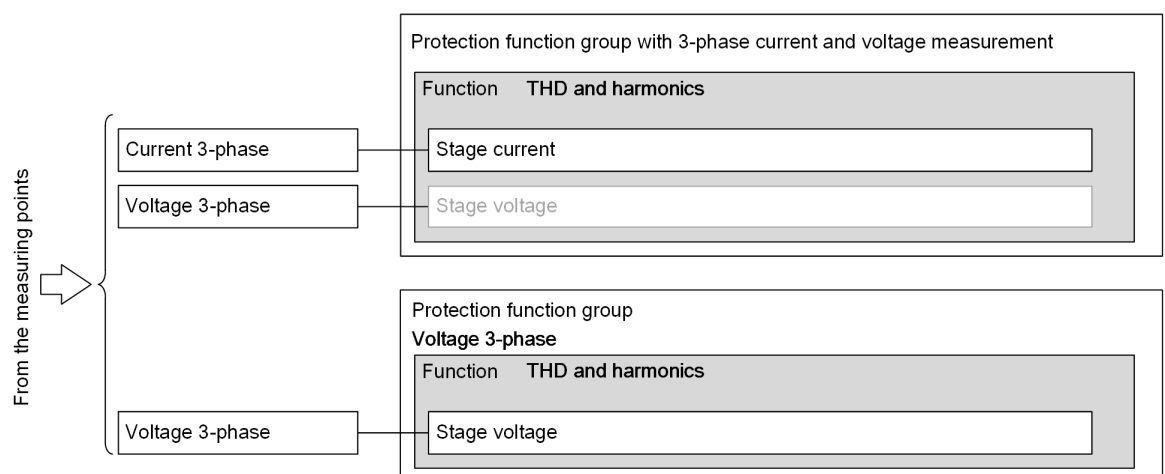

[dw_structure_THD harmonic_3_en_US]

Figure 12-14 Structure/Embedding of the Function

12.3.3 Stage Current

12.3.3.1 Function Description

The stage **Current** calculates and displays the THD values and harmonics for the 3-phase currents.

Calculation of THD Values and Harmonics Values

The THD value of the current is a percentage value calculated as follows:

$$I_{\text{THD}} = \frac{\sqrt{\sum_{n=2}^N I_n^2}}{I_s} \cdot 100 \%$$

[[fo_THD value_], 1, en_US]

Where

- N 20
 The function supports the THD calculation up to the 20th harmonic.
- I_n Harmonic value of order n
- I_s Fundamental-component value

The calculated harmonic values of the current are percentage values that take the fundamental-component value as reference:

$$I_{\text{Harmonic}_n} = \frac{I_n}{I_s} \cdot 100 \%$$

[[fo_harmonic ratio_], 1, en_US]

Functional Measured Values

Table 12-8 Functional Measured Values of the stage **Current**

Value	Description
THD:A	THD values of the 3-phase currents for the phases A, B, and C These values are percentage values.
THD:B	
THD:C	
H2:A	Harmonic values from the 2nd to 20th harmonics of the 3-phase currents for the phases A, B, and C These values are percentage values.
H2:B	
H2:C	
...	
H20:A	
H20:B	
H20:C	

Operating Range

The frequency operating range of the stage **Current** is 0.8 to 1.2 of the rated frequency:

- If the power frequency is in this range, the THD values and harmonics are calculated.
- If the power frequency is out of this range, the THD values and harmonics are shown as "---".

If the fundamental-component value is smaller than 1 % of the rated current, the THD values and harmonics are shown as "---".

12.3.3.2 Information List

No.	Information	Data Class (Type)	Type
Current			
_:22081:52	Current:Behavior	ENS	O
_:22081:53	Current:Health	ENS	O
_:22081:301	Current:THD	WYE	O
_:22081:302	Current:H2	WYE	O
_:22081:303	Current:H3	WYE	O
_:22081:304	Current:H4	WYE	O
_:22081:305	Current:H5	WYE	O
_:22081:306	Current:H6	WYE	O
_:22081:307	Current:H7	WYE	O
_:22081:308	Current:H8	WYE	O
_:22081:309	Current:H9	WYE	O
_:22081:310	Current:H10	WYE	O
_:22081:311	Current:H11	WYE	O
_:22081:312	Current:H12	WYE	O
_:22081:313	Current:H13	WYE	O
_:22081:314	Current:H14	WYE	O
_:22081:315	Current:H15	WYE	O
_:22081:316	Current:H16	WYE	O
_:22081:317	Current:H17	WYE	O
_:22081:318	Current:H18	WYE	O
_:22081:319	Current:H19	WYE	O
_:22081:320	Current:H20	WYE	O

12.3.4 Stage Voltage

12.3.4.1 Function Description

The stage **Voltage**:

- Calculates and displays the THD values and harmonics for the 3-phase voltages.
- Calculates and displays the aggregated THD values for the 3-phase voltages.
- Generates a warning signal if the aggregated THD value exceeds the threshold.

Logic of the Stage

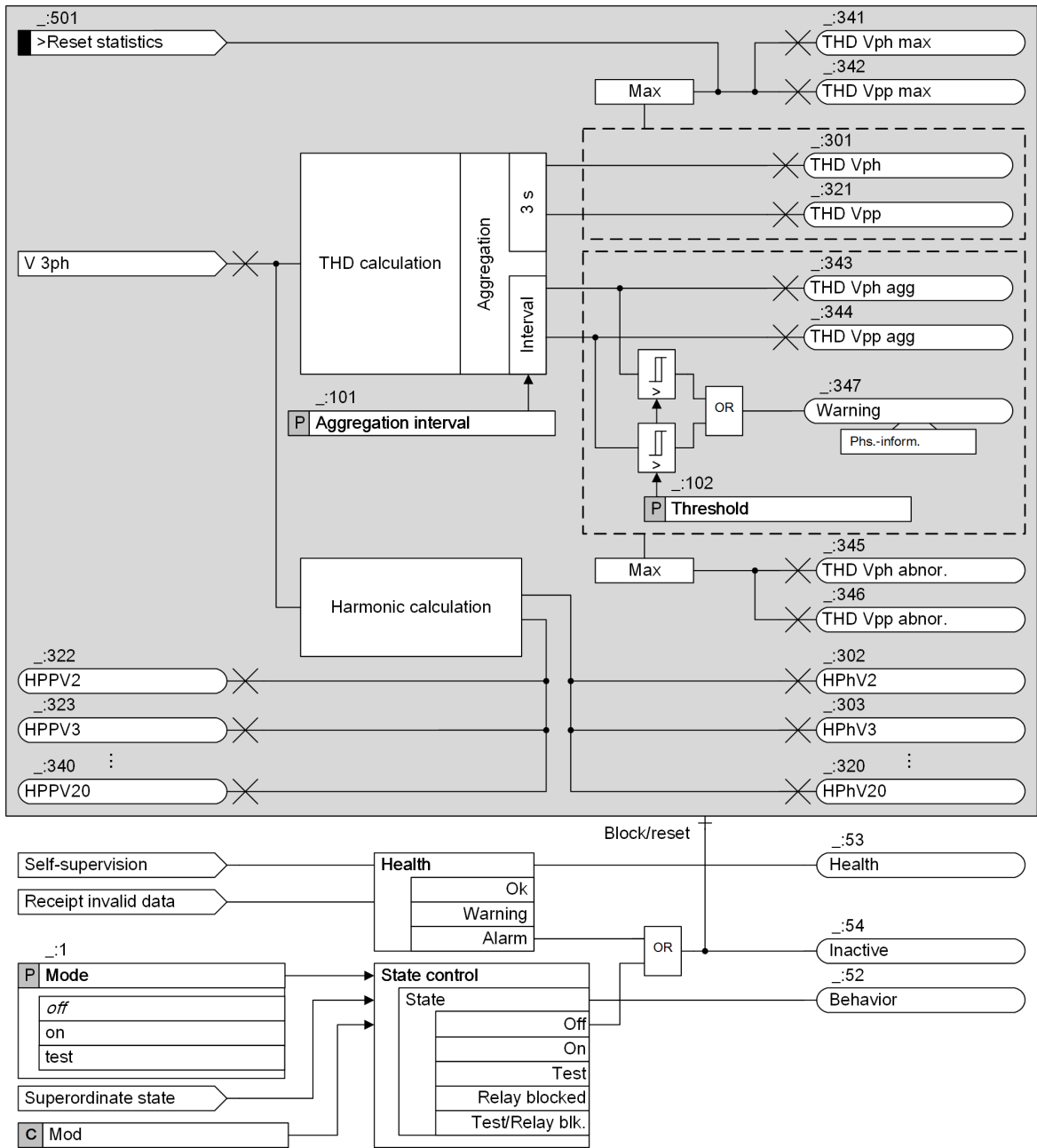

[lo_voltage stage_2_en_US]

Figure 12-15 Logic Diagram of the stage Voltage

Calculation of THD Values and Harmonic Values

The THD value of the voltage is a percentage value. The following table lists the formulas for the calculation of the raw value and the aggregated THD values.

Based on the raw value, the aggregated THD values of the phase-to-phase voltages and the phase-to-ground voltages are calculated.

Table 12-9 Calculation of THD Values

Value	Formula
Raw value	$V_{\text{Raw}} = \frac{\sqrt{\sum_{n=2}^N V_n^2}}{V_s} \cdot 100 \%$ <ul style="list-style-type: none"> • N: 20 The function supports the THD calculation up to the 20th harmonic. • V_n: Harmonic value of order n • V_s: Fundamental-component value
THD Vph THD Vpp	$V_{\text{THD}} = \frac{1}{N} \sum_{n=0}^{N(t=3s)} V_{\text{Raw}}(n)$ <ul style="list-style-type: none"> • N: Total number of the raw values over a 3-s interval
THD Vph max THD Vpp max	$V_{\text{THD, max}} = \text{MAX} \{V_{\text{THD, 1}}, V_{\text{THD, 2}}, V_{\text{THD, 3}} \dots\}$
THD Vph agg THD Vpp agg	$V_{\text{THD, agg}} = \frac{1}{N} \sum_{n=0}^N V_{\text{Raw}}(n)$ <ul style="list-style-type: none"> • N: Total number of the raw values over the aggregation interval of 1 min or 10 min

The calculated harmonic values of the voltage are percentage values that take the fundamental-component values as reference.

Table 12-10 Calculation of Harmonic Values

Value	Formula
HPhV2 HPhV3 ... HPhV20	$V_{\text{Harmonic}_n} = \frac{V_n}{V_s} \cdot 100 \%$ <ul style="list-style-type: none"> • V_n: Harmonic value of order n • V_s: Fundamental-component value
HPPV2 HPPV3 ... HPPV20	

Functional Values

For the stage **Voltage**, the functional values are divided into 2 submenus:

- Phase-to-ground voltage, as shown in [Table 12-11](#).
- Phase-to-phase voltage, as shown in [Table 12-12](#).

The functional values are all percentage values. They are calculated using the formulas in the section [Calculation of THD Values and Harmonic Values, Page 1500](#).

Table 12-11 Functional Values for the Phase-to-Ground Voltage

Value	Description
THD Vph:A THD Vph:B THD Vph:C	Average THD values of the phase-to-ground voltages for the phases A, B, and C over a 3-s interval
THD Vph max	Maximum 3-s average THD value of the phase-to-ground voltage in the period from the device startup or from the latest reset of this maximum value to the current time
THD Vph agg:A THD Vph agg:B THD Vph agg:C	Average THD values of the phase-to-ground voltages for the phases A, B, and C over the aggregation interval of 1 min or 10 min
HPhV2:A HPhV2:B HPhV2:C ... HPhV20:A HPhV20:B HPhV20:C	Harmonic values from the 2nd to 20th harmonics of the phase-to-ground voltages for the phases A, B, and C

Table 12-12 Functional Values for the Phase-to-Phase Voltage

Value	Description
THD Vpp:AB THD Vpp:BC THD Vpp:CA	Average THD values of the phase-to-phase voltages for the phases AB, BC, and CA over a 3-s intervals
THD Vpp max	Maximum 3-s average THD value of the phase-to-phase voltage in the period from the device startup or from the latest reset of this maximum value to the current time
THD Vpp agg:AB THD Vpp agg:BC THD Vpp agg:CA	Average THD values of the phase-to-phase voltages for the phases AB, BC, and CA over the aggregation interval of 1 min or 10 min
HPPV2:AB HPPV2:BC HPPV2:CA ... HPPV20:AB HPPV20:BC HPPV20:CA	Harmonic values from the 2nd to 20th harmonics of the phase-to-phase voltages for the phases AB, BC, and CA



NOTE

Considering the device resources, do not route non-required harmonic measured values for transmission via communication protocols.

Resetting the Statistical Values

The statistical values *THD Vph max* and *THD Vpp max* can be reset via the following methods:

- Via the binary input signal *>Reset statistics*
- Via the **Reset** button for the maximum value of statistic in the operation panel of the device
- Via communication protocols
- Via an online DIGSI connection to the device

Monitoring of the Aggregation Values

If the aggregated THD value *THD Vph agg* or *THD Vpp agg* exceeds the threshold, a phase-selective indication *warning* is generated. During the period when the indication *warning* is active, the maximum aggregated THD value of the phase-to-phase voltages or the phase-to-ground voltages is logged as an abnormal value. The abnormal value can be routed to the following logs:

- Operational log
- User-defined log 1
- User-defined log 2

Table 12-13 Abnormal Values

Value	Description
THD Vph abnor.:A THD Vph abnor.:B THD Vph abnor.:C	Abnormal THD values (THD value is above limiting value) of the phase-to-ground voltages for the phases A, B, and C over the aggregation interval of 1 min or 10 min A record is possible.
THD Vpp abnor.:AB THD Vpp abnor.:BC THD Vpp abnor.:CA	Abnormal THD values of the phase-to-phase voltages for the phases AB, BC, and CA over the aggregation interval of 1 min or 10 min A record is possible.

Aggregation by the UTC 10-Min Tick

If the parameter **Aggregation interval** is set to **10 min**, the THD values are aggregated by the UTC 10-min tick according to the standard IEC 61000-4-30. Each 10-min interval begins at a tick.

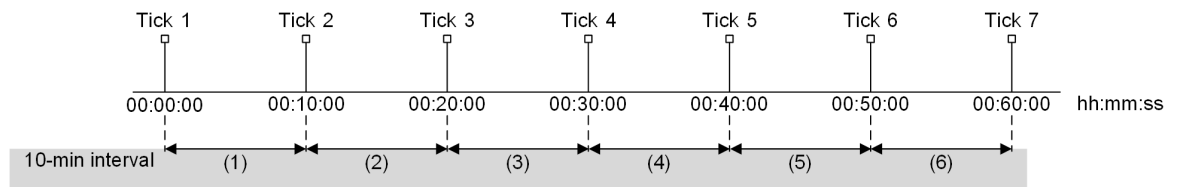

[dwr_tick_interval_1_en_US]

Figure 12-16 Ticks and 10-Min Intervals in an Hour

Influences Caused by the Change of the Device Time

If the device time is changed, the calculation of THD values is influenced. There are 2 cases:

- After the change, the time is still in the time interval of the calculation.
The calculation is not influenced and continues. The calculated value is refreshed at the end of the time interval.
- After the change, the time is out of the time interval of the calculation.
The calculation is influenced and is terminated immediately. Meanwhile, the calculated value is refreshed and the calculation of the next time interval is started.

Operating Range

The frequency operating range of the stage **Voltage** is 0.8 to 1.2 of the rated frequency:

- If the power frequency is in this range, the THD values and harmonics are calculated.
- If the power frequency is out of this range, the THD values and harmonics are not calculated and are shown as "---". Meanwhile, the function **THD and harmonics** becomes inactive.

If the fundamental-component value is smaller than 5 % of the rated voltage, the THD values and harmonics are shown as "---".

12.3.4.2 Application and Setting Notes

Parameter: Aggregation interval

- Default setting (_:101) **Aggregation interval = 10 min**

With the parameter **Aggregation interval**, you set the aggregation interval to 1 min or 10 min to determine the THD condition.

According to the standard IEC 61000-4-30, Siemens recommends using the default setting.

Parameter: Threshold

- Default setting (_:102) **Threshold = 8.0 %**

With the parameter **Threshold**, you set the threshold for the aggregated THD values. If the aggregated THD value exceeds the threshold, the indication *warning* is generated. Meanwhile, the maximum aggregated THD value is logged as an abnormal value.

According to the standard IEC TS 62749, for the low-voltage or medium-voltage system, the THD value should be smaller than or equal to 8 %. Siemens recommends using the default setting.

12.3.4.3 Settings

Addr.	Parameter	C	Setting Options	Default Setting
Voltage				
_:1	Voltage:Mode		<ul style="list-style-type: none"> • off • on • test 	on
_:101	Voltage:Aggregation interval		<ul style="list-style-type: none"> • 1 min • 10 min 	10 min
_:102	Voltage:Threshold		1.0 % to 25.0 %	8.0 %

12.3.4.4 Information List

No.	Information	Data Class (Type)	Type
Voltage			
_:501	Voltage:>Reset statistics	SPS	I
_:51	Voltage:Mode (controllable)	ENC	C
_:54	Voltage:Inactive	SPS	O
_:52	Voltage:Behavior	ENS	O
_:53	Voltage:Health	ENS	O
_:347	Voltage:Warning	ACT	O
_:301	Voltage:THD Vph	WYE	O
_:341	Voltage:THD Vph max	MV	O
_:343	Voltage:THD Vph agg	WYE	O
_:345	Voltage:THD Vph abnor.	WYE	O
_:321	Voltage:THD Vpp	DEL	O
_:342	Voltage:THD Vpp max	MV	O
_:344	Voltage:THD Vpp agg	DEL	O
_:346	Voltage:THD Vpp abnor.	DEL	O
_:302	Voltage:HPhV2	WYE	O
_:303	Voltage:HPhV3	WYE	O
_:304	Voltage:HPhV4	WYE	O
_:305	Voltage:HPhV5	WYE	O

No.	Information	Data Class (Type)	Type
_:306	Voltage:HPhV6	WYE	O
_:307	Voltage:HPhV7	WYE	O
_:308	Voltage:HPhV8	WYE	O
_:309	Voltage:HPhV9	WYE	O
_:310	Voltage:HPhV10	WYE	O
_:311	Voltage:HPhV11	WYE	O
_:312	Voltage:HPhV12	WYE	O
_:313	Voltage:HPhV13	WYE	O
_:314	Voltage:HPhV14	WYE	O
_:315	Voltage:HPhV15	WYE	O
_:316	Voltage:HPhV16	WYE	O
_:317	Voltage:HPhV17	WYE	O
_:318	Voltage:HPhV18	WYE	O
_:319	Voltage:HPhV19	WYE	O
_:320	Voltage:HPhV20	WYE	O
_:322	Voltage:HPPV2	DEL	O
_:323	Voltage:HPPV3	DEL	O
_:324	Voltage:HPPV4	DEL	O
_:325	Voltage:HPPV5	DEL	O
_:326	Voltage:HPPV6	DEL	O
_:327	Voltage:HPPV7	DEL	O
_:328	Voltage:HPPV8	DEL	O
_:329	Voltage:HPPV9	DEL	O
_:330	Voltage:HPPV10	DEL	O
_:331	Voltage:HPPV11	DEL	O
_:332	Voltage:HPPV12	DEL	O
_:333	Voltage:HPPV13	DEL	O
_:334	Voltage:HPPV14	DEL	O
_:335	Voltage:HPPV15	DEL	O
_:336	Voltage:HPPV16	DEL	O
_:337	Voltage:HPPV17	DEL	O
_:338	Voltage:HPPV18	DEL	O
_:339	Voltage:HPPV19	DEL	O
_:340	Voltage:HPPV20	DEL	O

12.4 Total Demand Distortion

12.4.1 Overview of Functions

At the connection point to the public power system, the allowed total demand distortion (TDD) is limited according to the power-quality related standards. The function **Total demand distortion** can be used to monitor the TDD value.

The function **Total demand distortion** serves for calculating the following values of the 3-phase currents:

- 3-s TDD value
- TDD value within an interval

If the TDD value **TDD intv1** exceeds the threshold value, a warning is generated.

The TDD values are displayed under **Power quality basic > TDD** of a specific function group in the HMI or via the DIGSI Online-Editor. If routed, the TDD values are available in the communication protocols and the fault records. Abnormal values can be logged in the operational log or user-defined logs.

12.4.2 Structure of the Function

The function **Total demand distortion** can be used in the protection function groups with 3-phase current measurements. When being used in such a function group, the function comes factory-set with 1 stage **Current**.

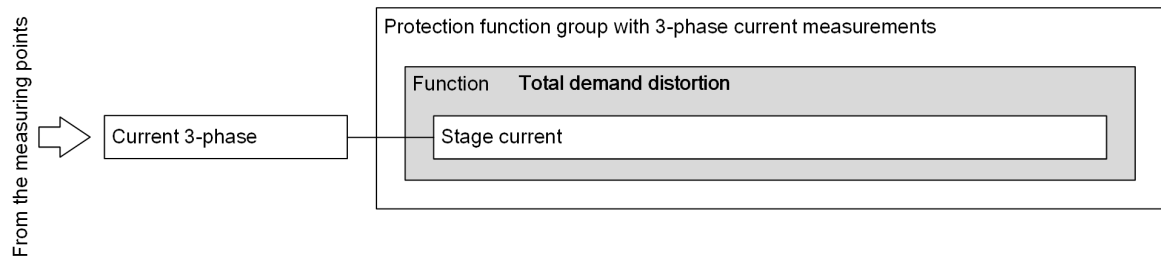

[dw_TDD_structure, 1, en_US]

Figure 12-17 Structure/Embedding of the Function

12.4.3 Stage Current

Logic of the Stage

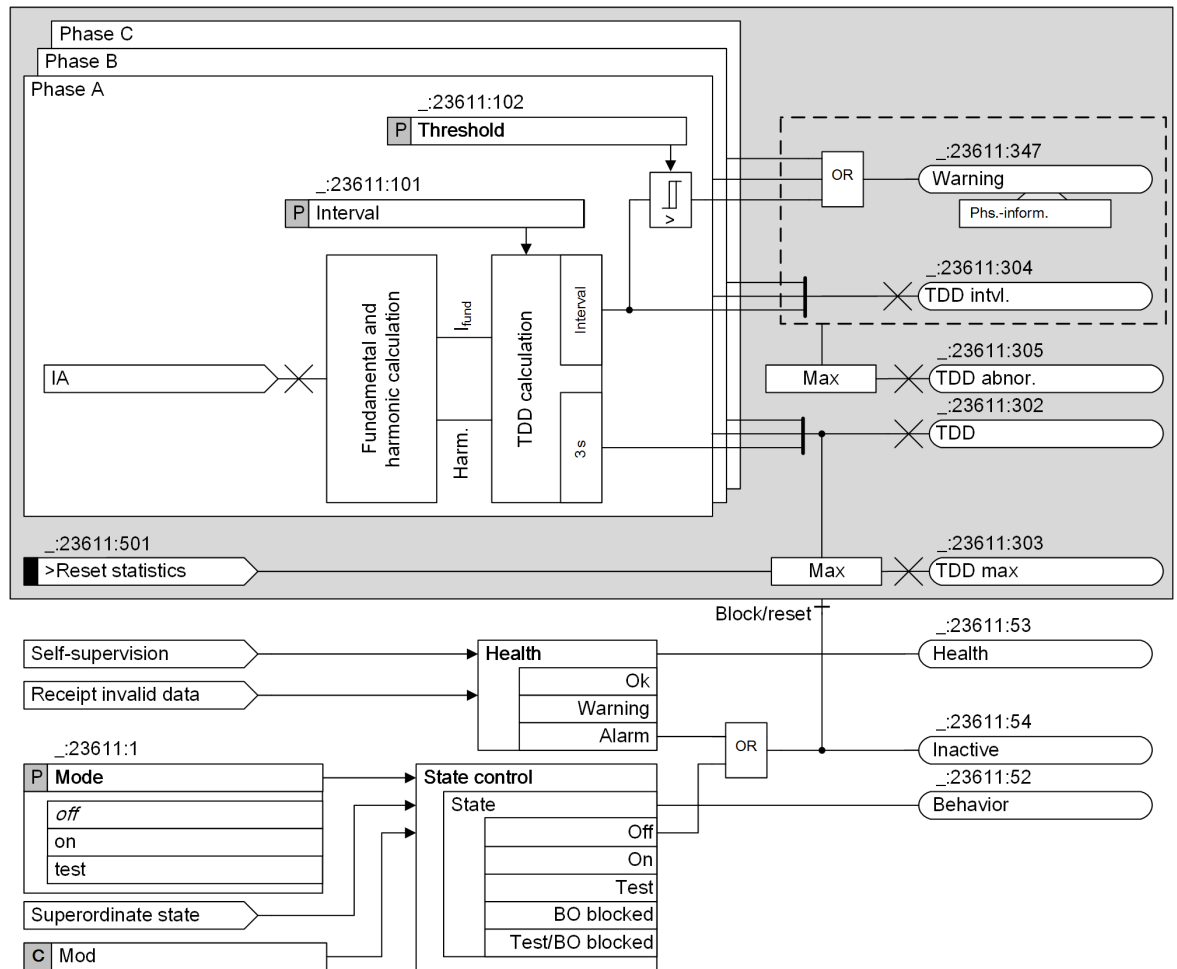

[fo_TDD_current stage, 1, en_US]

Figure 12-18 Logic Diagram of the Stage Current

Calculation of TDD Values

Both the 3-s TDD value and the TDD value within an interval are calculated as follows:

$$I_{TDD} = \frac{\sqrt{\sum_{k=2}^N [\text{mean}(I_k)]^2}}{I_{lmax}}$$

[fo_TDD_1, 1, en_US]

Where

- N 20
The function supports the TDD calculation up to the 20th harmonic.
- I_k Harmonic value of order k
- I_{lmax} Maximum fundamental-component value of the demand load current over an interval
- $\text{mean}(I_k)$ Arithmetic mean value of each order harmonic component over the whole interval

Functional Values

All functional values are given in percentage.

Table 12-14 Functional Values of the Stage Current

Value	Description
TDD:A TDD:B TDD:C	TDD values for phases A, B, and C over the 3-s intervals
TDD intvl.:A TDD intvl.:B TDD intvl.:C	TDD values for phases A, B, and C over the 15-min or 30-min interval
TDD max	Maximum TDD value in the period from the device startup or from the latest reset of this maximum value to the current time This value is the maximum value of the <i>TDD</i> which is calculated over the 3-s intervals.

Resetting the Statistical Values

The statistical value *TDD max* can be reset with the following methods:

- Via the binary input signal *>Reset statistics*
- Via the **Reset** button for the maximum value of the statistic in the operation panel of the device
- Via communication protocols
- Via an online DIGSI connection to the device

Supervision of the TDD Value within an interval

The stage **Current** monitors the TDD value **TDD intvl.** within an interval and generates the phase-selective indication *warning* if **TDD intvl.** exceeds the threshold.

When the indication *warning* drops out, the maximum TDD value since the beginning of this indication which contains the maximum value of all phases, is entered as an abnormal value in the log (if the value is routed). You can route the abnormal value to the following logs:

- Operational log
- User-defined log 1
- User-defined log 2

Table 12-15 Abnormal Value

Value	Description
TDD abnor.:A TDD abnor.:B TDD abnor.:C	TDD abnormal Maximum TDD value TDD intvl. during the event as long as the indication <i>warning</i> indication is active

Aggregation by the UTC 15-Min Tick

Based on the experience in THD values which are aggregated by the UTC 10-min tick according to the IEC 61000-4-30 standard, the parameter **Interval** in TDD is set to **15 min** by default. Each 15-min interval begins at a tick. The following figure shows the ticks and the 15-min intervals in an hour.

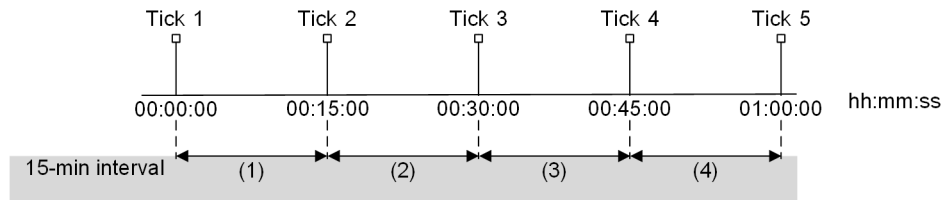

[dw_TDD_tick_interval_1_en_US]

Figure 12-19 Ticks and 15-Min Intervals in an Hour

Influences Caused by the Change of the Device Time

If the device time is changed, the calculation of TDD values is influenced. There are 2 cases:

- After the change, the time is still in the time interval of the calculation.
The calculation is not influenced and continues. The calculated value is refreshed at the end of the time interval.
- After the change, the time is out of the time interval of the calculation.
The calculation is influenced and is terminated immediately. Meanwhile, the calculated value is refreshed and the calculation of the next time interval is started.

Operating Range

The frequency operating range of the stage **Current** is 0.8 to 1.2 of the rated frequency:

- If the power frequency is in this range, the TDD values are calculated.
- If the power frequency is out of this range, the TDD values are not calculated and are shown as ---. Meanwhile, the function **Total demand distortion** becomes inactive.

If the fundamental-component value is smaller than 1 % of the rated current, TDD values and harmonics are set to ---.

12.4.4 Application and Setting Notes

Parameter: `_:23611:101 Interval`

- Default setting **Interval** = **15 min**

With the parameter **Interval**, you set the interval to 15 min or 30 min to determine the TDD condition.

Parameter: `_:23611:102 Threshold`

- Default setting **Threshold** = **5.0 %**

With the parameter **Threshold**, you set the threshold for the TDD value. If the demand TDD values exceed the threshold value, the indication **warning** is generated. Meanwhile, the maximum TDD value is taken as the abnormal value and is shown in the DIGSI 5 information lists.

Siemens recommends using the default setting.

12.4.5 Settings

Addr.	Parameter	C	Setting Options	Default Setting
Stage				
_:23611:1	Stage:Mode		<ul style="list-style-type: none"> • off • on • test 	off
_:23611:101	Stage:Interval		<ul style="list-style-type: none"> • 15 min • 30 min 	15 min
_:23611:102	Stage:Threshold		1.0 % to 25.0 %	5.0 %

12.4.6 Information List

No.	Information	Data Class (Type)	Type
Stage			
_:23611:501	Stage:>Reset statistics	SPS	I
_:23611:51	Stage:Mode (controllable)	ENC	C
_:23611:54	Stage:Inactive	SPS	O
_:23611:52	Stage:Behavior	ENS	O
_:23611:53	Stage:Health	ENS	O
_:23611:347	Stage:Warning	ACT	O
_:23611:302	Stage:TDD	WYE	O
_:23611:303	Stage:TDD max	MV	O
_:23611:304	Stage:TDD intvl.	WYE	O
_:23611:305	Stage:TDD abnor.	WYE	O

13 Functional Tests

13.1	General Notes	1512
13.2	Enabling/Disabling the Application/Test Mode for the Entire Device	1513
13.3	Direction Test of the Phase Quantities (Current and Voltage Connection)	1515
13.4	Direction Test of Ground Quantities for Directional Ground-Fault Functions	1516
13.5	Functional Test of Thermal Overload Protection	1520
13.6	Primary and Secondary Tests of the Circuit-Breaker Failure Protection	1522
13.7	Circuit-Breaker Test	1525
13.8	Functional Test of the Inrush-Current Detection	1528
13.9	Functional Test of Transient Ground-Fault Protection	1529
13.10	Functional Test of the Trip-Circuit Supervision	1530
13.11	Functional Test for the Phase-Rotation Reversal	1531
13.12	Functional Test for Overvoltage Protection with Zero-Sequence Voltage/Residual Voltage	1532
13.13	Primary and Secondary Testing of the Synchronization Function	1534
13.14	Testing the Negative-Sequence Current	1538
13.15	Functional Test for Reverse-Power Protection	1539
13.16	Functional Test for Overexcitation Protection	1542

13.1 General Notes

Various tests have to be performed for commissioning to warrant the correct function of the device.

For tests using secondary test equipment, make sure that no other measurands are locked in and trip and close commands to the circuit breakers are interrupted, unless otherwise indicated.

Secondary tests can never replace primary tests because they cannot include connection faults. They can be used to check the setting values.

Primary tests may be done only by qualified personnel who are familiar with the commissioning of protection systems, with the operation of the system, and with safety regulations and provisions (switching, grounding, etc.).

Switching operations also have to be performed for the commissioning. The described tests require that these be capable of being performed safely. They were not conceived for operational checks.

13.2 Enabling/Disabling the Application/Test Mode for the Entire Device

Siemens recommends to enable the test mode for the entire device before you start testing protection functions.

You can enable or disable the test mode for the entire device as follows:

- Via the on-site operation panel under **Device functions > Operating states > Application mode = Test or Test/Relay blk.**
- Via the binary inputs ($_ :91:510$) *General*:>*Test mode on* and ($_ :91:511$) *General*:>*Test mode off*
You can find the binary inputs in the DIGSI information routing under **General**.
- Via communication (IEC 61850) with the controllable ($_ :91:56$) *General*:*Application mode*
You can find the controllable in the DIGSI information routing under **General**.

When the test mode for the entire device is enabled, the indication ($_ :91:329$) *Functions in Test mode* is generated.

In the test mode of the device all device indications are marked with a test bit. This prevents the circuit breaker from switching unintentionally or protection functions from starting unintended actions. If you enable or disable the test mode for the entire device using the controllable ($_ :91:56$) *General*:*Application mode*, the device stores the state of the controllable in a voltage-fail-safe memory.

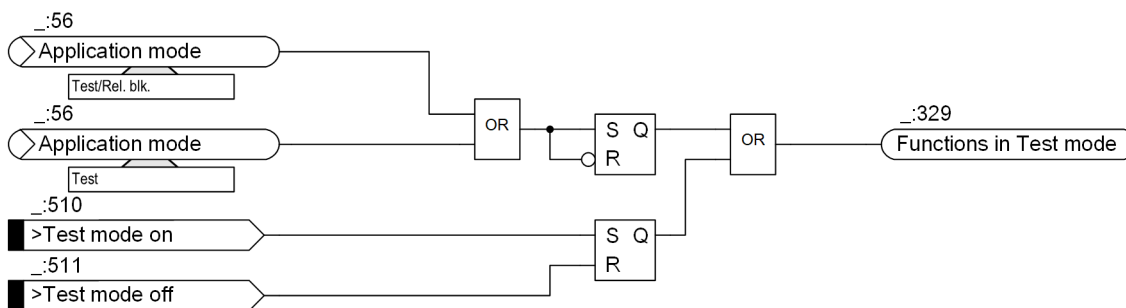

[to_application_mode_device, 1, en_US]

Figure 13-1 Logic Diagram: Enabling/Disabling the Test Mode for the Entire Device

The following figures show possible variants for enabling and disabling the test mode for the entire device using binary inputs. The following figure shows the use of push-buttons **Ta1** and **Ta2**:

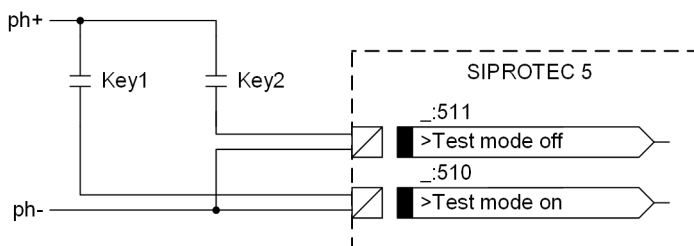

[to_application_mode_device_taster, 1, en_US]

Figure 13-2 External Wiring of Push-Buttons for Enabling/Disabling the Test Mode for the Entire Device

The following figure shows the use of a switch **S**. Route the logical binary input ($_ :91:510$) *General*:>*Test mode on* as **H** (high-active) and the logical binary input ($_ :91:511$) *General*:>*Test mode off* as **L** (low-active) to a physical binary input.

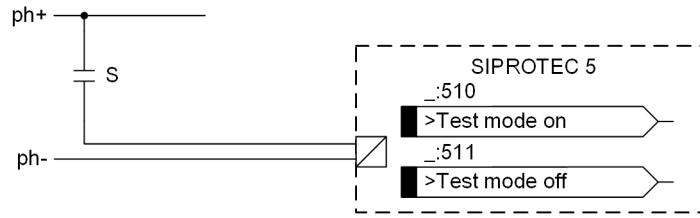

[[to_application_mode_device_switch, 1, en_US]]

Figure 13-3 External Wiring of Switches for Enabling/Disabling the Test Mode for the Entire Device

13.3 Direction Test of the Phase Quantities (Current and Voltage Connection)

The proper connection of the current and voltage transformer is checked with load current over the line to be protected. For this, the line must be switched on. A load current of at least $0.1 I_{rated}$ has to flow over the line; it should be ohmic to ohmic inductive. The direction of the load current has to be known. In case of doubt, meshed and ring systems should be unraveled. The line remains switched on for the duration of the measurements.

The direction can be derived directly from the operational measured value. First make sure that the power measured values correspond to the power direction. Normally, it can be assumed that the forward direction (measuring direction) goes from the busbar toward the line.

Using the power measured values at the device or DIGSI 5, make sure that it corresponds to the power direction:

- **P** is positive if the active power flows in the line or protected object.
- **P** is negative if the active power flows to the busbar or out of the protected object.
- **Q** is positive if the inductive reactive power flows in the line or protected object.
- **Q** is negative if the inductive reactive power flows to the busbar or out of the protected object.

If the power measured values have a different sign than expected, then the power flow is opposite the current-direction definition. This can be the case, for example, at the opposite end of the line. The current-transformer neutral point then points in the direction of the protected object (for example line).

If the values are not as expected, it may be due to a polarity reversal at the voltage connection.

As a final step, switch off the system.

13.4 Direction Test of Ground Quantities for Directional Ground-Fault Functions

13.4.1 Overview

If the CT and VT connections are in the way that the ground quantities (3I0 and V0) are calculated by the device from the phase quantities, then, no additional directional test is required. Testing according to [13.3 Direction Test of the Phase Quantities \(Current and Voltage Connection\)](#) is sufficient.

If the ground current IN or the ground voltage VN is directly measured via a device input (usually I4 or V4), the correct polarity of the ground current and the ground voltage path must be checked.



DANGER

Live system parts! Capacitive coupled voltages on dead parts!

Noncompliance with the following measures can lead to death, serious physical injury, or considerable material damage.

✧ Primary measures may be performed only on dead and grounded system parts.

13.4.2 Directional Testing for Solid or Resistive-Grounded Systems

Primary Test

The primary test is used for the evaluation of the correct polarity of the transformer connections for the determination of the ground-fault direction.

To generate a zero-sequence voltage V0, the e-n winding of one phase in the voltage-transformer set (for example, phase A) is bypassed, see [Figure 13-4](#). If no connection on the e-n windings of the voltage transformer is provided, the corresponding phase is disconnected on the secondary side, see [Figure 13-5](#). Only the current of the transformer in the phase of which the voltage is missing is transferred via the current circuit. If the line carries resistive-inductive load, the protection is subject to the same conditions as existing during a ground fault in line direction.

For directional testing, the **Directional ground-fault protection** function (67N) is configured and at least one stage is switched on. The pickup threshold of the stage must be below the load current of the line. If not, the binary input signal (`_:2311:501`) *>Test of direction* can be activated to lower the threshold temporarily for testing means without changing the respective parameter.

After switching the line on and off again, you can check the pickup signal of the directional protection stage in the fault log. A forward information must be logged. If no pickup information is logged at all, the 3I0 or U0 threshold is not exceeded.

If a wrong direction is logged, one of the following conditions may have occurred:

- The direction of the load flow is from the line towards the busbar.
- The ground-current connection is incorrect.
- The voltage connection is incorrect.



NOTE

Siemens recommends not to change parameter settings for the test. However, if parameters were changed for this test, they must be returned to their original state after completing the test!

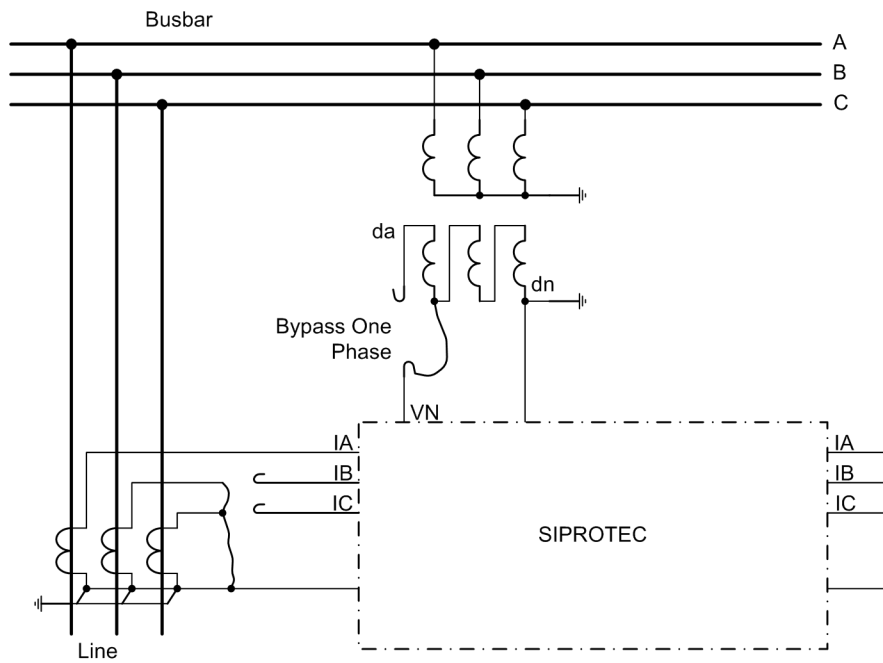

[dw_conn_polarit1_diagram_1_en_US]

Figure 13-4 Polarity Testing, Example with Current Transformers Configured in a Holmgreen-Connection and VTs with Broken-Delta Connection

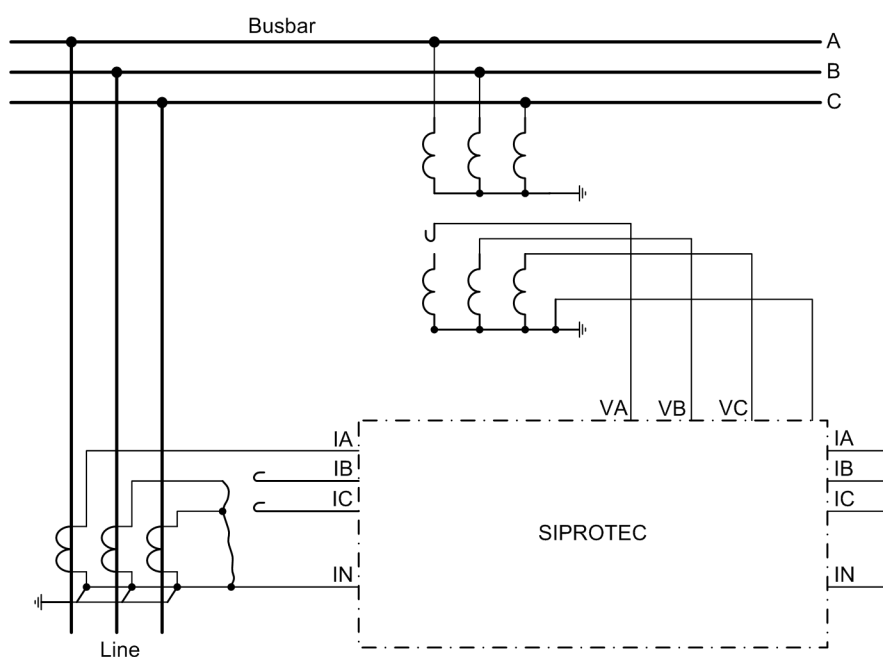

[dw_conn_polarit2_1_en_US]

Figure 13-5 Polarity Testing, Example with Current Transformers Configured in a Holmgreen-Connection and VTs with Star Connection

13.4.3 Directional Testing for Isolated or Resonant-Grounded Systems

Secondary Test with Core Balance Current Transformer

The secondary test is used for the evaluation of the correct ground-fault direction of the directional ground-fault protection functions. With this test, a core balance current transformer that is incorrectly connected can also be found.

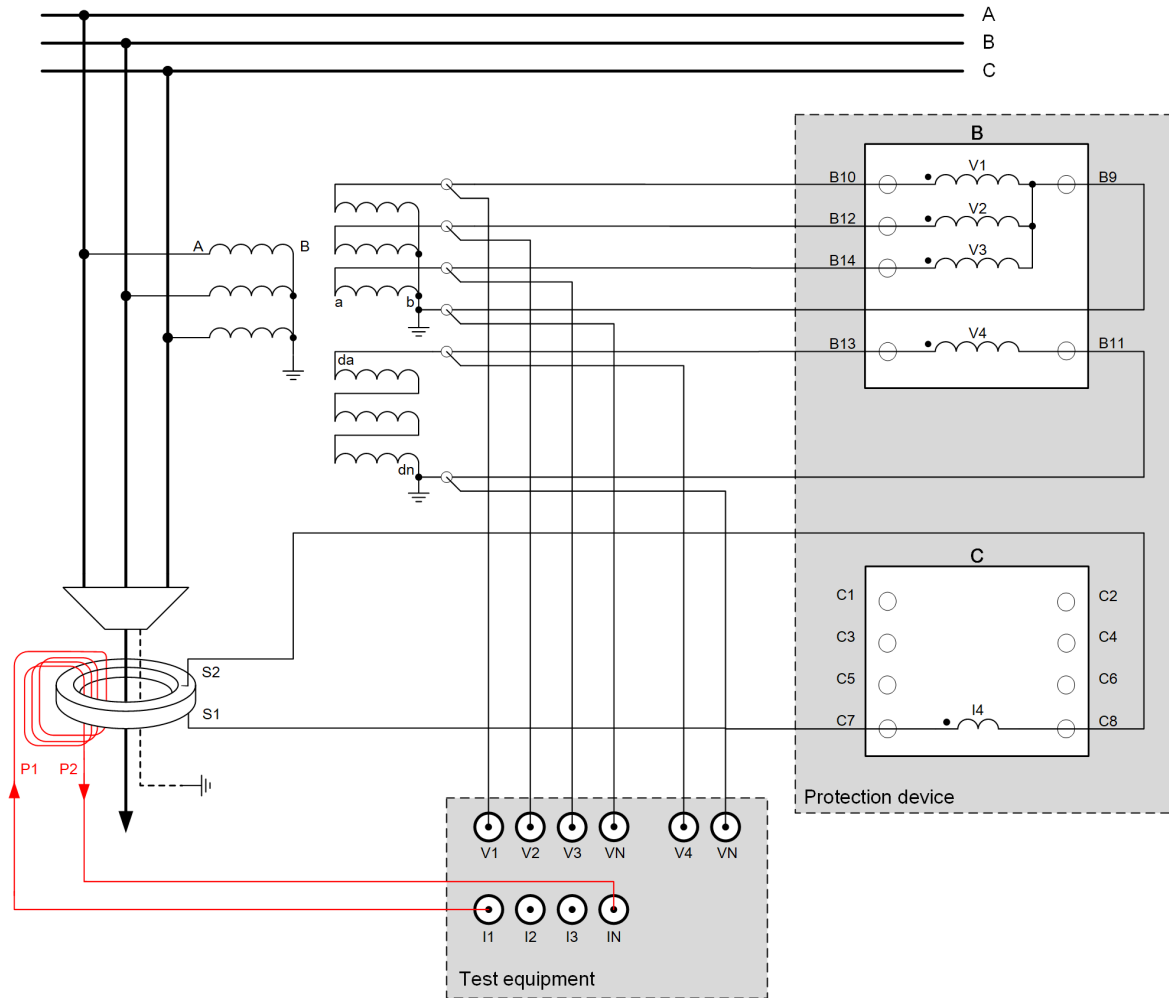

[dw_secondary_test_SGFP_for_75X800_1_en_US]

Figure 13-6 Connection with Primary Current Injection

In the preceding figure, the red pilot wire must be wired only for the testing purpose through the core balance current transformer.

- ✧ Make the connections of the test equipment according to [Figure 13-6](#).
- ✧ Route the pilot wire through the core balance current transformer in the direction towards the protection object (towards the feeder).
- ✧ To achieve a higher measured ground current, route the pilot wire multiple times through the core balance current transformer.
- ✧ The equivalent primary test current is the test current of the test device multiplied by the number of pilot-wire windings.
- ✧ Inject the test quantities according to the following table. Select the quantities according to the networking grounding and direction to be tested.

Neutral Point	Isolated				Resonant-Grounded			
	Forward		Reverse		Forward		Non-faulty	
V_A (V1)	0 V	0°	0 V	0°	0 V	0°	0 V	0°
V_B (V2)	100 V	-150°	100 V	-150°	100 V	-150°	100 V	-150°
V_C (V3)	100 V	+150°	100 V	+150°	100 V	+150°	100 V	+150°
$V_{da/dn}$ (V4)	100 V	+180°	100 V	+180°	100 V	+180°	100 V	+180°
$I_A = 3I_0$ (I145), see Figure 13-6	2 A	+90°	2 A	-90°	1 A	0°	2 A	-90°

✧ You can check the test result by the direction information from the log.

Primary Test

The primary test is used for the evaluation of the correct polarity of the transformer connections for the determination of the ground-fault direction.

For directional testing, the **Directional sensitive ground-fault detection** function (67Ns) is configured and a directional stage is switched on. For example, the directional 3I0> stage with $\cos \varphi$ or $\sin \varphi$ measurement.

The most reliable test is the one with a primary ground fault. Proceed as follows:

- ✧ Isolate the line and ground it on both sides; on the farthest line end it must remain open during the entire test.
- ✧ Place a **1-phase** ground fault bridge on the line. For overhead lines, this can be done at an arbitrary location, in any case behind the current transformer (as seen from the busbar of the feeder to be tested). For cables, the grounding is done on the farthest end (sealing end).
- ✧ Remove the protective grounding from the line.
- ✧ Switch on the circuit breaker on the line to be tested.
- ✧ Check direction indicator (LED if routed).
- ✧ Check the indication ($_ : 302$) *Ground fault* in the ground-fault log or fault log with regard to its direction. The indication ($_ : 302$) *Ground fault forward* must be logged as direction information. If *backward* is determined as the direction, either with the current connections or the voltage connections, there is an inversion in the neutral path. For the display *unknown*, the ground current is probably too low.
- ✧ Switch the line off and ground it.

This completes the test.

⁴⁵ Refers to I1 of the test equipment.

13.5 Functional Test of Thermal Overload Protection

Secondary Test

For the secondary test for the overload protection, note that all setting parameters refer to primary variables of the protected object. The protection device extracts the current transformer ratio from the power-system data and internally performs the adjustments to device nominal variables. Take these characteristics into account for the test.

- ✧ Reset the thermal memory before you repeat the test. This is possible, for instance, via the binary input indication **>Reset thermal replica**. If the function is reparameterized or is switched off, the thermal replica will also be reset.

Test without Previous Load

- ✧ Test the operate time at $1.5 I_{rated, obj}$.

In the example, the following power-system data are assumed:

$$I_{rated, obj} = 483 \text{ A}$$

$$I_{rated, transf.prim} = 750 \text{ A}$$

$$I_{rated, transf.sec} = 1 \text{ A}$$

The primary test current is $1.5 \cdot 483 \text{ A} = 724.5 \text{ A}$. This results in a secondary current of $724.5 \text{ A} \cdot 1\text{A}/750\text{A} = 0.966 \text{ A}$. A secondary current of 0.966 A must therefore be supplied.

- ✧ Calculate the operate time with the following formula. Enter only primary variables here.
- ✧ Set $I_{previous load} = 0$. The setting parameters reveal the **K-factor** (for example, 1.1) and the **Thermal time constant** (for example, 600 s or 10 min).
- ✧ Test from the cold state.

$$t = \tau_{th} \cdot \ln \left(\frac{\frac{1}{k^2} \left(\frac{I}{I_{rated,obj}} \right)^2 - \frac{1}{k^2} \left(\frac{I_{preload}}{I_{rated,obj}} \right)^2}{\frac{1}{k^2} \left(\frac{I}{I_{rated,obj}} \right)^2 - 1} \right) = 600 \text{ s} \cdot \ln \left(\frac{\frac{1}{1.1^2} \left(\frac{1.5 I_{rated,obj}}{I_{rated,obj}} \right)^2 - 0}{\frac{1}{1.1^2} \left(\frac{1.5 I_{rated,obj}}{I_{rated,obj}} \right)^2 - 1} \right) = 600 \text{ s} \cdot 0.772 = 463 \text{ s}$$

[fo_auslpr, 2, en_US]

- ✧ At a current of 0.966 A supplied on the secondary side, the protection function must trip after 463 s .

Test with Previous Load

- ✧ The object rated current ($I_{previous load} = I_{rated, obj}$) flows at a previous load of 1 (100 %).
- ✧ Supply $483 \text{ A} \cdot 1 \text{ A}/750 \text{ A} = 0.644 \text{ A}$ in this case.

After a finite time (greater than $5 \tau_{th}$), the stationary previous load sets in.

K-factor

- ✧ If you abruptly increase the supplied secondary current from 0.644 A to 0.966 A ($1.5 I_{rated, obj}$), the overload protection will trip in the following time.

$$t = \tau_{th} \cdot \ln \left(\frac{\frac{1}{k^2} \left(\frac{I}{I_{rated,obj}} \right)^2 - \frac{1}{k^2} \left(\frac{I_{preload}}{I_{rated,obj}} \right)^2}{\frac{1}{k^2} \left(\frac{I}{I_{rated,obj}} \right)^2 - 1} \right) = 600 \text{ s} \cdot \ln \left(\frac{\frac{1}{1.1^2} \left(\frac{1.5 I_{rated,obj}}{I_{rated,obj}} \right)^2 - \frac{1}{1.1^2} \left(\frac{1.0 I_{rated,obj}}{I_{rated,obj}} \right)^2}{\frac{1}{1.1^2} \left(\frac{1.5 I_{rated,obj}}{I_{rated,obj}} \right)^2 - 1} \right) = 600 \text{ s} \cdot 0.184 = 110 \text{ s}$$

[fo_auslpr, 2, en_US]

**NOTE**

Owing to the relatively large time constants in practice, the tests are carried out with significantly reduced time constants. Reset the original setting value after completing the tests.

13.6 Primary and Secondary Tests of the Circuit-Breaker Failure Protection

Integration of the Protection Function into the Station

The integration of the protection function into the station must be tested in the real-life application. Because of the multitude of possible applications and possible system configurations, the required tests cannot be described here in detail.



NOTE

Always keep the local conditions, the station plans, and protection plans in mind.



NOTE

Siemens recommends isolating the circuit breaker of the tested feeder at both ends before starting the tests. Line disconnecter switches and busbar disconnecter switches must be open so that the circuit breaker can be operated without risk.

General Precautions



CAUTION

Tests on the local circuit breaker of the feeder cause a trip command to the output to the adjacent (busbar) circuit breakers.

Noncompliance with the following measure can result in minor personal injury or material damage.

- ✧ In a first step, interrupt the trip commands to the adjacent (busbar) circuit breakers, for example, by disconnection of the corresponding control voltages.

For testing the circuit-breaker failure protection, it must be ensured that the protection (external protection device or device-internal protection functions) cannot operate the circuit breaker. The corresponding trip command must be interrupted.

Although the following list does not claim to be complete, it can also contain points, which have to be ignored in the current application.

Test Modes

The device and the function can be switched to test mode. These test modes support the test of the function in different ways:

Test Modes	Explanation
Device in test mode	This operating mode is relevant for the following tests: 1. Approach of current thresholds in the case of an external start: Supervision of the binary input signals in the case of an external start is disabled. This setting allows a static activation of the starting signals in order to approach the current threshold. 2. Check whether the issued trip commands actuate the corresponding circuit breakers, because the device contacts are also actuated in the device test mode.
CBFP function in test mode (device is NOT in test mode)	This operating mode is important for function tests in which the generated operate indications are NOT supposed to actuate the binary outputs.

**NOTE**

When the function or device is in test mode, all indications are given a test bit.

**NOTE**

In the mode **Device in test mode**, the operate indications generated by the function operate the binary outputs.

The function must also be tested in its normal, switched-on condition.

Consider the following in this case:

- ✧ The device contacts are actuated.
- ✧ Binary input signal supervision (in the case of an external start) is enabled and blocks the function.
- ✧ All indications generated are generated without test bit.

Circuit-Breaker Auxiliary Contacts

When circuit-breaker auxiliary contacts are connected to the device, they make an essential contribution to the reliability of the circuit-breaker failure protection, provided that their settings are set accordingly.

- ✧ Make sure that the correct assignment has been checked.

Internal Starting Conditions (Trip Command from Internal Protection Function)

The internal start can be tested by means of tripping a protection function, for example, the main protection function of the device.

- ✧ Check the settings for circuit-breaker failure protection. See also chapter [6.42.4 Application and Setting Notes](#).
- ✧ For the circuit-breaker failure protection to be able to pick up, a phase current (see current-flow criterion) must be present. This can be generated by a device-internal test sequence (see description in the *Operating manual*). It can also be a secondary test current.
- ✧ Generate the trip for the protection function. This can be generated within the device by a test sequence (see description in the *Operating manual*) or by creating corresponding secondary test values.
- ✧ The trip command(s) and their time delay compared to the pickup, depending on the parameterization.

External Starting Conditions (Trip Command from External Protection Function)

If external protection devices are also able to start the circuit-breaker failure protection, the external starting conditions require checking.

- ✧ Check the settings for circuit-breaker failure protection.
See also chapter [6.42.4 Application and Setting Notes](#).
- ✧ For the circuit-breaker failure protection to be able to pick up, a phase current (see current-flow criterion) must be present. This can be generated by a device-internal test sequence (see description in the *Operating manual*). It can also be a secondary test current.
- ✧ Activate the binary input or inputs to which the start signal and possibly also the release signal for the CBFP function are routed. This can be done in 2 ways:
 - 1) Via internal test sequences
 - 2) By controlling the binary input or inputs via an auxiliary voltage
- ✧ Check the start input signal, and if available, check the enable input signal in the spontaneous or fault messages.
- ✧ Check the pickup indication in spontaneous or fault indications.
- ✧ The trip command(s) and their time delay compared to the pickup, depending on the parameterization.

Start by Trip Command from the External Protection

- ✧ Check the static and - in case of 2-channel operation - also the dynamic supervision of the binary input signals. For this purpose, induce pickup of the supervision and check the supervision indications and the ready signal in the event log buffer.

Start by Trip Command from the External Protection without Current Flow

- ✧ If start is possible without current flow: (see **Start by trip command from the external protection**).

Repetition of the Local Tripping (T1)

- ✧ Make sure that the trip repeat signal controls a 2nd circuit (2nd coil) for switching off the circuit breaker.

Backup Tripping in the Case of a Circuit-Breaker Failure (T2)

For tests in the station, it is important to check that the distribution of trip commands to the adjacent circuit breakers in the case of a circuit-breaker failure is correct. The adjacent circuit breakers are all circuit breakers, which must be tripped in order to ensure interruption of the short-circuit current if the feeder circuit-breaker fails. They are therefore the circuit breakers of all feeders which feed the busbar or busbar section to which the feeder with the fault is connected.

A general detailed test guide cannot be specified because the layout of the adjacent circuit breakers depends largely on the system topology.

- ✧ With multiple busbars, the trip distribution logic for the adjacent circuit breakers must be checked.
The test has to check for every busbar section that, in case of a failure of the feeder circuit-breaker under observation, only those circuit breakers which are connected to the same busbar section are tripped.

Backup Tripping on Circuit-Breaker Failure (T2), Tripping of the Opposite End

If the trip command of the circuit-breaker failure protection must also trip the circuit breaker at the opposite end of the tested feeder, the communication channel for this remote trip has to be tested as well.

Termination

- ✧ All temporary measures taken for testing must be undone, such as special switch positions, interrupted trip commands, changes to setting values, or individually switched off protection functions.

13.7 Circuit-Breaker Test

The **Circuit-breaker test** function enables you to easily perform a complete test of the trip circuit, the closing circuit, and the circuit breaker. For this, the circuit-breaker test carries out an automatic opening and closing cycle or an only-open cycle of the circuit breaker during operation. You can also include a current-flow criterion in the test. The effect of the current-flow criterion is to ensure the circuit-breaker test is only carried out if the current flow across the circuit breaker is below the parametrizable threshold.



NOTE

If the circuit-breaker auxiliary contacts are not connected, a circuit breaker that has been opened can be permanently closed.

The following test program is available for you to carry out the circuit-breaker test.

No.	Test Program
1	3-phase open/closed cycle

Structure of the Function

The **Circuit-breaker test** function is used in protection function groups for circuit breakers.

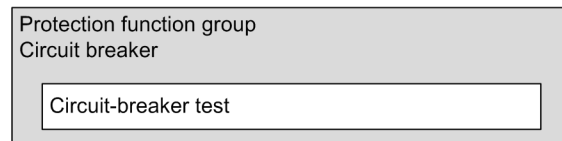

[dw_cbch01, 1, en_US]

Figure 13-7 Embedding of the Function

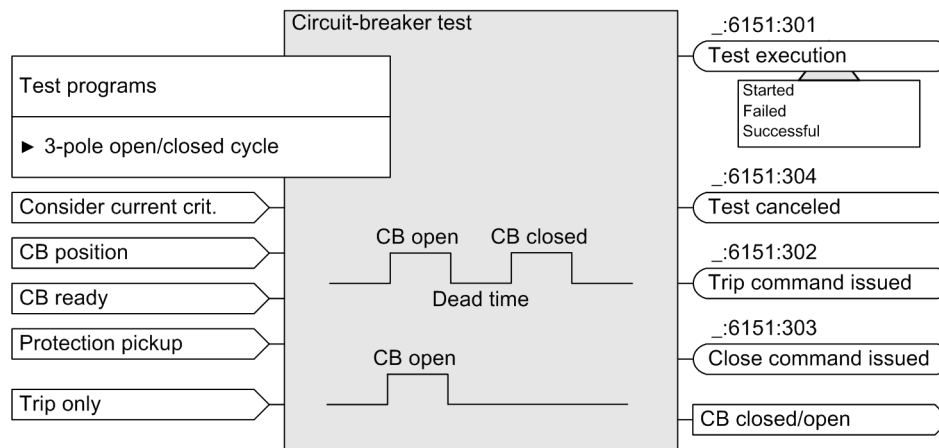

[dw_zecbc3p2, 2, en_US]

Figure 13-8 Structure of the Function

Test Procedure

The following conditions must be satisfied before the circuit-breaker test can start:

- ✧ If a circuit-breaker auxiliary contact signals the position of the breaker pole to the device via the binary inputs of the signal **Position**, the test cycle is not initiated unless the circuit breaker is closed.
- ✧ If the circuit-breaker auxiliary contact has not been routed, you must ensure that the circuit breaker is closed.
- ✧ The circuit breaker must be ready for an open-closed-open or only-open cycle (indication **>Ready**).

- ✧ A protection function must not have been picked up in the circuit-breaker protection function group responsible for the circuit breaker.

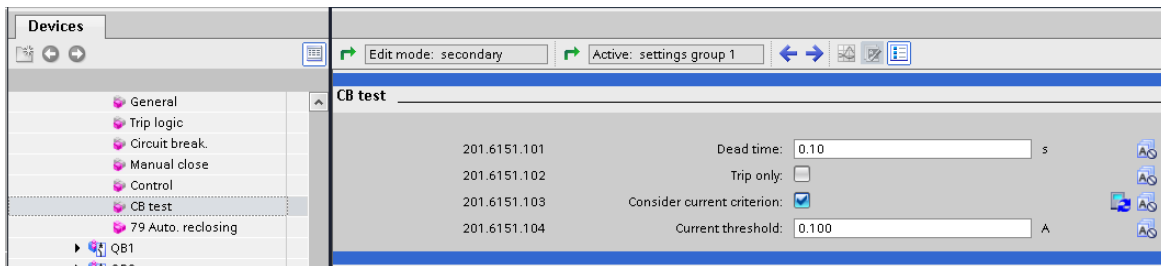

Figure 13-9 Settings for the Circuit-Breaker Test

Figure 13-10 shows the progression over time of an open-close cycle. If you activated the (`_ : 6151:102`) **Trip only** option, the close command will not be executed and the dead time will not be taken into account.

If a circuit-breaker auxiliary contact is connected, the function waits for the indication circuit breaker **Position = open** after the trip command is generated. When the indication **Position = open** is received, the close command is transmitted after a dead time (parameter (`_ : 6151:101`) **Dead time**) for an open-close cycle. If the feedback from the circuit-breaker positions is not received within the maximum transmission time (**Dead time + 2 · Output time + 5 s**), the circuit-breaker test is aborted and considered to be failed. The proper functioning of the circuit breaker is monitored via the feedback on the circuit-breaker positions.

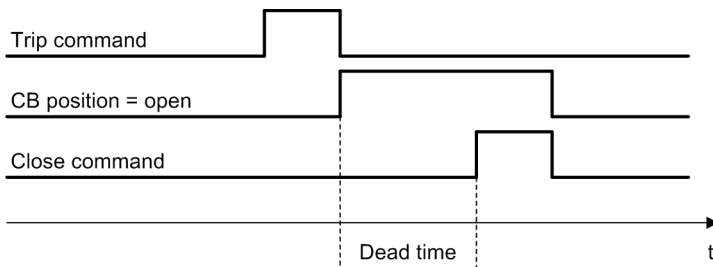

Figure 13-10 Progress over Time of a Circuit-Breaker Test Cycle

Use the (`_ : 6151:103`) **Consider current criterion** parameter to ensure the circuit-breaker test is only carried out when the current flowing through the circuit breaker does not exceed a specific current threshold (parameter (`_ : 6151:104`) **Current threshold**). Otherwise, the circuit-breaker test is not started.

- ✧ If the current-flowcriterion is deactivated, the current threshold is not evaluated. The circuit-breaker test is performed irrespective of the current-flow level through the circuit breaker.



NOTE

The circuit-breaker test does not perform a synchrocheck even if the synchrocheck has been configured in the protection-function groups for circuit breakers. This can cause stability problems in the system during a 3-pole interruption. Therefore, a 3-pole circuit-breaker test should be very short, or not performed at all under load.

You can start the test program as follows:

- Via the device-control panel
- Via DIGSI
- Via communication protocols
- Via control commands, which you can also connect in the CFC

The following figure illustrates operation of the circuit-breaker test in DIGSI.

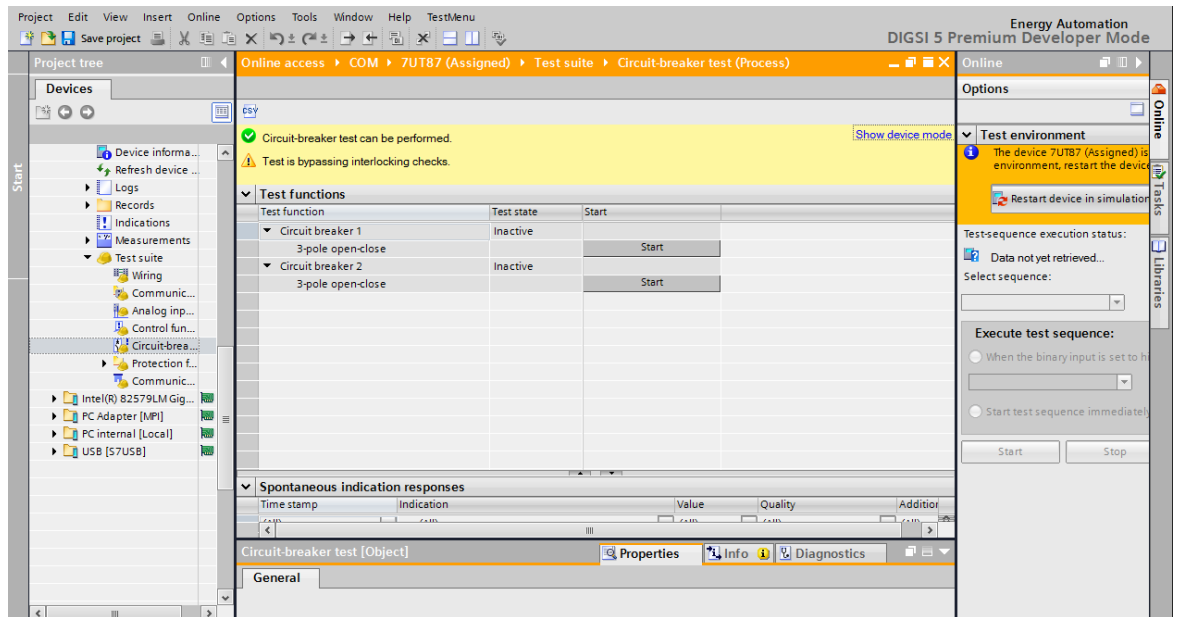

Figure 13-11 Circuit-Breaker Test in the Test Suite in DIGSI

- ✧ Select the function in the project tree on the left in the online access.
- ✧ Start the desired test program in the upper portion of the working area.
- ✧ The corresponding feedback is displayed in the bottom portion of the working area. Additional information about the behavior of other functions while the circuit-breaker test is being performed can be read in the operational log.

13.8 Functional Test of the Inrush-Current Detection

General

- ✧ For the test, make sure that the test current reflects the typical inrush current.
- ✧ Perform the test with transient signals. These can be recorded inrush currents or simulated currents from a transient system model.
- ✧ When using synthetic signals, observe the notes on the individual measuring principles.

Harmonic Analysis

- ✧ Superimpose on the fundamental-component current a test current of double frequency (2nd harmonic) and test the pickup behavior with this.
- ✧ Cause a threshold value excess (internal pickup) for one of the protection functions that you want to block.
- or -
- ✧ Apply a test current with a load current as lead (current step).

The inrush current detection creates a blocking signal.

CWA Process

- ✧ Create a test current that has flat ranges of a minimum width of 3 ms simultaneously in all 3 phase currents.

The inrush current detection creates a blocking signal.

13.9 Functional Test of Transient Ground-Fault Protection

General

This function requires the correct polarity of the ground current I_N and the neutral-point displacement voltage V_N respectively the zero-sequence voltage V_0 . For the direction test of these quantities, refer to [13.6 Primary and Secondary Tests of the Circuit-Breaker Failure Protection](#).

The function is based on the evaluation of the transient in the zero-sequence system after the ground-fault ignition.

For issuing the signal (`_:13021:302`) *Ground fault*, the following 2 conditions must be met:

- There is a transient in the ground quantities.
- The fundamental component of the zero-sequence voltage V_0 exceeds the threshold (`_:13021:103`) **$V_0 > \text{threshold value}$** .

The following 2 methods are available for testing of the signal (`_:13021:302`) *Ground fault*:

- Replaying real transient ground-fault recordings to the device
- Using secondary test equipment which allows to simulate transients ground faults

However, the setting of parameter (`_:13021:103`) **$V_0 > \text{threshold value}$** cannot be tested precisely with the mentioned 2 methods, since this test requires a static V_0 . An easy way to test the setting is described in the following.

Secondary Test

This test must be carried out by injecting static secondary quantities. The test equipment needs to be configured in a way that it generates zero-sequence current I_0 and zero-sequence voltage V_0 , which are injected to the SIPROTEC 5 device. By carrying out a shot, for example, a status change from zero-sequence values of 0 A and 0 V to the values not equal to zero, a transient is generated. The signal (`_:13021:302`) *Ground fault* is issued as long as the static zero-sequence voltage of the 2nd state is greater than the set threshold. As amplitude for the secondary I_0 , 100 mA is a suitable value. In this test, the directional result contained in the signal (`_:13021:302`) *Ground fault* is not defined and relevant, since the task is to test the setting of parameter (`_:13021:103`) **$V_0 > \text{threshold value}$** only.

For testing the threshold, shots must be carried out with a static V_0 slightly below the threshold and slightly above the threshold, for example, to 98 % and 102 % of the threshold value or to a threshold value of -0.2 V and +0.2 V (the greater absolute deviation of the threshold value must be selected).

Consider that the V_0 threshold is defined according to the definition of the symmetrical components. A full neutral-point displacement voltage V_N of 100 V causes $V_0 = 57.7$ V.

Example

- (`_:13021:103`) **$V_0 > \text{threshold value} = 15$ V**
- 3 shots from 0 to $V_0 = 14.7$ V and $I_0 = 100$ mA
No signal (`_:13021:302`) *Ground fault* is issued.
- 3 shots from 0 to $V_0 = 15.3$ V and $I_0 = 100$ mA
Signal (`_:13021:302`) *Ground fault* is issued

If the test result is not as expected, check the injected static V_0 voltage via the operational measurement of the device which contains the zero-sequence components.

13.10 Functional Test of the Trip-Circuit Supervision

General

- ✧ For the test, make sure that the switching threshold of the binary inputs is clearly below half the rated value of the control voltage.

2 Binary Inputs

- ✧ Make sure that the binary inputs used are isolated.

1 Binary Input

- ✧ Make sure that, in the circuit of the 2nd circuit-breaker auxiliary contact, an equivalent resistance R is connected.
- ✧ Observe the dimensioning notes under the section **Equivalent resistance R**.

13.11 Functional Test for the Phase-Rotation Reversal

- ✧ Check the phase sequence (direction of rotating field) at the device terminals. It must correspond to the setting of the **Phase sequence** parameter.
- ✧ The output indication *Phase sequence ABC* or *Phase sequence ACB* displays the determined phase sequence. This must correspond to the phase sequence that was set.
- ✧ You can also determine the phase sequence via the **Symmetrical components** measured values. If you obtain negative-sequence system variables (V_2 , I_2) and no positive-sequence system variables (V_1 , I_1) with symmetrical 3-phase infeed, the setting parameter **Phase sequence** does not correspond to the connection.

13.12 Functional Test for Overvoltage Protection with Zero-Sequence Voltage/Residual Voltage

Checking the Stator Ground-Fault Protection with the Machine

You have to check whether the protection function and the protection ranges are functioning correctly. The following tests are intended for the unit connection.

You can check the protection range by performing a test with a ground fault at the generator terminals. The ground fault test in the power system enables you to verify the noise suppression of the load resistor.

Checking the Protection Range with a Machine Ground Fault



DANGER

Do not touch live parts or reach into rotating machines.

Touching live parts or reaching into rotating machines will result in death or serious injury.

- ✧ Perform primary measures only when the machine is at standstill and the system components are de-energized and grounded.
-
- ✧ Insert a 1-phase-to-ground jumper into the terminal circuit of the machine.
 - ✧ Set the **Mode** parameter in the protection stage to **test**. This prevents the trip command from being generated for the stage.
 - ✧ Start the machine and excite it slowly up to approx. 20 % of the rated machine voltage.
 - ✧ From the operational measured values, check the plausibility of the zero-sequence voltage V_0 and the input voltage at the connected input.
 - ✧ Determine the protection range from the pickup voltage.
The following applies for the protection range S:

$$S = \frac{\frac{V_{NG}}{\sqrt{3}} - V_{0, \text{pickup value}}}{\frac{V_{NG}}{\sqrt{3}}} \cdot 100 \%$$

[fo_schzbe, 2, en_US]

Example: Measurement with secondary voltages

V_{NG} : Generator voltage transformed to the transformer secondary side = 100 V

$V_{0, \text{pickup value}}$: Measured zero-sequence voltage at pickup = 5.68 V

S: Resulting protection range = 90 %

- ✧ Check the messages in the message buffer. If the **Detection of faulty phase** parameter is set to **yes**, check the display of the phase affected by the fault.
- ✧ Shut the machine down and remove the ground fault bridge.
- ✧ Set the **Mode** protection stage parameter to **on**.

Checking Disturbance-Voltage Suppression in the Load Resistor with a System Ground Fault



DANGER

Do not touch live parts or reach into rotating machines.

Touching live parts or reaching into rotating machines will result in death or serious injury.

- ✧ Perform primary measures only when the machine is at standstill and the system components are de-energized and grounded.

-
- ✧ With the primary system de-energized and grounded, insert a 1-pole ground fault bridge on the high-voltage side of the unit transformer.
-



CAUTION

If there is a neutral-point grounding at the transformer and simultaneously a grounding on the high-voltage side, do not perform the test.

Material can be damaged during the test if there is a neutral-point grounding at the transformer and simultaneously a grounding on the high-voltage side.

- ✧ Neutral grounding at the transformer must be interrupted during the test.

-
- ✧ Start the machine and excite it slowly up to 30 % of the rated machine voltage.
 - ✧ Read the zero-sequence voltage $V_{0, \text{measured value}}$ from the operational measured values.
 - ✧ Extrapolate the zero-sequence voltage to 100 % of the machine voltage ($V_{0, \text{fault}}$).
 - ✧ Calculate the safety margin by dividing the calculated fault value by the set threshold value.

If the result is less than 0.5, the safety margin is sufficient. If the fault voltage is lower, you can increase the sensitivity of the protection function.

EXAMPLE:

$$V_{0, \text{meas.}} = 0.75 \text{ V}$$

$$V_{\text{threshold value}} = 5.68 \text{ V}$$

$$V_{0, \text{fault}} = 0.75 \text{ V} * 100 \% / 30 \% = 2.5 \text{ V}$$

$$\text{Safety margin} = 2.5 \text{ V} / 5.68 \text{ V} = 0.44$$

The calculated safety margin of 0.44 is sufficient because it is below 0.5.

- ✧ Shut the machine down and de-excite it. Remove the ground-fault bridge.
- ✧ Restore neutral-point grounding if you require grounded operation of the neutral on the high-voltage side of the unit transformer.

When using the function for startup ground-fault protection on a busbar connection, carry out the same check as for the unit connection, but only the part **Test during machine ground fault**.

13.13 Primary and Secondary Testing of the Synchronization Function

Measuring the Circuit-Breaker Make Time

Under asynchronous system conditions, the circuit-breaker make time must be measured and set correctly. This achieves an exact parallel switching with a phase angle 0°. If switching occurs only in synchronous system conditions, this section can be skipped.

The make time can be determined via the following 2 methods:

- By reading from a fault record (recommended method)
- With external timer

1. A simple option for determining the make time involves reading the time between the close command and closure of the switch pole via the fault record. The time determined here is the real make time and not the operating time of the circuit breaker. You do not have to add any further time.

Siemens recommends the following procedure:

- ✧ Establish a condition in which the circuit breaker can be closed without hazard.
- ✧ If V2 is switched through, activate the operating mode `Close cmd. at V1< & V2>` for the synchronization stage⁴⁶ or by setting it to `yes`.
If V1 is switched through, activate the operating mode `Close cmd. at V1> & V2<`.
- ✧ Make sure that the fault recorder is turned on. Via a temporary CFC chart, link the signal `Release close cmd.` of the active synchronization stage to the binary input signal `>Manual start` (of the fault recorder). With the release of closure, a fault record of the parameterized duration is set up (the default setting of 500 ms is more than adequate for this).
- ✧ Starting the synchronization stage. The device activates immediately.
- ✧ Read the fault record and determine the make time via SIGRA (see [Figure 13-12](#)).
Use the 2 cursors and the time-measuring function for this. Position the first cursor on the raising close command. The occurrence of the 2nd voltage signals the closed power-switching poles. Place the 2nd cursor on the raising 2nd voltage.
- ✧ Set the determined time with the parameter `CB make time`.
Proceed in the same way for all other synchronization stages.
- ✧ Set the parameter `Close cmd. at V1< & V2>` or parameter `Close cmd. at V1< & V2<` back to its source value.
- ✧ Delete the CFC chart.

⁴⁶ Synchronization stage represents the stage `Synchrocheck`, `Synchronous/Asynchronous (Synchr./Asyacr.)`, or `Synchronous/asynchronous with balancing commands (Syn./Asy.bal.)`.

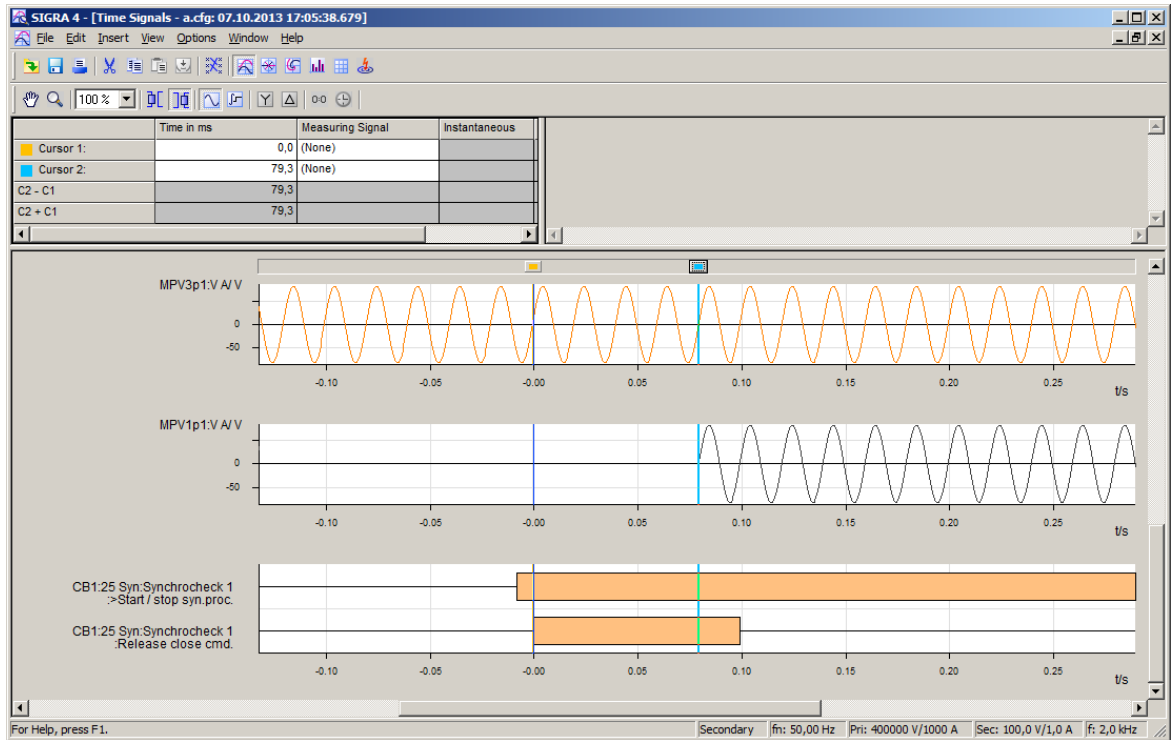

[sc_syn001-01_2_en_US]

Figure 13-12 Measurement of the Circuit-Breaker Make Time

2. The configuration in [Figure 13-13](#) is suitable for measuring the circuit-breaker operating time with an external timer. Set the timer to the range 1 s or a tripping of 1 ms.

Connect the circuit breaker manually. The timer is started simultaneously by this. After the poles of the circuit breaker close, the voltage V_{Line} appears. The timer is then stopped.

If the timer is not stopped owing to an unfavorable closing moment, repeat the attempt.

Siemens recommends calculating the average value from several (3 to 5) successful switching attempts.

**NOTE**

Add the OOT (Output Operating Time) of the protected device to the measured time. The OOT exclusively depends in good approximation on the binary output used for the close command. You can find the OOTs for different binary outputs in [14 Technical Data](#). Set the total time with the parameter **CB make time**. Proceed in the same way for all other synchronization stages used in the device.

Siemens recommends sending the close command via the hard-wired connection. If you use a GOOSE signal to send the close command, consider the time delay caused by the GOOSE communication while setting the parameter **CB make time**.

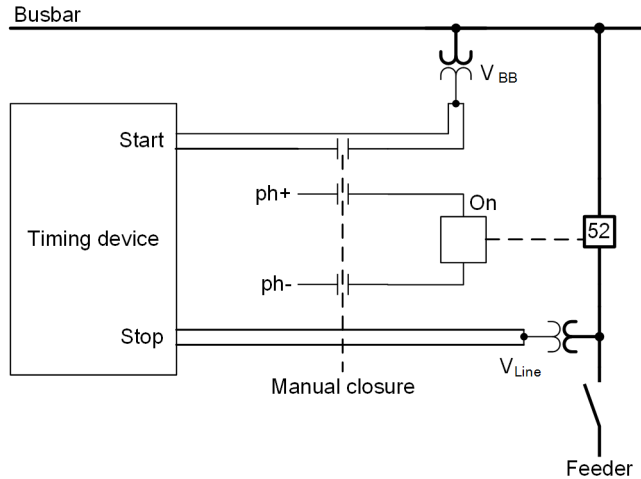

[dw_synae6-01, 2, en_US]

Figure 13-13 Measurement of the Circuit-Breaker Make Time

Checking the Measurement Chain

The measurement chain for the voltage measurement must be checked. As soon as one of the synchronization stages to be used is closed, all the necessary functional measured values are calculated. The synchronization stage, thus, does not have to be started for this check.

Proceed as follows when checking the measurement chain as a primary or secondary test:

a) As primary test

- ✧ Establish a synchronous state by closing the circuit breaker, if possible.
- ✧ Check the functional measured values within the synchronization function:
 - The delta values must be 0.
 - Check the voltages V1 and V2 for plausible values in comparison with the operational measured values for the voltage.
 - Check the frequencies f1 and f2 for plausible values in comparison with the operational measured value for the frequency.

b) As secondary test

- ✧ Establish a synchronous state by applying synchronous voltage values at both measuring points.
- ✧ Check the functional measured values within the synchronization function:
 - The delta values must be 0.
 - Check the voltages V1 and V2 for plausible values in comparison with the operational measured values for the voltage.
 - Check the frequencies f1 and f2 for plausible values in comparison with the operational measured value for the frequency.

Blind Switching Attempts when Used in Machines

Perform blind switching attempts when using the function in machines.

Prerequisite:

- ✧ You have checked the setting values again.
- ✧ The circuit breaker is switched off. The close command for the circuit breaker is interrupted (disconnecting the close command). The system voltage is switched through for the measurement.

a) Attempt with asynchronous systems:

- ✧ Via manual control, set the generator to a speed slightly below the permitted frequency difference according to the setting values **Max. frequency diff. $f_2 > f_1$** and **Max. frequency diff. $f_2 < f_1$** . The generator is excited to line voltage. You can read out the values in the operational measured values.
 - ✧ Start the synchronization stage, for example, externally with binary input signal or via the integrated controller. You can use a synchroscope to trigger the start at synchronism, that is, at **12 o'clock**. The duration until the close command then corresponds to a cycle with the duration $1/\Delta f$. At a frequency difference of 0.1 Hz, the duration is thus 10 s.
 - ✧ Insofar as permissible, perform this attempt several time for oversynchronous switching and subsynchronous switching.
 - ✧ The switching performance can be checked with an external recorder or the integrated fault recording function. You have to start the fault recording explicitly.
 - ✧ You can repeat the blind switching attempts at the limits of the permissible voltage difference.
- b) Attempt with synchronous systems:
- ✧ Start the synchronization stage, for example, externally with binary input signal or via the integrated controller.
 - ✧ Check the proper release for activation with the message log or via a fault record. You have to start the fault recording explicitly. All activation conditions have to be fulfilled within the time **Delay close command**.
If you observe the change between synchronous and asynchronous operation, raise the changeover threshold **f-threshold ASYN \leftrightarrow SYN** slightly.
- c) Attempt with synchrocheck:
- ✧ If you use this function in conjunction with the manual synchronization, check the proper release for closure.
 - ✧ Synchronize the generator manually. Start the synchronization stage externally via a binary input. Check the proper release for closure with the indication log or via the fault record. You have to start the fault recording explicitly.

13.14 Testing the Negative-Sequence Current

When testing, keep in mind that the measured values are standardized. In the setting $I_2/I_{\text{rated, obj.}}$, they are standardized to the rated current of the protected object. The conversion to secondary transformer values is accomplished in the device.

EXAMPLE:

The threshold value is set to 10 % of the protected object.

Transformer: 100 A/1 A

Rated current of the protected object: 80 A

Action Steps

- ✧ At a setting of 10 %, the primary negative-sequence current is $80 \text{ A} \cdot 10 \% / 100 \% = 8 \text{ A}$.

For a current transformer ratio of 100, test with a secondary current of 0.08 A.

- ✧ With a transformer of 100 A/5 A, the test current is higher by the factor 5. Test with 0.4 A. The pickup value is at $1.1 \cdot 0.4 \text{ A} = 0.44 \text{ A}$.
- ✧ If deviations occur during the testing, you must check whether the power-system data were entered correctly.



NOTE

Keep in mind that the function works starting from the set minimum current.

13.15 Functional Test for Reverse-Power Protection

13.15.1 Secondary Test

When performing the secondary test, note that the setting value for the reverse power refers to the machine variables. Due to the mismatching of the current transformer, you must check with reduced currents. You can deduce the reduction from the ratio $I_{\text{rated, generator}}/I_{\text{rated, CT}}$. Check the reverse-power protection at rated voltage. If the voltage transformer is not adjusted to the rated generator voltage, correct the secondary voltage, too. Use the following ratio:

$$V_{\text{rated, generator}}/V_{\text{rated, VT}}$$

13.15.2 Primary Test

For measurements on the protection current transformers and with sensitive setting of the reverse-power protection, Siemens recommends determining the reverse power and the angle-correction values. Regardless of the generator excitation, that is regardless of the reactive power Q , the reverse power P as a pure active power is constant. The resulting characteristic curve is a straight line that runs parallel to the Q axis. Due to possible angle errors of current transformers and voltage transformers, the protection device does not measure a constant active power. The current flowing at this time, which can be assumed as being proportional to the reactive power, has a substantial influence.

The deviations are determined with 3 measurements and the correcting quantity φ_{corr} is determined from the results.

To calculate the correction angle, enter the active power and reactive power measured with the device in the following table.

Use the functional measured values **P1avg** and **Q1avg** (type averaged).

Table 13-1 Value Table for Angle Correction

State	Reverse Power	Reactive Power
Reactive power near zero	$P_0 =$	$Q_0 =$
Overexcited	$P_1 =$	$Q_1 =$
Underexcited	$P_2 =$	$Q_2 =$

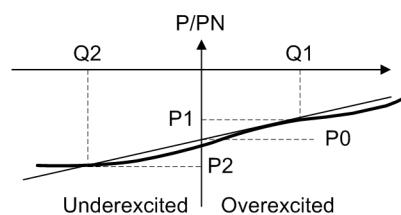

[dw_rpp_correction_angle_2_en_US]

Figure 13-14 Determining the Correction Angle φ_{corr}



CAUTION

Be careful if you operate the turbine without a certain minimum steam flow (cooling effect).

Operating the turbine without a certain minimum steam flow (cooling effect) can overheat the turbine blades!

◇ The consumption of reverse power for a turbo-generator set is only allowed for a short time!



CAUTION

If the generator is underexcited, there is the risk of an out-of-step condition!

Non-observance of the following measures can result in minor personal injury or material damage.

✧ The following measures prevent the risk of an out-of-step condition.

- ✧ Regulate the driving power to 0 by closing the control valves. The generator draws its reverse power from the electrical power system.
- ✧ Change the excitation until the reactive power $Q = 0$. As a control measurement, read the active power P_0 and the reactive power Q_0 with the sign, and enter the values in [Table 13-1](#).
- ✧ Increase the excitation slowly until reaching approx. 30 % of the rated apparent power of the generator (overexcited).
Read the reverse power P_1 with the sign (negative) and the reactive power Q_1 with the sign (positive) in the functional measured values and note these 2 values in the values table.
- ✧ Reduce the excitation slowly until reaching approx. 30 % of the rated apparent power of the generator (underexcited).
Read the reverse power P_2 with the sign (negative) and the reactive power Q_2 with the sign (negative) in the functional measured values and note these 2 values in the values table.
- ✧ Run the generator again at no-load excitation and select the desired operating state.
- ✧ With the measured value pairs (P_1, Q_1 and P_2, Q_2), calculate the correction angle ϕ_{corr} with the following formula:

$$\phi_{corr} = \arctan \frac{P_1 - P_2}{Q_1 - Q_2}$$

[fo_RPP correction angle, 2, en_US]



NOTE

Insert the power values with the signs that you read previously!

- ✧ Enter this angle ϕ_{corr} with the same sign as the new correction angle (parameter (`_:2311:101`) **Angle correction**):

Setting value (`_:2311:101`) **Angle correction** = ϕ_{corr}

- ✧ You can determine the pickup value of the reverse-power protection from the measured values P_1 and P_2 .

Use the following formula: $P_{pickup} = (P_1 + P_2) / 4$

Set the value as pickup value: Parameter (`_:991:3`) **Threshold** = P_{pickup}

Check of the Reverse-Power Protection

With a generator that is connected to the power system, the reverse power results from closing the control valves or from closing the quick stop.

- ✧ In both cases, check the consumed active power (reverse power). The valves could be leaking.
- ✧ Repeat the reverse-power measurement to confirm that the settings are correct.

- ✧ To check the efficiency of the reverse-power protection on the basis of the indications, use the parameter (**_:991:1**) **Mode** to switch the reverse-power protection to **test** .
Proceed as follows:
- ✧ Start the generator and synchronize it with the power system.
- ✧ Close the control valves.
- ✧ From the functional measured value, take the reverse power that was measured by the protection device as the active power. Use 50 % of the functional measured value as setting value for the reverse-power protection.
- ✧ Increase the driving power up to normal operation.
- ✧ Check the quick-stop criterion.
Proceed as follows:

**NOTE**

Make sure that the binary input **>Stop valve closed** is properly routed. The quick-stop criterion (the pressure-operated switch or the limit switch on the quick-stop valve) must control this binary input.

- ✧ Close the quick-stop valve.
- ✧ From the functional measured value **P1avg** , take the reverse power that was measured by the protection device as the active power.
- ✧ If – contrary to expectations – this value is smaller than the reverse power when the control valves are closed, take 50 % of this value as the setting value for the reverse-power protection.
- ✧ Shut down the machine by activating the reverse-power protection. Set the parameter (**_:991:1**) **Mode** to **on** .

13.16 Functional Test for Overexcitation Protection

Secondary Test



NOTE

While performing the secondary test, ensure that the data of the protected object refer to the protection function.

This means that a mismatch between the voltage transformer and the protected object will be corrected automatically. For instance, when applying the secondary rated voltage and the rated frequency, this must not result in a V/f value of 1.

The mismatch of the voltage transformer must be taken into consideration when selecting the test voltage. Multiply the secondary test voltage with the following 'k' factor.

$$k = \frac{V_{\text{rated,obj}}}{V_{\text{rated,transf.}}}$$

[fo_kfakuf, 1, en_US]

Example

$$V_{\text{rated,obj}} = 110 \text{ kV}; V_{\text{rated,transf.}} = 100 \text{ kV}$$

It follows from the above that $k = 1.1$. For example, when verifying the nominal conditions if the secondary rated voltage is 100 V, a voltage of $1.1 * 100 \text{ V} = 110 \text{ V}$ must be supplied. The measured value of the function **Measured value V/f** must display 1.0000.



NOTE

When checking the dependent stage, ensure it is associated with a **thermal replica**. When repeating a test, always reset the replica, using the binary input indication **>Reset therm. replica** (`_ : 13951 : 501`).

Primary Test

The plausibility check between instantaneous overexcitation and the displayed operational measured value is used to verify the functionality of overexcitation.

Instantaneous overexcitation is a result of the following function:

$$\frac{V}{f} \cdot \frac{f_{\text{rated}}}{V_{\text{rated}}}$$

[fo_moweuf, 1, en_US]

where:

- V Instantaneous voltage
- V_{rated} Primary rated voltage of the protected object
- f Instantaneous frequency in f
- f_{rated} Rated frequency

14 Technical Data

14.1	General Device Data	1546
14.2	Date and Time Synchronization	1550
14.3	Function Group Analog Units	1551
14.4	Overcurrent Protection, Phases	1552
14.5	Voltage-Dependent Overcurrent Protection, Phases	1566
14.6	Overcurrent Protection, Ground	1569
14.7	Directional Overcurrent Protection, Phases	1574
14.8	Directional Overcurrent Protection, Ground	1581
14.9	Inrush-Current Detection	1591
14.10	2nd Harmonic Detection Ground	1593
14.11	2nd Harmonic Detection 1-Phase	1595
14.12	Instantaneous High-Current Tripping	1597
14.13	Instantaneous Tripping at Switch onto Fault	1598
14.14	Overcurrent Protection, 1-Phase	1599
14.15	Overcurrent Protection, 1-Phase (Fast Stage)	1606
14.16	Positive-Sequence Overcurrent Protection	1607
14.17	Non-Directional Intermittent Ground-Fault Protection	1610
14.18	Directional Intermittent Ground-Fault Protection	1612
14.19	Sensitive Ground-Fault Detection	1614
14.20	Undercurrent Protection	1626
14.21	Negative-Sequence Protection	1628
14.22	Directional Negative-Sequence Protection with Definite-Time Delay	1632
14.23	Thermal Overload Protection, 3-Phase – Advanced	1634
14.24	Thermal Overload Protection, User-Defined Characteristic Curve	1637
14.25	Thermal Overload Protection, 1-Phase	1638
14.26	Unbalanced-Load Protection	1640
14.27	Overcurrent Protection for Capacitor Banks	1642
14.28	Current-Unbalance Protection for Capacitors, 1-Phase	1656
14.29	Overvoltage Protection with 3-Phase Voltage	1658
14.30	Overvoltage Protection with Zero-Sequence Voltage/Residual Voltage	1660
14.31	Overvoltage Protection with Positive-Sequence Voltage	1663
14.32	Overvoltage Protection with Negative-Sequence Voltage	1664
14.33	Overvoltage Protection with Any Voltage	1665
14.34	Peak Overvoltage Protection for Capacitors	1667

14.35	Overvoltage Protection with Negative-Sequence Voltage/Positive-Sequence Voltage	1669
14.36	Undervoltage Protection with 3-Phase Voltage	1670
14.37	Undervoltage Protection with Positive-Sequence Voltage	1673
14.38	Undervoltage Protection with Any Voltage	1675
14.39	Rate-of-Voltage-Change Protection	1677
14.40	Overfrequency Protection	1679
14.41	Underfrequency Protection	1680
14.42	Underfrequency Load Shedding	1681
14.43	Rate of Frequency Change Protection	1683
14.44	Vector-Jump Protection	1685
14.45	Power Protection (P,Q), 3-Phase	1686
14.46	Reverse-Power Protection	1688
14.47	Overexcitation Protection	1689
14.48	Undervoltage-Controlled Reactive-Power Protection	1691
14.49	Circuit-Breaker Failure Protection	1693
14.50	Circuit-Breaker Restrike Protection	1695
14.51	Restricted Ground-Fault Protection	1696
14.52	External Trip Initiation	1698
14.53	Automatic Reclosing	1699
14.54	Fault Locator	1700
14.55	Fault Locator Plus	1701
14.56	Protection and Automation Functions (CEI 0-16 Standard)	1702
14.57	Temperature Supervision	1706
14.58	Current-Jump Detection	1707
14.59	Voltage-Jump Detection	1708
14.60	Synchronization Function	1709
14.61	Current-Balance Supervision	1712
14.62	Voltage-Balance Supervision	1713
14.63	Current-Sum Supervision	1714
14.64	Voltage-Sum Supervision	1715
14.65	Current Phase-Rotation Supervision	1716
14.66	Voltage Phase-Rotation Supervision	1717
14.67	Voltage-Comparison Supervision	1718
14.68	Trip-Circuit Supervision	1719
14.69	Closing-Circuit Supervision	1720
14.70	Analog Channel Supervision via Fast Current Sum	1721
14.71	Measuring-Voltage Failure Detection	1722
14.72	Voltage-Transformer Circuit Breaker	1724
14.73	Operational Measured Values and Statistical Values	1725
14.74	Power Quality – Basic	1730
14.75	Energy Values	1733
14.76	Circuit-Breaker Monitoring	1734

14.77	Disconnecter Supervision	1735
14.78	CFC	1736

14.1 General Device Data

14.1.1 Analog Inputs

Current Inputs

All current, voltage, and power data are specified as RMS values.		
Rated frequency f_{rated}	50 Hz, 60 Hz	
Protection-class current transformers	Rated current I_{rated}	Measuring range
	5 A	0 A to 250 A
	1 A	0 A to 50 A
Instrument transformers	5 A	0 A to 8 A
	1 A	0 A to 1.6 A
Burden for rated current	Approx. 0.1 VA	
Thermal rating (protection and instrument transformers)	20 A continuously	
	25 A for 3 min	
	30 A for 2 min	
	150 A for 10 s	
	500 A for 1 s	
Dynamic load-carrying capacity	1250 A one half wave	

Voltage Input

All current, voltage, and power data are specified as RMS values.	
Rated frequency f_{rated}	50 Hz, 60 Hz
Measuring range	0 V to 200 V
Burden	< 0.1 VA
Thermal rating	230 V continuously

14.1.2 Supply Voltage

Power supply

Power supply via integrated power supply	
Permissible voltage ranges	DC 19 V to DC 250 V AC 92 V to AC 265 V at 50 Hz, 60 Hz
Auxiliary nominal voltage V_H	DC 24 V, 48 V, 60 V, 110 V, 220 V AC 100 V, 230 V at 50 Hz, 60 Hz
Ripple voltage, peak-peak, IEC 60255-11, IEC 61000-4-17	≤ 15 % of the DC auxiliary nominal voltage (applies to direct voltage only)
Inrush current	≤ 18 A
Recommended external protection	6 A miniature circuit breaker, characteristic C according to IEC 60898

Power supply via integrated power supply			
Internal fuse			
DC 24 V to DC 250 V AC 100 V to AC 230 V			
4 A time-lag, AC 250 V, DC 300 V, UL recognized SIBA type 179200			
Power consumption (life relay active)			
–	DC	AC 230 V	AC 100 V
	12 W	42 VA, power factor ≥ 0.25	28 VA, power factor ≥ 0.35
Stored-energy time on outage or short circuit of the auxiliary voltage IEC 61000-4-11 IEC 61000-4-29		In each permissible AC and DC voltage range ≥ 50 ms	

14.1.3 Binary Inputs

Binary Input

Standard Binary Input		
Rated voltage range	DC 24 V to 250 V	
Current consumption, picked up	Approx. DC 0.6 mA to DC 2.5 mA (independent of the control voltage)	
Power consumption, max.	0.6 W	
Pickup time	Approx. 3 ms	
Dropout time ⁴⁷	Capacitive load (supply-line capacitance)	Dropout time
	< 5 nF	< 4 ms
	< 10 nF	< 6 ms
	< 50 nF	< 10 ms
	< 220 nF	< 35 ms
Control voltage	Adapt the binary-input threshold to be set in the device to the control voltage.	
	Range 1 for 24 V, 48 V, and 60 V Control voltage	$V_{low} \leq DC 10 V$ $V_{high} \geq DC 19 V$
	Range 2 for 110 V and 125 V Control voltage	$V_{low} \leq DC 44 V$ $V_{high} \geq DC 88 V$
	Range 3 for 220 V and 250 V Control voltage	$V_{low} \leq DC 88 V$ $V_{high} \geq DC 176 V$
Maximum admissible voltage	DC 300 V	
The binary inputs contain interference suppression capacitors. To ensure EMC immunity, use the terminals shown in the terminal diagrams/connection diagrams to connect the binary inputs to the common potential.		

⁴⁷ For time-critical applications with low-active signals, consider the specified dropout times. If necessary, provide for active discharge of the binary input (for example, a resistor in parallel to the binary input or using a change-over contact).

14.1.4 Relay Outputs

Relay Outputs

Fast relay (type F)	
Making capacity	Max. 1000 W (L/R = 40 ms) Max. 3600 VA (power factor ≥ 0.35 , 50 Hz to 60 Hz)
Breaking capacity	Max. 30 W (L/R = 40 ms) Max. 360 VA (power factor ≥ 0.35 , 50 Hz to 60 Hz)
AC and DC contact voltage	250 V
Permissible current per contact (continuous)	5 A
Permissible current per contact (switching on and holding)	30 A for 1 s (make contact)
Short-time current across closed contact	250 A for 30 ms
Total permissible current for contacts connected to common potential	5 A
Switching time OOT ⁴⁸	Make time: typical: 4 ms; maximum: 5 ms Break time: typical: 2 ms; maximum: 5 ms
Rated data of the output contacts in accordance with UL certification	DC 24 V, 5 A, General Purpose DC 48 V, 0.8 A, General Purpose DC 240 V, 0.1 A, General Purpose AC 120 V, 5 A, General Purpose AC 250 V, 5 A, General Purpose AC 250 V, 0.5 hp B300 R300
Interference suppression capacitors across the contacts	4.7 nF, $\pm 20\%$, AC 250 V
Monitoring	2-channel activation

14.1.5 Design Data

Masses

	Device Size Mass
Type of construction	1/6
Flush-mounting device	2.55 kg
Bracket for the surface-mounting version	1.07 kg

⁴⁸ OOT (Output Operating Time): Additional delay of the output medium used, for example, 1 ms with electronic relays

Dimensions

Type of Construction	Max. Total Width x Max. Total Height x Max. Total Depth ⁴⁹ , Each Rounded up to the Next Full mm (in Inches)
Flush-mounting device	74 mm x 266 mm x 230 mm (2.91 x 10.47 x 9.06 mm)
Surface-mounted device	77 mm x 300 mm x 282 mm (3.03 x 11.81 x 11.1)

Degree of Protection According to IEC 60529

For equipment in the surface-mounting housing	IP51 for front (with enclosed seal)
For equipment in the flush-mounting housing	IP51 for front (with enclosed seal)
For operator protection (back side)	IP2x for current terminal (installed) IP2x for voltage terminal (installed)
Degree of pollution, IEC 60255-27	2
Maximum operating altitude above sea level	2000 m (6561.68 ft)

Tightening Torques for Terminal Screws

Type of Line	Current Terminal	Voltage Terminal with Spring-Loaded Terminals	Voltage Terminal with Screw Connection
Stranded wires with ring-type lug	2.7 Nm	No ring-type lug	No ring-type lug
Stranded wires with boot-lace ferrules or pin-type lugs	2.7 Nm	1.0 Nm	0.6 Nm
Solid conductor, bare (2 mm ²)	2.0 Nm	1.0 Nm	–
Blank stranded wire	Not permitted	1 Nm	0.6 Nm



NOTE

For current and voltage terminals, the maximum speed of the tool must not exceed 640 rpm.



NOTE

Use copper cables only.

Torques for Other Screw Types

Screw Type	Torque
M4 x 14 (front cover)	0.4 Nm
M4 x 14 (rear plate)	1.2 Nm
M4 x 8	1.2 Nm

⁴⁹ Including current terminal, excluding USB port cover

14.2 Date and Time Synchronization

Date format	DD.MM.YYYY (Europe)
	MM/DD/YYYY (USA)
	YYYY-MM-DD (China)
Time source 1, Time source 2	None IRIG B 002(003) IRIG B 006(007) IRIG B 005(004) with extension according to IEEE C37.118-2005 SNTP IEC 60870-5-103 DNP3 T104
Time zone 1, time zone 2	Local
	UTC
Fault indication after	0 s to 3600 s
Time zone and daylight saving time	Manually setting the time zones
Time zone offset with respect to GMT	-720 min to 840 min
Switching over to daylight saving time	Active
	Inactive
Beginning of daylight saving time	Input: day and time
End of daylight saving time	Input: day and time
Offset daylight saving time	0 min to 120 min [15 min. steps]

14.3 Function Group Analog Units

20-mA Inputs, Ethernet Interface 7XV5674-0KK00-1AA1

Max. number of connected 20-mA units	4
Max. number of channels per 20-mA unit	12

20-mA Unit Serial 7XV5674-0KK30-1AA1 (RS485) and 7XV5674-0KK40-1AA1 (Fiberglass)

Max. number of connected 20-mA units	4
Max. number of channels per 20-mA unit	12

RTD Unit 7XV5662-6AD10

Max. number of connected RTD units	4
Max. number of sensors per RTD unit	12
Sensor type	Pt 100 to EN 60751; connection of Ni 100 and Ni 120 sensors possible. The measured values must be converted in the evaluation unit.

Temperature Measured Values

Unit of measurement for temperature	°C or °F, adjustable
Pt 100	-199 °C to 800 °C (-326 °F to 1472 °F)
Ni 100	-54 °C to 278 °C (-65 °F to 532 °F)
Ni 120	-52 °C to 263 °C (-62 °F to 505 °F)
Resolution	1 °C or 1 °F
Tolerance	±0.5 % of the measured value ±1 °C (±0.56 °F)

14.4 Overcurrent Protection, Phases

14.4.1 Stage with Definite-Time Characteristic Curve

Setting Value for the Function Block Filter

h(0)	-100.000 to 100.000	Increments of 0.001
h(1)	-100.000 to 100.000	Increments of 0.001
h(2)	-100.000 to 100.000	Increments of 0.001
h(3)	-100.000 to 100.000	Increments of 0.001
h(4)	-100.000 to 100.000	Increments of 0.001

Setting Values for Protection Stage

Method of measurement		Fundamental component RMS value	–
Threshold value ⁵⁰	1 A @ 50 and 100 I _{rated}	0.030 A to 40.000 A	Increments of 0.001 A
	5 A @ 50 and 100 I _{rated}	0.15 A to 200.00 A	Increments of 0.01 A
	1 A @ 1.6 I _{rated}	0.001 A to 1.600 A	Increments of 0.001 A
	5 A @ 1.6 I _{rated}	0.005 A to 8.000 A	Increments of 0.001 A
Dropout ratio		0.90 to 0.99	Increments of 0.01
Operate delay		0.00 s to 100.00 s	Increments of 0.01 s
Dropout delay		0.00 s to 60.00 s	Increments of 0.01 s
Pickup delay		0.00 s to 60.00 s	Increments of 0.01 s

Dropout

The greater dropout differential (= | **pickup value** - **dropout value** |) of the following 2 criteria applies:

Dropout differential derived from the parameter Dropout ratio	
If this parameter is not available, a dropout ratio of 95 % applies for overcurrent and of 105 % for undercurrent functionality.	
Minimum absolute dropout differential	
Protection-class current transformer	15 mA sec. (I _{rated} = 1 A) or 75 mA sec. (I _{rated} = 5 A)
Instrument current transformer	0.5 mA sec. (I _{rated} = 1 A) or 2.5 mA sec. (I _{rated} = 5 A)

Times

Operate time with time delay = 0 ms	Approx. 25 ms + OOT ⁵¹ at 50 Hz Approx. 22 ms + OOT at 60 Hz
Extension of the operate time during operation with transformer inrush-current detection	Approx. 10 ms
Dropout time	Approx. 20 ms + OOT

⁵⁰ If you have selected the **method of measurement = RMS value**, do not set the threshold value under 0.1 I_{rated,sec}.

⁵¹ OOT (Output Operating Time): additional delay of the output medium used, for example 5 ms with fast relays

Frequency Operating Range

$0.9 \leq f/f_{\text{rated}} \leq 1.1$	According to specified tolerances
$10 \text{ Hz} \leq f < 0.9 f_{\text{rated}}$ $1.1 f_{\text{rated}} < f \leq 90 \text{ Hz}$	Slightly expanded tolerances
$f < 10 \text{ Hz}$ $f > 90 \text{ Hz}$	Active

Tolerances

Currents, method of measurement = fundamental component	1 % of the setting value or 5 mA ($I_{\text{rated}} = 1 \text{ A}$) or 25 mA ($I_{\text{rated}} = 5 \text{ A}$)
Currents, method of measurement = RMS value, no filter applied (33 % harmonics, in relation to fundamental component)	
Up to 30th harmonic	2 % of the setting value or 10 mA ($I_{\text{rated}} = 1 \text{ A}$) or 50 mA ($I_{\text{rated}} = 5 \text{ A}$)
Up to 50th harmonic, $f_{\text{rated}} = 50 \text{ Hz}$	4 % of the setting value or 20 mA ($I_{\text{rated}} = 1 \text{ A}$) or 100 mA ($I_{\text{rated}} = 5 \text{ A}$)
Up to 50th harmonic, $f_{\text{rated}} = 60 \text{ Hz}$	5 % of the setting value or 20 mA ($I_{\text{rated}} = 1 \text{ A}$) or 100 mA ($I_{\text{rated}} = 5 \text{ A}$)
Currents, method of measurement = RMS value with filter for the compensation of the amplitude attenuation due to the anti-aliasing filter (33 % harmonics, in relation to the fundamental component)	
Up to 30 harmonic	2 % of the setting value or 10 mA ($I_{\text{rated}} = 1 \text{ A}$) or 50 mA ($I_{\text{rated}} = 5 \text{ A}$)
Up to 50th harmonic, $f_{\text{rated}} = 50 \text{ Hz}$	3 % of the setting value or 20 mA ($I_{\text{rated}} = 1 \text{ A}$) or 100 mA ($I_{\text{rated}} = 5 \text{ A}$)
Up to 50th harmonic, $f_{\text{rated}} = 60 \text{ Hz}$	4 % of the setting value or 20 mA ($I_{\text{rated}} = 1 \text{ A}$) or 100 mA ($I_{\text{rated}} = 5 \text{ A}$)
Currents, method of measurement = RMS value with filter for the gain of harmonics (including compensation of the amplitude attenuation ⁵²) (33 % harmonics, in relation to the fundamental component)	
Up to 30 harmonic	2.5 % of the setting value or 10 mA ($I_{\text{rated}} = 1 \text{ A}$) or 50 mA ($I_{\text{rated}} = 5 \text{ A}$) ⁵³
Up to 50th harmonic, $f_{\text{rated}} = 50 \text{ Hz}$	4 % of the setting value or 20 mA ($I_{\text{rated}} = 1 \text{ A}$) or 100 mA ($I_{\text{rated}} = 5 \text{ A}$) ⁵⁴
Up to 50th harmonic, $f_{\text{rated}} = 60 \text{ Hz}$	5 % of the setting value or 20 mA ($I_{\text{rated}} = 1 \text{ A}$) or 100 mA ($I_{\text{rated}} = 5 \text{ A}$) ⁵⁵
Pickup delay	1 % of the setting value or 10 ms
Dropout delay	1 % of the setting value or 10 ms
Operate delay for the basic stage	1 % of the setting value or 10 ms

⁵² In case that the filter response exactly matches the user-defined gain factors

⁵³ In case that the user-defined gain factor is set below 3. The tolerance increases, if the gain factor is larger.

⁵⁴ In case that the user-defined gain factor is set below 7. The tolerance increases, if the gain factor is larger.

⁵⁵ In case that the user-defined gain factor is set below 7. The tolerance increases, if the gain factor is larger.

Operate delay for the advanced stage	Operate delay mode = Running dur. DO-delay	1 % of the setting value or 10 ms
	Operate delay mode = Frozen dur. DO-delay	1 % of the reference value or 10 ms (reference value = setting value + frozen time)

Influencing Variables for Threshold Values

Transient excess pickup in method of measurement = fundamental component, for $\tau > 100$ ms (with complete unbalance)	< 5 %
---	-------

14.4.2 Stage with Inverse-Time Characteristic Curve

Setting Value for the Function Block Filter

h(0)	-100.000 to 100.000	Increments of 0.001
h(1)	-100.000 to 100.000	Increments of 0.001
h(2)	-100.000 to 100.000	Increments of 0.001
h(3)	-100.000 to 100.000	Increments of 0.001
h(4)	-100.000 to 100.000	Increments of 0.001

Setting Values for Protection Stage

Method of measurement		Fundamental component RMS value	–
Threshold value	1 A @ 50 and 100 Irated	0.030 A to 40.000 A	Increments of 0.001 A
	5 A @ 50 and 100 Irated	0.15 A to 200.00 A	Increments of 0.01 A
	1 A @ 1.6 Irated	0.001 A to 1.600 A	Increments of 0.001 A
	5 A @ 1.6 Irated	0.005 A to 8.000 A	Increments of 0.001 A
Dropout		Disk emulation Instantaneous	–
Time multiplier		0.00 to 15.00	Increments of 0.01
Pickup delay		0.00 s to 60.00 s	Increments of 0.01 s

Dropout

The greater dropout differential (= | **pickup value** - **dropout value** |) of the following 2 criteria applies:

Dropout	95 % of 1.1 · threshold value
Minimum absolute dropout differential	
Protection-class current transformer	15 mA sec. ($I_{rated} = 1$ A) or 75 mA sec. ($I_{rated} = 5$ A)
Instrument current transformer	0.5 mA sec. ($I_{rated} = 1$ A) or 2.5 mA sec. ($I_{rated} = 5$ A)

Reset of the Integration Timer

Instantaneous	With dropout
Disk emulation	Approx. < 0.90 · threshold value

Operate Curves and Dropout-Time Characteristic Curves according to IEC

Extension of the operate time during operation with transformer inrush-current detection	Approx. 10 ms
--	---------------

NORMAL INVERSE: Type A

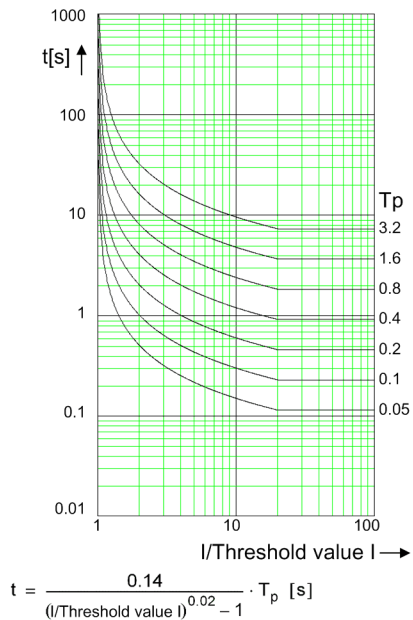

RESET NORMAL INVERSE: Type A

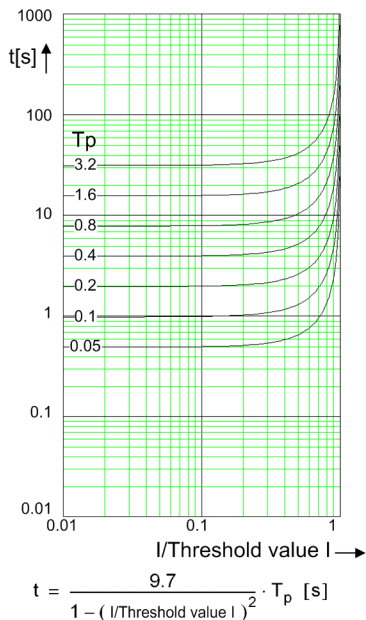

VERY INVERSE: Type B

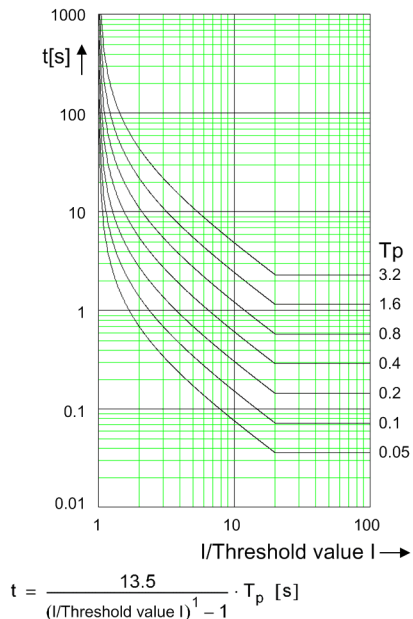

RESET VERY INVERSE: Type B

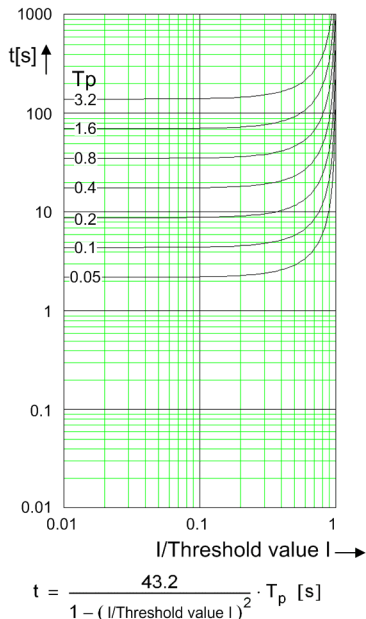

[dw_ocp_ki1_1_en_US]

Figure 14-1 Operate Curves and Dropout-Time Characteristic Curves According to IEC

EXTREMELY INVERSE: Type C

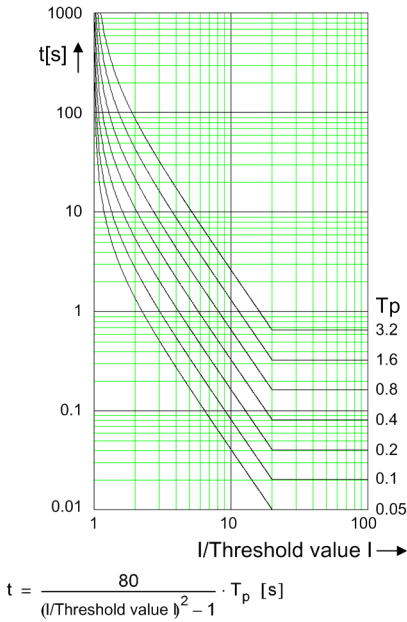

RESET EXTREMELY INVERSE: Type C

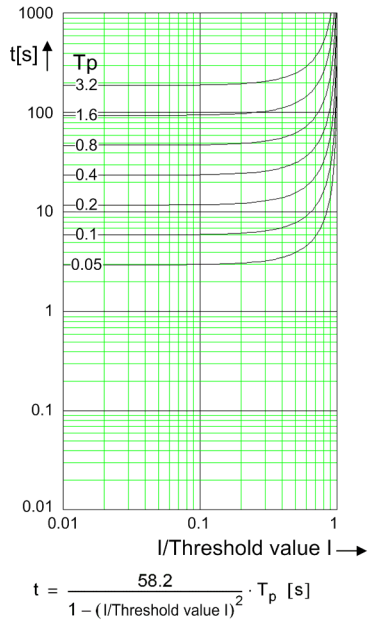

LONG-TIME INVERSE: Type B

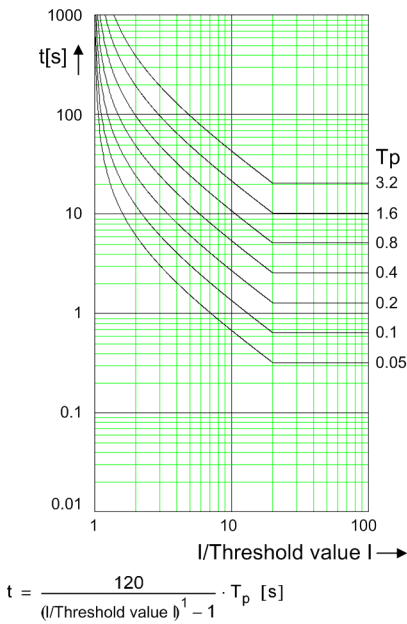

RESET LONG-TIME INVERSE: Type B

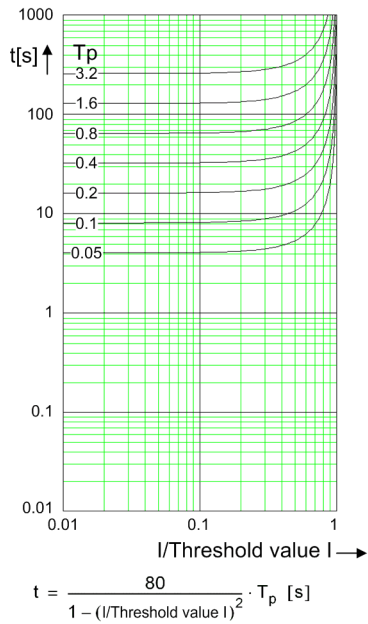

[dlw_ocp_ki2_1_en_US]

Figure 14-2 Operate Curves and Dropout-Time Characteristic Curves According to IEC

SHORT-TIME INVERSE

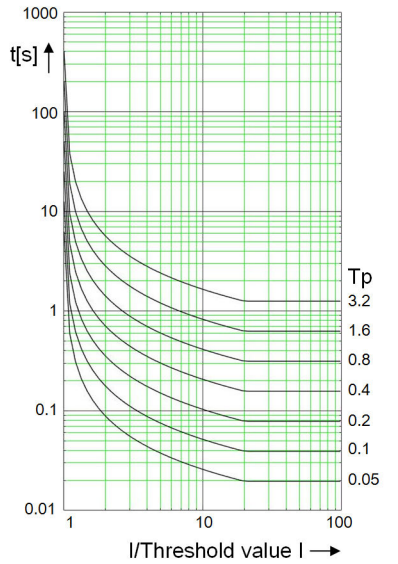

$$t = \frac{0.05}{(I/\text{Threshold value } I)^{0.04} - 1} \cdot T_p \text{ [s]}$$

RESET SHORT-TIME INVERSE

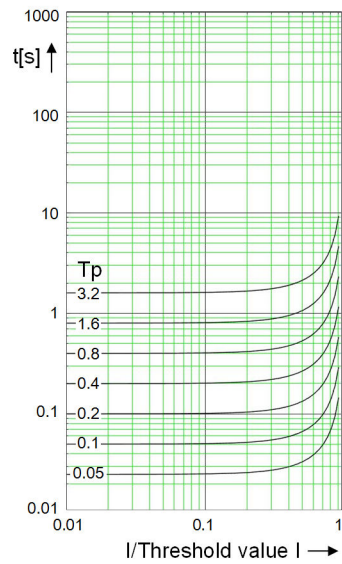

$$t = \frac{0.5}{1 - (I/\text{Threshold value } I)^2} \cdot T_p \text{ [s]}$$

[dw_iec-short-inverse, 1, en_US]

Figure 14-3 Operate Curves and Dropout-Time Characteristic Curves According to IEC (Advanced Stage)

Operate Curves and Dropout-Time Characteristic Curves According to ANSI/IEEE

Inverse: Type C

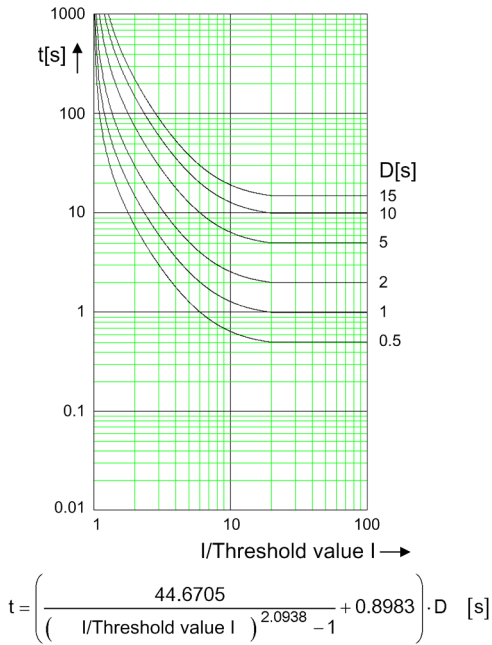

RESET INVERSE: Type C

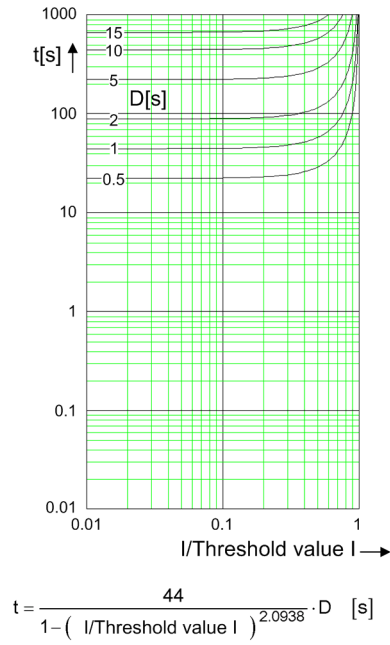

SHORT INVERSE

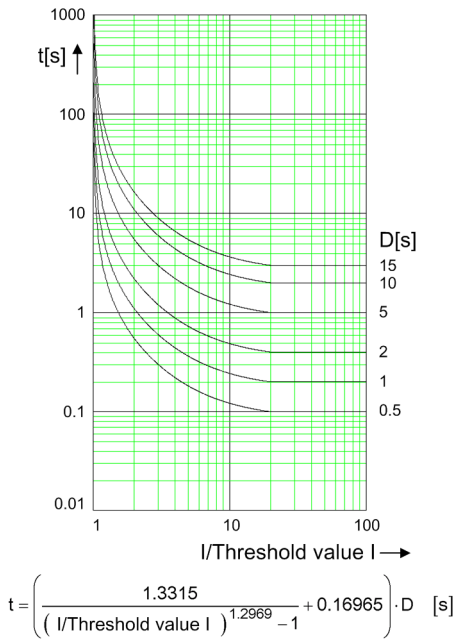

RESET SHORT INVERSE

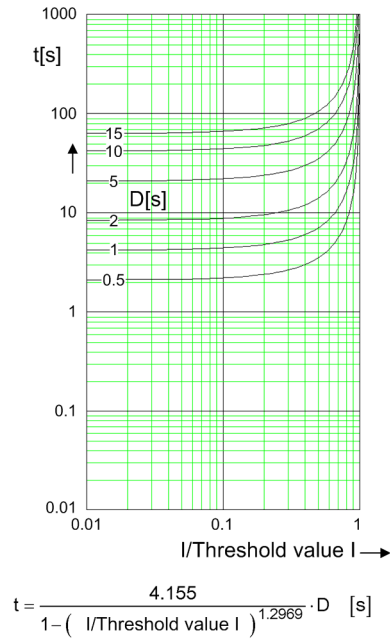

[dw_ocp_kat_2_en_US]

Figure 14-4 Operate Curves and Dropout-Time Characteristic Curves According to ANSI/IEEE

LONG INVERSE

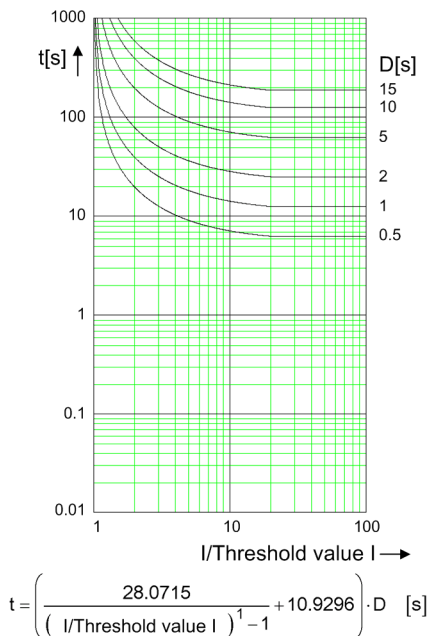

RESET LONG INVERSE

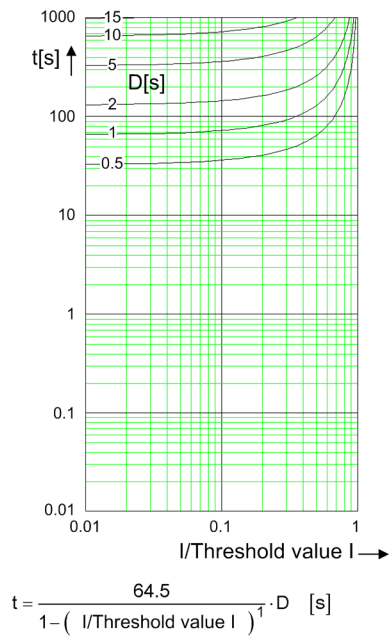

MODERATELY INVERSE

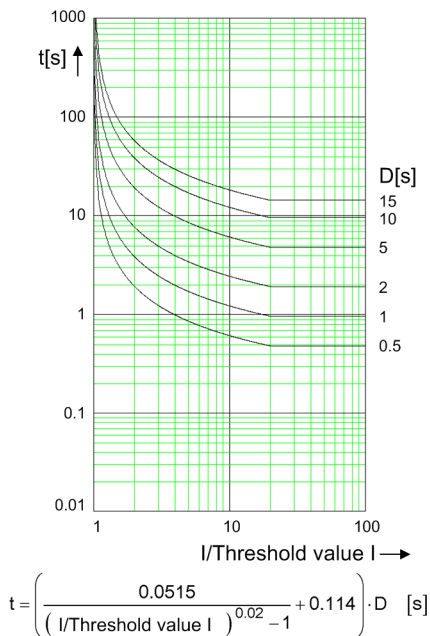

RESET MODERATELY INVERSE

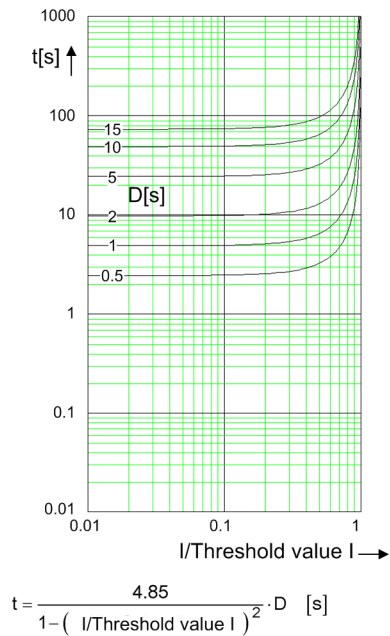

[dw_ocp_ka2_2_en_US]

Figure 14-5 Operate Curves and Dropout-Time Characteristic Curves According to ANSI/IEEE

VERY INVERSE

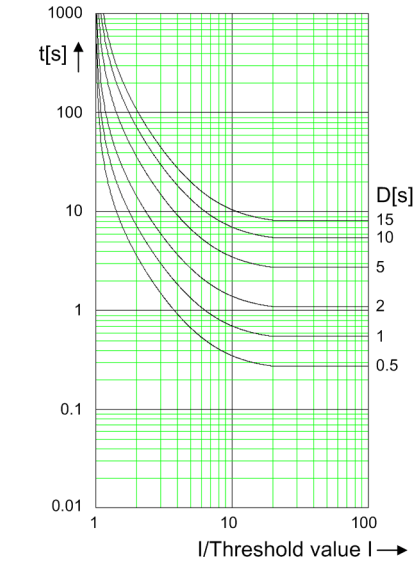

$$t = \left(\frac{19.61}{\left(\frac{I}{\text{Threshold value } I} \right)^2 - 1} + 0.491 \right) \cdot D \text{ [s]}$$

RESET VERY INVERSE

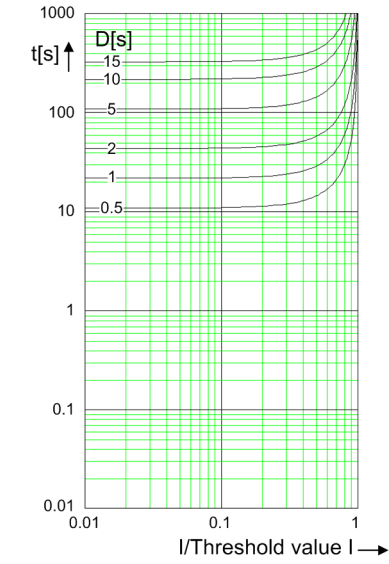

$$t = \frac{21.6}{1 - \left(\frac{I}{\text{Threshold value } I} \right)^2} \cdot D \text{ [s]}$$

EXTREMELY INVERSE

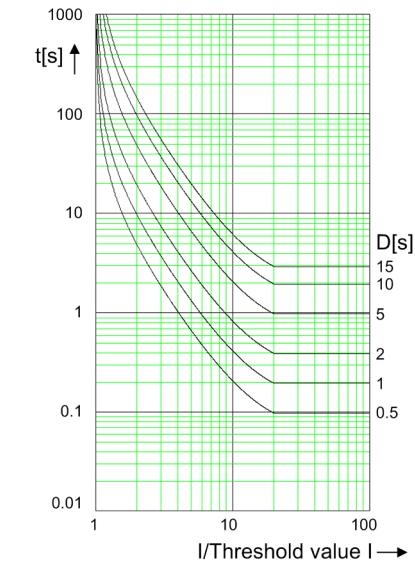

$$t = \left(\frac{28.2}{\left(\frac{I}{\text{Threshold value } I} \right)^2 - 1} + 0.1217 \right) \cdot D \text{ [s]}$$

RESET EXTREMELY INVERSE

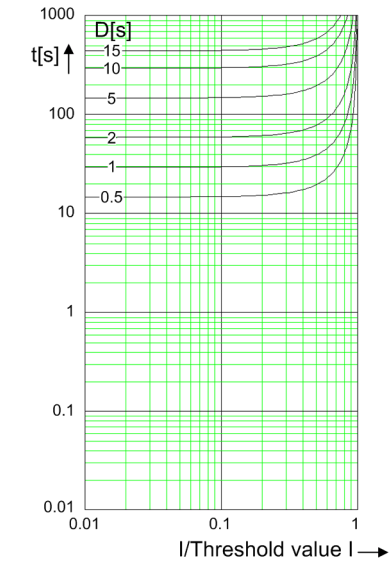

$$t = \frac{29.1}{1 - \left(\frac{I}{\text{Threshold value } I} \right)^2} \cdot D \text{ [s]}$$

[dw_ocp_ka3_2_en_US]

Figure 14-6 Operate Curves and Dropout-Time Characteristic Curves According to ANSI/IEEE

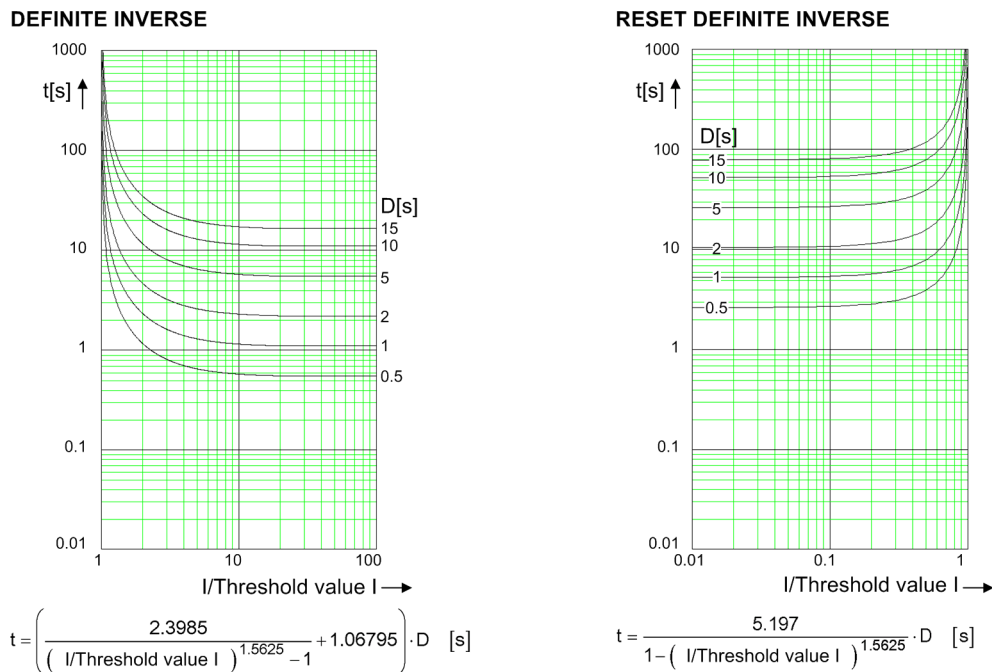

Note: IGnd threshold stands for ground fault instead of the I threshold.

[dw_ocp_ka4_2_en_US]

Figure 14-7 Operate Curves and Dropout-Time Characteristic Curves According to ANSI/IEEE



NOTE

In the preceding operate curves according to IEC and ANSI/IEEE, the inverse-time delays for **I/Threshold value I > 20** are identical to the inverse-time delay for **I/Threshold value I = 20**.

Frequency Operating Range

$0.9 \leq f/f_{\text{rated}} \leq 1.1$	According to specified tolerances
$10 \text{ Hz} \leq f < 0.9 f_{\text{rated}}$ $1.1 f_{\text{rated}} < f \leq 90 \text{ Hz}$	Slightly expanded tolerances
$f < 10 \text{ Hz}$ $f > 90 \text{ Hz}$	Active

Tolerances

Currents, method of measurement = fundamental component	1 % of the setting value or 5 mA ($I_{\text{rated}} = 1 \text{ A}$) or 25 mA ($I_{\text{rated}} = 5 \text{ A}$)
Currents, method of measurement = RMS value, no filter applied (33 % harmonics, in relation to fundamental component)	
Up to 30th harmonic	2 % of the setting value or 10 mA ($I_{\text{rated}} = 1 \text{ A}$) or 50 mA ($I_{\text{rated}} = 5 \text{ A}$)
Up to 50th harmonic, $f_{\text{rated}} = 50 \text{ Hz}$	4 % of the setting value or 20 mA ($I_{\text{rated}} = 1 \text{ A}$) or 100 mA ($I_{\text{rated}} = 5 \text{ A}$)
Up to 50th harmonic, $f_{\text{rated}} = 60 \text{ Hz}$	5 % of the setting value or 20 mA ($I_{\text{rated}} = 1 \text{ A}$) or 100 mA ($I_{\text{rated}} = 5 \text{ A}$)

Currents, method of measurement = RMS value with filter for the compensation of the amplitude attenuation due to the anti-aliasing filter (33 % harmonics, in relation to the fundamental component)	
Up to 30 harmonic	2 % of the setting value or 10 mA ($I_{rated} = 1 \text{ A}$) or 50 mA ($I_{rated} = 5 \text{ A}$)
Up to 50th harmonic, $f_{rated} = 50 \text{ Hz}$	3 % of the setting value or 20 mA ($I_{rated} = 1 \text{ A}$) or 100 mA ($I_{rated} = 5 \text{ A}$)
Up to 50th harmonic, $f_{rated} = 60 \text{ Hz}$	4 % of the setting value or 20 mA ($I_{rated} = 1 \text{ A}$) or 100 mA ($I_{rated} = 5 \text{ A}$)
Currents, method of measurement = RMS value with filter for the gain of harmonics (including compensation of the amplitude attenuation ⁵⁶) (33 % harmonics, in relation to the fundamental component)	
Up to 30 harmonic	2.5 % of the setting value or 10 mA ($I_{rated} = 1 \text{ A}$) or 50 mA ($I_{rated} = 5 \text{ A}$) ⁵⁷
Up to 50th harmonic, $f_{rated} = 50 \text{ Hz}$	4 % of the setting value or 20 mA ($I_{rated} = 1 \text{ A}$) or 100 mA ($I_{rated} = 5 \text{ A}$) ⁵⁸
Up to 50th harmonic, $f_{rated} = 60 \text{ Hz}$	5 % of the setting value or 20 mA ($I_{rated} = 1 \text{ A}$) or 100 mA ($I_{rated} = 5 \text{ A}$) ⁵⁸
Operate time for $2 \leq I/I$ threshold value ≤ 20	5 % of the reference (calculated) value +2 % current tolerance or 30 ms
Dropout time for I/I threshold value ≤ 0.90	5 % of the reference (calculated) value +2 % current tolerance or 30 ms
Time delays	1 % of the setting value or 10 ms

Influencing Variables for Threshold Values

Transient excess pickup in method of measurement = fundamental component, for $\tau > 100 \text{ ms}$ (with complete unbalance)	< 5 %
---	-------

14.4.3 Stage with User-Defined Characteristic Curve

Setting Value for the Function Block Filter

h(0)	-100.000 to 100.000	Increments of 0.001
h(1)	-100.000 to 100.000	Increments of 0.001
h(2)	-100.000 to 100.000	Increments of 0.001
h(3)	-100.000 to 100.000	Increments of 0.001
h(4)	-100.000 to 100.000	Increments of 0.001

⁵⁶ In case that the filter response exactly matches the user-defined gain factors

⁵⁷ In case that the user-defined gain factor is set below 3. The tolerance increases, if the gain factor is larger.

⁵⁸ In case that the user-defined gain factor is set below 7. The tolerance increases, if the gain factor is larger.

Setting Values for Protection Stage

Method of measurement		Fundamental component RMS value	–
Threshold value	1 A @ 50 and 100 I _{rated}	0.030 A to 40.000 A	Increments of 0.001 A
	5 A @ 50 and 100 I _{rated}	0.15 A to 200.00 A	Increments of 0.01 A
	1 A @ 1.6 I _{rated}	0.001 A to 1.600 A	Increments of 0.001 A
	5 A @ 1.6 I _{rated}	0.005 A to 8.000 A	Increments of 0.001 A
Absolute pickup value	1 A @ 50 and 100 I _{rated}	0.000 A to 40.000 A	Increments of 0.001 A
	5 A @ 50 and 100 I _{rated}	0.00 A to 200.00 A	Increments of 0.01 A
	1 A @ 1.6 I _{rated}	0.000 A to 1.600 A	Increments of 0.001 A
	5 A @ 1.6 I _{rated}	0.000 A to 8.000 A	Increments of 0.001 A
Dropout		Disk emulation Instantaneous	–
Time multiplier		0.05 to 15.00	Increments of 0.01
Number of value pairs for the operate curve		2 to 30	Increments of 1
X values of the operate curve		1.00 p.u. to 20.00 p.u.	Increments of 0.01 p.u.
Y values of the operate curve		0.00 s to 999.00 s	Increments of 0.01 s
Number of value pairs for the dropout characteristic curve		2 to 30	Increments of 1
X values of the dropout characteristic curve		0.05 p.u. to 0.95 p.u.	Increments of 0.01 p.u.
Y values of the dropout characteristic curve		0.00 s to 999.00 s	Increments of 0.01 s
Additional time delay		0.00 s to 60.00 s	Increments of 0.01 s

Dropout

The greater dropout differential (= | **pickup value** – **dropout value** |) of the following 2 criteria applies:

Dropout	95 % of 1.1 · threshold value or 95 % of the absolute pickup value
Minimum absolute dropout differential	
Protection-class current transformer	15 mA sec. (I _{rated} = 1 A) or 75 mA sec. (I _{rated} = 5 A)
Instrument current transformer	0.5 mA sec. (I _{rated} = 1 A) or 2.5 mA sec. (I _{rated} = 5 A)

Reset of the Integration Timer

Instantaneous	With dropout
Disk emulation	Approx. < 0.90 · threshold value

Frequency Operating Range

$0.9 \leq f/f_{\text{rated}} \leq 1.1$	According to specified tolerances
$10 \text{ Hz} \leq f < 0.9 f_{\text{rated}}$ $1.1 f_{\text{rated}} < f \leq 90 \text{ Hz}$	Slightly expanded tolerances
$f < 10 \text{ Hz}$ $f > 90 \text{ Hz}$	Active

Tolerances

Currents, method of measurement = fundamental component	1 % of the setting value or 5 mA ($I_{rated} = 1 A$) or 25 mA ($I_{rated} = 5 A$)
Currents, method of measurement = RMS value, no filter applied (33 % harmonics, in relation to fundamental component)	
Up to 30th harmonic	2 % of the setting value or 10 mA ($I_{rated} = 1 A$) or 50 mA ($I_{rated} = 5 A$)
Up to 50th harmonic, $f_{rated} = 50 Hz$	4 % of the setting value or 20 mA ($I_{rated} = 1 A$) or 100 mA ($I_{rated} = 5 A$)
Up to 50th harmonic, $f_{rated} = 60 Hz$	5 % of the setting value or 20 mA ($I_{rated} = 1 A$) or 100 mA ($I_{rated} = 5 A$)
Currents, method of measurement = RMS value with filter for the compensation of the amplitude attenuation due to the anti-aliasing filter (33 % harmonics, in relation to the fundamental component)	
Up to 30 harmonic	2 % of the setting value or 10 mA ($I_{rated} = 1 A$) or 50 mA ($I_{rated} = 5 A$)
Up to 50th harmonic, $f_{rated} = 50 Hz$	3 % of the setting value or 20 mA ($I_{rated} = 1 A$) or 100 mA ($I_{rated} = 5 A$)
Up to 50th harmonic, $f_{rated} = 60 Hz$	4 % of the setting value or 20 mA ($I_{rated} = 1 A$) or 100 mA ($I_{rated} = 5 A$)
Currents, method of measurement = RMS value with filter for the gain of harmonics (including compensation of the amplitude attenuation ⁵⁹) (33 % harmonics, in relation to the fundamental component)	
Up to 30 harmonic	2.5 % of the setting value or 10 mA ($I_{rated} = 1 A$) or 50 mA ($I_{rated} = 5 A$) ⁶⁰
Up to 50th harmonic, $f_{rated} = 50 Hz$	4 % of the setting value or 20 mA ($I_{rated} = 1 A$) or 100 mA ($I_{rated} = 5 A$) ⁶¹
Up to 50th harmonic, $f_{rated} = 60 Hz$	5 % of the setting value or 20 mA ($I_{rated} = 1 A$) or 100 mA ($I_{rated} = 5 A$) ⁶²
Operate time for $2 \leq I/I$ threshold value ≤ 20	5 % of the reference (calculated) value +2 % current tolerance or 30 ms
Dropout time for I/I threshold value ≤ 0.90	5 % of the reference (calculated) value +2 % current tolerance or 30 ms
Time delays	1 % of the setting value or 10 ms

Influencing Variables for Threshold Values

Transient excess pickup in method of measurement = fundamental component, for $\tau > 100 ms$ (with complete unbalance)	< 5 %
---	-------

⁵⁹ In case that the filter response exactly matches the user-defined gain factors

⁶⁰ In case that the user-defined gain factor is set below 3. The tolerance increases, if the gain factor is larger.

⁶¹ In case that the user-defined gain factor is set below 7. The tolerance increases, if the gain factor is larger.

⁶² In case that the user-defined gain factor is set below 7. The tolerance increases, if the gain factor is larger.

Operate Curves and Dropout-Time Characteristic Curves According to IEC

Extension of the operate time during operation with transformer inrush-current detection	Approx. 10 ms
--	---------------

14.5 Voltage-Dependent Overcurrent Protection, Phases

Setting Values for All Stage Types

Method of measurement		Fundamental component RMS value	–
Overcurrent threshold value	For $I_{rated} = 1$ A	0.030 A to 35.000 A	Increments of 0.001 A
	For $I_{rated} = 5$ A	0.15 A to 175.00 A	Increments of 0.01 A
Time delay		0.10 s to 60.00 s	Increments of 0.01 s

Setting Values for Inverse-Time Overcurrent Protection Stages

Method of measurement		Fundamental component RMS value	–
Dropout ratio of undervoltage ⁶³		1.01 to 1.20	Increments of 0.01
Undervoltage threshold value ⁶³		0.300 V to 175.000 V	Increments of 0.001 V
Dropout		Disk emulation Instantaneous	–
Time multiplier		0.05 to 15.00	Increments of 0.01

Setting Values for Definite-Time Overcurrent Protection Stages

Seal-in voltage	0.300 V to 175.000 V	Increments of 0.001 V
Phase-to-phase voltage	0.300 V to 175.000 V	Increments of 0.001 V
Negative-sequence voltage V2	0.300 V to 200.000 V	Increments of 0.001 V
Time delay	0.00 s to 60.00 s	Increments of 0.01 s
Duration of V-seal-in time	0.10 s to 60.00 s	Increments of 0.01 s

Dropout for Inverse-Time Overcurrent Protection Stages

The greater dropout differential (= | pickup value - dropout value |) of the following 2 criteria applies:

Dropout	
Current	95 % of 1.1 · threshold value
Voltage ⁶³	105 % of threshold value
Minimum absolute dropout differential	
Protection-class current transformer	15 mA sec. ($I_{rated} = 1$ A) or 75 mA sec. ($I_{rated} = 5$ A)
Instrument current transformer	0.5 mA sec. ($I_{rated} = 1$ A) or 2.5 mA sec. ($I_{rated} = 5$ A)
Voltage transformer ⁶³	150 mV sec.

Reset of the Integration Timer for Inverse-Time Overcurrent Protection Stages

Instantaneous	With dropout
Disk emulation	Approx. < 0.90 · threshold value

⁶³ The value is for the inverse-time overcurrent voltage-released stage.

Dropout for Definite-Time Overcurrent Protection Stages

Dropout differential derived from the parameter Dropout ratio	
If this parameter is not available, a dropout ratio of 95 % applies for overcurrent/overvoltage and of 105 % for undervoltage functionality.	
Minimum absolute dropout differential	
Protection-class current transformer	15 mA sec. ($I_{rated} = 1 \text{ A}$) or 75 mA sec. ($I_{rated} = 5 \text{ A}$)
Instrument current transformer	0.5 mA sec. ($I_{rated} = 1 \text{ A}$) or 2.5 mA sec. ($I_{rated} = 5 \text{ A}$)
Voltage transformer	150 mV sec.

Operate Curves and Dropout Characteristic Curves According to IEC

Extension of the operate time during operation with inrush-current detection	Approx. 10 ms
--	---------------

The operate curves and dropout characteristic curves according to IEC can be found in the chapter *Technical Data* under *Inverse-Time Overcurrent Protection*.

Operate Curves and Dropout Characteristic Curves According to ANSI/IEEE

The operate curves and dropout characteristic curves according to IEC can be found in the chapter *Technical Data* under *Inverse-Time Overcurrent Protection*.

Times for Definite-Time Overcurrent Protection Stages

Operate time with time delay = 0 ms, typical	Approx. 25 ms + OOT ⁶⁴ at 50 Hz Approx. 22 ms + OOT at 60 Hz
Operate time with time delay = 0 ms, maximum	Approx. 30 ms + OOT at 50 Hz Approx. 26 ms + OOT at 60 Hz
Dropout time, typical	Approx. 25 ms + OOT
Dropout time, maximum	Approx. 30 ms + OOT

Frequency Operating Range

$0.9 \leq f/f_{rated} \leq 1.1$	According to specified tolerances
$10 \text{ Hz} \leq f < 0.9 f_{rated}$ $1.1 f_{rated} < f \leq 90 \text{ Hz}$	Slightly expanded tolerances
$f < 10 \text{ Hz}$ $f > 90 \text{ Hz}$	Inactive

Tolerances

Currents, method of measurement = fundamental component	1 % of the setting value or 5 mA ($I_{rated} = 1 \text{ A}$) or 25 mA ($I_{rated} = 5 \text{ A}$)
Currents, method of measurement = RMS value (33 % part of harmonic in relation to fundamental component)	
Up to 30th harmonic	2 % of the setting value or 10 mA ($I_{rated} = 1 \text{ A}$) or 50 mA ($I_{rated} = 5 \text{ A}$)

⁶⁴ OOT (Output Operating Time): additional delay of the output medium used, see Chapter [14.1.4 Relay Outputs](#)

Up to 50th harmonic, $f_{\text{rated}} = 50 \text{ Hz}$	4 % of the setting value or 20 mA ($I_{\text{rated}} = 1 \text{ A}$) or 100 mA ($I_{\text{rated}} = 5 \text{ A}$)
Up to 50th harmonic, $f_{\text{rated}} = 60 \text{ Hz}$	5 % of the setting value or 20 mA ($I_{\text{rated}} = 1 \text{ A}$) or 100 mA ($I_{\text{rated}} = 5 \text{ A}$)
Voltage	0.5 % of the setting value or 0.05 V
Operate time for $2 \leq I/I$ threshold value ≤ 20	5 % of the reference (calculated) value + 2 % current tolerance or 30 ms
Dropout time for I/I threshold value ≤ 0.90	5 % of the reference (calculated) value + 2 % current tolerance or 30 ms
Time delays	1 % of the setting value or 10 ms

Influencing Variables for Threshold Values

Transient excess pickup in method of measurement = fundamental component, for $\tau > 100 \text{ ms}$ (with complete unbalance)	< 5 %
---	-------

14.6 Overcurrent Protection, Ground

14.6.1 Stage with Definite-Time Characteristic Curve

Setting Values

Method of measurement		Fundamental component RMS value	–
Threshold value ⁶⁵	1 A @ 50 and 100 I _{rated}	0.010 A to 40.000 A	Increments of 0.001 A
	5 A @ 50 and 100 I _{rated}	0.05 A to 200.00 A	Increments of 0.01 A
	1 A @ 1.6 I _{rated}	0.001 A to 1.600 A	Increments of 0.001 A
	5 A @ 1.6 I _{rated}	0.002 A to 8.000 A	Increments of 0.001 A
Dropout ratio		0.90 to 0.99	Increments of 0.01
Time delay		0.00 s to 60.00 s	Increments of 0.01 s
Dropout delay		0.00 s to 60.00 s	Increments of 0.01 s

Dropout

The greater dropout differential (= | **pickup value** – **dropout value** |) of the following 2 criteria applies:

Dropout differential derived from the parameter Dropout ratio	
If this parameter is not available, a dropout ratio of 95 % applies for overcurrent and of 105 % for undercurrent functionality.	
Minimum absolute dropout differential	
Protection-class current transformer	5 mA sec. (I _{rated} = 1 A) or 25 mA sec. (I _{rated} = 5 A)
Instrument current transformer	0.5 mA sec. (I _{rated} = 1 A) or 2.5 mA sec. (I _{rated} = 5 A)

Times

Operate time with time delay = 0 ms	Approx. 25 ms + OOT ⁶⁶ at 50 Hz Approx. 22 ms + OOT at 60 Hz
Extension of the operate time during operation with transformer inrush-current detection	Approx. 10 ms
Dropout time	Approx. 20 ms + OOT

Frequency Operating Range

$0.9 \leq f/f_{\text{rated}} \leq 1.1$	According to specified tolerances
$10 \text{ Hz} \leq f < 0.9 f_{\text{rated}}$ $1.1 f_{\text{rated}} < f \leq 90 \text{ Hz}$	Slightly expanded tolerances
$f < 10 \text{ Hz}$ $f > 90 \text{ Hz}$	Active

⁶⁵ If you have selected the **method of measurement = RMS value**, do not set the threshold value under $0.1 I_{\text{rated,sec}}$.

⁶⁶ OOT (Output Operating Time): additional delay of the output medium used, see [14.1.4 Relay Outputs](#)

Tolerances

3I0 measured via I4 ⁶⁷ , method of measurement = fundamental component		1 % of the setting value or 5 mA ($I_{rated} = 1 A$) or 25 mA ($I_{rated} = 5 A$)
3I0 measured via I4 ⁶⁸ , method of measurement = RMS value (33 % harmonics, in relation to fundamental component)		
Up to 30th harmonic		2 % of the setting value or 10 mA ($I_{rated} = 1 A$) or 50 mA ($I_{rated} = 5 A$)
Up to 50th harmonic, $f_{rated} = 50 Hz$		4 % of the setting value or 20 mA ($I_{rated} = 1 A$) or 100 mA ($I_{rated} = 5 A$)
Up to 50th harmonic, $f_{rated} = 60 Hz$		5 % of the setting value or 20 mA ($I_{rated} = 1 A$) or 100 mA ($I_{rated} = 5 A$)
Pickup delay		1 % of the setting value or 10 ms
Dropout delay		1 % of the setting value or 10 ms
Operate delay for the basic stage		1 % of the setting value or 10 ms
Operate delay for the advanced stage	Operate delay mode = Running dur. DO-delay	1 % of the setting value or 10 ms
	Operate delay mode = Frozen dur. DO-delay	1 % of the reference value or 10 ms (Reference value = Setting value + Frozen time)

Influencing Variables for Threshold Values

Transient excess pickup in method of measurement = fundamental component, for $\tau > 100 ms$ (with complete unbalance)	< 5 %
---	-------

14.6.2 Stage with Inverse-Time Characteristic Curve

Setting Values

Method of measurement		Fundamental component RMS value	–
Threshold value ⁶⁹	1 A @ 50 and 100 Irated	0.010 A to 40.000 A	Increments of 0.001 A
	5 A @ 50 and 100 Irated	0.05 A to 200.00 A	Increments of 0.01 A
	1 A @ 1.6 Irated	0.001 A to 1.600 A	Increments of 0.001 A
	5 A @ 1.6 Irated	0.002 A to 8.000 A	Increments of 0.001 A
Dropout		Disk emulation Instantaneous	–
Time multiplier		0.00 to 15.00	Increments of 0.01
Minimum time of the curve		0.00 s to 1.00 s	Increments of 0.01 s
Additional time delay		0.00 s to 60.00 s	Increments of 0.01 s

Dropout

The greater dropout differential (= | pickup value - dropout value |) of the following 2 criteria applies:

⁶⁷ Slightly expanded tolerances will occur during the calculation of 3I0, maximum factor of 2

⁶⁸ Slightly expanded tolerances will occur during the calculation of 3I0, maximum factor of 2

⁶⁹ If you have selected the **method of measurement = RMS value**, do not set the threshold value under $0.1 I_{rated,sec}$.

Dropout	95 % of 1.1 · threshold value
Minimum absolute dropout differential	
Protection-class current transformer	5 mA sec. ($I_{rated} = 1 \text{ A}$) or 25 mA sec. ($I_{rated} = 5 \text{ A}$)
Instrument current transformer	0.5 mA sec. ($I_{rated} = 1 \text{ A}$) or 2.5 mA sec. ($I_{rated} = 5 \text{ A}$)

Reset of the Integration Timer

Instantaneous	With dropout
Disk emulation	Approx. < 0.90 · threshold value

Operate Curves and Dropout-Time Characteristic Curves according to IEC

Normal inverse: type A	See Figure 14-1 in chapter 14.4.2 Stage with Inverse-Time Characteristic Curve
Very inverse: type B	
Extremely inverse: type C	See Figure 14-2 in chapter 14.4.2 Stage with Inverse-Time Characteristic Curve
Long-time inverse: type B	
Short-time inverse (Only in the advanced stage)	See Figure 14-3 in chapter 14.4.2 Stage with Inverse-Time Characteristic Curve

Operate Curves and Dropout-Time Characteristic Curves according to ANSI/IEEE

Inverse: type C	See Figure 14-4 in chapter 14.4.2 Stage with Inverse-Time Characteristic Curve
Short inverse	
Long inverse	See Figure 14-5 in chapter 14.4.2 Stage with Inverse-Time Characteristic Curve
Moderately inverse	
Very inverse	See Figure 14-6 in chapter 14.4.2 Stage with Inverse-Time Characteristic Curve
Extremely inverse	
Definite inverse	See Figure 14-7 in chapter 14.4.2 Stage with Inverse-Time Characteristic Curve

Frequency Operating Range

$0.9 \leq f/f_{rated} \leq 1.1$	According to specified tolerances
$10 \text{ Hz} \leq f < 0.9 f_{rated}$ $1.1 f_{rated} < f \leq 90 \text{ Hz}$	Slightly expanded tolerances
$f < 10 \text{ Hz}$ $f > 90 \text{ Hz}$	Active

Tolerances

3I0 measured via I470, method of measurement = fundamental component	1 % of the setting value or 5 mA ($I_{rated} = 1 \text{ A}$) or 25 mA ($I_{rated} = 5 \text{ A}$)
3I0 measured via I471, method of measurement = RMS value (33 % harmonics, in relation to fundamental component)	
Up to 30th harmonic	2 % of the setting value or 10 mA ($I_{rated} = 1 \text{ A}$) or 50 mA ($I_{rated} = 5 \text{ A}$)

70 Insignificantly increased tolerances will occur during the calculation of 3I0, maximum factor of 2

71 Insignificantly increased tolerances will occur during the calculation of 3I0, maximum factor of 2

Up to 50th harmonic, $f_{\text{rated}} = 50 \text{ Hz}$	4 % of the setting value or 20 mA ($I_{\text{rated}} = 1 \text{ A}$) or 100 mA ($I_{\text{rated}} = 5 \text{ A}$)
Up to 50th harmonic, $f_{\text{rated}} = 60 \text{ Hz}$	5 % of the setting value or 20 mA ($I_{\text{rated}} = 1 \text{ A}$) or 100 mA ($I_{\text{rated}} = 5 \text{ A}$)
Operate time for $2 \leq I/I$ threshold value ≤ 20	5 % of the reference (calculated) value +2 % current tolerance or 30 ms
Dropout time for $2 \leq I/\text{threshold value} \leq 0.90$	5 % of the reference (calculated) value +2 % current tolerance or 30 ms

Influencing Variables for Threshold Values

Transient excess pickup in method of measurement = fundamental component, for $\tau > 100 \text{ ms}$ (with complete unbalance)	< 5 %
---	-------

14.6.3 Stage with User-Defined Characteristic Curve

Setting Values

Method of measurement		Fundamental component RMS value	–
Threshold value	1 A @ 50 and 100 Irated	0.010 A to 40.000 A	Increments of 0.001 A
	5 A @ 50 and 100 Irated	0.05 A to 200.00 A	Increments of 0.01 A
	1 A @ 1.6 Irated	0.001 A to 1.600 A	Increments of 0.001 A
	5 A @ 1.6 Irated	0.002 A to 8.000 A	Increments of 0.001 A
Absolute pickup value	1 A @ 50 and 100 Irated	0.000 A to 40.000 A	Increments of 0.001 A
	5 A @ 50 and 100 Irated	0.00 A to 200.00 A	Increments of 0.01 A
	1 A @ 1.6 Irated	0.000 A to 1.600 A	Increments of 0.001 A
	5 A @ 1.6 Irated	0.000 A to 8.000 A	Increments of 0.001 A
Dropout		Disk emulation Instantaneous	–
Time multiplier		0.05 to 15.00	Increments of 0.01
Number of value pairs for the operate curve		2 to 30	Increments of 1
X values of the operate curve		1.00 p.u. to 20.00 p. u.	Increments of 0.01 p.u.
Y values of the operate curve		0.00 s to 999.00 s	Increments of 0.01 s
Number of value pairs for the dropout characteristic curve		2 to 30	Increments of 1
X values of the dropout characteristic curve		0.05 p.u. to 0.95 p. u.	Increments of 0.01 p.u.
Y values of the dropout characteristic curve		0.00 s to 999.00 s	Increments of 0.01 s
Additional time delay		0.00 s to 60.00 s	Increments of 0.01 s

Dropout

The greater dropout differential (= | **pickup value** - **dropout value** |) of the following 2 criteria applies:

Dropout	95 % of 1.1 · threshold value or 95 % of the absolute pickup value
Minimum absolute dropout differential	
Protection-class current transformer	5 mA sec. ($I_{\text{rated}} = 1 \text{ A}$) or 25 mA sec. ($I_{\text{rated}} = 5 \text{ A}$)
Instrument current transformer	0.5 mA sec. ($I_{\text{rated}} = 1 \text{ A}$) or 2.5 mA sec. ($I_{\text{rated}} = 5 \text{ A}$)

Reset of the Integration Timer

Instantaneous	With dropout
Disk emulation	Approx. $< 0.90 \cdot$ threshold value

Frequency Operating Range

$0.9 \leq f/f_{\text{rated}} \leq 1.1$	According to specified tolerances
$10 \text{ Hz} \leq f < 0.9 f_{\text{rated}}$ $1.1 f_{\text{rated}} < f \leq 90 \text{ Hz}$	Slightly expanded tolerances
$f < 10 \text{ Hz}$ $f > 90 \text{ Hz}$	Active

Tolerances

3I0 measured via I47 ² , method of measurement = fundamental component	1 % of the setting value or 5 mA ($I_{\text{rated}} = 1 \text{ A}$) or 25 mA ($I_{\text{rated}} = 5 \text{ A}$)
3I0 measured via I47 ³ , method of measurement = RMS value (33 % harmonics, in relation to fundamental component)	
Up to 30th harmonic	2 % of the setting value or 10 mA ($I_{\text{rated}} = 1 \text{ A}$) or 50 mA ($I_{\text{rated}} = 5 \text{ A}$)
Up to 50th harmonic, $f_{\text{rated}} = 50 \text{ Hz}$	4 % of the setting value or 20 mA ($I_{\text{rated}} = 1 \text{ A}$) or 100 mA ($I_{\text{rated}} = 5 \text{ A}$)
Up to 50th harmonic, $f_{\text{rated}} = 60 \text{ Hz}$	5 % of the setting value or 20 mA ($I_{\text{rated}} = 1 \text{ A}$) or 100 mA ($I_{\text{rated}} = 5 \text{ A}$)
Operate time for $2 \leq I/I$ threshold value ≤ 20	5 % of the reference (calculated) value +2 % current tolerance or 30 ms
Dropout time for I/I threshold value ≤ 0.90	5 % of the reference (calculated) value +2 % current tolerance or 30 ms

Influencing Variables for Threshold Values

Transient excess pickup in method of measurement = fundamental component, for $\tau > 100 \text{ ms}$ (with complete unbalance)	$< 5 \%$
---	----------

Operate Curves and Dropout-Time Characteristic Curves According to IEC

Extension of the operate time during operation with transformer inrush-current detection	Approx. 10 ms
--	---------------

⁷² Insignificantly increased tolerances will occur during the calculation of 3I0, maximum factor of 2

⁷³ Insignificantly increased tolerances will occur during the calculation of 3I0, maximum factor of 2

14.7 Directional Overcurrent Protection, Phases

14.7.1 Stage with Definite-Time Characteristic Curve

Setting Values

Rotation angle of the reference voltage	-180° to +180°	Increments of 1°
Directional mode	Forward Reverse	–
Method of measurement	Fundamental component RMS value	–
Threshold value ⁷⁴	1 A @ 50 and 100 I _{rated}	0.030 A to 40.000 A Increments of 0.001 A
	5 A @ 50 and 100 I _{rated}	0.15 A to 200.00 A Increments of 0.01 A
	1 A @ 1.6 I _{rated}	0.001 A to 1.600 A Increments of 0.001 A
	5 A @ 1.6 I _{rated}	0.005 A to 8.000 A Increments of 0.001 A
Dropout ratio	0.90 to 0.99	Increments of 0.01
Time delay	0.00 s to 60.00 s	Increments of 0.01 s
Dropout delay	0.00 s to 60.00 s	Increments of 0.01 s

Dropout

The greater dropout differential (= | pickup value - dropout value |) of the following 2 criteria applies:

Dropout differential derived from the parameter Dropout ratio	
If this parameter is not available, a dropout ratio of 95 % applies for overcurrent and of 105 % for undercurrent functionality.	
Minimum absolute dropout differential	
Protection-class current transformer	15 mA sec. (I _{rated} = 1 A) or 75 mA sec. (I _{rated} = 5 A)
Instrument current transformer	0.5 mA sec. (I _{rated} = 1 A) or 2.5 mA sec. (I _{rated} = 5 A)

Direction Determination

Type	With healthy voltages With voltage memory 2 s
Forward range	V _{ref,rot} ±88°
Dropout differential forward/reverse range	1°
Directional sensitivity	For 1 and 2-phase short circuits: unlimited For 3-phase short circuits: dynamically unlimited, stationary Approx. 13 V phase-to-phase

⁷⁴ If you have selected the **method of measurement = RMS value**, do not set the threshold value under 0.1 I_{rated,sec}.

Times

Operate time with time delay = 0 ms	Approx. 37 ms + OOT ⁷⁵ at 50 Hz Approx. 31 ms + OOT at 60 Hz
Extension of the operate time during operation with transformer inrush-current detection	Approx. 10 ms
Dropout time, typical	Approx. 25 ms + OOT
Dropout time, maximum	Approx. 30 ms + OOT

Frequency Operating Range

$0.9 \leq f/f_{\text{rated}} \leq 1.1$	According to specified tolerances
$10 \text{ Hz} \leq f < 0.9 f_{\text{rated}}$ $1.1 f_{\text{rated}} < f \leq 90 \text{ Hz}$	Slightly expanded tolerances
$f < 10 \text{ Hz}$ $f > 90 \text{ Hz}$	Active

Tolerances

Currents, method of measurement = fundamental component	1 % of the setting value or 5 mA ($I_{\text{rated}} = 1 \text{ A}$) or 25 mA ($I_{\text{rated}} = 5 \text{ A}$)
Currents, method of measurement = RMS value (33 % harmonics, in relation to fundamental component)	
Up to 30th harmonic	2 % of the setting value or 10 mA ($I_{\text{rated}} = 1 \text{ A}$) or 50 mA ($I_{\text{rated}} = 5 \text{ A}$)
Up to 50th harmonic, $f_{\text{rated}} = 50 \text{ Hz}$	4 % of the setting value or 20 mA ($I_{\text{rated}} = 1 \text{ A}$) or 100 mA ($I_{\text{rated}} = 5 \text{ A}$)
Up to 50th harmonic, $f_{\text{rated}} = 60 \text{ Hz}$	5 % of the setting value or 20 mA ($I_{\text{rated}} = 1 \text{ A}$) or 100 mA ($I_{\text{rated}} = 5 \text{ A}$)
Time delay	1 % of the setting value or 10 ms
Direction-determination angle error	1 °

Influencing Variables for Threshold Values

Transient excess pickup in method of measurement = fundamental component, for $\tau > 100 \text{ ms}$ (with complete unbalance)	< 5 %
---	-------

14.7.2 Stage with Inverse-Time Characteristic Curve
Setting Values

Rotation angle of the reference voltage	-180° to +180°	Increments of 1°
Directional mode	Forward Backward	–
Method of measurement	Fundamental component RMS value	–

⁷⁵ OOT (Output Operating Time): additional delay of the output medium used, for example 5 ms with fast relays

Threshold value ⁷⁶	1 A @ 50 and 100 I _{rated}	0.030 A to 40.000 A	Increments of 0.001 A
	5 A @ 50 and 100 I _{rated}	0.15 A to 200.00 A	Increments of 0.01 A
	1 A @ 1.6 I _{rated}	0.001 A to 1.600 A	Increments of 0.001 A
	5 A @ 1.6 I _{rated}	0.005 A to 8.000 A	Increments of 0.001 A
Dropout		Disk emulation Instantaneous	–
Time multiplier		0.00 to 15.00	Increments of 0.01
Minimum time of the curve		0.00 s to 1.00 s	Increments of 0.01 s
Additional time delay		0.00 s to 60.00 s	Increments of 0.01 s

Dropout

The greater dropout differential (= | pickup value - dropout value |) of the following 2 criteria applies:

Dropout	95 % of 1.1 · threshold value
Minimum absolute dropout differential	
Protection-class current transformer	15 mA sec. (I _{rated} = 1 A) or 75 mA sec. (I _{rated} = 5 A)
Instrument current transformer	0.5 mA sec. (I _{rated} = 1 A) or 2.5 mA sec. (I _{rated} = 5 A)

Reset of the Integration Timer

Instantaneous	With dropout
Disk emulation	Approx. < 0.90 · threshold value

Operate Curves and Dropout-Time Characteristic Curves according to IEC

Normal inverse: type A	See Figure 14-1 in chapter 14.4.2 Stage with Inverse-Time Characteristic Curve
Very inverse: type B	
Extremely inverse: type C	See Figure 14-2 in chapter 14.4.2 Stage with Inverse-Time Characteristic Curve
Long-time inverse: type B	
Short-time inverse (Only in the advanced stage)	See Figure 14-3 in chapter 14.4.2 Stage with Inverse-Time Characteristic Curve

Operate Curves and Dropout-Time Characteristic Curves according to ANSI/IEEE

Inverse: type C	See Figure 14-4 in chapter 14.4.2 Stage with Inverse-Time Characteristic Curve
Short inverse	
Long inverse	See Figure 14-5 in chapter 14.4.2 Stage with Inverse-Time Characteristic Curve
Moderately inverse	
Very inverse	See Figure 14-6 in chapter 14.4.2 Stage with Inverse-Time Characteristic Curve
Extremely inverse	
Definite inverse	See Figure 14-7 in chapter 14.4.2 Stage with Inverse-Time Characteristic Curve

⁷⁶ If you have selected the **method of measurement = RMS value**, do not set the threshold value under 0.1 I_{rated,sec}.

Direction Determination

Type	With healthy voltages With voltage memory 2 s
Forward range	$V_{ref,rot} \pm 88^\circ$
Dropout differential forward/reverse range	1°
Directional sensitivity	For 1 and 2-phase short circuits: unlimited For 3-phase short circuits: dynamically unlimited, stationary Approx. 13 V phase-to-phase

Times

Operate time with time delay = 0 ms	Approx. 37 ms + OOT ⁷⁷ at 50 Hz Approx. 31 ms + OOT at 60 Hz
Extension of the operate time during operation with transformer inrush-current detection	Approx. 10 ms
Dropout time, typical	Approx. 25 ms + OOT
Dropout time, maximum	Approx. 30 ms + OOT

Frequency Operating Range

$0.9 \leq f/f_{rated} \leq 1.1$	According to specified tolerances
$10 \text{ Hz} \leq f < 0.9 f_{rated}$ $1.1 f_{rated} < f \leq 90 \text{ Hz}$	Slightly expanded tolerances
$f < 10 \text{ Hz}$ $f > 90 \text{ Hz}$	Active

Tolerances

Currents, method of measurement = fundamental component	1 % of the setting value or 5 mA ($I_{rated} = 1 \text{ A}$) or 25 mA ($I_{rated} = 5 \text{ A}$)
Currents, method of measurement = RMS value (33 % harmonics, in relation to fundamental component)	
Up to 30th harmonic	2 % of the setting value or 10 mA ($I_{rated} = 1 \text{ A}$) or 50 mA ($I_{rated} = 5 \text{ A}$)
Up to 50th harmonic, $f_{rated} = 50 \text{ Hz}$	4 % of the setting value or 20 mA ($I_{rated} = 1 \text{ A}$) or 100 mA ($I_{rated} = 5 \text{ A}$)
Up to 50th harmonic, $f_{rated} = 60 \text{ Hz}$	5 % of the setting value or 20 mA ($I_{rated} = 1 \text{ A}$) or 100 mA ($I_{rated} = 5 \text{ A}$)
Operate time for $2 \leq I/\text{threshold value} I \leq 20$	5 % of the reference (calculated) value +2 % current tolerance or 30 ms
Dropout time for $I/\text{threshold value} I \leq 0.90$	5 % of the reference (calculated) value +2 % current tolerance or 30 ms
Direction-determination angle error	1°

⁷⁷ OOT (Output Operating Time): additional delay of the output medium used, for example 5 ms with fast relays

Influencing Variables for Threshold Values

Transient excess pickup in method of measurement = fundamental component, for $\tau > 100$ ms (with complete unbalance)	< 5 %
---	-------

14.7.3 Stage with User-Defined Characteristic Curve

Setting Values

Rotation angle of the reference voltage	-180° to +180°	Increments of 1°
Directional mode	Forward Reverse	–
Method of measurement	Fundamental component RMS value	–
Threshold value ⁷⁸	1 A @ 50 and 100 I _{rated}	0.030 A to 40.000 A Increments of 0.001 A
	5 A @ 50 and 100 I _{rated}	0.15 A to 200.00 A Increments of 0.01 A
	1 A @ 1.6 I _{rated}	0.001 A to 1.600 A Increments of 0.001 A
	5 A @ 1.6 I _{rated}	0.005 A to 8.000 A Increments of 0.001 A
Dropout	Disk emulation Instantaneous	–
Time multiplier	0.05 to 15.00	Increments of 0.01
Number of value pairs for the operate characteristic curve	2 to 30	Increments of 1
X values of the operate curve	1.00 p.u. to 66.67 p.u.	Increments of 0.01 p.u.
Y values of the operate curve	0.00 s to 999.00 s	Increments of 0.01 s
Number of value pairs for the dropout characteristic curve	2 to 30	Increments of 1
X values of the dropout characteristic curve	0.05 p.u. to 0.95 p.u.	Increments of 0.01 p.u.
Y values of the dropout characteristic curve	0.00 s to 999.00 s	Increments of 0.01 s

Dropout

The greater dropout differential (= | **pickup value** - **dropout value** |) of the following 2 criteria applies:

Dropout	95 % of 1.1 · threshold value
Minimum absolute dropout differential	
Protection-class current transformer	15 mA sec. (I _{rated} = 1 A) or 75 mA sec. (I _{rated} = 5 A)
Instrument current transformer	0.5 mA sec. (I _{rated} = 1 A) or 2.5 mA sec. (I _{rated} = 5 A)

Reset of the Integration Timer

Instantaneous	With dropout
Disk emulation	Approx. < 0.90 · threshold value

⁷⁸ If you have selected the **method of measurement = RMS value**, do not set the threshold value under 0.1 I_{rated,sec}.

Direction Determination

Type	With healthy voltages With voltage memory 2 s
Forward range	$V_{ref,rot} \pm 88^\circ$
Dropout differential forward/reverse range	1°
Directional sensitivity	For 1-phase and 2-phase short circuits: unlimited For 3-phase short circuits stationary: dynamically unlimited Approx. 13 V phase-to-phase

Times

Operate time with time delay = 0 ms	Approx. 37 ms + OOT ⁷⁹ at 50 Hz Approx. 31 ms + OOT at 60 Hz
Extension of the operate time during operation with transformer inrush-current detection	Approx. 10 ms
Dropout time, typical	Approx. 25 ms + OOT
Dropout time, maximum	Approx. 30 ms + OOT

Frequency Operating Range

$0.9 \leq f/f_{rated} \leq 1.1$	According to specified tolerances
$10 \text{ Hz} \leq f < 0.9 f_{rated}$ $1.1 f_{rated} < f \leq 90 \text{ Hz}$	Slightly expanded tolerances
$f < 10 \text{ Hz}$ $f > 90 \text{ Hz}$	Active

Tolerances

Currents, method of measurement = fundamental component	1 % of the setting value or 5 mA ($I_{rated} = 1 \text{ A}$) or 25 mA ($I_{rated} = 5 \text{ A}$)
Currents, method of measurement = RMS value (33 % harmonics, in relation to fundamental component)	
Up to 30th harmonic	2 % of the setting value or 10 mA ($I_{rated} = 1 \text{ A}$) or 50 mA ($I_{rated} = 5 \text{ A}$)
Up to 50th harmonic, $f_{rated} = 50 \text{ Hz}$	4 % of the setting value or 20 mA ($I_{rated} = 1 \text{ A}$) or 100 mA ($I_{rated} = 5 \text{ A}$)
Up to 50th harmonic, $f_{rated} = 60 \text{ Hz}$	5 % of the setting value or 20 mA ($I_{rated} = 1 \text{ A}$) or 100 mA ($I_{rated} = 5 \text{ A}$)
Operate time for $2 \leq I/\text{threshold value} I \leq 20$	5 % of the reference (calculated) value +2 % current tolerance or 10 ms
Dropout time for $I/\text{threshold value} I \leq 0.90$	5 % of the reference (calculated) value +2 % current tolerance or 10 ms
Direction-determination angle error	1°

⁷⁹ OOT (Output Operating Time): additional delay of the output medium used, for example 5 ms with fast relays

Influencing Variables for Threshold Values

Transient excess pickup in method of measurement = fundamental component, for $\tau > 100$ ms (with complete unbalance)	< 5 %
---	-------

14.8 Directional Overcurrent Protection, Ground

14.8.1 Stage with Definite-Time Characteristic Curve

Setting Values for the Function Direction Determination

Method for direction determination	Zero sequence Negative sequence	–
Minimum V0 or V2 threshold	0.150 V to 20.000 V	0.001 V
Rotation angle of the reference voltage	-180° to 180°	1°
Forward range	0° to 180°	1°

Setting Values

Direction mode	Forward Reverse	–	
Method of measurement	Fundamental component RMS value	–	
Threshold value	1 A @ 50 and 100 I _{rated}	0.030 A to 40.000 A	Increments of 0.001 A
	5 A @ 50 and 100 I _{rated}	0.15 A to 200.00 A	Increments of 0.01 A
	1 A @ 1.6 I _{rated}	0.001 A to 1.600 A	Increments of 0.001 A
	5 A @ 1.6 I _{rated}	0.005 A to 8.000 A	Increments of 0.001 A
Dropout ratio	0.90 to 0.99	Increments of 0.01	
Operate delay	0.00 s to 60.00 s	Increments of 0.01 s	
Dropout delay	0.00 s to 60.00 s	Increments of 0.01 s	

Dropout

The greater dropout differential (= | **pickup value** - **dropout value** |) of the following 2 criteria applies:

Dropout differential derived from the parameter Dropout ratio	
If this parameter is not available, a dropout ratio of 95 % applies for overcurrent and of 105 % for undercurrent functionality.	
Minimum absolute dropout differential	
Protection-class current transformer	15 mA sec. (I _{rated} = 1 A) or 75 mA sec. (I _{rated} = 5 A)
Instrument current transformer	0.5 mA sec. (I _{rated} = 1 A) or 2.5 mA sec. (I _{rated} = 5 A)

Times

The maximum pickup time with operate delay = 0 ms	Approx. 30 ms + OOT at 50 Hz Approx. 25 ms + OOT at 60 Hz
Extension of the operate time during operation with inrush-current detection	Approx. 10 ms
Dropout time	Approx. 20 ms + OOT

Frequency Operating Range

$0.9 \leq f/f_{rated} \leq 1.1$	According to specified tolerances
$10 \text{ Hz} \leq f < 0.9 f_{rated}$ $1.1 f_{rated} < f \leq 90 \text{ Hz}$	Slightly expanded tolerances
$f < 10 \text{ Hz}$ $f > 90 \text{ Hz}$	Active with reduced sensitivity

Tolerances

Currents, method of measurement = fundamental component	1 % of the setting value or 5 mA ($I_{rated} = 1 \text{ A}$) or 25 mA ($I_{rated} = 5 \text{ A}$)
Currents, method of measurement = RMS value (33 % part of harmonic, referring to fundamental component)	
Up to 30th harmonic	2 % of the setting value or 10 mA ($I_{rated} = 1 \text{ A}$) or 50 mA ($I_{rated} = 5 \text{ A}$)
Up to 50th harmonic, $f_{rated} = 50 \text{ Hz}$	4 % of the setting value or 20 mA ($I_{rated} = 1 \text{ A}$) or 100 mA ($I_{rated} = 5 \text{ A}$)
Up to 50th harmonic, $f_{rated} = 60 \text{ Hz}$	5 % of the setting value or 20 mA ($I_{rated} = 1 \text{ A}$) or 100 mA ($I_{rated} = 5 \text{ A}$)
Time delays	1 % of the setting value or 10 ms
Direction-determination angle error	1°

Influencing Variables for Threshold Values

Transient excess pickup in method of measurement = fundamental component, for $\tau > 100 \text{ ms}$ (with complete unbalance)	< 5 %
---	-------

14.8.2 Stage with Inverse-Time Characteristic Curve

Setting Values for the Function Direction Determination

Method for direction determination	Zero sequence Negative sequence	–
Minimum V0 or V2 threshold	0.150 V to 20.000 V	0.001 V
Rotation angle of the reference voltage	-180° to 180°	1°
Forward range	0° to 180°	1°

Setting Values

Direction mode	Forward Reverse	–	
Method of measurement	Fundamental component RMS value	–	
Threshold value	1 A @ 50 and 100 Irated	0.030 A to 40.000 A	Increments of 0.001 A
	5 A @ 50 and 100 Irated	0.15 A to 200.00 A	Increments of 0.01 A
	1 A @ 1.6 Irated	0.001 A to 1.600 A	Increments of 0.001 A
	5 A @ 1.6 Irated	0.005 A to 8.000 A	Increments of 0.001 A
Type of characteristic curve	Characteristic curves according to IEC and ANSI		

Dropout	Disk emulation Instantaneous	–
Time multiplier	0.00 to 15.00	Increments of 0.01
Minimum time of the curve	0.00 s to 1.00 s	Increments of 0.01 s
Additional time delay	0.00 s to 60.00 s	Increments of 0.01 s

Dropout

The greater dropout differential ($= | \text{pickup value} - \text{dropout value} |$) of the following 2 criteria applies:

Dropout	95 % of $1.1 \cdot \text{threshold value}$
Minimum absolute dropout differential	
Protection-class current transformer	15 mA sec. ($I_{\text{rated}} = 1 \text{ A}$) or 75 mA sec. ($I_{\text{rated}} = 5 \text{ A}$)
Instrument current transformer	0.5 mA sec. ($I_{\text{rated}} = 1 \text{ A}$) or 2.5 mA sec. ($I_{\text{rated}} = 5 \text{ A}$)

Reset of the Integration Timer

Instantaneous	With dropout
Disk emulation	Approx. $< 0.90 \cdot \text{threshold value}$

Operate Curves and Dropout-Time Characteristic Curves according to IEC

Normal inverse: type A	See Figure 14-1 in chapter 14.4.2 Stage with Inverse-Time Characteristic Curve
Very inverse: type B	
Extremely inverse: type C	See Figure 14-2 in chapter 14.4.2 Stage with Inverse-Time Characteristic Curve
Long-time inverse: type B	
Short-time inverse (Only in the advanced stage)	See Figure 14-3 in chapter 14.4.2 Stage with Inverse-Time Characteristic Curve

Operate Curves and Dropout-Time Characteristic Curves according to ANSI/IEEE

Inverse: type C	See Figure 14-4 in chapter 14.4.2 Stage with Inverse-Time Characteristic Curve
Short inverse	
Long inverse	See Figure 14-5 in chapter 14.4.2 Stage with Inverse-Time Characteristic Curve
Moderately inverse	
Very inverse	See Figure 14-6 in chapter 14.4.2 Stage with Inverse-Time Characteristic Curve
Extremely inverse	
Definite inverse	See Figure 14-7 in chapter 14.4.2 Stage with Inverse-Time Characteristic Curve

Times

The maximum pickup time with operate delay = 0 ms	Approx. 30 ms + OOT at 50 Hz Approx. 25 ms + OOT at 60 Hz
Extension of the operate time during operation with inrush-current detection	Approx. 10 ms
Dropout time	Approx. 20 ms + OOT

Frequency Operating Range

$0.9 \leq f/f_{\text{rated}} \leq 1.1$	According to specified tolerances
$10 \text{ Hz} \leq f < 0.9 f_{\text{rated}}$ $1.1 f_{\text{rated}} < f \leq 90 \text{ Hz}$	Slightly expanded tolerances
$f < 10 \text{ Hz}$ $f > 90 \text{ Hz}$	Active with reduced sensitivity

Tolerances

Currents, method of measurement = fundamental component	1 % of the setting value or 5 mA ($I_{\text{rated}} = 1 \text{ A}$) or 25 mA ($I_{\text{rated}} = 5 \text{ A}$)
Currents, method of measurement = RMS value (33 % part of harmonic, referring to fundamental component)	
Up to 30th harmonic	2 % of the setting value or 10 mA ($I_{\text{rated}} = 1 \text{ A}$) or 50 mA ($I_{\text{rated}} = 5 \text{ A}$)
Up to 50th harmonic, $f_{\text{rated}} = 50 \text{ Hz}$	4 % of the setting value or 20 mA ($I_{\text{rated}} = 1 \text{ A}$) or 100 mA ($I_{\text{rated}} = 5 \text{ A}$)
Up to 50th harmonic, $f_{\text{rated}} = 60 \text{ Hz}$	5 % of the setting value or 20 mA ($I_{\text{rated}} = 1 \text{ A}$) or 100 mA ($I_{\text{rated}} = 5 \text{ A}$)
Operate time for $2 \leq I/I$ threshold value ≤ 20	5 % of the reference (calculated) value + 2 % current tolerance or 30 ms
Dropout time for I/I threshold value ≤ 0.90	5 % of the reference (calculated) value + 2 % current tolerance or 30 ms
Direction-determination angle error	1°

Influencing Variables for Threshold Values

Transient excess pickup in method of measurement = fundamental component, for $\tau > 100 \text{ ms}$ (with complete unbalance)	< 5 %
---	-------

14.8.3 Stage with Inverse-Time Overcurrent Protection with Logarithmic-Inverse Characteristic Curve

Setting Values for the Function Direction Determination

Method for direction determination	Zero sequence Negative sequence	–
Minimum V0 or V2 threshold	0.150 V to 20.000 V	0.001 V
Rotation angle of the reference voltage	-180° to 180°	1°
Forward range	0° to 180°	1°

Setting Values

Direction mode	Forward Reverse	–
Method of measurement	Fundamental component RMS value	–

Threshold value	1 A @ 50 and 100 I _{rated}	0.030 A to 40.000 A	Increments of 0.001 A
	5 A @ 50 and 100 I _{rated}	0.15 A to 200.00 A	Increments of 0.01 A
	1 A @ 1.6 I _{rated}	0.001 A to 1.600 A	Increments of 0.001 A
	5 A @ 1.6 I _{rated}	0.005 A to 8.000 A	Increments of 0.001 A
Characteristic curve: see Figure 14-8			
Threshold value multiplier		1.00 to 4.00	Increments of 0.01
Time multiplier		0.000 s to 60.000 s	Increments of 0.001 s
Minimum time of the characteristic curve		0.000 s to 60.000 s	Increments of 0.001 s
Maximum time of the characteristic curve		0.000 s to 60.000 s	Increments of 0.001 s
Additional time delay		0.000 s to 60.000 s	Increments of 0.001 s

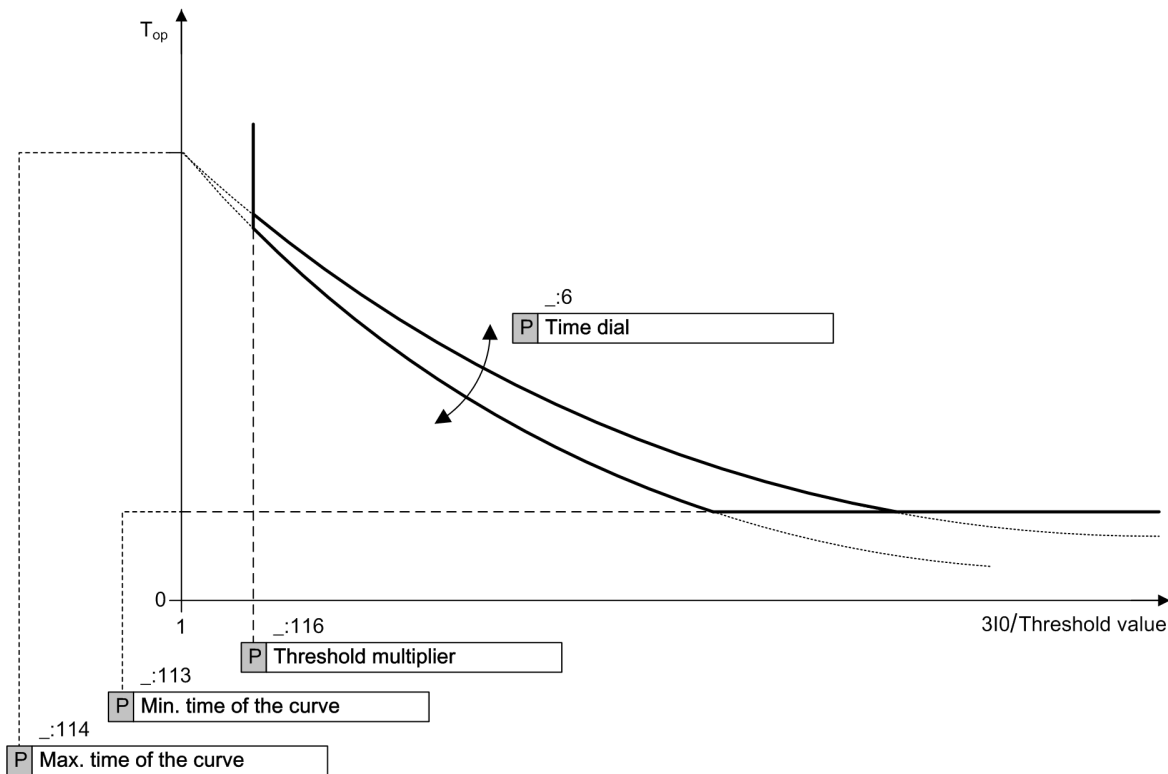

[dwc_loginv, 3, en_US]

Figure 14-8 Operate Curve of Logarithmic Inverse-Time Characteristic

Dropout

The greater dropout differential (= | pickup value - dropout value |) of the following 2 criteria applies:

Dropout differential derived from the parameter Dropout ratio	
If this parameter is not available, a dropout ratio of 95 % applies for overcurrent and of 105 % for undercurrent functionality.	
Minimum absolute dropout differential	
Protection-class current transformer	15 mA sec. (I _{rated} = 1 A) or 75 mA sec. (I _{rated} = 5 A)
Instrument current transformer	0.5 mA sec. (I _{rated} = 1 A) or 2.5 mA sec. (I _{rated} = 5 A)

Times

The maximum pickup time with operate delay = 0 ms	Approx. 30 ms + OOT at 50 Hz Approx. 25 ms + OOT at 60 Hz
Extension of the operate time during operation with inrush-current detection	Approx. 10 ms
Dropout time	Approx. 20 ms + OOT

Frequency Operating Range

$0.9 \leq f/f_{\text{rated}} \leq 1.1$	According to specified tolerances
$10 \text{ Hz} \leq f < 0.9 f_{\text{rated}}$ $1.1 f_{\text{rated}} < f \leq 90 \text{ Hz}$	Slightly expanded tolerances
$f < 10 \text{ Hz}$ $f > 90 \text{ Hz}$	Active with reduced sensitivity

Tolerances

Currents, method of measurement = fundamental component	1 % of the setting value or 5 mA ($I_{\text{rated}} = 1 \text{ A}$) or 25 mA ($I_{\text{rated}} = 5 \text{ A}$)
Currents, method of measurement = RMS value (33 % part of harmonic, referring to fundamental component)	
Up to 30th harmonic	2 % of the setting value or 10 mA ($I_{\text{rated}} = 1 \text{ A}$) or 50 mA ($I_{\text{rated}} = 5 \text{ A}$)
Up to 50th harmonic, $f_{\text{rated}} = 50 \text{ Hz}$	4 % of the setting value or 20 mA ($I_{\text{rated}} = 1 \text{ A}$) or 100 mA ($I_{\text{rated}} = 5 \text{ A}$)
Up to 50th harmonic, $f_{\text{rated}} = 60 \text{ Hz}$	5 % of the setting value or 20 mA ($I_{\text{rated}} = 1 \text{ A}$) or 100 mA ($I_{\text{rated}} = 5 \text{ A}$)
Inverse-time operate time to logarithmic inverse-time characteristic	5 % of the reference (calculated) value + 2 % current tolerance or 30 ms
Inverse-time dropout time to logarithmic inverse-time characteristic	5 % of the reference (calculated) value + 2 % current tolerance or 30 ms
Direction-determination angle error	1°

Influencing Variables for Threshold Values

Transient excess pickup in method of measurement = fundamental component, for $\tau > 100 \text{ ms}$ (with complete unbalance)	< 5 %
---	-------

14.8.4 Stage with Knee-Point Characteristic Curve

Setting Values for the Function Direction Determination

Method for direction determination	Zero sequence Negative sequence	–
Minimum V0 or V2 threshold value	0.150 V to 20.000 V	0.001 V
Rotation angle of the reference voltage	-180° to 180°	1°
Forward range	0° to 180°	1°

Setting Values

Direction mode		Forward Reverse	–
Method of measurement		Fundamental component RMS value	–
Threshold value	1 A @ 50 and 100 Irated	0.030 A to 40.000 A	Increments of 0.001 A
	5 A @ 50 and 100 Irated	0.15 A to 200.00 A	Increments of 0.01 A
	1 A @ 1.6 Irated	0.001 A to 1.600 A	Increments of 0.001 A
	5 A @ 1.6 Irated	0.005 A to 8.000 A	Increments of 0.001 A
Characteristic curve: see Figure 14-9			
Minimum time of the characteristic curve		0.00 s to 30.00 s	Increments of 0.01 s
Knee-point time of the curve		0.00 s to 100.00 s	Increments of 0.01 s
Maximum time of the characteristic curve		0.00 s to 200.00 s	Increments of 0.01 s
Knee-point value		0.030 A to 40.000 A	Increments of 0.001 A
Current at minimum time of the curve		0.030 A to 40.000 A	Increments of 0.001 A
Time multiplier		0.05 to 1.50	Increments of 0.01

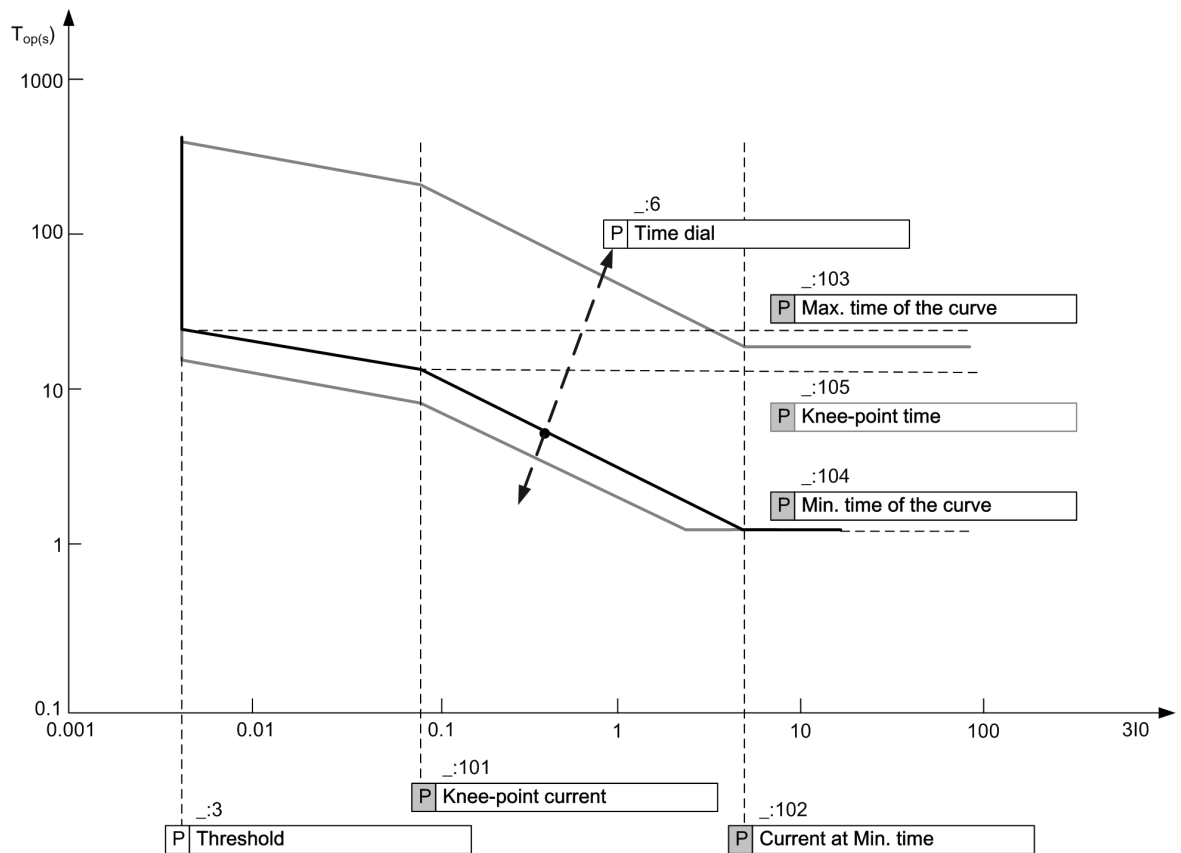

[dw_drloinkn, 1, en_US]

Figure 14-9 Operate Curve of the Logarithmic Inverse Time with Knee-Point Characteristic (In the Example of **Threshold = 0.004 A**)

Dropout

The greater dropout differential (= | pickup value - dropout value |) of the following 2 criteria applies:

Dropout differential derived from the parameter Dropout ratio	
If this parameter is not available, a dropout ratio of 95 % applies for overcurrent and of 105 % for undercurrent functionality.	
Minimum absolute dropout differential	
Protection-class current transformer	15 mA sec. ($I_{rated} = 1 \text{ A}$) or 75 mA sec. ($I_{rated} = 5 \text{ A}$)
Instrument current transformer	0.5 mA sec. ($I_{rated} = 1 \text{ A}$) or 2.5 mA sec. ($I_{rated} = 5 \text{ A}$)

Times

The maximum pickup time with operate delay = 0 ms	Approx. 30 ms + OOT at 50 Hz Approx. 25 ms + OOT at 60 Hz
Extension of the operate time during operation with inrush-current detection	Approx. 10 ms
Dropout time	Approx. 20 ms + OOT

Frequency Operating Range

$0.9 \leq f/f_{rated} \leq 1.1$	According to specified tolerances
$10 \text{ Hz} \leq f < 0.9 f_{rated}$ $1.1 f_{rated} < f \leq 90 \text{ Hz}$	Slightly expanded tolerances
$f < 10 \text{ Hz}$ $f > 90 \text{ Hz}$	Active with reduced sensitivity

Tolerances

Currents, method of measurement = fundamental component	1 % of the setting value or 5 mA ($I_{rated} = 1 \text{ A}$) or 25 mA ($I_{rated} = 5 \text{ A}$)
Currents, method of measurement = RMS value (33 % part of harmonic, referring to fundamental component)	
Up to 30th harmonic	2 % of the setting value or 10 mA ($I_{rated} = 1 \text{ A}$) or 50 mA ($I_{rated} = 5 \text{ A}$)
Up to 50th harmonic, $f_{rated} = 50 \text{ Hz}$	4 % of the setting value or 20 mA ($I_{rated} = 1 \text{ A}$) or 100 mA ($I_{rated} = 5 \text{ A}$)
Up to 50th harmonic, $f_{rated} = 60 \text{ Hz}$	5 % of the setting value or 20 mA ($I_{rated} = 1 \text{ A}$) or 100 mA ($I_{rated} = 5 \text{ A}$)
Inverse-time operate time to logarithmic inverse time with knee-point characteristic	5 % of the reference (calculated) value + 2 % current tolerance or 30 ms
Inverse-time dropout time to logarithmic inverse time with knee-point characteristic	5 % of the reference (calculated) value + 2 % current tolerance or 30 ms
Direction-determination angle error	1°

Influencing Variables for Threshold Values

Transient excess pickup in method of measurement = fundamental component, for $\tau > 100 \text{ ms}$ (with complete unbalance)	< 5 %
---	-------

14.8.5 Stage with User-Defined Characteristic Curve

Setting Values for the Function Direction Determination

Method for direction determination	Zero sequence Negative sequence	–
Minimum V0 or V2 threshold	0.150 V to 20.000 V	0.001 V
Rotation angle of the reference voltage	-180° to 180°	1°
Forward range	0° to 180°	1°

Setting Values

Direction mode	Forward Reverse	–	
Method of measurement	Fundamental component RMS value	–	
Threshold value	1 A @ 50 and 100 I _{rated}	0.030 A to 40.000 A	Increments of 0.001 A
	5 A @ 50 and 100 I _{rated}	0.15 A to 200.00 A	Increments of 0.01 A
	1 A @ 1.6 I _{rated}	0.001 A to 1.600 A	Increments of 0.001 A
	5 A @ 1.6 I _{rated}	0.005 A to 8.000 A	Increments of 0.001 A
Dropout	Disk emulation Instantaneous	–	
Time multiplier	0.05 to 15.00	Increments of 0.01	
X values of the operate curve	1.00 p. u. to 66.67 p. u.	Increments of 0.01 p. u.	
Y values of the operate curve	0.00 s to 999.00 s	Increments of 0.01 s	
Number of value pairs for the dropout characteristic curve	2 to 30	Increments of 1	
X values of the dropout characteristic curve	0.05 p. u. to 0.95 p. u.	Increments of 0.01 p. u.	
Y values of the dropout characteristic curve	0.00 s to 999.00 s	Increments of 0.01 s	

Dropout

The greater dropout differential (= | **pickup value** - **dropout value** |) of the following 2 criteria applies:

Dropout	95 % of 1.1 · threshold value
Minimum absolute dropout differential	
Protection-class current transformer	15 mA sec. (I _{rated} = 1 A) or 75 mA sec. (I _{rated} = 5 A)
Instrument current transformer	0.5 mA sec. (I _{rated} = 1 A) or 2.5 mA sec. (I _{rated} = 5 A)

Reset of the Integration Timer

Instantaneous	With dropout
Disk emulation	Approx. < 0.90 · threshold value

Times

The maximum pickup time with operate delay = 0 ms	Approx. 30 ms + OOT at 50 Hz Approx. 25 ms + OOT at 60 Hz
Extension of the operate time during operation with inrush-current detection	Approx. 10 ms
Dropout time	Approx. 20 ms + OOT

Frequency Operating Range

$0.9 \leq f/f_{\text{rated}} \leq 1.1$	According to specified tolerances
$10 \text{ Hz} \leq f < 0.9 f_{\text{rated}}$ $1.1 f_{\text{rated}} < f \leq 90 \text{ Hz}$	Slightly expanded tolerances
$f < 10 \text{ Hz}$ $f > 90 \text{ Hz}$	Active with reduced sensitivity

Tolerances

Currents, method of measurement = fundamental component	1 % of the setting value or 5 mA ($I_{\text{rated}} = 1 \text{ A}$) or 25 mA ($I_{\text{rated}} = 5 \text{ A}$)
Currents, method of measurement = RMS value (33 % part of harmonic, referring to fundamental component)	
Up to 30th harmonic	2 % of the setting value or 10 mA ($I_{\text{rated}} = 1 \text{ A}$) or 50 mA ($I_{\text{rated}} = 5 \text{ A}$)
Up to 50th harmonic, $f_{\text{rated}} = 50 \text{ Hz}$	4 % of the setting value or 20 mA ($I_{\text{rated}} = 1 \text{ A}$) or 100 mA ($I_{\text{rated}} = 5 \text{ A}$)
Up to 50th harmonic, $f_{\text{rated}} = 60 \text{ Hz}$	5 % of the setting value or 20 mA ($I_{\text{rated}} = 1 \text{ A}$) or 100 mA ($I_{\text{rated}} = 5 \text{ A}$)
Operate time for $2 \leq I/I$ threshold value ≤ 20	5 % of the reference (calculated) value + 2 % current tolerance or 30 ms
Dropout time for I/I threshold value ≤ 0.90	5 % of the reference (calculated) value + 2 % current tolerance or 30 ms
Direction-determination angle error	1°

Influencing Variables for Threshold Values

Transient excess pickup in method of measurement = fundamental component, for $\tau > 100 \text{ ms}$ (with complete unbalance)	< 5 %
---	-------

14.9 Inrush-Current Detection

Setting Values

Operating limit I_{max}	0.030 A to 35.000 A at $I_{rated} = 1$ A 0.15 A to 175.00 A at $I_{rated} = 5$ A	Increments of 0.001 A Increments of 0.01 A
Content 2nd harmonic	10 % to 45 %	Increments of 1 %
Duration of the crossblock function	0.03 s to 200.00 s	Increments of 0.01 s

Times

Operating times	Approx. 29 ms
-----------------	---------------

Pickup

Harmonic: $I_{2nd\ harm}/I_{1st\ harm}$	Setting value or at least
Protection-class current transformers	$I_{1st\ harm} = 10$ mA sec. and $I_{2nd\ harm} = 10$ mA sec. ($I_{rated} = 1$ A) $I_{1st\ harm} = 50$ mA sec. and $I_{2nd\ harm} = 50$ mA sec. ($I_{rated} = 5$ A)
Instrument transformers	$I_{1st\ harm} = 1$ mA sec. and $I_{2nd\ harm} = 1$ mA sec. ($I_{rated} = 1$ A) $I_{1st\ harm} = 5$ mA sec. and $I_{2nd\ harm} = 5$ mA sec. ($I_{rated} = 5$ A)

Dropout

The greater dropout differential (= | **pickup threshold** - **dropout threshold** |) of the following criteria is used:

Dropout differential derived from the parameter Dropout ratio	
If this parameter is not available, a dropout ratio of 95 % applies for the overcurrent protection and a dropout ratio of 105 % applies for the undercurrent protection.	
Minimum absolute dropout differential	
Protection-class current transformers	5 mA sec. ($I_{rated} = 1$ A) or 25 mA sec. ($I_{rated} = 5$ A)
Instrument transformers	0.5 mA sec. ($I_{rated} = 1$ A) or 2.5 mA sec. ($I_{rated} = 5$ A)
Harmonic: $I_{2nd\ harm}/I_{1st\ harm}$	0.75
Protection-class current transformers	$I_{2nd\ harm} = 5$ mA sec. ($I_{rated} = 1$ A) or $I_{2nd\ harm} = 25$ mA sec. ($I_{rated} = 5$ A)
Instrument transformers	$I_{2nd\ harm} = 0.5$ mA sec. ($I_{rated} = 1$ A) or $I_{2nd\ harm} = 2.5$ mA sec. ($I_{rated} = 5$ A)

Frequency Operating Range

$0.9 \leq f/f_{\text{rated}} \leq 1.1$	According to specified tolerances
$10 \text{ Hz} \leq f < 0.9 f_{\text{rated}}$ $1.1 f_{\text{rated}} < f \leq 90 \text{ Hz}$	Slightly expanded tolerances
$f < 10 \text{ Hz}$ $f > 90 \text{ Hz}$	Inactive

Tolerances

Current measurement I_{max}	1 % of the setting value or 5 mA
Harmonic: $I_{\text{2nd harm}}/I_{\text{1st harm}}$	1 % of the setting value
Time delays	1 % of the setting value or 10 ms

14.10 2nd Harmonic Detection Ground

Setting Values

Measured value	IN measured 3I0 calculated	
2nd harmonic content	10 % to 45 %	Increments of 1 %

Times

Operating times	Approx. 29 ms
-----------------	---------------

Pickup

Harmonic: $I_{2nd\ harm}/I_{1st\ harm}$	Setting value or at least
Protection-class current transformer	$I_{1st\ harm} = 10\ mA\ sec.$ and $I_{2nd\ harm} = 10\ mA\ sec. (I_{rated} = 1\ A)$ $I_{1st\ harm} = 50\ mA\ sec.$ and $I_{2nd\ harm} = 50\ mA\ sec. (I_{rated} = 5\ A)$
Instrument transformers	$I_{1st\ harm} = 1\ mA\ sec.$ and $I_{2nd\ harm} = 1\ mA\ sec. (I_{rated} = 1\ A)$ $I_{1st\ harm} = 5\ mA\ sec.$ and $I_{2nd\ harm} = 5\ mA\ sec. (I_{rated} = 5\ A)$

Dropout

The greater dropout differential (= | **pickup threshold** - **dropout threshold** |) of the following 2 criteria applies:

Dropout differential derived from the parameter Dropout ratio	
If this parameter is not available, a dropout ratio of 95 % applies for the overcurrent protection and a dropout ratio of 105 % applies for the undercurrent protection.	
Minimum absolute dropout differential	
Protection-class current transformers	5 mA sec. ($I_{rated} = 1\ A$) or 25 mA sec. ($I_{rated} = 5\ A$)
Instrument transformers	0.5 mA sec. ($I_{rated} = 1\ A$) or 2.5 mA sec. ($I_{rated} = 5\ A$)
Harmonics: $I_{2nd\ harm}/I_{1st\ harm}$	0.75 or
Protection-class current transformers	$I_{2nd\ harm} = 5\ mA\ sec. (I_{rated} = 1\ A)$ or $I_{2nd\ harm} = 25\ mA\ sec. (I_{rated} = 5\ A)$
Instrument transformers	$I_{2nd\ harm} = 0.5\ mA\ sec. (I_{rated} = 1\ A)$ or $I_{2nd\ harm} = 2.5\ mA\ sec. (I_{rated} = 5\ A)$

Frequency Operating Range

$0.9 \leq f/f_{rated} \leq 1.1$	According to specified tolerances
$10\ Hz \leq f < 0.9 f_{rated}$ $1.1 f_{rated} < f \leq 90\ Hz$	Slightly expanded tolerances
$f < 10\ Hz$ $f > 90\ Hz$	Inactive

Tolerances

Harmonics: $I_{2nd\ harm} / I_{1st\ harm}$	1 % of the setting value for setting values $I_{2nd\ harm} / I_{1st\ harm}$
--	--

14.11 2nd Harmonic Detection 1-Phase

Setting Values

Measured value	I	
2nd harmonic content	10 % to 45 %	Increments of 1 %

Times

Operating times	Approx. 29 ms
-----------------	---------------

Pickup

Harmonic: $I_{2nd\ harm}/I_{1st\ harm}$	Setting value or at least
Protection-class current transformers	$I_{1st\ harm} = 10\ mA\ sec.$ and $I_{2nd\ harm} = 10\ mA\ sec. (I_{rated} = 1\ A)$ $I_{1st\ harm} = 50\ mA\ sec.$ and $I_{2nd\ harm} = 50\ mA\ sec. (I_{rated} = 5\ A)$
Instrument transformers	$I_{1st\ harm} = 1\ mA\ sec.$ and $I_{2nd\ harm} = 1\ mA\ sec. (I_{rated} = 1\ A)$ $I_{1st\ harm} = 5\ mA\ sec.$ and $I_{2nd\ harm} = 5\ mA\ sec. (I_{rated} = 5\ A)$

Dropout

The greater dropout differential (= | **pickup threshold** - **dropout threshold** |) of the following criteria applies:

Dropout differential derived from the parameter Dropout ratio	
If this parameter is not available, a dropout ratio of 95 % applies for the overcurrent protection and a dropout ratio of 105 % applies for the undercurrent protection.	
Minimum absolute dropout differential	
Protection-class current transformers	15 mA sec. ($I_{rated} = 1\ A$) or 75 mA sec. ($I_{rated} = 5\ A$)
Instrument transformers	0.5 mA sec. ($I_{rated} = 1\ A$) or 2.5 mA sec. ($I_{rated} = 5\ A$)
Harmonics: $I_{2nd\ harm}/I_{1st\ harm}$	0.75 or
Protection-class current transformers	$I_{2nd\ harm} = 5\ mA\ sec. (I_{rated} = 1\ A)$ or $I_{2nd\ harm} = 25\ mA\ sec. (I_{rated} = 5\ A)$
Instrument transformers	$I_{2nd\ harm} = 0.5\ mA\ sec. (I_{rated} = 1\ A)$ or $I_{2nd\ harm} = 2.5\ mA\ sec. (I_{rated} = 5\ A)$

Frequency Operating Range

$0.9 \leq f/f_{rated} \leq 1.1$	According to specified tolerances
$10\ Hz \leq f < 0.9 f_{rated}$ $1.1 f_{rated} < f \leq 90\ Hz$	Slightly expanded tolerances
$f < 10\ Hz$ $f > 90\ Hz$	Inactive

Tolerances

Harmonics: $I_{2\text{nd harm}}/I_{1\text{st harm}}$	1 % of the setting value for setting values $I_{2\text{nd harm}}/I_{1\text{st harm}}$
--	--

14.12 Instantaneous High-Current Tripping

Setting Values

Threshold value	1 A @ 100 I _{rated}	0.030 A to 35.000 A	Increments of 0.001 A
	5 A @ 100 I _{rated}	0.15 A to 175.00 A	Increments of 0.01 A
	1 A @ 50 I _{rated}	0.030 A to 35.000 A	Increments of 0.001 A
	5 A @ 50 I _{rated}	0.15 A to 175.00 A	Increments of 0.01 A
	1 A @ 1.6 I _{rated}	0.001 A to 1.600 A	Increments of 0.001 A
	5 A @ 1.6 I _{rated}	0.005 A to 8.000 A	Increments of 0.001 A
Dropout ratio	0.50 to 0.90	Increments of 0.01	

Dropout

The greater dropout differential (= | **pickup value** - **dropout value** |) of the following 2 criteria applies:

Dropout differential derived from the parameter Dropout ratio	
If this parameter is not available, a dropout ratio of 95 % applies for overcurrent and of 105 % for undercurrent functionality.	
Minimum absolute dropout differential	
Protection-class current transformer	15 mA sec. (I _{rated} = 1 A) or 75 mA sec. (I _{rated} = 5 A)
Instrument current transformer	0.5 mA sec. (I _{rated} = 1 A) or 2.5 mA sec. (I _{rated} = 5 A)

Times

Operate time for current > 2 · √2 · threshold value	Approx. 8 ms + OOT ⁸⁰
---	----------------------------------

Frequency Operating Range

$0.9 \leq f/f_{rated} \leq 1.1$	According to specified tolerances
$10 \text{ Hz} \leq f < 0.9 f_{rated}$ $1.1 f_{rated} < f \leq 90 \text{ Hz}$	Slightly expanded tolerances
$f < 10 \text{ Hz}$ $f > 90 \text{ Hz}$	Active

Tolerances

Response tolerance, current	5 % of the setting value or 10 mA at I _{rated} = 1 A 5 % of the setting value or 50 mA at I _{rated} = 5 A
Time delays	1 % of the setting value or 10 ms

⁸⁰ OOT (Output Operating Time) Additional delay of the output medium used, see [14.1.4 Relay Outputs](#)

14.13 Instantaneous Tripping at Switch onto Fault

Setting Values

Tripping delay	0.00 s to 60.00 s	Increments of 0.01 s
----------------	-------------------	-------------------------

Tolerances

Times	< 1 % of the setting value or 10 ms
-------	-------------------------------------

14.14 Overcurrent Protection, 1-Phase

14.14.1 Stage with Definite-Time Characteristic Curve

Setting Values

Method of measurement		Fundamental component RMS value	–
Threshold value ⁸¹	For $I_{rated} = 1\text{ A}$	0.010 A to 35.000 A	Increments of 0.001 A
	For $I_{rated} = 5\text{ A}$	0.05 A to 175.00 A	Increments of 0.01 A
Dropout ratio (fixed)		0.95	–
Time delay		0.00 s to 60.00 s	Increments of 0.01 s

Dropout

The greater dropout differential (= | **pickup value** - **dropout value** |) of the following 2 criteria applies:

Dropout differential derived from the parameter Dropout ratio	
If this parameter is not available, a dropout ratio of 95 % applies for overcurrent and of 105 % for undercurrent functionality.	
Minimum absolute dropout differential	
Protection-class current transformer	15 mA sec. ($I_{rated} = 1\text{ A}$) or 75 mA sec. ($I_{rated} = 5\text{ A}$)
Instrument current transformer	0.5 mA sec. ($I_{rated} = 1\text{ A}$) or 2.5 mA sec. ($I_{rated} = 5\text{ A}$)

Times

Operate time with time delay = 0 ms	Approx. 15 ms + OOT ⁸² at 50 Hz Approx. 14 ms + OOT at 60 Hz
Extension of the operate time during operation with transformer inrush-current detection	Approx. 10 ms
Dropout time	Approx. 20 ms + OOT at 50 Hz Approx. 17 ms + OOT at 60 Hz

Frequency Operating Range

$0.9 \leq f/f_{rated} \leq 1.1$	According to specified tolerances
$10\text{ Hz} \leq f < 0.9 f_{rated}$ $1.1 f_{rated} < f \leq 90\text{ Hz}$	Slightly expanded tolerances
$f < 10\text{ Hz}$ $f > 90\text{ Hz}$	Active

⁸¹ If you have selected the **method of measurement = RMS value**, do not set the threshold value under $0.1 I_{rated,sec}$.

⁸² OOT (Output Operating Time): additional delay of the output medium used, see [14.1.4 Relay Outputs](#)

Tolerances

Currents, method of measurement = fundamental component	1 % of the setting value or 5 mA ($I_{rated} = 1 A$) or 25 mA ($I_{rated} = 5 A$) valid for protection-class current transformers
	1 % of the setting value or 0.1 mA ($I_{rated} = 1 A$) or 0.5 mA ($I_{rated} = 5 A$) valid for sensitive current transformers
Currents, method of measurement = RMS value (33 % harmonics, in relation to fundamental component)	
Up to 30th harmonic	2 % of the setting value or 10 mA ($I_{rated} = 1 A$) or 50 mA ($I_{rated} = 5 A$)
Up to 50th harmonic, $f_{rated} = 50 Hz$	4 % of the setting value or 20 mA ($I_{rated} = 1 A$) or 100 mA ($I_{rated} = 5 A$)
Up to 50th harmonic, $f_{rated} = 60 Hz$	5 % of the setting value or 20 mA ($I_{rated} = 1 A$) or 100 mA ($I_{rated} = 5 A$)
Time delays	1 % of the setting value or 10 ms

Influencing Variables for Threshold Values

Transient excess pickup in method of measurement = fundamental component, for $\tau > 100 ms$ (with complete unbalance)	< 5 %
---	-------

14.14.2 Stage with Inverse-Time Characteristic Curve

Setting Values

Method of measurement	Fundamental component RMS value	–
Threshold value ⁸³	For $I_{rated} = 1 A$	0.010 A to 35.000 A Increments of 0.001 A
	For $I_{rated} = 5 A$	0.05 A to 175.00 A Increments of 0.01 A
Dropout	Disk emulation Instantaneous	–
Time multiplier	0.05 to 15.00	Increments of 0.01

Dropout

The greater dropout differential (= | **pickup value** - **dropout value** |) of the following 2 criteria applies:

Dropout	95 % of 1.1 · threshold value
Minimum absolute dropout differential	
Protection-class current transformer	15 mA sec. ($I_{rated} = 1 A$) or 75 mA sec. ($I_{rated} = 5 A$)
Instrument current transformer	0.5 mA sec. ($I_{rated} = 1 A$) or 2.5 mA sec. ($I_{rated} = 5 A$)

⁸³ If you have selected the **method of measurement = RMS value**, do not set the threshold value under $0.1 I_{rated,sec}$.

Reset of the Integration Timer

Instantaneous	With dropout
Disk emulation	Approx. $< 0.90 \cdot \text{threshold value}$

Operate Curves and Dropout Characteristic Curves According to IEC

Extension of the operate time during operation with transformer inrush-current detection	Approx. 10 ms
--	---------------

For more information about the operate curves and dropout characteristic curves according to IEC, refer to [14.4.2 Stage with Inverse-Time Characteristic Curve](#).

Operate Curves and Dropout Characteristic Curves According to ANSI/IEEE

For more information about the operate curves and dropout characteristic curves according to ANSI/IEEE, refer to [14.4.2 Stage with Inverse-Time Characteristic Curve](#).

Frequency Operating Range

$0.9 \leq f/f_{\text{rated}} \leq 1.1$	According to specified tolerances
$10 \text{ Hz} \leq f < 0.9 f_{\text{rated}}$ $1.1 f_{\text{rated}} < f \leq 90 \text{ Hz}$	Slightly expanded tolerances
$f < 10 \text{ Hz}$ $f > 90 \text{ Hz}$	Active

Tolerances

Currents, method of measurement = fundamental component	1 % of the setting value or 5 mA ($I_{\text{rated}} = 1 \text{ A}$) or 25 mA ($I_{\text{rated}} = 5 \text{ A}$) valid for protection-class current transformers
	1 % of the setting value or 0.1 mA ($I_{\text{rated}} = 1 \text{ A}$) or 0.5 mA ($I_{\text{rated}} = 5 \text{ A}$) valid for sensitive current transformers
Currents, method of measurement = RMS value (33 % harmonics, in relation to fundamental component)	
Up to 30th harmonic	2 % of the setting value or 10 mA ($I_{\text{rated}} = 1 \text{ A}$) or 50 mA ($I_{\text{rated}} = 5 \text{ A}$)
Up to 50th harmonic, $f_{\text{rated}} = 50 \text{ Hz}$	4 % of the setting value or 20 mA ($I_{\text{rated}} = 1 \text{ A}$) or 100 mA ($I_{\text{rated}} = 5 \text{ A}$)
Up to 50th harmonic, $f_{\text{rated}} = 60 \text{ Hz}$	5 % of the setting value or 20 mA ($I_{\text{rated}} = 1 \text{ A}$) or 100 mA ($I_{\text{rated}} = 5 \text{ A}$)
Operate time for $2 \leq I/I \text{ threshold value} \leq 20$	5 % of the reference (calculated) value +2 % current tolerance or 30 ms
Dropout time for $I/I \text{ threshold value} \leq 0.90$	5 % of the reference (calculated) value +2 % current tolerance or 30 ms

Influencing Variables for Threshold Values

Transient excess pickup in method of measurement = fundamental component, for $\tau > 100 \text{ ms}$ (with complete unbalance)	$< 5 \%$
---	----------

14.14.3 Stage with Inverse-Time Overcurrent Protection with Logarithmic-Inverse Characteristic Curve

Setting Values

Method of measurement		Fundamental component RMS value	–
Threshold value	1 A @ 50 and 100 Irated	0.010 A to 35.000 A	Increments of 0.001 A
	5 A @ 50 and 100 Irated	0.050 A to 175.00 A	Increments of 0.01 A
	1 A @ 1.6 Irated	0.001 A to 1.600 A	Increments of 0.001 A
	5 A @ 1.6 Irated	0.002 A to 8.000 A	Increments of 0.001 A
Characteristic curve: see Figure 14-10			
Threshold value multiplier		1.00 to 4.00	Increments of 0.01
Time dial		0.000 s to 60.000 s	Increments of 0.001 s
Minimum time of the characteristic curve		0.000 s to 60.000 s	Increments of 0.001 s
Maximum time of the characteristic curve		0.000 s to 60.000 s	Increments of 0.001 s
Additional time delay		0.000 s to 60.000 s	Increments of 0.001 s

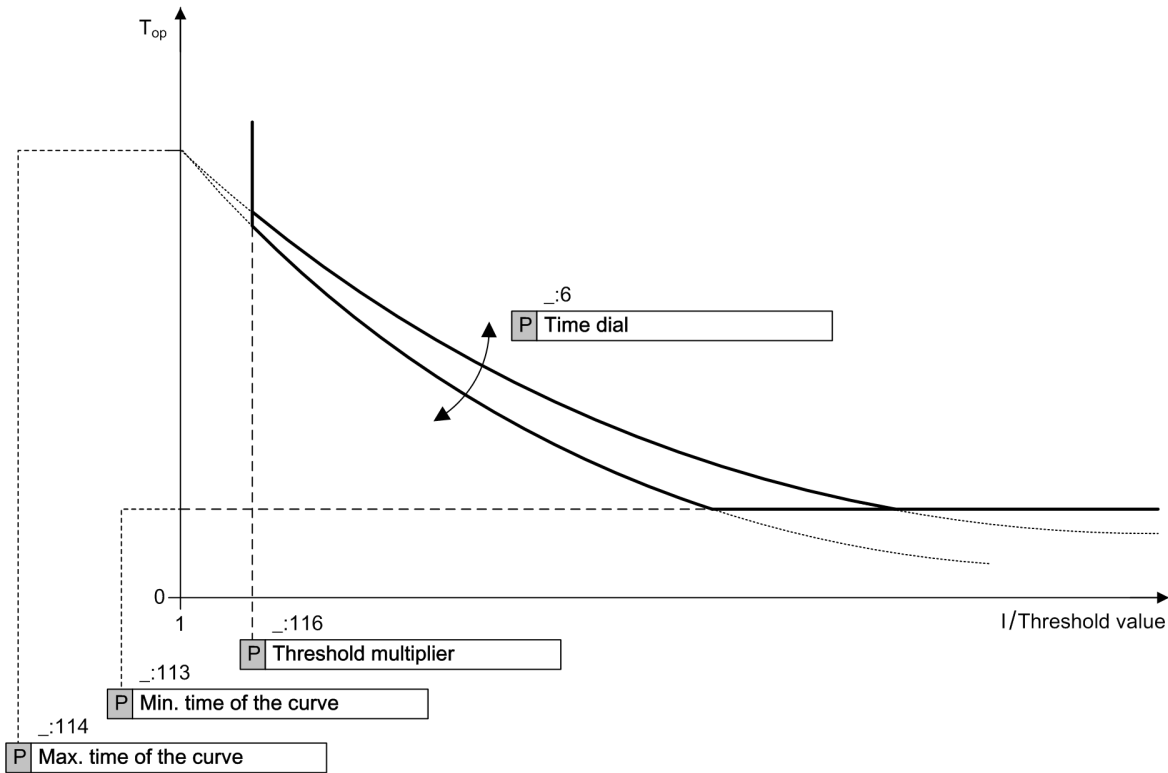

[dw_ocp 1phase logarithmic, 1, en_US]

Figure 14-10 Operate Curve of Logarithmic Inverse-Time Characteristic

Dropout

The greater dropout differential (= | pickup value - dropout value |) of the following 2 criteria applies:

Dropout differential derived from the parameter Dropout ratio	
If this parameter is not available, a dropout ratio of 95 % applies for overcurrent and of 105 % for undercurrent functionality.	
Minimum absolute dropout differential	
Protection-class current transformer	15 mA sec. ($I_{rated} = 1 \text{ A}$) or 75 mA sec. ($I_{rated} = 5 \text{ A}$)
Instrument current transformer	0.5 mA sec. ($I_{rated} = 1 \text{ A}$) or 2.5 mA sec. ($I_{rated} = 5 \text{ A}$)

Times

The maximum pickup time with operate delay = 0 ms	Approx. 30 ms + OOT at 50 Hz Approx. 25 ms + OOT at 60 Hz
Extension of the operate time during operation with inrush-current detection	Approx. 10 ms
Dropout time	Approx. 20 ms + OOT

Frequency Operating Range

$0.9 \leq f/f_{rated} \leq 1.1$	According to specified tolerances
$10 \text{ Hz} \leq f < 0.9 f_{rated}$ $1.1 f_{rated} < f \leq 90 \text{ Hz}$	Slightly expanded tolerances
$f < 10 \text{ Hz}$ $f > 90 \text{ Hz}$	Active with reduced sensitivity

Tolerances

Currents, method of measurement = fundamental component	1 % of the setting value or 5 mA ($I_{rated} = 1 \text{ A}$) or 25 mA ($I_{rated} = 5 \text{ A}$) valid for protection-class current transformers
	1 % of the setting value or 0.1 mA ($I_{rated} = 1 \text{ A}$) or 0.5 mA ($I_{rated} = 5 \text{ A}$) valid for sensitive current transformers
Currents, method of measurement = RMS value (33 % part of harmonic, referring to fundamental component)	
Up to 30th harmonic	2 % of the setting value or 10 mA ($I_{rated} = 1 \text{ A}$) or 50 mA ($I_{rated} = 5 \text{ A}$)
Up to 50th harmonic, $f_{rated} = 50 \text{ Hz}$	4 % of the setting value or 20 mA ($I_{rated} = 1 \text{ A}$) or 100 mA ($I_{rated} = 5 \text{ A}$)
Up to 50th harmonic, $f_{rated} = 60 \text{ Hz}$	5 % of the setting value or 20 mA ($I_{rated} = 1 \text{ A}$) or 100 mA ($I_{rated} = 5 \text{ A}$)
Inverse-time operate time to logarithmic inverse-time characteristic	5 % of the reference (calculated) value + 2 % current tolerance or 30 ms
Inverse-time dropout time to logarithmic inverse-time characteristic	5 % of the reference (calculated) value + 2 % current tolerance or 30 ms

Influencing Variables for Threshold Values

Transient excess pickup in method of measurement = fundamental component, for $\tau > 100$ ms (with complete unbalance)	< 5 %
---	-------

14.14.4 Stage with User-Defined Characteristic Curve

Setting Values

Method of measurement	Fundamental component	–
	RMS value	
Threshold value	1 A @ 50 and 100 I _{rated}	0.010 A to 35.000 A
	5 A @ 50 and 100 I _{rated}	0.05 A to 175.00 A
	1 A @ 1.6 I _{rated}	0.001 A to 1.600 A
	5 A @ 1.6 I _{rated}	0.002 A to 8.000 A
Dropout	Disk emulation	–
	Instantaneous	
Time multiplier	0.05 to 15.00	Increments of 0.01
Number of value pairs for the operate curve	2 to 30	Increments of 1
X values of the operate curve	1.00 p.u. to 66.67 p. u.	Increments of 0.01 p.u.
Y values of the operate curve	0.00 s to 999.00 s	Increments of 0.01 s
Number of value pairs for the dropout characteristic curve	2 to 30	Increments of 1
X values of the dropout characteristic curve	0.05 p.u. to 0.95 p. u.	Increments of 0.01 p.u.
Y values of the dropout characteristic curve	0.00 s to 999.00 s	Increments of 0.01 s

Dropout

The greater dropout differential (= | **pickup value** - **dropout value** |) of the following 2 criteria applies:

Dropout	95 % of 1.1 · threshold value
Minimum absolute dropout differential	
Protection-class current transformer	15 mA sec. (I _{rated} = 1 A) or 75 mA sec. (I _{rated} = 5 A)
Instrument current transformer	0.5 mA sec. (I _{rated} = 1 A) or 2.5 mA sec. (I _{rated} = 5 A)

Reset of the Integration Timer

Instantaneous	With dropout
Disk emulation	Approx. < 0.90 · threshold value

Frequency Operating Range

$0.9 \leq f/f_{\text{rated}} \leq 1.1$	According to specified tolerances
$10 \text{ Hz} \leq f < 0.9 f_{\text{rated}}$ $1.1 f_{\text{rated}} < f \leq 90 \text{ Hz}$	Slightly expanded tolerances
$f < 10 \text{ Hz}$ $f > 90 \text{ Hz}$	Active with reduced sensitivity

Tolerances

Currents, method of measurement = fundamental component	1 % of the setting value or 5 mA ($I_{rated} = 1 A$) or 25 mA ($I_{rated} = 5 A$) valid for protection-class current transformers
	1 % of the setting value or 0.1 mA ($I_{rated} = 1 A$) or 0.5 mA ($I_{rated} = 5 A$) valid for sensitive current transformers
Currents, method of measurement = RMS value (33 % harmonics, in relation to fundamental component)	
Up to 30th harmonic	2 % of the setting value or 10 mA ($I_{rated} = 1 A$) or 50 mA ($I_{rated} = 5 A$)
Up to 50th harmonic, $f_{rated} = 50 Hz$	4 % of the setting value or 20 mA ($I_{rated} = 1 A$) or 100 mA ($I_{rated} = 5 A$)
Up to 50th harmonic, $f_{rated} = 60 Hz$	5 % of the setting value or 20 mA ($I_{rated} = 1 A$) or 100 mA ($I_{rated} = 5 A$)
Operate time for $2 \leq I/I$ threshold value ≤ 20	5 % of the reference (calculated) value +2 % current tolerance or 30 ms
Dropout time for I/I threshold value ≤ 0.90	5 % of the reference (calculated) value +2 % current tolerance or 30 ms

Influencing Variables for Threshold Values

Transient excess pickup in method of measurement = fundamental component, for $\tau > 100 ms$ (with complete unbalance)	< 5 %
---	-------

Operate Curves and Dropout-Time Characteristic Curves according to IEC

Extension of the operate time during operation with transformer inrush-current detection	Approx. 10 ms
--	---------------

14.15 Overcurrent Protection, 1-Phase (Fast Stage)

Setting Values

Threshold value	For $I_{rated} = 1 \text{ A}$	0.030 A to 35.000 A	Increments of 0.001 A
	For $I_{rated} = 5 \text{ A}$	0.15 A to 175.00 A	Increments of 0.01 A
Dropout ratio (fixed)		0.90 to 0.99	Increments of 0.01
Time delay		0.00 s to 60.00 s	Increments of 0.01 s

Dropout

The greater dropout differential (= | pickup value - dropout value |) of the following 2 criteria applies:

Dropout differential derived from the parameter Dropout ratio	
If this parameter is not available, a dropout ratio of 95 % applies for overcurrent and of 105 % for undercurrent functionality.	
Minimum absolute dropout differential	
Protection-class current transformer	15 mA sec. ($I_{rated} = 1 \text{ A}$) or 75 mA sec. ($I_{rated} = 5 \text{ A}$)
Instrument current transformer	0.5 mA sec. ($I_{rated} = 1 \text{ A}$) or 2.5 mA sec. ($I_{rated} = 5 \text{ A}$)

Times

Operate time with time delay = 0 ms	Approx. 8 ms + OOT ⁸⁴
Dropout time	Approx. 25 ms + OOT

Frequency Operating Range

$0.9 \leq f/f_{rated} \leq 1.1$	According to specified tolerances
$10 \text{ Hz} \leq f < 0.9 f_{rated}$ $1.1 f_{rated} < f \leq 90 \text{ Hz}$	Slightly expanded tolerances
$f < 10 \text{ Hz}$ $f > 90 \text{ Hz}$	Active

Tolerances

Pickup tolerance, current	5 % of the setting value or 10 mA ($I_{rated} = 1 \text{ A}$) or 50 mA ($I_{rated} = 5 \text{ A}$)
Time delays	1 % of the setting value or 10 ms

⁸⁴ OOT (Output Operating Time): additional time delay of the output medium used, for example, 5 ms with fast relay

14.16 Positive-Sequence Overcurrent Protection

14.16.1 Stage with Definite-Time Characteristic Curve

Setting Values for Protection Stage

Threshold value	1 A @ 50 and 100 I _{rated}	0.030 A to 35.000 A	Increments of 0.001 A
	5 A @ 50 and 100 I _{rated}	0.15 A to 175.00 A	Increments of 0.01 A
	1 A @ 1.6 I _{rated}	0.001 A to 1.600 A	Increments of 0.001 A
	5 A @ 1.6 I _{rated}	0.005 A to 8.000 A	Increments of 0.001 A
Operate delay		0.00 s to 60.00 s	Increments of 0.01 s

Dropout

The greater dropout differential (= | **pickup value** - **dropout value** |) of the following 2 criteria applies:

Dropout differential derived from the parameter Dropout ratio	
If this parameter is not available, a dropout ratio of 95 % applies for overcurrent and of 105 % for undercurrent functionality.	
Minimum absolute dropout differential	
Protection-class current transformer	15 mA sec. (I _{rated} = 1 A) or 75 mA sec. (I _{rated} = 5 A)
Instrument current transformer	0.5 mA sec. (I _{rated} = 1 A) or 2.5 mA sec. (I _{rated} = 5 A)

Times

Operate time with time delay = 0 ms	Approx. 25 ms + OOT ⁸⁵ at 50 Hz Approx. 22 ms + OOT at 60 Hz
Extension of the operate time during operation with transformer inrush-current detection	Approx. 10 ms
Dropout time	Approx. 30 ms + OOT

Frequency Operating Range

$0.9 \leq f/f_{\text{rated}} \leq 1.1$	According to specified tolerances
$10 \text{ Hz} \leq f < 0.9 f_{\text{rated}}$ $1.1 f_{\text{rated}} < f \leq 90 \text{ Hz}$	Slightly expanded tolerances
$f < 10 \text{ Hz}$ $f > 90 \text{ Hz}$	Active

Tolerances

Current	1 % of the setting value or 5 mA (I _{rated} = 1 A) or 25 mA (I _{rated} = 5 A)
Time delays	1 % of the setting value or 10 ms

⁸⁵ OOT (Output Operating Time): additional delay of the output medium used, for example 5 ms with fast relays

14.16.2 Stage with Inverse-Time Characteristic Curve

Setting Values for Protection Stage

Threshold	1 A @ 50 and 100 I _{rated}	0.030 A to 35.000 A	Increments of 0.001 A
	5 A @ 50 and 100 I _{rated}	0.15 A to 175.00 A	Increments of 0.01 A
	1 A @ 1.6 I _{rated}	0.001 A to 1.600 A	Increments of 0.001 A
	5 A @ 1.6 I _{rated}	0.005 A to 8.000 A	Increments of 0.001 A
Reset		instantaneous disk emulation	–
Time dial		0.00 to 15.00	Increments of 0.01

Dropout

The greater dropout differential (= | pickup value - dropout value |) of the following 2 criteria applies:

Dropout	95 % of 1.1 · threshold value
Minimum absolute dropout differential	
Protection-class current transformer	15 mA sec. (I _{rated} = 1 A) or 75 mA sec. (I _{rated} = 5 A)
Instrument current transformer	0.5 mA sec. (I _{rated} = 1 A) or 2.5 mA sec. (I _{rated} = 5 A)

Reset of the Integration Timer

Instantaneous	With dropout
Disk emulation	Approx. < 0.90 · threshold value

Operate and Dropout Characteristic Curves

You can select from the following operate and dropout characteristic curves:

Table 14-1 Standard Characteristic Curves according to IEC

Normal inverse: type A	See chapter 14.4.2 Stage with Inverse-Time Characteristic Curve, Figure 14-1
Very inverse: type B	
Extremely inverse: type C	See chapter 14.4.2 Stage with Inverse-Time Characteristic Curve, Figure 14-2
Long-time inverse: type B	

Table 14-2 Standard Characteristic Curves according to ANSI

Inverse: type C	See chapter 14.4.2 Stage with Inverse-Time Characteristic Curve, Figure 14-4
Short inverse	
Long inverse	See chapter 14.4.2 Stage with Inverse-Time Characteristic Curve, Figure 14-5
Moderately inverse	
Very inverse	See chapter 14.4.2 Stage with Inverse-Time Characteristic Curve, Figure 14-6
Extremely inverse	
Definite inverse	See chapter 14.4.2 Stage with Inverse-Time Characteristic Curve, Figure 14-7

Times

Operate time with time delay = 0 ms	Approx. 25 ms + OOT ⁸⁶ at 50 Hz Approx. 22 ms + OOT at 60 Hz
Extension of the operate time during operation with transformer inrush-current detection	Approx. 10 ms
Dropout time	Approx. 30 ms + OOT

Frequency Operating Range

$0.9 \leq f/f_{rated} \leq 1.1$	According to specified tolerances
$10 \text{ Hz} \leq f < 0.9 f_{rated}$ $1.1 f_{rated} < f \leq 90 \text{ Hz}$	Slightly expanded tolerances
$f < 10 \text{ Hz}$ $f > 90 \text{ Hz}$	Active

Tolerances

Current	1 % of the setting value or 5 mA ($I_{rated} = 1 \text{ A}$) or 25 mA ($I_{rated} = 5 \text{ A}$)
Operate time for $2 \leq I/I$ threshold value ≤ 20	5 % of the reference (calculated) value + 2 % current tolerance or 30 ms
Dropout time for I/I threshold value ≤ 0.90	5 % of the reference (calculated) value + 2 % current tolerance or 30 ms
Time delays	1 % of the setting value or 10 ms

⁸⁶ OOT (Output Operating Time): additional delay of the output medium used, for example 5 ms with fast relays

14.17 Non-Directional Intermittent Ground-Fault Protection

Setting Values

Threshold value 3I ₀ > interm.	For current transformer type protection and I _{rated} = 1 A		0.030 A to 35.000 A	Increments of 0.001 A
	For current transformer type protection and I _{rated} = 5 A		0.15 A to 175.00 A	Increments of 0.01 A
	For I _N transformer type sensitive and I _{N-rated} = 1 A	For I _{ph-rated} = 1 A	0.001 A to 35.000 A	Increments of 0.001 A
		For I _{ph-rated} = 5 A	0.001 A to 175.000 A	Increments of 0.001 A
For I _N transformer type sensitive and I _{N-rated} = 5 A	For I _{ph-rated} = 1 A	0.005 A to 35.000 A	Increments of 0.001 A	
	For I _{ph-rated} = 5 A	0.005 A to 175.000 A	Increments of 0.001 A	
Number of pickups until intermittent ground fault			2 to 10	Increments of 1
Pickup extension time			0.00 s to 10.00 s	Increments of 0.01 s
Sum of extended pickup times			0.00 s to 180.00 s	Increments of 0.01 s
Reset time			0.00 s to 600.00 s	Increments of 0.01 s

Dropout

The greater dropout differential (= | **pickup value** - **dropout value** |) of the following 2 criteria applies:

Dropout differential derived from the parameter Dropout ratio	
If this parameter is not available, a dropout ratio of 95 % applies for overcurrent and of 105 % for undercurrent functionality.	
Minimum absolute dropout differential	
Protection-class current transformer	15 mA sec. (I _{rated} = 1 A) or 75 mA sec. (I _{rated} = 5 A)
Instrument current transformer	0.5 mA sec. (I _{rated} = 1 A) or 2.5 mA sec. (I _{rated} = 5 A)

Times

Operate time with time delay = 0 ms	Approx. 25 ms + OOT ⁸⁷ at 50 Hz Approx. 23 ms + OOT at 60 Hz
Dropout time	Approx. 25 ms + OOT at 50 Hz Approx. 22 ms + OOT at 60 Hz

Frequency Operating Range

$0.9 \leq f/f_{rated} \leq 1.1$	According to specified tolerances
$10 \text{ Hz} \leq f < 0.9 f_{rated}$ $1.1 f_{rated} < f \leq 90 \text{ Hz}$	Slightly expanded tolerances
$f < 10 \text{ Hz}$ $f > 90 \text{ Hz}$	Active with reduced sensitivity

⁸⁷ OOT (Output Operating Time): additional delay of the output medium used, for example 5 ms with fast relays

Tolerances

Currents	-310 via protection-class current transformers: 1 % of setting value or 5 mA ($I_{rated} = 1 \text{ A}$) or 25 mA ($I_{rated} = 5 \text{ A}$)
	-310 via sensitive current transformer: 1 % of setting value or 0.1 mA ($I_{rated} = 1 \text{ A}$) or 0.5 mA ($I_{rated} = 5 \text{ A}$)
Times	1 % of the setting value or $\pm 10 \text{ ms}$

14.18 Directional Intermittent Ground-Fault Protection

Setting Values

Threshold value 3I0>	For current transformer type protection and $I_{rated} = 1\text{ A}$	0.030 A to 35.000 A	Increments of 0.001 A	
	For current transformer type protection and $I_{rated} = 5\text{ A}$	0.15 A to 175.00 A	Increments of 0.01 A	
	For I_N transformer type sensitive and $I_{N-rated} = 1\text{ A}$	For $I_{ph-rated} = 1\text{ A}$	0.001 A to 35.000 A	Increments of 0.001 A
		For $I_{ph-rated} = 5\text{ A}$	0.001 A to 175.000 A	Increments of 0.001 A
For I_N transformer type sensitive and $I_{N-rated} = 5\text{ A}$	For $I_{ph-rated} = 1\text{ A}$	0.005 A to 35.000 A	Increments of 0.001 A	
	For $I_{ph-rated} = 5\text{ A}$	0.005 A to 175.000 A	Increments of 0.001 A	
No.of pulses for interm.GF		2 to 10	Increments of 1	
Pickup extension time		0.00 s to 10.00 s	Increments of 0.01 s	
Sum of extended PU times		0.00 s to 180.00 s	Increments of 0.01 s	
Reset time		0.00 s to 600.00 s	Increments of 0.01 s	
No. of pulses for operate		2 to 100	Increments of 1	
Minimum operate delay		0.00 s to 60.00 s	Increments of 0.01 s	

Dropout

The greater dropout differential (= | pickup value - dropout value |) of the following 2 criteria applies:

Dropout differential derived from the parameter Dropout ratio	
If this parameter is not available, a dropout ratio of 95 % applies for overcurrent and of 105 % for undercurrent functionality.	
Minimum absolute dropout differential	
Protection-class current transformer	15 mA sec. ($I_{rated} = 1\text{ A}$) or 75 mA sec. ($I_{rated} = 5\text{ A}$)
Instrument current transformer	0.5 mA sec. ($I_{rated} = 1\text{ A}$) or 2.5 mA sec. ($I_{rated} = 5\text{ A}$)

Times

Pickup time	Approx. 30 ms + OOT ⁸⁸ at 50 Hz Approx. 23 ms + OOT at 60 Hz
Dropout time	Approx. 25 ms + OOT at 50 Hz Approx. 22 ms + OOT at 60 Hz

Frequency Operating Range

$0.9 \leq f/f_{rated} \leq 1.1$	According to specified tolerances
$10\text{ Hz} \leq f < 0.9 f_{rated}$ $1.1 f_{rated} < f \leq 90\text{ Hz}$	Slightly expanded tolerances
$f < 10\text{ Hz}$ $f > 90\text{ Hz}$	Active with reduced sensitivity

⁸⁸ OOT (Output Operating Time): additional delay of the output medium used, for example 5 ms with fast relays

Tolerances

Currents	3I0 via protection-class current transformers: 1 % of the setting value or 5 mA ($I_{rated} = 1 \text{ A}$) or 25 mA ($I_{rated} = 5 \text{ A}$)
	3I0 via sensitive current transformer: 1 % of the setting value or 0.1 mA ($I_{rated} = 1 \text{ A}$) or 0.5 mA ($I_{rated} = 5 \text{ A}$)
Times	1 % of the setting value or $\pm 10 \text{ ms}$

14.19 Sensitive Ground-Fault Detection

14.19.1 General

Setting Values

Decay time V0			0.03 s to 0.20 s	Increments of 0.01 s
Dropout delay			0.00 s to 60.00 s	Increments of 0.01 s
Core balance current transformer current 1	Protection-class current transformers	For $I_{ph-rated} = 1\text{ A}$	0.030 A to 35.000 A	Increments of 0.001 A
		For $I_{ph-rated} = 5\text{ A}$	0.15 A to 175.00 A	Increments of 0.01 A
Core balance current transformer current 2	For I_N transformer type sensitive and $I_{N-rated} = 1\text{ A}$	For $I_{ph-rated} = 1\text{ A}$	0.001 A to 35.000 A	Increments of 0.001 A
		For $I_{ph-rated} = 5\text{ A}$	0.001 A to 175.000 A	Increments of 0.001 A
	For I_N transformer type sensitive and $I_{N-rated} = 5\text{ A}$	For $I_{ph-rated} = 1\text{ A}$	0.005 A to 35.000 A	Increments of 0.001 A
		For $I_{ph-rated} = 5\text{ A}$	0.005 A to 175.000 A	Increments of 0.001 A
Core balance current transformer angle correction F1			0.0° to 5.0°	Increments of 0.1°
Core balance current transformer angle correction F2				

Times

Pickup times	Approx. 25 ms + OOT ⁸⁹ at 50 Hz Approx. 23 ms + OOT at 60 Hz
Dropout times	Approx. 25 ms + OOT at 50 Hz Approx. 22 ms + OOT at 60 Hz

Frequency Operating Range

$0.9 \leq f/f_{rated} \leq 1.1$	According to specified tolerances
$10\text{ Hz} \leq f < 0.9 f_{rated}$ $1.1 f_{rated} < f \leq 90\text{ Hz}$	Slightly expanded tolerances ⁹⁰
$f < 10\text{ Hz}$ $f > 90\text{ Hz}$	Active with less sensitivity ⁹¹

Tolerances

Currents	-310 via sensitive current transformer: 1 % of the setting value or 0.1 mA ($I_{rated} = 1\text{ A}$) or 0.5 mA ($I_{rated} = 5\text{ A}$)
	-310 via protection-class current transformers: 1 % of the setting value or 5 mA ($I_{rated} = 1\text{ A}$) or 25 mA ($I_{rated} = 5\text{ A}$)
Voltages	1 % of the setting value or 0.05 V

⁸⁹ OOT (Output Operating Time): additional delay of the output medium used, for example 5 ms with fast relays

⁹⁰ Transient ground-fault stage is inactive

⁹¹ Transient ground-fault stage is inactive

Times	1 % of the setting value or ± 10 ms
Direction-calculation angle error ⁹²	$\leq 1^\circ$ at $3I_0 > 5$ mA, $V_0 = 0.6$ V $\leq 2^\circ$ at $3I_0 \leq 5$ mA, $V_0 = 0.6$ V

14.19.2 Directional 3I0 Stage with cos φ or sin φ Measurement

Setting Values

Direction method of measurement			cos φ	sin φ	–
Threshold value $3I_0 >$ Minimum directional $3I_0 >$ for direction determination	Protection-class current transformers	For $I_{ph-rated} = 1$ A	0.030 A to 35.000 A		Increments of 0.001 A
		For $I_{ph-rated} = 5$ A	0.15 A to 175.00 A		Increments of 0.01 A
	For I_N transformer type sensitive and $I_{N-rated} = 1$ A	For $I_{ph-rated} = 1$ A	0.001 A to 35.000 A		Increments of 0.001 A
		For $I_{ph-rated} = 5$ A	0.001 A to 175.000 A		Increments of 0.001 A
	For I_N transformer type sensitive and $I_{N-rated} = 5$ A	For $I_{ph-rated} = 1$ A	0.005 A to 35.000 A		Increments of 0.001 A
		For $I_{ph-rated} = 5$ A	0.005 A to 175.000 A		Increments of 0.001 A
Threshold value $V_0 >$			0.300 V to 200.000 V		Increments of 0.001 V
Time delay of the direction determination			0.00 s to 60.00 s		Increments of 0.01 s
$\alpha 1$ constraint of the direction range			1° to 15°		Increments of 1°
$\alpha 2$ constraint of the direction range					
Angle correction φ			-45° to 45°		Increments of 1°
Tripping delay			0.00 s to 60.00 s		Increments of 0.01 s

Dropout

The greater dropout differential (= | pickup value - dropout value |) of the following 2 criteria applies:

Dropout differential derived from the parameter Dropout ratio	
If this parameter is not available, a dropout ratio of 95 % applies for overcurrent/overvoltage and of 105 % for undercurrent/undervoltage functionality.	
Minimum absolute dropout differential	
Protection-class current transformer	15 mA sec. ($I_{rated} = 1$ A) or 75 mA sec. ($I_{rated} = 5$ A)
Instrument current transformer	0.5 mA sec. ($I_{rated} = 1$ A) or 2.5 mA sec. ($I_{rated} = 5$ A)
Voltage transformer	150 mV sec.

⁹² Not applicable to [14.19.4 Directional 3I0 Stage with φ\(V0,3I0\) Measurement](#)

Times

Operate time with time delay = 0 ms	Approx. 38 ms + OOT ⁹³ at 50 Hz Approx. 35 ms + OOT at 60 Hz
Extension of the operate time during operation with transformer inrush-current detection	Approx. 10 ms
Dropout time	Approx. 32 ms + OOT at 50 Hz Approx. 27 ms + OOT at 60 Hz

14.19.3 Directional Transient Ground-Fault Stage

Setting Values

3I0> threshold value 3I0> threshold for operate	Protection-class current transformers	For $I_{ph-rated} = 1\text{ A}$	0.000 A to 35.000 A	Increments of 0.001 A
		For $I_{ph-rated} = 5\text{ A}$	0.00 A to 175.00 A	Increments of 0.01 A
	Sensitive current transformer for I_N	$I_{N-rated} = 1\text{ A}$	0.000 A to 1.600 A	Increments of 0.001 A
		$I_{N-rated} = 5\text{ A}$	0.000 A to 8.000 A	Increments of 0.001 A
Threshold value V0>			0.300 V to 200.000 V	Increments of 0.001 V
Maximum operational V0			0.300 V to 200.000 V	Increments of 0.001 V
Dropout delay			0.00 s to 60.00 s	Increments of 0.01 s
Tripping delay			0.00 s to 60.00 s	Increments of 0.01 s

Dropout

The greater dropout differential (= | pickup value - dropout value |) of the following 2 criteria applies:

Dropout differential derived from the parameter Dropout ratio	
If this parameter is not available, a dropout ratio of 95 % applies for overcurrent/overvoltage and of 105 % for undercurrent/undervoltage functionality.	
Minimum absolute dropout differential	
Protection-class current transformer	15 mA sec. ($I_{rated} = 1\text{ A}$) or 75 mA sec. ($I_{rated} = 5\text{ A}$)
Instrument current transformer	0.5 mA sec. ($I_{rated} = 1\text{ A}$) or 2.5 mA sec. ($I_{rated} = 5\text{ A}$)
Voltage transformer	150 mV sec.

Times

Operate time with time delay = 0 ms	Approx. 115 ms + OOT ⁹⁴ at 50 Hz Approx. 112 ms + OOT at 60 Hz
Dropout time	Approx. 20 ms + OOT at 50 Hz Approx. 15 ms + OOT at 60 Hz

⁹³ OOT (Output Operating Time): additional delay of the output medium used, see chapter [14.1.4 Relay Outputs](#)

⁹⁴ OOT (Output Operating Time): additional delay of the output medium used, see chapter [14.1.4 Relay Outputs](#)

14.19.4 Directional 3I0 Stage with $\varphi(V0,3I0)$ Measurement

Setting Values

Threshold value 3I0>	Protection-class current transformers	For $I_{ph-rated} = 1\text{ A}$	0.030 A to 35.000 A	Increments of 0.001 A
		For $I_{ph-rated} = 5\text{ A}$	0.15 A to 175.00 A	Increments of 0.01 A
	For I_N transformer type sensitive and $I_{N-rated} = 1\text{ A}$	For $I_{ph-rated} = 1\text{ A}$	0.001 A to 35.000 A	Increments of 0.001 A
		For $I_{ph-rated} = 5\text{ A}$	0.001 A to 175.000 A	Increments of 0.001 A
	For I_N transformer type sensitive and $I_{N-rated} = 5\text{ A}$	For $I_{ph-rated} = 1\text{ A}$	0.005 A to 35.000 A	Increments of 0.001 A
		For $I_{ph-rated} = 5\text{ A}$	0.005 A to 175.000 A	Increments of 0.001 A
Min. V0> for direction determination			0.300 V to 200.000 V	Increments of 0.001 V
Time delay of the direction determination			0.00 s to 60.00 s	Increments of 0.01 s
Rotation angle of the reference voltage			-180° to 180°	Increments of 1°
Forward range +/-			0° to 180°	Increments of 1°
Tripping delay			0.00 s to 100.00 s	Increments of 0.01 s

Dropout

The greater dropout differential (= | pickup value - dropout value |) of the following 2 criteria applies:

Dropout differential derived from the parameter Dropout ratio	
If this parameter is not available, a dropout ratio of 95 % applies for overcurrent/overvoltage and of 105 % for undercurrent/undervoltage functionality.	
Minimum absolute dropout differential	
Protection-class current transformer	15 mA sec. ($I_{rated} = 1\text{ A}$) or 75 mA sec. ($I_{rated} = 5\text{ A}$)
Instrument current transformer	0.5 mA sec. ($I_{rated} = 1\text{ A}$) or 2.5 mA sec. ($I_{rated} = 5\text{ A}$)
Voltage transformer	150 mV sec.

Times

Operate time with time delay = 0 ms	Approx. 23 ms + OOT ⁹⁵ at 50 Hz Approx. 21 ms + OOT at 60 Hz
Extension of operate time during operation with transformer inrush-current detection	Approx. 10 ms
Dropout time	Approx. 21 ms + OOT at 50 Hz Approx. 20 ms + OOT at 60 Hz

Tolerances

Direction-calculation angle error	$\leq 1^\circ$ at $3I0 \geq 10\text{ mA}$, $V0 = 0.6\text{ V}$ $\leq 2^\circ$ at $2\text{ mA} < 3I0 < 10\text{ mA}$, $V0 = 0.6\text{ V}$ $\leq 3^\circ$ at $3I0 \leq 2\text{ mA}$, $V0 = 0.6\text{ V}$
-----------------------------------	---

⁹⁵ OOT (Output Operating Time): additional delay of the output medium used, see chapter [14.1.4 Relay Outputs](#)

14.19.5 Directional Y0 Stage with G0 or B0 Measurement (Admittance)

Setting Values

Direction method of measurement			B0 G0	–
Release Threshold value 3I0>	Protection-class current transformers	For $I_{ph-rated} = 1\text{ A}$	0.030 A to 35.000 A	Increments of 0.001 A
		For $I_{ph-rated} = 5\text{ A}$	0.15 A to 175.00 A	Increments of 0.01 A
	For I_N transformer type sensitive and $I_{N-rated} = 1\text{ A}$	For $I_{ph-rated} = 1\text{ A}$	0.001 A to 35.000 A	Increments of 0.001 A
		For $I_{ph-rated} = 5\text{ A}$	0.001 A to 175.000 A	Increments of 0.001 A
	For I_N transformer type sensitive and $I_{N-rated} = 5\text{ A}$	For $I_{ph-rated} = 1\text{ A}$	0.005 A to 35.000 A	Increments of 0.001 A
		For $I_{ph-rated} = 5\text{ A}$	0.005 A to 175.000 A	Increments of 0.001 A
Threshold value V0>			0.300 V to 200.000 V	Increments of 0.001 V
Threshold value Y0>			0.10 mS to 100.00 mS	Increments of 0.01 mS
Time delay of direction determination			0.00 s to 60.00 s	Increments of 0.01 s
α1 constraint of direction range α2 constraint of direction range			1° to 15°	Increments of 1°
Angle correction φ			-45° to 45°	Increments of 1°
Tripping delay			0.00 s to 60.00 s	Increments of 0.01 s

Dropout

The greater dropout differential (= | pickup value - dropout value |) of the following 2 criteria applies:

Dropout differential derived from the parameter Dropout ratio	
If this parameter is not available, a dropout ratio of 95 % applies for overcurrent/overvoltage and of 105 % for undercurrent/undervoltage functionality.	
Minimum absolute dropout differential	
Protection-class current transformer	15 mA sec. ($I_{rated} = 1\text{ A}$) or 75 mA sec. ($I_{rated} = 5\text{ A}$)
Instrument current transformer	0.5 mA sec. ($I_{rated} = 1\text{ A}$) or 2.5 mA sec. ($I_{rated} = 5\text{ A}$)
Voltage transformer	150 mV sec.

Times

Operate time with time delay = 0 ms	Approx. 39 ms + OOT ⁹⁶ at 50 Hz Approx. 35 ms + OOT at 60 Hz
Extension of operate time during operation with transformer inrush-current detection	Approx. 10 ms
Dropout time	Approx. 32 ms + OOT at 50 Hz Approx. 27 ms + OOT at 60 Hz

⁹⁶ OOT (Output Operating Time): additional delay of the output medium used, see chapter [14.1.4 Relay Outputs](#)

Tolerances

Admittance	1 % of the setting value or 0.05 mS ($I_{rated} = 1 \text{ A}$) or 0.25 mS ($I_{rated} = 5 \text{ A}$)
------------	--

14.19.6 Directional Stage with Phasor Measurement of a Harmonic

Setting Values

Min. 3I ₀ of the selected harmonic phasor	Protection-class current transformers	For $I_{ph-rated} = 1 \text{ A}$	0.030 A to 35.000 A	Increments of 0.001 A
		For $I_{ph-rated} = 5 \text{ A}$	0.15 A to 175.00 A	Increments of 0.01 A
	For I_N transformer type sensitive and $I_{N-rated} = 1 \text{ A}$	For $I_{ph-rated} = 1 \text{ A}$	0.001 A to 35.000 A	Increments of 0.001 A
		For $I_{ph-rated} = 5 \text{ A}$	0.001 A to 175.000 A	Increments of 0.001 A
For I_N transformer type sensitive and $I_{N-rated} = 5 \text{ A}$	For $I_{ph-rated} = 1 \text{ A}$	0.005 A to 35.000 A	Increments of 0.001 A	
	For $I_{ph-rated} = 5 \text{ A}$	0.005 A to 175.000 A	Increments of 0.001 A	
Dropout ratio of the direction determination in terms of the zero-sequence harmonic current			0.10 to 0.95	Increments of 0.01
Threshold value V_0			0.300 V to 200.000 V	Increments of 0.001 V
Time delay of the direction determination			0.00 s to 60.00 s	Increments of 0.01 s
Extension of the direction result			0.00 s to 60.00 s	Increments of 0.01 s
Forward range +/-			0° to 90°	Increments of 1°
Tripping delay			0.00 s to 60.00 s	Increments of 0.01 s

Dropout

The greater dropout differential (= | pickup value - dropout value |) of the following 2 criteria applies:

Dropout differential derived from the parameter Dropout ratio	
If this parameter is not available, a dropout ratio of 95 % applies for overcurrent/overvoltage and of 105 % for undercurrent/undervoltage functionality.	
Minimum absolute dropout differential	
Protection-class current transformer	15 mA sec. ($I_{rated} = 1 \text{ A}$) or 75 mA sec. ($I_{rated} = 5 \text{ A}$)
Instrument current transformer	0.5 mA sec. ($I_{rated} = 1 \text{ A}$) or 2.5 mA sec. ($I_{rated} = 5 \text{ A}$)
Voltage transformer	150 mV sec.

Times

Operate time with time delay = 0 ms	Approx. 70 ms + OOT ⁹⁷ at 50 Hz Approx. 60 ms + OOT at 60 Hz
Dropout time	Approx. 30 ms + OOT at 50 Hz Approx. 20 ms + OOT at 60 Hz

⁹⁷ OOT (Output Operating Time): additional delay of the output medium used, see chapter 14.1.4 Relay Outputs

Tolerances

Zero-sequence harmonic current 3I0harm.	-3I0harm. via sensitive current transformer: 2 % of the setting value or 0.2 mA ($I_{rated} = 1 \text{ A}$) or 1 mA ($I_{rated} = 5 \text{ A}$)
	-3I0harm. via protection-class current transformers: 2 % of the setting value or 10 mA ($I_{rated} = 1 \text{ A}$) or 50 mA ($I_{rated} = 5 \text{ A}$)
V0 fundamental-component value	1 % of the setting value or 0.05 V
Direction-calculation angle error of the 3rd, 5th, or 7th harmonic phasor	$\leq 1^\circ$ at 3I0harm. > 5 mA $\leq 2^\circ$ at 3I0harm. $\leq 5 \text{ mA}$

14.19.7 Non-Directional V0 Stage with Zero-Sequence Voltage/Residual Voltage

Setting Values

Threshold value ⁹⁸	0.300 V to 200.000 V	Increments of 0.001 V
Time delay	0.00 s to 100.00 s	Increments of 0.01 s
Pickup delay	0.00 s to 60.00 s	Increments of 0.01 s
Dropout ratio	0.90 to 0.99	Increments of 0.01
V< faulty ph-gnd vltg.	0.300 V to 200.000 V	Increments of 0.001 V
V> healthy ph-gnd. vltg.	0.300 V to 200.000 V	Increments of 0.001 V

Dropout

The greater dropout differential (= | **pickup value** - **dropout value** |) of the following 2 criteria applies:

Dropout differential derived from the parameter Dropout ratio	
If this parameter is not available, a dropout ratio of 95 % applies for the overvoltage and of 105 % for the undervoltage functionality.	
Minimum absolute dropout differential	150 mV sec.

Times

Operate time with time delay = 0 ms	
Standard filter, true RMS value	Approx. 25 ms + OOT ⁹⁹ at 50 Hz Approx. 22 ms + OOT at 60 Hz
2 cycle filters	Approx. 45 ms + OOT at 50 Hz Approx. 39 ms + OOT at 60 Hz
Dropout time	
Standard filter, true RMS value	Approx. 20 ms + OOT at 50 Hz Approx. 16.6 ms + OOT at 60 Hz
2 cycle filters	Approx. 31.06 ms + OOT at 50 Hz Approx. 27.06 ms + OOT at 60 Hz

Tolerances

Voltages	0.5 % of the setting value or 0.05 V
Time delays	1 % of the setting value or 10 ms

⁹⁸ If you have selected the **method of measurement = RMS value**, do not set the threshold value under 10 V.

⁹⁹ OOT (Output Operating Time): additional delay of the output medium used, see chapter [14.1.4 Relay Outputs](#)

14.19.8 Non-Directional 3I0 Stage

Setting Values

Method of Measurement			Fundamental component RMS value	
Threshold value 3I0>	Protection-class current transformers	For $I_{ph-rated} = 1\text{ A}$	0.030 A to 35.000 A	Increments of 0.001 A
		For $I_{ph-rated} = 5\text{ A}$	0.15 A to 175.00 A	Increments of 0.01 A
	For transformer type I-sensitive and $I_{N-rated} = 1\text{ A}$	For $I_{ph-rated} = 1\text{ A}$	0.001 A to 35.000 A	Increments of 0.001 A
		For $I_{ph-rated} = 5\text{ A}$	0.001 A to 175.000 A	Increments of 0.001 A
	For transformer type I-sensitive and $I_{N-rated} = 5\text{ A}$	For $I_{ph-rated} = 1\text{ A}$	0.005 A to 35.000 A	Increments of 0.001 A
		For $I_{ph-rated} = 5\text{ A}$	0.005 A to 175.000 A	Increments of 0.001 A
Pickup delay			0.00 s to 60.00 s	Increments of 0.01 s
Tripping delay			0.00 s to 100.00 s	Increments of 0.01 s

Dropout

The greater dropout differential (= | **pickup value** - **dropout value** |) of the following 2 criteria applies:

Dropout differential derived from the parameter Dropout ratio	
If this parameter is not available, a dropout ratio of 95 % applies for overcurrent and of 105 % for undercurrent functionality.	
Minimum absolute dropout differential	
Protection-class current transformer	15 mA sec. ($I_{rated} = 1\text{ A}$) or 75 mA sec. ($I_{rated} = 5\text{ A}$)
Instrument current transformer	0.5 mA sec. ($I_{rated} = 1\text{ A}$) or 2.5 mA sec. ($I_{rated} = 5\text{ A}$)

Times

Operate time with time delay = 0 ms	Approx. 25 ms + OOT ¹⁰⁰ at 50 Hz Approx. 23 ms + OOT at 60 Hz
Extension of the operate time during operation with transformer inrush-current detection	Approx. 10 ms
Dropout time	Approx. 25 ms + OOT at 50 Hz Approx. 22 ms + OOT at 60 Hz

14.19.9 Non-Directional Y0 Stage

Setting Values

V0> threshold value	0.300 V to 200.000 V	Increments of 0.001 V
Threshold Y0>	0.10 mS to 100.00 mS	Increments of 0.01 mS

¹⁰⁰ OOT (Output Operating Time): additional delay of the output medium used, see chapter [14.1.4 Relay Outputs](#)

Pickup delay	0.00 s to 60.00 s	Increments of 0.01 s
Operate delay	0.00 s to 60.00 s	Increments of 0.01 s

Dropout

The greater dropout differential (= | **pickup value** - **dropout value** |) of the following 2 criteria applies:

Dropout differential derived from the parameter Dropout ratio	
If this parameter is not available, a dropout ratio of 95 % applies for the overvoltage and of 105 % for the undervoltage functionality.	
Minimum absolute dropout differential	150 mV sec.

Times

Operate time with time delay = 0 ms	Approx. 32 ms + OOT ¹⁰¹ at 50 Hz Approx. 29 ms + OOT at 60 Hz
Extension of operate time during operation with transformer inrush-current detection	Approx. 10 ms
Dropout time	Approx. 32 ms + OOT at 50 Hz Approx. 27 ms + OOT at 60 Hz

Current Operating Range

Minimum 3I0 threshold value for Y0 calculation	Protection-class current transformers	30 mA sec. ($I_{rated} = 1 A$)
		150 mA sec. ($I_{rated} = 5 A$)
	Sensitive current transformer	1 mA sec. ($I_{rated} = 1 A$)
		5 mA sec. ($I_{rated} = 5 A$)

Tolerances

Admittance	1 % of the setting value or 0.05 mS ($I_{rated} = 1 A$) or 0.25 mS ($I_{rated} = 5 A$)
------------	---

14.19.10 Non-Directional 3I0 Harmonic Stage

Setting Values

3I0 harm. threshold	Protection-class current transformers	For $I_{ph-rated} = 1 A$	0.030 A to 35.000 A	Increments of 0.001 A
		For $I_{ph-rated} = 5 A$	0.15 A to 175.00 A	Increments of 0.01 A
	For I_N transformer type sensitive and $I_{N-rated} = 1 A$	For $I_{ph-rated} = 1 A$	0.001 A to 35.000 A	Increments of 0.001 A
		For $I_{ph-rated} = 5 A$	0.001 A to 175.000 A	Increments of 0.001 A
	For I_N transformer type sensitive and $I_{N-rated} = 5 A$	For $I_{ph-rated} = 1 A$	0.005 A to 35.000 A	Increments of 0.001 A
		For $I_{ph-rated} = 5 A$	0.005 A to 175.000 A	Increments of 0.001 A
3I0 harm. dropout ratio		0.10 to 0.95	Increments of 0.01	
Pickup extension time		0.00 s to 60.00 s	Increments of 0.01 s	
Operate delay		0.00 s to 60.00 s	Increments of 0.01 s	
Stabilization counter		1 to 10	Increments of 1	

¹⁰¹ OOT (Output Operating Time): additional delay of the output medium used, see chapter [14.1.4 Relay Outputs](#)

Dropout

The greater dropout differential (= | pickup value - dropout value |) of the following 2 criteria applies:

Dropout differential derived from the parameter Dropout ratio	
If this parameter is not available, a dropout ratio of 95 % applies for overcurrent and of 105 % for undercurrent functionality.	
Minimum absolute dropout differential	
Protection-class current transformer	15 mA sec. ($I_{rated} = 1 \text{ A}$) or 75 mA sec. ($I_{rated} = 5 \text{ A}$)
Instrument current transformer	0.5 mA sec. ($I_{rated} = 1 \text{ A}$) or 2.5 mA sec. ($I_{rated} = 5 \text{ A}$)

Times

Operate time with time delay = 0 ms and stabilization counter = 4	Approx. 70 ms + OOT ¹⁰² at 50 Hz Approx. 60 ms + OOT at 60 Hz
Dropout time	Approx. 40 ms + OOT at 50 Hz Approx. 30 ms + OOT at 60 Hz

Tolerances

Zero-sequence harmonic current 3I0harm.	-3I0harm. via sensitive current transformer: 2 % of the setting value or 0.2 mA ($I_{rated} = 1 \text{ A}$) or 1 mA ($I_{rated} = 5 \text{ A}$)
	-3I0harm. via protection-class current transformers: 2 % of the setting value or 10 mA ($I_{rated} = 1 \text{ A}$) or 50 mA ($I_{rated} = 5 \text{ A}$)

14.19.11 Pulse-Pattern Detection Stage

Setting Values

V0 > threshold value		0.300 V to 200.000 V	Increments of 0.001 V	
3I0 > threshold value	Protection-class current transformers	For $I_{ph-rated} = 1 \text{ A}$	0.030 A to 35.000 A	Increments of 0.001 A
		For $I_{ph-rated} = 5 \text{ A}$	0.15 A to 175.00 A	Increments of 0.01 A
	For I_N transformer type sensitive and $I_{N-rated} = 1 \text{ A}$	For $I_{ph-rated} = 1 \text{ A}$	0.001 A to 35.000 A	Increments of 0.001 A
		For $I_{ph-rated} = 5 \text{ A}$	0.001 A to 175.000 A	Increments of 0.001 A
	For I_N transformer type sensitive and $I_{N-rated} = 5 \text{ A}$	For $I_{ph-rated} = 1 \text{ A}$	0.005 A to 35.000 A	Increments of 0.001 A
		For $I_{ph-rated} = 5 \text{ A}$	0.005 A to 175.000 A	Increments of 0.001 A
3I0 delta pulse off-on		2 % to 50%	Increments of 1 %	
Pulse-on duration		0.20 s to 10.00 s	Increments of 0.01 s	
Pulse-off duration				

¹⁰² OOT (Output Operating Time): additional delay of the output medium used, see chapter 14.1.4 Relay Outputs

No. of pulses for operate Monitoring time(in pulses)	2 to 100	Increments of 1
Max.tolera.pulse-on or off	0.02 s to 2.00 s	Increments of 0.01 s

Dropout

The greater dropout differential (= | **pickup value** - **dropout value** |) of the following 2 criteria applies:

Dropout differential derived from the parameter Dropout ratio	
If this parameter is not available, a dropout ratio of 95 % applies for overcurrent/overvoltage and of 105 % for undercurrent/undervoltage functionality.	
Minimum absolute dropout differential	
Protection-class current transformer	15 mA sec. ($I_{rated} = 1 \text{ A}$) or 75 mA sec. ($I_{rated} = 5 \text{ A}$)
Instrument current transformer	0.5 mA sec. ($I_{rated} = 1 \text{ A}$) or 2.5 mA sec. ($I_{rated} = 5 \text{ A}$)
Voltage transformer	150 mV sec.

Times

Operate delay = 0 ms	Approx. $2.5 \text{ s} + 0.3 \text{ s} + \text{OOT}^{103}$ at 50 Hz and 60 Hz^{104}
Dropout time	Approx. $32 \text{ ms} + \text{OOT}$ at 50 Hz and 60 Hz

14.19.12 Intermittent Ground-Fault Blocking Stage

Setting Values

Threshold	For current transformer type protection and $I_{rated} = 1 \text{ A}$	0.030 A to 35.000 A	Increments of 0.001 A
	For current transformer type protection and $I_{rated} = 5 \text{ A}$	0.15 A to 175.00 A	Increments of 0.01 A
	For I_N transformer type sensitive and $I_{N-rated} = 1 \text{ A}$	0.001 A to 1.600 A	Increments of 0.001 A
	For I_N transformer type sensitive and $I_{N-rated} = 5 \text{ A}$	0.005 A to 8.000 A	Increments of 0.001 A
No.of pulses for interm.GF		2 to 50	Increments of 1
Reset time		1.00 s to 600.00 s	Increments of 0.01 s

Dropout

The greater dropout differential (= | **pickup value** - **dropout value** |) of the following 2 criteria applies:

¹⁰³ OOT (Output Operating Time): additional delay of the output medium used, see chapter [14.1.4 Relay Outputs](#)

¹⁰⁴ After the first valid pulse is detected, the function picks up. For the typical settings 1.00 s of Pulse-on duration, 1.50 s of Pulse-off duration, and 0.15 s of Max.tolera.pulse-on or off, the inherent pickup time is approx. $1 \text{ s} + 1.5 \text{ s} + 2 \cdot 0.15 \text{ s} + \text{OOT}$

Dropout differential derived from the parameter Dropout ratio	
If this parameter is not available, a dropout ratio of 95 % applies for overcurrent and of 105 % for undercurrent functionality.	
Minimum absolute dropout differential	
Protection-class current transformer	15 mA sec. ($I_{rated} = 1 \text{ A}$) or 75 mA sec. ($I_{rated} = 5 \text{ A}$)
Instrument current transformer	0.5 mA sec. ($I_{rated} = 1 \text{ A}$) or 2.5 mA sec. ($I_{rated} = 5 \text{ A}$)

Frequency Operating Range

$0.9 \leq f/f_{rated} \leq 1.1$	According to specified tolerances
$10 \text{ Hz} \leq f < 0.9 f_{rated}$	Slightly expanded tolerances
$1.1 f_{rated} < f \leq 90 \text{ Hz}$	
$f < 10 \text{ Hz}$ $f > 90 \text{ Hz}$	Active with reduced sensitivity

Tolerances

Currents	3I0 via protection-class current transformers: 1 % of the setting value or 5 mA ($I_{rated} = 1 \text{ A}$) or 25 mA ($I_{rated} = 5 \text{ A}$)
	3I0 via sensitive current transformer: 1 % of the setting value or 0.2 mA ($I_{rated} = 1 \text{ A}$) or 1 mA ($I_{rated} = 5 \text{ A}$)
Times	1 % of the setting value or $\pm 10 \text{ ms}$

14.20 Undercurrent Protection

Setting Values

Method of measurement		fundamental comp. RMS value	–
Threshold value I_k	1 A @ 100 I_{rated}	0.030 A to 35.000 A	Increments of 0.001 A
	5 A @ 100 I_{rated}	0.15 A to 175.00 A	Increments of 0.01 A
	1 A @ 1.6 I_{rated}	0.001 A to 1.600 A	Increments of 0.001 A
	5 A @ 1.6 I_{rated}	0.005 A to 8.000 A	Increments of 0.001 A
Pickup delay		0.00 s to 60.00 s	Increments of 0.01 s
Operate delay		0.00 s to 60.00 s	Increments of 0.01 s
Measurement repetition		0 to 10	Increments of 1

Dropout

The greater dropout differential (= | **pickup value** - **dropout value** |) of the following 2 criteria applies:

Dropout differential derived from the parameter Dropout ratio	
If this parameter is not available, a dropout ratio of 95 % applies for overcurrent and of 105 % for undercurrent functionality.	
Minimum absolute dropout differential	
Protection-class current transformer	15 mA sec. ($I_{rated} = 1$ A) or 75 mA sec. ($I_{rated} = 5$ A)
Instrument current transformer	0.5 mA sec. ($I_{rated} = 1$ A) or 2.5 mA sec. ($I_{rated} = 5$ A)

Times

Operate time with Measurement repetition = 0	Approx. 25 ms + OOT ¹⁰⁵ at 50 Hz Approx. 22 ms + OOT at 60 Hz
Dropout time	Approx. 25 ms + OOT at 50 Hz Approx. 22 ms + OOT at 60 Hz

Frequency Operating Range

$0.9 \leq f/f_{rated} \leq 1.1$	According to specified tolerances
$10 \text{ Hz} \leq f < 0.9 f_{rated}$ $1.1 f_{rated} < f \leq 90 \text{ Hz}$	Slightly expanded tolerances
$f < 10 \text{ Hz}$ $f > 90 \text{ Hz}$	Active

¹⁰⁵ OOT (Output Operating Time): additional delay of the output medium used, for example, 5 ms with fast relays, see chapter Relay Outputs

Tolerances

Currents, method of measurement = fundamental component	1 % of setting value or 5 mA ($I_{\text{rated}} = 1 \text{ A}$) or 25 mA ($I_{\text{rated}} = 5 \text{ A}$)
Currents, method of measurement = RMS value (33 % portion harmonic, referring to fundamental component)	
Up to 30th harmonic	2 % of setting value or 10 mA ($I_{\text{rated}} = 1 \text{ A}$) or 50 mA ($I_{\text{rated}} = 5 \text{ A}$)
Up to 50th harmonic, $f_{\text{rated}} = 50 \text{ Hz}$	4 % of setting value or 20 mA ($I_{\text{rated}} = 1 \text{ A}$) or 100 mA ($I_{\text{rated}} = 5 \text{ A}$)
Up to 50th harmonic, $f_{\text{rated}} = 60 \text{ Hz}$	5 % of setting value or 20 mA ($I_{\text{rated}} = 1 \text{ A}$) or 100 mA ($I_{\text{rated}} = 5 \text{ A}$)
Time delays	1 % of the setting value or 10 ms

14.21 Negative-Sequence Protection

14.21.1 Stage with Definite-Time Characteristic Curve

Setting Values

Reference value for I_2 (I_{ref})		Rated object current $I_{rated, obj}$ Positive-sequence current I_1	
Threshold		5.0 % to 999.9 % I_2/I_{ref}	Increments of 0.1
Dropout ratio		0.40 to 0.99	Increments of 0.01
Time delay		0.00 s to 60.00 s	Increments of 0.01 s
Release current (minimum current release)	1 A @ 50 and 100 I_{rated}	0.030 A to 10.000 A	Increments of 0.001 A
	5 A @ 50 and 100 I_{rated}	0.15 A to 50.00 A	Increments of 0.01 A
	1 A @ 1.6 I_{rated}	0.001 A to 1.600 A	Increments of 0.001 A
	5 A @ 1.6 I_{rated}	0.005 A to 8.000 A	Increments of 0.001 A
Maximum phase current (maximum current limiting)	1 A @ 50 and 100 I_{rated}	0.030 A to 35.000 A	Increments of 0.001 A
	5 A @ 50 and 100 I_{rated}	0.15 A to 175.00 A	Increments of 0.01 A
	1 A @ 1.6 I_{rated}	0.001 A to 1.600 A	Increments of 0.001 A
	5 A @ 1.6 I_{rated}	0.005 A to 8.000 A	Increments of 0.001 A

Dropout for the Threshold

The greater dropout differential (= | **pickup value** - **dropout value** |) of the following 2 criteria applies:

- Dropout differential derived from the parameter **Dropout ratio**
- Dropout differential of 0.5 % of the object rated current

Dropout for the Release Current

The greater dropout differential (= | **pickup value** - **dropout value** |) of the following 2 criteria applies:

Dropout differential derived from the parameter Dropout ratio	
If this parameter is not available, a dropout ratio of 95 % applies for overcurrent and of 105 % for undercurrent functionality.	
Minimum absolute dropout differential	
Protection-class current transformer	15 mA sec. ($I_{rated} = 1$ A) or 75 mA sec. ($I_{rated} = 5$ A)
Instrument current transformer	0.5 mA sec. ($I_{rated} = 1$ A) or 2.5 mA sec. ($I_{rated} = 5$ A)

Times

Pickup time	Approx. 40 ms + OOT ¹⁰⁶ at 50 Hz
	Approx. 35 ms + OOT at 60 Hz
Dropout time	Approx. 35 ms + OOT

¹⁰⁶ OOT (Output Operating Time): additional delay of the output medium used, see chapter [14.1.4 Relay Outputs](#)

Current Operating Range

Current range	At least one phase current \geq setting value I_{release}
	All phase currents \leq setting value $I_{\text{ph, max}}$

Frequency Operating Range

$0.9 \leq f/f_{\text{rated}} \leq 1.1$	According to specified tolerances
$10 \text{ Hz} \leq f < 0.9 f_{\text{rated}}$ $1.1 f_{\text{rated}} < f \leq 90 \text{ Hz}$	Slightly expanded tolerances
$f < 10 \text{ Hz}$ $f > 90 \text{ Hz}$	Inactive

Tolerances

Pickup value	
$I_2/I_{\text{rated, obj}}$	Approx. 1% of the setting value or 0.3% of the absolute value
I_2/I_1	Approx. 1 % of the setting value or 0.5 % of the absolute value ($I_1 > 50 \text{ mA}$ ($I_{\text{rated}} = 1 \text{ A}$) or 250 mA ($I_{\text{rated}} = 5 \text{ A}$))
Time delays	1 % of the setting value or 10 ms

14.21.2 Stage with Inverse-Time Characteristic Curve

Setting Values

Reference value for I_2 (I_{ref})		Rated object current $I_{\text{rated,obj}}$ Positive-sequence current I_1	
Threshold		5.0 % to 999.9 % I_2/I_{ref}	Increments of 0.1
Reset		Disk emulation Instantaneous	
Time dial		0.05 to 15.00	Increments of 0.01
Release current (minimum current release)	1 A @ 50 and 100 Irated	0.030 A to 10.000 A	Increments of 0.001 A
	5 A @ 50 and 100 Irated	0.15 A to 50.00 A	Increments of 0.01 A
	1 A @ 1.6 Irated	0.001 A to 1.600 A	Increments of 0.001 A
	5 A @ 1.6 Irated	0.005 A to 8.000 A	Increments of 0.001 A
Maximum phase current (maximum current limiting)	1 A @ 50 and 100 Irated	0.030 A to 35.000 A	Increments of 0.001 A
	5 A @ 50 and 100 Irated	0.15 A to 175.00 A	Increments of 0.01 A
	1 A @ 1.6 Irated	0.001 A to 1.600 A	Increments of 0.001 A
	5 A @ 1.6 Irated	0.005 A to 8.000 A	Increments of 0.001 A

Dropout for the Threshold

The greater dropout differential ($= | \text{pickup value} - \text{dropout value} |$) of the following 2 criteria applies:

- Dropout of 95 % of $1.1 \cdot \text{threshold value}$
- Dropout differential of 0.5 % of the object rated current

Reset of the Integration Timer

Instantaneous	With dropout
Disk emulation	Approx. $< 0.90 \cdot \text{threshold value}$

Dropout for the Release Current

The greater dropout differential (= | pickup value - dropout value |) of the following 2 criteria applies:

Dropout differential derived from the parameter Dropout ratio	
If this parameter is not available, a dropout ratio of 95 % applies for overcurrent and of 105 % for undercurrent functionality.	
Minimum absolute dropout differential	
Protection-class current transformer	15 mA sec. ($I_{\text{rated}} = 1 \text{ A}$) or 75 mA sec. ($I_{\text{rated}} = 5 \text{ A}$)
Instrument current transformer	0.5 mA sec. ($I_{\text{rated}} = 1 \text{ A}$) or 2.5 mA sec. ($I_{\text{rated}} = 5 \text{ A}$)

Times

Pickup time	Approx. 40 ms + OOT ¹⁰⁷ at 50 Hz
	Approx. 35 ms + OOT at 60 Hz
Dropout time	Approx. 35 ms + OOT

Operate and Dropout Characteristic Curves

You can select from the following operate and dropout characteristic curves:

Table 14-3 Standard Characteristic Curves to IEC

Normal inverse: type A	See chapter 14.4.2 Stage with Inverse-Time Characteristic Curve, Figure 14-1
Very inverse: type B	
Extremely inverse: type C	See chapter 14.4.2 Stage with Inverse-Time Characteristic Curve, Figure 14-2
Long-time inverse: type B	

Table 14-4 Standard Characteristic Curves to ANSI

Inverse: type C	See chapter 14.4.2 Stage with Inverse-Time Characteristic Curve, Figure 14-4
Short inverse	
Long inverse	See chapter 14.4.2 Stage with Inverse-Time Characteristic Curve, Figure 14-5
Moderately inverse	
Very inverse	See chapter 14.4.2 Stage with Inverse-Time Characteristic Curve, Figure 14-6
Extremely inverse	
Definite inverse	See chapter 14.4.2 Stage with Inverse-Time Characteristic Curve, Figure 14-7

Extension of the Operating Time

Extension of the operate time during operation with transformer inrush-current detection	Approx. 10 ms
--	---------------

¹⁰⁷ OOT (Output Operating Time): additional delay of the output medium used, see chapter [14.1.4 Relay Outputs](#)

Current Operating Range

Current range	At least one phase current \geq setting value I_{release}
	All phase currents \leq setting value $I_{\text{ph, max}}$

Frequency Operating Range

$0.9 \leq f/f_{\text{rated}} \leq 1.1$	According to specified tolerances
$10 \text{ Hz} \leq f < 0.9 f_{\text{rated}}$ $1.1 f_{\text{rated}} < f \leq 90 \text{ Hz}$	Slightly expanded tolerances
$f < 10 \text{ Hz}$ $f > 90 \text{ Hz}$	Inactive

Tolerances

Reference value = rated current	
Pickup value	Approx. 1 % of the setting value or 0.3 % of the absolute value
Operate time for $2 \leq I/I$ threshold value ≤ 20	5 % of the setting value or + 2 % of the current tolerance or 30 ms
Dropout time for I/I threshold value ≤ 0.90	5 % of the setting value or + 2 % of the current tolerance or 30 ms
Reference value = pos. seq. current	
Pickup value	Approx. 1 % of the setting value or 0.5 % of the absolute value ($I > 50 \text{ mA}$ ($I_{\text{rated}} = 1 \text{ A}$) or 250 mA ($I_{\text{rated}} = 5 \text{ A}$))
Operate time for $2 \leq I/I$ threshold value ≤ 20	5 % of the reference (calculated) value + 2 % current tolerance or 30 ms
Dropout time for I/I threshold value ≤ 0.90	5 % of the reference (calculated) value + 2 % current tolerance or 30 ms

14.22 Directional Negative-Sequence Protection with Definite-Time Delay

Setting Values

Directional mode	Forward, backward, non-directional	
Stabilization with phase currents	0 % to 30 %	Increments of 1 %
Threshold value (pickup value) at $I_{N-rated} = 1 \text{ A}$	0.030 A to 35.000 A	Increments of 0.001 A
Threshold value (pickup value) at $I_{N-rated} = 5 \text{ A}$	0.15 A to 175.00 A	Increments of 0.01 A
Extension time of the blocking after a 1-pole pause	0.00 s to 60.00 s	Increments of 0.01 s

Setting Values for Direction Determination

Minimum negative-sequence system voltage V2	0.150 V to 20.000 V		Increments of 0.001 V
Minimum negative-sequence system current I2	For $I_{rated} = 1 \text{ A}$	0.030 A to 10.000 A	Increments of 0.001 A
	For $I_{rated} = 5 \text{ A}$	0.15 A to 50.00 A	Increments of 0.01 A
Upper limit angle forward, β	0° to 360°		Increments of 1°
Lower limit angle forward, α	0° to 360°		Increments of 1°

Dropout

The greater dropout differential (= | **pickup value** - **dropout value** |) of the following 2 criteria applies:

- Dropout differential derived from the parameter **Dropout ratio**
- Dropout differential of 0.5 % of the object rated current

Times

Operate time with time delay = 0 ms	Approx. 40 ms + OOT ¹⁰⁸ at 50 Hz Approx. 40 ms + OOT at 60 Hz
Dropout time	Approx. 39 ms + OOT

Frequency Operating Range

$0.9 \leq f/f_{rated} \leq 1.1$	According to specified tolerances
$10 \text{ Hz} \leq f < 0.9 f_{rated}$ $1.1 f_{rated} < f \leq 80 \text{ Hz}$	Slightly expanded tolerances
$f < 10 \text{ Hz}$ $f > 80 \text{ Hz}$	Inactive

Tolerances

Threshold values:	
Negative-sequence voltage V2	1 % of the setting value or 0.05 V
Negative-sequence current I2	2 % of the setting value or 10 mA at $I_{rated} = 1 \text{ A}$
	1 % of the setting value or 50 mA at $I_{rated} = 5 \text{ A}$

¹⁰⁸ OOT (Output Operating Time) Additional delay of the output medium used, see chapter [14.1.4 Relay Outputs](#)

Times:	
Independent time delays	1 % of the setting value or 10 ms
Limit angle in determining the direction	1°

14.23 Thermal Overload Protection, 3-Phase – Advanced

Setting Value for the Function Block Filter

h(0)	-100.000 to 100.000	Increments of 0.001
h(1)	-100.000 to 100.000	Increments of 0.001
h(2)	-100.000 to 100.000	Increments of 0.001
h(3)	-100.000 to 100.000	Increments of 0.001
h(4)	-100.000 to 100.000	Increments of 0.001

Dropout Ratios

Tripping threshold (fixed at 100 %)	Dropout if value drops below operate indication dropout threshold
Thermal warning threshold	About 0.99 of the setting value
Current warning threshold	About 0.95 of the setting value

Frequency Range of the Input Signals

The function captures input signals up to the 50th harmonic.

Tolerances

No filter applied (33 % harmonics, in relation to the fundamental component)		
With reference to $k \cdot I_{rated}$	Up to 30th harmonic	2 % or 10 mA ($I_{rated} = 1 A$) or 50 mA ($I_{rated} = 5 A$), 2 % class acc. to IEC 60255-149
	Up to 50th harmonic, $f_{rated} = 50 Hz$	4 % or 20 mA ($I_{rated} = 1 A$) or 100 mA ($I_{rated} = 5 A$), 4 % class acc. to IEC 60255-149
	Up to 50th harmonic, $f_{rated} = 60 Hz$	5 % or 25 mA ($I_{rated} = 1 A$) or 125 mA ($I_{rated} = 5 A$), 5 % class acc. to IEC 60255-149
With the filter for compensation of the amplitude attenuation due to the anti-aliasing filter (33 % harmonics, in relation to the fundamental component)		
With reference to $k \cdot I_{rated}$	Up to 30th harmonic	2 % or 10 mA ($I_{rated} = 1 A$) or 50 mA ($I_{rated} = 5 A$), 2 % class acc. to IEC 60255-149
	Up to 50th harmonic, $f_{rated} = 50 Hz$	3 % or 20 mA ($I_{rated} = 1 A$) or 100 mA ($I_{rated} = 5 A$), 3 % class acc. to IEC 60255-149
	Up to 50th harmonic, $f_{rated} = 60 Hz$	4 % or 20 mA ($I_{rated} = 1 A$) or 100 mA ($I_{rated} = 5 A$), 4 % class acc. to IEC 60255-149

With the filter for gain of harmonics including compensation of the amplitude attenuation ¹⁰⁹ (33 % harmonics, in relation to the fundamental component)		
With reference to $k \cdot I_{\text{rated}}$	Up to 30th harmonic	2 % or 10 mA ($I_{\text{rated}} = 1 \text{ A}$) or 50 mA ($I_{\text{rated}} = 5 \text{ A}$), 2 % class acc. to IEC 60255-149 ¹¹⁰
	Up to 50th harmonic, $f_{\text{rated}} = 50 \text{ Hz}$	4 % or 20 mA ($I_{\text{rated}} = 1 \text{ A}$) or 100 mA ($I_{\text{rated}} = 5 \text{ A}$), 4 % class acc. to IEC 60255-149 ¹¹¹
	Up to 50th harmonic, $f_{\text{rated}} = 60 \text{ Hz}$	5 % or 25 mA ($I_{\text{rated}} = 1 \text{ A}$) or 125 mA ($I_{\text{rated}} = 5 \text{ A}$), 5 % class acc. to IEC 60255-149 ¹¹¹
With reference to the operate time	Up to 30th harmonic	3 % or 1 s for $I/(k \cdot I_{\text{rated}}) > 1.25$, 3 % class acc. to IEC 60255-149

Operate Curve

Operate curve	$t = \tau_{\text{th}} \cdot \ln \frac{\left(\frac{I}{k \cdot I_{\text{rated,obj}}}\right)^2 - \left(\frac{I_{\text{preload}}}{k \cdot I_{\text{rated,obj}}}\right)^2}{\left(\frac{I}{k \cdot I_{\text{rated,obj}}}\right)^2 - 1}$	
Where	t	Operate time
	τ_{th}	Time constant
	I	Current load current
	I_{preload}	Preload current
	k	Setting factor according to VDE 0435 part 3011 or IEC 60255-149 (K factor)
	$I_{\text{rated, obj}}$	Rated current of the protected object

¹⁰⁹ In case that the filter response exactly matches the user-defined gain factor.

¹¹⁰ In case that the user-defined gain factor is set below 3. The tolerance is increased if the gain factor is larger.

¹¹¹ In case that the user-defined gain factor is set below 7. The tolerance is increased if the gain factor is larger.

Table 14-5 Operate Curve Overload Protection

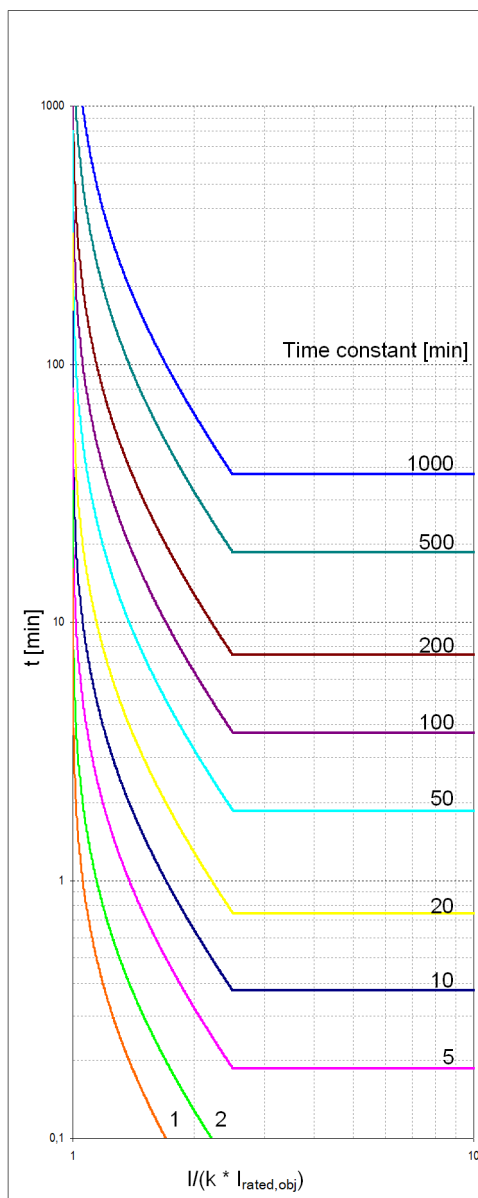

With 80 % preload temperature (θ_{preload}) and with $I_{\text{max, therm}} = 2.5 \cdot k \cdot I_{\text{rated}}$

$$t = \tau_{\text{th}} \cdot \ln \frac{\left(\frac{1}{k \cdot I_{\text{rated,obj}}}\right)^2 - \left(\frac{I_{\text{preload}}}{k \cdot I_{\text{rated,obj}}}\right)^2}{\left(\frac{1}{k \cdot I_{\text{rated,obj}}}\right)^2 - 1} \text{ [min]}$$

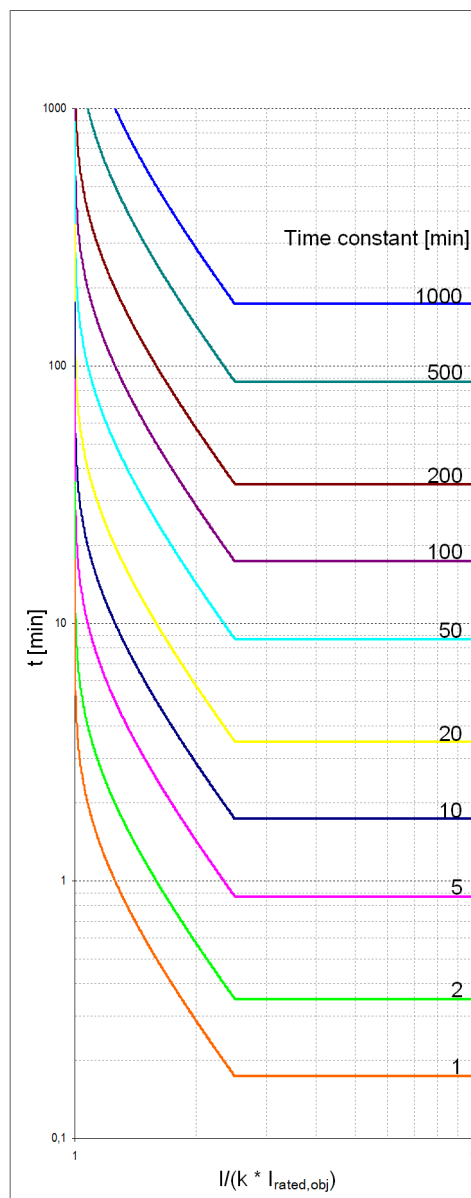

Without preload and with $I_{\text{max, therm}} = 2.5 \cdot k \cdot I_{\text{rated}}$

$$t = \tau_{\text{th}} \cdot \ln \frac{\left(\frac{1}{k \cdot I_{\text{rated,obj}}}\right)^2}{\left(\frac{1}{k \cdot I_{\text{rated,obj}}}\right)^2 - 1} \text{ [min]}$$

Frequency Operating Range

Unlimited

14.24 Thermal Overload Protection, User-Defined Characteristic Curve

Setting Values

Threshold current warning	1 A @ 50 and 100 I _{rated}	0.030 A to 35.000 A	Increments of 0.001 A
	5 A @ 50 and 100 I _{rated}	0.15 A to 175.00 A	Increments of 0.01 A
	1 A @ 1.6 I _{rated}	0.001 A to 1.600 A	Increments of 0.001 A
	5 A @ 1.6 I _{rated}	0.005 A to 8.000 A	Increments of 0.001 A
Threshold thermal warn.		50 % to 100 %	Increments of 1 %
Dropout threshold operate		50 % to 99 %	Increments of 1 %
Emerg. start T overtravel		0 s to 15 000 s	Increments of 10 s
I _{max} thermal	1 A @ 50 and 100 I _{rated}	0.030 A to 35.000 A	Increments of 0.001 A
	5 A @ 50 and 100 I _{rated}	0.15 A to 175.00 A	Increments of 0.01 A
	1 A @ 1.6 I _{rated}	0.001 A to 1.600 A	Increments of 0.001 A
	5 A @ 1.6 I _{rated}	0.005 A to 8.000 A	Increments of 0.001 A
I _{min} cooling	1 A @ 50 and 100 I _{rated}	0.000 A to 10.000 A	Increments of 0.001 A
	5 A @ 50 and 100 I _{rated}	0.00 A to 50.00 A	Increments of 0.01 A
	1 A @ 1.6 I _{rated}	0.000 A to 1.600 A	Increments of 0.001 A
	5 A @ 1.6 I _{rated}	0.000 A to 8.000 A	Increments of 0.001 A
Curve based on preload		1 % to 100 %	Increments of 1 %
Number of value pairs for the operate curve		2 to 30	Increments of 1
X values of the operate curve		1.011 p.u. to 20.00 p. u.	Increments of 0.001 p.u.
Y values of the operate curve		1.00 s to 20 000.00 s	Increments of 0.01 s

Dropout Ratios

Tripping threshold value (fixed at 100 %)	Dropout if value drops below operate indication dropout threshold
Thermal warning threshold value	About 0.99 of the setting value
Current warning threshold value	About 0.95 of the setting value

Frequency Range of the Input Signals

The function captures input signals up to the 50th harmonic.

Tolerances

With reference to $k \cdot I_{\text{rated}}$	For $I_{\text{rated}} = 1 \text{ A}$	2 % or 10 mA, class 2 % acc. to IEC 60255-149
	For $I_{\text{rated}} = 5 \text{ A}$	2 % or 50 mA, class 2 % acc. to IEC 60255-149
With reference to operate time		3 % or 1 s, class 3 % acc. to IEC 60255-149 for $I/(k \cdot I_{\text{rated}}) > 1.25$

Frequency Operating Range

Unlimited

14.25 Thermal Overload Protection, 1-Phase

Dropout Ratios

Tripping threshold (fixed at 100 %)	Dropout if value drops below operate indication dropout threshold
Thermal warning threshold	About 0.99 of the setting value
Current warning threshold	About 0.95 of the setting value

Frequency Range of the Input Signals

The function captures input signals up to the 50th harmonic.

Tolerances

With reference to $k \cdot I_{rated}$	Up to 30th harmonic	2 % or 10 mA ($I_{rated} = 1$ A) or 50 mA ($I_{rated} = 5$ A), 2 % class acc. to IEC 60255-149
	Up to 50th harmonic, $f_{rated} = 50$ Hz	4 % or 20 mA ($I_{rated} = 1$ A) or 100 mA ($I_{rated} = 5$ A), 4 % class acc. to IEC 60255-149
	Up to 50th harmonic, $f_{rated} = 60$ Hz	5 % or 25 mA ($I_{rated} = 1$ A) or 125 mA ($I_{rated} = 5$ A), 5 % class acc. to IEC 60255-149
With reference to the operate time	Up to 30th harmonic	3 % or 1 s for $I/(k \cdot I_{rated}) > 1.25$, 3 % class acc. to IEC 60255-149

Operate Curve

Operate curve	$t = \tau_{th} \cdot \ln \frac{\left(\frac{I}{k \cdot I_{rated,obj.}}\right)^2 - \left(\frac{I_{preload}}{k \cdot I_{rated,obj.}}\right)^2}{\left(\frac{I}{k \cdot I_{rated,obj.}}\right)^2 - 1}$	
Where	t	Operate time
	τ_{th}	Time constant
	I	Current load current
	$I_{preload}$	Preload current
	k	Setting factor according to VDE 0435 part 3011 or IEC 60255-8 (k factor)
	$I_{rated, obj}$	Rated current of the protected object

Table 14-6 Operate Curve Overload Protection

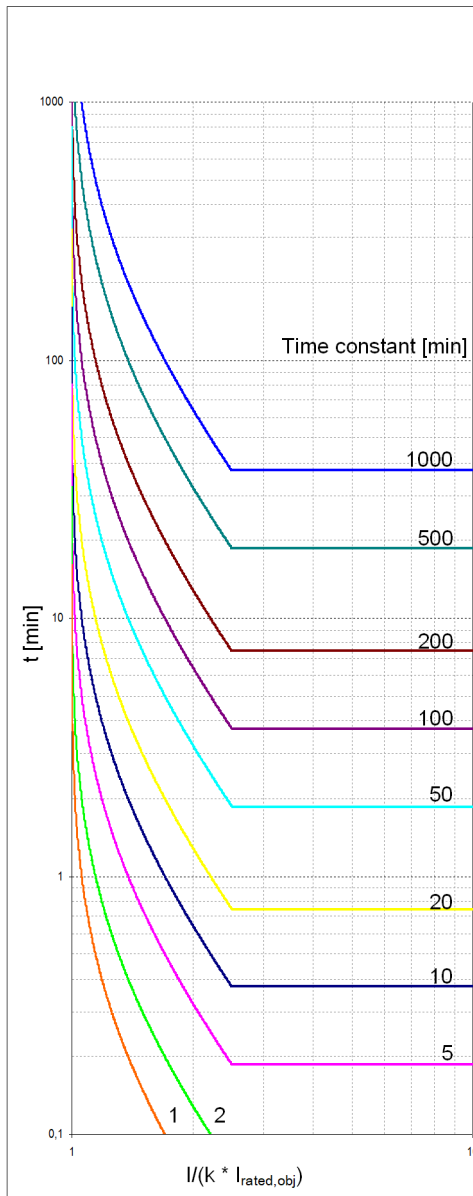

With 80 % preload temperature (θ_{preload}) and with $I_{\text{max, therm}} = 2.5 \cdot k \cdot I_{\text{rated}}$

$$t = \tau_{\text{th}} \cdot \ln \frac{\left(\frac{1}{k \cdot I_{\text{rated,obj}}}\right)^2 - \left(\frac{I_{\text{preload}}}{k \cdot I_{\text{rated,obj}}}\right)^2}{\left(\frac{1}{k \cdot I_{\text{rated,obj}}}\right)^2 - 1} \text{ [min]}$$

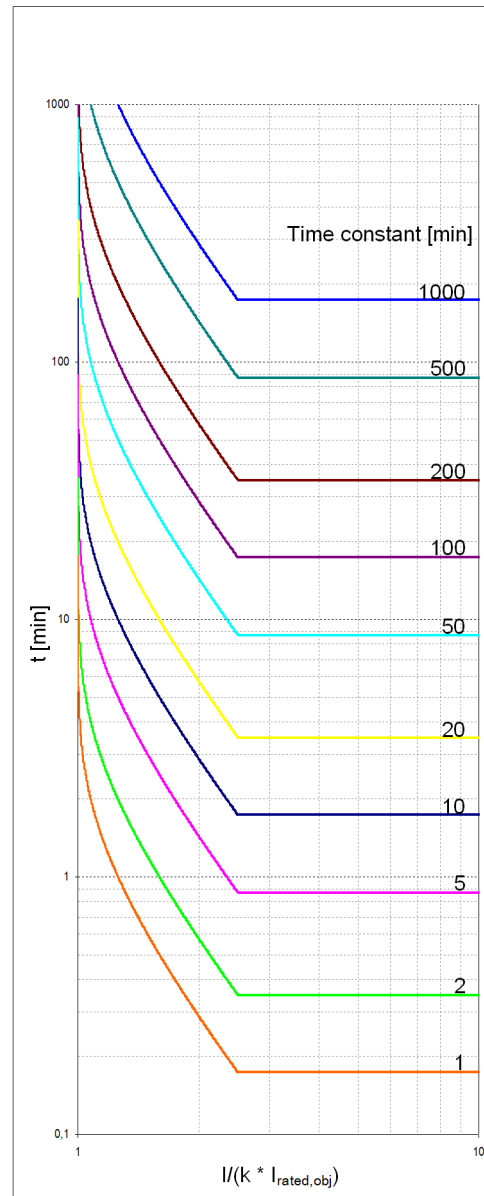

Without preload and with $I_{\text{max, therm}} = 2.5 \cdot k \cdot I_{\text{rated}}$

$$t = \tau_{\text{th}} \cdot \ln \frac{\left(\frac{1}{k \cdot I_{\text{rated,obj}}}\right)^2}{\left(\frac{1}{k \cdot I_{\text{rated,obj}}}\right)^2 - 1} \text{ [min]}$$

Frequency Operating Range

Unlimited

14.26 Unbalanced-Load Protection

Setting Values

Maximum continuously perm. I ₂	3.0 % to 30.0 % I ₂ /I _{rated,machine}	Increments of 0.1 %
Unbalanced load factor K	1.0 s to 100.0 s	Increments of 0.1 s
Warning delay	0.0 s to 60.0 s; ∞	Increments of 0.1 s
Cooling time thermal replica	0 s to 50 000 s	Increments of 1 s

Dropout

$I_{2perm} \cdot I_{rated,machine} \leq 10 \text{ mA}$	Dropout value = $0.5 \cdot I_{2perm} \cdot I_{rated,machine}$
$10 \text{ mA} < I_{2perm} \cdot I_{rated,machine} \leq 100 \text{ mA}$	Dropout value = $I_{2perm} \cdot I_{rated,machine} - 5 \text{ mA}$
$I_{2perm} \cdot I_{rated,machine} > 100 \text{ mA}$	Dropout value = $0.95 \cdot I_{2perm} \cdot I_{rated,machine}$

Operate Characteristics

Characteristic of the thermal replica	$t_{I2Perm} = \frac{K}{(I_2/I_{rated,machine})^2}$	
Where:	t _{I2perm}	Permissible application time of the negative-sequence current
	K	Unbalanced load factor K
	I ₂ /I _{rated,machine}	Unbalanced load (negative-sequence current/rated current of the machine)

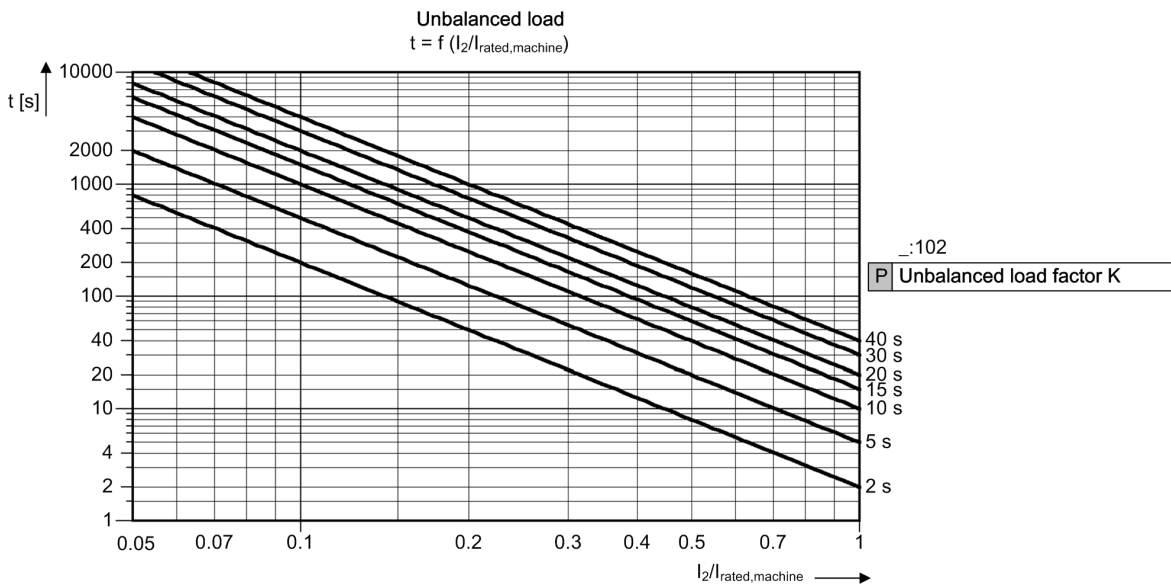

[dw_unbaop_1_en_US]

Figure 14-11 Thermal Characteristic for Unbalanced Load Protection

Times

Pickup time of the warning stage	Approx. 60 ms + OOT ¹¹² at 50 Hz Approx. 50 ms + OOT at 60 Hz
Dropout time	Approx. 50 ms or better

Frequency Operating Range

$0.9 \leq f/f_{\text{rated}} \leq 1.1$	According to specified tolerances
$10 \text{ Hz} \leq f < 0.9 f_{\text{rated}}$ $1.1 f_{\text{rated}} < f \leq 90 \text{ Hz}$	Slightly expanded tolerances
$f < 10 \text{ Hz}$ $f > 90 \text{ Hz}$	Inactive

Tolerances

Negative-sequence current I_2	The value can be any of the following: <ul style="list-style-type: none"> • $\leq 1\%$ of the setting value • 3 mA at $I_{\text{rated}} = 1 \text{ A}$ • 15 mA at $I_{\text{rated}} = 5 \text{ A}$
Warning delay	1 % of the setting value or 10 ms
Time for $I_2/I_{2\text{perm}} \leq 10$	< (5 % of the reference value + 2 % of the current tolerance) or 100 ms

Influencing Variables for the Thresholds

Harmonics	
– Up to 10 % 3rd harmonic	$\leq 1 \%$
– Up to 10 % 5th harmonic	$\leq 1 \%$

¹¹² OOT (Output Operating Time): additional delay of the output medium used, for example, 5 ms with fast relays

14.27 Overcurrent Protection for Capacitor Banks

14.27.1 Stage with Definite-Time Characteristic Curve

Setting Value for the Function Block Filter

h(0)	-100.000 to 100.000	Increments of 0.001
h(1)	-100.000 to 100.000	Increments of 0.001
h(2)	-100.000 to 100.000	Increments of 0.001
h(3)	-100.000 to 100.000	Increments of 0.001
h(4)	-100.000 to 100.000	Increments of 0.001

Setting Values for Protection Stage

Method of measurement		Fundamental component RMS value	–
Threshold value ¹¹³	1 A @ 50 and 100 Irated	0.030 A to 40.000 A	Increments of 0.001 A
	5 A @ 50 and 100 Irated	0.15 A to 200.00 A	Increments of 0.01 A
	1 A @ 1.6 Irated	0.001 A to 1.600 A	Increments of 0.001 A
	5 A @ 1.6 Irated	0.005 A to 8.000 A	Increments of 0.001 A
Dropout ratio		0.90 to 0.99	Increments of 0.01
Operate delay		0.00 s to 100.00 s	Increments of 0.01 s
Dropout delay		0.00 s to 60.00 s	Increments of 0.01 s
Pickup delay		0.00 s to 60.00 s	Increments of 0.01 s

Dropout

The greater dropout differential (= | pickup value - dropout value |) of the following 2 criteria applies:

Dropout differential derived from the parameter Dropout ratio	
If this parameter is not available, a dropout ratio of 95 % applies for overcurrent and of 105 % for undercurrent functionality.	
Minimum absolute dropout differential	
Protection-class current transformer	15 mA sec. ($I_{rated} = 1 A$) or 75 mA sec. ($I_{rated} = 5 A$)
Instrument current transformer	0.5 mA sec. ($I_{rated} = 1 A$) or 2.5 mA sec. ($I_{rated} = 5 A$)

Times

Operate time with time delay = 0 ms	Approx. 25 ms + OOT ¹¹⁴ at 50 Hz Approx. 22 ms + OOT at 60 Hz
Extension of the operate time during operation with transformer inrush-current detection	Approx. 10 ms
Dropout time	Approx. 20 ms + OOT

¹¹³ If you have selected the **method of measurement = RMS value**, do not set the threshold value under $0.1 I_{rated,sec}$.

¹¹⁴ OOT (Output Operating Time): additional delay of the output medium used, for example 5 ms with fast relays

Frequency Operating Range

$0.9 \leq f/f_{\text{rated}} \leq 1.1$	According to specified tolerances
$10 \text{ Hz} \leq f < 0.9 f_{\text{rated}}$ $1.1 f_{\text{rated}} < f \leq 90 \text{ Hz}$	Slightly expanded tolerances
$f < 10 \text{ Hz}$ $f > 90 \text{ Hz}$	Active

Tolerances

Currents, method of measurement = fundamental component	1 % of the setting value or 5 mA ($I_{\text{rated}} = 1 \text{ A}$) or 25 mA ($I_{\text{rated}} = 5 \text{ A}$)
Currents, method of measurement = RMS value, no filter applied (33 % harmonics, in relation to fundamental component)	
Up to 30th harmonic	2 % of the setting value or 10 mA ($I_{\text{rated}} = 1 \text{ A}$) or 50 mA ($I_{\text{rated}} = 5 \text{ A}$)
Up to 50th harmonic, $f_{\text{rated}} = 50 \text{ Hz}$	4 % of the setting value or 20 mA ($I_{\text{rated}} = 1 \text{ A}$) or 100 mA ($I_{\text{rated}} = 5 \text{ A}$)
Up to 50th harmonic, $f_{\text{rated}} = 60 \text{ Hz}$	5 % of the setting value or 20 mA ($I_{\text{rated}} = 1 \text{ A}$) or 100 mA ($I_{\text{rated}} = 5 \text{ A}$)
Currents, method of measurement = RMS value with filter for the compensation of the amplitude attenuation due to the anti-aliasing filter (33 % harmonics, in relation to the fundamental component)	
Up to 30 harmonic	2 % of the setting value or 10 mA ($I_{\text{rated}} = 1 \text{ A}$) or 50 mA ($I_{\text{rated}} = 5 \text{ A}$)
Up to 50th harmonic, $f_{\text{rated}} = 50 \text{ Hz}$	3 % of the setting value or 20 mA ($I_{\text{rated}} = 1 \text{ A}$) or 100 mA ($I_{\text{rated}} = 5 \text{ A}$)
Up to 50th harmonic, $f_{\text{rated}} = 60 \text{ Hz}$	4 % of the setting value or 20 mA ($I_{\text{rated}} = 1 \text{ A}$) or 100 mA ($I_{\text{rated}} = 5 \text{ A}$)
Currents, method of measurement = RMS value with filter for the gain of harmonics (including compensation of the amplitude attenuation) ¹¹⁵ (33 % harmonics, in relation to the fundamental component)	
Up to 30 harmonic	2.5 % of the setting value or 10 mA ($I_{\text{rated}} = 1 \text{ A}$) or 50 mA ($I_{\text{rated}} = 5 \text{ A}$) ¹¹⁶
Up to 50th harmonic, $f_{\text{rated}} = 50 \text{ Hz}$	4 % of the setting value or 20 mA ($I_{\text{rated}} = 1 \text{ A}$) or 100 mA ($I_{\text{rated}} = 5 \text{ A}$) ¹¹⁷
Up to 50th harmonic, $f_{\text{rated}} = 60 \text{ Hz}$	5 % of the setting value or 20 mA ($I_{\text{rated}} = 1 \text{ A}$) or 100 mA ($I_{\text{rated}} = 5 \text{ A}$) ¹¹⁸
Pickup delay	1 % of the setting value or 10 ms
Dropout delay	1 % of the setting value or 10 ms
Operate delay for the basic stage	1 % of the setting value or 10 ms

¹¹⁵ In case that the filter response exactly matches the user-defined gain factors

¹¹⁶ In case that the user-defined gain factor is set below 3. The tolerance increases, if the gain factor is larger.

¹¹⁷ In case that the user-defined gain factor is set below 7. The tolerance increases, if the gain factor is larger.

¹¹⁸ In case that the user-defined gain factor is set below 7. The tolerance increases, if the gain factor is larger.

Operate delay for the advanced stage	Operate delay mode = Running dur. DO-delay	1 % of the setting value or 10 ms
	Operate delay mode = Frozen dur. DO-delay	1 % of the reference value or 10 ms (reference value = setting value + frozen time)

Influencing Variables for Threshold Values

Transient excess pickup in method of measurement = fundamental component, for $\tau > 100$ ms (with complete unbalance)	< 5 %
---	-------

14.27.2 Stage with Inverse-Time Characteristic Curve

Setting Value for the Function Block Filter

h(0)	-100.000 to 100.000	Increments of 0.001
h(1)	-100.000 to 100.000	Increments of 0.001
h(2)	-100.000 to 100.000	Increments of 0.001
h(3)	-100.000 to 100.000	Increments of 0.001
h(4)	-100.000 to 100.000	Increments of 0.001

Setting Values for Protection Stage

Method of measurement		Fundamental component RMS value	–
Threshold value	1 A @ 50 and 100 Irated	0.030 A to 40.000 A	Increments of 0.001 A
	5 A @ 50 and 100 Irated	0.15 A to 200.00 A	Increments of 0.01 A
	1 A @ 1.6 Irated	0.001 A to 1.600 A	Increments of 0.001 A
	5 A @ 1.6 Irated	0.005 A to 8.000 A	Increments of 0.001 A
Dropout		Disk emulation Instantaneous	–
Time multiplier		0.00 to 15.00	Increments of 0.01
Pickup delay		0.00 s to 60.00 s	Increments of 0.01 s

Dropout

The greater dropout differential (= | pickup value - dropout value |) of the following 2 criteria applies:

Dropout	95 % of $1.1 \cdot \text{threshold value}$
Minimum absolute dropout differential	
Protection-class current transformer	15 mA sec. ($I_{\text{rated}} = 1$ A) or 75 mA sec. ($I_{\text{rated}} = 5$ A)
Instrument current transformer	0.5 mA sec. ($I_{\text{rated}} = 1$ A) or 2.5 mA sec. ($I_{\text{rated}} = 5$ A)

Reset of the Integration Timer

Instantaneous	With dropout
Disk emulation	Approx. $< 0.90 \cdot \text{threshold value}$

Operate Curves and Dropout-Time Characteristic Curves according to IEC

Extension of the operate time during operation with transformer inrush-current detection	Approx. 10 ms
--	---------------

NORMAL INVERSE: Type A

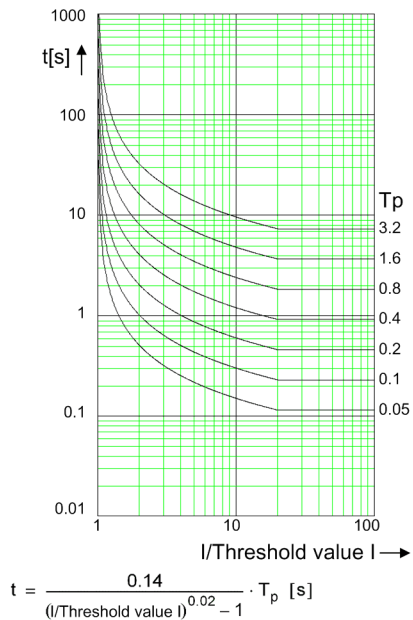

RESET NORMAL INVERSE: Type A

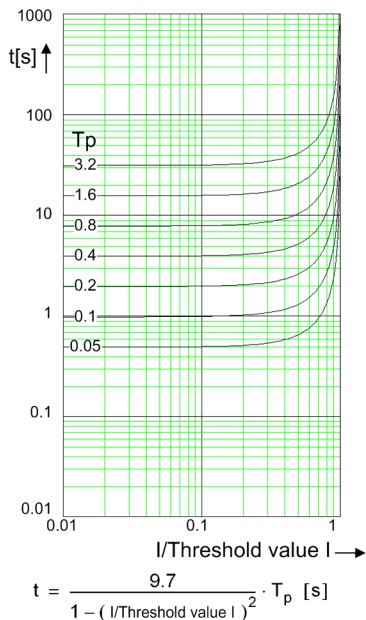

VERY INVERSE: Type B

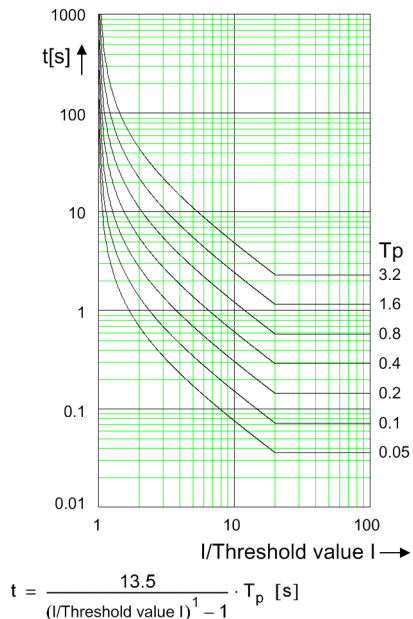

RESET VERY INVERSE: Type B

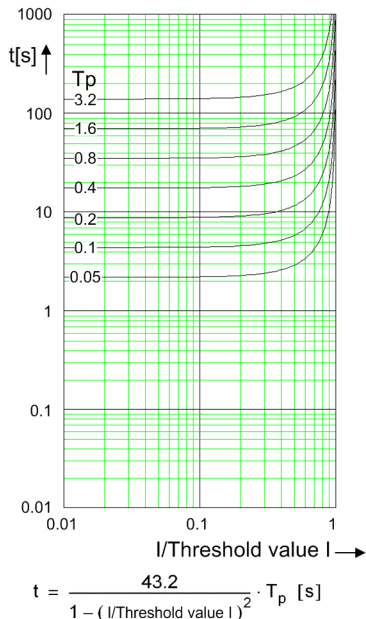

[dw_ocp_ki1, 1, en_US]

Figure 14-12 Operate Curves and Dropout-Time Characteristic Curves According to IEC

EXTREMELY INVERSE: Type C

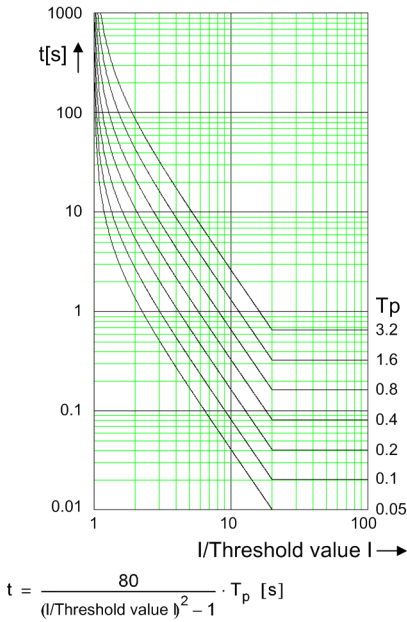

RESET EXTREMELY INVERSE: Type C

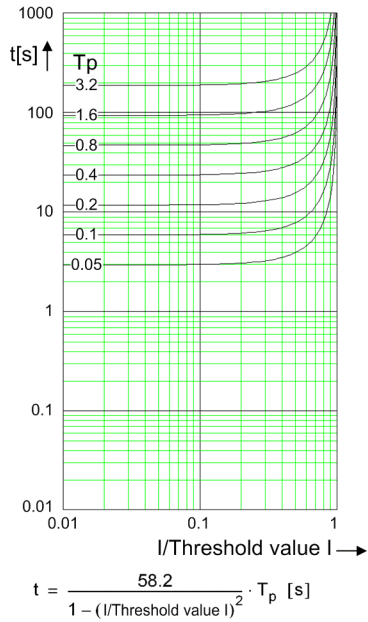

LONG-TIME INVERSE: Type B

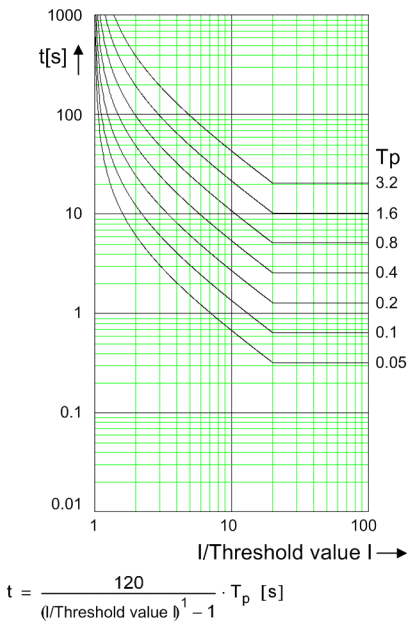

RESET LONG-TIME INVERSE: Type B

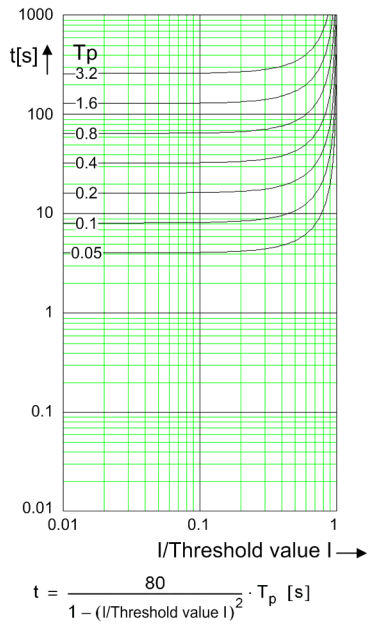

[dlw_ocp_ki2_1_en_US]

Figure 14-13 Operate Curves and Dropout-Time Characteristic Curves According to IEC

SHORT-TIME INVERSE

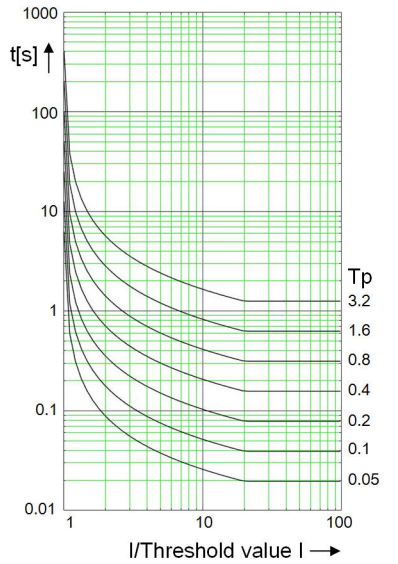

$$t = \frac{0.05}{(I/\text{Threshold value } I)^{0.04} - 1} \cdot T_p \text{ [s]}$$

RESET SHORT-TIME INVERSE

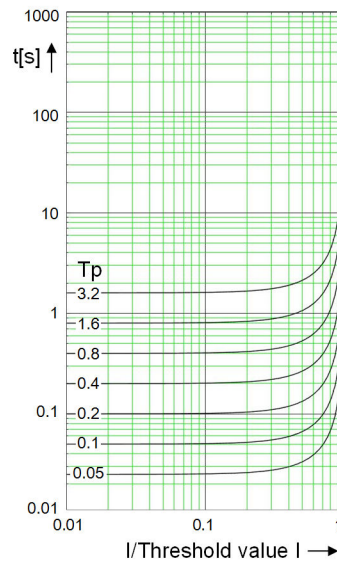

$$t = \frac{0.5}{1 - (I/\text{Threshold value } I)^2} \cdot T_p \text{ [s]}$$

[dw_iec-short-inverse, 1, en_US]

Figure 14-14 Operate Curves and Dropout-Time Characteristic Curves According to IEC (Advanced Stage)

Operate Curves and Dropout-Time Characteristic Curves According to ANSI/IEEE

Inverse: Type C

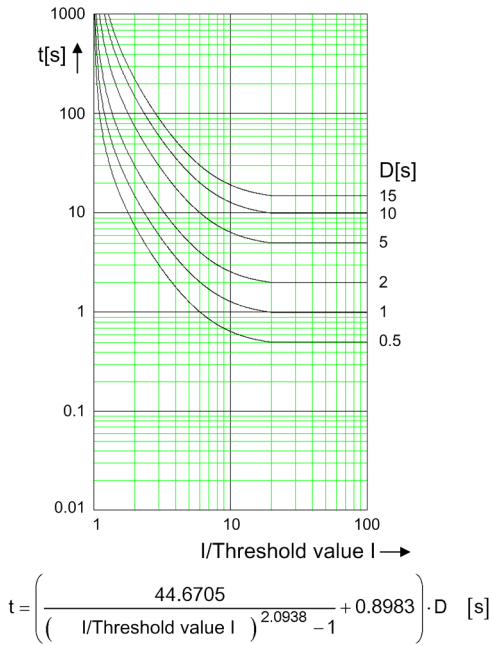

RESET INVERSE: Type C

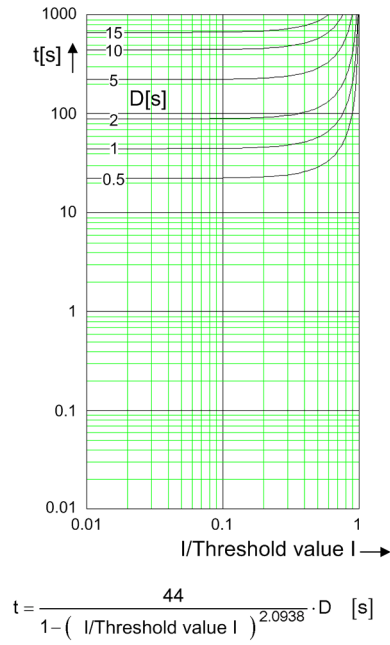

SHORT INVERSE

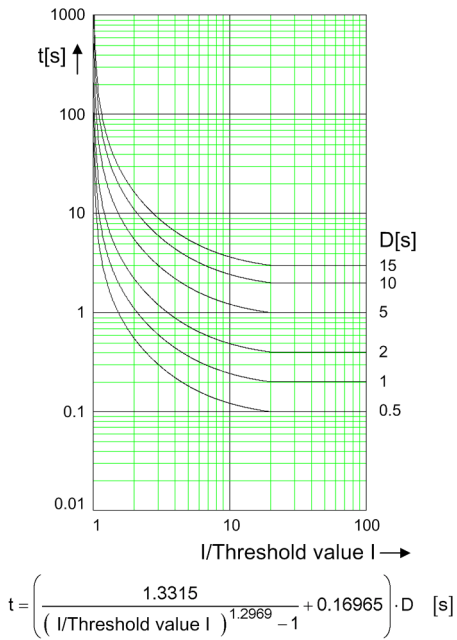

RESET SHORT INVERSE

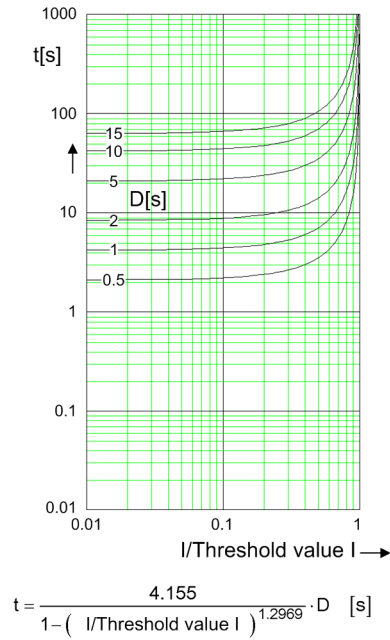

[dw_ocp_kat_2_en_US]

Figure 14-15 Operate Curves and Dropout-Time Characteristic Curves According to ANSI/IEEE

LONG INVERSE

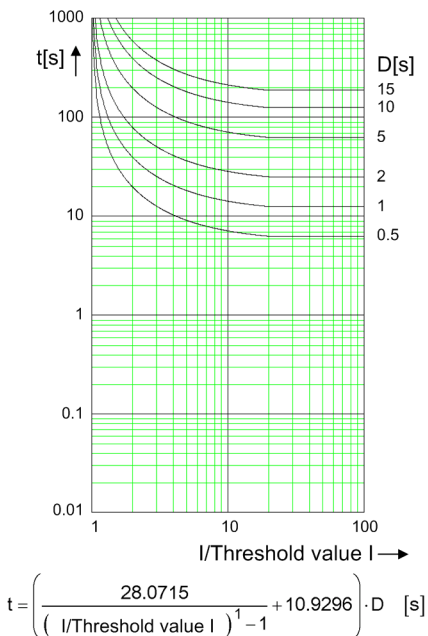

RESET LONG INVERSE

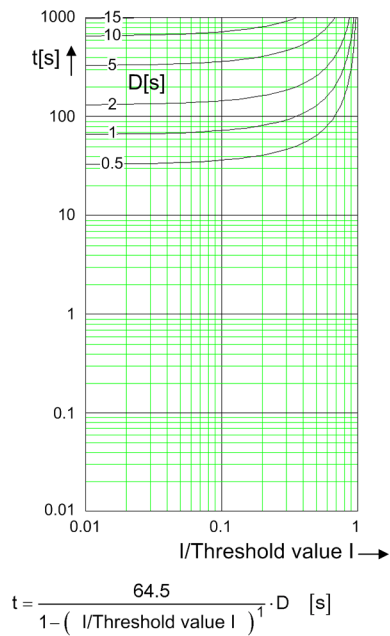

MODERATELY INVERSE

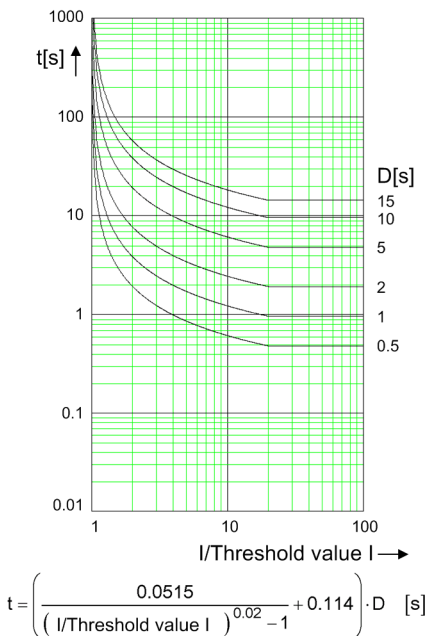

RESET MODERATELY INVERSE

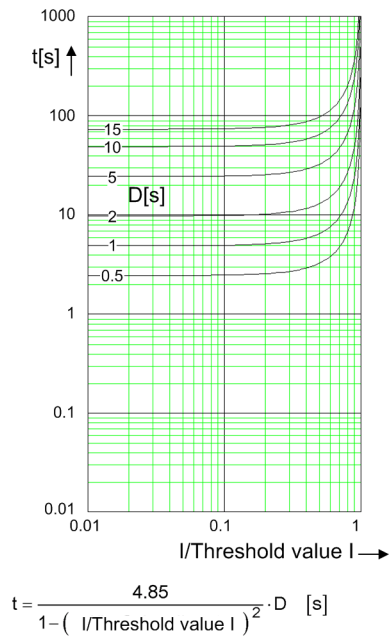

[dw_ocp_ka2_2_en_US]

Figure 14-16 Operate Curves and Dropout-Time Characteristic Curves According to ANSI/IEEE

VERY INVERSE

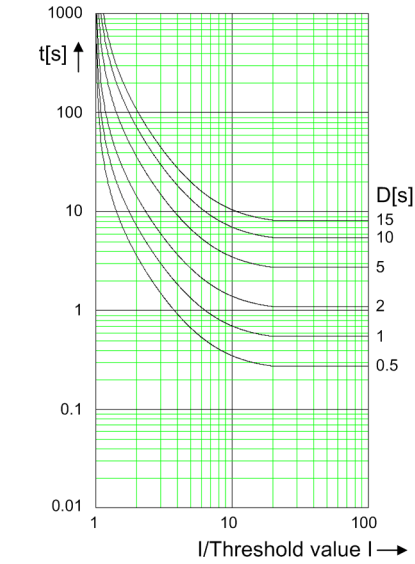

$$t = \left(\frac{19.61}{\left(\frac{I}{\text{Threshold value } I} \right)^2 - 1} + 0.491 \right) \cdot D \quad [\text{s}]$$

RESET VERY INVERSE

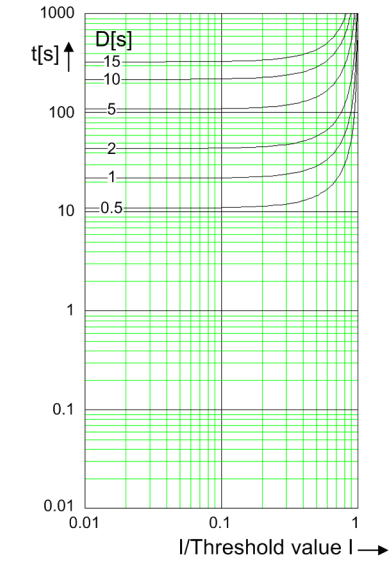

$$t = \frac{21.6}{1 - \left(\frac{I}{\text{Threshold value } I} \right)^2} \cdot D \quad [\text{s}]$$

EXTREMELY INVERSE

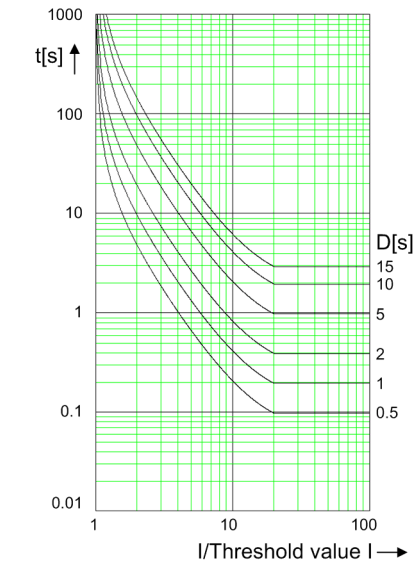

$$t = \left(\frac{28.2}{\left(\frac{I}{\text{Threshold value } I} \right)^2 - 1} + 0.1217 \right) \cdot D \quad [\text{s}]$$

RESET EXTREMELY INVERSE

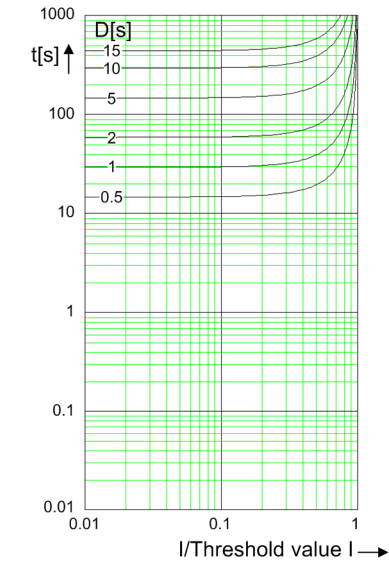

$$t = \frac{29.1}{1 - \left(\frac{I}{\text{Threshold value } I} \right)^2} \cdot D \quad [\text{s}]$$

[dw_ocp_ka3_2_en_US]

Figure 14-17 Operate Curves and Dropout-Time Characteristic Curves According to ANSI/IEEE

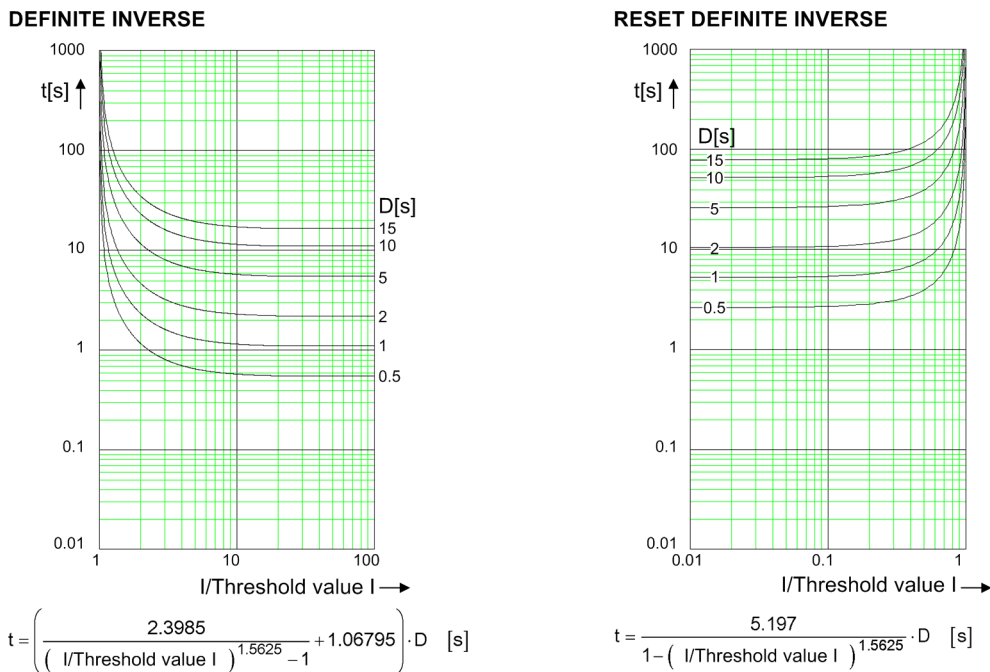

Note: IGnd threshold stands for ground fault instead of the I threshold.

[dw_ocp_ka4_2_en_US]

Figure 14-18 Operate Curves and Dropout-Time Characteristic Curves According to ANSI/IEEE



NOTE

In the preceding operate curves according to IEC and ANSI/IEEE, the inverse-time delays for **I/Threshold value I > 20** are identical to the inverse-time delay for **I/Threshold value I = 20**.

Frequency Operating Range

$0.9 \leq f/f_{\text{rated}} \leq 1.1$	According to specified tolerances
$10 \text{ Hz} \leq f < 0.9 f_{\text{rated}}$ $1.1 f_{\text{rated}} < f \leq 90 \text{ Hz}$	Slightly expanded tolerances
$f < 10 \text{ Hz}$ $f > 90 \text{ Hz}$	Active

Tolerances

Currents, method of measurement = fundamental component	1 % of the setting value or 5 mA ($I_{\text{rated}} = 1 \text{ A}$) or 25 mA ($I_{\text{rated}} = 5 \text{ A}$)
Currents, method of measurement = RMS value, no filter applied (33 % harmonics, in relation to fundamental component)	
Up to 30th harmonic	2 % of the setting value or 10 mA ($I_{\text{rated}} = 1 \text{ A}$) or 50 mA ($I_{\text{rated}} = 5 \text{ A}$)
Up to 50th harmonic, $f_{\text{rated}} = 50 \text{ Hz}$	4 % of the setting value or 20 mA ($I_{\text{rated}} = 1 \text{ A}$) or 100 mA ($I_{\text{rated}} = 5 \text{ A}$)
Up to 50th harmonic, $f_{\text{rated}} = 60 \text{ Hz}$	5 % of the setting value or 20 mA ($I_{\text{rated}} = 1 \text{ A}$) or 100 mA ($I_{\text{rated}} = 5 \text{ A}$)

Currents, method of measurement = RMS value with filter for the compensation of the amplitude attenuation due to the anti-aliasing filter (33 % harmonics, in relation to the fundamental component)	
Up to 30 harmonic	2 % of the setting value or 10 mA ($I_{rated} = 1 \text{ A}$) or 50 mA ($I_{rated} = 5 \text{ A}$)
Up to 50th harmonic, $f_{rated} = 50 \text{ Hz}$	3 % of the setting value or 20 mA ($I_{rated} = 1 \text{ A}$) or 100 mA ($I_{rated} = 5 \text{ A}$)
Up to 50th harmonic, $f_{rated} = 60 \text{ Hz}$	4 % of the setting value or 20 mA ($I_{rated} = 1 \text{ A}$) or 100 mA ($I_{rated} = 5 \text{ A}$)
Currents, method of measurement = RMS value with filter for the gain of harmonics (including compensation of the amplitude attenuation ¹¹⁹) (33 % harmonics, in relation to the fundamental component)	
Up to 30 harmonic	2.5 % of the setting value or 10 mA ($I_{rated} = 1 \text{ A}$) or 50 mA ($I_{rated} = 5 \text{ A}$) ¹²⁰
Up to 50th harmonic, $f_{rated} = 50 \text{ Hz}$	4 % of the setting value or 20 mA ($I_{rated} = 1 \text{ A}$) or 100 mA ($I_{rated} = 5 \text{ A}$) ¹²¹
Up to 50th harmonic, $f_{rated} = 60 \text{ Hz}$	5 % of the setting value or 20 mA ($I_{rated} = 1 \text{ A}$) or 100 mA ($I_{rated} = 5 \text{ A}$) ¹²¹
Operate time for $2 \leq I/I$ threshold value ≤ 20	5 % of the reference (calculated) value +2 % current tolerance or 30 ms
Dropout time for I/I threshold value ≤ 0.90	5 % of the reference (calculated) value +2 % current tolerance or 30 ms
Time delays	1 % of the setting value or 10 ms

Influencing Variables for Threshold Values

Transient excess pickup in method of measurement = fundamental component, for $\tau > 100 \text{ ms}$ (with complete unbalance)	< 5 %
---	-------

14.27.3 Stage with User-Defined Characteristic Curve

Setting Value for the Function Block Filter

h(0)	-100.000 to 100.000	Increments of 0.001
h(1)	-100.000 to 100.000	Increments of 0.001
h(2)	-100.000 to 100.000	Increments of 0.001
h(3)	-100.000 to 100.000	Increments of 0.001
h(4)	-100.000 to 100.000	Increments of 0.001

¹¹⁹ In case that the filter response exactly matches the user-defined gain factors

¹²⁰ In case that the user-defined gain factor is set below 3. The tolerance increases, if the gain factor is larger.

¹²¹ In case that the user-defined gain factor is set below 7. The tolerance increases, if the gain factor is larger.

Setting Values for Protection Stage

Method of measurement		Fundamental component RMS value	–
Threshold value	1 A @ 50 and 100 Irated	0.030 A to 40.000 A	Increments of 0.001 A
	5 A @ 50 and 100 Irated	0.15 A to 200.00 A	Increments of 0.01 A
	1 A @ 1.6 Irated	0.001 A to 1.600 A	Increments of 0.001 A
	5 A @ 1.6 Irated	0.005 A to 8.000 A	Increments of 0.001 A
Absolute pickup value	1 A @ 50 and 100 Irated	0.000 A to 40.000 A	Increments of 0.001 A
	5 A @ 50 and 100 Irated	0.00 A to 200.00 A	Increments of 0.01 A
	1 A @ 1.6 Irated	0.000 A to 1.600 A	Increments of 0.001 A
	5 A @ 1.6 Irated	0.000 A to 8.000 A	Increments of 0.001 A
Dropout		Disk emulation Instantaneous	–
Time multiplier		0.05 to 15.00	Increments of 0.01
Number of value pairs for the operate curve		2 to 30	Increments of 1
X values of the operate curve		1.00 p.u. to 20.00 p.u.	Increments of 0.01 p.u.
Y values of the operate curve		0.00 s to 999.00 s	Increments of 0.01 s
Number of value pairs for the dropout characteristic curve		2 to 30	Increments of 1
X values of the dropout characteristic curve		0.05 p.u. to 0.95 p.u.	Increments of 0.01 p.u.
Y values of the dropout characteristic curve		0.00 s to 999.00 s	Increments of 0.01 s
Additional time delay		0.00 s to 60.00 s	Increments of 0.01 s

Dropout

The greater dropout differential (= | **pickup value** – **dropout value** |) of the following 2 criteria applies:

Dropout	95 % of $1.1 \cdot \text{threshold value}$ or 95 % of the absolute pickup value
Minimum absolute dropout differential	
Protection-class current transformer	15 mA sec. ($I_{\text{rated}} = 1 \text{ A}$) or 75 mA sec. ($I_{\text{rated}} = 5 \text{ A}$)
Instrument current transformer	0.5 mA sec. ($I_{\text{rated}} = 1 \text{ A}$) or 2.5 mA sec. ($I_{\text{rated}} = 5 \text{ A}$)

Reset of the Integration Timer

Instantaneous	With dropout
Disk emulation	Approx. $< 0.90 \cdot \text{threshold value}$

Frequency Operating Range

$0.9 \leq f/f_{\text{rated}} \leq 1.1$	According to specified tolerances
$10 \text{ Hz} \leq f < 0.9 f_{\text{rated}}$ $1.1 f_{\text{rated}} < f \leq 90 \text{ Hz}$	Slightly expanded tolerances
$f < 10 \text{ Hz}$ $f > 90 \text{ Hz}$	Active

Tolerances

Currents, method of measurement = fundamental component	1 % of the setting value or 5 mA ($I_{rated} = 1 A$) or 25 mA ($I_{rated} = 5 A$)
Currents, method of measurement = RMS value, no filter applied (33 % harmonics, in relation to fundamental component)	
Up to 30th harmonic	2 % of the setting value or 10 mA ($I_{rated} = 1 A$) or 50 mA ($I_{rated} = 5 A$)
Up to 50th harmonic, $f_{rated} = 50 Hz$	4 % of the setting value or 20 mA ($I_{rated} = 1 A$) or 100 mA ($I_{rated} = 5 A$)
Up to 50th harmonic, $f_{rated} = 60 Hz$	5 % of the setting value or 20 mA ($I_{rated} = 1 A$) or 100 mA ($I_{rated} = 5 A$)
Currents, method of measurement = RMS value with filter for the compensation of the amplitude attenuation due to the anti-aliasing filter (33 % harmonics, in relation to the fundamental component)	
Up to 30 harmonic	2 % of the setting value or 10 mA ($I_{rated} = 1 A$) or 50 mA ($I_{rated} = 5 A$)
Up to 50th harmonic, $f_{rated} = 50 Hz$	3 % of the setting value or 20 mA ($I_{rated} = 1 A$) or 100 mA ($I_{rated} = 5 A$)
Up to 50th harmonic, $f_{rated} = 60 Hz$	4 % of the setting value or 20 mA ($I_{rated} = 1 A$) or 100 mA ($I_{rated} = 5 A$)
Currents, method of measurement = RMS value with filter for the gain of harmonics (including compensation of the amplitude attenuation ¹²²) (33 % harmonics, in relation to the fundamental component)	
Up to 30 harmonic	2.5 % of the setting value or 10 mA ($I_{rated} = 1 A$) or 50 mA ($I_{rated} = 5 A$) ¹²³
Up to 50th harmonic, $f_{rated} = 50 Hz$	4 % of the setting value or 20 mA ($I_{rated} = 1 A$) or 100 mA ($I_{rated} = 5 A$) ¹²⁴
Up to 50th harmonic, $f_{rated} = 60 Hz$	5 % of the setting value or 20 mA ($I_{rated} = 1 A$) or 100 mA ($I_{rated} = 5 A$) ¹²⁵
Operate time for $2 \leq I/I$ threshold value ≤ 20	5 % of the reference (calculated) value +2 % current tolerance or 30 ms
Dropout time for I/I threshold value ≤ 0.90	5 % of the reference (calculated) value +2 % current tolerance or 30 ms
Time delays	1 % of the setting value or 10 ms

Influencing Variables for Threshold Values

Transient excess pickup in method of measurement = fundamental component, for $\tau > 100 ms$ (with complete unbalance)	< 5 %
---	-------

¹²² In case that the filter response exactly matches the user-defined gain factors

¹²³ In case that the user-defined gain factor is set below 3. The tolerance increases, if the gain factor is larger.

¹²⁴ In case that the user-defined gain factor is set below 7. The tolerance increases, if the gain factor is larger.

¹²⁵ In case that the user-defined gain factor is set below 7. The tolerance increases, if the gain factor is larger.

Operate Curves and Dropout-Time Characteristic Curves According to IEC

Extension of the operate time during operation with transformer inrush-current detection	Approx. 10 ms
--	---------------

14.28 Current-Unbalance Protection for Capacitors, 1-Phase

Setting Values for the Function

Automatic compensation		Yes No	
Time between switch off and switch on		0.00 s to 60.00 s	Increments of 0.01 s
Normalization with I _c		Yes No	
Threshold of defective C-element	1 A @ 50 and 100 I _{rated}	0.030 A to 35.000 A	Increments of 0.001 A
	5 A @ 50 and 100 I _{rated}	0.15 A to 175.00 A	Increments of 0.01 A
	1 A @ 1.6 I _{rated}	0.001 A to 1.600 A	Increments of 0.001 A
	5 A @ 1.6 I _{rated}	0.005 A to 8.000 A	Increments of 0.001 A

Setting Values (Overcurrent-Protection Stage I>)

Current threshold I _{unbal.}	1 A @ 50 and 100 I _{rated}	0.030 A to 35.000 A	Increments of 0.001 A
	5 A @ 50 and 100 I _{rated}	0.150 A to 175.000 A	Increments of 0.01 A
	1 A @ 1.6 I _{rated}	0.001 A to 1.600 A	Increments of 0.001 A
	5 A @ 1.6 I _{rated}	0.005 A to 8.000 A	Increments of 0.005 A
Operate delay		0.00 s to 60.00 s	Increments of 0.01 s
Measured value			compensated non-compensated

Setting Values (Counter Stage)

Type of counting groups		segregated sum
Type of counting phases		segregated sum
Max. no. of def. elem. phs A	1 to 1000	Increments of 1
Max. no. of def. elem. phs B	1 to 1000	Increments of 1
Max. no. of def. elem. phs C	1 to 1000	Increments of 1
Max. no. of def. elem.	1 to 1000	Increments of 1
Operate delay	0.00 s to 10000.00 s	Increments of 0.01 s

Dropout

The greater dropout differential (= | pickup value - dropout value |) of the following 2 criteria applies:

Dropout differential derived from the parameter Dropout ratio	
If this parameter is not available, a dropout ratio of 95 % applies for overcurrent and of 105 % for undercurrent functionality.	
Minimum absolute dropout differential	
Protection-class current transformer	15 mA sec. (I _{rated} = 1 A) or 75 mA sec. (I _{rated} = 5 A)
Instrument current transformer	0.5 mA sec. (I _{rated} = 1 A) or 2.5 mA sec. (I _{rated} = 5 A)

Times

Operate time with time delay = 0 ms	Approx. 49 ms + OOT ¹²⁶ at 50 Hz Approx. 42 ms + OOT at 60 Hz
Dropout time	Approx. 32 ms + OOT at 50 Hz Approx. 27 ms + OOT at 60 Hz

Frequency Operating Range

$0.9 \leq f/f_{\text{rated}} \leq 1.1$	According to specified tolerances
$10 \text{ Hz} \leq f < 0.9 f_{\text{rated}}$ $1.1 f_{\text{rated}} < f \leq 90 \text{ Hz}$	Slightly expanded tolerances
$f < 10 \text{ Hz}$ $f > 90 \text{ Hz}$	Active

Tolerances

Currents $I_c, I_{\text{unbal.}}$ Protection-class current transformers	1 % of the setting value or 5 mA ($I_{\text{rated}} = 1 \text{ A}$) or 25 mA ($I_{\text{rated}} = 5 \text{ A}$)
Currents $I_{\text{unbal.}}$ Sensitive current transformer	1 % of the setting value or 0.1 mA ($I_{\text{rated}} = 1 \text{ A}$) or 0.5 mA ($I_{\text{rated}} = 5 \text{ A}$)
Time delays	1 % of the setting value or 10 ms

¹²⁶ OOT (Output Operating Time): additional delay of the output medium used, see [14.1.4 Relay Outputs](#)

14.29 Overvoltage Protection with 3-Phase Voltage

Setting Values for the Function

Stabilization counter	0 to 10	Increments of 1
-----------------------	---------	-----------------

Setting Values for Stage Type Definite-Time Overvoltage Protection

Measured value	Phase-to-phase Phase-to-ground	
Method of measurement	Fundamental component RMS value	
Pickup mode	1 out of 3 3 out of 3	
Pickup value ¹²⁷	0.300 V to 340.000 V	Increments of 0.001 V
Time delay	0.00 s to 300.00 s	Increments of 0.01 s
Dropout ratio	0.90 to 0.99	Increments of 0.01

Setting Values for Stage Type Inverse-Time Overvoltage Protection

Measured value	Phase-to-phase Phase-to-ground	
Method of measurement	Fundamental component RMS value	
Pickup mode	1 out of 3 3 out of 3	
Pickup value	0.300 V to 340.000 V	Increments of 0.001 V
Pickup factor	1.00 to 1.20	Increments of 0.01
Characteristic constant k	0.00 to 300.00	Increments of 0.01
Characteristic constant α	0.010 to 5.000	Increments of 0.001
Characteristic constant c	0.000 to 5.000	Increments of 0.001
Time multiplier	0.05 to 15.00	Increments of 0.01
Additional time delay	0.00 s to 60.00 s	Increments of 0.01 s
Reset time	0.00 s to 60.00 s	Increments of 0.01 s

Operate Curve for Stage Type Inverse-Time Overvoltage Protection

$$T_{op} = T_{inv} + T_{add}$$

Where

T_{op} Operate delay

T_{inv} Inverse-time delay

T_{add} Additional time delay (parameter **Additional time delay**)

$$T_{inv} = T_p \left(\frac{k}{\left(\frac{V}{V_{thresh}}\right)^\alpha - 1} + c \right) [s]$$

¹²⁷ If you have selected the **method of measurement = RMS value**, do not set the threshold value under 10 V.

Where

T_{inv}	Inverse-time delay
T_p	Time multiplier (parameter Time dial)
V	Measured voltage
V_{thresh}	Threshold value (parameter Threshold)
k	Curve constant k (parameter Charact. constant k)
α	Curve constant α (parameter Charact. constant α)
c	Curve constant c (parameter Charact. constant c)

Dropout

The greater dropout differential (= | pickup value - dropout value |) of the following 2 criteria applies:

Dropout differential derived from the parameter Dropout ratio	
If this parameter is not available, a dropout ratio of 95 % applies for the overvoltage and of 105 % for the undervoltage functionality.	
Minimum absolute dropout differential	150 mV sec.

Times

Operate time with time delay = 0 ms, typical	Approx. 25 ms + OOT ¹²⁸ at 50 Hz Approx. 22 ms + OOT at 60 Hz
Operate time with time delay = 0 ms, maximum	Approx. 30 ms + OOT at 50 Hz Approx. 26 ms + OOT at 60 Hz
Dropout time, typical	Approx. 25 ms + OOT
Dropout time, maximum	Approx. 30 ms + OOT

Frequency Operating Range

$0.9 \leq f/f_{rated} \leq 1.1$	According to specified tolerances
$10 \text{ Hz} \leq f < 0.9 f_{rated}$ $1.1 f_{rated} < f \leq 90 \text{ Hz}$	Slightly expanded tolerances
$f < 10 \text{ Hz}$ $f > 90 \text{ Hz}$	Active

Tolerances for Stage Type Definite-Time Overvoltage Protection

Voltages	0.5 % of the setting value or 0.05 V
Time delays	1 % of the setting value or 10 ms

Tolerances for Stage Type Inverse-Time Overvoltage Protection

Voltages	0.5 % of the setting value or 0.05 V
Operate time for $1.2 \leq V/V \text{ threshold value} \leq 20$	5 % of the setting value or 30 ms
Reset time delay	1 % of the setting value or 10 ms

¹²⁸ OOT (Output Operating Time): additional delay of the output medium used, see chapter [14.1.4 Relay Outputs](#)

14.30 Overvoltage Protection with Zero-Sequence Voltage/Residual Voltage

Setting Values for Stage Type Definite-Time Overvoltage Protection

Method of measurement	fundamental comp. fund. comp. long filter RMS value	
Blk. by meas.-volt. failure	no yes	
Detection of faulty phase	no yes	
Threshold ¹²⁹	0.300 V to 200.000 V	Increments of 0.001 V
Operate delay	0.00 s to 60.00 s	Increments of 0.01 s
Pickup delay	0.00 s to 320.00 s	Increments of 0.01 s
Dropout ratio	0.90 to 0.99	Increments of 0.01
V < faulty ph-to-gnd volt.	0.300 V to 200.000 V	Increments of 0.001 V
V > healthy ph-to-gnd volt.	0.300 V to 200.000 V	Increments of 0.001 V

Setting Values for Stage Type Inverse-Time Overvoltage Protection

Method of measurement	fundamental comp. fund. comp. long filter RMS value	
Blk. by meas.-volt. failure	no yes	
Detection of faulty phase	no yes	
Threshold ¹²⁹	0.300 V to 200.000 V	Increments of 0.001 V
Pickup factor	1.00 to 1.20	Increments of 0.01
Charact. constant k	0.00 to 300.00	Increments of 0.01
Charact. constant α	0.010 to 5.000	Increments of 0.001
Charact. constant c	0.000 to 5.000	Increments of 0.001
Time dial	0.05 to 15.00	Increments of 0.01
Additional time delay	0.00 s to 60.00 s	Increments of 0.01 s
Reset time	0.00 s to 60.00 s	Increments of 0.01 s
V < faulty ph-to-gnd volt.	0.300 V to 200.000 V	Increments of 0.001 V
V > healthy ph-to-gnd volt.	0.300 V to 200.000 V	Increments of 0.001 V

Operate Curve for Stage Type Inverse-Time Overvoltage Protection

$$T_{op} = T_{inv} + T_{add}$$

Where

T_{op} Operate delay

T_{inv} Inverse-time delay

T_{add} Additional time delay (parameter **Additional time delay**)

¹²⁹ If you have selected the **Method of measurement = RMS value**, do not set the threshold value under 10 V.

$$T_{inv} = T_p \left(\frac{k}{\left(\frac{V}{V_{thresh}} \right)^\alpha - 1} + c \right) [s]$$

Where

- T_{inv} Inverse-time delay
- T_p Time multiplier (parameter **Time dial**)
- V Zero-sequence voltage
- V_{thresh} Threshold value (parameter **Threshold**)
- k Curve constant k (parameter **Charact. constant k**)
- α Curve constant α (parameter **Charact. constant α**)
- c Curve constant c (parameter **Charact. constant c**)

Dropout

The greater dropout differential (= | **pickup value** - **dropout value** |) of the following 2 criteria applies:

Dropout differential derived from the parameter Dropout ratio	
If this parameter is not available, a dropout ratio of 95 % applies for the overvoltage and of 105 % for the undervoltage functionality.	
Minimum absolute dropout differential	150 mV sec.

Times

Operate time with time delay = 0 ms	
Standard filter, true RMS value, typical	Approx. 25 ms + OOT ¹³⁰ at 50 Hz Approx. 22 ms + OOT at 60 Hz
Standard filter, true RMS value, maximum	Approx. 30 ms + OOT at 50 Hz Approx. 26 ms + OOT at 60 Hz
2 cycle filters, typical	Approx. 40 ms + OOT at 50 Hz Approx. 35 ms + OOT at 60 Hz
2 cycle filters, maximum	Approx. 45 ms + OOT at 50 Hz Approx. 40 ms + OOT at 60 Hz
Dropout time	
Standard filter, true RMS value, typical	Approx. 20 ms + OOT at 50 Hz Approx. 17 ms + OOT at 60 Hz
Standard filter, true RMS value, maximum	Approx. 25 ms + OOT at 50 Hz Approx. 20 ms + OOT at 60 Hz
2 cycle filters, typical	Approx. 30 ms + OOT at 50 Hz Approx. 25 ms + OOT at 60 Hz
2 cycle filters, maximum	Approx. 35 ms + OOT at 50 Hz Approx. 30 ms + OOT at 60 Hz

¹³⁰ OOT (Output Operating Time): additional delay of the output medium used, see [14.1.4 Relay Outputs](#)

Frequency Operating Range

$0.9 \leq f/f_{\text{rated}} \leq 1.1$	According to specified tolerances
$10 \text{ Hz} \leq f < 0.9 f_{\text{rated}}$ $1.1 f_{\text{rated}} < f \leq 90 \text{ Hz}$	Slightly expanded tolerances
$f < 10 \text{ Hz}$ $f > 90 \text{ Hz}$	Active

Tolerances for Stage Type Definite-Time Overvoltage Protection

Voltages	0.5 % of the setting value or 0.05 V
Time delays	1 % of the setting value or 10 ms

Tolerances for Stage Type Inverse-Time Overvoltage Protection

Voltages	0.5 % of the setting value or 0.05 V
Operate time for $1.2 \leq V/V \text{ threshold value} \leq 20$	5 % of the setting value or 30 ms
Reset time delay	1 % of the setting value or 10 ms

14.31 Overvoltage Protection with Positive-Sequence Voltage

Setting Values

Pickup value	0.300 V to 200.000 V	Increments of 0.001 V
Time delay	0.00 s to 60.00 s	Increments of 0.01 s
Dropout ratio	0.90 to 0.99	Increments of 0.01

Dropout

The greater dropout differential (= | **pickup value** - **dropout value** |) of the following 2 criteria applies:

Dropout differential derived from the parameter Dropout ratio	
If this parameter is not available, a dropout ratio of 95 % applies for the overvoltage and of 105 % for the undervoltage functionality.	
Minimum absolute dropout differential	150 mV sec.

Times

Operate time with time delay = 0 ms, typical	Approx. 25 ms + OOT ¹³¹ at 50 Hz Approx. 22 ms + OOT at 60 Hz
Operate time with time delay = 0 ms, maximum	Approx. 30 ms + OOT at 50 Hz Approx. 26 ms + OOT at 60 Hz
Dropout time, typical	Approx. 25 ms + OOT
Dropout time, maximum	Approx. 30 ms + OOT

Frequency Operating Range

$0.9 \leq f/f_{\text{rated}} \leq 1.1$	According to specified tolerances
$10 \text{ Hz} \leq f < 0.9 f_{\text{rated}}$ $1.1 f_{\text{rated}} < f \leq 90 \text{ Hz}$	Slightly expanded tolerances
$f < 10 \text{ Hz}$ $f > 90 \text{ Hz}$	Active

Tolerances

Voltages	0.5 % of the setting value or 0.05 V
Time delays	1 % of the setting value or 10 ms

¹³¹ OOT (Output Operating Time): additional delay of the output medium used, see chapter [14.1.4 Relay Outputs](#)

14.32 Overvoltage Protection with Negative-Sequence Voltage

Setting Values for the Function

Measuring window	1 cycle to 10 cycles	Increments of 1 cycle
------------------	----------------------	-----------------------

Setting Values

Pickup value of V2	0.300 V to 200.000 V	Increments of 0.001 V
Operate delay	0.00 s to 60.00 s	Increments of 0.01 s
Dropout ratio	0.90 to 0.99	Increments of 0.01

Dropout

The greater dropout differential (= | **pickup value** - **dropout value** |) of the following 2 criteria applies:

Dropout differential derived from the parameter Dropout ratio	
If this parameter is not available, a dropout ratio of 95 % applies for the overvoltage and of 105 % for the undervoltage functionality.	
Minimum absolute dropout differential	150 mV sec.

Times

Pickup times	55 ms to 210 ms + OOT ¹³² (depends on the measuring-window length) at 50 Hz 48 ms to 185 ms + OOT (depends on the measuring-window length) at 60 Hz
Dropout time	20 ms to 70 ms + OOT (depends on the measuring-window length)

Frequency Operating Range

$0.9 \leq f/f_{\text{rated}} \leq 1.1$	According to specified tolerances
$10 \text{ Hz} \leq f < 0.9 f_{\text{rated}}$ $1.1 f_{\text{rated}} < f \leq 90 \text{ Hz}$	Slightly expanded tolerances
$f < 10 \text{ Hz}$ $f > 90 \text{ Hz}$	Inactive

Tolerances

Voltages	0.50 % of the setting value or 0.050 V
Time delays	1.00 % of the setting value or 10 ms

¹³² OOT (Output Operating Time): additional delay of the output medium used, for example 5 ms with fast relays

14.33 Overvoltage Protection with Any Voltage

Setting Values

Measured value ¹³³	Measured phase-to-ground voltage V_A Measured phase-to-ground voltage V_B Measured phase-to-ground voltage V_C Measured phase-to-phase voltage V_{AB} Measured phase-to-phase voltage V_{BC} Measured phase-to-phase voltage V_{CA} Measured phase-to-phase voltage V_{AB} Measured phase-to-phase voltage V_{BC} Measured phase-to-phase voltage V_{CA} Calculated voltage V_0	
Method of measurement	Fundamental component RMS value	
Pickup value ¹³⁴	0.300 V to 340.000 V	Increments of 0.001 V
Time delay	0.00 s to 60.00 s	Increments of 0.01 s
Dropout ratio	0.90 to 0.99	Increments of 0.01

Dropout

The greater dropout differential (= | **pickup value** - **dropout value** |) of the following 2 criteria applies:

Dropout differential derived from the parameter Dropout ratio	
If this parameter is not available, a dropout ratio of 95 % applies for the overvoltage and of 105 % for the undervoltage functionality.	
Minimum absolute dropout differential	150 mV sec.

Times

Operate time with time delay = 0 ms, typical	Approx. 25 ms + OOT ¹³⁵ at 50 Hz Approx. 22 ms + OOT at 60 Hz
Operate time with time delay = 0 ms, maximum	Approx. 30 ms + OOT at 50 Hz Approx. 26 ms + OOT at 60 Hz
Dropout time, typical	Approx. 25 ms + OOT
Dropout time, maximum	Approx. 30 ms + OOT

Frequency Operating Range

$0.9 \leq f/f_{rated} \leq 1.1$	According to specified tolerances
$10 \text{ Hz} \leq f < 0.9 f_{rated}$ $1.1 f_{rated} < f \leq 90 \text{ Hz}$	Slightly expanded tolerances
$f < 10 \text{ Hz}$ $f > 90 \text{ Hz}$	Active

¹³³ If the function **Overvoltage protection with any voltage** is used in a 1-phase function group, the measured-value parameter is not visible.

¹³⁴ If you have selected the **method of measurement = RMS value**, do not set the threshold value under 10 V.

¹³⁵ OOT (Output Operating Time): additional delay of the output medium used, see chapter [14.1.4 Relay Outputs](#)

Tolerances

Voltages	0.5 % of the setting value or 0.05 V
Time delays	1 % of the setting value or 10 ms

14.34 Peak Overvoltage Protection for Capacitors

Setting Values

Threshold value	0.80 to 3.00 p.u.	Increments of 0.01
Inverse-time stage	0.80 to 3.00 p.u.	Increments of 0.01
Definite-time stage	0.80 to 10.00 p.u.	Increments of 0.01
User-defined characteristic curve	0.80 to 3.00 p.u.	Increments of 0.01
Tripping delay	0.01 s to 3600.00 s	Increments of 0.01 s
Dropout delay	0.00 s to 3600.00 s	Increments of 1.00 s
Down integration time	1 min to 1500 min	Increments of 1 min
Time multiplier	0.05 to 15.00	Increments of 0.01
Number of value pairs for the operate curve	30	Increments of 1
X values of the operate curve	1.00 p.u. to 4.00 p.u.	Increments of 0.01 p.u.
Y values of the operate curve	0.00 s to 9999.99 s	Increments of 0.01 s
Number of value pairs for the dropout characteristic curve	30	Increments of 1
X values of the dropout characteristic curve	0.01 p.u. to 0.95 p.u.	Increments of 0.01 p.u.
Y values of the dropout characteristic curve	0.00 s to 9999.99 s	Increments of 0.01 s

Inverse-Time Characteristic Curve (IEC/IEEE)

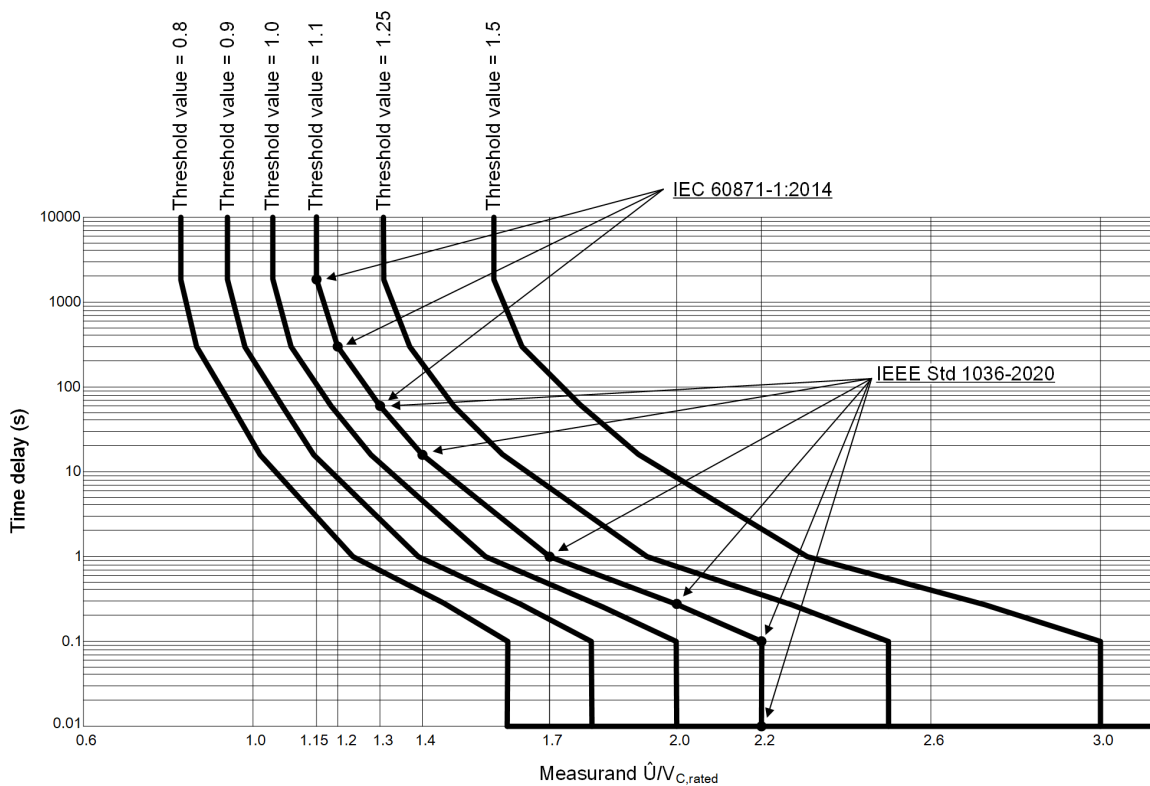

[dw_pecinv, 3, en_US]

Figure 14-19 Inverse-Time Characteristic Curve

The points on the characteristic curve defined in the standards result from a threshold setting of 1.1. These single points are connected via semi-logarithmic line segments.

Table 14-7 Peak Overvoltage Inverse-Time Characteristic (for Threshold Setting 1.1)

Measurand $\hat{U}/U_{c,rated}$	Time Delay	Curve Point According to
<1.15	∞ (no pickup)	Siemens definition
1.15	1800.00 s	IEC 60871-1:2014
1.2	300.00 s	IEC 60871-1:2014
1.3	60.00 s	IEC 60871-1:2014, IEEE Std 1036-2020
1.4	15.00 s	IEEE Std 1036-2020
1.7	1.00 s	IEEE Std 1036-2020
2	0.25 s	IEEE Std 1036-2020
2.2	0.1 s	IEEE Std 1036-2020
>2.2	0.01 s	IEEE Std 1036-2020

Times

Pickup time	Approx. 35 ms + OOT ¹³⁶ at 50 Hz Approx. 25 ms + OOT at 60 Hz
Dropout Time	Depending on settings

Frequency Operating Range

$f_{rated} - 3 \text{ Hz} \leq f \leq f_{rated} + 3 \text{ Hz}$	According to specified tolerances
$f < f_{rated} - 3 \text{ Hz}$ $f > f_{rated} + 3 \text{ Hz}$	Function blocked

Tolerances

Peak overvoltage (33 % harmonics, with reference to fundamental component)	
Up to 30th harmonic	1 % of the setting value or 0.005 p.u. ($f_{rated} \pm 3 \text{ Hz}$)
Up to 50th harmonic, $f_{rated} = 50 \text{ Hz}$	3 % of the setting value or 0.02 p.u. ($f_{rated} \pm 3 \text{ Hz}$)
Up to 50th harmonic, $f_{rated} = 60 \text{ Hz}$	4 % of the setting value or 0.02 p.u. ($f_{rated} \pm 3 \text{ Hz}$)
Time delays	
Measured value of definite-time stage	1 % of the setting value or 10 ms
Measured value of inverse-time stage and stage with user-defined characteristic curve	5 % of the setting value + 1 % of the measured value or 30 ms
Down integration time	5 % of the setting value or 30 ms

¹³⁶ OOT (Output Operating Time): additional delay of the output medium used, for example 5 ms with fast relays

14.35 Overvoltage Protection with Negative-Sequence Voltage/Positive-Sequence Voltage

Setting Values for the Function

Measuring window	1 cycle to 10 cycles	Increments of 1 cycle
Minimum voltage V1	0.300 V to 60.000 V	Increments of 0.001 V

Setting Values for Stage Types

Pickup value of V2/V1	0.50 % to 100.00 %	Increments of 0.01 %
Operate delay	0.00 s to 60.00 s	Increments of 0.01 s
Dropout ratio	0.90 to 0.99	Increments of 0.01

Dropout

The greater dropout differential (= | pickup value - dropout value |) of the following 2 criteria applies:

Dropout differential derived from the parameter Dropout ratio	
If this parameter is not available, a dropout ratio of 95 % applies for the overvoltage and of 105 % for the undervoltage functionality.	
Minimum absolute dropout differential	150 mV sec.

Times

Pickup times	55 ms to 210 ms + OOT ¹³⁷ (depends on the measuring-window length) at 50 Hz 48 ms to 190 ms + OOT (depends on the measuring-window length) at 60 Hz
Dropout times	22 ms to 55 ms + OOT (depends on the measuring-window length) at 50 Hz 18 ms to 45 ms + OOT (depends on the measuring-window length) at 60 Hz

Frequency Operating Range

$0.9 \leq f/f_{\text{rated}} \leq 1.1$	According to specified tolerances
$10 \text{ Hz} \leq f < 0.9 f_{\text{rated}}$ $1.1 f_{\text{rated}} < f \leq 90 \text{ Hz}$	Slightly expanded tolerances
$f < 10 \text{ Hz}$ $f > 90 \text{ Hz}$	Inactive

Tolerances

Voltages	0.50 % of the setting value or 0.050 V
Time delays	1.00 % of the setting value or 10 ms

¹³⁷ OOT (Output Operating Time): additional delay of the output medium used, for example 5 ms with fast relays

14.36 Undervoltage Protection with 3-Phase Voltage

Setting Values for the Function

Stabilization counter	0 to 10	Increments of 1
-----------------------	---------	-----------------

Setting Values for Stage Type Definite-Time Undervoltage Protection

Measured value	Phase-to-phase Phase-to-ground		
Method of measurement	Fundamental component RMS value		
Current-flow criterion	On Off		
Threshold value I>	1 A @ 50 and 100 Irated	0.030 A to 10.000 A	Increments of 0.001 A
	5 A @ 50 and 100 Irated	0.15 A to 50.00 A	Increments of 0.01 A
	1 A @ 1.6 Irated	0.001 A to 1.600 A	Increments of 0.001 A
	5 A @ 1.6 Irated	0.005 A to 8.000 A	Increments of 0.001 A
Threshold value ¹³⁸	0.300 V to 175.000 V	Increments of 0.001 V	
Time delay	0.00 s to 300.00 s	Increments of 0.01 s	
Dropout ratio	1.01 to 1.20	Increments of 0.01	

Setting Values for Stage Type Inverse-Time Undervoltage Protection

Measured value	Phase-to-phase Phase-to-ground		
Method of measurement	Fundamental component RMS value		
Current-flow criterion	On Off		
Threshold value I>	1 A @ 50 and 100 Irated	0.030 A to 10.000 A	Increments of 0.001 A
	5 A @ 50 and 100 Irated	0.15 A to 50.00 A	Increments of 0.01 A
	1 A @ 1.6 Irated	0.001 A to 1.600 A	Increments of 0.001 A
	5 A @ 1.6 Irated	0.005 A to 8.000 A	Increments of 0.001 A
Threshold	0.300 V to 175.000 V	Increments of 0.001 V	
Pickup factor	0.80 to 1.00	Increments of 0.01	
Characteristic constant k	0.00 to 300.00	Increments of 0.01	
Characteristic constant α	0.010 to 5.000	Increments of 0.001	
Characteristic constant c	0.000 to 5.000	Increments of 0.001	
Time multiplier	0.05 to 15.00	Increments of 0.01	
Additional time delay	0.00 s to 60.00 s	Increments of 0.01 s	
Reset time	0.00 s to 60.00 s	Increments of 0.01 s	

Operate Curve

$$T_{op} = T_{inv} + T_{add}$$

Where:

T_{op} Operate delay

¹³⁸ If you have selected the **Method of measurement = RMS value**, do not set the threshold value under 10 V.

T_{Inv} Inverse-time delay
 T_{add} Additional time delay (parameter **Additional time delay**)

$$T_{Inv} = T_p \left(\frac{k}{1 - \left(\frac{V}{V_{Thresh}} \right)^\alpha} + c \right) [s]$$

[fo_uvp_3ph_inverse, 2, en_US]

Where

T_{Inv} Inverse-time delay
 T_p Time multiplier (parameter **Time dial**)
 V Measured undervoltage
 V_{Thresh} Threshold value (parameter **Threshold**)
 k Curve constant k (parameter **Charact. constant k**)
 α Curve constant α (parameter **Charact. constant α**)
 c Curve constant c (parameter **Charact. constant c**)

Dropout

The greater dropout differential (= | **pickup value** - **dropout value** |) of the following 2 criteria applies:

Dropout differential derived from the parameter Dropout ratio	
If this parameter is not available, a dropout ratio of 95 % applies for the overvoltage and of 105 % for the undervoltage functionality.	
Minimum absolute dropout differential	150 mV sec.

Times

Operate time with time delay = 0 ms, typical	Approx. 25 ms + OOT ¹³⁹ at 50 Hz Approx. 22 ms + OOT at 60 Hz
Operate time with time delay = 0 ms, maximum	Approx. 30 ms + OOT at 50 Hz Approx. 26 ms + OOT at 60 Hz
Dropout time, typical	Approx. 25 ms + OOT
Dropout time, maximum	Approx. 30 ms + OOT

Frequency Operating Range

$0.9 \leq f/f_{rated} \leq 1.1$	According to specified tolerances
$10 \text{ Hz} \leq f < 0.9 f_{rated}$ $1.1 f_{rated} < f \leq 90 \text{ Hz}$	Slightly expanded tolerances
$f < 10 \text{ Hz}$ $f > 90 \text{ Hz}$	Inactive, maintained; Dropout of the pickup induced by blocking or by increasing the measurand beyond the dropout threshold

¹³⁹ OOT (Output Operating Time): additional delay of the output medium used, see chapter [14.1.4 Relay Outputs](#)

Tolerances for Stage Type Definite-Time Undervoltage Protection

Voltages	0.5 % of the setting value or 0.05 V
Currents	1 % of the setting value or 5 mA ($I_{\text{rated}} = 1 \text{ A}$) or 25 mA ($I_{\text{rated}} = 5 \text{ A}$), valid for protection-class current transformers
	1 % of the setting value or 0.1 mA ($I_{\text{rated}} = 1 \text{ A}$) or 0.5 mA ($I_{\text{rated}} = 5 \text{ A}$), valid for instrument transformers
Time delays	1 % of the setting value or 10 ms

Tolerances for Stage Type Inverse-Time Undervoltage Protection

Voltages	0.5 % of the setting value or 0.05 V
Currents	1 % of the setting value or 5 mA ($I_{\text{rated}} = 1 \text{ A}$) or 25 mA ($I_{\text{rated}} = 5 \text{ A}$), valid for protection-class current transformers
	1 % of the setting value or 0.1 mA ($I_{\text{rated}} = 1 \text{ A}$) or 0.5 mA ($I_{\text{rated}} = 5 \text{ A}$), valid for instrument transformers
Operate time for $0 < V/V_{\text{Thresh}} < 0.9$	5 % of the setting value or 30 ms
Reset time delay	1 % of the setting value or 10 ms

14.37 Undervoltage Protection with Positive-Sequence Voltage

Setting Values

Threshold value	0.300 V to 200.000 V	Increments of 0.001 V
Time delay	0.00 s to 60.00 s	Increments of 0.01 s
Dropout ratio	1.01 to 1.20	Increments of 0.01
Current-flow criterion	On Off	
Threshold value $I >$	$I_{\text{rated}} = 1 \text{ A}$	0.030 A to 10.000 A Increments of 0.001 A
	$I_{\text{rated}} = 5 \text{ A}$	0.15 A to 50.00 A Increments of 0.01 A

Dropout

The greater dropout differential (= | **pickup value** - **dropout value** |) of the following 2 criteria applies:

Dropout differential derived from the parameter Dropout ratio	
If this parameter is not available, a dropout ratio of 95 % applies for the overvoltage and of 105 % for the undervoltage functionality.	
Minimum absolute dropout differential	150 mV sec.

Times

Operate time with time delay = 0 ms, typical	Approx. 25 ms + OOT ¹⁴⁰ at 50 Hz Approx. 22 ms + OOT at 60 Hz
Operate time with time delay = 0 ms, maximum	Approx. 30 ms + OOT at 50 Hz Approx. 26 ms + OOT at 60 Hz
Dropout time, typical	Approx. 25 ms + OOT
Dropout time, maximum	Approx. 30 ms + OOT

Frequency Operating Range

$0.9 \leq f/f_{\text{rated}} \leq 1.1$	According to specified tolerances
$10 \text{ Hz} \leq f < 0.9 f_{\text{rated}}$	Slightly expanded tolerances
$1.1 f_{\text{rated}} < f \leq 90 \text{ Hz}$	
$f < 10 \text{ Hz}$ $f > 90 \text{ Hz}$	Inactive, maintained; Dropout of the pickup induced by blocking or by increasing the measurand beyond the dropout threshold

¹⁴⁰ OOT (Output Operating Time): additional delay of the output medium used, see chapter [14.1.4 Relay Outputs](#)

Tolerances

Voltages	0.5 % of the setting value or 0.05 V
Currents	1 % of the setting value or 5 mA ($I_{\text{rated}} = 1 \text{ A}$) or 25 mA ($I_{\text{rated}} = 5 \text{ A}$), valid for protection-class current transformers
	1 % of the setting value or 0.1 mA ($I_{\text{rated}} = 1 \text{ A}$) or 0.5 mA ($I_{\text{rated}} = 5 \text{ A}$), valid for instrument transformers
Time delays	1 % of the setting value or 10 ms

14.38 Undervoltage Protection with Any Voltage

Setting Values

Measured value	Measured phase-to-ground voltage V_A Measured phase-to-ground voltage V_B Measured phase-to-ground voltage V_C Measured phase-to-phase voltage V_{AB} Measured phase-to-phase voltage V_{BC} Measured phase-to-phase voltage V_{CA} Calculated phase-to-phase voltage V_{AB} Calculated phase-to-phase voltage V_{BC} Calculated phase-to-phase voltage V_{CA} Calculated voltage V_0	
Method of measurement	Fundamental component RMS value	
Threshold value ¹⁴¹	0.300 V to 340.000 V	Increments of 0.001 V
Time delay	0.00 s to 60.00 s	Increments of 0.01 s
Dropout ratio	1.01 to 1.20	Increments of 0.01

Dropout

The greater dropout differential (= | **pickup value** - **dropout value** |) of the following 2 criteria applies:

Dropout differential derived from the parameter Dropout ratio	
If this parameter is not available, a dropout ratio of 95 % applies for the overvoltage and of 105 % for the undervoltage functionality.	
Minimum absolute dropout differential	150 mV sec.

Times

Operate time with time delay = 0 ms, typical	Approx. 25 ms + OOT ¹⁴² at 50 Hz Approx. 22 ms + OOT at 60 Hz
Operate time with time delay = 0 ms, maximum	Approx. 30 ms + OOT at 50 Hz Approx. 26 ms + OOT at 60 Hz
Dropout time, typical	Approx. 25 ms + OOT
Dropout time, maximum	Approx. 30 ms + OOT

Frequency Operating Range

$0.9 \leq f/f_{rated} \leq 1.1$	According to specified tolerances
$10 \text{ Hz} \leq f < 0.9 f_{rated}$ $1.1 f_{rated} < f \leq 90 \text{ Hz}$	Slightly expanded tolerances
$f < 10 \text{ Hz}$ $f > 90 \text{ Hz}$	Inactive, maintained; Dropout of the pickup induced by blocking or by increasing the measurand beyond the dropout threshold

¹⁴¹ If you have selected the **method of measurement = RMS value**, do not set the threshold value under 10 V.

¹⁴² OOT (Output Operating Time): additional delay of the output medium used, see chapter [14.1.4 Relay Outputs](#)

Tolerances

Voltages	0.5 % of the setting value or 0.05 V
Time delays	1 % of the setting value or 10 ms

14.39 Rate-of-Voltage-Change Protection

Setting Value for the Function

Measuring window	2 periods to 50 periods	Increments of 1 period
------------------	-------------------------	------------------------

Setting Values for Stage Types

dV/second	0.500 V to 200.000 V	Increments of 0.001 V
Dropout delay	0.00 s to 60.00 s	Increments of 0.01 s
Operate delay	0.00 s to 60.00 s	Increments of 0.01 s

Dropout

The larger dropout differential (= pickup value - dropout threshold) of the following 2 criteria is used:	
Dropout differential derived from Dropout ratio	90 % for the dV/second parameter
Minimum absolute dropout differential	0.15 V per second

Times

Pickup time	<ul style="list-style-type: none"> At 50 Hz: Pickup time = Measuring window + 120 ms + OOT¹⁴³ Max. 220 ms + OOT with the default measuring window of 5 periods At 60 Hz: Pickup time = Measuring window + 100 ms + OOT Max. 183.3 ms + OOT with the default measuring window of 5 periods
Dropout time	<ul style="list-style-type: none"> At 50 Hz: Dropout time = Measuring window + 120 ms + OOT Max. 220 ms + OOT with the default measuring window of 5 periods At 60 Hz: Dropout time = Measuring window + 100 ms + OOT Max. 183.3 ms + OOT with the default measuring window of 5 periods

Frequency Operating Range

$0.9 \leq f/f_{rated} \leq 1.1$	According to specified tolerances
$10 \text{ Hz} \leq f < 0.9 f_{rated}$ $1.1 f_{rated} < f \leq 90 \text{ Hz}$	Slightly expanded tolerances
$f < 10 \text{ Hz}$ $f > 90 \text{ Hz}$	Inactive

¹⁴³ OOT (Output Operating Time): Additional delay of the output medium used, for example, 5 ms with fast relays, see chapter [14.1.4 Relay Outputs](#)

Tolerances

Threshold	1 % of the setting value or 0.05 V/s with a measuring window ≥ 5 periods For a measuring window < 5 periods, a slightly expanded tolerance results.
Time delays	1 % of the setting value or 10 ms

Functional Measured Value

Value	Description
dV/s	Calculated voltage change per second

14.40 Overfrequency Protection

Setting Values

Pickup values $f>$	Angle difference method	
	40.00 Hz to 90.00 Hz	Increments of 0.01 Hz
	Filtering method	
	40.00 Hz to 70.00 Hz	Increments of 0.01 Hz
Dropout differential	20 mHz to 2 000 mHz	Increments of 10 mHz
Time delay T	0.00 s to 600.00 s	Increments of 0.01 s
Minimum voltage	3.000 V to 175.000 V	Increments of 0.001 V

Times

Pickup times $f>$	Angle difference method	
	50 Hz	Approx. 70 ms + OOT ¹⁴⁴
	60 Hz	Approx. 60 ms + OOT
	Filtering method	
	50 Hz	Approx. 79 ms + OOT
	60 Hz	Approx. 65 ms + OOT
Dropout times $f>$	60 ms to 80 ms	

Dropout

The larger dropout differential (= | **pickup value** - **dropout threshold** |) of the following 2 criteria is used:

Dropout differential derived from the parameter Dropout ratio	
If this parameter is not present, a dropout ratio of 99.97 % applies to the overfrequency protection.	
Minimum absolute dropout differential	5 mHz

Operating Ranges

Voltage range	5 V to 230 V (phase-phase)	
Frequency range	Angle difference method	10 Hz to 90 Hz
	Filtering method	25 Hz to 80 Hz

Tolerances

Frequency $f>$	
$f_{\text{rated}} - 0.20 \text{ Hz} < f < f_{\text{rated}} + 0.20 \text{ Hz}$	$\pm 5 \text{ mHz}$ at $V = V_{\text{rated}}$
$f_{\text{rated}} - 3.0 \text{ Hz} < f < f_{\text{rated}} + 3.0 \text{ Hz}$	$\pm 10 \text{ mHz}$ at $V = V_{\text{rated}}$
Time delay T($f>$)	1 % of the setting value or 10 ms
Minimum voltage	1 % of the setting value or 0.5 V

¹⁴⁴ OOT (Output Operating Time): Additional delay of the output medium used, for example, 5 ms with fast relays, see chapter [14.1.4 Relay Outputs](#)

14.41 Underfrequency Protection

Setting Values

Pickup values $f<$	30.00 Hz to 70.00 Hz	Increments of 0.01 Hz
Dropout differential	20 mHz to 2 000 mHz	Increments of 10 mHz
Time delay T	0.00 s to 600.00 s	Increments of 0.01 s
Minimum voltage	3.000 V to 175.000 V	Increments of 0.001 V

Times

Pickup times $f<$	Angle difference method	
	50 Hz	Approx. 70 ms + OOT ¹⁴⁵
	60 Hz	Approx. 60 ms + OOT
	Filtering method	
Dropout times $f<$	50 Hz	Approx. 75 ms + OOT
	60 Hz	Approx. 64 ms + OOT
Dropout times $f<$		60 ms to 80 ms

Dropout

The larger dropout differential (= | **pickup value** - **dropout threshold** |) of the following 2 criteria is used:

Dropout differential derived from the parameter Dropout ratio	
If this parameter is not present, a dropout ratio of 100.03 % applies to the underfrequency protection.	
Minimum absolute dropout differential	5 mHz

Operating Ranges

Voltage range	5 V to 230 V (phase-phase)	
Frequency range	Angle difference method	10 Hz to 90 Hz
	Filtering method	25 Hz to 80 Hz

Tolerances

Frequency $f<$	
$f_{\text{rated}} - 0.20 \text{ Hz} < f < f_{\text{rated}} + 0.20 \text{ Hz}$	$\pm 5 \text{ mHz}$ at $V = V_{\text{rated}}$
$f_{\text{rated}} - 3.0 \text{ Hz} < f < f_{\text{rated}} + 3.0 \text{ Hz}$	$\pm 10 \text{ mHz}$ at $V = V_{\text{rated}}$
Time delay T($f<$)	1 % of the setting value or 10 ms
Minimum voltage	1 % of the setting value or 0.5 V

¹⁴⁵ OOT (Output Operating Time): Additional delay of the output medium used, for example, 5 ms with fast relays, see chapter [14.1.4 Relay Outputs](#)

14.42 Underfrequency Load Shedding

Setting Values for the Function

Minimum voltage	0.300 p.u. to 0.900 p.u.	Increments of 0.001 p.u.
Minimum current	0.020 p.u. to 0.200 p.u.	Increments of 0.001 p.u.
Power angle	-30° to 30°	Increments of 1°
Positive power direction	inv. to CT neu.pnt sett. acc. to CT neu.pnt sett.	
Threshold value for the df/dt-rising rate or df/dt-falling rate	0.1 Hz/s to 20.0 Hz/s	Increments of 0.1 Hz/s
df/dt measuring window	2 periods to 5 periods	Increments of 1 period
df/dt dropout differential	0.02 Hz/s to 0.99 Hz/s	Increments of 0.10 Hz/s
f < stabilization counter	1 to 20	Increments of 1

Setting Values for the Stage

Pickup threshold	40.00 Hz to 70.00 Hz	Increments of 0.01 Hz
Dropout differential	20 mHz to 2000 mHz	Increments of 10 mHz
Time delay	0.00 s to 60.00 s	Increments of 0.01 s

Times

Pickup times with stabilization counter = 6	Approx. 85 ms + OOT ¹⁴⁶ at 50 Hz Approx. 80 ms + OOT at 60 Hz
Dropout time	Approx. 80 ms + OOT at 50 Hz Approx. 75 ms + OOT at 60 Hz

Dropout

The greater dropout differential (= | **pickup value** - **dropout value** |) of the following 2 criteria applies:

Dropout	
Frequency	0.01 Hz
df/dt-rising rate and df/dt-falling rate	0.1 Hz/s
Voltage V1	105 % of the threshold value
Current I1	105 % of the threshold value at $\varphi \leq 0$ 95.23 % of the threshold value at $\varphi > 0$
Power angle	1°
Minimum absolute dropout differential	
Protection-class current transformer	15 mA sec. ($I_{rated} = 1 A$) or 75 mA sec. ($I_{rated} = 5 A$)
Instrument current transformer	0.5 mA sec. ($I_{rated} = 1 A$) or 2.5 mA sec. ($I_{rated} = 5 A$)
Voltage transformer	150 mV sec.

Tolerances

Frequency f<	
$f_{rated} - 0.20 \text{ Hz} < f < f_{rated} + 0.20 \text{ Hz}$	$\pm 5 \text{ mHz at } V = V_{rated}$

¹⁴⁶ OOT (Output Operating Time): additional time delay of the output medium used, for example, 5 ms with fast relay

14.42 Underfrequency Load Shedding

$f_{\text{rated}} - 3.0 \text{ Hz} < f < f_{\text{rated}} + 3.0 \text{ Hz}$	$\pm 10 \text{ mHz at } V = V_{\text{rated}}$
df/dt, measuring window > 3 periods	Approx. 3 % or 0.06 Hz/s
df/dt, measuring window ≤ 3 periods	Approx. 5 % or 0.06 Hz/s
Minimum voltage	0.5 % of the setting value or 0.05 V
Minimum current	1 % of the setting value or 5 mA ($I_{\text{rated}} = 1 \text{ A}$) or 25 mA ($I_{\text{rated}} = 5 \text{ A}$)
Power angle	1°
Time delays	1 % of the setting value or 10 ms

Frequency Operating Range

$0.9 \leq f/f_{\text{rated}} \leq 1.1$	According to specified tolerances
$10 \text{ Hz} \leq f < 0.9 f_{\text{rated}}$	Slightly expanded tolerances
$1.1 f_{\text{rated}} < f \leq 90 \text{ Hz}$	
$f < 10 \text{ Hz}$ $f > 90 \text{ Hz}$	Active

14.43 Rate of Frequency Change Protection

Setting Values for the Function

Minimum voltage	3.000 V to 175.000 V	Increments of 0.001 V
Measuring window	2 periods to 5 periods	Increments of 1 period

Setting Values for Stage Types

Threshold value	0.100 Hz/s to 20.000 Hz/s	Increments of 0.025 Hz/s
Dropout differential	0.02 Hz/s to 0.99 Hz/s	Increments of 0.01 Hz/s
Operate delay	0.00 s to 60.00 s	Increments of 0.01 s

Dropout

Frequency	Parameterizable dropout differential
Minimum voltage	
The larger dropout differential (= pickup value - dropout threshold) of the following 2 criteria is used:	
Dropout differential derived from Dropout ratio	105 % for the Minimum voltage parameter
Minimum absolute dropout differential	150 mV secondary

Times

Pickup time	Approx. 160 ms + OOT ¹⁴⁷ to 220 ms + OOT (depends on measuring window length) at 50 Hz Approx. 140 ms + OOT to 200 ms + OOT (depends on measuring window length) at 60 Hz
Dropout time	Approx. 160 ms + OOT to 220 ms + OOT (depends on measuring window length) at 50 Hz Approx. 140 ms + OOT to 200 ms + OOT (depends on measuring window length) at 60 Hz

Frequency Operating Range

$0.9 \leq f/f_{\text{rated}} \leq 1.1$	According to specified tolerances
$10 \text{ Hz} \leq f < 0.9 f_{\text{rated}}$ $1.1 f_{\text{rated}} < f \leq 90 \text{ Hz}$	Slightly expanded tolerances
$f < 10 \text{ Hz}$ $f > 90 \text{ Hz}$	Inactive

Tolerances

Threshold, measuring window > 3 periods	Approx. 3 % or 0.060 Hz/s
Threshold, measuring window ≤ 3 periods	Approx. 5 % or 0.060 Hz/s

¹⁴⁷ OOT (Output Operating Time): Additional delay of the output medium used, for example, 5 ms with fast relays, see chapter [14.1.4 Relay Outputs](#)

14.43 Rate of Frequency Change Protection

Minimum voltage	1 % of the setting value or 0.5 V
Time delays	1 % of the setting value or 10 ms

Functional Measured Value

Value	Description
df/dt	Calculated rate of frequency change

14.44 Vector-Jump Protection

Setting Values

Threshold V1 min	0.300 V to 175.000 V	Increments of 0.001 V
Threshold V1 max	0.300 V to 175.000 V	Increments of 0.001 V
Threshold $\Delta\varphi$	2.0° to 30.0°	Increments of 0.1°
Operate delay	0.00 s to 60.00 s	Increments of 0.01 s
T Reset	0.00 s to 60.00 s	Increments of 0.01 s
T Block	0.00 s to 60.00 s	Increments of 0.01 s
I < Threshold	0.030 A to 35.000 A at 1 A 0.150 A to 175.000 A at 5 A	Increments of 0.001 A

Times

Pickup times	Approx. 80 ms + OOT ¹⁴⁸ at 50 Hz Approx. 66.8 ms + OOT at 60 Hz
Dropout times	Approx. 80 ms + OOT at 50 Hz Approx. 66.8 ms + OOT at 60 Hz

Frequency Operating Range

$f_{\text{rated}} - 3 \text{ Hz} \leq f \text{ or } f_{\text{rated}} \leq f_{\text{rated}} + 3 \text{ Hz}$	According to specified tolerances
$f < f_{\text{rated}} - 3 \text{ Hz} \text{ or } f > f_{\text{rated}} + 3 \text{ Hz}$	Inactive

Tolerances

Angle jump	0.5° at $V > 0.5 V_{\text{rated}}$
Voltage blocking	1 % of the setting value or 0.500 V
Undercurrent release	For $I_{\text{rated}} = 1 \text{ A}$: 1 % of the setting value or 10 mA For $I_{\text{rated}} = 5 \text{ A}$: 1 % of the setting value or 50 mA
Time delay T	1 % or 10 ms

¹⁴⁸ OOT (Output Operating Time): additional delay of the output medium used, see chapter [14.1.4 Relay Outputs](#)

14.45 Power Protection (P,Q), 3-Phase

Setting Values

Measured value	Positive sequence power Power of phase A Power of phase B Power of phase C	
Threshold	-200.0 % to -1.0 % 1.0 % to 200.0 %	Increments of 0.1
Tilt-power characteristic	-89.0° to +89.0°	Increments of 0.1°
Dropout delay time	0.00 s to 60.00 s	Increments of 0.01 s
Time delay	0.00 s to 60.00 s	Increments of 0.01 s
Dropout ratio	Upper stage: 0.90 to 0.99 Lower stage: 1.01 to 1.10	Increments of 0.01 Increments of 0.01

Dropout

The greater dropout differential (= | **pickup value** - **dropout value** |) of the following 2 criteria applies:

Dropout differential derived from the parameter Dropout ratio	
Minimum absolute dropout differential	0.5 % S_{rated} for positive sequence power 0.1 % S_{rated} for power of phase A, phase B, phase C

Times

Pickup times	Approx. 55 ms + OOT ¹⁴⁹ at 50 Hz Approx. 45 ms + OOT at 60 Hz
Dropout times	Approx. 20 ms + OOT at 50-Hz Approx. 20 ms + OOT at 60 Hz

Tolerances

Power	0.5 % S_{rated} or ± 2 % of the setting value (S_{rated} : rated apparent power)
Time delays	1 % of the setting value or 10 ms

Variables That Influence Pickup Values

Auxiliary DC voltage in the range $0.8 \leq V_{aux.} / V_{aux.,rated} \leq 1.15$	≤ 1 %
Frequency in the range $0.95 \leq f/f_{rated} \leq 1.05$	≤ 1 %
Harmonics	≤ 1 %
- Up to 10 % of 3rd harmonics	≤ 1 %
- Up to 10 % of 5th harmonics	≤ 1 %

¹⁴⁹ OOT (Output Operating Time): additional delay of the output medium used, see chapter [14.1.4 Relay Outputs](#)

Frequency Operating Range

$0.9 \leq f/f_{\text{rated}} \leq 1.1$	According to specified tolerances
$10 \text{ Hz} < f < 0.9 f_{\text{rated}}$ $1.1 f_{\text{rated}} < f$	Slightly expanded tolerances
$f \leq 10 \text{ Hz}$	Inactive

14.46 Reverse-Power Protection

Setting Values

Reverse power P_{reverse} (p.u.)	-0.30 % to -30.00 %	Increments of 0.01 %
Angle correction	-10.00 ° to 10.00 °	Increments of 0.01 °
Minimum voltage V1	0.300 V to 60.000 V	Increments of 0.001 V
Tripping delay	0.00 s to 60.00 s	0.00 s to 60.00 s
Tripping delay with quick stop	0.00 s to 60.00 s	0.00 s to 60.00 s
Dropout delay	0.00 s to 60.00 s	Increments of 0.01 s
Dropout ratio	0.40 to 0.99	Increments of 0.01

Dropout

Reverse power P_{reverse} (p.u.)	Parameterizable dropout differential
---	--------------------------------------

Times

Pickup times	Approx. 360 ms at $f = 50$ Hz Approx. 300 ms at $f = 60$ Hz
Dropout times	Approx. 360 ms at $f = 50$ Hz Approx. 300 ms at $f = 60$ Hz

Frequency Operating Range

$0.9 \leq f/f_{\text{rated}} \leq 1.1$	According to specified tolerances
$10 \text{ Hz} \leq f < 0.9 f_{\text{rated}}$ $1.1 f_{\text{rated}} < f \leq 90 \text{ Hz}$	Slightly expanded tolerances
$f < 10 \text{ Hz}$ $f > 90 \text{ Hz}$	Inactive

Tolerances

Reverse power	0.15 % S_{rated} or 5 % of the setting value when $Q < 0.5 S_{\text{rated}}$
Time delays	1 % or 10 ms

14.47 Overexcitation Protection

Setting Values

Threshold value (Inverse-time characteristic curve pickup)	$\frac{V/V_{rated}}{f/f_{rated}}$	1.00 to 1.20	Increments of 0.01
Threshold value (Definite-time characteristic curve pickup)	$\frac{V/V_{rated}}{f/f_{rated}}$	1.00 to 1.40	Increments of 0.01
Time delay (warning delay and tripping delay)		0.00 s to 60.00 s	Increments of 0.01 s
Characteristic value pairs		2 to 30	
	Ranges of values	V/f	1.00 p.u. to 10.00 p.u.
		t	0 s to 100 000 s
Cooling time therm. replica		0 s to 100 000 s	Increments of 1 s

Functional Measured Values

Measured Value	Description
(_:2311:322) V/f	Value calculated from voltage and frequency.
(_:13591) <i>Therm. charact.</i>	Thermal tripping of the overexcitation protection. If the value reaches 100 %, tripping occurs.

Frequency Operating Range

$0.9 \leq f/f_{rated} \leq 1.1$	According to specified tolerances
$10 \text{ Hz} \leq f < 0.9 f_{rated}$ $1.1 f_{rated} < f \leq 90 \text{ Hz}$	Slightly expanded tolerances
$f < 10 \text{ Hz}$ $f > 90 \text{ Hz}$	Inactive

Operating Times

Operate times/dropout times		
Operate time at frequency	50 Hz	60 Hz
Minimum	33 ms + OOT ¹	30 ms + OOT ¹⁵⁰
Dropout time	10 ms + OOT ¹	10 ms + OOT ¹

Dropout Ratios

Warning, tripping (independent stage)	Approx. 0.98
---------------------------------------	--------------

Operate Curve

Thermal replica	For default setting refer to the following characteristic curve Figure 14-20
-----------------	--

Tolerances

V/f pickup	2 % of the setting value
Time delays	1 % of the setting value or 10 ms (min. 1.5 periods)
Thermal replica	5 % based on $V/f \pm 600 \text{ ms}$

¹⁵⁰ Refer to protection functions, for example overcurrent protection

Voltage measurement accuracy	0.5 % of the setting value or 0.5 V in the range $f_n \pm 10 \%$
Frequency measurement accuracy	1.0 % of the setting value or 1.0 Hz in the frequency range 10 Hz to 90 Hz

Influencing Quantities

Auxiliary direct voltage in the 0.8 range	$\leq 1 \%$
Time delays	$\leq 0.5 \%/10 \text{ K}$
Thermal replica	$\leq 1 \%$
Harmonics	
up to 10 % of 3rd harmonics	$\leq 1 \%$
up to 10 % of 5th harmonics	$\leq 1 \%$

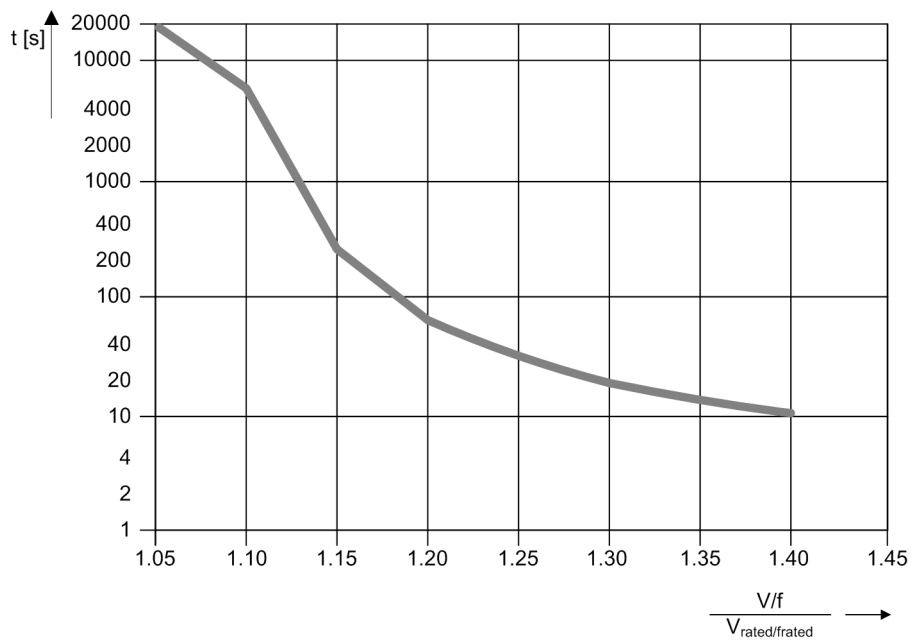

[dw_rsasuf_1_en_US]

Figure 14-20 Operate Curve from the Thermal Replica of the Overexcitation Protection (Default Setting)

14.48 Undervoltage-Controlled Reactive-Power Protection

Setting Values

Threshold value	Power Q	1.00 % to 200.00 %	Increments of 0.01 %
	Voltage of protection stage	3.000 to 175.000	Increments of 0.001 V
	Voltage of reclosure stage	3.000 V to 340.000 V	Increments of 0.001 V
Current I_1 release threshold value	1 A @ 50 and 100 Irated	0.030 A to 10.000 A	Increments of 0.001 A
	5 A @ 50 and 100 Irated	0.15 A to 50.00 A	Increments of 0.01 A
	1 A @ 1.6 Irated	0.001 A to 1.600 A	Increments of 0.001 A
	5 A @ 1.6 Irated	0.005 A to 8.000 A	Increments of 0.001 A
Operate delay		0.00 s to 60.00 s	Increments of 0.01 s
Release time delay of reclosure stage		0.00 s to 3600.00 s	Increments of 0.01 s

Dropout Ratio

Protection stage	
Reactive-power flow Q	Approx. 0.95
Voltage	Approx. 1.02
Release current	Approx. 0.95
Reclosure stage	
Voltage	Approx. 0.98
Release current	Approx. 0.95

Times

Pickup time	Approx. 55 ms + OOT ¹⁵¹ at 50 Hz Approx. 45 ms + OOT at 60 Hz
Dropout time	Approx. 55 ms + OOT at 50 Hz Approx. 45 ms + OOT at 60 Hz

Tolerances

Current I_1	1 % of the setting value or 5 mA ($I_{rated} = 1$ A) or 25 mA ($I_{rated} = 5$ A)
Voltage	0.5 % of the setting value or 0.05 V
Power Q	0.5 % $S_{rated} \pm 3$ % of the setting value (S_{rated} : rated apparent power)
Time delays	1 % of the setting value or 10 ms
Reclosure time delay	1 % of the setting value or 10 ms

¹⁵¹ OOT (Output Operating Time): additional delay of the output medium used, for example 5 ms with fast relays

Frequency Operating Range

$0.9 \leq f/f_{\text{rated}} \leq 1.1$	According to specified tolerances
$10 \text{ Hz} \leq f < 0.9 f_{\text{rated}}$ $1.1 f_{\text{rated}} < f \leq 90 \text{ Hz}$	Slightly expanded tolerances
$f < 10 \text{ Hz}$ $f > 90 \text{ Hz}$	Active

14.49 Circuit-Breaker Failure Protection

Starting Conditions

For circuit-breaker failure protection	3-pole tripping internal or external ¹⁵²
--	---

Dropout

The greater dropout differential (= | **pickup threshold** - **dropout threshold** |) of the following 2 criteria applies:

Dropout differential derived from the parameter Dropout ratio	
If this parameter is not available, a dropout ratio of 95 % applies to the current threshold values.	
Minimum absolute dropout differential	
Protection-class current transformers	15 mA sec. ($I_{\text{rated}} = 1 \text{ A}$) or 75 mA sec. ($I_{\text{rated}} = 5 \text{ A}$)
Instrument transformers	0.5 mA sec. ($I_{\text{rated}} = 1 \text{ A}$) or 2.5 mA sec. ($I_{\text{rated}} = 5 \text{ A}$)

Circuit-Breaker Supervision

Position supervision via circuit-breaker auxiliary contacts	
For 3-pole CB tripping	One input each for make contact and break contact



NOTE

The circuit-breaker failure protection can also work without the circuit-breaker auxiliary contacts stated. Auxiliary contacts are required for circuit-breaker failure protection in cases where the current flow is absent or too low for tripping (for example with a transformer or a Buchholz protection).

Times

Pickup time, in the case of an internal start	< 1 ms
Pickup time, in the case of an external start	< 5 ms
Typical dropout time	< 15 ms
Dropout time, via circuit-breaker auxiliary contact criterion ¹⁵³	< 5 ms



NOTE

Using the setting **Direct release** with the parameters **3I0 criterion** or **I2 criterion** can result in extended dropout times.

Frequency Operating Range

$0.9 \leq f/f_{\text{rated}} \leq 1.1$	According to specified tolerances
$10 \text{ Hz} \leq f < 0.9 f_{\text{rated}}$ $1.1 f_{\text{rated}} < f \leq 90 \text{ Hz}$	Slightly expanded tolerances
$f < 10 \text{ Hz}$ $f > 90 \text{ Hz}$	Active

¹⁵² Via binary inputs

¹⁵³ The use of the transformer connection types **2ph**, **2p. CT + IN-sep** result in slightly expanded tolerances

Tolerances

Threshold values, dropout thresholds	2 % of the setting value or 1 % of the rated current
Times	1 % of the setting value or 10 ms

14.50 Circuit-Breaker Restrike Protection

Setting Values

Threshold value	1 A @ 50 and 100 I _{rated}	0.030 A to 35.000 A	Increments of 0.001 A
	5 A @ 50 and 100 I _{rated}	0.15 A to 175.00 A	Increments of 0.01 A
	1 A @ 1.6 I _{rated}	0.001 A to 1.600 A	Increments of 0.001 A
	5 A @ 1.6 I _{rated}	0.005 A to 8.000 A	Increments of 0.001 A
Monitoring duration		1.00 s to 600.00 s	Increments of 0.01 s
Position recognition delay		0.00 s to 60.00 s	Increments of 0.01 s
Dropout delay		0.00 s to 60.00 s	Increments of 0.01 s
Trip delay time		0.05 s to 60.00 s	Increments of 0.01 s
Retrip delay time		0.00 s to 60.00 s	Increments of 0.01 s
Minimum operate (trip) time		0.00 s to 60.00 s	Increments of 0.01 s

Dropout

The greater dropout differential (= | pickup value - dropout value |) of the following 2 criteria applies:

Dropout differential derived from the parameter Dropout ratio	
If this parameter is not available, a dropout ratio of 95 % applies for overcurrent and of 105 % for undercurrent functionality.	
Minimum absolute dropout differential	
Protection-class current transformer	15 mA sec. (I _{rated} = 1 A) or 75 mA sec. (I _{rated} = 5 A)
Instrument current transformer	0.5 mA sec. (I _{rated} = 1 A) or 2.5 mA sec. (I _{rated} = 5 A)

Times

Operate time with time delay = 0 ms	Approx. 25 ms + OOT at 50 Hz Approx. 22 ms + OOT at 60 Hz
Dropout time	Approx. 20 ms + OOT

Frequency Operating Range

$0.9 \leq f/f_{\text{rated}} \leq 1.1$	According to specified tolerances
$10 \text{ Hz} \leq f < 0.9 f_{\text{rated}}$ $1.1 f_{\text{rated}} < f \leq 90 \text{ Hz}$	Slightly expanded tolerances
$f < 10 \text{ Hz}$ $f > 90 \text{ Hz}$	Active

Tolerances

Threshold	1 % of the setting value or 5 mA (I _{rated} = 1 A) or 25 mA (I _{rated} = 5 A)
Time delays	1 % of the setting value or 10 ms

14.51 Restricted Ground-Fault Protection

Setting Values

Threshold value ¹⁵⁴	0.05 A to 2.00 A	Increments of 0.01 A
Gradient	0.00 to 0.95	Increments of 0.01
Operate curve	See figure	
Pickup tolerance (for preset characteristic curve parameters; for 2 sides with 1 measuring point each)	2 %	
Tripping delay	0.00 s to 60.00 s or ∞ (no tripping)	Increments of 0.01 s
Timer tolerance	1 % of the setting value or 10 ms	

Functional Measured Values

Measured Value	Description
(_:306) I REF,operate	Operate quantity of the restricted ground-fault protection from the angle criterion and can be displayed in the fault record
(_:307) I Angle,REF	Stabilizing value (angle) of the restricted ground-fault protection from the angle criterion and can be displayed in the fault record
(_:311) I REF,Trip operate	Operate quantity of the restricted ground-fault protection when OFF; will be issued in the log
(_:312) I angle,REF operate	Stabilizing value of the restricted ground-fault protection when OFF; will be issued in the log
(_:301) I diff.	Differential current; can be displayed in the fault record
(_:302) I restr.	Restraint current; can be displayed in the fault record

Dropout Ratio

Threshold value	0.7
-----------------	-----

Dropout

The greater dropout differential (= | pickup value - dropout threshold |) of the following 2 criteria applies:

Dropout differential derived from the parameter Dropout ratio	
If this parameter is not available, a dropout ratio of 95 % applies for overcurrent and of 105 % applies for undercurrent functionality.	
Minimum absolute dropout differential	
Protection-class current transformers	15 mA sec. ($I_{rated} = 1 \text{ A}$) or 75 mA sec. ($I_{rated} = 5 \text{ A}$)

Times

7UT82/7UT85/7UT86/7UT87		
Frequency	50 Hz	60 Hz
	Operate time	Operate time

¹⁵⁴ The specified setting limit can be dynamically further limited, depending on the transformer adaptation factor, (for this refer to chapter [6.44.4 Application and Setting Notes](#)).

At 1.5 · setting value threshold value	33 ms + OOT	32 ms + OOT
At 2.5 · setting value threshold value	27 ms + OOT	26 ms + OOT
Dropout time approx.	30 ms	25 ms

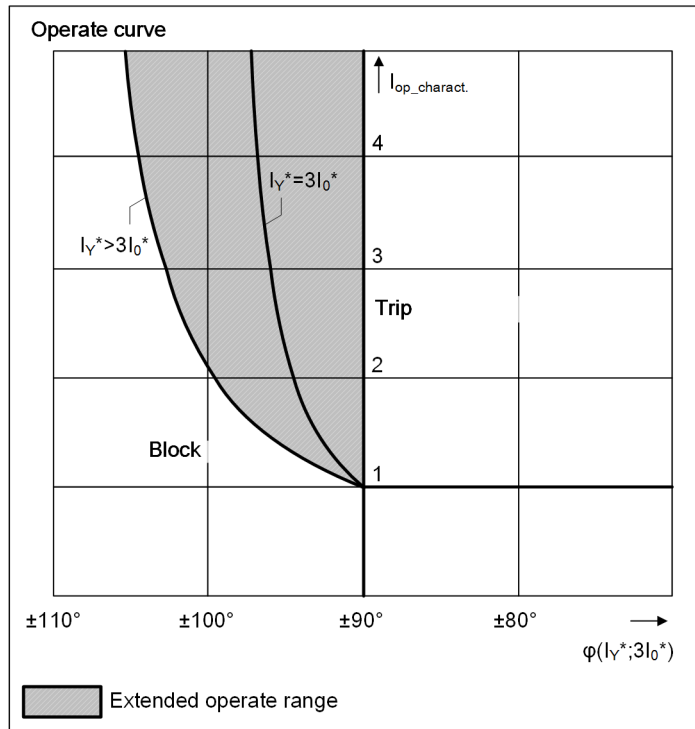

[dw_ausken, 3, en_US]

Figure 14-21 Restricted Ground-Fault Protection Operate Curve Depending on the Phase Angle between I_V^* and $3I_0^*$ with Extended Operate Range

14.52 External Trip Initiation

Setting Values

Tripping delay	0.00 s to 60.00 s	Increments of 0.01 s
----------------	-------------------	----------------------

Times

Operate time with time delay = 0 ms - At initiation via binary input signal	Approx. 10 ms + OOT ¹⁵⁵
--	------------------------------------

Tolerance

Sequence tolerance for time delays	1 % of the setting value or 10 ms
------------------------------------	-----------------------------------

¹⁵⁵ OOT (Output Operating Time) Additional delay of the output medium used, for example 5 ms with fast relay, see Chapter [14.1.4 Relay Outputs](#)

14.53 Automatic Reclosing

Function specifications	Cyclic automatic reclosing function Automatic reclosing function with adaptive dead time (ADT) Operation with external automatic reclosing function	
Number of reclosings	Max. 8, per individual settings	
Type (dependent on order variant)	1-pole, 3-pole, or 1-/3-pole	
Operating mode of the automatic reclosing function	With trip command, without action time With trip command, with action time With pickup, without action time With pickup, with action time	
Reclaim time after reclosing	0.50 s to 300.00 s	Increments of 0.01 s
Blocking time after dynamic blocking	0.5 s	-
Blocking time after manual closure	0.00 s to 300.00 s	Increments of 0.01 s
Start supervision time	0.01 s to 300.00 s	Increments of 0.01 s
Circuit-breaker supervision time	0.01 s to 300.00 s	Increments of 0.01 s
Evolving-fault detection	With trip command With Pickup	
Reaction to evolving faults	Blocks Automatic reclosing function Start, evolving fault, dead time	
Action times (separated for all cycles)	0.00 s to 300.00 s; oo (ineffective)	Increments of 0.01 s
Dead times after trip command (separated for all types and all cycles)	0.00 s to 1800.00 s; oo (ineffective)	Increments of 0.01 s
Dead time after evolving-fault detection (separated for all cycles)	0.00 s to 1800.00 s	Increments of 0.01 s
Synchrocheck after 3-pole dead time	None Internal External	
Transmission delay, inter close command	0.00 s to 300.00 s; oo (ineffective)	Increments of 0.01 s
Dead-line check/reduced dead time	Without Reduced dead time (VWE) Dead line checking	
Voltage supervision time	0.10 s to 30.00 s	Increments of 0.01 s
Limiting value for fault-free line	0.3 V to 340.0 V	Increments of 0.1 V
Limiting value for zero potential	0.3 V to 340.0 V	Increments of 0.1 V

14.54 Fault Locator

Setting Values

Reactance per unit length of the line per kilometer or per mile	
Line length for the correct output of the fault distance as a percentage of the line length	
The residual compensation factors in the setting format Kr and Kx or K0 and angle (K0)	
Consideration of the load current for 1-pole ground faults	Correction of the X value, for connection and disconnection

Fault Distance

Output of the fault distance (line length)	In Ω primary and secondary In km, miles or in percent. ¹⁵⁶
--	---

Tolerances

Measuring tolerances during sinusoidal measurands and error duration > 25 ms at 60 Hz or > 30 ms at 50 Hz	1.5 % from fault location at $V_k/V_{rated} \geq 0.01$ and one of the following scenarios: <ul style="list-style-type: none">• Metal fault• Non-metallic fault for one-side infeed without load
---	--

¹⁵⁶ The output of the fault distance in km, miles and percent presupposes a homogenous line.

14.55 Fault Locator Plus

Setting Values

<ul style="list-style-type: none"> • Cb per length unit, C0 per length unit, and X per length unit of the line per kilometer or per mile • Line angle in ° • Line length for the correct output of the fault distance in km or miles and percent of the line length • The residual compensation factors in the setting format Kr and Kx or K0 and angle (K0) 	
Parallel-line compensation (optional), only with instantiation of the function in the FG line	For connection or disconnection
Consideration of the load current in the case of 1-phase ground faults	Correction of the X value, for connection and disconnection

Output Values

Output of the fault distance (line length), for non-homogeneous lines with indication of the line section	In km, miles, or percent
Output of the fault resistance, fault contact resistance, and fault reactance	In Ω primary and secondary

Tolerances

Measuring tolerances during sinusoidal measurands and fault duration > 25 ms at 60 Hz or > 30 ms at 50 Hz	1.5 % from fault location ¹⁵⁷ with $V_K/V_{rated} \geq 0.01$ and $I_F/I_{rated} \geq 0.1$
---	--

¹⁵⁷ Tolerance referenced to the total line length

14.56 Protection and Automation Functions (CEI 0-16 Standard)

14.56.1 Overvoltage Protection with 3-Phase Voltage (CEI 0-16 Standard)

Setting Values

Threshold	0.300 V to 340.000 V	Increments of 0.001 V
Dropout ratio	0.90 to 0.99	Increments of 0.01
Operate delay	0.00 s to 300.00 s	Increments of 0.01 s

Dropout

The greater dropout differential (= | **pickup value** - **dropout value** |) of the following 2 criteria applies:

Dropout differential derived from the parameter Dropout ratio	
If this parameter is not available, a dropout ratio of 95 % applies for the overvoltage and of 105 % for the undervoltage functionality.	
Minimum absolute dropout differential	150 mV sec.

Times for the Stage with Definite-Time Characteristic Curve, Fundamental Component

Pickup time	Approx. 30 ms + OOT ¹⁵⁸ at 50 Hz Approx. 28 ms + OOT at 60 Hz
Dropout time	Approx. 20 ms + OOT at 50 Hz Approx. 16 ms + OOT at 60 Hz

Frequency Operating Range for the Stage with Definite-Time Characteristic Curve, Fundamental Component

$0.9 \leq f/f_{\text{rated}} \leq 1.1$	According to specified tolerances
$10 \text{ Hz} \leq f < 0.9 f_{\text{rated}}$	Slightly expanded tolerances
$1.1 f_{\text{rated}} < f \leq 90 \text{ Hz}$	
$f < 10 \text{ Hz}$ $f > 90 \text{ Hz}$	Active

Tolerances

Voltages	<ul style="list-style-type: none"> 1 % of the setting value or 0.10 V, for the stage Definite-time overvoltage protection, 10-min RMS value 0.5 % of the setting value or 0.05 V, for the stage Definite-time overvoltage protection, fundamental component
Time delays	1 % of the setting value or 10 ms

14.56.2 Frequency Protection (CEI 0-16 Standard)

Setting Values for the General Functionality

Voltmetric unblock		
Threshold V0>	0.300 V to 200.000 V	Increments of 0.001 V

¹⁵⁸ OOT (Output Operating Time): additional delay of the output medium used, see chapter [14.1.4 Relay Outputs](#)

Dropout ratio V0>	0.90 to 0.99	Increments of 0.01
Extension time V0>	0.00 s to 0.20 s	Increments of 0.01 s
Threshold V1<	0.300 V to 200.000 V	Increments of 0.001 V
Dropout ratio V1<	1.01 to 1.20	Increments of 0.01
Threshold V2>	0.300 V to 200.000 V	Increments of 0.001 V
Dropout ratio V2>	0.90 to 0.99	Increments of 0.01
Extension time	1.00 s to 240.00 s	Increments of 0.01 s
Undervoltage block		
Minimum voltage	3.000 V to 175.000 V	Increments of 0.001 V
Acceleration		
Accel. act. T	0.00 s to 60.00 s	Increments of 0.01 s

Setting Values for the Overvoltage-Protection Stage with Zero-Sequence Voltage/Residual Voltage

Operate delay	0.00 s to 300.00 s	Increments of 0.01 s
Accel.oper.T	0.00 s to 5.00 s	Increments of 0.01 s

Setting Values for Frequency-Protection Stages

Threshold	<ul style="list-style-type: none"> For overfrequency-protection stages: 40.00 Hz to 90.00 Hz For underfrequency-protection stages: 30.00 Hz to 70.00 Hz 	Increments of 0.01 Hz
Operate delay	0.00 s to 600.00 s	Increments of 0.01 s
Accel.oper.T for stage Overfrequency protection S2 and stage Underfrequency protection S2	0.00 s to 5.00 s	Increments of 0.01 s
Dropout differential	20 mHz to 2000 mHz	Increments of 10 mHz

Dropout

The larger dropout differential (= | pickup value - dropout threshold |) of the following 2 criteria is used:

Dropout differential derived from the parameter Dropout ratio	
If this parameter is not present, a dropout ratio of 99.97 % applies for the overfrequency and of 100.03 % for the underfrequency functionality.	
Minimum absolute dropout differential	5 mHz

Times for the Overvoltage-Protection Stage with Zero-Sequence Voltage/Residual Voltage

Pickup time	Approx. 25 ms + OOT ¹⁵⁹ at 50 Hz Approx. 22 ms + OOT at 60 Hz
Dropout time	Approx. 20 ms + OOT at 50 Hz Approx. 17 ms + OOT at 60 Hz

¹⁵⁹ OOT (Output Operating Time): additional delay of the output medium used, see chapter [14.1.4 Relay Outputs](#)

Times for Frequency-Protection Stages

Pickup time	Approx. 75 ms + OOT at 50 Hz Approx. 70 ms + OOT at 60 Hz
Dropout time	Approx. 72 ms + OOT at 50 Hz Approx. 67 ms + OOT at 60 Hz

Frequency Operating Range

$f_{\text{rated}} - 0.20 \text{ Hz} < f < f_{\text{rated}} + 0.20 \text{ Hz}$	According to specified tolerances
$f_{\text{rated}} - 3.0 \text{ Hz} < f < f_{\text{rated}} + 3.0 \text{ Hz}$	Slightly expanded tolerances
$f < 10 \text{ Hz}$ $f > 90 \text{ Hz}$	Inactive

Tolerances

Voltage threshold	0.5 % of the setting value or 0.05 V
Frequency	$\pm 5 \text{ mHz}$ at $V = V_{\text{rated}}$ $\pm 10 \text{ mHz}$ at $V = V_{\text{rated}}$
$f_{\text{rated}} - 0.20 \text{ Hz} < f < f_{\text{rated}} + 0.20 \text{ Hz}$ $f_{\text{rated}} - 3.0 \text{ Hz} < f < f_{\text{rated}} + 3.0 \text{ Hz}$	
Time delays	1 % of the setting value or 10 ms

14.56.3 Undervoltage Protection with 3-Phase Voltage (CEI 0-16 Standard)

Setting Values

Threshold I>	1 A @ 50 and 100 Irated	0.030 A to 10.000 A	Increments of 0.001 A
	5 A @ 50 and 100 Irated	0.15 A to 50.00 A	Increments of 0.01 A
	1 A @ 1.6 Irated	0.001 A to 1.600 A	Increments of 0.001 A
	5 A @ 1.6 Irated	0.005 A to 8.000 A	Increments of 0.001 A
Threshold		0.300 V to 175.000 V	Increments of 0.001 V
Dropout ratio		1.01 to 1.20	Increments of 0.01
Operate delay		0.00 s to 300.00 s	Increments of 0.01 s

Dropout

The greater dropout differential (= | pickup value - dropout value |) of the following 2 criteria applies:

Dropout differential derived from the parameter Dropout ratio	
If this parameter is not available, a dropout ratio of 95 % applies for the overvoltage and of 105 % for the undervoltage functionality.	
Minimum absolute dropout differential	150 mV sec.

Times

Pickup time	Approx. 30 ms + OOT ¹⁶⁰ at 50 Hz Approx. 25 ms + OOT at 60 Hz
Dropout time	Approx. 22 ms + OOT at 50 Hz Approx. 15 ms + OOT at 60 Hz

¹⁶⁰ OOT (Output Operating Time): additional delay of the output medium used, see chapter [14.1.4 Relay Outputs](#)

Frequency Operating Range

$0.9 \leq f/f_{\text{rated}} \leq 1.1$	According to specified tolerances
$10 \text{ Hz} \leq f < 0.9 f_{\text{rated}}$ $1.1 f_{\text{rated}} < f \leq 90 \text{ Hz}$	Slightly expanded tolerances
$f < 10 \text{ Hz}$ $f > 90 \text{ Hz}$	Inactive, maintained; Dropout of the pickup induced by blocking or by increasing the measurand beyond the dropout threshold

Tolerances

Voltages	0.5 % of the setting value or 0.05 V
Currents	1 % of the setting value or 5 mA ($I_{\text{rated}} = 1 \text{ A}$) or 25 mA ($I_{\text{rated}} = 5 \text{ A}$), valid for protection-class current transformers
	1 % of the setting value or 0.1 mA ($I_{\text{rated}} = 1 \text{ A}$) or 0.5 mA ($I_{\text{rated}} = 5 \text{ A}$), valid for instrument transformers
Time delays	1 % of the setting value or 20 ms

14.57 Temperature Supervision

Setting Values

Pickup value	-50 °C to 250 °C -58 °F to 482 °F	Increments of 1°C Increments of 1°F
Time delay	0 s to 60 s or ∞	Increments of 1 s

Dropout

Dropout differential	3 °C or 6 °F
----------------------	--------------

Tolerances

Tripping delay	±1 % of the setting value or ±10 ms
Measured temperature value	±0.5 % of the setting value or ±1 °C or ±2 °F

14.58 Current-Jump Detection

Times

Pickup time	Approx. 10 ms + OOT ¹⁶¹ at 50 Hz Approx. 8 ms + OOT at 60 Hz
-------------	--

Frequency Operating Range

$0.9 \leq f/f_{\text{rated}} \leq 1.1$	According to specified tolerances
$10 \text{ Hz} \leq f < 0.9 f_{\text{rated}}$ $1.1 f_{\text{rated}} < f \leq 90 \text{ Hz}$	Slightly expanded tolerances
$f < 10 \text{ Hz}$ $f > 90 \text{ Hz}$	Inactive

Tolerances

Currents	3 % of setting value or 10 mA ($I_{\text{rated}} = 1 \text{ A}$) or 50 mA ($I_{\text{rated}} = 5 \text{ A}$), ($f_{\text{rated}} \pm 10 \%$) for amplitude changes of sinusoidal measurands
Pulse time	1 % of the setting value or 10 ms

¹⁶¹ OOT (Output Operating Time) additional delay of the output medium used, for example 5 ms with fast relays

14.59 Voltage-Jump Detection

Times

Pickup time	Approx. 10 ms + OOT ¹⁶² at 50 Hz Approx. 8 ms + OOT at 60 Hz
-------------	--

Frequency Operating Range

$0.9 \leq f/f_{\text{rated}} \leq 1.1$	According to specified tolerances
$10 \text{ Hz} \leq f < 0.9 f_{\text{rated}}$ $1.1 f_{\text{rated}} < f \leq 90 \text{ Hz}$	Slightly expanded tolerances
$f < 10 \text{ Hz}$ $f > 90 \text{ Hz}$	Inactive

Tolerances

Voltages	2 % of the setting value or 0.100 V for amplitude changes of sinusoidal measurands
Pulse time	1 % of the setting value or 10 ms

¹⁶² OOT (Output Operating Time) additional delay of the output medium used, for example 5 ms with fast relays

14.60 Synchronization Function

Operating Modes

Synchrocheck
Switching synchronous systems
Switching asynchronous systems
Switching synchronous/asynchronous systems with balancing commands
De-energized switching
Direct closing command
Balancing voltage
Balancing frequency

Setting Values

Supervision/Delay/Pulse times:		
Max.durat. sync.process	0.00 s to 3 600.00 s or ∞ (ineffective)	Increments of 0.01 s
Supervision time de-energized switching	0.00 s to 60.00 s	Increments of 0.01 s
Closure delay	0.00 s to 60.00 s	Increments of 0.01 s
T V pulse min/T f pulse min	0.01 s to 1.00 s	Increments of 0.01 s
T V pulse max/T f pulse max	0.01 s to 60.00 s	Increments of 0.01 s
T pause V/T pause f	0.01 s to 60.00 s	Increments of 0.01 s
T close without balancing	1.00 s to 100.00 s	Increments of 0.01 s
Voltage threshold values:		
Upper voltage limit V_{max}	0.300 V to 340.000 V (phase-to-phase)	Increments of 0.001 V
Lower voltage limit V_{min}	0.300 V to 340.000 V (phase-to-phase)	Increments of 0.001 V
$V<$, for off-circuit conditions $V>$, for voltage present	0.300 V to 170.000 V (phase-to-phase) 0.300 V to 340.000 V (phase-to-phase)	Increments of 0.001 V Increments of 0.001 V
Differential values, changeover threshold values asynchronous/synchronous/balancing commands:		
Voltage differences $V2 > V1$; $V2 < V1$	0.000 V to 170.000 V	Increments of 0.001 V
Frequency difference $f2 > f1$; $f2 < f1$	0.000 Hz to 2.000 Hz (synchronous) 0.000 Hz to 4.000 Hz (asynchronous)	Increments of 0.001 Hz
Angle difference $\alpha2 > \alpha1$; $\alpha2 < \alpha1$	0° to 90°	Increments of 1°
Δf threshold ASYN \leftrightarrow SYN	0.010 Hz to 0.200 Hz	Increments of 0.001 Hz
Δf set point for balancing	-1.00 Hz to 1.00 Hz	Increments of 0.01 Hz
Δf for the kick pulse	-1.00 Hz to 1.00 Hz	Increments of 0.01 Hz
Adjustments of the sides:		
Angle adjustment	-179.0° to 180.0°	Increments of 0.1°
Voltage adjustment	0.500 to 2.000	Increments of 0.001
Circuit breaker		
Make time of the circuit breaker	0.010 s to 0.600 s	Increments of 0.001 s

Dropout Ratio

Min./max. operating limit	1 % of the setting value
Voltage differential	10 % of the setting value or 0.5 V
De-energized/energized	5 % of the setting value
Frequency difference	3 mHz
Angle difference	0.1°

Measured Values of the Synchronization Function

Reference voltage V1 • Range • Tolerance at rated frequency	In kV primary, in V secondary or in % V_{rated} Display always as phase-to-phase voltage 10 % to 120 % of V_{rated} ≤ 1 % of the measured value or 0.5 % V_{rated}
Voltage to be synchronized V2 • Range • Tolerance at rated frequency	In kV primary, in V secondary or in % V_{rated} Display always as phase-to-phase voltage 10 % to 120 % of V_{rated} ≤ 1 % of the measured value or 0.5 % V_{rated}
Frequency of the voltage V1f1 • Range • Tolerance at rated frequency	f1 in Hz 25 Hz $\leq f \leq$ 70 Hz 1 mHz
Frequency of the voltage V1f2 • Range • Tolerance at rated frequency	f2 in Hz 25 Hz $\leq f \leq$ 70 Hz 1 mHz
Voltage difference V2-V1 • Range • Tolerance at rated frequency	In kV primary, in V secondary or in % V_{rated} Display always as phase-to-phase voltage in relation to side 1 10 % to 120 % of V_{rated} ≤ 1 % of the measured value or 0.5 % V_{rated}
Frequency difference f2-f1 • Range • Tolerance at rated frequency	In mHz $f_{rated} \pm 10$ % 1 mHz
Angle difference $\lambda 2-\lambda 1$ • Range • Tolerance at rated frequency	In ° -180° to +180° 0.5°

Times

Measuring time, after switching on the variables	Approx. 80 ms
--	---------------

Operating Range

Voltage	20 V to 340 V
Frequency	$f_{rated} - 4$ Hz $\leq f_{rated} \leq f_{rated} + 4$ Hz

Tolerances

Tolerances of the voltage settings	2 % of the pickup value or 1 V
Voltage difference $V2 > V1$; $V2 < V1$	1 V

Frequency difference $f_2 > f_1$; $f_2 < f_1$	10 mHz
Angle difference $\alpha_2 > \alpha_1$; $\alpha_2 < \alpha_1$	1°
Pulse time	1 % of the calculated impulse or 10 ms
Tolerance of all time settings	10 ms
Max. phase displacement angle	5° for $\Delta f \leq 1$ Hz 10° for $\Delta f > 1$ Hz

14.61 Current-Balance Supervision

Setting Values

Release threshold	$I_{\text{rated}} = 1 \text{ A}$	0.030 A to 35.000 A	Increments of 0.001 A
	$I_{\text{rated}} = 5 \text{ A}$	0.15 A to 175.00 A	Increments of 0.01 A
Threshold min/max		0.10 to 0.95	Increments of 0.01
Delay failure indication		0.00 s to 100.00 s	Increments of 0.01 s

Dropout Ratio

Overcurrent dropout ratio	Approx. 0.97
Undercurrent dropout ratio	Approx. 1.05

Times

Tripping time	Approx. 500 ms
Dropout time	Approx. 500 ms

14.62 Voltage-Balance Supervision

Setting Values

Release threshold	0.300 V to 170.000 V	Increments of 0.001 V
Threshold min/max	0.58 to 0.95	Increments of 0.01
Delay failure indication	0.00 s to 100.00 s	Increments of 0.01 s

Dropout Ratio

Overvoltage dropout ratio	Approx. 0.97
Undervoltage dropout ratio	Approx. 1.05

Times

Tripping time	Approx. 500 ms
Dropout time	Approx. 500 ms

14.63 Current-Sum Supervision

Setting Values

Slope factor		0.00 to 0.95	Increments of 0.01
Threshold	1 A @ 50 and 100 Irated	0.030 A to 10.000 A	Increments of 0.001 A
	5 A @ 50 and 100 Irated	0.15 A to 50.00 A	Increments 0.01 A
	1 A @ 1.6 Irated	0.001 A to 1.600 A	Increments of 0.001 A
	5 A @ 1.6 Irated	0.005 A to 8.000 A	Increments of 0.001 A
Delay failure indication		0.00 s to 100.00 s	Increments of 0.01 s

Dropout Ratio

Dropout ratio	Approx. 0.97
---------------	--------------

Times

Tripping time	Approx. 500 ms
Dropout time	Approx. 500 ms

14.64 Voltage-Sum Supervision

Setting Values

Threshold	0.300 V to 170.000 V	Increments of 0.001 V
Delay failure indication	0.00 s to 100.00 s	Increments of 0.01 s

Dropout Ratio

Dropout ratio	Approx. 0.97
---------------	--------------

Times

Tripping time	Approx. 500 ms
Dropout time	Approx. 500 ms

14.65 Current Phase-Rotation Supervision

Setting Values

Release threshold	1 A @ 50 and 100 Irated	0.030 A to 10.000 A	Increments of 0.001 A
	5 A @ 50 and 100 Irated	0.15 A to 50.00 A	Increments of 0.01 A
	1 A @ 1.6 Irated	0.001 A to 1.600 A	Increments of 0.001 A
	5 A @ 1.6 Irated	0.005 A to 8.000 A	Increments of 0.001 A
Delay failure indication		0.00 s to 100.00 s	Increments of 0.01 s
Phase sequence		A B C A C B	

Dropout Ratio

Release-threshold dropout ratio	Approx. 0.97
---------------------------------	--------------

Times

Tripping time	Approx. 500 ms
Dropout time	Approx. 500 ms

14.66 Voltage Phase-Rotation Supervision

Setting Values

Tripping delay	0.00 s to 100.00 s	Increments of 0.01 s
Phase-rotation direction	A B C A C B	

Times

Tripping time	Approx. 500 ms
Dropout time	Approx. 500 ms

14.67 Voltage-Comparison Supervision

Times

Alarm times	Approx. 3 ms to 12 ms + OOT ¹⁶³ at 50 Hz Approx. 2.5 ms to 10 ms + OOT at 60 Hz
Dropout time	20 ms

Frequency Operating Range

$10 \text{ Hz} \leq f \leq 90 \text{ Hz}$	According to specified tolerances
$f < 10 \text{ Hz}$	Inactive
$f > 90 \text{ Hz}$	

Tolerances

Pickup threshold	
Voltage	0.5 % of the setting value or 0.05 V

¹⁶³ OOT (Output Operating Time): extra delay of the output medium used

14.68 Trip-Circuit Supervision

Setting Values

Number of monitored circuits per circuit-breaker function group	1 to 3	
Operating mode per circuit	With 1 binary input With 2 binary inputs	
Pickup and dropout time	About 1 s to 2 s	
Adjustable indication delay with 1 binary input	1.00 s to 600.00 s	Increments of 0.01 s
Adjustable indication delay with 2 binary inputs	1.00 s to 600.00 s	Increments of 0.01 s

14.69 Closing-Circuit Supervision

Setting Values (Closing-circuit supervision with 1 binary input or 2 binary inputs)

Operating mode per circuit	With 1 binary input With 2 binary inputs	
Adjustable indication delay with 1 binary input	1.00 s to 600.00 s	Increments of 0.01 s
Adjustable indication delay with 2 binary inputs	1.00 s to 30.00 s	Increments of 0.01 s

Setting Values (Closing-circuit supervision with 3 binary inputs)

Number of monitored circuits per circuit breaker function group	1 to 3	
Operating mode per circuit	With 2 binary inputs and 1 resistance With 3 binary inputs	
Pickup and dropout time	Approx. 1 s to 2 s	
Adjustable indication delay with 2 binary inputs and 1 resistance	1.00 s to 30.00 s	Increments of 0.01 s
Adjustable indication delay with 3 binary inputs	1.00 s to 30.00 s	Increments of 0.01 s

14.70 Analog Channel Supervision via Fast Current Sum

Times

Pickup times	Approx. 2 ms (faster than the fastest protection function)
Dropout time	Approx. 100 ms

Blockings

Blocked functions	All functions that process the measured values from this current measuring point (for example, differential protection).
-------------------	--

14.71 Measuring-Voltage Failure Detection

Setting Values

3ph.fail. - VA,VB,VC <		0.300 V to 340.000 V	Increments of 0.001 V
3ph.fail. - phs.curr.release	1 A @ 50 and100 Irated	0.030 A to 35.000 A	Increments of 0.001 A
	5 A @ 50 and100 Irated	0.15 A to 175.00 A	Increments of 0.01 A
	1 A @ 1.6 Irated	0.001 A to 1.600 A	Increments of 0.001 A
	5 A @ 1.6 Irated	0.005 A to 8.000 A	Increments of 0.001 A
3ph.fail. - phs.curr. jump	1 A @ 50 and100 Irated	0.030 A to 35.000 A	Increments of 0.001 A
	5 A @ 50 and100 Irated	0.15 A to 175.00 A	Increments of 0.01 A
	1 A @ 1.6 Irated	0.001 A to 1.600 A	Increments of 0.001 A
	5 A @ 1.6 Irated	0.005 A to 8.000 A	Increments of 0.001 A
Asym.fail. - time delay		0.00 s to 30.00 s	Increments of 0.01 s
SO 3ph.fail. - time delay		0.00 s to 30.00 s	Increments of 0.01 s

Dropout

The larger dropout differential (= | **pickup value** - **dropout threshold** |) of the following 2 criteria is used:

Dropout differential derived from the parameter Dropout ratio	
If this parameter is not available, a dropout ratio of 95 % applies to the current threshold value and a dropout ratio of 105 % applies to the voltage threshold value.	
Minimum absolute dropout differential	150 mV sec.

Times

Pickup time	Approx. 10 ms + OOT ¹⁶⁴ at 50 Hz Approx. 10 ms + OOT at 60 Hz
Dropout time	Approx. 20 ms + OOT

Times

Use in function group Line	
Pickup time	Approx. 10 ms + OOT ¹⁶⁵ at 50 Hz Approx. 9 ms + OOT at 60 Hz
Use in other function group types	
Pickup time	Approx. 20 ms + OOT ¹⁶⁶ at 50 Hz Approx. 18 ms + OOT at 60 Hz

¹⁶⁴ OOT (Output Operating Time) Additional delay of the output medium used, see chapter [14.1.4 Relay Outputs](#)

¹⁶⁵ OOT (Output Operating Time) Additional delay of the output medium used, for example 5 ms with fast relays, see chapter [14.1.4 Relay Outputs](#)

¹⁶⁶ OOT (Output Operating Time) Additional delay of the output medium used, for example 5 ms with fast relays, see chapter [14.1.4 Relay Outputs](#)

Frequency Operating Range

$0.9 \leq f/f_{\text{rated}} \leq 1.1$	According to specified tolerances
$10 \text{ Hz} \leq f < 0.9 f_{\text{rated}}$ $1.1 f_{\text{rated}} < f \leq 90 \text{ Hz}$	Slightly expanded tolerances
$f < 10 \text{ Hz}$ $f > 90 \text{ Hz}$	Active

Tolerances

Currents	1 % of the setting value or 5 mA ($I_{\text{rated}} = 1 \text{ A}$) or 25 mA ($I_{\text{rated}} = 5 \text{ A}$), ($f_{\text{rated}} \pm 10 \%$)
Voltages	0.5 % of the setting value or 0.5 V
Time delays	1 % of the setting value or 10 ms

14.72 Voltage-Transformer Circuit Breaker

Setting Values

Response time	0.000 s to 0.030 s	Increments of 0.001 s
---------------	--------------------	-----------------------

14.73 Operational Measured Values and Statistical Values

The following applies to the tolerances of the currents and voltages:

- The values apply both to the RMS values and the absolute value and phase angle of the fundamental components.
- These values were determined for pure sinusoidal signals – without harmonics.
- All measured values additionally have a tolerance of 1 DIGIT.

Voltages

$V_{A'}$, $V_{B'}$, V_C Voltage range	V secondary < 200 V
Secondary rated voltage Measuring range Frequency range	100 V to 125 V 0.1 V_{rated} to 2 V_{rated} 49 Hz to 51 Hz at $f_{rated} = 50$ Hz 59 Hz to 61 Hz at $f_{rated} = 60$ Hz
Tolerance	0.2 % of the measured value in the above mentioned measuring range
Frequency range (expanded)	45 Hz to 55 Hz at $f_{rated} = 50$ Hz 55 Hz to 65 Hz at $f_{rated} = 60$ Hz
Tolerance	0.3 % of the measured value in the above mentioned measuring range
$V_{AB'}$, $V_{BC'}$, V_{CA} Voltage range	V secondary < 200 V
Secondary rated voltage Measuring range Frequency range	100 V to 125 V 0.1 V_{rated} to 2 V_{rated} 49 Hz to 51 Hz at $f_{rated} = 50$ Hz 59 Hz to 61 Hz at $f_{rated} = 60$ Hz
Tolerance	0.2 % of the measured value in the above mentioned measuring range
Frequency range (expanded)	45 Hz to 55 Hz at $f_{rated} = 50$ Hz 55 Hz to 65 Hz at $f_{rated} = 60$ Hz
Tolerance	0.3 % of the measured value in the above mentioned measuring range
V_1 , V_2 , V_0 Voltage range	V secondary < 200 V
Secondary rated voltage Measuring range Frequency range	100 V to 125 V 0.1 V_{rated} to 2 V_{rated} 49 Hz to 51 Hz at $f_{rated} = 50$ Hz 59 Hz to 61 Hz at $f_{rated} = 60$ Hz
Tolerance	0.25 % of the measured value in the above mentioned measuring range or 0.05 V
Frequency range (expanded)	45 Hz to 55 Hz at $f_{rated} = 50$ Hz 55 Hz to 65 Hz at $f_{rated} = 60$ Hz
Tolerance	0.35 % of the measured value in the above mentioned measuring range or 0.05 V

Currents, Instrument Transformers

$I_A, I_B, I_C, 3I_0$ Current range	A secondary < 1.6 I_{rated}
Rated currents Measuring range Frequency range	1 A, 5 A 0.1 I_{rated} to 1.6 I_{rated} 49 Hz to 51 Hz at $f_{rated} = 50$ Hz 59 Hz to 61 Hz at $f_{rated} = 60$ Hz
Tolerance	0.15 % of the measured value in the above mentioned measuring range or 0.001 I_{rated}
Frequency range (expanded)	45 Hz to 55 Hz at $f_{rated} = 50$ Hz 55 Hz to 65 Hz at $f_{rated} = 60$ Hz
Tolerance	0.3 % of the measured value in the above mentioned measuring range or 0.002 I_{rated}
I_1, I_2, I_0 Current range	A secondary < 1.6 I_{rated}
Rated currents Measuring range Frequency range	1 A, 5 A 0.1 I_{rated} to 1.6 I_{rated} 49 Hz to 51 Hz at $f_{rated} = 50$ Hz 59 Hz to 61 Hz at $f_{rated} = 60$ Hz
Tolerance	0.2 % of the measured value in the above mentioned measuring range or 0.001 I_{rated}
Frequency range (expanded)	45 Hz to 55 Hz at $f_{rated} = 50$ Hz 55 Hz to 65 Hz at $f_{rated} = 60$ Hz
Tolerance	0.35 % of the measured value in the above mentioned measuring range or 0.002 I_{rated}

Currents, Protection-Class Current Transformer

$I_A, I_B, I_C, 3I_0$ Current range	A secondary < 100 I_{rated}
Rated currents Measuring range Frequency range	1 A, 5 A 0.1 I_{rated} to 5 I_{rated} 49 Hz to 51 Hz at $f_{rated} = 50$ Hz 59 Hz to 61 Hz at $f_{rated} = 60$ Hz
Tolerance	0.2 % of the measured value in the above mentioned measuring range or 0.001 I_{rated}
Frequency range (expanded)	45 Hz to 55 Hz at $f_{rated} = 50$ Hz 55 Hz to 65 Hz at $f_{rated} = 60$ Hz
Tolerance	0.35 % of the measured value in the above mentioned measuring range or 0.002 I_{rated}
I_1, I_2, I_0 Current range	A secondary < 100 I_{rated}

Rated currents	1 A, 5 A
Measuring range	$0.1 I_{rated}$ to $5 I_{rated}$
Frequency range	49 Hz to 51 Hz at $f_{rated} = 50$ Hz 59 Hz to 61 Hz at $f_{rated} = 60$ Hz
Tolerance	0.25 % of the measured value in the above mentioned measuring range or $0.001 I_{rated}$
Frequency range (expanded)	45 Hz to 55 Hz at $f_{rated} = 50$ Hz 55 Hz to 65 Hz at $f_{rated} = 60$ Hz
Tolerance	0.4 % of the measured value in the above mentioned measuring range or $0.002 I_{rated}$

Currents, Sensitive Ground-Current Transformer

$3I_0$	A secondary
Current range	$< 1.6 I_{rated}$
Rated currents	1 A, 5 A
Measuring range	$0.1 I_{rated}$ to $1.6 I_{rated}$
Frequency range	49 Hz to 51 Hz at $f_{rated} = 50$ Hz 59 Hz to 61 Hz at $f_{rated} = 60$ Hz
Tolerance	0.15 % of the measured value in the above mentioned measuring range or $0.001 I_{rated}$
Frequency range (expanded)	45 Hz to 55 Hz at $f_{rated} = 50$ Hz 55 Hz to 65 Hz at $f_{rated} = 60$ Hz
Tolerance	0.3 % of the measured value in the above mentioned measuring range or $0.002 I_{rated}$

Phase Angle

Φ_V	$^{\circ}$
Frequency range	47.5 Hz to 52.5 Hz at $f_{rated} = 50$ Hz 57.5 Hz to 62.5 Hz at $f_{rated} = 60$ Hz
Tolerance Φ_V	0.2° at rated voltage
Φ_I	$^{\circ}$
Frequency range	47.5 Hz to 52.5 Hz at $f_{rated} = 50$ Hz 57.5 Hz to 62.5 Hz at $f_{rated} = 60$ Hz
Tolerance Φ_I	0.2° at rated current

Power Values

Active power P	W secondary
Voltage range	$0.8 V_{rated}$ to $1.2 V_{rated}$
Current range	$0.1 I_{rated}$ to $2 I_{rated}$
Frequency range	45 Hz to 55 Hz at $f_{rated} = 50$ Hz 55 Hz to 65 Hz at $f_{rated} = 60$ Hz
Power factor	$ \cos\phi \geq 0.707$
Tolerance	0.5 % of S_{rated} in the above mentioned measuring range
Reactive power Q	var secondary

Voltage range	0.8 V_{rated} to 1.2 V_{rated}
Current range	0.1 I_{rated} to 2 I_{rated}
Frequency range	45 Hz to 55 Hz at $f_{rated} = 50$ Hz 55 Hz to 65 Hz at $f_{rated} = 60$ Hz
Power factor	$ \cos\phi \leq 0.707$
Tolerance	0.7 % of S_{rated} in the above mentioned measuring range
Apparent power S	VA secondary
Voltage range	0.8 V_{rated} to 1.2 V_{rated}
Current range	0.01 I_{rated} to 2 I_{rated}
Frequency range	45 Hz to 55 Hz at $f_{rated} = 50$ Hz 55 Hz to 65 Hz at $f_{rated} = 60$ Hz
Tolerance	0.5 % of S_{rated} in the above mentioned measuring range

Power Factor

Voltage range	0.8 V_{rated} to 1.2 V_{rated}
Current range	0.1 I_{rated} to 2 I_{rated}
Frequency range	45 Hz to 55 Hz at $f_{rated} = 50$ Hz 55 Hz to 65 Hz at $f_{rated} = 60$ Hz
Tolerance	0.02 in the above mentioned measuring range

Frequency

Frequency f	Hz
Range	$f_{rated} \pm 0.20$ Hz
Tolerance	± 2 mHz at $V = V_{rated}$ or at $I = I_{rated}$
Range	$f_{rated} \pm 3.00$ Hz
Tolerance	± 5 mHz at $V = V_{rated}$ or at $I = I_{rated}$
Range	25 Hz to 80 Hz; operational measured values 10 Hz to 90 Hz; functional measured values, system frequency
Tolerance	± 10 mHz at $V = V_{rated}$ or at $I = I_{rated}$

Statistical Values of the Device

Device operating hours	h
Range	0 h to 99999999 h
Tolerance	1 h

Statistical Values, Circuit Breaker

Op.cnt. (operation counter)	
Range	0 to 999999999
Tolerance	None
∑I Off (sum of the primary currents switched off)	A, kA, MA, GA, TA, PA primary
Range	0 to 9.2^{e+15}

Operating hours	h
Range	0 h to 9999999 h
Tolerance	1 h
Circuit breaker open hours	h
Range	0 h to 9999999 h
Tolerance	1 h

Statistical Values, Disconnecter

Op.cnt. (operation counter)	
Range	0 to 999999999
Tolerance	None

14.74 Power Quality – Basic

14.74.1 Voltage Variation

The function **Voltage variation** complies with Class S according to IEC 61000-4-30.

Setting Values

Threshold of the Dip stage	10.0 % to 100.0 %	Increments of 0.1 %
Threshold of the Swell stage	100.0 % to 140.0 %	Increments of 0.1 %
Threshold of the Interruption stage	1.0 % to 20.0 %	Increments of 0.1 %
Dropout differential	1.0 % to 10.0 %	Increments of 0.1 %
Warning delay	0.00 s to 60.00 s	Increments of 0.01 s

Tolerances

Threshold value	1 % of the parameter Rated voltage that is set in the function group Class S according to IEC 61000-4-30
Warning delay	1 % of the setting value or 10 ms
Dip, swell, or interruption duration	2 network cycles Class S according to IEC 61000-4-30 (For the stage Interruption , Class S is met when the threshold value of the stage Interruption is set to be equal to or greater than 3 %.)
Residual or swell voltage	1 % of the parameter Rated voltage that is set in the function group Class S according to IEC 61000-4-30

Frequency Operating Range

$0.85 f_{\text{rated}} \leq f \leq 1.15 f_{\text{rated}}$	According to specified tolerances
$10 \text{ Hz} \leq f < 0.85 f_{\text{rated}}$ $1.15 f_{\text{rated}} < f \leq 90 \text{ Hz}$	Slightly expanded tolerances
$f < 10 \text{ Hz}$ $f > 90 \text{ Hz}$	Inactive

14.74.2 Voltage Unbalance

The function **Voltage Unbalance** complies with Class S according to IEC 61000-4-30.

Setting Value for the Function

Value	Setting Range	Increment
Minimum voltage V1	0.300 V to 60.000 V	0.001 V

Setting Values for the Stages

Value	Setting Range	Increment
Threshold	0.50 % to 10.00 %	0.01 %
Dropout ratio	0.90 to 0.99	0.01
Observation period	<ul style="list-style-type: none"> • daily • weekly 	–

Value	Setting Range	Increment
Starting day of week	<ul style="list-style-type: none"> • Sunday • Monday • Tuesday • Wednesday • Thursday • Friday • Saturday 	–
Percentile	80 % to 99 %	1 %

Tolerance

For all functional values in the measuring interval of 3 s or 10 min	
V2/V1, V0/V1	±0.15 % Class S according to IEC 61000-4-30

Dropout Ratio

Dropout ratio of warning	5 % of the setting value or 0.25
--------------------------	----------------------------------

Frequency Operating Range

$0.85 f_{\text{rated}} \leq f \leq 1.15 f_{\text{rated}}$	According to specified tolerances
$10 \text{ Hz} \leq f < 0.85 f_{\text{rated}}$ $1.15 f_{\text{rated}} < f \leq 90 \text{ Hz}$	Slightly expanded tolerances
$f < 10 \text{ Hz}$ $f > 90 \text{ Hz}$	Inactive

14.74.3 THD and Harmonics

Setting Value for the Stage Voltage

Value	Setting Range	Increment
Threshold	1.0 % to 25.0 %	0.1
Aggregation interval	<ul style="list-style-type: none"> • 1 min • 10 min 	–

Stage Current

Current range (I_a, I_b, I_c)	Protection transformer: $0.02 I_{\text{rated}}$ to $2 I_{\text{rated}}$	
Tolerance THD value	$I_{\text{fund.}} \geq 0.1 I_{\text{rated}}$	0.5 % in the measured range
	$0.02 I_{\text{rated}} \leq I_{\text{fund.}} < 0.1 I_{\text{rated}}$	2.0 % in the measured range
Tolerance harmonic value (2nd to 20th)	$I_{\text{fund.}} \geq 0.1 I_{\text{rated}}$	0.5 % in the measured range
	$0.02 I_{\text{rated}} \leq I_{\text{fund.}} < 0.1 I_{\text{rated}}$	2.0 % in the measured range

Stage Voltage

Voltage range (Va, Vb, Vc)	0.1 V_{rated} to 2 V_{rated}
Tolerance THD value	0.5 % in the measured range
Tolerance harmonic value (2nd to 20th)	0.5 % in the measured range

Frequency Operating Range

$0.85 f_{rated} \leq f \leq 1.15 f_{rated}$	According to specified tolerances
$0.8 f_{rated} \leq f < 0.85 f_{rated}$ $1.15 f_{rated} < f \leq 1.2 f_{rated}$	Slightly expanded tolerances
$f < 0.8 f_{rated}$ $f > 1.2 f_{rated}$	Inactive

14.74.4 Total Demand Distortion

Setting Value for the Stage Voltage

Value	Setting Range	Increment
Threshold	1.0 % to 25.0 %	0.1
Interval	<ul style="list-style-type: none"> • 15 min • 30 min 	–

Stage Current

Current range (Ia, Ib, Ic)	Protection transformer: 0.02 I_{rated} to 2 I_{rated}	
Tolerance of the TDD value	$I_{fund.} \geq 0.1 I_{rated}$	0.5 % in the measured range
	$0.02 I_{rated} \leq I_{fund.} < 0.1 I_{rated}$	2.0 % in the measured range

Frequency Operating Range

$0.85 f_{rated} \leq f \leq 1.15 f_{rated}$	According to specified tolerances
$0.8 f_{rated} \leq f < 0.85 f_{rated}$ $1.15 f_{rated} < f \leq 1.2 f_{rated}$	Slightly expanded tolerances
$f < 0.8 f_{rated}$ $f > 1.2 f_{rated}$	Inactive

14.75 Energy Values

Active energy W_p	kWh, MWh, GWh
Measuring range	$ \cos\varphi \geq 0.01$
Voltage range	$(0.8 \text{ to } 1.2) \cdot V_{\text{rated}}$
Current range	$(0.1 \text{ to } 2) \cdot I_{\text{rated}}$
Frequency range	49 Hz to 51 Hz at $f_{\text{rated}} = 50 \text{ Hz}$ 59 Hz to 61 Hz at $f_{\text{rated}} = 60 \text{ Hz}$
Tolerance	0.3 % of the measured value in the above mentioned measuring range
Frequency range (expanded)	40 Hz to 69 Hz at $f_{\text{rated}} = 50 \text{ Hz}$ 50 Hz to 70 Hz at $f_{\text{rated}} = 60 \text{ Hz}$
Tolerance	0.5 % of the measured value in the above mentioned measuring range
Reactive energy W_q	kvarh, Mvarh, Gvarh
Measuring range	$ \cos\varphi \leq 0.984$
Voltage range	$(0.8 \text{ to } 1.2) \cdot V_{\text{rated}}$
Current range	$(0.1 \text{ to } 2) \cdot I_{\text{rated}}$
Frequency range	49 Hz to 51 Hz at $f_{\text{rated}} = 50 \text{ Hz}$ 59 Hz to 61 Hz at $f_{\text{rated}} = 60 \text{ Hz}$
Tolerance	1.0 % of the measured value in the above mentioned measuring range
Frequency range (expanded)	40 Hz to 69 Hz at $f_{\text{rated}} = 50 \text{ Hz}$ 50 Hz to 70 Hz at $f_{\text{rated}} = 60 \text{ Hz}$
Tolerance	1.5 % of the measured value in the above mentioned measuring range
Pulse metered values	
Maximum detection speed	50/s

14.76 Circuit-Breaker Monitoring

Setting Values

Threshold value	ΣI^x -method	0 to 10 000 000	Increments of 1
	2P-method	0 to 10 000 000	Increments of 1
	I^2t -method	0.00 I/I_r^*s to 21 400 000.00 I/I_r^*s	Increments of 0.01
	Make time	1 % to 100 %	Increments of 1 %
	Break time	1 % to 100 %	Increments of 1 %
	Pole scatter time open	1 ms to 100 ms	Increments of 1 ms
	Pole scatter time close	1 ms to 100 ms	Increments of 1 ms
	Mechanical switching time open	1 ms to 1000 ms	Increments of 1 ms
	Mechanical switching time close	1 ms to 1000 ms	Increments of 1 ms
CB opening time	1 ms to 500 ms	Increments of 1 ms	
CB break time	1 ms to 600 ms	Increments of 1 ms	
CB make time	1 ms to 600 ms	Increments of 1 ms	
Exponent for ΣI^x method	1.0 to 3.0	Increments of 0.1	
Switching cycles at I_r	100 to 10 000 000	Increments of 1	
Rated short-circuit current I_{sc}	10 A to 100 000 A	Increments of 1 A	
Switching cycles at I_{sc}	1 to 1000	Increments of 1	
Operating current threshold	1 A @ 50 and 100 Irated	0.030 A to 35.000 A	Increments of 0.001 A
	5 A @ 50 and 100 Irated	0.15 A to 175.00 A	Increments of 0.01 A
	1 A @ 1.6 Irated	0.001 A to 1.600 A	Increments of 0.001 A
	5 A @ 1.6 Irated	0.005 A to 8.000 A	Increments of 0.01 A
Delay correction time	-50 ms to 50 ms	Increments of 1 ms	
Auxiliary-contact time	1 ms to 1000 ms	Increments of 1 ms	
Response time	1 ms to 1000 ms	Increments of 1 ms	

Tolerances

Tolerance of the measured value Make time	± 2 ms
Tolerance of the measured value Break time	± 2 ms
Tolerance of the measured value Pole scatter time	± 2 ms
Tolerance of the measured value Aux.-contact time	± 2 ms
Tolerance of the measured value response time	± 2 ms

14.77 Disconnecter Supervision

Setting Values

Threshold value	Mechanical switching time open	0.02 s to 1800.00 s	Increments of 0.01 s
	Mechanical switching time close	0.02 s to 1800.00 s	Increments of 0.01 s
Auxiliary contact time		0.02 s to 1800.00 s	Increments of 0.01 s
Reaction time		0.02 s to 1800.00 s	Increments of 0.01 s

Tolerances

Tolerance of the make-time measured value	±2 ms
Tolerance of the break-time measured value	±2 ms
Tolerance of the reaction-time measured value	±2 ms

14.78 CFC

In order to estimate the tick consumption of a CFC chart, you can use the following formula:

$$T_{\text{Chart}} = 5 \cdot n_{\text{Inp}} + 5 \cdot n_{\text{Outp}} + T_{\text{TLev}} + \sum_i T_{\text{int}} + \sum_j T_{\text{Block}}$$

Where:

- n_{Inp} Number of indications routed as input in the CFC chart
- n_{Outp} Number of indications routed as output in the CFC chart
- T_{TLev} 101 Ticks in the High priority Event-triggered level
104 Ticks in the Event-triggered level
54 Ticks in Measurement level
74 Ticks in the Low priority Event-triggered level
- T_{int} Number of internal connections between 2 CFC blocks in one chart
- T_{Block} Used ticks per CFC block (see [Table 14-8](#))

Table 14-8 Ticks of the Individual CFC Blocks

Element	Ticks
ABS_D	2.3
ABS_R	1.5
ACOS_R	6.9
ADD_D4	3.4
ADD_R4	3.3
ADD_XMV	6.4
ALARM	1.8
AND_SPS	1.1
AND10	2.9
APC_DEF	1.2
APC_EXE	1.0
APC_INFO	3.9
ASIN_R	1.3
ATAN_R	1.2
BLINK	1.3
BOOL_CNT	2.0
BOOL_INT	1.5
BSC_DEF	1.3
BSC_EXE	1.1
BSC_INFO	2.7
BUILD_ACD	2.9
BUILD_ACT	2.2
BUILD_BSC	1.2
BUILD_CMV	2.3
BUILD_DEL	2.1
BUILD_DPS	1.4
BUILD_ENS	1.3
BUILD_INS	0.5
BUILD_Q	0.8
BUILD_SPS	0.6

Element	Ticks
BUILD_WYE	3.2
BUILD_XMV	2.9
BUILDQ_Q	3.0
CHART_STATE	5.9
CMP_DPS	1.5
CON_ACD	0.7
CON_ACT	0.5
CONNECT	0.4
COS_R	2.5
CTD	1.8
CTU	1.6
CTUD	2.3
DINT_REAL	3.0
DINT_UINT	3.0
DIV_D	2.9
DIV_R	1.6
DIV_XMV	2.2
DPC_DEF	0.4
DPC_EXE	0.4
DPC_INFO	1.1
DPC_OUT	1.3
DPS_SPS	1.0
DRAGI_R	1.7
ENC_DEF	3.6
ENC_EXE	3.8
EQ_D	1.0
EQ_R	1.9
EXP_R	1.5
EXPT_R	2.7
F_TRGM	0.3
F_TRIG	0.3
FF_D	0.9
FF_D_MEM	1.4
FF_RS	0.7
FF_RS_MEM	1.2
FF_SR	0.8
FF_SR_MEM	1.1
GE_D	0.9
GE_R	1.1
GT_D	0.9
GT_R	1.2
HOLD_D	1.1
HOLD_R	1.0
INC_INFO	0.9
LE_D	1.1
LE_R	1.1
LIML_R	1.5

Element	Ticks
LIMU_R	1.5
LN_R	3.3
LOG_R	1.2
LOOP	1.5
LT_D	0.9
LT_R	0.9
MAX_D	0.9
MAX_R	1.4
MEMORY_D	0.9
MEMORY_R	1.1
MIN_D	0.7
MIN_R	1.3
MOD_D	1.5
MUL_D4	2.5
MUL_R4	2.7
MUL_XMV	2.8
MUX_D	1.2
MUX_R	0.9
NAND10	3.5
NE_D	0.9
NE_R	0.9
NEG	1.2
NEG_SPS	0.8
NL_LZ	3.8
NL_MV	5.6
NL_ZP	2.7
NOR10	3.2
OR_DYN	1.1
OR_SPS	1.3
OR10	2.6
R_TRGM	0.4
R_TRIG	0.4
REAL_DINT	3.0
REAL_SXMV	3.0
SIN_R	0.8
SPC_DEF	0.4
SPC_EXE	0.4
SPC_INFO	0.4
SPC_OUT	0.4
SPLIT_ACD	3.4
SPLIT_ACT	1.0
SPLIT_BSC	1.3
SPLIT_CMV	2.2
SPLIT_DEL	2.0
SPLIT_DPS	1.0
SPLIT_INS	0.5
SPLIT_Q	0.7

Element	Ticks
SPLIT_SPS	0.8
SPLIT_WYE	2.6
SPLIT_XMV	2.1
SQRT_R	0.6
SUB_D	1.3
SUB_R	1.6
SUB_XMV	2.4
SUBST_B	1.0
SUBST_BQ	1.5
SUBST_D	1.0
SUBST_R	1.0
SUBST_XQ	1.4
SXMV_REAL	3.0
TAN_R	1.1
TLONG	2.2
TOF	1.0
TON	1.1
TP	2.5
TSHORT	1.9
UINT_DINT	3.0
XOR2	2.6

A Appendix

A.1	Order Configurator and Order Options	1742
A.2	Function Packages	1743
A.3	Accessories	1746
A.4	Typographic and Symbol Conventions	1747
A.5	Standard Variants for 7SX800	1750
A.6	Requirements for Current Transformers for Network Protection Applications with Overcurrent Protection	1752
A.7	Requirements for Current Transformers for Motor-Protection Applications with Overcurrent Protection	1758
A.8	Connection Examples for Current Transformers	1765
A.9	Connection Examples of Voltage Transformers	1772
A.10	Preroutings for Overcurrent-Protection Applications	1776
A.11	Preroutings for Motor and Power-System Decoupling Applications	1777

A.1 Order Configurator and Order Options

Order Configurator

The order configurator assists you in the selection of SIPROTEC 5 Compact products. The order configurator is a Web application that can be used with any browser. The order configurator can be used to configure complete devices or individual components and other accessories. At the end of the configuration process, the product code and a detailed presentation of the configuration result are provided. The product code unambiguously describes the selected product and also serves as an order number.

Order Options

**NOTE**

You can find the selection and order options for SIPROTEC 5 Compact in the order configurator under: <https://mall.industry.siemens.com/mall/en/de/entryPoints/StartConfigurator?ConfigId=33&nodeid=10313567&kmat=7SX800>

A.2 Function Packages

Table A-1 Standard Function Package (Current-Based Functions and Cybersecurity)

ANSI	Function	Function points (FP)
	Protection functions for 3-pole tripping	Basis (0)
14	Locked rotor	
37	Undercurrent protection	
46	Negative-sequence system overcurrent protection	
46	Unbalanced-Load Protection	
49	Thermal overload protection	
49R	Thermal overload protection, rotor (motor)	
50/51	Overcurrent protection, phases	
	Switch-Onto-Fault Tripping (SOTF)	
50HS	Instantaneous high-current tripping	
50/51	Overcurrent protection with positive-sequence current I1	
50N/51N	Overcurrent protection, ground	
50N/51N	Overcurrent protection, 1-phase	
50Ns/51Ns	Sensitive ground current protection for grounded arc suppression coils and isolated power systems (3I0>, 3I0-harm>)	
	Sensitive ground-fault detection via pulse detection	
	Intermittent ground-fault protection	
50BF	Circuit-breaker failure protection, 3-pole	
50RS	Circuit breaker reignition monitoring	
59C	Peak overvoltage protection, 3-phase, for capacitors	
60C	Current-unbalance protection for capacitor banks (1-phase)	
74TC	Trip-circuit supervision	
74CC	Single circuit monitoring	
79	Automatic reclosing, 3-pole	
86	Lockout	
87N	Restricted Ground-fault Protection	
	Measured values, extended: Min, max, average	
	Switching statistics counter	
	Power quality – basics, measured values: THD (Total Harmonic Distortion) and harmonic (current)	
	CFC (standard, control, arithmetic)	
	Circuit-breaker wear monitoring	
	Switching sequence function	
	Inrush-current detection	
	External trip initiation	
	Control	
	Fault recording of analog and binary signals	
	Monitoring	
	Cybersecurity: Role-based access control	
	Cybersecurity: Authenticated network access using IEEE 802.1x	
SSR	Slow-scan recorder	
CR	Continuous recorder	
TR	Trend recorder	

Table A-2 Voltage-Based Function Package

ANSI	Function	FP
	Voltage measurement	40
24	Overexcitation protection	
25	Synchrocheck, synchronization function	
27	Undervoltage protection: 3-phase or positive-sequence system V1 or universal Vx	
27R, 59R	Voltage change protection	
	Directional reactive power undervoltage protection (QU protection)	
32.37	Power protection active/reactive power	
32R	Reverse-power protection	
46	Negative-sequence system overcurrent protection with direction	
47	Overvoltage protection: negative-sequence system V2 or negative-sequence system V1/positive-sequence system V1	
51V	Overcurrent protection, voltage dependent	
59, 59N	Overvoltage protection: 3-phase or zero-sequence system V0 or positive-sequence system V1 or universal Vx	
	Voltage protection according to the standard CEI 0-16	
60	Voltage-comparison supervision	
67	Directional overcurrent protection, phases	
67N	Directional overcurrent protection, ground	
67Ns	Sensitive ground-fault detection for systems with resonant or isolated neutral including a) $3I_0 >$ b) $V_0 >$, c) $\cos/\sin \varphi$, d) Transient ground fault, e) $\varphi(V, I)$, f) Admittance	
	Directional intermittent ground-fault protection	
81	Frequency protection: $f >$ or $f <$ or df/dt	
81U	Underfrequency load shedding	
	Vector-jump protection	
FL	Fault locator, single-side	
FL+	Fault locator plus, single-side	
	Power Quality – Basic, measured values: THD (Total Harmonic Distortion) and harmonics (voltage)	

Table A-3 Motor Protection Functions

ANSI	Function	FP
48	Motor-starting time supervision	5
50L	Load-jam protection motor	5
66	Motor restart inhibit	5

Table A-4 Communication Package – Ethernet Protocols

	Ethernet Protocols	FP
	IEC 61850-8-1	50
	Modbus TCP	
	IEC 60870-5-104	
	DNP3	
	PROFINET IO	
	Redundancy protocols RSTP/PRP/HSR	

Table A-5 Communication Package – Serial Protocols

	Serial Protocols	FP
	IEC 60870-5-103	20
	DNP3	
	Modbus RTU	

Table A-6 PQ – Basic

	Measured Values	FP
	Voltage unbalance (required voltage-based protection functions)	20
	Voltage variations – supervision of voltage dips, swells, and interruptions (required voltage-based protection functions)	30
	TDD – Total demand distortion	10
	PQ-10/12 cycle values for continuous recorder	25
	PQ trend values for trend recorder	25
	PQ flicker values for trend recorder	25

A.3 Accessories

Table A-7 Accessories



Group	Accessories	Articles per packaging unit	Order no.
Terminal	Voltage terminal, terminal block, 14-pole	8	7XX8400-0VA00
Terminal	Current terminal, 4 x protection	1	7XX8410-0CF00
Terminal	Current terminal, 3 x protection and 1 x measurement	1	7XX8410-0CG00
Terminal	2-pole cross connector for current terminal	3	7XX8400-0XA00
Terminal	Terminals for expansion module	2	7XX8410-0TE00
Terminal	2-pole cross connector for voltage terminal	6	7XX8400-0XB00
Terminal	Cover for current terminal block	1	7XX8400-0XC00
Terminal	Cover for voltage terminal block	8	7XX8400-0XD00
Terminal	Transport safety, current terminal	2	7XX8400-0XE00
Terminal	Transport safety, voltage terminal	10	7XX8400-0XF00
Terminal	Terminal for direct connection to 400 V low voltage	4	7XX8400-0TD00
Accessories	USB cover	10	7XX8310-0MK00
Accessories	Set of angle rails	2	7XX8300-0ME00
Accessories	Panel surface mounting assembly frame (for mounting a device in the panel surface mounting)	1	7XX8310-0MG00
Accessories	DIGSI 5 USB cable 2.0	1	7XX8300-0CE00
Accessories	SFP RJ45	10	7XX8300-0EB00
Accessories	Y-adaptor cable for serial communication	1	7XV5103-2CA00
Accessories	RS485 bus termination plug	1	7XV5103-5BA00
Accessories	IRIG B adaptor cable	1	7XX8310-0CG00







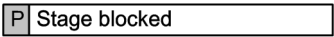
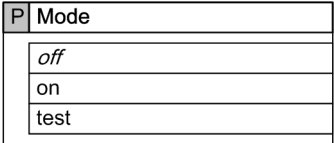
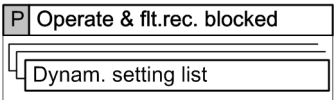
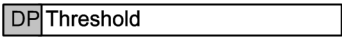
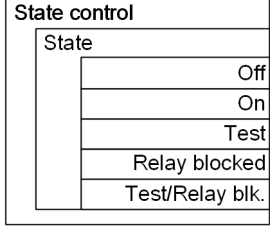
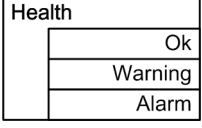
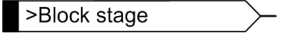
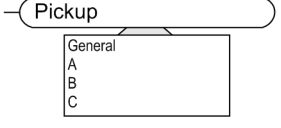

A.4 Typographic and Symbol Conventions

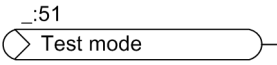
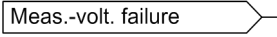
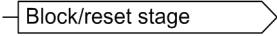
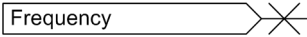



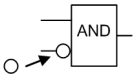

The following typefaces are used to characterize parameters in the text:

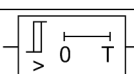
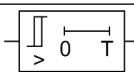
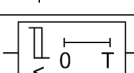
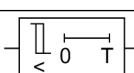
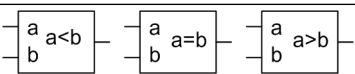
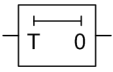
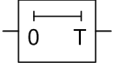
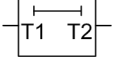
Mode	Parameter name
<i>_:661:1</i>	Parameter address _ stands for the address combination from function group:function 661, for example, stands for the address of the setting parameter
<i>off</i>	Parameter state

The following symbols are used in drawings:

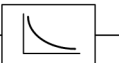
Icon	Description
<i>_:691:41</i> 	Parameter
<i>_:661:1</i> 	Parameters with setting values The default setting is in the 1st position and is displayed in italics.
<i>_:4861:2</i> 	Parameters with application-dependent setting values
<i>_:4861:3</i> 	Dynamic settings
	State logic
	Health of a function, stage, or function block
<i>_:691:81</i> 	External binary input signal with indication number
<i>_:55</i> 	External output signal with indication number and additional information
	External output signal without indication number
<i>_:3451:300</i> 	Measured output value

Icon	Description
	Binary input signal derived from an external output signal
	Internal input signal
	Internal output signal
	Analog input signal
	Reset/block a logic element
	AND gate
	OR gate
	XOR gate
	Negation
	Threshold stage exceeded
	Threshold stage exceeded with reset of input
	Threshold stage shortfall
	Threshold stage shortfall with reset of input
	Threshold stage exceeded with dropout delay
	Threshold stage exceeded with dropout delay and reset of input
	Threshold stage shortfall with dropout delay
	Threshold stage shortfall with dropout delay and reset of input
	Comparators
	Pickup delay
	Dropout delay
	Pickup and dropout delay

Icon	Description
	Trigger the pulse of duration T with a positive signal edge
	Trigger the pulse of duration T with a negative signal edge
	SR-flip-flop, RS-flip-flop, D-flip-flop
	Characteristic curve
	Minimum operate time
	Circuit breaker open
	Circuit breaker closed

A.5 Standard Variants for 7SX800

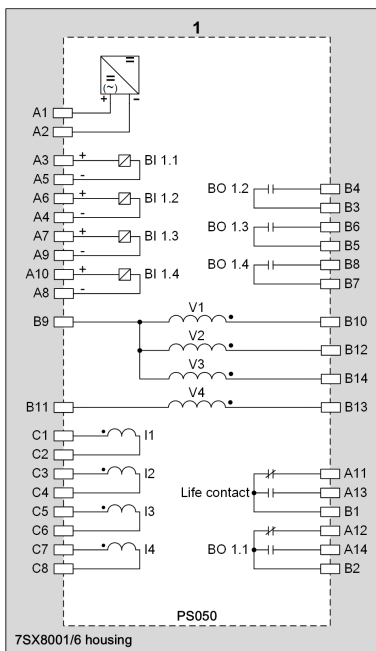

[sv_PS050, 1, en_US]

Figure A-1 Standard Variant Type 1

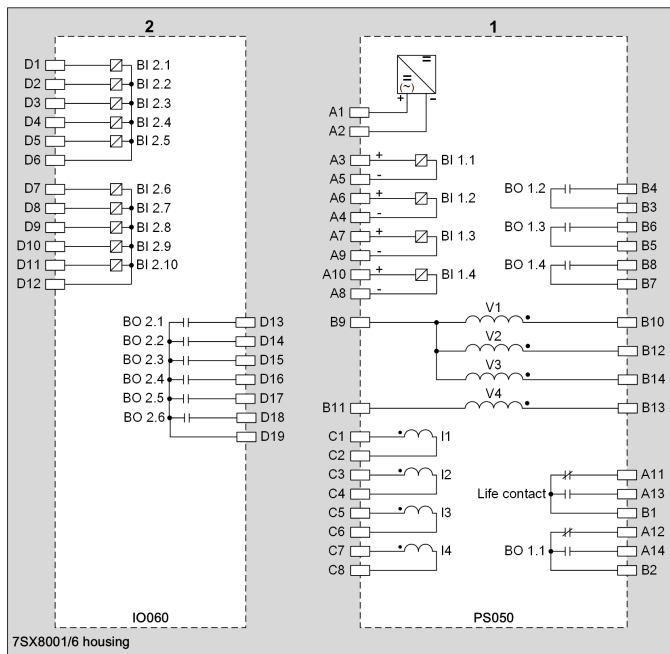

[sv_IO060_PS050, 1, en_US]

Figure A-2 Standard Variant Type 2

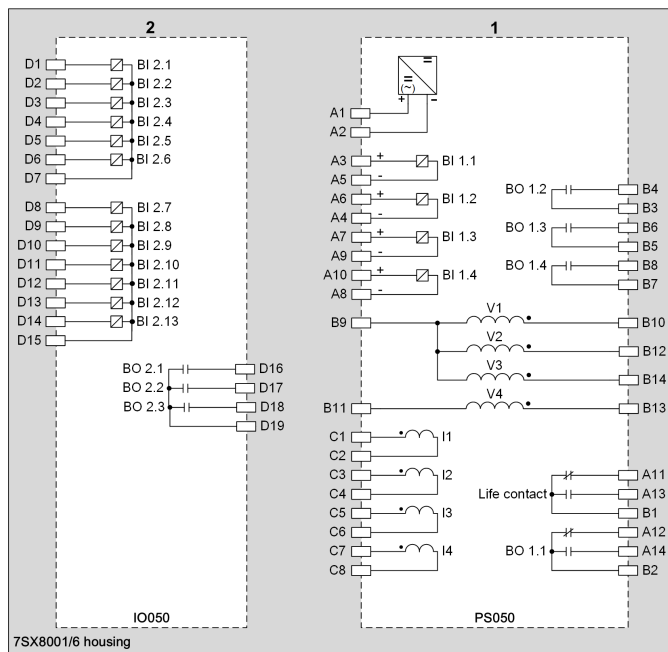

[sv_IO050_PS050, 1, en_US]

Figure A-3 Standard Variant Type 3

A.6 Requirements for Current Transformers for Network Protection Applications with Overcurrent Protection

The protection functions require current transformers that are dimensioned properly. This section describes the characteristics required for the dimensioning of the current transformer. The specified rules pertaining to dimensioning apply the definition of a protection current transformer from IEC 61869-2 (previously IEC 60044-1 and IEC 60044-6) as well as IEC TR 61869-100. Dimensioning according to ANSI C57.13 is also described.

Current Transformers

Parameter	Description
ALF	Accuracy limit factor
ALF'	Operational accuracy limit factor The operational accuracy limit factor is derived from the connected burden R_{bc} :
	$ALF' \approx ALF \cdot \frac{R_{ct} + R_b}{R_{ct} + R_{bc}}$
R_{ct}	Secondary winding resistance; corrected to 75 °C or another temperature as per the specification
R_b	Rated resistive burden
R_{bc}	Connected resistive operating burden
S_r	Rated power
K_{SSC}	Rated symmetrical short-circuit current factor $K_{SSC} = \frac{I_{psc}}{I_{pr}}$
I_{psc}	Rated primary short-circuit current
I_{pr}	Rated primary current
I_{sr}	Rated secondary current
K_{td}	Transient dimensioning factor
E_k	Rated knee-point EMF
V_{tc}	Current terminal voltage with 20-fold rated current and connected burden R_{bc} (ANSI C57.13)

Protected Object

Parameter	Description
I_{SC}	Symmetrical short-circuit current
$I_{max. threshold}$	Maximum primary threshold value for a current stage
I_{rM}	Rated current of the motor
I_{AM}	Motor starting current
$I_{AM trans}$	Max. motor starting current (transient starting current after starting from a standstill)

Definition of the Requirements for the Dimensioning of the Phase Current Transformer

The requirements for the phase current transformers predominantly arise from the high-current stage setting values for the overcurrent protection system, the high-current stage being the current stage with the max. threshold value. There are also minimum requirements that are derived from empirical values.

IEC Class	Minimum	Requirement
5P, 10P	$ALF' \geq 20$	$ALF' \geq \frac{I_{\max, \text{threshold}}}{I_{\text{pr}}}$
5PR, 10PR	$ALF' \geq 20$	$ALF' \geq \frac{I_{\max, \text{threshold}}}{I_{\text{pr}}}$
TPX, TPY, TPZ	20 (Burden $R_b \geq R_{bc}$)	$K_{td} \cdot K_{SSC} \geq \frac{I_{\max, \text{threshold}}}{I_{\text{pr}}}$
PX, PXR	$E_k \geq 16 \cdot I_{sr} \cdot (R_{ct} + R_{bc})$	$E_k \geq 0,8 \cdot \frac{I_{\max, \text{threshold}}}{I_{\text{pr}}} \cdot I_{sr} \cdot (R_{ct} + R_{bc})$
ANSI class C ($I_{sr} = 5 \text{ A}$)	$20 \cdot I_{sr} \cdot R_{bc}$	$V_{tc} \geq \frac{I_{\max, \text{threshold}}}{I_{\text{pr}}} \cdot I_{sr} \cdot R_{bc}$

Examples can be found in the sections:

- [EXAMPLE; Page 1760](#)
- [Application of Current Transformers Class IEC 5P, 10P, Page 1753](#)
- [Application of Current Transformers Class IEC TPY, Page 1754](#)
- [Application of Current Transformers Class ANSI C, Page 1755](#)
- [Application in the Electrical Power System, Page 1755](#)
- [Requirements for the Core Balance Current Transformer for Sensitive Ground-Fault Detection, Page 1756](#)
- [Special Case for Measuring the Ground Current via the Phase Current Transformer Return Line \(Holm-green Connection\), Page 1764](#)

Application of Current Transformers Class IEC 5P, 10P

For this example, a check is carried out to see whether an existing 10P10 current transformer meets the requirements. The high-current stage is used as a fast short-circuit protection system .

Parameter	Value	Description
I_{pr}	100 A	Rated primary current of the current transformer
I_{sr}	1 A	Rated secondary current of the current transformer
S_r	5 VA	Rated power
ALF	10	Accuracy limit factor
R_{ct}	0.5 Ω	Secondary winding resistance at 75 °C
l_{Cable}	50 m	Length of the secondary current transformer supply lines
A_{Cable}	4 mm ²	Core cross section of the secondary current transformer supply lines
ρ_{Cu}	0.0213 $\Omega \text{ mm}^2/\text{m}$	Copper cable resistance at 75 °C (the value is 0.0175 $\Omega \text{ mm}^2/\text{m}$ at 20 °C)
S_{Device}	0.1 VA	Protection device burden at the rated current

Calculation of the Connected Burden:

The burden R_{bc} that is connected to the terminals of the current transformer is derived from the double supply line resistance (supply and return line) and the device burden as indicated below.

$$R_{\text{Cable}} = \frac{2 \cdot \rho_{\text{Cu}} \cdot l_{\text{Cable}}}{A_{\text{Cable}}} = \frac{2 \cdot 0.0213 \frac{\Omega \cdot \text{mm}^2}{\text{m}} \cdot 50}{4 \text{ mm}^2} = 0.5325 \Omega$$

$$R_{\text{Device}} = \frac{S_{\text{Device}}}{I_{\text{sr}}^2} = \frac{0.1 \text{ VA}}{(1 \text{ A})^2} = 0.1 \Omega$$

$$R_{\text{b}} = \frac{S_{\text{r}}}{I_{\text{sr}}^2} = \frac{5 \text{ VA}}{(1 \text{ A})^2} = 5 \Omega$$

$$R_{bc} = R_{\text{Cable}} + R_{\text{Device}} = 0.5325 \Omega + 0.1 \Omega \approx 0.633 \Omega$$

$$ALF' \approx ALF \cdot \frac{R_{\text{ct}} + R_{\text{b}}}{R_{\text{ct}} + R_{\text{ba}}} = 10 \cdot \frac{0.5 \Omega + 5 \Omega}{0.5 \Omega + 0.633 \Omega} \approx 49$$

Estimation of the threshold value $I_{\text{max.threshold}}$ for a transformer with the following data:

Rated voltages 20 kV/0.4 kV

Rated apparent power $S_{\text{r}} = 1.4 \text{ MVA}$

Vector group Dyn5

Short-circuit voltage $v_{\text{sc}} = 6 \%$

Rated current:

$$I_{\text{r},20 \text{ kV}} = \frac{S_{\text{r}}}{\sqrt{3} \cdot V_{\text{r},20 \text{ kV}}} = \frac{1.4 \text{ MVA}}{\sqrt{3} \cdot 20 \text{ kV}} = 40.41 \text{ A}$$

Symmetrical short-circuit current for a fault on the 0.4 kV side:

$$I_{\text{sc}} \approx \frac{I_{\text{r},20 \text{ kV}}}{v_{\text{sc}} [\%]} \cdot 100 \% = \frac{40.41 \text{ A}}{6 \%} \cdot 100 \% = 674 \text{ A}$$

Threshold value of the overcurrent-protection stage:

$$I_{\text{max.threshold}} = 1.4 \cdot I_{\text{sc}} = 1.4 \cdot 674 \text{ A} = 944 \text{ A}$$

Conditions:

$$\text{Requirement: } ALF' \geq \frac{I_{\text{max.threshold}}}{I_{\text{pr}}} = \frac{944 \text{ A}}{50 \text{ A}} = 18.9 \text{ at least } 20$$

Comparison: ALF' current transformer $>$ ALF' requirement

Result: $49 > 20$

The current transformer meets the requirement.

Application of Current Transformers Class IEC TPY

The current transformers are specified by K_{SSC} , K_{td} , and R_{b} . The current transformer above should be replaced by a current transformer class TPY with the following parameters:

$$K_{\text{SSC}} = 20$$

$$K_{\text{td}} = 1.5$$

$$R_b = 1 \Omega$$

The requirements are compared with the data from the current transformer.

Rated symmetrical short-circuit current factor:

$$K_{SSC} = \frac{I_{psc}}{I_{pr}} = \frac{I_{max.threshold}}{I_{pr}} = \frac{786 \text{ A}}{100 \text{ A}} = 7.86$$

Required product: $K_{td} \cdot K_{SSC} \geq \frac{I_{max.threshold}}{I_{pr}} = \frac{786 \text{ A}}{100 \text{ A}} = 7.9$ at least 20

Current transformer: $K_{td} \cdot K_{SSC} = 1.5 \cdot 20 = 30$

Result: $30 > 20$

The required resistive dimensioning burden R_b of the current transformer must be greater than the connected resistive burden R_{bc} that was previously calculated.

Requirement: $R_b > R_{bc}$

Result: $1 \Omega > 0.663 \Omega$

The TPY class current transformer meets the requirements.

Application of Current Transformers Class ANSI C

This class is specified with a maximum secondary terminal voltage V_t . In this example, the current transformer uses the following parameters:

Class	C100
Transformer terminal voltage at a rated impedance of 1 Ω	$V_t = 100 \text{ V}$
Rated secondary current:	$I_{sr} = 5 \text{ A}$

The rated secondary current of $I_{sr} = 5 \text{ A}$ causes the connected burden to change.

$$R_{Device} = \frac{S_{Device}}{I_{sr}^2} = \frac{0.1 \text{ VA}}{(5 \text{ A})^2} = 0.004 \Omega$$

$$R_{bc} = R_{Cable} + R_{Device} = 0.5325 \Omega + 0.004 \Omega \approx 0.537 \Omega$$

Required transformer terminal voltage for the current transformer: $V_{tc} \geq \frac{I_{max.threshold}}{I_{pr}} \cdot I_{sr} \cdot R_{bc} = \frac{786 \text{ A}}{100 \text{ A}} \cdot 5 \text{ A} \cdot 0.537 \Omega = 21.10 \text{ V}$

Minimum requirement: $V_{tc} \geq 20 \cdot I_{sr} \cdot R_{bc} = 20 \cdot 5 \text{ A} \cdot 0.537 \Omega = 53.7 \text{ V}$

Current transformer terminal voltage: $V_t = 100 \text{ V}$

Result: $100 \text{ V} > 53.7 \text{ V}$

The C100 class current transformer meets the requirements.

Application in the Electrical Power System

The current transformer is selected for the system shown in the example. The primary impedances that have been converted to the 20 kV voltage level are shown in the figure below. These are used to estimate the short-circuit current.

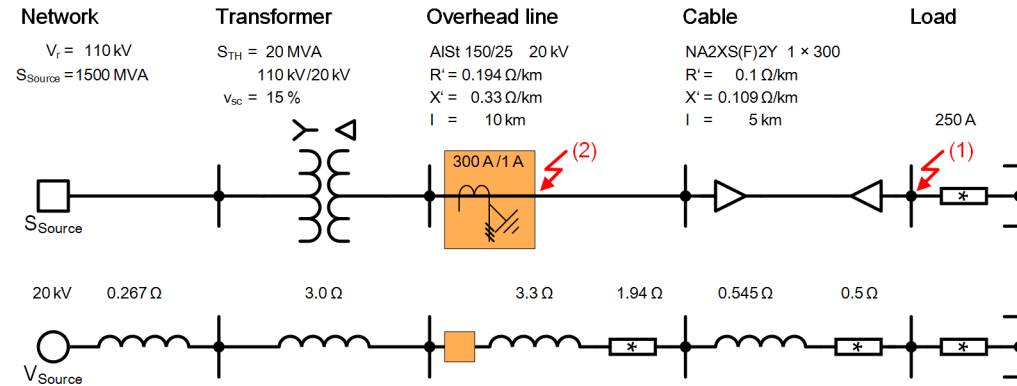

Figure A-4 Example for a System Design

The 3-phase short-circuit current is calculated as follows for remote faults:

$$I_{sc(1)} = \frac{1.1 \cdot \frac{V_Q}{\sqrt{3}}}{\sqrt{R_{sum}^2 + X_{sum}^2}} = \frac{1.1 \cdot \frac{20 \text{ kV}}{\sqrt{3}}}{\sqrt{((1.94 + 0.5)\Omega)^2 + ((0.267 + 3 + 3.3 + 0.545)\Omega)^2}}$$

$$= \frac{1.1 \cdot \frac{20 \text{ kV}}{\sqrt{3}}}{\sqrt{(5.95 + 50.58)\Omega^2}} = 1.69 \text{ kA}$$

The 3-phase short-circuit current is calculated as follows for near faults:

$$I_{sc(2)} = \frac{1.1 \cdot \frac{V_Q}{\sqrt{3}}}{\sqrt{X_N^2 + X_{Tr}^2}} = \frac{1.1 \cdot \frac{20 \text{ kV}}{\sqrt{3}}}{\sqrt{((0.267 + 3.0)\Omega)^2}} = \frac{1.1 \cdot \frac{20 \text{ kV}}{\sqrt{3}}}{\sqrt{10.67 \Omega^2}} = 3.89 \text{ kA}$$

Estimation of the overcurrent-protection stage pickup value:

$$I_{\text{Threshold value}} \approx 1.5 \cdot I_{pr} = 1.5 \cdot 300 \text{ A} = 450 \text{ A}$$

Ratio to the max. short-circuit current:

$$\frac{I_{sc(2)}}{I_{\text{Threshold value}}} = \frac{3890 \text{ A}}{450 \text{ A}} \approx 8.64$$

As the threshold value is significantly less than the maximum short-circuit current, protection by measuring the RMS value over a cycle will safely kick in even in the event of current-transformer saturation.

Selected current transformer: **10P10; 2.5 VA** or **5P10; 2.5 VA**

The calculation is based on a connected burden of $R_{bc} < 2 \Omega$. If a high-current stage is available, for example for reverse interlocking, Siemens recommends power of 5 VA for the current transformer or a current transformer 5P20; 2.5 VA.

Requirements for the Core Balance Current Transformer for Sensitive Ground-Fault Detection

The requirements for the core balance current transformer are determined by the **sensitive ground-fault detection** function. A directional sensitive ground-fault protection system is used for selective sensitive ground-fault detection in the busbar connection for motors and generators. The protection function trips with a delay.

The electrical power systems are predominantly isolated. A grounding transformer with load equipment is available that feeds in a maximum active current of 10 A to enable the stator ground-fault protection system to be 80 % to 90 % effective. The $\cos\phi$ method is used here. The capacitive current of the electrical power system is superimposed on the active current.

The following table shows the requirements and recommendations for the instrument transformer.

Parameter	Value	Note
I_{pr}	60 A	60 A is a recommended value for motor and generator protection applications.
I_{sr}	1 A	Preferred value
Class	1	This is the recommended class. If small currents need to be measured accurately, for example, up to 1 % I_{pr} , Siemens recommends the 0.5S class. Class 3 is sufficient for just measuring the ground current without being influenced by the angle accuracy. The measurement deviation for the transfer ratio of 3 % is defined in the range of (50 % to 120 %) I_{pr} .
S_r	1 VA	The accuracy specifications for the ratio error of measurement and the phase displacement in IEC 61869-2, <i>Section 5.6.201.3</i> refer to this rated power. The rated power is sufficient for a connected burden $R_{bc} < 1 \Omega$. If there are larger burdens, you must increase the power, where the value of 15 VA may not be exceeded in accordance with IEC 61869-2, <i>Section 5.6.201.4</i> .
R_{bc}	$< 1 \Omega$	The standard values of the accuracy classes apply for a burdening of 25 % to 100 % of the rated power. The connected burden must be R_{bc} in this range. In the event of deviations, you must adjust the rated power S_r . For small burdens, for example, during use in medium voltage cubicles, you must reduce the rated power to 0.5 VA.
FS	10	Required overcurrent limiting factor (FS 10). The number 10 expresses that the current is reduced to $10 \cdot I_{pr}$ and not transmitted by the current transformer. The standard does not dictate what current the current transformer may be saturated from.

The recommended current transformer has the following specification: 60 A/1 A; 1 VA, cl.1 FS 10



NOTE

The neutral point on the transformer is partially grounded via a resistor in industry networks to minimize transient overvoltages in the event of a ground fault, and this leads to larger ground currents. Adjust the primary rated current I_{pr} of the core balance current transformer if required. The sensitive ground-current measurement function meets the requirements for selectivity, as a sufficient zero-sequence current flows in the faulty motor in the event of a ground fault.

Table A-8 Limiting Values for the Recommended Instrument Transformers in accordance with IEC 61869-2, Section 5.6.201.3

Class	Ratio Error of Measurement (\pm %)					Phase Displacement (\pm Minutes)				
	for current (% of rated current)					for current (% of rated current)				
	1	5	20	100	120	1	5	20	100	120
0.5S	1.5	0.75	0.5	0.5	0.5	90	45	30	30	30
1	–	3.0	1.5	1.0	1.0	–	180	90	60	60

A.7 Requirements for Current Transformers for Motor-Protection Applications with Overcurrent Protection

The protection functions require current transformers that are dimensioned properly. This section describes the characteristics required for the dimensioning of the current transformer. The specified rules pertaining to dimensioning apply the definition of a protection current transformer from IEC 61869-2 (previously IEC 60044-1 and IEC 60044-6) as well as IEC TR 61869-100. Dimensioning according to ANSI C57.13 is also described.

Current Transformers

Parameter	Description
ALF	Accuracy limit factor
ALF'	Operational accuracy limit factor The operational accuracy limit factor is derived from the connected burden R_{bc} :
	$ALF' \approx ALF \cdot \frac{R_{ct} + R_b}{R_{ct} + R_{bc}}$
R_{ct}	Secondary winding resistance; corrected to 75 °C or another temperature as per the specification
R_b	Rated resistive burden
R_{bc}	Connected resistive operating burden
S_r	Rated power
K_{SSC}	Rated symmetrical short-circuit current factor
	$K_{SSC} = \frac{I_{psc}}{I_{pr}}$
I_{psc}	Rated primary short-circuit current
I_{pr}	Rated primary current
I_{sr}	Rated secondary current
K_{td}	Transient dimensioning factor
E_k	Rated knee-point EMF
V_{tc}	Current terminal voltage with 20-fold rated current and connected burden R_{bc} (ANSI C57.13)

Protected Object

Parameter	Description
I_{SC}	Symmetrical short-circuit current
$I_{max. threshold}$	Maximum primary threshold value for a current stage
I_{rM}	Rated current of the motor
I_{AM}	Motor starting current
$I_{AM trans}$	Max. motor starting current (transient starting current after starting from a standstill)

Definition of the Requirements for the Dimensioning of the Phase Current Transformer

The requirements for the phase current transformers predominantly arise from the high-current stage setting values for the overcurrent protection system, the high-current stage being the current stage with the max. threshold value. There are also minimum requirements that are derived from empirical values.

IEC Class	Minimum	Requirement
5P, 10P	$ALF' \geq 20$	$ALF' \geq \frac{I_{\max, \text{threshold}}}{I_{\text{pr}}}$
5PR, 10PR	$ALF' \geq 20$	$ALF' \geq \frac{I_{\max, \text{threshold}}}{I_{\text{pr}}}$
TPX, TPY, TPZ	20 (Burden $R_b \geq R_{bc}$)	$K_{td} \cdot K_{SSC} \geq \frac{I_{\max, \text{threshold}}}{I_{\text{pr}}}$
PX, PXR	$E_k \geq 16 \cdot I_{sr} \cdot (R_{ct} + R_{bc})$	$E_k \geq 0,8 \cdot \frac{I_{\max, \text{threshold}}}{I_{\text{pr}}} \cdot I_{sr} \cdot (R_{ct} + R_{bc})$
ANSI class C ($I_{sr} = 5 \text{ A}$)	$20 \cdot I_{sr} \cdot R_{bc}$	$V_{tc} \geq \frac{I_{\max, \text{threshold}}}{I_{\text{pr}}} \cdot I_{sr} \cdot R_{bc}$

Examples can be found in the sections:

- [EXAMPLE; Page 1760](#)
- [Application of Current Transformers Class IEC 5P, 10P, Page 1753](#)
- [Application of Current Transformers Class IEC TPY, Page 1754](#)
- [Application of Current Transformers Class ANSI C, Page 1755](#)
- [Application in the Electrical Power System, Page 1755](#)
- [Requirements for the Core Balance Current Transformer for Sensitive Ground-Fault Detection, Page 1756](#)
- [Special Case for Measuring the Ground Current via the Phase Current Transformer Return Line \(Holm-green Connection\), Page 1764](#)

Remanence may lead to a premature saturation, which is critical for the differential protection. For new plants, Siemens recommends anti-remance cores in classes 5PR, PXR, and TPY. For expected high direct current components, Siemens recommends class TPZ, which avoids overfunctions if there are external faults. Avoid using different classes of current transformer at measuring points. This is particularly the case when combining current transformers of 5P class with current transformers of TPY or TPZ class. In contrast with class 5P current transformers, class TPY and TPZ current transformers heavily suppress a direct current component in the short-circuit current. Additional differential currents will occur when current transformer classes are mixed.

The request of at least for class P, PX, TPX, and C current transformers ensures stability if external low-current faults occur with high direct current components or high current transformer remanence at the default settings of the differential protection characteristic. If these current transformers only have a minimum ALF' of 20, Siemens recommends using a Diff> threshold value of 0.25 for the transformer differential protection characteristic and increasing **Slope 1** to 0.35. With a minimum ALF' of 15, Siemens recommends using an I-Diff> threshold value of at least 0.3 and adjusting **Slope 1** to 0.4.



NOTE

To avoid current transformer remanence, Siemens recommends the use of anti-remance cores in classes 5PR, PXR, and TPY for differential protection systems. When using closed-iron transformers for low-impedance differential protection, ensure that the remanence factor¹⁶⁷ K_R , according to IEC 61869-2, is less than 80 %. Otherwise, Siemens recommends applying an additional dimensioning factor K_{hr} .

If you use current transformers with a remanence factor $K_R > 80 \%$ for differential protection, you need to take into account an additional dimensioning factor K_{hr} for the above equations resulting from the following table:

¹⁶⁷ Remanence factor K_R = manufacturer specification or data from measuring logs

IEC class	Internal fault	External fault
PX	$E_k \geq 0.4 \cdot K_{hr} \cdot \frac{I_{SC,Int}}{I_{pr}} \cdot I_{sr} \cdot (R_{ct} + R_{bc})$	$E_k \geq 1.6 \cdot K_{hr} \cdot \frac{I_{SC,ext}}{I_{pr}} \cdot I_{sr} \cdot (R_{ct} + R_{bc})$
The 5P, 10P ¹⁶⁸	$ALF' \geq 0.5 \cdot K_{hr} \cdot \frac{I_{SC,Int}}{I_{pr}}$	$ALF' \geq 2 \cdot K_{hr} \cdot \frac{I_{SC,ext}}{I_{pr}}$

If current transformers of classes 5P, 10P, PX, and TPX have a remanence factor¹⁶⁷ $K_R > 80\%$, Siemens recommends a dimensioning factor $K_{hr} = 2$.



NOTE

When using distance or line differential protection functions in transformer differential protection, the current transformer requirements of the line protection must be taken into account. You can find these in the *Line protection manual* (C53000-G5040-C010).



NOTE

When using restricted ground-fault protection, the neutral point transformer can be designed lower by a factor of 0.5 to 1.0, depending on the required accuracy limit factor (ALF) of the phase current transformer. When using the zero-sequence current correction of the transformer differential protection, Siemens recommends designing the neutral point transformer according to the required accuracy limit factor (ALF) of the phase current transformer.

EXAMPLE:

An asynchronous motor with the following technical data is used in the example:

- Rated active power: $P_r = 700\text{ kW}$
- Rated voltage: $V_r = 10\text{ kV}$
- Rated current: $I_{rM} = 46.5\text{ A}$
- Starting current: $I_{AM} = 6.5 \cdot I_{rM}$ during startup with rated voltage

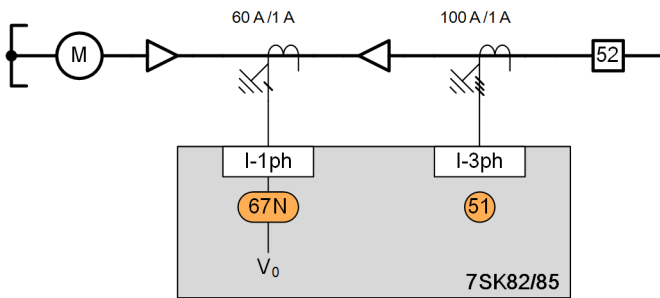

[idw_app-example_for_current-transf_connect-requirements_02_1_en_US]

Figure A-5 Application example

Application of Current Transformers Class IEC 5P, 10P

For this example, a check is carried out to see whether an existing 10P10 current transformer meets the requirements. The high-current stage is used as a fast short-circuit protection system .

Parameter	Value	Description
I_{pr}	100 A	Rated primary current of the current transformer
I_{sr}	1 A	Rated secondary current of the current transformer

¹⁶⁸ Phase displacement (displacement angle) is not specified in IEC 61869-2. Class 10P is not recommended for differential protection for this reason.

Parameter	Value	Description
S_r	5 VA	Rated power
ALF	10	Accuracy limit factor
R_{ct}	0.5 Ω	Secondary winding resistance at 75 °C
l_{cable}	50 m	Length of the secondary current transformer supply lines
A_{cable}	4 mm ²	Core cross section of the secondary current transformer supply lines
ρ_{Cu}	0.0213 $\Omega \text{ mm}^2/\text{m}$	Copper cable resistance at 75 °C (the value is 0.0175 $\Omega \text{ mm}^2/\text{m}$ at 20 °C)
S_{Device}	0.1 VA	Protection device burden at the rated current

Calculation of the Connected Burden:

The burden R_{bc} that is connected to the terminals of the current transformer is derived from the double supply line resistance (supply and return line) and the device burden as indicated below.

$$R_{Cable} = \frac{2 \cdot \rho_{Cu} \cdot l_{Cable}}{A_{Cable}} = \frac{2 \cdot 0.0213 \frac{\Omega \cdot \text{mm}^2}{\text{m}} \cdot 50}{4 \text{ mm}^2} = 0.5325 \Omega$$

$$R_{Device} = \frac{S_{Device}}{I_{sr}^2} = \frac{0.1 \text{ VA}}{(1 \text{ A})^2} = 0.1 \Omega$$

$$R_b = \frac{S_r}{I_{sr}^2} = \frac{5 \text{ VA}}{(1 \text{ A})^2} = 5 \Omega$$

$$R_{bc} = R_{Cable} + R_{Device} = 0.5325 \Omega + 0.1 \Omega \approx 0.633 \Omega$$

$$ALF' \approx ALF \cdot \frac{R_{ct} + R_b}{R_{ct} + R_{ba}} = 10 \cdot \frac{0.5 \Omega + 5 \Omega}{0.5 \Omega + 0.633 \Omega} \approx 49$$

Estimation of the threshold value $I_{\text{max.threshold}}$ for a transformer with the following data:

Rated voltages	20 kV/0.4 kV
Rated apparent power	$S_r = 1.4 \text{ MVA}$
Vector group	Dyn5
Short-circuit voltage	$v_{sc} = 6 \%$

Rated current:

$$I_{r,20 \text{ kV}} = \frac{S_r}{\sqrt{3} \cdot V_{r,20 \text{ kV}}} = \frac{1.4 \text{ MVA}}{\sqrt{3} \cdot 20 \text{ kV}} = 40.41 \text{ A}$$

Symmetrical short-circuit current for a fault on the 0.4 kV side:

$$I_{sc} \approx \frac{I_{r,20 \text{ kV}}}{v_{sc} [\%]} \cdot 100 \% = \frac{40.41 \text{ A}}{6 \%} \cdot 100 \% = 674 \text{ A}$$

Threshold value of the overcurrent-protection stage:

$$I_{\text{max.threshold}} = 1.4 \cdot I_{sc} = 1.4 \cdot 674 \text{ A} = 944 \text{ A}$$

Conditions:

$$\text{Requirement: } ALF' \geq \frac{I_{\text{max.threshold}}}{I_{\text{pr}}} = \frac{944 \text{ A}}{50 \text{ A}} = 18.9 \text{ at least } 20$$

Comparison: ALF' current transformer > ALF' requirement

Result: 49 > 20

The current transformer meets the requirement.

Application of Current Transformers Class IEC TPY

The current transformers are specified by K_{SSC} , K_{td} , and R_b . The current transformer above should be replaced by a current transformer class TPY with the following parameters:

$$K_{SSC} = 20$$

$$K_{td} = 1.5$$

$$R_b = 1 \Omega$$

The requirements are compared with the data from the current transformer.

Rated symmetrical short-circuit current factor:

$$K_{SSC} = \frac{I_{psc}}{I_{pr}} = \frac{I_{\text{max.threshold}}}{I_{pr}} = \frac{786 \text{ A}}{100 \text{ A}} = 7.86$$

$$\text{Required product: } K_{td} \cdot K_{SSC} \geq \frac{I_{\text{max.threshold}}}{I_{pr}} = \frac{786 \text{ A}}{100 \text{ A}} = 7.9 \text{ at least } 20$$

$$\text{Current transformer: } K_{td} \cdot K_{SSC} = 1.5 \cdot 20 = 30$$

Result: 30 > 20

The required resistive dimensioning burden R_b of the current transformer must be greater than the connected resistive burden R_{bc} that was previously calculated.

$$\text{Requirement: } R_b > R_{bc}$$

Result: $1 \Omega > 0.663 \Omega$

The TPY class current transformer meets the requirements.

Application of Current Transformers Class ANSI C

This class is specified with a maximum secondary terminal voltage V_t . In this example, the current transformer uses the following parameters:

Class C100

Transformer terminal voltage at a rated impedance of 1 Ω $V_t = 100 \text{ V}$

Rated secondary current: $I_{sr} = 5 \text{ A}$

The rated secondary current of $I_{sr} = 5 \text{ A}$ causes the connected burden to change.

$$R_{\text{Device}} = \frac{S_{\text{Device}}}{I_{sr}^2} = \frac{0.1 \text{ VA}}{(5 \text{ A})^2} = 0.004 \Omega$$

$$R_{bc} = R_{\text{Cable}} + R_{\text{Device}} = 0.5325 \Omega + 0.004 \Omega \approx 0.537 \Omega$$

$$\text{Required transformer terminal voltage for the current transformer: } V_{tc} \geq \frac{I_{\text{max.threshold}}}{I_{pr}} \cdot I_{sr} \cdot R_{bc} = \frac{786 \text{ A}}{100 \text{ A}} \cdot 5 \text{ A} \cdot 0.537 \Omega = 21.10 \text{ V}$$

$$\text{Minimum requirement: } V_{tc} \geq 20 \cdot I_{sr} \cdot R_{bc} = 20 \cdot 5 \text{ A} \cdot 0.537 \Omega = 53.7 \text{ V}$$

Current transformer terminal voltage: $V_t = 100 \text{ V}$
 Result: $100 \text{ V} > 53.7 \text{ V}$

The C100 class current transformer meets the requirements.

Requirements for the Core Balance Current Transformer for Sensitive Ground-Fault Detection

The requirements for the core balance current transformer are determined by the **sensitive ground-fault detection** function. A directional sensitive ground-fault protection system is used for selective sensitive ground-fault detection in the busbar connection for motors and generators. The protection function trips with a delay.

The electrical power systems are predominantly isolated. A grounding transformer with load equipment is available that feeds in a maximum active current of 10 A to enable the stator ground-fault protection system to be 80 % to 90 % effective. The $\cos\phi$ method is used here. The capacitive current of the electrical power system is superimposed on the active current.

The following table shows the requirements and recommendations for the instrument transformer.

Parameter	Value	Note
I_{pr}	60 A	60 A is a recommended value for motor and generator protection applications.
I_{sr}	1 A	Preferred value
Class	1	This is the recommended class. If small currents need to be measured accurately, for example, up to 1 % I_{pr} , Siemens recommends the 0.5S class. Class 3 is sufficient for just measuring the ground current without being influenced by the angle accuracy. The measurement deviation for the transfer ratio of 3 % is defined in the range of (50 % to 120 %) I_{pr} .
S_r	1 VA	The accuracy specifications for the ratio error of measurement and the phase displacement in IEC 61869-2, <i>Section 5.6.201.3</i> refer to this rated power. The rated power is sufficient for a connected burden $R_{bc} < 1 \Omega$. If there are larger burdens, you must increase the power, where the value of 15 VA may not be exceeded in accordance with IEC 61869-2, <i>Section 5.6.201.4</i> .
R_{bc}	$< 1 \Omega$	The standard values of the accuracy classes apply for a burdening of 25 % to 100 % of the rated power. The connected burden must be R_{bc} in this range. In the event of deviations, you must adjust the rated power S_r . For small burdens, for example, during use in medium voltage cubicles, you must reduce the rated power to 0.5 VA.
FS	10	Required overcurrent limiting factor (FS 10). The number 10 expresses that the current is reduced to $10 \cdot I_{pr}$ and not transmitted by the current transformer. The standard does not dictate what current the current transformer may be saturated from.

The recommended current transformer has the following specification: 60 A/1 A; 1 VA, cl.1 FS 10



NOTE

The neutral point on the transformer is partially grounded via a resistor in industry networks to minimize transient overvoltages in the event of a ground fault, and this leads to larger ground currents. Adjust the primary rated current I_{pr} of the core balance current transformer if required. The sensitive ground-current measurement function meets the requirements for selectivity, as a sufficient zero-sequence current flows in the faulty motor in the event of a ground fault.

Table A-9 Limiting Values for the Recommended Instrument Transformers in accordance with IEC 61869-2, Section 5.6.201.3

Class	Ratio Error of Measurement (\pm %)					Phase Displacement (\pm Minutes)				
	for current (% of rated current)					for current (% of rated current)				
	1	5	20	100	120	1	5	20	100	120
0.5S	1.5	0.75	0.5	0.5	0.5	90	45	30	30	30
1	–	3.0	1.5	1.0	1.0	–	180	90	60	60

Special Case for Measuring the Ground Current via the Phase Current Transformer Return Line (Holmgreen Connection)

You must design the phase current transformers in such a way that they are not saturated and thus lead to a zero-sequence current on the secondary side. There is a risk of overfunction due to the sensitive ground-current stage setting, for example at the 90 % protection range.

Rough estimate for the class P transformer (5 VA 10P10, see [Application of Current Transformers Class IEC 5P, 10P, Page 1753](#)):

$$ALF' \geq 25 \cdot \frac{I_{AM}}{I_{pr}} = 25 \cdot \frac{6.5 \cdot I_{rM}}{I_{pr}} = 25 \cdot \frac{6.5 \cdot 46.5 \text{ A}}{100 \text{ A}} \approx 76$$

[fo_alf_CT_IEC_P_75K-holmgreen, 1, --]

The previous phase current transformer 5 VA 10P10 has an $ALF' = 49$, and doesn't meet the requirement. The ALF accuracy limit factor must be increased by 20. This results in a transformer of 5 VA 10P20. If you retain the original 5 VA 10P10 transformer and want to prevent overfunctions, you must also analyze the zero-sequence voltage up to the zero-sequence current (3I0 and U0).

A.8 Connection Examples for Current Transformers



Current transformer 3-phase: connection = 3-phase

[ti_3-phase_1_4, en_US]

Figure A-6 Connection to 3 Phase Current Transformers (Zero-Sequence Current to be Calculated)

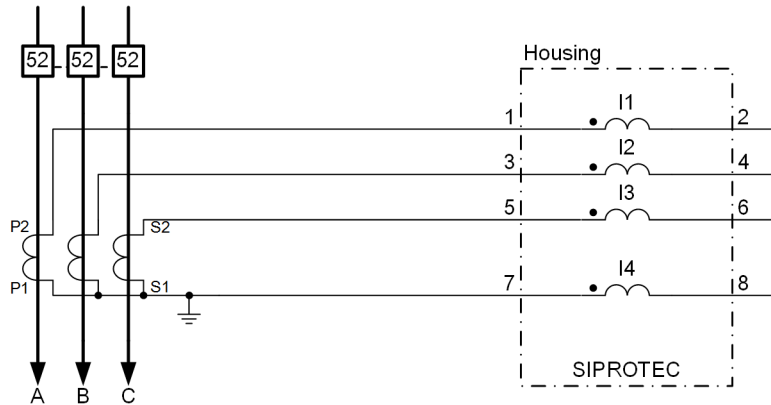

Current transformer 3-phase: connection = 3-phase + I_N

[ti_phase_2_4, en_US]

Figure A-7 Connection to 3 Phase Current Transformers and a Measured Zero-Sequence Current (Current in Common Return Conductor)



NOTE

The switchover of the current polarity at the 3-phase current transformer causes a rotation in the direction of electric current for current input I4 (I_N)!

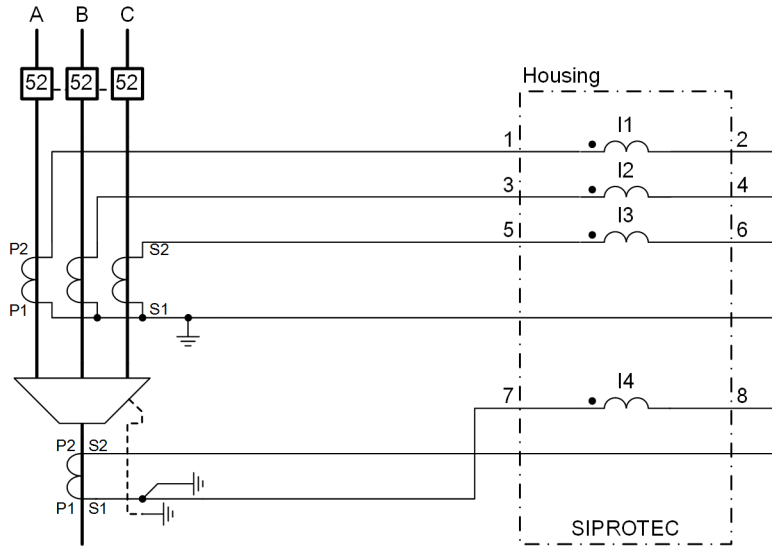

Current transformer 3-phase: connection = 3-phase + IN-separate

[ti_phase_3_4_en_US]

Figure A-8 Connection to 3 Phase Current Transformers and a Cable Type Current Transformer for Sensitive Ground-Fault Detection



NOTE

The switchover of the current polarity at the 3-phase current transformer causes a rotation in the direction of electric current for current input I4 (I_{N-sep})!

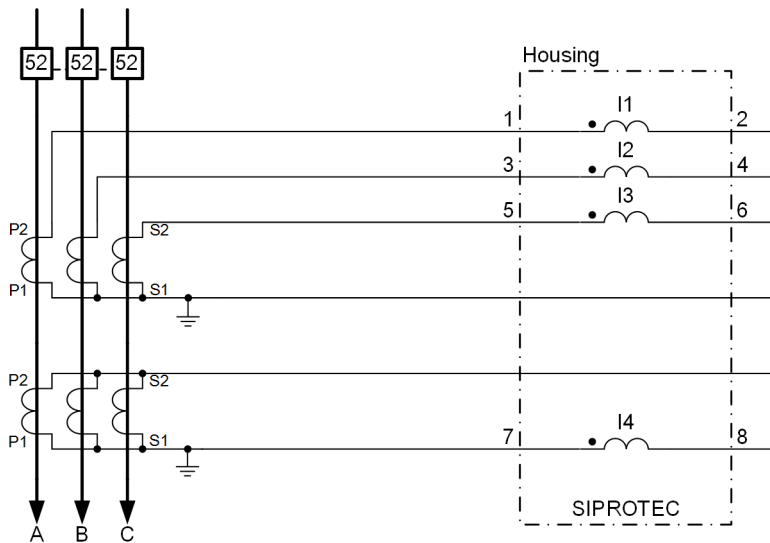

Current transformer 3-phase: connection = 3-phase + IN-separate

[tileite4-260313-01.tif, 4_en_US]

Figure A-9 Connection to 3 Phase Current Transformers and a Measured Ground Current from a Complete Holmgreen Connection



NOTE

The switchover of the current polarity at the 3-phase current transformer causes a rotation in the direction of electric current for current input I4 (I_{N-sep})!

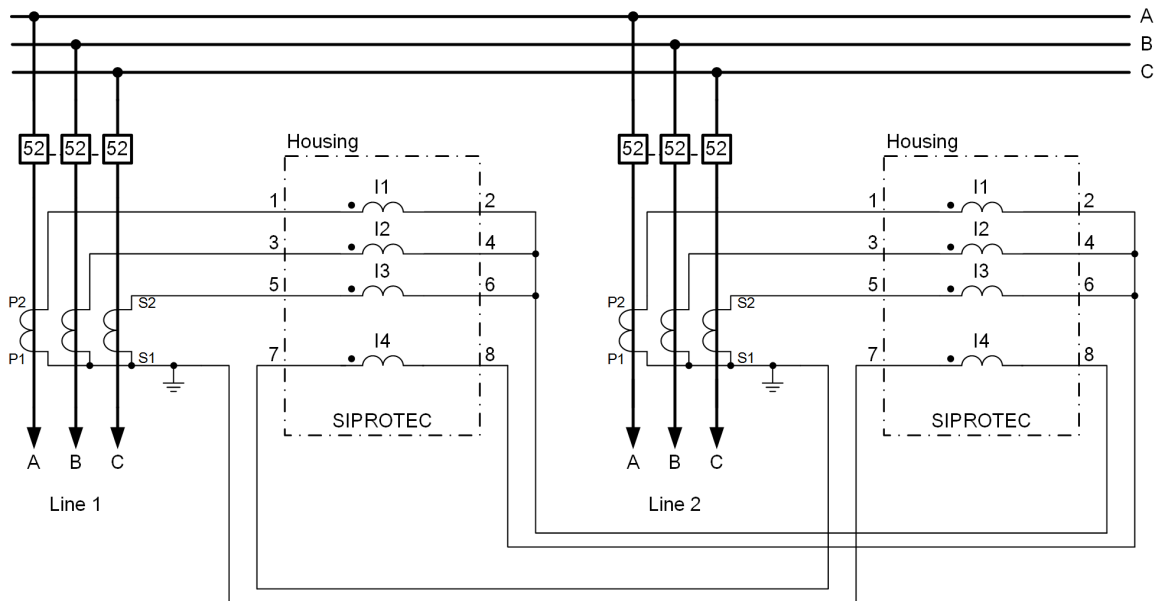

Current transformer 3-phase: connection = 3-phase
 Current transformer 1-phase: connection = Ix

[tileite5-060313-01.tif, 4, en_US]

Figure A-10 Connection to 3 Phase Current Transformers and a Measured Residual Current from the Current-Transformer Neutral Point of the Respective Parallel Line (for Parallel-Line Compensation)

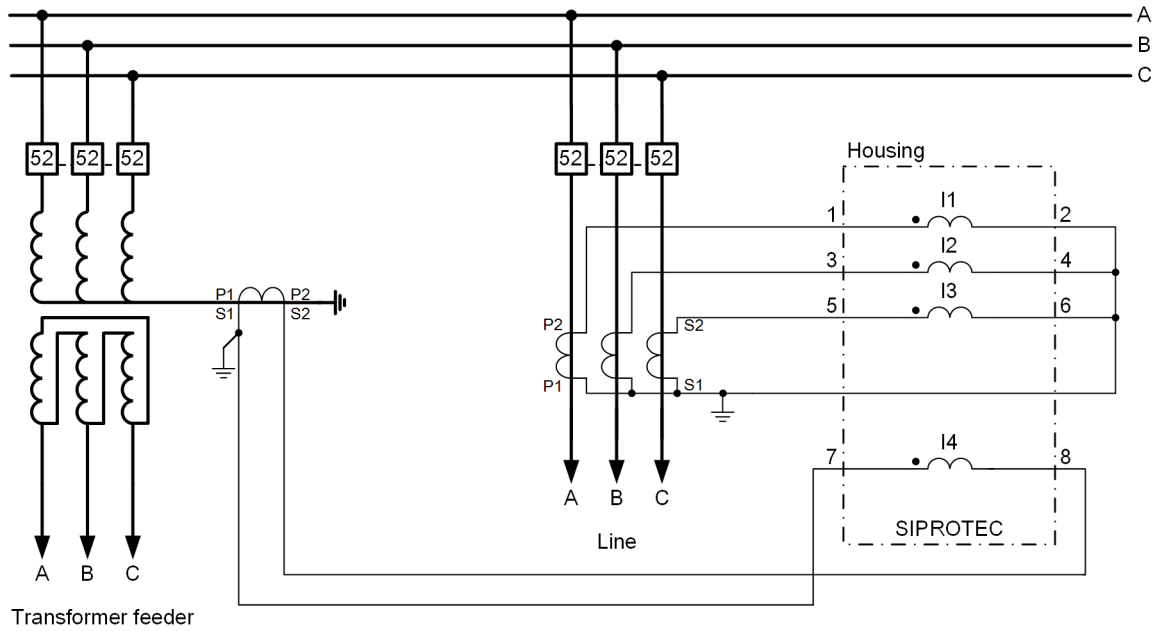

[fileite6-060313-01.tif, 4, en_US]

Figure A-11 Connection to 3 Phase Current Transformers and a Measured Ground Current via the Neutral-Point Current Transformer of a Grounded Power Transformer

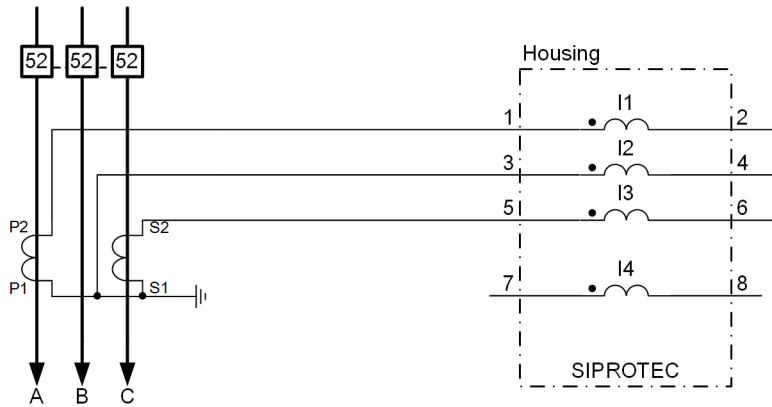

[fileite7-070211-01.tif, 4, en_US]

Figure A-12 Connection to a 2 Phase Current Transformers – for Isolated or Resonant-Grounded Systems Only

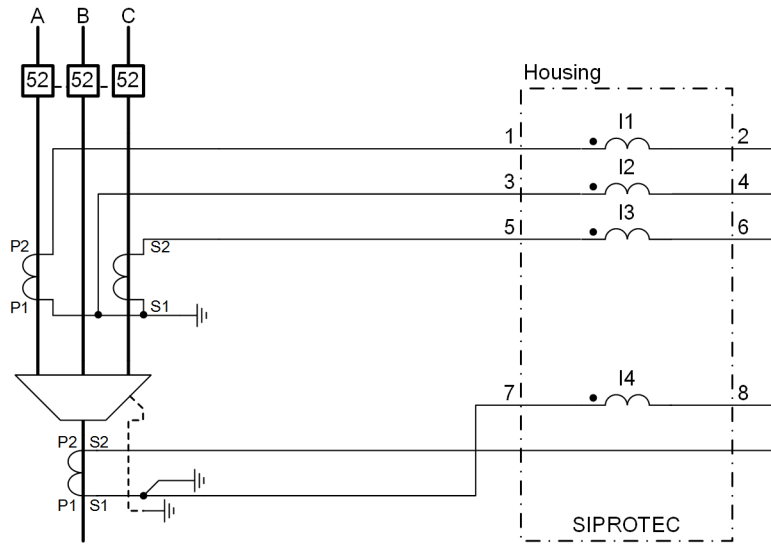

Current transformer 3-phase: connection = 3ph,2prim.CT + IN-sep

[tileite8-260313-01.tif, 4, en_US]

Figure A-13 Connection to 2 Phase Current Transformers and a Cable Type Current Transformer for Sensitive Ground-Fault Detection – for Isolated or Resonant-Grounded Systems Only



NOTE

The switchover of the current polarity at the 3-phase current transformer causes a rotation in the direction of electric current for current input I4 (I_{N-sep})!

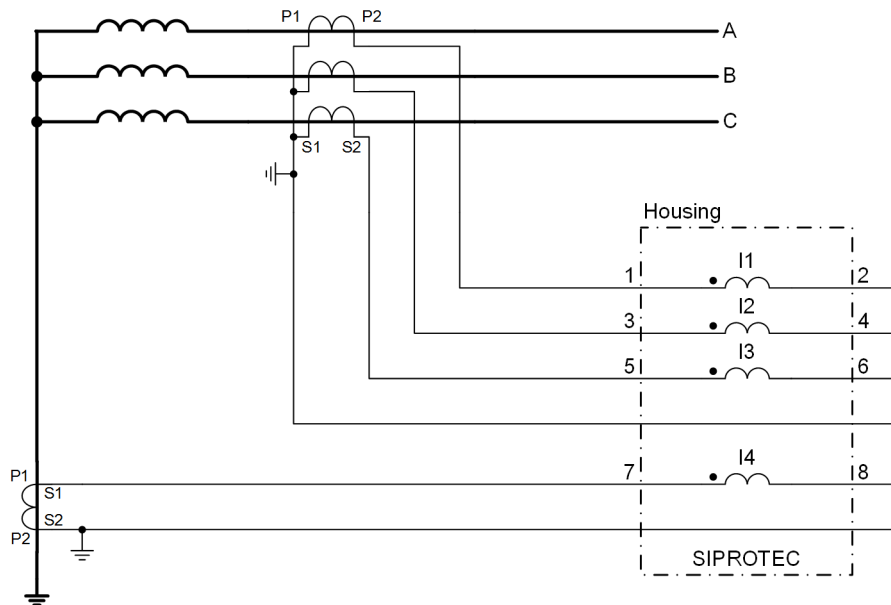

Current transformer 3-phase: connection = 3-phase
 Current transformer 1-phase: connection = 1x

[tileite9-260313-01.tif, 5, en_US]

Figure A-14 Connection to 3 Phase Current Transformers and an Additional Current Transformer in the Neutral Point of a Grounded Power Transformer

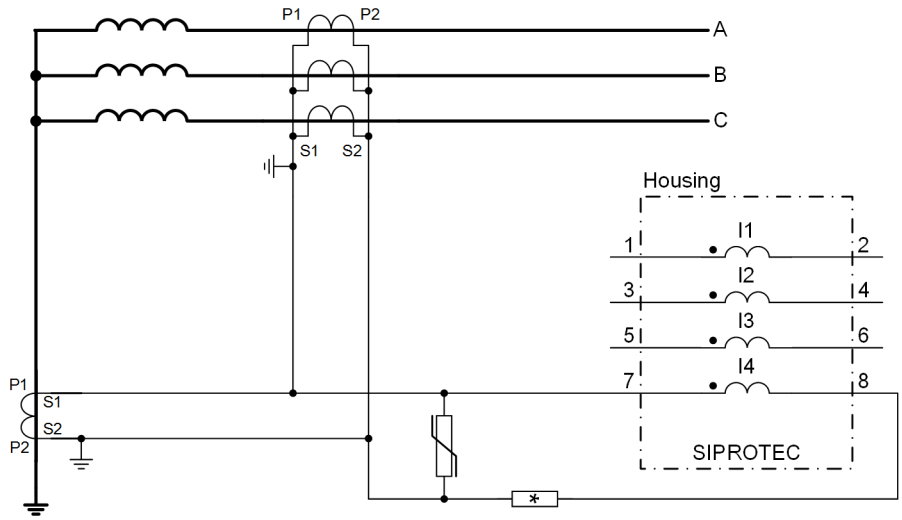

Current transformer 1-phase: connection = Ix

[ti_phase_10_5, en_US]

Figure A-15 Current Transformer Connection for High-Impedance Differential Protection (for Example, a Power Transformer, in Preparation)

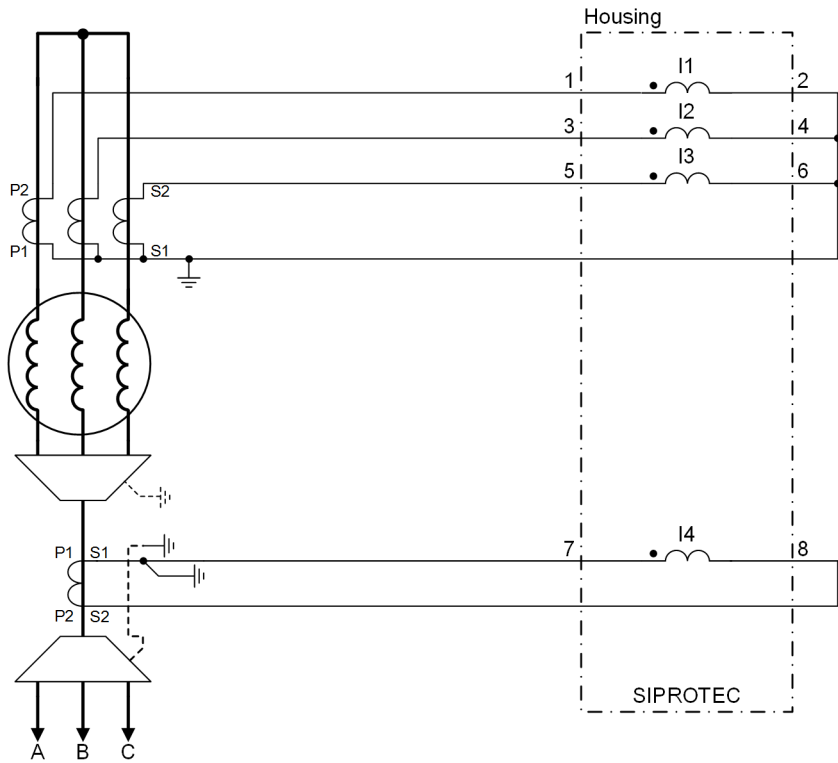

Current transformer 3-phase: connection = 3-phase
 Current transformer 1-phase: connection = Ix

[ti_phase_11_4, en_US]

Figure A-16 Connection to 3 Phase Current Transformers in the Neutral Point of a Generator and a Cable Type Current Transformer for Sensitive Ground-Fault Detection of the Line

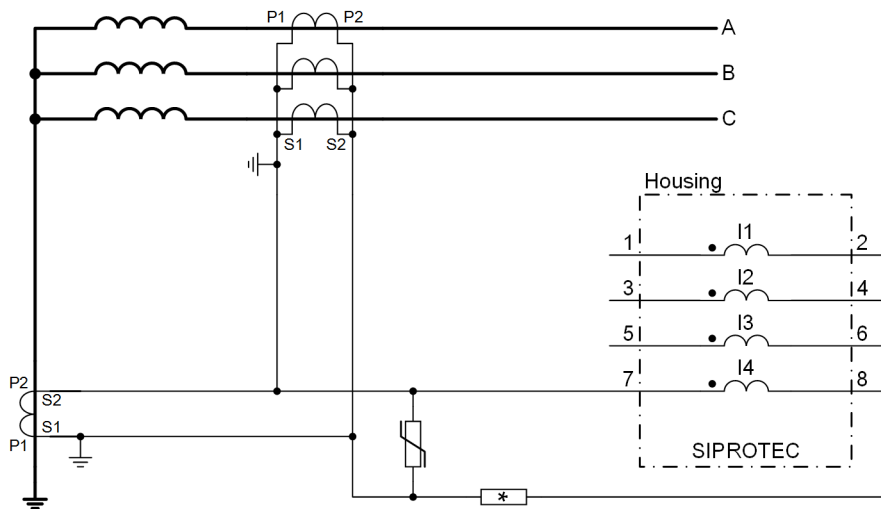

Current transformer 1-phase: connection = Ix

[1]_phase_12, 5, en_US]

Figure A-17 Current-Transformer Connection for High-Impedance Differential Protection (Example: Power Transformer)

A.9 Connection Examples of Voltage Transformers

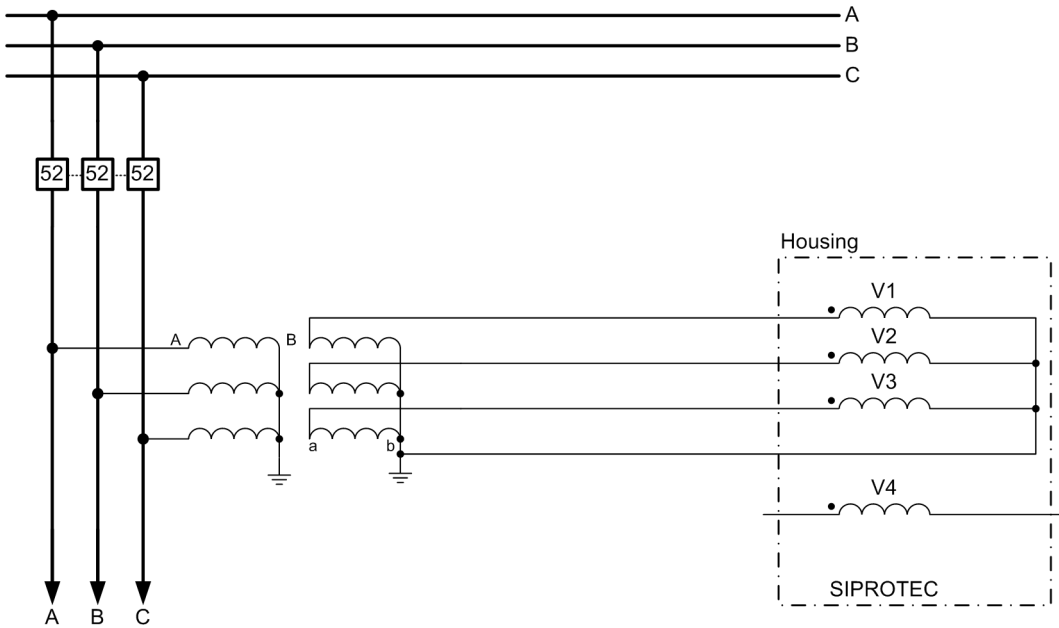

Voltage transformer 3-phase: connection = 3 phase-to-ground volt.

[tvvolta3phVN-260313-01.vsd, 1, en_US]

Figure A-18 Connection to 3 Star-Connected Voltage Transformers

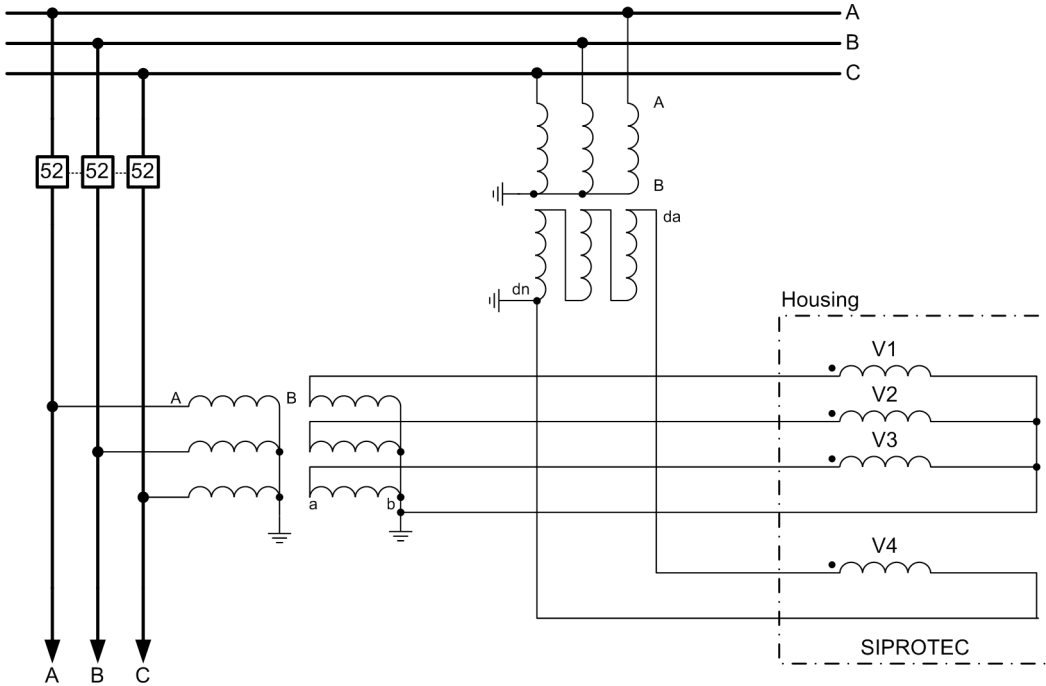

Voltage transformer 3-phase: connection = 3 phase-to-ground volt. + VN

[tvvolta4light-260313-01.vsd, 1, en_US]

Figure A-19 Connection to 3 Star-Connected Voltage Transformers and to the Broken-Delta Winding of a Separate Voltage Transformer (for Example Busbar)

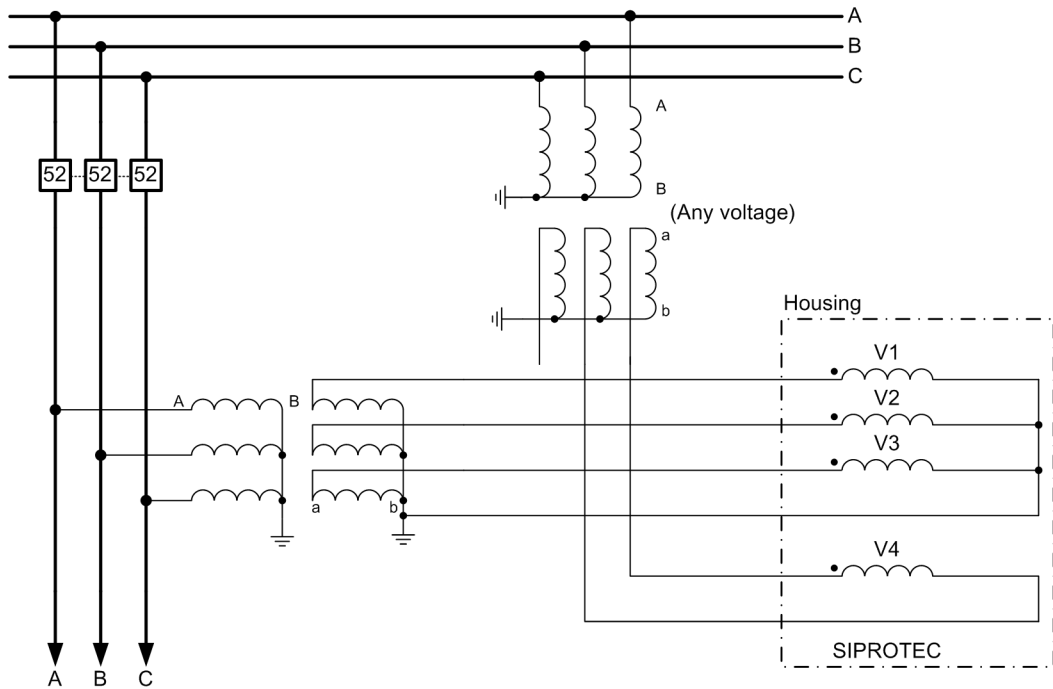

Voltage transformer 3-phase: connection = 3 ph-to-gnd voltages

Voltage transformer 1-phase: connection = VAB

[twvota45J82-260313-01.vsd, 1, en_US]

Figure A-20 Connection to 3 Star-Connected Voltage Transformers and to the Phase-to-Phase Voltage of a Busbar Voltage Transformer (for Example for Synchrocheck Applications)

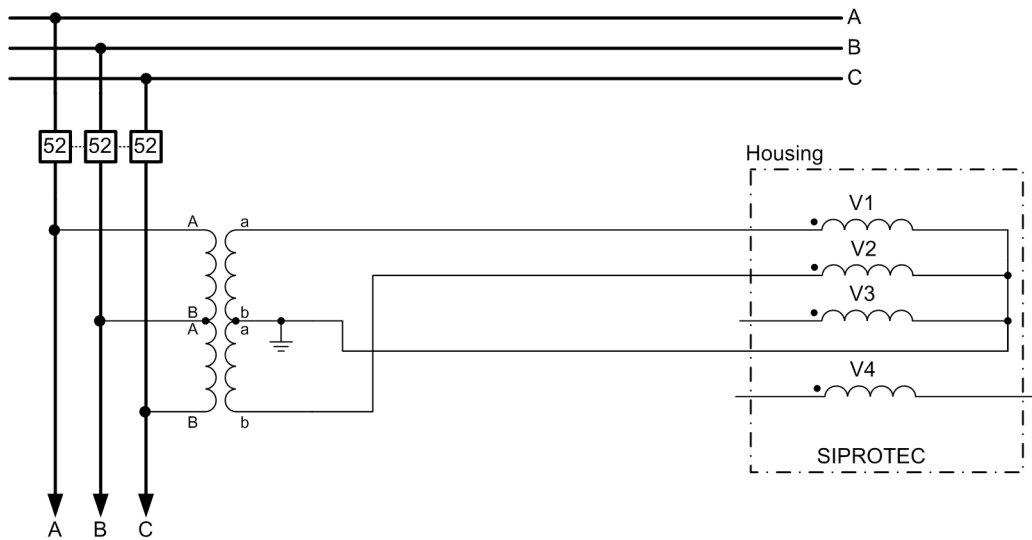

Voltage transformer 3-phase: connection = 2 ph-to-ph voltages

Phase voltages = VAB, VCB

[twvol2I82-260313-01.vsd, 1, en_US]

Figure A-21 Connection to V-Connected Voltage Transformer (Measurement of 2 Phase-to-Phase Voltages)



NOTE

When using the connection type 2-phase-to-phase voltage, the zero voltage cannot be detected.

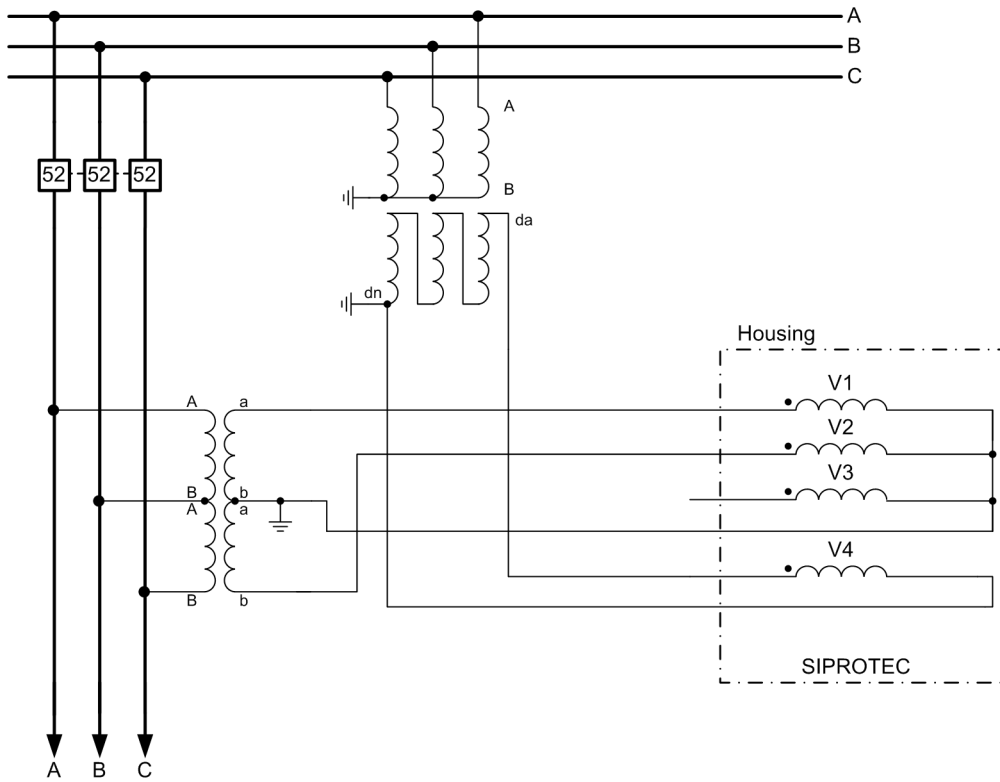

Voltage transformer 3-phase: connection = 2 ph-to-ph volt. + VN
 Phase voltages = VAB, VCB

[tv12luu82-260313-01.vsd, 1, en_US]

Figure A-22 Connection to V-Connected Voltage Transformer (Measurement of 2 Phase-to-Phase Voltages) and Connection to the Broken-Delta Winding of a Busbar Voltage Transformer

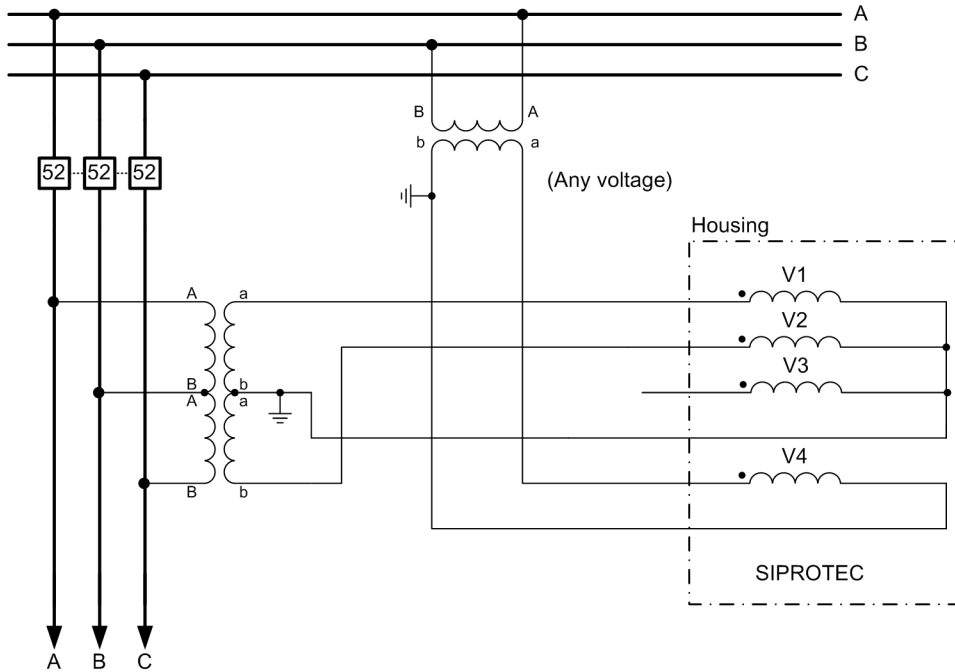

Voltage transformer 3-phase: connection = 2 ph-to-ph voltages

Phase voltages = VAB, VCB

Voltage transformer 1-phase: connection = VAB

[twvolta55I82-260313-01.vsd, 2, en_US]

Figure A-23 Connection to V-Connected Voltage Transformer (Measurement of 2 Phase-to-Phase Voltages) and Connection to the Broken-Delta Winding of a Busbar Voltage Transformer (for Example, for Synchrocheck Applications)



NOTE

When using the connection type 2-phase-to-phase voltage, the zero voltage cannot be detected.

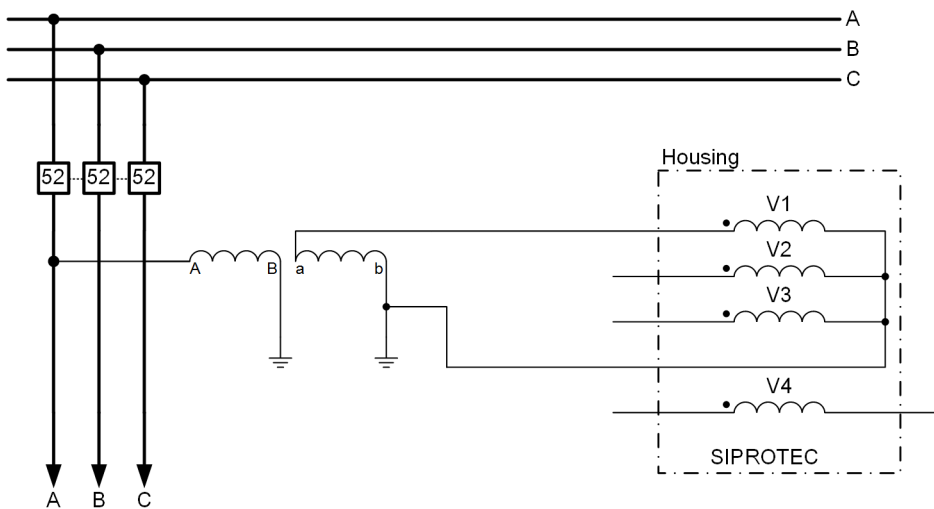

Voltage transformer 1-phase: connection = VA

[twvolta75I82-260313-01.vsd, 1, en_US]

Figure A-24 Connection to a 1-Pole Insulated Voltage Transformer (Phase-to-Ground Voltage)

A.10 Preroutings for Overcurrent-Protection Applications

Meaning of the abbreviations in DIGSI, see [9.2.2.3 Connection Variants of the Circuit Breaker](#).

Binary Inputs

Table A-10 Default Binary Inputs, Using the Example of Overcurrent Protection

Binary Input	Signal	Number	Signal Type	Configuration
BI1	Circuit breaker 1:Circuit break.:Position	201.4261.58	DPC	OH
BI2	Circuit breaker 1:Circuit break.:Position	201.4261.58	DPC	CH
BI3	Power system:Meas. point V-3ph 1:VT-miniature CB:>Open	11.941.2641.500	SPS	H

Binary Outputs

Table A-11 Default Output Relays, Using the Example of Overcurrent Protection

Binary Output	Signal	Number	Signal Type	Configuration
BO1	Circuit breaker 1:Circuit break.:Trip/open cmd.	201.4261.300	SPS	U
BO2	Circuit breaker 1:Circuit break.:Close command	201.4261.301	SPS	X

Function Keys

Table A-12 Default Setting Function Key Using the Example of Overcurrent Protection

Function Key	Signal	Number	Signal Type	Configuration
F-key1	Main menu:Logs:Operational log			X
F-key2	Main menu:Measurements:VI 3ph 1:Operational values			X
F-key3	Main menu:Logs:Fault log			X

Light-Emitting Diodes

Table A-13 Default LED Displays, Using the Example of Overcurrent Protection

LEDs	Signal	Number	Signal Type	Configuration
LED1	VI 3ph 1:Group indicat.:Pickup:phs A		SPS	NT
LED2	VI 3ph 1:Group indicat.:Pickup:phs B		SPS	NT
LED3	VI 3ph 1:Group indicat.:Pickup:phs C		SPS	NT
LED4	VI 3ph 1:Group indicat.:Pickup:phs gnd		SPS	NT
LED5	Circuit breaker 1:Circuit break.:Trip/open cmd.	201.4261.300	SPS	L
LED7	Alarm handling:Group warning	5971.301	SPS	U
LED8	Device:Process mode inactive		SPS	U
	General:Functions in Test mode	91 329	SPS	U

A.11 Preroutings for Motor and Power-System Decoupling Applications

Meaning of the abbreviations in DIGSI, see [9.2.2.3 Connection Variants of the Circuit Breaker](#).

Binary Inputs

Table A-14 Default Binary Inputs, Using the Example of Overcurrent Protection

Binary Input	Signal	Number	Signal Type	Configuration
BI1	Circuit breaker 1:Circuit break.:Position	201.4261.58	DPC	OH
BI2	Circuit breaker 1:Circuit break.:Position	201.4261.58	DPC	CH
BI3	Power system:Meas. point V-3ph 1:VT- miniature CB:>Open	11.941.2641.500	SPS	H

Binary Outputs

Table A-15 Default Output Relays, Using the Example of Overcurrent Protection

Binary Output	Signal	Number	Signal Type	Configuration
BO1	Circuit breaker 1:Circuit break.:Trip/open cmd.	201.4261.300	SPS	U
BO2	Circuit breaker 1:Circuit break.:Close command	201.4261.301	SPS	X

Function Keys

Table A-16 Default Setting Function Key Using the Example of Overcurrent Protection

Function Key	Signal	Number	Signal Type	Configuration
F-key1	Main menu:Logs:Opera- tional log			X
F-key2	Main menu:Meas- urements :Capacitor bank 1:Operational values			X
F-key3	Main menu:Logs:Fault log			X

Light-Emitting Diodes

Table A-17 Default LED Displays, Using the Example of Overcurrent Protection

LEDs	Signal	Number	Signal Type	Configuration
LED1	Capacitor bank 1:Group indicat.:Pickup:phs A		SPS	NT
LED2	Capacitor bank 1:Group indicat.:Pickup:phs B		SPS	NT
LED3	Capacitor bank 1:Group indicat.:Pickup:phs C		SPS	NT
LED4	Capacitor bank 1:Group indicat.:Pickup:phs gnd		SPS	NT
LED5	Circuit breaker 1:Circuit break.:Trip/open cmd.	201.4261.300	SPS	L
LED15	Alarm handling:Group warning	5971.301	SPS	U
LED16	Device:Process mode inac- tive		SPS	U
	General:Functions in Test mode	91 329	SPS	U

Literature

- /1/ Compact Class – 7SX800
C53000-G5040-C003
- /2/ Fault Recorder – 7KE85
C53000-G5040-C018
- /3/ Hardware Description
C53000-G5040-C002
- /4/ Communication Protocols
C53000-L1840-C055
- /5/ Process Bus
C53000-H3040-C054
- /6/ DIGSI 5 – Software Description
C53000-D5040-C001
- /7/ SIPROTEC 5 – Security
C53000-H5040-C081
- /8/ PIXIT, PICS, TICS IEC 61850
C53000-G5040-C013
- /9/ Operation
C53000-G5040-C003
- /10/ Engineering Guide
C53000-G5040-C004

Glossary

General Interrogation

The state of all process inputs, of the status, and of the fault image are scanned on system startup. This information is used to update the system-side process image. Likewise, the current process state can be interrogated after data loss with a general interrogation (GI).

Navigation window

The left area of the project window displays the names and icons of all containers of a project in the form of a folder tree structure.

Online

If there is a communication connection between a PC program (for example configuration program) and a runtime application (for example a PC application), the PC program is **online**. The PC program executes in Online mode.

Time stamp

A time stamp is a value in a defined format. The time stamp assigns a point in time to an event, for example, in a log file. Time stamps ensure that events can be found again.

Index

A

- Acknowledgment
 - Spontaneous fault display 89
- Acquisition blocking 139
- Application mode
 - Enabling/disabling test mode for the entire device 1513
- Application templates
 - 7SX800 169
- Automatic reclosing function
 - Overview of functions 943
 - Structure of the function 944
- Automatic reclosing function, cyclic
 - Blockings 972
 - Circuit-breaker readiness, circuit-breaker position 970
 - Closing indication, close command 967
 - Cycle control, operating mode 1 954
 - Cycle control, Operating mode 2 956
 - Cycle control, Operating mode 3 958
 - Cycle control, operating mode 4 959
 - Dead time, operating modes with pickup 963
 - Dead time, operating modes with tripping 961
 - Dead-line checking, reduced dead time 976
 - Evolving-fault detection 965
 - Input logic, Operating modes with pickup 952
 - Input logic, Operating modes with tripping 951
 - Operating modes 947
 - Stage release 960
 - Start 953
 - Structure 950
- Automatic reclosing function, Cyclic
 - Reclaim time 969

B

- Battery fault 1369
- Broken-wire detection
 - Application and setting notes 1330
 - Broken wire suspected 1329
 - Broken-wire check 1330
 - Overview of functions 1329
 - Protection blocking 1330
 - Structure of the function 1329

C

- Circuit breaker
 - Circuit breaker [without current] 295
 - Circuit-breaker failure protection 276
 - Circuit-breaker test 276
 - Trip logic 280
 - Trip-circuit supervision 276
 - Trip-command reset 280
- Circuit-breaker failure protection
 - CBFP 894
- Communication log 82
- Communication-supervision log 83
- Control functions
 - Command checks 1178
 - Command logging 1197
 - Controllables 1152
 - User-defined objects 129
- Current jump detection
 - Overview of functions 1042
- Current-jump detection
 - Function structure 1042

D

- Device-diagnosis log 81
- Dimensions 1549
- Directional intermittent ground-fault protection 580
- Directional mode 693
- Directional negative-sequence protection
 - Inrush-current detection 689
- Directional overcurrent protection, phases 436
- Directional sensitive ground-fault detection
 - Sensitive ground current with 3I0 649
- Disconnection of measuring point
 - Measuring point I-3ph 333
- DPC 132
- DPS 131

E

- External trip initiation 940

F

- Fault display
 - Configuration 88
 - Spontaneous 88
- Fault locator
 - Parallel-line compensation 997
 - Plus, 2-sided fault-location determination 1012
- Fault log 73
- Fault record 311
- FG Analog Transformers
 - Overview 20-mA Unit Serial 237
- FG Analog units
 - 20-mA unit Ether. 231
 - Application and setting notes for the RTD unit serial 251
 - Application and setting notes for the RTD-Unit Ether. 248
 - Communication with 20-mA unit Ether. 230
 - Communication with an RTD unit 247
 - Function-group structure 228
 - Overview 228
 - Overview 20-mA Unit Ether. 229
 - Overview of RTD Unit Ether. 246
 - Overview RTD unit serial 251
 - Technical data 1551
 - Temperature sensor 249
- FG Analog Units
 - Application and Setting Notes 20 mA Unit. Serial 238
- Function group VI 3-phase
 - Overview 174
 - Structure of the function group 174

G

- General Functionalities (Undervoltage Check, df/dt Calculation) 844
- Ground-fault log 75
- Group Indications
 - Time Overcurrent Protection Functions 348

I

- IEC 60529 1549
- INC 132
- Indication display
 - Spontaneous 88
- Indications 64
 - Displays 67
 - Read out 64
 - Reading 64
 - Reading with DIGSI 66
- INS 131, 132

- Instantaneous high-current tripping
 - Function structure 526
 - Overview of functions 526
 - Standard release 527
- Instantaneous tripping at switch onto fault 531

L

- Lockout 91
- Log 70
 - Configuring 70
 - Deleting 86
 - Management 70
 - Saving 86

M

- Manual updating 139
- Motor-starting log 85

N

- Negative-sequence protection 679
- Non-directional intermittent ground-fault protection 571

O

- Operational log 71
- Operational measured values 1380
- Ordering
 - Accessories 1746
- Other functions
 - Acquisition blocking 135
 - Chatter blocking 135
 - Manual updating 135
 - Persistent commands 135
 - Stored outputs 135
- Overcurrent protection
 - Dynamic settings 383, 434
- Overcurrent protection, 1-phase 534
 - Inrush-current detection 551
 - stage with definite-time characteristic curve (definite time-overcurrent protection) 536
 - Structure of the function 534
- Overcurrent Protection, 1-Phase
 - Application Example: High-Impedance Restricted Ground-Fault Protection 553
 - Application Example: Tank Leakage Protection 559
 - Fast stage 549

Stage with Inverse-Time Characteristic Curve
(Inverse Time-Overcurrent Protection) 539

Overcurrent protection, ground 405

- Inrush-current detection 432
- Structure of the function 405
- User-defined characteristic curve 426

Overcurrent protection, phases 350

- Inrush-current detection 382
- Structure of the function 350, 560
- User-defined characteristic curve 376, 547

Overexcitation protection

- Function structure 875
- Overview of functions 875

Overload protection 699, 724

P

Positive-sequence overcurrent protection 560

Q

Quality attributes 69

Quality processing for GOOSE Later Binding 99

R

Restricted ground-fault protection 922, 923

Reverse-power protection

- General functionality 868
- Stage description 872

S

Security log 80

Sensitive ground-fault detection

- Directional overcurrent protection stage with 3I₀- $\varphi(V, I)$ measurement 619
- Directional overcurrent-protection stage with $\cos \varphi$ or $\sin \varphi$ measurement 600
- Directional overcurrent-protection stage with G0 or B0 measurement 626
- Overvoltage protection stage with zero-sequence voltage/residual voltage 645
- Sensitive ground current with Y0 653

Sensitive Ground-Fault Detection

- Function Structure 591
- Overview of Functions 591
- Transient Ground-Fault Stage 610

Setting-history log 77

SIPROTEC 5 device

Application templates/Adaptation of functional scope 51

Embedding of functions 48

Function control 53

Reference number for parameters and indications 59

SPC 131, 132

SPS 130

SPS unsaved 130

Stage Control 478

Stage Description 817, 846, 1469, 1475, 1479, 1485, 1491

Stage Description of the Reclosure Stage 891

Stage description of the stage 886

Stored indications 90

Switching-device log 74

Synchrocheck 1219

Synchronization of asynchronous systems 1225, 1233

Synchronization of synchronous systems 1223, 1231

Synchronization stage 1205

T

Temperature Monitoring

- Application and Setting Notes 1028

- Technical Data 1706

Temperature supervision

- Function description 1027

- Function structure 1026

- Overview of functions 1026

Thermal overload protection

- Functional measured values 703, 725

- Thermal replica 703, 725

U

User log 78

V

Voltage jump detection

- Function structure 1045

Voltage protection

- Overvoltage protection with 3-phase voltage 742

- Overvoltage protection with any voltage 772

- Overvoltage protection with positive-sequence voltage 761

- Overvoltage protection with zero-sequence voltage/residual voltage 755

- Undervoltage protection with 3-phase voltage 785

- Undervoltage protection with any voltage 808

- Undervoltage protection with positive-sequence voltage 802

Voltage-jump detection
 Overview of functions 1045