

Rotary-Piston Meters

PN 10 to PN 63

7MR1...

Instructions

Ord. No.: C73000-B5176-C23-6

Rated size DN	15		25		32		50		80	
Rated pressure PN	25	40	10	25	63	25	63	25	63	63
Industrial design	7MR1020	7MR1030	7MR1120		7MR1140	7MR1220	7MR1240	7MR1420	7MR1440	7MR1620 7MR1640
Enamel/ plastic design	-	-	7MR1111	-	-	-	-	-	-	-

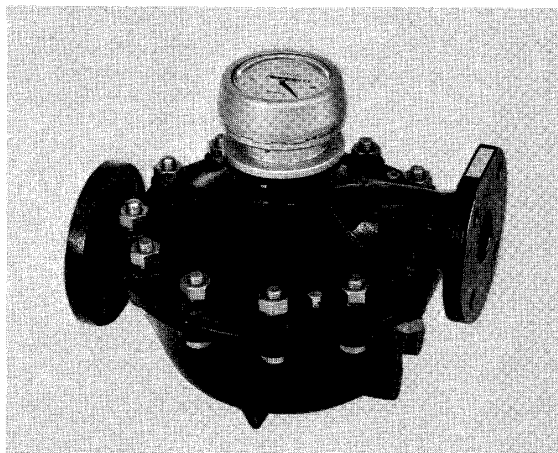

Fig. 1/1 Rotary-piston meter DN 50/PN 25 with dial and drum-type counter type 01

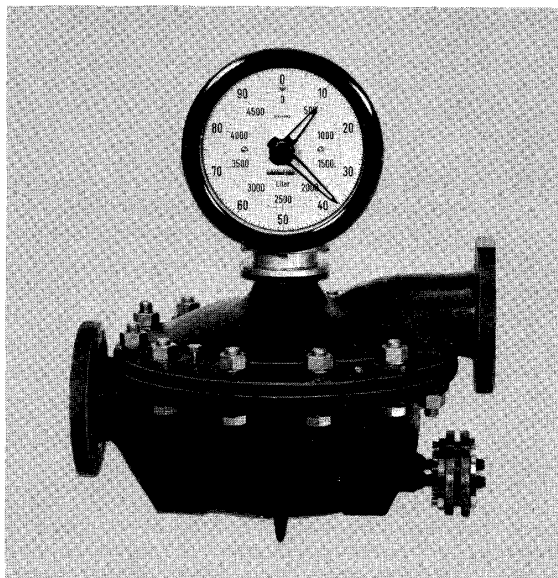

Fig. 1/2 Rotary-piston meter DN 80/PN 25 with heater and double-pointer dial and drum-type counter type 12



Fig. 1/3 Rotary-piston meter of enamel/plastic design DN 25 with resettable drum-type counter with ticket printer type 22 and pulser

Contents

	Page
1 Description	2
2 Installation and operation	13
3 Maintenance	14
4 Spare parts	21

NOTE

These instructions do not purport to cover all details or variations in equipment, nor to provide for every possible contingency to be met in connection with installation, operation or maintenance.

Should further information be desired or should particular problems arise which are not covered sufficiently for the Purchaser's purposes, the matter should be referred to the local Siemens Sales Office.

The contents of this instruction manual shall not become part or modify any prior or existing agreement, commitment or relationship. The Sales Contract contains the entire obligations of Siemens. The warranty contained in the contract between the parties is the sole warranty of Siemens. Any statements contained herein do not create new warranties or modify the existing warranty.



WARNING

The meters can be used with high pressures and corrosive media. Incorrect handling could therefore lead to severe personal injury or extensive damage to property.

Only suitably qualified staff should work on the meters.

Correct and safe operation of the meters is dependent on proper handling, installation, operation and maintenance.

QUALIFIED PERSON

For the purpose of this instruction manual and product labels, a "qualified person" is one who is familiar with the installation, construction and operation of the equipment and the hazards involved.

In addition, he has the following qualifications:

- Is trained and authorized to energize, de-energize, clear, ground and tag circuits and equipment in accordance with established safety practices.
- Is trained in the proper care and use of protective equipment in accordance with established safety practices.
- Is trained in rendering first aid.

1 Description

1.1 Application

The positive displacement meters with rotary-piston mechanisms described in these Instructions - referred to simply as rotary-piston meters below - are used for volumetric measurements in the delivery, distribution or processing of liquids of most different types (e.g. acids, bases, solvents, diluents, fuels etc.) especially in the primary industry, chemical industry, food industry as well as in power stations and district heating power stations. Their main features are high accuracy, great reliability and negligible pressure loss.

The meters are approved in Germany and in many other countries for custody transfer. The local licensing rules must be observed. Meters which are intended for custody transfer in Germany have already been tested by the authorities before delivery.



WARNING

The rotary-piston meters must only be used for the liquid they were ordered for and the specified flow range. The material of the rotary piston has been carefully selected to meet the requirements of the application and the measuring tolerance applies accordingly. Using the meters for a different liquid or for the same liquid at a different viscosity or temperature as well as violation of the rated pressure may lead to errors in measurement, excessive wear or failure of the meter.

In this case persons could be injured or property damaged.

If the operating data provided with the order were incomplete or missing, no guarantee can be accepted for correct design of the meters.

The liquid to be measured should not contain solid impurities such as suspended substances, sediments or sticky materials. The sieve in the rotary-piston meter is not designed to serve as a filter for such impurities. The use of a filter is prescribed in applications of the rotary-piston meters for custody transfer.

Sudden rises in pressure (liquid hammer), which occur for example in long lines when a shut-off valve is suddenly closed, should be avoided to prevent damaging the meter.

If a rotary-piston meter is used in a line under vacuum (e.g. suction line of a pump), care must be taken to prevent the entry of air and the evaporation of the measured liquid. Air or gas pockets in the liquid are also measured and lead to false results. To prevent this, a gas separator can be inserted in front of the meter.

1.2 Design

The rotary-piston meter consists of at least three modules: the metering mechanism, the intermediate gear and the register (Fig. 1/4). The three modules are combined into one unit. In addition, further modules, e.g. sensors, can be inserted between the flanges.

Metering mechanism

The metering mechanism consists of the housing (upper and lower parts with the flanges), the measuring system and the transmission system.

The measuring system consists of the chamber with lid, rotary piston and partition. The slotted rotary piston is arranged in the measuring chamber with the partition radially.

The piston movement in the transmission system is transmitted to the register by a driver, the mechanism shaft, a magnet coupling and the two adjustable gear wheels. One of the gear wheels belongs to the metering mechanism, the other to the intermediate gear.

The rotary-piston meters with heater are designed for hot liquids which must not cool down in the meter. A heating coil is fitted in the bottom part of the metering mechanism in the DN 32, 50 and 80 meters. In the DN 15 meters, heating channels are used instead of a heating coil. Oil, steam or hot water can be used for heating. The adjacent table provides details on the heating connections provided.

DN	PN	Connection	Dimensions in Fig.
15	25	Female thread R 3/4	1/11
15	40	Female thread R 3/8	1/11
32, 50 and 80	25 to 63	Flange DN 10/PN 10	1/15

In the enamel/plastic design of the rotary-piston meters, all parts which come into contact with the liquid are either made or lined with acid-resistant material; cf. the table of recommended materials in Catalog MP 13. With such meters, the maximum permissible temperature of the liquid depends on the material used.

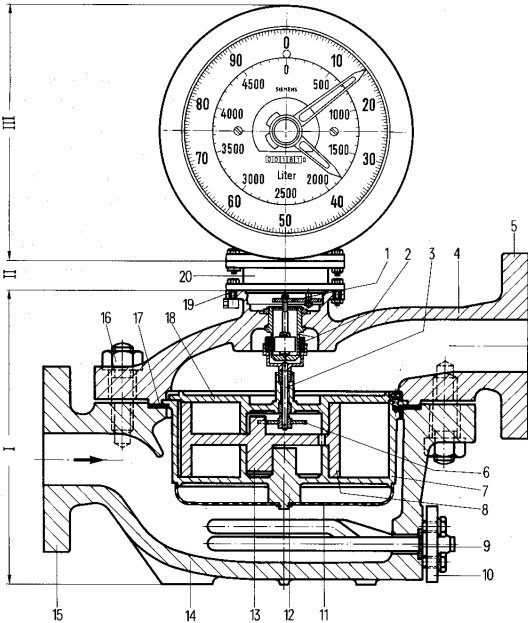

- | | |
|-------------------------------|--|
| I Metering mechanism | 10 Flange for heater (inlet and outlet) |
| II Intermediate gear | 11 Sieve |
| III Register | 12 Chamber pin |
| 1 Gear wheels | 13 Piston pin |
| 2 Magnetic coupling | 14 Lower part of housing |
| 3 Shaft of metering mechanism | 15 Flange for liquid inlet |
| 4 Upper part of housing | 16 Housing bolt with nut |
| 5 Flange for outlet line | 17 Housing gasket |
| 6 Drive | 18 Measuring chamber lid |
| 7 Measuring chamber | 19 Flange for fixing the intermediate gear |
| 8 Rotary piston | 20 Intermediate gear |
| 9 Heating coil | |

Fig. 1/4 Rotary-piston meter DN 50/PN 63 with heater and resettable double-pointer dial type 12

Intermediate gear

The intermediate gear is flanged between the metering mechanism and the register. Its gear wheel mechanism matches the measuring chamber contents (which depend on the meter size) to the rotational values.

Registers

All registers, such as dial or drum-type registers, are provided with a uniform flange for mounting on the intermediate gear. The registers are provided with a code number (Figs. 1/5 to 1/8 and 1/11 to 1/17) depending on the design and position of the scale with respect to the mounting flange.

The *non-resettable dial and drum-type counter type 01* is a single-pointer dial with a 5-digit drum-type counter. One revolution of the pointer corresponds to the progression by one digit on the fastest drum of the drum-type counter. Individual quantities are calculated from the difference between two readings. The scale is always horizontal (with reference to a vertical metering mechanism shaft) (Fig. 1/5).

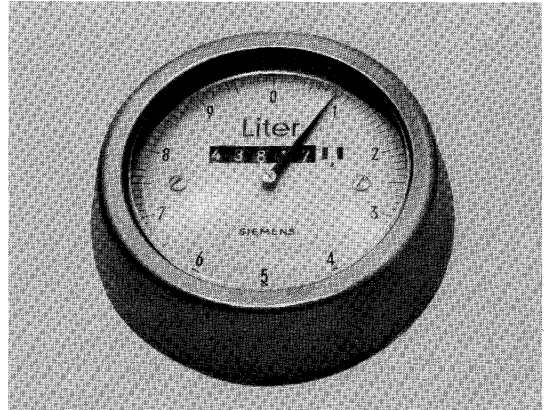

Fig. 1/5 Non-resettable dial and drum-type counter type 01

The *resettable dial and drum-type counters of types 11, 12, 13 and 14* are double-pointer dials with two resettable pointers and a 5-digit drum-type totalizer. The smaller pointer indicates the full revolution values of the larger pointer. One revolution of the larger pointer corresponds to one revolution of the last drum of the drum-type totalizer. The types of double-pointer dials only differ in the arrangement of the scale.

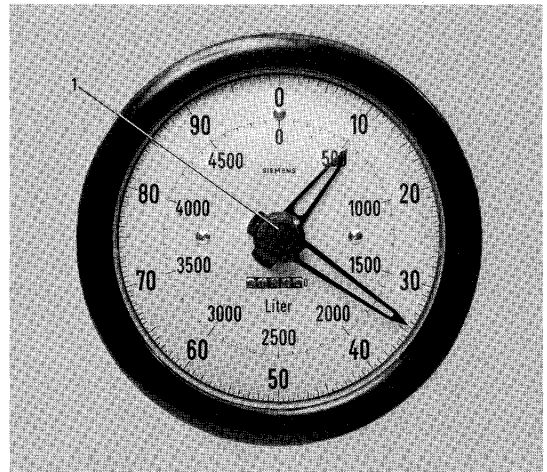

Fig. 1/6 Resettable dial and drum-type counters of types 11, 12, 13 and 14

Double-pointer dials	Scale
11	Horizontal
12	Vertical
13 and 14	Inclined by 45°

The drum-type totalizer counts all measured values continuously and cannot be reset. The pointers can be reset by rotating knob 1 (Fig. 1/6) in the counterclockwise direction.

The *resettable drum-type counter type 21* has a drum-type counter with 5 large, resettable drums and an 8-digit, non-resettable drum-type totalizer. The scale is inclined by 45°. The drum-type totalizer counts all measured values continuously. The large drums can be reset by turning the crank (Fig. 1/7) in the clockwise direction.

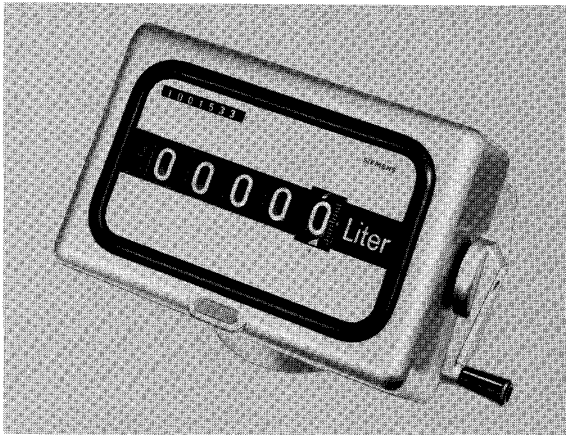

Fig. 1/7 Resettable drum-type counter type 21

The *resettable drum-type counter with ticket printer type 22* consists of the drum-type counter type 21 described above with an additional 6-digit ticket printer arranged in a common housing. Its application is recommended wherever a printed receipt is required for the quantities received or output. A digital resolution of the analog indication of the last drum with respect to the drum-type counter takes place with the additional 6th digit of the printer.

Additional print rollers enable a two-digit identification of the measuring point on the printed ticket. The scale is also inclined by 45° with this unit (Fig. 1/8).

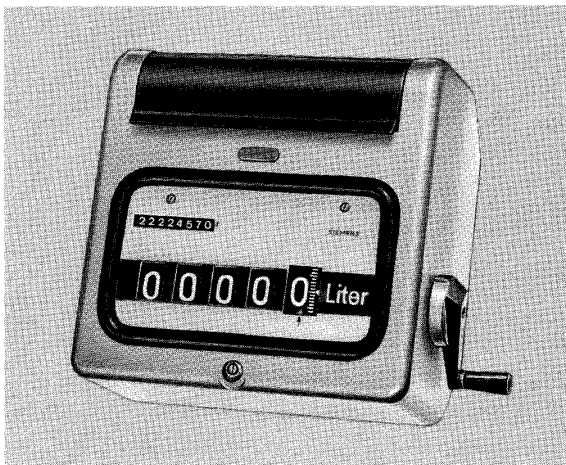
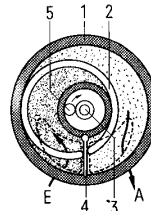

Fig. 1/8 Resettable drum-type counter with ticket printer type 22

1.3 Mode of operation

The measuring principle is based on the continuous filling and emptying of the measuring spaces formed by the walls of the measuring chamber and the rotary piston as well as the partition which is radially inserted between the inlet and outlet openings.

The liquid flowing through the mechanism moves the rotary piston. In the process, the piston is moved in such a way by the piston pin which runs in the guide slot around the chamber pin that it slides to and fro on the partition with its slot. The rotational movement of the piston pin is transferred to the indicator mechanism by the transmission system. One revolution of the piston pin corresponds to the flow of a liquid quantity equal to the volume of the measuring chamber.



Position 1

The liquid enters through the inlet (E) into the shaded part of the measuring chambers. Due to the overpressure, the liquid fills the inner space of the rotary piston and moves it in the direction of the arrow.

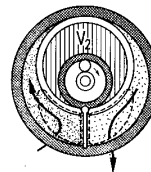

Position 2

The inner space of the rotary piston (volume V_2) is now filled and shut off. The liquid continues to flow into the measuring chamber and moves the piston further in the same direction.

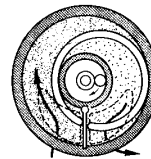

Position 3

The inner space of the rotary piston is partly over the outlet (A). The contents (V_2) can flow out or are forced through the outlet by the further movement of the piston.

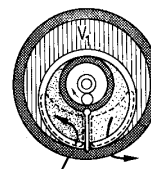

Position 4

The outer measuring space (V_1) is filled and shut off. The inner space of the rotary piston is partly over the inlet and continues to move back to position 1 again as it is filled. In the process, the contents (V_1) are over the outlet and flow through this.

The sum of the two volumes ($V_1 + V_2$) represents the displacement of the measuring chamber.

A Outlet for liquid
E Inlet for liquid

1 Measuring chamber
2 Rotary piston
3 Chamber pin
4 Partition
5 Piston pin

Fig. 1/9 Schematic representation of the measuring principle

1.4 Technical data

Error limits

Between $\pm 0.2\%$, $\pm 0.5\%$ and $\pm 2\%$ (with PTFE/carbon pistons) of the setpoint (depending on the measured liquid, the range and the respective calibration regulations), apart from enamel/plastic designs of the meters where $\pm 1\%$ of the setpoint applies, and also 15 mm Riko meters.

Permissible operating temperature

The permissible temperature of the measured liquid for rotary-piston meters depends on the piston material, the number of cooling attachments between the meter and accessory modules and, in the case of the plastic design of meters, on the type of plastic used. The ordering data apply in all cases.

Pressure loss

The pressure loss in the rotary-piston meters depends on the flow rate and the viscosity of the medium. Fig. 1/10 shows an example of the pressure loss for rotary-piston meters DN 15, 32, 50 and 80 depending on the flow rate at $1 \text{ mPa}\cdot\text{s}$.

Filters

Mesh size depending on measured liquid, e.g.
 approx. 0.2 mm for carburettor fuels, solvents etc.,
 approx. 0.4 mm for diesel fuels, heating oils, fruit juices etc.,
 approx. 0.8 mm for heavy heating oil, lubricating oils etc.

Rated size, rated pressure, flow rate

Rated size DN mm	Rated pressure PN (DIN 2401) bar	Permissible flow rate in l/min^1					
		Minimum flow rate with a liquid viscosity of				Maximum flow rate with	
		0.6 mPas	1 mPas	5 mPas	800 mPas	continuous operation	intermittent operation, approx. 1000 hours/year
15	25	1.5	1.5 (3)	1.5 (3)	0.5 (1)	10	20 (16)
	40	1.5	1.5 (3)	1.5 (3)	0.5 (1)	10	20 (16)
25 and 32	10	6	5 (10)	3 (6)	1 (2)	50	100 (60)
	10 ²⁾	10	8	4	–	50	100
	25	6	5 (10)	3 (6)	1 (2)	50	100 (60)
	63	6	5 (10)	3 (6)	1 (2)	50	100 (60)
50	10	20	18 (36)	10 (20)	2 (4)	165	500 (400)
	25	20	18 (36)	10 (20)	2 (4)	165	500 (400)
	63	20	18 (36)	10 (20)	2 (4)	165	500 (400)
80	25	35	25 (50)	10 (20)	5 (10)	350	1000 (800)
	63	35	25 (50)	10 (20)	5 (10)	350	1000 (800)

¹⁾ The values in parentheses apply to rotary-piston meters with metal pistons

²⁾ Enamel/plastic design

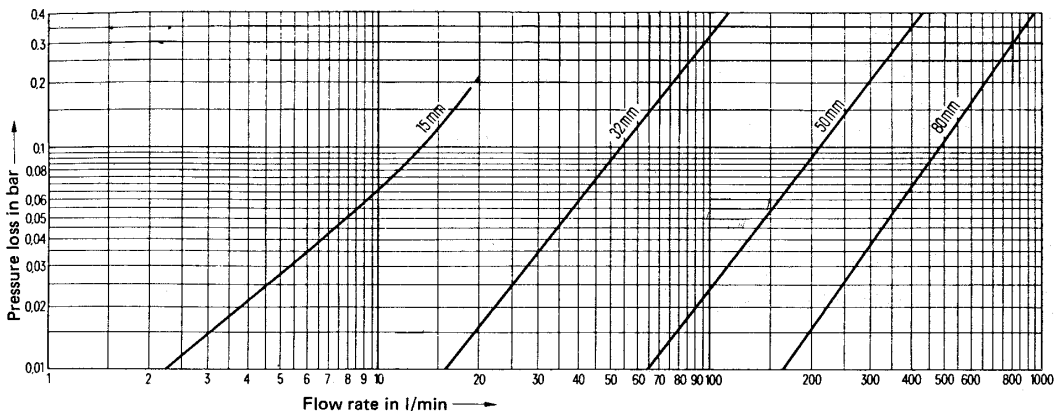
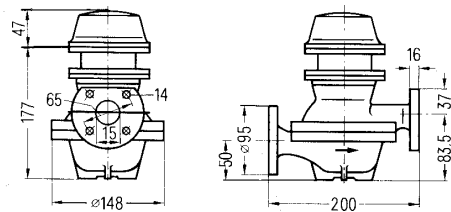

Fig. 1/10 Pressure loss depending on flow rate with a liquid viscosity of $1 \text{ mPa}\cdot\text{s}$ for meters DN 15, 32, 50 and 80

Dimensions of the rotary-piston meters, industrial design, with pointer dials and drum-type counters

DN 15
PN 25 and PN 40

With register type 01
DN 15/PN 25 *without* heater



With register type 11

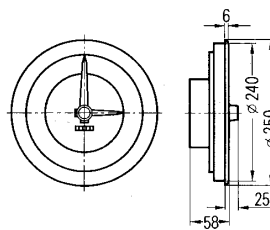

DN 15/PN 25 *with* heater
DN 15/PN 40

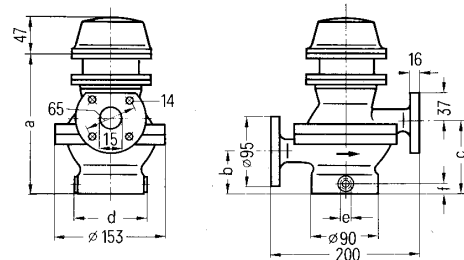

With register type 12

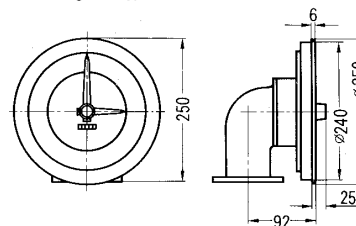

With register type 13

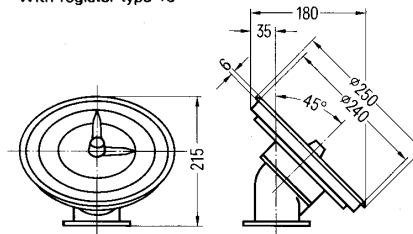

Metering mechanism				Connection for heater (PN 16)	
	a	b	c	d	e f
DN15					
PN 25 with heater	200	66	106	100	R 3/4 22
PN 40 without heater	194	60	100	-	-
PN 40 with heater	202	68	108	92	R 3/8 26

Fig. 1/11 Rotary-piston meters DN 15 (industrial design)

Dimensions of the rotary-piston meters, industrial design, with pointer dials

DN 25, DN 32, DN 50 and DN 80
PN 25 and PN 63

With register type 01

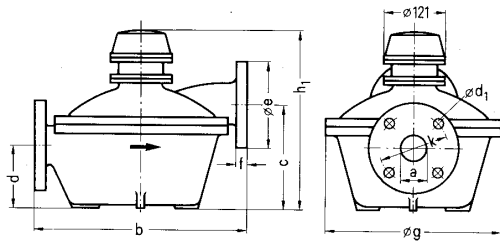

With register type 11

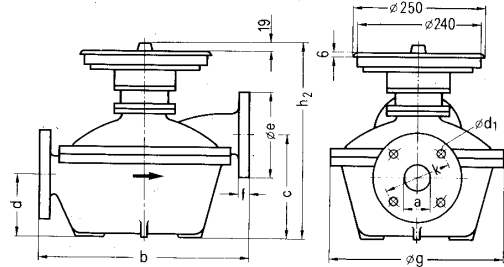

With register type 12

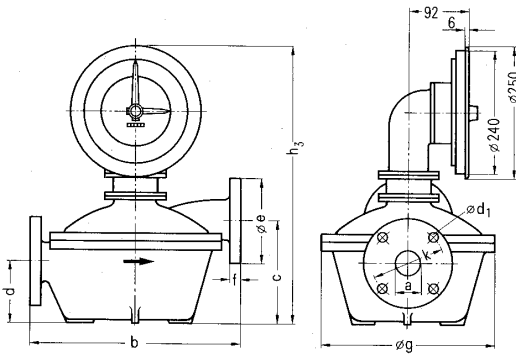

With register type 13

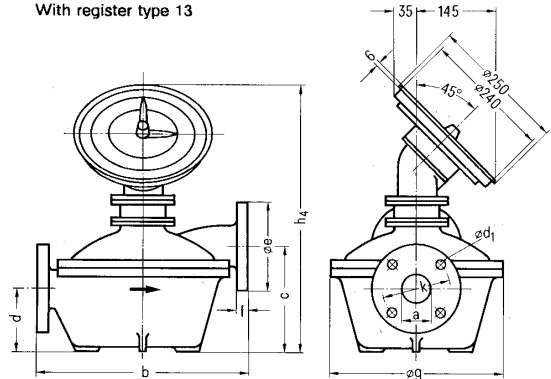

With register type 14

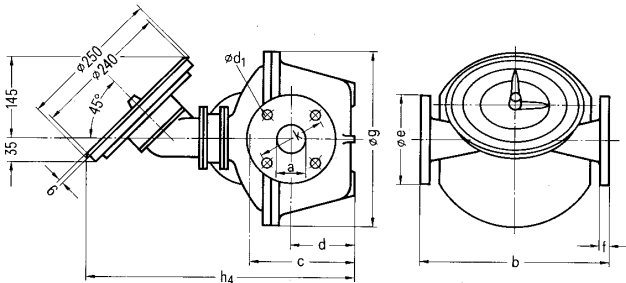

Rated size	Rated pressure	Dimensions (mm)						Number of holes	Dimensions (mm)						
		Ø a	b	c	d	Ø d ₁	Ø e		f	Ø g	h ₁	h ₂	h ₃	h ₄	Ø k
DN 25	PN 25	32	270	144	80	14	4	115	18	205	292	322	495	460	85
	PN 63	32	300	157	82	18	4	140	24	230	308	338	511	476	100
DN 32	PN 25	32	270	144	80	18	4	140	18	205	292	322	495	460	100
	PN 63	32	300	157	82	23	4	155	24	230	308	338	511	476	110
DN 50	PN 25	50	400	205	120	18	4	165	20	330	347	377	550	515	125
	PN 63	50	470	230	120	22	4	180	26	385	369	399	572	537	135
DN 80	PN 25	80	540	271	155	18	8	200	22	450	415	445	618	583	160
	PN 63	80	600	312	177	22	8	215	28	515	471	501	674	639	170

Fig. 1/12 Rotary-piston meters DN 25, DN 32, DN 50 and DN 80, PN 25 to PN 63 (industrial design) with pointer dials

Dimensions of the rotary-piston meters, industrial design, with drum-type counters

DN 25, DN 32, DN 50 and DN 80
 PN 25 and PN 63

With register type 21

With register type 23

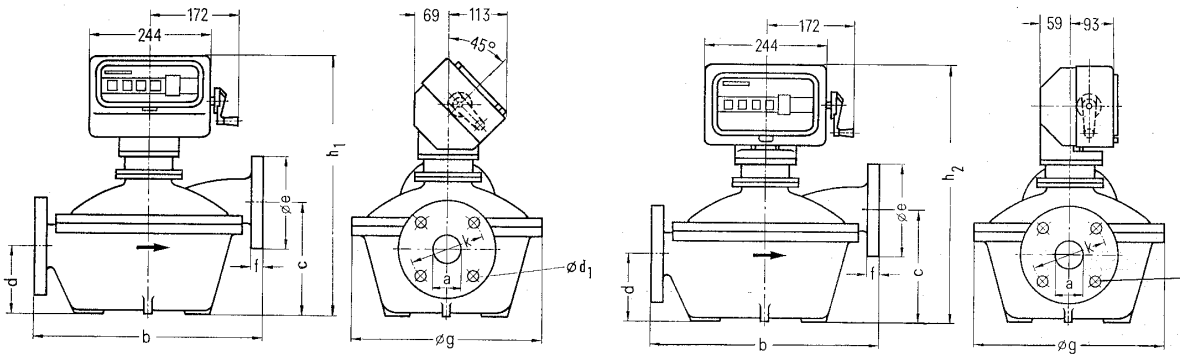

Rated size	Rated pressure							Number of holes						
		$\varnothing a$	b	c	d	$\varnothing d_1$	$\varnothing e$		f	$\varnothing g$	h_1	h_2	$\varnothing k$	
DN 25	PN 25	32	270	144	80	14	4	115	18	205	425	431	85	
	PN 63	32	300	157	82	18	4	140	24	230	441	447	100	
DN 32	PN 25	32	270	144	80	18	4	140	18	205	425	431	100	
	PN 63	32	300	157	82	23	4	155	24	230	441	447	110	
DN 50	PN 25	50	400	205	120	18	4	165	20	330	480	486	125	
	PN 63	50	470	230	120	22	4	180	26	385	502	508	135	
DN 80	PN 25	80	540	271	155	18	8	200	22	450	548	554	160	
	PN 63	80	600	312	177	22	8	215	28	515	604	610	170	

Fig. 1/13 Rotary-piston meters DN 25, DN 32, DN 50 and DN 80, PN 25 to PN 63 (industrial design) with drum-type counters

Dimensions of the rotary-piston meters, industrial design, with drum-type counters with ticket printers and with quantity preset registers

DN 25, DN 32, DN 50 and DN 80
PN 25 and PN 63

With register type 22 or type 42

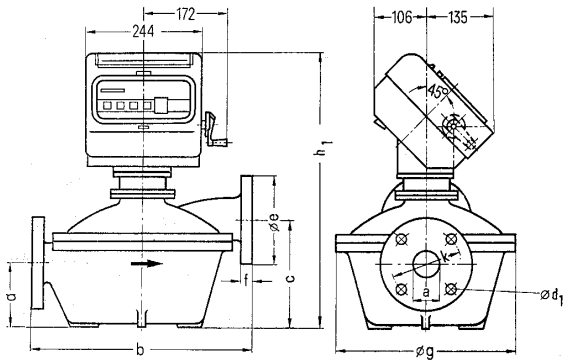

With register type 24 or type 44

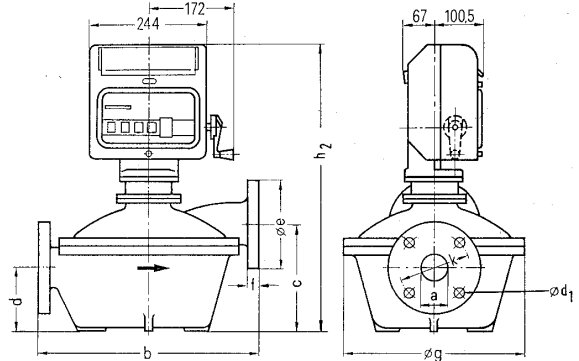

With register type 30, type 50, type 51, type 52, type 53 or type 54

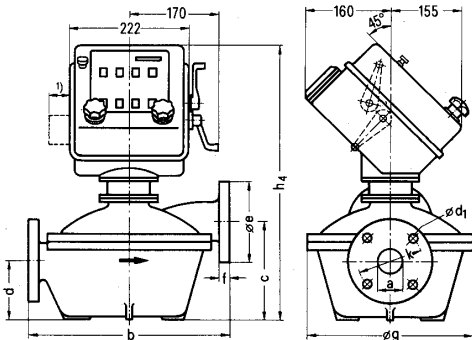

With register type 34 or type 35 (on request)

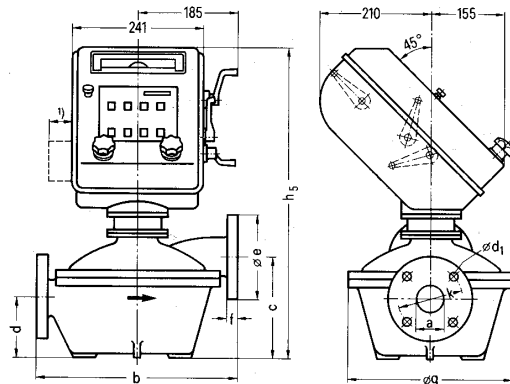

Rated size	Rated pressure							Number of holes							
		$\varnothing a$	b	c	d	$\varnothing d_1$	$\varnothing e$		f	$\varnothing g$	h_1	h_2	h_4	h_5	$\varnothing k$
DN 25	PN 25	32	270	144	80	14	4	115	18	205	480	520	495	550	85
	PN 63	32	300	157	82	18	4	140	24	230	496	536	511	566	100
DN 32	PN 25	32	270	144	80	18	4	140	18	205	480	520	495	550	100
	PN 63	32	300	157	82	23	4	155	24	230	496	536	511	566	110
DN 50	PN 25	50	400	205	120	18	4	165	20	330	535	575	550	605	125
	PN 63	50	470	230	120	22	4	180	26	385	557	597	572	627	135
DN 80	PN 25	80	540	271	155	18	8	200	22	450	603	643	618	673	160
	PN 63	80	600	312	177	22	8	215	28	515	659	699	674	729	170

Fig. 1/14 Rotary-piston meters DN 25, DN 32, DN 50 and DN 80, PN 25 to PN 63 (industrial design) with drum-type counters with ticket printers and with quantity preset registers

1) Take into account additional dimension for switch.

Dimensions for heater connection of the rotary-piston meters

DN 32, DN 50 and DN 80
PN 25 and PN 63

Meters with connection width 32 mm
Heater connection: DN 10/ PN 10

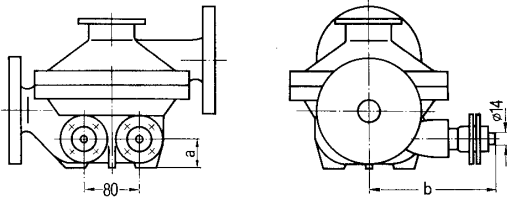

Rated pressure PN (DIN 2401)	a	b
25	39	140
63	49	140

Meters with connection widths 50 and 80 mm
Heater connection: DN 10/ PN 10

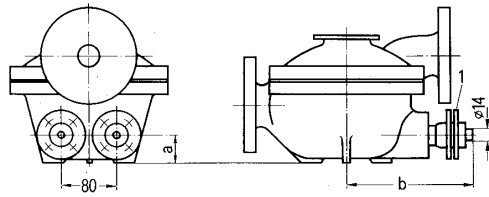

Rated size DN mm	Rated pressure PN (DIN 2401)	a	b
50	25	48	206 ¹⁾ 197 ²⁾
	63	40	165
80	25	63	256
	63	97	250

Fig. 1/15 Dimensions for heater connection of rotary-piston meters DN 32, 50 and 80, PN 25 and PN 63

- 1) With casing made of spheroidal graphite cast iron.
- 2) With casing made of CrNiMo steel.

Dimensions of the rotary-piston meters, enamel/plastic design, with drum-type counters and pointer dials

DN 25/PN 10

With register type 01

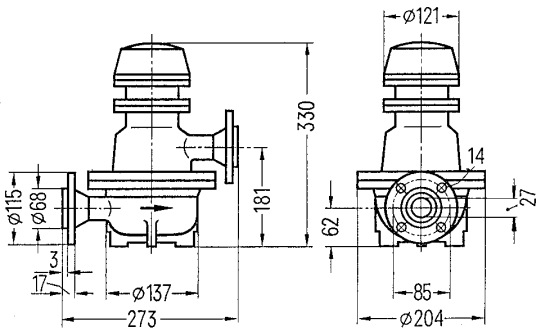

With register type 11

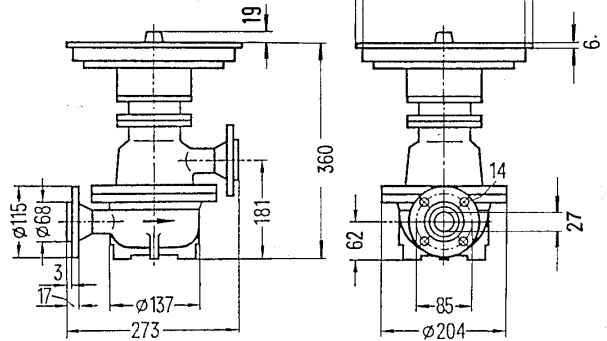

With register type 12

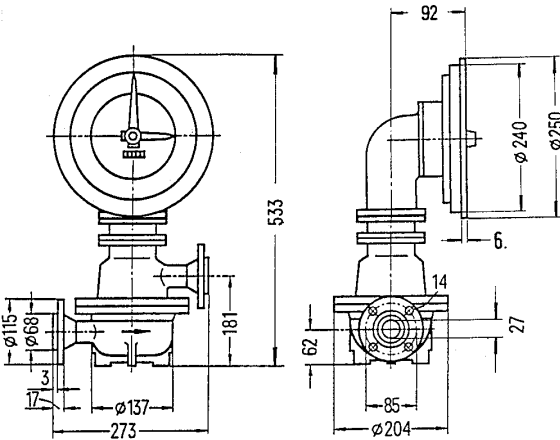

With register type 13

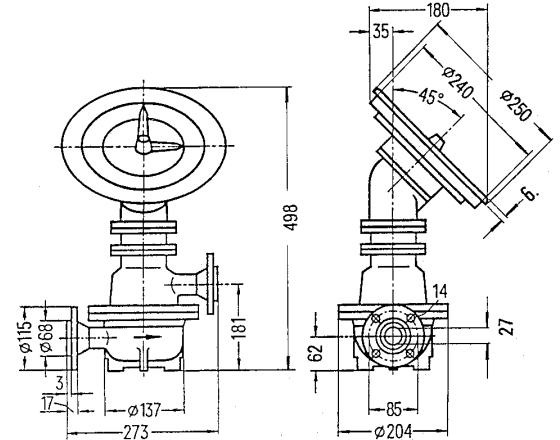

With register type 21

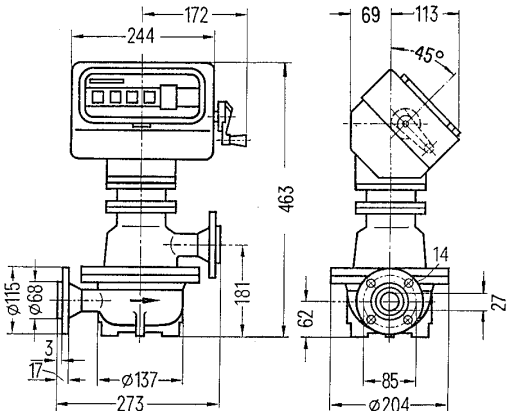

With register type 23

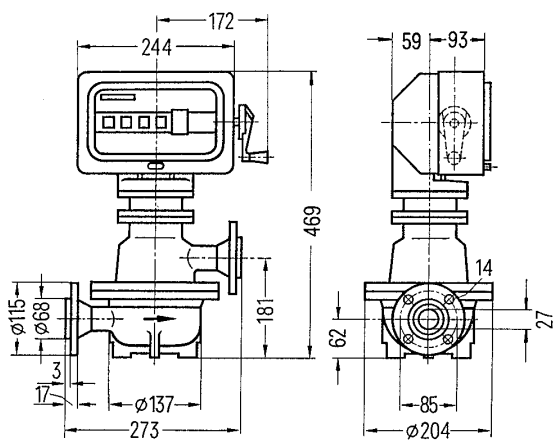
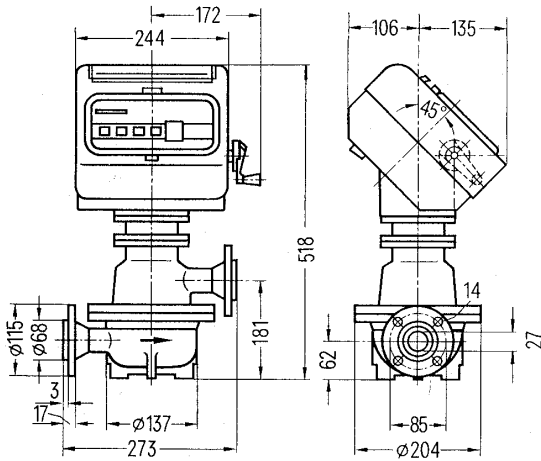

Fig. 1/16 Rotary-piston meters DN 25 (enamel/plastic design) with pointer dials and drum-type counters

Dimensions of the rotary-piston meters, enamel/plastic design, with drum-type counters with ticket printers and with quantity preset registers

DN 25/PN 10

With register type 22



With register type 24

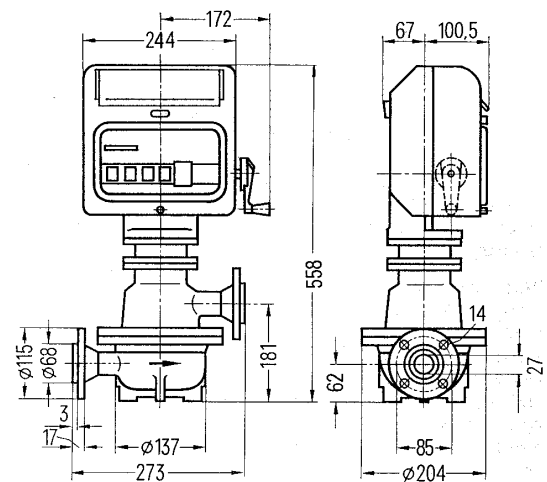

With register type 30, type 50, type 51, type 52, type 53 or type 54

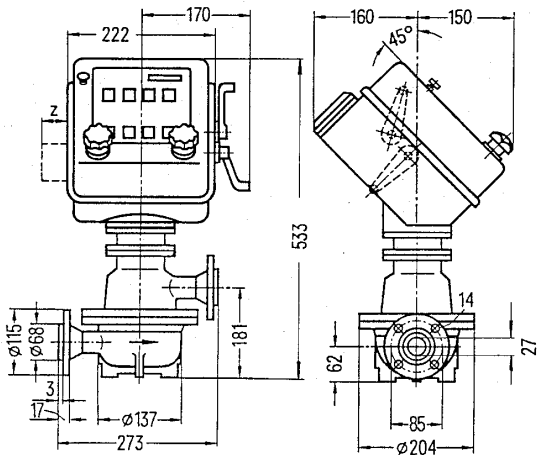

With register type 34 or type 35 (on request)

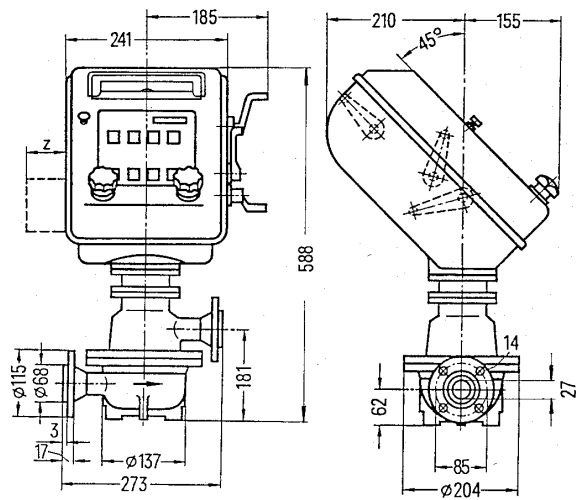

Fig. 1/17 Rotary-piston meters DN 25 (enamel/plastic design) with drum-type counters with ticket printers and quantity preset registers

1) Take into account additional dimension for switch.

2 Installation and operation

2.1 Unpacking

Remove all packing material from the rotary-piston meter. In order to prevent foreign matter from entering the internal parts of the meter, the cover plates over the flanges should be left in place until the meter is mounted in the plant.

2.2 Drilling the flanges

Rotary-piston meters can be delivered with undrilled flanges on request. In such a case, we recommend drilling of the flanges in accordance with the application specifications (DIN 2501 in Germany) (exception: enamel/plastic designs of the meters).

When drilling the flanges, care must be taken to ensure that no foreign matter or borings enter the meter. These materials may later block the meter when in operation or may cause damage to the sensitive rotary pistons (e.g. carbon pistons). Careful sealing of the two connection openings prevents the entry of foreign matter during drilling. The material used for covering must be completely removed again afterwards. To prevent borings from falling into the meter, hold the meter such that the stuffing material can only be removed downwards. The flanges must again be closed by the specially provided covers until the meters are finally mounted in the plant.

2.3 Mounting

If the rotary-piston meter is mounted outdoors, sufficient protection against climatic conditions is recommended; freezing of the liquid can destroy the meter. If possible, the rotary-piston meter should be mounted in the pressure line and, especially when measuring corrosive liquids, mounted in such a position that it remains filled with the liquid even during pauses in operation. The meter can be mounted in any position which only depends on the readability of the register. During installation of the piping, a fitting tube (a tube matching the mounting dimensions of the meter, see Section 1.4), must be mounted instead of the meter. In this manner the rotary-piston meter is protected from mechanical shocks or stresses in the piping during pipe work and also after it has been mounted. In the case of heated meters, the inlet and outlet lines for the heater must also be laid without causing additional stress. It is recommendable to support heavy meters (depending on the stability and anchoring of the piping).

If it is not permissible to interrupt the flow of liquid for manufacturing reasons when cleaning the rotary-piston meter or the sieve, a bypass line can be installed as in Fig. 2/1.

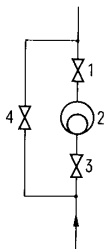

Shut-off valve	Flow through	
	meter	bypass
1	Open	Closed
3	Open	Closed
4	Closed	Open

1, 3 and 4 Shut-off valves
2 Rotary-piston meter

Fig. 2/1 Example of a bypass line

Before mounting the rotary-piston meter in the plant, all foreign matter must be completely removed from the piping. This is done most effectively with the fitting piece mounted and by flushing with the highest possible flow rate. The fitting piece can be removed following flushing and replaced by the rotary-piston meter. The meter must be installed with the correct direction of flow (marked by an arrow on the housing). The sealing surfaces of the flanges must be clean and the flange bolts must be tightened uniformly in a diagonally opposite sequence.

WARNING

The sealing material must be selected according to the liquid and the rated pressure (information can be obtained from manufacturer), especially as to avoid the possible danger to persons and property by escaping liquid.

2.4 Commissioning

The rotary-piston meters are tested before leaving the factory and operate trouble-free if they are correctly mounted.

When using a rotary-piston meter for the first time, it is advisable to start with a low flow and to check whether the register operates. In this manner, faults (e.g. solid foreign material in the metering mechanism) can be detected at an early stage and extensive damage can be prevented by immediately stopping the flow. Faults can be detected and corrected as in Section 3.7.

If no faults are observed with a low flow rate, the flow should be increased up to the maximum permissible value if possible (table on page 5). Any remaining air in the rotary-piston meter is removed by the fast flow of liquid. Otherwise air pockets which remain in the meter would lead to errors in the measurements. When removing the air, the maximum permissible flow rate must not be exceeded to prevent overloading. In addition, do not exceed the rated pressure (it is advisable to fit a pressure gauge in the inlet line to the meter) and the maximum permissible temperature of the liquid.

Meters used for custody transfer must be calibrated by the appropriate gauging authorities.

Before using the rotary-piston meter, reset the register to zero in the case of meters with a resettable register, or note the indicated value on meters with a non-resettable register.

3 Maintenance

3.1 Checking and servicing

Since the rotary-piston meters are provided with a magnetic coupling for transmitting the measured values from the metering mechanism to the register, regular servicing (e.g. lubrication etc.) is not required.

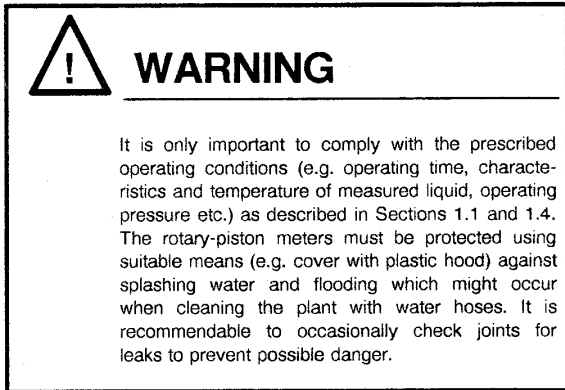

3.2 Recalibration

In the case of rotary-piston meters used for custody transfer, the meters must be recalibrated every 2 years by the appropriate calibration office. Checking and recalibration are also required following maintenance work (e.g. replacement of piston, cleaning of meter etc.) where a lead seal has been damaged or removed. The regulations of the local gauging authorities must be complied with in all cases.

3.3 Removing the rotary-piston meter, replacing the piston and cleaning the sieve

The meter must be removed from the plant in order to clean it, to replace the piston and to clean the sieve. The supply of liquid must first be shut off. If a bypass line has been provided, the meter can be taken out of operation as in Fig. 2/1 without disturbing the process. After removing the flange bolts and nuts on both sides of the meter, the meter can be removed from the plant (if it is without a heater).

When removing rotary-piston meters with a heater, the flange bolts and nuts of the heating lines must also be removed.

To replace the rotary piston, the measuring system must be removed from the meter housing and taken apart. The same procedure must be followed as when cleaning the rotary-piston meter (Section 3.4, 3.5 or 3.6).

The measuring system must also be taken out of the meter housing in order to clean the sieve. It is therefore advisable to clean the meter completely. The only additional work required is to take apart the measuring system and reassemble it, which can be carried out within a relatively short time. If it is not necessary to clean the measuring system, however, the taking apart and reassembling of the measuring system as described in Section 3.4, 3.5 or 3.6 does not apply.

3.4 Cleaning the rotary-piston meters, industrial design, DN 15, Fig. 3/1

3.4.1 Dismantling the rotary-piston meter

- Use a pointed tool (marking tool, screwdriver) to pierce and remove the lead sealing disks (12). Remove all sealing screws (14) and sealing blocks (13).
- After removing all screws on the connection flange of the metering mechanism, cautiously lift off the register and intermediate gear including any intermediate modules. Do not damage the transmission wheels for the measured value!
- Loosen the nuts (17) of the housing connection and open the housing by lifting the upper part (1). Do not tilt sideways in the process, otherwise the shaft (4) of the metering mechanism could be warped. If the gasket sticks, separate the parts of the housing by gently hitting with a plastic hammer.
- Remove the gasket.
- Take out the entire measuring chamber (9) including the shaft (4) of the metering mechanism from the lower part of the housing (15). Take out the sieve (19) after removing the split pin (18).
- Remove the lid (23) of the measuring chamber after unscrewing the securing screws (24). If the lid sticks, gently hit with a plastic hammer. Remove the rotary piston (21) and the partition from the chamber.
- Carry out thorough mechanical cleaning of the measuring chamber, measuring chamber lid and all sealing surfaces.
- After cleaning, the shaft of the metering mechanism must be easy to turn without noticeable friction. All parts of the metering mechanism must be clean and free of even minimum residues of cleaning material.

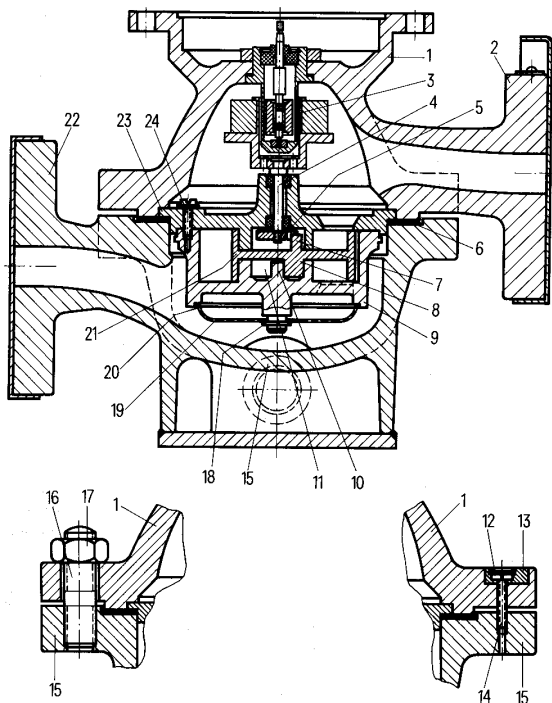

- | | |
|-----------------------------------|--|
| 1 Upper part of housing | 14 Sealing screw |
| 2 Flange for outlet line | 15 Lower part of housing |
| 3 Magnetic coupling | 16 Housing bolt (stud bolt) |
| 4 Shaft of metering mechanism | 17 Nut for housing bolt |
| 5 Driver | 18 Sieve holder (split pin or screw with washer) |
| 6 Housing gasket | 19 Sieve |
| 7 Upper piston pin (approx. 4 mm) | 20 Groove for sieve |
| 8 Lower piston pin (approx. 7 mm) | 21 Rotary piston |
| 9 Measuring chamber | 22 Flange for liquid inlet |
| 10 Chamber pin | 23 Measuring chamber lid |
| 11 Guide slot | 24 Securing screw for measuring chamber lid |
| 12 Sealing disk | |
| 13 Sealing block | |

Fig. 3/1 Rotary-piston meter DN 15/PN 40 with heater PN 16

3.4.2 Assembly of the rotary-piston meter

The rotary-piston meter is assembled as described above for dismantling, but in the reverse order. The parts dismantled last are assembled first. All parts must be undamaged and free of any foreign matter. Damaged or worn parts must be replaced by new parts made of the same material.



CAUTION

The following points must also be observed when assembling:

- The housing gasket (6) must be replaced by a new one. The gasket must be undamaged.
- The sieve (19) must fit with its edge in the groove (20) in the bottom of the measuring chamber. It can only be secured when it is correctly seated. Also ensure that the sieve holder (18) is secure.
- Insert the rotary piston (21) in such a way that the lower piston pin (8) fits into the guide slot (11) in the bottom of the measuring chamber. The piston must then move freely in the measuring chamber (9) as shown in Fig. 1/9.
- When replacing the measuring chamber lid (23) ensure that the driver (5) fits with its cut-out over the upper piston pin (7). The measuring chamber lid can then be fitted onto the measuring chamber (9) and pressed down firmly. When turning the coupling part carefully, the rotary piston must move freely in the measuring chamber. The piston movement can be observed through the outlet opening in the measuring chamber lid.
- Tighten the securing screws (24) for the measuring chamber lid uniformly. Check the free movement of the piston again as above.
- Do not damage the sieve when placing the measuring system into the lower part of the housing (15).
- Before replacing the upper part of the housing (1), the magnetic coupling (3), especially the inner part, must be free of any foreign material. The upper part of the housing can then be carefully placed onto the lower part.
Screw the nuts (17) onto the housing bolts (16) and tighten uniformly in a diagonally opposite sequence. It is recommendable to check for leaks. Screw in the sealing screw (14) with sealing block (13).
- Meters with worn or replaced pistons must be readjusted (Section 3.9).
- Meters used for custody transfer must be tested and recalibrated by the gauging authorities (see Section 3.2). If the rotary-piston meter is not immediately mounted in the plant after being assembled, the connection flanges must be covered to prevent the entry of foreign material. When storing for a short time, it is sufficient to pack the meter in a sealed plastic bag. When storing a meter for a longer period, it is advisable to grease the metering mechanism parts to protect them from corrosion.
- The comments made in Section 2 must be observed when mounting the rotary-piston meter in the plant and when commissioning.

3.5 Cleaning the rotary-piston meters, industrial design, DN 32, 50 and 80, Fig. 3/2

3.5.1 Dismantling the rotary-piston meter

- Use a pointed tool to pierce and remove the lead sealing disks (14). Unscrew the sealing screws (15) and remove with the sealing blocks (13).
- Remove the register with all additional units from the metering mechanism (see Section 3.4.1).
- Loosen the nuts (8) from the housing bolts (7) and remove. Remove the bolts (7) if they are not stud bolts.
- Loosen the upper part of the housing (1) from the lower part (12) by screwing in the jack screws (16) and then screw the latter back again. Lift off the upper part of the housing with the register from the lower part. Do not tilt sideways in the process, otherwise the shaft of the mechanism could be warped. Do not damage the coupling parts of the magnetic coupling (2), and keep away from ferro-magnetic materials (e.g. iron filings etc.).
- In the case of the DN 80 meters, lift out the measuring system using the 2 lugs provided on the chamber lid (5). Be careful not to damage the sieve (18).
- Unscrew the securing screws (22) of the measuring chamber lid and lift off the lid with the shaft of the metering mechanism and the coupling part.
- Lift out the rotary piston (10) from the measuring chamber (9). Be careful since carbon or hard rubber pistons are extremely brittle. In some meters a sliding roller is provided over the piston pin (21). Do not loose this roller.
- In the case of DN 32 and DN 50 meters, take out the measuring chamber from the lower part of the housing (12).
- Remove the sieve holder (17) and take off the sieve (18).
- Clean all parts. The upper part of the housing with the register must not come into contact with the cleaning agent or solvent. After cleaning, the shaft of the metering mechanism must be easy to turn without noticeable friction. All parts of the metering mechanism must be clean and free of even minimum residues of cleaning material.

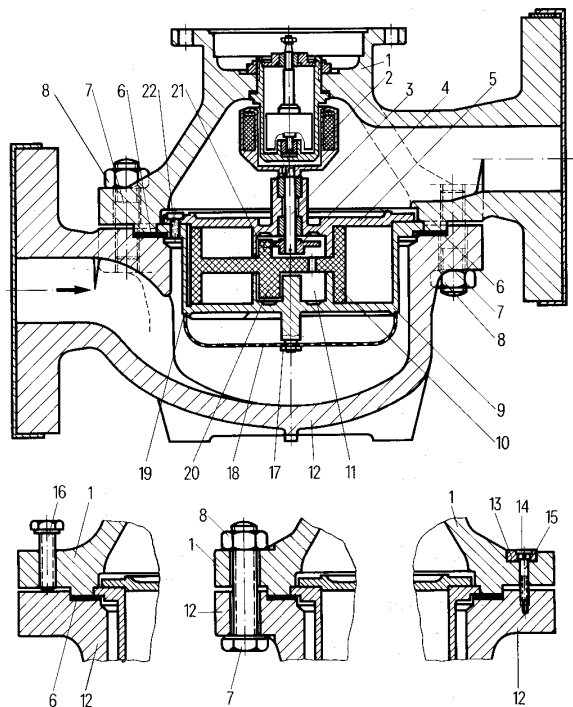

- | | |
|-------------------------------|---|
| 1 Upper part of housing | 14 Sealing disk |
| 2 Magnetic coupling | 15 Sealing screw |
| 3 Shaft of metering mechanism | 16 Jack screw |
| 4 Driver | 17 Sieve holder |
| 5 Measuring chamber lid | (split pin or screw with washer) |
| 6 Housing gasket | 18 Sieve |
| 7 Housing bolt | 19 Groove for sieve |
| (hexagon or stud bolt) | 20 Long piston pin |
| 8 Nut for housing bolt | 21 Short piston pin (in some meters a sliding roller is provided over the piston pin) |
| 9 Measuring chamber | 22 Securing screw for measuring chamber lid |
| 10 Rotary piston | |
| 11 Guide slot | |
| 12 Lower part of housing | |
| 13 Sealing block | |

Fig. 3/2 Rotary-piston meters DN 32/PN 25 and PN 63

3.5.2 Assembly of the rotary-piston meter

The rotary-piston meter is assembled as described above for dismantling, but in the reverse order. The parts dismantled last are assembled first. All parts must be undamaged and free of any foreign matter. Damaged or worn parts must be replaced by new parts made of the same material.



CAUTION

The following points must also be observed when assembling:

- The housing gasket (6) must be replaced by a new one. The gasket must be undamaged.
- The sieve (18) must fit with its edge in the groove (19) in the bottom of the measuring chamber. It can only be secured when it is correctly seated. Also ensure that the sieve holder (17) is secure.
- Insert the rotary piston (10) in such a way that the lower piston pin (20) fits into the guide slot (11) in the bottom of the measuring chamber. The piston must then move freely in the measuring chamber (9) as shown in Fig. 1/9. If a sliding roller was fitted on the piston pin (21), replace it.
- When replacing the measuring chamber lid (5) ensure that the driver (4) fits with its cut-out over the upper piston pin (21). The measuring chamber lid can then be fitted onto the measuring chamber (9) and pressed down firmly. When turning the coupling part carefully, the rotary piston must move freely in the measuring chamber. The piston movement can be observed through the outlet opening in the measuring chamber lid.
- Tighten the securing screws (22) for the measuring chamber lid uniformly. Check the free movement of the piston again as above.
- Do not damage the sieve when placing the measuring system into the lower part of the housing (12).
- Before replacing the upper part of the housing (1), check that the jack screws (16) are screwed back sufficiently that they no longer protrude out of the thread. The magnetic coupling (2), especially the inner part, must be free of any foreign material. The upper part of the housing can then be carefully placed onto the lower part.
- Insert the housing bolts (7) (if they are not stud bolts) and tighten the nuts (8) uniformly in a diagonally opposite sequence. It is recommendable to check for leaks. Screw in the sealing screw (15) with sealing block (13).
- Meters with worn or replaced pistons must be readjusted (Section 3.9).
- Meters used for custody transfer must be tested and recalibrated by the gauging authorities (see Section 3.2). If the rotary-piston meter is not immediately mounted in the plant after being assembled, the connection flanges must be covered to prevent the entry of foreign material. When storing for a short time, it is sufficient to pack the meter in a sealed plastic bag. When storing a meter for a longer period, it is advisable to grease the metering mechanism parts to protect them from corrosion.
- The comments made in Section 2 must be observed when mounting the rotary-piston meter in the plant and when commissioning.

3.6 **Cleaning the rotary-piston meters, enamel/plastic design, Fig. 3/3**



WARNING

Since highly corrosive media are measured using this type of meter, cautious handling is necessary to prevent skin burns by the liquid or its dry residues. In addition, the materials not belonging to the internal space of the meter are usually open to damage by corrosion.

3.6.1 *Dismantling the rotary-piston meter*

- Before dismantling the metering mechanism, disassemble the register with all additional units (see Section 3.4.1).
- Loosen the nuts (17) from the housing bolts (21) and remove the bolts.
- Loosen the upper part of the housing (1) from the lower part (10) and lift off. Do not tilt sideways in the process, otherwise the shaft of the mechanism could be warped. Do not damage the coupling parts of the magnetic coupling (4), and keep away from ferro-magnetic materials (e.g. iron filings etc.). Also take care not to damage the enamel lining (2). Carefully lift the spacer ring (24), taking care not to damage anything.
- Remove the upper housing gasket (22) from the measuring chamber groove. Take care not to damage any parts. Then lift off the measuring chamber lid (7) with the shaft of the metering mechanism and the coupling part. If the remaining measuring chamber sticks onto the chamber lid, remove as a whole and disassemble outside the meter housing. Caution: the parts are brittle.
- Lift the rotary piston (19) out of the measuring chamber, then the lower part of the chamber (8) and the lower housing gasket (23).
- Clean all parts. The register and the additional units must not come into contact with the cleaning agent or solvent. Do not damage the enamel lining.
- After cleaning, the shaft of the metering mechanism must be easy to turn without noticeable friction. All parts of the metering mechanism must be clean and free of even minimum residues of cleaning material.

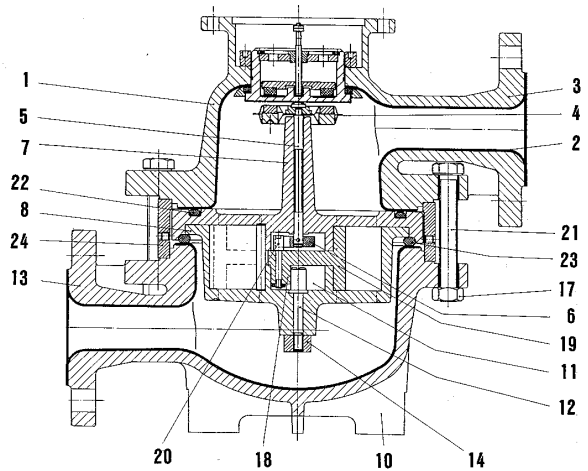

- | | |
|-----------------------------------|--|
| 1 Upper part of housing | 14 Nut for securing chamber pin |
| 2 Acid-resistant enamel lining | 17 Nut for housing bolt |
| 3 Flange for outlet line | 18 Long piston pin |
| 4 Magnetic coupling | 19 Rotary piston |
| 5 Shaft of metering mechanism | 20 Short piston pin, in some meters a sliding roller is provided |
| 6 Driver | 21 Housing bolt chamber |
| 7 Measuring chamber lid | 22 Upper O-ring |
| 8 Lower part of measuring chamber | 23 Lower O-ring |
| 10 Lower part of housing | 24 Spacer ring |
| 11 Guide slot | |
| 12 Chamber pin | |
| 13 Flange for liquid inlet | |

Fig. 3/3 Rotary-piston meter DN 32/PN 10 of enamel/plastic design

3.6.2 Assembly of the rotary-piston meter

The rotary-piston meter is assembled as described above for dismantling, but in the reverse order. The parts dismantled last are assembled first. All parts must be undamaged and free of any foreign matter. Damaged or worn parts must be replaced by new parts made of the same material.



CAUTION

The following points must also be observed when assembling:

- The two O-rings (22, 23) of the housing seal should be replaced by new ones. These must not be damaged.
- Insert the rotary piston (19) in such a way that the long piston pin (18) fits into the guide slot (11) in the bottom of the measuring chamber. The piston must then move freely in the measuring chamber (8) as shown in Fig. 1/9. If a sliding roller was fitted on the piston pin (20), replace it.
- When replacing the measuring chamber lid (7) ensure that the driver (6) fits with its cut-out over the upper piston pin (20). The measuring chamber lid (7) can then be fitted and pressed down firmly. When turning the coupling part carefully, the rotary piston must move freely in the measuring chamber. The piston movement can be observed through the outlet opening in the measuring chamber lid.
- When inserting the measuring system into the lower part of the housing (10) ensure that the two O-rings (22, 23) are correctly seated in order to guarantee a tight fitting of the meter and that the measuring system is fitted in the housing without any tension. Carefully fit the spacer ring (24).
- Before replacing the upper part of the housing (1), the magnetic coupling (4), especially the inner part, must be free of any foreign material. The upper part of the housing can then be carefully placed onto the lower part.
- Insert housing bolts and firmly tighten the nuts (17) in a diagonally opposite sequence. It is recommendable to check for leaks.
- Meters with worn or replaced pistons must be readjusted (Section 3.9).
- If the rotary-piston meter is not immediately mounted in the plant after being assembled, the connection flanges must be covered to prevent the entry of foreign material.
- Particular attention should be paid to the protection of the shock-sensitive sealing surfaces of the connection flanges.
- The comments made in Section 2 must be observed when mounting the rotary-piston meter in the plant and when commissioning.

3.7 Troubleshooting

The rotary-piston meters are of simple construction and, if used correctly, render years of reliable service. Besides normal wear, faults seldom occur. Should trouble or faulty measurements be encountered during commissioning or after an extended period in operation, however, the cause can be located by means of the following table and eliminated.

Fault	Cause	Fault in plant or meter	Remedy
1. Meter reading too high	Measured liquid contains air or gas	a) Meter is under vacuum and draws in air	Change installation or install gas separator
		b) Measured liquid contains air or gives off gas	
		c) Measured liquid evaporates due to too high vacuum	Install a stabilizer or gas separator tank
		d) Air is carried over from an overhead tank	
2. Meter reading too low	Flow rate below permissible minimum level	a) Pump delivery too small	Change installation
		b) Outlet into closed container, air vent not provided	
		c) Sieve in meter dirty, filter or pipeline blocked	Clean sieve (see Section 3.3), filter or pipeline
	Tolerance between rotary piston and measuring chamber too large because piston is worn	d) Piston slightly worn	Determine measuring error, replace gear wheels (see Sections 3.8 and 3.9)
		e) Piston severely worn	Replace piston (see Section 3.3)
3. Register remains stationary, flow through meter not possible	Piston does not rotate	a) Measuring chamber dirty	Clean meter (see Sections 3.4 to 3.6)
		b) Foreign matter in measuring chamber	
		c) Piston and measuring chamber corroded	Replace meter
4. Register stationary, flow through meter continues	Piston broken		Replace piston (see Section 3.3)
	Magnetic coupling or register damaged		Return meter for repair (remove meter as in Section 3.3)

3.8 Determining the error in indication

To determine the error in indication, proceed as follows:

1. In the case of single-pointer dials, note the reading. In the case of resettable dials, set to zero.
2. Collect the liquid flowing through the rotary-piston meter in a calibrated container (calibration standard).
3. The difference between the quantity N collected in the container and the meter reading A is the error F ($F = A - N$). A positive error is where the meter reading is too high, a negative error where it is too low.
4. Only certified standards may be used for official calibration purposes. The quantity used for testing should normally cause at least 3 rotations of the dial or drum of the fastest moving pointer or drum. The lowest flow quantity specified on the scale is also tested during official calibration.

When returning a rotary-piston meter to the factory because of incorrect accuracy, please supply the following information:

1. Test quantity in calibrated container (liters or ccm)
2. Value indicated by register for the test quantity
3. Type and temperature of liquid during test
4. Flow through the meter (liters/min) during the test.

The meter must be completely emptied before shipping. This is particularly important if the meter was used to measure flammable or corrosive liquids.

After an extended period of operation, the measuring accuracy can be affected by the normal wear of the metering mechanism parts. The meter then indicates a value smaller than the actual quantity. It is therefore advisable to check the measuring accuracy at regular intervals depending on the demands imposed on the meter. If the accuracy does not meet the requirements, the indicating error can be compensated by readjustment (matching the metering mechanism to the register). If the meter is readily accessible, it is not necessary to remove it from the plant. It is important to ensure that the meter can be taken out of operation from the beginning to the end of the adjustment and is protected from being mistakenly put into operation again. Proceed as in Section 3.3 if the rotary-piston meter is taken out of the plant for readjustment.

Once the quantity error has been determined, it is necessary to calculate the percentage error. The error of the meter must be referred to the actual reading. If the reading is taken as "A" (actual value) and the quantity collected in the calibration container as "N" (nominal value), the percentage error "F" is determined as follows:

$$F \text{ in } \% = \frac{A - N}{N} \cdot 100$$

If the error calculated according to this equation provides a value, for example, of $F = -0.44 \%$, this means that the meter indicates a quantity that is 0.44 % smaller than the actual quantity which has flown through.

3.9 Adjustment

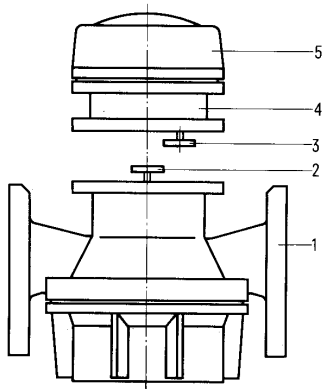

- | | |
|------------------------------------|---------------------|
| 1 Metering mechanism | 4 Intermediate gear |
| 2 Gear wheel of metering mechanism | 5 Register |
| 3 Gear wheel of intermediate gear | |

Fig. 3/4 Gear wheels on metering mechanism and on register with intermediate gear

The rotary-piston meter is adjusted by replacing the gear wheels (2 and 3, Fig. 3/4) arranged between the metering mechanism (1) and the intermediate gear (4). The gear wheels are not directly above the metering mechanism in the case when insulation attachments are used. Replace the gear wheels as follows:

- After dismantling the meter from the plant or, if it remains fitted, after closing the supply of liquid, remove the seal on the mounting flange of the meter (use a pointed tool to pierce and lift out the sealing disk) and unscrew the sealing screw. Loosen all flange bolts.
- Cautiously lift off the register (5) with the intermediate gear (4) from the metering mechanism flange. The gear wheel (2) of the metering mechanism and the gear wheel (3) of the intermediate gear are now accessible.
- Unscrew the nut from the gear wheel (2) (right-hand thread). Lift off the spring washer and the gear wheel and read and note the designation (stamped figures or figures and letters).
- Unscrew the nut from the gear wheel (3) (left-hand thread). Lift off spring washer and gear wheel and read and note the designation.
- Determine the new gear wheels required as in the following example:

A rotary-piston meter manufactured in 1967 has an indicating error of -0.44 % as determined by testing. The designation on the gear wheel of the metering mechanism is e.g. "1-54" or "F3" and on the intermediate gear "1-104" or "E25". The old designations (e.g. F3 and E25) have been replaced by the new designations (in this case 1-54 and 1-104) for the same gear wheels. Look up the pair of gear wheels in column 3 in the table on page 22. It is important to look for the pair of gear wheels on the same line within a column. In this example the pair of gear wheels can be found in column 3 (example shown in bold-face type).

In column 1 in the same line it can be seen that this pair of gear wheels already compensates an indicating error of -0.17 %. Thus the total deviation of the meter is

$$(-0.17) + (-0.44) = -0.61 \%$$

where:

- 0.17 = indicating error already compensated
- 0.44 = the indicating error determined and
- 0.61 = the sum of both values and therefore the total deviation of the reading from the nominal value.

Now look for the total error (-0.61 %) in column 1. The designations of the new pair of gear wheels to be fitted can be found in the same line, but in column 3. In this example, the value -0.61 % cannot be found in column 1. The closest value (-0.62 %) must then be taken. In this line, the designation "1-57" is found in column 3 for the gear wheel of the metering mechanism and "1-107" for the gear wheel of the intermediate gear. The existing pair of gear wheels must then be replaced by the pair found in this manner. The gear wheels belonging to a pair cannot be interchanged when inserting since they are provided with conical holes of different diameters.

Reassemble the meter in the reverse sequence to that described above for removing the gear wheels. The following information is important:

After fitting the new gear wheels, they must be well secured by means of the spring washers and nuts. When placing the register with intermediate gear onto the metering mechanism housing, care must be taken to ensure that the teeth of the gear wheels engage correctly. The gears must not rest on one another. The gear wheels would be damaged or the gear shafts bent if the register were then tightened. When correctly seated, the register can be secured with the bolts and nuts and the sealing screw. The rotary-piston meter is then ready for operation again. If the meter was removed from the plant for adjustment, install in accordance with Section 2. Meters in plants for custody transfer must be tested and recalibrated by the gauging authorities (Section 3.2).

To check whether the meter operates correctly, first carry out a test run with a low flow rate. If the meter operates correctly, it is advisable to recheck the measuring accuracy as carried out before. The required accuracy must now be obtained. Any deviation still present can only be caused by an error in determining the fault or selection of the gear wheels.

4 Spare parts

If a rotary-piston meter is repaired on site by the customer and not returned to the factory for repair or readjustment, the technical data of the meter must be exactly specified when ordering spare parts. The details can be obtained from the dispatch note of the original delivery. It is therefore advisable to keep the original dispatch note with the instruction manual. It is not possible to supply the correct spare parts without correct details on the serial number and the technical data.

Spare parts lists for the rotary-piston meters described in this manual can be obtained from us using the following Order Nos.:

DN 15	PN 25 and 40:	C73000-E5174-C10
DN 25...80	PN 25 and 63:	C73000-E5174-C1
DN 25	PN 10 enamel/plastic:	C73000-E5174-C20

Gear wheels

For rotary-piston meters after delivery year 1965/66						For rotary-piston meters up to delivery year 1965/66					
1		2		3		1		2		3	
Indicating error of meter	Number of teeth of wheels:		New designation 1) of gear wheels:		Indicating error of meter	Number of teeth of wheels:		New designation 1) of gear wheels:			
	on metering mechanism	on intermediate module	on metering mechanism	on intermediate module		on metering mechanism	on intermediate module	on metering mechanism	on intermediate module		
Positive	2.02 %	31	33	1-61	1-112	Positive	3.7 %	26	29	F5	1-108
	1.82 %	32	34	1-62	1-113		2.9 %	28	31	1-58	E8
	1.64 %	33	35	1-63	1-114		2.07 %	31	34	F10	1-113
	1.47 %	34	36	1-64	1-116		1.80 %	32	35	1-62	1-114
	1.31 %	35	37	1-65	1-117		1.55 %	22	24	1-52	1-103
	1.16 %	36	38	1-66	1-118		1.31 %	34	37	1-64	1-117
	1.01 %	37	39	1-67	1-120		1.19 %	23	25	1-53	E2
	0.88 %	38	40	1-68	1-121		1.08 %	35	38	1-65	1-118
	0.75 %	39	41	1-70	1-122		0.86 %	24	26	1-54	1-105
	0.63 %	40	42	1-71	1-123		(0.65 %)	37	40	1-67	1-121
	0.51 %	41	43	1-72	1-124		0.55 %	25	27	1-55	E4
	0.40 %	21	22	1-51	1-101		(0.45 %)	38	41	1-68	E18
	0.29 %	43	45	1-74	1-125		0.26 %	26	28	F5	1-107
	0.19 %	22	23	1-52	1-102		(0.08 %)	40	43	F18	E19
	0.09 %	45	47	1-76	1-126		0.00 %	27	29	1-57	1-108
	0.00 %	23	24	1-53	1-103		(0.08 %)	41	44	F19	E20
0.09 %	47	49	1-78	1-127	0.24 %	28	30	1-58	1-109		
0.17 %	24	25	1-54	1-104	(0.40 %)	43	46	F20	E21		
(0.25 %)	49	51	1-80	1-128	0.47 %	29	31	1-59	E8		
0.33 %	25	26	1-55	1-105	(0.55 %)	44	47	F21	E22		
(0.41 %)	51	53	1-82	1-129	0.69 %	30	32	F9	1-111		
0.48 %	26	27	1-56	1-106	0.90 %	31	33	F10	1-112		
(0.55 %)	53	55	1-83	1-131	1.09 %	32	34	1-62	1-113		
0.62 %	27	28	1-57	1-107	1.27 %	33	35	1-63	1-114		
0.75 %	28	29	1-58	1-108	1.44 %	34	36	1-64	1-116		
0.87 %	29	30	1-59	1-109	1.60 %	35	37	1-65	1-117		
0.98 %	30	31	1-60	1-110	1.75 %	36	38	1-66	1-118		
1.09 %	31	32	1-61	1-111	1.89 %	37	39	1-67	1-120		
1.19 %	32	33	1-62	1-112	2.03 %	38	40	1-68	1-121		
1.28 %	33	34	1-63	1-113	(2.29 %)	40	42	F18	E27		
1.37 %	34	35	1-64	1-115	2.53 %	21	22	1-51	1-101		
1.45 %	35	36	1-65	1-116	2.74 %	22	23	1-52	1-102		
1.53 %	36	37	1-66	1-117	2.93 %	23	24	1-53	1-103		
1.60 %	37	38	1-67	1-119	3.11 %	24	25	1-54	1-104		
1.68 %	38	39	1-68	1-120	3.28 %	25	26	1-55	1-105		
1.74 %	39	40	1-69	1-121	3.43 %	26	27	1-56	1-106		
1.80 %	40	41	1-71	1-122	3.58 %	27	28	1-57	1-107		
1.86 %	41	42	1-72	1-123	3.71 %	28	29	1-58	1-108		
1.92 %	42	43	1-73	1-124	3.83 %	29	30	1-59	1-109		
2.03 %	44	45	1-75	1-125	4.05 %	31	32	F10	1-111		
2.13 %	46	47	1-77	1-126	4.15 %	32	33	1-62	1-112		
2.22 %	48	49	1-79	1-127	4.25 %	33	34	1-63	1-113		
(2.30 %)	50	51	1-81	1-128	4.42 %	35	36	1-65	1-116		
(2.41 %)	53	54	1-83	1-130	4.51 %	36	37	1-66	1-117		
					4.66 %	38	39	1-68	1-120		

1) Old designation of wheels on:
 Metering mechanism: F...
 Intermediate module: E

Siemens AG
Bereich Automatisierungs- und
Antriebstechnik
Geschäftsgebiet A&D PA
D-76181 Karlsruhe

© Siemens AG 1992
Subject to change

Siemens Aktiengesellschaft

Order No. C73000-B5176-C23
Printed in Germany
AG 10.92 24 GB

