

## Continuous Gas Analysis

### Gas analyzers for determination of IR-active gases and oxygen ULTRAMAT 6, OXYMAT 6

#### Operating Instructions

7MB2011-.....-.....  
7MB2021-.....-.....  
7MB2023-.....-.....  
7MB2024-.....-.....  
7MB2026-.....-.....  
7MB2027-.....-.....

<u>Introduction</u>	<b>1</b>
<u>Safety information</u>	<b>2</b>
<u>Description</u>	<b>3</b>
<u>Application planning</u>	<b>4</b>
<u>Installing</u>	<b>5</b>
<u>Connecting</u>	<b>6</b>
<u>Commissioning</u>	<b>7</b>
<u>Operation</u>	<b>8</b>
<u>Functions</u>	<b>9</b>
<u>Service and maintenance</u>	<b>10</b>
<u>Messages</u>	<b>11</b>
<u>Decommissioning and disposal</u>	<b>12</b>
<u>Spare parts/accessories</u>	<b>13</b>
<u>Technical specifications</u>	<b>14</b>
<u>Dimension drawings</u>	<b>15</b>
<u>Appendix</u>	<b>A</b>
<u>List of abbreviations</u>	<b>B</b>

## Legal information

### Warning notice system

This manual contains notices you have to observe in order to ensure your personal safety, as well as to prevent damage to property. The notices referring to your personal safety are highlighted in the manual by a safety alert symbol, notices referring only to property damage have no safety alert symbol. These notices shown below are graded according to the degree of danger.

 <b>DANGER</b>
indicates that death or severe personal injury <b>will</b> result if proper precautions are not taken.

 <b>WARNING</b>
indicates that death or severe personal injury <b>may</b> result if proper precautions are not taken.

 <b>CAUTION</b>
indicates that minor personal injury can result if proper precautions are not taken.

<b>NOTICE</b>
indicates that property damage can result if proper precautions are not taken.

If more than one degree of danger is present, the warning notice representing the highest degree of danger will be used. A notice warning of injury to persons with a safety alert symbol may also include a warning relating to property damage.

### Qualified Personnel

The product/system described in this documentation may be operated only by **personnel qualified** for the specific task in accordance with the relevant documentation, in particular its warning notices and safety instructions. Qualified personnel are those who, based on their training and experience, are capable of identifying risks and avoiding potential hazards when working with these products/systems.

### Proper use of Siemens products

Note the following:

 <b>WARNING</b>
Siemens products may only be used for the applications described in the catalog and in the relevant technical documentation. If products and components from other manufacturers are used, these must be recommended or approved by Siemens. Proper transport, storage, installation, assembly, commissioning, operation and maintenance are required to ensure that the products operate safely and without any problems. The permissible ambient conditions must be complied with. The information in the relevant documentation must be observed.

### Trademarks

All names identified by ® are registered trademarks of Siemens AG. The remaining trademarks in this publication may be trademarks whose use by third parties for their own purposes could violate the rights of the owner.

### Disclaimer of Liability

We have reviewed the contents of this publication to ensure consistency with the hardware and software described. Since variance cannot be precluded entirely, we cannot guarantee full consistency. However, the information in this publication is reviewed regularly and any necessary corrections are included in subsequent editions.

# Table of contents

<b>1</b>	<b>Introduction</b> .....	<b>11</b>
1.1	Device variants .....	11
1.2	Security information .....	13
1.3	General information .....	13
1.4	Special information and warnings .....	14
1.5	Approved use .....	14
1.6	Qualified Personnel .....	15
1.7	Warranty conditions .....	15
1.8	Delivery information .....	15
1.9	Date of manufacture .....	15
1.10	Standards and regulations .....	16
<b>2</b>	<b>Safety information</b> .....	<b>17</b>
2.1	Requirements for safe use .....	17
2.1.1	Conformity with European directives .....	17
2.1.2	Laws and directives .....	18
2.2	Basic safety information .....	19
<b>3</b>	<b>Description</b> .....	<b>21</b>
3.1	Purpose .....	21
3.2	Features .....	21
3.2.1	ULTRAMAT 6 .....	23
3.2.2	OXYMAT 6 .....	23
3.3	Fields of application .....	24
3.3.1	Standard device variants .....	24
3.3.2	Special versions .....	24
3.4	Design of the enclosure .....	26
3.5	Operating principle .....	27
3.5.1	ULTRAMAT 6 .....	27
3.5.2	OXYMAT 6 .....	28
3.6	Communication .....	31
3.6.1	General information .....	31
3.6.2	ELAN interface .....	31
3.6.3	SIPROM GA functions .....	33
3.6.4	PROFIBUS DP/PA .....	34
<b>4</b>	<b>Application planning</b> .....	<b>37</b>
4.1	Requirements of location of use .....	37

4.2	Devices in hazardous areas.....	38
4.3	Approval according to FM/CSA.....	38
4.3.1	Field devices .....	39
4.3.2	Rack units .....	40
4.4	Usage for monitoring of ship emissions .....	41
4.5	Measuring of toxic, aggressive and corrosive gases .....	41
4.6	Measurement of oxygen in hydrogen .....	42
<b>5</b>	<b>Installing .....</b>	<b>45</b>
5.1	Safety information for installation .....	45
5.2	Mounting instructions.....	46
5.3	Dimension drawings for installation preparation.....	48
5.3.1	OXYMAT 6E rack units .....	48
5.3.2	ULTRAMAT 6E and ULTRAMAT/OXYMAT 6E rack units .....	49
5.3.3	ULTRAMAT 6F and OXYMAT 6F field devices .....	52
<b>6</b>	<b>Connecting .....</b>	<b>55</b>
6.1	Safety information for connecting .....	55
6.2	Gas and electrical connections on the device .....	57
6.2.1	OXYMAT 6E rack units .....	57
6.2.2	ULTRAMAT 6E and ULTRAMAT/OXYMAT 6E rack units .....	57
6.2.3	ULTRAMAT 6F and OXYMAT 6F field devices .....	59
6.3	Gas connections .....	60
6.3.1	Sample gas connections.....	60
6.3.2	Reference gas connections.....	61
6.3.2.1	OXYMAT 6 .....	61
6.3.2.2	ULTRAMAT 6 .....	62
6.3.3	Purging gas connection.....	62
6.4	Pressure sensor .....	63
6.5	Electrical connections .....	63
6.5.1	Power connection .....	63
6.5.2	Connection of the signal lines .....	64
6.5.3	Pin assignment .....	67
6.5.3.1	Motherboard pin assignment for rack units.....	67
6.5.3.2	Option board pin assignment for rack units .....	69
6.5.3.3	Example of an AUTOCAL circuit for rack units.....	70
6.5.3.4	Terminal assignment for inputs and outputs of field devices.....	71
6.5.3.5	Option board terminal assignment for field devices.....	72
6.5.3.6	Example of an AUTOCAL circuit for field devices.....	73
<b>7</b>	<b>Commissioning .....</b>	<b>75</b>
7.1	Safety information for commissioning .....	75
7.1.1	Use in hazardous areas.....	76
7.1.2	Usage for measuring of toxic, aggressive and corrosive gases.....	77
7.2	Preparations for commissioning .....	77
7.2.1	General information.....	78

7.2.2	Leak test of gas paths .....	78
7.2.3	ULTRAMAT channel .....	80
7.2.3.1	Interchange of the inputs and outputs for ULTRAMAT 6 with the reduced flow-type reference gas compartment .....	80
7.2.3.2	Measuring ranges with suppressed zero point .....	82
7.2.4	Reference gas for OXYMAT channel .....	83
7.2.5	Gas preparation .....	85
7.3	Commissioning .....	86
7.3.1	ULTRAMAT channel .....	86
7.3.2	OXYMAT channel .....	87
7.3.2.1	First steps .....	87
7.3.2.2	Calibration examples.....	88
7.3.2.3	Measurement of oxygen in hydrogen .....	90
<b>8</b>	<b>Operation.....</b>	<b>93</b>
8.1	General information about operation .....	93
8.1.1	Display and control panel .....	93
8.1.2	Editing inputs .....	94
8.1.3	Device operating modes.....	95
8.2	Measured value display .....	97
8.3	Menu control .....	97
8.3.1	Introduction to the main menu .....	97
8.3.2	Entering a submenu.....	98
8.3.3	Returning to display mode .....	98
8.3.4	Fast function selection .....	99
<b>9</b>	<b>Functions .....</b>	<b>101</b>
9.1	Overview of operating functions .....	101
9.2	Analyzer status .....	103
9.2.1	Analyzer configuration (function 1) .....	103
9.2.2	Diagnostic values (function 2).....	103
9.2.3	Logbook (function 3) .....	105
9.2.4	Display measuring ranges (function 4) .....	105
9.3	Calibration.....	105
9.3.1	Calibration of the zero point (function 20).....	106
9.3.2	Span calibration (function 21).....	107
9.3.3	Calibration via binary input .....	109
9.3.4	Zero/span setpoints (function 22).....	110
9.3.5	Calibration setting (function 23) .....	110
9.3.6	AUTOCAL (function 24).....	111
9.3.7	Drift values (function 25).....	118
9.4	Measuring ranges .....	119
9.4.1	Select measuring ranges (function 40) .....	119
9.4.2	Define measuring ranges (function 41) .....	122
9.5	Parameters .....	123
9.5.1	Electric time constants (function 50).....	123
9.5.2	Limits (function 51) .....	124
9.5.3	On/off functions (function 52).....	125
9.5.4	Status messages (function 53) .....	127

9.5.5	Graphical representation of measured values (function 54) .....	128
9.5.6	Measured value display (function 55) .....	129
9.5.7	LCD contrast (function 56) .....	130
9.5.8	Frequency setting (function 57) .....	130
9.5.8.1	Chopper frequency (function 57) .....	131
9.5.8.2	Magnetic field frequency (function 57) .....	131
9.5.9	Date/time (function 58) .....	132
9.5.10	Measuring point switching (function 59) .....	133
9.5.11	Logbook settings (function 60) .....	133
9.5.12	Shock compensation (function 61) .....	134
9.6	Configuration .....	135
9.6.1	Analog output (function 70) .....	135
9.6.2	Relay outputs (function 71) .....	136
9.6.3	Binary inputs (function 72) .....	138
9.6.4	ELAN configuration (function 73) .....	142
9.6.5	Reset (function 74) .....	143
9.6.6	Save, load data (function 75) .....	143
9.6.7	Suppression of short noise signals (function 76) .....	144
9.6.8	Measured value memory (function 77) .....	145
9.6.9	Calibration tolerances (function 78) .....	146
9.6.10	Change codes (function 79) .....	147
9.6.11	Device test .....	147
9.6.12	Select language .....	149
9.6.13	Pressure correction (function 82) .....	150
9.6.13.1	ULTRAMAT 6 .....	150
9.6.13.2	OXYMAT 6 .....	150
9.6.13.3	Pressure correction using an external pressure sensor via ELAN .....	151
9.6.14	Interference correction (function 83) .....	151
9.6.14.1	ULTRAMAT 6 .....	152
9.6.14.2	OXYMAT 6 .....	155
9.6.15	Phase adjustment (function 84) .....	158
9.6.15.1	ULTRAMAT 6 .....	158
9.6.15.2	OXYMAT 6 .....	159
9.6.16	Switch valves (function 85) .....	160
9.6.17	Linear temperature compensation (function 86) .....	160
9.6.18	Error on/off (function 87) .....	162
9.6.19	AK configuration (function 88) .....	162
9.6.20	Heating (function 89) .....	164
9.6.20.1	Heating of analyzer unit .....	164
9.6.20.2	Heating of sample chamber .....	164
9.6.21	PROFIBUS configuration (function 90) .....	165
<b>10</b>	<b>Service and maintenance .....</b>	<b>167</b>
10.1	General safety information for service and maintenance .....	167
10.2	Safety instructions for hazardous areas .....	169
10.3	General information .....	171
10.4	Note for explosion-proof devices .....	171
10.5	Cleaning the device .....	171
10.6	Software update/backup of the device data .....	172

10.7	Replacement of motherboard and add-on board .....	173
10.7.1	Rack units (ULTRAMAT 6E, OXYMAT 6E) .....	173
10.7.2	Field devices (ULTRAMAT 6F, OXYMAT 6F) .....	174
10.8	Replacement of heating components (ULTRAMAT 6F) .....	174
10.9	Replacement of fuses .....	175
10.9.1	Rack units .....	175
10.9.2	Field devices .....	176
10.10	ULTRAMAT channel .....	177
10.10.1	Heating .....	177
10.10.1.1	Design of the heating system .....	177
10.10.1.2	Replacing the fan .....	179
10.10.1.3	Replacement of the temperature fuse.....	180
10.10.1.4	Replacement of the self-regulating heating cartridges .....	181
10.10.2	Analyzer unit .....	181
10.10.2.1	Removing the analyzer unit.....	181
10.10.2.2	Design of the analyzer unit.....	185
10.10.2.3	Repair of the analyzer unit .....	188
10.10.2.4	Calibration of the analyzer unit .....	192
10.10.3	Compensation of influencing variables .....	198
10.10.3.1	Pressure compensation .....	198
10.10.3.2	Temperature compensation.....	199
10.10.3.3	Compensation of the cross-sensitivity.....	199
10.11	OXYMAT channel .....	201
10.11.1	Analyzer unit .....	201
10.11.1.1	Design of the analyzer unit.....	201
10.11.1.2	Disassembling the analyzer section .....	203
10.11.2	Calibrating the reference gas pressure switch .....	205
10.11.3	Removing the sample gas restrictor .....	205
<b>11</b>	<b>Messages .....</b>	<b>207</b>
11.1	Maintenance requests.....	208
11.2	Faults .....	210
11.3	Other faults .....	213
11.3.1	ULTRAMAT 6 .....	213
11.3.2	OXYMAT 6 .....	213
<b>12</b>	<b>Decommissioning and disposal .....</b>	<b>215</b>
12.1	Safety instructions for decommissioning .....	215
12.2	Decommissioning the device.....	216
12.3	Dismantling the device.....	217
12.4	Disposing of the device .....	217
12.5	Information on recycling .....	217
<b>13</b>	<b>Spare parts/accessories.....</b>	<b>219</b>
13.1	General information.....	219
13.2	Overview of the modules .....	221

13.2.1	OXYMAT 6 .....	221
13.2.2	ULTRAMAT/OXYMAT 6 .....	222
13.2.3	ULTRAMAT 6 .....	223
13.2.4	ULTRAMAT 6 multi-channel .....	224
13.3	OXYMAT 6 .....	225
13.3.1	Analyzer unit .....	225
13.3.2	Electronics .....	227
13.3.3	Gas paths.....	230
13.3.3.1	Sample gas path .....	230
13.3.3.2	Reference gas path .....	234
13.4	ULTRAMAT 6 .....	235
13.4.1	Analyzer unit .....	235
13.4.1.1	Analyzer units - Overview.....	235
13.4.1.2	Single-channel analyzer .....	238
13.4.1.3	2R channel .....	244
13.4.2	Electronics .....	251
13.4.3	Gas paths.....	255
13.4.3.1	Sample gas path .....	255
13.4.3.2	Reference gas path with reduced flow-type reference gas side .....	257
13.4.4	Heating .....	258
<b>14</b>	<b>Technical specifications .....</b>	<b>259</b>
14.1	ULTRAMAT 6E and ULTRAMAT channel in ULTRAMAT/OXYMAT 6 .....	259
14.2	OXYMAT 6E and OXYMAT channel in ULTRAMAT/OXYMAT 6 .....	261
14.3	ULTRAMAT 6F .....	264
14.4	OXYMAT 6F.....	267
14.5	Reference gases (OXYMAT 6).....	270
14.6	Zero point error of accompanying gases (OXYMAT 6).....	270
14.7	Parts in gas path wetted by sample gas.....	271
<b>15</b>	<b>Dimension drawings.....</b>	<b>273</b>
15.1	OXYMAT 6E rack units .....	273
15.2	ULTRAMAT 6E and ULTRAMAT/OXYMAT 6E rack units .....	274
15.3	ULTRAMAT 6F and OXYMAT 6F field devices .....	277
<b>A</b>	<b>Appendix.....</b>	<b>279</b>
A.1	Wiring diagrams.....	279
A.1.1	Pin assignment .....	279
A.1.1.1	Motherboard pin assignment for rack units.....	279
A.1.1.2	Option board pin assignment for rack units .....	282
A.1.1.3	Example of an AUTOCAL circuit for rack units.....	283
A.1.1.4	Terminal assignment for inputs and outputs of field devices.....	284
A.1.1.5	Option board terminal assignment for field devices.....	285
A.1.1.6	Example of an AUTOCAL circuit for field devices.....	286
A.1.2	Gas flow diagrams .....	287
A.1.2.1	ULTRAMAT 6E single-channel analyzer with flow-type reference gas compartment (option) .....	287



---

A.1.2.2	ULTRAMAT 6E two-channel device .....	288
A.1.2.3	ULTRAMAT 6F with flow-type reference gas compartment (option) .....	289
A.1.2.4	OXYMAT 6F with reference gas connection 1100 hPa absolute.....	290
A.1.2.5	OXYMAT 6F with reference gas connection 3000 ... 5000 hPa absolute.....	291
A.1.2.6	ULTRAMAT/OXYMAT 6, IR channel without flow-type reference gas side .....	292
A.1.2.7	ULTRAMAT/OXYMAT 6, IR channel with flow-type reference gas side .....	293
A.2	Firmware version numbers.....	294
A.2.1	ULTRAMAT 6 .....	294
A.2.2	OXYMAT 6 .....	296
A.2.3	Upgrading to other firmware versions.....	299
A.3	Lists of parameters.....	300
A.4	Pressure conversion table.....	304
A.5	Technical support.....	304
A.6	Return procedure .....	305
A.7	ESD guidelines .....	305
<b>B</b>	<b>List of abbreviations .....</b>	<b>309</b>
B.1	List of abbreviations.....	309
	<b>Glossary .....</b>	<b>315</b>
	<b>Index.....</b>	<b>323</b>



# Introduction

Before beginning work with this device, please read this manual! It contains important information and data that must be observed to ensure proper functioning of the device and to save on service costs. The manual will help you to operate the device more easily and efficiently, allowing you to achieve reliable results.

## 1.1 Device variants

You have purchased a device, which is available in different configurations:

- As a rack unit for installation in 19" control cabinets  
or
- As a field device in a closed enclosure for wall mounting. Field devices can be heated or unheated

Each device has one or more analyzer units, which are designated as channels. In general field devices only have one channel, whereas rack units can be equipped with one or two channels. All channels of a device are connected to the same control panel (display).

An ULTRAMAT (NDIR) channel can also measure two components simultaneously. In such a variant two detectors are connected in series. They are referred to as 2R channels or 2R physical systems.

This means that a field device can be used, at most, to measure oxygen (once) or up two IR-active components. A rack unit, in its maximum configuration, can measure four IR-active components (two channels with two detectors each) or oxygen (once) as a measured component together with two IR-active components.

This manual considers each of these possibilities. If there are differences in the operation between ULTRAMAT 6 and OXYMAT 6, they are specifically identified and described.

Rack units have the ending E as the designation, and field devices have the ending F. The ULTRAMAT/OXYMAT designation is used if both devices or channels are concerned.

The following table contains all available device versions as well as the first block of the article number.

Type	O2	NDIR single	NDIR single	NDIR-2R	NDIR-2R	Field device*	Rack unit*
OXYMAT	1 channel					7MB2011 7MB2017	7MB2021 7MB2027
ULTRAMAT/ OXYMAT	1 channel	2 channel					7MB2023 7MB2028
	1 channel			2 channel			7MB2024 7MB2026

Type	O2	NDIR single	NDIR single	NDIR-2R	NDIR-2R	Field device*	Rack unit*
ULTRAMAT			1 channel			7MB2111 <i>7MB2117</i>	7MB2121 <i>7MB2127</i>
		1 channel	2 channel				7MB2123 <i>7MB2128</i>
				1 channel		7MB2112 <i>7MB2118</i>	7MB2124 <i>7MB2126</i>
		2 channel		1 channel			7MB2124 <i>7MB2126</i>
				1 channel	2 channel		<i>7MB2126</i>

\* Italicized article numbers are special applications

### Special applications

Special devices are different from standard devices with respect to the measured component, design of the physical section, etc. They are the same with respect to their operation and the connection technology. An overview of all software product versions and their functionalities can be found in the sections ULTRAMAT 6 (Page 294) and OXYMAT 6 (Page 296) of this manual.

The data on the nameplates indicates which device version you have.

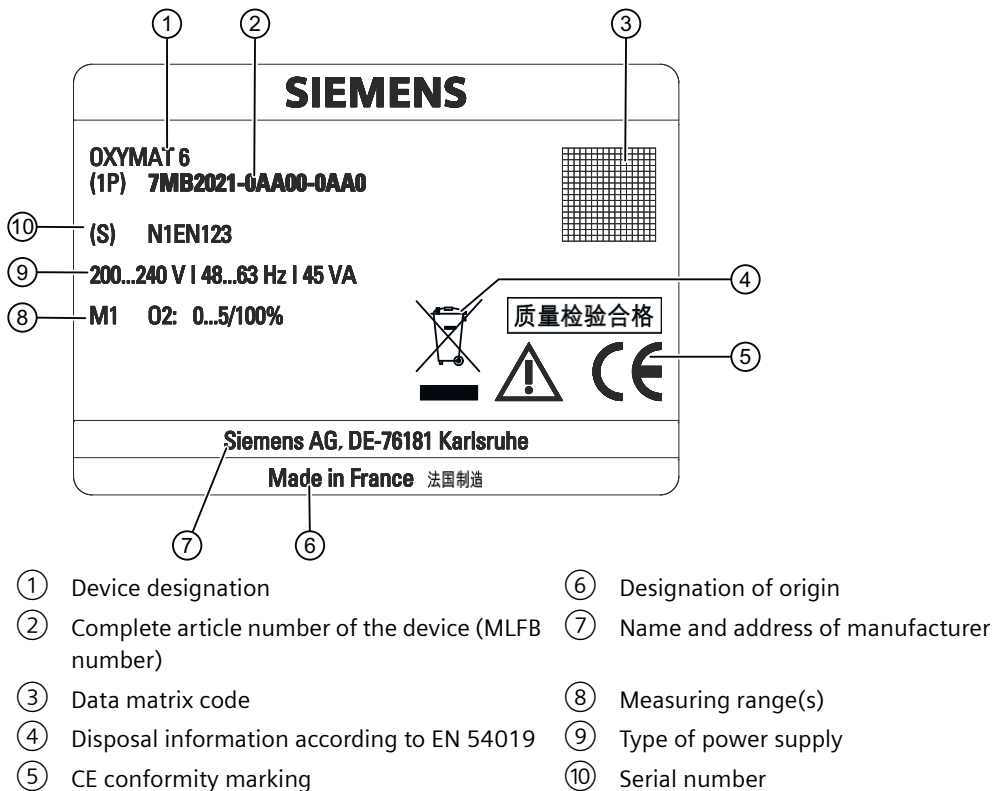

Figure 1-1 OXYMAT 6 nameplate

## 1.2 Security information

Siemens provides products and solutions with industrial security functions that support the secure operation of plants, systems, machines and networks.

To protect plants, systems, machines and networks from cyber threats, it is necessary to implement (and continuously maintain) a comprehensive industrial security concept that is state-of-the-art. Siemens products and solutions form an integral part of such a concept.

Customers are responsible for preventing unauthorized access to their plants, systems, machines and networks. Such systems, machines and components should only be connected to an enterprise network or the internet if and in as far as such a connection is necessary, and only when appropriate safety measures (e.g. firewalls and/or network segmentation) are in place.

Additional information on industrial safety measures can be found under the following address

Industrial security (<https://www.siemens.com/industrialsecurity>).

Siemens' products and solutions undergo continuous development to make them more secure. Siemens expressly recommends that product updates be applied as soon as they become available and that only the latest product versions be used. Use of product versions that are no longer supported, and failure to apply latest updates may increase customer's exposure to cyber threats.

To stay informed about product updates, subscribe to the Siemens Industrial Security RSS Feed under the following address: Industrial security (<https://www.siemens.com/industrialsecurity>)

## 1.3 General information

This device left the factory in a safe and proper condition and has been tested. In order to maintain this condition and to ensure safe operation, it should only be used in the manner described by the manufacturer. Furthermore, proper transportation, storage, installation, operation and maintenance of the device are vital for ensuring correct and safe operation.

This manual contains the information required for the intended use of the described product.

It is addressed to technically qualified personnel who are specially trained or who have the relevant knowledge of automation technology (measuring and control systems).

Knowledge and technically correct implementation of the safety notes and warnings contained in this manual are required for safe installation and commissioning, as well as for safety during the operation and maintenance of the described product. Only qualified personnel have the required professional knowledge for correctly interpreting the generally valid safety notes and warnings in this manual in each specific case and to act accordingly.

This manual is not included in the scope of delivery for the device. It can be downloaded under: Link (<https://support.industry.siemens.com/cs/ww/en/ps/25007/man>)

Due to the variety of technical details, it is not possible to consider every single detail for all versions of the described product and for every conceivable case in the set-up, operation, maintenance and use in systems. For further information, or in the case of problems which

are not covered in enough detail in this document, please request the required information from your local or responsible Siemens regional office.

---

**Note**

In particular, before using the device for new research and development applications, we recommend that you first contact us to discuss the application in question.

---

## 1.4 Special information and warnings

This manual provides you with information on commissioning, installing, operating, and maintaining the device.

Pay particular attention to all special information and warnings. Information of this type is set apart from the rest of the text and is marked with the corresponding pictograms. This information provides you with useful tips and helps avoid operating errors.

## 1.5 Approved use

Proper use within the context of this manual, means that the product may be used only for the applications described in the catalog or the technical description, and only in combination with the equipment, components and devices of other manufacturers recommended or permitted by Siemens.

The product described in this manual has been developed manufactured, tested and documented in compliance with relevant safety standards. When the handling rules described for the configuration, installation, proper operation and maintenance, as well as the safety guidelines are adhered to, therefore, there is normally no risk to the health of persons or in respect to damage to property.

This device was designed to ensure safe isolation of the primary and secondary circuits. Low voltages that are connected must therefore also be generated with safe isolation.



**WARNING**

**Dangerous contact voltage**

After removing the housing or protection against direct contact or after opening the system cabinet, certain parts of this device/system will be exposed that can carry hazardous voltage. Therefore, only appropriately qualified persons are permitted to perform work within this device. These persons must be thoroughly familiar with all sources of danger and service activities in accordance with these operating instructions.

## 1.6 Qualified Personnel

Qualified personnel are individuals who are familiar with the installation, mounting, commissioning, and operation of the product. These people have the following qualifications:

- They are authorized, trained or instructed in operating and maintaining devices and systems according to the safety regulations for electrical circuits, high pressures and aggressive as well as hazardous media.
- For explosion-proof devices: They are authorized, trained, or instructed in carrying out work on electrical circuits for hazardous systems.
- They are trained or instructed in the maintenance and use of appropriate safety equipment according to the safety regulations.

## 1.7 Warranty conditions

We expressly point out that the product quality is exclusively and conclusively described in the sales contract. The content of this product documentation is neither a part of a previous or existing agreement, promise or legal relationship, nor is it intended to modify these. All obligations on the part of Siemens AG are contained in the respective sales contract, which also contains the complete and solely applicable liability provisions. The provisions defined in the sales contract for the responsibility for defects are neither extended nor limited by the remarks in this document.

## 1.8 Delivery information

The respective scope of delivery is listed on the shipping documents in accordance with the valid sales contract. These are enclosed with the delivery.

When opening the packaging, please observe the corresponding information on the packaging material. Check the delivery for completeness and undamaged condition. In particular, the Order No. on the labels, if present, must be compared with the ordering data.

## 1.9 Date of manufacture

### Year of manufacture

The date of manufacture is included as coded information in the serial number (see rating plate). Details on the coding can be found in the following table.

Production year	Code <sup>1)</sup>	Month	Code <sup>1)</sup>
1950, 1970, 1990, 2010	A	January	1
1951, 1971, 1991, 2011	B	February	2
1952, 1972, 1992, 2012	C	March	3
1953, 1973, 1993, 2013	D	April	4
1954, 1974, 1994, 2014	E	May	5

1.10 Standards and regulations

1955, 1975, 1995, 2015	F	June	6
1956, 1976, 1996, 2016	H	July	7
1957, 1977, 1997, 2017	J	August	8
1958, 1978, 1998, 2018	K	September	9
1959, 1979, 1999, 2019	L	October	O
1960, 1980, 2000, 2020	M	November	N
1961, 1981, 2001, 2021	N	December	D
1962, 1982, 2002, 2022	P		
1963, 1983, 2003, 2023	R		
1964, 1984, 2004, 2024	S		
1965, 1985, 2005, 2025	T		
1966, 1986, 2006, 2026	U		
1967, 1987, 2007, 2027	V		
1968, 1988, 2008, 2028	W		
1969, 1989, 2009, 2029	X		

Example:

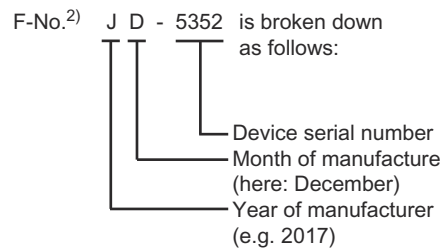

<sup>1)</sup> In conformance with DIN EN 60062

<sup>2)</sup> The identifier of the manufacturing location (e.g. N1) is added as a prefix to the actual serial number

## 1.10 Standards and regulations

As far as possible, the harmonized European standards were the basis for the specification and production of this device. If no harmonized European standards have been applied, the standards and regulations for the Federal Republic of Germany are valid.

When this product is used beyond the scope of these standards and regulations, the valid standards and regulations of the country of the operating company apply.





## Safety information

### 2.1 Requirements for safe use

In terms of safety, this device left the factory in perfect condition. In order to maintain this status and to ensure safe operation of the device, observe these operating instructions and all the information relevant to safety.

Observe the information and symbols on the device. Do not remove any information or symbols from the device. Always keep the information and symbols in a completely legible state and renew it, if necessary.

Symbol	Description
	Consult operating instructions
	Hot surface
	Dangerous electrical voltage

#### 2.1.1 Conformity with European directives

The CE mark on the device is a sign of conformity with the following European directives up to and including 19 April 2016:

Electromagnetic Compatibility EMC 2004/108/EC Directive of the European Parliament and of the Council on the approximation of the laws of the Member States relating to electromagnetic compatibility and repealing Directive 89/336/EEC.

Low voltage directive LVD 2006/95/EC Directive of the European Parliament and of the Council on the harmonization of the laws of Member States relating to electrical equipment designed for use within certain voltage limits.

Device versions which are intended for use in hazardous areas, also conform with the following directive.

Atmosphère explosive ATEX 94/9/EG Directive of the European Parliament and the Council on the approximation of the laws of the Member States concerning equipment and protective systems intended for use in potentially explosive atmospheres.

## 2.1 Requirements for safe use

The CE mark on the device is a sign of conformity with the following European directives from 20 April 2016:

Electromagnetic compatibility EMC 2014/30/EU	Directive of the European Parliament and of the Council of 26 February 2014 on the harmonization of the laws of the Member States relating to electromagnetic compatibility (new version)
Low voltage directive LVD 2014/35/EU	Directive of the European Parliament and of the Council of 26 February 2014 on the harmonization of the laws of the Member States relating to the making available on the market of electrical equipment designed for use within certain voltage limits (new version)
Restriction of certain Hazardous Substances RoHS 2011/65/EU	Directive of the European Parliament and of the Council of 8 June 2011 on the restriction of the use of certain hazardous substances in electrical and electronic equipment (new version)

The device versions which are intended for use in hazardous areas, also conform with the following directive:

Atmosphère explosive ATEX 2014/34/EU	Directive of the European Parliament and of the Council of 26 February 2014 on the harmonization of the laws of the Member States relating to equipment and protective systems intended for use in potentially explosive atmospheres (new version)
--------------------------------------	--

The application of the ATEX guideline only applies to devices, which were certified according to ATEX, not to devices with FM or CSA certificates.

The directives applied can be found in the EC declaration of conformity for the associated device.

### 2.1.2 Laws and directives

Observe the test certification, provisions and laws applicable in your country during connection, assembly and operation. These include, for example:

- National Electrical Code (NEC - NFPA 70) (USA)
- Canadian Electrical Code (CEC) (Canada)

Additional provisions for applications in hazardous areas are, for example:

- IEC 60079-14 (international)
- EN 60079-14 (EG)

## 2.2 Basic safety information

 <b>WARNING</b>
<b>Introduction of combustible gases</b> Explosion hazard Devices in standard version are not designed for use in hazardous areas. <ul style="list-style-type: none"><li>• Do not use a standard version of the analyzer in hazardous areas.</li><li>• Supply gases with flammable components at concentrations above the lower explosion limit (LEL) only in devices with pipes.</li></ul>

Devices that are to be used in hazardous areas are subject to special safety regulations. You can find them in compact operating instructions that are enclosed with the devices:

- For explosion-proof field devices: A5E03312404 and A5E45779389
- For explosion-proof rack units: A5E03084511 and A5E45779144

 <b>WARNING</b>
<b>Improper device modifications</b> Risk to personnel, system and environment can result from modifications to the device, particularly in hazardous areas. <ul style="list-style-type: none"><li>• Only carry out modifications that are described in the instructions for the device. Failure to observe this requirement cancels the manufacturer's warranty and the product approvals.</li></ul>

 <b>WARNING</b>
<b>Harmful gases</b> Danger to personnel, system and the environment can result from introducing harmful (corrosive, flammable and/or poisonous) gases into the device. If this should be required for the measuring task of the device, you must take the following measures: <ul style="list-style-type: none"><li>• Take into account the safety measures according to the German Occupational Safety Act (Arbeitsschutzgesetz - ArbSchG) or equivalent regulations. These safety measures must be coordinated with a local specialist. In particular, this includes measures to prevent any potential release of gases from the containment system as well as their monitoring and disposal.</li><li>• Monitor the gas to be discharged with a suitable gas warning unit (ex/tox alarm).</li><li>• Use a procedure backed by an Ex inspection authority when measuring gases with flammable components above the lower explosive limits.</li><li>• Purge the field devices and heated devices with purging gas (inert gas) with a flow rate of at least 1 l/min.</li></ul>

**Only field devices:**

 <b>WARNING</b>
<b>Damaged operator window</b>
Danger of poisoning
An operator window damaged by impact energy can cause gases to escape from the unit as a result of such a leak.
<ul style="list-style-type: none"><li>• Ensure that the device is sufficiently protected against impact energy &gt;2 joules in the area of the windows.</li></ul>

---

**Note**

**Sample gas pressure increase influences the sample gas pressure switch**

At the time of delivery of an OXYMAT 6 analyzer module, the internal pressure switch for reference gas monitoring is preset to approx. 2000 hPa (3000 hPa abs.). Changes in the sample gas pressure in the analyzer unit by more than 150 hPa require a change in the pressure switch switching point by the same amount. The monitoring functionality of the reference gas pressure switch is modified as a result.

- For changes to the sample gas pressure, contact the Service (Page 304).
  - Have the pressure switching point of the reference gas pressure switch adjusted by a Siemens technician or someone trained for this case.
-

## Description

### 3.1 Purpose

The **ULTRAMAT 6** single-channel or dual-channel gas analyzers operate according to the NDIR two-beam alternating light principle and highly selectively measure gases whose absorption bands lie in the infrared wavelength range from 2 to 9  $\mu\text{m}$ , such as CO, CO<sub>2</sub>, NO, SO<sub>2</sub>, NH<sub>3</sub>, H<sub>2</sub>O as well as CH<sub>4</sub> and other hydrocarbons. Single-channel analyzers measure up to 2 gas components simultaneously, dual-channel analyzers up to 4 gas components.

The function of the **OXYMAT 6** gas analyzers is based on the paramagnetic alternating pressure method and the devices are used to measure oxygen in gases.

The **ULTRAMAT/OXYMAT 6** gas analyzer is a practical combination of both analyzers, ULTRAMAT 6 and OXYMAT 6, in a single enclosure.

### 3.2 Features

The devices are characterized by the following features:

- Four measuring ranges per component can be user-configured, including with suppressed zero point, all measuring ranges are linear
- Autoranging or manual measuring range switchover possible; remote switching is also possible
- Measured values can be saved while calibrating
- Time constant can be selected within wide ranges (static/dynamic noise suppression); meaning that the response time of each component can be adapted to the respective measuring task.
- Easy to use thanks to menu-driven operator guidance (dialog mode)
- Short response time
- Low long-term drift
- Two control levels with separate authorization codes to prevent unintentional and unauthorized inputs
- Internal pressure sensor for correction of
  - Barometric pressure variations in the range of 700 to 1200 hPa absolute (ULTRAMAT 6 or IR channel)  
or
  - Process gas pressure variations in the range of 500 to 2000 hPa absolute (OXYMAT 6 or O<sub>2</sub> channel)

### 3.2 Features

- External pressure sensor can be connected for correction of process gas pressure fluctuations in the range of
  - 700 to 1500 hPa absolute (ULTRAMAT 6 or IR channel)  
or
  - 500 to 3000 hPa absolute (OXYMAT 6 or O<sub>2</sub> channel)
- Automatic measuring range calibration can be configured
- Operation based on the NAMUR recommendation
- Serial interface RS485 per channel
  - For connecting several gas analyzers of Series 6
  - For setting up local networks/systems
  - For remote control/maintenance via PC
- SIPROM-GA as service and maintenance tool
- PROFIBUS DP and PA, also PA Ex i
- Customer-specific analyzer options such as:
  - Customer acceptance
  - TAG labels
  - Drift recording
  - Clean for O<sub>2</sub> service
  - Seals made of FFKM
- Monitoring of sample gas and/or reference gas (option)
- Different minimum measuring spans possible (down to 0.5% O<sub>2</sub>) (OXYMAT 6 or O<sub>2</sub> channel)
- Analyzer unit with flow-type compensation circuit to reduce the vibration dependency. In the case of highly different densities of the sample and reference gases, a flow can be passed through the compensation branch (OXYMAT 6 or O<sub>2</sub> channel)
- Differential measuring ranges with flow-type reference cell (ULTRAMAT 6 or IR channel)

### Inputs and outputs

- One analog output per measured component (from 0, 2, 4 to 20 mA; NAMUR) configurable
- Two analog inputs freely configurable (e.g. for correction of cross-interference or connection of an external pressure sensor)
- Six binary inputs freely configurable (e.g. for measuring range switchover, processing of external signals from sample preparation)
- Six relay outputs, freely configurable (for example for malfunction, maintenance request, limit alarm, external solenoid valves)
- Possibility of expansion by eight additional binary inputs and eight additional relay outputs (for example for auto-calibration with up to four calibration gases)

### 3.2.1 ULTRAMAT 6

- High selectivity with double-layer detector and optical coupler, thus reliable measurements even in complex gas mixtures
- Low detection limits, thus suitable for measurements with low concentrations
- Corrosion-resistant materials in gas path (option), thus measurement in highly corrosive sample gases possible
- Analyzer cells can be cleaned as required on site, thus cost savings due to reuse after contamination
- Open interface architecture (RS485, RS232, PROFIBUS)
- SIPROM GA network for maintenance and service information (option)
- Gas-tight isolation between electronics and physical section (field device), device can be purged, IP65 – long service life even in harsh environments
- Heated versions (option), thus usage even in presence of gases condensing at low temperature
- Use in safety-instrumented systems (SIL 2)
- Explosion-proof variants for Ex Zones 1 and 2 in accordance with ATEX
- Explosion-proof variants in accordance with FM and CSA

### 3.2.2 OXYMAT 6

- Paramagnetic alternating pressure method allows small measuring ranges (for example 0 to 0.5% or 99.5 to 100% O<sub>2</sub>) and absolute linearity
- Detector element does not have any contact with the sample gas, therefore device can be used under "harsh conditions"
- Long service life
- Physically moved zero point through selection of suitable reference gas (air or O<sub>2</sub>), for example 98 to 100% O<sub>2</sub> for purity monitoring/air separation
- Open interface architecture (RS485, RS232, PROFIBUS)
- SIPROM GA network for maintenance and service information (option)
- Gas-tight isolation between electronics and physical section (field device), device can be purged, IP65 – long service life even in harsh environments
- Heated versions (optional), thus usage even in presence of condensing gases
- Use in safety-instrumented systems (SIL 2)
- Explosion-proof variants for Ex Zones 1 and 2 in accordance with ATEX
- Explosion-proof variants in accordance with FM and CSA

## 3.3 Fields of application

### 3.3.1 Standard device variants

The standard version devices can be used for the following:

- Measurements for boiler control in incineration plants
- Emission measurements in incineration plants
- In safety-oriented systems and areas (SIL 2)
- Measurements in the automotive industry (test benches)
- Warning equipment
- Measurements of process gas concentrations in chemical plants
- Trace measurements in ultra-pure gas processes
- Environmental protection
- TLV (Threshold Limit Value) monitoring at workplaces
- Quality monitoring
- Ex versions for analyzing flammable and non-flammable gases or vapors for use in hazardous areas

### 3.3.2 Special versions

In addition to the standard combinations, special applications are available on request. These differ from the standard applications with regard to the material in the gas path and in the sample chambers (for example titanium, Hastelloy C22) as well as the measured components.

#### **Application according to 13th and 17th versions of German Federal Immission Protection Regulations BImSchV and TA Luft**

For measurements of CO, NO, and SO<sub>2</sub> according to the 13th and 17th BImSchV and TA Luft, TÜV-approved versions of the ULTRAMAT 6 are available.

#### **TÜV-approved version according to EN 14956**

The device version 7MBxx-xxxxx-xxxx–Y17 is approved by the TÜV for measurements in accordance with EN 14956.



The smallest TÜV-approved and permitted measuring ranges are:

- 1-component analyzer
  - CO: 0 to 50 mg/m<sup>3</sup>
  - NO: 0 to 100 mg/m<sup>3</sup>
  - SO<sub>2</sub>: 0 to 75 mg/m<sup>3</sup>
- 2 component analyzer (series connection)
  - CO: 0 to 75 mg/m<sup>3</sup>
  - NO: 0 to 200 mg/m<sup>3</sup>.

In addition, the versions approved by the TÜV of the ULTRAMAT 6 meet the requirements in accordance with **EN 14956** and **QAL 1** in accordance with **EN 14181**. Conformity of the devices with both standards is TÜV-certified. Determination of the device drift according to EN 14181 (QAL 3) can be carried out manually or also with a PC using the SIPROM GA maintenance and servicing software. In addition, selected manufacturers of emission evaluation computers offer the option of downloading the drift data via the analyzer's serial interface and automatically recording and processing it in an evaluation computer.

#### Flow-type reference gas compartment

The flow through the flow-type reference gas compartment should be adapted to the sample gas flow.

The gas supply of the reduced flow-type reference gas compartment should have an upstream pressure of 2 000 to 4 000 hPa (abs.). The flow is then automatically controlled with a restrictor to approx. 8 ml/min.

This version is not suitable for measurements of flammable, corrosive and/or toxic gases or gas mixtures as well as oxygen at a concentration of >70%.

### TÜV-approved versions in accordance with EN 15267

The device versions 7MBxx-xxxxx-xxxx-**Y27** and **Y28** are approved by the TÜV for measurements in accordance with EN 15267.

The smallest TÜV-approved and permitted measuring ranges are:

- 1-component analyzer
  - CO: 0 to 50 mg/m<sup>3</sup>
  - NO: 0 to 100 mg/m<sup>3</sup>
  - SO<sub>2</sub>: 0 to 75 mg/m<sup>3</sup>

In addition, the versions of the ULTRAMAT 6 approved by the TÜV meet the requirements in accordance with **EN 15267** and **QAL 1** in accordance with **EN 14181**. Conformity of the devices with both standards is TÜV-certified. Determination of the device drift according to EN 14181 (QAL 3) can be carried out manually or also with a PC using the SIPROM GA maintenance and servicing software. In addition, selected manufacturers of emission evaluation computers offer the option of downloading the drift data via the analyzer's serial interface and automatically recording and processing it in an evaluation computer.

### 3.4 Design of the enclosure

#### Devices with flow-type reference gas compartment

The device version with flow-type reference gas compartment is not suitable for measurements of flammable, corrosive and/or toxic gases or gas mixtures as well as oxygen at a concentration of >70%.

The flow through the flow-type reference gas compartment must be adapted to the sample gas flow.

The gas supply of a reduced flow-type reference gas compartment must have an upstream pressure of 2 000 to 4 000 hPa (abs.). The flow is then automatically controlled with a restrictor to approx. 8 ml/min.

## 3.4 Design of the enclosure

### 19" rack unit

- 19" rack unit with 4 HU for installation
  - In hinged frame
  - In cabinets with or without telescope rails
- Front plate can be swung down for servicing purposes (PC connection)
- Internal gas paths: hose made of FKM (Viton) or pipe made of titanium or stainless steel (material no. 1.4571 / 1.4404)
- Gas connections for gas inlet and outlet: fittings, pipe diameter 6 mm or 1/4"
- Flow indicator for sample gas on front plate (optional)
- Pressure switch in sample gas path for flow monitoring (optional)

### Field device

- Two-door enclosure with gas-tight separation of the electronics modules from parts conveying gas
- Individually purgeable enclosure halves
- Parts in contact with sample gas can be heated up to 65 °C (ULTRAMAT 6) or up to 130 °C (OXYMAT 6) (option)
- Gas path: hose made of FKM (Viton) or pipe made of titanium or stainless steel (material no. 1.4571 / 1.4404), further materials possible as special applications
- Gas connections for sample gas inlet and outlet and reference gas inlet and outlet: Pipe connection fitting for pipe diameter 6 mm or 1/4"
- Purging gas connections Pipe diameter 10 mm or 3/8"

## 3.5 Operating principle

### 3.5.1 ULTRAMAT 6

The ULTRAMAT 6 gas analyzer operates according to the infrared two-beam alternating light principle with double-layer detector and optical coupler.

The measuring principle is based on the molecule-specific absorption of bands of infrared radiation. The absorbed wavelengths are characteristic for individual gases, but can partially overlap. This results in cross-sensitivities which are reduced to a minimum in the ULTRAMAT 6 gas analyzers by the following measures:

- Gas-filled filter cell (beam divider)
- Double-layer detector with optical coupler
- Optical filters if necessary

The figure shows the measuring principle. An IR source (1) which is heated to approx. 700 °C and which can be shifted to balance the system is divided by the beam divider (3) into two equal-sized beams (sample and reference beams). The beam divider acts as a filter cell at the same time.

The reference beam passes through a reference cell (8) filled with N<sub>2</sub> (a non-infrared-active gas) and reaches the right-hand side of the detector cell (11) practically unattenuated. The sample beam passes through the sample chamber (7) through which the sample gas flows and reaches the left-hand side of the detector cell (10) attenuated to a lesser or greater extent depending on the concentration of the sample gas. The detector cell is filled with a defined concentration of the gas component to be measured.

The detector is designed as a double-layer detector. The center of the absorption band is preferentially absorbed in the upper detector layer, the edges of the band are absorbed to approximately the same extent in the upper and lower layers. The upper and lower detector layers are connected together pneumatically via the microflow sensor (12). This coupling means that the spectral sensitivity has a very narrow band.

The optical coupler (13) lengthens the lower detector cell layer optically. The infrared absorption in the second detector cell layer is varied by changing the slider position (14). It is thus possible to individually minimize the influence of interfering components.

A chopper (5) rotates between the beam divider and the sample chamber and interrupts the two beams alternately and periodically. If absorption takes place in the sample chamber, a pulsating flow is generated between the two detector layers that is converted by the microflow sensor (12) into an electric signal.

The microflow sensor consists of two nickel-plated grids heated to approximately 120 °C, which, along with two supplementary resistors, form a Wheatstone bridge. The pulsating flow together with the dense arrangement of the Ni grids causes a change in resistance. This leads to an offset in the bridge which is proportional to the concentration of sample gas.

3.5 Operating principle

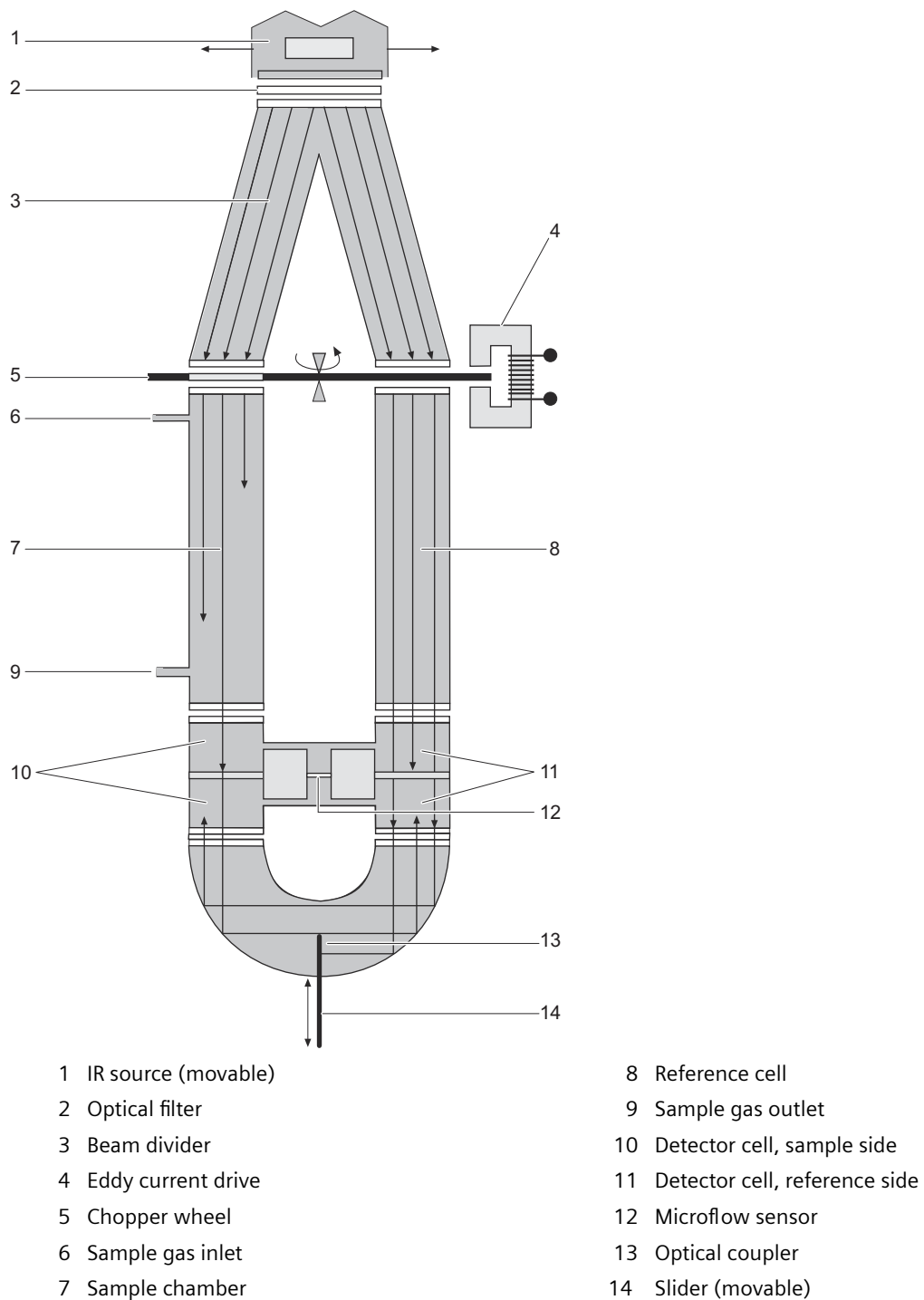

Figure 3-1 ULTRAMAT 6, operating principle

3.5.2 OXYMAT 6

In contrast to almost all other gases, oxygen is paramagnetic. This property is utilized as the measuring effect in the OXYMAT 6 gas analyzers.

Oxygen molecules in an inhomogeneous magnetic field are drawn in the direction of increased field strength due to their paramagnetism. When two gases with different oxygen contents meet in a magnetic field, a pressure difference is produced between them.

In the case of OXYMAT 6, one gas (1) is a reference gas ( $N_2$ ,  $O_2$  or air), the other is the sample gas (5). The reference gas is introduced into the sample chamber (6) through two channels (3). One of these reference gas streams meets the sample gas within the area of a magnetic field (7). Because the two channels are connected, the pressure, which is proportional to the oxygen content, causes a cross flow. This flow is converted into an electric signal by a microflow sensor (4).

The microflow sensor consists of two nickel-plated grids heated to approximately 120 °C, which, along with two supplementary resistors, form a Wheatstone bridge. The pulsating flow results in a change in the resistance of the Ni grids. This leads to an offset in the bridge that is proportional to the oxygen content of the sample gas.

Because the microflow sensor is located in the reference gas stream, the measurement is not influenced by the thermal conductivity, the specific heat or the internal friction of the sample gas. This also provides a high degree of corrosion resistance because the microflow sensor is not exposed to the direct influence of the sample gas.

By using a magnetic field with alternating strength (8), the effect of the background flow in the microflow sensor is not detected, and the measurement is thus independent of the instrument's operating position.

The direct flow-type sample chamber has a small volume, and the microflow sensor is a low-lag sensor. This results in a very short response time for the OXYMAT 6.

Vibrations frequently occur at the place of installation. These may distort the measured signal (noise). Therefore a further microflow sensor (10) through which no gas passes acts as a vibration sensor. Its signal can be applied to the measured signal as compensation.

If the density of the sample gas deviates by more than 50% from that of the reference gas, we recommend flow through the compensation branch (10) as well (option).

3.5 Operating principle

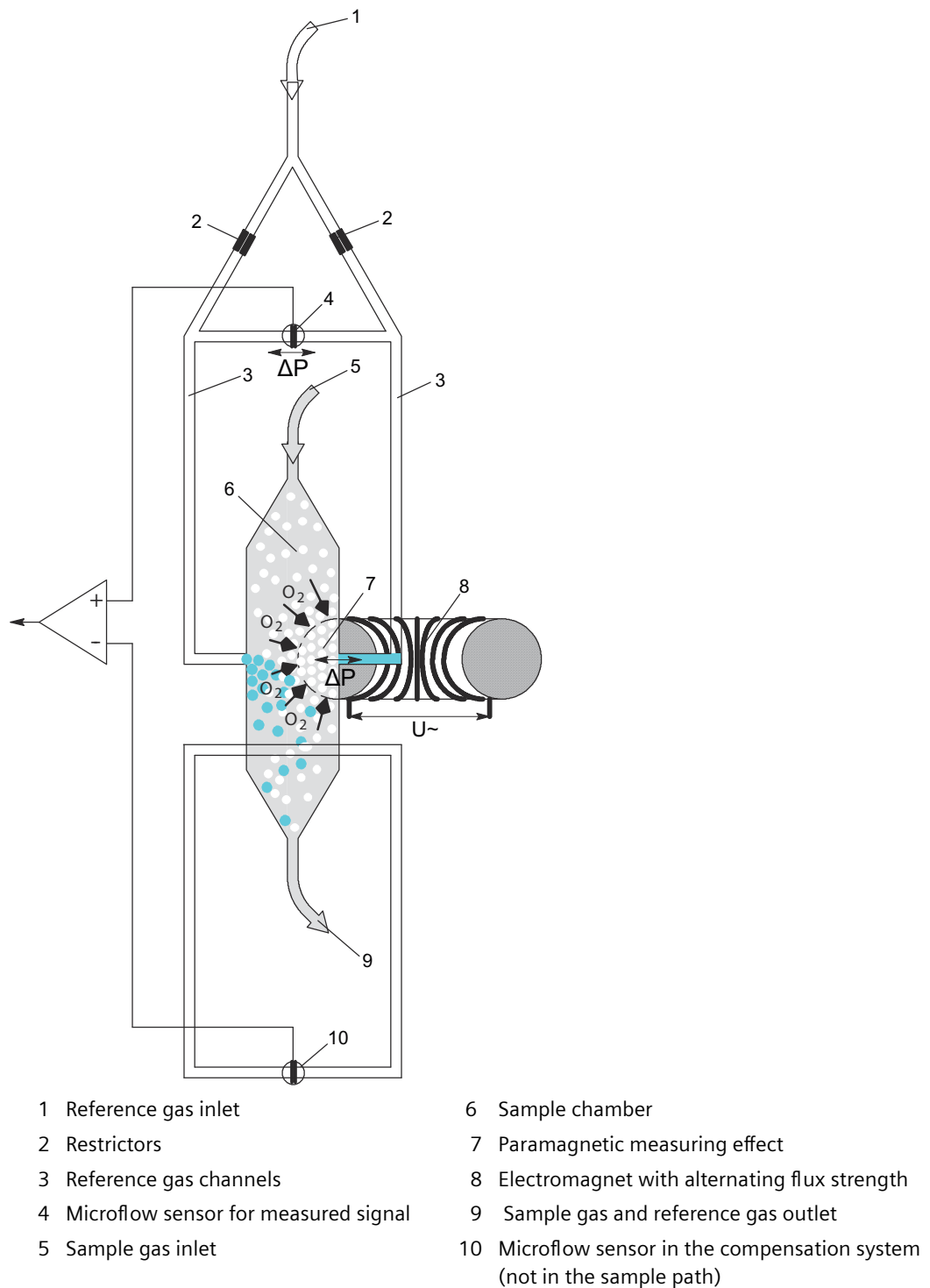

Figure 3-2 OXYMAT 6, operating principle

## 3.6 Communication

### 3.6.1 General information

This device provides the following communication options:

- ELAN interface (RS485 integrated)
- SIPROM GA (via the optional interface converter)
- PROFIBUS DP/PA (via the optional interface converter)
- USB interface (via the optional interface converter)

### 3.6.2 ELAN interface

#### ELAN interface

ELAN is a standard integrated serial interface (RS485) which allows communication with several analyzers. It networks up to 12 analyzers.

The functional principle of the ELAN interface is shown in the following figure:

3.6 Communication

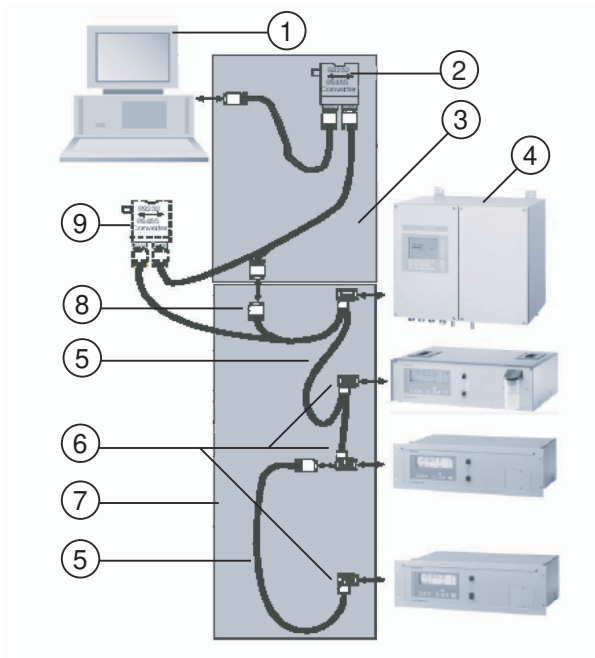

- ① Computer
- ② RS485 to RS232/USB/Ethernet converter with connecting cable
- ③ RS485 bus connector with jumper
- ④ Analyzer
- ⑤ RS485 cable
- ⑥ RS485 bus connector
- ⑦ RS485 network
- ⑧ 9-pin Sub-D plug
- ⑨ Optional: RS485 repeater

Figure 3-3 Typical structure of an ELAN network (RS485)

Interface parameters

Parameter	Value
Level	RS485
Baud rate	9600
Data bit	8
Stop bit	1
Start bit	1
Parity	None
No information feedback	

Product	Article number
RS485/RS232 converter	C79451-Z1589-U1
RS485/Ethernet converter	A5E00852383
RS485/USB converter	A5E00852382
SIMATIC cable/ bus cable	6XV1 830-0EH10
SIMATIC bus connector	6ES7972-0BB42-0XA0



Product	Article number
9-pin Sub-D plug	6ES7972-0BB42-0XA0
Repeater	6ES7972-0AA02-0XA0

All converters are delivered with a driver CD which also contains the SIPROM GA software.

Further information can be found in the ELAN interface description with article number:

- C79000-B5200-C176 German
- C79000-B5276-C176 English

### 3.6.3 SIPROM GA functions

SIPROM GA is a software tool especially for service and maintenance tasks. Many functions of analyzers, whether as a single device or several linked together, can be remotely operated and monitored this way.

The SIPROM GA software is available on the Internet and can be downloaded from the following address: SIPROM GA download (<https://support.industry.siemens.com/cs/ww/en/ps/17702/man>)

#### Functions

- Display and storage of device data
- Remote operation of device functions
- Parameter and configuration settings
- Comprehensive diagnostics information
- Remote calibration
- Online help
- Cyclic storage of measured values
- Status on hard disk and export to commercially available user programs
- Download of new software
- Drift values according to QAL 3, DIN EN 14181

#### Hardware requirements

- PC/laptop Pentium 133 MHz, RAM 32 MB, CD-ROM drive
- At least 35 MB free disk space
- VGA graphics card supported by Windows
- Printer supported by Windows

### 3.6 Communication

- A free COM port with RS485 or one of the available converters for RS232/Ethernet/USB with respective connector is necessary for the connection.
- In the case of an RS485 network, the distance should not exceed 500 m. If this distance is exceeded, a repeater must be used.

#### Software requirements

- Windows 7
- Windows 10

#### 3.6.4 PROFIBUS DP/PA

PROFIBUS DP/PA is the leading fieldbus on the market. All Siemens gas analyzers with an optional – also retrofittable – plug-in card are Profibus-compatible and comply with the binding "Device profile for analyzers" defined by the PNO (PROFIBUS International). Central access to the system analyzers is possible with the SIMATIC PDM software tool.

"Fieldbus" is the name of a digital communication system with which distributed field devices of a system are linked to each other over a single cable and are simultaneously connected to programmable controllers or a process control system.

The PROFIBUS-DP version is widespread in factory automation due to its high transmission speed per device, while PROFIBUS-PA takes the required properties of process engineering into account, such as use in hazardous areas.

The benefit is the considerable savings potential in all areas of the system, covering project planning and commissioning, operation and maintenance, up to subsequent system extensions.

Operation of the gas analyzers from a control system or a separate PC is possible with the SIMATIC PDM software tool (Process Device Manager). This software runs on Windows and can also be integrated in the SIMATIC PCS 7 process control system. With this, the integration of the devices in the system as well as the complex parameter structure of the analyzers can be clearly illustrated. Operating becomes simply a matter of "clicking".

PROFIBUS International (PNO) is an independent institution and represents the interests of many manufacturers and users. This organization offers services such as consulting, training and device certification, and understands its primary job as the further development, standardization and promotion of PROFIBUS technology. The binding functionality definition for a device class in the form of a profile is the condition for standardized device behavior from various manufacturers, the so-called interoperability. The binding profile for analyzers was defined at the end of 1999. With this, the interaction of all PROFIBUS-compatible devices of a system is guaranteed.

In this profile, the functionalities of the analyzers are defined in a block model: for example, the physical block describes the measuring procedure, analyzer and manufacturer name, serial number and the operating state (operation, maintenance). Different functional blocks contain the execution of certain functions, such as measured value and alarm processing. The transducer blocks describe the function of the actual measuring process, as well as its control, e.g. the pre-processing of a measured value, correction of cross-interferences, characteristics, measuring ranges, as well as switching and control processes. The data transmission between the bus participants is defined in protocols.

A distinction is made between cyclic and acyclic services. Time-critical data, such as measured values and status, are transmitted with cyclic services. The acyclic services allow device parameters to be queried or changed during operation.

All gas analyzers of Series 6 (ULTRAMAT 6, OXYMAT 6/61/64, CALOMAT 6/62 and FIDAMAT 6 as well as ULTRAMAT 23) are PROFIBUS-compatible with an optional plug-in card, which can also be retrofitted.

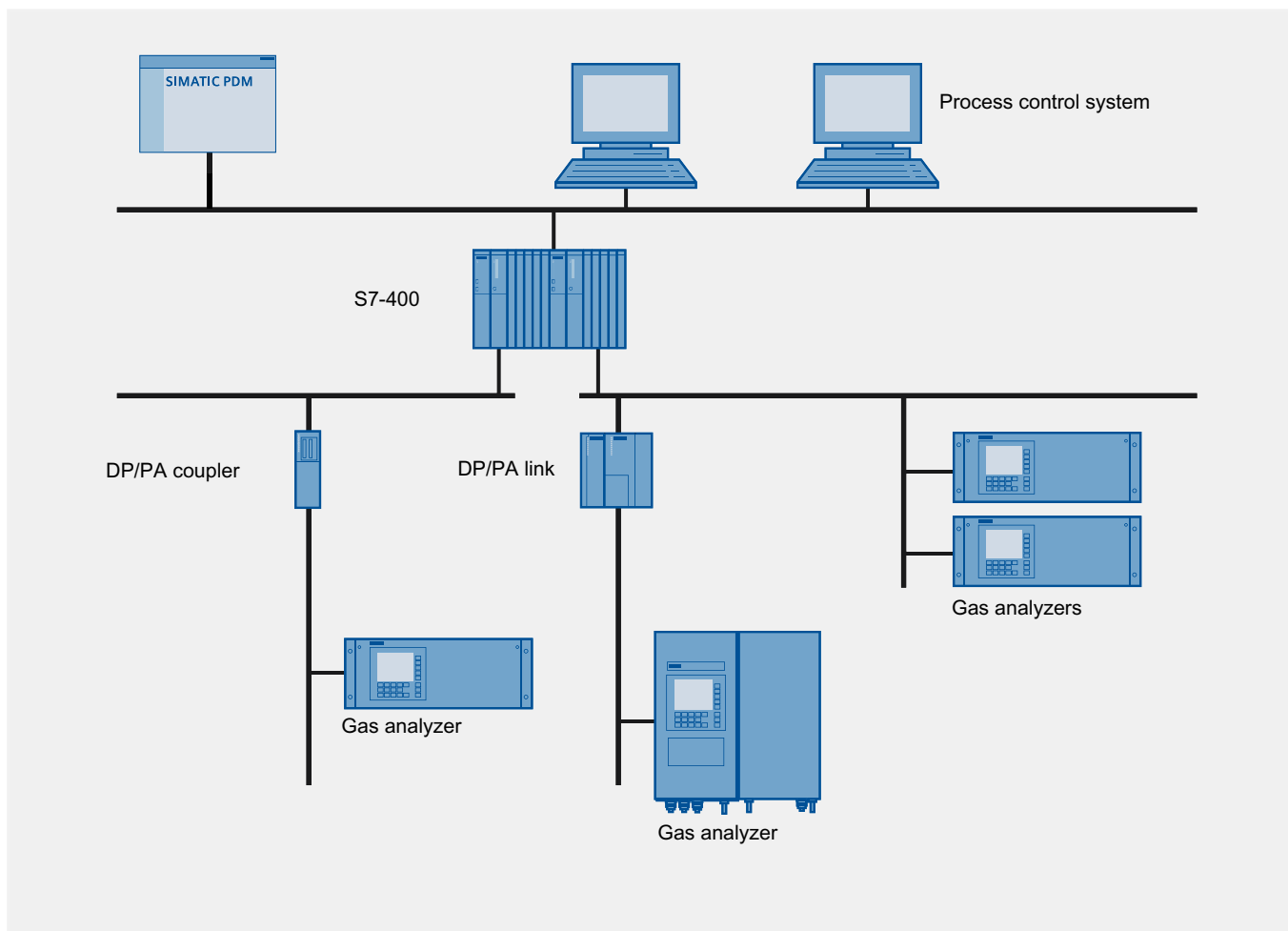

Figure 3-4 Typical structure of a PROFIBUS system

*3.6 Communication*

# Application planning

## 4.1 Requirements of location of use

### Installation in cabinets and enclosures

If an ULTRAMAT 6E and/or OXYMAT 6E built-in unit is installed in a cabinet or benchtop enclosure, it must be mounted on support rails. Front mounting is not sufficient, because the device's own weight creates too much load on the chassis. When installing in cabinets ensure sufficient ventilation between the devices. The ventilation rate must be  $>1/h$  (see also BGR 104, formerly ZH 1/10 of BG Chemie, or equivalent guidelines).

### Mounting of the field devices

For mounting of ULTRAMAT 6F and OXYMAT 6F field devices, use a support that is dimensioned according to the weight of the device. Secure the housing at all four mounting points.

### Device environment

#### Vibrations

To achieve the best possible measuring quality, the installation location must be free of vibrations.

#### Impact effects

Avoid impact effects of more than 2 joules.

#### Usage outdoors

If the device is used outdoors, protect it against direct solar radiation.

#### Ambient temperature

During operation, observe the permissible ambient temperature of 5 °C to 45 °C.

#### Ambient atmosphere

Correct measurement results can only be expected if the ambient air of the analyzer unit is as free as possible of the gas component to be measured. This also applies to gases that exhibit cross-sensitivity to the measured gas component. If such gases are present in the ambient air, purge the enclosure with inert gas (for example N<sub>2</sub>).

#### Magnetism

Based on its measuring principle, the OXYMAT 6 emits magnetic stray fields. Magnetically sensitive devices should therefore not be installed in the immediate vicinity of the OXYMAT 6. Depending on the sensitivity, you must maintain distances of up to 50 cm between devices.

#### Notes on gas preparation

The sample gases must be fed into the analyzer free of dust. Prevent the accumulation of condensate in the sample chambers.

In most applications it is necessary to use a gas preparation system adapted to the measuring task.

Do not operate devices with reduced flow-type reference gas compartments with flammable, corrosive or toxic gases or with gas mixtures with an oxygen percentage >70%.

## 4.2 Devices in hazardous areas

Devices that are to be used in hazardous areas are subject to special safety regulations. You can find them in compact operating instructions that are enclosed with the devices:

- For explosion-proof field devices: A5E03312404 and A5E45779389
- For explosion-proof rack units: A5E03084511 and A5E45779144

 <b>WARNING</b>
<b>Unsuitable device for the hazardous area</b>
Explosion hazard
<ul style="list-style-type: none"><li>• Only use devices that have been approved for use in the intended hazardous area and are labeled accordingly.</li></ul>



## 4.3 Approval according to FM/CSA

### Class I Div. 2

The **ULTRAMAT 6** and **OXYMAT 6** devices may be operated in areas in which explosive gas mixtures occur rarely (Class I Div. 2). Certain requirements apply to this operation, whose details are specified in the Certificates of Compliance of the CSA International, Certificate 1526657 and the FM Approvals, Project ID 3016050. It is imperative that these requirements be observed when these devices are operated in Class I Div. 2. The conditions for operating these devices are specified in the following sections.

### 4.3.1 Field devices

The following table contains the instructions and requirements for use of gas analyzers certified in accordance with CSA and FM guidelines in hazardous areas of Class 1, Division 2 and Class 1, Zone 2.

Requirement for	FM/CSA Class 1, Division 2	FM/CSA Class 1, Zone 2
Encapsulation	Degree of protection IP65 of the gas analyzer meets all requirements. No additional measures are required.	
Cable connections	<p>Only the types of cables and wiring methods listed below are permissible for the installation:</p> <ol style="list-style-type: none"> <li>Type <b>MI</b> (Mineral Insulated), Type <b>MC</b> (Metal Clad), Type <b>MV</b> (Medium Voltage), or Type <b>TC</b> (Tray Cable) with end connectors or cables that are routed in cable tray systems in such a way that tensile stress at the cable ends is reliably prevented.</li> <li>Type <b>ITC</b> (Instrumentation Tray Cable) in cable trays or cable channels, supported by communication cables. These require mechanical protection and are routed openly or concealed directly at the marked location.</li> <li>Type <b>PLTC</b> (Power Limited Tray Cable) in accordance with the provisions of the National Electrical Code, article 725 or the Canadian Electric Code, rule 12-2202 or in cable tray systems.</li> <li>Encapsulated, sealed bus cables, encapsulated, sealed connectors.</li> <li>Conduit thread</li> <li>Steel conduit adapter</li> <li>Any connection method that is suitable for Class 1, Division 1.</li> </ol>	<p>Only the types of cables and wiring methods listed below are permissible for the installation:</p> <ol style="list-style-type: none"> <li>Any connection method that is suitable for Class 1, Division 2 (see column on left)</li> <li>Any connection method that is suitable for Class 1, Zone 1.</li> </ol>
Combustible gases	Measurements of combustible gases are only permitted with devices having a pipe gas path and an additional purge gas monitoring unit (e.g. Siemens Minipurge, article number 7MB8000-1AA).	
Explosive gases	Measurements of gases/gas mixtures that are always explosive are not permitted. Measurements of gases/gas mixtures that are rarely or temporarily explosive are only permitted with devices made of piping that are provided with flame arrestors and have additional purge gas monitoring.	

### 4.3.2 Rack units

The following table contains the instructions and requirements for use of gas analyzers certified in accordance with CSA and FM guidelines in hazardous areas of Class 1, Division 2 and Class 1, Zone 2.

Requirement for	FM/CSA Class 1, Division 2	FM/CSA Class 1, Zone 2
Encapsulation	Degree of protection IP20 of the gas analyzer requires installation into suitable enclosures, cabinets or frames. These must be equipped with preparations for connections of the cabling types of Division 2 and be approved by the local authorities in charge.	Degree of protection IP20 of the gas analyzer requires installation into suitable enclosures, cabinets or frames. These must be equipped with preparations for connections of the cabling types of Zone 2 that meet at least the requirements of the IP54 degree of protection and are approved by the local authorities in charge.
Cable connections	<p>Only the types of cables and wiring methods listed below are permissible for the installation:</p> <ol style="list-style-type: none"> <li>1. Type <b>MI</b> (Mineral Insulated), Type <b>MC</b> (Metal Clad), Type <b>MV</b> (Medium Voltage), or Type <b>TC</b> (Tray Cable) with end connectors or cables that are routed in cable tray systems in such a way that tensile stress at the cable ends is reliably prevented.</li> <li>2. Type <b>ITC</b> (Instrumentation Tray Cable) in cable trays or cable channels, supported by communication cables. These require mechanical protection and are routed openly or concealed directly at the marked location.</li> <li>3. Type <b>PLTC</b> (Power Limited Tray Cable) in accordance with the provisions of the National Electrical Code, article 725 or the Canadian Electric Code, rule 12-2202 or in cable tray systems.</li> <li>4. Encapsulated, sealed bus cables, encapsulated, sealed connectors.</li> <li>5. Conduit thread</li> <li>6. Steel conduit adapter</li> <li>7. Any connection method that is suitable for Class 1, Division 1.</li> </ol>	<p>Only the types of cables and wiring methods listed below are permissible for the installation:</p> <ol style="list-style-type: none"> <li>1. Any connection method that is suitable for Class 1, Division 2 (see column on left)</li> <li>2. Any connection method that is suitable for Class 1, Zone 1.</li> </ol>
Combustible gases	For safety reasons we do not recommend using rack units for measurement of combustible gases. But because this is not explicitly prohibited in the regulations, the operator and the local authority in charge ultimately have to make this decision. Depending on the type of enclosure, cabinet or frame, the connection of a purging gas monitor may be necessary. The decision is made by the local authority handling these matters.	
Explosive gases	<b>Measurements of permanently explosive gases/gas mixtures are not permitted.</b> For safety reasons we do not recommend using rack units for applications in areas with a potential risk of explosive gases/gas mixtures.	



## 4.4 Usage for monitoring of ship emissions

The ULTRAMAT 6 in version 7MB2123-xNDxx-xCSx has been tested according to MEPC 184(59) chapter 6 "Emission Testing" and has been found suitable for the monitoring of ship emissions (Confirmation of Compliance).

The following conditions apply to this application:

- In addition to the ULTRAMAT 6, other suitable components (sampling probe, sample gas line, gas cooler, data recording system) need to be installed for continuous emission monitoring. In this case Sections 6.6 and 6.7 (MEPEC 184(59)) regarding the loss of SO<sub>2</sub> have to be observed.
- If ambient temperatures above 45 °C occur, the ULTRAMAT 6 must be installed in an air-conditioned cabinet.
- The operating instructions (equipment manual) must be observed with regard to installation, calibration and operation of the ULTRAMAT 6.
- The calibration interval can be extended to up to 4 weeks, without the requirements for the drift in the zero point and measured value being exceeded.

## 4.5 Measuring of toxic, aggressive and corrosive gases

 <b>WARNING</b>
<p><b>Introduction of flammable, toxic or oxygen-containing gas mixtures into ULTRAMAT 6 gas analyzers with reduced flow-type reference gas compartment.</b></p> <p>Danger of explosion or poisoning</p> <p>ULTRAMAT 6 gas analyzers with reduced flow-type reference gas compartment are not designed for measurements of flammable, toxic or oxygen-containing gas mixtures.</p> <ul style="list-style-type: none"> <li>• Do not introduce any flammable, toxic or oxygen-containing gas or gas mixtures.</li> </ul>

When introducing corrosive, flammable or toxic gases, safety measures in accordance with German Occupational Safety Act (Arbeitsschutzgesetz - ArbSchG) or equivalent international regulations must be taken. These safety measures are to be agreed with a local authorized expert.

In particular, this includes measures regarding any potential release of gases from the containment system as well as their monitoring and disposal. As a rule monitoring of the purging gas to be discharged must be provided in the form of a suitable gas warning unit (Ex/Tox alarm).

When measuring toxic, aggressive or corrosive gases, it is possible that sample gas will accumulate in the analyzer because of leaks in the gas path. To prevent the danger of poisoning or damage to parts of the analyzer, the analyzer or the system must be purged with inert gas (e.g. nitrogen). The gas to be displaced by purging must be collected using appropriate equipment and routed for environmentally-friendly disposal via an exhaust line. Analyzers provided with heating must always be purged when operated with toxic, aggressive or corrosive gases.

If corrosive media are used, discussion with and approval by our specialist department/Technical Support is required Support Request (<https://support.industry.siemens.com/My/ww/en/requests#createRequest>).

## 4.6 Measurement of oxygen in hydrogen

### NOTICE

#### Explosive gas mixtures

Gas mixtures of hydrogen H<sub>2</sub> in oxygen O<sub>2</sub> are explosive in a wide range. At an atmospheric pressure of 1000 hPa and 20 °C ambient temperature, the lower explosive limit (LEL) lies at 4 % H<sub>2</sub> in O<sub>2</sub>, the upper explosive limit (UEL) at 95.2 % H<sub>2</sub> in O<sub>2</sub>. At an ambient temperature of 80 °C the LEL lies at 3.8 % H<sub>2</sub> in O<sub>2</sub>, the UEL lies at 95.4 % H<sub>2</sub> in O<sub>2</sub>.

In general, a distinction is made between the following cases at the occurrence of explosive gas mixtures:

- Frequently or constantly explosive - more than 1000 hours/year
- Occasionally explosive - 10 to 1000 hours/year
- Rarely explosive - less than 10 hours/year

### DANGER

#### Danger of explosion!

#### Measuring explosive gas mixtures with OXYMAT 6E and OXYMAT 6F

**Non-explosive sample gases and gas mixtures below the LEL** may be introduced into the OXYMAT 6. Flame arrestors are not required. However, it must be guaranteed that the sample gas in the gas path (containment system, CS) always remains below the lower explosive limit!

**Rarely or occasionally explosive gas mixtures** must only be introduced into the gas analyzer if the inputs and outputs for sample gas have been each provided with a **flame arrestor**.

The **flame arrestors** must meet the safety requirements for the combustible medium.

A flame arrestor can be omitted at the reference gas inlet if it is guaranteed that the reference gas is introduced before the analyzer is switched on and that the reference gas pressure is monitored continuously.

**Frequently or continuously explosive gas mixtures** must not be connected to the gas analyzer.

**Gas mixtures above the upper explosive limit:** The introduction must be individually assessed in accordance with a separate certificate based on on-site acceptance testing.

**NOTICE****Checking leak tightness of the gas path**

In case of leakages of the gas path (containment system, CS), hydrogen (H<sub>2</sub>) and oxygen (O<sub>2</sub>) can concentrate in the gas analyzer to form an explosive mixture. Only after checking for a suitable leak tightness of the gas path, may these gases be fed into the gas analyzer.

**OXYMAT 6E (rack unit)**

The enclosure of the gas analyzer has to be equipped with sufficient openings so that a gas exchange with the environment takes place and an explosive mixture cannot build up in the device.

The device must be set up at a well ventilated place so that an explosive mixture cannot build up in the device environment.

If the device is installed into a cabinet, it must be insured through suitable measures that the ventilation rate in this cabinet amounts to at least 1/h (exhaust air at cabinet cover, supply air at cabinet bottom).

**OXYMAT 6F (field device)**

The enclosure of the field device must be flushed so that no enrichment can take place in it in case of a limited release of sample gas.



# Installing

## 5.1 Safety information for installation

<b>NOTICE</b>
<p><b>Improper installation</b></p> <p>The device can be damaged or destroyed or its functionality impaired through incorrect mounting.</p> <ul style="list-style-type: none"> <li>• Make sure before mounting the device that there is no visible damage.</li> <li>• Check that the process connections are clean and that suitable seals and cable glands have been used.</li> <li>• Mount the device only using a suitable tool.</li> </ul>

 <b>WARNING</b>
<p><b>Parts in contact with sample gases unsuitable for sample gas</b></p> <p>Danger of injury or poisoning, device damage</p> <p>Hot, poisonous and corrosive sample gases can be released at the connections if the device parts and accessories coming into contact with sample gas are unsuitable for the sample gas.</p> <ul style="list-style-type: none"> <li>• Use only sample gas-contacting connecting parts (pipes, unions and sealing material) that are suitable for the connection and for the sample gases. Refer to the information in the section "Technical specifications (Page 259)".</li> </ul>

<b>NOTICE</b>
<p><b>Direct sunlight</b></p> <p>Device damage</p> <p>The device can overheat or materials become brittle through the influence of UV radiation.</p> <ul style="list-style-type: none"> <li>• Protect the device from direct sunlight.</li> <li>• Make sure that the maximum permissible ambient temperature is not exceeded. For more information on this, see section "Technical specifications (Page 259)".</li> </ul>

## 5.2 Mounting instructions

---

### Note

#### Layout of the installation location

The installation location should be:

- Easily accessible
  - Shock-free and vibration-free
  - Within the ambient temperature limits
- 

---

### Note

#### Weatherproof installation

Install the device at a location where it is protected against:

- Direct heat and solar radiation
  - Mechanical damage
  - Vibrations
  - Contamination
  - Intrusion of dust
  - Corrosive media
  - Moisture
  - Significant and rapid temperature fluctuations
  - Strong air flow
- 

The ULTRAMAT 6 und OXYMAT 6 gas analyzers must be operated in such a way that the sample gas pressure does not accumulate within the analyzer unit. When several devices are connected in series, you must ensure that the gas path of the downstream devices has no restrictions (free exhaust gas flow). The restrictor that is installed in the gas path depending on the version of the analyzer may then have to be removed. The only restrictor that can be retained is the one between the sample gas line and the first analyzer unit of the first analyzer.

For devices in dual channel design, meaning with two parallel analyzer units (two ULTRAMAT channels or one ULTRAMAT channel and one OXYMAT channel), each analyzer unit has its own, independent gas path. Here too the restrictor of the downstream analyzer selection has to be removed if the analyzer units are connected in series.

---

### Note

The sample gas monitoring (pressure switch), which is optional for rack units, is inoperable for the downstream analyzer units after removal of the sample gas restrictors. To avoid error messages, disable the corresponding fault messages (Gas flow too low) in the configuration function of the software (section "Faults (Page 210)" Error S16). You should also note in this case that the assignment of a relay to the "Sample gas flow" fault message has no function.

---

If the sample gas is to flow into an exhaust line, you must note the following:

- The flow resistance in the exhaust line should be kept as low as possible by using as short a line as possible or transitioning to a line with a larger diameter.
- The exhaust line must be free of rapid pressure fluctuations. If this is not the case, either a special exhaust line must be installed, or a damping vessel (> 1 l) with downstream restrictor must be installed between the device and exhaust line (pneumatic low pass).

### Pressure fluctuations in the sample gas path in OXYMAT 6

The OXYMAT 6 is a pneumatic measuring system and therefore very sensitive to irregular or fast pressure fluctuations that can be superimposed over the sample gas flow. Therefore ensure that such pressure fluctuations are suppressed sufficiently. Normally a restrictor that is located in the sample gas inlet is sufficient. A further measure is the connection of a "pneumatic low pass" consisting of a restrictor and a damping vessel.

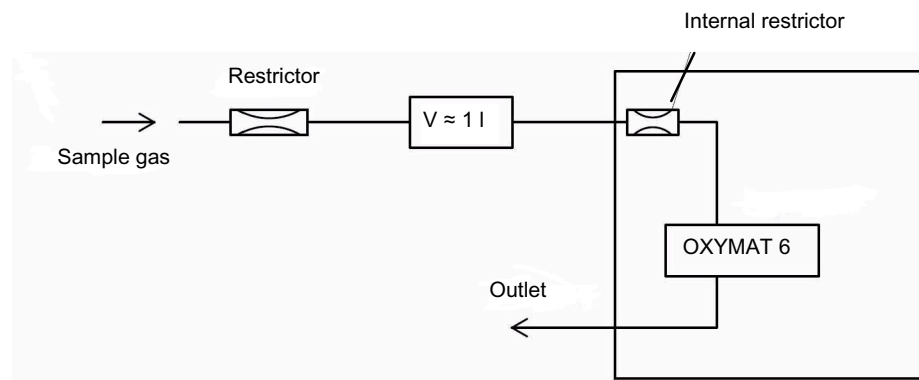

Figure 5-1 Damping measure against pressure fluctuations in the OXYMAT 6

## 5.3 Dimension drawings for installation preparation

### 5.3.1 OXYMAT 6E rack units

All dimensions are specified in mm.

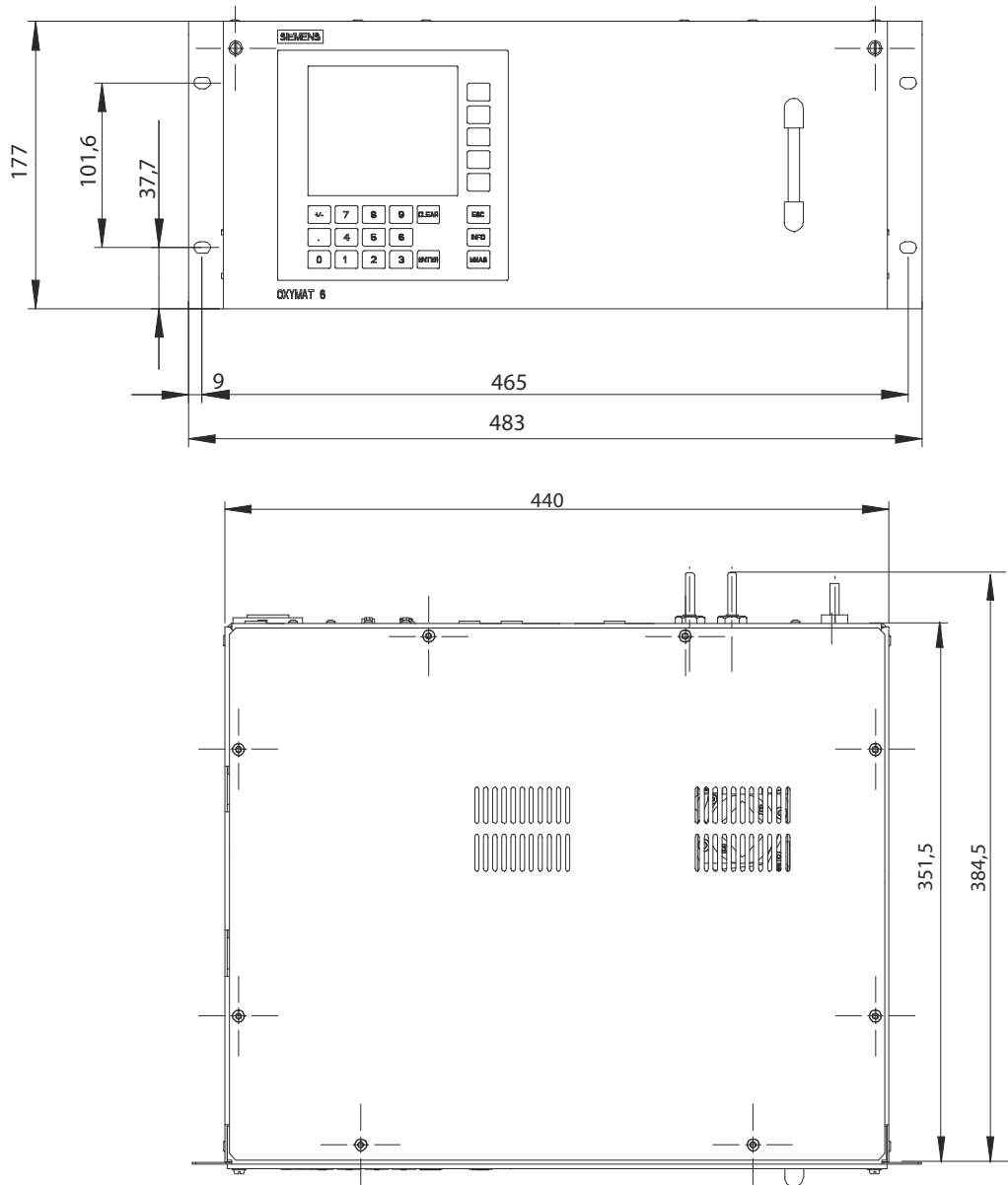

Figure 5-2 OXYMAT 6E, dimension drawing: Front view and top view



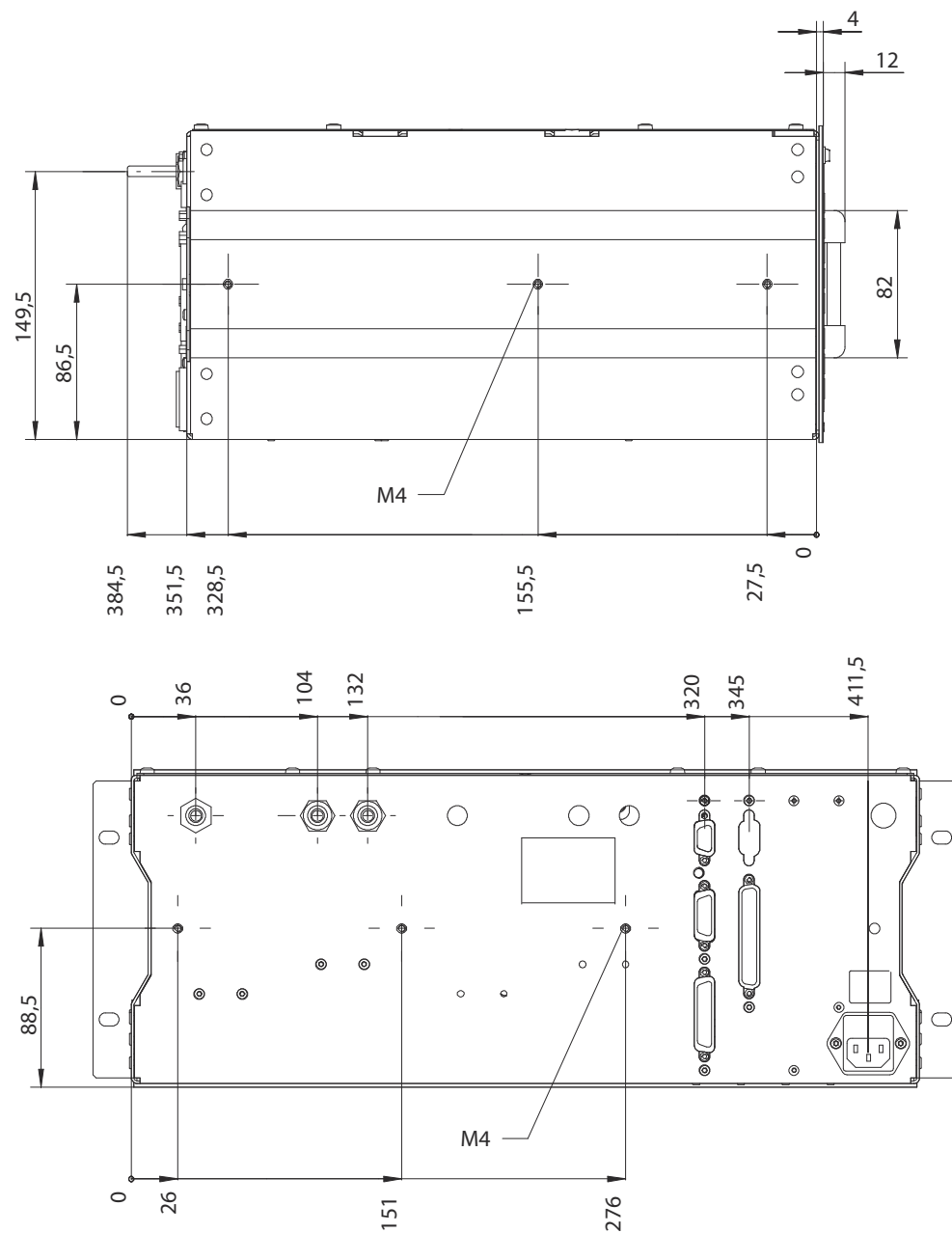

Figure 5-3 OXYMAT 6E, dimension drawing: Side view and rear of the device

### 5.3.2 ULTRAMAT 6E and ULTRAMAT/OXYMAT 6E rack units

When viewed from the rear, single channel devices have either an IR channel or an O<sub>2</sub> channel on the left. For dual channel devices, the second analyzer unit is always an IR channel.

All dimensions are specified in mm.

5.3 Dimension drawings for installation preparation

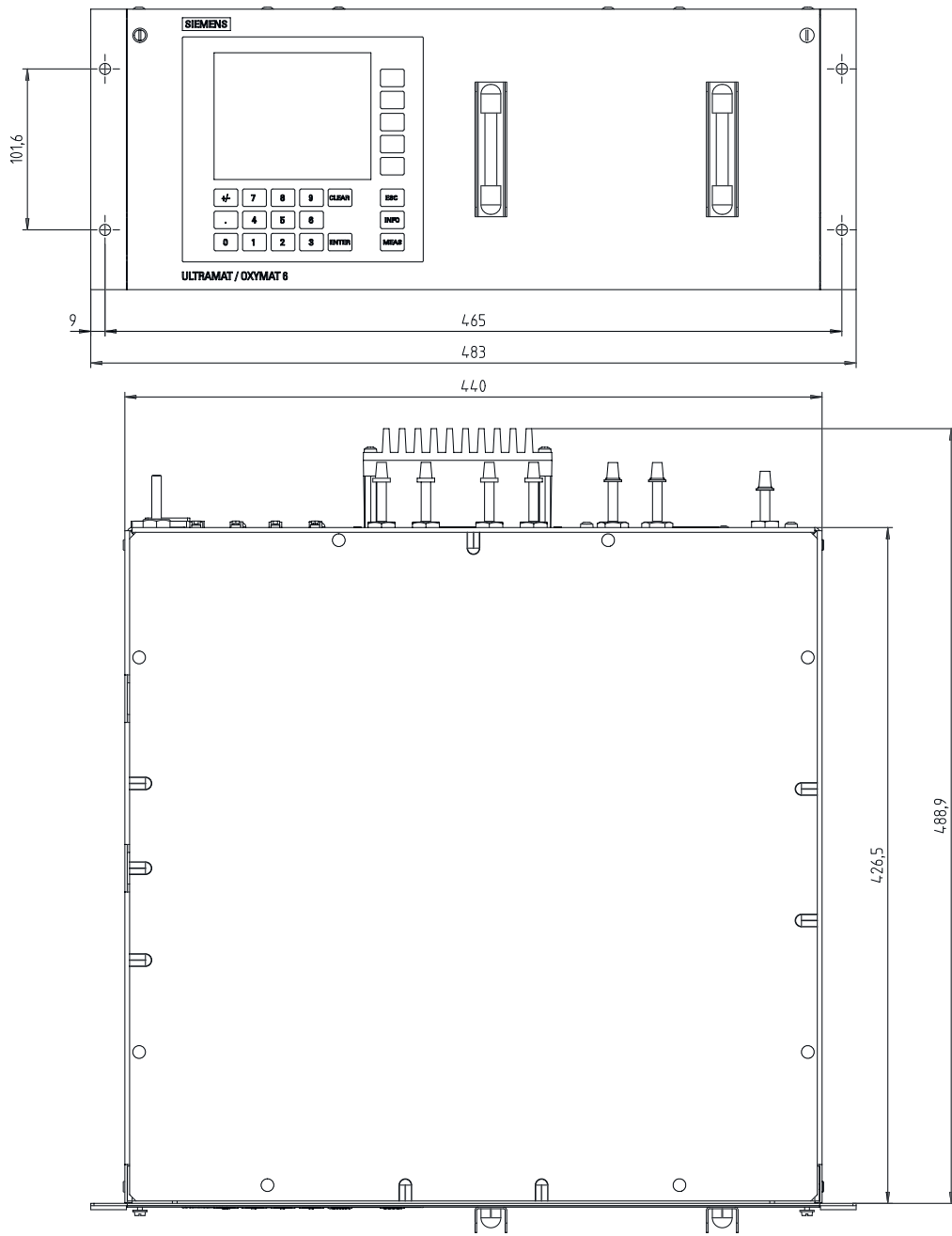

Figure 5-4 ULTRAMAT 6E and ULTRAMAT/OXYMAT 6E, dimension drawing: Front view and top view

5.3 Dimension drawings for installation preparation

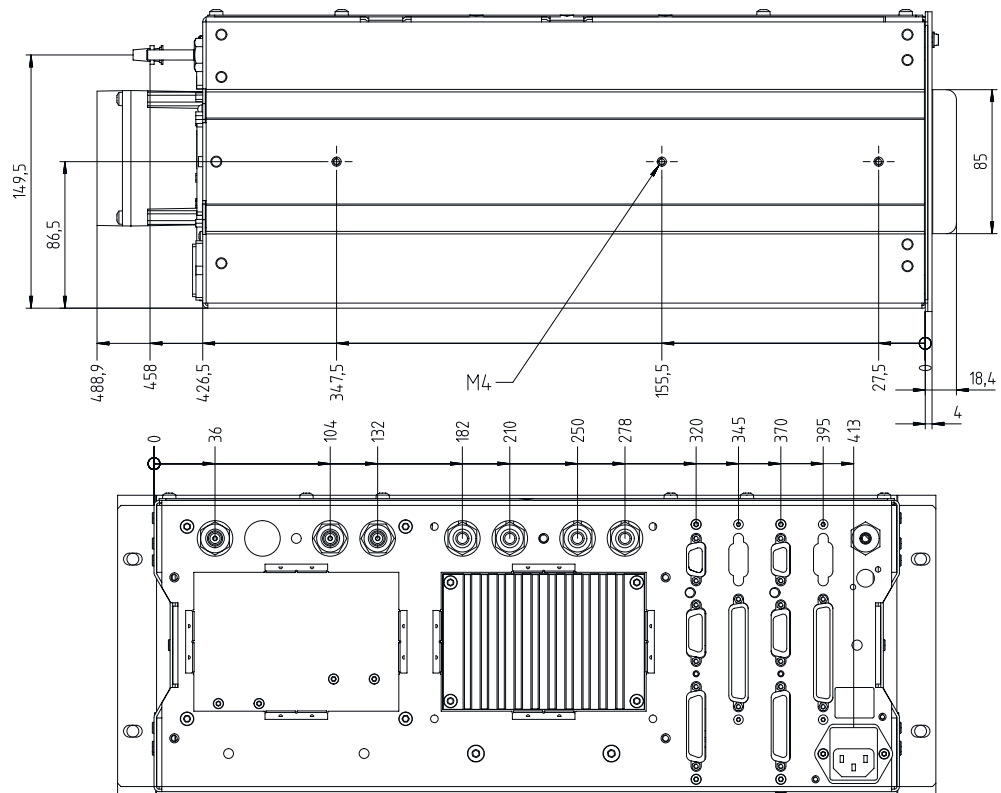

Figure 5-5 ULTRAMAT 6E and ULTRAMAT/OXYMAT 6E, dimension drawing: Side view and rear of the device

### 5.3.3 ULTRAMAT 6F and OXYMAT 6F field devices

All dimensions are specified in mm.

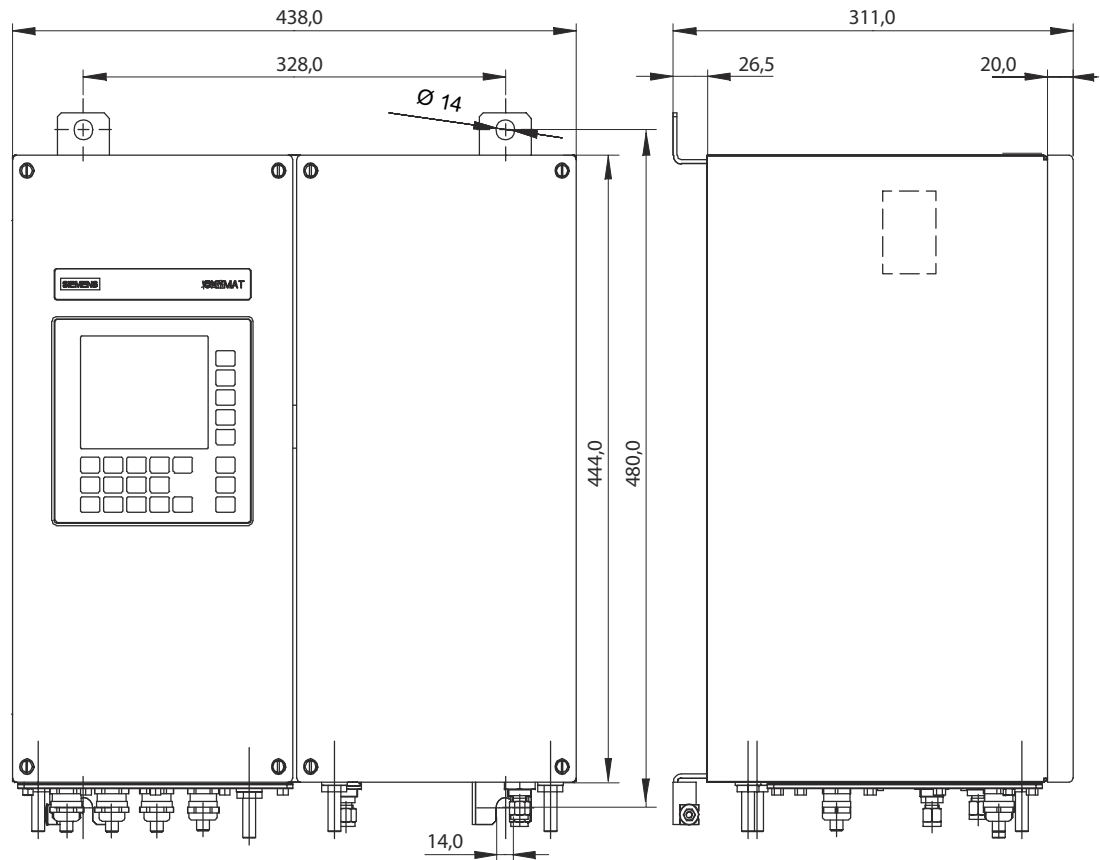

Figure 5-6 ULTRAMAT 6F and OXYMAT 6F, dimension drawing: Front view and side view

5.3 Dimension drawings for installation preparation

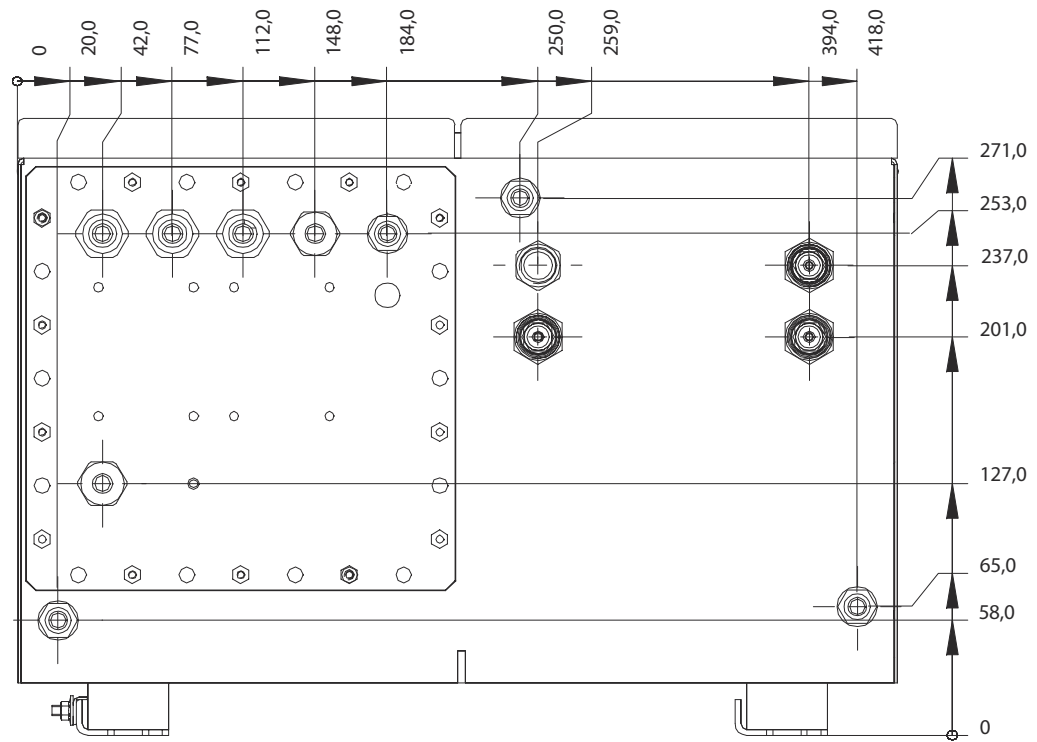



Figure 5-7 ULTRAMAT 6F and OXYMAT 6F, dimension drawing: Bottom view





# Connecting

## 6.1 Safety information for connecting

 <b>WARNING</b>
<b>Hazardous contact voltage</b> Risk of electric shock in case of incorrect connection. <ul style="list-style-type: none"><li>• For the electrical connection specifications, refer to the information in Technical specifications (Page 259).</li><li>• At the mounting location of the device observe the applicable directives and laws for installation of electrical power installations with rated voltages below 1000 V.</li></ul>

 <b>WARNING</b>
<b>Missing PE/ground terminal</b> Danger of electrocution If there is no ground terminal, there is a risk of electrocution. Depending on the device version, connect the power supply as follows: <ul style="list-style-type: none"><li>• Power plug: Ensure that the used socket has a PE/ground terminal. Check that the PE/ground terminal of the socket and power plug match.</li><li>• Connecting terminals: Connect the terminals according to the terminal assignment table. Connect the PE/ground conductor first.</li></ul>

 <b>WARNING</b>
<b>Introduction of toxic, corrosive or flammable gases</b> The limited release of toxic or corrosive gases during their introduction cannot be avoided with absolute certainty. <ul style="list-style-type: none"><li>• Before toxic, corrosive or flammable gases are introduced, carry out a leak test for the pipe connections.</li><li>• Flush the device with oil-free and dry purge air or inert gas.</li><li>• Collect the emerging purging gas for environmentally-friendly disposal with a suitable device.</li></ul>

 <b>WARNING</b>
<b>Leakiness of gas path</b> Danger of poisoning Leaky gas paths lead to accumulation of the sample gas in the device. <ul style="list-style-type: none"><li>• Tighten the unions in accordance with the mounting specifications of the manufacturer using a suitable open-ended wrench. In the process, make sure that you counter properly.</li><li>• Use only sample gas-contacting connecting parts (pipes, unions and sealing material) that are suitable for the connection and for the sample gases.</li></ul>

 <b>CAUTION</b>
<b>Cable damage</b> This device radiates heat. <ul style="list-style-type: none"><li>• For this reason, route all electrical cables at least 2 cm away from the device housing.</li></ul>



## 6.2 Gas and electrical connections on the device

### 6.2.1 OXYMAT 6E rack units

#### Connections of the OXYMAT 6E

All gas connections are pipe connections with a diameter of 6 mm or 1/4".

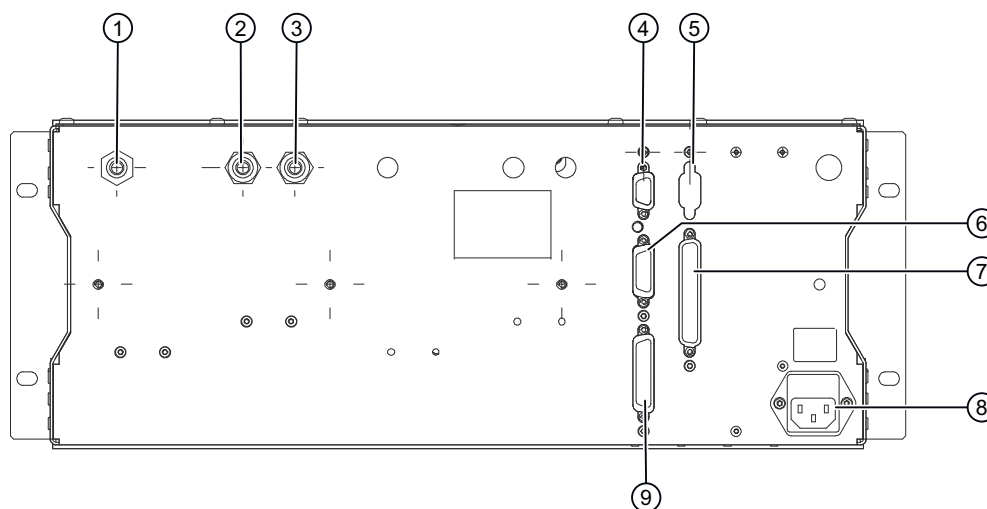

- ① Reference gas inlet, Channel 1;  
OXYMAT 6: Always used
- ② Sample gas outlet Channel 1
- ③ Sample gas inlet Channel 1
- ④ Channel 1: 9-pin connector RS485
- ⑤ Channel 1: 9-pin connector (option) e.g. for PROFIBUS
- ⑥ Channel 1: 15-pin connector, binary inputs and analog inputs and outputs
- ⑦ Channel 1: 37-pin connector (option) for binary inputs and relay outputs
- ⑧ Network connection and micro fuses
- ⑨ Channel 1: 25-pin connector, binary inputs and relay outputs

Figure 6-1 Gas and electrical connections of the OXYMAT 6E rack unit, rear of the device

### 6.2.2 ULTRAMAT 6E and ULTRAMAT/OXYMAT 6E rack units

#### Connections of the ULTRAMAT 6E and ULTRAMAT/ OXYMAT 6E

All gas connections are pipe connections with a diameter of 6 mm or 1/4".

6.2 Gas and electrical connections on the device

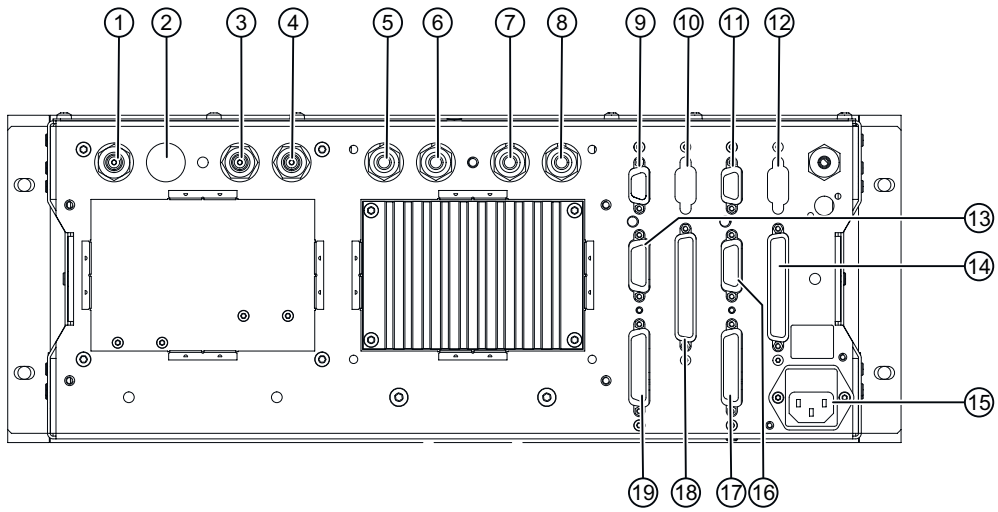

- ① Reference gas inlet Channel 1  
ULTRAMAT 6: only used for flow-type reference gas compartment
- ② Reference gas outlet Channel 1  
Used when Channel 1 is an IR channel and the reference gas compartment is a flow type
- ③ Sample gas outlet Channel 1
- ④ Sample gas inlet Channel 1
- ⑤ Reference gas inlet Channel 2 (option)
- ⑥ Reference gas outlet Channel 2 (option)
- ⑦ Sample gas outlet Channel 2
- ⑧ Sample gas inlet Channel 2
- ⑨ Channel 1: 9-pin connector RS485
- ⑩ Channel 1: 9-pin connector (option) e.g. for PROFIBUS
- ⑪ Channel 2: 9-pin connector RS485
- ⑫ Channel 2: 9-pin connector (option) e.g. for PROFIBUS
- ⑬ Channel 1: 15-pin connector, binary inputs and analog inputs and outputs
- ⑭ Channel 2: 37-pin connector (option) for binary inputs and relay outputs
- ⑮ Network connection and micro fuses
- ⑯ Channel 2: 15-pin connector, binary inputs and analog inputs and outputs
- ⑰ Channel 2: 25-pin connector, binary inputs and relay outputs
- ⑱ Channel 1: 37-pin connector (option) for binary inputs and relay outputs
- ⑲ Channel 1: 25-pin connector, binary inputs and relay outputs

Figure 6-2 Gas and electrical connections of the ULTRAMAT 6E rack unit, rear of the device

### 6.2.3 ULTRAMAT 6F and OXYMAT 6F field devices

#### Connections of the OXYMAT 6F and ULTRAMAT 6F

The sample gas and reference gas connections are connection fittings for pipe diameters of 6 mm or 1/4". The purging gas connections are pipe connections with a diameter of 10 mm or 3/8". The connection for the pressure sensor is realized as a pipe connection with a diameter of 1/4".

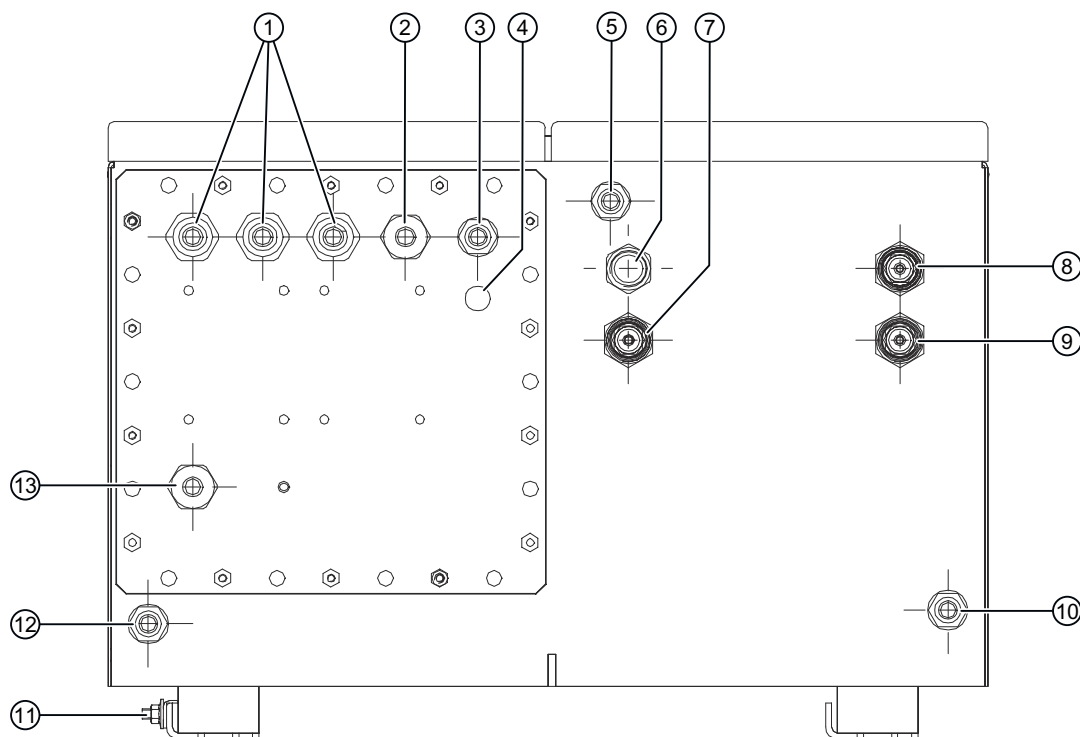

- ① M20 signal lines; permissible line cross-section 10 to 14 mm
- ② M20, e.g. RS485/PROFIBUS-PA-Ex; permissible line cross section 7 to 12 mm
- ③ Pipe connection  $\varnothing$  10 mm or 3/8"  
Purging gas inlet or outlet <sup>1)</sup>
- ④ Pipe connection  $\varnothing$  1/4"  
ULTRAMAT 6F: Connection of pressure sensor  
OXYMAT 6F: Not used
- ⑤ Pipe connection  $\varnothing$  10 mm or 3/8"  
Purging gas inlet or outlet <sup>1)</sup>
- ⑥ Connection fitting for pipe diameter  $\varnothing$  6 mm or 1/4"  
ULTRAMAT 6F: Sample gas inlet  
OXYMAT 6F: Not used
- ⑦ Connection fitting for pipe diameter  $\varnothing$  6 mm or 1/4"  
ULTRAMAT 6F: Sample gas outlet  
OXYMAT 6F: Sample gas inlet

- ⑧ Connection fitting for pipe diameter  $\varnothing$  6 mm or 1/4"  
ULTRAMAT 6F: Reference gas inlet  
OXYMAT 6F: Reference gas inlet
- ⑨ Connection fitting for pipe diameter  $\varnothing$  6 mm or 1/4"  
ULTRAMAT 6F: Reference gas outlet  
OXYMAT 6F: Sample gas outlet
- ⑩ Pipe connection  $\varnothing$  10 mm or 3/8"  
Purging gas inlet or outlet <sup>1)</sup>
- ⑪ M5 terminal clamp for external equipotential bonding terminal
- ⑫ Pipe connection  $\varnothing$  10 mm or 3/8" purging gas inlet or outlet 1)
- ⑬ M20 power cable; permissible cable cross-section 7 to 12 mm

<sup>1)</sup> Depending on the density of the sample gas, select an enclosure purging from bottom to top (purging gas inputs ③ and ⑤) or from top to bottom (purging gas inputs ⑩ and ⑪). This prevents the accumulation of explosive or toxic gases.

## 6.3 Gas connections

### Note

#### Outflow of reference gas for OXYMAT 6

In the event of blocking of the sample gas inlet and outlet, the reference gas still flowing in the analyzer unit can build up pressure that can destroy the internal pressure sensor or its connection to the analyzer unit. Ensure that the reference gas can still flow unimpeded from the device, e.g. via a 3-way valve at the sample gas outlet. We recommend against switching off the reference gas since the microflow sensor can be destroyed by aggressive sample gases. Dispose of the discharged gas in an environmentally friendly manner.

An overview of the gas path diagrams is available in section "Gas flow diagrams (Page 287)".

### 6.3.1 Sample gas connections

For the gas connections, connecting sockets with a pipe diameter of 6 mm or 1/4" (for rack units) or connection fittings for a pipe diameter of 6 mm or 1/4" (for field devices) are available. You need to select a suitable material for the sample gas supply and discharge lines from the device.

The ULTRAMAT 6 und OXYMAT 6 gas analyzers must be operated in such a way that the sample gas pressure does not accumulate within the analyzer unit. When several devices are connected in series, you must ensure that the gas path of the downstream devices has no restrictions (free exhaust gas flow). The restrictor that is installed in the gas path depending on the version of the analyzer may then have to be removed. The only restrictor that can be retained is the one between the sample gas line and the first analyzer unit of the first analyzer.

For devices in dual channel design, meaning with two parallel analyzer units (two ULTRAMAT channels or one ULTRAMAT channel and one OXYMAT channel), each analyzer unit has its

own, independent gas path. Here too the restrictor of the downstream analyzer selection has to be removed if the analyzer units are connected in series.

If the sample gas is to flow into an exhaust line, you must note the following:

- The flow resistance in the exhaust line should be kept as low as possible by using as short a line as possible or transitioning to a line with a larger diameter.
- The exhaust line must be free of rapid pressure fluctuations. If this is not the case, either a special exhaust line must be installed, or a damping vessel (> 1 l) with downstream restrictor must be installed between the device and exhaust line (pneumatic low pass).

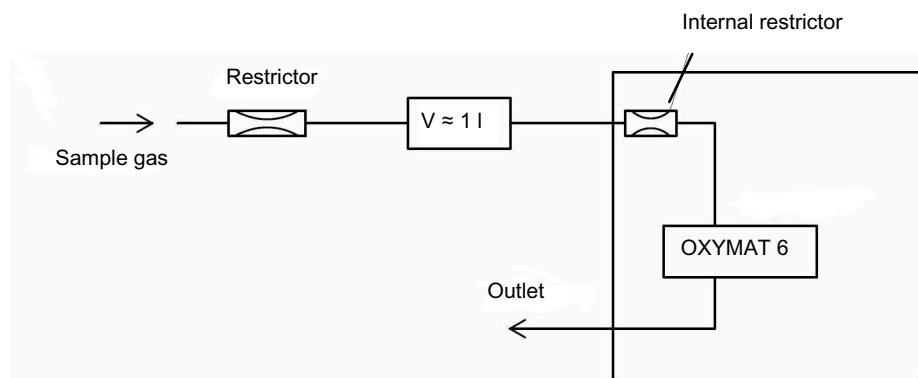

Figure 6-3 Damping measure against pressure fluctuations

## 6.3.2 Reference gas connections

The OXYMAT 6 is generally equipped with a reference gas connection, the ULTRAMAT 6 only for device versions with a flow-type reference gas compartment. Connecting sockets with a pipe diameter of 6 mm or 1/4" (rack units) or connection fittings for a pipe diameter of 6 mm or 1/4" (field devices) are available. A material suitable for the reference gas must be selected for gas inlets and outlet lines.

### 6.3.2.1 OXYMAT 6

Metal pipe must be used for the supply line in the case of the reference gases  $N_2$  and  $O_2$ . The line must be as short as possible and have a small cross-section.

If ambient air is used as the reference gas, it must be drawn in by means of an external pump across a fine filter with a pore width of approx. 40  $\mu m$ . In this case we recommend additionally inserting a dryer in the suction line to prevent a volume error on the reference gas side as a result of the air humidity.

If the device is subsequently switched to another reference gas supply, the connecting socket and the reference gas restrictor (low pressure operation 100 hPa (1.45 psi)) must be replaced. This may only be carried out by trained service engineers.

### 6.3.2.2 ULTRAMAT 6

For specific measuring tasks the ULTRAMAT 6 is supplied with a flow-type reference gas compartment. Depending on the version, this reference gas compartment can have either a normal flow or a reduced flow.

With a normal flow-type reference gas compartment, a flow rate of approx. 0.1 l/min to 1.5 l/min is possible. We recommend a flow rate of approx. 0.5 l/min.

With a reduced flow rate (approx. 8 ml/min), the reference gas line is connected to the reference cell via a pressure switch with a primary pressure of 3000 to 4000 hPa (3 to 4 bar) and a restrictor.

Devices without a flow-type reference cell do not any reference gas connections. The reference cell is tightly sealed.

---

#### Note

The reference gas supply of devices with a reduced flow-type reference gas compartment must have an absolute pressure of 2000 to 4000 hPa (2 to 4 bar). For devices used to measure CO<sub>2</sub> and gases that have a high cross-sensitivity to water vapor, a pipe must be used as the reference gas line to avoid diffusion-related measuring errors.

Due to the low flow rate, devices with a reduced flow-type reference side require approx. 3 to 6 hours after commissioning until they are fully functional. During this period, the zero point drifts significantly.

---

<b>NOTICE</b>
<b>Interchange of the inputs and outputs for ULTRAMAT 6 with the reduced flow-type reference gas compartment</b>
Device damage
If inputs and outputs are interchanged on device versions with the reduced flow-type reference gas compartment, the resulting overpressure can falsify the measurement result and/or damage the analyzer cell.
<ul style="list-style-type: none"><li>• Ensure that the inputs and outputs of the reduced flow-type reference gas compartment are not interchanged.</li></ul>

### 6.3.3 Purging gas connection

The field device versions of the ULTRAMAT 6 and OXYMAT 6 gas analyzers are equipped with four purging gas connecting sockets (10 mm or 3/8"). The position of these connections is shown in section ULTRAMAT 6F and OXYMAT 6F field devices (Page 52).

If required, the enclosure can be purged with inert gas (e. g. N<sub>2</sub>). Depending on the density of the sample gas, an enclosure purging from bottom to top or from top to bottom has to be selected to avoid a build-up of explosive or toxic gases in the enclosure.

We recommend always starting purging with the left half of the enclosure. The purging gas must be disposed of in an environmentally friendly manner through an exhaust hose having a suitable cross section. The purging gas overpressure in the enclosure must not exceed

165 hPa. If the device is operated without purging gas, the purging gas connections must be sealed gas-tight to prevent condensation inside the device caused by changes in climate.

## 6.4 Pressure sensor

The ULTRAMAT 6 and OXYMAT 6 gas analyzers are equipped with an internal pressure sensor. This pressure sensor is used for correcting the effect of pressure on the measured value.

For OXYMAT 6 this sensor is built into the analyzer unit and directly measures sample gas pressure using the reference gas supply. It does not have to be taken into consideration further during the installation.

For ULTRAMAT 6 the sensor measures the atmospheric pressure, its connection is routed out of the housing. Pressure correction therefore only functions correctly if the sample gas can flow out freely. If this is not ensured, the internal sensor must be deactivated and an external sensor mounted in the sample gas path.

## 6.5 Electrical connections

### 6.5.1 Power connection

Before connecting, check that the existing supply voltage at the location matches the supply voltage specified on the label of the analyzer.

The device comes with an appliance connector that may only be connected to the power cord by qualified personnel. The power cord must comply with the regulations and requirements applicable at the place of installation and be provided with a protective conductor at the potential of the housing. The cross-section of each wire must be  $\geq 1 \text{ mm}^2$ . The phased terminal conductors must be connected in the connector at the position marked.

Always route the power cable separately from the signal cables.

Install a power disconnect device in the direct vicinity of the device (see rating plate for loading capacity). It must be readily accessible and marked.

### Safety bracket in rack devices

Rack units for use in potentially explosive areas in accordance with FM/CSA are delivered with a safety bracket. This securing bracket protects the power plug from being disconnected unintentionally. It must be mounted before usage of the device.

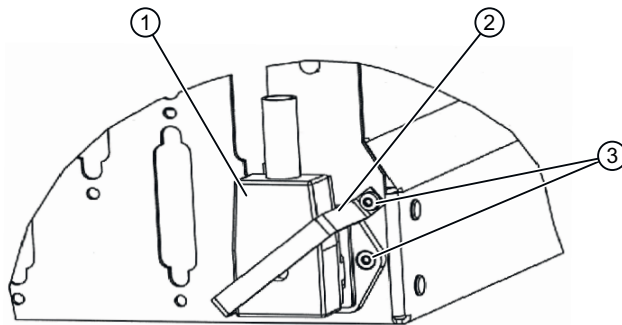

- ① Power connector
- ② Securing bracket
- ③ Screws

### 6.5.2 Connection of the signal lines

---

#### Note

##### Incorrect power supply

The 24 V/1 A supply voltage must be a power-limited safety extra-low voltage with safe electrical isolation (SELV).

Only connect the signal lines to devices which also have reliable electric isolation from their power supply.

---

If signals (for example 4 to 20 mA analog output) are to be introduced into a hazardous area of zone 1, they must be intrinsically-safe. Equipping or retrofitting with energy-limiting modules is also required. The Ex identification of these modules must be clearly visible on the device.

- The connection lines to the relay outputs, binary inputs, and analog outputs must be shielded.
- The analog outputs are floating, also with respect to one other. The cable length of the analog outputs is load-dependent.
- The reference ground of the analog inputs is the housing potential.





- **Rack units**  
Connect the signal lines to the D-SUB connectors at the rear of the device as shown in the pin assignment diagrams in section "Pin assignment (Page 67)".
- **Field devices**  
Connect the signal lines to the terminal blocks A and B (option). These are located on the flange plate on the base of the left-hand side of the enclosure.  
The shields of the connected cables must be connected to the respective cable glands continuously over a large area.  
The conductors of the connection cables have to be connected to the corresponding terminals in accordance with the pin assignment diagrams in section "Pin assignment (Page 67)".

---

**Note**

If the clock generation of the process electronics is faulty, the interfaces may take on an undefined state and the analog output might remain at approx. -1 mA or approx. +24.5 mA.

---

### 6.5.3 Pin assignment

#### 6.5.3.1 Motherboard pin assignment for rack units

##### Plug D-SUB 9F (RS 485)

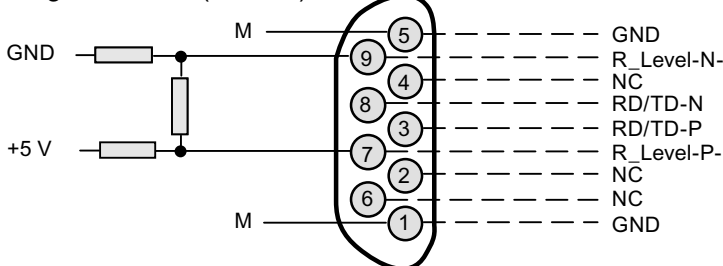

Bus terminating resistors can be connected to pins 7 and 9

##### Plug D-SUB 15F

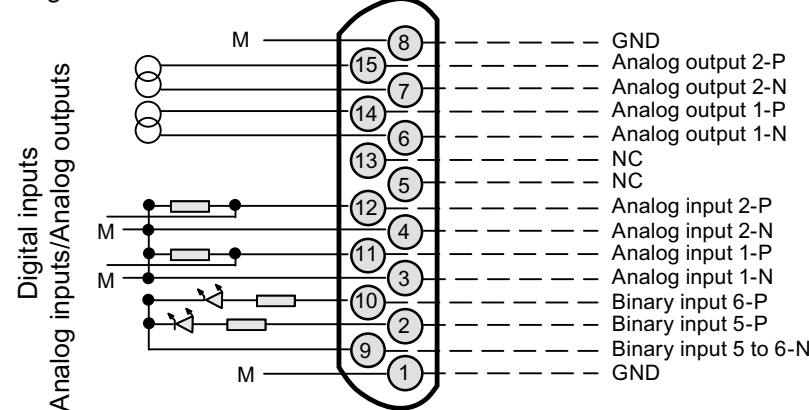

Analog outputs floating (also to one other),  $R_L \leq 750 \Omega$   
 Analog outputs floating (also to one other),  $R_L \leq 750 \Omega$

Pressure or interference-gas correction  
 Interference gas correction  
 Analog inputs non-floating, 0 to 20 mA/500  $\Omega$  or 0 to 10 V (low-resistance)

##### Plug D-SUB 25F

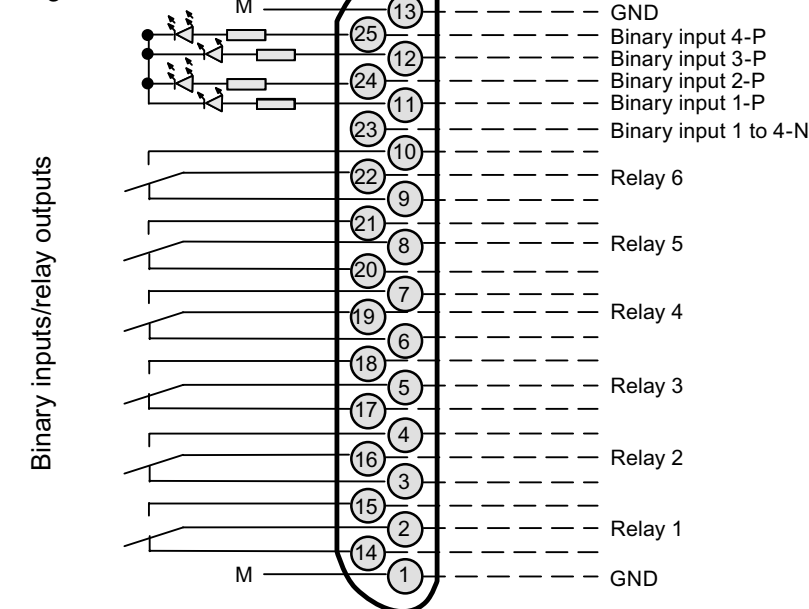

Binary inputs:  
 "1" = 24 V (13 to 33 V)  
 "0" = 0 V (0 to 4.5 V)  
 Floating via optocoupler

Contact loading  
 Max. 24 V AC/DC / 1 A;  
 shown relay contacts:  
 de-energized relay coil

Note:  
 Cable and connector must be shielded and connected to the housing potential

Figure 6-5 Pin assignment of the ULTRAMAT 6E motherboard

6.5 Electrical connections

Connector SUB-D 9F (RS 485)

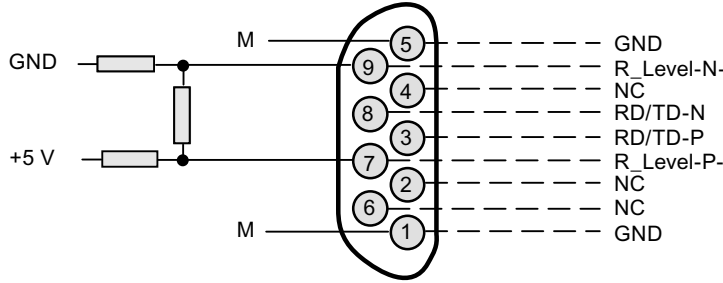

Terminating resistors for the bus can be connected to pins 7 and 9

Connector SUB-D 15F

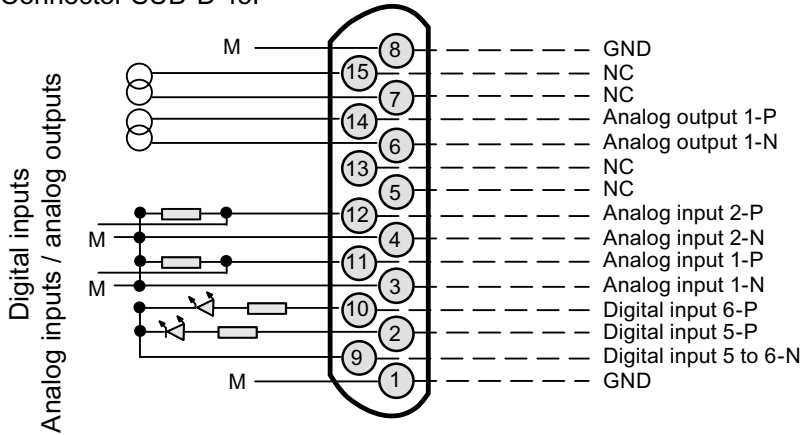

Analog outputs floating (mutually isolated as well),  $R_L \leq 750 \Omega$

Correction of compressed or interfering gas  
Correction of interfering gas

Analog inputs non-floating, 0 to 20 mA/500  $\Omega$  or 0 to 10 V (low impedance)

Connector SUB-D 25F

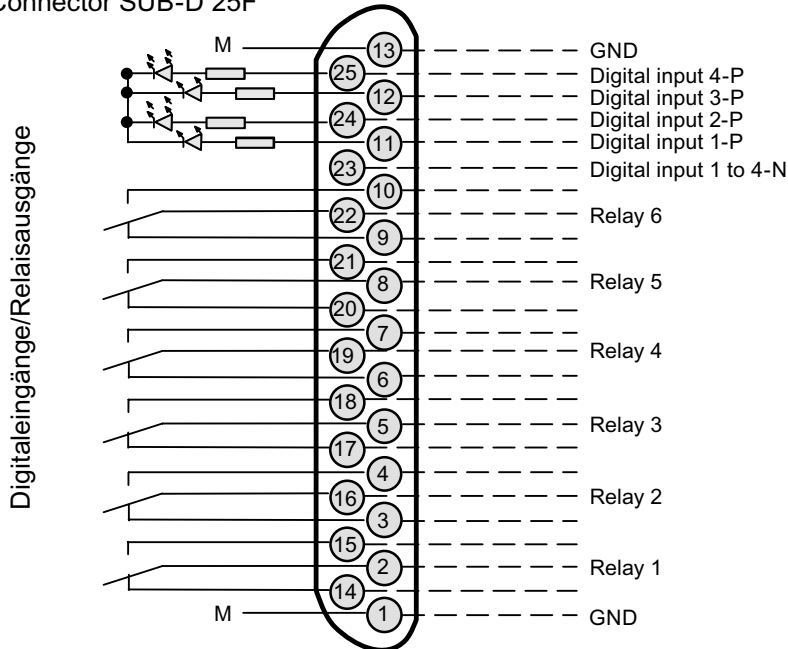

Digital inputs:  
"1" = 24 V (13 to 33 V)  
"0" = 0 V (0 to 4.5 V)  
floating via optocoupler

Contact load  
max. 24 V/1 A, AC/DC;  
relay contacts shown:  
de-energized relay coil

Note:  
The wire and connector must be shielded and be connected to the housing potential

Figure 6-6 Pin assignment of the OXYMAT 6E motherboard

6.5.3.2 Option board pin assignment for rack units

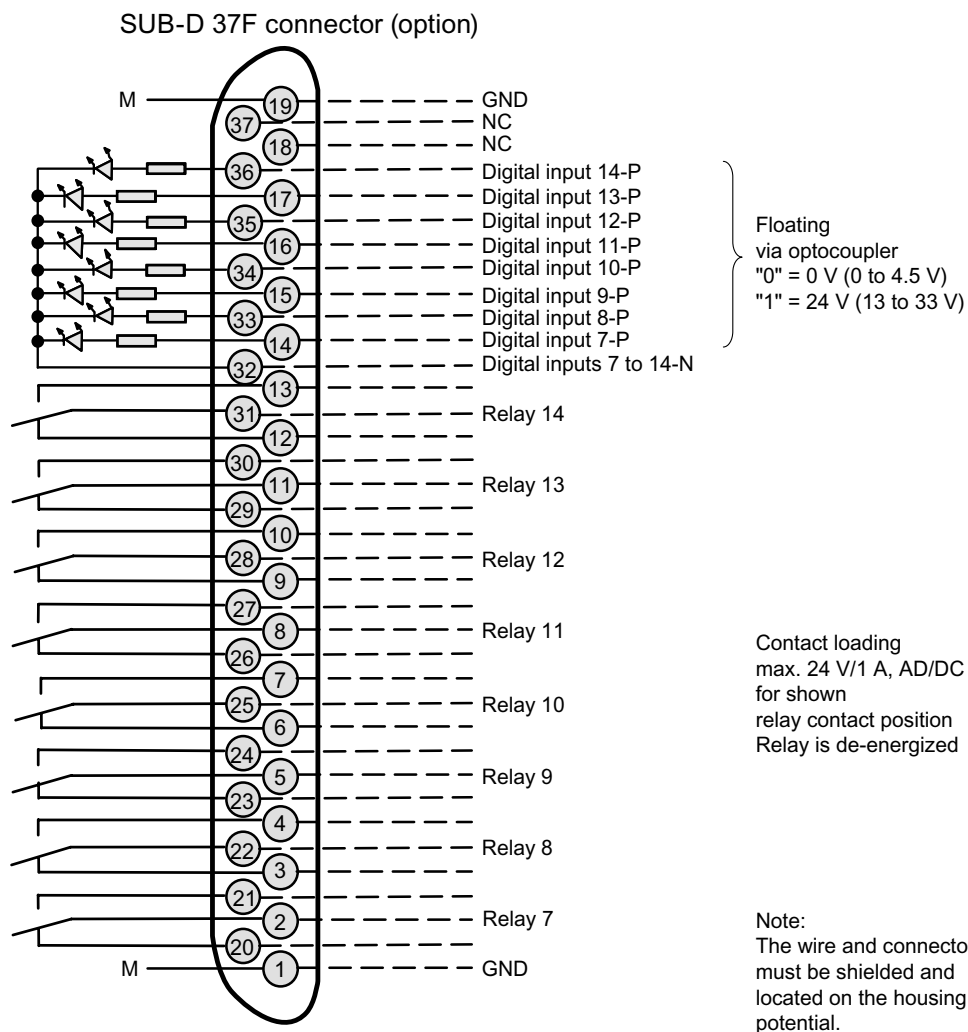

Figure 6-7 Pin assignment for the ULTRAMAT 6E and OXYMAT 6E option board

6.5.3.3 Example of an AUTOCAL circuit for rack units

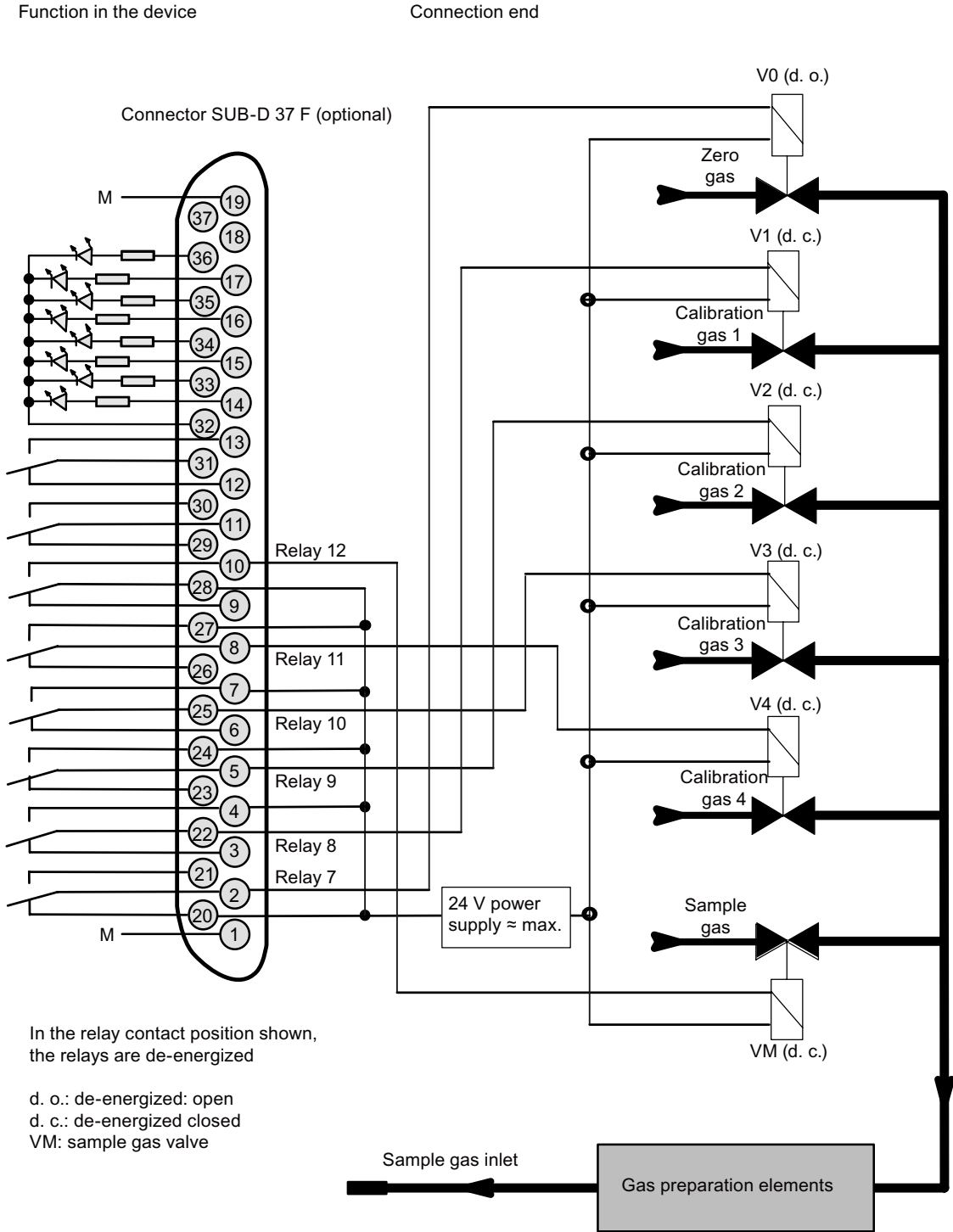

Figure 6-8 Pin assignment and valve diagram of an AUTOCAL circuit in rack units

### 6.5.3.4 Terminal assignment for inputs and outputs of field devices

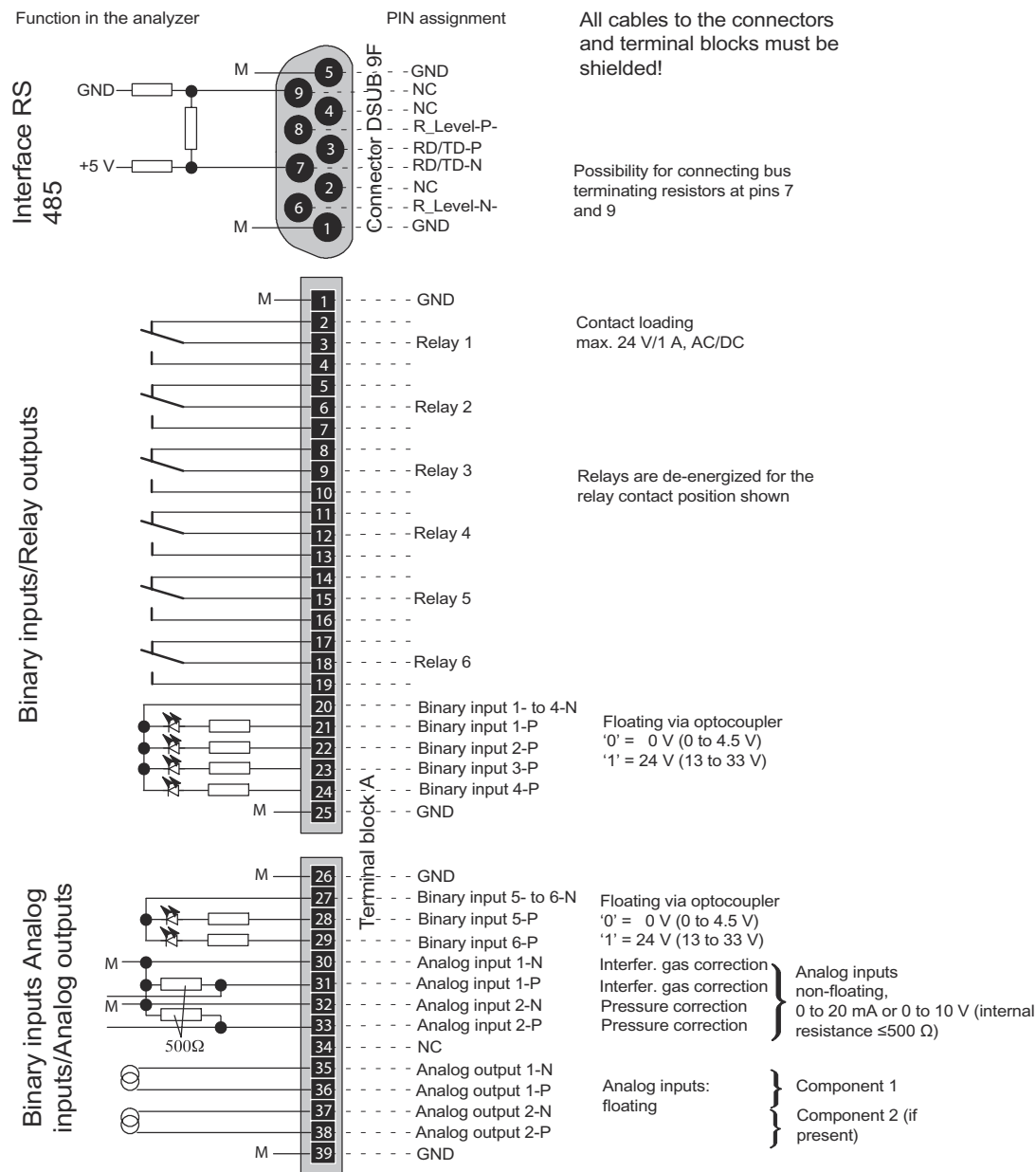

Figure 6-9 Terminal assignment in field devices of Series 6

6.5.3.5 Option board terminal assignment for field devices

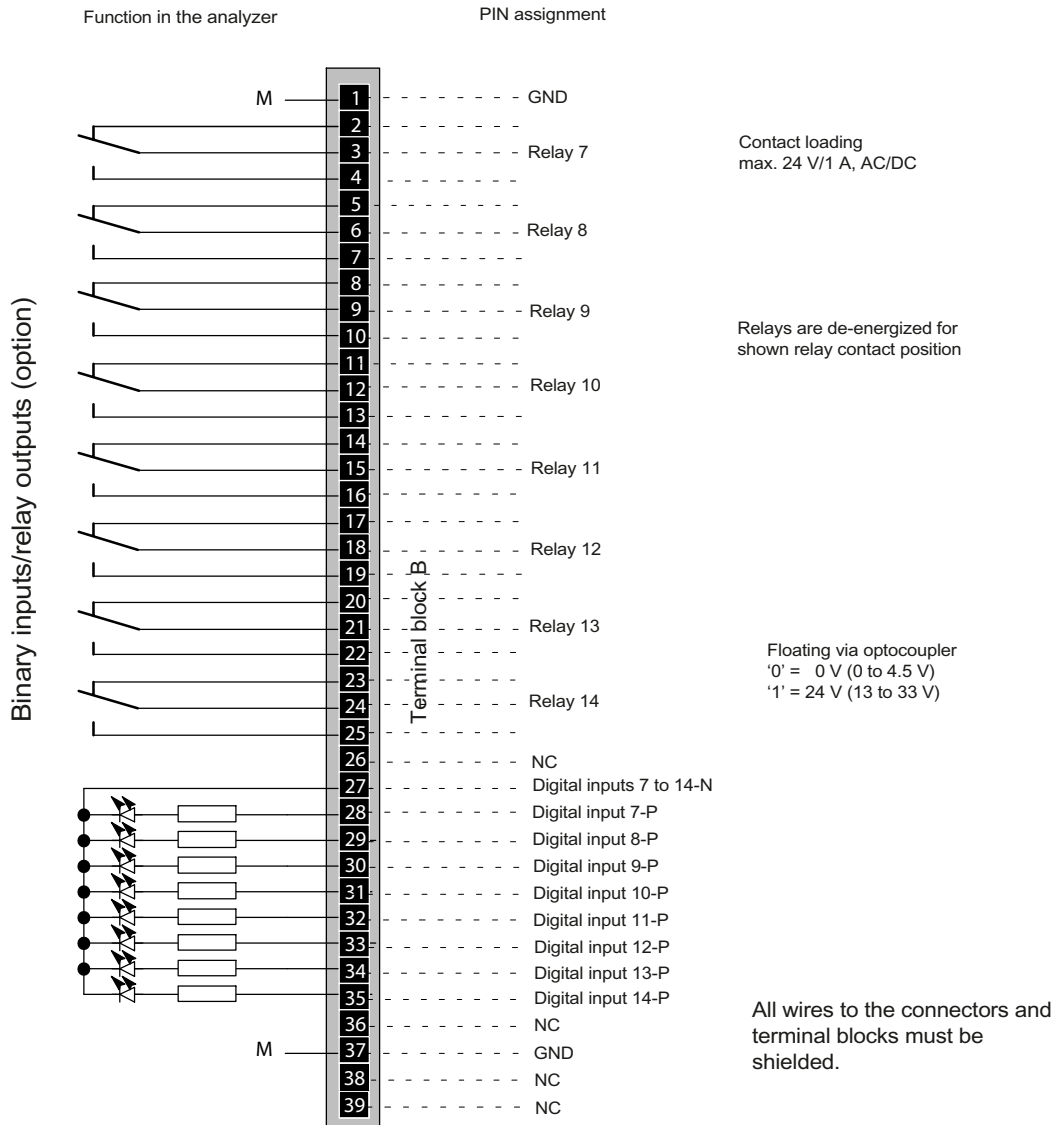

Figure 6-10 Terminal assignment of option board in field devices of Series 6



### 6.5.3.6 Example of an AUTOCAL circuit for field devices

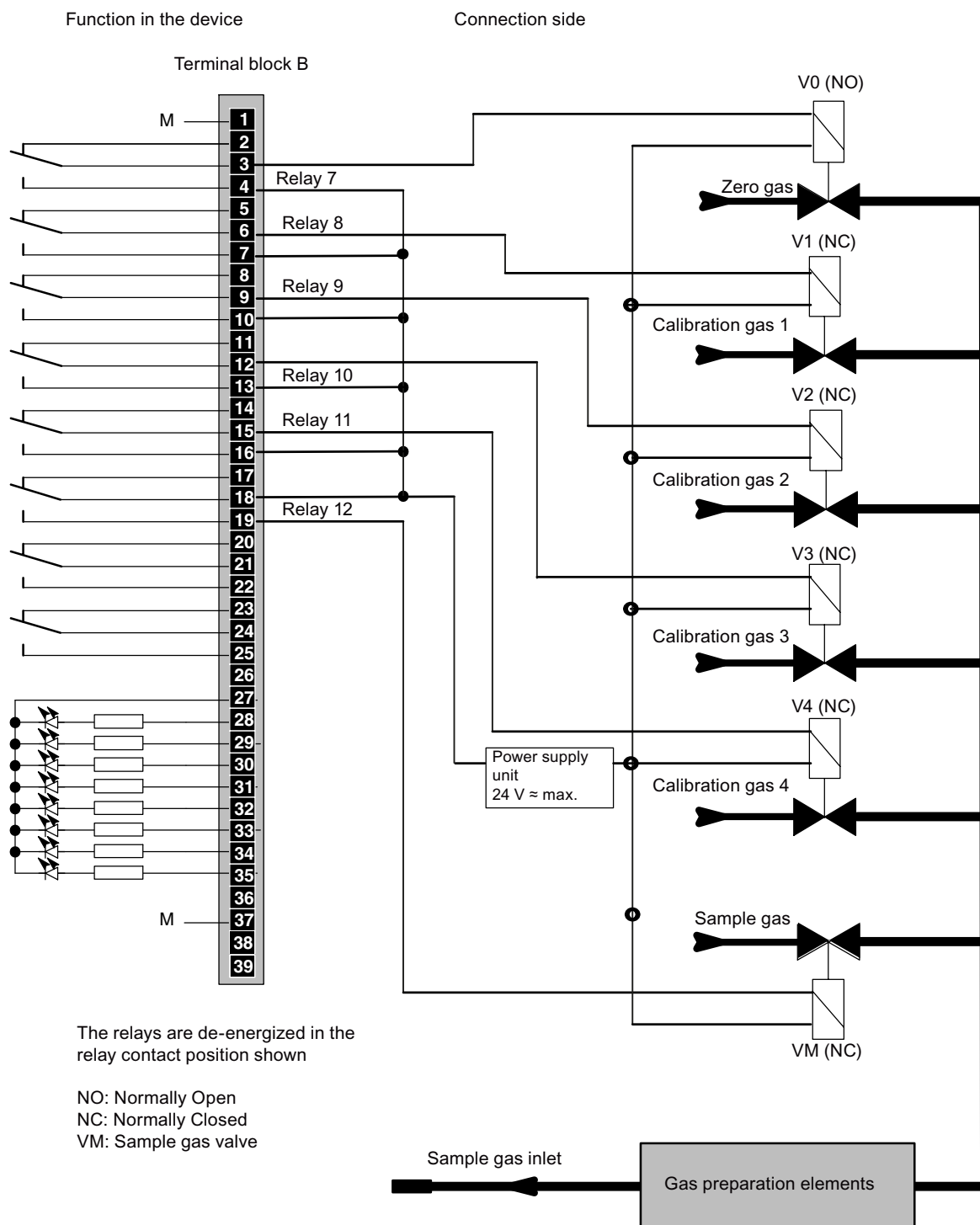



Figure 6-11 Example of an AUTOCAL connection for field devices of series 6





# Commissioning

# 7

## 7.1 Safety information for commissioning

 <b>WARNING</b>
<b>Dangerous contact voltage</b> Danger of injury through dangerous contact voltage when the device is open or not completely closed. The degree of protection specified on the nameplate is no longer guaranteed if the device is open or not closed correctly. <ul style="list-style-type: none"><li>• Make sure that the device is securely closed.</li></ul>

 <b>CAUTION</b>
<b>Loss of degree of protection</b> Damage to device if the enclosure is open or not properly closed. The type of protection specified on the nameplate is no longer guaranteed. <ul style="list-style-type: none"><li>• Make sure that the device is securely closed.</li></ul>

 <b>WARNING</b>
<b>Leakiness of gas path</b> Danger of poisoning Leaky gas paths lead to accumulation of the sample gas in the device. <ul style="list-style-type: none"><li>• Tighten the unions in accordance with the mounting specifications of the manufacturer using a suitable open-ended wrench. In the process, make sure that you counter properly.</li><li>• Use only sample gas-contacting connecting parts (pipes, unions and sealing material) that are suitable for the connection and for the sample gases.</li></ul>



 <b>CAUTION</b>
<b>Hot surfaces resulting from hot sample gases and heated devices</b> Danger of burns resulting from surface temperatures above 70 °C (155 °F). <ul style="list-style-type: none"><li>• Take appropriate protective measures, for example contact protection.</li><li>• Make sure that the maximum ambient temperature is not exceeded by implementing protective measures. Refer to the information in the section "Technical specifications (Page 259)".</li></ul>



**! CAUTION**

**Hot surfaces resulting from high-temperature devices**

Danger of burns resulting from surface temperatures above 130 °C.

The temperature of heated devices only drops slowly because of the high thermal capacity of the materials. Therefore, temperatures up to 130 °C can still be present for an extended period after devices have been switched off. This results in the danger of burns.

- Wait at least two hours after the shutdown before working on the heated devices.
- Take appropriate protective measures, such as wearing protective gloves.

**! WARNING**

**Commissioning and operation with pending error**

If an error message appears, correct operation in the process is no longer guaranteed.

- Check the gravity of the error.
- Correct the error.
- If the error still exists:
  - Take the device out of operation.
  - Prevent renewed commissioning.

### 7.1.1 Use in hazardous areas

**! WARNING**

**Opening device in energized state**

Risk of explosion in hazardous areas

- Only open the device in a de-energized state.
- Check prior to commissioning that the cover, cover locks, and cable inlets are assembled in accordance with the directives.

**Exception:** Devices having the type of protection "Intrinsic safety Ex i" may also be opened in energized state in hazardous areas.

Devices that are to be used in hazardous areas are subject to special safety regulations. You can find them in compact operating instructions that are enclosed with the devices:

- For explosion-proof field devices: A5E03312404 and A5E45779389
- For explosion-proof rack units: A5E03084511 and A5E45779144

## 7.1.2 Usage for measuring of toxic, aggressive and corrosive gases

<p> <b>WARNING</b></p> <p><b>Introduction of flammable, toxic or oxygen-containing gas mixtures into ULTRAMAT 6 gas analyzers with reduced flow-type reference gas compartment.</b></p> <p>Danger of explosion or poisoning</p> <p>ULTRAMAT 6 gas analyzers with reduced flow-type reference gas compartment are not designed for measurements of flammable, toxic or oxygen-containing gas mixtures.</p> <ul style="list-style-type: none"> <li>• Do not introduce any flammable, toxic or oxygen-containing gas or gas mixtures.</li> </ul>
--

When introducing corrosive, flammable or toxic gases, safety measures in accordance with German Occupational Safety Act (Arbeitsschutzgesetz - ArbSchG) or equivalent international regulations must be taken. These safety measures are to be agreed with a local authorized expert.

In particular, this includes measures regarding any potential release of gases from the containment system as well as their monitoring and disposal. As a rule monitoring of the purging gas to be discharged must be provided in the form of a suitable gas warning unit (Ex/Tox alarm).

When measuring toxic, aggressive or corrosive gases, it is possible that sample gas will accumulate in the analyzer because of leaks in the gas path. To prevent the danger of poisoning or damage to parts of the analyzer, the analyzer or the system must be purged with inert gas (e.g. nitrogen). The gas to be displaced by purging must be collected using appropriate equipment and routed for environmentally-friendly disposal via an exhaust line. Analyzers provided with heating must always be purged when operated with toxic, aggressive or corrosive gases.

If corrosive media are used, discussion with and approval by our specialist department/Technical Support is required Support Request (<https://support.industry.siemens.com/My/ww/en/requests#createRequest>).

## 7.2 Preparations for commissioning

### Note

#### Sample gas pressure increase influences the sample gas pressure switch

At the time of delivery of an OXYMAT 6 analyzer module, the internal pressure switch for reference gas monitoring is preset to approx. 2000 hPa (3000 hPa abs.). Changes in the sample gas pressure in the analyzer unit by more than 150 hPa require a change in the pressure switch switching point by the same amount. The monitoring functionality of the reference gas pressure switch is modified as a result.

- For changes to the sample gas pressure, contact the Service (Page 304).
- Have the pressure switching point of the reference gas pressure switch adjusted by a Siemens technician or someone trained for this case.

## 7.2.1 General information

### Gas preparation

In most cases the sample gas has to be prepared before being introduced into the analyzer. Get all devices to be used for this ready for operation (gas sampling devices, gas cooling devices, condensate vessels, filters and any connected controllers, recorders or indicators) (see operating instructions of the respective devices).

### Sample gas quality

The sample gas must be free from dust and condensation.

The dust filter must permanently retain dust particles  $>2 \mu\text{m}$ .

To avoid condensation in the sample gas line, you are advised to pipe the sample gas through a compressor cooler. The dew point should not exceed  $4 \text{ }^\circ\text{C}$ . If a higher dew point cannot be avoided in the sample gas, heatable devices should be used. In this case the sample gas line must also be heated. The temperature of the gas path to be heated must be selected in such a way that it is always at least  $10 \text{ K}$  **above** the dew point of the condensate components of the sample gas.

### Interfaces

Before commissioning, the interfaces must be correctly allocated and configured.

### Dual-channel devices

For devices in dual channel design, meaning with two parallel analyzer units (two ULTRAMAT channels or one ULTRAMAT channel and one OXYMAT channel), each analyzer unit has its own, independent gas path. In such devices, the parallel analyzer units operate independent of each other with regard to operation and interfaces.

### Operation

**Before** switching on the analyzer, make yourself acquainted with its operation (see section Operation (Page 93)).

## 7.2.2 Leak test of gas paths

### Calibration gases

Possible calibration gases for the leak test are:

- Air, dry, free of dust and/or oil
- 100%  $\text{N}_2$  with a purity of 4.6

### OXYMAT 6 test setup

1. Shut off the sample gas outlet.
2. Shut off the reference gas inlet.
3. Connect a pressure gauge and a shutoff valve via a T-piece to the sample gas inlet.
4. Connect the calibration gas before the shutoff valve via a suitable pressure regulator.

This results in the following test setup:

Calibration gas -> pressure regulator -> shutoff valve -> pressure gauge via T-piece - sample gas inlet

### ULTRAMAT 6 test setup reference gas path

1. Shut off the reference gas outlet.
2. Connect a pressure gauge and shutoff valve via a T-piece to the reference gas inlet.
3. Connect the calibration gas before the shutoff valve via a suitable pressure regulator.

This results in the following test setup:

Calibration gas -> pressure regulator -> shutoff valve -> pressure gauge via T-piece - reference gas inlet

### Test setup ULTRAMAT 6 sample gas path

1. Shut off the sample gas outlet.
2. Connect a pressure gauge and a shutoff valve via a T-piece to the sample gas inlet.
3. Connect the calibration gas before the shutoff valve via a suitable pressure regulator.

This results in the following test setup:

Calibration gas -> pressure regulator -> shutoff valve -> pressure gauge via T-piece - sample gas inlet

### Gas connections

The position of the gas connections is shown in the drawings in section Dimension drawings for installation preparation (Page 48).

### Procedure

#### Requirement:

The temperature of the device or analyzer unit must be stable before the start of the test. The pressures relevant for the test are specified in the pressure table at the end of this section. Proceed as follows for the leak test:

1. Apply calibration gas with a test pressure  $p + 10$  hPa to the gas inlet.
2. Wait for 10 seconds.
3. Close the shutoff valve.
4. Wait for 300 seconds ( $\pm 10$  s) for thermal and mechanical stabilization.

## 7.2 Preparations for commissioning

5. Read the pressure  $p_1$  on the pressure gauge.
6. Note the pressure  $p_1$ ,  $p_1$  has to be  $> p$ .
7. Wait another 300 s ( $\pm 5$  s).
8. Read the pressure  $p_2$  on the pressure gauge.
9. Note the pressure  $p_2$ .
10. Calculate the pressure difference according to this formula:  $\Delta p = p_1 - p_2$ .

The leak test has been passed if  $\Delta p > \Delta p_{\max}$ .

Device version	Test pressure p in hPa (rel.)	Maximum permissible pressure loss $\Delta p_{\max}$ in hPa	Test pressure p in psi (rel.)	$\Delta p_{\max}$ in psi
OXYMAT 6E with hoses and pressure switch	300	7.2	4.35	0.104
OXYMAT 6E with hoses and without pressure switch	500	14.0	7.25	0.203
OXYMAT 6E with pipes	2000	15.8	29.01	0.229
OXYMAT 6F with pipes	2000	27.3	29.01	0.396
ULTRAMAT 6E with hoses and with pressure switch	300	2.6	4.35	0.038
ULTRAMAT 6E with hoses and without pressure switch	500	3.2	7.25	0.046
ULTRAMAT 6E, reference gas compartment	500	3.2	7.25	0.046
ULTRAMAT 6E with pipes	500	1.7	7.25	0.025
ULTRAMAT 6F with hoses	500	3.1	7.25	0.045
ULTRAMAT 6F with pipes	500	1.6	7.25	0.023

## 7.2.3 ULTRAMAT channel

## 7.2.3.1 Interchange of the inputs and outputs for ULTRAMAT 6 with the reduced flow-type reference gas compartment

**NOTICE****Interchange of the inputs and outputs for ULTRAMAT 6 with the reduced flow-type reference gas compartment**

## Device damage

If inputs and outputs are interchanged on device versions with the reduced flow-type reference gas compartment, the resulting overpressure can falsify the measurement result and/or damage the analyzer cell.

- Ensure that the inputs and outputs of the reduced flow-type reference gas compartment are not interchanged.



**Note**

Leak tests are greatly influenced by temperature variations and should only be carried out at a constant temperature. If performing a leak test on devices that are in operation, wait for the corresponding warm-up periods.

---

**Note**

The gas supply of the reduced flow-type reference gas compartment should have a pressure of 2000 to 4000 hPa (2 to 4 bar). For CO<sub>2</sub> devices and for devices whose sample gas has a high cross-sensitivity to water vapor, the sample gas line must be made of pipes to prevent diffusion-related measuring errors.

---

**Selection of the reference gas**

- For ULTRAMAT channels with physically suppressed zero point, the reference gas listed in the delivered documents must be used. The concentration of the reference gas generally corresponds to the start-of-scale value or, in special cases, the full-scale value or an intermediate value (see section "Measuring ranges with suppressed zero point (Page 82)").
- In order to compensate for the influence of interfering gases, sample gas cleaned of the measured component can be connected to the reference gas compartment (absorber mode) or a cylinder gas corresponding to the mean composition of the interfering gas can be supplied.

**Note**

In case of doubt, we recommend that you discuss your application with our technical specialists using a Support Request (<https://support.industry.siemens.com/My/ww/en/requests#createRequest>)

---

**Reference gas connection**

Depending on the version, the reference gas connection is designed either for normal or reduced flow. For details please refer to section "Reference gas connections (Page 61)".

**Introducing reference gas**

Always introduce the reference gas before beginning the measurements. In the case of reduced flow, and depending on the length of the analyzer cell, you must wait at least three hours until the measured signal is stable before starting measurements. In the case of reduced flow, reference gas should always continue to flow even if there is a temporary interruption in measurements. This protects the microflow sensor. The increased consumption caused by this is negligible when the reference gas line is leak-tight.

**Compressed gas cylinder**

If the reference gas for a reduced-flow reference gas side is supplied from a compressed gas cylinder, the reference gas line has to be purged before commissioning. Then, check the line for leaks, because leakage losses are often greater than the reference gas consumption. To

do this, close the valve on the gas cylinder. If the pressure indicator at the reducer valve of the gas cylinder does not drop by more than 1000 hPa/min, the gas connection is sufficiently leak-tight. The reference gas pressure should lie constantly between 2000 und 4000 hPa (absolute).

### Checking the flow rate

Proceed as follows for this:

- Introduce the reference gas into the device (reference gas inlet).
- Connect a hose with an inner diameter of 4 mm to the reference gas outlet.
- Introduce the other end of the hose into a beaker filled with water.  
The gas must escape slowly (approx. 1 bubble per second).

#### 7.2.3.2 Measuring ranges with suppressed zero point

If a measuring range's start-of-scale value is not zero concentration, this is referred to as a measuring range with suppressed zero, for example, 200 to 300 ppm CO. In this example:

- 200 ppm is the start-of-scale value
- 300 ppm is the full-scale value and
- 100 ppm is the measuring span.

### Electronic zero point suppression

Channels with electronic zero suppression are physically identical to those with a non-suppressed zero. They only differ in the parameterization of the measuring ranges and the setpoint for the suppressed zero (for example, 200 ppm CO). The characteristic is stored from zero up to the full-scale value in accordance with the rating plate.

Devices with non-suppressed zero points can be reparameterized subsequently to suppressed zero points by changing these parameters (functions 22 and 41). Take into account, however, that influences such as noise, temperature errors and pressure errors increase by the factor

$$F = \frac{\text{Full-scale value of the smallest measuring range}}{\text{Full-scale value of the smallest measuring range} - \text{Start-of-scale value}}$$

. F should not exceed a value of 7 here. In general, we recommend that the smallest measuring span be increased by 30%.

---

#### Note

Applications with electrically suppressed zero point are available as standard devices. In any case we recommend that you discuss the planned application with our technical department. Support Request (<https://support.industry.siemens.com/My/ww/en/requests#createRequest>)

---

## Physical zero point suppression

Special applications (for example, with highly suppressed zero points) require a physical suppression of the zero point by passing a suitable reference gas through the reference gas compartment. The concentration of the reference gas should generally correspond to the full-scale value. As a result of the optimization to the measuring task, these channels have a start-of-scale that differs from zero in accordance with the nameplate. This value must not be fallen below when changing the start-of-scale value.

The advantage of this operating mode is that temperature and pressure errors occur on both the sample gas side and reference gas side and are largely offset.

---

### Note

Applications with physically suppressed zero point can only be supplied as special applications and always require a discussion with our specialist before ordering. Support Request (<https://support.industry.siemens.com/My/ww/en/requests#createRequest>)

---

## 7.2.4 Reference gas for OXYMAT channel

### Selection of the reference gas

In general, you must ensure that the various measuring spans have at least one common point. This point is then defined as the "physical zero point". It applies to all measuring ranges. When this point has been found, the reference gas can be selected.

#### Example

Four measuring ranges exist:

- 17 to 22% O<sub>2</sub>
- 15 to 25% O<sub>2</sub>
- 0 to 25% O<sub>2</sub>
- 0 to 100% O<sub>2</sub>

All these measuring ranges share the span 17-22% O<sub>2</sub>. The physical zero point may lie within this range. Therefore, air (20.95% O<sub>2</sub>) is a suitable reference gas.

An exception is possible if the smallest measuring span is ≤5% O<sub>2</sub> and the difference from the reference gas is not more than 20% O<sub>2</sub>. Then, the physical zero point can also be outside the measuring range. In this case the pressure correction (see "Pressure correction (function 82) (Page 150)") must be activated, since there a pressure dependency due to the large zero offset.

The purity of the reference gas has to be appropriate for the measuring task.

### Installing the reference gas connection

The reference gas connection has a different design depending on the order:

- **Air (low-pressure version)**

With air as the reference gas, the reference gas is supplied via an external reference gas pump with approx. 100 hPa delivery pressure. In this case the connecting socket is equipped with an outlet restrictor through which excess reference gas can flow out continuously. This ensures that the supply line is purged rapidly if false air was briefly sucked in. For protection against dirt particles, install a fine filter with a pore width of  $\leq 2 \mu\text{m}$  between the pump and the connecting socket.

- **Nitrogen, oxygen (high pressure version)**

If you use nitrogen or oxygen as the reference gas, ensure the purity of the gas (4.6). With nitrogen or oxygen as the reference gas, the supply normally comes from a compressed gas cylinder with a pressure setting of 2000 to 4000 hPa over the sample gas pressure. In this case there is no outlet restrictor in the connecting socket. The reference gas pressure may amount to a maximum of 5000 hPa. A sintered metal filter (porous filter) is pressed into the connecting socket to prevent entry of dirt particles into the gas path.

### Reference gas quality

The reference gas must be free of dust and condensate. The dust filter must permanently retain dust particles  $> 2 \mu\text{m}$ .

To avoid condensation in the reference gas line, we recommend introducing the reference gas via a compressor cooler. The dew point should not exceed  $4 \text{ }^\circ\text{C}$ . If a higher dew point cannot be avoided in the reference gas, heatable devices should be used. You must then also heat the supply line. Select the temperature of the gas path to be heated in such a way that it is always at least 10 K **above** the dew point of the condensate components of the reference gas.

### Introducing the reference gas

---

#### Note

The reference gas protects the microflow sensor from the sample gas and is indispensable for the measurement capability of the OXYMAT. We therefore recommend monitoring the reference gas pressure using a pressure monitor. In the case of insufficient reference gas pressure, the supply of sample gas should be interrupted and the system should be switched over to purging of the sample gas path with an inert gas.

---

The reference gas must always be introduced before the start of measurements and should then flow continuously. If there is a temporary interruption of measurements, reference gas should always flow. The increased consumption caused by this is negligible when the reference gas line is leak-tight.

#### Compressed gas cylinder

If the reference gas is taken from a compressed gas cylinder, the reference gas line should

be purged prior to commissioning. You should then check the line for leaks, because leakage losses are often greater than the reference gas consumption.

- To do this close the valve at the compressed gas cylinder. If the pressure indicator at the reducer valve of the gas cylinder does not drop by more than 1000 hPa/min, the gas connection is sufficiently leak-tight. The reference gas pressure must always be more than 2000 hPa above the sample gas pressure.

#### **Pressure test**

If a reference gas pressure switch is installed in the device (optional), its switching point is factory-set to 2000 hPa above atmospheric pressure. If the reference gas pressure has to be increased because of a higher sample gas pressure, you have to adjust the switching point of the pressure switch accordingly (see section "Calibrating the reference gas pressure switch (Page 205)").

#### **Flow check**

Proceed as follows for this:

- Close the sample gas inlet connection.
- Introduce a hose with an internal diameter of 4 mm from the sample gas outlet connection into a beaker filled with water.  
The reference gas must escape slowly (1 to 2 bubbles per second or 2 to 4 bubbles per second for flow-type compensation circuit) through the water.

## **7.2.5 Gas preparation**

An inadequate gas preparation can lead to contamination of the analyzer unit and as a result to a measured-value drift and/or temperature-dependent measuring errors.

The sample gas must be sufficiently conditioned to prevent contamination of the parts through which it flows. The following gas preparation elements are generally arranged upstream of the analyzer:

- Gas sampling device with filter
- Sample gas cooler
- Analysis filter (approx. 1-2  $\mu\text{m}$ )
- External gas suction pump (for sample gas lines > 20 m/65 1/2 ft)

Depending on the nature of the sample gas, additional aids are required such as

- A washbottle
- Additional filters
- Pressure reducer.

---

#### **Note**

Remove corrosive components or components that interfere with the measurement through the use of suitable absorber filters.

---

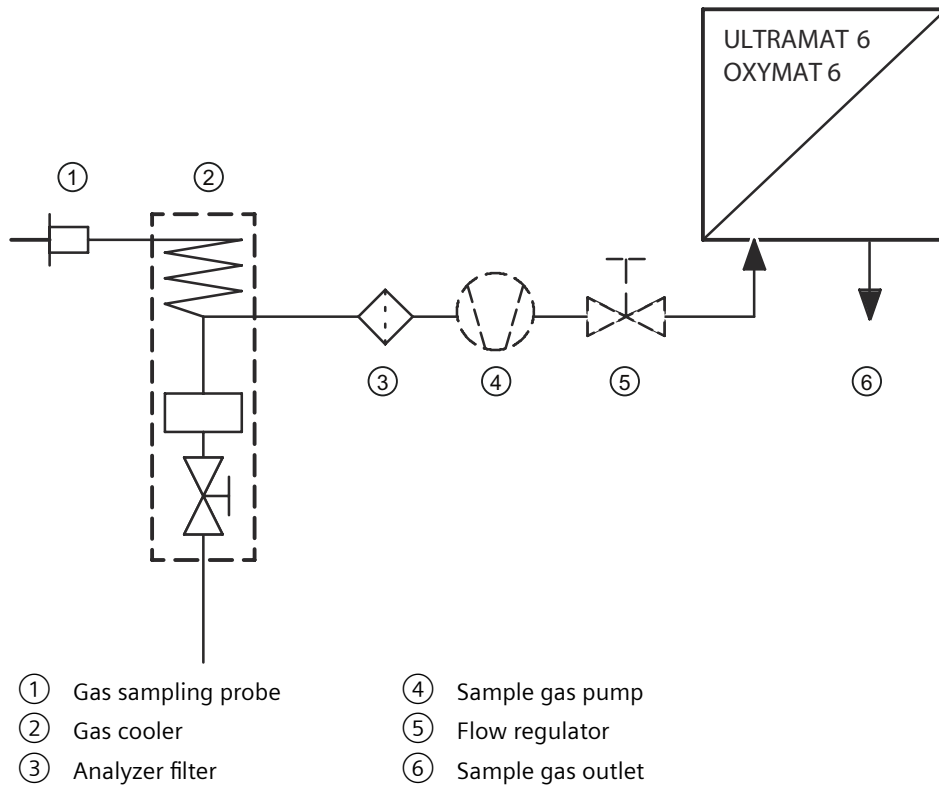

Figure 7-1 Gas preparation

## 7.3 Commissioning

### 7.3.1 ULTRAMAT channel

#### Switching on the power supply

After a short period, the measured value display appears in the display window. Above it in the top line is the status display (see section Display and control panel (Page 93)).

The ULTRAMAT is in the warm-up phase for the first 30 minutes. The "■CTRL" message (function check) appears in the status bar during this time. During this period, some functions (for example, calibration of zero point and full-scale value) are not available. The "Analyzer is not measuring" message appears during activation of these functions.

The device is ready for operation after completion of the warm-up phase, and full measurement accuracy is achieved after approx. 2 hours.

---

#### Note

Devices with a reduced flow-type reference gas compartment are only ready to take measurements after 3 to 6 hours.

---

## Calibrations and parameterizations

For first-time adaptation of the device to the measuring task, you perform the following steps:

1. Setting the analog output (function 70, see section Analog output (function 70) (Page 135)).
2. Setting the measuring range (functions 40 and 41, see sections Select measuring ranges (function 40) (Page 119) and Define measuring ranges (function 41) (Page 122)).
3. Setting the setpoints for the calibration (functions 22 and 23, see sections Zero/span setpoints (function 22) (Page 110) and Calibration setting (function 23) (Page 110)).
4. Calibrating the zero point (function 20, see section Calibration of the zero point (function 20) (Page 106)).
5. Calibrating the sensitivity (function 21, see section Span calibration (function 21) (Page 107)).
6. Saving the user data (function 75, see section Save, load data (function 75) (Page 143)).

### 7.3.2 OXYMAT channel

#### 7.3.2.1 First steps

#### Switching on the power supply

After a short period, the measured value display appears in the display window. Above it in the top line is the status display (see section Display and control panel (Page 93)).

The OXYMAT is in the warm-up phase for the first 30 minutes. The "■CTRL" message (function check) appears in the status bar during this time. During this period, some functions (for example, calibration of zero point and full-scale value) are not available. The "Analyzer is not measuring" message appears during activation of these functions.

The device is ready for operation after the warm-up phase is complete, and full measurement accuracy is achieved after approx. 2 hours.

## Calibrations and parameterizations

For first-time adaptation of the device to the measuring task, you perform the following steps:

1. Setting the analog output (function 70, see section Analog output (function 70) (Page 135)).
2. Setting the measuring range (functions 40 and 41, see sections Select measuring ranges (function 40) (Page 119) and Define measuring ranges (function 41) (Page 122)).
3. Setting the setpoints for the calibration (functions 22 and 23, see sections Zero/span setpoints (function 22) (Page 110) and Calibration setting (function 23) (Page 110)).
4. Calibrating the zero point (function 20, see section Calibration of the zero point (function 20) (Page 106)).

5. Calibrating the sensitivity (function 21, see section Span calibration (function 21) (Page 107)).
6. Saving the user data (function 75, see section Save, load data (function 75) (Page 143)).

### 7.3.2.2 Calibration examples

The following examples reflect typical applications for the OXYMAT.

#### O<sub>2</sub> monitoring in gases

Measurement task: Measurement of oxygen in any gas mixture;  
 Measuring range: 0 to 5% O<sub>2</sub>; Reference gas: N<sub>2</sub>; Calibration gas: 4.7% O<sub>2</sub>

Procedure	Function no.	Input	Remarks
Selection of measuring range start-of-scale value	41	0	0 ⇒ 0(2/4) mA
Selection of measuring range full-scale value	41	5	5 ⇒ 20 mA
Specification of the setpoint for the physical zero point	22	0	Setpoint for physical zero point
Specification of the setpoint for the sensitivity	22	4.7	Setpoint for sensitivity
Start zero point calibration	20		Introduce N <sub>2</sub>
Start sensitivity calibration	21		Introduce calibration gas

#### Room air monitoring

Measuring range: 15 to 21% O<sub>2</sub>; Reference gas: Air (20.95% O<sub>2</sub>); Calibration gas: 15.3% O<sub>2</sub>

Procedure	Function no.	Input	Remarks
Selection of measuring range start-of-scale value	41	15	15 ⇒ 0(2/4) mA
Selection of measuring range full-scale value	41	21	21 ⇒ 20 mA
Specification of the setpoint for the physical zero point	22	20.95	Setpoint for physical zero point
Specification of the setpoint for the sensitivity	22	15.3	Setpoint for sensitivity
Start zero point calibration	20		Introduce air
Start sensitivity calibration	21		Introduce calibration gas

#### O<sub>2</sub> measurement in flue gas

Measuring range: 0 to 10% O<sub>2</sub>; Reference gas: Air; Calibration gas: N<sub>2</sub>

##### Note

##### Reference gas out of range

In this example, the O<sub>2</sub> content of the reference gas is not within the measuring range of up to 10% O<sub>2</sub>. Since the measuring span is greater than 5%, however, an exception can be made in the selection of the reference gas.

However, in this case it is imperative to activate the pressure correction (see also Function 82 in section 5).



Procedure	Function no.	Input	Remarks
Selection of measuring range start-of-scale value	41	0	0 ⇒ 0(2/4) mA
Selection of measuring range full-scale value	41	10	10 ⇒ 20 mA
Specification of the setpoint for the physical zero point	22	20.95	Setpoint for physical zero point
Specification of the setpoint for the sensitivity	22	0	Setpoint for sensitivity
Start zero point calibration	20		Introduce air
Start sensitivity calibration	21		Introduce N <sub>2</sub>

### Purity monitoring of oxygen

Measuring range: 95 to 100% O<sub>2</sub>; Reference gas: Pure O<sub>2</sub>; Calibration gas: 95.6% O<sub>2</sub>

Procedure	Function no.	Input	Remarks
Selection of measuring range start-of-scale value	41	95	95 ⇒ 0(2/4) mA
Selection of measuring range full-scale value	41	100	100 ⇒ 20 mA
Specification of the setpoint for the physical zero point	22	100	Setpoint for physical zero point
Specification of the setpoint for the sensitivity	22	95.6	Setpoint for sensitivity
Start zero point calibration	20		Introduce pure O <sub>2</sub> (100%)
Start sensitivity calibration	21		Introduce calibration gas

Detailed operating instructions for performing all the required testing functions are provided in the section "Operation (Page 93)" or "Functions (Page 101)".

### Vibrations, oscillations

If vibrations occur at the installation location of the O6, they can lead to increased noise.

The device therefore operates with two measuring bridges. One measuring bridge supplies the measured signal. The second measuring bridge is used solely as a shock sensor and outputs a signal that is combined with the measured signal to compensate for the vibration effect (see section Shock compensation (function 61) (Page 134)). The vibration compensation is adapted to the conditions existing at the installation location using function 61.

Sometimes it is possible to reduce or eliminate vibration-dependent oscillations in the output signal by changing the magnetic field frequency (see function 57).

### Compensation of the influence of temperature

Compensation of the influence of temperature in the measured value is stored permanently in the software (firmware) for the OXYMAT 6. Changes can be made by the service. Compensation of the influence of temperature in the zero point is device-specific. The coefficients are specified in the data sheet of the respective analyzer unit and must be stored carefully.

### Noise suppression

Noise in the measured signal can be suppressed using function 50. This function allows you to configure a low pass filter, which is assigned a time constant of up to 100 s.

### 7.3.2.3 Measurement of oxygen in hydrogen

Use nitrogen (N<sub>2</sub>) as a reference gas. The consumption of reference gas lies at 50 ml/min. The filling of a gas cylinder of 50 liters and a filling pressure of 300 bar is sufficient for approx. ½ year.

#### Calibration

The OXYMAT 6 must be adjusted or calibrated at 2 points: At the zero point at 0 % O<sub>2</sub> and at the impact point (sensitivity) at 100 % O<sub>2</sub>. For operation of the OXYMAT 6, see the operating instructions OXYMAT 6 (C79000-G5200-C143) section 9.3.

Required gas concentrations:

- 100 % nitrogen (N<sub>2</sub>) – inert purging gas
- 100 % hydrogen (H<sub>2</sub>) (purity 99.999 % H<sub>2</sub> or better) – zero-point calibration
- 100 % hydrogen (H<sub>2</sub>) (purity 99.999 % O<sub>2</sub> or better) – sensitivity calibration

Proceed as follows:

1. Check the calibration setting in **Function 23**. The overall calibration must be activated. All measuring ranges are calibrated overall.
2. Check the settings for the setpoint values in **Function 22**. The value 0.000 must be entered as the setpoint value for the zero point. Measuring range 4 must be selected as leading measuring range. The final value concentration must be entered in the leading measuring range as 100 % vol.
3. Zero-point calibration: Select **Function 20**. First flush the gas path with inert gas N<sub>2</sub> to flush out any oxygen concentration in the gas path.
4. Apply 100 % H<sub>2</sub> concentration to the device. Wait long enough until the measured value is stable. This can take 5 minutes. The measured value should be close to the value 0 % vol. O<sub>2</sub> whereby it must be noted that between 100 % N<sub>2</sub> and 100 % H<sub>2</sub> there is an offset of approx. 0.26 % O<sub>2</sub>.
5. Trigger the calibration in **Function 20**.
6. Sensitivity calibration: Select **Function 21**. Flush the gas path with inert gas N<sub>2</sub>.
7. Apply the 100 % O<sub>2</sub> concentration to the device and wait again until the measured value is stable.
8. Trigger the sensitivity calibration in **Function 21**.
9. Then flush again with inert gas N<sub>2</sub>.
10. Apply and acknowledge the calibration by pressing the "MEAS" key.

#### Limit

A limit which lies at 1 % O<sub>2</sub> is set to ensure that the measured values lie safely below the lower explosive limit (LEL) in measuring mode. This corresponds to approx. 25 % of the LEL. Exceeding of the limit value is signaled at relay 4.

#### Function 51:

Limit 1: 1 % O<sub>2</sub>

At relay:	4
Switches in case of violation	On
Applies for all measuring ranges	All
Limit alarm:	On



## Operation

### 8.1 General information about operation

#### 8.1.1 Display and control panel

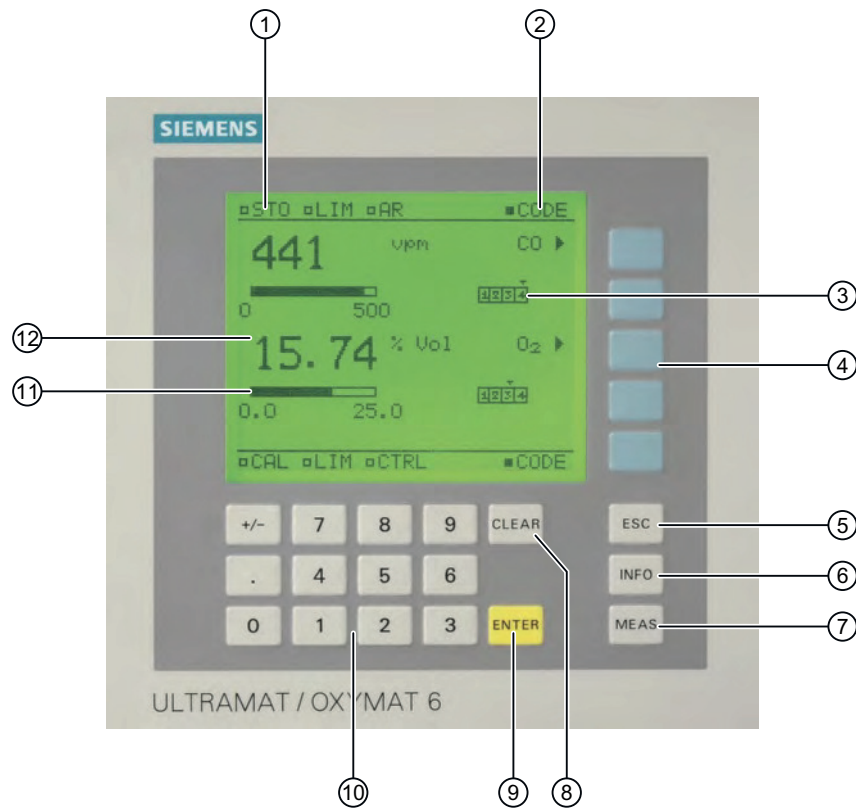

- ① Status line for display of analyzer state (configurable)
- ② Two code levels according to NAMUR (maintenance and specialist levels)
- ③ Display of activated measuring ranges
- ④ Five softkeys for menu control
- ⑤ ESC key
- ⑥ INFO key
- ⑦ MEAS key (MEAS stands for Measurement)
- ⑧ CLEAR key
- ⑨ ENTER key
- ⑩ Numerical keypad for entering numerical values
- ⑪ Display of start-of-scale and full-scale values
- ⑫ Display of concentrations as digits and bars

8.1 General information about operation

Figure 8-1 Membrane keyboard and control panel, here for the ULTRAMAT/OXYMAT 6

Table 8-1 Meaning of input keys

Key	Meaning/function
CLEAR	Clears a number entry you have started
ENTER	Every number entered (except fast activation of a function) must be confirmed with [ENTER].
ESC	Jumps back one step in the operating structure. Changes made in the meantime are accepted <b>without a prompt</b> .
INFO	Information about current menu / current function
MEAS	Jump back from every position in the operating structure to the "Decoded display mode" (you may be asked to confirm the entered data first). Pressing the [MEAS] key again changes the operating mode to "Coded display mode", i.e. another change to "Operator control mode" requires the entry of the corresponding code.
Softkey	Varying meaning. The following are possible here: <ul style="list-style-type: none"> <li>• Submenu selection / function selection</li> <li>• Selection of a subfunction</li> <li>• Switch function On/Off</li> <li>• Channel selection</li> </ul>

8.1.2 Editing inputs

The values in the menus shown in this chapter are meant as examples.

An active input field is shown with colons (e.g. :10:) as a limiter. The cursor blinks under the number to be entered.

By pressing the [ENTER] button, you finish your input and the value is stored. If there are several input fields on one function screen, the cursor positions itself at the next input field at the same time.

---

**Note**

Confirm every entered value, also the last of several values in a function, before exiting the function with [ENTER].

---

With the [CLEAR] button, you can clear a number which you have begun to enter. The cursor then jumps back to the first position of the input field.

Graphic symbols

- = activated (ON state; also in status message in the status line)
- = deactivated (OFF state; also in status message in the status line)
- = access a submenu/subfunction
- = trigger a function/subfunction (e.g. Start calibration...)

### 8.1.3 Device operating modes

Table 8-2 Device operating modes

Mode	Properties
Coded display mode <input checked="" type="checkbox"/> CODE	<ul style="list-style-type: none"> <li>• Measured value display is shown</li> <li>• Protected submenus can only be reached by entering a code</li> <li>• The current operating status of the measured component is displayed in the associated status bar</li> <li>• Functional check not active</li> </ul>
Decoded display mode <input type="checkbox"/> CODE	<ul style="list-style-type: none"> <li>• Measured value display is shown</li> <li>• The submenus protected by the entered code are accessible</li> <li>• The current operating status of the measured component is displayed in the associated status bar</li> <li>• Functional check active</li> <li>• Measured value can be influenced</li> </ul>
Operator control mode	<ul style="list-style-type: none"> <li>• Menu or function is displayed</li> <li>• Settings and inputs can be made</li> <li>• Functional check active</li> <li>• Measured value can be influenced</li> </ul>

Schematic diagram of the operating sequence with operating modes

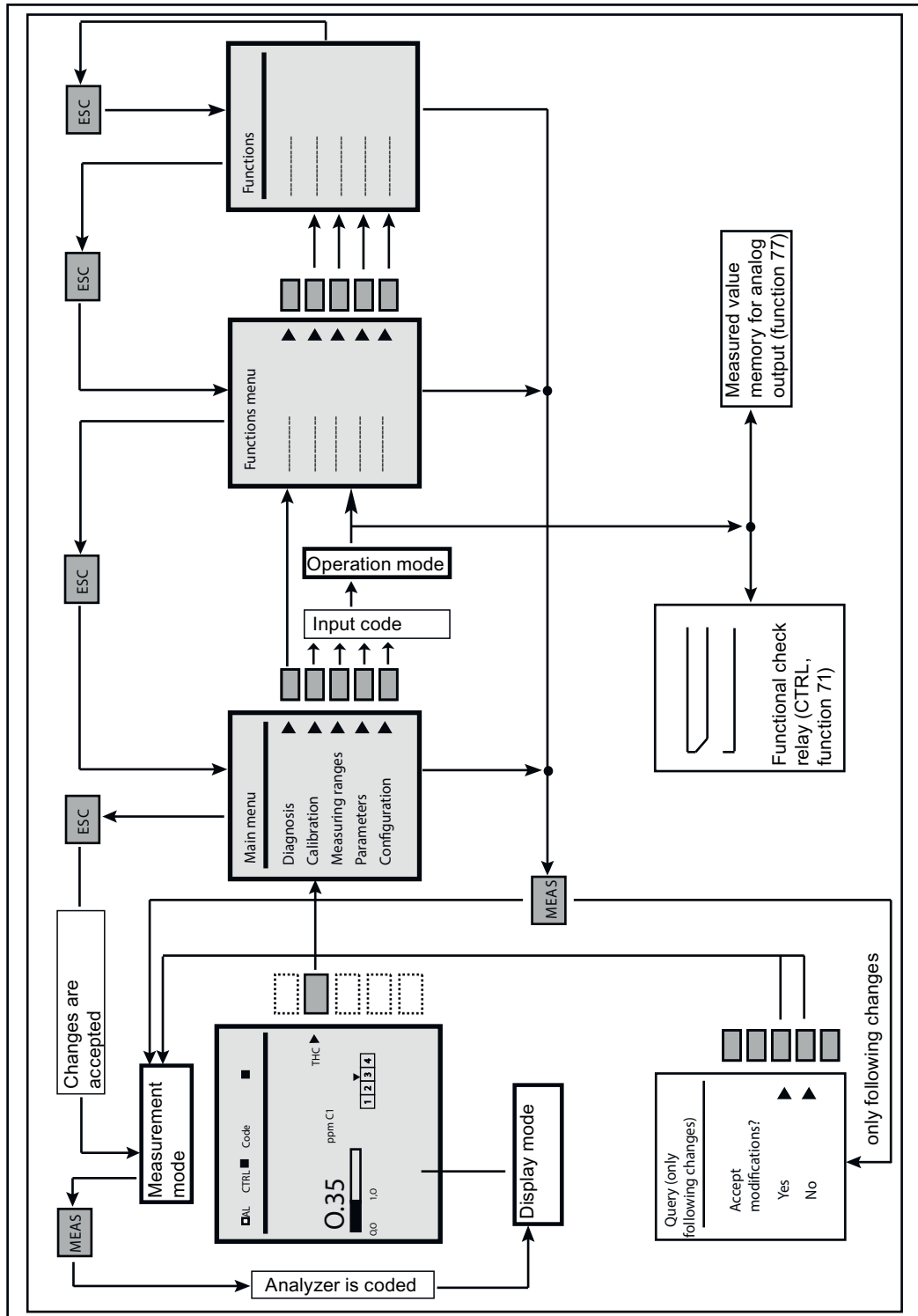

Figure 8-2 Operating sequence with operating modes



## 8.2 Measured value display

"Measured value display" is used in the following to designate the display shown below, which appears in both the "Coded display mode" and "Decoded display mode" operating modes.

### Note

#### Operating status of the device

In the "Measured value display", the current operating status of the channel can be read in the status bar. The "Measured value display" is neither an operating status nor an operating mode, but is simply a display. It must not be confused with the "Measuring" operating state (also "Measuring state") of the device.

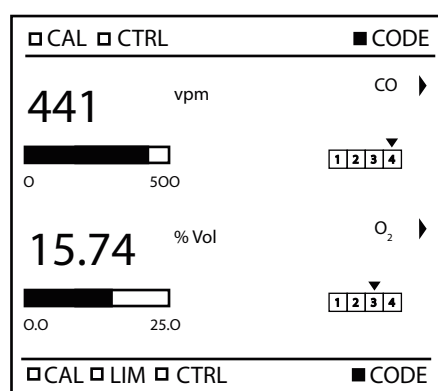

Figure 8-3 Measured value display

## 8.3 Menu control

### 8.3.1 Introduction to the main menu

The device must be in measuring mode. The right side of the display field shows the measured component, which is indicated with "MC" in the following illustrations of the display. A right arrow [▶] appears for it. This arrow indicates a softkey. The main menu can be opened by pressing this softkey.

The main menu consists of the following commands (with the associated code level on the right):

Function group	Code level
Analyzer status	Not coded
Calibration	Code of code level 1
Measuring ranges	Code of code level 1
Parameter	Code of code level 1
Configuration	Code of code level 2

The code of level 1 is factory set to "111", that of level 2 is factory set to "222".

### 8.3.2 Entering a submenu

You can branch to the submenus from the main menu.

Main menu	MC
Analyzer status	▶
Calibration	▶
Measuring ranges	▶
Parameters	▶
Configuration	▶

Figure 8-4 Main menu

If you select a submenu by pressing the associated softkey, the code of the corresponding operation level is queried once (exception: the submenu "Analyzer status" is freely accessible; selecting this does not change the operating mode).

Decoding level 2 also decodes level 1.

By entering a corresponding code, the device switches to the operator control mode, whereby the functional check is activated.

The functional check "CTRL" (shown in the status line of the measured value display) is always activated by the device when an intervention endangers correct measurement, e.g. when the code is entered. If you have configured a corresponding relay with "Functional check" using function 71, the decoding additionally triggers a signaling to the outside via a relay contact. This relay contact then signals every functional check activation, e.g. even the warm-up phases and calibration states of the device.

Decoding also activates the measured value memory, providing you have configured this using function 77.

The coding status of the device can be read in the status line of the measured value display as a symbol "■ CODE" for "coded" or "□ CODE" for "decoded".

### 8.3.3 Returning to display mode

You can use the [MEAS] key to jump back to "Decoded display mode" from any location in "Operator control mode". Any input started is aborted.

Before jumping back, the following query appears:

Return to meas. mode	MC
Accept modifications?	
YES	●
NO	●

Figure 8-5 Query before jumping back

- Press "YES" to accept changes permanently into the working memory of the parameter memory or "NO" to discard the changes. The device then changes to "Decoded display mode".

By pressing the [ESC] brings you back to the most recent function screen. Changes are accepted here without a further query.

#### Coding the device

After jumping back to "Decoded display mode" with [ESC] or [MEAS], if you press [MEAS] again you put the device back into "Coded display mode". Only now is the function check once again deactivated and all states invoked by the decoding are released again.

### 8.3.4 Fast function selection

In order to directly access the desired function when operating frequently from the display mode, a "Power user operation" was created. This allows you to directly access the desired function by entering the function number. This allows you to skip menu levels.

For fast function selection, proceed as follows:

1. Enter the number of the desired function using the number keys.
2. Press the softkey of the component with the arrow ►. If the desired function is protected by a code, you will be asked to enter the code.



## Functions

### 9.1 Overview of operating functions

Die operator function can be categorized into the following three categories:

- **Device-specific functions**  
These act on all channels and components of the device, irrespective of the component of the device via which the function was called.
- **Channel-specific functions**  
These act on all components of the corresponding channel, irrespective of the component of the device via which the function was called. They are grouped in the respective menus or are present only once.
- **Component-specific functions**  
These act on a single measured component and can only be called up via this component.

**OXYMAT 6:**

Since the OXYMAT only measures one component (O<sub>2</sub>), the component-specific functions are to be interpreted there as channel-specific functions.

The functions of the device are listed in the following overview.

Main menu item	Function number	Name of the function	1*	2*	3*
Analyzer status	1	Analyzer configuration		x	
	2	Diagnostic values		x	
	3	Logbook		x	
	4	Display measuring ranges			x
Calibration (Code 1)	20	Zero calibration		x	x
	21	Span calibration			x
	22	Setpoints total			x
	23	Total/single calibration			
	24	AUTOCAL		x	x
	25	Drift values			x
Measuring ranges (Code 1)	40	Select range			x
	41	Define range			x

## Functions

### 9.1 Overview of operating functions

Main menu item	Function number	Name of the function	1*	2*	3*
Parameters (Code 1)	50	Electric time constant			x
	51	Limits			x
	52	On/off configuration		x	x
	53	Status messages		x	
	54	Graphic signal display			x
	55	Select digits			x
	56	LCD contrast	x		
	57	Chopper frequency (only <b>ULTRAMAT 6</b> )		x	
	57	Magnetic field frequency (only <b>OXYMAT 6</b> )		x	
	58	Date/time		x	
	59	Sample selection		x	
	60	Setup logbook		x	
61	Shock compensation (only <b>OXYMAT 6</b> )		x		
Configuration (Code 2)	70	Analog output			x
	71	Relay outputs		x	
	72	Binary inputs		x	
	73	ELAN configuration		x	
	74	Reset		x	
	75	Save data		x	
	76	Suppress fault			x
	77	Store			x
	78	Calibration tolerance			x
	79	Codes program		x	
	80	Analyzer test		x	
	81	Select language		x	
	82	Pressure correction		x	
	83	Interference correction			
	84	Phase adjust			x
	85	Switch valves		x	x
	86	Linear temperature compensation			x
	87	Error On/Off		x	
	88	AK configuration		x	
	89	Heating (only <b>field devices</b> ) PROFIBUS configuration			
90					

1\* Device-specific function

2\* Channel-specific function

3\* Component-specific function

## 9.2 Analyzer status

After selecting the diagnostic functions in the main menu by pressing the first (top) softkey ('Analyzer status'), the following menu screen appears with additional choices.

Analyzer status	MC
1 Analyzer config.	▶
2 Diagnostic values	▶
3 Logbook	▶
4 Display meas. ranges	▶

Figure 9-1 Analyzer status submenu

The analyzer status functions are freely accessible. There is therefore no code query and no change in the operating mode.

The analyzer status submenu offers you various functions for displaying device parameters and stored data.

### 9.2.1 Analyzer configuration (function 1)

When this function is selected, important device manufacturing data can be viewed:

- Firmware No.  
Order No. of the software in the EPROM
- Order No.  
Information on device ordering data (see article number)
- Production No.  
Indication of date of manufacture and device serial number
- Object version  
Indication of the hardware design of the device
- Software version and date  
Indication of the functional scope of the device

### 9.2.2 Diagnostic values (function 2)

The most important diagnostic values may be called using function 2. They may allow conclusions to be drawn for evaluation of errors or setting work.

Examples of diagnostic values

ULTRAMAT 6:

2 Diagnostic values		MC
T [°C]	chamber :	38.5
	heater :	
	display :	46.6
P [hPa]	:	1013
Chopperf. [Hz]	:	13.1
Chopperdif. :-50>		303<
Meas. val. 1	-0.39	vpm
Meas v. 2	1.16	vpm
	...	continue ▶

Figure 9-2 Example for U6 single-channel device

2 ext. Diag. values			MC
Zerores.	Comp. 1 3	Comp. 2 0	
E (φ)	100	611	
U [μV]	20	0.05	
E (φ+90°)	186	532	
φ	30.5°	219.7°	
Minimum	0.00	0.00	
Maximum	100.00	100.00	
Meas.v. 1	5.28	vpm	
Meas.v. 2	1.14	vpm	
	...	continue ▶	

Figure 9-3 Example for U6 dual-channel device

OXYMAT 6:

2 Diagnostic values		O <sub>2</sub>
V	:	1622
E (φ)	:	1482
Meas. value	:	26.795 % Vol
Temperature		
-Bench	:	24.5 °C
-Meas.head	:	36.5 °C
-Display	:	29.8 °C
Pressure	:	1018 hPa
φ	:	13.6 °
Magn.Freq.	:	8.095 Hz

Figure 9-4 Example: OXYMAT 6



### 9.2.3 Logbook (function 3)

In the logbook, all errors which led to a maintenance request (W) or fault message (S) are listed. Section "Messages (Page 207)" contains a list of fault messages and maintenance requests.

The limit alarm (LIM) and functional check (CTRL) are also registered. However, these do not trigger a maintenance request or fault message.

The logbook contains a max. of eight pages, with four messages per page. It works according to the cyclic buffer principle, i.e. when all eight pages (all 32 locations) are occupied, the oldest message is overwritten.

You can delete or block logbook entries (function 60), but you can also switch them off individually (function 87).

---

#### Note

If an error occurs whose error message is switched off with function 87, there is no reaction at any configured interface. This applies to the ELAN interface, the analog output and the relay output.

---

### 9.2.4 Display measuring ranges (function 4)

The measuring ranges defined using function 41 are listed here. However, you cannot carry out any changes in this function.

## 9.3 Calibration

---

#### Note

No calibration is possible during the warm-up phase.

---

After selecting the calibration functions in the main menu by pressing the second softkey ('Calibration'), the following menu screen appears with additional choices.

Calibration	MC
20 Zero calibration	▶
21 Span calibration	▶
22 Setpoints total	▶
23 Total/single cal.	▶
continue	▶

Figure 9-5 Calibration submenu

This menu is protected by the code of code level 1.

You can calibrate the device using the functions available in this menu. If the function you are looking for is not included in this overview, press the fifth softkey "...Continue" to go to other functions.

The device allows you to perform calibration manually or automatically (function 24). The latter is only possible with an add-on board, which contains eight additional digital inputs and eight relay outputs. If the device is equipped with an option board, automatic calibration is **always** activated when the device is switched on. In order to then perform calibration manually or via binary input, the automatic calibration must first be switched off (function 24).

The setpoints for the zero and span adjustment are entered using function 22, the individual and total range calibration with function 23. The drift values can be viewed with function 25.

Following the selection of functions 20 and 21, the required gases must be introduced manually.

### 9.3.1 Calibration of the zero point (function 20)

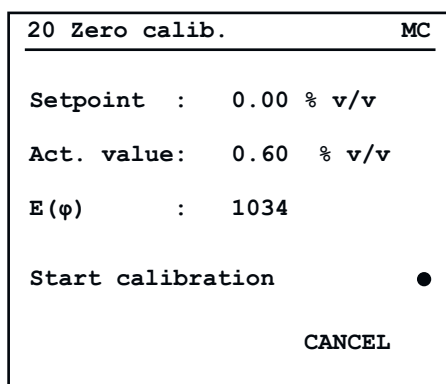

Figure 9-6 Zero calibration

In order to calibrate the zero, the device must be in the "Measure" operating mode. If this is not the case, calibration is not possible. The display will show the message "Analyzer is not measuring".

The zero point is calibrated simultaneously for all measuring ranges, even when the span of the measuring ranges is calibrated individually.

Only initiate calibration when the measured value (actual value) has stabilized after applying the zero gas. Otherwise, the calibration may be imprecise.

If there is a lot of noise or the measured value is unstable over time, increase the time constant before calibrating (function 50).

#### 2R-channels:

The zero points of 2R channels can be calibrated together or separately, depending on the setting made with function 23. The following screen is displayed for separate zero calibration:

20 Zero calib.		MC
Setpoint 1:	0.00 % v/v	
Setpoint 2:	0.00 % v/v	
Act. value 1:	0.60 % v/v	
Act. value 2:	0.55 % v/v	
Start calibration		●
	CANCEL	

Figure 9-7 Separate zero calibration for 2R channels

### 9.3.2 Span calibration (function 21)

A single or total calibration is carried out depending on the setting made with function 23. This function is specific for the component.

#### Single calibration

21 Span calib.		MC
Calibrate MR 1		▶
Calibrate MR 2		▶
Calibrate MR 3		▶
Calibrate MR 4		▶

Figure 9-8 Carry out single calibration

Single calibration is only possible if the "Total calibration" subfunction has been deactivated in function 23.

The display will show then number of measuring ranges that were set using function 41. The function screen above is therefore an example of the single calibration of four measuring ranges.

If you would like to calibrate measuring range 3, for example, press the corresponding softkey.

The setpoint and the current actual value of the selected measuring range then appear in the display.

**Note**

When automatic range switchover is active (function 40), the measured value of the active measuring range is also displayed in the calibration menu. It can be different from the measuring range selected for the calibration.

The measuring range selected for the calibration is always calibrated.

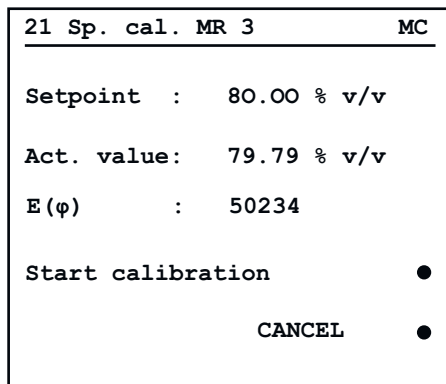

Figure 9-9 Calibrating the measuring range (single calibration)

When the actual value has stabilized, you can initiate the calibration process by pressing the fourth softkey. The actual value is now made to agree with the setpoint.

**Total calibration**

Total calibration is only possible if the "Total calibration" subfunction has been activated using function 23.

With a total calibration, you calibrate all measuring ranges together. Define the "leading" measuring range in function 22. We recommend that you use the largest measuring range for this.

After selecting this function, the display shows the setpoint and the current value of the "leading" measuring range.

21 Sp. cal. all MRs	MC
Setpoint : 100.00 % v/v	
Act. value: 97.79 % v/v	
E(φ) : 50234	
Start calibration	●
CANCEL	●

Figure 9-10 Calibrating the measuring range (total calibration)

When the actual value has stabilized, you can initiate the calibration process by pressing the fourth softkey. The actual value is now made to agree with the setpoint.

---

**Note**

**Measuring accuracy**

With a switching ratio of the spans of more than 1:10, an individual calibration should be carried out for each range to achieve a higher measuring accuracy.

---

### 9.3.3 Calibration via binary input

To trigger a calibration via a binary input, a voltage must be applied for a short-period (approx. 1 s).

Example for a zero calibration: At least two binary inputs (BIs) are required for a calibration:

- The first BI ("Zero gas on" function) is used to start the calibration. A parameterized relay output "Zero gas" becomes active.
- The second BI (function "Zero calibration") is used to complete the calibration and apply the new calibration factors. A parameterized relay output "Zero gas" becomes deactivated.

The device changes from measuring mode to calibration mode during the calibration. If parameterized, this is displayed in the status bar. The individual binary inputs are described in section Binary inputs (function 72) (Page 138). The "Function check" status is also set.

### 9.3.4 Zero/span setpoints (function 22)

22 Setpoints total	MC
Setpoint for zero : 0.00: % v/v	
Setpoint for MR 1 50.00 % v/v	<input type="checkbox"/>
Setpoint for MR 2 60.00 % v/v	<input type="checkbox"/>
Setpoint for MR 3 80.00 % v/v	<input checked="" type="checkbox"/>
Setpoint for MR 4 100.00 % v/v	<input type="checkbox"/>

Figure 9-11 Setting the setpoints

The function display shows the setpoint input with total calibration. The third measuring range is chosen here as the leading measuring range.

With single calibration, there is no choice for the leading measuring range.

### 9.3.5 Calibration setting (function 23)

23 Total/single cal.	MC
Total range calibration	<input type="checkbox"/>

Figure 9-12 Select calibration method

With this function, select between total and single calibration of the measuring ranges.

Total calibration means that you adjust one "leading measuring range" and all other measuring ranges are calibrated using the switching ratio.

If the total calibration is not activated, as shown here on the function display, you must calibrate every measuring range individually.

**2R channels:**

"zero calibration concerted" means that the zero points are calibrated together for the components of the 2R channel, see the following figure. If this function is not activated, the zero points of the two components are calibrated separately.

23 Calibr. settings	MC
Total range calibration	<input type="checkbox"/>
zero calib. concerted	<input checked="" type="checkbox"/>

Figure 9-13 Calibration setting for 2R channels

### 9.3.6 AUTOCAL (function 24)

---

#### Note

You can only make use of automatic calibration (AUTOCAL) if your device contains additional electronics (add-on board). If it does not, a corresponding message will appear on the display when the AUTOCAL function is called.

Automatic calibration can only be started when the device is in the "Measuring" operating state.

---

24 Autocal/-check	MC
Autocal/-check mode	▶
Autocal/-check sequence	▶
Autocal/-check cyclic parameters	▶
Autocal check	▶

Figure 9-14 AUTOCAL function

---

#### Note

The settings for "AUTOCAL/-check..." (subfunctions 1 to 3) are valid both for AUTOCAL (automatic calibration) and for AUTOCAL check (automatic check for adherence to the set calibration tolerances, without calibration).

The settings for "AUTOCAL Check" (4th subfunction) only refer to the check of the calibration tolerances without calibration.

---

**AUTOCAL/Check operating mode**

With this AUTOCAL function, you configure various AUTOCAL operating modes.

The AUTOCAL Check is only for checking the calibrations. As with AUTOCAL, the device executes the sequence configured in subfunction "AUTOCAL/Check sequence". In contrast to AUTOCAL, no new calibrations are performed; only the deviations are checked with respect to selectable calibration tolerances. Exceeding these tolerances leads to the maintenance request **W10 "Autocal check difference"**.

In the event of a fault, Autocal-Check is aborted. At the same time, the fault message **S15 "Calibration aborted"** appears in the logbook.

Autocal / -check mode	MC
Autocal / -check on/off	<input type="checkbox"/>
Start autocal / -check cyclically	<input type="checkbox"/>
Start autocal / -check via binary input	<input type="checkbox"/>
Trigger autocal once	
Abort autocal	

Figure 9-15 AUTOCAL/Check operating modes

**"AUTOCAL/Check on/off":**

In "AUTOCAL off" state (represented with:"□"), the settings of "Start autocal cyclically (parameter)" and "Start autocal via binary input" subfunctions have no effect on the device. "Trigger Autocal once" cannot be selected. A previously set cycle time continues to run, but without triggering automatic calibration.

If the device is equipped with an option board, automatic calibration is **always** activated when the device is switched on. In order to then perform calibration manually or via a binary input, the automatic calibration must first be switched off (parameter '**Autocal-check on/off**' to '**off**').

**"AUTOCAL/Check start cyclically":**

You can activate AUTOCAL to be a regularly repeated cycle if you first set a value for "Time from AUTOCAL to AUTOCAL (cycle time)" using subfunction "AUTOCAL/Check cycle parameter".

**"AUTOCAL/Check start via digital input":**

If you have previously configured a binary input with function 72, you can initiate AUTOCAL or AUTOCAL-check via a binary input.

The "AUTOCAL start via cycle parameter" and "AUTOCAL start via digital input" operating modes can be activated simultaneously in order e.g. to verify a weekly calibration and control this check via a digital input.



### "Trigger AUTOCAL once"

In the "AUTOCAL on" state, you can start an AUTOCAL sequence at any time using the softkey "Trigger AUTOCAL once" providing the device is in the "Measure" operating mode. A sequence initiated this way has no influence on the time cycle of an AUTOCAL, i.e. the cycle time continues to run independent of this.

After the initial trigger, the dot disappears until the process is finished.

### "Abort AUTOCAL"

A running automatic calibration process can be exited at any time using the softkey "Abort AUTOCAL". With this, all calibration data determined up to that point are discarded and the calibration data used before AUTOCAL was started are used further (zero and span).

Canceling has no influence on the time cycle. All valid calibration processes are retained.

## AUTOCAL/-check sequence

The AUTOCAL/-check sequence is configured in this submenu.

Autocal / -check sequence			MC
1.	Zero gas 1 :	1.0:min	●
2.	Zero gas 2	1.1:min	●
3.	Cal. gas 1	1.2:min	●
4.	Cal. gas 2	1.3:min	●
		continue	▶

Figure 9-16 AUTOCAL/-check sequence

A sequence can be composed of up to 12 individual steps.

Besides the supply of one zero gas and up to four calibration gases per component, you can also program purging with sample gas, sample gas intermediate operation, as well as a signaling contact. The signaling contact is only available if you have previously assigned it to a relay output using function 71.

For a single calibration, the number of the calibration gas always corresponds to the measuring range that is being calibrated. For example, when Calibration gas 1 is selected, a calibration is carried out in Measuring range 1, etc. For of a total calibration, the calibration is carried out in the measuring range that corresponds to the selected calibration gas number.

### Intermediate sample gas mode

Sample gas intermediate operation can be necessary if the system may only leave measuring mode for a certain time. If the sum of the required purge times are greater than the permissible downtime, you must return to the measuring mode between the individual calibrations.

**Signaling contact**

Use the signaling contact to initiate an automatic calibration process of a second device, for example, or to signal the beginning or end of an AUTOCAL.

**Relay outputs**

If you have defined relay outputs for the sample gas, zero gas, calibration gases and/or measuring/calibration (function 71), these are used to activate the corresponding external solenoid valves. The same also applies to the signaling contact. The relay signaling contact is displayed as "Signaling contact". This relay is closed for approximately 1 s when the command is executed.

**Example:**

You want to program the following sequence:

1. Zero gas calibration: 15 minutes
2. Calibration with calibration gas 1: 10 minutes
3. Purging with sample gas: 8 minutes
4. Sample gas intermediate operation: 30 minutes
5. Calibration with calibration gas 2: 5 minutes
6. Calibration with calibration gas 3: 8 minutes
7. Calibration with calibration gas 4: 11 minutes
8. Purging with sample gas: 8 minutes
9. Short-term signaling contact in order to be able to start AUTOCAL on another device.

The specified AUTOCAL sequence is shown in the following function displays.

Autocal / -check sequence	MC
1. Zero gas 1 :15.0: min	●
2. Cal. gas 1 10.0 min	●
3. SG purging 8.0 min	●
4. Int.SG mode 30.0 min	●
continue	▶

Figure 9-17 Example of AUTOCAL sequence

Autocal/-check sequence	MC
5. Cal. gas 2 : 5.0: min.	●
6. Cal. gas 3 : 8.0: min.	●
7. Cal. gas 4 :11.0: min.	●
8. Int.SG mode: 8.0: min.	●
continue	▶

Figure 9-18 Example of AUTOCAL sequence

Autocal/-check sequence	MC
9. Sig. cont :I: min.	●
10. **** min.	●
11. **** min.	●
12. **** min.	●
continue	▶

Figure 9-19 Example of AUTOCAL sequence

**List for the AUTOCAL/-check sequence:**

Step	Component
Zero gas 1	Component 1
Zero gas 2	Component 1
Calibration gas 1	Component 1
Calibration gas 2	Component 1
Calibration gas 3	Component 1
Calibration gas 4	Component 1
Flush sample gas	
Intermediate sample gas mode	
Signaling contact	
Zero gas 1b	Component 2
Calibration gas 1b	Component 2
Calibration gas 2b	Component 2
Calibration gas 3b	Component 2
Calibration gas 4b	Component 2

**Note**

The use of zero gas 2 is only required for AUTOCAL in the absorber mode.

**AUTOCAL/Check cycle parameters**

With this subfunction, you can configure various time constants for activating a cyclically repeated AUTOCAL sequence.

```

Autocal/-check cycle      MC
-----
Time from autocal to auto-
cal (cycle time): 0: [h]
Time up to next autocal
                  15 [min]
Carry out span calibration
at any 1st cycle

Total range calibration
Cal. gas 3
    
```

Figure 9-20 AUTOCAL/Check cycle parameters

**"Time from AUTOCAL to AUTOCAL (cycle time)":**

Any setting between 1 and 720 (hours) is accepted by the device.

**"Time to first AUTOCAL" (after the time of setting):**

If you enter "0" here and AUTOCAL is activated with "AUTOCAL on/off" subfunction, the device begins immediately with the AUTOCAL sequence.

**Note**

The clock inside the device also runs when AUTOCAL is deactivated! It starts the first time the device is switched on with the factory-set start time and must be set to the current time using function 58.

**"Carry out span calibration at any nth cycle":**

Here you set the number of cycles after which a calibration with the calibration gas is to be carried out.

If you would like to save on calibration gas, for example, and not calibrate the span along with every AUTOCAL cycle, enter in the line "Carry out scan calibration gas at any : : cycle" an integer > 1. Undesired cycle steps "Calibration gas x" marked in this way are skipped in this case.

**Information in the last two lines**

The information in the last (bottom) lines indicates that specified parameters relate to total calibration with calibration gas for measuring range 3. This measuring range was selected beforehand with function 22.

**Note**

As long as AUTOCAL is activated (AUTOCAL ■), access to functions 20 and 21 is blocked. If you activate these functions anyway, a corresponding message appears on the display.

**Settings for AUTOCAL Check**

The "AUTOCAL Check" subfunction is only used for checking the calibrations.

Similar to "AUTOCAL", sequence set in the "AUTOCAL Sequence" menu is performed. In contrast to "AUTOCAL", no new calibrations are performed; only the deviations are checked with respect to selectable calibration tolerances.

Autocal check	MC
Calib. tolerance at zero in % of smallest MR : 6:	
Calib. tolerance at sens. in % of current MR : 6:	
Start only Autocal check cyclically	<input type="checkbox"/>
Trigger acal check once	<input checked="" type="checkbox"/>
Abort autocal check	<input checked="" type="checkbox"/>

Figure 9-21 AUTOCAL Check

**Functions of the AUTOCAL Check**

In the "AUTOCAL Check" subfunction, enter the desired calibration tolerances to be checked by AUTOCAL Check. Using function 72, you can also select the binary input for "AUTOCAL Check".

When a calibration limit is exceeded, the maintenance request W10 is set, and also, if configured, the relay "Acal Chk Dif".

Both will be reset again after an error-free AUTOCAL Check. W10 is retained in the logbook.

*"When starting via cycle, initiate AUTOCAL Check":*

If this function is activated, the device executes an AUTOCAL Check when AUTOCAL is started via a cycle. In other words, it only checks that the calibration tolerances are observed, but does not carry out a calibration.

**Sequence:**

1. Start the AUTOCAL Check:
  - By means of the softkey "Trigger AUTOCAL Check once" in the subfunction "Acal/Check sequence"
  - Via digital input
  - Via cycle
2. The device executes the sequence as configured in the subfunction "Autocal/Check sequence".

**9.3.7 Drift values (function 25)**

This function shows deviations occurring for the calibrations (and AUTOCAL as well ) (actual value - setpoint) as a sum parameter. All rated zero point and sensitivity calibrations of each range are calculated here for the selected measured component. Every new deviation is added to the existing drift value.

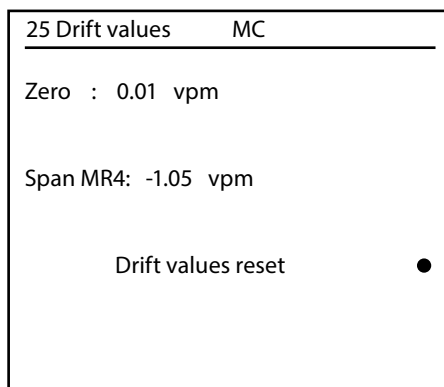

Figure 9-22 Drift values

The display of the drift values for the sensitivity calibration depends on the setting of the calibration method. If total calibration is selected here, only the selected measuring range for the sensitivity calibration is displayed. For single calibration, all measuring ranges can be individually adjusted and can therefore have different drift values, which are shown separately.

The drift values can reset to 0.0 with the 'Reset drift values' instruction. When you reboot the device all measuring ranges have 0.0 as the drift value.

## 9.4 Measuring ranges

After selecting the measuring range functions in the main menu, the following screen appears when the third softkey ("Measuring ranges") is pressed.

Meas. ranges	MC
40 Range selection	▶
41 Define meas. ranges	▶

Figure 9-23 Measuring ranges submenu

The measuring ranges menu contains all functions you need for selecting and setting the measuring ranges.

This menu is protected by the code of code level 1.

### 9.4.1 Select measuring ranges (function 40)

40 Select range	MC
MR1 0.0 - 50.0 % Vo1	<input type="checkbox"/>
MR2 0.0 - 60.0 % Vo1	<input type="checkbox"/>
MR3 0.0 - 80.0 % Vo1	<input type="checkbox"/>
MR4 0.0 - 100.0 % Vo1	<input type="checkbox"/>
Autorange	<input checked="" type="checkbox"/>

Figure 9-24 Select measuring ranges

You can select a fixed measuring range or switch to automatic measuring range switching. All selection options are subject to mutual interlocking.

Automatic measuring range switching is only possible under the following conditions:

- At least two measuring ranges must be available. A measuring range is assumed when the following condition is satisfied: Start-of-scale value  $\neq$  full-scale value
- The spans must become greater
- The measuring ranges must "border on" each other or overlap

**Measuring range types**

The permissible measuring range constellations result which are shown in the figure below:

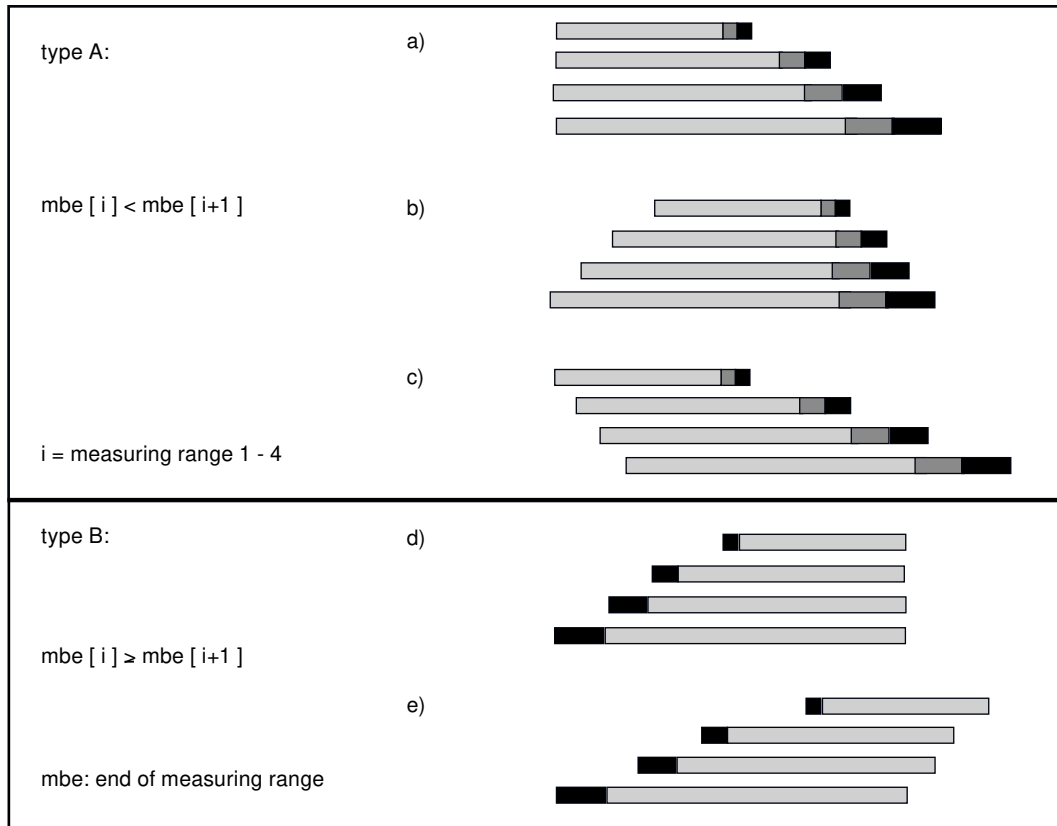
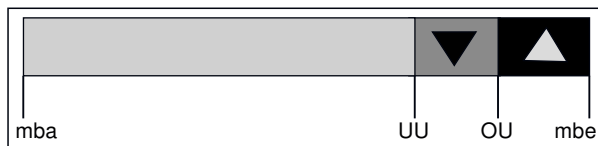

Figure 9-25 Measuring range types

Two measuring range types are distinguished:

**Type A:**

The full-scale value must be smaller than the full-scale value which follows it. The top measuring range limit therefore becomes larger with every measuring range.



- SSV Start-of-scale value
- FSV Full-of-scale value
- LS Low switchover point: select smaller measuring range
- HS High switchover point: select larger measuring range

Figure 9-26 Measuring range type A

The following applies to measuring range switching:



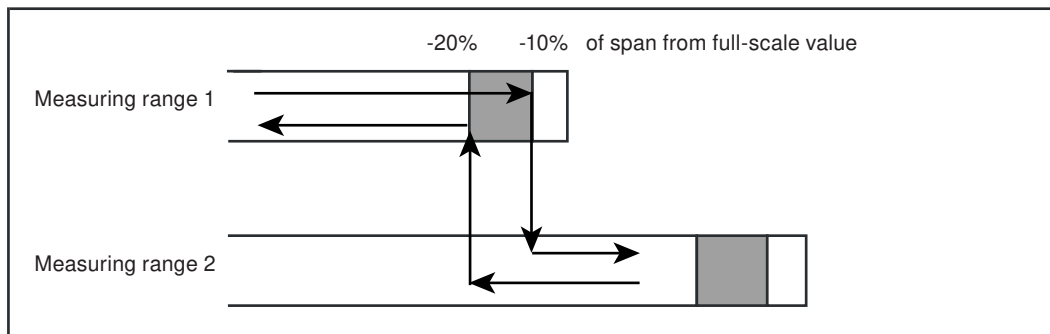
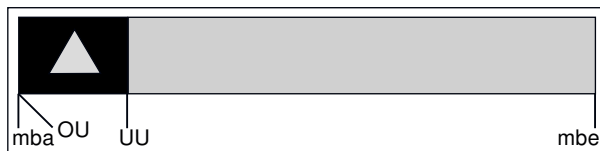

Figure 9-27 Measuring range switching, type A

When the upper switchover point (OU) is exceeded, the next larger measuring range available is selected. If the lower switchover point (UU) of the next smaller measuring range available is fallen below, this is selected. The UU lies at 80 % (HystS) of the measuring range. The OU lies at 90 % (HystE) of the measuring range.

**Type B:**

The full-scale value must be greater than or equal to the full-scale value following it. Since the measuring spans must simultaneously become larger, the start-of-scale values of the following measuring ranges become continuously smaller.



- SSV Start-of-scale value
- FSV Full-of-scale value
- LS Low switchover point: select smaller measuring range
- HS High switchover point: select larger measuring range

Figure 9-28 Measuring range type B

The following applies to measuring range switching:

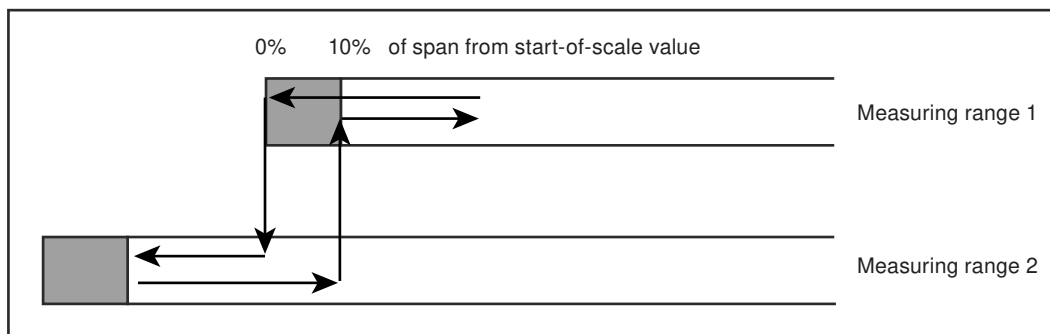

Figure 9-29 Measuring range switching, type B

When the upper switchover point (OU) is fallen below, the next larger measuring range available is selected. If the lower switchover point (UU) of the next smaller measuring range available is exceeded, this is selected.

The UU lies at 10 % (100 % - HystE) of the measuring range. The OU lies at the start of the measuring range (mba).

### 9.4.2 Define measuring ranges (function 41)

41 Define range			MC
MR No.	Start	End value	
1:	0.00:	50.00 % v/v	
2	0.00	60.00 % v/v	
3	0.00	80.00 % v/v	
4	0.00	100.00 % v/v	

Figure 9-30 Define measuring ranges

You can define a maximum of four measuring ranges whose start-of-scale values are allocated to the bottom value (0/ 2/ 4 mA) and whose full-scale values are allocated to the top value (20 mA) of the analog output.

If the message "Measuring ranges not plausible!" appears, this means that autoranging is not possible.

If the start-of-scale and full-scale values are "0", the measuring range is deactivated.

---

**Note**

If a start-of-scale value other than "0" is defined, you need to read the section "Preparations for startup - measuring ranges with suppressed zero point".

---

## 9.5 Parameters

Parameters	MC
50 El. time constants	▶
51 Limits	▶
52 On/off configuration	▶
53 Status messages	▶
continue	▶

Figure 9-31 Parameters submenu

The parameters menu contains all functions which are required for configuring the device.

After selecting the parameter functions in the main menu by pressing the fourth softkey ("Parameters"), the menu screen for the selection of parameter functions 50 to 53 appears. Pressing the fifth softkey "...Continue" brings you to additional parameter functions.

This menu is protected by the code of code level 1.

### 9.5.1 Electric time constants (function 50)

50 Electr. time con	MC
Effective bandwidth in % of smallest MR :	6.0:%
Time constant within bandwidth $t_i$ :	10.0:s
Time constant outside bandwidth $t_a$ :	1.0:s
Actual measured value:	0.00 % v/v

Figure 9-32 Electric time constants

With this function, you set various time constants, which reduce the underlying noise in an message value signal. The noise reduction is approximately equivalent to a low-pass filter with the corresponding time constant.

The time constant " $t_i$ " acts within an configurable effective interval which is defined in % of the smallest span. It attenuates small changes in the measurement (e.g. noise) on the one hand, but becomes ineffective immediately when the measured value exceeds the effective interval. In this case, the outer time constant " $t_a$ " attenuates the measured value.

You can configure values up to 100% for the effective interval, and values up to 300 s for the time constants " $t_i$ " and " $t_a$ ". By cleverly combining these three parameters, you can achieve a low display delay (90 % time) despite high noise suppression.

The effect on the configured attenuation parameters can be observed in the bottom line. The "live" measured value is displayed here.

### 9.5.2 Limits (function 51)

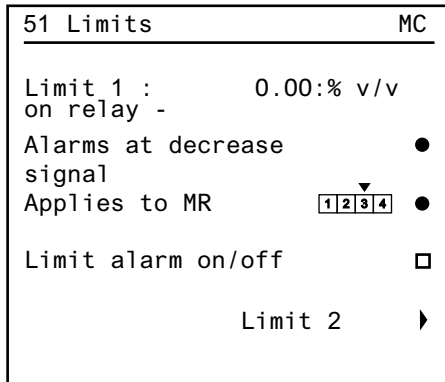

Figure 9-33 Limits

The device monitors up to four limits for every measured component, and these limits can be assigned to the measuring ranges as desired. Each limit can be allocated to any relay using function 71. If this was not configured, the "--" indicator appears in the limit screen.

You can only configure positive limits up to 100%.

*"Alarms at decrease signal":*

Here you select whether a limit alarm is to be switched if the entered limit is exceeded or fallen short of.

*"Applies to measuring range...":*

Here, you allocate the limit to the desired measuring range(s) by pressing the third softkey several times. When you do so, the pointers move over the measuring range numbers and indicate the ranges in which the limit monitor is to be active. The menu screen shown here is for measuring range 3.

*"Limit alarm":*

The limit alarm function of every limit can be switched off with this function, and it can also be switched off individually using function 52.

The limit alarm function of the device is not active during the warm-up phase of the device or the calibration phase. After pressing the fifth softkey ("continue"), the program jumps to the next limit value screen.

#### Resetting the limit alarm

If the limit relay is triggered, this state is obtained even when the measured value goes back to the permissible range. The response of a limit relay is registered in the logbook (function

3). As soon as the cause of the limit alarm has been eliminated, the limit relay can be reset as follows:

- Manually through function 51 and/or 52 or
- Via binary input (acknowledgment).

You can change to the next limit using the fifth softkey ("*Limit...*").

### 9.5.3 On/off functions (function 52)

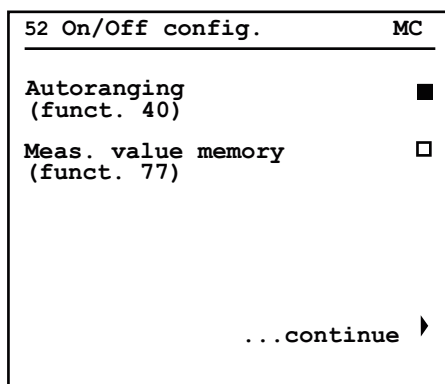

Figure 9-34 On/off functions

With this function, you can easily switch other functions on/off, for example, the ones listed in this function screen.

Thanks to this simplified operation, these functions do not have the longer paths through various menus and submenus. For better orientation, the function numbers have also been specified. In each of the callable screens, there is the possibility to switch four functions on and off.

Activated functions are marked by "■", deactivated ones by "□". Using the fifth softkey ("...continue"), jump to the next function screen with further functions.

Channel-specific on/off functions (e.g. check sample gas flow) can only be called up via the first component of a channel

Function 52 can be used to switch the following functions on and switch off:

Table 9-1 Functions switched on/off by function 52

Description	Fct. no.	Remarks	1*	2*	3*
Total calibration	23				x
Automatic calibration	24	Only with supplementary electronics		x	
Autoranging	40				x
Limit monitoring 1	51				x
Limit monitoring 2	51				x
Limit monitoring 3	51				x

Description	Fct. no.	Remarks	1*	2*	3*
Limit monitoring 4	51				x
Suppression of negative measured values	55		x		
Blocking of the logbook	60			x	
Suppression of output of negative measured values	70				x
Fault / WA / FCTRL acc. to NAMUR	72			x	
Measured-value memory	77				x
Signal tolerance violation	78				x
Additional temperature compensation of the zero point	86				x
Additional temperature compensation of span	86				x
Check sample gas flow		Only for devices with hoses			
Check reference gas flow		Only for devices with hoses or for <b>ULTRAMAT</b> with reduced flow-type reference gas side		x	
Measuring head heating				x	
Automatic setting of AUTOCAL for PROFIBUS		When a PROFIBUS option card is installed, the following operating modes of AUTOCAL (function 24) are set when the device is restarted: <ul style="list-style-type: none"> <li>'AUTOCAL/-check' to 'ON'</li> <li>'Start cyclically' and 'Start via binary input' to 'OFF'</li> </ul>		x	
Monitoring operating pause		After an operating pause of 30 minutes, the analyzer is set to the MEASURING state. All unsaved changes are discarded.			

1\* Device-specific function

2\* Channel-specific function

3\* Component-specific function

In addition to the functions listed in the table above, function 52 can also be used to activate other service functions. These are restricted to service engineers and are only visible when the service code is entered (code level 3).

### 9.5.4 Status messages (function 53)

53 Status messages	MC
Display automat. calibration [CAL]	■
Display stored value [STO]	□
Display limit [LIM]	□
Display autorange [AR]	□
Display control function [CTRL]	■

Figure 9-35 Status messages

With this function, you can configure the status message display in the status line of the measured value display. You can display a maximum of four different status messages. The message CODE ■/□ provides information on the current operating mode ("Coded display mode"/"Decoded display mode") and is therefore always displayed.

The device activates the functional check (softkey 5 in the function display) when it determines that the measured value was influenced.

This is the case:

- If the device is not in the measuring state (for example, during the warm-up phase, calibration)
- After entry of a code (i.e. switch to "Operator control mode")
- During the operation via an interface (REMOTE mode)

Table 9-2 Status messages

Status	What appears in the display depends on functions 52 and 53			
	Fct. 53 "□"	Fct. 52 "□" Fct. 53 "■"	Fct. 52 "■" Fct. 53 "■"	
Calibration: CAL	None	CAL	□ CAL	■ CAL; calibration running (also in Autocal)
Measured value memory: STO	None	STO	□ STO	■ STO; analog output applied to memory (see function 77)
Limit: LIM	None	LIM	□ LIM	■ LIM; limit has been violated (see function 51)
Automatic measuring range switching: AR	None	AR	□ AR	■ AR; measuring range switching (actively possible), see function 40
Functional check: CTRL	None	□ CTRL or ■ CTRL (functional check cannot be switched off using function 52)	□ CTRL	■ CTRL; device is not in "Measure" state or in "Operator control mode" or "Remote" mode

Alternately to the specified status messages, the following messages can be displayed in the status bar:

- A fault currently pending in the device: "Maintenance request" and/or "Fault"
- An activated measuring protection: "Measuring protection switched on" (see also function 72)
- During operation via the ELAN interface: "Remote" with display of the device state.

### 9.5.5 Graphical representation of measured values (function 54)

With this function, you can follow the trend of the measured values for the last ten minutes or 24 hours on the display.

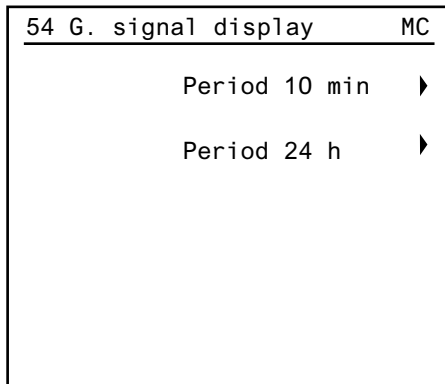

Figure 9-36 Graphical measured value representation

Select the desired time period with softkey 1 or 2.

The device now graphs the measured value vs. time:

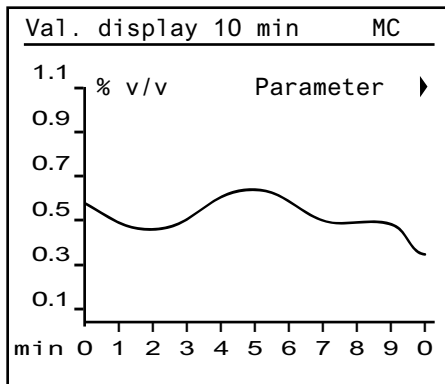

Figure 9-37 Measured value trend

The current measured value is on the time axis at the left at t = 0.

Select softkey 1 "Parameters".

Here, assign a certain measuring range to the measured value axis:



Meas. value disp. par.	MC
Optimum meas. val. dis.	<input checked="" type="checkbox"/>
Range 1	<input type="checkbox"/>
Range 2	<input type="checkbox"/>
Range 3	<input type="checkbox"/>
Range 4	<input type="checkbox"/>

Figure 9-38 Parameters for measured value representation

Instead, select "*Optimum measured value display*". This way the software automatically performs a scaling of the measured value axis. The device adapts the scale to the measured value scatter.

### 9.5.6 Measured value display (function 55)

With this function, you can configure the display of measured values.

55 Select digits	MC
Suppress negative measured values	<input type="checkbox"/>
Automatic	<input type="checkbox"/>
Total digits 5	<input checked="" type="checkbox"/>
Digits after 3 decimal point	<input checked="" type="checkbox"/>
The decimal point counts as a digit	

Figure 9-39 Configuring the measured value display

You have the following options for this:

- With softkey 1, you suppress the display of negative measured values.
- With softkey 2 "Automatic", you can activate the automatic display of the measured value with 5 digits. The number of decimal places depends on the size of the measured value.
- With the softkeys 3 and 4, you can choose the total number of digits and the maximum number of decimal places.

Note that a maximum of five digits can be displayed (decimal point also counts as one digit).

### 9.5.7 LCD contrast (function 56)

With this function, you can make the display contrast brighter or darker.

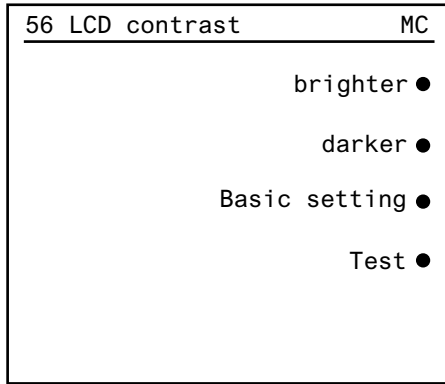

Figure 9-40 Setting the LCD contrast

If the contrast is misadjusted, you can restore the factory settings using the third softkey "Basic settings".

With the fourth softkey "Test", you can carry out an LCD test. Various test screens are then displayed in succession.

From "Coded/decoded display mode", you can restore the basic setting by entering [8] [8] [8] [8] [ENTER].

### 9.5.8 Frequency setting (function 57)

With this function you configure the frequency values. These are device dependent as follows:

- **ULTRAMAT 6:** Chopper frequency
- **OXYMAT 6:** Magnetic field frequency

<b>NOTICE</b>
<b>Malfunction</b>
To prevent malfunctions perform a zero and span calibration after each frequency change.

When an ULTRAMAT 6 is combined with an OXYMAT 6, note that the alternating magnetic fields of the OXYMAT 6 can be coupled into the signal flow of the ULTRAMAT 6. This may cause oscillations to occur at the analog output of the ULTRAMAT 6.

If the ratio between chopper frequency and magnetic field frequency is 1.618, no oscillations occur. This has been taken into account in the factory-set frequencies.

### 9.5.8.1 Chopper frequency (function 57)

You can use this function to set the chopper frequency of the **ULTRAMAT 6**.

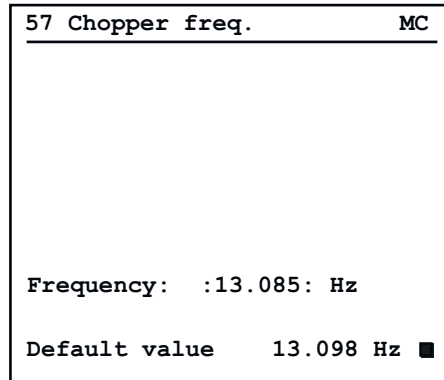

Figure 9-41 Chopper frequency for ULTRAMAT 6

The chopper frequency is set to the following values at the factory:

- First channel: 13.098 Hz
- Second channel (if it exists): 11.201 Hz.

A change in the permissible range of 10 to 15 Hz becomes necessary if an interfering frequency (caused, for example, by vibrations) is superimposed on the measured signal. The output signal then shows low frequency oscillations. Each change of the chopper frequency on the ULTRAMAT 6 also results in a change of the phase position. Therefore a phase adjustment is necessary after each change of the chopper frequency (function 84).

### 9.5.8.2 Magnetic field frequency (function 57)

You can use this function to set the magnetic field frequency of the **OXYMAT 6** magnetic field.

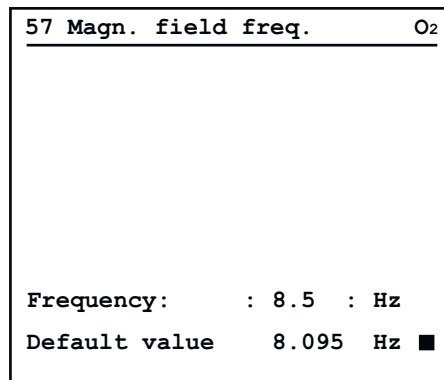

Figure 9-42 Magnetic field frequency for OXYMAT 6

By setting the magnetic field frequency you can, for example, minimize vibration-related frequency overlays (oscillations) at the analog output, or even eliminate them in the ideal case.

To do this, the desired frequency value must be entered in the "Frequency" input field after calling function 57. The permissible values for this lie between 7 and 11 Hz.

If the change to a specific frequency does not have the desired effect, the setting should be tried with other frequencies.

After each change of the magnetic field frequency, a phase adjustment is required (function 84).

Pressing the fifth softkey resets clock frequency back to the factory default of 8.095 Hz.

### 9.5.9 Date/time (function 58)

With this function, you can set the date and time.

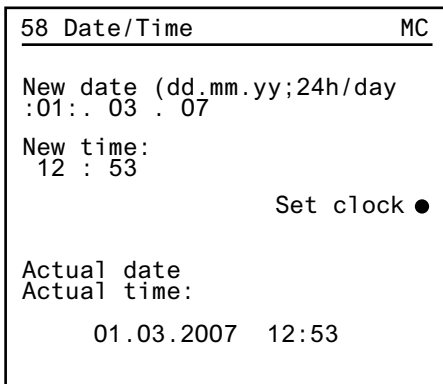

Figure 9-43 Setting the date/time

The device features a system clock that is not buffered against mains failure (no a real-time clock). When starting the device, the clock starts with the date 1.1.1995.

When the function is called, the cursor is placed at the first place of the date display. Enter the new settings in the order: day, month, year. By pressing [ENTER], jump to the next input field. With a 24-hour based system (hours, minutes), set the time in the same way.

---

#### Note

When the device is switched off, the clock stops and is not updated.

---

The settings are especially important for troubleshooting. Errors which are always stored in the logbook (function 60) can be allocated more easily with the help of the date and time.

Press the third softkey "Set clock" in order to accept the set data. These then appear at the bottom edge of the display.

With multi-channel devices, each channel has its own system clock.

### 9.5.10 Measuring point switching (function 59)

With this function, you can assign the device up to six measuring points, which are switched automatically at the expiration of a configured period.

59 Sample selection		MC
M. pt. 1	Rel. 2 : 45: min	
M. pt. 2	Rel. 1 20 min	
-----	----- 0 min	
-----	----- 0 min	
-----	----- 0 min	
-----	----- 0 min	
M. p. switching on/off		<input type="checkbox"/>

Figure 9-44 Measuring point switching

The condition is that you configured the measuring point relay beforehand using function 71 "Relay outputs", which then actuates the corresponding solenoid valves.

Every measuring point relay is also allocated a time period, which you can enter in the respective input field. Values between 0 and 60 (minutes) are possible for this input.

Press the fifth softkey to activate/deactivate the measuring point switching.

You can allocate a signal relay to each measuring point relay. This allows measuring point identification separate from the measuring point relay. You also use function 71 to configure the signal relay.

### 9.5.11 Logbook settings (function 60)

With this function, you delete or block logbook entries.

60 Setup logbook		MC
Clear logbook ●		
Lock logbook □		

Figure 9-45 Configuring the logbook

Status messages such as maintenance requests or faults cannot be suppressed by "blocking". They still appear, despite the blocked logbook.

### 9.5.12 Shock compensation (function 61)

You can use this function to set the vibration compensation of the **OXYMAT 6**.

61 Shock comp.	O <sub>2</sub>
Amplification of the shock compensation in % : 30.8 :	
Meas.val.: 36.3 % vol	
autom. search	●
cancel autom. search	●

Figure 9-46 Vibration compensation

The second microflow sensor positioned in the compensation circuit measures any vibration signals that occur, which can also be superimposed on the measured signal. By subtracting the two signals, the pure measured signal is obtained in the ideal case. This way the device can be adjusted to the circumstances of the place of installation.

During the manual or automatic determination, zero gas must be passed through the analyzer

- Manual determination means: The amplification of the compensation circuit can be configured manually in the range of 0 to 100% of the amplification of the measuring circuit.
- Automatic determination means: The device autonomously searches for the optimum amplification for the compensation circuit. This process can take up to 6 minutes. The measured value varies during this time.
- If no vibrations occur at the place of installation of the device, the compensation circuit should be switched off since it represents an additional noise source. This is done by entering the value '0.0' as the amplification factor.

## 9.6 Configuration

This menu contains all functions required for configuring the device.

Configuration	MC
70 Analog output	▶
71 Relay outputs	▶
72 Binary inputs	▶
73 ELAN configuration	▶
	continue ▶

Figure 9-47 Configuration submenu

All functions of this menu are only accessible via the code of level 2.

Press the fifth softkey ("...continue") to branch to further configuration functions.

### 9.6.1 Analog output (function 70)

With this function, you can configure the analog output.

70 Analog output	MC
4 - 20 mA	<input checked="" type="radio"/>
Output inverted	<input type="checkbox"/>
Suppress negative measured values	<input type="checkbox"/>

Figure 9-48 Configuring the analog output

With softkey 1, define the start-of-scale value of the measuring range. The following settings (see also table "Configurations of the analog output") are possible:

- 0 – 20 mA
- 2 – 20 mA
- 4 – 20 mA
- NAMUR/4 – 20 mA (with limit at 3.8 mA).

You can invert the analog output with softkey 2: e.g. 0 ... 20 % O<sub>2</sub> ≡ 0 ... 20 mA → 0 ... 20 % O<sub>2</sub> ≡ 20 ... 0 mA

With softkey 3, you can suppress the negative measured values. If a negative value has an unfavorable effect on further processing, the negative measured values at the analog output can be limited to 0 (or 2/4/4 (NAMUR) mA) when this function is activated. The display continues to show the actual measured value.

Table 9-3 Configurations of the analog output

Defined analog output / mA	Measuring range limit in normal operation		Measuring range limit in case of fault/ CTRL	
	Start-of-scale value / mA	Full-scale value / mA	Start-of-scale value / mA	Full-scale value / mA
0 – 20	-1	21	0	21
2 – 20	1	21	2	21
4 – 20	2	21	4	21
4 – 20 (NAMUR)	3.8	20.5	3	21.5

**Note**

If the electronics is defective, it is possible that the analog output may get stuck at approx. -1 mA or approx. +24 mA.

**9.6.2 Relay outputs (function 71)**

With this function, you can assign each relay functions listed in the table "Relay outputs (possible functions)", whereby you may only assign each function once. In other words, for example, "Fault" may not be assigned to two relays at the same time.

**Note**

**Changing the configuration**

Every change to the configuration of the relay outputs should always be saved in the user data memory by means of function 75.

If you neglect to do this, there is a danger that a previous (unwanted) configuration will be loaded by "Load user data" (function 75).



71 Relay outputs		MC
R 1	Fault	●
R 2	Maint. req.	●
R 3	Funct. cont.	●
R 4	not used	●
	continue	▶

Figure 9-49 Assigning the relays

There are six freely configurable relays included in the standard equipment whose switchable output contacts (max. 24 V/1 A) can be used for signaling, actuating valves, etc.

If these six relays are insufficient, you can retrofit additional electronics with eight further relays (add-on board).

The connection assignments for the individual relays in the zero-current state can be found in the routing assignments "Motherboard pin assignments".

Press the fifth softkey ("...continue"), to access the next function screen, thus branching to further relays.

Table 9-4 Relay outputs (possible functions)

Function	Relay is passive when	Relay conducts current	Remark
Not assigned			Relay is permanently passive (zero current)
Fault	Fault		Also shown in the status line of the measured value display
Maintenance request	Maintenance request		Also shown in the status line of the measured value display
Calibration		Calibration running	For identification purposes
Measuring range 1 to 4; (1b to 4b)*		Measuring range 1 to 4 on	Measuring range identification
Limit 1 to 4; (1b to 4b)*	Limit 1 (to 4b) has triggered		Limit monitoring
Functional check (CTRL)	Function check active		Signal when: <ul style="list-style-type: none"> <li>● Device is decoded,</li> <li>● Warm-up phase (approx. 30 min),</li> <li>● Calibration running (Autocal)</li> <li>● Remote (operation via interface)</li> </ul>
Sample gas		Supply of sample gas	Valve actuation for Autocal
Zero gas 1, 1b*		Supply of zero gas	
Zero gas 2		Supply of zero gas	Only required for AUTOCAL in absorber mode

Function	Relay is passive when	Relay conducts current	Remark
Calibration gas 1 to 4		Supply of calibration gas	Control of valves for AUTOCAL
Measuring point 1 to 6		Measuring point 1 to 6 selected	For taking a gas sample via solenoid valves at various measuring points
Measuring point signal 1 to 6		Measuring point 1 to 6 selected	For identifying the measuring point (runs parallel to measuring point)
Signaling contact		When there's a signal, the relay conducts current for a short time	e.g. in the case of AUTOCAL: actuation of a second device
Sample gas flow		Sample gas flow too low	For identification purposes
Reference gas pressure		Reference gas pressure too low	For identification purposes
Heating		Heating ready for operation	For information, only applies to the heating of the gas path
AUTOCAL check difference	AUTOCAL difference too large (function 24)		

\* 1b ... 4b for 2nd component for 2R channels

**Note**

If the clock generation of the process electronics is faulty, the relay outputs may take on an undefined state.

### 9.6.3 Binary inputs (function 72)

#### Digital input functions

Six floating digital inputs are included in the standard equipment ("0" = 0 V [0 to 4.5 V]; "1" = 24 V [13 to 33 V]).

If these six inputs are insufficient, you can add eight more binary inputs through supplementary electronics (option board).

**Note**

**Saving changes**

Make sure you save every change made to the configuration of the binary inputs in the user data memory using function 75. If you neglect to do this, there is a danger that a previous (unwanted) configuration will be loaded by "Load user data" (function 75).

72 Binary inputs	MC
Fault/Maint.r/CTRL NAMUR	<input type="checkbox"/>
Binary inputs define	▶

Figure 9-50 Digital input function

The operation of the digital inputs are defined with softkey 1. If you activate the "NAMUR" ("■") operating mode, the digital inputs behave as in table "Digital input activation functions" marked with "N".

If you deactivate the "NAMUR" ("□") operating mode, the digital inputs behave compatibly with the software outputs of the older version V 4.3.0 (in the table "Digital input activation functions" marked with "X").

Select softkey 2. The following function screen appears on the display.

72 Binary inputs	MC
D 1 Autocal Check	●
D 2 Vacant	●
D 3 Vacant	●
D 4 Vacant	●
continue	▶

Figure 9-51 Define digital inputs

Assign one of the activation functions listed below to each input as you like, whereby every function may only be assigned once.

The pin assignment for the individual inputs can be found in the section "Electrical connection".

No digital input has been preassigned in the factory.

Up to four digital inputs can be configured in a menu screen. Press the fifth softkey ("...continue"), to access the next function screen, thus branching to further digital inputs.

Table 9-5 Digital input activation functions

Function	Necessary activation voltage			Remark / effect
	0 V	24 V	24 V pulse (min. 1 s)	
Not assigned				No effect when activated
External fault 1 to 7	N	X		e.g. due to: <ul style="list-style-type: none"> <li>• Signal from a gas preparation system:                             <ul style="list-style-type: none"> <li>– Condensate overflow</li> <li>– Gas cooler fault</li> </ul> </li> </ul> see also section 'Maintenance requests and fault messages'
External maintenance request 1 to 7	N	X		
Deleting the logbook entries			N, X	After deletion, the device is restored to the initial state. If the cause of a fault or maintenance request is not eliminated, the corresponding message reappears in the logbook.
Function check (CTRL) 1 to 4	N	X		The relay under function 71 must be configured for function check if, for example, the function check is to be set for a second device as well.
Start AUTOCAL			N, X	Note: Effective control is only possible in the "Measuring" operating state. AUTOCAL must be configured (functions 23, 24 and 25).
Measuring range on (1 to 4, 1b to 4b)			N, X	For measuring range switching Note: Automatic measuring range switching (function 40) must be switched off

Function	Necessary activation voltage			Remark / effect
	0 V	24 V	24 V pulse (min. 1 s)	
Zero gas on (1, 1b)			N, X	When controlled, a calibration of the zero point is started. Note: Note: Effective control is only possible in the "Measuring" operating state. The relay function under 71 must be set to zero gas and the corresponding valves must be connected.
Calibration gas on (1, 1b)				When controlled, a calibration of the span is started. For a total range calibration, the calibration gas is selected in function 22. In case of a single range calibration, the calibration gas is determined by the measuring range active at the time the input is controlled. Note: Effective control is only possible in the "Measuring" operating state. The relay must be set to a calibration gas under function 71 and the corresponding valves must be connected.
Sample gas on (1, 1b)				When controlled, a running zero point or span calibration is aborted. Note: Effective control is only possible during zero point or span calibration. The relay must be set to zero gas under function 71 and the corresponding valves must be connected.
Zero calibration (1, 1b)			N, X	When controlled, the new calibration factors are determined and the calibration completed. See also Calibration via binary input (Page 109)
Span calibration (1, 1b)				
Autorange			N, X	Activate "Automatic measuring range switching"
Autocal check			N, X	Note: Effective control is only possible in the "Measuring" operating state. Start AUTOCAL check (function 24)
Measuring protection		N, X		It is possible to define a digital input "Measuring protection" which has the following effect: If the device is in the "Measure" operating mode (functional check deactivated), it remains in this state, i.e.: <ul style="list-style-type: none"> <li>The device can no longer be decoded.</li> <li>The device can no longer be set to "Remote".</li> </ul> The message "Measuring protection activated" appears in the status line of the measured value display.

### 9.6.4 ELAN configuration (function 73)

With this function, you set the parameters for an ELAN network.

73 ELAN config.	MC
Channel address	01 ●
Measured value telegram:	off ●
ELAN tag	:OXULTRA ●

Figure 9-52 Configuring ELAN

**Channel address:**

Set the channel address for the device here. Addresses from 1 to 12 can be set. In an ELAN network, each address may only be used once.

For 2R channels (ULTRAMAT 6), the same settings apply to both components (in particular the same channel number).

**Measured value telegrams on/off:**

Here you can switch the cyclic, independent transmission of measured values on or off every 500 ms.

---

**Note**

**Independent sending of measured values**

If you have set up your own communication control system, this option offers a simple way of checking an ELAN telegram. In order to avoid unnecessarily loading the device and the ELAN network, however, the function should only be switched on as needed!

---

**ELAN tag:**

Display of the tag assigned to the device in the ELAN network.

---

**Note**

For additional details on ELAN, refer to the ELAN interface description (article number: C79000-B5200-C176 German, C79000-B5276-C176 English).

---

### 9.6.5 Reset (function 74)

With this function, you can carry out a warm restart.

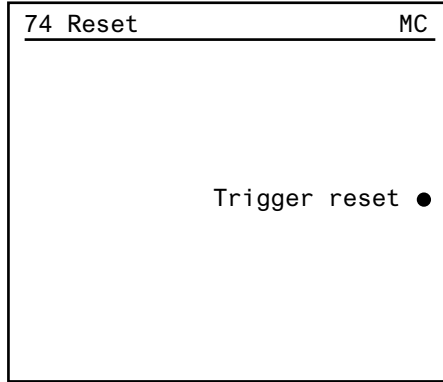

Figure 9-53 Carrying out a reset

When this function is called, the channel executes a restart and then changes to the "Warm-up phase" operating state, which activates the function check at the same time. The device is only completely ready for operation again after successfully running through this phase.

### 9.6.6 Save, load data (function 75)

This function is used to exchange the data records of your working area.

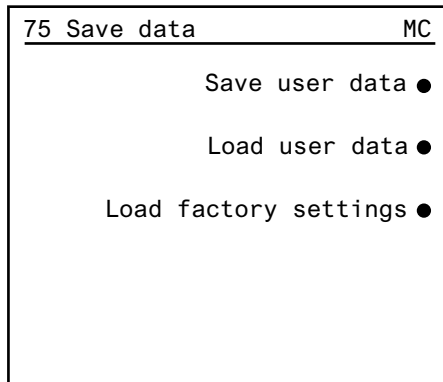

Figure 9-54 User data memory

Press the softkey 1 "Save user data" e.g. after the system has been successfully commissioned. All individual settings are then saved.

Press the softkey 2 "Load user data", to load the last user data saved.

These functions are important when the device is undergoing repairs or maintenance work, or, for example, if new parameter settings are to be tested.

Press softkey 3 to restore the factory settings.

A confirmation query is set up in this function. In order to actually load the respective data in the memory, you must confirm with "yes". If you select "no", this is canceled.

**Note**

Note that all previous settings are lost with "Load user data" and "Load factory data".

The following figure shows an overview of the interaction between the various memory modules.

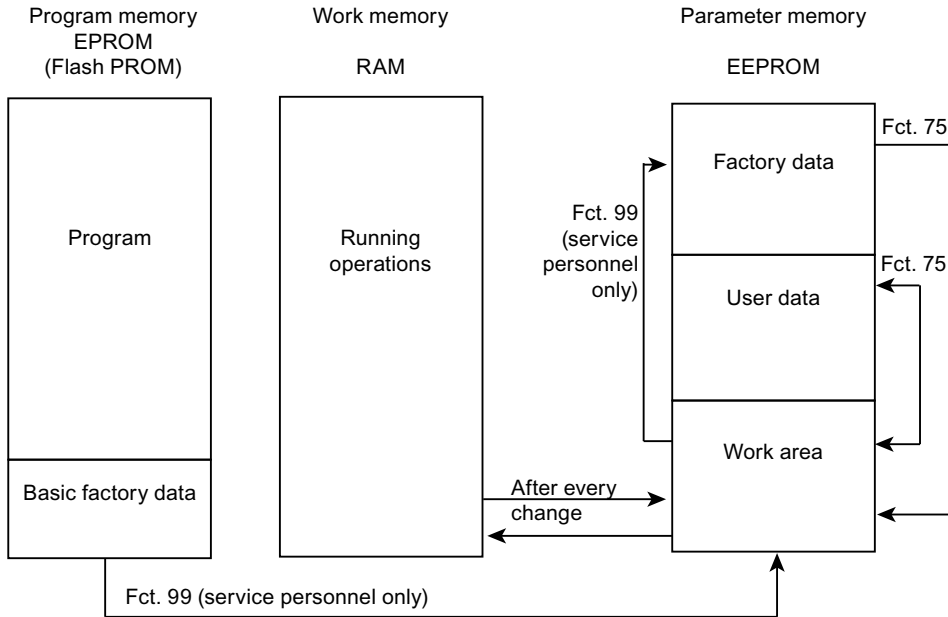

Figure 9-55 Memory modules

**9.6.7 Suppression of short noise signals (function 76)**

With function 76, you can eliminate undesired spikes which exceed a configurable threshold.

76 Suppress fault.	MC
Suppress noise signals with a duration of up to : 0.0: s	
Level in % of smallest MR:	12.0 %

Figure 9-56 Suppressing noise



Spikes are created by electromagnetic interferences or sometimes by mechanical shocks. These noise signals can be suppressed by entering a "blanking time" of 0 to 5 s. The entered time has the effect that the last measured value before the spike occurred is displayed so that the measured result is not influenced.

Times can be entered in steps of 0.1 s.

Under "*Level in % of smallest MR*", enter the threshold value in % of the smallest measuring range above which the noise signals are to be suppressed.

---

#### Note

If a change in concentration directly follows a noise signal, this may be displayed after a delay.

When this function is activated, the settings of function 50 ("Electric time constants") must also be taken into account. Here you need to ensure that the "Threshold in % of smallest range" is greater than the effect interval set using function 50.

---

### 9.6.8 Measured value memory (function 77)

This function is used to define the response of the analog output when the device assumes a specific state.

77 Store	MC
Analog out. to meas.value	<input checked="" type="checkbox"/>
Analog out. to 0/2/4 mA	<input type="checkbox"/>
Analog out. to 21 mA	<input type="checkbox"/>
Store on/off	<input type="checkbox"/>

Figure 9-57 Setting the analog output

For following states:

- Fault (F)
- Function check based on
  - Decoding
  - Calibration
  - Warm-up phase
  - Device not in Measure
  - Remote access

One of these values is sent permanently to the analog output:

- The last registered measured value  
or
- The start-of-scale value of the selected analog current range (0, 2, 4 A)  
or
- The full-scale value of the selected analog current range (21 A)

'Memory on' (■) activates the respective setting.

### 9.6.9 Calibration tolerances (function 78)

With this function, you define the calibration tolerances. If these tolerances are exceeded during a calibration, the maintenance request W1 (calibration difference too large) is triggered.

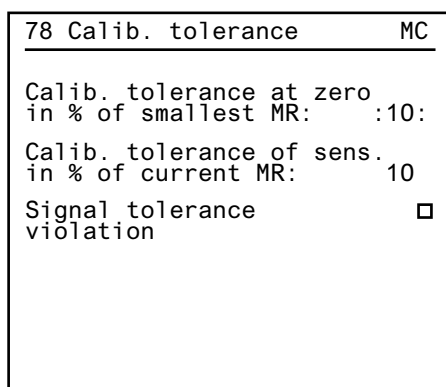

Figure 9-58 Setting the calibration tolerances

With softkey 3 "Signal tolerance violation", you activate or deactivate the tolerance monitoring.

If you previously configured a relay output to "Maintenance request" using function 71, the device outputs large changes of the zero point or scan compared with the last calibration as a "Maintenance request".

With "Calibration tolerance at zero...", you define the maximum deviation as a % of the smallest measuring range.

With "Calibration tolerance of sensitivity...", you define the maximum deviation as a % of the span of the measuring range in which the calibration is taking place.

The calibration tolerance, which can be set from 0 to 99%, refers to the measuring range with the smallest measuring span in the case of the zero point, and to the measuring range where the calibration is being carried out in the case of the span.

### Example

Measuring range 1	95 to 100% O <sub>2</sub>
Measuring range 2	90 to 100% O <sub>2</sub>
Smallest span	(100%-95%) O <sub>2</sub> = 5% O <sub>2</sub>

Measuring range in which calibration takes place	Measuring range 2
Selected calibration tolerances	Both 6%
Response threshold for zero point	$5\% O_2 \times 0.06 = 0.3\% O_2$
Response threshold for span	$10\% O_2 \times 0.06 = 0.6\% O_2$

If the measured value deviates from the most recently performed zero point calibration or span calibration by more than the configured value and if "Signal tolerance violation" is activated, the corresponding relay signals a maintenance request.

### 9.6.10 Change codes (function 79)

With this function, you replace the factory-set codes ("111" for level 1, "222" for level 2) by your own.

79 Codes program.		MC
Code 1	:111:	
Code 2	222	

Figure 9-59 Change codes

### 9.6.11 Device test

The individual steps of the device test are assigned as follows for the ULTRAMAT 6 and OXYMAT 6:

- Keyboard test  
Device-specific, since only one keyboard is connected
- Relay and binary test  
Channel-specific
- Analog test  
Channel-specific

You can check the functionality of the device by performing the following three tests.

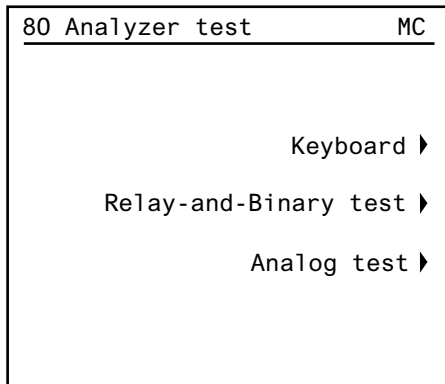

Figure 9-60 Testing the device

### Keyboard test

You can test all keys on the control panel by means of the keyboard test. The five softkeys on the right edge can be used to make the associated item appear/disappear. If a number key or the sign key is pressed, this is displayed in the bottom line of the display.

After pressing the [INFO] key, a message is displayed in plain text. The [MEAS] and [ESC] keys retain their "jump back" function.

### Relay and binary test

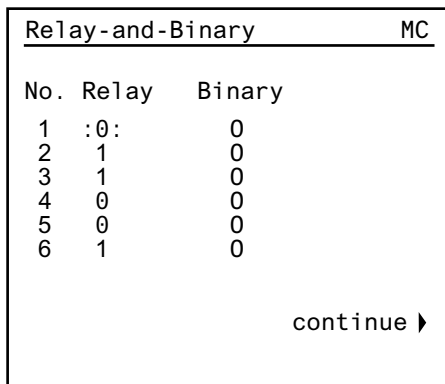

Figure 9-61 Test relay outputs and digital inputs

The first function screen shows the state of the six relay and binary inputs of a channel with basic configuration. With an add-on board, there are another eight relay/digital inputs on a second page.

With the relay test, individual relays can be activated. This is done via the input field. With "1", the relay is on, with "0", it returns to its release condition. Numbers other than "0" and "1" are not accepted by the input field.

After leaving function 80, the relays are back in the state they had before calling the relay and binary test.

The current state of the digital inputs is displayed in the "Binary" column.

## Analog test

With the analog test, the analog output is set to a constant current of 0 to 24 000  $\mu\text{A}$  for testing purposes.

The analog input displays the input currents in  $\mu\text{A}$ .

### 9.6.12 Select language

With this function, you set the channel to a second dialog language.

81 Select language	MC
English	<input checked="" type="checkbox"/>
Deutsch	<input type="checkbox"/>

Figure 9-62 Selecting a language

The device is always delivered in the ordered language. Usually, English is included as a second language (if English is the first language, Spanish is set as the second language).

### 9.6.13 Pressure correction (function 82)

This function can be used to select the pressure sensor that performs the pressure correction. Here you have the following options:

- Pressure correction using the internal pressure sensor
- Pressure correction using an external pressure sensor via analog input 2 (example as shown in the following figure) and
- Pressure correction using an external pressure sensor via ELAN (RS485).

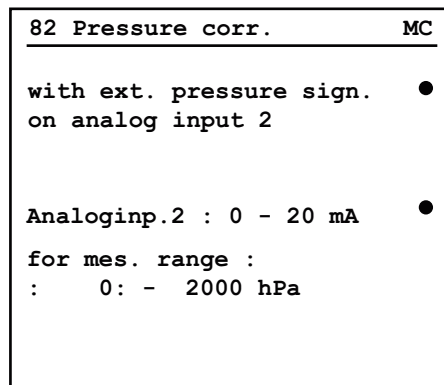

Figure 9-63 Selecting the pressure correction

The parameters for the pressure correction in the respective factory function are component-specific, the selection of the pressure sensor in function 82 is channel-specific.

If the pressure correction is performed by means of an external pressure sensor, it must be equipped with a diaphragm suitable for the application. Its analog output signal range must be 0/2/4 to 20 mA (this corresponds approximately to 0/1/2 to 10 V).

The characteristic data of the external pressure sensor can be entered using function 82. The pressure measuring range is entered in hPa (1 hPa = 1 mbar).

The value of an internal pressure sensor can be offset if it does not correspond to the real value anymore.

#### 9.6.13.1 ULTRAMAT 6

The **ULTRAMAT 6** comes equipped with a pressure sensor that allows correction of fluctuations of the sample gas pressure as a result of atmospheric pressure fluctuations in the range of 700 to 1200 hPa (0.7 to 1.2 bar). This compensation was already performed at the factory.

In a closed sample gas circuit, an external process gas pressure sensor must be used for the compensation. In this case the compensation acts in the range of 700 to 1500 hPa (0.7 to 1.5 bar).

#### 9.6.13.2 OXYMAT 6

With the **OXYMAT 6**, variations in the sample gas pressure can be corrected within the range of 500 to 2000 hPa (0.5 to 2 bar) (absolute).

If a larger sample gas pressure range is to be covered (up to 3000 hPa or 3 bar absolute), a standard absolute pressure sensor with a suitable measuring range can be connected to the device.

### 9.6.13.3 Pressure correction using an external pressure sensor via ELAN

A pressure correction can also be carried out via ELAN if, for example, a further gas analyzer has already been provided with an external pressure sensor and if this is connected via a serial interface to the device.

**Channel** parameter: Entry of the channel number of the measuring instrument that supplies the measured "Pressure" value (e. g. ULTRAMAT 6). The line underneath shows the the component, the pressure and the status of the channel connected via ELAN.

```

82 Pressure corr.          MC
-----
ext. pressure transmitter ●
via ELAN

Channel   :4:
NO:       994   hPa ctrl
    
```

Figure 9-64 Pressure correction via ELAN

The measured "Pressure" value is an internal measured value, which can be supplied via ELAN to another gas analyzer. Prerequisite for this, however, is that all the gas analyzers connected via ELAN work on the same pressure level.

### 9.6.14 Interference correction (function 83)

This function can be used to compensate for the influence of interfering accompanying gases (interference gases) on the result of a measurement.

A interference correction is only useful if the sample gas equivalent to be corrected is not greater than the smallest measuring span.

---

**Note**

During a calibration process (zero point or span), the interference correction is deactivated. It is activated again after completion of the calibration and the device has returned to measuring mode.

---

For the interference correction, a differentiation must always be made as to whether the interference gas has a constant or variable concentration. To do this you must first determine

the type of interference correction by pressing the first softkey. Specifically, the following options are available:

- No interference correction

83 Interf. correction	MC
No interference corr.	●

Figure 9-65 Interference correction switched off

- Interference correction with constant interference influence
- Interference correction with variable interference influence via analog input
- Interference correction with variable interference influence via ELAN
- Interference correction with variable interference influence internally for 2R channels (= other internal component)  
This possibility is only available for **ULTRAMAT 6**.

### 9.6.14.1 ULTRAMAT 6

For the interference correction, the analyzer must be informed of value of the zero offset - also called the sample gas equivalent.

You can also specify the measuring ranges to which the interference correction is to apply.



## Interference correction with constant interference influence

### Example:

If the sample gas of a CO<sub>2</sub> analyzer with a measuring range 0 to 10% contains a interference gas whose concentration is approximately constant and that results in a display deviation of -0.24% CO<sub>2</sub>, enter the value -0.24 as the interference. It is also clear from the example that the interference correction applies to all 4 measuring ranges.

83 Interf. correction		CO <sub>2</sub>
With const. interference correction		●
valid for range	▼▼▼▼ 1 2 3 4	●
Interference:	:-0.24:	

Figure 9-66 Interference correction with constant interference influence

## Interference correction with variable interference influence via analog input

In the case of variable interference influence, the interference gas is measured with a suitable separate gas analyzer and its measured signal is supplied to the analyzer for the interference calculation.

### Example:

The sample gas of a CO<sub>2</sub> analyzer with a measuring range 0 to 100 ppm contains a concentration of CO interference gas varying from approx. 1 - 7% CO. This is measured with a CO analyzer (measuring range 0 to 10% CO, analog output 0 to 20 mA). A calibration gas with 8.2% CO is available for this device. The interference correction is to apply to all 4 measuring ranges.

### Note

No interference correction is permitted to be activated before the beginning of parameter assignment.

### Procedure:

1. Ensure that the interference correction is deactivated.
2. Bring the device to the display mode
3. Connect the CO<sub>2</sub> analyzer to the calibration gas (8.2% CO) and introduce it.
4. Read the measured value. (In the example, 8.2% CO on the CO<sub>2</sub> device generates a measured value on the analyzer that corresponds to +8 ppm CO<sub>2</sub>).

5. Call up function 83.
6. Enter the parameters. These are:
  - Analog input (here: 1)
  - Measuring ranges that are to be corrected (here: 1, 2, 3, 4)
  - Calibration gas concentration (here: 8.2)
  - Interference (here: 8)
  - Input current range: (here: 0 to 20 mA)
  - Associated measuring range of the second analyzer (here 0 to 10)

```

83 Interfer. corr.          CO2
-----
With var. interference      ●
influence on an. input 1
      ▼▼▼▼▼
valid for range             1|2|3|4 ●

Interfering gas:           8.2 :
causes an
interference :              8
Analog inp. 1:             :0 - 20 mA ●

for range
: 0 : - : 10 :
    
```

Figure 9-67 Interference correction with variable influence via analog input 1

### Interference correction with variable interference influence internally for 2R channels

Here the interference gas is measured via the 2nd component of the 2R channel and its measured signal is supplied the for interference calculation.

The procedure for setting the parameters is the same as that for the interference correction via analog input. The parameters for analog input and measuring range are omitted.

```

83 Interf. correction      CO2
-----
With var. interference      ●
influence on 2R-Phy.
      ▼▼▼▼▼
valid for range             1|2|3|4 ●

Interfering gas:           8.2:
causes an
interference :              8
    
```

Figure 9-68 Interference correction with variable influence internally for 2R channels

### Interference correction with variable interference influence via ELAN

In the case of variable interference influence, the interference gas is measured with a suitable separate gas analyzer and its measured signal is supplied to the analyzer for the interference calculation via the RS485 interface (ELAN).

The procedure for setting the parameters is the same as that for the interference correction via analog input.

The following parameters are also to be considered:

- Channel number of the gas analyzer
- Component number of the gas analyzer

The type of gas associated with the channel and the component then appears in the display along with the measured value and, if applicable, device status (see Pressure correction using an external pressure sensor via ELAN (Page 151)).

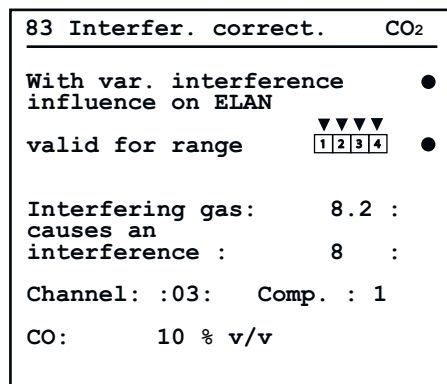

Figure 9-69 Interference correction with variable influence via ELAN

#### 9.6.14.2 OXYMAT 6

When the reference gas and residual gas (= sample gas without O<sub>2</sub> component) have different compositions, a zero offset (interference) occurs as a result of the paramagnetic or diamagnetic difference between the two gases. To compensate for this offset, the analyzer must be informed of the value of the zero offset.

You can also specify the measuring ranges to which the interference correction is to apply.

### Interference correction with constant interference influence

#### Example:

With a constant residual gas composition and a low concentration of O<sub>2</sub>, there is a residual gas influence that only varies because of fluctuations in the O<sub>2</sub> concentration and can therefore be regarded as approximately constant. The zero offset (interference) is determined as follows:

The sample gas without O<sub>2</sub> (residual gas) consists of 50% propane, the rest is nitrogen. Nitrogen is used as the reference gas.

The diamagnetic zero offset (O<sub>2</sub> equivalent) of the propane is -0.86% O<sub>2</sub> (see Zero point error of accompanying gases (OXYMAT 6) (Page 270)). A propane percentage of 50% therefore results in a interference of -0.43% O<sub>2</sub>. Therefore you enter the value -0.43 as the interference. It is also clear from the example that the interference correction applies to all 4 measuring ranges.

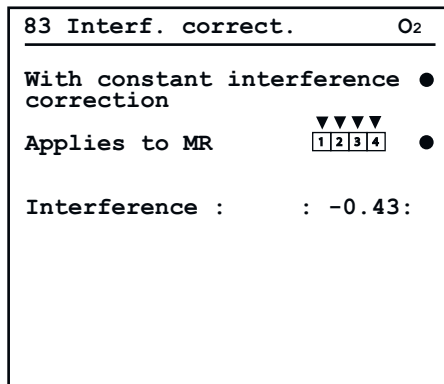

Figure 9-70 Interference correction with constant interference influence

### Interference correction with variable interference influence via analog input 1

In the case of variable interference influence, the interference gas is measured with a suitable separate gas analyzer and its measured signal is supplied to the analyzer for the interference calculation.

The interference (O<sub>2</sub> equivalent) to be specified must always be that of the pure residual gas. By entering the measuring range of the residual gas analyzer in % as well as its current output, an internal calculation of the actual O<sub>2</sub> offset is possible.

**Example:**

A sample gas consists of 4% NO and 96% N<sub>2</sub>. It is to be monitored for O<sub>2</sub>.

The O<sub>2</sub> equivalent of 100% NO is 42.94% O<sub>2</sub> (see Zero point error of accompanying gases (OXYMAT 6) (Page 270))

This is measured with an NO analyzer (measuring range 0 to 5% NO, analog output 0 to 20 mA). The interference correction is to apply to all 4 measuring ranges.

**Procedure:**

1. Enter the parameters. These are:
  - Measuring ranges to which the interference correction is to apply (e.g. 1, 2, 3, 4)
  - Analog output 1 0 to 20 mA output current range
  - Start of measuring range: 0 (% NO)
  - End of measuring range: 5% NO)
2. Enter the value 100 (%) as the interfering gas concentration.
3. Enter the value 42.94 as the interference.

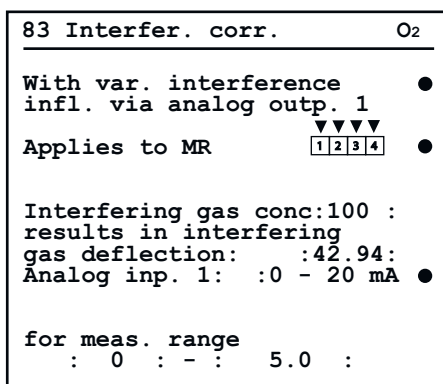

Figure 9-71 Interference correction with variable influence via analog input 1

**Interference correction with variable interference influence via ELAN**

In the case of variable interference influence, the interference gas is measured with a suitable separate gas analyzer and its measured signal is supplied to the analyzer for the interference calculation via the RS485 interface (ELAN).

The procedure for setting the parameters is the same as that for the interference correction via analog input.

The following parameters are also to be considered:

- Channel number of the gas analyzer
- Component number of the gas analyzer

The type of gas associated with the channel and the component then appears in the display along with the measured value and, if applicable, device status (see Pressure correction using an external pressure sensor via ELAN (Page 151)).

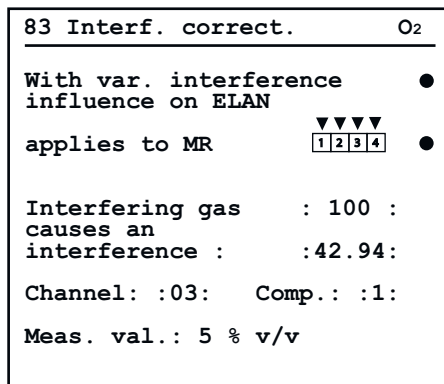

Figure 9-72 Interference correction with variable influence via ELAN

## 9.6.15 Phase adjustment (function 84)

### 9.6.15.1 ULTRAMAT 6

A phase adjustment must always be performed after

- Change of the chopper frequency
- Replacement of the chopper
- Replacement of the detector cell

---

#### Note

The phase adjustment may only be performed when the optical coupler is removed.

---

The physical principle of measurement and the mechanical design result in a delayed reaction (phase offset) of the analog measured value signal compared with the synchronous signal that is detected by a photodetector at the chopper wheel.

This delay (phase offset) also depends on the length of the installed analyzer chamber. Therefore the phase position of the rectifier signal must be delayed in a synchronized manner (by the same value).

To do this, insert an approx. 3 cm wide paper strip between the analyzer cell and the detector on the sample gas side, thereby simulating a large measured value signal. Then, trigger the phase adjustment by pressing the respective softkey.

84 Phase adjust		CO <sub>2</sub>
E (φ)	:	312400
E (φ+90°)	:	-104
φ	:	280°
Meas.val.	:	99,3 vpm
Attenuat.	:	39400
Phase adjust		●

Figure 9-73 Phase adjustment

### 9.6.15.2 OXYMAT 6

The physical principle of the measurement procedure and the mechanical design of the detector result in a delayed reaction (phase offset) of the analog measured value signal compared with the clock signal of the magnet control. This phase shift can be adjusted if necessary with the help of this function.

84 Phase adjust		O <sub>2</sub>
V	:	144349
W	:	9
φ	:	31.2:°
Meas.val.	:	20,5 %
Phase adjust		●

Figure 9-74 Phase adjustment

With the maximum possible signal (sample gas: e.g. air) the gain is automatically adjusted so that V assumes a value of approximately 500,000. The phase angle φ is then calculated using this signal value and saved, whereby V is maximized and W minimized.

This angle was determined at the factory and should only be readjusted when the magnetic field frequency is changed.

### 9.6.16 Switch valves (function 85)

With this function, you can manually switch up to six valves. This is done via the relays which are allocated to the individual valves and are available on the motherboard and add-on board. The precondition is that the corresponding relays have been previously configured with function 71 ("Relay outputs")

85 Switch valves			0 <sub>2</sub>
01	Zero gas	Rel. 3	<input type="checkbox"/>

Figure 9-75 Switching valves

The "Switch valves" function only applies to the relay functions "Zero gas", "Calibration gas 1 to 4" and "Sample gas".

Only one of the six valves can be switched at a time, since the valves are mutually interlocked.

### 9.6.17 Linear temperature compensation (function 86)

The device is temperature compensated for the zero point and the span. If an additional temperature error occurs during operation, for instance, due to light contamination of the sample chamber, it can be compensated with this function.

86 Lin. temp. comp.	MC
Aftercompensation of the zero point	<input type="checkbox"/>
Aftercompensation of the span	<input type="checkbox"/>

Figure 9-76 Linear temperature compensation

#### Temperature compensation at the zero point

Assuming an average temperature  $T_M$ , two different correction values can be specified for ranges of increased temperature and decreased temperature.



**Example (ULTRAMAT):**

If an increase in temperature of the detector cell from  $T_M$  to  $T_M'$  changes the zero point by +0.3% (relative) of the difference between the full-scale value and start-of-scale value (according to rating plate), the value determined according to the 'TC zero point formula' is to be entered under " $\Delta$ " for a temperature increase.

**Example (OXYMAT):**

If an increase in temperature of the detector cell from  $T_M$  to  $T_M'$  changes the zero point by +0.3% (relative) of the difference between 100% O<sub>2</sub> and the start-of-scale value of the smallest span, the value determined according to the following formula is to be entered under " $\Delta$ " for a temperature increase.

**TC zero point formula**

$$\Delta = - \frac{(+0.3)}{[T_M - T_M']} \times 10 \text{ [%/10 } ^\circ\text{C]}$$

A factor can be determined for a temperature decrease in the same manner.

If only a correction factor is determined, the first value of opposite sign is entered for the second correction value.

**Temperature compensation in the measured value:**

The procedure is the same as for the zero point, however, the percentage change refers to the measured value itself.

**Example:**

If the measured value changes from 70 % to 69 % with a temperature increase of 4 °C, the percentage change is

$$\frac{(70 - 69)}{70} \times 100 = 1.42 \text{ [%/4 } ^\circ\text{C]}$$

and therefore  
 $\Delta = 3.55 \text{ [%/10} ^\circ\text{C]}$ .

**Note**

If the zero point changes to negative with temperature change,  $\Delta$  has a positive sign and vice versa. The same applies to a measured value which becomes smaller.

### 9.6.18 Error on/off (function 87)

With this function, you switch the message for maintenance requests and faults (see Tables "Causes of maintenance requests" and "Causes of error messages") off individually so that there is no entry in the logbook, no message in the status line of the measured value display, and no external signal sent.

87 Error On/Off	MC
S1 Parameter memory	■
S2	■
S3	■
S4 External fault	■
	continue ▶

Figure 9-77 Switching errors on and off

Error messages which do not apply to this analyzer are identified by the absence of text following the fault number.

### 9.6.19 AK configuration (function 88)

This function can only be called if the device is equipped with suitable add-on electronics.

88 AK Config.	O2
Baudrate:	9600 ●
Format:	8DB, kP, 1SB ●
Start sign :	: 2:
End sign :	: 3:
Don't care sign :	:10:

Figure 9-78 AK configuration

The following parameters of the serial interface can be set:

- Baud rate:  
300; 600; 1200; 2400; 4800; 9600  
(basic setting: 9600)
- Format  
This is the transmission format with the following variables:
  - Number of data bits (DB)
  - Parity (**nP** = no parity, **uP** = odd parity, **eP** = even parity)
  - Number of stop bits (SB)

Table 9-6 The following combinations are possible

7 data bits	No parity	2 stop bits
7 data bits	Even parity	1 stop bit
7 data bits	Odd parity	1 stop bit
8 data bits	No parity	1 stop bit *)
7 data bits	Even parity	2 stop bits
7 data bits	Odd parity	2 stop bits
8 data bits	Even parity	1 stop bit
8 data bits	Odd parity	1 stop bit
8 data bits	No parity	2 stop bits
*) Factory setting		

- Start character:  
All characters from 1 to 255 are possible. However, the start character must differ from the end character.  
Basic setting: 02 (STX)
- End character  
All characters from 1 to 255 are possible: However, the end character must differ from the start character.  
Basic setting: 03 (ETX)
- Don't care character:  
All characters from 1 to 255 are possible. However, the don't care character must differ from the start character and the end character.  
Basic setting: 10 (line feed)

## 9.6.20 Heating (function 89)

### 9.6.20.1 Heating of analyzer unit

#### Device-specific function in ULTRAMAT 6F

The setpoint temperature of the analyzer unit of the heated ULTRAMAT 6F is set to 65 °C. In addition to the circulating air heating, the gas inlets and outlets are heated by self-regulating heating elements.

To protect against overtemperature, the heating block of the circulating air heating has a temperature fuse that permanently interrupts the heating circuit at a temperature of approx. 167 °C.

As long as the actual temperature deviates by more than 5 °C from the setpoint temperature, the "Function check (CTRL)" status message occurs. In addition, if configured, a signaling contact is triggered (see also Relay outputs (function 71) (Page 136)).

If there is a fault in the heater control electronics, the measuring capability of the device is impaired. A fault message is generated in this case.

89 Heating		CO <sub>2</sub>
Heating	ON/OFF	■
Nominal temperature		
Bench	:	: 65: °C
Actual temperature		
Bench	:	64.9 °C

Figure 9-79 Heating of analyzer unit

### 9.6.20.2 Heating of sample chamber

#### Device-specific function in OXYMAT 6F

The setpoint temperature of the sample chamber of the heated OXYMAT 6F is freely selectable between 65 °C and 130 °C. In addition to the sample chamber, all parts coming into contact with sample gas are heated indirectly as well.

To protect against overtemperature, the analyzer unit has a temperature fuse that permanently interrupts the heating circuit at a temperature of 167 °C.

As long as the actual temperature deviates by more than 5 °C from the setpoint temperature, the "Function check (CTRL)" status message occurs. In addition, if configured, a signaling contact is triggered (see also Relay outputs (function 71) (Page 136)).

If there is a fault in the heater control electronics, the measuring capability of the device is impaired. A fault message is generated in this case.

89 Heating		O <sub>2</sub>
Heating	ON/OFF	■
Nominal temperature		
Bench	:	:130: °C
Actual temperature		
Bench	:	112 °C

Figure 9-80 Heating of sample chamber

Note that the setpoint of the sample chamber temperature influences the smallest measuring range (Measuring ranges (Page 119)) as follows:

Setpoint	Deviation
<65 °C	0.5 vol %
65 to 90 °C	1 vol %
90 to 130 °C	2 vol %

### 9.6.21 PROFIBUS configuration (function 90)

This function is used to set the PROFIBUS parameters. This function can only be called if the device contains additional PROFIBUS electronics (add-on board).

90 PROFIBUS config.		MC
Address	:126:	
TAG	: CALOMATSIXTYTWO	
Ident number	: 1:	●
Relay on PB	:off:	●
Software vers: 2.0.0		
Boot software: 0.2.0		

Figure 9-81 Configuring PROFIBUS

Specifically, you can set the following PROFIBUS parameters:

- Address (PROFIBUS station address): The address can be set from 0 to 126.
- Under TAG you can display an identifier assigned to the device in the PROFIBUS network (or the first 16 characters thereof).
- The configuration behavior of the device is configured with the "Ident number" (softkey 2). Parameters 0, 1 and 3 can be selected and have the following meaning:

Parameter	Meaning
0	Only the PROFILE ID number is positively acknowledged
1	Only the device-specific ID number is positively acknowledged
3	Only the PROFILE ID number for multivariable devices (complex analyzers) is positively acknowledged.

---

**Note**

In order to work with the provided GSD and EDD, the value 1 must be entered for 'Ident number'.

- Relay on PB. This can be used to enable the 8 relays of the additional electronics (add-on board) so that they can be remotely controlled via PROFIBUS. For activating, however, none of these relays are permitted to have a function assigned to them.

---

**Note**

For remote control via PROFIBUS, the software version of the additional PROFIBUS electronics (add-on board) must be 2.0.0 or higher.

---

The current software version of the PROFIBUS card and the boot software version are indicated in the bottom lines of the display.

## Service and maintenance

### 10.1 General safety information for service and maintenance

 **WARNING**

**Dangerous voltage at open device**

Danger of electrocution

Danger of electrocution exists when the enclosure is opened or enclosure parts are removed.

- Before you open the enclosure or remove enclosure parts, deenergize the device and wait another 10 minutes. Ensure that the device cannot be switched back on inadvertently.
- Observe the special precautionary measures if maintenance is required while the device is live. Have the maintenance work carried out by certified personnel with special training for live-line working.
- Open the enclosure only for installation or maintenance. Close the enclosure after completing this work.

 **WARNING**

**Faulty adjustment and reassembly**

Faulty mounting or calibration can lead to dangerous gas leaks. This can lead to intoxications or burns as well as corrosion damage at the device.

- Only carry out adjustments using appropriate tools in order to avoid short-circuits on the electronic PCBs.

 **WARNING**

**Danger of poisoning by escaping gas**

The device is designed for operation with toxic, lightly corrosive gases. Therefore, dangerous substances may exit from the gas lines when they are opened.

- Prevent gases from exiting prior to opening or removing the device, for example:
  - Shut off the gas inlets and gas outlets.
  - Disconnect the gas lines from the device.

 <b>WARNING</b>
<b>Danger from gas lines under pressure</b>
Danger of injury during maintenance work
Hot, toxic or corrosive sample gases can be released when the gas lines are opened. Prevent gases from exiting prior to opening or removing the device.
<ul style="list-style-type: none"><li>• Do not loosen process connections and do not remove any pressurized parts while the device is under pressure.</li><li>• Depressurize the device. Shut off the gas inlets and gas outlets. Disconnect the gas lines from the device.</li><li>• Before opening or removing the device, ensure that process media cannot be released.</li></ul>

 <b>WARNING</b>
<b>Danger of suffocation by inert gas</b>
Inert gas in the housing can cause suffocation. The housing also contains a flammable substance which may be within the flammable range when it comes into contact with air.
<ul style="list-style-type: none"><li>• Ensure sufficient ventilation in the room. When opening the device, avoid breathing in directly beside the housing.</li></ul>



 <b>CAUTION</b>
<b>Hot surfaces resulting from hot sample gases and heated devices</b>
Danger of burns resulting from surface temperatures above 70 °C (155 °F)
After being switched off, the device and its parts are still very hot. Touching can result in skin burns.
<ul style="list-style-type: none"><li>• Begin the maintenance / shutting down once the device has cooled off.</li><li>• Take appropriate protective measures, for example contact protection.</li></ul>



 <b>CAUTION</b>
<b>Hot surfaces resulting from high-temperature devices</b>
Danger of burns resulting from surface temperatures above 130 °C.
The temperature of heated devices only drops slowly because of the high thermal capacity of the materials. Therefore, temperatures up to 130 °C can still be present for an extended period after devices have been switched off. This results in the danger of burns.
<ul style="list-style-type: none"><li>• Wait at least two hours after the shutdown before working on the heated devices.</li><li>• Take appropriate protective measures, such as wearing protective gloves.</li></ul>





 <b>CAUTION</b>
<b>Faults at the device</b>
For faults which you are unable to eliminate, place the device out of service and protect it against inadvertent commissioning.

<b>NOTICE</b>
<b>Penetration of moisture into the device</b>
Device damage
<ul style="list-style-type: none"><li>• Make sure when carrying out cleaning and maintenance work that no moisture penetrates the inside of the device.</li></ul>

## 10.2 Safety instructions for hazardous areas

 <b>WARNING</b>
<b>Impermissible accessories and spare parts</b>
Danger of explosion in areas subject to explosion hazard or device damage.
<ul style="list-style-type: none"><li>• Only use original accessories or original spare parts.</li><li>• Observe all relevant installation and safety instructions described in the instructions for the device or enclosed with the accessory or spare part.</li></ul>

 <b>WARNING</b>
<b>Improper connection after maintenance</b>
Danger of explosion in areas subject to explosion hazard or device damage.
<ul style="list-style-type: none"><li>• Connect the device correctly after maintenance.</li><li>• Close the device after maintenance work.</li></ul>
See chapter "Note for explosion-proof devices (Page 171)".

 <b>WARNING</b>
<b>Open enclosure</b> Danger of explosion in hazardous areas as a result of hot components and/or charged capacitors inside the device. Follow these steps when you open the device in a hazardous area: <ol style="list-style-type: none"><li>1. Disconnect the device from the power supply.</li><li>2. Make sure you observe the wait time listed on the warning label before you open the device.</li><li>3. Carry out a visual check of the sensor inlet and outlet.</li></ol> <b>Exception:</b> Devices with "Intrinsic safety Ex i" explosion protection type only may also be opened in an energized state in hazardous areas.

 <b>WARNING</b>
<b>Electrostatic charging</b> Explosion hazard If electrostatic charging develop in explosive areas, there is a risk of an explosion. <ul style="list-style-type: none"><li>• Prevent electrostatic charging in hazardous areas. When installing the components, observe the measures against electrostatic charging (ESD Guidelines) and IEC 60079-0 7.4.2 e).</li><li>• Clean plastic surfaces with a damp cloth.</li></ul>

 <b>WARNING</b>
<b>Maintenance during ongoing operation in a hazardous area</b> There is a danger of explosion when carrying out repairs and maintenance on the device in a hazardous area. <ul style="list-style-type: none"><li>• Isolate the device from power.</li><li>• Alternatively: Make sure that the atmosphere is explosion-free (hot work permit).</li><li>• Wait 10 minutes after disconnecting the power supply before you open all doors and covers.</li></ul>

 <b>WARNING</b>
<b>Dust layers above 5 mm</b> Danger of explosion in hazardous areas. A dust deposit with a thickness exceeding 5 mm can lead to overheating of the device and as a consequence to explosion. <ul style="list-style-type: none"><li>• Remove any dust layers in excess of 5 mm.</li></ul>

## 10.3 General information

### Opening the device

For rack units you can remove the upper cover fold down the front panel.

For field devices you can open the front doors. When closing the doors again you must turn the screws until the the door rests against the enclosure frame.

Always close the device when maintenance work is interrupted.

### Annual maintenance work

Check the device annually for electrical safety and functionality as well as leakage of the sample gas path within the device.

Check the device following each intervention in the gas path (containment system) for leaks. The leak test is described in the section "Leak test of gas paths (Page 78)".

The owner can extend maintenance intervals in individual cases if no negative effects can be expected on wetted parts materials (gaskets in particular).

Determine a maintenance interval for the recurring tests on the basis of the use of the device and your own empirical values. The maintenance intervals will vary from site to site depending on corrosion resistance.

---

#### Note

##### Undefined states after maintenance and/or repair work

If undefined states occur after maintenance or repair work, the device can be returned to an operational state again by loading the factory settings (function 75 "Load factory settings"). The device has to be recalibrated subsequently.

---

## 10.4 Note for explosion-proof devices

After repair, have the device checked by an Ex specialist before the device is put back into operation. The Ex specialist determines whether the analyzer has the essential features and meets the requirements for explosion protection and issues a certificate to this effect and/or provides the equipment with a test symbol.

## 10.5 Cleaning the device

### Cleaning the surface

The front panels and doors are washable. Use a sponge or cloth dipped in water containing dishwashing detergent. Use only solvent-free, commercial detergents.

Clean the display and the membrane keyboard with care and without pressure using a moist cloth. Water must not enter the interior of the device.

## Cleaning the interior

 **WARNING**

**Dangerous voltage at open device**

After opening the analyzer, voltages that are dangerous to the touch are openly accessible.

- Isolate the device from power before you open it.

Open the device. If necessary, you can blow out the interior carefully with a compressed air gun.

## 10.6 Software update/backup of the device data

After each commissioning or changes of the software we recommend backing up the current device parameterization.

A backup can take place both internally and externally.

- Internal backup
  - The internal storage takes place in the device storage with function 75 (see Save, load data (function 75) (Page 143)).
  - No additional hardware or software is required to this purpose.
  - The backed up software can be reloaded quickly.
  - Disadvantage: The saved software is not accessible anymore in case of a defective motherboard.
- External backup
  - A separate computer/PC is required for this.
  - After replacement of the motherboard the software can be loaded into the device again.
  - The saved parameter assignment can also be transferred to other devices of the same type.
  - For the external backup you require additional hardware (interface converter RS485 to RS232/USB/Ethernet) as well as software (SIPROM GA).

The use of the SIPROM GA maintenance software not only offers the possibility of a device backup. The analyzer can also be operated via SIPROM GA and be upgraded to new versions of the device software (see SIPROM GA functions (Page 33)).

## 10.7 Replacement of motherboard and add-on board

### 10.7.1 Rack units (ULTRAMAT 6E, OXYMAT 6E)

#### Position of the boards

Display	Analyzer unit	Motherboard	Option board
Upper component (component 1)	Right (seen from front)	Right	Next to the corresponding motherboard
Lower component (component 2)	Left (as seen from the front)	Left	Next to the corresponding motherboard

#### Replacing the motherboard

To do this, proceed as follows:

1. Disconnect the analyzer from the power supply.
2. Remove all data plugs from the rear panel.
3. If necessary, remove the device from the cabinet.
4. Unscrew the cover from the housing.
5. Remove the locking mechanism.
6. Disconnect all cables from the motherboard.
7. Loosen the mounting screws from the rear of the motherboard.
8. If applicable, loosen the hose from the pressure sensor.
9. Remove the motherboard from the device.

#### Removing the option board

The procedure is the same as for the motherboard. In contrast to this motherboard, the option board is attached to the enclosure with only two screws.

#### Mounting

Proceed in reverse order to install both boards.

### 10.7.2 Field devices (ULTRAMAT 6F, OXYMAT 6F)

#### Replacing the motherboard

To do this, proceed as follows:

1. Disconnect the analyzer from the power supply.
2. Open the left housing door
3. Remove the ribbon cable connectors from the connection terminal boards.
4. Remove the sheet-metal cover.
5. Disconnect all cables leading to the motherboard.
6. Remove the sheet metal cassette in which the motherboard is installed from the device.
7. Remove the mounting screws.
8. Remove the locking mechanism on the top of the motherboard.
9. Remove the motherboard from the device.

#### Removing the option board

The procedure is the same as for the motherboard. In contrast to the motherboard, the option board is attached to the sheet metal cassette with only two screws.

#### Mounting

Proceed in reverse order to install both boards.

<b>NOTICE</b>
<b>Only ULTRAMAT 6: Incorrect connection of the detector cell(s)</b>
Ensure correct connection of the detector cell(s):
<ul style="list-style-type: none"><li>• Devices with only one measured component: Detector cell 1</li><li>• Devices with 2 measured components Detector cells 1 and 2</li></ul>

### 10.8 Replacement of heating components (ULTRAMAT 6F)

Field devices are available both in an unheated as well as a heated version.

The heating system consists of a circulating air heater installed in the right door of the enclosure and the heating board for regulation installed in the left half of the enclosure. The heating system ensures that the temperature in the right half of the enclosure is kept constantly at 65 °C.

The replacement of the heating components is described in section "Heating (Page 177)".

## 10.9 Replacement of fuses

 <b>WARNING</b>
--

<b>Improper handling</b>
--------------------------

The fuses may be only be replaced by trained or instructed personnel. You may only use fuses of the same type!
--

The device is protected by multiple fuses, the values of which depend on the device model (e.g. supply voltage, heating, etc.). The fuse ratings of the individual devices can be found in section "Technical specifications (Page 259)".

### 10.9.1 Rack units

#### Fuses F3, F4

These fuses are located in a drawer in the power socket on the back of the device. This drawer can be opened and pulled out with a suitable tool (for example a screwdriver) in order to replace the fuses.

---

**Note**

Note that dual-channel devices require fuses with higher ratings than single-channel devices. You can find the exact values in section ULTRAMAT 6E and ULTRAMAT channel in ULTRAMAT/OXYMAT 6 (Page 259).

---

## 10.9.2 Field devices

### Location of the fuses

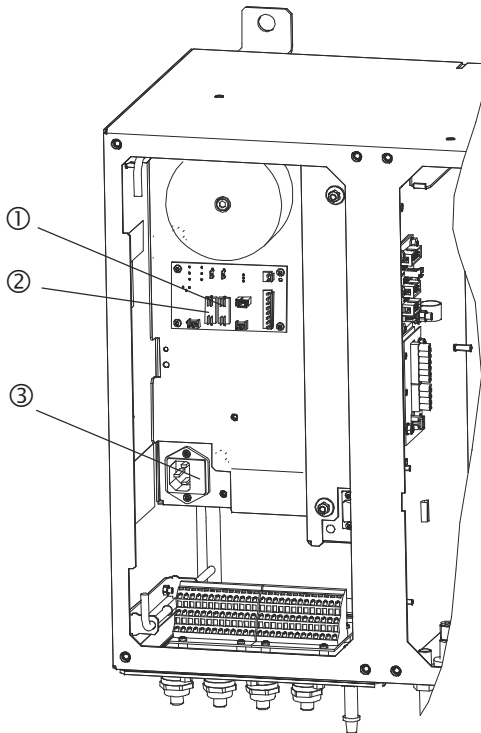

Figure 10-1 Location of the fuses in the field devices

### Fuses F3, F4

These fuses are located in a drawer in the power connection socket in the left half of the enclosure ③. This drawer can be opened and pulled out with a suitable tool (for example a screwdriver) in order to replace the fuses.

### Fuses F1, F2 (heating)

The F1 ① and F2 ② fuses are located on the heating control board behind the left cover plate.



## **10.10 ULTRAMAT channel**

### **10.10.1 Heating**

#### **10.10.1.1 Design of the heating system**

Only the field device is available in a heated version.

The heated version of the field device is equipped with circulating air heating as well as heated sample gas inlets and outlets. For heated devices with a normal flow-type reference gas compartment, the reference gas inlets and outlets are also heated.

The circulating air heating regulates the inside temperature of the right half of the enclosure so that the gas path and the analyzer unit do not fall below a temperature of 65 °C. Here, the controlled variable is the temperature of the detector cell.

The heating elements of the gas ports are self-regulating at approx. 70 °C.

To protect against excess temperature, the heating block of the circulating air heating has a temperature fuse that permanently interrupts the heating current when a temperature of approximately 167 °C is exceeded.

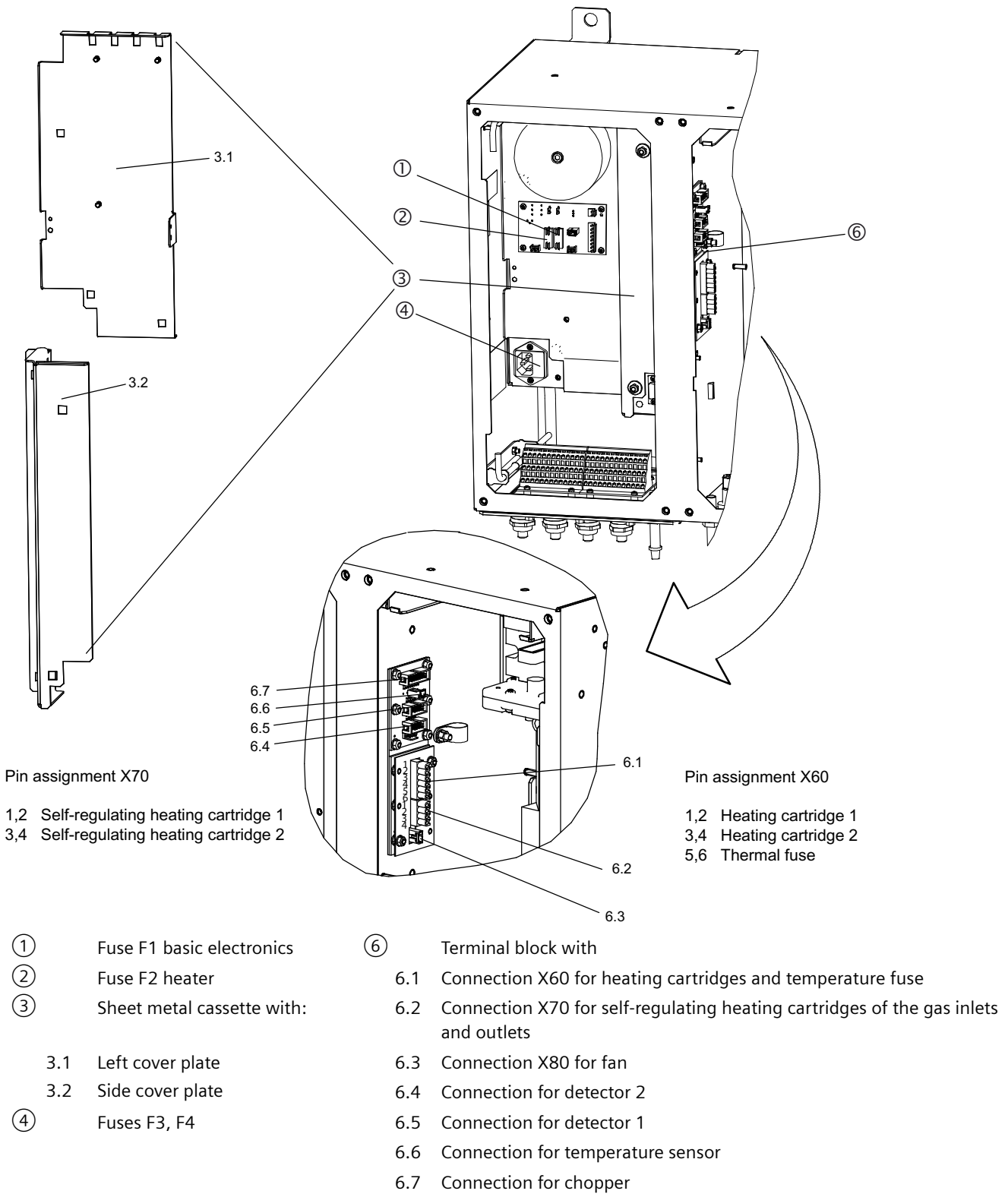
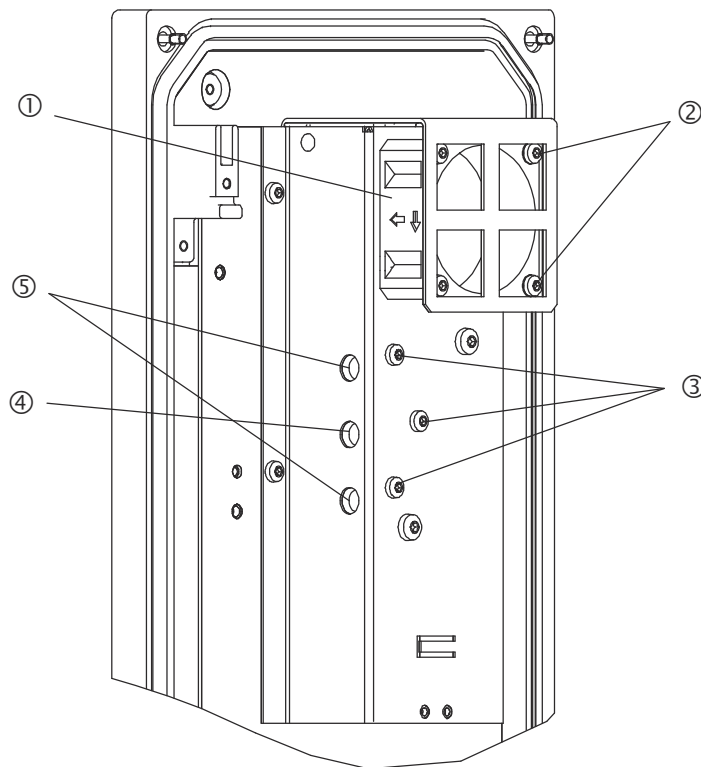

Figure 10-2 Heating components of heated field devices



- |  |                      |
|--|----------------------|
| ① Fan                                  | ④ Temperature fuse   |
| ② Mounting screws of the fan (4 units) | ⑤ Heating cartridges |
| ③ Locking screws                       |                      |

Figure 10-3 Circulating air heating of the ULTRAMAT 6

### 10.10.1.2 Replacing the fan

Replace the fan as follows:

1. Disconnect the analyzer from the power supply.
2. Remove the cable connector (X80) of the fan.
3. Remove the supply cable of the fan from the cable harness.
4. Loosen the four mounting screws of the fan.
5. Remove the fan.

The fan is installed in the reverse order taking into account the blade position.

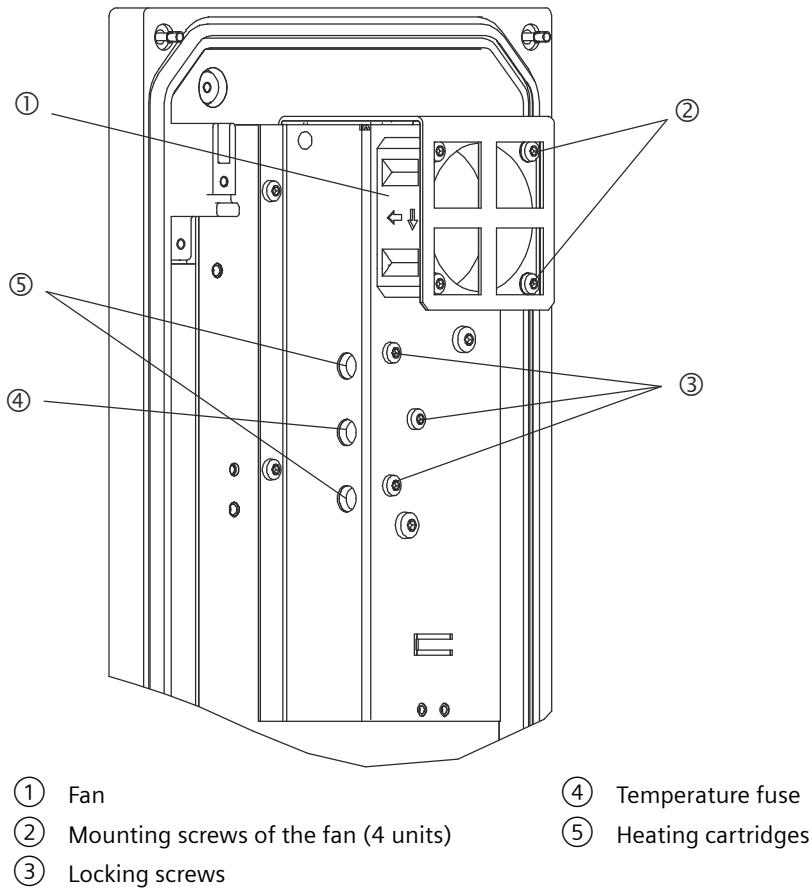

Figure 10-4 Circulating air heating of the ULTRAMAT 6

### 10.10.1.3 Replacement of the temperature fuse

#### Replacement of the temperature fuse

After the temperature fuse has tripped, replace it as follows:

1. Disconnect the analyzer from the power supply.
2. Remove the cable connector (X60) of the heating cartridges and the temperature fuse
3. Loosen the connecting cable from the plug
4. Remove the cable from the cable harness
5. Loosen the lock screw of the temperature fuse.
6. Pull the fuse from the heating element

Proceed in reverse order to install the temperature fuse.

#### 10.10.1.4 Replacement of the self-regulating heating cartridges

##### Replacement of the self-regulating heating cartridges

Proceed as follows for this:

1. Disconnect the analyzer from the power supply.
2. Remove the cable connector (X70) of the self-regulating heating cartridges.
3. Loosen the connecting cable from the plug
  - Pins 1 and 2 for heating cartridge 1
  - Pins 3 and 4 for heating cartridge 3
4. Remove the supply cable from the cable harness
5. Loosen the locking screw of the heating cartridge
6. Pull the heating cartridge from the heating element

Proceed in reverse order to install the heating cartridge.

#### 10.10.2 Analyzer unit

##### 10.10.2.1 Removing the analyzer unit

<b>NOTICE</b>
<b>Damage to sensitive parts</b>
The IR-permeable windows made of $\text{CaF}_2$ are very sensitive to mechanical stress. <ul style="list-style-type: none"><li>• Handle the windows made of <math>\text{CaF}_2</math> with care when installing or removing them.</li><li>• Always tighten the screws evenly when reinstalling them.</li></ul>

ULTRAMAT 6E

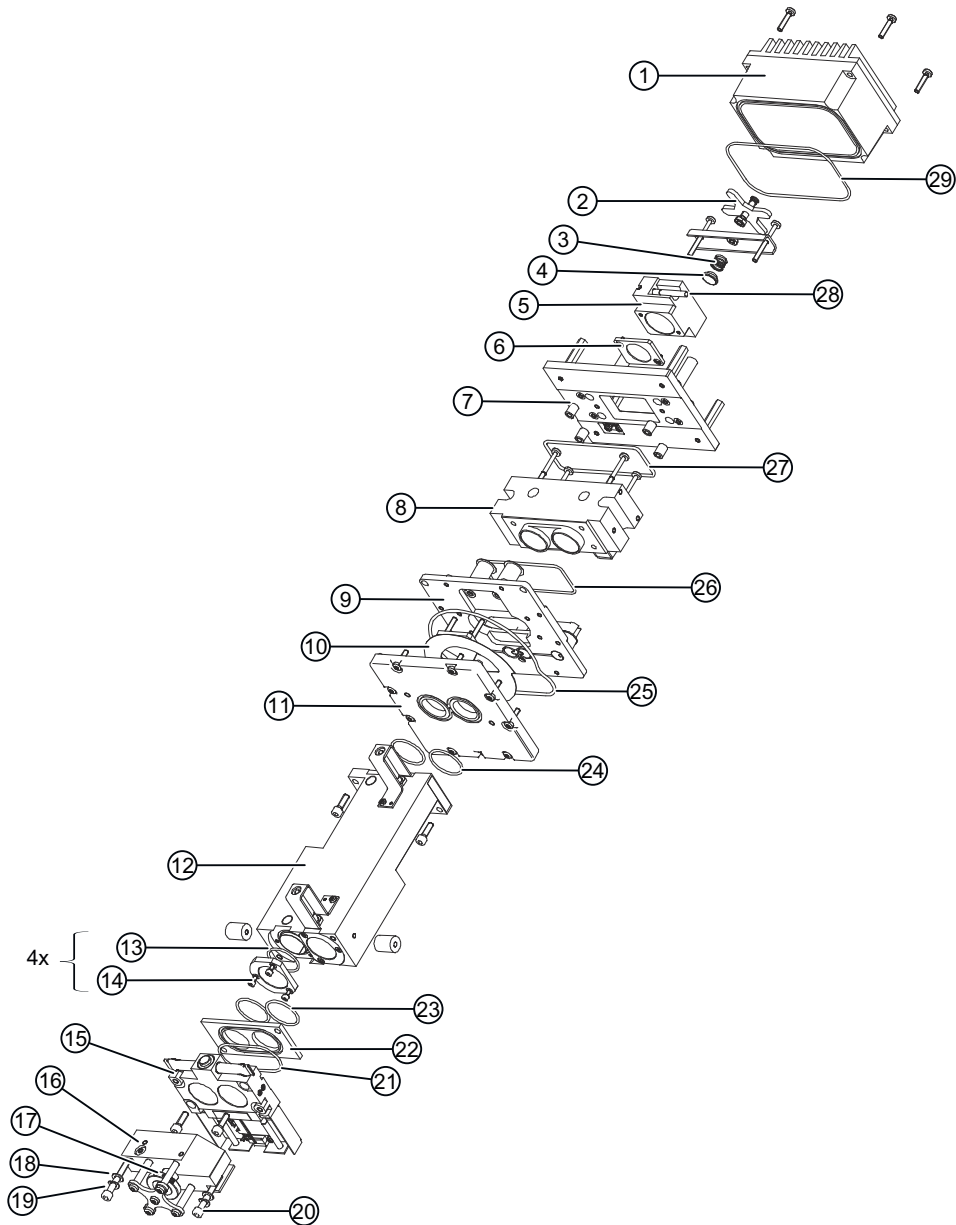

- |                      |                          |                          |                       |
|----------------------|--------------------------|--------------------------|-----------------------|
| ① Heat sink          | ⑦ Plate                  | ⑬ O-ring                 | ⑲ Spring washer       |
| ② Star knob          | ⑧ Beam divider           | ⑭ Cover                  | ⑳ Screw               |
| ③ Compression spring | ⑨ Top part of chopper    | ⑮ Detector cell          | 22 Adapter            |
| ④ Thrust pad         | ⑩ Chopper wheel          | ⑯ Optical coupler        | 21, 23-27, 29 O-rings |
| ⑤ IR source          | ⑪ Bottom part of chopper | ⑰ Adjuster (knurled nut) |                       |
| ⑥ Optical filter     | ⑫ Analyzer chamber       | ⑱ Washer                 | 28 Adjustment screw   |

Parts 21-27 are only present on CO<sub>2</sub> devices

Figure 10-5 ULTRAMAT 6E analyzer unit

Remove the analyzer unit of the ULTRAMAT 6E as follows:

1. Shut off the supply of the sample gas and, if necessary, also the supply of the reference gas and calibration gases.
2. Purge all gas paths with nitrogen.
3. Disconnect all gas supply lines
4. Disconnect the analyzer from the power supply.
5. Remove the signal and voltage cables from the rear of the device.
6. If the device is installed in a cabinet, remove it.
7. If necessary, remove the securing bracket from the rear of the device.
8. Open the enclosure cover.
9. Loosen the cable for the chopper and detector from the motherboard.
10. The optical bench is fastened in a mounting rail. It is attached with 2 screws to the enclosure bottom and with 3 screws to the rear of the enclosure. Loosen these five screws.
11. Fold down the front panel.
12. Remove the optical bench with the mounting rail.

To install, carry out the above steps in reverse order.

Then check the gas path for leak tightness (see "Leak test of gas paths (Page 78)" section on this).

## ULTRAMAT 6F

 <b>WARNING</b>
<b>Danger of burns</b> The temperature of heated devices only drops slowly because of the high thermal capacity of the materials. Therefore, temperatures up to 130°C can still be present long after devices have been switched off. <ul style="list-style-type: none"><li>• Therefore wait for approx. 2 hours until the temperature has cooled down sufficiently before beginning maintenance work.</li><li>• In case of doubt, use protective gloves</li></ul>

Remove the analyzer unit of the ULTRAMAT 6F as follows:

1. Shut off the supply of the sample gas and, if necessary, also the supply of the reference gas and calibration gases.
2. Purge all gas paths with nitrogen.

 <b>WARNING</b>
<b>Toxic, corrosive and/or explosive gases</b>
If the device was used to measure toxic, corrosive and/or explosive gases, the gases released by the purging operation must be conveyed in such a way that no harm occurs to people, the environment or devices.

3. If necessary, purge the enclosure.

 <b>WARNING</b>
<b>Explosive gases</b>
If the device was used to measure explosive gases, the gases released by the purging operation must be conveyed in such a way that no harm occurs to people, the environment or devices.

4. Disconnect the analyzer from the power supply.
5. Heated devices: Wait until the device has cooled down.
6. Open the right enclosure side by loosening the 4 screws.
7. Disconnect the lines from the bushing of the inner wall of the enclosure.
  - Devices with hoses: Remove the hose clamps at the gas bushings and remove the hoses.
  - Devices with pipes: Loosen the screws on the gas bushings. Be sure not to damage the gaskets.
8. The optical bench is fastened in a mounting rail. It is attached with 4 screws to the rear of the enclosure. Loosen these four screws.
9. Remove the optical bench with the mounting rail.

To install, carry out the above steps in reverse order.

Then check the gas path for leak tightness (see "Leak test of gas paths (Page 78)" section on this).



### 10.10.2.2 Design of the analyzer unit

#### Design of the 1-channel analyzer unit

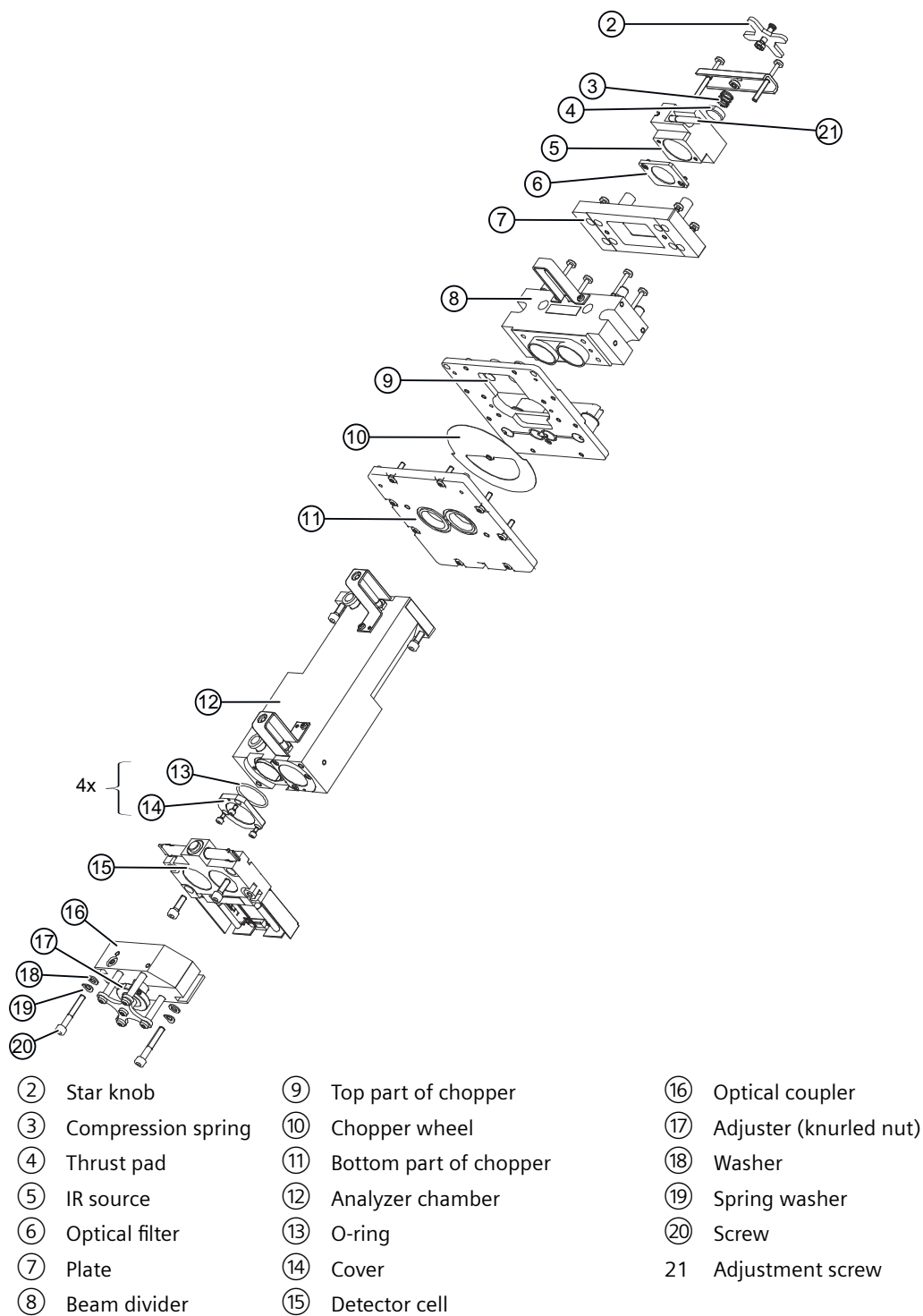

Figure 10-6 1-channel analyzer unit for ULTRAMAT 6F

Design of the 2R analyzer unit

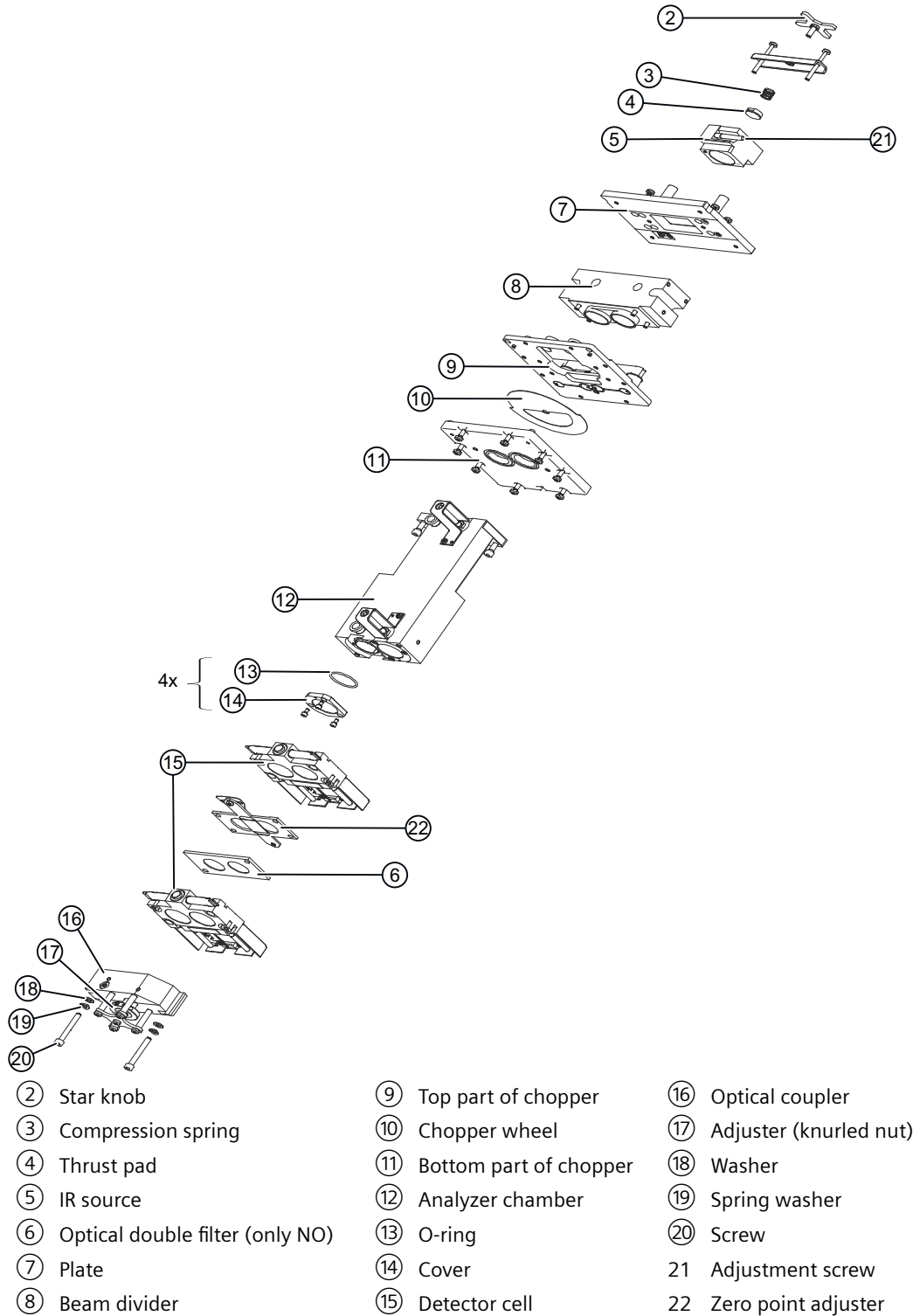

Figure 10-7 Analyzer unit for ULTRAMAT 6F-2R

## How the individual components work

### Mode of operation

The mode of operation of this device is described in section Operating principle (Page 27). The installation and function of individual components are explained below.

### IR source

The IR source consists of a round ceramic plate, in which a resistance wire is embedded. It is heated to 700 °C with a load-independent current of approx. 0.5 A (11 watts). The IR source housing is sealed gas-tight to the outside. For certain measuring tasks, it is equipped with an absorber cartridge for CO<sub>2</sub>. An aluminum framed optical filter can be screwed onto the IR source itself. The IR source is constructed in a movable way.

There are different versions of the IR source for field devices and rack units.

### Beam divider

The beam divider is used for dividing the IR beam into a sample beam and a reference beam. Because of its gas filling it is used at the same as a filter.

### Chopper

The chopper is a rotating black disk which converts the continuous IR beam into a pulsating beam.

The disk is balanced through its asymmetrical rim design. It is used at the same time to interrupt a light barrier that supplies the square-wave voltage for the phase controlled rectifier.

The chopper wheel is driven by current that is induced into the disk by magnet coils (excitation frequency 1 kHz). Through the phase shift of the voltage in one coil each, the speed can be changed in the range from 10 to 15 Hz and thus also controlled. Digital control is used.

### Analyzer chamber

The analyzer chamber consists of a sample side and a reference side. As a rule the reference side is filled with N<sub>2</sub> and equipped with a water vapor absorber cartridge.

### Detector

The detector represents a gas-tight volume system filled with the gas type to be measured. It reacts to the pulsed IR beam with a temperature rise, pressure increase and compensation flow via a microflow sensor (two heated miniature nickel resistors). This resistance change is used for the signal evaluation.

With 2R channels, two detectors are mounted in series. A zero point adjuster is located in between. The zero point adjuster allows independent calibration of both detectors. It mainly

### 10.10 ULTRAMAT channel

affects the first detector (as seen from the first IR source). The second detector is only slightly influenced.

Special device versions also contain a dual filter carrier with two optical filters between the zero point adjuster and the rear detector.

#### Optical coupler

The optical coupler lengthens the lower detector cell layer optically. The infrared absorption in the second detector cell layer is varied by changing the slider position. Thus it is possible to individually minimize the influence of interfering components.

With 2R devices the optical coupler mainly affects the second detector (as seen from the IR source).

Specific device versions are equipped with a sealed coupler that is filled with a desiccant. This prevents measuring errors caused by fluctuations in the ambient humidity.

#### 10.10.2.3 Repair of the analyzer unit

If you want to perform repair or maintenance work on the analyzer unit, you must first remove the analyzer unit from the analyzer. Proceed as follows for this:

1. **Only ULTRAMAT 6E:** Unscrew the heat sink (1) from the IR source.
2. Unscrew the optical coupler.

---

##### Note

##### **Incorrect mounting position of the optical coupler**

Note that the optical coupler is designed symmetrically. We therefore recommend marking the mounting position of the optical coupler before starting maintenance work on the analyzer unit.

---

Remount the optical coupler only after adjusting the IR source symmetry (see "IR source adjustment for symmetry and zero voltage (Page 196)").

#### Replacement of the IR source

A replacement of the IR source is only necessary if it is defective. To do this, proceed as follows:

1. **Only ULTRAMAT 6E:** Unscrew the heat sink (1) from the IR source.
2. Unsolder the IR source supply line from the chopper board.

3. Loosen the four mounting screws and remove the IR source with the mounting plate.
4. If necessary, replace the optical filter of the defective IR source and mount it on the spare part.

**NOTICE****Malfunction**

For devices used for the measured component nitrogen monoxide (NO), always observe the mounting position of the optical filter. The front and back of the filter must not be interchanged.

Reinstallation of the new IR source takes place in reverse order.

You then adjust the IR source symmetry as described in section "IR source adjustment for symmetry and zero voltage (Page 196)".

### Replacement of the beam divider

A replacement of the beam divider is only necessary if it is physically damaged or the absorbing liquid is exhausted in the absorber tube.

To replace the beam divider, proceed as follows:

1. Loosen the four mounting screws of the IR source and fold down the IR source with the mounting plate. It is not necessary to unsolder the IR source from the chopper board.
2. Loosen the four countersunk screws.  
The beam divider is now freely moveable.
3. Remove the beam divider pulling it upwards.

Reinstallation of the new beam divider takes place in reverse order.

### Replacement of the chopper

A replacement of the chopper is necessary if it does not rotate anymore.

Note that the error message S2 "Chopper error" (see "Faults (Page 210)") does not necessarily indicate a physical defect of the chopper. It is also possible for the IR source or beam divider to cause this message.

To replace the chopper, proceed as follows:

1. Remove the IR source (see "Replacement of the IR source (Page 188)").
2. Remove the beam divider.
3. Loosen the two screws with which the analyzer chamber is attached to the chopper.  
Now the chopper is free and can be removed.

To replace the bottom part of the chopper, loosen the eight screws on the rim and the remove the bottom part of the chopper and the chopper wheel.

<b>NOTICE</b>
<b>Damage to sensitive bearings</b> Ensure extreme cleanliness during work.

Reinstallation of the new chopper takes place in reverse order.

<b>NOTICE</b>
<b>Malfunction</b> A phase adjustment is mandatory after replacement of the chopper or the bottom part of the chopper (see "ULTRAMAT 6 (Page 158)").

**See also**

Replacement of the beam divider (Page 189)

**Removing the detector**

To clean the analyzer chamber, the detector must first be removed from the analyzer unit. Proceed as follows for this:

1. Unscrew the optical coupler.
2. Unscrew the detector cell.
3. Unscrew the analyzer chamber from the bottom part of the chopper.
4. Unscrew the windows of the sample side

<b>NOTICE</b>
<b>Damage to sensitive components</b> The IR-permeable windows made of CaF <sub>2</sub> are very sensitive to mechanical stress. <ul style="list-style-type: none"><li>• Handle the windows made of CaF<sub>2</sub> with care when installing or removing them.</li><li>• Always tighten the screws evenly when reinstalling them.</li></ul>

5. Remove the O-rings from the window support.
6. Carefully clean the analyzer chamber.

To install, carry out the above steps in reverse order, whereby the coupler is not screwed on for the moment.

## Analyzer chamber

<b>NOTICE</b>
<b>Damage to sensitive bearings</b>
Ensure extreme cleanliness during work.

### Length of the analyzer chamber

The product of the gas concentration (%) to be measured and the cell length (mm) represents an important benchmark (%mm) of the measurement, for example for sag of the characteristic or sensitivity.

Analyzer chambers of different optical lengths are used depending on the measured component and application:

- 0.2 mm
- 0.6 mm
- 2.0 mm
- 6.0 mm
- 20.0 mm
- 60.0 mm
- 90.0 mm
- 180.0 mm

An exact overview is provided in the table in section Analyzer units - Overview (Page 235).

The cells of 20 to 180 mm are lined with a thin sheet of aluminum or tantalum.

These cells can be opened for cleaning. The following cleaning agents should be used: alcohol, ether, distilled water and a bottle brush wrapped with a lint-free cloth (e.g. nylon).

### Removal of the analyzer chamber

A removal of the analyzer chamber is required when it is damaged, the absorber fluids are exhausted on the reference gas side or the analyzer chamber is contaminated.

The analyzer chamber must be cleaned if the zero point of the ULTRAMAT 6 drifts. Since contamination of the analyzer chamber is mostly a result of a defective or inadequate gas preparation, we recommend a critical check of the gas preparation in such cases.

Remove the analyzer chamber as follows:

1. Unscrew the detector.
2. Loosen the side mounting of the analyzer chamber, if necessary.
3. Unscrew the analyzer chamber from the bottom part of the chopper.

To install a new analyzer chamber, carry out the above steps in reverse order.

### Cleaning the analyzer chamber

Proceed as follows for this:

- Remove the analyzer chamber (see "Removal of the analyzer chamber")
- Unscrew the windows on the sample side.
- Remove the O-rings.
- Screw on the windows evenly.

The sample side of the analyzer chamber can be carefully cleaned with a lint-free cloth (e.g. nylon). Alcohol, ether or distilled water can be used as the cleaning agent. When cleaning long chambers, ensure that the thin lining is not creased or damaged.

The CaF<sub>2</sub> windows can also be cleaned carefully.

Before assembly and reinstallation, the chambers must be thoroughly dry and should therefore be purged up to 30 min with N<sub>2</sub> or oil-free compressed air.

Proceed as follows for assembly:

1. Put the O-rings on the window support or carefully around the lining.
2. Screw on the window support. Avoid mechanical stresses by tightening the screws as evenly as possible.

### Removal the optical coupler

Proceed as follows when removing the optical coupler:

1. Select the top side of the optical coupler.
2. Remove the mounting screws.
3. Remove the optical coupler.

To install, carry out the above steps in reverse order. After each removal of the optical coupler, perform a calibration of the analyzer unit, see section "Calibration of the analyzer unit (Page 192)".

### Reinstallation

Reinstallation takes place in the reverse order.

For devices with pipes, check the tightness of all connection parts of the gas path after the installation. Tighten the nuts again, if necessary.

Then carry out a leak test according to section "Leak test of gas paths (Page 78)".

### 10.10.2.4 Calibration of the analyzer unit

#### Principles

The sample gas channel is opened and closed again during one revolution of the chopper and at the same time the reference gas channel is closed and opened again. The IR beam modulated in this way then reaches the gas layers of the detector with the same intensity but inversely.



As a result of the radiation absorption, the temperature of the gas increases in the detector volumes on the left and decreases in the detector volumes on the right. The gas expansion of one cell is compensated through gas contraction in the other cell of the same layer.

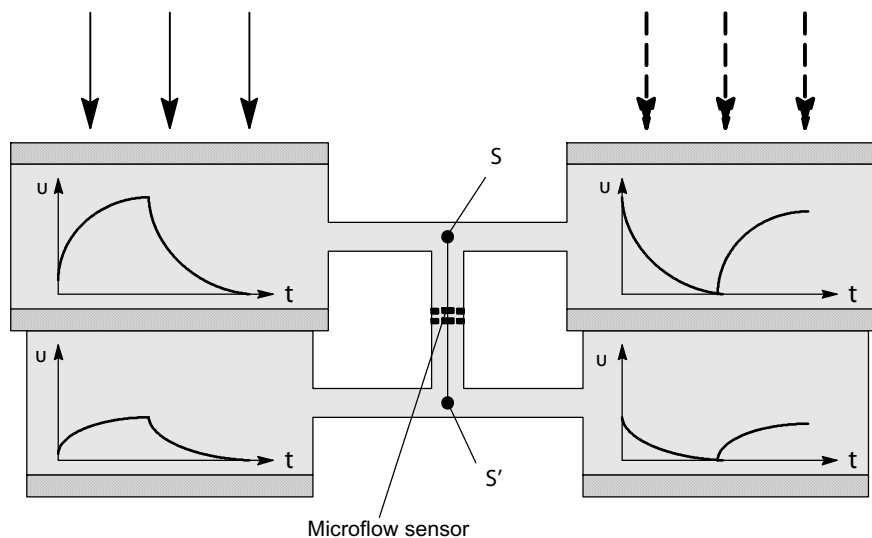

Figure 10-8 Dual-layer detector

If the heating procedures in the top and bottom gas layers on the left and right have exactly the same amplitude and phase relation, no pulsation flow occurs in the connection channel between the pneumatic focal points S and S' (see image), meaning that no signal is output by the microflow sensor (balanced pneumatic bridge).

A pulsed flow is produced in the microflow sensor when sample gas is present in the sample chamber. This flow is converted by a phase-controlled rectifier into an electric signal. To ensure optimum signal processing, the analyzer unit must be calibrated correctly.

This means:

- In the absence of IR-active gases, the radiation amplitudes or signal components in the detector on the sample gas and reference gas sides must be equal (zero setting)
- The modulated IR radiation of the sample gas and reference gas channel must be exactly inverse (minimization of zero voltage)
- The phase-controlled rectifier must be optimized with regard to the detector signals (signal phase adjustment)

## General information on calibration procedure

The following description refers to the mechanical calibration of standard devices.

The calibration of devices with physically suppressed zero point (see section "Measuring ranges with suppressed zero point (Page 82)") differs from the procedure described here. In such a case, please contact Technical Support: CGA Help Desk (<https://support.industry.siemens.com/My/ww/en/requests#createRequest>)

The ULTRAMAT 6 can measure either one or two components with an optical bench. The latter is a 2R detector with 2 detector cells in series. The particularities of the mechanical calibration of 2R detectors are explained at the end of each step.

**Note**

**False results for devices used to measure of CO<sub>2</sub>**

Avoid breathing into the device during calibration.

**Preparation**

1. Ensure that the following parts are removed:
  - Optical coupler
  - Heat sink (for rack units)
2. Fit the optical bench back into the device again.
3. Connect the device to all gas supply and discharge lines.
4. Lay the optical coupler for the thermal compensation in the device.
5. Connect the power supply.

 <b>WARNING</b>
<b>Dangerous contact voltage</b>
When working on the open enclosure, live parts are accessible that may cause death or injury due to electric shock if touched.
<ul style="list-style-type: none"><li>• Shield these points well while working.</li></ul>

6. Let the device warm up for at least 1 hour and if possible for 2 hours.
7. Ensure that the sample gas outlet and, if applicable, the reference gas outlet are connected to a suitable disposal unit.
8. Connect the sample gas inlet to nitrogen (100%).  
No flow is necessary.

**Phase adjustment**

<b>NOTICE</b>
<b>False measurement results due to incorrect adjustments</b>
Under no circumstances may the optical coupler be mounted during the phase adjustment.
After replacement of the analyzer chamber and/or detector cell, the factory-set temperature characteristic may be altered slightly. If such a temperature error is determined, it can be compensated for with function 86.

Proceed as follows to perform the phase adjustment:

1. Check whether the optical coupler has been removed.
2. Insert an approx. 3 cm wide paper strip between the analyzer chamber and the detector on the sample gas side.  
The maximum measured value possible is simulated by inserting the paper strip.
3. Call up function 84 (see Phase adjustment)
4. Start the phase adjustment by pressing the respective softkey.
5. After completion of the phase adjustment, save the new phase angle by pressing the <MEAS> key and Yes key (softkey).
6. Remove the paper strip again.

### Phase adjustment for 2R devices

Perform the phase adjustment as follows:

1. Check whether the optical coupler has been removed.
2. Insert an approx. 3 cm wide paper strip between the analyzer chamber and the detector on the sample gas side.  
The maximum measured value possible is simulated by inserting the paper strip.
3. Call up function 84 (see phase adjustment) for the first measuring component
4. Start the phase adjustment by pressing the respective softkey.
5. After completion of the phase adjustment, save the new phase angle by pressing the <MEAS> key and Yes key (softkey).
6. Repeat steps 3 to 5 for the second measured component.
7. Remove the paper strip again.

### Remarks

In rack units, analyzer units that are intended to be used for measurement of CO<sub>2</sub> are sealed up to the CO<sub>2</sub> detector cell by O-rings. Therefore, on such devices, you must first loosen the detector a little so that the paper strip is not hindered by the O-ring.

A possible alternative to the use of a paper strip is to pass a gas containing nitrogen and a high concentration of the measured component (end-of-scale value or higher) into the analyzer unit.

### See also

Phase adjustment (function 84) (Page 158)

**IR source adjustment for symmetry and zero voltage**

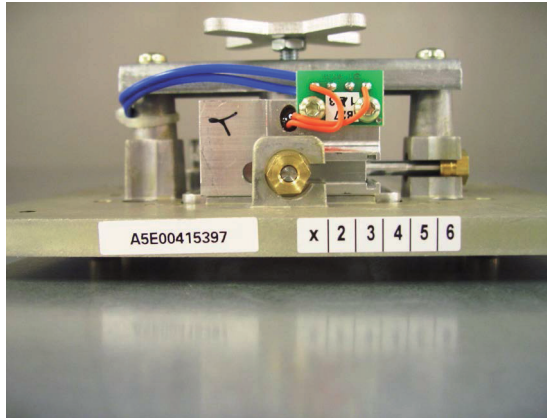

IR source unit for rack units

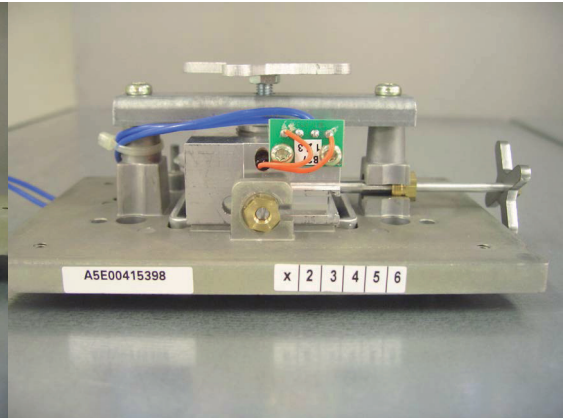

IR source unit for field devices

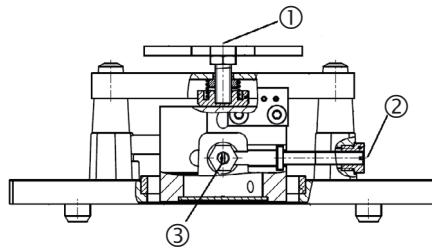

IR source for rack units

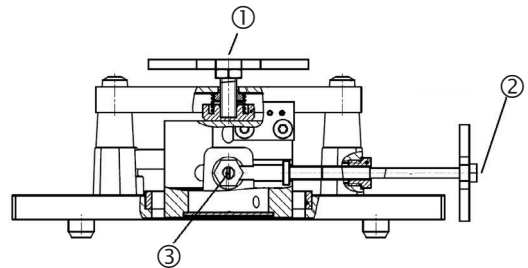

IR source for field devices

Proceed as follows to adjust the IR source:

1. Pass nitrogen gas (100%) through the sample gas side of the analyzer.
2. If the reference gas side is flow-type, also pass nitrogen gas (100%) through it.
3. Call up the function 2, figure 2 (Diagnostic values, see "Diagnostic values (function 2) (Page 103)") and observe the values for  $E(\varphi)$  and  $E(\varphi+90)$ .
4. Loosen the locking screw of the IR source ①.
5. Adjust the adjustment screw for the symmetry or the knurled nut of the IR source ② until  $E(\varphi)$  has a value between -1000 und +1000 units.
6. Adjust the adjusting screw of the zero voltage ③ until  $E(\varphi+90)$  has a value between -10000 und +10000 units.
7. Then check  $E(\varphi)$  and readjust if necessary.
8. Then check  $E(\varphi+90)$  and readjust if necessary.
9. If necessary, repeat steps 7 and 8 until the values for  $E(\varphi)$  and  $E(\varphi+90)$  lie within the required tolerance ranges.

10. Secure the IR source with the locking screw ①. Ensure that the values for  $E(\varphi)$  and  $E(\varphi+90)$  remain within the required tolerance ranges.
11. Rack units only: Screw on the heat sink again.

### Symmetry for 2R detectors

Proceed as follows:

1. Pass nitrogen gas (100%) through the sample gas side of the analyzer.
2. If the reference gas side is flow-type, also pass nitrogen gas (100%) through it.
3. Call up the function 2, figure 2 (Diagnostic values, see "Diagnostic values (function 2) (Page 103)") and observe the values for  $E(\varphi)$  and  $E(\varphi+90)$ .
4. Loosen the zero adjuster between the two detector cells.
5. Bring the zero adjuster to the middle position (neutral setting).
6. Loosen the locking screw of the IR source ①.
7. Move the IR source and the zero adjuster so that  $E(\varphi)$  has a value between -1000 und +1000 units. Since both corrections influence each other, the adjustment may have to be repeated.
8. Adjust the adjusting screw of the zero voltage ③ until  $E(\varphi+90)$  has a value between -10000 und +10000 units.
9. Then check  $E(\varphi)$  and readjust if necessary.
10. Secure the locking screw of the IR source ①. Ensure that the values for  $E(\varphi)$  and  $E(\varphi+90)$  remain within the required tolerance ranges.
11. Rack units only: Screw on the heat sink again.

### Coupler-side adjustment for symmetry and zero voltage

Proceed as follows for this:

1. Continue passing nitrogen gas (100%) through the sample gas side of the analyzer.
2. If the reference gas side is flow-type, keep passing nitrogen gas (100%) through it as well
3. Call up the function 2, figure 2 (Diagnostic values, see "Diagnostic values (function 2) (Page 103)") and observe the values for  $E(\varphi)$  and  $E(\varphi+90)$ .
4. Screw on the optical coupler in a way that it can just still be moved. Ensure that the mounting position is correct (marking, see "Removal the optical coupler (Page 192)").
5. Move the optical coupler so that  $E(\varphi)$  has a value between -1000 und +1000 units.
6. Tighten the screws of the optical coupler. In the process ensure that the value for  $E(\varphi)$  stays within the required tolerance range.
7. Loosen the adjusting screw of the zero voltage.
8. Adjust the adjusting screw of the zero voltage until  $E(\varphi+90)$  has a value between -10000 und +10000 units.

9. Tighten the adjusting screw of the zero voltage again, and ensure that the values for  $E(\varphi)$  and  $E(\varphi+90)$  remain within the required tolerance ranges.
10. Rack units only: Screw on the heat sink again.

### Coupler-side symmetry and zero voltage for 2R detectors.

Proceed as follows:

1. Continue passing nitrogen gas (100%) through the sample gas side of the analyzer.
2. If the reference gas side is flow-type, keep passing nitrogen gas (100%) through it as well
3. Call up the function 2, figure 2 (Diagnostic values, see "Diagnostic values (function 2) (Page 103)") and observe the values for  $E(\varphi)$  and  $E(\varphi+90)$ .
4. Screw on the optical coupler in a way that it can just still be moved. Ensure that the mounting position is correct (marking, see "Removal the optical coupler (Page 192)").
5. Move the optical coupler and the zero point adjuster so that  $E(\varphi)$  has a value between -1000 und +1000 units.
6. Tighten the screws of the optical coupler. In the process ensure that the value for  $E(\varphi)$  stays within the required tolerance range.
7. Loosen the adjusting screw of the zero voltage.
8. Adjust the adjusting screw of the zero voltage until  $E(\varphi+90)$  has a value between -10000 und +10000 units.
9. Tighten the adjusting screw of the zero voltage again, and ensure that the values for  $E(\varphi)$  and  $E(\varphi+90)$  remain within the required tolerance ranges.

## 10.10.3 Compensation of influencing variables

### 10.10.3.1 Pressure compensation

For physical reasons the measured value display is dependent on the sample gas pressure. With an open sample gas discharge line, variations in atmospheric pressure have an effect, whereas with a closed sample gas circuit (such as when sample gas is discharged to the process) only the current pressure in the cell (max. 1500 hPa absolute permitted) is influential. The influence of atmospheric pressure in the range of 700 to 1200 hPa is mostly compensated automatically using the installed pressure sensor. With a closed sample gas circuit, the influence of pressure in the range of 700 to 1500 hPa (absolute) must be compensated using an external pressure sensor. The internal pressure compensation must be switched to external pressure compensation and the parameters of the external pressure sensor must be entered. This is done with function 82. The internal pressure compensation has already been set at the factory.

#### Compensation of the influence of pressure in the zero point

If a device works with suppressed zero point (e.g. 70% CO for a CO measuring range of 70 to 80%), a gas concentration that is subject to a pressure fluctuation also has an effect on the zero point.

### 10.10.3.2 Temperature compensation

The temperature compensation in the zero point and measured value was already set at the factory. After replacement of the analyzer chamber and/or detector cell, the factory-set temperature characteristic may be altered slightly. If such a temperature error is determined, it can be compensated with function 86.

---

**Note**

Dirty analyzer chambers can lead to an additional temperature error in the zero point and measured value.

---

#### Compensation of the influence of temperature in the zero point

Temperature influences in the zero point have an impact in particular with sensitive measuring ranges because (e. g. for dual-trace NDIR devices) the zero point is always based on the compensation of two radiation intensities.

#### Compensation of the influence of temperature in the measured value

For non-thermostatically controlled devices, the sensitivity is influenced by temperature fluctuations. Theoretically, the deviation in the measured value is

$1/273 \times 100 = 0.37\%$  of the "reference value" per 1 °C (1.8°F) temperature increase.

### 10.10.3.3 Compensation of the cross-sensitivity

#### Compensation of the cross-sensitivity through optical coupler

The operating principle of the optical coupler is described in section "Operating principle (Page 27)" It was set at the factory and must only be recalibrated in exceptional cases (e.g.: after replacement of the detector).

The detector including the coupler has been factory set in a way that the cross-sensitivity is minimized for water vapor. Because of the different characteristics of individual gases, it is generally not possible to achieve zero (elimination of the influence) consistently for all concentrations of a cross-sensitive gas or for multiple gases. Generally we can therefore only speak of a minimization.

Proceed as follows for compensation of the cross-sensitivity:

1. Adjust the zero point as described in section "Calibration of the zero point (function 20) (Page 106)".
2. Pass nitrogen gas (100%) through the analyzer chamber.

 <b>WARNING</b>
<b>Opened device in energized state</b>
Danger of electrocution in case of improper electrical connection
Danger of explosion in hazardous areas
<ul style="list-style-type: none"><li>• Ensure that an explosive atmosphere is not present when opening the device (hot work permit).</li></ul>

3. Switch on the device.
4. Call up the measuring range 1 with function 40.
5. Then apply interference gas and observe the measured value.  
If the measured value increases, purge the analyzer chamber with nitrogen and rotate the knurled nut to the left until a value of zero or close to zero is displayed in the display.
6. Apply the interference gas again and repeat step 5 until an optimal result exists.
7. If the measured value decreases in step 5, turn the knurled nut to the right.

### Compensation of cross-sensitivity through second gas analyzer

The sensitivity of a gas component other than the one to be measured can not only be compensated with the optical coupler but also with a second measurement channel or a measuring instrument that measures this interfering component. If a second measuring instrument is used, a signal (0/2/4 to 20 mA or 0/1/2 to 10 V) must be supplied via analog output 1 for a specific interference gas concentration (see Interference correction with variable interference influence via analog input (Page 153)).

If this is, for example, the channel of an ULTRAMAT 6, the correction can be made via ELAN for networked systems (see function 83 (Page 155)).

With a constant interference gas concentration, a constant value is added to or subtracted from the measured value in measuring mode (without use of a second analyzer), depending on whether the cross-interference is positive or negative.



## 10.11 OXYMAT channel

### 10.11.1 Analyzer unit

#### 10.11.1.1 Design of the analyzer unit

The analyzer unit consists of three functional parts: magnetic circuit, sample chamber and measuring head.

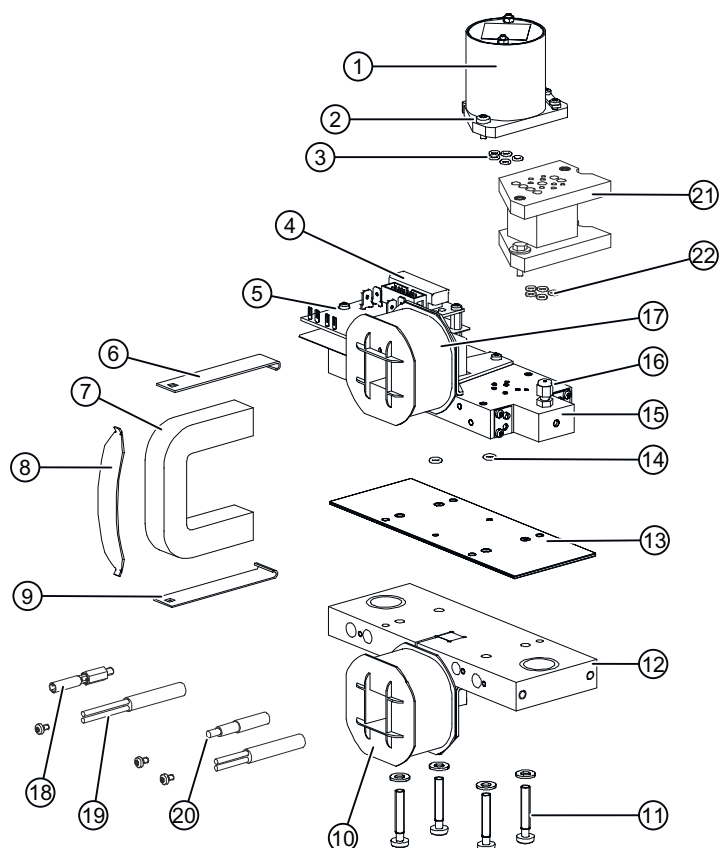

- |                               |                             |                                      |
|-------------------------------|-----------------------------|--------------------------------------|
| ① Measuring head              | ⑨ Retaining plate           | ⑰ Coil                               |
| ② Restrictor plate            | ⑩ Coil                      | Additional parts for heated devices: |
| ③ O-ring for measuring head   | ⑪ Mounting screws           | ⑱ Temperature sensor                 |
| ④ Pressure sensor             | ⑫ Bottom part of casing     | ⑲ Heating cartridge                  |
| ⑤ Electrical connection board | ⑬ Sample chamber            | ⑳ Temperature fuse                   |
| ⑥ Retaining plate             | ⑭ O-ring for sample chamber | 21 O-rings for spacer                |
| ⑦ Cut strip-wound core        | ⑮ Top part of casing        | 22 Spacer                            |
| ⑧ Tension spring              | ⑯ Reference gas connection  |                                      |

Figure 10-9 Analyzer unit of OXYMAT 6E

### **Magnet circuit**

A magnetic pole shoe is glued into each part of the casing. The cut strip-wound core placed upon it is held down by a tension spring. This design deflects the forces of the magnetostriction away from the sample chamber.

### **Sample chamber**

The sample chamber consists of a 1-mm thick center plate in which the sample gas channel is punched, and two 0.3-mm thick cover plates, which contain the openings for the supply of the sample gas and the reference gas. Since the sample gas only comes into contact with the chamber plates, the OXYMAT 6 can be used for very many sample gas compositions. Reference gas passes through the other channels of the measuring system. In the fully-assembled analyzer unit, the sample chamber is placed between the two parts of the casing.

### **Measuring head**

The microflow sensor of the measuring circuit is located in the measuring head. This is installed in a thermostatted aluminum block. The strong magnetic field needed for a sufficient measuring effect causes interferences in the microflow sensor. To eliminate this effect, the aluminum block with the preamplifier electronics is shielded.

This shield is composed of

- Shielding cup
- Restrictor plate

This includes restrictors, the function of which is described in section "OXYMAT 6 (Page 28)"

Both parts are made of a material with high permeability.

### **Spacer**

For the heated version of the OXYMAT 6F, a spacer made of a material with low thermal conductivity is located between the measuring head and the top part of the casing.

## **Reference gas path**

The reference gas line between the connecting sockets and the analyzer unit consists of a steel pipe, which is crimped. This acts as a restrictor which decreases the active reference gas pressure to such an extent that a flow rate of 5 to 10 ml/min results (correspondingly 10 to 20 ml/min for flow-type compensation branch (ordering option)).

Depending on the sample gas primary pressure (see section "Reference gases (OXYMAT 6) (Page 270)"), a reference gas line with high (approx. 2000 to 4000 hPa) or low (approx. 100 hPa) restrictor effect is installed in the device.

The reference gas line is installed and removed as follows:

1. Loosen the reference gas line at the connection and on the analyzer unit.
2. Remove the reference gas line.

To install, carry out the above steps in reverse order.

**NOTICE****Soiled reference gas path**

It is important to ensure that no liquid or dust can get inside the connecting socket or the reference gas line.

The measurement function may deteriorate or the device may even fail as a result.

### 10.11.1.2 Disassembling the analyzer section

#### Removing the measuring head

Proceed as follows for this:

1. Pull out the measuring head connector cable out of its socket.
2. Loosen socket screws.  
Now you can remove the measuring head.

To install, carry out the above steps in reverse order. It is important here to ensure that all O-rings are re-inserted. In addition, the shielding cup must never be removed from the measuring head.

#### Cleaning the sample chamber

The sample chamber is not particularly susceptible to faults. If condensation passes through the analyzer as a result of a fault in the gas conditioning, although there is a temporary fault in the measurement (highly oscillating values are displayed), the device is ready for measurements again once the sample chamber has dried out. However, one of the inlets for the reference gas may become clogged and measurement may fail if there is extremely high contamination. This will be apparent from extremely strong fluctuations in the display of measured values. In such situations, you need to clean the sample chamber as follows:

1. Remove the measuring head (as described in the section "Removing the measuring head")
2. Blow compressed gas into the sample chamber to clean it. The compressed air escapes through the sample gas outlet and the reference gas channels in the upper part of the casing. You can also purge the sample chamber with trichloroethylene or alcohol. In such situations, you need to dry it afterwards with a stream of dry air.
3. Install the measuring head again.

If the cleaning procedure described above does not produce the desired result, the sample chamber must be completely removed and cleaned in an ultrasonic bath. If this measure does not succeed, you may need to replace the sample chamber.

### Removing the analyzer unit in the field device

Proceed as follows for this:

1. Loosen the plug-in connections between the analyzer unit and pass-through board.
2. Remove the reference gas supply pipe at the pipe pass-through.
3. Unscrew the sample gas supply line and exhaust line from the device.
4. Remove the fastening nuts from the sample gas pass-through fitting.
5. Unscrew the nut of the analyzer unit from the inside of the rear panel.
6. Remove the analyzer unit with mounting block.
7. Unscrew the analyzer unit from the mounting block.

### Removing the analyzer unit in the rack unit

Proceed as follows for this:

1. Pull out the measuring head connector cable out of its socket on the magnetic field terminal board.
2. Remove the reference gas inlet hose from the analyzer section.
3. Disconnect the hoses at a suitable location (for version with hoses) or Loosen the pipe pass-through at the back wall of the housing (version with pipes).
4. Remove the analyzer unit together with the retaining plate and remove both parts from the analyzer  
(for version with pipes, together with the sample gas lines).
5. Remove the analyzer section from the retaining plate.
6. Remove the sample gas lines from the analyzer section.

### Removing the sample chamber

Proceed as follows for this:

1. Remove the measuring head (as described in the section "Removing the measuring head")
2. Insert a suitable tool (e.g. screwdriver) between the retaining plate and the cut strip-wound core (U core) and pry out the retaining plate until the tension spring is released.
3. Remove cut strip-wound core and retaining plate.
4. Loosen the four mounting screws and pull the two parts of the casing apart.

The sample chamber is now accessible and can be removed. To install, carry out the above steps in reverse order. It is important to note the following in this regard:

- Check all O-rings to ensure they are OK, and replace them if they are damaged.
- Tighten the mounting screws diagonally opposed with a torque of 6 Nm.

## Calibration

Each time a measuring head is replaced or the analyzer unit is reassembled, you need to recalibrate the device, see "Calibration (Page 105)".

## Leak test

A leak test must be carried out following every maintenance measure that affects the analyzer unit or the gas path, see "Leak test of gas paths (Page 78)". If the device fails the leak test, replace all seals and hoses or pipes.

### 10.11.2 Calibrating the reference gas pressure switch

The reference gas pressure switch of a delivered OXYMAT 6 analyzer has been preset to a switching point of approx. 2000 hPa (2 bar). If measurements are to be taken with a higher gas pressure, the reference gas pressure and thus the pressure switching point of the reference gas pressure switch must be increased accordingly (also see section "Reference gases (OXYMAT 6) (Page 270)" on this).

To adjust the reference gas pressure switch, a suitable pressure gauge has to be connected to the sample gas inlet using a T-piece. A setscrew (hexagon socket-head) for adjusting the pressure switching point is located between the terminal contacts of the pressure switch. The pressure switching point is adjusted as follows:

1. To increase the switching point, turn the screw clockwise until the switch contact opens (check with continuity tester) at a defined pressure (read at pressure gauge).
2. The lower switching point can be determined by lowering the pressure until the switching contact closes again (lower switching point).

There is a hysteresis < 800 hPa (0.8 bar) between the upper and lower switching point. The pressure switch can be placed under pressure to a maximum of 6000 hPa (6 bar).

### 10.11.3 Removing the sample gas restrictor

If the sample gas restrictor is clogged by condensate and therefore needs to be cleaned, or if it is a hindrance to the measurement task for other reasons (e.g. due to the use of OXYMAT 6 with gas analyzers of the type ULTRAMAT 6 in certain measuring configuration), you must remove the restrictor.

10.11 OXYMAT channel

To do this, proceed as follows:

- Device version with hoses (rack units)  
The sample gas restrictor is located between the flow indicator and the analyzer unit.
  - Loosen the hose section in which the restrictor is located.
  - Use a suitable object (stick, etc.) to push the restrictor out of the hose.
- Device version with pipes (rack units)  
The sample gas restrictor is located in the sample gas inlet fitting on the inside of the device.
  - Remove the internal sample gas line from the connection fitting of the sample gas inlet.
  - Unscrew the restrictor from the connection fitting.
- Device version with pipes (field devices)  
The sample gas restrictor is located in the connection fitting of the sample gas inlet on the outside of the device.
  - Remove the sample gas connection line.
  - Unscrew the restrictor from the connection fitting.

## Messages

The device is able to detect functional irregularities. Such irregularities appear, depending on the severity, as either a 'Maintenance request' or 'Fault' in the status line of the display. At the same time, they are recorded in the logbook (function 3) and can also be called up there. Logbook entries which have to be acknowledged are identified by a dot.

### Latching

Certain logbook messages are latching (e. g. "Magnetic field supply faulty"). To reset such messages, they must be acknowledged (manually or via binary input). However, they appear immediately again if the cause of the message has not been eliminated.

Note: Acknowledgment via a binary input should be carried out only with brief setting (approx. 1 s) since latching of the associated fault message otherwise remains ineffective. When a new message appears, the log stored in the logbook is shifted back one place in the memory. Overall there are 32 memory cells so that the oldest of the 32 logs is overwritten by a new log. A power failure deletes all logs.

It cannot be excluded that all pages of the logbook are rapidly used up in the case of a high message rate (logbook "overflows"). It is possible that unacknowledged messages are no longer visible in the logbook, but are nevertheless still saved. These entries will continue to result in fault messages. Deletion is only possible if the entries are deleted completely using operator function 60 or in the main menu through "5555 ENTER".

Logbook entries that must be acknowledged were marked with a "Q" under the number in the No. column in the lists in the sections Maintenance requests (Page 208) and Faults (Page 210).

You can disable the logbook or delete the messages contained in it using function 60. The occurrence of larger amounts of messages is especially distracting during test operation. You can switch off the logging of messages using function 87. In normal operation, it is recommended that this option not be used. You should not do this during normal operation, since you need to be able to detect any faults that may occur.

### Maintenance requests

If there are indications of changes to device-internal parameters, "Maintenance request" appears in the status line. Changes of this type do not affect the measurement capability of the device or affect it only minimally the first time they appear. In order to continue to guarantee the measuring capability, however, it may be necessary to carry out remedial measures.

If the relay output of the device was configured accordingly (see also Relay outputs (function 71) (Page 136)), an external signaling may also occur.

### Fault

Defects in the hardware or changes in the device parameters that would make the device unfit to take measurements trigger a fault message. "Fault" then appears in the status line if the device is in measuring mode. The measuring value flashes and remedial measures must always be taken here.

11.1 Maintenance requests

As with the maintenance request, an external signal can be sent via the relay output (Relay outputs (function 71) (Page 136)). In addition the analog output can be applied to the output current area, which was set by means of Measured value memory (function 77) (Page 145).

Further messages

In addition to the maintenance request and fault messages, other important messages are listed in the logbook:

- LIM 1 (... 4) (high/low violation of limits) and
- CTRL (function check)

11.1 Maintenance requests

The following error messages result in a maintenance request (output in the display) and are signaled externally if a corresponding relay has been configured using function 71.

Function 87 can be used to switch off (disable) each maintenance request individually.

Each maintenance requests labeled with "Q" in the left column of the following table must be acknowledged.

Table 11-1 Causes of maintenance requests

No.	Message	Possible causes	Remedy	Remarks
W1 Q	Calibration tolerance exceeded	Calibration gas was changed	Repeat calibration	Calibration tolerance, see also function 78; Drift of device according to technical specifications: Zero point: >1% of upper range value (URV)/week, Sensitivity: >1% of URV/week
		Drift characteristics	Check that drift is normal	
		Only <b>ULTRAMAT 6</b> : Contamination of the analyzer chambers	Clean the analyzer chamber	
W2 Q	<b>ULTRAMAT 6</b> : Zero adjustment reserve <20 %	Contamination of the analyzer chambers	Clean the analyzer chamber	Also see W1
		Drift characteristics	"Readjust IR source (see section Replacement of the IR source (Page 188))"	
	<b>OXYMAT 6</b> : Signal voltage too high for zero adjustment	Reference gas contains too much oxygen	Check reference gas	Zero gas and reference gas should be identical
		Zero gas contains too much oxygen	Check zero gas	



No.	Message	Possible causes	Remedy	Remarks
W3 Q	<b>ULTRAMAT 6:</b> Signal voltage <30% of URV during sensitivity adjustment	Incorrect calibration gas; Incorrect measuring range; Detector defective	Check: After detector replacement, calibrate full-scale value and if necessary calibrate sag	If the device measured correctly beforehand, a defect of the detector is likely.
	<b>OXYMAT 6:</b> Signal voltage too low during sensitivity adjustment	Zero gas contains too little oxygen	Check calibration gas	
		Reference gas flow is too low	Check reference gas flow and correct if necessary	
		An incorrect measuring range has been selected for the calibration	Select the correct measuring range	
W4 Q	Set clock	The device was switched off	Reenter the date and time	See function 58
W6 Q	Temperature of LCD is too high or too low	Ambient temperature outside tolerances specified in the technical specifications (5 to 45 °C)	Make sure that the ambient temperature is in the range from 5 to 45 °C	
W7 Q	<b>ULTRAMAT 6:</b> Temperature of detector cell	Temperature $\geq 70$ °C	Check ambient temperature (max. 45 °C), in particular with built-in analyzers	
	<b>OXYMAT 6:</b> Temperature of analyzer section	Ambient temperature too high ( $\geq 45$ °C)		
		Measuring head temperature too high ( $\geq 78$ °C) (only applies to non-heated model)	Contact service department	
		With a heated sample chamber: selected setpoint temperature is too low or heating is switched off. Message W7 appears until the new setpoint temperature has been reached	<b>No error</b> Wait until the analyzer unit has cooled down to the new setpoint temperature	
W8 Q	Only <b>OXYMAT 6:</b> Temperature of measuring head outside tolerance	More than $\pm 3$ °C deviation from the setpoint temperature (see also S7)	If temperature remains constant: no need for action; otherwise: contact service department	
W9	External maintenance request	Signal from external source	Check	Function 72 must be configured accordingly
W10	AUTOCAL/Check error	Tolerances that are exceeded in AUTOCAL/Check or false sample gas (assignment to the measuring range is wrong)	Perform AUTOCAL again	This message disappears only when the AUTOCAL has been successfully completed.

## 11.2 Faults

The following faults result in a fault message (output in the display) and are signaled externally if a corresponding relay has been configured using function 71. The measurement capability of the device is restricted if these messages appear. Immediate remedial measures should always be carried out here by qualified maintenance personnel.

Function 87 can be used to switch off (disable) each fault message individually.

Each maintenance requests labeled with "Q" in the left column of the following table must be acknowledged.

Table 11-2 Causes of fault messages

No.	Message	Possible causes	Remedy
S1 Q	Parameter memory test failed	EEPROM contains incorrect or incomplete data in the working range	<ol style="list-style-type: none"> <li>1. Execute RESET or switch the device off and on again. If the error message S1 appears again:</li> <li>2. Load user data (function 75)</li> <li>3. Contact service department. Make sure you leave the device in operation in order to assist the fault diagnostics of the service staff.</li> </ol>
S2 Q	<b>ULTRAMAT 6:</b> Chopper motor disrupted	Connector loose	Inform service department
		Ball bearing soiled	
		Control defective	
		IR source faulty	
	<b>OXYMAT 6:</b> Magnetic field supply defective	Ribbon cable connection interrupted	Check connection
		Motherboard faulty	contact service department
S3 Q	Microflow sensor faulty	One half of the grid has been destroyed	Replace detector ( <b>ULTRAMAT 6</b> ) or measuring head ( <b>OXYMAT 6</b> ) or contact service department
	Only <b>OXYMAT 6:</b>	Incorrect calibration	Recalibrate zero point and full-scale value
S4	External fault message	Signal from external source	Check: Function 72 must be configured accordingly

No.	Message	Possible causes	Remedy
S5 Q	<b>ULTRAMAT 6:</b> Temperature of detector cell too high or too low	Temperature of detector cell is too high ( $\geq 75$ °C)	Inform service department
		Ambient temperature outside tolerances specified in the technical specifications (5 to 45 °C)	Make sure that the ambient temperature is in the permissible range from 5 to 45 °C
	<b>OXYMAT 6:</b> Temperature of analyzer unit is too high or too low	Measuring head temperature too high ( $> 80$ °C) or too low ( $< 10$ °C), this only applies for the non-heated version	Perform restart (RESET); if this is not successful: contact service department
		Temperature sensor faulty: ⇒ Temperature rises above setpoint temperature	
		Replacement of measuring head took place with device switched on	Call up function 52 and the switch the measuring head heating off and then on again under 'Measuring head heating on/off' parameter. Check whether the measuring head temperature increases (see diagnostics screen under function 2). If no success: Inform service department.
If a low setpoint temperature is selected for a heated sample chamber or if the heating system was switched off, the Message S5 appears until the new setpoint temperature has been reached.	<b>No error</b> Wait until the analyzer unit has reached the new setpoint temperature.		
S6 Q	Heating is defective	Fuse on controller board defective	Replace defective parts or contact service department
		Controller board defective	
		Temperature fuse defective	
		Temperature sensor defective	
		Heating cartridge defective	
S7 Q	(only <b>OXYMAT 6</b> ): Temperature of measuring head outside tolerance	More than $\pm 5$ °C deviation from the setpoint temperature (75 °C or 91 °C, depending on the selected temperature of the analyzer unit)	Replace measuring head or contact service department
		Temperature of the measuring head is not plausible: (120 °C or 0 °C)	

No.	Message	Possible causes	Remedy
S8 Q	Signal of selected pressure sensor outside tolerance	<b>ULTRAMAT 6:</b> Gas flow impeded	<ol style="list-style-type: none"> <li>1. Check pressure sensor</li> <li>2. Eliminate impediment</li> <li>3. Inform service department</li> </ol>
		<b>OXYMAT 6:</b> Sample gas blocked at outlet (> 2000 hPa with internal pressure sensor or > 3000 hPa with external pressure sensor) or system pressure too high	<p><b>Caution</b> The internal pressure sensor may be destroyed if the system pressure exceeds 4000 hPa</p> <ol style="list-style-type: none"> <li>1. Take suitable measures to reduce the flow resistance at the device outlet until the sample gas is back within the tolerance limits.</li> <li>2. Regulate system pressure correspondingly</li> <li>3. Check leak-tightness (see section Preparations for commissioning (Page 77)), if leaking: contact service department</li> </ol>
		Sample gas pressure too low (< 500 hPa)	Set system pressure > 500 hPa
S9 Q	(Only <b>OXYMAT 6</b> ): Signal too high	Sample gas pressure > 3000 hPa or O <sub>2</sub> concentration in range 2000 to 3000 hPa too high	Reduce pressure or O <sub>2</sub> concentration or contact service department
S10 Q	24 h RAM/Flash check	RAM PROM	Replace motherboard or contact service department
S11	Reference gas supply has failed or is too low  (only <b>ULTRAMAT 6 with reduced flow-type reference gas compartment</b> )	Reference gas line leaks, is interrupted or blocked	Check flow of reference gas (see section Preparations for commissioning (Page 77))
		Reference gas source is empty	Connect new reference gas source
		Pressure of the reference side is too low (the pressure must be between 2000 and 4000 kPa (2 and 4 bar))	Set primary pressure to a value between 2000 and 4000 hPa (2 and 4 bar).
S12 Q	Mains power supply	Mains voltage outside tolerance limits	Line voltage must be within the specified limits specified by the rating plate
S13 Q	Hardware	Crystal or external ADC defective	Replace motherboard
S14	Measured value greater than operating full-scale value (+ 5 %)	<b>ULTRAMAT 6:</b> - Incorrect calibration gas - Built-up pressure at analyzer chamber outlet - Sample gas concentration too high	Check respectively
		<b>OXYMAT 6:</b> Sample gas pressure surpasses the pressure correction range of 2000 or 3000 hPa	Check the sample gas pressure and possibly reduce it or switch to an external pressure sensor with an appropriate measuring range
		Incorrect calibration of the measuring range	Repeat calibration and possibly check the sample test

No.	Message	Possible causes	Remedy
S 15 Q	Calibration aborted	Fault if the device is in AUTOCAL mode	Remedy the cause
		Fault in calibration via digital input	
S16	Sample gas flow is too low		Ensure sufficient flow

## 11.3 Other faults

### 11.3.1 ULTRAMAT 6

Apart from the fault messages that can be shown in the logbook, the following influences could lead to an unsteady or fluctuating display:

Table 11-3 Causes for unstable measured value display

Cause	Remedy
Large positive zero point drift	Check gas preparation (filter) Clean the analyzer chamber (see section "Removing the analyzer unit (Page 181)")
Large span drift --> Detector leaking	Replace detector (inform service department)
Sensitivity depends strongly on flow --> Exhaust gas line is restricted	Reducing the restriction
Vibration influence (oscillation of analog output) --> Interfering frequency is close to the chopper frequency or its harmonics.	Adjust the chopper frequency with function 57 in steps of $\pm 0.2$ Hz by a max. of 2 Hz and check after each step for a possible improvement.
With one of the following error profiles it is possible that the clock generation of the process electronics is defective: <ul style="list-style-type: none"> <li>Analog output remains at -1 mA or +24.5 mA</li> <li>The interfaces take on an undefined state</li> <li>The device cannot be operated</li> </ul>	Replace motherboard (inform service department)

### 11.3.2 OXYMAT 6

Apart from the fault messages that can be shown in the logbook, the following influences could lead to an unsteady or fluctuating display:

Table 11-4 Causes for unstable measured value display

Cause	Remedy
Pressure differences during the sample gas flow	A damping unit must be installed in the sample gas line
Pressure surges or variations in the sample gas outlet	The sample gas outlet must be routed separately from the outlets of other analyzers, and/or a damping unit must be installed in the sample gas outlet (pneumatic "filter chain")

## Messages

### 11.3 Other faults

Cause	Remedy
Sample chamber is contaminated. This typically happens when condensate accidentally gets into the sample chamber.	Clean the sample chamber (see section "Disassembling the analyzer unit" in chapter 6)
Sample gas flow is too high (> 1 l/min). Turbulences occur in the measuring chamber.	Restrict sample gas flow to a flow rate of < 1 l/min
Powerful shocks at the installation site	Change the magnetic field frequency and/or increase the electrical time constants
Occurrence of sporadic spikes	See also function 76; inform service department if necessary
Oscillation of the output signal	Change the magnetic field frequency
Green LED on the rear of the analyzer (rack unit) or at the bottom of the cartridge (field device) flashes in a certain sequence (not regular flashing)	Inform service department

## Decommissioning and disposal

### 12.1 Safety instructions for decommissioning

 <b>WARNING</b>
<b>Incorrect disassembly</b> The following dangers may result through incorrect disassembly: <ul style="list-style-type: none"><li>- Injury through electric shock</li><li>- Danger through emerging media when connected to the process</li><li>- Danger of explosion in hazardous area</li></ul> Observe the following for correct disassembly: <ul style="list-style-type: none"><li>• Before starting work, ensure that the power supply and pressure supply are disconnected and hot device surfaces have cooled off.</li><li>• If the device contains dangerous process media, empty the device prior to disassembly. Make sure that no media are released which are environmentally hazardous.</li><li>• Secure the remaining connections so that no damage can result if the process is started unintentionally.</li></ul>

 <b>WARNING</b>
<b>Dangerous voltage at open device</b> Danger of electrocution Danger of electrocution when the enclosure is opened or enclosure parts are removed. <ul style="list-style-type: none"><li>• Disconnect the device and wait another 10 minutes before you open the enclosure or remove enclosure parts. Ensure that the device cannot be switched back on unintentionally.</li></ul>

 <b>WARNING</b>
<b>Danger of poisoning by escaping gas</b> The device is designed for operation with toxic, lightly corrosive gases. Therefore, dangerous substances may exit from the gas lines when they are opened. <ul style="list-style-type: none"><li>• Prevent gases from exiting prior to opening or removing the device, for example:<ul style="list-style-type: none"><li>– Shut off the gas inlets and gas outlets.</li><li>– Disconnect the gas lines from the device.</li></ul></li></ul>

 <b>WARNING</b>
<b>Danger from gas lines under pressure</b> Danger of injury during maintenance work Hot, toxic or corrosive sample gases can be released when the gas lines are opened. Prevent gases from exiting prior to opening or removing the device. <ul style="list-style-type: none"><li>• Do not loosen process connections and do not remove any pressurized parts while the device is under pressure.</li><li>• Depressurize the device. Shut off the gas inlets and gas outlets. Disconnect the gas lines from the device.</li><li>• Before opening or removing the device, ensure that process media cannot be released.</li></ul>



 <b>CAUTION</b>
<b>Hot surfaces resulting from hot sample gases and heated devices</b> Danger of burns resulting from surface temperatures above 70 °C (155 °F) After being switched off, the device and its parts are still very hot. Touching can result in skin burns. <ul style="list-style-type: none"><li>• Begin the maintenance / shutting down once the device has cooled off.</li><li>• Take appropriate protective measures, for example contact protection.</li></ul>

The device may be decommissioned for the following reasons:

- Repair
- New location of use
- Scrapping

## 12.2 Decommissioning the device

Proceed as follows during decommissioning of a rack unit:

1. Make sure that gas is no longer flowing through the analyzer. Shut off all gas lines to the device.  
Ensure that no hazardous gases escape when removing the gas lines from the device.
2. If external pumps are present, switch all of them off.
3. Purge the sample gas path with air or nitrogen.
4. Disconnect the device from the power supply. Disconnect the connection to the power supply.
5. Disconnect all hose connections and pipe connections from the rear of the analyzer.  
With pipe versions, unscrew all pipes.
6. Ensure that the device cannot be started up again unintentionally.



## 12.3 Dismantling the device

### Requirement

The device has been decommissioned.

### Procedure

#### Rack unit

1. Remove the rack unit from the control cabinet or housing. To do this, loosen the fixing screws.
2. Remove the rack unit.

## 12.4 Disposing of the device

The device has to be fully emptied before the disposal. When disposing of the device observe the statutory regulations applying in the respective country of use (for example guidelines on the disposal of electronic waste).

Have the device fetched by a certified waste disposal company and disposed of in accordance with the national regulations of the country of use.

## 12.5 Information on recycling



This product is from an environmentally-friendly manufacturer and complies with the directive 2012/19/EU on Waste Electrical and Electronic Equipment (WEEE).

This product may contain substances that are potentially harmful to the environment if disposed of improperly (landfills, incineration plants). It must therefore not be disposed of in this way.

Therefore, please be environmentally conscious:

- Ensure that this product is recycled at the end of its life cycle through the relevant local facilities!
- Observe the relevant regulations in your country.



## Spare parts/accessories

### 13.1 General information

This spare parts list corresponds to the technical status of November 2020.

The nameplate shows the year of construction of the gas analyzer (coded in the production no.) (see section "Date of manufacture (Page 15)" on this).

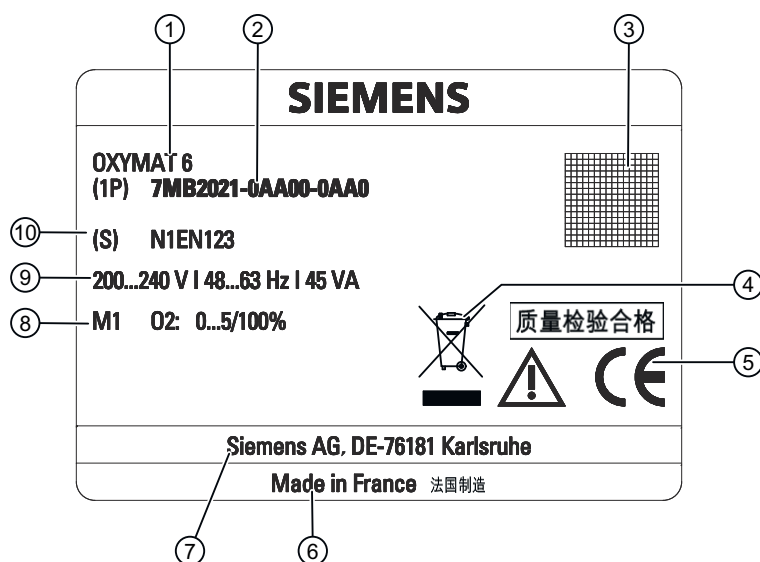

- |   |                                    |
|---|------------------------------------|
| ① Device designation                                  | ⑥ Designation of origin            |
| ② Complete article number of the device (MLFB number) | ⑦ Name and address of manufacturer |
| ③ Data matrix code                                    | ⑧ Measuring range(s)               |
| ④ Disposal information according to EN 54019          | ⑨ Type of power supply             |
| ⑤ CE conformity marking                               | ⑩ Serial number                    |

Figure 13-1 OXYMAT 6 nameplate

An order for spare parts must contain the following information:

- Quantity
- Designation of the spare part
- Article number of the spare part
- Device name, order number, and production no. of the gas analyzer for which the spare part is intended
- Special cleaning for usage in the presence of high O<sub>2</sub> concentrations (cleaned for O<sub>2</sub> service)

### Example for ordering

2 measuring heads  
C79451-A3460-B525  
for OXYMAT 6, MLFB 7MB2021-0AA00-0AA0

### Analyzer units for special applications

Contact the technical support under Support Request (<https://support.industry.siemens.com/My/ww/en/requests#createRequest>) if your device has one of the following MLFB numbers:

- 7MB2017
- 7MB2026
- 7MB2027
- 7MB2028
- 7MB2117
- 7MB2118
- 7MB2126
- 7MB2127
- 7MB2128

If your device was delivered with a specially cleaned gas path for high oxygen contents "Cleaned for O<sub>2</sub>", this must definitely be specified during the spare part acquisition. This is the only way to guarantee that the gas path will continue to comply with the special requirements of this version.

## 13.2 Overview of the modules

### 13.2.1 OXYMAT 6

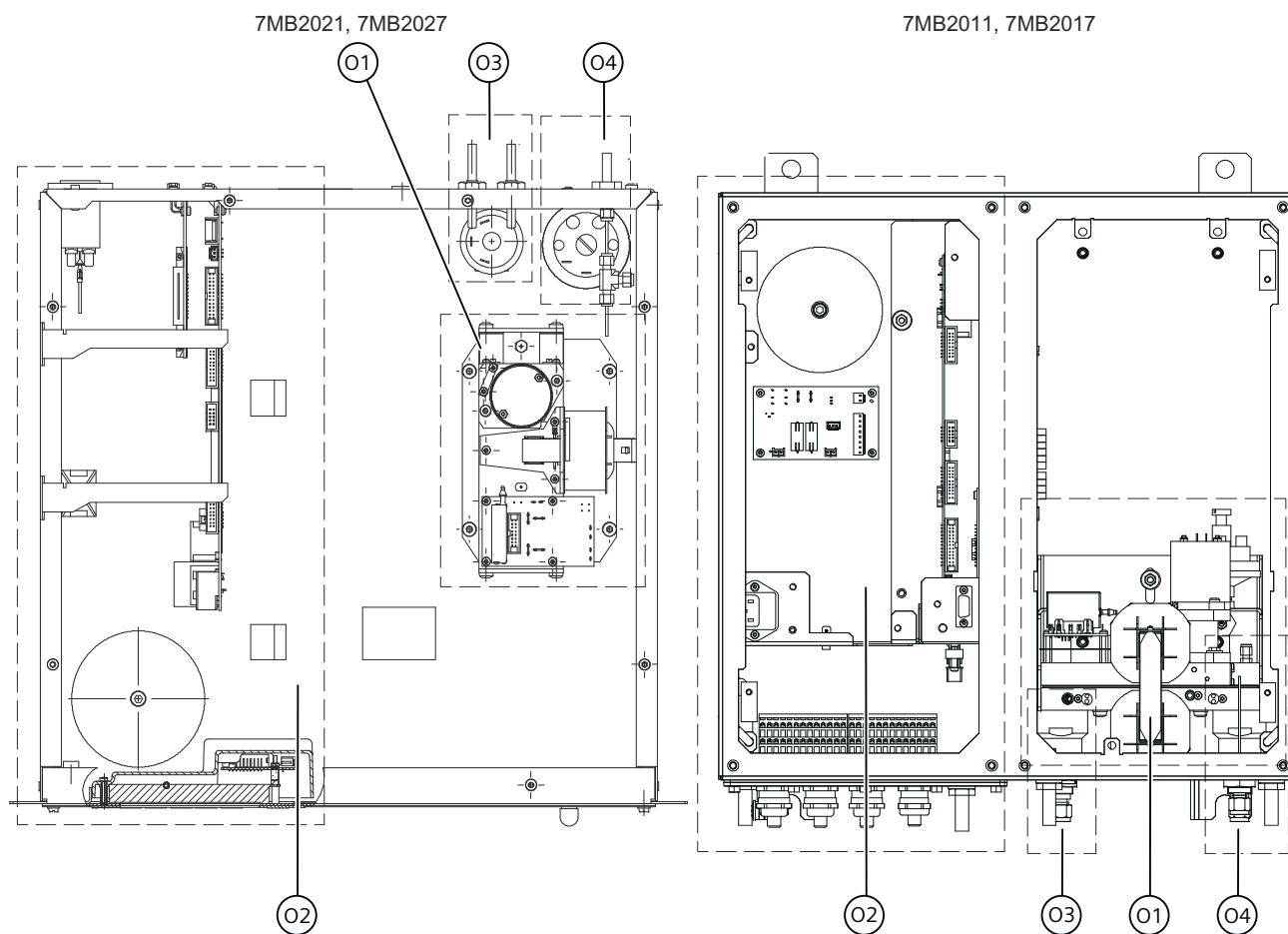

- O1 Analyzer section
- O2 Electronics
- O3 Sample gas channel
- O4 Reference gas channel

Figure 13-2 OXYMAT 6 modules (7MB2021, 7MB2011, 7MB2027, 7MB2017)

### 13.2.2 ULTRAMAT/OXYMAT 6

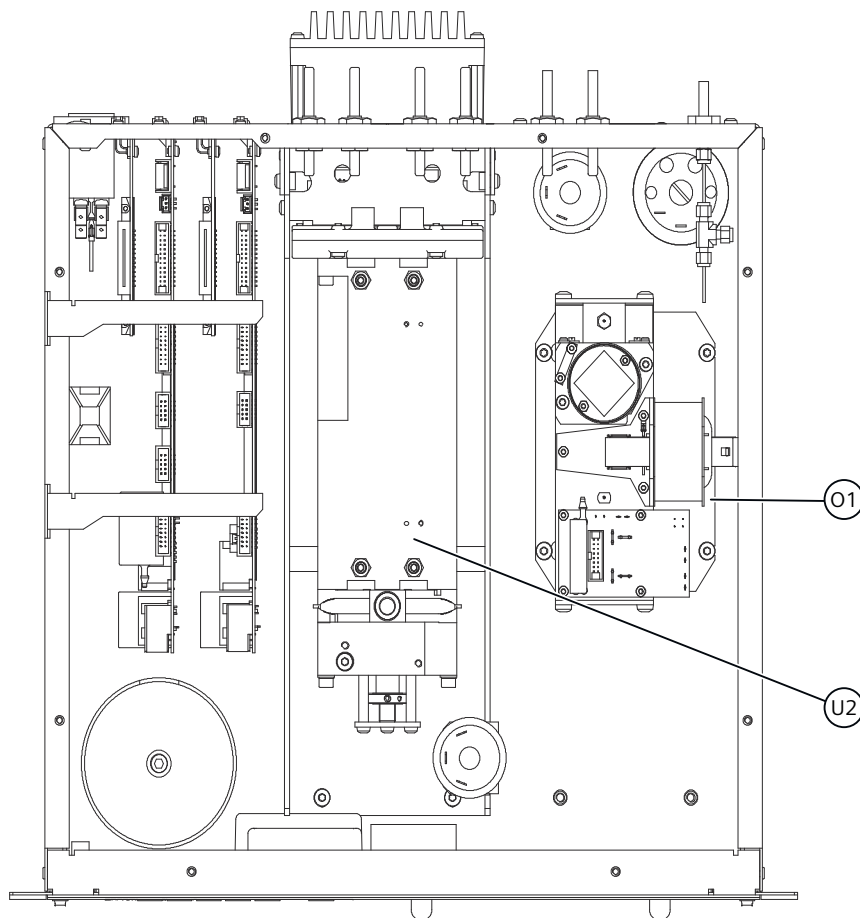

O1 Analyzer unit 1 (OXYMAT)

U2 Analyzer unit 2 (ULTRAMAT 6, ULTRAMAT 6-2R)

Figure 13-3 ULTRAMAT/OXYMAT 6 modules (7MB2023, 7MB2028) Modules ULTRAMAT/OXYMAT 6-2R (7MB2024, 7MB2026)

### 13.2.3 ULTRAMAT 6

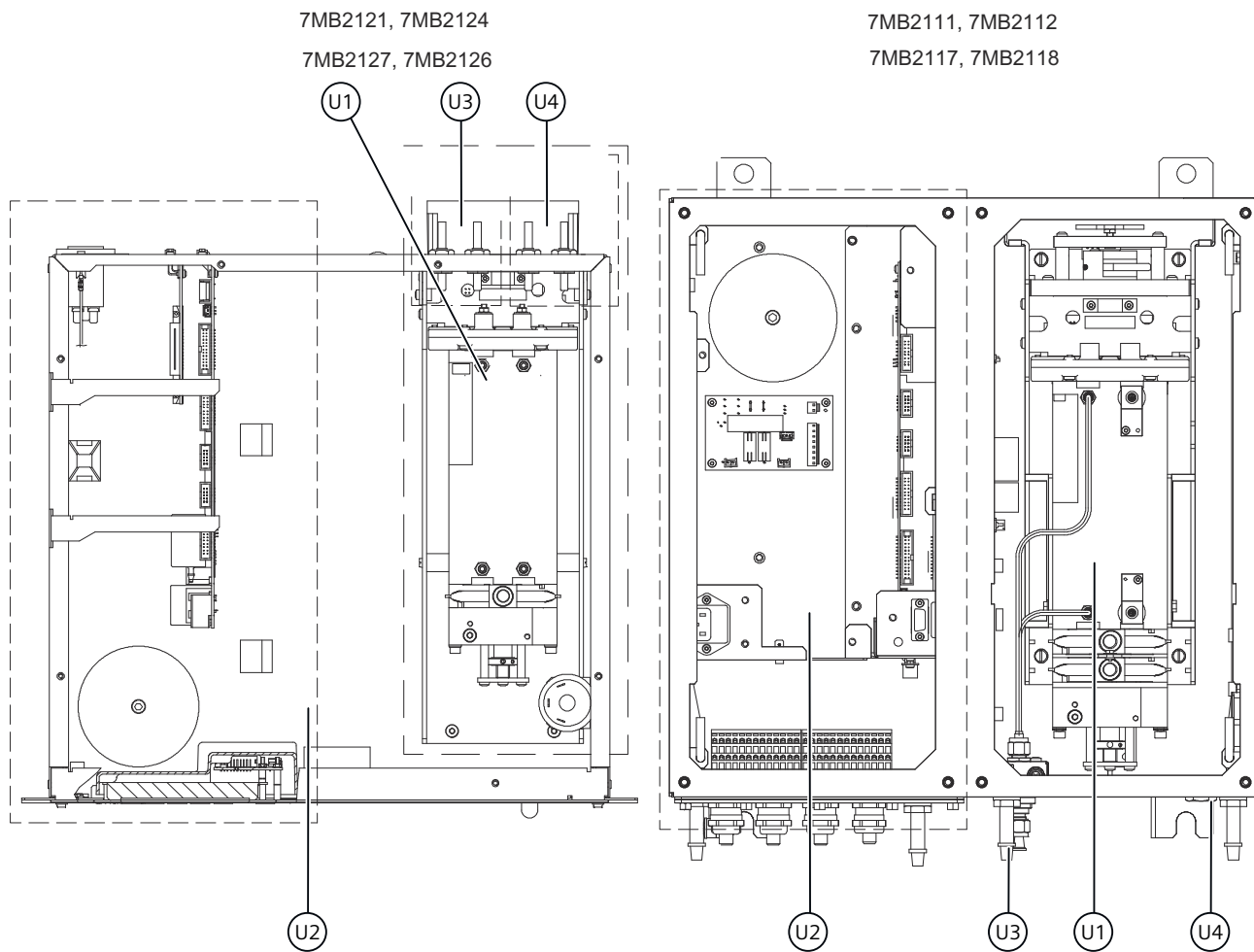

- U1 Analyzer unit
- U2 Electronics
- U3 Sample gas path
- U4 Reference gas path

Figure 13-4 Modules ULTRAMAT 6 (7MB2121, 7MB2111, 7MB2127, 7MB2117) Modules ULTRAMAT 6-2R (7MB2124, 7MB2112, 7MB2126, 7MB2118)

### 13.2.4 ULTRAMAT 6 multi-channel

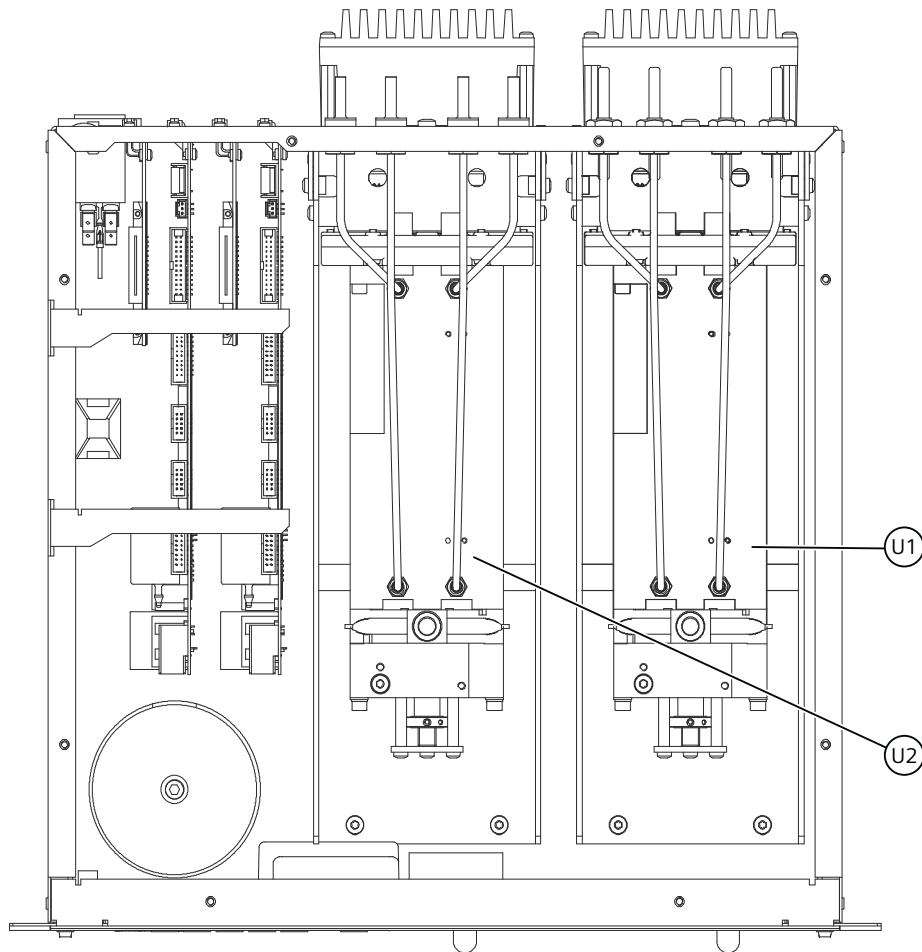

U1 Analyzer unit 1 (ULTRAMAT 6, ULTRAMAT 6-2R)

U2 Analyzer unit 2 (ULTRAMAT 6, ULTRAMAT 6-2R)

Figure 13-5 Modules ULTRAMAT 6-2P (7MB2123, 7MB2128) Modules ULTRAMAT 6-3K/4K (7MB2124, 7MB2126)



## 13.3 OXYMAT 6

### 13.3.1 Analyzer unit

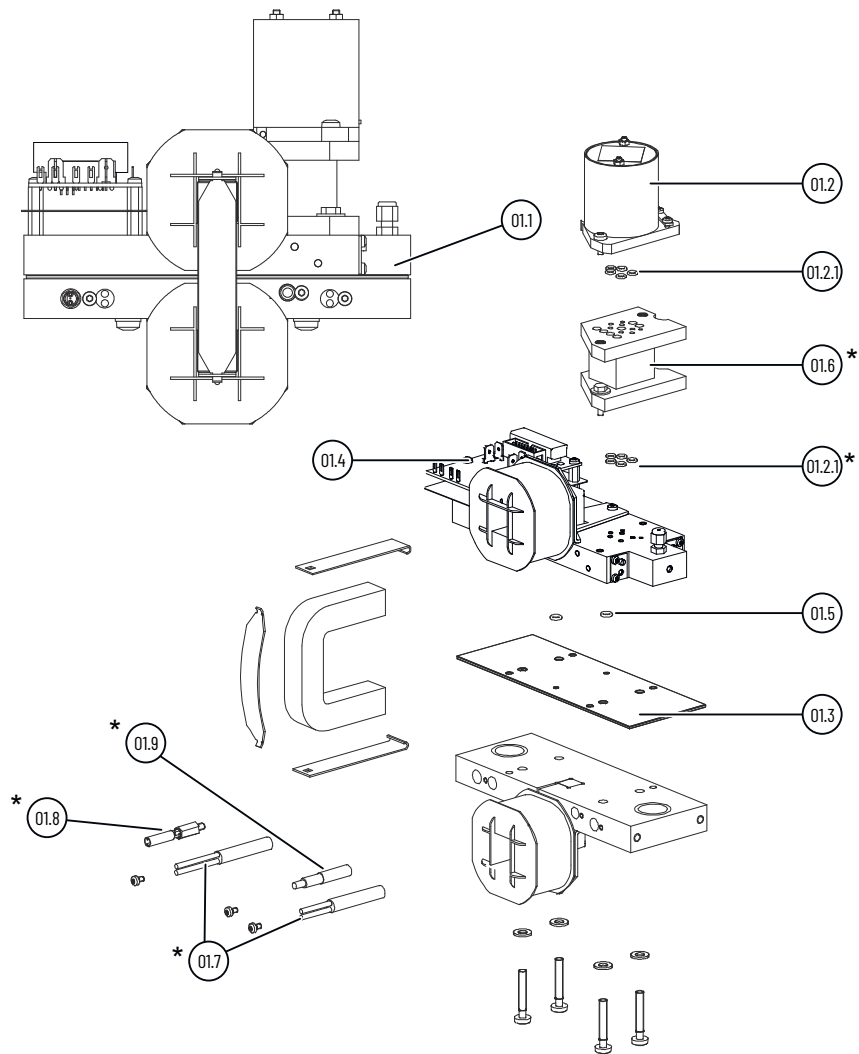

\*) Spare parts only for heated device versions

Figure 13-6 OXYMAT 6 analyzer unit

## 13.3 OXYMAT 6

Part No.	Name	Article number	Remarks
O1.1	Analyzer unit complete, Mat. No. 1.4571	C79451-A3460-B31	Without flow-type compensation side
	Analyzer unit complete, Mat. No. 1.4571	C79451-A3460-B61	Without flow-type compensation side, heated version
	Analyzer unit complete, tantalum	C79451-A3460-B34	Without flow-type compensation side
	Analyzer unit complete, tantalum	C79451-A3460-B63	Without flow-type compensation side, heated version
	Analyzer unit complete, Mat. No. 1.4571	C79451-A3460-B37	With flow-type compensation side
	Analyzer unit complete, Mat. No. 1.4571	C79451-A3460-B65	With flow-type compensation side, heated version
	Analyzer unit complete, tantalum	C79451-A3460-B40	With flow-type compensation side
	Analyzer unit complete, tantalum	C79451-A3460-B67	With flow-type compensation side, heated version
	Analyzer unit complete, Hastelloy C22	A5E46385272	Without flow-type compensation side
	Analyzer unit complete, Hastelloy C22	A5E46385552	Without flow-type compensation side, heated version
	Analyzer unit complete, Hastelloy C22	A5E46385490	With flow-type compensation side
	Analyzer unit complete, Hastelloy C22	A5E46385671	With flow-type compensation side, heated version
O1.2	Measuring head	C79451-A3460-B525	Without flow-type compensation side
	Measuring head	C79451-A3460-B526	With flow-type compensation side
O1.2.1	O-ring	C79121-Z100-A32	1 unit
O1.3	Sample chamber, Mat. No. 1.4571	C79451-A3277-B535	Without flow-type compensation side
	Sample chamber, tantalum	C79451-A3277-B536	Without flow-type compensation side
	Sample chamber, Mat. No. 1.4571	C79451-A3277-B537	With flow-type compensation side
	Sample chamber, tantalum	C79451-A3277-B538	With flow-type compensation side
	Sample chamber, Hastelloy C22	A5E03790053	Without flow-type compensation side
	Sample chamber, Hastelloy C22	A5E03790052	With flow-type compensation side
O1.4	Magnet terminal board	C79451-A3474-B606	
O1.5	O-ring, FKM (Viton)	C71121-Z100-A159	1 unit
	O-ring, FFKM (Kalrez)		see part no. O3.3
O1.6	Spacer	C79451-A3277-B22	1 unit
O1.7	Heating cartridge	W75083-A1004-F120	1 unit
O1.8	Temperature sensor	C79451-A3480-B25	
O1.9	Temperature fuse	W75054-T1001-A150	

### 13.3.2 Electronics

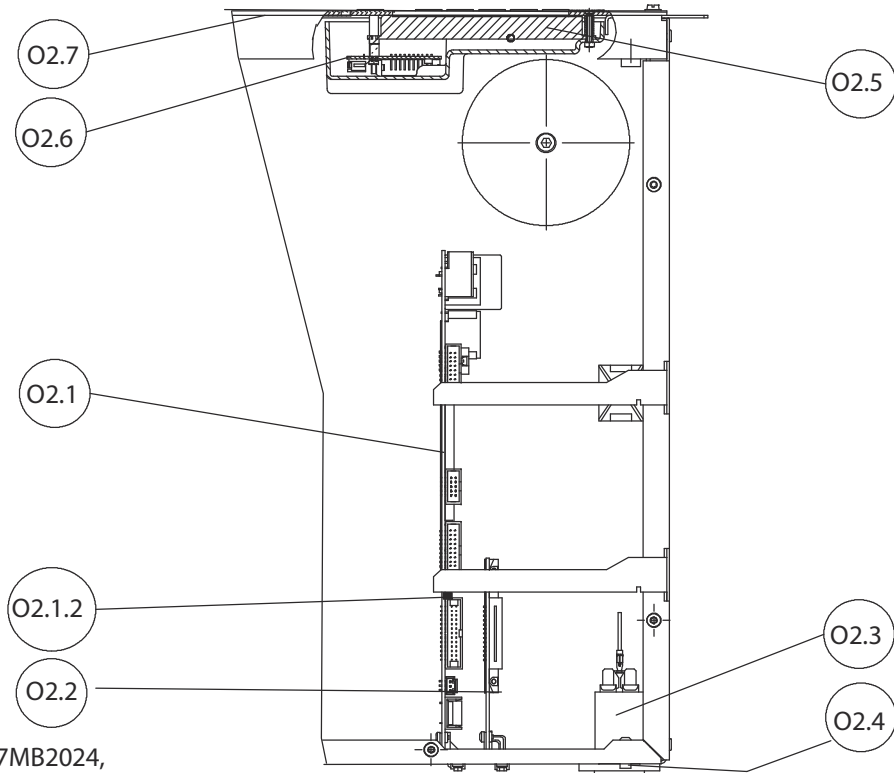

7MB2021, 7MB2023, 7MB2024,  
7MB2027, 7MB2028, 7MB2026

Figure 13-7 OXYMAT 6E, electronics

13.3 OXYMAT 6

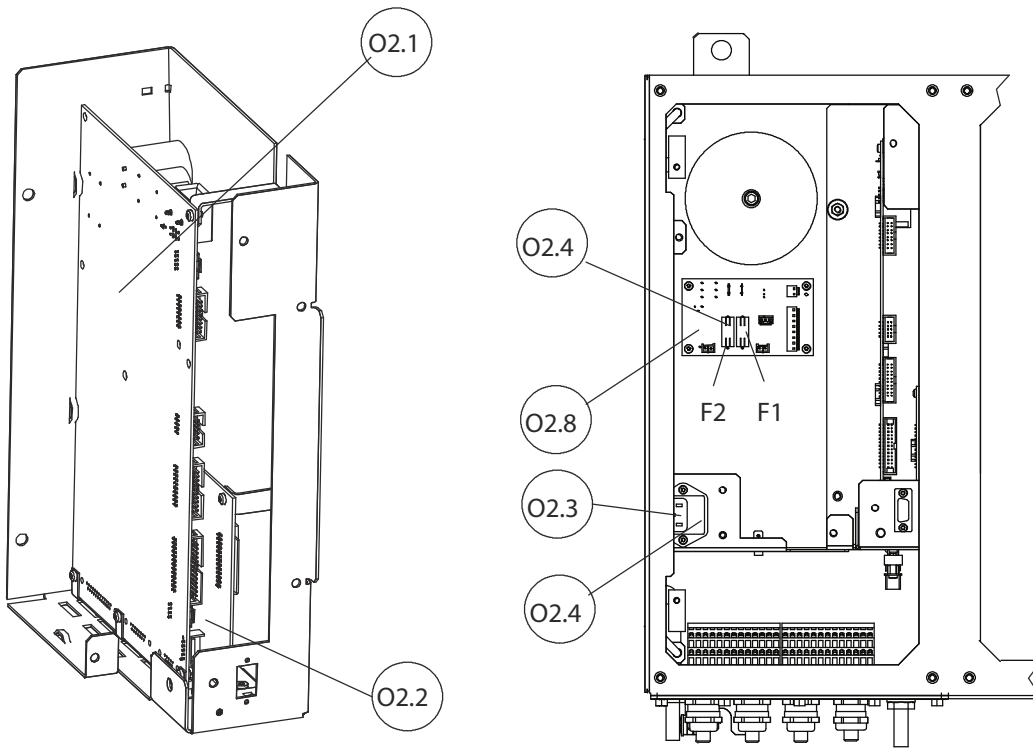

7MB2011, 7MB2017

Figure 13-8 OXYMAT 6F, electronics

Part No.	Name	Article number	Remarks
O2.1	Motherboard	C79451-A3480-D501	Motherboard with firmware, German
		C79451-A3480-D502	Motherboard with firmware, English
		C79451-A3480-D503	Motherboard with firmware, French
		C79451-A3480-D504	Motherboard with firmware, Spanish
		C79451-A3480-D505	Motherboard with firmware, Italian
O2.1.2	Firmware (FlashPROM)	C79451-A3480-S501	German
		C79451-A3480-S502	English
		C79451-A3480-S503	French
		C79451-A3480-S504	Spanish
		C79451-A3480-S505	Italian

Part No.	Name	Article number	Remarks				
O2.2	Option board	A5E00064223	Relay, for MLFB 7MB2011, 7MB2017				
		C79451-A3480-D511	Relay, for MLFB 7MB2021, 7MB2023, 7MB2024, 7MB2026, 7MB2027, 7MB2028				
		C79451-A3480-D512	With serial interface for the automotive industry (AK)				
		A5E00057315	PROFIBUS PA, for MLFB 7MB2011, 7MB2017				
		A5E00057307	PROFIBUS PA, for MLFB 7MB2021, 7MB2023, 7MB2024, 7MB2026, 7MB2027, 7MB2028				
		A5E00057318	PROFIBUS DP, for MLFB 7MB2011, 7MB2017				
		A5E00057312	PROFIBUS DP, for MLFB 7MB2021, 7MB2023, 7MB2024, 7MB2026, 7MB2027, 7MB2028				
		A5E00057317	PROFIBUS PA Ex i, for MLFB 7MB2011, 7MB2017				
		A5E00057164	Firmware update for PROFIBUS				
O2.3	Plug filter	W75041-E5602-K2					
O2.4	Fuse (G-type fuse) T 0.63 A / 250 V T 1 A / 250 V T 1.6 A / 250 V T 2.5 A / 250 V T 4 A / 250 V	W79054-L1010-T630 W79054-L1011-T100 W79054-L1011-T160 W79054-L1011-T250 W79054-L1011-T400	Select from the following list:				
			<b>200 to 240 V</b>	<b>F1</b>	<b>F2</b>	<b>F3</b>	<b>F4</b>
			7MB2011	-	-	0.63	0.63
			7MB2011 heated	0.63	2.5	2.5	2.5
			7MB2017	-	-	0.63	0.63
			7MB2017 heated	0.63	2.5	2.5	2.5
			7MB2021	-	-	0.63	0.63
			7MB2023	-	-	1	1
			7MB2024	-	-	1	1
			7MB2026	-	-	1	1
			7MB2027	-	-	0.63	0.63
			7MB2028	-	-	1	1
			<b>100 to 120 V</b>	<b>F1</b>	<b>F2</b>	<b>F3</b>	<b>F4</b>
			7MB2011	-	-	1	1
			7MB2011 heated	1	4	4	4
			7MB2017	-	-	1	1
			7MB2017 heated	1	4	4	4
			7MB2021	-	-	1	1
			7MB2023	-	-	2.5	2.5
			7MB2024	-	-	2.5	2.5
7MB2026	-	-	2.5	2.5			
7MB2027	-	-	1	1			
7MB2028	-	-	2.5	2.5			
O2.5	LC display	A5E31474846					
O2.6	Adapter board for LCD, key-board	C79451-A3474-B605					
O2.7	Front panel with membrane keyboard	C79165-A3042-B505	For MLFB 7MB2021, 7MB2027 (OXYMAT 6E)				
		C79165-A3042-B506	For MLFB 7MB2023, 7MB2024, 7MB2026, 7MB2028 (ULTRAMAT/OXYMAT 6E)				
O2.8	Temperature controller electronics	A5E00118530	115 V AC, without fuses F1, F2				
		A5E00118527	230 V AC, without fuses F1, F2				

### 13.3.3 Gas paths

#### 13.3.3.1 Sample gas path

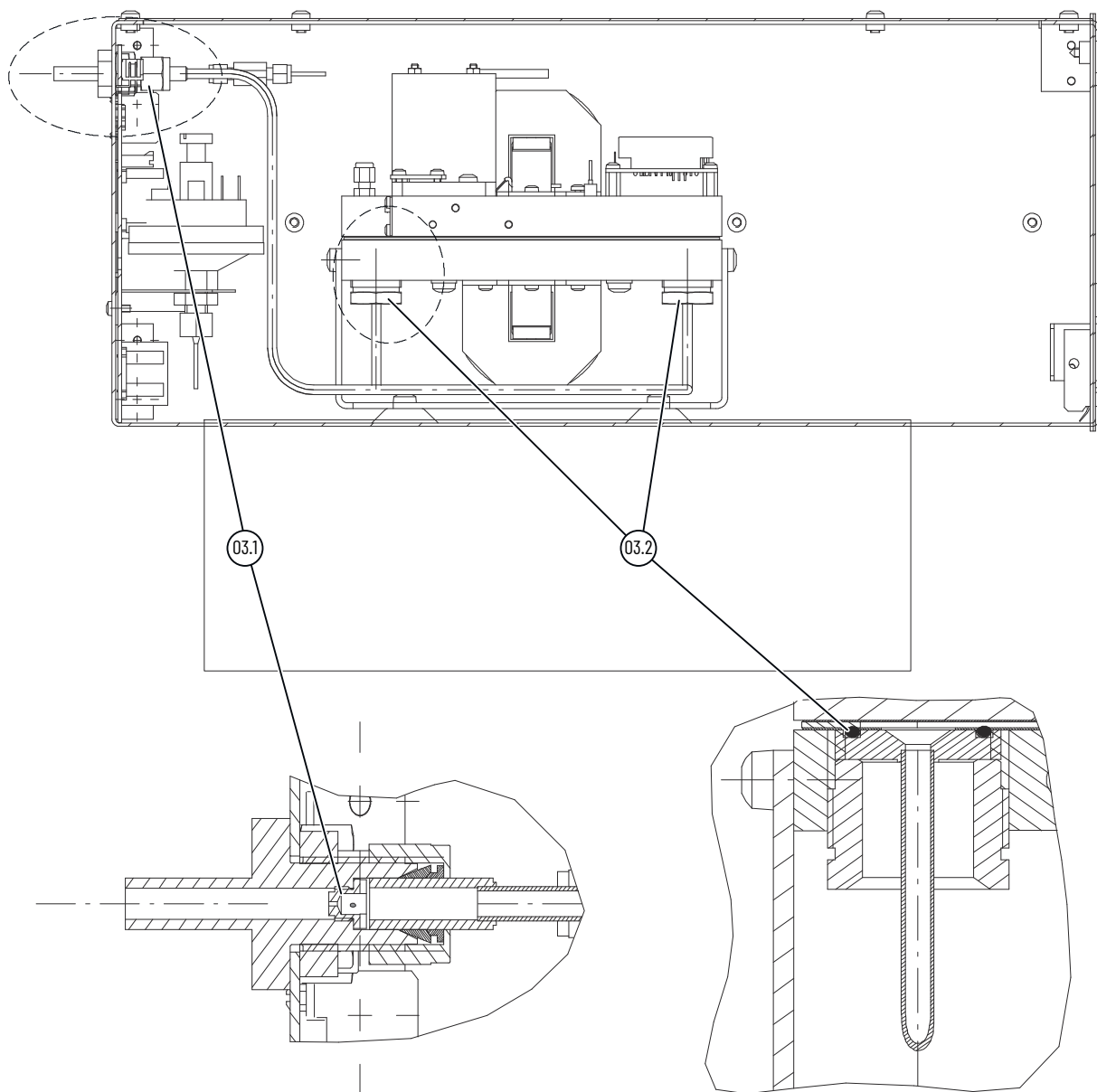

Figure 13-9 OXYMAT 6E, sample gas path pipe

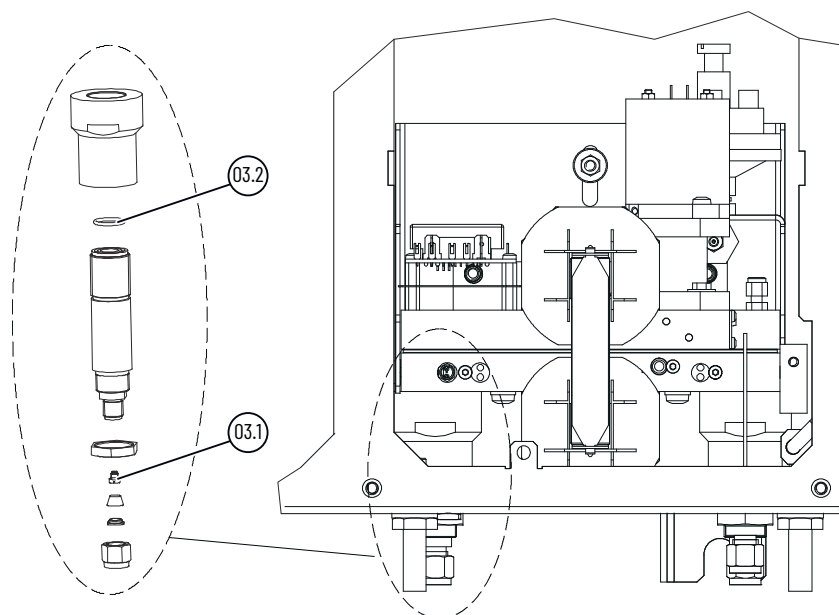

Figure 13-10 OXYMAT 6F, sample gas path, pipe

Part No.	Name	Article number	Remarks
O3.1	Restrictor	C79451-A3480-C37	Titanium, for gas paths with pipes
		C79451-A3520-C5	Stainless steel (1.4571), for gas paths with pipes
O3.2	O-ring	C74121-Z100-A6	FKM (Viton), 1 unit
			FFKM (Kalrez), see Part No. 3.3
O3.3	O-ring	C79451-A3277-D11	Set of O-rings FFKM (Kalrez), consists of 2 items of the Part No. O1.5 and O3.2

13.3 OXYMAT 6

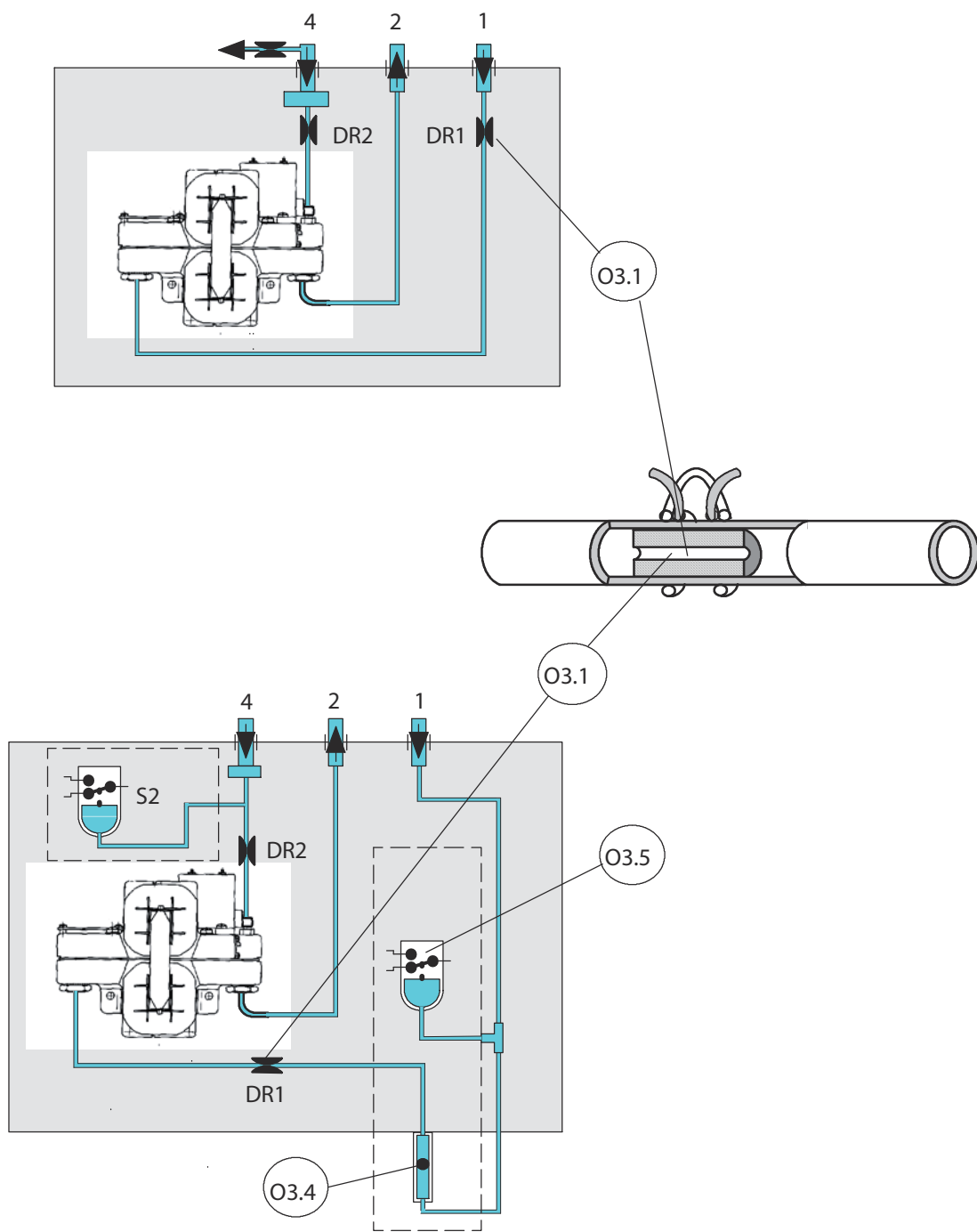

Figure 13-11 OXYMAT 6, sample gas path hose



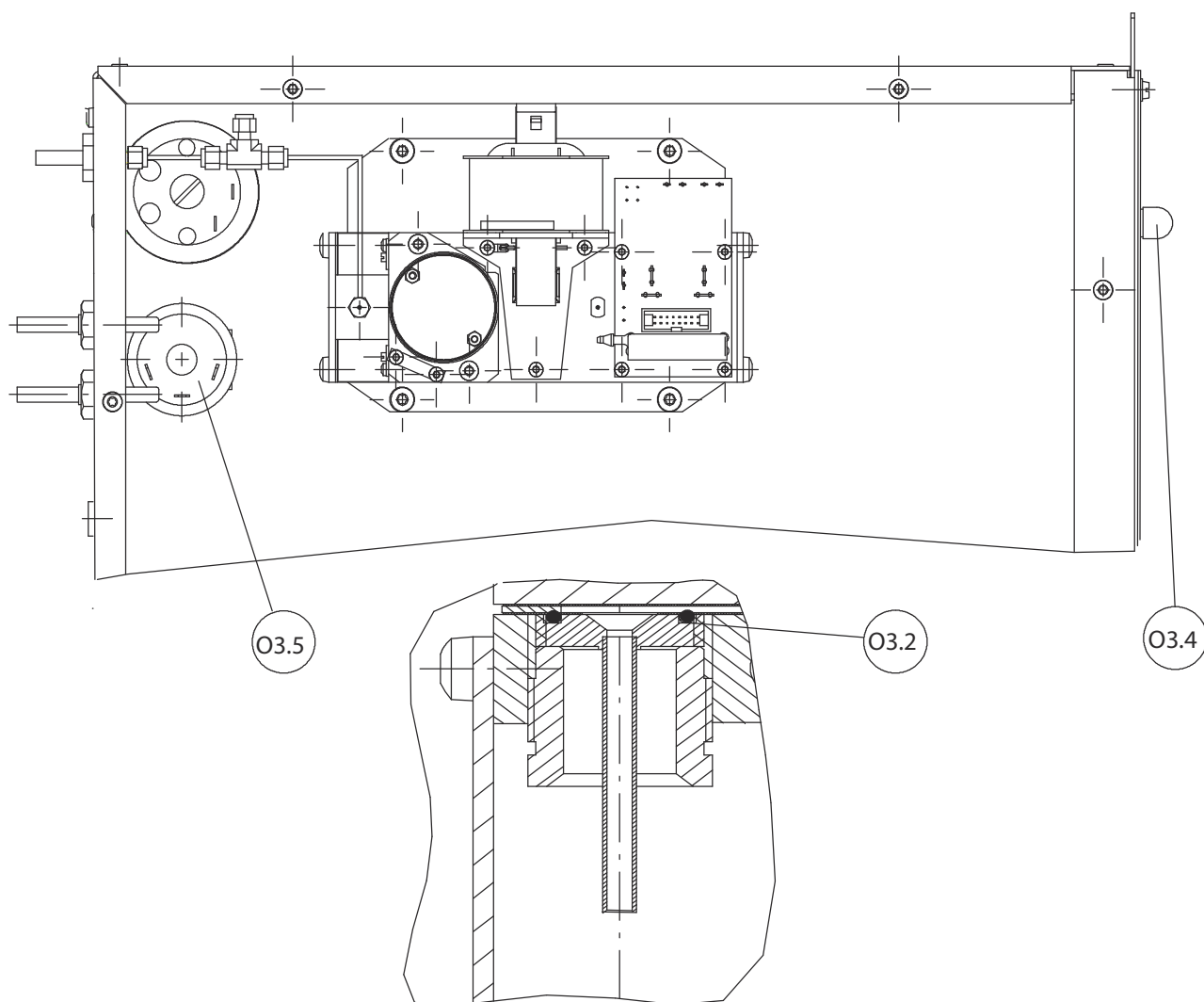

Figure 13-12 OXYMAT 6, sample gas path hose

Part No.	Name	Order No.	Remarks
O3.1	Restrictor	C79451-A3480-C10	For gas paths with hoses
O3.2	O-ring	C74121-Z100-A6	FKM (Viton), 1 unit FFKM (Kalrez), see Part No. O3.3
O3.3	O-ring	C79451-A3277-D11	Set of O-rings FFKM (Kalrez), consists of 2 items of the Part No. O1.5 and O3.2
O3.4	Flowmeter	C79402-Z560-T1	
O3.5	Pressure switch	C79302-Z1210-A2	

## 13.3 OXYMAT 6

## 13.3.3.2 Reference gas path

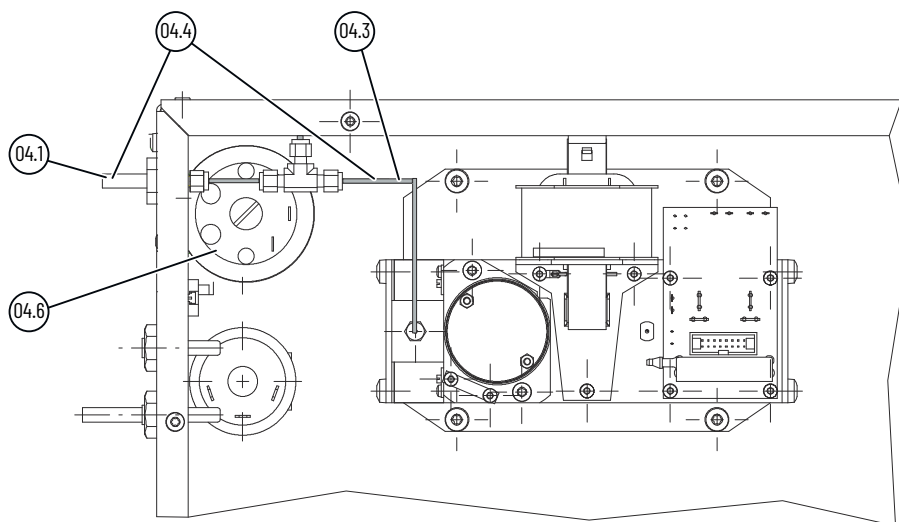

Figure 13-13 OXYMAT 6, reference gas path, 7MB2021, 7MB2023, 7MB2024, 7MB2027, 7MB2028, 7MB2026

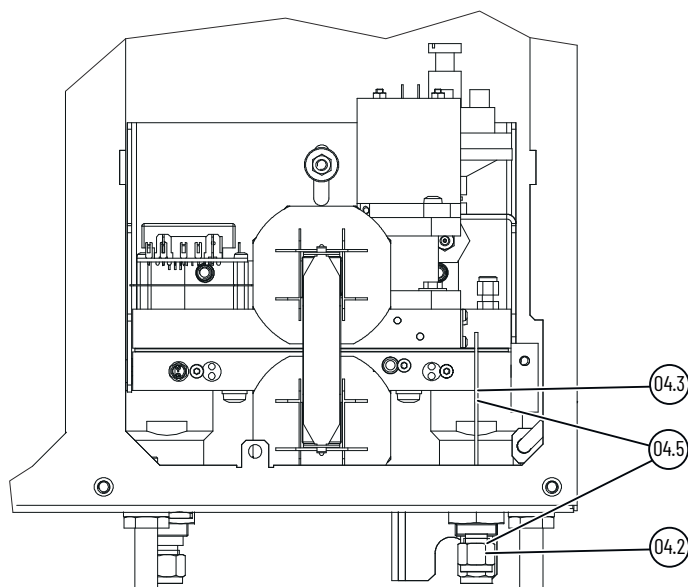

Figure 13-14 OXYMAT 6, reference gas path, 7MB2011, 7MB2017

Part No.	Name	Article number	Remarks
04.1	Connection, complete (for MLFB 7MB2021, 7MB2023, 7MB2024, 7MB2026, 7MB2027, 7MB2028)	C79451-A3480-B1	Diameter 6 mm, 3000 hPa (3 bar)
		C79451-A3480-B2	Diameter 1/4", 3000 hPa (3 bar)
04.2	Pipe connection fitting, complete (for MLFB 7MB2011)	C79451-A3520-B1	Diameter 6 mm, 3000 hPa (3 bar)
		C79451-A3520-B2	Diameter 1/4", 3000 hPa (3 bar)

Part No.	Name	Article number	Remarks
O4.3	Capillary tube (for MLFB 7MB2011, 7MB2021, 7MB2023, 7MB2024, 7MB2026, 7MB2027, 7MB2028)	C79451-A3480-D518	Capillary tube and connection fitting parts, 3000 hPa (3 bar)
O4.4	Capillary tube connection set (for MLFB 7MB2021, 7MB2023, 7MB2024, 7MB2026, 7MB2027, 7MB2028)	C79451-A3480-D519	Connection and capillary tube, 100 hPa, only available as set Connections for diameter 6 mm and 1/4" are contained together in the same set
O4.5	Capillary tube connection set (for MLFB 7MB2011)	C79451-A3520-D511	Pipe connection fitting and capillary tube, 100 hPa, only available as set Pipe connection fittings for diameter 6 mm and 1/4" are contained together in the same set
O4.6	Reference gas pressure switch	A5E31751919	3000 hPa (3 bar)

## 13.4 ULTRAMAT 6

### 13.4.1 Analyzer unit

After replacement of the IR source, analyzer chamber and/or detector cell, the factory-set temperature characteristic may be altered slightly. If this is the case, the temperature characteristic can be compensated using function 86 (see section Linear temperature compensation (function 86) (Page 160)).

After replacement of the detector cell or the optical coupler, the compensation must be checked against interference gases and, if necessary, readjusted using function 83 (see section Interference correction (function 83) (Page 151)).

After replacement of the optical coupler, it must be readjusted (see Linear temperature compensation (function 86) (Page 160)).

#### 13.4.1.1 Analyzer units - Overview

Analyzer chambers of different optical lengths are used depending on the measured component and application:

The different analyzer chamber lengths are listed as follows in the order scheme:

7MB2nnn-nxyyn-nxyn  
where

- **x** corresponds to the code of the first measured component (first column) and
- **y** corresponds to the code of the measuring range (upper row).

## 13.4 ULTRAMAT 6

The specification of the code in the first block applies for the one-component devices, those in the second block for multi-component devices.

Length of the analyzer chambers for standard analyzers in mm (* not for U/O 6, ** only for heated versions)												
Code (MK)	Code (MB)	A	B	C	D	E	F	G	H	J	K	L
	Small MB Large MB Unit	5 100 ppm	10 200 ppm	20 400 ppm	50 1000 ppm	100 1000 ppm	300 3000 ppm	500 5000 ppm	1000 10000 ppm	3000 10000 ppm	3000 30000 ppm	5000 15000 ppm
A	CO	-	180*	180	180	180	60	60	20	20	6	6
B	CO <sub>sel</sub>	-	-	180*	180	180	60	60	20	20	6	6
X	CO TÜV	-	-	-	180	-	60	60	20	-	6	-
C	CO <sub>2</sub>	180*	180	180	180	90	60	20	20	6	6	6
D	CH <sub>4</sub>	-	-	-	180*	180	90	60	20	20	6	6
E	C <sub>2</sub> H <sub>2</sub>	-	-	-	-	-	180*	90	60	60	20	20
F	C <sub>2</sub> H <sub>4</sub>	-	-	-	-	-	180*	180	180	90	90	90
G	C <sub>2</sub> H <sub>6</sub>	-	-	-	-	180*	90	60	60	20	20	20
H	C <sub>3</sub> H <sub>6</sub>	-	-	-	-	180*	180	60	60	20	20	20
J	C <sub>3</sub> H <sub>8</sub>	-	-	-	180*	180	90	90	60	20	6	6
K	C <sub>4</sub> H <sub>6</sub>	-	-	-	-	-	180*	90	60	20	20	20
L	C <sub>4</sub> H <sub>10</sub>	-	-	-	-	180*	90	60	20	20	6	6
M	C <sub>6</sub> H <sub>14</sub>	-	-	-	-	180*	90	60	60	20	20	20
N	SO <sub>2</sub>	-	-	180*	180*	180	60	60	20	20	6	6
P	NO	-	-	-	-	180*	90	60	20	20	6	6
Q	NH <sub>3</sub>	-	-	-	-	180*	180	60	20	20	20	6
R	H <sub>2</sub> O	-	-	-	-	-	-	-	180*	180	90	90
S	N <sub>2</sub> O	-	-	-	180*	180	60	60	20	20	6	6

Length of the analyzer chambers for standard analyzers in mm (* not for U/O 6, ** only for heated versions), continuation											
Code (MK)	Code (MB)	M	N	P	Q	R	S	T	U	V	W
	Small MB Large MB Unit	5000 50000 ppm	1 3 %	1 10 %	3 10 %	3 30 %	5 15 %	5 50 %	10 30 %	10 100 %	30 100 %
A	CO	6	6	2	2	0.6	0.6	0.6	0.2	0.2	0.2
B	CO <sub>sel</sub>	6	6	2	2	0.6	0.6	0.6	0.2	0.2	0.2
X	CO TÜV	-	-	2	-	0.6	-	-	-	0.2	-
C	CO <sub>2</sub>	2	2	0.6	0.6	0.6	0.6	0.2	0.2	0.2	0.2
D	CH <sub>4</sub>	6	6	2	2	0.6	0.6	0.6	0.6	0.2	0.2
E	C <sub>2</sub> H <sub>2</sub>	20	6	6	6	2	2	2	0.6	0.6	0.2
F	C <sub>2</sub> H <sub>4</sub>	60	60	20	20	20	20	6	20	6	6
G	C <sub>2</sub> H <sub>6</sub>	6	6	6	2	2	2	0.6	0.6	0.6	0.2
H	C <sub>3</sub> H <sub>6</sub>	6	6	2	2	0.6	0.6	0.6	0.6	0.2	0.2
J	C <sub>3</sub> H <sub>8</sub>	6	6	2	2	0.6	0.6	0.6	0.6	0.2	0.2
K	C <sub>4</sub> H <sub>6</sub>	6	6	6	2	2	2	0.6	0.6	0.6	0.2
L	C <sub>4</sub> H <sub>10</sub>	6	6	2	2	0.6	0.6	0.6	0.6	0.2	0.2
M	C <sub>6</sub> H <sub>14</sub>	6	6	6	2	2	2	0.6	0.6	0.6	0.2
N	SO <sub>2</sub>	6	6	2	2	0.6	0.6	0.6	0.2	0.2	0.2
P	NO	6	6	2	2	0.6	0.6	0.6	0.6	0.2	0.2
Q	NH <sub>3</sub>	6	6	2	2	0.6	0.6	0.6	0.6	0.2	0.2
R	H <sub>2</sub> O	90**	90	60**	20**	-	6**	-	-	-	-
S	N <sub>2</sub> O	6	2	2	0.6	0.6	0.6	0.6	0.2	0.2	0.2

### 13.4.1.2 Single-channel analyzer

7MB2111, 7MB2121, 7MB2123, 7MB2124 (1st and 2nd channel), 7MB2023 (2nd channel)

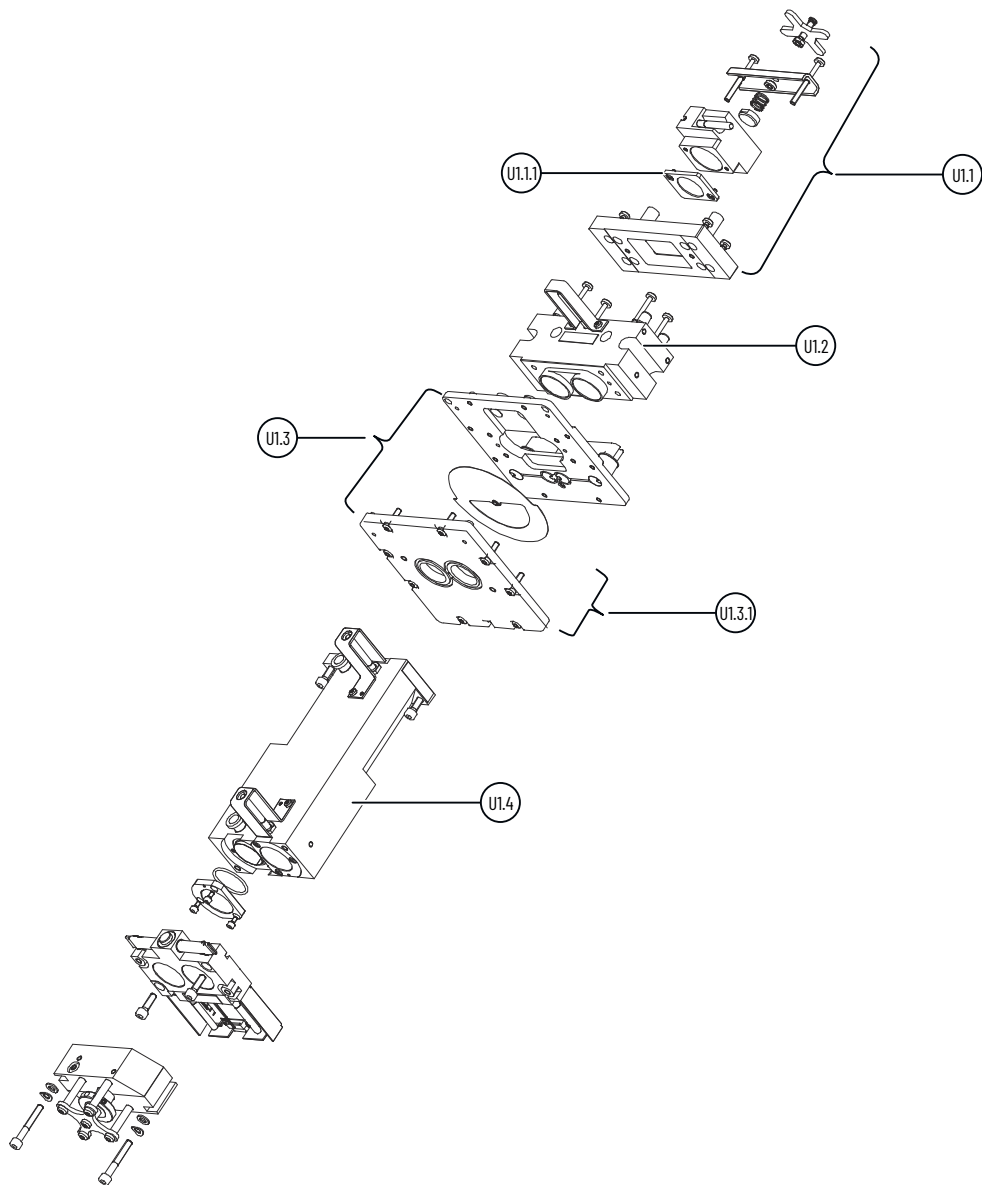











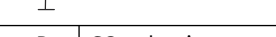
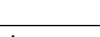





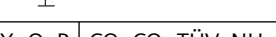



Figure 13-15 ULTRAMAT 6, single-channel analyzer unit

Part No.	Name	Article number	Remarks	
U 1.1	IR source For product number: < N1-T9-0766 please contact technical support under Support Request ( <a href="https://support.industry.siemens.com/My/ww/en/requests#createRequest">https://support.industry.siemens.com/My/ww/en/requests#createRequest</a> )	7MB2121 -  -  7MB2123 -  -  7MB2023, 7MB2124 -  -  C		
	IR source	A5E02320429	For CO <sub>2</sub>	
	IR source (for MLFB 7MB2121, 7MB2123, 7MB2023, 7MB2124)	A5E02326861	For all components except for CO <sub>2</sub>	
	IR source (for MLFB 2111)	A5E02326863		
U 1.1.1	For MLFB ->	7MB2111 -  -  7MB2121 -  -  7MB2123 -  -  7MB2023, 7MB2124 -  -  I		
	Optical filter	A5E00354271	B	CO selective
		A5E00354273	F	C <sub>2</sub> H <sub>4</sub>
		A5E00354269	M, G, J, L, E	C <sub>6</sub> H <sub>14</sub> , C <sub>2</sub> H <sub>6</sub> , C <sub>3</sub> H <sub>8</sub> , C <sub>4</sub> H <sub>10</sub> , C <sub>2</sub> H <sub>2</sub>
		A5E00354270	N	SO <sub>2</sub>
		A5E00354275	P	NO; P with optical filter
		A5E00354272	Q	NH <sub>3</sub>
		A5E00354268	S	N <sub>2</sub> O
U 1.2	For MLFB ->	7MB2111 -  -  7MB2121 -  -  7MB2123 -  -  7MB2023, 7MB2124 -  -  I		
	Beam divider	C79451-A3462-B537	A, X, Q, P	CO, CO--TÜV, NH <sub>3</sub> , NO
		C79451-A3462-B540	B	CO selective
		C79451-A3462-B534	C	CO <sub>2</sub>
		C79451-A3462-B536	D ... M, R, S	HC, H <sub>2</sub> O. N <sub>2</sub> O
		C79451-A3462-B539	N	SO <sub>2</sub>
U 1.3	Chopper	A5E02951936	Only ULTRAMAT 6E (CO <sub>2</sub> )	
		A5E02951937	All but ULTRAMAT 6E (CO <sub>2</sub> )	
U 1.3.1	Bottom part of chopper	C79451-A3462-B501	Not suitable for ULTRAMAT 6E (CO <sub>2</sub> )	

## 13.4 ULTRAMAT 6

Part No.	Name	Article number		Remarks
U 1.4	Analyzer chamber	Length 0.2 mm	A5E00117417	Non-flow-type reference gas chamber
			A5E00117418	Flow-type reference gas chamber
		Length 0.6 mm	A5E00117419	Non-flow-type reference gas chamber
			A5E00117420	Flow-type reference gas chamber
		Length 2 mm	A5E00117421	Non-flow-type reference gas chamber
			A5E00117422	Flow-type reference gas chamber
		Length 6 mm	A5E00117423	Non-flow-type reference gas chamber
			A5E00117424	Flow-type reference gas chamber
		Length 20 mm	A5E00117425	Non-flow-type reference gas chamber, aluminum
			A5E00117426	Flow-type reference gas chamber, aluminum
			A5E00117427	Non-flow-type reference gas chamber, tantalum
			A5E00117428	Non-flow-type reference gas chamber, tantalum
		Length 60 mm	A5E00117429	Non-flow-type reference gas chamber, aluminum
			A5E00117430	Flow-type reference gas chamber, aluminum
			A5E00117431	Non-flow-type reference gas chamber, tantalum
			A5E00117432	Non-flow-type reference gas chamber, tantalum
		Length 90 mm	A5E00117433	Non-flow-type reference gas chamber, aluminum
			A5E00117434	Flow-type reference gas chamber, aluminum
			A5E00117435	Non-flow-type reference gas chamber, tantalum
			A5E00117436	Non-flow-type reference gas chamber, tantalum
Length 180 mm	A5E00117437	Non-flow-type reference gas chamber, aluminum		
	A5E00117438	Flow-type reference gas chamber, aluminum		
	A5E00117439	Non-flow-type reference gas chamber, tantalum		
	A5E00117440	Non-flow-type reference gas chamber, tantalum		



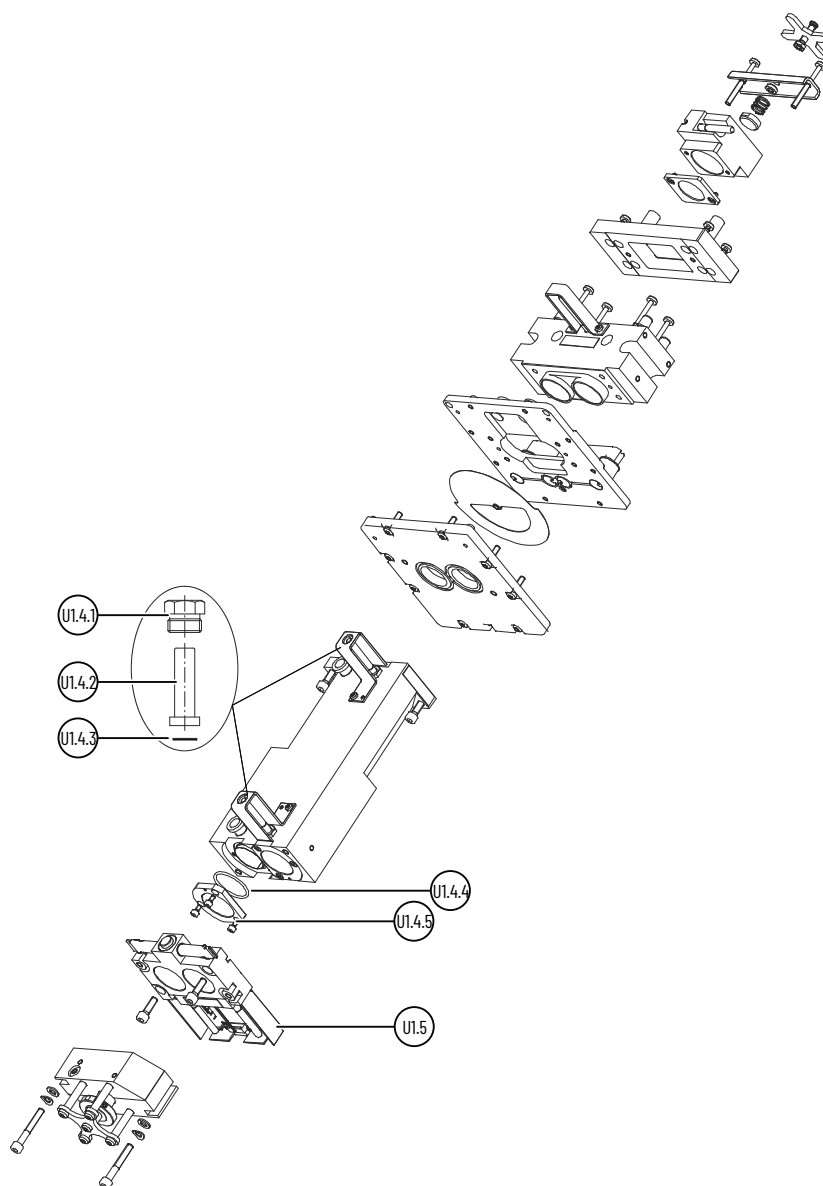

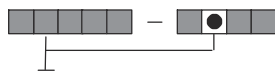

Figure 13-16 ULTRAMAT 6, single-channel analyzer unit, Part 2

Part No.	Name	Article number	Remarks
U 1.4.1	Union nut	C79451-A3478-C8	
U 1.4.2	Hose connection	C79451-A3478-C9	
U 1.4.3	O-ring	C71121-Z100-A159	
U 1.4.4	O-ring	C79121-Z100-A24	
U 1.4.5	Cover	C79451-A3462-B152	For cell length 0.2 mm to 6 mm
		C79451-A3462-B151	For cell length 20 mm to 180 mm

## 13.4 ULTRAMAT 6

Part No.	Name	Article number	Remarks	
U 1.5	For MLFB ->	7MB2111 7MB2121		
		7MB2123		
		7MB2023, 7MB2124		
		Detector cell	C79451-A3462-B581	A
	C79451-A3462-B598	B, X	CO selective, CO TÜV	
	C79451-A3462-B58	2 C	CO <sub>2</sub>	
	C79451-A3462-B588	D	CH <sub>4</sub>	
	C79451-A3462-B591	E	C <sub>2</sub> H <sub>2</sub>	
	C79451-A3462-B590	F	C <sub>2</sub> H <sub>4</sub>	
	C79451-A3462-B587	G	C <sub>2</sub> H <sub>6</sub>	
	C79451-A3462-B586	H	C <sub>3</sub> H <sub>6</sub>	
	C79451-A3462-B589	J	C <sub>3</sub> H <sub>8</sub>	
	C79451-A3462-B595	K	C <sub>4</sub> H <sub>6</sub>	
	C79451-A3462-B593	L	C <sub>4</sub> H <sub>10</sub>	
	C79451-A3462-B584	M	C <sub>6</sub> H <sub>14</sub>	
	C79451-A3462-B599	N	SO <sub>2</sub>	
	A5E00076341	P	NO	
C79451-A3462-B585	Q	NH <sub>3</sub>		
C79451-A3462-B596	R	H <sub>2</sub> O		
C79451-A3462-B592	S	N <sub>2</sub> O		

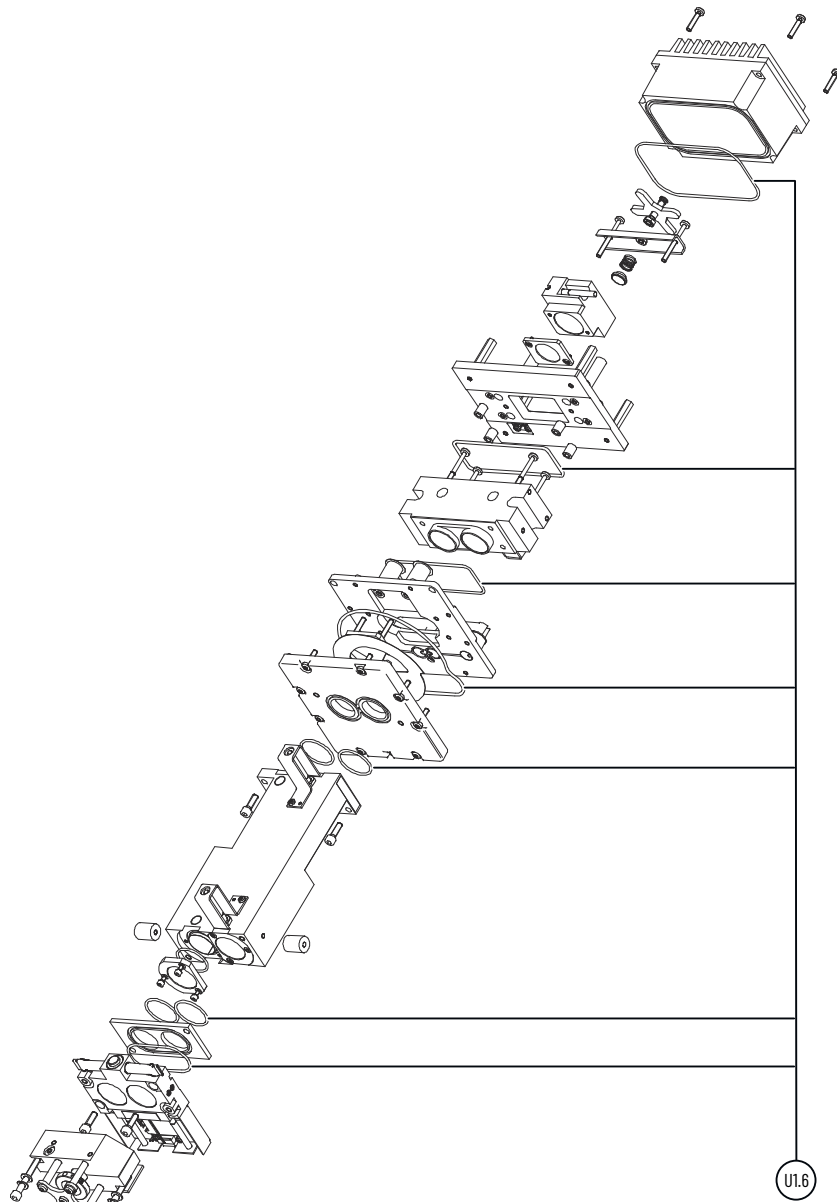

Figure 13-17 ULTRAMAT 6, single-channel analyzer unit, Part 3

Part No.	Name	Article number	Remarks
U 1.6	O-ring set	C79451-A3462-D501	For sealed analyzer unit (CO <sub>2</sub> , rack units)

13.4.1.3 2R channel

7MB2112, 7MB2124 (1st channel), 7MB2024 (2nd channel)

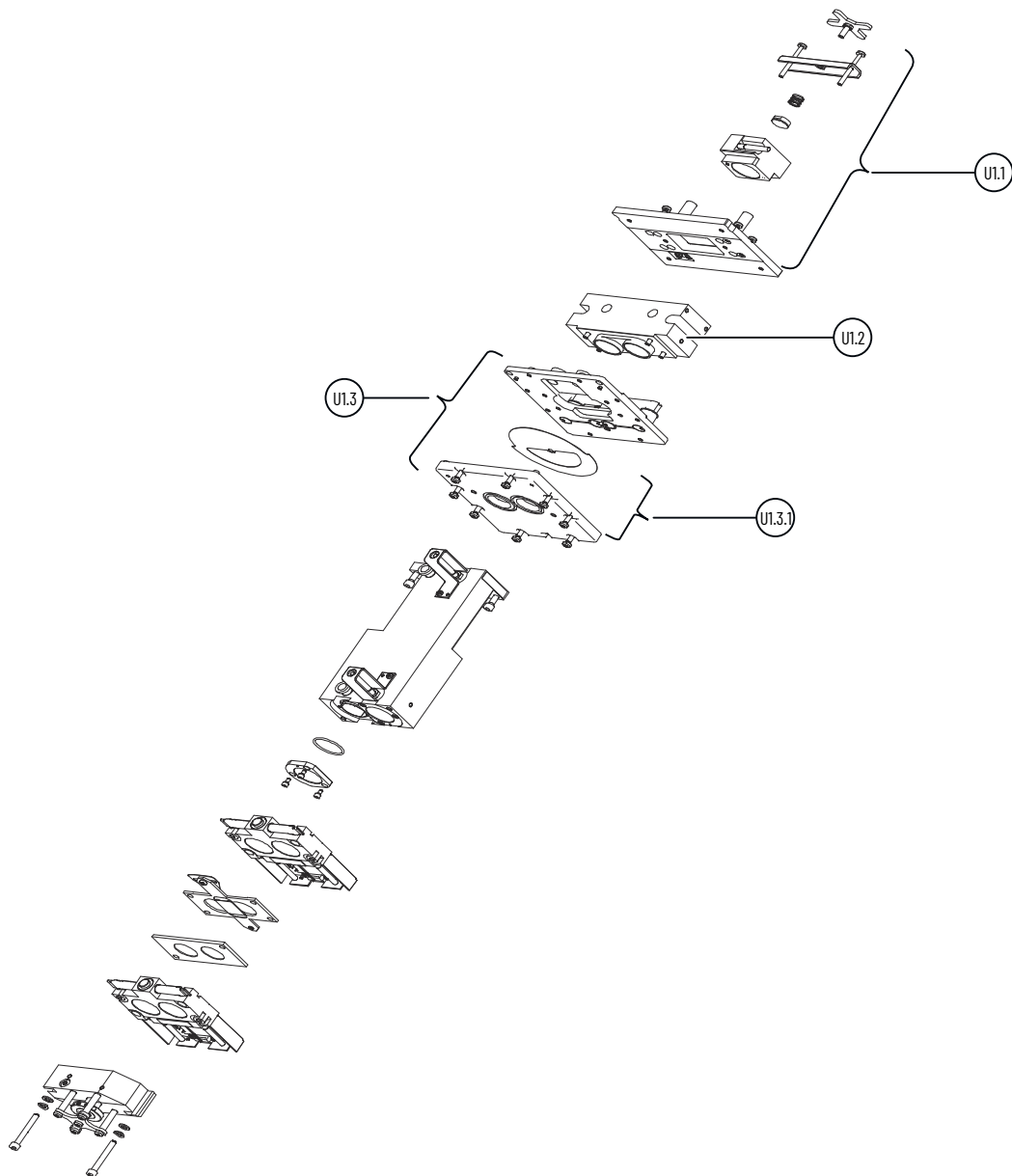

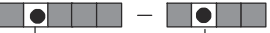
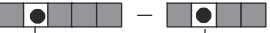





Figure 13-18 ULTRAMAT 6-2R analyzer unit, Part 1

Part No.	Name	Article number	Remarks	
U 1.1	IR source For product number: < N1-T9-0766 please contact technical support under Support Request ( <a href="https://support.industry.siemens.com/My/ww/en/requests#createRequest">https://support.industry.siemens.com/My/ww/en/requests#createRequest</a> )	7MB2121 –  –  7MB2123 –  7MB2023, 7MB2124 –  C		
	IR source	A5E02320429	For CO <sub>2</sub>	
	IR source (for MLFB 7MB2121, 7MB2123, 7MB2023, 7MB2124)	A5E03326861	For all components except for CO <sub>2</sub>	
	IR source (for MLFB 7MB2111)	A5E02326863		
U 1.2	For MLFB ->	7MB2112 7MB2124 –  7MB2024 –  C		
	Beam divider	C79451-A3462-B537	A	CO/NO
		C79451-A3462-B539	B	CO <sub>2</sub> /CO
		C79451-A3462-B534	C	CO <sub>2</sub> /CH <sub>4</sub>
		C79451-A3462-B539	D	CO <sub>2</sub> /NO
U 1.3	Chopper	A5E02951936	Only ULTRAMAT 6E (CO <sub>2</sub> )	
		A5E02951937	All but ULTRAMAT 6E (CO <sub>2</sub> )	
U 1.3.1	Bottom part of chopper	C79451-A3462-B501	Not suitable for ULTRAMAT 6E (CO <sub>2</sub> )	

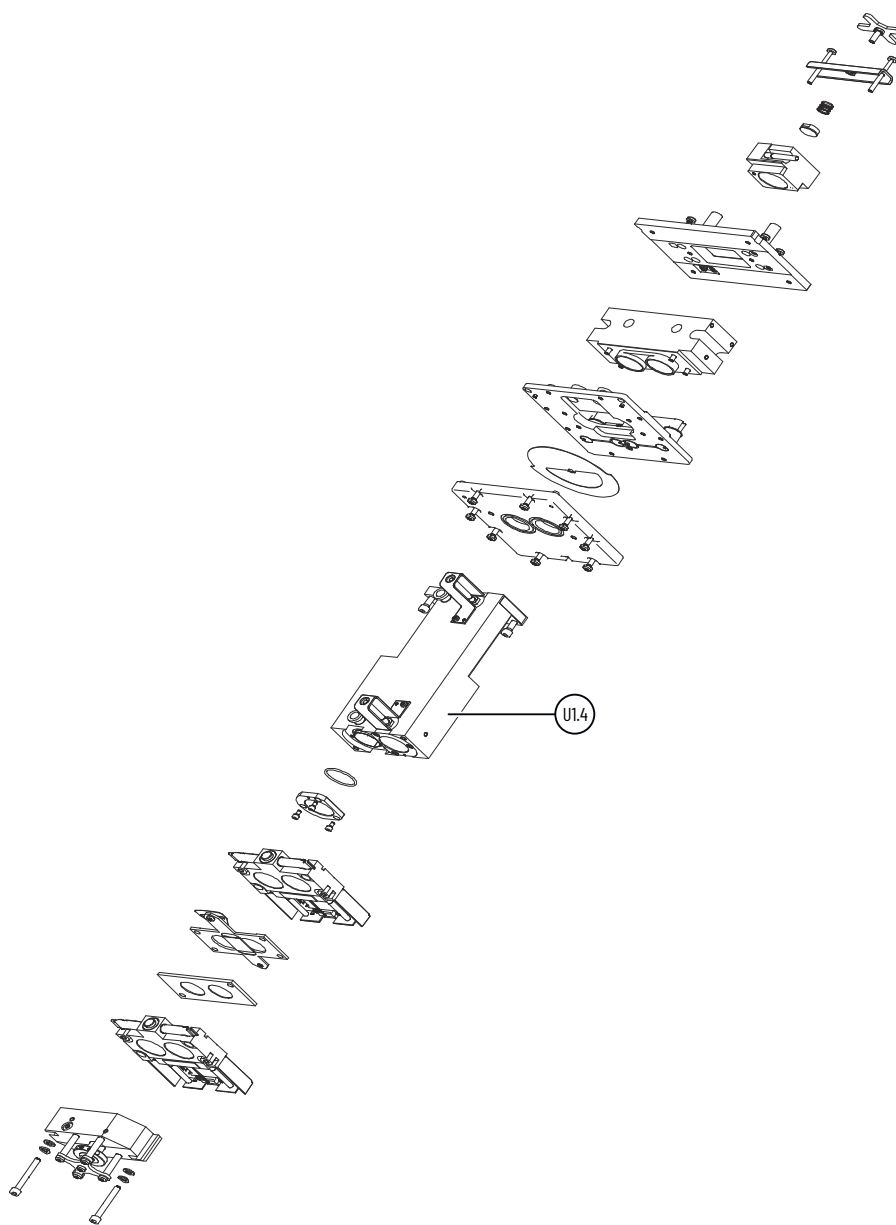

Figure 13-19 ULTRAMAT 6-2R analyzer unit, Part 2

Part No.	Name	Article number		Remarks
U 1.4	Analyzer chamber	Length 0.2 mm	A5E00117417	Non-flow-type reference gas chamber
			A5E00117418	Flow-type reference gas chamber
		Length 0.6 mm	A5E00117419	Non-flow-type reference gas chamber
			A5E00117420	Flow-type reference gas chamber
		Length 2 mm	A5E00117421	Non-flow-type reference gas chamber
			A5E00117422	Flow-type reference gas chamber
		Length 6 mm	A5E00117423	Non-flow-type reference gas chamber
			A5E00117424	Flow-type reference gas chamber
		Length 20 mm	A5E00117425	Non-flow-type reference gas chamber, aluminum
			A5E00117426	Flow-type reference gas chamber, aluminum
			A5E00117427	Non-flow-type reference gas chamber, tantalum
			A5E00117428	Non-flow-type reference gas chamber, tantalum
		Length 60 mm	A5E00117429	Non-flow-type reference gas chamber, aluminum
			A5E00117430	Flow-type reference gas chamber, aluminum
			A5E00117431	Non-flow-type reference gas chamber, tantalum
			A5E00117432	Non-flow-type reference gas chamber, tantalum
		Length 90 mm	A5E00117433	Non-flow-type reference gas chamber, aluminum
			A5E00117434	Flow-type reference gas chamber, aluminum
			A5E00117435	Non-flow-type reference gas chamber, tantalum
			A5E00117436	Non-flow-type reference gas chamber, tantalum
Length 180 mm	A5E00117437	Non-flow-type reference gas chamber, aluminum		
	A5E00117438	Flow-type reference gas chamber, aluminum		
	A5E00117439	Non-flow-type reference gas chamber, tantalum		
	A5E00117440	Non-flow-type reference gas chamber, tantalum		

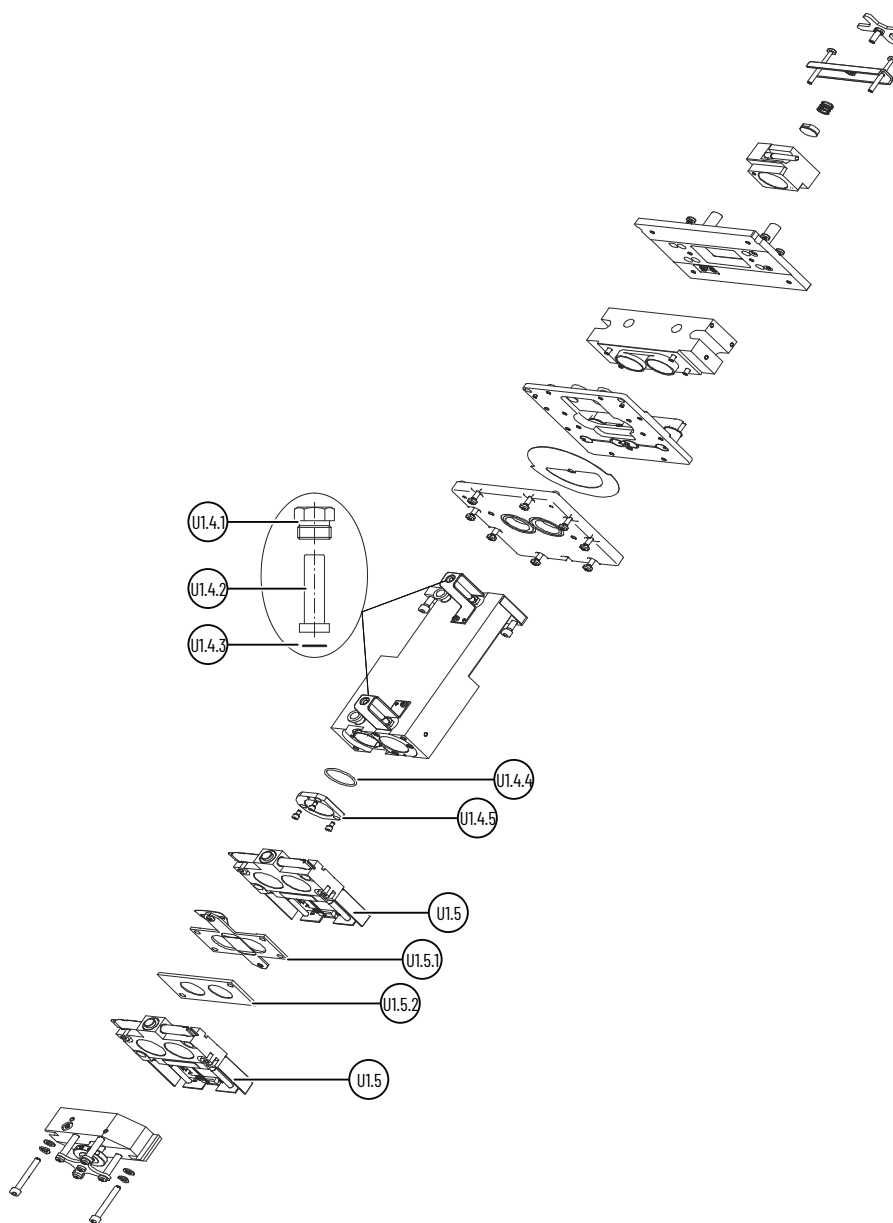
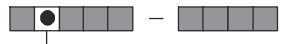







Figure 13-20 ULTRAMAT 6-2R analyzer unit, Part 3

Part No.	Name	Article number	Remarks
U 1.4.1	Union nut	C79451-A3478-C8	
U 1.4.2	Hose connection	C79451-A3478-C9	
U 1.4.3	O-ring	C71121-Z100-A159	
U 1.4.4	O-ring	C79121-Z100-A24	
U 1.4.5	Cover	C79451-A3462-B152	For cell length 0.2 mm to 6 mm
		C79451-A3462-B151	For cell length 20 mm to 180 mm



Part No.	Name	Article number	Remarks	
U 1.5	For MLFB ->	7MB2112		
		7MB2124		
		7MB2024		
		Detector cell	C79451-A3462-B581	A CO/NO A. 1st Detector CO
		A5E00076341	A A 2. Detector NO	
		C79451-A3462-B582	B CO <sub>2</sub> /CO B 1. Detector CO <sub>2</sub>	
C79451-A3462-B581	B B 2. Detector CO			
C79451-A3462-B582	C CO <sub>2</sub> /CH <sub>4</sub> C 1. Detector CO <sub>2</sub>			
C79451-A3462-B588	C C 2. Detector CH <sub>4</sub>			
C79451-A3462-B582	D CO <sub>2</sub> /NO D. 1st Detector CO <sub>2</sub>			
A5E00076341	D D 2nd Detector NO			
U 1.5.1	Zero point slider	C79451-A3278-B191		
U 1.5.2	For MLFB ->	7MB2112		
		7MB2124		
		7MB2024		
Optical filter	C79451-A3462-B154	A CO/NO		
	C79451-A3462-B154	D CO <sub>2</sub> /NO		

13.4 ULTRAMAT 6

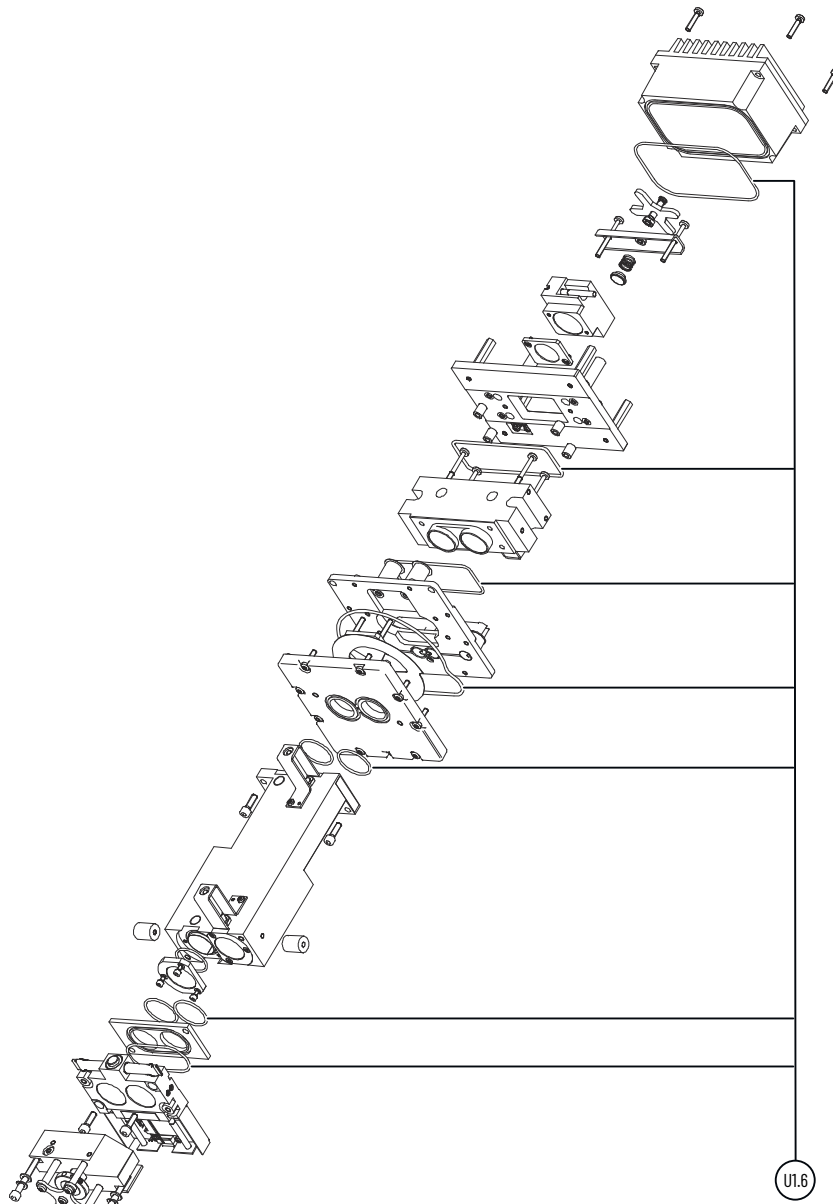
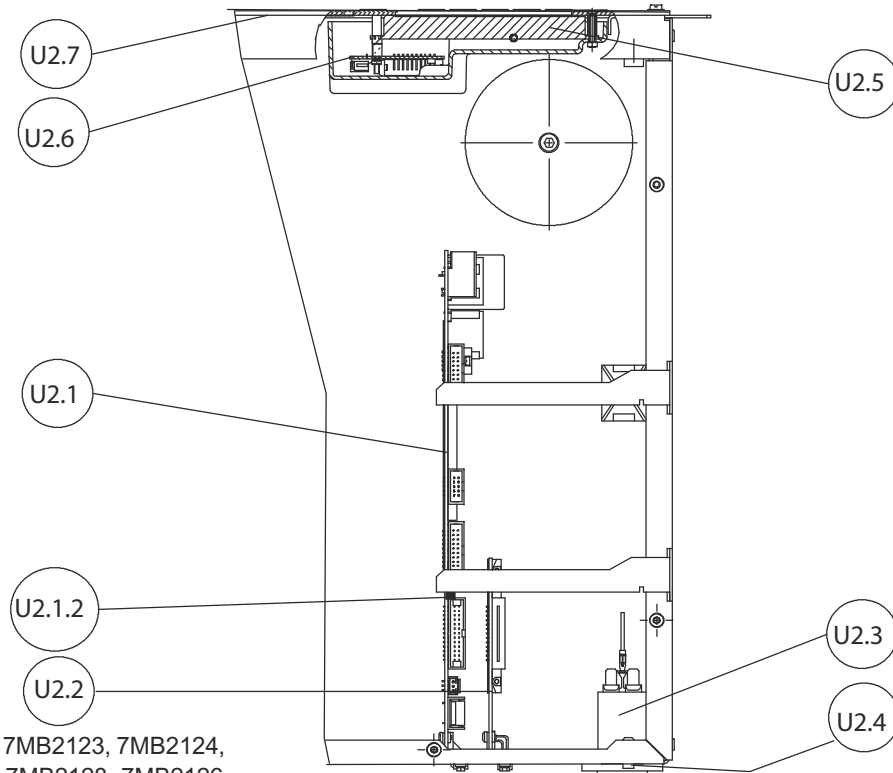

Figure 13-21 ULTRAMAT 6-2R analyzer unit, Part 4, representation in maximum configuration

Part No.	Name	Article number	Remarks
U 1.6	O-ring set	C79451-A3462-D501	for sealed analyzer unit (CO <sub>2</sub> , only rack units)

### 13.4.2 Electronics



7MB2121, 7MB2023, 7MB2123, 7MB2124,  
7MB2127, 7MB2028, 7MB2128, 7MB2126,  
7MB2024, 7MB2026

Figure 13-22 ULTRAMAT 6E, electronics

13.4 ULTRAMAT 6

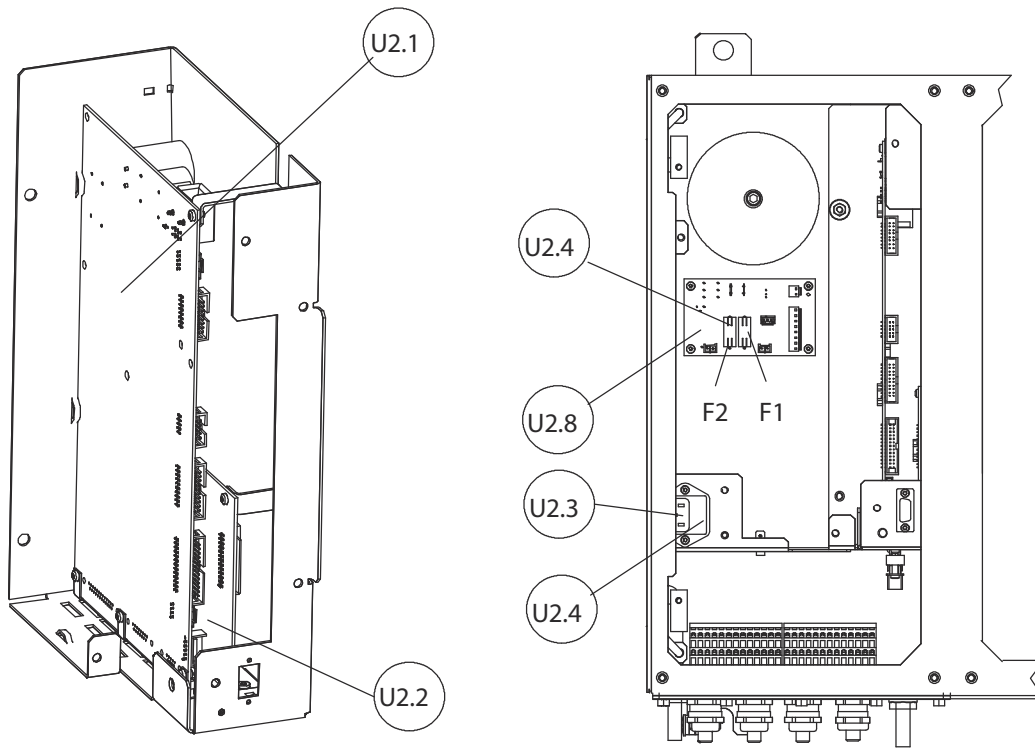

7MB2111, 7MB2112, 7MB2117, 7MB2118

Figure 13-23 ULTRAMAT 6F, electronics

Part No.	Name	Article number	Remarks
U2.1	Motherboard	C79451-A3478-D507	Motherboard with firmware, German
		C79451-A3478-D508	Motherboard with firmware, English
		C79451-A3478-D509	Motherboard with firmware, French
		C79451-A3478-D510	Motherboard with firmware, Spanish
		C79451-A3478-D511	Motherboard with firmware, Italian
U2.1.2	Firmware (FlashPROM)	C79451-A3478-S501	German
		C79451-A3478-S502	English
		C79451-A3478-S503	French
		C79451-A3478-S504	Spanish
		C79451-A3478-S505	Italian

Part No.	Name	Article number	Remarks
U2.2	Option board	A5E00064223	Relay, for MLFB 7MB2111, 7MB2112, 7MB2117, 7MB218
		C79451-A3480-D511	Relay, for MLFB 7MB2121, 7MB2023, 7MB2123, 7MB2124, 7MB2024, 7MB2127, 7MB2028, 7MB2128, 7MB2126, 7MB2026
		C79451-A3480-D512	With serial interface for the automotive industry (AK)
		A5E00057315	PROFIBUS PA, for MLFB 7MB2111, 7MB2112, 7MB2117, 7MB218
		A5E00057307	PROFIBUS PA, for MLFB 7MB2121, 7MB2023, 7MB2123, 7MB2124, 7MB2024, 7MB2127, 7MB2028, 7MB2128, 7MB2126, 7MB2026
		A5E00057318	PROFIBUS DP, for MLFB 7MB2111, 7MB2112, 7MB2117, 7MB218
		A5E00057312	PROFIBUS DP, for MLFB 7MB2121, 7MB2023, 7MB2123, 7MB2124, 7MB2024, 7MB2127, 7MB2028, 7MB2128, 7MB2126, 7MB2026
		A5E00057317	PROFIBUS PA Ex i, for MLFB 7MB2111, 7MB2112, 7MB2117, 7MB218
		A5E00057164	Firmware update for PROFIBUS
U2.3	Plug filter	W75041-E5602-K2	

## 13.4 ULTRAMAT 6

Part No.	Name	Article number	Remarks				
U2.4	Fuse (G-type fuse) T 0.63 A /250 V T 1 A /250 V T 1.6 A /250 V T 2.5A / 250V T 4A / 250V	W79054-L1010-T630 W79054-L1011-T100 W79054-L1011-T160 W79054-L1011-T250 W79054-L1011-T400	Select from the following list:				
			<b>200 to 240 V</b>	<b>F1</b>	<b>F2</b>	<b>F3</b>	<b>F4</b>
			7MB2111	-	-	0.63	0.63
			7MB2111 heated	0.63	2.5	2.5	2.5
			7MB2112	-	-	0.63	0.63
			7MB2112 heated	0.63	2.5	2.5	2.5
			7MB2117	-	-	0.63	0.63
			7MB2117 heated	0.63	2.5	2.5	2.5
			7MB2118	-	-	0.63	0.63
			7MB2118 heated	0.63	2.5	2.5	2.5
			7MB2121	-	-	0.63	0.63
			7MB2123	-	-	1	1
			7MB2124 (2R)	-	-	0.63	0.63
			7MB2124 (3K)	-	-	1	1
			7MB2126 (2R)	-	-	0.63	0.63
			7MB2126 (3-4K)	-	-	1	1
			7MB2127	-	-	0.63	0.63
			7MB2128	-	-	1	1
			<b>100 to 120 V</b>	<b>F1</b>	<b>F2</b>	<b>F3</b>	<b>F4</b>
			7MB2111	-	-	1	1
			7MB2111 heated	1	4	4	4
			7MB2112	-	-	1	1
			7MB2112 heated	1	4	4	4
			7MB2117	-	-	1	1
			7MB2117 heated	1	4	4	4
			7MB2118	-	-	1	1
			7MB2118 heated	1	4	4	4
7MB2121	-	-	1	1			
7MB2123	-	-	1.6	1.6			
7MB2124 (2R)	-	-	1	1			
7MB2124 (3K)	-	-	1.6	1.6			
7MB2126 (2R)	-	-	1	1			
7MB2126 (3-4K)	-	-	1.6	1.6			
7MB2127	-	-	1	1			
7MB2128	-	-	1.6	1.6			
U2.5	LC display	A5E31474846					
U2.6	Adapter board for LCD, keyboard	C79451-A3474-B605					
U2.7	Front panel with membrane keyboard	C79165-A3042-B505	For MLFB 7MB2021, 7MB2027 (ULTRAMAT 6E)				
		C79165-A3042-B506	For MLFB 7MB2023, 7MB2024, 7MB2026, 7MB2028 (ULTRAMAT/OXYMAT 6E)				
U2.8	Temperature controller electronics	A5E00118530	115 V AC, without fuses F1, F2				
		A5E00118527	230 V AC, without fuses F1, F2				

### 13.4.3 Gas paths

#### 13.4.3.1 Sample gas path

##### Sample gas path hose

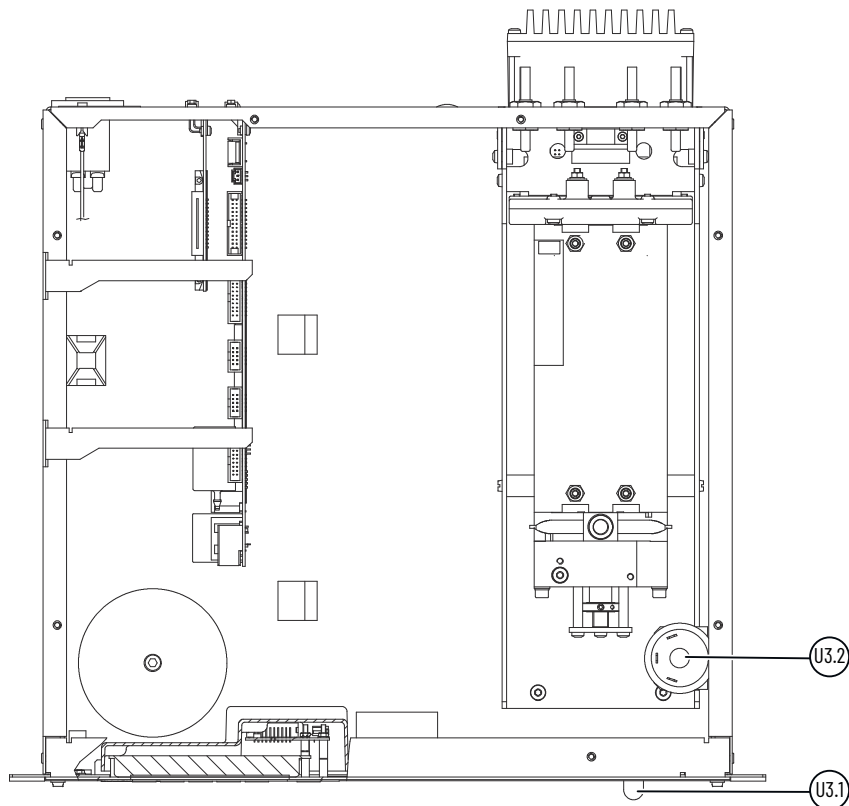
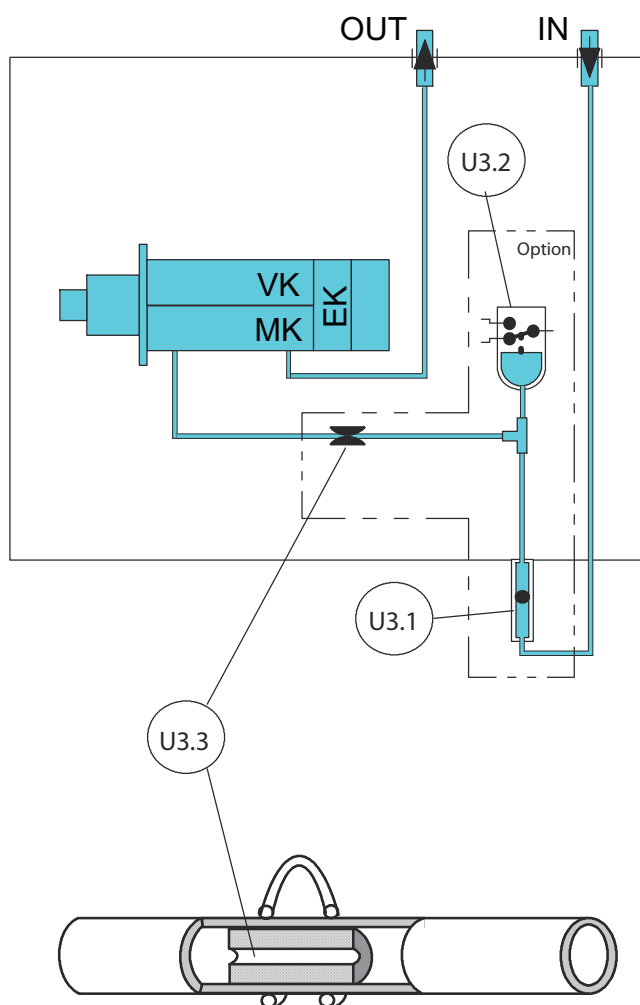

Figure 13-24 Sample gas path hose ULTRAMAT 6 (7MB2023, 7MB2024, 7MB2121, 7MB2123, 7MB2124, 7MB2028, 7MB2026, 7MB2127, 7MB2128, 7MB2126)

13.4 ULTRAMAT 6



- |             |                     |    |                       |
|-------------|---------------------|----|-----------------------|
| IN          | Sample gas inlet    | VK | Reference gas chamber |
| OUT         | Sample gas outlet   | MC | Sample gas chamber    |
| Op-<br>tion | Optional components | EK | Detector cell         |

Figure 13-25 ULTRAMAT 6, sample gas path hose

Part No.	Name	Article number	Remarks
U3.1	Flowmeter	C79402-Z560-T1	
U3.2	Pressure switch	C79302-Z1210-A2	
U3.3	Restrictor	C79451-A3480-C10	Inserted into the hose



## 13.4.3.2 Reference gas path with reduced flow-type reference gas side

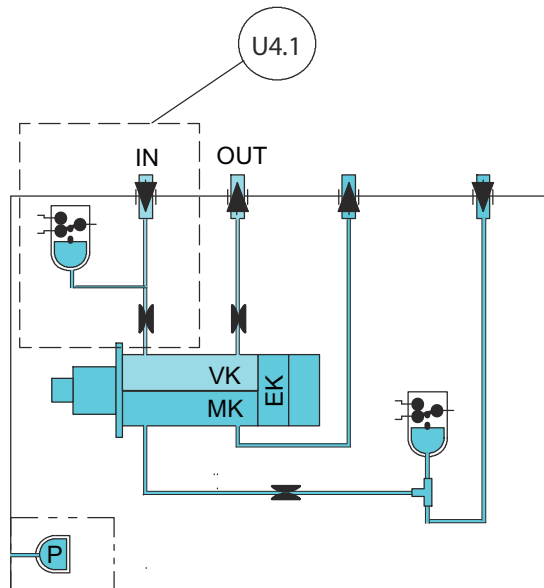

IN Reference gas inlet  
 OUT Reference gas outlet  
 P Pressure switch

VK Reference gas chamber  
 MC Sample gas chamber  
 EK Detector cell

Figure 13-26 ULTRAMAT 6, reference gas path with reduced flow-type reference gas side (7MB2023, 7MB2024, 7MB2111, 7MB2112, 7MB2121, 7MB2123, 7MB2124)

Part No.	Name	Article number	Remarks
U4.1	Reference gas path with reduced flow-type reference gas side (7MB2023, 7MB2024, 7MB2121, 7MB2123, 7MB2124)	C79451-A3478-D34	Diameter 6 mm
		C79451-A3478-D35	Diameter 1/4"
	(7MB2111, 7MB2112)	C79451-A3526-D60	Diameter 6 mm
		C79451-A3526-D61	Diameter 1/4"

13.4.4 Heating

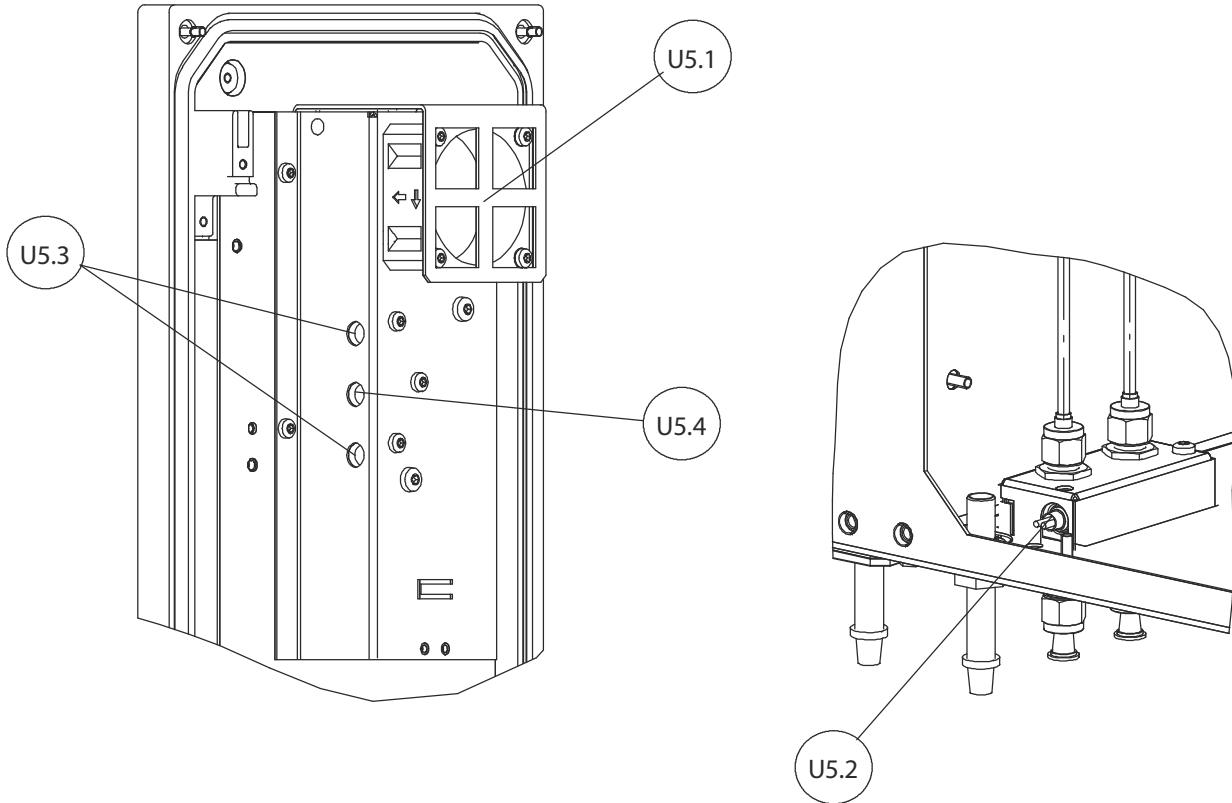

Figure 13-27 Heating ULTRAMAT 6 (7MB2111, 7MB2112, 7MB2117, 7MB2118)

Part No.	Name	Article number	Remarks
U5.1	Fan	A5E00302916	Replacement kit incl. temperature fuse and installation instructions, without heating cartridges; only for devices with serial number < N1-S2-404
		W75087-A1005-A40	Only for devices with serial number > N1--S2--404
U5.2	Heating cartridge	A5E00016674	1 unit
U5.3	Heating cartridge	W75083-A1004-F120	1 unit
U5.4	Temperature fuse	W75054-T1001-A150	

## Technical specifications

### 14.1 ULTRAMAT 6E and ULTRAMAT channel in ULTRAMAT/OXYMAT 6

<b>General information</b>	
Measuring ranges	4, internally and externally switchable, manual and automatic range switching is also possible
Smallest possible measuring range (depending on specification on the nameplate)	Depending on the application, e. g. CO: 0 to 10 vpm CO <sub>2</sub> : 0 to 5 vpm
Largest possible measuring range	Depending on the application
Characteristics	Linearized
Measured value display and control panel	Graphic display, digital concentration display (5 digits with floating decimal point), function keys and numerical keypad
<b>Enclosure</b>	
Weight	Approx. 15 kg (33 lbs.) with one IR channel approx. 21 kg (46 lbs.) with two IR channels
Dimensions	see section "ULTRAMAT 6E and ULTRAMAT/OXYMAT 6E rack units (Page 49)"
Operating position of the analyzer	Front panel vertical
Degree of protection	IP20 according to EN 60529
<b>Electrical characteristics</b>	
EMC interference immunity (with safety extra-low voltage (SELV) with safe isolation)	In accordance with standard requirements of NAMUR NE21 (08/98) or EN 61236
Electrical safety	According to EN 61010-1, overvoltage category III
Power supply	100 to 120 V AC (nominal range of use 90 V to 132 V), 48 to 63 Hz or 200 to 240 V AC (nominal range of use 180 V to 264 V), 48 to 63 Hz
Power consumption	1-channel unit: Approx. 40 VA 2 channel unit: Approx. 70 VA
Fuse values	1-channel unit (7MB2121, 7MB2127, 7MB2124, 7MB2126) <ul style="list-style-type: none"> <li>• 100 to 120 V: 1T/250</li> <li>• 200 to 240 V: 0.63T/250</li> </ul> 2-channel unit (double device ULTRAMAT 6: 7MB2123, 7MB2128, 7MB2124, 7MB2126) <ul style="list-style-type: none"> <li>• 100 to 120 V: 1.6 T/250</li> <li>• 200 to 240 V: 1T/250</li> </ul>
<b>Electrical inputs and outputs</b>	

14.1 ULTRAMAT 6E and ULTRAMAT channel in ULTRAMAT/OXYMAT 6

<b>Electrical characteristics</b>	
Analog output	1 per component, 0/2/4/NAMUR to 20 mA, floating, max. load 750 Ω
Relay outputs	6, with changeover contacts, freely selectable, e.g. for fault, loading capacity 24 V AC/DC/1 A, floating, non-sparking
Analog inputs	2, designed for 0/2/4 to 20 mA for external pressure sensor and correction of associated gas influences (cross-interference correction)
Binary inputs	6, designed for 24 V, user-configurable, e.g. for measuring range switching, floating
Serial interface	RS485
Options	Autocal function with 8 additional binary inputs and eight additional relay outputs, also with PROFIBUS PA or PROFIBUS DP
<b>Gas inlet conditions</b>	
Maximum permissible sample gas pressure	1500 hPa (21.8 psi) absolute 1300 hPa (18.9 psi) absolute with installed pressure switch
Sample gas flow rate	18 to 90 l/h (0.3 to 1.5 l/min)
Sample gas temperature	0 to 50 °C (32 to 122 °F)
Sample gas humidity	< 90% RH (relative humidity), non-condensing or dependent on measuring task
<b>Time response</b>	
Warm-up period	Approx. 30 min at room temperature, maximum accuracy is achieved after approx. 2 hours
Response time (T <sub>90</sub> time)	Dependent on length of analyzer chamber, sample gas supply line and damping setting
Damping	0 to 100 s, can be configured
Dead time (purging time of gas path in the device at 1 l/min flow rate)	0.5 to 5 s, depending on the device version
Time for device-internal signal processing	< 1 s
<b>Pressure correction range</b>	
Permissible pressure fluctuations	
• For internal pressure sensor	700 to 1200 hPa absolute
• For external pressure sensor	700 to 1500 hPa absolute
<b>Measuring response</b>	
Output signal fluctuation	< ±1% of the smallest possible measuring range according to rating plate, with device-specific damping constant (corresponds to ±0.33% at 2 σ)
Zero point drift	< ±1% of the respective measuring range per week
Measured value drift	< ±1% of the respective measuring range per week

14.2 OXYMAT 6E and OXYMAT channel in ULTRAMAT/OXYMAT 6

<b>Measuring response</b>	
Linearity deviation	< ±0.5% of the full-scale value of the biggest possible measuring range
Repeatability	≤ ±1% of the respective measuring range

<b>Influencing variables (referenced to 1000 hPa absolute sample gas pressure, 0.5 l/min sample gas flow and 25 °C ambient temperature)</b>	
Sample gas pressure	< 0.15% of the setpoint per 1% air pressure change when pressure compensation is switched on
Ambient temperature	< ±1% of the current measuring range/10 K
Sample gas flow rate	Negligible
Auxiliary power supply	< 0.1% of the output signal span with rated voltage ±10%
Environmental conditions	Application-dependent sample gas influences possible, if the ambient air contains the measured component or influencing gases

<b>Climatic conditions</b>	
Permissible ambient temperature	
• During operation	+5 to +45 °C (41 to 113 °F)
• During transportation and storage	-30 to +70 °C (-22 to 158 °F)
Permissible ambient humidity	< 90% RH (relative humidity) average annual value, during transportation and storage, no falling below dew point
Permissible ambient pressure	700 to 1200 hPa absolute

**Note**

Since measuring ranges can be changed, the specifications regarding accuracy relate to the measuring ranges specified on the nameplate.

The information on the technical specifications is based on EN 61207/IEC 61207.

## 14.2 OXYMAT 6E and OXYMAT channel in ULTRAMAT/OXYMAT 6

<b>General information</b>	
Measuring ranges	4, internally and externally switchable, manual and automatic range switching is also possible
Smallest possible measuring span, related to sample gas pressure 1000 hPa absolute, sample gas flow 0.5 l/min. and ambient temperature 25 °C	0.5 Vol. %, 2 Vol. %, 5 Vol. % O <sub>2</sub>
Largest possible measuring span	100 Vol. % O <sub>2</sub>

14.2 OXYMAT 6E and OXYMAT channel in ULTRAMAT/OXYMAT 6

<b>General information</b>	
Measuring ranges with zero offset	Any zero point between 0 to 100% is possible provided that a suitable reference gas is used (see section "Reference gases (OXYMAT 6) (Page 270)")
Measured value display and control panel	Graphic display, digital concentration display (5 digits with floating decimal point), function keys and numerical keypad
<b>Enclosure</b>	
Weight	Approx. 13 kg (29 lbs.) with one O <sub>2</sub> -channel Approx. 19 kg (42 lbs.) with one O <sub>2</sub> and one IR channel
Dimensions	See sections "OXYMAT 6E rack units (Page 48)" and "ULTRAMAT 6E and ULTRAMAT/OXYMAT 6E rack units (Page 49)"
Operating position of the analyzer	Front panel vertical
Degree of protection	IP20 according to EN 60529
<b>Electrical characteristics</b>	
EMC interference immunity (with safety extra-low voltage (SELV) with safe isolation)	In accordance with standard requirements of NAMUR NE21 (08/98) or EN 61236
Electrical safety	In accordance with EN 61010-1, overvoltage category III
Auxiliary power (see rating plate)	100 to 120 V AC (nominal range of use 90 V to 132 V), 48 to 63 Hz or 200 to 240 V AC (nominal range of use 180 V to 264 V), 48 to 63 Hz
Power consumption	1-channel unit: Approx. 45 VA 2 channel unit: Approx. 70 VA
Fuse values	1-channel unit (7MB2021, 7MB2027) <ul style="list-style-type: none"> <li>• 100 to 120 V: 1T/250</li> <li>• 200 to 240 V: 0.63T/250</li> </ul> 2-channel unit (double device ULTRAMAT/OXYMAT 6: 7MB2023, 7MB2028, 7MB2024, 7MB2026) <ul style="list-style-type: none"> <li>• 100 to 120 V: 1.6 T/250</li> <li>• 200 to 240 V: 1T/250</li> </ul>
<b>Electrical inputs and outputs</b>	
Analog output	1 per component, 0/2/4/NAMUR to 20 mA, floating, max. load 750 Ω
Relay outputs	6, with changeover contacts, freely selectable, e.g. for fault, loading capacity 24 V AC/DC/1 A, floating
Analog inputs	2, designed for 0/2/4 to 20 mA for external pressure sensor and correction of associated gas influences (cross-interference correction)
Binary inputs	6, designed for 24 V, user-configurable, e.g. for measuring range switching, floating
Serial interface	RS485
Options	Autocal function with 8 additional binary inputs and eight additional relay outputs, also with PROFIBUS PA or PROFIBUS DP

14.2 OXYMAT 6E and OXYMAT channel in ULTRAMAT/OXYMAT 6

<b>Gas inlet conditions</b>		
Maximum permissible sample gas pressure	• Devices with hoses	1500 hPa (21.8 psi) absolute 1300 hPa (18.9 psi) absolute with installed sample gas pressure switch
	• Devices with pipes	3000 hPa (43.5 psi) absolute
Sample gas flow rate		18 to 60 l/h (0.3 to 1 l/min)
Sample gas temperature		0 to 50 °C (32 to 122 °F)
Sample gas humidity		< 90% RH (relative humidity), non-condensing (OXYMAT channel)

<b>Pressure correction range</b>	
Pressure sensor internal	500 to 2000 hPa absolute
Pressure sensor external	500 to 3000 hPa absolute

<b>Time response</b>	
Warm-up period	< 30 min. at room temperature, maximum accuracy is achieved after approx. 2 hours
Response time ( $T_{90}$ time) at a flow rate of 1 l/min. and a signal damping of 0 s	Min. 1.5 to 3.5 s, depending on version
Damping (electrical time constant)	0 to 100 s, can be configured
Dead time (purging time for gas paths in the device at 1 l/min flow rate)	0.5 to 2.5 s, depending on the device version
Time for device-internal signal processing	< 1 s

<b>Measuring response</b>	
Output signal fluctuation	< $\pm 0.75\%$ of the smallest possible measuring range according to nameplate, with electronic damping constant of 1 s (corresponds to $\pm 0.25\%$ at $2\sigma$ )
Zero point drift	< 0.5% per month of smallest possible span according to nameplate
Measured value drift	< 0.5% per month of respective measuring span
Linearity deviation	< $\pm 0.1\%$ of the full-scale value
Repeatability	$\leq \pm 1\%$ of the respective measuring range

<b>Influencing variables</b>	
Sample gas pressure	
• When pressure compensation has been switched off	< 2% of the measuring span at 1% pressure change < 0.2% of the measuring span at 1% pressure change
• When pressure compensation has been switched on	
Ambient temperature	< 0.5% of the smallest measuring span according to nameplate/10 K; With measuring span 0.5%: 1%/10 K

14.3 ULTRAMAT 6F

Influencing variables	
Sample gas flow rate	< 1% of the smallest possible measuring span according to nameplate with a change in flow of 0.1 l/min within the permissible flow range
Auxiliary power supply	< 0.1% of the output signal span with rated voltage $\pm 10\%$
Accompanying gases	Deviation from zero point corresponding to paramagnetic or diamagnetic deviation of accompanying gas (see section "OXYMAT 6E rack units (Page 48)")

Climatic conditions	
Permissible ambient temperature	
• During operation	+5 to +45 °C (41 to 113 °F)
• During transportation and storage	-30 to +70 °C (-22 to 158 °F)
Permissible ambient humidity	< 90% RH (relative humidity) average annual value, during transportation and storage, no falling below dew point

**Note**

Since measuring ranges can be changed, the specifications regarding accuracy relate to the measuring ranges specified on the nameplate.

The information on the technical specifications is based on EN 61207/IEC 61207.

## 14.3 ULTRAMAT 6F

General information	
Measuring ranges	4, internally and externally switchable, manual and automatic range switching is also possible
Smallest possible measuring range (depending on specification on the nameplate)	Depending on the application, e. g. CO: 0 to 10 vpm CO <sub>2</sub> : 0 to 5 vpm
Largest possible measuring range	Depending on the application
Characteristics	Linearized
Measured value display and control panel	Digital concentration display (5 digits with floating decimal point)

Enclosure	
Weight	Approx. 32 kg (71 lbs.)
Dimensions	see section "ULTRAMAT 6F and OXYMAT 6F field devices (Page 52)"
Operating position of the analyzer	Front panel vertical
Degree of protection	IP65 according to EN 60529



<b>Electrical characteristics</b>	
EMC interference immunity (with safety extra-low voltage (SELV) with safe isolation)	In accordance with standard requirements of NAMUR NE21 (08/98) or EN 61236
Electrical safety	In accordance with EN 61010-1, overvoltage category II (heated devices) or overvoltage category III (non-heated devices)
Power supply	100 to 120 V AC (nominal range of use 90 V to 132 V), 48 to 63 Hz or 200 to 240 V AC (nominal range of use 180 V to 264 V), 48 to 63 Hz
Power consumption	Unheated devices: Approx. 45 VA Heated units: Approx. 330 VA
Fuse values	Unheated devices <ul style="list-style-type: none"> <li>• 100 to 120 V: 1T/250 (F3; F4)</li> <li>• 200 to 240 V: 0,63T/250 (F3; F4)</li> </ul> Heated devices <ul style="list-style-type: none"> <li>• 100 to 120 V: 1 T/250 (F1) 4 T/250 (F2; F3; F4)</li> <li>• 200 to 240 V: 0.63T/250 (F1) 2.5 T/250 (F2; F3; F4)</li> </ul>
<b>Electrical inputs and outputs</b>	
Analog output	1 per component, 0/2/4/NAMUR to 20 mA, floating, max. load 750 Ω
Relay outputs	6, with changeover contacts, freely selectable, e.g. for fault, loading capacity 24 V AC/DC/1 A, floating, non-sparking
Analog inputs	2, designed for 0/2/4 to 20 mA for external pressure sensor and correction of associated gas influences (cross-interference correction)
Binary inputs	6, designed for 24 V, user-configurable, e.g. for measuring range switching, floating
Serial interface	RS485
Options	Autocal function with 8 additional binary inputs and eight additional relay outputs, also with PROFIBUS PA or PROFIBUS DP
<b>Gas inlet conditions</b>	
Maximum permissible sample gas pressure	1500 hPa (21.8 psi) absolute
Purging gas pressure	< 165 hPa (2.4 psi) over ambient pressure
Sample gas flow rate	18 to 90 l/h (0.3 to 1.5 l/min)
Sample gas temperature	Unheated devices: 0 to 50 °C (32 to 122 °F) Heated devices: 0 to 80 °C (32 to 176 °F)
Sample gas humidity	< 90% RH (relative humidity), non-condensing or dependent on measuring task

14.3 ULTRAMAT 6F

<b>Time response</b>	
Warm-up period	Approx. 30 min at room temperature, maximum accuracy is achieved after approx. 2 hours
Response time ( $T_{90}$ time)	Dependent on length of analyzer chamber, sample gas supply line and damping setting
Damping	0 to 100 s, can be configured
Dead time (purging time of gas path in the device at 1 l/min flow rate)	0.5 to 5 s, depending on the device version
Time for device-internal signal processing	< 1 s
<b>Pressure correction range</b>	
Permissible pressure fluctuations	
<ul style="list-style-type: none"> <li>For internal pressure sensor</li> <li>For external pressure sensor</li> </ul>	700 to 1200 hPa absolute 700 to 1500 hPa absolute
<b>Measuring response</b>	
Output signal fluctuation	< $\pm 1\%$ of the smallest possible measuring range according to rating plate, with device-specific damping constant (corresponds to $\pm 0.33\%$ at $2\sigma$ )
Zero point drift	< $\pm 1\%$ of the respective measuring range per week
Measured value drift	< $\pm 1\%$ of the respective measuring range per week
Linearity deviation	< $\pm 0.5\%$ of the full-scale value of the biggest possible measuring range
Repeatability	$\leq \pm 1\%$ of the respective measuring range
<b>Influencing variables</b>	
Sample gas pressure	< 0.15% of the setpoint per 1% air pressure change when pressure compensation is switched on
Ambient temperature	< $\pm 1\%$ of the current measuring range/10 K (unheated devices)
Sample gas flow rate	Negligible
Auxiliary power supply	< 0.1% of the output signal span with rated voltage $\pm 10\%$
Environmental conditions	Application-dependent sample gas influences possible, if the ambient air contains the measured component or influencing gases
<b>Climatic conditions</b>	
Permissible ambient temperature	
<ul style="list-style-type: none"> <li>During operation</li> <li>During transportation and storage</li> </ul>	+5 to +45 °C (41 to 113 °F) -30 to +70 °C (-22 to 158 °F)
Permissible ambient humidity	< 90% RH (relative humidity) average annual value, during transportation and storage, no falling below dew point
Permissible ambient pressure	700 to 1200 hPa (8.7 to 17.4 psi) absolute

**Note**

Since measuring ranges can be changed, the specifications regarding accuracy relate to the measuring ranges specified on the nameplate.

The information on the technical specifications is based on EN 61207/IEC 61207.

## 14.4 OXYMAT 6F

<b>General information</b>	
Measuring ranges	4, internally and externally switchable, manual and automatic range switching is also possible
Smallest possible measuring span	Unheated devices: 0.5 Vol. %, 2 Vol. %, 5 Vol. % O <sub>2</sub> ; Heated devices: 2 Vol. %; 5 Vol. % O <sub>2</sub>
Largest possible measuring span	100 Vol. % O <sub>2</sub>
Measuring ranges with zero offset	Any zero point between 0 to 100% is possible provided that a suitable reference gas is used (see section "Reference gases (OXYMAT 6) (Page 270)")
Measured value display and control panel	Digital concentration display (5 digits with floating decimal point)
<b>Enclosure</b>	
Weight	Approx. 28 kg (62 lbs.)
Dimensions	see section "ULTRAMAT 6F and OXYMAT 6F field devices (Page 52)"
Operating position of the analyzer	Front panel vertical
Degree of protection	IP65 according to EN 60529
<b>Electrical characteristics</b>	
EMC interference immunity (with safety extra-low voltage (SELV) with safe isolation)	In accordance with standard requirements of NAMUR NE21 (08/98) or EN 61236
Electrical safety	In accordance with EN 61010-1, overvoltage category III (non-heated devices) or overvoltage category II (heated devices)
Auxiliary power (see rating plate)	100 to 120 V AC (nominal range of use 90 V to 132 V), 48 to 63 Hz or 200 to 240 V AC (nominal range of use 180 V to 264 V), 48 to 63 Hz
Power consumption	Unheated devices: Approx. 45 VA Heated units: Approx. 330 VA

14.4 OXYMAT 6F

<b>Electrical characteristics</b>	
Fuse values	Unheated devices: <ul style="list-style-type: none"> <li>• 100 to 120 V: 1T/250 (F3; F4)</li> <li>• 200 to 240 V: 0.63T/250 (FG3; F4)</li> </ul> Heated devices: <ul style="list-style-type: none"> <li>• 100 to 120 V: 1 T/250 (F1) 4 T/250 (F2; F3; F4)</li> <li>• 200 to 240 V: 0.63T/250 (F1) 2.5 T/250 (F2; F3; F4)</li> </ul>
<b>Electrical inputs and outputs</b>	
Analog output	1 per component, 0/2/4/NAMUR to 20 mA, floating, max. load 750 Ω
Relay outputs	6, with changeover contacts, freely selectable, e.g. for fault, loading capacity 24 V AC/DC/1 A, floating
Analog inputs	2, designed for 0/2/4 to 20 mA for external pressure sensor and correction of associated gas influences (cross-interference correction)
Binary inputs	6, designed for 24 V, user-configurable, e.g. for measuring range switching, floating
Serial interface	RS485
Options	Autocal function with 8 additional binary inputs and eight additional relay outputs, also with PROFIBUS PA or PROFIBUS DP
<b>Gas inlet conditions</b>	
Maximum permissible sample gas pressure	3000 hPa (43.5 psi) absolute
Purging gas pressure	< 165 hPa (2.4 psi) over ambient pressure,
Sample gas flow rate	18 to 60 l/h (0.3 to 1 l/min)
Sample gas temperature	Unheated devices: 0 to 50 °C (32 to 122 °F) Heated devices: Max. 15 °C (27 °F) above temperature of analyzer unit
Sample gas humidity	< 90% RH (relative humidity), non-condensing
Pressure correction range	500 to 2000 hPa (7.3 to 29 psi) absolute (internal pressure sensor) 500 to 3000 hPa (7.3 to 43.5 psi) absolute (external pressure sensor)
<b>Time response</b>	
Warm-up period	< 30 min. at room temperature, maximum accuracy is achieved after approx. 2 hours
Response time ( $T_{90}$ time) at a flow rate of 1 l/min. and a signal damping of 0 s	< 1.5 s
Damping (electrical time constant)	0 to 100 s, can be configured
Dead time (purging time for gas paths in the device at 1 l/min flow rate)	Approx. 0.5 s
Time for device-internal signal processing	< 1 s

<b>Measuring response</b>	
Output signal fluctuation	< $\pm 0.75\%$ of the smallest possible measuring range according to nameplate, with electronic damping constant of 1 s (corresponds to $\pm 0.25\%$ at $2\sigma$ )
Zero point drift	< 0.5% per month of smallest possible span according to nameplate
Measured value drift	< 0.5% per month of respective measuring span
Linearity deviation	< $\pm 0.1\%$ of the respective measuring span
Repeatability	$\leq \pm 1\%$ of the respective measuring span

<b>Influencing variables</b>	
Sample gas pressure	
<ul style="list-style-type: none"> <li>When pressure compensation has been switched off</li> <li>When pressure compensation has been switched on</li> </ul>	<ul style="list-style-type: none"> <li>&lt; 2% of the measuring span at 1% pressure change</li> <li>&lt; 0.2% of the measuring span at 1% pressure change</li> </ul>
Ambient temperature	< 0.5% of the smallest measuring span according to nameplate/10 K; With measuring span 0.5%: 1%/10 K
Sample gas flow rate	< 1% of the smallest possible measuring span according to nameplate with a change in flow of 0.1 l/min within the permissible flow range
Auxiliary power supply	< 0.1% of the output signal span with rated voltage $\pm 10\%$
Accompanying gases	Deviation from zero point corresponding to paramagnetic or diamagnetic deviation of accompanying gas (see section "Zero point error of accompanying gases (OXYMAT 6) (Page 270)")

<b>Climatic conditions</b>	
Permissible ambient temperature	
<ul style="list-style-type: none"> <li>During operation</li> <li>During transportation and storage</li> </ul>	<ul style="list-style-type: none"> <li>+5 to +45 °C (41 to 113 °F)</li> <li>-30 to +70 °C (-22 to 158 °F)</li> </ul>
Permissible ambient humidity	< 90% RH (relative humidity) average annual value, during transportation and storage, no falling below dew point

**Note**

Since measuring ranges can be changed, the specifications regarding accuracy relate to the measuring ranges specified on the nameplate.

The information on the technical specifications is based on EN 61207/IEC 61207.

## 14.6 Zero point error of accompanying gases (OXYMAT 6)

## 14.5 Reference gases (OXYMAT 6)

Measuring range	Recommended reference gas	Reference gas connection pressure	Remarks
0 to ... Vol. % O <sub>2</sub>	N <sub>2</sub> , 4.6		
... to 100 vol. % O <sub>2</sub> , (suppressed zero point with full-scale value 100 vol. % O <sub>2</sub> )	O <sub>2</sub>	High-pressure version: 2000 to 4000 hPa above sample gas pressure (max. 5000 hPa absolute)	The reference gas flow is set automatically to 5 to 10 ml/min (up to 20 ml/min for flow-type compensation branch)
≈ 21% vol. O <sub>2</sub> (suppressed zero point with 21 vol. % O <sub>2</sub> within the measuring span)	Air	Low-pressure version 100 hPa above sample gas pressure, which may vary by a maximum of ± 50 hPa around the air pressure	

## 14.6 Zero point error of accompanying gases (OXYMAT 6)

Cross-sensitivities (for an accompanying gas concentration of 100%)

Accompanying gas	Formula	Deviation from zero point in Vol. % O <sub>2</sub> absolute	Accompanying gas	Formula	Deviation from zero point in Vol. % O <sub>2</sub> absolute
<b>Organic gases</b>			<b>Inert gases</b>		
Ethane	C <sub>2</sub> H <sub>6</sub>	-0,49	Argon	Ar	-0,25
Ethene (ethylene)	C <sub>2</sub> H <sub>4</sub>	-0,22	Helium	He	+0,33
Ethyne (acetylene)	C <sub>2</sub> H <sub>2</sub>	-0,29	Krypton	Kr	-0,55
1.2-butadiene	C <sub>4</sub> H <sub>6</sub>	-0,65	Neon	Ne	+0,17
1.3-butadiene	C <sub>4</sub> H <sub>6</sub>	-0,49	Xenon	Xe	-1,05
Isobutane	C <sub>4</sub> H <sub>10</sub>	-1,3	<b>Inorganic gases</b>		
n-butane	C <sub>4</sub> H <sub>10</sub>	-1,26	Ammonia	NH <sub>3</sub>	-0,20
1-butene	C <sub>4</sub> H <sub>8</sub>	-0,96	Hydrogen bromide	HBr	-0,76
Isobutene	C <sub>4</sub> H <sub>8</sub>	-1,06	Chlorine	Cl <sub>2</sub>	-0,94
Cyclohexane	C <sub>6</sub> H <sub>12</sub>	-1,84	Hydrogen chloride, hydrochloric acid	HCl	-0,35
Dichlorodifluoromethane (R12)	CCl <sub>2</sub> F <sub>2</sub>	-1,32	Dinitrogen monoxide	N <sub>2</sub> O	-0,23
Acetic acid	CH <sub>3</sub> COOH	-0,64	Hydrogen fluoride HF, hydrofluoric acid	HF	+0,10
n-heptane	C <sub>7</sub> H <sub>16</sub>	-2,4	Hydrogen iodide	HJ	-1,19
n-hexane	C <sub>6</sub> H <sub>14</sub>	-2,02	Carbon dioxide	CO <sub>2</sub>	-0,30
Methane	CH <sub>4</sub>	-0,18	Carbon monoxide	CO	+0,07
Methanol	CH <sub>3</sub> OH	-0,31	Oxygen	O <sub>2</sub>	+100
n-octane	C <sub>8</sub> H <sub>18</sub>	-2,78	Sulfur dioxide	SO <sub>2</sub>	-0,20
Isopentane	C <sub>5</sub> H <sub>12</sub>	-1,49			

14.7 Parts in gas path wetted by sample gas

Accompanying gas	Formula	Deviation from zero point in Vol. % O <sub>2</sub> absolute	Accompanying gas	Formula	Deviation from zero point in Vol. % O <sub>2</sub> absolute
n-pentane	C <sub>5</sub> H <sub>12</sub>	-1,68	Sulfur hexafluoride	SF <sub>6</sub>	-1,05
Propane	C <sub>3</sub> H <sub>8</sub>	-0,87	Hydrogen sulfide	H <sub>2</sub> S	-0,44
Propylene, propene	C <sub>3</sub> H <sub>6</sub>	-0,64	Nitrogen	N <sub>2</sub>	0
Trichlorofluoromethane (R11)	CCl <sub>3</sub> F	-1,63	Nitrogen dioxide	NO <sub>2</sub>	+20,0
Vinyl chloride	C <sub>2</sub> H <sub>3</sub> Cl	-0,77	Nitrogen oxide	NO	+42,94
Vinyl fluoride	C <sub>2</sub> H <sub>3</sub> F	-0,55	Water (vapor)	H <sub>2</sub> O	-0,03
1.1 vinylidene chloride	C <sub>2</sub> H <sub>2</sub> Cl <sub>2</sub>	-1,22	Hydrogen	H <sub>2</sub>	+0,26

Zero point error due to diamagnetism or paramagnetism of some residual gases referenced to nitrogen (N<sub>2</sub>) at 60 °C and 1000 hPa (1 bar).

## 14.7 Parts in gas path wetted by sample gas

Standard		19" rack unit	Field device	Field device Ex
Gas path with hoses	Gas feedthrough	Stainless steel 1.4571 / 1.4404		-----
	Hose	FPM		
	Hose coupling (ULTRAMAT 6)	PA 6		
	Sample chamber (OXYMAT 6)	Stainless steel 1.4571 / 1.4404 or Ta or Hastelloy C22		
	Sample chamber (ULTRAMAT 6) <ul style="list-style-type: none"> <li>• Body</li> <li>• Lining</li> <li>• Gaskets (O-rings)</li> <li>• Window</li> </ul>	Alu Alu FPM or FFKM CaF <sub>2</sub> ; epoxy resin adhesive		
Gas path with pipes	Gas feedthrough	Hastelloy C22 (OXYMAT 6F) or Ti or stainless steel 1.4571 / 1.4404		
	Pipe	Hastelloy C22 (OXYMAT 6F) or Ti or stainless steel 1.4571 / 1.4404		
	Sample chamber (OXYMAT 6)	Stainless steel 1.4571 / 1.4404 or Ta or Hastelloy C22		
	Sample chamber (ULTRAMAT 6) <ul style="list-style-type: none"> <li>• Body</li> <li>• Lining</li> <li>• Gaskets (O-rings)</li> <li>• Window</li> </ul>	Alu Alu or Ta FPM or FFKM CaF <sub>2</sub> ; epoxy resin adhesive		

14.7 Parts in gas path wetted by sample gas

Special applications (selection)		19" rack unit	Field device	Field device Ex
Gas path with pipes (ULTRAMAT 6)	Gas feedthrough	Ti or stainless steel 1.4571 / 1.4404 or Hastelloy C22		
	Pipe	Ti or stainless steel 1.4571 / 1.4404 or Hastelloy C22		
	Sample chamber <ul style="list-style-type: none"> <li>• Body</li> <li>• Lining</li> <li>• Gaskets (O-rings)</li> <li>• Window</li> </ul>	Ti or stainless steel 1.4571 / 1.4404 or Hastelloy C22 Ta or Alu Material according to specification  CaF <sub>2</sub> ; without adhesive		
Gas path with pipes (OXYMAT 6)	Gas feedthrough	Hastelloy C22		
	Pipe/nozzle	Hastelloy C22		
	Sample chamber	Hastelloy C22		
	Gaskets (O-rings)	Material according to specification		

Further designs upon request

Options		19" rack unit	Field device	Field device Ex
Flowmeter	Measurement pipe	Duran glass	-----	-----
	Variable area	Duran glass		
	Suspension boundary	PTFE		
	Angle pieces	FPM		
Pressure switch sample gas	Diaphragm	FPM	-----	-----
	Enclosure	PA 6.3 T		



## Dimension drawings

### 15.1 OXYMAT 6E rack units

All dimensions are specified in mm.

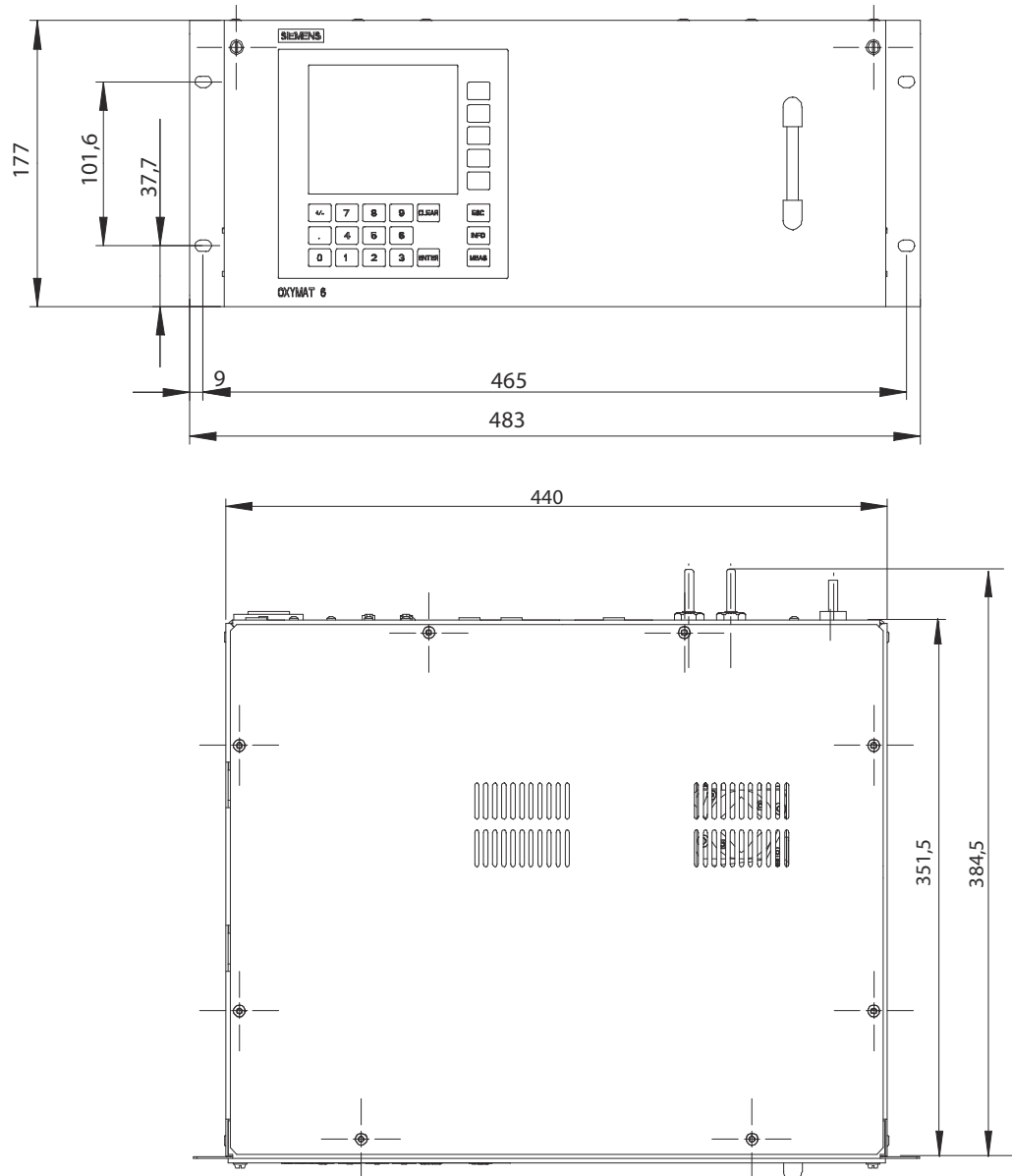

Figure 15-1 OXYMAT 6E, dimension drawing: Front view and top view

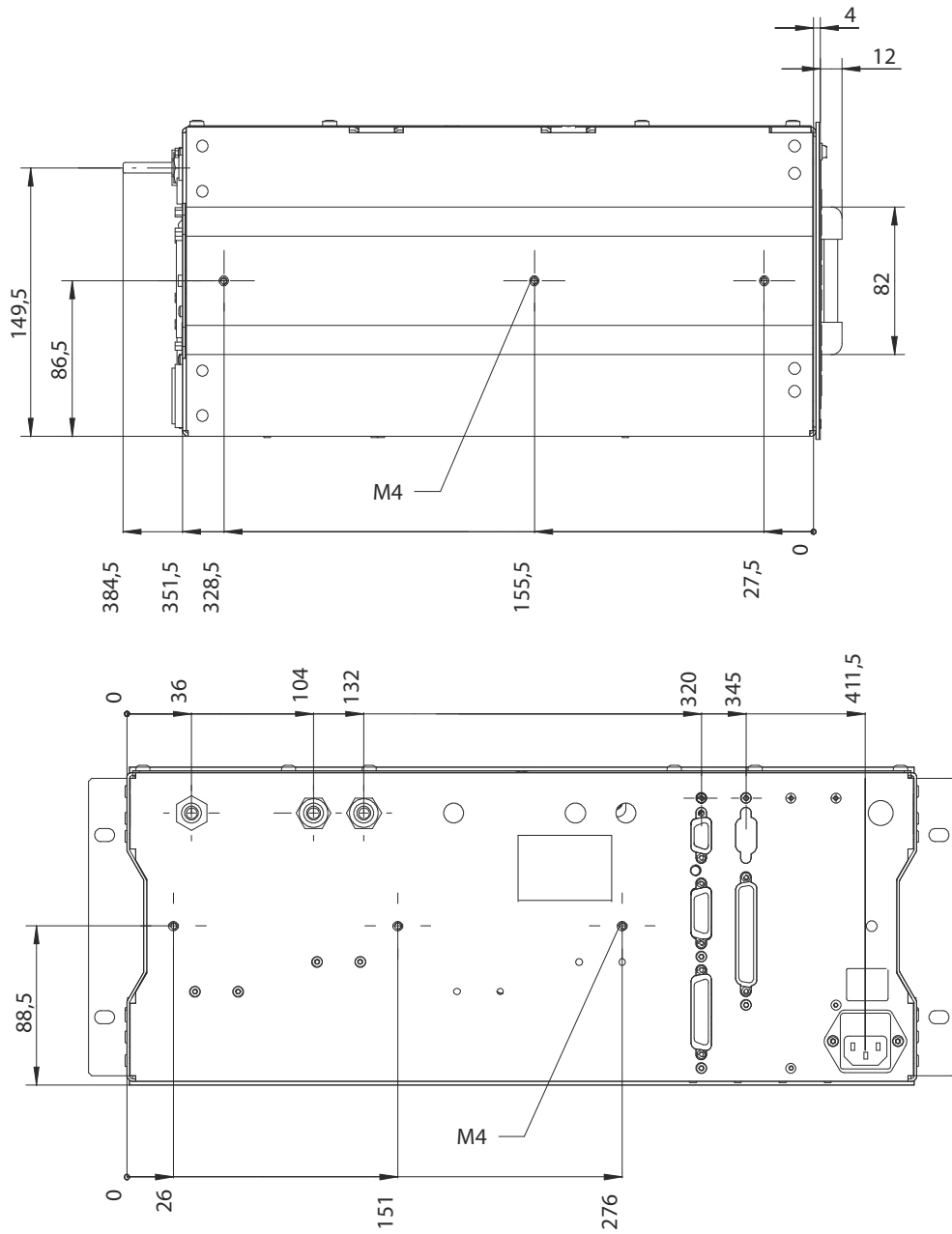

Figure 15-2 OXYMAT 6E, dimension drawing: Side view and rear of the device

## 15.2 ULTRAMAT 6E and ULTRAMAT/OXYMAT 6E rack units

When viewed from the rear, single channel devices have either an IR channel or an O<sub>2</sub> channel on the left. For dual channel devices, the second analyzer unit is always an IR channel.

All dimensions are specified in mm.

15.2 ULTRAMAT 6E and ULTRAMAT/OXYMAT 6E rack units

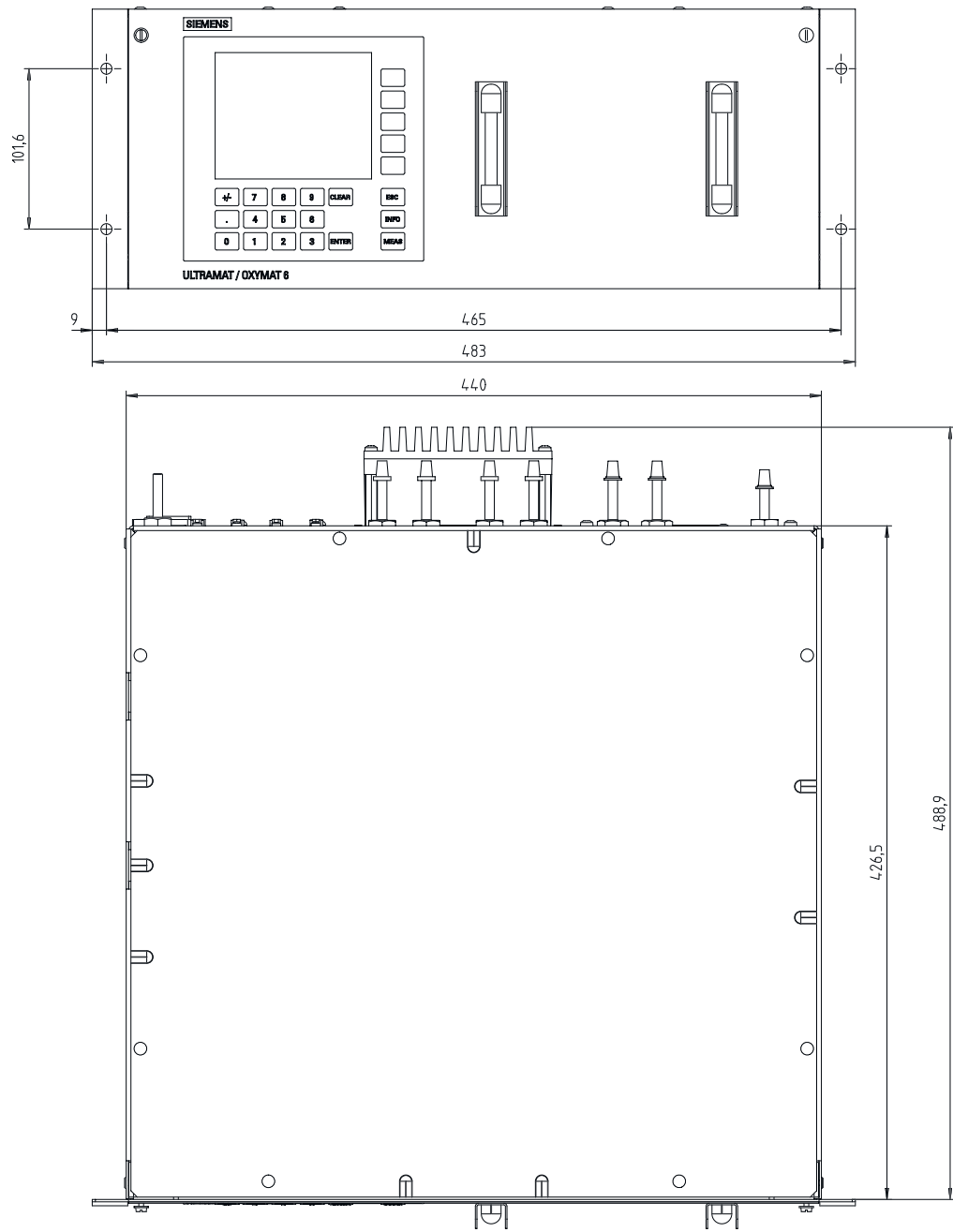

Figure 15-3 ULTRAMAT 6E and ULTRAMAT/OXYMAT 6E, dimension drawing: Front view and top view

15.2 ULTRAMAT 6E and ULTRAMAT/OXYMAT 6E rack units

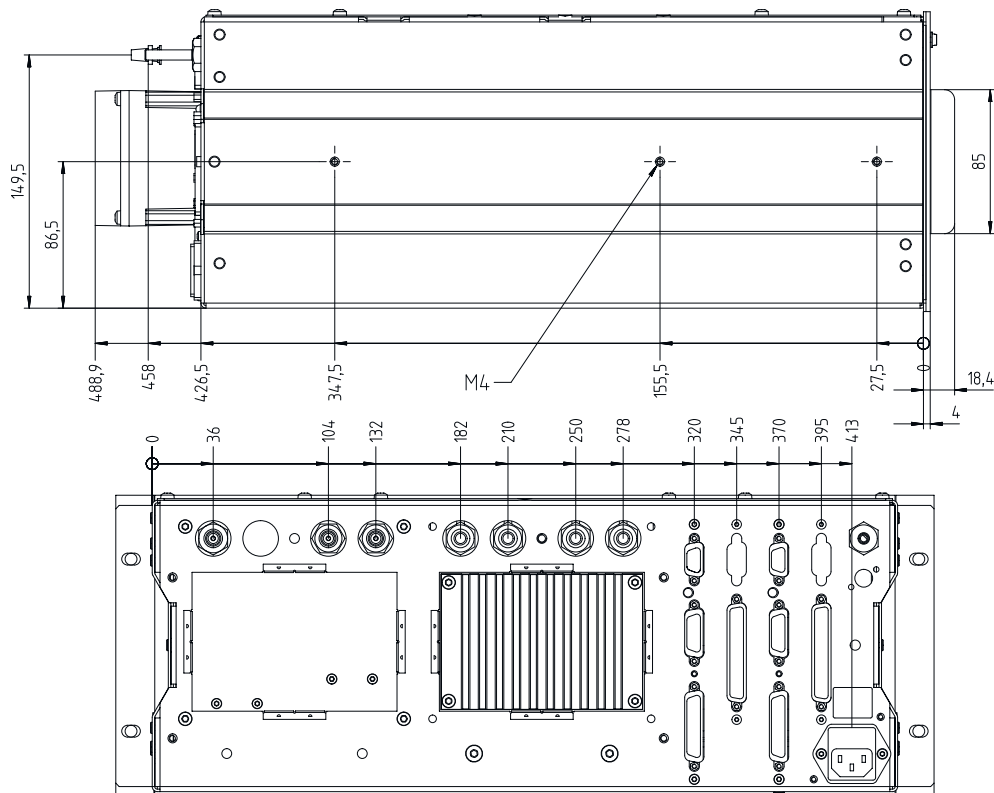

Figure 15-4 ULTRAMAT 6E and ULTRAMAT/OXYMAT 6E, dimension drawing: Side view and rear of the device

## 15.3 ULTRAMAT 6F and OXYMAT 6F field devices

All dimensions are specified in mm.

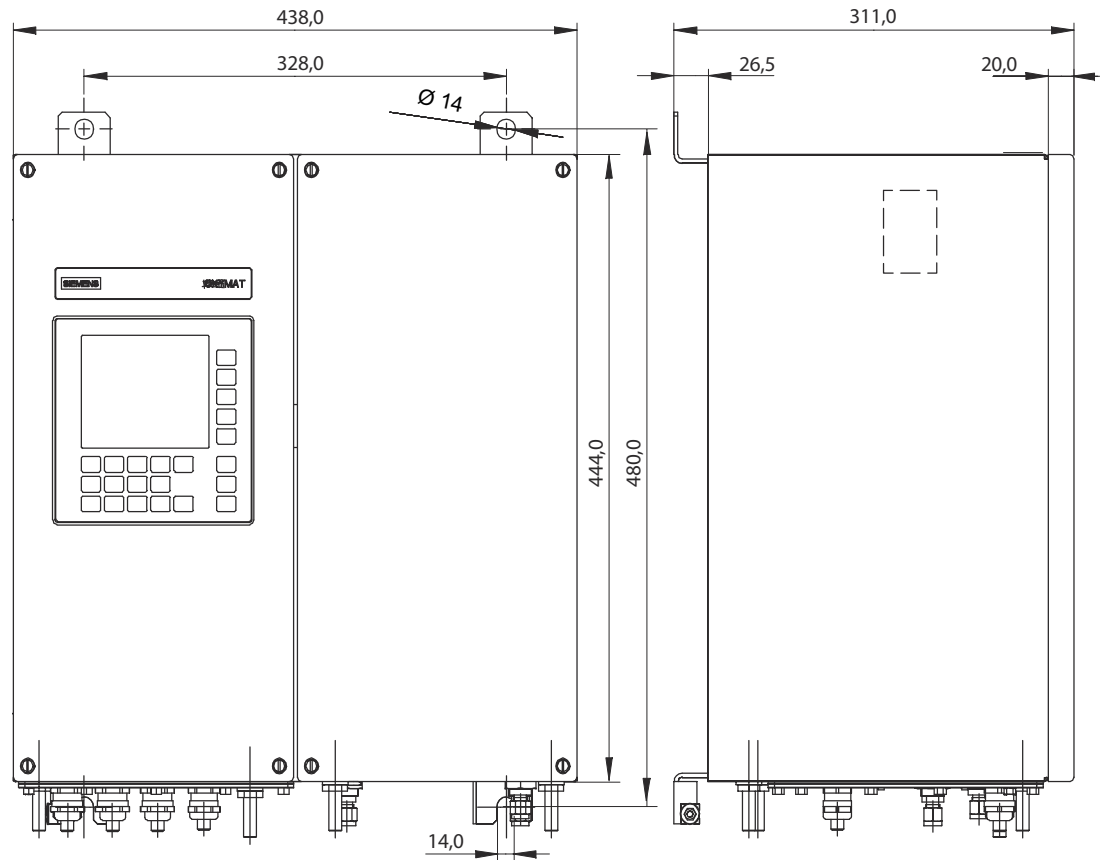

Figure 15-5 ULTRAMAT 6F and OXYMAT 6F, dimension drawing: Front view and side view

15.3 ULTRAMAT 6F and OXYMAT 6F field devices

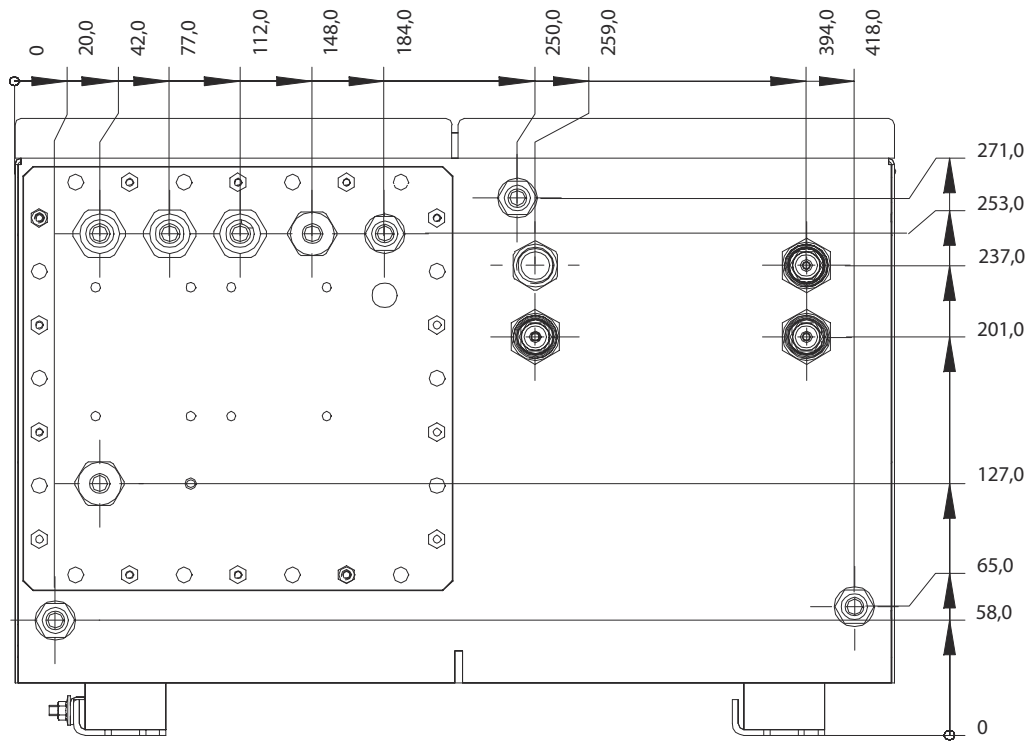

Figure 15-6 ULTRAMAT 6F and OXYMAT 6F, dimension drawing: Bottom view

## Appendix

### A.1 Wiring diagrams

#### A.1.1 Pin assignment

##### A.1.1.1 Motherboard pin assignment for rack units

A.1 Wiring diagrams

Plug D-SUB 9F (RS 485)

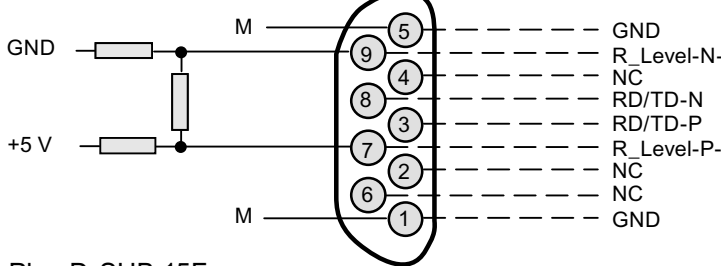

Bus terminating resistors can be connected to pins 7 and 9

Plug D-SUB 15F

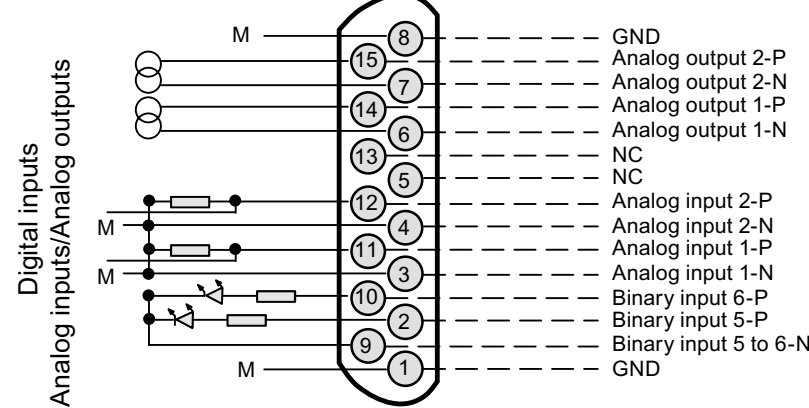

Analog outputs floating (also to one other),  $R_L \leq 750 \Omega$   
 Analog outputs floating (also to one other),  $R_L \leq 750 \Omega$

Pressure or interference-gas correction  
 Interference gas correction  
 Analog inputs non-floating, 0 to 20 mA/500  $\Omega$  or 0 to 10 V (low-resistance)

Plug D-SUB 25F

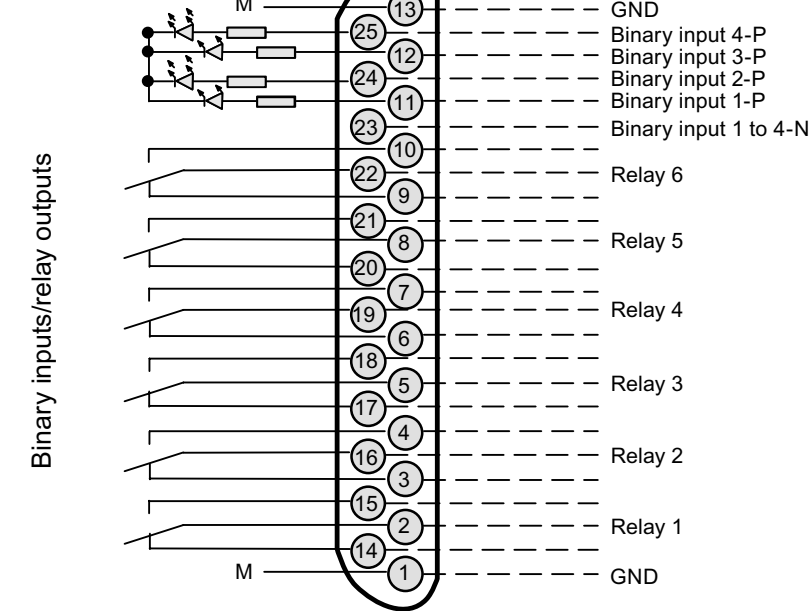

Binary inputs:  
 "1" = 24 V (13 to 33 V)  
 "0" = 0 V (0 to 4.5 V)  
 Floating via optocoupler

Contact loading  
 Max. 24 V AC/DC / 1 A;  
 shown relay contacts:  
 de-energized relay coil

Note:  
 Cable and connector must be shielded and connected to the housing potential

Figure A-1 Pin assignment of the ULTRAMAT 6E motherboard



Connector SUB-D 9F (RS 485)

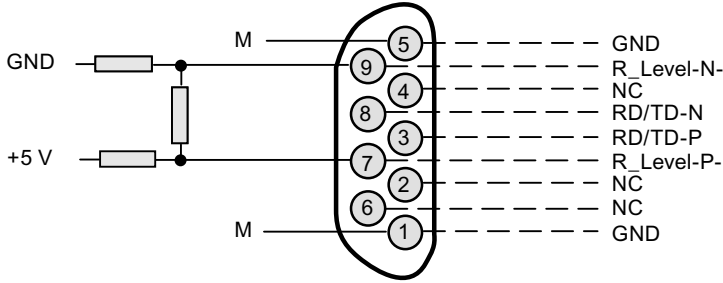

Terminating resistors for the bus can be connected to pins 7 and 9

Connector SUB-D 15F

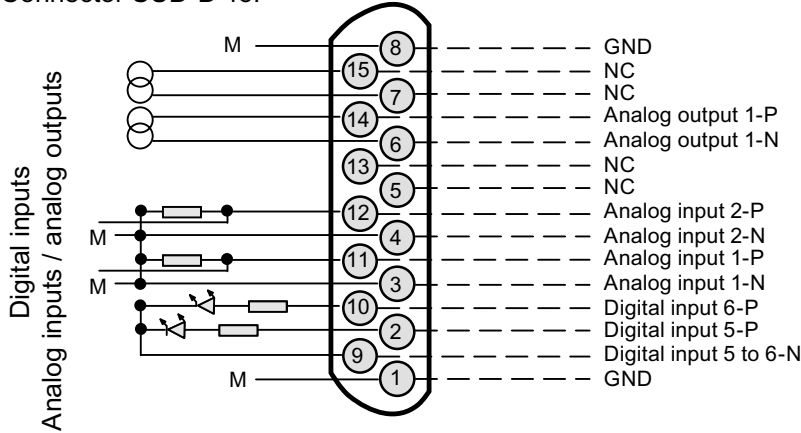

Analog outputs floating (mutually isolated as well),  $R_L \leq 750 \Omega$

Correction of compressed or interfering gas  
Correction of interfering gas

Analog inputs non-floating, 0 to 20 mA/500  $\Omega$  or 0 to 10 V (low impedance)

Connector SUB-D 25F

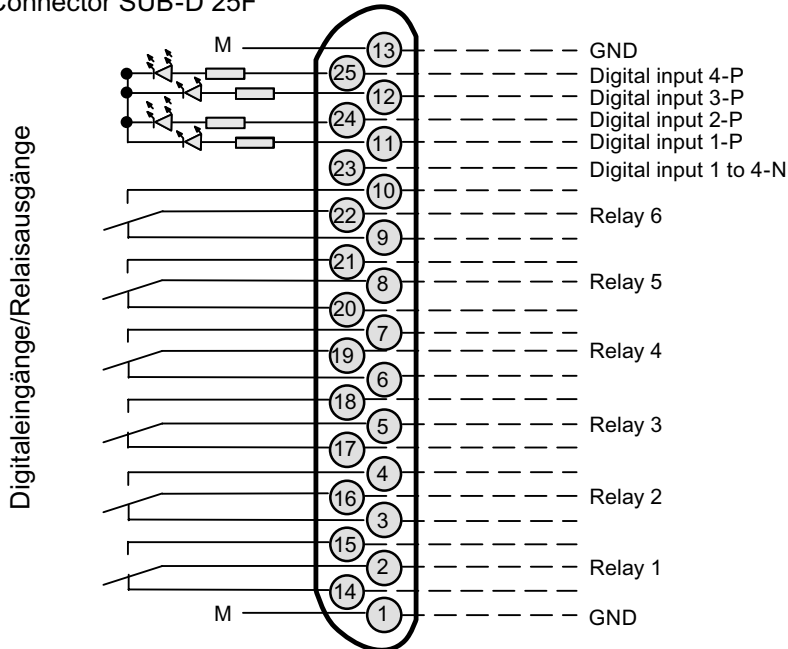

Digital inputs:  
"1" = 24 V (13 to 33 V)  
"0" = 0 V (0 to 4.5 V)  
floating via optocoupler

Contact load max. 24 V/1 A, AC/DC; relay contacts shown: de-energized relay coil

Note:  
The wire and connector must be shielded and be connected to the housing potential

Figure A-2 Pin assignment of the OXYMAT 6E motherboard

A.1.1.2 Option board pin assignment for rack units

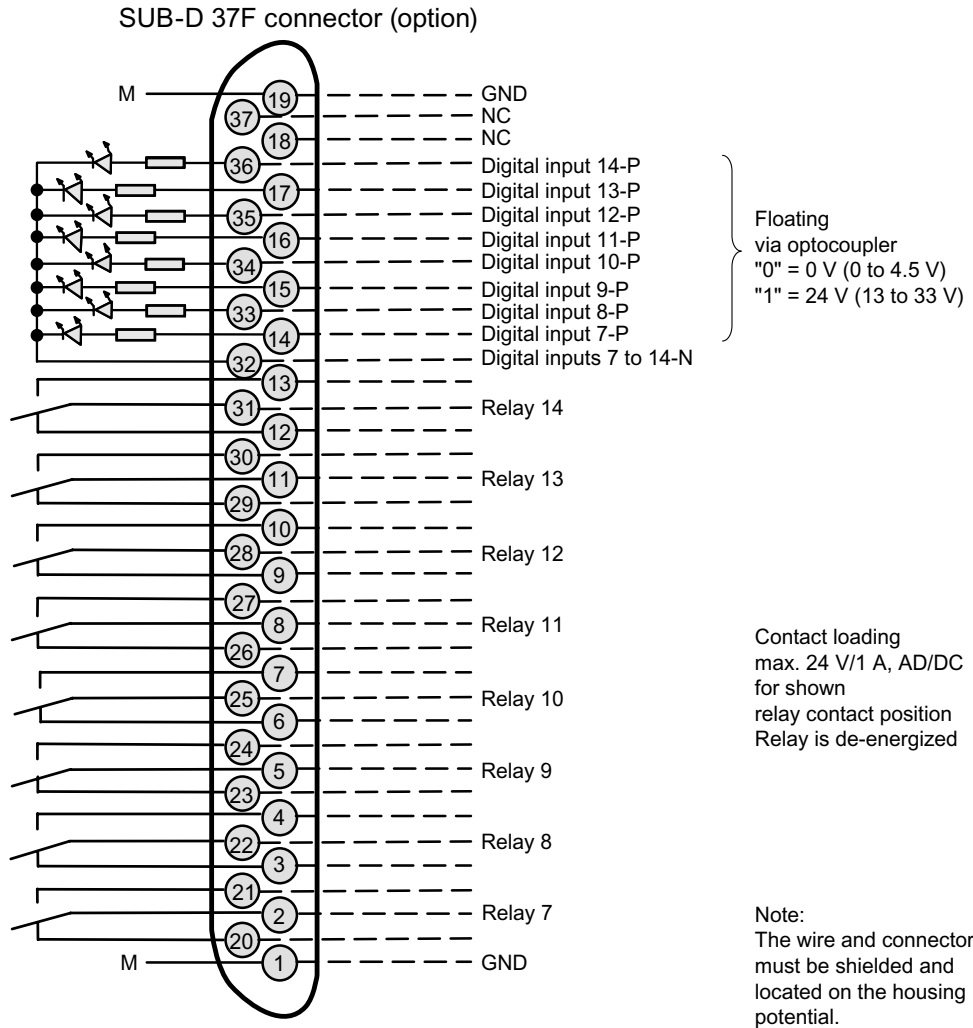

Figure A-3 Pin assignment for the ULTRAMAT 6E and OXYMAT 6E option board



**A.1.1.4 Terminal assignment for inputs and outputs of field devices**

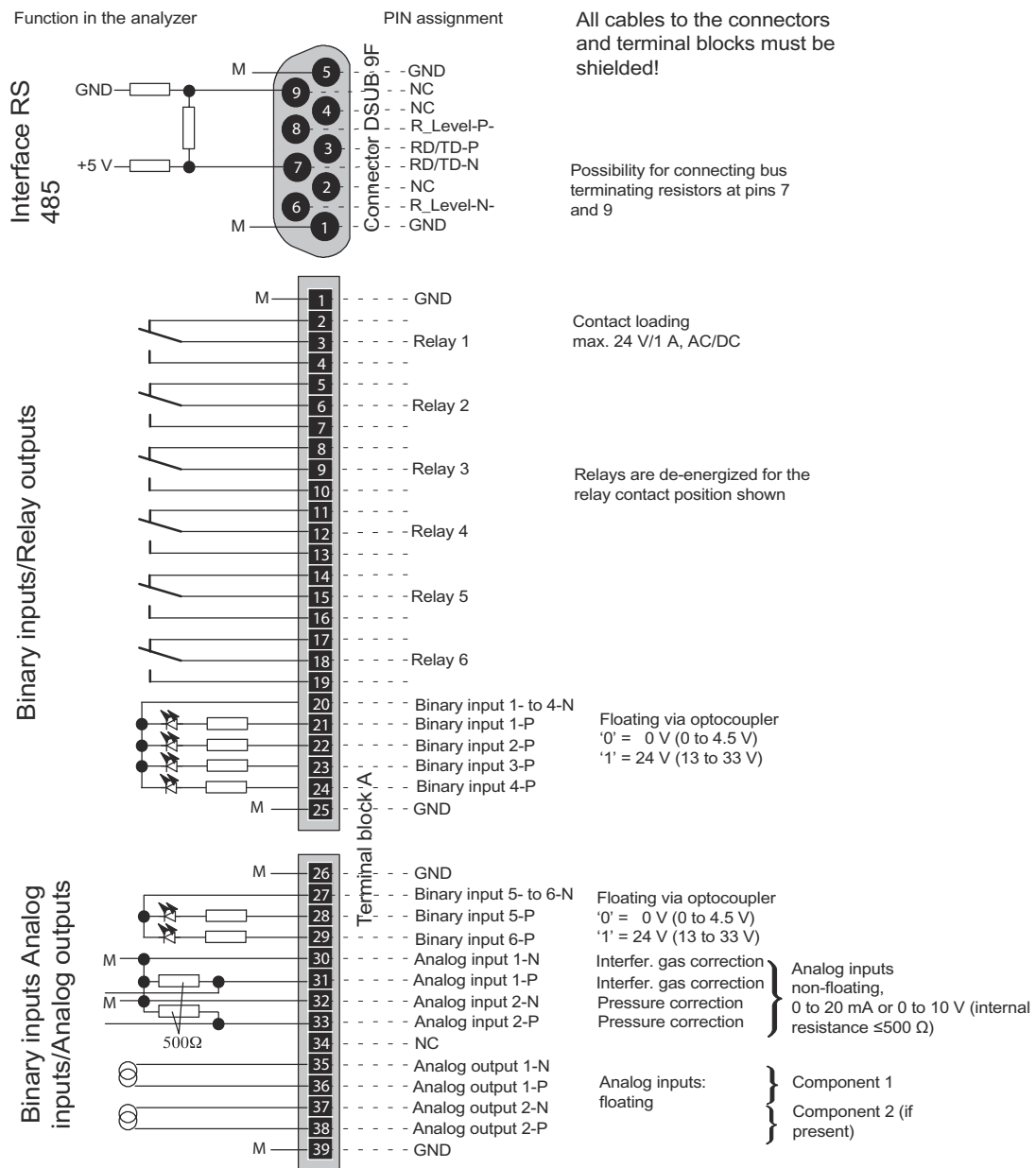

Figure A-5 Terminal assignment in field devices of Series 6

A.1.1.5 Option board terminal assignment for field devices

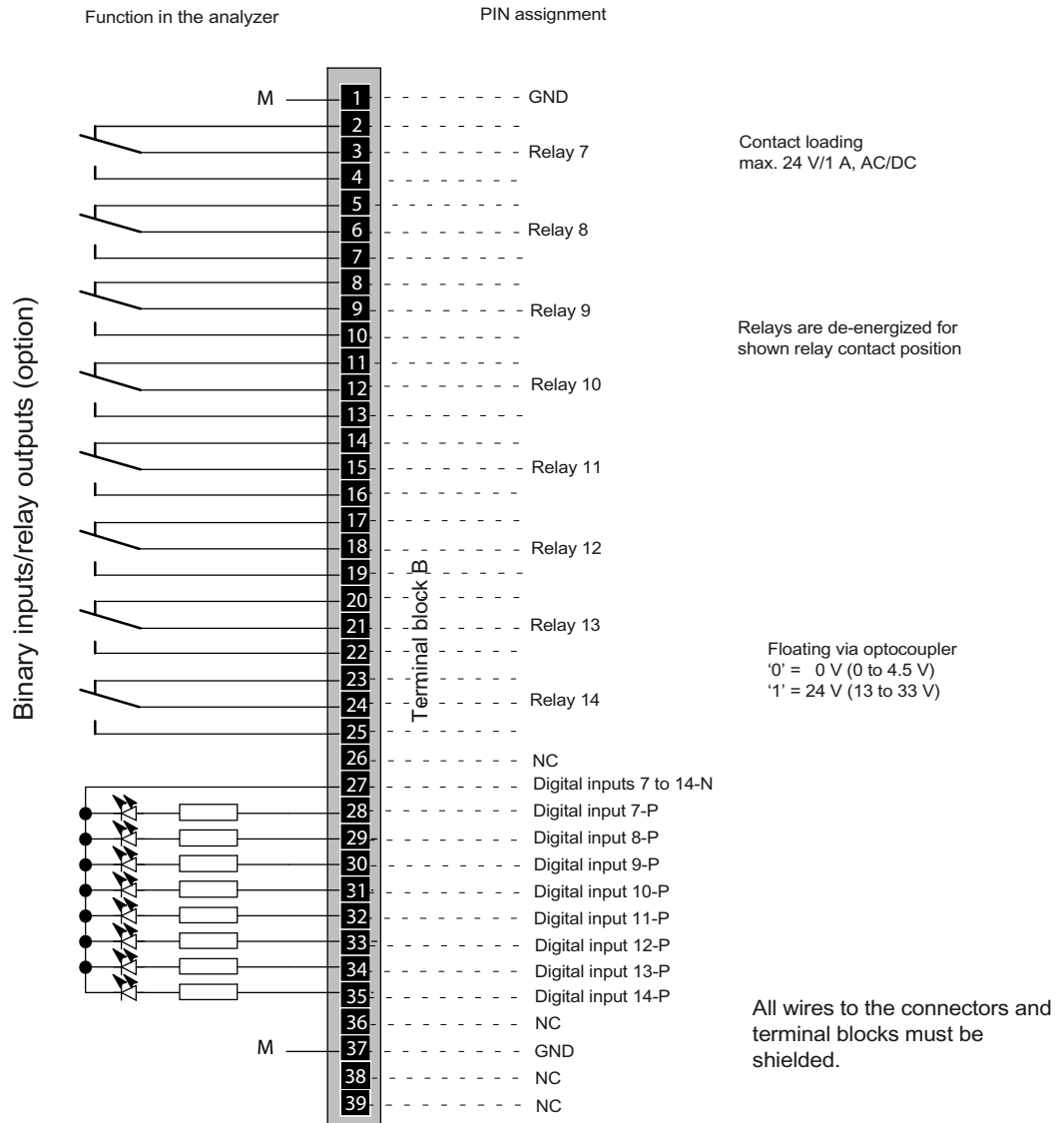

Figure A-6 Terminal assignment of option board in field devices of Series 6

A.1.1.6 Example of an AUTOCAL circuit for field devices

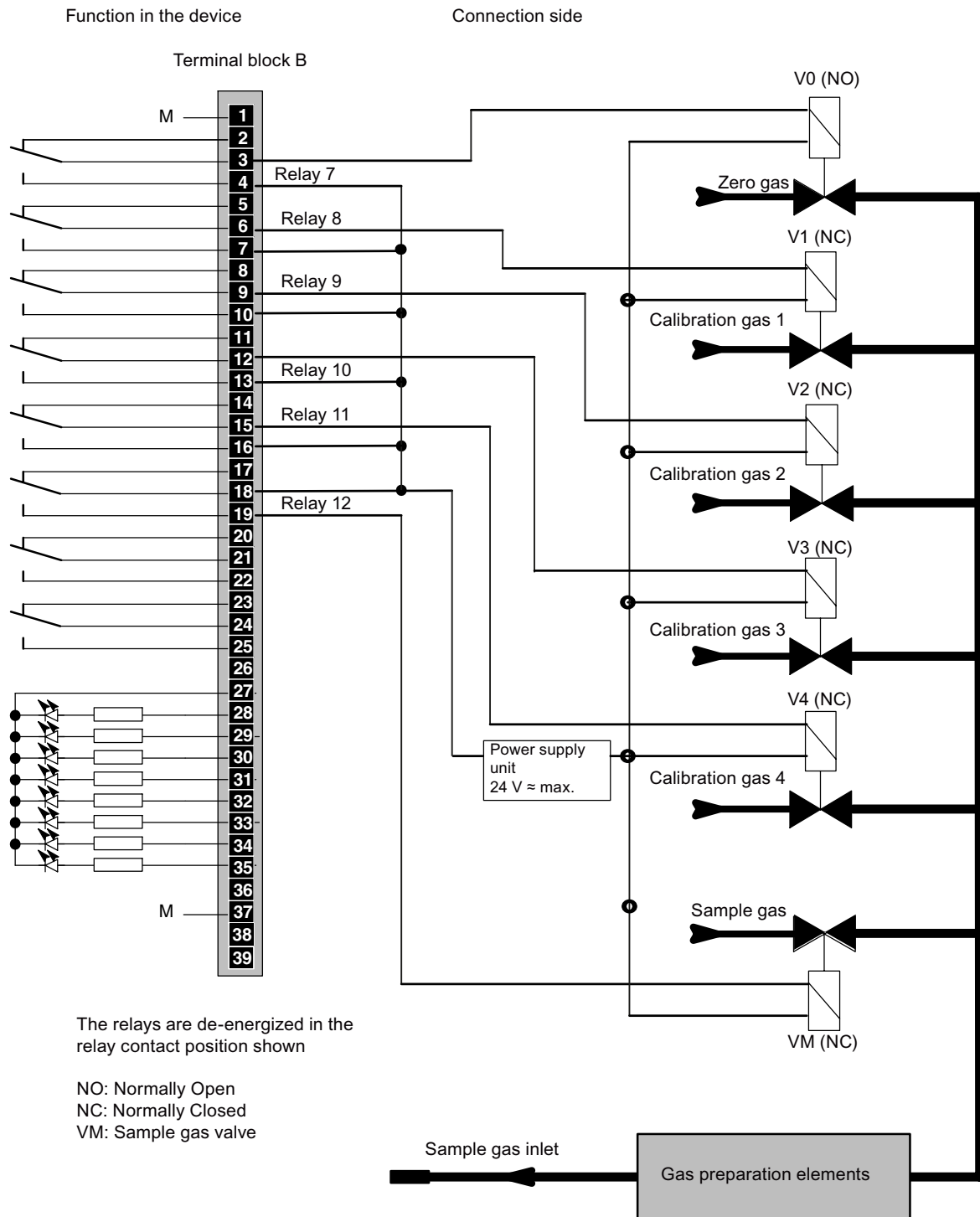
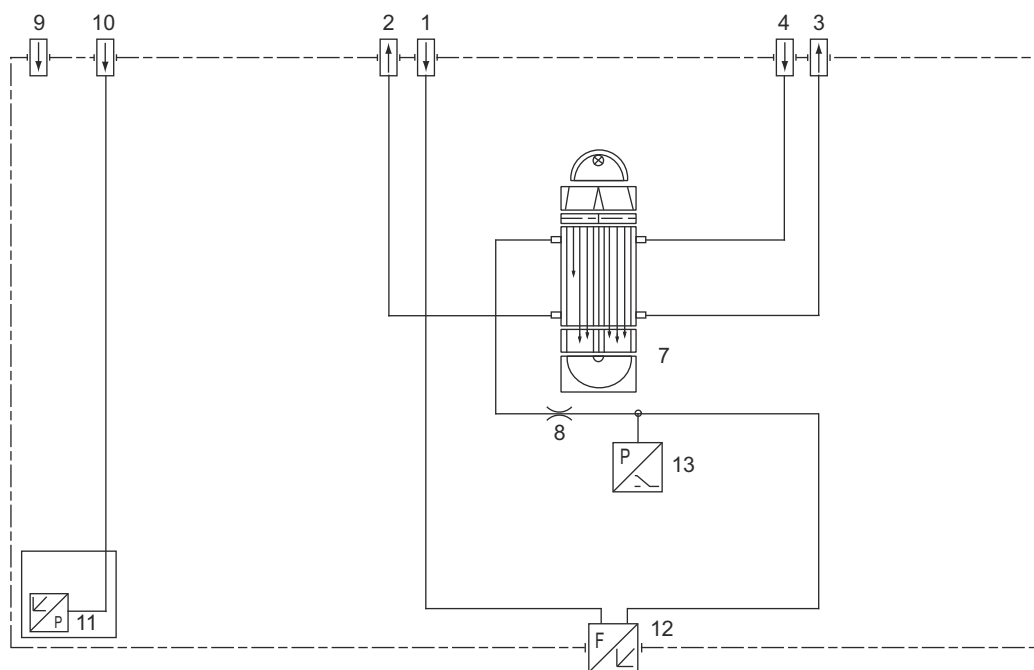

Figure A-7 Example of an AUTOCAL connection for field devices of series 6

## A.1.2 Gas flow diagrams

### A.1.2.1 ULTRAMAT 6E single-channel analyzer with flow-type reference gas compartment (option)



- |                                 |  |
|---------------------------------|--|
| 1 Sample gas inlet              | 9 Purging gas inlet                            |
| 2 Sample gas outlet             | 10 Gas inlet atmospheric pressure sensor       |
| 3 Reference gas outlet (option) | 11 Atmospheric pressure sensor                 |
| 4 Reference gas inlet (option)  | 12 Flow indicator in sample gas path (option)  |
| 7 IR analyzer unit              | 13 Pressure switch in sample gas path (option) |
| 8 Restrictor                    |  |

Figure A-8 Gas path ULTRAMAT 6, single-channel unit, 19" rack unit, with flow-type reference cell (option)

A.1.2.2 ULTRAMAT 6E two-channel device

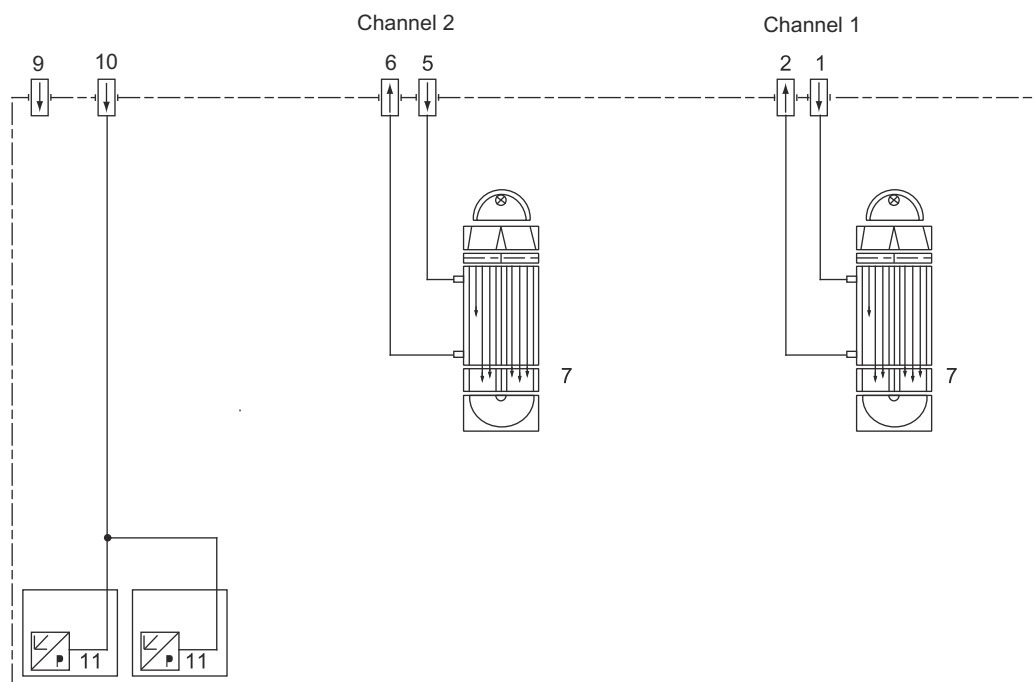

- |                               |  |
|-------------------------------|--|
| 1 Sample gas inlet Channel 1  | 7 IR analyzer unit                       |
| 2 Sample gas outlet Channel 1 | 9 Purging gas inlet                      |
| 5 Sample gas inlet Channel 2  | 10 Gas inlet atmospheric pressure sensor |
| 6 Sample gas outlet Channel 2 | 11 Atmospheric pressure sensor           |

Figure A-9 Gas path ULTRAMAT 6, dual-channel device, 19" rack unit



### A.1.2.3 ULTRAMAT 6F with flow-type reference gas compartment (option)

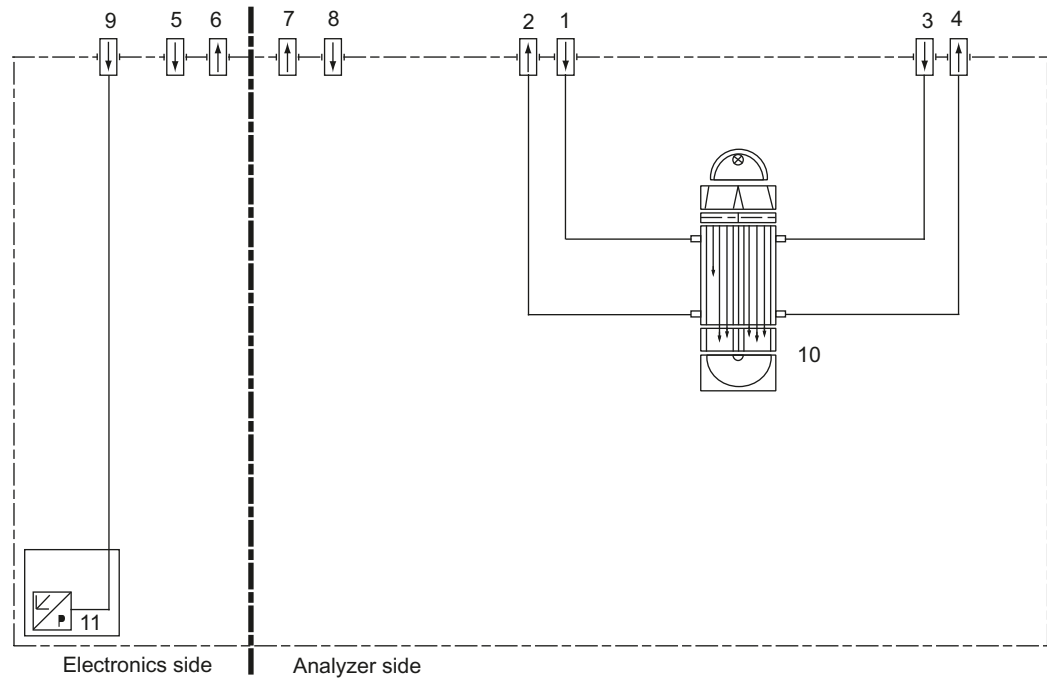

- |   |   |
|---|---|
| 1 Sample gas inlet                      | 7 Purging gas outlet (analyzer side)        |
| 2 Sample gas outlet                     | 8 Purging gas inlet (analyzer side)         |
| 3 Reference gas inlet (option)          | 9 Connection of atmospheric pressure sensor |
| 4 Reference gas outlet (option)         | 10 IR analyzer unit                         |
| 5 Purging gas inlet (electronics side)  | 11 Atmospheric pressure sensor              |
| 6 Purging gas outlet (electronics side) |   |

Figure A-10 Gas path ULTRAMAT 6, field unit, with flow-type reference gas side (option)

A.1.2.4 OXYMAT 6F with reference gas connection 1100 hPa absolute

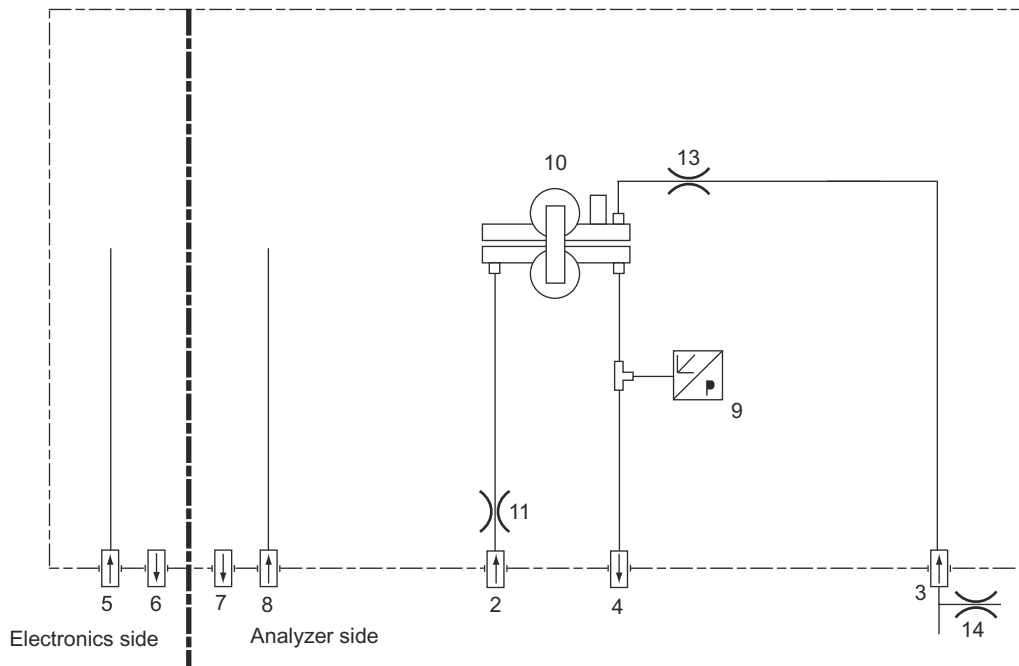

- |   |                                     |
|---|-------------------------------------|
| 2 Sample gas inlet                      | 8 Purging gas inlet (analyzer side) |
| 3 Reference gas inlet                   | 9 Pressure sensor                   |
| 4 Sample gas outlet                     | 10 O <sub>2</sub> analyzer unit     |
| 5 Purging gas inlet (electronics side)  | 11 Restrictor in sample gas path    |
| 6 Purging gas outlet (electronics side) | 13 Restrictor                       |
| 7 Purging gas outlet (analyzer side)    | 14 Outlet restrictor                |

Figure A-11 Gas flow OXYMAT 6, field device with reference gas connection 1100 hPa absolute

## A.1.2.5 OXYMAT 6F with reference gas connection 3000 ... 5000 hPa absolute

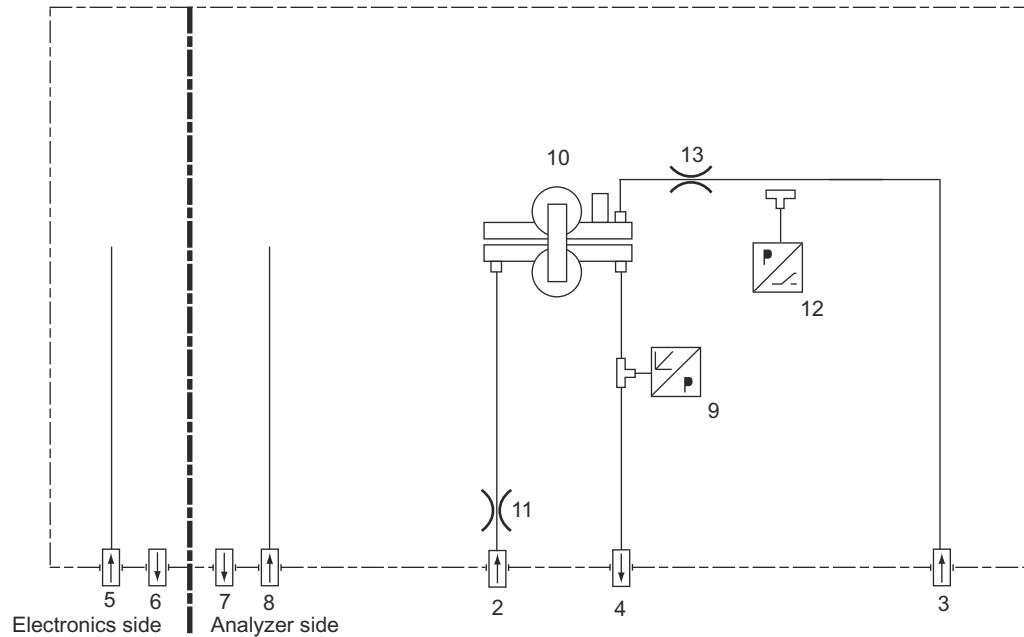

Electronics side | Analyzer side

- |   |   |
|---|---|
| 2 Sample gas inlet                      | 8 Purging gas inlet (analyzer side)               |
| 3 Reference gas inlet                   | 9 Pressure sensor                                 |
| 4 Sample gas outlet                     | 10 O <sub>2</sub> analyzer unit                   |
| 5 Purging gas inlet (electronics side)  | 11 Restrictor in sample gas path                  |
| 6 Purging gas outlet (electronics side) | 12 Pressure switch in reference gas path (option) |
| 7 Purging gas outlet (analyzer side)    | 13 Restrictor                                     |

Figure A-12 Gas flow OXYMAT 6, field device with reference gas connection 3000 to 5000 hPa absolute

**A.1.2.6 ULTRAMAT/OXYMAT 6, IR channel without flow-type reference gas side**

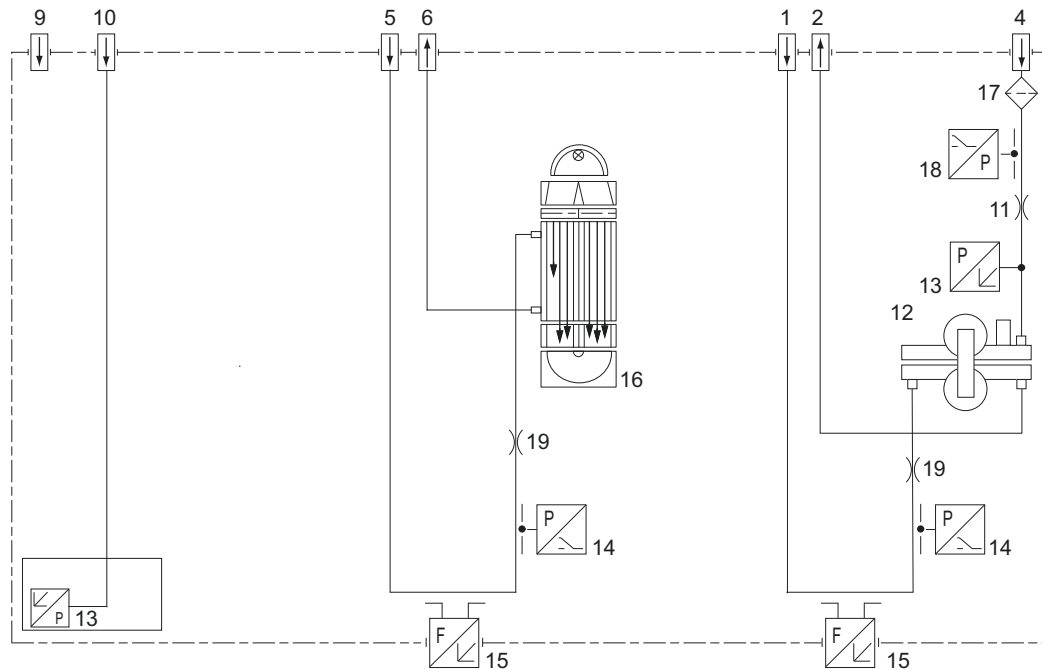

- |  |   |
|--|---|
| 1 Sample gas inlet OXYMAT channel              | 12 O <sub>2</sub> analyzer unit                   |
| 2 Sample gas outlet OXYMAT channel             | 13 Pressure sensor                                |
| 4 Reference gas inlet OXYMAT channel           | 14 Pressure switch in sample gas path (option)    |
| 5 Sample gas inlet ULTRAMAT channel            | 15 Flow indicator in sample gas path (option)     |
| 6 Sample gas outlet ULTRAMAT channel           | 16 IR analyzer unit                               |
| 9 Purging gas inlet                            | 17 Filter   |
| 10 Pressure sensor connection ULTRAMAT channel | 18 Pressure switch in reference gas path (option) |
| 11 Restrictor in reference gas inlet           | 19 Restrictor in sample gas path                  |

Figure A-13 Gas flow ULTRAMAT/OXYMAT 6 (example), IR channel without flow-type reference gas side

## A.1.2.7 ULTRAMAT/OXYMAT 6, IR channel with flow-type reference gas side

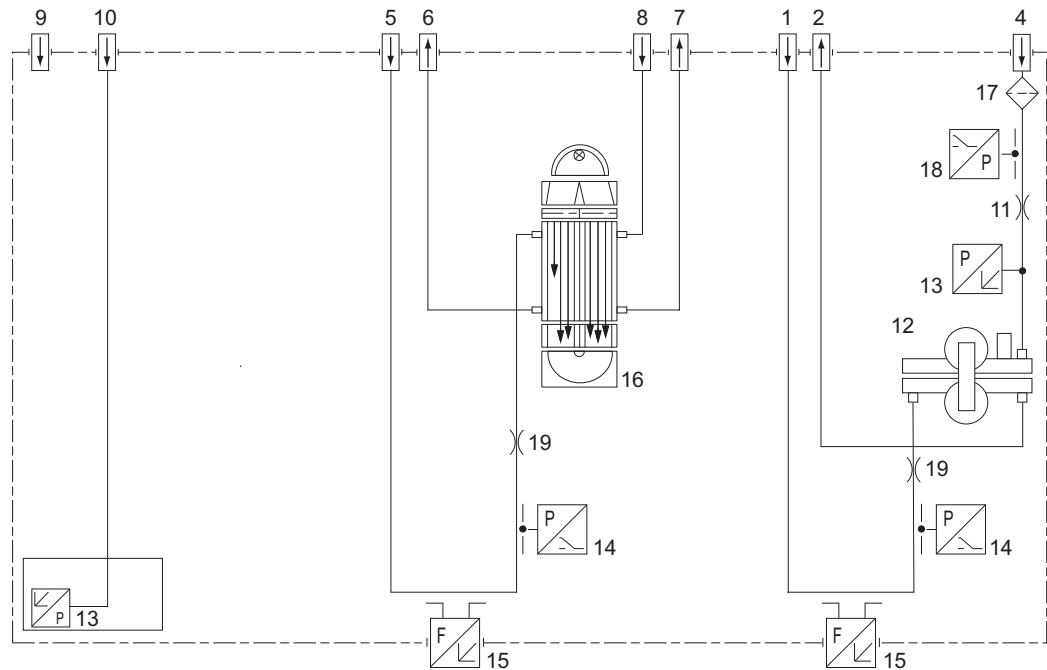

- |  |   |
|--|---|
| 1 Sample gas inlet OXYMAT channel                | 11 Restrictor in reference gas inlet              |
| 2 Sample gas outlet OXYMAT channel               | 12 O <sub>2</sub> analyzer unit                   |
| 4 Reference gas inlet OXYMAT channel             | 13 Pressure sensor                                |
| 5 Sample gas inlet ULTRAMAT channel              | 14 Pressure switch in sample gas path (option)    |
| 6 Sample gas outlet ULTRAMAT channel             | 15 Flow indicator in sample gas path (option)     |
| 7 Reference gas outlet ULTRAMAT channel (option) | 16 IR analyzer unit                               |
| 8 Reference gas inlet ULTRAMAT channel (option)  | 17 Filter   |
| 9 Purging gas inlet                              | 18 Pressure switch in reference gas path (option) |
| 10 Pressure sensor connection ULTRAMAT channel   | 19 Restrictor in sample gas path                  |

Figure A-14 Gas flow ULTRAMAT/OXYMAT 6 (example), IR channel with flow-type reference gas compartment

## A.2 Firmware version numbers

### A.2.1 ULTRAMAT 6

Delivered firmware versions of the ULTRAMAT 6 (C79451--A3478--S50x):

x = language version as follows:

- 1 - German/English
- 2 - English/Spanish
- 3 - French/English
- 4 - Spanish/English
- 5 - Italian/English

Software version	Manufacturing period starting	Most important innovations
1.1	06/96	Start version
1.3	12/96	Slowly increase and decrease LCD voltage
1.5	01/97	Languages revised Layout of the logbook changed Checksum active
1.8	04/97	Compensation can be switched on and off, and partially revised Dual-analyzer communication improved ELAN extended
2.0.0	10/97	Warm device skips the warm-up phase Measurement display without maintenance switch Status bar changed REMOTE display as new status bar The following should be carefully noted: <ul style="list-style-type: none"> <li>• When upgrading to Versions as of V2.0.0 the parameters of the following functions have to be checked: <b>41, 55, 76, 77, 86, 87, 108</b></li> <li>• GAL V4 is required as of V2.0.0</li> </ul>
2.1.1	11/97	Delay of the function check <ul style="list-style-type: none"> <li>• instead of 30 sec., now 1 sec.</li> </ul> Function of the 2P device (2 motherboards) improved Display of function 59 (selecting measurement locations) corrected ELAN extended
2.2.0	12/97	ELAN commands extended
2.3.3	03/98	Analog output improved Broadcast telegram extended with pressure value ELAN extended and improved

Software version	Manufacturing period starting	Most important innovations
3.0.0	07/98	Interference gas and pressure correction selection changed Maintenance requests and faults revised Resolution of analog current output increased
3.0.1	08/98	ELAN improved Sample gas types CHF <sub>3</sub> , C <sub>2</sub> F <sub>6</sub> and COCl <sub>2</sub> introduced
3.0.2	10/98	Sample gas type CHClF <sub>2</sub> introduced
4.0.1	05/99	Separate pressure switches for sample gas and reference gas Phase adjustment improved Temperature post-compensation revised Logbook recording improved Function 76 - fault suppression - improved Sample selection active after on/off Function 70 - analog output - adapted to NAMUR requirements
4.1.0	07/00	PROFIBUS board can be connected Binary inputs extended
4.2.0	09/00	Banking realized for 2 languages Full-scale value/sag calibration with Newton New AK linearization Software version detection introduced AUTOCAL check introduced
4.3.0	05/01	New mode of operation of the device: <ul style="list-style-type: none"> <li>Menu cannot be left as long as operation sequence is being executed. Cancellation of the operation sequence and leaving the menu is done by pressing the F5 key.</li> </ul> Behavior of the binary inputs according to NAMUR can be configured New binary input: "Measurement protection" If a fault occurs, the calibration is terminated Suppression of the output of negative measured values Measured value processing with suppressed zero point
4.3.4	07/01	Abort ACAL-/Check after fault; acknowledgeable error message S15 with entry in logbook
4.5.0	08/03	Parameterized transmission via ELAN added 24 hours RAM/Flash check Network frequency measurement Changes in the "ACAL-/Check cycle time" menu Universal code changed
4.6.0	03/05	Analog output: Suppression of overshoots when changing the measuring range Improvement of the 24 hour RAM/Flash check
4.6.1	04/05	Startup characteristics of the analog outputs after reset improved Switching of PROFIBUS relay introduced
4.7.0	12/05	Switching of the limit relay according to menu 107 delayed Drift values for QAL 3 introduced Reference temperature mg/m <sup>3</sup> switchable to g/m <sup>3</sup>

## A.2 Firmware version numbers

Software version	Manufacturing period starting	Most important innovations
4.7.1	03/07	Switching of PROFIBUS relay corrected Download of the PROFIBUS software introduced After a field device heating system fault, the heating system can be restarted by acknowledgment.
4.7.2	12/07	Logbook behavior after restart corrected New limits for large CO <sub>2</sub> and SO <sub>2</sub> measuring ranges
4.7.3	11/08	Display of the PROFIBUS tag in menu 73 Monitoring for network frequency errors (S13) corrected
4.8.0	05/09	Switching of the limit relay of component 2 revised
4.8.1	10/09	Switching of PROFIBUS relay always possible AUTOCAL cancelation via binary input introduced
4.8.2	05/10	Unnecessary monitoring for network frequency errors (S13) removed
4.8.3	03/11	Switching of PROFIBUS relay without REMOTE Response to disabled logbook improved
4.8.4	05/14	Response of analog inputs to incorrect connection and current peaks improved Monitoring duration for fault "Signal pressure sensor" (S8) increased to 5 seconds Monitoring of the supply voltage adapted to the device expansion stage
V4.8.5	07/2017	TC-CO: P5A00192852 Calibration menu extended with display of raw value Setting of AUTOCAL function possible for PROFIBUS and AK ELAN extended with "Read code" ELAN extended by check commands for simulation New "COD O2" component added Network frequency monitoring removed "Monitor operating pause" extended Monitoring of the P20V for ATEX2022 Monitoring of the IR source for failure Text adjusted for fault S13 Gaps in the data record marked Incorrect texts for the relay function corrected
V4.8.6	02/2018	TC-CO: P5A00244359 "AO incl. cross-interference correction" error is eliminated for AUTOCAL routine Temperature control for U6F provided with more stable control parameters Undershooting and overshooting of the AO improved

## A.2.2 OXYMAT 6

**Delivered firmware versions of the OXYMAT 6 (C79451-A3480-S50x):**

x = language version as follows:

- 1 - German/English
- 2 - English/Spanish



- 3 - French/English
- 4 - Spanish/English
- 5 - Italian/English

Software version	Manufacturing period starting	Most important innovations
1.1	06/96	Start version
1.3	12/96	Slowly increase and decrease LCD voltage
1.5	01/97	Languages revised Layout of the logbook changed Checksum active
1.8	04/97	Compensation can be switched on and off, and partially revised Dual-analyzer communication improved ELAN extended
2.0.0	10/97	Warm device skips the warm-up phase Measurement display without maintenance switch Status bar changed REMOTE display as new status bar The following should be carefully noted: <ul style="list-style-type: none"> <li>• When upgrading to Versions as of V2.0.0 the parameters of the following functions have to be checked: <b>41, 55, 76, 77, 86, 87, 108</b></li> <li>• GAL V4 is required as of V2.0.0</li> </ul>
2.1.1	11/97	Delay of the function check <ul style="list-style-type: none"> <li>• instead of 30 sec., now 1 sec.</li> </ul> Function of the 2P device (2 motherboards) improved Display of function 59 (selecting measurement locations) corrected ELAN extended
2.2.0	12/97	ELAN commands extended
2.3.2	03/98	Heating system for field devices introduced Analog output improved Broadcast telegram extended with pressure value ELAN extended and improved
3.0.0	07/98	Interference gas and pressure correction selection changed Maintenance requests and faults revised Resolution of analog current output increased
3.0.1	08/98	ELAN improved

## A.2 Firmware version numbers

Software version	Manufacturing period starting	Most important innovations
4.0.1	05/99	Dynamics improved (0.5% to 100% O <sub>2</sub> ) Phase adjustment improved Temperature post-compensation revised Logbook recording improved Function 76 - fault suppression - improved Sample selection active after on/off Function 70 - analog output - adapted to NAMUR requirements
4.1.0	07/00	PROFIBUS board can be connected Binary inputs extended
4.2.0	09/00	Banking realized for 2 languages Full-scale value/sag calibration with Newton New AK linearization Software version detection introduced AUTOCAL check introduced
4.3.0	05/01	New mode of operation of the device: <ul style="list-style-type: none"> <li>Menu cannot be left as long as operation sequence is being executed. Cancellation of the operation sequence and leaving the menu is done by pressing the F5 key.</li> </ul> Behavior of the binary inputs according to NAMUR can be configured New binary input: "Measurement protection" If a fault occurs, the calibration is terminated Suppression of the output of negative measured values
4.3.4	07/01	Abort ACAL-Check after fault; acknowledgeable error message S15 with entry in logbook
4.5.0	08/03	Parameterized transmission via ELAN added 24 hours RAM/Flash check Network frequency measurement Changes to the "ACAL/Check cycle time" menu Universal code changed
4.6.0	03/05	Analog output: Suppression of overshoots when changing the measuring range Improvement of the 24 hour RAM/FlashPROM check Function 52: 'Measuring head on/off' removed
4.6.1	04/05	Startup characteristics of the analog outputs after reset improved Switching of PROFIBUS relay introduced
4.7.0	12/05	Switching of the limit relay according to menu 107 delayed Drift values for QAL 3 introduced Reference temperature mg/m <sup>3</sup> switchable to g/m <sup>3</sup>
4.7.1	03/07	Switching of PROFIBUS relay corrected Download of the PROFIBUS software introduced After a field device heating system fault, the heating system can be restarted by acknowledgment.
4.7.2	12/07	Logbook behavior after restart corrected
4.7.3	11/08	Display of the PROFIBUS tag in menu 73 Monitoring for network frequency errors (S13) corrected
4.8.0	05/09	Switching of the limit relay of component 2 revised

Software version	Manufacturing period starting	Most important innovations
4.8.1	10/09	Switching of PROFIBUS relay always possible AUTOCAL cancelation via binary input introduced
4.8.2	05/10	Unnecessary monitoring for network frequency errors (S13) removed
4.8.3	03/11	Switching of PROFIBUS relay without REMOTE Response to disabled logbook improved
4.8.4	05/14	Response of analog inputs to incorrect connection and current peaks improved Monitoring duration for fault "Signal pressure sensor" (S8) increased to 5 seconds Monitoring of the supply voltage adapted to the device expansion stage
V4.8.5	07/2017	TC-CO: P5A00192852 Calibration menu extended with display of raw value Setting of AUTOCAL function possible for PROFIBUS and AK ELAN extended with "Read code" ELAN extended by check commands for simulation New "COD O2" component added Network frequency monitoring removed "Monitor operating pause" extended Monitoring of the P20V for ATEX2022 Monitoring of the IR source for failure Text adjusted for fault S13 Gaps in the data record marked Incorrect texts for the relay function corrected
V4.8.6	02/2018	TC-CO: P5A00244359 "AO incl. cross-interference correction" error is eliminated for AUTOCAL routine Temperature control for U6F provided with more stable control parameters Undershooting and overshooting of the AO improved

### A.2.3 Upgrading to other firmware versions

Note the following during upgrade:

- A firmware as of Version 1.1 requires a motherboard as of Version 2.
- A firmware as of V2.0.0 requires a GAL as of Version 2.
- The operation in a field enclosure (with or without heating system) requires a motherboard as of Version 5 (**ULTRAMAT 6**) or Version 4 (**OXYMAT 6**).
- The operation of a heating system requires a firmware as of Version 3.0.0 (**ULTRAMAT 6**) or Version 2.3.2 (**OXYMAT 6**).
- During the upgrade of a device with a firmware < version 2.0.0 to a firmware as of version 2.0.0, the parameters of the *functions 41, 55, 76, 77, 86, 87 and 108 have to be checked*.
- A boot software as of Version 2 (displayed version number 2.5) is required for safe function of a download.
- A firmware as of Version 3.1.0 is required for operation with the PC program "SIPROM GA".

- Firmware as of Version 3.0.0 is required for operation of an option board with serial interface for the automotive industry (AK)
- A firmware as of Version 3.0.0 is required for operation of an adapter board LCD/TAST (see spare parts list) as of Version 2.
- For OXYMAT devices with software versions 1.5 and older the zero point temperature compensation is performed via LogX and LogY, for devices with newer software versions via LogV with a different polynomial. The coefficients therefore have to be completely changed and might have to be redetermined.
- During replacement of the chopper motor (the new ones are without temperature sensor), the device must contain a software as of Version 3.0.3 (15.01.99).
- If a device with a firmware < Version 3.0.0 receives a newer firmware version, a "Save user data" (function 75) and "Save factory data" (function 106) must be performed after a firmware replacement and the possible correction of some data, since these data blocks contain a check sum.  
**Caution:** Execution of one of the functions "Load user data" or "Load factory data" (function 75) after the firmware replacement can possibly delete all existing data.

## A.3 Lists of parameters

F.-No.	Function designation	Parameter list/device settings		Value range/switching status	Typical value/setting	
22	Setpoints for zero / sensitivity	Zero point		-1 ... 100%	0%	
		Sensitivity		-1 ... 100%	20.95%	
23	Single, total calibration				Total calibration	
24	AUTOCAL/-check	Mode	AUTOCAL/-check		Off	
			Start cyclically		Off	
			Start via binary input		Off	
		Sequence			Application-dependent	
		Cyclic parameters	Time from AUTOCAL to AUTOCAL (cycle time)	1 ... 500 h		Application-dependent
			Time up to next AUTOCAL	0 to 30000 min		Application-dependent
			Carry out span calibration at any nth cycle	1 to 99		Application-dependent
		AUTOCAL/-check	Calibration tolerance at zero	0 to 99%		Application-dependent
Calibration tolerance at sensitivity	0 to 99%			Application-dependent		
Start only AUTOCAL check cyclically	On/Off			Off		
25	Drift values					
40	Select range			Direct or automatic	Automatic	

F.-No.	Function designation	Parameter list/device settings		Value range/switching status	Typical value/setting
41	Define range	Measuring range 1		--1 to 100%	0.000 to 2.000%
		Measuring range 2		--1 to 100%	0.000 ... 5.000%
		Measuring range 3		--1 to 100%	0.000 ... 10.000%
		Measuring range 4		--1 to 100%	0.000 ... 25.000%
50	Electric time constants	Effective bandwidth		0 ... 100%	6%
		Time constant within bandwidth		0 to 300 s	10 s
		Time constant outside bandwidth		0 to 300 s	1 s
51	Limits	Limit 1	Alarms at decrease/increase signal	Alarms at decrease signal, increase signal	Alarms at increase signal
			Applies to measuring range	1 to 4	1, 2, 3, 4
		Limit alarm on/off	On/Off	Off	
		Limit 2 to 4	Limit alarm on/off	On/Off	Off
52	On/off function	Autoranging		On/Off	On
		Measured value memory		On/Off	Off
		Pressure compensation		On/Off	Off
		Linearization		On/Off	Off
		Temperature post-compensation of zero point		On/Off	Off
		Temperature post-compensation of sensitivity		On/Off	Off
		Signal tolerance violation		On/Off	Off
		Limit monitoring 1 to 4		On/Off	Off
		Suppression of negative measured values		On/Off	Off
		Automatic calibration		On/Off	Off
		Total calibration		On/Off	On
		Lock logbook		On/Off	Off
		Check sample gas flow		On/Off	Off
		Check reference gas flow		On/Off	On
		Fault/Maintenance request/CTRL NAMUR		On/Off	On
		Negative measured value suppression display		On/Off	Off
Measuring head heating		On/Off	On		

F.-No.	Function designation	Parameter list/device settings		Value range/switching status	Typical value/setting
53	Status messages	Display automatic calibration (CAL)		On/Off	Off
		Display stored value (STO)		On/Off	Off
		Display limit (LIM)		On/Off	Off
		Display Autorange (AR)		On/Off	On
		Display control function (CTRL)		On/Off	On
54	Graphic signal display	Period 10 min		10 min to 24 h	10 min
			Parameter:		
			Optimum measured value display	On/Off	On
			Measuring range 1 to 4	On/Off	Off
55	Select digits	Suppress negative measured values		On/Off	Off
				Automatic/manual	Automatic
		Total digits		3 to 5	5
57	Magnetic field frequency (OXYMAT 6)	Frequency		7 to 11 Hz	8.095 Hz
	Chopper frequency (ULTRAMAT 6)	Frequency		10 to 15 Hz	13.098 Hz
58	Date/Time	Date			Enter date
		Time			Enter time
59	Sample selection	Measuring point 1 to 6		0 to 60000 min	0 min
		Sample selection		On/Off	Off
61	Shock compensation (OXYMAT 6)	Amplification		0 to 100%	0%
70	Analog output	Analog output selection		0/2/4/NAMUR	NAMUR 4 -- 20 mA
		Output inverted		On/Off	Off
		Suppress negative measured values		On/Off	Off
71	Relay outputs	R1 to R6 (only motherboard)		Free assignment	See Operator function 71
72	Binary inputs	Fault/Maintenance request/ CTRL NAMUR		On/Off	On
		Binary inputs define		On/Off	See Operator function 72
73	ELAN configuration	Channel address		01 to 12	01
		Measured value telegram		On/Off	Off

F.-No.	Function designation	Parameter list/device settings		Value range/switching status	Typical value/setting
76	Suppress fault	Suppression duration of noise		0 to 5 s	0 s
		Threshold value		1 to 100%	12%
77	Store	1st option	Analog output to measuring value	On/Off	Off
		2nd option	Analog output to 0/2/4 mA	On/Off	On
		3rd option	Analog output to 21 mA	On/Off	Off
78	Calibration tolerance	Calibration tolerance at zero		0 to 99%	6%
		Calibration tolerance at sensitivity		0 to 99%	6%
79	Codes program	Code level 1		0 to 999	111
		Code level 2		0 to 999	222
81	Select language	1st option	German	On/Off	On
		2nd option	English	On/Off	Off
82	Pressure correction	With internal pressure sensor		External via analog output 2	With internal pressure sensor
				External via ELAN	
				Internal pressure sensor	Off
		Pressure offset	--100 to 100 hPa	0 hPa	
83	Interference correction	No interference correction			Selected
		With constant interference correction			
		With variable interference influence on analog			
		With variable interference influence on ELAN			
84	Phase adjustment	$\varphi$		0 to 360°	275°
85	Switch valves	see Function 71			
86	Linear temperature compensation	Aftercompensation of the zero point	Temperature compensation	On/Off	On
			TM	% per -999 ... 999 °C	
			Decrease $\Delta$ temperature	% per -99 to 99 °C	
			Increase $\Delta$ temperature	% per -99 to 99 °C	
		Aftercompensation of the span	Temperature compensation	On/Off	On
			TM	% per -999 ... 999 °C	
			Increase $\Delta$ temperature	% per -99 to 99 °C	
87	Error On/Off	S 1 to S 16		On/Off	On
		W 1 to W 10		On/Off	On
		LIM to CTRL		On/Off	On

F.-No.	Function designation	Parameter list/device settings		Value range/switching status	Typical value/setting
89	Heating	Heating		On/Off	On
		Nominal temperature bench	OXYMAT 6F	65 to 130 °C	65 °C
		Nominal temperature detector cell	ULTRAMAT 6F	65 °C	65 °C

## A.4 Pressure conversion table

	hPa	kPa	MPa	psi	mbar	bar
hPa	1	10	10000	69	1	0.001
kPa	0.1	1	1000	6.9	0.1	0.1
MPa	0.0001	0.001	1	0.0069	0.0001	1
psi	0.0145	0.145	145.04	1	0.0145	14.5
mbar	1	10	10000	69	1	1000
bar	0.001	0.01	10	0.069	0.001	1

## A.5 Technical support

### Technical Support

If you have any technical questions, contact Technical Support (<https://support.industry.siemens.com/cs/ww/en/sc/4867>).

Use our online request form Support Request (<https://support.industry.siemens.com/My/ww/en/requests#createRequest>).

### Service & Support on the Internet

In addition to our documentation, we offer further information online on the Internet:

Industry Online Support (<https://support.industry.siemens.com/cs/ww/en/sc>)

There you will find:

- The latest product information, FAQs, downloads, tips and tricks.
- A newsletter that provides you with up-to-date information about the products.
- The Knowledge Manager that finds the right documents for you.
- Your local contact partner for automation technology in our contacts database.
- Information about on-site services, repairs, spare parts and much more is available on our "Services" pages.

Our bulletin board, where users and specialists share their knowledge worldwide.



## Additional Support

Contact your local Siemens partner if you have any questions about the use of products described in this manual and cannot find the answers here.

Find your contact partner at:

Partner (<https://www.automation.siemens.com/partner>)

A signpost to the documentation of the various products and systems is available at:

Operating instructions and manuals (<https://support.industry.siemens.com/cs/ww/en/ps/17703/man>)

## A.6 Return procedure

The device has to be returned in its original packaging. If the original packaging is no longer available, return the device in appropriate packaging.

Include the delivery note, the goods document with the returned goods process mark and decontamination certificate in a firmly attached clear plastic pouch on the outside of the packaging.

With this decontamination declaration you warrant that the device/replacement part has been carefully cleaned and is free of residues. The device/replacement part does not pose a hazard for humans and the environment. If the returned device/replacement part has come into contact with poisonous, corrosive, flammable or water-polluting substances, you must thoroughly clean the device/replacement part before returning it, in order to ensure that all hollow areas are free of hazardous substances. Check the item after it has been cleaned. Devices/replacement parts without decontamination certificate will be returned to you at your expense.

The forms are available on the supplied CD.

For more detailed information, refer to Return procedure (<https://support.industry.siemens.com/cs/ww/en/sc/4529>)

## A.7 ESD guidelines

### Definition of ESD

All electronic modules are equipped with large-scale integrated ICs or components. Due to their design, these electronic elements are highly sensitive to overvoltage, and thus to any electrostatic discharge.

The electrostatic sensitive components/modules are commonly referred to as ESD devices. This is also the international abbreviation for such devices.

ESD modules are identified by the following symbol:



**NOTICE**

ESD devices can be destroyed by voltages well below the threshold of human perception. These static voltages develop when you touch a component or electrical connection of a device without having drained the static charges present on your body. The electrostatic discharge current may lead to latent failure of a module, that is, this damage may not be significant immediately, but in operation may cause malfunction.

**Electrostatic charging**

Anyone who is not connected to the electrical potential of their surroundings can be electrostatically charged.

The figure below shows the maximum electrostatic voltage which may build up on a person coming into contact with the materials indicated. These values correspond to IEC 801-2 specifications.

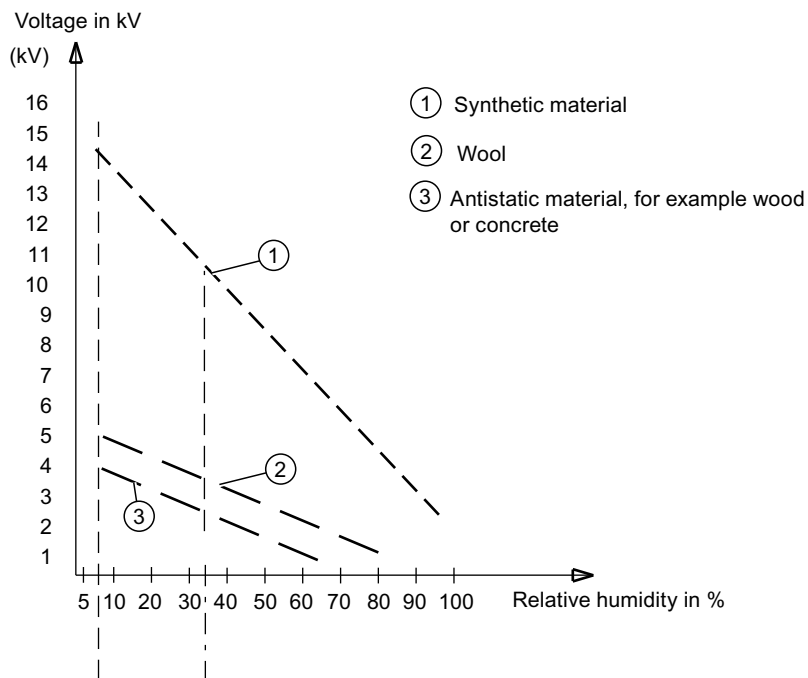

Figure A-15 Electrostatic voltages on an operator

### Basic protective measures against electrostatic discharge

- Ensure good equipotential bonding:  
When handling electrostatic sensitive devices, ensure that your body, the workplace and packaging are grounded. This prevents electrostatic charge.
- Avoid direct contact:  
As a general rule, only touch electrostatic sensitive devices when this is unavoidable (e.g. during maintenance work). Handle the modules without touching any chip pins or PCB traces. In this way, the discharged energy can not affect the sensitive devices.  
Discharge your body before you start taking any measurements on a module. Do so by touching grounded metallic parts. Always use grounded measuring instruments.



## List of abbreviations

### B.1 List of abbreviations

Table B-1

Abbreviation/ symbol	Description
<	Smaller than
>	Greater than
=	Equal to
≤	Smaller than or equal to
≥	Greater than or equal to
△	corresponds to
≈	Approximately
±	Plus/minus
%	percent; 100th part of whole
vol. %	Volume percent
"	1 inch ≅ 25.4 mm)
°C	Degrees centigrade (1 °C ≅ 1.8 °F)
°F	Degrees Fahrenheit (1 °F ≅ 0.555 °C)
4.6	(Gas with a) degree of purity ≤ 99.996%
A	<b>A</b> mpere
abs.	<b>abs</b> olute
sec.	<b>Sec</b> tion
AC	<b>Al</b> ternate <b>C</b> urrent (English for alternating current)
ADC	<b>A</b> nalog to <b>D</b> igital <b>C</b> onverter
Al, aluminum	<b>Al</b> uminum
Ar	<b>Ar</b> gon, a noble gas
AR	<b>A</b> utoranging
ATEX	<b>At</b> mosphère <b>exp</b> losible (French for explosive atmosphere)
AUTOCAL	Automatic calibration function, derived from <b>AUTOMATIC CALIBRATION</b>
BImSchV	<b>B</b> undes <b>i</b> missionsschutz <b>v</b> erordnung (Federal German Emission Protection Direc- tive)
Bit	<b>b</b> inary <b>d</b> igit (English for binary digit)
C <sub>2</sub> H <sub>2</sub>	C <sub>2</sub> H <sub>2</sub> = Ethyne (acetylene)
C <sub>2</sub> H <sub>2</sub> Cl <sub>2</sub>	C <sub>2</sub> H <sub>2</sub> Cl <sub>2</sub> = Vinylidene chloride
C <sub>2</sub> H <sub>3</sub> Cl	C <sub>2</sub> H <sub>3</sub> Cl = Vinyl chloride
C <sub>2</sub> H <sub>3</sub> F	C <sub>2</sub> H <sub>3</sub> F = Vinyl fluoride
C <sub>2</sub> H <sub>4</sub>	C <sub>2</sub> H <sub>4</sub> = Ethene (ethylene)
C <sub>2</sub> H <sub>6</sub>	C <sub>2</sub> H <sub>6</sub> = Ethane

List of abbreviations

B.1 List of abbreviations

Abbreviation/ symbol	Description
C <sub>3</sub> H <sub>6</sub>	C <sub>3</sub> H <sub>6</sub> = Propylene
C <sub>3</sub> H <sub>8</sub>	C <sub>3</sub> H <sub>8</sub> = Propane
C <sub>4</sub> H <sub>6</sub>	C <sub>4</sub> H <sub>6</sub> = Butadiene
C <sub>4</sub> H <sub>8</sub>	C <sub>4</sub> H <sub>8</sub> = Butane
C <sub>4</sub> H <sub>10</sub>	C <sub>4</sub> H <sub>10</sub> = Butane
C <sub>5</sub> H <sub>12</sub>	C <sub>5</sub> H <sub>12</sub> = Pentane
C <sub>6</sub> H <sub>12</sub>	C <sub>6</sub> H <sub>12</sub> = Cyclohexane
C <sub>6</sub> H <sub>14</sub>	C <sub>6</sub> H <sub>14</sub> = Hexane
C <sub>7</sub> H <sub>16</sub>	C <sub>7</sub> H <sub>16</sub> = Heptane
C <sub>8</sub> H <sub>18</sub>	C <sub>8</sub> H <sub>18</sub> = Octane
ca.	<b>Approx.</b>
CaF <sub>2</sub>	CaF <sub>2</sub> = calcium fluoride
CCl <sub>2</sub> F <sub>2</sub>	CCl <sub>2</sub> F <sub>2</sub> = Dichlorodifluoromethane (R12)
CCl <sub>3</sub> F	CCl <sub>3</sub> F = Trichlorofluoromethane (R11)
CD	<b>Compact Disk</b> , a storage medium
CE	Communauté Européenne (French for European Community)
CH <sub>3</sub> COOH	CH <sub>3</sub> COOH = Acetic acid
CH <sub>3</sub> OH	CH <sub>3</sub> OH = Methanol
CH <sub>4</sub>	CH <sub>4</sub> = methane
Cl <sub>2</sub>	Cl <sub>2</sub> = Chlorine
CO	CO = carbon monoxide
CO <sub>2</sub>	CO <sub>2</sub> = carbon dioxide
COM	<b>common</b>
CSA	<b>Canadian Standards Association</b> , a technical testing organization in Canada
DC	<b>Direct Current</b>
DD	<b>Device Description</b>
i.e.	In other words
DIN	<b>Deutsches Institut für Normung e. V.</b> (German standards association)
Div.	<b>Division</b>
DP	<b>Distributed Periphery</b> , a PROFIBUS component
D-Sub	<b>D-shaped Subminiature</b> connector
EEPROM	<b>Electrically Erasable Programmable Read Only Memory</b>
EC	<b>European Community</b>
ELAN	<b>Economic Local Area Network</b> , an interface protocol
EN	<b>European Norm</b> (European standard)
Engl.	English
EMC	<b>Electro Magnetic Compatibility</b>
EPDM	<b>Ethylene Propylene Diene Monomer</b> , a plastic
ESD	<b>Electrostatic Discharge</b>
Serial No.	<b>Serial Number</b>
FFKM	Polyamide rubber, a plastic, commercial name, e. g. nylon
FM	<b>Factory Mutual</b> , a certification organization for the USA

Abbreviation/ symbol	Description
FKM, FPM	Fluorinated Polymer rubber, a plastic, tradename e.g. Viton
Fct.	Function
ft	<b>foot</b> , measure of length; 1 ft $\triangleq$ 30.48 cm
GND	<b>Ground</b>
GSD	<b>Generic Station Description</b>
h	<b>hora</b> (Latin for hour)
H <sub>2</sub>	H <sub>2</sub> = hydrogen
H <sub>2</sub> O	H <sub>2</sub> O = Water
H <sub>2</sub> S	H <sub>2</sub> S = hydrogen sulfide
H <sub>2</sub> SO <sub>4</sub>	H <sub>2</sub> SO <sub>4</sub> = sulfuric acid
HBr	HBr = Hydrogen bromide
HC	<b>Hydrocarbons</b>
HCl	HCl = Hydrogen chloride, hydrochloric acid
HD-PE	<b>Polyethylene of high density (HD = High density)</b>
He	He = Helium, an inert gas
HU	<b>Height Unit</b>
HF	HF = Hydrogen fluoride HF,
HJ	HJ = Hydrogen iodide
hPa	<b>hectopascal</b>
Hz	<b>Hertz</b>
IEC	<b>International Electrotechnical Commission</b>
IEEE	<b>Institute of Electrical and Electronics Engineers</b>
O K	<b>OK</b>
IP	<b>Internal Protection</b>
IR	<b>Infrared</b>
ISO	<b>International Standards Organization</b> (from Greek: "isos"; in English "equal")
kg	<b>Kilogram</b>
kPa	<b>Kilopascal</b>
Kr	Kr = Krypton, an inert gas
l	<b>Liter</b>
L	<b>Live wire</b>
lb, lbs.	pound(s), 1 lb. $\triangleq$ 435.6 g
LCD	<b>Liquid Crystal Display</b>
LED	<b>Light Emitting Diode</b>
m	<b>Meter</b>
m <sup>3</sup>	Cubic meter
mA	<b>milliampere</b>
TLV	<b>Threshold Limit Value</b> , limit for pollutants at the workplace
max.	<b>Maximum</b>
MB = Mbit	10 <sup>6</sup> bit
MR	<b>Measuring Range</b>
MBA, mba	Measuring range start-of-scale value

## List of abbreviations

### B.1 List of abbreviations

Abbreviation/ symbol	Description
mbar	<b>Millibar</b> , 1 mbar $\triangleq$ 1 hPa
MBE, mbe	Measuring range full-scale value
MEPC	<b>Marine Environmental Protection Committee</b> (Committee for environmental protection of the oceans)
mg	<b>Milligram</b>
MHz	<b>Megahertz</b>
min	<b>Minute(s)</b>
MC	<b>Measured component</b>
ml	<b>milliliter</b>
MLFB	Machine-readable Order No. (German <b>Maschinenlesbare FabrikateBezeichnung</b> )
mm	<b>Millimeter</b>
mm <sup>2</sup>	Square <b>millimeter</b>
MPa	<b>Megapascal</b>
mV	<b>Millivolt</b>
MV	Solenoid valve
MV	<b>Measured Value</b>
N	<b>Neutral</b> (conductor)
N <sub>2</sub>	N <sub>2</sub> = nitrogen
N <sub>2</sub> O	N <sub>2</sub> O = Nitrous oxide, laughing gas
nA	<b>Nanoampere</b>
NAMUR	<b>Normenarbeitsgemeinschaft für Mess- und Regeltechnik</b> in der chemischen Industrie (standardization body for instrumentation and control technology in the chemical industry)
NBR	<b>Nitrile Butadiene Rubber</b> , a plastic, common name e.g. Buna
NC	<b>Not Connected</b>
NDIR	<b>Non-dispersive infrared-(absorption)</b> , the measuring method of the ULTRAMAT
Ne	Ne = Neon, an inert gas
neg.	<b>negative</b>
nF	<b>Nanofarad</b>
NFPA	<b>National Fire Protection Association</b> , a non-profit fire protection organization in the USA
NH <sub>3</sub>	NH <sub>3</sub> = ammonia
NO	NO = nitrogen monoxide
NO <sub>2</sub>	NO <sub>2</sub> = Nitrogen dioxide
NO <sub>x</sub>	Name for total nitrogen oxides
No.	<b>Number</b>
LVD	<b>Low Voltage Directive</b>
O <sub>2</sub>	O <sub>2</sub> = oxygen
or similar	or similar
PA	<b>Process Analytics</b>
PA	<b>Polyamide</b> , a plastic
PC	<b>Personal Computer</b> , a stationary single-user computer
PCS	<b>Process Control System</b>



Abbreviation/ symbol	Description
PDM	Process Device Manager, software for operating devices
PE	Polyethylene, a plastic
PE	Protective Earth (conductor)
PI	PROFIBUS International
ppm	parts per million ( $\triangleq 10^{-6}$ )
PROFIBUS	Process Field Bus
psi	pounds per square inch; 1 psi $\approx$ 69 hPa
PTB	Physikalisch-Technische Bundesanstalt (German technical inspectorate)
PTFE	Polytetrafluoroethylene, a plastic, tradename e.g. Teflon
PVDF	Polyvinylidene fluoride, a plastic, tradename e.g. Kynar
QAL	Quality Assurance Level
R22	Common name for chlorodifluoromethane, $\text{CHClF}_2$
RAM	Random Access Memory (write and read memory)
rel.	relative
RH	Relative Humidity
RJ45	RJ = Registered Jack (standardized plug), plug-in connection that is used for network cables in particular
ROM	Read Only Memory
RS	Recommended Standard, designation for standardized interfaces
RS 232	(also EIA-232) Identifies an interface standard for a sequential, serial data transmission
RS 485	(also EIA-485) Identifies an interface standard for a differential, serial data transmission
s	Second(s)
s.	Refer to
SELV	Safety Extra Low Voltage
$\text{SF}_6$	$\text{SF}_6$ = sulfur hexafluoride
$\text{SO}_2$	$\text{SO}_2$ = sulfur dioxide
SW	Software
t	time
T	Temperature
Ta	Tantalum
TA Luft	Technical Instructions on Air Quality Control (Germany)
TCP/IP	Transmission Control Protocol/Internet Protocol; a reference model for Internet communication
Ti	Titanium
TÜV	Technischer Überwachungsverein, German Technical Inspectorate
U	Symbol for electric voltage
LEL	Lower Explosion Limit
USB	Universal Serial Bus
etc.	and so on
UV	Ultraviolet
V	Volt

## List of abbreviations

### B.1 List of abbreviations

Abbreviation/ symbol	Description
V.	Version
VA	Voltampere
VDE	Verband der Elektrotechnik, Elektronik und Informationstechnik (German Association for Electrical, Electronic and Information Technologies)
VGA	Video Graphics Array, a graphics card standard
Vol. %	Volume percent
vpb	volume parts per billion ( $\cong 10^{-9}$ of a volume)
vpm	volume parts per million ( $\cong 10^{-6}$ of a volume)
Xe	Xe = Xenon, an inert gas
e.g.	For example
$\mu\text{m}$	Micrometer
$\Omega$	Ohm

# Glossary

## **Back wall of housing**

Part for sealing the rear housing opening of the device.

## **Calibration**

Elimination of deviations between the setpoint and actual value of certain measured variables.

## **Calibration gas**

Gas used for calibration procedures.

## **Code**

A selectable sequence of characters for enabling a protected submenu.

## **Code level**

Area of protected functions or states which are enabled after entering a certain code.

## **Coded display mode**

Operating mode in which the measured value is displayed and the device is protected against unauthorized access by codes.

## **Commissioning**

Totality of measures and actions required to make a machine or system capable of running.

## **Containment system**

Gas channel within the gas analyzer.

## **Control panel**

Panel with operating elements used to make inputs on the device.

## **Correction of cross-interference**

Computed correction of the measured value falsification caused by the interfering gas.

**Cross-interference deflection**

The falsification of a measurement caused by an interfering gas.

**Cursor**

Tool (insertion mark, writing mark, input mark) for identifying the current processing position of a program.

**Decoded display mode**

Operating mode in which the measured value is displayed, the device is partially or completely decoded, and the functional check is active.

**Dialog language**

Language in which communication between the user and device takes place.

**Display unit**

Device component which outputs/shows device information and visualizes the communication via the control panel.

**Factory functions**

Function for device maintenance. This function is protected by the highest code level and is only accessible to maintenance personnel.

**Factory setting**

Standard settings of the device at the time of delivery.

**Front panel**

Front boundary of a device, normally with clear identification features (e.g. device designation, manufacturer's logo, etc.).

**Function**

Numbered software function of a device. Functions are listed in submenus.

**Function display**

Screen display depending on the called function.

**Functional check**

Identification activated by the device if it determines that the measured value was influenced (e.g. when changing to operator control mode by decoding the device).

**Gas analyzer**

Device for quantitative analysis of gases and gas mixtures.

**Gas inlet**

Defined point for connecting a gas to the analyzer.

**Gas outlet**

Defined point for directing a gas out of the gas analyzer.

**Input field**

Single or multi-line area for entering data.

**Interfering gas**

A gas which interferes with the measurement, and which may be contained in the sample gas.

**Limit alarm**

Signaling of violation of a high or low limit.

**Limit monitoring**

Function which monitors adherence to adjustable limits, and signals if high or low limit is violated.

**Limit relay**

Relay to which a certain limit is assigned and which is switched when there is a limit alarm.

**Main menu**

Menu of the highest hierarchical level. It contains the submenus.

**Measured signal**

Representation of measured variables in the path of the signal flow by assigned physical quantities of the same or different type. Depending on the position of the measured signal at

the input or output of the relevant measuring element, one distinguishes between an input signal and an output signal.

### **Measured value**

The measured value is an output value which reflects a determined variable.

### **Measured value display**

Totality of the displayed information in "Coded display mode" and "Decoded display mode". The following are displayed, for example: measured value, status line with status messages, footer, measuring ranges, components, etc.

### **Measuring point**

Location where a measured value is recorded.

### **Measuring point relay**

Relay to which a measuring point is allocated.

### **Measuring range**

Range within which the result of a measurement moves. The measuring range has a reference number, e.g. 1. It is characterized by a start-of-scale value and a full-scale value.

### **Measuring range switching**

Automatic switching over of measuring ranges. Also referred to as "autorange" in the software.

### **Membrane keyboard**

Keyboard whose keys are protected against atmospheric influences by a membrane.

### **Motherboard**

Board which contains the basic data and firmware for the device.

### **Noise**

Totality of all phenomena which could disturb the transmission and/or recording of information.

**Operating mode**

Various modes into which the device can be put by intervening from the outside. Three modes are distinguished:

- Coded display mode
- Decoded display mode
- Operator control mode

Generic term for a number of independent states which the device can assume during operation (e.g. measure, standby, pause, etc.).

**Operation level**

Certain operating area (menus and functions) which is either freely accessible or protected by a code.

**Operator control mode**

Operating mode in which the device is partially or entirely decoded and the functional check is activated. The device is configured in this mode.

**Sample gas**

A gas which has been extracted from a process for analysis.

**Sealing**

Protection of the materials against escaping of gases.

**Signaling contact**

Usually a floating contact contained in electronic components (e.g. relay) which signals the occurrence of an event defined as a fault to a control unit.

**Span**

Difference between defined start-of-scale value and defined full-scale value.

**Span calibration**

Adjustment of the span using a suitable calibration gas.

**Spike**

English.: Thorn, pin, prong: Undesired, briefly occurring peaked interference of a measured signal.

### **Standard configuration**

Totality of standard features contained in the device at the time of delivery without optional extensions.

### **Start-up state**

Settable operating mode to which the device changes after the warm-up phase has been successfully run through.

### **Status message**

Selectable output of various messages in the status line of the measured value display.

### **Subfunction**

Independent functional unit within a function.

### **Submenu**

Menu which is listed under a higher-order menu item.

### **T<sub>90</sub> time**

The **T<sub>90</sub> time** is a common value in measurement engineering. It defines the time that a sensor takes to display 90 percent of the correct measured value after a measuring edge (abrupt change of the signal).

### **Time constant**

System parameter which determines the way a system-relevant variable changes with time.

### **Warm restart**

Restarting the device from its "warm" state with the last set parameters.

### **Warm-up phase**

Time which the analyzer needs to reach operating temperature. The warm-up phase counts as one of the operating modes.

### **Weighting**

Evaluation of single factors of a solution approach with regard to their importance. It has the effect that more relevant factors have a greater influence on the result.



**Zero calibration**

Calibration of the zero point with a suitable zero gas.

**Zero gas**

Gas used to calibrate the zero point.

**Zero point**

Smallest possible point of a measuring range (usually the start of the measuring range).



# Index

## 1

13th BImSchV, 24  
17th BImSchV, 24

## A

Access code, 147  
Adjusting  
    IR source, 196  
Ambient atmosphere, 37  
Ambient temperature, 37  
Analog output, 135, 145  
Analyzer chamber  
    Cleaning, 192  
    Length, 191  
    Removal, 191  
Analyzer status, 103  
    Diagnostics values, 104  
Analyzer unit  
    Calibration, 192  
    Design of OXYMAT 6E, 201  
    Design of ULTRAMAT 6F 1-channel analyzer unit, 185  
    Design of ULTRAMAT 6F 2-channel analyzer unit, 186  
    Field device, 204  
    Heating, 164  
    Length, 235  
    Measuring head of OXYMAT 6E, 202  
    Rack unit, 204  
    Repair, 188  
    Replacing, 188  
    Spacer for OXYMAT 6E, 202  
    Spare parts, 226, 235  
Application areas, 24  
Application examples, 88  
Article number, 219  
AUTOCAL  
    Check, 112  
    Connection, 70, 73, 283, 286  
    Cycle, 116  
    Function, 111  
    Operating mode, 112  
    Sequence, 113

## B

Board  
    Replacing, 173, 174

## C

Calibration, 205  
    Analyzer unit, 192  
    AUTOCAL, 111  
    Automatic calibration, 111  
    Measuring range, 108  
    Reference gas pressure switch, 205  
    Sensitivity, 107  
    Setpoints, 110  
    Single calibration, 107, 110  
    Total calibration, 108, 110  
    Zero point, 106  
Calibration gases, 78  
Calibration tolerances, 146  
CE mark, 17  
Chopper frequency, 131  
Cleaning  
    Device, 171  
    Sample chamber, 203  
Code, 147  
Commissioning  
    OXYMAT, 87  
    Preparation, 78  
    ULTRAMAT, 86  
Communication interface  
    ELAN, 31  
    PROFIBUS-DP/PA, 34  
    SIPROM GA, 33  
Compensation of interferences  
    Accompanying gases, 151  
    Cross-sensitivity, 151, 199  
    Interference gases, 151  
    Noise, 144  
    Pressure, 150, 198  
    Temperature, 160, 199  
    Vibrations, 134  
Configuration, 135  
    Analog output, 135  
    Device test, 147  
    Digital inputs, 138  
    ELAN, 142

- Relay assignment, 136
- Temperature compensation, 160
- User data memory, 143
- Connections
  - Electrical connections, 18
  - Gas connections, 60
  - OXYMAT 6E, 57
  - OXYMAT 6F/ULTRAMAT 6F, 59
  - Purging gas, 63
  - Reference gas, 61, 81, 84
  - Sample gas, 60
  - ULTRAMAT 6E and ULTRAMAT/OXYMAT 6E, 57
- Contrast, 130
- Cross-sensitivity, 270

## D

- Date, 132
- Date of manufacture, 15
- Decommissioning, 216
- Delivery, 15
- Design, 187
  - Analyzer unit of OXYMAT 6E, 201
  - Enclosure, 26
  - Heating, 177
  - Sample chamber of OXYMAT 6E, 201
  - ULTRAMAT 6E analyzer unit, 183
  - ULTRAMAT 6F 1-channel analyzer unit, 185
  - ULTRAMAT 6F 2-channel analyzer unit, 186
- Device parameters, 103
- Device test, 147
- Device variants, 11
- Diagnostics
  - Logbook, 105
- Diagnostics functions, 103
- Diagnostics values, 104
- Diagrams
  - Pin assignment, 67, 280
  - Terminal assignment, 71, 284
- Dialog language, 149
- Digital inputs, 138, (See Digital inputs)
- Dimension drawings
  - OXYMAT 6E, 48, 273
  - ULTRAMAT 6E, 49, 274
  - ULTRAMAT 6F and OXYMAT 6F, 52, 277
  - ULTRAMAT/OXYMAT 6E, 49, 274
- Display, 94
  - Contrast, 130
  - Error, 213
  - Measured value, 97, 129
- Display unit, 128
  - Contrast, 130

- Disposal
  - Rack unit, 217
- Drift values, 118

## E

- Edit mode, 94
- ELAN, 142
  - Interface, 31
  - Operating principle, 31
  - Parameters, 142
- Electric time constants, (See Time constants)
- Electrical connections
  - AUTOCAL circuit, 73, 286
  - AUTOCAL connection, 70, 283
  - Inspection regulations, 18
  - Power connection, 63
  - Signal connections, 64
- Emission measurement, 24, 41
- Enclosure, 26
- Error messages, 162, 207
- ESD guidelines, 305

## F

- Factory data, 103
- Fan, 179
- Fault, 207
  - Message, 210
- Fault messages, 162, 210
- Field device
  - Analyzer unit, 204
- Field devices
  - Dimension drawings, 52, 277
- Fields of application, 24
- Firmware
  - Editions, 294
  - Update, 172
- Flue gas measurement, 88
- Fuses, 175

## G

- Gas connection, 60
- Gas cooler, 85
- Gas flow diagram
  - OXYMAT 6F with reference gas connection  
1100 hPa abs., 290
  - OXYMAT 6F with reference gas connection  
3000 to 5000 hPa abs., 291

- ULTRAMAT 6E 1 channel device with flow-type reference gas compartment, 287
- ULTRAMAT 6E 2-channel device, 288
- ULTRAMAT 6E with flow-type reference gas compartment, 293
- ULTRAMAT 6F with flow-type reference gas compartment, 289
- ULTRAMAT/OXYMAT 6E without flow-type reference gas side, 292

#### Gas path

- Leak test, 78
- Spare parts, 231, 255
- Used materials, 271

Gas preparation, 37, 78, 85

Gas pump, 85

Gas sampling device, 85

#### Guidelines

- ESD guidelines, 305

## H

Heating, 177

- Analyzer unit, 164
- Sample chamber, 164
- Spare parts, 258

## I

Input dialogs, 94

Input keys, 94

Installation, 46

#### Installing

- Requirements, 46

#### Interface

- ELAN, 142
- PROFIBUS, 165
- RS485, 31
- Setting parameters, 162

Interference correction, 151

- OXYMAT, 155
- ULTRAMAT, 152

Interference gases

- OXYMAT, 270

IR source, 187, 196

## L

Language, 149

Language setting, 149

Leak test, 78, 205

- ULTRAMAT, 78

Limit monitoring, 124

Limits, 124

List of abbreviations, 309

Location of use, 37

- Ambient, 37

- Gas preparation, 37

- Magnetic radiation, 37

- Monitoring of ship emissions, 41

- Outdoors, 37

- Vibrations, 37

Logbook, 105, 133, 207

## M

Magnetic field frequency, 131

Main inlet, 179

Main menu, 98

Maintenance, 171

- Cleaning the device, 171

Maintenance request, 207

Maintenance requests

- Message, 208

Measured value

- Display, 97, 129

- Graphical representation, 128

- Negative measured value, 136

- Phase adjustment, 159

- Progress display, 128

- Signal, 159

- Temperature compensation, 160

Measuring head, 203

- OXYMAT 6E, 202

Measuring point switching, 133

Measuring range, 119

- Calibration, 108

- select, 119

- Specify, 122

- Suppressed zero, 82

- Switching, 119

Measuring range switching, 119

Memory modules, 144

Messages, 207

Modifications

- correct usage, 19

- improper, 19

Modules, 221

Motherboard, 174

- Pin assignment, 67, 280

- Replacing, 173

- Terminal assignment, 71, 284

Mounting location

- Requirements, 46

- N**
- Nameplate, 219
  - Noise, 144
  - Noise suppression, 123
- O**
- On/off functions, 125
  - Operating language, 149
  - Operating mode, 95
  - Operating principle, 27
    - ELAN interface, 31
    - OXYMAT, 28
    - PROFIBUS, 35
    - ULTRAMAT, 27, 187
  - Operating sequence, 96
  - Operation
    - Display, 94
    - Input keys, 94
    - Inputs, 94
    - Menu structure, 97
    - Power User, 99
    - Sequence, 96
  - Operator functions, 101
    - AK configuration, 162
    - Analyzer status, 103
    - AUTOCAL, 111
    - Calibration, 105
    - Chopper frequency, 130
    - Configuring the analog output, 135
    - Device test, 147
    - Digital inputs, 138
    - Drift values, 118
    - ELAN, 142
    - Electric time constants, 123
    - Graphical measured value representation, 128
    - Heating, 164
    - Interference correction, 151
    - Limits, 124
    - Load user data, 143
    - Logbook, 133
    - Magnetic field frequency, 130
    - Measuring point switching, 133
    - Measuring ranges, 119
    - Noise suppression, 123
    - Operating language, 149
    - Phase adjustment, 159
    - Pressure correction, 150
    - PROFIBUS, 165
    - Quick selection, 99
    - Relay assignment, 136
    - Reset, 143
    - Save user data, 143
    - Select language, 149
    - Set contrast, 130
    - Setting the calibration tolerances, 146
    - Setting the code, 147
    - Setting the date/time, 132
    - Setting the measured display, 129
    - Show/hide error messages, 162
    - Span calibration, 107
    - Status messages, 127
    - Suppressing noise, 144
    - Switch on/off functions, 125
    - Switching valves, 160
    - Temperature compensation, 160
    - Vibration compensation, 134
    - Warm restart, 143
    - Zero calibration, 106
  - Option board, 174
    - Pin assignment, 69, 282
    - Replacing, 173
    - Terminal assignment, 72, 285
  - Order No., 103
  - OXYMAT
    - Accompanying gases, 270
    - Commissioning, 87
    - Interference correction, 155
    - Interference gases, 270
    - Operating principle, 28
    - Reference gas, 83
    - Reference gases, 270
    - Spare parts, 226
  - OXYMAT 6
    - Analyzer unit, 225
    - Pressure fluctuations in the sample gas path, 47
  - OXYMAT 6E
    - Dimension drawings, 48, 273
    - Technical specifications, 261, 262
  - OXYMAT 6F
    - Technical specifications, 267
- P**
- Parameter table, 300
  - Parameters, 123, 300
    - Analog output, 135
    - Calibration tolerances, 146
    - Chopper frequency, 130
    - Code, 147
    - Date, 132

- Digital inputs, 138
- Display contrast, 130
- ELAN, 142
- Graphical measured value representation, 128
- Interface, 162
- Interference correction, 151
- Limits, 124
- Logbook, 133
- Magnetic field frequency, 130
- Measured-value display, 129
- Measuring point switching, 133
- On/off functions, 125
- Overview, 300
- PROFIBUS, 165
- Relay assignment, 136
- Status messages, 127
- Time, 132
- Time constants, 123
- Vibration compensation, 134
- Phase adjustment, 195
- Pin assignment
  - Motherboard, 67, 280
  - Option board, 69, 282
- Pin assignments
  - AUTOCAL, 70, 283
- Pressure correction, 150
- Pressure sensor, 63
- Process tags, 133
- Production No., 103
- PROFIBUS, 165
- PROFIBUS-DP/PA, 34
- Proper use, 14
- Purging gas, 63
- Purity monitoring, 89

## Q

- Qualified personnel, 15

## R

- Rack unit
  - Analyzer section, 204
- Reference gas
  - Connections, 61, 81, 84
  - Line, 202
  - OXYMAT, 83
  - OXYMAT 6, 270
  - ULTRAMAT, 81
- Reference gas pressure switch, 205
- Relay assignment, 136

- Relay function, 136
- Replacing
  - Analyzer unit, 188
  - Boards, 173
  - Fan, 179
  - Fuses, 175
  - Sample chamber, 204
  - Temperature fuse, 180
- Reset, 143
- Return procedure, 305
- Room air monitoring, 88
- RS485, 31

## S

- Safety extra-low voltage, 64
- Safety instructions
  - Signal connections, 64
- Sample chamber, 203
  - Cleaning, 203
  - Design of OXYMAT 6E, 201
  - Heating, 164
  - Replacing, 204
  - Spare parts, 226
- Sample gas
  - Conditioning, 78, 85
  - Connections, 60
  - Quality, 78
- Sample gas restrictor, 205
- Self-test, 147
- Sensitivity
  - Calibration, 107
  - Setpoint, 110
- Serial number, 15
- Service, 304
- Setting
  - Analog output, 135, 145
  - Analyzer unit, 192
  - Calibration method, 110
  - Calibration tolerances, 146
  - Chopper frequency, 131
  - Code, 147
  - Contrast, 130
  - Date, 132
  - Digital inputs, 138
  - Display contrast, 130
  - ELAN parameters, 142
  - Electric time constants, 123
  - Heating, 164
  - Interface parameters, 162
  - Language, 149
  - Limits, 124

- Magnetic field frequency, 131
- Measured-value display, 129
- Noise suppression, 123
- Operating language, 149
- PROFIBUS parameters, 165
- Relay function, 136
- Setpoints, 110
- Status messages, 127
- Suppressing noise, 144
- Time, 132
- Vibration compensation, 134
- Shutting down, 216
- SIPROM GA, 33, 172
- Software
  - Editions, 294
  - Update, 172
- Software release, 103
- Spare parts, 219
  - Analyzer unit, 226, 235
  - Electronics, 227, 251
  - Gas paths, 231, 255
  - Heating, 258
  - Modules, 221
  - OXYMAT, 226
  - Sample chamber, 226
  - ULTRAMAT, 235
- Special applications, 12, 24
- Status messages, 127
- Submenu, 98
  - Analyzer status, 103
  - Calibration, 105
  - Configuration, 135
  - Measuring ranges, 119
  - Parameters, 123
- Support, 304
- Symbols, (Refer to warning symbols)

## T

- TA Luft, 24
- Technical specifications, 259, 261, 262, 264, 267
  - General information, 259, 261, 262, 267
  - OXYMAT, (Reference gases), (Zero point error)
  - OXYMAT 6F, 267
  - OXYMAT 6E, 261, 262
  - ULTRAMAT 6F, 264
  - ULTRAMAT 6E, 259
- Technical Support, 305
- Temperature compensation, 160
- Temperature fuse, 177, 180

- Terminal assignment
  - Motherboard, 71, 284
  - Option board, 72, 285
- Time, 132
- Time constants, 123

## U

- ULTRAMAT, 27
  - Analyzer unit, (Design)
  - Commissioning, 86
  - Interference correction, 152
  - IR source, 187
  - Leak test, 78
  - Reference gas, 81
  - Spare parts, 235
- ULTRAMAT 6
  - Dimension drawings, 49, 274
- ULTRAMAT 6E analyzer unit
  - Design, 183
- ULTRAMAT 6E
  - Technical specifications, 259
- ULTRAMAT 6F
  - Technical specifications, 264
- ULTRAMAT 6F and OXYMAT 6F
  - Dimension drawings, 52, 277
- User data memory, 143

## V

- Vibration compensation, 134

## W

- Warm restart, 143
- Warning symbols, 17
- Warranty, 15

## Y

- Year of manufacture, 15

## Z

- Zero point
  - Calibration, 106
  - Setpoint, 110
  - Suppressed zero, 82
  - Temperature compensation, 160
- Zero point error, 270