

**SIEMENS**

System Manual

**SINAMICS**

**S120**

Hydraulic Drives

Edition

12/2018

[www.siemens.com/drives](http://www.siemens.com/drives)



# SIEMENS

## SINAMICS

### S120 Hydraulic Drive

#### System Manual

---

#### Preface

---

Fundamental safety instructions

1

---

System overview

2

---

Configuration

3

---

Commissioning

4

---

Drive functions

5

---

Hardware

6

---

Appendix

A

Valid from:  
Firmware version 5.2



12/2018

6SL3097-5BA00-0BP0

## Legal information

### Warning notice system

This manual contains notices you have to observe in order to ensure your personal safety, as well as to prevent damage to property. The notices referring to your personal safety are highlighted in the manual by a safety alert symbol, notices referring only to property damage have no safety alert symbol. These notices shown below are graded according to the degree of danger.

|  |
|--|
|  <b>DANGER</b>        |
| indicates that death or severe personal injury <b>will</b> result if proper precautions are not taken. |
|  <b>WARNING</b>       |
| indicates that death or severe personal injury <b>may</b> result if proper precautions are not taken.  |
|  <b>CAUTION</b>       |
| indicates that minor personal injury can result if proper precautions are not taken.                   |
| <b>NOTICE</b>  |
| indicates that property damage can result if proper precautions are not taken.                         |

If more than one degree of danger is present, the warning notice representing the highest degree of danger will be used. A notice warning of injury to persons with a safety alert symbol may also include a warning relating to property damage.

### Qualified Personnel

The product/system described in this documentation may be operated only by **personnel qualified** for the specific task in accordance with the relevant documentation, in particular its warning notices and safety instructions. Qualified personnel are those who, based on their training and experience, are capable of identifying risks and avoiding potential hazards when working with these products/systems.

### Proper use of Siemens products

Note the following:

|  |
|--|
|  <b>WARNING</b>   |
| Siemens products may only be used for the applications described in the catalog and in the relevant technical documentation. If products and components from other manufacturers are used, these must be recommended or approved by Siemens. Proper transport, storage, installation, assembly, commissioning, operation and maintenance are required to ensure that the products operate safely and without any problems. The permissible ambient conditions must be complied with. The information in the relevant documentation must be observed. |

### Trademarks

All names identified by ® are registered trademarks of Siemens AG. The remaining trademarks in this publication may be trademarks whose use by third parties for their own purposes could violate the rights of the owner.

### Disclaimer of Liability

We have reviewed the contents of this publication to ensure consistency with the hardware and software described. Since variance cannot be precluded entirely, we cannot guarantee full consistency. However, the information in this publication is reviewed regularly and any necessary corrections are included in subsequent editions.

# Preface

## SINAMICS documentation

The SINAMICS documentation is organized in the following categories:

- General documentation/catalogs
- User documentation
- Manufacturer/service documentation

## Additional information

You can find information on the topics below at the following address (<https://support.industry.siemens.com/cs/de/en/view/108993276>):

- Ordering documentation/overview of documentation
- Additional links to download documents
- Using documentation online (find and search in manuals/information)

Please send any questions about the technical documentation (e.g. suggestions for improvement, corrections) to the following email address (<mailto:docu.motioncontrol@siemens.com>).

## Siemens MySupport/Documentation

At the following address (<https://support.industry.siemens.com/My/ww/en/documentation>), you can find information on how to create your own individual documentation based on Siemens' content, and adapt it for your own machine documentation.

## Training

At the following address (<http://www.siemens.com/sitrain>), you can find information about SITRAIN (Siemens training on products, systems and solutions for automation and drives).

## FAQs

You can find Frequently Asked Questions in the Service&Support pages at Product Support (<https://support.industry.siemens.com/cs/de/en/ps/faq>).

## SINAMICS

You can find information about SINAMICS at the following address (<http://www.siemens.com/sinamics>).

## Usage phases and their documents/tools (as an example)

| Usage phase            | Document/tool   |
|------------------------|---|
| Orientation            | SINAMICS S Sales Documentation  |
| Planning/configuration | <ul style="list-style-type: none"> <li>• SIZER Engineering Tool</li> <li>• Configuration Manuals, Motors</li> </ul>   |
| Deciding/ordering      | SINAMICS S120 catalogs <ul style="list-style-type: none"> <li>• SINAMICS S120 and SIMOTICS (Catalog D 21.4)</li> <li>• SINAMICS Converters for Single-Axis Drives and SIMOTICS Motors (Catalog D 31)</li> <li>• SINAMICS Converters for Single-Axis Drives – Built-In Units (D 31.1)</li> <li>• SINAMICS Converters for Single-Axis Drives – Distributed Converters (D 31.2)</li> <li>• SINUMERIK 840 Equipment for Machine Tools (Catalog NC 62)</li> </ul>  |
| Installation/assembly  | <ul style="list-style-type: none"> <li>• SINAMICS S120 Equipment Manual for Control Units and Additional System Components</li> <li>• SINAMICS S120 Equipment Manual for Booksize Power Units</li> <li>• SINAMICS S120 Equipment Manual for Booksize Power Units C/D Type</li> <li>• SINAMICS S120 Equipment Manual for Chassis Power Units</li> <li>• SINAMICS S120 Equipment Manual for Chassis Power Units, Liquid-cooled</li> <li>• SINAMICS S120 Equipment Manual water-cooled chassis power units for common cooling circuits</li> <li>• SINAMICS S120 Equipment Manual for Chassis Power Units, Air-cooled</li> <li>• SINAMICS S120 Equipment Manual for AC Drives</li> <li>• SINAMICS S120 Equipment Manual Combi</li> <li>• SINAMICS S120M Equipment Manual Distributed Drive Technology</li> <li>• SINAMICS HLA System Manual Hydraulic Drives</li> </ul> |
| Commissioning          | <ul style="list-style-type: none"> <li>• Startdrive Commissioning Tool</li> <li>• SINAMICS S120 Getting Started</li> <li>• SINAMICS S120 Commissioning Manual</li> <li>• SINAMICS S120 Function Manual Drive Functions</li> <li>• SINAMICS S120 Safety Integrated Function Manual</li> <li>• SINAMICS S120 Function Manual Communication</li> <li>• SINAMICS S120/S150 List Manual</li> <li>• SINAMICS HLA System Manual Hydraulic Drives</li> </ul>  |
| Usage/operation        | <ul style="list-style-type: none"> <li>• SINAMICS S120 Commissioning Manual</li> <li>• SINAMICS S120/S150 List Manual</li> <li>• SINAMICS HLA System Manual Hydraulic Drives</li> </ul>   |
| Maintenance/servicing  | <ul style="list-style-type: none"> <li>• SINAMICS S120 Commissioning Manual</li> <li>• SINAMICS S120/S150 List Manual</li> </ul>  |
| References             | <ul style="list-style-type: none"> <li>• SINAMICS S120/S150 List Manual</li> </ul>  |

## Where can the various topics be found?

| Software                              |  | Manual  |
|---------------------------------------|--|---|
| Alarms                                | Described in order of ascending numbers  | SINAMICS S120/S150 List Manual  |
| Parameters                            | Described in order of ascending numbers  | SINAMICS S120/S150 List Manual  |
| Function block diagrams               | Sorted according to topic  | SINAMICS S120/S150 List Manual  |
|                                       | Described in order of ascending numbers  |   |
| Drive functions                       |  | SINAMICS S120 Function Manual Drive Functions   |
| Communication topics                  |  | SINAMICS S120 Function Manual Communication (from firmware V5.2)  |
| Safety Integrated                     | Basic and Extended Functions   | SINAMICS S120 Safety Integrated Function Manual   |
|                                       | Basic Functions  | SINAMICS S120 Function Manual Drive Functions   |
| Commissioning                         | Of a simple SINAMICS S120 drive with STARTER   | Getting Started (up to Firmware V5.1 SP1)   |
| Commissioning                         | With STARTER   | SINAMICS S120 Commissioning Manual (up to firmware V5.1 SP1)  |
| Commissioning                         | Of a simple SINAMICS S120 drive with Startdrive  | Getting Started (from Firmware V5.2)  |
| Commissioning                         | With Startdrive  | SINAMICS S120 Commissioning Manual (from firmware V5.2)   |
| Web server                            |  | SINAMICS S120 Function Manual Drive Functions   |
| Hardware                              |  | Manual  |
| Control Units                         | And expansion components: <ul style="list-style-type: none"> <li>• Control Units</li> <li>• Option Boards</li> <li>• Terminal Modules</li> </ul> | <ul style="list-style-type: none"> <li>• HUB Modules</li> <li>• VSM10</li> <li>• Encoder system connection</li> </ul>                 |
| Power units booksize                  | <ul style="list-style-type: none"> <li>• Line connection</li> <li>• Line Modules</li> <li>• Motor Modules</li> </ul>                             | <ul style="list-style-type: none"> <li>• DC link components</li> <li>• Braking resistors</li> <li>• Control cabinet design</li> </ul> |
| Power units, booksize C/D type format |  | SINAMICS S120 Equipment Manual for Booksize Power Units C/D Type  |
| Chassis power units                   |  | SINAMICS S120 Equipment Manual for Chassis Power Units, Air-cooled or Liquid-cooled   |
| AC drive components                   |  | SINAMICS S120 Equipment Manual for AC Drives  |
| S120 Combi components                 |  | SINAMICS S120 Equipment Manual Combi  |
| Diagnostics via LEDs                  | STARTER  | SINAMICS S120 Commissioning Manual (up to firmware V5.1 SP1)  |
|                                       | Startdrive   | SINAMICS S120 Commissioning Manual (from firmware V5.2)   |
| Meaning of the LEDs                   |  | Equipment Manuals   |
| High Frequency Drive components       |  | SINAMICS S120 System Manual High Frequency Drives   |

## Target group

This documentation is intended for machine manufacturers, commissioning engineers, and service personnel who use the SINAMICS drive system.

## Benefits

This manual provides all of the information, procedures and operator actions required for the particular usage phase.

## Standard scope

The scope of the functionality described in this document can differ from that of the drive system that is actually supplied.

- Other functions not described in this documentation might be able to be executed in the drive system. However, no claim can be made regarding the availability of these functions when the equipment is first supplied or in the event of service.
- The documentation can also contain descriptions of functions that are not available in a particular product version of the drive system. Please refer to the ordering documentation only for the functionality of the supplied drive system.
- Extensions or changes made by the machine manufacturer must be documented by the machine manufacturer.

For reasons of clarity, this documentation does not contain all of the detailed information on all of the product types, and cannot take into consideration every conceivable type of installation, operation and service/maintenance.

## Technical Support

Country-specific telephone numbers for technical support are provided in the Internet at the following address (<https://support.industry.siemens.com/sc/ww/en/sc/2090>) in the "Contact" area.

## SINAMICS introduction: Hardware introduction

### Relevant directives and standards

You can obtain an up-to-date list of currently certified components on request from your local Siemens office. If you have any questions relating to certifications that have not yet been completed, please ask your Siemens contact person.

### Certificates for download

The certificates can be downloaded from the Internet:

Certificates





### EC Declaration of Conformity

You can find the EC Declaration of Conformity for the relevant directives as well as the relevant certificates, prototype test certificates, manufacturers declarations and test certificates for functions relating to functional safety ("Safety Integrated") on the Internet at the following address.

The following directives and standards are relevant for SINAMICS S devices:

- **European Low Voltage Directive**

SINAMICS S devices fulfil the requirements stipulated in the Low-Voltage Directive 2014/35/EU, insofar as they are covered by the application area of this directive.

- **European Machinery Directive**

SINAMICS S devices fulfil the requirements stipulated in the Low-Voltage Directive 2006/42/EU, insofar as they are covered by the application area of this directive.

However, the use of the SINAMICS S devices in a typical machine application has been fully assessed for compliance with the main regulations in this directive concerning health and safety.

- **Directive 2011/65/EU**

SINAMICS S devices comply with the requirements of Directive 2011/65/EU on the restriction of the use of certain hazardous substances in electrical and electronic devices (RoHS II).

- **European EMC Directive**

SINAMICS S devices comply with the EMC Directive 2014/30/EU.

- **EMC requirements for South Korea**

SINAMICS S devices with the KC marking on the type plate satisfy the EMC requirements for South Korea.

- **Eurasian conformity**

SINAMICS S comply with the requirements of the Russia/Belarus/Kazakhstan customs union (EAC).

- **North American market**

SINAMICS S devices provided with one of the test symbols displayed fulfill the requirements stipulated for the North American market as a component of drive applications.

You can find the relevant certificates on the Internet pages of the certifier.

- **Specification for semiconductor process equipment voltage drop immunity**

SINAMICS S devices meet the requirements of standard SEMI F47-0706.





- **Australia and New Zealand (RCM formerly C-Tick)**

SINAMICS S devices showing the test symbols fulfill the EMC requirements for Australia and New Zealand.

- **Quality systems**

Siemens AG employs a quality management system that meets the requirements of ISO 9001 and ISO 14001.

### Not relevant standards



#### China Compulsory Certification

SINAMICS S devices do not fall in the area of validity of the China Compulsory Certification (CCC).

### EMC limit values in South Korea

|  |
|--|
| <p>이 기기는 업무용(A급) 전자파적합기기로서 판매자 또는 사용자는 이 점을 주의하시기 바라며, 가정외의 지역에서 사용하는 것을 목적으로 합니다.<br/>For sellers or other users, please bear in mind that this device is an A-grade electromagnetic wave device.<br/>This device is intended to be used in areas other than at home.</p> |
|--|

The EMC limit values to be observed for Korea correspond to the limit values of the EMC product standard for variable-speed electric drives EN 61800-3 of category C2 or the limit value class A, Group 1 to KN11. By implementing appropriate additional measures, the limit values according to category C2 or limit value class A, Group 1, are observed. Further, additional measures may be required, such as using an additional radio interference suppression filter (EMC filter).

The measures for EMC-compliant design of the system are described in detail in this manual respectively in the EMC Installation Guideline Configuration Manual.

The final statement regarding compliance with the standard is given by the respective label attached to the individual unit.

### Ensuring reliable operation

The manual describes a desired state which, if maintained, ensures the required level of operational reliability and compliance with EMC limit values.

Should there be any deviation from the requirements in the manual, appropriate actions (e.g. measurements) must be taken to check/prove that the required level of operational reliability and compliance with EMC limit values are ensured.

### Spare parts

Spare parts are available on the Internet at the following address.

### Product maintenance

The components are subject to continuous further development within the scope of product maintenance (improvements to robustness, discontinuations of components, etc).

These further developments are "spare parts-compatible" and do not change the article number.

In the scope of such spare parts-compatible further developments, connector/connection positions are sometimes changed slightly. This does not cause any problems with proper use of the components. Please take this fact into consideration in special installation situations (e.g. allow sufficient clearance for the cable length).

## Use of third-party products



This document contains recommendations relating to third-party products. Siemens accepts the fundamental suitability of these third-party products.

You can use equivalent products from other manufacturers.

Siemens does not accept any warranty for the properties of third-party products.

## Ground symbols

Table 1 Symbols

| Icon  | Meaning   |
|---|---|
|  | Connection for protective conductor/PE connection |
|  | Ground (e.g. M 24 V)                              |
|  | Connection for function potential bonding         |

## Notation

The following notation and abbreviations are used in this documentation:

### Notation for faults and alarms (examples):

- F12345            Fault 12345
- A67890            Alarm 67890
- C23456            Safety message

### Notation for parameters (examples):

- p0918            Adjustable parameter 918
- r1024            Display parameter 1024
- p1070[1]        Adjustable parameter 1070, index 1
- p2098[1].3      Adjustable parameter 2098, index 1 bit 3
- p0099[0...3]    Adjustable parameter 99, indices 0 to 3
- r0945[2](3)     Display parameter 945, index 2 of drive object 3
- p0795.4         Adjustable parameter 795, bit 4

---

### Note

#### Mixed operation of hydraulic and electrical components

SINAMICS HLA is operated together with electrical components: As a consequence, this manual also provides information that goes beyond pure hydraulic operation.

---

# Table of contents

|          |  |           |
|----------|--|-----------|
|          | <b>Preface .....</b>   | <b>3</b>  |
| <b>1</b> | <b>Fundamental safety instructions .....</b>                             | <b>15</b> |
| 1.1      | Fundamental safety instructions for Hydraulic Drive .....                | 15        |
| 1.2      | Fundamental safety instructions .....                                    | 16        |
| 1.2.1    | General safety instructions .....  | 16        |
| 1.2.2    | Equipment damage due to electric fields or electrostatic discharge ..... | 22        |
| 1.2.3    | Warranty and liability for application examples .....                    | 22        |
| 1.2.4    | Industrial security .....  | 23        |
| 1.2.5    | Residual risks of power drive systems.....                               | 25        |
| <b>2</b> | <b>System overview.....</b>  | <b>27</b> |
| 2.1      | Structure of a hydraulic drive .....                                     | 27        |
| 2.1.1    | Machine guidance .....   | 28        |
| 2.1.2    | Cylinder .....   | 28        |
| 2.1.3    | Servo solenoid valve.....  | 29        |
| 2.1.4    | Valve amplifier .....  | 29        |
| 2.1.5    | Shutoff valve .....  | 29        |
| 2.1.6    | Position measuring system.....   | 30        |
| 2.1.7    | SINUMERIK / SINAMICS.....  | 30        |
| 2.1.8    | Hydraulic power unit .....   | 30        |
| 2.2      | SINAMICS S120 HLA module components.....                                 | 31        |
| 2.3      | Comparison of electric and hydraulic drive systems .....                 | 32        |
| 2.4      | System data .....  | 34        |
| 2.4.1    | Climatic and mechanical environmental conditions in operation .....      | 34        |
| 2.4.2    | Transport and storage conditions .....                                   | 35        |
| 2.4.3    | Environmental conditions.....  | 35        |
| <b>3</b> | <b>Configuration .....</b>   | <b>37</b> |
| 3.1      | Configuring steps .....  | 37        |
| 3.1.1    | Procedure for the electrical configuring .....                           | 37        |
| 3.1.2    | Procedure for configuring the hydraulics .....                           | 38        |
| 3.2      | Integration in SINUMERIK/SINAMICS S120 .....                             | 38        |
| 3.3      | Configuring the hydraulics .....   | 39        |
| 3.3.1    | Cylinder selection.....  | 39        |
| 3.3.2    | Selection of servo solenoid valves.....                                  | 41        |
| 3.3.3    | Selection of shutoff valves .....  | 45        |
| 3.3.4    | Natural frequency of the hydraulic drive .....                           | 48        |
| 3.3.5    | Hydraulic power unit .....   | 50        |
| 3.4      | Interconnection .....  | 52        |
| 3.4.1    | 24 V power supply for the electronics.....                               | 52        |
| 3.4.2    | 26.5 V power supply for the hydraulics.....                              | 53        |
| 3.4.3    | Grounding concept/Electromagnetic compatibility (EMC) .....              | 54        |

|          |  |           |
|----------|--|-----------|
| <b>4</b> | <b>Commissioning .....</b>   | <b>55</b> |
| 4.1      | Commissioning overview .....   | 55        |
| 4.2      | Configuration - hydraulic module .....                                 | 56        |
| 4.3      | Configuration - valve selection .....                                  | 57        |
| 4.4      | Configuration - valve data .....                                       | 58        |
| 4.5      | Configuration - save valve data .....                                  | 59        |
| 4.6      | Configuration - cylinder data .....                                    | 60        |
| 4.7      | Configuration - supply data .....                                      | 61        |
| 4.8      | Configuration - connection data .....                                  | 62        |
| 4.9      | Configuration - calculations.....                                      | 63        |
| 4.10     | Configuration - Encoder assignment.....                                | 65        |
| 4.11     | Configuration - encoder 1 ... 3 .....                                  | 67        |
| 4.12     | Configuration - control mode/setpoints .....                           | 68        |
| 4.13     | Configuration - BICO interconnection .....                             | 70        |
| 4.14     | Configuration - summary.....   | 72        |
| 4.15     | Overviews .....  | 73        |
| 4.15.1   | Overview of the hydraulic module.....                                  | 73        |
| 4.15.2   | Valve/cylinder overview .....  | 75        |
| 4.15.3   | Encoder overview.....  | 76        |
| 4.15.4   | Overview of connection data.....                                       | 77        |
| 4.15.5   | Overview of the reference variables/function modules .....             | 78        |
| 4.15.6   | Configuration - reference variables.....                               | 79        |
| 4.16     | Importing valve lists .....  | 81        |
| 4.17     | Editing the valve characteristic .....                                 | 82        |
| 4.17.1   | General .....  | 82        |
| 4.17.2   | Simplified sequence .....  | 85        |
| 4.17.3   | Measure characteristic.....  | 87        |
| 4.17.4   | Measurement .....  | 89        |
| 4.17.5   | Measurement parameters.....  | 91        |
| 4.17.6   | Valve characteristic parameters.....                                   | 92        |
| 4.17.7   | Valve characteristic - numeric.....                                    | 93        |
| 4.17.8   | Valve characteristic - graphic.....                                    | 98        |
| 4.17.9   | Characteristic information .....                                       | 100       |
| 4.17.10  | Valve characteristic - copying .....                                   | 103       |
| 4.17.11  | Function diagram 4975 – valve characteristic and plane adaptation..... | 104       |
| 4.18     | Fine calibration and tuning.....                                       | 105       |
| 4.18.1   | Calibration .....  | 105       |
| 4.18.2   | Control sense, traversing direction .....                              | 107       |
| 4.18.3   | Offset calibration .....   | 111       |
| 4.18.4   | Velocity calibration .....   | 112       |
| 4.18.5   | Controller optimization .....  | 115       |
| 4.18.6   | Controller adaptation.....   | 120       |
| 4.18.7   | Piston calibration.....  | 122       |

|          |   |            |
|----------|---|------------|
| 4.18.8   | Hydraulic/electrical interpolation .....                      | 124        |
| 4.19     | Commissioning functions .....                                 | 124        |
| 4.19.1   | Measuring function.....                                       | 125        |
| 4.19.2   | Function generator.....                                       | 132        |
| 4.19.2.1 | Valve spool setpoint (control voltage).....                   | 133        |
| 4.19.2.2 | Velocity setpoint.....  | 134        |
| 4.19.2.3 | Position setpoint.....  | 135        |
| 4.19.3   | Circularity test .....  | 136        |
| 4.19.4   | Trace.....  | 137        |
| <b>5</b> | <b>Drive functions .....</b>                                  | <b>139</b> |
| 5.1      | Block diagram of closed-loop control.....                     | 139        |
| 5.2      | Functions .....   | 140        |
| 5.2.1    | Overview of functions.....                                    | 140        |
| 5.2.2    | Drive dataset switchover.....                                 | 141        |
| 5.3      | Closed-loop velocity control.....                             | 142        |
| 5.3.1    | Velocity adaptation/precontrol .....                          | 142        |
| 5.3.2    | Velocity controller.....                                      | 149        |
| 5.3.3    | Dynamic Servo Control (DSC).....                              | 156        |
| 5.3.4    | PROFIdrive communication .....                                | 156        |
| 5.4      | Force control .....   | 158        |
| 5.4.1    | Force limitation.....   | 162        |
| 5.4.2    | Stiction compensation.....                                    | 163        |
| 5.4.2.1  | Stiction compensation using the force controller .....        | 163        |
| 5.4.2.2  | Stiction compensation with voltage pulse / voltage ramp ..... | 166        |
| 5.4.3    | Force controller .....  | 168        |
| 5.5      | Control voltage output.....                                   | 172        |
| 5.5.1    | Characteristic correction .....                               | 172        |
| 5.5.2    | Manipulated variable filter .....                             | 177        |
| 5.5.3    | Control voltage limiting.....                                 | 178        |
| 5.6      | Supply unit data .....  | 180        |
| 5.7      | Valve .....   | 180        |
| 5.8      | Cylinder drive .....  | 182        |
| 5.9      | Drive data.....   | 183        |
| 5.10     | Position measuring system.....                                | 186        |
| 5.11     | Pressure sensor system .....                                  | 187        |
| 5.12     | Terminals .....   | 188        |
| 5.13     | Monitoring functions.....                                     | 194        |
| 5.13.1   | Faults and alarms .....                                       | 194        |
| 5.13.2   | Variable signaling function .....                             | 196        |
| 5.14     | Safety Integrated.....  | 198        |
| 5.14.1   | Supported functions: HLA module .....                         | 198        |
| <b>6</b> | <b>Hardware.....</b>  | <b>199</b> |
| 6.1      | Description .....   | 199        |

|          |   |            |
|----------|---|------------|
| 6.2      | Interfaces .....  | 200        |
| 6.2.1    | X200-X203 DRIVE-CLiQ interfaces .....   | 201        |
| 6.2.2    | X224 electronics power supply .....   | 202        |
| 6.2.3    | X231 and X232 encoder system interface .....                                    | 203        |
| 6.2.4    | X241 and X242 pressure sensors on the cylinder side (A/B) .....                 | 206        |
| 6.2.5    | X251 and X252 pressure sensors to sense the pressure at the shutoff valve ..... | 207        |
| 6.2.6    | X261 and X262 servo solenoid valves.....  | 210        |
| 6.2.7    | X271 26.5 V supply for the hydraulic components .....                           | 212        |
| 6.2.8    | X272 shutoff valves.....  | 214        |
| 6.2.9    | X281 and X282 sensors for shutoff valves .....                                  | 215        |
| 6.2.10   | X291 and X292 EP terminals to enable the power .....                            | 217        |
| 6.3      | Meaning of the LEDs on the HLA module .....                                     | 220        |
| 6.4      | Dimension drawing .....   | 221        |
| 6.5      | Available prefabricated cables .....  | 222        |
| 6.6      | Connection example .....  | 223        |
| 6.7      | Technical data.....   | 224        |
| <b>A</b> | <b>Appendix .....</b>   | <b>225</b> |
| A.1      | List of abbreviations .....   | 225        |
| A.2      | Documentation overview.....   | 235        |
| A.3      | Hydraulic .....   | 236        |
| A.3.1    | Servo solenoid valves .....   | 236        |
| A.3.1.1  | General .....   | 236        |
| A.3.1.2  | Directly-controlled servo solenoid valves.....                                  | 245        |
| A.3.1.3  | Precontrolled servo solenoid valves .....                                       | 247        |
| A.3.1.4  | HR servo solenoid valves .....  | 250        |
| A.3.2    | Cylinder .....  | 252        |
| A.4      | Screw terminals.....  | 254        |
|          | <b>Index .....</b>  | <b>255</b> |



# Fundamental safety instructions

## 1.1 Fundamental safety instructions for Hydraulic Drive

|  |
|--|
|  <b>WARNING</b>   |
| <b>Risk of death if the safety instructions and remaining risks are not carefully observed</b>   |
| If the safety instructions and residual risks are not observed in the documentation associated with the hydraulic components, accidents involving severe injuries or death can occur.        |
| <ul style="list-style-type: none"><li>• Observe the safety instructions given in the hydraulic documentation.</li><li>• When assessing the risk, take into account residual risks.</li></ul> |

---

### Note

#### Using hydraulic and electrical components together

SINAMICS Hydraulic Drive is always operated together with electrical components.

- As a consequence, also observe the fundamental safety instructions on the electrical components in the following section.
-

## 1.2 Fundamental safety instructions

### 1.2.1 General safety instructions



**! WARNING**

**Electric shock and danger to life due to other energy sources**

Touching live components can result in death or severe injury.

- Only work on electrical devices when you are qualified for this job.
- Always observe the country-specific safety rules.

Generally, the following six steps apply when establishing safety:

1. Prepare for disconnection. Notify all those who will be affected by the procedure.
2. Isolate the drive system from the power supply and take measures to prevent it being switched back on again.
3. Wait until the discharge time specified on the warning labels has elapsed.
4. Check that there is no voltage between any of the power connections, and between any of the power connections and the protective conductor connection.
5. Check whether the existing auxiliary supply circuits are de-energized.
6. Ensure that the motors cannot move.
7. Identify all other dangerous energy sources, e.g. compressed air, hydraulic systems, or water. Switch the energy sources to a safe state.
8. Check that the correct drive system is completely locked.

After you have completed the work, restore the operational readiness in the inverse sequence.



**! WARNING**

**Risk of electric shock and fire from supply networks with an excessively high impedance**

Excessively low short-circuit currents can lead to the protective devices not tripping or tripping too late, and thus causing electric shock or a fire.

- In the case of a conductor-conductor or conductor-ground short-circuit, ensure that the short-circuit current at the point where the inverter is connected to the line supply at least meets the minimum requirements for the response of the protective device used.
- You must use an additional residual-current device (RCD) if a conductor-ground short circuit does not reach the short-circuit current required for the protective device to respond. The required short-circuit current can be too low, especially for TT supply systems.



**! WARNING**

**Risk of electric shock and fire from supply networks with an excessively low impedance**

Excessively high short-circuit currents can lead to the protective devices not being able to interrupt these short-circuit currents and being destroyed, and thus causing electric shock or a fire.

- Ensure that the prospective short-circuit current at the line terminal of the inverter does not exceed the breaking capacity (SCCR or Icc) of the protective device used.



**! WARNING**

**Electric shock if there is no ground connection**

For missing or incorrectly implemented protective conductor connection for devices with protection class I, high voltages can be present at open, exposed parts, which when touched, can result in death or severe injury.

- Ground the device in compliance with the applicable regulations.



**! WARNING**

**Electric shock due to connection to an unsuitable power supply**

When equipment is connected to an unsuitable power supply, exposed components may carry a hazardous voltage that might result in serious injury or death.

- Only use power supplies that provide SELV (Safety Extra Low Voltage) or PELV- (Protective Extra Low Voltage) output voltages for all connections and terminals of the electronics modules.



**! WARNING**

**Electric shock due to equipment damage**

Improper handling may cause damage to equipment. For damaged devices, hazardous voltages can be present at the enclosure or at exposed components; if touched, this can result in death or severe injury.

- Ensure compliance with the limit values specified in the technical data during transport, storage and operation.
- Do not use any damaged devices.



**! WARNING**

**Electric shock due to unconnected cable shield**

Hazardous touch voltages can occur through capacitive cross-coupling due to unconnected cable shields.

- As a minimum, connect cable shields and the conductors of power cables that are not used (e.g. brake cores) at one end at the grounded housing potential.



**! WARNING**

**Arcing when a plug connection is opened during operation**

Opening a plug connection when a system is operation can result in arcing that may cause serious injury or death.

- Only open plug connections when the equipment is in a voltage-free state, unless it has been explicitly stated that they can be opened in operation.



**! WARNING**

**Electric shock due to residual charges in power components**

Because of the capacitors, a hazardous voltage is present for up to 5 minutes after the power supply has been switched off. Contact with live parts can result in death or serious injury.

- Wait for 5 minutes before you check that the unit really is in a no-voltage condition and start work.

**NOTICE**

**Property damage due to loose power connections**

Insufficient tightening torques or vibration can result in loose power connections. This can result in damage due to fire, device defects or malfunctions.

- Tighten all power connections to the prescribed torque.
- Check all power connections at regular intervals, particularly after equipment has been transported.

 **WARNING**

**Spread of fire from built-in devices**

In the event of fire outbreak, the enclosures of built-in devices cannot prevent the escape of fire and smoke. This can result in serious personal injury or property damage.

- Install built-in units in a suitable metal cabinet in such a way that personnel are protected against fire and smoke, or take other appropriate measures to protect personnel.
- Ensure that smoke can only escape via controlled and monitored paths.

 **WARNING**

**Active implant malfunctions due to electromagnetic fields**

Inverters generate electromagnetic fields (EMF) in operation. People with active implants in the immediate vicinity of this equipment are at particular risk.

- As the operator of an EMF-emitting installation, assess the individual risks of persons with active implants. The following clearances are usually adequate:
  - No clearance to closed control cabinets and shielded MOTION-CONNECT supply cables
  - Forearm length (approx. 35 cm clearance) to distributed drive systems and open control cabinets

 **WARNING**

**Unexpected movement of machines caused by radio devices or mobile phones**

When radio devices or mobile phones with a transmission power  $> 1$  W are used in the immediate vicinity of components, they may cause the equipment to malfunction. Malfunctions may impair the functional safety of machines and can therefore put people in danger or lead to property damage.

- If you come closer than around 2 m to such components, switch off any radios or mobile phones.
- Use the "SIEMENS Industry Online Support app" only on equipment that has already been switched off.

**NOTICE**

**Damage to motor insulation due to excessive voltages**

When operated on systems with grounded line conductor or in the event of a ground fault in the IT system, the motor insulation can be damaged by the higher voltage to ground. If you use motors that have insulation that is not designed for operation with grounded line conductors, you must perform the following measures:

- IT system: Use a ground fault monitor and eliminate the fault as quickly as possible.
- TN or TT systems with grounded line conductor: Use an isolating transformer on the line side.

 **WARNING**

**Fire due to inadequate ventilation clearances**

Inadequate ventilation clearances can cause overheating of components with subsequent fire and smoke. This can cause severe injury or even death. This can also result in increased downtime and reduced service lives for devices/systems.

- Ensure compliance with the specified minimum clearance as ventilation clearance for the respective component.

 **WARNING**

**Unrecognized dangers due to missing or illegible warning labels**

Dangers might not be recognized if warning labels are missing or illegible. Unrecognized dangers may cause accidents resulting in serious injury or death.

- Check that the warning labels are complete based on the documentation.
- Attach any missing warning labels to the components, where necessary in the national language.
- Replace illegible warning labels.

**NOTICE**

**Device damage caused by incorrect voltage/insulation tests**

Incorrect voltage/insulation tests can damage the device.

- Before carrying out a voltage/insulation check of the system/machine, disconnect the devices as all converters and motors have been subject to a high voltage test by the manufacturer, and therefore it is not necessary to perform an additional test within the system/machine.

 **WARNING**

**Unexpected movement of machines caused by inactive safety functions**

Inactive or non-adapted safety functions can trigger unexpected machine movements that may result in serious injury or death.

- Observe the information in the appropriate product documentation before commissioning.
- Carry out a safety inspection for functions relevant to safety on the entire system, including all safety-related components.
- Ensure that the safety functions used in your drives and automation tasks are adjusted and activated through appropriate parameterizing.
- Perform a function test.
- Only put your plant into live operation once you have guaranteed that the functions relevant to safety are running correctly.

---

**Note**

**Important safety notices for Safety Integrated functions**

If you want to use Safety Integrated functions, you must observe the safety notices in the Safety Integrated manuals.

---

 **WARNING**

**Malfunctions of the machine as a result of incorrect or changed parameter settings**

As a result of incorrect or changed parameterization, machines can malfunction, which in turn can lead to injuries or death.

- Protect the parameterization (parameter assignments) against unauthorized access.
- Handle possible malfunctions by taking suitable measures, e.g. emergency stop or emergency off.

### 1.2.2 Equipment damage due to electric fields or electrostatic discharge

Electrostatic sensitive devices (ESD) are individual components, integrated circuits, modules or devices that may be damaged by either electric fields or electrostatic discharge.



**NOTICE**

**Equipment damage due to electric fields or electrostatic discharge**

Electric fields or electrostatic discharge can cause malfunctions through damaged individual components, integrated circuits, modules or devices.

- Only pack, store, transport and send electronic components, modules or devices in their original packaging or in other suitable materials, e.g. conductive foam rubber or aluminum foil.
- Only touch components, modules and devices when you are grounded by one of the following methods:
  - Wearing an ESD wrist strap
  - Wearing ESD shoes or ESD grounding straps in ESD areas with conductive flooring
- Only place electronic components, modules or devices on conductive surfaces (table with ESD surface, conductive ESD foam, ESD packaging, ESD transport container).

### 1.2.3 Warranty and liability for application examples

Application examples are not binding and do not claim to be complete regarding configuration, equipment or any eventuality which may arise. Application examples do not represent specific customer solutions, but are only intended to provide support for typical tasks.

As the user you yourself are responsible for ensuring that the products described are operated correctly. Application examples do not relieve you of your responsibility for safe handling when using, installing, operating and maintaining the equipment.



## 1.2.4 Industrial security

---

### Note

#### Industrial security

Siemens provides products and solutions with industrial security functions that support the secure operation of plants, systems, machines and networks.

In order to protect plants, systems, machines and networks against cyber threats, it is necessary to implement – and continuously maintain – a holistic, state-of-the-art industrial security concept. Siemens' products and solutions constitute one element of such a concept.

Customers are responsible for preventing unauthorized access to their plants, systems, machines and networks. Such systems, machines and components should only be connected to an enterprise network or the Internet if and to the extent such a connection is necessary and only when appropriate security measures (e.g. firewalls and/or network segmentation) are in place.

For additional information on industrial security measures that may be implemented, please visit:

Industrial security (<http://www.siemens.com/industrialsecurity>)

Siemens' products and solutions undergo continuous development to make them more secure. Siemens strongly recommends that product updates are applied as soon as they are available and that the latest product versions are used. Use of product versions that are no longer supported, and failure to apply the latest updates may increase customer's exposure to cyber threats.

To stay informed about product updates, subscribe to the Siemens Industrial Security RSS Feed at:

Industrial security (<http://www.siemens.com/industrialsecurity>)

---

Further information is provided on the Internet:

Industrial Security Configuration Manual  
(<https://support.industry.siemens.com/cs/ww/en/view/108862708>)

 **WARNING**

**Unsafe operating states resulting from software manipulation**

Software manipulations (e.g. viruses, trojans, malware or worms) can cause unsafe operating states in your system that may lead to death, serious injury, and property damage.

- Keep the software up to date.
- Incorporate the automation and drive components into a holistic, state-of-the-art industrial security concept for the installation or machine.
- Make sure that you include all installed products into the holistic industrial security concept.
- Protect files stored on exchangeable storage media from malicious software by with suitable protection measures, e.g. virus scanners.
- Protect the drive against unauthorized changes by activating the "know-how protection" drive function.

## 1.2.5 Residual risks of power drive systems

When assessing the machine- or system-related risk in accordance with the respective local regulations (e.g., EC Machinery Directive), the machine manufacturer or system installer must take into account the following residual risks emanating from the control and drive components of a drive system:

1. Unintentional movements of driven machine or system components during commissioning, operation, maintenance, and repairs caused by, for example,
  - Hardware and/or software errors in the sensors, control system, actuators, and cables and connections
  - Response times of the control system and of the drive
  - Operation and/or environmental conditions outside the specification
  - Condensation/conductive contamination
  - Parameterization, programming, cabling, and installation errors
  - Use of wireless devices/mobile phones in the immediate vicinity of electronic components
  - External influences/damage
  - X-ray, ionizing radiation and cosmic radiation
2. Unusually high temperatures, including open flames, as well as emissions of light, noise, particles, gases, etc., can occur inside and outside the components under fault conditions caused by, for example:
  - Component failure
  - Software errors
  - Operation and/or environmental conditions outside the specification
  - External influences/damage
3. Hazardous shock voltages caused by, for example:
  - Component failure
  - Influence during electrostatic charging
  - Induction of voltages in moving motors
  - Operation and/or environmental conditions outside the specification
  - Condensation/conductive contamination
  - External influences/damage
4. Electrical, magnetic and electromagnetic fields generated in operation that can pose a risk to people with a pacemaker, implants or metal replacement joints, etc., if they are too close
5. Release of environmental pollutants or emissions as a result of improper operation of the system and/or failure to dispose of components safely and correctly
6. Influence of network-connected communication systems, e.g. ripple-control transmitters or data communication via the network

For more information about the residual risks of the drive system components, see the relevant sections in the technical user documentation.



## System overview

### 2.1 Structure of a hydraulic drive

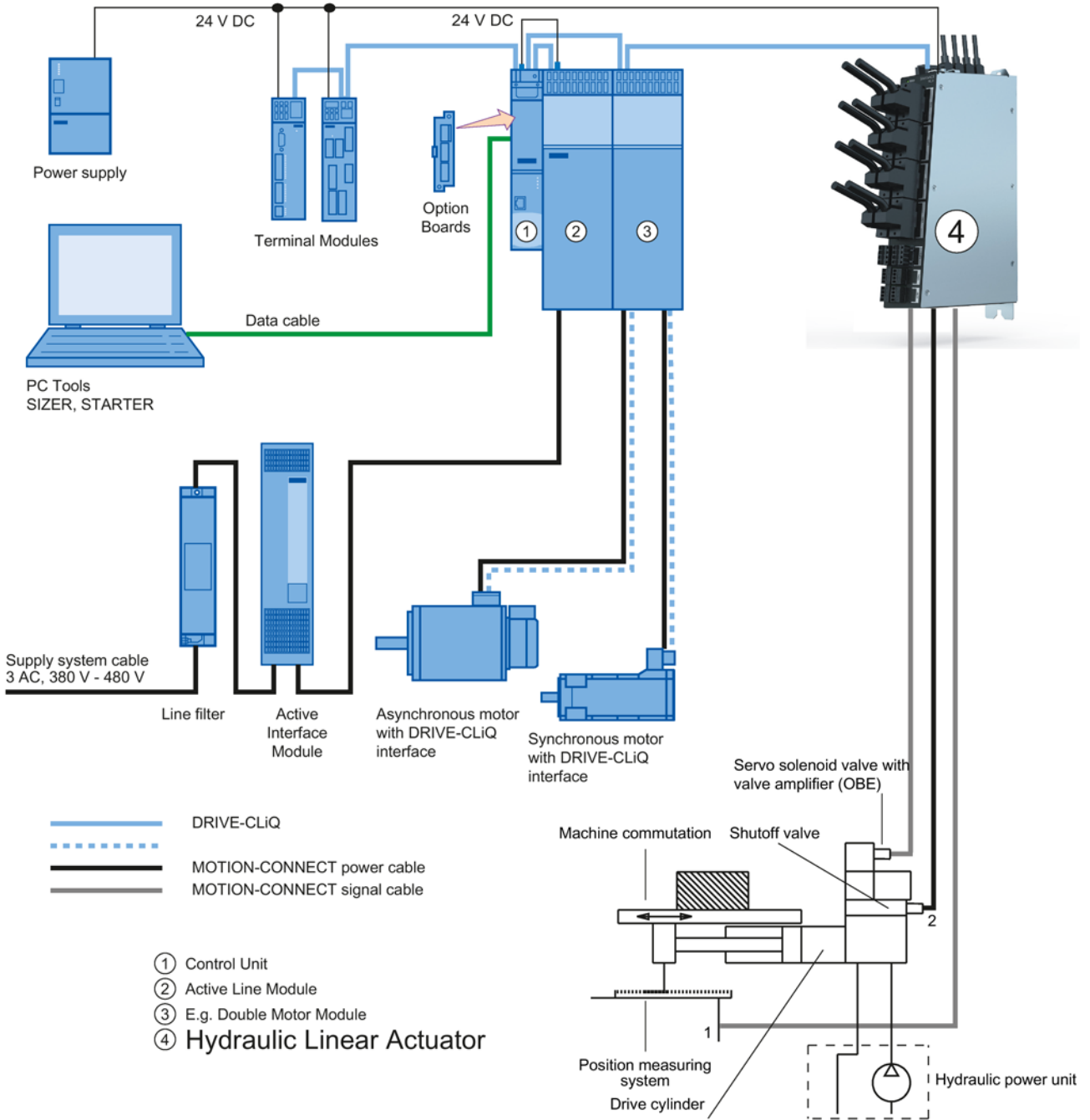

Figure 2-1 Example of a SINAMICS drive system with electrical and hydraulic components

## 2.1 Structure of a hydraulic drive

### 2.1.1 Machine guidance

#### Guidance systems

Guidance for straight-line movement of machine slides and tables is accomplished with minimum friction and maximum precision using hydrodynamic and hydrostatic slideways or roller slideways.

#### Friction

A certain degree of friction can be very useful for damping oscillations.

However, excessive friction, especially pronounced transitions from static to sliding friction, has a negative effect on the control result and impairs control loop stability.

### 2.1.2 Cylinder

#### Design

The cylinder represents the simplest form of a hydraulic linear actuator and can easily be integrated into the machine guidance system. The cylinder normally has a piston rod at one end.

#### Quality criteria

The following are critical quality criteria

- The surface quality of cylinder itself and piston rod
- The seals and guides (low friction, servo quality, ...)

### 2.1.3 Servo solenoid valve

#### Task

The servo solenoid valve is the final controlling element in the control loop and forms the electro-hydraulic converter.

#### Function

The valve continuously converts electrical signals into hydraulic flow.

Its quality is defined by static and dynamic parameters, such as:

- Zero overlap
- Hysteresis
- Frequency limit

### 2.1.4 Valve amplifier

The valve amplifier contains the power electronics for the solenoids in the servo solenoid valve, which the valve spool moves.

The position controller in the valve amplifier (onboard electronics – OBE) controls the position of the valve spool proportionally to the manipulated variable ( $U = -10 \dots +10 \text{ V}$ ).

### 2.1.5 Shutoff valve

Shutoff valves are used to add safety functions to a valve control with servo solenoid valve. Shutoff valves can prevent uncontrolled motion of the cylinder.

Special designs include a sensor for the mechanical position of the valve spool (monitoring for increased safety).

### 2.1.6 Position measuring system

The position measuring system supplies the actual value for the position of the moving machine element.

#### Function

The velocity is acquired by continuously differentiating the distance with respect to time. Various systems are available depending on the level of accuracy required.

Highest accuracy requirements are achieved by digital systems (glass scale with photoelectric evaluation circuit) mounted directly on the machine.

Most digital incremental systems require a reference point approach at the beginning of a machining operation.

### 2.1.7 SINUMERIK / SINAMICS

SINUMERIK control systems and SINAMICS drive systems are specially designed for machine tools, manipulators and special-purpose machines.

The numerical control processes the machine program and converts it into control commands. It also monitors command execution continuously.

The HLA contains the following control structures for the electro-hydraulic control loop and the interfaces:

- To the shutoff valve
- To the servo solenoid valve
- To the position measuring system
- To the pressure sensors
- To the force sensors
- To the central processing unit

The HLA is a part of the SINAMICS S system.

A range of different modules with graded scope of functions is provided to allow the SINUMERIK 840D sl NCU system to address a wide range of functional requirements of machines. This allows optimal adaptation to the machine and machining task, as well as allowing standard machine series to be equipped.

### 2.1.8 Hydraulic power unit

The hydraulic power unit provides the hydraulic energy.

It is installed remotely from the drive axis. Accumulators are employed to compensate for strongly fluctuating hydraulic energy requirements and to minimize the installed power.



## 2.2 SINAMICS S120 HLA module components

### HLA module

The HLA module is a DRIVE-CLiQ component and part of the SINAMICS S120 drive system. The HLA module is designed for use in presses, rotary indexing machines and forming and bending machines, for example.

The HLA module is used in conjunction with a SINUMERIK 840Dsl and a CU320-2 Control Unit, CU-integrated or NX. Closed-loop control for the hydraulic axis (linear axis) is largely performed by the Control Unit. From a topology viewpoint, the HLA module can be considered to be a hydraulic double-axis Motor Module. From a functional viewpoint, the HLA module is more like an option module or a Terminal Module.

### Other SINAMICS components required

Additional SINAMICS components are required to provide the required functions:

- CU320-2 Control Unit, NCU-integrated or NX for processing drive and technology functions
- 24 V power supply

This power supply is used to internally supply the SINAMICS S120 HLA and is also required by the various sensors.

- 26.5 V power supply

This power supply is required for the hydraulic components (servo solenoid valves, shutoff valves, pressure sensors, shutoff valve spool sensors) connected to the SINAMICS S120 HLA.

The SINAMICS S120 HLA is solely intended for installation in a control cabinet.

In addition, the following are required:

- Sensor system connections to expand the functionality and provide various interfaces to sensors.

## 2.3 Comparison of electric and hydraulic drive systems

Table 2- 1 Comparison of electric and hydraulic drive systems

| Criterion                         | Direct electric drive   | Electric drive with leadscrew   | Hydraulic drive   |
|-----------------------------------|---|---|---|
| Power density / space requirement | <ul style="list-style-type: none"> <li>• Low weight</li> <li>• Lower space requirement of the electrical section on the machine table.</li> </ul> | <ul style="list-style-type: none"> <li>• Servomotor and leadscrew large and heavy.</li> <li>• Problematic where mounting space is restricted</li> </ul>                           | <ul style="list-style-type: none"> <li>• Cylinder and servo solenoid valve are light and compact.</li> <li>• The electric motor is shifted to the hydraulic unit</li> </ul>   |
| Moment of inertia of moving parts | Low weight of the electrical section on the machine table   | Servomotor and leadscrew have high moments of inertia   | Piston and piston rod have very low weights   |
| Operational safety, service life  | In principle, the service life only depends on the linear guides  | <ul style="list-style-type: none"> <li>• Shock sensitive</li> <li>• Service life is limited by leadscrew</li> <li>• Sudden failure is possible</li> </ul>                         | <ul style="list-style-type: none"> <li>• Protected against overload through pressure limiting</li> <li>• Sturdy, insensitive to shock</li> <li>• Cylinder seals and valve control edges have long service lives.</li> <li>• Wear warning</li> </ul> |
| Service                           | Simple replacement  | Complex replacement and repair of leadscrew by specialists  | <ul style="list-style-type: none"> <li>• Simple fault diagnostics</li> <li>• Simple replacement and repair of valves and cylinders</li> </ul>   |
| Energy storage                    | Peak requirement must be installed as no storage is possible  | Peak requirement must be installed as no storage is possible  | <ul style="list-style-type: none"> <li>• Compensation of energy requirement peaks using a hydraulic accumulator</li> <li>• Rapid traverse in a differential connection</li> <li>• Reduction of installed power</li> </ul>                           |
| Maximum forces                    | Peak thrust per unit area approx. 40 to 80 kN/m <sup>2</sup>  | High forces are limited   | Practically unlimited (cylinder diameter, p <sub>max</sub> = 700 bar)   |
| Load stiffness                    | Very good; Servo gain (Kv) can be set 10-100 times higher than on the other two drives.   | <ul style="list-style-type: none"> <li>• Elasticity when large forces are involved</li> <li>• Elasticity of leadscrew is largely compensated using closed-loop control</li> </ul> | <ul style="list-style-type: none"> <li>• Oil compressibility is compensated using closed-loop control (I component)</li> <li>• Good zero overlap quality of valve ensures very high load stiffness</li> </ul>                                       |
| Maximum velocity                  | Up to 500 m/min   | $v_{max} = h_s \cdot \omega_{max} / 2\pi$<br>$h_s = \text{pitch}$<br>$\omega_{max} = \text{maximum motor speed}$  | 30 ... 300 m/min (depending on the cylinder sealing set)  |
| Maximum traversing distance       | Unlimited   | ≤6 m  | ≤3 m  |
| Collision protection              | Mechanically difficult  | Mechanically possible   | Mechanically possible   |

## 2.3 Comparison of electric and hydraulic drive systems

| Criterion                          | Direct electric drive           | Electric drive with leadscrew               | Hydraulic drive   |
|------------------------------------|---------------------------------|---|---|
| Noise                              | Linear guide noise in operation | Servomotor and leadscrew noise in operation | <ul style="list-style-type: none"> <li>Possible noise caused by flow through the valve</li> <li>Pump noise of the hydraulic unit</li> </ul> |
| Acceleration characteristics       | Maximum 45 g                    | Maximum 1 g                                 | Maximum 2 g   |
| Drive cooling                      | Absolutely essential            | Only required at high speeds                | Required in some cases, only in the unit  |
| Sensitivity to ferromagnetic swarf | High                            | Low   | Low   |

Table 2- 2 Analogy of characteristic values

| Electrical            | Hydraulic                           |
|-----------------------|-------------------------------------|
| Speed                 | Speed                               |
| Velocity              | Velocity                            |
| Current               | Flow rate                           |
| DC link voltage       | System pressure                     |
| Power                 | Flow rate valve pressure difference |
| Transistor/power unit | Valve                               |
| Motor                 | Drive cylinder                      |

## 2.4 System data

### 2.4.1 Climatic and mechanical environmental conditions in operation

---

**Note**

The following information refers to the electrical section of the HLA module, however, not to external hydraulic components.

---

#### Climatic environmental conditions

If the specified values cannot be maintained, then a heat exchanger or air conditioner must be provided.

Table 2-3 Environmental conditions

|  |  |
|--|--|
| Degree of protection                         | IP20 according to EN 60529   |
| <b>Climatic environmental conditions</b>     |  |
| Long-term storage in the transport packaging | Class 1K4 according to EN 60721-3-1<br>Temperature: -25°C ... +55°C  |
| Transport in the transport packaging         | Class 2K4 according to EN 60721-3-2<br>Temperature: -40°C ... +70°C  |
| Operation                                    | Temperature: 0 ... +55 °C <sup>1)2)</sup><br>Relative humidity: 5 ... 95 %<br>Oil mist, salt mist, ice formation, condensation, dripping water, spraying water, splashing water and water jets are not permitted |

1) Current derating above 40 °C at the output of the servo solenoid valve

2) At altitudes exceeding 1500 m above sea level, the upper temperature limit must be reduced by 3.5 °C / 500 m.

#### Mechanical environmental conditions

Classification using 3M1 according to IEC 60721-3-X.

---

**Note**

The limit values (test values) listed in the standards are not permissible as continuous load.

---

## 2.4.2 Transport and storage conditions

### Originally packaged modules

The following data applies to modules in their original packaging.

Table 2- 4 Climatic conditions

| Function                | Remark  | Value                            |
|-------------------------|---|----------------------------------|
| Temperature range       | Lower temperature limit   | -25 °C                           |
|                         | Upper temperature limit   | +55 °C                           |
| Relative air humidity U | No rain, no condensation, no spray water, no formation of ice, no salt mist | 5 ... 95 %                       |
| Condensation            | Regarding condensation, the following conditions may apply simultaneously   | Seldom, brief, slight            |
|                         | Max. condensation period  | 3 hours                          |
|                         | Frequency of condensation   | Annual average: 3<br>Maximum: 10 |
|                         | Shortest sequence of condensation cycles                                    | 1 day                            |
| Temperature change      | Within one minute   | 0.5 K                            |
|                         | Within one hour   | 30 K                             |

## 2.4.3 Environmental conditions

### Relevant standards

- Contaminants: Class 3C1 according to EN 62477-1 or IEC 61800-2 draft (referred to 2013).
- It is only permissible to operate the device in rooms/areas with degree of pollution 2 (according to EN 61800-5-1).
- If the HLA module is operated in rooms/areas with levels of dust that could impair the functionality, it must be operated in a cabinet with a heat exchanger or in a cabinet with a suitable air intake.



# Configuration

## 3.1 Configuring steps

### 3.1.1 Procedure for the electrical configuring

The procedure for configuring an HLA is divided into steps in such a way that the user is guided through the full range of relevant settings, from the required force, to the hydraulic components, and finally the HLA and its sensor evaluation functions. This initial configuring phase may be followed by a second in some cases, in which the corresponding circuit recommendations and EMC measures are taken into account.

The functions of SINAMICS components are described with keywords in this manual. Limit values for functions may be specified in some cases.

Please refer to the SINAMICS S120 and SINUMERIK 840Dsl commissioning instructions for additional details (e.g. characteristics).

#### Phase 1

1. Selecting the hydraulic components
2. Selecting and dimensioning the power supply
3. Selecting and dimensioning the closed-loop control components
4. Selecting and dimensioning the position sensing (measuring system)

#### Phase 2

1. Circuit recommendations relating to EMC measures
2. Block diagrams/connection diagrams
3. Abbreviations, terms and index

### 3.1.2 Procedure for configuring the hydraulics

The hydraulic configuring phase is divided into the following steps:

1. Selecting the cylinder  
Based on the required forces and velocities required and the cylinder mounting conditions in the machine
2. Selecting servo solenoid valves  
Based on the cylinder data, forces, velocities and the dynamic requirements
3. Selecting the position measuring system and possibly the pressure sensors  
With reference to the measuring range, precision and linearity
4. Selecting and dimensioning the drive unit  
Taking into account all of the loads
5. Determining the natural frequency of the drive  
For the first estimate regarding the feasibility of the expected control results
6. Dynamic drive simulation  
In difficult cases, it may be worthwhile carrying out a dynamic simulation of the drive to support the configuring process.

## 3.2 Integration in SINUMERIK/SINAMICS S120

SINAMICS HLA is supported from the following SINAMICS firmware versions and higher:

- |             |                                   |
|-------------|-----------------------------------|
| Standalone  | from V4.7 and higher with CU320-2 |
| Drive based | from V4.7 SP1 with SINUMERIK      |



## 3.3 Configuring the hydraulics

### 3.3.1 Cylinder selection

#### Piston and rod diameters

The piston and rod diameters are calculated according to Pascal's theorem on the basis of the necessary compressive and tensile forces  $F$  and a standard pressure value of  $p = 40$  bis  $100$  bar for machine tools (a maximum pressure of  $350$  bar is permitted).

$$p = \frac{F}{A}$$

The force value calculation must include friction and acceleration forces as well as the actual feed force. Pistons and rods with the following standard diameter dimensions are available:

Table 3- 1 Typical cylinder data

| Designation            | Diameter        |    |    |    |    |    |    |     |
|------------------------|-----------------|----|----|----|----|----|----|-----|
|                        | Piston diameter | 25 | 32 | 40 | 50 | 63 | 80 | 100 |
| Rod diameter, standard | 12              | 14 | 18 | 22 | 28 | 36 | 45 | 56  |
| Rod diameter, optional | 18              | 22 | 28 | 36 | 45 | 56 | 70 | 90  |

#### Stroke length

The stroke is identical to the working stroke of the drive except that it includes a few additional safety reserves.

### Mounting

In order to ensure good control quality, backlash-free mountings, e.g. base or flange mountings, must be used.

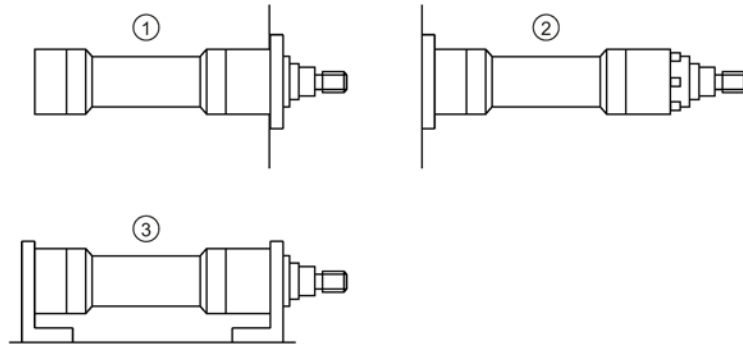

Flange mounting

- ① Flange at front
- ② Flange at rear
- ③ Foot mounting

Figure 3-1 Cylinder mounting

### Mounting position

The mounting position depends on the actual machine situation, and influences the choice of shutoff valves. Vertical loads must be secured using poppet (face) valves. Forces due to weight must be taken into account in the final calculation of the operating pressure (p0344).

Possible cylinder mounting position, see "Figure 5-19 Mounting position of the drive referred to the A side (Page 184)".

### Seal, friction

Suitable seals must be used to minimize friction. Transitions from static (stiction) to sliding friction have a particularly adverse effect on the control result.

The slide guide friction must be added to the cylinder friction.

### Cylinder pipes

The distance between the cylinder and servo solenoid valve must be kept as short as possible for the sake of the drive's natural frequency (compressibility of the oil volume). In ideal cases, the servo solenoid valve is flange-mounted directly on the cylinder.

### Position measuring system

The incremental and absolute position measuring systems supported by the HLA module are mounted on the machine slides. It is also possible to use position measuring systems (SSI encoders) integrated in the cylinder.

## 3.3.2 Selection of servo solenoid valves

### Overview of valve types

The HLA supports servo solenoid valves with integrated electronics (OBE) as well as third-party valves. The drive is automatically parameterized when the article number is entered. The valve parameters can also be manually entered.

A valve is selected for a particular application based on the subsequently described criteria.

### Servo solenoid or HR servo solenoid valves

HR servo solenoid valves set themselves apart as a result of their higher dynamic performance, i.e. a higher frequency limit when compared to servo solenoid valves. They respond with greater sensitivity to setpoint changes especially in the very low signal range. The use of HR servo solenoid valves is recommended in the following cases:

- When extremely high contour precision is required in high-speed continuous-path control machining operations.
- When very high response sensitivity is required to achieve the best possible positioning accuracy.

### Valve size

The valve size is determined by the maximum flow rate  $Q_x$ . This maximum flow rate is calculated according to the fluid flow law:

$$Q_x = v \cdot A$$

$v$ : Maximum drive velocity for extension and retraction

$A$ : associated cylinder surface area

The calculated maximum flow rate must not exceed the valve operating limit. The valve operating limit is generally specified in the catalog by the valve manufacturer.

Within the valve operating limit, the flow rate that can be achieved with the valve is calculated as follows:

$$Q = Q_{\text{nenn}} \cdot \sqrt{\frac{\Delta p}{\Delta p_{\text{nenn}}}}$$

In practice, the cylinder velocities that can actually be achieved depend on the operating pressure, the load pressure and flow-specific characteristics of the drive. The dimensioning is the responsibility of the hydraulic application engineer, who has access to a number of design calculation and simulation programs.

### Flow rate characteristic, linear/with transition point

Valves with either a linear characteristic or with transition point characteristic can be selected. Valves with a characteristic with a transition point are suitable for obtaining a higher resolution in the low signal range (machining) and sufficient flow rate in the high signal range (rapid traverse).

The definition of the transition point position as 40 % or 60 % means that only 10% of the nominal opening cross-section (nominal flow rate) is released for 40 % or 60 % of the nominal control signal (i.e. at  $U=4\text{ V}$  or  $6\text{ V}$ ).

The valve characteristic with transition point must be linearized in the HLA module to adapt it to the closed-loop control of the entire drive (cylinder).

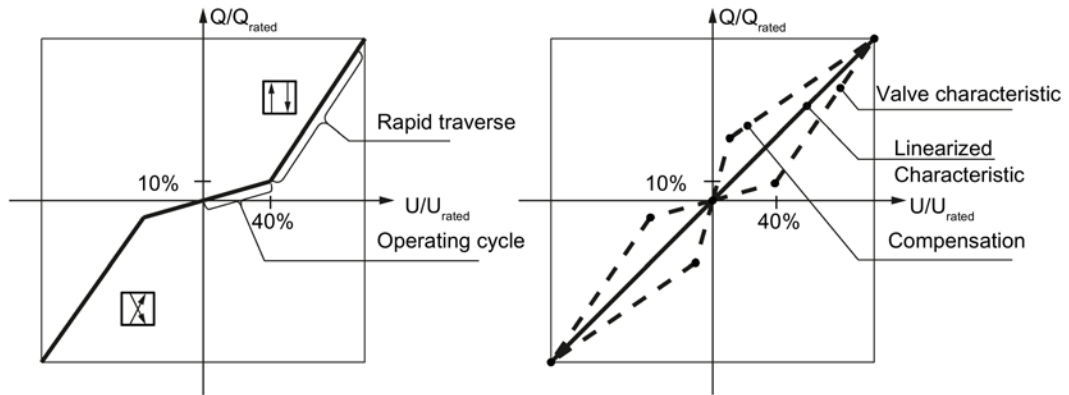

Figure 3-2 Diagram of a servo solenoid valve characteristic with transition point and its compensation in the HLA module

---

#### Note

##### Recommended selection

Servo solenoid valves are generally recommended for applications where there is a clear separation between machining operation and rapid traverse.

---

### Asymmetrical flow rate characteristic

It is a good idea to use valves with asymmetrical restriction cross-sections for differential cylinders or for cylinders that are not arranged horizontally and move large loads.

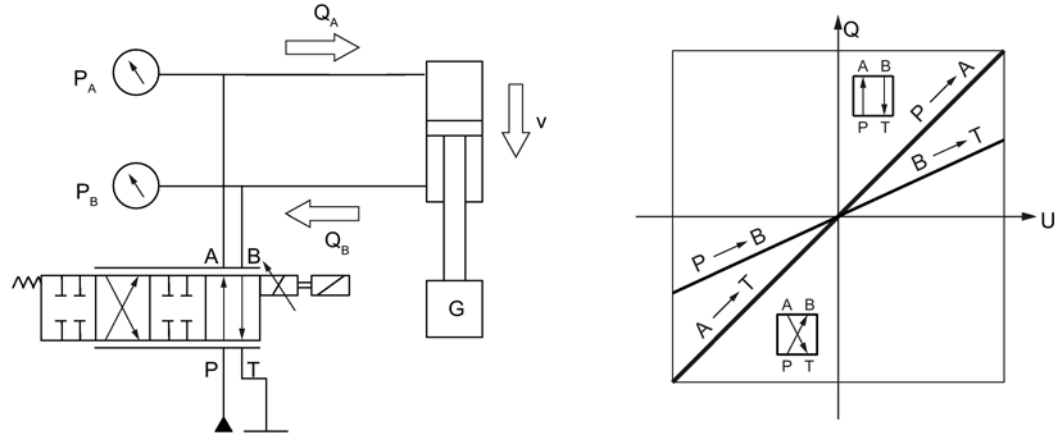

Figure 3-3 Asymmetrical characteristics

### Fail-safe position

Directly-controlled servo solenoid valves have a fail-safe position, i.e. the control spool moves to a safe position when the valve is disconnected from the power supply. The fail-safe position is either "closed" (A, B, P, T disabled) or "open" (A, B and T connected and P disabled). It should be noted that the "crossover" switching position must be passed through when the valve is switched on and off, and there can be temporary responses from the cylinder at these instants in time. Separate shutoff valves are therefore required in order to implement safety functions, such as a safety-related cylinder stop.

Precontrolled servo solenoid valves, precontrolled HR servo solenoid valves and directly-controlled HR servo solenoid valves do not have a fail-safe position and thus do not have a safe basic position when switched off. Any safety functions must therefore be implemented via separate shutoff valves.

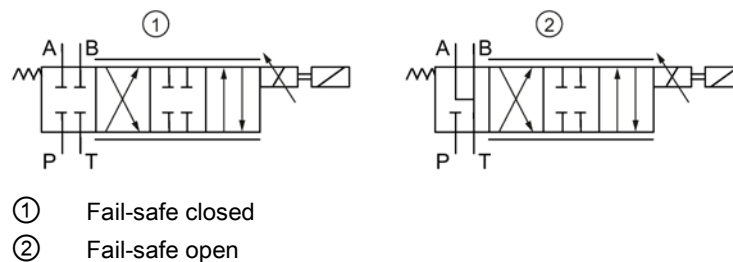
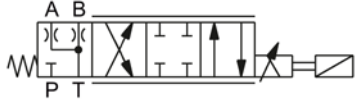
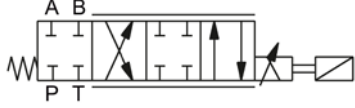
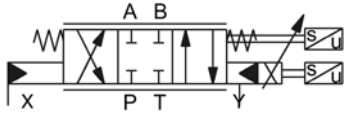
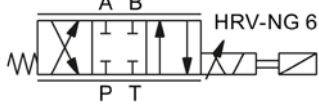

Figure 3-4 Fail-safe position in the valve symbol

Symbols, servo solenoid valves

| Symbol  | Designation  |
|---|--|
|  | Directly controlled servo solenoid valve NG 6, open    |
|  | Directly controlled servo solenoid valve NG 6, closed  |
|  | Precontrolled servo solenoid valve NG 10               |
|  | Directly controlled HR servo solenoid valve NG 6, open |

### 3.3.3 Selection of shutoff valves

#### General

The shutoff valves are automatically enabled and disabled in the correct switching sequence by the HLA module.

#### Start precondition

When using safety functions, only safe shutoff valves with at least 1 feedback signal are permitted.

The hydraulic pressure must be available before the system is switched on.

In the event of sudden failure (e.g. broken cable) of the external 26.5 V supply, the energy storage capacitor for each axis on the HLA module provides energy to supply the servo solenoid valve until such time as the pressure supply for a configured shutoff valve is switched off. Note the following boundary conditions when selecting the valves:

- The energy content of the storage capacitors is dependent on:
  - The tolerances of the capacitors
  - The voltage level of the external supply
  - The charging time of the integrated capacitors (instant of voltage failure)
- The available response time is mainly defined by:
  - The power required for the actual machining step
  - The response time of the shutoff valves
  - The shutdown voltage threshold of the servo solenoid valves

|   |
|---|
|  <b>WARNING</b>  |
| <b>Failure of the external 26.5 V power supply</b>  |
| A failure of the external power supply when the energy content of the storage capacitors is too low can cause the shutoff valves to remain open. This can lead to critical situations that may result in death or serious injury. |
| <ul style="list-style-type: none"><li>• The machine manufacturer must verify the interaction between valves, making allowance for all tolerances in the controlled system.</li></ul>  |

**Principle of operation**

For the HLA module, the STO safety function corresponds to shutting off a safety-relevant shutoff valve.

The figure below shows the interconnection of a shutoff valve (based on the example of one axis) and the most important elements for its operation and testing:

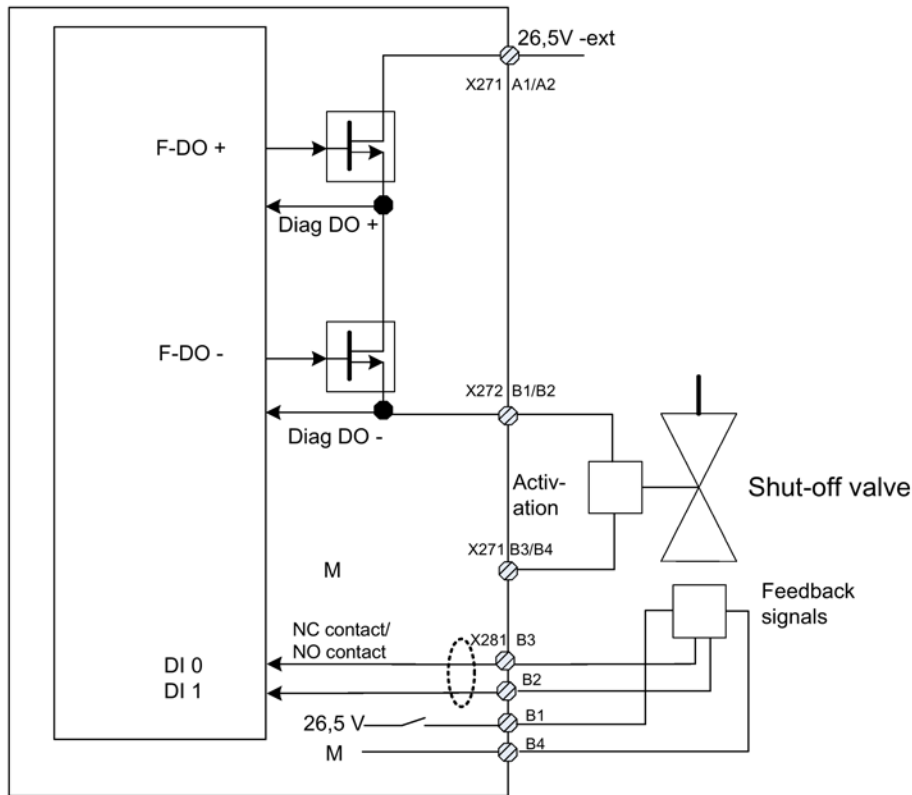

Figure 3-5 Interconnection of the shutoff valve

The shutoff valve controls the infeed to the hydraulic circuit. The shutoff valve is controlled via an F-DO of the HLA module, which in turn is monitored by the safety functions.

The F-DO has the following properties:

- The F-DO is designed to be P/P switching
- The F-DO+ is an FET, the F-DO- is a semiconductor switch with an additional short-circuit protection function
- The voltages behind the two switches can be read in by the software (digital) and evaluated for the purposes of diagnosing the shut-off path (diagnostics signals Diag DO+ and Diag DO-).

Every time STO is selected/deselected, the F-DO undergoes a dynamization process (check of Diag DO+ and Diag DO- when switching F-DO+ and F-DO-).



The following control and test sequence applies:

| Release the shutoff valve | Step | F-DO + | F-DO - | Diag DO + | Diag DO - | Step | Close the shutoff valve |
|---------------------------|------|--------|--------|-----------|-----------|------|-------------------------|
|                           | 1    | 0      | 0      | 0         | 0         | 3    |                         |
|                           | 2    | 1      | 0      | 1         | 0         | 2    |                         |
|                           | 3    | 1      | 1      | 1         | 1         | 1    |                         |

The Diag DO signals are checked cyclically by the safety functions in both monitoring channels. To do so, the HLA module of the Control Unit provides the Diag DO signals via DRIVE-CLiQ.

The following faults are output in the event of an error:

- F01632 SI HLA channel 1: shutoff valve control/feedback signal error
- F30632 SI HLA channel 2: shutoff valve control/feedback signal error

The following may be possible causes of a fault:

- Shutoff valve either not connected or not correctly connected (X271, X272)
- Feedback signal of the shutoff valve either not connected or not correctly connected (X281, X282)
- p9626 (channel 1) or p9826 (channel 2) incorrectly set
- Shutoff valve defective
- HLA module defective

### 3.3.4 Natural frequency of the hydraulic drive

#### Controlled system gain

The possible controlled system gain is essentially determined by the natural frequency  $\omega_0$  of the cylinder and its load, as well as the frequency limit of the servo solenoid valve  $\omega_v$ .

The cylinder and its load constitute a spring/mass damping system whose natural frequency is calculated using the following formula:

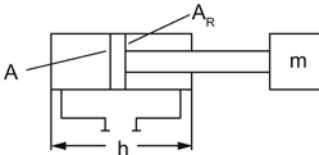
$$\omega_0 \sim \sqrt{\frac{4 \cdot E \cdot A}{m \cdot h} \left( \frac{1 + \alpha}{2} \right)}$$

- Where:
- E = modulus of elasticity [N/m<sup>2</sup>]
  - A = piston surface area [m<sup>2</sup>]
  - A<sub>R</sub> = ring surface area [m<sup>2</sup>]
  - α = surface area relationship A<sub>R</sub>/A
  - h = stroke [m]
  - m = weight [kg]

Oil volumes in the cylinder pipes must also be taken into account.

The minimum natural frequency only occurs at a certain position around the middle and increases as the end positions are approached.

After you have entered the HLA parameters, the HLA module automatically calculates the natural frequency of the hydraulic drive, which is then taken into account in the controller.

The dynamic response of the servo solenoid valves depends on the amplitude of the valve modulation. For valves that are used in controlled axes, the natural frequency is typically determined for a modulation amplitude of "10% and a phase offset of -180°. The relevant information is specified in the valve manufacturer's catalog.

For precontrolled servo solenoid valves, the dynamic response is determined by the precontrol pressure  $p_{pre}$  in addition to the valve type:

$$f_0 \sim \sqrt{p_{vor}}$$

Servo valves can reach corner frequencies of up to 1000 Hz, but are very sensitive to pollution.

**Overview of important parameters (see SINAMICS S120/S150 List Manual)**

- p0310[0...n] Cylinder piston diameter
- p0311[0...n] Cylinder piston rod diameter A side
- p0312[0...n] Cylinder piston rod diameter B side
- p0313[0...n] Cylinder piston stroke
- p0314[0...n] Cylinder dead volume A side
- p0315[0...n] Cylinder dead volume B side
- p0341[0...n] Cylinder mass
- p0343[0...n] Valve/cylinder configuration
- p0344[0...n] Cylinder mounting position A side
- p0345[0...n] Required damping controlled axis
- p0346[0...n] Line length A side
- p0347[0...n] Line length B side
- p0348[0...n] Internal line diameter
- p0351[0...n] Piston position natural frequency minimum
- p0352[0...n] Axis natural frequency A side
- p0353[0...n] Axis natural frequency center
- p0354[0...n] Axis natural frequency B side

### 3.3.5 Hydraulic power unit

The hydraulic power is supplied by a hydraulic power unit installed separately or integrated in the machine. The power unit is individually configured to meet the requirements of all hydraulic loads. The following individual factors are of particular importance:

- Pressure p
- Flow rate Q
- Drive power P
- Pump type
- Filtration
- Cooling

#### Pressure p

The pressure is determined from the cylinder geometry, hydraulic characteristics of the servo solenoid valve and other data such as load forces and flow resistance values in the hydraulic circuit due to the drive speeds and forces required. The standard value for the system pressure for machine tool feed drives is around 40 ... 100 bar.

#### Flow rate Q

The maximum flow rate is calculated from the rapid traverse velocity.

If several cylinders are operating simultaneously, the sum of all loads must be taken into account.

Maximum flow is often reached for only brief periods and can be supplied by an accumulator.

The pump capacity is selected to satisfy the mean flow rate.

#### Drive power P

The power P output by the electric motor to drive the pump is calculated as the product of pressure p, flow rate Q and efficiency  $\eta$ .

$$P = p \cdot Q \cdot \eta$$

#### Pump type

Variable displacement pumps with pressure regulators in combination with an accumulator are generally employed in order to prevent power losses and to match the energy supply to the fluctuating flow rate required during the cycle.

## Filtration

Classic servo valves with fluid converters as initial stages are extremely sensitive to pollution. However, even the control edges of modern servo solenoid valves require filtration.

To ensure general operational reliability, but more importantly, to protect the control edges against premature erosion and to maintain the quality of zero overlap, the oil pollution must be limited in compliance with Class 7 to 9 according to NAS 1638.

This is achieved by using for instance full flow filters, which must be located in the pressure line directly upstream of the servo solenoid valve.

Commissioning is the most critical phase, as pollution frequently results in failures. For this reason, it is advisable to purge the system before the servo solenoid valves are fitted.

## Cooling

Since considerable power losses occur when the flow is throttled using the control edges on the valve, which cannot be compensated for solely through heat radiated from the oil reservoir, additional oil/air or oil/water heat exchangers must be provided in most cases.

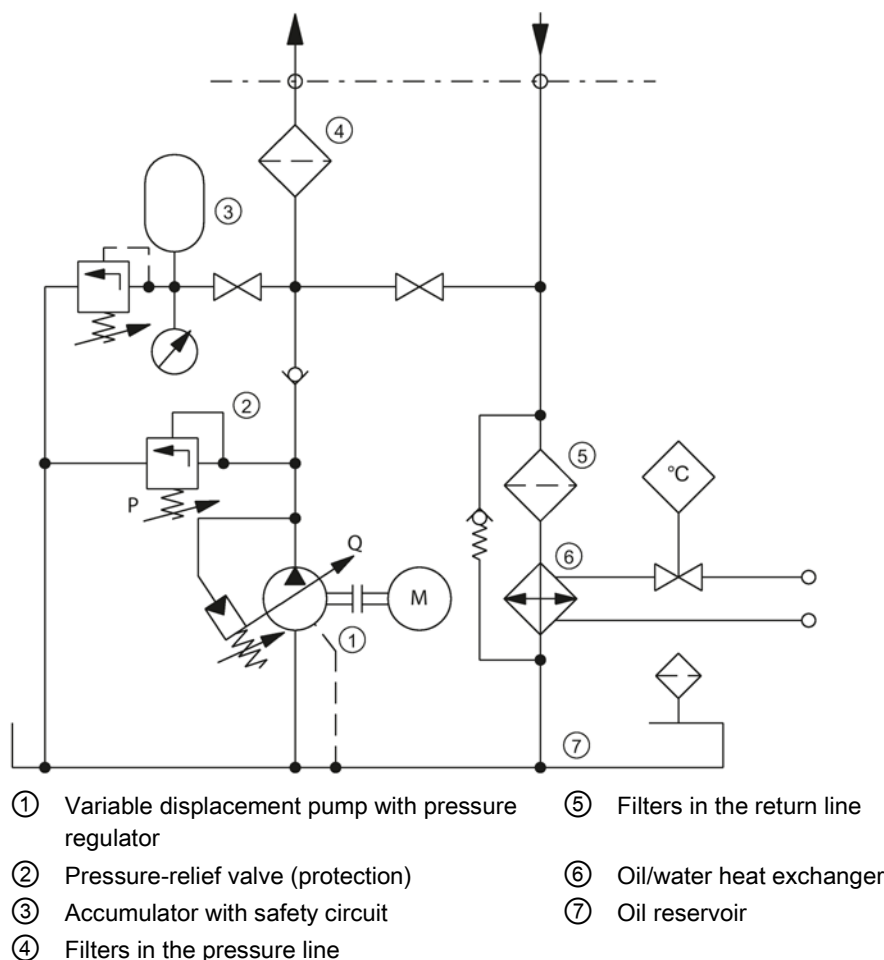

Figure 3-6 Overview of a typical hydraulic power unit

### 3.4 Interconnection

#### 3.4.1 24 V power supply for the electronics

---

**Note**

Only use power supplies that provide SELV (Safety Extra Low Voltage) or PELV (Protective Extra Low Voltage) output voltages for all connections and terminals of the electronics modules.

---

The 24 V power supply for the electronics is required for the following components:

- Internal electronics
- Supplying DRIVE-CLiQ encoders
- Supplying SSI and TTL encoders

**NOTICE**

**Overvoltage**

For overvoltages exceeding 35 V (even briefly) there is the risk that the internal overvoltage protection will respond, the internal fuse ruptures – and therefore the module becomes defective.

- Make sure that you take into account the specified voltage limits.

#### Characteristic values

|                     |                     |  |
|---------------------|---------------------|--|
| Voltage             |                     | 24 V DC (20.4 V to 28.8 V) (24 V -15 %+20 %) |
| Current consumption | with 2 TTL encoders | max. 0.5 A                                   |
|                     | with 2 SSI encoders | max. 0.9 A                                   |
|                     | with 2 DQ encoders  | max. 1.1 A                                   |

## 3.4.2 26.5 V power supply for the hydraulics

### Requirements

---

#### Note

Only use power supplies that provide SELV (Safety Extra Low Voltage) or PELV (Protective Extra Low Voltage) output voltages for all connections and terminals of the electronics modules.

---

This power supply is used to switch and supply the following hydraulic components via the closed-loop control:

- Servo solenoid valves
- Pressure sensors
- Shutoff valves
- Valve spool sensors of shutoff valves

Primary-clocked regulated power supplies must be used as a result of the specified voltage tolerance and the high currents.

#### Current consumption

Approx. 0.2 A intrinsic current demand + external loads (servo solenoid valve, shutoff valve + valve spool sensor, pressure sensors)

- Other requirements placed on the external 26.5 V supply:
  - Voltage range 26.5 V  $\pm$ 2 % (26.0 V ... 27.0 V)
  - Ripple 265 mVpp
  - No interruptions/dips

Brief interruptions/dips on the 26.5 V power supply are also not permitted, as otherwise an internal undervoltage will be detected resulting in shutdown.

|   |
|---|
| <b>NOTICE</b>   |
| <b>Overvoltage</b><br>For overvoltages exceeding 35 V (even briefly) there is the risk that the internal overvoltage protection will respond, the internal fuse ruptures – and therefore the module becomes defective. <ul style="list-style-type: none"><li>• Make sure that you take into account the specified voltage limits.</li></ul> |



The voltage tolerance is required at the module terminals: At higher currents, significant voltage drops can occur across the P and M feeder cables. This is the reason that the cables must be kept as short as possible and very large cross-sections must be used. Alternatively, a power supply with remote sense terminals to compensate the voltage drop along the feeder cables can be used.

Just a few 100 mV below the 26.0 V, the internal monitoring function identifies an undervoltage condition; the shutoff valves represent an upper limit as they can be thermally overloaded for higher voltages.

### 3.4.3 Grounding concept/Electromagnetic compatibility (EMC)

The maximum power loss of the SINAMICS S120 HLA in the control cabinet is approx. 12 W.

In the HLA module, the M input of the 24 V power supply (X224), the M input of the 26.5 V power supply as well as the internal ground are connected with one another and to the enclosure.

The switch-on and switch-off sequence of the 24 V electronics power supply and the 26.5 V power supply for the hydraulics is in principle arbitrary; however, naturally various responses are obtained depending on the sequence.

Taking into account the current load capacity and the voltage tolerances, the electronics in the HLA module can also be supplied from the 26.5 V power supply; however, frequently this does not make sense as a result of the cable routing and/or the voltage drops.



# Commissioning

## 4.1 Commissioning overview

### Commissioning with SINUMERIK Operate

You commission SINAMICS HLA devices using SINUMERIK Operate. A brief overview of the commissioning steps is provided in the following section.

- Configuration - hydraulic module (Page 56)
- Configuration - valve selection (Page 57)
- Configuration - valve data (Page 58)
- Configuration - save valve data (Page 59)
- Configuration - cylinder data (Page 60)
- Configuration - supply data (Page 61)
- Configuration - connection data (Page 62)
- Configuration - calculations (Page 63)
- Configuration - Encoder assignment (Page 65)
- Configuration - encoder 1 ... 3 (Page 67)
- Configuration - control mode/setpoints (Page 68)
- Configuration - BICO interconnection (Page 70)
- Configuration - summary (Page 72)
- Overviews (Page 73)
- Importing valve lists (Page 81)
- Importing valve lists (Page 81)

---

#### Note

Using the expert list, the STARTER commissioning tool can also provide support when commissioning HLA devices.

---

#### Note

The response of the SINAMICS HLA can manifest slight differences, depending on whether you operate the HLA with a CU320-2 or SINUMERIK.

---

## 4.2 Configuration - hydraulic module

The article number and code number of the hydraulic module are displayed in this dialog.

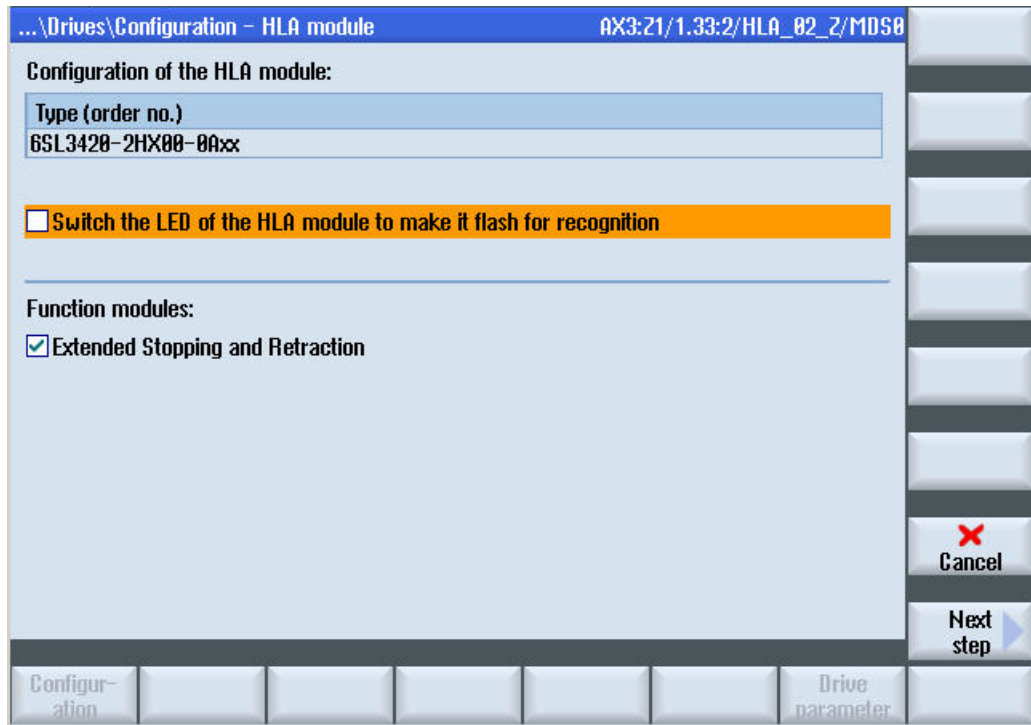

Figure 4-1 Configuration - HLA module

- If you activate the option "LED of the HLA module to flash for recognition", the selected HLA module will flash red-green. In this way, you can identify the selected HLA module in the control cabinet.
- You can activate the displayed objects in the "Function modules" area.

## 4.3 Configuration - valve selection

You select the method of entering valve data under "Valve selection".

### Note

There is no data in this list in the factory setting. However, you can import valve lists (e.g. from 840D Powerline); see Chapter "Importing valve lists (Page 81)".

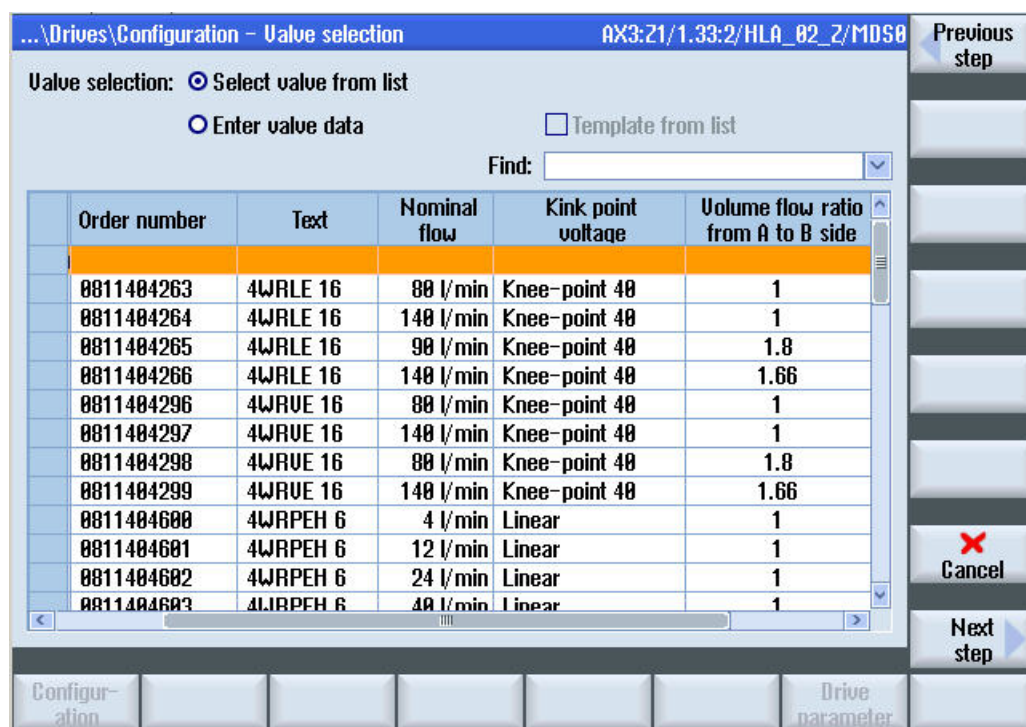

Figure 4-2 Configuration - valve selection

For the "Select valve from list" option, the selection list for valve configuration is displayed.

Select the appropriate valve. The valve data are transferred. The "Valve data" dialog box is skipped.

For the "Enter valve data" option, the selection list to configure a valve is not displayed. The valve selection list is displayed again if you activate the checkbox "Template from list". You can preassign the data of the selected valve in the "Valve data" dialog.

Using the combo box "Search" you can restrict the drop-down list of valves using a free text filter. While entering a search text, the list is updated with each keystroke. The combo box contains such texts previously used.

Using the "Manipulated variable inversion" option, you can invert the output voltage of the hydraulic module. The output voltage of the hydraulic module is the input voltage of the valve.

## 4.4 Configuration - valve data

You edit the valve data in this dialog.

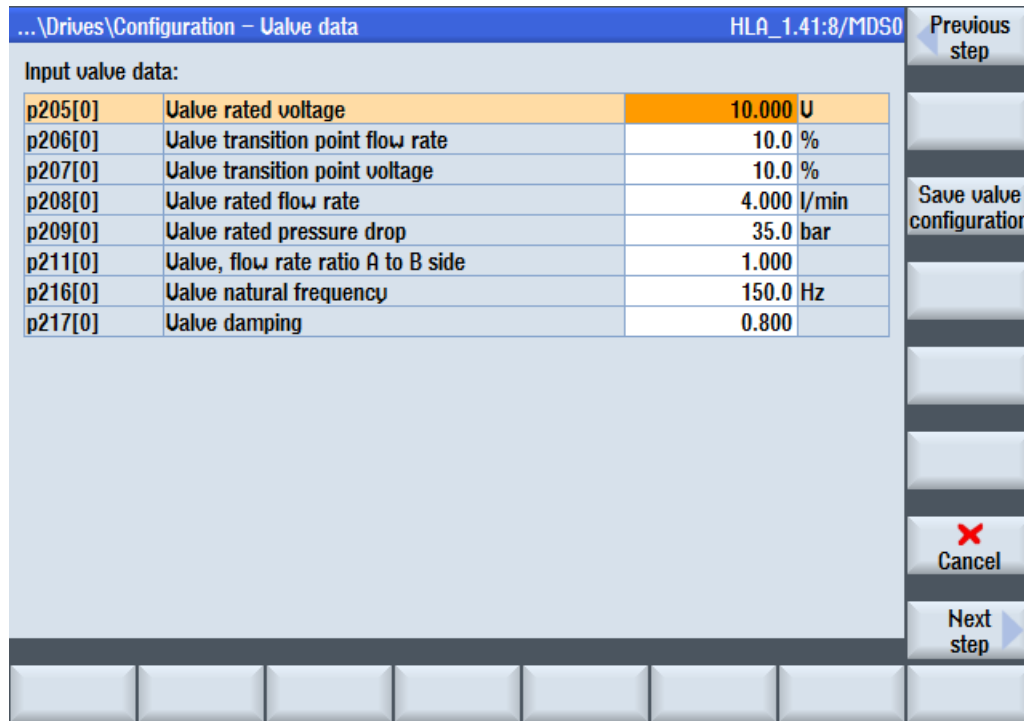

Figure 4-3 Configuration - valve data

Using the "Save valve config." softkey you open the "Save valve data" dialog. You can enter additional data in this dialog.

### Overview of important parameters (see SINAMICS S120/S150 List Manual)

- p0205[0...n] Valve rated voltage
- p0206[0...n] Valve transition point flow rate
- p0207[0...n] Valve transition point voltage
- p0208[0...n] Valve rated flow rate
- p0209[0...n] Valve rated pressure drop
- p0211[0...n] Valve flow rate ratio A to B side
- p0216[0...n] Valve natural frequency
- p0217[0...n] Valve damping

## 4.5 Configuration - save valve data

Additional valve data are entered in this dialog.

Figure 4-4 Configuration - save valve data

The "Valve number" entry field is preassigned the next free valve number. The valve is uniquely identified based on the valve number. You can also enter your own valve number. If you enter an already assigned valve number, you will be asked whether the data of the existing valve should be overwritten.

The valve number is not saved in the drive. As SINAMICS does not support a valve code, the valve number is only of significance for the user interface; for example, you can search for valves in the valve list based on the valve number.

You can enter any text in the entry fields "Manufacturer", "Article number", and "Designation".

The data is accepted when you press the "OK" softkey. You then return to the "Valve data" dialog.

## 4.6 Configuration - cylinder data

In this dialog, you enter the cylinder data and define the safety circuit for the cylinder.

... \Drives\ Configuration - Cylinder data      AX3:21/1.33:2/HLA\_02\_2/MDS0

Input cylinder data:

|         |                                     |                     |
|---------|-------------------------------------|---------------------|
| p310[0] | Cylinder piston diameter            | 57.0 mm             |
| p311[0] | Cylinder piston rod diameter A side | 50.0 mm             |
| p312[0] | Cylinder piston rod diameter B side | 50.0 mm             |
| p313[0] | Cylinder piston stroke              | 148.5 mm            |
| p314[0] | Cylinder dead volume A side         | 6.0 cm <sup>3</sup> |
| p315[0] | Cylinder dead volume B side         | 6.0 cm <sup>3</sup> |

Manipulated variable inversion

Safety circuit:

Close shutoff valve for power inhibit (PI)

Shutdown control valve supply for power inhibit (PI)

Valve feedback signal available

Invert valve feedback signal

Note:  
 Valve position setpoint locked at 0 when servo solenoid valve switched on. If the option 'Close shut-off valve with disabled power' is not selected, the drive may drift.

Previous step

Cancel

Next step

Configur-ation      Drive parameter

Figure 4-5 Configuration - cylinder data

In this dialog, you enter the cylinder data and define the safety circuit that is used.

### Overview of important parameters (see SINAMICS S120/S150 List Manual)

- p0310[0...n]      Cylinder piston diameter
- p0311[0...n]      Cylinder piston rod diameter A side
- p0312[0...n]      Cylinder piston rod diameter B side
- p0313[0...n]      Cylinder piston stroke
- p0314[0...n]      Cylinder dead volume A side
- p0315[0...n]      Cylinder dead volume B side

## 4.7 Configuration - supply data

In this dialog, you define the parameters of the "supply unit" and define for which drive objects the supply unit is to be used.

... \Drives\ Configuration - Supply data AX3:Z1/1.33:2/HLA\_02\_2/MDS0

Input data of supply unit:

|         |                                     |             |
|---------|-------------------------------------|-------------|
| p220[0] | Hydraulic oil modulus of elasticity | 14000.0 bar |
| p221[0] | System pressure                     | 105.0 bar   |
| p222[0] | Valve precontrol pressure           | 0.0 bar     |

Previous step

Cancel

Next step

Configur- ation Drive parameter

Figure 4-6 Configuration - supply data

Enter the parameters of the supply unit here.

## 4.8 Configuration - connection data

You can configure the following connection data:

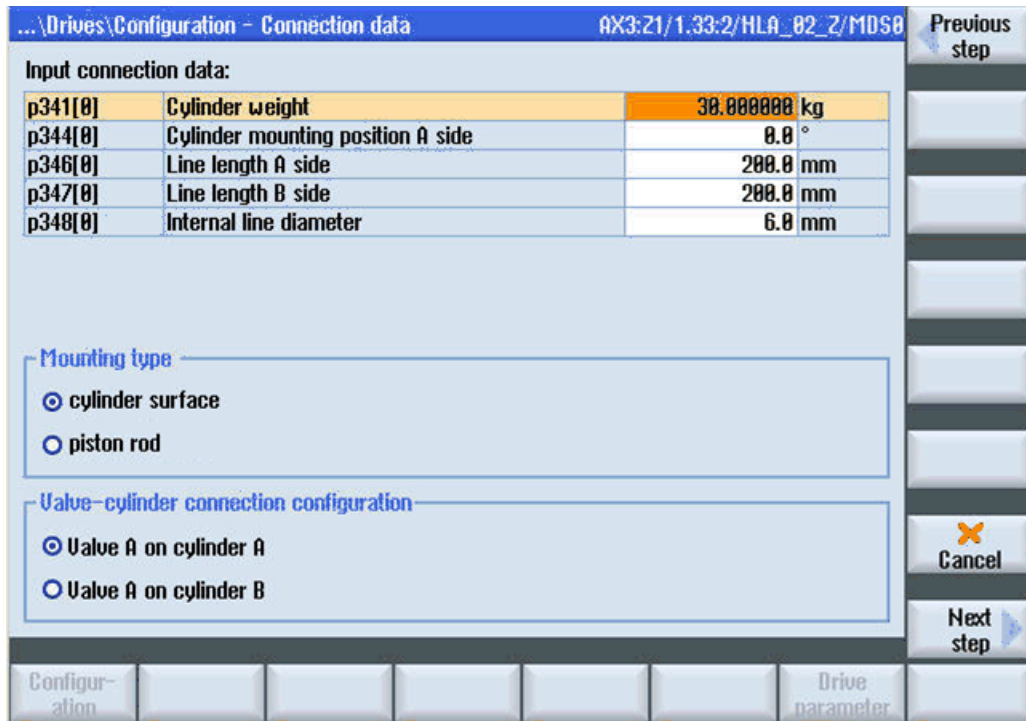

Figure 4-7 Configuration - connection data

- Cylinder mass  
Inertial mass of the cylinder in kilograms.
- Cylinder mounting position A side  
Mounting position in relation to the A side of the cylinder in degrees.
- Line length A side  
Length of the hydraulic line on the A side in millimeters.
- Line length B side  
Length of the hydraulic line on the B side in millimeters.
- Internal line diameter  
Inner diameter of the hydraulic lines for the A and B sides in millimeters.

For the HLA, a distinction is made between two different mounting methods:

- The cylinder is fixed, the moved mass is attached to the piston rod  $p0343[0].1 = 0$
- The piston is stationary, the moved mass is attached to the cylinder  $p0343[0].1 = 1$

You can select from the following options under "Connection configuration valve-cylinder":

- Valve A to cylinder A  
Valve side A is connected to cylinder side A.
- Valve A to cylinder B  
Valve side A is connected to cylinder side B.



## 4.9 Configuration - calculations

This dialog is only displayed in the change run if previously data were changed in the dialogs.

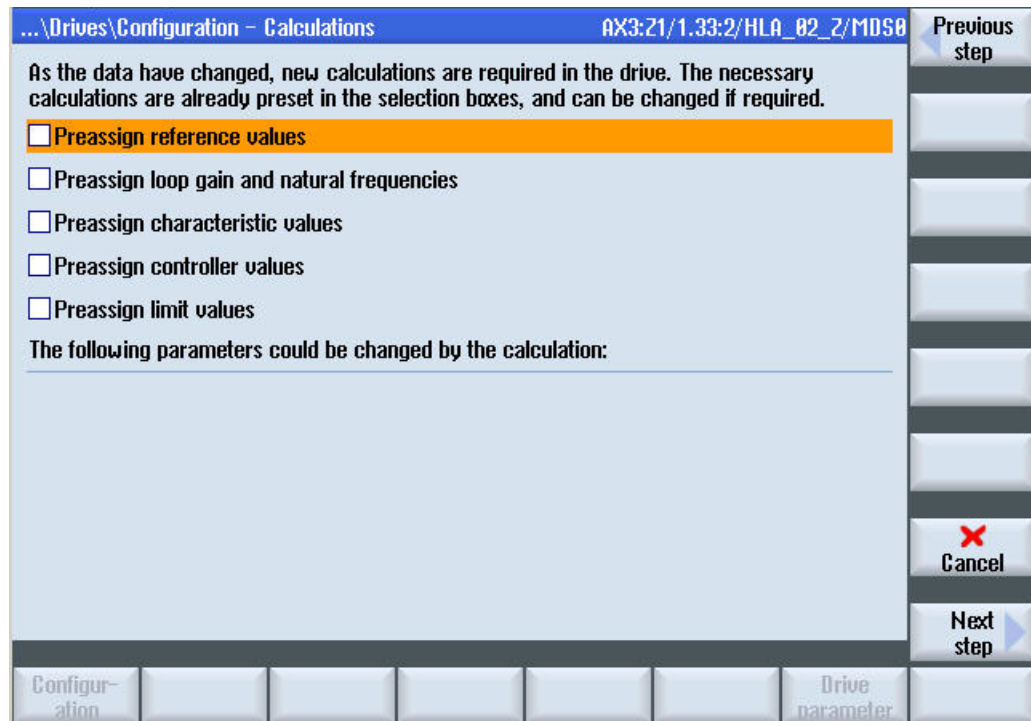

Figure 4-8 Configuration - calculations

The values to preassign the parameters are calculated from the valve, cylinder and system data.

You can activate the pre-assignment of the following parameters:

- Reference values
- Controlled system gain and natural frequencies
- Characteristic data
- Controller values
- Limit values

The table in the lower section of the dialog shows a list of the parameters, which can be influenced by the calculation as a result of the activated checkbox. See the following example:

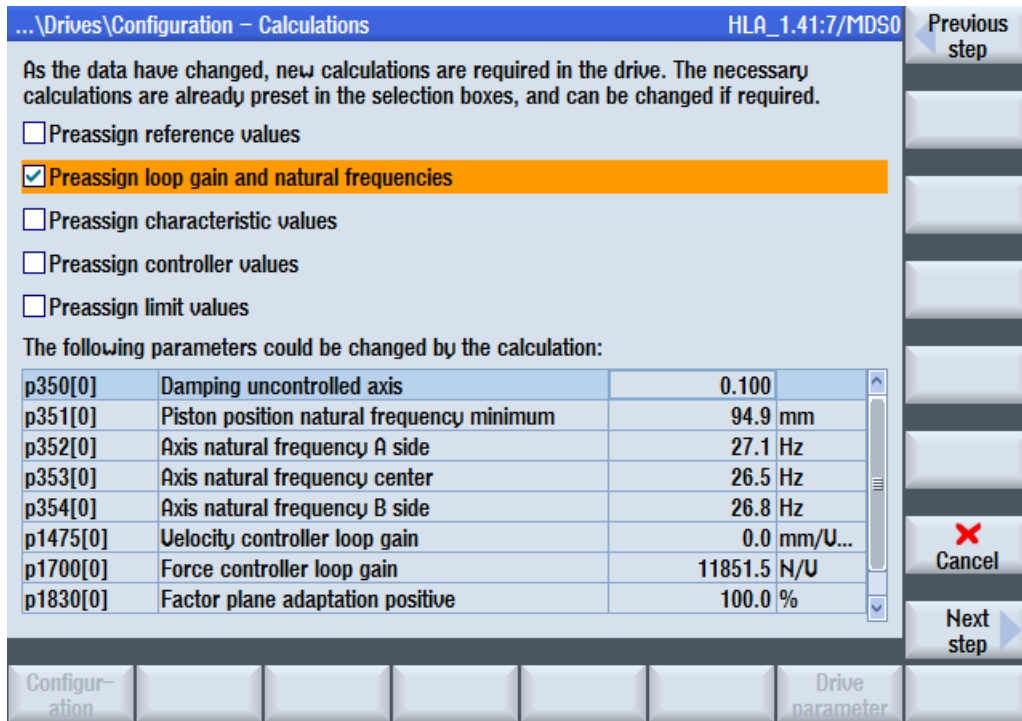

Figure 4-9 Configuration - calculations: Example of parameters to be preassigned

This list has the same properties as the expert list for the drive parameters. The values cannot be changed.

## 4.10 Configuration - Encoder assignment

Here you can assign a maximum of 3 encoders to the selected drive object:

Figure 4-10 Configuration - encoder assignment

Identification of the encoder in the control cabinet: If the encoder interface has the capability to flash, then you will receive an optical response (red/green).

- If the Sensor Module (SMx) is already inserted correctly on the drive object, then it is automatically assigned here. More than one measuring system can also be assigned automatically.

The encoders are automatically assigned in accordance with the following scheme:

|               |  |
|---------------|--|
| X202 and X203 | External encoder evaluation via DRIVE-CLiQ |
| X231 and X232 | Internal encoder evaluation                |

- With an automatic configuration, an encoder at the DRIVE-CLiQ socket X202 is assigned as encoder\_1 to the first drive. The encoder at X231 then becomes encoder\_2. If X202 is not assigned, the encoder is configured as encoder\_1 at X231.
- With an automatic configuration, an encoder at the DRIVE-CLiQ socket X203 is assigned as encoder\_1 to the second drive. The encoder at X232 then becomes encoder\_2. If X203 is not assigned, the encoder is configured as encoder\_1 at X232.

#### 4.10 Configuration - Encoder assignment

- If the SMx is not inserted in this drive object, it must be selected and assigned manually here. The designation of the encoder in the standard selection list is structured according to the following scheme:

Name and number of the HLA module with Sensor Module slot

Name and number of the Sensor Module -

Name and number of the encoder

- Select the encoder data set number: With automatic device configuration the associated data sets are already preset. It is possible to change the number of the EDS.

---

#### **Note**

#### **Change the encoder assignment**

If the assignment is changed, then check the topology and the DRIVE-CLiQ connections!

---

## 4.11 Configuration - encoder 1 ... 3

The name of the encoder and the Sensor Module are displayed here via which the encoder is connected. Encoder selection:

... \Drives\ Configuration - Encoder 1      AX3:21/1.33:2/HLA\_02\_2/MDS0

Encoder: Encoder\_31  
Sensor Module: SMC30: SM\_30 (30) X500

Select a motor encoder

| Encoder type   | Code number |
|--|-------------|
| <input type="radio"/> 2048 HTL A/B                       | 3007        |
| <input type="radio"/> 2048 TTL A/B                       | 3008        |
| <input type="radio"/> 1024 HTL A/B unipolar              | 3009        |
| <input type="radio"/> 2048 HTL A/B unipolar              | 3011        |
| <input type="radio"/> 2048 TTL A/B R, with sense         | 3020        |
| <input type="radio"/> SSI, Singleturn, 24 V              | 3081        |
| <input type="radio"/> SSI, Multiturn 4096, 24 V          | 3082        |
| <input type="radio"/> ???                                | 3088        |
| <input type="radio"/> 4096, HTL, A/B, SSI, Singleturn    | 3090        |
| <input type="radio"/> 2000 nm, TTL, A/B R distance-coded | 3109        |
| <input checked="" type="radio"/> User-defined            | 9999        |

Select 'Identify', so that the drive device identifies the connected encoder. This is conditional upon the encoder supporting the drive device.

Navigation buttons: Previous step, Identify, Enter data, Cancel, Next step

Figure 4-11 Configuration - encoder 1 ... 3

- Case 1: Automatically selected with EnDat and DRIVE-CLiQ, no further settings required. To check the default settings, press the "Enter data" softkey.
- Case 2: Encoder was not automatically detected. If the connected encoder is in the list, select the encoder based on the name/code number. Otherwise, select a similar encoder from the list and press the "Enter data" softkey to enter the encoder data.

### Further actions:

- With the "Identify" softkey restart the identification of the encoder in order to check whether the displayed encoder matches the encoder that is actually connected. The encoder can only be identified if it is an absolute encoder or a DRIVE-CLiQ encoder.

## 4.12 Configuration - control mode/setpoints

Here you set the control type and the PROFIBUS telegram type as well as the number of DDS drive data sets.

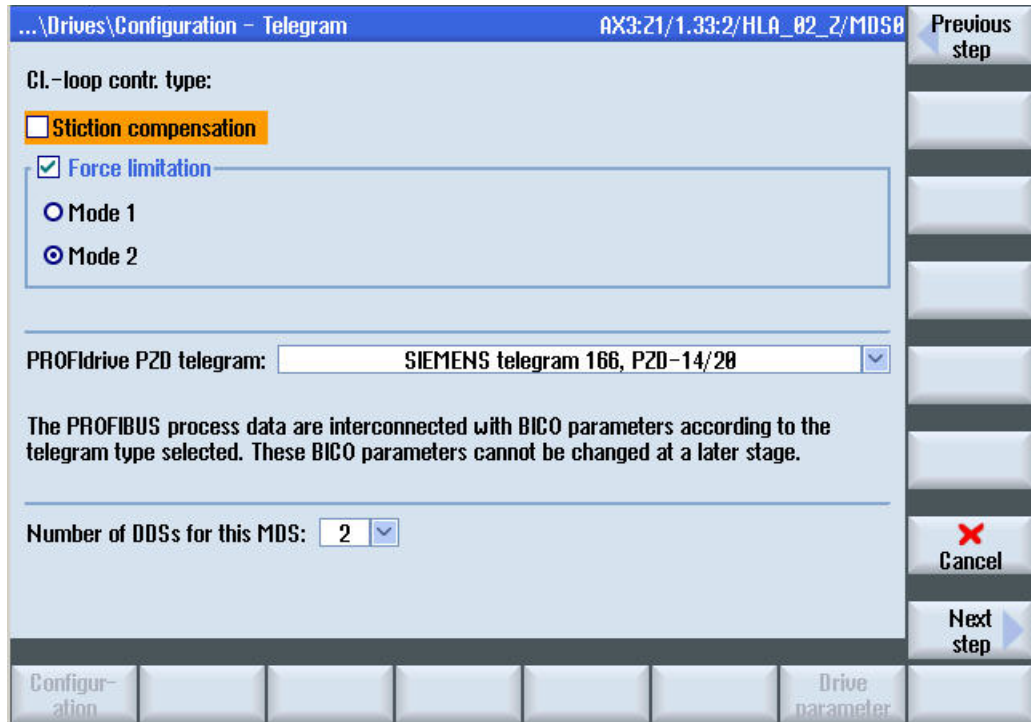

Figure 4-12 Configuration - control mode/setpoints

The control type, PROFIBUS PZD telegram and the number of DDS are generally pre-assigned correctly.

- Control mode

The control modes "Stiction compensation" and "Force limiting" can be used. You can find additional information on the types of force limiting in Chapter "Force control (Page 158)".

- PROFIBUS PZD telegram

When commissioning for the first time (not a change run), the telegram that was determined from the STEP7 HW configuration is set. If a telegram was not able to be uniquely determined from the STEP7 HW configuration, then the selection box is preassigned "SIEMENS telegram 166 PZD-14/20". In the change run, the telegram set in the drive is displayed.

---

**Note**

**Telegram 166 mandatory**

Telegram 166 must be set for the operation of HLA drives.

---

- Number of DDS

The default number of DDSs is 1. If a drive data set switchover is required then several DDSs can be created. Points to bear in mind: A higher number of DDSs extends the time that the SINAMICS system requires to boot. Further DDSs can also be created subsequently in the Data set wizard.

## 4.13 Configuration - BICO interconnection

Make the following selection with both of these checkboxes:

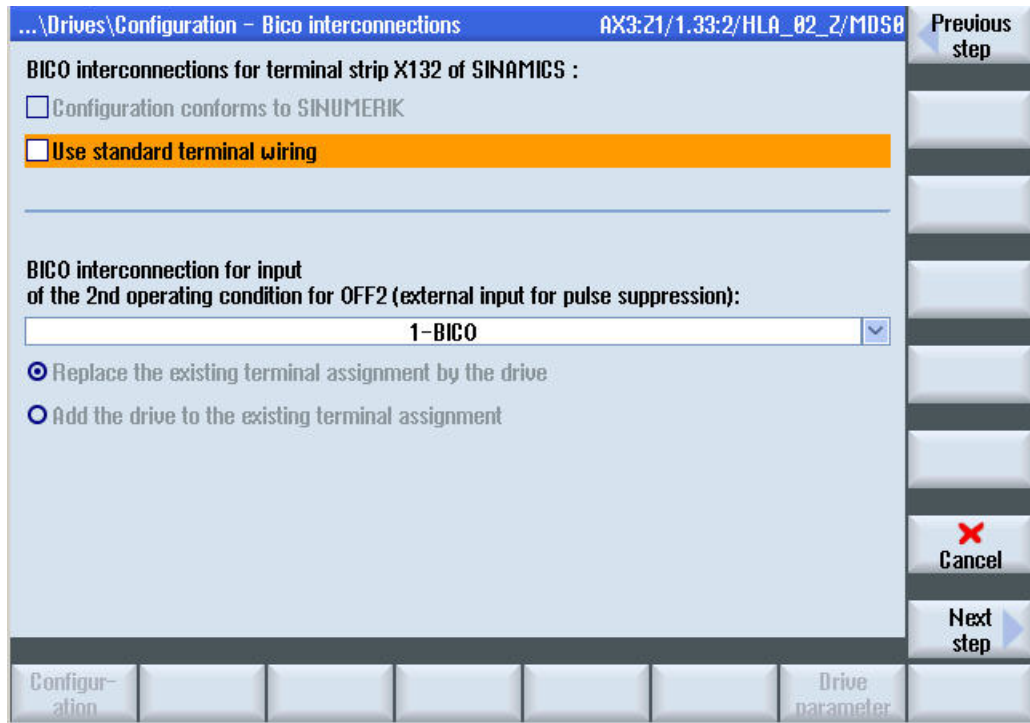

Figure 4-13 Configuration - BICO interconnection

- Default setting: "Configuration is in conformance with SINUMERIK"  
This means that the BICO interconnections for the terminal wiring are set in such a way that all releases and responses communicate correctly.  
If the option is not activated (checkbox is not selected), then changes have been made in the BICO interconnection in relation to the standard interconnection. If these changes were not intended you can use the "Set standard terminal wiring set" option to restore the SINUMERIK compliant interconnection.
- Option: "Set standard terminal wiring"  
Enable this option in order to set the standard terminal wiring. This means that the configuration is interconnected in compliance with SINUMERIK.



## **BICO interconnection for 2nd OFF2**

The 2nd OFF2 signal of this drive can be wired to one of the terminals in the selection list. When selecting, a distinction is made as to whether the drive is connected to a Control Unit or an NX. For a Control Unit, connection can be made to terminal block X132 and for an NX expansion module, connection can be made to terminal block X122.

If you select a terminal that is already linked with another drive, then the following options are available:

- "Replace available terminal assignment by the drive"

The terminal assignment already existing on this terminal is removed in other drives. A new terminal assignment is established to this drive alone.

- "Add drive of the existing terminal assignment"

The new assignment to this terminal is established in addition to the already existing terminal assignments for this drive.

## 4.14 Configuration - summary

All data with which the drive object has been configured is displayed in the summary.

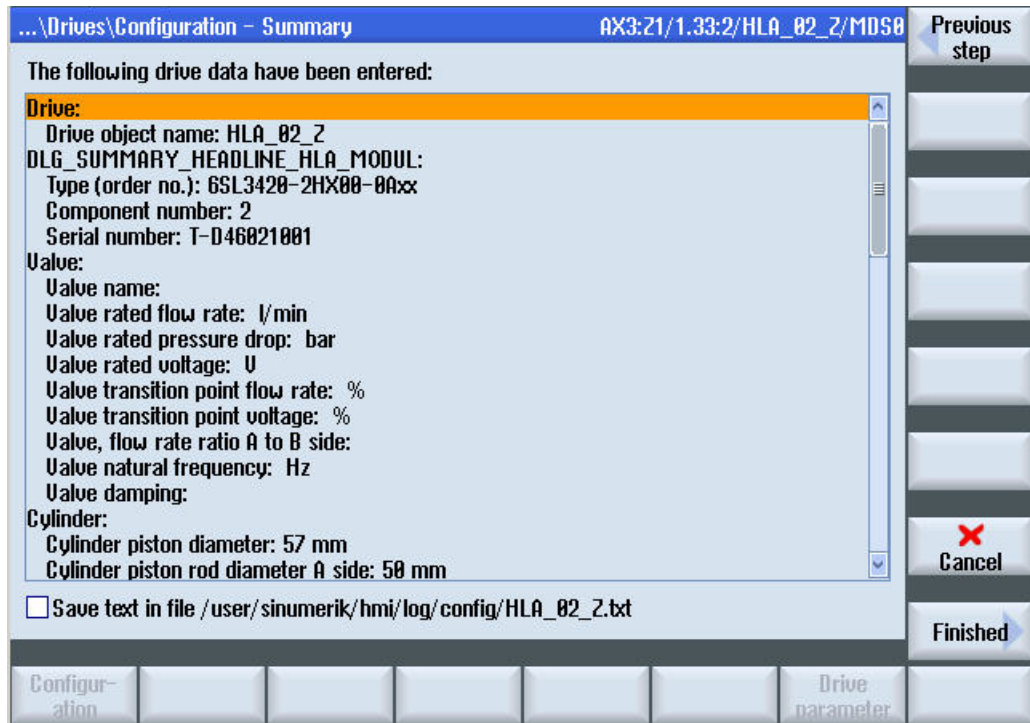

Figure 4-14 Configuration - summary

### Further actions:

- "< Previous step" softkey to be able to return to previous dialog.
- "Finish" softkey to terminate the commissioning of this drive object.

In case of changes, a query to save is output: To ensure that the data after power ON/OFF is retained, confirm with "Yes". The data are saved to the memory card, and are contained in a commissioning archive with drive data.

- Option "Save text in the file ..."

In order to save the summary of the configuration in a file, activate this option.

## 4.15 Overviews

### 4.15.1 Overview of the hydraulic module

In the overview of the drive object Hydraulic Drive (HLA), all the data is displayed, which was capable of being determined with the automatic device configuration.

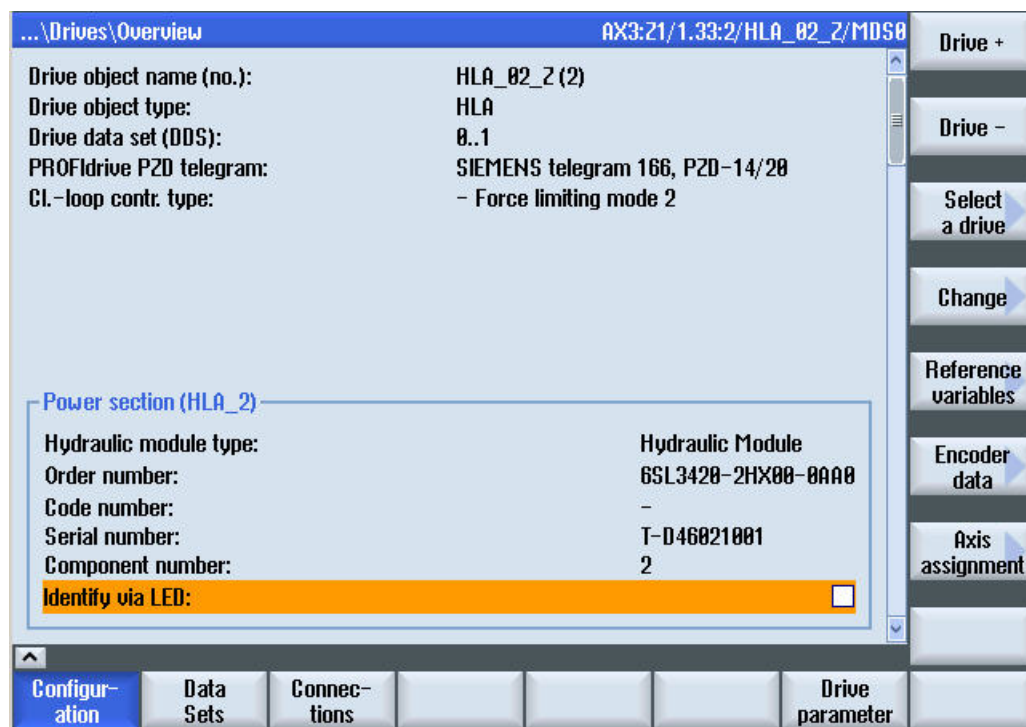

Figure 4-15 Overview of the hydraulic module

#### Further actions:

- You can scroll between all of the drive objects using the "Drive +" and "Drive -" softkeys. If the actual drive object is a Hydraulic Drive, the overview page of the HLA commissioning wizard is displayed. These softkeys are only active if there are several drives.
- You open the direct selection dialog using the "Select drive" softkey. This dialog displays all servo and HLA drive objects. This softkey is only active if there are several drives.
- Click on the "Change" softkey to make changes and other settings on the displayed drive object, e.g. assign the encoders.
- The "Encoder data" softkey opens a window for subsequently configuring the assigned encoders.

- With the "Axis assignment" softkey, you open the dialog to assign the HLA drive axis.
- With the "Reference variables" softkey, you open the dialog to enter reference variables.

---

**Note**

**Initial commissioning**

A message will notify you if the drive has still not been commissioned. Click on the "Change" softkey to start the initial commissioning.

---

## 4.15.2 Valve/cylinder overview

The data read out of the valve and cylinder is displayed in the valve/cylinder overview.

| Valve                               |             |
|-------------------------------------|-------------|
| Nominal flow:                       | 80.00 l/min |
| Nominal pressure loss:              | 5.00 bar    |
| Nominal voltage:                    | 10.00 U     |
| Kink point volume flow:             | 10.00 %     |
| Kink point voltage:                 | 40.00 %     |
| Volume flow ratio A side to B side: | 1.00        |

| Cylinder                    |                    |
|-----------------------------|--------------------|
| Piston diameter:            | 57 mm              |
| Piston rod diameter A side: | 50 mm              |
| Piston rod diameter B side: | 50 mm              |
| Stroke:                     | 148.5 mm           |
| Dead volume A side:         | 6 HLA_AK2_UNIT_CM3 |
| Dead volume B side:         | 6 HLA_AK2_UNIT_CM3 |

Figure 4-16 Valve/cylinder overview

### 4.15.3 Encoder overview

The data read out of the Sensor Module is displayed in the encoder overview.

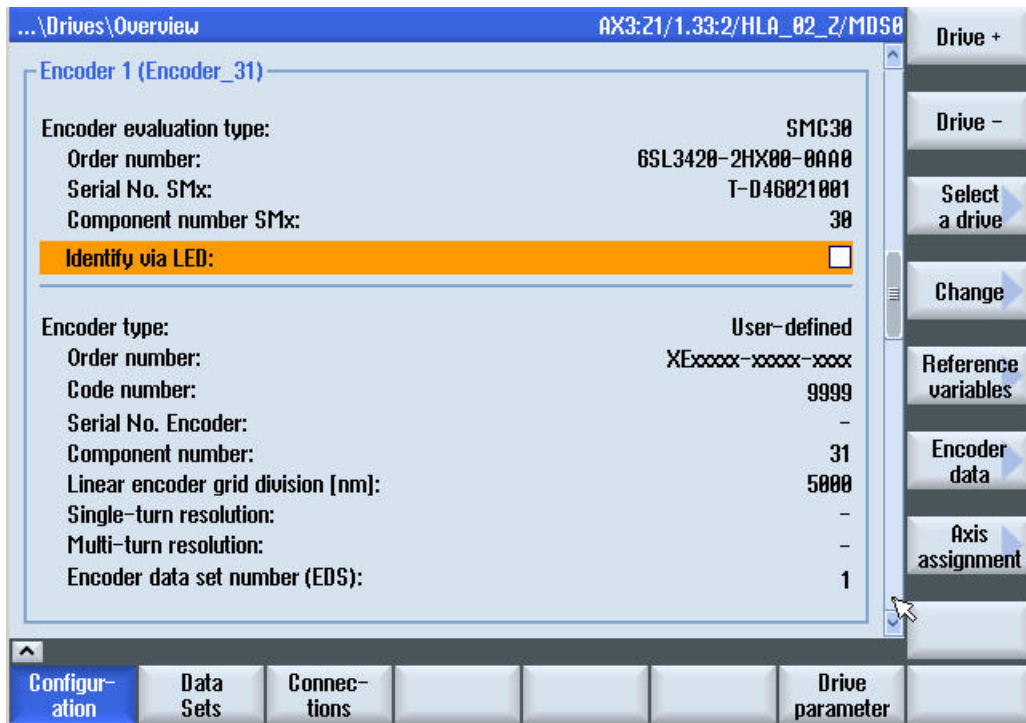

Figure 4-17 Encoder overview

In addition, the following data is also displayed:

- Data ascertained with the automatic device configuration.
- Data entered manually for encoders which are not connected via DRIVE-CLiQ.

**Further actions:**

With the "Encoder data" softkey, you open the window for configuring the encoder displayed so that you can subsequently make changes.

---

**Note**

When selecting an encoder offered by Siemens, all the required parameter settings are automatically accepted in the configuration and can no longer be modified.

---

#### 4.15.4 Overview of connection data

- The connection data read out of the valve and cylinder are displayed in the connection data overview.
- The data read out of the supply unit is displayed in the supply unit overview.
- The data read out of the shutoff valve is displayed in the shutoff valve overview.

The screenshot displays a software window titled "...\Drives\Overview" for drive "AX3:Z1/1.33:2/HLA\_02\_2/MDS0". The interface is divided into three main sections: Connection data, Supply data, and Shutoff valve. On the right side, there is a vertical toolbar with buttons for "Drive +", "Drive -", "Select a drive", "Change", "Reference variables", "Encoder data", and "Axis assignment". At the bottom, there is a navigation bar with tabs for "Configur-ation", "Data Sets", "Connec-tions", and "Drive parameter".

| Connection data                                    |                         |
|--|-------------------------|
| Value-cylinder connection configuration:           | Valve A on cylinder A   |
| Line length A side:                                | 200.0 mm                |
| Line length B side:                                | 200.0 mm                |
| Interior diameters of lines A & B (nominal width): | 6.0 mm                  |
| Mounting position A side:                          | 0 deg.                  |
| Cylinder fastening:                                | on the cylinder surface |

| Supply data                        |           |
|------------------------------------|-----------|
| Elasticity module hydraulic fluid: | 14000 bar |
| System pressure:                   | 105 bar   |
| Pilot pressure:                    | 0 bar     |
| Power enable delay:                | 100 ms    |

**Shutoff valve**

- Close shut-off valve with disabled power (LS)
- Switch off servo solenoid valve supply with disabled power (LS)
- Valve feedback signal available

Figure 4-18 Overview of the connection data/data of the supply unit/shutoff valve

### 4.15.5 Overview of the reference variables/function modules

The reference variables and activated function modules are displayed in the reference variable and function module overview.

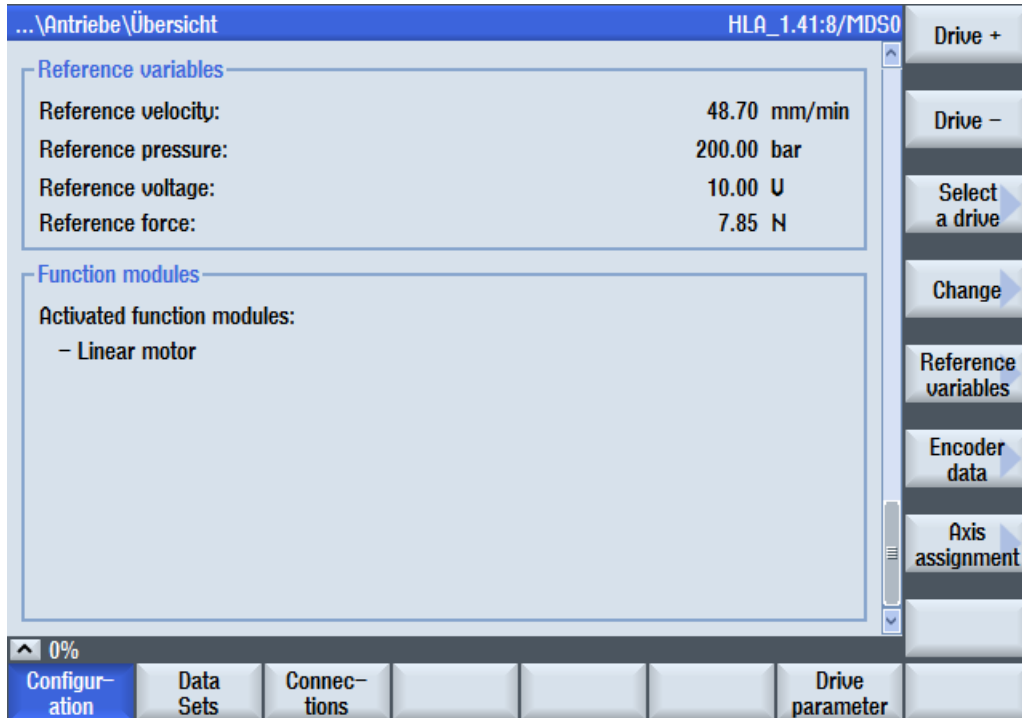

Figure 4-19 Overview of the reference variables/function modules

Note the following:

- Create additional data sets with the "Data sets" softkey. The reference variables are not recalculated when creating additional drive data sets. The reference variables are locked using parameter p0573.
- A license is required for certain function modules (→ "Licenses" → "All options").



## 4.15.6 Configuration - reference variables

The reference variables are calculated once at the first commissioning of the drive. The reference variables are not dependent on the parameter set. You can define as to whether reference variables should be automatically preassigned using parameter p0340.0.

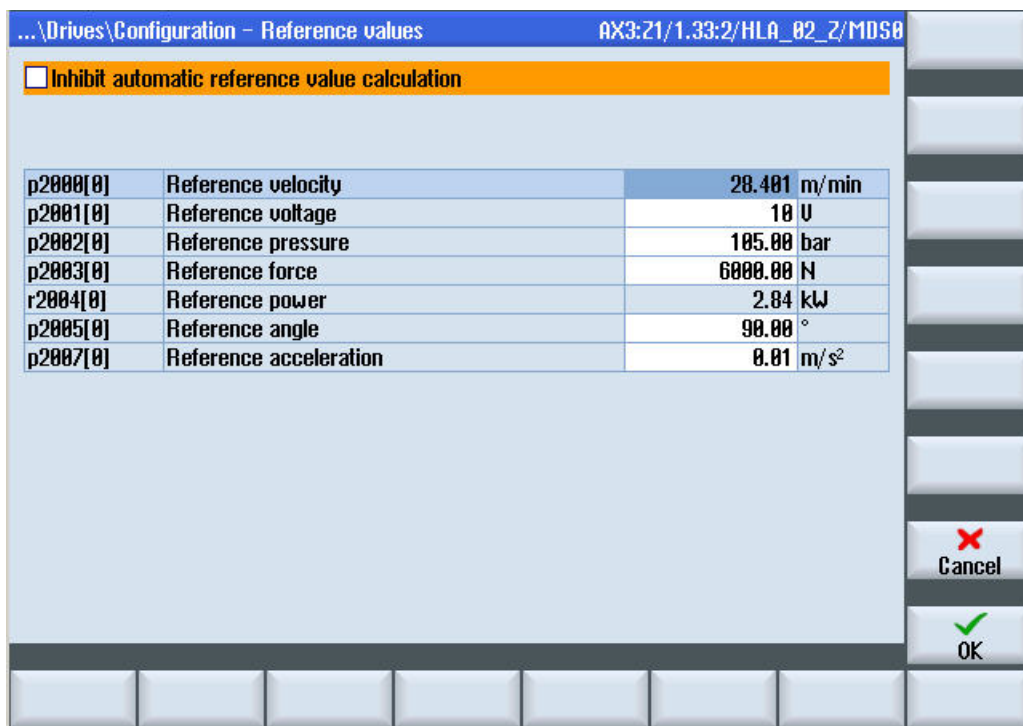

| Parameter | Variable               | Value   | Unit             |
|-----------|------------------------|---------|------------------|
| p2000[0]  | Reference velocity     | 28.481  | m/min            |
| p2001[0]  | Reference voltage      | 10      | U                |
| p2002[0]  | Reference pressure     | 105.00  | bar              |
| p2003[0]  | Reference force        | 6000.00 | N                |
| r2004[0]  | Reference power        | 2.84    | kW               |
| p2005[0]  | Reference angle        | 90.00   | °                |
| p2007[0]  | Reference acceleration | 0.01    | m/s <sup>2</sup> |

Figure 4-20 Configuration - reference variables

In order to prevent reference values being calculated, activate the checkbox "Inhibit automatic reference value calculation".

In this dialog you define reference variables for velocity, pressure, force, power, angle and acceleration.

### Note

#### Reference variables as limits

The reference variables only act additionally as limits (with factor 2) at the PROFIdrive interface. If this range is not sufficient, you must adapt the reference variables manually.

The reference variables act as scaling between the NC and drive for actual value sensing, setpoint output as well as for measuring functions. All specified relative values, e.g. for the trace, refer to these reference variables.

Save the reference variables with the "OK" softkey. Then return to the overview page.

---

**Note**

If you are working with different DDS with different valve characteristics, the reference variables remain the same as these are not switched over with the DDS. You must take the resulting conversion factor into consideration (e.g. when recording a trace).

---

**Overview of important parameters (see SINAMICS S120/S150 List Manual)**

- p2000            Reference velocity
- p2001            Reference voltage
- p2002            Reference pressure
- p2003            Reference force
- p2004            Reference power
- p2005            Reference angle
- p2006            Reference temperature
- p2007            Reference acceleration

## 4.16 Importing valve lists

### Importing valve lists

You can import a list with suitable valves as follows:

1. Select the "System data" softkey from the "Basic commissioning menu".
2. In the following "System data" dialog, select entry "HMI data > Data backup > IB data".
3. You can access the "Machine data loaded" dialog using the "Manage data" softkey.

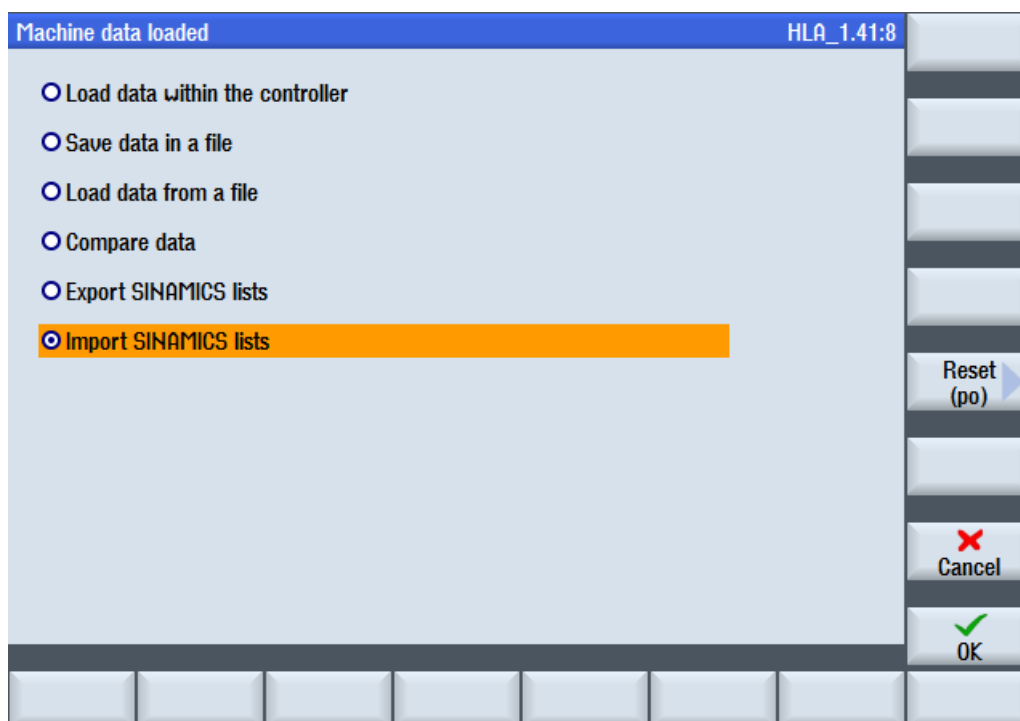

Figure 4-21 Loading machine data

4. Select the "Import SINAMICS lists" option and press the "OK" softkey.
5. Select the valve list in the following "Import SINAMICS list" dialog. Import the selected list using the "OK" softkey.

### Exporting valve lists

You can export a list with suitable valves as follows:

1. Select the "System data" softkey from the "Basic commissioning menu".
2. In the following "System data" dialog, select entry "HMI data > Data backup > IB data".
3. You can access the "Machine data loaded" dialog using the "Manage data" softkey (see Figure 4-21 Loading machine data (Page 81)).
4. Select the "Export SINAMICS lists" option and press the "OK" softkey.

5. Select the valve list in the following "Export SINAMICS list" dialog. Go to the target directory selection using the "OK" softkey.

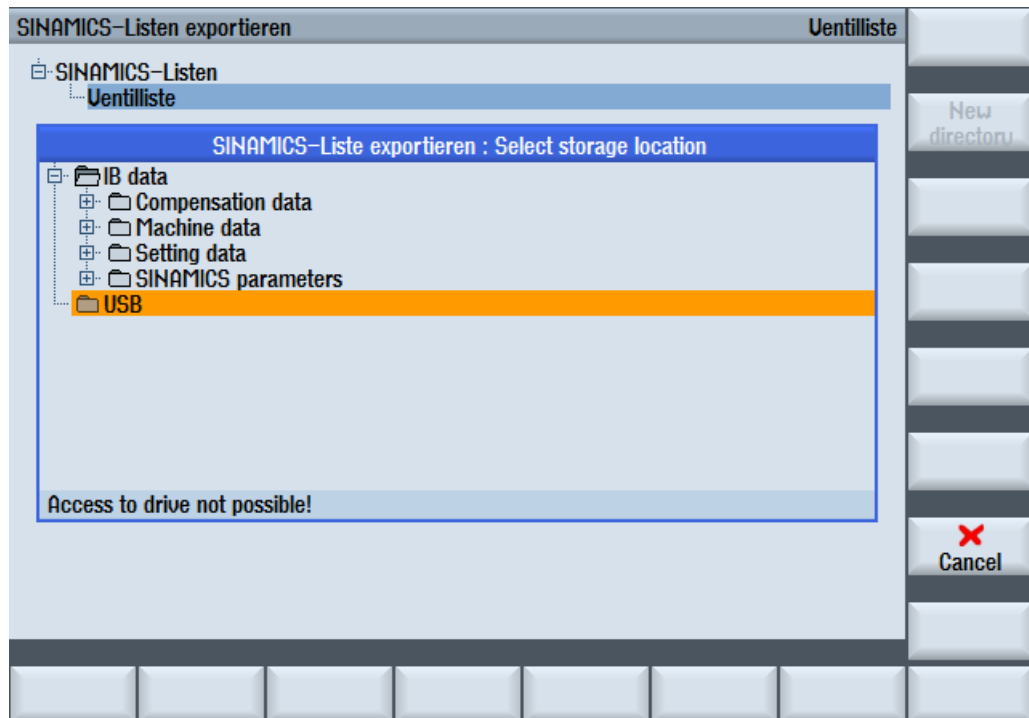

Figure 4-22 Selecting an archive

6. Select a directory and confirm your selection with the "OK" softkey. Before you save the list, you can change the file name (default setting: slsuhlvls.ini).

## 4.17 Editing the valve characteristic

### 4.17.1 General

Every servo solenoid valve has an individual characteristic, which represents the flow rate with respect to the control voltage (valve opening as a percentage). This characteristic must be measured after commissioning an HLA module and must be set in the drive. After the measurement, you have the option to automatically adapt the characteristic approximated in the drive using straight lines and parabolas to the measured characteristic using an optimization algorithm. In addition, you can adapt the characteristic more precisely to the measured characteristic manually (and graphically) or by directly entering values. The quality of the match will be quite apparent when viewing the graphic display of both characteristics.

A measured characteristic is stored in the drive, simply defined section-by-section using straight lines and parabolic segments. The simplified characteristic is configured using the following parameters:

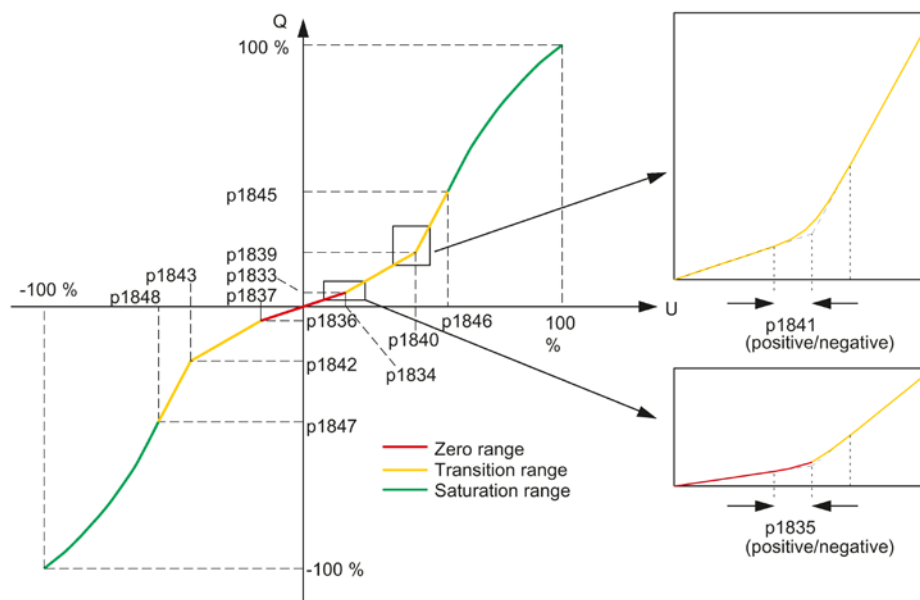

Figure 4-23 Measured characteristic → SINAMICS parameters

The calculated characteristic starts at the zero point and comprises short straight lines (zero range). Rounded off by a parabola, this range transitions into the straight line of the fine control range. Also rounded off by a parabola, the fine control straight line transitions into the saturation range. This starts with a straight line followed by a parabola along a continuous tangent open to the bottom, which ends at the point ( $Q = 100\%$ ,  $U = 100\%$ ).

#### Overview of important parameters (see SINAMICS S120/S150 List Manual)

- p1833[0...n] Transition point compensation Q1 positive zero range
- p1834[0...n] Transition point compensation U1 positive zero range
- p1835[0...n] Transition point compensation rounding 1 positive zero range
- p1836[0...n] Transition point compensation Q1 negative zero range
- p1837[0...n] Transition point compensation U1 negative zero range
- p1838[0...n] Transition point compensation rounding 1 negative zero range
- p1839[0...n] Transition point compensation Q2 positive
- p1840[0...n] Transition point compensation U2 positive
- p1841[0...n] Transition point compensation rounding 2 positive
- p1842[0...n] Transition point compensation Q2 negative
- p1843[0...n] Transition point compensation U2 negative
- p1844[0...n] Transition point compensation rounding 2 negative
- p1845[0...n] Transition point compensation Q3 positive saturation
- p1846[0...n] Transition point compensation U3 positive saturation
- p1847[0...n] Transition point compensation Q3 negative saturation
- p1848[0...n] Transition point compensation U3 negative saturation

4.17 Editing the valve characteristic

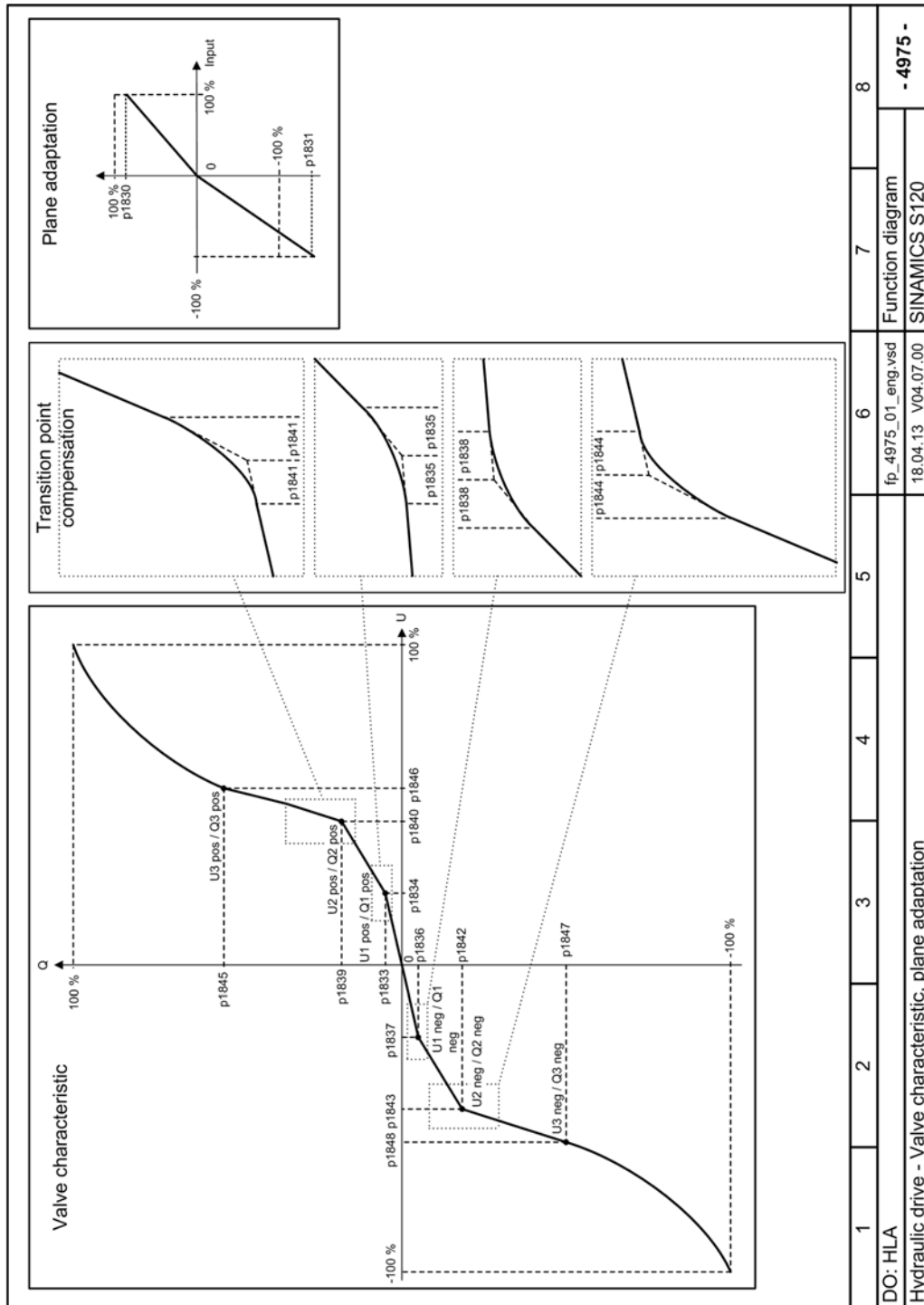

Figure 4-24 Function diagram 4975 – valve characteristic and plane adaptation

## 4.17.2 Simplified sequence

Measuring the characteristic and optimizing the HLA is shown in a simplified fashion as follows:

1. After calling the HLA optimization, you go to the start dialog:

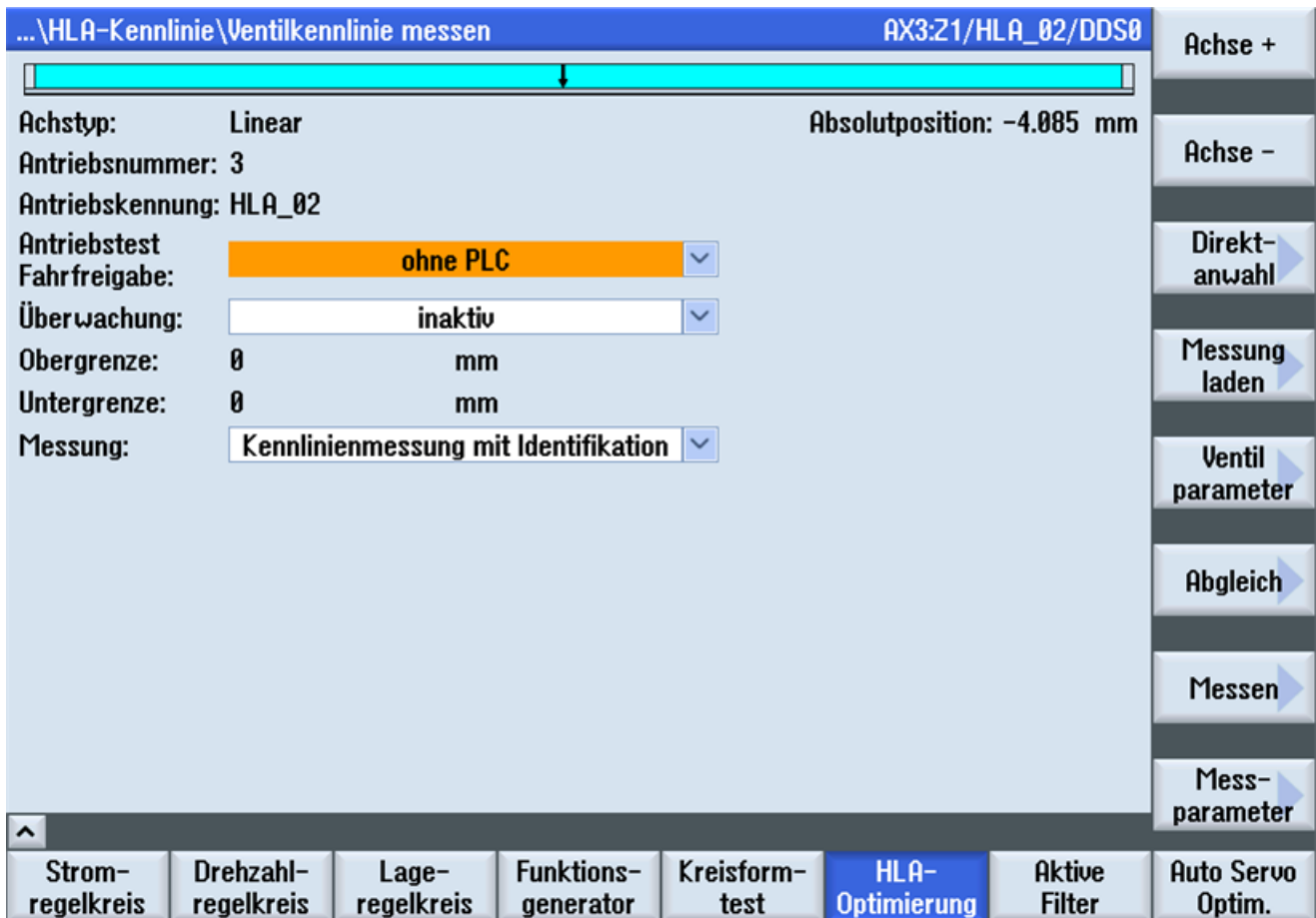

Figure 4-25 Measure valve characteristic

2. Using the "Measure" softkey, go to the "Measurement" dialog, and there, start the characteristic measurement using the "Start measurement" softkey:

3. After you have completed the measurement, go to the "Tuning" dialog by pressing the "OK" softkey:

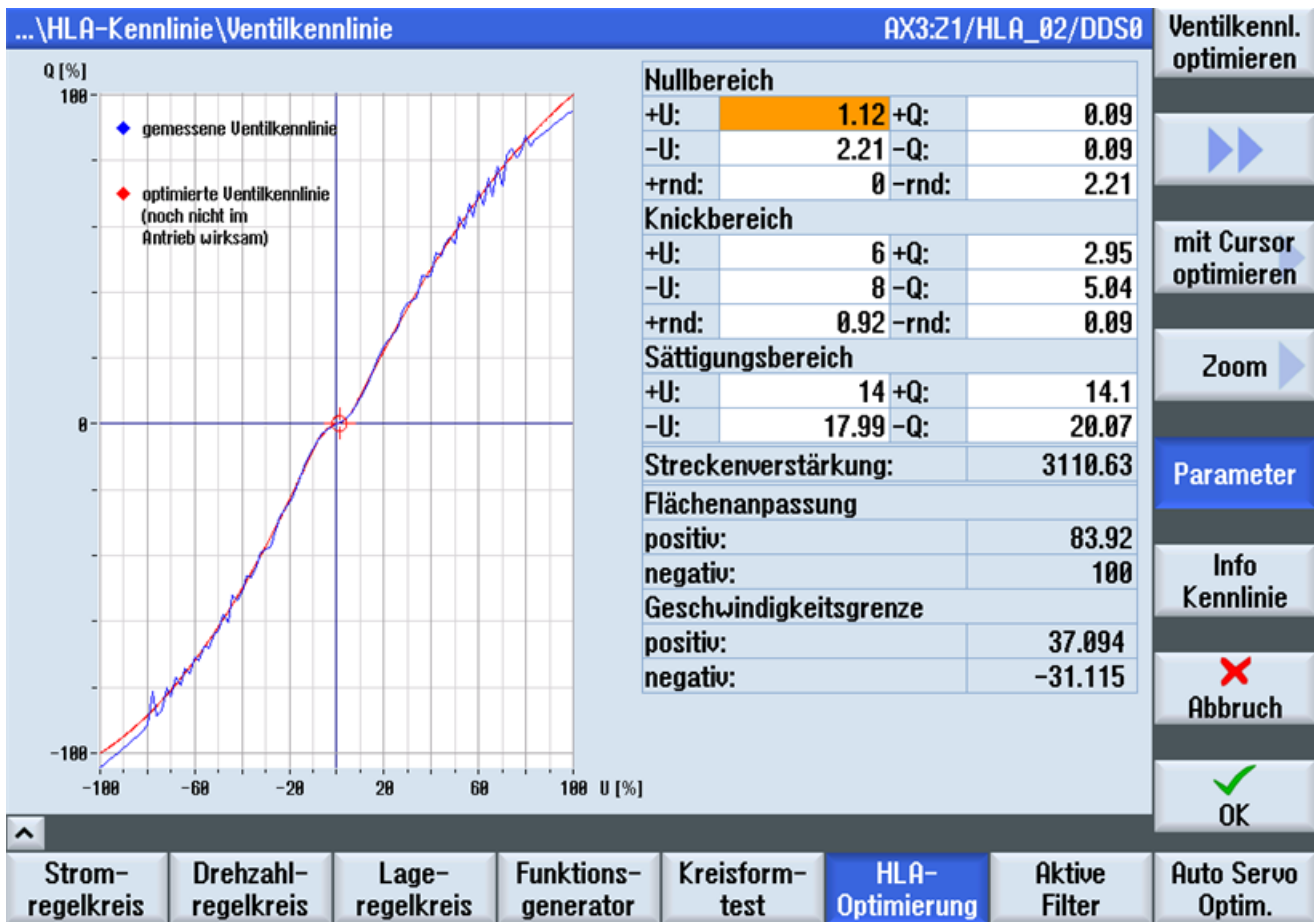

Figure 4-26 Tuning the characteristic

4. Optional step  
Adapt the set characteristic to the measured characteristic using an optimization algorithm by pressing the "Tune valve characteristic" softkey.
  5. Press the "OK" softkey to accept the characteristic.
- A detailed description of the individual steps is given in the following chapters.



### 4.17.3 Measure characteristic

After starting the HLA optimization, you go to this dialog. You can measure, parameterize and tune the valve characteristic of the hydraulic control valve on this page. Measuring the valve characteristic is also known as "moving measurement".

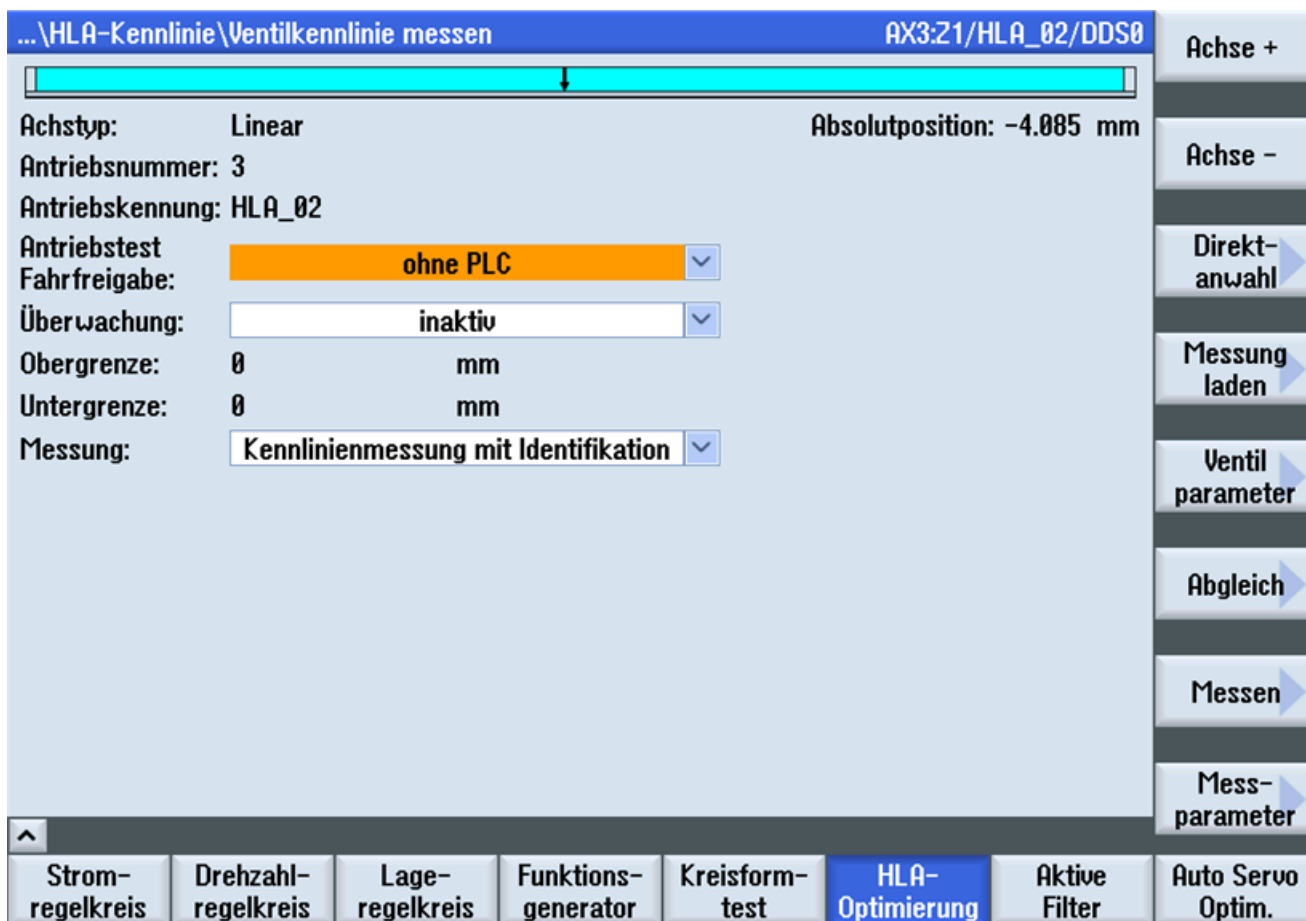

Figure 4-27 Measure valve characteristic

The following parameters are displayed:

- **Bar diagram**

The bar diagram represents the traversing range of the axis, which is used to measure the valve characteristic.

The bar positions are converted to absolute positions from the relative piston position of the drive and the cylinder stroke. The absolute position corresponds to the piston position. The left (minimum) position corresponds to the absolute position minus the piston position. The right (maximum) position corresponds to the absolute position plus the cylinder stroke minus the piston position.

- **Display of the "Axis type" ("Linear"), absolute position, drive number and drive name**

- **Drive test traversing enable**

Here, select whether the drive test to enable traversing should be performed with or without the PLC.

- **Monitoring**

Possible settings are:

- Active

The system monitors that upper and lower limits are complied with. The measurement is stopped when a limit is violated.

- Inactive

The upper/lower limit is not monitored.

- **Upper limit / lower limit**

Here, enter the upper limit and the lower limit for the axis position.

- **Measurement**

Possible settings are:

- Characteristic measurement

Select this setting when the axis has already been calibrated.

- Characteristic measurement with identification

Select this setting if the axis is to be automatically calibrated during the measurement (see Chapter "Calibration (Page 105)"). Observe the preconditions listed in Chapter "Calibration (Page 105)". Further, for this measurement, the complete traversing path must be free. Additional information on the actions (control sense correction, valve offset correction, piston calibration, ...), which are performed with this measurement, is provided in parameter p1959 in the SINAMICS S120/S150 List Manual.

## Further actions

- Use the "Axis +" / "Axis -" softkeys to change to the next/previous axis.
- Use the "Select axis >" softkey to open a dialog in order to select the axis from a list.
- Use the "Load meas. >" softkey to open a file selection dialog to load a measurement. The file can contain characteristic data saved automatically or saved manually.
- Use the "Valve parameter >" softkey to open the "Valve characteristic parameters" dialog. The valve characteristic parameters are displayed there in a list.
- Use the "Calibrate >" softkey to open the "Configuration - calibrate" dialog. You can calibrate the position of the piston, the pressure and the valve offset there.
- Use the "Measure >" softkey to open the "Measurement" dialog. You can start a measurement of the valve characteristic there. After the measurement, the measured characteristic and the characteristic set in the drive are displayed in a diagram (see the following chapter).
- Use the "Meas. parameters >" softkey to open the "Measurement parameters" dialog. The measurement parameters are displayed there in a list.

#### 4.17.4 Measurement

When the dialog opens, the characteristic set in the drive is displayed first. After a measurement, the measured characteristic and the characteristic set in the drive are displayed.

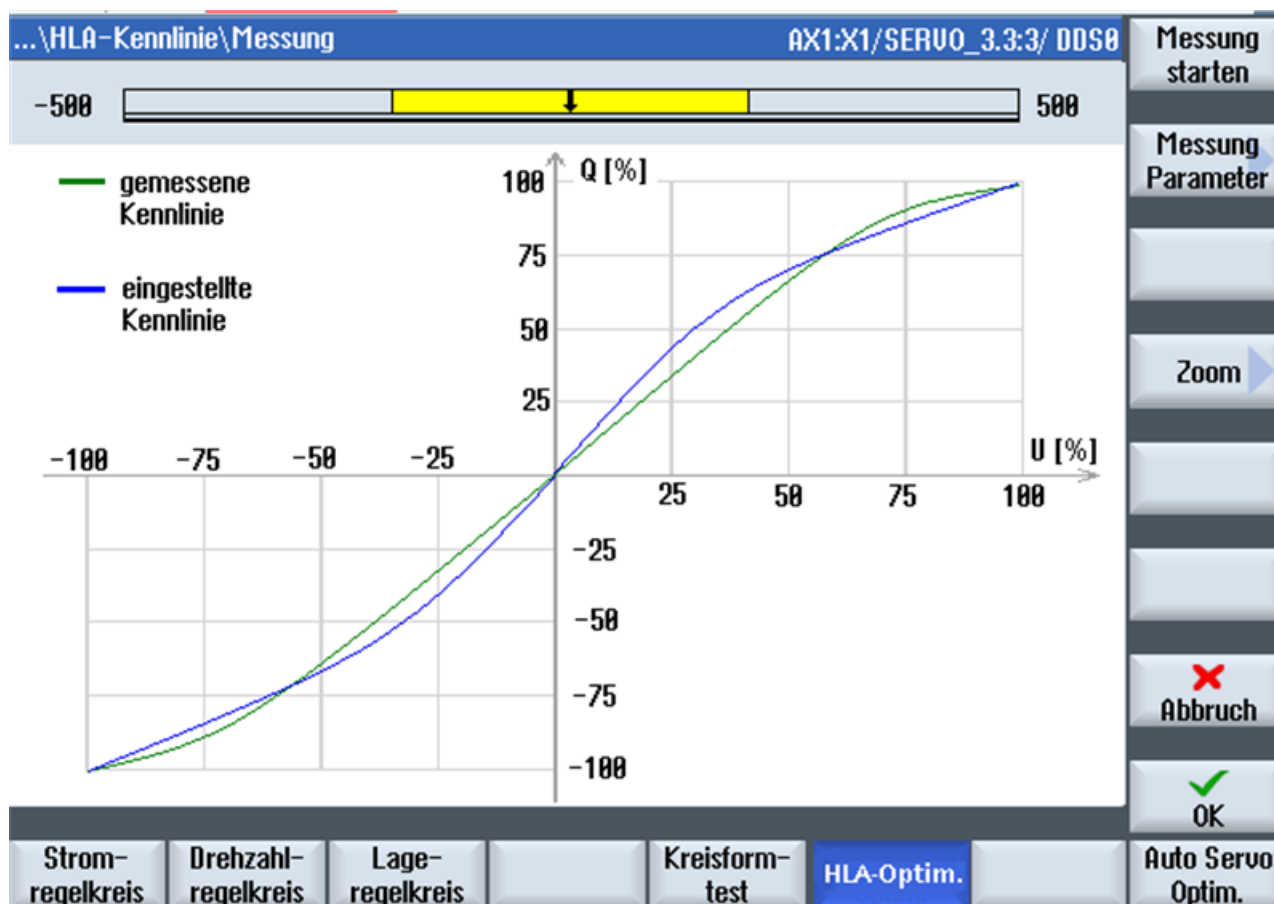

Figure 4-28 Characteristic: Measurement

#### Requirement for the characteristic measurement

One of the following requirements must be satisfied before starting the measurement:

- All calibrations have been performed manually in the "Calibration" dialog.
- The setting "Characteristics measurement with identification" has been selected under "Measurement" in the "Valve characteristics measurement" dialog. The calibrations are performed automatically with this setting.

If you start the measurement without a previous calibration, a corresponding prompt is displayed. The axis must be in the referenced state for both calibration types. If this condition is not satisfied, a prompt appears.

### Start of the characteristic measurement

You start the characteristic measurement with the "Start meas." softkey. The current axis position is displayed in a bar diagram. The measurement may take several minutes. The labeling of the "Start meas." softkey changes to "Stop meas.". All other softkeys are disabled.

You can stop the measurement with the "Stop meas." softkey. No measured characteristic is then displayed in the diagram. An error message is not displayed.

### Result of the characteristic measurement

If the drive has completed the measurement, the measurement results are available in the parameters r1961[0..511] and r1962[0..511].

After completion of the measurement, the success or failure is output as a message. The softkeys are activated again.

If the measurement is successful, the measured data is displayed in the diagram as a characteristic. An automatic tuning of the set characteristic is performed. The tuned, set characteristic is displayed in the "Graphic tuning" dialog.

If the measurement fails, an error message is output. Rectify the problem and perform the measurement again.

To cancel the drive disable, you must press the RESET button on the machine control panel.

### Further actions

- Start the measurement of the valve characteristic with the "Start meas." softkey. The labeling of the "Start meas." softkey changes to "Stop meas." after the measurement is started. All other softkeys are disabled during the measurement. The measurement progress is displayed in a progress bar.
- Stop the measurement of the valve characteristic with the "Stop meas." softkey.
- Use the "Meas. parameters >" softkey to open the "Measurement parameters" dialog. The measurement parameters are displayed there in a parameter list.
- Use the "Zoom >" softkey to display the "Zoom" softkey bar. The "Measurement" dialog remains unchanged.
- Use the "Cancel" softkey to return to the "Valve characteristics measurement" dialog.
- Use the "OK" softkey to open the "Graphic tuning" dialog. An **Automatic measurement** is performed once after a measurement.

### Overview of important parameters (see SINAMICS S120/S150 List Manual)

- r1961[0...511]      Valve identification characteristic voltage
- r1962[0...511]      Valve identification characteristic velocity

### 4.17.5 Measurement parameters

The measurement parameters are displayed in a parameter list.

| ...\HLA-Kennlinie\Messparameter |                                   | AX3:Z1/HLA_02/DDS0 |
|---------------------------------|-----------------------------------|--------------------|
| p1850[0]                        | Stellspannung Begrenzung positiv  | 10.0 V             |
| p1851[0]                        | Stellspannung Begrenzung negativ  | -10.0 V            |
| p1955[0]                        | Messbereich Anfang                | 0.00 V             |
| p1955[1]                        | Messbereich Ende                  | 10.00 V            |
| p1955[2]                        | Fahren positiv                    | 2.00 V             |
| p1955[3]                        | Fahren negativ                    | 2.00 V             |
| p1956[0]                        | Minimal                           | 1.0 %              |
| p1956[1]                        | Maximal                           | 99.0 %             |
| p1957[0]                        | Anzahl                            | 50                 |
| p1957[1]                        | Stillstandserkennung Geberstriche | 4                  |
| p1958[0]                        | Rampenzeit                        | 0.10 s             |
| p1958[1]                        | Einschwingzeit                    | 0.10 s             |
| p1958[2]                        | Messzeit                          | 0.10 s             |
| p1958[3]                        | Stillstandszeit                   | 2.00 s             |
| p1958[4]                        | Wartezeit                         | 2.00 s             |

Messen

<< Zurück

Stromregelkreis Drehzahlregelkreis Lageregelkreis Funktionsgenerator Kreisformtest **HLA-Optimierung** Aktive Filter Auto Servo Optim.

Figure 4-29 Measurement parameters

The parameters displayed in the list are read from the drive. You can adapt all parameters to your requirements. Write the changed values to the drive using the enter key.

#### Further actions

- Use the "Measure >" softkey to open the "Measurement" dialog. You can start a measurement of the valve characteristic there. After the measurement, the measured characteristic and the characteristic set in the drive are displayed in a diagram.
- Use the "Back" softkey to return to the "Valve characteristics measurement" dialog.

### 4.17.6 Valve characteristic parameters

The valve characteristic parameters are displayed in a list.

| ...\HLA-Kennlinie\Ventilkennlinienparameter |  | AX3:21/HLA_02/DDS0 | Achse +           |
|---|--|--------------------|-------------------|
| p1083[0]                                    | Geschwindigkeitsgrenze positive Richtung         | 39.318 m/min       |                   |
| p1086[0]                                    | Geschwindigkeitsgrenze negative Richtung         | -33.985 m/min      |                   |
| p1475[0]                                    | Geschwindigkeitsregler Streckenverstärkung       | 3398.5 mm/V...     | Achse -           |
| p1830[0]                                    | Faktor Flächenanpassung positiv                  | 86.4 %             |                   |
| p1831[0]                                    | Faktor Flächenanpassung negativ                  | 100.0 %            |                   |
| p1833[0]                                    | Knickkompensation Q1 positiv Nullbereich         | 0.01 %             | Direkt-<br>anwahl |
| p1834[0]                                    | Knickkompensation U1 positiv Nullbereich         | 0.00 %             |                   |
| p1835[0]                                    | Knickkompensation Verrundung 1 positiv Nullbe... | 1.86 %             | DDS<br>auswählen  |
| p1836[0]                                    | Knickkompensation Q1 negativ Nullbereich         | 0.01 %             |                   |
| p1837[0]                                    | Knickkompensation U1 negativ Nullbereich         | 0.00 %             |                   |
| p1838[0]                                    | Knickkompensation Verrundung 1 negativ Nullb...  | 2.37 %             |                   |
| p1839[0]                                    | Knickkompensation Q2 positiv                     | 10.00 %            |                   |
| p1840[0]                                    | Knickkompensation U2 positiv                     | 10.00 %            |                   |
| p1841[0]                                    | Knickkompensation Verrundung 2 positiv           | 2.50 %             |                   |
| p1842[0]                                    | Knickkompensation Q2 negativ                     | 10.00 %            |                   |
| p1843[0]                                    | Knickkompensation U2 negativ                     | 10.00 %            |                   |
| p1844[0]                                    | Knickkompensation Verrundung 2 negativ           | 2.50 %             |                   |

Navigation buttons: Zurück

Bottom menu: Stromregelkreis, Drehzahlregelkreis, Lageregelkreis, Funktionsgenerator, Kreisformtest, **HLA-Optimierung**, Aktive Filter, Auto Servo Optim.

Figure 4-30 Valve characteristic parameters

The parameters displayed in the list are read from the drive.

#### Note

##### Only change the parameters during a pulse inhibit

Do not change the parameters in the "U" (Run) drive state because this can have unpredictable effects on a traversing axis. Write the changed values to the drive using the enter key.

#### Further actions

- Use the "Axis +" / "Axis -" softkeys to change to the next/previous axis.
- Use the "Select axis >" softkey to open a dialog in order to select the axis from a list.

- Use the "Select DDS" softkey to open a dialog to select the drive data set (DDS) whose parameters are to be displayed in the list. You can also select the active drive data set in this dialog.

The selected drive data set does not apply for the measurement of the characteristic. The measurement is always performed with drive data set that is active in the drive at the time of the measurement.

The drive data set to which the dialog refers is displayed at the far right of the window title, e.g. DDS0.

- Use the "Copy characteristic" softkey to open a dialog to select the drive data sets to which the characteristic parameters are to be copied.
- Use the "Back" softkey to return to the "Valve characteristics measurement" dialog.

#### 4.17.7 Valve characteristic - numeric

The measured valve characteristic is not stored in the drive, but a simplified characteristic, defined section-by-section. The sections of the characteristic are defined by 16 parameters.

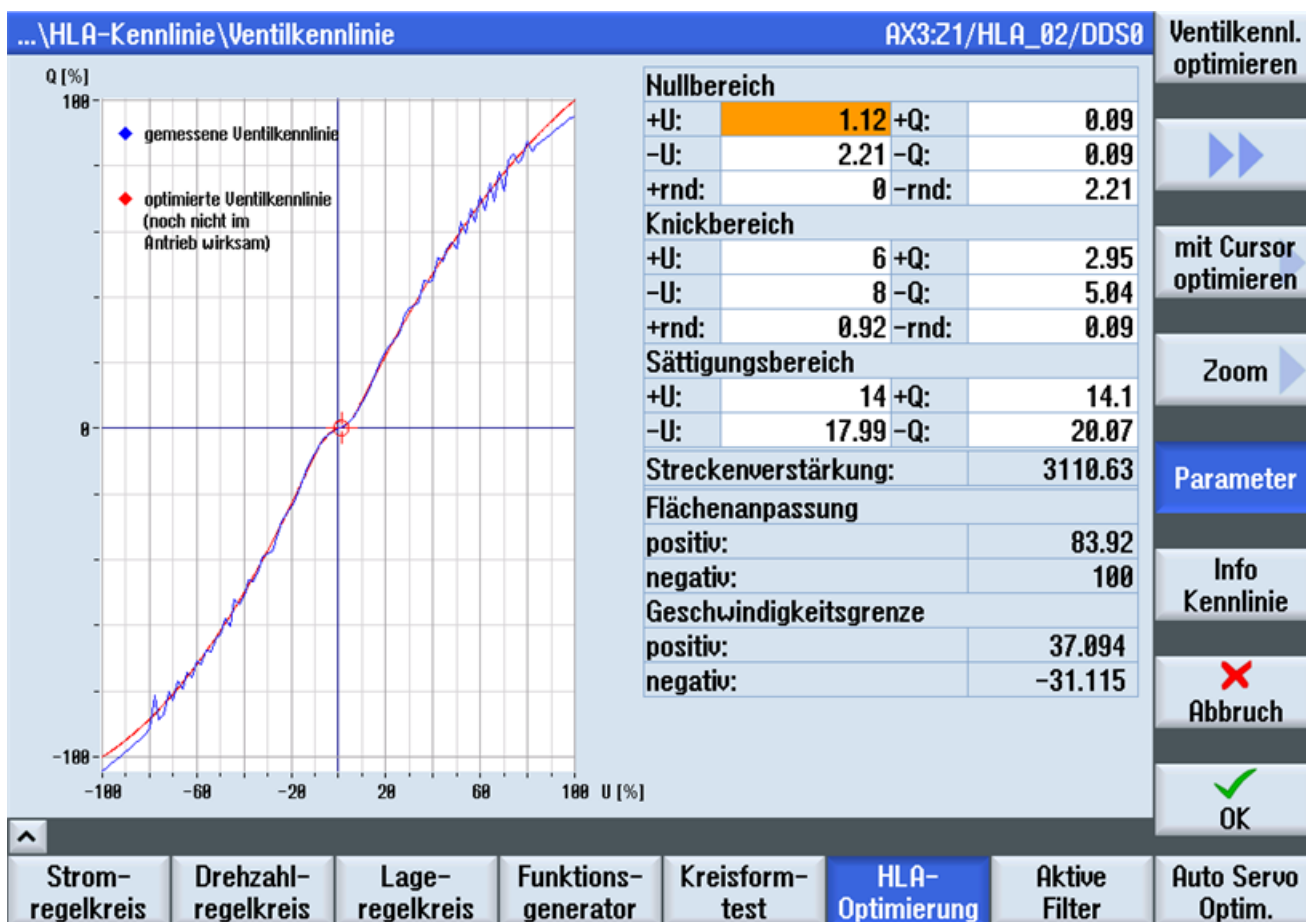

Figure 4-31 Tuning the valve characteristic

After every characteristic measurement, the "Tune valve characteristic" function is called automatically when the "Tuning" dialog is opened the first time. The simplified valve characteristic is generated. You can adapt this simplified valve characteristic as exactly as possible to the measured characteristic in this dialog. You can perform the adaptation as follows:

- Entering the parameters
- Editing with the cursor

You can switch between the adjustment types with the softkeys.

In this dialog, you can tune the valve characteristic by entering parameters.

### Automatic tuning

You can perform the automatic tuning with the "Tune valve characteristic" softkey. Through a limited number of iteration increments, the automatic tuning determines the position of the transition points and the gradient of the straight lines so that the sum of the deviations between the individual points of the tuned characteristic is as small as possible to the measured characteristic. To obtain information on the set characteristic, press the "Characteristic information" softkey.

The positive and negative velocity limits are also calculated during the automatic tuning. They are only displayed in the dialog and cannot be changed.

The result of the automatic tuning depends on the characteristic set in the drive. If you change the curve points manually and then press the "Tune valve characteristic" softkey, the automatic tuning returns a different tuning result.

In an incomplete measurement, the controlled system gain and the area adaptation are determined through extrapolation of the measured values. An incomplete measurement characteristic must be extrapolated if, when the hydraulic drive operates, the complete velocity range is to be used, although this was not able to be passed through when measuring the valve characteristic. The control system gain is the conversion factor between the control voltage and the piston velocity  $Q_{\max}$  at  $U = 100\%$ .

The area adaptation is used to compensate the different piston areas of an asymmetric differential cylinder. For the same volume flow (valve control voltage), this results in different piston velocities in the positive and negative direction.

### Performing manual tuning

Perform the tuning of the valve characteristic as follows:

- Use the LEFT, RIGHT, DOWN and UP cursor keys to select the parameter that you want to change. The selected parameter is highlighted in orange in the value field.
- Enter the value with the numeric keypad.
- Press the ENTER key to update the graphic display of the characteristic.
- Use the "Accept" softkey to close the tuning of the characteristic. The measured values as well as the measurement parameters and valve characteristic parameters are stored in an XML file.



## Meaning of the parameters

To obtain information on the characteristic diagram, press the "Characteristic information" softkey.

---

### Note

#### Manual entries are only required in exceptional cases

This data is automatically determined from the measurement. It is only necessary to manually intervene here if the complete range was not measured and if the automatic extrapolation of the characteristic does not satisfy the particular requirements.

---

- Zero range  
Enter the coordinates of the transition point of the valve characteristic in the zero range.  
Parameter: +Q = p1833 / +U = p1834, -Q = p1836 / -U = p1837, +rnd = p1835 / -rnd = p1838
- Fine control range  
Enter the coordinates of the transition point of the valve characteristic in the fine control range.  
Parameter: +Q = p1839 / +U = p1840, -Q = p1842 / -U = p1843, +rnd = p1841 / -rnd = p1844
- Saturation range  
Enter the coordinates of the start of the parabolic saturation range of the valve characteristic.  
Parameter: +Q = p1845 / +U = p1846, -Q = p1847 / -U = p1848
- Controlled system gain  
Enter the controlled system gain of the velocity controller here. The controlled system gain specifies the drive velocity (after transition compensation) at 1 V.  
Parameter: p1475
- Plane adaptation  
Here, enter the differences of the maximum velocities (dependent on the direction of the velocity).  
Parameter: p1830/p1831
- Velocity limit  
The maximum velocity in the positive and negative direction is displayed here. You cannot change these values.

## Further actions

The "Graphic tuning" dialog has several softkey bars in numeric input mode. You can switch between the softkey bars with softkeys.

"Tuning 1" softkey bar

- Use the "Tune valve characteristic" softkey to start the automatic characteristic tuning. The characteristic is drawn again after the tuning.
- Use the ">>" softkey to switch to the "Tuning 2" softkey bar.
- Use the "Tune with cursor >" softkey to switch to the graphic cursor mode. The graphic cursor is switched on. The softkey bar to tune the valve characteristic with the graphic cursor is displayed
- Use the "Zoom >" softkey to switch to the "Zoom" softkey bar.
- Use the "Parameters" softkey to show/hide the grid with the numeric values on the right-hand side of the dialog. The diagram is adapted to the dialog width.
- Use the "Characteristic information" softkey to show a full-page screen with the display of the individual ranges of the characteristic. The screen is used to explain the characteristic.
- Use the "Cancel" softkey to return to the "Valve characteristics measurement" dialog. The changes to the set characteristic and its parameters are rejected.
- Use the "Accept" softkey to write and save the adapted characteristic to the drive. The "Measure valve characteristic" dialog is displayed. If the drive is in the "Pulse enable" state, an alarm is output. The measured values as well as the measurement parameters and valve characteristic parameters are stored in an XML file. Information about the saving procedure and the generated file names is provided in the status line.

"Tuning 2" softkey bar

- Use the "Remeasure" softkey to switch to the "Measure" dialog.
- Use the "<<" softkey to switch to the "Tuning 1" softkey bar.
- Use the "Save in file" softkey to open a file selection dialog to save the parameters of both characteristics.

"Zoom" softkey bar

- Use the "X axis" softkey to select the X axis.
- Use the "Y axis" softkey to select the Y axis.
- Use the "Change quadrant" softkey to change the coordinate sign of the displayed zoom area.
- Use the "Show areas" softkey to change the display to the right-hand side of the diagram. The start and end values of the two axes are shown instead of the characteristic parameters. The diagram is updated when the values change.
- Use the "Zoom+/-" softkey to enlarge/reduce the scale of the selected axes in the diagram.

**Overview of important parameters (see SINAMICS S120/S150 List Manual)**

- r1468 Velocity controller P gain effective
- p1830[0...n] Factor plane adaptation positive
- p1831[0...n] Factor plane adaptation negative
- p1832[0...n] Valve offset
- p1833[0...n] Transition point compensation Q1 positive zero range
- p1834[0...n] Transition point compensation U1 positive zero range
- p1835[0...n] Transition point compensation rounding 1 positive zero range
- p1836[0...n] Transition point compensation Q1 negative zero range
- p1837[0...n] Transition point compensation U1 negative zero range
- p1838[0...n] Transition point compensation rounding 1 negative zero range
- p1839[0...n] Transition point compensation Q2 positive
- p1840[0...n] Transition point compensation U2 positive
- p1841[0...n] Transition point compensation rounding 2 positive
- p1842[0...n] Transition point compensation Q2 negative
- p1843[0...n] Transition point compensation U2 negative
- p1844[0...n] Transition point compensation rounding 2 negative
- p1845[0...n] Transition point compensation Q3 positive saturation
- p1846[0...n] Transition point compensation U3 positive saturation
- p1847[0...n] Transition point compensation Q3 negative saturation
- p1848[0...n] Transition point compensation U3 negative saturation

### 4.17.8 Valve characteristic - graphic

You can tune the valve characteristic using a graphic cursor in this dialog. The graphic cursor is displayed as a small colored cross in the diagram.

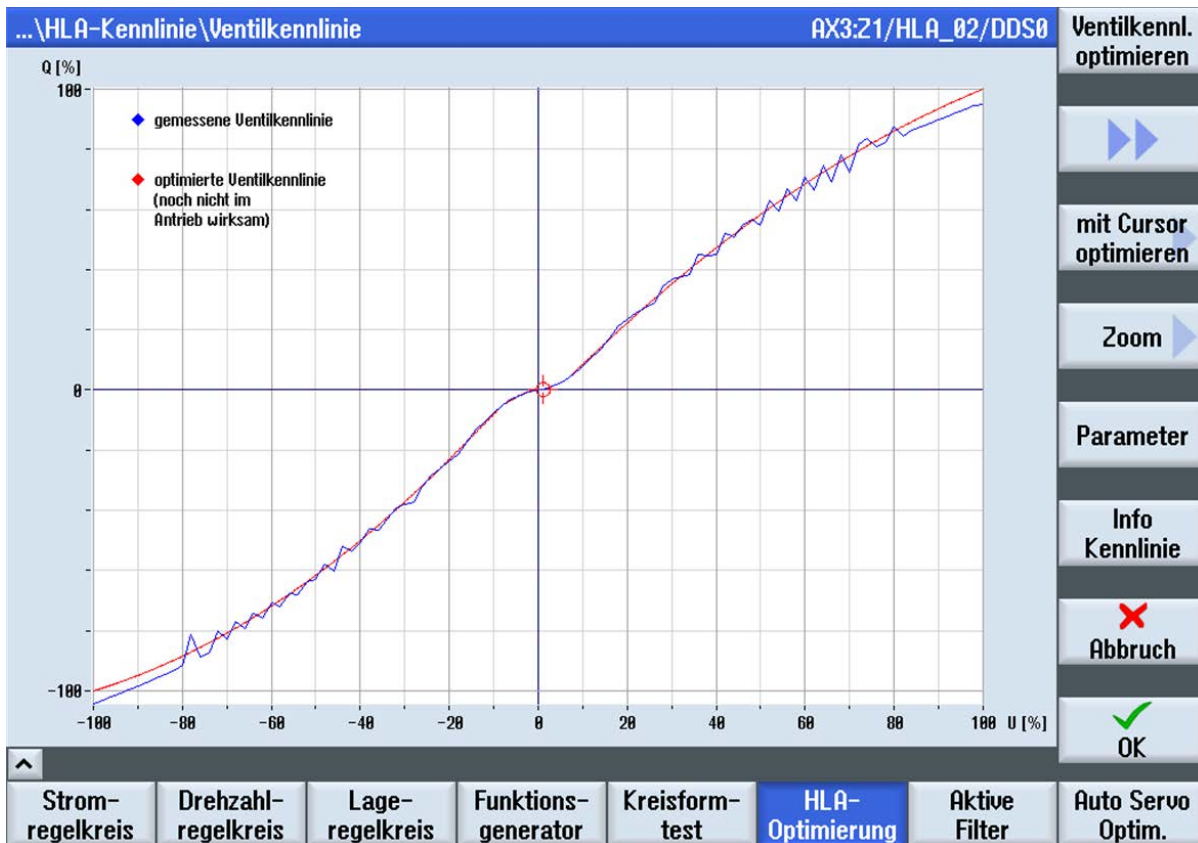

Figure 4-32 Graphically tuning the valve characteristic

### Tuning the valve characteristic

You can tune the valve characteristic with the graphic cursor as follows:

- You can use the softkeys to select the range of the characteristic that you want to tune, e.g. positive zero range. The selected range is highlighted in orange in the value field.
- Cursor keys LEFT, RIGHT, DOWN and UP to move the graphic cursor in the diagram. When the cursor reaches the edge of the diagram enlarged with "Zoom", the displayed area of the diagram is shifted. You can move the cursor until the maximum/minimum coordinates are reached.
- You can shift the characteristic with the graphic cursor.
- By pressing the ENTER key, you transfer the pair of values of the cursor coordinates to the line highlighted in orange.

You cannot set the size of the rounding area at the transition between two curve sections (rnd) using the graphic cursor. To do this, you must return to the numerical tuning and enter the values there.

## Incomplete measurement

The "End point" softkey is only active for an incomplete measurement if this was planned as complete measurement (up to 100 %). The measurement cannot be performed completely if the piston cannot be accelerated to the end velocity because the measurement path is too short.

The graphic cursor can only be moved vertically at  $U = \pm 100\%$  when the "End point" curve range is selected.

- In the positive range, the cursor movement changes the controlled system gain. The value of the plane adaptation remains at 100%.
- In the negative range, the cursor movement changes the negative plane adaptation. The value of the controlled system gain remains constant.

If the cursor is moved up or down out of the display area, the zoom factor of the diagram is adapted dynamically. If the cursor exceeds 200% on the Q axis, an appropriate message is issued. You must change the controlled system gain.

## Further actions

Use the softkeys to select the pair of values that you want to change.

- Use the "Positive range" softkey to select the positive range of the valve characteristic (first quadrant of the coordinate system).
- Uses the "Negative range" softkey to select the negative range of the valve characteristic (third quadrant of the coordinate system).
- Use the "Zero range" softkey to select the zero range of the valve characteristic.
- Use the "Transition range" softkey to select the transition range of the valve characteristic.
- Use the "Saturation range" softkey to select the saturation range of the valve characteristic.
- Is the "End point" softkey to change the controlled system gain and the plane adaptation.  
The "End point" softkey is only active for an incomplete characteristic measurement.
- Use the "Back" softkey to return to the numeric input mode.

### 4.17.9 Characteristic information

#### Measured characteristic

The measured characteristic represents the piston velocity depending on the valve control voltage as percentage values. When measuring the characteristic, the piston moves between the end points with increasing velocity and generates alternately a positive and negative measured value at each movement.

The measured characteristic comprises maximum 512 measuring points.

A characteristic stored in the drive is specifically for a drive data set (DDS). The measurement of the characteristic from which the characteristic stored in the drive is determined, therefore always refers to the currently active drive data set.

#### Calculated characteristic

A simplified characteristic is stored in the drive, defined section-by-section from straight lines and parabolic segments. These are configured using 16 parameters.

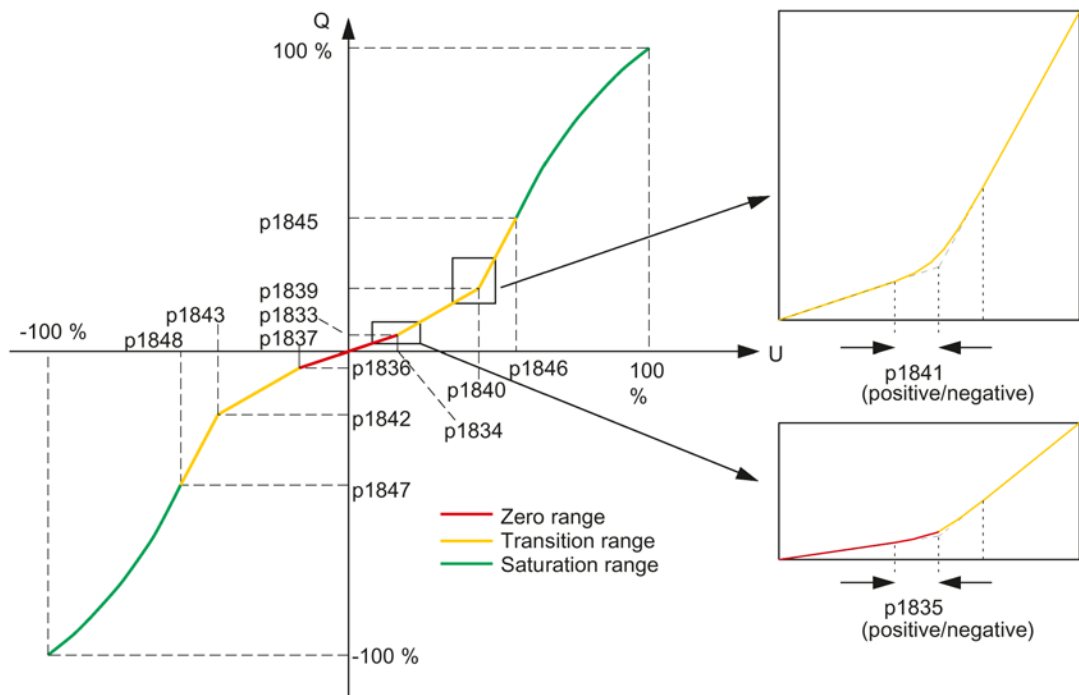

Figure 4-33 Definition of the characteristic

Starting at the zero point, the calculated characteristic comprises a short straight line, the zero range, which is rounded through a parabola into a further straight line of the fine control range. Also rounded off by a parabola, the fine control straight line transitions into the saturation range. This starts with a straight line followed by a parabola along a continuous tangent open to the bottom, which ends at point  $Q = 100\%$ ,  $U = 100\%$ .

In order to display the measured and the calculated characteristics as congruent characteristics, the piston velocity must be converted to percentage values with the aid of the area adaptation and the controlled system gain.

## Plane adaptation

Various non-linear effects of the valve or drive can be compensated using characteristics. The characteristics are cascaded so that they can be set separately.

In order to compensate the direction-dependent controlled system gain for differential cylinders, a characteristic with a gradient that can be changed depending on the direction has been implemented. The following figure shows a characteristic example and illustrates how the associated SINAMICS parameter works. In practice, only one of the gradients is weighted with a factor not equal to 100 %. Normally, the gradient that causes the cylinder drive to extend is weighted with a factor less than 100 %.

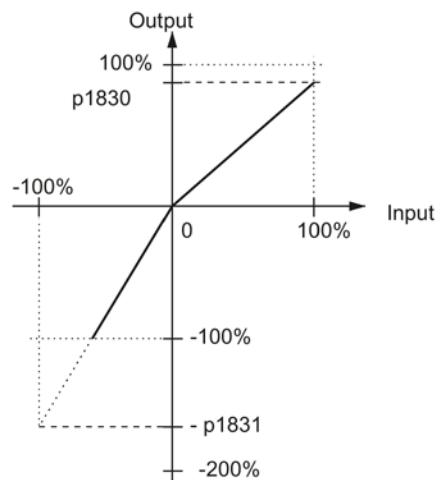

Figure 4-34 Characteristic plane adaptation

## Linearization of the valve

An inverse characteristic is applied to compensate the non-linear characteristic of valves with fine control range. The transition for real valves is rounded. For this reason, the transition range in the compensation is also rounded. The rounding is based on a root characteristic in such a way that the intersection points lie on a continuous tangent; the rounding range can be set as required.

The transition point is defined by the percentage for input (voltage) and output (volume flow).

- Valve characteristic with transition in the zero range

To calculate the inverse characteristic, a transition point is specified in the positive zero range of the valve characteristic with p1833 and p1834 and in the negative zero range with p1836 and p1837.

The positive valve flow rate at the transition point in relation to the rated flow rate is entered in p1833 and the negative value in p1836.

The positive valve voltage at the transition point in relation to the rated valve voltage is entered in p1834 and the negative value in p1837.

With the factory setting "0" in p1834, there is no transition in the positive zero range. With the factory setting "0" in p1837, there is no transition in the negative zero range.

The rounding range is parameterized in p1835.

- Valve characteristic with transition point in the fine control range

To calculate the inverse characteristic, the transition point is specified in the positive quadrant of the valve characteristic with p1839 and p1840 and in the negative quadrant with p1842 and p1843.

The positive valve volume flow at the transition point in relation to the rated volume flow is entered in p1839 and the negative value in p1842.

The positive valve voltage at the transition point in relation to the rated valve voltage is entered in p1840 and the negative value in p1843.

With equal values (default value) in p1839 and p1840, the characteristic is linear, with no transition in the zero range (default value) and no saturation (default value).

This transition point data is preset from the valve data (p0205, p0206) using "Calculate controller data". It can be changed later. The rounding range is not valve data and is therefore only preset to a default value. It can however be changed later with the p1841 data. If necessary, a measurement can be taken to obtain a precise setting.

---

### Note

A constant machining velocity of the drive directly at the transition point of the valve is not recommended.

---

- Valve characteristic with transition point at the start of a saturation range

To calculate the inverse characteristic, the start of a parabolic, rounded saturation range in the positive and negative quadrants of the valve characteristic are specified with p1845 and p1846 and with p1847 and p1848.

The positive valve flow rate at the start of the saturation range in relation to the rated valve flow rate is entered in p1845 and the negative value in p1847.

The positive valve voltage in relation to the rated valve voltage is entered in p1846 and the negative valve voltage in p1848.

The saturation range is compensated by a root characteristic in such a way that the intersection point lies on a continuous tangent and the characteristic ends at the point (100%, 100%).



There is no saturation range in the positive or negative quadrant with default value 100% in p1845 and p1846 or in p1847 and p1848.

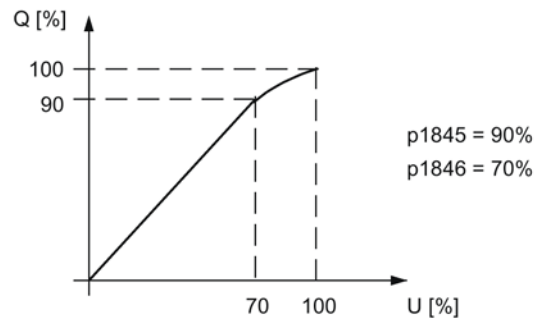

Figure 4-35 Characteristic to linearize the valve

#### 4.17.10 Valve characteristic - copying

With this dialog, you can copy the characteristic of the drive data set (DDS) currently selected in the drive to another drive data set.

##### Further actions

- Use the "Select target DDS" softkey to open a dialog to select the drive data set into which the characteristic data should be copied.
- Use the "Cancel" softkey to return to the "Valve characteristics measurement" dialog. No action is executed.
- Use the "OK" softkey to return to the "Valve characteristics measurement" dialog. The characteristic is copied into the selected drive data set.

4.17.11 Function diagram 4975 – valve characteristic and plane adaptation

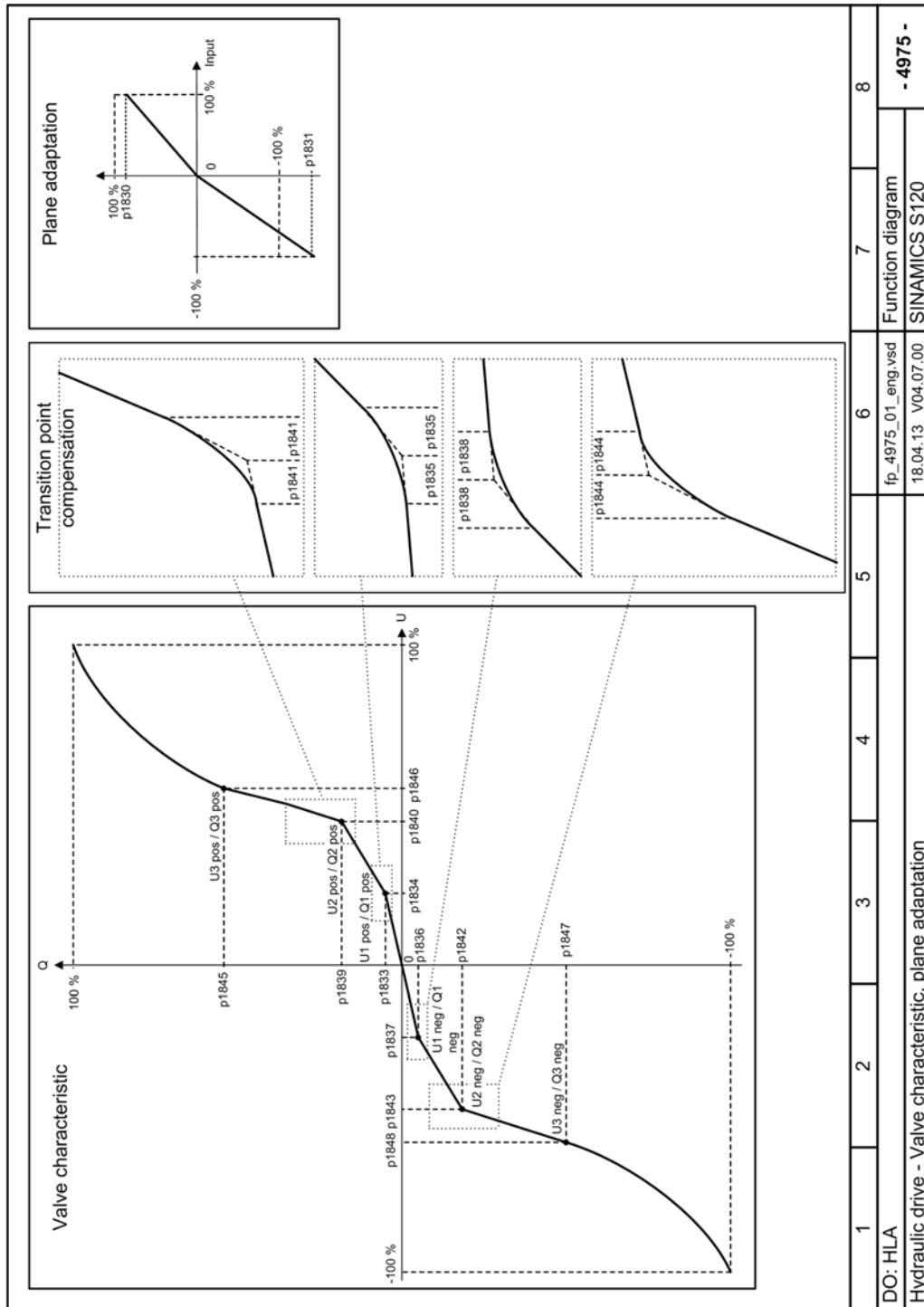

Figure 4-36 Function diagram 4975 – valve characteristic and plane adaptation

## 4.18 Fine calibration and tuning

### 4.18.1 Calibration

The following requirements must be satisfied before the three calibrations are performed:

- Position calibration  
The axis must be referenced and the piston must be at position A.
- Pressure calibration  
The system must be in a no pressure state.
- Valve offset calibration  
The axis must be in closed-loop controlled operation.

The screenshot shows a software interface for calibration. The title bar indicates the path "... \Antriebe \Konfiguration - Abgleich" and the device "AX1:X1/SERVO\_3.3:3/DDS8".

Calibration status:

- Lageabgleich:** nicht abgeglichen  
Um den Lageabgleich durchzuführen, muss die Achse referenziert werden und der Kolben in Position A stehen.
- Druckabgleich:** nicht abgeglichen  
Zum Abgleichen der Drucksensoren muss sich das System im Drucklosen Zustand befinden
- Ventiloffsetabgleich:** nicht abgeglichen  
Zum Abgleichen der Ventilstellspannung muss die Achse im geregelten Betrieb sein

System status:

- Referenzierstatus: nicht referenziert
- Achsposition: 0.000 mm
- Ventilstellspannung: 0.0 U

|          |                                   |            |
|----------|-----------------------------------|------------|
| r0067[1] | Druckistwert A                    | 7.0 bar    |
| r0068[1] | Druckistwert B                    | 8.40 bar   |
| p0241[0] | HLA Drucksensor A Offsetkorrektur | 27.00 bar  |
| p0243[0] | HLA Drucksensor B Offsetkorrektur | 16.300 bar |
| p1832[0] | HLA D/A-Wandlung Offsetkorrektur  | 0.986      |
| p0476[0] | Lageoffset zu Kolbennullpunkt     | 0.986      |

Navigation buttons on the right: Achse +, Achse -, Achse auswählen, Lage-abgleich, Druck-abgleich, Ventiloffset-abgleich, Zurück.

Bottom navigation bar: Strom-regelkreis, Drehzahl-regelkreis, Lage-regelkreis, Kreisform-test, HLA-Optim. (highlighted), Auto Servo Optim.

Figure 4-37 Calibration required

To perform the calibrations, press the "Position calibration", "Pressure calibration" and "Valve offset calibration" softkeys in this sequence. The progress of the respective calibration is displayed. The dialog looks like this once all 3 calibration types have been carried out.

... \Antriebe\Konfiguration - Abgleich DP3.SLAVE3:SPINDLE (3) MDS0 AX3:MC1

Lageabgleich: abgeglichen

Druckabgleich: abgeglichen

Ventiloffsetabgleich: abgeglichen

---

Referenzierstatus: referenziert  
 Achsposition: 0.000 mm  
 Ventilstellspannung: 0.0 U

|          |                                   |            |
|----------|-----------------------------------|------------|
| r0067[1] | Druckistwert A                    | 7.0 bar    |
| r0068[1] | Druckistwert B                    | 8.40 bar   |
| p0241[0] | HLA Drucksensor A Offsetkorrektur | 27.00 bar  |
| p0243[0] | HLA Drucksensor B Offsetkorrektur | 16.300 bar |
| p1832[0] | HLA D/A-Wandlung Offsetkorrektur  | 0.986      |
| p0476[0] | Lageoffset zu Kolbennullpunkt     | 0.986      |

Stromregelkreis Drehzahlregelkreis Lageregelkreis Kreisformtest **HLA-Optim.** Auto Servo Optim.

Figure 4-38 Calibrations performed

If required, change the offset values for the pressure sensors, the D/A conversion and the piston zero point.

**Further actions**

- Use the "Axis +" / "Axis -" softkeys to change to the next/previous axis.
- Use the "Select axis >" softkey to open a dialog in order to select the axis from a list.
- Perform the piston calibration with the "Position calibration" softkey. The softkey is disabled if the requirements for the calibration are not satisfied.
- Perform the calibration for the pressure sensors with the "Pressure calibration" softkey.
- Perform the calibration for the control voltage for the valves with the "Valve offset calibration" softkey.
- Use the "Back" softkey to return to the "Valve characteristics measurement" dialog.

**Note**

**Manual fine calibration**

If, in an exceptional case, these automatic calibration functions are not sufficient, then you can manually perform the fine calibration. This fine calibration is described in the following sections.

## 4.18.2 Control sense, traversing direction

### General

The control sense can be reversed using the following methods:

- Inversion of the control voltage
- Inversion of the actual value
- Rotation of the scale
- Piping A → A to A → B (inversion)

Any adjustment in the hydraulic piping can be canceled by inverting the control voltage.

If the scale is rotated or attached at the wrong point (jacket or rod of the cylinder), the control direction can be adapted by inverting the actual value.

### Limitation of control voltage

The control voltage must be limited before the system is first switched on to check the control sense (p1850, p1851).

**Determining the control sense (step 1)**

When the enable signals are set, the axis may move in an uncontrolled manner. Causes:

- Incorrect control sense of the velocity controller
  - Actual value encoder mounting
  - Combined connection, servo solenoid valve and cylinder
  - Control voltage polarity reversed
- Incorrect control sense of the position controller
  - Actual value encoder mounting

The options that can be used to calibrate traversing motion for any uncontrolled traversing motion are shown in Fig. "Commissioning flowchart, determining the control sense".

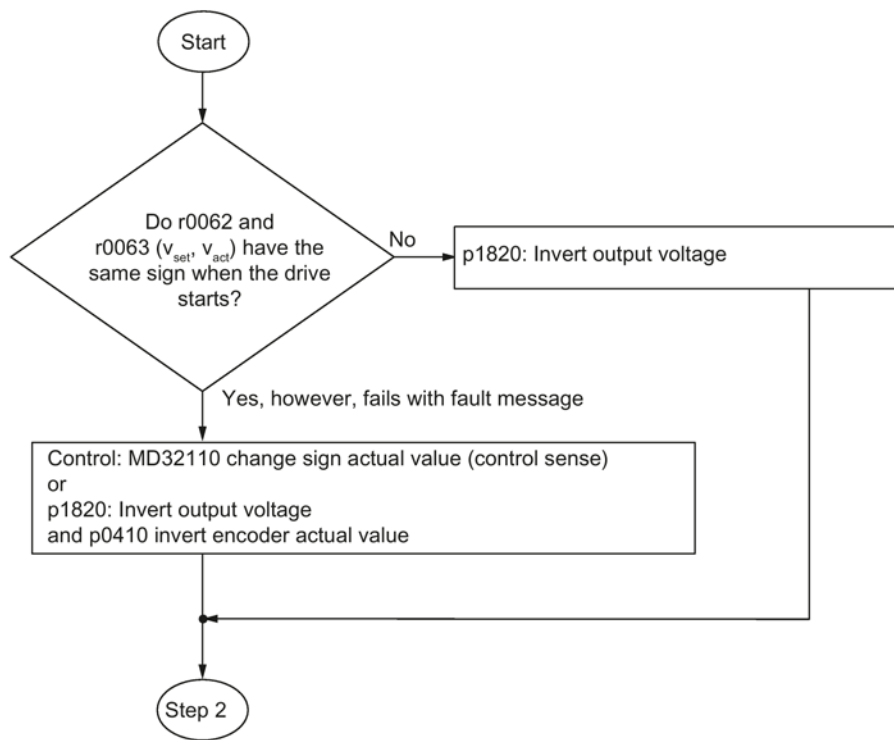

Figure 4-39 Commissioning flowchart, determining the control sense

### Defining the drive traversing direction (step 2)

For a traversing direction of the cylinder piston from A → B (flow rate  $Q > 0$ ), the velocity actual value  $V_{act}$  must be positive.

This definition is absolutely necessary on the drive side for the other functions:

- Velocity control adaptation and
- Force limitation

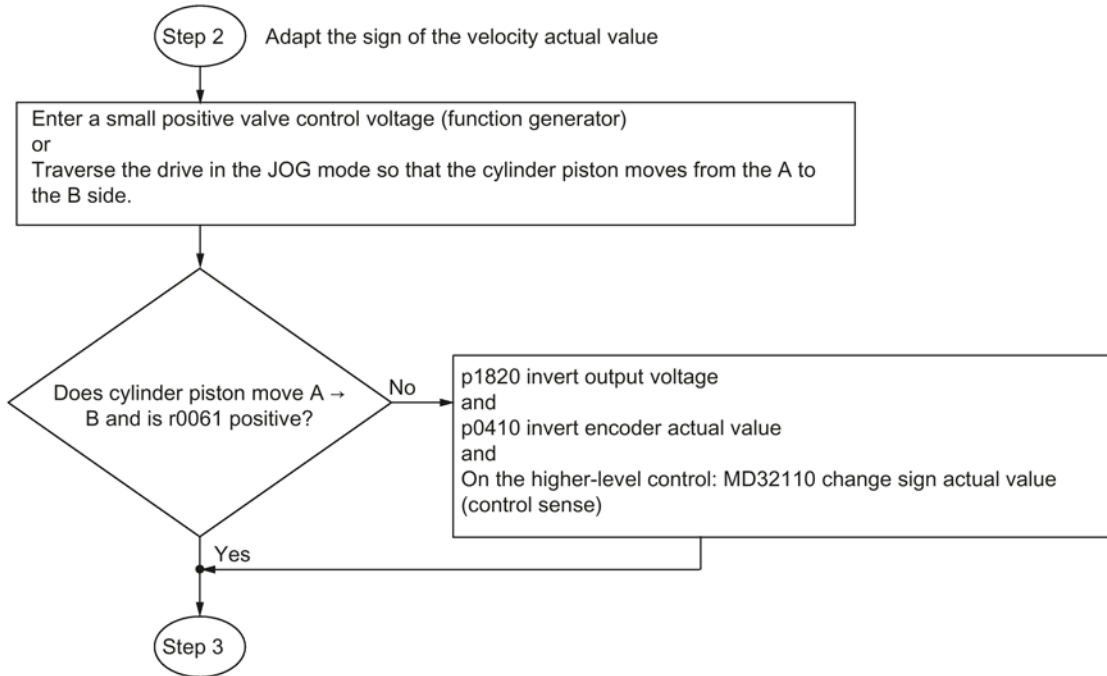

Figure 4-40 Commissioning flowchart, definition of the drive traversing direction

### Defining the traversing direction in the NC (step 3)

The user defines the positive traversing direction of the machine.

On the control side, the traversing direction must be changed in MD32100.

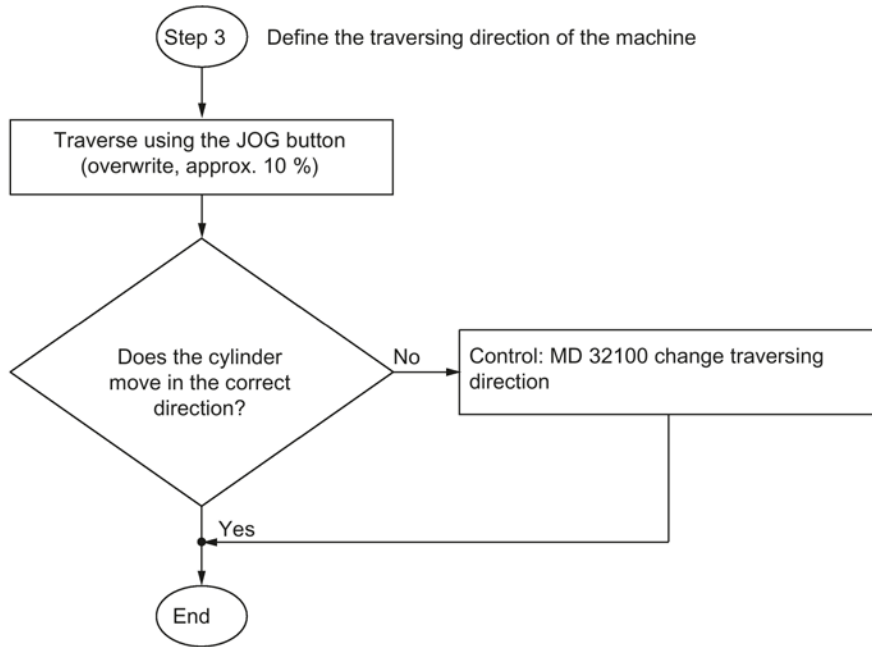

Figure 4-41 Commissioning flowchart, defining the traversing direction in the NC

### Canceling control voltage limitation

The setpoint limitation must be set to 10 V in the following parameters:

- p1850
- p1851



### 4.18.3 Offset calibration

#### Offset of pressure sensors

---

**Note**

Calibration is only possible when pressure sensing is available.

---

- **Condition**  
The precondition for the offset calibration is that the pressure at all pressure sensors = 0.
- **Objective**  
The pressure display should indicate 0 bar at zero pressure.
- **Calibration**
  - Set p1909.0 = 1  
The offset for the pressure sensors is calibrated. The determined values are automatically entered into parameter p0241 (pressure sensor A), p0243 (pressure sensor B) and p0245 (pressure sensor P; system pressure).
- The particular offset is immediately calibrated when writing to p1909. The associated bit is automatically reset if the function was executed.

#### Reference value for pressure sensors

---

**Note**

Calibration is only possible when pressure sensing is available.

---

Enter the characteristic data of the pressure sensors into the datasheet:

- p0240[0...n] pressure sensor A reference value at 10 V
- p0242[0...n] pressure sensor B reference value at 10 V
- p0244[0...n] pressure sensor P reference value at 10 V

#### Offset of valve control voltage

Objective: Calibration of the electro-hydraulic zero point

Calibration is realized automatically according to the following sequence:

1. The adjustment is made in the position controlled mode at standstill.
2. Set p1910 = 1.
3. Calibration starts when enabled and is automatically reset to a value of zero after data identification has been completed.
4. This process can take up to 60 s.
5. The valve offset is entered in p1832.

**Overview of important parameters (see SINAMICS S120/S150 List Manual)**

- p0240[0...n]      Pressure sensor A reference value at 10 V
- p0241[0...n]      Pressure sensor A offset correction
- p0242[0...n]      Pressure sensor B reference value at 10 V
- p0243[0...n]      Pressure sensor B offset correction
- p0244[0...n]      Pressure sensor P reference value at 10 V
- p0245[0...n]      Pressure sensor P offset correction
- p1832[0...n]      Valve offset
- p1909              Data identification without enabling activation
- p1910              Valve offset calibration standstill activation

**4.18.4 Velocity calibration**

As a result of the valve and drive unit tolerances, the control system gain must be subsequently adjusted with the objective to achieve a symmetrical actual velocity with

- real planes
- real valve control edges

The objective is to achieve a symmetrical velocity when extending and retracting:  $\Delta v_{\text{extend}} = \Delta v_{\text{retract}}$

**Automatic velocity calibration**

The velocity calibration can be performed within the scope of the valve characteristic measurement (see Chapter "Measurement (Page 89)").

If, in an exceptional case, this automatic calibration function is not sufficient, then you can manually perform the fine calibration. This fine calibration is described below.

**Manual calibration**

Calibration is performed using the parameter:

- p1475: Velocity controller loop gain
- and
- p1830: HLA factor plane adaptation positive /  
p1831: HLA factor plane adaptation negative (stage 2)

To do this, the following controller parameters should be set to a value = 0:

- P: P gain velocity controller (p1460/p1461/p1462)
- I: Integral time velocity controller (p1463)
- D: Derivative-action time velocity controller (p1465/p1466/p1467)

## Calibrating the controlled system gain

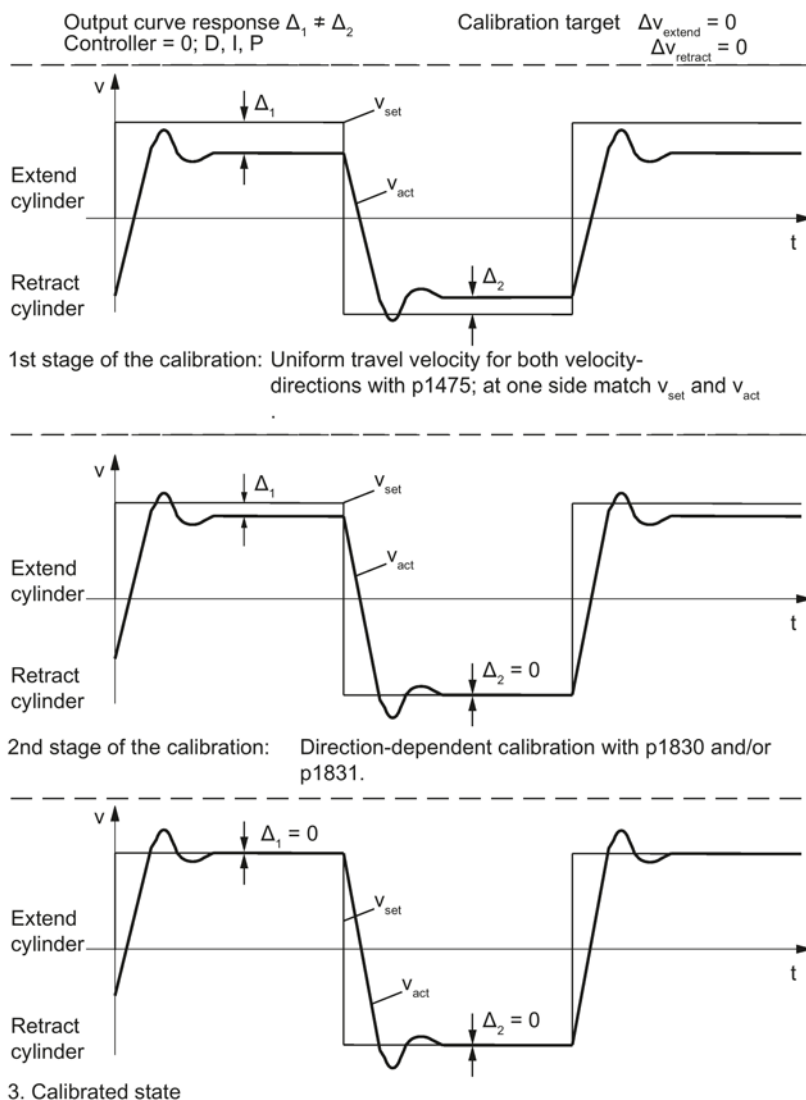

Figure 4-42 Calibrating the controlled system gain

### Note

- The setting must be checked at different velocities.
  - Generally speaking, the average value of the calculated controlled system gain must be set or
  - the gain can be adjusted to match the relevant operating range.
- Both calibrations are equivalent, i.e. calibration according to stage 2 using p1830 and p1831 produces equivalent results when the preset value (setting) of the controlled system gain (p1475) is kept.

**Overview of important parameters (see SINAMICS S120/S150 List Manual)**

- p1460[0...n] Velocity controller P gain A
- p1461[0...n] Velocity controller P gain
- p1462[0...n] Velocity controller P gain B
- p1463[0...n] Velocity controller integral time
- p1464[0...n] Velocity controller D component smoothing time constant
- p1465[0...n] Velocity controller derivative-action time A
- p1466[0...n] Velocity controller derivative-action time
- p1467[0...n] Velocity controller derivative-action time B
- r1468[0...n] Velocity controller P gain effective
- p1475[0...n] Velocity controller loop gain
- p1830[0...n] Factor plane adaptation positive
- p1831[0...n] Factor plane adaptation negative

## 4.18.5 Controller optimization

### General

The most important travel motion is implemented using the precontrol path.

The function of the controller parameters is to damp the oscillation characteristics of the valve/cylinder grouping.

In this respect, we distinguish between three different scenarios relating to the corner frequency ( $f$ ):

- $f_{\text{valve}} \ll f_{\text{cylinder}}$

The valve cannot actively influence any cylinder frequency that is higher than the valve corner frequency.

Disturbances with frequencies  $f_{\text{dis}} > f_{\text{valve}}$  cannot be damped.

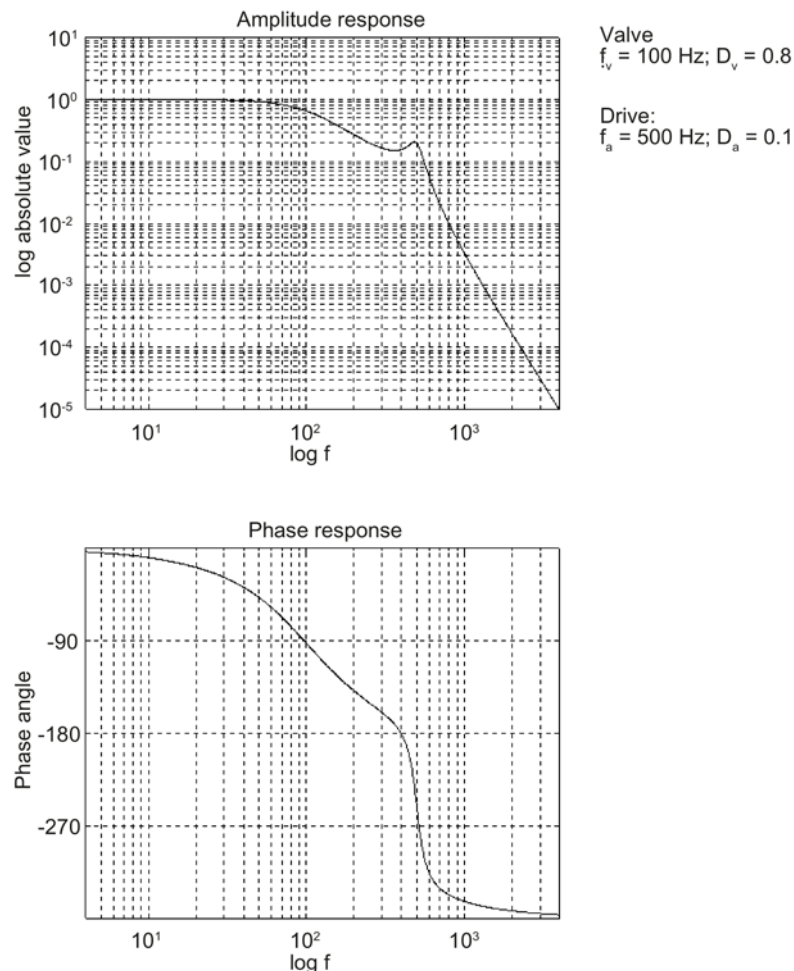

Figure 4-43 Frequency response of controlled system ( $f_{\text{valve}} \ll f_{\text{cylinder}}$ )

- $f_{\text{valve}} \approx f_{\text{cylinder}}$

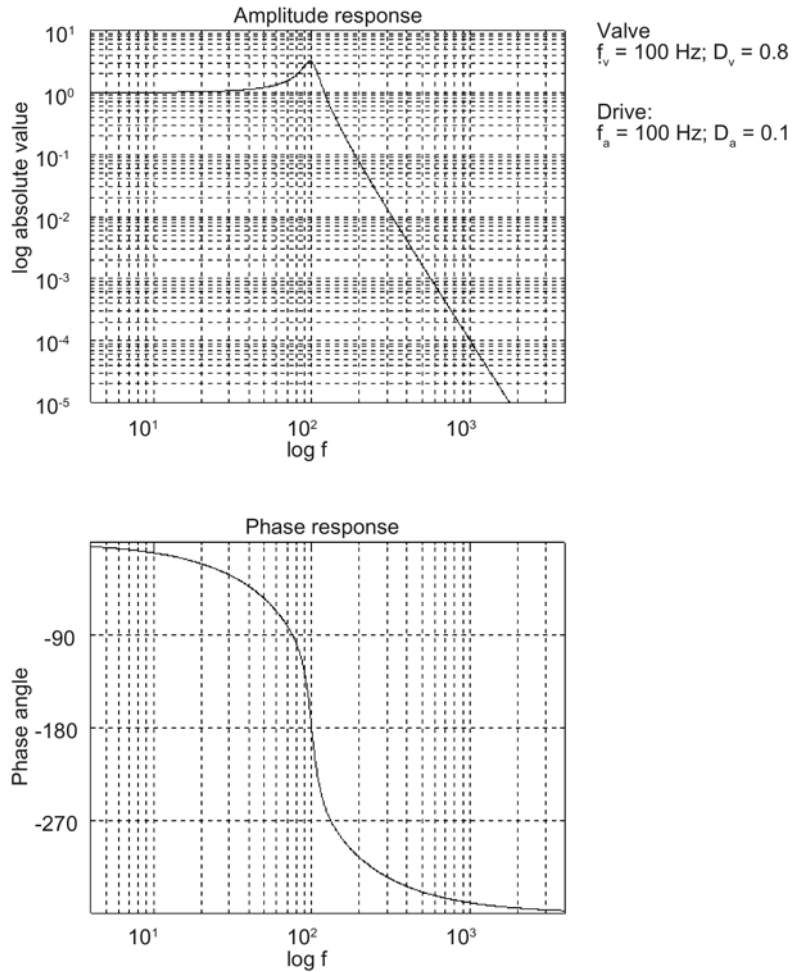

Figure 4-44 Frequency response of controlled system ( $f_{\text{valve}} \approx f_{\text{cylinder}}$ )

- $f_{\text{valve}} \gg f_{\text{cylinder}}$

The valve can actively influence all natural frequencies of the drive.

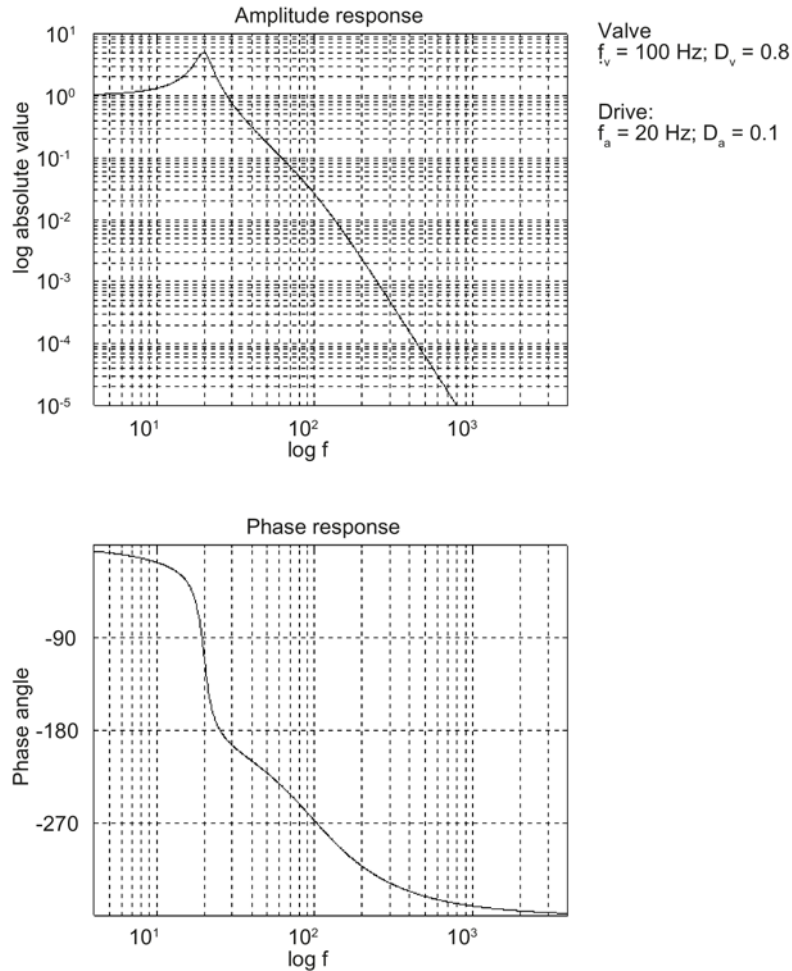

Figure 4-45 Frequency response of controlled system ( $f_{\text{valve}} \gg f_{\text{cylinder}}$ )

The controller is optimized in the following order:

1. D component (derivative component; if required)
2. P component (proportional component)
3. I component (integral component)

The preferred method of optimization uses step functions (step response), where you enter a velocity setpoint  $v_{\text{set}}$  using a function generator (FG).

The measuring function with noise signals (FFT, PBRs) may be difficult to interpret owing to non-linearities in the controlled system.

Differences in the characteristic data may be caused as follows:

- Theoretical valve: Real valve
- Lines: Control pressure =  $f(Q)$
- Additional valves; shutoff valves; filters; throttles (pressure measuring plates)

### Controller optimization D component

Relevant machine data:

- p1465: HLA velocity controller rate time A (rate time  $T_V$  of the velocity controller A)
- p1466: HLA velocity controller rate time (rate time  $T_V$  of the velocity controller)
- p1467: HLA velocity controller rate time B (rate time  $T_V$  of the velocity controller B)
- p1464: HLA velocity controller D component smoothing time constant (smoothing time constant velocity controller)

The positive phase displacement of the derivative term can be used to actively damp the controlled system for a  $f_{\text{Ⓢ}}$  type.

The derivative-action time constant/corner frequency parameters must be set to values higher than the minimum natural frequency of valve and drive.

Test run:

- The rate time can be increased if better damping is required:
- Keep the old values if damping is not improved.

(see diagram, frequency response of the controlled system -  $f_{\text{Ⓢ}}$ )

The smoothing time constant is set to values  $\geq 1$  ms as a function of the controlled system for "Calculate controller".

Derivative action increases the actual value noise, which is why a compromise must be found here between:

- derivative action (and thus oscillation damping)  
p1464, set as low as possible, i.e. high corner frequency of D component or wide D-action frequency range)  
and
- noise behavior of the manipulated variable

Also here, the optimization criterion is the maximum acceptable overshoot of the velocity control loop.

The main area of application is the valve cylinder combination  $f_{\text{Ⓢ}}$  with values  $T_V \gg 0$ .

For applications  $f_{\text{Ⓢ}} + f_{\text{Ⓢ}}$  (see diagrams), for  $T_V \geq 0$ , improved damping characteristics can only be expected at specific points, generally,  $T_V = 0$  is the best selection here.

---

#### Note

You can add a second downstream iteration loop to additionally improve the response (optimize the P and D component).

---



## Controller optimization, P component

Relevant parameters:

- p1460: HLA velocity controller P gain A (P gain velocity controller A)
- p1461: HLA velocity controller P gain (P gain velocity controller)
- p1462: HLA velocity controller P gain B (P gain velocity controller B)

The theoretical characteristic data of the valve and cylinder are used to calculate a recommended P gain value. The positive feedback area (p1460 ... p1462 <0) is also used to dampen the drive system.

The adjustment to real conditions on the machine (special damping requirements) should be made according to the following criteria:

1. P component: positive and as large as possible.

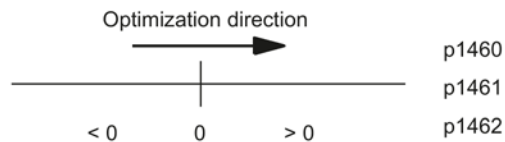

2. The acceptable overshoot response represents the upper limit for the setting.

---

### Note

$P < 0$  (positive feedback) may be necessary to achieve the required damping behavior.

Negative P gain can worsen disturbances. Negative P gain is, however, sometimes used for damping, but has negative effects on disturbance forces, as its use results in greater load dropping. Friction in particular causes longer settling times.

---

Values used (typical):

- $f_{\odot}P > 0$
- $f_{\ominus}P < 0$ , or around zero
- $f_{\oplus}P > 0$

---

### Note

The P gain is indicated as a % of p1475.  $P = -100\%$  compensates the precontrol.

---

## Controller optimization I component

Integrator/integral time (TN)

1. Objective: Compensate errors in the precontrol channel.
2. Implementation:  $TN > 5$  ms, taking into account the overshoot behavior of the valve frequency response

### Overview of important parameters (see SINAMICS S120/S150 List Manual)

- p1460[0...n] Velocity controller P gain A
- p1461[0...n] Velocity controller P gain
- p1462[0...n] Velocity controller P gain B
- p1464[0...n] Velocity controller D component smoothing time constant
- p1465[0...n] Velocity controller derivative-action time A
- p1466[0...n] Velocity controller derivative-action time
- p1467[0...n] Velocity controller derivative-action time B

## 4.18.6 Controller adaptation

### General

Since the natural frequency of the cylinder changes as a function of position, it may be useful to adapt the position of the velocity controller. The maximum values occur at the two edges, and the minimum approximately at the center (p0351) of the traversing range.

### Preconditions

- Referencing on the NC side
- Calibrating the cylinder piston at the zero position according to Chapter Piston calibration (Page 122).
- Optimized control parameters are obtained depending on the operating range being considered.

## Procedure

Optimize the velocity controller (P and D components) with the associated parameters at the edges as well as the position of p0351

Example: (Refer to Chapter "Velocity controller (Page 149), Figure 5-7 Adaptation (Page 150)") operating range = entire piston stroke

|                       |  |                  |
|-----------------------|--|------------------|
| Interpolation point 1 | Optimization at the A side of the cylinder                     |                  |
|                       | → p1460<br>→ p1465   | P gain<br>D gain |
| Interpolation point 2 | Optimization at the piston position according to               |                  |
|                       | p0351: HLA axis natural frequency A side<br>→ p1461<br>→ p1466 | P gain<br>D gain |
| Interpolation point 3 | Optimization at the B side of the cylinder                     |                  |
|                       | → p1462<br>→ p1467   | P gain<br>D gain |

### Note

If one side of a cylinder cannot be approached, then the adaptation process can be limited to two interpolation points.

Adaptation speed closed-loop controller active

p1400.5 = 1 Position-dependent adaptation (for speed und closed-loop force control)

### Note

p1400 is switched through only when the axis has been referenced and calibrated.

For  $f_{\odot}$  (see chapter "Control optimization") the adaptation is deactivated in "Calculate controller data".

## Typical sequence for position adaptation

1. Activate position adaptation p1400.5 = 1.
2. Make the controller settings for the edge on side A (p1460, p1465).
3. Make the controller settings for the center (defined via p0351) (p1461, p1465).
4. Make the controller settings for the edge on side B (p1462, p1467).
5. Adjust the integral time (p1463).

Linear interpolation takes place between the edges and the center of the cylinder. This means that if a drive is positioned between side A and the center, a mixture of the controller settings from side A and the center applies. If position adaptation is deactivated via p1400.5 = 0, only the controller settings for the center apply.

### Overview of important parameters (see SINAMICS S120/S150 List Manual)

- p0351[0...n]      Piston position natural frequency minimum
- p1400[0...n]      Velocity control configuration
- p1460[0...n]      Velocity controller P gain A
- p1461[0...n]      Velocity controller P gain
- p1462[0...n]      Velocity controller P gain B
- p1463[0...n]      Velocity controller integral time
- p1465[0...n]      Velocity controller derivative-action time A
- p1466[0...n]      Velocity controller derivative-action time
- p1467[0...n]      Velocity controller derivative-action time B

#### 4.18.7 Piston calibration

Piston calibration is required for the following actions:

- Velocity controller adaptation
- Force controller
- Friction pulse
- Automatic characteristic measurement

Piston calibration is not required for all other traversing motion.

#### Automatic piston calibration

The piston calibration can be performed automatically within the scope of the valve characteristic measurement (see Chapter "Measurement (Page 89)").

If, in an exceptional case, this automatic calibration function is not sufficient, then you can manually perform the fine calibration. This fine calibration is described below.

#### Piston calibration using absolute measuring systems

The piston position can be determined and the piston calibrated almost completely independently in the drive without any additional information from the control system.

**Determining machine position A**

1. Retract the piston → piston is at position A
  - The traversing block to retract the piston comes from the control system
2. Calibrate (p1909.1 = 1)
  - Can be performed using a parameter task as part of commissioning and can be repeated when required.
  - Encoder measured value G1\_XIST1: Transfer absolute position as machine position A for the drive → the drive saves the assigned encoder position as piston position A.

**Piston calibration with incremental or distance-coded measuring systems**

Determining the piston position and calibrating the piston are only possible using supplementary information from the control system. This is because when switched-off, encoder signals are lost if the drive has not been configured with an absolute measuring system. Saving a suitable image of the machine position in the form of a value pair allows the piston position to be calculated on the drive side from its offset.

For incremental/distance-coded encoders, a reference point approach (homing) is always required for the associated axis to calculate the piston position after power up. It is not possible to establish a reference between the machine position and piston position as long as the axis has not been referenced (validity check).

**Determining machine position A**

1. Precondition:
  - The machine/axis is referenced.
2. Retract the piston → piston is at position A
  - The traversing block to retract the piston comes from the control system.
3. Calibrate
  - This operation is initiated once using a parameter task as a part of commissioning.
  - Telegram value G1\_MP is transferred as machine position A (MP\_A) for the drive.
  - after a validity check, the drive saves the encoder position assigned to piston position A.

**Determining the piston position**

The piston position is available in r0094 following piston calibration.

### 4.18.8 Hydraulic/electrical interpolation

#### Objective

Contour precision is achieved with a drive dynamic response, which is set the same for all of the axes involved. The statement applies to both hydraulic and electric drives.

In addition to identical  $K_v$  settings, it must be ensured that the step response of the velocity controller is "identical".

#### Implementation

A velocity setpoint filter of the faster axis (e.g. electric) must be set to the difference between the time constants of the velocity control loop ( $T_{v,ers}$ )

$$T_{\text{filter, el}} = T_{\text{ers, hyd}} - T_{\text{ers, el}}$$

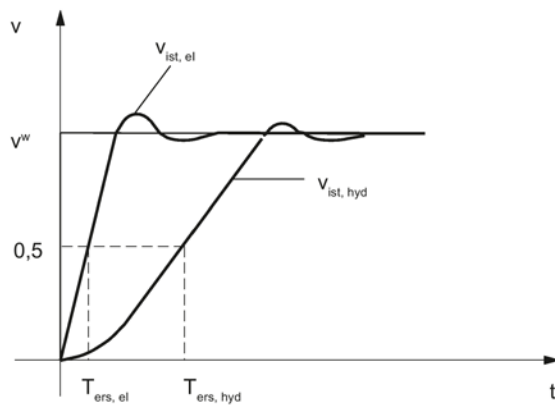

Figure 4-46 Hydraulic/electrical interpolation

When dynamic servo control (DSC) is active, the DSC function must be activated on all interpolating axes.

## 4.19 Commissioning functions

The following commissioning functions are available for HLA drives:

- Measuring function (Page 125)
- Function generator (Page 132)
- Circularity test (Page 136)
- Trace (Page 137)

### 4.19.1 Measuring function

The measuring functions can be used to evaluate the most important velocity and position control loop variables in the time and frequency domain on a screen without having to use external measuring equipment.

An overview of the measurement functions provided for HLA is given below. Only the hydraulic-specific functionality for HLA is described in detail.

The following measurement functions can be performed in conjunction with the HLA:

- Valve control loop measurement
  - Valve frequency response
- Velocity control loop measurement
  - Reference frequency response
  - Setpoint step change
  - Disturbance frequency response
  - Disturbance step
  - Velocity controlled system
  - Velocity control system + controller
- Position control loop measurement
  - Reference frequency response
  - Setpoint step change
  - Setpoint ramp

---

#### Note

The figures show the basic response. Measurements on real valves may deviate from this.

---

### Valve control loop measurement

Table 4-1 Measurement types and measured variables for the valve control loop measurement

| Measurement              | Excitation   | Measured variables                                |
|--------------------------|--|---|
| Valve frequency response | Valve spool setpoint in velocity controller cycle, valve control loop closed, velocity control loop open | Valve spool actual value/<br>valve spool setpoint |

Table 4-2 Parameterization of the valve control loop measurement

| Parameters           | Typical values | Physical unit |
|----------------------|----------------|---------------|
| Amplitude            | 1              | V             |
| Bandwidth            | 1000           | Hz            |
| Averaging operations | 10             | -             |
| Settling time        | 100            | ms            |
| Offset               | 0              | V             |

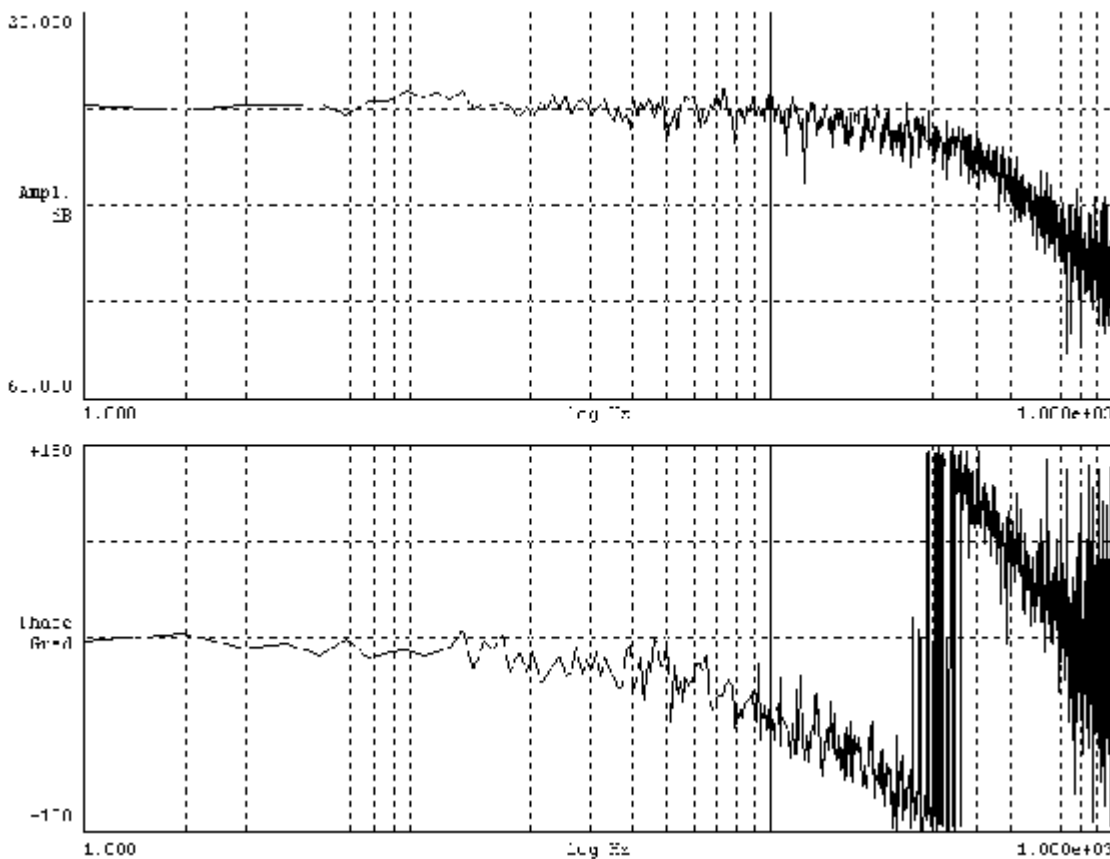

Figure 4-47 Valve frequency response for an HR servo solenoid valve (example)



## Measurement of velocity control loop

Table 4- 3 Measurement types and measured variables for the velocity control loop measurement

| Measurement                                | Excitation   | Measured variables  |
|--|--|---|
| Reference frequency re-<br>sponse          | Velocity setpoint in velocity controller cycle,<br>valve control loop closed,<br>velocity control loop closed    | Actual velocity value/<br>velocity setpoint   |
| Setpoint step change                       | Velocity setpoint in velocity controller cycle,<br>valve control loop closed,<br>velocity control loop closed    | <b>Measured variable 1:</b> <ul style="list-style-type: none"> <li>• Velocity setpoint</li> <li>• Valve spool setpoint</li> </ul> <b>Measured variable 2:</b> <ul style="list-style-type: none"> <li>• Velocity actual value</li> </ul> |
| Disturbance frequency re-<br>sponse        | Valve spool setpoint in velocity controller cycle,<br>valve control loop closed,<br>velocity control loop closed | Actual velocity value/<br>valve spool setpoint  |
| Disturbance step                           | Valve spool setpoint in velocity controller cycle,<br>valve control loop closed,<br>velocity control loop closed | <b>Measured variable 1:</b> <ul style="list-style-type: none"> <li>• Valve spool setpoint</li> </ul> <b>Measured variable 2:</b> <ul style="list-style-type: none"> <li>• Velocity actual value</li> </ul>                              |
| Velocity controlled system                 | Valve spool setpoint in velocity controller cycle,<br>valve control loop closed,<br>velocity control loop closed | Actual velocity value/<br>valve spool actual value  |
| Velocity controlled system +<br>controller | Velocity setpoint in velocity controller cycle,<br>valve control loop closed,<br>velocity control loop closed    | Actual velocity value/<br>control deviation   |

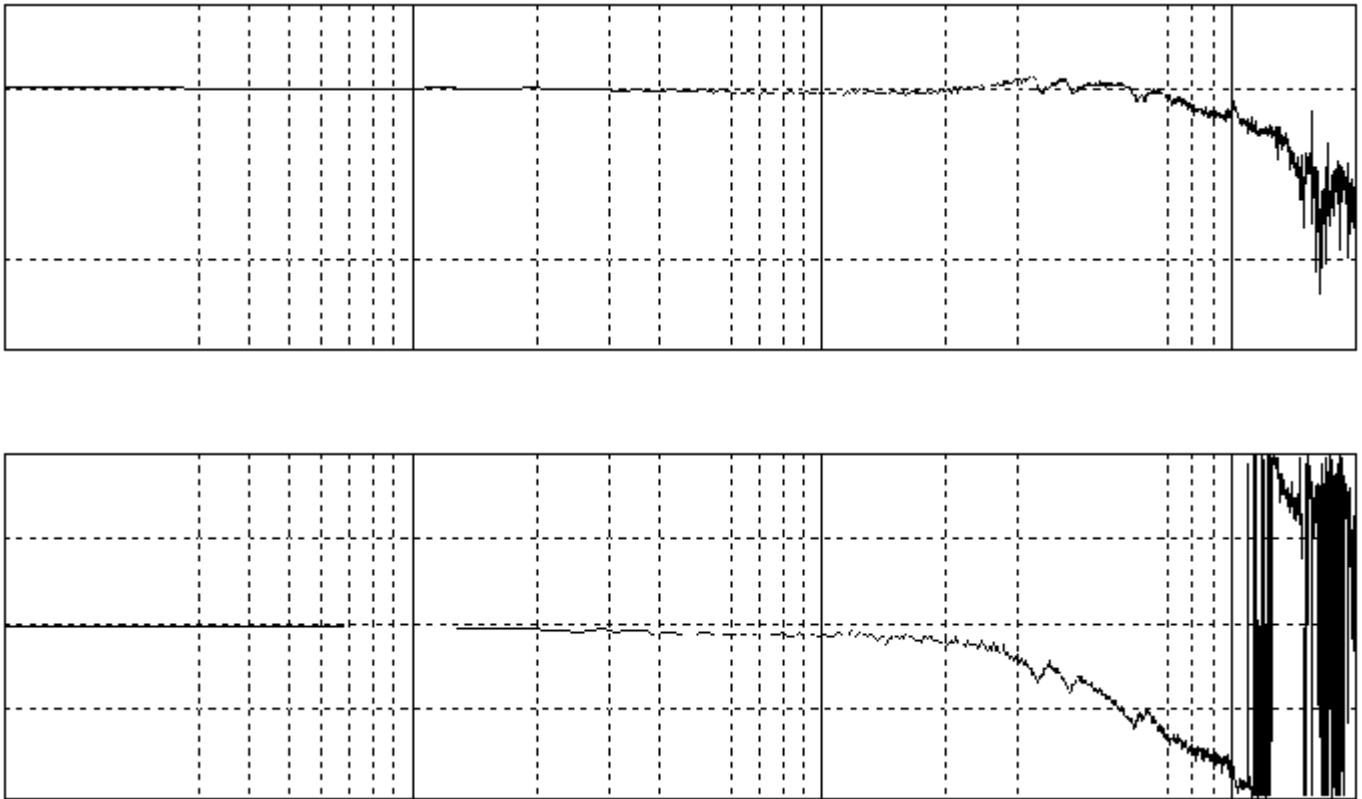

Figure 4-48 Bode diagram of the reference frequency response velocity control loop (example)

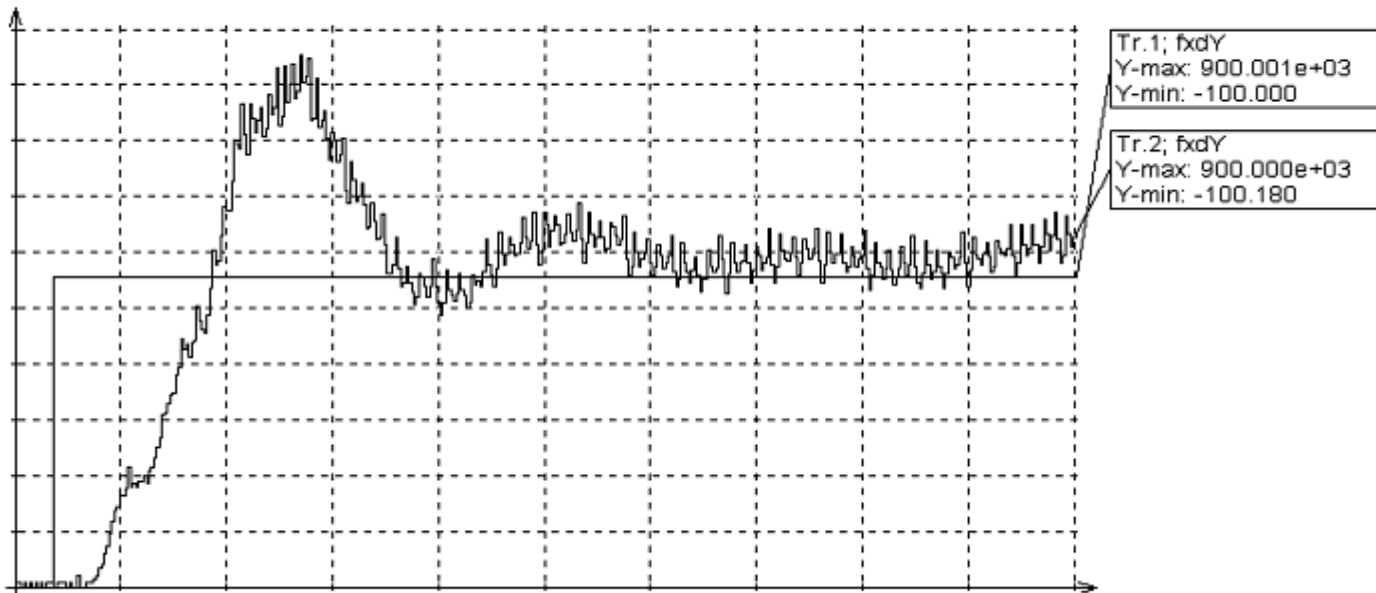

Figure 4-49 Time response of setpoint step change in the velocity control loop (example)

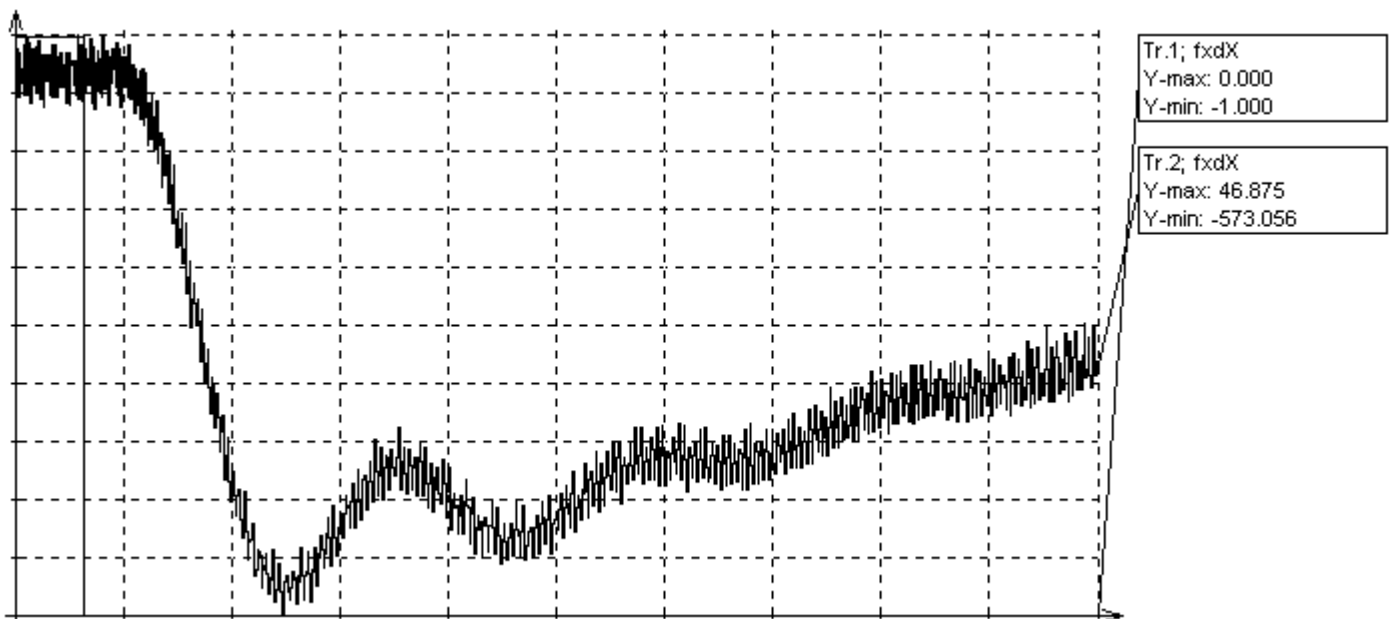

Figure 4-50 Time response of disturbance step change, integral branch of velocity controller deactivated (example)

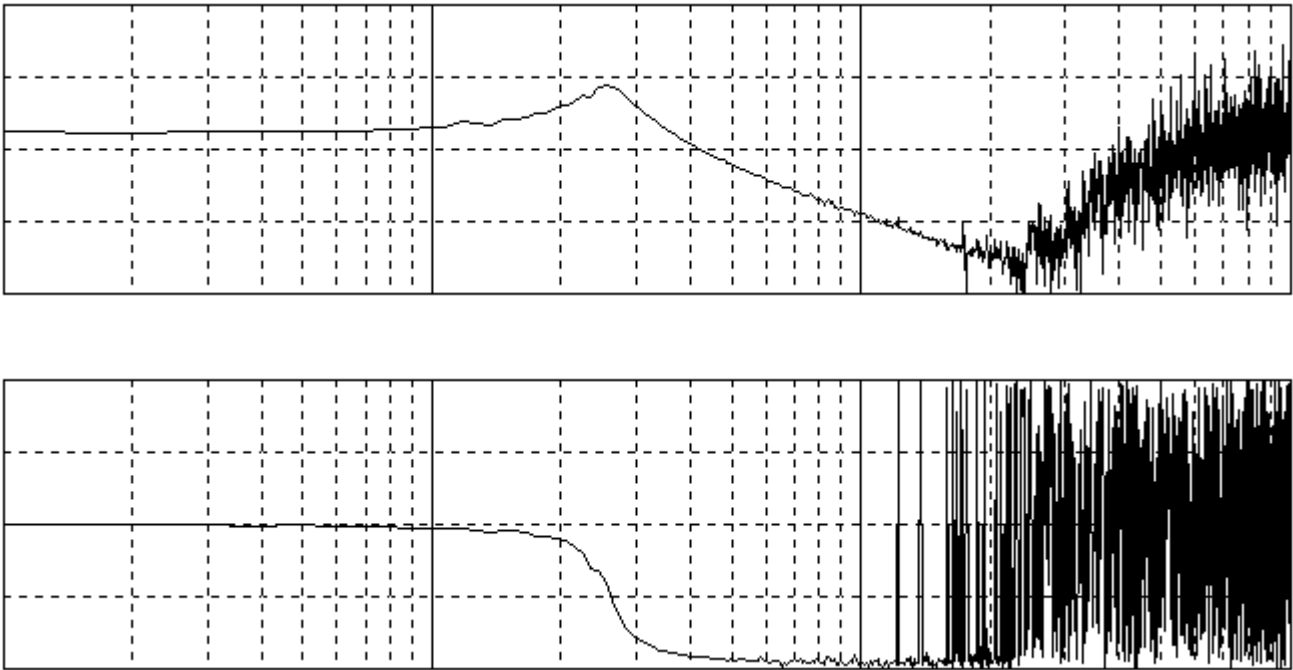

Figure 4-51 Bode diagram showing velocity controlled system  $v_{act}/Q_{act}$  (example)

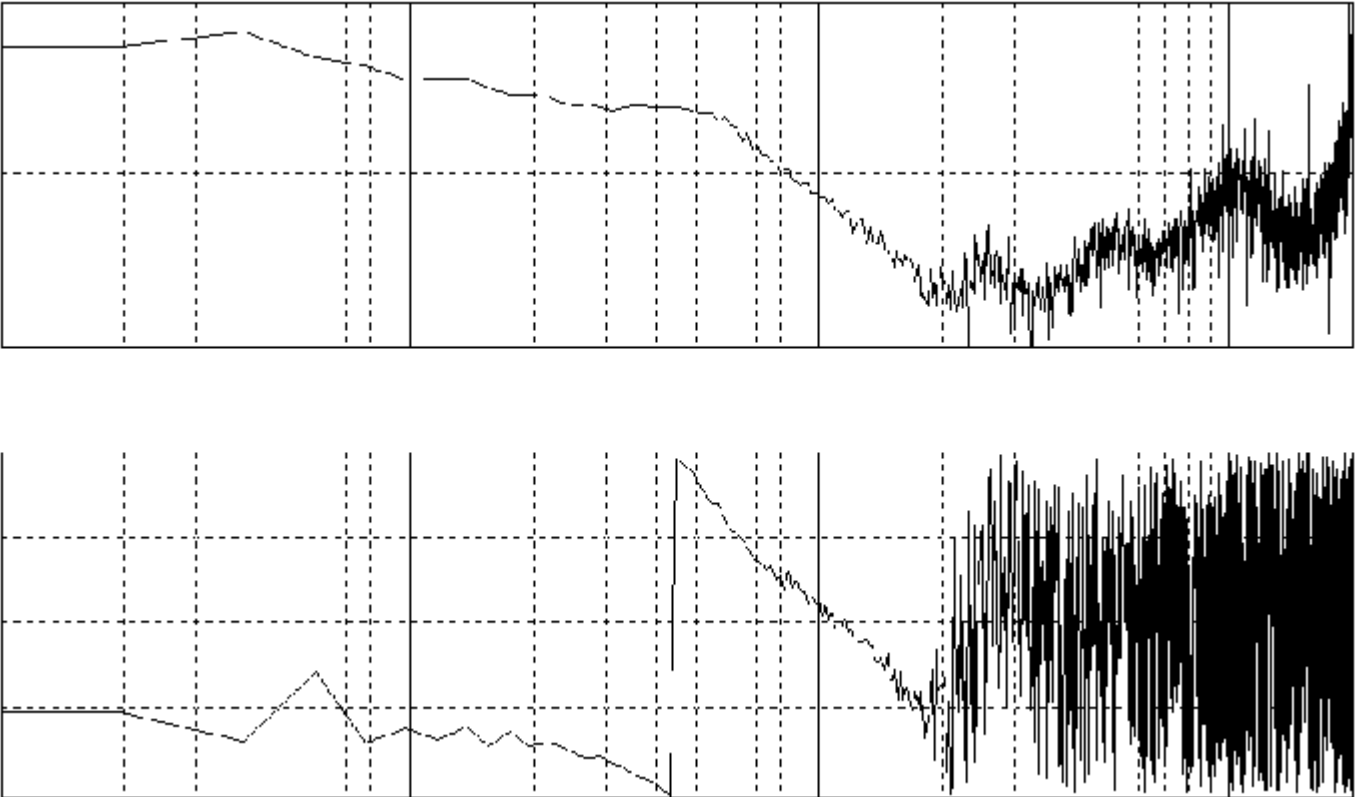

Figure 4-52 Bode diagram for velocity controlled system + controller (example)

### Position control loop measurement

Table 4- 4 Measurement types and measured variables for position control loop measurement

| Measurement                           | Excitation   | Measured variables  |
|---------------------------------------|--|---|
| Reference frequency re-<br>sponse     | Position setpoint in position controller cycle,<br>position control loop closed,<br>velocity control loop closed | Actual position value / position<br>setpoint  |
| Setpoint step change<br>Setpoint ramp | Position setpoint in position controller cycle,<br>position control loop closed,<br>velocity control loop closed | <b>Measured variable 1:</b> <ul style="list-style-type: none"> <li>• Position setpoint</li> </ul> <b>Measured variable 2:</b> <ul style="list-style-type: none"> <li>• Actual position value</li> <li>• System deviation</li> <li>• Following error</li> <li>• Velocity actual value</li> </ul> |

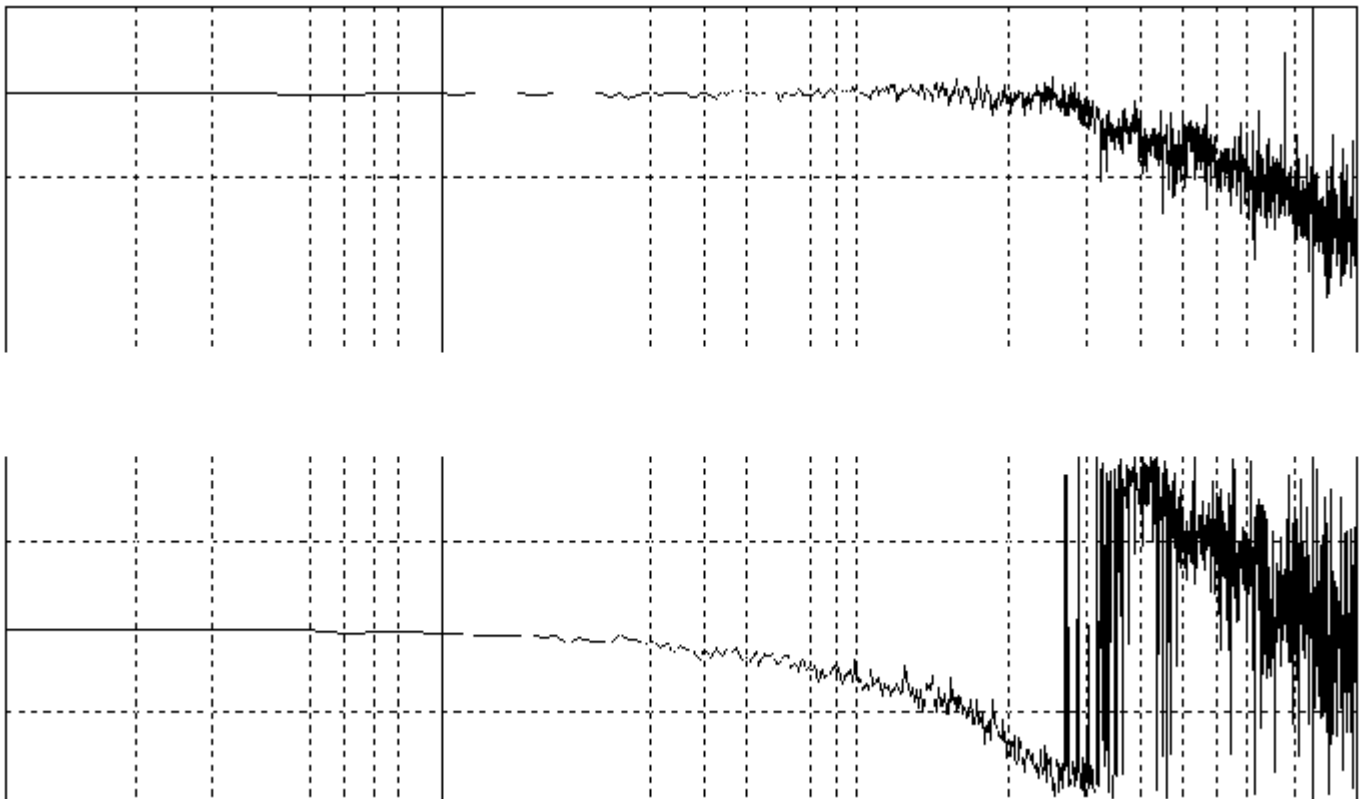

Figure 4-53 Measuring the position control loop (example)

### 4.19.2 Function generator

The function generator for HLA is based on the existing functionality available for existing drive types.

The function generator excites the drive with a periodic signal, the type of which you can parameterize. You can record the system reactions using the trace function.

The following signals (operating modes) and signal types are available for the HLA:

- Signals (operating modes)
  - Valve spool setpoint
  - Velocity setpoint
  - Force setpoint
- Signal type
  - Square-wave
  - Noise signal
  - Staircase
  - Sinusoidal
  - Triangular

For an explanation of how to use the function generator, please refer to the SINAMICS S120 Commissioning Manual.

An overview of the function generator functions provided for HLA is given below, with only the purely hydraulic-specific functionality for HLA described in detail.

### 4.19.2.1 Valve spool setpoint (control voltage)

Table 4- 5 Signal (operating mode) for the valve spool setpoint

| Excitation   | Signal type |
|--|-------------|
| Valve spool setpoint in velocity controller cycle,<br>valve control loop closed,<br>velocity control loop open | Square-wave |

Table 4- 6 Parameter settings for the signal (operating mode) for valve spool setpoint

| Parameters                      | Physical unit |
|---------------------------------|---------------|
| <b>Signal type: Square-wave</b> |               |
| Amplitude                       | V             |
| Cycle duration                  | ms            |
| Pulse width                     | ms            |
| Offset                          | V             |
| Limitation                      | V             |

Tr. 1: valve stroke setpoint  
Tr. 2: Actual valve stroke

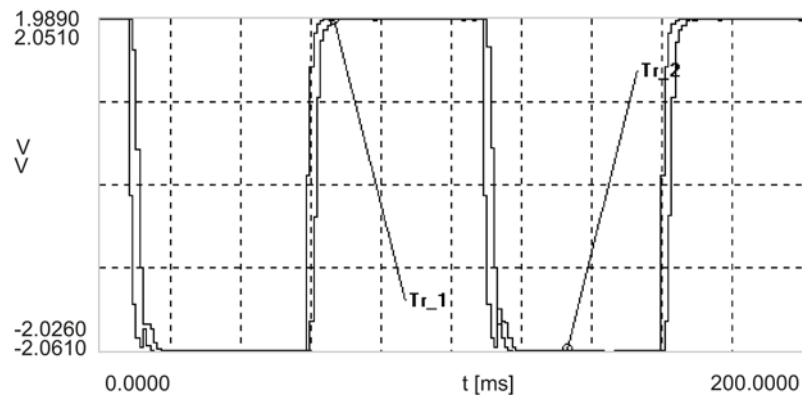

Figure 4-54 Trace "valve actual value" for "square-wave" signal at the valve setpoint

4.19.2.2 Velocity setpoint

Table 4- 7 Signal (operating mode) for velocity setpoint

| Excitation  | Signal type |
|---|-------------|
| Velocity setpoint in velocity controller cycle,<br>valve control loop closed,<br>velocity control loop closed | Square-wave |

Table 4- 8 Signal (operating mode) for velocity setpoint parameter settings

| Parameters                      | Physical unit |
|---------------------------------|---------------|
| <b>Signal type: Square-wave</b> |               |
| Amplitude (linear axis)         | mm/min        |
| Cycle duration                  | ms            |
| Pulse width                     | ms            |
| Offset (linear axis)            | mm/min        |
| Limitation (linear axis)        | mm/min        |

The following diagram was created using a servo trace.

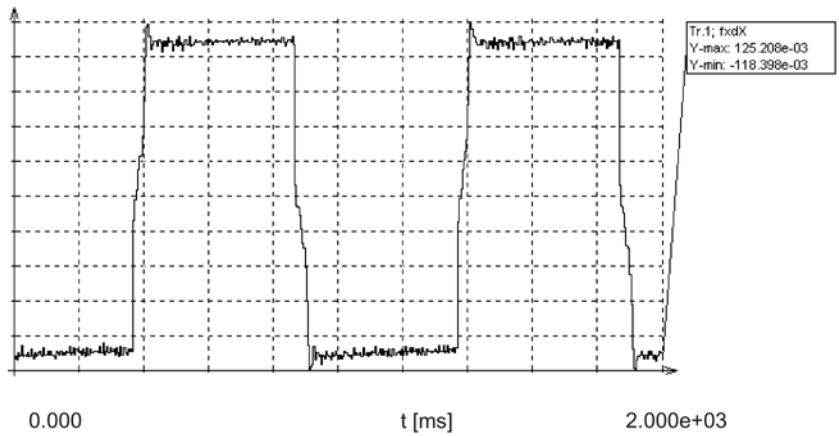

Amplitude 100 mm/min

Figure 4-55 Trace "velocity actual value" for "square-wave" signal at the velocity setpoint



### 4.19.2.3 Position setpoint

Table 4- 9 Signal (operating mode) for position setpoint

| Excitation   | Signal type |
|--|-------------|
| Position setpoint in position controller cycle,<br>position control loop closed,<br>velocity control loop closed | Square-wave |

Table 4- 10 Signal (operating mode) for position setpoint parameter settings

| Parameters                      | Physical unit |
|---------------------------------|---------------|
| <b>Signal type: Square-wave</b> |               |
| Amplitude (linear axis)         | mm            |
| Cycle duration                  | ms            |
| Pulse width                     | ms            |
| Offset (linear axis)            | mm/min        |
| Limitation (linear axes)        | mm            |

The following diagram was created using a servo trace.

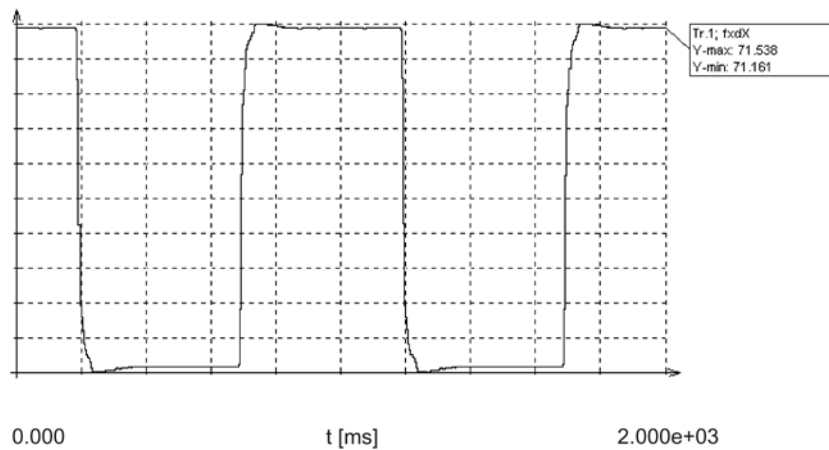

Amplitude 100 mm/min

Figure 4-56 Trace "position actual value" for "square-wave" signal at the position setpoint

### 4.19.3 Circularity test

The circularity test is used among other things as a way of checking the resulting contour precision. It functions by measuring the actual positions during a circular movement and displaying the deviations from the programmed radius as a diagram (especially at the quadrant transitions).

#### Example

The following example refers to a drive with an HR valve.

- X1 axis: Moved in the horizontal axis by an electric drive
- Y1 axis: Moved in the vertical axis by a hydraulic drive

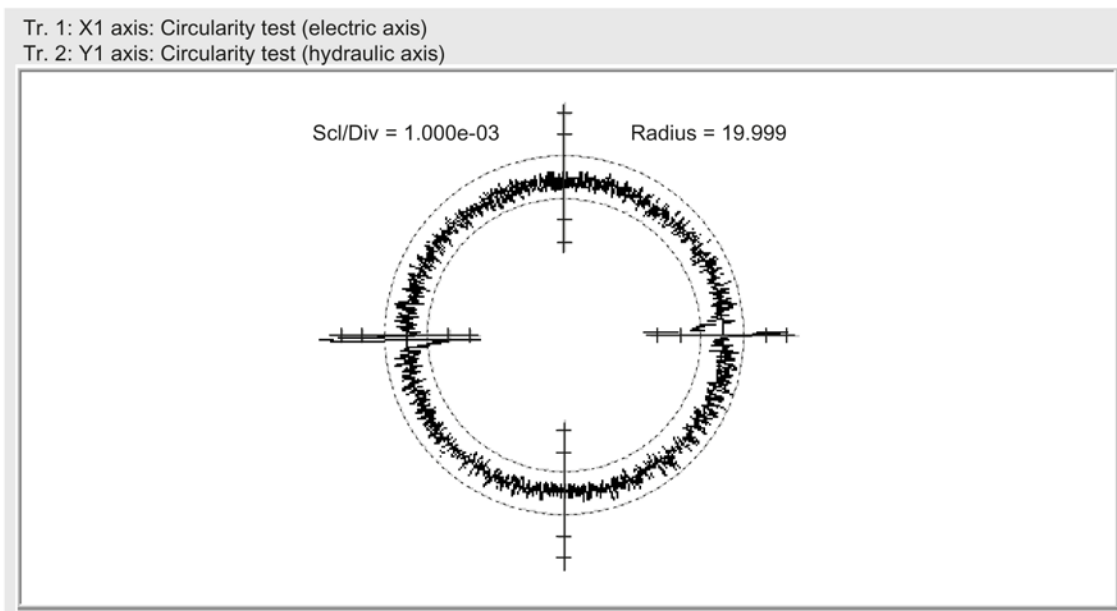

Figure 4-57 Example of circularity test on an HR valve size 06, 15 l/min, transition point 60 %; V=400 mm/min (traversing velocity)

#### **4.19.4 Trace**

You can use the trace function to record parameter values over a defined period, depending on trigger conditions. The trace function is used to graphically represent signals and operating conditions. These traces can be used, for example, for diagnostic purposes when commissioning the system.



## Drive functions

### 5.1 Block diagram of closed-loop control

#### System integration

Diagrams showing how the HLA module is principally embedded between the control system and the hydraulic drive – as well as additional logic overviews are provided in the function diagrams:

- 4965 Figure 5-8 Function diagram 4965 - velocity controller (Page 155)
- 4966 Figure 5-18 Function diagram 4966 - transition point compensation (Page 179)
- 4970 Figure 5-14 Function diagram 4970 - force controller (Page 171)
- 4975 Figure 4-36 Function diagram 4975 – valve characteristic and plane adaptation (Page 104)

The control-related functions of the HLA module are shown in greatly simplified form. They are shown in more detail in the following.

#### Possible dynamic response

The dynamic response that can be achieved depends on the following values:

- Natural frequency of the servo solenoid valve
- Natural frequency of drive

With increasing natural frequency, a higher dynamic response can be achieved.

For the purpose of oscillation damping, the natural frequency of the servo solenoid valve must be greater than that of the drive.

## 5.2 Functions

### 5.2.1 Overview of functions

SINAMICS Hydraulic Drive offers the following main functions, which are described in more detail in the following:

- Velocity precontrol
  - Controlled system gain
  - Velocity setpoint filter
  - Setpoint limitation
- Velocity controller
  - P/I/D component
  - Adaptation
  - Integrator feedback
  - Reference model
  - Manipulated variable filter velocity controller
- Force control
  - P/I/D component
  - Force limitations
  - Controlled system gain
- Control voltage output
  - Characteristic compensation
  - Manipulated variable filter
  - Control voltage limiting

## 5.2.2 Drive dataset switchover

It is possible to switch between 32 different parameter sets. Data that are assigned to specific parameter sets are identified by an [n] in the string code [0...31].

The data set switchover allows the system to be adapted or optimized to different operating points, for example.

A PLC coordinates the data set switchover.

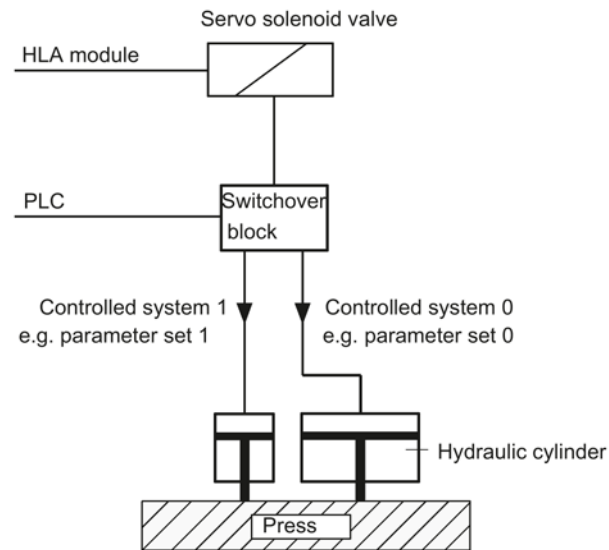

Figure 5-1 Example of a parameter set switchover

## 5.3 Closed-loop velocity control

### 5.3.1 Velocity adaptation/precontrol

#### Velocity setpoint adaptation

The transition interface NC → drive scales the maximum velocity set in p2000.

Velocity limitation is set using p1083 and p1086.

#### Velocity setpoint interpolation

The velocity control is configured using parameter p1400.

Velocity setpoints are preset in the position controller cycle.

In order to prevent rigorous drive positioning motion at the beginning of each position controller cycle, the last and the actual velocity setpoint are interpolated linearly in the drive.

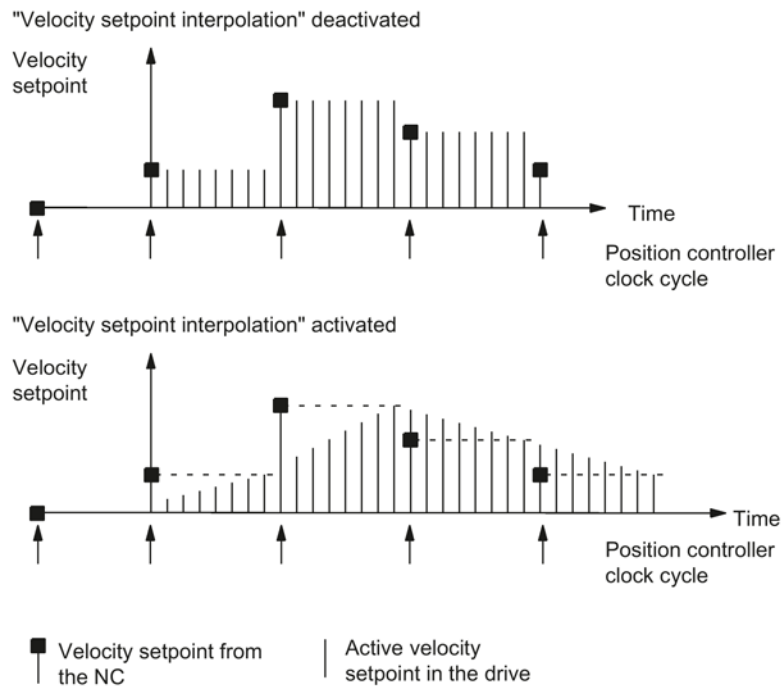

Figure 5-2 Velocity setpoint interpolation



## Velocity setpoint filters 1 and 2

The complexity of applying velocity setpoint filters means that it is not possible to provide generally applicable, definitive guidelines for their use. However, criteria for selecting filters and their parameters are defined below.

The velocity setpoint filters are used to adapt the velocity-controlled drive grouping to the higher-level position control. You can choose between bandstop and low pass filters (PT2/PT1).

The filter has the following tasks:

- Smooth the control response characteristic
- Dampen mechanical resonance
- Symmetrize different dynamic responses of axes, especially the response of interpolating axes

---

### Note

Low-pass filters can be employed on interpolating axis groupings to compensate for differences in dynamic response in velocity control loops.

The total equivalent time constant (equivalent time constant of velocity control loop + equivalent time constant of velocity setpoint filter) must be set to an identical value for all mutually interpolating axes.

Entering damping values close to the minimum input limits results in overshoots in the time range up to a factor of 2.

---

Using p1414.0 and/or p1414.1, the filters can be activated (= 1) and deactivated (= 0). No filter is active in the default setting. Using p1415, the type of velocity filter can be parameterized as PT1 or PT2 low-pass or bandstop filter.

The main filter data are defined using p1416 to p1426.

Where p1415 = 0 (PT1), the following applies: The respective filter is deactivated if a value of 0 is entered in p1416 and/or p1421.

Entering a value < 10 Hz as the low-pass natural frequency deactivates the filter.

5.3 Closed-loop velocity control

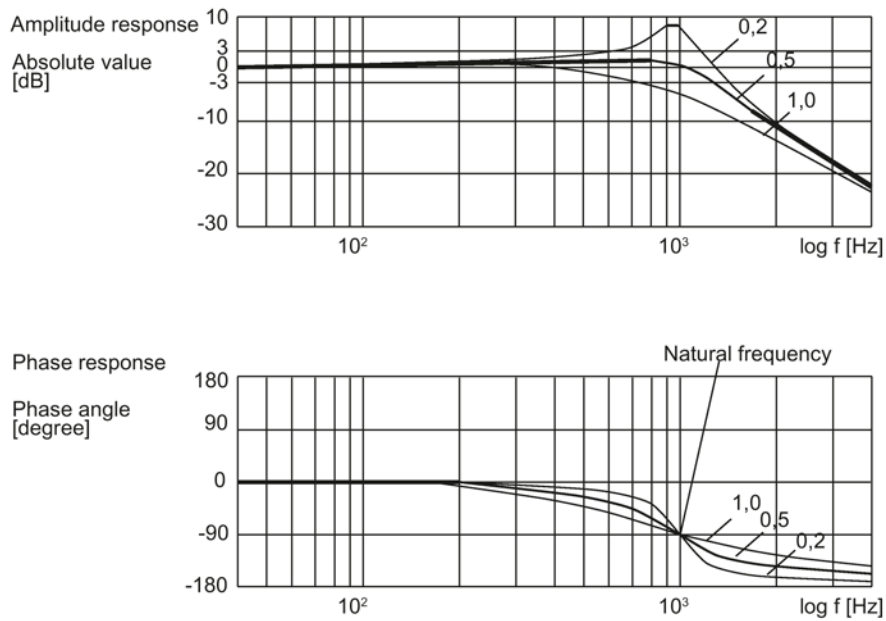

Natural frequency 1000 Hz  
(p1417)  
Variation in the damping (p1418) 0.2  
0.5  
1.0

Figure 5-3 Low-pass response (PT2)

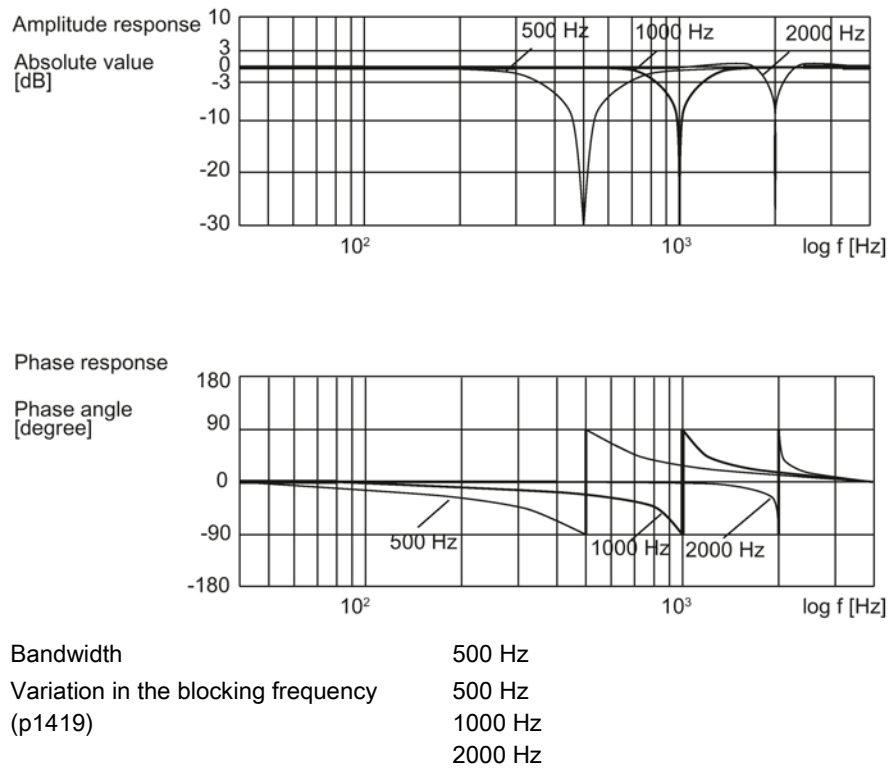
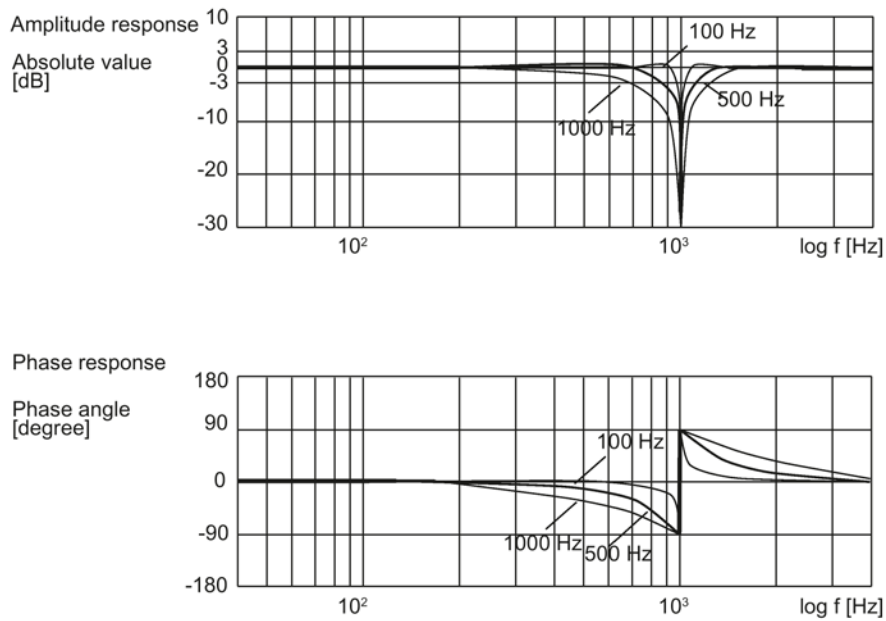

Figure 5-4 Frequency response of the non-damped bandstop filter

5.3 Closed-loop velocity control



|                                    |         |
|------------------------------------|---------|
| Blocking frequency                 | 1000 Hz |
| Variation in the bandwidth (p1420) | 100 Hz  |
|                                    | 500 Hz  |
|                                    | 1000 Hz |

The bandwidth is the difference between the two frequencies with 3 dB drop in amplitude.

Figure 5-5 Frequency response of the non-damped bandstop filter

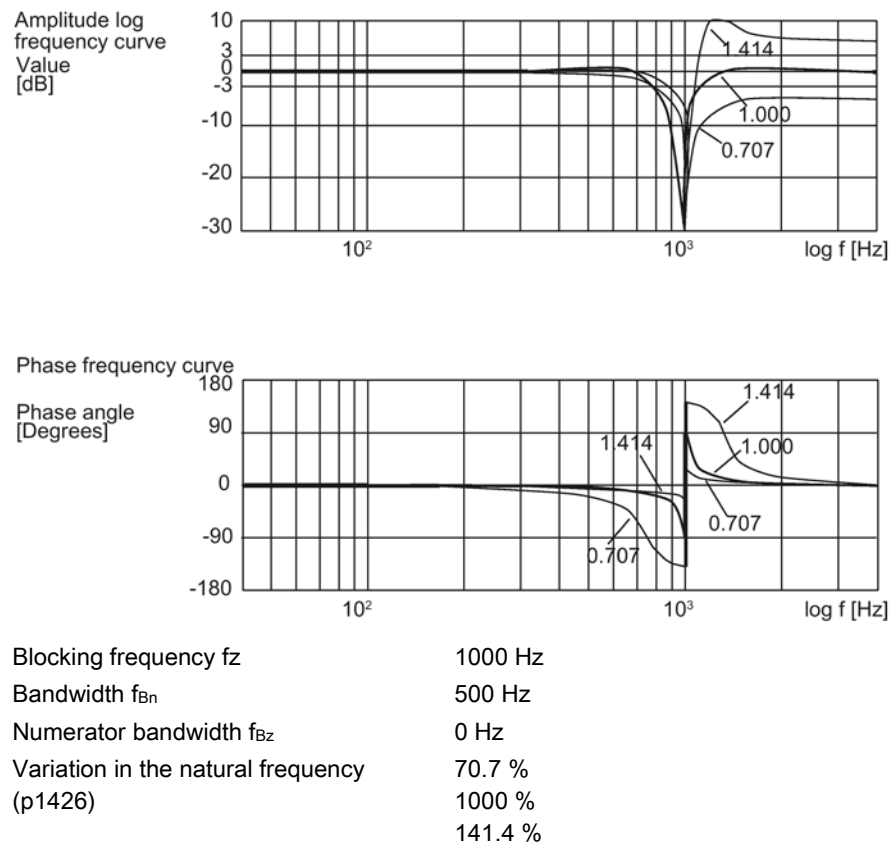

Figure 5-6 Frequency response of the general bandstop filter

### Velocity setpoint limitation

The velocity setpoint is limited in the positive (p1083) and negative directions (p1086).

#### Note

The maximum rapid traverse velocity of the drive (G0 function) is determined by NC machine parameter 32000.

With a differential cylinder, the physically possible velocities for piston retraction and extension are asymmetrical. For this reason, it is advisable to set asymmetrical limitations. A message is sent to the PLC if the limit is violated.

### Acceleration limiting

To protect mechanical components against excessive wear and damage, the drive acceleration setpoints can be limited by the higher-level control system. Linearly interpolating the velocity setpoints (p1400) ensures that the drive accelerates at the rate specified by the control system. The acceleration is not limited in the drive. A braking ramp is only active when the velocity controller is inhibited, see p1121.

### Controlled system gain

The controlled system gain is automatically entered into p1475 after "Calculate drive model data". Only change this value if it cannot be used for your particular application. The value in p1475 is the reference value for the P gain of the velocity controller. The most accurate way to determine loop gain is characteristic measurement.

### Overview of important parameters (see SINAMICS S120/S150 List Manual)

- p1083[0...n] CO: Velocity limit, positive direction
- p1086[0...n] CO: Velocity limit, negative direction
- p1121[0...n] Ramp-function generator ramp-down time
- p1400[0...n] Closed-loop control configuration
- p1414[0...n] Velocity setpoint filter activation
- p1415[0...n] Velocity setpoint filter 1 type
- p1416[0...n] Velocity setpoint filter 1 time constant
- p1417[0...n] Velocity setpoint filter 1 denominator natural frequency
- p1418[0...n] Velocity setpoint filter 1 denominator damping
- p1419[0...n] Velocity setpoint filter 1 numerator natural frequency
- p1420[0...n] Velocity setpoint filter 1 numerator damping
- p1421[0...n] Velocity setpoint filter 2 type
- p1422[0...n] Velocity setpoint filter 2 time constant
- p1423[0...n] Velocity setpoint filter 2 denominator natural frequency
- p1424[0...n] Velocity setpoint filter 2 denominator damping
- p1425[0...n] Velocity setpoint filter 2 numerator natural frequency
- p1426[0...n] Velocity setpoint filter 2 numerator damping
- p1475[0...n] Velocity controller loop gain
- p2000 Reference velocity

## 5.3.2 Velocity controller

### Velocity controller cycle

The velocity controller cycle p0115[0] is the sampling time, with which the velocity control loop is calculated.

Note the following points when setting this cycle:

- Short cycle

Good dynamic response, but measurement noise from actual velocity value is higher.

- Long cycle

Poor dynamic response, actual velocity values have low noise levels

Recommended setting:

Increase cycle time for measuring systems with wide scale graduations or large derivative-action time of D component.

### Adaptation of P and D components

Adaptation is recommended where the natural frequency of the servo solenoid valve is higher than that of the drive.

Precondition:

As adaptation is performed via the piston position, you must calibrate the piston before you perform adaptation.

With p1400.5, adaptation is activated (p1400.5 = 1) or deactivated (p1400.5 = 0). If adaptation is deactivated, then p1461 and p1464 apply.

- Adaptation on (see diagram "Adaptation")

At the A and B cylinder sides, the P gain is set with p1460 and p1462, and the derivative-action time (D component) is set with p1465 and p1467.

p1461 and p1466 are active for position p0351

- Adaptation OFF

p1461 and p1466 are active over the complete range.

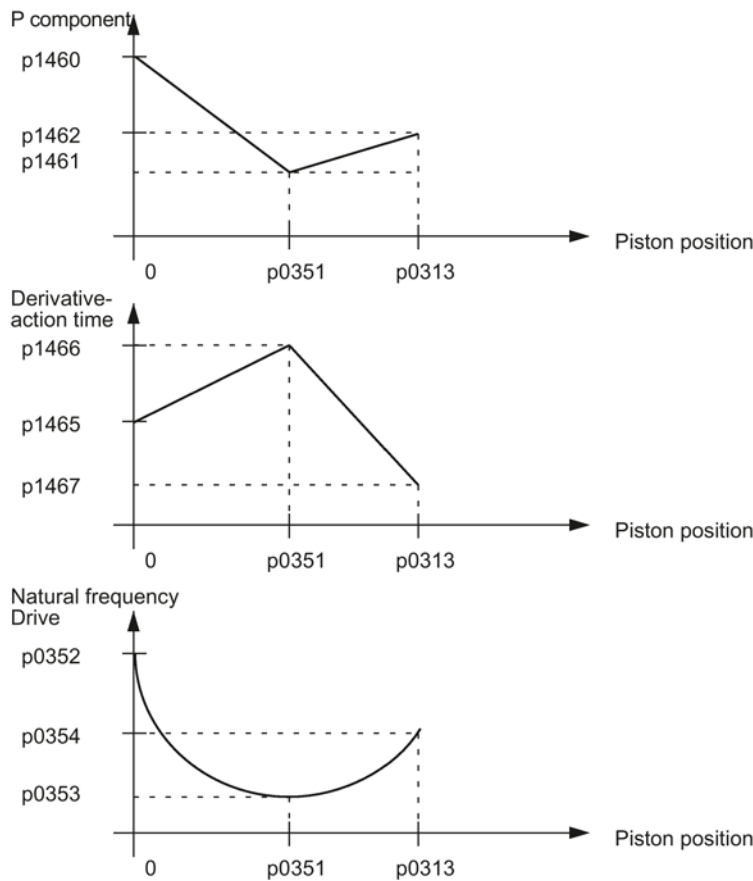

Figure 5-7 Adaptation

A graphic representation of the relationships can be found in Figure 5-8 Function diagram 4965 - velocity controller (Page 155).

The natural frequency of the drive varies as a function of distance. Extreme values occur at the two limits and approximately at the center (p0351) of the traversing range. It may therefore be useful to adapt the velocity controller position (P and D components), with the extreme range limits specified as interpolation points.

If the piston zero has not been calibrated, the adaptation will not be effective, even if it is activated.

When adaptation is active, the P gain and D action component of the velocity controller are interpolated linearly between two points.

"Calculate controller data" alters the settings for the controllers and the adaptation selection.

## P component

A negative P gain setting may be useful for oscillation damping (p1460 or p1462). The gain is specified in relation to the drive servo gain setting. 100 % means that for a setpoint-actual value difference having the magnitude of the maximum velocity (p1083, p1086), the full rated valve voltage is output as P component.

The P gain, set with p1461, refers to the controlled system gain set using p1475.



## I component

The integral-action component can be deactivated by setting the integral time to zero (p1463). For a negative P gain setting, the integral time is interpreted as a negative value so that the compensation always acts as negative feedback.

The integrator can be activated/deactivated from the PLC. The current status is returned to the PLC.

## Integrator feedback

The integrator of the velocity controller loop is reduced to a 1st order low-pass response with the configured time constant (p1494) using weighted feedback.

- **Effect:**  
The output of the velocity controller integrator is limited to a value proportional to the difference between setpoint and actual values (steady-state proportional action).
- **Applications:**  
Machining motion for position setpoint zero and dominant stiction can be suppressed, but result in a permanent distance-to-go, e.g. oscillation of the position-controlled axis at zero speed (stick-slip effect) or overshoot for the  $\mu$ m-step method.
- **Setting note:**  
Optimize this data starting from a high value until you find the best compromise.

## Integrator feedback threshold

Velocity below which the integrator feedback takes effect (p1495).

The integrator feedback function is mainly used when stiction problems are encountered, i.e. to suppress undesirable movements caused by stiction (slip-stick effect) in position-controlled operation and at zero speed.

p1495 can be used to ensure that the integrator feedback is activated only for low velocity setpoints and stabilizes the axis at zero speed. At high velocities, however, the effect of the I component is not restricted.

## D component (acceleration feedback)

A derivative-action component (acceleration feedback) is implemented in the controller in addition to the P component. This derivative-action component is located in the feedback branch. The setting is realized using the derivative-action time (p1465, p1466 and p1467). It can be negative or positive. No D component is active if 0 is entered.

Similar to the P component setting, it is possible to set a D component at the A and B sides of the cylinder.

Since precise differentiation is not possible, an additional denominator component must be provided. This component is set using a smoothing time constant (p1464). If the D component is deactivated, then the smoothing constant also becomes inactive.

**Reference model**

The dynamic response of the velocity control loop to control commands without an I component in the velocity controller is simulated in the reference model. In the ideal case of exact simulation, there is no deviation after the setpoint/actual value comparison at the integrator under no-load conditions. In practice, velocity overshoot in response to control commands can be reduced in this way.

The reference model is defined using the natural frequency (p1433) and damping (p1434) parameters.

**Manipulated variable, velocity controller**

Four manipulated variable filters have been implemented. You can activate the number of manipulated variable filters required in the velocity controller in parameter p1656. No filter is active in the default setting. You can choose between bandstop filters and 2nd order low-pass filters, which you can set in p1657. Examples:

- Manipulated variable filter 1 active  
p1656.0 = 1
- Manipulated variable filter 1 and 2 active  
p1656.0 = p1656.1 = 1

Input of the configuration for four manipulated variable filters. The following options are available:

- General 2nd order filter
- Low pass

---

**Note**

The filter machine data must be assigned before the filter type is configured.

---

Table 5- 1 Manipulated variable filter type in the velocity controller

| Filter     | Select type | Value | Required settings   |
|------------|-------------|-------|---|
| 1st filter | p1657       | 1     | Low pass (see p1658, p1659)                               |
|            |             | 2     | General 2nd order filter (see p1658, p1659, p1660, p1661) |
| 2nd filter | p1662       | 1     | Low pass (see p1663, p1664)                               |
|            |             | 2     | General 2nd order filter (see p1663, p1664, p1665, p1666) |
| 3rd filter | p1667       | 1     | Low pass (see p1668, p1669)                               |
|            |             | 2     | General 2nd order filter (see p1668, p1669, p1670, p1671) |
| 4th filter | p1672       | 1     | Low pass (see p1673, p1674)                               |
|            |             | 2     | General 2nd order filter (see p1673, p1674, p1675, p1676) |

**Overview of important parameters (see SINAMICS S120/S150 List Manual)**

- p0115[0...6] Sampling times for internal control loops
- p0351[0...n] Piston position natural frequency minimum
- p1400[0...n] Closed-loop control configuration
- p1433[0...n] Velocity controller reference model natural frequency
- p1434[0...n] Velocity controller reference model damping
- p1460[0...n] Velocity controller P gain A
- p1461[0...n] Velocity controller P gain
- p1462[0...n] Velocity controller P gain B
- p1463[0...n] Velocity controller integral time
- p1464[0...n] Velocity controller D component smoothing time constant
- p1465[0...n] Velocity controller derivative-action time A
- p1466[0...n] Velocity controller derivative-action time
- p1467[0...n] Velocity controller derivative-action time B
- p1475[0...n] Velocity controller loop gain
- p1494[0...n] Velocity controller integrator feedback time constant
- p1495[0...n] Integrator feedback velocity threshold
- p1656[0...n] Manipulated variable filter velocity controller activation
- p1657[0...n] Manipulated variable filter 1 velocity controller type
- p1658[0...n] Manipulated variable filter 1 velocity controller denominator natural frequency
- p1659[0...n] Manipulated variable filter 1 velocity controller denominator damping
- p1660[0...n] Manipulated variable filter 1 velocity controller numerator natural frequency
- p1661[0...n] Manipulated variable filter 1 velocity controller numerator damping
- p1662[0...n] Manipulated variable filter 2 velocity controller type
- p1663[0...n] Manipulated variable filter 2 velocity controller denominator natural frequency
- p1664[0...n] Manipulated variable filter 2 velocity controller denominator damping
- p1665[0...n] Manipulated variable filter 2 velocity controller numerator natural frequency
- p1666[0...n] Manipulated variable filter 2 velocity controller numerator damping
- p1667[0...n] Manipulated variable filter 3 velocity controller type
- p1668[0...n] Manipulated variable filter 3 velocity controller denominator natural frequency
- p1669[0...n] Manipulated variable filter 3 velocity controller denominator damping

5.3 Closed-loop velocity control

- p1670[0...n] Manipulated variable filter 3 velocity controller numerator natural frequency
- p1671[0...n] Manipulated variable filter 3 velocity controller numerator damping
- p1672[0...n] Manipulated variable filter 4 velocity controller type
- p1673[0...n] Manipulated variable filter 4 velocity controller denominator natural frequency
- p1674[0...n] Manipulated variable filter 4 velocity controller denominator damping
- p1675[0...n] Manipulated variable filter 4 velocity controller numerator natural frequency
- p1676[0...n] Manipulated variable filter 4 velocity controller numerator damping

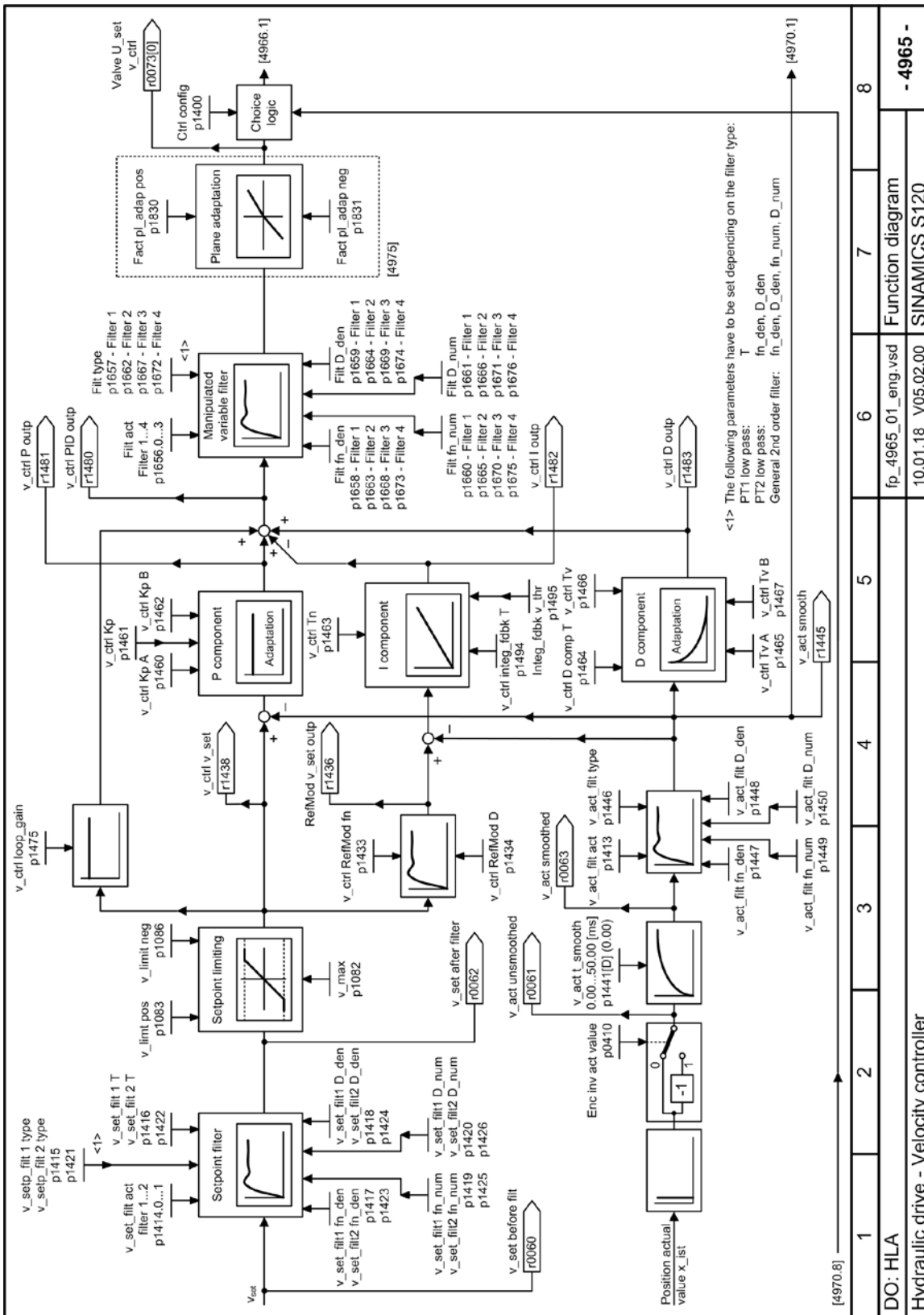

Figure 5-8 Function diagram 4965 - velocity controller

Hydraulic Drive

System Manual, 12/2018, 6SL3097-5BA00-0BP0

### 5.3.3 Dynamic Servo Control (DSC)

The DSC (dynamic servo control) function is supported, allowing higher P gain settings in the position controller. The function is implemented in the same way as for an electrical drive. It is also activated via the control system (in the same way as for an electrical drive).

### 5.3.4 PROFIdrive communication

PROFIdrive communication between the control and SINAMICS HLA is realized using PROFIdrive telegram 166.

#### Structure of telegram 166

Telegram 166 is a manufacturer-specific (proprietary) telegram for HLA, and transfers two encoder channels and HLA supplementary signals as user data. It is structured as follows:

|       | Output data |   | Input data    |                                   |
|-------|-------------|---|---------------|-----------------------------------|
|       | Signal      | Meaning   | Signal        | Meaning                           |
| PZD1  | STW1        | Control word 1  | ZSW1          | Status word 1                     |
| PZD2  | NSOLL_B     | Velocity setpoint B                                     | NIST_B        | Velocity actual value B           |
| PZD3  |             |   |               |                                   |
| PZD4  | STW2        | Control word 2  | ZSW2          | Status word 2                     |
| PZD5  | MOMRED      | Torque reduction  | MELDW         | Message word                      |
| PZD6  | G1_STW      | Encoder 1 control word                                  | G1_ZSW        | Encoder 1 status word             |
| PZD7  | G2_STW      | Encoder 2 control word                                  | G1_XIST1      | Encoder 1 position actual value 1 |
| PZD8  | XERR        | Position deviation                                      |               |                                   |
| PZD9  |             |   | G1_XIST2      | Encoder 1 position actual value 2 |
| PZD10 | KPC         | Position controller gain factor                         | G2_ZSW        | Encoder 2 status word             |
| PZD11 |             |   |               |                                   |
| PZD12 | G1_MP       | Reference value machine position for piston calibration | G2_XIST1      | Encoder 2 position actual value 1 |
| PZD13 |             |   |               |                                   |
| PZD14 | G1_MP_ZSW   | Status machine position for piston calibration          | G2_XIST2      | Encoder 2 position actual value 2 |
| PZD15 |             |   |               |                                   |
| PZD16 | –           | –   | VA_VALVELIFT  | Valve spool value                 |
| PZD17 | –           | –   | VA_TORQUE     | Force actual value                |
| PZD18 | –           | –   | VA_POWER      | Active power                      |
| PZD19 | –           | –   | VA_PRESSURE_A | Cylinder pressure A               |
| PZD20 | –           | –   | VA_PRESSURE_B | Cylinder pressure B               |

Function diagram 4985 shows the sequence control for Hydraulic Drive:

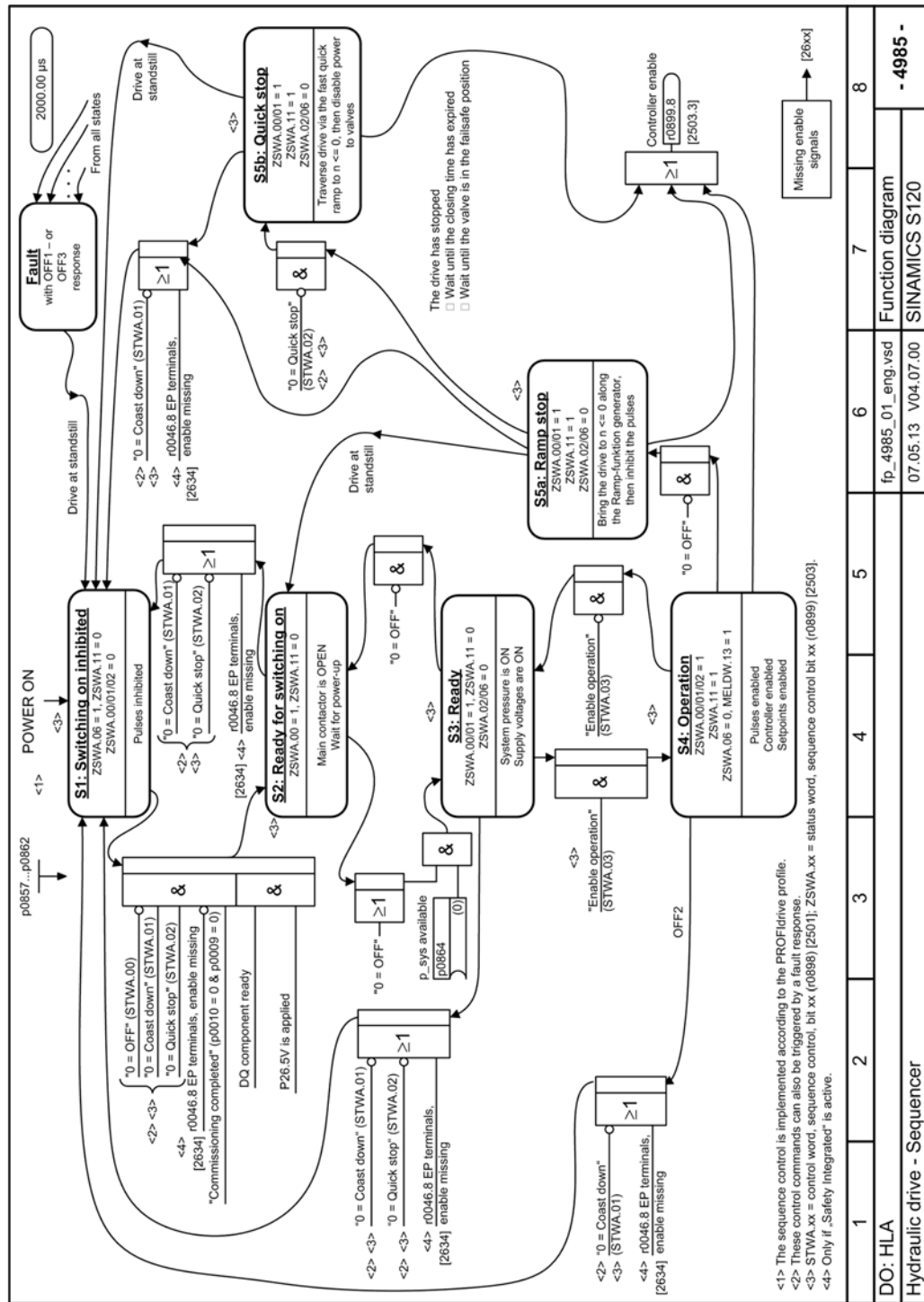

Figure 5-9 Function diagram 4985 - sequence control/sequencer

|                             |   |   |   |   |   |   |   |
|-----------------------------|---|---|---|---|---|---|---|
| 1                           | 2 | 3 | 4 | 5 | 6 | 7 | 8 |
| DO: HLA                     |   |   |   |   |   |   |   |
| Hydraulic drive - Sequencer |   |   |   |   |   |   |   |
| Function diagram            |   |   |   |   |   |   |   |
| fp_4985_01_eng.vsd          |   |   |   |   |   |   |   |
| 07.05.13 V04.07.00          |   |   |   |   |   |   |   |
| - 4985 -                    |   |   |   |   |   |   |   |
| SINAMICS S120               |   |   |   |   |   |   |   |

## 5.4 Force control

### Preconditions

- Axis is referenced (only for non-absolute scales)
- Piston has been calibrated
- Pressure sensors available for A and B or force sensor

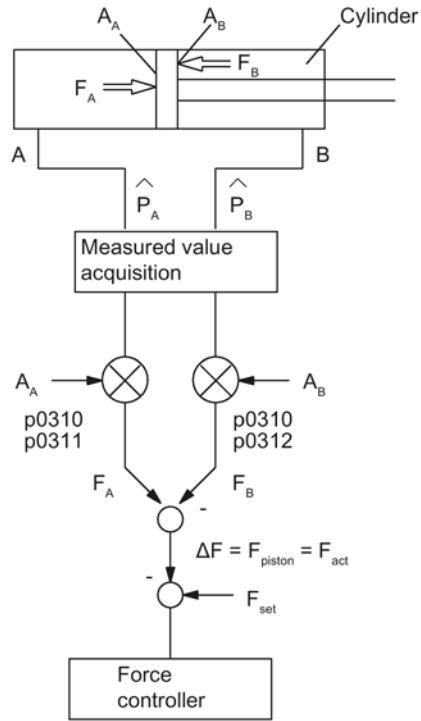

A Area  
 F Force  
 P Pressure

Figure 5-10 Actual force measurement sensing



## Commissioning the force controller

To commission the force controller, the measuring functions and the function generator can be used to determine the following parameters:

- Force controller reference frequency response
  - Set p4810 = 2 (function generator operating mode = input as disturbing torque and r4818)
  - Set p4820 = 4 (function generator signal waveform = binary noise)
  - Measure r0079 (CO: Total force setpoint) and r0080 (CO: Force actual value)
  - Set the signal amplitude using p4824. This signal (as is the case for electric drives) can be converted into physical unit "N". p2003 (reference force) corresponds to 100 %.
  - Set the signal offset using p4826. This signal (as is the case for electric drives) can be converted into physical unit "N". p2003 (reference force) corresponds to 100 %.
- Force controller setpoint step
  - Set p4810 = 2 (function generator operating mode = input as disturbing torque and r4818)
  - Set p4820 = 1 (function generator signal waveform = square-wave)
  - Measure r0079 (CO: Total force setpoint) and r0080 (CO: Force actual value)
  - Set the signal amplitude using p4824. This signal (as is the case for electric drives) can be converted into physical unit "N". p2003 (reference force) corresponds to 100 %.
  - Set the signal offset using p4826. This signal (as is the case for electric drives) can be converted into physical unit "N". p2003 (reference force) corresponds to 100 %.

In order to commission the force controller, the drive must be located on a counter-support. You have to set the force setpoint and offset in such a way that the force always pushes against the counter-support. Otherwise, the drive accelerates with the specified force. This can result in a hazardous situation.

## Force limitation

The force must be limited in the following situations:

- For certain machining processes for which the "Travel to fixed stop" function must be implemented
- For metal forming (machining using force profiles)

### Stiction compensation

This compensation function is needed to compensate the effects of stiction occurring when the traversing direction changes (reduction of contour errors, see e.g. circularity test). There are 2 types of stiction compensation:

- Stiction compensation using a force controller (see "Stiction compensation using the force controller (Page 163)")
- Stiction compensation with voltage pulse / voltage ramp (see "Stiction compensation with voltage pulse / voltage ramp (Page 166)")

### Force controller configuration

If a pressure sensor is installed and connected for the pressures at A and B, the force limitation and/or stiction input functions in p1400 can be activated.

Before the force limitation and/or stiction input is activated, the associated machine data for force limitation (p1520, p1521, p1532) or friction force (p1554, p1555) should be set. These data may contain the force of weight values and might not be preset correctly by the default values.

If the cylinder load changes and the force of weight must be held by the cylinder, then the stiction input function cannot be utilized, as the values in p1554 and p1555 vary depending on the load.

- Force limitation mode 1 (p1400.0 = 1)

Force limitation mode 1 is always effective, even without FFA (NC function "Travel to fixed stop"). The force limit is specified using p1520, p1521. If FFA is active, the lowest force limit always takes effect (p1520/p1521 or value of FXST[x]). You define the reference value (100 % value) of the force limit for the NC using parameters p1522 and p1523.

If the actual current force limit is exceeded, the speed controller again becomes active, also for FFA. This can have a negative effect on the FFA. At higher velocities, this can also cause the system to continuously alternate between the force and velocity controllers. Therefore, this mode is only suitable for low velocities (< 10% of the maximum velocity).

- Force limitation mode 2 (p1400.1 = 1)

Force limitation mode 2 becomes active when the force limit value is exceeded and FFA is active. In each case, the lowest force limitation becomes active (p1520/p1521 or MD 37010 or the value of FXST[x]). You define the reference value (100 % value) of the force limit for the NC using parameters p1522 and p1523.

Force limitation remains active until the function FFA is deactivated, even if the force has already fallen below the actual force limit.

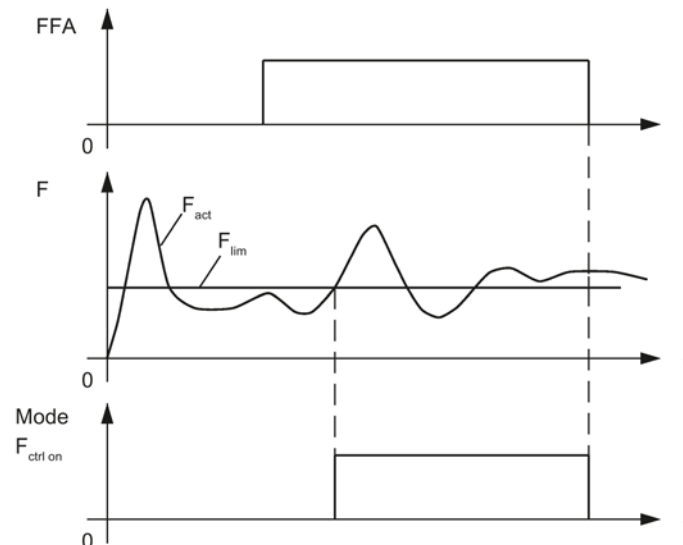

Figure 5-11 Deselecting force control by deactivating the "Travel to fixed stop" function.

- Stiction input (p1400.2 = 1)

The force for both velocity signs must be constant, and parameterized in p1555 and p1556. Further, all of the preconditions for operation of the force controller must be fulfilled.

**Overview of important parameters (see SINAMICS S120/S150 List Manual)**

- r0079 CO: Total force setpoint
- r0080 CO: Force actual value
- p1400[0...n] Closed-loop control configuration
- p1520[0...n] CO: Force limit upper/motoring
- p1521[0...n] CO: Force limit lower/regenerative
- p1522[0...n] CI: Force limit upper/motoring
- p1523[0...n] CI: Force limit lower/regenerative
- p2003 Reference force
- p4810 Function generator mode
- p4820 Function generator signal shape
- p4824 Function generator amplitude
- p4826 Function generator offset

**5.4.1 Force limitation**

Force limitation threshold (plus/minus) around the force of weight and weight force limiting.

If a pressure sensor is installed and connected for the pressures at A and B, the force limitation in p1400 can be activated.

The force limit is calculated as follows:

- Upper limit by  $\min\{F_{NC}; p1520\} + p1532$ , lower limit  $\max\{-F_{NC}; p1521\} + p1532$ .  $F_{NC}$  is the force limit of the NC, which is only specified in terms of the amount.

Since only the cylinder force is measured and controlled, it may be necessary to take into account the force due to weight in parameter p1532 and the friction force in parameters p1520 and p1521.

An additional force limitation value, with the same effect as p1520/p1521, can be entered from the control, e.g. when traversing to the fixed stop. The lower of the two force limit thresholds is then applied.

**Overview of important parameters (see SINAMICS S120/S150 List Manual)**

- p1400[0...n] Closed-loop control configuration
- p1520[0...n] CO: Force limit upper/motoring
- p1521[0...n] CO: Force limit lower/regenerative
- p1532[0...n] CO: Force offset, force limit

## 5.4.2 Stiction compensation

### 5.4.2.1 Stiction compensation using the force controller

If the pressures at A and B are sensed, then the stiction compensation using the force controller can be activated (p1400.2=1).

Static force compensation using the force controller should not be activated if the cylinder is required to hold a fluctuating force due to weight. In addition, the offset of the valve control voltage and the piston must already have been calibrated. Parameters p1552 to p1556 can be calibrated using the circularity test.

#### Preconditions

The following preconditions must be fulfilled to use stiction compensation with the force controller:

- Pressure sensors must be available for  $p_A$  and  $p_B$
- The force controller must have already been commissioned.
- External force ( $F_{center}$ ) does not change.
- Axis has been referenced (homed)
- The piston has been calibrated (r1407.3 = 1)
- The dead volume has been correctly parameterized (p0341, p0315, p0346 to p0348)

#### Velocity threshold

The velocity threshold (p1552) is the threshold, below which standstill and therefore stiction are recognized.

When this threshold is fallen below, the force controller ensures that the force set in p1554 or p1555 is controlled as long as the drive is at standstill (stationary).

Which of the two force setpoints is applied (p1554 or p1555) is determined by the sign of the velocity setpoint.

#### Cutoff limit

The force controller is deactivated just before the setpoint is reached via the cutoff limit (p1554) to prevent overshoots occurring while the servo solenoid valve is operational.

If p1554 is set to 100 %, then the force controller is not switched off until the force setpoint (p1555 or p1556) is reached or unless the drive moves beforehand. This setting results in overshoots in the actual velocity value.

### Cylinder friction force

The cylinder friction force at a positive or negative velocity is set in p1555 or p1556 respectively.

Allowance must be made for the force of weight applied to the cylinder in p1555 or p1556 (e.g. with a cylinder mounting position other than 0 degrees, p0344). The value to be set can be read in r0080 when the cylinder is moved slowly (e.g. in the JOG mode) in the positive or negative direction.

If the force of weight applied to the cylinder varies as a function of load, then static force compensation with force controller cannot be utilized.

### Overview of important parameters (see SINAMICS S120/S150 List Manual)

- p1400[0...n] Closed-loop control configuration
- p1552[0...n] Stiction velocity threshold
- p1554[0...n] Stiction shutdown rate action
- p1555[0...n] Stiction force velocity positive
- p1556[0...n] Stiction force velocity negative

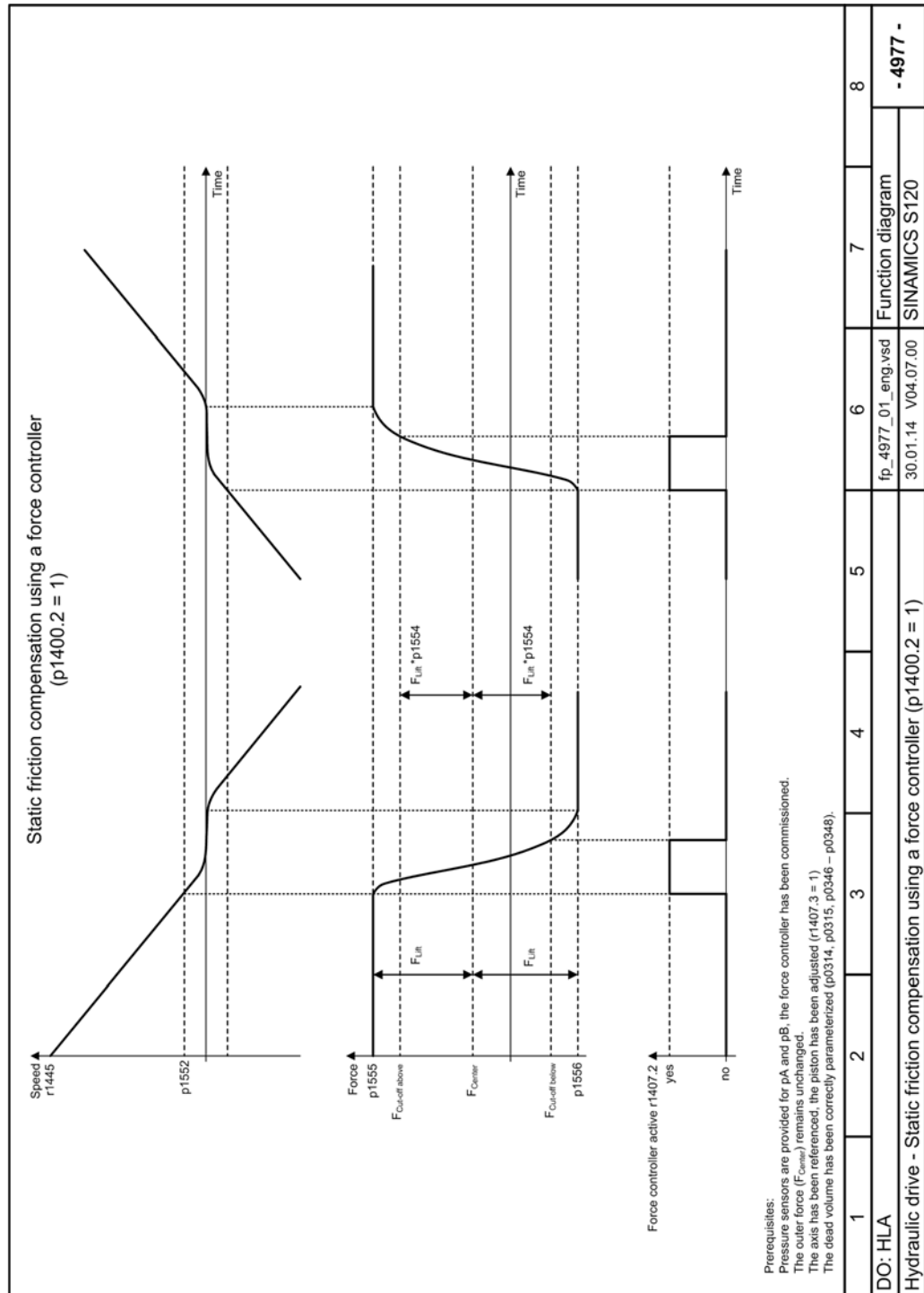

Figure 5-12 Function diagram 4977 – stiction compensation with force controller (p1400.2 = 1)

### 5.4.2.2 Stiction compensation with voltage pulse / voltage ramp

If the pressures at A and B are sensed, then the stiction compensation using the voltage pulse/voltage ramp can be activated (p1400.9 = 1).

Without force control and pressure sensors, stiction can be essentially compensated using a voltage pulse when reversing the traversing direction. The duration and magnitude of the voltage pulse must be set in p1570, p1571 and p1572. Further, the standstill threshold in p1552 is active. The piston must be calibrated. It is not necessary to know the adhesive forces.

#### Preconditions

The following preconditions must be fulfilled to use stiction compensation with voltage pulse/voltage ramp:

- The axis was referenced (homed)
- The piston has been calibrated (r1407.3 = 1)
- The dead volume has been correctly parameterized (p0341, p0315, p0346 to p0348).

#### Velocity threshold

When the velocity entered in p1552 is fallen below, SINAMICS Hydraulic Drive ensures that the stiction is compensated using a voltage pulse/voltage ramp.

#### Voltage pulse/voltage ramp

You define the voltage pulse/voltage ramp to compensate the stiction using the following parameters:

- Using parameter p1570, you adjust the magnitude of the voltage pulse/voltage ramp for the stiction compensation when changing from a negative to a positive traversing direction.
- Using parameter p1571, you adjust the magnitude of the voltage pulse/voltage ramp for the stiction compensation when changing from a positive to a negative traversing direction.
- Using parameter p1572 you adjust the duration of the voltage pulse/voltage ramp for the stiction compensation. The duration can only be set precisely the same for both directions.

---

#### Note

The gradient of the voltage pulse/voltage ramp is automatically obtained from the specified magnitude and duration. You can obtain more information from the function diagram 4978 (see "Figure 5-13 Function diagram 4978 – stiction compensation with voltage pulse / voltage ramp (Page 167)")

---

#### Overview of important parameters (see SINAMICS S120/S150 List Manual)

- p1400.9      Closed-loop control configuration: Stiction compensation voltage pulse
- p1570[0...n]      Stiction voltage pulse positive
- p1571[0...n]      Stiction voltage pulse negative
- p1572[0...n]      Stiction voltage pulse duration



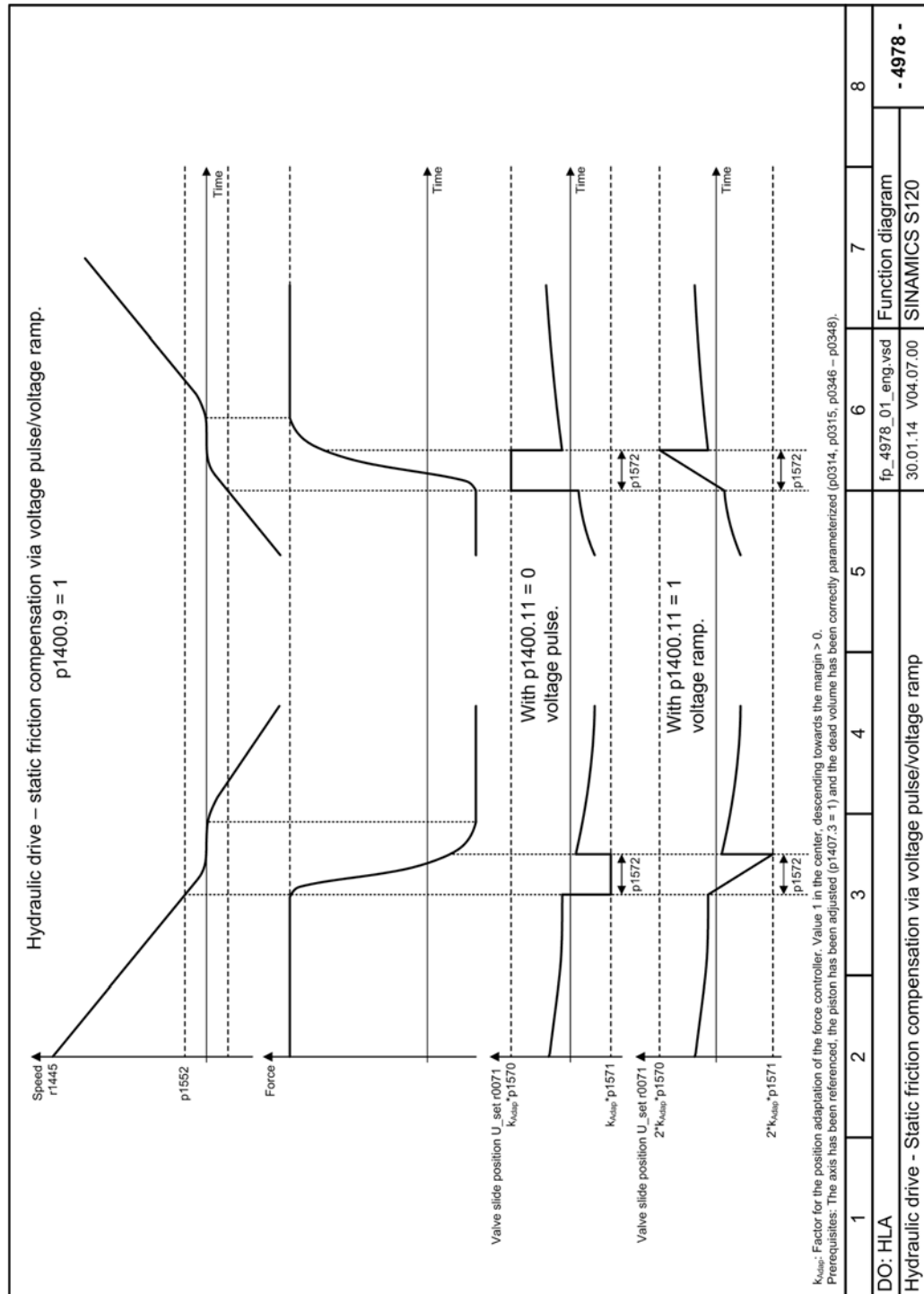

Figure 5-13 Function diagram 4978 – stiction compensation with voltage pulse / voltage ramp

### 5.4.3 Force controller

#### Precontrol gain force controller

The factor to set the precontrol gain in the force controller (p1720) is only effective if the force limiting or stiction input in p1400 is activated and the force controller is also activated (p1400.14 = 1).

The more accurate the precontrol setting, the more effective the force limitation at high velocities. An excessively high setting can result in continuous switching between force and velocity controllers.

The plane adaptation (p1830 and p1831) and controlled system gain (p1475) are taken into account by the precontrol.

#### Controlled system gain force controller

p1700 contains the proportional controlled system gain of the force control loop and is preassigned by "Calculate drive model data".

The controlled system gain depends on the volume of oil in the cylinder and the nominal flow rate of the servo solenoid valve. The value should not be changed.

The value in p1700 is the reference for the P gain of the force controller.

p1700 makes allowance for the effects of geometric dimensions.

The effect of the valve dynamic response is taken into account in p1715, which means that the same gain value can always be set for an identical valve dynamic response at different cylinders.

#### P component force controller

p1700 is the reference value, in which the influence of the geometrical dimensions is summarized.

The effect of the valve dynamic response is taken into account in p1715, which means that the same gain value can always be set for an identical valve dynamic response at different cylinders.

If force limitation and/or stiction input are activated in p1400, the reduction in the force controller P gain in response to higher setpoint-actual value deviations (large-signal response) is entered in p1716. The P component of the force controller must be reduced since the dynamic limitations of the actuator regarding large-signal response also reduce the potential dynamic response of the control loop.

Small-signal response is set in p1715.

The factor in p1716 specifies as a percentage the value to which a P component of 10 V is reduced.

### I component force controller

If force limitation and/or stiction injection is activated in p1400, then the integral time of the force controller is entered into parameter p1717. Entering a value of 0 for the integral time deactivates the I component.

### D component force controller

If force limitation and/or stiction input is activated in p1400, a smoothing time constant of the force controller for derivative action is set in p1718 and, in addition to the force controller P component (p1715), a D-action component (jerk feedback) for the force controller is entered in p1719.

If the D-action component of the force controller is deactivated (p1719), then the smoothing function (p1718) is also deactivated.

The derivative-action time (p1719) can be negative or positive. No D component is active if zero is entered.

### Precontrol filter force controller

The precontrol filter of the force controller is activated using p1721 = 1.

The type of precontrol filter in the force controller is entered in parameter p1722:

- p1722[x] = 0  
Low-pass filter (see p1723/p1724)
- p1722[x] = 1  
Bandstop filter (see p1725/p1726)

The main filter data are defined using p1724 to p1727.

- Enter damping for precontrol filter 1 (PT2 low-pass filter) in force controller (p1724)
- Enter the blocking frequency for precontrol filter 1 (bandstop) in force controller (p1725)
- Enter the precontrol filter numerator natural frequency (p1726)
- Enter the precontrol filter numerator damping (p1727)

**Overview of important parameters (see SINAMICS S120/S150 List Manual)**

- p1400[0...n] Closed-loop control configuration
- p1475[0...n] Velocity controller loop gain
- p1700[0...n] Force controller loop gain
- p1715[0...n] Force controller P gain
- p1716[0...n] Force controller P gain weakening
- p1717[0...n] Force controller integral time
- p1718[0...n] Force controller D component smoothing time constant
- p1719[0...n] Force controller derivative-action time
- p1720[0...n] Force controller precontrol factor
- p1721[0...n] Precontrol filter activation
- p1722[0...n] Precontrol filter type
- p1724[0...n] Precontrol filter denominator natural frequency
- p1725[0...n] Precontrol filter denominator damping
- p1726[0...n] Precontrol filter numerator natural frequency
- p1830[0...n] Factor plane adaptation positive
- p1831[0...n] Factor plane adaptation negative

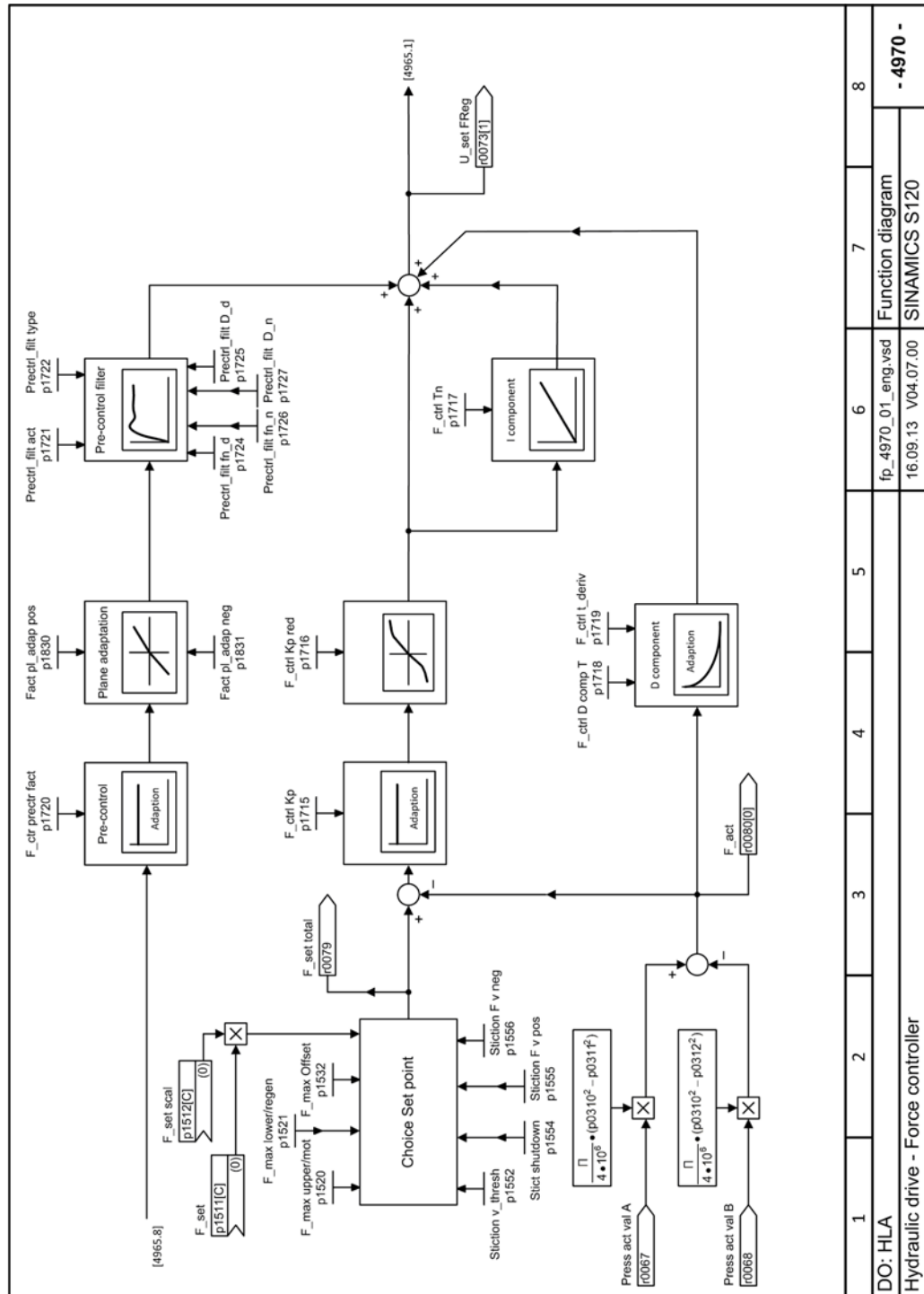

Figure 5-14 Function diagram 4970 - force controller

## 5.5 Control voltage output

### 5.5.1 Characteristic correction

#### Plane adaptation

Various non-linear effects of the valve or drive can be compensated using characteristics. The characteristics are cascaded so that they can be set separately.

In order to compensate the direction-dependent controlled system gain for differential cylinders, a characteristic with a gradient that can be changed depending on the direction has been implemented. The following figure shows a sample characteristic and illustrates how the associated machine data works. In practice, only one of the two gradients is weighted with a factor not equal to 100 %. Normally, it is the gradient that causes the cylinder piston to travel out that is weighted with a factor of less than 100 %.

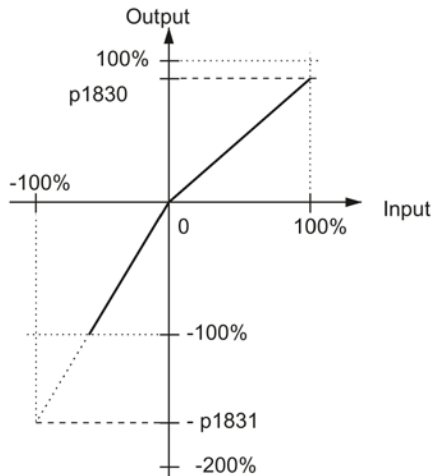

Figure 5-15 Example of piston plane adaptation characteristic

## Linearization of the valve

Valves with a fine control range are non-linear valves. An inverse characteristic is applied to compensate the nonlinear characteristic of these valves. The transition for real valves is rounded. For this reason, the transition range in the compensation is also rounded. The rounding is based on a root characteristic in such a way that the intersection points lie on a continuous tangent; the rounding range can be set as required. The following diagram shows an example of a characteristic and illustrates how the associated machine data works.

The transition point is defined by the percentage for input (voltage) and output (volume flow).

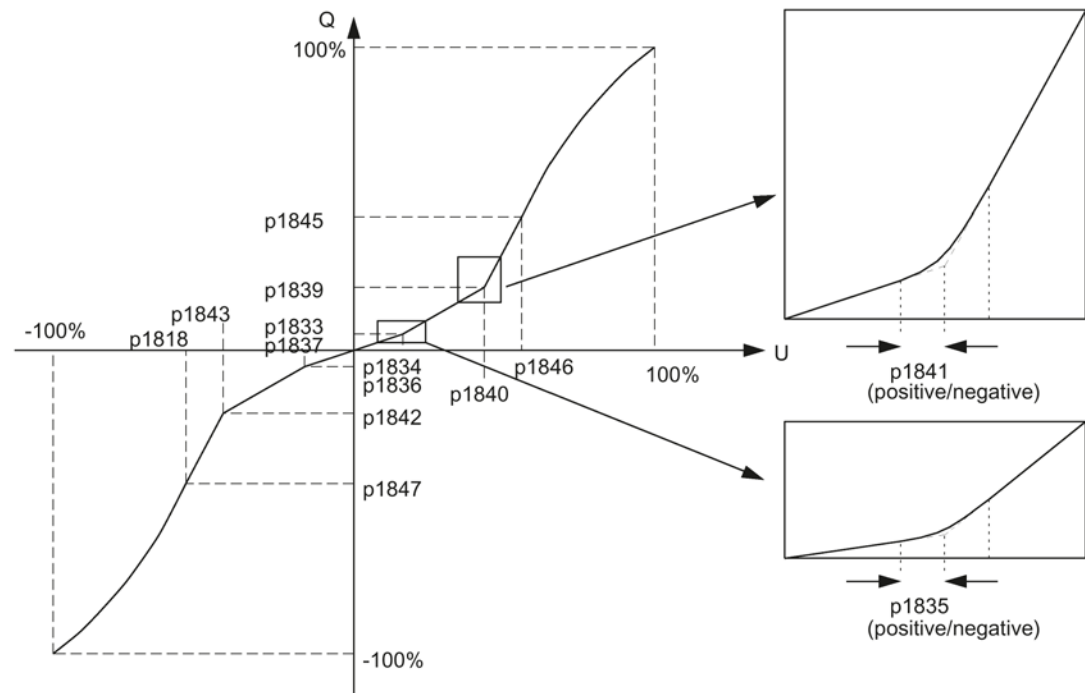

Figure 5-16 Valve characteristic with transition point in zero, fine control and saturation ranges

- Valve characteristic with transition in the zero range

To calculate the inverse characteristic, a transition point is defined in the positive zero range of the valve characteristic with p1833 and p1834 and in the negative zero range with p1836 and p1837.

The positive and negative valve flows at the transition point are entered in p1833 and p1836 respectively. The reference points for the positive side are  $(p1475 \cdot 10 \text{ V} \cdot 100 \%) / p1830$ . For the negative side they are  $(p1475 \cdot 10 \text{ V} \cdot 100 \%) / p1831$ .

The valve voltage at the transition point in relation to the nominal valve voltage drop (p0209) is entered in p1834.

For factory setting "0" in p1834 there is no transition point in the positive zero range.

For factory setting "0" in p1834 there is no transition point in the negative zero range.

The rounding range is parameterized in p1835.

- Valve characteristic with transition point in the fine control range

To calculate the inverse characteristic, a transition point is defined in the positive quadrant of the valve characteristic with p1839 and p1840 – and in the negative quadrant with p1842 and p1843.

The positive and negative valve flow rates at the transition point are entered in p1839 and p1842 respectively. The reference points for the positive side are  $(p1475 \cdot 10 \text{ V} \cdot 100 \%) / p1830$ . For the negative side they are  $(p1475 \cdot 10 \text{ V} \cdot 100 \%) / p1831$ .

The positive and negative valve voltages at the transition point in relation to the nominal valve voltage (p0205) are entered in p1840 and p1843 respectively.

When the same values (defaults) are set in p1839 and p1840, the characteristic is linear (without transition point in the zero range (default) and without saturation (default)).

This transition point data is preset from the valve data (p0206, p0207) using "Calculate controller data". It can be changed later. The rounding range is not a valve data and is therefore only preset to a default value. It can however be changed later by the user (p1841). If necessary, a measurement can be taken to obtain a precise setting.

---

**Note**

A constant machining velocity of the drive directly at the transition point of the valve is not recommended.

---

- Valve characteristic with transition point at the start of a saturation range

To calculate the inverse characteristic, the beginning of a saturation range with parabolic rounding in the positive quadrant of the valve characteristic is defined in p1845 and p1846 and in the negative quadrant with p1847 and p1848.

The positive and negative valve flow rates at the start of the saturation range are entered in p1845 and p1847 respectively. The reference points for the positive side are  $(p1475 \cdot 10 \text{ V} \cdot 100 \%) / p1830$ . For the negative side they are  $(p1475 \cdot 10 \text{ V} \cdot 100 \%) / p1831$ .

The positive and negative valve voltages in relation to the nominal valve voltage (p0205) are entered in p1846 and p1848 respectively.



The saturation range is compensated by a root characteristic such that the intersection point lies on a continuous tangent and the characteristic ends at the point (100%, 100%).

For a standard value of 100% in p1845 and p1846 or p1847 and p1848 there is no saturation range in the positive or negative quadrants.

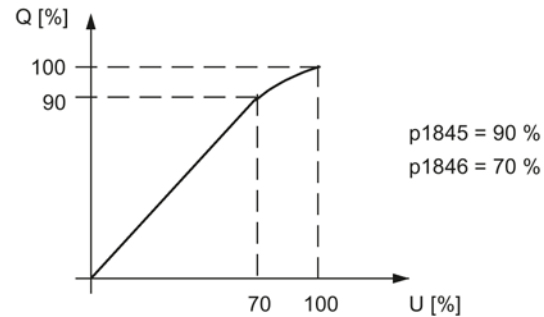

Figure 5-17 Example of transition point compensation

## Offset

Since the valves are operated under analog control, an offset voltage of the D/A converter or valve amplifier may cause a zero point error and thus a position deviation (if no I component has been activated). By adding a compensation value, the offset error can be largely eliminated.

Automatic offset compensation can be initiated using p1910 or p1960.

---

### Note

When force control is active (p1400), offset compensation is absolutely necessary because the I component of the velocity controller is deactivated for force control.

---

**Overview of important parameters (see SINAMICS S120/S150 List Manual)**

- p0208[0...n] Valve rated flow rate
- p0205[0...n] Valve rated voltage
- p1400[0...n] Closed-loop control configuration
- p1830[0...n] Factor plane adaptation positive
- p1831[0...n] Factor plane adaptation negative
- p1832[0...n] Valve offset
- p1833[0...n] Transition point compensation Q1 positive zero range
- p1834[0...n] Transition point compensation U1 positive zero range
- p1835[0...n] Transition point compensation rounding 1 positive zero range
- p1836[0...n] Transition point compensation Q1 negative zero range
- p1837[0...n] Transition point compensation U1 negative zero range
- p1838[0...n] Transition point compensation rounding 1 negative zero range
- p1839[0...n] Transition point compensation Q2 positive
- p1840[0...n] Transition point compensation U2 positive
- p1841[0...n] Transition point compensation rounding 2 positive
- p1842[0...n] Transition point compensation Q2 negative
- p1843[0...n] Transition point compensation U2 negative
- p1844[0...n] Transition point compensation rounding 2 negative
- p1845[0...n] Transition point compensation Q3 positive saturation
- p1846[0...n] Transition point compensation U3 positive saturation
- p1847[0...n] Transition point compensation Q3 negative saturation
- p1848[0...n] Transition point compensation U3 negative saturation
- p1909 Data identification without enabling activation
- p1910 Valve offset calibration standstill activation
- p1960 Rotating measurement selection

## 5.5.2 Manipulated variable filter

You activate the manipulated variable filter using parameter p1800.0 = 1. Entering a nominal natural frequency = 0 or deactivating with p1800.0 = 0 deactivates the filter.

### Note

The filter machine data must be assigned before the filter type is configured.

The type of manipulated variable filter is entered in parameter p1801.

Table 5- 2 Type of manipulated variable filter

|       |   |  |
|-------|---|--|
| Bit 0 | 0 | PT2 low-pass filter (see p1802/p1803)      |
|       | 1 | General 2nd order filter (see p1804/p1805) |

The main filter data are defined using p1802, p1803 and p1804 up to p1805.

Enter the natural frequency for the manipulated variable filter (PT2 low-pass filter).

- Enter the damping for the manipulated variable filter (PT2 low-pass filter, p1803).
- Enter the numerator natural frequency for the manipulated variable filter (general 2nd order filter, p1804)
- Enter the numerator damping for the manipulated variable filter (general 2nd order filter, p1805)

### Overview of important parameters (see SINAMICS S120/S150 List Manual)

- p1800[0...n] Manipulated variable filter activation
- p1801[0...n] Manipulated variable filter type
- p1802[0...n] Manipulated variable filter denominator natural frequency
- p1803[0...n] Manipulated variable filter denominator damping
- p1804[0...n] Manipulated variable filter numerator natural frequency
- p1805[0...n] Manipulated variable filter numerator damping

### 5.5.3 Control voltage limiting

You can limit the control voltage using the following parameters:

- Control voltage limiting positive (p1850)

The manipulated variable setpoint is limited in the positive direction to the value set in p1850 before D/A conversion. A message is sent to the PLC if the limit is violated.

- Control voltage limiting negative (p1851)

The manipulated variable setpoint is limited in the negative direction to the value set in p1851 before D/A conversion. A message is sent to the PLC if the limit is violated.

### Manipulated variable inversion

The voltage output (manipulated variable) can be inverted in machine data p1820 in order to compensate for differences in sign in the piping or wiring. Alternatively, the wiring of the manipulated variable for the valve could be altered.

Definition of direction: see Chapter "Control sense, traversing direction (Page 107)"

### Overview of important parameters (see SINAMICS S120/S150 List Manual)

- p1820[0...n]      Invert output voltage
- p1850[0...n]      Control voltage limiting positive
- p1851[0...n]      Control voltage limiting negative

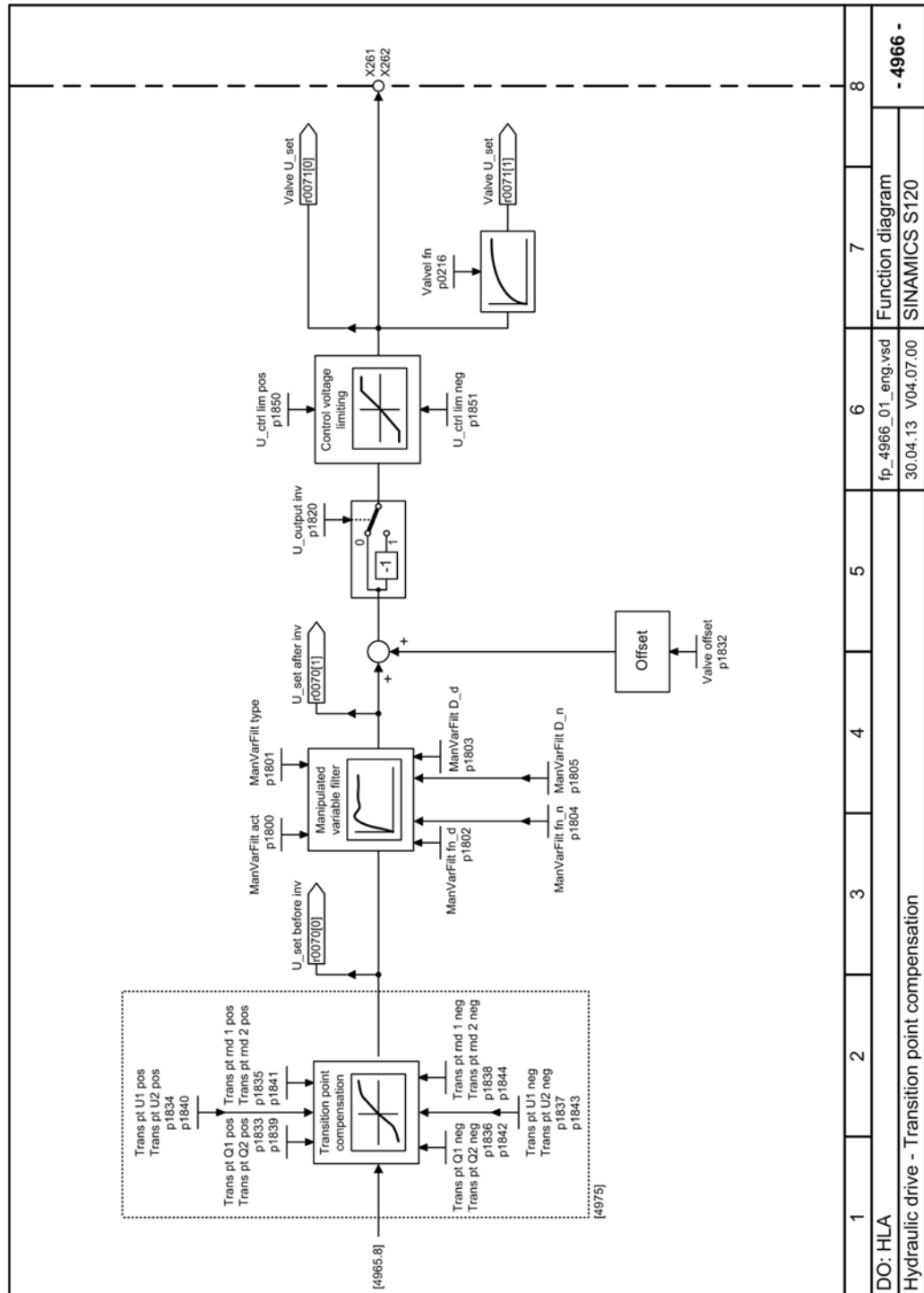

Figure 5-18 Function diagram 4966 - transition point compensation

## 5.6 Supply unit data

The following factors describe the supply unit:

- Modulus of elasticity of the hydraulic fluid (p0220) p0220 defines the compressibility of the hydraulic fluid. This value specifies the pressure change that is required to achieve a certain volume change. The modulus of elasticity refers to a relative volume.
- System pressure (p0221) p0221 defines the pressure supplied by the drive unit. The system pressure and the size of the piston area determine the force available at the piston rod.
- Valve precontrol pressure (p0222) p0222 defines the pressure for a precontrolled valve. In the case of non-precontrolled valves, zero must be entered. p0222 is used in "Calculate controller data."  
Only applies for precontrolled valves.

This data influences the limit data (maximum velocity, maximum force...) as well as the dynamic response characteristics of the drive system (corner frequencies).

---

### Note

The elasticity of oil variable as a function of the temperature can be ignored for industrial hydraulics.

---

### Overview of important parameters (see SINAMICS S120/S150 List Manual)

- p0220 Hydraulic oil modulus of elasticity
- p0221 System pressure
- p0222 Valve precontrol pressure

## 5.7 Valve

### Valve data

The nominal valve data defines the key valve data at the nominal operating point. This is defined by:

- Rated flow rate
- Rated pressure drop
- Rated voltage

Parameter:

- p0208: Valve rated flow rate
- p0209: Valve rated pressure drop

**Other valve data includes:**

- Transition point characteristic
  - p0206 valve transition point flow rate
  - p0207 valve transition point voltage
- Flow rate ratio
  - p0211 valve flow rate ratio A to B side
- Dynamically written to with natural frequency and damping
  - p0216 valve natural frequency
  - p0217 valve damping
- Valve configuration
  - p0218 cylinder safety configuration

**Parameter:**

- p0205 valve rated voltage
- p0206 valve transition point flow rate

A valve characteristic according to Figure 3-2 Diagram of a servo solenoid valve characteristic with transition point and its compensation in the HLA module (Page 42) results in an entry of 10 % in p0205 and 40 % in p0206. If the same value is entered in both parameters, then a linear characteristic is involved (default setting).

- p0211 valve flow rate ratio A to B side

The flow rate ratio specifies the ratio between the nominal flow towards the A side and the nominal flow towards the B side.

- p0216 valve natural frequency

To dimension the velocity controller, the transfer response of the valve when converting the voltage setpoint to the spool position is approximated as a PT2 low-pass filter.

The valve natural frequency can be read for a phase shift of  $-180^\circ$ . The valve natural frequency for a valve modulation of 10% in relation to 100 bar precontrol pressure is specified in p0216.

For values less than 0.7, the valve damping can be calculated from the amplitude overshoot at resonant frequency. The valve damping for a valve modulation of 20 % in relation to 100 bar precontrol pressure is specified in p0216.

## 5.8 Cylinder drive

### Cylinder data

In addition to the piston diameter (p0310), the rod diameter at the A and B sides (p0311, p0312) must be entered. For a differential cylinder, both rod diameters are different, one of the rods might even have a zero diameter. The maximum piston stroke (p0313) and the cylinder dead volume (p0314, p0315) are also required.

The cylinder dead volume is the liquid volume between the cylinder and servo solenoid valve which cannot be displaced by the piston.

The dead volume attributable to the pipework is separately parameterized (p0346 to p0348).

### Overview of important parameters (see SINAMICS S120/S150 List Manual)

- p0310[0...n] Cylinder piston diameter
- p0311[0...n] Cylinder piston rod diameter A side
- p0312[0...n] Cylinder piston rod diameter B side
- p0313[0...n] Piston stroke
- p0314[0...n] Cylinder dead volume A side
- p0315[0...n] Cylinder dead volume B side
- p0346[0...n] Line length A side
- p0347[0...n] Line length B side
- p0348[0...n] Internal line diameter



## 5.9 Drive data

### Valve/drive connection

Parameters p0343, p0346, p0347 and p0348 provide information about the valve/drive connection. They are used to preset other parameters for "Calculate drive model data" and "Calculate controller data". If there is a line between the valve and cylinder, then the dead volume of the line can be calculated from the pipe length (A and B sides) and the inner line diameter. If the valve is mounted directly onto the cylinder, then zero must be entered as line length. The dead volume influences the drive natural frequency and the position adaptation of the force controller or the stiction compensation with voltage pulse.

### Mechanical design of drive

The movement of the piston rod is transmitted to other mechanical components (e.g. table, tools, ...). The total moved mass must be specified as parameter (p0341).

---

#### Note

The mass of the drive is a critical parameter and should be calculated as exactly as possible!

---

The mounting position of the cylinder (p0344) specifies to what degree the force due to the weight of the moved mass (p0341) is taken into account in calculating the servo gain and maximum retraction/extension velocity.

It is assumed that the moved mass will act in the direction of the cylinder axis. If the weight of the moved mass does not act in this direction, then p0344 must be converted accordingly.

For the HLA, a distinction is made between two different mounting methods:

- The cylinder is fixed, the moved mass is attached to the piston rod p0343[0].1 = 0
- The piston is stationary, the moved mass is attached to the cylinder p0343[0].1 = 1

"Calculate drive model data" and p0340.4 =1 calculates the force due to weight applied to the cylinder from p0341 to p0344 and enters the result in p1532.

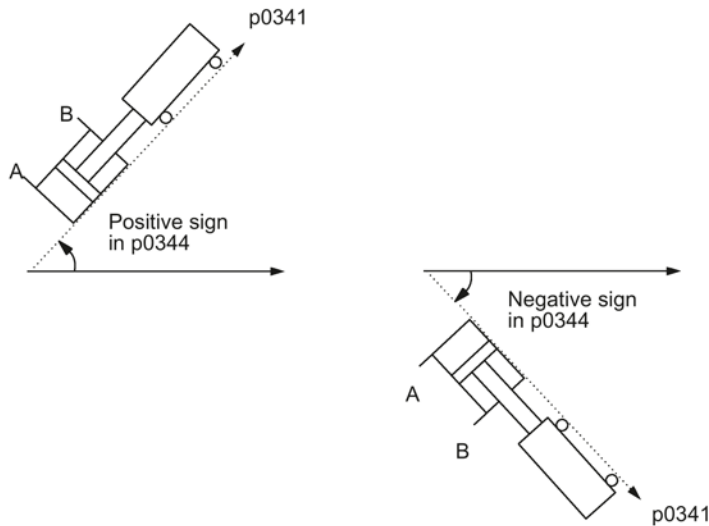

Figure 5-19 Mounting position of the drive referred to the A side

### Dynamic drive model data

The drive is approximated as a PT2 low-pass filter for the purpose of dimensioning the closed-loop velocity control. The characteristic values "natural frequency" and "damping" are calculated and preset from other drive data by the "Calculate drive model data" function.

p0345 can be set to specify the degree of damping to be applied when calculating the control loop for "Calculate controller data".

- |           |             |   |
|-----------|-------------|---|
| Examples: | Damping 0.9 | Slow control loop, which only has a low amount of overshoot |
|           | Damping 0.5 | Fast control loop, which has a higher tendency to overshoot |

**Overview of important parameters (see SINAMICS S120/S150 List Manual)**

- p0340 Automatic parameter calculation
- p0341[0...n] Cylinder mass
- p0343[0...n] Valve/cylinder configuration
- p0344[0...n] Cylinder mounting position A side
- p0345[0...n] Required damping controlled axis
- p0346[0...n] Line length A side
- p0347[0...n] Line length B side
- p0348[0...n] Internal line diameter
- p0350[0...n] Damping uncontrolled axis
- p0351[0...n] Piston position natural frequency minimum
- p0352[0...n] Axis natural frequency A side
- p0353[0...n] Axis natural frequency center
- p0354[0...n] Axis natural frequency B side
- p1532[0...n] CO: Force offset, force limit

## 5.10 Position measuring system

### Description

One measuring system must be used for each axis as a piston rod position sensor. SINAMICS HLA can simultaneously evaluate a maximum of 3 measuring systems. The velocity control always operates with the first measuring system.

### Possible connection configurations

- Using the integrated interface
  - Incremental encoder (TTL) with (A, B and R track)
  - Absolute encoder (SSI)  
Measurement evaluation without incremental track is permitted.
- Using DRIVE-CLiQ encoders
  - SMC30
  - TTL
  - SMC/SME20
  - DQI encoder

### Rotary encoder

To deploy a rotary encoder (p0404.0 = 0) that converts linear movement into a rotary motion using a specific mechanism (e.g. ball screw), enter the conversion factor with p4631. Thus, the use of a DQI encoder is also possible. If you don't parametrize p4631, HLA expects a linear encoder that you will have to parametrize accordingly (p0404.0 = 1).

### Encoder assignment

You can find a description of the encoder assignment in Chapter "Configuration - Encoder assignment (Page 65)".

### Encoder configuration

You can find a description of the encoder configuration in Chapter "Configuration - encoder 1 ... 3 (Page 67)".

### Overview of important parameters (see SINAMICS S120/S150 List Manual)

- p0400[0...n] Encoder type selection
- p0401[0...n] Encoder type OEM selection
- p0404[0...n] Encoder configuration active
- p0405[0...n] Square-wave encoder A/B track
- p0407[0...n] Linear encoder scale
- p0408[0...n] Rotary encoder pulse No.
- p0410[0...n] Encoder inversion actual value

## 5.11 Pressure sensor system

---

### Note

#### Sensors that are permitted

SINAMICS Hydraulic Drive uses sensors with the voltage range 0 V up to +10 V.

The appropriate signal converters must be used for sensor types -20 mA up to +20 mA or +4 mA up to +20 mA.

---

### Sensor adjustment

The pressure sensor should have a range of 0 to 10 V, where a pressure of 0 bar is represented by 0 V and the reference value (p0240 or p0242) by 10 V.

The pressure is entered in bar in p0240 and p0242, where the pressure sensor outputs 10 V at the A or B cylinder side.

### Offset adjustment

The pressure indicator should also display 0 bar at 0 pressure. The offset must be readjusted if the velocity controller cycle is modified.

The offset of the pressure sensor in the A or B cylinder side is adjusted in p0241 and p0243.

You can perform the offset adjustment with p1909.0 = 1 in the pressureless state (all pressures = 0).

### Overview of important parameters (see SINAMICS S120/S150 List Manual)

- p0240[0...n]      Pressure sensor A reference value at 10 V
- p0241[0...n]      Pressure sensor A offset correction
- p0242[0...n]      Pressure sensor B reference value at 10 V
- p0243[0...n]      Pressure sensor B offset correction

## 5.12 Terminals

### 26.5 V hydraulic power supply

The 26.5 V voltage for the shutoff valve and valve electronics is supplied from an external source connected via the HLA module. The HLA module monitors this voltage source. When the HLA module identifies that the 26.5 V hydraulic power supply is not available, or does not maintain the permitted limits, then r0046.7 is set to = 1 ("26.5 V power supply missing"). This prevents the drive control from being commissioned.

- Failure of the 26.5 V supply during operation  
The power is disabled and status bit "Velocity controller enable" canceled.
- The 26.5 V power supply returns – or when the 26.5 V power supply is switched on for the first time  
The power is not enabled until the power enable delay set in (p0231) has expired.

In the event of sudden failure (e.g. broken cable) of the external 26.5 V supply, the energy storage capacitor for each axis on the HLA module provides energy to supply the servo solenoid valve until such time as the pressure supply for a configured shutoff valve is switched off. Note the following boundary conditions when selecting the valves:

- The energy content of the storage capacitors is dependent on:
  - The tolerances of the capacitors
  - The voltage level of the external supply
  - The charging time of the integrated capacitors (instant of voltage failure)
- The available response time is mainly defined by:
  - The power required for the actual machining step
  - The response time of the shutoff valves
  - The shutdown voltage threshold of the servo solenoid valves



#### WARNING

##### Failure of the external 26.5 V power supply

A failure of the external power supply when the energy content of the storage capacitors is too low can cause the shutoff valves to remain open. This can lead to critical situations that may result in death or serious injury.

- The machine manufacturer must verify the interaction between valves, making allowance for all tolerances in the controlled system.

#### Power enable inhibit time

If a shutoff valve is connected (p0218.0 = 1), the switch for the shutoff valve remains open for the power enable inhibit time, i.e. the shutoff valve is closed. This gives the servo solenoid valve enough time to move to the middle position from the fail-safe position without pressure. In such cases, the power enable inhibit time must be set to the time required by the valve to move from the fail-safe to the middle position. If this operation were to take place under pressure, the drive would move. If no shutoff valve is connected, "0" can be entered as the power enable inhibit time.

The following diagrams show the response when switching on and switching off the 26.5 V supply for a configuration with and without shutoff valve.

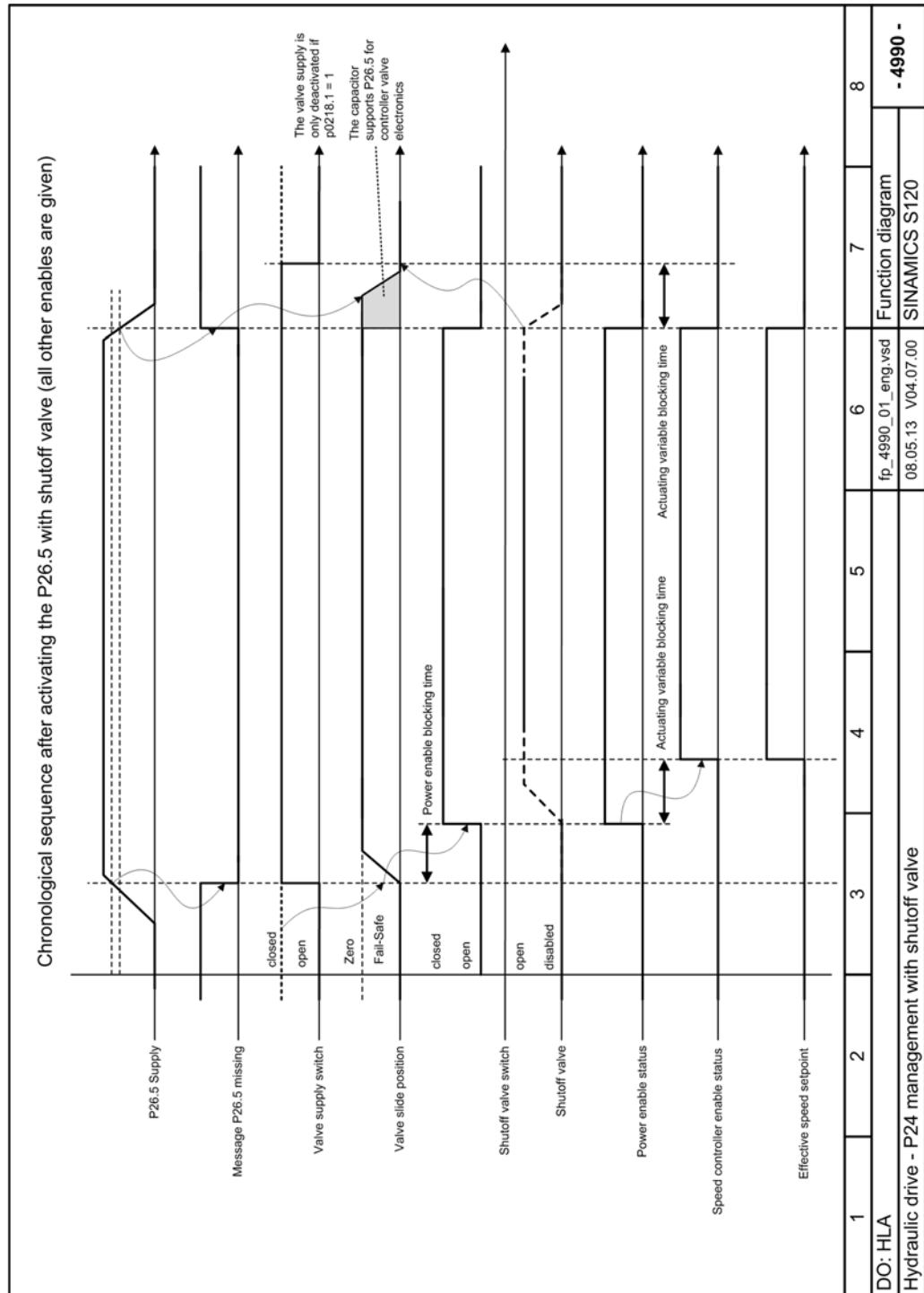

Figure 5-20 Function diagram 4990 – P26V5 management with shutoff valve

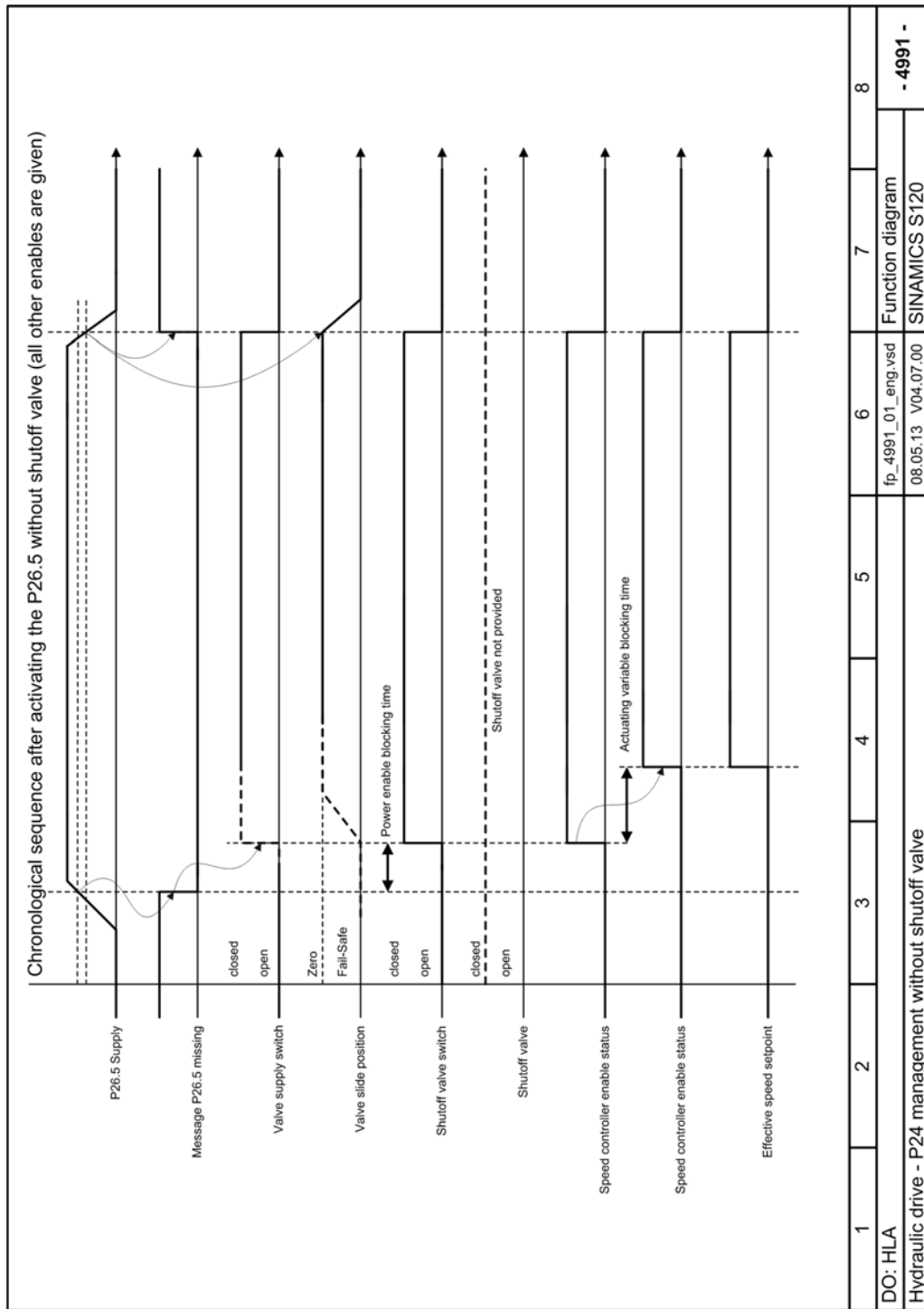

Figure 5-21 Function diagram 4991 – P26V5 management without shutoff valve



## Power enable

- The power enable command (corresponding to pulse enable for an electrical drive) can be issued and/or canceled via the following paths:
- Control word (from NC)
- Faults

The manipulated variable inhibit time (p0230) starts after controlling the shutoff valve (opening the valve) or after switching on the power supply

### Switching off the shutoff valve supply

If a shutoff valve has been parameterized (p0218.1 = 1), and if the power supply voltage of the servo solenoid valve for a power inhibit is to be switched off (p0218.1 = 1), then the manipulated variable inhibit time (p0230) is the time that the system should wait until the power supply for the servo solenoid valve is disconnected. The shutoff valve can be closed during this period.

### Actions for power enable (external 26.5 V power supply available, control has been enabled):

- The 26.5 V power supply for the servo solenoid valve is switched on immediately (if it has not already been switched on).
- If the 26.5 V power supply for the servo solenoid valve was available, then the 26.5 V power supply for the shutoff valve is immediately switched on, otherwise the 26.5 V power supply for the shutoff valve is switched on after the power enable inhibit time.
- After the 26.5 V power supply for the shutoff valve has been switched on, during the manipulated variable inhibit time, a velocity setpoint "= 0" is maintained.

### Actions for a power inhibit

- The 26.5 V power supply for the shutoff valve is switched off immediately, if p218.0=1 (the shutoff valve closes).
- If p0218.1 = 1, the 26.5 V supply for the servo solenoid valve is also switched off when the manipulated variable inhibit time (p0230) expires (the servo solenoid valve moves to the fail-safe position).
- If p0218.1 = 0, the 26.5 V power supply for the servo solenoid valve is switched on.
- If p0218.0 = 0 and p0218.1 = 1 (no shutoff valve), then the 26.5 V power supply for the servo solenoid valve is switched off immediately (servo solenoid valve moves to the fail-safe position).
- A valve setpoint = 0 V is output.
- I components of the controller are deleted.
- Valve spool monitoring is deactivated.
- If a central shutoff valve is installed, it is the responsibility of the user to appropriately interlock the signals (e.g. using the PLC) such that the central shutoff valve is actuated when the power is inhibited.

After the power has been disabled, the switch for the 26.5 V supply is either opened or not (depending on the setting of p0218.4) at the end of the manipulated variable inhibit time. The default setting has been selected such that the 26.5 V valve supply voltage is disconnected (p0218.4 = 0), thus moving the valve into the fail-safe position.

This will not be necessary if a shutoff valve is installed and actuated. This function has been integrated for cases where a shutoff valve has been set, but is not actually connected. In such cases, this function prevents the drive from being able to drift after a power inhibit. p0218.1 can be set = 1 after the function has been carefully checked.

#### Overview of important parameters (see SINAMICS S120/S150 List Manual)

- p0218[0...n]      Cylinder safety configuration
- p0230[0...n]      Manipulated variable inhibit time

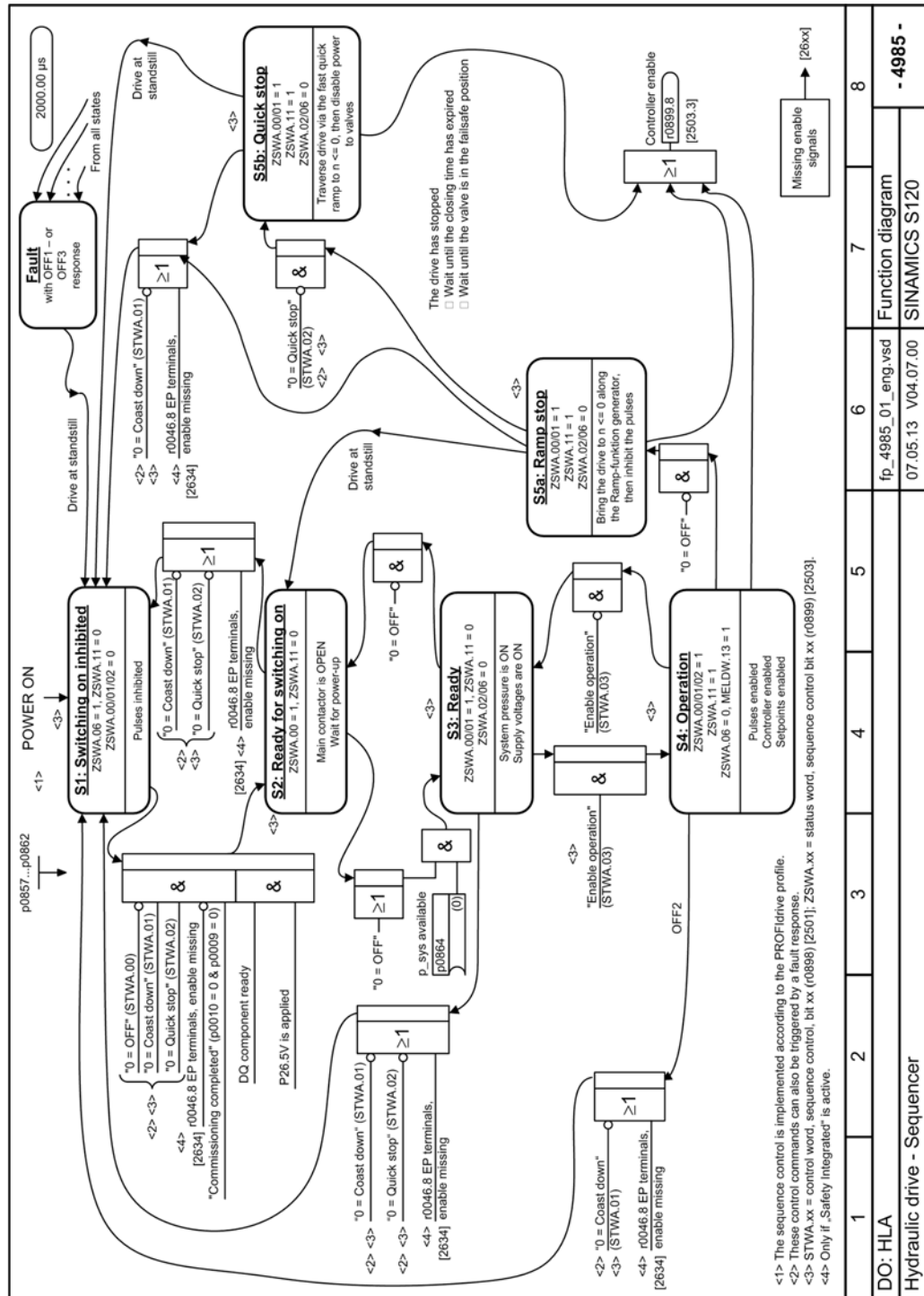

Figure 5-22 Function diagram 4985 - sequence control/sequencer

## 5.13 Monitoring functions

### 5.13.1 Faults and alarms

- You can change the numbers and types of faults and alarms using the following parameters:
  - p2118: Change message type, message number
  - p2119: Change message type type
  - r0949: Fault value
- You can use the following parameters to modify fault responses:
  - p2100: Change fault response, fault number
  - p2101: Change fault response, response

Note that you can only change a fault response if the fault is not pending.

#### Important alarms for the HLA module

- F07900: Motor blocked / speed controller at its limit
  - p2175: Motor blocked velocity threshold

A message is output if the manipulated voltage at the D/A converter is at the limit for a parameterizable time and, at the same time, the actual velocity is lower than a parameterizable threshold (p2175).
  - p2177: Motor blocked delay time
- F07751: Drive: Valve does not respond
  - p0232: Valve monitoring time

The valve spool position is signaled back. The message "Valve spool is not responding" is output if the valve spool position exits the tolerance field of 10% of maximum stroke around the setpoint for longer than the time set in p0232 when the power is enabled. This fault cannot be initiated if a feedback signal has not been configured for the valve spool position (p0218).
- F07752: Drive: Piston position not possible

The piston was calibrated (p0476 ≠ 0) and the absolute position is available (p1407.3 = 1). However, the piston position (r0094) is not plausible (negative or higher than the stroke in p0313).
- F07753: Drive: No valid pressure actual value available

The function "Force controller", "Forced limiting" or "Stiction compensation" is activated (p1400), and at least one of the two pressure sensors required for pressure actual value A or B is not supplying a valid value. The two pressure actual values A and B are required for the functions listed above.

- F07754: Drive: Incorrect shutoff valve configuration  
An incorrect shutoff valve configuration was detected. Fault value (r0949, interpret decimal):
  - 100:  
Safety Integrated enabled (p9601/p9801), however, p0218.0 = 0 (shutoff valve not available).
  - 101:  
The manipulated variable inhibit time has been set less than the wait time to evaluate the feedback signal contacts when switching on the shutoff valve (p0230 < p9625[0]/p9825[0]).
  - 102:  
The manipulated variable inhibit time has been set less than the wait time to evaluate the feedback signal contacts when switching off the shutoff valve (p0230 < p9625[1]/p9825[1]).
- F07755: Drive: Travel to fixed end stop without force controller  
The function "Travel to fixed end stop" (p1545) was selected, although no "Force controller" or no "Force limiting" has been activated (p1400). If this is the case, then the drive would traverse and hit the fixed end stop with maximum force.
- F07901: Drive: Motor overspeed  
The maximum permissible speed was either in positively or negatively exceeded.  
The maximum permissible positive speed is derived as follows: Minimum (p1082, Cl: p1085) + p2162  
The maximum permissible negative speed is derived as follows: Maximum (-p1082, Cl: 1088) - p2162

### Overview of important parameters (see SINAMICS S120/S150 List Manual)

- p0232[0...n]      Valve monitoring time
- r0949[0...63]      Fault value
- p2118[0...19]      Change message type message number
- p2119[0...19]      Change message type type
- p2175[0...n]      Motor blocked velocity threshold
- p2177[0...n]      Motor blocked delay time

## 5.13.2 Variable signaling function

### Definition: Attribute "traceable"

A parameter whose value can be acquired using the trace function of STARTER or SCOUT, is allocated the "traceable" attribute. These parameters can be called in STARTER or SCOUT in the "Device trace" function. The attribute itself is not visible.

### Variable signaling function for monitoring

Using the "Variable signaling" function, BICO interconnections and parameters that have the attribute "traceable" can be monitored.

---

#### Note

The variable signaling function works with an accuracy of 8 ms (also to be taken into account for pickup and dropout delay).

---

Enter the desired data source into parameter p3291 of the drive object expert list. In parameter p3295 define a threshold value for the data source. The hysteresis of the threshold value can be set with p3296. If the threshold value is violated, then an output signal is generated from r3294.

A pickup delay can be set with p3297 and a dropout delay with p3298 for the output signal r3294.

The setting of a hysteresis results in a tolerance band around the threshold value. If the upper band limit is exceeded, the output signal r3294 is set to "1", if it drops below the lower band limit the output signal is set to "0"

You set the sampling time of the variable signaling function in p3299.

After completing the configuration, activate the variable signaling function with p3290.0 = 1.

### Example

The pressure as process variable is to be monitored, whereby a temporary overpressure is tolerated. For this, the output signal of an external sensor is connected with the variable signaling function. The pressure thresholds and a pull-in delay are set as tolerance time.

When the output signal of the variable signaling function is set, bit 5 in message word "MELDW" is set during cyclic communication. The "MELDW" message word is part of telegram 166 to be used for the HLA.

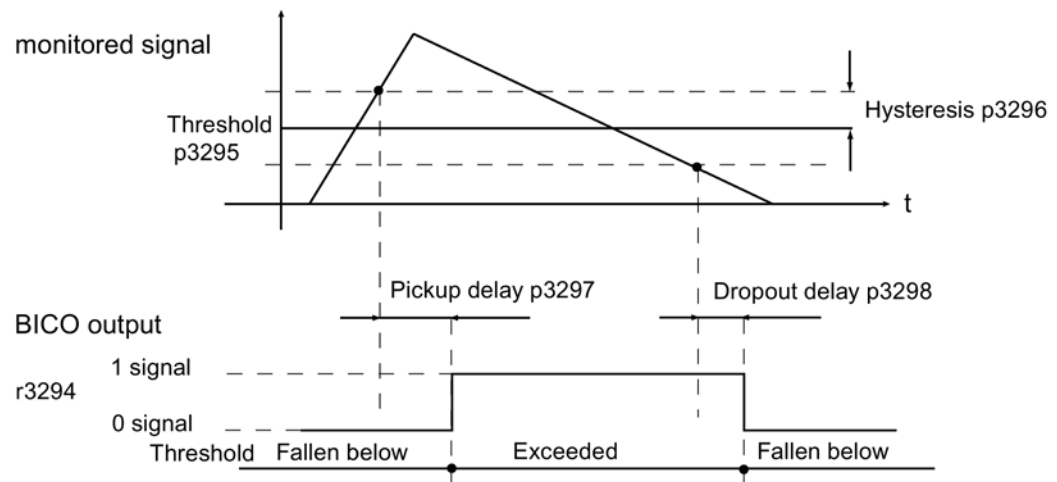

Figure 5-23 Variable signaling function

### Function diagrams (see SINAMICS S120/S150 List Manual)

- 5301 Servo control - variable signaling function

### Overview of important parameters (see SINAMICS S120/S150 List Manual)

- p3290 Variable signaling function, start
- p3291 CI: Variable signaling function signal source
- r3294 BO: Variable signaling function, output signal
- p3295 Variable signaling function, threshold value
- p3296 Variable signaling function, hysteresis
- p3297 Variable signaling function, pickup delay
- p3298 Variable signaling function, dropout delay
- p3299 Variable signaling function, sampling time

## 5.14 Safety Integrated

### 5.14.1 Supported functions: HLA module

SINAMICS HLA supports the following Safety Integrated functions:

- Safety Integrated Basic Functions
- Safety Integrated Extended Functions
- Safety Integrated Advanced Functions

---

#### Note

##### Only "linear" axis type permitted

For SINAMICS HLA, only the "linear" axis type is permitted.

---

#### Note

##### Commissioning

SINAMICS HLA can only be commissioned with STARTER.

---

#### Note

##### Further information

For further information on Safety Integrated, see the SINAMICS S120 Safety Integrated Function Manual.

---

### Comparison, description of electric ↔ hydraulic drives

In the Safety Integrated Function Manual, Safety Integrated functions are described from the perspective of an electric drive. However, these descriptions essentially also apply in the same way for hydraulic systems. You will find parameters and messages for the drive object HLA in the SINAMICS S120/S150 List Manual.



# Hardware

## 6.1 Description

The HLA module is a DRIVE-CLiQ component and part of the SINAMICS S120 drive system. The HLA module is designed for use in rotary indexing machines, forming and bending machines. Third-party hydraulic components are connected to the HLA module using electrical cables.

The HLA module has an IP20 degree of protection.

The HLA module has the following interfaces:

| Type  | Number              |
|---|---------------------|
| DRIVE-CLiQ interfaces                                   | 4                   |
| 24 V for the electronics power supply                   | 1                   |
| 26.5 V to supply the hydraulic components               | 1                   |
| TTL/SSI encoder connections                             | 2 (1 for each axis) |
| Pressure sensor inputs                                  | 6 (3 for each axis) |
| Servo solenoid valve interfaces                         | 2 (1 for each axis) |
| Outputs for shutoff valves                              | 2 (1 for each axis) |
| Terminals for valve spool sensors of the shutoff valves | 2 (1 for each axis) |
| EP terminals  | 2 (1 for each axis) |

## 6.2 Interfaces

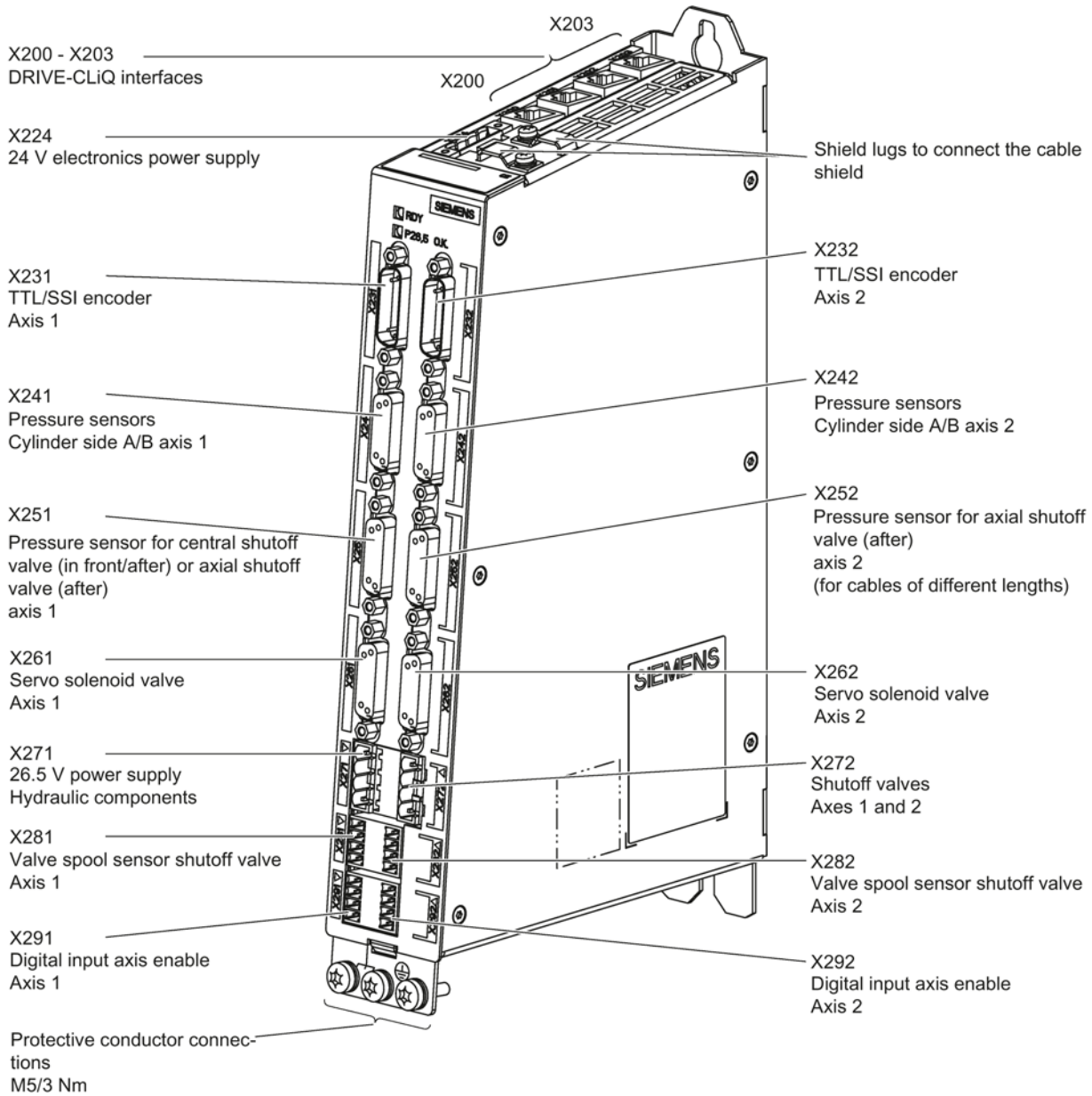

Figure 6-1 Overview of the HLA module interfaces

## 6.2.1 X200-X203 DRIVE-CLiQ interfaces

The HLA module has 4 DRIVE-CLiQ interfaces on the upper side of the module. Each interface has a 24 V supply for the connected DRIVE-CLiQ encoders. Pairs of DRIVE-CLiQ interfaces are equipped with short-circuit protection (0.45 A for each interface pair).

### Note

#### Maximum DRIVE-CLiQ cable length

The maximum DRIVE-CLiQ cable length is 100 m.

Table 6- 1 X200-X203: DRIVE-CLiQ interfaces

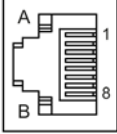
|   | Pin | Name                 | Technical data     |
|---|-----|----------------------|--------------------|
|  | 1   | TXP                  | Transmit data +    |
|   | 2   | TXN                  | Transmit data -    |
|   | 3   | RXP                  | Receive data +     |
|   | 4   | Reserved, do not use | –                  |
|   | 5   | Reserved, do not use | –                  |
|   | 6   | RXN                  | Receive data -     |
|   | 7   | Reserved, do not use | –                  |
|   | 8   | Reserved, do not use | –                  |
|   | A   | + (24 V)             | Power supply       |
|   | B   | M (0 V)              | Electronics ground |

The blanking covers for the DRIVE-CLiQ interfaces are included in the scope of delivery.

Blanking cover (50 pcs.) Article number: 6SL3066-4CA00-0AA0

The intended standard configuration for the connected DRIVE-CLiQ components are listed in the following table:

Table 6- 2 Standard configuration for connected DRIVE-CLiQ components

| X200  | X201  | X202  | X203  |
|---|---|---|---|
| Connection to the Control Unit<br>or<br>Connection to the previous HLA module<br>or<br>Connection to a Motor Module | Connection to the next HLA module<br>or<br>Connection to a Motor Module | Encoder interface axis 1<br>(DRIVE-CLiQ encoder or SMCx / SMEx) | Encoder interface axis 2<br>(DRIVE-CLiQ encoder or SMCx / SMEx) |
| 24 V power supply: X200 / X202: Maximum total current, 0.45 A<br>X201 / X203: Maximum total current, 0.45 A         |   |   |   |

### 6.2.2 X224 electronics power supply

Table 6- 3 X224: Electronics power supply

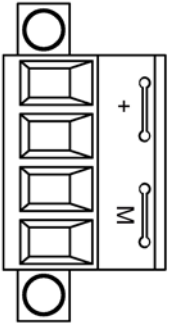
|   | Terminal | Designation              | Technical data   |
|---|----------|--------------------------|--|
|                        | +        | Electronics power supply | Voltage: 24 V DC (20.4 ... 28.8 V)   |
|   | +        | Electronics power supply | Current consumption  |
|   | M        | Electronics ground       | <ul style="list-style-type: none"> <li>• With 2 DRIVE-CLiQ encoders: max. 1.1 A</li> </ul>   |
|   | M        | Electronics ground       | <ul style="list-style-type: none"> <li>• With 2 SSI encoders: max. 0.9 A</li> <li>• With 2 TTL encoders: max. 0.5 A</li> </ul> <p>(without the other encoder)</p> <p>Max. current via jumper in connector: 20 A (15 A according to UL/CSA)</p> |
| <p>Max. connectable cross-section: 2.5 mm<sup>2</sup><br/>                     Type: Screw terminal</p> |          |                          |  |

**Note**

**Maximum cable lengths**

The maximum permissible cable length is 30 m.

**NOTICE**

**High infeed voltage at the electronics power supply**

A voltage connected to the electronics power supply that is above the specified upper limit (28.8 V) can shorten the service life of the connected components. The internal fuses will rupture for a voltage > 35 V. The internal fuses cannot be replaced.

- Only connect the specified voltages between 20.4 ... 28.8 V to the electronics power supply.

**Note**

The two "+" and/or "M" terminals are jumpered in the connector. This ensures that the supply voltage is looped through.

**Note**

Tighten the terminal strip using a screwdriver.

### 6.2.3 X231 and X232 encoder system interface

The HLA module evaluates one TTL or one SSI encoder for each axis. As TTL encoder and SSI encoder are connected to the same interface, TTL and SSI encoders cannot be simultaneously operated on one axis. Further, it is not possible to connect encoders with TTL track signals and in addition SSI signals. Operation without encoder is not permitted.

The use of TTL and SSI encoders influences the current carrying capacity of the DRIVE-CLiQ interfaces.

#### Note

##### Maximum cable lengths

The maximum permissible cable length is 40 m.

#### Connecting TTL encoders

For TTL encoders, the encoder power supply is designed for 5 V / 350 mA with remote sense. It can be switched over between a fixed voltage (approx. 5.25 V) and remote sense operation (up to max. 8 V at the module).

Table 6- 4 X231/X232: Connecting TTL encoders

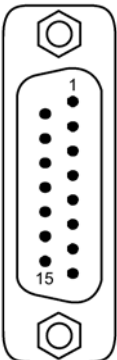
|   | Pin                    | Signal name | Function   |
|---|------------------------|-------------|--|
|  | 1                      | PENCn       | Encoder power supply, +5 V                       |
|   | 2                      | M           | Electronics ground                               |
|   | 3 <sup>1)</sup>        | APn         | TTL track signal, track A                        |
|   | 4 <sup>2)</sup>        | ANn         | Inverse TTL track signal, track A                |
|   | 5 <sup>1)</sup>        | SSIDATn     | --   |
|   | 6                      | BPn         | TTL track signal, track B                        |
|   | 7                      | BNn         | Inverse TTL track signal, track B                |
|   | 8 <sup>2)</sup>        | XSSIDATn    | --   |
|   | 9                      | PSENSEn     | Sense line encoder power supply for TTL encoders |
|   | 10                     | RPn         | TTL track signal zero pulse                      |
|   | 11                     | MSENSEn     | Sense line encoder power supply for TTL encoders |
|   | 12                     | RNn         | Inverse TTL track signal zero pulse              |
|   | 13                     | P24         | --   |
|   | 14                     | SSICLKn     | --   |
|   | 15                     | XSSICLKn    | --   |
| Connector type:   | 15-pin SUB D connector |             |  |

<sup>1)</sup> Pin 3 jumpered with pin 5

<sup>2)</sup> Pin 4 jumpered with pin 8

**Connecting SSI encoders**

For SSI encoders, the encoder power supply is designed for 24 V / 350 mA. The supply is switched on or switched off in the software (the encoder is parameterized in Starter). The output is short-circuit proof, and is directly supplied from the module with 24 V. When a short-circuit occurs, a diagnostic signal is **not** output.

Table 6- 5 X231/X232: Connecting SSI encoders

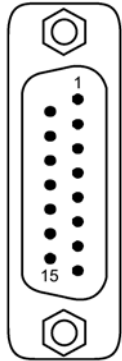
|   | Pin                    | Signal name | Function                   |
|---|------------------------|-------------|----------------------------|
|  | 1                      | PENCn       | --                         |
|   | 2                      | M           | Electronics ground         |
|   | 3 <sup>1)</sup>        | APn         | --                         |
|   | 4 <sup>2)</sup>        | ANn         | --                         |
|   | 5 <sup>1)</sup>        | SSIDATn     | SSI data signal            |
|   | 6                      | BPn         | --                         |
|   | 7                      | BNn         | --                         |
|   | 8 <sup>2)</sup>        | XSSIDATn    | Inverse SSI data signal    |
|   | 9                      | PSENSEn     | --                         |
|   | 10                     | RPn         | --                         |
|   | 11                     | MSENSEn     | --                         |
|   | 12                     | RNn         | --                         |
|   | 13                     | P24         | Encoder power supply +24 V |
|   | 14                     | SSICLKn     | SSI cycle                  |
|   | 15                     | XSSICLKn    | Inverse SSI cycle          |
| Connector type:   | 15-pin SUB D connector |             |                            |

1) Pin 3 jumpered with pin 5

2) Pin 4 jumpered with pin 8

### Reduction in the permissible total current drain when additional encoders are connected

When additional encoders are connected, the permissible total current drain (0.9 A) of the DRIVE-CLiQ interfaces is reduced.

- **Connecting SSI encoders (24 V)**

The HLA module provides 900 mA to connect encoders. This current must be distributed across the connected encoders.

- **Example**

A 24 V SSI encoder has a current drain of 150 mA; this means that 750 mA still remains available for DRIVE-CLiQ encoders.

- **Connecting TTL encoders (5 V encoder power supply with remote sense)**

The permissible total current drain of DRIVE-CLiQ interfaces is reduced by 0.5 x current drain of the connected encoder.

- **Example**

An additional TTL encoder at axis 2 with 200 mA current drain reduces the permissible total current drain for all DRIVE-CLiQ interfaces by 100 mA from 0.9 A down to 0.8 A.

### 6.2.4 X241 and X242 pressure sensors on the cylinder side (A/B)

Two pressure sensors are provided for each axis to determine the cylinder pressure at the A and B sides. The assignment at the connectors is fixed.

The pressure sensors are supplied from the 26.5 V supply. A maximum of 50 mA is available for each sensor. The supply voltage is short-circuit proof.

**Note**

All three pressure sensors (X241/X242/X251/X252) as well as the sensor for the shut-off valve (X281/X282) are guided **per axis** via a **common current limitation**, i.e. a total current of 200 mA is provided per axis.

Table 6- 6 X241/X242: Pressure sensors on the cylinder side, axis 1 or axis 2

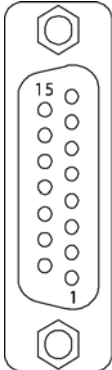
|  | PIN                 | Signal name        | Function   |
|--|---------------------|--------------------|--|
|  | 1                   | P26.5DS            | Supply voltage, pressure sensor +26.5 V  |
|  | 2                   | P26.5DS            | Supply voltage, pressure sensor +26.5 V  |
|  | 3                   | -                  | Not assigned   |
|  | 4                   | -                  | Not assigned   |
|  | 5                   | M                  | Supply voltage, pressure sensor ground   |
|  | 6                   | -                  | Not assigned   |
|  | 7                   | -                  | Not assigned   |
|  | 8                   | -                  | Not assigned   |
|  | 9                   | M                  | Supply voltage, pressure sensor ground   |
|  | 10                  | M                  | Auxiliary pin ground   |
|  | 11                  | PISTBN1 or PISTBN2 | Analog actual value pressure signal, reference potential, B side, axis 1 or axis 2 |
|  | 12                  | PISTBP1 or PISTBP2 | Analog actual value pressure signal, 0 ... +10 V, B side, axis 1 or axis 2         |
|  | 13                  | M                  | Auxiliary pin ground   |
|  | 14                  | PISTAN1 or PISTAN2 | Analog actual value pressure signal, reference potential, A side, axis 1 or axis 2 |
|  | 15                  | PISTAP1 or PISTAP2 | Analog actual value pressure signal, 0 ... +10 V, A side, axis 1 or axis 2         |
| Connector type:  | 15-pin Sub-D socket |                    |  |

**Note**

**Pressure sensors with current output**

You must use a signal converter upstream if you use pressure sensors with current output.



---

## Cables

---

### Note

#### Maximum cable lengths

The maximum permissible cable length is 40 m.

---

To connect the pressure sensors on the A and B sides to the cylinder, use two-line SIMODRIVE cables with article number 6FX8002-2BA20-.... With these cables, the two sensor lines connected to the SUB-D connector have the same length when supplied.

---

### Note

#### Connector type

The connector used must establish a continuous shield connection between the cable shield and the metal housing of the pressure sensor. Even for connectors with metal housing, the shield connection is not always continuous for all types.

- Ensure that there is a shield connection available.
- 

## 6.2.5 X251 and X252 pressure sensors to sense the pressure at the shutoff valve

You can connect 2 additional pressure sensors to the HLA module to evaluate central pressure sensors. For instance, you can use the pressure sensor inputs for the following applications:

- Outputs of two shutoff valves (axial assignment, axis 1 and 2)
- Measuring the pressure before and after the central shutoff valve when using a common shutoff valve

2 sensing channels X and Y are available. The input for channel X is only connected at connector X251. If 2 separate cables are used for the pressure sensors, then the input for channel Y is connected at connector X251 (for two-line cables 6FX8002-2BA20-...) and in parallel, at connector X252. Separate cables are used, e.g. when using one shutoff valve for each axis, therefore requiring different cable lengths (new cable 6FX8002-2BA21-...).

The correct logical assignment is not fixed, and must be realized in the software or must be appropriately parameterized.

The pressure sensors are supplied from the 26.5 V supply. A maximum of 50 mA is available for each sensor. The supply voltage is short-circuit proof.

---

### Note

All three pressure sensors (X241/X242/X251/X252) as well as the sensor for the shut-off valve (X281/X282) are guided **per axis** via a **common current limitation**, i.e. a total current of 200 mA is provided per axis.

---

**NOTICE**

**Short circuit of the signal outputs**

If you simultaneously use 3 pressure sensors at interfaces X251 and X252, this will result in a short-circuit at the signal outputs of the pressure sensors.

- Only connect a maximum of 2 pressure sensors. The 2nd pressure sensor can alternatively be connected at interface X251 or X252.

**Pin assignment of the pressure sensors at the module side**

Table 6-7 X251: Pressure sensor connection, channels X and Y

|  | PIN | Signal name | Function  |
|--|-----|-------------|---|
|  | 1   | P26.5DSY    | Pressure sensor Y:<br>supply voltage +26.5 V  |
|  | 2   | P26.5DSX    | Pressure sensor X:<br>supply voltage +26.5 V  |
|  | 3   | -           | Not assigned  |
|  | 4   | -           | Not assigned  |
|  | 5   | MX          | Pressure sensor X:<br>supply voltage ground   |
|  | 6   | -           | Not assigned  |
|  | 7   | -           | Not assigned  |
|  | 8   | -           | Not assigned  |
|  | 9   | MY          | Pressure sensor Y:<br>supply voltage ground   |
|  | 10  | MHY         | Auxiliary pin Y: Ground   |
|  | 11  | PISTYN2     | Pressure sensor Y:<br>analog pressure actual value signal, refer-<br>ence potential |
|  | 12  | PISTYP2     | Pressure sensor Y:<br>analog pressure actual value signal, 0 ...<br>+10 V           |
|  | 13  | MHX         | Auxiliary pin X: Ground   |
|  | 14  | PISTXN1     | Pressure sensor X:<br>analog pressure actual value signal, refer-<br>ence potential |
|  | 15  | PISTXP1     | Pressure sensor X:<br>analog pressure actual value signal, 0 ...<br>+10 V           |

Table 6- 8 X252: Pressure sensor connection, channel Y (for two separate cables)

|   | Pin | Signal name | Function  |
|---|-----|-------------|---|
|  | 1   | -           | Not assigned  |
|   | 2   | P26.5DS     | Pressure sensor Y:<br>supply voltage +26.5 V  |
|   | 3   | -           | Not assigned  |
|   | 4   | -           | Not assigned  |
|   | 5   | M           | Pressure sensor Y:<br>supply voltage ground   |
|   | 6   | -           | Not assigned  |
|   | 7   | -           | Not assigned  |
|   | 8   | -           | Not assigned  |
|   | 9   | -           | Not assigned  |
|   | 10  | -           | Not assigned  |
|   | 11  | -           | Not assigned  |
|   | 12  | -           | Not assigned  |
|   | 13  | MHY         | Auxiliary pin Y: Ground   |
|   | 14  | PISTYN2     | Pressure sensor Y:<br>analog pressure actual value signal, refer-<br>ence potential |
|   | 15  | PISTYP2     | Pressure sensor Y:<br>analog pressure actual value signal, 0 ...<br>+10 V           |

### Cables

#### Note

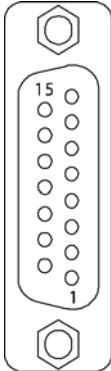
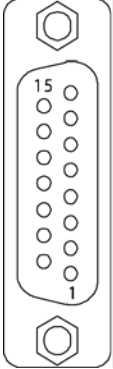
##### Maximum cable lengths

The maximum permissible cable length is 40 m.

#### Note

##### Connector type

The connector used must establish a continuous shield connection between the cable shield and the metal housing of the pressure sensor. Even for connectors with metal housing, the shield connection is not always continuous for all types.

- Ensure that there is a shield connection available.

## 6.2.6 X261 and X262 servo solenoid valves

Table 6- 9 X261/X262: Servo solenoid valves, axis 1 and axis 2

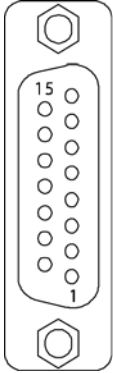
|   | Pin                 | Signal name | Function  |
|---|---------------------|-------------|---|
|  | 1                   | P26.5RVn    | Supply, servo solenoid valve +26.5 V switched, buffered   |
|   | 2                   | P26.5RVn    | Supply, servo solenoid valve +26.5 V switched, buffered   |
|   | 3                   | P26.5RVn    | Supply, servo solenoid valve +26.5 V switched, buffered   |
|   | 4                   | P26.5RVn    | Supply, servo solenoid valve +26.5 V switched, buffered   |
|   | 5                   | M           | Electronics ground  |
|   | 6                   | USOLLNn     | Analog valve spool setpoint, reference ground axis n      |
|   | 7                   | USOLLPn     | Analog valve spool setpoint, -10 ... +10 V, axis n        |
|   | 8                   | M           | Electronics ground  |
|   | 9                   | M           | Electronics ground  |
|   | 10                  | M           | Electronics ground  |
|   | 11                  | M           | Electronics ground  |
|   | 12                  | -           | Not assigned  |
|   | 13                  | M           | Electronics ground  |
|   | 14                  | UISTNn      | Analog valve spool actual value, reference ground, axis n |
|   | 15                  | UISTPn      | Analog valve spool actual value, -10 ... +10 V, axis n    |
| Connector type:   | 15-pin Sub-D socket |             |   |

n = [1, 2] for axis 1 or axis 2

Interface X261/262 is the only interface to the servo solenoid valve and transfers the supply voltage, setpoint and actual value.

The analog inputs for the valve spool actual value (pin 14 and 15) are differential inputs.

The analog output (pin 7) for the valve spool setpoint is designed for a minimum pin input resistance of the servo solenoid valve of 5 kΩ.

The supply outputs for the servo solenoid valves (pins 1, 2, 3 and 4) have the following current rating for the average value of the current for a 10 s load cycle:

- At an ambient temperature of 40 °C: 2.0 A
- At an ambient temperature of 55 °C: 1.5 A

A brief maximum current of 2.5 A is permissible.

The outputs are short-circuit proof.

## **Cables**

---

### **Note**

#### **Maximum cable lengths**

The maximum permissible cable length to the connected servo solenoid valve is 40 m.

---

### **Note**

#### **Connector type**

The connector used must establish a continuous shield connection between the cable shield and the housing of the servo solenoid valve. Even for connectors with metal housing, the shield connection is not always continuous for all types.

- Ensure that there is a shield connection available.
-

### 6.2.7 X271 26.5 V supply for the hydraulic components

To supply the hydraulic components (shutoff valves, possibly sensors of the shutoff valves, servo solenoid valves and pressure sensors), 26.5 V DC must be externally connected to the HLA module via terminal X271.

**NOTICE**

**Unsuitable supply voltage**

Voltages > 35 V at interface X271 cause the internal fuses to rupture. The internal fuses cannot be replaced.

- In operation (max. 8.5 A per module) maintain the specified voltage tolerance range at the module terminals, taking into account the voltage drops along the supply cables in the control cabinet.

You can achieve this by:

- Suitable cable cross-sections
- Short feeder cables
- Optional: Use a power supply with remote sense functionality

Voltages < 26 V at interface X271 cause the HLA module to internally shut down.

Table 6- 10 X271: External 26.5 V DC power supply for the hydraulic components

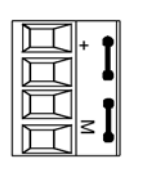
|   | Terminal | Designation | Technical data   |
|---|----------|-------------|--|
|  | +        | +26.5 V     | Voltage: 26.5 V DC (26 ... 27 V)<br>Current consumption: max. 8.5 A<br>Max. current via jumper in connector: 20 A (15 A according to UL/CSA) |
|   | +        | +26.5 V     |  |
|   | M        | Ground      |  |
|   | M        | Ground      |  |
| Maximum connectable cross-section: 2.5 mm <sup>2</sup><br>Type: Screw terminal      |          |             |  |

**Note**

**Maximum cable length**

The maximum permissible cable length is 30 m.

**Note**

The two "+" and/or "M" terminals are jumpered in the connector. This ensures that the supply voltage is looped through.

 **WARNING**

**Failure of the external 26.5 V power supply**

A failure of the external power supply where the energy content of the storage capacitors is too low and the power inhibit is parameterized accordingly can mean that the servo solenoid valves cannot be supplied with voltage long enough until the shutoff valves close.

- Ensure that the storage capacitors contain a sufficient amount of energy for the servo solenoid valves to be supplied with voltage long enough until the shutoff valves have closed.
- Check that this correctly functions for the shutoff and servo solenoid valves being used in the real application.

### 6.2.8 X272 shutoff valves

You can connect one shutoff valve for each axis using terminal X272. Contrary to other axial connector distributions, both shutoff valves are located one above the other at one connector.

Table 6- 11 X272: Shutoff valve connection

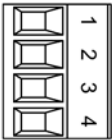
|   | Terminal | Designation | Technical data                           |
|---|----------|-------------|--|
|    | 1        | AV1P        | Output shutoff valve axis 1, P-switching |
|   | 2        | AV2P        | Output shutoff valve axis 2, P-switching |
|   | 3        | AV1N        | Output shutoff valve axis 1, ground      |
|   | 4        | AV2N        | Output shutoff valve axis 2, ground      |
| <ul style="list-style-type: none"> <li>• Max. connectable cross-section: 2.5 mm<sup>2</sup></li> <li>• Max. continuous current-carrying capacity: 2 A (at max. 55 C)</li> <li>• Type: Screw terminal</li> </ul> |          |             |  |

#### Cables

The maximum permissible cable length is 40 m.

Use a 3-conductor, oiltight cable with the appropriate jacket to connect the shutoff valves. Route the cable with jacket up to the connector.

Connect the PE conductor using a cable lug to the protective conductor connections provided at the HLA module.

To achieve the surge strength specified in the appropriate standards, shielded cables must be used for cable lengths > 30 m. The shield must be connected with the shield connection bars at the upper side of the HLA module. Depending on the design, at the shutoff valve, the shield can be connected at the connector. It is sufficient if the shield is connected at one end, at the HLA module.

#### Coding

In order to prevent the connectors being inadvertently interchanged at terminal X271 or X272, both terminals and the associated connectors are equipped with coding elements.

#### NOTICE

##### Interchanging the connectors at terminals X271 and X272

If the connections at terminal blocks X271 and X272 are interchanged, when the 26.5 V is connected, the shutoff valves can immediately open. The resulting uncontrolled axis movement may damage the device.

- Correctly connect the conductors/cables to terminal blocks X271 and X272.



## 6.2.9 X281 and X282 sensors for shutoff valves

For especially safety-critical applications, you can use shutoff valves whose spool position is monitored using inductive sensors. The sensors, certified from a safety-related perspective, signal the "open" and "closed" valve states using 2 signal outputs. The signals emulate the hysteresis of the mechanical overlap. Excluding the overlap instants when opening or closing, the signal outputs are complementary with respect to one another.

The connector at the HLA module contains:

- Short-circuit proof 26.5 V supply
- Ground
- 2 inputs for the NO and NC signals

This means that all of the cables are directly connected using one connector.

Table 6- 12 X281: Sensors for the spool position of the shutoff valves, axis 1

|   | Terminal | Signal name | Function                       |
|---|----------|-------------|--------------------------------|
|  | 1        | P26.5_AVS   | +26.5 V supply for the sensors |
|   | 2        | AVS1NC      | Sensor input axis 1, NC        |
|   | 3        | AVS1NO      | Sensor input axis 1, NO        |
|   | 4        | M           | Supply, sensor ground          |
| Max. connectable cross-section: 1.5 mm <sup>2</sup><br>Type: Screw terminal       |          |             |                                |

Table 6- 13 X282: Sensors for the spool position of the shutoff valves, axis 2

|   | Terminal | Signal name | Function                       |
|---|----------|-------------|--------------------------------|
|  | 1        | P26.5_AVS   | +26.5 V supply for the sensors |
|   | 2        | AVS2NC      | Sensor input axis 2, NC        |
|   | 3        | AVS2NO      | Sensor input axis 2, NO        |
|   | 4        | M           | Supply, sensor ground          |
| Max. connectable cross-section: 1.5 mm <sup>2</sup><br>Type: Screw terminal         |          |             |                                |

The sensors for the shut-off valves are supplied from the 26.5 V supply. A maximum of 50 mA is available for each sensor. The supply voltage is short-circuit proof.

### Note

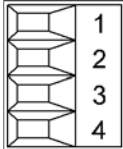
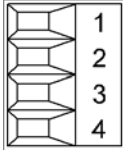
All three pressure sensors (X241/X242/X251/X252) as well as the sensor for the shut-off valve (X281/X282) are guided **per axis** via a **common current limitation**, i.e. a total current of 200 mA is provided per axis.

## Cables

---

### Note

#### Maximum cable lengths

The maximum permissible cable length is 40 m.

---

Only use shielded cables to connect the sensors. Only use round cables to ensure that they remain sealed. Connect the cables to the sensor using a round connector. Connect the cable shields to the upper side of the module using the shield connection elements.

---

### Note

#### Connector type

The connector used must establish a continuous shield connection between the cable shield and the sensor of the shutoff valve. Even for connectors with metal housing, the shield connection is not always continuous for all types.

- Ensure that there is a shield connection available.
- 

## Coding

In order to prevent interchanging the mating connectors between axes 1 and 2 and between the shutoff valve sensors, as well as the enable input, the terminals and the associated connectors X281 / X282 are equipped with coding elements when they are supplied.

## 6.2.10 X291 and X292 EP terminals to enable the power

The power enable signal for the HLA module is switched using the EP terminals. Each channel of the HLA module is equipped with its own EP terminal.

### Note

The EP terminals are only effective when using Safety Integrated. See Chapter Safety Integrated (Page 198).

The shutoff valves and the EP terminals are permanently assigned to the axes through the hardware. The EP terminal can be parameterized.

Table 6- 14 X291: EP terminal for axis enable, axis 1

|   | Pin | Signal name | Function                                 | Electrical data   |
|---|-----|-------------|--|---|
|  | 1   | -           | Not assigned                             | <ul style="list-style-type: none"> <li>• Input voltage (incl. ripple)                             <ul style="list-style-type: none"> <li>- Signal 1: 15 ... 30 V</li> <li>- Signal "0": -3 ... +5 V</li> </ul> </li> <li>• Input current                             <ul style="list-style-type: none"> <li>- At 24 V DC: typ. 3.5 mA</li> <li>- At &lt;0.5 mA: "0" will be positively detected</li> </ul> </li> <li>• Input delay                             <ul style="list-style-type: none"> <li>- For "0" → "1": typ. 0.7 ms</li> <li>- For "1" → "0": typ. 1.7 ms</li> </ul> </li> </ul> |
|   | 2   | ENA1P       | Axis enable, axis 1<br>P input, floating |   |
|   | 3   | ENA1N       | Axis enable, axis 1<br>N input, floating |   |
|   | 4   | M           | Ground for the axis enable signal        |   |
| Max. connectable cross-section: 1.5 mm <sup>2</sup><br>Type: Screw terminal       |     |             |  |   |

Table 6- 15 X292: EP terminal for axis enable, axis 2

|   | Pin | Signal name | Function                                 |   |
|---|-----|-------------|--|---|
|  | 1   | -           | Not assigned                             | <ul style="list-style-type: none"> <li>• Input voltage (incl. ripple)                             <ul style="list-style-type: none"> <li>- Signal 1: 15 ... 30 V</li> <li>- Signal "0": -3 ... +5 V</li> </ul> </li> <li>• Input current                             <ul style="list-style-type: none"> <li>- At 24 V DC: typ. 3.5 mA</li> <li>- At &lt;0.5 mA: "0" will be positively detected</li> </ul> </li> <li>• Input delay                             <ul style="list-style-type: none"> <li>- For "0" → "1": typ. 0.7 ms</li> <li>- For "1" → "0": typ. 1.7 ms</li> </ul> </li> </ul> |
|   | 2   | ENA2P       | Axis enable, axis 2<br>P input, floating |   |
|   | 3   | ENA2N       | Axis enable, axis 2<br>N input, floating |   |
|   | 4   | M           | Ground for the axis enable signal        |   |
| Max. connectable cross-section: 1.5 mm <sup>2</sup><br>Type: Screw terminal       |     |             |  |   |

**Note**

**Maximum cable length**

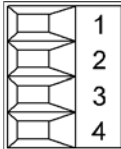
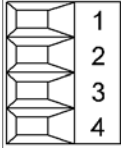
The maximum permissible cable length is 30 m.

**Power enable**

When the power is enabled, the switch for the shutoff valve is closed and the shutoff valve opens.

In the following section, you will see an example wiring of the enabling terminals incl. the internal optocoupler.

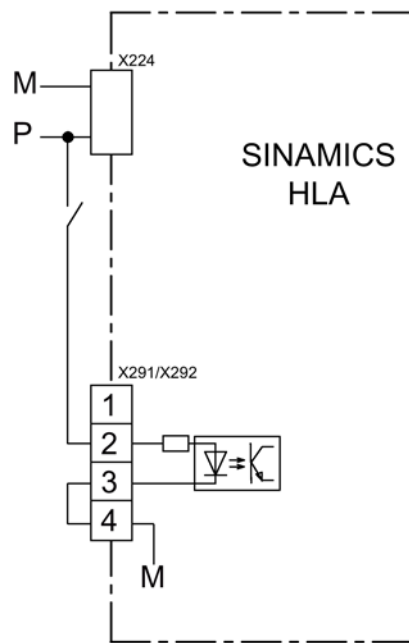

Figure 6-2 Wiring the enabling terminals incl. the internal optocoupler

#### Withdrawing the power enable (power inhibit)

When the power enable is withdrawn, the switch for the shutoff valve is opened and the shutoff valve closes.

---

#### Note

##### Using a central shutoff valve

If there is only one central shutoff valve, you must logically interconnect the signals (e.g. using the PLC), so that the central shutoff valve is triggered when the power is inhibited. To prevent faults at the other axes, it must be ensured that all axes whose pressure is supplied via this shutoff valve also receive the power inhibit command when the central shutoff valve is triggered.

If each axis has its own dedicated shutoff valve, connect the shutoff valve with the "shutoff valve" output of the associated axis.

---

## 6.3 Meaning of the LEDs on the HLA module

Table 6- 16 Meaning of the LEDs on the HLA module

| LED      | Color                      | Status           | Description, cause  | Remedy  |
|----------|----------------------------|------------------|---|---|
| RDY      | -                          | Off              | The electronics power supply is missing or outside the permissible tolerance range.   | –   |
|          | Green                      | Continuous light | The component is ready for operation. Cyclic DRIVE-CLiQ communication is taking place.  | –   |
|          | Orange                     | Continuous light | DRIVE-CLiQ communication is being established.  | –   |
|          | Red                        | Continuous light | This component has at least one fault.<br><b>Note</b><br>The LED is activated regardless of whether the corresponding messages have been reconfigured.  | Acknowledge the fault.  |
|          | Green/red                  | Flashing 0.5 Hz  | Firmware is being downloaded.   | –   |
|          | Green/red                  | Flashing 2 Hz    | Firmware download has been completed. The module waits for POWER ON.  | Carry out a POWER ON.   |
|          | Green/orange or Red/orange | Flashing light   | Component recognition via LED is activated. This response is parameterizable (see SINAMICS S120/150 List Manual).<br><b>Note:</b><br>Both options depend on the LED status when component recognition is activated. | –   |
| P26.5 OK | -                          | Off              | The 26.5 V supply is missing or outside the permissible tolerance range.  | Connect the power supply.<br>Check the voltage tolerance at the HLA module connector. When doing this, take into account the load-dependent voltage tolerance as a result of the cable resistances. |
|          | Green                      | Continuous light | The 26.5 V supply is available.<br>The system does not monitor and display an overvoltage.  | –   |

## 6.4 Dimension drawing

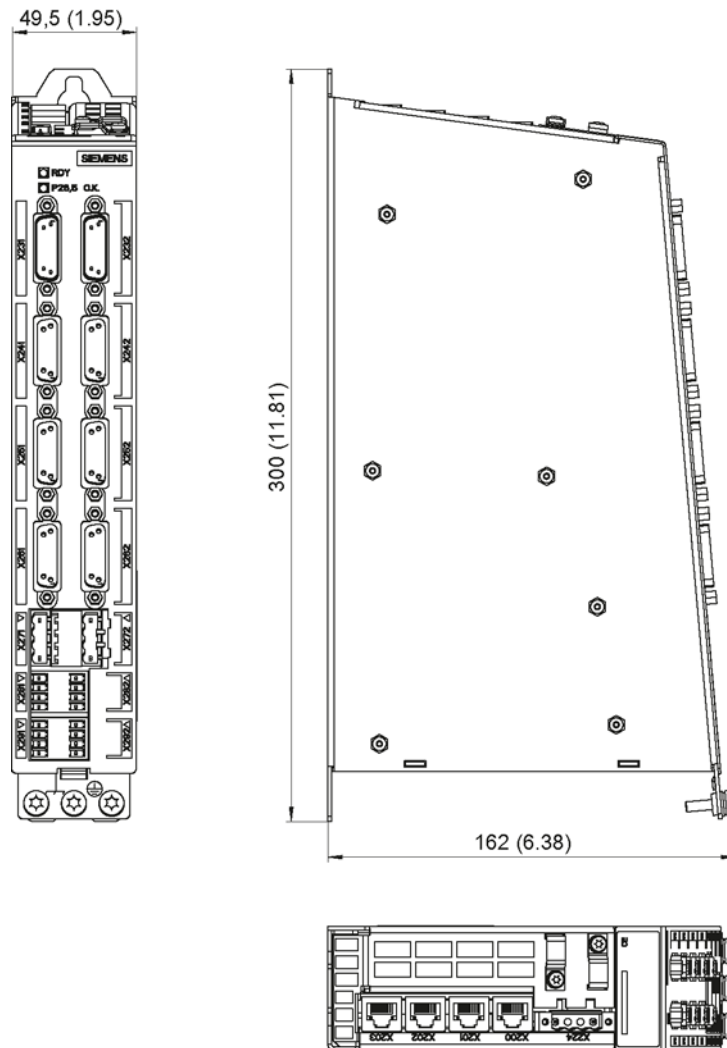

Figure 6-3 Dimension drawing of the HLA module, all dimensions in mm and (inches)

## 6.5 Available prefabricated cables

Table 6- 17 Cables available for SINAMICS HLA

| Article number                    | 6FX8002-2BA00  | 6FX8002-2BA10  | 6FX8002-2BA20  | 6FX8002-2BA21   | 6FX8002-2CA11  | 6FX8002-2CC81   |
|-----------------------------------|--|--|--|---|--|---|
| Applications                      | Connection of a standard servo solenoid valve (directly controlled)<br>X261 (axis 1)/<br>X262 (axis 2) | Connection of an HRV servo solenoid valve (high response)<br>X261 (axis 1)/<br>X262 (axis 2) | Connection of 2 pressure sensors to<br>X241 (axis 1)/<br>X242 (axis 2)<br>Connection of 2 pressure sensors behind shutoff valves<br>X251 (X/Y) | Connection of one pressure sensor to<br>X251 (axis 1)/<br>X252 (axis 2)   | Connection of one position measuring system with TTL interface to<br>X231 (axis 1)/<br>X232 (axis 2) | Connection of one position measuring system with SSI interface to<br>X231 (axis 1)/<br>X232 (axis 2)                        |
| Characteristic feature            | The cables are adapted to servo solenoid valves from Bosch Rexroth AG.                                 | The cables are adapted to servo solenoid valves from Bosch Rexroth AG.                       | For applications with one shutoff valve per axis with the same cable lengths:<br>Measurement of the system pressure (after the shutoff valve)  | For applications with a central shutoff valve or when using one shutoff valve per axis with different cable lengths:<br>Measurement of the system pressure (behind the shutoff valve) | 5 V encoder power supply (remote sense)  | 24 V encoder supply is not fed into the connector on the HLA side from outside; instead this now comes from the HLA module. |
| Connection on the HLA side        | Sub-D connector (male)   | Sub-D connector (male)   | Sub-D connector (male)   | Sub-D connector (male)  | Sub-D socket   | Sub-D socket  |
| Connection for peripheral devices | 7-pin signal connector (cap nut full thread/socket contacts)   | 12-pin signal connector (cap nut full thread/socket contacts)                                | Open cable ends  | Open cable ends   | 12-pin M23 signal connector (cap nut full thread/socket contacts)                                    | 12-pin M23 signal connector (cap nut full thread/socket contacts)   |



## 6.6 Connection example

| SINAMICS S120 HLA module | Article number<br>Prefabricated cable      |  |
|--------------------------|--|--|
|                          | 6FX8002-2DC30-....<br>≤ 30 m               | Measuring systems with M12<br>DRIVE-CLiQ interface   |
| X200-<br>X203            | 6SL3060-4A..-0AA0<br>≤ 5 m                 | X500 SMC10/SMC20/<br>SMC30/SMC40   |
|                          | 6FX8002-2DC10-....<br>≤ 75 m               | X500 SME20/SME25/<br>SME120/SME125   |
| X224                     | — — — — —<br>≤ 30 m                        | 24 V electronics power supply  |
| X231-<br>X232            | 6FX.0.2-2CA11-....<br>≤ 40 m               | Incremental encoder (TTL)<br>Axis 1 or 2   |
|                          | 6FX.0.2-2CC81-....<br>≤ 40 m               | Absolute value encoder with SSI<br>Axis 1 or 2   |
| X241                     | 6FX8002-2BA20-....<br>≤ 40 m               | Pressure sensor<br>Cylinder side A - axis 1  |
|                          |  | Pressure sensor<br>Cylinder side B - axis 1  |
| X242                     | 6FX8002-2BA20-....<br>≤ 40 m               | Pressure sensor<br>Cylinder side A - axis 2  |
|                          |  | Pressure sensor<br>Cylinder side B - axis 2  |
|                          | 6FX8002-2BA20-....<br>≤ 40 m               | Central pressure sensor<br>Shut-off valve (before)   |
| X251 <sup>3)</sup>       |  | Central pressure sensor<br>Shut-off valve (following)  |
|                          | 6FX8002-2BA21-....<br>≤ 40 m               | Axial pressure sensor<br>Shut-off valve (following) - axis 1                                 |
| X252 <sup>3)</sup>       | 6FX8002-2BA21-....<br>≤ 40 m               | Axial pressure sensor<br>Shut-off valve (following) - axis 2                                 |
| X261-<br>X262            | 6FX8002-2BA00-....<br>≤ 40 m               | Connectors<br>7-pole<br>Standard servo solenoid valve<br>(directly controlled) axis 1 oder 2 |
|                          | 6FX8002-2BA10-.... <sup>1)</sup><br>≤ 40 m | Connectors<br>12-pole<br>HRV servo solenoid valve (high<br>response) axis 1 or 2             |
| X271                     | — — — — — <sup>2)</sup><br>≤ 30 m          | 26.5 V supply voltage for hydraulic<br>components  |
| X272                     | — — — — — <sup>2)</sup><br>≤ 40 m          | Shutoff valves<br>Axes 1 and 2   |
| X281-<br>X282            | — — — — — <sup>2)</sup><br>≤ 40 m          | Valve spool sensor<br>Shutoff valve axis 1 or 2  |
| X291-<br>X292            | — — — — — <sup>2)</sup><br>≤ 30 m          | Digital input axis enable<br>Axis 1 or 2   |

1) The cable is adapted to servo solenoid valves from Bosch Rexroth AG.

2) For cable cross-sections and pin assignment, see Chapter "Interfaces (Page 200)".

3) Only one configuration can be connected. When connecting pressure sensors with the central shut-off valve to X251, no additional pressure sensors may be connected to X252.

## 6.7 Technical data

Table 6- 18 Technical data, HLA module

| 6SL3420-2HX00-0AA0   | Unit            | Value   |
|--|-----------------|---|
| <b>Electronics power supply</b>  |                 |   |
| Voltage  | V <sub>DC</sub> | 20.4 ... 28.8 (24 - 15 % + 20 %)  |
| Current  | A <sub>DC</sub> | Max. 1.1  |
| Power loss   | W               | Max. 12   |
| <b>Supply of the hydraulic components</b>                                  |                 |   |
| Voltage  | V <sub>DC</sub> | 26.0 ... 27.0 (26.5 ± 2 %)  |
| Current  | A <sub>DC</sub> | Max. 8.5 A  |
| Temperature range  | °C              | 0...40 (without derating)<br>40...55 (derating with reduction of the output current by 2.67 % per °C) |
| Max. cable lengths<br>to valves<br>to sensors<br>to the encoder (SSI, TTL) | m               | 40  |
| DRIVE-CLiQ cables/encoder  | m               | 100   |
| 24 V, 26.5 V and EP terminals  | m               | 30  |
| PE/ground connection   | Nm              | At the housing with M5/3 screw  |
| Weight (without mating connector)  | kg              | 1.75  |
| Degree of protection   | -               | IP20  |

# Appendix

## A.1 List of abbreviations

### Note

The following list of abbreviations includes all abbreviations and their meanings used in the entire SINAMICS family of drives.

| Abbreviation | Source of abbreviation                                    | Meaning  |
|--------------|---|--|
| <b>A</b>     |   |  |
| A...         | Alarm   | Warning  |
| AC           | Alternating Current                                       | Alternating current                                      |
| ADC          | Analog Digital Converter                                  | Analog digital converter                                 |
| AI           | Analog Input  | Analog input   |
| AIM          | Active Interface Module                                   | Active Interface Module                                  |
| ALM          | Active Line Module  | Active Line Module                                       |
| AO           | Analog Output   | Analog output  |
| AOP          | Advanced Operator Panel                                   | Advanced Operator Panel                                  |
| APC          | Advanced Positioning Control                              | Advanced Positioning Control                             |
| AR           | Automatic Restart   | Automatic restart  |
| ASC          | Armature Short-Circuit                                    | Armature short-circuit                                   |
| ASCII        | American Standard Code for Information Interchange        | American coding standard for the exchange of information |
| AS-i         | AS-Interface (Actuator Sensor Interface)                  | AS-Interface (open bus system in automation technology)  |
| ASM          | Asynchronmotor  | Induction motor  |
| AVS          | Active Vibration Suppression                              | Active load vibration damping                            |
| <b>B</b>     |   |  |
| BB           | Betriebsbedingung   | Operation condition                                      |
| BERO         | -   | Contactless proximity switch                             |
| BI           | Binector Input  | Binector input   |
| BIA          | Berufsgenossenschaftliches Institut für Arbeitssicherheit | BG Institute for Occupational Safety and Health          |
| BICO         | Binector Connector Technology                             | Binector connector technology                            |
| BLM          | Basic Line Module   | Basic Line Module  |
| BO           | Binector Output   | Binector output  |
| BOP          | Basic Operator Panel                                      | Basic operator panel                                     |
| <b>C</b>     |   |  |
| C            | Capacitance   | Capacitance  |

## A.1 List of abbreviations

| Abbreviation | Source of abbreviation                | Meaning                                  |
|--------------|---------------------------------------|--|
| C...         | -                                     | Safety message                           |
| CAN          | Controller Area Network               | Serial bus system                        |
| CBC          | Communication Board CAN               | Communication Board CAN                  |
| CBE          | Communication Board Ethernet          | PROFINET communication module (Ethernet) |
| CD           | Compact Disc                          | Compact disc                             |
| CDS          | Command Data Set                      | Command data set                         |
| CF Card      | CompactFlash Card                     | CompactFlash card                        |
| CI           | Connector Input                       | Connector input                          |
| CLC          | Clearance Control                     | Clearance control                        |
| CNC          | Computerized Numerical Control        | Computer-supported numerical control     |
| CO           | Connector Output                      | Connector output                         |
| CO/BO        | Connector Output/Binector Output      | Connector/binector output                |
| COB-ID       | CAN Object-Identification             | CAN Object Identification                |
| CoL          | Certificate of License                | Certificate of License                   |
| COM          | Common contact of a change-over relay | Center contact of a change-over contact  |
| COMM         | Commissioning                         | Commissioning                            |
| CP           | Communication Processor               | Communications processor                 |
| CPU          | Central Processing Unit               | Central processing unit                  |
| CRC          | Cyclic Redundancy Check               | Cyclic redundancy check                  |
| CSM          | Control Supply Module                 | Control Supply Module                    |
| CU           | Control Unit                          | Control Unit                             |
| CUA          | Control Unit Adapter                  | Control Unit Adapter                     |
| CUD          | Control Unit DC                       | Control Unit DC                          |
| <b>D</b>     |                                       |  |
| DAC          | Digital Analog Converter              | Digital analog converter                 |
| DC           | Direct Current                        | Direct current                           |
| DCB          | Drive Control Block                   | Drive Control Block                      |
| DCBRK        | DC Brake                              | DC braking                               |
| DCC          | Drive Control Chart                   | Drive Control Chart                      |
| DCN          | Direct Current Negative               | Direct current negative                  |
| DCP          | Direct Current Positive               | Direct current positive                  |
| DDC          | Dynamic Drive Control                 | Dynamic Drive Control                    |
| DDS          | Drive Data Set                        | Drive Data Set                           |
| DI           | Digital Input                         | Digital input                            |
| DI/DO        | Digital Input/Digital Output          | Digital input/output, bidirectional      |
| DMC          | DRIVE-CLiQ Hub Module Cabinet         | DRIVE-CLiQ Hub Module Cabinet            |
| DME          | DRIVE-CLiQ Hub Module External        | DRIVE-CLiQ Hub Module External           |
| DMM          | Double Motor Module                   | Double Motor Module                      |
| DO           | Digital Output                        | Digital output                           |
| DO           | Drive Object                          | Drive object                             |
| DP           | Decentralized Peripherals             | Distributed I/O                          |
| DPRAM        | Dual Ported Random Access Memory      | Dual-Port Random Access Memory           |

| Abbreviation | Source of abbreviation                              | Meaning   |
|--------------|---|---|
| DQ           | DRIVE-CLiQ  | DRIVE-CLiQ  |
| DRAM         | Dynamic Random Access Memory                        | Dynamic Random Access Memory                        |
| DRIVE-CLiQ   | Drive Component Link with IQ                        | Drive Component Link with IQ                        |
| DSC          | Dynamic Servo Control                               | Dynamic Servo Control                               |
| DSM          | Doppelsubmodul                                      | Double submodule                                    |
| DTC          | Digital Time Clock                                  | Timer   |
| <b>E</b>     |   |   |
| EASC         | External Armature Short-Circuit                     | External armature short-circuit                     |
| EDS          | Encoder Data Set                                    | Encoder data set                                    |
| EEPROM       | Electrically Erasable Programmable Read-Only Memory | Electrically Erasable Programmable Read-Only Memory |
| EGB          | Elektrostatisch gefährdete Baugruppen               | Electrostatic sensitive devices                     |
| EIP          | EtherNet/IP   | EtherNet Industrial Protocol (real-time Ethernet)   |
| ELCB         | Earth Leakage Circuit Breaker                       | Residual current operated circuit breaker           |
| ELP          | Earth Leakage Protection                            | Ground-fault monitoring                             |
| EMC          | Electromagnetic Compatibility                       | Electromagnetic compatibility                       |
| EMF          | Electromotive Force                                 | Electromotive force                                 |
| EMK          | Elektromotorische Kraft                             | Electromotive force                                 |
| EMV          | Elektromagnetische Verträglichkeit                  | Electromagnetic compatibility                       |
| EN           | Europäische Norm                                    | European standard                                   |
| EnDat        | Encoder-Data-Interface                              | Encoder interface                                   |
| EP           | Enable Pulses                                       | Pulse enable  |
| EPOS         | Einfachpositionierer                                | Basic positioner                                    |
| ES           | Engineering System                                  | Engineering system                                  |
| ESB          | Ersatzschaltbild                                    | Equivalent circuit diagram                          |
| ESD          | Electrostatic Sensitive Devices                     | Electrostatic sensitive devices                     |
| ESM          | Essential Service Mode                              | Essential service mode                              |
| ESR          | Extended Stop and Retract                           | Extended stop and retract                           |
| <b>F</b>     |   |   |
| F...         | Fault   | Fault   |
| FAQ          | Frequently Asked Questions                          | Frequently Asked Questions                          |
| FBLOCKS      | Free Blocks   | Free function blocks                                |
| FCC          | Function Control Chart                              | Function control chart                              |
| FCC          | Flux Current Control                                | Flux current control                                |
| FD           | Function Diagram                                    | Function diagram                                    |
| F-DI         | Failsafe Digital Input                              | Fail-safe digital input                             |
| F-DO         | Failsafe Digital Output                             | Fail-safe digital output                            |
| FEPRM        | Flash-EPROM   | Non-volatile write and read memory                  |
| FG           | Function Generator                                  | Function generator                                  |
| FI           | -   | Fault current                                       |
| FOC          | Fiber-Optic Cable                                   | Fiber-optic cable                                   |
| FP           | Funktionsplan                                       | Function diagram                                    |

## A.1 List of abbreviations

| Abbreviation | Source of abbreviation                    | Meaning   |
|--------------|---|---|
| FPGA         | Field Programmable Gate Array             | Field Programmable Gate Array   |
| FW           | Firmware                                  | Firmware  |
| <b>G</b>     |   |   |
| GB           | Gigabyte                                  | Gigabyte  |
| GC           | Global Control                            | Global control telegram (broadcast telegram)  |
| GND          | Ground                                    | Reference potential for all signal and operating voltages, usually defined as 0 V (also referred to as M) |
| GSD          | Gerätstammdatei                           | Generic Station Description: Describes the features of a PROFIBUS slave                                   |
| GSV          | Gate Supply Voltage                       | Gate supply voltage   |
| GUID         | Globally Unique Identifier                | Globally Unique Identifier  |
| <b>H</b>     |   |   |
| HF           | High frequency                            | High frequency  |
| HFD          | Hochfrequenzdrossel                       | Radio frequency reactor   |
| HLA          | Hydraulic Linear Actuator                 | Hydraulic linear actuator   |
| HLG          | Hochlaufgeber                             | Ramp-function generator   |
| HM           | Hydraulic Module                          | Hydraulic Module  |
| HMI          | Human Machine Interface                   | Human Machine Interface   |
| HTL          | High-Threshold Logic                      | Logic with high interference threshold  |
| HW           | Hardware                                  | Hardware  |
| <b>I</b>     |   |   |
| i. V.        | In Vorbereitung                           | Under development: This property is currently not available   |
| I/O          | Input/Output                              | Input/output  |
| I2C          | Inter-Integrated Circuit                  | Internal serial data bus  |
| IASC         | Internal Armature Short-Circuit           | Internal armature short-circuit   |
| IBN          | Inbetriebnahme                            | Commissioning   |
| ID           | Identifier                                | Identification  |
| IE           | Industrial Ethernet                       | Industrial Ethernet   |
| IEC          | International Electrotechnical Commission | International Electrotechnical Commission   |
| IF           | Interface                                 | Interface   |
| IGBT         | Insulated Gate Bipolar Transistor         | Insulated gate bipolar transistor   |
| IGCT         | Integrated Gate-Controlled Thyristor      | Semiconductor power switch with integrated control electrode  |
| IL           | Impulslöschung                            | Pulse suppression   |
| IP           | Internet Protocol                         | Internet Protocol   |
| IPO          | Interpolator                              | Interpolator  |
| IT           | Isolé Terre                               | Non-grounded three-phase line supply  |
| IVP          | Internal Voltage Protection               | Internal voltage protection   |
| <b>J</b>     |   |   |
| JOG          | Jogging                                   | Jogging   |

| Abbreviation | Source of abbreviation   | Meaning   |
|--------------|--|---|
| <b>K</b>     |  |   |
| KDV          | Kreuzweiser Datenvergleich   | Data cross-check  |
| KHP          | Know-how protection  | Know-how protection   |
| KIP          | Kinetische Pufferung   | Kinetic buffering   |
| Kp           | -  | Proportional gain   |
| KTY84-130    | -  | Temperature sensor  |
| <b>L</b>     |  |   |
| L            | -  | Symbol for inductance   |
| LED          | Light Emitting Diode   | Light emitting diode  |
| LIN          | Linearmotor  | Linear motor  |
| LR           | Lageregler   | Position controller   |
| LSB          | Least Significant Bit  | Least significant bit   |
| LSC          | Line-Side Converter  | Line-side converter   |
| LSS          | Line-Side Switch   | Line-side switch  |
| LU           | Length Unit  | Length unit   |
| LWL          | Lichtwellenleiter  | Fiber-optic cable   |
| <b>M</b>     |  |   |
| M            | -  | Symbol for torque   |
| M            | Masse  | Reference potential for all signal and operating voltages, usually defined as 0 V (also referred to as GND) |
| MB           | Megabyte   | Megabyte  |
| MCC          | Motion Control Chart   | Motion Control Chart  |
| MDI          | Manual Data Input  | Manual data input   |
| MDS          | Motor Data Set   | Motor data set  |
| MLFB         | Maschinenlesbare Fabrikatebezeichnung  | Machine-readable product code   |
| MM           | Motor Module   | Motor Module  |
| MMC          | Man-Machine Communication  | Man-machine communication   |
| MMC          | Micro Memory Card  | Micro memory card   |
| MSB          | Most Significant Bit   | Most significant bit  |
| MSC          | Motor-Side Converter   | Motor-side converter  |
| MSCY_C1      | Master Slave Cycle Class 1   | Cyclic communication between master (class 1) and slave   |
| MSR          | Motorstromrichter  | Motor-side converter  |
| MT           | Messtaster   | Probe   |
| <b>N</b>     |  |   |
| N. C.        | Not Connected  | Not connected   |
| N...         | No Report  | No report or internal message   |
| NAMUR        | Normenarbeitsgemeinschaft für Mess- und Regeltechnik in der chemischen Industrie | Standardization association for measurement and control in chemical industries                              |
| NC           | Normally Closed (contact)  | NC contact  |
| NC           | Numerical Control  | Numerical control   |

## A.1 List of abbreviations

| Abbreviation | Source of abbreviation                        | Meaning  |
|--------------|---|--|
| NEMA         | National Electrical Manufacturers Association | Standardization association in USA (United States of America)                        |
| NM           | Nullmarke                                     | Zero mark  |
| NO           | Normally Open (contact)                       | NO contact   |
| NSR          | Netzstromrichter                              | Line-side converter  |
| NTP          | Network Time Protocol                         | Standard for synchronization of the time of day                                      |
| NVRAM        | Non-Volatile Random Access Memory             | Non-volatile read/write memory   |
| <b>O</b>     |   |  |
| OA           | Open Architecture                             | Software component which provides additional functions for the SINAMICS drive system |
| OAIF         | Open Architecture Interface                   | Version of the SINAMICS firmware as of which the OA application can be used          |
| OASP         | Open Architecture Support Package             | Expands the commissioning tool by the corresponding OA application                   |
| OC           | Operating Condition                           | Operation condition  |
| OCC          | One Cable Connection                          | One-cable technology   |
| OEM          | Original Equipment Manufacturer               | Original equipment manufacturer  |
| OLP          | Optical Link Plug                             | Bus connector for fiber-optic cable  |
| OMI          | Option Module Interface                       | Option Module Interface  |
| <b>P</b>     |   |  |
| p...         | -   | Adjustable parameters  |
| P1           | Processor 1                                   | CPU 1  |
| P2           | Processor 2                                   | CPU 2  |
| PB           | PROFIBUS                                      | PROFIBUS   |
| PcCtrl       | PC Control                                    | Master control   |
| PD           | PROFIdrive                                    | PROFIdrive   |
| PDC          | Precision Drive Control                       | Precision Drive Control  |
| PDS          | Power unit Data Set                           | Power unit data set  |
| PDS          | Power Drive System                            | Drive system   |
| PE           | Protective Earth                              | Protective ground  |
| PELV         | Protective Extra Low Voltage                  | Safety extra-low voltage   |
| PFH          | Probability of dangerous failure per hour     | Probability of dangerous failure per hour  |
| PG           | Programmiergerät                              | Programming device   |
| PI           | Proportional Integral                         | Proportional integral  |
| PID          | Proportional Integral Differential            | Proportional integral differential   |
| PLC          | Programmable Logical Controller               | Programmable logic controller  |
| PLL          | Phase-Locked Loop                             | Phase-locked loop  |
| PM           | Power Module                                  | Power Module   |
| PMI          | Power Module Interface                        | Power Module Interface   |
| PMSM         | Permanent-magnet synchronous motor            | Permanent-magnet synchronous motor   |
| PN           | PROFINET                                      | PROFINET   |
| PNO          | PROFIBUS Nutzerorganisation                   | PROFIBUS user organization   |
| PPI          | Point to Point Interface                      | Point-to-point interface   |



| Abbreviation | Source of abbreviation           | Meaning   |
|--------------|----------------------------------|---|
| PRBS         | Pseudo Random Binary Signal      | White noise   |
| PROFIBUS     | Process Field Bus                | Serial data bus   |
| PS           | Power Supply                     | Power supply  |
| PSA          | Power Stack Adapter              | Power Stack Adapter   |
| PT1000       | -                                | Temperature sensor  |
| PTC          | Positive Temperature Coefficient | Positive temperature coefficient  |
| PTP          | Point To Point                   | Point-to-point  |
| PWM          | Pulse Width Modulation           | Pulse width modulation  |
| PZD          | Prozessdaten                     | Process data  |
| <b>Q</b>     |                                  |   |
| <b>R</b>     |                                  |   |
| r...         | -                                | Display parameters (read-only)  |
| RAM          | Random Access Memory             | Memory for reading and writing  |
| RCCB         | Residual Current Circuit Breaker | Residual current operated circuit breaker   |
| RCD          | Residual Current Device          | Residual current device   |
| RCM          | Residual Current Monitor         | Residual current monitor  |
| REL          | Reluctance motor textile         | Reluctance motor textile  |
| RESM         | Reluctance synchronous motor     | Synchronous reluctance motor  |
| RFG          | Ramp-Function Generator          | Ramp-function generator   |
| RJ45         | Registered Jack 45               | Term for an 8-pin socket system for data transmission with shielded or non-shielded multi-wire copper cables  |
| RKA          | Rückkühlanlage                   | Cooling unit  |
| RLM          | Renewable Line Module            | Renewable Line Module   |
| RO           | Read Only                        | Read only   |
| ROM          | Read-Only Memory                 | Read-only memory  |
| RPDO         | Receive Process Data Object      | Receive Process Data Object   |
| RS232        | Recommended Standard 232         | Interface standard for cable-connected serial data transmission between a sender and receiver (also known as EIA232)  |
| RS485        | Recommended Standard 485         | Interface standard for a cable-connected differential, parallel, and/or serial bus system (data transmission between a number of senders and receivers, also known as EIA485) |
| RTC          | Real Time Clock                  | Real-time clock   |
| RZA          | Raumzeigerapproximation          | Space-vector approximation  |
| <b>S</b>     |                                  |   |
| S1           | -                                | Continuous operation  |
| S3           | -                                | Intermittent duty   |
| SAM          | Safe Acceleration Monitor        | Safe acceleration monitoring  |
| SBC          | Safe Brake Control               | Safe brake control  |
| SBH          | Sicherer Betriebshalt            | Safe operating stop   |
| SBR          | Safe Brake Ramp                  | Safe brake ramp monitoring  |
| SBT          | Safe Brake Test                  | Safe brake test   |

## A.1 List of abbreviations

| Abbreviation | Source of abbreviation               | Meaning  |
|--------------|--------------------------------------|--|
| SCA          | Safe Cam                             | Safe cam   |
| SCC          | Safety Control Channel               | Safety Control Channel                                 |
| SCSE         | Single Channel Safety Encoder        | Single-channel safety encoder                          |
| SD Card      | SecureDigital Card                   | Secure digital memory card                             |
| SDC          | Standard Drive Control               | Standard Drive Control                                 |
| SDI          | Safe Direction                       | Safe motion direction                                  |
| SE           | Sicherer Software-Endschalter        | Safe software limit switch                             |
| SESM         | Separately-excited synchronous motor | Separately excited synchronous motor                   |
| SG           | Sicher reduzierte Geschwindigkeit    | Safely limited speed                                   |
| SGA          | Sicherheitsgerichteter Ausgang       | Safety-related output                                  |
| SGE          | Sicherheitsgerichteter Eingang       | Safety-related input                                   |
| SH           | Sicherer Halt                        | Safe stop  |
| SI           | Safety Integrated                    | Safety Integrated                                      |
| SIC          | Safety Info Channel                  | Safety Info Channel                                    |
| SIL          | Safety Integrity Level               | Safety Integrity Level                                 |
| SITOP        | -                                    | Siemens power supply system                            |
| SLA          | Safely-Limited Acceleration          | Safely limited acceleration                            |
| SLM          | Smart Line Module                    | Smart Line Module                                      |
| SLP          | Safely-Limited Position              | Safely Limited Position                                |
| SLS          | Safely-Limited Speed                 | Safely limited speed                                   |
| SLVC         | Sensorless Vector Control            | Sensorless vector control                              |
| SM           | Sensor Module                        | Sensor Module  |
| SMC          | Sensor Module Cabinet                | Sensor Module Cabinet                                  |
| SME          | Sensor Module External               | Sensor Module External                                 |
| SMI          | SINAMICS Sensor Module Integrated    | SINAMICS Sensor Module Integrated                      |
| SMM          | Single Motor Module                  | Single Motor Module                                    |
| SN           | Sicherer Software-Nocken             | Safe software cam                                      |
| SOS          | Safe Operating Stop                  | Safe operating stop                                    |
| SP           | Service Pack                         | Service pack   |
| SP           | Safe Position                        | Safe position  |
| SPC          | Setpoint Channel                     | Setpoint channel                                       |
| SPI          | Serial Peripheral Interface          | Serial peripheral interface                            |
| SPS          | Speicherprogrammierbare Steuerung    | Programmable logic controller                          |
| SS1          | Safe Stop 1                          | Safe Stop 1 (time-monitored, ramp-monitored)           |
| SS1E         | Safe Stop 1 External                 | Safe Stop 1 with external stop                         |
| SS2          | Safe Stop 2                          | Safe Stop 2  |
| SS2E         | Safe Stop 2 External                 | Safe Stop 2 with external stop                         |
| SSI          | Synchronous Serial Interface         | Synchronous serial interface                           |
| SSL          | Secure Sockets Layer                 | Encryption protocol for secure data transfer (new TLS) |
| SSM          | Safe Speed Monitor                   | Safe feedback from speed monitor                       |
| SSP          | SINAMICS Support Package             | SINAMICS support package                               |

| Abbreviation | Source of abbreviation              | Meaning   |
|--------------|-------------------------------------|---|
| STO          | Safe Torque Off                     | Safe torque off   |
| STW          | Steuerwort                          | Control word  |
| <b>T</b>     |                                     |   |
| TB           | Terminal Board                      | Terminal Board  |
| TEC          | Technology Extension                | Software component which is installed as an additional technology package and which expands the functionality of SINAMICS (previously OA application) |
| TIA          | Totally Integrated Automation       | Totally Integrated Automation   |
| TLS          | Transport Layer Security            | Encryption protocol for secure data transfer (previously SSL)   |
| TM           | Terminal Module                     | Terminal Module   |
| TN           | Terre Neutre                        | Grounded three-phase line supply  |
| Tn           | -                                   | Integral time   |
| TPDO         | Transmit Process Data Object        | Transmit Process Data Object  |
| TSN          | Time-Sensitive Networking           | Time-Sensitive Networking   |
| TT           | Terre Terre                         | Grounded three-phase line supply  |
| TTL          | Transistor-Transistor-Logic         | Transistor-transistor logic   |
| Tv           | -                                   | Rate time   |
| <b>U</b>     |                                     |   |
| UL           | Underwriters Laboratories Inc.      | Underwriters Laboratories Inc.  |
| UPS          | Uninterruptible Power Supply        | Uninterruptible power supply  |
| USV          | Unterbrechungsfreie Stromversorgung | Uninterruptible power supply  |
| UTC          | Universal Time Coordinated          | Universal time coordinated  |
| <b>V</b>     |                                     |   |
| VC           | Vector Control                      | Vector control  |
| Vdc          | -                                   | DC link voltage   |
| VdcN         | -                                   | Partial DC link voltage negative  |
| VdcP         | -                                   | Partial DC link voltage positive  |
| VDE          | Verband Deutscher Elektrotechniker  | Verband Deutscher Elektrotechniker [Association of German Electrical Engineers]   |
| VDI          | Verein Deutscher Ingenieure         | Verein Deutscher Ingenieure [Association of German Engineers]   |
| VPM          | Voltage Protection Module           | Voltage Protection Module   |
| Vpp          | Volt peak to peak                   | Volt peak to peak   |
| VSM          | Voltage Sensing Module              | Voltage Sensing Module  |
| <b>W</b>     |                                     |   |
| WEA          | Wiedereinschaltautomatik            | Automatic restart   |
| WZM          | Werkzeugmaschine                    | Machine tool  |
| <b>X</b>     |                                     |   |
| XML          | Extensible Markup Language          | Extensible markup language (standard language for Web publishing and document management)   |
| <b>Y</b>     |                                     |   |

A.1 List of abbreviations

| Abbreviation | Source of abbreviation | Meaning     |
|--------------|------------------------|-------------|
| <b>Z</b>     |                        |             |
| ZK           | Zwischenkreis          | DC link     |
| ZM           | Zero Mark              | Zero mark   |
| ZSW          | Zustandswort           | Status word |

## A.2 Documentation overview

| General documentation/catalogs     |  |                                       |   |
|------------------------------------|--|---------------------------------------|---|
| SINAMICS                           | G110                                   | D 11                                  | - Converter Built-In Units 0.12 kW to 3 kW  |
|                                    | G120                                   | D 31                                  | - SINAMICS Converters for Single-Axis Drives and SIMOTICS Motors  |
|                                    | G130, G150                             | D 11                                  | - Converter Built-In Units<br>- Converter Cabinet Units   |
|                                    | S120, S150                             | D 21                                  | - SINAMICS S120 Chassis Built-In Units and Cabinet Modules<br>- SINAMICS S150 Converter Cabinet Units   |
|                                    | S120                                   | D 21.4                                | - SINAMICS S120 and SIMOTICS  |
| Manufacturer/service documentation |  |                                       |   |
| SINAMICS                           | G110                                   |                                       | - Getting Started<br>- Operating Instructions<br>- List Manuals   |
|                                    | G120                                   |                                       | - Getting Started<br>- Operating Instructions<br>- Hardware Installation Manuals<br>- Safety Integrated Function Manual<br>- List Manuals   |
|                                    | G130                                   |                                       | - Operating Instructions<br>- List Manual   |
|                                    | G150                                   |                                       | - Operating Instructions<br>- List Manual   |
|                                    | GM150,<br>SM120/SM150,<br>GL150, SL150 |                                       | - Operating Instructions<br>- List Manuals  |
|                                    | S110                                   |                                       | - Equipment Manual<br>- Getting Started<br>- Function Manual<br>- List Manual   |
|                                    | S120                                   |                                       | - Getting Started<br>- Commissioning Manual<br>- Function Manual Drive Functions<br>- Function Manual Communication (from firmware V5.2)<br>- Safety Integrated Function Manual<br>- DCC Function Manual<br>- List Manual<br>- Equipment Manual for Control Units and Additional System Components<br>- Equipment Manual for Booksize Power Units<br>- Equipment Manual for Booksize Power Units C/D Type<br>- Equipment Manual for Chassis Air-Cooled Power Units<br>- Equipment Manual for Chassis Power Units, Liquid-cooled<br>- Equipment Manual for Chassis Water-Cooled Power Units for Common Cooling Circuits<br>- Equipment Manual Combi<br>- Equipment Manual for Cabinet Modules<br>- Equipment Manual for AC Drives<br>- SINAMICS S120M Equipment Manual Distributed Drive Technology<br>- SINAMICS HLA System Manual Hydraulic Drives |
|                                    | S150                                   |                                       | - Operating Instructions<br>- List Manual   |
| Motors                             |  | - Configuration Manuals, Motors       |   |
| General                            |  | - Configuration Manual, EMC Guideline |   |

## A.3 Hydraulic

### A.3.1 Servo solenoid valves

#### A.3.1.1 General

The servo solenoid valve is the final control element in an electro-hydraulic control loop. It converts the electrical manipulated variable  $U = -10 \dots +10 \text{ V}$  into the hydraulic variables pressure  $p$  and flow rate  $Q$ , and thus into a cylinder movement.

#### Sliding spool principle

These valves are of the sliding-spool type. A valve spool with 4 control edges moves inside a steel sleeve, the control bore of which is connected to the 4 ports in the valve casing.

The main stages of precontrolled valves do not typically have the steel sleeve, in which case the control geometry is represented directly by the valve casing.

The individual ports in the valve casing are:

- P: Pressure port (inlet)
- T: Tank port (return)
- A and B: Operating ports (cylinder)

The valve spool slides steplessly through 3 switching positions (continuous valve).

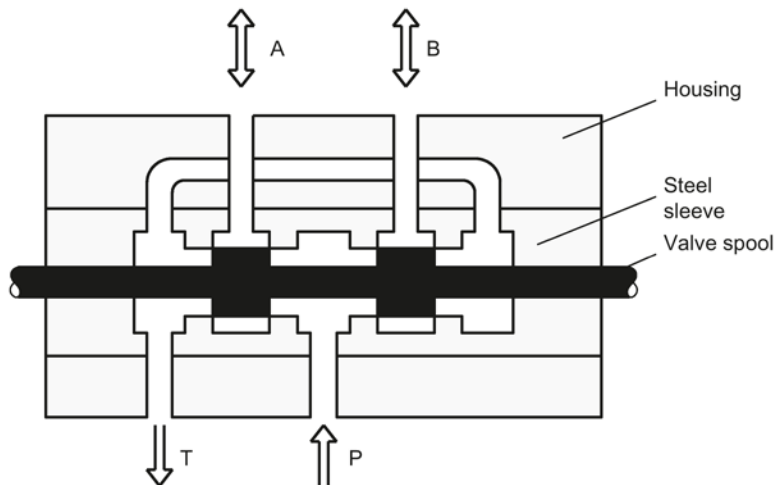

Figure A-1 Sliding spool principle

### Solenoid actuation with valve spool position control

For standard servo solenoid valves, the valve spool is actuated directly by a stepless solenoid. This converts a current  $I$  into a force  $F$ , which is compared to the force of the reset spring. This comparison of forces finally produces a travel  $s$ , and thus an opening cross-section at the control edges of the valve spool.

To compensate for disturbance forces acting on the valve spool (flow forces) and to reduce the hysteresis and response sensitivity or range of inversion, the position of the armature, and therefore the spool travel, is scanned and applied to a position control loop as an actual value. Any deviations from the spool position setpoint are thus continuously corrected. This method is particularly successful in reducing the valves' sensitivity to dirt.

Very small control deviations, such as those caused when the valve spool sticks, can be corrected by mobilizing the entire available magnetic force.

A wear-resistant, proximity-type differential transformer (LVDT) is used as the spool travel sensor.

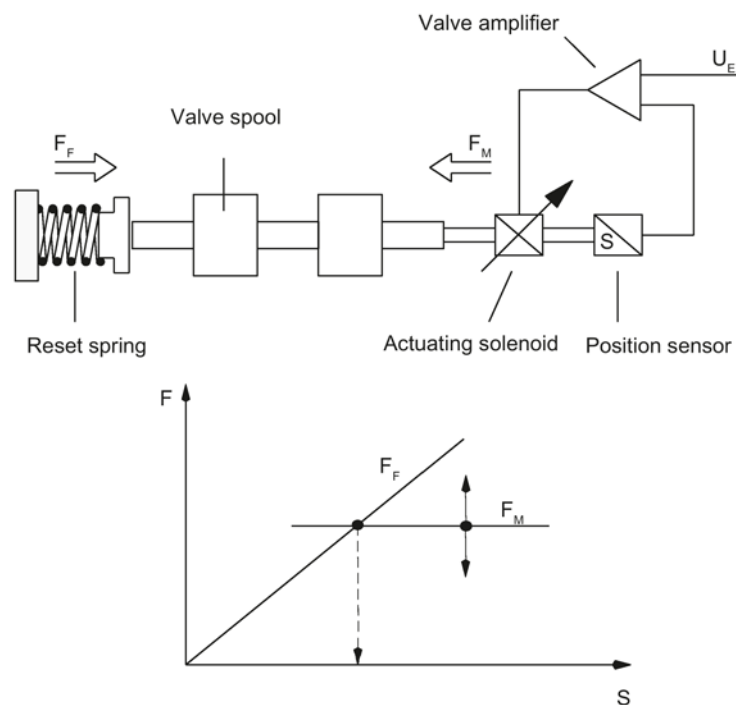

Figure A-2 Solenoid actuation with valve spool position control

Symbol

The operating principle of the servo solenoid valve is represented by a symbol in the hydraulic circuit diagram. The symbol comprises a series of different boxes denoting the valve positions.

The three stepless-transition valve positions are represented by additional lines. The symbol also indicates how the valve is actuated. In this case, by direct solenoid actuation with spring return at one end.

If the valve has a fail-safe position, then the valve spool moves into a fourth (safety) position when the valve is not powered. There are two alternative positions.

The symbol also illustrates the principle of position control applied to the valve spool.

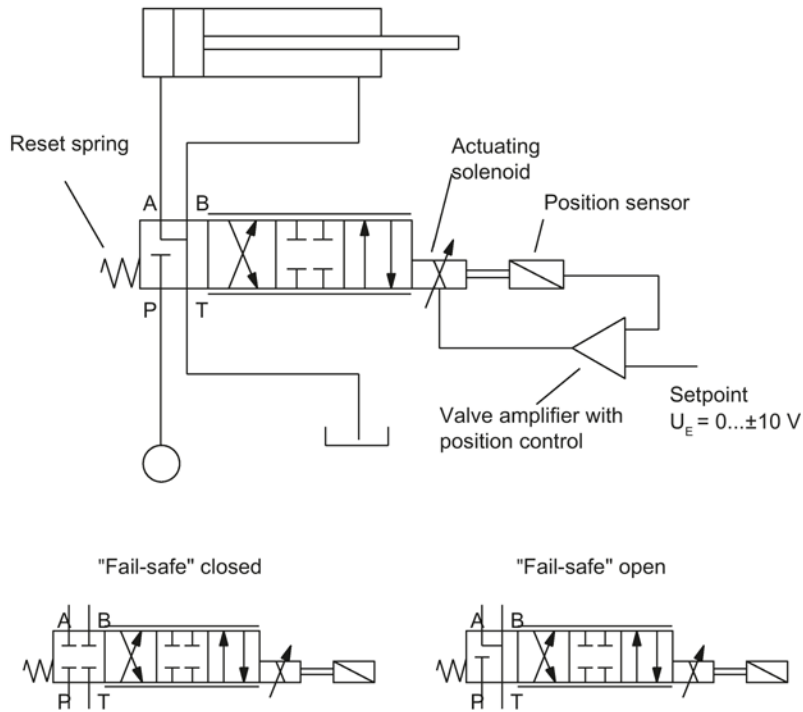

Figure A-3 Symbol



### Zero overlap at the middle position

A continuous valve must have zero overlap around its middle position if it is to be used in a position control loop.

A positive overlap will be perceived negatively in the form of a dead zone of the final control element.

In contrast, a negative overlap results in a marked increase in oil leakage.

To achieve zero overlap, valve spools, spool housings and spool sleeves must be manufactured with extreme precision and made of wear-resistant materials. The production costs incurred are correspondingly high.

To maintain the zero overlap over prolonged operating periods, it is essential to ensure that a clean pressure medium is used (to prevent erosion of control edges).

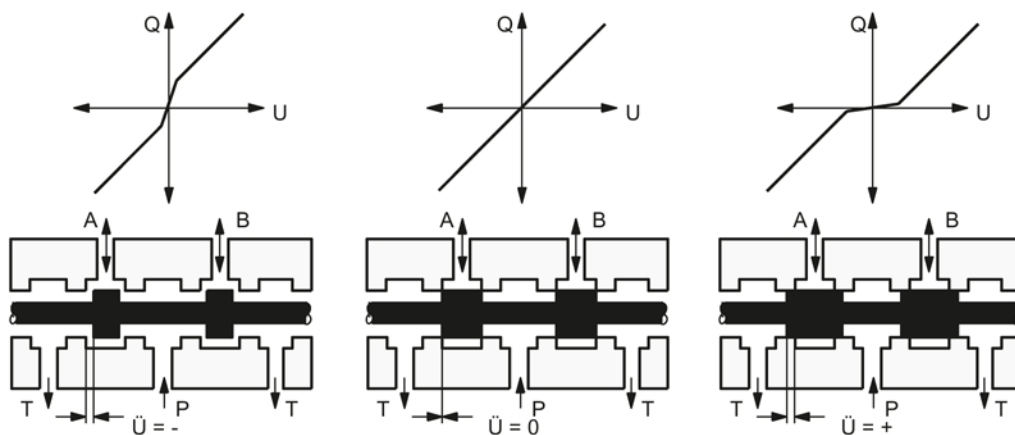

Figure A-4 Zero overlap at the middle position

### Pressure amplification

The quality of zero overlap at the middle position is represented by the pressure amplification.

This states what percentage of the control spool deflection from the hydraulic zero point is needed to achieve a pressure differential of 80% system pressure at the closed load ports. The values typically lie in the 1...3% range.

The following graphical representation of the measurement, which covers all 4 control edges, shows this clearly.

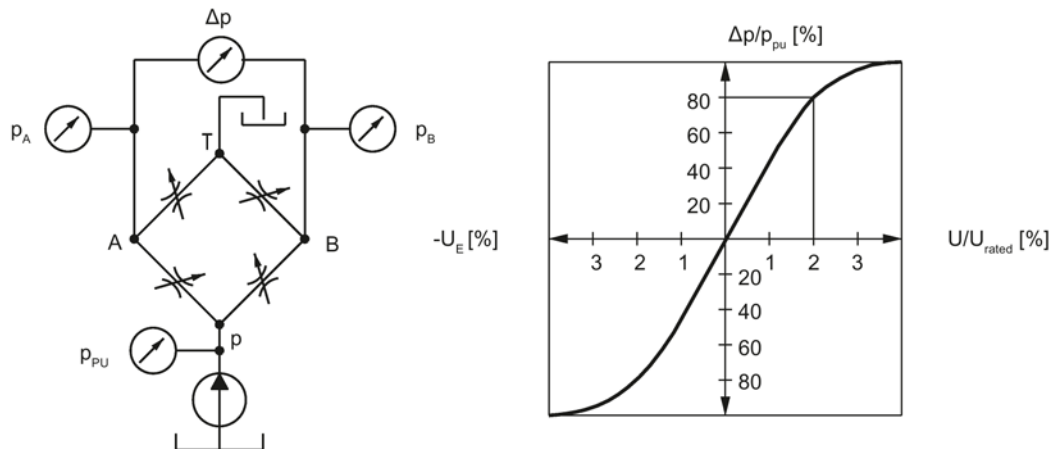

Figure A-5 Pressure amplification

### Flow rate characteristic, linear

The stepless spool movement, and thus the change in throttle cross-section at the control edges, results in a corresponding flow rate, which is represented as a function of the spool travel  $s$  or of the electrical input signal  $U$  (manipulated variable). In addition to the opening cross-section, the flow rate is also dependent on the pressure drop corresponding to the fluid-flow law:

$$Q \sim \sqrt{\Delta p}$$

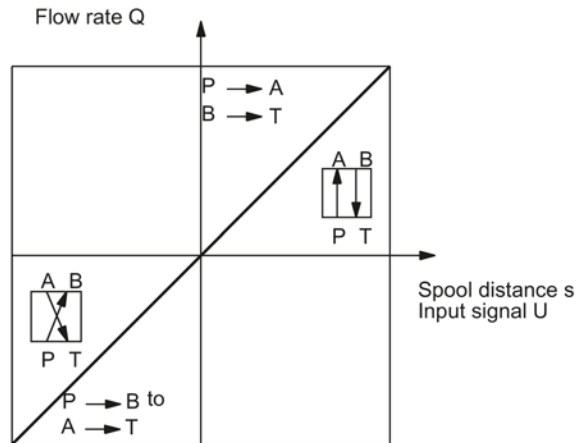

Figure A-6 Linear flow rate characteristic

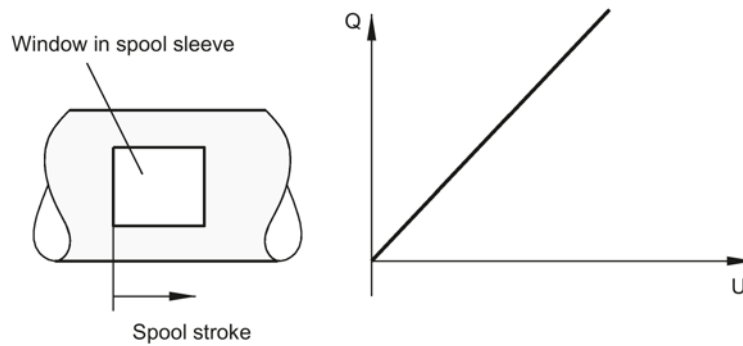

Figure A-7 Control window in the spool sleeve

**Flow rate characteristic, with transition point**

Valves with a flow characteristic with transition point give the drive greater manipulated variable resolution in the lower signal range (better machining quality) and, at the same time, offer sufficient flow rate in the upper range (high rapid traverse velocity).

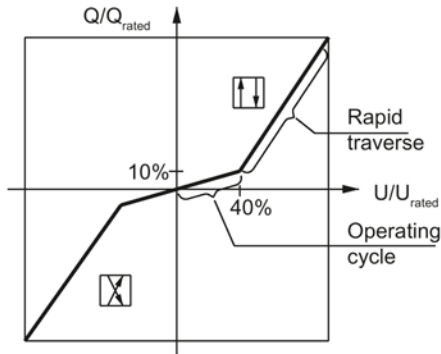

Figure A-8 Flow rate characteristic with transition point, example 40 % transition

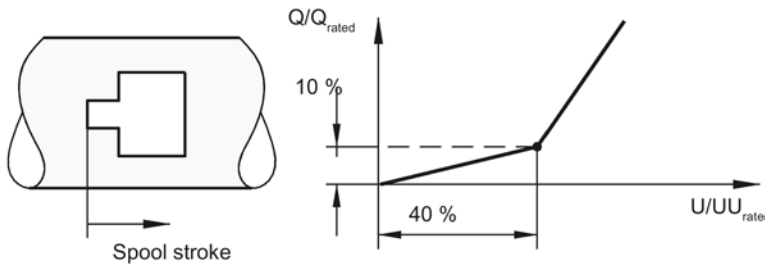

Figure A-9 Stepped control spool window in the spool sleeve, example 40 % transition

**Linearization of flow rate characteristic with a transition point**

The valve characteristic with transition point is linearized in the HLA module to match it to the closed-loop control of the overall drive (cylinder). No steady-state operating point should be defined in the area of the transition point.

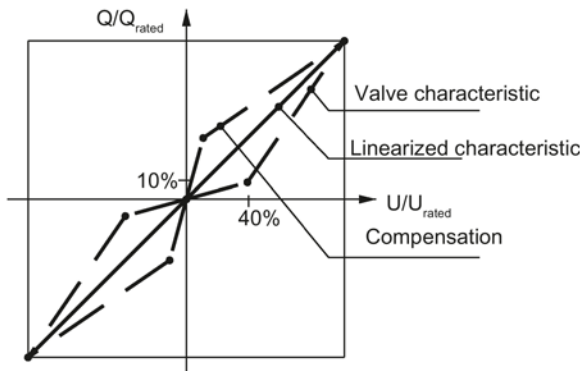

Figure A-10 Electrical valve transition point compensation

## Rated flow rate

The rated flow rate expresses the flow rate with fully opened valve in relation to a specific pressure drop per control edge.

The flow rate for specific pressure conditions is calculated according to fluid-flow law by the following formula:

$$Q_x = Q_{\text{rated}} \cdot \sqrt{\frac{\Delta p_x}{\Delta p_{\text{rated}}}}$$

## Asymmetrical flow rate characteristic

Also see Chapter "Selection of servo solenoid valves (Page 41)".

## Dynamic response

The dynamic response parameters provide information on the servo solenoid valve's ability to respond to rapid signal changes.

The valve actuation time is a basic statement regarding the dynamic response. This is the time that it takes the valve spool to follow a step in the valve spool setpoint of typically 0 to 100 %.

More exact information about the dynamic response is provided by the Bode diagram or frequency response. In this case, a sinusoidal setpoint is applied to the valve. The amplitude ratio and phase shift curves are then determined with respect to the frequency from the actual and setpoint values of the valve spool. The valve frequency response is highly dependent on the setpoint amplitude, which should therefore be specified as a parameter. The dynamic response of servo solenoid valves is of particular interest in the range of smaller signal amplitudes of 5 to 20 %  $U_{\text{rated}}$ .

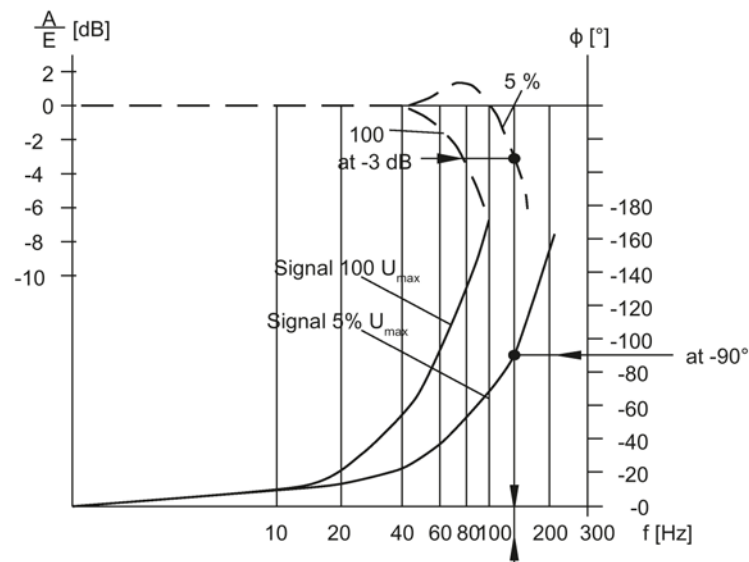

Figure A-11 Dynamic response of the valve

### Hysteresis, response sensitivity, range of inversion

These 3 terms define similar properties.

Hysteresis means the greatest difference in the input signal for identical output signals when passing through a complete signal range.

For a servo solenoid valve, hysteresis is caused by:

- mechanical friction,
- magnetic hysteresis of the electromagnetic signal transducer and
- the play between transmission elements.

The position control corrects the hysteresis.

The terms response sensitivity and range of inversion refer to the signal level required to set a valve in motion again after it has stopped. The values of these characteristics correspond to about half the hysteresis.

To overcome residual hysteresis or initial valve friction, a friction compensation function can be activated in the HLA module.

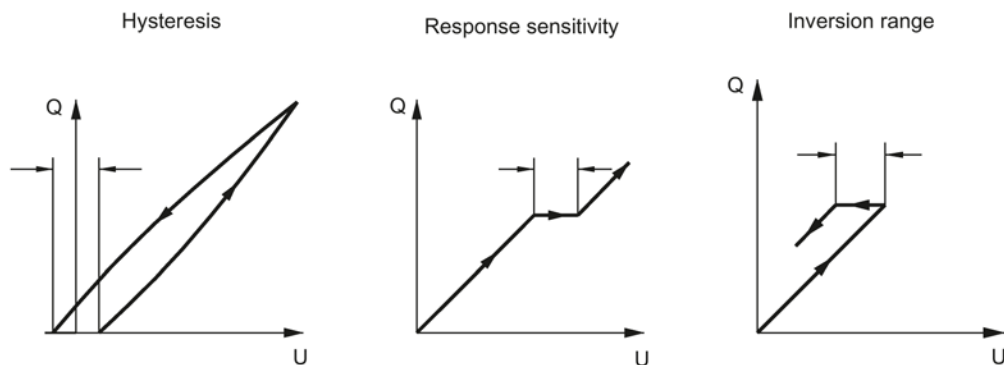

Figure A-12 Hysteresis, response sensitivity and range of inversion of a servo solenoid valve

### Filter mesh width

To maximize the service life of the control edges, thus ensuring the quality of zero overlap, a certain degree of purity of the hydraulic fluid must be maintained.

The objective is to achieve pollution class 7...9 to NAS 1638. This can normally be achieved with a pressure filter  $\beta_{10}=75$ .

### A.3.1.2 Directly-controlled servo solenoid valves

#### Mechanical design

The valve spool in its steel sleeve is pushed against the reset spring directly by the actuating solenoid. The armature axis of the solenoid is mechanically coupled to the ferrite core of the position sensor integrated in the solenoid.

This sensor is a proximity-type, wear-resistant differential transformer (Linear Variable Differential Transducer LVDT).

The housing of the integrated valve amplifier (On Board Electronic OBE) is bolted directly onto the solenoid/position sensor module.

Electrical power is supplied and the setpoint injected using a 7-pin connector.

If the valve is operating around its middle position, the solenoid is energized by about 50%. When the power supply is switched off, it assumes a 4th position, known as the fail-safe position. When switching on and switching off, it slides through the crossed position.

The valves are available with a variety of nominal flow rates and two different fail-safe positions.

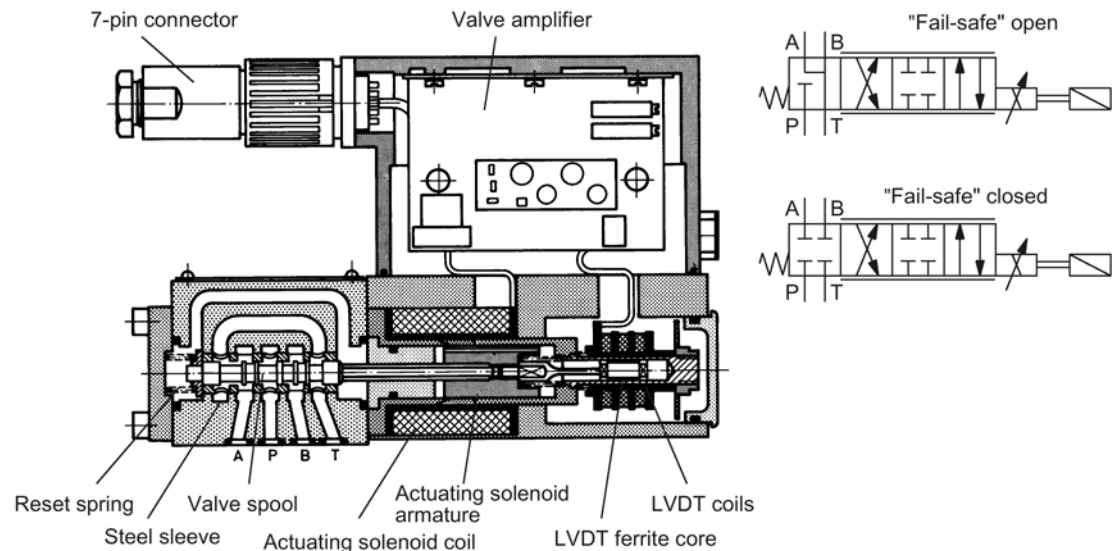

LVDT      Differential transformer                      Linear variable differential transformer

Figure A-13 Directly-controlled servo solenoid valve

#### Valve amplifier

The functions of the integral valve amplifier utilize analog electronics, and are illustrated in the following block diagram.

The main functions include:

- Supply and evaluation of the position sensor (AC/DC converter)
- Comparison of the setpoint input signal with valve spool actual value

- Formation of manipulated variable via a PID controller for the output stage
- Clocked output stage with pulse length modulation

The amplifier is calibrated to match the valve at the factory. The zero point is adjusted at the NC when the system is being commissioned.

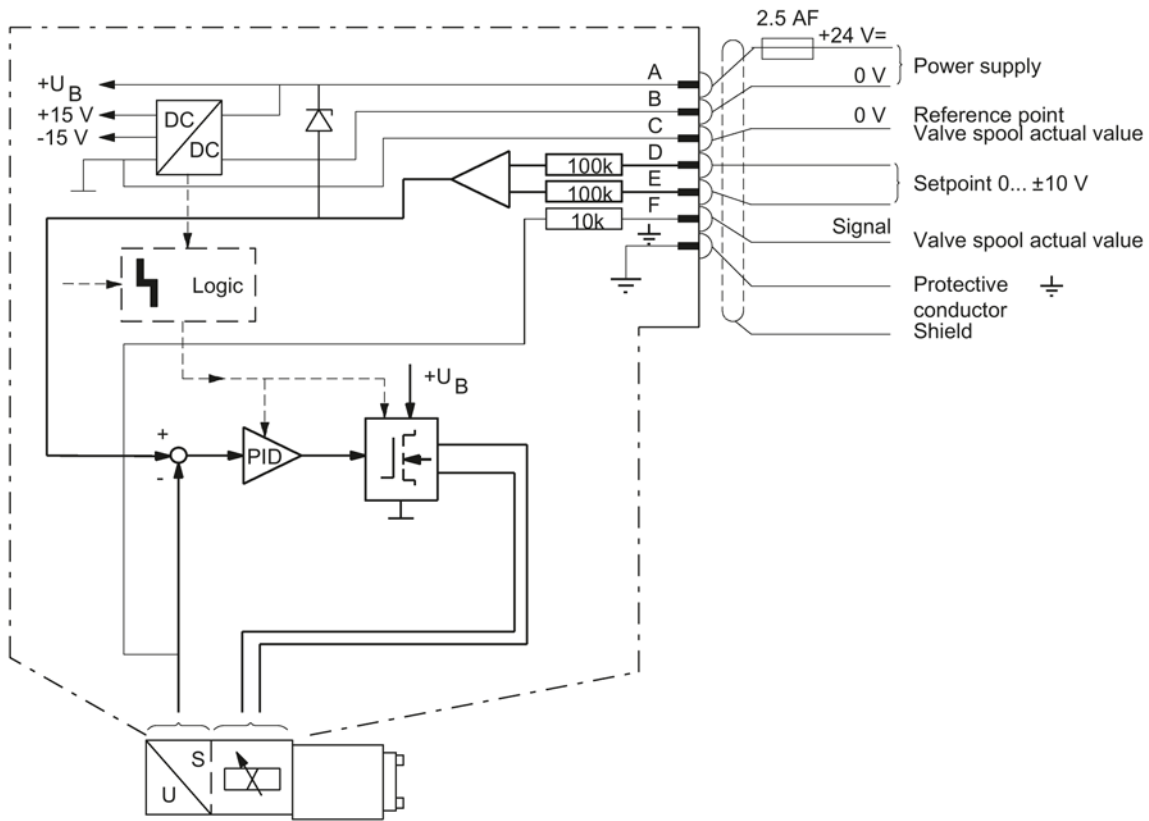

Figure A-14 Valve amplifier: Block diagram of directly controlled servo solenoid valves



### **A.3.1.3 Precontrolled servo solenoid valves**

The principle of precontrol is applied in order to be able to handle higher flow rates.

#### **Mechanical design**

A directional control valve with appropriate control edges at the valve spool is used as main stage. Like the piston of a cylinder, this stage is hydraulically clamped and positioned by a precontrol valve.

The position of the main spool is scanned by another position sensor and the corresponding actual value applied to a second, subordinate position control loop.

#### **Hydraulic fluid intake and discharge**

The control fluid can be supplied and removed either internally via ports P and T or, as often is the case in practice, externally via additional ports X and Y. The unit is converted over using suitable plugs.

#### **Switch settings**

Precontrolled servo solenoid valves have only three stepless-transition valve positions.

The 4th fail-safe position is omitted. If the supply voltage is disconnected, the spring force of the main spool causes the valve to assume an indifferent middle position.

### Valve amplifier

The integral valve amplifier is mounted on the precontrol stage and contains both position control loops. A cable is used to connect the position sensor on the main stage to the amplifier.

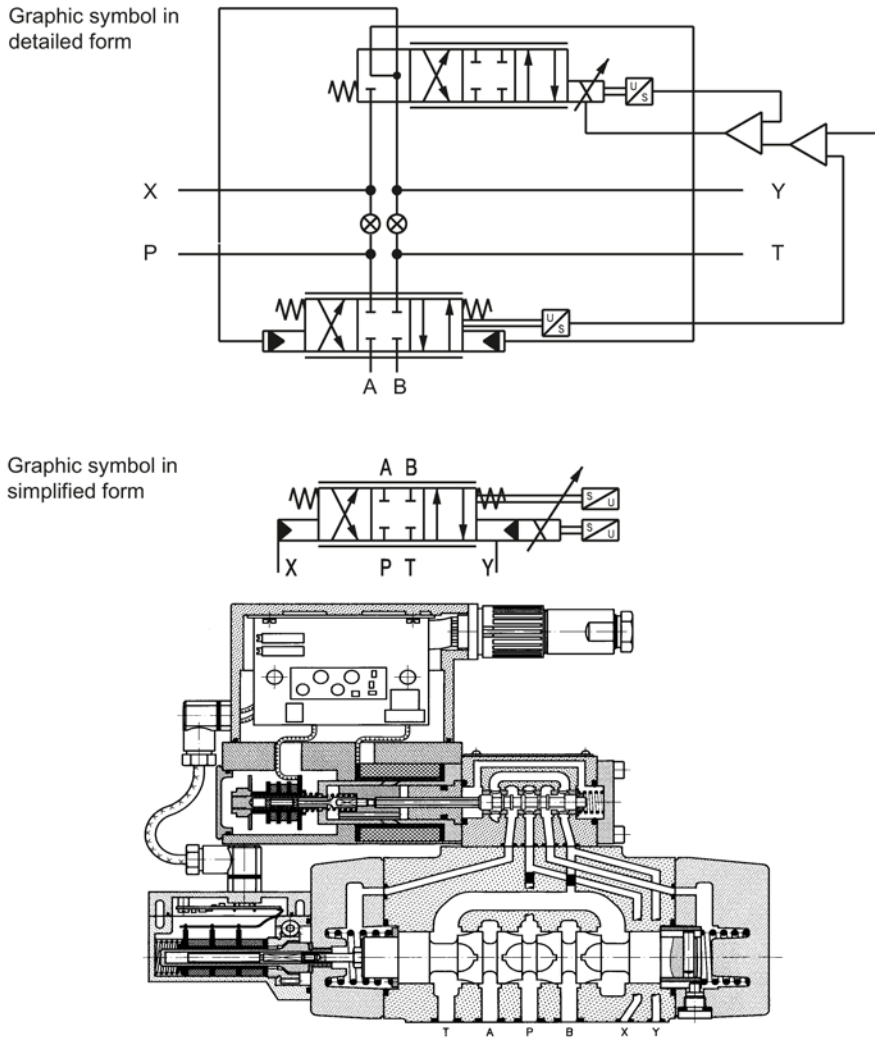

Figure A-15 Precontrolled servo solenoid valve

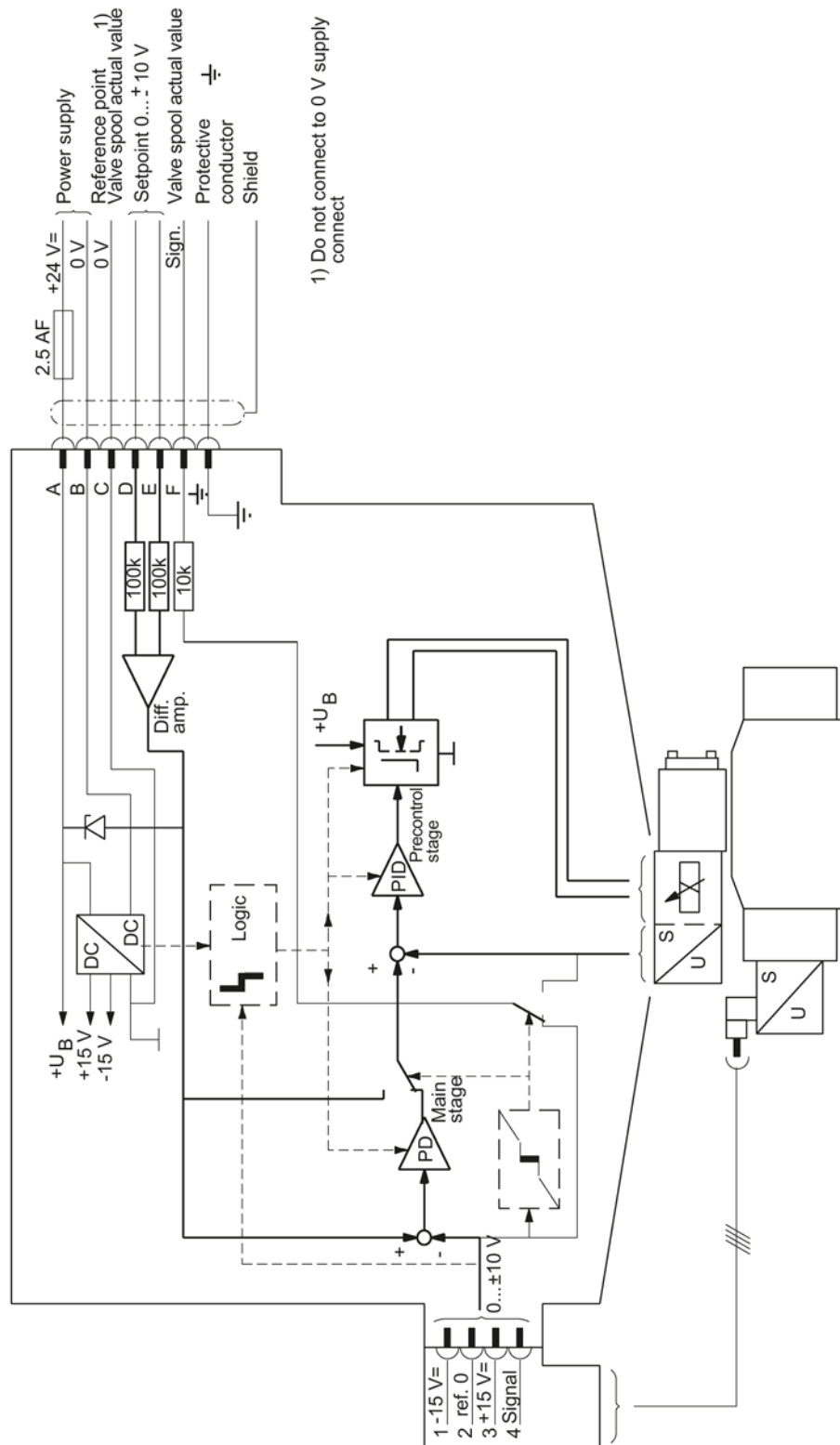

Figure A-16 Block diagram of the valve amplifier for a precontrolled servo solenoid valve

### A.3.1.4 HR servo solenoid valves

#### General

The HR (High Response) servo solenoid valves offer particularly good dynamic and static characteristics, making it the ideal addition to the portfolio to address highly sophisticated applications.

Both valve stages for precontrolled valves operate with position control.

#### Features

In contrast to the other servo solenoid valves, HR servo solenoid valves have the following features:

- A significantly better dynamic response
- A smaller size
- A higher hydraulic switching capacity

HR valves do not have the fail-safe position provided on other servo solenoid valves. Many applications therefore require external non-return valves, such as those available as sandwich-plate valves.

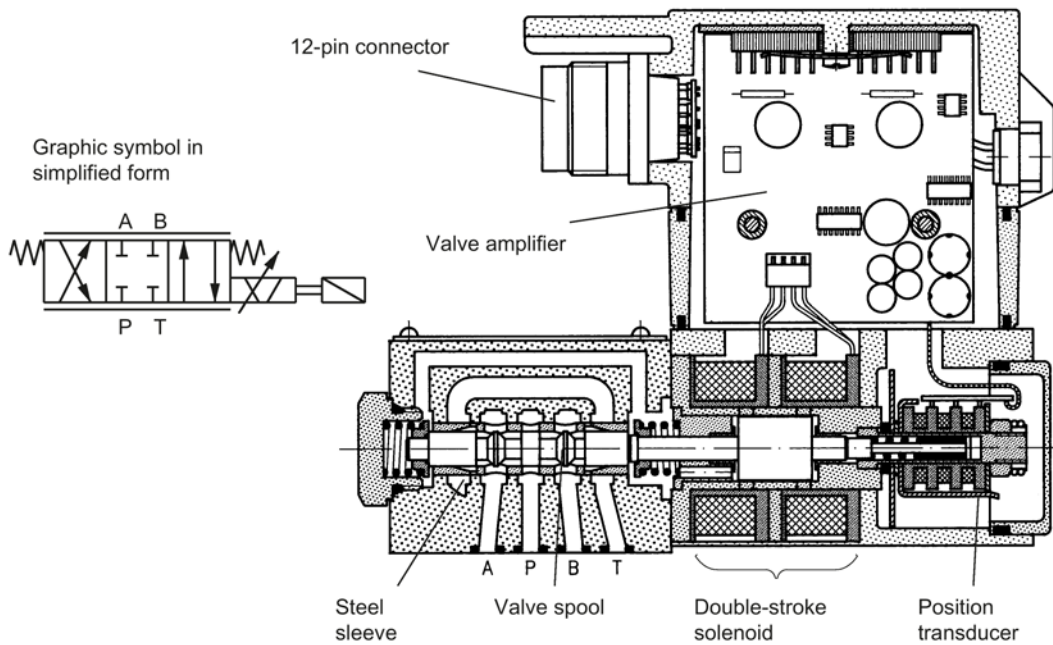

Figure A-17 Directly-controlled HR servo solenoid valves

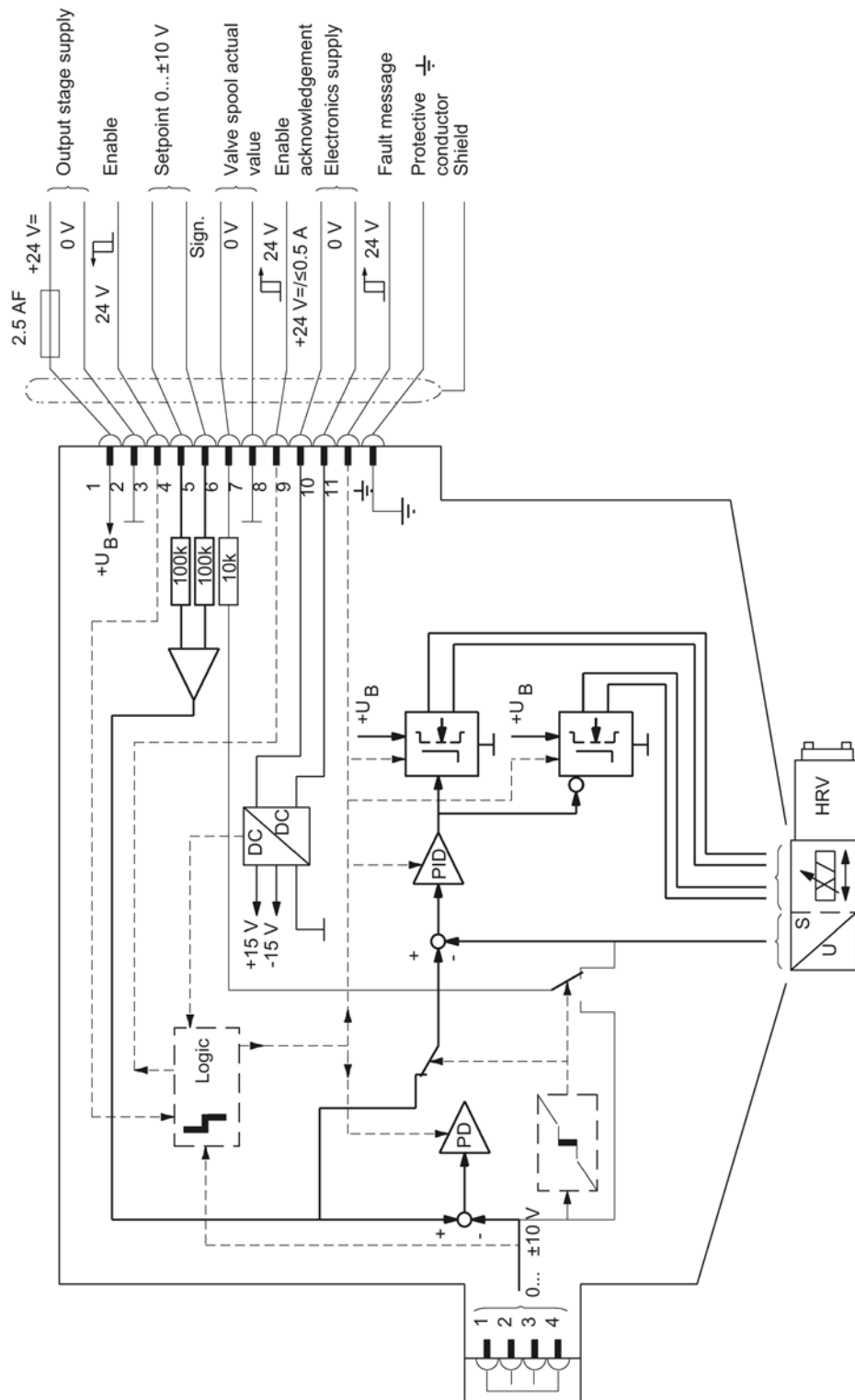

Figure A-18 Valve amplifier: Block diagram of directly-controlled HR servo solenoid valves

### A.3.2 Cylinder

#### General

The cylinder acts as the drive element in the electro-hydraulic control loop.

It converts the flow rate into linear motion. In this case, high velocities are required for rapid traverse movements as well as slow velocities for machining operations.

#### Synchronizing or differential cylinder

For a synchronizing cylinder, a piston rod with the same diameter is mounted at both ends to transmit the force. Consequently, the piston areas at the A and B sides are identical. Likewise, at a constant piston speed, the incoming flow is equal to the displaced flow in the settled state. As a consequence, the synchronizing cylinder acts symmetrically when extending and retracting.

In contrast to the synchronizing cylinder, a differential cylinder has either a piston rod to transfer the force at one end only, or the piston rods have different diameters. Consequently, the piston areas at the A and B sides are different. Furthermore, at a constant piston velocity, the displaced flow rate is not the same as the incoming flow rate. The maximum extension and retraction velocities are not the same for a differential cylinder.

However, at the HLA module this can be taken into account using the "Plane adaptation" (p0211) function.

Apart from the piston diameter, it is necessary to specify the rod diameters at the A and B sides. For a differential cylinder, both rod diameters are different, one of the rods might even have a zero diameter. The maximum piston stroke and cylinder dead volume are also required.

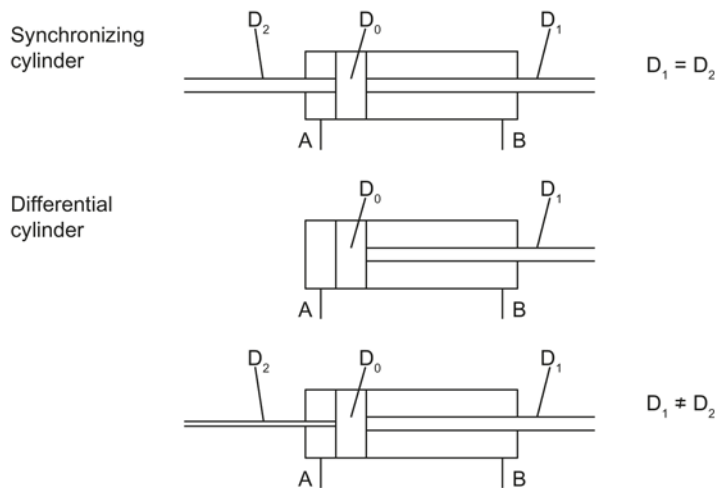
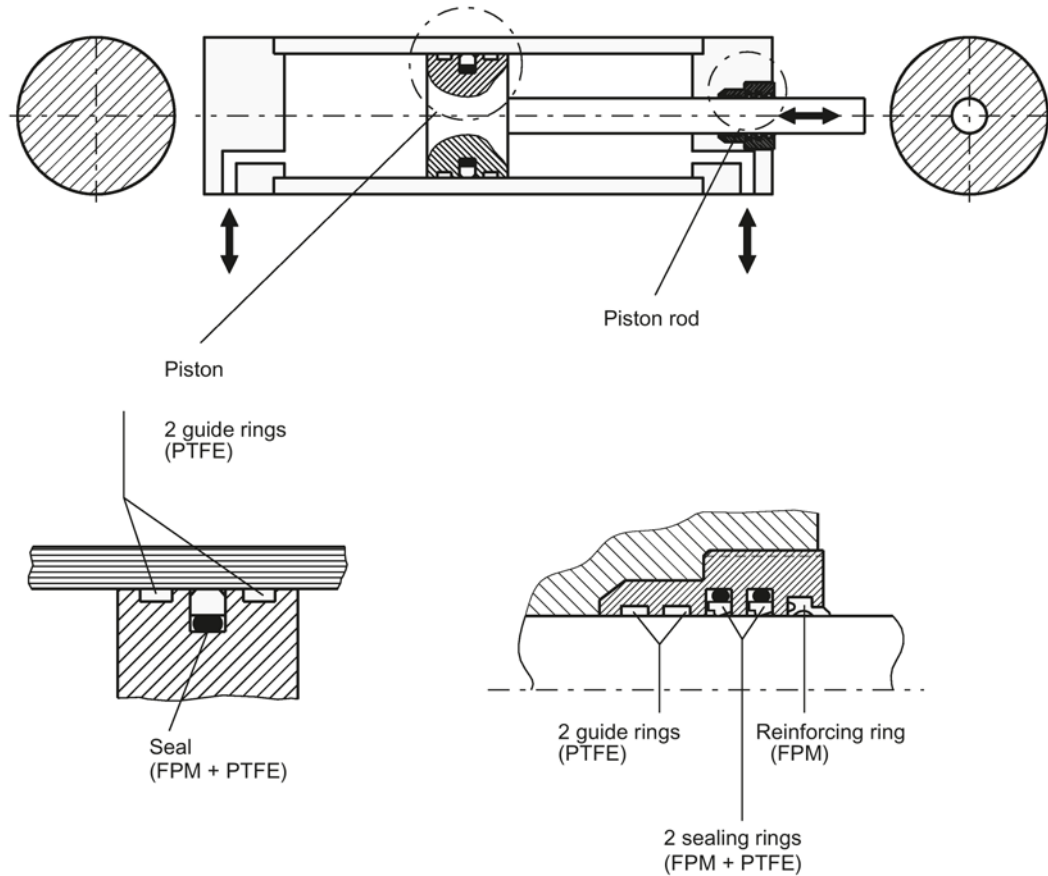

Figure A-19 Cylinder principle

## Quality of seals

The quality of the seals and guides used for the piston and the piston rod must be particularly high in order to minimize the friction.

Transitions from static to sliding friction have a particularly adverse effect on the quality of control accuracy.



FPM Fluororubber  
PTFE Polytetrafluoroethylene (Teflon)≠

Figure A-20 Cylinder

## Dead volume

The dead volume is the volume between the cylinder and servo solenoid valve that is not displaced by one piston stroke. It reduces the natural frequency of the drive and should be avoided wherever possible.

Cylinder pipework should be kept as short as possible, i.e. the servo solenoid valve should be mounted directly on the cylinder.

The dead volume is parameterized in the HLA module (p0314, p0315 and p0346 to p0348).

## A.4 Screw terminals

The type of screw terminal can be taken from the interface description of the component.

Table A- 1 Connectable conductor cross-sections and tightening torques for screw terminals

| Screw terminal type |                                  |  |   |
|---------------------|----------------------------------|--|---|
| 1                   | Connectable cable cross-sections | Rigid, flexible<br>With end sleeve, without plastic sleeve<br>With end sleeve, with plastic sleeve | 0.08 ...2.5 mm <sup>2</sup><br>0.5 ... 2.5 mm <sup>2</sup><br>0.5 ... 1.5 mm <sup>2</sup> |
|                     | Stripping length                 | 7 mm   |   |
|                     | Tool                             | Screwdriver 0.6 x 3.5 mm   |   |
|                     | Tightening torque                | 0,5 ... 0.6 Nm   |   |



# Index

## A

- Ambient conditions
  - Climatic, 34
  - Mechanical, 34
- Analogy of characteristic values, 33

## B

- BICO interconnection, 70

## C

- Calculations, 63
- Calibration
  - Manual fine calibration, 106
  - Position calibration, 105
  - Pressure calibration, 105
  - Valve offset calibration, 105
- Characteristic
  - Calculated, 100
  - Measured, 100
  - Tuning, 86
- Characteristic measurement, 89
- Climatic environmental conditions, 34
- Commissioning
  - STARTER, 55
- Comparison of electric and hydraulic drive systems, 32
- Configuration
  - BICO interconnection, 70
  - Calculations, 63
  - Connection data, 62
  - Control type / setpoints, 68
  - Cylinder data, 60
  - Encoder 1...3, 67
  - Encoder assignment, 65
  - HLA module, 56
  - Reference variables, 79
  - Saving valve data, 59
  - Summary, 72
  - Supply data, 61
  - Valve data, 58
  - Valve selection, 57
- Configuring steps
  - Hydraulic, 38
- Connection configuration valve cylinder, 62

- Connection data, 62
- Control sense
  - General, 107
- Control type / setpoints, 68
- Control voltage limiting, 178
- Control voltage output, 172
- Controller adaptation
  - General, 120
  - Implementation, 121
- Controller optimization
  - D action, 118
  - General, 115
  - P action, 119
- Copying valve characteristic, 103
- Cylinder, 28
- Cylinder data, 60
- Cylinder mounting method, 62
- Cylinder safety circuit, 60

## D

- Data set Wizard, 69
- Data sets, 78
  - Creating, 78
- Diagnostics via LEDs
  - HLA module, 220
- Drive
  - Encoder overview, 76
  - Overview of the hydraulic module, 73
- Drive data set, 69
  - Switchover, 69
- Drive dataset switchover, 141
- Dynamic Stiffness Control (DSC), 156, 156

## E

- Encoder 1...3, 67
- Encoder assignment, 65

## F

- Fine calibration and tuning, 107
- Flow rate characteristic
  - Linear, 42
  - with transition point, 42
- Force control, 158
  - Force controller, 168

- Force limitation, 162
  - Stiction compensation, 163, 166
- Force controller
  - Function diagram, 171
- Force limitation
  - Mode 1, 161
  - Mode 2, 161
- Function diagram
  - 4966, 179
  - 4970, 171
  - 4975, 84
  - 4977, 165
  - 4978, 167
  - 4985, 156, 193
  - 4990, 189
  - 4991, 189
  - Force controller, 171
  - P24 management with shutoff valve, 189
  - P24 management without shutoff valve, 189
  - Sequence control, 156
  - Sequence control/sequencer, 193
  - Sequencer, 156
  - Stiction compensation using the force controller, 165
  - Stiction compensation with voltage pulse / voltage ramp, 167
  - Transition point compensation, 179
  - Valve characteristic and plane adaptation, 84, 104

- Function generator
  - Signal types, 132
  - Signals, 132

## G

- Graphic tuning, 98

## H

- HLA, 198
- HLA module, 56
  - Interface overview, 200
- Hydraulic Drive, 198
- Hydraulic power unit, 30
  - Cooling, 51
  - Drive power, 50
  - Filtration, 51
  - Flow rate, 50, 50
  - Pressure, 50
  - Pump type, 50

## I

- Interface overview, 200

## L

- LEDs
  - HLA module, 220
- Linearization of the valve, 102

## M

- Measurement, 89
- Measurement parameters, 91
- Mechanical environmental conditions, 34
- Monitoring functions, 194
- Moving measurement, 87

## N

- Natural frequency of the hydraulic drive
  - Controlled system gain, 48
- Numeric tuning, 93

## O

- Overview
  - Commissioning, 55
  - Connection data, 77
  - Cylinder, 75
  - Encoders, 76
  - Hydraulic module, 73
  - Shutoff valve, 77
  - Supply unit, 77
  - Valve, 75
- Overview of functions of HLA firmware, 140
- Overview, function modules, 78

## P

- P24 management with shutoff valve
  - Function diagram, 189
- P24 management without shutoff valve
  - Function diagram, 189
- Parameters
  - Encoder type selection, 67
- Piston calibration, 105
- Plane adaptation
  - Function diagram, 84, 104
- Position calibration, 105

Position measuring system, 30, 186  
 Power inhibit, 191  
 Pressure calibration, 105

## R

Reference acceleration, 79  
 Reference angle, 79  
 Reference flow rate, 79  
 Reference force, 79  
 Reference power, 79  
 Reference pressure, 79  
 Reference variable overview, 78  
 Reference velocity, 79

## S

Saving valve data, 59  
 Selection of servo solenoid valves  
   Fail-safe position, 43  
   Flow rate characteristic, 42  
   HR servo solenoid valves, 41  
   Servo solenoid valve, 41  
   Valve size, 41  
 Sequence control  
   Function diagram, 156  
 Sequence control/sequencer  
   Function diagram, 193  
 Sequencer  
   Function diagram, 156  
 Servo solenoid valve, 29  
 Servo solenoid valves  
   Features of HR servo solenoid valves, 250  
   Precontrol principle, 247  
 Shutoff valve, 29  
 STARTER  
   Commissioning, 55  
 Stiction compensation  
   Force controller, 163  
   Voltage pulse/voltage pulse/voltage ramp, 166  
 Stiction compensation using the force controller  
   Function diagram, 165  
 Stiction compensation with voltage pulse / voltage ramp  
   Function diagram, 167  
 Storage conditions, 35  
 Summary, 72  
 Supply unit data, 180

## T

Terminal wiring, 70  
 Terminals  
   Power inhibit, 191  
 Transition point compensation  
   Function diagram, 179  
 Transportation conditions, 35  
 Traversing direction  
   Canceling control voltage limitation, 110  
   Defining the drive traversing direction, 109  
   Defining the traversing direction in the NC, 110  
 Tuning  
   Characteristic, 86

## V

Valve  
   Linearization, 102  
 Valve amplifier, 29  
 Valve characteristic  
   Function diagram, 84, 104  
   Measuring, 87  
 Valve characteristic parameters, 92  
 Valve data, 58  
 Valve list  
   Exporting, 81  
   Importing, 81  
 Valve offset calibration, 105  
 Valve selection, 57  
 Velocity controller, 149  
   Velocity precontrol, 142





## Further information

Siemens:

[www.siemens.com](http://www.siemens.com)

Industry Online Support (service and support):

[www.siemens.com/online-support](http://www.siemens.com/online-support)

IndustryMall:

[www.siemens.com/industrymall](http://www.siemens.com/industrymall)

Siemens AG

Digital Factory

Motion Control

Postfach 3180

D-91050 Erlangen

Germany

Scan the QR-Code  
for product  
information

