

**⚠ Warning**

**Lebensgefahr durch Berührung unter Spannung stehende Teile**

Das vorliegende Gerät führt gefährliche Spannungen. Beim Berühren unter Spannung stehender Teile erleiden Sie Tod oder schwere Körperverletzungen. Beachten Sie die Hinweise in den Handbüchern des zugehörigen Umrichters.

**⚠ Warning**

**Danger to life when live parts are touched**

The present device conducts hazardous voltages. Touching live components can result in death or severe injury. Observe the notes in the manuals of the corresponding converter.

**⚠ 警告**

**接触带电部件会引发生命危险**

本设备会传导危险电压。接触带电部件可能会造成人员重伤，甚至是死亡。务必遵循变频器手册中的说明。

**⚠ Attention**

**Danger de mort en cas de contact avec des pièces sous tension**

L'appareil présente des tensions électriques dangereuses. Tout contact avec des parties sous tension peut entraîner la mort ou des blessures graves. Respecter les consignes figurant dans les manuels du variateur concerné.

**⚠ Advertencia**

**Peligro de muerte al tocar piezas bajo tensión**

En el presente equipo hay aplicadas tensiones peligrosas. Tocar piezas que están bajo tensión puede provocar lesiones corporales graves o incluso la muerte. Respete las indicaciones que se especifican en los manuales del convertidor correspondiente.

**⚠ Avvertenza**

**Pericolo di morte per contatto con parti sotto tensione**

In questo apparecchio sono presenti tensioni pericolose. Il contatto con parti sotto tensione può provocare la morte o gravi lesioni. Attenersi alle avvertenze contenute nei manuali del rispettivo convertitore.

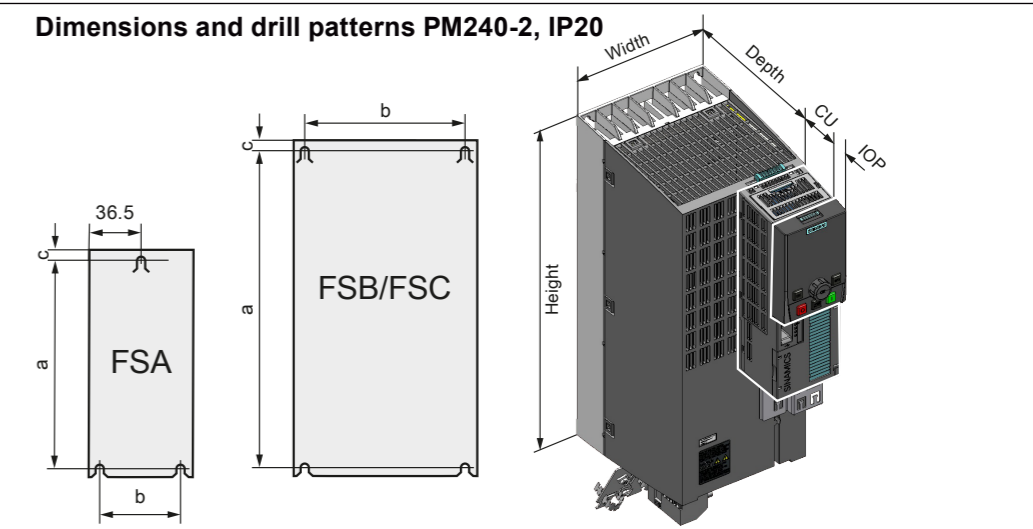
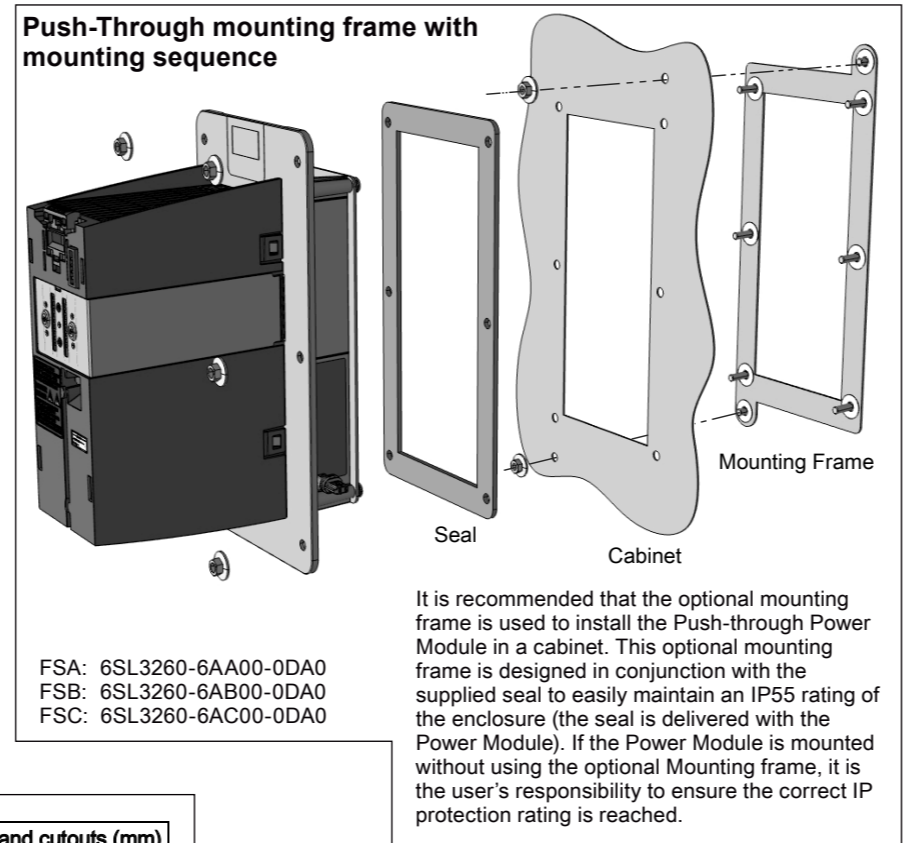
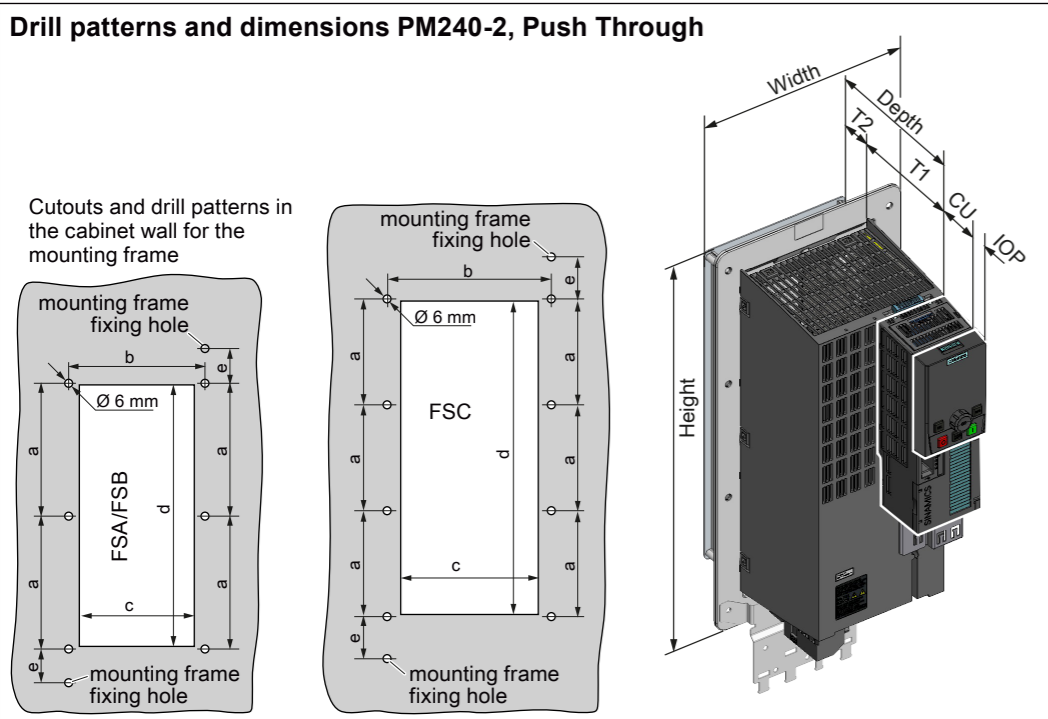

Frame size	Dimensions (mm)					Distances (mm) <sup>1)</sup>		Fixings		Drill pattern (mm)		
	Height	With Shielding Plate	Width	Depth	Max. depth with CU and OP	Above	Below	Screw	Tightening Torque (Nm)	a	b	c
FSA	196	276	73	165	250	80	100	M4	2.5	186	62.3	6
FSB	291	370	100	165	250	80	100	M4	2.5	281	80	6
FSC	355	432	140	165	250	80	100	M5	3.5	343	120	6

<sup>1)</sup> The Power Modules can be mounted side-by-side. Due to tolerance reasons, we recommend a lateral distance of about 1 mm

Frame size	Dimensions (mm)						Distances (mm) <sup>1)</sup>		Fixings		Drill pattern and cutouts (mm)					
	Height	With Shielding Plate	Width	Depth	T1	T2	Max. depth with CU and OP	Above	Below	Screw	Tightening Torque (Nm)	a	b	c	d	e
FSA	238	322	126	171	117.7	53.1	256	80	100	M5	3.5	103	106	88	198	27
FSB	345	430	154	171	117.7	53.1	256	80	100	M5	3.5	147.5	134	116	304	34.5
FSC	411	500	200	171	117.7	53.1	256	80	100	M5	3.5	123	174	156	365	30.5

<sup>1)</sup> The Power Modules can be mounted side-by-side. Due to tolerance reasons, we recommend a lateral distance of about 1 mm

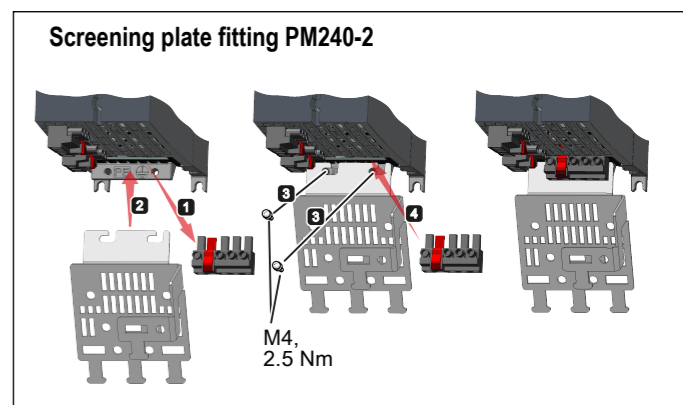
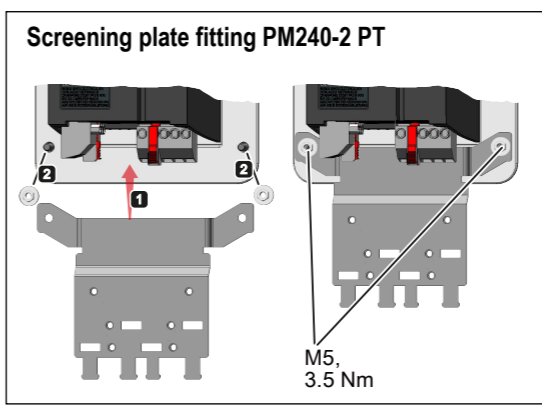
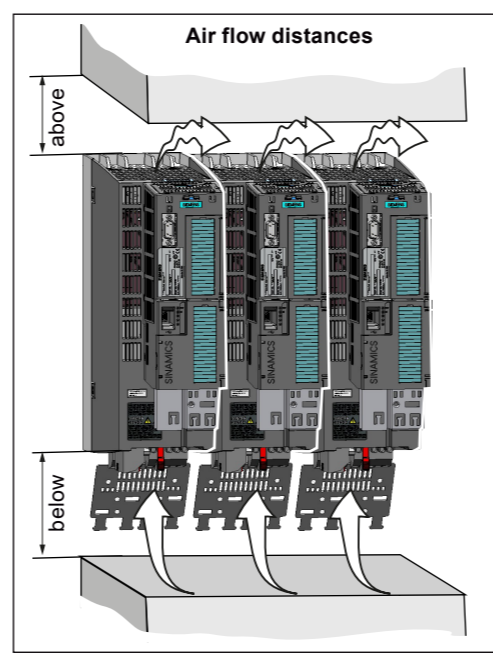

Declaration of Conformity:  
The Declaration of Conformity can be found at the following link:  
<http://support.automation.siemens.com/WW/view/en/30563514/134200>

For detailed information refer to Hardware Installation Manual PM240-2, Issue 08/2015 or younger under:  
<http://support.automation.siemens.com/WW/view/de/30563173/133300>

Siemens AG,  
Frauenauracher Str. 80,  
DE-91056 Erlangen

Issue 09/2016

Feature	Specification
Line voltage	3 AC 380 V ... 480 V ± 10 % up to 2000 m installation altitude. 1 AC / 3 AC 200 V ... 240 V ± 10 % up to 2000 m installation altitude.
Output voltage	3 AC 0 V ... input voltage * 0.93
Input frequency	50 Hz ... 60 Hz, ± 3 Hz
Output frequency	0 Hz ... 550 Hz, depending on the control mode
Power factor λ	0.7 without line reactor; 0.85 with line reactor
Inrush current	Less than rated input current
Pulse frequency (factory setting)	4 kHz. Can be increased in 2 kHz steps up to 16 kHz. Increasing the pulse frequencies leads to an output current reduction.
Electromagnetic compatibility	<b>Interference emission:</b> The devices are suitable for second environment category C2 in accordance with IEC61800-3 if the following conditions are fulfilled: The motor cable is a shielded cable with low capacitance and is not longer than 50 m. The pulse frequency does not exceed 4 kHz, the current does not exceed the LO input value. For details, refer to the Hardware Installation Manual. <b>Interference immunity:</b> The devices are suitable for second environment category C3
Braking methods	DC braking, Compound braking, Dynamic braking with integrated chopper plus external Braking resistor
Environmental rating	Built in units (open type equipment): IP20, Push through units: IP54 / UL type 12 when mounted on a flat surface of an enclosure
Motor overload protection	This equipment is capable of providing internal motor overload protection according to UL508C. The protection level is 115 %, 230 % and 400 % full load current of the equipment. This is adjusted via parameter P640 and assumes the equipment has had basic motor commissioning for the motor used as described in the documentation.
LO Operation temperature 1)	0 °C ... 40 °C (32 °F ... 104 °F) without current derating / up to 60 °C (140 °F) with current derating
HO Operating temperature 1)	0 °C ... 50 °C (32 °F ... 122 °F) without current derating / up to 60 °C (140 °F) with current derating
Storage temperature	- 40 °C ... +70 °C (- 40 °F ... 158 °F)
Installation altitude above sea level	Up to 1000 m (3300 ft) without derating / Up to 4000 m (13000 ft) with derating
Humidity	< 95% RH - non-condensing
Environmental conditions	Suitable for environmental class 3C2 according to IEC 60721-3-3 against damaging chemical substances
Pollution	For open type equipment according to pollution degree level 2. Protection against conductive pollution is required e.g. using an IP54 cabinet. For enclosed type/Push Through equipment according pollution degree level 3.
Shock	Long-term storage in the transport packaging according to Class 1M2 of IEC 60721-3-1 : Transport in the transport packaging according to Class 2M3 of IEC 60721-3-2. See Hardware Installation Manual for detailed specifications.
Vibration	Long-term storage in the transport packaging according to Class 1M2 to IEC 60721-3-1 : Transport in the transport packaging according to Class 2M3 to IEC 60721-3-2. See Hardware Installation Manual for detailed specifications.
Line impedance	200 V Units: Uk ≥ 2 %, for lower values, a line reactor must be used. 400 V Units: Uk ≥ 1 %, for lower values, a line reactor must be used.
Short Circuit Current Rating (SCCR) 400 V units	Suitable for use on a circuit capable of delivering not more than 65 kA rms symmetrical amperes; 480 Vac maximum when protected by Class J or R/C (JFHR2) semiconductor fuses only as stated
Short Circuit Current Rating (SCCR) 200 V units	Suitable for use on a circuit capable of delivering not more than 40 kA rms symmetrical amperes; 240 Vac maximum when protected by Class J or R/C (JFHR2) semiconductor fuses only as stated

1) according to UL, operation with temperatures > 50 °C (122 °F) is not permitted at all

**CAUTION - Cable cross-section for grounding:** The earth cable must be at least as big as the power cables.

**For United States / Canadian installations (UL/cUL):** In order that the system is UL/cUL-compliant, use UL/cUL-certified J-type fuses. Use 75° C copper wire only.

**Additional requirements for Canadian compliance:**

400 V supply:  
Transient surge suppression must be installed on the line side of this equipment and shall be rated 480 V (phase to ground), 480 V (phase to phase), suitable for overvoltage category III and shall provide protection for a VPR maximum of 2 kV, type 1 or type 2 SPD application.

200 V supply:  
Transient surge suppression must be installed on the line side of this equipment and shall be rated 240 V (phase to ground), 240 V (phase to phase), suitable for overvoltage category III and shall provide protection for a VPR maximum of 2 kV, type 1 or type 2 SPD application.

Cable lengths, using	EMI Level (Emission)
Screened cables, filtered units (class A)	50 m Second Environment, C2
Screened cables, unfiltered units,	50 m EMI Standard not fulfilled
Unscreened cables, filtered or unfiltered units	100 m EMI Standard not fulfilled

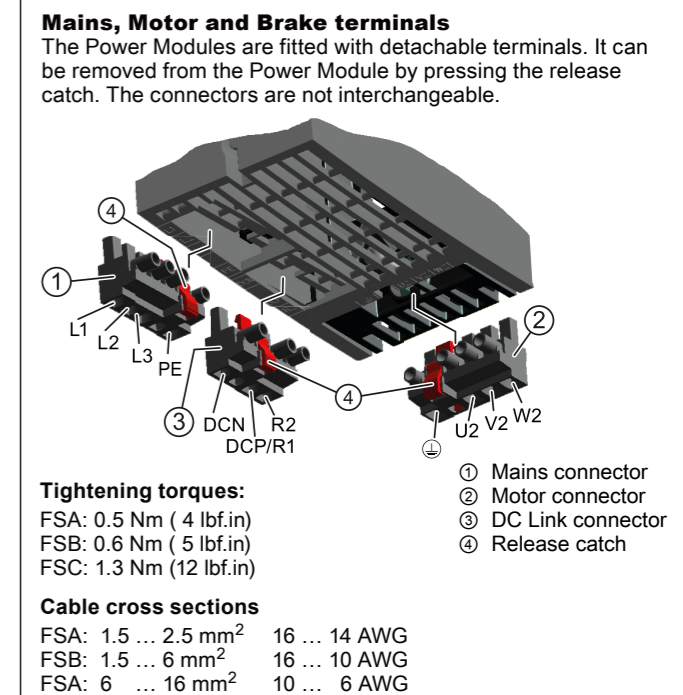
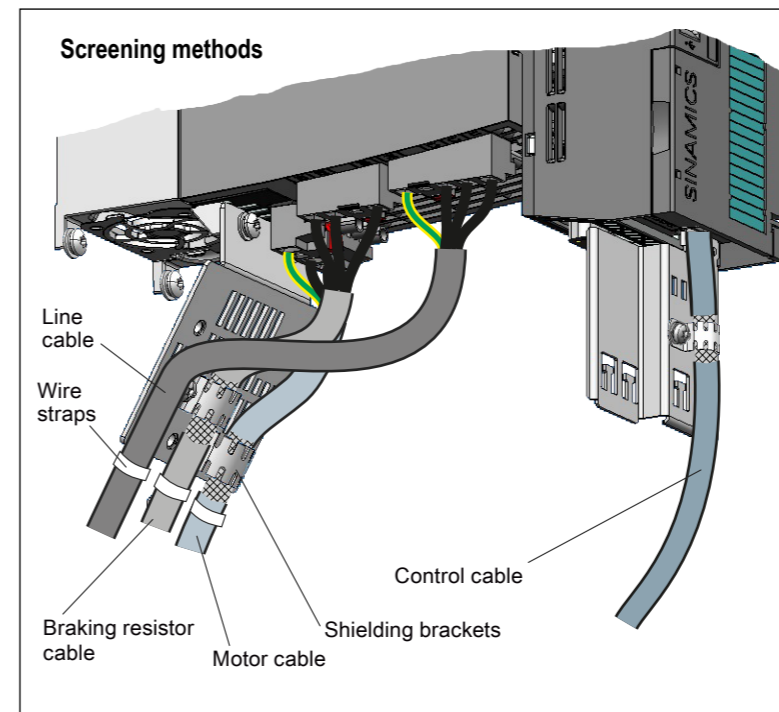
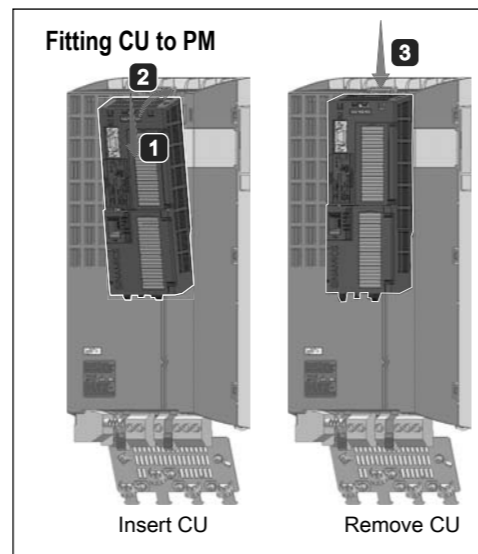
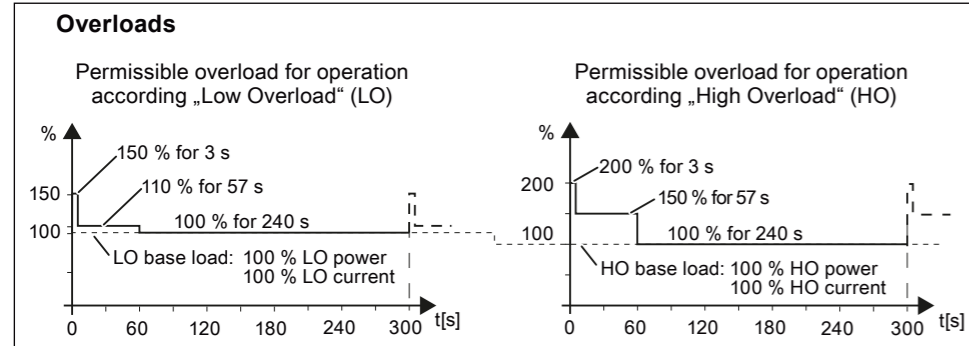

LO values		HO values		Rated (LO) input current	Frame Size	Order No. *)	Line fuses		
Power	Output current	Power	Output current				Siemens	UL, J-type	
kW	hp	A	kW	hp	A				
<b>PM240-2, Built in units, 3 AC 380 V ... 480 V</b>									
0.55	0.75	1.7	0.37	0.50	1.3	2.3	FSA	6SL3210-1PE11-8_L1	3NA3 804 (4 A) 10 A
0.75	1.00	2.2	0.55	0.75	1.7	2.9	FSA	6SL3210-1PE12-3_L1	3N A3 804 (4 A) 10 A
1.10	1.50	3.1	0.75	1.00	2.2	4.1	FSA	6SL3210-1PE13-2_L1	3N A3 801 (6 A) 15 A
1.50	2.00	4.1	1.10	1.50	3.1	5.5	FSA	6SL3210-1PE14-3_L1	3N A3 803 (10 A) 15 A
2.20	3.00	5.9	1.50	2.00	4.1	7.7	FSA	6SL3210-1PE16-1_L1	3N A3 803 (10 A) 15 A
3.00	4.00	7.7	2.20	3.00	5.9	10.1	FSA	6SL3210-1PE18-0_L1	3N A3 805 (16 A) 15 A
4.00	5.00	10.2	3.00	4.00	7.7	13.3	FSB	6SL3210-1PE21-1_L0	3NE 1814-0 (20 A) 35 A
5.50	7.50	13.2	4.00	5.00	10.2	17.2	FSB	6SL3210-1PE21-4_L0	3NE 1815-0 (25 A) 35 A
7.50	10.00	18.0	5.50	7.50	13.2	22.2	FSB	6SL3210-1PE21-8_L0	3NE 1803-0 (35 A) 35 A
11.00	15.00	26.0	7.50	10.00	18.0	32.6	FSC	6SL3210-1PE22-7_L0	3NE 1817-0 (50 A) 50 A
15.00	20.00	32.0	11.00	15.00	26.0	39.9	FSC	6SL3210-1PE23-3_L0	3NE 1817-0 (50 A) 50 A
<b>PM240-2, Push through units, 3 AC 380 V ... 480 V</b>									
3.00	4.00	7.7	2.20	3.00	5.9	10.1	FSA	6SL3211-1PE18-0_L1	3N A3 805 (16 A) 15 A
7.50	10.00	18.0	5.50	7.50	13.2	22.2	FSB	6SL3211-1PE21-8_L0	3NE 1803-0 (35 A) 35 A
15.00	20.00	32.0	11.00	15.00	26.0	39.9	FSC	6SL3211-1PE23-3_L0	3NE 1817-0 (50 A) 50 A
<b>PM240-2, Built in units, 1 AC/3 AC 200 V ... 240 V</b>									
0.55	0.75	3.2	0.37	0.50	2.3	7.5	FSA	6SL3210-1PB13-0_L0	3NA3 803 (10 A) 15 A
0.75	1.00	4.2	0.55	0.75	3.2	9.6	FSA	6SL3210-1PB13-8_L0	3NA3 805 (16 A) 15 A
1.10	1.50	6	0.75	1.00	4.2	13.5	FSB	6SL3210-1PB15-5_L0	3NE 1814-0 (20 A) 35 A
1.50	2.00	7.4	1.10	1.50	6	18.1	FSB	6SL3210-1PB17-4_L0	3NE 1815-0 (25 A) 35 A
2.20	3.00	10.4	1.50	2.00	7.4	24.0	FSB	6SL3210-1PB21-0_L0	3NE 1803-0 (35 A) 35 A
3.00	4.00	13.6	2.20	3.00	10.4	35.9	FSC	6SL3210-1PB21-4_L0	3NE 1817-0 (50 A) 50 A
4.00	5.00	17.5	3.00	4.00	13.6	43.0	FSC	6SL3210-1PB21-8_L0	3NE 1818-0 (63 A) 50 A
<b>PM240-2, Built in units, 3 AC 200 V ... 240 V</b>									
5.50	7.50	22.0	4.00	5.00	17.5	28.6	FSC	6SL3210-1PC22-2_L0	3NE 1802-0 (40A) 50 A
7.50	10.00	28.0	5.50	7.50	22.0	36.4	FSC	6SL3210-1PC22-8_L0	3NE 1817-0 (50A) 50 A
<b>PM240-2, Push through units, 1 AC/3 AC 200 V ... 240 V</b>									
0.75	1.00	4.2	0.55	0.75	3.2	9.6	FSA	6SL3211-1PB13-8_L0	3NA3 805 (16 A) 15 A
2.20	3.00	10.4	1.50	2.00	7.4	24.0	FSB	6SL3211-1PB21-0_L0	3NE 1803-0 (35 A) 35 A
4.00	5.00	17.5	3.00	4.00	13.6	43.0	FSC	6SL3211-1PB21-8_L0	3NE 1818-0 (63 A) 50 A
<b>PM240-2, Push through units, 3 AC 200 V ... 240 V</b>									
5.50	7.50	22.0	4.00	5.00	17.5	28.6	FSC	6SL3211-1PC22-2_L0	3NE 1802-0 (40A) 50 A
7.50	10.00	28.0	5.50	7.50	22.0	36.4	FSC	6SL3211-1PC22-8_L0	3NE 1817-0 (50A) 50 A

\*) \_: A = filtered unit, U = unfiltered unit