

Siemens

OPERATING INSTRUCTIONS FOR MICROMASTER ECO & MIDIMASTER ECO V1.19

Variable speed drive for
Fans and Pumps (HVAC)
from 0,75kW to 315kW



CONTENS

SAFETY AND CE COMPLIANCE.....	2
INTRODUCTION	4
MECHANICAL INSTALLATION	5
ELECTRICAL INSTALLATION.....	6
APPLICATION EXAMPLES.....	8
KEYPAD.....	9
PARAMETERS.....	10
PARAMETER LISTING.....	17
FAULT CODES	

SAFETY AND CE COMPLIANCE

Before installing and putting this equipment into operation, read these safety instructions and warnings carefully. Also read and obey all the warning signs attached to the equipment. Make sure that the warning labels are kept in a legible condition and replace any missing or damaged labels.

WARNING

This equipment contains dangerous voltages and controls dangerous rotating mechanical parts. Loss of life, severe personal injury or property damage can result if the instructions contained in this manual are not followed.

Only suitably qualified personnel should work on this equipment, and only after becoming familiar with all safety notices, installation, operation and maintenance procedures contained in this manual.

- Use only permanently wired input power connections. The equipment must be grounded (IEC 536 Class 1, NEC and other applicable standards)
- Use only Residual Current-operated protective Device (RCD) type B if an RCD is required
- Wait at least five minutes after the power has been turned off, before opening the equipment. The dc-link capacitor remains charged to dangerous voltages even when the power is removed. When working on open equipment, note that live parts are exposed and do not touch these parts
- Do not connect machines with a three-phase power supply, fitted with EMC filters, to a supply via an ELCB (Earth Leakage Circuit Breaker - see EN50178, section 6.5)
- Note that certain parameter settings may cause the inverter to restart automatically after an input power failure
- Do not use this equipment as an “emergency stop” mechanism (see EN 60204, 9.2.5.4)
- Obey all general and regional installation and safety regulations relating to work on high voltage installations, as well as regulations covering correct use of tools and personal protective equipment

- Note that the following terminals can carry dangerous voltages even when the inverter is inoperative:

Power supply terminals

L/L1, N/L2 and L3
U, V and W

Motor terminals

Additional terminals

MICROMASTER Eco B+/DC+ and B-
MIDIMASTER Eco DC+ and DC-

- This equipment is capable of providing internal motor overload protection in accordance with UL508C section 42. Refer to P074. Motor overload protection can also be provided by using an external PTC.
- This equipment is suitable for use in a circuit capable of delivering not more than 100,000 symmetrical amperes (rms), for a maximum voltage of 230 / 460 V * when protected by a time delay fuse *.
* As detailed in the Eco Reference Manual.
- Do not use the unit with a motor of a higher nominal power rating than the inverter, or a nominal power less than half that of the inverter. Only operate the inverter when the nominal current in P083 exactly matches the motor rating plate nominal current
- Enter the motor data parameters (P080-P085) and do an auto-calibration (P088) before the motor is started. Unstable/unpredictable motor operation (e.g. Reverse rotation) may result if this is not done. If this instability occurs, the mains supply to the inverter must be disconnected.
- When using the analog input, the DIP switches must be correctly set and the analog input type selected (P023) before enabling the analog input with P006. If this is not done the motor may start inadvertently.
- Lowering the fan tray on Frame size C MICROMASTER Eco exposes rotating parts. Power must be isolated prior to this operation.

.....

⚠ CAUTION

- Do not allow children or the general public to access or approach this equipment
- Do not install the inverter where it will be subject to shock, vibration, electro-magnetic radiation, water hazards, or atmospheric pollutants such as dust or corrosive gases
- High voltage insulation test equipment must not be used on cables connected to the Eco.
- Keep operating instructions within easy reach and give them to all users
- Use this equipment only for the purpose specified by the manufacturer. Do not carry out any modifications, or fit any spare parts, which are not sold or recommended by the manufacturer; this could cause fires, electric shock or other injuries.

EUROPEAN LOW VOLTAGE DIRECTIVE

The MICROMASTER Eco and MIDIMASTER Eco product range complies with the requirements of the Low Voltage Directive 73/23/EEC as amended by Directive 93/68/EEC. The units are certified for compliance with the following standards:

EN 60146-1-1 Semiconductor converters-
General requirements and
line commutated converters

EN 60204-1 Safety of machinery-
Electrical equipment
of machines

EUROPEAN MACHINERY DIRECTIVE

The MICROMASTER Eco and MIDIMASTER Eco product range do not fall under the scope of the Machinery Directive. However, the products have been fully evaluated for compliance with the essential Health & Safety requirements of the directive when used in a typical machine application. A declaration of incorporation is available on request.

EUROPEAN EMC DIRECTIVE

When installed according to the recommendations described in this manual, the MICROMASTER Eco and MIDIMASTER Eco product range fulfil the requirements of the EMC Directive as defined by the EMC Product Standard for Power Drive Systems EN 61800-3

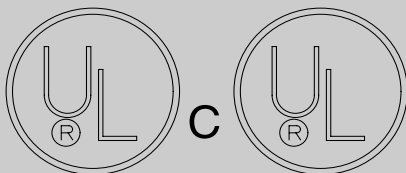

UL and CUL listed power conversion equipment type 5B33 for use in pollution degree 2 environment

ISO 9001

Siemens plc operates a quality management system which complies with the requirements of ISO 9001.

INTRODUCTION

GENERAL

These are the Operating Instructions for the MICROMASTER Eco and MIDIMASTER Eco and are to be used for quick and simple commissioning only.



For more details and the complete parameter list for specific applications consult the Eco Reference Manual on our website (details available on back page).

The Eco range of inverters comprises variable frequency inverters for controlling the speed of fans and pump motors. The Eco can also be programmed to manage many other motor functions and limits. These functions are set by parameters which are programmed using the keypad.

TYPES OF SYSTEM CONTROL

The MICROMASTER and MIDIMASTER Eco inverters are normally controlled using the keypad or input/output terminals. However, there is an option for remote operation using the RS485 D-type connection on the front panel, see the Eco Reference Manual for further details.

The output frequency and hence the motor speed can be controlled by digital or analog inputs. The digital inputs can be programmed to control the motor speed by means of:

- frequency set points, using the   keys
- fixed frequencies, via binary inputs
- motorized potentiometer function

The analog inputs can be programmed for voltage or current input in conjunction with DIP selector switches.

Closed loop process control, using a standard Proportional, Integral, Derivative (PID) control loop function can be selected. This control is set-up using DIP selector switches and analog input 2. A 15V, 50 mA supply is provided to power the feedback transducer.

MECHANICAL INSTALLATION

MOUNTING

The IP20/21 range of Eco units can be mounted side-by-side without space in between. A clearance distance of at least 100mm top and 160 mm bottom must be left free for the movement of cooling air.

IP56 Eco units must have a clearance distance of at least 150mm in all directions.

A good bonding between the Eco and the metal back plate is necessary to ensure good grounding and low RF (radio frequency) impedance. If necessary remove some back plate paint and/or use toothed washers to ensure safety and EMC (electro-magnetic compatibility). Use an earth braid on 400V ratings 1.5KW and below.

Ambient temperature
MICROMASTER Eco 0°C to 50°C.
MIDIMASTER Eco (IP20/21/56) 0°C to 40°C.

Ensure that the Eco is not subject to shock, vibration or atmospheric pollutants.

MOTOR CABLES

To minimise the effects of radio frequency emissions:-

- Screened cables should be used between the Eco and the motor.
- Keep cables to motor as short as possible, generally under 25m.
- Terminate cable screens correctly (use gland fittings which give 360 deg. conduction) on both the Eco gland plate and the motor terminal box.
- Fit suppressors on all contactor coils.
- If an external input EMC filter is to be fitted then ensure that it is positioned as close as possible to the Eco and is well grounded to the metal back plate. Use screened cable between the external input EMC filter and the Eco input terminals, and ground cable screen correctly.

All MICRO/MIDIMASTER Eco products comply with the requirements of the EMC Directive when installed in accordance with the wiring recommendations of this manual. The units comply with European Norm EN61800-3 “Adjustable speed electrical power drive systems”. This standard specifies different limits for domestic and industrial applications, which defines whether an integral EMC filter is required. For further information refer to the Eco Reference Manual.

When units are selected which include integral filters they will meet the conducted and radiated RF emissions limits specified in EN 55011.

CONTROL AND SERIAL COMMUNICATION CABLES

To minimise the effects of radio frequency emissions and interference:-

- Screened control and data cables should be used with the Eco.
- Terminate the control and data cable screens correctly on the Eco by using the gland plate and/or clamps provided. Consult the instructions for the Building Management System or controller at the opposite cable end.
- IT IS MOST IMPORTANT THAT THE MOTOR AND CONTROL CABLES ARE KEPT APART. IF CONTROL AND POWER CABLES NEED TO CROSS, ARRANGE THE CABLES SO THAT THEY CROSS AT 90° IF POSSIBLE.

CIRCULATING CURRENTS

If there is a slight difference between the chassis potential of the Eco and the Building Management System (or controller) then circulating currents can occur in the control or data cable screens.

These circulating currents should be avoided by separately connecting the chassis of both pieces of equipment securely to the same earthing point.

ELECTRICAL INSTALLATION

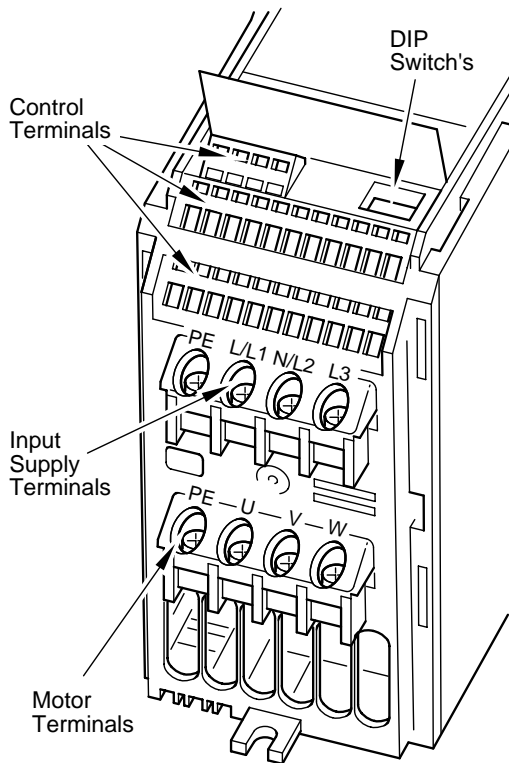

MICROMASTER Eco - Mains supply, motor and control connections

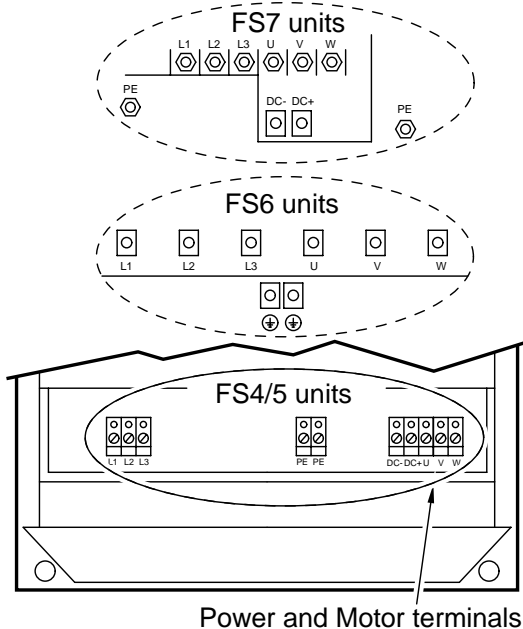

MIDIMASTER Eco - Power and motor connections.

Make sure that the Eco is securely mounted.

For 110kW to 315kW units the mains supply terminals are at the top, and the motor connection terminals are at the bottom.

CONNECTING TO MAINS

Terminals L/L1, N/L2 & L3

Ensure that the nameplate voltage of the Eco (and the motor) corresponds to the mains supply voltage to be used.

Check that the supply circuit protection is correctly rated for the Eco nameplate input current.

Ensure that all power cables are adequately rated for the expected duty.

CONNECTING TO MOTOR

Terminals U, V, & W

Only use the Eco with fan or pump motors (variable torque).

DIRECTION OF ROTATION

The direction of rotation of the motor can be reversed by changing over two of the output connections on the Eco.

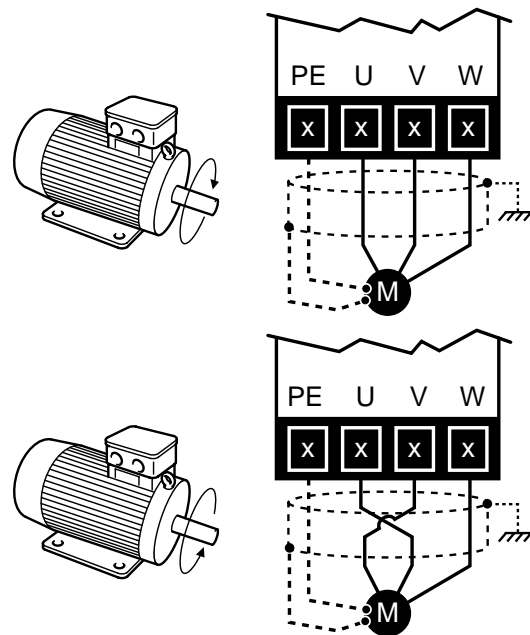

NOTE

The power cable screen and control wiring screen must be connected to the inverter gland plate.

ELECTRICAL INSTALLATION.....

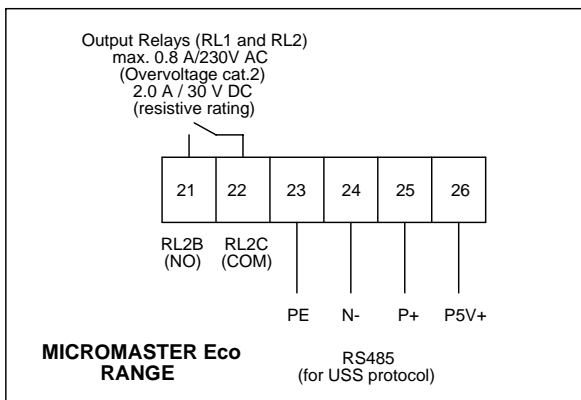
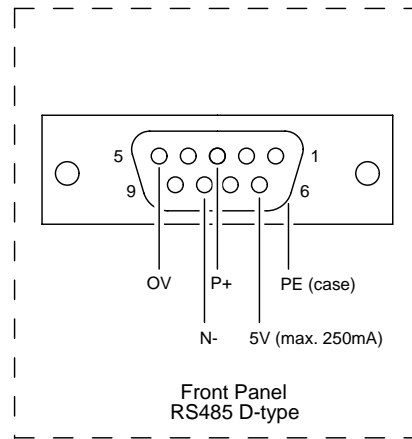
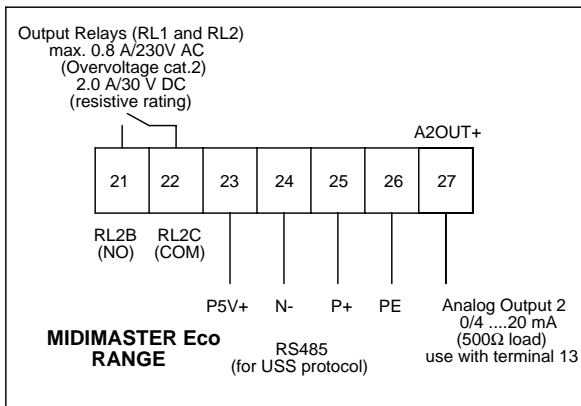
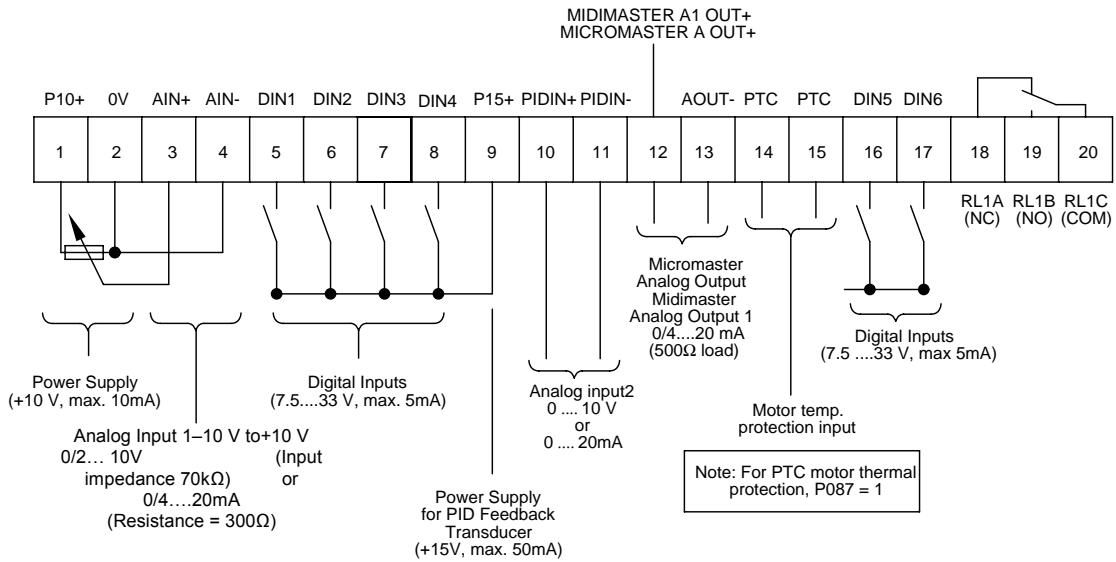

APPLICATION EXAMPLES

FAN CONNECTION

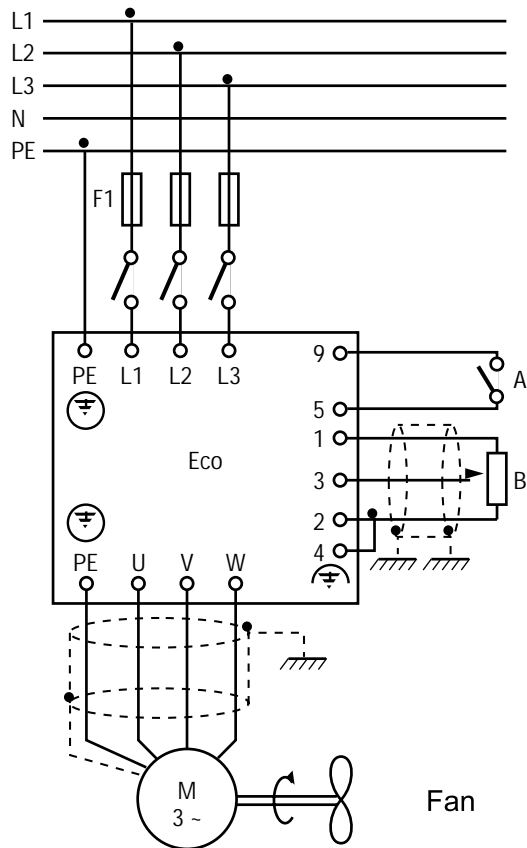

Typical fan connection

To speed control a fan between 0-50 Hz, (60 Hz in North America) a potentiometer is used or 0-10V speed setting signal.

DIP Switch Configuration

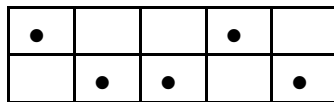

PUMP CONNECTION

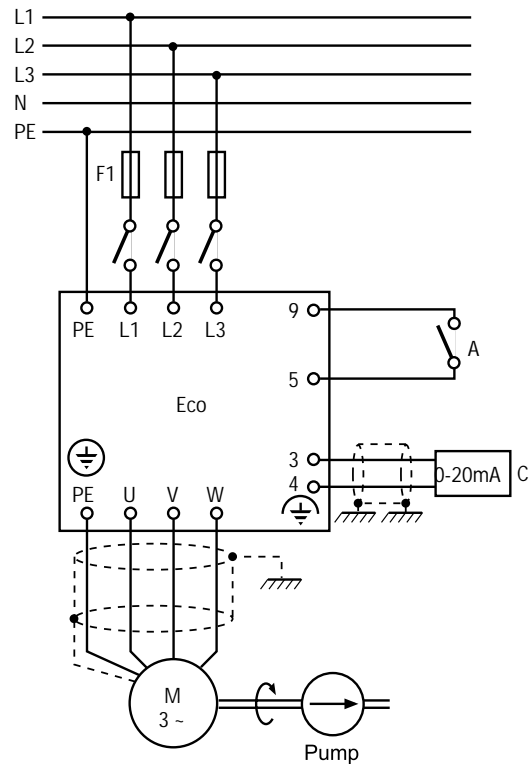

Typical pump connection

To control the speed of the pump in a pumping system a 0-20 mA control signal is used; this corresponds to a 0-100% motor speed - normally 0-50 Hz (60 Hz in North America).

A signal representing the output frequency is required, i.e. as an indication of the motor speed. An analog output (terminals 12 & 13) of 0-20 mA is used, which corresponds to a frequency of 0-50 Hz (60 Hz in North America).

DIP Switch Configuration

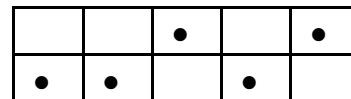

P006=1, P007=0 (Basic mode Parameter changes from factory default)

- A External switch or relay, contact
- B Potentiometer or 0-10 V signal
- C Speed control signal

KEYPAD

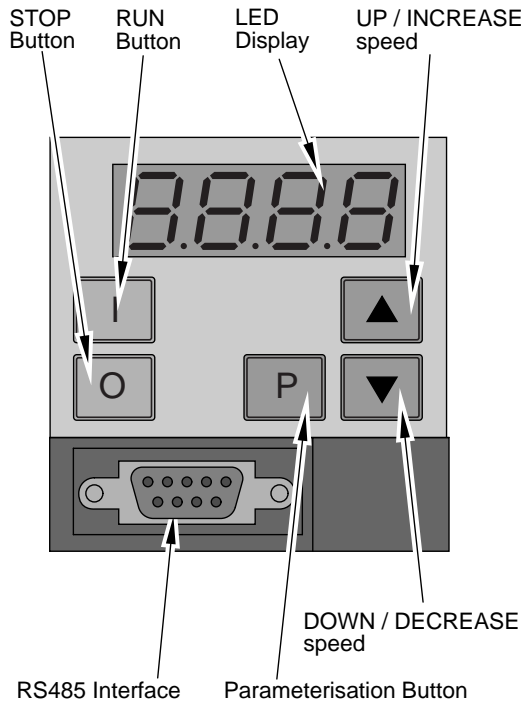

THE KEYPAD

The keypad comprises membrane-type keys as well as an integral 4-digit 7-segment LED display. The keys are limited to [run], [stop], [up], [down] and [P]. All parameters can be accessed and changed using the keys.

PARAMETER TYPES



There are three types of parameter:

- 1 **True value parameters.** For example, setting parameter P003 to 10 seconds tells the Eco to take 10 seconds to slow the motor from its normal operating speed to stopped (ramp-down time).
- 2 **Limited range parameters.** The values themselves are not relevant and only represent the function required. For example, parameter P199 can only be set to 0 to 1. Setting the value to 0 tells the Eco to give access to the basic parameters only. Setting the value to 1 gives access to the expert parameters.
- 3 **'Read only' parameters.** The values of these parameters are factory set and provide the user with information. For instance, parameter P111 is a read only parameter and indicates the inverter's variable torque power rating in kW.













PARAMETER RANGES

The Eco has three ranges of parameters; Display mode, Basic mode and Expert mode. One of the Basic mode parameters (P199) controls access to the Expert mode parameters. The Basic mode parameters are described in this section. A list of the Expert mode parameters is contained in the next section. For further information on using Expert mode, refer to the Reference Manual (G85139-H1750-U630).

ACCESSING PARAMETERS AND CHANGING VALUES

The  and  keys are used to change parameter values. The keys have two modes of operation. A single momentary press will change the value by a value of 1. Keeping the button pressed for longer initiates scrolling and allows values to be changed rapidly.

To access a parameter and change its value, follow the simple sequence described below:

Key	Action	Display
	Press P to enter parameter mode	
	Use the [up] and [down] keys to select the required parameter number (e.g. ramp-up time)	
	Press P to confirm that you wish to enter a value for that parameter. The current value is displayed	
	Use the [up] and [down] keys to enter the required value	
	Press P to confirm that you have changed the value as required. The parameter number is re-displayed.	
	Use the [up] and [down] keys to return the parameter number to the display default parameter.	
	Press P to return to default display	

The display will alternate between the setpoint frequency and actual output frequency, which will be 0 Hz.

DISPLAY MODE PARAMETERS.....

Parameter	Function	Range	Default	Units
P000	Operating display	-	(output frequency)	Hz

Displays the output selected by P001 (an Expert mode parameter).

Display selection via P001:

0 = Output frequency (Hz)	4 = Motor torque (% nominal)
1 = Frequency setpoint (i.e. speed at which inverter is set to run) (Hz)	5 = Motor speed (rpm)
2 = Motor current (A)	6 = USS serial bus status (Code)
3 = DC-link voltage (V)	7 = PID Feedback signal (%)
	8 = Output voltage (V)

The default setting (0) displays the inverter output frequency. If the inverter is in stand-by mode, the flashing display will alternate between the setpoint frequency and actual output frequency, which will be 0 Hz when not being run.

In the event of a failure, the relevant fault code (Fnnn) is displayed.

BASIC MODE PARAMETERS.....

Parameter	Function	Range	Default	Units
P002	Ramp-up time	0 - 650.0	20	Seconds

This is the time taken for the motor to accelerate from standstill to the maximum frequency. The maximum frequency is set by parameter P013. Setting the ramp-up time too short can cause the inverter to trip (Fault code F002 = overcurrent).

P003	Ramp-down time	0 - 650.0	20	Seconds
------	----------------	-----------	----	---------

This is the time taken for the motor to decelerate from maximum frequency to standstill. The maximum frequency is set by parameter P013. Setting the ramp-down time too short can cause the inverter to trip (Fault code F001 = DC link overvoltage). This is also the period for which injection braking is applied, if selected (refer to parameter P073 in Expert mode).

P003	Frequency setpoint source selection	0 - 2	0	-
------	-------------------------------------	-------	---	---

The value of this parameter (0, 1 or 2) selects the mode of control of the inverter's frequency setpoint.

0 = digital motorised potentiometer. The inverter runs at the frequency set in P005 (refer to Expert mode) and can be controlled with the [up] and [down] keys. If P007 (see below) is set to 0, the frequency can be increased or decreased by setting any two of the digital inputs (P051 to P055 or P356 - refer to Expert mode) to the values of 11 and 12.

1 = Analog. The inverter output frequency is controlled by analog input signals (0-10V, 0/4-20mA or potentiometer).

2 = Fixed frequency. Fixed frequency is only selected by setting the value of at least one of the digital inputs (P051 to P055 or P536 - refer to Expert mode) to the value of 6 or 7.

BASIC MODE PARAMETERS.....

Parameter	Function	Range	Default	Units
P007	Keypad control	0 or 1	1	-

The value of this parameter (0 or 1) configures keypad control.

- 0 = Control is by digital inputs (P051 to P055 or P356 - refer to Expert mode)
- 1 = Front panel (keypad) control enabled. However, the level of control enabled from the keypad is determined by the values of P121 to P124 (refer to Expert mode).

P012	Minimum motor frequency	0.0- 150.0	0.00	Hz
------	-------------------------	------------	------	----

This value sets the minimum motor frequency and must logically be less than the value of P013 (see below)

P013	Maximum motor frequency	0.0- 150.0	50,00 (60.00 = North America)	Hz
------	-------------------------	------------	-------------------------------	----

This value sets the maximum motor frequency. To maintain stable operation, this value should not exceed 3x the motor rating plate nominal frequency (see below).

P016	Start on the fly	0 or 2	0	
------	------------------	--------	---	--

- Flying restart
- P016=0 Flying restart disabled
- P016=2 Flying restart enabled

Allows the inverter to start onto a spinning motor.

Always enter the correct motor nameplate details when enabling this feature.

P081*	Motor rating plate nominal frequency	0 - 150.00	50.00 60,00 (North America)	Hz
P082*	Motor rating plate nominal speed	0 – 9999	Depends on inverter rating	RPM
P083*	Motor rating plate nominal current	0.1 - 590.0	Depends on inverter rating	A
P084*	Motor rating plate nominal voltage	0 – 1000	Depends on inverter rating	V
P085*	Motor rating plate nominal power	0.12 - 400.0	Depends on inverter rating	kW (hp - North America)

* Parameters P081 to P085 - Notes

- These parameters must be set for the particular motor being controlled by the inverter. You must use the data provided on the motor's rating plate.
- Perform an automatic calibration (P088 = 1 - refer to Expert mode) if any of the parameters P081 to P085 are changed from their factory default settings.
- When the inverter is set-up for North America operation (P101 = 1 - refer to Expert mode), P081 will default to 60 Hz and P085 will indicate in hp (range = 016 to 530).

P199	Access to Expert mode	0 or 1	-	-
------	-----------------------	--------	---	---

This value enables or disables access to Expert mode parameters.

- 0 = Normal mode parameter values only can be changed.
- 1 = Expert mode parameter values can be changed in addition to the Normal mode parameters. It is possible to reset all parameter values (including motor data, P081 to P085) to their factory default settings using Expert parameter P944=1.

EXPERT MODE - IMPORTANT PARAMETERS

The Expert Parameters shown below are the more frequently used Expert Parameters. Consult the Eco Reference Manual for the full parameter set.

CAUTION

- Consult the Reference manual before changing an Expert Parameter

Parameter	Function	Range (Default)	Description/Notes
P001	Display Mode	0-8 [0]	Display selection: 0 = Output frequency (Hz) 1 = Frequency setpoint (i.e. speed at which inverter is set to run)(H) 2 = Motor current (A) 3 = DC-link voltage (V) 4 = Motor torque (% nominal) 5 = Motor speed (rpm) 6 = USS serial bus status (Code) 7 = PID Feedback signal (%) 8 = Output voltage (V) Notes: The display can be scaled via P010
P015*	Automatic re-start after mains break	0-1 [1]	0 = No re-start after mains break - run signal must be re-generated 1 = Automatic re-start after mains break if run signal is present
P018*	Automatic re-start after fault	0-1 [0]	Automatic re-start after fault: 0 = Disabled 1 = The inverter will attempt to start up to 5 times after a fault. If fault is not cleared after the 5th attempt, the inverter will remain in the fault state. WARNING: This means that a start is pending and may happen at any time. Fault codes can be observed in P930.
P023*	Analog input 1 type	0-2 [0]	Sets analog input type for analog input 1, in conjuncture with the settings of the DIP selector switches 1, 2 and 3: 0 = 0V to 10V/0 to 20 mA Unipolar input 1 = 2V to 10V/4 to 20 mA Unipolar input 2 = 2V to 10V/4 to 20 mA Unipolar input with controlled start/stop when using analog input control. Motor starts when > 2V.
P027*	2 nd Skip frequency (Hz)	0-150.0 [0.0]	A skip frequency can be set with this parameter to avoid the effects of mechanical resonance. Frequencies within +/-2Hz (value of P019) of this setting are suppressed. Stationary operation is not possible within the suppressed frequency range - the range is just passed through.
P028*	3 rd Skip frequency (Hz)	0-150.0 [0.0]	See P027
P029*	4 th Skip frequency (Hz)	0-150.0 [0.0]	See P027

EXPERT MODE - IMPORTANT PARAMETERS

Parameter	Function	Range (Default)
P051	Selection control function, DIN1 (terminal 5), fixed frequency 5. (P046)**	0-24 [01]
P052	Selection control function, DIN2 (terminal 6), fixed frequency 4. (P044)**	0-24 [10]
P053	Selection control function, DIN3 (terminal 7), fixed frequency 3. (P043)**	0-24 [6]
P054	Selection control function, DIN4 (terminal 8), fixed frequency 2. (P042)**	0-24 [6]
P055	Selection control function, DIN5 (terminal 16), fixed frequency 1. (P041)**	0-24 [6]
P356	Selection control function, DIN6 (terminal 17), fixed frequency 6. (P047)**	0-24 [6]

* Only effective when P007 = 0.

** Fixed frequency enabled when P051 to P055 and P356 is set to 6 or 18. P006 should then be set to 2

*** The motor must be stopped before downloading begins Downloading takes approx. 30 seconds

**** Top left hand segment in the display flashes

Description/Notes			
Value	Function of P051 to P055 and P356	Function, low state (0 V)	Function, high state (>10V)
0	Input disabled	-	-
1	ON right	Off	On right
4	OFF2	OFF2	On
5	OFF3	OFF3	On
6	Fixed frequencies 1-6	Off	On
9	Start / stop command selection from keypad OR digital terminals (for USS communications operation P910 = 1 or 3)	Local keypad start / stop	Digital terminal start / stop (or USS communication control)
10	Fault reset	Off	Reset on rising edge
11	Increase frequency*	Off	Increase
12	Decrease frequency*	Off	Decrease
13	Switch between analog input frequency setting and digital/keypad frequency setting	Analog setpoint	Keypad / Digital setpoint
14	Disable ability to change parameters	P' enabled	P' disabled
18	Fixed frequencies 1-6, but input high will also request RUN when P007 = 0 See P040 to P047	Off	On
19	External trip	Off	On
22	Download parameter set 0 from OPe***	Off	Download
23	Download parameter set 1 from OPe***	Off	Download
24	Switch analog setpoint	Analog input 1 active	Analog input 2 active ****

EXPERT MODE - IMPORTANT PARAMETERS

Parameter	Function	Range (Default)	Description/Notes
P061	Selection relay output RL1	0-13 [6]	Sets the relay function, output RL1 (terminals 18,19 and 20)
P062	Selection relay output RL2	0-13 [1]	Sets the relay function, output RL2 (terminals 21 and 22)

Value	Relay function	Active ³
0	No function assigned (relay not active)	Low
1	Inverter is running	High
2	Inverter frequency 0.0 Hz	Low
5	Inverter frequency less than or equal to minimum frequency	Low
6	Fault indication ¹	Low
7	Inverter frequency greater than or equal to setpoint	High
9	Output current greater than or equal to P065	High
12	PID closed loop motor LOW speed limit	High
13	PID closed loop motor HIGH speed limit	High

¹ Inverter switches off (see parameter P930 and P140).

³ 'Active low' = relay OFF/de-energised or 'Active high' = relay ON/energised.

EXPERT MODE - IMPORTANT PARAMETERS

Parameter	Function	Range (Default)	Description/Notes
P071	Slip compensation (%)	0-200 [90]	The inverter can estimate the amount of slip in an asynchronous motor at varying loads and increase its output frequency to compensate for this. This parameter 'fine tunes' the compensation for different motors in the range 0 - 200% of the calculated slip. WARNING: This parameter must be set to zero when using synchronous motors or motors that are connected in parallel. This is because over-compensation can cause instability.
P073	DC injection braking (%)	0-200 [0] Range is variant dependent	This rapidly stops the motor by applying a DC braking current and holds the shaft stationary until the end of the braking period. Additional heat is generated within the motor. Braking is effective for a period of time set by P003. The DC brake can be activated using DIN 1 to DIN 6 (see P051 to P055 and P356). WARNING: Frequent use of long periods of DC injection braking can cause the motor to overheat. If DC injection braking is enabled via a digital input then DC current is applied for as long as the digital input is high. This causes heating of the motor.
P076	Pulse frequency	0-7 [0]	Sets the pulse frequency (from 2 to 16 kHz) and PWM mode. If silent operation is not absolutely necessary, the losses in the inverter as well as the RFI emissions can be reduced by selecting lower pulse frequencies. 0/1 = 16 kHz 2/3 = 8 kHz 4/5 = 4 kHz (400 V default) 6/7 = 2 kHz The default switching frequency FS8 and FS9 (110 kW to 315 kW) is set to 2 kHz. Even numbers = normal modulation technique. Odd numbers = lower loss modulation technique used when operating mainly at speeds above 5 Hz. Note: Selecting 8KHz or 16KHz may reduce the output current rating.
P077	Control mode	0 to 6 [0]	0 = Multi-motor mode 4 = Energy saving mode 5 = Linear V/f characteristic with variable torque 6 = Square V/f (Fan and Pump characteristic)

EXPERT MODE - IMPORTANT PARAMETERS

Parameter	Function	Range (Default)	Description/Notes
P079	Starting boost	0 -250 [50]	Sets additional current during ramping to ensure consistent starting and to overcome stiction effects
P080*	Nominal rating plate motor power factor	0,00 -1,00 (cos.φ)	If efficiency is shown on the motor rating plate, calculate the power factor as follows: $pf = \frac{hp \times 746}{1.732 \times \text{efficiency} \times \text{nom. volts} \times \text{nom. amps}}$
P086	Motor current limit (%)	0-200 [100]	Defines the motor overload current as a % of the nominal motor current (P083) allowed for up to one minute. With this parameter, the motor current can be limited and overheating of the motor prevented. If this set value is exceeded for one minute; the output frequency is reduced until the current falls to that set in P083. The inverter can be made to trip by using the relay in conjunction with P074. Note: The maximum value that P086 can be set to is automatically limited by the rating of the inverter.
P088	Automatic calibration	0 - 1 [1]	When P088 is set to '1' and the RUN button is pressed, the inverter automatically measures the stator resistance; stores it in P089 and then resets P088 to '0'. This calibration has to be carried out each time the motor is changed.

For further information on using Expert mode, refer to the Reference Manual G85139-H1750-U630

PARAMETER LISTING.....

Parameter	Function	Range	Default	Unit
*P000	Operating display	0-8	0 (output frequency)	Hz
P001	Display mode	0-8	0	
*P002	Ramp-up time	0-650.0	20	sec
*P003	Ramp-down time	0-650.0	20	sec
P005	Digital frequency setpoint	0-150.0	50.00 (60,00 = North America)	Hz
*P006	Frequency setpoint source selection	0-2	0	-
*P007	Keypad control	0 or 1	1	-
P010	Display scaling	0.01-500.0	1.00	-
*P012	Minimum motor frequency	0-150.0	0,0	Hz
*P013	Maximum motor frequency	0-150.0	50.00 (60,00 = North America)	Hz
P014	Skip frequency 1	0-150.0	0.0	Hz
P015	Automatic re-start after mains break	0-1	1	
*P016	Start on the fly	0 or 2	0	V
P018	Automatic re-start after fault	0-1	0	
P019	Skip frequency bandwidth	0.0-10.0	2.0	Hz
P021	Minimum analog frequency	0-150.0	0.0	Hz
P022	Maximum analog frequency	0-150.0	50.00 (60,00 = North America)	Hz
P023	Analog input 1 type	0-2	0	
P025	Analog output 1,	0-105	0	
P026	Analog output 2 (MIDIMASTER Eco only)	0-105	2	
P027	Skip frequency 2	0-150.0	0.0	Hz
P028	Skip frequency 3	0-150.0	0.0	Hz
P029	Skip frequency 4	0-150.0	0.0	Hz
P041	Fixed frequency 1	0-150.0	5.0	Hz
P042	Fixed frequency 2	0-150.0	10.00	Hz
P043	Fixed frequency 3	0-150.0	15.00	Hz
P044	Fixed frequency 4	0-150.0	20.00	Hz
P046	Fixed frequency 5	0-150.0	25.00	Hz
P047	Fixed frequency 6	0-150.0	30.00	Hz
P051	Selection control function, DIN1 (terminal 5), fixed frequency 5	024	1	
P052	Selection control function, DIN2 (terminal 6), fixed frequency 4	024	10	
P053	Selection control function, DIN3 (terminal 7), fixed frequency 3	024	6	
P054	Selection control function, DIN4 (terminal 8), fixed frequency 2	024	6	
P055	Selection control function, DIN5 (terminal 16), fixed frequency 1	024	6	
P061	Selection relay output RL1	0-13	6	
P062	Selection relay output RL2	0-13	1	
P065	Current threshold for relay	0.0-300.0	1.0	A
P066	Compound braking	0-250	0	
P073	DC injection braking	0-200	0 range is variant dependent	%
P074	1 st motor de-rating	0-7	1	
P076	Pulse frequency	0-7	0	
P077	Energy saving mode or multi-motor mode selection	0-6	4	
P079	Starting boost	0-250	50	
P080	Nominal rating plate motor power factor (cosφ)	0.00-1.00	***	
*P081	Motor rating plate nominal frequency	0-150.00	50.00 (60,00 = North America)	Hz
*P082	Motor rating plate nominal speed	0-9999	***	RPM
*P083	Motor rating plate nominal current	0.1-590	***	A
*P084	Motor rating plate nominal voltage	0-1000	***	V

* Indicates Basic Parameters

*** Value depends on rating of the inverter

PARAMETER LISTING

Parameter	Function	Range	Default	Unit
*P085	Motor rating plate nominal power	0.12-400.0	***	kW <small>(hp = North America)</small>
P086	Motor current limit	0-200	100	%
P087	Motor PTC enable	0-1	0	
P088	Automatic calibration	0-1	0	
P089	Stator resistance	0.01-199.99	***	Ω
P091	Serial link slave address	0-30	0	
P092	Serial link baud rate	3-7	6	
P093	Serial link time-out	0-240	0	sec
P094	Serial link nominal system setpoint	0-150.0	50.00 (60.00 = North America)	Hz
P095	USS compatibility	0-2	0	
P101	Operator for Europe or North America (goes to either 0 or 1 after first energised)	0-2	2	
P111	Inverter power rating	1.1-90.0	***	kW/hp
P112	Inverter type	1-10	***	
P113	Drive model	0-47	***	
P121	Enable/disable RUN button	0-1	1	
P124	Enable/disable ▲ and ▼ buttons	0-1	1	
P128	Fan switches-off delay time (MMV only)	0-600	120	Sec
P131	Frequency setpoint	0.00-150.0	-	Hz
P132	Motor current	0.0-590.0	-	A
P133	Motor torque	0-250	-	%
P134	DC link voltage	0-1000	-	V
P135	Motor speed	0-9999	-	RPM
P136	Output voltage	0-1000	-	V
P140	Most recent fault code	0-255	-	
P141	Most recent fault code - 1	0-255	1	
P142	Most recent fault code - 2	0-255	-	
P143	Most recent fault code - 3	0-255	-	
*P199	Access to Expert mode	0 or 1	0	
P201	PID closed loop mode	0-1	0	
P202	P gain	0.0-999.9	1.0	
P203	I gain	0.00-99.9	0	
P204	D gain	0.0-999.9	0	
P205	Sample interval (x 25ms)	1-2400	1	
P206	Transducer filtering	0-255	0	
P207	Integral capture range	0-100	100	%
P208	Transducer type	0-1	0	
P210	Transducer reading	0.00-100.00	-	%
P211	0% setpoint	0.0-100.00	0.0	
P212	100% setpoint	0.0-100.00	100.00	
P220	PID frequency cut-off	0-1	0	
P321	Minimum analog frequency for analog setpoint 2	0-150.00	0.00	Hz
P322	Maximum analog frequency for analog setpoint 2	0-150.0	50.00 (60.00 = North America)	Hz
P323	Analog input 2 type	0-2	0	
P356	Digital input 6 configuration	0-24	6	
P386	Inertia compensation	0.0-20.0	1.0	
P720	Direct input/output functions	0-7	0	
P721	Analog input 1 voltage	0.0-10.0	-	V
P722	Analog output 1 current	0.0-20.0	0.0	mA
P723	State of digital inputs	0-3F	-	
P724	Relay output control	0-3	0	
P725	Analog input 2 voltage	0.0-10.0	-	V
P726	Analog output 2 current. Models above 7.5kW only	0.0-20.0	0.0	mA
P910	Local/Remote mode	0-4	0	
P922	Software version	0.00-99.99	-	
P923	Equipment system number	0-255	0	
P930	Most recent fault code	0-255	-	
P944	Reset to factory default settings	0-1	0	

* Indicates Basic Parameters

*** Value depends on rating of the invert

Fault Codes

Fault Code	Cause	Corrective Action
F001	Overvoltage	Check whether supply voltage is within the limits indicated on the rating plate Increase the Ramp-down time (P003)
F002	Overcurrent	Check whether the motor is obstructed or overloaded Check whether the motor power corresponds to the inverter power Increase the ramp-up time (P002) Check that the cable length limits have not been exceeded Check motor cable and motor for short circuits and earth faults Check whether the motor parameters (P081-P085) correspond with the motor being used Check the stator resistance (P089) Reduce the boost set in P079
F003	Overload	Check whether motor is overloaded
F004	Overheating of motor (monitoring with PTC)	Check if motor is overloaded Check the connections to the PTC Check that P087 has not been set to 1 without a PTC being connected
F005	Inverter overtemperature (internal PTC at the heat sink)	Please check the following: The drive inverter load, the ambient temperature The pulse frequency; the cable length; The cooling and air discharge; the integrated fan
F008	USS protocol time-out	Check the serial interface Check the settings of the bus master and P091-P093 Check whether the time-out interval is too short (P093)
F010	Initialisation fault	Check the entire parameter set. Set P199 to '0000' before power down
F011	Internal interface fault	Switch off power and switch on again
F012	External trip	Source of trip is digital input (configured as an external trip input) going low - check the external source
F013	Programme fault	Switch off power and switch on again
F016	Start on Fly	Check that the motor name plate data (P081 to P085) is correct Disable then enable P016 again
F018	Auto-restart after fault	Automatic re-start after fault (P018) is pending. The inverter will attempt to restart up to 5 times after a fault. If the fault is not cleared after the 5th attempt, the inverter will remain in the fault state. WARNING: Inverter may start at any time.
F074	Motor overtemperature by I^2t calculation	Trip occurs only if P074 = 4,5,6 or 7. Check that the motor current does not exceed the value set in P083 and P086
F105	Inverter overtemperature (internal sensor at the PCB)	Please check the following: The drive inverter load, the ambient temperature The pulse frequency; the cable length; The cooling and air discharge; the integrated fan

Fault Codes

Fault Code	Cause	Corrective Action
F106	Parameter fault P006	Parameterise fixed frequency(ies) on the digital inputs
F112	Parameter fault P012/P013	Set parameter P012 < P013
F151-156	Digital input parameter fault	Change the settings of digital inputs P051 to P055 and P0356
F188	Automatic calibration failure	Motor not connected to inverter - connect motor If the fault persists, set P088 = 0 and enter the measured stator resistance of the motor into P089 manually
F212	Parameter fault P211/P212	Set parameter P211 < P212
F231	Output current measurement imbalance	Check motor cable and motor for short-circuits and earth faults

YOUR PARAMETER SETTINGS.....

Parameter	Default	Your setting
P000	-	
P001	0	
P002	20.0	
P003	20.0	
P004	30	
P005	50 (60 North America)	
P006	0	
P007	1	
P010	1.00	
P012	0.0	
P013	50 (60 North America)	
P014	0.0	
P015	1	
P016	0	
P018	0	
P019	2.0	
P021	0.0	
P022	50 (60 North America)	
P023	0	
P025	0	
P026	2	
P027	0.0	
P028	0.0	
P029	0.0	
P041	5.00	
P042	10.00	
P043	15.00	
P044	20.00	
P046	25.00	
P047	30.00	
P051	1	
P052	10	
P053	6	
P054	6	
P055	6	
P061	6	
P062	1	
P065	1.0	
P066	0	
P073	0 Range is variant dependent	
P074	1	
P076	0	
P077	4	
P079	50	
P080	***	
P081	50 (60 North America)	
P082	***	
P083	***	
P084	***	
P085	***	
P086	100	
P087	0	
P088	1	

Parameter	Default	Your setting
P089	***	
P091	0	
P092	6	
P093	0	
P094	50 (60 North America)	
P095	0	
P101	2 Go to either 0 or 1 after first energised	
P111	***	
P112	***	
P113	***	
P121	1	
P124	1	
P128	120	
P131	-	
P132	-	
P133	-	
P134	-	
P135	-	
P136	-	
P140	-	
P141	-	
P142	-	
P143	-	
P199	0	
P201	0	
P202	1.0	
P203	0	
P204	0	
P205	1	
P206	0	
P207	100	
P208	0	
P210	-	
P211	0.0	
P212	100.00	
P220	0	
P321	0.00	
P322	50 (60 North America)	
P323	0	
P356	6	
P386	1.0	
P720	0	
P721	-	
P722	0.0	
P723	-	
P724	0	
P725	0	
P726	0.0	
P910	0	
P922	-	
P923	0	
P930	-	
P944	0	

*** Value depends on rating of the inverter

Order No.: 6SE9586-4AA86

Published by
Automation and Drives Group A&D
Standard Drives Business Division
Postfach 32 69, D-91050 Erlangen
Germany

Siemens plc
Automation & Drives
Standard Drives Division
Siemens House
Varey Road
Congleton CW12 1PH

Internet: <http://www.siemens.com/micromaster>

We reserve the right to make changes

