

SIEMENS

MICROMASTER 411 & COMBIMASTER 411 AS-i Module

Operating Instructions

Issue 01/03



SIEMENS

MICROMASTER 411 & COMBIMASTER 411 AS-i Module

Operating Instructions
User Documentation

Valid for

MICROMASTER 411 &
COMBIMASTER 411

Issue 01/03

Description

1

Installing the AS-i
Module

2

Commissioning

3

Diagnostics and
Troubleshooting

4

Technical Data

5

Further information is available on the Internet under:

<http://www.siemens.de/micromaster>

Approved Siemens Quality for Software and Training
is to DIN ISO 14001, Reg. No. 2160-01

The reproduction, transmission or use of this document,
or its contents is not permitted unless authorized in
writing. Offenders will be liable for damages. All rights
including rights created by patent grant or registration of a
utility model or design are reserved.

© Siemens AG 2003. All Rights Reserved.

MICROMASTER® is a registered trademark of Siemens.

Other functions not described in this document may be
available. However, this fact shall not constitute an
obligation to supply such functions with a new control, or
when servicing.

We have checked that the contents of this document
correspond to the hardware and software described.
There may be discrepancies nevertheless, and no
guarantee can be given that they are completely identical.
The information contained in this document is reviewed
regularly and any necessary changes will be included in
the next edition. We welcome suggestions for
improvement.

Siemens handbooks are printed on chlorine-free paper
that has been produced from managed sustainable
forests. No solvents have been used in the printing or
binding process.

Document subject to change without prior notice.

Order Number. 6SE6400-5AT00-0BP0
Printed in the Federal of Germany

Siemens-Aktiengesellschaft.

Foreword

User Documentation



WARNING

Before installing and commissioning the inverter, you must read all safety instructions and warnings carefully including all the warning labels attached to the equipment. Make sure that the warning labels are kept in a legible condition and replace missing or damaged labels.

Information is also available from:

Technical Support Nuremberg

Tel: +49 (0) 180 5050 222

Fax: +49 (0) 180 5050 223

Email: techsupport@ad.siemens.de

Internet Home Address

Customers can access technical and general information at:

<http://www.siemens.de/micromaster>

Contact address

Should any questions or problems arise while reading this manual, please contact the Siemens office concerned using the form provided at the back this manual.

Definitions and Warnings

Safety guidelines

This manual contains notices intended to ensure your personal safety, as well as to protect products and connected equipment against damage. Information relating to your personal safety is highlighted by a warning triangle. Warnings about property damage are displayed without a warning triangle. Depending on the degree of risk involved, safety-related information is presented in the following categories:



DANGER

For the purpose of this documentation and the product warning labels, "Danger" indicates that death, severe personal injury or substantial damage to property **will** result if proper precautions are not taken.



WARNING

For the purpose of this documentation and the product warning labels, "Warning" indicates that death, severe personal injury or substantial damage to property **can** result if proper precautions are not taken.



CAUTION

With a warning triangle, "Caution" indicates that minor personal injury can result if proper precautions are not taken.

CAUTION

Without a warning triangle, "Caution" indicates that material damage can result if proper precautions are not taken.

ATTENTION

indicates that an undesirable effect or state can occur if attention is not paid to the advice given.

NOTE

For the purpose of this documentation, "Note" indicates important information relating to the product or highlights part of the documentation for special attention.

Qualified personnel

For the purpose of this Instruction Manual and product labels, a "Qualified person" is someone who is familiar with the installation, mounting, start-up and operation of the equipment and the hazards involved.

He or she must have the following qualifications:

1. Trained and authorized to energize, de-energize, clear, ground and tag circuits and equipment in accordance with established safety procedures.
 2. Trained in the proper care and use of protective equipment in accordance with established safety procedures.
 3. Trained in rendering first aid.
-

User Documentation



WARNING

Before installing and commissioning, please read these safety instructions and warnings carefully and all the warning labels attached to the equipment. Make sure that the warning labels are kept in a legible condition and replace missing or damaged labels.

Proper use

Please note the following:



WARNING

This equipment contains dangerous voltages and controls potentially dangerous rotating mechanical parts.

Non-compliance with Warnings or failure to follow the instructions contained in this manual can result in loss of life, severe personal injury or serious damage to property.

Only suitably qualified personnel should work on this equipment, and only after becoming familiar with all safety notices and maintenance procedures contained in this manual.

The successful and safe operation of this equipment is dependent upon its proper handling, storage, installation, operation and maintenance.

National safety regulations are also applicable.

Use for intended purpose only

The equipment may be used only for the application stated in the manual and only in conjunction with devices and components recommended and authorized by Siemens.

Table of Contents

1	Description.....	9
2	Installing the AS-i Module	11
2.1	Preparation of Inverter Terminal Housing	12
2.2	AS-i Module Installation	13
2.3	Addressing the AS-i Module.....	15
3	Commissioning	17
3.1	Parameter settings	17
3.2	AS-i Module Parameters	18
3.3	AS-i use data.....	19
4	Diagnostics and Troubleshooting.....	21
5	Technical Data	23
5.1	Technical Specifications.....	23
5.2	EMC Information	23

1 Description

The AS-i Module (Actuator sensor-Interface Communications Module) has been designed to control the COMBIMASTER 411 and MICROMASTER 411 inverters via:

- ON/OFF commands
- Fixed frequency selection
- Reverse commands
- Fault acknowledge commands

In the standard AS-i system up to 31 slaves can be connected, each slave having up to 4 input and output bits.

Without the use of repeaters or extenders the maximum length of a cable segment in the network is 100 meters (328 feet).

The AS-i Module is connected to the network via the FK cable adapter on the lower housing of the module casing by a simple two-wire cable without any shielding; this cable supplies both the data path and power supply to the slave nodes simultaneously.

Contact needles pierce the cable through the cable insulation and make contact with the copper conductors. When the cable is removed from the cable adaptor the outer insulation of the cable self-seals the holes made by the cable adaptor needles.

Figure 1-1 on page 10 shows the general layout and connections of the AS-i Module.

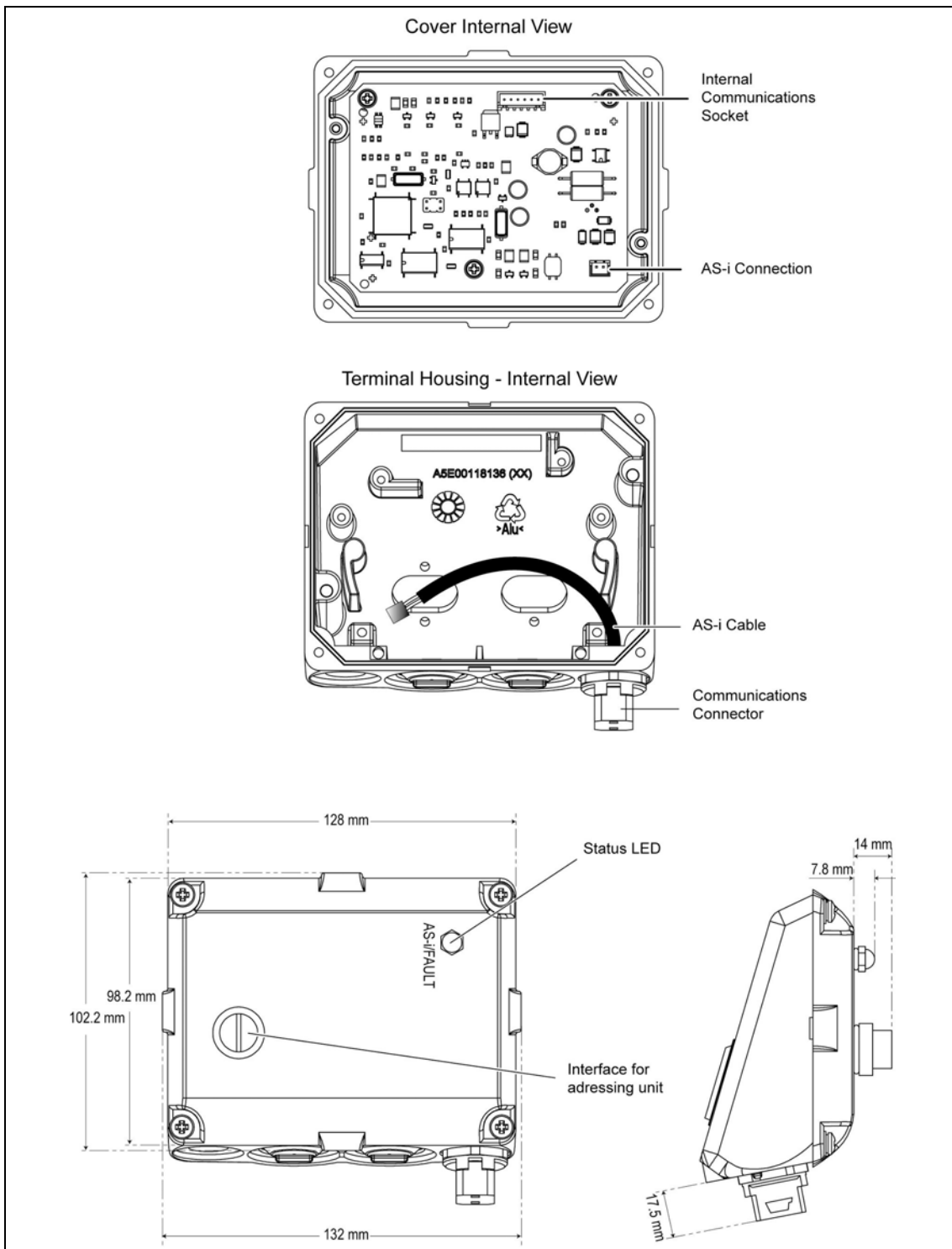

Figure 1-1 View of the COMBIMASTER 411 & MICROMASTER 411 AS-i Module

2 Installing the AS-i Module



WARNING

Make sure that the MICROMASTER 411/COMBIMASTER 411 inverter is isolated from the electrical supply before you install or remove the AS-i Module.

**CAUTION**

- Do not knock out cable gland blanking plates unless inverter 'electronics' (Filter & I/O boards) have been removed!
 - The inverter and AS-i Module electronics contain static sensitive devices therefore precautions must be taken against electrostatic discharge (ESD) when handling the separated inverter assembly. These include not touching the internal surfaces of the inverter and ensuring that personnel are earthed while handling the unit. The terminal housing, including Filter and I/O modules, contain no sensitive components and therefore no special handling precautions are required when separated.
-



List of Accessories

A list of the accessories provided with the AS-i Module is given below.

- | | |
|--|-----------------------------------|
| 1. 1-off U-clamp (for earth connection) | 5. 1-off Communication Link Cable |
| 2. 1-off Option Gland Fixing Plate | 6. 2-off O-ring Sealing Gasket |
| 3. 1-off Option Gland fixing Plate with Earth Lead | 7. 5-off M4 x 10 Screws |
| 4. 4-off M4 x 20 Screws | 8. I/O-Replacement board |

2.1 Preparation of Inverter Terminal Housing



CAUTION

The AS-i Module **MUST** be mounted on the inverter on the opposite side to the Rating Label (see Figure 2-6).

To mount the AS-i Module on the inverter body the following procedure should be performed:

1. If the Inverter has already been fitted unscrew the four crosshead captive screws ❶ on the inverter cover (as shown in Figure 2-1).
2. Remove inverter top cover.
3. Remove the I/O Board ❷ (as shown in Figure 2-2).
4. Remove the Filter Board ❸ (as shown in Figure 2-2).
5. Using a hammer and a flat-head screwdriver (as shown in Figure 2-3) strike the gland plate or “knockout”.

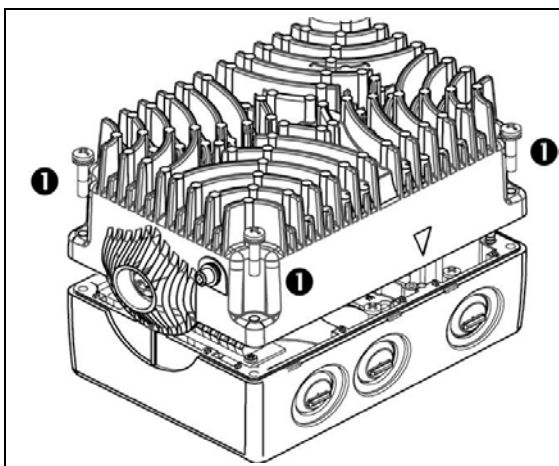

Figure 2-1 Removing Inverter cover

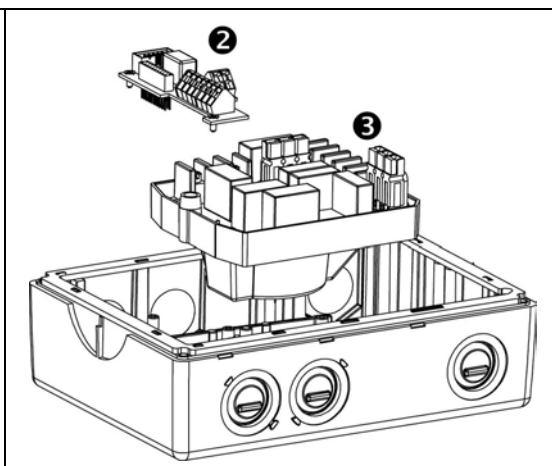

Figure 2-2 Removing the Filter and I/O Boards

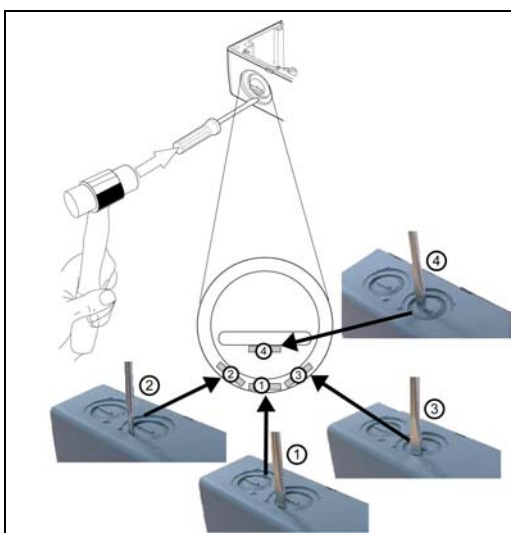

Figure 2-3 Gland Plate or “knockout” Removal

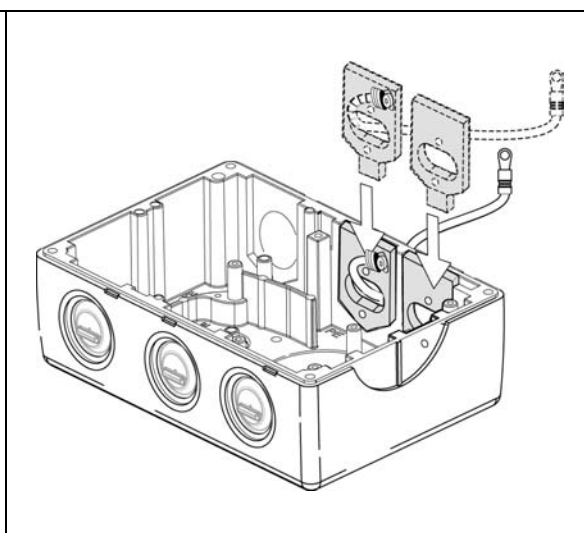

Figure 2-4 Fitting Gland Fixing Plates

6. Remove any sharp edges/burrs/swarf in the knockouts and terminal housing.
7. Slide the fixing plates into the slots provided immediately behind the gland access holes (as shown in Figure 2-4).
8. Ensure that the earth lead is fed back through the fixing plate.
9. Feed the earth lead into the AS-i Module housing and connect it at the fixing plate.
10. Replace the Filter Module.

2.2 AS-i Module Installation

With the fixing plates inserted it is now possible to mount the AS-i Module by carrying out the following procedure:

1. Unscrew the four M4x10 cover retaining screws ⑤ (see Figure 2-5).
2. Carefully detach the module cover ④ from the base ⑥.
3. Insert the “O” ring sealing gaskets (see Figure 2-6). Gaskets should be placed in position adhesive-side to the inverter.
4. Detach internal cables between option cover and base.
5. Align the Options case with the Fixing plates (See Figure 2-6).
6. Fasten the Options module base to the fixing plates using the M4x20 retaining screws ⑦ (see Figure 2-5 above).
7. Using the U-clamp and M4x10 screw, connect the earth lead (attached to the fixing plate) to the earth stud (shown as ⊕ in Figure 2-6 above) within the module housing.

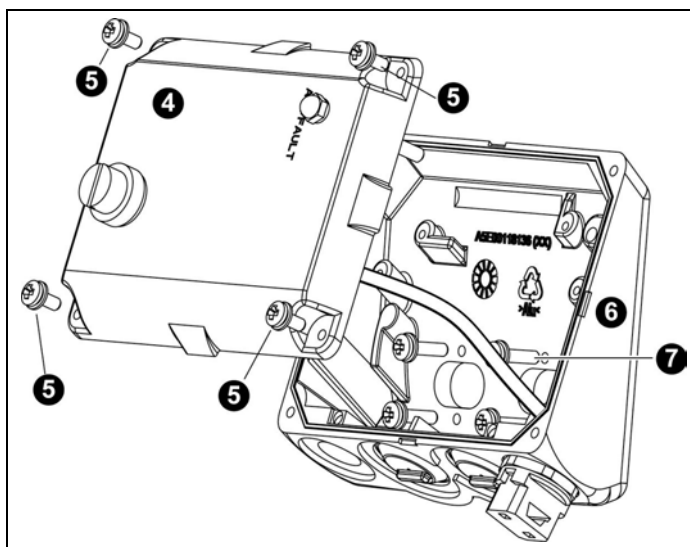

Figure 2-5 AS-i Module Layout

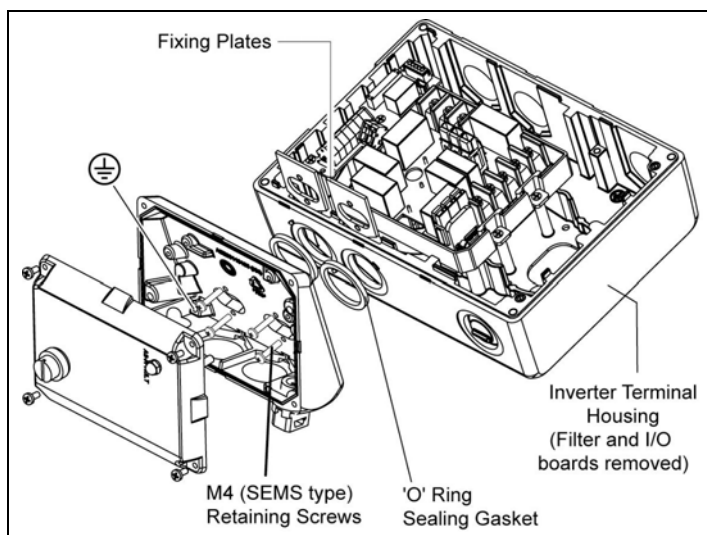

Figure 2-6 AS-i Module Fixing to Inverter

8. Feed the supplied comms link cable between the AS-i Module (see Figure 2-5 page 13) and the corresponding comms socket on the replacement inverter I/O board, supplied with the module (see Figure 2-7).
9. Replace I/O board.
10. Connect the AS-I Cable to the two-way connector in the upper housing of the module (see Figure 2-8 below).
11. Connect the internal communications cable to the five-way socket in the upper housing of the module (see Figure 2-8 below).
12. When the Options module has been correctly installed bring the two AS-i Module halves together.
13. Apply a gentle pressure until the lid ⑧ is firmly closed.
14. Secure the lid via retaining screws ⑤ at each corner.

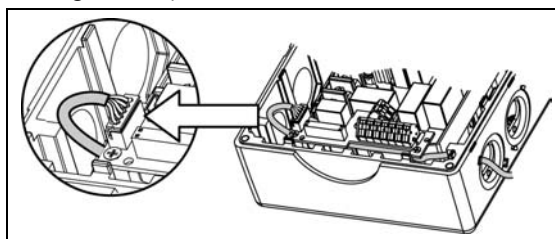

Figure 2-7 Fitting the Communications Cable

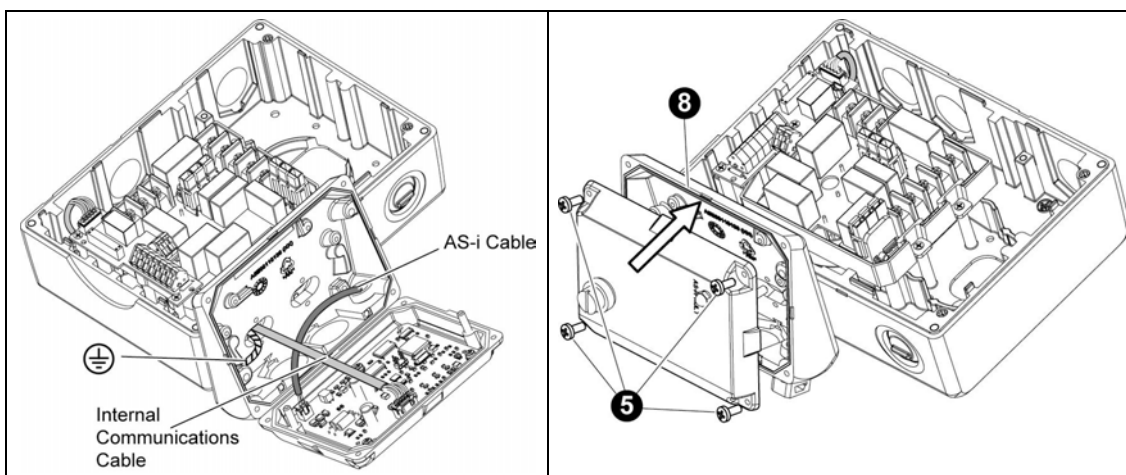

Figure 2-8 Cable Connections

Figure 2-9 Closing the AS-i Module Housing

Table 2-1 Torque Values

Thread Size	Retention Screw	Torque Value	
		Nm	lbf.in
M3	Filter and I/O board screw.	0.8	7.0
M4	CSB Inverter Cover Screw, CSB & C Module Fixing, Cover Retaining Screw.	1.2	10.6
M5	CSC Inverter Cover screws.	2.4	21.3
M4	Options module earth wires	1.2	10.6

2.3 Addressing the AS-i Module

Before data transfer can take place between the AS-i Master and the slave devices each slave must be assigned an address. The address of a AS-I slave can be assigned using the following methods:

- Addressing off-line using the Siemens Addressing and Diagnostic Instrument (Order Number: 3RK1904-2AB00)
- Addressing on-line using the controlling system, such as a PLC via the AS-i Master (it should be noted that only one slave with address 0 may be present on the bus if this method is to be implemented).

The addresses are designated numbers between 1 and 31, with each slave device having a preset address of 0. If the AS-i master detects a slave with address 0, it recognizes the device but does not integrate the device into the AS-i network.

The addresses of the slave devices do not have to be sequential, for example the first slave device can have the address 21, the next 10.

The AS-I slave device has been designed with an external addressing connector on the upper housing of the module to allow the connection of a dedicated addressing unit. See Figure 2-10.

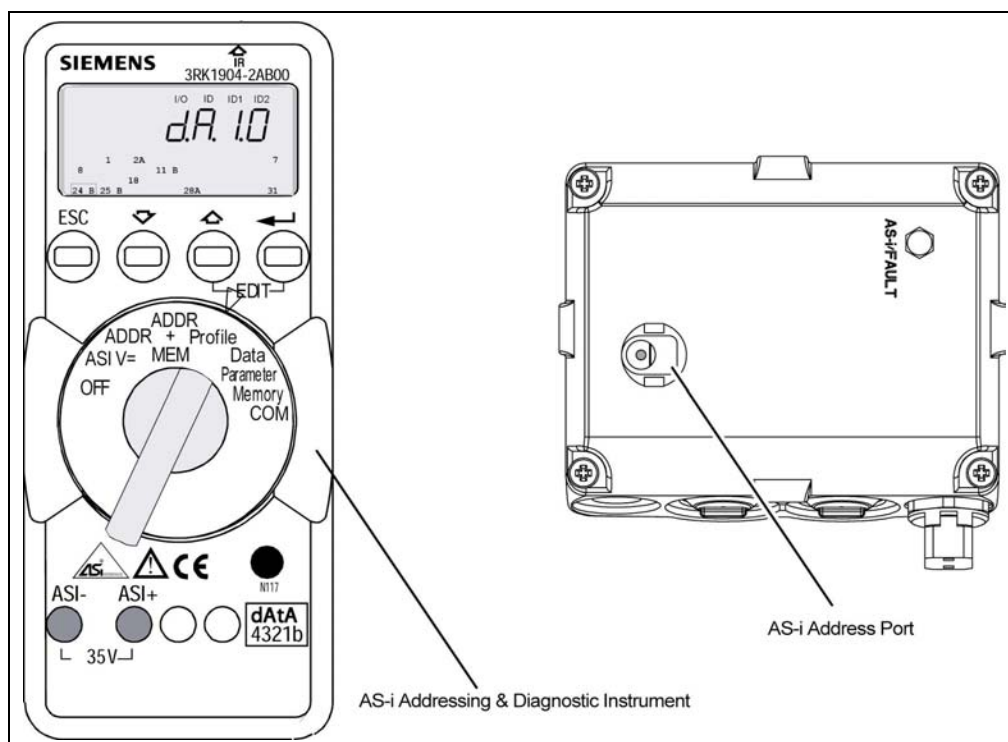

Figure 2-10 AS-i Addressing & Diagnostic Instrument

3 Commissioning

Time critical data should be sent over the AS-i bus in cyclic mode. Using this mode data is sent reliably in a precisely defined time frame. Unfortunately, only 4 bits of data can be sent to and received from the inverter in this manner.

3.1 Parameter settings

The following parameter descriptions are given to enable the user to control and monitor the correct functioning of the AS-i slave module and the COMBIMASTER 411 / MICROMASTER 411. For parameterization you need either an Operator panel (BOP or AOP) or a Commissioning software (DriveMonitor or Starter, delivered with with the inverter).

Command Source and Setpoint Parameters

The following settings have to be performed in the COMBIMASTER 411 / MICROMASTER 411 inverter:

Parameter	Value	Description
P0700	6	Command source is "CB on COM link"
P1000	3	Frequency setpoint is "Fixed Frequency"
P1020	P2091.0	Fixed frequency selection bit 0 source is "control word 2, bit 0 from CB"
P1021	P2091.1	Fixed frequency selection bit 1 source is "control word 2, bit 1 from CB"
P1022	P2091.2	Fixed frequency selection bit 2 source is "control word 2, bit 2 from CB"

NOTE

P0719 must be set to 0 (default) when BICO technology is used with "P0700" and "P1000".

The fixed frequency modes bits have to be set to appropriate values, for example, so that 7 independent fixed frequencies are used:

Parameter	Value	Description
P1016	3	Fixed frequency mode – bit 0 is "binary coded selection + ON command"
P1017	3	Fixed frequency mode – bit 1 is "binary coded selection + ON command"
P1018	3	Fixed frequency mode – bit 2 is "binary coded selection + ON command"

Parameter P2040 (Telegram Failure Time) should be set to zero (0) if the function is not required or to a value above 10 ms. Reasonable values are between 40 ms to 100 ms.

Table 3-1 BCD selection

		P1018 FF Bit 2	P1017 FF Bit 1	P1016 FF Bit 0
	OFF	Inactive	Inactive	Inactive
P1001	FF1	Inactive	Inactive	Active
P1002	FF2	Inactive	Active	Inactive
P1003	FF3	Inactive	Active	Active
P1004	FF4	Active	Inactive	Inactive
P1005	FF5	Active	Inactive	Active
P1006	FF6	Active	Active	Inactive
P1007	FF7	Active	Active	Active

3.2 AS-i Module Parameters

P2041 — CB Parameter

P2041 is reserved for use by any communications module connected into the inverter. All functionality associated with P2041 is implemented in the communication module and not the inverter.

Parameter	Value	Description
P2041[0]	0 to 63	GP1 source selection
P2041[1]	0 to 63	GP2 source selection

r2053 — CB Identification

This parameter is used to obtain information that will identify an AS-i slave module on an COMBIMASTER 411 / MICROMASTER 411.

Parameter	Value	Description
r2053[0]	4	CB Type: AS-Interface
r2053[1]	10	Firmware version: 1.0

r2054 — CB Diagnosis

This parameter is used to monitor and report faults on an AS-i slave module on an COMBIMASTER 411 / MICROMASTER 411.

Parameter	Value	Description
r2054[0]	0	No data telegram exchange between AS-I master and CB.
	1	The AS-i master is exchanging data telegrams with the CB.

Parameters "r2050" and "P2051" (BICO)

Much greater flexibility is afforded by the interconnection of process data using binectors/connectors.

Detailed connection of commands to and from the Master through the AS-i Module optional board is parameterized in "r2050" and "P2051".

The following table shows the parameters specific to the AS-i Module relating to the connection of process data:

Table 3-1 Parameters for flexible interconnection of process data

Telegram: Link parameters for setpoints Master → Inverter Link parameters for actual values Inverter → Master	PZD1 STW/ZSW	PZD: Process data STW: Control word ZSW: Status word
	r2050.00	
	P2051.00	

NOTE

r2050 also acts as a display parameter by which the setpoints received from the Master can be checked. These displays are always in decimal – for example if r2050.00 = 1150, this would be 047E in hex.

3.3 AS-i use data

In order to maximize the functionality of the AS-i module the following bit assignments are used (see Figure 3-1 and Figure 3-2 for an explanation of PZD values to and from the inverter):

Bits to Inverter

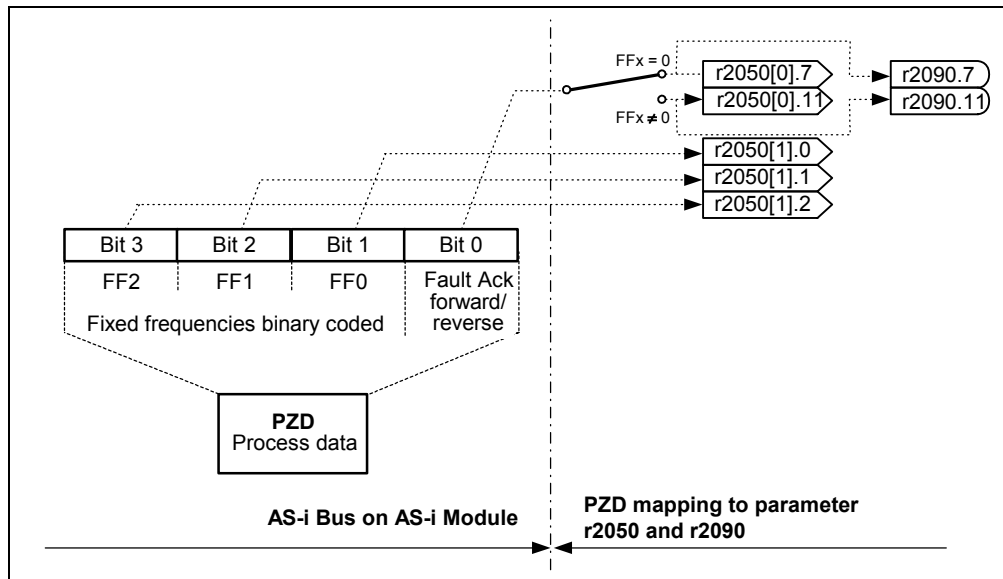

Figure 3-1 Bits to the Inverter

The nibble sent to the inverter consists of three fixed frequency selection bits and one forward-reverse/fault acknowledge bit.

The three FF selection bits map to the lowest three bits of control word 2. When one or more of these bits are active then the inverter is started and bit 0 acts as a forward or reverse bit.

When all three FF selection bits are inactive then the inverter is stopped and bit 0 acts as a fault acknowledgement bit.

Bits from Inverter

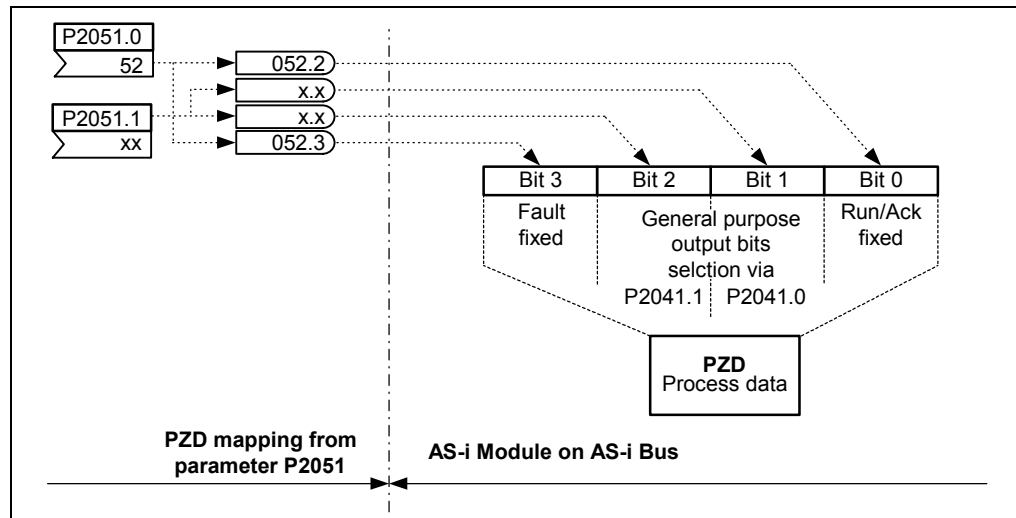

Figure 3-2 Bits from the Inverter

Bit 3 is an inverter fault indicator. This is mapped from STW1 bit 3.

When bit 3 is inactive (no fault), bit 0 is the inverter running indicator mapped from STW1 bit 2.

When bit 3 is active (fault), bit 0 is an AS-i fault acknowledge received indicator (not mapped directly from the inverter).

Bits 1 and 2 are general purpose output bits. The function of these two bits are controlled by P2041[0] and P2041[1] respectively. For this purpose the PZD is mapped as a linear bit address space from STW1 bit 0 to bit 15 and the word mapped to P2051.1 bit 0 to bit 15. The number written to P2041[0] and P2041[1] controls which of these bits is mapped to bits 1 and 2 of the AS-i message from the inverter.

NOTE

The PZD from the inverter is linked through P2051[0] to P2051[3].

Examples

1. Bit 1 should indicate status word 1 bit 11: motor current warning. (Bit 11 in r0052)
To achieve this, set P2041[0] to $0 * 16 + 11 = 11$.
2. Bit 1 should indicate status word 2 bit 9: ramping finished. (Bit 09 in r0053)
To achieve this, set P2051[0] to 53 and P2041[0] to $0 * 16 + 9 = 9$.
3. Bit 2 should indicate the state of digital input 1.
To achieve this, set P2051[1] to 722. This maps r0722 (digital input states).
Now set P2041[1] to $1 * 16 + 0 = 16$.

NOTE

Bit 0 and Bit 3 are fixed.

Example 1 and 2 are mutually exclusive.

4 Diagnostics and Troubleshooting

To aid in troubleshooting, there is a two color LED on the front side of the AS-i Module. It provides a quick indication of the operating status of the module.

The following table gives the meaning of the standard AS-i Module Combined Module/Network Status (MNS) LED.

Table 4-1 LED Display AS-i Module

LED Color		Status	Reason
Green	Red		
OFF	OFF	Supply voltage not present	No supply voltage
ON	OFF	Normal Operation	
OFF	ON	No Data Communications with AS-i bus.	Slave address coded incorrectly; data communications watchdog has been triggered.
ON	Flashing	230 V missing, 30 V DC available	
Flashing	ON	No slave address coded	AS-I slave has factory default address (0)
Flashing	Flashing	Hardware failure in sensor/actuator circuitry	No communications with inverter. (inverter power off)
OFF	Flashing	Internal Fault	-

5 Technical Data

5.1 Technical Specifications

Table 5-1 Technical Specifications

Size (height x width x depth)	126.6 mm x 132 mm x 57.75 mm
Degree of protection	IP66
Mechanical strength	Acc. to DIN IEC 68-2-6 (with correctly installed board)
In stationary state	
- Deflection	0.15 mm in 10 Hz to 58 Hz frequency range
- Acceleration	19.6 m/s ² in > 58 Hz to 500 Hz frequency range
During transportation	
- Deflection	3.5 mm in 5 Hz to 9 Hz frequency range
- Acceleration	9.8 m/s ² in > 9 Hz to 500 Hz frequency range
Environment class	Class 3K3 to DIN IEC 721-3-3 (in operation)
Cooling method	Natural air cooling
Permissible ambient or coolant temperature	
- In operation	-10 °C to +40 °C (14 °F to 104 °F)
- In storage	-25 °C to +70 °C (-13 °F to 158 °F)
- In transit	-25 °C to +70 °C (-13 °F to 158 °F)
Permissible humidity rating	Transit, Storage and Operation: 99% RH – non-condensing
Supply voltage	6.5 V ± 5 %, max. 300 mA, internal from basic converter and 24 V max. 80 mA, from AS-i Module bus
Output voltage	None
Data transmission rate	125, 250 and 500 kBaud

5.2 EMC Information

The board complies with the following standards governing radio emissions and interference immunity:

- Radio emissions in accordance with EN 55011 1991 Class A
- Interference immunity in accordance with IEC 801-3 and EN 61000-4-3

Suggestions and/or Corrections

To: Siemens AG Automation & Drives Group SD VM 4 P.O. Box 3269 D-91050 Erlangen Federal Republic of Germany Email: Technical.documentation@con.siemens.co.uk	Suggestions
	Corrections For Publication/Manual: MICROMASTER 411 & COMBIMASTER 411 AS-i Module User Documentation
From Name: Company/Service Department Address: _____ Telephone: _____ / _____ Telefax: _____ / _____	Operating Instructions Order Number: 6SE6400-5AT00-0BP0 Date of Issue: 01/03 Should you come across any printing errors when reading this publication, please notify us on this sheet. Suggestions for improvement are also welcome.

Siemens AG
Group Automation and Drives (A&D)
Division Standard Drives (SD)
P.O. Box 3269, D-91050 Erlangen
Federal Republic of Germany

© Siemens AG, 2003
Subject to change without prior notice

Siemens Aktiengesellschaft

Order No.: 6SE6400-5AT00-0BP0
Date: 01/03

