

# SIEMENS

SIDOOR

6FB1211-5AT10-7AT2, 6FB1211-1AT10-7AT3

DE	Steuergerät für Aufzugtüren	ES	Unidad de mando para puertas de ascensores	TR	Asansör kapıları için kumanda cihazı
EN	Controller for elevator doors	IT	Dispositivo di comando per porte di ascensori	PY	Прибор управления для дверей лифтов
FR	Appareil de commande de portes d'ascenseurs	PT	Aparelho de comando para portas de elevador	中文	电梯门专用控制设备



IP20

SIDOOR ATE500E	≥ V1.2
SIDOOR User Software	V1.2

Betriebsanleitung	DE
Operating Instructions	EN
Instructions de service	FR
Instructivo	ES
Istruzioni operative	IT
Instruções de Serviço	PT
İşletme Kılavuzu	TR
Руководство по эксплуатации	PY
使用说明	中文

<b>Technical Support:</b>	Telephone: +49 (0)911 895 7 222
	Fax: +49 (0)911 895 7 223
	E-mail: <a href="mailto:support.automation@siemens.com">support.automation@siemens.com</a>
	Internet: <a href="http://www.siemens.com/automation/service&amp;support">http://www.siemens.com/automation/service&amp;support</a>
	Support Request: <a href="http://www.siemens.com/automation/support-request">http://www.siemens.com/automation/support-request</a>

DE		<b>Systemhandbuch</b>	<a href="http://support.automation.siemens.com/WWW/view/de/101978636">http://support.automation.siemens.com/WWW/view/de/101978636</a>
EN		<b>System Manual</b>	<a href="http://support.automation.siemens.com/WWW/view/en/101978636">http://support.automation.siemens.com/WWW/view/en/101978636</a>

DE	<b>Systemübersicht</b>	ES	<b>Vista general del sistema</b>	TR	<b>Sisteme genel bakış</b>
EN	<b>System overview</b>	IT	<b>Panoramica del sistema</b>	PY	<b>Обзор системы</b>
FR	<b>Présentation du système</b>	PT	<b>Visão geral do sistema</b>	中文	<b>系统概览</b>

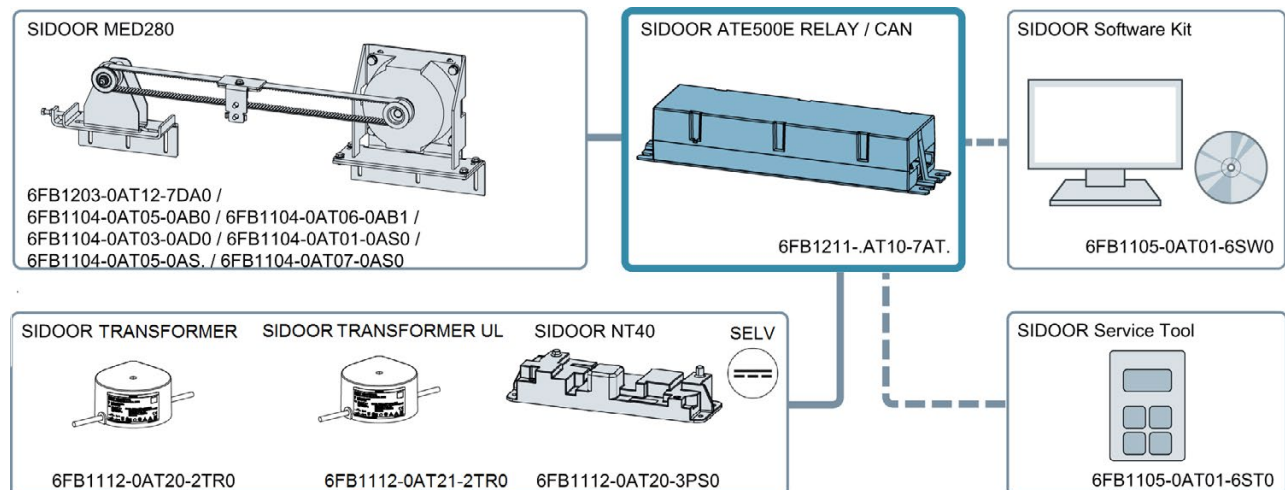

DE	<b>Lieferumfang</b>	<p>1 x ATE500E</p>
EN	<b>Scope of delivery</b>	
FR	<b>Etendue de la fourniture</b>	
ES	<b>Alcance de suministro</b>	
IT	<b>Dotazione di fornitura</b>	
PT	<b>Volume de fornecimento</b>	
TR	<b>Teslimat kapsamı</b>	
PY	<b>Комплект поставки</b>	
中文	<b>供货范围</b>	



DE	<b>Benötigtes Montagematerial</b>	<p>4 x (M6x10*)</p> <p>* Vorgeschlagene Schraubengröße / Recommended screw size / Taille de vis proposée / Tamaño de tornillo recomendado / Grandezza di vite proposta / Tamanho dos parafusos sugerido / Önerilen civata ebadı / Предложенный размер болтов / 建议螺丝规格</p>
EN	<b>Required installation materials</b>	
FR	<b>Matériel nécessaire au montage</b>	
ES	<b>Material de montaje necesario</b>	
IT	<b>Materiale di montaggio necessario</b>	
PT	<b>Material de montagem necessário</b>	
TR	<b>Gerekli olan montaj malzemesi</b>	
PY	<b>Необходимый для монтажа материал</b>	
中文	<b>所需装配材料</b>	

DE	<b>VORSICHT</b>	<b>Verlust der Sachmängelhaftung und Sachschaden</b> Veränderungen am Türantrieb führen zum Verlust der Sachmängelhaftung und Ersatzansprüchen und die korrekte Funktion des Türantriebs wird nicht mehr gewährleistet. Führen Sie keine Veränderungen am Türantrieb (Motor, Steuerung, Netzteil) durch.
EN	<b>CAUTION</b>	<b>Loss of liability for defects and damage to property</b> Changes to the door drive lead to the loss of liability for defects and compensation rights, and the correct function of the door drive is no longer guaranteed. Do not make any changes to the door drive (motor, controller, power supply).
FR	<b>PRUDENCE</b>	<b>Annulation de la garantie pour vices cachés et dommages matériels</b> Toute modification de la commande de porte annule la garantie pour vices cachés et les droits à réparation et ne garantit plus le fonctionnement correct de la commande de porte. N'apportez aucune modification à la commande de porte (moteur, commande, bloc d'alimentation).
ES	<b>PRECAUCIÓN</b>	<b>Pérdida de la exclusión de todas las garantías por defectos y daños materiales</b> Cualquier cambio en el accionamiento de puerta supone la pérdida de todas las garantías por defectos; además ya no queda garantizado su correcto funcionamiento. No haga cambio alguno en el accionamiento de puerta (motor, mando, fuente de alimentación).
IT	<b>CAUTELE</b>	<b>Perdita della garanzia per vizi della cosa e risarcimento danni</b> Modifiche eseguite sull'azionamento porte determinano la perdita della garanzia per vizi della cosa e dei diritti di risarcimento danni. Il corretto funzionamento dell'azionamento porte non è più garantito. Non eseguire nessuna modifica sull'azionamento porte (motore, dispositivo di comando, alimentatore).
PT	<b>CUIDADO</b>	<b>Perda da garantia por defeitos e danos materiais</b> Modificações no acionamento da porta resultam na perda da garantia por defeitos e na perda do direito a reclamação de substituição, deixando de ser possível garantir o correto funcionamento do acionamento da porta. Não efetue quaisquer alterações no acionamento da porta (motor, controle, fonte de alimentação).
TR	<b>ÖNEMLİ DİKKAT</b>	<b>Malzeme hatası sorumluluğunun ortadan kalkması ve maddi hasar</b> Kapı tahrik sisteminde yapılan değişiklikler üreticinin malzeme hatası sorumluluğunun ve tazminat talep etme hakkının ortadan kalkmasına yol açar ve kapı tahrik sisteminin doğru fonksiyonu artık sağlanmış değildir. Kapı tahrik sisteminde (motor, kontrol sistemi, güç kaynağı) herhangi bir değişiklik yapmayınız.
RU	<b>ОСТОРОЖНО</b>	<b>Потеря гарантии и материальный ущерб</b> Изменения на приводе двери ведут к потере гарантии и права требовать гарантийные услуги, правильность функционирования дверного привода больше не гарантируется. Не производите никаких изменений на дверном приводе (двигатель, блок управления, блок питания).
中文	<b>小心</b>	<b>保修失效和财产损失</b> 改装门驱动器将导致质保和赔偿请求权失效，且无法保证门驱动器的功能性。请勿改装门驱动器（电机、控制器、电源）。

DE		<b>Recycling und Entsorgung</b> Für ein umweltverträgliches Recycling und die Entsorgung Ihres Altgeräts wenden Sie sich an einen zertifizierten Entsorgungsbetrieb für Elektronikschrott bzw. entsorgen Sie das Gerät entsprechend der jeweiligen Vorschriften in Ihrem Land.
EN		<b>Recycling and disposal</b> For ecologically sustainable recycling and disposal of your old device, contact a certificated disposal service for electronic scrap or dispose of the device in accordance with the regulations in your country.
FR		<b>Recyclage et élimination</b> Adressez-vous à une entreprise certifiée dans la mise au rebut de déchets électroniques pour un recyclage et une mise au rebut de votre appareil dans le respect de l'environnement et de la législation de votre pays.
ES		<b>Reciclaje y eliminación</b> Para el reciclaje y la eliminación respetuosa con el medio ambiente de su antiguo aparato, diríjase a una empresa certificada de eliminación de residuos de aparatos electrónicos o deseche el aparato de acuerdo a las normativas vigentes en su país.
IT		<b>Riciclaggio e smaltimento</b> Per un riciclaggio rispettoso dell'ambiente e per lo smaltimento delle vecchie apparecchiature rivolgersi a un'azienda certificata nel settore dei materiali elettronici e smaltire i dispositivi in conformità delle norme vigenti nel proprio paese.
PT		<b>Reciclagem e eliminação</b> Para uma reciclagem ecológica e eliminação de seus aparelhos antigos, consulte um centro de eliminação de sucata eletrônica certificado ou elimine o aparelho em conformidade com as normas vigentes no seu país.
TR		<b>Geri dönüşüm ve tasfiye</b> Eski cihazınızın çevreyle uyumlu şekilde geri dönüştürülmesi ve tasfiyesi için, sertifikalı bir elektronik hurdası tasfiye işletmesine başvurun veya cihazı, ülkenizdeki yönetmeliklere uygun şekilde tasfiye edin.
RU		<b>Переработка и утилизация</b> Чтобы обеспечить экологически безопасную переработку и утилизацию старого оборудования, обратитесь в сертифицированную организацию по утилизации электронного оборудования или утилизируйте оборудование в соответствии с действующими в стране нормами.
中文		<b>回收和处置</b> 要对旧设备进行环保回收和处理，请根据本国相应法规联系一家具有电子废料处理资质的公司。

DE	HINWEIS	Das Steuergerät darf nur im Innenbereich verwendet werden. Endanwendungsspezifische Anforderungen müssen beachtet werden. Umfeld NFPA Industrie: Das Steuergerät erfüllt die Anforderungen an eine Brandschutzumhüllung nur bei Montage außerhalb eines Schaltschranks nur in waagerechter Einbaulage Umfeld NFPA Aufzug: Einbau muss in einem Brandschutzgehäuse erfolgen
EN	NOTE	The controller must only be used in indoors. You have to follow the application-specific requirements. NFPA industrial environment: The controller fulfills the requirements for insulation against fire only if it is installed outside of a control cabinet, only when installed horizontally. NFPA elevator environment: Installation must be in an enclosure with insulation against fire
FR	REMARQUE	L'automate peut être utilisé uniquement en intérieur. Les exigences spécifiques à l'application finale doivent être respectées. Environnement NFPA Industrie : l'automate respecte les exigences d'un boîtier coupe-feu uniquement avec le couvercle fermé et, lors du montage hors d'une armoire électrique, uniquement en position verticale Environnement NFPA Ascenseur : le montage doit s'effectuer dans un boîtier coupe-feu
ES	NOTA	La unidad de control puede utilizarse únicamente en interiores. Deben tenerse en cuenta las exigencias específicas de la aplicación final. Entorno industrial NFPA: la unidad de control cumple las exigencias de un revestimiento de protección contra incendios solamente si va montada fuera del armario de distribución y únicamente en posición horizontal Entorno ascensor NFPA: debe montarse en una carcasa de protección contra incendios
IT	NOTA	La centralina può essere utilizzata solo in ambienti chiusi. Tenere presente i requisiti specifici delle applicazioni finali. Ambiente NFPA industria: la centralina soddisfa i requisiti di protezione antincendio solo con il coperchio chiuso e con il montaggio fuori da un quadro elettrico solo in posizione di montaggio orizzontale Ambiente NFPA ascensori: è necessario il montaggio in un alloggiamento antincendio
PT	INDICAÇÃO	O aparelho de comando só pode ser utilizado no interior. Os requisitos específicos da utilização final têm de ser respeitados. Âmbito indústria NFPA: O aparelho de comando cumpre os requisitos para um invólucro de protecção contra incêndio apenas com montagem fora de um armário de distribuição, apenas em posição de montagem horizontal Âmbito elevador NFPA: A montagem deve ser feita numa caixa de protecção contra incêndio
TR	NOT	Kontrol ünitesi sadece iç alanda kullanılmalıdır. Nihai uygulamaya özel gereklilikler dikkate alınmalıdır. NFPA endüstri ortami: Kontrol ünitesi, yangın koruma kaplamasının gerekliliklerini sadece kapak kapalıyken ve kontrol panosunun dışındaki yatay montaj konumuna takılması durumunda karşılar NFPA asansör ortami: Montaj, yangın koruma muhafazasında gerçekleştirilmelidir
PY	УКАЗАНИЕ	Использование прибора управления допускается только в закрытых помещениях. Необходимо учитывать требования конечного использования. Производственная среда согласно стандарту NFPA: прибор управления соответствует требованиям, предъявляемым к противопожарным корпусам только при установке вне шкафов управления, при горизонтальном монтажном положении. Среда лифтов согласно стандарту NFPA: установка допускается только в противопожарных корпусах.
中文	说明	该控制器只能在室内使用。必须遵守最终用途的相关要求。 NFPA 工业环境标准：开关柜内部安装时盖板必须关闭，外部安装时只能采取水平安装方式，才能满足关于防火外罩的相关要求。 NFPA 电梯标准：必须安装在防火外壳中

DE		Montieren Sie alle dazugehörigen Komponenten (siehe Systemübersicht) bevor Sie das Steuergerät in Betrieb nehmen. Die Betriebsanleitungen mit ausführlicher Montageanleitung finden Sie auch im Internet ( <a href="http://support.automation.siemens.com/WW/view/de/50249479/133300">http://support.automation.siemens.com/WW/view/de/50249479/133300</a> ).
EN		Install all associated components (see System overview) before commissioning the controller. The operating instructions, which feature detailed installation instructions, can also be found online at ( <a href="http://support.automation.siemens.com/WW/view/en/50249479/133300">http://support.automation.siemens.com/WW/view/en/50249479/133300</a> ).
FR		Installer tous les constituants nécessaires (voir vue d'ensemble) avant de mettre le bloc logique en service. Vous trouverez les instructions de service complètes sur Internet ( <a href="http://support.automation.siemens.com/WW/view/en/50249479/133300">http://support.automation.siemens.com/WW/view/en/50249479/133300</a> ).
ES		Monte todos los componentes asociados (ver Sinopsis del sistema) antes de poner en marcha la unidad de mando. Las instrucciones de servicio, que incluyen detalladas instrucciones de montaje, están también disponibles en Internet ( <a href="http://support.automation.siemens.com/WW/view/en/50249479/133300">http://support.automation.siemens.com/WW/view/en/50249479/133300</a> ).
IT		Montare tutti i componenti appartenenti (vedi Panoramica del sistema) prima di mettere in servizio il dispositivo di comando. Le istruzioni operative con informazioni di montaggio dettagliate si trovano anche in Internet ( <a href="http://support.automation.siemens.com/WW/view/en/50249479/133300">http://support.automation.siemens.com/WW/view/en/50249479/133300</a> ).
PT		Monte todos os respectivos componentes (ver visão geral do sistema) antes de colocar o aparelho de comando em funcionamento. Você pode consultar os manuais de instruções com instruções de montagem detalhadas na internet ( <a href="http://support.automation.siemens.com/WW/view/en/50249479/133300">http://support.automation.siemens.com/WW/view/en/50249479/133300</a> ).
TR		Kontrol cihazını işletmeye almadan önce kontrol cihazına ait olan tüm bileşenleri (bkz. sisteme genel bakış) monte edin. Ayrıntılı montaj talimatlarını içeren işletme kılavuzlarını internette de bulabilirsiniz ( <a href="http://support.automation.siemens.com/WW/view/en/50249479/133300">http://support.automation.siemens.com/WW/view/en/50249479/133300</a> ).
PY		Смонтируйте все соответствующие компоненты (см. обзор системы), прежде чем ввести в эксплуатацию устройство управления. Руководства по эксплуатации с подробными инструкциями по монтажу см. в Интернете ( <a href="http://support.automation.siemens.com/WW/view/en/50249479/133300">http://support.automation.siemens.com/WW/view/en/50249479/133300</a> ).
中文		请安装好所有组件（参见系统概览）后再运行控制设备。您也可以在线 ( <a href="http://support.automation.siemens.com/WW/view/en/50249479/133300">http://support.automation.siemens.com/WW/view/en/50249479/133300</a> ) 下载操作说明书，其中附有详细的安装说明。

DE	 GEFAHR	<p><b>Verletzungsgefahr durch gefährliche elektrische Spannungen</b></p> <ul style="list-style-type: none"> <li>Bei geöffnetem Gehäusedeckel darf am Steuergerät nur Sicherheitskleinspannung (Spannungen kleiner 42 V) anliegen.</li> <li>Verwenden Sie die vorgesehene Schutzkappe am Relay- bzw. CAN-Modul und stellen Sie vor der Inbetriebnahme des Steuergeräts sicher, dass diese angebracht und fest verschraubt ist.</li> <li>Angeschlossene Leitungen müssen für die verwendete Spannung geeignet sein und eine entsprechende Isolierung (doppelte oder verstärkte Isolierung) aufweisen. Empfohlen werden Leitungen mit einem Außendurchmesser von 6 bis 7 mm.</li> <li>Bauelemente der Steuerung und Anschlusskabel, wie der Motorstecker und dessen Leitungen dürfen nur mit der zusätzlichen (bzw. verstärkten) Isolierung der spannungsführenden Leitungen in Berührung kommen.</li> <li>Es dürfen keine Spannungen unterschiedlicher Netze (z. B. 24 V und 230 V) an das Relaismodul angeschlossen werden.</li> </ul>
EN	 DANGER	<p><b>Risk of injury from dangerous electrical voltages</b></p> <ul style="list-style-type: none"> <li>When the housing cover is opened, only a safety extra-low voltage of less than 42 V may be present.</li> <li>Use the protective cover provided on the relay and/or CAN module and ensure that it is attached and firmly screwed in place prior to commissioning of the controller.</li> <li>The cables connected must be suitable for the voltage used and have appropriate (double or reinforced) insulation. Cables with an external diameter of 6 to 7 mm are recommended.</li> <li>Components of the controller and connecting cable, such as the motor connector and its wires, may only come in contact with the additional (or reinforced) insulation of the current-carrying wires.</li> <li>Networks with different voltages (e.g. 24 V and 230 V) must not be connected to the relay module.</li> </ul>
FR	 DANGER	<p><b>Risque de blessure dû à des tensions électriques dangereuses</b></p> <ul style="list-style-type: none"> <li>Lorsque le couvercle du boîtier est ouvert, seule une très faible tension de sécurité (inférieure à 42 V) doit être présente au niveau du bloc logique.</li> <li>Utilisez le couvercle de protection prévu au niveau du module à relais ou du module CAN et assurez-vous qu'il est présent et bien vissé avant de procéder à la mise en service de l'appareil de commande.</li> <li>Les câbles raccordés doivent être adaptés à la tension utilisée et comporter une isolation suffisante (isolation double ou renforcée). Il est recommandé d'utiliser des câbles d'un diamètre extérieur de 6 à 7 mm.</li> <li>Les constituants de la commande et les câbles de raccordement, de même que le connecteur moteur et ses câbles ne doivent être en contact qu'avec l'isolation supplémentaire (ou renforcée) des câbles sous tension.</li> <li>Il est interdit de raccorder des tensions de différents réseaux au module relais (par exemple 24 V et 230 V).</li> </ul>
ES	 PELIGRO	<p><b>Peligro de lesiones debido a tensiones eléctricas peligrosas</b></p> <ul style="list-style-type: none"> <li>Estando abierta su tapa, en la unidad de mando solo deberán estar aplicadas muy bajas tensiones de seguridad (inferiores a 42 V).</li> <li>Use la cubierta de protección prevista en el módulo CAN o de relé y, antes de la puesta en marcha de la unidad de mando, asegúrese de que la cubierta está montada y bien atornillada.</li> <li>Los cables conectados deberán ser aptos para la tensión usada y tener un aislamiento (doble o reforzado) acorde con ella. Se recomiendan cables con un diámetro externo de 6 a 7 mm.</li> <li>Los componentes del mando y los cables de conexión preconectorizados, como el conector al motor o sus cables, solo deberán entrar en contacto con el aislamiento adicional (o reforzado) de los cables energizados.</li> <li>El módulo de relés no deberá conectarse simultáneamente a redes de alimentación diferentes (p. ej. 24 V y 230 V).</li> </ul>
IT	 PERICOLO	<p><b>Pericolo di lesioni a causa di tensioni elettriche pericolose</b></p> <ul style="list-style-type: none"> <li>Con il coperchio dell'involucro aperto deve essere presente sul dispositivo di comando solo una bassissima tensione di sicurezza (tensioni più basse di 42 V).</li> <li>Utilizzare la calotta di protezione prevista sul modulo a relè o sul modulo CAN ed assicurarsi prima della messa in servizio del dispositivo di comando che questa sia applicata e saldamente avvitata.</li> <li>I cavi collegati devono essere adatti alle tensioni utilizzate ed essere provvisti di un isolamento idoneo (isolamento doppio o rafforzato). Si consigliano cavi con un diametro esterno da 6 a 7 mm.</li> <li>Gli elementi costruttivi del dispositivo di comando e del cavo di collegamento, come il connettore del motore e i suoi cavi, possono entrare in contatto solo con l'isolamento aggiuntivo (rafforzato) dei cavi sotto tensione.</li> <li>Non è consentito collegare il modulo relè a tensioni di reti diverse (ad es. 24 V e 230 V).</li> </ul>
PT	 PERIGO	<p><b>Perigo de ferimentos devido a tensões elétricas perigosas</b></p> <ul style="list-style-type: none"> <li>Com a tampa da caixa aberta, é possível verificar apenas uma baixa tensão de segurança (tensões inferiores a 42 V) no aparelho de comando.</li> <li>Utilize a cobertura de proteção prevista no módulo CAN ou de relé e, antes da colocação em funcionamento do aparelho de comando, certifique-se de que esta foi colocada e está bem parafusada.</li> <li>Os cabos ligados devem ser adequados à tensão utilizada e apresentar um isolamento adequado (isolamento duplo ou reforçado). São recomendados cabos com um diâmetro exterior de 6 a 7 mm.</li> <li>Componentes do comando e do cabo de ligação, como o conector do motor e respectivos cabos, podem entrar em contato apenas com o isolamento adicional (ou reforçado) dos cabos condutores de tensão.</li> <li>Não podem ser conectadas tensões de diferentes redes (por ex. 24 V e 230 V) do módulo do relé.</li> </ul>
TR	 TEHLIKE	<p><b>Tehlikeli elektrik gerilimleri nedeniyle yaralanma tehlikesi</b></p> <ul style="list-style-type: none"> <li>Kontrol cihazında gövde kapağı açıldıkten sadece güvenli alçak gerilim (42 V'tan küçük gerilim) mevcut olabilir.</li> <li>Röle veya CAN modülü için öngörülen koruyucu başlığı kullanın ve işletime almadan önce takılmış ve sıkı vidalanmış olduğundan emin olun.</li> <li>Bağlanan kablolar kullanılan gerilim için uygun ve yüksek gerilime dayanıklı izolasyon malzemesi (çift veya güçlendirilmiş izolasyon) ile donatılmış olmak zorundadır. Dış çapları 6 - 7 mm arasında olan kablolar tavsiye edilir.</li> <li>Kontrol ünitesinin elemanları ve bağlantı kabloları, motor konektörü ve kabloları sadece gerilim taşıyan kabloların ilave (veya güçlendirilmiş) izolasyonuna temas edebilir.</li> <li>Röle modülüne farklı şebekelere ait gerilimlerin (örneğin 24 V ve 230 V) bağlanması yasaktır.</li> </ul>
РУ	 ОПАСНОСТЬ	<p><b>Опасность травмирования из-за опасного электрического напряжения</b></p> <ul style="list-style-type: none"> <li>При открытой крышке корпуса на приборе управления может присутствовать только незначительное безопасное напряжение (напряжение меньше 42 В).</li> <li>Используйте защитный колпачок на модуле реле и CAN и обеспечьте установку и крепкое соединение колпачка перед началом эксплуатации прибора.</li> <li>Подключенные провода должны подходить для используемого напряжения и иметь соответствующую изоляцию (двойную или усиленную изоляцию). Рекомендуются кабели с наружным диаметром от 6 до 7 мм.</li> <li>Компоненты управления и соединительные кабели, например, штекер двигателя и его проводка могут соприкасаться только с дополнительной (и/или усиленной) изоляцией токопроводящих проводов.</li> <li>К модулю реле нельзя присоединять напряжение разных сетей (напр., 24 В и 230 В).</li> </ul>
中文	 危险	<p><b>危险电压可能导致人员受伤</b></p> <ul style="list-style-type: none"> <li>外壳盖打开时，控制设备上只能存在安全低电压（电压小于 42V）。</li> <li>请在继电器模块或 CAN 模块上使用规定的防护罩，在调试控制设备前确认已将其安装并拧紧。</li> <li>连接的导线必须适用于所用电压，并进行相应绝缘（双重绝缘或强化绝缘）。建议使用外径为 6 至 7 mm 的电缆。</li> <li>控制器元件和连接电缆（比如电机插头及其导线）只能接触导电路的附加（强化）绝缘层。</li> <li>不得在继电器模块上连接不同的电网电压（比如 24 V 和 230 V）。</li> </ul>

DE	Montagevorschriften	ES	Instrucciones de montaje	TR	Montaj talimatları
EN	Installation guidelines	IT	Prescrizioni di montaggio	PY	Монтажные предписания
FR	Instructions de montage	PT	Normas de montagem	中文	装配规定

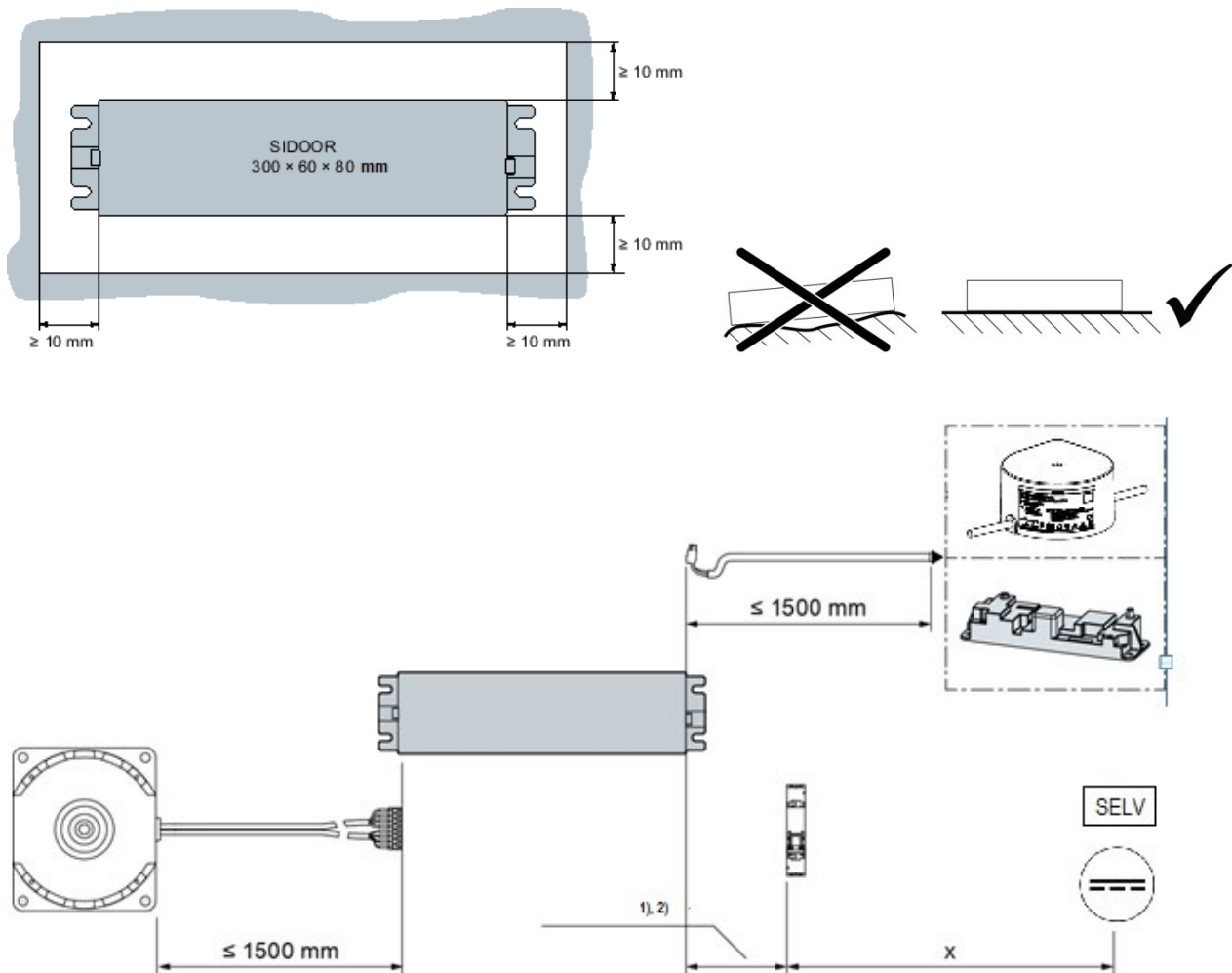

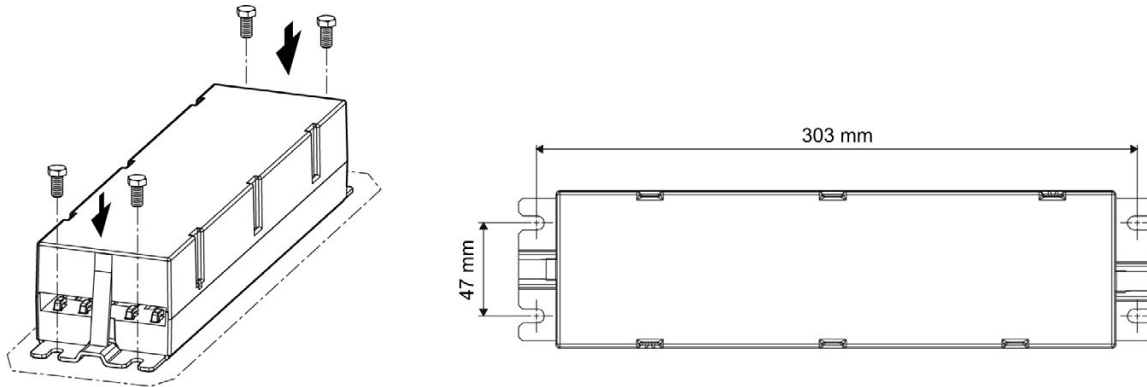

- 1) Leitungsschutzschalter in der Nähe des SIDOOR Steuergeräts montieren (ähnliche Umgebungstemperatur) / Install the circuit breaker near the SIDOOR controller (similar ambient temperature) / Monter le disjoncteur modulaire à proximité du bloc logique SIDOOR (température ambiante similaire) / Montar el interruptor automático cerca de la unidad de mando SIDOOR (temperatura ambiente similar) / Installare l'interruttore magnetotermico nelle vicinanze del dispositivo di comando SIDOOR (analoga temperatura ambiente) / Montar o disjuntor na proximidade do aparelho de comando SIDOOR (temperatura ambiente semelhante) / Hat koruma şalterini SIDOOR kumanda cihazının yakınına monte ediniz (benzer ortam sıcaklığı) / Линейный защитный автомат должен монтироваться вблизи устройства управления SIDOOR (та же температура окружающей среды) / 在 SIDOOR 控制装置旁安装断路器 (确保环境温度相近)
- 2) Leitungsschutzschalter bei bauseitiger Gleichspannungsversorgung zwingend erforderlich. / Circuit breaker mandatory with DC power supply at customer end. / Disjoncteur modulaire indispensable en cas d'alimentation en courant continu côté client. / Interruptor automático imprescindible en caso de alimentación de corriente continua en el lugar de instalación. / Gli interruttori magnetotermici sono tassativamente previsti con l'alimentazione in tensione continua a cura del cliente. / O disjuntor é indispensável no caso de alimentação de tensão contínua junto do cliente. / Yarı tarafında doğru voltaj beslemesi halinde hat koruma şalteri mutlaka gerekli. / Наличие линейного защитного автомата обязательно требуется при обеспечении питания постоянным током со стороны заказчика. / 施工方必须为断路器配置直流电源。

DE	Montage	ES	Montaje	TR	Montaj
EN	Assembly	IT	Montaggio	PY	Монтаж
FR	Montage	PT	Montagem	中文	安装



DE		<b>WARNUNG</b>	<p><b>Verletzungsgefahr während der Inbetriebnahme</b> Stellen Sie sicher, dass die Tür vor dem Start einer Lernfahrt und während der Inbetriebnahme durch Abschrankung gesichert ist.</p> <ul style="list-style-type: none"> <li>Während der Inbetriebnahme der Steuerung können die Türbewegungen von außen nicht beeinflusst werden. Die Lichtschranke ist während der Lernfahrt nicht aktiv.</li> <li>Während der Lernfahrt treten erhöhte Kräfte, Geschwindigkeiten und Energien in Schließ- und Öffnungsrichtung auf.</li> <li>Vor Beginn der Lernfahrt sind die Positionen "Geschlossen" und "Offen" unbekannt. Deshalb ist die Bewegungsrichtung der Tür bei Betätigung der Servicetaster AUF (S402) und ZU (S403) undefiniert und hängt von der Einbausituation der Tür und des Motors ab.</li> <li>Bei der Türpositionierung durch die Servicetaster AUF (S402) und ZU (S403), vor einer Lernfahrt (H401 zeigt " " oder "P" an), treten erhöhte Kräfte in Schließ- und Öffnungsrichtung auf.</li> </ul>
EN		<b>WARNING</b>	<p><b>Risk of injury during commissioning</b> Ensure that the door is secured with physical barriers prior to a learn run and during commissioning.</p> <ul style="list-style-type: none"> <li>Door movements cannot be influenced externally while the controller is being commissioned. The light barrier is not active during the learn run.</li> <li>Increased forces, speeds and energies arise in the closing and opening directions during the learn run.</li> <li>Prior to the learn run, the "closed" and "open" positions are unknown. For this reason, the direction of movement of the door resulting from pressing the OPEN (S402) or CLOSE (S403) service buttons is dependent on the way that the door and motor have been installed.</li> <li>Increased forces arise in the opening and closing directions when positioning the door using the OPEN (S402) and CLOSE (S403) service buttons and before a learn run (H401 displays " " or "P").</li> </ul>
FR		<b>ATTENTION</b>	<p><b>Risque de blessures pendant la mise en service</b> S'assurer que la porte est sécurisée par des barrières avant le début d'une course d'apprentissage et pendant la mise en service.</p> <ul style="list-style-type: none"> <li>Pendant la mise en service de la commande, il n'est pas possible d'influer de l'extérieur sur les mouvements de la porte. La barrière photoélectrique n'est pas active pendant la course d'apprentissage.</li> <li>Les forces, vitesses et énergies dans le sens de fermeture et d'ouverture sont plus élevées pendant la course d'apprentissage.</li> <li>Avant le début de la course d'apprentissage, les positions "Fermé" et "Ouvert" sont inconnues. Le sens de déplacement de la porte lors de l'actionnement des boutons de service OUVRIER (S402) et FERMER (S403) est donc indéfini et dépend de la situation de montage de la porte et du moteur.</li> <li>Lors du positionnement de la porte via les boutons de service OUVRIER (S402) et FERMER (S403) avant une course d'apprentissage (H401 indique " " ou "P"), les forces dans le sens de fermeture et d'ouverture sont plus élevées.</li> </ul>
ES		<b>ADVERTENCIA</b>	<p><b>Peligro de lesiones durante la puesta en marcha</b> Asegúrese de que la puerta esté asegurada con barreras antes de iniciar un recorrido de aprendizaje y durante la puesta en marcha.</p> <ul style="list-style-type: none"> <li>Durante la puesta en marcha del control no se puede actuar sobre los movimientos de puerta desde fuera. La barrera fotoeléctrica no está activa durante el aprendizaje.</li> <li>Durante el aprendizaje se generan fuerzas, velocidades y energías elevadas en sentido de cierre y de apertura.</li> <li>Antes de iniciar el aprendizaje se desconocen las posiciones "Cerrada" y "Abierta". Por lo tanto, el sentido en que se moverá la puerta al accionar el pulsador de servicio ABRIR (S402) y CERRAR (S403) no está definido, sino que dependerá de la situación de montaje de la puerta y del motor.</li> <li>Al posicionar la puerta con el pulsador de servicio ABRIR (S402) y CERRAR (S403), antes de un aprendizaje (H401 indica " " o bien "P"), se generan fuerzas elevadas en sentido de cierre y de apertura.</li> </ul>
IT		<b>AVVERTENZA</b>	<p><b>Pericolo di lesioni durante la messa in servizio</b> Assicurarsi che la porta sia transennata prima dell'avvio di un movimento di apprendimento e durante la messa in servizio.</p> <ul style="list-style-type: none"> <li>Durante la messa in servizio del dispositivo di comando i movimenti della porta non possono essere influenzati dall'esterno. La barriera fotoelettrica non è attiva durante il movimento di apprendimento.</li> <li>Durante il movimento di apprendimento si verificano forze, velocità ed energie aumentate in direzione di chiusura ed apertura.</li> <li>Prima dell'inizio del movimento di apprendimento le posizioni "CHIUSA" e "APERTA" sono sconosciute. Pertanto la direzione di movimento della porta non è definita all'azionamento del tasto di service APERTA (S402) e CHIUSA (S403) e dipende dal tipo di montaggio della porta e del motore.</li> <li>Durante il posizionamento della porta con il tasto di service APERTA (S402) e CHIUSA (S403), prima di un movimento di apprendimento (H401 visualizza " " o "P"), si verificano forze elevate in direzione di chiusura ed apertura.</li> </ul>
PT		<b>AVISO</b>	<p><b>Perigo de ferimentos durante a colocação em funcionamento</b> Certifique-se de que a porta está protegida com bloqueio antes do início de uma viagem de programação e durante a colocação em funcionamento.</p> <ul style="list-style-type: none"> <li>Os movimentos da porta não podem ser influenciados pelo exterior durante a colocação em funcionamento do comando. A barreira de luz não está ativa durante a viagem de programação.</li> <li>Durante a viagem de programação ocorrem forças, velocidades e energias elevadas na direção de fechamento e abertura.</li> <li>As posições "Fechado" e "Aberto" são desconhecidas antes do início da viagem de programação. Por isso, a direção do movimento da porta está indefinida ao acionar a tecla de serviço ABERTO (S402) e FECHADO (S403) e depende da situação de montagem da porta e do motor.</li> <li>Ao posicionar a porta através da tecla de serviço ABERTO (S402) e FECHADO (S403), antes de uma viagem de programação (H401 indica " " ou "P"), ocorrem forças elevadas na direção de fechamento e abertura.</li> </ul>
TR		<b>IKAZ</b>	<p><b>İşletime almadan önce ve öğrenme sürüşü esnasında kapının bir bariyeri ile emniyete alınmış olduğundan emin olun.</b></p> <ul style="list-style-type: none"> <li>Kontrol sistemi işletime alınırken kapı hareketlerine dışarıdan müdahale edilemez. Fotosel, öğrenme sürüşü sırasında aktif değildir.</li> <li>Öğrenme sürüşü esnasında açılma ve kapanma yönünde daha yüksek güçler, hızlar ve enerjiler ortaya çıkar.</li> <li>Öğrenme sürüşünden önce "Kapalı" ve "Açık" pozisyonlar bilinmez. Bu nedenle KAPALI (S402) ve AÇIK (S403) servis tuşuna basılması sonucunda kapının hareket yönü tanımlı değildir ve kapı ile motorun montaj pozisyonuna bağlı olarak değişiklik gösterir.</li> <li>KAPALI (S402) ve AÇIK (S403) servis tuşuna basılarak kapı konumlandırıldığında, öğrenme sürüşü (H401, " " veya "P" görüntülenir) öncesinde kapanma ve açılma yönünde daha yüksek güçler ortaya çıkar.</li> </ul>

РУ	 Предупреждение	<p><b>Опасность получения травмы во время ввода в эксплуатацию</b></p> <p>Обеспечьте, чтобы дверь перед началом учебной эксплуатации и во время ввода в эксплуатацию была обеспечена заграждением.</p> <ul style="list-style-type: none"> <li>Во время ввода в эксплуатацию управления на движения двери снаружи повлиять нельзя. Фотозлектрический барьер во время учебной эксплуатации не активен.</li> <li>Во время учебной эксплуатации возникают увеличенные силы, скорости и энергии в направлении закрывания и открывания.</li> <li>Перед началом учебной эксплуатации позиции "Закрывать" и "Открыть" неизвестны. Поэтому направление движения двери при нажатии сервисного переключателя ОТКР. (S402) и ЗАКР. (S403) не определено и зависит от монтажного положения двери и двигателя.</li> <li>При позиционировании двери сервисным переключателем ОТКР. (S402) и ЗАКР. (S403), перед учебной эксплуатацией (H401 показывает " " или "P"), возникают увеличенные силы в направлении закрывания и открывания.</li> </ul>
中文	 警告	<p><b>调试工作可能导致人身伤害</b></p> <p>务必在试运行启动前和进行调试时拦住电梯门禁止其移动。</p> <ul style="list-style-type: none"> <li>在调试控制系统时电梯门的运动应不受外界影响。在试运行时光栅应处于未激活状态。</li> <li>在试运行期间，电梯门关闭和打开方向都会被施加更大的力量和能量，以更快的速度移动。</li> <li>在试运行开始前，门的“关闭”和“开启”位置都处于未定义状态。因此在按动服务按键“开”(S402)和“关”(S403)时，门的运动方向并不确定，它取决于电梯门和电机的安装状态。</li> <li>在试运行前（H401显示为“ ”或“P”）通过服务按键“开”(S402)和“关”(S403)对门进行定位时，门在关闭和打开方向都会被施加更大的力量。</li> </ul>

DE	Anschluss und Inbetriebnahme	ES	Conexión y puesta en marcha	TR	Bağlantı ve işletmeye alma
EN	Connection and commissioning	IT	Collegamento e messa in servizio	РУ	Подключение и ввод в эксплуатацию
FR	Raccordement et mise en service	PT	Conexão e colocação em funcionamento	中文	连接和调试

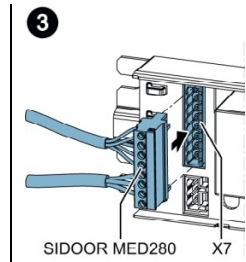
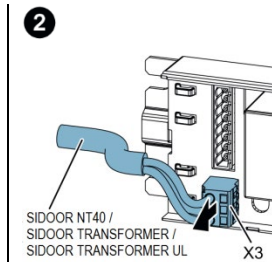
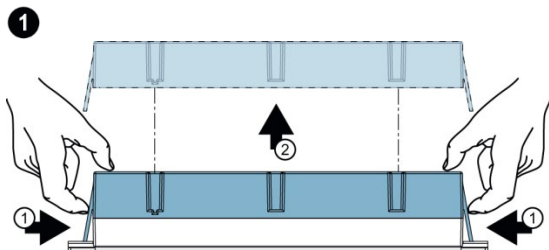

DE	<p><b>Schutzmaßnahmen ESD</b></p> <ul style="list-style-type: none"> <li>Trennen Sie das Steuergerät von allen spannungsführenden Leitungen.</li> <li>Durch Erdung muss sichergestellt werden, dass der Benutzer / Monteur, das Steuergerät und andere Leiter dasselbe Spannungspotenzial besitzen. Beachten Sie deshalb die allgemeinen ESD-Richtlinien.</li> </ul>
EN	<p><b>ESD protective measures</b></p> <ul style="list-style-type: none"> <li>Disconnect the controller from all live cables.</li> <li>It must be ensured by means of grounding that the user / installation personnel, door controller and other conductors have the same voltage potential. Please therefore observe the general ESD guidelines..</li> </ul>
FR	<p><b>Mesures de protection CSDE</b></p> <ul style="list-style-type: none"> <li>Coupez l'unité de commande de tous les câbles sous tension.</li> <li>Assurez par une mise à la terre appropriée que l'utilisateur/le monteur, l'unité de commande et les autres câbles possèdent le même potentiel de tension. Observez les directives CSDE générales.</li> </ul>
ES	<p><b>Medidas de protección contra cargas electrostáticas</b></p> <ul style="list-style-type: none"> <li>Desconecte de la unidad de mando todos los cable energizados.</li> <li>Mediante una puesta a tierra adecuada es necesario asegurarse de que el usuario/instalador, la unidad de mando y otros conductores estén al mismo potencial eléctrico. Respete por ello las instrucciones generales de protección de componentes sensibles a cargas electrostáticas.</li> </ul>
IT	<p><b>Misure di protezione ESD</b></p> <ul style="list-style-type: none"> <li>Scollegare il dispositivo di comando da tutti i cavi sotto tensione.</li> <li>Con la messa a terra si deve assicurare che l'utente / il montatore, il dispositivo di comando e gli altri conduttori possiedano lo stesso potenziale di tensione. Osservare pertanto le direttive ESD generali.</li> </ul>
PT	<p><b>Medidas de proteção ESD</b></p> <ul style="list-style-type: none"> <li>Separe o aparelho de comando de todos cabos condutores de tensão.</li> <li>Ao efetuar o aterramento deve ser assegurado que o usuário / técnico de montagem, aparelho de comando e outros condutores possuem o mesmo potencial de tensão. Observe as seguintes diretrizes gerais ESD.</li> </ul>
TR	<p><b>ESD koruma önlemleri</b></p> <ul style="list-style-type: none"> <li>Kontrol cihazını tüm gerilim taşıyan hatlardan ayırın.</li> <li>Topraklama yapılarak operatörün/montaj elemanının, kontrol cihazının ve diğer iletkenlerin aynı gerilim potansiyeline sahip olmaları sağlanacaktır. Bu nedenle genel ESD direktiflerini dikkate alın.</li> </ul>
РУ	<p><b>Меры по защите от электростатического разряда</b></p> <ul style="list-style-type: none"> <li>Отсоедините прибор управления от всех кабелей, по которым подается напряжение.</li> <li>Путем заземления обеспечить, чтобы у пользователя/ремонтника, прибора управления и других проводников был одинаковый потенциал напряжения. Для этого соблюдать общие положения по защите от электростатического разряда.</li> </ul>
中文	<p><b>ESD（静电放电）防护措施</b></p> <ul style="list-style-type: none"> <li>将控制器与所有电源线断开。</li> <li>必须要通过接地来确保用户/ 安装工、控制器和其他导体具有相同的电势能。 因此请遵守通用的 ESD 指令。</li> </ul>

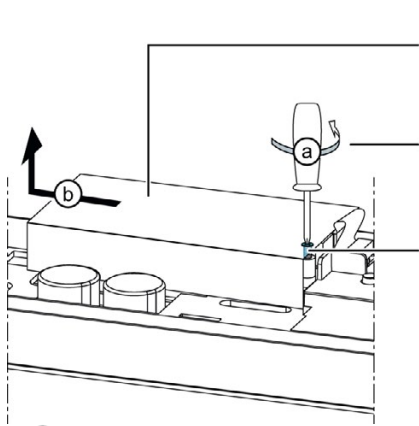

DE	Schutzkappe	ES	Cubierta protectora	TR	Koruyucu kapak
EN	Protective cover	IT	Calotta di protezione	PY	Защитный колпачок
FR	Couvercle protecteur	PT	Cobertura de protecção	中文	防护罩

⊕ PH 1

	DE	Befestigungsschraube Schutzkappe	ES	Tomillo de fijación cubierta de protección	TR	Koruyucu kapak için sabitleme vidası
	EN	Fixing screw for protective cover	IT	Vite di fissaggio calotta di protezione	PY	Крепежный винт защитного колпачка
	FR	Vis de fixation capot de protection	PT	Parafuso de fixação Capa de protecção	中文	防护罩紧固螺栓

5 a) SDOOR ATE500E RELAY

DE	<b>WARNUNG</b>	<b>Verletzungsgefahr</b> Das Türsteuergerät ist keine Sicherheitseinrichtung. Die Relaiskontakte dürfen deshalb nicht für den Sicherheitskreis des Aufzugs verwendet werden.
EN	<b>WARNING</b>	<b>Risk of injury</b> The door controller is not a safety mechanism. Therefore, the relay contacts must not be used for the elevator safety circuit.
FR	<b>ATTENTION</b>	<b>Risque de blessure</b> L'unité de commande de porte n'est pas un dispositif de sécurité. Les contacts de relais ne doivent donc pas être utilisés pour le circuit de sécurité de l'ascenseur.
ES	<b>ADVERTENCIA</b>	<b>Peligro de lesiones</b> La unidad de mando de puerta no es un dispositivo de seguridad. Por esta razón los contactos de los relés no deben usarse para el circuito de seguridad del ascensor.
IT	<b>AVVERTENZA</b>	<b>Pericolo di lesioni</b> Il dispositivo di comando porta non è un dispositivo di sicurezza. Pertanto i contatti di relè non devono essere utilizzati per il circuito di sicurezza dell'ascensore.
PT	<b>AVISO</b>	<b>Perigo de ferimentos</b> O aparelho de comando da porta não é um dispositivo de segurança. Os contatos do relé não podem por isso ser utilizados para o circuito de segurança do elevador.
TR	<b>İKAZ</b>	<b>Yaralanma tehlikesi</b> Kapi kontrol cihazı bir güvenlik donanımı değildir. Dolayısıyla, röle kontakları asansörün güvenlik devresi için kullanılamaz.
PY	<b>Предупреждение</b>	<b>Опасность травм</b> Прибор управления дверью не является устройством, обеспечивающим безопасность. Поэтому релейные контакты не могут использоваться для контура безопасности лифта.
中文	<b>警告</b>	<b>受伤危险</b> 门控制器不是安全装置。因此继电器触点不允许用于电梯的安全回路。

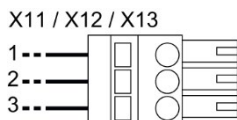
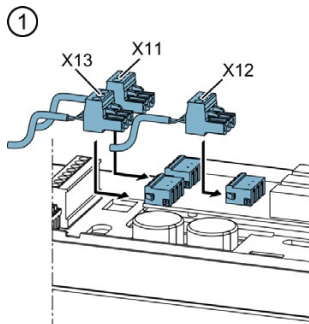

DE	<b>Funktionen</b>	ES	<b>Funciones</b>	TR	<b>Fonksiyonlar</b>	
EN	<b>Functions</b>	IT	<b>Funzioni</b>	PY	<b>Функции</b>	
FR	<b>Fonctions</b>	PT	<b>Funções</b>	中文	<b>功能</b>	

	X11	X12	X13
DE	Tür hat Position ZU erreicht	Tür reversiert auf Grund einer Blockierung, Lichtschrankenunterbrechung oder Öffnungsanforderung	Tür hat Position AUF erreicht
EN	The door has reached the CLOSED position	Door reverses because of an obstruction, interruption of the light barrier or an opening command	The door has reached the OPEN position
FR	La porte a atteint la position FERMÉE.	La porte inverse son sens de déplacement à la suite d'un blocage, d'une interruption de la barrière photoélectrique ou d'une demande d'ouverture.	La porte a atteint la position OUVERTE.
ES	Puerta ha llegado a la posición CERRADA	Puerta invierte su sentido de marcha debido a una obstrucción, interrupción de la barrera fotoeléctrica o comando de apertura	Puerta ha llegado a la posición ABIERTA
IT	La porta ha raggiunto la posizione CHIUSA	La porta riapre a causa di un'ostruzione, interruzione della barriera fotoelettrica o richiesta di apertura	La porta ha raggiunto la posizione APERTA
PT	Porta atingiu a posição FECHADO	Porta inverte o sentido de deslocação devido a um bloqueio, uma interrupção da barreira de luz ou um requisito de abertura.	Porta atingiu a posição ABERTO
TR	Kapi KAPALI pozisyonuna erişti	Kapi bir engel, fotosel kesintisi veya açma talebi nedeniyle ters hareket ediyor	Kapi AÇIK pozisyonuna erişti
PY	Дверь достигла позиции Закрыто	Дверь возвращается из-за блокировки, прерывания фотоэлектрического барьера или требования открывания	Дверь достигла позиции Открыто
中文	门到达“关闭”位置	门由于受到阻挡、光栅中断或打开请求而反转开启	门到达“打开”位置



②	DE	Kabelbinder
	EN	Cable ties
	FR	Serre-câble
	ES	Brida de cable
	IT	Fascette serracavi
	PT	Cintas de cabo
	TR	Kablo bağı
	PY	Кабельные соединители
	中文	电缆束线带

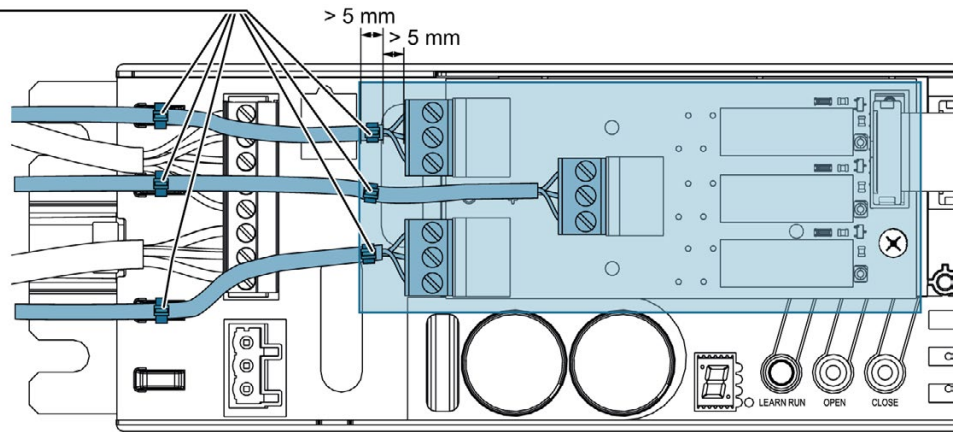

⑤ b) SIDOOR ATE500E CAN

DE	Kabelbinder
EN	Cable ties
FR	Serre-câble
ES	Brida de cable
IT	Fascette serracavi
PT	Cintas de cabo
TR	Kablo bağı
PY	Кабельные соединители
中文	电缆束线带

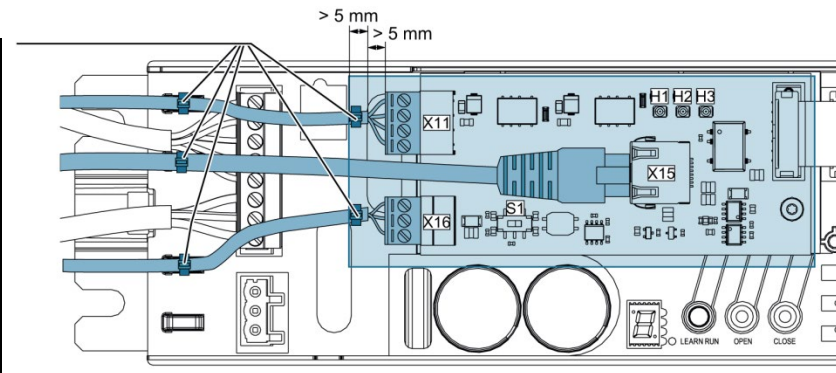

X15 (RJ45)

	1	CAN_H
	2	CAN_L
	3	GND
	4	-
	5	-
	6	Schirm / Shield / Blindage / Pantalla / Schermo / Blindagem / Blendaj / Экран / 屏蔽
	7	GND
	8	-

X16

	1	CAN_H
	2	Schirm / Shield / Blindage / Pantalla / Schermo / Blindagem / Blendaj / Экран / 屏蔽
	3	CAN_L

S1

Busabschluss / Bus terminator / Terminaison de bus / Terminación del bus / Terminazione bus / Terminação do bus / Veriyol sonlandırması / Оконечная нагрузка шины / 总线终端	120 Ω
--	-------

X11 (U<sub>max</sub> 30 V / I<sub>max</sub> 0,5 A)

	1	Position ZU erreicht / CLOSED position reached / Position FERMÉE atteinte / Posición CERRADA alcanzada / Posizione CHIUSA raggiunta / Posição FECHADO atingida / KAPALI pozisyonuna erişildi / Достигнута позиция Закрыто / 到达“关闭”位置	H1
	2		
	3	Position AUF erreicht / OPEN position reached / Position OUVERTE atteinte / Posición ABIERTA alcanzada / Posizione APERTA raggiunta / Posição ABERTO atingida / AÇIK pozisyonuna erişildi / Достигнута позиция Открыто / 到达“打开”位置	H2
	4		

H3 (CANopen-Zustandsmaschine / CANopen machine state / Machine d'état CANopen / Máquina de estados CANopen / Macchina a stati finiti CANopen / Máquina de estado CANopen / CANopen durum makinesi / Машина состояния CANopen / CANopen 状态机)

	"Pre-operational" / "Stopped"		Empfang CAN-Telegramm / Receive CAN telegram / Réception du télégramme CAN / Recepción de telegrama CAN / Ricezione di telegramma CAN / Recepção de telegrama CAN / CAN telegramı alımı / Прием сообщения CAN / 接收 CAN 报文
	"Operational"		
	Automatische Baudrateermittlung / Automatic determination of baud rate / Détermination automatique de la vitesse de transmission / Determinación automática de velocidad de transferencia / Determinazione automatica del baud rate / Determinação automática da taxa de transmissão / Otomatik baud oranı tespiti / Автоматическое определение скорости передачи данных / 自动波特率测定		



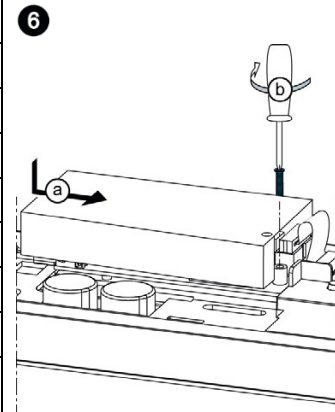





DE	<b>EMV Entstörmaßnahme:</b> Die Klappferrite (RFC-6 Kitagawa, im Lieferumfang) sind jeweils am Anfang und am Ende der CAN-Leitung (außerhalb vom Gehäuse, nah am Steuergerät) anzubringen.
EN	<b>EMC interference suppression measure:</b> The folding ferrites (RFC-6 Kitagawa, in scope of supply) must be attached to the beginning and end of the CAN cable (outside the housing, close to the controller).
FR	<b>Mesure d'antiparasitage CEM :</b> Les noyaux de ferrite rabattables (RFC-6 Kitagawa, compris dans la livraison) doivent être montés au début et à l'extrémité du câble CAN (à l'extérieur du boîtier et à proximité de l'unité de commande).
ES	<b>Medida contra interferencias electromagnéticas:</b> Las ferritas (Kitagawa RFC-6, incluidas en suministro) deben colocarse una al comienzo y otra al final del cable CAN (fuera de la caja, pero próximas a la unidad de mando).
IT	<b>Misura di protezione contro i disturbi EMC:</b> Le ferriti a morsetto (RFC-6 Kitagawa, nella dotazione di fornitura) sono da applicare all'inizio e alla fine del cavo CAN (all'esterno della custodia, vicino al dispositivo di comando).
PT	<b>Medidas de supressão de interferências CEM:</b> As ferrites dobráveis (RFC-6 Kitagawa, no material fornecido) devem ser colocadas respectivamente no início e no final da conexão CAN (fora da caixa, perto do aparelho de comando).
TR	<b>EMU parazit giderme:</b> Katlanır ferritler (RFC-6 Kitagawa, teslimat kapsamına dahildir) CAN hattının (gövde dışında, kontrol cihazına yakın) başına ve sonuna takılacaktır.
PY	<b>Мера по устранению помех ЭМС:</b> Притягивающиеся ферриты (RFC-6 Kitagawa, в комплекте поставки) размещать соответственно в начале и в конце линии CAN (вне корпуса, рядом с прибором управления).
中文	<b>EMC 去干扰措施:</b> 分别在 CAN 导线（外壳以外靠近控制器）的开端和末端安装铁氧体磁芯 (RFC-6 Kitagawa, 包含在供货范围内)。



DE	<b>Bauseitige Gleichspannungsversorgung</b>	ES	<b>Alimentación eléctrica externa (cliente)</b>	TR	<b>Yapı tarafında doğru gerilim beslemesi</b>
EN	<b>DC power supply at customer end</b>	IT	<b>Alimentazione in tensione continua a cura del cliente</b>	PY	<b>Обеспечении питания постоянным током со стороны заказчика.</b>
FR	<b>Alimentation en tension continue côté client</b>	PT	<b>Alimentação de tensão contínua junto do cliente</b>	中文	<b>客户提供的直流电源</b>





	<b>X3</b>		
	<b>X3.1<sup>1)</sup></b>	<b>X3.2</b>	<b>X3.3<sup>1)</sup></b>
DE	Eingang Gleichspannungsversorgung (+)	Funktionserde	Eingang Gleichspannungsversorgung (-)
EN	Input DC Power Supply (+)	Functional grounding	Input DC Power Supply (-)
FR	Arrivée alimentation en tension continue (+)	Terre fonctionnelle	Arrivée alimentation en tension continue (-)
ES	Entrada alimentación eléctrica (+)	Tierra funcional	Entrada alimentación eléctrica (-)
IT	Ingresso alimentazione in tensione continua (+)	Terra funzionale	Ingresso alimentazione in tensione continua (-)
PT	Entrada de alimentação de tensão contínua (+)	Ligação à terra funcional	Entrada de alimentação de tensão contínua (-)
TR	Doğru gerilim beslemesi girişi (+)	Fonksiyonel topraklama	Doğru gerilim beslemesi girişi (-)
PY	Вход питания постоянным током (+)	функциональное заземление	Вход питания постоянным током (-)
中文	直流输入(+)	功能接地	直流输入(-)

<sup>1)</sup> Anschluss von ungeerdete SELV Spannung, 19,2V DC...38V DC / Connection of ungrounded SELV voltage, 19,2V DC...38V DC / Raccordement tension TBTS non mise à la terre, 19,2V DC...38V DC / Conexión de tensión extra baja de seguridad (SELV) 19,2V DC...38V DC / Collegamento della tensione SELV senza messa a terra, valore 19,2V DC...38V DC / Ligação de tensão BTP não ligada à terra 19,2V DC...38V DC / Topraklanmamış SELV voltajı bağlantısı tipik olarak 19,2V DC...38V DC / Подключение незаземленного сверхнизкого напряжения (SELV), как правило, 19,2V DC...38V DC / 未接地的安全电压连接通常为 19,2V DC...38V DC

DE	 <b>GEFAHR</b>	Bitte beachten Sie die Hinweise zur bauseitigen Gleichspannungsversorgung im Systemhandbuch ( <a href="http://support.automation.siemens.com/WW/view/de/109477185">http://support.automation.siemens.com/WW/view/de/109477185</a> )
EN	 <b>DANGER</b>	Please observe the information on DC voltage supply at the customer end in the system manual ( <a href="http://support.automation.siemens.com/WW/view/en/109477185">http://support.automation.siemens.com/WW/view/en/109477185</a> )
FR	 <b>DANGER</b>	Tenir compte de la remarque sur l'alimentation en courant continu côté client dans le manuel ( <a href="http://support.automation.siemens.com/WW/view/en/109477185">http://support.automation.siemens.com/WW/view/en/109477185</a> )
ES	 <b>PELIGRO</b>	Tenga en cuenta las indicaciones relativas a la alimentación eléctrica externa que figuran en el manual de sistema ( <a href="http://support.automation.siemens.com/WW/view/en/109477185">http://support.automation.siemens.com/WW/view/en/109477185</a> )
IT	 <b>PERICOLO</b>	Osservare le avvertenze sull'alimentazione in tensione continua a cura del cliente riportate nel Manuale di sistema ( <a href="http://support.automation.siemens.com/WW/view/en/109477185">http://support.automation.siemens.com/WW/view/en/109477185</a> )
PT	 <b>PERIGO</b>	Respeite as indicações a respeito da alimentação de tensão contínua junto do cliente no manual do sistema ( <a href="http://support.automation.siemens.com/WW/view/en/109477185">http://support.automation.siemens.com/WW/view/en/109477185</a> )
TR	 <b>TEHLİKE</b>	Lütfen sistem el kitabı içinde yapı tarafında doğru gerilim beslemesiyle ilgili bilgilere dikkat ediniz ( <a href="http://support.automation.siemens.com/WW/view/en/109477185">http://support.automation.siemens.com/WW/view/en/109477185</a> )
РУ	 <b>ОПАСНОСТЬ</b>	Соблюдайте указания по обеспечению питания постоянным током со стороны заказчика, приведенные в справочнике по системе ( <a href="http://support.automation.siemens.com/WW/view/en/109477185">http://support.automation.siemens.com/WW/view/en/109477185</a> )
中文	 <b>危险</b>	请遵守系统手册中关于客户提供的直流电源的相关提示 ( <a href="http://support.automation.siemens.com/WW/view/en/109477185">http://support.automation.siemens.com/WW/view/en/109477185</a> )

DE	<b>Verdrahtungshinweise</b>	ES	<b>Notas de cableado</b>	TR	<b>Kablaj bilgileri</b>
EN	<b>Wiring notes</b>	IT	<b>Avvertenze di cablaggio</b>	РУ	<b>Указания по монтажу</b>
FR	<b>Remarques de raccordement</b>	PT	<b>Indicações sobre cablagem</b>	中文	<b>布口口明</b>

DE	<b>ACHTUNG</b>	<b>Sachschaden</b> Verwenden Sie nur Kabel mit einem Temperaturbereich $\geq 85^{\circ}\text{C}$
EN	<b>CAUTION</b>	<b>Material damage</b> Use only cables with a temperature range $\geq 85^{\circ}\text{C}$ .
FR	<b>ATTENTION</b>	<b>Domages matériels</b> Utilisez uniquement un câble ayant une plage de température $\geq 85^{\circ}\text{C}$
ES	<b>ATENCIÓN</b>	<b>Daños materiales</b> Utilice únicamente cables con un rango de temperatura $\geq 85^{\circ}\text{C}$
IT	<b>ATTENZIONE</b>	<b>Danni materiali</b> Utilizzare solo cavi con un campo di temperatura $\geq 85^{\circ}\text{C}$
PT	<b>ATENÇÃO</b>	<b>Danos materiais</b> Utilize apenas cabos com uma gama de temperaturas $\geq 85^{\circ}\text{C}$
TR	<b>DİKKAT</b>	<b>Maddi hasar</b> Sadece $\geq 85^{\circ}\text{C}$ sıcaklık aralığına sahip kablolar kullanınız
РУ	<b>ВНИМАНИЕ</b>	<b>Материальный ущерб</b> Использовать только кабели, предусмотренные для эксплуатации при температуре окружающей среды $\geq 85^{\circ}\text{C}$
中文	<b>注意</b>	<b>财物损失</b> 只能使用额定温度范围 $\geq 85^{\circ}\text{C}$ 的电缆

	X3	X4	X6	Relay X11, X12, X13	CAN X11	CAN X16
<b>Connector</b>	WAGO 721-103/026-045	PHOENIX 1792757	PHOENIX 1792799	PHOENIX 1757022	PHOENIX 1803594	PHOENIX 1803581
	SZS 0,6x3,5	SZS 0,6x3,5	SZS 0,6x3,5	SZS 0,6x3,5	SZS 0,4x2,5	SZS 0,4x2,5
	1x1,5 - 2,5mm <sup>2</sup>	1x0,2 - 2,5mm <sup>2</sup>	1x0,2 - 2,5mm <sup>2</sup>	1x0,2 - 2,5mm <sup>2</sup>	1x0,14 - 1,5mm <sup>2</sup>	1x0,14 - 1,5mm <sup>2</sup>
	1x1,5 - 2,5mm <sup>2</sup>	1x0,2 - 2,5mm <sup>2</sup>	1x0,2 - 2,5mm <sup>2</sup>	1x0,2 - 2,5mm <sup>2</sup>	1x0,14 - 1,5mm <sup>2</sup>	1x0,14 - 1,5mm <sup>2</sup>
<b>AWG</b>	15 - 12	30 - 12	30 - 12	30 - 12	30 - 14	30 - 14
<b>Nm</b>	-	0,5 - 0,6	0,5 - 0,6	0,5 - 0,6	0,22 - 0,25	0,22 - 0,25
	8 - 9mm	7mm	7mm	7mm	7mm	7mm
	L < 30m	L < 30m	-	L > 30m	L > 30m	L > 30m

DE	VORSICHT	<p>Eine Lernfahrt kann auf zwei unterschiedliche Arten durchgeführt werden. Beachten Sie deshalb vor dem Start einer Lernfahrt die folgenden Hinweise:</p> <ul style="list-style-type: none"> <li>• <b>Lernfahrt beim Anlegen der Netzspannung (Urlernfahrt):</b> Die aktuellen Parameter werden durch die Werksparameter (Seite 21) überschrieben, wenn direkt beim Anlegen der Netzspannung der Lernfahrttaster (S401) betätigt wird. Die Durchführung Lernfahrt beim Anlegen der Netzspannung ist im Nachfolgenden beschrieben.</li> <li>• <b>Lernfahrt im laufenden Betrieb:</b> Wird im laufenden Betrieb der Lernfahrttaster betätigt, wird nur eine Türweiten- und Masseermittlung durchgeführt. Informationen zur Durchführung einer Lernfahrt im laufenden Betrieb finden Sie auf Seite 18</li> </ul>
EN	CAUTION	<p>A learn run can be performed in two different ways. Please therefore note the following before starting a learn run:</p> <ul style="list-style-type: none"> <li>• <b>Learn run when the line voltage is applied (initial learn run):</b> All currently set parameters are reset to their factory defaults (Page 21) if the learn run button (S401) is pressed at the same time as the line voltage is applied. The procedure for the learn run sequence when the line voltage is applied is described below.</li> <li>• <b>Learn run during operation:</b> If the learn run button is pressed during operation, only the door width and weight are determined. You can find more information about performing a learn run during operation on page 18.</li> </ul>
FR	PRUDENCE	<p>Une course d'apprentissage peut être exécutée de deux manières. Tenir compte de la remarque suivante avant de démarrer la course d'apprentissage :</p> <ul style="list-style-type: none"> <li>• <b>Course d'apprentissage à l'application de la tension réseau (course d'apprentissage d'origine) :</b> Les paramètres actuels sont écrasés avec les paramètres d'usine (page 21) lorsque la touche de course d'apprentissage (S401) est actionnée à la mise sous tension. La course d'apprentissage à l'application de la tension réseau est décrite plus loin.</li> <li>• <b>Course d'apprentissage en cours de fonctionnement :</b> Si le bouton de course d'apprentissage est activé en cours de fonctionnement, seules la largeur et la masse de la porte sont déterminées. Informations pour exécution d'une course d'apprentissage en service, voir page 18.</li> </ul>
ES	PRECAUCIÓN	<p>Un movimiento de aprendizaje puede ejecutarse de dos formas diferentes. Por esta razón, antes de iniciar un movimiento de aprendizaje respete las siguientes instrucciones:</p> <ul style="list-style-type: none"> <li>• <b>Movimiento de aprendizaje al aplicar la tensión de red (movimiento de aprendizaje inicial):</b> los parámetros actuales son sobrescritos con los ajustes de fábrica (pág. 21) si al aplicar la tensión de red se aprieta directamente la tecla de movimiento de aprendizaje (S401). La forma de ejecutar el movimiento de aprendizaje (S401) al aplicar la tensión de red se describe seguidamente.</li> <li>• <b>Marcha de aprendizaje durante la operación normal:</b> Si el pulsador de marcha de aprendizaje se aprieta durante la operación normal, entonces solo se determinan las aberturas de las puertas y las masas de la mismas. información relativa a la ejecución del movimiento de aprendizaje figura en la pág. 18.</li> </ul>
IT	CAUTELA	<p>L'esecuzione di un movimento di apprendimento può avvenire in due modi diversi. Prima dell'avvio di un movimento di apprendimento osservare le seguenti avvertenze:</p> <ul style="list-style-type: none"> <li>• <b>Movimento di apprendimento all'applicazione della tensione di rete (primo movimento di apprendimento):</b> I parametri attuali vengono sovrascritti dai parametri di fabbrica (pag. 21), se applicando la tensione di rete si aziona contemporaneamente il tasto del movimento di apprendimento (S401). L'esecuzione del movimento di apprendimento all'applicazione della tensione di rete è descritta di seguito.</li> <li>• <b>Movimento di apprendimento durante l'esercizio:</b> Se si aziona il tasto del movimento di apprendimento durante l'esercizio, vengono solo determinate la massa e l'ampiezza della porta. Per informazioni sull'esecuzione di un movimento di apprendimento durante l'esercizio vedere a pag. 18.</li> </ul>
PT	CUIDADO	<p>É possível efetuar uma viagem de programação de duas formas diferentes. Assim, observe as seguintes indicações antes do início da viagem de programação:</p> <ul style="list-style-type: none"> <li>• <b>Viagem de programação ao criar a tensão de rede (primeira viagem de programação):</b> Os parâmetros atuais são substituídos pelos parâmetros de fábrica (página 21) se o botão de viagem de programação (S401) for acionado logo após a criação da tensão de rede. A seguir é descrita a realização da viagem de programação ao criar a tensão de rede.</li> <li>• <b>Viagem de programação durante o funcionamento:</b> Se o botão de viagem de programação for acionado durante o funcionamento, só é efetuada uma determinação da amplitude da porta e de medidas. Pode encontrar informações sobre a realização de uma viagem de programação durante o funcionamento na página 18.</li> </ul>
TR	ÖNEMLİ DİKKAT	<p>Bir öğrenme hareketi iki farklı türde uygulanabilir. Bu nedenle, bir öğrenme hareketini başlatmadan önce aşağıdaki bilgilere dikkat edin:</p> <ul style="list-style-type: none"> <li>• <b>Şebeke gerilimi verilirken uygulanan öğrenme hareketi (ilk öğrenme hareketi):</b> Şebeke gerilimi verilirken direkt olarak öğrenme hareketi tuşuna (S401) basılırsa, fabrika parametreleri (Sayfa 21) güncel parametrelerin üzerine yazılır. Şebeke gerilimi verilirken öğrenme hareketinin uygulanması aşağıda açıklanmıştır.</li> <li>• <b>İşletme devam ederken uygulanan öğrenme hareketi:</b> İşletme devam ederken öğrenme hareketi tuşuna basılırsa, kapı genişliği ve ağırlık tespiti gerçekleştirilir. İşletme devam ederken bir öğrenme hareketinin uygulanması hakkındaki bilgileri 18. sayfada bulabilirsiniz.</li> </ul>
РУ	ОСТОРОЖНО	<p>Учебная эксплуатация выполняется двумя разными способами. В связи с этим перед началом учебной эксплуатации учтите следующие указания:</p> <ul style="list-style-type: none"> <li>• <b>Учебная эксплуатация при подаче сетевого напряжения (первоначальная учебная эксплуатация):</b> Текущие параметры переписываются заводскими данными (страница 21), если непосредственно при подаче сетевого напряжения нажимается кнопка учебной эксплуатации (S401). Ниже приводится описание проведения учебной эксплуатации при подаче сетевого напряжения.</li> <li>• <b>Учебная эксплуатация во время текущей эксплуатации:</b> Если во время текущей эксплуатации нажимается кнопка учебной эксплуатации, проводится определение ширины двери и массы. Информация касательно учебной эксплуатации во время текущей эксплуатации приведена на странице 18.</li> </ul>
中文	小心	<p>可通过两种方式执行学习运行。请在开始学习运行前注意以下提示:</p> <ul style="list-style-type: none"> <li>• <b>接通电源后开始学习运行 (原始学习运行):</b> 如果在接通电源后直接按动试运行按钮 (S401), 当前参数将被出厂设置覆盖 (第 21 页) 以下文字描述了接通电源后开始的学习运行。</li> <li>• <b>运行期间的学习运行:</b> 如在运行期间按动学习运行按键, 那么将只执行门宽确定和规格确定。相关信息第 18 页对运行期间的学习运行进行了描述。</li> </ul>

DE	 <b>WARNUNG</b>	<p><b>Verletzungsgefahr durch bewegliche mechanische Teile während der Lernfahrt</b></p> <ul style="list-style-type: none"> <li>• Stellen Sie sicher, dass die Tür in Position ZU ist.</li> <li>• Stellen Sie sicher, dass während der Lernfahrt der Fahrbereich 15 bis 25 cm aus der Position ZU frei ist.</li> <li>• Während der Lernfahrt muss die Motortemperatur über 0 °C liegen, da sonst der Wert der Türmasse falsch ermittelt wird und sich die Schließgeschwindigkeit im unerlaubten Bereich befinden könnte.</li> <li>• Nach Abschluss der Lernfahrt wird ein möglicherweise anliegender Fahrbefehl sofort ausgeführt.</li> </ul>
EN	 <b>WARNING</b>	<p><b>Risk of injury from moving mechanical parts during the learn run</b></p> <ul style="list-style-type: none"> <li>• Ensure that the door is in the CLOSED position.</li> <li>• Ensure that 15 to 25 cm of the door's range of motion from the CLOSED position are unobstructed during the learn run.</li> <li>• The motor temperature must not be below 0 °C during the learn run, as otherwise the weight of the door will be incorrectly determined, and the closing speed may lie in an impermissible range.</li> <li>• After completion of the learn run, any pending door command is executed immediately.</li> </ul>
FR	 <b>ATTENTION</b>	<p><b>Risque de blessure en raison de pièces en mouvement pendant la course d'apprentissage</b></p> <ul style="list-style-type: none"> <li>• Vérifiez que la porte est en position FERMÉE.</li> <li>• Vérifiez qu'une zone de 15 à 25 cm est libre depuis la position FERMÉE pendant la course d'apprentissage.</li> <li>• La température de moteur ne doit pas être inférieure à 0 °C lors de la course d'apprentissage des paramètres. Cela risquerait de fausser la détermination de la masse de la porte, et la vitesse de fermeture pourraient se situer dans une plage non admissible.</li> <li>• Tout ordre de déplacement présent à la fin de la course d'apprentissage sera immédiatement exécuté..</li> </ul>
ES	 <b>ADVERTENCIA</b>	<p><b>Peligro de lesiones debido a piezas mecánicas en movimiento durante el movimiento de aprendizaje</b></p> <ul style="list-style-type: none"> <li>• Asegúrese de que la puerta esté en la posición CERRADA.</li> <li>• Asegúrese de que durante la marcha de aprendizaje esté libre un tramo de 15 a 25 cm a partir de la posición CERRADA.</li> <li>• Durante el movimiento de aprendizaje no debe ser inferior a 0 °C la temperatura del motor, ya que si no se calcula mal la masa de la puerta, lo que puede provocar una velocidad de cierre superior a la permitida.</li> <li>• Tras finalizar la marcha de aprendizaje se ejecuta inmediatamente, de estar presente, un comando de cierre.</li> </ul>
IT	 <b>AVVERTENZA</b>	<p><b>Pericolo di lesioni a causa di parti meccaniche in movimento durante il movimento di apprendimento</b></p> <ul style="list-style-type: none"> <li>• Assicurarsi che la porta sia in posizione CHIUSA.</li> <li>• Assicurarsi che durante il movimento di apprendimento il campo di spostamento sia libero da 15 a 25 cm dalla posizione CHIUSA.</li> <li>• Durante il movimento di apprendimento la temperatura del motore non deve essere sotto 0 °C, altrimenti ne risulta un valore errato della massa della porta e la velocità di chiusura può essere in un campo non consentito.</li> <li>• Alla conclusione del movimento di apprendimento, un comando eventualmente presente viene subito eseguito.</li> </ul>
PT	 <b>AVISO</b>	<p><b>Perigo de ferimentos por peças mecânicas móveis durante a viagem de programação</b></p> <ul style="list-style-type: none"> <li>• Certifique-se de que a porta se encontra na posição FECHADO.</li> <li>• Certifique-se de que, durante a viagem de programação, a área de deslocamento se encontra 15 a 25 cm fora da posição FECHADO.</li> <li>• Durante a viagem de programação, a temperatura do motor não pode ser inferior a 0 °C, caso contrário é determinado um valor errado das dimensões da porta e a velocidade de fechamento pode situar-se em um intervalo não permitido.</li> <li>• Após a conclusão da viagem de programação, é executado imediatamente um comando de deslocação potencialmente adjacente.</li> </ul>
TR	 <b>İKAZ</b>	<p><b>Öğrenme hareketi sırasındaki hareketli mekanik parçalar nedeniyle yaralanma tehlikesi</b></p> <ul style="list-style-type: none"> <li>• Kapının KAPALI pozisyonunda olduğundan emin olun.</li> <li>• Öğrenme sürüşü sırasında KAPALI pozisyonundan başlayan harekette 15 ila 25 cm arasındaki hareket alanının serbest olmasını sağlayın.</li> <li>• Motor sıcaklığı öğrenme sürüşü sırasında 0 °C'nin altında olmamalıdır, aksi takdirde kapı ağırlığı yanlış tespit edilir ve kapatma hızı izin verilmeden aralıktaki olabilir.</li> <li>• Öğrenme sürüşü tamamlandıktan sonra olası bir hareket komutu derhal gerçekleştirilir.</li> </ul>
PY	 <b>Предупреждение</b>	<p><b>Опасность получения травмы из-за подвижных частей во время учебной эксплуатации</b></p> <ul style="list-style-type: none"> <li>• Убедитесь в том, что дверь находится в позиции Закрыто.</li> <li>• Обеспечьте, чтобы во время учебной эксплуатации был свободен диапазон движения от 15 до 25 см из позиции Закрыто.</li> <li>• Во время учебной эксплуатации температура двигателя не должна быть ниже 0 °C, так как в противном случае масса двери определяется не верно и скорость закрывания может находиться в неразрешенном диапазоне.</li> <li>• После завершения учебной эксплуатации может немедленно выполняться другая команда, если она дана.</li> </ul>
中文	 <b>警告</b>	<p><b>在学习运行过程中，可以移动的机械部件可能导致人员受伤</b></p> <ul style="list-style-type: none"> <li>• 请确认门位于“关闭”位置。</li> <li>• 请确认在进行学习运行时，从“关闭”位置开始的 15 至 25 cm 移动范围内无障碍物。</li> <li>• 学习运行时电机温度不得低于 0 °C，否则无法确定门的正确尺寸，关闭速度也可能处于禁止范围内。</li> <li>• 学习运行结束后将执行等待处理（如果存在）的移动指令。</li> </ul>

①

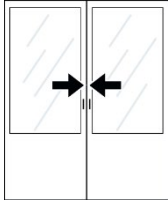

②

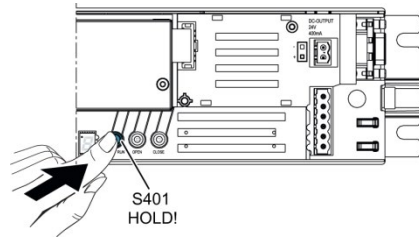

③

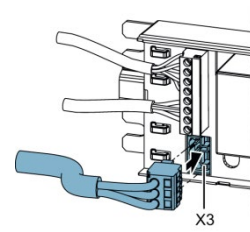

④

DE	Start Lernfahrt	ES	Start Lernfahrt	TR	Start Lernfahrt
EN	Start Lernfahrt	IT	Start Lernfahrt	PY	Start Lernfahrt
FR	Start Lernfahrt	PT	Start Lernfahrt	中文	Start Lernfahrt

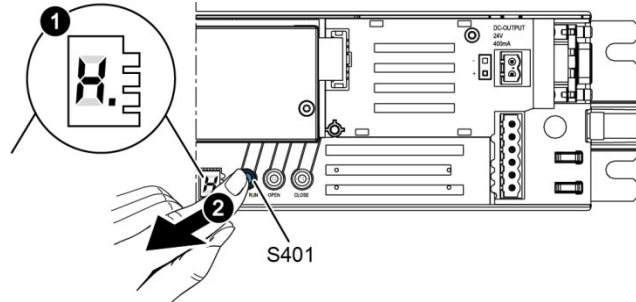

DE	<p><b>Ablauf Lernfahrt</b> Die Tür öffnet und schließt 1- bis 2-mal, ca. 10 cm weit mit verminderter Geschwindigkeit. Anschließend folgt ein zweimaliges Öffnen und Schließen der Tür (2 vollständige Fahrten). Die erste Fahrt erfolgt mit verminderter Geschwindigkeit zur Ermittlung der Türweite, die zweite Fahrt erfolgt mit bis zu 700 mm/s zur Ermittlung der Türmasse. Am Ende der Lernfahrt befindet sich die Tür in der Position ZU. In der Position ZU werden die ermittelten Türparameter abgespeichert. Die Betätigung eines Tasters (S401, S402, S403) während einer Lernfahrt bricht die Lernfahrt ab.</p>
EN	<p><b>Structure of learn run</b> The door opens and closes approximately 10 cm 1 to 2 times at reduced speed. The door then opens and closes completely twice (2 complete cycles). The first cycle is at reduced speed to establish the door width, the second cycle is performed at up to 700 mm/s to determine the door weight. At the end of the learn run, the door is in the CLOSED position. The determined door parameters are saved when the door is in the CLOSED position. Pressing one of the service buttons (S401, S402, S403) during the learn run results in it being cancelled.</p>
FR	<p><b>Déroulement de la marche d'apprentissage</b> La porte se ferme et s'ouvre 1 à 2 fois d'environ 10 cm à vitesse réduite. Ensuite, la porte effectue 2 courses (complètes) d'ouverture et de fermeture. La première course s'effectue à vitesse réduite pour déterminer la largeur de porte, et la deuxième s'effectue à une vitesse jusqu'à 700 mm/s pour déterminer la masse de la porte. A la fin de la course d'apprentissage, la porte se trouve en position FERMÉE. En position FERMÉE, les paramètres de porte déterminés sont enregistrés. L'actionnement d'un bouton (S401, S402, S403) pendant une course d'apprentissage a pour effet d'interrompre cette dernière.</p>
ES	<p><b>Secuencia de movimientos durante el aprendizaje</b> La puerta se abre y se cierra a velocidad lenta 1 o 2 veces recorriendo aprox. 10 cm. A continuación tiene lugar una segunda apertura y cierre de la puerta (2 recorridos completos). El primer recorrido se realiza a velocidad lenta para determinar el ancho de la puerta; el segundo recorrido se realiza a 700 mm/s como máximo para determinar la masa de la puerta. Al final del recorrido de aprendizaje la puerta se encuentra en la posición CERRADA. En la posición CERRADA se guardan los parámetros de puerta que se han determinado. Al accionar un pulsador (S401, S402, S403) durante un aprendizaje se interrumpe el recorrido de aprendizaje.</p>
IT	<p><b>Sequenza del movimento di apprendimento</b> La porta si apre e si chiude 1 o 2 volte, per ca. 10 cm a velocità ridotta. Segue poi una doppia sequenza di apertura e chiusura della porta (2 movimenti completi). Il primo movimento avviene a velocità ridotta per determinare l'apertura della porta, il secondo movimento avviene con fino a 700 mm/s per determinare la massa della porta. Alla fine del movimento di apprendimento la porta si trova nella posizione CHIUSA. Nella posizione CHIUSA vengono salvati i parametri della porta determinati. L'azionamento di un tasto (S401, S402, S403) durante un movimento di apprendimento interrompe il movimento stesso.</p>
PT	<p><b>Decurso da viagem de programação</b> A porta abre e fecha 1 a 2 vezes, aprox. 10 cm com uma velocidade reduzida. Em seguida, há duas aberturas e fechamentos da porta (2 viagens completas). A primeira viagem é realizada com uma velocidade reduzida para determinar a largura da porta, a segunda viagem é realizada a até 700 mm/s para determinar a massa da porta. No final da viagem de programação a porta encontra-se na posição FECHADO. Na posição FECHADO, os parâmetros da porta determinados são armazenados. A viagem de programação é cancelada através do acionamento de uma tecla (S401, S402, S403) durante a mesma.</p>
TR	<p><b>Öğrenme sürüşü</b> Kapi daha yavaş bir hızda olmak üzere 1 - 2 kez yakl. 10 cm açılır ve kapanır. Ardından kapi iki kez açılır ve kapanır (2 tam sürüş). Birinci sürüş kapi genişliğini tespit etmek üzere daha düşük hızda; ikinci sürüş ise kapi kütleini tespit etmek üzere 700 mm/s'ye kadar bir hızda gerçekleşir. Öğrenme sürüşünün sonunda kapi KAPALI pozisyonunda bulunur. KAPALI pozisyonunda kapi parametreleri hafızalanır. Öğrenme sürüşü esnasında bir tuşa (S401, S402, S403) basılması durumunda öğrenme sürüşü iptal edilir.</p>
PY	<p><b>Ход учебной эксплуатации</b> Дверь открывается и закрывается 1-2 раза, на ширину ок. 10 см на уменьшенной скорости. Затем следует двукратное открывание и закрывание двери (2 полных движения). Первое движение выполняется на уменьшенной скорости для выяснения ширины двери, вторая поездка выполняется на скорости до 700 мм/с для выяснения массы двери. В конце учебной эксплуатации дверь находится в позиции ЗАКРЫТО. В позиции ЗАКРЫТО полученные параметры двери сохраняются. Нажатие кнопки (S401, S402, S403) во время учебной эксплуатации отменяет учебную эксплуатацию.</p>
中文	<p><b>试运行过程</b> 门开关 1 至 2 次，缓慢运行大约 10 cm。之后门会打开和关闭两次（2 次完整运行）。电梯门将以缓慢的速度进行第一次运行以获取门的宽度，第二次运行的速度将达到 700 mm/s 以获取门的质量。试运行结束后门将处于“关闭”位置。在“关闭”位置存储门参数。在试运行期间按下按钮 S401、S402 或 S403 将使试运行结束。</p>

⑧

DE	Lernfahrt erfolgreich abgeschlossen
EN	Learn run successfully completed
FR	Course d'apprentissage terminée avec succès
ES	Movimiento de aprendizaje terminado correctamente
IT	Movimento di apprendimento concluso correttamente
PT	Viagem de programação concluída com sucesso
TR	Öğrenme sürüşü başarıyla tamamlandı
PY	Обучение успешно завершено
中文	学习运行成功结束

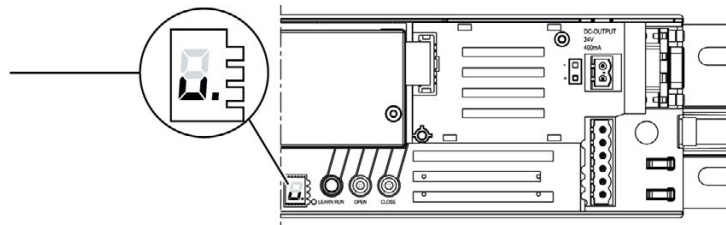

9

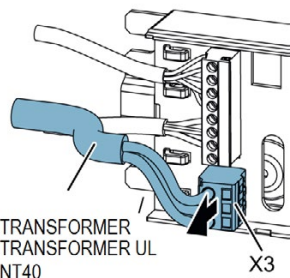

SIDOOR TRANSFORMER  
SIDOOR TRANSFORMER UL  
SIDOOR NT40

10

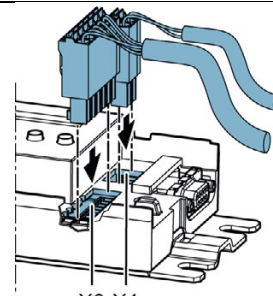

X6 X4

DE	Versorgung intern (24 V)	
EN	Internal supply (24 V)	
FR	Alimentation interne (24 V)	
ES	Alimentación interna (24 V)	
IT	Alimentazione interna (24 V)	
PT	Alimentação interna (24 V)	
TR	Dahili besleme (24 V)	
PY	Питание внутреннее (24 В)	
中文	内部电源 (24 V)	

DE	Versorgung extern	
EN	External supply	
FR	Alimentation externe	
ES	Alimentación externa	
IT	Alimentazione esterna	
PT	Alimentação externa	
TR	Harici besleme	
PY	Питание внешнее	
中文	外部电源	

DE	<b>HINWEIS</b>	X4 darf nicht an fremdes Spannungspotential gelegt werden.
EN	<b>NOTE</b>	X4 must not be connected to an external voltage supply.
FR	<b>REMARQUE</b>	Ne pas raccorder X4 à une source de tension externe.
ES	<b>NOTA</b>	En X4 no debe aplicarse una tensión eléctrica externa.
IT	<b>NOTA</b>	Non collegare X4 a un potenziale di tensione esterno al sistema.
PT	<b>INDICAÇÃO</b>	X4 não pode ser colocado em um potencial de tensão externo
TR	<b>NOT</b>	X4'ün yabancı gerilim potansiyeline bağlanması yasaktır.
PY	<b>УКАЗАНИЕ</b>	X4 нельзя укладывать на сторонний потенциал напряжения.
中文	<b>说明</b>	不得将 X4 与外部电势相接。

DE		Lichtschanke, Door Closed Position Sensor (DCPS) oder inaktiv.
EN		Light barrier, door closed position sensor (DCPS) or inactive.
FR		Barrière photoélectrique, Door Closed Position Sensor (DCPS) ou inactif.
ES		Barrera fotoeléctrica, sensor de posición de puerta cerrada (DCPS) o inactividad.
IT		Barriera fotoelettrica, sensore di posizione porta chiusa (DCPS) o inattivo.
PT		Barreira de luz, Door Closed Position Sensor (DCPS) ou inativo.
TR		Fotosel, Door Closed Position Sensor (DCPS) veya aktif değil.
PY		Фотоэлектрический барьер, датчик закрытого положения двери (DCPS) или не активно.
中文		光栅, 关门位置传感器 (DCPS) 或处于未激活状态。

LIGHT BARRIER / DCPS LICHTSCHRANKE / DCPS		NUDGING DRÄNGELN		CLOSE ZU		OPEN AUF	
DE	Lichtschanke oder Door Closed Position Sensor (DCPS)	DE	Drängeln (ZU- und Drängel-Befehl gleichzeitig aufschalten (nur in Schließrichtung wirksam))	DE	TÜR-ZU	DE	TÜR-AUF
EN	Light barrier or Door Closed Position Sensor (DCPS)	EN	Nudge (simultaneous activation of the CLOSE and Nudge commands (effective only in the closing direction))	EN	DOOR CLOSE	EN	DOOR OPEN
FR	Barrière photoélectrique ou Door Closed Position Sensor (DCPS)	FR	Forçage (connecter ensemble la commande FERMETURE et la commande forçage ; ceci est uniquement actif dans le sens de fermeture)	FR	OUVRIRE PORTE	FR	FERMER PORTE
ES	Barrera fotoeléctrica o sensor de posición de puerta cerrada (DCPS)	ES	Cierre lento forzado (aplicar simultáneamente comandos CERRAR y Cierre lento forzado (solo actúa en sentido de cierre))	ES	CERR PUERTA	ES	ABR PUERTA
IT	Barriera fotoelettrica o sensore di posizione porta CHIUSA (DCPS)	IT	Chiusura forzata (inserire contemporaneamente i comandi CHIUSURA e Chiusura forzata (attivi solo in direzione di chiusura))	IT	PORTA CHIUSA	IT	PORTA APERTA
PT	Barreira de luz ou Door Closed Position Sensor (DCPS)	PT	Avanço (comandos de avanço e FECHADO devem ser conectados simultaneamente (só tem efeito no sentido de fechamento))	PT	PORTA-FECHADA	PT	PORTA-ABERTA
TR	Fotosel veya Door Closed Position Sensor (DCPS)	TR	Sıkışma (KAPALI ve sıkışma komutunun aynı anda anahtarılanması (sadece kapatma yönünde etkilidir))	TR	KAPİYİ KAPAT	TR	KAPİYİ AÇ
PY	Фотоэлектрический барьер или датчик закрытого положения двери (DCPS)	PY	Толкание (команда Закрыть и толкание выключить одновременно (работает только в направлении закрытия))	PY	ДВЕРЬ ЗАКРЫТА	PY	ДВЕРЬ ОТКРЫТА
中文	光栅或关门位置传感器(DCPS)	中文	强制关闭 (“关闭”和“强制关闭”命令同时发出(仅在关门方向有效))	中文	门闭合	中文	门打开

11

DE	HINWEIS	<b>DCPS aktiviert:</b> Nach Anlegen der Netzspannung kann die Tür sofort mit Normalgeschwindigkeit fahren, wenn die Tür in Position ZU ist und der DCPS geschlossen ist.
EN	NOTE	<b>DCPS active:</b> The door can travel at normal speed immediately after the supply voltage has been applied if the door is in the CLOSED position and the DCPS is closed.
FR	REMARQUE	<b>DCPS activado:</b> Tras aplicar la tensión de red la puerta puede moverse inmediatamente con su velocidad normal si la puerta está en posición CERRADA y el sensor DCPS está cerrado.
ES	NOTA	<b>DCPS activado:</b> Tras aplicar la tensión de red la puerta puede moverse inmediatamente con su velocidad normal si la puerta está en posición CERRADA y el sensor DCPS está cerrado.
IT	NOTA	<b>DCPS attivato:</b> Dopo l'applicazione della tensione di rete la porta può muoversi subito a velocità normale, se la porta è in posizione CHIUSA e il DCPS è chiuso.
PT	INDICAÇÃO	<b>DCPS ativo:</b> Após a criação da tensão de rede a porta pode deslocar-se de imediato à velocidade normal se a porta estiver na posição FECHADO e o DCPS estiver fechada.
TR	NOT	<b>DCPS devreye sokuldu:</b> Şebeke gerilimi verildikten sonra, kapı KAPALI pozisyonundayken ve DCPS kapalı ise, kapı hemen normal hızla hareket ettirilebilir.
PY	УКАЗАНИЕ	<b>DCPS активирован:</b> После подачи сетевого напряжения движение двери возможно сразу с нормальной скоростью, если дверь находится в позиции Закрыто, а датчик закрытого положения двери (DCPS) закрыт.
中文	说明	<b>DCPS 已激活:</b> 接通电源后, 当门处于“关闭”位置并且已连接 DCPS 时, 门可立即以正常速度运行

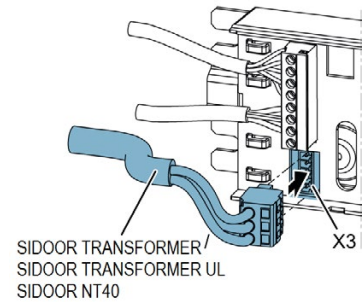









12

DE	<ul style="list-style-type: none"> <li>• Lichtschanke / DCPS einstellen (Seite 19)</li> <li>• Aktivierung CAN-Schnittstelle (AT40 CAN) (Seite 19)</li> </ul>	ES	<ul style="list-style-type: none"> <li>• Ajuste de barrera fotoeléctrica/ DCPS (pág. 19)</li> <li>• Activación de la interfaz CAN (AT40 CAN) (pág. 19)</li> </ul>	TR	<ul style="list-style-type: none"> <li>• Fotoselin / DCPS'in ayarlanması (Sayfa 19)</li> <li>• CAN arayüzünün aktifleştirilmesi (AT40 CAN) (Sayfa 19)</li> </ul>
EN	<ul style="list-style-type: none"> <li>• Set light barrier / DCPS (page 19)</li> <li>• Activate CAN interface (AT40 CAN) (page 19)</li> </ul>	IT	<ul style="list-style-type: none"> <li>• Barriera fotoelettrica / regolazione del sensore DCPS (pag. 19)</li> <li>• Attivazione dell'interfaccia CAN (AT40 CAN) (pag. 19)</li> </ul>	PY	<ul style="list-style-type: none"> <li>• Настройка фотоэлектрического барьера / DCPS (страница 19)</li> <li>• Активирование интерфейса CAN (AT40 CAN) (страница 19)</li> </ul>
FR	<ul style="list-style-type: none"> <li>• Réglage de la barrière photoélectrique/du DCPS (page 19)</li> <li>• Activation de l'interface CAN (page 19)</li> </ul>	PT	<ul style="list-style-type: none"> <li>• Ajustar DCPS / barreira de luz (Página 19)</li> <li>• Ativação interface CAN (AT40 CAN) (Página 19)</li> </ul>	中文	<ul style="list-style-type: none"> <li>• 光栅 / 设置 DCPS (参见第 19 页)</li> <li>• 激活 CAN 接口 (AT40 CAN) (参见第 19 页)</li> </ul>

DE		<b>WARNUNG</b> Verletzungsgefahr durch bewegliche mechanische Teile Untersetzen oder Übersetzungen am Zahnriemen sind nicht erlaubt, da hierdurch die kinetische Energie der Aufzugtür bzw. die statischen Kräfte an der Aufzugtür verändert werden. Die Türweite ist dann nicht mehr gültig.
EN		<b>WARNING</b> Risk of injury from moving mechanical parts Gearing up or down is not allowed on the toothed belt because this would change the kinetic energy of the elevator door or the static forces on the elevator door. The door width would then no longer be valid.
FR		<b>ATTENTION</b> Risque de blessure en raison de pièces en mouvement Les démultiplications et surmultiplications ne sont pas autorisées au niveau de la courroie crantée, car cela modifierait l'énergie cinétique de la porte d'ascenseur et les forces statiques exercées au niveau de la porte. La valeur de largeur de porte ne serait alors plus valable.
ES		<b>ADVERTENCIA</b> Peligro de lesiones debido a piezas mecánicas en movimiento No se permite aumentar ni disminuir la relación de transmisión en los órganos que mueven la correa, ya ello modifica la energía cinética de la puerta y las fuerzas estáticas que actúan en ella. El ancho de apertura de la puerta ya no es entonces válido.
IT		<b>AVVERTENZA</b> Pericolo di lesione a causa di parti meccaniche in movimento Demoltiplicazioni o rapporti di trasmissione sulla cinghia dentata non sono consentiti, poiché modificherebbero le energie cinetiche o le forze statiche sulla porta dell'ascensore. L'ampiezza della porta non sarebbe più valida.
PT		<b>AVISO</b> Perigo de ferimentos devido a peças mecánicas móveis Não são permitidas desmultiplicações das correias dentadas, visto que isso alteraria as energias cinéticas ou forças estáticas na porta do elevador. A amplitude da porta deixa de ser válida.
TR		<b>İKAZ</b> Hareketli mekanik parçalar nedeniyle yaralanma tehlikesi Triger kayışlarında düşük ya da yüksek aktarımlara izin verilmemektedir, zira bu sayede asansör kapısının kinetik enerjisi veya asansör kapısındaki statik güçler değişir. Kapı genişliği bu durumda artık geçerli değildir.
PY		<b>Предупреждение</b> Опасность травмирования под воздействием подвижных механических частей преобразование с понижением или повышением на зубчатом ремне не разрешены, так как вследствие этого меняются кинетические энергии двери лифта или статические усилия на двери лифта. Ширина двери в этом случае больше не действует.
中文		<b>警告</b> 可移动机械部件可能导致受伤 齿形皮带不得出现减速或提速, 因为这两者可能导致电梯门的动能或静力发生改变。之后门宽将失效。



DE	 WARNUNG	<p><b>Verletzungsgefahr durch Überschreitung der Grenzwerte für Kräfte und Energien an der Tür</b> Prüfen Sie die zulässigen Kräfte und Energien nach Inbetriebnahme der Aufzugtür am Gesamtsystem (Aufzug) mit gekoppelter Schacht- und Kabinentür, an der schwersten Schachttür und passen Sie diese bei einer Überschreitung auf die Grenzwerte an. Beachten Sie dabei die folgenden Vorgaben:</p> <ul style="list-style-type: none"> <li>• Grenzwerte für die kinetische Energie (analog zur EN 81) Max. kinetische Energie der Aufzugtür in Schließrichtung: <math>\leq 10</math> Joule / bei abgeschalteter Reversiereinrichtung <math>\leq 4</math> Joule</li> <li>• Grenzwerte für die Schließ- und Klemmkkräfte (analog zur EN81) Max. statische Schließkraft: <math>\leq 150</math> N</li> <li>• Öffnungskraft bei Glastüren: <math>\leq 150</math> N</li> </ul>
EN	 WARNING	<p><b>Risk of injury from exceeded force and energy limit values on the door</b> After commissioning, check the forces and energies of the elevator door on the entire system (elevator) with landing door and cabin door coupled, and on the heaviest landing door, and adjust them if they exceed their limit values. Observe the following guidelines:</p> <ul style="list-style-type: none"> <li>• Limit values for kinetic energy (as in EN 81) Max. kinetic energy of the elevator door in the closing direction: <math>\leq 10</math> joules / <math>\leq 4</math> joules with reversing device disabled</li> <li>• Limit values for closing and clamping forces (as in EN81) Max. static closing force: <math>\leq 150</math> N</li> <li>• Opening force for glass doors: <math>\leq 150</math> N</li> </ul>
FR	 ATTENTION	<p><b>Risque de blessures par le dépassement des valeurs limites d'effort et d'énergie sur la porte.</b> Vérifiez les puissances et forces admissibles après la mise en service de la porte d'ascenseur sur le système entier (ascenseur) lorsque les portes de cage et de cabine sont couplées, au niveau de la porte de cage la plus lourde, et adaptez-les aux valeurs limites en cas de dépassement. Respectez les consignes suivantes :</p> <ul style="list-style-type: none"> <li>• Valeurs limites pour l'énergie cinétique (analogue à EN 81) Énergie cinétique maximale de la porte d'ascenseur dans le sens de fermeture : <math>\leq 10</math> Joule / <math>\leq 4</math> Joule lorsque le dispositif d'inversion est désactivé</li> <li>• Valeurs limites pour les efforts de fermeture et de pincement (analogue à EN81) Effort statique de fermeture max : <math>\leq 150</math> N</li> <li>• Force d'ouverture pour portes en verre : <math>\leq 150</math> N</li> </ul>
ES	 ADVERTENCIA	<p><b>Peligro de lesión debido a la superación de los límites de fuerzas y energías en la puerta</b> Una vez puesta en marcha la puerta del ascensor en el sistema global con puertas de cabina y rellano, compruebe las fuerzas y energías en la puerta de rellano asociada; si se superan los valores permitidos deberán reajustarse los límites. Preste atención a lo siguiente:</p> <ul style="list-style-type: none"> <li>• Límites de energía cinética (análogo a EN 81) Energía cinética máx. de la puerta del ascensor en sentido de cierre: <math>\leq 10</math> Joule / con dispositivo inversor de sentido desconectado <math>\leq 4</math> Joule</li> <li>• Límites de fuerzas de cierre y aprisionamiento (análogo a EN81) Fuerza estática de cierre máx.: <math>\leq 150</math> N</li> <li>• Fuerza de apertura para puertas de vidrio: <math>\leq 150</math> N</li> </ul>
IT	 AVVERTENZA	<p><b>Pericolo di lesioni a causa del superamento dei valori limite per forze ed energie esercitate sulla porta</b> Controllare dopo la messa in servizio della porta dell'ascensore le forze ed energie consentite nell'intero sistema (ascensore), con porte accoppiate di piano e di cabina, sulla porta di piano più pesante e adattarle ai valori limite in caso di superamento. Osservare le seguenti prescrizioni:</p> <ul style="list-style-type: none"> <li>• Valori limite per l'energia cinetica (analogamente a EN 81) Energia cinetica max. della porta dell'ascensore in direzione di chiusura: <math>\leq 10</math> Joule / <math>\leq 4</math> Joule con dispositivo di inversione disinserito</li> <li>• Valori limite per le forze di chiusura e blocco (analogamente a EN81) Forza di chiusura statica max.: <math>\leq 150</math> N</li> <li>• Forza di apertura con porte in vetro: <math>\leq 150</math> N</li> </ul>
PT	 AVISO	<p><b>Perigo de ferimentos devido a ultrapassagem dos valores limite para as forças e energias na porta</b> Verifique as forças e energias permitidas em todo o sistema (elevador) após a colocação em funcionamento da porta do elevador com porta de cabine e de patamar acopladas, na porta de patamar mais pesada adapte-as aos valores limite, no caso de ultrapassagem. Observe as seguintes indicações:</p> <ul style="list-style-type: none"> <li>• Valores limite para a energia cinética (analogamente à EN 81) Energia cinética máx. da porta do elevador no sentido do fechamento: <math>\leq 10</math> Joules / com dispositivo de reserva desligado <math>\leq 4</math> Joules</li> <li>• Valores limite para as forças de fechamento e aperto (analogamente à EN81) Força máxima estática de fechamento: <math>\leq 150</math> N</li> <li>• Forças de abertura em portas de vidro: <math>\leq 150</math> N</li> </ul>
TR	 İKAZ	<p><b>Kapıdaki kuvvet ve enerji limitlerinin aşılması nedeniyle yaralanma tehlikesi</b> İzin verilen güç ve enerjileri, asansör kapısı işletmeye alındıktan sonra kat ve kabin kapısı birbirine bağlantılı olan komple sistemdeki (asansör) en ağır kat kapısında kontrol edin ve değerlerin aşılması durumunda sınır değerlerle uyumlu hale getirin. Bunu yaparken aşağıdaki talimatları dikkate alın:</p> <ul style="list-style-type: none"> <li>• Kinetik enerji sınır değerleri (EN 81'e uygun) Maks. kinetik enerji, asansör kapısının kapatma yönünde: <math>\leq 10</math> Joule / ters hareket donanımı kapatılmış vaziyetteyken <math>\leq 4</math> Joule</li> <li>• Kapatma ve sıkma kuvvetleri için sınır değerler (EN81'ye uygun) Maks. statik kapatma kuvveti: <math>\leq 150</math> N</li> <li>• Cam kapıları açma gücü: <math>\leq 150</math> N</li> </ul>
RU	 Предупреждение	<p><b>Опасность получения травм в случае превышения предельных значений усилий и энергий</b> Проверить допустимые усилия и энергию после ввода в эксплуатацию двери лифта в общей системе (лифт) с соединенной дверью шахты и кабины, на самой тяжелой двери шахты и в случае превышения граничных показателей произвести соответствующие изменения. При этом соблюдайте следующие пункты:</p> <ul style="list-style-type: none"> <li>• граничные показатели для кинетической энергии (аналогично EN 81) Макс. кинетическая энергия двери лифта в направлении закрытия: <math>\leq 10</math> Джоуль / при выключенном направлении возврата <math>\leq 4</math> Джоуль</li> <li>• граничные показатели для усилий закрытия и сдавливания (аналогично EN81) Макс. статическое усилие закрытия: <math>\leq 150</math> Н</li> <li>• Усилие открывания при стеклянных дверях: <math>\leq 150</math> Н</li> </ul>
中文	 警告	<p><b>超过门可承受的力量和能量极值时可导致人员受伤</b> 电梯门调试过程结束后请对整个系统（耦合在一起的电梯内外门）以及最沉重的外门进行检查，看力量和能量是否处于允许范围内，如果超出该范围，则需调整为极限值。请遵守以下规定：</p> <ul style="list-style-type: none"> <li>• 动能极限值（参考 EN81） 电梯门在闭合方向上的最大动能为：<math>\leq 10</math> 焦耳 / 反转开启装置关闭时 <math>\leq 4</math> 焦耳</li> <li>• 闭合力和夹紧力的极限值（参考 EN81） 最大静态闭合力：<math>\leq 150</math> N</li> <li>• 玻璃门的打开力：<math>\leq 150</math> N</li> </ul>

DE	Lernfahrt (im laufenden Betrieb) ausführen	ES	Ejecutar (durante el funcionamiento normal) el movimiento de aprendizaje	TR	Öğrenme sürüşünü (işletim sırasında) gerçekleştir
EN	Conduct learn run (during operation)	IT	Eseguire un movimento di apprendimento (in esercizio)	PY	Выполнить включение для обучения (в текущем режиме)
FR	Exécuter une marche d'apprentissage (en service)	PT	Executar viagem de programação (durante o funcionamento)	中文	(在持续运行中) 执行学习运行

DE	⚠️ WARNUNG	Verletzungsgefahr durch bewegliche mechanische Teile Beachten Sie die Hinweise zur Lernfahrt ab Seite 12.
EN	⚠️ WARNING	Risk of injury from moving mechanical parts Observe the notes on the learn run, as from page 12.
FR	⚠️ ATTENTION	Risque de blessure en raison de pièces en mouvement Tenez compte des indications relatives à la course d'apprentissage à partir de la page 12.
ES	⚠️ ADVERTENCIA	Peligro de lesiones debido a piezas mecánicas en movimiento Respete las indicaciones sobre la marcha de aprendizaje en la pág. 12 y siguientes.
IT	⚠️ AVVERTENZA	Pericolo di lesione a causa di parti meccaniche in movimento Osservare le avvertenze sul movimento di apprendimento da pag. 12.
PT	⚠️ AVISO	Perigo de ferimentos devido a peças mecânicas móveis Observe as instruções relacionadas à viagem de programação a partir da página 12.
TR	⚠️ İKAZ	Hareketli mekanik parçalar nedeniyle yaralanma tehlikesi Öğrenme sürüşü ile ilgili olarak 12. sayfadan itibaren belirtilmiş olan uyarıları dikkate alın.
PY	⚠️ Предупреждение	Опасность травмирования под воздействием подвижных механических частей Учитывайте указания по учебной эксплуатации на стр. 12.
中文	⚠️ 警告	可移动机械部件可能导致受伤 请参见第 12 页起的学习运行提示。

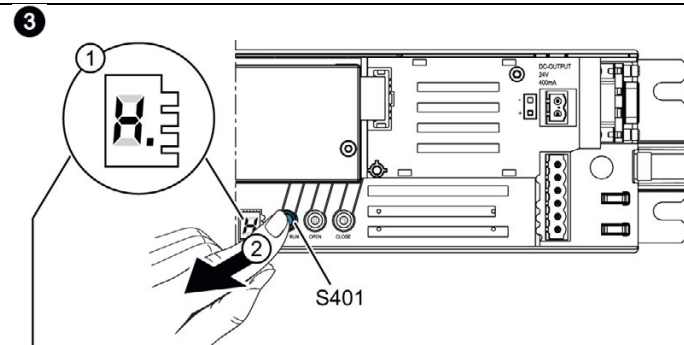
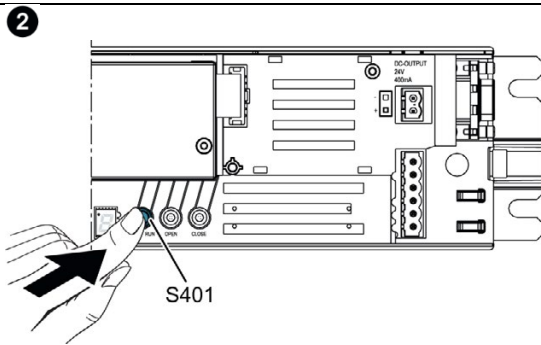
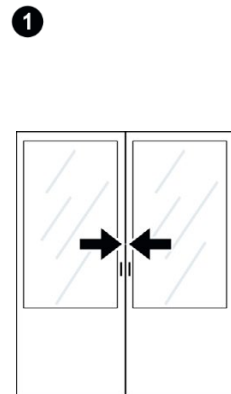

DE	Start Lernfahrt	ES	Start Lernfahrt	TR	Start Lernfahrt
EN	Start Lernfahrt	IT	Start Lernfahrt	PY	Start Lernfahrt
FR	Start Lernfahrt	PT	Start Lernfahrt	中文	Start Lernfahrt

DE	Lernfahrt erfolgreich abgeschlossen
EN	Learn run successfully completed
FR	Course d'apprentissage terminée avec succès
ES	Movimiento de aprendizaje terminado correctamente
IT	Movimento di apprendimento concluso correttamente
PT	Viagem de programação concluída com sucesso
TR	Öğrenme sürüşü başarıyla tamamlandı
PY	Обучение успешно завершено
中文	学习运行成功结束

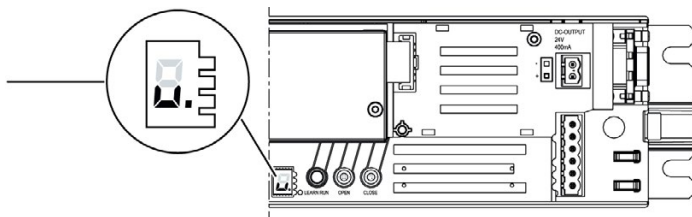

DE	Die max. Schließgeschwindigkeit und die Drängelgeschwindigkeit werden in Abhängigkeit der ermittelten Masse begrenzt.
EN	The maximum closing speed and the nudge speed are limited as a function of the determined weight.
FR	La vitesse de fermeture maximale et la vitesse de forçage sont limitées en fonction de la masse déterminée.
ES	La velocidad máx. de cierre y la velocidad de cierre lento forzado (nudging) se limitan en función de la masa determinada.
IT	La max. velocità di chiusura e la velocità di chiusura forzata vengono limitate in funzione della massa determinata.
PT	As velocidades máx. de fechamento e de avanço são limitadas dependendo das dimensões determinadas.
TR	Maks. kapatma hızı ve sıkışma hızı tespit edilen ağırlığa bağlı olarak sınırlanır.
PY	Макс. скорость закрывания и скорость толкания ограничиваются в зависимости от определенной массы.
中文	最大关门速度和强制关门速度受测得的质量所限。

DE	Bedienen (Terminalmodul)	ES	Operación (Módulo de terminales)	TR	Kullanım (Terminal modülü)
EN	Operation (Terminal module)	IT	Comando (Modulo terminale)	PY	Управление (Терминальный модуль)
FR	Commande (Module terminal)	PT	Operação (Módulo terminal)	中文	操作 ( 端子模块)

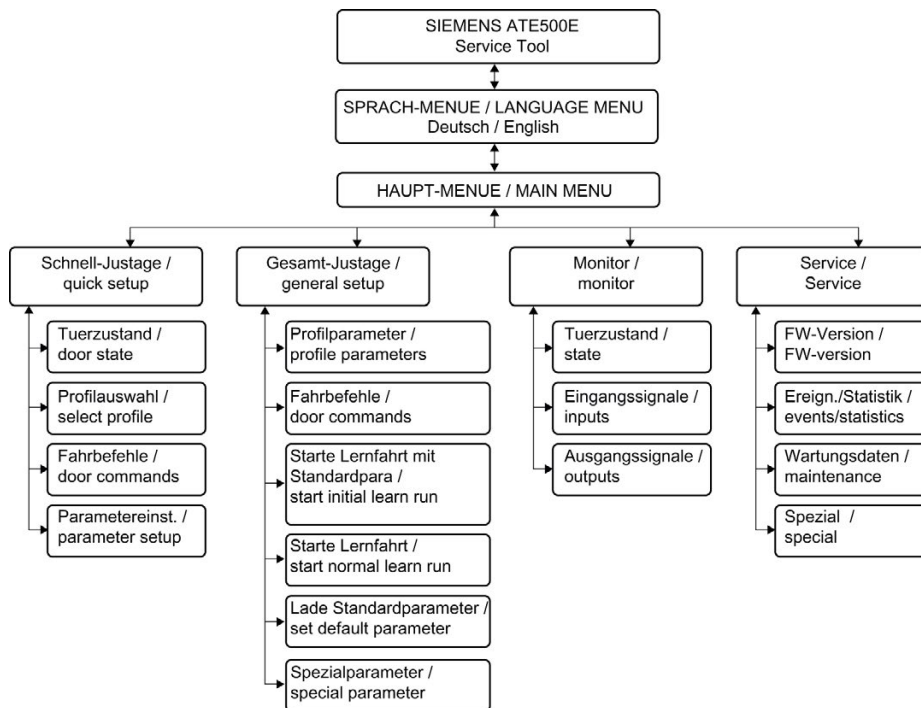

DE	Lichtschranke / DCPS einstellen	ES	Ajuste de barrera fotoeléctrica/DCPS	TR	Fotoselin / DCPS'in ayarlanması
EN	Set light barrier / DCPS	IT	Barriera fotoelettrica / regolazione del sensore DCPS	PY	Настройка фотоэлектрического барьера / DCPS
FR	Réglage de la barrière photoélectrique/du DCPS	PT	Ajustar DCPS / barreira de luz	中文	光栅 / 设置 DCPS

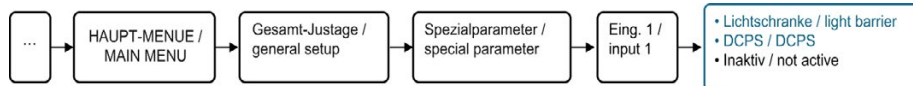

DE	Aktivierung CAN-Schnittstelle (AT40 CAN)	ES	Activación de la interfaz CAN (AT40 CAN)	TR	CAN arayüzünün aktifleştirilmesi (AT40 CAN)
EN	Activate CAN interface (AT40 CAN)	IT	Attivazione dell'interfaccia CAN (AT40 CAN)	PY	Активирование интерфейса CAN (AT40 CAN)
FR	Activation de l'interface CAN (AT40 CAN)	PT	Ativação interface CAN (AT40 CAN)	中文	激活 CAN 接口 (AT40 CAN)

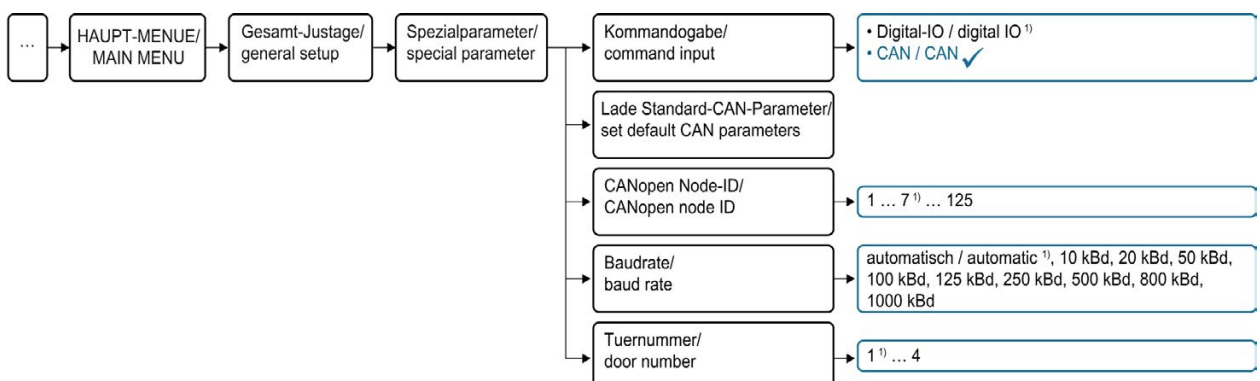

<sup>1)</sup> = Werkseinstellung / Factory setting / Réglage d'usine / Ajustes de fábrica / Impostazione di fabbrica / Ajuste de fábrica / Fabrika ayarı / Заводская настройка / 出厂设置

DE	Profile	ES	Perfiles	TR	Profiller
EN	Profiles	IT	Profili	PY	Профили
FR	Profils	PT	Perfis	中文	配置文件

DE	Die Fahrkurve
EN	Travel curve
FR	La courbe de déplacement
ES	Curva de movimientos
IT	La curva di movimento
PT	A curva de andamento
TR	Hareket eğrisi
PY	Кривая движения
中文	运行曲线

**i** Reverse ramp  
> Brake ramp

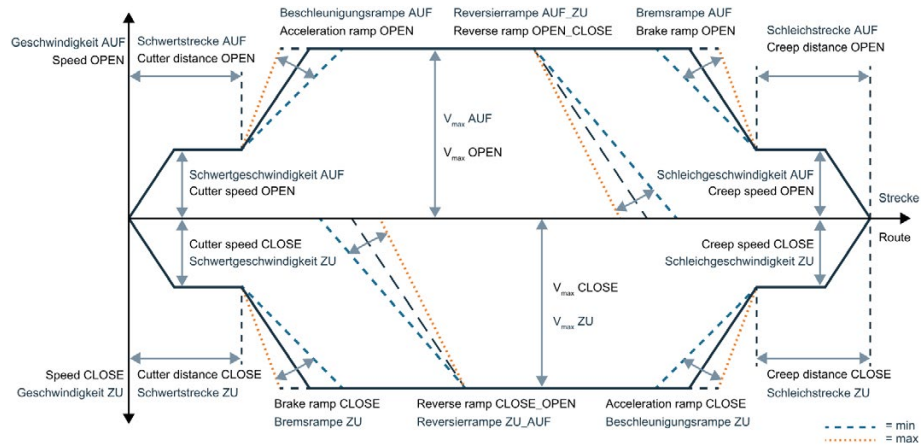











DE	<b>Hinweise zur Parametrierung</b> <ul style="list-style-type: none"> <li>Übernahme der Parameter: bei Stillstand, Endanschlag "ZU" oder Endanschlag "AUF".</li> <li>Die Auswahl eines Profils überschreibt alle Profil-Werte.</li> </ul>	ES	<b>Instrucciones de parametrización</b> <ul style="list-style-type: none"> <li>Aplicación de los parámetros: con puerta parada, en tope "CERRADA" o "ABIERTA".</li> <li>Al seleccionar un perfil se modifican también todos los valores de perfiles.</li> </ul>	TR	<b>Parametrelendirme ilgili bilgiler</b> <ul style="list-style-type: none"> <li>Parametrelerin devralınması: Durağan konumda, dayanak "KAPALI" veya dayanak "YUKARI".</li> <li>Bir profilin seçilmesi durumunda tüm profil değerlerinin üzerine yazılır.</li> </ul>
EN	<b>Notes on parameter assignment</b> <ul style="list-style-type: none"> <li>Accepting parameters: parameters are accepted with the door stationary at the end stop "CLOSED" or end stop "OPEN".</li> <li>Selecting a profile overwrites all profile values.</li> </ul>	IT	<b>Avvertenze relative alla parametrizzazione</b> <ul style="list-style-type: none"> <li>Applicazione dei parametri: in stato di fermo, finecorsa "CHIUSA" o finecorsa "APERTA".</li> <li>La selezione di un profilo sovrascrive tutti i valori del profilo.</li> </ul>	PY	<b>Указания по параметрированию</b> <ul style="list-style-type: none"> <li>Прием параметров: во время остановки, концевой упор "ЗАКРЫТО" или концевой упор "ОТКРЫТО".</li> <li>Выбор профиля переписывает все значения профиля.</li> </ul>
FR	<b>Consignes de paramétrage</b> <ul style="list-style-type: none"> <li>Validation des paramètres : pour arrêt, butée finale FERMETURE ou butée finale OUVERTURE.</li> <li>La sélection d'un profil écrase toutes les valeurs de profil.</li> </ul>	PT	<b>Indicações para parametrização</b> <ul style="list-style-type: none"> <li>Aceitação dos parâmetros: durante a imobilização, encosto terminal "FECHADO" ou encosto final "ABERTO".</li> <li>A seleção de um perfil substitui todos os valores de perfil.</li> </ul>	中文	<b>编程说明</b> <ul style="list-style-type: none"> <li>应用参数: 停机时, 末端挡块 "关" 或 末端挡块 "开".</li> <li>选择一个配置文件会覆盖所有配置文件值。</li> </ul>

SIDOOR ATE500E	SIDOOR MED280 (280 kg)							Min... Max.	📄
	P1*	P2	P3	P4	P5	P6			
Schleichstrecke AUF / Slow end distance open	mm	30	20	20	30	30	30	0 ... 100	
Schwertstrecke AUF / Slow start distance open	mm	50	30	30	40	40	40	0 ... 150	
Schleichstrecke ZU / Slow start distance close	mm	0	0	0	0	0	0	0 ... 100	
Schwertstrecke ZU / Slow end distance close	mm	60	40	40	60	60	40	0 ... 150	
Maximale Geschwindigkeit AUF / Maximum speed open	mm/s	700	400	500	700	800	750	100 ... 800	
Schleichgeschwindigkeit AUF / Slow end speed open	mm/s	40	40	50	60	70	70	30 ... 90	
Schwertgeschwindigkeit AUF / Slow start speed open	mm/s	60	40	50	60	70	70	30 ... 90	
Initialgeschwindigkeit AUF / Slow initial speed open	mm/s	90	50	60	70	90	90	30 ... 90	
Maximale Geschwindigkeit ZU / Maximum speed close	mm/s	262	225	250	262	262	250	100 ... 500	
Schleichgeschwindigkeit ZU / Slow start speed close	mm/s	60	40	50	60	70	50	30 ... 90	
Schwertgeschwindigkeit ZU / Slow end speed close	mm/s	40	40	50	60	70	50	30 ... 90	
Initialgeschwindigkeit / Slow initial speed close	mm/s	90	50	60	70	90	60	30 ... 90	
Drängelgeschwindigkeit ZU / Nudging speed	mm/s	150	100	100	150	100	100	50 ... 250	
Beschleunigungsrampe AUF / Acceleration ramp open	mm/s <sup>2</sup>	2200	800	1000	2500	3000	3000	300 ... 3000	
Bremsrampe ZU / Deceleration ramp close	mm/s <sup>2</sup>	800	600	800	1000	1200	1200	300 ... 1200	
Reversierrampe AUF ZU / Reversal ramp op->cl	mm/s <sup>2</sup>	1200	600	800	1000	1200	1200	300 ... 1200	
Beschleunigungsrampe ZU / Acceleration ramp close	mm/s <sup>2</sup>	800	600	800	2500	2500	500	300 ... 3000	
Bremsrampe ZU / Deceleration ramp close	mm/s <sup>2</sup>	600	600	800	1000	1200	500	300 ... 1200	
Reversierrampe ZU / AUF / Reversal ramp cl->op	mm/s <sup>2</sup>	850	800	1000	1200	1200	1200	300 ... 1200	
Dauermoment (Strom) AUF / Idle torque open	A	4	4	4	4	4	4	0 ... 6	
Dauermoment (Strom) ZU / Idle torque close	A	4	4	4	4	4	4	0 ... 6	
Schwertandruckmoment / Peak torque close	A	6	6	6	6	6	6	0 ... 7	
Öffnungskraft statisch / Limit force open	N	350	300	300	350	350	350	70 ... 350	
Schließkraft statisch / Limit force close	N	90	90	90	90	90	90	70 ... 230	
Schwertkraft statisch ZU / Limit force end close	N	90	90	90	90	90	90	70 ... 230	
Drängelkraft statisch ZU / Limit force close nudging	N	70	70	70	70	70	70	70 ... 230	

SIDOOR MED280	
P1 <sup>1)</sup>	M6 Default Prof. / M6 default prof.
P2	M6 Min. Profil 1 / M6 min.profile 1
P3	M6 Min. Profil 2 / M6 min.profile 2
P4	M6 Max. Profil 1 / M6 max.profile 1
P5	M6 Max. Profil 2 / M6 max.profile 2
P6	M6 Spez. Profil / M6 spec. profile 1

<sup>1)</sup> Standardprofil / Default profile / Profil standard / Perfil estándar / Profilo standard / Perfil padrão / Standart profil / Стандартный профиль / 默认配置

DE	<b>Betriebszustände (H401)</b>	ES	<b>Estados operativos (H401)</b>	TR	<b>İşletim durumları (H401)</b>	
EN	<b>Operating states (H401)</b>	IT	<b>Stati operativi (H401)</b>	PY	<b>рабочие состояния (H401)</b>	
FR	<b>États de fonctionnement (H401)</b>	PT	<b>Estados de operação (H401)</b>	中文	<b>运行状态 (H401)</b>	
	DE	<ul style="list-style-type: none"> <li>Signal Lichtschranke liegt an (Lichtschranke unterbrochen)</li> <li>DCPS-Fehler, wenn Input 1 als DCPS konfiguriert ist</li> </ul>	ES	<ul style="list-style-type: none"> <li>Señal de barrera fotoeléctrica presente (barrera fotoeléctrica interrumpida)</li> <li>Error de DCPS si la entrada 1 se configuró como DCPS</li> </ul>	TR	<ul style="list-style-type: none"> <li>Fotosel sinyali mevcut (fotosel kesildi)</li> <li>DCPS hatası, Input 1 DCPS olarak yapılandırıldığında</li> </ul>
	EN	<ul style="list-style-type: none"> <li>Light barrier signal present (light barrier interrupted)</li> <li>DCPS error if input 1 is configured as DCPS</li> </ul>	IT	<ul style="list-style-type: none"> <li>È presente il segnale della barriera fotoelettrica (barriera fotoelettrica interrotta)</li> <li>Errore DCPS, se l'ingresso 1 è configurato come DCPS</li> </ul>	PY	<ul style="list-style-type: none"> <li>Сигнал фотозлектрический барьер сработал (фотозлектрический барьер прерван)</li> <li>Ошибка DCPS, если ввод 1 сконфигурирован в качестве DCPS</li> </ul>
	FR	<ul style="list-style-type: none"> <li>Signal de la barrière photoélectrique activé (barrière photoélectrique interrompue)</li> <li>Erreur DCPS, si input 1 est configuré comme DCPS</li> </ul>	PT	<ul style="list-style-type: none"> <li>Sinal Barreira de luz presente (barreira de luz interrompida)</li> <li>Erro DCPS se Input 1 estiver configurada como DCPS</li> </ul>	中文	<ul style="list-style-type: none"> <li>有光栅信号等待处理 (光栅中断)</li> <li>如将输入端 1 设置为 DCPS 将引发 DCPS 故障</li> </ul>
	DE	RAM-, EEPROM oder CPU-Fehler (Systemfehler)	ES	Error en RAM, EEPROM o CPU (error del sistema)	TR	RAM-, EEPROM veya CPU hatası (sistem hatası)
	EN	RAM, EEPROM or CPU error (system error)	IT	Errore di RAM, EEPROM o CPU (errore di sistema)	PY	Ошибка ОЗУ, ЭП-ПЗУ или ЦП (системная ошибка)
	FR	Erreur RAM, EEPROM ou CPU (erreur système)	PT	Erro do CPU, EEPROM ou RAM (erro de sistema)	中文	RAM 错误、EEPROM 错误或 CPU 错误 (系统错误)
	DE	Brems-Chopper defekt	ES	Chopper de frenado defectuoso	TR	Frenleme devresi arızalı
	EN	Braking chopper defective	IT	Chopper di frenatura difettoso	PY	Тормозной обтюратор неисправен
	FR	Hacheur de freinage défectueux	PT	Chopper de frenagem com defeito	中文	制动斩波器损坏
	DE	Fehler im 2. Abschaltweg	ES	Error en 2.º circuito de desconexión	TR	2. kapatma yolunda hata
	EN	Error in the second shutdown route	IT	Errore nel 2º percorso di disinserzione	PY	Ошибка на втором пути отключения
	FR	Erreur dans la 2e voie de déconnexion	PT	Erro no método 2 de desconexão	中文	第 2 关断路径出错
	DE	<ul style="list-style-type: none"> <li>Verlängerung der Offenhaltezeit bei erhöhter Einschaltdauer des Motors</li> <li>Motorschutzmodus aktiv</li> <li>Übertemperatur im Motor oder Steuergerät</li> </ul>	ES	<ul style="list-style-type: none"> <li>Prolongación del tiempo con apertura abierta en caso de mayor duración de conexión del motor</li> <li>Modo de protección de motor activo</li> <li>Sobrettemperatura en el motor o en el aparato de mando</li> </ul>	TR	<ul style="list-style-type: none"> <li>Daha uzun motor çalışma süresinde açık tutma süresinin uzatılması</li> <li>Motor koruması modu aktif</li> <li>Motor veya kumanda cihazında aşırı sıcaklık</li> </ul>
	EN	<ul style="list-style-type: none"> <li>Increased hold-open time with longer motor switch-on time</li> <li>Motor protection mode active</li> <li>Motor or controller overtemperature</li> </ul>	IT	<ul style="list-style-type: none"> <li>Prolungamento del tempo di mantenimento apertura in caso di durata d'inserzione aumentata del motore</li> <li>Modalità di protezione motore attiva</li> <li>Sovrattemperatura nel motore o dispositivo di comando</li> </ul>	PY	<ul style="list-style-type: none"> <li>Увеличение времени удерживания в открытом состоянии при увеличенной продолжительности включения двигателя</li> <li>Режим защиты двигателя активен</li> <li>Повышенная температура двигателя или прибора управления</li> </ul>
	FR	<ul style="list-style-type: none"> <li>Prolongation du temps d'ouverture pour une durée accrue de fonctionnement du moteur</li> <li>Mode protection moteur actif</li> <li>Surchauffe du moteur ou de l'appareil de commande</li> </ul>	PT	<ul style="list-style-type: none"> <li>Prorrogação do período de mantimento da abertura em um período de conexão do motor elevado</li> <li>Modo de proteção do motor ativo</li> <li>Temperatura excessiva no motor e no aparelho de comando</li> </ul>	中文	<ul style="list-style-type: none"> <li>提高电机的负载工作周期以延长开门保持时间</li> <li>已激活电机保护模式</li> <li>电机或控制设备过热</li> </ul>
	DE	Motor undefiniert – keine Lernfahrt mit diesem Motortyp durchgeführt (Bei Einsatz einer anderen Variante des Motors ist eine erneute Durchführung der Lernfahrt beim Anlegen der Netzspannung (Seite 12) erforderlich)	ES	Motor indefinido, no se ejecuta el movimiento de aprendizaje con este tipo de motor (si se usa otra variante del motor es preciso repetir al movimiento de aprendizaje al aplicar la tensión de red (página 12))	TR	Motor tanımsız – bu motor tipli hiçbir öğrenme hareketi uygulanmadı (başka modelde bir motorun kullanılması durumunda, şebeke gerilimi venilirken (Sayfa 12) öğrenme hareketi tekrar uygulanmalıdır)
	EN	Undefined motor – no learn run performed with this motor (if another motor variant is used then a new learn run must be performed when switching on the line voltage (see page 12))	IT	Motore indefinito – nessun movimento di apprendimento eseguito con questo tipo di motore (impiegando un'altra variante del motore si deve rieseguire il movimento di apprendimento all'applicazione della tensione di rete (pag. 12))	PY	Двигатель не определен – с этим типом двигателя учебная эксплуатация не проведена (При применении другого типа двигателя требуется повторное проведение учебной эксплуатации при подаче сетевого напряжения (стр. 12))
	FR	Moteur indéfini – aucune course d'apprentissage exécutée avec ce type de moteur (l'utilisation d'un autre moteur nécessite une nouvelle course d'apprentissage à l'application de la tension d'alimentation (page 12))	PT	Motor indefinido – não é efetuada qualquer viagem de programação com este tipo de motor (utilizando uma outra variante do motor é necessário efetuar a viagem de programação ao criar a tensão de rede (página 12) novamente)	中文	电机未定义 – 无法使用此电机类型进行学习运行 (在使用其他型号的电机前必须在接通电源后重新进行学习运行 (第 12 页))
	DE	Motor blockiert in Schließrichtung	ES	Motor obstruido en sentido de cierre	TR	Motor kapatma yönünde bloke ediyor
	EN	Motor obstructed in the closing direction	IT	Motore si blocca in direzione di chiusura	PY	Мотор блокируется в направлении закрытия
	FR	Moteur bloqué dans le sens de la fermeture	PT	Motor bloqueia no sentido de fechamento	中文	电机在关门方向受阻
	DE	Fehler Motor Impulsgeber	ES	Falla en generador de impulsos motor	TR	Enkoder motor hatası
	EN	Motor encoder fault	IT	Errore del trasduttore del motore	PY	Ошибка датчика импульсов двигателя
	FR	Erreur du générateur d'impulsions du moteur	PT	Erro motor sensor de impulso	中文	电机脉冲发送器错误
	DE	<ul style="list-style-type: none"> <li>Minimaleditor wird gestartet</li> <li>Einschalt-Wartezeit bis Motor erkannt wurde</li> </ul>	ES	<ul style="list-style-type: none"> <li>Se inicia el editor mínimo</li> <li>Tiempo de espera a la conexión hasta que se detecta el motor</li> </ul>	TR	<ul style="list-style-type: none"> <li>Minimal editör başlatılıyor</li> <li>Motor algılandık kadar çalıştırma bekleme süresi</li> </ul>
	EN	<ul style="list-style-type: none"> <li>Minimal editor is started</li> <li>Switch-on delay until motor is recognized</li> </ul>	IT	<ul style="list-style-type: none"> <li>Avvio dell'editor minimale</li> <li>Tempo di attesa inserzione fino al riconoscimento del motore</li> </ul>	PY	<ul style="list-style-type: none"> <li>Запускается Minimaleditor</li> <li>Время ожидания включения пока двигатель не будет распознан</li> </ul>
	FR	<ul style="list-style-type: none"> <li>Démarrage de l'éditeur minimal</li> <li>Délai d'enclenchement jusqu'à ce que le moteur soit détecté</li> </ul>	PT	<ul style="list-style-type: none"> <li>Minimaleditor é iniciado</li> <li>Tempo de espera ao ligar até o motor ser reconhecido</li> </ul>	中文	<ul style="list-style-type: none"> <li>启动迷你编辑器</li> <li>直至电机识别前的开启等待时间</li> </ul>
	DE	Motor Überstrom	ES	Sobrecorriente en motor	TR	Motorda aşırı akım
	EN	Motor overcurrent	IT	Sovracorrente del motore	PY	Двигатель ток перегрузки
	FR	Surintensité du moteur	PT	Motor sobrecorrente	中文	电机过电流

	DE	Minimaleditor (Krafteinstellung) aktiv	ES	Editor mínimo (ajuste de fuerza) activo	TR	Minimal editör (güç ayarı) aktif
	EN	Minimal editor (force setting) active	IT	Editor minimale (impostazione di forza) attivo	PY	Minimaleditor (регулировка усилия) активен
	FR	Éditeur minimal actif (réglage de la force)	PT	Minimaleditor (Ajuste da força) ativo	中文	(力量设置) 迷你编辑器激活
	DE	15 V-Überspannung	ES	Sobretensión 15 V	TR	15 V aşırı gerilim
	EN	15 V overvoltage	IT	Sovratensione 15 V	PY	Повышенное напряжение 15 В
	FR	Surtension de 15 V	PT	Sobretensão de 15 V	中文	15 V 过电压
	DE	Blockierung beim Öffnen	ES	Obstrucción al abrir	TR	Açılırken blokaj
	EN	Obstruction while opening	IT	Bloccaggio all'apertura	PY	Блокировка при открывания
	FR	Blocage lors de l'ouverture	PT	Bloqueio ao abrir	中文	开门受阻
	DE	Minimaleditor (Profileinstellung) aktiv	ES	Editor mínimo (ajuste de perfil) activo	TR	Minimal editör (profil ayarı) aktif
	EN	Minimal editor (profile setting) is active	IT	Editor minimale (impostazione profilo) attivo	PY	Minimaleditor (регулировка профиля) активен
	FR	Éditeur minimal actif (réglage du profil)	PT	Minimaleditor (Ajuste do perfil) ativo	中文	(配置设置) 迷你编辑器激活
	DE	Tür bleibt während Initialisierungsfahrt stehen (Signale AUF oder ZU liegen nicht an bzw. Endstellung der Tür erreicht)	ES	La puerta no se mueve durante la marcha de inicialización (señal ABIERTA o CERRADA no presente o puerta ha llegado a posición final)	TR	Kapı ilk baslatma sürüşü sırasında duruyor (AÇIK veya KAPALI sinyalleri yok ya da kapı son pozisyonuna erişildi)
	EN	Door remains stationary during initialization run (no OPEN or CLOSE signal present, or door has reached end position)	IT	La porta resta ferma durante il movimento di inializzazione (nessun segnale di APERTURA o CHIUSURA presente o la porta ha raggiunto la posizione finale)	PY	Дверь во время инициализирующего движения неподвижна (сигналы Откр. или Закр. отсутствуют или достигнуто конечное положение двери)
	FR	Porte immobilisée lors du déplacement d'initialisation (signal OUVRIR ou FERMER absent / position finale de la porte atteinte)	PT	Porta para durante a viagem de inicialização (Sinais FECHADO ou ABERTO não presentes ou posição final da porta atingida)	中文	在进行初始化移动时门保持静止 (不存在“打开”或“关闭”信号, 或门已经达到最终位置)
	DE	Motor Überspannung	ES	Sobretensión en motor	TR	Motorda aşırı gerilim
	EN	Motor overvoltage	IT	Sovratensione del motore	PY	Двигатель максимальное напряжение
	FR	Surtension du moteur	PT	Motor sobretensão	中文	电机过电压
	DE	Motor Unterspannung	ES	Subtensión en motor	TR	Motorda düşük gerilim
	EN	Motor undervoltage	IT	Sottotensione del motore	PY	Двигатель минимальное напряжение
	FR	Sous-tension du moteur	PT	Motor subtensão	中文	电机欠电压
	DE	Riemen gerissen	ES	Correa rota	TR	Kayış yırtıldı
	EN	Belt torn	IT	Rottura della cinghia	PY	Ремень разорвался
	FR	Courroie déchirée	PT	Correia com ruptura	中文	皮带撕裂
	DE	15 V-Unterspannung	ES	Subtensión 15 V	TR	15 V düşük gerilim
	EN	15 V undervoltage	IT	Sottotensione 15 V	PY	Пониженное напряжение 15 В
	FR	Sous-tension de 15 V	PT	Subtensão de 15 V	中文	15 V 欠压
	DE	Ermittlung der Parameter (Lernfahrt)	ES	Determinación de parámetros (marcha de aprendizaje)	TR	Parametrelerin tespiti (öğrenme sürüşü)
	EN	Determination of parameters (learn run)	IT	Determinazione dei parametri (movimento si apprendimento)	PY	Определение параметров (учебная эксплуатация)
	FR	Détermination des paramètres (course d'apprentissage)	PT	Determinação dos parâmetros (viagem de programação)	中文	测定参数 (学习运行)
	DE	Endstufe defekt	ES	Etapas de salida defectuosa	TR	Son kademe arızalı
	EN	Output stage defective	IT	Stadio finale difettoso	PY	Концевая ступень неисправна
	FR	Étage de puissance défectueux	PT	Nível final com defeito	中文	输出级损坏
	DE	Strommessfehler	ES	Error de medida de corriente	TR	Akım ölçüm hatası
	EN	Current measurement error	IT	Errore di misura corrente	PY	Ошибка измерения тока
	FR	Erreur de mesure du courant	PT	Erro de medição de corrente	中文	电流测量错误
	DE	Funktion O. K.	ES	Función O.K.	TR	Fonksiyon O.K
	EN	Function OK	IT	Funzione O.K.	PY	Функция O.K.
	FR	Fonction OK	PT	Função O.K.	中文	功能正常
	DE	Parameter-Fehler (Fehler in der Lernfahrt)	ES	Error en parámetros (error en marcha de aprendizaje)	TR	Parametre hatası (öğrenme sürüşünde hata)
	EN	Parameter error (error during learn run)	IT	Errore di parametro (errore nel movimento di apprendimento)	PY	Ошибка параметра (ошибка во время учебной эксплуатации)
	FR	Erreur de paramètre (erreurs dans la course d'apprentissage)	PT	Erro de parametrização (erro na viagem de programação)	中文	参数错误 (学习运行出错)
	DE	CAN-Fehler	ES	Error en CAN	TR	CAN hatası
	EN	CAN error	IT	Errore CAN	PY	Ошибка CAN
	FR	Erreur CAN	PT	Erro de CAN	中文	CAN 错误
	DE	Überwachungsfehler	ES	Falla de monitoreo	TR	İzleme hatası
	EN	Monitoring error	IT	Errore di sorveglianza	PY	Ошибка контроля
	FR	Défaut de surveillance	PT	Erro de monitoração	中文	监控故障
	DE	Tür ist zu	ES	Puerta está cerrada	TR	Kapı kapalı
	EN	Door closed	IT	La porta è chiusa	PY	Дверь закрыта
	FR	Porte fermée	PT	Porta está fechada	中文	门已关闭
	DE	Max. Türmasse überschritten	ES	Masa máx. de la puerta sobrepasada	TR	Maks. kapı ağırlığı aşıldı
	EN	Maximum door weight exceeded	IT	Max. massa della porta superata	PY	Макс. масса двери превышена
	FR	Masse max. de porte dépassée	PT	Dimensões máx. da porta ultrapassadas	中文	超出门的最大质量
	DE	• Steuerung ist parameterlos und wartet auf Lernfahrt • Lernfahrt wurde abgebrochen	ES	• La unidad no tiene parámetros ajustados y espera a marcha de aprendizaje • Aprendizaje cancelado	TR	• Kontrol ünitesi parametresizdir ve öğrenme sürüşünü bekliyor • Öğrenme sürüşü iptal edildi
	EN	• Controller has no parameters and is waiting for learn run • Learn run was canceled	IT	• Il dispositivo di comando non ha parametri e attende il movimento di apprendimento • Il movimento di apprendimento è stato interrotto.	PY	• Блок управления без параметров и ждет учебной эксплуатации • Учебная эксплуатация была отменена
	FR	• Commande sans paramètres, en attente de la course d'apprentissage • La course d'apprentissage a été interrompue	PT	• O comando encontra-se sem parâmetros e espera pela viagem de programação • A viagem de programação foi cancelada	中文	• 控制系统无参数, 等待进行学习运行 • 已中断试运行

**For Resellers: In order to avoid infringements of the license conditions by the reseller or the buyer these instructions and license conditions and accompanying CD – if applicable - have to be forwarded to the buyers.**

**License Conditions and Disclaimers for Open Source Software and other Licensed Software**

In the product "SIDOOR ATE500E / MED280 ", Copyright Siemens AG, 2015 (hereinafter "Product"), the following Open Source Software is used either unchanged or in a form that we have modified, and additionally the other License Software noted below:

**Liability for Open Source Software**

Open Source Software is provided free of charge. We are liable for the Product including Open Source Software contained in accordance with the license conditions applicable to the Product. Any liability for use of Open Source Software beyond the program flow intended for the Product is explicitly excluded. Furthermore, any liability for defects resulting from modifications to the Open Source Software by you or third parties is excluded.

We do not provide any technical support for the Product if it has been modified.

**Please note the following license conditions and copyright notices applicable to Open Source Software and other License Software:**

Component	Open Source Software [Yes/No]	Acknowledgements	Copyright Information / File
ARM CMSIS Library (STM32F0xx) - 2.10	NO		LICENSE AND COPYRIGHT INFORMATION FOR COMPONENT ARM CMSIS LIBRARY (STM32F0XX) – 2.10

**LICENSE CONDITIONS AND COPYRIGHT NOTICES**

**Commercial Software: ARM CMSIS Library (STM32F0xx) – 2.10**

Enclosed you'll find the license conditions and copyright notices applicable for Commercial Software ARM CMSIS Library (STM32F0xx) – 2.10

**License conditions:**

<p>ARM Limited (ARM) is supplying this software for use with Cortex-M processor based microcontrollers. This file can be freely distributed within development tools that are supporting such ARM based processors.</p> <p>@par</p> <p>THIS SOFTWARE IS PROVIDED "AS IS". NO WARRANTIES, WHETHER EXPRESS, IMPLIED OR STATUTORY, INCLUDING, BUT NOT LIMITED TO, IMPLIED WARRANTIES OF MERCHANTABILITY AND FITNESS FOR A PARTICULAR PURPOSE APPLY TO THIS SOFTWARE.</p> <p>ARM SHALL NOT, IN ANY CIRCUMSTANCES, BE LIABLE FOR SPECIAL, INCIDENTAL, OR CONSEQUENTIAL DAMAGES, FOR ANY REASON WHATSOEVER.</p>
<p>BSD 3-clause</p> <p>Redistribution and use in source and binary forms, with or without modification, are permitted provided that the following conditions are met:</p> <ol style="list-style-type: none"> <li>1) Redistributions of source code must retain the above copyright notice, this list of conditions and the following disclaimer.</li> <li>2) Redistributions in binary form must reproduce the above copyright notice, this list of conditions and the following disclaimer in the documentation and/or other materials provided with the distribution.</li> <li>3) Neither the name of the ORGANIZATION nor the names of its contributors may be used to endorse or promote products derived from this software without specific prior written permission.</li> </ol> <p>THIS SOFTWARE IS PROVIDED BY THE COPYRIGHT HOLDERS AND CONTRIBUTORS "AS IS" AND ANY EXPRESS OR IMPLIED WARRANTIES, INCLUDING, BUT NOT LIMITED TO, THE IMPLIED WARRANTIES OF MERCHANTABILITY AND FITNESS FOR A PARTICULAR PURPOSE ARE DISCLAIMED. IN NO EVENT SHALL THE COPYRIGHT HOLDER OR CONTRIBUTORS BE LIABLE FOR ANY DIRECT, INDIRECT, INCIDENTAL, SPECIAL, EXEMPLARY, OR CONSEQUENTIAL DAMAGES (INCLUDING, BUT NOT LIMITED TO, PROCUREMENT OF SUBSTITUTE GOODS OR SERVICES; LOSS OF USE, DATA, OR PROFITS; OR BUSINESS INTERRUPTION) HOWEVER CAUSED AND ON ANY THEORY OF LIABILITY, WHETHER IN CONTRACT, STRICT LIABILITY, OR TORT (INCLUDING NEGLIGENCE OR OTHERWISE) ARISING IN ANY WAY OUT OF THE USE OF THIS SOFTWARE, EVEN IF ADVISED OF THE POSSIBILITY OF SUCH DAMAGE.</p>

**Copyrights:**

(C) COPYRIGHT 2012 STMicroelectronics	Copyright (C) 2010 ARM Limited	Copyright © ARM Ltd
(C) COPYRIGHT STMicroelectronics	Copyright (C) 2010-2011 ARM Limited	Copyright © ARM Ltd801176
(c) Copyright Atollic AB.	Copyright (C) 2011 ARM Limited	
Copyright (C) 2009-2011 ARM Limited	Copyright 2011-2012 Altium BV	