

Edition 10/2023

SYSTEM MANUAL

# SIDOOR

## Automatic door control units

AT40, ATD400V



# SIEMENS

## SIDOOR

### Automatic door control units AT40 and ATD400V for elevators

#### System Manual

<u>Introduction</u>	<b>1</b>
<u>Basic safety information</u>	<b>2</b>
<u>System overview</u>	<b>3</b>
<u>SIDOOR functions</u>	<b>4</b>
<u>Controllers</u>	<b>5</b>
<u>Geared motors</u>	<b>6</b>
<u>Power supply</u>	<b>7</b>
<u>Optional additional units</u>	<b>8</b>
<u>Connecting and commissioning</u>	<b>9</b>
<u>Diagnostics and maintenance</u>	<b>10</b>
<u>Disposal</u>	<b>11</b>
<u>Appendixes</u>	<b>A</b>

## Legal information

### Warning notice system

This manual contains notices you have to observe in order to ensure your personal safety, as well as to prevent damage to property. The notices referring to your personal safety are highlighted in the manual by a safety alert symbol, notices referring only to property damage have no safety alert symbol. These notices shown below are graded according to the degree of danger.

 <b>DANGER</b>
indicates that death or severe personal injury <b>will</b> result if proper precautions are not taken.

 <b>WARNING</b>
indicates that death or severe personal injury <b>may</b> result if proper precautions are not taken.

 <b>CAUTION</b>
indicates that minor personal injury can result if proper precautions are not taken.

<b>NOTICE</b>
indicates that property damage can result if proper precautions are not taken.

If more than one degree of danger is present, the warning notice representing the highest degree of danger will be used. A notice warning of injury to persons with a safety alert symbol may also include a warning relating to property damage.

### Qualified Personnel

The product/system described in this documentation may be operated only by **personnel qualified** for the specific task in accordance with the relevant documentation, in particular its warning notices and safety instructions. Qualified personnel are those who, based on their training and experience, are capable of identifying risks and avoiding potential hazards when working with these products/systems.

### Proper use of Siemens products

Note the following:

 <b>WARNING</b>
Siemens products may only be used for the applications described in the catalog and in the relevant technical documentation. If products and components from other manufacturers are used, these must be recommended or approved by Siemens. Proper transport, storage, installation, assembly, commissioning, operation and maintenance are required to ensure that the products operate safely and without any problems. The permissible ambient conditions must be complied with. The information in the relevant documentation must be observed.

### Trademarks

All names identified by ® are registered trademarks of Siemens AG. The remaining trademarks in this publication may be trademarks whose use by third parties for their own purposes could violate the rights of the owner.

### Disclaimer of Liability

We have reviewed the contents of this publication to ensure consistency with the hardware and software described. Since variance cannot be precluded entirely, we cannot guarantee full consistency. However, the information in this publication is reviewed regularly and any necessary corrections are included in subsequent editions.

# Table of contents

<b>1</b>	<b>Introduction</b>	<b>7</b>
1.1	About SIDOOR	7
1.2	About this manual	8
1.2.1	Sales law	8
1.2.2	Contents	8
1.2.3	Target group	9
1.2.4	What's new?	9
1.2.5	Standard scope	9
1.2.6	Use of third-party products in this documentation	10
1.2.7	Websites of third-party companies	10
1.3	SIDOOR documentation	10
1.4	Service and support	11
1.4.1	Siemens Industry Online Support on the Web	11
1.5	Important product information	12
1.5.1	Intended use	12
<b>2</b>	<b>Basic safety information</b>	<b>13</b>
2.1	General safety instructions	13
2.1.1	Electric shock and danger to life due to other energy sources	13
2.2	Equipment damage due to electric fields or electrostatic discharge	16
2.3	Warranty and liability for application examples	16
2.4	Cybersecurity information	17
2.5	Residual risks of power drive systems	18
<b>3</b>	<b>System overview</b>	<b>19</b>
3.1	System configuration and area of application	19
3.2	Products	20
3.2.1	Controllers	20
3.2.2	Geared motors	21
3.2.3	Power supply	23
3.2.4	Optional additional units	23
3.2.4.1	SIDOOR SERVICE TOOL	25
3.2.4.2	SIDOOR SUPPORT app and SIDOOR LINK	26
3.2.4.3	SIDOOR SOFTWARE KIT	28
3.2.5	Accessories	30
<b>4</b>	<b>SIDOOR functions</b>	<b>31</b>
4.1	Basic functions	32
4.1.1	Learn run	32
4.1.2	Learn run button	33
4.1.3	DCPS (Door Closed Position Sensor)	36

4.1.4	DOOR CLOSE (command given via digital inputs) .....	38
4.1.5	DOOR OPEN (command given via digital inputs) .....	39
4.1.6	Nudge .....	40
4.2	System functions .....	40
4.2.1	Restart after power failure.....	41
4.2.2	Overload protection .....	42
4.2.3	Vandalism protection/continuous door monitoring .....	42
4.2.4	Oscillation protection .....	42
4.2.5	Automatic energy limitation.....	43
4.2.6	Emergency release.....	46
4.2.7	External closing force .....	47
4.3	Extended functions .....	48
4.3.1	Obstruction detection .....	48
4.3.1.1	Obstruction detection CLOSE.....	48
4.3.1.2	Obstruction detection OPEN.....	48
4.3.2	SERVICE TOOL maintenance data .....	49
4.3.2.1	Operating data .....	49
4.3.2.2	Travel measurement .....	51
4.3.3	Glass doors and folding doors .....	54
4.3.4	Spring mechanism in closed position .....	55
4.3.5	Emergency power mode .....	56
4.4	Light barrier.....	57
<b>5</b>	<b>Controllers .....</b>	<b>59</b>
5.1	Description of controller.....	59
5.2	Mounting the controller .....	59
5.3	Wiring instructions.....	61
5.4	Connecting terminals.....	62
5.4.1	Digital input signals .....	62
5.4.2	Voltage output.....	65
5.4.3	Motor plug.....	65
5.5	Relay and field bus interfaces .....	66
5.5.1	Relay module.....	66
5.5.2	CAN module .....	69
5.5.3	Virtual CAN terminal .....	72
5.6	Technical specifications .....	74
5.7	Operating and parameterizing controllers.....	80
5.7.1	Operator panel .....	81
5.7.1.1	Service buttons.....	81
5.7.1.2	Minimal editor .....	82
5.7.2	Parameterizing via the Terminal Module, SIDOOR SOFTWARE KIT or SIDOOR SERVICE TOOL. ....	85
5.7.3	Parameter names.....	87
5.7.4	Adjustable parameters .....	87
5.7.4.1	Driving curve .....	87
5.7.4.2	Forces.....	88

<b>6</b>	<b>Geared motors .....</b>	<b>95</b>
6.1	Description .....	95
6.2	Installation .....	96
6.3	Connecting terminals.....	100
6.3.1	Conductor assignment of the motor plug .....	100
6.4	Technical specifications .....	101
6.4.1	Dimension drawing of SIDOOR M2 with rubber-metal anti-vibration mount and mounting bracket .....	105
6.4.2	Dimension drawing of SIDOOR M3 with rubber-metal anti-vibration mount and mounting bracket .....	106
6.4.3	Dimension drawing of SIDOOR M4 with rubber-metal anti-vibration mount and mounting bracket .....	107
6.4.4	Dimension drawing of SIDOOR M5 .....	108
6.4.5	Dimension drawing of deflector pulley with tensioning device and mounting bracket.....	109
6.4.6	Dimension drawing of door clutch holder .....	110
<b>7</b>	<b>Power supply .....</b>	<b>111</b>
7.1	SIDOOR NT40 .....	111
7.1.1	Description .....	111
7.1.2	Installation .....	112
7.1.3	Connecting terminals.....	113
7.1.4	Technical specifications .....	116
7.2	SIDOOR TRANSFORMER.....	119
7.2.1	Description .....	119
7.2.2	Installation .....	120
7.2.3	Connecting.....	121
7.2.4	Technical specifications .....	122
7.2.5	Dimensional drawing SIDOOR TRANSFORMER.....	124
7.3	SIDOOR TRANSFORMER UL .....	125
7.3.1	Description .....	125
7.3.2	Installation .....	126
7.3.3	Connection.....	127
7.3.4	Test voltage .....	129
7.3.5	Technical specifications .....	131
7.3.6	Dimension drawing SIDOOR TRANSFORMER UL .....	133
7.4	Uninterruptible power supply (UPS).....	134
<b>8</b>	<b>Optional additional units .....</b>	<b>137</b>
8.1	SIDOOR SERVICE TOOL .....	137
8.1.1	Description .....	137
8.1.2	Connection.....	137
8.1.3	Operation .....	138
8.1.4	Navigator structure in the SIDOOR SERVICE TOOL .....	140
8.1.5	Technical specifications .....	147
8.2	SIDOOR LINK and SIDOOR SUPPORT App.....	147
8.2.1	Description .....	147
8.2.2	Connecting.....	148
8.2.3	Operating the SIDOOR SUPPORT app .....	148

8.2.4	Start page of the SIDOOR SUPPORT app .....	150
8.2.5	Technical specifications .....	151
<b>9</b>	<b>Connecting and commissioning .....</b>	<b>153</b>
9.1	Overview of safety and commissioning.....	153
9.2	Preparing the control unit .....	156
9.3	Connecting a geared motor to the control unit .....	156
9.4	Connecting the power supply to the network and executing a learn run.....	157
9.5	Connecting digital inputs .....	158
9.6	Final settings and checks.....	159
<b>10</b>	<b>Diagnostics and maintenance .....</b>	<b>161</b>
10.1	Operating state display .....	161
10.2	Maintenance.....	162
<b>11</b>	<b>Disposal .....</b>	<b>163</b>
<b>A</b>	<b>Appendixes .....</b>	<b>165</b>
A.1	Profiles and adjustment ranges.....	165
A.1.1	Profile name.....	165
A.1.2	SIDOOR M2 L / R.....	165
A.1.2.1	SIDOOR AT40 .....	165
A.1.3	SIDOOR M3 L / R.....	166
A.1.3.1	SIDOOR AT40 .....	166
A.1.4	SIDOOR M4 L / R.....	167
A.1.4.1	SIDOOR AT40 .....	167
A.1.4.2	SIDOOR ATD400V.....	169
A.1.5	SIDOOR M5 L / R.....	170
A.1.5.1	SIDOOR AT40 .....	170
A.1.5.2	SIDOOR ATD400V.....	171
A.2	Configuration record .....	172
A.3	Standards, directives and laws.....	174



# Introduction

## 1.1 About SIDOOR

### What is SIDOOR?

The SIDOOR product series is a door control system mainly for operation of sliding doors as well as lifting and roller doors. SIDOOR door drives are drives for doors and gates in various areas of application.

### What is a door control system?

Door control system is the general term for the controller of an access system.

Door control systems are characterized by the fact that there are always two defined states, namely for the open and closed positions of the door. The door is always controlled between these two positions in accordance with the guidelines of the respective application.

### SIDOOR for elevators

The SIDOOR door control systems for elevators are intelligent solutions that allow the opening and closing of cabin and shaft doors with adjustable speeds, accelerations and forces.

### Customer benefits

- The controllers are optimally configured for their areas of application. With SIDOOR, doors are always checked and controlled in an application-specific manner.
- Our intelligent system solution calculates the optimal drive characteristics for a door automatically, and ensures that these are continuously maintained – in accordance with the guidelines of the application.
- The entire commissioning process requires just the push of a single button. In a defined learn run, the door system independently determines the values for the door width, the dynamic mass to be moved and the drive direction of the geared motor, and stores this data in a non-volatile memory.
- The screwless enclosure concept, with pluggable terminal connections, allows the device to be opened and closed without tools, thereby reducing installation times.
- The system's reliability, ruggedness and long-term precision minimize the need for maintenance and repair work. Obstruction and belt tear detection provides more safety.

### See also

SIDOOR homepage (<http://www.siemens.com/sidoor>)

## 1.2 About this manual

### 1.2.1 Sales law

To illustrate possible application areas for our products, typical use cases are listed in this product documentation and in the online help. These are purely exemplary and do not constitute a statement on the suitability of the respective product for applications in specific individual cases. Unless explicitly contractually agreed, Siemens assumes no liability for such suitability. Suitability for a particular application in specific individual cases must be assessed by the user, taking into account all technical, legal, and other requirements on a case-by-case basis. Always observe the descriptions of the technical properties and the relevant constraints of the respective product contained in the product documentation.

### 1.2.2 Contents

#### Content of the System Manual

This system manual describes:

- The AT40 CAN, AT40 CAN ADV, AT40 RELAY and ATD400V RELAY controllers are automatic door controllers for use in elevators.
- Geared motors, power supplies, additional units that you can use with the control units.

#### Firmware versions

This System Manual applies to SIDOOR AT40 as of firmware version V01.49 and SIDOOR ATD400V as of firmware version V01.10.

---

#### Note

The current firmware versions for the controllers **SIDOOR AT40 CAN, AT40 CAN ADV, AT40 RELAY and ATD400V RELAY** are available in the Industry Online Support (<https://support.industry.siemens.com/cs/ww/en/ps/18269/dl>).

---

#### Figures

The illustrations in this system manual represent SIDOOR User Software Version 1.2, the SIDOOR control unit and SIDOOR SUPPORT App Version 1.0. The illustrations for earlier product versions may differ slightly.

This documentation should be kept in a location where it can be easily accessed and made available to the personnel responsible.

## Information regarding third-party products

### Note

#### Recommendation relating to third-party products

This document contains recommendations relating to third-party products. Siemens accepts the fundamental suitability of these third-party products.

You can use equivalent products from other manufacturers.

Siemens does not accept any warranty for the properties of third-party products.

### 1.2.3 Target group

The system manual is intended for:

- Assemblers
- Commissioning engineers
- Operators
- Service personnel
- Project engineers

### 1.2.4 What's new?

Revision of the system manual	Change
02/2018	First edition
05/2018	New edition
10/2018	New edition
08/2019	Revision due to SIDOOR AT40 CAN ADV
12/2020	New edition
05/2022	<ul style="list-style-type: none"> <li>• Supplement SIDOOR LINK and SIDOOR SUPPORT App</li> <li>• Supplement Warnings</li> <li>• Text corrections</li> </ul>

### 1.2.5 Standard scope

#### Description

This documentation describes the functionality of the standard scope. This scope may differ from the scope of the functionality of the system that is actually supplied. Please refer to the ordering documentation only for the functionality of the supplied drive system.

## 1.3 SIDOOR documentation

Further functions may be executable in the system, which are not explained in this documentation. However, there is no entitlement to these functions in the case of a new delivery or service.

This documentation does not contain all detailed information on all types of the product. Furthermore, this documentation cannot take into consideration every conceivable type of installation, operation and service/maintenance.

The machine manufacturer must document any additions or modifications they make to the product themselves.

### 1.2.6 Use of third-party products in this documentation

#### Description

This documentation contains recommendations relating to third-party products. Siemens accepts the fundamental suitability of these third-party products. You can use equivalent products from other manufacturers.

Siemens does not accept any warranty for the use of third-party products.

### 1.2.7 Websites of third-party companies

#### Description

This document may contain hyperlinks to third-party websites. Siemens is not responsible for and shall not be liable for these websites and their content. Siemens has no control over the information which appears on these websites and is not responsible for the content and information provided there. The user bears the risk for their use.

## 1.3 SIDOOR documentation

### System manuals

For each application (industrial applications, elevators, railway applications) there are system manuals describing the SIDOOR system with the applicable devices and their commissioning.

### Quick start operating instructions

The quick start operating instructions provide an overview of the SIDOOR devices:

- Which devices you can use together
- The article numbers for ordering these devices
- Information on installation

- Important safety information
- Where you can get more information about the devices

## 1.4 Service and support

---

### Note

#### Parameter documentation for support questions

Record the determined, optimal parameter settings in the configuration protocol (see appendix "Configuration record (Page 172)"). Have this record to hand when for questions from Support.

---

### 1.4.1 Siemens Industry Online Support on the Web

Important product information is available through Siemens Industry Online Support using the following options:

- Website: SIOS (<https://support.industry.siemens.com/cs/ww/en/>)
- App Industry Online Support (for Apple iOS and Android)

#### Content of Siemens Online Support

- Product support
- Global forum for information and best practice sharing between users and specialists
- Local contact persons via the contact person database (→ Contact)
- Product information
- FAQs (frequently asked questions)
- Application examples
- Manuals
- Downloads
- Compatibility tool
- Newsletter with product selection
- Catalogs/brochures
- Certificates

For products with QR code, the manual and certificate can be directly called.



## 1.5 Important product information

### 1.5.1 Intended use

Use the products described in this manual only for elevator door systems and always in conjunction with the motor, power supply unit and control unit.

Observe the permissible product combination options: Table 3-1 Reliable control unit - geared motor combinations (Page 22) / Table 3-2 Reliable power pack - geared motor combinations (Page 23).

#### See also

Geared motors (Page 21)

Power supply (Page 23)

## Basic safety information

### 2.1 General safety instructions

#### 2.1.1 Electric shock and danger to life due to other energy sources



**⚠ WARNING**

**Electric shock and danger to life due to other energy sources**

Touching live components can result in death or severe injury.

- Only work on electrical devices when you are qualified for this job.
- Always observe the country-specific safety rules.

Generally, the following steps apply when establishing safety:

1. Prepare for disconnection. Notify all those who will be affected by the procedure.
2. Isolate the drive system from the power supply and take measures to prevent it being switched back on again.
3. Wait until the discharge time specified on the warning labels has elapsed.
4. Check that there is no voltage between any of the power connections, and between any of the power connections and the protective conductor connection.
5. Check whether the existing auxiliary supply circuits are de-energized.
6. Ensure that the motors cannot move.
7. Identify all other dangerous energy sources, e.g. compressed air, hydraulic systems, or water. Switch the energy sources to a safe state.
8. Check that the correct drive system is completely locked.

After you have completed the work, restore the operational readiness in the inverse sequence.



**⚠ WARNING**

**Electric shock due to connection to an unsuitable power supply**

When equipment is connected to an unsuitable power supply, exposed components may carry a hazardous voltage. Contact with hazardous voltage can result in severe injury or death.

- Only use power supplies that provide SELV (Safety Extra Low Voltage) or PELV- (Protective Extra Low Voltage) output voltages for all connections and terminals of the electronics modules.

**NOTICE**

**Damage to equipment due to unsuitable tightening tools.**

Unsuitable tightening tools or fastening methods can damage the screws of the equipment.

- Only use screw inserts that exactly match the screw head.
- Tighten the screws with the torque specified in the technical documentation.
- Use a torque wrench or a mechanical precision nut runner with a dynamic torque sensor and speed limitation system.
- Adjust the tools used regularly.

**NOTICE**

**Property damage due to loose power connections**

Insufficient tightening torques or vibration can result in loose power connections. This can result in damage due to fire, device defects or malfunctions.

- Tighten all power connections to the prescribed torque.
- Check all power connections at regular intervals, particularly after equipment has been transported.



**WARNING**

**Unexpected machine movement caused by radio devices or mobile phones**

Using radio devices, cellphones, or mobile WLAN devices in the immediate vicinity of the components can result in equipment malfunction. Malfunctions may impair the functional safety of machines and can therefore put people in danger or lead to property damage.

- Therefore, if you move closer than 20 cm to the components, be sure to switch off radio devices, cellphones or WLAN devices.
- Use the "SIEMENS Industry Online Support App" or a QR code scanner only on equipment that has already been switched off.



**WARNING**

**Fire due to inadequate ventilation clearances**

Inadequate ventilation clearances can cause overheating of components with subsequent fire and smoke. This can cause severe injury or even death. This can also result in increased downtime and reduced service lives for devices/systems.

- Ensure compliance with the specified minimum clearance as ventilation clearance for the respective component.



**NOTICE****Overheating due to inadmissible mounting position**

The device may overheat and therefore be damaged if mounted in an inadmissible position.

- Only operate the device in admissible mounting positions.

 **WARNING****Unrecognized dangers due to missing or illegible warning labels**

Dangers might not be recognized if warning labels are missing or illegible. Unrecognized dangers may cause accidents resulting in serious injury or death.

- Check that the warning labels are complete based on the documentation.
- Attach any missing warning labels to the components, where necessary in the national language.
- Replace illegible warning labels.

**NOTICE****Device damage caused by incorrect voltage/insulation tests**

Incorrect voltage/insulation tests can damage the device.

- Before carrying out a voltage/insulation check of the system/machine, disconnect the devices as all converters and motors have been subject to a high voltage test by the manufacturer, and therefore it is not necessary to perform an additional test within the system/machine.

 **WARNING****Unexpected movement of machines caused by inactive safety functions**

Inactive or non-adapted safety functions can trigger unexpected machine movements that may result in serious injury or death.

- Observe the information in the appropriate product documentation before commissioning.
- Carry out a safety inspection for functions relevant to safety on the entire system, including all safety-related components.
- Ensure that the safety functions used in your drives and automation tasks are adjusted and activated through appropriate parameterizing.
- Perform a function test.
- Only put your plant into live operation once you have guaranteed that the functions relevant to safety are running correctly.

**Note**

**Important Safety instructions for Safety Integrated**

If you want to use Safety Integrated functions, you must observe the Safety instructions in the Safety Integrated documentation.



**WARNING**

**Malfunctions of the machine as a result of incorrect or changed parameter settings**

As a result of incorrect or changed parameterization, machines can malfunction, which in turn can lead to injuries or death.

- Protect the parameterization against unauthorized access.

## 2.2 Equipment damage due to electric fields or electrostatic discharge

Electrostatic sensitive devices (ESD) are individual components, integrated circuits, modules or devices that may be damaged by either electric fields or electrostatic discharge.



**NOTICE**

**Equipment damage due to electric fields or electrostatic discharge**

Electric fields or electrostatic discharge can cause malfunctions through damaged individual components, integrated circuits, modules or devices.

- Only pack, store, transport and send electronic components, modules or devices in their original packaging or in other suitable materials, e.g. conductive foam rubber or aluminum foil.
- Only touch components, modules and devices when you are grounded by one of the following methods:
  - Wearing an ESD wrist strap
  - Wearing ESD shoes or ESD grounding straps in ESD areas with conductive flooring
- Only place electronic components, modules or devices on conductive surfaces (table with ESD surface, conductive ESD foam, ESD packaging, ESD transport container).

## 2.3 Warranty and liability for application examples

Application examples are not binding and do not claim to be complete regarding configuration, equipment or any eventuality which may arise. Application examples do not represent specific customer solutions, but are only intended to provide support for typical tasks.

As the user you yourself are responsible for ensuring that the products described are operated correctly. Application examples do not relieve you of your responsibility for safe handling when using, installing, operating and maintaining the equipment.

## 2.4 Cybersecurity information

Siemens provides products and solutions with industrial cybersecurity functions that support the secure operation of plants, systems, machines and networks.

In order to protect plants, systems, machines and networks against cyber threats, it is necessary to implement – and continuously maintain – a holistic, state-of-the-art industrial cybersecurity concept. Siemens' products and solutions constitute one element of such a concept.

Customers are responsible for preventing unauthorized access to their plants, systems, machines and networks. Such systems, machines and components should only be connected to an enterprise network or the internet if and to the extent such a connection is necessary and only when appropriate security measures (e.g. firewalls and/or network segmentation) are in place.

For additional information on industrial cybersecurity measures that may be implemented, please visit <https://www.siemens.com/global/en/products/automation/topic-areas/industrial-cybersecurity.html>.

Siemens' products and solutions undergo continuous development to make them more secure. Siemens strongly recommends that product updates are applied as soon as they are available and that the latest product versions are used. Use of product versions that are no longer supported, and failure to apply the latest updates may increase customer's exposure to cyber threats.

To stay informed about product updates, subscribe to the Siemens Industrial Cybersecurity RSS Feed under <https://new.siemens.com/global/en/products/services/cert.html>.

Further information is provided on the Internet:

Industrial Security Configuration Manual (<https://support.industry.siemens.com/cs/ww/en/view/108862708>)

### WARNING

#### Unsafe operating states resulting from software manipulation

Software manipulations, e.g. viruses, Trojans, or worms, can cause unsafe operating states in your system that may lead to death, serious injury, and property damage.

- Keep the software up to date.
- Incorporate the automation and drive components into a state-of-the-art, integrated industrial cybersecurity concept for the installation or machine.
- Make sure that you include all installed products in the integrated industrial cybersecurity concept.
- Protect files stored on exchangeable storage media from malicious software by with suitable protection measures, e.g. virus scanners.
- Carefully check all cybersecurity-related settings once commissioning has been completed.

## 2.5 Residual risks of power drive systems

When assessing the machine or system-related risk in accordance with the respective local regulations (e.g. EC Machinery Directive), the machine manufacturer or system integrator must take into account the following residual risks emanating from the control and drive components of a drive system:

1. Unintentional movements of driven machine or system components during commissioning, operation, maintenance, and repairs caused by, for example,
  - Hardware faults and/or software errors in the sensors, control system, actuators, and connections
  - Response times of the control system and of the drive
  - Operation and/or environmental conditions outside the specification
  - Condensation/conductive contamination
  - Parameterization, programming, cabling, and installation errors
  - Use of wireless devices/mobile phones in the immediate vicinity of electronic components
  - External influences/damage
  - X-ray, ionizing radiation and cosmic radiation
2. Unusually high temperatures, including open flames, as well as emissions of light, noise, particles, gases, etc., can occur inside and outside the components under fault conditions caused by, for example:
  - Component failure
  - Software errors
  - Operation and/or environmental conditions outside the specification
  - External influences/damage
3. Hazardous shock voltages caused by, for example:
  - Component failure
  - Influence during electrostatic charging
  - Operation and/or environmental conditions outside the specification
  - Condensation/conductive contamination
  - External influences/damage
4. Release of environmental pollutants or emissions as a result of improper operation of the system and/or failure to dispose of components safely and correctly
5. Influence of network-connected communication systems, e.g. ripple-control transmitters or data communication via the network
6. Motors for use in potentially explosive areas:

When moving components such as bearings become worn, this can cause enclosure components to exhibit unexpectedly high temperatures during operation, creating a hazard in areas with a potentially explosive atmosphere.

For more information about the residual risks of the drive system components, see the relevant sections in the technical user documentation.

## System overview

### 3.1 System configuration and area of application

#### Overview of system configuration

The graphic uses the example of a horizontal elevator door to illustrate the general structure of an automatic door control unit with the SIDOOR system including the additional components such as the power supply and drive.

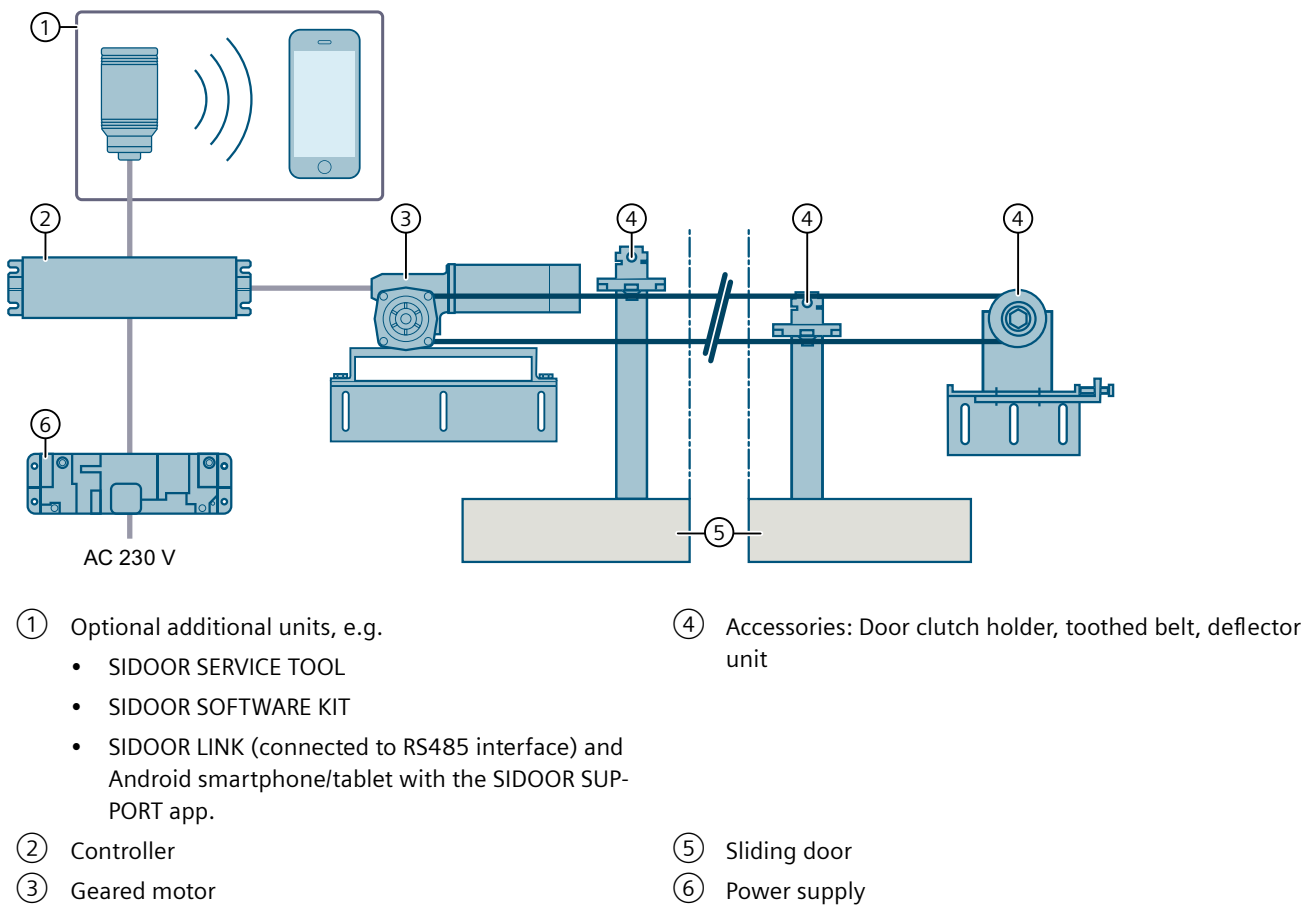

Figure 3-1 System configuration

## Elevators

The following controllers are offered for use in elevators:

- **SIDOOR AT40 product family**  
The convenient elevator door drive of the SIDOOR AT40 product family is an "intelligent" door drive, with which car and landing doors are operated with adjustable speeds and accelerations.
- **SIDOOR ATD400V**  
The rising gate and rolling shutter door drive SIDOOR ATD400V is an "intelligent" door drive with which cabin and shaft doors can be operated with adjustable speeds and accelerations.

## 3.2 Products

The included parts are described in the following chapters:

- Controllers (Page 59)
- Geared motors (Page 95)
- Power supply unit (Page 111)

---

### Note

The SIDOOR AT12 product is described in a separate documentation. You can find the Equipment Manual on the Internet (<https://support.industry.siemens.com/cs/ww/en/view/58497029>)

---

### 3.2.1 Controllers



Controllers are electronic control units connected to the power supply via an external power supply unit (SIDOOR NT40, SIDOOR TRANSFORMER, SIDOOR TRANSFORMER UL). They can be parameterized via a user interface.

The controllers are designed for different areas of application. The following table provides an overview of the available controllers.

## Controllers for elevator door systems

The following table provides you with an overview of the controllers for elevator doors.

Controller	Article No.	Description
<b>Elevator door control units</b>		
SIDOOR AT40 RELAY	6FB1111-0AT10-3AT2	<ul style="list-style-type: none"> <li>Controller for horizontal elevator doors, up to 600 kg door weight</li> <li>Including relay module</li> </ul>
SIDOOR AT40 CAN	6FB1111-1AT10-3AT3	<ul style="list-style-type: none"> <li>Controller for horizontal elevator doors, up to 600 kg door weight</li> <li>Including CAN module (interface for superior elevator control)</li> </ul>
SIDOOR AT40 CAN ADV	6FB1111-1AT11-3AT3	<ul style="list-style-type: none"> <li>Controller for horizontal elevator doors, up to 600 kg door weight</li> <li>Including CAN module (interface for higher-level elevator control)</li> <li>Remote maintenance data</li> </ul>
SIDOOR ATD400V RELAY	6FB1111-1AT10-3VE2	<ul style="list-style-type: none"> <li>Controller for rising gate and rolling shutter doors in the elevator field of application, vertical, up to 600 kg (M4 and M5) door weight</li> <li>Including relay module</li> </ul>

### 3.2.2 Geared motors



Geared motors form the maintenance-free drive unit in the door drive. The geared motors feature DC motors with non-self-locking gearing and are speed-controlled. The set force and speed limits are not exceeded.

Transmission takes place via a toothed belt, which passes over a guide pulley and can be

fitted with two door clutch holders. This enables both single-sided and centrally-opening doors to be driven.

### Reliable control unit - geared motor combinations

Table 3-1 Reliable control unit - geared motor combinations

Control unit/geared motor	SIDOOR M2	SIDOOR M3	SIDOOR M4	SIDOOR M5
AT40	✓	✓	✓	✓
ATD400V	-	-	✓	✓

### Ordering data

Geared motor	Article No.	Description
SIDOOR M2 L	6FB1103-0AT10-5MAO	<ul style="list-style-type: none"> <li>Geared motor, pinion left, max. 120 kg moved mass</li> <li>Cable length 1.5 m</li> </ul>
SIDOOR M2 R	6FB1103-0AT11-5MAO	<ul style="list-style-type: none"> <li>Geared motor, pinion right, max. 120 kg moved mass</li> <li>Cable length 1.5 m</li> </ul>
SIDOOR M3 L	6FB1103-0AT10-4MBO	<ul style="list-style-type: none"> <li>Geared motor, pinion left, max. 180 kg moved mass</li> <li>Cable length 1.5 m</li> </ul>
SIDOOR M3 R	6FB1103-0AT11-4MBO	<ul style="list-style-type: none"> <li>Geared motor, pinion right, max. 180 kg moved mass</li> <li>Cable length 1.5 m</li> </ul>
SIDOOR M4 L	6FB1103-0AT10-3MCO	<ul style="list-style-type: none"> <li>Geared motor, pinion left, max. 400 kg moved mass</li> <li>Cable length 1.5 m</li> </ul>
SIDOOR M4 R	6FB1103-0AT11-3MCO	<ul style="list-style-type: none"> <li>Geared motor, pinion right, max. 400 kg moved mass</li> <li>Cable length 1.5 m</li> </ul>
SIDOOR M5 L	6FB1103-0AT10-3MDO	<ul style="list-style-type: none"> <li>Geared motor, pinion left, max. 600 kg moved mass</li> <li>Cable length 1.5 m</li> </ul>
SIDOOR M5 R	6FB1103-0AT11-3MDO	<ul style="list-style-type: none"> <li>Geared motor, pinion right, max. 600 kg moved mass</li> <li>Cable length 1.5 m</li> </ul>

### See also

Accessories (Page 30)



### 3.2.3 Power supply



SIDOOR power supplies connect the controllers to the respective application-specific power supply.

### Reliable power pack - geared motor combinations

Table 3-2 Reliable power pack - geared motor combinations

Power supply unit / geared motor	SIDOOR M2	SIDOOR M3	SIDOOR M4	SIDOOR M5
SIDOOR NT40	✓	✓	✓	✓
SIDOOR TRANSFORMER	✓	✓	✓	Not permitted
SIDOOR TRANSFORMER UL	✓	✓	✓	Not permitted

### Ordering data

Table 3-3 Ordering data

Power supply	Article No.	Description
SIDOOR NT40	6FB1112-0AT20-3PS0	Power supply for controllers without an integrated power supply unit.
SIDOOR TRANSFORMER	6FB1112-0AT20-2TR0	
SIDOOR TRANSFORMER UL	6FB1112-0AT21-2TR0	

### See also

Power supply (Page 111)

### 3.2.4 Optional additional units

Additional units meet a range of requirements in order to ensure the universal implementation and maintenance of the system.

### 3.2 Products

The following additional units are possible:

- SIDOOR SERVICE TOOL
- SIDOOR LINK adapter
- SIDOOR SOFTWARE KIT

Connect the additional units to the control unit in a de-energized state via the interfaces provided. After applying the mains supply, the additional units are immediately available.

### 3.2.4.1 SIDOOR SERVICE TOOL

The SIDOOR SERVICE TOOL offers the same functionality as the SIDOOR TERMINAL MODULE. In special installation situations, using the SIDOOR SERVICE TOOL is helpful.

The scope of functions is described in the navigation structure (Page 140).

Connect the SIDOOR SERVICE TOOL to the RS 485 interface using a 1.5 m cable.

#### Ordering data

	Article No.
SIDOOR SERVICE TOOL	6FB1105-0AT01-6ST0

#### Note

##### Protection against unauthorized access

Use the SIDOOR SERVICE TOOL only for commissioning and maintenance purposes only.

Following commissioning or maintenance, remove the SIDOOR SERVICE TOOL and its connecting cable from the SIDOOR control unit.

#### See also

SIDOOR SERVICE TOOL (Page 137)

### 3.2.4.2 SIDOOR SUPPORT app and SIDOOR LINK



The optional SIDOOR LINK adapter, in combination with the SIDOOR SUPPORT app on the Android smartphone or Android tablet, enables you to conveniently operate, diagnose and configure the SIDOOR control unit.

#### Requirements

You need an Android smartphone or Android tablet from Android operating system V11.0 with Bluetooth LE V5.0 for the installation of the SIDOOR SUPPORT app.

#### Principle of operation

Establish a Bluetooth LE 5.0 connection to an Android smartphone or Android tablet with the SIDOOR SUPPORT app installed via the SIDOOR LINK adapter.

Conveniently perform the commissioning of a door system via the SIDOOR SUPPORT app with a SIDOOR control unit.

#### Ordering data

	Article No.	Scope of delivery
SIDOOR LINK adapter	6FB1305-0AT00-0AS4	The package includes the following components: <ul style="list-style-type: none"><li>• 1 x SIDOOR LINK adapter</li><li>• 1 x D-Sub connecting cable (9-pin, plug/socket)</li></ul>

Additional information can be found in the function manual for the SIDOOR SUPPORT App (<https://support.industry.siemens.com/cs/de/de/view/109802679>).

**NOTICE****Protection against unauthorized access**

Use the SIDOOR SUPPORT and the SIDOOR LINK for commissioning and maintenance purposes only.

Following commissioning or maintenance, remove the SIDOOR LINK adapter and its connecting cable from the SIDOOR control unit.

---

**Note**

The terminal module function is also available via the SIDOOR SUPPORT.

---

**See also**

SIDOOR LINK and SIDOOR SUPPORT App (Page 147)

## 3.2.4.3 SIDOOR SOFTWARE KIT



The optional SIDOOR Software Kit facilitates user-friendly operation and detailed diagnostics via a PC.

## Selection

Software	Article No.	Description
SIDOOR SOFTWARE KIT	6FB1105-0AT01-6SW0	<p>The package includes the following components:</p> <ul style="list-style-type: none"> <li>• Installation CD (Software Kit)               <ul style="list-style-type: none"> <li>– SIDOOR User Software</li> <li>– Siemens HCS12 Firmware Loader</li> <li>– SIDOOR USB to UART Bridge Driver</li> <li>– License provisions</li> <li>– SIDOOR SOFTWARE KIT Operating Instructions</li> </ul> </li> <li>• 1 x USB adapter</li> <li>• 1 x USB connecting cable</li> <li>• 1x D-SUB connecting cable (9-pin, plug/socket)</li> <li>• 1x D-SUB connecting cable (9-pin, socket/socket)</li> </ul>

The entire contents of the installation CD from the SIDOOR SOFTWARE KIT are also available Installation package (<https://support.industry.siemens.com/cs/ww/en/view/109481599>) in the Industry Online Support.

You can find additional information about the SIDOOR SOFTWARE KIT in the SIDOOR SOFTWARE KIT Operating Instructions (<https://support.industry.siemens.com/cs/ww/en/view/92711247>).

**Note****Protection against unauthorized access**

Use the SIDOOR SOFTWARE KIT and the SIDOOR USB adapter for commissioning and maintenance purposes only.

Following commissioning or maintenance, remove the SIDOOR USB adapter and its connecting cable from the SIDOOR control unit.

---

**Note**

The terminal module function is also available via the SIDOOR SOFTWARE KIT.

---

### 3.2.5 Accessories

Accessories	Article No.	Description
SIDOOR rubber-metal anti-vibration mount	6FB1104-0AT01-0 ADO	<ul style="list-style-type: none"> <li>Rubber-metal anti-vibration mount for quiet operation of the door drive system</li> <li>Recommended for mounting SIDOOR M4 R / L and M5 R / L geared motors</li> </ul>
	6FB1104-0AT02-0 ADO	<ul style="list-style-type: none"> <li>Rubber-metal anti-vibration mount for quiet operation of the door drive system</li> <li>Recommended for mounting SIDOOR M2 R / L and M3 R / L geared motors</li> </ul>
SIDOOR mounting bracket	6FB1104-0AT01-0 AS0	Mounting bracket for mounting the SIDOOR rubber-metal anti-vibration mount on which, in turn, a SIDOOR geared motor is mounted
	6FB1104-0AT02-0 AS0	<ul style="list-style-type: none"> <li>Mounting bracket with tensioning device for deflector pulley</li> <li>For mounting the SIDOOR deflector unit and for tensioning the SIDOOR toothed belt</li> </ul>
SIDOOR deflector pulley	6FB1104-0AT04-0 AS0	Deflector pulley for deflecting the SIDOOR toothed belt
SIDOOR deflector unit	6FB1104-0AT03-0 AS2	<ul style="list-style-type: none"> <li>Deflector unit with deflector pulley</li> <li>For deflecting the SIDOOR toothed belt in the same height and depth, aligned with motor drive pinion</li> </ul>
SIDOOR door clutch holder	6FB1104-0AT01-0 CPO	<ul style="list-style-type: none"> <li>Door clutch holder for 12 mm-wide toothed belt (<b>Note:</b> Toothed belt width of 12 mm is to be used preferentially for SIDOOR M2 and SIDOOR M3.)</li> <li>For attaching both ends of the toothed belt, and for connecting the respective door panel to the toothed belt</li> </ul>
	6FB1104-0AT02-0 CPO	<ul style="list-style-type: none"> <li>Door clutch holder for 14 mm-wide toothed belt (<b>Note:</b> Toothed belt width of 14 mm is to be used preferentially for SIDOOR M4 and SIDOOR M5.)</li> <li>For attaching both ends of the toothed belt, and for connecting the respective door panel to the toothed belt</li> </ul>
SIDOOR toothed belt	6FB1104-0AT01-0 ABO	<ul style="list-style-type: none"> <li>Single-toothed STS Super Torque toothed belt</li> <li>Length 4 m, width 12 mm.</li> </ul>
	6FB1104-0AT02-0 ABO	<ul style="list-style-type: none"> <li>Single-toothed STS Super Torque toothed belt</li> <li>Length 45 m, width 12 mm.</li> </ul>
	6FB1104-0AT03-0 ABO	<ul style="list-style-type: none"> <li>Single-toothed STS Super Torque toothed belt</li> <li>Length 4 m, width 14 mm.</li> </ul>
	6FB1104-0AT04-0 ABO	<ul style="list-style-type: none"> <li>Single-toothed STS Super Torque toothed belt</li> <li>Length 55 m, width 14 mm.</li> </ul>

You will find more accessories in the Industry Mall (<https://www.siemens.com/siplus/mall>)



# SIDOOR functions

## Overview

This section describes all the functions of the SIDOOR control devices.

The functions are divided into:

- **Basic functions:** Functions that you always require to use a SIDOOR door control system.
- **System functions:** Functions that enable you to better monitoring and diagnose the system.
- **Extended functions:** Functions that you can use to implement application-specific requirements.

## Functions

Table 4-1 Available SIDOOR functions

Functions	SIDOOR			
	AT40 RE-LAY	AT40 CAN	AT40 CAN ADV	ATD400V
<b>Basic functions</b>				
Learn run (Page 32)	✓	✓	✓	✓
DCPS (Door Closed Position Sensor) (Page 36)	✓ <sup>1)</sup>	✓ <sup>1)</sup>	✓ <sup>1)</sup>	✓ <sup>1)</sup>
CLOSE DOOR (command given via digital inputs) (Page 38)	✓	✓	✓	✓
OPEN DOOR (command given via digital inputs) (Page 39)	✓	✓	✓	✓
Nudge (Page 40)	✓	✓	✓	✓
<b>System functions</b>				
Restart after power failure (Page 41)	✓	✓	✓	✓
Overload protection (Page 42)	✓	✓	✓	✓
Vandalism protection/continuous door monitoring (Page 42)	✓	✓	✓	✓
Oscillation protection (Page 42)	✓	✓	✓	✓
Automatic energy limiting (Page 43)	✓	✓	✓	✓
Emergency release (Page 46)	✓	✓	✓	✓
External closing force (Page 47)	✓	✓	✓	✓
<b>Extended functions</b>				
Obstruction detection (Page 48)	✓	✓	✓	✓
SERVICE TOOL maintenance data (Page 49)	✓	✓	✓	✓
Emergency power mode (Page 56)	✓ <sup>2)</sup>	✓ <sup>2)</sup>	✓ <sup>2)</sup>	✓ <sup>2)</sup>
Spring mechanism in closed position (Page 55)	✓	✓	✓	✓
Terminal module (Page 85)	✓	✓	✓	✓
CAN module (Page 69)	-	✓	✓	-
Relay module (Page 66)	✓	-	-	✓

4.1 Basic functions

Functions	SIDOOR			
	AT40 RE-LAY	AT40 CAN	AT40 CAN ADV	ATD400V
CANopen maintenance data ( <a href="https://support.industry.siemens.com/cs/ww/en/ps/18268/man">https://support.industry.siemens.com/cs/ww/en/ps/18268/man</a> )	-	-	✓	-
<b>Light barrier</b>				
Light barrier (Page 57)	✓ <sup>1) 2)</sup>	✓ <sup>1) 2)</sup>	✓ <sup>1) 2)</sup>	✓ <sup>1) 2)</sup>

- 1) Light barrier and DCPS cannot be implemented at the same time.
- 2) Emergency power mode and light barriers with feedback contact cannot be implemented simultaneously.

## 4.1 Basic functions

The basic functions described below are always available when using a SIDOOR controller.

### 4.1.1 Learn run

#### Description of function

A learn run is used to determine and store the characteristics of a particular system.

 <b>WARNING</b>
<p><b>Risk of injury due to persons present in the range of motion</b></p> <p>If persons are present in the range of motion during the learn run, there is a considerable risk of injury due to the increased forces and energies on the doors. Therefore, secure the door area during the learn run. This will prevent unauthorized persons from entering the range of motion of the doors.</p>

#### Note

If a DCP sensor is used, the position of the DCP sensor is determined during the learn run. If the DCP sensor position is changed, a new learn run must be carried out.

### Types of learn run (via learn run button)

Two types of learn run can be performed if the learn run button is pressed for at least one second as follows:

- **When the line voltage is applied**

If the learn run button is operated directly when the line voltage is applied, the connected motor type is learned. All driving parameters as well as force and energy limiting parameters are automatically reset to their factory defaults before the learn run is begun. The learn run determines the door width, weight and CLOSED position. In addition, the speed in nudging mode and the maximum closing speed are preset depending on the permissible energy and the moved mass.

Application examples: initial commissioning or when commissioning a new motor type

- **During operation**

If the learn run button is actuated during ongoing operation, a learn run is started to determine the door's width, weight and CLOSED position. In addition, the speed in nudging mode and the maximum closing speed are preset depending on the permissible energy and the moved mass.

Application examples: Modifying the properties of the door system (door width or door weight)

### Starting a learn run via the learn run button

You can start a learn run by pressing the learn run button (S401). Proceed as described in the section Learn run button (Page 33).

### Querying determined values

The values determined for the effective weight and the door width can be queried via the terminal module and also via the SIDOOR SOFTWARE KIT, the SIDOOR SUPPORT app and the SIDOOR SERVICE TOOL.

#### 4.1.2 Learn run button

Use the learn run button (S401) to start a learn run. The direction of travel, the door width and the moved mass are determined during the learn run.

---

**Note**

Two types of learn run can be performed. See section Learn run (Page 32).

---

 <b>WARNING</b>
<p><b>Physical injury due to door movements</b></p> <p>Increased forces, speeds and energies arise in the closing and opening directions during the learn run.</p> <p>After completion of the learn run, any pending door command will be performed immediately.</p> <p>The door movements cannot be externally controlled while the controller is being commissioned.</p> <ul style="list-style-type: none"> <li>• Ensure that the door is secured with physical barriers prior to a learn run and during commissioning.</li> <li>• Make sure that the door is in CLOSED position.</li> <li>• Make sure that the range of motion is clear 10 to 20 cm from the CLOSED position.</li> <li>• Ensure that the motor temperature is above 0 °C, otherwise the value of the door weight will be determined incorrectly and the closing speed could be in the impermissible range.</li> </ul>

**Learn run with standard parameters:**

In case of the following displays, a learn run should be started via the service menu "General setup > Start learn run with default parameters":

7-segment display	Description
" _ "	No motor has yet been learned. Learn run required.
"5"	New motor type detected.
"p"	Learn run canceled.

**Maximum door width:**

The direction of travel, the door width and the moved mass are determined during the learn run.

The maximum door width must be between 30 cm and 5 m.

The maximum moved mass depends on the motor used.

**Note**

If a DCP sensor is used, the position of the DCP sensor is determined during the learn run.

If the DCP sensor position is changed, a new learn run must be carried out.

**Parameter assignment**

Using the service menu "General setup > Special parameters > Opening force learn run" and "General setup > Special parameters > Closing force learn run" the effective force limitation during the learn run can be set for the opening and closing direction.

The default value for the force limit in the opening direction during the learn run corresponds to the high force limit in the opening direction.

The default value for the effective force limit during the learn run in the closing direction is 230 N for AT40 and ATD400V.

The higher effective force limit from the opening or closing direction is used to determine the closed position.

### Note

If a slightly too large door width is determined during the learn run, it can happen that after the mains voltage is applied again, the active "initial mode" is not exited and the door always runs at initial speed. In this case, the effective force during the learn run should be reduced.





If an obstruction occurs during the learn run (e.g. sluggish door), the effective force during the learn run can be increased.

After changing the effective forces during the learn run, a "normal" learn run should be performed.

During a learn run with default parameters, the effective forces for a learn run are reset to the default values.

### Learn run (when the supply voltage is applied)

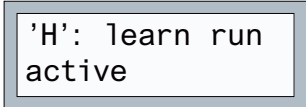
Table 4-2 Starting a learn run when the line voltage is applied

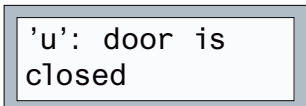
Procedure		H401 display	H1 display
1.	Push the door into the CLOSED position.		
2.	Disconnect the power supply from X3 (DC).		
3.	Press the learn run button (S401) and keep it pressed.		
4.	Connect the power supply to X3 (DC).		
5.	The learn run starts automatically and the learn run button can be released.		
6.	During the learn run, the door is opened about 10 cm, and closed once or twice at creep speed. The friction of the door system is then determined by opening and closing the door once through a range of 25 cm at creep speed.  The door then opens and closes through its complete range of movement at reduced speed. After the door has opened by approximately 15 cm, it passes through an additional short acceleration ramp to determine the weight of the door.		
7.	The door parameters and the determined door width are saved when the door is in the CLOSED position.  This means that the door width and weight are re-adapted and saved. In addition, the default values for the driving curve parameters are loaded and the speed limits are preset on the basis of the determined mass and permissible energies.		
8.	Learn run completed. <b>Note:</b> If the light barrier / DCPS is set to light barrier and no light barrier is connected or if the light barrier bypass is not inserted or if the light barrier is interrupted, the 7-segment display shows "0".		

4.1 Basic functions

**Learn run (during operation)**

Table 4-3 Starting a learn run during operation

Procedure		H401 display	H1 display
1.	Push the door into the CLOSED position.		
2.	Press the learn run button (S401) and keep it pressed.		
3.	The learn run starts automatically and the learn run button can be released.		<div style="border: 1px solid black; padding: 5px; width: fit-content;">'H': learn run active</div>
4.	During the learn run, the door is opened about 10 cm, and closed once or twice at creep speed. The friction of the door system is then determined by opening and closing the door once through a range of 25 cm at creep speed. The door then opens and closes through its complete range of movement at reduced speed. After the door has opened by approximately 15 cm, it passes through an additional short acceleration ramp to determine the weight of the door.		
5.	The door parameters and the determined door width are saved when the door is in the CLOSED position. This means that the door width, door weight, energy limitation and speed limitation are re-adapted and saved.		
6.	Learn run completed. <b>Note:</b> If the light barrier / DCPS is set to light barrier and no light barrier is connected or if the light barrier bypass is not inserted or if the light barrier is interrupted, the 7-segment display shows "0".		<div style="border: 1px solid black; padding: 5px; width: fit-content;">'u': door is closed</div>

**4.1.3 DCPS (Door Closed Position Sensor)**

**Description of function**

DCPS stands for Door Closed Position Sensor or DOOR CLOSED sensor. The Door Closed Position Sensor is not a special sensor, but an open or closed contact as far as the controller is concerned. If the contact is closed, the door is in the CLOSED position. The user is responsible for the design of the contact.

The DCPS enables the door to travel in normal operation immediately after the line voltage is switched on without an initialization run. This requires the door to be in the CLOSED position when the power is switched on. This enables the controller to be completely switched off if the elevator is not going to be used for a lengthy period, for example during the night.

If the contact remains closed although the door has left its CLOSED position, the controller switches to initial operation after 10 cm, and continues the movement at initial speed. The door does not resume moving at normal speed until after it has traveled to both end positions.

## Connection and parameter assignment

The DCPS signal can be connected via the input terminal X6 Pin 5/6. See also section Digital input signals (Page 62). The connected signal must be activated via the SIDOOR SERVICE TOOL, Terminal Module or SIDOOR SOFTWARE KIT (*MAIN MENU > General setup > Special parameters > Input 1*).

When the DCPS has been configured (service menu "*General setup > Special parameters > Input 1 = DCPS*"), the "DOOR CLOSE" status is signaled under the following conditions:

- In initial mode, when the DCPS signal is active, no opening command is applied and no DCPS error is pending.
- In normal mode, when the DCPS signal is active, no opening command is applied and the door is in the slow start / end distance mode.
- During closing travel the CLOSE relay (X11) picks up when the DCPS signal is active and the door is in the slow start / end distance mode.
- When the door is pushed open manually, the CLOSE relay drops out (as soon as the DCPS signal becomes inactive).
- If the DCPS signal is active for a longer stretch than 10 cm, or at a distance of more than 10 cm to the CLOSE position, this is recognized as a DCPS error and the system changes to the initial mode.
- A DCPS error is reset when both end positions of the door have been recognized and the door control unit is in the normal mode.
- The control system changes from the initial mode into the normal mode, "Closed" state, when the DCPS signal is active in the initial module during an obstruction in the closing direction or during switching on.

---

### Note

The light barrier and DCPS functions cannot be implemented simultaneously.

---

### Note

During the learn run, the position of the DCP sensor is determined and saved. If the position of the DCP sensor was changed, you have to execute another learn run.

---

## Signals

Signal	Meaning
1 (voltage applied)	Door is in the CLOSED position
0 (voltage not applied)	Door is not in the CLOSED position

### 4.1.4 DOOR CLOSE (command given via digital inputs)

#### Description of function

The DOOR CLOSE command closes the door according to the set driving curve as long as the command is present. The door reaches the CLOSED position at slow end speed close. In the area of the slow start and end distances, the force is limited to the configured limit force. Then, at an active DOOR CLOSE command, the door is kept closed for 2 seconds with the "Peak torque close" parameter and subsequently with the "Idle torque close" parameter.

As of version AT40 V1.47 and ATD400V V1.08, the idle torque in the end position can also be activated without an active door command by using the service menu "General setup -> Special parameters -> Idle torque without door command". The default value for this parameter is "OFF" (no idle torque without door command). The following function is active when the set value is "ON":

- In the CLOSE position, the door is kept closed with the set torque even if no active Door CLOSE command is pending. If in this case the door is pushed out more than 5 mm from the CLOSE position, no new travel into the CLOSE position takes place.

---

#### Note

The "Idle torque (power) CLOSE" parameter has to be adjusted in such a way that the door cannot be pushed out of the end position, e.g. through a spring in the closing mechanism, or rubber buffer in the end stop. See also the sections "Forces (Page 88)" and "Oscillation protection (Page 42)"

To ensure an emergency release, observe the section "Emergency release (Page 46)".

---

#### Note

If the commands DOOR CLOSE and DOOR OPEN are present simultaneously, the door moves in the OPEN direction.

---

#### Connection

The "DOOR CLOSE" function is connected to the input terminal X6 Pin 2. See also section Digital input signals (Page 62).

#### Signals

Signal	Meaning
1 (voltage applied)	The DOOR CLOSE command is present
0 (voltage not applied)	The DOOR CLOSE command is not present



## 4.1.5 DOOR OPEN (command given via digital inputs)

### Description of function

The DOOR OPEN command opens the door according to the set driving curve as long as the command is present. The door reaches the OPEN position at creep speed. Then, if the DOOR OPEN command is present, the door is held open by the torque that can be adjusted by the parameter "*Idle torque OPEN*".

The DOOR OPEN command has priority over all other control commands.

---

#### Note

If the commands DOOR CLOSE and DOOR OPEN are present simultaneously, the door moves in the OPEN direction.

---

As of version AT40 V1.47 and ATD400V V1.08, the idle torque in the end position can also be activated without an active door command by using the service menu "*General setup -> Special parameters -> Idle torque without door command*". The default value for this parameter is "OFF" (no idle torque without door command). The following function is active when the set value is "ON":

- In the OPEN position, the door is kept open with set torque, even if no active Door OPEN command is pending. If in this case the door is pulled out more than 20 mm from the OPEN position, no new travel into the OPEN position takes place. Relay X13 (OPEN position detected) becomes active when the door control unit has detected the door end stop.

---

#### Note

The idle torque has to be set so that the door cannot be pulled from the end position, e.g. through the counterweight or rubber buffers in the end stop. See also the sections "Forces (Page 88)" and "Oscillation protection (Page 42)".

---

As of version AT40 V1.47 and ATD400V V1.08 the creep speed can be reduced to 3 cm/s when 2 cm in front of the end position OPEN, using the service menu "*General setup -> Special parameters -> Slow travel to OPEN end position*", irrespective of the parameterized value. The default value for this parameter is "OFF" (no change of the slow end speed). The following function will become active when the set value is "ON":

- During the last 2 cm of the opening travel, the door is decelerated to 3 cm/s. The kinetic energy is reduced when the open position is reached.

The reversal behavior in opening direction is described in the section Obstruction detection OPEN (Page 48).

As standard, no command output via the digital inputs is possible with an activated CAN interface.

As of version AT40 V1.49 and ATD400V V1.10, a DOOR OPEN command can be output via the digital input signal DOOR OPEN, also with activated CAN interface. This command has a higher priority than the door commands via the CAN interface. This function can be activated using the service menu "*General setup -> Special parameters -> OpenCAN inp.*" For compatibility reasons, this function is deactivated by default.

### Connection

The "DOOR OPEN" function is connected to the input terminal X6 Pin 1. See also section Digital input signals (Page 62).

### Signals

Signal	Meaning
1 (voltage applied)	The DOOR OPEN command is present
0 (voltage not applied)	The DOOR OPEN command is not present

## 4.1.6 Nudge

### Description of function

If a "Nudge" command is present, the reversing unit is deactivated. The input signals CLOSE and NUDGE must be active so that the NUDGE operating state is only effective in the closing direction. When an obstacle is detected, the motor current after 1 s is reduced to the rated motor current.

### Connection

The "Nudge" function is connected to "Input 2" (X6). For more, see also section Digital input signals (Page 62).

The function is only active in conjunction with the CLOSE input signal.

### Signals

Signal	Meaning
1 (voltage applied)	The nudge command is present if the DOOR CLOSE command is activated at the same time. The reversing unit is deactivated.
0 (voltage not applied)	The nudge command is not present.

## 4.2 System functions

The system functions described below allow you to better monitor and run diagnostics on the system.

## 4.2.1 Restart after power failure

### Description of function

After a power failure, the controller has to redetermine the end positions of the door travel (initial mode). To do this, the door travels at reduced speed (initial speed) until the controller has detected the OPEN and CLOSED end positions. The door then resumes traveling at normal speed.

Changes in the driving curve parameters are applied in the initial mode at a standstill.

The CLOSE relay (X11) picks up when a "DOOR CLOSE" command is active and the door is blocked for at least 1 second in the CLOSE direction. The CLOSE relay (X11) drops off when the door has moved from the blocking position by 1 cm in the OPEN direction, or a "DOOR OPEN" command is active.

The OPEN relay (X13) picks up when a "DOOR OPEN" command is active and the door is blocked for at least 1 second in the initial mode in the OPEN direction. The OPEN relay (X13) drops off when the door has moved from the blocking position by 2 cm in the CLOSE direction, or a "DOOR CLOSE" command is active.

The initial mode can be skipped by connecting an end position sensor (DCPS) in the closed position.

The door travels open immediately with the normal speed when the DCPS (see section DCPS (Door Closed Position Sensor) (Page 36)) is set up. In this case, the door must be in the CLOSED position for the restart.

If a defect in the end position sensor is recognized (sensor is active across a distance of more than 10 cm), the system changes back to the initial mode (see section DCPS (Door Closed Position Sensor) (Page 36)).

### 4.2.2 Overload protection

#### Description of function

If the drive motor placed under a high load with frequent DOOR OPEN and DOOR CLOSE commands in quick succession, the hold-open time is automatically lengthened. The next closing movement is delayed even if a DOOR CLOSE command is present, the 7-segment display (H401)/digital display (H1) shows "4". This function prevents thermal overloading of the motor.

Reversing the direction of rotation or restarting the controller several times puts a disproportionate strain on the drive motor.

The controller switches to motor protection mode for 30 seconds and does not accept any door commands. This state is signaled by a "4" on the 7-segment display (H401)/the digital display (H1).

This function prevents thermal overloading of the motor.

### 4.2.3 Vandalism protection/continuous door monitoring

#### Description of function

The vandalism protection/continuous door monitoring function offers protection against undesired external system motion. If the motor is deenergized, the motor speed is monitored by the controller.

If no door command is applied and the door speed exceeds 200 mm/s, the controller actively brakes the drive down to 50 mm/s and then deenergizes the motor again.

### 4.2.4 Oscillation protection

The oscillation protection prevents permanent oscillation of the door at the end stop.

#### End position "open"

If the system is pressed out of the end position with the drive order "open" present, the system detects that the "open" position has been left, and attempts to return to the end stop with the set static opening force.

After reaching the end stop, the drive is energized with the set continuous torque.

The behavior described may be repeated five times (oscillation). After the fifth repetition, the drive is energized for 30 s with the set continuous torque without any response to further oscillations. After a protective period of 30 s, the system responds once again to corresponding oscillations.

## End position "closed"

If the system is pressed out of the end position with the drive order "close" present, the system detects that the "closed" position has been left, and attempts to return to the end stop with the set static cutter force.

After reaching the end stop, the drive is energized with the set peak torque close. After 2 s, the peak torque close is limited to the set continuous torque.

The behavior described may be repeated five times (oscillation). After the fifth repetition, the drive is energized for 30 s with the set continuous torque without any response to further oscillations. After a protective period of 30 s, the system responds once again to corresponding oscillations.

---

### Note

The behavior during restart in the end positions of the door is described in connection with the relays X11 "CLOSE" and X13 "OPEN" in the section 3.2.1 Restart after power failure (Page 41).

---

## 4.2.5 Automatic energy limitation

### Description of function

SIDOOR control devices have a system that automatically limits the kinetic energy in the closing direction.

 <b>WARNING</b>
--

<b>Risk of injury due to moving mechanical parts</b>
--

Irrespective of the maximum closing speed determined automatically during the learn run, after a learn run the kinetic energy of the door in the closing direction must be checked by the commissioning engineer.
---

- |  |
|--|
| <ul style="list-style-type: none"><li>• According to EN 81, the kinetic energy of the door in the closing direction must not exceed the value of 10 joules while the reversing unit is enabled.</li><li>• Without an enabled reversing unit, the kinetic energy of the door in the closing direction must not exceed the value of 4 joules according to EN 81 and each closing operation must be signaled acoustically. The acoustic signal required in the standard is not part of the SIDOOR system and must be provided and ensured externally by the operator.</li></ul> |
|--|

The set maximum closing speed and the nudging speed must be reduced accordingly.
--

Check the final application-specific limit values and adjust them accordingly.
--

4.2 System functions

After a learn run, the parameter "Maximum speed close" is set to 10 J and the parameter "Nudging speed close" is set to 4 J based on the moved weight as determined during the learn run.

**Note**

The actual kinetic energy occurring in the closing direction has to be checked during commissioning, and the parameters "Maximum speed close" and "Nudging speed close" may have to be adapted.

The maximum kinetic energy of the door is limited to 100 J. The maximum attainable door speed is limited according to the dynamic mass determined during the learn run.

Calculation of the door speed (v) on the basis of the kinetic energy (W) and the dynamic mass (m) determined during the learn run:

$$v = \sqrt{\frac{2 \cdot W}{m}}$$

**Speed limit curve (in the closing direction\*)**

The speed limit curve is the characteristic that determines the maximum permissible door speed (closing speed),  $v_{max}$ , as a function of the total mass to be moved. According to EN 81, the maximum kinetic energy of the door in the closing direction must not exceed 10 joules.

$$W_{KIN} = 1/2 m \cdot v^2 = 10 \text{ J.}$$

Example using the following speed limit curve:

- Mass to be moved  $m = 180 \text{ kg} \Rightarrow v_{max} = 0.33 \text{ m / s.}$

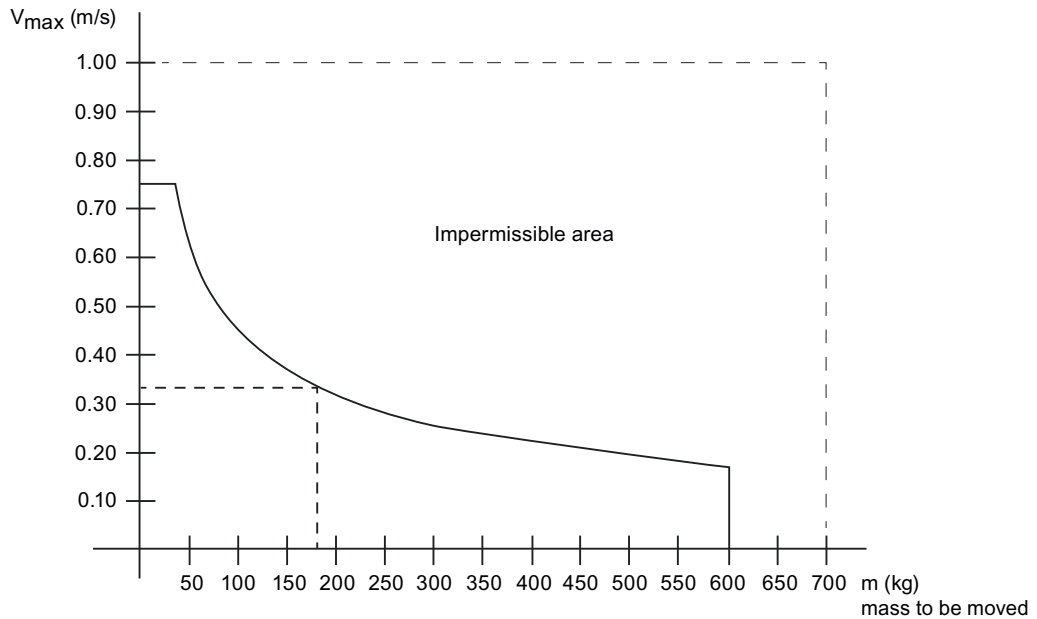

Figure 4-1 Speed limit curve for  $W_{KIN}=10\text{J}$

If the reversing unit is switched off, the maximum kinetic energy must not exceed 4 joules.

$$W_{\text{KIN}} = 1/2 m \cdot v^2 = 4 \text{ J.}$$

Example using the following speed limit curve:

- Mass to be moved  $m = 180 \text{ kg} \Rightarrow v_{\text{max}} = 0.21 \text{ m/s}$ .

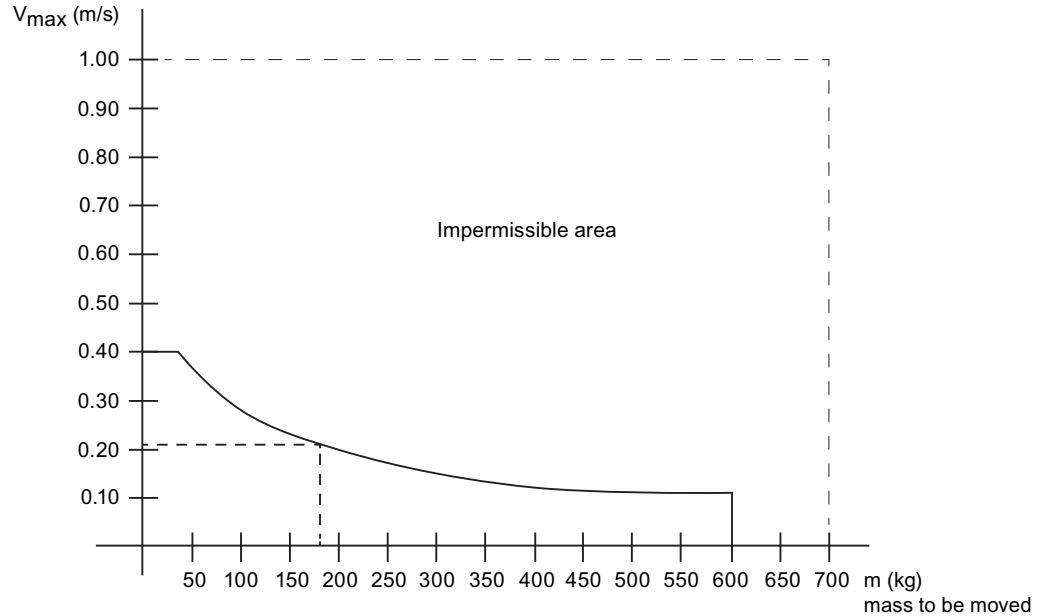

Figure 4-2 Speed limit curve for  $W_{\text{KIN}}=4\text{J}$

### Adjustment ranges

You can find the adjustment ranges in the section Profiles and adjustment ranges (Page 165).

### Maximum speeds

The following table shows the maximum speeds depending on door weight to be moved and energy limiting:

Table 4-4 Maximum speed [mm/s] depending on door weight to be moved and energy limiting

Weight to be moved [kg]	Energy [J]					
	4	10	25	50	75	100
50	400	632	1000	1414	1732	2000
100	283	447	707	1000	1225	1414
150	231	365	577	816	1000	1155
200	200	316	500	707	866	1000
250	179	283	447	632	775	894
300	163	258	408	577	707	816
350	151	239	378	535	655	756
400	141	224	354	500	612	707
450	133	211	333	471	577	667
500	126	200	316	447	548	632

Weight to be moved [kg]	Energy [J]					
	4	10	25	50	75	100
550	121	191	302	426	522	603
600	115	183	289	408	500	577

### 4.2.6 Emergency release

#### Description of function

<p> <b>WARNING</b></p> <p><b>An emergency release can only be actuated if the following conditions are met:</b></p> <ul style="list-style-type: none"> <li>• Neither a DOOR OPEN nor a DOOR CLOSE command is present,</li> <li>• The service buttons are not pressed.</li> <li>• The terminal module, SIDOOR SERVICE TOOL and SIDOOR USER SOFTWARE are <b>not</b> in the Quick setup or General setup menu items or one of their sub-menus.</li> <li>• The "Idle torque without door commands" parameter is set to "OFF".</li> <li>• The door has come to a complete stop.</li> </ul> <p>The door drive is only torque-free if these conditions are fulfilled.</p> <p>With pending command DOOR CLOSE or if the parameter "Idle torque without door command" has the value "ON", the emergency release is only possible when the parameter "Idle torque CLOSE" is adjusted and a "release time" has been parameterized (see the following function description).</p> <p>The door control unit can only support an emergency rescue. The closing mechanism of the door must be designed so that an emergency rescue is possible.</p> <p>According to DIN EN81-20, the force required to open the door must be less than 300 N.</p>
--

According to DIN EN81-20 it must be possible to open the door by hand with a force that does not exceed 300 N. In order to support this requirement by means of the door control unit, it is possible to parameterize a "Release time" between 0 and 60 seconds via the service menu "General setup > Special parameters > Release time" .

The default value for the release time is 0 seconds (deactivated). The "Idle torque CLOSE" parameter must be set so that the door can be pushed at least 5 mm out of the closed position with a force of less than 300 N when the DOOR CLOSE command is pending.

If the release time is set to a value greater than zero (for example 10 s), the following function is active:

Normal mode:

If at an active command "DOOR CLOSE" the door is pressed by at least 5 mm from the CLOSED position in the opening direction, the motor is deenergized for the duration of the release time. If the door is moved during the deenergized state in the opening direction, the release time is extended by the duration of the movement.



After the release time has expired and a "DOOR CLOSE" command is active, the door closes with the values set in the parameters "*Nudge speed CLOSE*" and "*Static nudge force CLOSE*". If the door is blocked again for at least 1 second during this closing operation, the motor is deenergized again for the duration of the release time.

After the CLOSE position is reached or a "DOOR OPEN" command is given, the door closes with the normal drive profile again in the next closing movement and thus with the values set in the "*Maximum speed CLOSE*" and "*Limit force close*" parameters.

Initial mode:

If at an active command "DOOR CLOSE" the door is pressed by at least 5 mm from the blocking position in the opening direction, the motor is deenergized for the duration of the release time.

After the release time has expired, the door closes with the parameterized "*Slow speed close initial*" and "*Static nudge force CLOSE*".

 <b>WARNING</b>
<b>In order to allow release with a force below 300 N, the door and closing mechanisms have to be designed and set correspondingly.</b>
<b>The parameter "<i>Idle torque (power) CLOSE</i>" has to be set, depending on the closing mechanism, counterweight and door friction, so that manual opening of the door (release) at an active "DOOR CLOSE" command is possible with a force lower than 300 N.</b>
<b>The emergency release function is only active in the CLOSED position at an active "DOOR CLOSE" command or the parameter "<i>Idle torque without door command</i>" has the value "ON".</b>

## 4.2.7 External closing force

### Description of function

Closing mechanisms in the form of a counterweight or a spring are permissible for a particular system.

You will find the permissible counterweights in Section Technical specifications (Page 74).

 <b>WARNING</b>
<b>Risk of injury due to moving mechanical parts</b>
Make sure that with an additional external closing force the sum of external closing force and force set in the controller does not exceed the maximum force limit of 150 N (according to EN 81).
Check the final application-specific limit values and adjust the limit values accordingly.

## 4.3 Extended functions

You can use the advanced features described below to implement application-specific requirements.

### 4.3.1 Obstruction detection

#### 4.3.1.1 Obstruction detection CLOSE

##### Description of function

If the door is obstructed in the CLOSE direction with a DOOR CLOSE command present, the door stops and reverses direction. After reaching the OPEN position, the door closes again at normal speed to within about 2 cm of the obstruction. It then travels at reduced speed against the obstruction before reversing again. This function is repeated continuously, as long as the obstruction remains. Once the obstruction has been cleared, the door travels at reduced speed to approximately 2 cm past the stored position of the obstruction, and then continues the rest of the way at normal closing speed.

#### 4.3.1.2 Obstruction detection OPEN

##### Description of function

The door stops if it is obstructed in the "OPEN" direction when the OPEN DOOR command is set. After approximately 2 s, the door automatically tries to reach the OPEN position again. This action is repeated a maximum of 3 times. The door then remains stationary in this position.

If the OPEN DOOR command is canceled, the close command given, and the OPEN DOOR command is then repeated, the door travels at normal speed to within about 2 cm of the stored position of the obstruction, and then up to the obstruction at reduced speed.

The door drive stops at the obstruction and the opening action is repeated another 3 times. If the obstruction has been removed beforehand, the door travels at a reduced speed approximately 2 cm past the stored position of the obstruction, and then continues to the OPEN position at normal speed.

The number of opening attempts can be set when an obstruction is detected in the opening direction via the service menu with "*Quick setup > Reversing system > Opening attempts*".

This setting may be required when using glass and folding doors.

The default value is 3 opening attempts. If the value 0 is set, no opening attempts are performed and the motor is deenergized once the obstruction has been detected.

## 4.3.2 SERVICE TOOL maintenance data

### Description of function

For maintenance purposes, the SIDOOR controller determines operating data of the controller, the motor and the door mechanics. These values can be used to determine the service life and frequency of use. In addition, changes in the driving characteristics of the motor and the door can be detected and evaluated for maintenance purposes.

The maintenance data can be queried via the SIDOOR SERVICE TOOL (Page 140) or the SIDOOR SUPPORT app (Page 147). As of FW version V01.48, SIDOOR AT40 CAN ADV provides the maintenance data via the CANopen interface.

Via "MAIN MENU -> General setup -> Special parameters -> CAN Cond. Monitoring", transfer of the maintenance data by MPDOs can be activated for AT40 CAN ADV.

The MPDO data is transmitted after each complete door cycle.

You will find information about manufacturer-specific CANopen objects at Industry Online Support on the Internet (<https://support.industry.siemens.com/cs/ww/en/ps/18268/man>).

---

#### Note

The transfer of the maintenance data via the CANopen protocol has been modified in the firmware version AT40 V1.49 to the new CANopen standard for "Condition Monitoring" CiA 417, Part 4. Therefore, the transfer of the maintenance data via CANopen is no longer compatible with the firmware predecessor version, AT40 V1.48.

---

### 4.3.2.1 Operating data

Based on the operating data, the service life and frequency of use of the engine and the door control unit can be determined and evaluated for maintenance purposes. The operating data can be queried via the operating menu (see "Service -> Maintenance data -> Operating data").

The operating data can be deleted via the operating menu (see "Service -> Maintenance data -> Delete operating data").

---

#### Note

The operating hours counter cannot be deleted.

---

The following operating data are determined:

- Number of openings
- Number of obstructions
- Number of learn runs
- Number of power failures
- Number of operating hours

### 4.3 Extended functions

- Total electrical energy of the motor (as of FW version AT40 V01.48)
- Total mechanical energy of the motor (as of FW version AT40 V01.48)

#### **Number of openings**

The counter is incremented when an opening movement is started from the closed position. The counter reading is stored retentively.

#### **Number of obstructions**

The counter is incremented when the door moves against an obstacle in closing direction. The counter reading is stored retentively.

#### **Number of learn runs**

The counter is incremented when a learn run has been successfully completed. The counter reading is stored retentively.

#### **Number of power failures**

The counter is incremented with a valid parameter set after a restart of the controller. The counter reading is stored retentively.

#### **Number of operating hours**

The counter is incremented every hour, after 60 minutes of operation in each case, and stored retentively. After a restart, the minute count restarts from zero. The counter for the operating hours cannot be deleted.

#### **Total electrical and mechanical energy of the motor (as of FW version AT40 V01.48)**

- Total electrical energy consumed by the motor
- Total mechanical energy output by the motor

The electrical energy consumed by the motor and the mechanical energy generated are continuously measured.

The energy values correspond to the current values at the time of the query. The energy consumption can be determined for different situations by calculating the energy difference between two points in time.

The measured electrical energy does not take into account the control unit's own energy consumption.

The energy values are retentively stored every hour. After a restart, the energy measurement starts with the last retentively stored value.

---

**Note**

**Power failure**

After a power failure, the energy values are reset to the last stored value.

---

**Note**

If the door is obstructed, or if there is an opening or closing command in the end positions, the motor is energized but the door does not move. This means that the electrical energy consumed by the motor increases continuously, but the mechanical energy generated remains unchanged.

---

**Application example:**

Upon arrival on one floor and before leaving the floor, the total energy can be queried from the door control unit. The difference between the two energy values corresponds to the converted motor energy for one floor. Since all door movements, i.e. even travel with obstruction and reversing, are taken into account here, the energy requirement can be calculated for each travel.

#### 4.3.2.2 Travel measurement

##### Description of function (as of FW version AT40 V01.48)

During door travel, the controller measures various motor and door mechanics data. In addition, changes in the driving characteristics of the motor and the door can be detected and evaluated for maintenance purposes using this data.

The following travel data are measured:

- Opening and closing times of the door
- Mechanical door energy
- Motor peak current in the slow start and end distance
- Mean power dissipation of the motor
- Current motor power

##### Opening and closing times of the door

- Time for the full opening operation
- Time for the full closing operation
- Opening time outside of the slow start distance
- Closing time outside of the end distance

If the measured times increase over time, this can be a sign of mechanical problems, contamination or wear.

The times are only measured in normal operation for uninterrupted travel. No time information is provided during initial operation, the learn run, or during reversing, obstructions or braking due to a previous obstruction. The value zero is displayed for the time in such cases.

The time measurement begins when the door has moved 5 mm from the opened or closed position and ends 5 mm before the end stop.

In the slow end distance, the door interlock (slow distance) is activated, but the door is closed. In order to distinguish between the pure travel time of the door and the time when the door interlock is actuated, the times for the complete opening or closing operation and the pure opening or closing travel are determined without a slow start or end distance.

**Application example:**

After the elevator door has been opened and closed on one floor, the opening and closing time can be queried from the door control unit. If the value zero is read as time, this measurement must be ignored and only the next complete opening or closing movement on this floor must be taken into account.

The measured times can be compared with a reference value. If a permissible tolerance is exceeded, this can indicate a mechanical problem in the slow start or slow end mechanics.

## Mechanical door energy

- Mechanical energy for a complete opening travel.
- Mechanical energy for a complete closing travel.
- Mechanical energy within the slow start distance in the opening direction.
- Mechanical energy within the slow end distance in the closing direction.

The mechanical energy required for opening and closing the door is measured for each door travel.

If the measured mechanical energy increases over time, this can be a sign of mechanical problems, contamination or wear.

The mechanical energy is only measured in normal operation for uninterrupted travel. No mechanical energy is provided during initial operation, the learn run, or during reversing, obstructions or braking due to a previous obstruction. The value zero is returned for the mechanical energy in this case.

The energy measurement begins when the door has moved 5 mm from the opened or closed position and ends 5 mm before the end stop.

In the slow end distance, the door interlock (slow distance) is activated, the door is closed mechanically. In order to distinguish between the mechanical energy for the door travel and the mechanical energy for the actuation of the door interlock mechanism, the mechanical energies are determined for the complete opening or closing operation (travel with a slow start or end distance) and the mechanical energy in the slow distances.

**Application example:**

After the elevator door has been opened and closed on one floor, the mechanical energy for the opening and closing travel can be queried.

If the value zero is read for the energy, this measurement must be ignored and only the next complete opening or closing movement on this floor must be taken into account.

The measured mechanical energy values can be compared with a reference value. If a

permissible tolerance is exceeded, this can indicate a mechanical problem in the slow start or slow end mechanics.

### Motor peak current in the slow start and end distance

- Peak current within the slow start distance in the opening direction
- Peak current within the slow end distance in the closing direction

Peak currents occurring in the slow start or end distance are measured for opening and closing direction.

If the peak currents increase, this is a sign of mechanical problems, contamination or wear in the slow start or end mechanics.

Peak currents are only measured for uninterrupted travel. No peak currents are provided during obstruction, reversing, or braking due to a previous obstruction. The value zero is returned for the peak currents in this case.

The peak current measurement is carried out in the area of the slow start or end distance:

- In opening direction: 5 mm before the closed position and 10 mm before the end of the slow start distance.
- In closing direction: 5 mm after the start of the slow start distance and 5 mm before the end of the slow end distance.

#### Application example:

After the elevator door has been opened and closed on one floor, the peak power in the slow start open and slow end close distance for the opening and closing travel can be queried. If the value zero is read for the currents, this measurement is to be ignored and the travel is to be repeated.

The measured peak currents can be compared with a reference value. If a permissible tolerance is exceeded, this can indicate a mechanical problem in the slow start or slow end mechanics.

### Mean power dissipation of the motor

The mean motor power dissipation is continuously calculated. This is a measurement for the thermal load of the motor. If the mean motor power dissipation exceeds the permissible motor power dissipation, the motor is overloaded or overheated.

Possible causes for an excessive mean motor power dissipation:

- Motor is undersized.
- Increased friction of the travel distance
- High travel cycle number
- Oscillation in the door end positions

After a power failure, the calculation of the average motor power dissipation starts again at zero. This means that a previous load on the motor is not taken into account.

### 4.3 Extended functions

The time constant for calculating the mean motor power dissipation depends on the motor type and ranges from 0.5 to 2 hours.

**Application example:**

The average power dissipation of the motor can be queried cyclically (cycle times in the range of minutes) and evaluated over a longer period of time (hours).

The measured average power dissipation of the motor can be compared with a reference value. If a permissible tolerance is exceeded, this can indicate an overloading of the motor.

### Current motor power

- Current electric motor input power.
- Current mechanical motor output power
- Current motor power dissipation.

The current power values of the motor can be queried for diagnostic purposes. The values correspond to the power values at the time of query.

**Application example:**

The current power values can be queried cyclically or at specific times to determine the motor power in specific operating states.

## 4.3.3 Glass doors and folding doors

### Description of function

According to EN 81-20, the opening force for glass and folding doors must be limited to 150 N and a function must be provided for stopping in the event of hands being pulled in.

### Parameter assignment

**Opening force 150 N:**

The "*Static opening force*" parameter can be set to a value of 150 N, taking the counterweight into account, using the service menu "*Quick setup > Glass doors > Opening force 150 N*".

After selecting the menu command, a counterweight (m) can be set in the range from 0 to 8 kg. The resulting opening force (F) is calculated on the basis of the set counterweight:

$$F = 150 \text{ N} + m \cdot 10 \text{ m/s}^2$$

This allows an opening force in the range of 150 N to 230 N to be set.

If the set opening force is outside this range, "*Opening force 150 N inactive*" is displayed in the service menu.



#### Stopping in case where hands are pulled in:

Via the service menu "*Quick setup > Reversing behavior > Opening attempts*", the number of opening attempts can be set when an obstruction is detected in the opening direction.

The default value is 3 opening attempts. If the value 0 is set, the door stops after an obstruction and no opening attempts are made.

 <b>CAUTION</b>
<b>Risk of injury</b>
If the force in the opening direction is not set correctly, there is a risk of limbs being pulled in.
<ul style="list-style-type: none"><li>• Set the force in the opening direction to 150 N + counterweight for glass and folding doors.</li><li>• When commissioning the door, ensure that an opening force of 150 N is not exceeded.</li><li>• Set the number of opening attempts to 0.</li></ul>

### 4.3.4 Spring mechanism in closed position

#### Description of function

If the closing mechanism of the door contains a spring and if the motor is switched to the CLOSED position by the door control unit, the spring often relaxes abruptly. With the function described here, the spring can be slowly released and the door can be moved to a parking position.

#### Parameter assignment

A distance of 0 to 100 mm can be set using the service menu "*General setup > Special parameters > Park position*". The default value for the parking position is 0 mm (no spring). If a value greater than zero is set, the following function is active:

##### Normal mode:

If the front door edge is in front of the parking position and the motor is to be de-energized, the door is first moved to the parking position, then the motor is de-energized.

##### Initial mode:

An obstruction in closing direction for 1 second is detected as CLOSED position. If the motor is then to be de-energized, the door is first moved from the obstruction position by the distance of the configured parking position in the opening direction, then the motor is de-energized.

4.3 Extended functions

Travel to the parking position takes place with the parameterized slow start speed open and the configured static opening force. If an obstruction is detected during this travel (300 ms standstill), the motor is immediately de-energized.

**Note**

To release a spring in the closing mechanism, the spring travel can be set with the parameter "General setup -> Special parameters -> Park position".

If the "Door CLOSE" input command is reset in the "CLOSED" position, the door first moves to the parking position, then the motor is de-energized. The parking position must be set so that the door leaf is closed in the parking position.

**4.3.5 Emergency power mode**

**Description of function**

If the mains voltage fails and the emergency power supply is active, the controller can be switched to emergency power mode via an input signal, terminal X5. This function can be implemented, for example, by means of a UPS with an appropriate output signal.

In emergency power mode, a speed-reduced driving curve profile is used. Emergency power mode cannot be exited until the controller has reached the closed or open state in normal mode.

**Connection and parameter assignment**

The "emergency power mode" function block is already linked to the input signal at terminal X5 via the factory default.

**Signals**

Input "Input 0" (terminal X5) can be parameterized via the service menu "General setup > Special parameters > Input X5" as an emergency power signal (emergency power mode). For more, see also section Digital input signals (Page 62).

Signal: X5 (input 0) emergency power mode	Meaning
1 (voltage applied)	Emergency power mode active
0 (voltage not applied)	Emergency power mode not active

## 4.4 Light barrier

### Description of function

If the light barrier signal is interrupted while the DOOR CLOSE command is active, the door is moved in the OPEN direction.

**Exception:** If the door is open less than 1 cm, the light barrier signal is ignored. If no power is supplied at the light barrier input, this is interpreted as an interruption of the light barrier. The door cannot close in this case.

An interruption of the light barrier signal while the CLOSE DOOR command is inactive does not change the state.

### Complete opening in case light barrier is interrupted

The reaction of the door in case the light barrier is interrupted can be set as of V1.47. If the "MAIN MENU > General setup > Special parameters > Full opening" parameter is deactivated (default setting), the door only travels as long as the light barrier is interrupted. If the parameter is activated, the door opens completely in case the light barrier is interrupted.

### Connection and parameter assignment

The light barrier signal can be connected to the light barrier/DCPS input of terminal X6 pin 5/6. See also section Digital input signals (Page 62). The evaluation of the light barrier signal must be activated via the SIDOOR SERVICE TOOL, Terminal Editor or SIDOOR SOFTWARE KIT (MAIN MENU > General setup > Special parameters > Inp. 1).

Input "Input 0" (terminal X5) can be configured via the service menu "General setup > Special parameters > Input X5" as a light barrier feedback contact (FC light barrier). For more, see also section Digital input signals (Page 62).

---

#### Note

The light barrier and DCPS (Door Closed Position Sensor) (Page 36) functions cannot be implemented simultaneously.

The light barrier and emergency power mode (Page 56) functions cannot be implemented simultaneously.

This function must be enabled for the light barrier to work correctly (*Special parameters -> Input 1*).

---

#### Note

A learn run "when the line voltage is applied (Page 32)" resets input 1 to the basic setting "light barrier". If no light barrier is connected to the door control unit, either input 1 must be deactivated via the menu "General setup -> Special parameters -> Input 1" - or the light barrier bridges must be inserted (see (Page 62)).

---

## Signals

Signal: X5 (Input 0) FC light barrier	Meaning
1 (voltage applied)	The door travels in the CLOSE direction with the value set in the parameter " <i>Maximum speed CLOSE</i> " (normal operation).
0 (voltage not applied)	The door travels in the CLOSE direction with the value set in the parameter " <i>Nudge speed CLOSE</i> ". The obstruction and reversing behavior corresponds to normal operation (nudging function is disabled).

Signal: X6-5 (Input 1) light barrier	Meaning
1 (voltage applied)	Light barrier is not interrupted and the door closes when the CLOSE DOOR command is set
0 (voltage not applied)	Light barrier is interrupted and the door opens when the CLOSE DOOR command is set*

### Note

If the light barrier feedback contact is used, its operation must be checked during commissioning or maintenance of the door.

### Note

When the light barrier is activated, by default the closing door only opens back up again until the light barrier is no longer blocked. This reaction can be configured as of AT40 V1.47 and ATD400V V1.08, see paragraph "Complete opening in case light barrier is interrupted" in this section.

If the seven segment display displays "0" after the learn run or after switching on the controller and if no light barrier is used, there is the possibility to deactivate input 1 via the menu item "*MAIN MENU->General setup -> Special parameters -> Input 1*" or to insert the light barrier bridge between connector X4 and X6.

## Controllers

### 5.1 Description of controller

#### Overview

#### SIDOOR AT40 / ATD400V

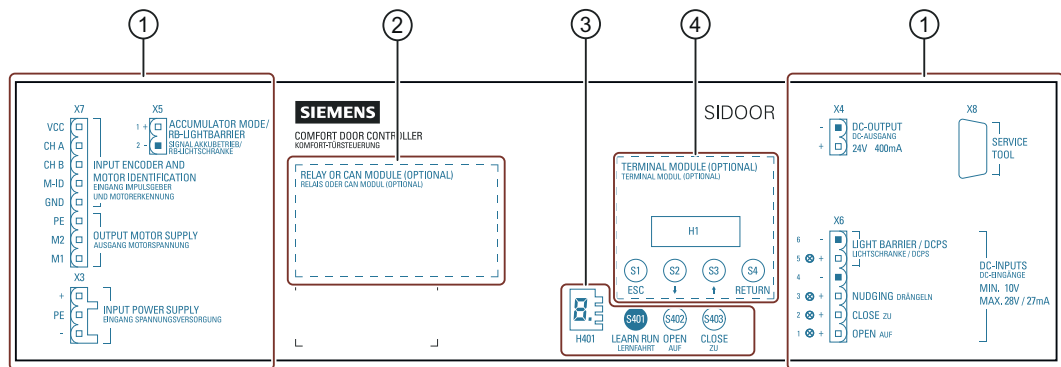

- ① Connecting terminals
- ② Relay module / CAN module
- ③ Service buttons / Minimal editor
- ④ Terminal module

### 5.2 Mounting the controller

#### Requirements

The installation site must meet the following requirements:

- Minimum clearance to surrounding parts 1 cm
- Even mounting surface

5.2 Mounting the controller

- Maximum distance from the power supply due to the cable length:
  - SIDOOR NT40 / SIDOOR TRANSFORMER: 1.5 m
- Maximum distance from the geared motor due to the cable length:
  - For SIDOOR M2, M3, M4 and M5: 1.5 m

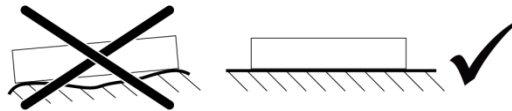
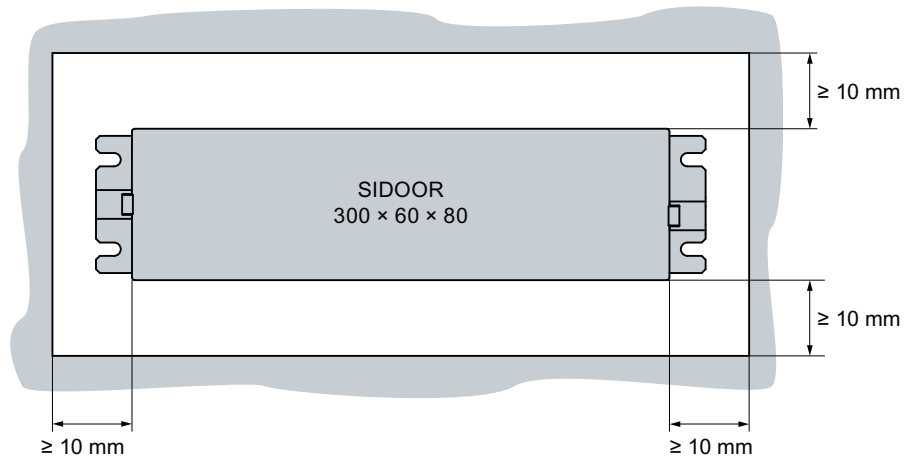

**⚠ WARNING**

**Risk of injury as a result of incorrect installation**

Final application-specific requirements must be observed.

Outside of the control cabinet enclosure, the controller must be installed (ideally horizontal) so that the cable outlet does not point down for fire protection reasons.

## Installation

Proceed as follows to install the control device:

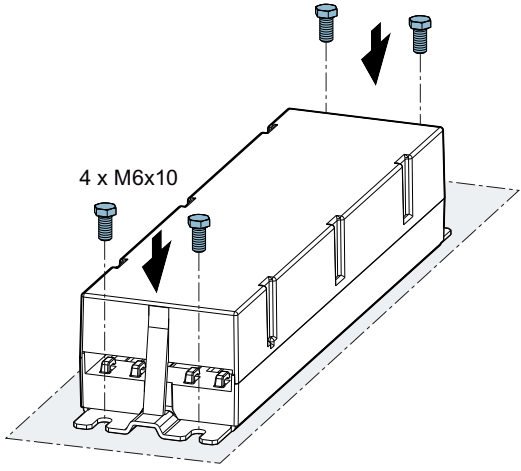
Steps	Figure
1. Drill the holes for the screws as shown in the dimension drawing.	
2. Secure the control device with 4 screws (M6 x 10).	

### NOTICE

#### Material damage

Only use cables with a temperature range  $\geq 85\text{ }^{\circ}\text{C}$

## 5.3 Wiring instructions

### NOTICE

#### Material damage

Only use cables with a temperature range  $\geq 85\text{ }^{\circ}\text{C}$ .

5.4 Connecting terminals

Terminal information and wiring rules

Table 5-1 Terminal information SIDOOR AT40 / ATD400V

Interface	Name	Terminal	Tool	Solid conductor	Stranded conductor	AWG	Nm	Stripping insulation
X3	Input power supply	WAGO: 721-103/026-045	SZS 0.6X3.5  WAGO 231-159	1x 1.5-2.5 mm <sup>2</sup>	1x 1.5-2.5 mm <sup>2</sup>	15 - 12	-	8-9 mm
X4	DC output	PHOENIX: 1792757	SZS 0.6X3.5	1x 0.2-2.5 mm <sup>2</sup>	1x 0.2-2.5 mm <sup>2</sup>	30 - 12	0.5 - 0.6	7 mm
X5	Input 0	PHOENIX: 1779987	SZS 0.6X3.5	1x 0.2-2.5 mm <sup>2</sup>	1x 0.2-2.5 mm <sup>2</sup>	30 - 12	0.5 - 0.6	7 mm
X6	Input 1...4	PHOENIX: 1792799	SZS 0.6X3.5	1x 0.2-2.5 mm <sup>2</sup>	1x 0.2-2.5 mm <sup>2</sup>	30 - 12	0.5 - 0.6	7 mm
X7	Motor plug	PHOENIX: 1757077	SZS 0.6x3.5	1x 0.2-2.5 mm <sup>2</sup>	1x 0.2-2.5 mm <sup>2</sup>	30 - 12	0.5 - 0.6	7 mm
X11, X12, X13	Relay module relay outputs <sup>1</sup> * (AT40 RELAY and ATD400V)	PHOENIX: 1757022	SZS 0.6X3.5	1x 0.2 – 2.5 mm <sup>2</sup>	1x 0.25 – 2.5 mm <sup>2</sup>	30 - 12	0.5 - 0.6	7 mm
X11	CAN module <sup>1</sup> (AT40 CAN)	PHOENIX: 1803594	SZS 0.4X2.5	1x 0.14 – 1.5 mm <sup>2</sup>	1x 0.14 – 1.5 mm <sup>2</sup>	30 – 14	0.22 - 0.25	7 mm
X16	CAN module <sup>1</sup> (AT40 CAN)	PHOENIX: 1803581	SZS 0.4x2.5	1x 0.14 – 1.5 mm <sup>2</sup>	1x 0.14 – 1.5 mm <sup>2</sup>	30 – 14	0.22 - 0.25	7 mm

<sup>1</sup> Only for modules with the corresponding module

\* Only for modules with relay module

## 5.4 Connecting terminals

### 5.4.1 Digital input signals

#### Slots X6 and X5

Control signals for drive functions can be connected to the digital input signals on connectors X6 and X5. The following table shows how the drive function and input are assigned depending on the control device.

Table 5-2 Overview of signals for drive functions at slots X6 and X5

Slots X6 and X5	AT40 / ATD400V
X6 Pin6 (Inp1) <sup>2)</sup>	Light barrier/DCPS -



<b>X6 Pin5 (Inp1)</b> <sup>2)</sup>	Light barrier/DCPS +
<b>X6 Pin4 (Inp2-4)</b>	GND
<b>X6 Pin3 (Inp2)</b>	Nudge
<b>X6 Pin2 (Inp3)</b>	CLOSE
<b>X6 Pin1 (Inp4)</b>	OPEN
<b>X5 Pin1 (Inp0)</b> <sup>1)</sup>	Emergency power mode / FC light barrier +
<b>X5 Pin2 (Inp0)</b> <sup>1)</sup>	Emergency power mode / FC light barrier -

<sup>1)</sup> Adjustable via the service menu "General setup > Special parameters > Input X5".

<sup>2)</sup> Adjustable via the service menu "General setup > Special parameters > Input 1"

**Note**

**As of FW AT40 V1.49:**

With the digital input signal OPEN, X6-1 (Inp4), issuing an open command is also possible when the CAN interface is open. The open command via the digital input has a higher priority than a close command, or another drive command of the CAN interface. If this behavior is desired, the function described can be activated via the menu "*General setup -> Special parameters -> Open CAN input*". For compatibility reasons, this function is deactivated by default.

**Note**

If Input 1 is set as the light barrier input (default setting) and no light barrier is connected, X6 must be jumpered with X4 according to the connection diagrams (see following table "Wiring diagrams for digital input signals") or deactivated using the menu "*General setup -> Special parameters -> Input 1*".

**Note**

The inputs Input 0 and Input 1 (see section (Page 57) Signals table) are electrically isolated from the inputs Input 2, Input 3 and Input 4. Therefore, Input X5, Pin 1, and X6, Pin 5, can be connected as follows, irrespective of the inputs X6 Pin 1, 2, 3:

1. Connection to the internal 24 V control voltage (see following figure under a.)
2. Connection of the inputs at the same or different external control voltages (see following figures under b., c. and d.).

Wiring diagrams

Table 5-3 Wiring diagrams for digital input signals

<p><b>a. Connection to an internal 24 V control voltage</b></p>	<p><b>b. Connection to an external control voltage</b></p>
<p><b>c. Connection to an internal 24 V control voltage (input 1) and an external control voltage (input 0, input 2, input 3 and input 4)</b></p>	<p><b>d. Connection to an external 24 V control voltage (input 0 isolated from input 1 and isolated from input 2, input 3 and input 4)</b></p>

① Light barrier, DCPS sensor, jumpered or switch. The wiring depends on the sensor type and the configuration of input 1.

## 5.4.2 Voltage output

Slot X4	Function
DC OUTPUT	24 V $\pm$ 15 %, max. 400 mA

## 5.4.3 Motor plug

### SIDOOR AT40 / ATD400V

Slot X7	Function
VCC	+5 V
CH A	Channel A
CH B	Channel B
M-ID	Motor identification (motor ID)
GND	GND
PE	PE
M2	Motor +
M1	Motor -

## 5.5 Relay and field bus interfaces

### 5.5.1 Relay module

#### Overview

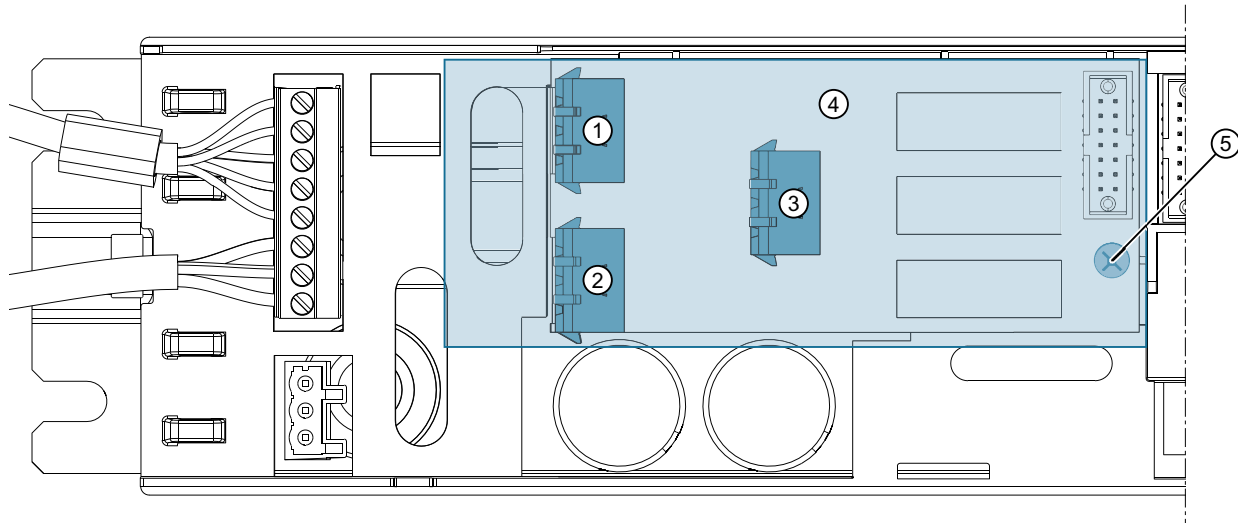

- ① X11
- ② X13
- ③ X12
- ④ Protective cover
- ⑤ Fixing screw for the protective cover

Figure 5-1 Relay module

## Task

The relay module's relay contacts can be used to report the following door states to the higher-level control device:

Table 5-4 Door states SIDOOR AT40 RELAY / ATD400V

Relay contact	Function
X11	<p><b>The door has reached the "CLOSED" position.</b></p> <p>The relay switches on when the controller has detected the CLOSED position and the incremental sensor ceases to output pulses, i.e. the door is stationary or the DCPS signal is active. Pin 3 only remains connected to Pin 1 until the "DOOR OPEN" command is issued. The relay then drops out again immediately, and pin 3 is once again connected to pin 2.</p>
X12	<p><b>Door reverses because of an obstruction, interruption of the light barrier or an opening command.</b></p> <p>The relay switches on when the door reverse because of an obstruction, interruption of the light barrier or an opening command. Pin 1 is then connected to Pin 3 until the OPEN position is reached.</p> <p>If the door blocks at a move command "DOOR CLOSE with nudge", the relay X12 remains inactive by default.</p> <p>The relay X12 can be activated if obstructed during nudging by using the service menu "<i>General setup &gt; Special parameters &gt; BLK at nudge Rev.Relay</i>".</p>
X13	<p><b>The door has reached the "OPEN" position.</b></p> <p>The relay switches on when the distance of the door from the OPEN position falls below 2 cm. Pin 1 and pin 3 are then connected. The relay drops out immediately as soon as the distance exceeds 2 cm again, and pin 3 is once again connected to pin 2.</p> <p>As of <b>FW AT40 V1.49, ATD400V V1.10:</b></p> <p>If the idle torque was activated in the end position without an active door command using the service menu "<i>General setup -&gt; Special parameters -&gt; Idle torque without door command</i>", the relay only switches to the "OPEN" position when detecting the end stop.</p>

 **WARNING**

**Risk of injury**

The door control system is not a safety mechanism. Therefore the relay contacts must not be used for the elevator safety circuit.

## Connecting

 **DANGER**

**Risk of injury from dangerous electrical voltages**

When the enclosure cover of the control device is open, only a safety extra-low voltage of less than 42 V may be present. The protective cover provided must be used when a higher voltage (max. 230 V AC) is connected to the relay module. Please follow the procedures described below for connecting a relay module.

**Terminal circuit diagram of the relay contacts**

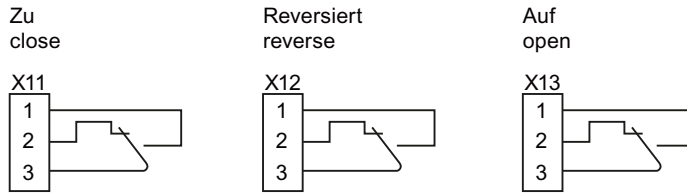

**Procedure**

**Note**

**Specifications for connecting the relay module**

- The cables connected must be suitable for the voltage used and have appropriate (double or reinforced) insulation. Cables with an external diameter of 6 to 7 mm are recommended.
- Components of the control device and connecting cable, such as the motor plug and its wires, may only come in contact with the additional (or reinforced) insulation of the current-carrying wires.
- Networks with different voltages (for example 24 V and 230 V) must not be connected to the relay module.

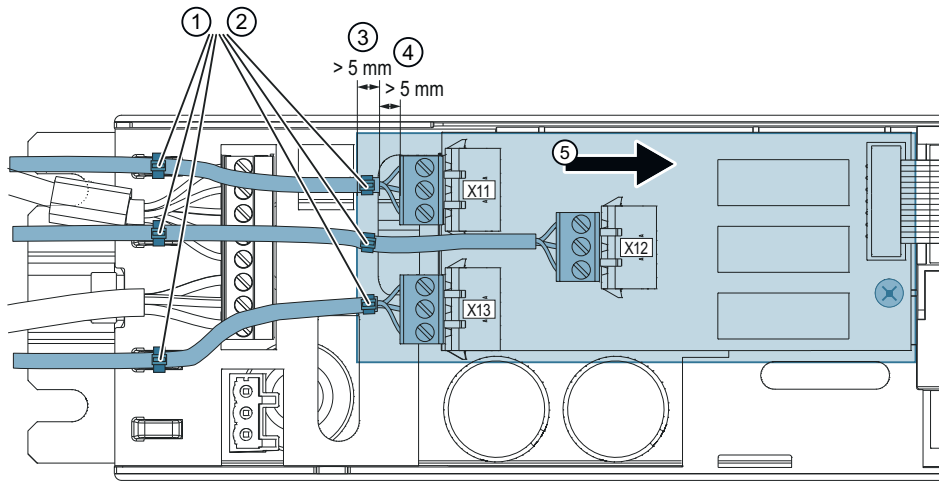

- ① Cable ties (strain relief in enclosure)
- ② Cable ties (security against being pulled out within the protective cover)
- ③ Minimum length of the cable jacket within the protective cover: 5 mm
- ④ Minimum length of the single-insulation on the single cores: 5 mm
- ⑤ Insertion direction for the protective cover

1. Unscrew the fixing screw holding the protective cover on the relay module.
2. Slide the protective cover against the insertion direction and remove it.
3. Connect connectors X11, X12 and X13.

4. Ensure that the single-insulation inside the cover is removed from the single cores at least 5 mm from the cable entry openings, and the wires connected to the terminal connectors are as short as possible.
5. Secure the cables inside the plastic cover against being pulled out through the oval aperture in the relay cover. Use cable ties for this purpose, tie each of them tightly round the cable. Ensure that the cable tie is tied so that at least 5 mm of the outer cable jacket lies inside the protective cover.
6. Provide additional strain relief by attaching more cable ties to the fixing points provided in the enclosure.
7. Slide the protective cover in the insertion direction back into its correct position.
8. Screw the fixing screw holding the protective cover on the relay module back in.

## 5.5.2 CAN module

### Overview

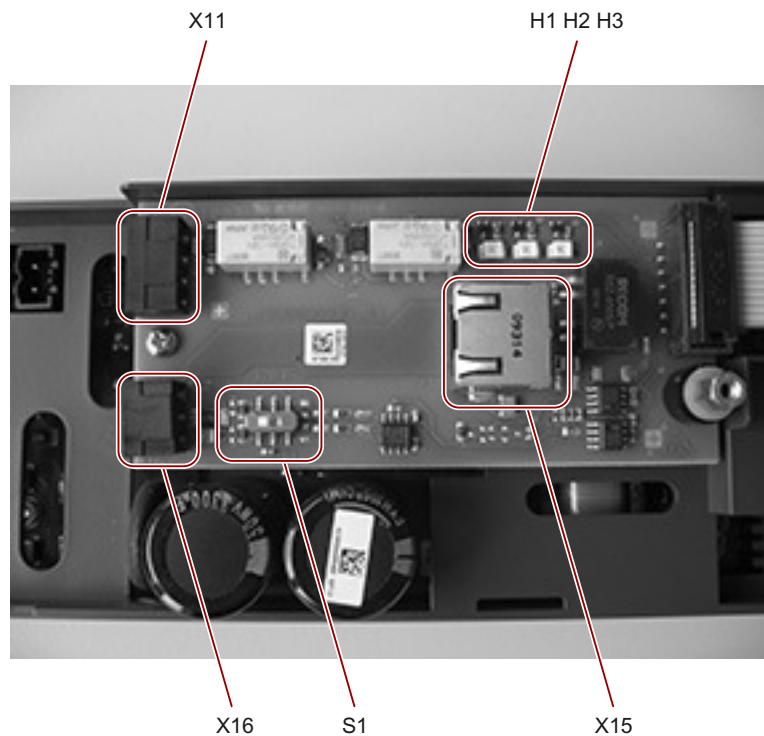

Figure 5-2 CAN module

### Task

The CAN module enables the SIDOOR AT40 door controller to be connected to a CAN bus. A maximum of 32 nodes can be connected to the CAN bus.

## Interface

The interface is implemented according to CiA 301, profile 417. The SIDOOR SERVICE TOOL must be used to set the command input to CAN, so that the controller can be addressed via the CAN bus. The factory settings of the major parameters are:





Parameter	Factory setting
Command output	CAN*
CANopen node ID	7
Baud rate	Automatic
Door number	1
CAN Cond. Monitoring*	OFF

\* as of version 1.47

When the baud rate is set to "automatic", the CAN module automatically determines the baud rate on the CAN bus. To do this, the CAN module must have received some valid CAN telegrams. The LED H3 flashes at 10 Hz (quick flashing) while the baud rate is being automatically determined.

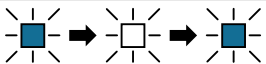
## LED signals

All LED signals are listed in the following table.

LED signal (H3)	CANopen state machine
	"Stopped"
 (2.5 Hz)	"Pre-operational"
	"Operational"
 (10 Hz)	Automatic determination of the baud rate



## Connection

 <b>DANGER</b>
<p><b>Risk of injury due to electrical voltages</b></p> <p>The protective cover has to be removed to connect the CAN cable or to activate/deactivate the terminating resistor.</p> <p>Perform the following protective measures before removing the protective cover:</p> <ul style="list-style-type: none"> <li>• Disconnect the controller from all live cables.</li> <li>• By grounding, ensure that the user/fitter, the controller and other conductors have the same voltage potential. Observe the general ESD guidelines.</li> </ul>

Table 5-5 Connector X15

Pin assignment	Pin	Signal
	1	CAN_H
	2	CAN_L
	3	GND
	4	–
	5	–
	6	Shield
	7	GND
	8	–

Table 5-6 Connector X16

Pin assignment	Pin	Signal	Description
	1	CAN_H	CAN high bus cable
	2	Shield	CAN cable shield
	3	CAN_L	CAN low bus cable

The bus can be terminated with 120 ohms via the switch S1.

You will find information about manufacturer-specific CANopen objects at Industry Online Support on the Internet (<https://support.industry.siemens.com/cs/ww/en/ps/18268/man>).

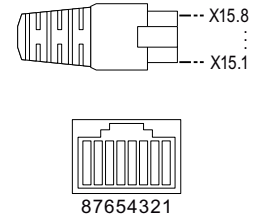
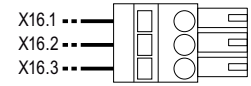
5.5 Relay and field bus interfaces

In addition to the CAN interface, there are also two relays on the CAN module. They can switch a maximum of 30 V and 0.5 A. The pin assignments are:

Table 5-7 Connector X11

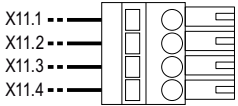
Pin assignment	Pin	Assignment	Description
	1, 2	NO contact. CLOSED position reached.	The relay switches on when the controller has detected the CLOSED position and the incremental sensor ceases to output pulses or the DCPS signal is active. LED H1 is on.
	3, 4	NO contact. OPEN position reached.	The relay switches on when the distance of the door from the OPEN position falls below 2 cm. LED H2 is on.

**Note**

A folding ferrite (RFC-6 Kitagawa) must be attached to the beginning and end of the CAN cable (outside the housing).

**5.5.3 Virtual CAN terminal**

The controller supports the virtual terminal interface according to CANopen "CiA-417 Virtual terminal interface" in conjunction with character encoding according to "ISO-8859-15 Character encoding".

This functionality is available in the following controllers:

- SIDOOR AT40 CAN (as of firmware version AT40 V01.47)
- SIDOOR AT40 CAN ADV (as of firmware version AT40 V01.48)

Operation of the SIDOOR service menu of the SIDOOR control devices is available completely for CAN Bus master via CANopen. This allows the service menu of the SIDOOR controller to be displayed and operated via the CAN bus on third-party devices.

**Note**

To use the SIDOOR service menu without restrictions via the virtual terminal interface, you need four control keys and a display with a display capacity of at least 2 x 16 characters.

 <b>WARNING</b>
<p><b>Unauthorized access to parameters and door commands</b></p> <p>If you do not secure access to the virtual terminal via CAN, there is a risk that unauthorized persons may gain access to the SIDOOR control unit and change parameters or trigger door commands. These can lead to injuries due to corresponding door movements.</p> <p>Therefore, secure access to the virtual terminal via CAN.</p>

**Note**

Door commands can be suppressed by the control unit if the service menu has not been closed correctly (SERVICE TOOL, terminal module, SIDOOR SUPPORT app or SIDOOR SOFTWARE KIT)

**Overview**

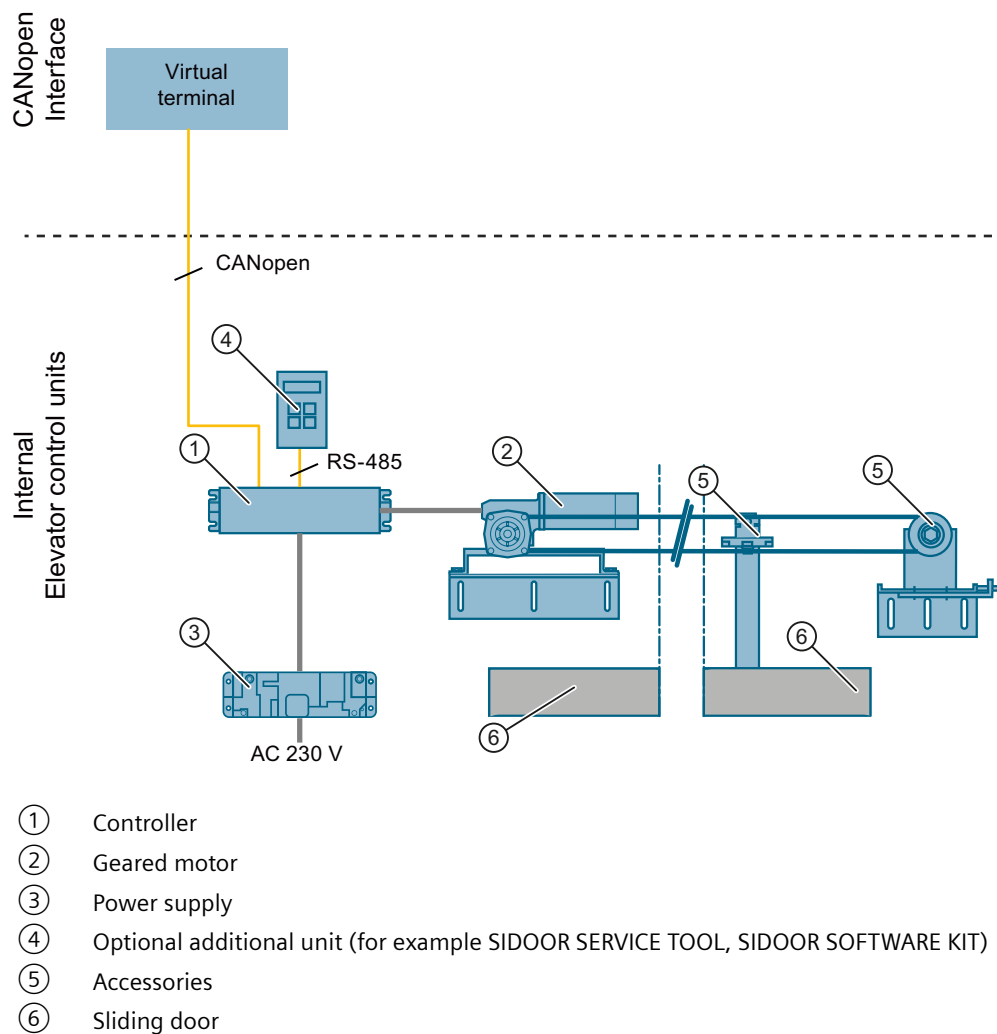

## 5.6 Technical specifications

Article number	6FB1111-0AT10-3AT2	6FB1111-1AT10-3VE2
<b>General information</b>		
Product brand name	SIDOOR	
Product type designation	AT40 RELAY	ATD400V RELAY
Product version	With relay outputs	
Manufacturer's article no. of the usable motor	6FB1103-0AT10-5MA0, 6FB1103-0AT11-5MA0, 6FB1103-0AT10-4MBO, 6FB1103-0AT11-4MBO, 6FB1103-0AT10-3MCO, 6FB1103-0AT11-3MCO, 6FB1103-0AT10-3MDO, 6FB1103-0AT11-3MDO	6FB1103-0AT10-3MCO, 6FB1103-0AT11-3MCO, 6FB1103-0AT10-3MDO, 6FB1103-0AT11-3MDO
Manufacturer's article no. of the usable power supply unit	6FB1112-0AT20-2TR0, 6FB1112-0AT21-2TR0, 6FB1112-0AT20-3PS0	6FB1112-0AT20-3PS0
<b>Supply voltage</b>		
Design of the power supply	via SIDOOR TRANSFORMER / NT40	Via SIDOOR NT40
<b>Input current</b>		
Current consumption, max.	10 A	
I <sup>2</sup> t, min.	30 A <sup>2</sup> ·s	
<b>Encoder supply</b>		
Output voltage (DC)	24 V; Ensure correct polarity! CAUTION: Do not supply with external voltage!	
short-circuit proof	Yes	
<b>24 V encoder supply</b>		
• Output current, max.	400 mA	
<b>Power</b>		
Active power input	80 W	
Active power input, max.	540 W	
Active power input (standby mode)	5 W	
<b>Digital inputs</b>		
Control inputs isolated	Yes	
Control inputs p-switching	Yes	
<b>Input current</b>		
• for signal "1", min.	9 mA	
• for signal "1", max.	27 mA	
<b>Digital outputs</b>		
<b>Relay outputs</b>		
<b>Switching capacity of contacts</b>		
– at 30 V DC, min.	0.01 A	
– at 30 V DC, max.	1 A	
– at 50 V DC, min.	0.01 A; Switching voltage 50 V DC	

Article number	6FB1111-0AT10-3AT2	6FB1111-1AT10-3VE2
<ul style="list-style-type: none"> <li>– at 50 V DC, max.</li> <li>– at 230 V AC, min.</li> <li>– at 230 V AC, max.</li> </ul>	1 A; Switching voltage 50 V DC	
	0.01 A	
	1 A	
<b>Mechanical data</b>		
Opening width of door, min.	0.3 m	
Opening width of door, max.	5 m	
Weight of door, max.	600 kg	
Operating cycle frequency of door, max.	180 1/h	
Counterforce, max.	80 N	
Kinetic energy, max.	100 J	
<b>Counterweight</b>		
<ul style="list-style-type: none"> <li>• with SIDOOR M2 geared motor, max.</li> <li>• with SIDOOR M3 geared motor, max.</li> <li>• with SIDOOR M4 geared motor, max.</li> <li>• with SIDOOR M5 geared motor, max.</li> </ul>	4 kg	
	6 kg	
	8 kg	
	8 kg	
<b>Interfaces</b>		
Interfaces/bus type	without	
<b>Isolation</b>		
Overtoltage category	2	
Degree of pollution	2	
<b>Degree and class of protection</b>		
IP degree of protection	IP20	
<b>Standards, approvals, certificates</b>		
Certificate of suitability according to EN 81	Yes	
CE mark	Yes	
UL approval	No	
EAC (formerly Gost-R)	Yes	
TÜV Inspectorate approval	Yes	
TÜV prototype tested	Yes	
China RoHS compliance	Yes	
Standard for EMC	EN 12015 / EN 12016	
Standard for safety	EN 61010-1 / EN 61010-2-201 / EN 81-20	
<b>Ambient conditions</b>		
<b>Ambient temperature during operation</b>		
<ul style="list-style-type: none"> <li>• min.</li> <li>• max.</li> </ul>	-20 °C	
	50 °C	
<b>Ambient temperature during storage/transportation</b>		
<ul style="list-style-type: none"> <li>• Storage, min.</li> <li>• Storage, max.</li> </ul>	-40 °C	
	50 °C	
<b>Altitude during operation relating to sea level</b>		
<ul style="list-style-type: none"> <li>• Installation altitude above sea level, max.</li> </ul>	2 000 m	
<b>Relative humidity</b>		

5.6 Technical specifications

Article number	6FB1111-0AT10-3AT2	6FB1111-1AT10-3VE2
• No condensation, min.	10 %	
• No condensation, max.	93 %	
<b>Dimensions</b>		
Width	320 mm	
Height	60 mm	
Depth	80 mm	

Article number	6FB1111-1AT10-3AT3	6FB1111-1AT11-3AT3
<b>General information</b>		
Product type designation	With CAN interface	AT40 CAN ADV
Product version		With CAN interface and maintenance data via CAN-open
<b>Supply voltage</b>		
Design of the power supply	via SIDOOR TRANSFORMER / NT40	
<b>Input current</b>		
Current consumption, max.	10 A	
I <sup>2</sup> t, min.	30 A <sup>2</sup> ·s	
<b>Encoder supply</b>		
Output voltage (DC)	24 V; Ensure correct polarity! CAUTION: Do not supply with external voltage!	
short-circuit proof	Yes	
<b>24 V encoder supply</b>		
• Output current, max.	400 mA	
<b>Power</b>		
Active power input	80 W	
Active power input, max.	540 W	
Active power input (standby mode)	6 W	
<b>Digital inputs</b>		
Control inputs isolated	Yes	
Control inputs p-switching	Yes	
<b>Input voltage</b>		
• permissible voltage at input, min.	10 V; Observe polarity !	
• permissible voltage at input, max.	28 V; Observe polarity !	
<b>Input current</b>		
• for signal "1", min.	9 mA	
• for signal "1", max.	27 mA	
<b>Digital outputs</b>		
<b>Relay outputs</b>		
<b>Switching capacity of contacts</b>		
– at 30 V DC, min.	0.01 A	
– at 30 V DC, max.	0.5 A	
<b>Mechanical data</b>		
Opening width of door, min.	0.3 m	
Opening width of door, max.	5 m	
Weight of door, max.	600 kg	
Operating cycle frequency of door, max.	180 1/h	
Counterforce, max.	80 N	
Kinetic energy, max.	100 J	
<b>Counterweight</b>		
• with SIDOOR M2 geared motor, max.	4 kg	

5.6 Technical specifications

Article number	6FB1111-1AT10-3AT3	6FB1111-1AT11-3AT3
<ul style="list-style-type: none"> <li>with SIDOOR M3 geared motor, max.</li> <li>with SIDOOR M4 geared motor, max.</li> <li>with SIDOOR M5 geared motor, max.</li> </ul>	6 kg	8 kg
<b>Interfaces</b>		
Interfaces/bus type	CANopen, CiA standard 301, profile 417	
Number of bus nodes	32	
<b>Standards, approvals, certificates</b>		
Certificate of suitability according to EN 81	Yes	
CE mark	Yes	
UL approval	No	
EAC (formerly Gost-R)	Yes	
TÜV Inspectorate approval	Yes	
TÜV prototype tested	Yes	
China RoHS compliance	Yes	
Standard for safety	EN 61010-1 / EN 61010-2-201 / EN 81-20	
<b>Ambient conditions</b>		
<b>Ambient temperature during operation</b>		
<ul style="list-style-type: none"> <li>min.</li> <li>max.</li> </ul>	-20 °C	50 °C
<b>Ambient temperature during storage/ transportation</b>		
<ul style="list-style-type: none"> <li>Storage, min.</li> <li>Storage, max.</li> </ul>	-40 °C	50 °C
<b>Altitude during operation relating to sea level</b>		
<ul style="list-style-type: none"> <li>Installation altitude above sea level, max.</li> </ul>	2 000 m	
<b>Relative humidity</b>		
<ul style="list-style-type: none"> <li>No condensation, min.</li> <li>No condensation, max.</li> </ul>	10 %	93 %
<b>Dimensions</b>		
Width	320 mm	
Height	60 mm	
Depth	80 mm	



Dimension drawing

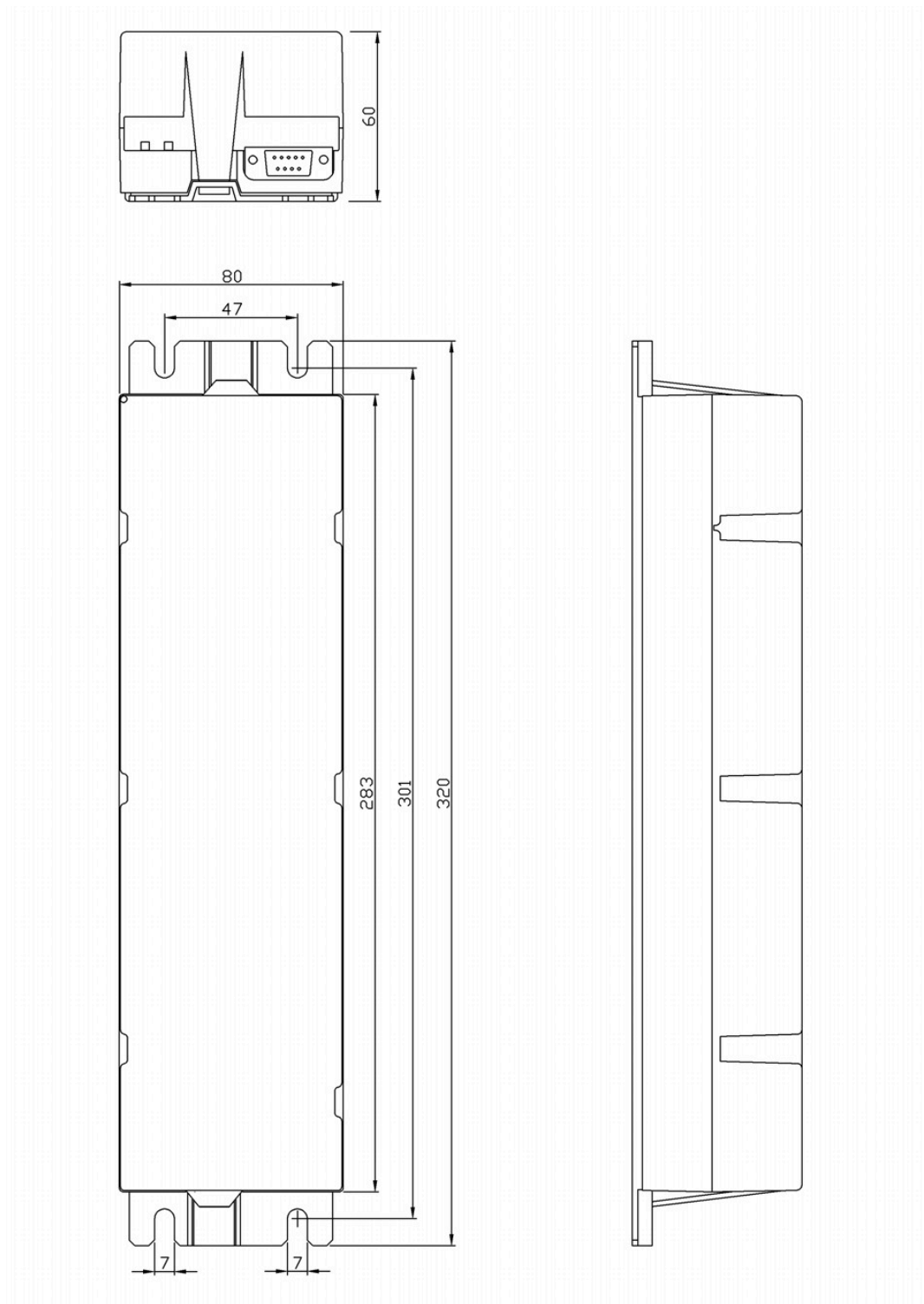

Figure 5-3 Controller

## 5.7 Operating and parameterizing controllers

The service buttons can be used to operate the control device.

The following options are available to configure the control device.

1. Parameter assignment with the minimal editor
2. Parameter assignment with the terminal module
3. Parameter assignment via supplementary devices (SIDOOR SERVICE TOOL, SIDOOR SOFTWARE KIT)

---

### Note

After the optimal parameter settings have been determined, note them in the configuration record (see Appendix Configuration record (Page 172)). Have this record to hand when you call the Hotline.

---

### Note

The SIDOOR SOFTWARE KIT or the SIDOOR SUPPORT app allows you to read the currently set drive curve parameters from the control unit and save them on the PC.

This parameter set can then be reloaded on any other door or on a new control unit via the SIDOOR SOFTWARE KIT or the SIDOOR SUPPORT app.

This means that the doors are set with the same driving curve parameter set.

---

### Note

#### Parameter changes

Changes to the driving curve parameters should only be performed after a successful learn run. Changes to the driving curve parameters are applied immediately if the doors are at a standstill.

---

## 5.7.1 Operator panel

### Overview

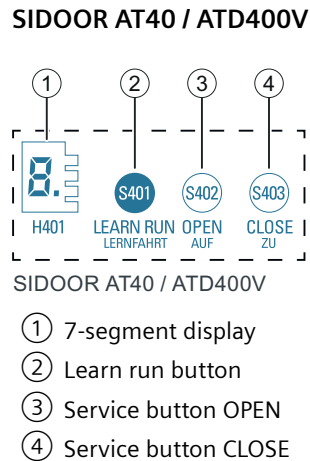

Figure 5-4 Overview of operator panel

### 5.7.1.1 Service buttons

#### "H401" 7-segment display

You can see the operating states as well as the status and error display on the "H401" 7-segment display. You can find the description of the 7-segment display in the section Operating state display (Page 161).

#### Service buttons OPEN and CLOSE

Door movements in the OPEN and CLOSE directions can also be made manually with the service buttons S402 (OPEN) and S403 (CLOSE).

The service buttons have a higher priority than external control signals (service menu, digital input signals, CANopen).

Controlling of the door for servicing purposes is therefore possible, irrespective of externally applied control signals.

To detect the end position of the door, the respective service button has to be pushed continuously in the end position (min. 1 second), because control of the door stops prematurely otherwise.

5.7 Operating and parameterizing controllers

If the DOOR OPEN and DOOR CLOSE commands are issued simultaneously, the door always moves in the **OPEN** direction.

**Note**

**Operating SIDOOR SERVICE TOOL, SIDOOR SUPPORT App or SIDOOR USER SOFTWARE**

Alternatively, you can also control the doors via the SIDOOR SERVICE TOOL, the SIDOOR SUPPORT app or the SIDOOR USER SOFTWARE. In this case, the external input signals are blocked. Additional information is available in the section SIDOOR SERVICE TOOL (Page 137) and in the SIDOOR SOFTWARE KIT Operating Instructions (<https://support.industry.siemens.com/cs/ww/en/view/92711247>).

5.7.1.2 Minimal editor

Using the minimal editor

The SIDOOR AT40 and ATD400V control devices have a minimal editor.

The minimal editor is a utility for changing specific parameters on a control unit when the terminal module, the SIDOOR SERVICE TOOL, SIDOOR SUPPORT app or the SIDOOR USER SOFTWARE is not available. In this case, the learn run button (S401) and the two service buttons (S402, S403) are assigned second functions. The 7-segment display (H401) is used to visualize messages.

You can use the minimal editor to perform the following settings:

- Select a fixed profile
- Set the closing forces (input of the counterweight)
- Setting the light barrier functionality

 <b>WARNING</b>
<b>Risk of injury due to moving mechanical parts</b>
Selecting a profile overwrites the specification of the counterweight.
For this reason, set the value for the counterweight (parameter "A") last.

The minimal editor can only be activated by pressing the service buttons S402 and S403 at the same time as the network is reset.

Activating the minimal editor

1. Disconnect the control device from the power supply by pulling the power plug. The line voltage can alternatively be connected and disconnected with the X3 connector directly on the control device.
2. Press and hold down the S402 and S403 buttons simultaneously and reestablish the line voltage by plugging the power plug back in. Continue to hold down both buttons.
3. An "8" appears on the 7-segment display for approximately 5 seconds as confirmation.

4. Once the display stops, let go of both buttons within approximately 3 seconds. Do not operate these two buttons until the end of this time window.
5. To confirm the successful activation of the minimal editor, the 7-segment display alternates between a "C" and the currently assigned profile in the form of a number from 1 to 6.

### Selecting a profile

1. Select the desired profile (1 to 6) by pressing the service button S402 (downwards) or S403 (upwards).
2. Confirm the profile you have set by pressing and holding down the learn run button (S401) until the dot lights up on the 7-segment display (> 2 seconds).  
The dot on the 7-segment display indicates that the settings have been successfully stored.

---

**Note**

If the learn run button (S401) is pressed only briefly, the minimal editor switches to the closing forces setting menu. The newly set profile is not saved.

---

### Setting the closing forces

1. Press the learn run button (S401) to set the closing forces.
2. The 7-segment display alternates between displaying an "A" and the currently set counterweight in the form of a number from 0 to 8.
3. Select the desired counterweight (0 to 8) by pressing the service button S402 (downwards) or S403 (upwards).

---

**Note**

The closing forces are set in the form of a counterweight, whereby 1 kg is simply taken as 10 N. The input can range from 0 to 8, where 0 stands for "no counterweight" and 8 for an "8 kg counterweight".

Specification of the counterweight changes the closing force, as it is subtracted from the maximum value of 150 N. The setting "8" therefore reduces the closing force to 70 N ( $150\text{ N} - 80\text{ N} = 70\text{ N}$ ).

---

4. Confirm the closing force you have selected by pressing and holding down the learn run button (S401) until the dot lights up on the 7-segment display (> 2 seconds).  
The dot on the 7-segment display indicates that the settings have been successfully stored.

---

**Note**

If the learn run button (S401) is pressed only briefly, the minimal editor switches to the setting of the light barrier functionality. The newly set counterweight value is not saved.

---

### Setting of the function of input 1

Selecting the function of input 1:

1. Press the learn run button (S401) to set input 1.
2. The 7-segment display alternates between displaying an "||" and the current setting in the form of a number from 0 to 2. (0: Light barrier, 1: DCPS, 2: deactivated)
3. Set the required function (0: Light barrier, 1: DCPS, 2: deactivated) by pressing the service button S402 (downwards) or S403 (upwards).
4. Confirm by pressing and holding down the learn run button (S401) until the dot lights up on the 7-segment display (> 2 seconds).

The dot on the 7-segment display indicates that the settings have been successfully stored.

### Deactivating (exiting) the minimal editor

1. Disconnect the control device from the power supply by pulling the power plug.
2. Connect the control device to the power supply by plugging in the power plug.

---

#### Note

The line voltage can alternatively be connected and disconnected with the X3 connector directly on the control device.

---

### Performing a learn run

---

#### Note

The current driving parameters are overwritten by the factory parameters at the end of the learn run if the learn run button (S401) is pressed at the same time as the line voltage is applied. If the learn run button is pressed during operation, only the door width and weight are determined. The driving parameters, force limits and continuous torques remain unchanged. The maximum closing speed and the nudging speed are limited as a function of the determined weight.

The values preset by the minimum editor (travel profile, closing force) are overwritten by a subsequent learn run with default parameters. A "normal" learn run does not overwrite the preset values.

---

1. Push the door into the CLOSED position.
2. Perform a learn run **during operation**. Proceed as described in Table 4-3 Starting a learn run during operation (Page 36).

## 5.7.2 Parameterizing via the Terminal Module, SIDOOR SOFTWARE KIT or SIDOOR SERVICE TOOL.

### Overview

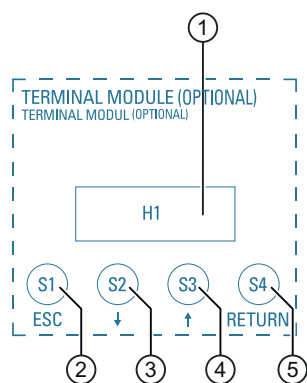

SIDOOR AT40 / ATD400V

- ① Digital display
- ② Escape key
- ③ Menu selection key
- ④ Menu selection key
- ⑤ Enter key

Figure 5-5 Overview of terminal module

### Function

The integrated terminal module can be used for diagnostics and setting parameters.



#### Note

The operation and displays on the integrated terminal module are identical to those on the SIDOOR SERVICE TOOL, the SIDOOR SERVICE TOOL emulation in the SIDOOR SOFTWARE KIT, and the virtual CAN terminal or the SIDOOR SERVICE TOOL emulation in the SIDOOR SUPPORT app.

### Operation



	Enter key – jumps to the next menu below
	Escape key – jumps back to the menu above

5.7 Operating and parameterizing controllers

	Menu selection key – increases a parameter value
	Menu selection key – decreases a parameter value

Parameters can be changed in the following three menus:

- "MAIN MENU > Quick setup > Parameter setting"
- "MAIN MENU > General setup > Profile parameters"
- "MAIN MENU > General setup > Special parameters"

The desired parameter is selected with the menu selection keys  and , and activated for the setting with the Enter key  (parameter value flashes).

The parameter value can then be increased or decreased by pressing the corresponding key (see above). The value is applied by pressing the Enter key again.

**Menu navigation**

You can find the menu navigation of the terminal module, SIDOOR SOFTWARE KIT, SIDOOR SUPPORT app or SIDOOR SERVICE TOOL in the section SIDOOR SERVICE TOOL (Page 137).

**Digital display "H1"**

You can see the operating states on the "H1" display. You can find the meaning of the digital display in the section Operating state display (Page 161).

**Description**

In addition to the parameter assignment options integrated in the controller, you can also assign parameters via additional units. The following additional units are available for parameter assignment:

- **SIDOOR SOFTWARE KIT**  
The SIDOOR USER SOFTWARE is part of the SIDOOR SOFTWARE KIT. You can find a detailed description of the SIDOOR SOFTWARE KIT in the SIDOOR SOFTWARE KIT Operating Instructions (<http://support.automation.siemens.com/WW/view/en/92711247>).
- **SIDOOR SERVICE TOOL**  
You can find a detailed description of the SIDOOR SERVICE TOOL in the section SIDOOR SERVICE TOOL (Page 137).
- **Virtual CAN terminal in accordance with CiA-417**  
A detailed description of the virtual CAN terminal functionality in accordance with CiA-417 is available in the section Virtual CAN Terminal (Page 72)
- **SIDOOR LINK with SIDOOR SUPPORT app**  
You can find a detailed description in the section SIDOOR SUPPORT app and SIDOOR LINK (Page 26).



### 5.7.3 Parameter names

Some of the parameter names are abbreviated in the software because of the limited number of characters in the display. The full names of the parameters are used in this manual.

The following table shows the full parameter names and the equivalent names used in the software:

Full parameter name	Parameter name as shown in the software
<b>Profile parameter</b>	
Creep distance OPEN	slow end open distance
Cutter distance OPEN	slow start open distance
Creep distance CLOSE	slow start close distance
Cutter distance CLOSE	slow end close distance
Maximum speed OPEN	maximum speed open
Creep speed OPEN	slow end speed open
Cutter speed OPEN	slow start speed open
Initial speed OPEN	slow speed open initial
Maximum speed CLOSE	maximum speed close
Creep speed CLOSE	slow start speed close
Cutter speed CLOSE	slow end speed close
Initial speed CLOSE	slow speed close initial
Nudge speed CLOSE	Nudging speed close
Acceleration ramp OPEN	acceler. ramp open
Deceleration ramp OPEN	Braking ramp OPEN
Reversing ramp OPEN/CLOSE	reversal ramp op/cl
Acceleration ramp CLOSE	acceler. ramp close
Braking ramp CLOSE	deceler. ramp close
Reversing ramp CLOSE/OPEN	reversal ramp cl/op
Continuous torque (power) OPEN	idle torque open
Continuous torque (power) CLOSE	idle torque close
Peak torque CLOSE	peak torque close
Static opening force	limit force open
Static closing force	limit force close
Static cutter force CLOSE	limit force end close
Static nudge force CLOSE	Static nudge force close

### 5.7.4 Adjustable parameters

#### 5.7.4.1 Driving curve

The optimum drive characteristics of the door are calculated and maintained continuously.

The driving curve transitions are rounded off so that the door movement is smooth and jerk-free.

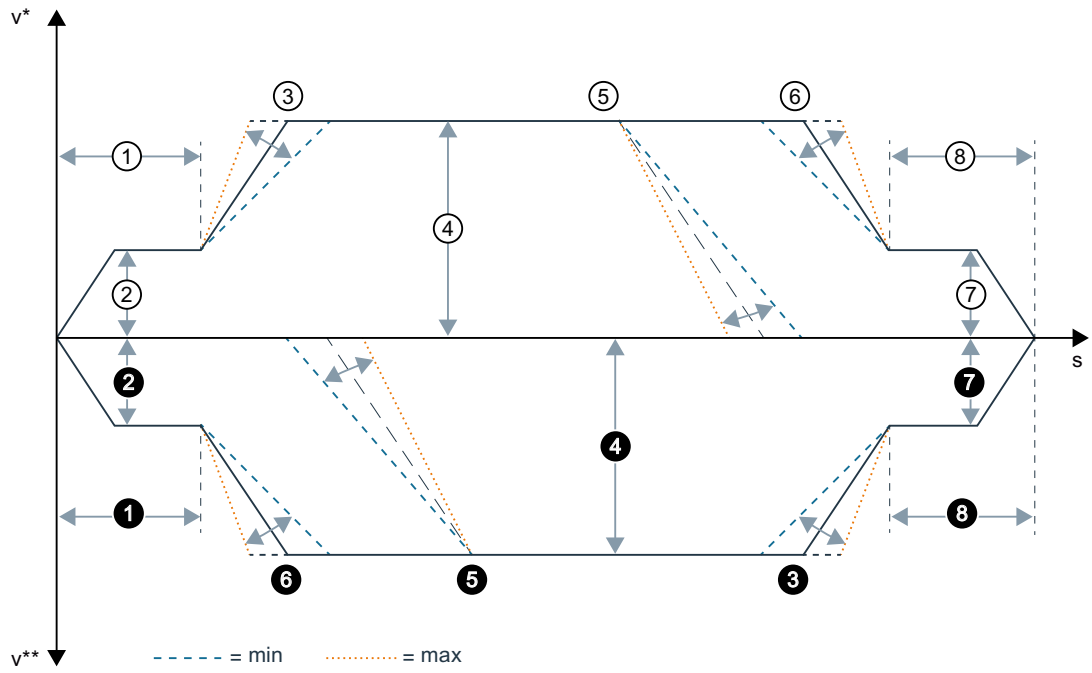

v\* Speed OPEN

v\* Speed CLOSE  
\*

- |  |   |
|--|---|
| <ul style="list-style-type: none"> <li>① Cutter distance OPEN</li> <li>② Cutter speed OPEN</li> <li>③ Acceleration ramp OPEN</li> <li>④ Maximum speed OPEN</li> <li>⑤ Reversing ramp OPEN → CLOSE</li> <li>⑥ Braking ramp OPEN</li> <li>⑦ Creep speed OPEN</li> <li>⑧ Creep distance OPEN</li> </ul> | <ul style="list-style-type: none"> <li>❶ Cutter distance CLOSE</li> <li>❷ Cutter speed CLOSE</li> <li>❸ Acceleration ramp CLOSE</li> <li>❹ Maximum speed CLOSE</li> <li>❺ Reversing ramp CLOSE → OPEN</li> <li>❻ Braking ramp CLOSE</li> <li>❼ Creep speed CLOSE</li> <li>❽ Creep distance CLOSE</li> </ul> |
|--|---|

Reversing ramp CLOSE\_OPEN = direction of travel reverses from "CLOSE" to "OPEN".

When reversing from the opening to the closing direction, the door is braked with the reversing ramp OPEN\_CLOSE, and starts the closing movement with the acceleration ramp CLOSE.

**Note**

The attainable accelerations depend on the door mass, the parameterized opening and closing forces, and the power of the power supply unit used.

**5.7.4.2 Forces**

The following forces and currents can be configured for the driving curve (see section DOOR OPEN (Page 39)):

### Idle torque open

Idle torque in the door position OPEN.

This parameter is in effect when an open command is set and the door is in the OPEN position.

This parameter is also effective when the special parameter "*Idle torque without door command*" is switched on and the door is in the OPEN position.

The current generates an idle torque against the end position of the door in the opening direction.

#### Adjustment ranges

The parameter can be adjusted in accordance with the adjustment ranges of the parameters (see section Profiles and adjustment ranges (Page 165)). The value of the parameter must be selected so that the door is held in the OPEN position. This prevents the door from oscillating in the end position.

---

#### Note

The "Idle torque (power) OPEN" has to be adjusted in such a way that the door cannot be pulled out of the OPEN position, e.g. through a counterweight or rubber buffers in the end stop. (See the section Oscillation protection (Page 42)).

---

### Idle torque close

Idle torque in the door position CLOSED.

This parameter is in effect when a close command is set and the door is in the CLOSED position.

This parameter is also effective when the special parameter "*Idle torque without door command*" is switched on and the door is in the CLOSED position.

The current generates an idle torque against the end position of the door in the closing direction.

#### Adjustment ranges

The parameter can be adjusted in accordance with the adjustment ranges of the parameters (see section Profiles and adjustment ranges (Page 165)). The value of the parameter must be selected so that the door is held in the CLOSED position. This prevents the door from oscillating in the end position.

---

#### Note

The "Idle torque (power) CLOSE" parameter has to be adjusted in such a way that the door cannot be pushed from the CLOSE position, for example through the spring of the closing mechanism or rubber buffers in the end stop. (See the section Oscillation protection (Page 42)).

To ensure an emergency release, observe the section Emergency release (Page 46).

---

**Peak torque close**

The peak torque close presses the door against a door cutter.

If an obstruction is detected within a tolerance range of 1 cm around the CLOSED position, then the peak torque close is applied for approx. 2 seconds.

**Adjustment ranges**

The parameter can be adjusted in accordance with the adjustment ranges of the parameters (see section Profiles and adjustment ranges (Page 165)). The value of the parameter must be selected so that the force end counter opposing the door is overcome, and the door is closed completely.

**Note**

Idle torque OPEN, idle torque CLOSE, peak torque close:

So that the press-on torques can be activated in the end positions of the door, the door command must be pending for at least 1 second after reaching the end position.

**Static force limit open**

This force is in effect during the opening movement if an open command is set.

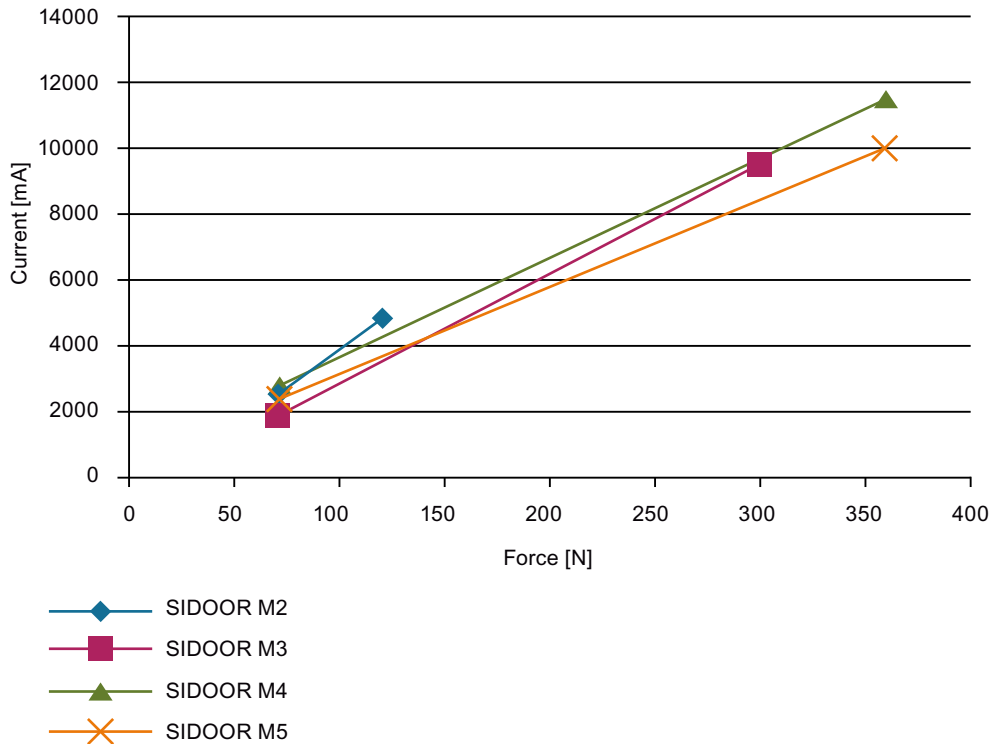

Figure 5-6 Current – force – motor characteristic in opening direction

### Adjustment ranges

The parameter can be adjusted in accordance with the adjustment ranges of the parameters (see section Profiles and adjustment ranges (Page 165)). The value of the parameter must be selected so that the door moves across the entire door width in the opening direction if an open command is set. Inadequate force can lead to an obstruction of the door.

**⚠ WARNING**

**Danger of injury and damage to property through excessive opening force of the door.**

Limit the opening force of glass and folding doors to 150 N.

See section Glass leaf and folding leaf doors (Page 54).

### Static force limit close

This force is in effect during the closing movement if a close command is set.

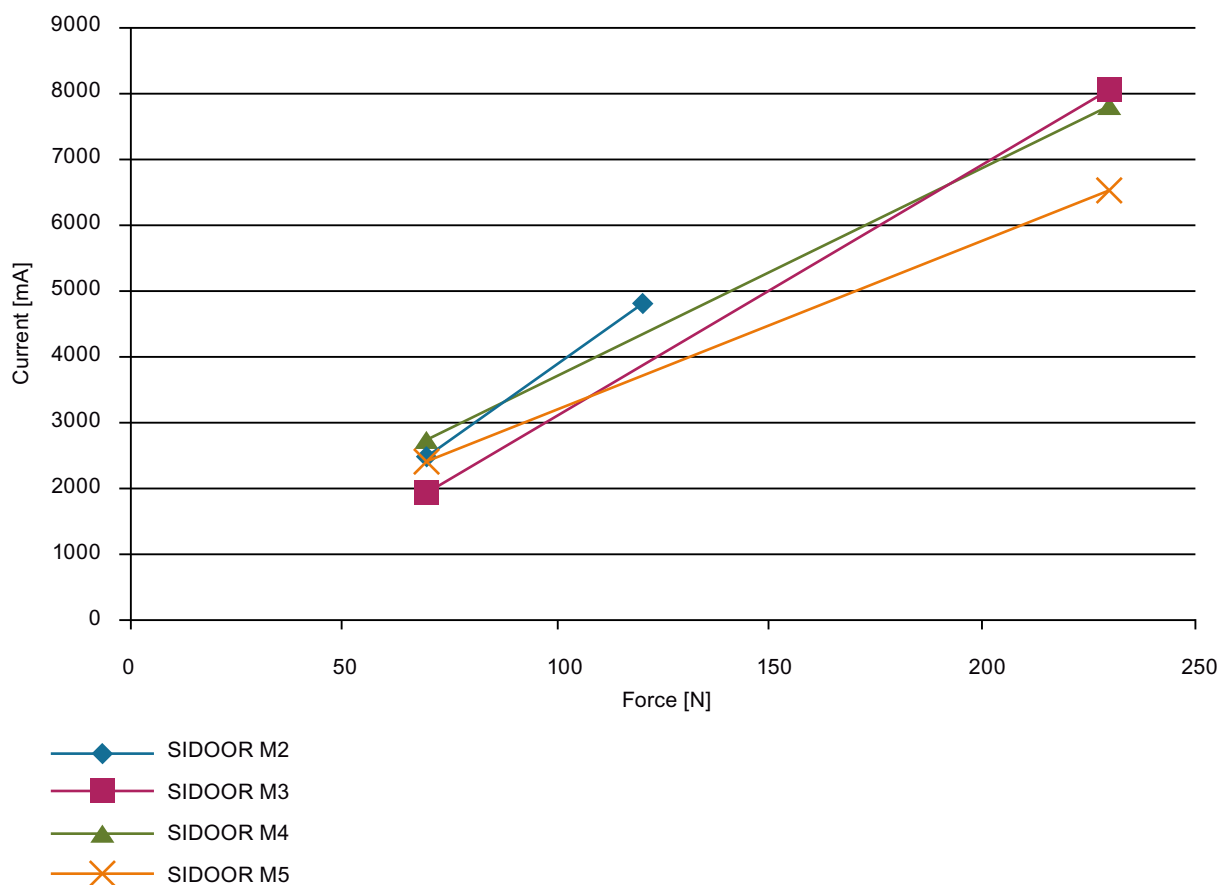



Figure 5-7 Current – force – motor characteristic in closing direction

### Adjustment ranges

The value of the parameter must be selected so that the door moves across the entire door width in the closing direction if a close command is set. Inadequate force can lead to an obstruction of the door.

The closing force can be set for the geared motors within the adjustment ranges of the parameters (see section Profiles and adjustment ranges (Page 165)).

A warning appears on the digital display of the terminal module if the set closing force of 150 N is exceeded. The stated values refer to doors opening to one side. A load cell in the middle of centrally opening doors would show only half the value.

 <b>WARNING</b>
<b>Risk of injury and material damage due to excessive closing force of the door</b>
When the closing force is set, it is imperative that any effective closing weight is taken into account.
The desired closing force must be reduced by 10 N for each 1 kg of counterweight. This affects the:
<ul style="list-style-type: none"><li>• Limit force close</li><li>• Limit force slow start close distance</li><li>• Nudge force CLOSE</li></ul>

### Example: Closing weight = 4 kg

Desired static force limit CLOSE = 150 N

The counterweight of 4 kg corresponds to a force of 40 N. The force limit then has to be adjusted to  $150\text{ N} - 40\text{ N} = 110\text{ N}$ .

The factory settings are pre-configured for the following counterweights:

The resulting static closing force for the enabled motors is preset in the default profiles to 70 N, 90 N or 110 N depending on the motor.

### Limit force end close

This force serves to overcome the slow start distance in the closing direction.

A higher force is often required to overcome the low start distance than for the rest of the distance the door travels.

This parameter is in effect in the closing direction when the door is within the slow start distance.

### Adjustment ranges

The parameter can be adjusted in accordance with the adjustment ranges of the parameters (see section Profiles and adjustment ranges (Page 165)). The value of the parameter must be selected so that the slow start distance is overcome in the closing direction.



#### **WARNING**

##### **Risk of injury due to excessive closing force of the door**

The door must be closed completely within the slow end distance in the closing direction. The driving curve parameter "Cutter distance CLOSE" must be checked and set accordingly.





## Geared motors

### 6.1 Description

#### Overview



Figure 6-1 Geared motors (pinion left\*)

\* The gearbox output direction is defined as left or right when viewing the gearbox from the front.

The maintenance-free drive unit consists of a speed-controlled DC motor with non-self-locking gearing. The geared motors must be selected according to the mass to be moved.

## 6.2 Installation

### Overview

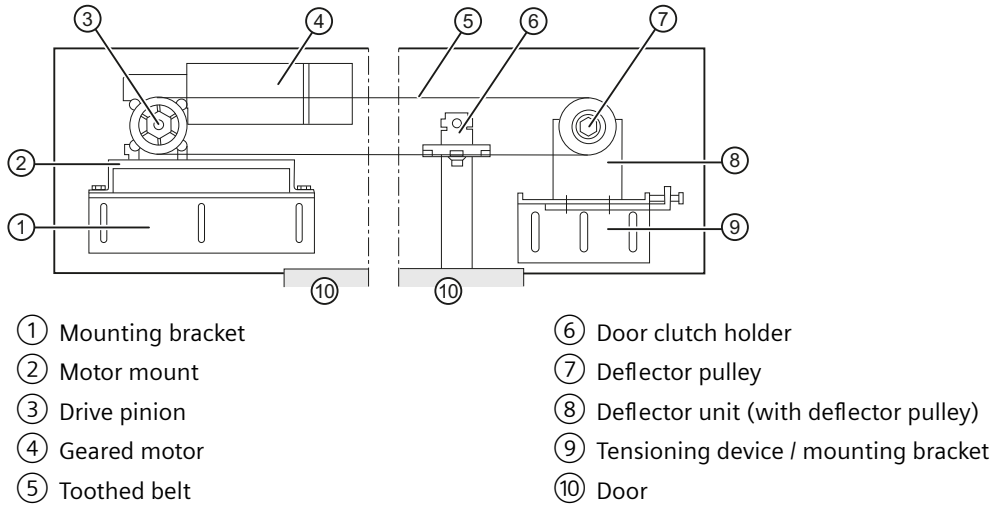

#### Note

##### Optional components

The rubber-metal anti-vibration mount, mounting bracket, tensioning device / mounting bracket, deflector unit / deflector pulley, and door clutch holder are optional components and can be obtained from Siemens. You will find further information in the section Accessories (Page 30).

### Procedure

**⚠ WARNING**

**Risk of injury and damage to property as a result of incorrect installation**

Improper and incorrect installation can lead to serious injuries.

Observe the instructions for safe installation.

The mechanical installation of the geared motor is performed in the following steps:

1. Mount the geared motor on the rubber-metal anti-vibration motor mounting.

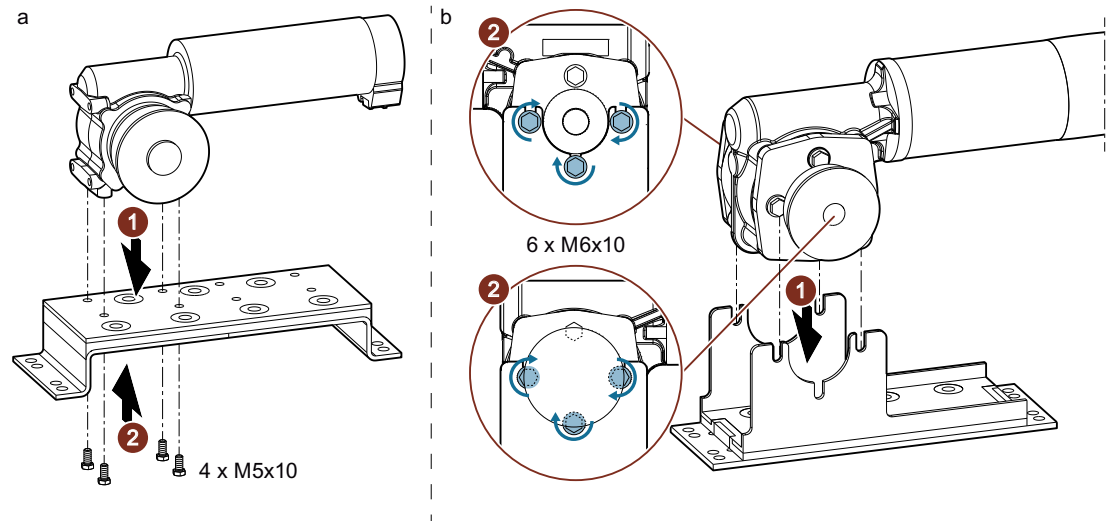

a SIDOOR M2 / M3

b SIDOOR M4 / M5

Then, if necessary, mount the geared motor on the mounting bracket.

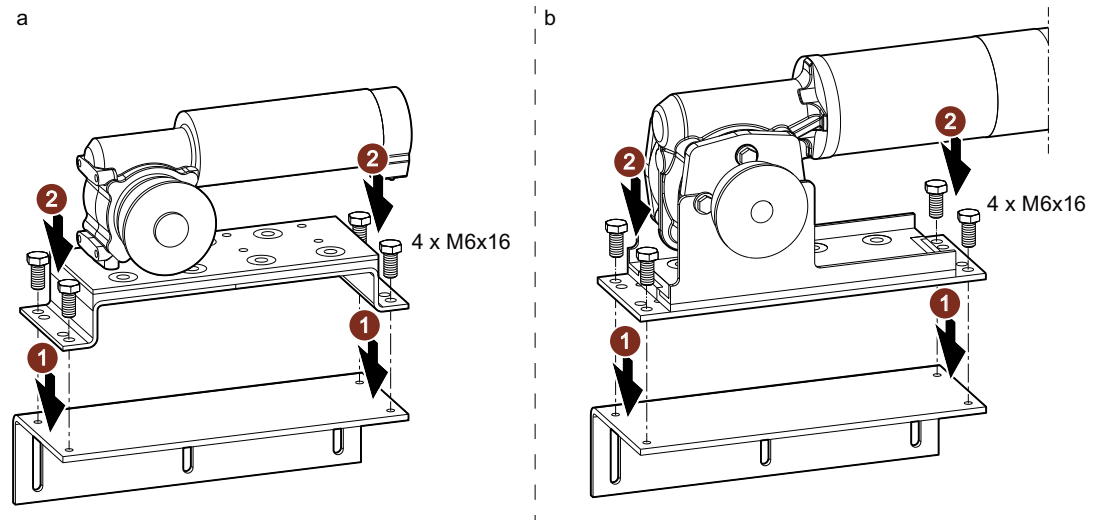

a SIDOOR M2 / M3

b SIDOOR M4 / M5

2. Mount the deflector unit, if necessary with a mounting bracket.

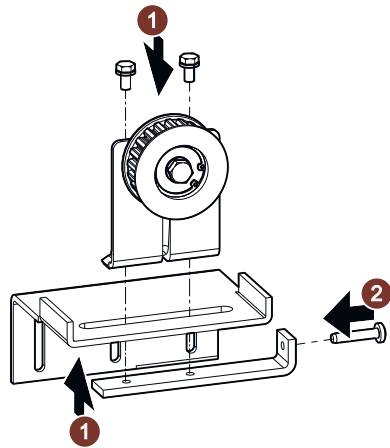

Ensure that the drive pinion and deflector pulley are aligned when doing so. They have to be exactly aligned to ensure a long drive service life.

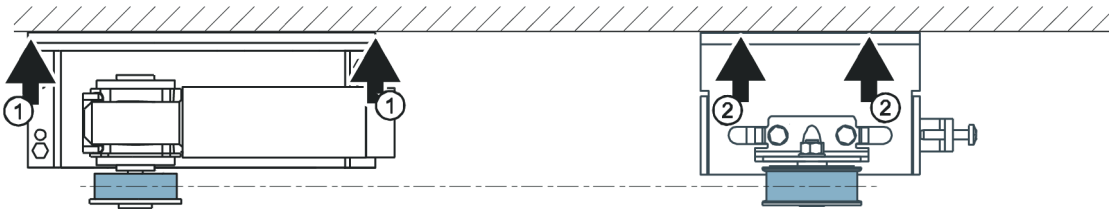

3. Pass the toothed belt over the deflector pulley and drive pinion. Place both open ends of the toothed belt in the door clutch holder. Screw the door clutch holder together.

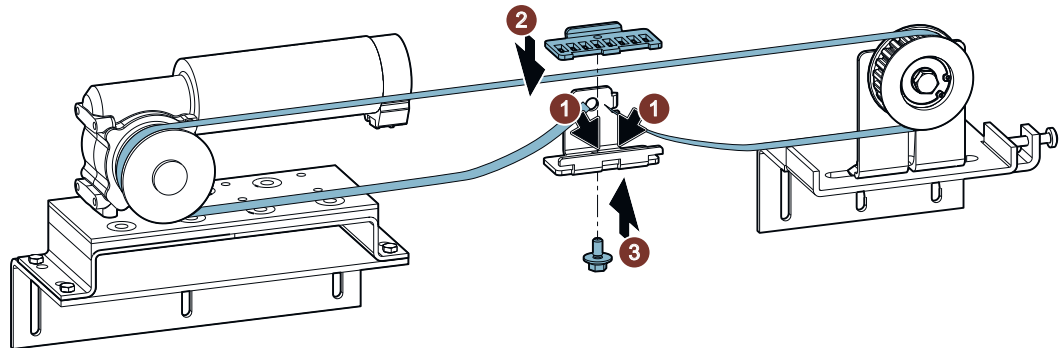

4. Tension the toothed belt with the aid of the tensioning device.

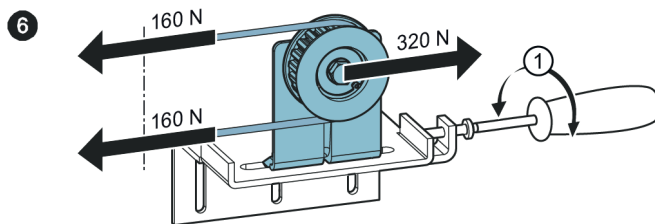

## Span tension

The span tension  $T$  of the belt is calculated as follows:

$$T = 4 \cdot k \cdot L^2 \cdot f^2$$

$T$ : Span tension [N]

$k$ : Meter weight [kg/m]

$L$ : Belt length [m]

$f$ : Frequency [Hz]

The following table shows the natural frequency ( $f$ ) of the belt for the recommended span tension ( $T$ ) at different belt lengths ( $L$ ).

Belt system	Conti SYNCHROLINE STS-S8M, 12 mm	Conti SYNCHROLINE STS-S8M, 14 mm
Article number	6FB1104-OAT01-OAB0 6FB1104-OAT02-OAB0	6FB1104-OAT03-OAB0 6FB1104-OAT04-OAB0
Recommended span tension ( $T$ )	160 N $\pm$ 10 N	160 N $\pm$ 10 N
Meter weight ( $k$ )	0.062 kg/m	0.072 kg/m
Belt length ( $L$ )	Frequency ( $f$ )	Frequency ( $f$ )
0.3 m	84.7 Hz	78.6 Hz
0.5 m	50.8 Hz	47.1 Hz
1.0 m	25.4 Hz	23.5 Hz
1.5 m	16.9 Hz	15.7 Hz
2.0 m	12.7 Hz	11.8 Hz
2.5 m	10.2 Hz	9.4 Hz
3.0 m	8.5 Hz	7.9 Hz
3.5 m	7.2 Hz	6.7 Hz
4.0 m	6.3 Hz	5.9 Hz
4.5 m	5.6 Hz	5.2 Hz
5.0 m	5.0 Hz	4.7 Hz

In some applications it may be sufficient to set the belt tension as follows:

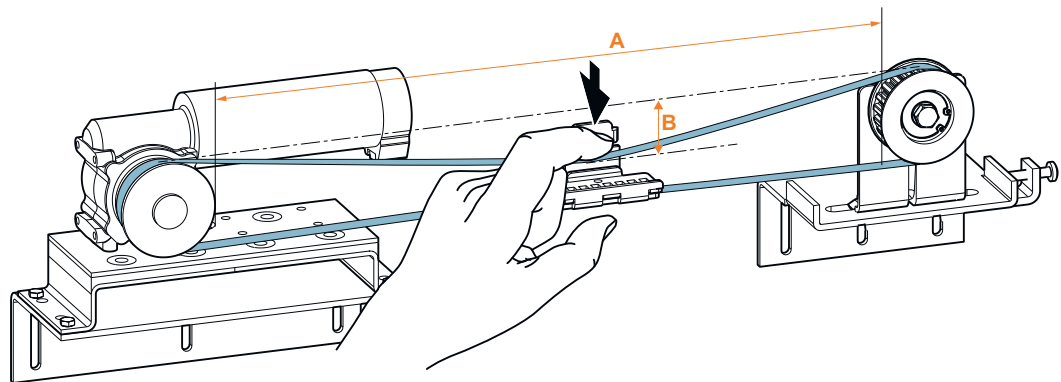

6.3 Connecting terminals

You will recognize the correct belt tension by how far the belt is pressed in (B). The depth (B) the belt is pressed in depends on the distance between the drive pinion and deflector pulley (A).

The following depths of the pressed-in belt (B) apply as a function of the distance between the drive pinion and deflector pulley (A).

<b>A (cm)</b>	50	100	150	200
<b>B (cm)</b>	1.5	3	4.5	6

### 6.3 Connecting terminals

#### 6.3.1 Conductor assignment of the motor plug

SIDOOR M2, M3, M4, and M5

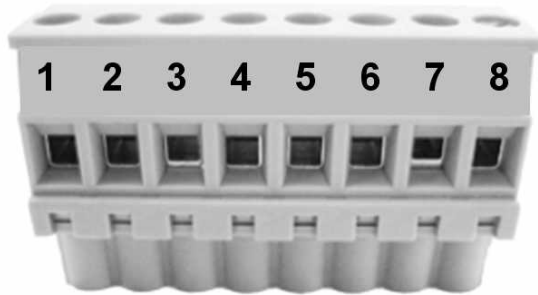

Figure 6-2 Conductor assignment of the motor plug

Table 6-1 Motor plug (slot X7)

Terminal	Signal	SIDOOR M2	SIDOOR M3	SIDOOR M4	SIDOOR M5
1	+5 V	White Black	Gray	Gray	Gray
2	Channel A	Yellow	Yellow	Yellow	Yellow
3	Channel B	Green	Green	Green	Green
4	Motor identification (motor ID)	Black	Brown	Brown	Brown
5	GND	Brown	White	White	White
6	PE	Omitted	Yellow-green	Yellow-green	Yellow-green
7	Motor+	Brown	Black	Black	Black
8	Motor-	Black	Black	Black	Black

## 6.4 Technical specifications

### Geared motors

Order number		6FB1103-0AT10-5 MA0	6FB1103-0AT11-5 MA0	6FB1103-0AT10-4 MB0	6FB1103-0AT11-4 MB0
<b>General technical data:</b>					
product brand name		SIDOOR			
Product designation		Motor for door control			
Design of the product		M2 L	M2 R	M3 L	M3 R
<b>Supply voltage:</b>					
Supply voltage					
• at DC	V	24		30	
Active power consumption rated value	W	43		120	
Operating current Rated value	A	1.8		4	
<b>Mechanical data:</b>					
Torque of the rotary actua- tor Rated value	N·m	1.05		3	
Speed maximum	m/s	0.5		0.65	
Transmission ratio of gear- box		15			
Number of pulses per revo- lution maximum		100			
Weight of door maximum	kg	120		180	
<b>Ambient conditions:</b>					
Ambient temperature					
• during operation	°C	-20 ... +50			
• during storage	°C	-40 ... +85			
Protection class IP					
• of the motor		IP20		IP54	
• of gearbox		IP20		IP40	
<b>Installation/ mounting/ di- mensions:</b>					
Height of the motor	mm	90		98	
Length of the motor	mm	207		236	
Diameter of the motor	mm	48		63	
Width of gearbox including drive pinion	mm	90		85	

6.4 Technical specifications

Article number	6FB1103-0AT11-3MD0	6FB1103-0AT10-3MD0
<b>General technical data:</b>		
product brand name	SIDOOR	SIDOOR
design of the product	With driven gear on the right	With driven gear on the left
<b>Supply voltage:</b>		
operational current / rated value	7.5 A	7.5 A
<b>Mechanical data:</b>		
torque / of the rotary actuator / rated value	6.8 N·m	6.8 N·m
Speed / maximum	0.5 m/s	0.5 m/s
transmission ratio / of gearbox	15	15
number of pulses / per revolution / maximum	100	100
Weight / of door / maximum	600 kg	600 kg
<b>Ambient conditions:</b>		
ambient temperature		
• during operation	-20 ... +50 °C	-20 ... +50 °C
• during storage	-40 ... +85 °C	-40 ... +85 °C
protection class IP		
• of the motor	IP54	IP54
• of gearbox	IP54	IP54
<b>Installation/ mounting/ dimensions:</b>		
Height / of the motor	124 mm	124 mm
length / of the motor	344 mm	344 mm
diameter / of the motor	80 mm	80 mm
Width / of gearbox / including drive pinion	111 mm	111 mm

Accessories

SIDOOR rubber-metal anti-vibration mount

Article number	6FB1104-0AT02-0AD0	6FB1104-0AT01-0AD0
<b>General information</b>		
Product type designation	rubber-metal anti-vibration mount	
Suitability for use	Motor M2, M3, MEG250	Motor M4, M5
<b>Dimensions</b>		
Width	78 mm	
Height	35 mm	78 mm
Length	230 mm	



**SIDOOR mounting bracket**

Article number	6FB1104-0AT02-0AS0	6FB1104-0AT01-0AS0
<b>General information</b>		
Product brand name	SIDOOR	
Product designation	mounting bracket	
Product version	with tensioning device for deflector pulley	for rubber-bonded metal mounting
<b>Dimensions</b>		
Width of mounting bracket	100 mm	90 mm
Height of mounting bracket	60 mm	
Length of mounting bracket	135 mm	230 mm

**SIDOOR deflector unit**

Article number	6FB1104-0AT03-0AS0	
<b>General information</b>		
Product brand name	SIDOOR	
Product designation	deflector unit	
Product version	with deflector pulley	
<b>Dimensions</b>		
Width of holder, including belt pulley	55 mm	
Height of holder, including belt pulley	100 mm	
Length of holder	70 mm	
Width of belt pulley, including flanged pulley	25 mm	
Diameter of belt pulley, including flanged pulley	61 mm	

**SIDOOR door clutch holder**

Article number	6FB1104-0AT02-0CP0	6FB1104-0AT01-0CP0
<b>General information</b>		
Product brand name	SIDOOR	
Product designation	door clutch holder	
<b>Dimensions</b>		
Width of door clutch holder		40 mm
Height of door clutch holder	43 mm	
Length of door clutch holder	68 mm	
Width of toothed belt	14 mm	12 mm

**SIDOOR toothed belt**

Article number	6FB1104-0AT01 -0AB0	6FB1104-0AT02 -0AB0	6FB1104-0AT03 -0AB0	6FB1104-0AT04 -0AB0
<b>General information</b>				
Product brand name	SIDOOR			
Product designation	toothed belt			
Type of toothed belt	STS-S8M			
<b>Dimensions</b>				
Width of toothed belt	12 mm		14 mm	
Length of toothed belt	4 m	45 m	4 m	55 m

**6.4.1 Dimension drawing of SIDOOR M2 with rubber-metal anti-vibration mount and mounting bracket**

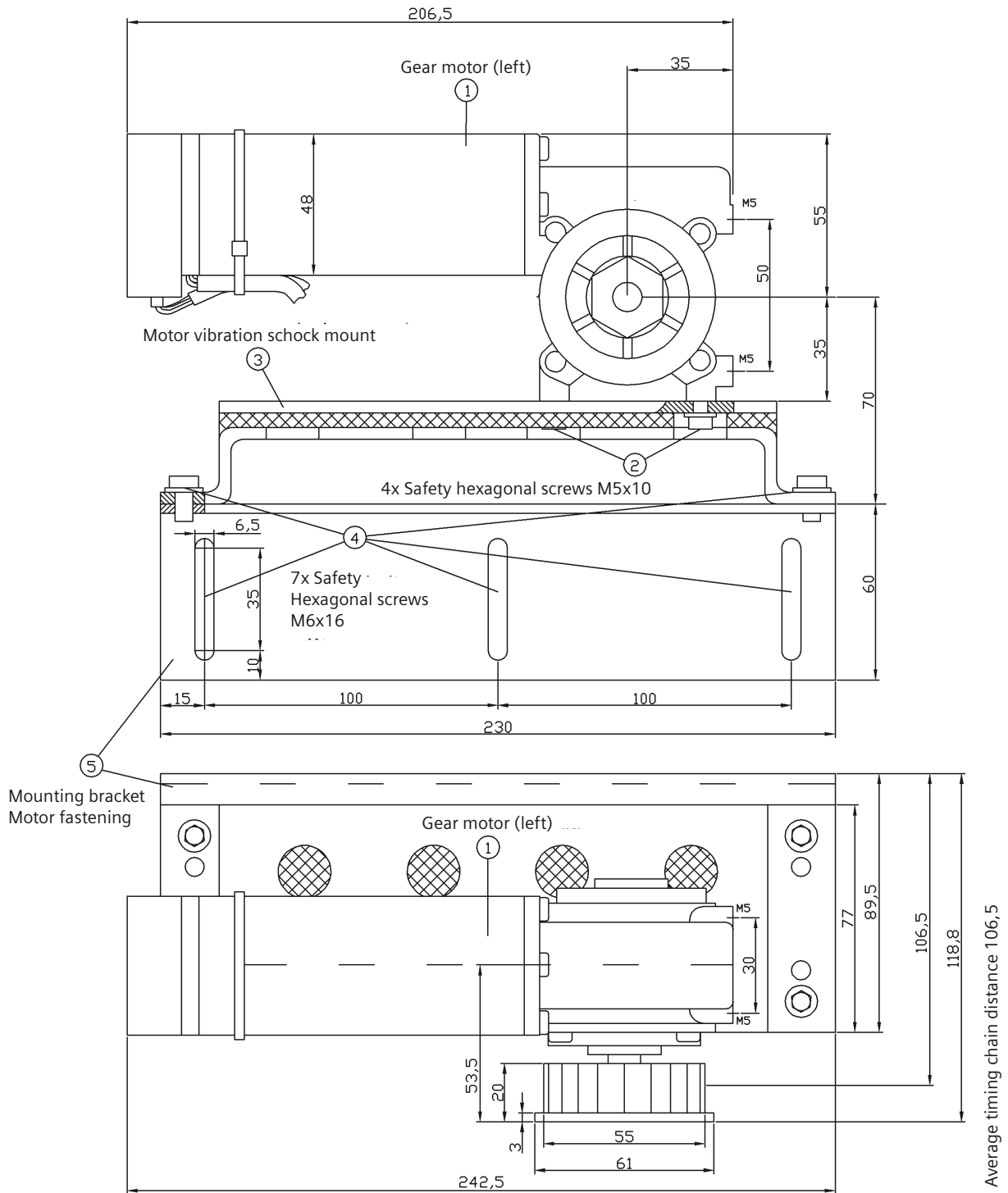
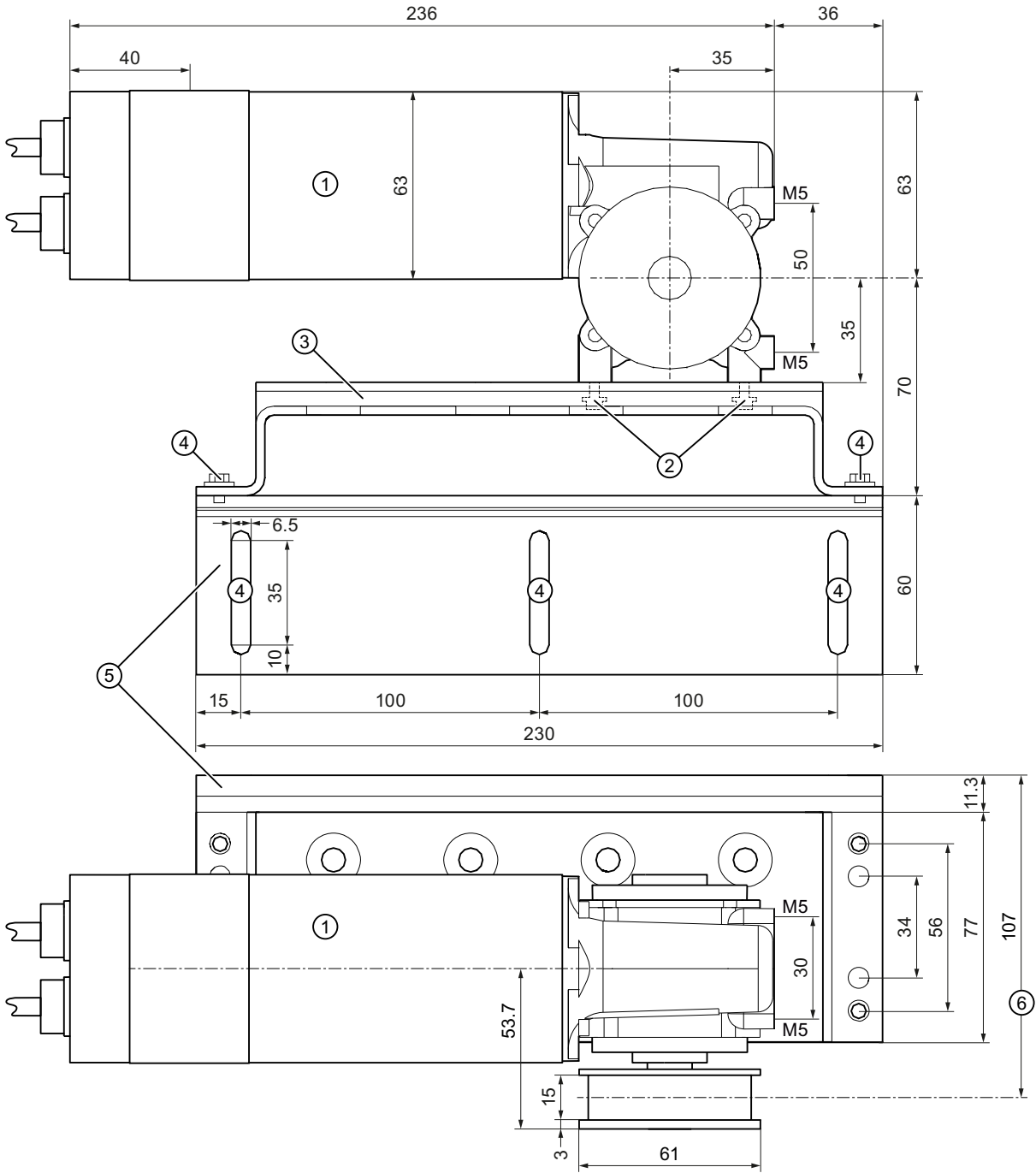

Figure 6-3 24 V geared motor with rubber-metal anti-vibration mount and mounting bracket (motor M2)

6.4.2 Dimension drawing of SIDOOR M3 with rubber-metal anti-vibration mount and mounting bracket



- ① SIDOOR M3 L geared motor
- ② 4 x M5x10 safety hexagonal screws
- ③ SIDOOR rubber-metal anti-vibration mount
- ④ 7 x M6x16 safety hexagonal screws
- ⑤ SIDOOR mounting bracket
- ⑥ Mean toothed belt clearance

Figure 6-4 30 V geared motor with rubber-metal anti-vibration mount and mounting bracket (motor M3)

**6.4.3 Dimension drawing of SIDOOR M4 with rubber-metal anti-vibration mount and mounting bracket**

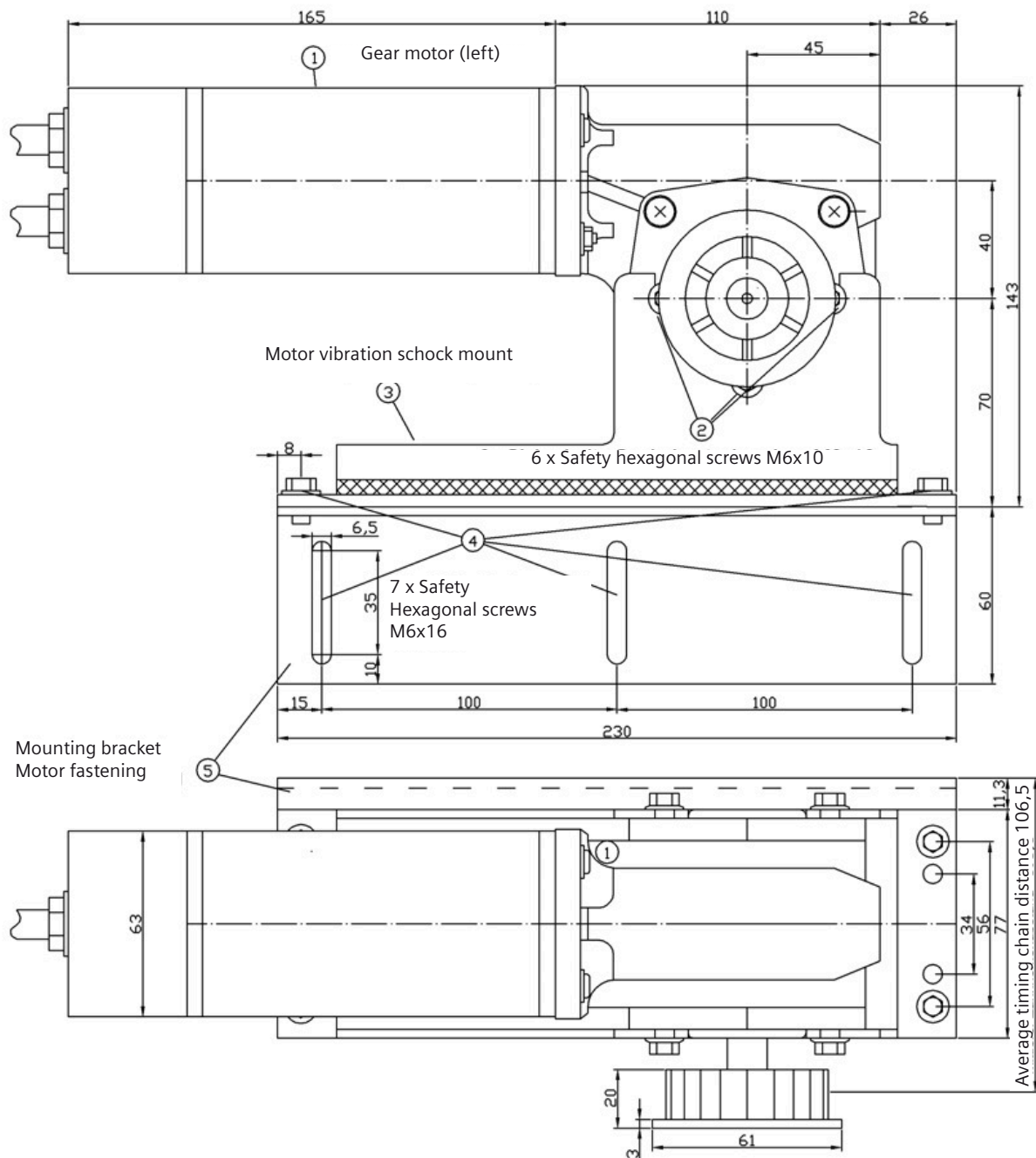
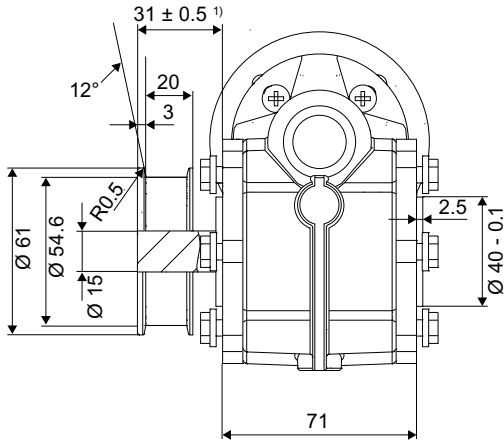

Figure 6-5 30 V geared motor with rubber-metal anti-vibration mount and mounting bracket (M4 motor)

6.4.4 Dimension drawing of SIDOOR M5

Front view

Motor on left



Motor on right

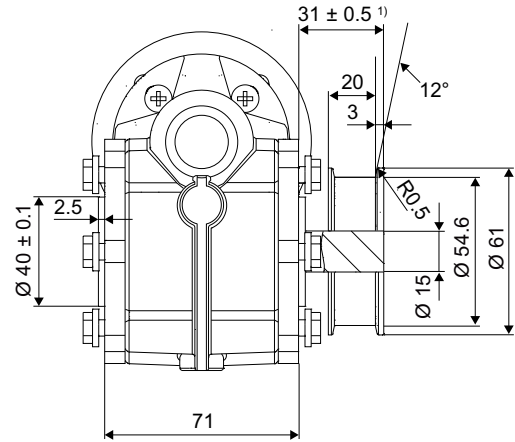

Side view

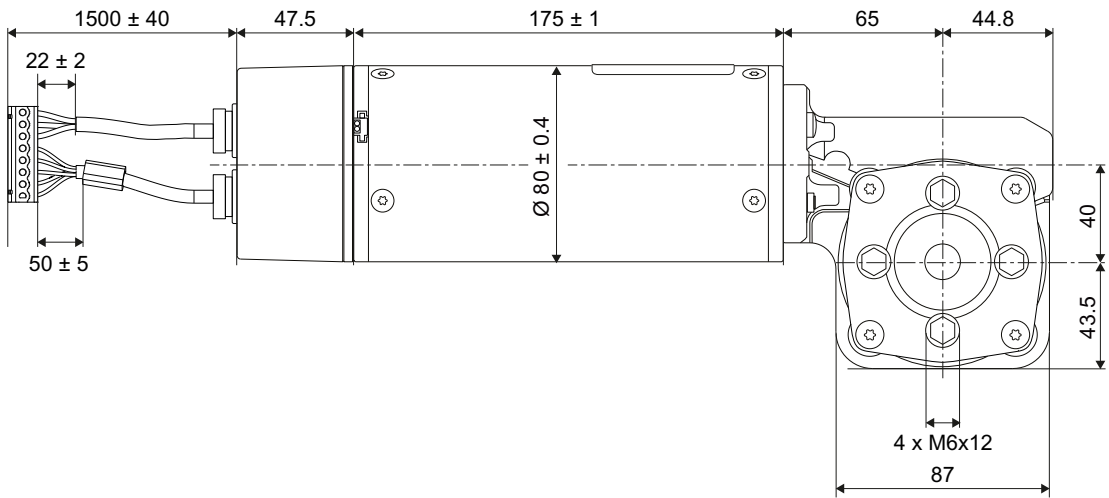

Note

Rubber-metal anti-vibration mount

When installing the M5 motor, use the same rubber-metal anti-vibration mount as for the M4 motor. See Section Dimension drawing of SIDOOR M4 with rubber-metal anti-vibration mount and mounting bracket (Page 107) and Section Accessories (Page 30).

### 6.4.5 Dimension drawing of deflector pulley with tensioning device and mounting bracket

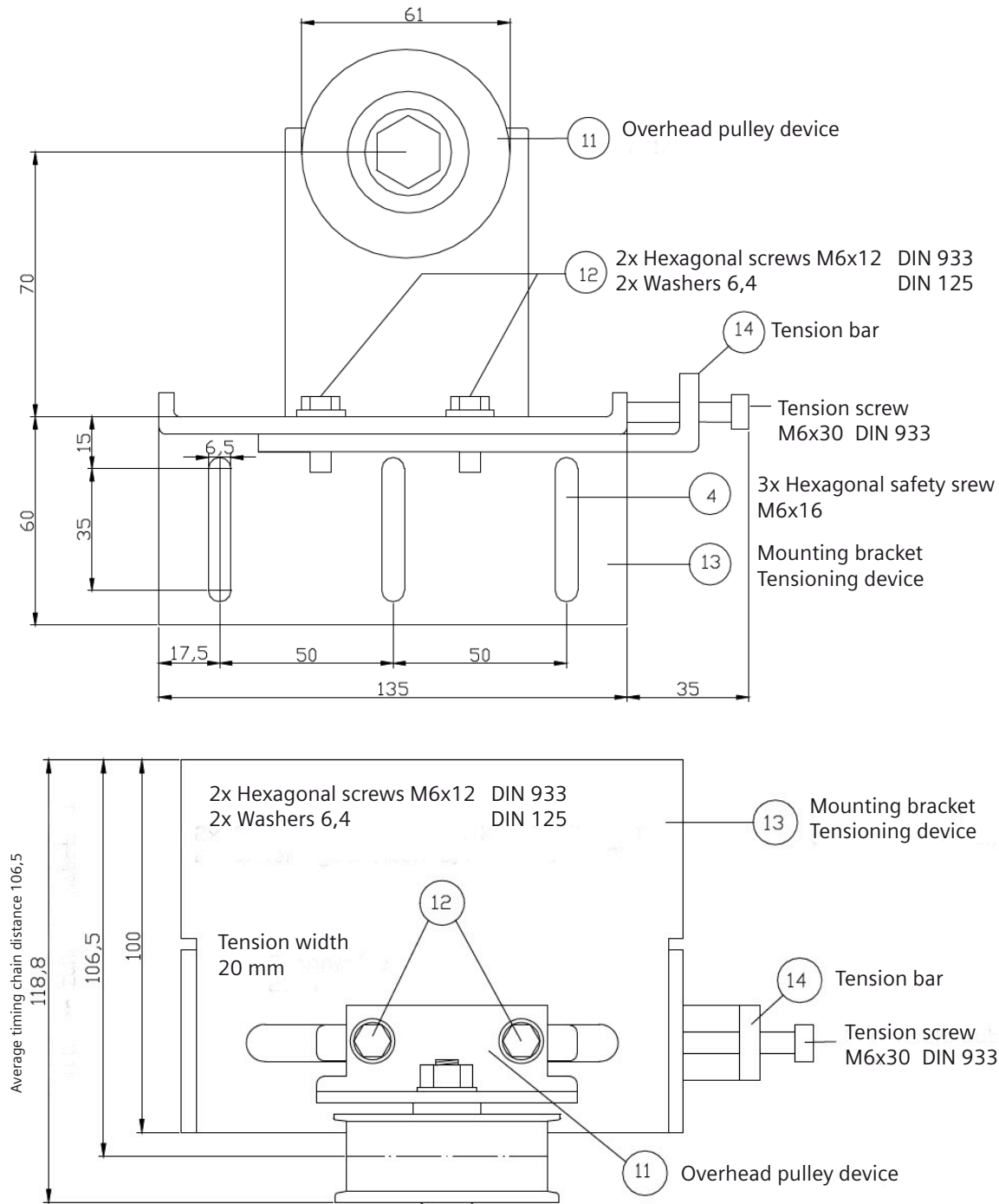

Figure 6-6 Deflector pulley with tensioning device and mounting bracket

### 6.4.6 Dimension drawing of door clutch holder

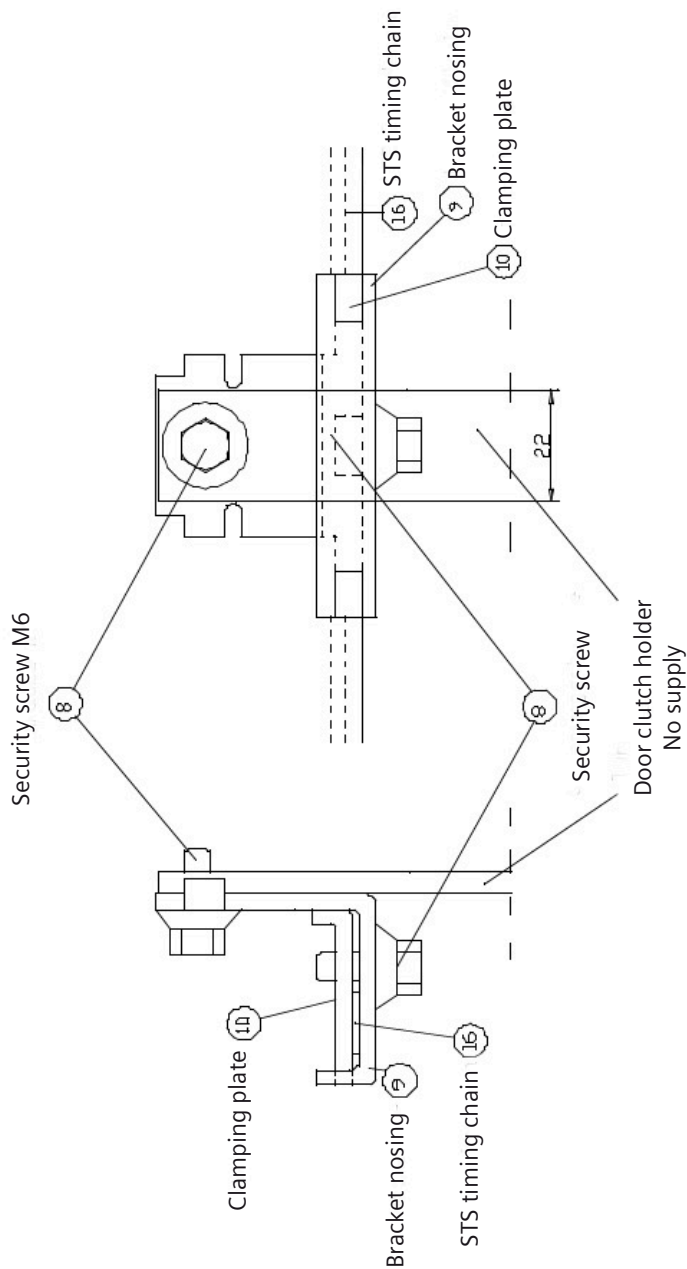

Figure 6-7 Door clutch holder



## Power supply

### 7.1 SIDOOR NT40

#### 7.1.1 Description

##### Intended use

The device may only be used in combination with the control devices specified in the product combination.

---

##### Note

##### Electromagnetic compatibility

The SIDOOR NT40 power supply meets the requirements of the EMC standard EN 61000-6-4. The SIDOOR NT40 power supply can cause interference if used in a residential environment. The commissioning engineer is responsible for interference suppression.

---

##### Design

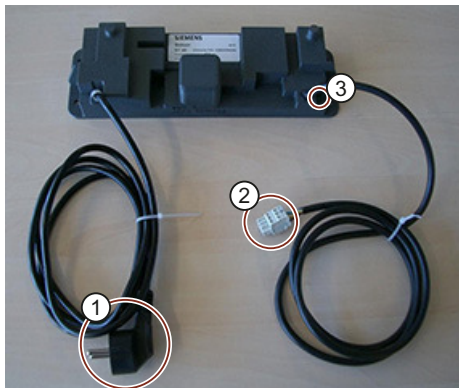

- ① Power plug X1 (Schuko plug)  
230 V AC ( $\pm 15\%$ ) 50 / 60 Hz
- ② Output X2 (connection to control device)  
36 V DC ( $\pm 3\%$ ) 2.5 A (15 A for  $< 2$  s)
- ③ LED L1

Figure 7-1 SIDOOR NT40

## Function

The SIDOOR NT40 is a 230 V AC ( $\pm 15\%$ ) 50 / 60 Hz power supply unit for supplying SIDOOR control devices for door weights up to 600 kg.

On the output side, the switch mode power supply supplies a 36 V DC ( $\pm 3\%$ ) SELV at a rated output power  $< 100$  W. The device can briefly ( $< 2$  s) deliver a 15 A current to enable fast acceleration (corresponds to a brief power output of 540 W).

### Short-circuit protection

Output X2 is short-circuit proof.

### LED display

LED L1 indicates the presence of the output voltage.

---

### Note

If the LED does not light up despite being correctly connected to the X1 supply line and if there is no measurable output voltage, this indicates a short circuit on the output side or a defective module!

The device can be operated by the control device without load to establish whether the module is defective. If the LED at the output does not light up in this mode of operation, and there is no measurable voltage at the output, this indicates that the device is defective!

---

## 7.1.2 Installation

### Requirements

Observe the following installation rules:

- Minimum clearance to surrounding parts: 1 cm
- Even mounting surface
- The installation point should, as far as possible, be vibration-free. The permissible climatic conditions (operating, storage and transport temperatures) must be observed (see AUTOHOTSPOT).
- Maximum distance from the power supply due to cable length:
  - Connecting cable input line (mains  $\leftrightarrow$  NT40): 200 cm
  - Connecting cable output line (NT40  $\leftrightarrow$  controller): 150 cm
- Operation outside the specified temperature range can lead to danger, malfunctions and failure of the equipment.
- Protection class I
- The device must be installed in places that are accessible only to qualified personnel.

- In order to protect the modules from static electrical discharges, personnel must discharge themselves electrostatically before opening control cabinets or terminal boxes.
- It is essential to ensure that the maximum temperature of 55 °C is not exceeded in the mounting position. The device must not be exposed to direct sunlight.

 <b>WARNING</b>
<b>Dangerous electrical voltage!</b>
When operating electrical devices, certain parts of these devices are necessarily under dangerous voltage. Failure to observe the operating instructions can therefore result in serious injury or material damage.
Observe the operating instructions.

## Procedure

Carry out the following steps in the given order:

1. Check that the operating data matches the values on the rating plate.
2. Mount the device with the aid of 4 (M6) screws and washers.

### 7.1.3 Connecting terminals

#### Input line X1

X1 is the connection line to the power supply.

Connections	L, N, PE 195 - 265 VAC
Cable type	H05RN-F 3G1
Cable length	2 m
Connector(s)	Extruded protective Schuko-type socket, 10 / 16 A, 250 V AC, double-protected connecting cable according to DIN 49.441, CEE7 / VII.

#### Output line X2

X2 is the output line connecting to the SIDOOR controller.

Connections	UA+, UA-, FE
Cable type	H05RN-F 3G1
Cable length	1.5 m
Connector(s)	WAGO 721-103/026-045

The rated data of the output are:

Rated output voltage	36 V
Rated output current	2.5 A
Continuous output power rating	<100 W

 **WARNING**

**Dangerous electrical voltage.**

May cause death, serious injury or property damage.

The third line brought out at the output is only a functional grounding connection, this must not be regarded or used as a ground in the sense of a PE connection!

## Connection specifications

 **WARNING**

**Dangerous electrical voltage!**

When operating electrical devices, certain parts of these devices are necessarily under dangerous voltage. Failure to observe the operating instructions can therefore result in serious injury or material damage.

Observe the operating instructions.

Observe the following connection regulation:

- The regulations for the construction of high voltage installations must be observed when carrying out the electrical installation.
- The switch mode power supply may only be connected to the power supply by connected supply lines.
- The power supply (230 V AC  $\pm$  15%) must be connected according to VDE 0100 and VDE 0160.
- The supply voltage to the device must be equipped with a protective device (automatic circuit breaker) (10 A / tripping characteristic B).
- The protective conductor is connected via the supply line X1.
- Output lines may only to be connected to the SIDOOR control device.
- When connecting the device to the power system, it must be ensured that this network fulfils the requirements for the overvoltage category II. If required, an external overvoltage protection is to be connected upstream of the device so that the requirements for the overvoltage category II are fulfilled.
- Ensure that the power outlet is clearly recognizable and easily accessible.

## Procedure

---

### Note

#### **Risk of injury due to moving mechanical parts.**

The controller is ready for operation after the supply line has been connected. If a control signal is present, the door will move in the set direction.

Always connect the supply lines last of all!

---

Carry out the following steps in the given order:

1. Connect the control device to the output line, observing the polarity printed on the device.
2. Connect the supply lines to the network.
3. When the supply is switched on, the device is ready for operation.  
The green LED lights up.

See section Connecting and commissioning. (Page 153)

## 7.1.4 Technical specifications

<b>Article number</b>	<b>6FB1112-0AT20-3PS0</b>
<b>General information</b>	
Product brand name	SIDOOR
Product type designation	NT40
<b>Installation type/mounting</b>	
Mounting type	Four 5 mm screws
<b>Supply voltage</b>	
Rated value (AC)	230 V
relative symmetrical tolerance of the supply voltage	15 %
<b>Line frequency</b>	
• permissible range, lower limit	50 Hz
• permissible range, upper limit	60 Hz
<b>Input current</b>	
Current consumption for 2 s, max.	3.5 A
Rated value at 230 V AC	0.7 A
Operational current of fuse protection at input, min.	6 A
Operational current of fuse protection at input, max.	10 A
Tripping characteristic class of fuse protection at input	B
<b>Output voltage</b>	
Rated value (DC)	36 V; SELV
Relative symmetrical tolerance of the output voltage	3 %
<b>Output current</b>	
Current output (rated value)	2.5 A
Temporary overload current (for 2 s maximum)	15 A
<b>Power</b>	
Active power input, max.	100 W
Emitted active power, max.	100 W
Emitted active power (restricted to 2 s)	540 W
Efficiency at 230 V AC (with 100 W emitted active power)	90 %
Active apparent power, max.	650 V·A
<b>Isolation</b>	
Overvoltage category	2
Degree of pollution	2
<b>Degree and class of protection</b>	
IP degree of protection	IP54
Equipment protection class	I
<b>Standards, approvals, certificates</b>	
CE mark	Yes
EAC (formerly Gost-R)	Yes
TÜV Inspectorate approval	Yes
China RoHS compliance	Yes
Standard for EMC	EMC Directive 2004/108/EC, EN 12015, EN 12016

<b>Article number</b>	<b>6FB1112-0AT20-3PS0</b>
Standard for safety	EN 61010-1 / EN 61010-2-201
<b>Ambient conditions</b>	
<b>Ambient temperature during operation</b>	
• min.	-20 °C
• max.	55 °C
• Remark	No direct exposure to the sun
<b>Ambient temperature during storage/transportation</b>	
• Storage, min.	-20 °C
• Storage, max.	70 °C
• Transportation, min.	-40 °C
• Transportation, max.	70 °C
<b>Altitude during operation relating to sea level</b>	
• Installation altitude above sea level, max.	2 000 m
<b>Relative humidity</b>	
• No condensation, min.	10 %
• No condensation, max.	93 %
<b>Cables</b>	
Cable length	
• Input side	2 m
• Output side	1.5 m
<b>Connection method</b>	
Design of electrical connection at input	SCHUKO connector DIN 49.441, CEE7/VII
Design of electrical connection at output	WAGO 721-103/026
<b>Dimensions</b>	
Width	270 mm
Height	55 mm
Depth	80 mm

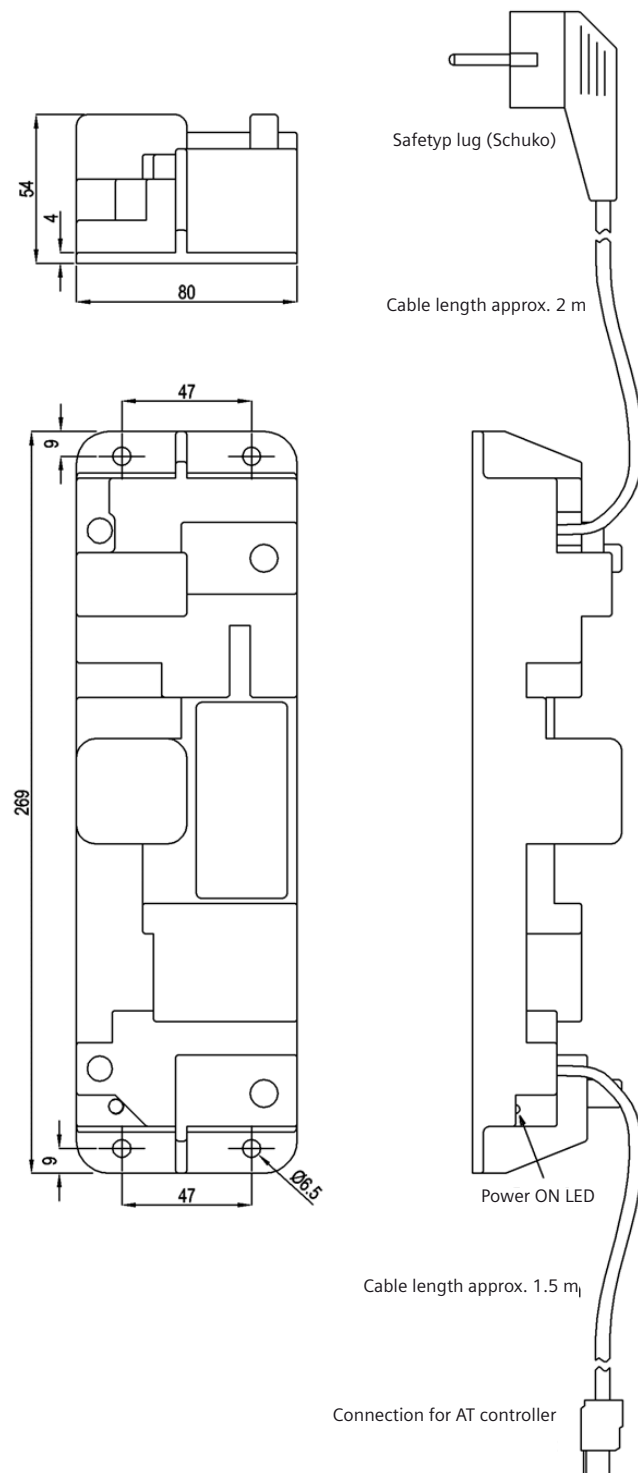

Figure 7-2 Dimensions of switch mode power supply NT40



## 7.2 SIDOOR TRANSFORMER

### 7.2.1 Description

#### Intended use

The device may only be used in combination with the control devices specified. Other loads must not be connected to the output connector.

#### Design



- ① Schuko plug  
220-240 V AC +/-10% 50/60 Hz
- ② Length approx. 2 m
- ③ Connection to the controller
- ④ Length approx. 1.5 m
- ⑤ Height of the mains transformer approx. 65 mm; width approx. 145 mm, depth approx. 126 mm
- ⑥  $\varnothing$  6.1 mm, width across flats 10, L > 70 mm

Figure 7-3 SIDOOR TRANSFORMER

## Function

The SIDOOR TRANSFORMER is a 220-240 V AC ( $\pm 10\%$ ) 50/60 Hz standard power supply unit for supplying SIDOOR controllers without an integrated power supply unit.

### Note

When using the SIDOOR TRANSFORMER, performance losses in force, acceleration and speed may occur depending on the output transmission, door mass and system friction.

## 7.2.2 Installation

### Requirements

The installation site must fulfill the following requirements:

- Minimum clearance to surrounding parts: 1 cm
- Even mounting surface
- Maximum distance from the power supply due to cable length:
  - Connecting cable input line (mains  $\leftrightarrow$  transformer): 200 cm
  - Connecting cable output line (transformer  $\leftrightarrow$  control unit): 150 cm
  - Ensure that the power outlet is clearly recognizable and easily accessible.



#### CAUTION

##### Risk of fire

The temperature of the housing of the transformer can rise to over 105 °C in the event of a fault in the controller or a short circuit in the output line of the transformer.

As a result, you should take the following safety measures:

- Only mount the transformer on surfaces with no risk of ignition, and which cannot be touched by unauthorized persons.
- Inform the service personnel about the risk of fire.

#### CAUTION

##### Material damage

The transformer power supply cable cannot be replaced.

If the cable is damaged, the device must be scrapped.

**Procedure**

Proceed as follows to install the transformer:

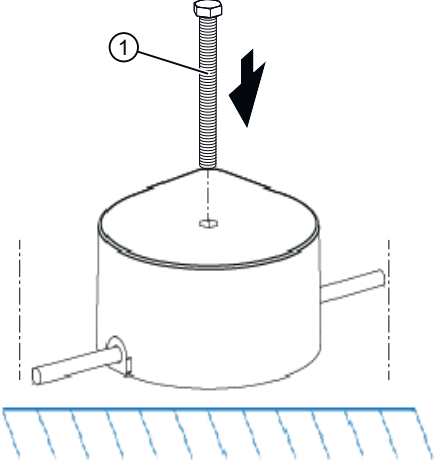
Steps	Figure
1. Drill the hole for the screw ① as shown in the dimension drawing.	
2. Secure the transformer with 1 screw (M6, minimum length 70 mm) ① on a flat metal surface.	

**7.2.3 Connecting**

**Slots**

The slots for the SIDOOR TRANSFORMER are as follows:

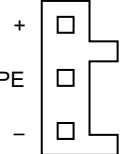
Controller	Slot
SIDOOR AT40 / ATD400V	<p>X3</p> 

## 7.2.4 Technical specifications

<b>Article number</b>	<b>6FB1112-0AT20-2TRO</b>
<b>General information</b>	
Product brand name	SIDOOR
Product type designation	TRANSFORMER
Product version	Power supply unit for SIDOOR controllers
<b>Installation type/mounting</b>	
Mounting type	Hexagon head bolt M6, L > 70 mm
<b>Supply voltage</b>	
permissible range, lower limit (AC)	220 V
permissible range, upper limit (AC)	240 V
relative symmetrical tolerance of the supply voltage	10 %
<b>Line frequency</b>	
• permissible range, lower limit	50 Hz
• permissible range, upper limit	60 Hz
<b>Mains filter</b>	
• integrated	Yes
<b>Input current</b>	
Current consumption, max.	1.6 A
Operational current of fuse protection at input, min.	6 A
Operational current of fuse protection at input, max.	10 A
Tripping characteristic class of fuse protection at input	D6, C10
<b>Output voltage</b>	
RMS value (pulsating DC voltage at full load)	17.3 V; at 230 V AC
RMS value (pulsating DC voltage at full load), min.	16.5 V
RMS value (pulsating DC voltage at full load), max.	18 V
RMS value (pulsating DC voltage at 0.7 mA peak current), max.	27 V; At 264 V AC
<b>Output current</b>	
Current output (rated value)	14.3 A; t on 2 s / t off 8 s
<b>Power</b>	
Emitted active power, max.	115 W; Average value above 10 s
<b>Isolation</b>	
Overtoltage category	2
Degree of pollution	2
<b>Degree and class of protection</b>	
IP degree of protection	IP54
<b>Standards, approvals, certificates</b>	
CE mark	Yes

<b>Article number</b>	<b>6FB1112-0AT20-2TRO</b>
EAC (formerly Gost-R)	Yes
RoHS conformity	Yes
China RoHS compliance	Yes
Standard for EMC	EN 12015 / EN 12016 / EN 61000-6-2 / EN 61000-6-3 / EN 61000-3-2 / EN 61000-3-3
Standard for safety	Low Voltage Directive (LVD) 2014/35/EU
<b>Ambient conditions</b>	
<b>Ambient temperature during operation</b>	
• min.	-20 °C
• max.	55 °C
• Remark	No direct exposure to the sun
<b>Ambient temperature during storage/transportation</b>	
• Storage, min.	-20 °C
• Storage, max.	70 °C
• Transportation, min.	-40 °C
• Transportation, max.	70 °C
<b>Altitude during operation relating to sea level</b>	
• Installation altitude above sea level, max.	2 000 m
<b>Relative humidity</b>	
• No condensation, min.	10 %
• No condensation, max.	93 %
<b>Cables</b>	
Cable length	
• Input side	2 m
• Output side	1.5 m
<b>Connection method</b>	
Design of electrical connection at input	SCHUKO connector DIN 49.441, CEE7/III
Design of electrical connection at output	WAGO 721-103/026
<b>Dimensions</b>	
Width	145 mm
Height	65 mm
Depth	126 mm

### 7.2.5 Dimensional drawing SIDOOR TRANSFORMER

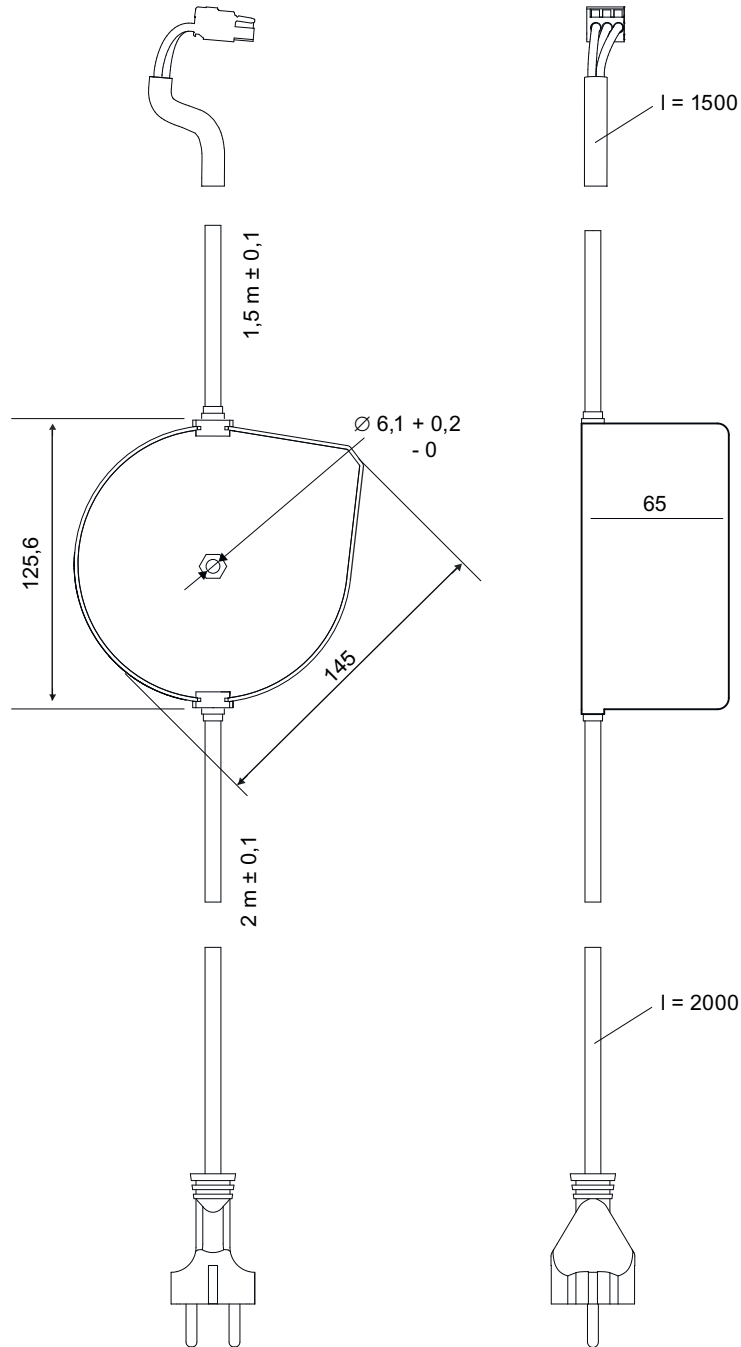

Figure 7-4 Dimensions of the SIDOOR TRANSFORMER

## 7.3 SIDOOR TRANSFORMER UL

### 7.3.1 Description

#### Intended use

The device is only intended for operation in combination with the controllers specified in 2.3.1. Other loads must not be connected to the output connector.

#### Design

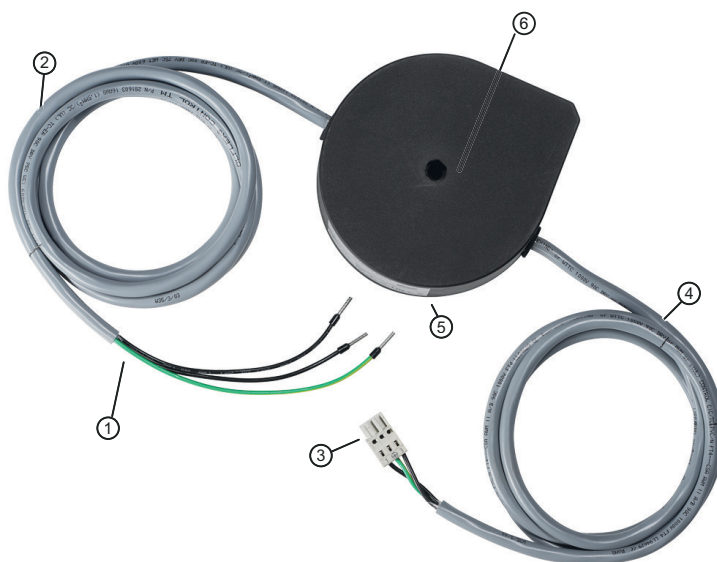

- ① No mains connection 220-240 V AC  $\pm 10\%$  50/60 Hz
- ② Length approx. 2 m
- ③ Connector for connection to the controller
- ④ Length approx. 1.5 m
- ⑤ Height of the mains transformer approx. 65 mm; width approx. 145 mm, depth approx. 126 mm
- ⑥ Diam. 6.1 mm, Size 10, L>70 mm

Figure 7-5 SIDOOR TRANSFORMER UL

#### Function

The SIDOOR TRANSFORMER UL is a 220-240 V AC ( $\pm 10\%$ ) 50/60 Hz standard power supply unit for supplying SIDOOR controllers without an integrated power supply.

#### Note

When using the SIDOOR TRANSFORMER UL performance losses in force, acceleration and speed may occur depending on the door mass and system friction.

### Output line

The output line is connected to slot X3 of the SIDOOR controller.

The pin assignment at slot X3 is as follows:

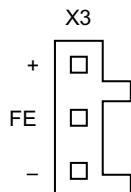

## 7.3.2 Installation

### Requirements

The installation site must fulfill the following requirements:

- Minimum clearance to surrounding parts: 1 cm
- Flat mounting surface made of metal
- Maximum distance from the power supply due to cable length:
  - Connecting cable input line (mains ⇔ transformer): 200 cm
  - Connecting cable output line (transformer ⇔ control unit): 150 cm



#### CAUTION

##### Risk of fire

The transformer housing temperature can rise to over 105 °C in the event of a fault in the controller or a short circuit in the output line of the transformer.

As a result, you should take the following safety measures:

- Only mount the transformer on surfaces with no risk of ignition, and which cannot be touched by unauthorized persons.
- Inform the service personnel about the risk of fire.



#### NOTICE

Use the SIDOOR Transformer UL indoors only.



**⚠ CAUTION****Material damage**

The connection cables of the transformer cannot be replaced.

- Scrap the unit if the line is damaged.

**Procedure**

Proceed as follows to install the transformer:

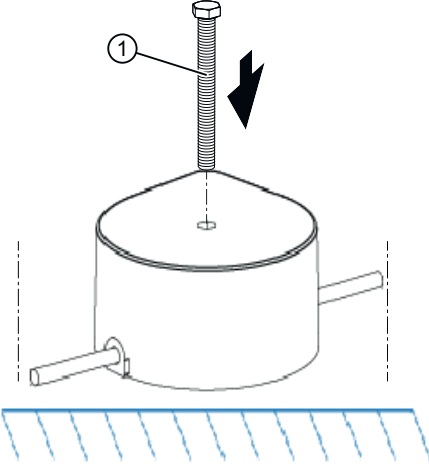
Steps	Figure
1. Drill the hole for the screw ① as shown in the dimension drawing.	
2. Secure the transformer with 1 screw (M6, minimum length 70 mm) ① on a flat metal surface.	

**7.3.3 Connection****Requirements****⚠ WARNING****Dangerous electrical voltage!**

When operating electrical devices, certain parts of these devices are necessarily under dangerous voltage. Failure to observe the operating instructions can therefore result in serious injury or material damage.

- Observe the operating instructions.
- Switch off all current sources and provide them with a switch-on guard before performing any work on the device.
- Adhere to national regulations.



<b>WARNING</b>
<b>Installation and maintenance work</b>
Installation and maintenance work may only be performed by qualified personnel.

- If the SIDOOR TRANSFORMER UL is supplied by two ungrounded wires (for example L1, L2), fusing has to be implemented by a 2-pole miniature circuit breaker with coupled switching element. When there is a connection between an ungrounded wire (L) and a grounded wire (N), only a 1-pole miniature circuit breaker in the L-branch is required.
- Make sure that the on-site (customer-provided) fuse meets these requirements:
  - For the CE setting with a miniature circuit breaker to IEC60898-1, 10 A tripping characteristic C or 6 A tripping characteristic D  
for example 1-pole miniature circuit breaker: 5SY4110-7 or 5SY4106-8  
e.g. 2 pole miniature circuit breakers: 5SY4210-7 or 5SY4206-8
  - For the NFPA setting miniature circuit breaker to UL489 listed, CCN DIVQ, UR $\geq$ 240VAC, 10 A Class C or 6 A Class D  
e.g. 1-pole miniature circuit breakers: 5SJ4110-7HG41 or 5SJ4106-8HG41  
e.g. 2-pole circuit breaker: 5SJ4210-7HG41 or 5SJ4206-8HG41

**Procedure**

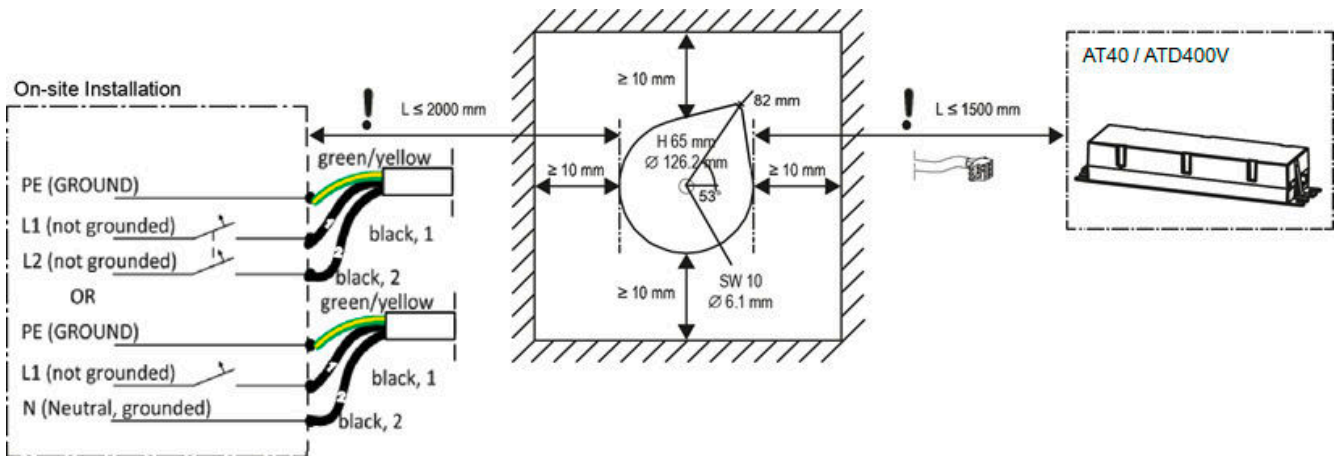

- Connect the wires as shown in the drawing.
- Be sure to connect the protective ground (green-yellow) correctly.
- Ensure that there is a mains disconnecting device near the equipment that is easily accessible clearly marked (for example, using a suitable miniature circuit breaker).
- The description of the complete electrical setting and commissioning of the controller and of the associated components is available in the section Connecting and commissioning (Page 153).

**Note****Risk of injury due to moving mechanical parts.**

The controller is ready for operation after the supply line has been connected. If a control signal is present, the door will move in the set direction.

Always connect the supply lines last of all!

Carry out the following steps in the given order:

1. Connect the output line of the SIDOOR TRANSFORMER UL to slot X3 on the controller.  
Observe the polarity printed on the device.
2. Connect the supply line to the network.

See section Connecting and commissioning (Page 153).

### 7.3.4 Test voltage

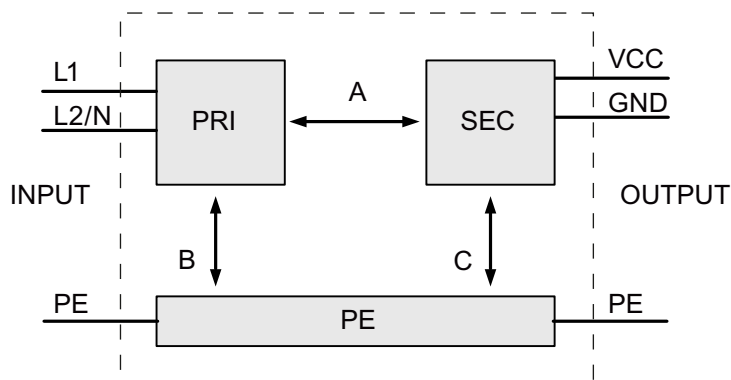

Figure 7-6 Diagram test voltage

The type test and the manufacturing test can only be performed by the manufacturer. The field can also be performed by the user.

Requirements for performing the field test:

**General**

Disconnecting SIDOOR TRANSFORMER UL

disconnect the connection to the SIDOOR control circuit device.

Inspection (A) & (B)

- Interconnecting input lines (PRI) L1 and L2/N
- Interconnecting output cables (SEC) VCC, GND and PE

Inspection (C)

- Interconnecting output cables (SEC) VCC and GND and measuring against PE

Table 7-1 Test voltage

	Test time	PRI<->SEC (A)	PRI<->PE (B)	SEC<->PE (C)
Type test	60 s	4000 VAC	4000 VAC	1500 VAC
Manufacturing test	1 s	4000 VAC	4000 VAC	1500 VAC
Field test	1 s	1500 VAC	1500 VAC	350 VAC
	1 s	2250 VDC	2250 VDC	500 VDC

Remark:

Tripping current for measuring DC: 0 mA

tripping current for measuring AC: <100 mA

### 7.3.5 Technical specifications

<b>Article number</b>	<b>6FB1112-0AT21-2TRO</b>
<b>General information</b>	
Product version	Power supply unit for SIDOOR controllers
<b>Installation type/mounting</b>	
Mounting type	Hexagon head bolt M6, L > 70 mm
<b>Supply voltage</b>	
permissible range, lower limit (AC)	220 V
permissible range, upper limit (AC)	240 V
relative symmetrical tolerance of the supply voltage	10 %
<b>Line frequency</b>	
• permissible range, lower limit	50 Hz
• permissible range, upper limit	60 Hz
<b>Mains filter</b>	
• integrated	Yes
<b>Input current</b>	
Current consumption, max.	1.6 A
Operational current of fuse protection at input, min.	6 A
Operational current of fuse protection at input, max.	10 A
Tripping characteristic class of fuse protection at input	D6, C10
<b>Output voltage</b>	
RMS value (pulsating DC voltage at full load)	17.3 V; at 230 V AC
RMS value (pulsating DC voltage at full load), min.	16.5 V
RMS value (pulsating DC voltage at full load), max.	18 V
RMS value (pulsating DC voltage at 0.7 mA peak current), max.	27 V; At 264 V AC
<b>Power</b>	
Emitted active power, max.	115 W; Average value above 10 s
<b>Standards, approvals, certificates</b>	
CE mark	Yes
EAC (formerly Gost-R)	Yes
RoHS conformity	Yes
China RoHS compliance	Yes
Standard for EMC	EN 12015 / EN 12016 / EN 61000-6-2 / EN 61000-6-3 / EN 61000-3-2 / EN 61000-3-3
Standard for safety	UL 61010-1, CSA C22.2 No. 61010-1-12, Low Voltage Directive (LVD) 2014/35/EU
<b>Ambient conditions</b>	
<b>Ambient temperature during operation</b>	

## 7.3 SIDOOR TRANSFORMER UL

<b>Article number</b>	<b>6FB1112-0AT21-2TRO</b>
<ul style="list-style-type: none"> <li>• min.</li> <li>• max.</li> <li>• Remark</li> </ul>	<ul style="list-style-type: none"> <li>-20 °C</li> <li>55 °C</li> <li>No direct exposure to the sun</li> </ul>
<b>Ambient temperature during storage/transportation</b>	
<ul style="list-style-type: none"> <li>• Storage, min.</li> <li>• Storage, max.</li> <li>• Transportation, min.</li> <li>• Transportation, max.</li> </ul>	<ul style="list-style-type: none"> <li>-20 °C</li> <li>70 °C</li> <li>-40 °C</li> <li>70 °C</li> </ul>
<b>Altitude during operation relating to sea level</b>	
<ul style="list-style-type: none"> <li>• Installation altitude above sea level, max.</li> </ul>	2 000 m
<b>Relative humidity</b>	
<ul style="list-style-type: none"> <li>• No condensation, min.</li> <li>• No condensation, max.</li> </ul>	<ul style="list-style-type: none"> <li>10 %</li> <li>93 %</li> </ul>
<b>Cables</b>	
Cable length	
<ul style="list-style-type: none"> <li>• Input side</li> <li>• Output side</li> </ul>	<ul style="list-style-type: none"> <li>2 m</li> <li>1.5 m</li> </ul>
<b>Connection method</b>	
Design of electrical connection at input	equipped with ferrules
<b>Dimensions</b>	
Width	145 mm
Height	65 mm
Depth	126 mm

7.3.6 Dimension drawing SIDOOR TRANSFORMER UL

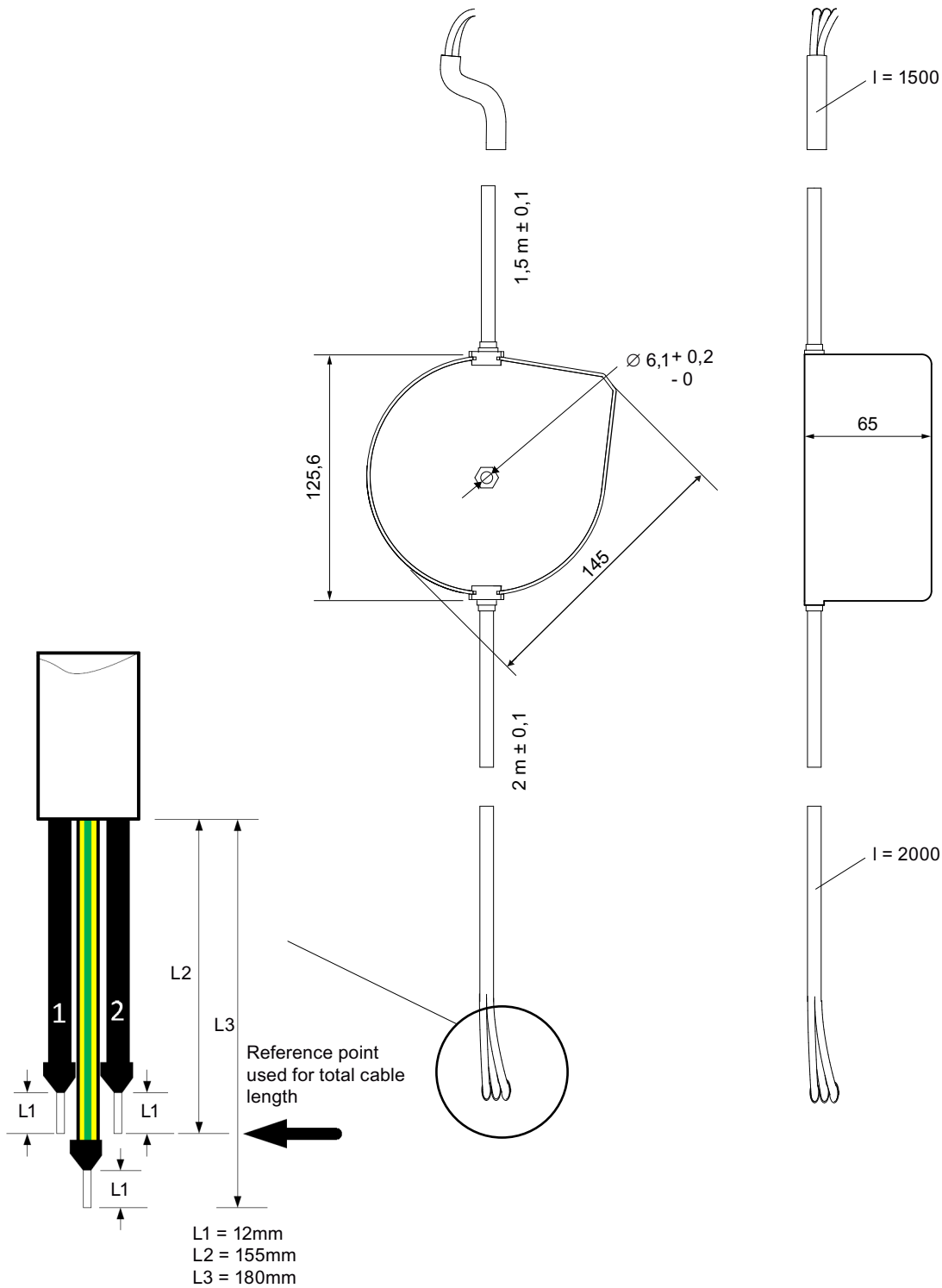

Figure 7-7 Dimension drawing TRANSFORMER UL

## 7.4 Uninterruptible power supply (UPS)

### Overview

The SIDOOR drive system can be supplied with an uninterruptible power supply (UPS) for a certain period of time. The criteria on the design of the UPS described below must be taken into account here.

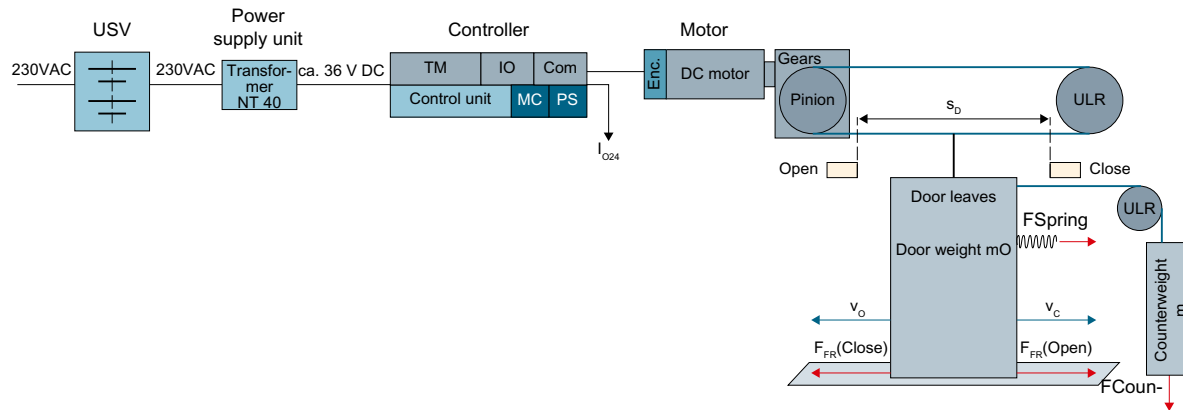

Figure 7-8 SIDOOR system block diagram

In the observation, three main criteria need to be considered:

1. The peak power of the UPS (for approx. 3 seconds) should be  $\geq 600$  W.
2. With the use of the transformer, the UPS must be designed as an online double converter. Classification: VFI (according to IEC 62040-3)
3. The energy storage of the UPS must be adapted to the entire drive system and the time to be bridged.

### Note

Optionally, the door control unit can be switched to emergency power mode via connector X5 ("General setup > Special parameters > Input X5"), see section Emergency power mode (Page 56). In emergency power mode, a speed-reduced driving curve profile is used to save energy.



## Energy requirements

The entire energy requirements are derived from the following three physical effects:

- Energy requirements of the control unit →  $W_{AT}$   
Quiescent current consumption of the controller over the time to be bridged
- Energy requirements due to holding powers →  $W_{HOLD}$   
Current consumption due to continuous torques
- Energy requirements due to door movement  $W_{MOVE}$   
Current consumption during traversing due to system friction and acceleration of the door leaves

The energy to be stored by the UPS is therefore derived as follows:

$$W_{AKKU} := W_{AT} + W_{HOLD} + W_{MOVE}$$

The corresponding mathematical equations of these terms are as follows:

Energy requirements of the control unit	$W_{AT} := \frac{4W + 24V \cdot I_{O24}}{0.4} \cdot (T_{STBY} + T_{HO} + T_{HC})$
Energy requirements of the holding powers	$W_{HOLD} := \frac{1 \cdot W}{140 \cdot N^2} \cdot (F_{HO}^2 \cdot T_{HO} + F_{HC}^2 \cdot T_{HC})$
Energy requirements of the door movement	$W_{MOVE} := 4.1N_C \cdot [0.5m_D \cdot (v_O^2 + v_C^2) + 2F_{FR} \cdot s_D]$
Energy requirements of the UPS ACCU	$W_{AKKU} := W_{AT} + W_{HOLD} + W_{MOVE}$

## Definitions of tags

Tag	Unit	Definition
$F_{FR}$	N	Friction force door
$F_{HC}$	N	Holding power door closed
$F_{HO}$	N	Holding power door open
$I_{O24}$	A	Current consumption 24 V external
$m_D$	kg	Door weight
$N_C$	–	Number of OPEN/CLOSED cycles
$s_D$	m	Distance door leaves
$T_{HC}$	s	Holding time CLOSED
$T_{HO}$	s	Holding time OPEN
$T_{STBY}$	s	Standstill time without holding power
$v_C$	m/s	Closing speed
$v_O$	m/s	Opening speed

## Recommendations on UPS data

Output voltage	230V ± 10%
Output frequency	47 ... 53 Hz
Output power	> 600 W
Wave type	Sine
Current voltage distortion	< 5% at full load
Classification (according to IEC 62040-3)	VFI

## Example calculation for an M3 motor

Input data			Calculation
Tag	Value	Definition	
$F_{FR}$	80 N	Door friction without counter-weight	$W_{AT} := \frac{4W + 24V \cdot I_{O24}}{0.4} \cdot (T_{STBY} + T_{HO} + T_{HC})$ $W_{AT} = 5.6 \cdot 10^3 \text{ J}$
$F_{HC}$	60 N	Holding time CLOSED	
$F_{HO}$	70 N	Holding power OPEN	$W_{HOLD} := \frac{1 \cdot W}{140 \cdot N^2} \cdot (F_{HO}^2 \cdot T_{HO} + F_{HC}^2 \cdot T_{HC})$ $W_{HOLD} = 1 \cdot 10^3 \text{ J}$
$I_{O24}$	0.1 A	External power supply 24 V	
$m_D$	180 kg	Door weight, total	$W_{MOVE} := 4.1N_C \cdot [0.5m_D \cdot (v_O^2 + v_C^2) + 2F_{FR} \cdot s_D]$ $W_{MOVE} = 3 \cdot 10^3 \text{ J}$
$N_C$	5	Cycles OPEN/CLOSED	
$s_D$	0.8 m	Door width, 1 leaf in meters	$W_{USV} := W_{AT} + W_{HOLD} + W_{MOVE}$ $W_{USV} = 1 \cdot 10^4 \text{ J}$
$T_{HC}$	20 s	Hold time closed	
$T_{HO}$	20 s	Hold time open	
$T_{STBY}$	310 s	Standstill time without holding power	
$v_C$	0.3 m/s	Closing speed	

A UPS with 600 W and a bridging time of 10 minutes makes approx. 30,000 J available.

## Optional additional units

### 8.1 SIDOOR SERVICE TOOL

#### 8.1.1 Description

##### Overview

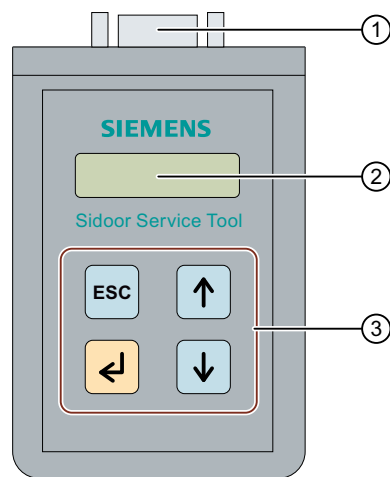

- ① Connection plug to connect the SIDOOR SERVICE TOOL to the controller
- ② Display
- ③ Control keys

#### 8.1.2 Connection

Connection of the SIDOOR SERVICE TOOL is effected with the associated cable to the plug-in connector **X8** of the controller.

##### Note

The cover of the controller does not have to be removed to connect the SIDOOR SERVICE TOOL.

##### CAUTION

##### Material damage

For this reason, only connect suitable SIDOOR accessories.

### 8.1.3 Operation

Parameters can be changed in the following three menus:

- MAIN MENU > Quick setup > Parameter setting
- MAIN MENU > General setup > Profile parameters
- MAIN MENU > General setup > Special parameters





---

**Note**







If the SIDOOR SERVICE TOOL is in the "Quick setup" or "General setup" menu, the door commands of the controller are blocked by the command inputs of the terminal strip X6.

---

#### Key functions

Key	Description	Function
	Enter key	Jump to next menu below
	Escape key	Jump back to menu above
	Menu selection key	Increases a parameter value
	Menu selection key	Decreases a parameter value

#### Operating principle

Action	Key	Remarks
1 Select required parameter	 	
2 Activate parameter for setting using the Return key		Parameter value flashes
3 Increase or decrease parameter value	 	
4 Accept parameter value by pressing Return key again		Displayed parameter value stops flashing after acceptance.
5 <ul style="list-style-type: none"> <li>• Select the next parameter (Step 1) or</li> <li>• exit the menu</li> </ul>	-  	

---

**Note**

Changes to the driving curve parameters are accepted with the door at a complete stop or in the OPEN or CLOSED position.

---

 **WARNING**

**Risk of injury due to moving mechanical parts**

After changes to the parameters of the door the permissible energies and forces have to be checked by service staff and adjusted if they exceed their limit values.

**Menu navigation**

You can find the menu navigation for the SIDOOR SERVICE TOOL in the section Navigation structure in the SIDOOR SERVICE TOOL (Page 140).

### 8.1.4 Navigator structure in the SIDOOR SERVICE TOOL

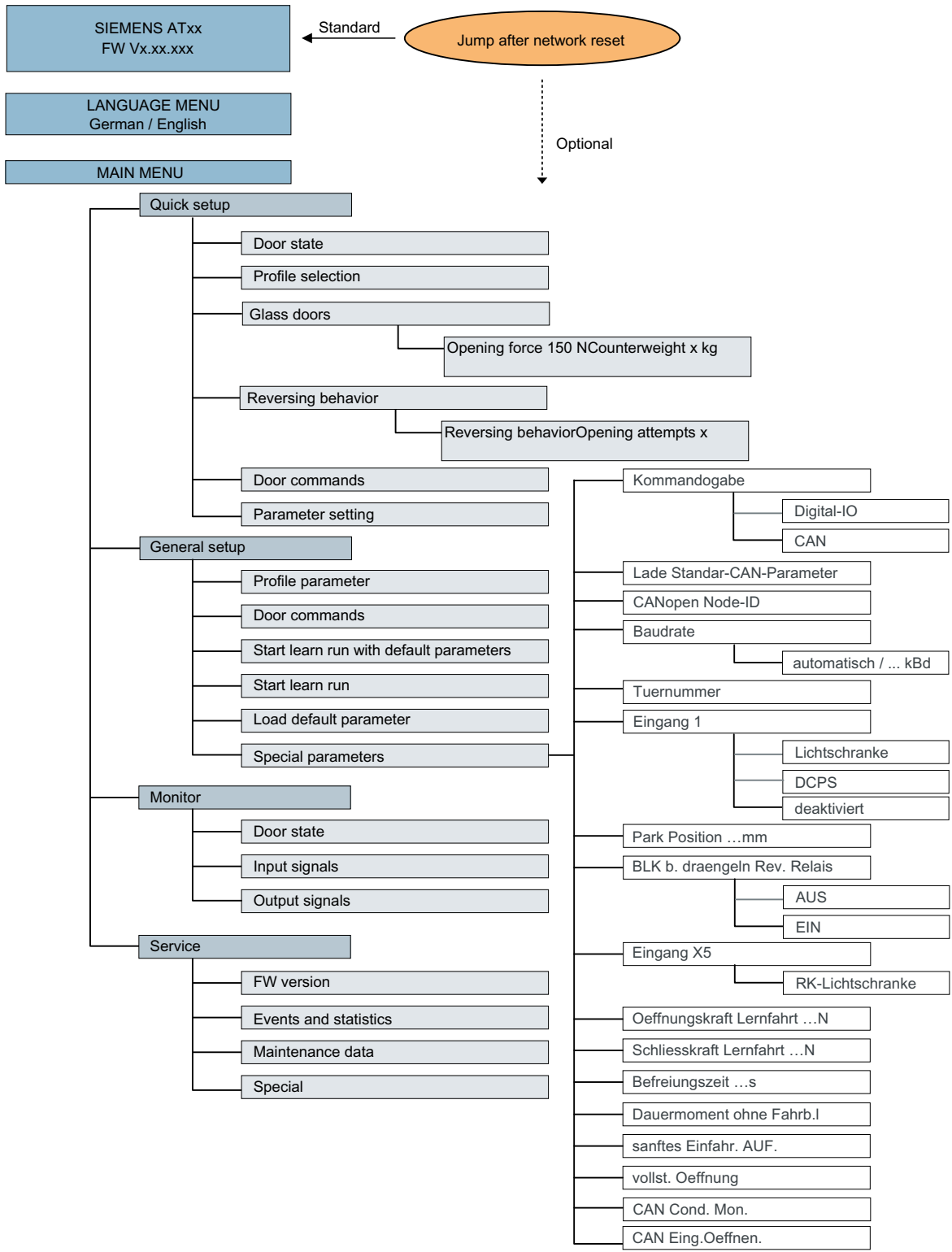

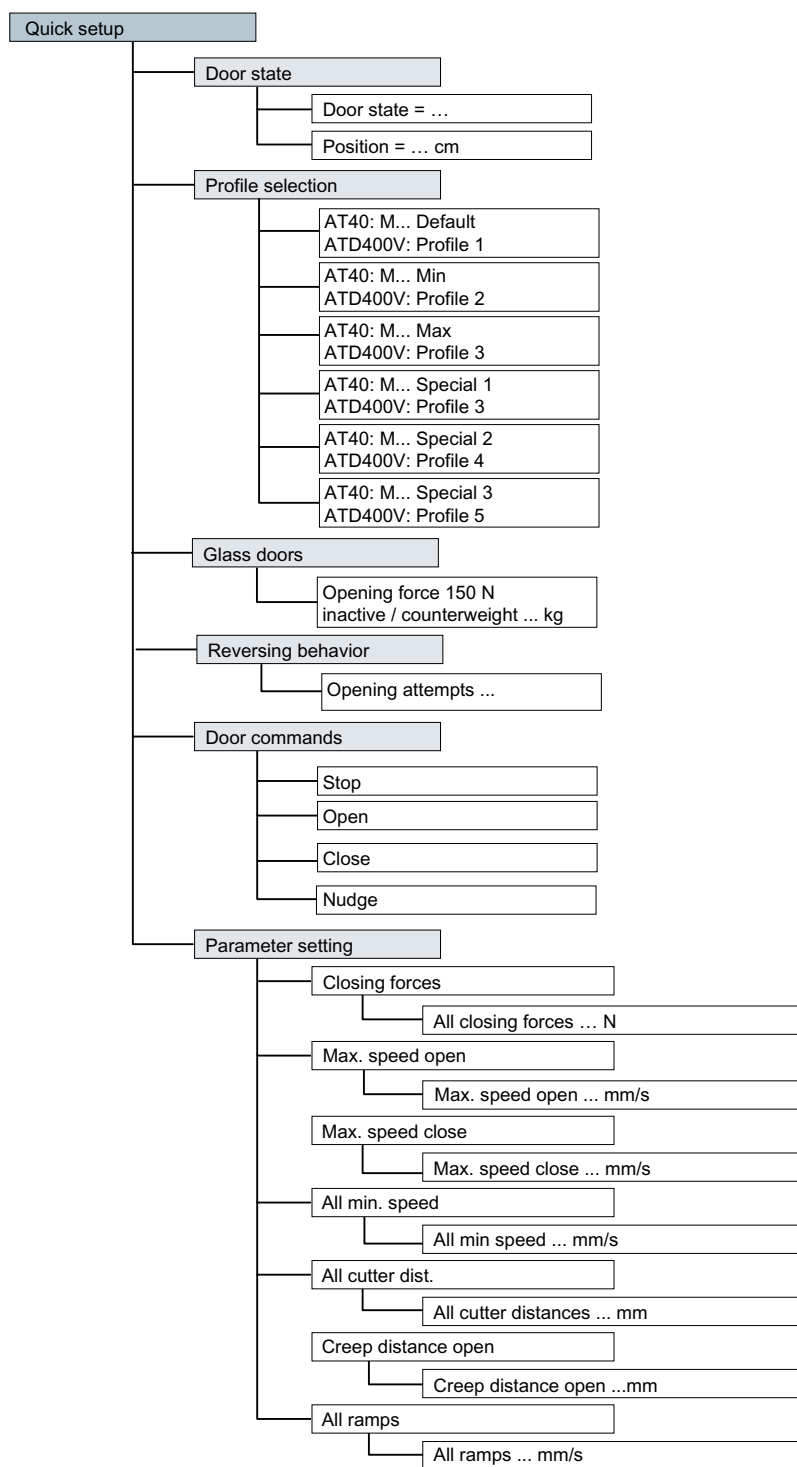

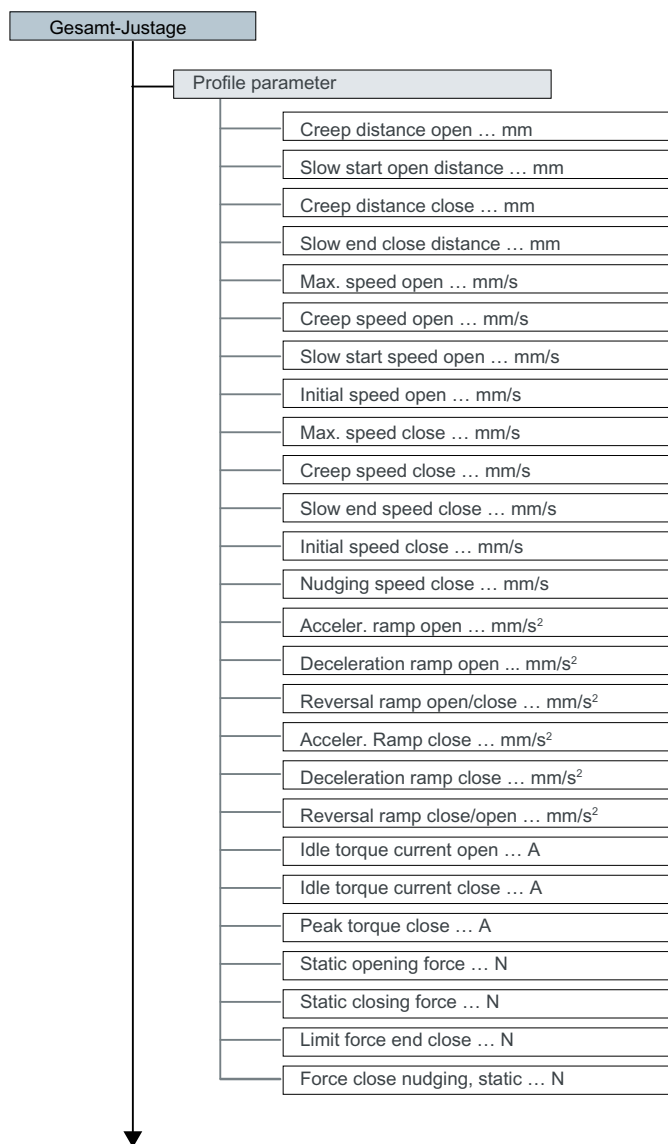

Continue to next page



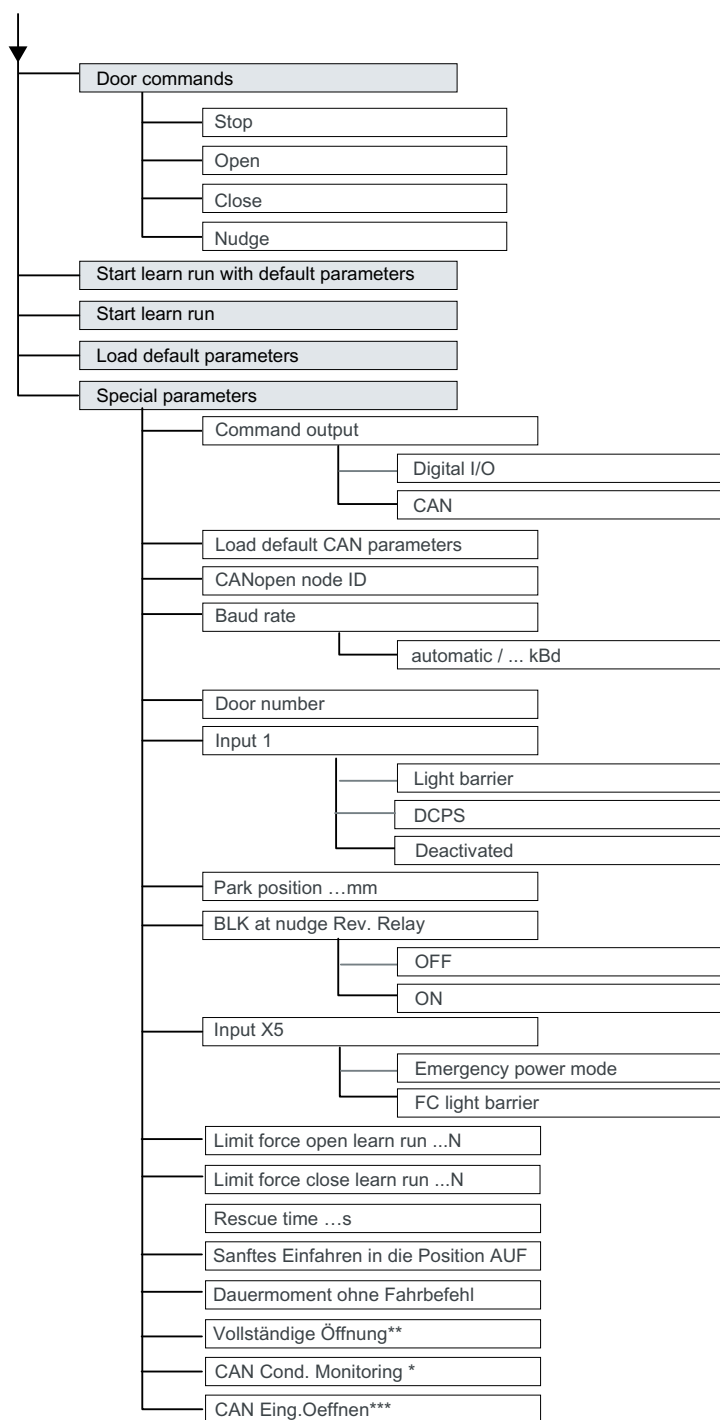

\* Funktion ist nur in AT40 CAN ADV aktivierbar

\*\* Lichtschrankenreaktion

\* see section Maintenance data (Page 49)

\*\* see section Complete opening (Page 57)

\*\*\* see section Digital input signals (Page 158)

8.1 SIDOOR SERVICE TOOL

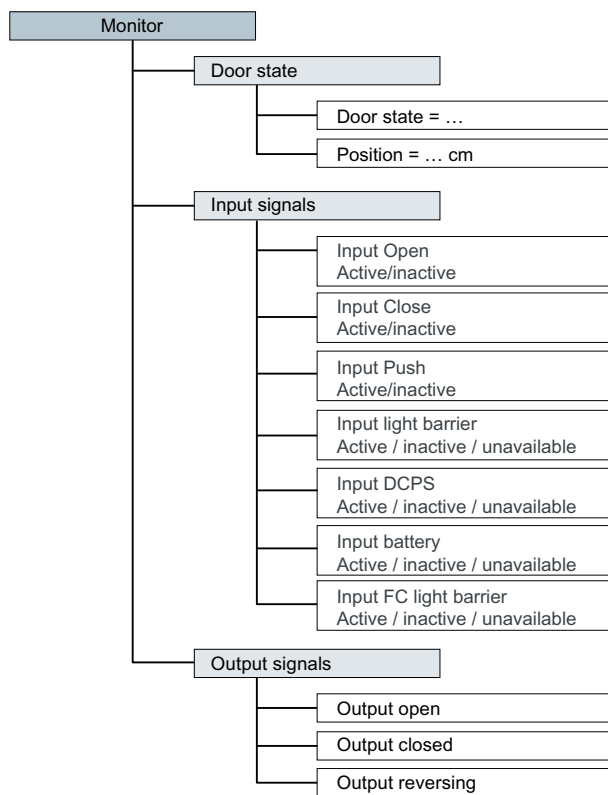

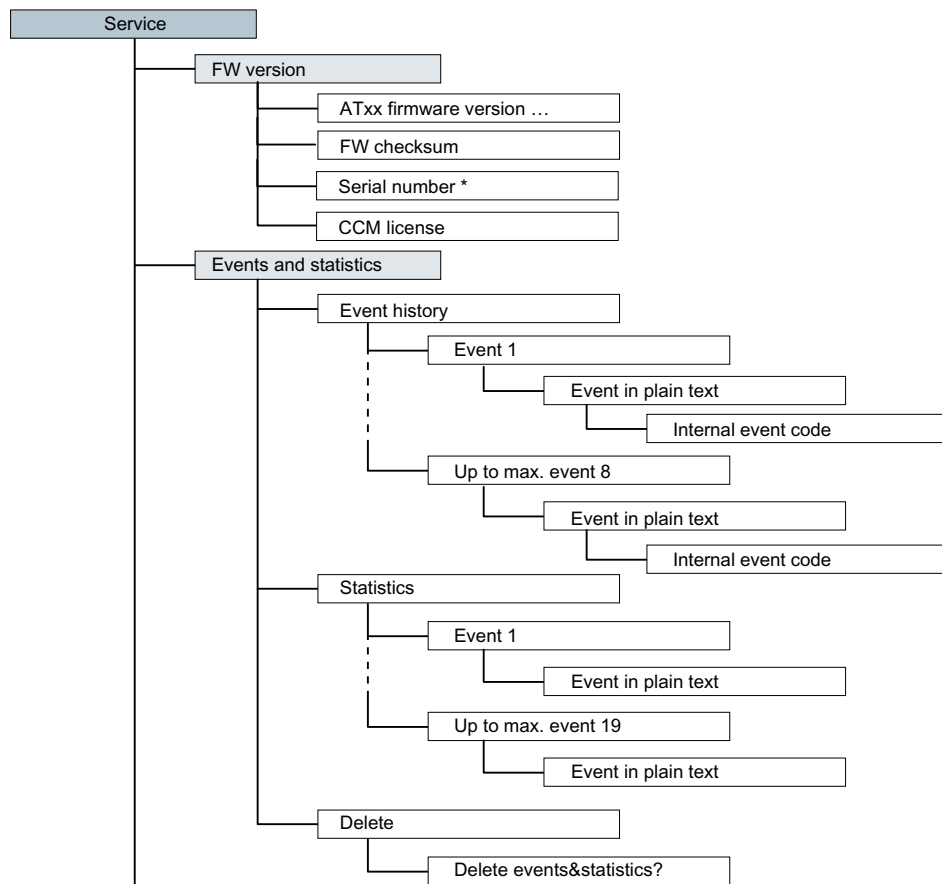

\* Can be blank for old devices

Continue to next page

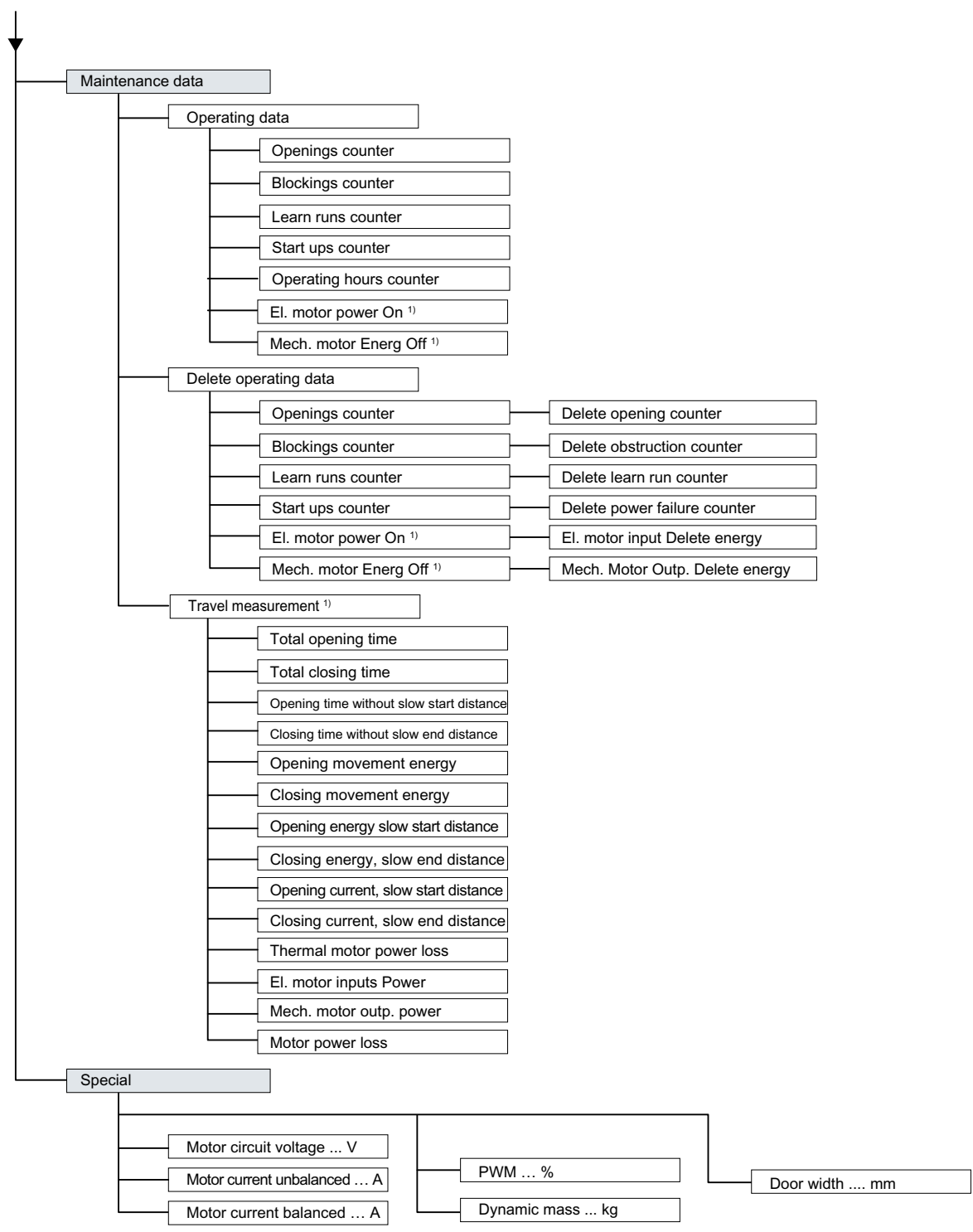

1) Only available as of FW version AT40 V01.48 and ATD400V V01.09

### 8.1.5 Technical specifications

Article number	6FB1105-0AT01-6ST0	
Product brand name	SIDOOR	
Product designation	SIDOOR SERVICE TOOL	
Design of the product	Diagnostic and parameterization tool	
Wire length of the connecting cable	m	2
Width	mm	65
Height	mm	100
Depth	mm	25

## 8.2 SIDOOR LINK and SIDOOR SUPPORT App

### 8.2.1 Description

The SIDOOR LINK and the SIDOOR SUPPORT app are used for convenient commissioning of a door system with SIDOOR control unit.



- ① LED status display of SIDOOR LINK
- ② Connection plug for connecting the SIDOOR LINK to the SIDOOR control unit.

### 8.2.2 Connecting

1. Connect the SIDOOR LINK to plug connector X8 of the SIDOOR control unit using the corresponding cable.
2. Install the SIDOOR SUPPORT app on the Android smartphone/tablet (min. Android version 11.0 with Bluetooth LE 5.0).

<b>NOTICE</b>
<b>Material damage</b>
Connect the SIDOOR LINK to the X8 plug of the SIDOOR control unit using only the cable supplied.

### 8.2.3 Operating the SIDOOR SUPPORT app

#### Requirements

The following requirements must be met in order to use all functions of the SIDOOR SUPPORT app:

- You have assigned a 4-digit PIN during initial commissioning.
- You have registered the serial number of the SIDOOR LINK in the SIDOOR SUPPORT app.

#### Procedure

1. Start the SIDOOR SUPPORT app.  
A list with all accessible SIDOOR LINK adapters appears in the SIDOOR SUPPORT app.
2. Select a SIDOOR LINK adapter.  
A Bluetooth connection is then established between the Android smartphone / tablet and SIDOOR LINK.

#### Functions

The SIDOOR SUPPORT app offers the following functions:

Function	Description
Displaying, saving and comparing service data	<ul style="list-style-type: none"> <li>• Operating hours</li> <li>• Openings</li> <li>• Learn runs</li> <li>• Power failures</li> <li>• Obstructions</li> <li>• Driving curve parameters</li> </ul>
Display of the SIDOOR status (7-segment display)	with detailed explanations
Emulation of the Service Tool function	See SIDOOR SERVICE TOOL (Page 137)

Function	Description
Configuration of the SIDOOR control unit	<ul style="list-style-type: none"> <li>• Configuration of the driving profile</li> <li>• Exporting and importing driving profile parameters</li> <li>• Importing and exporting of maintenance data</li> <li>• Definition of parameter favorites</li> </ul>
Command output to the SIDOOR control unit	<ul style="list-style-type: none"> <li>• Drive commands: Open, Close, Nudge, Stop, Deenergize.</li> <li>• Start learn run</li> <li>• Loading parameter default values</li> </ul>
SIDOOR Firmware Update	<ul style="list-style-type: none"> <li>• Save the SIDOOR firmware on the SIDOOR LINK</li> <li>• Update the SIDOOR control unit with the saved SIDOOR firmware on the SIDOOR LINK.</li> </ul>

**Note****Detailed description of functions**

For a detailed description of the SIDOOR SUPPORT app functions, see SIDOOR SUPPORT App Function Manual (<https://support.industry.siemens.com/cs/de/de/view/109802679/en>), A5E51332023.

**Note****Input of door commands via digital inputs blocked**

If you control the SIDOOR control unit via the SIDOOR SUPPORT app, the transmission of door commands via the digital inputs of the X6 terminal strip is blocked.

### 8.2.4 Start page of the SIDOOR SUPPORT app

The home page of the app opens as soon as there is a Bluetooth connection to the SIDOOR LINK.

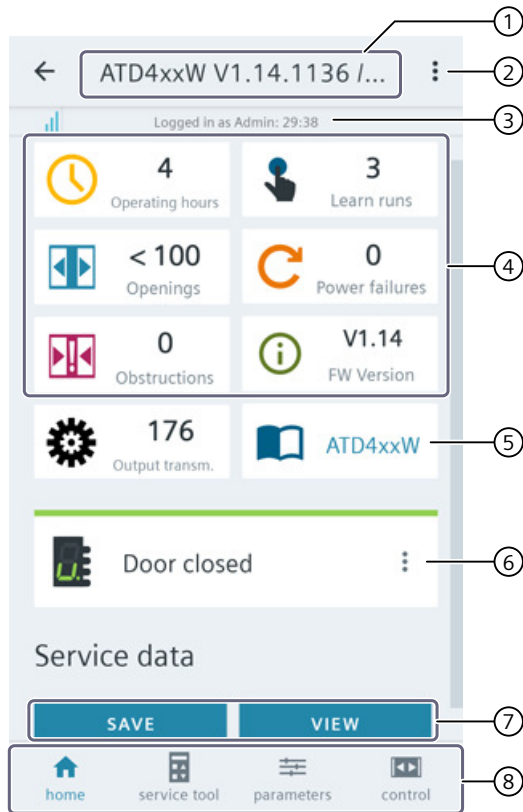

- ① Name and firmware version of the SIDOOR control unit
- ② 3-point menu, for main function and tab
- ③ Login information
- ④ Current operating data
- ⑤ Link to system manual
- ⑥ 7-segment display with operating status of the control unit;
  - the last messages are called up via the 3 dots.
  - If error message occurs, the ✓ icon appears, via which the message is displayed in detail with an additional description of the possible cause of the error
- ⑦ Buttons to save the service data in a file and to open files with saved service data
- ⑧ Navigation bar with the main functions of the app



## 8.2.5 Technical specifications

<b>Article number</b>	<b>6FB1305-0AT00-0AS4</b>
<b>General information</b>	
Product brand name	SIDOOR
Product type designation	LINK
Product version	Android APP SIDOOR APP user, SIDOOR LINK with Bluetooth 5.0
<b>Product function</b>	
• Oscilloscope function	No
<b>Installation type/mounting</b>	
Mounting type	temporary insertion to the X8 service connector of the door controller via the supplied cable
<b>Supply voltage</b>	
Rated value (DC)	36 V; directly supplied from X8 connection from the command device
<b>Input current</b>	
Current consumption, max.	20 mA
<b>Interfaces</b>	
Interfaces/bus type	Bluetooth 5.0
<b>Standards, approvals, certificates</b>	
CE mark	Yes
EAC (formerly Gost-R)	Yes
China RoHS compliance	Yes
<b>Ambient conditions</b>	
<b>Ambient temperature during operation</b>	
• min.	0 °C
• max.	45 °C
<b>Cables</b>	
Cable length	
• of the connection cable	2 m
<b>Dimensions</b>	
Width	95 mm
Height	24 mm
Depth	42 mm



## Connecting and commissioning

### 9.1 Overview of safety and commissioning

 <b>WARNING</b>
<b>Dangerous electrical voltage!</b>
When operating electrical devices, certain parts of these devices are necessarily under dangerous voltage. Failure to observe the operating instructions can therefore result in serious injury or material damage.
Observe the operating instructions.

 <b>WARNING</b>
<b>Risk of injury during commissioning</b>
<ul style="list-style-type: none"> <li>• The door movements cannot always be externally controlled while the controller is being commissioned (in particular during the automatic determination of parameters). The light barrier is not active during the learn run.</li> <li>• Increased forces and energies can occur during the learn run. The force during the learn run can be configured. The default values for closing direction Motor M2 are: 120 N; M3, M4, M5: 230 N. Opening direction motor M2: 120 N; M3: 300 N; M4, M5: 360N.</li> </ul>
An authorized person must therefore be posted near the door to ensure that no one else can enter the vicinity of the door during commissioning.

---

#### Note

The motor temperature must not lie below 0 °C during the learn run, as otherwise the mass to be moved will be incorrectly determined, and the opening and closing speed may lie in an impermissible range.

---

#### Working on the door drive

 <b>WARNING</b>
<b>Risk of injury due to dangerous electrical voltages and moving mechanical parts.</b>
Disconnect the door drive by unplugging the power plug from the power supply before you start work on the door drive.

## Parameter assignment and configuration

 **WARNING**

**Risk of injury and material damage due to excessive force of the door**

Exceeding the maximum static closing force or the opening force in some cases may lead to injuries to persons or damage to the door drive and mechanical components of the door.

After commissioning, have the maximum static forces checked by the service personnel, and adjusted to the limit value if it is excessive.

Note the limits of the applicable standard and adjust the setting accordingly.

**Note**

**Application-specific measures for emergency operation**

In the event of a control device failure, measures must be taken for emergency operation according to the application.

 **WARNING**

**Risk of injury due to excessive closing force of the door**

The door must be closed completely within the slow end distance in the closing direction. The driving curve parameter "Cutter distance CLOSE" must be checked and set accordingly.

## Modifications to the door drive

 **CAUTION**

**Loss of liability for defects and material damage**

Changes to the door drive lead to the loss of liability for defects and compensation rights, and the correct function of the door drive is no longer guaranteed.

Observe the following rules:

- Do not make any modifications to the door drive (motor, controller, power supply).
- Do not make a permanent connection as this does not ensure a proper and required necessary disconnection from the mains.
- Do not remove the protective Schuko plug under any circumstances (for example by cutting it off).
- The connection of the SIDOOR Transformer UL may only take place via a two-pole disconnecting safety device.
- The power supply cord of the power supply (SIDOOR TRANSFORMER, SIDOOR TRANSFORMER UL or SIDOOR NT 40) cannot be replaced. Scrap the power supply if the supply cable is damaged.

## Notes on maintenance

The SIDOOR system should be included in the maintenance schedule for the system as a whole, and inspected in the course of the maintenance intervals stated in the schedule.

An inspection should cover the following points:

- Visual inspection of the control device for contamination and damage
- Visual inspection of the motor for dirt and damage
- Visual and mechanical inspection of the mechanical system, in as far as it is part of the SIDOOR elevator system. This includes checking the following components:
  - Attachment of the motor holder, deflector pulley and mounting bracket
  - Wear on the toothed belt
  - Check and remeasure the parameters for the safety-related force and energy settings set during commissioning.

## Overview of commissioning a door drive

We recommend the following initial commissioning procedure for a door drive:

Table 9-1 Procedure for commissioning a door drive

Step	Procedure	Reference
1	Preparing the control device	Preparing the control device (Page 156) section
2	Connecting a geared motor to the control device	Connecting a geared motor to the control device (Page 156) section
5	Connecting the power supply to the network and executing a learn run	Connecting the power supply to the network and executing a learn run (Page 157) section
6	Connecting digital input signals	Digital input signals (Page 158) section
7	Commissioning the control device on the CAN bus (optional, only for control devices with corresponding module)	
8	Final settings and checks	Final settings and checks (Page 159) section

## 9.2 Preparing the control unit

### Preparing the control unit for connection and installation

1. Nudge the door into the CLOSED position.
2. Open the housing cover.

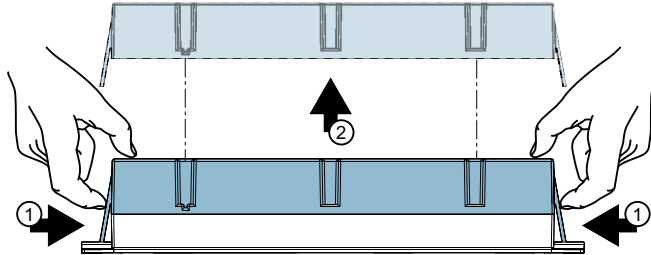

## 9.3 Connecting a geared motor to the control unit

### Connecting a geared motor to the control unit

Connect the motor plug(s) as follows:

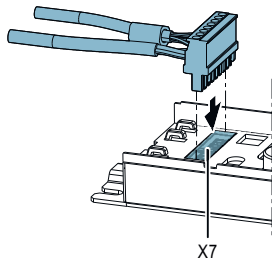

- SIDOOR AT40, ATD400V: Slot X7 on the controller

---

#### Note

#### SIDOOR AT40, ATD400V

The X6 control inputs plug is not plugged in during commissioning in order to prevent uncontrolled movements.

---

## 9.4 Connecting the power supply to the network and executing a learn run

### Connecting the power supply to the network

1. Connect the power supply to the network.
  - SIDOOR NT40: When the supply is switched on, the device is ready for operation. The green LED lights up.

---

**Note****On-site fuse**

The on-site fuse must not exceed 10 A.

---

### Perform a learn run

---

**Note**

Ensure that 15 to 25 cm of the door's range of motion from the CLOSED position are unobstructed during the learn run.

---

1. Make sure that the door is in the CLOSED position.
2. Press and hold down the learn run button S401.
3. Connect the power supply to slot X3 on the control device.

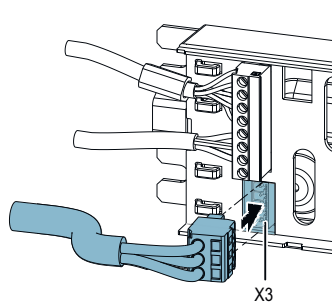

4. The learn run starts automatically and the learn run button can be released. (See table Starting a learn run when the line voltage is applied (Page 33))

5. The display on the control device is as follows:
  - The 7-segment display (H401) shows "H.". The decimal point in the 7-segment display (H401) flashes during the save process.  
The 7-segment display (H401) shows "u" when saving has finished. If a light barrier / pressure sensitive edge is used, the 7-segment display (H401) shows "0." because X6 is not connected yet.

The following must be noted when connecting X6:

- If no light barrier is used, input 1 must be deactivated or light barrier jumpers must be installed
- If a light barrier is connected, input 1 must be assigned the "Light barrier" function. (Details on input 1 are available in the section Digital input signals (Page 62).)

---

**Note**

You can deactivate the light barrier by using the service menu function if the light barrier is not going to be connected to the door controller.

In this case, it is connected via the elevator control unit.

---

**Note**

Optionally the feedback contact of a light barrier can be connected via connector X5, see section Light barrier (Page 57).

---

6. The door can now be opened with the OPEN button (S402).
  - The 7-segment display (H401) shows "o." while the door is opening.
7. Switch off the controller by pulling out the power plug or the connector X3.

**See also**

Learn run (Page 32)

## 9.5 Connecting digital inputs

### Connecting digital inputs

#### Connecting digital input signals

1. Insert the terminal connectors for the digital control inputs in X6, X5 and X4. See section Digital input signals (Page 62) for more on this.

---

**Note**

**Risk of injury due to moving mechanical parts.**

The controller will be operative after the switch-on. If a control signal is present, the door will move in the set direction.

---



## 9.6 Final settings and checks

### Final settings

1. Activate the application-specific relay module functionalities. (Optional, only for control devices with a relay module)  
Proceed as described in the section Relay module (Page 66).
2. Configure the connected sensor type.
3. Switch on the control device by connecting the power supply to the control device and to the network.  
The four LEDs alongside the plug connector X6 indicate which control signal is currently active. If input 1 is configured as a light barrier input and there is no obstacle in the travel direction, the LED for light barrier/DCPS input lights up continuously.  
If the control signal CLOSE is present, the door moves into the CLOSED position at initial speed.  
If an OPEN control signal is set, the door moves into the OPEN position at initial speed. The OPEN signal has priority over the CLOSE signal!  
Once the controller has detected the door OPEN and CLOSED end positions, the subsequent opening and closing movements proceed at normal speed once again.

---

#### Note

An opening or closing command must be present until the entire travel distance from OPEN to CLOSE or from CLOSE to OPEN can be completely traversed and the doors dwells for an additional second in the OPEN and CLOSE door position.

---

### Final checks

Final check of the permissible energies and forces.



#### WARNING

##### Risk of injury due to moving mechanical parts

Check permissible forces and energies after the door drive has been commissioned in the complete system and adjust them if they exceed their limit values.

Please observe the valid applicable standards and directives for the respective application, as well as the following guidelines:

- Gearing up or down is not allowed on the toothed belt because this would change the kinetic energies or static forces on the door. The door width would then no longer be valid.



**WARNING**

**Risk of injury and material damage due to excessive closing or opening force of the door**

Exceeding the maximum static closing and opening force may lead to personal injuries or damage to the door drive and to mechanical components of the door.

The maximum static closing and opening forces at the closing edge without additional protective equipment must not exceed 150 N (150 N in opening direction applies according to EN81-20 only for glass leaf and folding leaf doors).



**WARNING**

**Risk of injury due to excessive closing force of the door**

The door must be closed completely within the slow end distance in the closing direction. The driving curve parameter "Cutter distance CLOSE" must be checked and set accordingly.

## Diagnostics and maintenance

### 10.1 Operating state display

Operating states are indicated on the "H401" 7-segment display or the "H1" digital display.

The following operating states are shown:

Display	Meaning
<b>Info</b>	
<sup>2)</sup>	Minimal editor (input 1 setting) active
O <sup>1)</sup>	Light barrier interrupted
6	Motor obstructed in the closing direction
8 <sup>2)</sup>	Minimal editor is started (press the service buttons OPEN and CLOSE simultaneously with power on).
A <sup>2)</sup>	Minimal editor (force setting) active
c	Obstruction while opening
C <sup>2)</sup>	Minimal editor (profile setting) is active
d	Door remains stationary during initialization run (no OPEN or CLOSE signal present, or door has reached end position)
H	Determination of parameters (learn run)
o	Function OK
r	CAN error
u	Door closed
<b>Fault</b>	
1	RAM, EEPROM or CPU error (system error)
2	Braking chopper defective
3	Error in the second shutdown route
5	Motor undefined – no learn run carried out with this motor type (If a different motor version is used, the learn run must be repeated with power on as described in these Operating Instructions. See Learn run button (Page 33))
7	Error in pulse generator
9	Motor overcurrent
E	Motor overvoltage
F	Motor undervoltage
n	Output stage defective
L	Current measurement error
U	Maximum door weight exceeded
<b>Alarm</b>	
4	Automatic extension of the hold-open time (motor protection)
P	Parameter error (error during learn run)
–	Controller has no parameters and is waiting for learn run

<sup>1)</sup> See section "Digital input signals (Page 62)"

<sup>2)</sup> See section "Minimal editor (Page 82)"

## 10.2 Maintenance

The SIDOOR system should be included in the maintenance schedule for the door system as a whole, and inspected in the course of the maintenance cycles stated in the schedule.

---

### Note

Recommended maintenance cycles provided in the table below may vary according to the ambient conditions and the stress on the system.

---

Object	Recommended maintenance interval
DC geared motor	Maintenance-free
SIDOOR control unit	Maintenance-free
Visual inspection of the control unit, the fastening of the motor mount, the pulley and the mounting brackets for dirt, damage and proper installation. In addition, an inspection of the door function is recommended for running or grinding noises.	1 year
The belt tension should be checked	1 year
With mechanical changes of the system, for example, due to maintenance or wear (friction, dirt, engine replacement, belt replacement or modification of the general door mechanism), an inspection is recommended for the commissioning parameters relating to the safety-related settings for forces and energies/velocities.	

# Disposal

## Recycling and disposal



For environmentally-friendly recycling and disposal of your old device, please contact a company certified for the disposal of waste electrical and electronic equipment, and dispose of the old device as prescribed in the respective country of use.



## Appendixes

### A.1 Profiles and adjustment ranges

#### A.1.1 Profile name

Profile	SIDOOR AT40				SIDOOR AT40	
	M2 R / L	M3 R / L	M4 R / L	M5 R / L	M4 R / L	M5 R / L
1	M2 Default	M3 Default	M4 Default	M5 Default	M4 Profile 1	M5 Profile 1
2	M2 Min	M3 Min	M4 Min	M5 Min	M4 Profile 2	M5 Profile 2
3	M2 Max	M3 Max	M4 Max	M5 Max	M4 Profile 3	M5 Profile 3
4	M2 Special 1	M3 Special 1	M4 Special 1	M5 Special 1	M4 Profile 4	M5 Profile 4
5	M2 Special 2	M3 Special 2	M4 Special 2	M5 Special 2	M4 Profile 5	M5 Profile 5
6	M2 Special 3	M3 Special 3	M4 Special 3	M5 Special 3	M4 Profile 6	M5 Profile 6

#### A.1.2 SIDOOR M2 L / R

##### A.1.2.1 SIDOOR AT40

Table A-1 Parameter SIDOOR M2 L / R valid for controller SIDOOR AT40

Parameter	Unit	De- fault*	Min	Max	Spe- cial 1	Spe- cial 2	Spe- cial 3	Adjust- ment range
Creep distance OPEN	mm	25	20	25	25	25	25	0 ... 100
Cutter distance OPEN	mm	30	30	40	30	35	40	0 ... 150
Creep distance CLOSE	mm	20	0	0	20	20	20	0 ... 100
Cutter distance CLOSE	mm	40	30	40	40	35	40	0 ... 150
Maximum speed OPEN	mm/s	500	300	500	500	375	375	100 ... 500
Creep speed OPEN	mm/s	40	40	60	40	70	70	30 ... 90
Cutter speed OPEN	mm/s	60	40	60	60	30	50	30 ... 90
Initial speed OPEN	mm/s	90	50	70	90	90	90	30 ... 90
Maximum speed CLOSE	mm/s	250	150	300	150	280	280	100 ... 500
Creep speed CLOSE	mm/s	60	40	60	60	90	90	30 ... 90
Cutter speed CLOSE	mm/s	40	40	60	40	30	50	30 ... 90
Initial speed CLOSE	mm/s	90	50	70	90	90	90	30 ... 90

A.1 Profiles and adjustment ranges

Parameter	Unit	De- fault*	Min	Max	Spe- cial 1	Spe- cial 2	Spe- cial 3	Adjust- ment range
Nudge speed CLOSE	mm/s	150	100	150	150	150	150	50 ... 250
Acceleration ramp OPEN	mm/s <sup>2</sup>	850	600	850	850	750	750	300 ... 850
Braking ramp OPEN	mm/s <sup>2</sup>	600	500	800	850	750	750	300 ... 850
Reversing ramp OPEN/CLOSE	mm/s <sup>2</sup>	850	500	800	850	750	750	300 ... 850
Acceleration ramp CLOSE	mm/s <sup>2</sup>	500	500	800	500	750	750	300 ... 850
Braking ramp CLOSE	mm/s <sup>2</sup>	500	500	800	500	750	750	300 ... 850
Reversing ramp CLOSE/OPEN	mm/s <sup>2</sup>	850	600	850	850	850	750	300 ... 850
Continuous torque (power) OPEN	A	1.5	0.8	1.2	1	1.5	1.5	0 ... 1.5
Continuous torque (power) CLOSE	A	1	0.8	1	1	1	1	0 ... 1.5
Cutter press-on torque	A	5	2	2.6	2.5	5	5	0 ... 5
Static opening force	N	120	120	120	120	120	120	70 ... 120
Static closing force	N	110	110	110	110	120	120	70 ... 120
Static cutter force CLOSE	N	120	110	110	110	120	120	70 ... 120
Static nudge force CLOSE	N	70	110	110	110	120	120	70 ... 120

\* Default profile (this profile is automatically loaded at the first commissioning)

### A.1.3 SIDOOR M3 L / R

#### A.1.3.1 SIDOOR AT40

Table A-2 Parameter SIDOOR M3 L / R valid for controller SIDOOR AT40

Parameter	Unit	De- fault*	Min	Max	Spe- cial 1	Spe- cial 2	Spe- cial 3	Adjust- ment range
Creep distance OPEN	mm	30	20	30	30	15	15	0 ... 100
Cutter distance OPEN	mm	30	30	40	30	35	40	0 ... 150
Creep distance CLOSE	mm	20	0	0	0	15	15	0 ... 100
Cutter distance CLOSE	mm	40	30	40	30	35	50	0 ... 150
Maximum speed OPEN	mm/s	650	400	650	650	500	500	100 ... 650
Creep speed OPEN	mm/s	40	40	60	70	75	75	30 ... 90
Cutter speed OPEN	mm/s	60	40	60	70	30	40	30 ... 90
Initial speed OPEN	mm/s	90	50	70	90	90	90	30 ... 90



Parameter	Unit	De- fault*	Min	Max	Spe- cial 1	Spe- cial 2	Spe- cial 3	Adjust- ment range
Maximum speed CLOSE	mm/s	319	250	319	250	350	350	100 ... 500
Creep speed CLOSE	mm/s	60	40	60	50	90	90	30 ... 90
Cutter speed CLOSE	mm/s	40	40	60	50	30	40	30 ... 90
Initial speed CLOSE	mm/s	90	50	70	60	90	90	30 ... 90
Nudge speed CLOSE	mm/s	150	100	150	100	150	150	50 ... 250
Acceleration ramp OPEN	mm/s <sup>2</sup>	1300	800	1200	1400	1100	1100	300 ... 1400
Braking ramp OPEN	mm/s <sup>2</sup>	600	600	1000	1200	1100	1100	300 ... 1400
Reversing ramp OPEN/CLOSE	mm/s <sup>2</sup>	1200	600	1000	1200	1100	1100	300 ... 1400
Acceleration ramp CLOSE	mm/s <sup>2</sup>	500	600	1000	500	900	900	300 ... 1400
Braking ramp CLOSE	mm/s <sup>2</sup>	500	600	1000	500	1100	1100	300 ... 1400
Reversing ramp CLOSE/OPEN	mm/s <sup>2</sup>	850	800	1200	1200	1400	1400	300 ... 1400
Continuous torque (power) OPEN	A	2.5	0.7	1.2	1.2	2.5	2.5	0 ... 2.5
Continuous torque (power) CLOSE	A	2.5	0.7	1.2	1.2	2.5	2.5	0 ... 2.5
Cutter press-on torque	A	5	2	3	3	5	5	0 ... 5
Static opening force	N	300	300	300	300	300	300	70 ... 300
Static closing force	N	90	90	90	90	90	90	70 ... 230
Static cutter force CLOSE	N	230	90	90	90	230	230	70 ... 230
Static nudge force CLOSE	N	70	90	90	90	100	100	70 ... 230

\* Default profile (this profile is automatically loaded at the first commissioning)

## A.1.4 SIDOOR M4 L / R

### A.1.4.1 SIDOOR AT40

Table A-3 Parameter SIDOOR M4 L / R valid for controller SIDOOR AT40

Parameter	Unit	De- fault*	Min	Max	Spe- cial 1	Spe- cial 2	Spe- cial 3	Adjust- ment range
Creep distance OPEN	mm	30	20	30	30	20	20	0 ... 100
Cutter distance OPEN	mm	30	30	40	30	30	40	0 ... 150
Creep distance CLOSE	mm	20	0	0	0	20	20	0 ... 100
Cutter distance CLOSE	mm	40	30	40	30	30	40	0 ... 150

## Appendixes

### A.1 Profiles and adjustment ranges

Parameter	Unit	De- fault*	Min	Max	Spe- cial 1	Spe- cial 2	Spe- cial 3	Adjust- ment range
Maximum speed OPEN	mm/s	600	400	650	650	400	400	100 ... 750
Creep speed OPEN	mm/s	40	40	60	70	40	40	30 ... 90
Cutter speed OPEN	mm/s	60	40	60	70	30	40	30 ... 90
Initial speed OPEN	mm/s	90	50	70	90	90	90	30 ... 90
Maximum speed CLOSE	mm/s	319	250	319	250	250	250	100 ... 500
Creep speed CLOSE	mm/s	60	40	60	50	60	60	30 ... 90
Cutter speed CLOSE	mm/s	40	40	60	50	30	45	30 ... 90
Initial speed CLOSE	mm/s	90	50	70	60	90	90	30 ... 90
Nudge speed CLOSE	mm/s	150	100	150	100	130	130	50 ... 250
Acceleration ramp OPEN	mm/s <sup>2</sup>	1300	800	1200	1400	1100	1100	300 ... 1400
Braking ramp OPEN	mm/s <sup>2</sup>	600	600	1000	1200	600	600	300 ... 1400
Reversing ramp OPEN/CLOSE	mm/s <sup>2</sup>	1200	600	1000	1200	850	850	300 ... 1400
Acceleration ramp CLOSE	mm/s <sup>2</sup>	500	600	1000	500	800	800	300 ... 1400
Braking ramp CLOSE	mm/s <sup>2</sup>	500	600	1000	500	900	900	300 ... 1400
Reversing ramp CLOSE/OPEN	mm/s <sup>2</sup>	850	800	1200	1200	1400	1400	300 ... 1400
Continuous torque (power) OPEN	A	2.5	0.7	1.2	1.2	2.5	2.5	0 ... 2.5
Continuous torque (power) CLOSE	A	2.5	0.7	1.2	1.2	2.5	2.5	0 ... 2.5
Cutter press-on torque	A	5	2	3	3	5	5	0 ... 5
Static opening force	N	360	300	300	300	360	360	70 ... 360
Static closing force	N	70	70	70	70	90	90	70 ... 230
Static cutter force CLOSE	N	230	70	70	70	230	230	70 ... 230
Static nudge force CLOSE	N	70	70	70	70	90	90	70 ... 230

\* Default profile (this profile is automatically loaded at the first commissioning)

## A.1.4.2 SIDOOR ATD400V

Table A-4 SIDOOR M4 L / R parameters valid for the SIDOOR ATD400V controller

Parameter	Unit	Pro- file 1	Pro- file 2*	Pro- file 3	Pro- file 4	Pro- file 5	Pro- file 6	Adjust- ment range
Creep distance OPEN	mm	30	30	30	30	30	30	0 ... 100
Cutter distance OPEN	mm	30	30	30	30	30	30	0 ... 150
Creep distance CLOSE	mm	30	30	30	30	30	30	0 ... 100
Cutter distance CLOSE	mm	30	30	30	30	30	30	0 ... 150
Maximum speed OPEN	mm/s	300	400	650	400	400	400	100 ... 750
Creep speed OPEN	mm/s	40	40	40	40	40	40	30 ... 90
Cutter speed OPEN	mm/s	30	30	30	30	30	30	30 ... 90
Initial speed OPEN	mm/s	90	90	90	90	90	90	30 ... 90
Maximum speed CLOSE	mm/s	200	300	300	300	300	300	100 ... 300
Creep speed CLOSE	mm/s	60	60	60	60	60	60	30 ... 90
Cutter speed CLOSE	mm/s	30	30	30	30	30	30	30 ... 90
Initial speed CLOSE	mm/s	90	90	90	90	90	90	30 ... 90
Nudge speed CLOSE	mm/s	130	130	130	130	130	130	50 ... 250
Acceleration ramp OPEN	mm/s <sup>2</sup>	1000	1100	1400	1100	1100	1100	300 ... 1400
Braking ramp OPEN	mm/s <sup>2</sup>	500	600	850	600	600	600	300 ... 1400
Reversing ramp OPEN/CLOSE	mm/s <sup>2</sup>	750	850	850	850	850	850	300 ... 1400
Acceleration ramp CLOSE	mm/s <sup>2</sup>	700	800	1100	800	800	800	300 ... 1400
Braking ramp CLOSE	mm/s <sup>2</sup>	800	900	1000	900	900	900	300 ... 1400
Reversing ramp CLOSE/OPEN	mm/s <sup>2</sup>	1400	1400	1400	1400	1400	1400	300 ... 1400
Continuous torque (power) OPEN	A	1.5	1.5	1.5	1.5	1.5	1.5	0 ... 2.5
Continuous torque (power) CLOSE	A	1.5	1.5	1.5	1.5	1.5	1.5	0 ... 2.5
Cutter press-on torque	A	3.0	3.0	3.0	3.0	3.0	3.0	0 ... 5
Static opening force	N	300	300	300	300	300	300	70 ... 360
Static closing force	N	150	150	150	150	150	150	70 ... 230
Static cutter force CLOSE	N	150	150	150	150	150	150	70 ... 230
Static nudge force CLOSE	N	150	150	150	150	150	150	70 ... 230

\* Default profile (this profile is automatically loaded at the first commissioning)

## A.1.5 SIDOOR M5 L / R

## A.1.5.1 SIDOOR AT40

Table A-5 SIDOOR M5 L / R parameters valid for the SIDOOR AT40 controller

Parameter	Unit	De- fault*	Min	Max	Spe- cial 1	Spe- cial 2	Spe- cial 3	Adjust- ment range
Creep distance OPEN	mm	40	40	30	40	40	40	0 ... 100
Cutter distance OPEN	mm	40	40	40	40	40	40	0 ... 150
Creep distance CLOSE	mm	20	20	20	20	20	20	0 ... 100
Cutter distance CLOSE	mm	40	40	40	40	40	40	0 ... 150
Maximum speed OPEN	mm/s	350	200	450	350	350	350	100 ... 500
Creep speed OPEN	mm/s	40	40	40	40	40	40	30 ... 90
Cutter speed OPEN	mm/s	40	40	40	40	40	40	30 ... 90
Initial speed OPEN	mm/s	90	90	90	90	90	90	30 ... 90
Maximum speed CLOSE	mm/s	200	150	250	200	200	200	100 ... 500
Creep speed CLOSE	mm/s	40	40	40	40	40	40	30 ... 90
Cutter speed CLOSE	mm/s	45	45	45	45	45	45	30 ... 90
Initial speed CLOSE	mm/s	90	90	90	90	90	90	30 ... 90
Nudge speed CLOSE	mm/s	115	115	115	115	115	115	50 ... 250
Acceleration ramp OPEN	mm/s <sup>2</sup>	450	450	500	450	450	450	300 ... 650
Braking ramp OPEN	mm/s <sup>2</sup>	350	300	400	350	350	350	300 ... 650
Reversing ramp OPEN/CLOSE	mm/s <sup>2</sup>	500	500	500	500	500	500	300 ... 650
Acceleration ramp CLOSE	mm/s <sup>2</sup>	450	400	450	450	450	450	300 ... 650
Braking ramp CLOSE	mm/s <sup>2</sup>	400	400	400	400	400	400	300 ... 650
Reversing ramp CLOSE/OPEN	mm/s <sup>2</sup>	650	650	650	650	650	650	300 ... 650
Continuous torque (power) OPEN	A	2.5	2.5	2.5	2.5	2.5	2.5	0 ... 2.5
Continuous torque (power) CLOSE	A	2.5	2.5	2.5	2.5	2.5	2.5	0 ... 2.5
Cutter press-on torque	A	5.0	5.0	5.0	5.0	5.0	5.0	0 ... 5
Static opening force	N	360	360	360	360	360	360	70 ... 360
Static closing force	N	90	90	90	90	90	90	70 ... 230
Static cutter force CLOSE	N	230	90	90	90	230	230	70 ... 230
Static nudge force CLOSE	N	90	90	90	90	90	90	70 ... 230

\* Default profile (this profile is automatically loaded at the first commissioning)

## A.1.5.2 SIDOOR ATD400V

Table A-6 SIDOOR M5 L / R parameters valid for the SIDOOR ATD400V control device

Parameter	Unit	Pro- file 1	Pro- file 2*	Pro- file 3	Pro- file 4	Pro- file 5	Pro- file 6	Adjust- ment range
Slow end distance open	mm	40	40	40	40	40	40	0 ... 100
Slow start distance open	mm	40	40	40	40	40	40	0 ... 150
Slow start distance close	mm	20	20	20	20	20	20	0 ... 100
Slow end distance close	mm	40	40	40	40	40	40	0 ... 150
Maximum speed open	mm/s	250	400	450	400	400	400	100 ... 500
Slow end speed open	mm/s	40	40	40	40	40	40	30 ... 90
Slow start speed open	mm/s	40	40	40	40	40	40	30 ... 90
Slow initial speed open	mm/s	90	90	90	90	90	90	30 ... 90
Maximum speed close	mm/s	150	200	250	200	200	200	100 ... 300
Slow start speed close	mm/s	40	40	40	40	40	40	30 ... 90
Slow end speed close	mm/s	45	45	45	45	45	45	30 ... 90
Slow speed close initial	mm/s	90	90	90	90	90	90	30 ... 90
Nudging speed close	mm/s	115	115	115	115	115	115	50 ... 250
Acceleration ramp open	mm/s <sup>2</sup>	400	450	500	450	450	450	300 ... 650
Deceleration ramp OPEN	mm/s <sup>2</sup>	300	350	400	350	350	350	300 ... 650
Reversal ramp open/close	mm/s <sup>2</sup>	500	500	500	500	500	500	300 ... 650
Acceleration ramp close	mm/s <sup>2</sup>	400	450	450	450	450	450	300 ... 650
Deceleration ramp close	mm/s <sup>2</sup>	400	400	400	400	400	400	300 ... 650
Reversal ramp close/open	mm/s <sup>2</sup>	650	650	650	650	650	650	300 ... 650
Idle torque open	A	2.5	2.5	2.5	2.5	2.5	2.5	0 ... 2.5
Idle torque close	A	2.5	2.5	2.5	2.5	2.5	2.5	0 ... 2.5
Peak torque close	A	5	5	5	5	5	5	0 ... 5
Static force limit open	N	360	360	360	360	360	360	70 ... 360
Static force limit close	N	150	150	150	150	150	150	70 ... 230
Limit force end close	N	150	150	150	150	150	150	70 ... 230
Static nudge force CLOSE	N	150	150	150	150	150	150	70 ... 230

\* Default profile (this profile is automatically loaded at the first commissioning)

## A.2 Configuration record

Commissioning engineer	
Date	

### Controller

- SIDOOR AT40 RELAY
- SIDOOR AT40 CAN
- SIDOOR AT40 CAN ADV
- SIDOOR ATD400V RELAY

FW version: \_\_\_\_\_

### Motor

- SIDOOR M2 L
- SIDOOR M2 R
- SIDOOR M3 L
- SIDOOR M3 R
- SIDOOR M4 L
- SIDOOR M4 R
- SIDOOR M5 L
- SIDOOR M5 R

### Power supply

- SIDOOR NT40
- SIDOOR TRANSFORMER
- SIDOOR TRANSFORMER UL

### Note

#### Changes to travel profile parameters

Changes to travel profile parameters should only be performed after a successful learn run, during standstill of the door because the controller then applies the values immediately.

Parameter	Unit	Set value
Slow end distance open	mm	
Slow start distance open	mm	
Slow start distance close	mm	
Slow end distance close	mm	

Parameter	Unit	Set value
Maximum speed open	mm/s	
Slow end speed open	mm/s	
Slow start speed open	mm/s	
Slow initial speed open	mm/s	
Maximum speed close	mm/s	
Slow start speed close	mm/s	
Slow end speed close	mm/s	
Slow initial speed close	mm/s	
Nudge speed CLOSE	mm/s	
Acceleration ramp open	mm/s <sup>2</sup>	
Deceleration ramp open	mm/s <sup>2</sup>	
Reversal ramp open/close	mm/s <sup>2</sup>	
Acceleration ramp close	mm/s <sup>2</sup>	
Deceleration ramp close	mm/s <sup>2</sup>	
Reversal ramp close/open	mm/s <sup>2</sup>	
Idle torque open	A	
Idle torque close	A	
Peak torque close	A	
Static force limit open	N	
Static force limit close	N	
Limit force end close	N	
Limit force close nudging	N	

## A.3 Standards, directives and laws

Here you can find information on standards, directives and laws:

- SIDOOR AT40 elevator door drive-TUEV Nord certificate: (<https://support.industry.siemens.com/cs/ww/en/view/109483536>)
- SIDOOR ATD400V elevator door drive-TUEV Nord certificate: (<https://support.industry.siemens.com/cs/ww/en/view/109745686>)
- SIDOOR controllers for elevator doors with drive motors M2-M5, EC/EU Declaration of conformity:

### See also

EC/EU Declaration of conformity (<https://support.industry.siemens.com/cs/ww/en/view/80479406>)





## More information

Siemens:  
[www.siemens.com/sidoor](http://www.siemens.com/sidoor)

Industry Online Support (Service and Support):  
[www.siemens.com/online-support](http://www.siemens.com/online-support)

Industry Mall:  
[www.siemens.com/industrymall](http://www.siemens.com/industrymall)

Siemens AG  
Digital Industries  
Motion Control  
Postfach 31 80  
91050 ERLANGEN  
Germany

Scan the QR code  
for more informa-  
tion on SIDOOR.

