



Edition

10/2023

SYSTEM MANUAL

# SIDOOR

## Automatic door control units

ATD4xxW for industrial applications



## SIDOOR

### Automatic door control units ATD4xxW for industrial applications

System Manual

<u>Introduction</u>	<b>1</b>
<u>Basic safety information</u>	<b>2</b>
<u>System overview</u>	<b>3</b>
<u>SIDOOR functions</u>	<b>4</b>
<u>Controllers</u>	<b>5</b>
<u>Geared motors</u>	<b>6</b>
<u>Power supply</u>	<b>7</b>
<u>Optional additional units</u>	<b>8</b>
<u>Configuration and Programming in STEP 7 / via TIA Portal</u>	<b>9</b>
<u>Connecting and commissioning</u>	<b>10</b>
<u>Diagnostic and maintenance</u>	<b>11</b>
<u>Disposal</u>	<b>12</b>
<u>Appendices</u>	<b>A</b>

## Legal information

### Warning notice system

This manual contains notices you have to observe in order to ensure your personal safety, as well as to prevent damage to property. The notices referring to your personal safety are highlighted in the manual by a safety alert symbol, notices referring only to property damage have no safety alert symbol. These notices shown below are graded according to the degree of danger.

 <b>DANGER</b>
indicates that death or severe personal injury <b>will</b> result if proper precautions are not taken.

 <b>WARNING</b>
indicates that death or severe personal injury <b>may</b> result if proper precautions are not taken.

 <b>CAUTION</b>
indicates that minor personal injury can result if proper precautions are not taken.

<b>NOTICE</b>
indicates that property damage can result if proper precautions are not taken.

If more than one degree of danger is present, the warning notice representing the highest degree of danger will be used. A notice warning of injury to persons with a safety alert symbol may also include a warning relating to property damage.

### Qualified Personnel

The product/system described in this documentation may be operated only by **personnel qualified** for the specific task in accordance with the relevant documentation, in particular its warning notices and safety instructions. Qualified personnel are those who, based on their training and experience, are capable of identifying risks and avoiding potential hazards when working with these products/systems.

### Proper use of Siemens products

Note the following:

 <b>WARNING</b>
Siemens products may only be used for the applications described in the catalog and in the relevant technical documentation. If products and components from other manufacturers are used, these must be recommended or approved by Siemens. Proper transport, storage, installation, assembly, commissioning, operation and maintenance are required to ensure that the products operate safely and without any problems. The permissible ambient conditions must be complied with. The information in the relevant documentation must be observed.

### Trademarks

All names identified by ® are registered trademarks of Siemens AG. The remaining trademarks in this publication may be trademarks whose use by third parties for their own purposes could violate the rights of the owner.

### Disclaimer of Liability

We have reviewed the contents of this publication to ensure consistency with the hardware and software described. Since variance cannot be precluded entirely, we cannot guarantee full consistency. However, the information in this publication is reviewed regularly and any necessary corrections are included in subsequent editions.

# Table of contents

<b>1</b>	<b>Introduction</b> .....	<b>11</b>
1.1	About SIDOOR .....	11
1.2	About this manual .....	12
1.2.1	Sales law .....	12
1.2.2	Contents.....	12
1.2.3	Target group .....	13
1.2.4	Standard scope .....	14
1.2.5	Use of third-party products in this documentation .....	14
1.2.6	Websites of third-party companies.....	15
1.3	SIDOOR documentation .....	15
1.4	Service and support .....	15
1.4.1	Parameter documentation.....	15
1.4.2	Siemens Industry Online Support on the Web.....	16
1.4.3	Spare parts services .....	16
1.5	Important product information .....	17
1.5.1	Intended use.....	17
<b>2</b>	<b>Basic safety information</b> .....	<b>19</b>
2.1	General safety instructions.....	19
2.1.1	Electric shock and danger to life due to other energy sources.....	19
2.2	Equipment damage due to electric fields or electrostatic discharge .....	22
2.3	Warranty and liability for application examples .....	22
2.4	Cybersecurity information .....	23
2.5	Residual risks of power drive systems .....	24
<b>3</b>	<b>System overview</b> .....	<b>25</b>
3.1	System configuration and area of application .....	25
3.2	Products .....	27
3.2.1	Controllers.....	27
3.2.2	Geared motors .....	28
3.2.3	Power supply .....	30
3.2.4	Optional additional units.....	30
3.2.4.1	SIDOOR SERVICE TOOL .....	31
3.2.4.2	SIDOOR SUPPORT app and SIDOOR LINK .....	32
3.2.4.3	SIDOOR SOFTWARE KIT .....	34
3.2.5	Accessories .....	35
<b>4</b>	<b>SIDOOR functions</b> .....	<b>37</b>
4.1	Basic functions.....	39
4.1.1	Learn run.....	40
4.1.2	Force limit for learn run.....	48

4.1.3	Output transmission .....	48
4.1.4	Drive orders .....	49
4.1.5	DOOR CLOSE (command given via digital inputs) .....	55
4.1.6	DOOR OPEN (command given via digital inputs) .....	56
4.1.7	Stopping .....	57
4.1.8	Partial opening .....	57
4.1.9	Obstruction detection CLOSE .....	58
4.1.10	Obstruction detection OPEN .....	58
4.1.11	Force and energy profiles (NDG mode) .....	58
4.1.12	Slow driving curve profile .....	60
4.1.13	DCOPS (door closed/opened position sensor) .....	61
4.2	System functions .....	62
4.2.1	Initial run/reference run after restart .....	62
4.2.2	Overload protection of the geared motor .....	63
4.2.3	Vandalism protection/continuous door monitoring .....	63
4.2.4	Belt break monitoring .....	64
4.2.5	Friction compensation .....	64
4.2.6	Oscillation protection .....	65
4.2.7	Automatic energy limitation .....	67
4.2.8	External closing force .....	70
4.2.9	Synchronization of the door position .....	70
4.2.10	Cyclic process values via fieldbus .....	71
4.2.11	Parameter checksum (as of V1.12) .....	71
4.2.12	Loading of the factory setting .....	73
4.3	Extended functions .....	73
4.3.1	ImpulseDrive .....	74
4.3.2	Automatic ImpulseDrive .....	75
4.3.3	ImpulseStop .....	75
4.3.4	Automatic ImpulseStop .....	76
4.3.5	AssistedDrive .....	77
4.3.6	Automatic AssistedDrive .....	78
4.3.7	Positioning mode .....	79
4.3.8	Obstruction detection .....	80
4.3.8.1	Obstruction detection process .....	81
4.3.8.2	Overcome obstruction .....	82
4.3.8.3	Reversing (Retraction attempt) .....	82
4.3.8.4	Combination of retry and reverse .....	83
4.3.8.5	Slow obstruction approach .....	83
4.3.8.6	Wait mode .....	84
4.3.8.7	Expert configuration .....	84
4.3.9	Free function blocks (FBLOCK) .....	86
4.3.9.1	Overview .....	86
4.3.9.2	Configuring the logic .....	89
4.3.9.3	Digital and logical input signals .....	91
4.3.9.4	Control bits (as of V1.10) .....	92
4.3.9.5	Special function blocks .....	92
4.3.9.6	Discrepancy analysis blocks .....	93
4.3.9.7	Basic blocks .....	93
4.3.9.8	Frequency analysis blocks .....	93
4.3.9.9	On delay block .....	94
4.3.9.10	Counter block .....	94

4.3.9.11	Position function block (as of V1.12) .....	95
4.3.9.12	Cold storage function block (as of V1.12) .....	97
4.3.9.13	Specific door range of motion.....	99
4.3.9.14	Emergency power mode .....	100
4.3.10	Basic parameter editor (as of V1.10) .....	100
4.3.11	Masking of door commands (as of V1.12) .....	102
4.3.12	Test run (as of V1.12).....	103
4.3.13	Operation as cold store door (as of V1.13).....	104
4.4	Safety functions .....	106
4.4.1	Optional safety equipment.....	106
4.4.1.1	Light barrier .....	106
4.4.1.2	ESPE .....	108
4.4.1.3	Pressure-sensitive edge (SR) .....	109
4.4.1.4	Deactivation of the service buttons during emergency stop (as of V1.12).....	110
4.4.2	Security policy .....	111
4.4.2.1	Safe force output .....	111
4.4.2.2	Safe speed observance (energy limiting) .....	111
4.4.2.3	Safe input signals according to PLd.....	111
4.4.2.4	Internal signal routing.....	112
4.4.2.5	Redundant antivalent signal logic with discrepancy analysis .....	112
4.4.2.6	Frequency-based input signals .....	114
4.4.2.7	Two-hand operation concept (according to Cat. IIIA).....	114
4.4.2.8	Emergency stop concept in accordance with stop category 1 .....	116
4.4.2.9	Concept of fail-safe digital control (door OPEN/CLOSE) with emergency stop via 3 digital inputs.....	117
4.4.2.10	Learn run with emergency stop connection .....	119
<b>5</b>	<b>Controllers .....</b>	<b>121</b>
5.1	Description of controller.....	121
5.2	Installing the control unit.....	121
5.3	Wiring instructions.....	124
5.4	Connecting terminals.....	126
5.4.1	Digital input signals .....	126
5.4.2	Voltage output.....	129
5.5	Relay and fieldbus interfaces .....	130
5.5.1	Relay module .....	130
5.5.2	PROFIBUS.....	133
5.5.2.1	PROFIBUS module .....	133
5.5.2.2	Wiring and connecting PROFIBUS connectors.....	136
5.5.2.3	Wiring and connecting relay outputs .....	137
5.5.2.4	PROFIBUS communication.....	139
5.5.3	PROFINET.....	143
5.5.3.1	PROFINET module .....	143
5.5.3.2	Wiring and connecting a PROFINET connector .....	149
5.5.3.3	Wiring and connecting relay outputs .....	150
5.5.3.4	PROFINET communication.....	151
5.5.4	Local/master operation .....	155
5.5.5	Master monitoring .....	156
5.6	Sequential control.....	157

5.7	Sensors and external sensor interface module .....	160
5.7.1	Overview .....	160
5.7.2	Sensor function test .....	164
5.7.3	Reaction times .....	165
5.7.4	Stopping distances .....	165
5.8	Technical specifications .....	166
5.9	Operation and configuration of the control unit .....	170
5.9.1	Service buttons .....	171
5.9.1.1	Operation using service buttons .....	171
5.9.2	Parameter assignment via the terminal module .....	174
5.9.3	Parameter assignment using additional devices .....	175
5.9.4	Adjustable parameters .....	176
5.9.4.1	Driving curve .....	176
5.9.4.2	Forces .....	177
5.9.4.3	Parameter assignment .....	180
<b>6</b>	<b>Geared motors .....</b>	<b>197</b>
6.1	Description .....	197
6.2	Installation .....	198
6.3	Connecting terminals .....	203
6.3.1	Conductor assignment of the motor plug .....	203
6.4	Technical specifications .....	206
6.4.1	Technical specifications MDG3 R/L .....	206
6.4.2	Technical specifications MDG4 R/L .....	208
6.4.3	Technical Specifications MDG5 R/L .....	210
6.4.4	Technical specifications M3 R/L .....	212
6.4.5	Technical specifications M4 R/L .....	213
6.4.6	Technical specifications M5 R/L .....	214
6.4.7	Technical specifications for rubber-metal anti-vibration mount .....	215
6.4.8	Technical specifications for mounting bracket .....	215
6.4.9	Technical specifications for deflector unit .....	215
6.4.10	Technical specifications for door clutch holder .....	216
6.4.11	Technical specifications for toothed belt .....	216
6.4.12	Technical specifications standard mounting rail holder .....	216
6.4.13	Technical specifications motor cable (cable MDG) .....	217
6.4.14	Dimension drawing of SIDOOR M3 with rubber-metal anti-vibration mount and mounting bracket .....	218
6.4.15	Dimension drawing SIDOOR MDG3 .....	219
6.4.16	Dimension drawing of SIDOOR M4 with rubber-metal anti-vibration mount and mounting bracket .....	220
6.4.17	Dimension drawing SIDOOR MDG4 .....	221
6.4.18	Dimension drawing of SIDOOR M5 .....	223
6.4.19	Dimension drawing SIDOOR MDG5 .....	224
6.4.20	Dimension drawing of motor cable MDG-CABLE .....	225
6.4.21	Dimension drawing of deflector pulley with tensioning device and mounting bracket .....	226
6.4.22	Dimension drawing of door clutch holder .....	227
6.4.23	Dimension drawing SIDOOR MDG PULLEY .....	228



<b>7</b>	<b>Power supply .....</b>	<b>229</b>
7.1	SIDOOR NT40 .....	229
7.1.1	Description .....	229
7.1.2	Installation .....	230
7.1.3	Connecting terminals.....	231
7.1.4	Technical specifications .....	234
7.2	SIDOOR TRANSFORMER.....	237
7.2.1	Description .....	237
7.2.2	Installation .....	238
7.2.3	Connecting terminals.....	239
7.2.4	Test voltage .....	240
7.2.5	Technical specifications .....	241
7.2.5.1	SIDOOR TRANSFORMER.....	241
7.2.5.2	Dimensional drawing SIDOOR TRANSFORMER.....	243
7.3	SIDOOR TRANSFORMER UL .....	244
7.3.1	Description .....	244
7.3.2	Installation .....	245
7.3.3	Connection.....	247
7.3.4	Test voltage .....	249
7.3.5	Technical specifications .....	250
7.3.5.1	SIDOOR TRANSFORMER UL .....	250
7.3.5.2	Dimension drawing SIDOOR TRANSFORMER UL .....	252
7.4	SITOP PSU8200 13A/36V 3-phase .....	253
7.4.1	Power supply requirements of SITOP PSU8200.....	253
7.4.2	Installation .....	254
7.4.3	Technical specifications .....	255
7.5	Building DC voltage supply.....	258
7.5.1	Power supply requirements.....	258
7.5.2	Installation .....	260
7.6	Uninterruptible power supply (UPS).....	261
<b>8</b>	<b>Optional additional units.....</b>	<b>265</b>
8.1	SIDOOR SERVICE TOOL .....	265
8.1.1	Description .....	265
8.1.2	Connection.....	265
8.1.3	Operation .....	266
8.1.4	Navigation structure .....	268
8.1.5	Technical specifications .....	274
8.2	SIDOOR LINK and SIDOOR SUPPORT App.....	274
8.2.1	Description .....	274
8.2.2	Connecting.....	275
8.2.3	Operating the SIDOOR SUPPORT app .....	275
8.2.4	Start page of the SIDOOR SUPPORT app.....	277
8.2.5	Technical specifications .....	278
<b>9</b>	<b>Configuration and Programming in STEP 7 / via TIA Portal .....</b>	<b>279</b>
9.1	PROFINET integration via GSD file .....	279
9.2	PROFIBUS integration via GSD file .....	279

9.3	Programming SIDOOR instructions .....	280
9.3.1	"SIDOOR_CDat" data type .....	282
9.3.2	"SIDOOR_SDat" data type .....	282
<b>10</b>	<b>Connecting and commissioning .....</b>	<b>285</b>
10.1	Overview of safety and commissioning.....	285
10.2	Preparing the control unit .....	289
10.3	Connecting a geared motor to the control unit .....	290
10.4	Connecting the power supply to the network and executing a learn run.....	292
10.5	Connecting digital inputs .....	293
10.6	Commissioning the control unit on the fieldbus .....	293
10.7	Final settings and checks.....	295
<b>11</b>	<b>Diagnostic and maintenance .....</b>	<b>297</b>
11.1	Operating state display .....	297
11.2	Fault management.....	298
11.3	Maintenance.....	299
<b>12</b>	<b>Disposal .....</b>	<b>301</b>
<b>A</b>	<b>Appendices .....</b>	<b>303</b>
A.1	Structure of user data/process data.....	303
A.1.1	Parameter interface .....	304
A.1.1.1	Parameter ID (PKE).....	305
A.1.1.2	Parameter index (IND).....	307
A.1.1.3	Parameter value (PWE).....	309
A.1.1.4	Parameter ID.....	309
A.1.1.5	Parameter description (PBE) .....	310
A.1.2	Process data.....	311
A.1.2.1	STW1 - control word (CtrlW).....	311
A.1.2.2	TSW0 - technology control word 0.....	313
A.1.2.3	TSW1 - technology control word 1 .....	313
A.1.2.4	TSW2 - technology control word 2.....	314
A.1.2.5	ZSW1 - status word (StatW).....	315
A.1.2.6	TZW0 - Technology status word 0 .....	316
A.1.2.7	TZW1 - Technology status word 1 .....	317
A.1.2.8	TZW2 - Technology status word 2.....	319
A.1.2.9	TZW3, TZW4, TZW5 - Technology status words 3, 4, 5.....	321
A.2	Profiles and adjustment ranges.....	323
A.2.1	Profile name.....	323
A.2.2	SIDOOR M3 L / R.....	324
A.2.3	SIDOOR MDG3 L / R (as of V1.12) .....	325
A.2.4	SIDOOR M4 L / R.....	327
A.2.5	SIDOOR MDG4 L / R .....	328
A.2.6	SIDOOR M5 L / R.....	330
A.2.7	SIDOOR MDG5 L / R .....	331
A.3	Configuration record .....	333

A.4	Standards, directives and laws .....	335
A.4.1	Safety .....	335
A.4.2	EMC.....	335
A.4.3	Communications.....	336
A.4.4	Application-specific standards .....	336
A.4.5	Protective devices .....	338
A.5	Abbreviations .....	339



# Introduction

## 1.1 About SIDOOR

### What is SIDOOR?

The SIDOOR product series is a door control system mainly for operation of sliding doors as well as lifting and roller doors. SIDOOR door drives are drives for doors and gates in various areas of application.

### What is a door control system?

Door control system is the general term for the controller of an access system.

Door control systems are characterized by the fact that there are always two defined states, namely for the open and closed positions of the door. The door is always controlled between these two positions in accordance with the guidelines of the respective application.

### SIDOOR for industrial applications

The door control systems are primarily designed for machine doors in industrial applications. In accordance with the integration of the machine in industrial communication networks, the controllers can be integrated in the networks with different communication options, including safety functionality.

### Customer benefits

- The controllers are optimally configured for their areas of application. With SIDOOR, doors are always checked and opened and closed in an application-specific manner.
- Our intelligent system solution calculates the optimal drive characteristics for a door automatically, and ensures that these are continuously maintained – in accordance with the guidelines of the application.
- The entire commissioning process requires just the push of a single button. In a defined learn run, the door system independently determines the values for the door width, the dynamic mass to be moved and the drive direction of the geared motor, and stores these data in a non-volatile memory.
- Assisted Drive and Impulse Stop support the movement of the heaviest doors without buttons or sensors. Impulse Drive allows doors to be opened at closed with a brief, light touch. The door moves completely autonomously.
- The screwless enclosure concept, with plug-in terminal connectors, allows the device to be opened and closed without tools, thereby reducing installation times.

## 1.2 About this manual

- Thanks to the independence of the door system, SIDOOR is highly flexible and can be easily expanded with modular communication interfaces. SIDOOR door controllers can be completely controlled by a SIMATIC S7 controller. Control, parameterization and diagnostics takes place via PROFIBUS or PROFINET.
- The system's reliability, ruggedness and long-term precision minimize the need for maintenance and repair work. Obstruction and belt tear detection provides more safety.

### See also

SIDOOR homepage (<http://www.siemens.com/sidoor>)

## 1.2 About this manual

### 1.2.1 Sales law

To illustrate possible application areas for our products, typical use cases are listed in this product documentation and in the online help. These are purely exemplary and do not constitute a statement on the suitability of the respective product for applications in specific individual cases. Unless explicitly contractually agreed, Siemens assumes no liability for such suitability. Suitability for a particular application in specific individual cases must be assessed by the user, taking into account all technical, legal, and other requirements on a case-by-case basis. Always observe the descriptions of the technical properties and the relevant constraints of the respective product contained in the product documentation.

### 1.2.2 Contents

#### Content of the System Manual

This system manual describes:

- The ATD401W, ATD420W and ATD430W control units, which you use for industrial applications.
- Geared motors, power supplies, additional units that you can use with the control units.

#### Firmware versions

This system manual applies to SIDOOR ATD401W, ATD420W and ATD430W industrial door control units with firmware version 1.12 or higher.

---

#### Note

You will find the current firmware versions for **SIDOOR ATD4xxW** control unit at Industry Online Support (<http://support.automation.siemens.com/WW/view/en/50247080/133100>).

---

## Figures

The illustrations in this system manual represent SIDOOR User Software Version 1.2, the SIDOOR control unit and SIDOOR SUPPORT App Version 1.0. The illustrations for earlier product versions may differ slightly.

This documentation should be kept in a location where it can be easily accessed and made available to the personnel responsible.

## Information regarding third-party products

### Note

#### Recommendation relating to third-party products

This document contains recommendations relating to third-party products. Siemens accepts the fundamental suitability of these third-party products.

You can use equivalent products from other manufacturers.

Siemens does not accept any warranty for the properties of third-party products.

### 1.2.3 Target group

The system manual is intended for:

- Assemblers
- Commissioning engineers
- Operators
- Service personnel
- Project engineers of machine protection doors

Revision of the system manual	Change
06/2016	First edition
01/2017	Revision of MDG700 NMS
06/2018	Changes according to firmware update V1.12 <b>Note:</b> Read the instructions in the following sections before updating to V1.12: <ul style="list-style-type: none"> <li>• Deactivation of the service buttons during emergency stop (as of V1.12) (Page 110)</li> </ul>
11/2018	Change for motors

Revision of the system manual	Change
09/2020	<p>Integration of changes from document "Release Notes Firmware ATD4xxW V1.13".</p> <p>Changes according to firmware update V1.14.</p> <p><b>Note:</b> After the update to V1.14 all parameters are set to default values. User-specific settings have to be set again.</p>
08/2021	<ul style="list-style-type: none"> <li>• System configuration (Page 25) figure changed</li> <li>• Learn run (Page 40) section revised</li> <li>• New List of abbreviations (Page 339)</li> <li>• Sensor technology and external sensor connection (Page 160)</li> <li>• Correction of the motor cable documentation (Page 217)</li> <li>• Text corrections</li> </ul>
05/2022	<ul style="list-style-type: none"> <li>• Supplement SIDOOR LINK and SIDOOR SUPPORT App</li> <li>• Supplement Warnings</li> <li>• Text corrections</li> </ul>

## 1.2.4 Standard scope

### Description

This documentation describes the functionality of the standard scope. This scope may differ from the scope of the functionality of the system that is actually supplied. Please refer to the ordering documentation only for the functionality of the supplied drive system.

Further functions may be executable in the system, which are not explained in this documentation. However, there is no entitlement to these functions in the case of a new delivery or service.

This documentation does not contain all detailed information on all types of the product. Furthermore, this documentation cannot take into consideration every conceivable type of installation, operation and service/maintenance.

The machine manufacturer must document any additions or modifications they make to the product themselves.

## 1.2.5 Use of third-party products in this documentation

### Description

This documentation contains recommendations relating to third-party products. Siemens accepts the fundamental suitability of these third-party products. You can use equivalent products from other manufacturers.



Siemens does not accept any warranty for the use of third-party products.

## 1.2.6 Websites of third-party companies

### Description

This document may contain hyperlinks to third-party websites. Siemens is not responsible for and shall not be liable for these websites and their content. Siemens has no control over the information which appears on these websites and is not responsible for the content and information provided there. The user bears the risk for their use.

## 1.3 SIDOOR documentation

### System manuals

For each application (industrial applications, elevators, railway applications) there are system manuals describing the SIDOOR system with the applicable devices and their commissioning.

### Quick start operating instructions

The quick start operating instructions provide an overview of the SIDOOR devices:

- Which devices you can use together
- The article numbers for ordering these devices
- Information on installation
- Important safety information
- Where you can get more information about the devices

## 1.4 Service and support

### 1.4.1 Parameter documentation

---

#### Note

#### Parameter documentation for support questions

Record the determined, optimal parameter settings in the configuration protocol (see appendix "Configuration record (Page 333)"). Have this record to hand when for questions from Support.

---

### 1.4.2 Siemens Industry Online Support on the Web

Important product information is available through Siemens Industry Online Support using the following options:

- Website: SIOS (<https://support.industry.siemens.com/cs/ww/en/>)
- App Industry Online Support (for Apple iOS and Android)

#### Content of Siemens Online Support

- Product support
- Global forum for information and best practice sharing between users and specialists
- Local contact persons via the contact person database (→ Contact)
- Product information
- FAQs (frequently asked questions)
- Application examples
- Manuals
- Downloads
- Compatibility tool
- Newsletter with product selection
- Catalogs/brochures
- Certificates

For products with QR code, the manual and certificate can be directly called.



### 1.4.3 Spare parts services

#### Description

Information on the online spare parts service "Spares on Web" is provided in the Internet at the following address (<https://www.sow.siemens.com>).

## 1.5 Important product information

### 1.5.1 Intended use

SIDOOR controllers may only be used in the system configurations and specifications provided by Siemens.

Use the products described in this manual only for **machine protection doors** and always in conjunction with the motor, power supply unit and control unit.



## Basic safety information

### 2.1 General safety instructions

#### 2.1.1 Electric shock and danger to life due to other energy sources



##### **WARNING**

##### **Electric shock and danger to life due to other energy sources**

Touching live components can result in death or severe injury.

- Only work on electrical devices when you are qualified for this job.
- Always observe the country-specific safety rules.

Generally, the following steps apply when establishing safety:

1. Prepare for disconnection. Notify all those who will be affected by the procedure.
2. Isolate the drive system from the power supply and take measures to prevent it being switched back on again.
3. Wait until the discharge time specified on the warning labels has elapsed.
4. Check that there is no voltage between any of the power connections, and between any of the power connections and the protective conductor connection.
5. Check whether the existing auxiliary supply circuits are de-energized.
6. Ensure that the motors cannot move.
7. Identify all other dangerous energy sources, e.g. compressed air, hydraulic systems, or water. Switch the energy sources to a safe state.
8. Check that the correct drive system is completely locked.

After you have completed the work, restore the operational readiness in the inverse sequence.



##### **WARNING**

##### **Electric shock due to connection to an unsuitable power supply**

When equipment is connected to an unsuitable power supply, exposed components may carry a hazardous voltage. Contact with hazardous voltage can result in severe injury or death.

- Only use power supplies that provide SELV (Safety Extra Low Voltage) or PELV- (Protective Extra Low Voltage) output voltages for all connections and terminals of the electronics modules.

**NOTICE**

**Damage to equipment due to unsuitable tightening tools.**

Unsuitable tightening tools or fastening methods can damage the screws of the equipment.

- Only use screw inserts that exactly match the screw head.
- Tighten the screws with the torque specified in the technical documentation.
- Use a torque wrench or a mechanical precision nut runner with a dynamic torque sensor and speed limitation system.
- Adjust the tools used regularly.

**NOTICE**

**Property damage due to loose power connections**

Insufficient tightening torques or vibration can result in loose power connections. This can result in damage due to fire, device defects or malfunctions.

- Tighten all power connections to the prescribed torque.
- Check all power connections at regular intervals, particularly after equipment has been transported.



**WARNING**

**Unexpected machine movement caused by radio devices or mobile phones**

Using radio devices, cellphones, or mobile WLAN devices in the immediate vicinity of the components can result in equipment malfunction. Malfunctions may impair the functional safety of machines and can therefore put people in danger or lead to property damage.

- Therefore, if you move closer than 20 cm to the components, be sure to switch off radio devices, cellphones or WLAN devices.
- Use the "SIEMENS Industry Online Support App" or a QR code scanner only on equipment that has already been switched off.



**WARNING**

**Fire due to inadequate ventilation clearances**

Inadequate ventilation clearances can cause overheating of components with subsequent fire and smoke. This can cause severe injury or even death. This can also result in increased downtime and reduced service lives for devices/systems.

- Ensure compliance with the specified minimum clearance as ventilation clearance for the respective component.

**NOTICE****Overheating due to inadmissible mounting position**

The device may overheat and therefore be damaged if mounted in an inadmissible position.

- Only operate the device in admissible mounting positions.

 **WARNING****Unrecognized dangers due to missing or illegible warning labels**

Dangers might not be recognized if warning labels are missing or illegible. Unrecognized dangers may cause accidents resulting in serious injury or death.

- Check that the warning labels are complete based on the documentation.
- Attach any missing warning labels to the components, where necessary in the national language.
- Replace illegible warning labels.

**NOTICE****Device damage caused by incorrect voltage/insulation tests**

Incorrect voltage/insulation tests can damage the device.

- Before carrying out a voltage/insulation check of the system/machine, disconnect the devices as all converters and motors have been subject to a high voltage test by the manufacturer, and therefore it is not necessary to perform an additional test within the system/machine.

 **WARNING****Unexpected movement of machines caused by inactive safety functions**

Inactive or non-adapted safety functions can trigger unexpected machine movements that may result in serious injury or death.

- Observe the information in the appropriate product documentation before commissioning.
- Carry out a safety inspection for functions relevant to safety on the entire system, including all safety-related components.
- Ensure that the safety functions used in your drives and automation tasks are adjusted and activated through appropriate parameterizing.
- Perform a function test.
- Only put your plant into live operation once you have guaranteed that the functions relevant to safety are running correctly.

**Note**

**Important Safety instructions for Safety Integrated**

If you want to use Safety Integrated functions, you must observe the Safety instructions in the Safety Integrated documentation.



**WARNING**

**Malfunctions of the machine as a result of incorrect or changed parameter settings**

As a result of incorrect or changed parameterization, machines can malfunction, which in turn can lead to injuries or death.

- Protect the parameterization against unauthorized access.

## 2.2 Equipment damage due to electric fields or electrostatic discharge

Electrostatic sensitive devices (ESD) are individual components, integrated circuits, modules or devices that may be damaged by either electric fields or electrostatic discharge.



**NOTICE**

**Equipment damage due to electric fields or electrostatic discharge**

Electric fields or electrostatic discharge can cause malfunctions through damaged individual components, integrated circuits, modules or devices.

- Only pack, store, transport and send electronic components, modules or devices in their original packaging or in other suitable materials, e.g. conductive foam rubber or aluminum foil.
- Only touch components, modules and devices when you are grounded by one of the following methods:
  - Wearing an ESD wrist strap
  - Wearing ESD shoes or ESD grounding straps in ESD areas with conductive flooring
- Only place electronic components, modules or devices on conductive surfaces (table with ESD surface, conductive ESD foam, ESD packaging, ESD transport container).

## 2.3 Warranty and liability for application examples

Application examples are not binding and do not claim to be complete regarding configuration, equipment or any eventuality which may arise. Application examples do not represent specific customer solutions, but are only intended to provide support for typical tasks.

As the user you yourself are responsible for ensuring that the products described are operated correctly. Application examples do not relieve you of your responsibility for safe handling when using, installing, operating and maintaining the equipment.



## 2.4 Cybersecurity information

Siemens provides products and solutions with industrial cybersecurity functions that support the secure operation of plants, systems, machines and networks.

In order to protect plants, systems, machines and networks against cyber threats, it is necessary to implement – and continuously maintain – a holistic, state-of-the-art industrial cybersecurity concept. Siemens' products and solutions constitute one element of such a concept.

Customers are responsible for preventing unauthorized access to their plants, systems, machines and networks. Such systems, machines and components should only be connected to an enterprise network or the internet if and to the extent such a connection is necessary and only when appropriate security measures (e.g. firewalls and/or network segmentation) are in place.

For additional information on industrial cybersecurity measures that may be implemented, please visit <https://www.siemens.com/global/en/products/automation/topic-areas/industrial-cybersecurity.html>.

Siemens' products and solutions undergo continuous development to make them more secure. Siemens strongly recommends that product updates are applied as soon as they are available and that the latest product versions are used. Use of product versions that are no longer supported, and failure to apply the latest updates may increase customer's exposure to cyber threats.

To stay informed about product updates, subscribe to the Siemens Industrial Cybersecurity RSS Feed under <https://new.siemens.com/global/en/products/services/cert.html>.

Further information is provided on the Internet:

Industrial Security Configuration Manual (<https://support.industry.siemens.com/cs/ww/en/view/108862708>)

### WARNING

#### Unsafe operating states resulting from software manipulation

Software manipulations, e.g. viruses, Trojans, or worms, can cause unsafe operating states in your system that may lead to death, serious injury, and property damage.

- Keep the software up to date.
- Incorporate the automation and drive components into a state-of-the-art, integrated industrial cybersecurity concept for the installation or machine.
- Make sure that you include all installed products in the integrated industrial cybersecurity concept.
- Protect files stored on exchangeable storage media from malicious software by with suitable protection measures, e.g. virus scanners.
- Carefully check all cybersecurity-related settings once commissioning has been completed.

## 2.5 Residual risks of power drive systems

When assessing the machine or system-related risk in accordance with the respective local regulations (e.g. EC Machinery Directive), the machine manufacturer or system integrator must take into account the following residual risks emanating from the control and drive components of a drive system:

1. Unintentional movements of driven machine or system components during commissioning, operation, maintenance, and repairs caused by, for example,
  - Hardware faults and/or software errors in the sensors, control system, actuators, and connections
  - Response times of the control system and of the drive
  - Operation and/or environmental conditions outside the specification
  - Condensation/conductive contamination
  - Parameterization, programming, cabling, and installation errors
  - Use of wireless devices/mobile phones in the immediate vicinity of electronic components
  - External influences/damage
  - X-ray, ionizing radiation and cosmic radiation
2. Unusually high temperatures, including open flames, as well as emissions of light, noise, particles, gases, etc., can occur inside and outside the components under fault conditions caused by, for example:
  - Component failure
  - Software errors
  - Operation and/or environmental conditions outside the specification
  - External influences/damage
3. Hazardous shock voltages caused by, for example:
  - Component failure
  - Influence during electrostatic charging
  - Operation and/or environmental conditions outside the specification
  - Condensation/conductive contamination
  - External influences/damage
4. Release of environmental pollutants or emissions as a result of improper operation of the system and/or failure to dispose of components safely and correctly
5. Influence of network-connected communication systems, e.g. ripple-control transmitters or data communication via the network
6. Motors for use in potentially explosive areas:

When moving components such as bearings become worn, this can cause enclosure components to exhibit unexpectedly high temperatures during operation, creating a hazard in areas with a potentially explosive atmosphere.

For more information about the residual risks of the drive system components, see the relevant sections in the technical user documentation.

## System overview

### 3.1 System configuration and area of application

#### Overview of system configuration

The graphic uses an example of a machine protection door to illustrate the general configuration of automatic door control with the SIDOOR system including additional components, such as a power supply and drive.

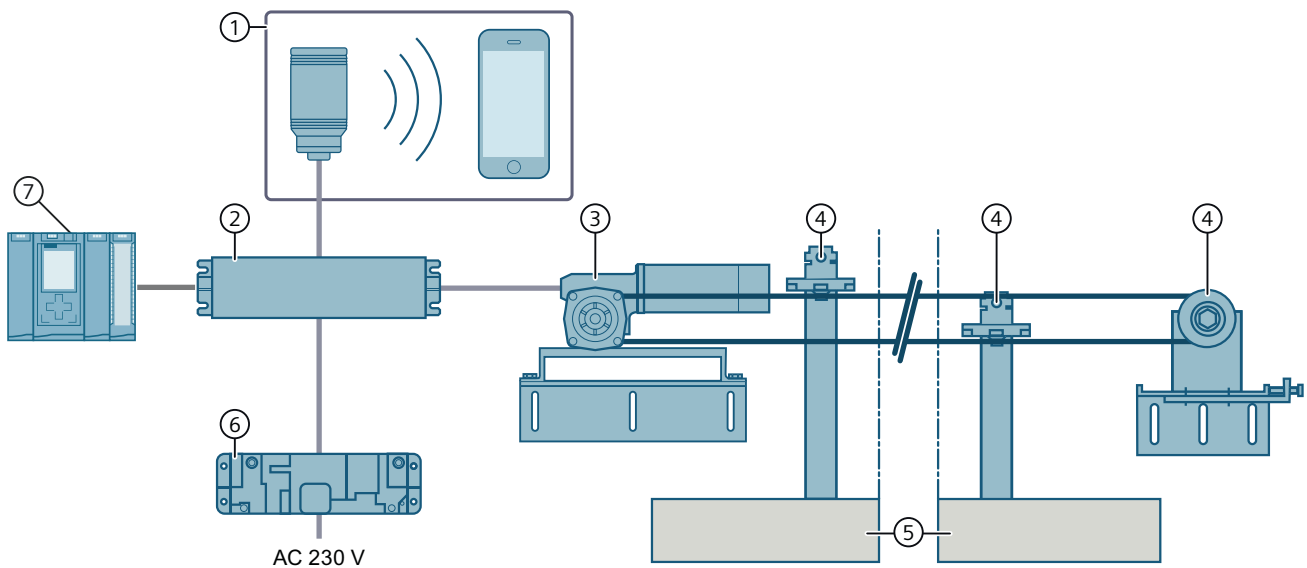

- |   |                   |
|---|-------------------|
| ① Optional additional units, e.g.                                       | ⑤ Sliding door    |
| • SIDOOR SERVICE TOOL   |                   |
| • SIDOOR SOFTWARE KIT   |                   |
| • SIDOOR LINK and Android smartphone/tablet with the SIDOOR SUPPORT app |                   |
| ② Controller  | ⑥ Power supply    |
| ③ Geared motor  | ⑦ SIMATIC S7-1500 |
| ④ Accessories: Door clutch holder, toothed belt, deflector unit         |                   |

Figure 3-1 System configuration

#### System configuration with higher-level controller

Operation commands, parameter assignment, system status via field bus (PROFIBUS or PROFINET) or terminal module and/or digital input signals possible.

### System configuration without higher-level controller

SIDOOR operates autonomously. Control, parameter assignment, system status only possible via terminal module and/or door commands via digital input signals.

### System configuration with safety functionality

SIDOOR also offers a system structure with safety functionality, because safe limitation of forces and energies is guaranteed within the drive system.

The system allows for the implementation of additional customized safety measures, such as two-hand operation.



#### **WARNING**

##### **Danger of injury and material damage when determining position**

Position determination, as described in the relevant chapters and generally available, is not guaranteed with a view to safe travel without endangering man or machine. All available and determined position data of the SIDOOR control unit must be regarded as a guideline with an equivalent inaccuracy, which is strongly dependent on the overall structure of the door and the associated mechanical components. In addition, when changing speed, the distances for acceleration, braking distances and controller deceleration must also be taken into account. The precision and reliability of the position determination must therefore be determined anew for each application as a whole.

### Industrial applications

The SIDOOR ATD4xxW door control units are "intelligent" door drives. They are used, for example, to drive machine protection doors. The force limitation and energy limitation safe functions fulfill the requirements according to DIN EN ISO 13849-1:2016 for Category 2 and Performance Level d. The drives are suitable for power-operated isolating guards according to EN ISO 14120:2015 section 5.2.5.4 "Operating forces".

The SIDOOR ATD4xxW door control units enable connection to various fieldbus systems. This makes integration into the industrial//SIMATIC environment possible. PROFINET IO and PROFIBUS DP are currently specified as fieldbuses. Structure (contents and structure) of the user and process data of the fieldbus communication largely correspond to the specifications for the cyclic data exchange of the PROFIBUS "variable-speed drives" profile.

- **SIDOOR ATD401W**  
The "offline" relay variant can be used for simple automation tasks. As there is no possibility of interfacing to a bus, it provides a limited scope of functions.
- **SIDOOR ATD420W**  
The **PROFIBUS DP** interface is realized with a permanently integrated PROFIBUS module. This module comes with its own firmware.
- **SIDOOR ATD430W**  
The **PROFINET IO** interface is realized with a permanently integrated PROFINET module. This module comes with its own firmware.

The contents and structure of the user data transferred by the fieldbus systems correspond to the PROFIdrive "variable speed drives" profile. Use of this profile is also the basis for

integration of the control unit in the industrial environment. Both communicative integration via a fieldbus system and safety-related aspects play an important role here.

SIDOOR ATD4xxW machine door drives enable connection of door closed/opened position sensors (DCOPS), simple light barriers, pressure sensitive edges as well as light curtains in compliance with IEC 61496 (ESPE - electro-sensitive protective equipment).

The SIDOOR ATD420W and SIDOOR ATD430W door control units are characterized by their numerous functions, including "AssistedDrive" (motor-assisted sliding of the door) and "ImpulseDrive" (automatic door movement initiated by applying light force).

## 3.2 Products

### 3.2.1 Controllers



Control units are electronic controllers connected to the power supply via an external power supply unit (e.g. SITOP PSU 8200, SIDOOR NT40). They are generally connected to the higher-level controller via digital or fieldbus interfaces, and can be configured via a user interface.

The controllers are designed for different areas of application.

### Controllers for industrial applications

The following table provides an overview of the control units for doors in industrial applications.

Controller	Article No.	Description
SIDOOR ATD401W	6FB1141-1AT11-3WE2	Relay module
SIDOOR ATD420W	6FB1141-2AT10-3WE2	PROFIBUS interface to the higher-level controller (PROFIBUS module)
SIDOOR ATD430W	6FB1141-3AT10-3WE2	PROFINET interface to the higher-level control system (PROFINET module)

### 3.2.2 Geared motors



Geared motors form the maintenance-free drive unit in the door drive. The geared motors feature DC motors with non-self-locking gearing and are speed-controlled. The set force and speed limits are not exceeded.

The power is transmitted to the door by a toothed belt, gear rack or chain.

Toothed belts or chains pass over a deflector pulley, and can be fitted with two door clutch holders. This enables it to drive both single-sided and centrally-opening doors.

#### Versions

Geared motor	Article No.	Description
SIDOOR M3 L	6FB1103-0AT10-4MB0	<ul style="list-style-type: none"> <li>Geared motor, fixed pinion (size 176 mm) left, max. 180 kg weight to be moved</li> <li>Cable length 1.5 m</li> </ul>
SIDOOR M3 R	6FB1103-0AT11-4MB0	<ul style="list-style-type: none"> <li>Geared motor, fixed pinion (size 176 mm) right, max. 180 kg weight to be moved</li> <li>Cable length 1.5 m</li> </ul>
SIDOOR MDG3 L	6FB1103-0AT14-4MB1	<ul style="list-style-type: none"> <li>Geared motor, drive shaft left, max. 180 kg weight to be moved</li> <li>Without cable*</li> </ul>
SIDOOR MDG3 R	6FB1103-0AT13-4MB1	<ul style="list-style-type: none"> <li>Geared motor, drive shaft right, max. 180 kg weight to be moved</li> <li>Without cable*</li> </ul>
SIDOOR M4 L	6FB1103-0AT10-3MCO	<ul style="list-style-type: none"> <li>Geared motor, fixed pinion (size 176 mm) left, max. 400 kg weight to be moved</li> <li>Cable length 1.5 m</li> </ul>
SIDOOR M4 R	6FB1103-0AT11-3MCO	<ul style="list-style-type: none"> <li>Geared motor, fixed pinion (size 176 mm) right, max. 400 kg weight to be moved</li> <li>Cable length 1.5 m</li> </ul>

Geared motor	Article No.	Description
SIDOOR MDG4 L	6FB1103-0AT14-3MC2	<ul style="list-style-type: none"> <li>• Geared motor, drive shaft left, max. 400 kg weight to be moved</li> <li>• Without cable*</li> </ul>
SIDOOR MDG4 R	6FB1103-0AT13-3MC2	<ul style="list-style-type: none"> <li>• Geared motor, drive shaft right, max. 400 kg weight to be moved</li> <li>• Without cable*</li> </ul>
SIDOOR M5 L	6FB1103-0AT10-3MD0	<ul style="list-style-type: none"> <li>• Geared motor, fixed pinion (size 176 mm) left, max. 600 kg weight to be moved</li> <li>• Cable length 1.5 m</li> </ul>
SIDOOR M5 R	6FB1103-0AT11-3MD0	<ul style="list-style-type: none"> <li>• Geared motor, fixed pinion (size 176 mm) right, max. 600 kg weight to be moved</li> <li>• Cable length 1.5 m</li> </ul>
SIDOOR MDG5 L	6FB1103-0AT14-3MG2	<ul style="list-style-type: none"> <li>• Geared motor, without pinion, max. 700 kg weight to be moved</li> <li>• Without cable*</li> </ul>
SIDOOR MDG5 R	6FB1103-0AT13-3MG2	<ul style="list-style-type: none"> <li>• Geared motor, without pinion, max. 700 kg weight to be moved</li> <li>• Without cable*</li> </ul>

\* Cable can be ordered: See section Accessories (Page 35)

### 3.2.3 Power supply



SIDOOR power supplies connect the controllers to the respective application-specific power supply.

#### Device selection

Power supply	Article No.	Description
SITOP PSU8200	6EP3446-8SB10-0AY0	Power supply for controllers without an integrated power supply unit.
SIDOOR NT40	6FB1112-0AT20-3PS0	
SIDOOR TRANSFORMER	6FB1112-0AT20-2TRO	
SIDOOR TRANSFORMER UL	6FB1112-0AT21-2TRO	
DC voltage supply	-	

### 3.2.4 Optional additional units

Additional units meet a range of requirements in order to ensure the universal implementation and maintenance of the system.

The following additional units are possible:

- SIDOOR SERVICE TOOL
- SIDOOR LINK adapter
- SIDOOR SOFTWARE KIT

Connect the additional units to the control unit in a de-energized state via the interfaces provided. After applying the mains supply, the additional units are immediately available.



### 3.2.4.1 SIDOOR SERVICE TOOL

The SIDOOR SERVICE TOOL offers the same functionality as the SIDOOR TERMINAL MODULE. In special installation situations, using the SIDOOR SERVICE TOOL is helpful.

The scope of functions is described in the navigation structure (Page 268).

Connect the SIDOOR SERVICE TOOL to the RS 485 interface using a 1.5 m cable.

#### Ordering data

	Article No.
SIDOOR SERVICE TOOL	6FB1105-0AT01-6ST0

#### Note

##### Protection against unauthorized access

Use the SIDOOR SERVICE TOOL only for commissioning and maintenance purposes only.

Following commissioning or maintenance, remove the SIDOOR SERVICE TOOL and its connecting cable from the SIDOOR control unit.

#### See also

SIDOOR SERVICE TOOL (Page 265)

### 3.2.4.2 SIDOOR SUPPORT app and SIDOOR LINK



The optional SIDOOR LINK adapter, in combination with the SIDOOR SUPPORT app on the Android smartphone or Android tablet, enables you to conveniently operate, diagnose and configure the SIDOOR control unit.

#### Requirements

You need an Android smartphone or Android tablet from Android operating system V11.0 with Bluetooth LE V5.0 for the installation of the SIDOOR SUPPORT app.

#### Principle of operation

Establish a Bluetooth LE 5.0 connection to an Android smartphone or Android tablet with the SIDOOR SUPPORT app installed via the SIDOOR LINK adapter.

Conveniently perform the commissioning of a door system via the SIDOOR SUPPORT app with a SIDOOR control unit.

#### Ordering data

	Article No.	Scope of delivery
SIDOOR LINK adapter	6FB1305-0AT00-0AS4	The package includes the following components: <ul style="list-style-type: none"><li>• 1 x SIDOOR LINK adapter</li><li>• 1 x D-Sub connecting cable (9-pin, plug/socket)</li></ul>

Additional information can be found in the function manual for the SIDOOR SUPPORT App (<https://support.industry.siemens.com/cs/de/en/view/109802679>).

**NOTICE****Protection against unauthorized access**

Use the SIDOOR SUPPORT and the SIDOOR LINK for commissioning and maintenance purposes only.

Following commissioning or maintenance, remove the SIDOOR LINK adapter and its connecting cable from the SIDOOR control unit.

**Note**

The terminal module function is also available via the SIDOOR SUPPORT.

**See also**

SIDOOR LINK and SIDOOR SUPPORT App (Page 274)

3.2.4.3 SIDOOR SOFTWARE KIT



The optional SIDOOR SOFTWARE KIT enables convenient operation as well as detailed diagnostics on a PC.

Selection

Software	Article No.	Description
SIDOOR SOFTWARE KIT	6FB1105-0AT01-6SW0	<p>The package includes the following components:</p> <ul style="list-style-type: none"> <li>• Installation CD (Software Kit)                             <ul style="list-style-type: none"> <li>– SIDOOR USER SOFTWARE</li> <li>– SIDOOR MANAGER</li> <li>– Siemens HCS12 Firmware Loader</li> <li>– SIDOOR USB to UART Bridge Driver</li> <li>– License provisions</li> <li>– SIDOOR SOFTWARE KIT operating cables</li> </ul> </li> <li>• 1 x USB adapter</li> <li>• 1 x USB connecting cable</li> <li>• 1x D-SUB connecting cable (9-pin, plug/socket)</li> <li>• 1x D-SUB connecting cable (9-pin, socket/socket)</li> </ul>

All the contents of the installation CD from the SIDOOR SOFTWARE KIT are also available as installation package (<https://support.industry.siemens.com/cs/ww/en/view/109481599>) in the Industry Online Support.

You can find additional information about the SIDOOR SOFTWARE KIT in the SIDOOR SOFTWARE KIT operating instructions (<https://support.automation.siemens.com/WW/view/en/92711247>).

**Note**

**Protection against unauthorized access**

Use the SIDOOR SOFTWARE KIT and the SIDOOR USB adapter for commissioning and maintenance purposes only. Following commissioning or maintenance, remove the SIDOOR USB adapter and its connecting cable from the SIDOOR control unit.

**Note**

The terminal module function is also available via the SIDOOR SOFTWARE KIT.

**3.2.5 Accessories**

Accessories	Article No.	Description
SIDOOR rubber-metal anti-vibration mount	6FB1104-0AT01-0ADO	<ul style="list-style-type: none"> <li>Rubber-metal anti-vibration mount for quiet operation of the door drive system</li> <li>Recommended for mounting SIDOOR M4 R / L, MDG4 R / L, M5 R / L and MDG5 R / L geared motors</li> </ul>
	6FB1104-0AT02-0ADO	<ul style="list-style-type: none"> <li>Rubber-metal anti-vibration mount for quiet operation of the door drive system</li> <li>Recommended for mounting SIDOOR M3 R / L and MDG3 R / L geared motors</li> </ul>
SIDOOR MDG-PULLEY 10-S8M-56	6FB1104-0AT10-0AS1	Belt pulley MDG PULLEY for DC geared motor MDG3 and toothed belt S8M, pitch diameter 56 mm
SIDOOR MDG PULLEY 14-S8M-56	6FB1104-0AT14-0AS1	Belt pulley MDG PULLEY for DC geared motor MDG4, MDG5 and toothed belt S8M, pitch diameter 56 mm
SIDOOR mounting bracket	6FB1104-0AT01-0AS0	Mounting bracket for mounting the SIDOOR rubber-metal anti-vibration mount on which, in turn, a SIDOOR geared motor is mounted
	6FB1104-0AT02-0AS0	<ul style="list-style-type: none"> <li>Mounting bracket with tensioning device for deflector pulley</li> <li>For mounting the SIDOOR deflector unit and for tensioning the SIDOOR toothed belt</li> </ul>
SIDOOR deflector pulley	6FB1104-0AT04-0AS2	Deflector pulley for deflecting the SIDOOR toothed belt (1 unit)
SIDOOR deflector unit	6FB1104-0AT03-0AS0	<ul style="list-style-type: none"> <li>Deflector unit with deflector pulley</li> <li>For deflecting the SIDOOR toothed belt in the same height and depth, aligned with motor drive pinion</li> </ul>
SIDOOR door clutch holder	6FB1104-0AT01-0CPO	<ul style="list-style-type: none"> <li>Door clutch holder for 12 mm-wide toothed belt</li> <li>For attaching both ends of the toothed belt, and for connecting the respective door panel to the toothed belt</li> </ul>
	6FB1104-0AT02-0CPO	<ul style="list-style-type: none"> <li>Door clutch holder for 14 mm wide toothed belt</li> <li>For attaching both ends of the toothed belt, and for connecting the respective door panel to the toothed belt</li> </ul>

## 3.2 Products

Accessories	Article No.	Description
SIDOOR toothed belt	6FB1104-OAT01-OAB0	<ul style="list-style-type: none"> <li>• Single-toothed STS</li> <li>• Super Torque toothed belt</li> <li>• Length 4 m, width 12 mm.</li> </ul>
	6FB1104-OAT02-OAB0	<ul style="list-style-type: none"> <li>• Single-toothed STS</li> <li>• Super Torque toothed belt</li> <li>• Length 45 m, width 12 mm.</li> </ul>
	6FB1104-OAT03-OAB0	<ul style="list-style-type: none"> <li>• Single-toothed STS</li> <li>• Super Torque toothed belt</li> <li>• Length 4 m, width 14 mm.</li> </ul>
	6FB1104-OAT04-OAB0	<ul style="list-style-type: none"> <li>• Single-toothed STS</li> <li>• Super Torque toothed belt</li> <li>• Length 55 m, width 14 mm.</li> </ul>
SIDOOR MDG-CABLE 5 m	6FB1104-OAT05-OCB2	<ul style="list-style-type: none"> <li>• Cable for connecting the SIDOOR MDG3, MDG4 and MDG5 geared motors and the SIDOOR ATD4xxW controllers</li> <li>• Cable length 5 m</li> </ul>
SIDOOR MDG-CABLE 10 m	6FB1104-OAT10-OCB2	<ul style="list-style-type: none"> <li>• Cable for connecting the SIDOOR MDG3, MDG4 and MDG5 geared motors and the SIDOOR ATD4xxW controllers</li> <li>• Cable length 10 m</li> </ul>
SIDOOR MDG-CABLE 15 m	6FB1104-OAT15-OCB2	<ul style="list-style-type: none"> <li>• Cable for connecting the SIDOOR MDG3, MDG4 and MDG5 geared motors and the SIDOOR ATD4xxW controllers</li> <li>• Cable length 15 m</li> </ul>
SIDOOR MDG CABLE 20 m	6FB1104-OAT20-OCB2	<ul style="list-style-type: none"> <li>• Cable for connecting the SIDOOR MDG3, MDG4 and MDG5 geared motors and the SIDOOR ATD4xxW controllers</li> <li>• Cable length 20 m</li> </ul>
PROFIBUS FC bus connector RS 485	6GK1500-0FC10	Bus connector with axial cable outlet (180°, 20 m cable) for connecting the ATD420W controller to the PROFIBUS bus cable
PROFIBUS FC Standard Cable GP	6XV1830-0EH10	PROFIBUS cable for connecting the SIDOOR ATD420W controller to the higher-level SIMATIC controller
IE FC RJ45 plug 180 4X2	6GK1901-1BB11-2AB0	Plug connector with axial cable outlet (180°) for connecting the SIDOOR ATD430W controller to the PROFINET bus cable
IE FC TP Standard Cable GP	6XV1878-2A	Cable for connecting the SIDOOR ATD430W controller to the higher-level SIMATIC controller
DIN rail holder	6FB1144-OAT00-3AS0	DIN rail holder with fixing screws for SIDOOR ATD4xxW controllers

You will find more accessories in the Industry Mall (<https://mall.industry.siemens.com/>)

# SIDOOR functions

## Overview

This section describes all the functions of the SIDOOR control units.

The functions are divided into:

- **Basic functions:** Functions that you always require to use a SIDOOR door control unit.
- **System functions:** Functions that enable you to better monitoring and diagnose the system.
- **Extended functions:** Functions that you can use to implement application-specific requirements.
- **Safety functions:** Functions you use to extend the system for safety-specific requirements, as well to use the inputs according to Performance Level d (PL d).

## Functions

Table 4-1 Available SIDOOR functions

Functions	SIDOOR	
	ATD401W	ATD420W / ATD430W
<b>Basic functions</b>		
Learn run (Page 40)	✓	✓
Force limit for learn run (Page 48)	✓ (as of V1.05)	✓ (as of V1.05)
Output transmission (Page 48)	✓ (as of V1.05)	✓ (as of V1.05)
Drive orders (Page 49)	✓	✓
CLOSE DOOR (command given via digital inputs) (Page 55)	✓	✓ <sup>4)</sup>
OPEN DOOR (command given via digital inputs) (Page 56)	✓	✓ <sup>4)</sup>
Stop (Page 57)	✓	✓
Partial opening (Page 57)	✓	✓
Obstruction detection CLOSE (Page 58)	✓	✓
Obstruction detection OPEN (Page 58)	✓	✓
Force and energy profiles (NDG mode) (Page 58)	✓	✓
Slow door profile (Page 60)	—	✓
DCOPS (Door Closed / Opened Position Sensor) (Page 61)	✓ <sup>1) 3)</sup>	✓ <sup>2) 3)</sup>
<b>System functions</b>		
Restart after power failure	✓	✓
Initial run/reference run (Power ON) (Page 62)	✓	✓
Overload protection (Page 63)	✓	✓

Functions	SIDOOR	
	ATD401W	ATD420W / ATD430W
Vandalism protection/continuous door monitoring (Page 63)	✓	✓
Belt break monitoring (Page 64)	✓	✓
Friction compensation (Page 64)	✓	✓
Oscillation protection (Page 65)	✓	✓
Automatic energy limiting (Page 67)	✓	✓
External closing force (Page 70)	—	—
Synchronizing the door position (Page 70)	✓	✓
Cyclic process values via fieldbus (Page 71)	—	✓
Parameter checksum (as of V1.12) (Page 71)	✓	✓
<b>Extended functions</b>		
ImpulseDrive (Page 74)	—	✓
Automatic ImpulseDrive (Page 75)	—	✓
ImpulseStop (Page 75)	—	✓
Automatic ImpulseStop (Page 76)	—	✓
AssistedDrive (Page 77)	—	✓
Automatic AssistedDrive (Page 78)	—	✓
Positioning mode (Page 79)	—	✓
Obstruction detection (Page 80)	✓	✓
Free function blocks (Page 86)	—	✓
Special range of motion can be configured (as of V1.12) (Page 99)	—	✓ (As of V1.12)
Cold-storage function (as of V1.12) (Page 97)	✓ (As of V1.12)	✓ (As of V1.12)
Basic parameter editor (Page 100)	✓ (as of V1.10)	✓ (as of V1.10)
Masking of the fieldbus drive commands (as of V1.12) (Page 102)	—	✓ (As of V1.12)
Emergency power mode (Page 100)		✓
Test run (as of V1.12) (Page 103)	✓ (As of V1.12)	✓ (As of V1.12)
<b>Safety functions</b>		
<b>Optional safety equipment</b>		
Light barrier (Page 106)	✓ (as of V1.14)	✓ <sup>2)</sup>
ESPE (Page 108)	✓ <sup>3)</sup>	✓ <sup>3)</sup>
Pressure-sensitive edge (Page 109)	✓ <sup>3)</sup>	✓ <sup>3)</sup>
Deactivation of the service buttons during emergency stop (as of V1.12) (Page 110)	—	✓ (As of V1.12)
<b>Safe input signals according to PL d</b>		
Internal signal routing (Page 112)	✓	✓
Redundant antivalent signal logic with discrepancy analysis (Page 112)	—	✓



Functions	SIDOOR	
	ATD401W	ATD420W / ATD430W
Frequency-based input signals (Page 114)	—	✓
Two-hand operation (Page 114)	—	✓
Emergency stop (Page 116)	✓	✓
Fail-safe digital control	—	✓

- 1) Light barrier and DCPS/DCOPS (ATD401W) cannot be implemented simultaneously.
- 2) Light barrier and DCOPS can be implemented simultaneously by connecting to a fieldbus system.
- 3) Light barrier, DCOPS, ESPE or pressure sensitive edge cannot be implemented at the same time.
- 4) Evaluated by PLC.

### Drive function parameter assignment

The relevant parameters for the drive functions in ATD401W control units can be changed to a limited extent.

Configure the drive functions with one of the following options:

- With the service menu via the integrated terminal module.
- With an optional additional unit:
  - SIDOOR SERVICE TOOL
  - SIDOOR SOFTWARE KIT
  - SIDOOR SUPPORT app

The drive functions listed above can have parameters assigned, be calibrated and configured on SIDOOR ATD420W and SIDOOR ATD430W control units. This is mainly done using the higher-level controller (parameter channel). Refer to the corresponding function descriptions for details of the parameters associated with the drive functions listed. You can find additional information on parameters in the section Parameter assignment (ATD4xxW) (Page 180).

#### ATD401W

The input signal wiring can be switched between three fixed configurations (for more, see Digital input signals (Page 126)).

The SIDOOR SUPPORT app also makes available all the drive functions mentioned above to the ATD401W control unit.

### See also

Concept of fail-safe digital control (door OPEN/CLOSE) with emergency stop via 3 digital inputs (Page 117)

## 4.1 Basic functions

You will also need the basic functions described below to use a SIDOOR door controller.

### 4.1.1 Learn run

#### Function description

The following system properties are determined and stored with a learn run:

- Door width
- Weight to be moved and counterweight
- Door friction
- Direction of rotation of the motor and pulse encoder
- For initial commissioning: the motor type and the output transmission

As of V1.10: As an alternative to the learn run, the basic parameters determined during the learn run can be configured using the basic parameters editor. This allows initial commissioning of the SIDOOR door control unit without a learn run (see section "Basic parameters editor (Page 100)").

---

#### Note

Before the start of the learn run, the door must be in the closed position.

The output transmission should be examined before each learn run and adjusted if necessary.

For the M3, M4 and M5 SIDOOR motors, set the default value to 176 mm/rev for the output transmission.

For the other MDG3, MDG4 and MDG5 SIDOOR motors, the output transmission [mm/rev] must be configured according to the effective range of the motor pinion used.

When using the M5 or MDG5 motor, no mass determination is performed during the learn run. Instead, the weight to be moved is set to the maximum permissible weight as a function of the output transmission. This weight value must be subsequently corrected to the actual weight to be moved using the basic parameter editor (see also the following section "Mass determination").

---

#### Types of learn runs

The following types of learn runs can be performed:

- **Learn run with new motor (initial commissioning)**
- **Learn run after initial commissioning**
- **Learn run without determination of the weight to be moved (as of V1.14)**

#### Learn run with new motor (initial commissioning)

A learn run with a new motor must be performed when the door control unit is commissioned for the first time, when the motor type is changed, and when changes are made to the output transmission.

If the status display of the door control unit shows status code "5" (new motor type detected) or status code "\_" (Control unit has no parameters), a learn run with a new motor must be performed (see also section 10.1 Operating status display).

After changing the output transmission, status code "\_" (Control unit has no parameters) is displayed and a learn run with a new motor must be performed.

Before starting this type of learn run, all driving curve parameters as well as the force and energy limitation parameters are automatically reset to factory settings.

The motor type, the output transmission, the direction of travel of the door, the door width, the weight to be moved and the friction of the door are determined and saved.

The maximum closing and opening speed of the door is limited depending on the determined mass and the configured energy limitation, and the friction compensation is also adjusted to the determined door friction.

The learn run with a new motor can be started in the following ways:

- When the supply voltage is applied and the learn run button S401 is actuated at the same time (see section "Operation via service button (Page 171)").
- Via the service menu "General setup > Start learn run with new motor"
- Via technology control word 1 (TSW1) with DCMD signal 4 (Start learn run) and set DCMD extension bit 11 (special) (see section "TSW1- Technology control word 1 (Page 313)").

The following procedure is recommended when commissioning a door control unit for the first time:

1. Door is in the closed position
2. Start a learn run with a new motor.
3. Enter output transmission (control unit shows diagnostic code "\_" (Control unit has no parameters)).
4. Restart learn run with a new motor.

---

### Note

If a learn run is started with a new motor type, all drive curve parameters, the energy limitation parameters and the internal friction compensation are reset to default values.

For the M3, M4 and M5 SIDOOR motors, set the default value to 176 mm/rev for the output transmission.

For the other MDG3, MDG4 and MDG5 SIDOOR motors, the output transmission [mm/rev] must be configured according to the effective range of the motor pinion used.

The learn run does not start when a value is set outside the permitted value range for the output transmission (for example, default value: 0).

The output transmission is only saved permanently after a successful learn run. In other words, this value must be set again after an aborted learn run and a restart of the door control unit.

---

### Learn run after initial commissioning

A learn run must be performed after initial commissioning if the door parameters (e.g. door width, door friction) are changed.

With this type of learn run, the set drive curve parameters and the force and energy limitation parameters are retained. The travel direction of the door, the door width, the weight to be moved and the friction of the door are determined and stored. The friction compensation is adjusted to the determined door friction.

The learn run after initial commissioning can be started in the following ways:

- By pressing the learn run button S401 during operation
- Via the service menu "General setup > Start learn run"
- Via technology control word 1 (TSW1) with DCMD signal 4 (Start learn run) (see "DCMD signal (Page 313)") and DCMD extension bit "special" (see "DCMD extension bits (Page 313)").

The following procedure is recommended for the learn run after initial commissioning:

1. Door is in the closed position
2. Start learn run

#### **Learn run without determination of the weight to be moved (from V1.14)**

The function corresponds to the learn run after initial commissioning, except that a previously stored weight to be moved is not changed.

If the weight to be moved was set manually with the basic parameter editor (see section Basic parameter editor (Page 100)) or if the door weight to be moved is to remain unchanged for other reasons, a learn run can be performed without determining the weight to be moved.

The learn run without determining the weight to be moved can be started in the following ways:

- Via the service menu "General setup > Start learn run without mass determination"
- Via technology control word 1 (TSW1) with DCMD signal 9 (Start learn run without mass determination) (see section "TSW1 - Technology control word 1 (Page 313)")

The following procedure is recommended for learn run without determining the weight to be moved:

1. Set the weight to be moved via the basic parameter editor.
2. Door is in the closed position
3. Start learn run

---

#### **Note**

This type of learn run is recommended when using the M5 or MDG5 motor, since the weight to be moved for these motors was usually set manually via the basic parameter editor and should not be overwritten again by a learn run.

---

### **Interrupting the learn run**

Users can interrupt the learn run. After an interruption of the learn run, the status display of the door control unit shows status code "P" (Error in the learn run), status code "\_" (Control unit has no parameters) or status code "U" (Maximum door weight exceeded) (see also section Operating status display (Page 297)). The learn run can be started again after interruption of the learn run.

The following actions interrupt an active learn run:

- Repeated operation of the learn run button (S401)
- Operating the OPEN or CLOSE service buttons (S402 or S403)

- Door command change (except "deenergized") via the terminal, the service interface or the fieldbus system
- Interruption of the ESPE, pressure sensitive edge or light barrier
- Exceeding the maximum weight to be moved

## Mass determination

 <b>WARNING</b>
<b>Weight to be moved determined with the learn run</b>
Depending on the mechanical coupling between the motor and door panel, the weight to be moved determined during the learn run can differ from the actual weight to be moved. For the M5 and MDG5 motors, the maximum possible weight is always preset after the learn run. The weight to be moved determined during the learn run must be checked and, if necessary, corrected via the basic parameter editor (as of V1.10).

During the learn run, the weight to be moved ( $m_{\text{eff}}$ ) (effective total weight) of all moving elements of the motor, the door mechanism and the door is determined.

The weight to be moved ( $m_{\text{eff}}$ ) is calculated from the sum of the mass equivalent of the rotor inertia of the motor ( $m_{\text{rot}}$ ), the moving door weight ( $m_{\text{door}}$ ) and the moving weight of the door mechanism ( $m_{\text{mech}}$ ):

$$m_{\text{eff}} = m_{\text{door}} + m_{\text{rot}} + m_{\text{mech}}$$

No general specifications can be made for the mass to be moved of the door ( $m_{\text{door}}$ ) and the moved mass of the door mechanism ( $m_{\text{mech}}$ ). These values are determined for the specific door system.

The mass equivalent of the rotor inertia of the motor ( $m_{\text{rot}}$ ) depends on the motor type, the output ratio on the motor axis and the transmission efficiency.

The following tables list the mass equivalent of the rotor inertia for SIDOOR motors with a transmission efficiency of 85%.

For the SIDOOR M3, M4 and M5 motors, the mass equivalent of the rotor inertia of the motor is constant:

Motor	Mass equivalent ( $m_{\text{rot}}$ )
M3	22 kg
M4	22 kg
M5	93 kg

For the SIDOOR MDG3, MDG4 and MDG5 motors, the mass equivalent of the rotor inertia of the motor is:

MDG3, MDG4	
Output transmission	Mass equivalent ( $m_{\text{rot}}$ )
88 mm/rev	86 kg
90 mm/rev	82 kg

4.1 Basic functions

<b>MDG3, MDG4</b>	
95 mm/rev	74 kg
100 mm/rev	67 kg
105 mm/rev	60 kg
110 mm/rev	55 kg
115 mm/rev	50 kg
120 mm/rev	46 kg
125 mm/rev	43 kg
130 mm/rev	39 kg
140 mm/rev	34 kg
150 mm/rev	30 kg
160 mm/rev	26 kg
170 mm/rev	23 kg
180 mm/rev	21 kg
190 mm/rev	18 kg
200 mm/rev	17 kg
210 mm/rev	15 kg
220 mm/rev	14 kg
230 mm/rev	13 kg
240 mm/rev	12 kg
250 mm/rev	11 kg
260 mm/rev	10 kg
270 mm/rev	9 kg
280 mm/rev	8 kg
300 mm/rev	7 kg
330 mm/rev	6 kg
350 mm/rev	5 kg

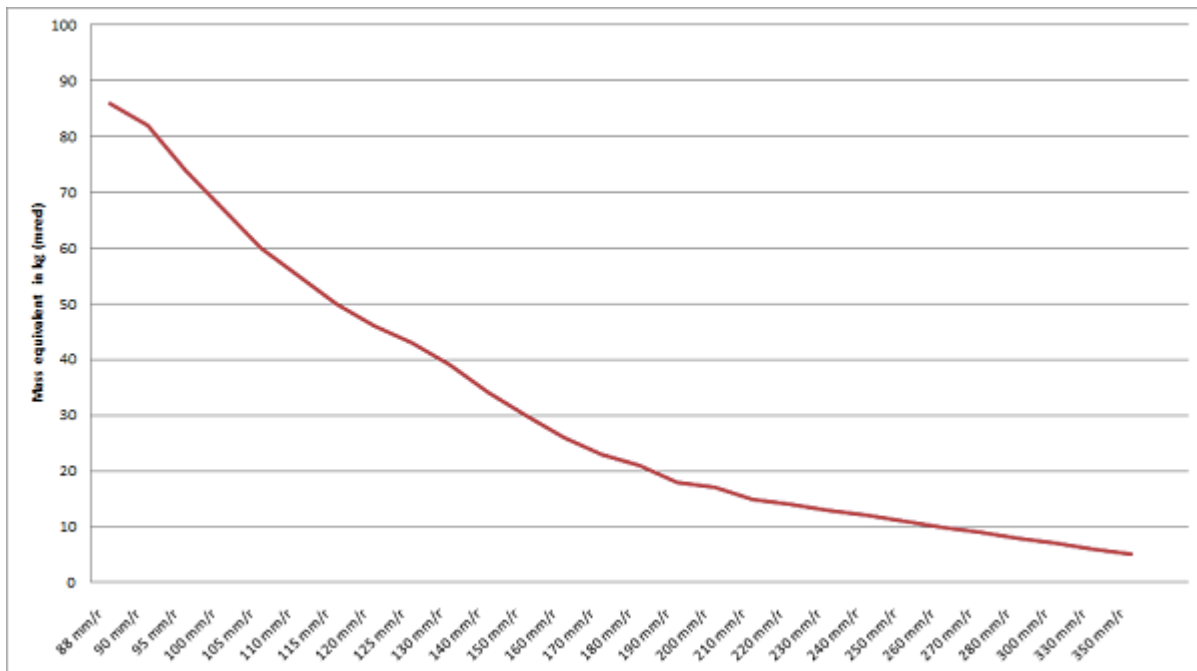

Figure 4-1 MDG3, MDG4

MDG5	
Output transmission	Mass equivalent ( $m_{rot}$ )
88 mm/rev	367 kg
90 mm/rev	351 kg
95 mm/rev	315 kg
100 mm/rev	284 kg
105 mm/rev	258 kg
110 mm/rev	235 kg
115 mm/rev	215 kg
120 mm/rev	197 kg
125 mm/rev	182 kg
130 mm/rev	168 kg
135 mm/rev	156 kg
140 mm/rev	145 kg
144 mm/rev	135 kg
150 mm/rev	126 kg
155 mm/rev	118 kg
160 mm/rev	111 kg
165 mm/rev	104 kg
170 mm/rev	98 kg
175 mm/rev	93 kg
180 mm/rev	88 kg
185 mm/rev	83 kg
190 mm/rev	79 kg

## SIDOOR functions

### 4.1 Basic functions

<b>MDG5</b>	
195 mm/rev	75 kg
200 mm/rev	71 kg
205 mm/rev	68 kg
210 mm/rev	64 kg
220 mm/rev	59 kg
230 mm/rev	51 kg
240 mm/rev	49 kg
250 mm/rev	45 kg
260 mm/rev	42 kg
270 mm/rev	39 kg
280 mm/rev	36 kg
290 mm/rev	34 kg
300 mm/rev	32 kg
310 mm/rev	30 kg
320 mm/rev	28 kg
330 mm/rev	26 kg
340 mm/rev	25 kg
350 mm/rev	23 kg
360 mm/rev	22 kg
370 mm/rev	21 kg
380 mm/rev	20 kg
388 mm/rev	19 kg



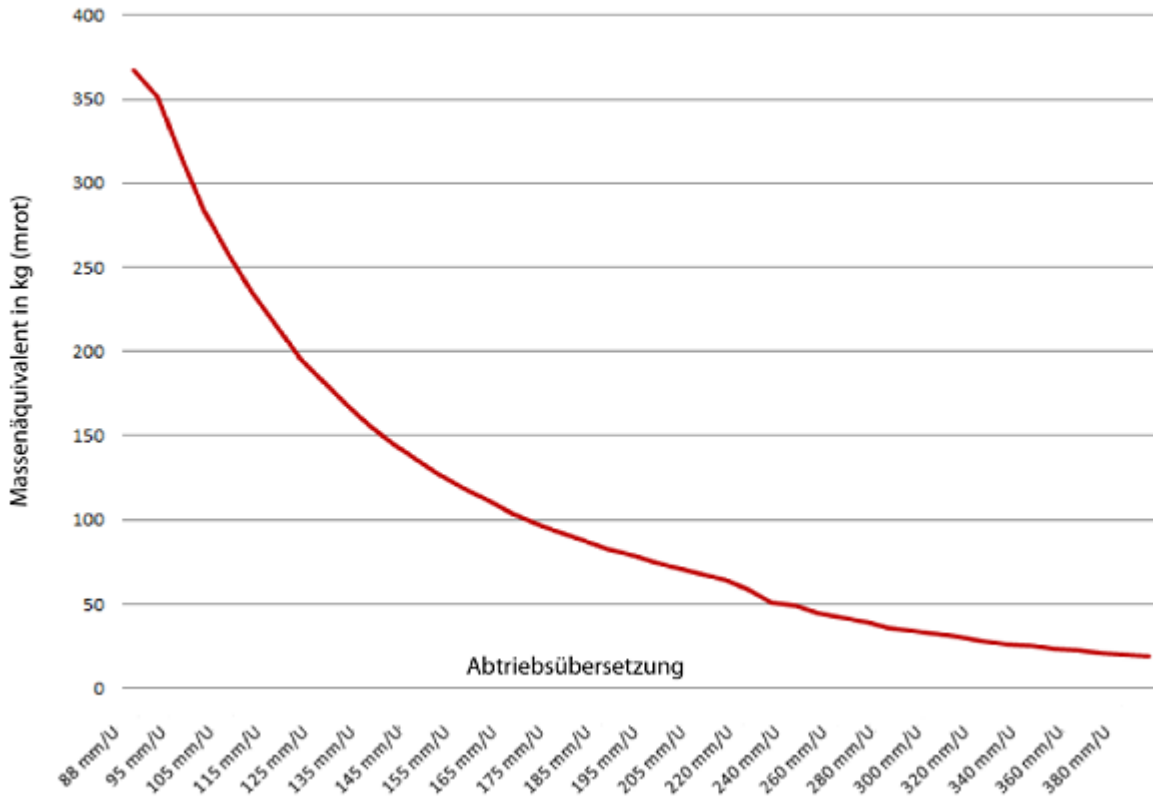

Figure 4-2 MDG5

## Querying values determined with the learn run

The values determined during the learn run (basic parameters) can be queried via the terminal module.

The SIDOOR ATD420W, ATD430W control units also enable the parameters to be queried via the fieldbus interface.

Table 4-2 Values (basic parameters) determined with the learn run

Parameter ID	Description
p2101	Mass to be moved
p2103	Door width
p2104	Friction in the opening direction (as of V1.10)
p2105	Friction in the closing direction (as of V1.10)
p2107	Average current for the friction in the opening direction (as of V1.10)
p2108	Average current for the friction in the closing direction (as of V1.10)
p2109	Direction of rotation of the motor (as of V1.10)
p2110	Direction of rotation of the pulse encoder (as of V1.10)

## See also

Output transmission (Page 48)

Diagnostic and maintenance (Page 297)

### 4.1.2 Force limit for learn run

#### Description of function

Maximum force that is active during the learn run. The force limit is active in the closing and opening direction.

The maximum value of the parameter depends on the existing output transmission and the maximum permissible output force of the motor gearbox. In the basic setting, the force limit is set to the maximum value for the default output transmission of 176 mm/rev.

---

#### Note

The maximum force limit preset as a default for the learn run should be reduced for smooth-running door systems or door systems with smooth end stops. A smooth-running door system has a mass to be moved <100 kg and maximum frictional forces of <20N. If the force limit is set too small for the learn run, the learn run aborts with the display code 'P'. If it is set too high, a door width that is too large can be determined for smooth end stops or low belt tension. This results in the initial operation not being left after switching on the supply voltage (the display code remains at 'd' and does not change to 'u').

---

#### Connection and parameter assignment

The force limit can be configured via the terminal module (*Main menu > General setup > Special parameters > Force limit for learn run*).

#### SIDOOR ATD420W / ATD430W

The force limit is set via the parameter p1242. See section Calibration and function parameters (Page 186) for more on this.

### 4.1.3 Output transmission

#### Description of function

The output transmission must be configured for the M3, MDG3, M4, MDG4, M5 and MDG5 motors. The output transmission describes the transformation of rotational into translational motion. Therefore: The distance [mm] that the door travels with one revolution [rev] of the transmission output shaft. The output transmission can be adjusted within the range 0...384 mm/rev. The permitted values are between 88...384 mm/rev. The default value for a newly trained motor type is 0 mm/rev.

For the M3, M4 and M5 motors, set the default value to 176 mm/rev. The output transmission [mm/rev] must be configured for the other MDG3, MDG4 and MDG5 motors.

MDG3 Mass to be moved	MDG4 Mass to be moved	MDG5 Mass to be moved	Output transmission [mm/rev] < 200	Output transmission [mm/rev] < 250	Output transmission [mm/rev] < 300	Output transmission [mm/rev] < 384
< 50 kg	< 100 kg	< 150 kg	X	X	X	X
< 100 kg	< 200 kg	< 350 kg	X	X	X	n.r.
< 150 kg	< 300 kg	< 500 kg	X	X	n.r.	n.r.
< 180 kg	< 400 kg	< 700 kg	X	n.r.	n.r.	n.r.

n.r. = not recommended

---

#### Note

For the M3, M4 and M5 motors, set the default value to 176 mm/rev.

---

#### Note

The output transmission should be checked before each learn run and adjusted if necessary.

---

#### Note

The determined door width has to be checked after each learn run.

---

#### Note

##### Activation of the learn run via the bus interface (as of V1.09)

The learn run can only be started when a permissible output transmission (parameter p4602) has been configured. The value for the door width should then be read back via the parameter r2103 and checked.

---

## Connection and parameter assignment

The drive transmission can be configured via the terminal module (*Main menu > General setup > Special parameters > Output transmission*).

### SIDOOR ATD420W / ATD430W

The output transmission is set via the parameter p4602. See section Calibration and function parameters (Page 186) for more on this.

## 4.1.4 Drive orders

The drive is controlled by means of drive orders. A drive order is composed of the following:

**Drive order = door command + door command expansion bit**

4.1 Basic functions

**Combinations**

The following table shows the combination of the door command and the door command expansion bit that lead to modification of the applicable door command. In the case of combinations/fields that are not marked, only the door command is effective. In the case of some drive orders, the dependence of the normal, initial or learn run modes must also be considered.

Table 4-3 Combining door command and door command expansion bit

Door command expansion bit	Door command								
	Deenergize (not a door command)	Stop	Open	Close	Automatic Assisted Drive (Page 78)	Automatic Impulse Drive (Page 75)	Positioning (Page 79)	Learn run (Page 40)	Stop with disable DCU
Specific drive range			x	x					
Slow (Page 60)			x	x	x	x	x		
ImpulseStop (Page 75)						Automatic Impulse-Stop (Page 76)			
NDG (Page 58)			x	x	x	x	x		
Special		Corresponds to Deenergize (EMF brake inactive)						Learn run with a new motor (Page 40)	Corresponds to Deenergize (EMF brake inactive)
Partial opening (Page 57)			x	x	x	x			
DCOPS (Page 61)			x	x		x			
LB sensor (Page 106)	x	x	x	x	x	x	x	x	

**Not a door command (Deenergize)**

The system evaluates the Deenergized (no current) door command as "inactive" or "not a door command".

**"Special stop" drive order**

The door command with the highest priority is Stop. The status following the ramp stop can be defined by means of the "special" door command expansion bit: EMF brake activated or de-energized (corresponds to free running mode).

You can find more information on individual drive orders in the sections linked in the "Combining door commands and door command expansion bits" table above.

### Stop with disable DCU

The door command is a separate command without DCMD extension or no combination with DCMD extension bits. It has the value 8 in the "DCMD signals" table. Causes a stop and the door commands via the other source, such as service buttons, are disabled.

## Shutdown/deceleration functions

In an unlimited system, the shutdown and deceleration functions are split into the following: "rapid stop", "ramp stop" and "coasting down". These definitions **do not** apply in a door system because these are to be considered as limited systems.

Table 4-4 Shutdown/deceleration functions in an unlimited system

Function	Description
Rapid stop	Decelerates the drive to standstill with the maximum deceleration ramp (taking into account technical and safety-related limit areas).
Ramp stop	Same meaning as rapid stop, but a configured ramp is used to decelerate the drive to standstill.
Coasting down	The drive is not actively braked, it can run freely and is only slowed by the friction inherent in the system (e.g. gearing).



In SIDOOR systems, coasting down is equivalent to the Deenergize (no current) door command. For safety reasons, however, direct coasting down must not take place due to the limits implemented in a door system (safety reasons). This is why the following definitions apply to the SIDOOR door drive:

Table 4-5 SIDOOR door drive shutdown/deceleration functions (limited system)

Function	Description
Not a door command/Deenergize	Decelerates the drive with a configured ramp (p3674 "DecRampOp" or p3677 "DecRampCls") down to a standstill and subsequently goes into free running mode.
Special stop	
Stop	Decelerates the drive with a configured ramp (p3674 "DecRampOp" or p3677 "DecRampCls") down to a standstill and subsequently goes into virtual short-circuit mode (50% PWM → EMF brake active).
Reverse	Direction of travel reversal by local sensor (e.g. light curtain and pressure-sensitive edge) or "Open → Close" or "Close → Open" drive order change. Decelerates the drive to standstill with a configured ramp (p3675 "RevRampOpToCls" or p3678 "RevRampClsToOp"). The further behavior depends on the current system state and the parameterized reversing behavior.

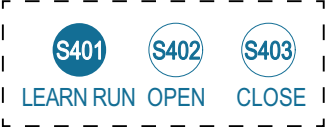
Sources of drive orders

Drive order source	Description
<p><b>Service button</b></p>	<p>Activating a service button results an immediate switchover to the local mode (see Local/master operation (Page 155)). The Deenergize drive order is active where no button is pressed. If the "Stop with disable DCU" command is active, the controller cannot be operated via the service buttons.</p> <div style="border: 1px dashed black; padding: 5px; display: inline-block; margin: 10px 0;">  </div> <p><b>S401 (learn run)</b>                      If S401 is pressed for approx. 5 s in the Power ON state, the special learn run (learn run with new motor) drive order is activated. You can find additional information in Learn run (Page 40).                      The button can be released once the learn run has started. The learn run can be canceled at any time (see Learn run (Page 40)).</p> <p><b>S402</b>                      The Open drive order is active as long as the button is pressed.</p> <p><b>S403</b>                      The Close drive order is active as long as the button is pressed.</p>

Drive order source	Description
<b>Software Kit (PC), SIDOOR SUPPORT app and SERVICE TOOL or local terminal</b>	<p><b>Service Tool or local terminal</b></p> <p>Some areas of the service menu are classified as safety-related. Read the notes from the section Local/master operation (Page 155) on this. The Stop drive order is activated within this area.</p> <p>In addition, the drive orders Open, Close, NDG close, Learn run and Learn run with new motor can be activated via the service menu (<i>Main menu &gt; General setup or Quick setup</i>). If the "Stop with disable DCU" command is active, the controller cannot be operated via the service buttons.</p> <p><b>Software Kit (PC)</b></p> <div data-bbox="370 549 683 834" style="border: 1px solid black; padding: 5px; width: fit-content;">  </div> <p>Drive orders can be simulated via the "Drive orders" window. The following applies to the ATD4xxW:</p> <ul style="list-style-type: none"> <li>Open → "Open" drive order</li> <li>Close → "Close" drive order</li> <li>Nudge → "NDG close" drive order</li> <li>Stop → "Stop" drive order</li> </ul> <p><b>SIDOOR SUPPORT app (smartphone)</b></p> <div data-bbox="370 889 603 995" style="border: 1px solid black; padding: 5px; width: fit-content;">  </div> <p>You can simulate drive orders via the "Control" page. The following applies to the ATD4xxW:</p> <ul style="list-style-type: none"> <li>• OPEN → Open drive order</li> <li>• CLOSE → Close drive order</li> <li>• STOP → Stop drive order</li> <li>• Deenergized → Deenergize drive order</li> </ul>
<b>Process data (PROFIBUS, PROFINET)</b> <b>FBLOCK system (digital INPUT1, 2, 3, 4 and X5)</b>	<p><b>Process data</b></p> <p>Drive orders can be sent via the process image. To this end, the DCMD (door command) and DCMD expansion bit (door command expansion bit) signals are defined in TSW1 – Technology control word 1. Drive orders are part of control words and are valid only when the drive is in the "S4: Z_BETRIEB" (see Figure 5-4 Sequential control state graph (Page 157)).</p> <p><b>FBLOCK system</b></p> <p>The digital inputs of the SIDOOR controller can be combined with drive orders via the parameterizable FBLOCK logic (see Free function blocks (FBLOCK) (Page 86)).</p> <p>The default command mode is defined by the p100 parameter. See description of parameter p100, section Parameter assignment (Page 180).</p>

**Prioritization of door command sources**

Door commands can be issued via different sources. A higher-priority drive order overwrites a lower-priority drive order. The service interfaces generally have the highest priority because they are intended for commissioning and service purposes.

Table 4-6 Prioritization of door command sources

Priority		Door command source	Remarks
High	1.	Service buttons S401, S402 and S403	Local command at the controller. If the "Stop with disable DCU" command is active, the controller cannot be operated via the service buttons.
	2.	SIDOOR SOFTWARE KIT (PC), SIDOOR SUPPORT app SIDOOR SERVICE TOOL or local terminal	Command local via service terminal or PC tool. If the "Stop with disable DCU" command is active, the controller cannot be operated via the software kit (PC) and Service Tool.
	3.	Process data (PROFIBUS, PROFINET) FBLOCK system (digital INPUT1, 2, 3, 4 and X6)	Drive orders are mutually prioritized
Low	4.	FBLOCK system (edge-controlled drive orders "latched")	Only for edge-controlled digital input signals of the FBLOCK system (latched drive orders)

**Note**

If the "Stop with disable DCU" command is active, command input via the service buttons, the terminal module and the Software Kit (PC) is disabled.



## Mutual prioritization of door commands

When a command is issued via the process image, there can be no mutual prioritization of door commands because the corresponding DCMD signal is based on an enumerative structure and therefore only ever one door command can be active. Prioritization is applied in the case of interconnections within the FBLOCK system or the service buttons, for example.

Table 4-7 Prioritization of the door commands

Priority	Door command	Remarks
High	1. Stop	After the ramp down, the EMF brake is deactivated with the extension "special" (as of V1.12: Stop with disable DCU). If the "Stop with disable DCU" command is active, the controller cannot be operated via the service buttons. → Free running mode / deenergized with highest priority
	2. Open	
	3. Close	
	4. Automatic AssistedDrive, Automatic ImpulseDrive, Positioning	Same priority (internal processing sequence determines the drive order)
	5. Learn run	Learn run can be interrupted
Low	6. Deenergize	Neutral door command corresponds to the idle state, equivalent to inactive → Free running mode / deenergized with highest priority via "Special stop" drive order

### 4.1.5 DOOR CLOSE (command given via digital inputs)

#### Description of function

The DOOR CLOSE command closes the door according to the set driving curve as long as the command is present. The door reaches the CLOSED position at slow end speed close.

The CLOSE DOOR command must remain present continuously in order to close the door. After the door has closed, it is held in this position by the torque that can be adjusted by the parameter "Continuous torque CLOSE" as long as the command remains present.

---

#### Note

If the commands CLOSE DOOR and OPEN DOOR are present simultaneously, the door always moves in the OPEN direction.

---

#### SIDOOR ATD420W / ATD430W

See also section Free function blocks (FBLOCK) (Page 86).

---

#### Note

As an alternative, the signal can also be evaluated via the PLC (process image).

---

### Connection

**SIDOOR ATD401W:**

The "CLOSE DOOR" function is connected to "Input 3" (X6). See also section Digital input signals (Page 126).

"Main menu → General setup → Special parameters → FBLOCK configuration → Default input" has to be selected in the control menu so that door commands can be issued via the digital inputs.

### Signals

Signal	Meaning
1 (voltage applied)	The CLOSE DOOR command is pending
0 (voltage not applied)	The CLOSE DOOR command is not pending

### 4.1.6 DOOR OPEN (command given via digital inputs)

#### Description of function

The OPEN DOOR command opens the door according to the configured travel curve as long as the command is present. The door reaches the OPEN position at slow start speed. Then, if the OPEN DOOR command is present, the door is held open by the torque that can be adjusted by the parameter "Continuous torque open".

The OPEN DOOR command has priority over all other control commands.

---

**Note**

If the commands CLOSE DOOR and OPEN DOOR are present simultaneously, the door always moves in the OPEN direction.

---

**SIDOOR ATD420W / ATD430W**

See also section Free function blocks (FBLOCK) (Page 86).

---

**Note**

As an alternative, the signal can also be evaluated via the PLC (process image).

---

### Connection

**SIDOOR ATD401W:**

The "DOOR OPEN" function is connected to "Input 4" (X6). See also section Digital input signals (Page 126).

"Main menu → General setup → Special parameters → FBLOCK configuration → Default input" has to be selected in the control menu so that door commands can be issued via the digital inputs.

## Signals

Signal	Meaning
1 (voltage applied)	The OPEN DOOR command is pending
0 (voltage not applied)	The OPEN DOOR command is not pending

### 4.1.7 Stopping

#### Function description

See Table 4-4 Shutdown/deceleration functions in an unlimited system (Page 51)

#### See also

Drive orders (Page 49)

### 4.1.8 Partial opening

#### Function description

A second open position can be implemented using the "partial opening" drive function. A "partial opening" describes an opening movement with a set curve profile up to the partial opening position.

When partial opening is active, the learned or real door width is replaced with the parameterized partial opening width. All drive functions are supported in partial opening mode (e.g. curve profile, force and energy limiting, obstruction detection, etc.). Activating positioning mode overwrites partial opening mode.

If the drive is in the area between the first and second open positions when partial opening mode is activated, this is detected as an invalid area. In this area, the control unit reduces the drive's speed automatically. The normal curve profile becomes active again as soon as the drive has moved out of the invalid area or has exited partial opening mode. The scenario described is not to be evaluated as a fault or an invalid situation.

The continuous torque in the opening direction is not applied at the virtual end stop of the second open position. The drive is stopped as soon as the opening command is applied. At standstill the motor is energized with 50% PWM. This operates similar to an EMF brake.

## 4.1 Basic functions

### Requirements for partial opening mode

The drive can only switch to partial opening mode if the corresponding drive order with expansion bit is active and the following conditions are met:

- The control unit is in normal mode
- The drive is at a stop

Partial opening mode can only be terminated actively (reset of the DCMD expansion bit "partial") at standstill, but is terminated automatically if the control unit switches to initial or learn run mode.

### Connection and parameter assignment

The partial opening width can be configured via the driving parameters or the terminal module (*Main menu > General setup > Special parameters > Partly open width*).

#### SIDOOR ATD401W

The "Partial opening" function is connected to "Input 2" of terminal X6. See also section Digital input signals (Page 126).

#### SIDOOR ATD420W / ATD430W

The partial open width is defined via the parameter p1206. See section Calibration and function parameters (Page 186).

### 4.1.9 Obstruction detection CLOSE

#### Description of function

See the section Obstruction detection (Page 80).

### 4.1.10 Obstruction detection OPEN

#### Description of function

See the section Obstruction detection (Page 80).

### 4.1.11 Force and energy profiles (NDG mode)

SIDOOR ATD4xxW controllers support two individually parameterizable force and energy profiles.

## Parameter assignment

You can configure the following parameters equally via the parameter interface, the service tool and the terminal.

Table 4-8 Force and energy profile parameter overview

Normal operation	NDG operation
<i>Force limiting</i>	
p3682 "LimForceOp"	p3685 "LimForceNdg"
p3683 "LimForceCls"	
p3684 "LimForceEndCls"	
<i>Energy limiting</i>	
p1202 "KinEnergyLimCls"	p1204 "KinEnergyLimNdg"
p1203 "KinEnergyLimOp"	
<i>Speed limiting (influenced by energy limiting)</i>	
p3668 "MaxSpdCls"	p3672 "NdgSpd"
p3664 "MaxSpdOp"	

## Drive order for profile switching

To switch to NDG mode, the DCMD expansion bit "NDG" must be set (see Table A-17 DCMD expansion bits (Page 314)). In combination with an applicable DCMD drive order (see Table A-16 DCMD signal (Page 313)), the drive travels with the NDG force and energy profile.

## Switching profiles

The drive switches over to the NDG force and energy profile when the corresponding drive order with expansion bit is active and the controller is in normal mode. If the NDG mode is activated or deactivated during travel, the system automatically stops with the configured braking ramp and continues moving with the applicable force and energy profile after having stopped.

Independent values, which are not influenced by the force and energy profiles described here, apply to force and energy limiting in the initial or learn run mode.

## Drive response in NDG mode

In NDG mode, all drive functions are supported without restriction.

### 4.1.12 Slow driving curve profile

The SIDOOR ATD4xxW controllers support a parameterizable, speed-reduced speed profile (slow profile) to which a changeover can be carried out flexibly.

#### Parameter assignment

You can configure the following parameters equally via the parameter interface, the service tool and the terminal.

Table 4-9 Force and energy profile parameter overview

Normal profile	Slow profile
<i>Energy limiting</i>	p3667 "SlowIniSpdOp"
p1202 "KinEnergyLimCls"	p3671 "SlowIniSpdCls"
p1203 "KinEnergyLimOp"	
p1204 "KinEnergyLimNdg"	
<i>Speed limit (influenced by energy limiting)</i>	
p3668 "MaxSpdCls"	
p3664 "MaxSpdOp"	
p3672 "NdgSpd"	

#### Drive order for profile switching

To switch to the slow profile, the DCMD expansion bit "slow" (see Table A-17 DCMD expansion bits (Page 314)) must be set. In combination with an applicable DCMD drive order (see Table A-16 DCMD signal (Page 313)), the drive switches to the slow profile.

#### Switching profiles

The drive switches over to the slow profile when the corresponding drive order with expansion bit is active and the controller is in normal mode. The slow profile can be activated or deactivated dynamically during travel. The activation of the slow profile brakes the drive automatically to the speed of the Slow profile in accordance with the parameterized reversal ramp. Minimally, however, with 500 mm/s<sup>2</sup>. When the Slow profile is deactivated, the drive accelerates with 1500 mm/s<sup>2</sup> to the specified end speed.

Independent values, which are not influenced by the speed parameters described here, apply to the speed in the initial or learn run mode.

#### Drive response

When the slow profile is active, all drive functions are supported without restriction.

### 4.1.13 DCOPS (door closed/opened position sensor)

#### Function description

"DCOPS" stands for door closed/opened position sensor. A door closed/opened position sensor can consist of two end position sensors (closed/open).

The DCOPS enables the door to travel immediately after the line voltage is switched on without an initialization run in normal operation.

In the case of an active DCOPS signal in initial mode, the control unit switches directly to normal mode with corresponding drive order "Open" or "Close" and detected blocking (end stop). To prevent the erroneous detection of a blocking obstruction as an end stop, the DCOPS signal must not be activated until 1 to 2 cm before the respective end stop.

#### Example sequence when using DCOPS

1. Power ON
2. Control unit is in the initial mode. No fault present. The system is in any position along the travel path.
3. A door command "Open" or "Close" is applied.
4. The system opens or closes.
5. The DCOPS signal is activated as from 2 cm before the respective end stop.
6. The system reaches the end stop and detects it as an "obstruction".
7. The system switches to the normal mode and assumes the applicable "open" or "closed" status.

#### Connection and parameter assignment

The DCOPS signal can be connected to SIDOOR ATD4xxW control units via "Input 1" of the terminal X6. See also section Digital input signals (Page 126).

The connected signal must be activated via the SIDOOR service menu (*Main menu > General setup > Special parameters > Input 1*).

---

#### Note

The ESPE, pressure sensitive edge, light barrier and DCOPS functions cannot be implemented at the same time.

---

**SIDOOR ATD420W / ATD430W**

The DCOPS signal can be sent as shown in Figure 5-5 Sensor signals (Page 160), via the process image (see Table A-17 DCMD expansion bits (Page 314)) and/or via the local sensor input ("Input 1" via p4600 - see Table 5-31 Other parameters (Page 182)).

**Note**

- The status of the control unit must be considered when using the DCOPS signal (process image). The process data are only valid in the status "S4: Z\_ operation" (see AUTOHOTSPOT).
- The light barrier and DCOPS functions can be implemented simultaneously by connecting to a fieldbus system (process image).
- The DCOPS, ESPE, light barrier or pressure sensitive edge functions cannot be implemented simultaneously as sensor functions at Input 1.

You can find more detailed information on DCOPS in section Overview (Page 160).

## 4.2 System functions

### Introduction

The system functions described below enable better monitoring and diagnostics of the system.

### 4.2.1 Initial run/reference run after restart

#### Function description

After a restart, the control unit is in initial mode. Initial mode is necessary because there is no absolute value encoder. The control unit must therefore verify the previously learned end stops after the restart (= reference run). As long as both end stops OPEN and CLOSE have not been verified by reaching them, the drive only moves with a slowed driving profile (initial driving profile). Force limitation is active in accordance with the learned parameters (friction compensation is active). The tolerance with which the learned end stops are detected in the initial mode can be adjusted.

- **Speed** Initial speed of the drive is defined by the parameters p3667 "Slow initial speed open" or p3671 "Slow initial speed close".
- **Force limit** during the initial drive and in normal operation, "Static force limit open" is defined by the parameter p3682 and "Static force limit close" by the parameter p3683.
- **Door width tolerance** with which the learned end stops are detected in initial mode is adjustable via the parameter p1208.

**SIDOOR ATD420W/ATD430W**

After the restart, the control unit is in state "S1: Z\_Switch-on inhibit" (see Fig. 4-4 State graph (Page 157) Sequential control (Page 157)).



### Using an end position sensor

You can skip initial mode by connecting a DCOPS end position sensor (Door Closed/Opened Position Sensor). Depending on the application, 1 end position sensor can be used in the open or closed position or 2 end position sensors can be used in both end positions. The responsibility for verification of the learned end positions is thus transferred to the user (see section DCOPS (door closed/opened position sensor) (Page 61)).

## 4.2.2 Overload protection of the geared motor

### Function description

The overload protection should prevent a thermal overload of the motor. While the overload protection is active, the 7-segment display (H401) shows the fault code "4". The overload protection is activated by the cases listed below:

- If the geared motor placed under a high load with frequent OPEN DOOR and CLOSE DOOR commands in quick succession, the hold-open time is automatically lengthened. The next closing movement is delayed even if a DOOR CLOSE command is present. An extension of the hold-open time may occur if the dwell time of the door in both end positions together, per drive cycle, is less than 12 seconds on average.
- If the drive is operated continuously for more than 65 seconds in one direction, fault "4" is displayed and the motor stops. After acknowledgment of the fault a restart of the control unit takes place. This can occur only with extremely high system friction, low door speeds and large door widths.
- If the door is blocked longer than 5 seconds outside the obstruction detection area (p3856, p3857, p3873, p3874), the motor current is reduced to the nominal motor current. If a motion of the door in the drive direction is detected, the motor current is increased in accordance with the parameterized force limit and fault "4" is terminated.

## 4.2.3 Vandalism protection/continuous door monitoring

### Description of function

The vandalism protection/continuous door monitoring function offers protection against undesired external system motion. If the motor is deenergized, the motor speed is monitored by the controller.

If the maximum speed of 250 mm/s is exceeded, the controller actively decelerates the motor to 50 mm/s, and then switches the drive back to "deenergize".

As of V1.10: With the M5 and MDG5 motors, the maximum speed at which vandalism protection is applied is 200 mm/s.

### SIDOOR ATD420W / ATD430W

If the maximum configurable speed (p1200) is exceeded, the controller actively decelerates the motor to 50 mm/s, and then switches the drive back to "deenergize".

### Parameter assignment

#### SIDOOR ATD420W / ATD430W

The "Continuous door monitoring" function is pre-installed and activated, and can be deactivated if necessary with parameter p1200. This is done by setting the value of parameter p1200 to "0". See Table 5-33 Calibration and function parameters (Page 186).

### 4.2.4 Belt break monitoring

#### Description of function

The function detects a torn belt. The detection is active in normal mode and initial mode.

A torn belt is detected when the door movement exceeds the defined distance\* (in the opening or closing direction).

\* The distance is defined as follows:

Mode	Distance	
Initial operation	Learnt door width +	50 cm (p1201)
Normal operation	Learnt door width +	50 cm (p1201)

### Parameter assignment

Belt break detection is suppressed if parameter p1201 is set to "0". In this case, there is no fault or fault reaction on the part of the controller.

The status code "t" signals a torn belt. The controller changes to the status "S6: Z\_Störung" (see Figure 5-4 Sequential control state graph (Page 157)).

If the parameter set of the controller is invalid, the maximum possible door width of 5 m is used for the door width.

See Table 5-33 Calibration and function parameters (Page 186).

### 4.2.5 Friction compensation

#### Description of function

The friction force profile of the door system is recorded with the current measuring device of the controller. The measurement data for both the opening and closing directions is recorded during the learn run.

### Recording of measurement data

The recording of measurement data **in the opening direction** is divided into two subranges because the door movement is not constant throughout the total range. The ranges are:

- Travel path  $\leq 25$  cm
  - The measurement data in this range are recorded in the second opening movement and after reaching the speed trigger level (learn run speed). As from this moment, the door movement is almost constant. The measurement data are recorded every 2 cm, the first measured value is recorded 2 cm after the trigger level position (transient distance).
- Travel path > "End of weight determination"
  - The measurement data in this range are recorded after the weight determination has finished and the speed trigger level has been reached (learn run speed). As from this moment, the door movement is almost constant. The measurement data are recorded every 2 cm, the first measured value is recorded 2 cm after the trigger level position (transient distance).

The measurement data are recorded **in the closing direction** throughout the entire closing movement within the learn run and after reaching the speed trigger level (learn run speed). As from this moment, the door movement is almost constant. The measurement data are recorded every 2 cm, the first measured value is recorded 2 cm after the trigger level position (transient distance). The measured values are recorded until the system reaches the "Cutter distance CLOSE" range (p3663).

### Calculations

1. The values "MEAN FRICTION FORCE OPEN/CLOSE [A]" and "STANDARD DEVIATION OPEN/CLOSE [A]" in the "open" and "closed" positions are calculated on the basis of the measurement data.
2. The values calculated in step 1 are converted to a force [N] with the aid of the motor constants [N/A]
3. The force calculated in step 2 is added internally to the parameterized forces p3682, p3683, p3684, and p3685

---

#### Note

The friction force is not taken into account in the parameterized torques p3679, p3680 and p3681 (effective in the end stops) in order to avoid unnecessary heating of the motor.

---

---

#### Note

The corresponding internal force value, which is the result of the addition of the parameterized force value and the calculated friction force, is limited to the maximum value of the respective parameter.

---

## 4.2.6 Oscillation protection

The oscillation protection prevents permanent oscillation of the door at the end stop.

### End position "open"

If the system is pressed further than 2 cm from the door width (open position) determined in the learn run while an "Open" drive command is active, the controller detects that the "Opened" position has been left and tries to move back to the end stop with the set static opening force.

After reaching the end stop, the drive is energized with the set continuous torque.

The behavior described may be repeated five times (oscillation). After the fifth repetition, the drive is energized for 30 s with the set continuous torque without any response to further oscillations. After a protective period of 30 s, the system responds once again to corresponding oscillations.

### End position "closed"

If the system is pressed further than 1 cm out of the minimally reached closed position while a "Close" door command is active, the controller detects that the Closed position has been left and tries to move back to the end stop with the set static cutter force.

After reaching the end stop, the drive is energized with the set peak torque close. After 2 s, the peak torque close is limited to the set continuous torque.

The behavior described may be repeated five times (oscillation). After the fifth repetition, the drive is energized for 30 s with the set continuous torque without any response to further oscillations. After a protective period of 30 s, the system responds once again to corresponding oscillations.

## 4.2.7 Automatic energy limitation

### Function description

SIDOOR control units have a system that automatically limits the kinetic energy in the closing direction.

 <b>WARNING</b>
<p><b>Risk of injury due to moving mechanical parts</b></p> <p>After the door drive has been commissioned in the complete system, arrange for the forces and energies to be checked by the service personnel, and adjusted if they exceed their limit values. Take the standards and directives valid for the respective application as well as the following specifications into account:</p> <ul style="list-style-type: none"> <li>• The drive is suitable for use with power-operated isolating guards in accordance with EN ISO 14120:2015, section 5.2.5.4.</li> <li>• In the factory state, the force and energy limitation parameters in the opening/closing direction are 4 J and 75 N. Subject to a safety assessment of the overall system and with the reversing function activated (automatic reopening of guard) these parameters can be increased in accordance with the standard up to a maximum of 10 J and 150 N.</li> <li>• If an additional protective device is used (e.g. an ESPE or pressure sensitive edge), the force and energy limitation parameters may also be set beyond this, depending on the application.</li> </ul>

SIDOOR ATD4xxW control units include a system that automatically limits the kinetic energy in the opening and closing directions.

The values for the energy limit are determined via the parameter p1202 (in the closing direction) or p1203 (in the opening direction) and P1204 (NDG mode). After successfully completing the learn run, the speed values of the drive curve parameters p3668, p3664 and p3672 are determined according to the mass and configured energy limit are determined and overwritten.

As of V1.10: If a value greater than 0 is set for parameter p1202 (Energy limit close), p1203 (Energy limit open) and p1204 (Energy limit NDG), a value greater than 0 is set, the parameters p3664 (Maximum speed OPEN), p3668 (Maximum speed CLOSE) and p372 (NDG speed) are always permanently set to the speed (v) calculated from the set energy limit (E) and the configured mass (m):

$$v = \sqrt{\frac{2 \cdot E}{m}}$$

If the value 0 is set for the energy limit, the automatic energy limit is switched off and any speed within the parameter limits can be selected.

### Force and energy profiles

See section Force and energy profiles (NDG mode) (Page 58).

**Speed limit curve (in opening and closing direction)**

The speed limit curve is the characteristic that determines the maximum permissible door speed (closing speed),  $v_{max}$ , as a function of the total door panel weight. According to machine protection guideline EN ISO 14120:2015, the maximum kinetic energy of the door in the closing direction must not exceed 10 joules.

$$W_{KIN} = \frac{1}{2} m \cdot v^2 = 10 \text{ J.}$$

Example from the following speed limit curve:

- Moved mass  $m = 180 \text{ kg} \Rightarrow v_{max} = 0.33 \text{ m / s.}$

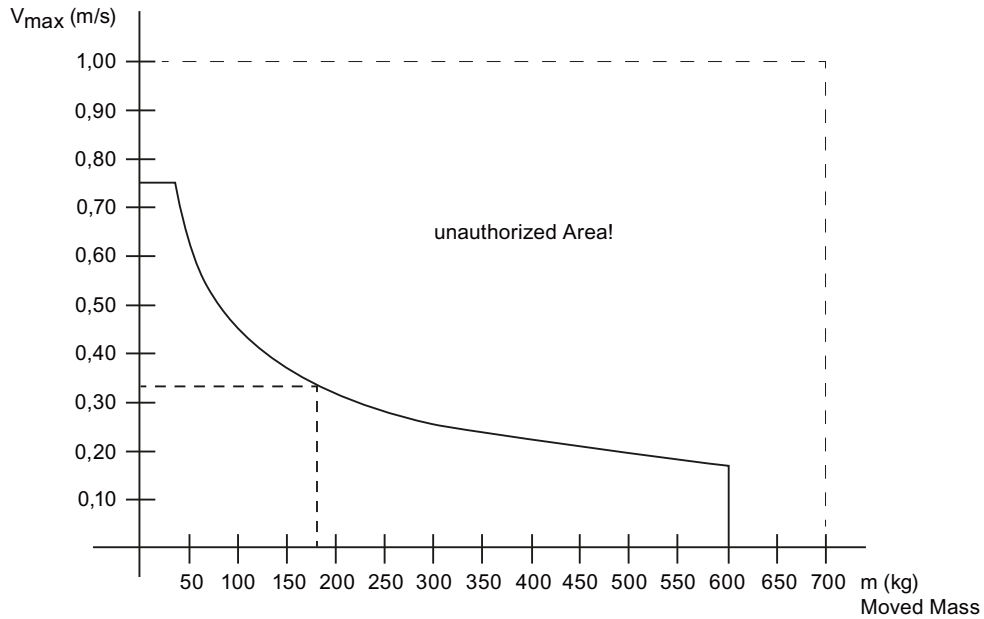

Figure 4-3 Speed limit curve for  $W_{KIN}=10\text{J}$

If the reversing device is switched off, the maximum kinetic energy must not exceed 4 joules.

$$W_{\text{KIN}} = \frac{1}{2} m \cdot v^2 = 4 \text{ J.}$$

Example from the following speed limit curve:

- Moved mass  $m = 180 \text{ kg} \Rightarrow v_{\text{max}} = 0.21 \text{ m / s.}$

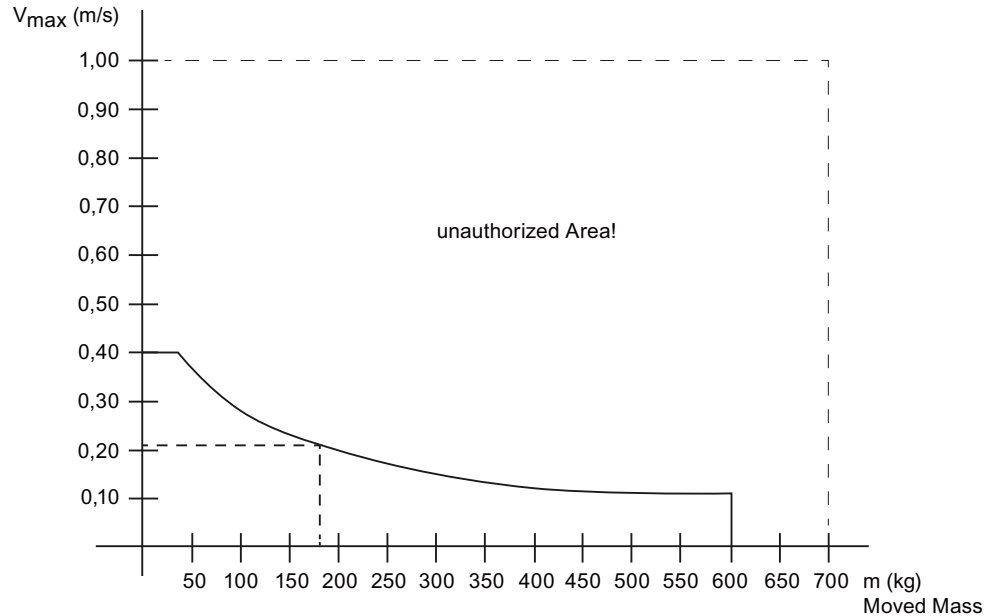

Figure 4-4 Speed limit curve for  $W_{\text{KIN}}=4\text{J}$

### Adjustment ranges

You can find the adjustment ranges in section Profiles and adjustment ranges (Page 323).

### Maximum speeds

The following table shows the maximum speeds depending on moved weight and energy limit:

Table 4-10 Maximum speeds [mm/s] as a function of moving mass and energy limit

Weight to be moved [kg]	Energy [J]					
	4	10	25	50	75	100
50	400	632	1000	1414	1732	2000
100	283	447	707	1000	1225	1414
150	231	365	577	816	1000	1155
200	200	316	500	707	866	1000
250	179	283	447	632	775	894
300	163	258	408	577	707	816
350	151	239	378	535	655	756
400	141	224	354	500	612	707
450	133	211	333	471	577	667
500	126	200	316	447	548	632

Weight to be moved [kg]	Energy [J]					
	4	10	25	50	75	100
550	121	191	302	426	522	603
600	115	183	289	408	500	577

### Parameter assignment

The determination of the values for the energy limit is performed using the following parameters:

- In closing direction: p1202
- In opening direction: p1203
- NDG mode: p1204

Parameter assignment is possible via the driving parameters or the terminal module.

If an energy limitation parameter is set to 0, the speed limitation is suppressed in accordance with the kinetic energy.

### 4.2.8 External closing force

#### Description of function

 <b>WARNING</b>
<b>Risk of injury due to moving mechanical parts</b>
<p>Make sure that with an additional external closing force the sum of external closing force and force set in the controller does not exceed the maximum force limit of 150 N (according to EN ISO 14120:2015).</p>
<p>Check the final application-specific limit values and adjust the limit values accordingly.</p>

### 4.2.9 Synchronization of the door position

#### Description of function

The determined door position is set to zero when a blocking of the door in the area of 1 cm before the minimally reached CLOSED position has been detected or if the door position is below the minimally reached CLOSED position.

As of V1.09: The determined door position is set to zero when the CLOSED position is reached. If the last reached OPEN position is larger than the door width plus 1 cm which was determined during the learn run or if the door position is below the minimally reached CLOSED position.



This way the accumulation of contamination does not result in an "escape" of the door from the closed position.

#### 4.2.10 Cyclic process values via fieldbus

As of firmware version V1.09, cyclic process values can be transferred to a higher-level controller using PROFIBUS or PROFINET by means of the technology status words TZW3, TZW4 and TZW5. The content of these technology status words can be configured with the parameters p4700, p4701 and p4702. The following process values are available:

- Digital inputs, D-IN
- Digital outputs, D-OUT
- Button
- Door position in mm
- Door setpoint speed in mm/s
- Door actual speed in mm/s
- Motor current in mA
- Motor current limitation in mA
- Voltage of the motor output stage in V
- Remaining power capacity of the braking resistor in J
- Currently displayed operating status (as of V1.12)

The default values of parameters p4700, p4701, p4702 correspond to the settings for TZW3, TZW4, TZW5 in firmware versions prior to V1.09.

To use the technology status words, see also Appendix TZW3, TZW4, TZW5 - Technology status words 3, 4, 5 (Page 321).

#### 4.2.11 Parameter checksum (as of V1.12)

##### Description of function

Firmware version V1.12 or higher:

To ensure that certain parameter ranges have not been changed, it is possible to read out a checksum:

- r200: Checksum for the default parameters
- r201: Checksum for the learn run/basic parameters (p2101 to p2111)

As soon as a parameter of the respective range changes, its checksum is recalculated.

A retentive change counter (r202) is incremented by one every time a parameter from the default range is changed. After resetting the parameters to the factory setting with p91, the change counter is set to zero.

The respective checksums can also be read out via the service menu.

Parameter	Meaning	Included in default checksum (r200)	Included in learn run checksum (r201)	Change counter default parameter (r202)
p90	Write protection	No	No	+1
p91	Reset to factory settings	Yes	Yes	Set to "0"
p92	Reset FBLOCK parameter set to factory settings (command parameters)	No	No	0
p93	Load factory settings of the driving curve parameter set	No	No	+1
p95	Activation of a test run	No	No	0
p100	Default command mode	Yes	No	+1
r200 – r202	Checksums/change counters of the parameters (Read-Only) (new)	No	No	0
p1200 – p1242	Calibration and function parameters	Yes	No	+1
p1250 – p1252	Calibration and function parameters for old calibration functions	Yes	No	+1
p2020 – p2023	Fieldbus communication channel parameters	No	No	0
p2040	Fieldbus monitoring time for the master monitoring	Yes	No	+1
p2080 – p2081	DCMD fieldbus/ext.DCMD filter	Yes	No	+1
p2101 – p2111	Calibration and function parameters - basic parameters	No	Yes	0
p2200 – p2205	Parameters for position block	Yes	No	+1
p3660 – p3685	Driving parameters	Yes	No	+1
p3686 – p3689	Parameters for reduced door range of motion	Yes	No	+1
p3850 – p3885	Obstruction and reversing parameters	Yes	No	+1
p4600	Local sensor type	Yes	No	+1
p4601	Discrepancy time in the function test of the OSSD system	Yes	No	+1
p4602	Output transmission	Yes	No	+1
p4610 – p4611	Discrepancy analysis times (AND0 and AND2)	Yes	No	+1
p4700 – p4702	Fieldbus value selection for cyclic transfer of process values	No	No	0
p20000 – p20030	FBLOCK DCMD	Yes	No	+1
p20057 – p20060	FBLOCK DCMD for old calibration functions	Yes	No	+1
p20100 – p20122	FBLOCK REF	Yes	No	+1
p20127 – p20130	FBLOCK REF for old calibration functions	Yes	No	+1

### Validity of checksums

If parameters were changed and not yet stored retentively, parameter r204 returns the value 0 (checksum invalid) and the parameter checksums r200 and r201 also have the value 0.

When the retentive storage of the parameters is finished, parameter r204 returns the value 1 and the parameter checksums r200 and r201 have a value unequal to 0.

The transfer of the parameter values to the retentive storage and the calculation of the related parameter checksum is only performed in standstill, during initial or normal operation.

## 4.2.12 Loading of the factory setting

### Function description

Loading the factory setting with subsequent restart of the control unit can be triggered with the service menu "General setup -> Load factory setting" and using the parameter p91.

The value of parameter p100, "Default command mode" is not overwritten in the process since it is preset in the factory for the control unit variants ATD401W and ATD420W, as well as ATD430W.

As soon as a parameter of the respective range changes, its checksum is recalculated.

The following functions are performed when factory settings are loaded:

- All parameters (up to p100) are loaded with default values.
- All event and statistical data is deleted.
- All maintenance data (counter and operating hours) is deleted.
- A restart of the control unit is triggered after approx. 18 seconds.

A learn run and a reparameterization have to be performed for the subsequent operation of the control unit.

---

#### Note

After loading the factory setting via the service menu, wait until the control unit has automatically triggered a restart (duration approx. 18 s). If the supply voltage of the control unit is switched off prematurely, the loading of the factory setting can be incomplete.

If the reset of the factory setting was incomplete, error code '5' is displayed during the restart of the control unit with connected motor and the menu language is set to English. If this is not the case, repeat the loading of the factory setting.

---

## 4.3 Extended functions

### Introduction

You can use the advanced features described below to implement application-specific requirements.

### 4.3.1 ImpulseDrive

#### Function description

The ImpulseDrive analysis process detects and evaluates external impulses applied to the door system (for example, slight force exerted on the door in the opening or closing direction).

In conjunction with the automatic ImpulseDrive system (see section Automatic ImpulseDrive (Page 75)), it is possible to open a heavy door by pressing lightly on the door handle or door frame.

When the process detects an external impulse, corresponding status information (see Table A-30 IMPDRVIncr signal (Page 319) and Table A-31 IMPDRVVelo signal (Page 319)) is generated.

The ImpulseDrive detection properties can be individually parameterized to enable adaption to different door systems.

#### Parameter assignment

The detection algorithm consists of a distance and a speed component. The sensitivity levels of both components can be parameterized separately (p1221 and p1222). A parameterizable lead time (p1220) is added to the detection algorithm to prevent problems caused by the spring effects of sealing or rubber lips.

See Table 5-33 Calibration and function parameters (Page 186).

---

#### Note

The configuration of the ImpulseDrive detection has a direct effect on the automatic ImpulseDrive, the automatic AssistedDrive and the automatic AssistedStop system.

---

#### Requirements for ImpulseDrive detection

- Parameters are matched to the target system
- Control unit is not in learn run
- Drive command is "deenergize" ("DCMD := 0")
- No obstruction has been detected in the detected direction of motion

#### Distance-based ImpulseDrive analysis

The analysis is based on the increments of the motor encoder in relation to an internal reference value. This reference value is always set if within the system state "S4: Z\_mode" (see Figure 5-4 Sequential control state graph (Page 157)) the change to the "deenergize" door command has been made and the lead time (p1220) has expired.

The sensitivity level can be specified in parameter p1221. The higher it is, the higher the number of increments counted before the signal IMPDRVInc changes to high (active).

#### Speed-based ImpulseDrive analysis

The analysis is based on the increments of the motor encoder or the actual speed derived from it. The evaluation only takes place within the system state "S4: Z\_Mode" (see Figure

5-4 Sequential control state graph (Page 157)), after the change to the "deenergize" door command has been made and the lead time (p1220) has expired.

Both analyses use a sign to distinguish the directions.

## 4.3.2 Automatic ImpulseDrive

### Function description

The automatic ImpulseDrive system generates a drive order based on the ImpulseDrive detection.

If an external pulse is detected by the ImpulseDrive analysis procedure, the automatic ImpulseDrive system generates a drive order with a normal driving profile. Both ImpulseDrive detection output signals, IMPDRVIncr and IMPDRVVelo, are evaluated. If an enable command is present, the automatic system initiates opening or closing with a normal drive profile.

The automatic ImpulseDrive can only be used with active enable. The enabling signal (DCMD := 7) is an element of the DCMD signal (see Table A-16 DCMD signal (Page 313)).

### Note

The configuration of the ImpulseDrive detection has a direct effect on the automatic ImpulseDrive system.

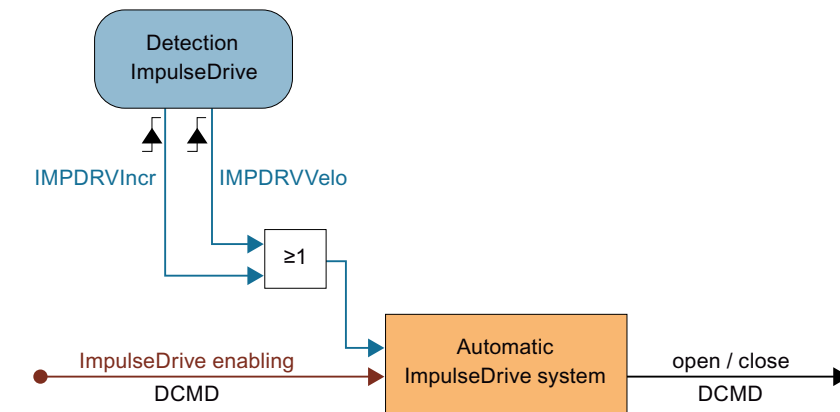

Figure 4-5 Automatic ImpulseDrive system

## 4.3.3 ImpulseStop

### Function description

The ImpulseStop analysis process detects and analyzes external forces acting on the door system/ drive system.

In conjunction with the automatic ImpulseStop system (see section Automatic ImpulseStop (Page 76)), it is possible to stop a door by gently jerking it (against the direction of travel).

The process signals when an external opposing force (force with an opposite direction vector to that of the door movement) acts on the door or the drive. It is signaled by the ASStp signal (see Table A-33 ASStp signal (Page 320)).

#### Parameter assignment

The detection properties of ImpulseStop can be individually parameterized, thus enabling the feature to be adapted to different door systems. The limit values for detecting an external opposing force can be specified for each drive direction with the following parameters:

- p1240 in the opening direction
- p1241 in the closing direction

The parameters define a proportion of the learned reference value for each direction. This proportion is added to the reference value, and thus forms the limit value for detecting ImpulseStop.

### 4.3.4 Automatic ImpulseStop

#### Function description

The automatic ImpulseStop system is an extension of the automatic ImpulseDrive system. This means that all the properties, configurations and preconditions defined for it are also applicable here.

The system can be activated via the extension bit "ImpulseStop" (see Table A-17 DCMD expansion bits (Page 314)), in connection with the automatic ImpulseDrive enable (see Table A-16 DCMD signal (Page 313)).

If the "ImpulseStop" extension bit is active, the automatic ImpulseDrive system operates with the slow driving profile. The drive orders "slow open" and "slow close" are generated instead of "open" and "close" respectively. The active drive order is canceled ("deenergized") as soon as the ImpulseStop analysis/detection signals a corresponding opposing force (the rising signal edge is decisive).

---

#### Note

The configuration of the ImpulseDrive analysis and detection directly affects the automatic ImpulseStop system.

---

#### Note

The automatic ImpulseStop system is a dynamic function. It can be enabled and disabled during a door movement.

---

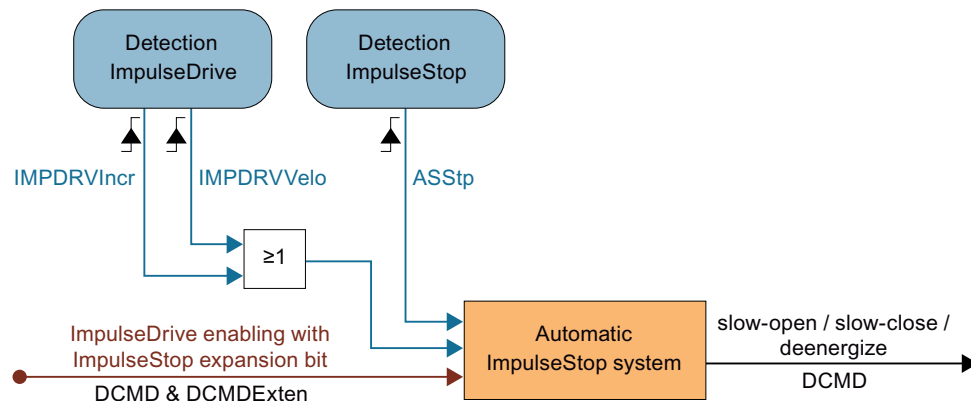

Figure 4-6 Automatic ImpulseStop system

### 4.3.5 AssistedDrive

#### Function description

AssistedDrive is an analysis process that detects and analyzes external forces acting on the door or drive system.

In conjunction with the automatic AssistedDrive system (see section Automatic AssistedDrive (Page 78)), the motor-assisted sliding of the door is made possible without buttons or sensors.

AssistedDrive signals (see Table A-32 ASDRV signal (Page 320)) whenever an external assisting force (force with the same direction vector as that of the door movement) acts on the door or the drive.

#### Parameter assignment

The detection properties of AssistedDrive can be individually parameterized, thus enabling the feature to be adapted to different door systems. The thresholds for the detection of external opposing forces can be specified for each drive direction with the following parameters:

- p1231 in the opening direction
- p1232 in the closing direction

The "slow" speed profile is adjusted with both of the following driving parameters:

- p3666 in the opening direction
- p3669 in the closing direction

See Table 5-30 Driving parameters (Page 181).

#### Note

The configuration of the AssistedDrive detection has a direct effect on the automatic AssistedDrive system.

**Prerequisites for AssistedDrive**

AssistedDrive detection is only active during the following internal system states:

- **Initial mode** (closing, closed, opening and open)
- **Normal mode** (closing, partial closure, closed, opening, partial opening and open)
- **Slow drive profile** (DCMD – expansion bit "slow", see Table A-17 DCMD expansion bits (Page 314))

If the system switches into one of the three system states, the signal ASDrv is always set to active. The actual threshold analysis of the motor current starts after the parameterized switch-off delay (p1230) and as soon as the value of the square of the difference between the setpoint and actual speeds falls below 70 mm/s.

The result of the analysis is output by the signal state ASDrv. The falling signal edge therefore indicates that the support force has become too low. Assisted mode can be exited. This signal is independent of the drive direction.

---

**Note**

The falling edge of the ASDRV signal can only be reached when the difference between the setpoint and actual speeds falls below the defined value. Therefore a speed and/or force adjustment of the system may be required.

---

### 4.3.6 Automatic AssistedDrive

**Function description**

The automatic AssistedDrive system consists of the two detection systems, ImpulseDrive and AssistedDrive.

In the process, on the one hand ImpulseDrive is used to generate a corresponding drive order with normal driving profile. On the other hand, the drive order is canceled ("deenergized") with the aid of AssistedDrive.

Automatic AssistedDrive evaluate the edges of the IMPDRVIncr, IMPRDRVVelo and ASDR signals for this.

The automatic AssistedDrive system can only be used when the enable signal is active. The enable signal for the automatic AssistedDrive system (DCMD: = 6) is an element of the DCMD signal (see Table A-16 DCMD signal (Page 313)). This ensures the unambiguity of the active drive order at all times.



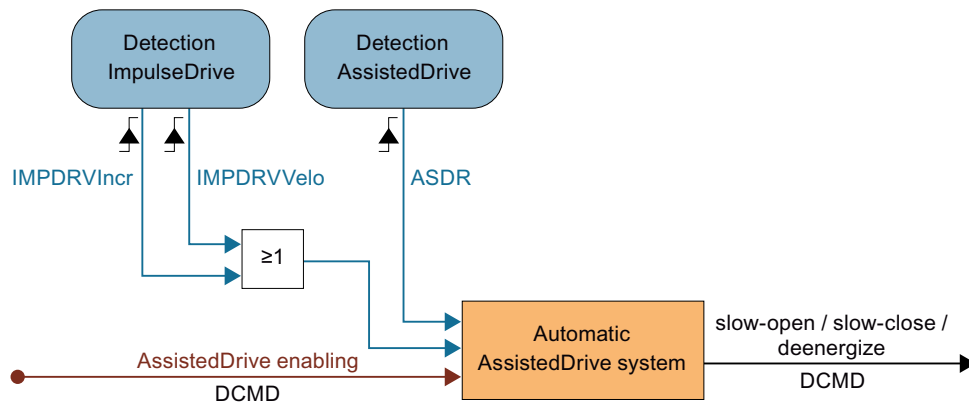

Figure 4-7 Automatic AssistedDrive system

**Note**

Once the automatic AssistedDrive system has deleted a drive order due to insufficient support force, the ImpulseDrive detection becomes active again. However, the ImpulseDrive lead time (p1220) must be taken into account. It has a direct effect on the signal chain of the automatic AssistedDrive system.

**Note**

The configuration of the ImpulseDrive and the AssistedDrive detection has a direct effect on the automatic AssistedDrive system.

### 4.3.7 Positioning mode

Positioning mode serves to absolutely position the drive. The positioning system calculates a drive profile for the optimum movement of the drive to the required target position on the basis of the driving curve parameters and the current distance from the target position. Positioning mode does not include any position control and operates with an accuracy of 1 cm. The source voltage brake is activated once the target position has been reached. After the target position has been reached, the door can be moved  $\pm 2$  cm out of the target position before the drive returns to the target position. The positioning system operates with hysteresis. The drive responds dynamically (including reversing) to changes in the target position data while keeping to the values parameterized for force and energy limiting.

**NOTICE**

**Obstruction detection**

The obstruction detection system is not active in positioning mode (see section Obstruction detection SIDOOR ATD4xxW (Page 80)).

## Activation

Positioning mode can only be activated from normal mode and at standstill via the "positioning" door command. It can be modified by the "NDG" and "slow" door command extensions. The target position is transferred as the DESTPOS signal (see DESTPOS signal (Page 314)) in technology control word 2 (TSW2) of the process image. The target position is automatically limited to the learned door boundaries.

## Sensors

Sensor signals are evaluated in positioning mode. You can find the reaction of the control/drive unit to the corresponding sensor signals in the section ESPE (Page 108) or Pressure sensitive edge (SR) (Page 109).

## Motor protection

To protect the motor, a monitoring function is active that switches off (deenergizes) the drive if the specified target position cannot be reached, e.g. due to an obstruction.

### 4.3.8 Obstruction detection

#### Description of function

##### SIDOOR ATD401W

If the controller detects an obstruction in the opening or closing direction with the aid of obstruction detection, it reverses once by 20 cm, starts an attempt to retract and then switches to wait mode. Slow obstruction approach, force obstruction detection and stop obstruction detection are active.

---

#### Note

##### Obstruction detection

The factory-set obstruction detection response of the ATD420W and ATD430W controllers corresponds to that of the SIDOOR ATD401W controller.

The factory-set obstruction behavior of the SIDOOR ATD420W and ATD430W controllers can be parameterized.

The factory-set obstruction behavior of the SIDOOR ATD401W controller is not parameterizable.

---

A detected obstruction is signaled by the DBLOCK (see DBLOCK signal (Page 317)).

The subsequent response to a detected obstruction depends on the user-defined parameter assignment. The following properties can be configured separately for the opening and closing directions:

- Obstruction detection
- Direct response
- Behavior following an obstruction

Basically, the same parameters are available for both drive directions. This means that either the same or different obstruction behavior can be configured for each direction.

The obstruction detection is a dynamic system that responds as a function of both position and time. The obstruction detection is dynamically activated or deactivated according to these dependencies. You can find more detailed information in the section Expert configuration (Page 84).

#### 4.3.8.1 Obstruction detection process

The obstruction detection is based on two processes that are independent of the direction: force obstruction detection and stop obstruction detection.

The following definitions are based on the speeds and are thus independent of the direction.

The obstruction detection systems assume that the system is actively being moved (drive order).

- **Force obstruction detection**

The current speed is  $> 90$  mm/s, and drops by more than 90 mm/s in comparison to the maximum speed reached during the current movement.

If the system then moves for the set duration (p3854 and/or p3871) at the upper force limitation, a force obstruction is detected in the current drive direction.

- **Stop obstruction detection**

If the current speed for the configured time (p3853 or p3870) is less than 10 mm/s, a stop obstruction corresponding to the current direction of travel is detected.

As of V1.09:

If the door was in the CLOSED position for at least 3 seconds and the door is then pushed open by an external force when the DOOR CLOSED command is set, no obstruction is detected when the door is moved to the CLOSE direction.

### 4.3.8.2 Overcome obstruction

The overcome obstruction system can be used to overcome a blocking obstruction by repeated pushing. The system remains active as long as the initial drive order is not actively changed.

#### Example

1. The drive order "close" is present.
2. The system closes.
3. An obstruction is detected before reaching the "Closed" end stop.
4. The second of four retries is made.
5. The "Close" drive order is overwritten by any other drive order.
6. The retry system is immediately exited.
7. The system responds according to the new drive order.

#### Parameter assignment

The number of retries to overcome the obstruction can be set in parameter p3860 or p3877. If the number is set to "0", the overcome obstruction system is disabled in the corresponding direction.

A variable waiting time can be configured before each retry (p3861 or p3878).

The type of drive control during this wait time can be "stop" or "deenergize" (p3862 or p3879).

After the configured number of retries have been made, wait mode is activated (see the following section "Wait mode"). A following drive order can also be configured, which is activated at the same time as the switch to wait mode (p3863 or p3880).

While the retry system is active, any external change to a drive order (see Table A-16 DCMD signal (Page 313)) immediately ends all open retry actions (including the cancelation of wait mode).

### 4.3.8.3 Reversing (Retraction attempt)

When an obstruction is detected, the obstruction reversing system can be used to initiate an immediate full or partial reverse - a retraction attempt. This system is simply termed "reverse". The system remains active as long as the initial drive order is not actively changed. You can find an example of this in section Overcome obstruction (Page 82).

#### Parameter assignment

The number of reversals (retraction attempts) can be defined in parameters p3864 and p3881. If the number is set to "0", the obstruction reversing system is disabled in the corresponding direction.

<b>NOTICE</b>
<b>As of V1.14 the counting of the reverses has to be changed. The number of drives in reverse direction is counted. Value 1 means that the door only drives once in reverse direction to the end position. The reverse procedure is completed after that.</b>

A variable wait time can be configured (p3865 and p3882) after each retraction attempt (on reaching the corresponding reverse target position). The drive remains stopped during the wait time.

The reversing distance or the type of reverse (full or partial reverse) can be configured to an accuracy of  $\pm 2$  cm in parameters p3866 and p3883.

If the system is blocked during reversing, all reversing processes that are still open are terminated immediately and wait mode is activated (see Wait mode (Page 84)). A following drive order can also be configured in parameters p3867 and p3884, which is activated at the same time as the switch to wait mode.

After the configured number of reversing operations/retraction attempts have been made, wait mode is activated (see Wait mode (Page 84)). A following drive order can also be configured, which is activated at the same time as the switch to wait mode (p3868 and p3885).

While the obstruction reversing system is active, any change in an external drive order (see Table A-16 DCMD signal (Page 313)) immediately ends all open reversing actions (including the cancelation of wait mode).

---

**Note**

A reverse due to a drive order being changed is part of the basic software, and is not affected by the reversing on account of an obstruction described here (Open → Close, Close → Open).

---

#### 4.3.8.4 Combination of retry and reverse

The reverse and retry systems can be combined. The combination is subject to the following rules:

- A reverse is made after executing the configured number of retries. The action is repeated for the number of configured reverses.
- Parameters p3863 and p3880 have no effect when reversing is activated.
- Wait mode becomes active after the last reverse.
- If the number of retries and reversing operations is set to "0", the "retry" following drive order has a higher priority than the "reverse" drive order.

#### 4.3.8.5 Slow obstruction approach

The position of the last obstruction in the drive direction is automatically stored in the system. The speed is automatically reduced to the corresponding creep speed (p3670 or p3666) on approaching this position. The system calculates a braking ramp so that the reduced speed is reached at the set distance (parameter p3855 or p3872) from the stored position of the obstruction. If the obstruction can be overcome, the system adjusts the speed after the same distance back to the "normal" driving curve.

Slow obstruction approach can be activated or deactivated for each drive direction in parameter p3850.

4.3 Extended functions

**4.3.8.6 Wait mode**

Wait mode is activated according to the configurations of the overcome obstruction system and the obstruction reversing system. If the system is in wait mode, this is ended any external change to a drive order. Wait mode is signaled by the process data signal "DBLCWAIT" (see "Table A-27 DBLCWAIT signal (Page 318)").

---

**Note**

If the parameters p3860 and p3864, or p3877 and p3881 are set to "0", the signal DBLCWAIT becomes active immediately after an obstruction is detected.

---

**4.3.8.7 Expert configuration**

The obstruction detection system was conceived so that it can be adapted to a wide variety of system environments, types of construction and properties. The following parameters are mainly provided for such adaptations, and have to be changed for standard systems.

### Parameter assignment

- **Function configuration**

Stop and force obstruction detection can be deactivated for each drive direction in parameter p3850 (bits 0 and 1, and 4 and 5 respectively). In addition, counting of the obstructions can be suppressed in accordance with the direction of travel (Bit 2 or 5).

- **Lead times**

After a drive order is changed or the direction of motion is reversed, the obstruction detection is activated after a variable ON-delay time (p3852 and p3869).

- **Range restriction**

The obstruction detection is suppressed in a variable area **before the respective end stop is reached** (p3856 or p3873).

It is also suppressed **after leaving** the relevant end stop (p3857 and p3874).

Force obstruction detection, in particular, is suppressed **before** the creep distance (p3858 and p3875). It is suppressed in a variable range **after** the last obstruction (p3859 and p3876). If blocking of the door takes place in a tolerance range of 10 mm before the closed position, this blocking is detected as a door end stop and the door controller switches to the "Closed" state.

The tolerance range of 10 mm for the detection of the closed position is permanently stored in the firmware of the door controller and independently of the range defined with the parameters p3856 or p3873 for the obstruction detection.

To detect obstacles smaller than 10 mm before the closed position and trigger a blocking reaction, e.g. reverse, the corresponding constructive measures have to be carried out at the door. These can, for example, be rubber lips at the door edge or door pockets before the closed position.

The tolerance range of 10 mm is necessary to consider mechanical changes of the door mechanism. Changes can, for example, occur at the following components through temperature or abrasion:

- Rubber buffer at the door edges
- Expansion und tension of the drive belt
- Contamination of the rail
- Modifications to the door frame

## **4.3.9 Free function blocks (FBLOCK)**

### **4.3.9.1 Overview**

In some applications it is necessary to control the drive via digital signals. To this end, you can configure an individual logic using the logic elements shown in the following figure.



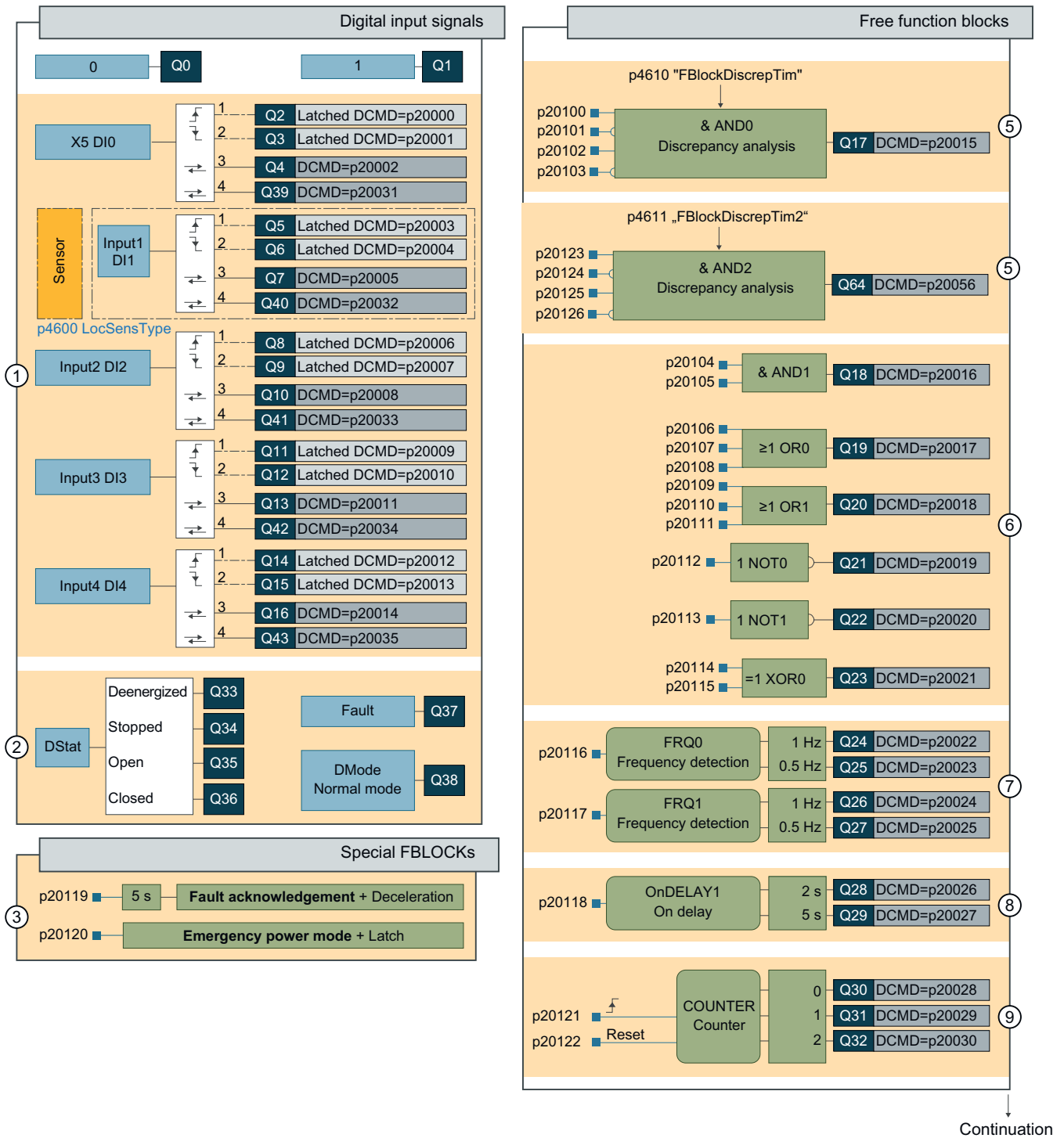

4.3 Extended functions

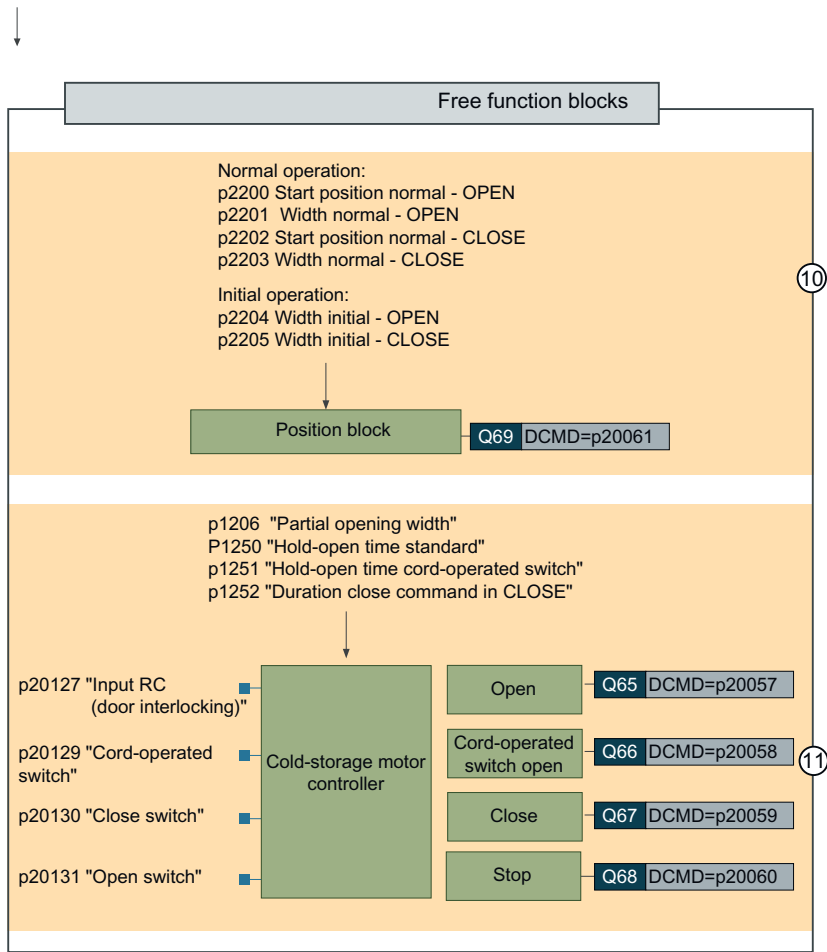

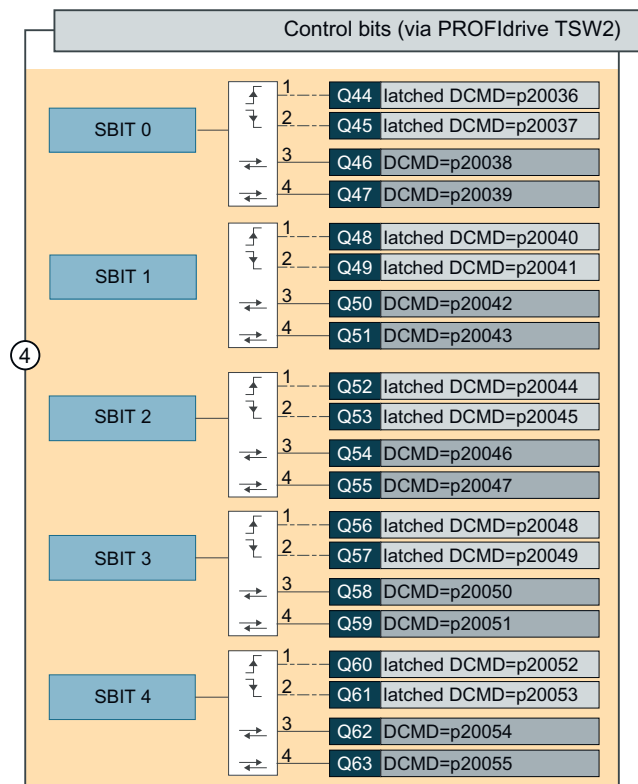

- ① Digital and logical input signals (Page 91)
- ② Digital and logical input signals (Page 91)
- ③ Special function blocks (Page 92)
- ④ Control bits (Page 92)
- ⑤ Discrepancy analysis blocks (Page 93)
- ⑥ Basic blocks (Page 93)
- ⑦ Frequency analysis blocks (Page 93)
- ⑧ On delay block (Page 94)
- ⑨ Counter block (Page 94)
- ⑩ Position function block (Page 95)
- ⑪ Cold storage function block (Page 97)

Figure 4-8 FBLOCK overview

### 4.3.9.2 Configuring the logic

The free function blocks are configured at the parameter level. The input of a function block can be linked to any output by entering the output's Q number in the input's REF parameter.

The Q numbers of the outputs can be found in the Overview (Page 86).

The REF parameters can be found in Table 5-38 FBLOCK-REF parameters (Page 195).

**Example logic**

The following figure shows an example logic. In the example logic the level-controlled outputs of the digital inputs DI3 and DI2 are linked via the FBLOCK "AND1" with the FBLOCK "Error acknowledgement".

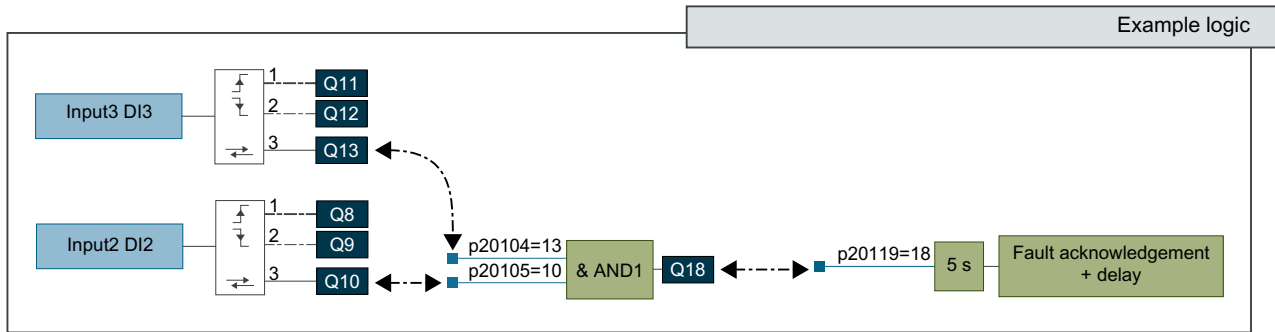

Figure 4-9 Example logic

**Drive orders**

In parallel with logical signal combination, a drive order can be assigned to the Q outputs. Door commands that are assigned to the outputs are only active as long as the assigned output is active (jog mode). A drive order is composed of a door command "DCMD" and an optional door command expansion bit "DCMD expansion".

Drive order = door command + door command expansion bit

Both commands are expressed as 16-bit values. The structure of the DCMD and DCMD expansion bit fields corresponds to the technology control world 1 (TSW 1) signals of the same names, see Table A-15 Technology control word 1 (TSW1) (Page 313). The "LB" and "DCOPS" and expansion bits are not evaluated here.

15 ... 8	7	6	5	4	3	2	1	0
<b>DCMD</b>	<b>DCMD expansion</b>							

**Example**

- The value 0x0301<sub>hex</sub> corresponds to the "close slowly" drive order.
- The value 0x0215<sub>hex</sub> corresponds to the "slow, partial opening in NDG mode" drive order.

The default command mode is defined by the p100 parameter.

For the controllers ATD420W, ATD430W command input via the bus system is activated in the factory setting. Parameter p100 is set to the value 0. This means that the FBLOCK drive orders can only be executed in the drive state "S4: Z\_OPERATION" (see Figure 5-4 Sequential control state graph (Page 157)).

For the ATD401W controller with relay module, no command input is possible via the bus system. Parameter p100 is set to the value 1. See description of parameter p100, section 4.9.5.3 Parameter assignment (Page 180).

---

**Note**

If the controllers ATD420W, ATD430W are to be operated without bus connection (offline), the default command mode must be redirected to the FBLOCK logic. Set parameter p100 to the value 1.

---

You can find more detailed information in section Drive orders (Page 49).

### Parallel drive orders

Door commands that are active during a processing cycle are assigned the following priorities:

- Stop > Open > Close

All other door commands are determined on the basis of the processing sequence.

### Parallel door command expansion bits

The door command expansion bits that are active during a processing cycle are combined (logically ORed).

### Signal processing

All outputs are recalculated in each processing cycle (10 ms) on the basis of the current input signal states. The cycle's output signals are calculated exactly in the order of the Q numbers (beginning with Q0). If the output Q22 ("NOT0") is used as the input signal of "AND0", its output Q17 is not recalculated until the next cycle.

#### 4.3.9.3 Digital and logical input signals

### Digital input signals

#### Level-controlled

The controller possesses 5 digital inputs (with 30 ms debouncing), which can be combined with any function blocks and/or can be combined directly with drive orders. Drive orders that are assigned to the level-controlled input signals are only active as long as the assigned digital input is active (jog mode).

---

**Note**

The signals of the digital inputs are additionally provided in an inverted form.

---

**Edge-controlled**

Each digital input can also be evaluated edge-controlled. Note that edge-controlled signals are available for the current processing cycle only. Drive orders that are assigned directly to the edge-controlled input signals are, therefore, "latched" automatically. "Latched" means that the drive orders are stored and stay active until they are overwritten by another drive order. These elements are identified accordingly in the Overview (Page 86).

**Note**

Latched drive orders are processed separately and are stored as door commands with an associated door command expansion bit. Any other, unlatched door command apart from "deenergized" overwrites or clears the latched drive order including the expansion bit.

**Logical input signals**

To be able to map internal dependencies in the logic, selected system states are made available as logical input signals.

Logical signal source	Meaning
Q0	Logical 0 "low"
Q1	Logical 1 "high"
Q33	Motor deenergized
Q34	Motor stopped
Q35	System opened
Q36	System closed
Q37	Fault
Q38	System in normal mode

**4.3.9.4 Control bits (as of V1.10)**

5 control bits SBIT 0 ... 4, can be transmitted via the technology control word 2 (TSW2), bit 10 ... bit 14.

Like digital input signals, these control bits can be controlled by their edge, level, inverted and non-inverted, linked to any function blocks and/or directly with motion tasks.

See also A.1.2.4 TSW2 - Technology control word 2 (Page 314).

**4.3.9.5 Special function blocks**

An active system fault can be acknowledged by means of the special "fault acknowledgement" function block. The acknowledgement is triggered after the input signal has been active for at least 5 s.

The controller's emergency power mode can be activated by means of the special "emergency power mode" function block. You can find additional details about the emergency power mode in the section Emergency power mode (Page 100).

#### 4.3.9.6 Discrepancy analysis blocks

The discrepancy analysis block "AND0" has four time-monitored inputs, two of which are negated or inverted. The output signal at Q17 behaves according to the following rules:

- The output signal only becomes active if all inputs were activated synchronously within the time defined via parameter p4610.
- The output signal becomes inactive as soon as at least one input signal has become inactive.
- The output signal can only be reactivated after all input signals have been inactive.

As of V1.10: The second discrepancy analysis block "AND2" behaves like "AND0". The output signal is available at Q64. The discrepancy time is set with parameter p4611.

As of V1.12: A violation of the discrepancy time is indicated for "AND0" and for "AND2" in the following ways:

- TZW2 – bits 6 (AND0) and 7 (AND2) - see section TZW2 - technology status word 2 (Page 319)
- As "a" on the operating status display - see section Status display (Page 297)

#### 4.3.9.7 Basic blocks

The basic function blocks "AND", "OR", "NOT" and "XOR" are provided to be able to map basic logical combinations.

#### 4.3.9.8 Frequency analysis blocks

An input signal can be analyzed for specific frequencies and duty factors via the "FRQ" frequency blocks. Two identical frequency analysis blocks are available, capable of detecting frequencies of 1 Hz and 0.5 Hz with a duty factor of 20 %.

The detection criteria and the valid tolerances are described in detail in the following figure.

4.3 Extended functions

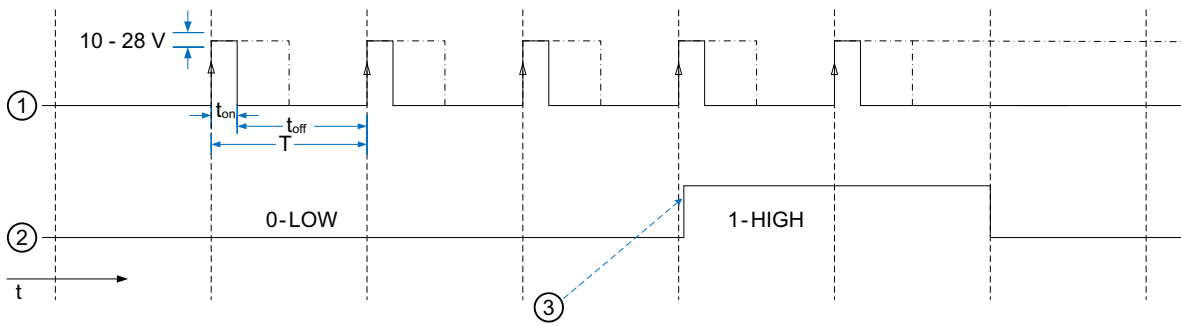

- ① Input signal
- ② Output signal
- ③ The output signal changes after 3 detected signal periods after the 4th edge

- An input tolerance of  $(\pm) 40$  ms is assumed.
- Duty cycle: 20 % (17 to 23 %)
- **1 Hz frequency detection:**
  - $T = 1000$  ms ( $\pm 2$  %)
  - $t_{on} = 200$  ms
  - $t_{off} = 800$  ms
  - Pulse/pulse ratio  $V = 25$  %
- **0.5 Hz frequency detection:**
  - $T = 2000$  ms ( $\pm 2$  %)
  - $t_{on} = 400$  ms
  - $t_{off} = 1600$  ms
  - Pulse/pulse ratio  $V = 25$  %

Figure 4-10 Frequency-based input signal detection

The outputs Q24 or Q26 become active when the analysis algorithm detects a frequency of 1 Hz with a 20 % duty factor in the input signal. The outputs Q25 or Q27 become active when the analysis algorithm detects a frequency of 0.5 Hz with a 20 % duty factor in the input signal.

The maximum response time at the output, i.e. the time after which the system can detect an error or a deviation in the input signal frequency, corresponds to the period of the frequency to be detected. Accordingly, a frequency of 1 Hz results in a maximum response time of 1 s and a frequency of 0.5 Hz results in a maximum response time of 2 s.

4.3.9.9 On delay block

The "OnDELAY" block delays the input signal at the output Q28 by 2 s and at the output Q29 by 5 s.

4.3.9.10 Counter block

The "COUNTER" block increments the internal counter value in the event of a positive edge at the input.



The maximum counter value is 2. The counter value is reset in the event of an overflow:  
0 → 1 → 2 → 0

- Counter value 0 → output Q30 active
- Counter value 1 → output Q31 active
- Counter value 2 → output Q32 active

After the controller has been switched on, the counter value is initialized automatically with 0. You can reset the counter value to 0 via the "reset" input. As long as the "reset" input is active, the counter value is 0.

### 4.3.9.11 Position function block (as of V1.12)

#### Function description

Depending on the current position of the door, the position function block outputs a corresponding door command. The configured drive command is triggered as long as the door lies within the parameterized range.

A corresponding area can be specified during normal operation for the opening direction as well as the closing direction. The area is configured with a start position and a width in centimeters (cm).

During initial mode, the position block is viewed as distance from the current door position. Therefore, one parameter exists for the opening direction and one for the closing direction.

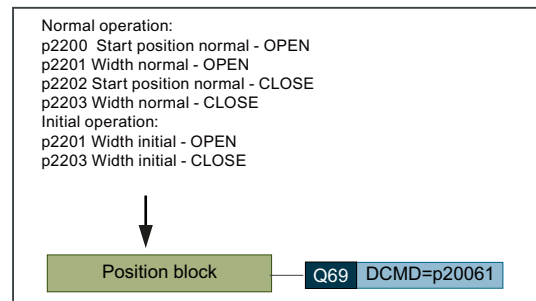

A distinction is made for the specific door area whether the control unit is in initial mode or normal operation.

Parameter ID	Meaning	Direction	Explanations/Definitions
<b>Normal operation:</b>			
p2200	Start position	OPEN	In centimeters, starting from the closed position.
p2201	Width	OPEN	Specification in cm. = 0: Output signal is always <b>inactive</b> (no reduced door range of motion defined). <>0: Output signal from start position to Startpos.+width <b>active</b> .
p2202	End position	CLOSE	In centimeters, starting from the closed position.

4.3 Extended functions

Parameter ID	Meaning	Direction	Explanations/Definitions
p2203	Width	CLOSE	Specification in cm. = 0: Output signal is always <b>inactive</b> (no reduced door range of motion defined). <>0: Output signal from start position to Startpos.+width <b>active</b> .
<b>Initial mode (absolute position is unknown):</b>			
p2204	Width	OPEN	Specification in cm. =0: Output signal is always <b>inactive</b> . >= Door width: Output signal is always <b>active</b> . < Door width: Output signal for the travel distance, relative from the current start position of the door command <b>active</b> .
p2205	Width	CLOSE	Specification in cm. =0: Output signal is always <b>inactive</b> . >= Door width: Output signal is always <b>active</b> . < Door width: Output signal for the travel distance, relative from the current start position of the door command <b>active</b> .

 **WARNING**

The position function block is not a safe function and must not be used in the context of an area where injuries can occur. To ensure safe use, the appropriate guards must be used by the user.

 **WARNING**

**Danger of injury and material damage when determining position**

Position determination, as described in the relevant chapters and generally available, is not guaranteed with a view to safe travel without endangering man or machine. All available and determined position data of the SIDOOR control unit must be regarded as a guideline with an equivalent inaccuracy, which is strongly dependent on the overall structure of the door and the associated mechanical components. In addition, when changing speed, the distances for acceleration, braking distances and controller deceleration must also be taken into account. The precision and reliability of the position determination must therefore be determined anew for each application as a whole.

According to the technical options, a maximum deviation between the determined position in the control unit and the actual position of the door of up to +/- 2 cm can occur during position detection.

Example calculation for the determination of the driving accuracy: When using accessories offered by Siemens (toothed belts, pulleys, etc.), a maximum position variance of +/-1 cm can be expected for an effective force of 300 N over an effective length of 4 m. The condition for this example calculation is a properly tensioned toothed belt, which means that any skipping of the toothed belt can also be ruled out.

## Accuracy of the position detection

According to the technical options, a maximum deviation between the determined position in the control unit and the actual position of the door of up to  $\pm 2$  cm can occur during position detection. The distances required for acceleration and braking also must be taken into account when the user changes the speed.

## Application example

In the following example the drive behavior in the close direction is to be switched in the door range of 30 cm to 100 cm. The door width is 150 cm.

A switchover of the drive behavior in the close direction is parameterized as follows:

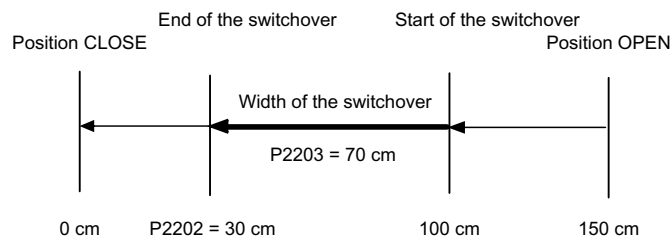

The distances are specified relative to the CLOSED position. Parameter P2202 defines the end position of the switchover (30 cm) and parameter P2203 defines the width of the switchover (70 cm).

This setting switches the drive behavior of the door in the area 100 cm to 30 cm in the closing direction.

A switchover of the drive behavior in the opening direction is parameterized as follows:

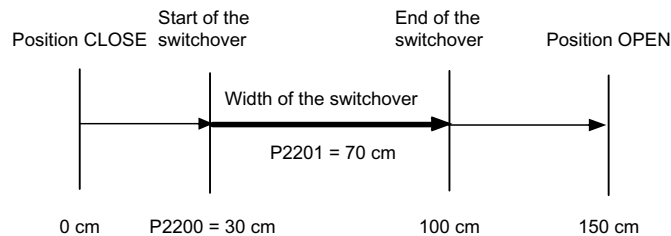

The distances are also specified here relative to the CLOSED position. Parameter P2200 defines the start position of the switchover (30 cm) and parameter P2201 defines the width of the switchover (70 cm). This setting switches the drive behavior of the door in the range of 30 cm to 100 cm in the opening direction.

### 4.3.9.12 Cold storage function block (as of V1.12)

This function block can be used to link inputs and door commands especially for use with cold storage doors.

4.3 Extended functions

The main functions in this context are:

- The inputs "Cord-operated switch", "Close pushbutton" and "Open pushbutton" are pulse inputs, which means a positive edge at the input signal triggers a drive command.
- With the "Input RC" input the motor can be switched de-energized (for example at a locked door)
- Automatic closing of the door after parameterizable times
- With the input "Cord operated switch" the door can be alternatingly opened or closed. A special drive command (e. g partial opening) can be parameterized for the opening with a cord operated switch.

**Note**

Although the RC input is activated, it is possible to move the door using the service buttons.

**SIDOOR ATD401W:**

For the ATD401W there is a special menu command available for activating the cold storage functions (see section Navigation structure in the SIDOOR SERVICE TOOL (Page 268) and section Digital input signals (Page 126)).

When the menu item "FBLOCK config. Cold storage mode" is selected, the existing FBLOCK logic is deleted and the parameterization is preset with the values described in the table below. For the commissioning of a cold storage door further settings are required. These are described in the section Operation as cold storage door (Page 104).

Parameter	Value	Unit	Description
FBLOCK cold storage door			
p20127	4	-	Logic operation input "RC input" with digital input "DI0"
p20129	10	-	Logic operation input "Cord-operated switch" with digital input "DI2"
p20130	13	-	Logic operation input "CLOSE switch" with digital input "DI3"
p20131	16	-	Logic operation input "OPEN switch" with digital input "DI4"
p20057	512	-	Logic operation output "Open" with DCMD drive command "Open"
p20058	528	-	Logic operation output "Cord-operated switch open" with DCMD drive command "Partial opening"
p20059	768	-	Logic operation output "Close" with DCMD drive command "Close"
p20060	256	-	Logic operation output "Stop" with DCMD drive command "Stop"
p1250	6	s	OPEN switch: Automatic closing after 6 seconds
p1251	0	s	Cord-operated switch: No automatic closing
p1252	3000	ms	Close command remains applied 3 seconds in closed position
FBLOCK Position block			
p20061	32	-	Switchover to "Specific door range of motion"
p2200	0	cm	Normal operation: Start position in open direction
p2201	10	cm	Normal operation: Width in opening direction
p2202	0	cm	Normal operation: Start position in close direction (is not used here)
p2203	0	cm	Normal operation: Width in close direction (is not used here)

Parameter	Value	Unit	Description
p2204	500	cm	Initial operation: Width in opening direction (max door width)
p2205	0	cm	Initial operation: Width in close direction (is not used here)
Specific door range of motion			
p3686	400	N	Force limit specific door range in the opening direction
p3687	Current parameter value close force limit	N	Force limit specific door range of motion in close direction (is not used here)
p3688	Current parameter value opening speed	mm/s	Speed limit specific door range of motion in opening direction (the current value of parameter p3664 is used)
p3689	Current parameter value close speed	mm/s	Speed limit specific door range of motion in close direction (is not used here)
Fault acknowledgement			
p20119	37	-	Automatic fault acknowledgement active

### 4.3.9.13 Specific door range of motion

#### Description of function

A separate motion behavior with regard to force and speed can be defined with the help of the specific door range of motion within a door motion in opening direction as well as in closing direction across a range. This is helpful, for example, when the machine needs a change of force and / or speed in a specific range.

The motion behavior of the door can be dynamically adapted during a door movement with the help of the specific door range of motion. Using the DCMD extension bit "Specific door range of motion" the specific door range of motion can be activated (see DCMD extension bits (Page 314))

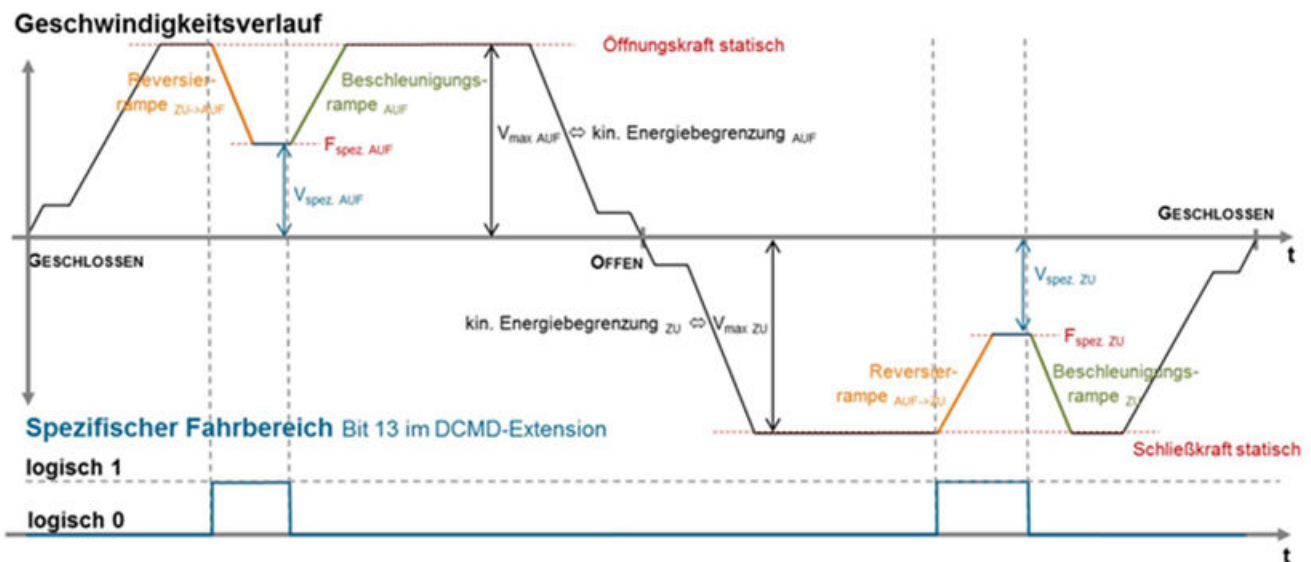

The speeds and force limits for the specific range of motion are set with the parameters p3686 – p3689. The speeds for the specific door range of motion can only be reduced with

### 4.3 Extended functions

regard to the active motion profile. If a higher value is set, the value from the active motion profile is used. The distances required for acceleration and braking also have to be taken into account for speed changes.

#### 4.3.9.14 Emergency power mode

SIDOOR ATD420W / ATD430W:

##### Description of function

If the mains voltage fails and the emergency power supply is active, the door controller can be switched to emergency power mode via the "Emergency power mode" FBLOCK function block, see section 3.3.9 Free function blocks (Page 86). This function can be implemented, for example, by means of a UPS with an appropriate output signal.

##### Parameter assignment

The FBLOCK function block "Emergency power mode" (p20120) has to be connected with a signal which shows the activation of the emergency power supply. This can, for example, be a digital input signal (DIO to DI4), a control bit (SBIT0 to SBIT4) or the output signal of another function block.

In emergency power mode, a speed-reduced driving curve profile is used. Emergency power mode cannot be exited until the controller has reached the closed or open state in normal mode.

#### 4.3.10 Basic parameter editor (as of V1.10)

##### Function description

The parameters determined in a test run can be set using a fieldbus or the control menu. These parameters are called "basic parameters (Page 180)".

The basic parameters editor can be used to perform initial commissioning of a door control unit only by setting parameters without a learn run.

For example, the parameter set can be determined once for identical door systems. Each door control unit is configured with this parameter set at the factory. When replacing a door control unit, the parameter set can be copied from the old control unit to the new control unit.

It is recommended to determine the basic parameters for a door system once with a learn run and then to adapt or copy it to other door control units.

When the motor type or the door mechanism are changed, the basic parameters must be adjusted accordingly.

 **WARNING**

**Basic parameter editor**

There is no plausibility check of the basic parameters by the control unit when basic parameters are changed. Incorrect parameter assignment may result in undesirable travel behavior of the door. When the moving mass and configured energy limit are changed, the configured speed is automatically adjusted for the permissible kinetic energy. After changing the basic parameters, the drive curve parameters must be checked and adjusted if necessary.

Changed basic parameters only take effect at standstill.

If the write protection is set via parameters p90, the basic parameters cannot be changed through the menu system.

The basic parameters are reset to default values during the first commissioning or after resetting of the parameter storage via p91 or after changing the motor type.

After setting the basic parameters, the limits for the driving curve parameters (braking and acceleration ramps, maximum speeds and forces) are calculated according to the basic parameters (weight to be moved and output transmission). If the previously set driving curve parameters are outside the calculated limits, the driving curve parameters are corrected so that they are within the parameter limits.

After changing the basic parameters (in particular the weight to be moved and output transmission), it is recommended to check and adjust the driving curve parameters or to load the default parameters.

As of V1.14: If the basic parameter "dynamic mass" is changed using the basic parameter editor, a learn run which does not change this parameter can be started via the drive command "Learn run without mass determination".

## Operation of the basic parameter editor via fieldbus

The status of the basic parameters editor can be determined and changed via parameter p2111:

Read p2111:

0 -> Basic parameter editor is not active. The basic parameters are read-only.

1 -> Basic parameter editor is running. The basic parameters can be changed.

Write p2111:

0 -> Cancel basic parameter editor. Changed basic parameters are discarded.

1 -> Start basic parameter editor. Basic parameters can be changed.

2 -> Close basic parameter editor and save the parameters.

If not all basic parameters were written during a first commissioning or during the reset of the parameter storage with p91, the write operation is finished with an error message (6 wrong value). Changes to the basic parameter settings are discarded.

### Control of the basic parameter editor via menu system

With the menu command "General setup -> Basic parameters", you can open basic parameters editor in the menu (see also section "Navigation Structure in SIDOOR Service Tool (Page 268)").

As of V1.10:

If the menu command "Change Basic Parameters" is not selected with CR, the basic parameters are only displayed.

If the menu command "Change Basic Parameters" was selected with CR, it changes to "Save Basic Parameters" and the basic parameters can be changed.

After all basic parameters have been changed or confirmed with CR, you can select "Save basic parameters". The basic parameters are saved and the menu command returns to "Change Basic Parameters".

If not all basic parameters were changed or confirmed with CR with an initial commissioning or after resetting the parameter memory via p91, an error message is displayed. Changes to the parameter settings are discarded.

As of V1.14:

The basic parameters can be directly changed after selection with CR. When the menu level "General setup -> Basic parameter" is left by using the "ESC" button, an "ESC -> Abort / CR -> Save" query prompt is displayed. The changes to the basic parameter are rejected with the "ESC" basic parameter, the changes are applied and saved with the "CR" button.

#### 4.3.11 Masking of door commands (as of V1.12)

##### Description of function

With this function it is possible to mask door commands from the two door command sources "Fieldbus" and "FBLOCK". In particular, masking is provided for the DCMD extension bits.

The masks can be used to define which bits of the door commands are still to be effective according to Section (Page 313) and which are not.



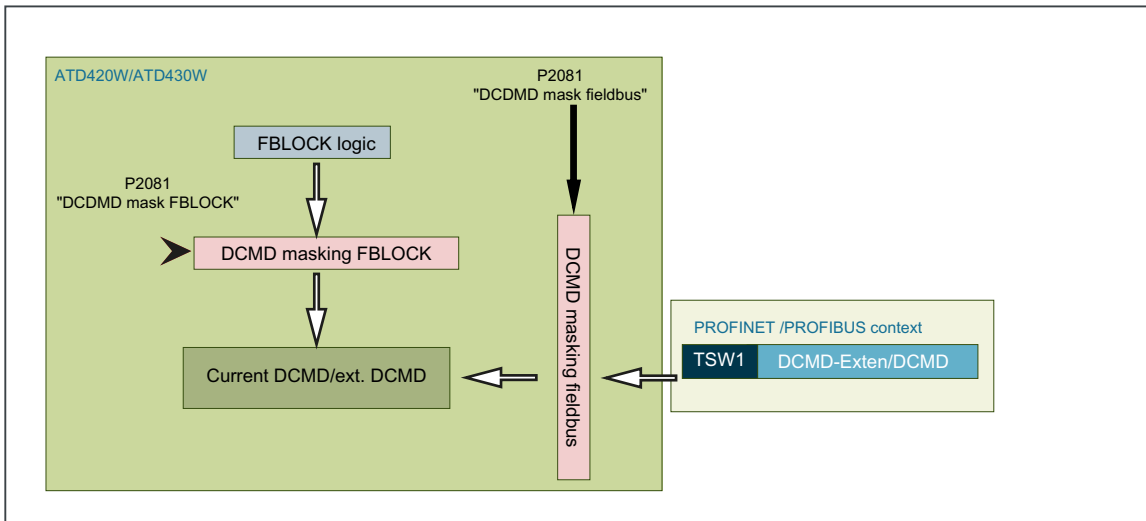

The two masks are stored in the following parameters:

Table 4-11 Masking of door commands

Parameter ID	Value range	Default value:	Description
p2080	0..65535	<b>0xFFFF</b> (All bits of TSW1 from the fieldbus are allowed to pass.)	<b>DCMD masking fieldbus</b> Each bit in the mask filters the corresponding bit in TSW1: 0: CMD bit is not allowed to pass 1: CMD bit is allowed to pass
p2081	0..65535	<b>0xFFFF</b> (All bits of the DCMD/ext. DCMD are allowed to pass.)	<b>DCMD masking FBLOCK</b> 0: CMD bit is not allowed to pass 1: CMD bit is allowed to pass

Because DCMD is normally not to be considered bitwise (but as a numeric value), the mask for DCMD should be either 0xFF or 0x00. As soon as the user enters a value unequal to 0 (0x01 to 0xFE), it is immediately and automatically corrected to 0xFF by the firmware.

Example:

To deactivate the NDG switchover via the fieldbus, the parameter value must be set to 0xFBFF (see section (Page 313)).

### 4.3.12 Test run (as of V1.12)

#### Description of function

The test run is used to measure the closing and opening forces during final inspection and commissioning. There is no reversing reaction during the test run.

The test run can be activated with the menu command "Test run" in the "General setup" menu and via the fieldbus interface, parameter p95. The test run enables the reversing to be deactivated after blocking for exactly the next door command. Afterwards, the test run

function is automatically deactivated again. The menu command and the parameter p95 show the status of an active test run.

During the test run, all other drive parameter values (e.g. speed and force) are maintained as they were previously configured. This means that even though a test obstruction is detected during the test run, the present force remains in effect until a new door command, e.g. STOP, is issued.

### 4.3.13 Operation as cold store door (as of V1.13)

#### Function description

To use the ATD4xxW control unit to control a cold store door, further settings have to be made in addition to the FBLOCK configuration of the input signals (see section "5.4.1 Digital input signals (Page 126)")

Note: The increased force in the first 10 cm to open the cold store door is only available when the opening signal is issued via the digital inputs.

This means that it is possible that the door cannot be opened when commands are given via the service buttons on the control unit, the service menu or via the SIDOOR user software.

The procedure for the configuration of the ATD4xxW control unit as a cold store door is described below:

1. Start a learn run with a new motor, service menu: "General setup -> Start learn run with new motor"
2. If no output transmission has been previously parameterized, the input prompt: "Output transmission" is now displayed.  
The value 176 mm/rev has to be set here for the SIDOOR default motors M3, M4 or M5.
3. After entering the output transmission, start the learn run again via the service menu: "General setup -> Start learn run with new motor".
4. If the learn run has been performed successfully, the 7 segment display shows "u"
5. Set the FBLOCK logic for the circuiting of the input signals as a cold store door, service menu: "General setup > Special parameters > Default command mode > FBLOCK configuration > FBLOCK config. cold storage mode"
6. Set the command priority (for ATD401W this should already have been preset at the factory), service menu: "General setup > Special parameters -> Default command mode -> FBLOCK + relay".
7. If required, the hold-open time for the opening button can be modified, service menu: "General setup > Special parameters > Hold-open time standard"  
If the FBLOCK logic is set to cold storage door 6 seconds is preset as the default value for the hold-open time. The value 0 means pulsed operation. This means Press button once = OPEN, press button again = CLOSED.
8. If required, the behavior of the cord-operated switch can be modified, service menu: "General setup -> Special parameters -> Hold-open time cord-operated switch".  
The default value is 0. The value 0 means pulsed operation. This means Actuate cord-operated switch once = OPEN, actuate button again = CLOSE.

9. The partial opening width for the cord operated switch should be modified, service menu: "General setup > Special parameters > Partial opening width".  
The default value is 30 cm. This value should be increased for cold storage operation.
10. If required, the speed can be modified for the first 10 cm in the opening direction (increased force range), service menu: "General setup > Special parameters > Speed critical range OPEN". The default value for the setting of the FBLOCK logic (Item 5) corresponds to the parameterized opening speed.
11. If required, the force can be modified for the first 10 cm in the opening direction (increased force range), service menu: "General setup -> Special parameters -> Force-specific range OPEN".  
The default value is the maximum force for the respective motor type of the set transmission output.
12. The service menu points "Speed critical range CLOSE" and "Force-specific range CLOSE" are not relevant for the cold storage operation.
13. The default values for the force limits are set to 75 N. For cold storage operation the force should be increased to 150 N depending on the door mechanism and the standardization:  
Menu: "General setup > Profile parameters > Opening force static: 150 N"  
Menu: "General setup > Profile parameters > Static force limit close: 150 N"  
Menu: "General setup > Profile parameters > Limit force end static CLOSE: 150 N"  
Menu: "General setup > Profile parameters > NDG force static: 150N"  
Remark: The increased force for the first 10 cm in the opening direction is set using the parameter "Force-specific range OPEN", see Item 11.
14. The default values for the energy limit are set to 4 Joule. The speeds, depending on the weight to be moved, are fixed to these energy limits ( $v=2E/m$ ). To increase the speeds the energy limits can be increased or, if the energy limits are parameterized to the value 0, the speeds can be set freely.  
Menu: "General setup > Profile parameters > Kin. energy limitation close"  
Menu: "General setup > Profile parameters > Maximum speed close"  
Menu: "General setup > Profile parameters > Kin. energy limitation open"  
Menu: "General setup > Profile parameters > Maximum speed open"  
Menu: "General setup > Profile parameters > Kin. energy limitation NDG"  
Menu: "General setup > Profile parameters > NDG speed"
15. As of V1.14: Optionally a simple light barrier can be connected to the input "Input 1" (see section "5.4.1 Digital input signals (Page 126)"). To this purpose set the input "Input 1" as a light barrier input, service menu: "General setup -> Special parameters -> Function input 1 -> Light barrier".  
The default value for input "Input 1" is "inactive".  
A de-energized input means that the light barrier is interrupted.
16. As of V1.14: The duration of the close command when reaching the closed position can be parameterized. (Service menu "General setup -> Special parameters -> Duration close command in CLOSE"). The peak torque close and the idle torque CLOSE are applied in the closed position for this duration. When the FBLOCK logic is set as a cold storage door (see Item 5) a duration of 3 seconds is preset.
17. As of V1.14: An automatic acknowledgment of faults can be parameterized. This leads to an automatic restart of the control unit after a fault (service menu "General setup -> Special parameters -> Automatic restart"). When the FBLOCK logic is set as a cold storage door (see Item 5), automatic restart in case of a fault is preset.

## 4.4 Safety functions

### Introduction

Using the safety functions described below, you can:

- Expand the system with optional safety devices
- Use the inputs with secure input signals

 <b>WARNING</b>
--

The effectiveness of the safety functions must be checked during commissioning of the system and at regular intervals, depending on the application.
--

### 4.4.1 Optional safety equipment

#### 4.4.1.1 Light barrier

---

**Note**

If the light barrier is operated according to this chapter (without sensor function test), no performance level is determined for it.

---

### Description of function

If no power is supplied at the light barrier input, this is interpreted as an interruption of the light barrier. The door cannot then close.

If the light barrier is interrupted while the DOOR CLOSE command is active, the door is moved in the OPEN direction. An interruption of the light barrier while the DOOR CLOSE command is inactive does not change the state.

**Exception:** If the door is open less than 1 cm, the light barrier signal is ignored.

### Connection and parameter assignment

#### SIDOOR ATD420W / ATD430W

The sensor signal must be generated by the PLC as part of the process image. See Table A-17 DCMD expansion bits (Page 314).

The status of the sequential control must be considered when using the light barrier (LB) signal. The process data (including the LB signal) are only valid in the status "S4: Z\_

operation" (see Figure 5-4 Sequential control state graph (Page 157)). The LB signal is evaluated in the low-active state, but is not tested during the sensor function test.

---

**Note**

The light barrier signal is evaluated in the low-active state and must therefore be assigned 1 (= not interrupted).

---

When not in operating status "S4: Z\_ operation" (see Figure 5-4 Sequential control state graph (Page 157)), the sensor signals are automatically assigned their resting signal value so that they have no effect on the system status.

The travel range within which the controller reacts to the light barrier signal can be restricted by parameter p1210. See Calibration and function parameters (Page 186).

You can find more detailed information on the light barrier in section Overview (Page 160).

**As of V1.14: SIDOOR ATD401W / ATD420W / ATD430W**

The input "Input 1" can be parameterized as an input signal for a "simple" light barrier, without sensor function test.

## Signals

Signal	Meaning
1 (voltage applied)	Light barrier is not interrupted and the door closes when the DOOR CLOSE command is present
0 (voltage not applied)	Light barrier is interrupted and the door opens when the DOOR CLOSE command is present*

\* The response of SIDOOR ATD4xxW controllers also depends on the particular system mode. See the table below.

Table 4-12 Response of SIDOOR ATD4xxW controllers to an interrupted light barrier

Mode	Response
Learn run mode	Learn run is canceled and the drive is <b>deenergized</b> .
Initial mode	The system is <b>stopped</b> via a ramp down in conjunction with the active "Close" drive order.
Normal mode	<b>Reverses</b> the system in conjunction with the active "Close" drive order.  The system response to an obstruction detected while reversing can be configured accordingly. The following drive order can be defined with parameter p1211 (see section Calibration and function parameters (Page 186)).  In positioning mode, the drive is <b>stopped</b> via a ramp down.
Special mode	The system is <b>stopped</b> via a ramp down in conjunction with the active "Close" drive order.

4.4.1.2 ESPE

**Function description**

A light array / light curtain is the part of the electro-sensitive protective equipment (ESPE) that is connected to the machine control system and assumes a defined state when the sensing device is triggered during intended use.

**Connection and parameter assignment**

An ESPE can be connected to SIDOOR ATD4xxW control units via "Input 1" of the terminal X6.

An ESPE with type 3 or 4 OSSD outputs can also be used by using switchgear. You can find additional information in the section Sensor technology and external sensor connection (Page 160).

If the SIDOOR control unit's sensor logic is configured for ESPE, the "TestOUT" function test signal is output automatically at the terminal X100.1 (ATD420W, ATD430W) or X12 (ATD401W). See section Sensor function test (Page 164).

The sensor type of the sensor connected to "Input 1" of terminal X6 can be configured as follows:

- Parameter p4600
- Service menu: *MAIN MENU > General setup > Special parameters > Function Input 1*

The travel range within which the control unit reacts to the OSSD signal can be restricted by parameter p1210 (see section Calibration and function parameters (Page 186)).

You can find a schematic connection as well as detailed information on the connection of an ESPE in the Overview (Page 160) section.

---

**Note**

The light barrier, DCOPS, ESPE or pressure sensitive edge functions cannot be implemented simultaneously as sensor functions at Input 1.

---

**Signals**

Signal	Meaning
1 (voltage applied)	Light curtain is not interrupted.
0 (voltage not applied)	Light curtain is interrupted*.

\* The response of SIDOOR ATD4xxW control units also depends on the particular system mode. See the table below.

Table 4-13 Response of SIDOOR ATD4xxW control units to an active light curtain signal

Mode	Response
Learn run mode	Learn run is canceled and the drive is <b>deenergized</b> .
Initial mode	The system is <b>stopped</b> via a ramp down in conjunction with the active "Close" drive order.
Normal mode	<b>Reverses</b> the system in conjunction with the active "Close" drive order. The system response to an obstruction detected while reversing can be configured accordingly. The following drive order can be defined with parameter p1211 (see section Calibration and function parameters (Page 186)). In positioning mode, the drive is <b>stopped</b> via a ramp down.
Special mode	The system is <b>stopped</b> via a ramp down in conjunction with the active "Close" drive order.

### 4.4.1.3 Pressure-sensitive edge (SR)

#### Function description

The pressure sensitive edge is connected to the machine control system and assumes a defined state if the sensing device is addressed during proper operation.

#### Connection and parameter assignment

The output signal switching device of the pressure-sensitive edge is connected to "Input 1" of the terminal X6.

If the SIDOOR control unit's sensor logic is configured for a pressure sensitive edge, the "TestOUT" function test signal is output automatically at the terminal X100.1 (ATD420W, ATD430W) or X12 (ATD401W). See section Sensor function test (Page 164).

The sensor type of the sensor connected to "Input 1" of terminal X6 can be configured as follows:

- Parameter p4600
- Service menu: *MAIN MENU > General setup > Special parameters > Function Input 1*

The travel range before the "Closed" position in which the control unit responds to the pressure sensitive edge's signal can be restricted by parameter p1210 (see section Calibration and function parameters (Page 186)). The control unit does not respond to the pressure sensitive edge's signal in the range of  $\pm 2$  cm before the "Open" position.

---

#### Note

The light barrier, DCOPS, ESPE or pressure sensitive edge functions cannot be implemented simultaneously as sensor functions at Input 1.

---

You will find a circuit diagram and detailed information about connection of a pressure-sensitive edge in section Overview (Page 160).

Signals

Signal	Meaning
1 (high)	Pressure-sensitive edge is not interrupted and is fault-free.
0 (low)	Pressure-sensitive edge is interrupted or defective*.

\* The response of SIDOOR ATD4xxW control units also depends on the particular system mode. See the table below.

Table 4-14 Response of SIDOOR ATD4xxW control units to an active pressure sensitive edge signal

Mode	Response
Learn run mode	Learn run is canceled and the drive is <b>deenergized</b> .
Initial mode	The system is <b>stopped</b> and then <b>deenergized</b> via a ramp down in conjunction with the active drive order.
Normal mode	The system reverses by <b>20 cm</b> in conjunction with the active drive order. The drive is <b>stopped</b> and then <b>deenergized</b> if an obstruction is detected during reversing. In positioning mode, the drive is <b>stopped</b> and <b>deenergized</b> via a ramp down.
Special mode	No response

4.4.1.4 Deactivation of the service buttons during emergency stop (as of V1.12)

Description of function

To prevent a door command being issued during a triggered emergency stop (e.g. using the service buttons), you can block door commands after an emergency stop as of firmware version V1.12.

First of all, the emergency stop function must be defined as such in the emergency stop circuit. This is done by using the door command available as of V1.12 with the value "8" (Stop with disable DCU) (see TCW1 - technology control word 1 (Page 313)) in the emergency stop interconnections in accordance with the sections Emergency stop after category 1 stop concept (Page 116) and Safe digital control door OPEN/CLOSE with emergency stop via 3 digital inputs concept (Page 117).

Note

To activate this function after the update to version V1.12, a new selection of the pre-configured emergency stop interconnection according to section Digital input signals (Page 126) is required for the ATD401W.

In the case of an ATD4x0W controller, the emergency stop door command must be changed to activate this function. The door command is not adapted automatically.



## 4.4.2 Security policy

The SIDOOR controllers ATD4xxW dispose of an extensive safety package. With the available safety functions of the SIDOOR controller the requirements according to DIN EN ISO 13849-1 Cat 2 PL d (performance level) can be fulfilled.



### WARNING

The specifications of the performance level and the stop categories only refer to the examples described in this section.

The determination of the performance level and stop categories must always be carried out by the user in the overall system under consideration of all links of the safety chain.

The scope of the safety functions includes:

- Safe force output
- Safe speed observance (energy limiting)
- Safe input signals

### 4.4.2.1 Safe force output

The maximum forces configured by the user must always be observed for safety reasons. The safe force output of the SIDOOR system ensures that the torque output by the motor does not increase in case of an error. Unintentional increases in the torque are recognized and result in a defined error response.

### 4.4.2.2 Safe speed observance (energy limiting)

The speeds configured by the user must always be observed for safety reasons. The safe speed observance of the SIDOOR system ensures that the energy of the door does not increase in case of an error. Unintentional increases in speed are recognized and result in a defined error response.

### 4.4.2.3 Safe input signals according to PLd

SIDOOR ATD4xxW controllers have five digital inputs (see Digital input signals (Page 126)), through which safety-related signals can also be sent. This section describes two different methods for transferring safety-related signals to the controller.

Two concepts are also presented for two-hand operation and emergency stop applications.

The concepts described in this section for implementing safe input signals according to PLd (Performance Level d) enable detection of the following faults:

- Discontinuity of one single terminal
- Short-circuit between any two terminals
- Stuck-at fault (short-circuit to 1 and 0 in the case of an isolated input or an interrupted output)
- Static signal "0" and "1" at all inputs and outputs, individually or simultaneously

- Parasitic oscillation of outputs
- Modification of characteristic values (e.g. input/output voltage of analog devices)

#### 4.4.2.4 Internal signal routing

The following figure illustrates the input terminals and the internal wiring to the processor. The input signals are located at processor port M. Separate reference potentials 0M, 1M and 2M can each be defined for Input 2, Input 3, Input 4 and for Input 1 and Input 0. The input signals are provided with internal pull-ups and there are no components between the input terminals and the processor that are capable of oscillation.

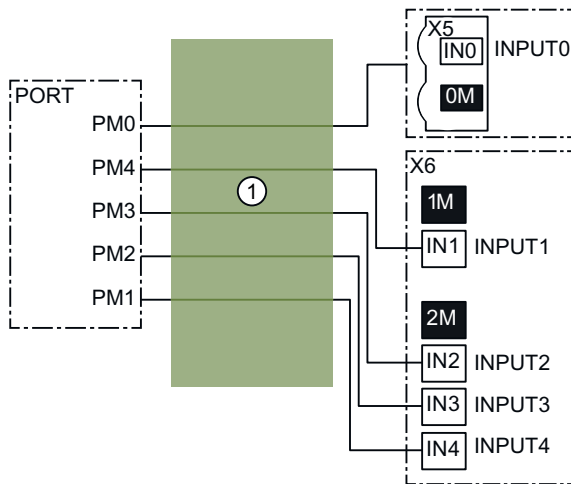

- ① No components capable of oscillation and internal pull-up circuit
- 0M Ground potential 1
- 1M Ground potential 2
- 2M Ground potential 3

Figure 4-11 Internal wiring of input terminals

#### 4.4.2.5 Redundant antivalent signal logic with discrepancy analysis

In the case of 1oo2 evaluation, the sensor is routed to two different, mutually antivalent channels and is therefore evaluated by the controller twice. The discrepancy analysis is performed between the two channels of the 1oo2 evaluation in the controller. If there is a discrepancy between the input signals after expiry of the parameterized discrepancy time, e.g. due to breakage of a sensor cable, the internal signal is set to "0". The discrepancy analysis at the input channels is performed with the "AND0" discrepancy analysis block (for more, see also section Free function blocks (Page 86)). This special kind of signal routing achieves PLd and enables both high availability and error detection.

The following graphics show an example of 2-channel antivalent wiring of a sensor (antivalent).

##### Antivalent connection of an antivalent sensor to two channels

A 2-channel sensor is required for the signal (1oo2 evaluation)

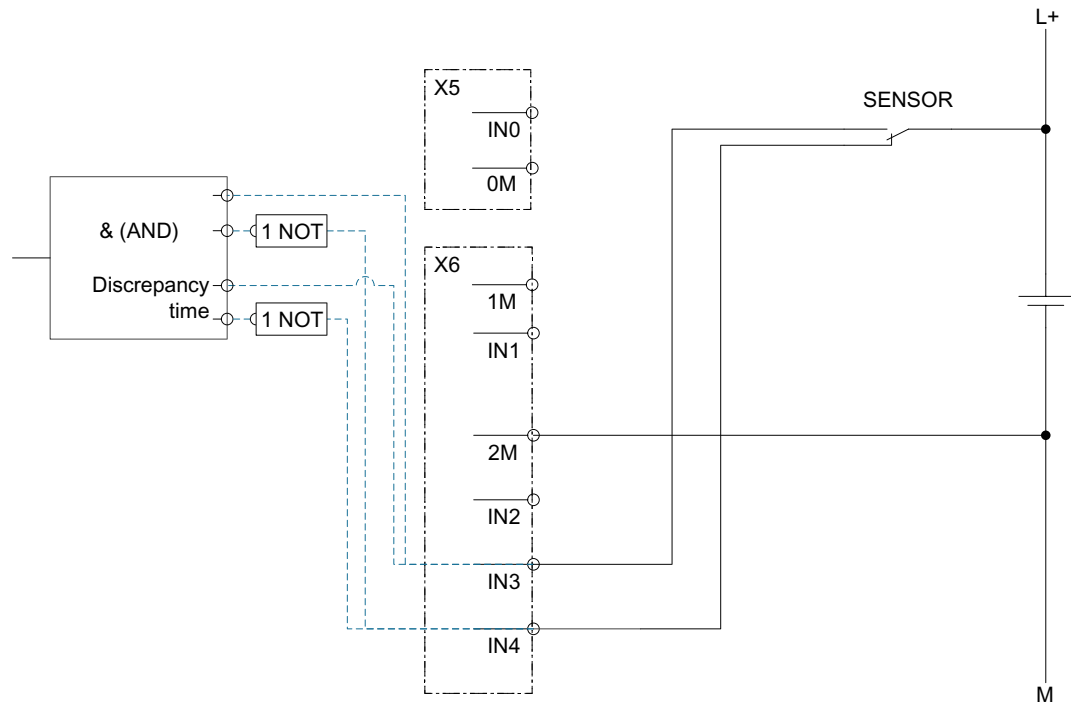

Figure 4-12 Connect the switchgear to the change-over contact, 2-channel nonequivalent

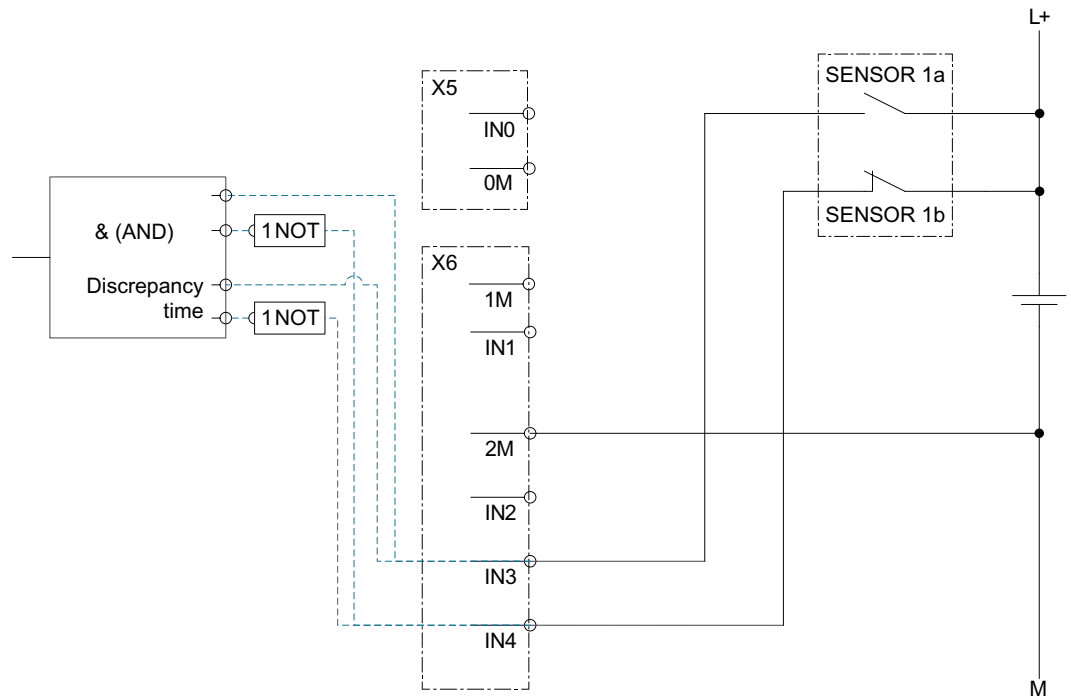

Figure 4-13 Connect the switchgear to two separate non-equivalent change-over contacts, 2-channel non-equivalent\*

\* Two 1-channel sensors can also be connected as an alternative.

**4.4.2.6 Frequency-based input signals**

As well as 1oo2 evaluation with antivalent channels, a frequency-based system can also be used to implement fail-safe inputs according to PLd.

Two frequency analysis blocks are available for this purpose, and can be linked to any input channel. For more, see also section Free function blocks (Page 86).

**4.4.2.7 Two-hand operation concept (according to Cat. IIIA)**

This concept describes implementation of two-hand operation in compliance with DIN EN 574:2008-12, Category IIIA. To achieve the specified Category IIIA, it is imperative that a discrepancy time of  $\leq 500$  ms be parameterized.

**Note**

Only Category I is possible with discrepancy times  $> 500$  ms.

Where a two-hand control device is used, two sensors are routed to the SIDOOR controller in a safety-related fashion and are internally evaluated via the "AND0" discrepancy analysis block.

**Antivalent connection of two redundant antivalent sensors to two channels**

Two redundant antivalent sensors are needed for the signal (1oo2 evaluation)

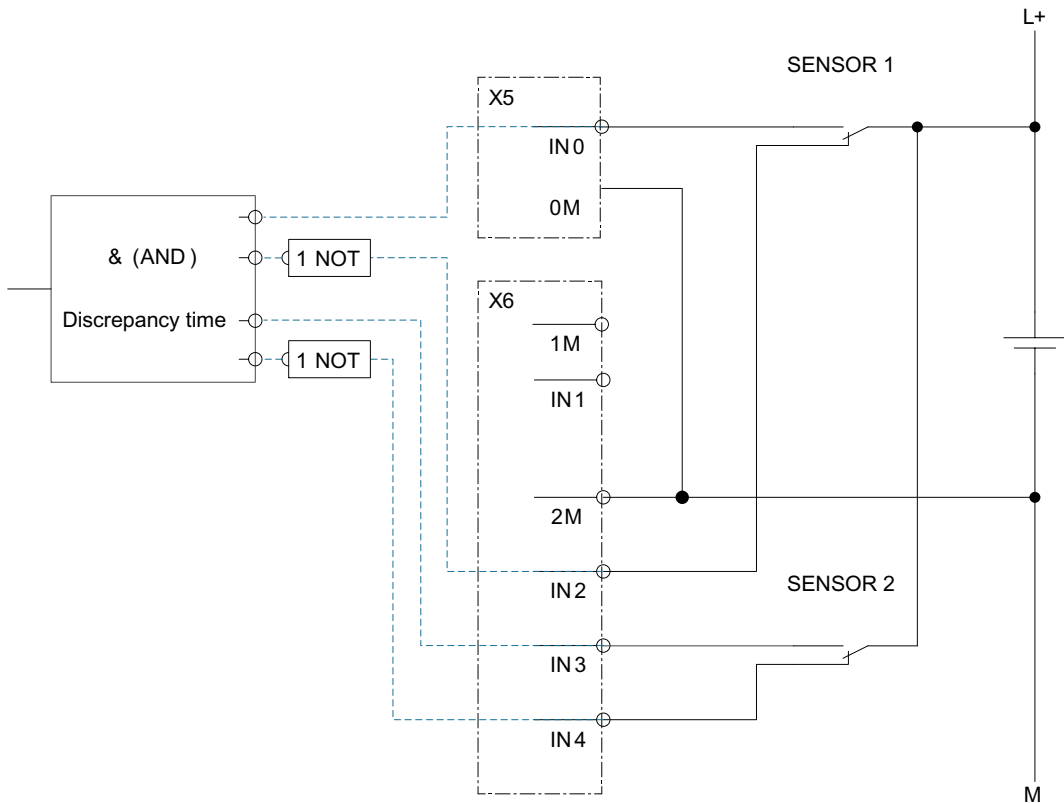

Figure 4-14 Two-hand control device example

### Antivalent connection of two redundant, two-channel antivalent sensors to two channels

Two redundant 2-channel antivalent sensors are needed for the signal (1oo2 evaluation)

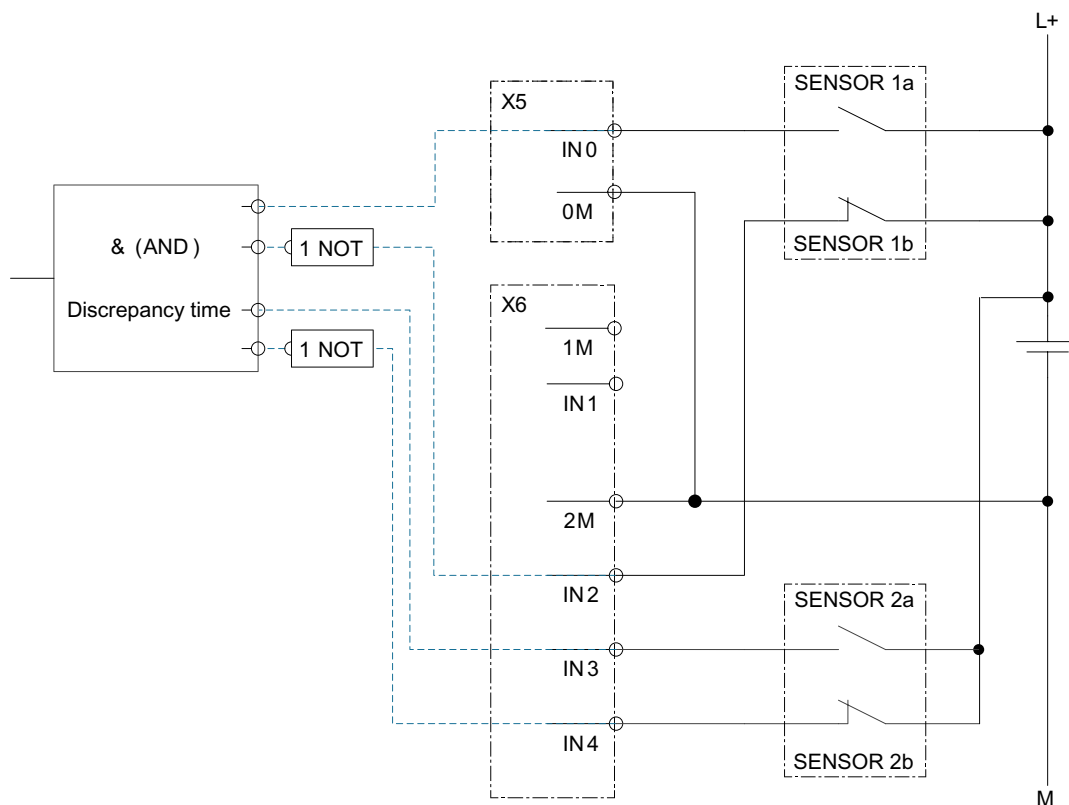

Figure 4-15 Two-hand control device example

The output of the "AND0" block can be directly assigned a drive order or can be assigned the prioritized STOP door command via an additional negation block. This corresponds to enabling for the actual drive order. The following example illustrates this:

- Open drive order is activated.
- 2-hand control device inactive → STOP (highest priority)
- 2-hand control device active → STOP is cleared → OPEN becomes active

4.4 Safety functions

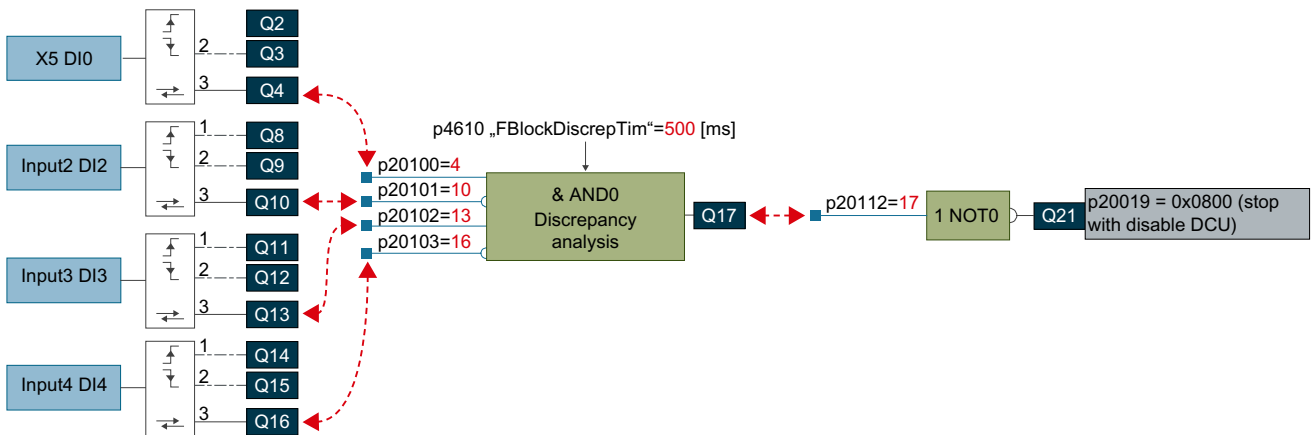

Figure 4-16 Two-hand control device example parameterization

4.4.2.8 Emergency stop concept in accordance with stop category 1

This concept describes the implementation of the emergency stop function according to stop category 1 according to EN ISO 13850:2015 section 4.1.3 Stop category 1.

Safe motor shutdown

SIDOOR ATD4xxW controllers have an internal, cyclically tested and monitored second shutdown route according to PLd. This ensures safe shutdown of the motor (emergency stop).

Door commands

The door command with the highest priority is STOP → ramp stop.

The status following the ramp stop can be defined with the "special" door command expansion bit: EMF brake activated or de-energized (free running mode or de-energized).

Implementation

For the implementation of an emergency stop circuit, the emergency stop signal must be routed to the SIDOOR controller in a safety-related manner (frequency-based or 2-channel antivalent evaluation) and internally linked with a stop door command. A negation block must be configured if a low-active emergency stop signal is used.

The following figure shows an example of a low-active emergency stop signal with frequency-based channel protection at INPUT0.

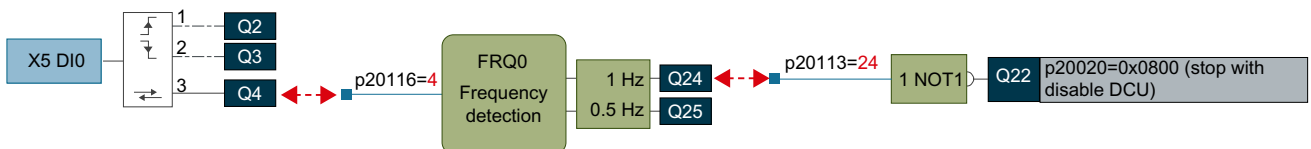

Figure 4-17 Example emergency stop parameterization

#### 4.4.2.9 Concept of fail-safe digital control (door OPEN/CLOSE) with emergency stop via 3 digital inputs

This concept describes an implementation variant of the emergency stop function according to stop category 1 of EN ISO 13850, with safe control (according to PLd) of the drive orders OPEN/CLOSED via three digital inputs.

##### Safe motor shutdown

SIDOOR controllers have an internal, cyclically tested and monitored second shutdown route according to PLd. This ensures safe shutdown of the motor (emergency stop).

The figures below show examples of the safe control (to PLd) Door OPEN/CLOSE with emergency stop according to stop category 1 via 3 digital inputs via a redundant antivalent channel protection.

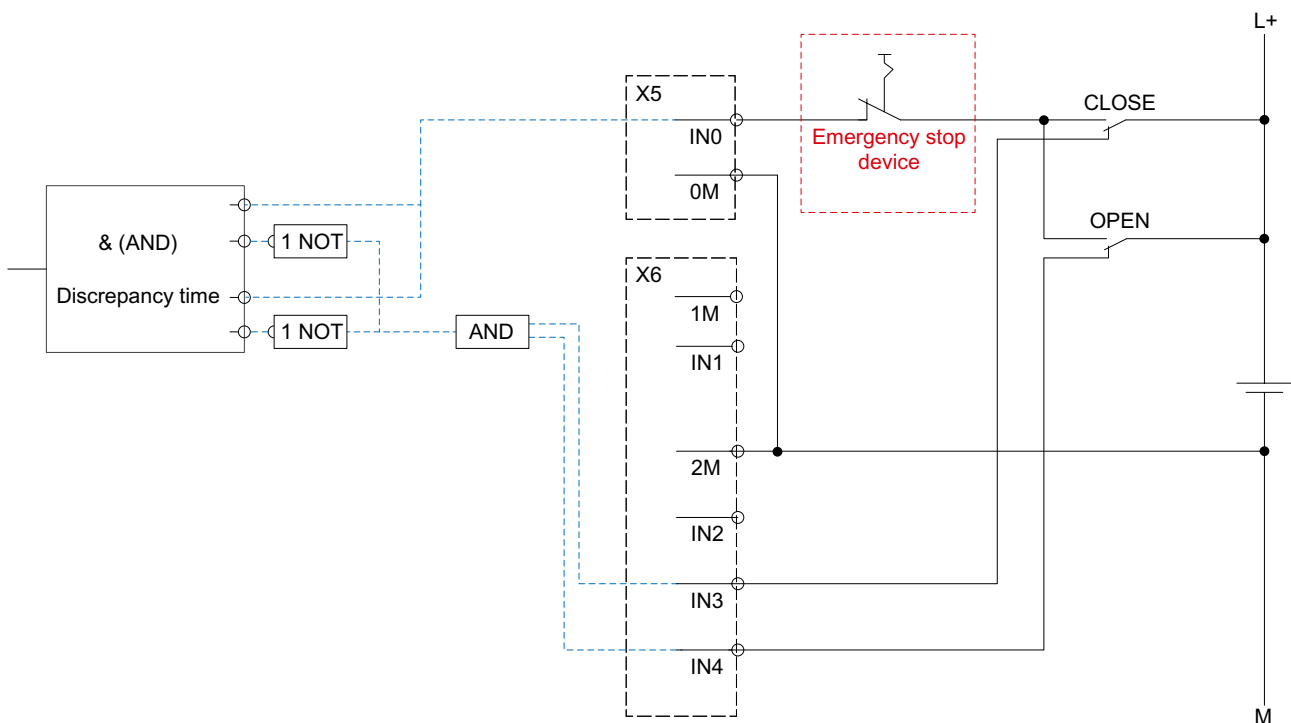

Figure 4-18 Connection safe (PLd) digital command output Door OPEN/CLOSE and emergency stop (sensor type1) via 3 digital inputs.

#### Door commands

The door command with the highest priority is STOP → ramp stop.

The follow-up status after the ramp down can be defined with the door command extension "Special", optionally: EMF brake activated or de-energized (free running mode or de-energized). With ATD401W, the drive command extension is permanently set to "free running mode".

### Implementation

For the implementation of this interfacing variant, the emergency stop signal is integrated into the redundant antivalent safety circuit. The emergency stop element itself is only routed to the SIDOOR controller through 1 channel. It is combined via an internal enabling logic with a STOP door command of the highest priority.

The OPEN (door OPEN) and CLOSE (door CLOSE) door commands can only become active if no emergency stop signal is present. The emergency stop signal is integrated in a low-active branch. This is taken into account in the internal enabling logic.

After an emergency stop, a door command can only be activated again after both door commands have been inactive together.

The OPEN (door OPEN) and CLOSE (door CLOSE) door commands are read in at the inputs 4 or 3 with negative logic (low-active).

The emergency stop signal is only active in combination with the issuing of a door command via the external OPEN (door OPEN) or CLOSE (door CLOSE) encoders.

All digital inputs available on the SIDOOR controller can be used for this application.

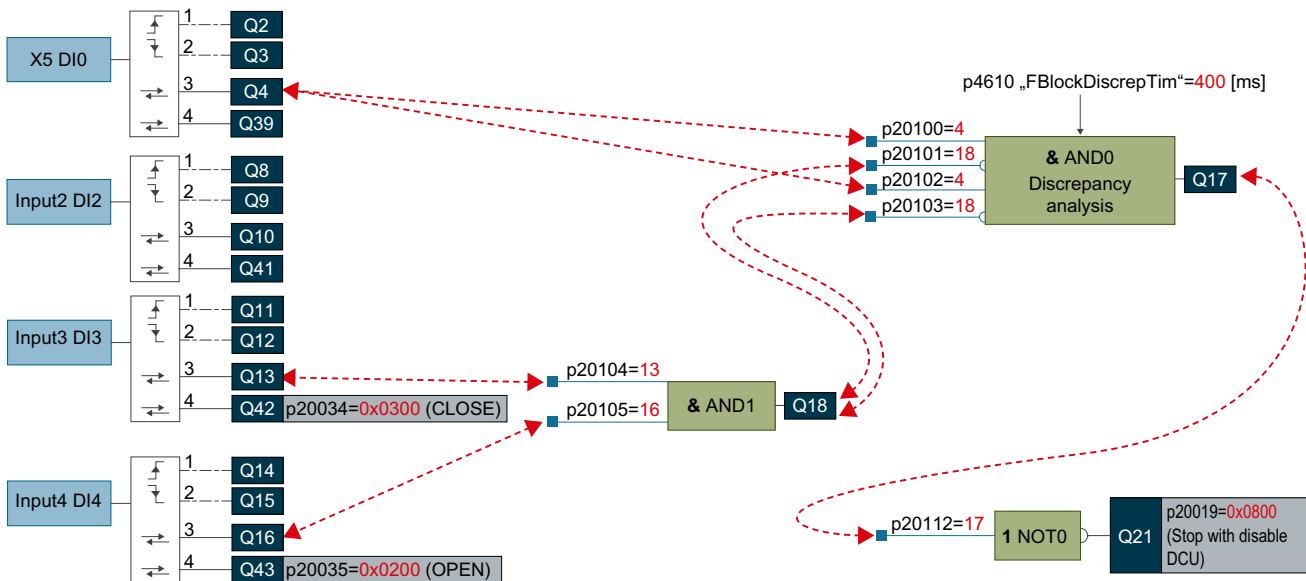

Figure 4-19 Example emergency stop parameterization (digital control) via 3 digital inputs

### Information regarding PLd

This interface is only ensures according to PLd that the motor control is safely read in with the drive commands OPEN (door OPEN) or CLOSE (door CLOSE) and the emergency stop signal according to stop category 1. This does not affect the distinction between the OPEN (door OPEN) and CLOSE (door CLOSE) door commands.



#### 4.4.2.10 Learn run with emergency stop connection

In the previous sections and examples on the emergency stop connection a command "Stop with disable DCU" or "Special stop" is always output via FBLOCK logic if no drive command OPEN or CLOSE is pending. If one of these stop commands is pending, no learn run can be started.

---

##### **Note**

To start a learn run with the emergency stop connection, a drive command "OPEN" or "CLOSE" must first be specified via the digital inputs so that the FBLOCK logic does not output one of the stop commands mentioned above.

---

The learn run can then be started. Since the door should be located near the closed position when the learn run is started, it makes sense to start the learn run with the drive command "CLOSE". This drive command must be permanently active during the learn run. The learn run is aborted if the drive command is switched.



## Controllers

### 5.1 Description of controller

#### Overview

SIDoor ATD4xxW

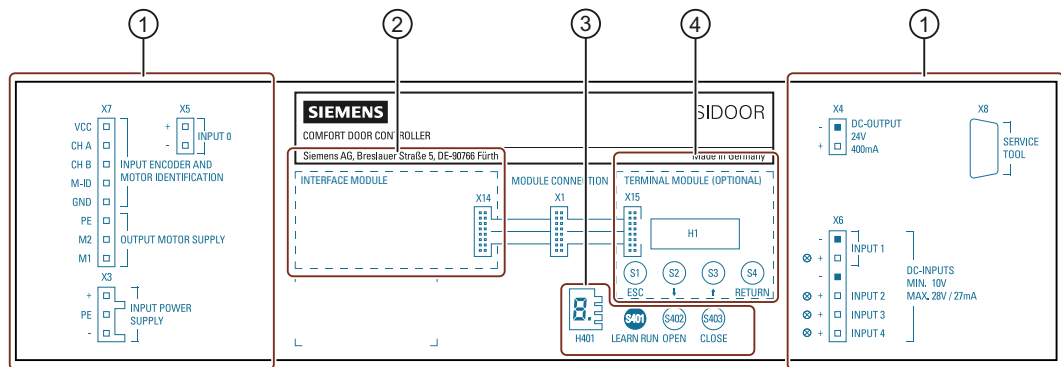

- ① Connecting terminals
- ② Relay module / PROFIBUS module / PROFINET module
- ③ Service buttons/Minimal editor
- ④ Terminal module

### 5.2 Installing the control unit

#### Requirement

The installation site must fulfill the following requirements:

- Minimum clearance to surrounding parts 1 cm
- Even mounting surface

5.2 Installing the control unit

- Maximum distance from the power supply on account of the cable length:
  - SIDOOR NT40 / SIDOOR TRANSFORMER / SIDOOR TRANSFORMER UL: 1.5 m
- Maximum distance from the geared motor on account of the cable length:
  - For SIDOOR M3, M4 and M5: 1.5 m
  - With SIDOOR MDG3, MDG4, MDG5: 5m / 10m / 15m / 20m  
(Length depends on the MDG cable used)

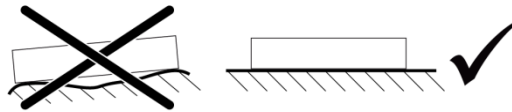
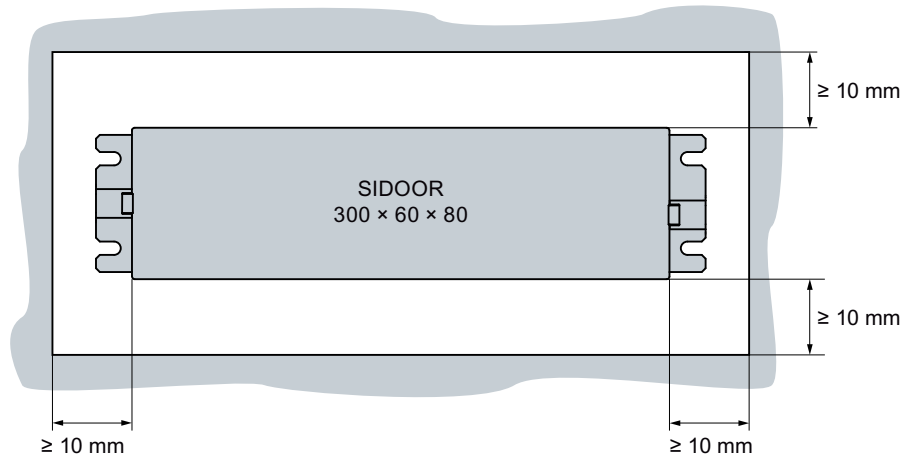

 <b>WARNING</b>
<p><b>Risk of injury as a result of incorrect installation</b></p> <p>Final application-specific requirements must be observed.</p> <p>Only when installed horizontally outside a control cabinet in a</p>

## Installation

Proceed as follows to install the controller:

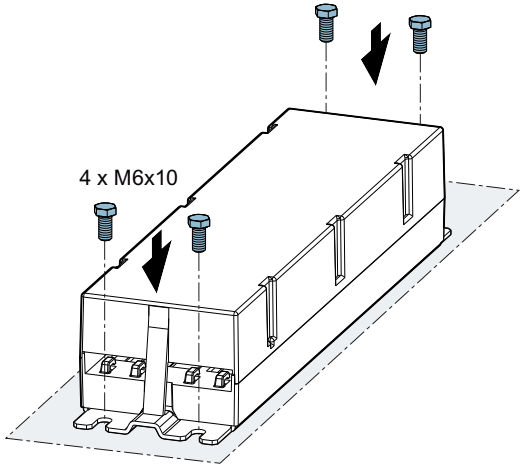
Steps	Figure
1. Drill the holes for the screws as shown in the dimension drawing.	
2. Secure the controller with 4 (M6 x 10) screws.	

### Installation on a mounting rail

You need the SIDOOR standard rail mounting to mount a SIDOOR controller on a standard mounting rail.

The SIDOOR standard rail mounting can be mounted on the controller in two different ways. This enables the controller to be mounted both vertically and horizontally on a standard mounting rail.

#### NOTICE

##### Material damage

The maximum screw depth when mounting a SIDOOR standard rail mounting on a controller is 2.5 mm. The use of longer screws can result in damage to the controller.

For this reason, use only the fixing screws supplied for mounting the SIDOOR standard rail mounting.

5.3 Wiring instructions

Proceed as follows to mount the standard rail mounting:

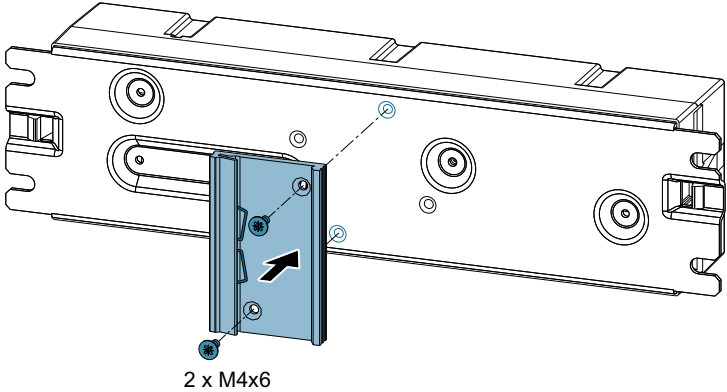
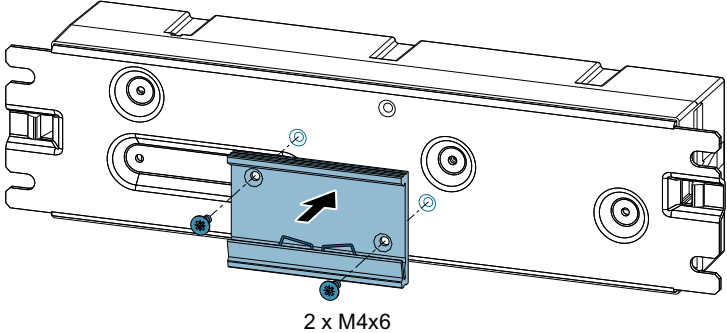
Steps	Figure
<p>1. Select either a vertical or horizontal orientation for mounting the controller on the standard mounting rail.</p>	<p><b>Vertical</b></p> 
<p>2. Screw the SIDOOR standard rail mounting tightly to the controller with 2 (M4 x 6) screws. Use the pre-drilled holes in the controller for this purpose.</p>	<p><b>Horizontal</b></p> 

5.3 Wiring instructions

<p><b>NOTICE</b></p>
<p><b>Material damage</b> Use only cables with a temperature range <math>\geq 85^{\circ}\text{C}</math></p>

## Terminal information and wiring rules

Table 5-1 Terminal information for SIDOOR ATD4xxW

Interface	Name	Terminal	Tool	Solid conductor	Stranded conductor	AWG	Nm	Strip-ping insulation
X3	Input power supply	WAGO: 721-103/026-045	SZS 0.6X3.5	1x 1.5-2.5 mm <sup>2</sup>	1x 1.5-2.5 mm <sup>2</sup>	15 - 12	-	8-9 mm
X4	DC output	PHOENIX: 1792757	SZS 0.6X3.5	1x 0.2-2.5 mm <sup>2</sup>	1x 0.2-2.5 mm <sup>2</sup>	30 - 12	0.5 - 0.6	7 mm
X5	Input 0	PHOENIX: 1792249 Only with ATD420W, ATD430W	SZS 0.6X3.5	1x 0.2-2.5 mm <sup>2</sup>	1x 0.2-2.5 mm <sup>2</sup>	30 - 12	0.5 - 0.6	7 mm
		PHOENIX: 1779987 for ATD401W	SZS 0.6X3.5	1x 0.2-2.5 mm <sup>2</sup>	1x 0.2-2.5 mm <sup>2</sup>	30 - 12	0.5 - 0.6	7 mm
X6	Input 1...4	PHOENIX: 1792799	SZS 0.6X3.5	1x 0.2-2.5 mm <sup>2</sup>	1x 0.2-2.5 mm <sup>2</sup>	30 - 12	0.5 - 0.6	7 mm
X7	Motor plug	PHOENIX: 1757077	SZS 0.6x3.5	1x 0.2-2.5 mm <sup>2</sup>	1x 0.2-2.5 mm <sup>2</sup>	30 - 12	0.5 - 0.6	7 mm
X11, X12, X13	Relay module Relay outputs <sup>1</sup> *	PHOENIX: 1757022	SZS 0.6X3.5	1x 0.2 – 2.5 mm <sup>2</sup>	1x 0.25 – 2.5 mm <sup>2</sup>	30 - 12	0.5 - 0.6	7 mm
X100	PROFIBUS/ PROFINET module relay outputs <sup>1</sup> **	PHOENIX: 1803594	SZS 0.4X2.5	1x 0.14 – 1.5 mm <sup>2</sup>	1x 0.14 – 1.5 mm <sup>2</sup>	30 – 14	0.22 - 0.25	7 mm

<sup>1</sup> Only for modules with the corresponding module

\* Only with ATD401W

\*\* Only ATD420W, ATD430W

## 5.4 Connecting terminals

### 5.4.1 Digital input signals

#### Slot X6

You can connect certain signals for drive functions at the inputs Input 1, Input 2, Input 3, Input 4 (X6) and Input 0 (X5). The following table shows how the drive function and input are assigned depending on the control unit.

Table 5-2 Overview of signals for drive functions at slots X5 and X6

Slot X5/X6	ATD401W Standard input <sup>1)</sup>	ATD401W Emergency stop with three inputs <sup>2)</sup> (see Fail-safe digital control concept Door OPEN/CLOSE with emergency stop via 3 digital inputs (Page 117))	ATD401W Cold storage func- tion <sup>3)</sup>	ATD420W / ATD430W
<b>Input 0</b>	NDG (second force and ener- gy profile)	Stop (inverted)	RC <sup>4)</sup> (door interlocking)	INPUT 0: Functions con- figurable (Page 80) via free function blocks (FBLOCK) INPUT 1: Configurable as a local sensor type or via function blocks (FBLOCK) (Page 80)
<b>Input 1</b>	Parameterizable (local sensor type)	Parameterizable (local sensor type)	Parameterizable (local sensor type)	
<b>Input 2</b>	Partial opening opera- tion	Partial opening opera- tion	Cord-operated switch (cord-operated switch OPEN/CLOSE)	
<b>Input 3</b>	CLOSE DOOR	CLOSE DOOR (inverted)	CLOSE DOOR (pulse controlled)	Functions configurable (Page 80) via free func- tion blocks (FBLOCK)
<b>Input 4</b>	OPEN DOOR	OPEN DOOR (inverted)	OPEN DOOR (pulse controlled)	
<b>Input 1, Input 2, In- put 3 and Input 4 inac- tive</b>	Deenergize (not a door command)	–	–	–

- <sup>1)</sup> Adjustable via the service menu "General setup > Special parameters > FBLOCK configuration > FBLOCK config. Standard input"
- <sup>2)</sup> Adjustable via the service menu "General setup > Special parameters > FBLOCK configuration > FBLOCK config. Emergency stop 3 inp."
- <sup>3)</sup> Adjustable via the service menu "General setup > Special parameters > FBLOCK configuration > FBLOCK config. Cold storage mode"
- <sup>4)</sup> Note: Although the RC input is activated, it is always possible to move the door using the service buttons.



**Note**

To avoid issuing unintentional door commands, remove the terminals X6 and X5 before changing the FBLOCK input configuration.

---

**Note****SIDOOR ATD401W**

In the delivery state of the control unit ATD401W the "Default input" configuration is specified for the input signals Input 0 to Input 4 and the parameter for the default command mode (p100) is set to "FBLOCK + relay".

If the control unit does not respond to input signals, select the desired configuration of the input signals again in the service menu under "General setup > Special parameters > FBLOCK configuration".

If the control unit still does not respond to input signals, check whether the standard command input is set to "FBLOCK + relay" (p100=1) in the service menu under "General setup > Special parameters > Std. command input".

---

**Note**

When the predefined FBLOCK configurations are selected for the input signals Input 0 to Input 4, all FBLOCK parameters as well as the speed and force parameters (p3686 – p3689) for the "Specific door range of motion" are reset to their default values.

---

**Note****SIDOOR ATD420W / ATD430W**

In the state of delivery of the control units with fieldbus connection no functions are assigned to the inputs Input 0 to Input 4. Parameters are assigned via the function blocks (FBLOCK) (Page 80).

---

**Note**

The inputs Input 0 and Input 1 are implemented isolated from the inputs Input 2, Input 3 and Input 4. Therefore the inputs Input 0 and Input 1 can be connected independently of Input 2, Input 3 and Input 4 as follows:

1. Connection to the internal 24 V control voltage (see the following figure under a. and c.)
  2. Connection to the same or other external control voltages (see following figures under b. and d.)
-

Terminal circuit diagrams

Here you will find an overview of the signals for drive functions at slots X5 and X6, see section Digital input signals (Page 117), Table 4-2 (Page 126).

Table 5-3 Terminal circuit diagrams for digital input signals

<p><b>a. Connection to an internal 24 V control voltage</b></p>	<p><b>b. Connection to an external control voltage</b></p>
<p><b>c. Connection to an internal 24 V control voltage (input 1) and an external control voltage (input 0, input 2, input 3 and input 4)</b></p>	<p><b>d. Connection to an external 24 V control voltage (input 0 isolated from input 1 and isolated from input 2, input 3 and input 4)</b></p>

① Light barrier, DCPS sensor, jumpered or switch. The wiring depends on the sensor type and the configuration of Input 1.

Here you will find an overview of the signals for drive functions at the X5 and X6 slots, see section Digital input signals, Table 4-2 (Page 126).

You can find information on safe digital control Door OPEN/CLOSE with emergency stop via 3 digital inputs in the section Concept of safe digital control of Door OPEN/CLOSE with emergency stop via 3 digital inputs.

Table 5-4 Terminal circuit diagrams for emergency stop with 3 digital inputs

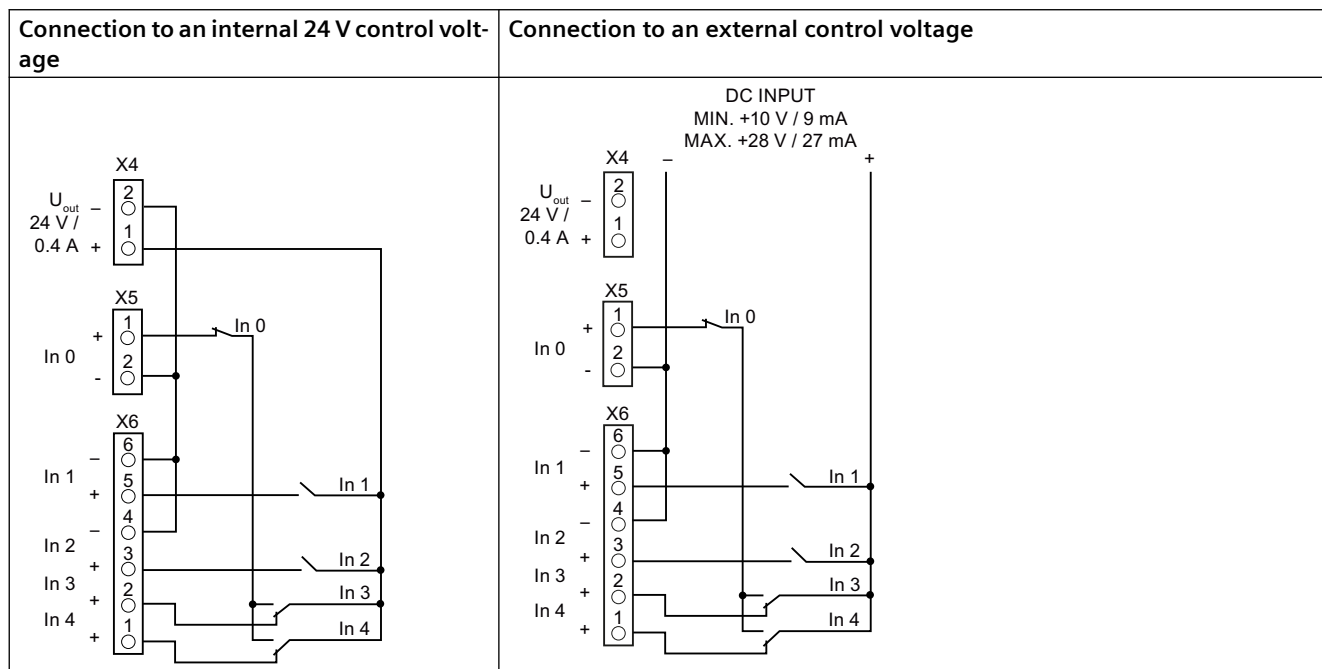

Configurable via the service menu "General setup > Special parameters > FBLOCK configuration > FBLOCK Config. Emergency stop 3 inp."

In 0: Emergency stop device

In 1: Wiring depends on the sensor type and the configuration of Input 1.

### 5.4.2 Voltage output

Slot X4	Function
DC OUTPUT	24 V ±15 %, max. 400 mA

## 5.5 Relay and fieldbus interfaces

### 5.5.1 Relay module

#### Overview

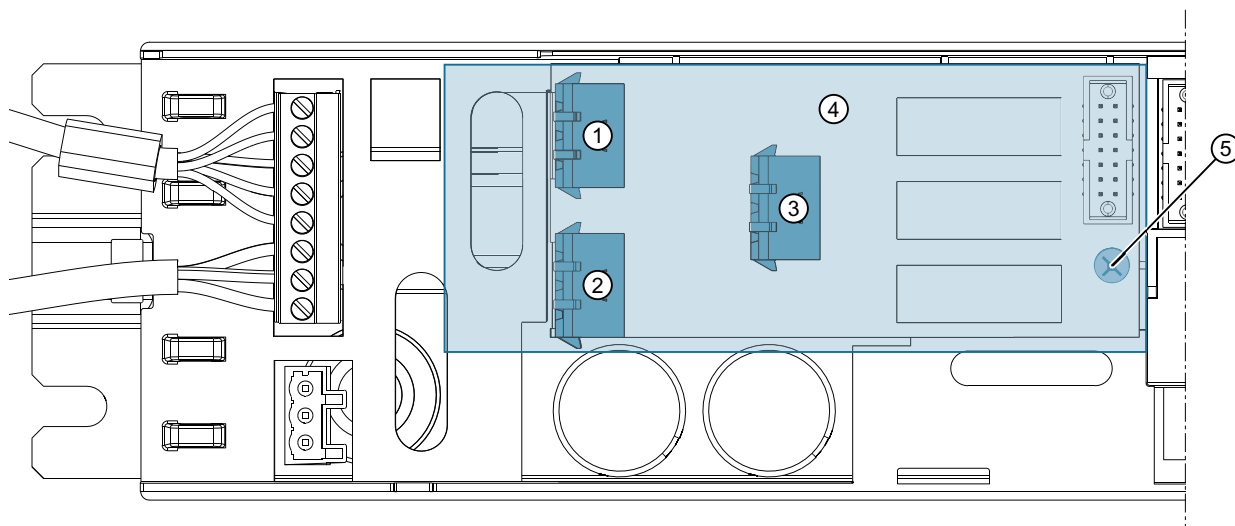

- ① X11
- ② X13
- ③ X12
- ④ Protective cover
- ⑤ Fixing screw for the protective cover

Figure 5-1 Relay module

### Task

The relay module's relay contacts can be used to report the following door states to the higher-level controller:

Table 5-5 SIDOOR ATD401W door states

Relay contact	Designation	Function
X11	CLOSE (closed)	<p>The system's internal door state "closed" is signaled via this relay (relay contact is closed). This state is not only position-dependent. Note the following conditions:</p> <ul style="list-style-type: none"> <li>The "closed" state can <b>only</b> be achieved with a drive order</li> <li>The "closed" state cannot be achieved by external pushing</li> <li>The "closed" state can be terminated by means of a drive order or external pushing</li> </ul>
X12	REVERSE (reversing)	<p>The relay is additionally influenced by the sensor configuration (parameter p4600). See also section Sensors and external sensor interface module (Page 160).</p> <ul style="list-style-type: none"> <li><b>Sensor function test inactive</b> The control signals that the current drive order's direction is reversed. Example: automatic reversing due to an obstruction, provided that the applicable reversing response is parameterized. The relay is active as long as the current drive order is reversed.</li> <li><b>Sensor function test active</b> The "TestOUT" sensor function test signal is output.</li> </ul>
X13	OPEN	<p>The system's internal door state "open" is signaled via this relay (relay contact is closed). This state essentially depends on the current door position.</p> <ul style="list-style-type: none"> <li>The "open" state can be achieved both by means of a drive order and also by external pushing.</li> <li>The state can be terminated by means of a drive order or external pushing</li> </ul>
X11 and X13	FAULT	There is a fault in the system if both relays are simultaneously active (relay contacts closed).

### Connection

 <b>DANGER</b>
<p><b>Risk of injury from dangerous electrical voltages</b></p> <p>Only safety extra-low voltages may be applied to the relay module. &lt;=30 V DC.</p>

#### Terminal circuit diagram of the relay contacts

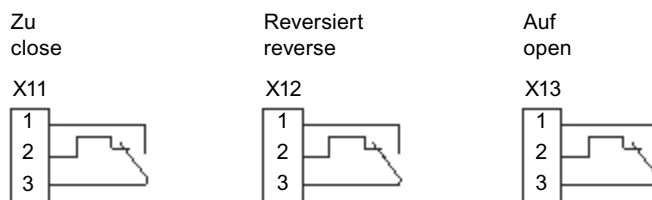

**Procedure**

**Note**

**Specifications for connecting the relay module**

- The cables connected must be suitable for the voltage used and have appropriate (double or reinforced) insulation. Cables with an external diameter of 6 to 7 mm are recommended.
- Components of the controller and connecting cable, such as the motor plug and its wires, may only come in contact with the additional (or reinforced) insulation of the current-carrying wires.

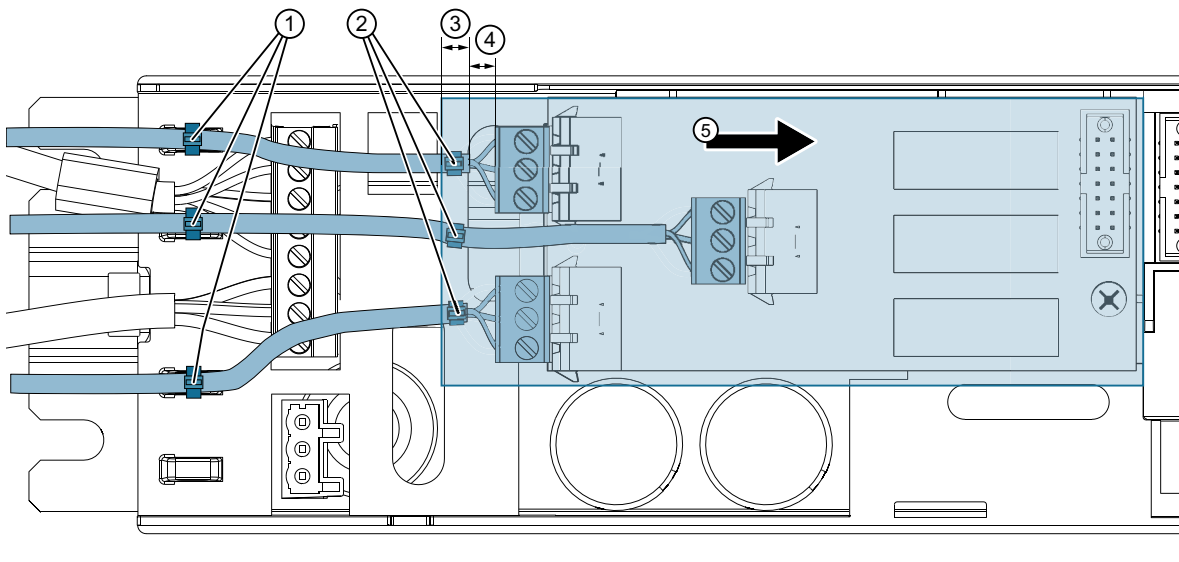

- ① Cable ties (strain relief in housing)
- ② Cable ties (security against being pulled out within the protective cover)
- ③ Minimum length of the cable jacket within the protective cover: 5 mm
- ④ Minimum length of the single-insulation on the single cores: 5 mm
- ⑤ Insertion direction for the protective cover

1. Unscrew the fixing screw holding the protective cover on the relay module.
2. Slide the protective cover against the insertion direction and remove it.
3. Connect connectors X11, X12 and X13.
4. Ensure that, inside the cover, the single-insulation is removed from the single cores at least 5 mm from the cable entry openings, and the cores connected to the terminal connectors are as short as possible.
5. Secure the cables inside the plastic cover against being pulled out through the oval aperture in the relay cover. Use cable ties for this purpose, tie each of them tightly round the cable. Ensure that the cable tie is tied so that at least 5 mm of the outer cable jacket lies inside the protective cover.
6. Provide additional strain relief by attaching more cable ties to the fixing points provided in the housing.

7. Slide the protective cover in the insertion direction back into its correct position.
8. Screw the fixing screw holding the protective cover on the relay module back in.

## 5.5.2 PROFIBUS

### 5.5.2.1 PROFIBUS module

#### Overview

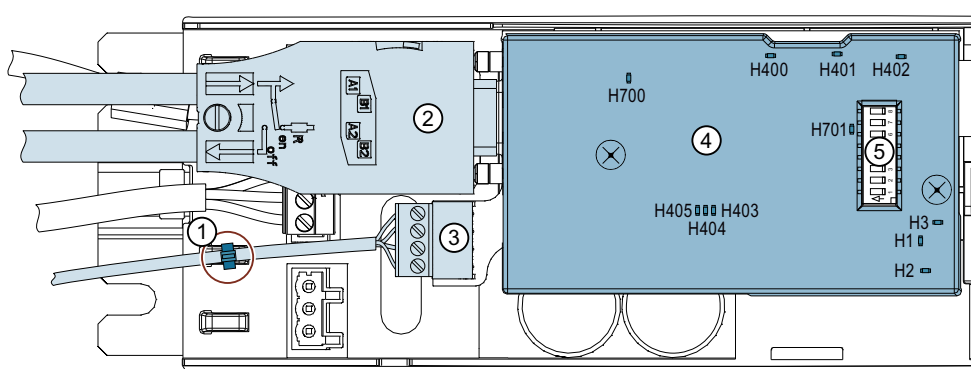

- ① Cable ties
- ② X705
- ③ X100
- ④ Protective cover
- ⑤ DIP switches

All standard PROFIBUS baud rates from 9.6 to 12,000 Kbps are supported. The baud rate is detected automatically.

#### GSD file

All other slave functionality is described in the corresponding GSD file.

Table 5-6 GSD file

GSD file	Download
SIEM81BA.GSD	The GSD file is available online at Industry online support ( <a href="http://support.automation.siemens.com/WW/view/en/99008084">http://support.automation.siemens.com/WW/view/en/99008084</a> ).

You can find explanations of the basic functions and communication properties of the DP slave in the section PROFIBUS communication (Page 139).

**Task**

The PROFIBUS module enables the SIDOOR ATD420W door controller to be connected to a PROFIBUS fieldbus.

**Interface**

The ATD420W system is implemented as DP slave using the DP-V0 protocol. Data transfer is cyclic with a class 1 DP master.

An ASIC of the "SPC3" type is used for interfacing to PROFIBUS. RS 485 in accordance with ANSI TIA/EIA 485-A is used as the transmission technology. Corresponding bus connections must be provided at the individual bus stations or nodes for fail-safe functioning of the PROFIBUS.

**LED signals**

The following five status LEDs are available on the PROFIBUS module:

LED	Color	Description	Position
H1	Green	<b>Relay K1 picked up</b> LED H1 switches on when the controller has detected the CLOSED position and the pulse generator ceases to output pulses. The LED H1 is controlled by the basic module (signal X200.11).	
H2	Green	<b>Relay K2 picked up</b> LED H2 switches on when the current distance of the door to the OPEN position falls below 2 cm and the relay has switched on. The LED H2 is controlled by the basic module (signal X200.9).	
H3	Green	<b>Valid incoming telegram</b> LED H3 is controlled by the basic module (signal X200.12), and indicates the communication status. The LED flashes to indicate incoming, valid telegrams. Each signal change stands for such a telegram.	
H400	Red	<b>"Bus error" PROFIBUS communication disrupted</b> The H400 LED flashes red in the event of PROFIBUS communication errors.	
H401	Red	<b>"Group error" internal communication disrupted</b> The H401 LED flashes red in the event of internal communication errors. Extended PROFIBUS diagnostic data is being transferred	
H402	Green	<b>Power on</b> LED H401 lights a continuous green after Power on.	
H403	Yellow	<b>Internal communication to main controller</b> LEDs H403 and H404 toggle each time after the master has sent or received an error-free telegram.	
H404	Yellow		
H405	Yellow	<b>Boot</b>	
H700	Orange	<b>P5V_ISO (X705.6) = OK</b>	
H701	Yellow	<b>P5V = OK</b>	



## DIP switches (S501)

The DIP switches (S501) on the device are used to set the PROFIBUS address of the DP slave.

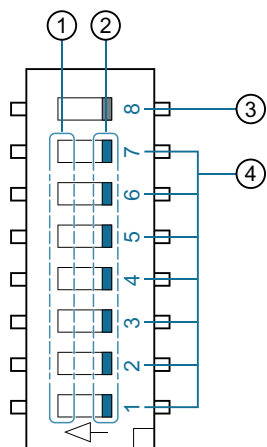

- ① Status: 1 ≙ on
- ② Status: 0 ≙ off
- ③ DIP switch without function
- ④ DIP switches for setting the address

Figure 5-2 DIP switches (S501)

### Setting the address

The individual DIP switches 1 to 7 (④) are used to specify the address. DIP switch 8 (③) is reserved.

Addresses within the range from 0 to 127 can be set with combinations of the seven DIP switches (①, ②). The addresses are coded according to BCD code (Binary Coded Decimal).

### Note

A DP slave address change only becomes effective after a power-on reset or system restart.

The following example shows the setting for the address "89":

DIP switches	1	2	3	4	5	6	7
Status (0 ≙ off / 1 ≙ on)	1	0	0	1	1	0	1
Address	89 (≙ 59 <sub>hex</sub> )						

### 5.5.2.2 Wiring and connecting PROFIBUS connectors

#### Requirement

<b>NOTICE</b>
<b>PROFIBUS connector</b>
Use only the recommended PROFIBUS connectors from Siemens. For more, see also section Accessories (Page 35).

<b>NOTICE</b>
<b>Material damage resulting from the connection of a PROFIBUS connector to service connection X8</b>
Connecting a PROFIBUS connector to service connection X8 can damage the SIDOOR controller and the connected device.
For this reason, only connect a bus connector to connection X705.

**Note**

- Always use shielded cables.
- For stationary operation, it is advisable to remove the insulation of the shielded cable and to establish contact on the shield/PE conductor bar.
- If there is a potential difference between the grounding points, an impermissibly high compensating current can flow through the shield grounded at both ends. To rectify the problem, do not, under any circumstances, open the shield of the bus cable. Install an additional equipotential bonding conductor parallel to the bus cable to carry the shield current.
- You can find additional information in the manual SIMATIC NET PROFIBUS Networks (<https://support.industry.siemens.com/cs/ww/en/view/1971286>).

#### Wiring

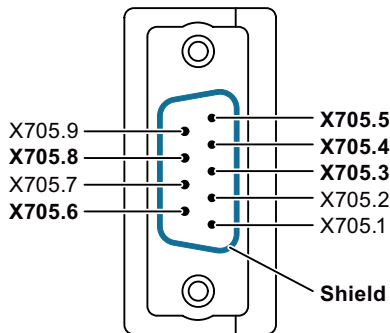

Table 5-7 Assignment of X705

Pin	Assignment	Description
1	NC	Not connected
2	NC	Not connected
3	RS 485P	RS 485 interface (receive and send signals (+)) <b>Note:</b> For 6GK1500-0FC10: "B" (red)
4 <sup>1)</sup>	CNTR-P	Repeater direction control
5	GND	Interface ground
6	P5V	5 V max. 10 mA, to be used in connector for bus network terminator only
7	NC	Not connected
8	RS 485N	RS 485 interface (receive and send signals (-)) <b>Note:</b> For 6GK1500-0FC10: "A" (green)
9	NC	Not connected
Shield	Shield	FE - functional grounding (bus cable shield)

<sup>1)</sup> with SIDOOR ATD420W

## Connection

The wired PROFIBUS connector is connected to connection X705 and fastened by tightening the screws.

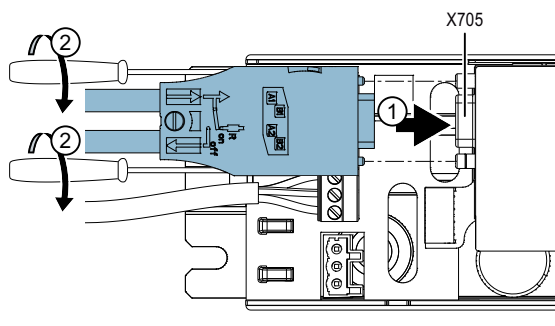

### 5.5.2.3 Wiring and connecting relay outputs

#### Wiring

The PROFIBUS module has 2 relay outputs (closer contact).

A maximum voltage of 42.0 V (SELV) may be applied to the PROFIBUS module.

Contact rating of the relay outputs:

- DC max: 30 V DC, 500 mA

The matching 4-pole mating connector (PHOENIX MC1.5/4-ST-3.81) with the screw terminals is delivered along with the module (plugged in).

The pin assignments are:

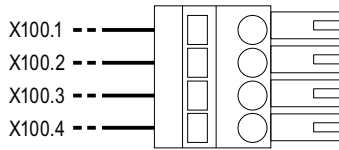

### Relay control

Table 5-8 Relay control for PROFIBUS module

Terminal	Assignment	Description
X100.1 X100.2	CLOSE (closed)	<p>The relay is additionally influenced by the sensor configuration (parameter p4600). For more, see also section Sensors and external sensor interface module (ATD4xxW) (Page 160).</p> <ul style="list-style-type: none"> <li> <b>Sensor function test inactive</b>                      The system's internal door state "closed" is signaled via this relay (relay contact is closed). This state is not only position-dependent. Note the following conditions:                     <ul style="list-style-type: none"> <li>The "closed" state can <b>only</b> be achieved with a drive order.</li> <li>The "closed" state cannot be achieved by external pushing.</li> <li>The "closed" state can be terminated by means of a drive order or external pushing.</li> </ul> </li> <li> <b>Sensor function test active</b> <ul style="list-style-type: none"> <li>The "TestOUT" sensor function test signal is output.</li> </ul> </li> </ul>
X100.3 X100.4	OPEN (open)	<p>The system's internal door state "open" is signaled via this relay (relay contact is closed). This state essentially depends on the current door position.</p> <ul style="list-style-type: none"> <li>The "open" state can be achieved both by means of a drive order and also by external pushing.</li> <li>The "open" state can be terminated by means of a drive order or external pushing.</li> </ul>

### Connection

The wired relay connector is connected to connection X100.

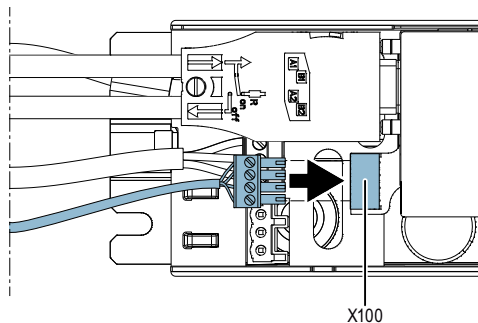

#### 5.5.2.4 PROFIBUS communication

##### Parameter assignment

The DP master transfers parameters during initialization of the DP slave. This includes the transfer of standard parameters and specific SIDOOR parameters for the device. The specific parameters are written in the GSD file. No user data can be exchanged without initialization.

The DP master sends the parameters to the DP slave in a set parameters telegram. The DP slave answers with a short acknowledgment.

The set parameters telegram consists of user data with 7 to 244 bytes. The first 7 bytes of the parameters are bindingly specified in the standard. Bytes 8 to 10 are permanently written in DP-V1, and are not used here. The subsequent bytes are manufacturer-specific. Another 8 bytes are reserved for this with the PROFIBUS module.

##### SIDOOR-specific parameters

The SIDOOR internal communication channel (internal bus) can be configured with the following parameters:

- Data communication
- Baud rate
- Slave address
- Telegram type
- Cycle time

5.5 Relay and fieldbus interfaces

In order to establish error-free, stable communication, the settings on the connected SIDOOR controller (internal bus) have to be matched.

Table 5-9 User parameter byte 1

Bit 7	Bit 6	Bit 5	Bit 4	Bit 3	Bit 2	Bit 1	Bit 0	User parameter byte 1
							x	<b>Data communication</b> Data communication is deactivated if this bit is set to 0. Factory setting = 1 (activated)
			x	x	x	x		<b>Baud rate</b> The baud rate is set with bits 1 to 4. Codes: 9600 = 0000 19200 = 0001 38400 = 0010 57600 = 0011 115200 = 0100 187500 = 0101 250000 = 0110 300000 = 0111 375000 = 1000 500000 = 1001 750000 = 1010 Factory setting = 115200 (0100)
0	0	0						Reserved

Table 5-10 User parameter byte 2

Bit 7	Bit 6	Bit 5	Bit 4	Bit 3	Bit 2	Bit 1	Bit 0	User parameter byte 1
			x	x	x	x	x	<b>Slave address</b> The slave address is set with bits 0 to 4. Address range = 0 to 31 Factory setting = address 1
0	0	0						Reserved

Table 5-11 User parameter byte 3

Bit 7	Bit 6	Bit 5	Bit 4	Bit 3	Bit 2	Bit 1	Bit 0	User parameter byte 1
			x	x	x	x	x	<b>Telegram type</b> The telegram type is set with bits 0 to 2. Codes: Standard telegram = 0000 Mirror telegram = 0001 Broadcast = 0010 Special telegram = 0011 Special telegram with broadcast = 0100 Factory setting = standard telegram (0000)
0	0	0						Reserved

Table 5-12 User parameter bytes 4 and 5

Bit 7	Bit 6	Bit 5	Bit 4	Bit 3	Bit 2	Bit 1	Bit 0	User parameter byte 1
0 to 234 (0x00 to 0xEA)								<b>Cycle time (high byte)</b>
0 to 96 (0x00 to 0x60)								<b>Cycle time (low byte)</b> The cycle time is given in [ms]. The cycle time defines the minimum time intervals at which the slave is queried by the master. Time range = 10 to 60000 ms. Factory setting = 100 ms (0x0014)

Table 5-13 User parameter bytes 6, 7 and 8

Bit 7	Bit 6	Bit 5	Bit 4	Bit 3	Bit 2	Bit 1	Bit 0	User parameter byte 1
0	0	0	0	0	0	0	0	Reserved

## Configuration

For efficient communication between DP master (higher-level controller (PLC)) and DP slave, the DP master has to know how many bytes it sends to the DP slave, and how many bytes it receives from the DP slave. The values for the outputs and inputs are specified in the configuration.

The configuration of a DP slave is specified in the GSD file. Before the DP slave can exchange user data with a DP master, the valid configuration must be transferred from the DP master to the DP slave and confirmed.

Each DP slave has slots . Each slot can be a module. The SIDOOR ATD420W controller is designed as a modular DP slave and has exactly one slot. The standard module is available for this slot.

The configuration for the standard module consists of 22-byte inputs and outputs, and a manufacturer-specific byte.

The 22-byte inputs and outputs form the process image which, as standard, consists of 7 words for the process data (PZD) and 4 words for the parameter identifier value (PKW). The reserved manufacturer-specific byte is currently used only as a placeholder.

The configuration described gives the following code for the standard module: 0xC1 0x15 0x15 0x00

### Diagnostics

Extensive diagnostic possibilities are supported in the PROFIBUS DP. A DP master can query the current diagnostics from the DP slave at any time. Diagnostic telegrams can write additional device-specific diagnostics in the GSD file next to the standard diagnostics.

The DP slave can report in the data telegram at any time that current diagnostics are queued. To do this it labels its data telegram (High Priority) in the cyclic data communication.

In normal cyclic data communication, the DP slave always answers with a (Low Priority) data telegram. If an event requires a diagnostic query, the DP slave answers in the next cycle with high priority. The DP master queries the diagnostics, and continues with the cyclic data communication.

The diagnostic telegram is divided into several parts. The first 6 bytes and their meanings are bindingly specified in the standard. The obligatory 6 bytes are followed by optionally one or several diagnostic blocks.

Three additional device-related diagnostic bytes are defined for the PROFIBUS module. The first device-related diagnostic byte defines the header, and the next two define the number of diagnostic bytes.

These diagnostic blocks have the format for the device-related diagnostics, and are not specified any further in DP-V0. The meanings of the individual bits are specified in the GSD file. The following table shows the exact meanings of the bits for the SIDOOR ATD420W controller. The diagnostic data relate exclusively to the internal communication bus between the SIDOOR controller and the communication module.

Table 5-14 Device-related diagnostic bits

1.2	1.1	1.0	0.7	0.6	0.5	0.4	0.3	0.2	0.1	0.0	Device-related diagnostic bits
										x	Telegram length (LGE) false
									x		Remaining runtime exceeded
								x			Block check character (BCC) false
						x					Telegram start (STX) false
					x						Telegram type unknown (ADR)
				x							Slave address false
			x								Memory overflow
		x									Parity error
	x										Internal error
											Answer delay time exceeded
x											Telegram type not identical

The 11 diagnostic bits are correspondingly divided between the two device-related diagnostic bytes, i.e. bits 1.3 to 1.7 are not used or are reserved.



## 5.5.3 PROFINET

### 5.5.3.1 PROFINET module

#### Overview

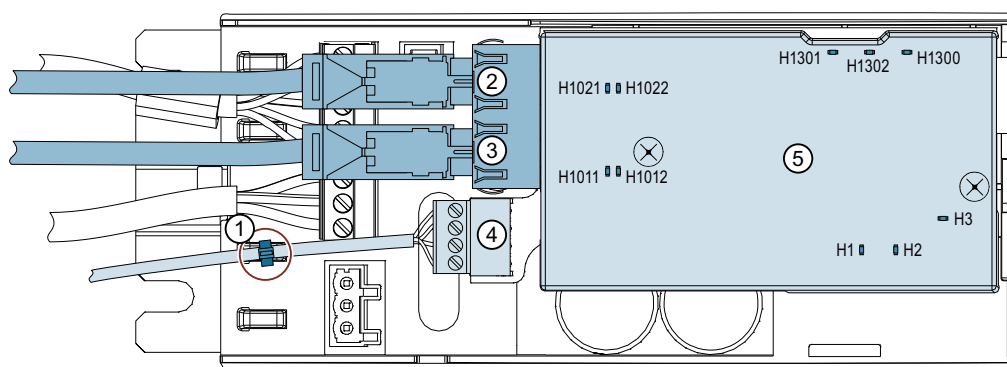

- ① Cable ties
- ② X1000 - Port 2
- ③ X1000 - Port 1
- ④ X100
- ⑤ Protective cover

The ASIC of the type "ERTEC200P" is used for the PROFINET connection. Ethernet is used as the transmission technology. The SIDOOR ATD430W controller supports conformance class C (CC-C).

All further IO device functionality of the SIDOOR ATD430W controller is described in the GSD file.

You can find explanations of the basic functions and communication properties of the SIDOOR ATD430W IO device in section PROFINET communication (Page 151).

#### Task

The PROFINET module enables the SIDOOR ATD430W door controller to be connected to a PROFINET fieldbus.

**LED signals**

The following five status LEDs are available on the PROFINET module:

LED	Color	Description	Position
H1	Green	<b>Relay K1 picked up</b> LED H1 switches on when the controller has detected the CLOSED position and the pulse generator ceases to output pulses. The LED H1 is controlled by the basic module (signal X200.11).	
H2	Green	<b>Relay K2 picked up</b> LED H2 switches on when the current distance of the door to the OPEN position falls below 2 cm and the relay has switched on. The LED H2 is controlled by the basic module (signal X200.9).	
H3	Green	<b>Valid incoming telegram</b> LED H3 is controlled by the basic module (signal X200.12), and indicates the communication status. The LED flashes to indicate incoming, valid telegrams. Each signal change stands for such a telegram.	
H1011	Green	Port 1: LINK	
H1012	Orange	Port 1: ACT	
H1021	Green	Port 2: LINK	
H1022	Orange	Port 2: ACT	
H1300	Green	Power on	
H1301	Red	<b>"Bus error" PROFINET communication disrupted</b> The H1301 LED flashes red in the event of a PROFINET communication error.	
H1302	Red	<b>"Group error" internal communication disrupted</b> The H1302 LED flashes red in the event of an internal communication error.	

**Network structure/network topologies**

The ATD430W IO device supports the star, line, tree and ring structure network topologies.

The IO device has an integrated switch for the line and ring structures. The MRP redundancy process is used in the case of the ring structure. In this case, the IO device is the MRP client and cannot be used as the redundancy manager (MRP manager). This must be provided for separately in the network structure.

**GSD file**

The characteristic communication features of the ATD430W IO device are specified in the form of an electronic device data sheet (device master data file, GSD file). The GSD file has been certified by the ComDeC test center for PROFINET field devices according to EN 61158 and IEC 61784.

The GSD file is provided in various GSDML scheme versions to ensure compatibility with older configuration tools.

Table 5-15 GSD files

Scheme	GSD file
2.31	GSDML-V2.31-Siemens-SIDOOOR-TD430W-20140829.xml
2.3	GSDML-V2.3-Siemens-SIDOOOR-TD430W-20140829.xml
2.25	GSDML-V2.25-Siemens-SIDOOOR-TD430W-20140829.xml

The GSD files are equivalent in terms of the ATD430W controller's functional scope.

## PROFINET communication

Besides using the MAC address and the IP address, PROFINET also uses a device name to identify PROFINET devices. The device name must be unique in the PROFINET network.

### Assigning a device name

During commissioning, each PROFINET device is assigned a device name using the configuration system (node initialization).

The device name is written to the IO device via an IO supervisor using the DCP (Discovery and Configuration Protocol). The device name is stored retentively in the ATD430W.

If the device is replaced, this operation must be repeated with the replacement device. Since the name is assigned with the standardized DCP, this step can be performed with any tool (e.g. SIMATIC Manager or TIA Portal).

### Topology-based initialization

Device names can also be assigned by the IO controller based on the topology. This requires the topology to be structured as planned and all involved devices to fulfill the requirements of class B (support of LLDP and SNMP) as a minimum. The device must also be set to its factory default settings (IP address = 0.0.0.0 and device name = "").

### Assigning an IP address

For the expansion of an application relationship, each PROFINET device must have an IP address. To ensure that the right device is accessed online, it is recommended that IP addresses be assigned to every PROFINET device at the start of the commissioning process. When configuring the IO system, both the IO controller and the IO devices are assigned an IP address by the configuration tool. The IO controller receives an IP assignment list via the system configuration. The IP addresses are assigned to the IO devices on initialization of the application relationships.

The IO device ATD430W offers the possibility of having the IP address assigned by the IO controller. This function is activated in many configuration tools by default. For this, there has to be a PROFINET connection between the IO device and the IO controller and the device name of the IO device have to agree with the configured device name. When this function is used, a communication connection to the IO controller must be established so that the IO device is assigned an IP address and TCP services (e.g. firmware updates) are available.

When the device is used for the first time, it has the pre-configured IP address **192.168.0.1** (subnet mask 255.255.255.0).

---

**Note**

If reset to the factory defaults, the pre-configured IP address is deleted and set to 0.0.0.0. If the IP address is assigned by the IO controller based on the system configuration, the retentively stored IP address is deleted and is replaced with 0.0.0.0 in accordance with the PROFINET standard.

---

### Identification flashing

Identification is performed via flash test. The flash test can be initiated via the configuration tool. The two LINK LEDs H1011 (Port1) and H1021 (Port2) flash synchronously, at a frequency of 2 Hz.

### Restore factory settings

The "Restore factory settings" function clears the previously defined settings and restores the default values.

- IP Address: 0.0.0.0
- Device name: (empty)

The I&M data 1 to 4 are additionally cleared when the factory settings are restored.

### MAC addresses

The ATD430W IO device uses a total of three MAC addresses. The IO device itself has one MAC address and the two ports (Port 1, Port 2) each have an incremented MAC address. See the following example:

IO device: 00-1B-1B-65-AC-61  
Port 1: 00-1B-1B-65-AC-62  
Port 2: 00-1B-1B-65-AC-63

### Supported PROFINET functionality

The ATD430W IO device supports the following functionality of conformance classes A, B and C (CC-A, CC-B, CC-C).

- Cyclic data exchange (RT)
- Acyclic parameter data (read / write record)
- Device diagnostics, alarms (alarm handling)
- Device identification (I&M 0)
- Extended device identification (I&M 1 to 4)
- Topology information (LLDP)
- Network diagnostics (SNMP)

- Port-related statistics (PDEV)
- Automatic addressing (DCP)
- Media redundancy (MRP)
- Isochronous data exchange (IRT)

### Cyclic data exchange

Cyclic data communication contains the data that the central processing unit sends to the IO devices so that it can be output to the outputs as well as the data that an IO device reads in at its inputs and sends to the central processing unit for processing. Non-isochronous data exchange is called RT. RT telegrams are transferred directly via Ethernet.

### Acyclic parameter data

Acyclic data communication consists of sending parameterization and configuration data to the IO device on starting or sending a diagnostic message from the IO device to the central processing unit during ongoing operation. Acyclic data uses UDP/IP.

### Device diagnostics, alarms

Alarms are special acyclic messages that are sent from the IO device to the controller whenever required. They are time-critical and therefore sent directly via Ethernet just like cyclic data. Contrary to cyclic data, however, they must be confirmed by the recipient.

Besides generating standard alarms, the ATD430W generates a diagnostic alarm, based on the GSD definition, in the event of disruptions on the internal SIDOOR bus.

### I&M 0 and I&M 1 to 4

Device parameters can be read and written for device identification.

The data record for the unique identification of the IO device is the Identification and Maintenance data record 0 (I&M 0 - device identification). This record is **read-only**.

The standardized records I&M 1 to 4 are intended for extended device identification. These can be both **read** and **written** (on DAP).

The I&M records consists of the following parameters:

Table 5-16 I&M 0 and I&M 1 to 4 data

I&M record	Fields (standardized)	Access authorization
I&M 0	MANUFACTURER_ID ORDER_ID SERIAL_NUMBER HARDWARE_REVISION SOFTWARE_REVISION REV_COUNTER PROFILE_ID PROFILE_SPECIFIC_TYPE IM_VERSION IM_SUPPORTED	Read
I&M 1	TAG_FUNCTION TAG_LOCATION	Read and write (on DAP)
I&M 2	INSTALLATION_DATE	
I&M 3	DESCRIPTOR	
I&M 4	SIGNATURE	

**Topology information**

The Link Layer Discovery Protocol (LLDP) is used to detect the network neighborhood and thus also to determine topology information. The status of individual connections can be read out at any time.

**Network diagnostics**

The Simple Network Management Protocol (SNMP) is used to support network diagnostics. The ATD430W IO device supports MIB-II for TCP/IP in accordance with RFC1213.

**Port-related statistics**

The topology presentation data is stored in the physical device of the ATD430W IO device. The PDEV data is addressed as from subslot 0x8000. From a communication perspective, the ATD430W IO device always consists of the interface and the ports 1 and 2.

The PDEV is represented by the following submodules of the device access point (DAP):

- Submodule 0x8000 → Interface
- Submodule 0x8001 → Port1
- Submodule 0x8002 → Port 2

**Automatic addressing**

The Discovery and basic Configuration Protocol (DCP) is compulsory for the automatic assignment of IP addresses.

**Media redundancy**

In the case of PROFINET, the Media Redundancy Protocol (MRP) is used for the media redundancy of ring topologies. The ATD430W IO device assumes the role of an MRP client. The MRP manager function is not supported.

### Isochronous data exchange

The ATD430W IO device also supports the IRT protocol and thus class C functionality (CC-C). This supports isochronous data exchange up to 250  $\mu$ s. The IO device forwards all data isochronously. The application program on the ATD430W does not operate isochronously.

### 5.5.3.2 Wiring and connecting a PROFINET connector

#### Requirement

#### Note

Use an Industrial Ethernet cable with a maximum length of 100 m to connect RJ45 connectors.

#### Wiring

The PROFINET module provides two PROFINET ports:

- **Port 1:** Signals are connected crossed. The assignments correspond to switch assignments (MDI-X)
- **Port 2:** signals are connected on a 1:1 basis. The assignments correspond to the default assignments for terminal devices (MDI) 1.

The RJ45 sockets used do not contain any integrated transmitters or LEDs for signaling.

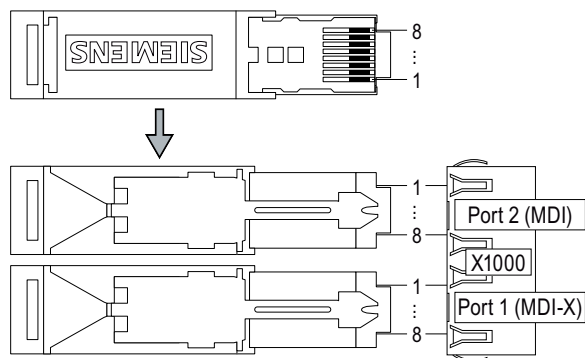
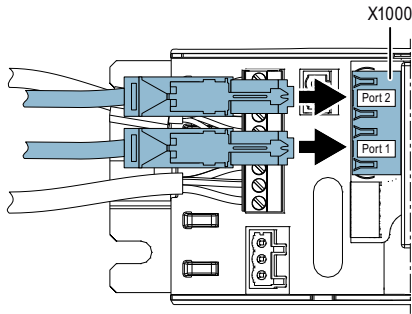

Table 5-17 X1000 assignments (Port 1/Port 2)

Pin	Signal name	Type	Description
1	TXP	O	Ethernet transmit differential signal
2	TXN	O	Ethernet transmit differential signal
3	RXP	I	Ethernet receive differential signal
4	TERM		Termination
5	TERM		Termination
6	RXN	I	Ethernet receive differential signal
7	TERM		Termination
8	TERM		Termination

### Connection

The wired RJ45 connectors are connected to the two X1000 Port 1 and X1000 Port 2 terminals.



### 5.5.3.3 Wiring and connecting relay outputs

#### Wiring

The PROFINET module has 2 relay outputs (closer contact).

A maximum voltage of 42.0 V (SELV according to EN60950-1) may be applied to the PROFINET module.

Contact rating of the relay outputs:

- DC max: 30 V DC, 500 mA

The matching 4-pole mating connector (PHOENIX MC1.5/4-ST-3.81) with the screw terminals is delivered along with the module (plugged in).

The pin assignments are:

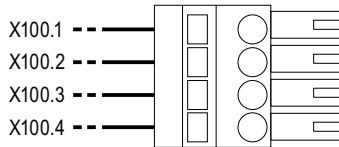



## Relay control

Table 5-18 Relay control for PROFINET module

Terminal	Assignment	Description
X100.1 X100.2	CLOSE (closed)	<p>The relay is additionally influenced by the sensor configuration (parameter p4600). For more, see also section Sensors and external sensor interface module (ATD4xxW) (Page 160).</p> <ul style="list-style-type: none"> <li> <b>Sensor function test inactive</b>                      The system's internal door state "closed" is signaled via this relay (relay contact is closed). This state is not only position-dependent. Note the following conditions:                     <ul style="list-style-type: none"> <li>The "closed" state can <b>only</b> be achieved with a drive order.</li> <li>The "closed" state cannot be achieved by external pushing.</li> <li>The "closed" state can be terminated by means of a drive order or external pushing.</li> </ul> </li> <li> <b>Sensor function test active</b> <ul style="list-style-type: none"> <li>The "TestOUT" sensor function test signal is output.</li> </ul> </li> </ul>
X100.3 X100.4	OPEN (open)	<p>The system's internal door state "open" is signaled via this relay (relay contact is closed). This state essentially depends on the current door position.</p> <ul style="list-style-type: none"> <li>The "open" state can be achieved both by means of a drive order and also by external pushing.</li> <li>The "open" state can be terminated by means of a drive order or external pushing.</li> </ul>

## Connection

The wired relay connector is connected to connection X100.

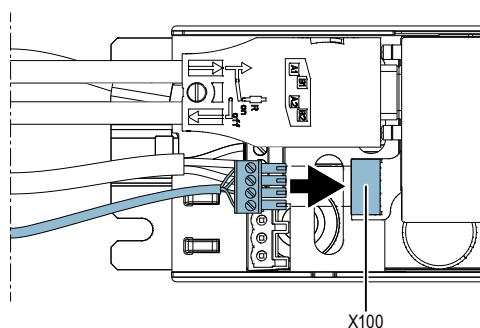

### 5.5.3.4 PROFINET communication

#### Parameterization/startup record

When setting up a connection, the startup parameter record (record 1) is sent from the IO controller to the ATD430W as specified in the GSD file (see Table 5-15 GSD files (Page 145)). Only the **cycle time** parameter is visible in the configuration tool.

The structure of the 8-byte startup parameter record 1 is described in the following:

Table 5-19 Startup parameter record byte 1

Bit 7	Bit 6	Bit 5	Bit 4	Bit 3	Bit 2	Bit 1	Bit 0	Data exchange and baud rate parameter
							X	<b>Data communication</b> Data communication on the internal bus is deactivated if this bit is set to 0. Default = 1 (activated)
			X	X	X	X		<b>Baud rate</b> The baud rate is set with bits 1 to 4. The following coding results: 9600 = 0000 19200 = 0001 38400 = 0010 57600 = 0011 115200 = 0100 187500 = 0101 250000 = 0110 300000 = 0111 375000 = 1000 500000 = 1001 750000 = 1010 Default = 11520
0	0	0						Reserved

Table 5-20 Startup parameter record byte 2

Bit 7	Bit 6	Bit 5	Bit 4	Bit 3	Bit 2	Bit 1	Bit 0	Slave address parameter
			X	X	X	X	X	<b>Slave address</b> The slave address on the internal bus is set via bits 0 to 4. The address range is from 0 to 31. Default = address 0
0	0	0						Reserved

Table 5-21 Startup parameter record byte 3

Bit 7	Bit 6	Bit 5	Bit 4	Bit 3	Bit 2	Bit 1	Bit 0	Telegram type parameter
			X	X	X	X	X	<b>Telegram type</b> The telegram type on the internal bus is set via bits 0 to 2. The following coding results: Default telegram = 0000 <sub>b</sub> Mirror telegram = 0001 <sub>b</sub> Broadcast = 0010 <sub>b</sub> Special telegram = 0011 <sub>b</sub> Default = default telegram
0	0	0						Reserved

Table 5-22 Startup parameter record bytes 4 and 5

Bit 7	Bit 6	Bit 5	Bit 4	Bit 3	Bit 2	Bit 1	Bit 0	Cycle time parameter
0 to 234 (0x00 to 0xEA)								<b>Cycle time (high byte)</b>
0 to 96 (0x00 to 0x60)								<b>Cycle time (low byte)</b> The cycle time is given in [ms]. The time range is between 10 and 60000 ms. The cycle time specifies the minimum time intervals in which the communication on the internal bus runs. The default is 100 ms = 0064 <sub>hex</sub>

Table 5-23 Startup parameter record bytes 6, 7 and 8

Bit 7	Bit 6	Bit 5	Bit 4	Bit 3	Bit 2	Bit 1	Bit 0	Parameter
0	0	0	0	0	0	0	0	Reserved

## Configuration

The resulting configuration data is in the GSD file (see Table 5-15 GSD files (Page 145)).

The structure expected from the PROFINET module is described in the following:

Table 5-24 PROFINET configuration data

Slot	Api	Subslot	Module ID	Submodule ID	Description
0	0	0001 <sub>hex</sub>	1	1	DAP (ATD430W)
0	0	8000 <sub>hex</sub>	1	2	Interface
0	0	8001 <sub>hex</sub>	1	3	Port 1

Slot	Api	Subslot	Module ID	Submodule ID	Description
0	0	8002 <sub>hex</sub>	1	3	Port 2
1	0	0001 <sub>hex</sub>	28 <sub>hex</sub>	1	22 bytes IO (4 words of PKW and 7 words of PZD are mapped)

### Diagnostics

The internal communication bus between the SIDOOR controller and the communication module is monitored by the master driver of the communication module (PROFINET module). A PROFINET diagnostic alarm is triggered if communication is interrupted or quality becomes too poor. This diagnostic alarm is then present for at least 5 seconds and is structured as follows:

Table 5-25 Properties of diagnostic alarm

Property of diagnostic alarm	Value											
Slot	1											
Subslot	1											
Channel	1											
Error ID	1B <sub>hex</sub>											
Extended channel error type	1											
Extended channel error value	<b>Bit</b>	<b>10</b>	<b>9</b>	<b>8</b>	<b>7</b>	<b>6</b>	<b>5</b>	<b>4</b>	<b>3</b>	<b>2</b>	<b>1</b>	<b>0</b>
	Telegram length (LGE) false											X
	Remaining runtime exceeded										X	
	Block check character (BCC) false								X			
	Telegram start (STX) false							X				
	Telegram type unknown (ADR)						X					
	Slave address false					X						
	Memory overflow				X							
	Parity error			X								
	Internal error		X									
	Answer delay time exceeded		X									
	Telegram type not identical	X										
	Bits 15 to 11 are reserved.											
	Maintenance	No										

### Device roles and provider-consumer model

#### IO Controller

A PROFINET IO controller has control over the field devices. The process data and alarms arrive in the IO controller and are processed in the user program. In an automation system, an IO controller is normally a programmable logic controller (PLC). The communication channels are established by the IO controller during system startup.

### IO supervisor

A PROFINET IO supervisor is an engineering station in a system, for example, that can have temporary access to the field devices for commissioning purposes.

### IO device

The PROFINET IO device is a process-oriented field device that is connected in a distributed fashion. It expects the configuration from an IO controller/supervisor and cyclically transfers its process data to the IO controller.

### Provider-consumer model

During data exchange, PROFINET IO operates according to the provider/consumer model. The provider provides the data and the consumer processes it. The SIDOOR ATD430W controller is an IO device. If the IO controller's output data is invalid ("poor" output data provider status), e.g. if the user program in the IO controller is stopped, then communication in the internal SIDOOR bus is stopped. The corresponding response can be performed by the master monitoring of the SIDOOR controller (see Section Master monitoring (Page 156)).

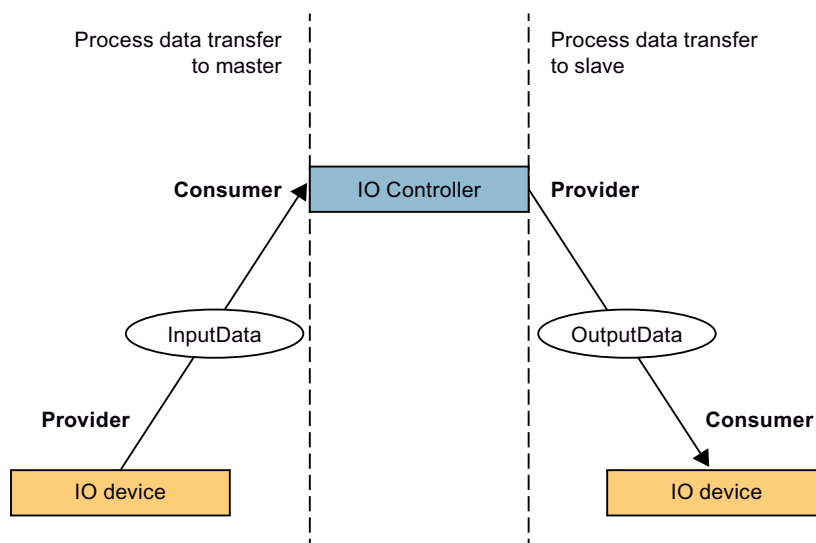

Figure 5-3 Provider-consumer model

### 5.5.4 Local/master operation

The slave (= SIDOOR control unit) generally signals via StatW1 (bit 9 = 1 "control requested") that the master (= higher-level PLC on the fieldbus) should assume control. If the PLC signals via STW1 (bit 10 = 1 "control by the programmable logic controller") that it is taking over control, the process data is deemed to be valid and must be processed accordingly. See Figure 5-4 Sequential control state graph (Page 157).

If the PLC does not assume control (bit 10 = 0 "no control") or if the slave does not request control (ZSW1 bit 9 = 0 "local operation"), the process data is discarded and the sequential

control remains in the "S1:Z\_switching on inhibited" state (see Figure 5-4 Sequential control state graph (Page 157)).

For safety reasons, the controller automatically switches to local mode under the following conditions:

- Service button S402 (Open), S403 (Close) or S401 (Learn run) operated
- An external drive order is pending via the service interface (X8, terminal for service tool and USB adapter)
- The local commissioning terminal module (H1, terminal module with S1 to S4, operator control buttons for terminal module) is in a safety-related state by using the operator control buttons

---

**Note**

**Protected areas**

Some areas of the navigation system are categorized as being safety-related. These include, among others, all areas that affect the processing of the travel curve parameters. Local operation mode ends and control is requested again by the PLC only upon leaving these protected areas.

---

### 5.5.5 Master monitoring

Master monitoring monitors the internal communication channel to the higher-level PLC. This ensures a defined response to the following situations:

- Cable breakage (or bus interruption)
- Hardware fault in the sending/receiving unit
- Incorrect communication configuration (e.g. baud rate, polling list/slave addresses)
- Failure of the master system

Master monitoring is also referred to as a process timeout because it operates based on the user data received at the application level. The parameter p2040 defines the monitoring time in ms. If no user data is received within this period, the sequential control assumes the "S1:Z\_switching on inhibited" state (see Figure 5-4 Sequential control state graph (Page 157)). Monitoring can be deactivated by setting the parameter p2040 to "0". The master cycle time and the type of telegram communication must be considered when configuring the monitoring time. The occurrence of a process timeout is visualized by the status code "y". A master timeout does not need to be acknowledged because it is only to be evaluated as an alarm. A process timeout error is subject to an off delay of 2 s.

## 5.6 Sequential control

The following figure illustrates the sequential control of SIDOOR ATD4xxW control unit in the form of a state graph:

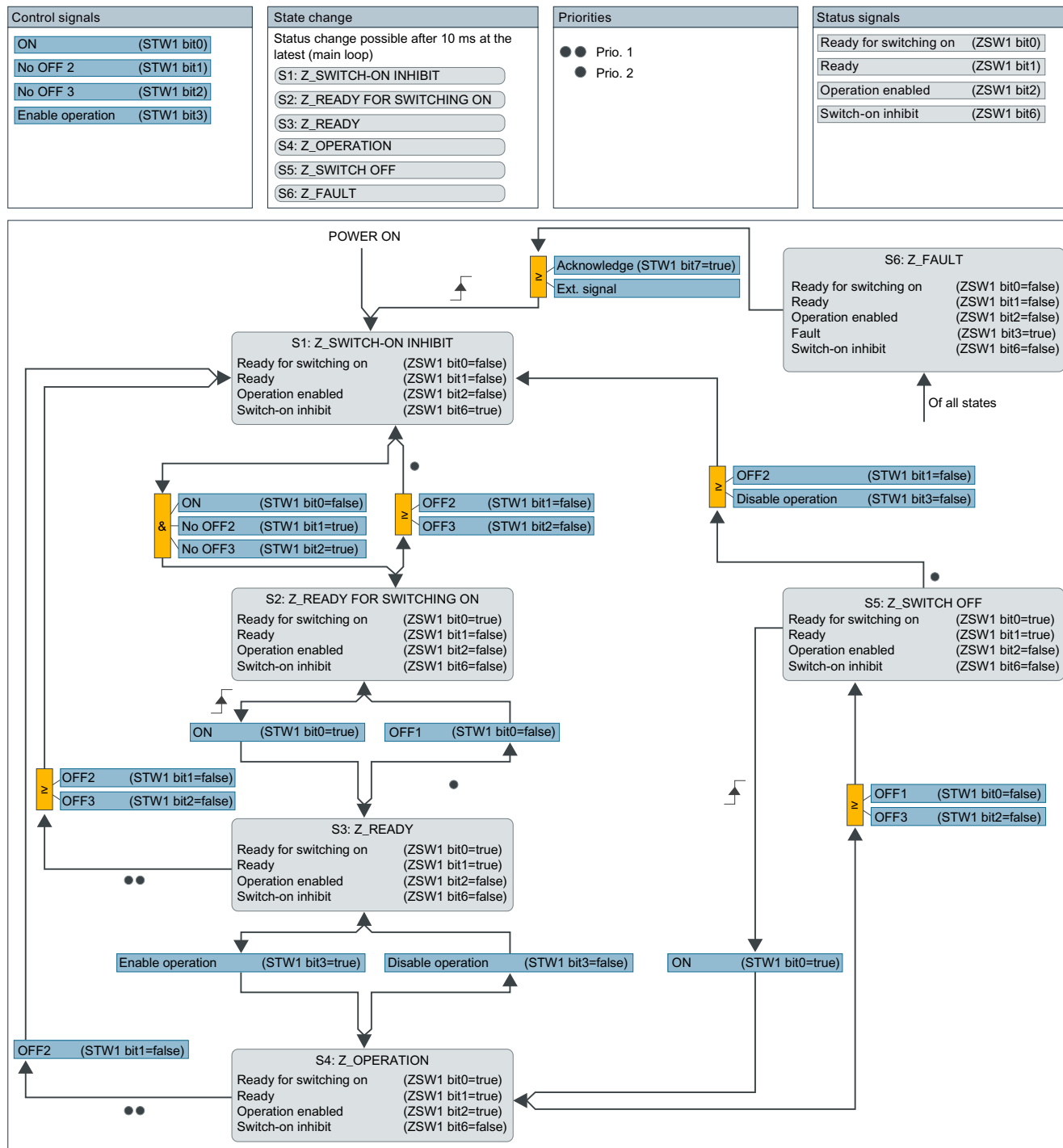

Figure 5-4 Sequential control state graph

5.6 Sequential control

The following table describes the properties of different states of the sequential control and their impact on the system with respect to the slave (= SIDOOR control unit).

Status	Status word	Control word	System impact	Comment/note
S1: Z_EINSCHALTSPERRE	Valid	Invalid	Deenergize	After a ramp down the motor is switched to the free-running mode (deenergize).
S2: Z_EINSCHALTBEREIT	Valid	Invalid	Deenergize	After a ramp down the motor is switched to the free-running mode (deenergize).
S3: Z_BETRIEBSBEREIT	Valid	Invalid	Deenergize	After a ramp down the motor is switched to the free-running mode (deenergize).
S4: Z_BETRIEB	Valid	Valid	Control via PLC (TSW1 evaluation)	ImpDrv is reset at the state transition.
S5: Z_ABSCHALTEN	Valid	Invalid	Ramp stop (stop/source voltage brake)	
S6: Z_STOERUNG	Valid	Invalid	Ramp stop (stop/source voltage brake)	



## Switching the SIDOOR control unit to operating mode

The door drive can be transferred to operating mode via the sequential control. The following illustration shows an example for the two necessary steps:

Step 1		
→ Set the control word STW = 0x040E		
Bit	Name	Value
0	ON/OFF	0
1	OFF2	1
2	OFF3	1
3	Operation enable	1
7	Acknowledge fault	0
10	Control by PLC	1



Step 1		
→ Status word ZSW = 0x0231		
Bit	Name	Value
0	Ready for switching on	1
1	Ready	0
2	Operation enabled	0
3	Fault	0
4	No OFF2	1
5	No OFF3	1
6	Switch-on inhibit	0
9	Controlled by PLC	1

Step 2		
→ Set the control word STW = 0x040F		
Bit	Name	Value
0	ON/OFF	1
1	OFF2	1
2	OFF3	1
3	Operation enable	1
7	Acknowledge fault	0
10	Control by PLC	1



Step 2		
→ Status word ZSW = 0x0237		
Bit	Name	Value
0	Ready for switching on	1
1	Ready	1
2	Operation enabled	1
3	Fault	0
4	No OFF2	1
5	No OFF3	1
6	Switch-on inhibit	0
9	Controlled by PLC	1

### Note

#### Operation enable

The operation enable can also be set later. In this example, it is set immediately.

## 5.7 Sensors and external sensor interface module

### 5.7.1 Overview

The signals in the figure below are processed and generated via the internal signal logic of SIDOOR ATD4xxW controllers. The system reaction to the displayed signals is described in the section Optional safety settings (Page 106).

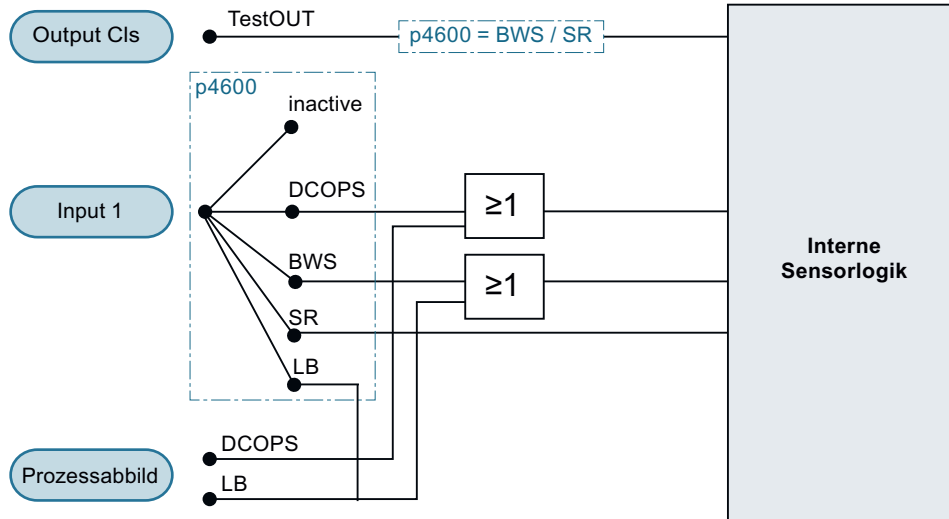

Figure 5-5 Sensor signals

Table 5-26 Sensor signals

Signal	Meaning	Source
DCOPS	Door Closed / Opened Position Sensor (Door Closed / Opened Position Sensor)	Signal can be transferred locally (terminal X6, "Input1") and/or via the process image (for more, see table DCMD extension bits (Page 314))
LB	Light barrier (Light barrier)	Signal is only contained in the process image (see DCMD extension bits (Page 314)). As of V1.14: Signal can be transferred locally (terminal X6, "input1") and / or via the process image (for more information, see the table DCMD extension bits (Page 314)). 0-active local signal without function test.
TestOUT	Function test signal	Signal is automatically output by the controller via a digital relay output. <ul style="list-style-type: none"> <li>Relay module terminal X12 (reversing relay)</li> <li>Fieldbus module terminal X100.1, X100.2 (closed relay)</li> </ul>

Signal	Meaning	Source
ESPE	Electrosensitive protective equipment	Function-tested 0 active local signal (terminal X6, "Input 1")
SR	Pressure-sensitive edge	Function-tested 0 active local signal (terminal X6, "Input 1")

### Configuration of the connected sensor type

The sensor type of the sensor connected to "Input 1" of terminal X6 can be configured as follows:

- Parameter p4600
- Service menu: *MAIN MENU > General setup > Special parameters > Function Input 1*

Note that, internally, some signals (e.g. ESPE and LB) are logically ORed (corresponding to the depiction in the "Sensor signals" figure). If the signal logic is configured for ESPE or SR, the TestOUT function test signal is generated automatically.

An ESPE\* can be connected to the SIDOOR ATD4xxW control units.

\* according to DIN EN 61496-1:2013: Safety of machinery - Electrosensitive protective equipment – Part 1: "General requirements and tests"

#### Take into consideration the following:

- ESPE of type 2 usually have PL c
- ESPE of type 3 usually have PL d
- ESPE of type 4 usually have PL e
- The resulting overall PL, for example, is to be determined according to EN ISO 13849-1: 2015 Section "6.3 Combination of SRP/CS to achieve an overall PL" (series connection subsystems: sensors, switchgear if applicable, ATD4xxW):
  - For type 2 ESPE, the resulting PL is maximum PL c (limitation by light curtain)
  - For type 3 or type 4 ESPE, the resulting PL is maximum PL d (limitation by ATD4xxW)

The following figure schematically shows the interconnection of a type 2 ESPE with the SIDOOR ATD4xxW control unit:

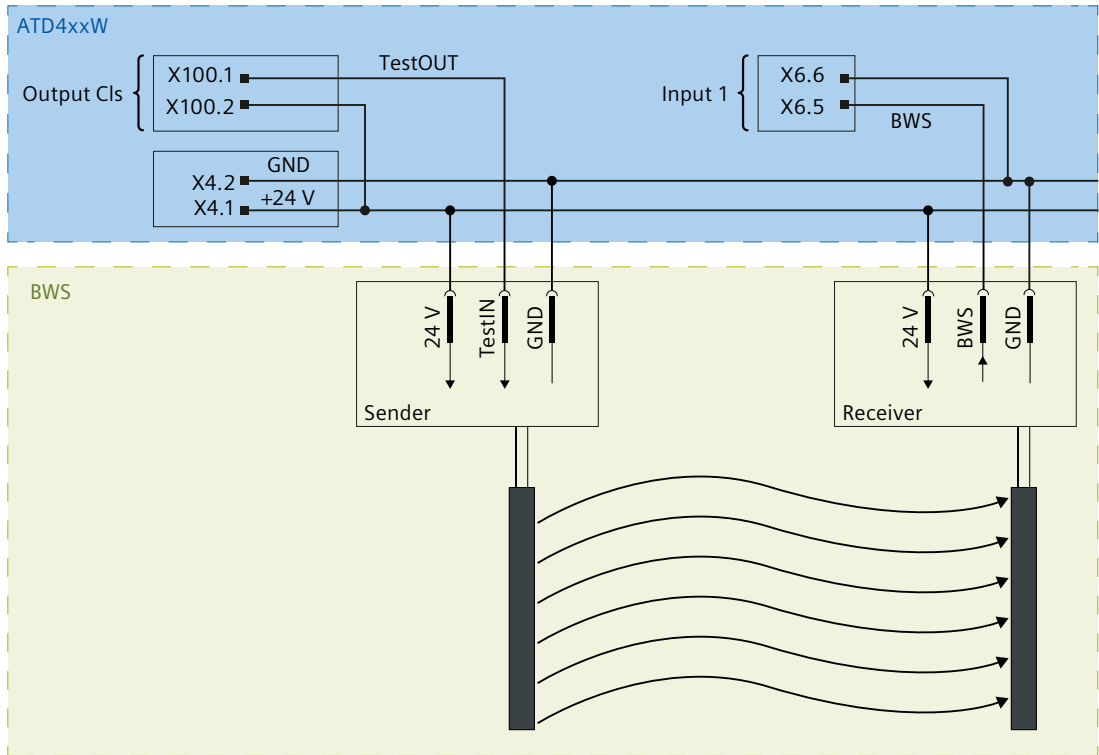

As an alternative to the ESPE system, a pressure sensitive edge (SR) can be connected to the SIDOOR ATD4xxW control unit.

The figure below is a schematic diagram of a pressure sensitive edge according to ISO13856-2 connected to a SIDOOR control unit:

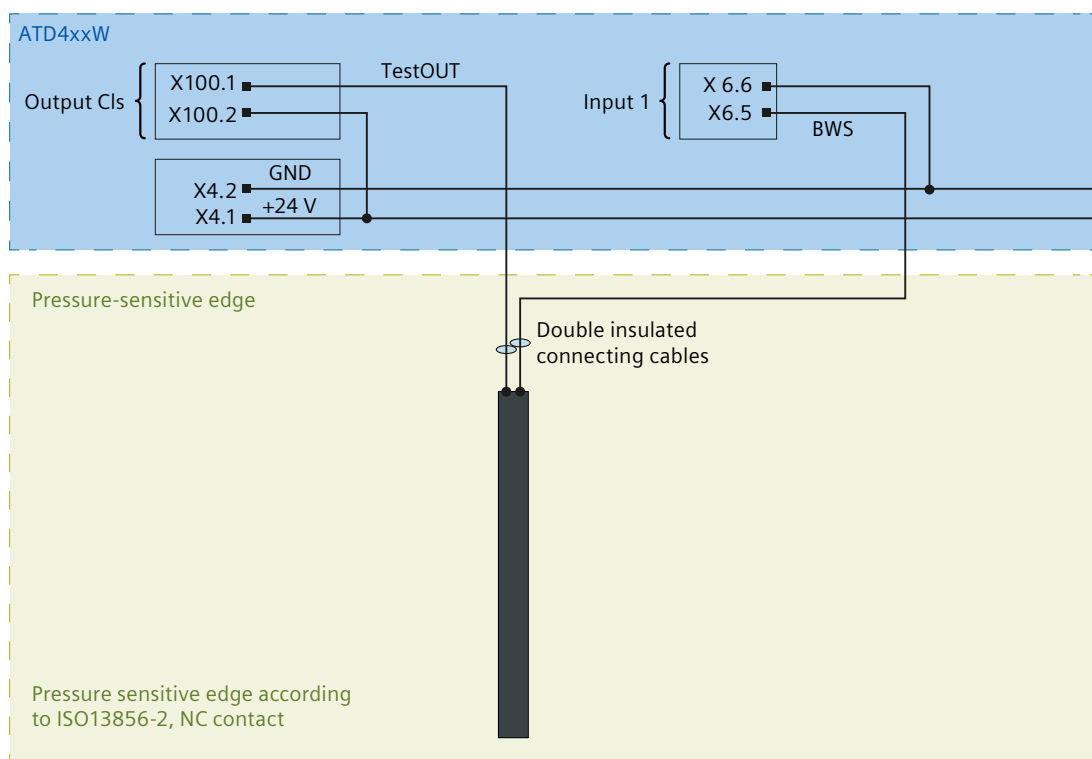

The following figure schematically shows the interconnection of a type 3 or type 4 ESPE with the SIDOOR ATD4xxW control unit using SIEMENS 3SK1111-2AB30 switchgear. For this series connection of these three units (1x sensor PL $\geq$  d, 1x switchgear PL $\geq$ d, 1x ATD4xxW PL d), this results in an overall PL of PL d according to EN ISO 13849-1:2015 section 6.3:

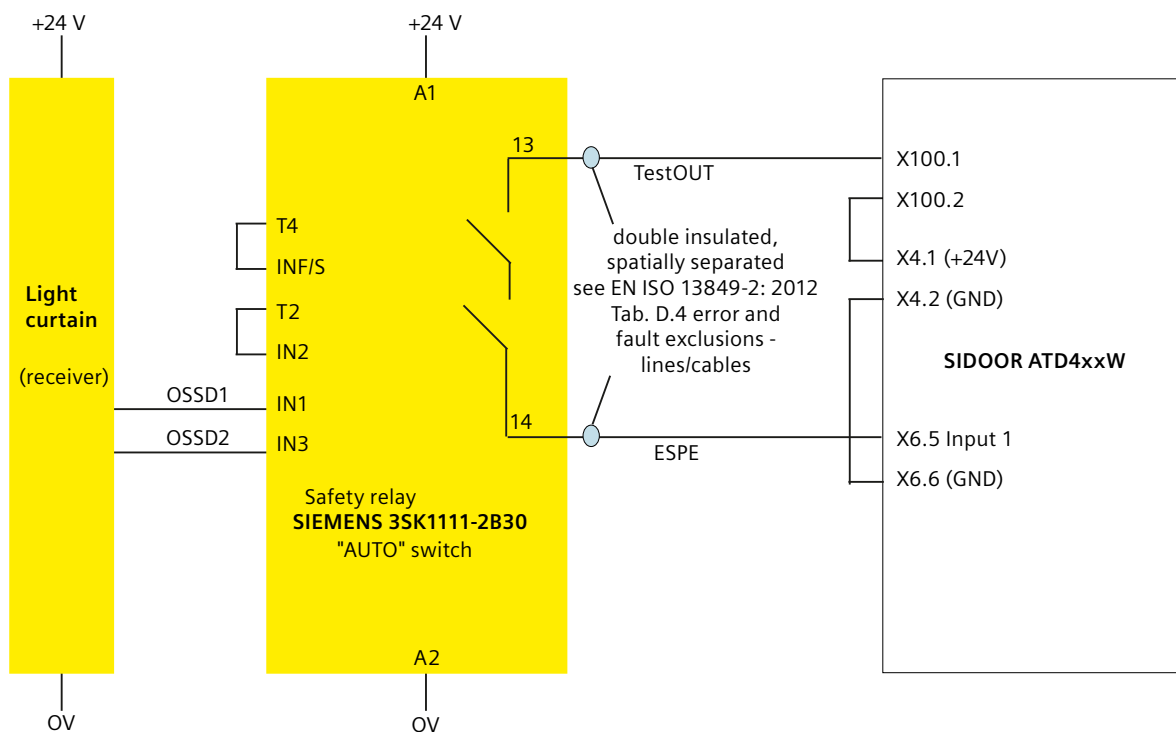

### 5.7.2 Sensor function test

When an ESPE or pressure sensitive edge is connected, equipment for a periodic test is required. This test is intended to detect a dangerous failure before the dangerous function is used. If the SIDOOR control unit's sensor logic is configured for an ESPE or pressure sensitive edge, the "TestOUT" function test signal is output automatically via X100.1 (ATD420W, ATD430W) or X12 (ATD401W), see Relay and field bus interfaces (Page 130).

As soon as the system exits the "opened" end stop active in **Normal mode** (by door command), a function test signal is automatically generated.

The appropriate configuration results in the following minimum test sequence duration:

$$t_{\text{test,min}} = 2 \times (t_{\text{reaction}} + t_{\text{discrepancy,min}})$$

The maximum possible test sequence duration before the test fails corresponds to  $t_{\text{Testr, max}} = 2 \times p4601$ .

The fault "8" is generated if the test operation fails. This fault must be acknowledged in accordance with the control unit (cf. Fault management (Page 298)).

The following figure describes the timing of the "TestOUT" functional test signal generated by the SIDOOR control unit and the timing requirements for the ESPE signal from the ESPE.

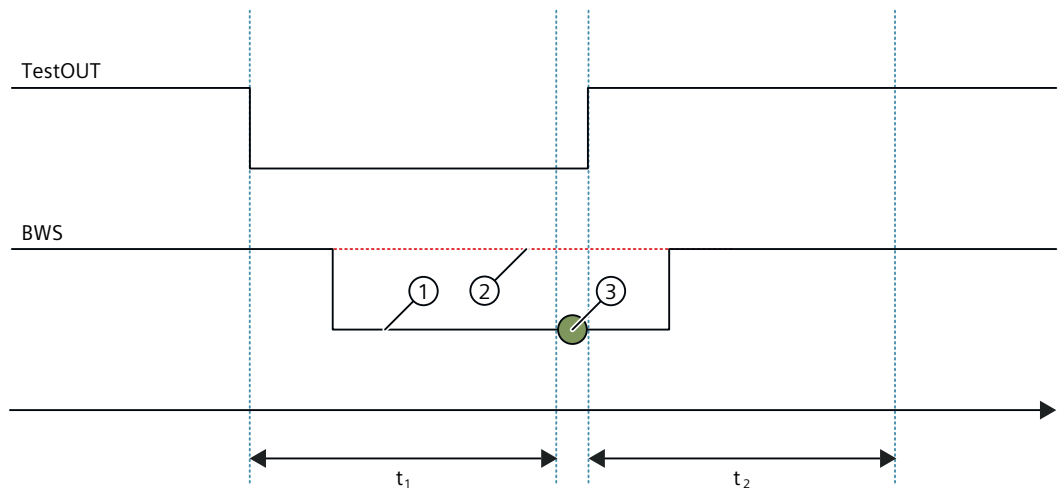

- ① Protective equipment is fault-free
- ② A fault occurs when controlling the protective equipment
- $t_1; t_2$   $t_1 = t_2 = t_{\text{reaction}} + t_{\text{discrepancy}}$
- $t_{\text{reaction}}$  Internal reaction time and switching times
- $t_{\text{discrepancy}}$  Discrepancy time of the OSSD  $t_{\text{discrepancy}} = p4601$
- $y$
- ③ Test point, evaluation of the OSSD signal
  - Signal profile 1 "low level" → fault-free
  - Signal profile 2 "high level" → fault

Figure 5-6 Sensor function test

### 5.7.3 Reaction times

The reaction time to an interrupted light array (ESPE) or a pressure-sensitive edge can be determined by measuring the motor current reduction. To this end, the ESPE or pressure-sensitive edge system can be activated (interrupted or triggered) during constant travel so that the drive reverses.

The reaction times are independent of the sensor type (ESPE or pressure-sensitive edge). The minimal response time amounts to 70 ms and the maximum response time amounts to 90 ms. The delay caused by additional switchgear in the signal chain and by the sensor technology itself must be added.

### 5.7.4 Stopping distances

The following table shows the expected stopping distances depending on the different deceleration ramps and different initial speeds, under consideration of a response time of 90 ms (ESPE and / or pressure-sensitive edge, see section Reaction times (Page 165)).

Table 5-27 Expected stopping distances [mm] under consideration of the ESPE execution time (90 ms)

Initial speed [mm/s]	Set deceleration ramp [mm/s <sup>2</sup> ]					
	1400	1200	1000	800	600	400
300	59	65	72	83	102	140
350	75	83	93	108	134	185
400	93	103	116	136	169	236
450	113	125	142	167	209	294
500	134	149	170	201	253	358
550	158	176	201	239	302	428
600	183	204	234	279	354	504
650	209	235	270	323	411	587
700	238	267	308	369	471	676
750	268	302	349	419	536	771

## 5.8 Technical specifications

### Technical specifications

Article number	6FB1141-1AT11-3WE2	6FB1141-2AT10-3WE2	6FB1141-3AT10-3WE2
<b>General information</b>			
Product brand name	SIDOOR		
Product type designation	ATD401W	ATD420W	ATD430W
Product version	With relay outputs	With PROFIBUS interface	With PROFINET interface
Optional product expansion	TRANSFORMER (6FB1112-OAT20-2TRO), TRANSFORMER UL (6FB1112-OAT21-2TRO), NT40 (6FB1112-OAT20-3PSO), DIN rail holder (6FB1144-OAT00-3ASO)		
Manufacturer's article no. of the usable motor	6FB1103-OAT10-4MB0, 6FB1103-OAT10-3MC0, 6FB1103-OAT10-3MD0, 6FB1103-OAT11-4MB0, 6FB1103-OAT11-3MC0, 6FB1103-OAT11-3MD0, 6FB1103-OAT14-4MB1, 6FB1103-OAT13-4MB1, 6FB1103-OAT14-3MC2, 6FB1103-OAT13-3MC2, 6FB1103-OAT14-3MG2, 6FB1103-OAT13-3MG2		
Manufacturer's article no. of the usable power supply unit	6FB1112-OAT20-2TRO, 6FB1112-OAT21-2TRO, 6FB1112-OAT20-3PSO, 6EP3446-8SB10-OAYO		
<b>Installation type/mounting</b>			
Installation and mounting instructions	No direct solar radiation, final application-specific requirements must be observed. Installation outside a control cabinet only in horizontal mounting position		
<b>Supply voltage</b>			
Design of the power supply	Via SIDOOR TRANSFORMER / SIDOOR TRANSFORMER UL / NT40 / SI-TOP PSU8200 13 A, 36 V or via DC		
Rated value (DC)	36 V		
permissible range, lower limit (DC)	19.2 V		
permissible range, upper limit (DC)	38 V		
Protection in case of DC supply	Use of a circuit breaker in the supply path according to 60898-1, 8A, C-characteristic type SIEMENS: 5SY4108-7 or 5SY4108-7KK11		
<b>Input current</b>			
$I^2t$ , min.	30 A <sup>2</sup> ·s		
<b>Encoder supply</b>			
Output voltage (DC)	24 V; Ensure correct polarity! CAUTION: Do not supply with external voltage!		
short-circuit proof	Yes		
Overload-proof	Yes		
<b>24 V encoder supply</b>			
• Output current, max.	400 mA		
<b>Power</b>			
Active power input	145 W		
Active power input, max.	540 W		



Article number	6FB1141-1AT11-3W E2	6FB1141-2AT10-3W E2	6FB1141-3AT10-3W E2
Active power input (standby mode)	5 W		
<b>Digital inputs</b>			
Control inputs isolated	Yes		
Control inputs p-switching	Yes		
<b>Input voltage</b>			
• permissible voltage at input, min.	10 V; Observe polarity !		
• permissible voltage at input, max.	28 V; Observe polarity !		
<b>Input current</b>			
• for signal "1", min.	9 mA		
• for signal "1", max.	27 mA		
<b>Digital outputs</b>			
<b>Relay outputs</b>			
<b>Switching capacity of contacts</b>			
– at 30 V DC, min.	0.01 A		
– at 30 V DC, max.	1 A		0.5 A
<b>Mechanical data</b>			
Opening width of door, min.	0.3 m		
Opening width of door, max.	5 m		
Weight of door, max.	600 kg		
Operating cycle frequency of door, max.	180 1/h		
Counterforce, max.	75 N		
Kinetic energy, max.	100 J		
<b>Interfaces</b>			
Interfaces/bus type	without	PROFIBUS according to IEC 61784-3	PROFINET IO according to Conformance Class C
Number of bus nodes		32	
<b>Isolation</b>			
Overvoltage category	2		
Degree of pollution	2		
<b>Degree and class of protection</b>			
IP degree of protection	IP20		
<b>Standards, approvals, certificates</b>			
Certificate of suitability according to EN 81	No		
CE mark	Yes		
UL approval	Yes		
EAC (formerly Gost-R)	Yes		
TÜV Inspectorate approval	Yes		

5.8 Technical specifications

Article number	6FB1141-1AT11-3W E2	6FB1141-2AT10-3W E2	6FB1141-3AT10-3W E2
PNO certificate		Yes	
China RoHS compliance	Yes		
Standard for EMC	EN 61000-6-2 / EN 61000-6-4		
Standard for safety	EN 61010-1 / EN 61010-2-201 / UL 61010-1 / UL 61010-2-201 / EN ISO 13849-1 Cat. 2 PL d		
<b>Ambient conditions</b>			
<b>Ambient temperature during operation</b>			
• min.	-20 °C		
• max.	50 °C		
• Remark			Screw control device thermally conductive onto a metallic mounting surface or standard rail mounting, otherwise the maximum operating temperature is only 40 °C
<b>Ambient temperature during storage/transportation</b>			
• Storage, min.	-40 °C		
• Storage, max.	70 °C		
<b>Altitude during operation relating to sea level</b>			
• Installation altitude above sea level, max.	2 000 m		
<b>Relative humidity</b>			
• No condensation, min.	10 %		
• No condensation, max.	93 %		
<b>Dimensions</b>			
Width	320 mm		
Height	60 mm		
Depth	80 mm		

Dimension drawing

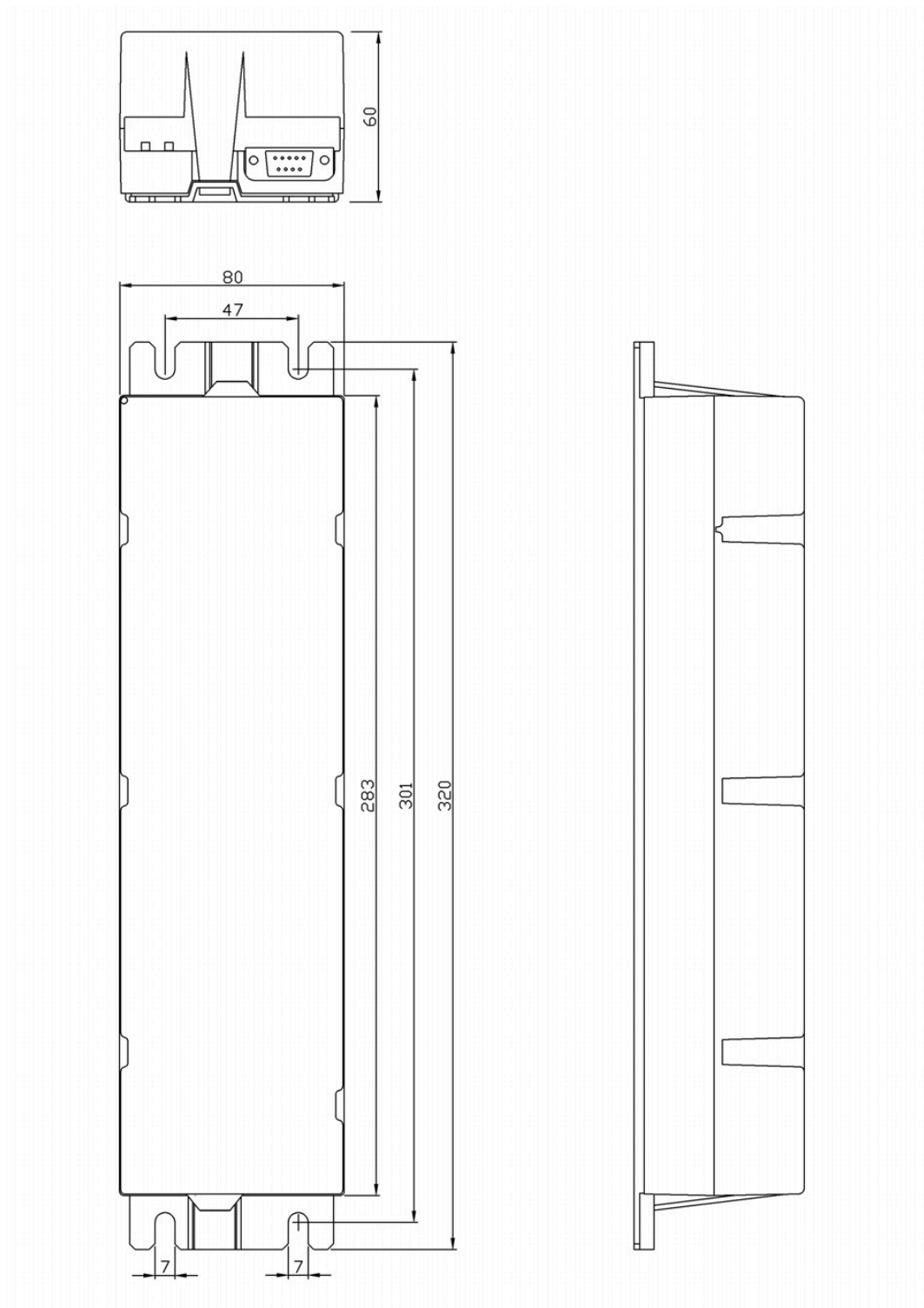

Figure 5-7 Controller

## 5.9 Operation and configuration of the control unit

The service buttons can be used to operate the controller.

The following options are available to parameterize the controller.

1. Parameter assignment via the fieldbus PKW interface
2. Parameter assignment with the terminal module
3. Parameter assignment via supplementary devices (SIDOOR SERVICE TOOL, SIDOOR SOFTWARE KIT)

 **WARNING**

**Verify parameters.**

In the case of parameter assignment via the SIDOOR SOFTWARE KIT or via the fieldbus PKW interface, parameter values must be read back and verified after modification.

 **WARNING**

**Access protection to the controllers/parameters.**

Access to the controller and the parameter assignment of the controller must be protected against unauthorized access. Appropriate measures must be taken for specific applications, e.g. installation in a closed control cabinet, to ensure access only by authorized personnel.

 **WARNING**

**Verification of safety-related functions**

The SIDOOR controller is only a subsystem (incomplete machine). In general, the correct parameter assignment of the SIDOOR controller and the effectiveness of the safety-related functions must be checked at regular intervals by testing the safety-related functions during commissioning and depending on the application.

**Note**

**ATD401W Detecting parameter changes**

For the SIDOOR ATD401W controller the checksums of the parameters have to be checked as part of the maintenance intervals. This allows changes of parameters to be detected. The checksums of the parameters can be requested via the service menu "Service menu -> Checksums".

**Note**

**ATD420W / ATD430W Detecting parameter changes**

The checksums of the parameters for controllers SIDOOR ATD420W und ATD430W have to be monitored cyclically through a higher-level control. This way changes to parameters can be detected. The checksums of the parameters can be requested via the parameters r200 and r201.

**Note**

**ATD420W / ATD430W Access protection to the parameters**

The write protection must be activated via parameter p90 for the SIDOOR ATD420W and ATD430W controllers. This way the change of parameters is blocked via the service menu.

**Note**

After the optimal parameter settings have been determined, note them in the configuration protocol (see appendix Configuration record (Page 333)). Have this record to hand when you call the Hotline.

**Note**

**Parameter changes**

Parameters should always be adjusted during normal operation with the door at standstill, because the controller then accepts the values immediately.

As of V1.09: The parameter changes are also applied in initial mode with standstill of the door.

### 5.9.1 Service buttons

#### Overview

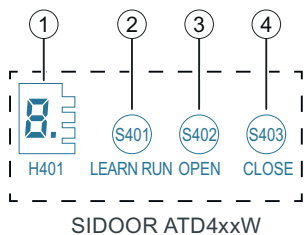

- ① 7-segment display
- ② Learn run button
- ③ Service button OPEN
- ④ Service button CLOSE

Figure 5-8 Overview of minimal editor

#### 5.9.1.1 Operation using service buttons

##### 7-segment display "H401"

You can see the operating states on the "H401" 7-segment display. You can find the description of the 7-segment display in the section Operating state display (Page 297).

**Learn run button**

You can start a learn run with the learn run button (S401).

**Note**

Two types of learn run can be carried out. See section Learn run (Page 40).





**Learn run (when the supply voltage is applied)**

Table 5-28 Starting a learn run when the line voltage is applied

Procedure		H401 display	H1 display
1.	Push the door into the CLOSED position.		
2.	Disconnect the power supply from X3 (DC).		
3.	Press and hold the learn run button (S401).		
4.	Connect the power supply to X3 (DC).		
5.	Initial commissioning or motor adaptation: For the M3, M4 and M5 motors, set the default value to 176 mm/rev. The output transmission [mm/rev] must be configured for the other MDG3, MDG4 and MDG5 motors.		
	<div style="display: flex; justify-content: space-around;"> <div style="border: 1px solid black; padding: 5px; background-color: #e0f0e0;"> <b>Abtriebsuebers</b> 176 mm / Umd                 </div> <div style="border: 1px solid black; padding: 5px; background-color: #e0f0e0;"> <b>output trans. fac.</b> 176 mm / rot                 </div> </div>		
6.	Press and hold the learn run button (S401)		
7.	The learn run starts automatically, and the learn run button can be released.		<div style="border: 1px solid black; padding: 5px; background-color: #e0f0e0;">'H': learn run active</div>
8.	During the learn run, the door is opened about 10 cm, and closed once or twice at slow start speed. The friction of the door system is then determined by opening and closing the door once through a range of 25 cm at slow start speed.  The door then opens and closes through its complete range of movement at reduced speed. After the door has opened by approximately 15 cm, it passes through an additional short acceleration ramp to determine the mass to be moved.		
9.	The door parameters and the determined door width are saved when the door is in the CLOSED position.  This means that the door width and the mass to be moved are re-adapted and saved. The default parameters for energy limitation, speed limitation, friction compensation and all other driving curve parameters are also loaded.		
10.	Learn run completed.		<div style="border: 1px solid black; padding: 5px; background-color: #e0f0e0;">'u': door is closed</div>
11.	First commissioning or motor adaptation. The currently determined door width is saved for the M3, M4, MDG4, MDG5 motors.		
	<div style="display: flex; justify-content: space-around;"> <div style="border: 1px solid black; padding: 5px; background-color: #e0f0e0;"> <b>Tuerweite</b> 613 mm                 </div> <div style="border: 1px solid black; padding: 5px; background-color: #e0f0e0;"> <b>door width</b> 613 mm                 </div> </div>		

### Learn run (during operation)

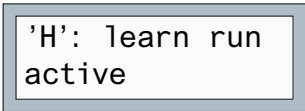
Table 5-29 Starting a learn run during operation

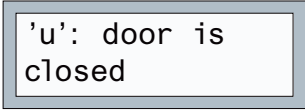
Procedure		H401 display	H1 display
1.	Push the door into the CLOSED position.		
2.	Press and hold the learn run button (S401).		
3.	The learn run starts automatically, and the learn run button can be released.		
4.	During the learn run, the door is opened about 10 cm, and closed once or twice at slow start speed. The friction of the door system is then determined by opening and closing the door once through a range of 25 cm at slow start speed. The door then opens and closes through its complete range of movement at reduced speed. After the door has opened by approximately 15 cm, it passes through an additional short acceleration ramp to determine the mass to be moved.		
5.	The door parameters and the determined door width are saved when the door is in the CLOSED position. This means that the door width, mass to be moved, energy limiting, speed limiting and friction compensation <sup>3)</sup> are re-adapted and saved.		
6.	Learn run completed.		

### Service buttons open/close

**Note**

The service buttons are not evaluated when the command Stop with disable DCU is active.

Door movements in the OPEN and CLOSE directions can also be made manually with the service buttons S402 (OPEN) and S403 (CLOSE).

The service buttons have the highest command priority. Commands via the FBLOCK logic or fieldbus are overridden by it. Each of these service buttons has to be pushed continuously to reach the limit position of the door, because the door stops when the button is released.

If the OPEN and CLOSE buttons are pressed simultaneously or the OPEN and CLOSE drive commands are used simultaneously, the door always moves in the **OPEN** direction.

**Note**

**Operation with the SIDOOR SERVICE TOOL, the SIDOOR SUPPORT app or the SIDOOR USER SOFTWARE.**

Alternatively, you can also operate the doors using the service menu via the SIDOOR SERVICE TOOL, the SIDOOR SUPPORT app or the SIDOOR USER SOFTWARE. In this case, the external input signals are disabled in some menus. For more information, refer to the SIDOOR SERVICE TOOL (Page 265) section, the SIDOOR SUPPORT App Function Manual and the SIDOOR SOFTWARE KIT Operating Instructions (<http://support.automation.siemens.com/WW/view/en/92711247>).

See also

SIDOOR SUPPORT App Function Manual (<https://support.industry.siemens.com/cs/de/en/view/109802679>)

### 5.9.2 Parameter assignment via the terminal module

Overview

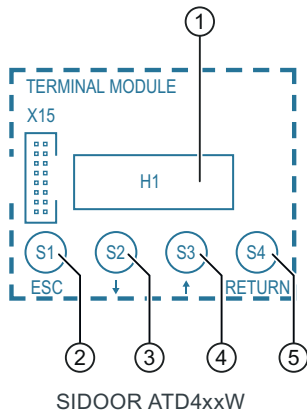

- ① Digital display
- ② Escape key
- ③ Menu selection key
- ④ Menu selection key
- ⑤ Enter key

Figure 5-9 Overview of terminal module



Function

The integrated terminal module can be used for diagnostics and setting parameters.

Operation

	Enter key – jumps to the next menu below
	Escape key – jumps back to the menu above



	Menu selection key – increases a parameter value
	Menu selection key – decreases a parameter value

Parameters can be changed in both of the following menus:

- "MAIN MENU > Quick setup > Parameter setting"
- "MAIN MENU > General setup > Profile parameters"

The desired parameter is selected with the menu selection keys ↑ and ↓, and activated for the setting with the Enter key ↵ (parameter value flashes).

The parameter value can then be increased or decreased by pressing the corresponding key (see above). The value is accepted by pressing the Enter key again.

### Menu navigation

You can find the menu navigation of the SIDOOR SERVICE TOOL in the section (Page 265).

### Digital display "H1"

You can see the operating states on the "H1" display. You can find the meaning of the digital display in the section Operating state display (Page 297).

## 5.9.3 Parameter assignment using additional devices

### Description

In addition to the parameter assignment options integrated in the controller, you can also assign parameters via additional units. The following additional units are available for parameter assignment:

- **SIDOOR USER SOFTWARE**  
The SIDOOR USER SOFTWARE is part of the SIDOOR SOFTWARE KIT. You can find a detailed description of the SIDOOR SOFTWARE KIT in the SIDOOR SOFTWARE KIT Operating Instructions (<http://support.automation.siemens.com/WW/view/en/92711247>).
- **SIDOOR SERVICE TOOL**  
A detailed description of the SIDOOR SERVICE TOOL is available in the section SIDOOR SERVICE TOOL (Page 265).
- **SIDOOR SUPPORT app**  
You can find a detailed description of the SIDOOR SUPPORT app in the section SIDOOR LINK and SIDOOR SUPPORT App (Page 274).

### 5.9.4 Adjustable parameters

#### 5.9.4.1 Driving curve

The optimum drive characteristics of the door are calculated and maintained continuously. The driving curve transitions are rounded off so that the door movement is smooth and jerk-free.

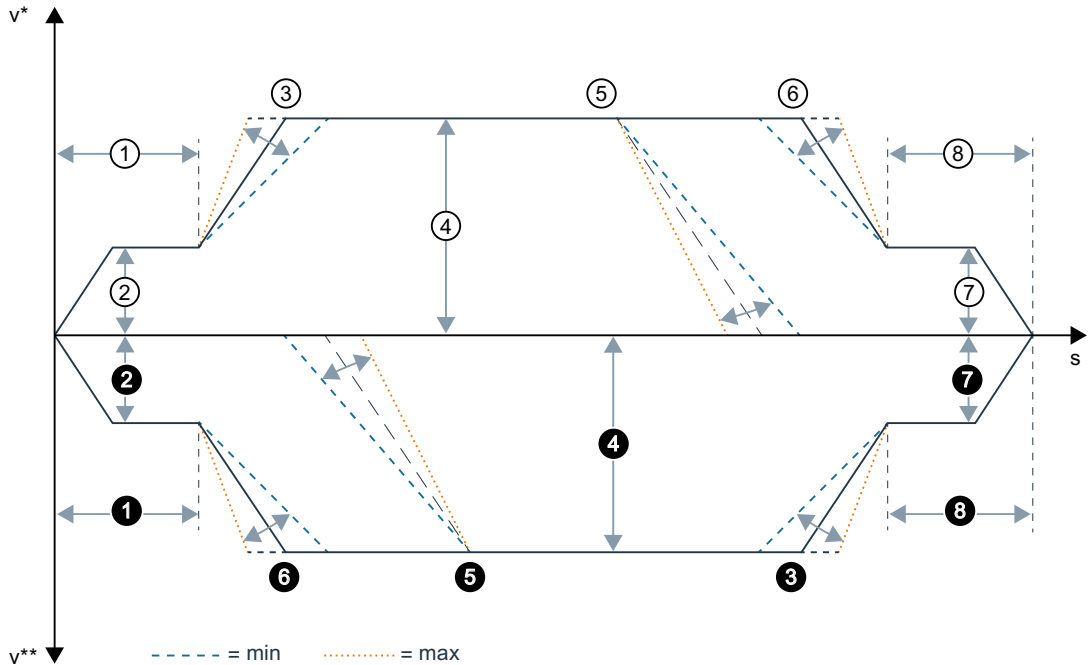

$v^*$  Speed open

- ① Slow start distance open
- ② Slow start speed open
- ③ Acceleration ramp open
- ④ Maximum speed open
- ⑤ Reversal ramp open/close
- ⑥ Deceleration ramp open
- ⑦ Slow end speed open
- ⑧ Slow end distance open

$v^*$  Speed close

- ① Slow end distance close
- ② Slow end speed close
- ③ Acceleration ramp close
- ④ Maximum speed close
- ⑤ Reversal ramp close/open
- ⑥ Deceleration ramp close
- ⑦ Slow start speed close
- ⑧ Slow start distance close

Reversal ramp close/open = Reversal of travel in direction "CLOSE" in direction "OPEN".

Reversal ramp open/close = Reversal of travel in direction "OPEN" in direction "CLOSE".

When reversing, the door is braked with the reversal ramp and starts the travel in the opposite direction with the acceleration ramp.

### 5.9.4.2 Forces

The following forces and currents can be configured for the travel curve:

#### Continuous torque (power) OPEN

Continuous torque in the door position OPEN.

This parameter is effective when an open command is present and the door is in the OPEN position.

The current generates a continuous torque against the end position of the door in the opening direction.

#### Adjustment ranges

The parameter can be adjusted in accordance with the adjustment ranges of the parameters (see section Profiles and adjustment ranges (Page 323)). The value of the parameter must be selected so that the door is held in the OPEN position.

#### Continuous torque (power) CLOSE

Continuous torque in the door position CLOSED.

This parameter is effective when a close command is present and the door is in the CLOSED position.

The current generates a continuous torque against the end position of the door in the closing direction.

#### Adjustment ranges

The parameter can be adjusted in accordance with the adjustment ranges of the parameters (see section Profiles and adjustment ranges (Page 323)). The value of the parameter must be selected so that the door is held in the CLOSED position.

#### Peak torque close

The peak torque close can be set via a current value and is used to press the door within the last centimeter within the CLOSED door position.

If an obstruction is detected within a tolerance range of 1 cm around the CLOSED position, then the peak torque close is applied for approx. 2 seconds.

#### Adjustment ranges

The parameter can be adjusted in accordance with the adjustment ranges of the parameters (see section Profiles and adjustment ranges (Page 323)). The value of the parameter must be selected so that the cutter force opposing the door is overcome, and the door is closed completely.

#### Static opening force

This force is effective during the opening movement if an open command is present.

The following diagram shows the dependence on motor current and force for motors with standard pinion (output transmission ratio 176 mm/rev).

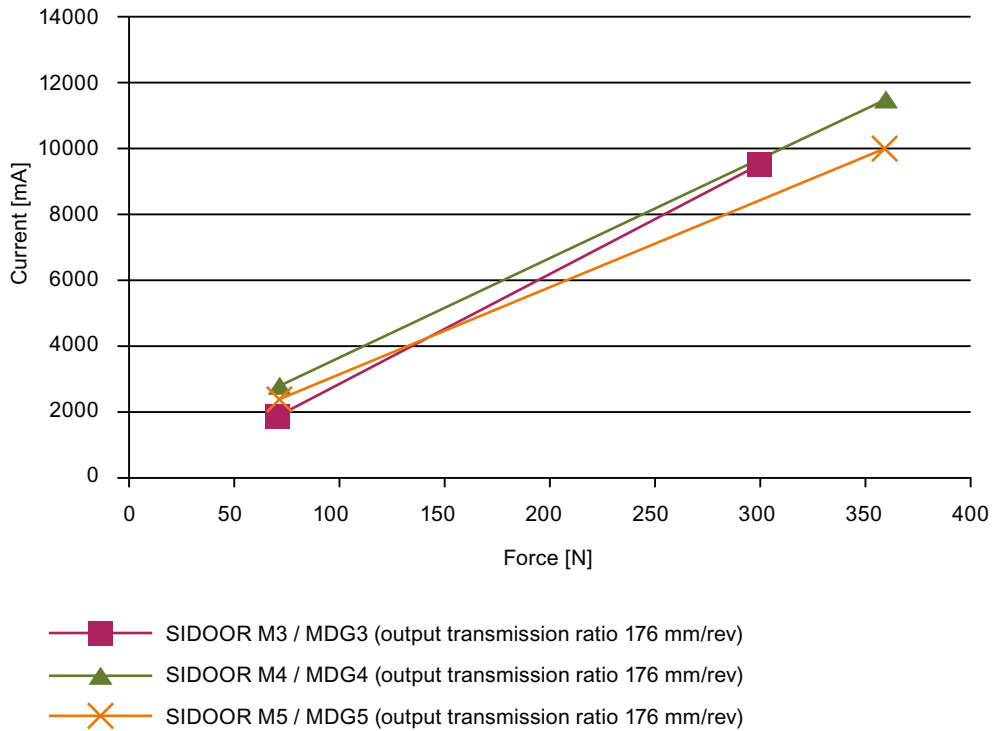

Figure 5-10 Current – force – motor characteristic in opening direction for drive transmission ratio 176 mm/rev

**Adjustment ranges**

The parameter can be adjusted in accordance with the adjustment ranges of the parameters (see section Profiles and adjustment ranges (Page 323)). The value of the parameter must be selected so that the door moves across the entire door width in the opening direction if an open command is present. Inadequate force can lead to an obstruction of the door.

In the factory setting, the opening force is preset to a minimum value (see section Profiles and adjustment ranges (Page 323)).

**Static closing force**

This force is effective during the closing movement if a close command is present.

The following diagram shows the dependence on motor current and force for motors with standard pinion (output transmission ratio 176 mm/rev).

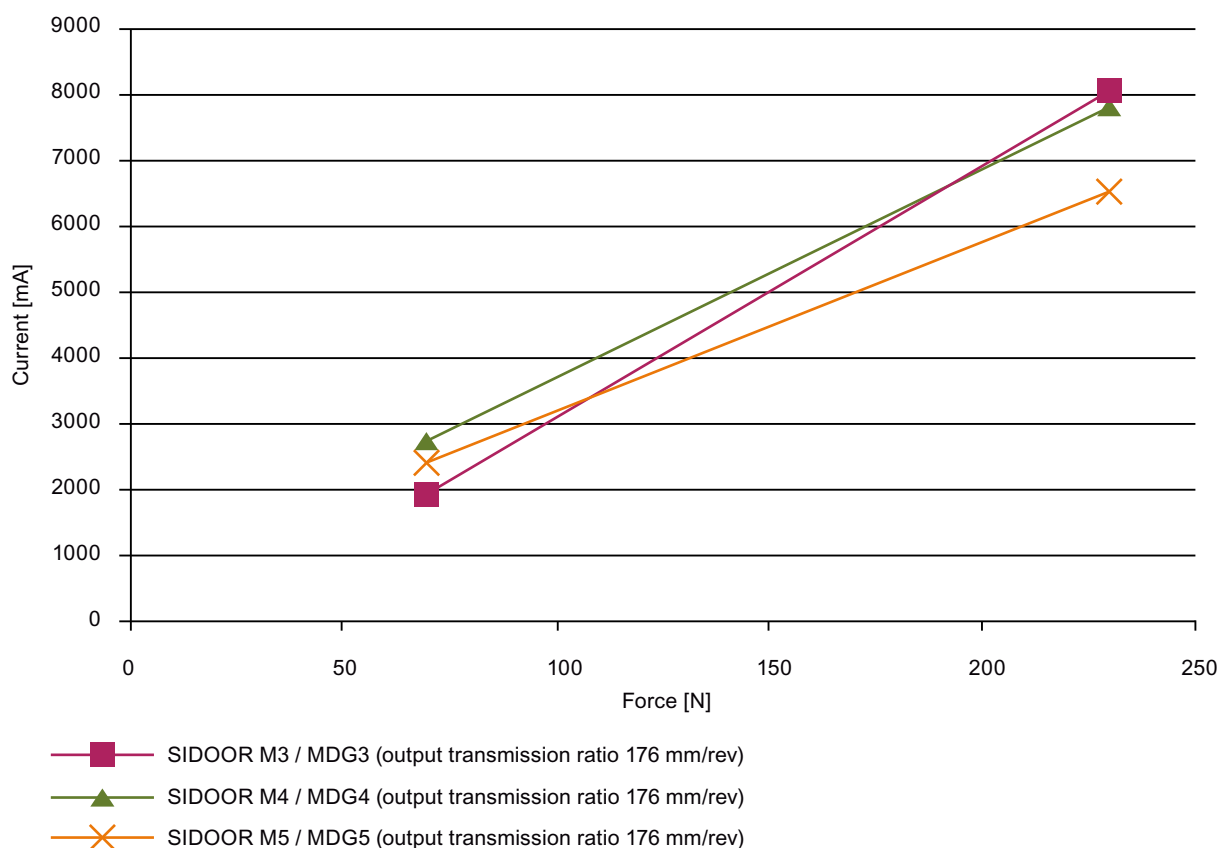



Figure 5-11 Current – force – motor characteristic in closing direction for output transmission ratio 176 mm/rev

### Adjustment ranges

The value of the parameter must be selected so that the door moves across the entire door width in the closing direction if a close command is present. Inadequate force can lead to an obstruction of the door.

The closing force can be set for the geared motors within the adjustment ranges of the parameters (see section Profiles and adjustment ranges (Page 323)).

A warning appears on the digital display of the terminal module if the set closing force of 150 N is exceeded. The stated values refer to doors opening to one side. A load cell in the middle of centrally opening doors would show only half the value.

 <b>WARNING</b>
<p><b>Risk of injury and material damage due to excessive closing force of the door</b></p> <p>When the closing force is set, it is imperative that any effective closing weight is taken into account.</p> <p>The desired closing force must be reduced by 10 N for each 1 kg of counterweight. This affects the:</p> <ul style="list-style-type: none"> <li>• Closing force CLOSE</li> <li>• Closing force cutter distance CLOSE</li> </ul>

**Example: Closing weight = 4 kg**

Desired static force limit CLOSE = 150 N

The counterweight of 4 kg corresponds to a force of 40 N. The force limit then has to be adjusted to  $150\text{ N} - 40\text{ N} = 110\text{ N}$ .

In the factory setting, the closing force is preset to a minimum value (see section Profiles and adjustment ranges (Page 323)).

**Limit force end CLOSE**

This force serves to overcome the cutter distance in the closing direction.

A higher force is often required to overcome the cutter distance than for the rest of the distance the door travels.

This parameter is effective in the closing direction when the door is within the cutter distance.

**Adjustment ranges**

The parameter can be adjusted in accordance with the adjustment ranges of the parameters (see section Profiles and adjustment ranges (Page 323)). The value of the parameter must be selected so that the cutter distance is overcome in the closing direction.

In the factory setting, the closing force is preset to a minimum value (see section Profiles and adjustment ranges (Page 323)).

**5.9.4.3 Parameter assignment**

The tables below show all the parameters that are available via the PKW interface. The parameters are generally subdivided into:

- Driving parameters
- Fieldbus parameters
- Other parameters
- Calibration and function parameters
- Obstruction and reversing parameters
- FBLOCK parameters
- Basic parameters

---

**Note**

Write-protected parameters (read only) are indicated in the documentation by an "r" before the parameter number.

Read / write parameters can be changed, and are indicated by a "p" before the parameter number.

---

## Driving parameters

### Note

For safety reasons, changes to the driving parameters are only accepted when the controller is at a complete stop.

### Note

#### Write protection

When write protection is activated (see Table 5-31 Other parameters (Page 182)), the drive curve parameters can only be changed via the SIDOOR user commissioning software and the PKW interface. A write-protected parameter can only be configured via the PKW interface, and is automatically reset by an initial learn run (learn run when line voltage applied) as well as while loading the factory setting.

Table 5-30 Driving parameters

Parameter ID	Unit	Parameter name	Description
<b>Distances</b>			
p3660	mm	Slow end distance open	End distance in opening direction at the open position
p3661	mm	Slow start distance open	Start distance in opening direction at the closed position
p3662	mm	Slow start distance close	Start distance in closing direction at the open position
p3663	mm	Slow end distance close	End distance in closing direction at the closed position
<b>Speeds</b>			
p3664	mm/s	Maximum speed open	Maximum speed in the opening direction
p3665	mm/s	Slow end speed open	Speed in the creep distance in opening direction
p3666	mm/s	Slow start speed open	Speed in the slow start distance in opening direction
p3667	mm/s	Slow initial speed open	Initial speed in the opening direction
p3668	mm/s	Maximum speed close	Maximum speed in the closing direction
p3669	mm/s	Slow start speed close	Speed in the slow start distance in closing direction
p3670	mm/s	Slow end speed close	Speed in the slow end distance in closing direction
p3671	mm/s	Slow initial speed close	Initial speed in the closing direction
p3672	mm/s	NDG speed (reduced)	Speed in NDG mode in the opening and closing directions
<b>Acceleration and deceleration</b>			
p3673	mm/s <sup>2</sup>	Acceleration ramp open	Acceleration ramp in the opening direction
p3674	mm/s <sup>2</sup>	Deceleration ramp open	Deceleration ramp in the opening direction
p3675	mm/s <sup>2</sup>	Reversal ramp open/close	Reversal ramp OPEN → CLOSE
p3676	mm/s <sup>2</sup>	Acceleration ramp close	Acceleration ramp in the closing direction
p3677	mm/s <sup>2</sup>	Deceleration ramp CLOSE	Deceleration ramp in the closing direction
p3678	mm/s <sup>2</sup>	Reversal ramp close/open	Reversal ramp CLOSE → OPEN
p3679	mA	Idle torque OPEN	Continuous torque in open position. The current generates a continuous torque against the end position of the door in the opening direction.

5.9 Operation and configuration of the control unit

Parameter ID	Unit	Parameter name	Description
p3680	mA	Idle torque CLOSE	Continuous torque in closed position. The current generates a continuous torque against the end position of the door in the closing direction.
p3681	mA	Peak torque close	Peak torque close in closed position for approx. 2 s
<b>Forces</b>			
p3682	N	Static force limit open	Static force limit open
p3683	N	Static force limit close	Static force limit close
p3684	N	Limit force end close	Limit force end in the closing direction
p3685	N	Static NDG-force (reduced)	Force in NDG mode in the opening and closing directions

You will find the corresponding factory settings and adjustment ranges (depending on the motor used) for the driving parameters in section Profiles and adjustment ranges (Page 323).

**Other parameters**

Table 5-31 Other parameters

Parameter ID	Adjustment range	Factory setting	Unit	Description
<b>Sensor Module</b>				
p4600	0 ≙ inactive 1 ≙ ESPE 2 ≙ DCOPS 3 ≙ pressure sensitive edge 4 ≙ Light barrier (as of V1.14)	0	—	Local sensor type
p4601	20 ... 5000	30	ms	Discrepancy time in the function test of the OSSD system
p4610	0 ... 30000 0 ≙ "AND0" discrepancy analysis deactivated	400	ms	Discrepancy analysis time of the input monitoring block FBLOCK "AND0"
p4611	10 ... 30000 0 ≙ discrepancy analysis "AND2" deactivated	400	ms	Discrepancy analysis time of the input monitoring block FBLOCK "AND2"
<b>Faults and alarms</b>				
r2100	—	—	—	Status code ASCII code of the 7-segment display (see section Figure 5-4 Sequential control state graph (Page 157))
r2102	0 ≙ special motor 1 ≙ M2 2 ≙ M3 / MDG3 3 ≙ M4 / MDG4 4 ≙ M5 / MDG5 255 ≙ unknown motor			Connected motor
<b>Display and operation</b>				



5.9 Operation and configuration of the control unit

Parameter ID	Adjustment range	Factory setting	Unit	Description
p90	0 ≙ deactivated 1 ≙ activated	0	—	Write protection Activates (1) or deactivates (0) write protection for all driving curve parameters in the service menu. As of V1.09: When write protection is activated via parameter p90, the FBLOCK configuration, the force for the learn run and the configuration of digital input 1 can no longer be changed via the operating menu. As of V1.10: When write protection is activated, the basic parameter cannot be changed via the operating menu.
p91	<b>Write:</b> 1 ≙ reset complete parameter set (load all factory defaults) (As of V1.10) 2 ≙ Trigger restart of the control unit 3 ≙ Reset full parameter set and trigger restart of the control unit <b>Read:</b> 1 ≙ parameter set validated and valid 0 ≙ parameter set invalid and/or reset to factory settings	—	—	<b>Note:</b> All saved parameters are reset to factory setting! The control unit must be restarted for the factory settings to take effect. <b>Note:</b> A learn run is mandatory for "0" (parameter set invalid or factory settings loaded)!
p92	1 ≙ Reset FBLOCK configuration 2 ≙ FBLOCK configuration "Default input" 3 ≙ FBLOCK configuration "Emergency stop 3 inp." 4 ≙ FBLOCK configuration "Cold storage mode"	—	—	Default setting of FBLOCK configurations. <b>Note:</b> If a value of 1 to 4 is written to this parameter, all the FBLOCK parameters are preset to the selected configuration. The parameter can only be written. Reading always supplies the value 0.
p93	1 ≙ load factory defaults of the driving curve parameter set	—	—	<b>Note:</b> All saved driving curve parameters are reset to their factory defaults! <ul style="list-style-type: none"> <li>• Loads driving curve parameters of the default driving curve profile</li> <li>• In addition, the following parameters are reset: p1202, p1203, p1204, p2104, p2105, p1242</li> </ul>
p95	0 ≙ deactivated ≥1 ≙ activated	0	—	Activation of a test run. The reverse after block is switched off during the test run. The test run is performed with the next drive command. After the drive command has switched, the test run is deactivated again, see section "4.3.12 Test run (as of V1.12) (Page 103)".

5.9 Operation and configuration of the control unit

Parameter ID	Adjustment range	Factory setting	Unit	Description
p100	0 = FBLOCK + Bus 1 = FBLOCK + relay	0	—	Default command mode: For the ATD420W, ATD430W control units the command input via the bus system is activated in the default setting -> parameter p100 = 0. This means that the FBLOCK drive orders can only be executed in the drive state "S4: Z_MODE" (see Figure 4-4 State graph control unit (Page 157)). For the ATD401W control unit with relay module, no command mode is possible via the bus system. For this control unit variant, parameter p100 = 1 must always be set. Otherwise, the control unit cannot be controlled via the digital inputs.
r200	1 ... 65535 0 = Checksum invalid	—	—	Checksum for the default parameters (see Checksum parameters (as of V1.12) (Page 71))
r201	1 ... 65535 0 = Checksum invalid	—	—	Checksum for the learn run parameters (see Checksum parameters (as of V1.12) (Page 71))
r202	0 ... 65535	—	—	Change counter for the default parameters (see Checksum parameters (as of V1.12) (Page 71))
r203	0 ... 65535	—	—	Firmware version The version is output as "MajorVer*100 + MinorVer". e. g. firmware version "1.13.1234" is output as "113".
r204	0 = Checksum invalid 1 = Checksum valid	—	—	Validity of the checksum for the default parameters r200, r201.
p2080	0 ... 65535	FFFF (hex)	—	<b>DCMD masking fieldbus</b> Each bit in the mask filters the corresponding bit in TSW1: 0: CMD bit is not allowed to pass 1: CMD bit is allowed to pass
p2081	0 ... 65535	FFFF (hex)	—	<b>DCMD masking FBLOCK</b> Each bit in the mask filters the corresponding bit in TSW1: 0: CMD bit is not allowed to pass 1: CMD bit is allowed to pass

## Fieldbus parameters

Table 5-32 Fieldbus parameters

Parameter ID	Adjustment range	Factory setting	Description
<b>Communication channel</b>			
p2020	0 ≙ 9600 1 ≙ 19200 2 ≙ 38400 3 ≙ 57600 4 ≙ 115200 5 ≙ 187500 6 ≙ 250000 7 ≙ 300000 8 ≙ 375000 9 ≙ 500000 10 ≙ 750000	4	Baud rate
p2021	0 ... 31	0	Slave address
p2022	0 to 16 words	7	Number of PZDs
p2023	0 ≙ no PKW proportion 3 ≙ (3 words) 4 ≙ (4 words)	4	Number of PKWs
<b>Statistical data</b>			
r2029	0 ≙ rejected telegrams 1 ≙ character frame 2 ≙ start character 3 ≙ block check character 4 ≙ telegram length 5 ≙ remaining execution time 6 ≙ telegram type 7 ≙ buffer overflow	—	Error statistics
<b>Monitoring</b>			
p2040	0 to 65535 ms 0 ≙ monitoring deactivated	1000 ms	Monitoring time for master monitoring
<b>Cyclic process values</b>			
p4700	0 ... 10	0	As of V1.09: Value selection for cyclic transmission of process value TZW3 (Page 321)
p4701	0 ... 10	1	As of V1.09: Value selection for cyclic transmission of process value TZW4 (Page 321)
p4702	0 ... 10	2	As of V1.09: Value selection for cyclic transmission of process value TZW5 (Page 321)

### Calibration and function parameters

Table 5-33 Calibration and function parameters

Parameter ID	Adjustment range	Factory setting	Unit	Description
<b>Advanced functions</b>				
p1200	50 ... 1000 0 ≙ deactivated	250 Motor M5 / MDG5: 200	mm/s	Speed from which vandalism protection is activated.
p1201	1 ... 4000 0 ≙ deactivated	500	mm	Belt break monitoring Distance after which a torn belt is detected / reported.
p1202	0 ... 100 0 ≙ no limit	4	J	Kinetic energy limiting in closing direction 0 ≙ no limiting based on energy
p1203	0 ... 100 0 ≙ no limit	4	J	Kinetic energy limiting in opening direction 0 ≙ no limiting based on energy
p1204	0 ... 100 0 ≙ no limit	4	J	Kinetic energy limiting in NDG mode 0 ≙ no limiting based on energy
p1206	30 ... 500	30	cm	Partial opening width (virtual open position)
p1208	1 ... 20	10	mm	Door width tolerance (buffer distance at the end stops)
p1242	70 ... 360/k	360/k	N	Force limit for learn run (Page 48) The maximum value of the parameter depends on the output transmission and is defined by the k factor (existing output transmission/176 [mm/rev]). The value is limited to the motor-specific maximum value depending on the motor, see motor type in section Profiles and adjustment ranges. (Page 323)
<b>Light barrier</b>				
p1210	0 ... 60000	10	mm	Distance from the closed stop at which the light barrier and pressure-sensitive edge reaction are suppressed.
p1211	0 ≙ deenergize 1 ≙ stop 2 ≙ open 3 ≙ close	0	—	Continuous torque if there is obstruction in the opening direction during reversing due to interrupted light barrier.
<b>ImpulseDrive</b>				
p1220	500 ... 60000	1000	ms	Lead time effective after the door command "deenergize" (current-free)
p1221	1 ... 1000 0 ≙ deactivated	80	—	Detection sensitivity for distance-based detection <b>Note:</b> 1 ≙ very sensitive
p1222	1 ... 1000 0 ≙ deactivated	20	—	Detection sensitivity for speed-based detection <b>Note:</b> 1 ≙ very sensitive
<b>AssistedDrive</b>				
p1230	0 ... 60000	100	ms	Switch-off delay for the ASDrv signal. After expiry of this delay time, the ASDrv signal switches from active to inactive.

5.9 Operation and configuration of the control unit

Parameter ID	Adjustment range	Factory setting	Unit	Description
p1231	1 ... 100	60	%	Threshold value for digital detection of external slide support during the opening movement (The proportion of force from which AssistedDrive is detected in relation to the learnt reference value)
p1232	1 ... 100	60	%	Threshold value for digital detection of external slide support during the closing movement (The proportion of force from which AssistedDrive is detected in relation to the learnt reference value)
<b>Output transmission</b>				
p4602	88...384	0	mm/rev	M3, MDG3, M4, MDG4, M5 and MDG5 motors The permissible values are between 88...384 mm/rev. After change of the output transmission ratio, a learn run must be carried out or the basic parameters must be adjusted and confirmed.
<b>ImpulseStop</b>				
p1240	1 ... 100	50	%	Limit value for digital detection of an external opposing force during the opening movement (The proportion of force before ImpulseStop is detected in relation to the learnt reference value/friction force)
p1241	1 ... 100	50	%	Limit value for digital detection of an external opposing force during the closing movement (The proportion of force before ImpulseStop is detected in relation to the learnt reference value/friction force)
<b>Cold-storage function (as of V1.12)</b>				
p1250	1 ... 60	0	s	"Standard" hold-open time in the cold storage function in seconds. As soon as the door receives the open status, the specified time starts running and closes automatically when the time has elapsed. If 0 s is specified, the function is deactivated.
p1251	1 ... 60	0	s	"Cord-operated switch" hold-open time in the cold storage function in seconds. As soon as the door receives the open status, the specified time starts running and closes automatically when the time has elapsed. If 0 s is specified, the function is deactivated.
p1252 (as of V1.14)	0 ... 65535	0	ms	Period for issuing the command "Close" (p20059) in the closed position. 0 = No closing command 65535 = Continuous closing command
<b>Basic parameters</b>				
<V1.10: r2101 >=V1.10: p2101	0 ... 1100	1100	Kg	Effective door weight As of V1.10: Writable

5.9 Operation and configuration of the control unit

Parameter ID	Adjustment range	Factory setting	Unit	Description
<V1.10: r2103 >=V1.10: p2103	300 ... 5000	300	Mm	Door width As of V1.10: Writable
<V1.10: r2104 >=V1.10: p2104	0 ... 300	0	N	Friction in open direction As of V1.10: Writable
<V1.10: r2105 >=V1.10: p2105	0 ... 300	0	N	Friction in close direction As of V1.10: Writable
p2107	-12000 ... 12000	0	mA	As of V1.10: Average current for the friction in the opening direction
p2108	-12000 ... 12000	0	mA	As of V1.10: Average current for the friction in the closing direction
p2109	0 ... 1	1	—	As of V1.10: Direction of rotation of the motor 1 = normal, 0 = inverse
p2110	0 ... 1	1	—	As of V1.10: Direction of rotation of the pulse encoder 1 = normal, 0 = inverse
p2111	0 ... 2	0	—	As of V1.10: Status of the basic parameter editors: Read: 0 = Basic parameter editor is not running, 1 = Basic parameter editor active Write: 0 = Close basic parameter editor 1 = Start Basic parameter editor 2 = Transfer data to basic parameter editor
<b>Position block (as of V1.12)</b>				
p2200	0..500	0	cm	Normal operation: Indication of the position of the area in the OPEN direction starting from the "Closed" position.
p2201	0..500	0	cm	Normal operation: Specifies the width of the area in the OPEN direction. 0 ≙ area deactivated.
p2202	0..500	0	cm	Normal operation: Indication of the position of the area in CLOSE direction starting from the "Closed" position.
p2203	0..500	0	cm	Normal operation: Specifies the width of the area in the CLOSE direction. 0 ≙ area deactivated.
p2204	0..500	0	cm	Initial operation: Because the absolute position is not known in initial operation, the width in OPEN direction is specified here starting from the current position. 0 ≙ area deactivated.

Parameter ID	Adjustment range	Factory setting	Unit	Description
p2205	0..500	0	cm	Initial operation: Because the absolute position is not known in initial operation, the width in Close direction is specified here starting from the current position. 0 $\triangleq$ area deactivated.
<b>Specific door range of motion</b>				
p3686	See p3682 corresponding motor type in section Profiles and adjustment ranges (Page 323)		N	Force limit in specific door range in OPEN direction
p3687	See p3683 corresponding motor type in section Profiles and adjustment ranges (Page 323)		N	Force limit in specific door range in CLOSE direction
p3688	See p3664 corresponding motor type in section Profiles and adjustment ranges (Page 323)		mm/s	Speed limit in specific door range in OPEN direction
p3689	See p3668 corresponding motor type in section Profiles and adjustment ranges (Page 323)		mm/s	Speed limit in specific door range in CLOSE direction

### Obstruction and reversing parameters

Table 5-34 Obstruction and reversing parameters (general)

Parameter ID	Adjustment range	Factory setting	Unit	Description
<b>General</b>				
p3850 <sup>1)</sup>	0..255 Bit x = 1 $\triangleq$ function activated Bit x = 0 $\triangleq$ function deactivated	255	—	Function control Bit 0 $\triangleq$ stop obstruction detection in the closing direction Bit 1 $\triangleq$ force obstruction detection in the closing direction Bit 2 $\triangleq$ obstruction counter in the closing direction Bit 3 $\triangleq$ slow obstruction approach in the closing direction Bit 4 $\triangleq$ stop obstruction detection in the opening direction Bit 5 $\triangleq$ force obstruction detection in the opening direction Bit 6 $\triangleq$ obstruction counter in the opening direction Bit 7 $\triangleq$ slow obstruction approach in the opening direction

<sup>1)</sup> Expert parameters, see section Expert configuration (Page 84).

The parameters in the table below refer to the closing direction only.

Table 5-35 Obstruction and reversing parameters (in the closing direction)

Parameter ID	Adjustment range	Factory setting	Unit	Description
<b>Timing</b>				
p3852 <sup>1)</sup>	0 ... 65535	1000	ms	ON-delay time for obstruction detection
p3853 <sup>1)</sup>	0 ... 65535	300	ms	Minimum detection time for stop obstruction
p3854 <sup>1)</sup>	0 ... 65535	100	ms	Minimum detection time for force obstruction
<b>Ranges</b>				
p3855 <sup>1)</sup>	0 ... 65535	20	mm	Distance for slow obstruction approach before and after the obstruction
p3856 <sup>1)</sup>	0 ... 65535	10	mm	Range of suppression of obstruction detection before the closed end stop
p3857 <sup>1)</sup>	0 ... 65535	10	mm	Range of suppression of obstruction detection after the open end stop
p3858 <sup>1)</sup>	0 ... 65535	20	mm	Range of suppression of force obstruction detection before the creep distance
p3859 <sup>1)</sup>	0 ... 65535	50	mm	Range of suppression of force obstruction detection after the last obstruction
<b>Retries</b>				
p3860	0 ... 65535 (0xFFFF) 0 ≙ no attempt, 65535 (0xFFFF) ≙ unlimited attempts.	0	—	Number of retries to overcome the obstruction
p3861	0 ... 65535	2000	ms	Wait time before each retry
p3862	0 ≙ deenergize 1 ≙ stop 2 ≙ open 3 ≙ close	0	—	Drive control during the wait time (before retries)
p3863	0 ≙ deenergize 1 ≙ stop 2 ≙ open 3 ≙ close	0	—	Drive control after all retries have been executed (if reversing is not configured)
<b>Reversing</b>				
p3864	0 ... 65535 (0xFFFF) 0 ≙ no reversing 65535 (0xFFFF) ≙ Unlimited reversing	2 1 (V1.03 and higher) 2 (as of V1.14)	—	Number of reverses <b>Caution!</b> As of V1.14 the counting of the reverses has changed. The value 1 means that the door travels once in the reverse direction after blocking. The value 2 means that the door first travels in the reverse direction after blocking. After the value time (p3865) has expired, the door travels once again against the obstacle and then in reverse direction again. This behavior corresponds to the behavior before V1.14 with the parameter value 1.



Parameter ID	Adjustment range	Factory setting	Unit	Description
p3865	0 ... 65535	2000	ms	Wait time before each reverse
p3866	0 ... 65535 0 $\triangleq$ full reverse	200	mm	Reversing distance
p3867	0 $\triangleq$ deenergize 1 $\triangleq$ stop 2 $\triangleq$ open 3 $\triangleq$ close	0	—	Drive control for obstruction while reversing
p3868	0 $\triangleq$ deenergize 1 $\triangleq$ stop 2 $\triangleq$ open 3 $\triangleq$ close	0	—	Drive control after all reverses have been executed

<sup>1)</sup> Expert parameters, see section Expert configuration (Page 84).

The parameters in the table below refer to the opening direction only.

Table 5-36 Obstruction and reversing parameters (in the opening direction)

Parameter ID	Adjustment range	Factory setting	Unit	Description
<b>Timing</b>				
p3869 <sup>1)</sup>	0 ... 65535	1000	ms	ON-delay time for obstruction detection
p3870 <sup>1)</sup>	0 ... 65535	500	ms	Minimum detection time for stop obstruction
p3871 <sup>1)</sup>	0 ... 65535	100	ms	Minimum detection time for force obstruction
<b>Ranges</b>				
p3872 <sup>1)</sup>	0 ... 65535	20	mm	Distance for slow obstruction approach before and after the obstruction
p3873 <sup>1)</sup>	0 ... 65535	10	mm	Range of suppression of obstruction detection after the closed end stop
p3874 <sup>1)</sup>	0 ... 65535	10	mm	Range of suppression of obstruction detection before the open end stop
p3875 <sup>1)</sup>	0 ... 65535	20	mm	Range of suppression of force obstruction detection before the creep distance
p3876 <sup>1)</sup>	0 ... 65535	50	mm	Range of suppression of force obstruction detection after the last obstruction
<b>Retries</b>				
p3877	0 ... 65535 (0xFFFF) 0 $\triangleq$ no retry 65535 (0xFFFF) $\triangleq$ Unlimited attempts	3 0 (V1.03 and higher)	—	Number of retries to overcome the obstruction
p3878	0 ... 65535	2000	ms	Wait time before each retry
p3879	0 $\triangleq$ deenergize 1 $\triangleq$ stop 2 $\triangleq$ open 3 $\triangleq$ close	0	—	Drive control during the wait time (before retries)

5.9 Operation and configuration of the control unit

Parameter ID	Adjustment range	Factory setting	Unit	Description
p3880	0 ≙ deenergize 1 ≙ stop 2 ≙ open 3 ≙ close	0	—	Drive control after all retries have been executed (if reversing is not configured)
<b>Reversing</b>				
p3881	0 ... 65535 (0xFFFF) 0 ≙ no reversing 65535 (0xFFFF) ≙ Unlimited reversing	0 1 (V1.03 and higher)	—	Number of reverses
p3882	0 ... 65535	2000	ms	Wait time before each reverse
p3883	0 ... 65535 0 ≙ full reverse	0 200 (V1.03 and higher)	mm	Reversing distance
p3884	0 ≙ deenergize 1 ≙ stop 2 ≙ open 3 ≙ close	0	—	Drive control for obstruction while reversing
p3885	0 ≙ deenergize 1 ≙ stop 2 ≙ open 3 ≙ close	0	—	Drive control after all reverses have been executed

<sup>1)</sup> Expert parameters, see section Expert configuration (Page 84).

**FBLOCK parameters**

**FBLOCK-DCMD parameters**

Drive orders can be assigned to the "Q" outputs with the following FBLOCK-DCMD parameters. A drive order only becomes active if the assigned output "Q" is active (positive logic). In the case of edge-controlled signals, the output signal is active for one cycle only. This is why a correspondingly assigned drive order is latched automatically.

You will find details of the functions and logic of the individual function blocks in Section Free function blocks (FBLOCK) (Page 86).

Table 5-37 FBLOCK-DCMD parameters

Parameter ID	Name	Description	
<b>Digital Input</b>			
p20000	DCMD_DIO_Q2	Rising (positive) edge	Output is active for one cycle when input edge is detected.
p20001	DCMD_DIO_Q3	Falling (negative) edge	The entered drive order (DCMD) is automatically latched (stored).
p20002	DCMD_DIO_Q4	Level-controlled output; output follows the input directly	

5.9 Operation and configuration of the control unit

Parameter ID	Name	Description	
p20003	DCMD_DI1_Q5	Rising (positive) edge	Output is active for one cycle when input edge is detected.
p20004	DCMD_DI1_Q6	Falling (negative) edge	The entered drive order (DCMD) is automatically latched (stored).
p20005	DCMD_DI1_Q7	Level-controlled output; output follows the input directly	
p20006	DCMD_DI2_Q8	Rising (positive) edge	Output is active for one cycle when input edge is detected.
p20007	DCMD_DI2_Q9	Falling (negative) edge	The entered drive order (DCMD) is automatically latched (stored).
p20008	DCMD_DI2_Q10	Level-controlled output; output follows the input directly	
p20009	DCMD_DI3_Q11	Rising (positive) edge	Output is active for one cycle when input edge is detected.
p20010	DCMD_DI3_Q12	Falling (negative) edge	The entered drive order (DCMD) is automatically latched (stored).
p20011	DCMD_DI3_Q13	Level-controlled output; output follows the input directly	
p20012	DCMD_DI4_Q14	Rising (positive) edge	Output is active for one cycle when input edge is detected.
p20013	DCMD_DI4_Q15	Falling (negative) edge	The entered drive order (DCMD) is automatically latched (stored).
p20014	DCMD_DI4_Q16	Level-controlled output; output follows the input directly	
p20031	DCMD_DI0_39	Level-controlled output; output follows the input inverted (firmware version 1.03 or higher)	
p20032	DCMD_DI1_40		
p20033	DCMD_DI2_41		
p20034	DCMD_DI3_42		
p20035	DCMD_DI4_43		
<b>Control bits (as of V1.10)</b>			
p20036	DCMD_SBIT0_Q44	Rising (positive) edge	Output is active for one cycle when input edge is detected.
p20037	DCMD_SBIT0_Q45	Falling (negative) edge	The entered drive order (DCMD) is automatically latched (stored).
p20038	DCMD_SBIT0_Q46	Level-controlled output, output follows the input directly	
p20040	DCMD_SBIT1_Q48	Rising (positive) edge	Output is active for one cycle when input edge is detected.
p20041	DCMD_SBIT1_Q49	Falling (negative) edge	The entered drive order (DCMD) is automatically latched (stored).
p20042	DCMD_SBIT1_Q50	Level-controlled output, output follows the input directly	
p20044	DCMD_SBIT2_Q52	Rising (positive) edge	Output is active for one cycle when input edge is detected.
p20045	DCMD_SBIT2_Q53	Falling (negative) edge	The entered drive order (DCMD) is automatically latched (stored).
p20046	DCMD_SBIT2_Q54	Level-controlled output, output follows the input directly	
p20048	DCMD_SBIT3_Q56	Rising (positive) edge	Output is active for one cycle when input edge is detected.
p20049	DCMD_SBIT3_Q57	Falling (negative) edge	The entered drive order (DCMD) is automatically latched (stored).
p20050	DCMD_SBIT3_Q58	Level-controlled output, output follows the input directly	
p20052	DCMD_SBIT4_Q60	Rising (positive) edge	Output is active for one cycle when input edge is detected.
p20053	DCMD_SBIT4_Q61	Falling (negative) edge	The entered drive order (DCMD) is automatically latched (stored).
p20054	DCMD_SBIT4_Q62	Level-controlled output, output follows the input directly	

5.9 Operation and configuration of the control unit

Parameter ID	Name	Description
p20039	DCMD_SBIT0_Q47	Level-controlled output; output follows the input inverted
p20043	DCMD_SBIT1_Q51	
p20047	DCMD_SBIT2_Q55	
p20051	DCMD_SBIT3_Q59	
p20055	DCMD_SBIT4_Q63	
<b>AND</b>		
p20015	DCMD_AND0_Q17	Output is logically ANDed with inputs. a discrepancy analysis of the inputs can be additionally activated.
p20016	DCMD_AND1_Q18	Output is logically AND-combined with inputs.
(As of V1.10)		
p20056	DCMD_AND2_Q64	Output is logically ANDed with inputs. a discrepancy analysis of the inputs can be additionally activated.
<b>OR</b>		
p20017	DCMD_OR0_Q19	Output is logically OR-combined with inputs.
p20018	DCMD_OR1_Q20	
<b>NOT</b>		
p20019	DCMD_NOT0_Q21	Output is logically NOT-combined with inputs (negation).
p20020	DCMD_NOT1_Q22	
<b>XOR</b>		
p20021	DCMD_XOR0_Q23	Output is logically exclusively OR-combined with inputs.
<b>FRQ</b>		
p20022	DCMD_FRQ0_Q24	Output becomes active as soon as the frequency is detected.
p20023	DCMD_FRQ0_Q25	
p20024	DCMD_FRQ1_Q26	
p20025	DCMD_FRQ1_Q27	
<b>DELAY</b>		
p20026	DCMD_OnDELAY_Q28	Output follows positive input signal delayed by the set delay time.
p20027	DCMD_OnDELAY_Q29	
<b>COUNTER</b>		
p20028	DCMD_COUNTER_Q30	Output is active as long as the counter value is 0.
p20029	DCMD_COUNTER_Q31	Output is active as long as the counter value is 1.
p20030	DCMD_COUNTER_Q32	Output is active as long as the counter value is 2.
<b>COLD-STORAGE FUNCTION (as of V1.12)</b>		
p20057	DCMD_CSR_Q65	Output is active as long as the cold storage FBLOCK applies the open signal (see cold storage function block (as of V1.12)). Replace with "function block" here and in the following block).
p20058	DCMD_CSR_Q66	Output is active as long as the cold storage FBLOCK applies the cord-operated switch open signal (see Cold storage function block (as of V1.12) (Page 97)).
p20059	DCMD_CSR_Q67	Output is active as long as the cold storage FBLOCK applies the open signal (see Cold storage function block (as of V1.12) (Page 97)).
p20060	DCMD_CSR_Q68	Output is active as long as the cold storage FBLOCK applies the stop signal (see Cold storage function block (as of V1.12) (Page 97)).

Parameter ID	Name	Description
<b>Position block (as of V1.12)</b>		
p20061	DCMD_POS_Q69	Output is active as long as the door position is within the parameterized range.

### FBLOCK-REF parameters

The inputs of the various F blocks can be connected or linked to any "Q" outputs (signal sources) via the following FBLOCK-REF parameters. To this end, the number of the Q element must be entered directly in the REF parameter (Q{0 to 38}).

Table 5-38 FBLOCK-REF parameters

Parameter ID	Name	Description
<b>AND</b>		
p20100	REF_AND0_IN1	Input 1 logical AND gate 0
p20101	REF_AND0_IN2	Input 2 logical AND gate 0
p20102	REF_AND0_IN3	Input 3 logical AND gate 0
p20103	REF_AND0_IN4	Input 4 logical AND gate 0
p20104	REF_AND1_IN1	Input 1 logical AND gate 1
p20105	REF_AND1_IN2	Input 2 logical AND gate 1
(As of V1.10)		
p20123	REF_AND2_IN1	Input 1 logical AND gate 2
p20124	REF_AND2_IN2	Input 2 logical AND gate 2
p20125	REF_AND2_IN3	Input 3 logical AND gate 2
p20126	REF_AND2_IN4	Input 4 logical AND gate 2
<b>OR</b>		
p20106	REF_OR0_IN1	Input 1 logical OR gate 0
p20107	REF_OR0_IN2	Input 2 logical OR gate 0
p20108	REF_OR0_IN3	Input 3 logical OR gate 0
p20109	REF_OR1_IN1	Input 1 logical OR gate 1
p20110	REF_OR1_IN2	Input 2 logical OR gate 1
p20111	REF_OR1_IN3	Input 3 logical OR gate 1
<b>NOT</b>		
p20112	REF_NOT0_IN1	Input logical NOT gate 1 (negation)
p20113	REF_NOT1_IN1	Input logical NOT gate 2 (negation)
<b>XOR</b>		
p20114	REF_XOR0_IN1	Input 1 logical exclusive OR (XOR)
p20115	REF_XOR0_IN2	Input 2 logical exclusive OR (XOR)
<b>FRQ</b>		
p20116	REF_FRQ0_IN1	Input frequency detection
p20117	REF_FRQ1_IN1	Input frequency detection
<b>DELAY</b>		
p20118	REF_OnDELAY_IN1	ON delay
<b>Special</b>		

5.9 Operation and configuration of the control unit

Parameter ID	Name	Description
p20119	REF_ACK	Fault acknowledgement (preceded by 5 s ON delay)
p20120	REF_BATTMODE	Emergency power mode (drive order is automatically latched until next end stop is reached)
<b>COUNTER</b>		
p20121	REF_COUNTER_IN	Count input of the counter (a positive edge increments the counter)
p20122	REF_COUNTER_RESET	Reset input of the counter (counter is reset to 0)
<b>COLD-STORAGE FUNCTION (as of V1.12)</b>		
p20127	REF_CSR_IN_RC	Door interlocking input Input that prevents any movement of the door in the corresponding state (Deenergize).
p20129	REF_CSR_IN_PS	Cord-operated switch input "Partial OPEN" / "CLOSE" pulse until door is either partially opened or closed again. As of V1.14: After the controller has been switched on or the FBLOCK cooling storage door unlocked, an opening command is output first.
p20130	REF_CSR_IN_CLOSE	Close button input Normal travel "CLOSE" pulse until door is completely closed
p20131	REF_CSR_IN_OPRN	Close button input Normal travel OPEN pulse until the door is completely open.

**Note**

After the optimal parameter settings have been determined, they can be noted in the configuration protocol (see appendix Configuration protocol (Page 333)). These records should also be kept at hand when asking questions on the Hotline.

## Geared motors

### 6.1 Description

#### Overview



Figure 6-1 Geared motors (pinion left\*)

\* The gear outlet direction is defined as left or right when viewing the gear unit from the front.

The maintenance-free drive unit consists of a speed-controlled DC motor with non-self-locking gearing. The geared motors must be selected according to the mass to be moved.

## 6.2 Installation

### Overview

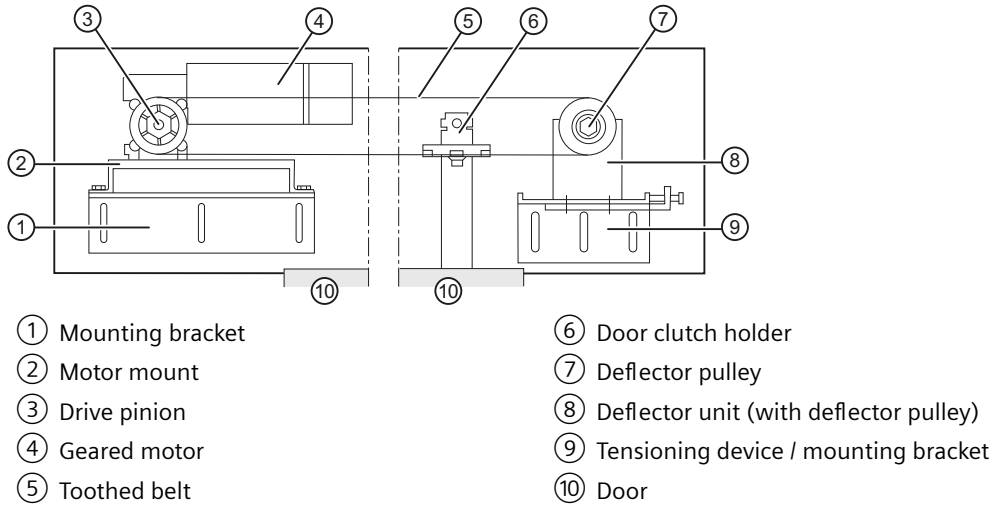

---

#### Note

#### Optional components

The rubber-metal anti-vibration mount, mounting bracket, tensioning device / mounting bracket, deflector unit / deflector pulley, and door clutch holder are optional components and can be obtained from Siemens. You can find additional information in the section Technical specifications (Page 206).

---

### MDG3, MDG4 and MDG5 motors

---

#### Note

Do not strike the shaft and bearings of the motors. Do not exceed the permissible axial and radial forces on the shaft extension as specified by the configuration regulations.

---

Only fit and remove output elements (for example, coupling, gear, belt pulley) using suitable equipment (see figure):

- Using threaded hole in the shaft extension.
- Warm output element if necessary.



- Use washers to maintain the centering in the shaft extension for removal.
- If necessary, fully balance the motor with output elements according to ISO 1940.

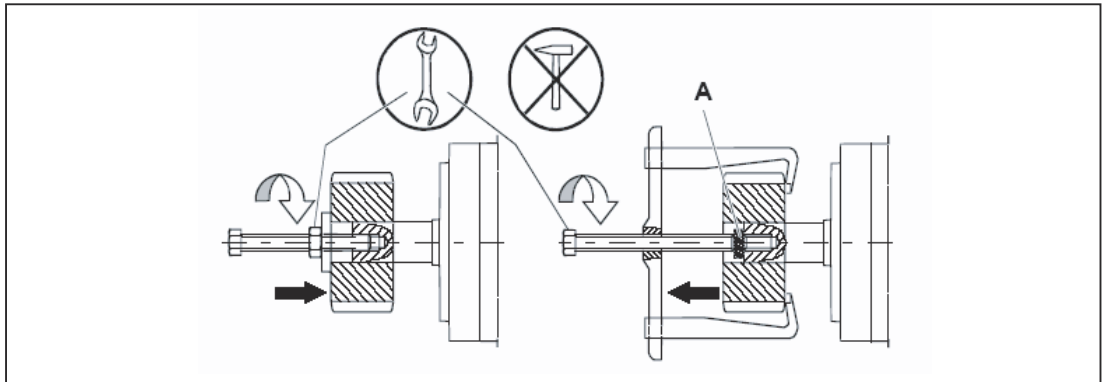

Figure 6-2 Fitting and removing output elements; A = intermediate washer (for maintaining the centering in the shaft extension)

## Procedure

### WARNING

#### **Risk of injury and damage to property as a result of incorrect installation**

Improper and incorrect installation can lead to serious injuries.

Observe the instructions for safe installation.

The mechanical installation of the geared motor is performed in the following steps:

1. Mount the geared motor on the rubber-metal anti-vibration motor mounting.

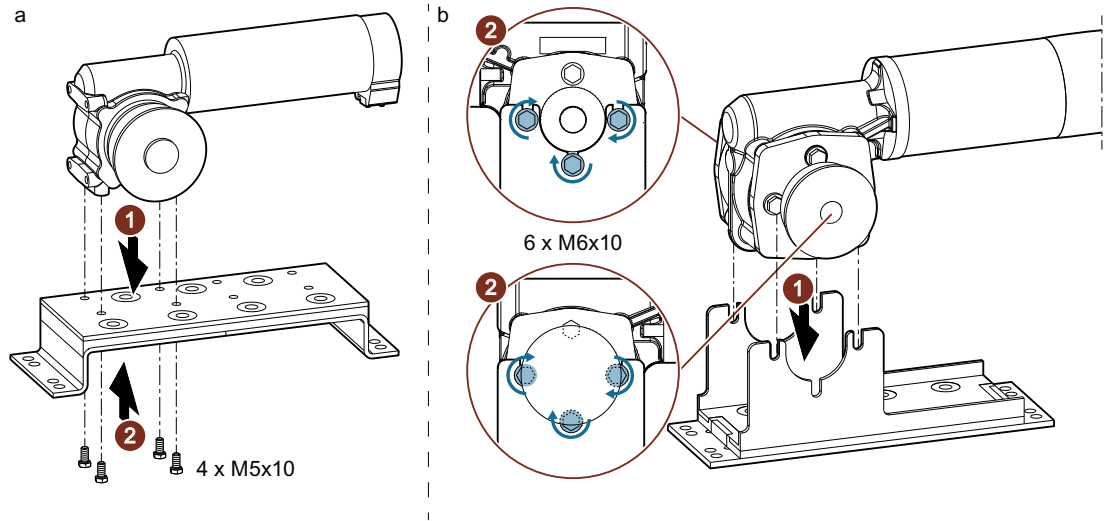

- a SIDOOR M3 / MDG3
- b SIDOOR M4 / MDG4 / M5 / MDG5

Then, if required, mount the motor mounting (rubber-bonded metal) on the mounting bracket.

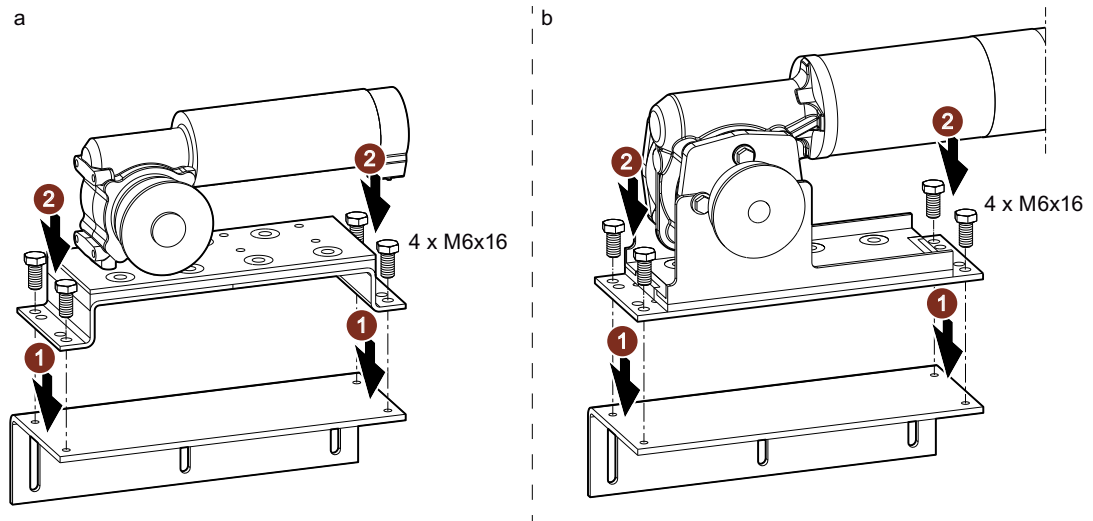

- a SIDOOR M3 / MDG3
- b SIDOOR M4 / MDG4 / M5 / MDG5

2. Mount the deflector unit, if necessary with a mounting bracket.

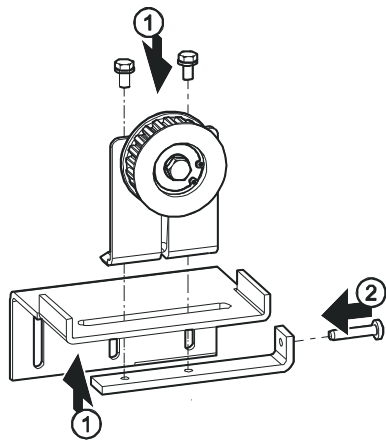

Ensure that the drive pin and deflector pulley are aligned when doing so. They have to be exactly aligned to ensure a long drive service life.



3. Pass the toothed belt over the deflector pulley and drive pin. Place both open ends of the toothed belt in the door clutch holder. Screw the door clutch holder together.

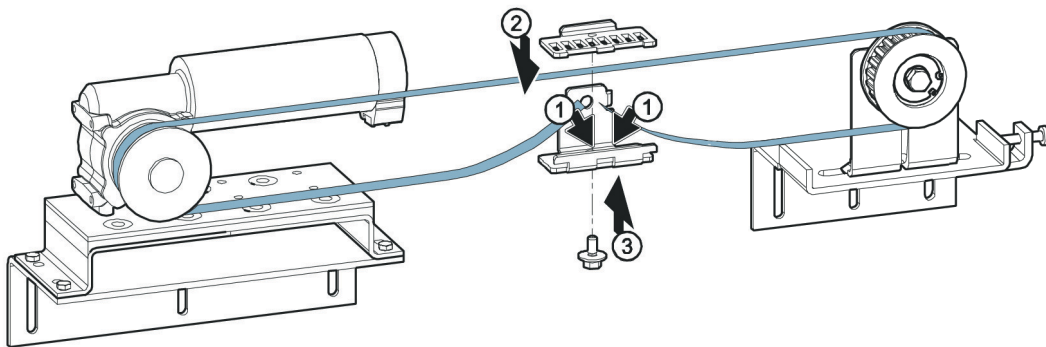

4. Tension the toothed belt with the aid of the tensioning device.

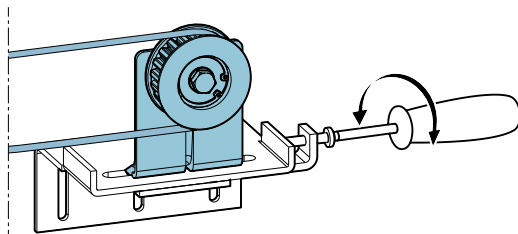

## Span tension

The span tension T of the belt is calculated as follows:

$$T = 4 \cdot k \cdot L^2 \cdot f^2$$

T: Span tension [N]

k: Weight per meter [kg/m]

L: Belt length [m]

f: Frequency (Hz)

The following table shows the natural frequency (f) of the belt for the recommended span tension (T) at different belt lengths (L).

Belt system	CONTI SYNCHROLINE STS-S8M, 12 mm (Length: 4 m and 45 m)	CONTI SYNCHROLINE STS-S8M, 14 mm (length: 4 m and 55 m)
Article No.	6FB1104-OAT01-OAB0 6FB1104-OAT02-OAB0	6FB1104-OAT03-OAB0 6FB1104-OAT04-OAB0
Recommended span tension (T)	160 N ±10 N	160 N ±10 N
Weight per meter (k)	0.062 kg/m	0.072 kg/m
Belt length (L)	Frequency (f)	Frequency (f)
0.3 m	84.7 Hz	78.6 Hz
0.5 m	50.8 Hz	47.1 Hz
1.0 m	25.4 Hz	23.5 Hz
1.5 m	16.9 Hz	15.7 Hz
2.0 m	12.7 Hz	11.8 Hz
2.5 m	10.2 Hz	9.4 Hz
3.0 m	8.5 Hz	7.9 Hz
3.5 m	7.2 Hz	6.7 Hz
4.0 m	6.3 Hz	5.9 Hz
4.5 m	5.6 Hz	5.2 Hz
5.0 m	5.0 Hz	4.7 Hz

In some applications a simple adjustment of the belt tension as follows may be sufficient:

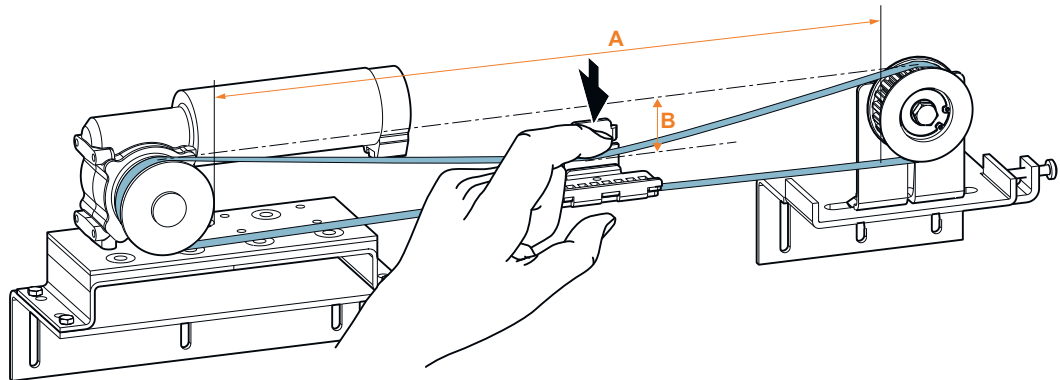

You will recognize the correct belt tension by how far the belt is pressed in (B). The depth (B) the belt is pressed in depends on the distance between the drive pinion and deflector pulley (A).

The following depths of the pressed-in belt (B) apply as a function of the distance between the drive pinion and deflector pulley (A).

A (cm)	50	100	150	200
B (cm)	1.5	3	4.5	6

## 6.3 Connecting terminals

### 6.3.1 Conductor assignment of the motor plug

SIDoor M3, MDG3, M4, MDG4, M5 and MDG5

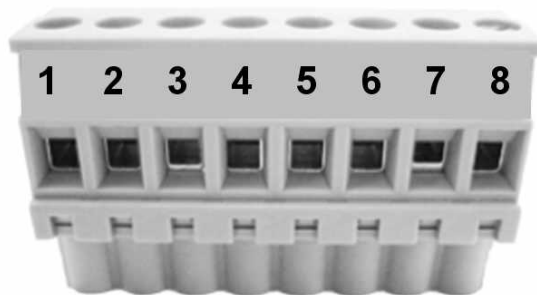

Figure 6-3 Conductor assignment of the motor plug

6.3 Connecting terminals

Table 6-1 Motor plug (slot X7)

Terminal (X7)	Signal	SIDOOR M3 / M4 / M5 wire color
1	+5 V	Gray
2	Channel A	Yellow
3	Channel B	Green
4	Motor ID	Brown
5	GND	White
6	PE	Yellow/green
7	Motor +	Black
8	Motor -	Black

**Note**

M3/M4/M5: The cables of these motors are permanently connected to the motor and have a cable length of 1.5m.

You can find additional information about connecting to the MDG-CABLE motor cable here: (Page 225)

You can find the technical specifications of the various motor cables here: (Page 217)

Klemme (X7)

Motorstecker 4 pol. (Power)

Motorstecker 5 pol. (Encoder)



Terminal (X7)	Motor plug 4 pin. (Power)	Motor plug 5 pin (Encoder)	Signal	SIDOOR MDG3 / MDG4 / MDG5 wire color
1		1	+5 V	Brown
2		2	Channel A	White
3		4	Channel B	Black
4		5	Motor ID	Gray
5		3	GND	Blue
6	Shield	Shield	Functional ground	Yellow

---

Terminal (X7)	Motor plug 4 pin. (Power)	Motor plug 5 pin (Encoder)	Signal	SIDOOR MDG3 / MDG4 / MDG5 wire color
7	1		Motor +	Brown
	2			White
8	3		Motor -	Blue
	4			Black

## 6.4 Technical specifications

### 6.4.1 Technical specifications MDG3 R/L

Article number	6FB1103-0AT13-4MB1	6FB1103-0AT14-4MB1
<b>General information</b>		
Product brand name	SIDOOR	SIDOOR
Product type designation	MDG3 R	MDG3 L
Product version	Right gearbox output with groove and feather key	Left gearbox output with groove and feather key
<b>Supply voltage</b>		
Rated value (DC)	30 V	30 V
<b>Input current</b>		
Operational current (rated value)	4 A	4 A
<b>Power</b>		
Active power input	120 W	120 W
<b>Mechanical data</b>		
Torque of the rotary operating mechanism (rated value)	3 N·m	3 N·m
Speed, max.	0.65 m/s	0.65 m/s
Mass to be moved, max.	180 kg	180 kg
Gear unit	Yes	Yes
Gear ratio	15	15
Number of pulses per revolution, max.	100	100
Fixed output gear	No	No
<b>Degree and class of protection</b>		
IP degree of protection		
• of the motor	IP56	IP56
• of the gear unit	IP56	IP56
<b>Standards, approvals, certificates</b>		
CE mark	Yes	Yes
UL approval	Yes	Yes
EAC (formerly Gost-R)	Yes	Yes
China RoHS compliance	Yes	Yes
<b>Ambient conditions</b>		
<b>Ambient temperature during operation</b>		
• min.	-20 °C	-20 °C
• max.	50 °C	50 °C
<b>Ambient temperature during storage/transportation</b>		
• Storage, min.	-40 °C	-40 °C
• Storage, max.	85 °C	85 °C
<b>Cables</b>		



Article number	6FB1103-0AT13-4MB1	6FB1103-0AT14-4MB1
Fixed connecting cable	No	No
<b>Dimensions</b>		
Diameter of output gear, min.	28 mm	28 mm
Diameter of output gear, max.	122 mm	122 mm
Height of motor	98 mm	98 mm
Length of motor	264 mm	264 mm
Diameter of motor	63 mm	63 mm
Width of gearbox	85 mm	85 mm

## 6.4.2 Technical specifications MDG4 R/L

Article number	6FB1103-0AT13-3MC2	6FB1103-0AT14-3MC2
<b>General information</b>		
Product brand name	SIDOOOR	SIDOOOR
Product type designation	MDG4 R	MDG4 L
Product version	Right gearbox output with groove and feather key	Left gearbox output with groove and feather key
<b>Supply voltage</b>		
Rated value (DC)	30 V	30 V
<b>Input current</b>		
Operational current (rated value)	4 A	4 A
<b>Power</b>		
Active power input	120 W	120 W
<b>Mechanical data</b>		
Torque of the rotary operating mechanism (rated value)	3 N·m	3 N·m
Speed, max.	0.75 m/s	0.75 m/s
Mass to be moved, max.	400 kg	400 kg
Gear unit	Yes	Yes
Gear ratio	15	15
Number of pulses per revolution, max.	100	100
Fixed output gear	No	No
<b>Degree and class of protection</b>		
IP degree of protection		
• of the motor	IP56	IP56
• of the gear unit	IP56	IP56
<b>Standards, approvals, certificates</b>		
CE mark	Yes	Yes
UL approval	Yes	Yes
EAC (formerly Gost-R)	Yes	Yes
China RoHS compliance	Yes	Yes
<b>Ambient conditions</b>		
<b>Ambient temperature during operation</b>		
• min.	-20 °C	-20 °C
• max.	50 °C	50 °C
<b>Ambient temperature during storage/transportation</b>		
• Storage, min.	-40 °C	-40 °C
• Storage, max.	85 °C	85 °C
<b>Cables</b>		
Fixed connecting cable	No	No
<b>Dimensions</b>		
Diameter of output gear, min.	28 mm	28 mm
Diameter of output gear, max.	122 mm	122 mm

Article number	6FB1103-0AT13-3MC2	6FB1103-0AT14-3MC2
Height of motor	115 mm	115 mm
Length of motor	303 mm	303 mm
Diameter of motor	63 mm	63 mm
Width of gearbox	106 mm	106 mm

## 6.4.3 Technical Specifications MDG5 R/L

Article number	6FB1103-0AT13-3MG2	6FB1103-0AT14-3MG2
<b>General information</b>		
Product brand name	SIDOOOR	SIDOOOR
Product type designation	MDG5 R	MDG5 L
Product version	Right gearbox output with groove and feather key	Left gearbox output with groove and feather key
<b>Supply voltage</b>		
Rated value (DC)	30 V	30 V
<b>Input current</b>		
Operational current (rated value)	7.5 A	7.5 A
<b>Power</b>		
Active power input	225 W	225 W
<b>Mechanical data</b>		
Torque of the rotary operating mechanism (rated value)	6 N·m	6 N·m
Speed, max.	0.5 m/s	0.5 m/s
Mass to be moved, max.	700 kg	700 kg
Gear unit	Yes	Yes
Gear ratio	15	15
Number of pulses per revolution, max.	100	100
Fixed output gear	No	No
<b>Degree and class of protection</b>		
IP degree of protection		
• of the motor	IP56	IP56
• of the gear unit	IP56	IP56
<b>Standards, approvals, certificates</b>		
CE mark	Yes	Yes
UL approval	Yes	Yes
EAC (formerly Gost-R)	Yes	Yes
China RoHS compliance	Yes	Yes
<b>Ambient conditions</b>		
<b>Ambient temperature during operation</b>		
• min.	-20 °C	-20 °C
• max.	50 °C	50 °C
<b>Ambient temperature during storage/transportation</b>		
• Storage, min.	-40 °C	-40 °C
• Storage, max.	85 °C	85 °C
<b>Cables</b>		
Fixed connecting cable	No	No
<b>Dimensions</b>		
Diameter of output gear, min.	28 mm	28 mm
Diameter of output gear, max.	122 mm	122 mm

---

Article number	6FB1103-0AT13-3MG2	6FB1103-0AT14-3MG2
Height of motor	124 mm	124 mm
Length of motor	348 mm	348 mm
Diameter of motor	80 mm	80 mm
Width of gearbox	109 mm	109 mm

## 6.4.4 Technical specifications M3 R/L

Article number	6FB1103-0AT11-4MB0	6FB1103-0AT10-4MB0
<b>General information</b>		
Product brand name	SIDOOR	
Product type designation	M3 R	M3 L
Product version	With driven gear on the right	With driven gear on the left
<b>Supply voltage</b>		
Rated value (DC)	30 V	
<b>Input current</b>		
Operational current (rated value)	4 A	
<b>Power</b>		
Active power input	120 W	
<b>Mechanical data</b>		
Torque of the rotary operating mechanism (rated value)	3 N·m	
Speed, max.	0.65 m/s	
Gear ratio	15	
Number of pulses per revolution, max.	100	
Weight of door, max.	180 kg	
<b>Degree and class of protection</b>		
IP degree of protection		
• of the motor	IP54	
• of the gear unit	IP40	
<b>Standards, approvals, certificates</b>		
CE mark	Yes	
UL approval	Yes	
EAC (formerly Gost-R)	Yes	
TÜV Inspectorate approval	Yes	
China RoHS compliance	Yes	
<b>Ambient conditions</b>		
<b>Ambient temperature during operation</b>		
• min.	-20 °C	
• max.	50 °C	
<b>Ambient temperature during storage/transportation</b>		
• Storage, min.	-40 °C	
• Storage, max.	85 °C	
<b>Dimensions</b>		
Height of motor	98 mm	
Length of motor	236 mm	
Diameter of motor	63 mm	
Width of gear unit, including drive pinion	85 mm	

## 6.4.5 Technical specifications M4 R/L

Article number	6FB1103-0AT11-3MCO	6FB1103-0AT10-3MCO
<b>General information</b>		
Product brand name	SIDOOR	SIDOOR
Product type designation	M4 R	M4 L
Product version	With driven gear on the right	With driven gear on the left
<b>Supply voltage</b>		
Rated value (DC)	30 V	30 V
<b>Input current</b>		
Operational current (rated value)	4 A	4 A
<b>Power</b>		
Active power input	120 W	120 W
<b>Mechanical data</b>		
Torque of the rotary operating mechanism (rated value)	3 N·m	3 N·m
Speed, max.	0.75 m/s	0.75 m/s
Gear ratio	15	15
Number of pulses per revolution, max.	100	100
Weight of door, max.	400 kg	400 kg
<b>Degree and class of protection</b>		
IP degree of protection		
• of the motor	IP54	IP54
• of the gear unit	IP40	IP40
<b>Standards, approvals, certificates</b>		
CE mark	Yes	Yes
UL approval	Yes	Yes
EAC (formerly Gost-R)	Yes	Yes
TÜV Inspectorate approval	Yes	Yes
China RoHS compliance	Yes	Yes
<b>Ambient conditions</b>		
<b>Ambient temperature during operation</b>		
• min.	-20 °C	-20 °C
• max.	50 °C	50 °C
<b>Ambient temperature during storage/ transportation</b>		
• Storage, min.	-40 °C	-40 °C
• Storage, max.	85 °C	85 °C
<b>Dimensions</b>		
Height of motor	115 mm	115 mm
Length of motor	275 mm	275 mm
Diameter of motor	63 mm	63 mm
Width of gear unit, including drive pinion	105 mm	105 mm

## 6.4.6 Technical specifications M5 R/L

Article number	6FB1103-0AT11-3MD0	6FB1103-0AT10-3MD0
<b>General information</b>		
Product brand name	SIDOOR	
Product type designation	M5 R	M5 L
Product version	With driven gear on the right	With driven gear on the left
<b>Supply voltage</b>		
Rated value (DC)	30 V	
<b>Input current</b>		
Operational current (rated value)	7.5 A	
<b>Power</b>		
Active power input	225 W	
<b>Mechanical data</b>		
Torque of the rotary operating mechanism (rated value)	6.8 N·m	
Speed, max.	0.5 m/s	
Gear ratio	15	
Number of pulses per revolution, max.	100	
Weight of door, max.	600 kg	
<b>Degree and class of protection</b>		
IP degree of protection		
• of the motor	IP54	
• of the gear unit	IP54	
<b>Standards, approvals, certificates</b>		
CE mark	Yes	
UL approval	Yes	
EAC (formerly Gost-R)	Yes	
TÜV Inspectorate approval	Yes	
China RoHS compliance	Yes	
<b>Ambient conditions</b>		
<b>Ambient temperature during operation</b>		
• min.	-20 °C	
• max.	50 °C	
<b>Ambient temperature during storage/ transportation</b>		
• Storage, min.	-40 °C	
• Storage, max.	85 °C	
<b>Dimensions</b>		
Height of motor	124 mm	
Length of motor	344 mm	
Diameter of motor	80 mm	
Width of gear unit, including drive pinion	111 mm	



### 6.4.7 Technical specifications for rubber-metal anti-vibration mount

Article number	6FB1104-0AT01-0AD0	6FB1104-0AT02-0AD0
<b>General technical data:</b>		
Product brand name	SIDOOR	
<b>Installation/ mounting/ dimensions:</b>		
Width of rubber-bonded metal	mm	78
Height of rubber-bonded metal	mm	78
Length of rubber-bonded metal	mm	230

### 6.4.8 Technical specifications for mounting bracket

Article number	6FB1104-0AT01-0AS0	6FB1104-0AT02-0AS0
<b>General technical data:</b>		
Product brand name	SIDOOR	
Design of the product		with tensioning device for deflector pulley
<b>Installation/ mounting/ dimensions:</b>		
Width of mounting bracket	mm	90
Height of mounting bracket	mm	60
Length of mounting bracket	mm	230

### 6.4.9 Technical specifications for deflector unit

Article number	6FB1104-0AT03-0AS0
<b>General technical data:</b>	
Product brand name	SIDOOR
Design of the product	with deflector pulley
<b>Installation/ mounting/ dimensions:</b>	
Width of the support including belt pulley	mm
Height of the support including belt pulley	mm
Length of the support	mm
Width of belt pulley including flanged pulley	mm
Diameter of belt pulley including flanged pulley	mm

### 6.4.10 Technical specifications for door clutch holder

Article number	6FB1104-0AT02-0CPO	6FB1104-0AT01-0CPO
<b>General technical data:</b>		
Product brand name	SIDOOR	
<b>Installation/ mounting/ dimensions:</b>		
Width of door clutch holder	mm	40
Height of door clutch holder	mm	43
Length of door clutch holder	mm	68
Width of toothed belt	mm	14

### 6.4.11 Technical specifications for toothed belt

Article number	6FB1104-0AT01-0 ABO	6FB1104-0AT02-0 ABO	6FB1104-0AT03-0 ABO	6FB1104-0AT04-0 ABO
<b>General technical data:</b>				
Product brand name	SIDOOR			
Design of the product	With STS tooth profile, 12 mm wide and 4 m long	With STS tooth profile, 12 mm wide and 45 m long	With STS tooth profile, 14 mm wide and 4 m long	With STS tooth profile, 14 mm wide and 55 m long
<b>Installation/ mounting/ dimensions:</b>				
Type of toothed belt	STS-S8M			
Length of toothed belt	m	4	45	4
Width of toothed belt	mm	12	14	55

### 6.4.12 Technical specifications standard mounting rail holder

Article number	6FB1144-0AT00-3ASO
<b>General technical data:</b>	
Product brand name	SIDOOR
<b>Installation/ mounting/ dimensions:</b>	
Length of the support	mm
	70

## 6.4.13 Technical specifications motor cable (cable MDG)

Article number	6FB1104-0AT05-0CB2	6FB1104-0AT10-0CB2	6FB1104-0AT15-0CB2	6FB1104-0AT20-0CB2
<b>General information</b>				
Product brand name	SIDOOR			
Product type designation	CABLE-MDG2-5M	CABLE-MDG2-10M	CABLE-MDG2-15M	CABLE-MDG2-20M
Product version	Cable set			
<b>Degree and class of protection</b>				
IP degree of protection	IP67 motor connection			
<b>Standards, approvals, certificates</b>				
Certificate of suitability	CE / cRUus			
China RoHS compliance	Yes			
<b>Ambient conditions</b>				
<b>Ambient temperature during operation</b>				
• min.	-25 °C			
• max.	80 °C			
<b>Ambient temperature during storage/transportation</b>				
• Storage, min.	-40 °C			
• Storage, max.	90 °C			
<b>Cables</b>				
Cable length	5 m	10 m	15 m	20 m
<b>Connection method</b>				
Type of connection	plugged, screwed			
Connector type	Plug / socket			

**6.4.14 Dimension drawing of SIDOOR M3 with rubber-metal anti-vibration mount and mounting bracket**

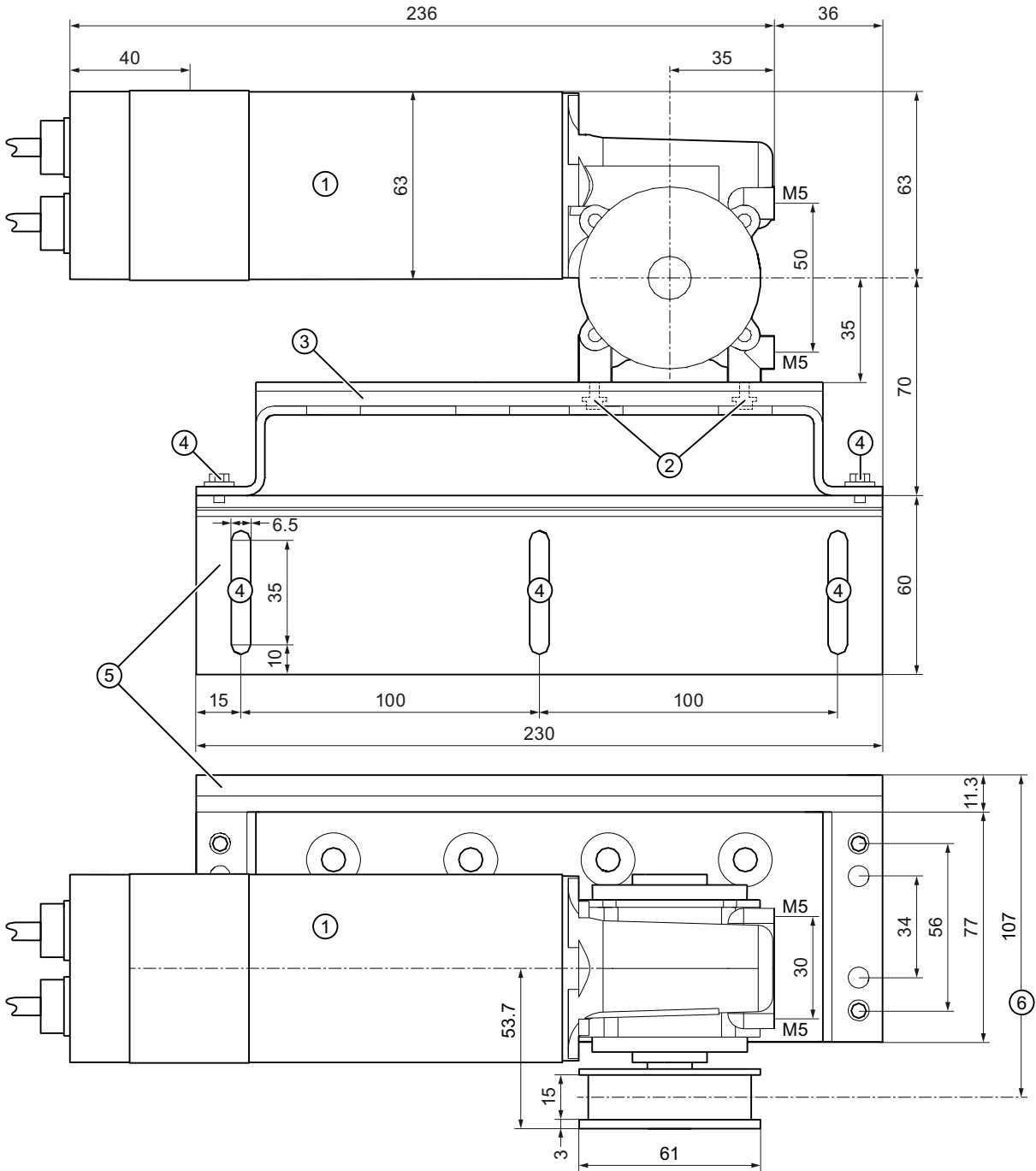

- ① Geared motor SIDOOR M3 L / MDG3 L
- ② 4 x M5x10 safety hexagonal screws
- ③ SIDOOR rubber-metal anti-vibration mount
- ④ 7 x M6x16 safety hexagonal screws
- ⑤ SIDOOR mounting bracket
- ⑥ Mean toothed belt clearance

Figure 6-4 Geared motor with rubber-metal anti-vibration mount and mounting bracket (motor M3)

### 6.4.15 Dimension drawing SIDOOR MDG3

#### Front view

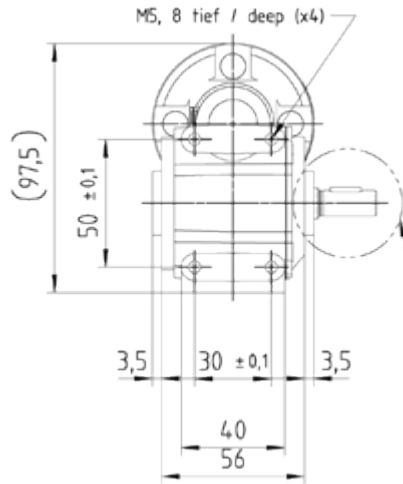

Figure 6-5 SIDOOR MDG3 Front view

#### Side view

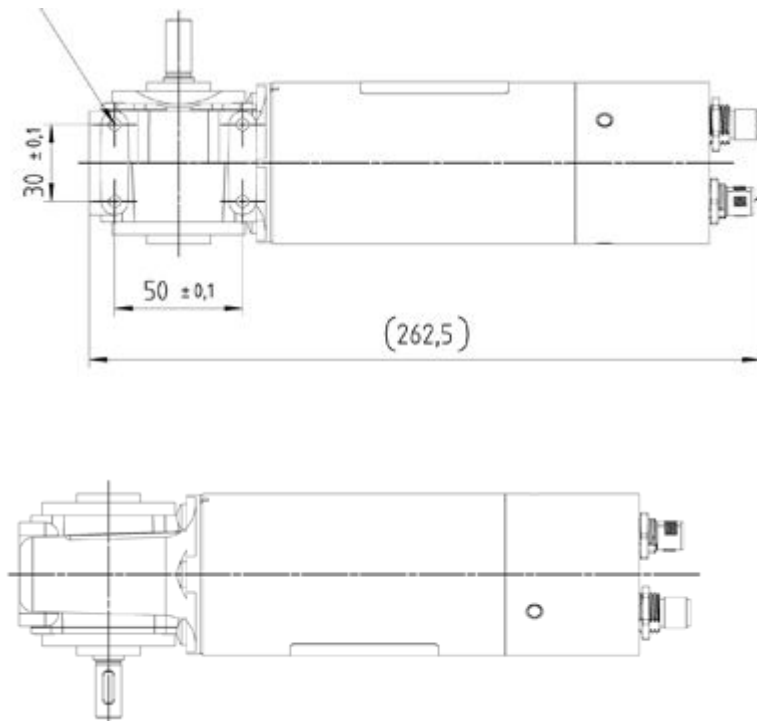

Figure 6-6 Dimension drawing SIDOOR MDG3

**6.4.16 Dimension drawing of SIDOOR M4 with rubber-metal anti-vibration mount and mounting bracket**

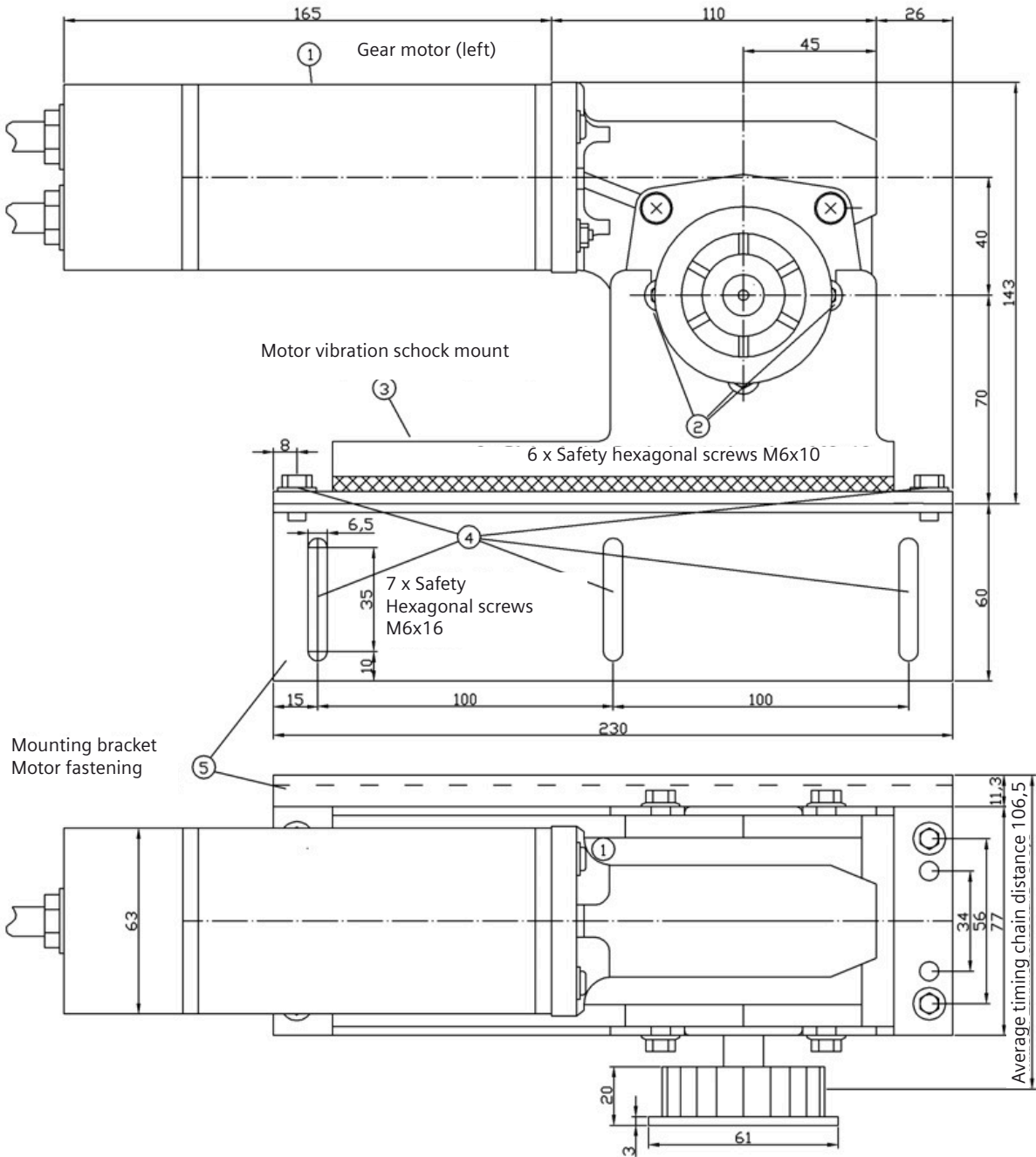

Figure 6-7 Geared motor with rubber-metal anti-vibration mount and mounting bracket (M4 motor)

### 6.4.17 Dimension drawing SIDOOR MDG4

#### Front view

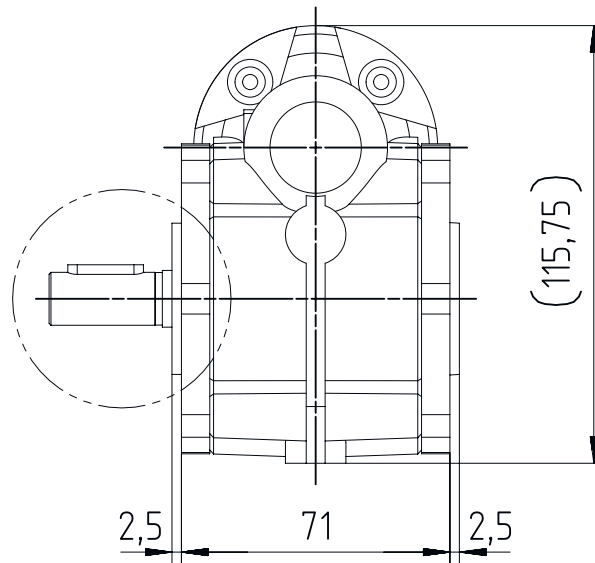

Figure 6-8 SIDOOR MDG4 Front view

Side view

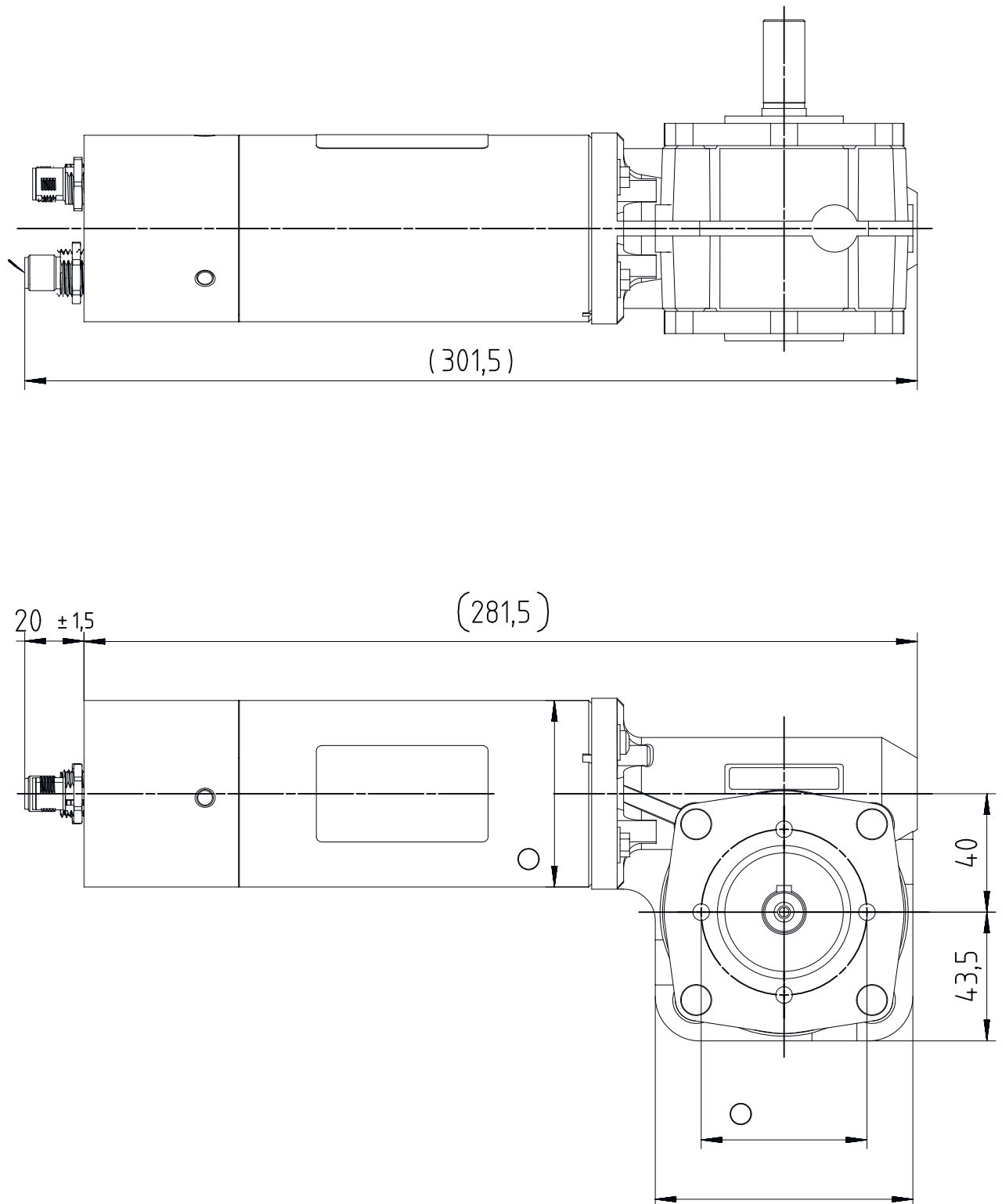

Figure 6-9 Dimension drawing SIDOOR MDG4



### 6.4.18 Dimension drawing of SIDOOR M5

#### Front view

##### Motor on left

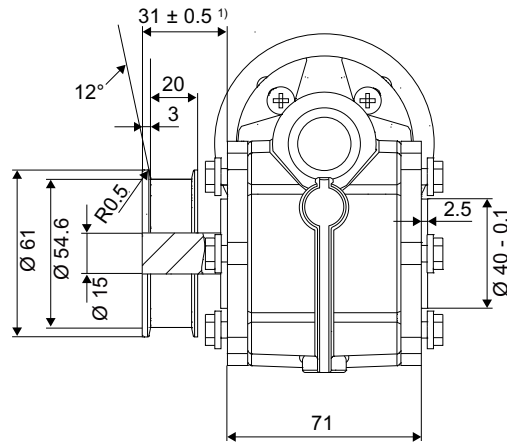

##### Motor on right

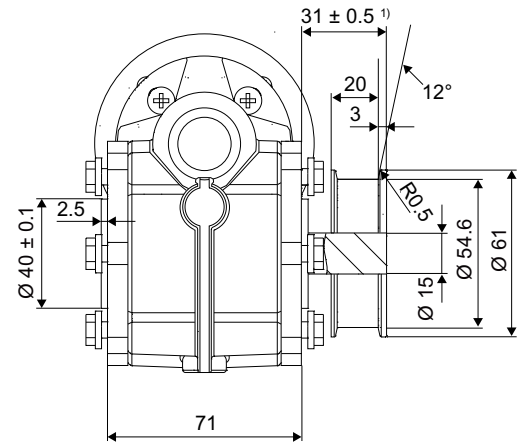

#### Side view

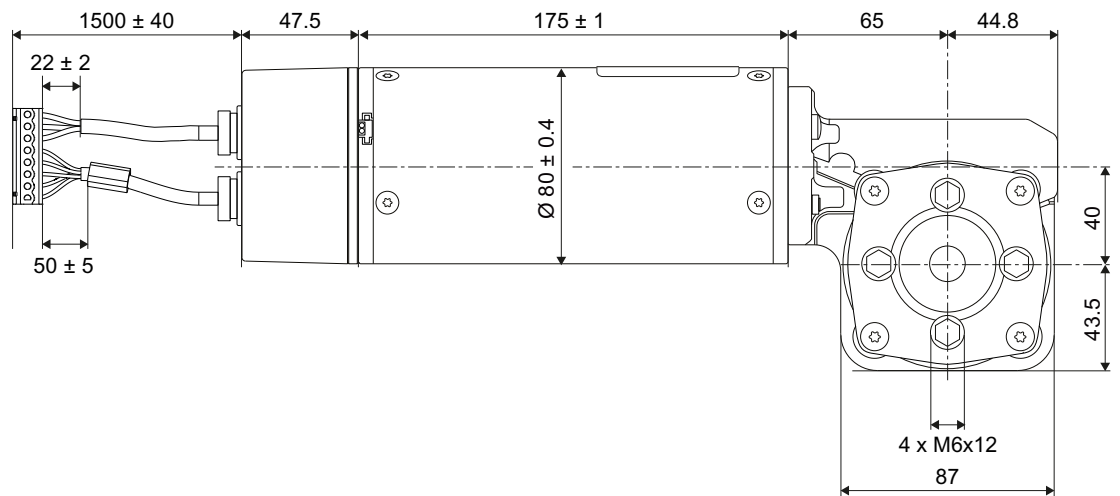

Figure 6-10 SIDOOR M5

#### Note

##### Rubber-metal anti-vibration mount

When installing the M5 motor, use the same rubber-metal anti-vibration mount as for the M4 motor. See section Dimension drawing of SIDOOR M4 with rubber-metal anti-vibration mount and mounting bracket (Page 220) and section Accessories (Page 35).

### 6.4.19 Dimension drawing SIDOOR MDG5

#### Front view

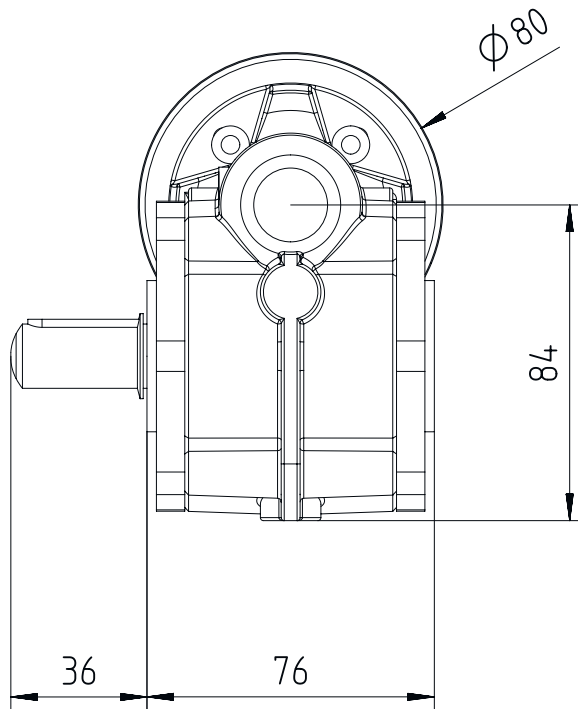

Figure 6-11 SIDOOR MDG5 Front view

Side view

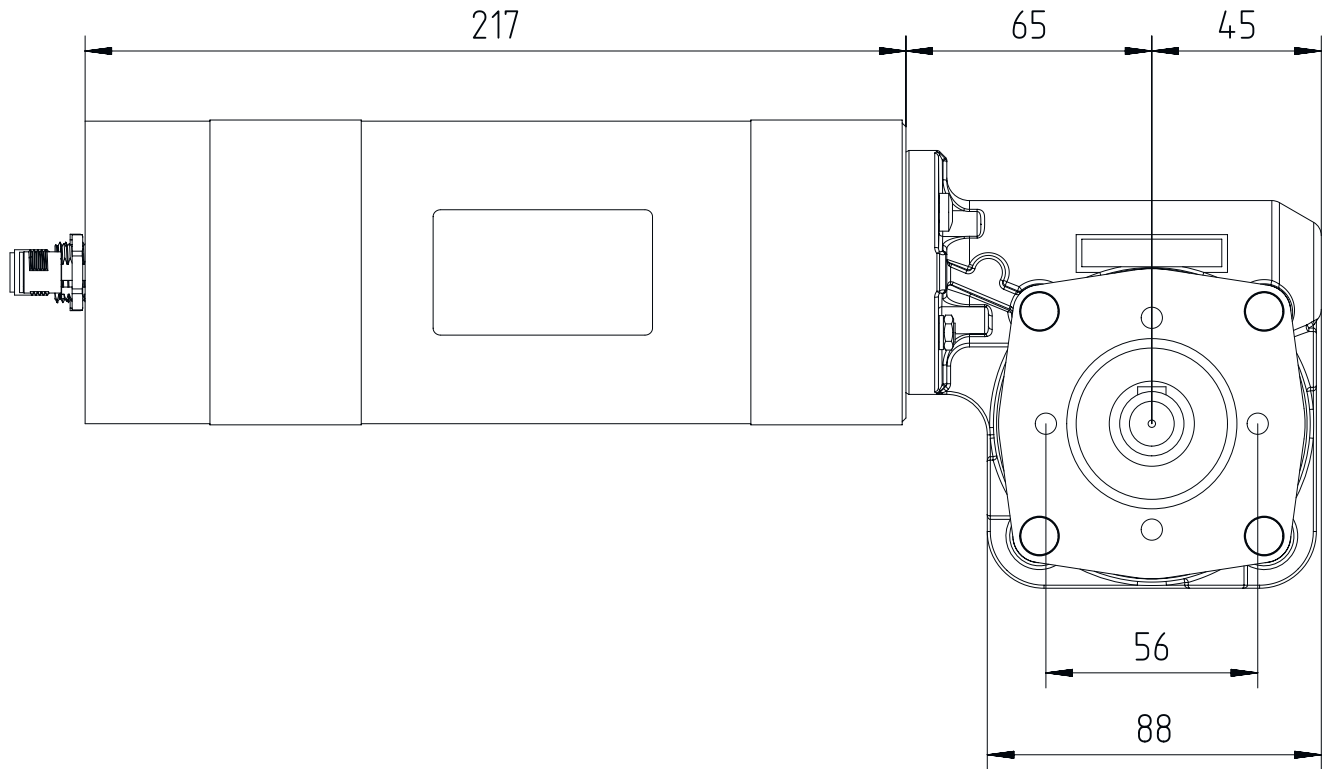

Figure 6-12 SIDOOR MDG5 Side view

6.4.20 Dimension drawing of motor cable MDG-CABLE

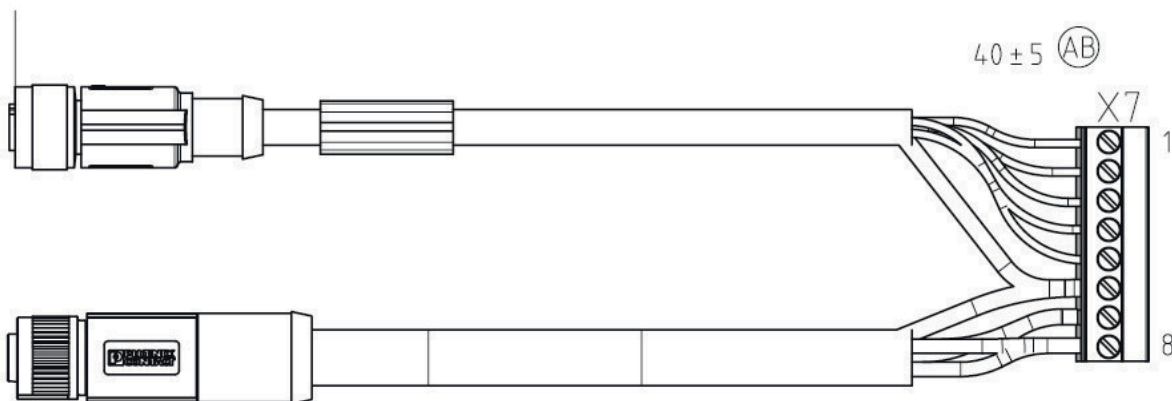

Figure 6-13 Motor cable MDG-CABLE

**6.4.21 Dimension drawing of deflector pulley with tensioning device and mounting bracket**

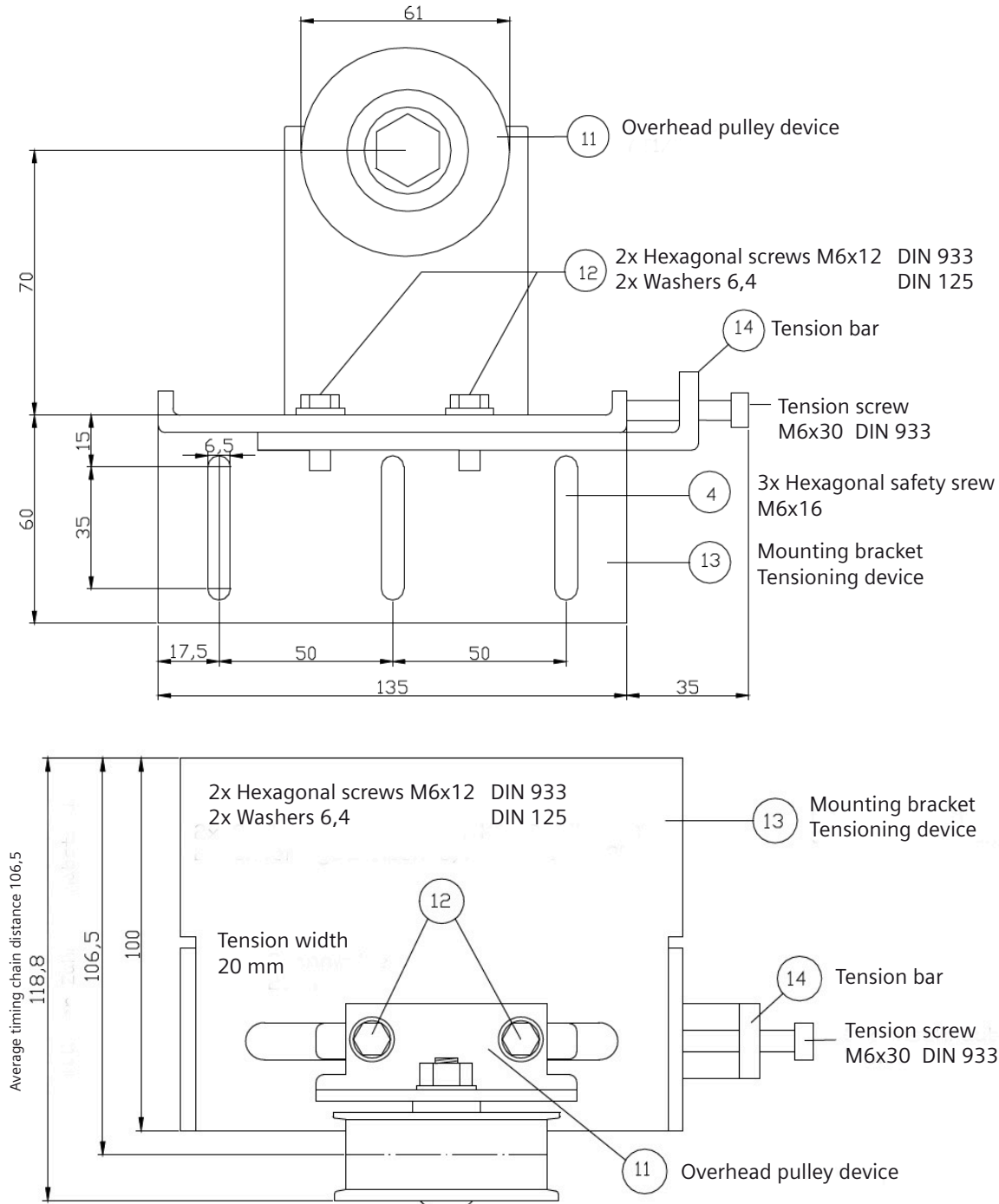

Figure 6-14 Deflector pulley with tensioning device and mounting bracket

6.4.22 Dimension drawing of door clutch holder

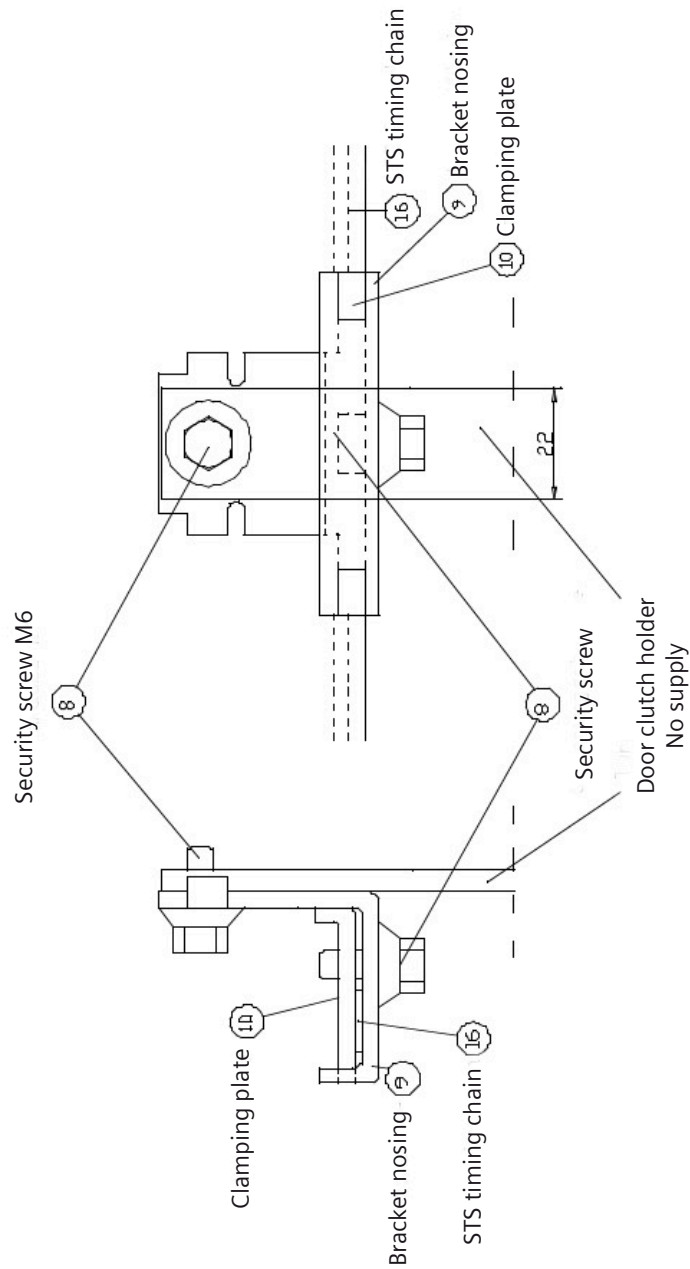

Figure 6-15 Door clutch holder

### 6.4.23 Dimension drawing SIDOOR MDG PULLEY

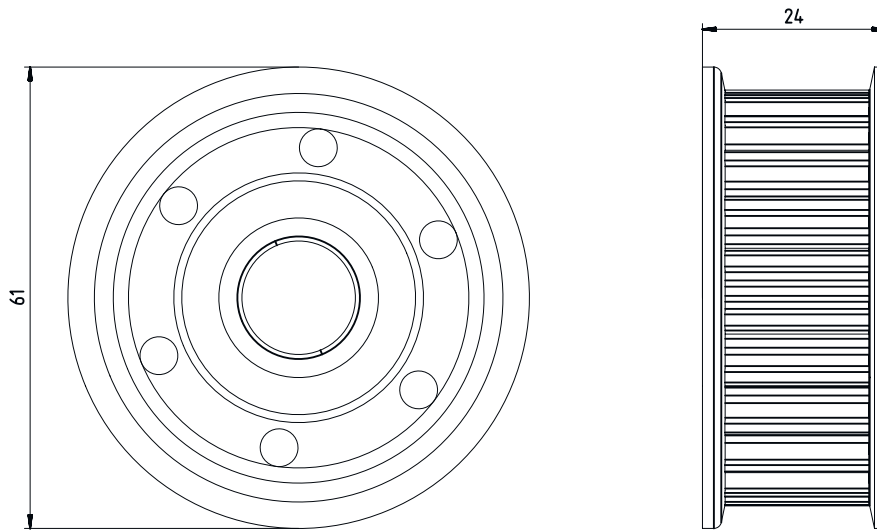

Figure 6-16 SIDOOR MDG Pulley transmission ratio 176 mm/rev

## Power supply

### 7.1 SIDOOR NT40

#### 7.1.1 Description

---

##### Note

##### Electromagnetic compatibility

The SIDOOR NT40 power supply meets the requirements of the EMC standard EN 61000-6-4. The SIDOOR NT40 power supply can cause interference if used in a residential environment. The commissioning engineer is responsible for interference suppression.

---

#### Design

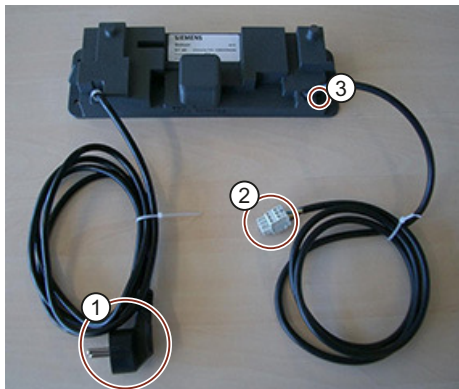

- ① Power plug X1 (Schuko plug)  
230 V AC ( $\pm 15\%$ ) 50 / 60 Hz
- ② Output X2 (output to control unit)  
36 V DC ( $\pm 3\%$ ) 2.5 A (15 A for  $< 2$  s)
- ③ LED L1

Figure 7-1 SIDOOR NT40

#### Function

The SIDOOR NT40 is a 230 V AC ( $\pm 15\%$ ) 50 / 60 Hz power supply unit for supplying SIDOOR control units for weights to be moved up to 600 kg.

On the output side, the switch mode power supply supplies a 36 V DC ( $\pm 3\%$ ) SELV at a rated output power  $< 100$  W. The device can briefly ( $< 2$  s) deliver a 15 A current to enable fast acceleration (corresponds to a brief power output of 540 W).

#### Short-circuit protection

Output X2 is short-circuit proof.

#### LED display

LED L1 indicates the presence of the output voltage.

---

#### Note

If the LED does not light up despite being correctly connected to the X1 supply line and if there is no measurable output voltage, this indicates a short circuit on the output side or a defective module!

The device can be operated by the control unit without load to establish whether the module is defective. If the LED at the output does not light up in this mode of operation, and there is no measurable voltage at the output, this indicates that the device is defective!

---

#### See also

Controllers (Page 27)

## 7.1.2 Installation

### Requirements

Observe the following installation rules:

- Minimum clearance to surrounding parts: 1 cm
- Even mounting surface
- The installation point should, as far as possible, be vibration-free. The permissible climatic conditions (operation or storage and transport temperature) must be adhered to (see Technical data (Page 234)).
- Maximum distance to power supply depending on cable length:
  - Connecting cable input line (mains  $\leftrightarrow$  NT40): 200 cm
  - Connecting cable output line (NT40  $\leftrightarrow$  control unit): 150 cm
- Operation outside the specified temperature range can lead to danger, malfunctions and failure of the equipment.
- Protection class I
- The device must be installed in places that are accessible only to qualified personnel.



- In order to protect the modules from static electrical discharges, personnel must discharge themselves electrostatically before opening control cabinets or terminal boxes.
- It is essential to ensure that the maximum temperature of 55 °C is not exceeded in the mounting position. The device must not be exposed to direct sunlight.

 <b>WARNING</b>
<b>Dangerous electrical voltage!</b>
When electrical devices are used, certain parts of them have to carry dangerous voltages. Failure to observe the operating instructions can therefore lead to serious injuries or material damage.
Observe the operating instructions.

## Procedure

Carry out the following steps in the given order:

1. Check that the operating data matches the values on the rating plate.
2. Mount the device with the aid of 4 (M6) screws and washers.

### 7.1.3 Connecting terminals

#### Input line X1

X1 is the connection line to the power supply.

Connections	L, N, PE 195 - 265 VAC
Cable type	H05RN-F 3G1
Cable length	2 m
Connector(s)	Extruded protective Schuko-type socket, 10 / 16 A, 250 V AC, double-protected connecting cable according to DIN 49.441, CEE7 / VII.

#### Output line X2

X2 is the output line connecting to the SIDOOR controller.

Connections	UA+, UA-, FE
Cable type	H05RN-F 3G1
Cable length	1.5 m
Connector(s)	WAGO 721-103/026-045

The rated data of the output are:

Rated output voltage	36 V
Rated output current	2.5 A
Continuous output power rating	<100 W

 **WARNING**

**Dangerous electrical voltage.**

May cause death, serious injury or property damage.

The third line brought out at the output is only a functional grounding connection, this must not be regarded or used as a ground in the sense of a PE connection!

## Connection specifications

 **WARNING**

**Dangerous electrical voltage!**

When electrical devices are used, certain parts of them have to carry dangerous voltages. Failure to observe the operating instructions can therefore lead to serious injuries or material damage.

Observe the operating instructions.

Observe the following connection regulation:

- The regulations for the construction of high voltage installations must be observed when carrying out the electrical installation.
- The switch mode power supply may only be connected to the power supply by connected supply lines.
- The power supply (230 V AC  $\pm$  15%) must be connected according to VDE 0100 and VDE 0160.
- The supply voltage to the device must be equipped with a protective device (automatic circuit breaker) (10 A / tripping characteristic B).
- The protective conductor is connected via the supply line X1.
- Output lines may only to be connected to the SIDOOR controller.
- When connecting the device to the power system it has to be ensured that this network fulfils the requirements for the overvoltage category II. If required, an external overvoltage protection is to be connected upstream of the device so that the requirements for the overvoltage category II are fulfilled.
- Ensure that the power outlet is clearly recognizable and easily accessible.

## Procedure

---

### Note

#### **Risk of injury through moving mechanical parts.**

The control system will become ready for operation after the supply line has been connected. If a control signal is present, the door will move in the set direction.

Always connect the supply lines last of all!

---

Carry out the following steps in the given order:

1. Connect the controller to the output line, observing the polarity printed on the device.
2. Connect the supply lines to the network.
3. When the supply is switched on, the device is ready for operation.  
The green LED lights up.

For more, see also section Connecting and commissioning (Page 285)

## 7.1.4 Technical specifications

<b>Article number</b>	<b>6FB1112-0AT20-3PS0</b>
<b>General information</b>	
Product brand name	SIDOOR
Product type designation	NT40
<b>Installation type/mounting</b>	
Mounting type	Four 5 mm screws
<b>Supply voltage</b>	
Rated value (AC)	230 V
relative symmetrical tolerance of the supply voltage	15 %
<b>Line frequency</b>	
• permissible range, lower limit	50 Hz
• permissible range, upper limit	60 Hz
<b>Input current</b>	
Current consumption for 2 s, max.	3.5 A
Rated value at 230 V AC	0.7 A
Operational current of fuse protection at input, min.	6 A
Operational current of fuse protection at input, max.	10 A
Tripping characteristic class of fuse protection at input	B
<b>Output voltage</b>	
Rated value (DC)	36 V; SELV
Relative symmetrical tolerance of the output voltage	3 %
<b>Output current</b>	
Current output (rated value)	2.5 A
Temporary overload current (for 2 s maximum)	15 A
<b>Power</b>	
Active power input, max.	100 W
Emitted active power, max.	100 W
Emitted active power (restricted to 2 s)	540 W
Efficiency at 230 V AC (with 100 W emitted active power)	90 %
Active apparent power, max.	650 V·A
<b>Isolation</b>	
Overvoltage category	2
Degree of pollution	2
<b>Degree and class of protection</b>	
IP degree of protection	IP54
Equipment protection class	I
<b>Standards, approvals, certificates</b>	
CE mark	Yes
EAC (formerly Gost-R)	Yes
TÜV Inspectorate approval	Yes
China RoHS compliance	Yes
Standard for EMC	EMC Directive 2004/108/EC, EN 12015, EN 12016

<b>Article number</b>	<b>6FB1112-0AT20-3PS0</b>
Standard for safety	EN 61010-1 / EN 61010-2-201
<b>Ambient conditions</b>	
<b>Ambient temperature during operation</b>	
• min.	-20 °C
• max.	55 °C
• Remark	No direct exposure to the sun
<b>Ambient temperature during storage/transportation</b>	
• Storage, min.	-20 °C
• Storage, max.	70 °C
• Transportation, min.	-40 °C
• Transportation, max.	70 °C
<b>Altitude during operation relating to sea level</b>	
• Installation altitude above sea level, max.	2 000 m
<b>Relative humidity</b>	
• No condensation, min.	10 %
• No condensation, max.	93 %
<b>Cables</b>	
Cable length	
• Input side	2 m
• Output side	1.5 m
<b>Connection method</b>	
Design of electrical connection at input	SCHUKO connector DIN 49.441, CEE7/VII
Design of electrical connection at output	WAGO 721-103/026
<b>Dimensions</b>	
Width	270 mm
Height	55 mm
Depth	80 mm

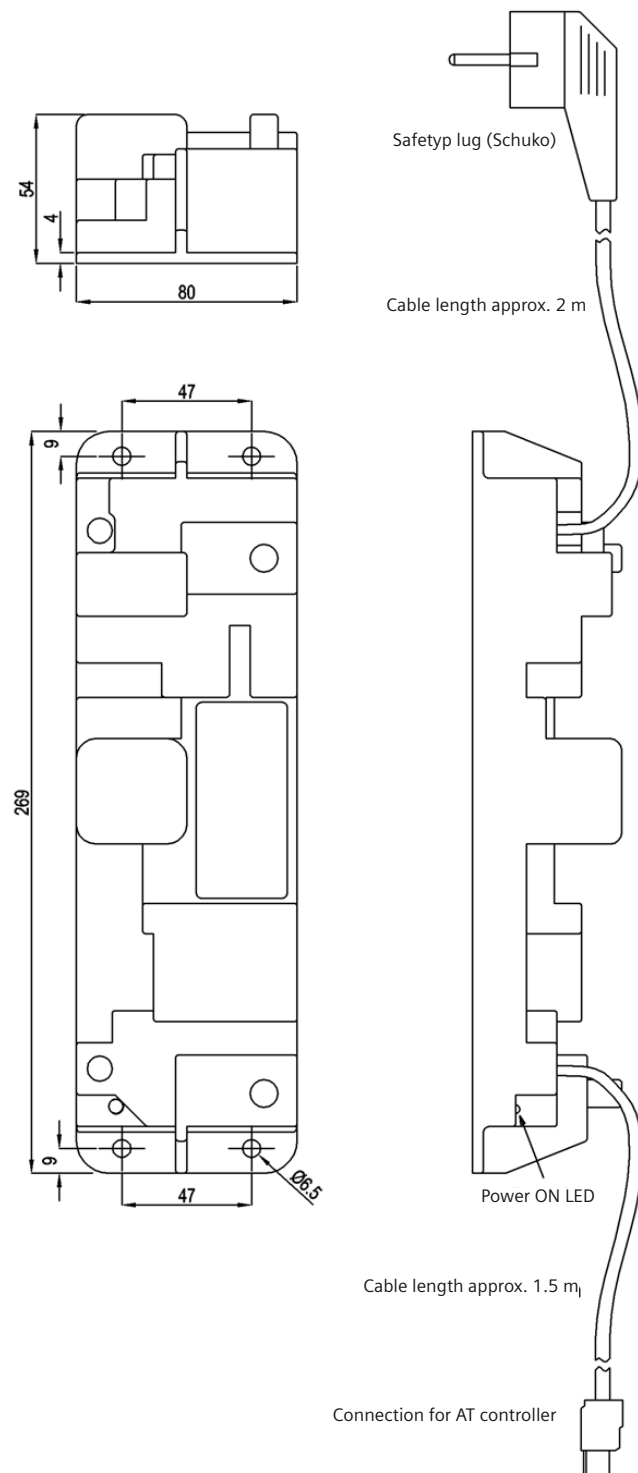

Figure 7-2 Dimensions of switch mode power supply NT40

## 7.2 SIDOOR TRANSFORMER

### 7.2.1 Description

#### Design



- ① Schuko plug  
220-240 V AC  $\pm$ 10% 50/60 Hz
- ② Length approx. 2 m
- ③ Connection to the control unit
- ④ Length approx. 1.5 m
- ⑤ Height of the mains transformer approx. 65 mm; width approx. 145 mm, depth approx. 126 mm
- ⑥  $\varnothing$  6.1 mm, width across flats 10, L > 70 mm

Figure 7-3 SIDOOR TRANSFORMER

#### Function

The SIDOOR TRANSFORMER is a 220-240 V AC ( $\pm$  10%) 50/60 Hz standard power supply unit for supplying SIDOOR controllers without an integrated power supply unit.

---

#### Note

When using the SIDOOR TRANSFORMER, performance losses in power, acceleration and speed can occur depending on the output transmission, weight to be moved and system friction.

---

**See also**

Controllers (Page 27)

## 7.2.2 Installation

### Requirements

The installation site must fulfill the following requirements:

- Minimum clearance to surrounding parts: 1 cm
- Even mounting surface
- Maximum distance from the power supply due to cable length:
  - Connecting cable input line (mains ↔ transformer): 200 cm
  - Connecting cable output line (transformer ↔ control unit): 150 cm
  - Ensure that the power outlet is clearly recognizable and easily accessible.



**⚠ CAUTION**

**Risk of fire**

The temperature of the housing of the transformer can rise to over 105 °C in the event of a fault in the controller or a short circuit in the output line of the transformer.

As a result, you should take the following safety measures:

- Only mount the transformer on surfaces with no risk of ignition, and which cannot be touched by unauthorized persons.
- Inform the service personnel about the risk of fire.

**⚠ CAUTION**

**Material damage**

The transformer power supply cable cannot be replaced.

If the cable is damaged, the device must be scrapped.



**Procedure**

Proceed as follows to install the transformer:

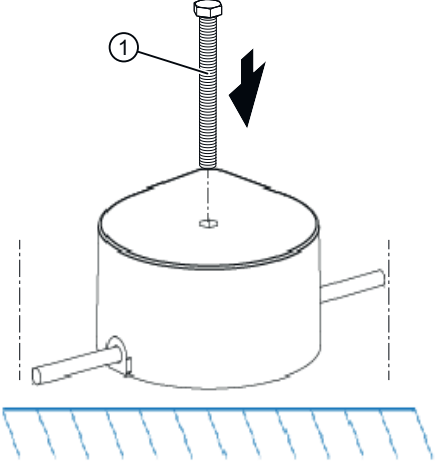
Steps	Figure
1. Drill the hole for the screw ① as shown in the dimension drawing.	
2. Secure the transformer with 1 screw (M6, minimum length 70 mm) ① on a flat metal surface.	

**7.2.3 Connecting terminals**

**Slots**

The slots for the SIDOOR TRANSFORMER are as follows:

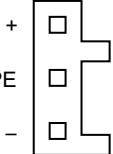
Controller	Slot
SIDOOR ATD4xxW	<p>X3</p> 

7.2.4 Test voltage

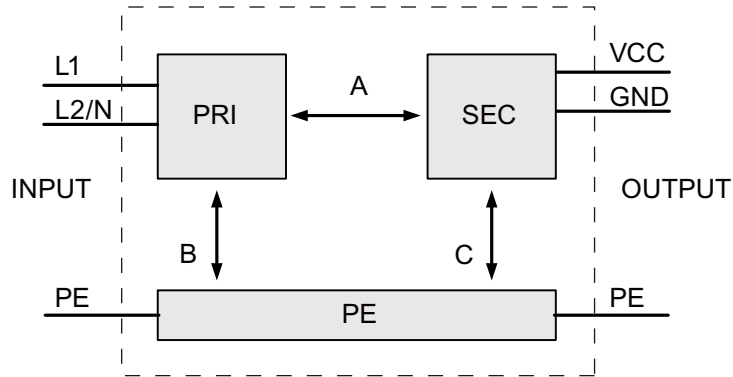

Figure 7-4 Diagram test voltage

The type test and the manufacturing test can only be performed by the manufacturer. The field can also be performed by the user.

Requirements for performing the field test:

**General**

The following applies to SIDOOR TRANSFORMER:

Disconnect SIDOOR TRANSFORMER from the power supply by pulling out the power plug, disconnect the connection to the SIDOOR control circuit device.

Inspection (A) & (B)

- Interconnecting input lines (PRI) L1 and L2/N
- Interconnecting output cables (SEC) VCC, GND and PE

Inspection (C)

- Interconnecting output cables (SEC) VCC and GND and measuring against PE

Table 7-1 Test voltage

	Test time	PRI<->SEC (A)	PRI<->PE (B)	SEC<->PE (C)
Type test	60 s	4000 VAC	4000 VAC	1500 VAC
Manufacturing test	1 s	4000 VAC	4000 VAC	1500 VAC
Field test	1 s	1500 VAC	1500 VAC	350 VAC
	1 s	2250 VDC	2250 VDC	500 VDC

Remark:

Tripping current for measuring DC: 0 mA

tripping current for measuring AC: <100 mA

## 7.2.5 Technical specifications

### 7.2.5.1 SIDOOR TRANSFORMER

<b>Article number</b>	<b>6FB1112-0AT20-2TR0</b>
<b>General information</b>	
Product brand name	SIDOOR
Product type designation	TRANSFORMER
Product version	Power supply unit for SIDOOR controllers
<b>Installation type/mounting</b>	
Mounting type	Hexagon head bolt M6, L > 70 mm
<b>Supply voltage</b>	
permissible range, lower limit (AC)	220 V
permissible range, upper limit (AC)	240 V
relative symmetrical tolerance of the supply voltage	10 %
<b>Line frequency</b>	
• permissible range, lower limit	50 Hz
• permissible range, upper limit	60 Hz
<b>Mains filter</b>	
• integrated	Yes
<b>Input current</b>	
Current consumption, max.	1.6 A
Operational current of fuse protection at input, min.	6 A
Operational current of fuse protection at input, max.	10 A
Tripping characteristic class of fuse protection at input	D6, C10
<b>Output voltage</b>	
RMS value (pulsating DC voltage at full load)	17.3 V; at 230 V AC
RMS value (pulsating DC voltage at full load), min.	16.5 V
RMS value (pulsating DC voltage at full load), max.	18 V
RMS value (pulsating DC voltage at 0.7 mA peak current), max.	27 V; At 264 V AC
<b>Output current</b>	
Current output (rated value)	14.3 A; t on 2 s / t off 8 s
<b>Power</b>	
Emitted active power, max.	115 W; Average value above 10 s
<b>Isolation</b>	
Overvoltage category	2
Degree of pollution	2
<b>Degree and class of protection</b>	

## 7.2 SIDOOR TRANSFORMER

<b>Article number</b>	<b>6FB1112-0AT20-2TRO</b>
IP degree of protection	IP54
<b>Standards, approvals, certificates</b>	
CE mark	Yes
EAC (formerly Gost-R)	Yes
RoHS conformity	Yes
China RoHS compliance	Yes
Standard for EMC	EN 12015 / EN 12016 / EN 61000-6-2 / EN 61000-6-3 / EN 61000-3-2 / EN 61000-3-3
Standard for safety	Low Voltage Directive (LVD) 2014/35/EU
<b>Ambient conditions</b>	
<b>Ambient temperature during operation</b>	
• min.	-20 °C
• max.	55 °C
• Remark	No direct exposure to the sun
<b>Ambient temperature during storage/transportation</b>	
• Storage, min.	-20 °C
• Storage, max.	70 °C
• Transportation, min.	-40 °C
• Transportation, max.	70 °C
<b>Altitude during operation relating to sea level</b>	
• Installation altitude above sea level, max.	2 000 m
<b>Relative humidity</b>	
• No condensation, min.	10 %
• No condensation, max.	93 %
<b>Cables</b>	
Cable length	
• Input side	2 m
• Output side	1.5 m
<b>Connection method</b>	
Design of electrical connection at input	SCHUKO connector DIN 49.441, CEE7/II
Design of electrical connection at output	WAGO 721-103/026
<b>Dimensions</b>	
Width	145 mm
Height	65 mm
Depth	126 mm

7.2.5.2 Dimensional drawing SIDOOR TRANSFORMER

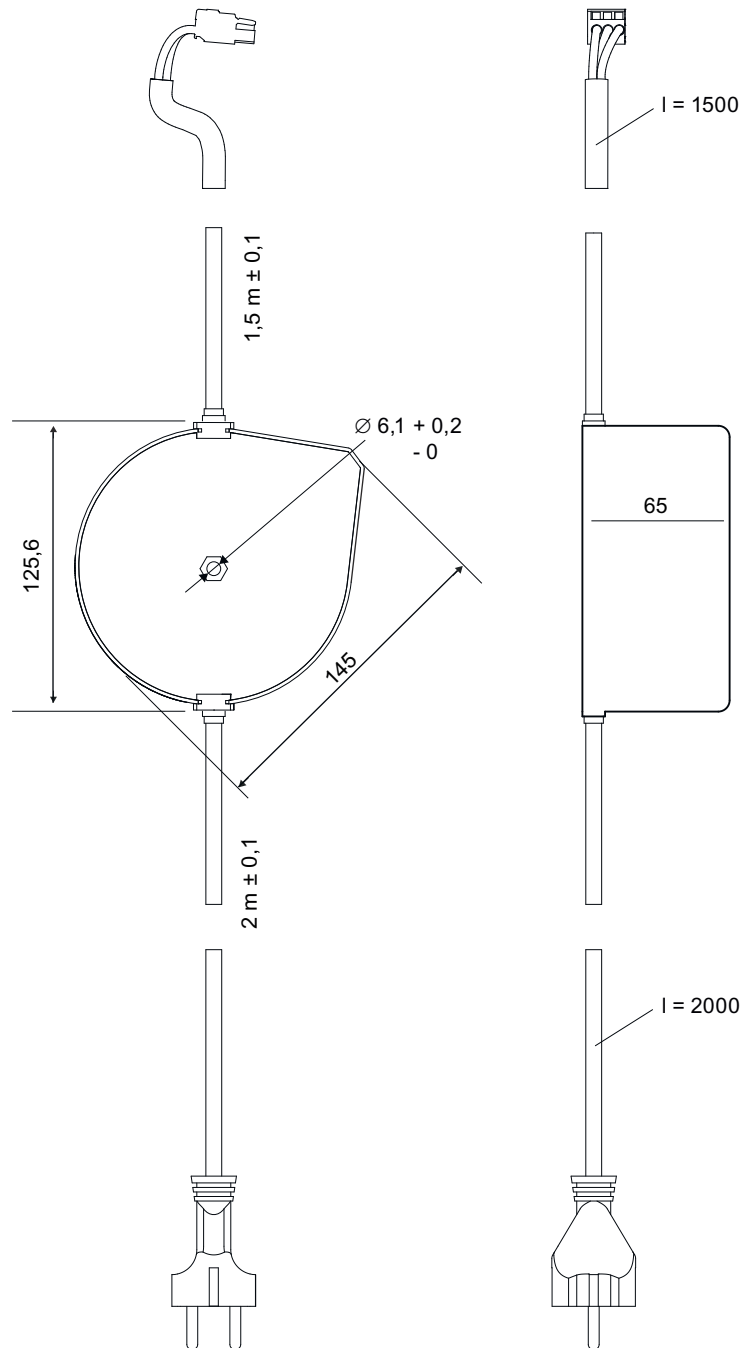
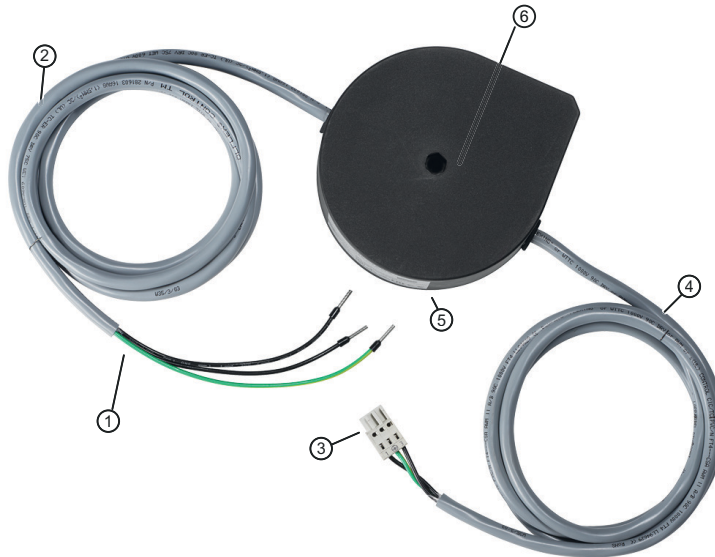

Figure 7-5 Dimensions of the SIDOOR TRANSFORMER

## 7.3 SIDOOR TRANSFORMER UL

### 7.3.1 Description

#### Design



- ① No mains connection 220-240 V AC +/-10% 50/60 Hz
- ② Length approx. 2 m
- ③ Connector for connection to the control unit
- ④ Length approx. 1.5 m
- ⑤ Height of the mains transformer approx. 65 mm; width approx. 145 mm, depth approx. 126 mm
- ⑥ Diam. 6.1 mm, Size 10, L>70 mm

Figure 7-6 SIDOOR TRANSFORMER UL

#### Function

The SIDOOR TRANSFORMER UL is a 220-240 V AC ( $\pm 10\%$ ) 50/60 Hz standard power supply unit for supplying SIDOOR control units without an integrated power supply.

#### Note

When using the SIDOOR TRANSFORMER UL performance losses in force, acceleration and speed may occur depending on the output transmission, weight to be moved and system friction.

#### Output line

The output line is connected to slot X3 of the SIDOOR control unit.

The pin assignment at slot X3 is as follows:

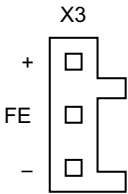

**See also**

Controllers (Page 27)

**7.3.2 Installation**

**Requirements**

The installation site must fulfill the following requirements:

- Minimum clearance to surrounding parts: 1 cm
- Flat mounting surface made of metal
- Maximum distance from the power supply due to cable length:
  - Connecting cable input line (mains ↔ transformer): 200 cm
  - Connecting cable output line (transformer ↔ control unit): 150 cm



	<b>CAUTION</b>
<b>Risk of fire</b>	
The transformer housing temperature can rise to over 105 °C in the event of a fault in the controller or a short circuit in the output line of the transformer.	
As a result, you should take the following safety measures:	
<ul style="list-style-type: none"> <li>• Only mount the transformer on surfaces with no risk of ignition, and which cannot be touched by unauthorized persons.</li> <li>• Inform the service personnel about the risk of fire.</li> </ul>	



<b>NOTICE</b>
Use the SIDOOR Transformer UL indoors only.

**⚠ CAUTION**

**Material damage**

The connection cables of the transformer cannot be replaced.

- Scrap the unit if the line is damaged.

**Procedure**

Proceed as follows to install the transformer:

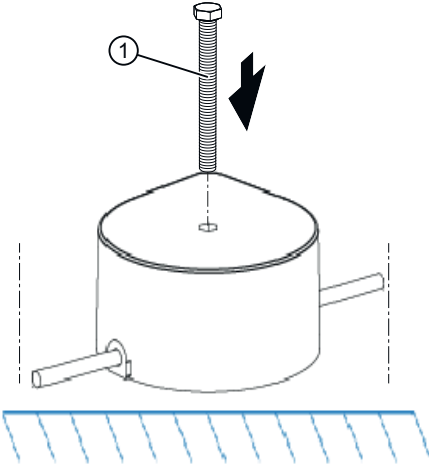
Steps	Figure
1. Drill the hole for the screw ① as shown in the dimension drawing.	
2. Secure the transformer with 1 screw (M6, minimum length 70 mm) ① on a flat metal surface.	



### 7.3.3 Connection

#### Requirements



#### **WARNING**

##### **Dangerous electrical voltage!**

When electrical devices are operated, parts of these devices will necessarily carry dangerous voltages. Failure to observe the operating instructions can therefore lead to serious injuries or material damage.

- Observe the operating instructions.
- Switch off all current sources and provide them with a switch-on guard before performing any work on the device.
- Adhere to national regulations.



#### **WARNING**

##### **Installation and maintenance work**

Installation and maintenance work may only be performed by qualified personnel.

- If the SIDOOR TRANSFORMER UL is supplied by two ungrounded wires (for example L1, L2), fusing has to be implemented by a 2-pole miniature circuit breaker with coupled switching element. When there is a connection between an ungrounded wire (L) and a grounded wire (N), only a 1-pole miniature circuit breaker in the L-branch is required.
- Make sure that the on-site (customer-provided) fuse meets these requirements:
  - For the CE setting with a miniature circuit breaker to IEC60898-1, 10 A tripping characteristic C or 6 A tripping characteristic D  
for example 1-pole miniature circuit breaker: 5SY4110-7 or 5SY4106-8  
e.g. 2-pole miniature circuit breakers: 5SY4210-7 or 5SY4206-8
  - For the NFPA setting miniature circuit breaker to UL489 listed, CCN DIVQ, UR $\geq$ 240VAC, 10 A Class C or 6 A Class D  
e.g. 1-pole miniature circuit breaker: 5SJ4110-7HG41 or 5SJ4106-8HG41  
e.g. 2-pole miniature circuit breakers: 5SJ4210-7HG41 or 5SJ4206-8HG41

**Procedure**

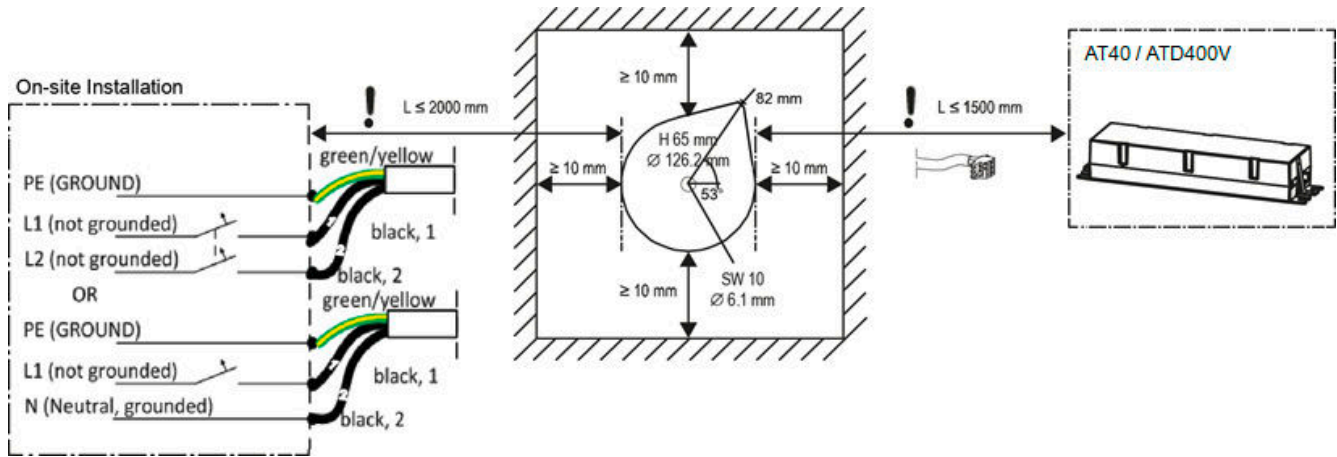

- Connect the wires as shown in the drawing.
- Be sure to connect the protective ground (green-yellow) correctly.
- Ensure that there is a mains disconnecting device near the equipment that is easily accessible clearly marked (for example, using a suitable miniature circuit breaker).
- The description of the complete electrical setting and commissioning of the controller and of the associated components is available in the section Connecting and commissioning (Page 285).

**Note**

**Risk of injury through moving mechanical parts.**

The control system will become ready for operation after the supply line has been connected. If a control signal is present, the door will move in the set direction.

Always connect the supply lines last of all!

Carry out the following steps in the given order:

1. Connect the output line of the SIDOOR TRANSFORMER UL to slot X3 on the controller. Observe the polarity printed on the device.
2. Connect the supply line to the network.

See the section Connecting and commissioning (Page 285).

### 7.3.4 Test voltage

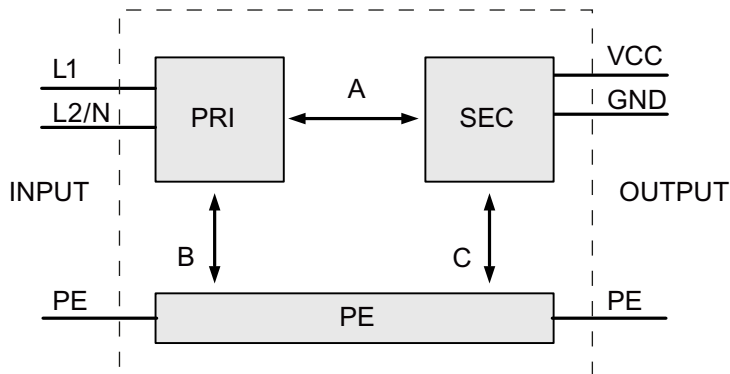

Figure 7-7 Diagram test voltage

The type test and the manufacturing test can only be performed by the manufacturer. The field can also be performed by the user.

Requirements for performing the field test:

#### General

Disconnecting SIDOOR TRANSFORMER UL

disconnect the connection to the SIDOOR control circuit device.

Inspection (A) & (B)

- Interconnecting input lines (PRI) L1 and L2/N
- Interconnecting output cables (SEC) VCC, GND and PE

Inspection (C)

- Interconnecting output cables (SEC) VCC and GND and measuring against PE

Table 7-2 Test voltage

	Test time	PRI<->SEC (A)	PRI<->PE (B)	SEC<->PE (C)
Type test	60 s	4000 VAC	4000 VAC	1500 VAC
Manufacturing test	1 s	4000 VAC	4000 VAC	1500 VAC
Field test	1 s	1500 VAC	1500 VAC	350 VAC
	1 s	2250 VDC	2250 VDC	500 VDC

Remark:

Tripping current for measuring DC: 0 mA

tripping current for measuring AC: <100 mA

## 7.3.5 Technical specifications

### 7.3.5.1 SIDOOR TRANSFORMER UL

<b>Article number</b>	<b>6FB1112-0AT21-2TRO</b>
<b>General information</b>	
Product version	Power supply unit for SIDOOR controllers
<b>Installation type/mounting</b>	
Mounting type	Hexagon head bolt M6, L > 70 mm
<b>Supply voltage</b>	
permissible range, lower limit (AC)	220 V
permissible range, upper limit (AC)	240 V
relative symmetrical tolerance of the supply voltage	10 %
<b>Line frequency</b>	
• permissible range, lower limit	50 Hz
• permissible range, upper limit	60 Hz
<b>Mains filter</b>	
• integrated	Yes
<b>Input current</b>	
Current consumption, max.	1.6 A
Operational current of fuse protection at input, min.	6 A
Operational current of fuse protection at input, max.	10 A
Tripping characteristic class of fuse protection at input	D6, C10
<b>Output voltage</b>	
RMS value (pulsating DC voltage at full load)	17.3 V; at 230 V AC
RMS value (pulsating DC voltage at full load), min.	16.5 V
RMS value (pulsating DC voltage at full load), max.	18 V
RMS value (pulsating DC voltage at 0.7 mA peak current), max.	27 V; At 264 V AC
<b>Power</b>	
Emitted active power, max.	115 W; Average value above 10 s
<b>Standards, approvals, certificates</b>	
CE mark	Yes
EAC (formerly Gost-R)	Yes
RoHS conformity	Yes
China RoHS compliance	Yes
Standard for EMC	EN 12015 / EN 12016 / EN 61000-6-2 / EN 61000-6-3 / EN 61000-3-2 / EN 61000-3-3

<b>Article number</b>	<b>6FB1112-0AT21-2TRO</b>
Standard for safety	UL 61010-1, CSA C22.2 No. 61010-1-12, Low Voltage Directive (LVD) 2014/35/EU
<b>Ambient conditions</b>	
<b>Ambient temperature during operation</b>	
• min.	-20 °C
• max.	55 °C
• Remark	No direct exposure to the sun
<b>Ambient temperature during storage/transportation</b>	
• Storage, min.	-20 °C
• Storage, max.	70 °C
• Transportation, min.	-40 °C
• Transportation, max.	70 °C
<b>Altitude during operation relating to sea level</b>	
• Installation altitude above sea level, max.	2 000 m
<b>Relative humidity</b>	
• No condensation, min.	10 %
• No condensation, max.	93 %
<b>Cables</b>	
Cable length	
• Input side	2 m
• Output side	1.5 m
<b>Connection method</b>	
Design of electrical connection at input	equipped with ferrules
<b>Dimensions</b>	
Width	145 mm
Height	65 mm
Depth	126 mm

7.3.5.2 Dimension drawing SIDOOR TRANSFORMER UL

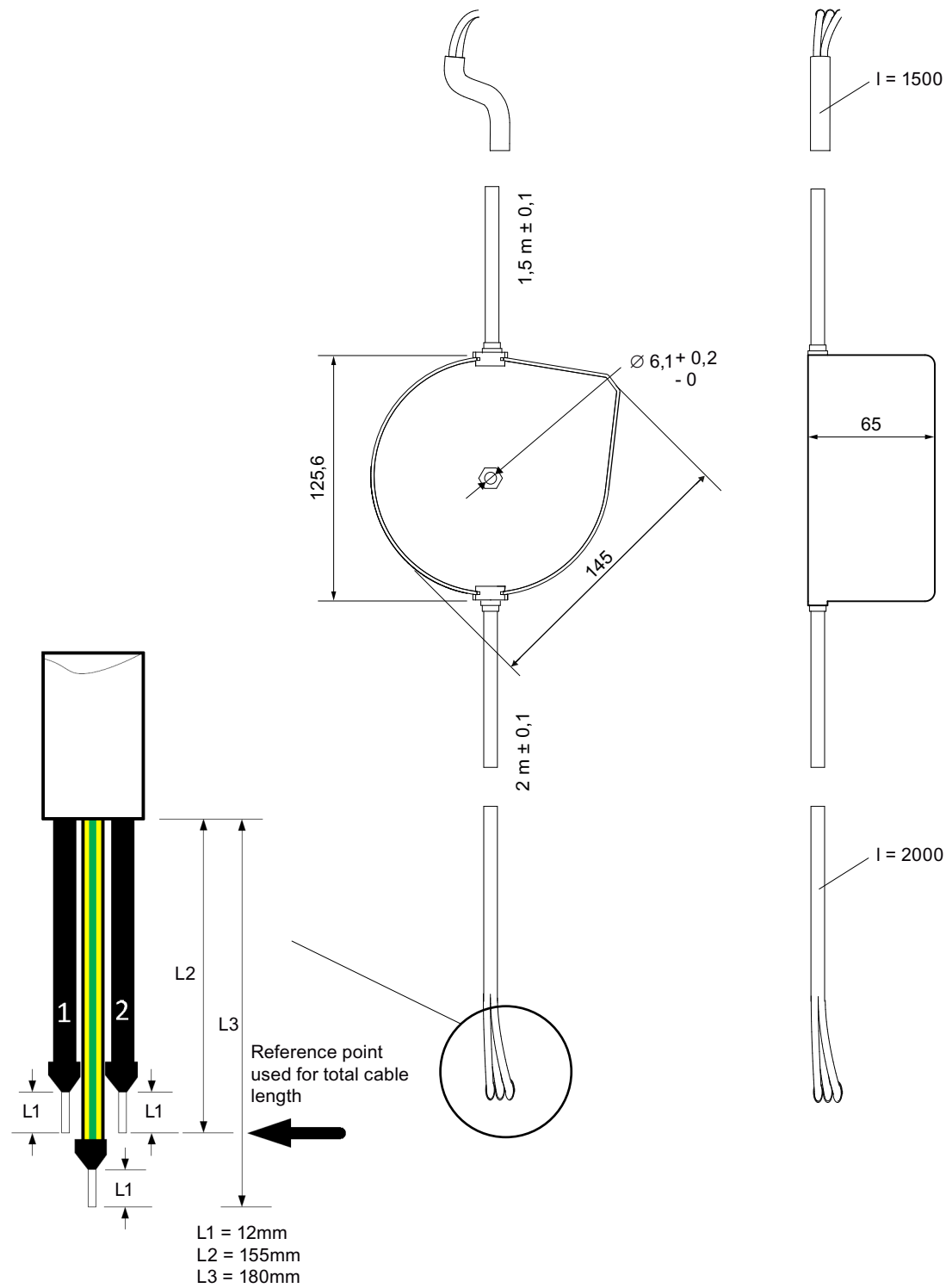

Figure 7-8 Dimension drawing TRANSFORMER UL

## 7.4 SITOP PSU8200 13A/36V 3-phase

### SITOP PSU8200 13A/36V

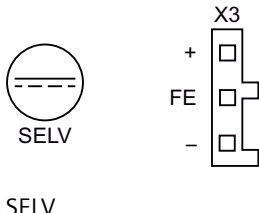

#### Connecting SITOP PSU8200 on the ATD4xxW door control unit

Slot			Function
		X3	
	1	+	Plus
	2	FE	Functional grounding
	3	-	Minus

#### 7.4.1 Power supply requirements of SITOP PSU8200

##### NOTICE

SITOP PSU8200 may be used only as of firmware version ATD4xxW  $\geq$  1.04.

##### Fuse protection

An MCB according to EN 60898-1, 8 A, C-characteristic of the type SIEMENS: 5SY4108-7 is to be inserted into the supply network by the customer.

Ensure that the MCB is operated only within the permissible range. The miniature circuit breaker must be installed in the vicinity of the SIDOOR control unit at a similar ambient air temperature.

##### Default topology

Only the SIDOOR controller may be connected to the SITOP PSU8200; additional loads are not allowed. The spatial extension of the supply circuit used must be less than 30 m.

## 7.4.2 Installation

A miniature circuit breaker (type SIEMENS: 5SY4108-7) is an absolute requirement for SITOP PSU8200.

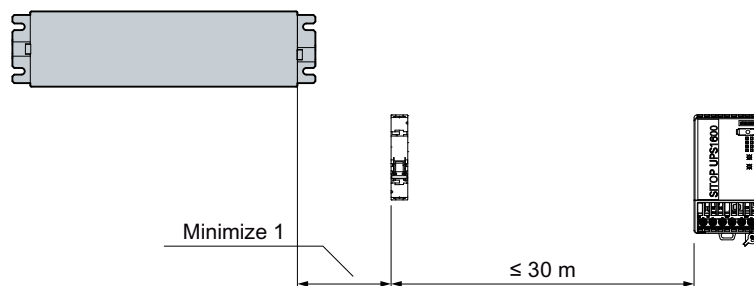

<sup>1</sup> The circuit breaker must be mounted close to the SIDOOR controller (at a similar ambient temperature).



### 7.4.3 Technical specifications

#### Core statement

<b>Order number</b>	<b>6EP3446-8SB10-0AY0</b>
Product	SITOP PSU8200
Power supply, type	36 V/13 A
<b>Input</b>	
Input	3-phase AC
Rated voltage value $V_{in}$ rated	400 ... 500 V
Voltage range AC	320 ... 575 V
Wide-range input	Yes
Mains buffering at $I_{out}$ rated, min.	15 ms; at $V_{in} = 400$ V
Rated line frequency 1	50 Hz
Rated line frequency 2	60 Hz
Rated line range	47 ... 63 Hz
Input current	
• at rated input voltage 400 V	1.2 A
• at rated input voltage 500 V	1 A
Switch-on current limiting (+25 °C), max.	16 A
$I^2t$ , max.	0.8 A <sup>2</sup> ·s
Built-in incoming fuse	none
Protection in the mains power input (IEC 898)	Required: 3-pole connected miniature circuit breaker 6 ... 16 A characteristic C or circuit breaker 3RV2011-1DA10 (setting 3 A) or 3RV2711-1DD10 (UL 489)
<b>Output</b>	
Output	Controlled, isolated DC voltage
Rated voltage $V_{out}$ DC	36 V
Total tolerance, static $\pm$	3 %
Static mains compensation, approx.	0.1 %
Static load balancing, approx.	0.2 %
Residual ripple peak-peak, max.	100 mV
Spikes peak-peak, max. (bandwidth: 20 MHz)	200 mV
Adjustment range	36 ... 42 V
Product function Output voltage adjustable	Yes
Output voltage setting	via potentiometer; max. 480 W
Status display	Green LED for 36 V OK
Signaling	Relay contact (NO contact, rating 60 V DC/ 0.3 A) for 36 V OK
On/off behavior	No overshoot of $V_{out}$ (soft start)
Startup delay, max.	2.5 s
Voltage increase time of the output voltage maximum	500 ms
Rated current value $I_{out}$ rated	13 A
Current range	0 ... 13 A

<b>Order number</b>	<b>6EP3446-8SB10-0AY0</b>
Product	SITOP PSU8200
Power supply, type	36 V/13 A
<ul style="list-style-type: none"> <li>Note</li> </ul>	+60 ... +70 °C: Derating 2%/K
Supplied active power typical	468 W
Short-term overload current	
<ul style="list-style-type: none"> <li>at short-circuit during operation typical</li> </ul>	39 A
Duration of overloading capability for excess current	
<ul style="list-style-type: none"> <li>at short-circuit during operation</li> </ul>	25 ms
Constant overload current	
<ul style="list-style-type: none"> <li>on short-circuiting during the start-up typical</li> </ul>	14 A
Parallel switching for enhanced performance	Yes; switchable characteristic
Numbers of parallel switchable units for enhanced performance	2
<b>Efficiency</b>	
Efficiency at Vout rated, Iout rated, approx.	94 %
Power loss at Vout rated, Iout rated, approx.	30 W
<b>Closed-loop control</b>	
Dynamic mains compensation (Vin rated ±15 %), max.	0.1 %
Dynamic load smoothing (Iout: 50/100/50 %), Uout ± typ.	1 %
Load step setting time 50 to 100%, typ.	0.2 ms
Load step setting time 100 to 50%, typ.	0.2 ms
Dynamic load smoothing (Iout: 10/90/10 %), Uout ± typ.	2 %
Load step setting time 10 to 90%, typ.	0.2 ms
Load step setting time 90 to 10%, typ.	0.2 ms
Setting time maximum	10 ms
<b>Protection and monitoring</b>	
Output overvoltage protection	< 48 V
Current limitation, typ.	14 A
Property of the output Short-circuit proof	Yes
Short-circuit protection	Alternatively, constant current characteristic approx. 14 A or latching shutdown
Enduring short circuit current RMS value	
<ul style="list-style-type: none"> <li>typical</li> </ul>	14 A
Overcurrent overload capability in normal operation	overload capability 150 % Iout rated up to 5 s/min
Overload/short-circuit indicator	LED yellow for "overload", LED red for "latching shutdown"
<b>Safety</b>	
Primary/secondary isolation	Yes
Galvanic isolation	Safety extra low output voltage Vout according to EN 60950-1
Protection class	Class I

<b>Order number</b>	<b>6EP3446-8SB10-0AY0</b>
Product	SITOP PSU8200
Power supply, type	36 V/13 A
Leakage current	
• maximum	3.5 mA
• typical	0.9 mA
CE mark	Yes
UL/cUL (CSA) approval	cULus-Listed (UL 508, CSA C22.2 No. 107.1), File E197259
Explosion protection	No
FM approval	-
CB approval	Yes
Marine approval	GL, ABS
Degree of protection (EN 60529)	IP20
<b>EMC</b>	
Emitted interference	EN 55022 Class B
Supply harmonics limitation	EN 61000-3-2
Noise immunity	EN 61000-6-2
<b>Operating data</b>	
Ambient temperature	
• during operation	-25 ... +70 °C
– Note	with natural convection
• during transport	-40 ... +85 °C
• during storage	-40 ... +85 °C
Humidity class according to EN 60721	Climate class 3K3, no condensation
<b>Mechanics</b>	
Connection technology	screw-type terminals
Connections	
• Supply input	L1, L2, L3, PE: 1 screw terminal each for 0.2 ... 4 mm <sup>2</sup> single-core/finely stranded
• Output	+, -: 2 screw terminals each for 0.2 ... 4 mm <sup>2</sup>
• Auxiliary	13, 14 (alarm signal): 1 screw terminal each for 0.14 ... 1.5 mm <sup>2</sup> ; 15, 16 (Remote): 1 screw terminal each for 0.14 ... 1.5 mm <sup>2</sup>
Width of the enclosure	70 mm
Height of the enclosure	125 mm
Depth of the enclosure	125 mm
Required spacing	
• top	50 mm
• bottom	50 mm
• left	0 mm
• right	0 mm
Weight, approx.	1.2 kg
Product feature of the enclosure housing for side-by-side mounting	Yes

7.5 Building DC voltage supply

<b>Order number</b>	<b>6EP3446-8SB10-0AY0</b>
Product	SITOP PSU8200
Power supply, type	36 V/13 A
Installation	Snaps onto DIN rail EN 60715 35x7.5/15
Electrical accessories	Buffer module
Mechanical accessories	Device identification label 20 mm × 7 mm, pale turquoise 3RT1900-1SB20
Other information	Specifications at rated input voltage and ambient temperature +25 °C (unless otherwise specified)

## 7.5 Building DC voltage supply

### Connector pin assignment

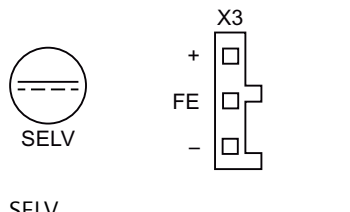
Slot			Function
X3			
 <p>SELV</p> <p>SELV</p>	1	+	Plus
	2	FE	Functional grounding
	3	-	Minus

### 7.5.1 Power supply requirements

**NOTICE**

The DC power supply for the SIDOOR ATD4xxW controller may be used only with firmware version ATD4xxW > = 1.04.

The following requirements must be met by the building DC power supply:

#### Supply voltage

In **normal operation** a non-grounded SELV voltage according to EN 61010-2-201:2018, NFPA environment UL61010-2-201: 1st Edition 2014 with a typical voltage of 36 V is to be used.

Note 1: Operation of the SIDOOR device is possible down to 19.2V. However, this is associated with performance loss for the drive with respect to the achievable forces, speeds and acceleration.

Note 2: With >45V, irreversible damage is done to the SIDOOR device!

In case of a **fault scenario** of the **power supply unit** the output voltage of the power supply unit has to remain smaller than 60 V.

In case of a **fault** in the **SIDOOR controller** voltages of up to 60 V can occur.

## Supply current

Normal operation requires an operational peak current of up to 14A for up to 3s as well as a continuous current of up to 9A. Smaller current values can result in operating faults, depending on the selected settings (ramps, end speeds, forces) and the door properties (friction, weight).

To ensure triggering of the automatic circuit breaker in case of a fault of the SIDOOR controller, the utilized power supply unit must have the following properties (see figure below):

- $\geq 13\text{A}$  continuous current, even in case of a short-circuit
- OR -
- Effective short-circuit current  $\leq 8\text{ARMS}$ , period duration  $\leq 10\text{s}$ , peak current  $\leq 55\text{A}$

In the case of a fault on the part of the power supply unit or of the SIDOOR controller the current is limited by the miniature circuit breaker C8 Automat according to EN 60898-1.

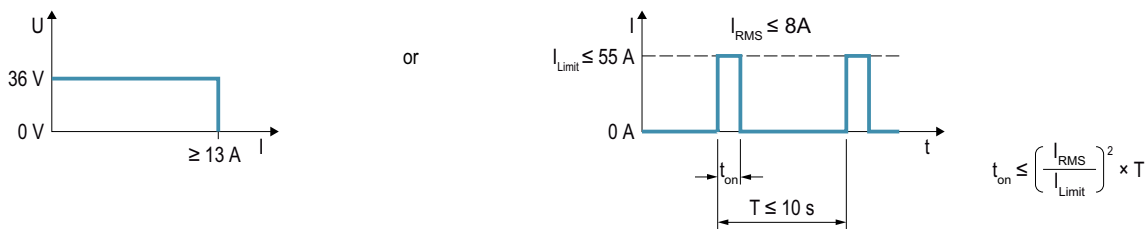

Figure 7-9 Properties of the supplying power supply unit in case of an error of the SIDOOR controller

## Fuse protection

A miniature circuit breaker according to EN 60898-1, 8A, C-characteristic of the type SIEMENS: 5SY4108-7 or 5SY4108-7KK11 is to be inserted into the supply network by the customer. It must be ensured that the miniature circuit breaker is only operated within the permissible range. The circuit breaker must be mounted close to the SIDOOR controller at a similar ambient temperature.

## Voltage immunity of the power supply unit at an energetic recovery system

The controller does not have an energetic recovery system protection.

This means the voltage at the terminals increases when the doors are braked. In normal operation, this voltage is limited to values less than 42V by the ballast circuit integrated in the controller. In faulty operation, however, this voltage can increase to values of less than 60V. This must be considered when selecting the supply.

### Default topology

Only the SIDOOR controller may be connected to the incoming power supply; additional consumers are not allowed. The spatial expanse of the used power supply circuit must be less than 30m.

### Requirements for the supplying mains

The supplied alternating current mains may have a maximum overvoltage category 2 according to EN 61010-2-201, NFPA environment UL60101-2-201: 1st Edition 2014.

### EMC

Immunity according to EN 61000-6-2:2005, Table 3, Table 3 – Interference immunity – direct current network inputs and outputs.

Conducted interference emission is not defined for direct current supply according to EN 61000-6-4:2007+A1:2011. If the limits of the 61000-6-4: 2007+A1:2011, Table 2 (Emission – Low voltage AC mains port) are applied, an appropriate filter must be connected upstream.

Without filters, these limits are exceeded by up to 12dB $\mu$ V in the range of 150KHz ... 4.6MHz.

The limits can be maintained with an upstream B84112-B-B110 filter, for example, from the company EPCOS. The cable length between ATD4xxW and the filter must be kept as short as possible, less than 0.5m. The filter and the ATD4xxW need to be electrically connected over a common flat metallic structure.

### 7.5.2 Installation

A miniature circuit breaker (type SIEMENS: 5SY4108-7 or 5SY4108-7KK11) is mandatory at a direct voltage supply by the customer (for example SITOP PSU300S 20A).

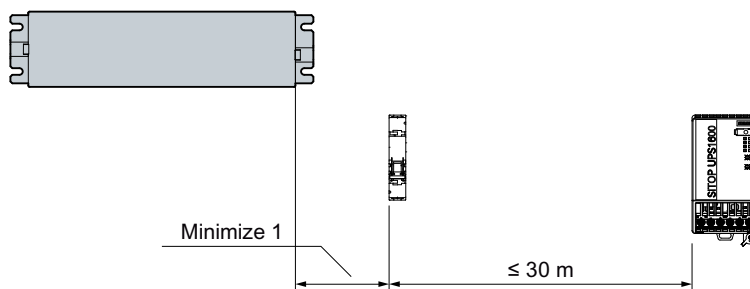

<sup>1</sup> Install the miniature circuit breaker in the vicinity of the SIDOOR controller (similar ambient air temperature).

## 7.6 Uninterruptible power supply (UPS)

### Overview

The SIDOOR drive system can be supplied with an uninterruptible power supply (UPS) for a certain period of time. The criteria on the design of the UPS described below must be taken into account here.

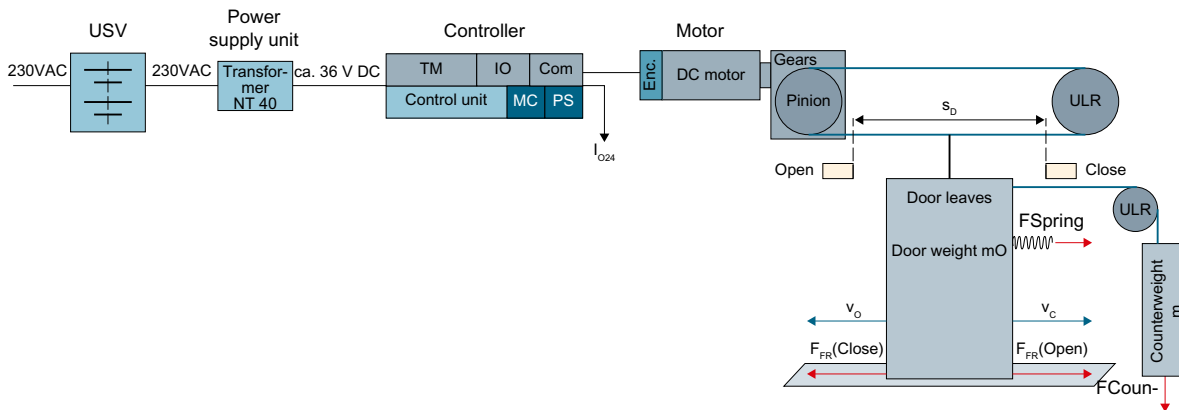

Figure 7-10 SIDOOR system block diagram

In the observation, three main criteria need to be considered:

1. The peak power of the UPS (for approx. 3 seconds) should be  $\geq 600$  W.
2. With the use of the transformer, the UPS must be designed as an online double converter. Classification: VFI (according to IEC 62040-3)
3. The energy storage of the UPS must be adapted to the entire drive system and the time to be bridged.

### Energy requirements

The entire energy requirements are derived from the following three physical effects:

- Energy requirements of the control unit  $\rightarrow W_{AT}$   
Quiescent current consumption of the control unit over the time to be bridged
- Energy requirements due to holding powers  $\rightarrow W_{HOLD}$   
Current consumption due to continuous torques
- Energy requirements due to door movement  $W_{MOVE}$   
Current consumption during traversing due to system friction and acceleration of the door leaves

The energy to be stored by the UPS is therefore derived as follows:

$$W_{AKKU} := W_{AT} + W_{HOLD} + W_{MOVE}$$

## 7.6 Uninterruptible power supply (UPS)

The corresponding mathematical equations of these terms are as follows:

Energy requirements of the control unit	$W_{AT} := \frac{4W + 24V \cdot I_{O24}}{0.4} \cdot (T_{STBY} + T_{HO} + T_{HC})$
Energy requirements of the holding powers	$W_{HOLD} := \frac{1 \cdot W}{140 \cdot N^2} \cdot (F_{HO}^2 \cdot T_{HO} + F_{HC}^2 \cdot T_{HC})$
Energy requirements of the door movement	$W_{MOVE} := 4.1N_C \cdot [0.5m_D \cdot (v_O^2 + v_C^2) + 2F_{FR} \cdot s_D]$
Energy requirements of the UPS ACCU	$W_{AKKU} := W_{AT} + W_{HOLD} + W_{MOVE}$

## Definitions of tags

Tag	Unit	Definition
$F_{FR}$	N	Friction force door
$F_{HC}$	N	Holding power door closed
$F_{HO}$	N	Holding power door open
$I_{O24}$	A	Current consumption 24 V external
$m_D$	kg	Weight to be moved
$N_C$	–	Number of OPEN/CLOSED cycles
$s_D$	m	Distance door leaves
$T_{HC}$	s	Holding time CLOSED
$T_{HO}$	s	Holding time OPEN
$T_{STBY}$	s	Standstill time without holding power
$v_C$	m/s	Closing speed
$v_O$	m/s	Opening speed

## Recommendations on UPS data

Output voltage	230V ± 10%
Output frequency	47 ... 53 Hz
Output power	> 600 W
Wave type	Sine
Current voltage distortion	< 5% at full load
Classification (according to IEC 62040-3)	VFI



## Example calculation for an M3 motor

Input data			Calculation
Tag	Value	Definition	
$F_{FR}$	80 N	Door friction without counterweight	$W_{AT} := \frac{4W + 24V \cdot I_{O24}}{0.4} \cdot (T_{STBY} + T_{HO} + T_{HC})$
$F_{HC}$	60 N	Holding time CLOSED	$W_{AT} = 5.6 \cdot 10^3 \text{ J}$
$F_{HO}$	70 N	Holding power OPEN	
$I_{O24}$	0.1 A	External power supply 24 V	$W_{HOLD} := \frac{1 \cdot W}{140 \cdot N^2} \cdot (F_{HO}^2 \cdot T_{HO} + F_{HC}^2 \cdot T_{HC})$
$m_D$	180 kg	Weight to be moved, total	$W_{HOLD} = 1 \cdot 10^3 \text{ J}$
$N_C$	5	Cycles OPEN/CLOSED	
$s_D$	0.8 m	Door width, 1 leaf in meters	$W_{MOVE} := 4.1N_C \cdot [0.5m_D \cdot (v_O^2 + v_C^2) + 2F_{FR} \cdot s_D]$
$T_{HC}$	20 s	Hold time closed	$W_{MOVE} = 3 \cdot 10^3 \text{ J}$
$T_{HO}$	20 s	Hold time open	
$T_{STBY}$	310 s	Standstill time without holding power	$W_{USV} := W_{AT} + W_{HOLD} + W_{MOVE}$
$v_C$	0.3 m/s	Closing speed	$W_{USV} = 1 \cdot 10^4 \text{ J}$

A UPS with 600 W and a bridging time of 10 minutes makes approx. 30,000 J available.



## Optional additional units

### 8.1 SIDOOR SERVICE TOOL

#### 8.1.1 Description

##### Overview

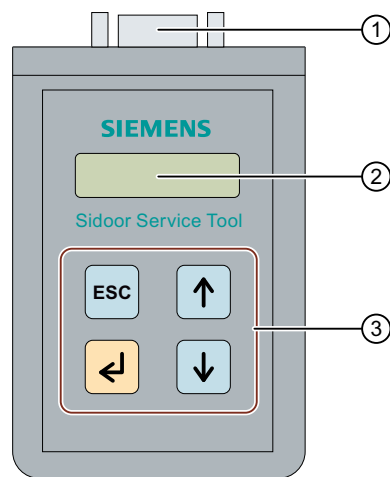

- ① Connection plug to connect the SIDOOR SERVICE TOOL to the control unit
- ② Display
- ③ Control keys

---

#### Note

The terminal module function is also available via the SIDOOR SERVICE TOOL, the SIDOOR SOFTWARE KIT and the SIDOOR SUPPORT app.

---

#### 8.1.2 Connection

Connection of the SIDOOR SERVICE TOOL is effected with the associated cable to the plug-in connector **X8** of the controller.

---

#### Note

The cover of the controller does not have to be removed to connect the SIDOOR SERVICE TOOL.

---

 <b>CAUTION</b>
<b>Material damage</b>
For this reason, only connect suitable SIDOOR accessories.

### 8.1.3 Operation





Parameters can be changed in both of the following menus:

- MAIN MENU > Quick setup > Parameter setting
- MAIN MENU > General setup > Profile parameters







**Note**

If the SIDOOR SERVICE TOOL is in the "Quick setup" or "General setup" menu, the door commands of the controller are blocked by the command inputs of the terminal strip X6.

### Key functions

Key	Description	Function
	Enter key	Jump to next menu below
	Escape key	Jump back to menu above
	Menu selection key	Increases a parameter value
	Menu selection key	Decreases a parameter value

### Operating principle

Action	Key	Remarks
1   Select required parameter	 	
2   Activate parameter for setting using the Return key		Parameter value flashes
3   Increase or decrease parameter value	 	
4   Accept parameter value by pressing Return key again		Displayed parameter value stops flashing after acceptance.

Action	Key	Remarks
5	-	
<ul style="list-style-type: none"> <li>• Select the next parameter (Step 1) or</li> <li>• Exit the menu</li> </ul>		

**Note**

Parameter changes are accepted with the door at a complete stop or in the OPEN or CLOSED position.

 <b>WARNING</b>
<p><b>Risk of injury due to moving mechanical parts</b></p> <p>The permissible energies, forces and safety-related functions such as light barriers, emergency stop or two-hand operation must be checked by the service personnel after changing the parameters on the door in the overall system.</p>

**Menu navigation**

The menu-based operation of the SIDOOR SERVICE TOOL is described in the section Navigation structure SIDOOR SERVICE TOOL (Page 268).

### 8.1.4 Navigation structure

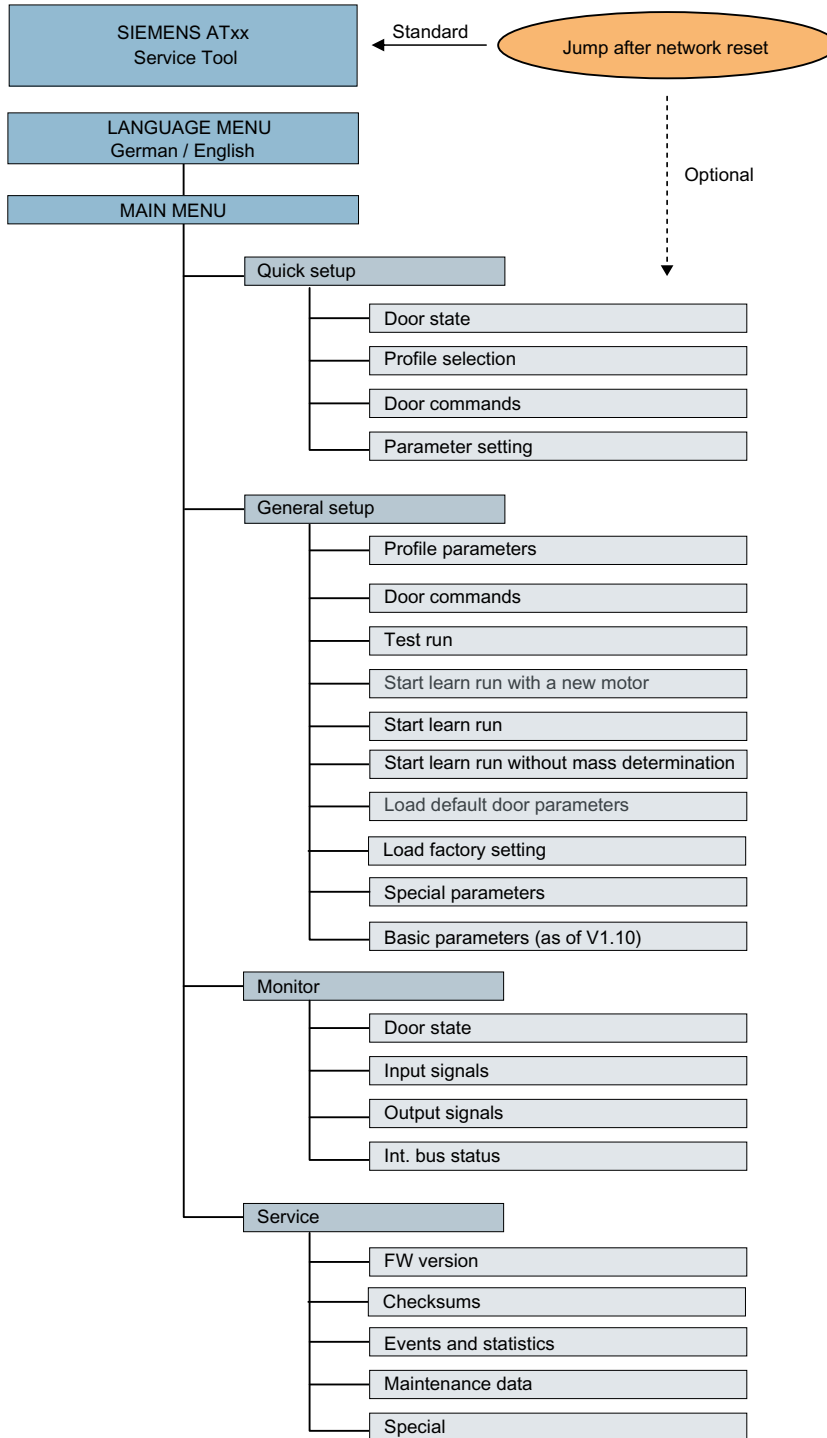

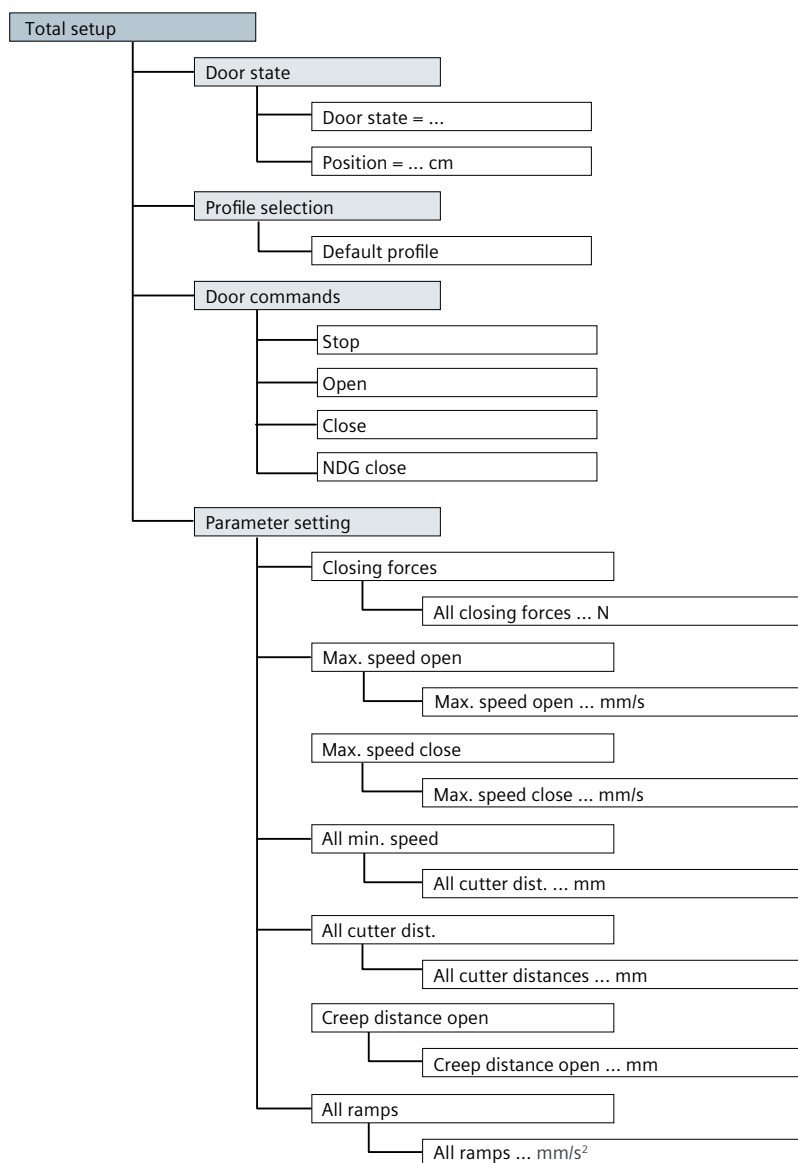

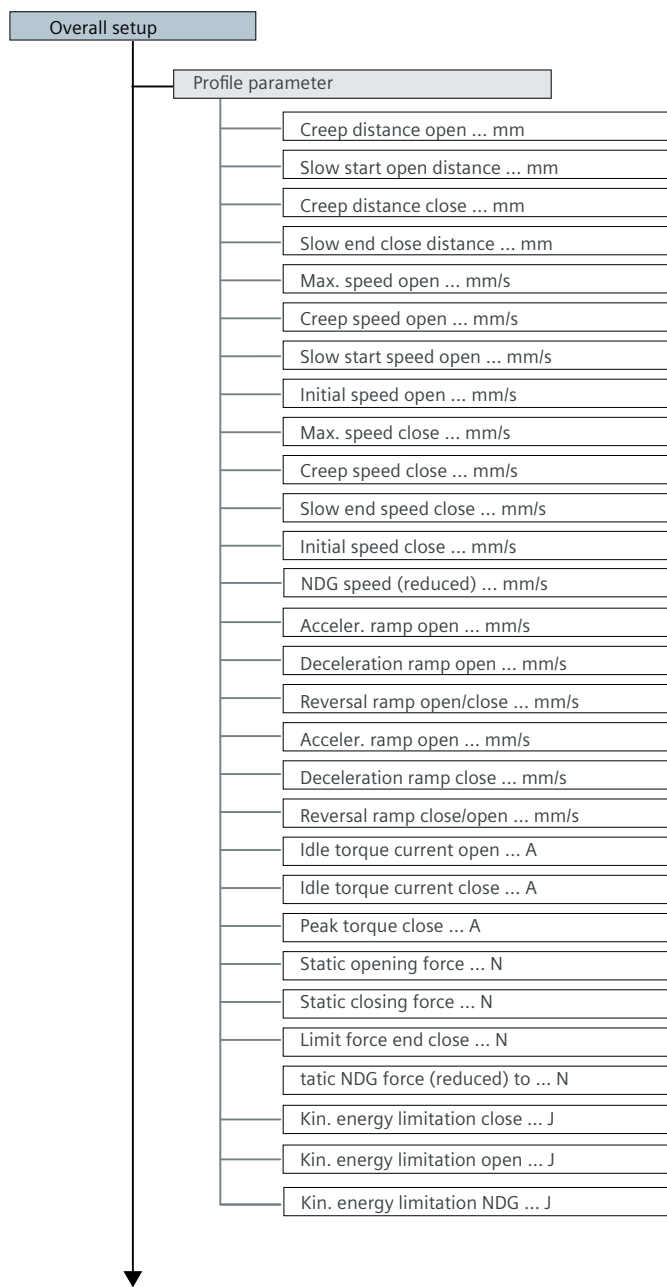

Continue to next page



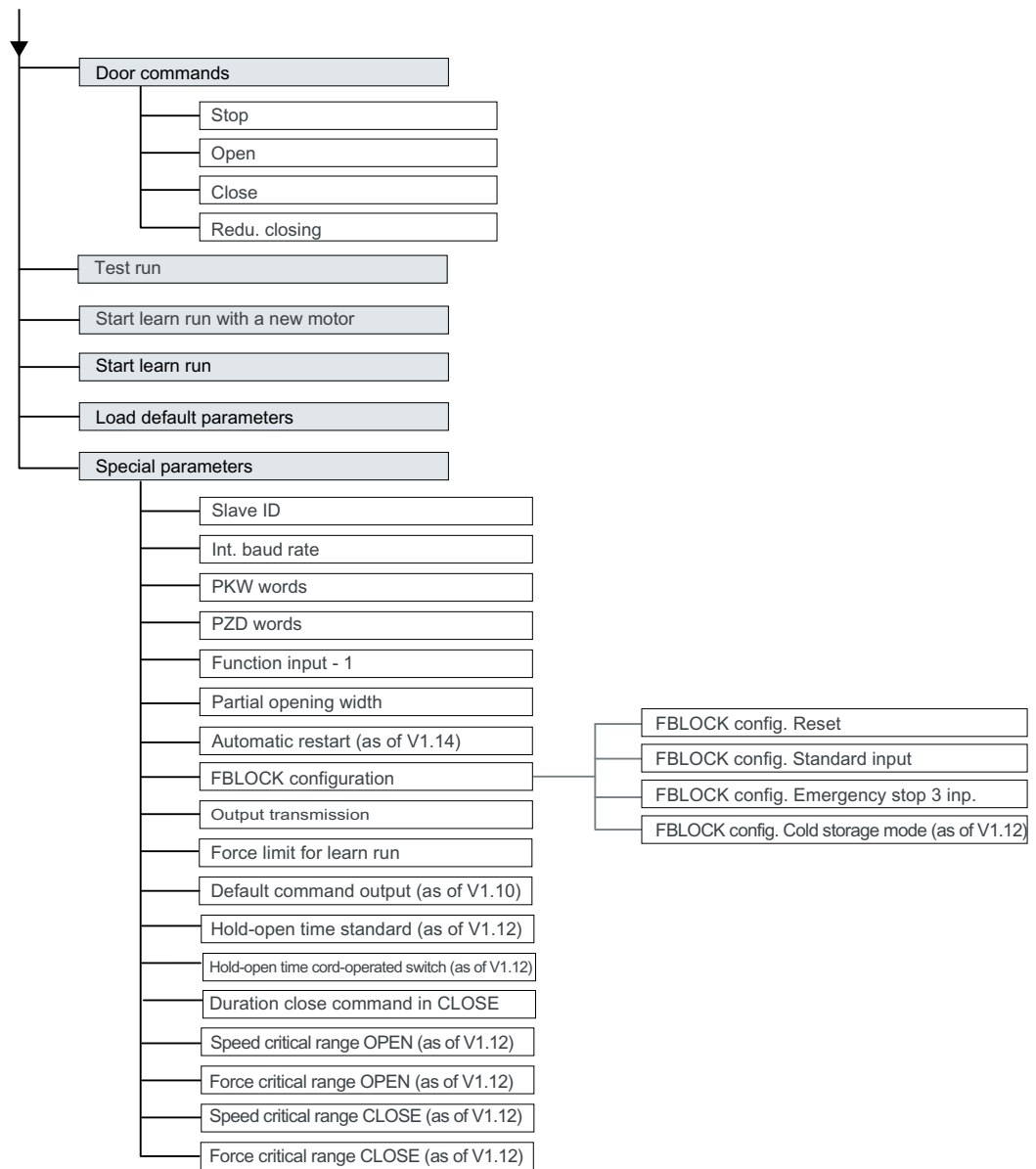

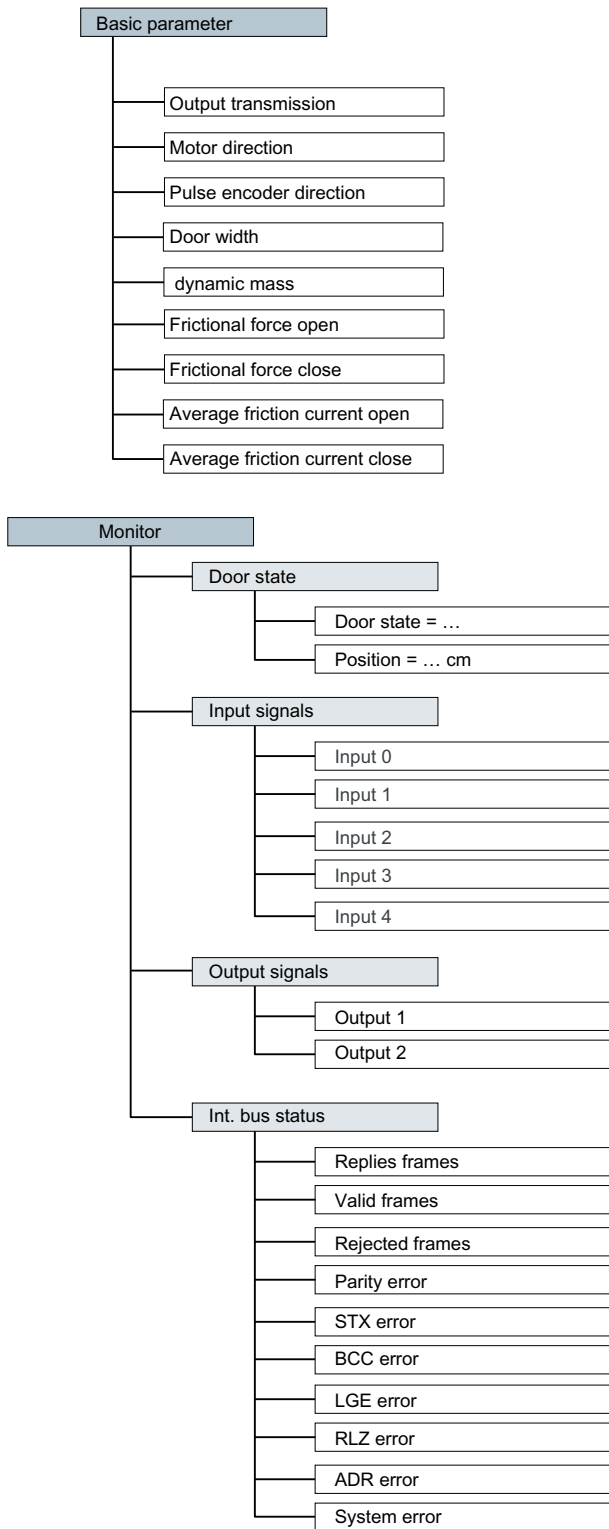

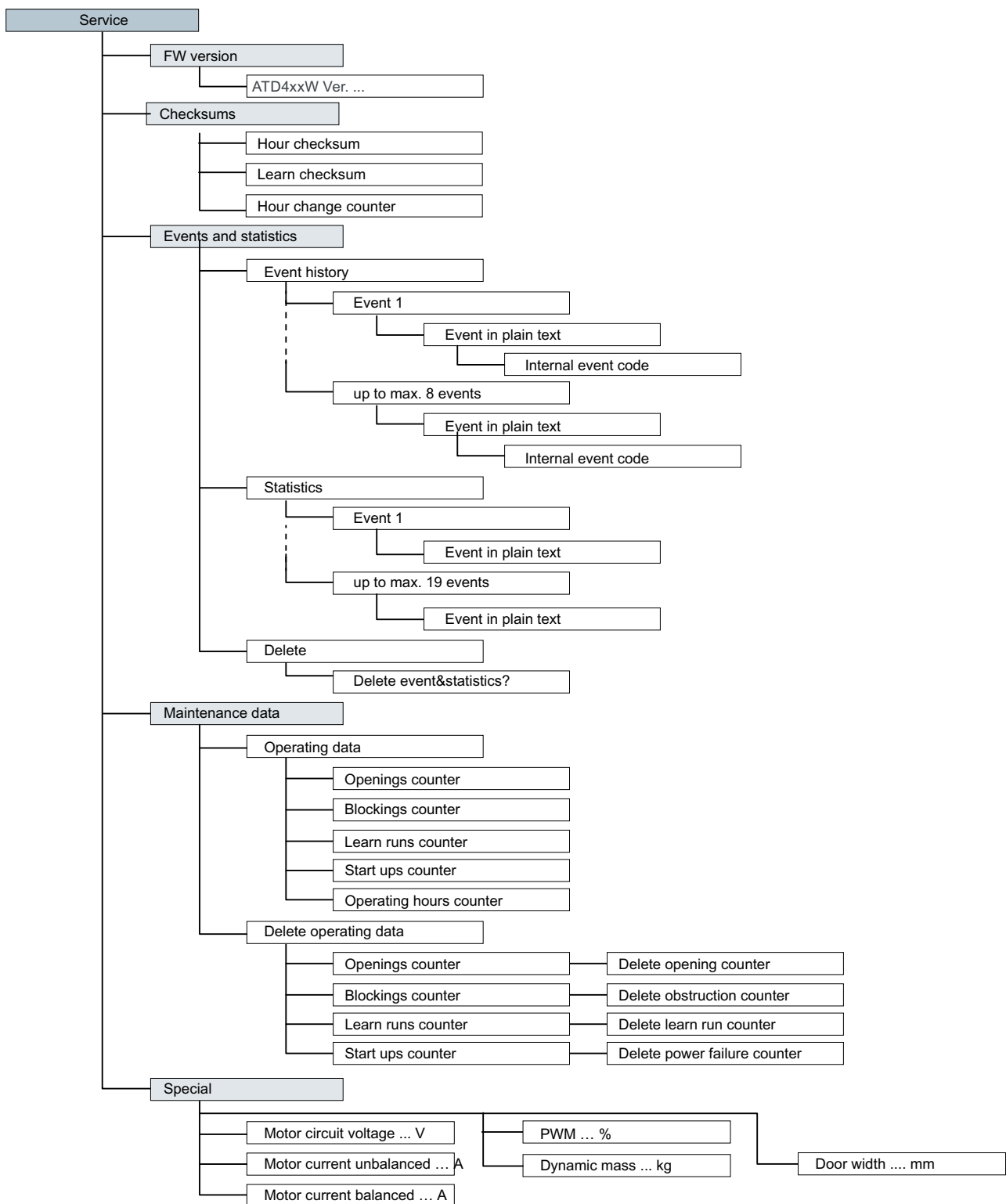

### 8.1.5 Technical specifications

Article number	6FB1105-0AT01-6ST0	
Product brand name	SIDOOR	
Product designation	SIDOOR SERVICE TOOL	
Design of the product	Diagnostic and parameterization tool	
Wire length of the connecting cable	m	2
Width	mm	65
Height	mm	100
Depth	mm	25

## 8.2 SIDOOR LINK and SIDOOR SUPPORT App

### 8.2.1 Description

The SIDOOR LINK and the SIDOOR SUPPORT app are used for convenient commissioning of a door system with SIDOOR control unit.



- ① LED status display of SIDOOR LINK
- ② Connection plug for connecting the SIDOOR LINK to the SIDOOR control unit.

## 8.2.2 Connecting

1. Connect the SIDOOR LINK to plug connector X8 of the SIDOOR control unit using the corresponding cable.
2. Install the SIDOOR SUPPORT app on the Android smartphone/tablet (min. Android version 11.0 with Bluetooth LE 5.0).

### NOTICE

#### Material damage

Connect the SIDOOR LINK to the X8 plug of the SIDOOR control unit using only the cable supplied.

## 8.2.3 Operating the SIDOOR SUPPORT app

### Requirements

The following requirements must be met in order to use all functions of the SIDOOR SUPPORT app:

- You have assigned a 4-digit PIN during initial commissioning.
- You have registered the serial number of the SIDOOR LINK in the SIDOOR SUPPORT app.

### Procedure

1. Start the SIDOOR SUPPORT app.  
A list with all accessible SIDOOR LINK adapters appears in the SIDOOR SUPPORT app.
2. Select a SIDOOR LINK adapter.  
A Bluetooth connection is then established between the Android smartphone / tablet and SIDOOR LINK.

### Functions

The SIDOOR SUPPORT app offers the following functions:

Function	Description
Displaying, saving and comparing service data	<ul style="list-style-type: none"> <li>• Operating hours</li> <li>• Openings</li> <li>• Learn runs</li> <li>• Power failures</li> <li>• Obstructions</li> <li>• Driving curve parameters</li> </ul>
Display of the SIDOOR status (7-segment display)	with detailed explanations
Emulation of the Service Tool function	See SIDOOR SERVICE TOOL (Page 265)

Function	Description
Configuration of the SIDOOR control unit	<ul style="list-style-type: none"> <li>• Configuration of the driving profile</li> <li>• Exporting and importing driving profile parameters</li> <li>• Importing and exporting of maintenance data</li> <li>• Definition of parameter favorites</li> </ul>
Command output to the SIDOOR control unit	<ul style="list-style-type: none"> <li>• Drive commands: Open, Close, Stop, Deenergize</li> <li>• Start of the learn run with new motor</li> <li>• Start of the learn run without weight determination</li> <li>• Restore factory settings</li> <li>• Activate test run</li> <li>• Loading parameter default values</li> </ul>
SIDOOR Firmware Update	<ul style="list-style-type: none"> <li>• Save the SIDOOR firmware on the SIDOOR LINK</li> <li>• Update the SIDOOR control unit with the saved SIDOOR firmware on the SIDOOR LINK.</li> </ul>

**Note**

**Detailed description of functions**

For a detailed description of the SIDOOR SUPPORT app functions, see SIDOOR SUPPORT App Function Manual (<https://support.industry.siemens.com/cs/de/de/view/109802679/en>), A5E51332023.

**Note**

**Input of door commands via digital inputs blocked**

If you control the SIDOOR control unit via the SIDOOR SUPPORT app, the transmission of door commands via the digital inputs of the X6 terminal strip is blocked.

## 8.2.4 Start page of the SIDOOR SUPPORT app

The home page of the app opens as soon as there is a Bluetooth connection to the SIDOOR LINK.

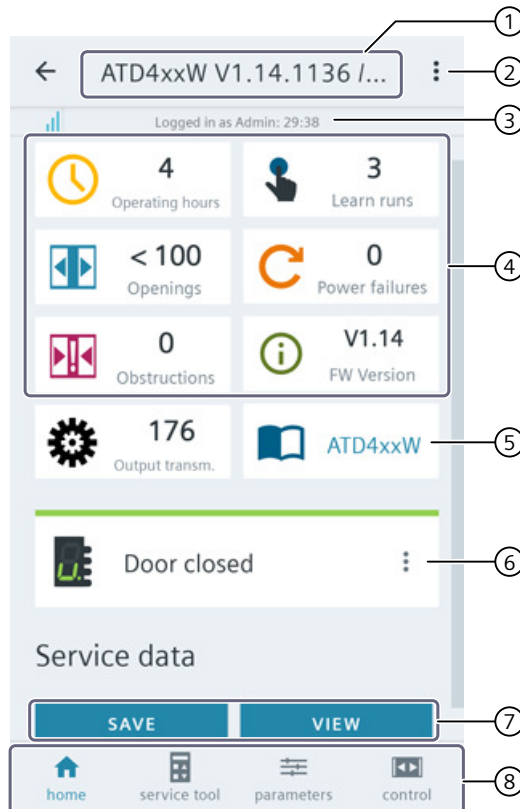

- ① Name and firmware version of the SIDOOR control unit
- ② 3-point menu, for main function and tab
- ③ Login information
- ④ Current operating data
- ⑤ Link to system manual
- ⑥ 7-segment display with operating status of the control unit;
  - the last messages are called up via the 3 dots.
  - If error message occurs, the √ icon appears, via which the message is displayed in detail with an additional description of the possible cause of the error
- ⑦ Buttons to save the service data in a file and to open files with saved service data
- ⑧ Navigation bar with the main functions of the app

## 8.2.5 Technical specifications

<b>Article number</b>	<b>6FB1305-0AT00-0AS4</b>
<b>General information</b>	
Product brand name	SIDOOR
Product type designation	LINK
Product version	Android APP SIDOOR APP user, SIDOOR LINK with Bluetooth 5.0
<b>Product function</b>	
• Oscilloscope function	No
<b>Installation type/mounting</b>	
Mounting type	temporary insertion to the X8 service connector of the door controller via the supplied cable
<b>Supply voltage</b>	
Rated value (DC)	36 V; directly supplied from X8 connection from the command device
<b>Input current</b>	
Current consumption, max.	20 mA
<b>Interfaces</b>	
Interfaces/bus type	Bluetooth 5.0
<b>Standards, approvals, certificates</b>	
CE mark	Yes
EAC (formerly Gost-R)	Yes
China RoHS compliance	Yes
<b>Ambient conditions</b>	
<b>Ambient temperature during operation</b>	
• min.	0 °C
• max.	45 °C
<b>Cables</b>	
Cable length	
• of the connection cable	2 m
<b>Dimensions</b>	
Width	95 mm
Height	24 mm
Depth	42 mm



# Configuration and Programming in STEP 7 / via TIA Portal

# 9

## Configuration

The configuration of the control unit ATD420W on PROFIBUS or ATD430W on PROFINET is made via certified GSD files. This ensures compatibility with different industrial automation systems.

Before configuring, you must import the relevant GSD file into the configuration tool, for example STEP 7.

## Programming

A function block is provided for quick and easy connection of an SIDOOR drive to a SIMATIC controller via PROFIBUS or PROFINET communication.

## 9.1 PROFINET integration via GSD file

Install the GSD file (see GSD files (<https://support.industry.siemens.com/cs/ww/en/view/103949094>)) in the applicable configuration tool before configuring the SIDOOR ATD430W PROFINET controller.

After installation, you will find the ATD430W controller under the following category:

"PROFINET IO > Drives > SIDOOR"

---

### Note

#### Configuration notes

- Modify the Ethernet or PROFINET settings according to the applicable system.
  - Make sure that the I/O addresses start at the same value.
  - When the system is configured, the device parameters are assigned the following default values specified by the GSD:  
Cycle time [ms]: "100"
- 

You can find additional information on the supported PROFINET functions and protocols in the PROFINET module (Page 143) and PROFINET communication (Page 151) sections.

## 9.2 PROFIBUS integration via GSD file

Install the GSD file (see Industry Online Support (<https://support.industry.siemens.com/cs/ww/en/view/99008084>)) in the applicable configuration tool before configuring the SIDOOR ATD420W PROFIBUS controller.

After installation, you will find the ATD420W controller under the following category:

"PROFIBUS DP > Further field devices > Drives > SIDOOR"

**Note**

When configuring the device, ensure that the input and output addresses both start with the same value.

When the system is configured, the device parameters are automatically assigned the following default values specified by the GSD.

- Data exchange: "Enabled"
- Baud rate: "115200"
- Slave address: "0"
- Frame type: "Standard telegram"
- Cycle time [ms]: "100"

You can find additional information in the section PROFIBUS module (Page 133).

### 9.3 Programming SIDOOR instructions

PROFINET or PROFIBUS SIDOOR controllers are configured via certified GSD files. This ensures compatibility with different industrial automation systems. A function block is provided for fast and simple interfacing of a SIDOOR drive to a SIMATIC. This function block was implemented for PROFIBUS or PROFINET communication and for various SIMATIC families. The blocks always operate in accordance with the principle described below.

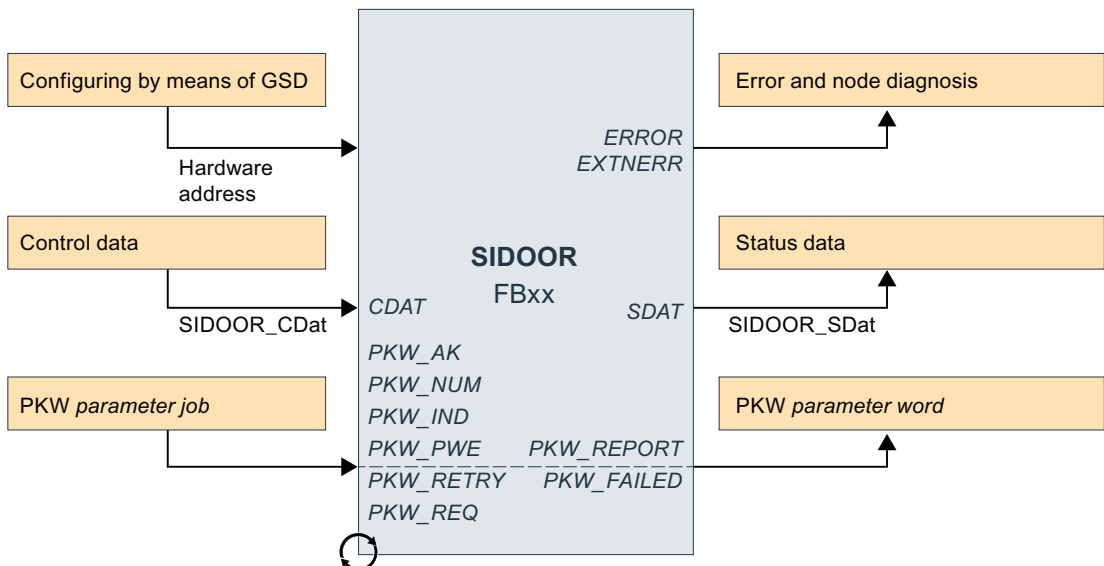

Figure 9-1 SIDOOR function block

The SIDOOR function block handles the data processing of exactly one SIDOOR controller. Therefore the block has to be called with a data instance for each SIDOOR bus node. There

are no restrictions on the call cycle of the SIDOOR function block. A cycle time of >10 ms is recommended to make optimal use of the resources.

The selected SIDOOR bus node is localized by specifying a hardware address ID. Every time the function block is called, the control data is transferred to the controller according to the "SIDOOR\_CDat" structure. Additionally, the current status data is updated in accordance with the "SIDOOR\_SDat" structure. The availability of the SIDOOR bus node is also checked, and the node diagnostics data is updated. A parameter job is acyclic, and is processed during the course of several call cycles of the SIDOOR function block. The block returns the result and the status of the parameter job. The block number can be changed.

## Response to errors

If communication and/or the block is interrupted ( $\text{ERROR} \neq 0000_{\text{hex}}$ ), the response is as follows:

- No parameter job is accepted.
- The states of the output parameters PKW\_REPORT and PKW\_FAILED remain unchanged.
- All control data (CDAT) is rejected.
- All elements of the SDAT status data structure are set to 0.

## Parameter channel (PKW)

The parameter channel is only used actively when a parameter job mapped by the parameters PKW\_NUM, PKW\_IND, PKW\_PWE and PKW\_RETRY is started by a positive edge on PKW\_REQ. Therefore, all "PKW" parameters can be set to "0" if the parameter channel is inactive or will not be used.

On a positive edge of PKW\_REQ, a parameter job is copied into the internal job buffer, and the evaluation is started. PKW\_REQ is automatically reset after the job has been executed or terminated by an error. An active job is canceled by resetting PKW\_REQ. The job is canceled automatically if a diagnostic or communication error occurs during processing. A job is not evaluated as error-free until the empty job has been sent automatically in the last step and correspondingly answered.

---

### Note

After a job has finished, the parameter channel is automatically reset by an empty job. This need not be done by the user.

---

The function block can be called at any cyclic frequency. Please note, however, that the parameter channel is processed step-by-step. Each block call executes precisely one step in the processing of the parameter job.

1. Check parameter job data and start job
2. Wait for a response from the addressed node
3. Evaluate the response, and enable the job interface with an empty job

The number of wait steps is limited by the input parameter PKW\_RETRY, and depends directly on the call cycle. Depending on the job, the SIDOOR ATD430W controller requires at least 30 ms to process a parameter job (including response).

### 9.3.1 "SIDOOR\_CDat" data type

The "SIDOOR\_CDat" data type maps the structure of the control words (master → slave). These are identical for the process image in the case of PROFIBUS and PROFINET. The terminal block assignments are specified in Process data (Page 311). The data type is used for all S7 systems in SIMATIC Manager and TIA Portal.

Table 9-1 "SIDOOR\_CDat" UDT

Name	Data type	Description	See also
CtrlW	WORD	Control word (STW1)	Table A-13 Control word 1 (STW1) (Page 312)
DCMD	BYTE	Door commands / drive orders	Table A-16 DCMD signal (Page 313)
DCMDExten	BYTE	Extension/modification of door commands	Table A-17 DCMD expansion bits (Page 314)
DESTPOS	WORD	Target position in positioning mode	Table A-19 DESTPOS signal (Page 315)
SBIT	BIT	The control bits SBit0 to 4 can be linked as input signals to the FBLOCK logic. See the section Free function blocks (FBLOCK) (Page 86)	Control bits (as of V1.10) (Page 315)

### 9.3.2 "SIDOOR\_SDat" data type

The "SIDOOR\_SDat" data type maps the structure of the control words (slave → master). These are identical for the process image in the case of PROFIBUS and PROFINET. The terminal block assignments are specified in Process data (Page 311). The data type is used for all S7 systems in SIMATIC Manager and TIA Portal.

Table 9-2 UDT "AT\_SDat"

Name	Data type	Description	See also
StatW	WORD	Status word (ZSW1)	Table A-21 Status word 1 (ZSW1) (Page 315)
DPos	BYTE	Percentage door position	Table A-28 DPOS signal (Page 318)
DBlock	BYTE	Obstruction detection	Table A-26 DBLOCK signal (Page 318)
DBlcWait	BOOL	Wait obstruction mode	Table A-27 DBLCWAIT signal (Page 318)
ASDrv	BOOL	(Basic signal) AssistedDrive	Table A-32 ASDRV signal (Page 320)
ASStp	BOOL	(Basic signal) ImpulseStop	Table A-33 ASStp signal (Page 320)
DTErrAND2	BOOL	Discrepancy error at AND2 (as of firmware V1.12)	AND2 (Page 321)
DTErrAND0	BOOL	Discrepancy error at AND0 (as of firmware V1.12)	AND0 (Page 320)

Name	Data type	Description	See also
DMode	BYTE	Door mode	Table A-25 DMODE signal (Page 317)
DStat	BYTE	Door state	Table A-24 DSTAT signal (Page 317)
ImpDrv_s	BYTE	ImpulseDrive (distance-based)	Table A-30 IMPDRVIncr signal (Page 319)
ImpDrv_v	BYTE	ImpulseDrive (speed-based)	Table A-31 IMPDRVVelo signal (Page 319)
DIn	BYTE	Digital inputs	D_IN (Page 322)
DOut	BYTE	Digital outputs	D_OUT (Page 322)
PB	BYTE	Function button	Button (Page 323)



## Connecting and commissioning

### 10.1 Overview of safety and commissioning

 <b>WARNING</b>
<b>Dangerous electrical voltage!</b> When electrical devices are used, certain parts of them have to carry dangerous voltages. Failure to observe the operating instructions can therefore lead to serious injuries or material damage. Observe the operating instructions.

 <b>WARNING</b>
<b>Risk of injury during commissioning</b> <ul style="list-style-type: none"><li>• The door movements cannot always be externally controlled while the control unit is being commissioned (in particular during the automatic determination of parameters). The light barrier is not active during the learn run.</li><li>• During the learn run, the force is <math>&gt; 75 \text{ N}</math> and the energy <math>&gt; 4 \text{ J}</math>.</li></ul> An authorized person must therefore be posted near the door to ensure that no one else can enter the vicinity of the door during commissioning.

 <b>WARNING</b>
<b>Verification of safety-relevant functions</b> The SIDOOR control unit is only a subsystem (incomplete machine). In general, the correct parameter assignment of the SIDOOR control unit and the effectiveness of the safety-relevant functions must be checked at regular intervals by testing the safety-relevant functions during commissioning and depending on the application.

---

**Note**

The motor temperature must not be below  $0^{\circ}\text{C}$  during the learn run, as otherwise the mass to be moved will be incorrectly determined, and the opening and closing speed may lie in an impermissible range.

---

### Working on the door drive

 <b>WARNING</b>
<b>Risk of injury due to dangerous electrical voltages and moving mechanical parts.</b> Disconnect the door drive by unplugging the power plug from the power supply before you start work on the door drive.

 <b>WARNING</b>
<b>Risk of injury due to moving mechanical parts</b> If power-operated guards are used, ensure that they have been tested prior to initial commissioning. Power-operated guards must also be tested annually.

 <b>CAUTION</b>
<b>Risk of injury due to moving mechanical parts</b> Depending on the safety requirements of the door system to be operated, an additional protective device has to be provided as protection equipment (e.g. mechanical interlock of the door) for the case of unexpected door movement or failure of the door control unit. This protection equipment has to operate independently of the SIDOOR door control unit.

### Parameter assignment and configuration

 <b>WARNING</b>
<b>Risk of injury and material damage due to excessive force of the door</b> Exceeding the maximum static closing force or the opening force in some cases may lead to injuries to persons or damage to the door drive and mechanical components of the door. After commissioning, have the maximum static force checked by the service personnel, and adjusted to the limit value if it is excessive. Note the limits of the applicable standard and adjust the setting accordingly.

 <b>WARNING</b>
<b>Weight to be moved determined with the learn run</b> Depending on the mechanical coupling between the motor and door panel, the weight to be moved determined during the learn run can differ from the actual weight to be moved. The weight to be moved determined during the learn run must be checked and, if necessary, corrected via the basic parameter editor (from V1.10).



** WARNING****Change to basic parameters**

There is no plausibility check of the basic parameters by the control unit when basic parameters are changed. Incorrect parameter assignment may result in undesirable travel behavior of the door. After changing the basic parameters, the drive curve parameters must be checked and adjusted if necessary (as of V1.10).

** WARNING****Verify parameters**

In the case of parameter assignment via the SIDOOR SOFTWARE KIT or via the fieldbus PKW interface, parameter values must be read back and verified after modification.

** WARNING****Access protection to the control units/parameters**

Access to the control unit and the parameter assignment of the control unit must be protected against unauthorized access. Appropriate measures must be taken for specific applications, e.g. installation in a closed control cabinet, to ensure access only by authorized personnel.

**Note****ATD420W / ATD430W Access protection to the parameters**

The write protection for the SIDOOR ATD420W and ATD430W control units must generally be activated by using parameter p90. This way the change of parameters is blocked via the service menu.

**Note****ATD420W / ATD430W Detecting parameter changes**

The checksums of the parameters for control units SIDOOR ATD420W und ATD430W have to be monitored cyclically through a higher-level control. This way changes to parameters can be detected. The checksums of the parameters can be requested via the parameters r200 and r201.

**Note****ATD401W Detecting parameter changes**

For the SIDOOR ATD401W control unit the checksums of the parameters have to be checked as part of the maintenance intervals. This allows changes of parameters to be detected. The checksums of the parameters can be requested via the service menu "Service menu -> Checksums".

**Note****Application-specific measures for emergency operation**

In the event of a control unit failure, measures must be taken for emergency operation according to the application.

---

**Note**

**Vertical mode**

When operating vertical applications, the system must be weight-balanced in every position, e.g. by counterweights or springs.

---

**Modifications to the door drive**



**CAUTION**

**Loss of liability for defects and material damage**

Changes to the door drive lead to the loss of liability for defects and compensation rights, and the correct function of the door drive is no longer guaranteed.

Observe the following rules:

- Do not make any modifications to the door drive (motor, control unit, power supply).
- Never remove the grounding-type (Schuko) plug of the SIDOOR TRANSFORMER and NT40 (e.g. by cutting). IT IS USED FOR THE REQUIRED DISCONNECTION FROM THE MAINS.
- The power supply cord of the power supply (SIDOOR TRANSFORMER, SIDOOR TRANSFORMER UL or SIDOOR NT 40) cannot be replaced. Scrap the power supply if the supply cable is damaged.

**Notes on maintenance**

The SIDOOR system should be included in the maintenance schedule for the system as a whole, and inspected in the course of the maintenance intervals stated in the schedule.

An inspection should cover the following points:

- Visual inspection of the control unit for contamination and damage
- Visual inspection of the motor for dirt and damage
- Visual and mechanical inspection of the mechanical system, in as far as it is part of the SIDOOR elevator system. This includes checking the following components:
- Attachment of the motor holder, deflector pulley and mounting bracket
- Wear on the toothed belt
- Check and remeasure the parameters for the safety-relevant force and energy settings set during commissioning.
- Effectiveness of safety-relevant functions, e.g. light barriers, emergency stop, two-hand operation.

**Overview of commissioning a door drive**

We recommend the following initial commissioning procedure for a door drive:

Table 10-1 Procedure for commissioning a door drive

Step	Procedure	Reference
1	Preparing the control unit	Preparing the control unit (Page 289) section
2	Connecting a geared motor to the control unit	Connecting a geared motor to the control unit (Page 290) section
3	Connect relay outputs of the control unit (optional, only for control units with relay outputs)	Relay module (Page 130) section
4	Connecting the control unit to the fieldbus (optional, only for control units with the corresponding module): <ul style="list-style-type: none"> <li>• PROFIBUS</li> <li>• PROFINET</li> </ul>	<ul style="list-style-type: none"> <li>• PROFIBUS module (Page 133) section</li> <li>• PROFINET (Page 143) section</li> </ul>
5	Connecting the power supply to the network and executing a learn run	Connecting the power supply to the network and executing a learn run (Page 292) section
6	Connecting digital input signals	Digital input signals (Page 293) section
7	Commissioning the control unit on the fieldbus (optional, only for control units with corresponding module)	Commissioning the control unit on the fieldbus (Page 293) section
8	Final settings and checks	Final settings and checks (Page 295) section

## 10.2 Preparing the control unit

### Preparing the control unit for connection and installation

1. Nudge the door into the CLOSED position.
2. Open the housing cover.

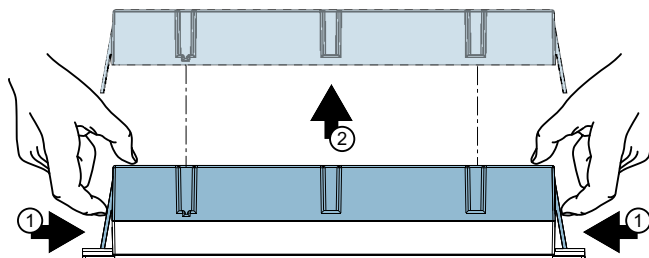

## 10.3 Connecting a geared motor to the control unit

### Connecting a geared motor to the control unit

1. Connect the motor connector with slot X7 on the SIDOOR ATD4xxW control unit

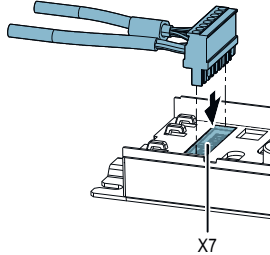

---

#### Note

The X6 control inputs plug is not plugged in during commissioning in order to prevent uncontrolled movements.

---

2. Plug the motor cable connector into the SIDOOR MDG3, MDG4 or MDG5 geared motor.
  - Remove the protective cover from the connection plug of the motor.
  - Plug the round connector of the cable (6FB1104-0AT..-OCB.) into the motor plug socket (6FB1103-0AT1.-.M..). Ensure that the round connector is in the correct position. Turn the round connector so that the outer code rings match the code rings on the plug socket.

- Fasten the round connector in place with screws. Ensure that the round connector is screwed tightly in place to comply with IP56 degree of protection.

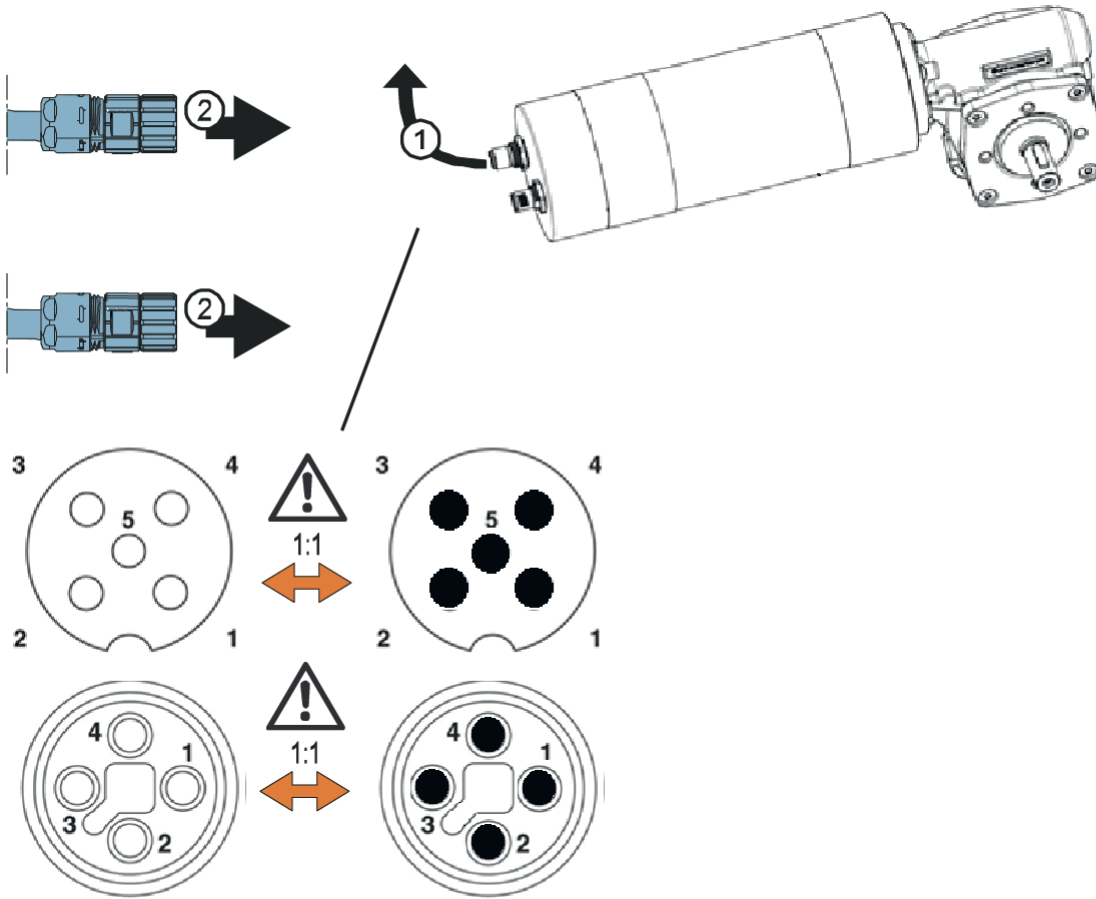

## 10.4 Connecting the power supply to the network and executing a learn run

### Connecting the power supply to the network

1. Connect the power supply to the network.
  - SIDOOR NT40: When the supply is switched on, the device is ready for operation. The green LED lights up.

---

**Note****On-site fuse**

The on-site fuse must not exceed 10 A.

---

**Note**

For all motors, the output transmission must be checked prior to each learn run with SIDOOR ATD4xxW and adjusted if necessary.

---

### Perform a learn run

---

**Note**

Make sure that the entire travel range of the door is free during the learn run.

---

1. Make sure that the door is in the CLOSED position.
2. Press and hold down the learn run button S401.
3. Connect the power supply with slot X3 on the SIDOOR ATD4xxW control unit

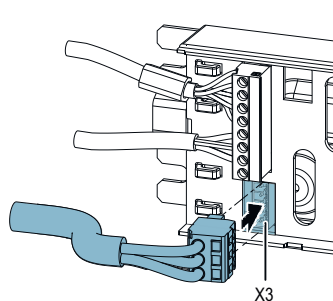

4. Set the default value to 176 mm/rev for the M3, M4 and M5 motors. The output transmission [mm/rev] must be configured for the other MDG3, MDG4 and MDG5 motors (see section Learn run (Page 40)). The learn run buttons S401 on the SIDOOR ATD4xxW must be pressed and held again.
5. The learn run starts automatically, and the learn run button can be released. (See table Starting a learn run when the line voltage is applied (Page 171))

6. The display on the control unit is as follows:
  - The 7-segment display (H401) shows "H.". The decimal point in the 7-segment display (H401) flashes during the save process.  
The 7-segment display (H401) shows "u" when saving has finished. If a light barrier / pressure sensitive edge (SIDOOR ATD4xxW) is used, the 7-segment display (H401) shows "O." because X6 is not connected yet.  
For the M3, M4 and M5 motors, the determined door width is shown on the LCD for the first commissioning or motor adaptation.
  - The LCD display (H1) shows "'H': learn run activated".
7. The door can now be opened with the OPEN button (S402).
  - The 7-segment display (H401) shows "o" while the door is opening.
8. Switch off the control unit by pulling out the power plug or the connector X3.

## 10.5 Connecting digital inputs

### Connecting digital inputs

#### Connecting digital input signals

1. Insert the terminal connectors for the digital control inputs in X6, X5 and X4. See section Digital input signals (Page 126) for more on this.

---

**Note****Risk of injury through moving mechanical parts.**

The controller will be operative after the next switch-on. If a control signal is present, the door will move in the set direction.

---

2. Select the FBLOCK configuration according to the wiring of the input signals via the service menu. See section Digital input signals (Page 126) for more on this.

## 10.6 Commissioning the control unit on the fieldbus

### Introduction

If your controller is equipped with a PROFIBUS or PROFINET module, you can operate the controller at the respective fieldbus with a higher-level controller.

The following procedure describes how to commission a SIDOOR control unit on the respective fieldbus.

## Commissioning the control unit on PROFIBUS

We recommend the following initial commissioning procedure for a control unit as DP slave on PROFIBUS DP:

Table 10-2 Procedure for commissioning the control unit as a DP slave on PROFIBUS DP

Step	Procedure	See...
1	Commission the control unit without a fieldbus connection as described in the previous sections.	Sections Preparing the control unit (Page 289) to Connecting digital inputs (Page 293)
2	Configure the DP master (including PROFIBUS address)	Documentation of the DP master
3	Switch on supply voltage for DP master	Documentation of the DP master
4	Switch on supply voltage for control unit (DP slave)	Connecting the power supply to the network and executing a learn run (Page 292) section
5	Load the configuration in the DP master	Online help of the configuration tool, e.g. STEP 7
6	Switch DP master to RUN mode	Documentation of the DP master
7	Controlling LEDs on the control unit	Final settings and checks (Page 295) section

## Commissioning the control unit on PROFINET

We recommend the following initial commissioning procedure for a control unit as IO device on PROFINET IO:

Table 10-3 Procedure for commissioning the control unit as an IO device on PROFINET IO

Step	Procedure	See...
1	Commission the control unit without a fieldbus connection as described in the previous sections.	Sections Preparing the control unit (Page 289) to Connecting digital inputs (Page 293)
2	Configuring an IO controller	Documentation of the IO controller
3	Switch on the supply voltage for IO controller	Documentation of the IO controller
4	Switch on supply voltage for control unit (IO device)	Connecting the power supply to the network and executing a learn run (Page 292) section
5	Load the configuration into the I/O controller	Online help of the configuration tool, e.g. STEP 7
6	Switch I/O controller to RUN mode	Documentation of the IO controller
7	Controlling LEDs on the control unit	Final settings and checks (Page 295) section



## 10.7 Final settings and checks

### Final settings

1. Activate the application-specific relay module functionalities. (Optional, only for controllers with a relay module)  
Proceed as described in the section Relay module (Page 130).
2. Configure the connected sensor type.  
Proceed as described in the section Sensors and external sensor interface module (ATD4xxW) (Page 160).
3. Switch on the controller by connecting the power supply to the controller and to the network.

The four LEDs alongside the plug connector X6 indicate which control signal is currently active. The function of the control signals depends on the selected configuration, or FBLOCK parameter assignment, see section Digital input signals (Page 126), or Free function blocks (FBLOCK) (Page 86). After switching on, the controller is in initial mode until the end positions of the door have been detected or the closed or open position has been signaled via the DCOPS limit switch. In initial mode, the door moves at initial speed. Once the controller has detected the door settings, the subsequent traversing movements proceed at normal speed once again.

### Final checks

Final check of the permissible energies and forces.

#### **WARNING**

##### **Risk of injury due to moving mechanical parts**

Check permissible forces and energies after the door drive has been commissioned in the complete system and adjust them if they exceed their limit values.

Observe the valid applicable standards and directives for the respective application, as well as the following guidelines:

- The drive is suitable for use with power-operated isolating guards in accordance with EN ISO 14120:2015, section 5.2.5.2. Protective devices trigger an automatic reopening of the guard (reversing function).
- Gearing up or down is not allowed on the toothed belt because this would change the kinetic energies or static forces on the door. The door width would then no longer be valid.



**WARNING**

**Risk of injury and material damage due to excessive closing or opening force of the door**

Exceeding the maximum static closing and opening force may lead to personal injuries or damage to the door drive and to mechanical components of the door.

The maximum static closing and opening forces at the closing edge without additional protective equipment must not exceed 150 N!

Under the application of standard EN ISO 14120:2015, section 5.2.5.4, and with the reversing device disabled and without additional protective equipment, the maximum static closing and opening forces must not exceed 75 N.



**WARNING**

All safety functions (e.g. forces, energies, configured safety-related input signals, emergency stop, two-hand control, light grid or pressure-sensitive safety edges) must be verified on commissioning or re-parameterization of the mounted drive.

## Diagnostic and maintenance

### 11.1 Operating state display

Operating states are indicated on the "H401" 7-segment display or the "H1" digital display of the control unit.

The SIDOOR ATD420W / ATD430W control units additionally enable retrieval of status information via the parameter r2100 ("Status code") or, as of firmware version V1.12, via the technology status word TZW3, TZW4 and TZW5 (see section TZW3, TZW4, TZW5 - Technology status words - 3, 4, 5 (Page 321)).

The following operating states are shown:

Display	Meaning
<b>Info</b>	
O <sup>1)</sup>	Light barrier / pressure-sensitive edge interrupted
6	Motor obstructed in the closing direction
c	Obstruction while opening
d	Door remains stationary during initialization run (no OPEN or CLOSE signal present, or door has reached end position)
H	Determination of parameters (learn run)
o	Function OK
u	Door is closed
<b>Fault</b>	
1	RAM, EEPROM or CPU error (system error)
2	Braking chopper defective or overheated.
3	Error in the second shutdown route
4	Motor protection, maximum opening or closing time of 65 s has been exceeded
5	Motor undefined – no learn run carried out with this motor type (If a different motor version is used, the learn run must be repeated at power on as described in these Operating Instructions. See Table 5-28 Starting a learn run when the line voltage is applied (Page 172))
7	Error in pulse generator
8	OSSD (ESPE or pressure sensitive edge) - function test failed
9	Motor overcurrent
E	Motor overvoltage
F	Motor undervoltage
n	Power stage error
L	Current measurement error
t	Belt torn
U	Max. mass to be moved:
<b>Alarm</b>	
4	Automatic extension of the hold-open time (motor protection) or the door is blocked for more than 5 seconds outside the obstruction detection area (p3856, p3857, p3873, p3874) and the motor current was reduced to the nominal motor current.

Display	Meaning
5	New motor type detected - learn run is required
P	Parameter error (error during learn run)
y	Master timeout
_	Controller has no parameters and is waiting for learn run
a	As of V1.12: Discrepancy error occurred with AND0 or AND2 (Discrepancy analysis blocks (Page 93))
<b>Reserve</b>	
b	–
h	–

<sup>1)</sup> See section SIDOOR functions (Page 37)

## 11.2 Fault management

### Faults

Faults are all occurring system errors that require acknowledgment.

You will find a list of faults in the section Operating state display (Page 297).

#### SIDOOR ATD401W

Automatic fault acknowledgment. You can activate the automatic acknowledgment of faults in the service menu via the menu item "General setup -> Special parameters -> Automatic restart".

#### SIDOOR ATD420W / ATD430W

The system responds to faults according to the control unit (see Figure 5-4 Sequential control state graph (Page 157)). After acknowledgment, the control unit automatically triggers a reset after a protection time of 5 s.

#### Fault acknowledgment

The fault acknowledgment can be carried out with one of the following four possibilities:

- Corresponding terminal input prompt
- FBLOCK "Error acknowledgment" <sup>1)</sup>
- Corresponding acknowledgment bit (bit 7) in the STW1 (see section STW1 - control word (CtrlW) (Page 311)) <sup>1)</sup>
- Automatic, through activation of the "Automatic restart" using the service menu (see "Special parameters", chapter 7.4 navigation structure ...) or through logic operation of the FBLOCK signal "Fault" (Q37) with the error acknowledgment (p20119).

<sup>1)</sup> SIDOOR ATD420W / ATD430W

If "FBLOCK + relay" (p100=1) is set in the service menu under "General setup > Special parameters > Std. command input", the relay outputs Open and Close are active if a fault occurs. (See e.g. Table 4-5 (Page 131) in section Relay module)

## Alarms

### Remedying alarms

Display	Solution
4	If possible, the system's drive cycle time should be reduced. Check whether the door oscillates in the end positions. Then possibly increase the continuous pressure torque or leave the door command in the end positions.
5	The new motor type must undergo a learn run. See section Learn run (Page 40).
P / _	It is imperative that a new learn run be performed during ongoing operation.
a	As of V1.12: All inputs of the triggering discrepancy analysis block must be reset/set (Page (Page 93)).
y <sup>1)</sup>	Communication with the master system is interrupted. The alarm is cleared as soon as communication is restored.

<sup>1)</sup> SIDOOR ATD420W / ATD430W

## 11.3 Maintenance

The SIDOOR system should be included in the maintenance schedule for the door system as a whole, and inspected in the course of the maintenance cycles stated in the schedule.

### Note

Recommended maintenance cycles provided in the table below may vary according to the ambient conditions and the stress on the system.

Object	Recommended maintenance interval
DC geared motor	Maintenance-free
SIDOOR control unit	Maintenance-free
Visual inspection of the control unit, the fastening of the motor mount, the pulley and the mounting brackets for dirt, damage and proper installation. In addition, an inspection of the door function is recommended for running or grinding noises.	1 year
The belt tension should be checked	1 year
With mechanical changes of the system, for example, due to maintenance or wear (friction, dirt, engine replacement, belt replacement or modification of the general door mechanism), an inspection is recommended for the commissioning parameters relating to the safety-related settings for forces and energies/velocities.	



## Disposal

### Recycling and disposal



For environmentally-friendly recycling and disposal of your old device, please contact a company certified for the disposal of waste electrical and electronic equipment, and dispose of the old device as prescribed in the respective country of use.





## Appendices

### A.1 Structure of user data/process data

The structure of the user data block in the telegram is independent of the PROFINET/PROFIBUS specification used for data transfer. The structure (contents and structure) of the user/process data largely corresponds to the specifications for the cyclic data exchange of the PROFIBUS "variable-speed drives" profile. This ensures that users can use the same mechanisms to access the process data (= control/status words and setpoints/actual values) and parameters of a device irrespective of whether this is done via PROFIBUS DP or PROFINET IO.

#### Telegram data structure

The user data for cyclic data transfer are subdivided into two areas that can be transferred in every telegram:

- Parameter area (PKW)**  
 The PKW area handles the parameter transfer between two communication partners (for example SIMATIC and SIDOOR). This involves, for example, reading and writing parameter values and reading parameter descriptions. The PKW interface generally contains tasks for operation and display, maintenance and diagnostics.
- Process data area (PZD)**  
 The PZD area consists of signals that are required for automation:
  - Control words and setpoints from the master to the slave
  - Status words and actual values from the slave to the master

The contents of the parameter area and the process data area are defined by the slave drives. You will find additional information about this in the drive documentation.

Report data	Parameter channel (PKW)								Process data channel (PZD)										
Word representation	PKW1	PKW2	PKW3	PKW4					PKWx	PZD1	PZD2	PZD3	PZD4	...	PZD16				
PKW / PZD structure	PWE	IND	PWE1	PWE2					PWEx	STW1 ZSW1	Data	Data	Data	...	Data				
Byte representation	1	2	3	4	5	6	7	8	P	P+1	P+2	P+2	P+4	P+5	P+6	P+7	P+8	...	N

Figure A-1 User data structure

**Length of the PKW and PZD areas**

The lengths of the PKW and PZD areas can be parameterized independently (p2022 (number of PZDs), p2023 (number of PKWs)). The master and slave communication partners have to agree on the lengths of the individual areas.

- **Constant number of user data**  
If telegrams are to be used only with a constant number of user data, the sum of the numbers of PKWs and PZDs must not exceed 126. According to the specification, a maximum of 252 bytes (126 words) of user data are permissible.
- **Variable PKW proportions**  
If telegrams with variable proportions of PKWs are to be used, the parameter for the number of PKWs (p2023) must be set to 127, irrespective of how the parameter for the number of PZDs is parameterized.

You can find additional information on the PKW number can be found in section Parameter value (PWE) (Page 309) and on the PZD number in section Process data (Page 311).

**A.1.1 Parameter interface**

The PROFIBUS "variable-speed drives" profile defines the user data structure with which a master can access slaves.

The area for the parameter channel of the telegram can be used for monitoring and / or changing any parameters in the slave.

The parameter channel can be used to edit and monitor process data (read / write) as described below.

**Parameter channel**

The parameter channel comprises 3 or 4 words according to the channel type.

Parameter channel		
PKE	IND	PWE
1st word	2nd word	3rd and 4th word

- PKE Parameter ID
- IND Parameter index
- PWE Parameter value

Figure A-2 Structure of the parameter channel in the telegram structure

### A.1.1.1 Parameter ID (PKE)

#### Overview

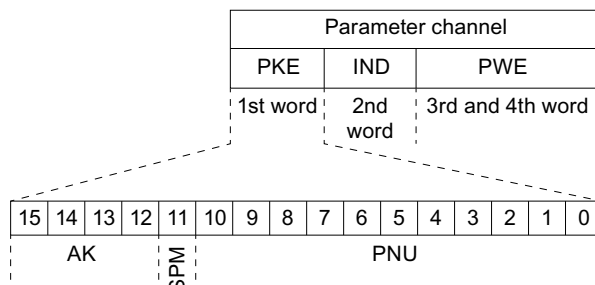

#### Structure

Table A-1 Composition of the parameter ID (PKE)

Area	Bits	Description	Function
PNU	0 ... 10	Parameter number	Contains the rest of the parameter number Value range is defined from 0 to 1999. If parameter numbers $\geq 1999$ are addressed, a parameter page must be selected from the high byte of the IND array (page index). Each parameter page contains 2000 parameter numbers
SPM	11	Spontaneous message	Function currently not supported
AK	12 ... 15	Requirement or response ID	Defines the requirement ID (master $\rightarrow$ slave) and the corresponding response ID (slave $\rightarrow$ master)

#### Requirement ID (AK)

In the following table, the abbreviation "W" is used for word (16 bits) and "DW" for double word (32 bits).

Table A-2 Requirement ID (master  $\rightarrow$  slave)

Requirement ID					Description	Response ID			
Dec.	Bit 15	Bit 14	Bit 13	Bit 12		Positive			Negative
0	0	0	0	0	No PKW order	0	No response	–	7
1	0	0	0	1	Request PWE (parameter value)	1 / 2	Transfer PWE (parameter value)	W, DW	7
2	0	0	1	0	Change PWE (parameter value)	W	Transfer PWE (parameter value)	W	7
3	0	0	1	1	Change PWE (parameter value)	DW	Transfer PWE (parameter value)	DW	7

A.1 Structure of user data/process data

Requirement ID					Description	Response ID				
Dec.	Bit 15	Bit 14	Bit 13	Bit 12		Positive				Negative
4	0	1	0	0	Request PBE (parameter description element) <sup>1)</sup>		3	Transfer PBE element	–	7
5	0	1	0	1	Change PBE (parameter description element) <sup>1)</sup>		3	Transfer PBE element	–	7
6	0	1	1	0	Request PWE (parameter value) <sup>2)</sup>	Array	4 / 5	Transfer PWE (parameter value)	Array, W, DW	7
7	0	1	1	1	Change PWE (parameter value) <sup>2)</sup>	Array, W	4	Transfer PWE (parameter value)	Array, W	7
8	1	0	0	0	Change PWE (parameter value) <sup>2)</sup>	Array, DW	5	Transfer PWE (parameter value)	Array, DW	7
9	1	0	0	1	Request number of array elements	–	6	Transfer number of array elements	–	7
10	1	0	1	0	<i>Reserved</i>	–	–	–	–	7
11	1	0	1	1	<i>Reserved</i>	–	–	–	–	7
12	1	1	0	0	<i>Reserved</i>	–	–	–	–	7
13	1	1	0	1	<i>Reserved</i>	–	–	–	–	7
14	1	1	1	0	<i>Reserved</i>	–	–	–	–	7
15	1	1	1	1	<i>Reserved</i>	–	–	–	–	7

<sup>1)</sup> The element number used is transferred in the IND array subindex.

<sup>2)</sup> The position in the array is stated in the IND array subindex.

Response ID (AK)

Table A-3 Response ID (slave → master)

Response ID					Description	
Dec.	Bit 15	Bit 14	Bit 13	Bit 12		
0	0	0	0	0	No response	
1	0	0	0	1	Transfer PWE (parameter value)	Word
2	0	0	1	0	Transfer PWE (parameter value)	Double word
3	0	0	1	1	Transfer PBE (parameter description element) <sup>1)</sup>	
4	0	1	0	0	Transfer PWE (parameter value) <sup>2)</sup>	Array, word
5	0	1	0	1	Transfer PWE (parameter value) <sup>2)</sup>	Array, double word
6	0	1	1	0	Transfer number of array elements	
7	0	1	1	1	Order not executable (with error number)	
8	1	0	0	0	<i>Reserved</i>	
9	1	0	0	1	<i>Reserved</i>	
10	1	0	1	0	<i>Reserved</i>	
11	1	0	1	1	<i>Reserved</i>	
12	1	1	0	0	<i>Reserved</i>	

Response ID					Description
Dec.	Bit 15	Bit 14	Bit 13	Bit 12	
13	1	1	0	1	Reserved
14	1	1	1	0	Reserved
15	1	1	1	1	Reserved

- 1) The element number used is transferred in the IND array subindex.
- 2) The position in the array is stated in the IND array subindex.

If orders cannot be executed, the order receiver sends the response ID "Order not executable", and transfers the corresponding error ID in the parameter value (PWE).

Table A-4 Error IDs for the response ID "Order not executable"

Error ID	Description
0	Impermissible parameter ID
1	Parameter value cannot be changed.
2	Parameter limits not observed
3	Subindex outside the array
4	Parameter is not an array
5	Parameter type is invalid (mismatch word and double word)
102	Communication channel too small for the required response
104	Invalid value, parameter allows only certain values
106	Request not observed or task not supported

### A.1.1.2 Parameter index (IND)

#### Overview

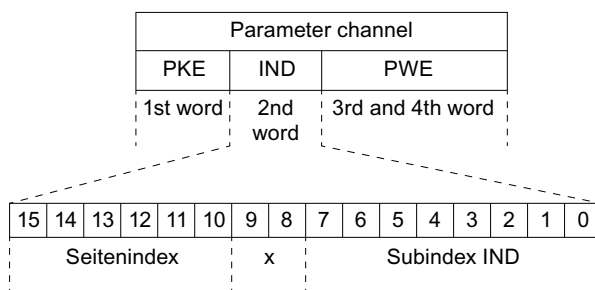

### Structure

The IND array (parameter index) is subdivided as follows:

Table A-5 IND structure

IND															
Bit 15	Bit 14	Bit 13	Bit 12	Bit 11	Bit 10	Bit 9	Bit 8	Bit 7	Bit 6	Bit 5	Bit 4	Bit 3	Bit 2	Bit 1	Bit 0
Page index						x	x	IND subindex							

### IND subindex

The IND subindex array is an 8-bit value that is transferred in the low byte (bits 0 to 7) of the (IND) parameter index. In the PROFIBUS "variable-speed drives" profile, the subindex field is simply named "Subindex".

### Parameter page index

The page index is used to select parameter pages. This enables the PNU value range to the extended (0 to 1999). The resulting parameter ID then has the value range from 0 to 65,999.

The page index is coded in bits 10 to 15 of the high byte of IND.

Bits 8 and 9 are reserved, and not used.

The page index is defined as multiple of 2000. The binary representation is also scrambled. The exact assignment of the bits is described below.

Table A-6 Parameter page index

IND															
Bit 15	Bit 14	Bit 13	Bit 12	Bit 11	Bit 10	Bit 9	Bit 8	Bit 7	Bit 6	Bit 5	Bit 4	Bit 3	Bit 2	Bit 1	Bit 0
a	d	c	b	f	e										

Table A-7 Page index assignment

Value range of parameter ID		Bits for page index						Hex value	+ parameter number (PNU)
from	to	a	d	c	b	f	e		
0000	1999	0	0	0	0	0	0	0x00	0x0000 to 0x07CF
2000	3999	1	0	0	0	0	0	0x80	0x0000 to 0x07CF
4000	5999	0	0	0	1	0	0	0x10	0x0000 to 0x07CF
6000	7999	1	0	0	1	0	0	0x90	0x0000 to 0x07CF
8000	9999	0	0	1	0	0	0	0x20	0x0000 to 0x07CF
...	...	...	...	...	...	...	...	...	
32,000	33,999	0	0	0	0	0	1	0x04	0x0000 to 0x07CF
...	...	...	...	...	...	...	...	...	
64,000	65,999	0	0	0	0	1	0	0x08	0x0000 to 0x07CF

### A.1.1.3 Parameter value (PWE)

The number of PWEs can vary according to the configuration. The number can be configured in parameter p2023 (Number of PKWs).

A PKW channel width of at least 3 words is required to transfer 16-bit values. This means that PWE1 is provided.

If 32-bit values are transferred, the PKW channel has to be expanded to 4 words. Correspondingly, PWE1 and PWE2 are then available.

---

**Note**

Variable PKW proportions and variable telegram lengths are not currently supported. This means that description texts, texts and complete arrays cannot be transferred.

---

**Note**

If a 16-bit value is transferred in a 32-bit channel in the PWE2, then the content of PWE1 is 0.

---

## Structure

Table A-8 32-bit PKW channel

32-bit parameter channel (PKW)			
Word 1	Word 2	Word 3	Word 4
PKE	IND	PWE1	PWE2

Table A-9 16-bit PKW channel

16-bit parameter channel (PKW)		
Word 1	Word 2	Word 3
PKE	IND	PWE1

Table A-10 Variable PKW channel

Variable parameter channel (PKW)				
Word 1	Word 2	Word 3	...	Word x <sup>1)</sup>
PKE	IND	PWE1		PWE <sub>x</sub> <sup>1)</sup>

<sup>1)</sup>  $0 < x < (124 - \text{"number of PZDs"})$

### A.1.1.4 Parameter ID

The parameter ID comprises the PNU (array within PKE) and the page index (array within IND). In general, the parameter ID name is simplified to just PNU (parameter number).

The SIDOOR controller supports parameter numbers in the range of 0 to 65535. The exact assignment of the parameter number is described in the section Parameter assignment (Page 180).

### A.1.1.5 Parameter description (PBE)

The notation of the parameter description states the element number of the parameter description in the IND array subindex.

Table A-11 Elements of the parameter description

Element number	Description	Data type
0	<i>Reserved</i>	–
1	Designation ID	16 bit
2	Number of array elements	8 bit
3	<i>Reserved</i>	–
4	<i>Reserved</i>	–
5	<i>Reserved</i>	–
6	<i>Reserved</i>	–
7	Lower limit value	16 bit
8	Upper limit value	16 bit
9	Default value (factory setting)	16 bit
10 ... 15	<i>Reserved</i>	–

The subindex 255 for transferring a complete parameter description or a complete array requires a variable telegram length which is not currently supported.

The designation ID (element number 1) consists of the following bits:

Bit	Description
0 ... 7	Data type of the parameter value
8	Scaling and major attribute relevant
9	Write-protected
10	Additional text available
11	<i>Reserved</i>
12	Parameter differs from factory settings
13	Parameter can only be reset
14	Parameter is an array
15	<i>Reserved</i>



## A.1.2 Process data

### Telegrams

The type of telegram on the drive side defines which process data is to be transferred between master and slave.

From the point of view of the slave, there are receive words and send words.

The receive and send words comprise the following elements:

- **Receive words:** Control words or setpoints
- **Send words:** Status words or actual values

### Telegram type used

The supported telegram type is specific to the manufacturer, and structured according to internal company specifications. The internal process data connections are set automatically by the system.

### Process data

The desired scope of the process data can be configured with parameter p2022 (number of PZDs). The assignment order is not additionally configurable.

The table below describes the structure of the process data and its subdivision into:

- Control word (STW) – status word (ZSW)
- Technology control words (TSW) – technology status words (TZW)

Table A-12 Overview of process data

PZD	1	2	3	4	5	6	7		16
<b>Master → slave</b>	STW1 (Page 311)	TSW0 (Page 313)	TSW1 (Page 313)	TSW2 (Page 314)	<i>Reserved</i>	<i>Reserved</i>	<i>Reserved</i>	...	<i>Reserved</i>
<b>Slave → master</b>	ZSW1 (Page 315)	TZW0 (Page 316)	TZW1 (Page 317)	TZW2 (Page 319)	TZW3 (Page 321)	TZW4	TZW5		<i>Reserved</i>

#### A.1.2.1 STW1 - control word (CtrlW)

Control word -1 (STW1) is identical to the specification in the PROFIBUS profile "Variable-speed drives".

Bits 0 to 10 correspond exactly to the specifications for the PROFIBUS profile "Variable-speed drives". The use and non-use of specific bits is marked accordingly.

The table below describes the assignments of the bits in control word 1.

Table A-13 Control word 1 (STW1)

Bit	Description
0	ON / OFF 1 (0 → 1)
1	OFF2 (coast down of the drive), after a ramp down the motor is switched to the free-running mode (deenergize).
2	OFF3 (rapid stop of the drive)
3	Operation enable (drive start)
4	Reserved
5	Reserved
6	Reserved
7	Acknowledge fault (0 → 1)
8	Reserved
9	Reserved
10	Control by PLC
11 ... 15	Reserved

The following overview describes the relevant bits in control word 1. See also Figure 5-4 Sequential control state graph (Page 157).

Table A-14 Explanation of bits in STW1

Bit	Description	Value	Remarks
0	ON / OFF1	1	Switch drive ready for operation (master switched on and voltage ready)
		0	Not ready for switching on (master switched off and voltage off) Shutdown according to defined ramp → corresponds to stop
<b>Note:</b> The positive edge is decisive here (0 → 1).			
1	OFF2 (drive coasts down)	1	OFF2 command is canceled Does not run down to standstill
		0	Coast down motor (coasts down to a standstill) → After a ramp down the motor is switched to the free-running mode (deenergize).
2	OFF3 (Rapid stop of the drive)	1	OFF3 commands are canceled
		0	Motor stop
3	Operation enable (drive start)	1	Execution of drive orders (evaluation of technology control words)
		0	No execution of drive orders
7	Acknowledge fault	1	Acknowledge fault
		0	No significance
<b>Note:</b> The positive edge is decisive here (0 → 1).			

10	Control by PLC	1	Control via PLC (master) Process data are marked as valid, and are thus accepted and effective
		0	No control via PLC (master) Process data invalid Local operation is possible Signs of life are excluded from this (master monitoring)
<b>Note:</b> Do not set the bit to 1 until control is requested by the master (ZSW1 bit 9 = true)			

### A.1.2.2 TSW0 - technology control word 0

Technology control word 0 (TSW0) is not assigned for compatibility reasons. It serves as a placeholder.

### A.1.2.3 TSW1 - technology control word 1

Table A-15 Technology control word 1 (TSW1)

TSW1								
15	14	13	12	11	10	9	8	7 ... 0
DCMD expansion							DCMD	

### DCMD signal

The DCMD signal is located in the low byte (bits 0 to 7) of TSW1. It has an enumerative structure and is assigned door commands (DCMDs).

If a reserved value is transferred, it is rejected and the last valid value is retained.

You can find more information on door commands in section Drive orders (Page 49).

Table A-16 DCMD signal

DCMD signal value	Name	Description
0	Deenergize	Motor coasts down, is not energized
1	Stop	The door system is stopped. At standstill the motor is energized with 50% PWM. This operates similar to an EMF brake.
2	Open	Drive moves in learned opening direction
3	Close	Drive moves in learned closing direction
4	Start learn run	Learn run with active parameter set (see section Learn run (Page 40))
5	Positioning	Enable command for positioning mode (see section Positioning mode (Page 79))
6	Automatic AssistedDrive	Enable command for automatic AssistedDrive (see section Automatic Assisted-Drive (Page 78))
7	Automatic ImpulseDrive	Enable command for automatic ImpulseDrive (see section Automatic Impulse-Drive (Page 75))

A.1 Structure of user data/process data

8	Stop with disable DCU	As of V1.12: An additional door command is disabled by a different command source (e.g. service control button) when this stop command is executed.
9	Start learn run without mass determination	As of V1.14: Learn run without mass determination
...		
255	Reserved	

**DCMD expansion bits**

The door command expansion bits for the DCMD signal are located in the high byte (bits 8 to 15) of TSW1.

Table A-17 DCMD expansion bits

Bit	Meaning
8	Slow (see section Slow driving curve profile (Page 60))
9	Automatic ImpulseStop (see section Automatic ImpulseStop (Page 76))
10	NDG (second force and energy profile; see Force and energy profiles (NDG mode) (Page 58))
11	Special (see section Learn run (Page 40))
12	Partial (see section Partial opening (Page 57))
13	Spec. Drive range (see section Specific drive range (Page 99))
14	DCOPS sensor (see section DCOPS (door closed/opened position sensor) (Page 61))
15	LB sensor (see section Light barrier (Page 106))

**Note**

The light barrier signal is low-active. The signal must, therefore, be connected to a 1 (high) in the idle state. Closing commands would otherwise be converted to an opening command due to the reversing effect of the interrupted light barrier signal.

**A.1.2.4 TSW2 - technology control word 2**

Table A-18 Technology control word 2 (TSW2)

TSW2		
15	(as of V1.10) 14 ... 10	9 ... 0
	<b>SBIT4 ... 0</b>	<b>DESTPOS</b>

The value of the target position for positioning mode is located in the bit 0 to bit 9 range of TSW2. It has a numerical structure.

See section Positioning mode (Page 79).

(As of V1.10) Control bits SBit0 to 4 are located in the area bit 10 to 14 of TSW2. The control bits can be linked to the FBLOCK logic as input signals. For more, see section Free function blocks (FBLOCK) (Page 86)

Table A-19 DESTPOS signal

DESTPOS signal value	Name	Description
0 ... 1024	Target position	Target position in [cm] (the value is automatically limited to the learnt door width)

Table A-20 Control bits (as of V1.10)

Bit	SBIT	Value	Meaning
10	0	0/1	Control bit 0 inactive/active
11	1	0/1	Control bit 1 inactive/active
12	2	0/1	Control bit 2 inactive/active
13	3	0/1	Control bit 3 inactive/active
14	4	0/1	Control bit 4 inactive/active

### A.1.2.5 ZSW1 - status word (StatW)

Status word 1 (ZSW1) is identical to the specification in the PROFIBUS profile "Variable-speed drives".

Bits 0 to 10 correspond exactly to the specifications for the PROFIBUS profile "Variable-speed drives". The use and non-use of specific bits is marked accordingly.

The table below describes the assignments of the bits in status word 1.

Table A-21 Status word 1 (ZSW1)

Bit	Description
0	Ready for switching on
1	Ready
2	Operation enabled
3	Fault active
4	No OFF2 (no coast down)
5	No OFF3 (no rapid stop)
6	Switch-on inhibit
7	Reserved
8	Reserved
9	Control requested by PLC

Bit	Description
10	Reserved
11 ... 15	Reserved

The following overview describes the relevant bits in status word 1. See also Figure 5-4 Sequential control state graph (Page 157).

Table A-22 Explanation of bits in ZSW1

Bit	Description	Value	Note
0	Ready for switching on	1	Power supply switched on and system initialized
		0	Not ready for switch on
1	Ready	1	Ready to run, system is switched on ("ON" command present), no fault active, system can start as soon as the "Enable operation" command is given (see also STW1 bit 0)
		0	Not ready to run, no "ON" command
2	Operation enabled	1	Operation enabled, drive order is executed (system follows the setpoints) See also STW1 bit 3
		0	Drive order is not executed, operation is locked
3	Fault active	1	Drive is faulty and therefore out of service. The drive switches to "switching on inhibited" once the fault has been acknowledged and the cause has been remedied
		0	No fault present
4	No OFF2 (no coast down)	1	No OFF2 active
		0	Coast down (deenergize) active, an OFF2 command is present
5	No OFF3 (no rapid stop)	1	No OFF3 active
		0	Rapid stop (stop) active, an OFF3 command is present
6	Switch-on inhibit	1	Switching on inhibited, restart is only possible by means of OFF1 and then ON
		0	No switching on inhibited, switching on is possible
9	Control requested by PLC	1	Control requested, the automation system (PLC) is requested to take over control
		0	Control is only possible on the device, the PLC is not the current controller

**Note**

The operation is also conditional on the operating mode of the door control system.

Initial mode is active in the event of a non-learnt or incorrectly learnt door. Normal mode is not attained until both end positions have been determined after power on, and these end positions match those that have been learnt.

**A.1.2.6 TZW0 - Technology status word 0**

Technology status word 0 is not assigned for compatibility reasons. It serves as a placeholder.

### A.1.2.7 TZW1 - Technology status word 1

Table A-23 Technology status word 1 (TZW1)

TZW1				
15 ... 9	8	7 ... 6	5 ... 4	3 ... 0
<b>DPOS</b>	<b>DBLCW AIT</b>	<b>DBLOCK</b>	<b>DMODE</b>	<b>DSTAT</b>

#### DSTAT signal

The DSTAT signal is located in the low nibble of the low byte of TZW1 (bits 0 to 3). It has an enumerative structure and is assigned the door status (DSTAT).

Table A-24 DSTAT signal

DSTAT signal word	Name	Description
0	Undefined	Door status is unknown.
1	Motor not energized	Motor current-free (deenergized)
2	Closing	The door system is moving in the learnt closing direction
3	Opening	The door system is moving in the learnt opening direction
4	Stopped (source voltage brake)	The door system is stopped. The motor is energized with 50% PWM.
5	Closed	The door system is completely closed.
6	Open	The door system is completely open.
7	Error	The door system is in an error state
...		
16	<i>Reserved</i>	

#### DMODE signal

The DMODE signal is located in the low byte of TZW1 (bits 4 to 5). It has an enumerative structure and is assigned the door mode (DMODE).

Table A-25 DMODE signal

DMODE signal value	Name	Description
0	Normal mode	Both end positions determined after power on, ready to run
1	Initial mode	Both end positions must be determined after power on
2	Learn run mode	Both end positions and other door properties are determined
3	Special mode	The system is in an error state or special mode (system is shutting down, powering up or saving safety-related parameters)

### DBLOCK signal

The DBLOCK signal is located in the low byte of TZW1 (bits 6 to 7). It has an enumerative structure and is assigned the obstruction detection (DBLOCK).

Table A-26 DBLOCK signal

DBLOCK signal value	Name	Description
0	None	There is no obstruction
1	In opening direction	An obstruction was detected in the opening direction
2	In closing direction	An obstruction was detected in the closing direction
3	<i>Reserved</i>	

### DBLCWAIT signal

The DBLCWAIT signal is located in the high byte of TZW1 (bit 9). It has a binary structure and is assigned the special obstruction mode "wait mode".

Table A-27 DBLCWAIT signal

DBLCWAIT signal value	Name	Description
0	Wait mode inactive	See section Wait mode (Page 84) for a signal description
1	Wait mode active	See section Wait mode (Page 84) for a signal description

### DPOS signal

The DPOS signal is located in the high byte of TZW1 (bits 9 to 15). It has an enumerative structure and is assigned the current door position (DPOS) in %.

Table A-28 DPOS signal

DPOS signal value	Name	Description
0 ... 100	Door position	<p>Door position in %</p> <p><b>Note:</b> The value is only valid in normal mode.</p> <p>The 100 % and 0 % door positions can only be reached in conjunction with the "open" or "close" drive orders.</p> <p>The 99 % and 1 % door positions correspond to fully open or fully closed without an active drive order.</p> <p>Values between 99 % and 1 % specify the door position as a percentage value.</p> <p>127 or 7F<sub>hex</sub> is sent (&gt;100 %) if no valid position value is available.</p> <p>In partial opening mode, the door position continues to be referred to the real door width. The values 100 and 99 % are not reached in partial opening mode.</p>



### A.1.2.8 TZW2 - Technology status word 2

Table A-29 Technology status word 2 (TZW2)

TZW2								
15 ... 12	11	10	9	8	7	6	5 ... 3	2 ... 0
<i>Reserved</i>	<b>Op</b>	<i>Re-served</i>	<b>ASStp</b>	<b>ASDRV</b>	<b>DTEr-rAND2</b>	<b>DTEr-rAND0</b>	<b>IM-PDRVVelo</b>	<b>IM-PDRVIncr</b>

### IMPDRVIncr and IMPDRVVelo signals

The signals IMPDRVIncr and IMPDRVVelo are in the low byte of TZW2 (bits 0 to 2, and bits 3 to 5). Both have a numeric structure.

Table A-30 IMPDRVIncr signal

IMPDRVIncr signal value	Name	Description
0	ImpDrvInaktiv	No ImpDrv detected or inactive ( <i>distance-dependent detection</i> )
1	ImpDrvOpen	ImpDrv is detected in the opening direction ( <i>distance-dependent detection</i> )
2	ImpDrvClose	ImpDrv is detected in the closing direction ( <i>distance-dependent detection</i> )
...		
8	<i>Reserved</i>	

Table A-31 IMPDRVVelo signal

IMPDRVVelo signal value	Name	Description
0	ImpDrvInaktiv	No ImpDrv detected or inactive ( <i>speed-dependent detection</i> )
1	ImpDrvOpen	ImpDrv is detected in the opening direction ( <i>speed-dependent detection</i> )
2	ImpDrvClose	ImpDrv is detected in the closing direction ( <i>speed-dependent detection</i> )
...		
8	<i>Reserved</i>	

#### Note

When the sequential control system changes to the state "S4: Z\_Mode" (see Figure 5-4 Sequential control state graph (Page 157)) the IMPDRVIncr and IMPDRVVelo signals as well as the lead time are reset. This decouples the ImpDrv signals from the service mode (local operation) and operating mode.

You will find further information about the IMPDRVIncr and IMPDRVVelo signals and the corresponding drive function in section ImpulseDrive (Page 74).

## ASDRV signal

The ASDRV signal is located in the high byte of TZW2 (bit 8). It has a binary structure.

Table A-32 ASDRV signal

ASDRV signal value	Name	Description
0	AssistedDrive active	An external assisting force within the parameterized threshold values has been found
1	AssistedDrive inactive	An external assisting force within the parameterized threshold values has not been found

You will find further information about the ASDRV signal and the corresponding drive function in section AssistedDrive (Page 77).

## ASStp signal

The ASStp signal is located in the high byte of TZW2 (bit 9). It has a binary structure.

Table A-33 ASStp signal

ASStp signal value	Name	Description
0	ImpulseStop inactive	An external opposing force within the parameterized limit values was not found
1	ImpulseStop active	An external opposing force within the parameterized limit values was found

You will find further information about the ASStp signal and the corresponding drive function in the section ImpulseStop (Page 75).

## DTErrAND0 signal

Firmware version V1.12 or higher:

The DTErrAND0 signal is located in the upper byte of the TZW2 (bit 6). It has a binary structure.

Table A-34 DTErrAND0 signal

DTErrAND0 signal value	Name	Description
0	No discrepancy error AND0	No discrepancy error was detected at function block AND0.
1	Discrepancy error AND0	A discrepancy error was detected at function block AND0.

You can find more information on the DTErrAND0 signal and the corresponding function in the section Discrepancy analysis blocks (Page 93).

## DTErrAND2 signal

Firmware version V1.12 or higher:

The DTErrAND2 signal is located in the upper byte of the TZW2 (bit 7). It has a binary structure.

Table A-35 DTErrAND2 signal

DTErrAND0 signal value	Name	Description
0	No discrepancy error AND2	No discrepancy error was detected at function block AND2.
1	Discrepancy error AND2	A discrepancy error was detected at function block AND2.

You can find more information on the DTErrAND2 signal and the corresponding function in the section Discrepancy analysis blocks (Page 93).

## Op signal

As of firmware version V1.14:

The Op signal (operable) is located in the upper byte of the TZW2 (Bit 11). It has a binary structure.

The readiness for operation of the controller is signaled with this signal. The "Not ready to run" status is signaled in the following states:

- During the storage of parameter values after a parameter change.

Table A-36 Op signal

Op signal value	Name	Description
0	Not ready to run	Drive command can currently not be executed.
1	Ready for operation	Drive command can be executed.

### A.1.2.9 TZW3, TZW4, TZW5 - Technology status words 3, 4, 5

The values monitored in the technology status words TZW3, TZW4 and TZW5 can be set via the parameters p4700, p4701 and p4702.

Table A-37 Value setting for TZW3, TZW4, TZW5

Parameter	Value range	Default value	Description
p4700	0 ... 10	0	Value selection for TZW3 (see following tables)
p4701	0 ... 10	1	Value selection for TZW4 (see following tables)
p4702	0 ... 10	2	Value selection for TZW5 (see following tables)

A.1 Structure of user data/process data

The default values of the parameters p4700, p4701, p4702 correspond to the settings for TZW3, TZW4, TZW5 in FW versions < V1.09.

Table A-38 Value selection for TZW3, TZW4, TZW5

Value	Description	Format
0	D-IN	Data structure see table A-40
1	D-OUT	Data structure see table A-41
2	Button	Data structure see table A-43
3	Door position in mm	16-bit unsigned integer
4	Door setpoint speed in mm/s	16-bit unsigned integer
5	Door actual speed in mm/s	16-bit unsigned integer
6	Motor current in mA	16-bit signed integer
7	Motor current limitation in mA	16-bit signed integer
8	Voltage of the motor output stage in V	16-bit unsigned integer
9	Remaining power capacity of the braking resistor in J	16-bit signed integer
10	As of V1.12: Operating status display	ASCII value of the currently displayed operating status (see section Operating status display (Page 297))

Table A-39 TZW data structure for value "D-IN"

TZW3, TZW4, TZW5					
15 - 5	4	3	2	1	0
Reserved	<b>D-IN</b>				

Table A-40 Bits "D-IN"

Group	Bit	Meaning	Remarks
D-IN	0	Input 4	X6, INPUT 4
	1	Input 3	X6, INPUT 3
	2	Input 2	X6, INPUT 2
	3	Input 1	X6, INPUT 1
	4	Input 0	X5, INPUT 0
	5 - 15	Reserved	

Table A-41 Data structure for value "D-OUT"

TZW3, TZW4, TZW5			
15 - 3	2	1	0
Reserved	<b>D-OUT</b>		

Table A-42 Bits "D-OUT"

Group	Bit	Meaning	Comment
D-OUT	0	Output 1	Digital output "close"
	1	Output 2	Not available
	2	Output 3	Digital output "open"
	3 - 15	<i>Reserved</i>	

Table A-43 TZW data structure for value "Button"

TZW3, TZW4, TZW5			
15 - 3	2	1	0
Reserved	<b>Button</b>		

Table A-44 Bits "Button"

Group	Bit	Meaning	Comment
Button	0	Service button	S401, Service button learn run
	1	Close button	S403, Service button close
	2	Button Open	S402, Service button OPEN
	3 - 15	<i>Reserved</i>	

## A.2 Profiles and adjustment ranges

### A.2.1 Profile name

Profile	SIDOOR ...		
	M3 R / L	M4 R / L	M5 R / L
	MDG3 R / L	MDG4 R / L	MDG5 R / L
1	M3/MDG3 default prof.	M4/MDG4 default prof.	M5/MDG5 default prof.

## A.2.2 SIDOOR M3 L / R

Table A-45 Parameters and setting ranges for SIDOOR M3 L / R

Parameter	Parameter ID	Unit	Profile 1*	Adjustment range
				ATD4xxW
Slow end distance open	p3660	mm	30	0 ... 100
Slow start distance open	p3661	mm	30	0 ... 100
Slow start distance close	p3662	mm	20	0 ... 100
Slow end distance close	p3663	mm	40	0 ... 100
Maximum speed open	p3664	mm/s	650	100 ... 650 30 ... 650 (as of V1.03)
Slow end speed open	p3665	mm/s	40	30 ... 90
Slow start speed open	p3666	mm/s	60	30 ... 90
Slow initial speed open	p3667	mm/s	90	30 ... 90
Maximum speed close	p3668	mm/s	281	100 ... 650 30 ... 650 (as of V1.03)
Slow start speed close	p3669	mm/s	60	30 ... 90
Slow end speed close	p3670	mm/s	40	30 ... 90
Slow initial speed close	p3671	mm/s	90	30 ... 90
NDG speed (reduced)	p3672	mm/s	281	50 ... 650 30 ... 650 (as of V1.03)
Acceleration ramp open	p3673	mm/s <sup>2</sup>	1300	300 ... 1400 As of (V1.09): 250 ... 1400
Deceleration ramp open	p3674	mm/s <sup>2</sup>	600	300 ... 1400 (V1.09): 250 ... 1400 (as of V1.10): 150 ... 1400
Reversal ramp open/close	p3675	mm/s <sup>2</sup>	1200	300 ... 1400 (V1.09): 250 ... 1400 (as of V1.10): 150 ... 1400
Acceleration ramp close	p3676	mm/s <sup>2</sup>	500	300 ... 1400 As of (V1.09): 250 ... 1400
Deceleration ramp CLOSE	p3677	mm/s <sup>2</sup>	500	300 ... 1400 (V1.09): 250 ... 1400 (as of V1.10): 150 ... 1400

Parameter	Parameter ID	Unit	Profile 1*	Adjustment range
				ATD4xxW
Reversal ramp close/open	p3678	mm/s <sup>2</sup>	850	300 ... 1400 (V1.09): 250 ... 1400 (as of V1.10): 150 ... 1400
Idle torque open	p3679	mA	1000	0 ... 2500
Idle torque close	p3680	mA	1000	0 ... 2500
Peak torque close	p3681	mA	3000	0 ... 5000
Static force limit open	p3682	N	75	70 ... 300
Static force limit close	p3683	N	75	70 ... 300
Limit force end close	p3684	N	75	70 ... 300
Static NDG-force (reduced)	p3685	N	75	70 ... 300
Limit energy close	p1202	J	4	0 ... 100
Limit energy open	p1203	J	4	0 ... 100
Limit energy NDG	p1204	J	4	0 ... 100

\* Default profile (this profile is automatically loaded at the first commissioning)

### A.2.3 SIDOOR MDG3 L / R (as of V1.12)

Firmware version V1.12 or higher:

The following parameter values depend on the output transmission and are defined by the factor  $k1$ .

Maximum parameter values:

- Speeds: 999 mm/s  
As of V1.12: Speeds: 1500 mm/s
- Acceleration ramps: 3000 mm/s<sup>2</sup>
- The maximum force is limited to 300 N.

$$k1 = \frac{\text{Existing output transmission ratio}}{\text{Standard output transmission ratio}} = \frac{x}{176 \frac{\text{mm}}{\text{Umd}}}$$

The following parameter values depend on the maximum motor force and are defined by the factor  $k2$ .

Maximum parameter values:

- Deceleration ramp: 3000 mm/s<sup>2</sup>

$$k2 = \frac{\text{Force limit}}{\text{Determined dynamic mass}} * 1000$$

The default values and the set values are automatically set to the upper limit if the upper limit is exceeded. It is therefore possible that the actual default values differ from the default values in the table below.

Table A-46 Parameters and setting ranges for SIDOOR MDG3 L / R

Parameter	Parameter ID	Unit	Profile 1*	Adjustment range
				ATD4xxW
Slow end distance open	p3660	mm	30	0 ... 100
Slow start distance open	p3661	mm	30	0 ... 100
Slow start distance close	p3662	mm	20	0 ... 100
Slow end distance close	p3663	mm	40	0 ... 100
Maximum speed open	p3664	mm/s	650	30 ... 650*k1
Slow end speed open	p3665	mm/s	40	30 ... 90
Slow start speed open	p3666	mm/s	60	30 ... 90
Slow initial speed open	p3667	mm/s	90	30 ... 90
Maximum speed CLOSE	p3668	mm/s	281	30 ... 650*k1
Slow start speed close	p3669	mm/s	60	30 ... 90
Slow end speed close	p3670	mm/s	40	30 ... 90
Slow initial speed close	p3671	mm/s	90	30 ... 90
NDG speed (reduced)	p3672	mm/s	281	30 ... 650*k1
Acceleration ramp open	p3673	mm/s <sup>2</sup>	1300	250 ... 1400*k1
Deceleration ramp open	p3674	mm/s <sup>2</sup>	600	150 ... k2
Reversal ramp open/close	p3675	mm/s <sup>2</sup>	1200	150 ... k2
Acceleration ramp close	p3676	mm/s <sup>2</sup>	500	250 ... 1400*k1
Deceleration ramp CLOSE	p3677	mm/s <sup>2</sup>	500	150 ... k2
Reversal ramp close/open	p3678	mm/s <sup>2</sup>	850	150 ... k2
Idle torque open	p3679	mA	1000	0 ... 2500
Idle torque close	p3680	mA	1000	0 ... 2500
Peak torque close	p3681	mA	3000	0 ... 5000
Static force limit open	p3682	N	75	70 ... 300/k1
Static force limit close	p3683	N	75	70 ... 300/k1
Limit force end close	p3684	N	75	70 ... 300/k1
Static NDG-force (reduced)	p3685	N	75	70 ... 300/k1
Limit energy close	p1202	J	4	0 ... 100
Limit energy open	p1203	J	4	0 ... 100
Limit energy NDG	p1204	J	4	0 ... 100

\* Default profile (this profile is automatically loaded at the first commissioning)



### A.2.4 SIDOOR M4 L / R

Table A-47 Parameters and setting ranges for SIDOOR M4 L / R

Parameter	Parameter ID	Unit	Profile 1*	Adjustment range
				ATD4xxW
Slow end distance open	p3660	mm	30	0 ... 100
Slow start distance open	p3661	mm	30	0 ... 100
Slow start distance close	p3662	mm	20	0 ... 100
Slow end distance close	p3663	mm	40	0 ... 100
Maximum speed open	p3664	mm/s	600	100 ... 800 30 ... 800 (as of V1.03)
Slow end speed open	p3665	mm/s	40	30 ... 90
Slow start speed open	p3666	mm/s	60	30 ... 90
Slow initial speed open	p3667	mm/s	90	30 ... 90
Maximum speed close	p3668	mm/s	177	100 ... 800 30 ... 800 (as of V1.03)
Slow start speed close	p3669	mm/s	60	30 ... 90
Slow end speed close	p3670	mm/s	40	30 ... 90
Slow initial speed close	p3671	mm/s	90	30 ... 90
NDG speed (reduced)	p3672	mm/s	177	50 ... 800 30 ... 800 (as of V1.03)
Acceleration ramp open	p3673	mm/s <sup>2</sup>	1300	300 ... 1400 As of (V1.09): 250 ... 1400
Deceleration ramp open	p3674	mm/s <sup>2</sup>	600	300 ... 1400 (V1.09): 250 ... 1400 (as of V1.10): 150 ... 1400
Reversal ramp open/close	p3675	mm/s <sup>2</sup>	1200	(V1.09): 250 ... 1400 (as of V1.10): 150 ... 1400
Acceleration ramp close	p3676	mm/s <sup>2</sup>	500	300 ... 1400 As of (V1.09): 250 ... 1400
Deceleration ramp CLOSE	p3677	mm/s <sup>2</sup>	500	300 ... 1400 (V1.09): 250 ... 1400 (as of V1.10): 150 ... 1400
Reversal ramp close/open	p3678	mm/s <sup>2</sup>	850	300 ... 1400 (V1.09): 250 ... 1400 (as of V1.10): 150 ... 1400

Parameter	Parameter ID	Unit	Profile 1 *	Adjustment range
				ATD4xxW
Idle torque open	p3679	mA	1000	0 ... 2500
Idle torque close	p3680	mA	1000	0 ... 2500
Peak torque close	p3681	mA	3000	0 ... 5000
Static force limit open	p3682	N	75	70 ... 360
Static force limit close	p3683	N	75	70 ... 360
Limit force end close	p3684	N	75	70 ... 360
Static NDG-force (reduced)	p3685	N	75	70 ... 360
Limit energy close	p1202	J	4	0 ... 100
Limit energy open	p1203	J	4	0 ... 100
Limit energy NDG	p1204	J	4	0 ... 100

\* Default profile (this profile is automatically loaded at the first commissioning)

### A.2.5 SIDOOR MDG4 L / R

Firmware version V1.12 or higher:

The following parameter values depend on the output transmission and are defined by the factor  $k1$ .

Maximum parameter values:

- Speeds: 999 mm/s  
As of V1.12: Speeds: 1500 mm/s
- Acceleration ramps: 3000 mm/s<sup>2</sup>
- The maximum force is limited to 500 N.

$$k1 = \frac{\text{Existing output transmission ratio}}{\text{Standard output transmission ratio}} = \frac{x}{176 \frac{mm}{Umd}}$$

The following parameter values depend on the maximum motor force and are defined by the factor  $k2$ .

Maximum parameter values:

- Deceleration ramp: 3000 mm/s<sup>2</sup>

$$k2 = \frac{\text{Force limit}}{\text{Determined dynamic mass}} * 1000$$

The default values and the set values are automatically set to the upper limit if the upper limit is exceeded. It is therefore possible that the actual default values differ from the default values in the table below.

Table A-48 Parameters and setting ranges for SIDOOR MDG4 L / R

Parameter	Parameter ID	Unit	Profile 1*	Adjustment range
				ATD4xxW
Slow end distance open	p3660	mm	30	0 ... 100
Slow start distance open	p3661	mm	30	0 ... 100
Slow start distance close	p3662	mm	20	0 ... 100
Slow end distance close	p3663	mm	40	0 ... 100
Maximum speed open	p3664	mm/s	600	30 ... 800*k1
Slow end speed open	p3665	mm/s	40	30 ... 90
Slow start speed open	p3666	mm/s	60	30 ... 90
Slow initial speed open	p3667	mm/s	90	30 ... 90
Maximum speed CLOSE	p3668	mm/s	177	30 ... 800*k1
Slow start speed close	p3669	mm/s	60	30 ... 90
Slow end speed close	p3670	mm/s	40	30 ... 90
Slow initial speed close	p3671	mm/s	90	30 ... 90
NDG speed (reduced)	p3672	mm/s	177	30 ... 800*k1
Acceleration ramp open	p3673	mm/s <sup>2</sup>	1300	300 ... 1400*k1 250 ... 1400*k1 (as of V1.09)
Deceleration ramp open	p3674	mm/s <sup>2</sup>	600	300 ... k2 250 ... k2 (V1.09) 150 ... k2 (as of V1.10)
Reversal ramp open/close	p3675	mm/s <sup>2</sup>	1200	300 ... k2 250 ... k2 (V1.09) 150 ... k2 (as of V1.10)
Acceleration ramp close	p3676	mm/s <sup>2</sup>	500	300 ... 1400*k1 250 ... 1400*k1 (as of V1.09)
Deceleration ramp CLOSE	p3677	mm/s <sup>2</sup>	500	300 ... k2 250 ... k2 (V1.09) 150 ... k2 (as of V1.10)
Reversal ramp close/open	p3678	mm/s <sup>2</sup>	850	300 ... k2 250 ... k2 (V1.09) 150 ... k2 (as of V1.10)
Idle torque open	p3679	mA	1000	0 ... 2500
Idle torque close	p3680	mA	1000	0 ... 2500
Peak torque close	p3681	mA	3000	0 ... 5000
Static force limit open	p3682	N	75	70 ... 360/k1
Static force limit close	p3683	N	75	70 ... 360/k1
Limit force end close	p3684	N	75	70 ... 360/k1

A.2 Profiles and adjustment ranges

Static NDG-force (reduced)	p3685	N	75	70 ... 360/k1
Limit energy close	p1202	J	4	0 ... 100
Limit energy open	p1203	J	4	0 ... 100
Limit energy NDG	p1204	J	4	0 ... 100

\* Default profile (this profile is automatically loaded at the first commissioning)

### A.2.6 SIDOOR M5 L / R

Table A-49 Parameters and setting ranges for SIDOOR M5 L / R

Parameter	Parameter ID	Unit	Profile 1*	Adjustment range
				ATD4xxW
Slow end distance open	p3660	mm	30	0 ... 100
Slow start distance open	p3661	mm	30	0 ... 100
Slow start distance close	p3662	mm	20	0 ... 100
Slow end distance close	p3663	mm	40	0 ... 100
Maximum speed open	p3664	mm/s	200	100 ... 500 30 ... 500 (as of V1.03)
Slow end speed open	p3665	mm/s	40	30 ... 90
Slow start speed open	p3666	mm/s	60	30 ... 90
Slow initial speed open	p3667	mm/s	90	30 ... 90
Maximum speed close	p3668	mm/s	162	100 ... 500 30 ... 500 (as of V1.03)
Slow start speed close	p3669	mm/s	60	30 ... 90
Slow end speed close	p3670	mm/s	40	30 ... 90
Slow initial speed close	p3671	mm/s	90	30 ... 90
NDG speed (reduced)	p3672	mm/s	162	50 ... 500 30 ... 500 (as of V1.03)
Acceleration ramp open	p3673	mm/s <sup>2</sup>	450	300 ... 650 250 ... 650 (as of V1.09)
Deceleration ramp open	p3674	mm/s <sup>2</sup>	300	300 ... 650 250 ... 650 (V1.09) 150 ... 650 (as of V1.10)
Reversal ramp open/ close	p3675	mm/s <sup>2</sup>	500	300 ... 650 250 ... 650 (V1.09) 150 ... 650 (as of V1.10)
Acceleration ramp close	p3676	mm/s <sup>2</sup>	400	300 ... 650 250 ... 650 (as of V1.09)

Parameter	Parameter ID	Unit	Profile 1*	Adjustment range
				ATD4xxW
Deceleration ramp CLOSE	p3677	mm/s <sup>2</sup>	400	300 ... 650 250 ... 650 (V1.09) 150 ... 650 (as of V1.10)
Reversal ramp close/ open	p3678	mm/s <sup>2</sup>	650	300 ... 650 250 ... 650 (V1.09) 150 ... 650 (as of V1.10)
Idle torque open	p3679	mA	2500	0 ... 2500
Idle torque close	p3680	mA	2500	0 ... 2500
Peak torque close	p3681	mA	5000	0 ... 5000
Static force limit open	p3682	N	75	70 ... 360
Static force limit close	p3683	N	75	70 ... 360
Limit force end close	p3684	N	75	70 ... 360
Static NDG-force (re- duced)	p3685	N	75	70 ... 360
Limit energy close	p1202	J	4	0 ... 100
Limit energy open	p1203	J	4	0 ... 100
Limit energy NDG	p1204	J	4	0 ... 100

\* Default profile (this profile is automatically loaded at the first commissioning)

## A.2.7 SIDOOR MDG5 L / R

The following parameter values depend on the output transmission and are defined by the factor  $k1$ .

Maximum parameter values:

- Velocities: 999 mm/s  
As of V1.09: Velocities: 1500 mm/s
- Acceleration ramps: 3000 mm/s<sup>2</sup>
- The maximum force is limited to 500 N.

$$k1 = \frac{\text{Existing output transmission}}{\text{Standard output transmission}} = \frac{x}{176 \frac{\text{mm}}{\text{rev}}}$$

The following parameter values depend on the maximum motor force and are defined by the factor  $k2$ .

Maximum parameter values:

- Deceleration ramp: 3000 mm/s<sup>2</sup>

$$k2 = \frac{\text{Force limit}}{\text{Determined dynamic mass}} * 1000$$

The default values and the set values are automatically set to the upper limit if the upper limit is exceeded. It is therefore possible that the actual default values differ from the default values in the table below.

Table A-50 Parameters for SIDOOR MDG5 L / R

Parameter	Parameter ID	Unit	Profile 1*	Adjustment range
				ATD4xxW
Slow end distance open	p3660	mm	30	0 ... 100
Slow start distance open	p3661	mm	30	0 ... 100
Slow start distance close	p3662	mm	20	0 ... 100
Slow end distance close	p3663	mm	40	0 ... 100
Maximum speed open	p3664	mm/s	200	30 ... 500*k1
Slow end speed open	p3665	mm/s	40	30 ... 90
Slow start speed open	p3666	mm/s	60	30 ... 90
Slow initial speed open	p3667	mm/s	90	30 ... 90
Maximum speed close	p3668	mm/s	162	30 ... 500*k1
Slow start speed close	p3669	mm/s	60	30 ... 90
Slow end speed close	p3670	mm/s	40	30 ... 90
Slow initial speed close	p3671	mm/s	90	30 ... 90
NDG speed (reduced)	p3672	mm/s	162	30 ... 500*k1
Acceleration ramp open	p3673	mm/s <sup>2</sup>	450	250 ... 650*k1
Deceleration ramp open	p3674	mm/s <sup>2</sup>	300	150 ... k2
Reversal ramp open/close	p3675	mm/s <sup>2</sup>	500	150 ... k2
Acceleration ramp close	p3676	mm/s <sup>2</sup>	400	250 ... 650*k1
Deceleration ramp CLOSE	p3677	mm/s <sup>2</sup>	400	150 ... k2
Reversal ramp close/open	p3678	mm/s <sup>2</sup>	650	150 ... k2
Idle torque open	p3679	mA	2500	0 ... 2500
Idle torque close	p3680	mA	2500	0 ... 2500
Peak torque close	p3681	mA	5000	0 ... 5000
Static force limit open	p3682	N	75	70 ... 360/k1
Static force limit close	p3683	N	75	70 ... 360/k1
Limit force end close	p3684	N	75	70 ... 360/k1
Static NDG-force (reduced)	p3685	N	75	70 ... 360/k1
Limit energy close	p1202	J	4	0 ... 100
Limit energy open	p1203	J	4	0 ... 100
Limit energy NDG	p1204	J	4	0 ... 100

\* Default profile (this profile is automatically loaded at the first commissioning)

## A.3 Configuration record

<b>Commissioning engineer</b>	
<b>Date</b>	

### Controller

#### Industrial applications

- SIDOOR ATD401W
- SIDOOR ATD420W
- SIDOOR ATD430W

**FW version:** \_\_\_\_\_

### Motor

- SIDOOR M3 L/R
- SIDOOR MDG3 L/R
- SIDOOR M4 L/R
- SIDOOR MDG4 L/R
- SIDOOR M5 L/R
- SIDOOR MDG5 L/R

### Power supply

- SIDOOR NT40
- SIDOOR TRANSFORMER
- SIDOOR TRANSFORMER UL
- SITOP PSU8200
- Building DC voltage supply

### Software / additional devices

- SIDOOR SOFTWARE KIT
- SIDOOR SERVICE TOOL
- SIDOOR LINK

---

### Note

#### Parameter changes

Parameters should always be adjusted during normal operation with the door in the CLOSED position, because the controller then accepts the values immediately.

---

 <b>WARNING</b>
When changing parameters, also refer to the section Final settings and checks (Page 295).

Parameter	Unit	Set value
Slow end distance open	mm	
Slow start distance open	mm	
Slow start distance close	mm	
Slow end distance close	mm	
Maximum speed open	mm/s	
Slow end speed open	mm/s	
Slow start speed open	mm/s	
Slow initial speed open	mm/s	
Maximum speed close	mm/s	
Slow start speed close	mm/s	
Slow end speed close	mm/s	
Slow initial speed close	mm/s	
NDG speed (reduced)	mm/s	
Acceleration ramp open	mm/s <sup>2</sup>	
Deceleration ramp open	mm/s <sup>2</sup>	
Reversal ramp open/close	mm/s <sup>2</sup>	
Acceleration ramp close	mm/s <sup>2</sup>	
Deceleration ramp CLOSE	mm/s <sup>2</sup>	
Reversal ramp close/open	mm/s <sup>2</sup>	
Idle torque open	mA	
Idle torque close	mA	
Peak torque close	mA	
Static force limit open	N	
Static force limit close	N	
Limit force end close	N	
Static NDG-force (reduced)	N	
<b>Additional profile parameters</b>		
Limit energy close	J	
Limit energy open	J	
Limit energy NDG	J	
<b>Special parameters</b>		
Slave ID	–	
Int. baud rate	Bd	
PKW words	–	
PZD words	–	
Function input 1	–	
Partial opening width	cm	
Automatic restart	–	



Parameter	Unit	Set value
FBLOCK configuration	–	
Output transmission	mm/rev	
Force limit for learn run	N	
Default command input	–	
Hold-open time standard	s	
Hold-open time cord-operated switch	s	
Duration close command in CLOSE	–	
Speed critical Range OPEN	mm/s	
Force-specific range OPEN	N	
Speed critical Range CLOSE	mm/s	
Force-specific range CLOSE	N	
<b>Basic parameters (as of V1.09)</b>		
Output transmission	mm/rev	
Motor direction		
Pulse encoder direction		
Door width	mm	
Dynamic mass	kg	
Frictional force open	N	
Frictional force close	N	
Average friction current open	mA	
Average friction current close	mA	

## A.4 Standards, directives and laws

### A.4.1 Safety

#### EN ISO 13849-1:2015

The safety standard EN ISO 13849 deals with the general design principles for the safety-related parts of control systems. Part 1 defines general design principles.

### A.4.2 EMC

#### Immunity

#### EN 61000-6-2:2005

Generic standards – Immunity for industrial environments

### Emission standard for residential environments

#### EN 61000-6-3: 2007+A1:2011

Generic standards – Interference emission for residential, business and commercial areas as well as small businesses

---

#### Note

The specifications of DIN EN 61000-6-3 are met when the SIDOOR TRANSFORMER or SIDOOR TRANSFORMER UL is used as a power supply component. EN 61000-6-3 is not fulfilled if the SIDOOR NT40 is used as the power supply component.

---

### Emission standard for industrial environments

#### EN 61000-6-4:2007 +A1:2011

Generic standards – Interference emission for industrial environments

### A.4.3 Communications

The EIA 485 standard applies to physical data transfer (RS 485 interface).

**USS protocol specification**, Edition 09.94 by Walter Möller-Nehring, Siemens AG, ASI 1 D SP, Erlangen and Wolfgang Bohrer, Siemens AG, ASI 1 D SP, Erlangen

**PROFIBUS** was defined in DIN 19245 in 1991/1993, changed to EN 50170 in 1996 and has been defined in IEC 61158/IEC 61784 since 1999.

**PROFINET** DIN EN 61158 and IEC 61784-2

### A.4.4 Application-specific standards

 <b>WARNING</b>
Compliance with these standards requires appropriate hardware, parameter assignment, setup and verification.

### power-operated guards

#### EN ISO 14120:2015 Safety of machinery – Isolating protective devices –

General requirements for the design and construction of fixed and movable guards, Type B Standard

For EN ISO 14120:2015, particular attention must be paid to section 5.2.5.4:

### Power-operated guards

"Where guards are power operated they shall not be capable of causing injury (e.g. from contact pressure, force, speed, sharp edges). If an isolating or a non-isolating protective device is fitted which automatically initiates a reopening of the non-isolating protective device as soon as a person or an object comes into the contact with the isolating protective device, the closing force must not exceed 150 N and the kinetic energy of the isolating protective device must not exceed 10 J. If no such protective device is fitted these values shall be reduced to 75 N and 4 J, respectively. These values only apply if there is a wide closing edge and no risk of cutting or shearing."

## Machine tools – Safety – Turning machines

### EN ISO 23125:2015 Machine tools safety – Turning machines, Type C standard

Section 5.2.2.2 b) "For power-operated guards"

Excerpt from ISO 23125:2015, Section 5.2.2.2 b):

"3) the force to prevent the guard from closing shall not exceed 75 N and the kinetic energy of the guard shall not exceed 4 J. When the guard is fitted with a protective device which automatically initiates reopening of the guard on actuation, this may be a maximum of 150 N and the kinetic energy a maximum of 10 J;"

## Injection molding machines

EN 201:2009 Plastics and rubber machines – Injection molding machines – Safety requirements; Type C standard

Section 5.8.10 "Power operated guards"

Excerpt from DIN EN 201:2009, Section 5.8.10:

"For power operated guards the following additional requirements shall apply:

- where there are contact forces more than 75 N and less or equal to 150 N, a pressure sensitive edge in accordance with EN 1760-2:2001+A1:2009 shall be supplied. Actuation of the sensitive edge shall stop the closing movement of the guard in accordance with EN ISO 13849-1:2008, PLr = c;
- where there are contact forces more than 150 N, these shall not exceed 300 N and a pressure sensitive edge in accordance with EN 1760-2:2001+A1:2009 shall be supplied. When the pressure sensitive edge is activated, the closing movement of the disconnecting protection equipment must be shut down in accordance with EN ISO 13849-1:2015, PLr = c and must allow the motion into the opposite direction without additional danger. Closing the disconnecting protection equipment must take place through a controller with automatic resetting mechanism in accordance with EN ISO 13849-1:2015, PLr = c; ..."

## A.4.5 Protective devices

### Electrosensitive protective equipment

EN 61496-1:2013 Safety of machinery - Electrosensitive protective equipment – Part 1: General requirements and tests, Type B standard.

This part defines the general requirements for design, production and testing of electrosensitive protective equipment (ESPE) that is specially designed for detection of persons as part of a safety-related system.

### Pressure-sensitive protective equipment

EN ISO 13856-2:2013 Safety of machinery — Pressure-sensitive protective devices — Part 2: General principles for the design and testing of pressure-sensitive edges and pressure-sensitive bars, Type B2 standard

This part of ISO 13856 establishes general principles and specifies requirements for the design and testing of pressure-sensitive edges and pressure-sensitive bars used as safeguards and not as actuating devices for normal operation.

---

**Note**

Die EN1760-2:2001+A1:2009 has been withdrawn and replaced with ISO 13856-2:2013.

---

### Two-hand control devices

EN 574:1996+A1:2008 Safety of machinery – Two-hand control devices – Functional aspects – Design principles.

Chapters 6 describes the requirements for controllers

Table A-51 List of two-hand control device types and the minimum safety requirements

Requirements	Section	Types				
		I	II	III		
				A	B	C
Use of both hands (simultaneous actuation)	5.1	x	x	x	x	x
Relationship between input signals and output signal	5.2	x	x	x	x	x
Termination of the output signal	5.3	x	x	x	x	x
Avoidance of unintentional operation	5.4	x	x	x	x	x
Preventing bypassing	5.5	x	x	x	x	x
Recreating the output signal	5.6	*)	x	x	x	x
Synchronous actuation	5.7			x	x	x
Use of category 1 (EN 574:1996+A1:2008)	6.2	x		x		

Requirements	Section	Types				
		I	II	III		
				A	B	C
Use of category 3 (EN 574:1996+A1:2008)	6.3		x		x	
Use of category 4 (EN 574:1996+A1:2008)	6.4					x

\*) NOTE for the selection of Type I see 8.6.

Source: EN 574:1996+A1:2008, table 1

ISO 13851:2019 Safety of machinery – Two-hand control devices – Functional aspects

Chapter 4 describes the requirements for controllers

Table A-52 List of two-hand control device types and the minimum safety requirements

Requirements	Section	Types				
		I	II	III		
				A	B	C
Use of both hands (simultaneous actuation)	5.1	x	x	x	x	x
Relationship between input signals and output signal	5.2	x	x	x	x	x
Termination of the output signal	5.3	x	x	x	x	x
Avoidance of unintentional operation	5.4	x	x	x	x	x
Preventing bypassing	5.5	x	x	x	x	x
Recreating the output signal	5.6	*)	x	x	x	x
Synchronous actuation	5.7			x	x	x
Application of category 1 (ISO 13849-1)	6.2	x		x		
Application of category 3 (ISO 13849-1)	6.3		x		x	
Application of category 4 (ISO 13849-1)	6.4					x

\*) NOTE for the selection of Type I see 8.6.

Source: ISO 13849-1

## A.5 Abbreviations

Table A-53 List of abbreviations

Term / abbreviations	Explanation
AC	Alternating Current
ADV	Advanced
Accu	Accumulator
AND	Logical "and" operation, discrepancy analysis
ANSI	American National Standard Institute
ARMS	Rms current in amperes
ASIC	User-specific integrated circuitry
AWG	American Wire Gauge

Term / abbreviations	Explanation
BCD	Binary Coded Decimal
ESPE	Electrosensitive Protective Equipment
CD	Compact disc
CE	Communautés Européenes (CE marking European Community)
CH	Channel
CPU	Central Processing Unit
CR	Carriage Return (confirmation key)
CSR	Cold Storage Room
DAP	Device Access Point (PROFINET)
DC	Direct Current
DCMD	Door Command
DCPS	Door Closed Position Sensor
DCOPS	Door Closed / Opened Position Sensor
DIN	Deutsche Industrie Norm (German Industry Standard)
DIP	Dual Inline Package Switch
DP	PROFIBUS Distributed I/O
D-SUB	D subminiature plug-in connector
EAC	Eurasian Conformity (certification)
EEPROM	Electrically Erasable Programmable Read-Only Memory
EMC	Electromagnetic Compatibility
EMF	Electric Motor Force
EN	European standard
ESD	Electrostatic Discharge
ESC	Escape (cancel key)
FBLOCK	Function block
Functional ground	Functional ground
fit	Failure in time (failures over a specific period of time)
FW	Firmware
GND	Ground (reference potential)
GSD	General Station Description (PROFIBUS / PROFINET device description)
HCS12	Microcontroller from Freescale / NXP
HW	Hardware
I/O or IO	Input / Output
I&M	Identification and Maintenance (PROFINET)
ID	Identification
In	Input
IP	Degree of protection or Internet protocol
IRT	Isochronous Real Time Protocol (PROFINET)
COI	Compact operating instructions
LB	Light barrier
LED	Light-emitting diode

Term / abbreviations	Explanation
LLDP	Link Layer Discovery Protocol (PROFINET)
max	Maximum
min	Minimum
MAC	Media Access Control Address (PROFINET)
MIB	Management Information Base (PROFINET)
MRP	Media Redundancy Protocol (PROFINET)
MTBF	Mean Time Between Failure
NC	Not Connected
NDG	Nudge, second driving profile
NFPA	National Fire Protection Association
NMS	Neutral motor interface
OSSD	Output Switching Signal Device
Out	Output
PC	Personal computer
PDEV	Physical Device (PROFINET)
PDF	Portable Document Format
PE	Protective Earth
PKW	Parameter word (PROFIBUS, PROFINET)
PL	Performance Level
PLC	Programmable Logic Controller
PRI	Primary
PZD	Process status data (PROFIBUS / PROFINET)
PWM	Pulse width modulation
RAM	Random Access Memory
REF	Reference
ROM	Read Only Memory
RoHS	Restriction of Hazardous Substances (certification)
RK	Feedback contact (e.g. for light barrier)
SBIT	Control bit of the function block logic
SEC	Secondary
SELV	Safety Extra Low Voltage
SIL	Safety Integrity Level
SNMP	Simple Network Management Protocol (PROFINET)
PLC	Programmable logic controller
SR	Switch Rail (pressure sensitive edge)
STS	Super Torque Synchronous Belt (toothed belt profile)
STW	Control word (PROFIBUS / PROFINET)
SW	Software
TCP	Transmission Control Protocol (PROFINET)
Trafo	Transformers
TSW	Technology control word (PROFIBUS / PROFINET)
TÜV	German Technical Inspectorate (certification)

Term / abbreviations	Explanation
TZW	Technology status word (PROFIBUS / PROFINET)
UART	Universal Asynchronous Serial Receiver and Transmitter
UDP	User Datagram Protocol (PROFINET)
UL	Underwriters Laboratories (certification)
USB	Universal Serial Bus
USS	Universal serial interface
UPS	Uninterruptible power supply
VCC	Supply voltage
VDE	Association of Electrical, Electronic & Information Technologies e. V.
ZSW	Status word (PROFIBUS / PROFINET)





## More information

Siemens:  
[www.siemens.com/sidoor](http://www.siemens.com/sidoor)

Industry Online Support (Service and Support):  
[www.siemens.com/online-support](http://www.siemens.com/online-support)

Industry Mall:  
[www.siemens.com/industrymall](http://www.siemens.com/industrymall)

Siemens AG  
Digital Industries  
Motion Control  
Postfach 31 80  
91050 ERLANGEN  
Germany

Scan the QR code  
for more informa-  
tion on SIDOOR.

