

# SIEMENS

## SIMATIC

### S7-1500, ET 200MP, ET 200SP, ET 200AL, ET 200pro, ET 200eco PN Analog value processing

Function Manual

Preface

---

Documentation guide

---

1

What you should know about  
analog technology

---

2

Representation of analog  
values

---

3

Connecting transducers

---

4

Thermocouples

---

5

Wiring loads/actuators

---

6

Supported functions

---

7

High-speed analog modules

---

8

## Legal information

### Warning notice system

This manual contains notices you have to observe in order to ensure your personal safety, as well as to prevent damage to property. The notices referring to your personal safety are highlighted in the manual by a safety alert symbol, notices referring only to property damage have no safety alert symbol. These notices shown below are graded according to the degree of danger.

<b>⚠ DANGER</b>
indicates that death or severe personal injury <b>will</b> result if proper precautions are not taken.

<b>⚠ WARNING</b>
indicates that death or severe personal injury <b>may</b> result if proper precautions are not taken.

<b>⚠ CAUTION</b>
indicates that minor personal injury can result if proper precautions are not taken.

<b>NOTICE</b>
indicates that property damage can result if proper precautions are not taken.

If more than one degree of danger is present, the warning notice representing the highest degree of danger will be used. A notice warning of injury to persons with a safety alert symbol may also include a warning relating to property damage.

### Qualified Personnel

The product/system described in this documentation may be operated only by **personnel qualified** for the specific task in accordance with the relevant documentation, in particular its warning notices and safety instructions. Qualified personnel are those who, based on their training and experience, are capable of identifying risks and avoiding potential hazards when working with these products/systems.

### Proper use of Siemens products

Note the following:

<b>⚠ WARNING</b>
Siemens products may only be used for the applications described in the catalog and in the relevant technical documentation. If products and components from other manufacturers are used, these must be recommended or approved by Siemens. Proper transport, storage, installation, assembly, commissioning, operation and maintenance are required to ensure that the products operate safely and without any problems. The permissible ambient conditions must be complied with. The information in the relevant documentation must be observed.

### Trademarks

All names identified by ® are registered trademarks of Siemens AG. The remaining trademarks in this publication may be trademarks whose use by third parties for their own purposes could violate the rights of the owner.

### Disclaimer of Liability

We have reviewed the contents of this publication to ensure consistency with the hardware and software described. Since variance cannot be precluded entirely, we cannot guarantee full consistency. However, the information in this publication is reviewed regularly and any necessary corrections are included in subsequent editions.

# Preface

## Purpose of the documentation

This documentation covers general topics applicable to all products.

In addition to introductory information about analog value processing, this manual covers the following topics:

- Wiring transducers to analog inputs
- Wiring actuators/loads to analog outputs
- Compensating for reference junction temperatures
- Calibrating analog modules
- Diagnostics options of an analog module
- High-speed analog modules

## Basic knowledge required

The following knowledge is required in order to understand the documentation:

- General knowledge of automation technology
- Knowledge of analog value processing (analog technology)
- Knowledge of the industrial automation system SIMATIC
- Knowledge about how to use STEP 7 (TIA Portal)

## Scope of the documentation

This manual is considered the basic documentation for all analog input and analog output modules of the S7-1500, ET 200MP, ET 200SP, ET 200AL, ET 200pro and ET 200eco PN product series.

## Changes compared to previous version

Changes / enhancements described in this manual, compared to the previous version (version 12/2013):

- Extension of the scope of validity to the distributed I/O system ET 200AL

## Conventions

STEP 7: In this documentation, "STEP 7" is used as a synonym for "STEP 7 as of V12 (TIA Portal)" and subsequent versions of the configuration and programming software. This documentation includes images of the products it describes. The products supplied may differ slightly from these images.

Please observe notes labeled as follows:

---

### Note

Notes contain important information on a point in the documentation of particular importance.

---

## Additional support

Additional information on SIMATIC products is available on the Internet. The associated documentation is also available on the Internet.

- The portfolio of technical documentation for SIMATIC products and systems can be accessed on the Internet (<http://www.siemens.com/simatic-tech-doku-portal>).
- The online catalog and the ordering system are available on the Internet (<http://mall.automation.siemens.com>).

## Security information

Siemens provides products and solutions with industrial security functions that support the secure operation of plants, solutions, machines, equipment and/or networks. They are important components in a holistic industrial security concept. With this in mind, Siemens' products and solutions undergo continuous development. Siemens recommends strongly that you regularly check for product updates.

For the secure operation of Siemens products and solutions, it is necessary to take suitable preventive action (e.g. cell protection concept) and integrate each component into a holistic, state-of-the-art industrial security concept. Third-party products that may be in use should also be considered. You can find more information about industrial security on the Internet (<http://www.siemens.com/industrialsecurity>).

To stay informed about product updates as they occur, sign up for a product-specific newsletter. You can find more information on the Internet (<http://support.automation.siemens.com>).

# Table of contents

	<b>Preface</b> .....	<b>3</b>
<b>1</b>	<b>Documentation guide</b> .....	<b>7</b>
<b>2</b>	<b>What you should know about analog technology</b> .....	<b>9</b>
2.1	Overview .....	9
2.2	Precision/resolution .....	13
2.3	Scaling analog values .....	17
2.4	Unscaling analog values .....	19
2.5	Linearity errors .....	21
2.6	Repeat accuracy .....	22
2.7	Operational and basic error limits .....	23
2.8	Temperature error .....	26
2.9	Interference frequency suppression .....	27
2.10	Common mode interference (UCM) .....	29
2.11	Series mode interference (USM) .....	31
2.12	Interference voltage suppression .....	32
2.13	Crosstalk between channels .....	34
2.14	Diagnostics .....	36
2.15	Value status .....	46
2.16	Conversion time of an analog module .....	49
2.17	Cycle time of an analog module .....	51
2.18	Settling and response times of analog output modules .....	52
2.19	Smoothing .....	54
2.20	Burden with 2-wire transducers .....	57
<b>3</b>	<b>Representation of analog values</b> .....	<b>60</b>
3.1	Overview .....	60
3.2	Representation of input ranges .....	62
3.3	Representation of output ranges .....	63

<b>4</b>	<b>Connecting transducers .....</b>	<b>65</b>
4.1	Overview .....	65
4.2	Wiring analog inputs with MANA connection .....	67
4.3	Wiring analog inputs without MANA connection .....	69
4.4	Wiring voltage transducers.....	71
4.5	Wiring current transducers .....	72
4.6	Wiring thermal resistors and resistors.....	74
4.7	Wiring thermocouples .....	76
<b>5</b>	<b>Thermocouples .....</b>	<b>77</b>
5.1	Selecting thermocouples.....	77
5.2	Structure and operating principle of thermocouples .....	79
5.3	Compensation for the reference junction temperature .....	81
5.3.1	Overview .....	81
5.3.2	Compensation with internal reference junction .....	84
5.3.3	Compensation with reference channel of the module.....	86
5.3.4	Compensation, reference channel of Group 0 .....	88
5.3.5	Compensation with fixed reference temperature .....	91
5.3.6	Compensation by means of dynamic reference temperature .....	94
5.3.7	"None" or external compensation.....	98
5.3.8	Compensation type RTD (0) .....	100
<b>6</b>	<b>Wiring loads/actuators.....</b>	<b>103</b>
6.1	Overview .....	103
6.2	Wiring loads/actuators.....	104
<b>7</b>	<b>Supported functions .....</b>	<b>106</b>
7.1	Calibrating analog modules.....	106
7.1.1	Overview .....	106
7.1.2	Calibrating analog modules.....	107
7.1.3	Canceling a calibration.....	111
7.1.4	Resetting analog modules to factory settings .....	112
<b>8</b>	<b>High-speed analog modules.....</b>	<b>113</b>
8.1	Basics.....	113
8.2	ST modules vs HS modules.....	119
	<b>Index .....</b>	<b>125</b>

# Documentation guide

## Introduction

The documentation of the SIMATIC products has a modular structure and covers diverse topics concerning your automation system.

The complete documentation for the S7-1500, ET 200MP, ET 200SP, ET 200AL, ET 200pro and ET 200eco PN systems consists of the respective system manuals, function manuals and product manuals.

## Overview of additional documents related to analog value processing

The following table lists further references that supplement this description of analog value processing.

Table 1- 1 References for analog value processing

Topic	Documentation	Most important contents
System description	System manual S7-1500 Automation System ( <a href="http://support.automation.siemens.com/WW/view/en/59191792">http://support.automation.siemens.com/WW/view/en/59191792</a> )	<ul style="list-style-type: none"> <li>• Application planning</li> <li>• Installation</li> <li>• Connecting</li> <li>• Commissioning</li> </ul>
	System manual ET 200SP distributed I/O system ( <a href="http://support.automation.siemens.com/WW/view/en/58649293">http://support.automation.siemens.com/WW/view/en/58649293</a> )	
	System Manual ET 200MP Distributed I/O System ( <a href="http://support.automation.siemens.com/WW/view/en/59193214">http://support.automation.siemens.com/WW/view/en/59193214</a> )	
	System manual Distributed I/O System ET 200AL ( <a href="http://support.automation.siemens.com/WW/view/en/89254965">http://support.automation.siemens.com/WW/view/en/89254965</a> )	
	Operating instructions ET 200pro Distributed I/O System ( <a href="http://support.automation.siemens.com/WW/view/en/21210852">http://support.automation.siemens.com/WW/view/en/21210852</a> )	
	Operating instructions ET 200eco PN Distributed I/O System ( <a href="http://support.automation.siemens.com/WW/view/en/29999018">http://support.automation.siemens.com/WW/view/en/29999018</a> )	

Topic	Documentation	Most important contents
Configuring interference-free controllers	Function manual Configuring Interference-Free Controllers ( <a href="http://support.automation.siemens.com/WW/view/en/59193566">http://support.automation.siemens.com/WW/view/en/59193566</a> )	<ul style="list-style-type: none"><li>• Basics</li><li>• Electromagnetic compatibility</li><li>• Lightning protection</li></ul>
Analog module	Product manual of the respective analog module	<ul style="list-style-type: none"><li>• Connecting</li><li>• Parameters</li><li>• Technical specifications</li><li>• Parameter data record</li><li>• Tables of analog values</li></ul>

### SIMATIC manuals

All current manuals for SIMATIC products are available for download free of charge from the Internet (<http://www.siemens.com/automation/service&support>).



# What you should know about analog technology

## 2.1 Overview

### Introduction

This chapter is intended to familiarize you with the essential parameters of analog input modules and analog output modules based on the fundamentals of analog technology. The descriptions and examples provided on the following pages serve as a reference to the manuals for the respective analog module and are intended to facilitate the handling of these manuals.

### Analog and binary signals

Binary signals can assume only 2 signal states: signal state 1 (voltage present) and signal state 0 (no voltage present). In control engineering, it is frequently necessary to read, process and output analog signals in addition to binary signals. In contrast to binary signals, analog signals take on any number of values within a specific range. Possible analog variables include:

- Temperature
- Pressure
- Speed
- Fill level
- pH value

### Transducers

Controllers are only capable of processing analog values in the form of bit patterns. For this purpose, transducers which can be connected to the analog module measure physical variables such as pressure or temperature. The analog input module reads this analog value in the form of current, voltage or resistance. To enable the CPU to process the current or voltage measured, an integrated analog-to-digital converter in the analog input module converts the value into a 16-bit integer value. Depending on the type of measurement, you can use the following transducers:

- Voltage transducers
- Current transducers
  - 2-wire transducers
  - 4-wire transducers
- Resistance transducers
  - 4-wire connection
  - 3-wire connection
  - 2-wire connection
- Thermocouples

Additional information on wiring various types of transducers to analog inputs can be found in Wiring transducers (Page 65).

#### Example

Speed is acquired using a transducer which converts the speed range of 0 to 1500 rpm to a voltage range of 1 to 5 V. At a measured speed of 865 rpm, the transducer outputs a value of 3.3 V.

The resulting voltage value is calculated as follows:

$$U = \frac{5\text{ V} - 1\text{ V}}{1500 \frac{\text{rpm}}{\text{min}}} * 865 \frac{\text{rpm}}{\text{min}} + 1\text{ V} = 3.3\text{ V}$$

The graph below illustrates voltage acquisition:

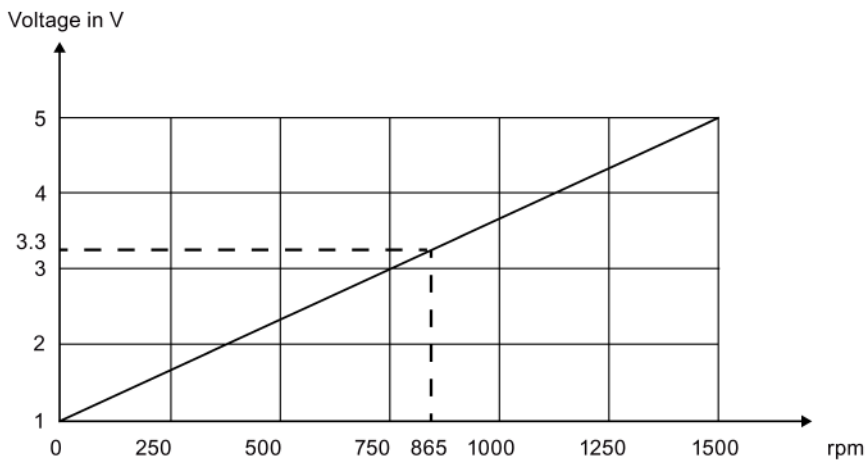

Figure 2-1 Speed measurement

## Analog-to-digital conversion

A CPU processes information exclusively in digital format. The analog value is therefore converted into a bit pattern. Conversion is done using an integrated ADC (analog-to-digital converter) in the analog input module. For the CPU, this conversion always returns a 16-bit word for SIMATIC products. The ADC used digitalizes the analog signal and approximates its value with a stepped curve. Resolution and conversion speed are the most important ADC parameters.

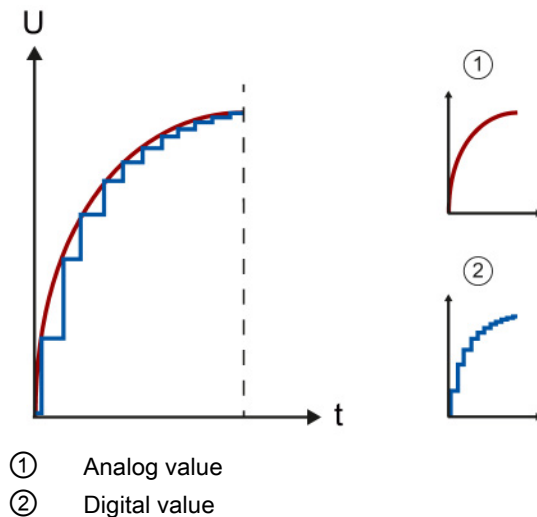

Figure 2-2 Approximation of an analog graph with low- and high-resolution stepped curves

## Digital-to-analog conversion

Once the CPU has processed the digital signal, an integrated DAC (digital-to-analog converter) in the analog output module converts the output signal to an analog current or voltage value. The resulting value of the output signal corresponds to the output value used to control the analog actuators. Such actuators include, for example, small servo drives or proportional valves. You will find more information on wiring actuators in Wiring loads/actuators (Page 103).

### Important parameters of analog modules

Alongside the type and range of measurement, the precision, resolution and conversion time are the main points to consider when selecting an analog module. For some applications such as systems which cover a large area, common mode or channel isolation are also important. The parameters listed here are examined in more detail in the following pages.

### Processing analog signals

The following figure demonstrates analog signal processing in a PLC.

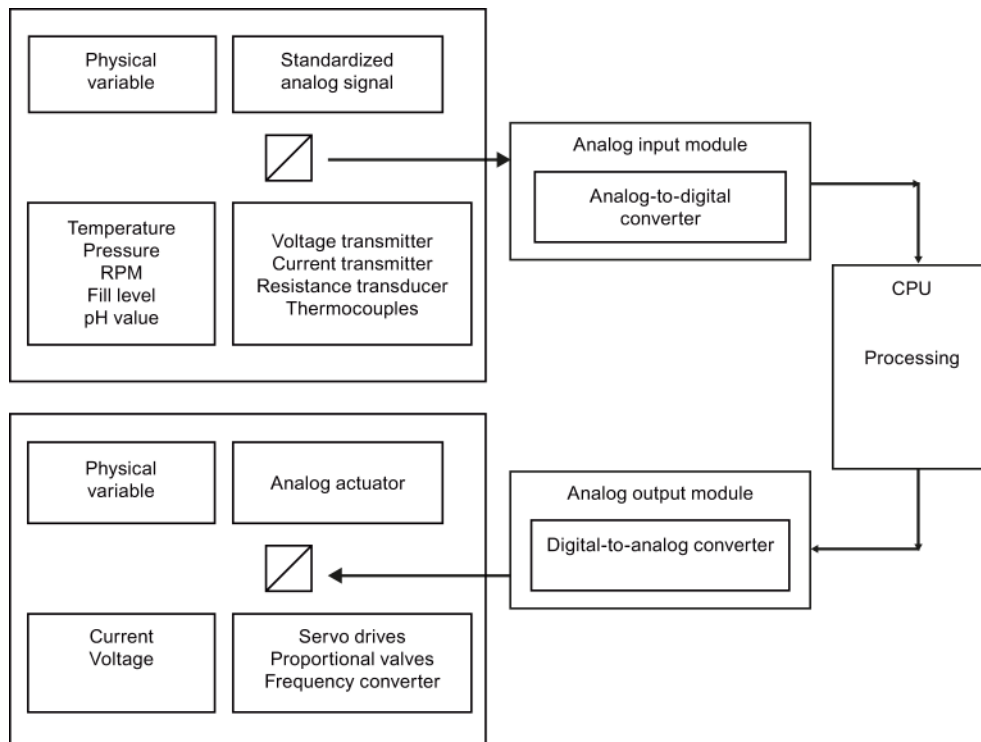

Figure 2-3 Analog value processing

## 2.2 Precision/resolution

The resolution of an analog module depends on the converter and its external circuitry. An approximation of the analog signal to be acquired/output is returned by a stepped curve. The resolution determines the number of increments of the analog value along this stepped curve. A higher module resolution reduces the length of increments and adds precision to the digitization of the analog signal.

### Approximation of an analog value

The figures below show the approximation of an analog value by means of a stepped curve. A low resolution only returns a rough approximation of the actual curve (left figure), while the approximation is more precise at higher resolutions (right figure).

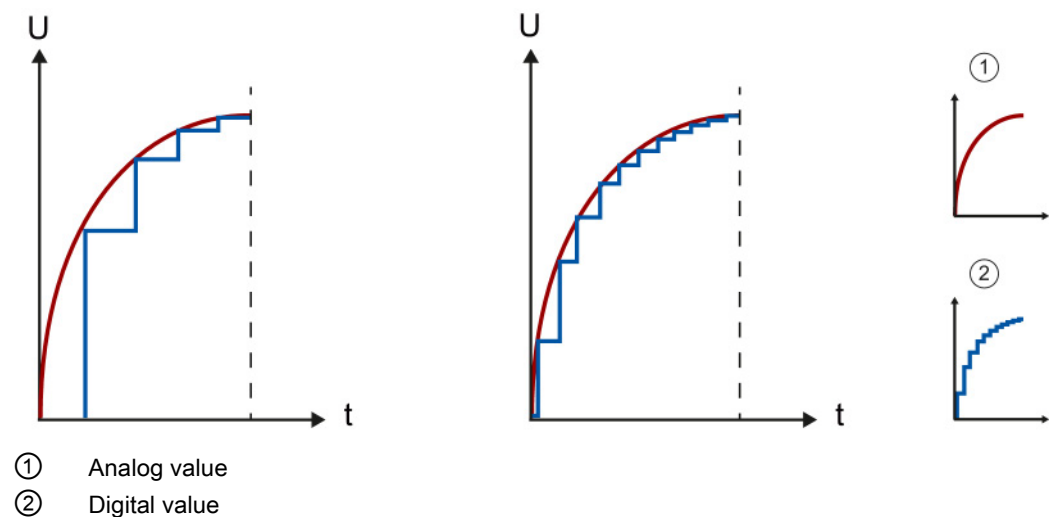

Figure 2-4 Approximation of an analog curve with a stepped curve

### Visualization of the measuring range at a resolution of 13 bits and 16 bits

The unipolar measured value from a module having a resolution of 13 bits (= 12 bits + S) is segmented into a total of  $2^{12} = 4096$  increments. The smallest increment in a measuring range of 0 to 10 V is  $10 \text{ V}/4096$ , equal to 2.4 mV.

A module with 16-bit (= 15 bits + S) resolution thus provides an increment of 0.3 mV. If the resolution increases by one bit, the number of increments doubles and the width of an increment halves.

If the resolution increases from 13 bits to 16 bits, the number of increments increases eightfold from 4096 to 32768. With a resolution of 13 bits, the smallest value that can be displayed is therefore 2.4 mV. By contrast, this value is approximately 0.3 mV at a resolution of 16 bits.

### Measuring ranges

For the display of the measuring range, SIMATIC S7 distinguishes between the rated range, the overrange and underrange, and the overflow or underflow. This distinction allows you to recognize whether the measured value is actually in the measuring range determined in the technical specifications. The overflow and underflow ranges are reserved for error detection.

At a resolution of 16 bits the theoretically possible 32768 increments are distributed across a voltage range of 11.852 V, which means that only 27648 increments are actually available for the resolution of a measuring range of 10 V. The minimum value which can be represented is therefore 0.3617 mV (see table).

Table 2- 1 Example of resolution for the 0 to 10 V measuring range of a SIMATIC S7 module

Value (increments)	Voltage measuring range	
	0 to 10 V	Range
32767	11.852 V	Overflow
32512		
32511	11.759 V	Overrange
27649		
27648	10.0 V	Rated range
20736	7.5 V	
1	361.7 $\mu$ V	
0	0 V	
not relevant for this example as negative values are not possible		
		Underflow

The digitized visualization of the input ranges, separated into bipolar and unipolar input ranges, is shown in the section Visualization of the input ranges (Page 62). The digitized visualization of the output ranges, separated into bipolar and unipolar output ranges, is shown in the section Visualization of the output ranges (Page 63). You will find a summary of all measuring ranges which you can use with your analog module in the corresponding device manual.

### Over and underrange

It may happen for control processes with high signal jumps that the settling curve of the signal briefly leaves the rated range until it reaches the setpoint. The over and underrange ensures that no error is reported while the signal is not in the rated range. If the signal exceeds the over or underrange, however, and reaches the overflow or underflow range, the error state "Overflow" or "Underflow" is diagnosed. This means the over or underrange correspond to a tolerance range between the rated range and the overflow or underflow. Additional information on the settling time is available in the section Settling and response times of analog output modules (Page 52).

The figure below shows the rated range, the overrange and overflow of a unipolar measuring range. The signal leaves the rated range briefly during the settling phase.

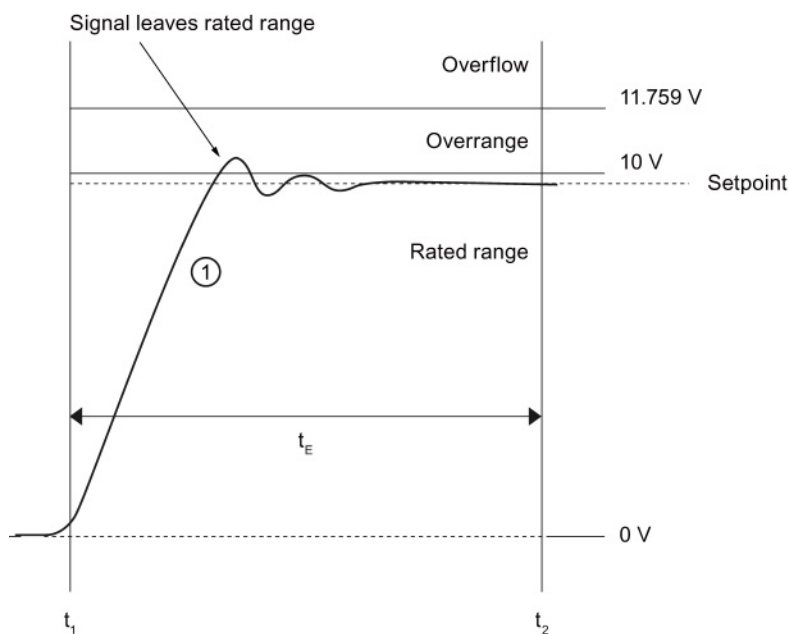

- ① Analog output signal
- $t_E$  Settling time of the signal to the setpoint
- $t_1$  Module ends conversion at the terminal of the analog output channel and outputs the signal
- $t_2$  Signal has settled and the specified analog output value has been reached

### Analog module precision

The precision of an analog module is specified as a percentage value or absolute value, for example, in K or °C. This characterizes the total error of measured value acquisition. The basic error limit at 25 °C, as well as the operational limit, are specified in accordance with international standard IEC 61131, which also forms the basis for European Standard EN 61131. For more information on the operational/basic error limits, refer to the Operational and basic error limits (Page 23) section.

### **Relation between resolution and precision**

A certain resolution must be given to reach a specific precision (operational error).

### **Example**

#### **Measuring error as a result of digitization at a resolution of 8 bits and 14 bits**

An analog module has a measuring range of 0 V to 10 V. A resolution of 8 bits represents a total of 256 values. This is equivalent to a minimum possible voltage step of 39 mV or 0.4% of the measuring range end value. A resolution of 14 bits represents a total of 16384 values. This is equivalent to a minimum possible voltage step of 0.61 mV or 0.006% of the measuring range end value.

The percentages derived in this way also represent the theoretical best-case values for the operational limit. With a resolution of 8 bits and a measuring range of 0 to 10 V, it is therefore impossible to achieve a precision of more than 0.4 %. In practical life, this value would be clearly worse, depending on the implemented circuitry.

### **Calculating the maximum measuring error**

The maximum measuring error of a 0 to 10 V analog module with an operational limit of  $\pm 0.5\%$  across the entire temperature range is calculated as follows:

$$10 \text{ V} \times 0.5/100 = 50 \text{ mV}$$

This means the maximum measuring error is approximately  $\pm 50$  mV. This also means that each analog voltage input is subject to a distortion of  $\pm 50$  mV across the entire input range. A voltage of 3.5 V that is to be measured can therefore be visualized by any value between 3.45 V and 3.55 V.

For more information on the operational/basic error limits, refer to the Operational and basic error limits (Page 23) section.



## 2.3 Scaling analog values

### Scaling

It is often necessary to calculate the actual process value rather than increments (e.g., 10 V = 27648 increments) for further processing of digitalized analog values. The conversion of a value range (e.g., -27648 to +27648 increments) to the original physical quantity (e.g., 0 to 500 liters) is referred to as scaling.

### Scaling blocks

STEP 7 offers the suitable program block for scaling of analog values. The SCALE block is included in the STEP 7 scope of delivery and permits input of a high and low limit (e.g., 0 to 500 liters).

### Example

In the example below the fill level of a tank with a capacity of 500 liters is to be measured. The transducer used measures a voltage of -10 V with an empty tank and a voltage of +10 V with a full tank. The analog module converts the voltage range from -10 V to +10 V into the value range -27648 to +27648 and converts this range into the original quantity of 0 to 500 liters with the SCALE program block.

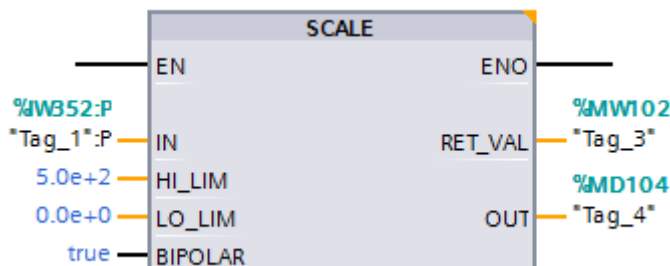

Figure 2-5 Scaling in the SCALE program block

The analog value at input **IN** is read directly by the module or is transferred by a data interface in INT format. The input **LO\_LIM** is used to determine the low limit (0 liters) and **HI\_LIM** to determine the high limit (500 liters) of the physical quantity. The output **OUT** outputs the scaled value (physical quantity) as floating-point number ( $LO\_LIM \leq OUT \leq HI\_LIM$ ). You can assign parameters via the input **BIPOLAR** to specify if only positive or only negative values are to be converted. If the parameter receives an operand with the state '0', there is a unipolar scaling. An operand with the state '1' results in a bipolar scaling. The output **RET\_VAL** outputs an error code in case of an error (e.g., overflow) and the value '0' in case of an error-free execution.

Additional information on the SCALE block can be found in the STEP 7 online help.

### Unipolar and bipolar measuring ranges

The measurement of the fill level in our example took place within a bipolar measuring range. In addition to the positive voltage the transducer also provides negative voltage. Because the tank volume is mapped to the range from -27648 to +27648 increments, the measurement of the fill level takes place with twice the resolution ( $\Delta$ ) as in the unipolar measuring range.

---

#### Note

##### Transducers

The prerequisite for a measurement within a bipolar measuring range is that the used transducer supports bipolar measuring ranges.

---

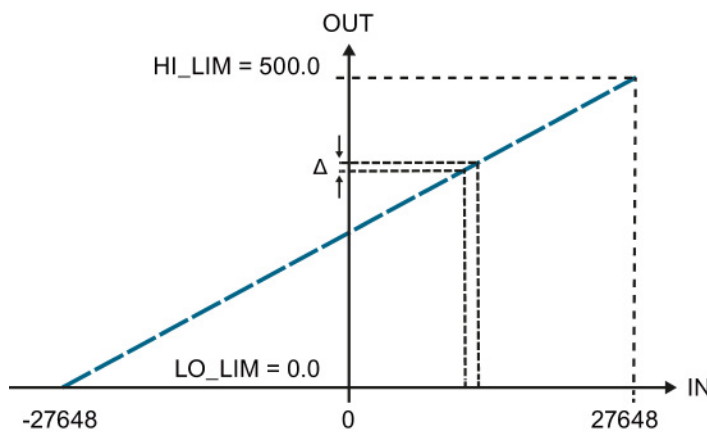

Figure 2-6 Bipolar measuring range

The measurement of the fill level in the bipolar measuring range takes place with twice the resolution ( $\Delta$ ) as in the unipolar measuring range.

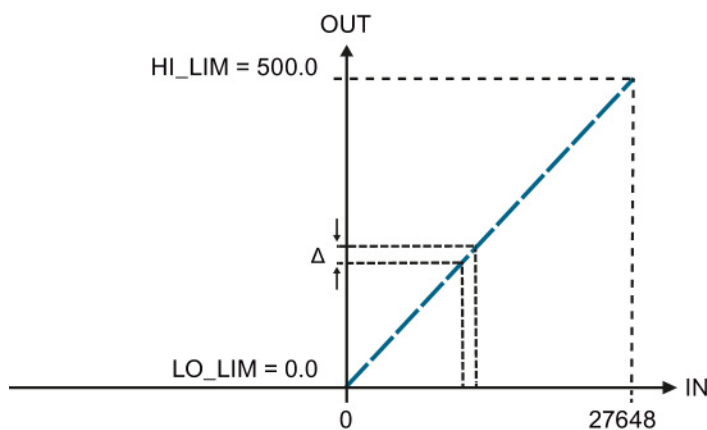

Figure 2-7 Unipolar measuring range

## 2.4 Unscaling analog values

### Unscaling

The output of scaled analog values often requires conversion of the analog value calculated by the user program into the value range of the analog output module. This conversion is referred to as unscaling.

### Unscaling blocks

STEP 7 offers the suitable program block for unscaling of analog values. The UNSCALE block is included in the STEP 7 scope of delivery and permits the input of a high and low limit that defines the range of the program value.

### Example

An analog value from 0.0 to 100.0% calculated by the user program is to be converted with the UNSCALE block to the value range -27648 to +27648. When the unscaled value is output to an analog output module, this module addresses an analog actuator (e.g., modulating valve). The actuator is to be addressed at a program value of 0% with the minimum value (-10 V or -20 mA) and at 100% with the maximum value (+10 V or +20 mA).

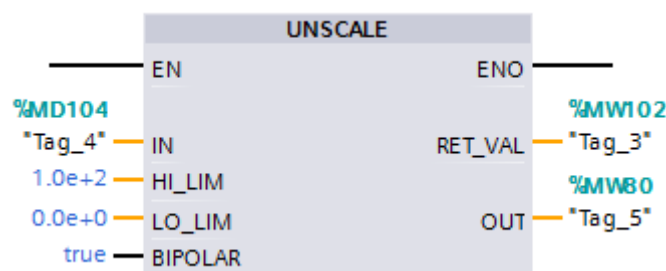

Figure 2-8 Unscaling in the UNSCALE program block

The value calculated by the program must be transferred in the REAL format (**IN**). You use the input **LO\_LIM** to determine the low limit (0.0%), and **HI\_LIM** to determine the high limit (100.0%) within which the program value moves. The unscaled value is output in INT format at the **OUT** output. You can assign parameters via the input **BIPOLAR** to specify if only positive or only negative values are to be converted. If the parameter receives an operand with the state '0', there is a unipolar scaling. An operand with the state '1' results in a bipolar scaling. The output **RET\_VAL** outputs an error code in case of an error and the value '0' in case of an error-free execution.

Additional information on the UNSCALE block can be found in the STEP 7 online help.

### Unipolar and bipolar measuring ranges

The figure below shows the scaling for an actuator that is to be addressed at a program value of 0% with the minimum value 0 (0 V or 0 mA) and at 100% (+27648) with the maximum value (10 V or 20 mA).

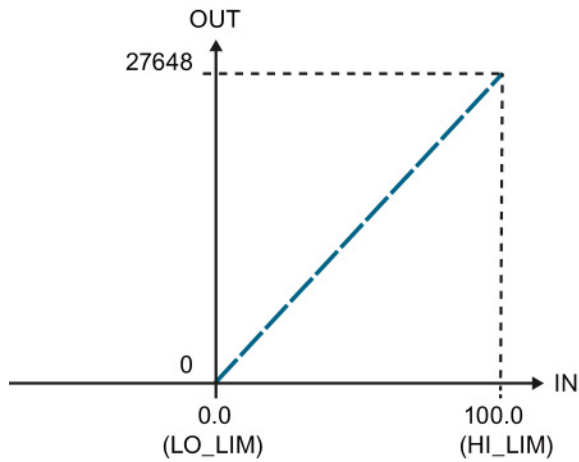

Figure 2-9 Unipolar measuring range

The figure below shows the scaling for an actuator that is to be addressed at a program value of 0% (-27648) with the minimum value 0 (-10 V or -20 mA) and at 100% (+27648) with the maximum value (+10 V or +20 mA).

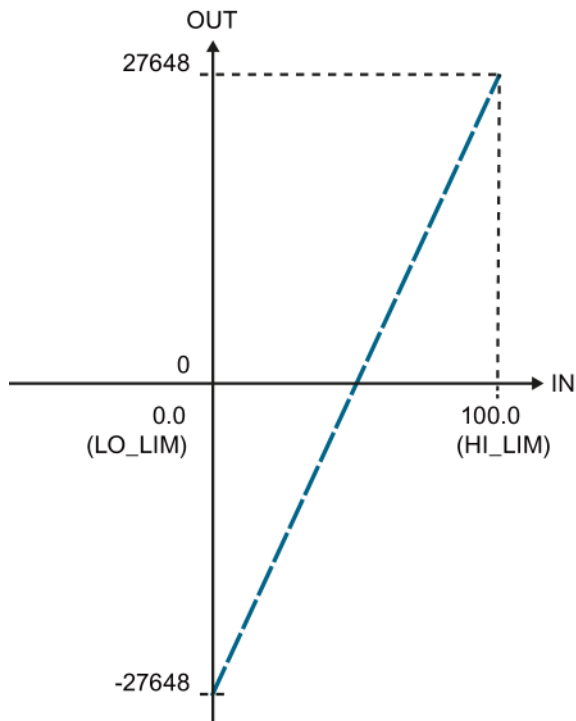

Figure 2-10 Bipolar measuring range

## 2.5 Linearity errors

### Definition

Linearity denotes the deviation of the actual A/D or D/A conversion from the ideal lines within a specified measuring range. The linearity error therefore represents the deviation of the real transmission function from the ideal straight line. The error is given in the technical data as a percentage of the rated range of the analog module.

The figure below shows the linearity error of an ADC, magnified for better visibility.

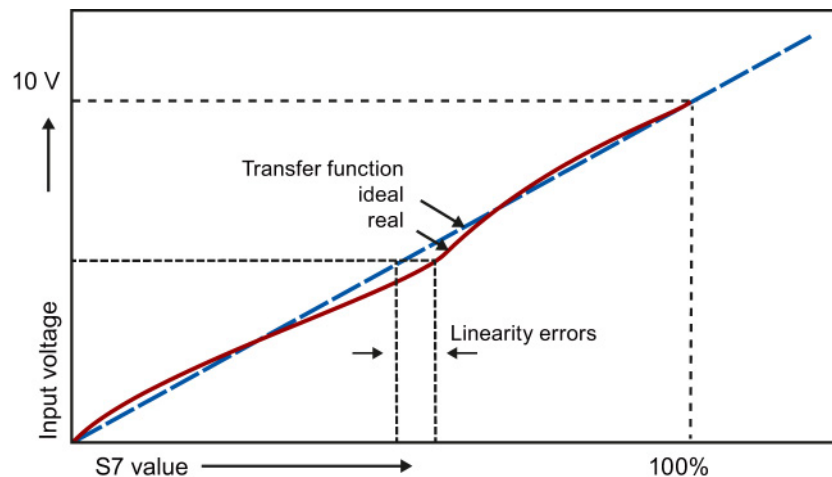

Figure 2-11 Linearity errors

### Example

An error of  $\pm 1$  mV is returned at an input range of  $\pm 10$  V and a linearity error of  $\pm 0.01\%$ . The error is calculated as follows:  $10 \text{ V} \cdot 0.01 \% = 1 \text{ mV}$

The linearity error information given in the technical specifications is taken into account in the operational limit. You will find a detailed description of the operational limit in Operational and basic error limits (Page 23).

## 2.6 Repeat accuracy

### Definition

The repeat accuracy is the maximum deviation in measured/output value for the same input signal or output value after another value has been created or output. Other parameters, e.g. the Temperature parameter, remain unchanged. The repeat accuracy refers to the rated range of the module and applies in a steady temperature state.

### Measured value variance

The repeat accuracy provides information on the variance of individual measurements. The smaller the variance, the greater the repeat accuracy. The repeat accuracy is therefore one of the most important properties of measuring devices. In the technical data, the repeat accuracy is given as a percentage of the input or output range at 25°C in the steady state.

### Example

The specified repeat accuracy for an analog input module as a percentage of the measuring range end value is  $\pm 0.02\%$ . This corresponds to a repeat accuracy of 2 mV for any value within the measuring range of  $\pm 10\text{ V}$ . If you change the measured value from 10 V to -10 V, for example, and then measure with 10 V again, the measured value deviation may not exceed  $\pm 2\text{ mV}$ .

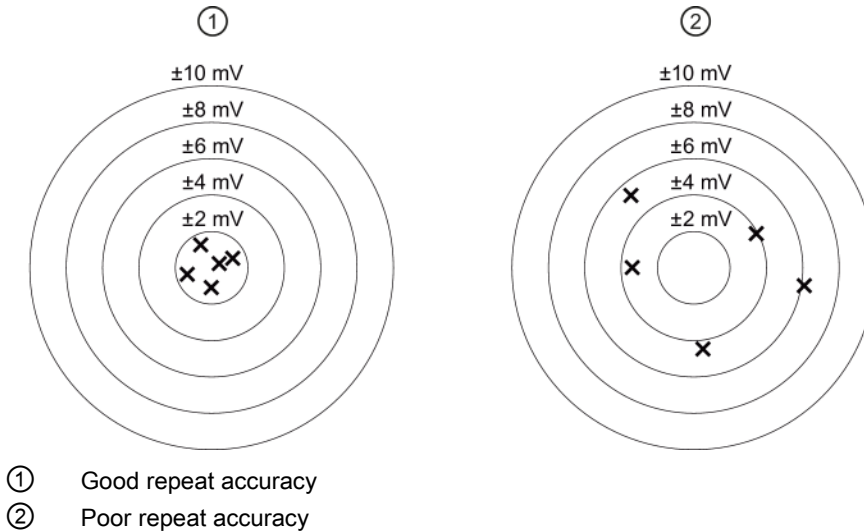

Figure 2-12 Repeat accuracy of measured values output

## **2.7 Operational and basic error limits**

### **Introduction**

The following section shows you how to determine the operational or basic error limits and thus the measurement error or output error with the help of the technical specification. The worst-case configuration ensures that the module will not exceed the specified value within the valid operational range.

The precision of analog input or output modules is only part of the precision of the entire measurement section. A measurement section usually consists of transducer, transmitter, transmission line as well as input / output module.

### **Operational limit**

The operational limit is the entire measurement or output error rate of the analog module in the rated range in temperature-settled state within the approved temperature range.

### Basic error limit

The basic error limit is the entire measurement or output error rate in the rated range at an ambient temperature of 25 °C and temperature-settled state.

The basic error limit of the module is more or less a theoretical value, because a constant ambient temperature of 25 °C is rarely maintained in plants. For this reason, the operational limit always takes priority in terms of the practical selection and assessment of a module.

#### Note

The operational limit and basic error limit percentages listed in the technical specifications always relate to the **maximum possible** I/O value (the measuring range end value) in the rated range of the module.

The following image shows an example of operational and basic error limits in comparison with the ideal curve.

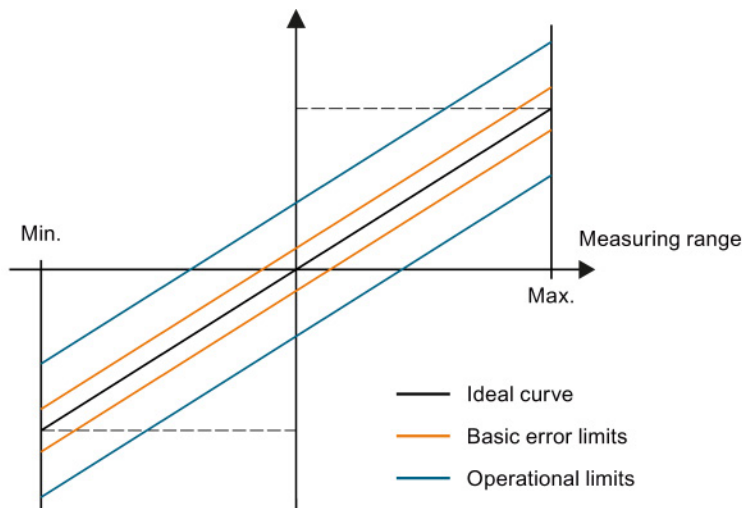

Figure 2-13 Operational and basic error limits



### **Example of output error calculation**

An analog output module is used for voltage output in a range of 0 to 10 V. The module is operating at an ambient temperature of 30 °C, which means that the operational limit applies. Technical specifications of the module:

- Operational limit for the voltage output:  $\pm 0.1\%$

The result is an output error of approximately  $\pm 10$  mV ( $\pm 0.1\%$  of 10 V) across the rated range of the module.

For example, the output value may range from 2.49 V to 2.51 V at an actual voltage of 2.50 V.

---

#### **Note**

##### **Bipolar measuring ranges**

The calculation also applies to bipolar measuring ranges.

An error of  $\pm 10$  mV is also returned at an input range of  $\pm 10$  V and a linearity error of  $\pm 0.1\%$ .

## 2.8 Temperature error

### Introduction

Analog modules are exposed to operational conditions that have an impact on their precision and on the measurement results they return. Temperature errors develop, for example, if the operating temperature of the module deviates from the ambient temperature of 25 °C. These temperature errors within the approved temperature range are taken into account in the operational limit.

### Definition

The temperature error identifies the maximum drift of measuring/output values caused by fluctuation of the ambient temperature at the analog module. The maximum drift can occur at any ambient temperature. The temperature error is specified depending on the module used in percent per degree Celsius and/or percent per Kelvin, e.g.  $\pm 0.005\%/K$ , and relates to the measuring range end value of the analog module.

### Operational limits of compensation

The temperature error of the reference junction temperature compensation function only occurs with thermocouple measurements. The temperature error of compensation is added to the actual temperature error if "Internal reference junction" operating mode is selected. The temperature error of compensation is defined in the technical specifications as a percentage of the physical rated range of the analog module or as an absolute value in °C.

---

#### Note

##### Calculating the error in thermocouple measurements

Add the error of a thermocouple measurement to the error of the compensation measurement to determine the total error of a thermocouple measurement. These errors are defined in the respective manual.

---

### Example

In this example, the total error of the temperature measurement is determined with the help of a type K thermocouple. The type K thermocouple takes measurements at a temperature range from -270 °C to +1372 °C.

The technical specifications state an operational limit of  $>-200\text{ °C} \pm 2.4\text{ K}$  for the type K thermocouple. The temperature error of compensation amounts to  $\pm 6\text{ °C}$ . The total temperature error is measured as follows at a temperature of  $>-200\text{ °C}$ :

Operational error ( $\pm 2.4\text{ K}$ ) + temperature error of compensation ( $\pm 6\text{ °C}$ ) =  $\pm 8.4\text{ °C}$ .

## 2.9 Interference frequency suppression

### Definition

The interference frequency suppression function is applied to analog input modules to suppress the noise caused by the frequency of the AC voltage supply used.

The frequency of the AC voltage supply is likely to have a negative effect particularly on the values returned by measurements in the low voltage range and on thermocouples.

### Parameter assignment

The line frequency at which the system is operated can be set by means of module parameters, for example, in STEP 7.

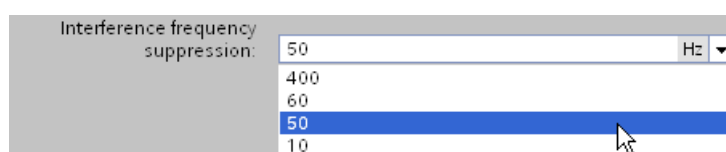

Figure 2-14 Interference frequency suppression

The conversion time changes depending on the set interference frequency suppression. The data sheets of the respective module define this dependency.

Please note the following when selecting interference frequency suppression:

The higher the frequency setting, the shorter the conversion time.

---

### Note

#### Line frequency

Always select the interference frequency based on the line frequency used. Mismatch errors must be expected if a frequency that deviates from this line frequency is set, for example, to reduce the conversion time. In this case, the specified technical data and, in particular, precision are possibly outside the specified range.

#### Smoothing

By smoothing analog values, you achieve an additional improvement for the suppression of interference frequencies. For more information on the smoothing of analog values, refer to the section Smoothing (Page 54).

---

### **Line frequencies used**

The line frequency is the frequency used in an electricity network for AC supply. It is measured in hertz and indicates the number of oscillations per second in a periodic signal. A line frequency of 50 Hz, for example, means 50 oscillations per second.

Europe, Australia and most countries in Asia and Africa use a line frequency of 50 Hz. North and Central America and most countries in South America have electricity networks with a line frequency of 60 Hz.

Frequencies of 400 Hz are most commonly used in on-board networks for airplanes, in the aerospace sector and for military applications. One reason for this is that engines with a line frequency of 400 Hz can usually be made smaller and lighter. As, however, it is not economic to transport such high frequencies over large distances, 400 Hz applications are usually subject to significant spatial limits.

A frequency of  $16 \frac{2}{3}$  Hz is used for the traction power supply in Germany, Austria and Switzerland. Some modules of the SIMATIC S7 product range also support the interference frequency suppression of this line frequency. The configurable interference frequency suppression in these cases is 16.6 Hz.

## 2.10 Common mode interference (UCM)

### Definition

Common mode interference denotes interference voltages and currents in the lines connecting electrical devices and system components. They affect both the positive and negative line with the same phase angle and amplitude. The interference signal needs an additional current path to affect the utility signal. This current path is usually provided by common reference potential, e.g. earth or ground connection, of the utility signal and interference source.

### Common mode interference in analog modules

Common mode interference occurs in analog input and output modules if their reference potential is different from the reference potential of the connected sensor or actuator.

Common mode interference is most likely to occur when analog modules are operated with grounded sensors. The size of the overall system means that voltage differences may develop between machine components with grounded sensors and the analog module reference. These voltage differences affect both the positive and negative signal path equally, which is why they are termed common mode interference.

In operation with non-grounded sensors, the occurrence of common mode interference is not as obvious as in grounded operation. Nevertheless, capacitive or inductive coupling can also create voltage differences in such cases which have the effect of common mode interference. Depending on the conditions in grounded and non-grounded operation, common mode voltage can occur as direct or as alternating voltage.

**Example**

The following figure of an analog module with two inputs (Ch<sub>1</sub>/Ch<sub>2</sub>) shows the coupled interference voltages at the inputs (U<sub>CM1</sub>/U<sub>CM2</sub>) as well as an interference voltage coupled between these inputs (U<sub>CM3</sub>). Common mode rejection indicates the extent to which these interference signals can be suppressed. It is calculated using the following equation:  
CMR [dB] = 20 · log (U<sub>CM</sub> / U<sub>a</sub>)

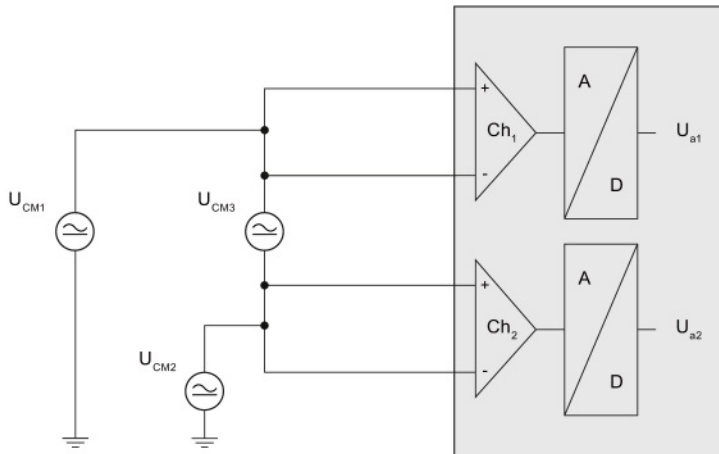

Figure 2-15 Common mode voltage coupled between two inputs

If there is common-mode voltage (U<sub>CM</sub>), the equation is solved for U<sub>a</sub> to calculate the measuring error (U<sub>a</sub>):

$$U_a = U_{CM} * 10^{-\frac{CMR}{20}}$$

**Note**

The common mode rejection (CMR) is detailed in "Common mode interference" in the technical data of the device manual for your analog module.

## 2.11 Series mode interference (USM)

### Definition

Series mode interference is interference voltages and currents affecting the connection lines in opposite directions. They have opposite polarity in the positive and negative directions. Series mode interference currents cause a voltage drop at the input impedance that has the effect of an interference voltage.

### Causes

Series mode interference is caused by capacitive or inductive coupling. Inductive coupling generates a magnetic flow that is radiated between adjacent current-carrying conductors. This induces an interference voltage in the conductor. Galvanic coupling is given where different circuits influence each other due to common conductor sections, e.g. common ground connection.

The diagram below shows series mode interference as a voltage source ( $U_{SM}$ ) connected in series to the actual measuring signal ( $U_M$ ). The index "SM" stands for "Series Mode". Series Mode rejection indicates the extent to which these interference signals are suppressed. It is calculated using the following equation:  $SMR [dB] = 20 \cdot \log (U_{SM} / U_a)$

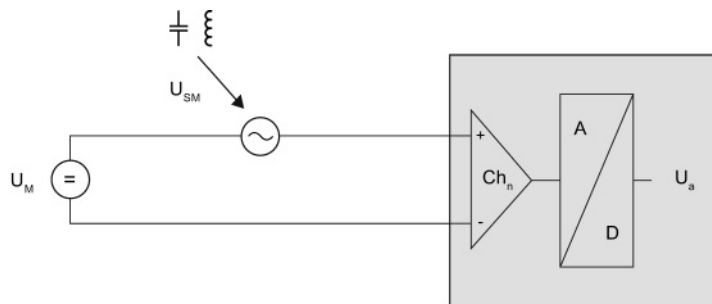

Figure 2-16 Capacitive or inductive interference coupling to the signal cable

The voltage ( $U_a$ ) measurement error is calculated by solving the equation for  $U_a$ .

$$U_a = U_{SM} * 10^{-\frac{SMR}{20}}$$

The following equation shows the calculation of current ( $I_a$ ) measuring errors using a current input.

$$I_a = \frac{U_{SM}}{R_{ein}} * 10^{-\frac{SMR}{20}}$$

### Note

The series mode rejection (SMR) is detailed in "Series mode interference" in the technical data of the device manual for your analog module. The level of input resistance ( $R_{ein}$ ) is also specified in the technical data.

## 2.12 Interference voltage suppression

### Definition

Interference voltage suppression gives the factor by which the interference signal is suppressed in measurement value acquisition. Higher values reduce the effect of interference on the measurement signal. The technical data differentiates between "Common mode interference" and "Series mode interference". Interference voltage suppression is specified in decibels.

### Example

The diagram below shows the measuring error for interference voltages in volts and interference voltage suppression of 0 to 120 dB.

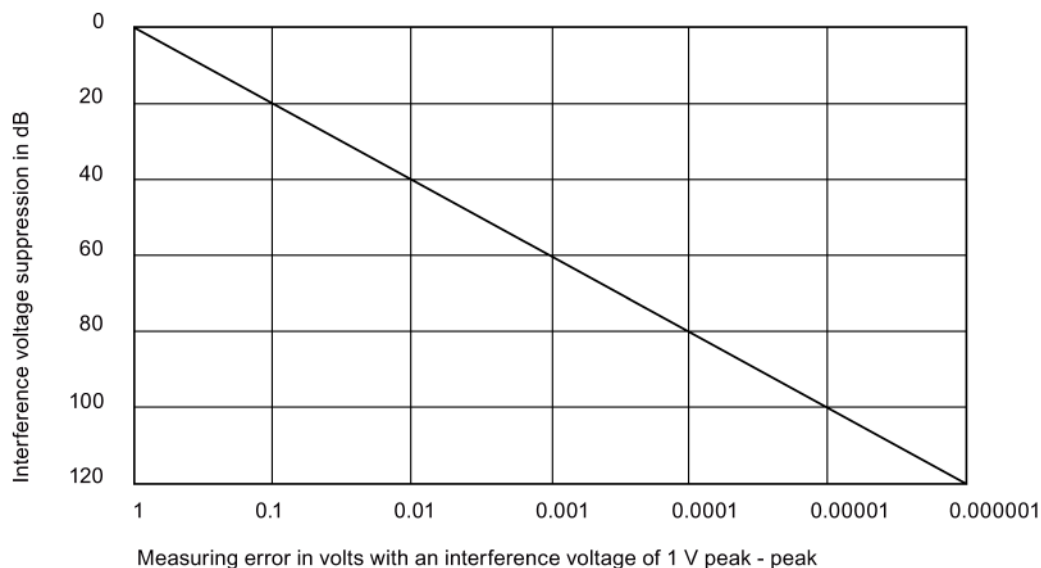

Figure 2-17 Interference voltage suppression

With an interference voltage suppression of 40 dB and an interference voltage of 1 V, the measured value is only distorted by 0.01 V.

### Note

#### Interference-free design

Disturbance variables can be substantially reduced by means of appropriate grounding and shielding to increase interference immunity of the configuration. You will find a detailed description of how to avoid interference in the Configuring interference-free controllers (<http://support.automation.siemens.com/WW/view/en/59193566>) function manual.



### Common mode rejection

The table below sets out the possible common mode rejection specifications in the technical data of an analog input module:

Interference voltage suppression for $f = n \times (f_1 \pm 1 \%)$ , ( $f_1 =$ interference frequency), $n = 1, 2, \dots$	
Common mode interference	> 100 dB
Common mode voltage, max.	10 V

If the interference frequency is configured as 50 Hz, the specified interference voltage suppression for common mode interference will only apply for the frequencies 50 Hz  $\pm 1 \%$ , 100 Hz  $\pm 1 \%$ , 150 Hz  $\pm 1 \%$ , etc. Immunity is lower for all other frequencies. Interferences caused by the line voltage distort the measured utility signal in the ratio of 100,000 : 1. An interference voltage amplitude of 1 V, for example, will affect the utility signal by 10  $\mu$ V.

The Common Mode voltage ( $U_{CM}$ ) defines the maximum permitted deviation of the potential between two channels and between one channel and analog ground. The interference voltage suppression defined in the technical specifications must not be exceeded. If the maximum common mode voltage specified, for example, 10 V, is exceeded, the analog signal is processed incorrectly. Depending on the module used, this error may be diagnosed and an error message output. The maximum common mode voltage may be exceeded as a result of varying input or overly long lines.

### Series mode rejection

The table below sets out the possible series mode rejection specifications in the technical data of an analog module:

Interference voltage suppression for $f = n \times (f_1 \pm 1 \%)$ , ( $f_1 =$ interference frequency), $n = 1, 2, \dots$	
Series mode interference	> 60 dB

If the interference frequency is configured as 50 Hz, the specified interference voltage suppression for series mode interference will only apply for the frequencies 50 Hz  $\pm 1 \%$ , 100 Hz  $\pm 1 \%$ , 150 Hz  $\pm 1 \%$ , etc. Immunity is lower for all other frequencies. Overall, interference caused by the line voltage distorts the utility signal measured by 1000 : 1. For example, an interference voltage amplitude of 1 V will affect the utility signal by 1 mV.

## 2.13 Crosstalk between channels

### Origin of the term

The term crosstalk/XT was originally used in the field of telecommunication to denote unwanted coupling of voice signals between two cable conductors of different subscribers.

### Definition

Crosstalk between signal channels denotes the interactive influence between two independent channels as a result of leakage currents and capacitive or inductive coupling. Crosstalk between the channels changes the signal by the value of the amplitude of the crosstalk signal.

### Causes

Technically, it is not feasible to totally isolate the module channels from environmental conditions. This means that it is always possible for leakage currents or disturbance coupling having an interactive effect.

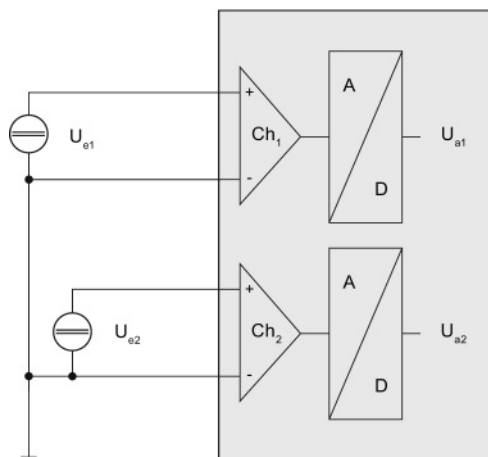

Figure 2-18 Crosstalk between two channels

The diagram shows the effects of crosstalk for the user with two channels (Ch<sub>1</sub>/Ch<sub>2</sub>) of an analog module. The crosstalk value is the factor by which the utility signal at a second channel U<sub>a2</sub> is affected by the signal at the first channel U<sub>e1</sub>. The measuring error (U<sub>a1</sub>) can be calculated using the following equation:

$$U_{a1} = U_{e2} * 10^{\frac{XT [dB]}{20}}$$

### Example of crosstalk attenuation

The "crosstalk between inputs" value in the technical specifications is defined as a value of >-100 dB at a measuring range of -10 V to +10 V on channel 1 of an eight-channel analog input module. The voltage at the input has an amplitude of 10 V. What is the error caused by crosstalk at channel 0 (measuring range ±10 V) and channel 2 (measuring range ±80 mV)?

100 dB are equal to a factor of 100,000. The measured values at channels 0 and 2 to 7 are therefore affected by  $10 \text{ V} / 100,000 = 100 \text{ } \mu\text{V}$ . This distortion is added to or subtracted from the pending measuring signal and its effect depends on the selected measuring range.

- Channel 0:  $100 \text{ } \mu\text{V} / 10 \text{ V} = 0.001 \%$
- Channel 2:  $100 \text{ } \mu\text{V} / 80 \text{ mV} = 0.125 \%$

A voltage of 10 V set at channel 1 distorts the measured value at channel 0 by 0.001% and the measured value at channel 2 by 0.125%. The measuring error resulting from crosstalk in this example is therefore 0.001 % or 0.125 %. The basic error limit already includes the error generated as a result of crosstalk between the channels.

### Calculating measuring error

You calculate the measurement error at channel 1 in this example based on a change in the measurement voltage of 10 V at channel 2. The crosstalk (XT [dB]) value is defined in the technical specifications in the manual of the analog module that you are using.

$$\text{Measured value error channel 1 [in V]} = \text{measured value change at channel 2 [in V]} * 10^{\frac{\text{XT [dB]}}{20}}$$

$$\text{Measured value error channel 1 [in V]} = 10 \text{ V} * 10^{\frac{-80 \text{ dB}}{20}} = 0.001 \text{ V}$$

A change in the measurement voltage of 10 V at channel 2 causes a measurement deviation of 0.001 V at channel 1.

## 2.14 Diagnostics

### Diagnostics for analog modules

SIMATIC analog modules can diagnose errors. A number of different types of diagnostics are available for analog modules in STEP 7. Please note that the parameter assignment options vary depending on the analog module and product family used. More detailed information on the types of diagnostics can be found in the device manual for your analog input or analog output module.

Proceed as follows to select the diagnostics types of the analog module used:

1. Open STEP 7.
2. Select the analog module in the Device view.
3. Select the "Properties" tab.
4. Select the inputs or the required channel of the analog module in the Inspector window.

Table 2- 2 Overview of diagnosable errors

Type of diagnostics	Analog input module	Analog output module
Wire break	✓	✓
No supply voltage L+	✓	✓
Overflow	✓	✓
Underflow	✓	✓
Common mode error	✓	-
Short-circuit	✓	✓
Overload	-	✓
Reference junction	✓	-

Diagnostics of the analog module are carried out while the system is in operation, on the basis of the current output variables such as current or voltage. If the output current or output voltage is no longer sufficient, the module will not be able to run reliable diagnostics. The limits within which diagnostics are possible are specified in the technical data for each module.

The module reports the diagnosed state to the CPU using a diagnostics error interrupt. If several diagnostics are pending at the same time, the diagnostics with the highest priority is reported to the CPU first. Diagnostics are output on LED displays on the affected module, on the CPU display, on the Web server or on an HMI device.

The configurable diagnostics types depend on the respective selected measuring type or output type. The following tables shows the relationship between the diagnostics types, measuring types or output types of an analog input module or analog output module.

**Diagnostics Analog input modules**

Table 2- 3 **Diagnostics types of an analog input module to be configured depending on the measurement type "Voltage"**

	No supply voltage L+	Wire break (1 to 5 V)	Overflow	Underflow	Common mode error	Reference junction	Short-circuit
S7-1500	✓	✓	✓	✓	✓	-	-
ET 200MP	✓	✓	✓	✓	✓	-	-
ET 200SP	✓	-	✓	✓	-	-	✓
ET 200AL	-	✓	✓	✓	-	-	✓
ET 200eco PN	✓	✓	✓	✓	-	-	-
ET 200pro	-	✓	✓*	✓*	-	-	✓

\* For ET 200pro, the parameters "Overflow" and "Underflow" are combined to the parameter "Overflow/Underflow"

Table 2- 4 **Diagnostics types of an analog input module to be configured depending on the measurement type "Current (4-wire transducer)"**

	No supply voltage L+	Wire break (4 to 20 mA)	Overflow	Underflow	Common mode error	Reference junction	Short-circuit
S7-1500	✓	✓	✓	✓	✓	-	-
ET 200MP	✓	✓	✓	✓	✓	-	-
ET 200SP	✓	✓	✓	✓	-	-	✓**
ET 200AL	-	✓	✓	✓	-	-	✓**
ET 200eco PN	✓	✓	✓	✓	-	-	-
ET 200pro	-	✓	✓*	✓*	-	-	✓

\* For ET 200pro, the parameters "Overflow" and "Underflow" are combined to the parameter "Overflow/Underflow"

\*\* Diagnostics for encoder supply only

Table 2- 5 **Diagnostics types of an analog input module to be configured depending on the measurement type "Current (2-wire transducer)"**

	No supply voltage L+	Wire break (4 to 20 mA)	Overflow	Underflow	Common mode error	Reference junction	Short-circuit
S7-1500	✓	✓	✓	✓	✓	-	-
ET 200MP	✓	✓	✓	✓	✓	-	-
ET 200SP	✓	✓	✓	-	-	-	✓**
ET 200AL	-	✓	✓	✓	-	-	✓**
ET 200eco PN	✓	✓	✓	✓	-	-	-
ET 200pro	-	✓	✓*	✓*	-	-	✓

\* For ET 200pro, the parameters "Overflow" and "Underflow" are combined to the parameter "Overflow/Underflow"

\*\* Diagnostics for encoder supply only

2.14 Diagnostics

Table 2- 6 Configurable diagnostics types of an analog input module depending on the measurement type "Resistor (4-wire connection)"

	No supply voltage L+	Wire break	Overflow	Underflow	Common mode error	Reference junction	Short-circuit
S7-1500	✓	✓	✓	✓	-	-	-
ET 200MP	✓	✓	✓	✓	-	-	-
ET 200SP	✓	✓	✓	✓	-	-	-
ET 200eco PN	✓	✓	✓	-	-	-	-
ET 200pro	-	✓	✓*	✓*	-	-	-

\* For ET 200pro, the parameters "Overflow" and "Underflow" are combined to the parameter "Overflow/Underflow"

Table 2- 7 Configurable diagnostics types of an analog input module depending on the measurement type "Resistor (3-wire connection)"

	No supply voltage L+	Wire break	Overflow	Underflow	Common mode error	Reference junction	Short-circuit
S7-1500	✓	✓	✓	✓	-	-	-
ET 200MP	✓	✓	✓	✓	-	-	-
ET 200SP	✓	✓	✓	✓	-	-	-
ET 200AL	-	✓	✓	-	-	-	-
ET 200eco PN	✓	✓	✓	-	-	-	-
ET 200pro	-	✓	✓*	✓*	-	-	-

\* For ET 200pro, the parameters "Overflow" and "Underflow" are combined to the parameter "Overflow/Underflow"

Table 2- 8 Configurable diagnostics types of an analog input module depending on the measurement type "Resistor (2-wire connection)"

	No supply voltage L+	Wire break	Overflow	Underflow	Common mode error	Reference junction	Short-circuit
S7-1500	✓	-	-	✓	-	-	-
ET 200MP	✓	-	-	✓	-	-	-
ET 200SP	✓	✓	✓	✓	-	-	-
ET 200AL	-	✓	✓	-	-	-	-
ET 200eco PN	✓	✓	✓	-	-	-	-
ET 200pro	-	✓	✓*	✓*	-	-	-

\* For ET 200pro, the parameters "Overflow" and "Underflow" are combined to the parameter "Overflow/Underflow"

Table 2- 9 Configurable diagnostics types of an analog input module depending on the measurement type "Thermal resistor (4-wire connection)"

	No supply voltage L+	Wire break	Overflow	Underflow	Common mode error	Reference junction	Short-circuit
S7-1500	✓	✓	✓	✓	-	-	-
ET 200MP	✓	✓	✓	✓	-	-	-
ET 200SP	✓	✓	✓	✓	-	-	-
ET 200eco PN	✓	✓	✓	✓	-	-	-
ET 200pro	-	✓	✓*	✓*	-	-	-

\* For ET 200pro, the parameters "Overflow" and "Underflow" are combined to the parameter "Overflow/Underflow"

Table 2- 10 Configurable diagnostics types of an analog input module depending on the measurement type "Thermal resistor (3-wire connection)"

	No supply voltage L+	Wire break	Overflow	Underflow	Common mode error	Reference junction	Short-circuit
S7-1500	✓	✓	✓	✓	-	-	-
ET 200MP	✓	✓	✓	✓	-	-	-
ET 200SP	✓	✓	✓	✓	-	-	-
ET 200AL	-	✓	✓	✓	-	-	-
ET 200eco PN	✓	✓	✓	✓	-	-	-
ET 200pro	-	✓	✓*	✓*	-	-	-

\* For ET 200pro, the parameters "Overflow" and "Underflow" are combined to the parameter "Overflow/Underflow"

Table 2- 11 Configurable diagnostics types of an analog input module depending on the measurement type "Thermal resistor (2-wire connection)"

	No supply voltage L+	Wire break	Overflow	Underflow	Common mode error	Reference junction	Short-circuit
S7-1500	-	-	-	✓	-	-	-
ET 200MP	-	-	-	✓	-	-	-
ET 200SP	✓	✓	✓	✓	-	-	-
ET 200AL	-	✓	✓	✓	-	-	-
ET 200eco PN	✓	✓	✓	✓	-	-	-
ET 200pro	-	✓	✓*	✓*	-	-	-

\* For ET 200pro, the parameters "Overflow" and "Underflow" are combined to the parameter "Overflow/Underflow"

Table 2- 12 Diagnostics types of an analog input module to be configured depending on the measurement type "Thermocouple"

	No supply voltage L+	Wire break	Overflow	Underflow	Common mode error	Reference junction	Short-circuit
S7-1500	✓	✓	✓	✓	✓	✓	-
ET 200MP	✓	✓	✓	✓	✓	✓	-
ET 200SP	✓	✓	✓	✓	-	✓	-
ET 200eco PN	✓	-	✓	✓	-	✓	-
ET 200pro	-	-	✓*	✓*	-	✓	-

\* For ET 200pro, the parameters "Overflow" and "Underflow" are combined to the parameter "Overflow/Underflow"

**Diagnostics for analog output modules**

Table 2- 13 Diagnostics types of an analog output module to be configured depending on the measurement type "Voltage"

	No supply voltage L+	Wire break	Overflow	Underflow	Short-circuit	Overload
S7-1500	✓	-	✓	✓	✓	-
ET 200MP	✓	-	✓	✓	✓	-
ET 200SP	✓	-	✓	✓	✓	-
ET 200eco PN	✓	-	-	-	✓	✓
ET 200pro	-	-	-	-	✓	-

Table 2- 14 Diagnostics types of an analog output module to be configured depending on the measurement type "Current"

	No supply voltage L+	Wire break	Overflow	Underflow	Short-circuit	Overload
S7-1500	✓	✓	✓	✓	-	-
ET 200MP	✓	✓	✓	✓	-	-
ET 200SP	✓	✓	✓	✓	-	-
ET 200eco PN	✓	✓	-	-	-	✓
ET 200pro	-	✓	-	-	-	-

**Note**

**Measuring ranges**

Note that the diagnostics types that can be parameterized depend on the selected measurement/output type as well as on the respective measuring range.

**Note**

**Minimum output values**

Certain errors such as wire break and short circuit cannot be diagnosed below a given current or voltage value. Diagnostics are only possible again once the output returns to above this minimum value.



## No supply voltage L+

You can diagnose a missing or low supply voltage L+ at the analog module by activating the "No supply voltage L+" checkbox. If the supply voltage is missing or too low, the status and error display on the analog module will provide the relevant information. The entry in the diagnostics buffer also makes this information available to the CPU.

If there is no supply voltage, no other types of diagnostics available are possible either.

## Wire break

The term wire break denotes a failure state that is triggered by the interruption of a usually closed electrical circuit.

### Wire break in analog input modules

The "Wire break" diagnostics function facilitates the detection of errors during system operation. In STEP 7 you define the module properties by setting various parameters. Depending on the module used, you may, for example, be able to set a current limit parameter at which a wire break is to be reported.

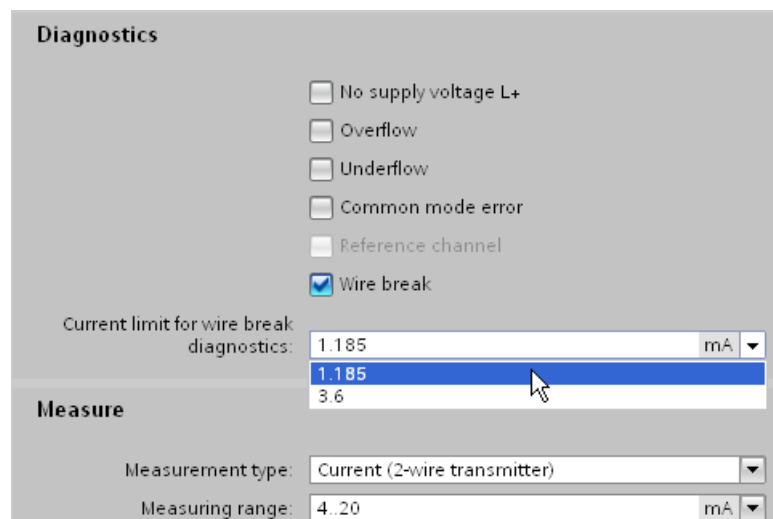

Figure 2-19 Configuring the wire break current limit for an analog input module in STEP 7

Usually, the live zero technique is deployed to detect wire breaks. The start of the measuring range for the standard live zero signal of 4 to 20 mA is assigned the 4 mA signal value. A wire break between the input and sensor can therefore be detected based on the missing current flow. Instead of a current signal, you may also use a voltage signal from 1 to 5 V to detect a wire break. The "Wire break" diagnostics function can therefore only be configured for a range of 4 to 20 mA or 1 to 5 V.

For "Resistor", "Thermal resistor" and "Thermocouple" measurements, a current is impressed into the line. If a wire break occurs, the flow of current is interrupted and the analog module therefore detects the wire break.

**Wire break in analog output modules**

The analog signal output is used for wire break detection. Reliable wire break diagnostics is not possible if the voltage is too low. In this case, the diagnostics function is deactivated without triggering a change of the diagnostics status.

The current limit up to which the module will diagnose wire break can be found in the technical data for the module.

**Overflow/underflow**

The resolution of the measuring range of an analog input module distinguishes between the rated range, the overrange or underrange, and the overflow or underflow. The following table assign the number of increments into which the measured signal is divided to the various voltage measuring ranges.

Table 2- 15 Voltage measuring range  $\pm 10$  V of an analog input module

Value (increments)	Voltage measuring range	Range
<b>Decimal</b>	<b><math>\pm 10</math> V</b>	
32767	> 11.759 V	Overflow
32511	11.759 V	Overrange
27649		
27648	10.0 V	Rated range
0	0 V	
-27648	-10 V	
-27649		Underrange
-32512	-11.759 V	
-32768	< -11.759 V	Underflow

As of a decimal value of 32512, the value acquired is beyond the overrange and is no longer valid. If this is the case, the error status "Overflow" is diagnosed. The overrange is a tolerance range before overflow is reached.

As of a decimal value of -32513, the value acquired is below the configured measuring range and is no longer valid. If this is the case, the error status "Underflow" is diagnosed. The underrange is the equivalent of the overrange, but for negative values.

An "Overflow" or "Underflow" diagnostics may be caused, for example, by a wire break, an incorrect measuring range or incorrect wiring.

---

**Note**

**Accuracy**

The accuracy specified in the technical data of the relevant module is only guaranteed within the rated range.

---

## Common mode error

Activating the "Common mode" checkbox diagnoses a violation of the maximum potential difference  $U_{CM}$ . A violation of the permitted potential difference  $U_{CM}$  has occurred, for example, between the reference point of the measuring inputs and the analog ground  $M_{ANA}$ .

Possible causes:

- Wiring error
- Environments with EMC disturbance
- Incorrectly grounded transducers
- Long line lengths
- Sensor not connected
- 2-wire transducer connected to  $M_{ANA}$

---

### Note

With 4-wire transducers, a current meter connected in series will result in too great a drop in voltage.

---

Potential differences  $U_{CM}$  beyond the valid limits may lead to measurement errors and malfunctions. If you want to ensure that the maximum value is not exceeded, interconnect the measuring inputs and analog ground  $M_{ANA}$  with an equipotential bonding cable. More detailed information can be found in *Wiring transducers*.

## Short-circuit

Activating the "Short circuit" checkbox activates short-circuit diagnostics for an analog channel. The diagnostics function is triggered by channel overload.

Possible causes:

- Wiring error (e.g. short circuit between conductors at the connections or in the cable)
- Use of faulty or incorrect actuators (e.g. internal short circuit or low input resistance as a result of actuator failure)

The analog signal output is used for short circuit detection. If the voltage is too low, reliable short-circuit diagnostics are not possible. In this case, the diagnostics function is deactivated without triggering a change of the diagnostics status. The voltage limit up to which the module will diagnose a short circuit can be found in the technical data for the module.

SIMATIC modules have a special protective circuit to prevent short circuit. The short circuit current is limited internally in the module. The level of short circuit current is specified in the technical data of your analog module.

---

### Note

#### Overload

Please note that overload exposes the modules are exposed to a greater thermal load. This can affect the output channels. You should therefore avoid continuously running analog output modules in overload.

---

## Reference junction

This type of diagnostics can only be selected for analog input modules for "Thermocouple" measuring. Selecting the "Reference junction" check box diagnoses an error on the reference channel for compensating the reference junction temperature.

The temperature at the reference junction of a thermocouple is measured at the reference channel of the module using an external thermal resistor (RTD). If an error occurs, for example as a result of a wire break, the temperature measured at the reference junction of the thermocouple will no longer be compensated. The reference temperature may then be outside the valid range.

Additional information on connecting thermocouples and thermal resistors and on how they operate can be found in Thermocouples and Wiring transducers.

## **Overload**

Activating the "Overload" checkbox activates the diagnostics of the thermal monitoring of the output level. The "Overload" diagnostics is triggered when the maximum temperature is exceeded at the output and is detected channel by channel.

The maximum temperature may be exceeded for the following reasons:

- Ambient temperature is too high
- Output is being operated outside the specification

---

### **Note**

#### **Overload**

Please note that overload exposes the modules to a high thermal load. This can affect the output channels. You should therefore avoid continuously running analog output modules in overload.

---

## 2.15 Value status

### Value status

In case of a faulty analog value, the analog module outputs the error values 0x7FFF (error value for overflow and all other error states) or 0x8000 (error value for underflow) for the affected channel. The user program is now able to detect and evaluate a channel error. The user also has the option to evaluate the system diagnostics event-driven by means of diagnostics alarms.

In addition to the error values 0x7FFF or 0x8000 and the configured diagnostic types, analog input and output modules provide diagnostics information by means of the Process image input (PII). It is referred to as Value status and transferred synchronously with the user data. The value status (Quality Information = QI) provides a statement regarding the validity of the input signal. A distinction is made between the quality level "Good" (signal valid = 1) and "Bad" (signal invalid = 0).

---

#### Note

For analog input modules, the use of the value status is an alternative to the evaluation of the channels by the error values 0x7FFF or 0x8000. Compared to the error values, the binary evaluation of the value status (0 or 1) in the user program is simpler and more clearly arranged.

For analog output modules, the value status informs you as to whether the written value can be output by the respective channel. Using the value status you can respond to this information without having to evaluate the diagnostics of the module in the first place.

---

## Example

### Enabling the value status of an analog input module

To enable the value status of an analog input module, follow these steps:

- Select the required analog module in STEP 7.
- Select "AI configuration" in the "Properties" tab of the analog module.
- Click the "Value status" button.

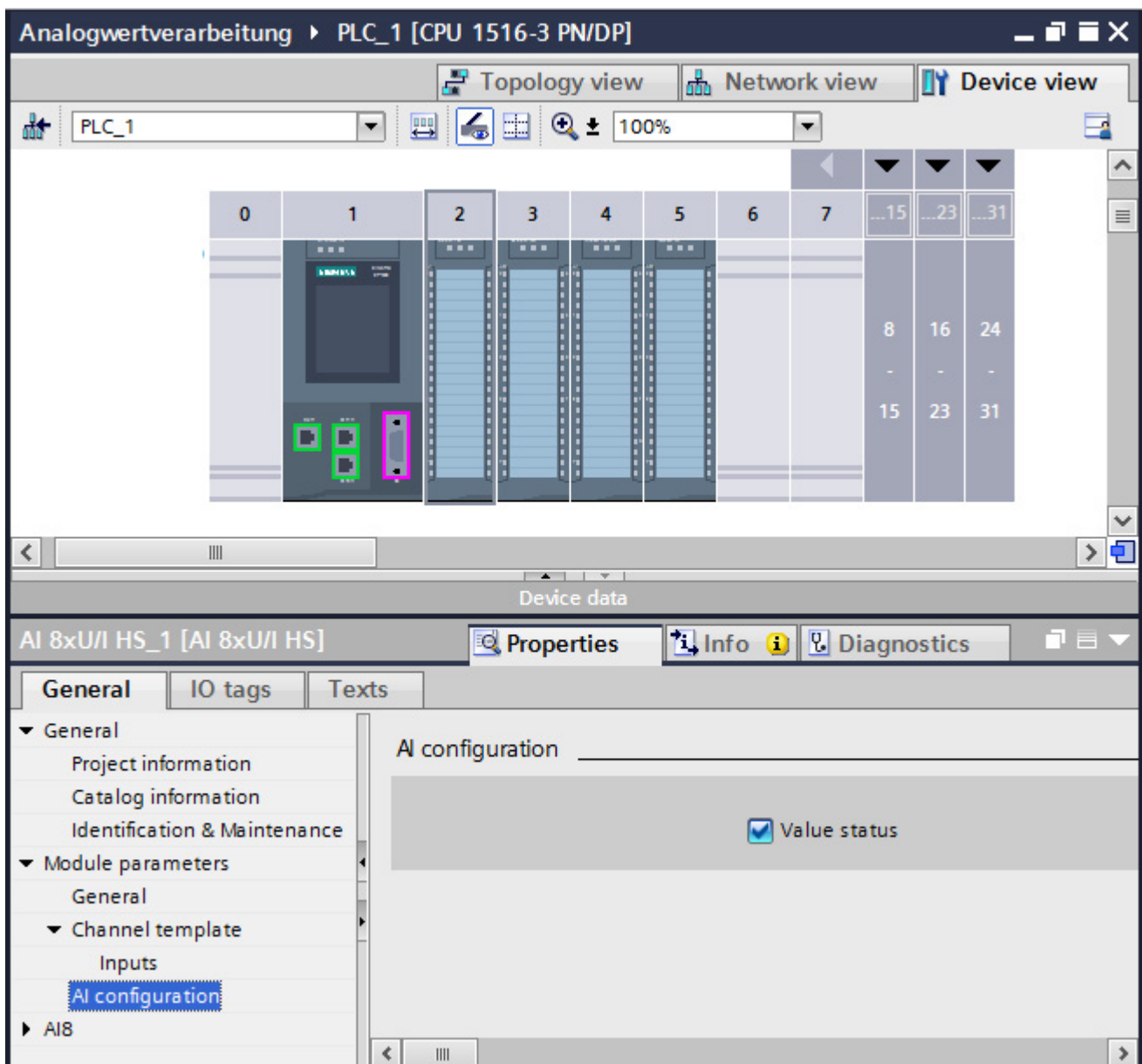

Figure 2-20 Enabling the value status in STEP 7

## *2.15 Value status*

An additional byte is occupied in the input address space of the respective module when you enable the value status. Each bit in this byte is assigned to a channel and provides information on, for example, whether the output value specified by the user program is actually queued at the module terminal (0= value is invalid; 1= value is valid).

### **Error occurrence**

If a wire break occurs at an analog input module, for example, the current signal state is entered in the process image and the value status of the signal is set to "invalid". To trigger an indicator light in case of an error, for example, evaluate the value status in the user program.

### **Diagnostics alarms and value status**

If you configure analog modules in a third-party product with the help of a GSD file and the diagnostics alarms are not evaluated event-driven, it is best to use the value status.

---

#### **Note**

The Value status represents a group diagnostics which only gives the user a Good or Bad information. The Value status is not suitable for a more specific identification of the cause of the error (e.g., wire break, short circuit in the encoder cable or load voltage failure).

---



## 2.16 Conversion time of an analog module

### Basic conversion time and conversion time of an analog input channel

The basic conversion time is the minimum time required by one single channel to convert analog values. The actual conversion time comprises both the basic conversion time and, depending on the analog input module used:

- Processing time for measuring resistance
- Processing time for wire break monitoring
- Processing time for overflow/underflow monitoring
- Processing time for checking common mode errors

### Example

This example shows channel 6 of an analog input module for resistance measurement in the range of 6000  $\Omega$ , a configured integration time of 20 ms, and activated wire break monitoring.

The conversion time of the channel is derived from the total of the following measurement variables:

Measurement variable	Time in ms
Basic conversion time	27
Processing time for RTD/resistance (6000 $\Omega$ )	4
Processing time for wire break monitoring in the RTD/resistance and thermocouple areas	9
<b>Conversion time of the channel</b>	<b>40</b>

### Conversion time of the analog output channels

The conversion time of an output channel starts with the transfer of the digital value from the internal memory of the module and ends with the digital-to-analog conversion.

The conversion time does not include the settling time for the analog signal at the module terminal. Detailed information on the settling time can be found in Settling and response times of analog output modules (Page 52).

---

#### Note

##### Relationship between diagnostics and conversion time

While some diagnostics run parallel to the conversion and do not extend the conversion time, other diagnostics types can lead to an extension of the conversion time, as demonstrated in the example above.

---

### **Conversion time for high-speed analog modules**

High-Speed analog modules (HS modules) are designed for faster processing of signals. HS modules offer fewer diagnostics and measurement types than standard modules (ST modules). You can find more information on HS modules in the section High-Speed analog modules (Page 113).

## 2.17 Cycle time of an analog module

### Definition

The cycle time of an analog module represents the time that the module needs to process all channels used. The cycle time depends on the form of measured value acquisition used, e.g. multiplex or parallel measured value acquisition.

### Sequential measured value processing

This procedure processes the analog channels in the module one after another (sequentially). For analog inputs, the values are connected to a converter, for example using a multiplexer, and sequentially converted.

The cycle time of the analog module is derived from the total conversion time of all activated analog channels of the module. STEP 7 provides the option of deactivating unused analog channels. to reduce the cycle time.

The figure below gives an overview of the factors that determine the cycle time of an n-channel analog module.

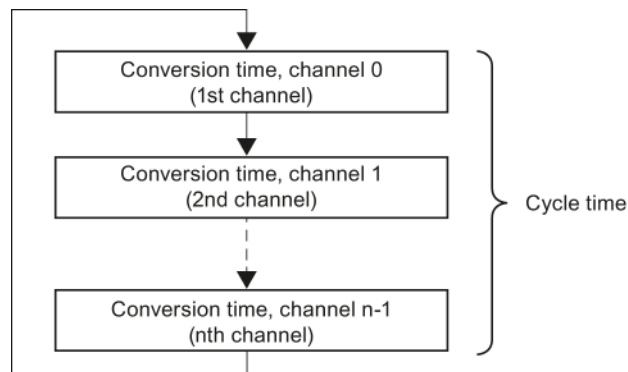

Figure 2-21 Cycle time of an analog module with multiplex conversion

### Parallel measured value acquisition

This procedure processes the analog channels of a module at the same time (in parallel) rather than one after another. In parallel measured value processing, the cycle time of the module is usually constant and does not depend on the number of channels used. The goal of parallel measured value acquisition as it is applied by high-speed analog modules, for example, is a shorter cycle time. You can find more information on HS modules in the section High-Speed analog modules (Page 113).

## 2.18 Settling and response times of analog output modules

Settling and response times provide information on the delay of the output of a specified analog output variable and its availability to the process.

### Response time

The response time for a new output value is defined as the time between the input of a digital output value to the internal memory of the module and the value to be output at the analog output being reached (with a residual error of 1 %).

The response time ( $t_A$ ) is the sum of application time ( $t_x$ ), conversion time ( $t_w$ ) and settling time ( $t_E$ ):

$$t_A = t_x + t_w + t_E$$

### Settling and response times of analog output modules

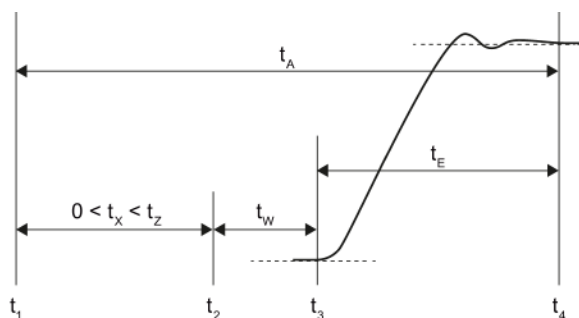

- $t_A$  Response time
- $t_x$  Application time
- $t_z$  Module cycle time
- $t_w$  Conversion time
- $t_E$  Settling time
- $t_1$  New digital output value is available in the internal memory of the module
- $t_2$  Module activates the digital output value and starts conversion
- $t_3$  Module ends conversion at the terminal of the analog output channel and outputs the analog signal
- $t_4$  Signal has settled and the specified analog output value has been reached (residual error 1 %)

Figure 2-22 Settling and response time of an output channel

### Application time

The CPU/IM (interface module) writes new output values to the internal memory of the analog output module. The time required for this is not determined by the CPU/IM. These output values are converted asynchronously to their entry in buffer memory. The worst-case application time ( $t_x$ ) may be equal to the cycle time ( $t_z$ ). This situation develops if the CPU writes a new value to the internal memory of the module immediately after the transfer of the value for conversion. This new value will not be processed until the next conversion.

The figure below shows acyclic access of the analog output module to output values from the internal memory in non-isochronous mode. You can find more information on isochronous mode in the paragraph on isochronous mode of the section High-Speed analog modules (Page 113).

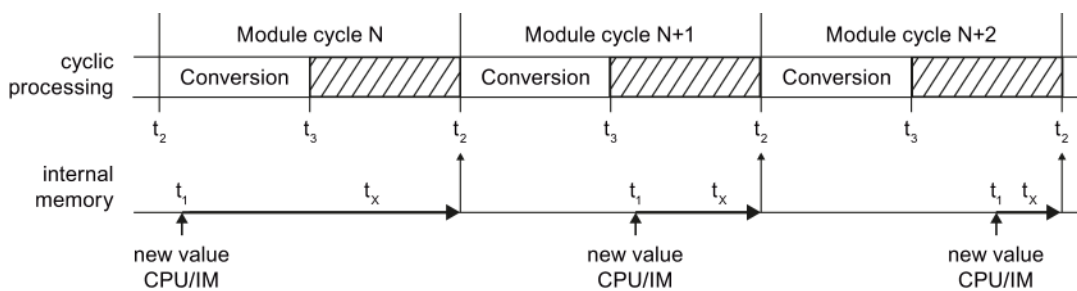

- $t_x$  Application time
- $t_1$  New digital output value is available in the internal memory of the module
- $t_2$  Module activates the digital output value and starts conversion
- $t_3$  Module ends conversion at the terminal of the analog output channel and outputs the analog signal

Figure 2-23 Application of the output values

### Conversion time

The conversion time of an output channel starts with the transfer of the digital value from the internal memory of the module ( $t_2$ ) and ends with the digital-to-analog conversion ( $t_3$ ).

### Settling time

The settling time starts when the analog signal is output to the module ( $t_3$ ) terminals and ends when the output value ( $t_4$ ) is reached. The output value is reached as soon as the output signal has settled at its final value, taking into account a residual error of 1%.

The settling time depends on the type of output for the module, and on the connected load. The load for the analog output consists of connecting line and connected actuator. When the output is "Current", the settling time increases with high ohmic resistance. Inductive loads cause subsequent fluctuation in the output value. When the output is "Voltage", the capacitive load causes subsequent fluctuation.

## 2.19 Smoothing

### Using the smoothing functions

Most analog input modules allow you to configure smoothing for the measuring signal in STEP 7. Smoothing analog values reduces the effect of interference signals. Smoothing is useful with slow changes in measured values, for example in temperature measurements.

### Smoothing principle

The measured values are smoothed by means of filtering. The module forms mean values from a specified number of converted (digitalized) analog values. Smoothing should not be confused with the integration of measured values over a defined period of time. It is therefore not possible to smooth measured signals to filter out a specific interference frequency. However, this smoothing returns more "stable" data values because it suppresses peaks which overlay the measured signal.

4 (none, weak, medium, strong) or more levels of smoothing can be configured by the user depending on the module used. The level determines the number of analog values from which the mean value is generated. The greater the smoothing factor, the better the filtering.

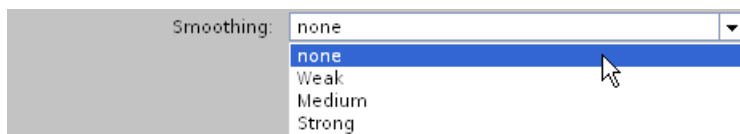

Figure 2-24 Selecting the smoothing level in STEP 7

### Smoothing method

A smoothing algorithm is applied to a configurable number of measured values (e.g. 4, 8, 32) in line with the moving average. Each new measured value is factored in, and the oldest measured value then ignored. This mechanism suppresses interference peaks which overlay the measured signal. Utility signal jumps only become evident in the data after some time (see examples below).

The modules of the various product ranges use different smoothing algorithms. Smoothing is either linear or exponential. The differences are apparent particularly with strong smoothing and lead to a faster or slower rate of rise depending on the product used.

For information on whether or not a specific module supports customization of the smoothing function, please refer to the manual of the analog input module.

**Example 1: Linear smoothing**

The diagram below shows the number of module cycles (k) it takes for each smoothing level setting for the smoothed analog value to reach approximately 100 % after a step response. This specification is valid for all signal changes at the analog input.

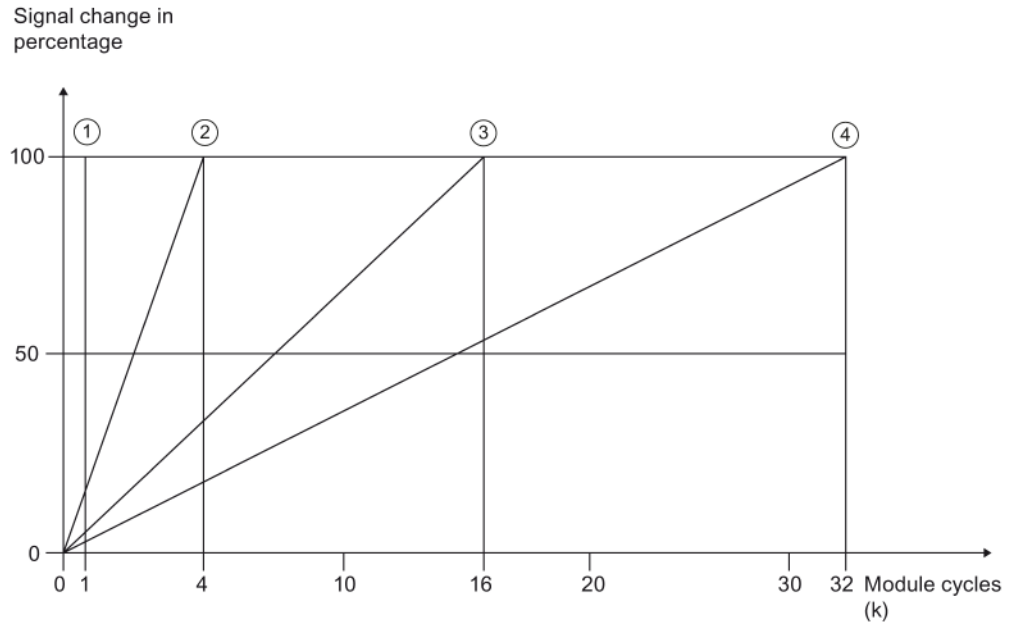

- ① No smoothing (k = 1)
- ② Weak smoothing (k = 4)
- ③ Medium smoothing (k = 16)
- ④ Strong smoothing (k = 32)

Figure 2-25 Linear smoothing with four smoothing levels

### Example 2: Exponential smoothing

The diagram below shows the step response of the smoothing factor for different numbers of module cycles.

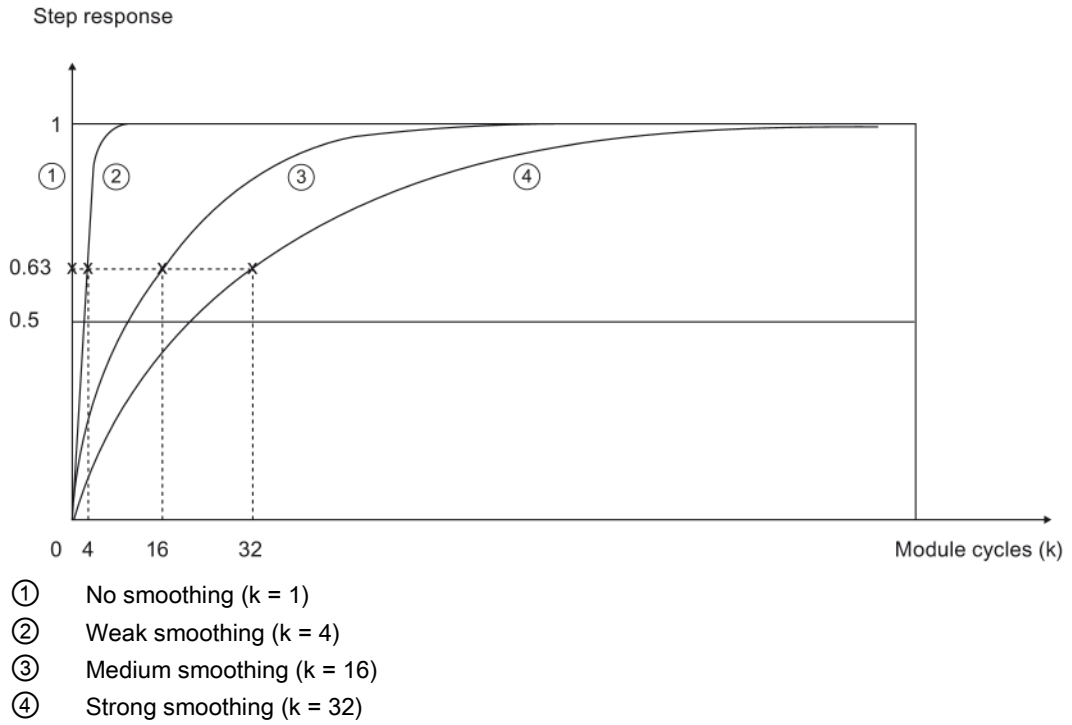

Figure 2-26 Exponential smoothing with four smoothing levels



## **2.20 Burden with 2-wire transducers**

### **2-wire transducers**

2-wire transducers are current transducers which convert the process variable into a current signal of between 4 and 20 mA. Two connection lines supply the transducer with an output current of at least 4 mA. Additional information on connecting 2-wire transducers to analog input modules can be found in the section Wiring current transducers (Page 72).

### **Burden**

The burden indicates how great the external resistance in a current loop may be. If the external resistance is greater than the specified burden, the 2-wire transducer supply voltage is too low. The burden consists of the resistance of the transducer and all other resistances connected to the current loop.

The maximum admissible burden of the transducer, e.g. 820  $\Omega$ , is specified in the technical data of the analog module.

**Example 1: Connecting a transducer to the electrical circuit**

In accordance with the technical data of the 2-wire transducer used, it requires a supply voltage ( $U_{min}$ ) of at least 8.5 V. Using Ohm's Law, you can calculate the resistance of the transducer used ( $R_{2DMU}$ ) for a current of 20 mA.

$$R_{2DMU} = \frac{U_{min}}{I} = \frac{8.5 \text{ V}}{0.020 \text{ A}} = 425 \Omega$$

With a supply voltage of at least 8.5 V, the transducer has a resistance of 425  $\Omega$ . The resistance is less than 820  $\Omega$ . You can therefore connect the transducer to the analog input module (AI) without exceeding the maximum burden.

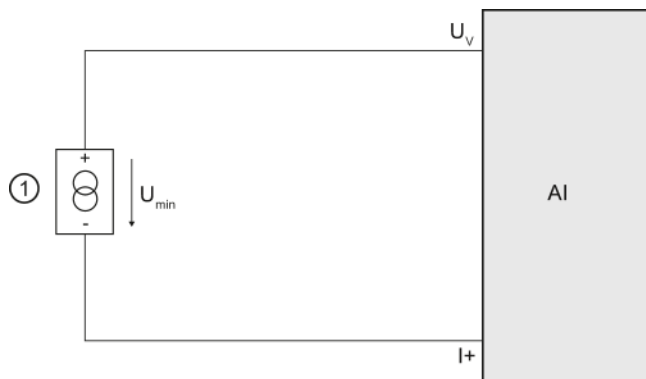

- ① 2-wire transducers
- $U_v$  Terminal for feed voltage at the channel
- $I+$  Terminal for current input
- $U_{min}$  Voltage drop at 2-wire transducer

Figure 2-27 Connecting a transducer to the electrical circuit

### Example 2: Connecting a transducer and other devices

If multiple measuring devices are connected in series, the sum of all connected resistances may not exceed the value of the maximum burden.

If you have connected a 2-wire transducer to a supply voltage of 8.5 V, you will need to allow for the resistance of the measuring device connected ②.

Maximum transducer burden:	820 Ω
Transducer resistance upon a voltage drop of 8.5 V:	425 Ω
Maximum resistance of additional devices connected:	395 Ω

The resistance of the measuring instrument may therefore not exceed 395 Ω.

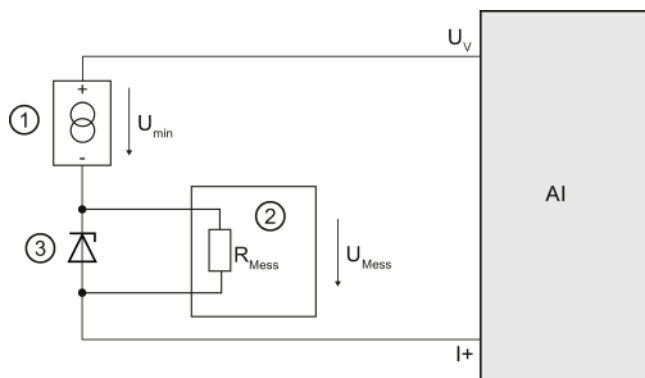

- ① 2-wire transducers
- ② Digital multimeter
- ③ Zener diode
- $U_v$  Terminal for feed voltage at the channel
- $I+$  Terminal for current input
- $U_{min}$  Voltage drop at 2-wire transducer
- $R_{Mess}$  Resistance at measuring instrument
- $U_{Mess}$  Voltage drop at the measuring instrument

Figure 2-28 Connecting a transducer and other devices to the circuit

### Calculating admissible voltage drop

The maximum additional resistance in the current loop may not exceed 395 Ω at a maximum current of 20 mA. You can calculate the voltage drop at the connected measuring instrument ( $U_{Mess}$ ) as follows using Ohm's Law:

$$U_{Mess} = R_{Mess} * I = 395 \Omega * 0.020 A = 7.9 V$$

The voltage drop at the measuring instrument should therefore not exceed 7.9 V.

## Representation of analog values

### 3.1 Overview

#### Conversion of analog values

The CPU only processes analog values in digitalized format.

Analog input modules convert the analog signal into a digital value for further processing by the CPU.

Analog output modules convert the digital output value from the CPU into an analog signal.

#### Analog value representation at 16-bit resolution

The digitized analog value is the same for all I/O values at the same rated range. The analog values are represented as fixed point numbers in twos complement. This leads to the following conditions:

Table 3- 1 Representation of analog values

Resolution	Analog value															
Bit number	15	14	13	12	11	10	9	8	7	6	5	4	3	2	1	0
Significance of the bits	S	$2^{14}$	$2^{13}$	$2^{12}$	$2^{11}$	$2^{10}$	$2^9$	$2^8$	$2^7$	$2^6$	$2^5$	$2^4$	$2^3$	$2^2$	$2^1$	$2^0$

#### Sign

The sign (S) of the analog value is always set in bit 15:

- "0" → +
- "1" → -

#### Resolution less than 16 bits

The analog value is left-aligned in the memory of analog modules with a resolution of less than 16 bits. The unused least significant digits are padded with "0" values.

This reduces the number of measured values that can be represented. Modules occupy a range of values of between +32767 and -32768 regardless of the resolution. The scaling between two successive values depends on the resolution of the module.

## Example

The following example shows how the least significant digits are padded with "0" values:

- The module with 16-bit resolution is capable of incrementing the values in steps of one unit ( $2^0 = 1$ ).
- The module with 13-bit resolution is capable of incrementing the values in steps of 8 units ( $2^3 = 8$ ).

Table 3- 2 Example: Bit pattern of a 16-bit and 13-bit analog value

Resolution	Analog value															
Bit	15	14	13	12	11	10	9	8	7	6	5	4	3	2	1	0
16-bit	S	$2^{14}$	$2^{13}$	$2^{12}$	$2^{11}$	$2^{10}$	$2^9$	$2^8$	$2^7$	$2^6$	$2^5$	$2^4$	$2^3$	$2^2$	$2^1$	$2^0$
13-bit	S	$2^{14}$	$2^{13}$	$2^{12}$	$2^{11}$	$2^{10}$	$2^9$	$2^8$	$2^7$	$2^6$	$2^5$	$2^4$	$2^3$	0	0	0

S = sign

### Note

For information on the resolution supported by each analog module, please refer to the technical data for the relevant module.

### 3.2 Representation of input ranges

The tables below set out the digitalized representation of the input ranges by bipolar and unipolar input ranges. The resolution is 16 bits.

Please see the device manuals for each analog input module for assignment of the values to the specific measured values in each measuring range.

Table 3- 3 Bipolar input ranges

Dec. value	Measured value in %	Data word																Range
		2 <sup>15</sup>	2 <sup>14</sup>	2 <sup>13</sup>	2 <sup>12</sup>	2 <sup>11</sup>	2 <sup>10</sup>	2 <sup>9</sup>	2 <sup>8</sup>	2 <sup>7</sup>	2 <sup>6</sup>	2 <sup>5</sup>	2 <sup>4</sup>	2 <sup>3</sup>	2 <sup>2</sup>	2 <sup>1</sup>	2 <sup>0</sup>	
32767	>117.589	0	1	1	1	1	1	1	1	1	1	1	1	1	1	1	1	Overflow
32511	117.589	0	1	1	1	1	1	1	0	1	1	1	1	1	1	1	1	Over range
27649	100.004	0	1	1	0	1	1	0	0	0	0	0	0	0	0	0	1	
27648	100.000	0	1	1	0	1	1	0	0	0	0	0	0	0	0	0	0	Rated range
1	0.003617	0	0	0	0	0	0	0	0	0	0	0	0	0	0	0	1	
0	0.000	0	0	0	0	0	0	0	0	0	0	0	0	0	0	0	0	
-1	-0.003617	1	1	1	1	1	1	1	1	1	1	1	1	1	1	1	1	
-27648	-100.000	1	0	0	1	0	1	0	0	0	0	0	0	0	0	0	0	
-27649	-100.004	1	0	0	1	0	0	1	1	1	1	1	1	1	1	1	1	Under range
-32512	-117.593	1	0	0	0	0	0	0	1	0	0	0	0	0	0	0	0	
-32768	<-117.593	1	0	0	0	0	0	0	0	0	0	0	0	0	0	0	0	Underflow

Table 3- 4 Unipolar input ranges

Dec. value	Measured value in %	Data word																Range
		2 <sup>15</sup>	2 <sup>14</sup>	2 <sup>13</sup>	2 <sup>12</sup>	2 <sup>11</sup>	2 <sup>10</sup>	2 <sup>9</sup>	2 <sup>8</sup>	2 <sup>7</sup>	2 <sup>6</sup>	2 <sup>5</sup>	2 <sup>4</sup>	2 <sup>3</sup>	2 <sup>2</sup>	2 <sup>1</sup>	2 <sup>0</sup>	
32767	>117.589	0	1	1	1	1	1	1	1	1	1	1	1	1	1	1	1	Overflow
32511	117.589	0	1	1	1	1	1	1	0	1	1	1	1	1	1	1	1	Over range
27649	100.004	0	1	1	0	1	1	0	0	0	0	0	0	0	0	0	1	
27648	100.000	0	1	1	0	1	1	0	0	0	0	0	0	0	0	0	0	Rated range
1	0.003617	0	0	0	0	0	0	0	0	0	0	0	0	0	0	0	1	
0	0.000	0	0	0	0	0	0	0	0	0	0	0	0	0	0	0	0	
-1	-0.003617	1	1	1	1	1	1	1	1	1	1	1	1	1	1	1	1	Under range
-4864	-17.593	1	1	1	0	1	1	0	1	0	0	0	0	0	0	0	0	
-32768	<-17.593	1	0	0	0	0	0	0	0	0	0	0	0	0	0	0	0	Underflow

### 3.3 Representation of output ranges

The tables below set out the digitalized representation of the output ranges by bipolar and unipolar range. The resolution is 16 bits.

Please see the device manuals for each analog output module for assignment of the values to the specific output values in each measuring range.

Table 3- 5 Bipolar output ranges

Dec. value	Output value in %	Data word																Range
		2 <sup>15</sup>	2 <sup>14</sup>	2 <sup>13</sup>	2 <sup>12</sup>	2 <sup>11</sup>	2 <sup>10</sup>	2 <sup>9</sup>	2 <sup>8</sup>	2 <sup>7</sup>	2 <sup>6</sup>	2 <sup>5</sup>	2 <sup>4</sup>	2 <sup>3</sup>	2 <sup>2</sup>	2 <sup>1</sup>	2 <sup>0</sup>	
32511	117.589	0	1	1	1	1	1	1	0	1	1	1	1	1	1	1	1	Maximum output value*
32511	117.589	0	1	1	1	1	1	1	0	1	1	1	1	1	1	1	1	Over range
27649	100.004	0	1	1	0	1	1	0	0	0	0	0	0	0	0	0	1	
27648	100.000	0	1	1	0	1	1	0	0	0	0	0	0	0	0	0	0	Rated range
1	0.003617	0	0	0	0	0	0	0	0	0	0	0	0	0	0	0	1	
0	0.000	0	0	0	0	0	0	0	0	0	0	0	0	0	0	0	0	
-1	-0.003617	1	1	1	1	1	1	1	1	1	1	1	1	1	1	1	1	
-27648	-100.000	1	0	0	1	0	1	0	0	0	0	0	0	0	0	0	0	
-27649	100.004	1	0	0	1	0	0	1	1	1	1	1	1	1	1	1	1	Under range
-32512	-117.593	1	0	0	0	0	0	0	1	0	0	0	0	0	0	0	0	
-32512	-117.593	1	0	0	0	0	0	0	1	0	0	0	0	0	0	0	0	Minimum output value**

\* When values > 32511 are specified, the output value is limited to 117.589 % or 0 % (0.0 V / 0.0 mA), depending on the module used.

\*\* When values < -32512 are specified, the output value is limited to -117.593 % or 0 % (0.0 V / 0.0 mA), depending on the module used.

Representation of analog values

3.3 Representation of output ranges

Table 3- 6 Unipolar output ranges

Dec. value	Output value in %	Data word																Range
		2 <sup>15</sup>	2 <sup>14</sup>	2 <sup>13</sup>	2 <sup>12</sup>	2 <sup>11</sup>	2 <sup>10</sup>	2 <sup>9</sup>	2 <sup>8</sup>	2 <sup>7</sup>	2 <sup>6</sup>	2 <sup>5</sup>	2 <sup>4</sup>	2 <sup>3</sup>	2 <sup>2</sup>	2 <sup>1</sup>	2 <sup>0</sup>	
32511	117.589	0	1	1	1	1	1	1	1	x	x	x	x	x	x	x	x	Maximum output value*
32511	117.589	0	1	1	1	1	1	1	0	1	1	1	1	1	1	1	1	Over range
27649	100.004	0	1	1	0	1	1	0	0	0	0	0	0	0	0	0	1	
27648	100.000	0	1	1	0	1	1	0	0	0	0	0	0	0	0	0	0	Rated range
1	0.003617	0	0	0	0	0	0	0	0	0	0	0	0	0	0	0	1	
0	0.000	0	0	0	0	0	0	0	0	0	0	0	0	0	0	0	0	Minimum output value**
0	0.000	0	0	0	0	0	0	0	0	0	0	0	0	0	0	0	0	

\* When values > 32511 are specified, the output value is limited to 117.589 % or 0 % (0.0 V / 0.0 mA), depending on the module used.

\*\* When values < 0 are specified, the output value is limited to 0% (0.0 V / 0.0 mA).



# Connecting transducers

## 4.1 Overview

### Introduction

This chapter describes the basic procedure for wiring transducers to analog inputs. Information on specific wiring options is available in the manual of each module.

For more information, e.g. on cable routing and shielding or potential equalization, etc., refer to the function manual for Configuring interference-free controllers (<http://support.automation.siemens.com/WW/view/en/59193566>).

### Transducers that can be wired to analog inputs

You can wire the following transducers to the analog input modules, depending on the type of measurement:

- Voltage transducers
- Current transducers
  - 2-wire transducers
  - 4-wire transducers
- Resistance transducers
  - 4-wire connection
  - 3-wire connection
  - 2-wire connection
- Thermocouples

### Isolated transducers and non-isolated transducers

Transducers are available in various models:

- Isolated transducers are **not connected** locally to the ground potential. Floating operation is possible.
- Non-isolated transducers are **connected** locally to the ground potential.

Non-isolated transducer connections are connected to the conductive enclosure.

Note: All non-isolated transducers must have a galvanic connection to each other and be locally connected to the ground potential.

### Abbreviations used in the figures

Key to the abbreviations in the figures below:

AI	Analog input module
M	Ground connection
L+	Supply voltage connection
$M_n^+/M_n^-$	Measuring input, channel n
$I_{Cn}^+/I_{Cn}^-$	Current output to thermal resistor (RTD) channel n
$U_n^+/U_n^-$	Voltage input channel n
$I_n^+/I_n^-$	Current input channel n
COMP+/COMP-	Compensation input
$I_{Comp}^+/I_{Comp}^-$	Current output for compensation
$U_V$	Feed voltage at channel (the connection can be used for 2-wire transducer (2DMU) or with ET 200eco PN and ET 200pro for 2/4-wire transducer).
$U_{CM}$	Potential difference between the reference points of the measuring inputs / the analog ground $M_{ANA}$
$U_{ISO}$	Potential difference between the reference points of the measuring inputs and the central ground
$M_{ANA}$	Reference point of the analog ground

### Lines for analog signals

Always use shielded twisted-pair cables to wire the analog signals. This improves immunity.

## 4.2 Wiring analog inputs with MANA connection

The reference potentials of the measuring inputs and the central ground are electrically isolated in analog input modules with MANA connection.

### Limited potential difference $U_{ISO}$ (insulation voltage)

Always verify that the admissible potential difference  $U_{ISO}$  between the reference point of the analog ground  $M_{ANA}$  and the central ground is not exceeded.

Potential difference  $U_{ISO}$  may be caused by: Maximum line lengths exceeded.

If you want to ensure that the permitted value  $U_{ISO}$  is not exceeded, install an equipotential bonding cable between the terminal  $M_{ANA}$  and the central grounding point.

### Limited potential difference $U_{CM}$ (common mode)

Always verify that the admissible potential difference  $U_{CM}$  between the reference point of the measuring inputs and the analog ground  $M_{ANA}$  is not exceeded.

Potential differences  $U_{CM}$  may be caused by:

- Environments with EMC disturbance
- Use of grounded transducers
- Use of long cable lengths

Measuring errors / malfunctions can occur if the admissible potential difference  $U_{CM}$  is exceeded.

Some modules can detect an invalid potential difference  $U_{CM}$  and report this error with an entry in the diagnostics buffer of the CPU.

If you want to ensure that the maximum value  $U_{CM}$  is not exceeded, interconnect the reference points of the measuring inputs and the analog ground  $M_{ANA}$  with an equipotential bonding cable.

4.2 Wiring analog inputs with MANA connection

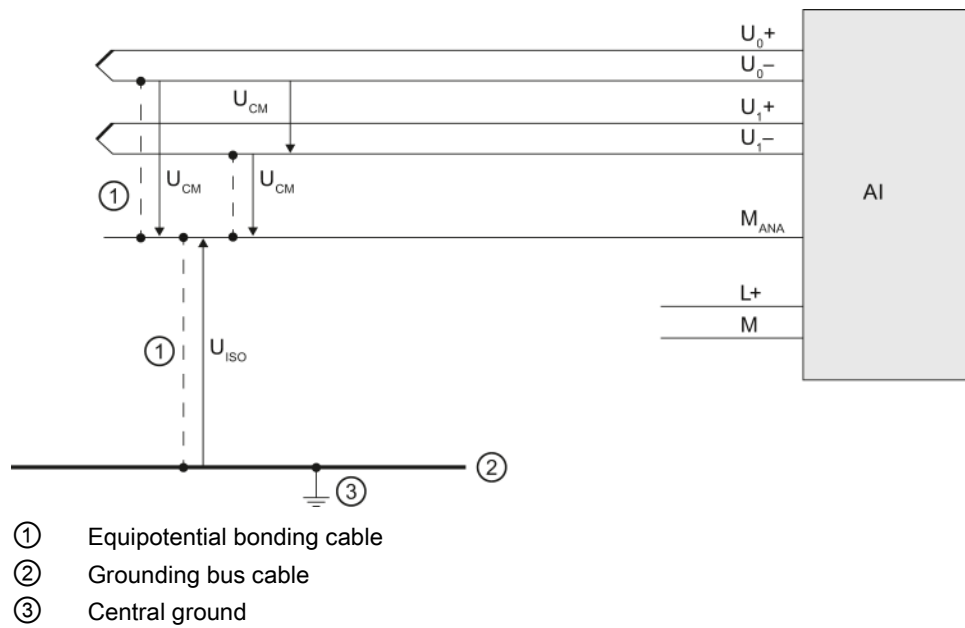

Figure 4-1 Example: Reference potential for analog input modules with  $M_{ANA}$  connection

## 4.3 Wiring analog inputs without MANA connection

The reference potentials of the measuring inputs and the central ground are electrically isolated from each other in analog input modules without an MANA connection.

### Limited potential difference $U_{ISO}$ (insulation voltage)

Always verify that the maximum potential difference  $U_{ISO}$  between the reference points of the measuring inputs and central ground is not exceeded.

Potential difference  $U_{ISO}$  may be caused by: Maximum line lengths exceeded.

If you want to ensure that the permitted value  $U_{ISO}$  is not exceeded, install an equipotential bonding cable between the reference points of the measuring inputs and the central grounding point.

### Limited potential difference $U_{CM}$ (common mode)

Always ensure that the permitted potential difference  $U_{CM}$  between the reference points of the measuring inputs is not exceeded.

Potential differences  $U_{CM}$  may be caused by:

- Environments with EMC disturbance
- Use of grounded transducers
- Use of long cable lengths

Measuring errors / malfunctions can occur if the admissible potential difference  $U_{CM}$  is exceeded.

Some modules can detect an invalid potential difference  $U_{CM}$  and report this error with an entry in the diagnostics buffer of the CPU.

If you want to ensure that the permitted value  $U_{CM}$  is not exceeded, install equipotential bonding cables between the reference points of the measuring inputs or, with the ET 200eco PN and ET 200pro, between the reference points of the measuring inputs and ground.

4.3 Wiring analog inputs without MANA connection

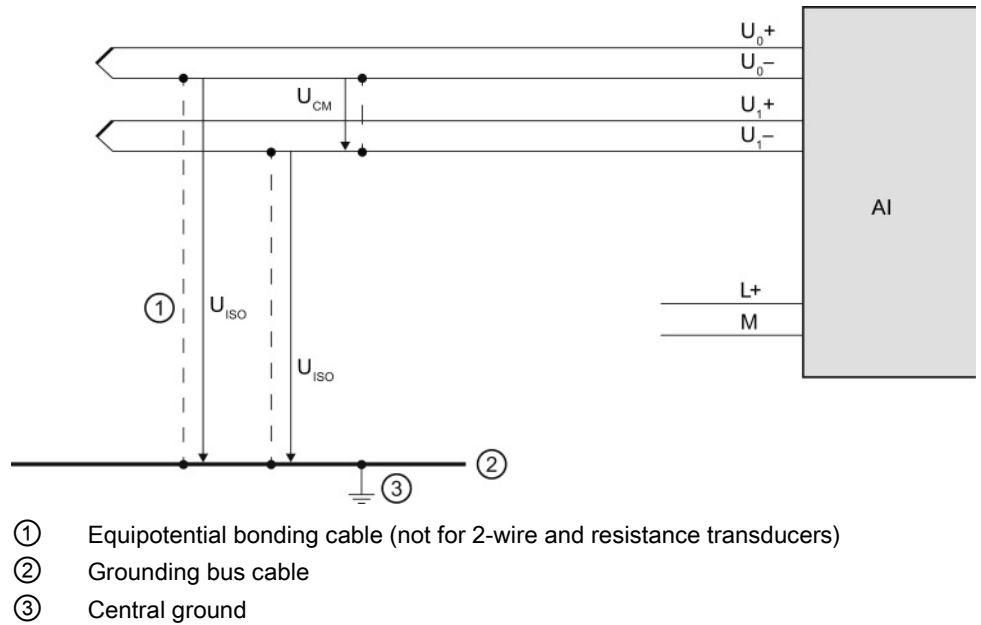
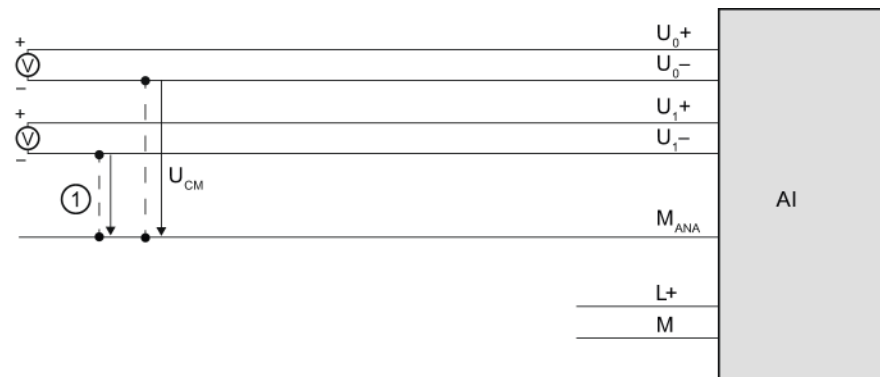

Figure 4-2 Example: Reference potential for analog input modules without MANA connection

## 4.4 Wiring voltage transducers

The figure below shows how to connect voltage transducers. If you want to ensure that the permitted value  $U_{CM}$  is not exceeded, install equipotential bonding cables to connect the reference points of the measuring inputs to the analog ground  $M_{ANA}$ , or with ET 200eco PN and ET 200pro the reference points of the measuring inputs to the ground.



① Equipotential bonding cable (only relevant to modules with  $M_{ANA}$  connection)

Figure 4-3 Example: Wiring voltage transducers to an analog input module

## 4.5 Wiring current transducers

Current transducers are available as 2-wire transducers and 4-wire transducers. Below are a number of ways to supply current transducers with voltage.

### Wiring 2-wire transducers with power supply from the module

The 2-wire transducer converts the process variable into a current. The 2-wire transducer is wired to the short circuit-proof supply voltage at the terminals of the analog input module. The transducer is therefore frequently also called a "passive transducer". Its simple wiring means that the 2-wire transducer is frequently used in industrial environments. If you use this type of connection, you will need to set the "Current (2-wire transducer)" measurement type in STEP 7.

---

#### Note

2-wire transducers must be electrically isolated.

---

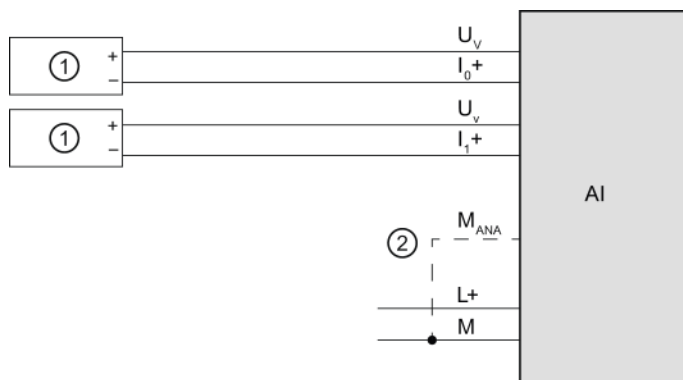

- ① 2-wire transducers (2WT)
- ② Equipotential bonding cable (only relevant to modules with  $M_{ANA}$  connection)

Figure 4-4 Example: Wiring 2-wire transducers to an analog input module



### Wiring 2-wire transducers to an analog input for 4-wire transducers

The figure below shows an alternative to the above connection: supplying the 2-wire transducer from supply line L+ of the module. If you use this type of connection, you will need to set the "Current (**4-wire transducer**)" measurement type in STEP 7.

In this type of connection, galvanic isolation between the supply voltage L+ and the analog circuit will be removed.

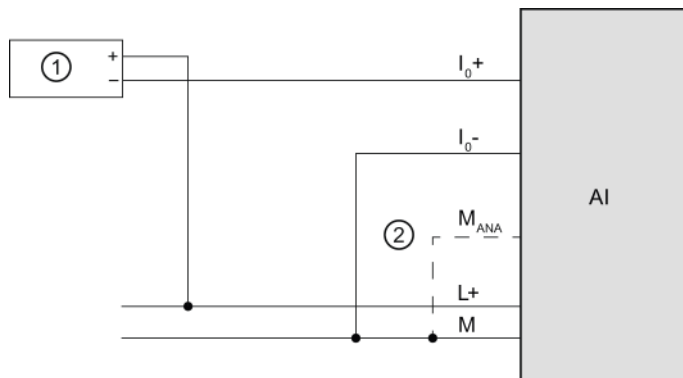

- ① 2-wire transducers (2WT)
- ② Equipotential bonding cable (only relevant to modules with M<sub>ANA</sub> connection)

Figure 4-5 Example: Wiring 2-wire transducers to an analog input for 4-wire transducers

### Wiring and connecting 4-wire transducers

4-wire transducers provide terminals for connecting a separate supply voltage. They are powered with an external supply and are frequently called "active transducers". If you use this type of connection, you will need to set the "Current (**4-wire transducer**)" measurement type in STEP 7.

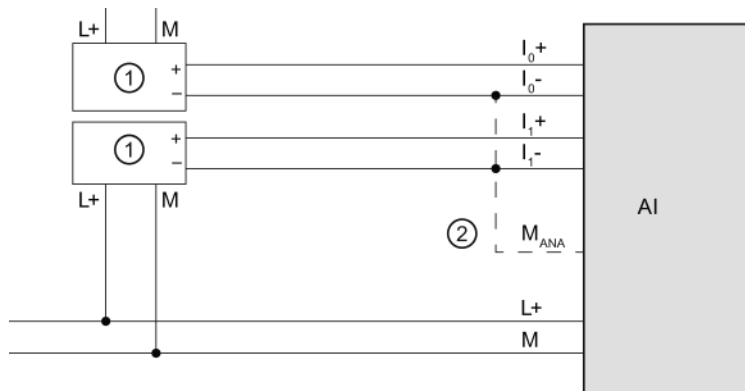

- ① 4-wire transducers (4WT)
- ② Equipotential bonding cable (only relevant to modules with M<sub>ANA</sub> connection)

Figure 4-6 Example: Wiring 4-wire transducers to an analog input module

## 4.6 Wiring thermal resistors and resistors

The module provides a constant current at terminals  $I_{C+}$  and  $I_{C-}$  for resistance measurements. The constant current is fed to the resistance to be measured where it is measured as voltage drop. It is important to wire the connected constant current cables directly to the thermal resistor/resistor.

Measurements with 4-wire or 3-wire connection compensate for line resistance and therefore achieve greater accuracy compared to measurements with 2-wire connection.

Measurements with two-wire connection always acquire line resistance in addition to the actual resistance; you must therefore allow for a significant loss of precision in the measuring results.

The figures below give some connection examples.

### 4-wire connection of a thermal resistor

The voltage at the thermal resistor is acquired using high-impedance measurement via the  $M_0+$  and  $M_0-$  terminals. Make sure the wiring is correctly poled ( $I_{C0+}$  and  $M_0+$ , and  $I_{C0-}$  and  $M_0-$  at the thermal resistor).

Always wire the  $I_{C0+}$  and  $M_0+$  lines, and the  $I_{C0-}$  and  $M_0-$  lines directly to the thermal resistor.

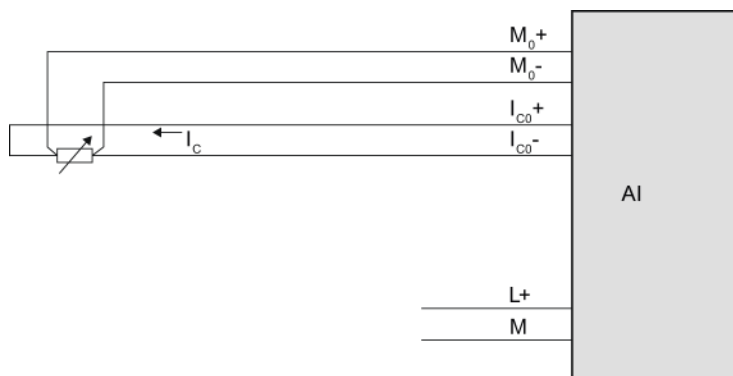

Figure 4-7 Example: 4-wire connection of thermal resistor to an analog input module

### 3-wire connection of a thermal resistor

Depending on the module, for a 3-wire connection to modules with 4 terminals (per channel), you may need to insert a bridge between **M<sub>0-</sub>** and **I<sub>C0-</sub>** (see figure below) or between **M<sub>0+</sub>** and **I<sub>C0+</sub>**. Always wire the **I<sub>C0+</sub>** and **M<sub>0+</sub>** lines directly to the thermal resistor. Use cable with wires with identical cross-section.

For ET 200AL, ET 200eco PN and ET 200pro, no bridge is required as all necessary connections are implemented internally.

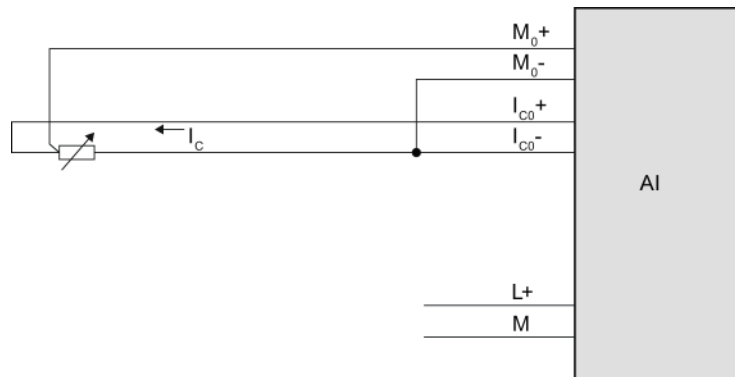

Figure 4-8 Example: 3-wire connection of thermal resistor to an analog input module

### 2-wire connection of a thermal resistor

When installing a 2-wire device on modules with 4 terminals (per channel), you will need to insert bridges at the module between **M<sub>0+</sub>** and **I<sub>C0+</sub>** and between **M<sub>0-</sub>** and **I<sub>C0-</sub>** as shown in the figure below. The line resistance is measured, but not compensated. As a result of physical limitations, this measurement type is less accurate than measurement with 3-wire or 4-wire connections. The wiring for this type of measurement is, however, simple as the bridges required can be wired in the plug, saving line.

For ET 200AL, ET 200eco PN and ET 200pro, no bridge is required as all necessary connections are implemented internally.

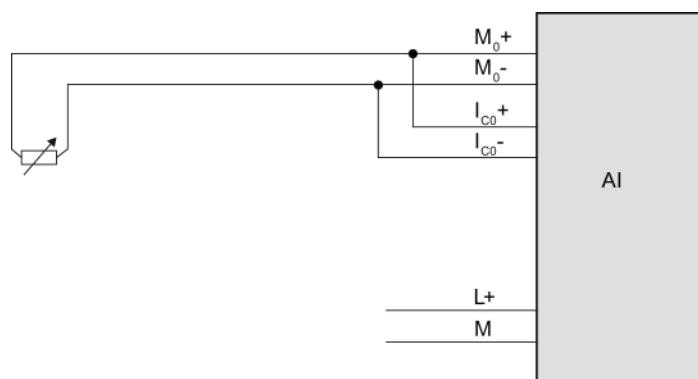

Figure 4-9 Example: 2-wire connection of thermal resistor to an analog input module

## 4.7 Wiring thermocouples

### Introduction

Thermocouples are generally supplied ready-to-use. Protective casing prevents the thermocouples from being destroyed by mechanical force, for example.

### Compensating lines

The compensating lines belonging to the respective thermocouples are identified by a special color code, because only the compensating line that is made of the material matching the thermocouple may be used. The standardized compensating lines are specified in DIN EN 60584. Observe the maximum temperatures in the manufacturer's specifications.

### Thermocouple connection options

There are various different ways to wire thermocouples to an analog input module:

- Directly ①.
- Using compensating lines ②.
- With a compensating line to the reference junction, connected with a supply line, e.g. copper ③.

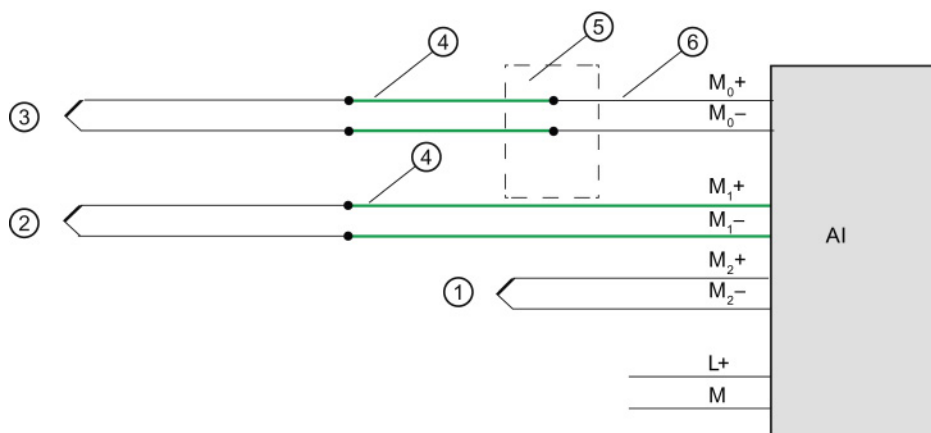

- ① Thermocouple without compensating line
- ② Thermocouple with compensating line
- ③ Thermocouple with compensating line and supply line
- ④ Compensating line (same material as thermocouple)
- ⑤ External reference junction
- ⑥ Copper supply cable, for example

Figure 4-10 Example: Wiring thermocouples to an analog input module

### Further information

Further information, such as the selection of thermocouples and how they operate, can be found in the section Thermocouples (Page 77).

# Thermocouples

## 5.1 Selecting thermocouples

### Introduction

Thermocouples are electrical devices for precise temperature measurement. They consist of two different metals connected at one point. Temperature affecting this point generates a voltage difference from which the temperature can be calculated.

Thermocouples can measure a wide range of temperatures and come in extremely robust models. They are therefore frequently used in industrial applications. Below are some of the criteria to consider when selecting the right thermocouple:

- Temperature range
- Atmospheric conditions
- Price

### Grounded thermocouples

In grounded thermocouples, a conductive thermocouple wire is attached to the inside of the sensor housing. This results in good heat transfer from the sensor housing to the thermocouple measuring tip.

### Non-grounded thermocouples

In non-grounded thermocouples, the thermocouple is not connected to the sensor housing. The response time following temperature changes is longer than with grounded thermocouples. The measuring point is galvanically isolated.

**Type and temperature range**

The different thermocouple types are derived from different material compositions.

**Note**

Due to physical conditions, thermocouples are extremely inaccurate outside the specified temperature range. Only use thermocouple in the temperature range specified by the manufacturer.

The following table lists the types and material compositions, as well as the temperature measuring range of different thermocouples:

Type	Material composition	Temperature range
B	PtRh-PtRh	250 to 1820 °C
C	W-Re	0 to 2315 °C
E	NiCr-CuNi	-270 to 1000 °C
J	Fe-CuNi	-210 to 1200 °C
K	NiCr-Ni	-270 to 1372 °C
L	Fe-CuNi	-200 to 900 °C
N	NiCrSi-NiSi	-270 to 1300 °C
R	PtRh-Pt (Pt 13%)	- 50 to 1769 °C
S	PtRh-Pt (Pt 10%)	-50 to 1769 °C
T	Cu-CuNi	-270 to 400 °C
U	Cu-CuNi	-200 to 600 °C
TXK/XKL	NiCr-CuCr	-200 to 800 °C

## 5.2 Structure and operating principle of thermocouples

### Thermocouple structure

A thermocouple consists of a pair of thermal sensors and the respective installation and wiring elements. Two wires made of different metals/alloys are welded together at their ends (hot end). The welding point forms the so-called measuring point, while the free ends of the thermocouple form the reference junction.

The free ends are interconnected with the evaluation device (e.g. analog input module) via insulated wires or cables.

The different thermocouple types, e.g. K/J/N, are derived from different material composition; the same measuring principle is applied to all thermocouples, independent on their type.

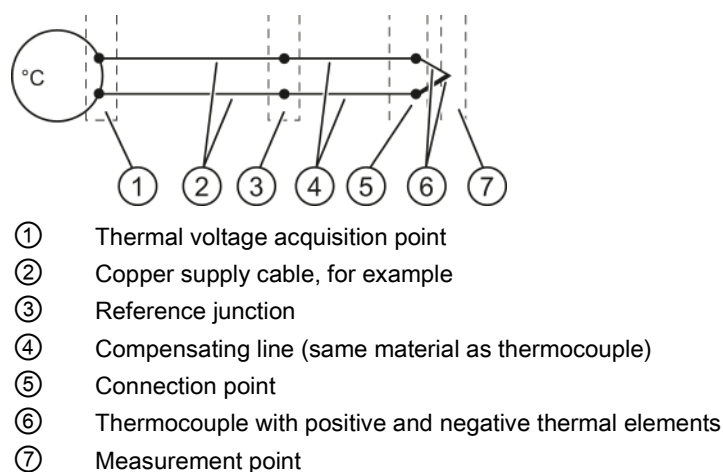

Figure 5-1 Thermocouple

### **Operating principle of thermocouples**

Temperature differences between the measuring point and the free ends of the pair of thermal sensors (connection point) generate a thermal voltage at the reference junction. The value of the thermal voltage is determined by the temperature difference between the measuring point and the free ends, as well as by the material composition of the pair of thermal sensors.

Thermocouples always acquire a differential temperature, which means that the temperature at their free ends (reference junction) must be known to determine the temperature at the measuring point.

The thermocouple can be extended with compensating lines from the connection point. This allows the reference junction to be located at a specific point, for example, where the temperature can be kept constant or the temperature sensor is easy to install. The compensating lines and thermocouple wires are made of the same material. Copper cables are used to connect the reference junction to the module.

---

#### **Note**

Always observe the polarity, as incorrect wiring will result in unacceptable measuring errors.

---



## 5.3 Compensation for the reference junction temperature

### 5.3.1 Overview

#### Introduction

You have several options for measuring the reference junction temperature in order to obtain a correct temperature value as a function of the temperature difference between the reference junction and the measuring point.

You have various compensation options to suit requirements at the location of the reference junction.

The compensation options supported by the analog module used are specified in the manual of the respective module.

#### Options of compensating for the reference junction temperature

Table 5- 1 Compensation options: Explanation and use case

Compensation options	Explanation	Use case / special feature
Internal reference junction	<p><b>Function principle</b></p> <p>With this type of compensation, the temperature of the reference junction is measured using an integrated sensor in the analog module.</p> <p><b>Procedure</b></p> <p>Connect the thermocouple to the I/O module directly, or with compensating lines; see chapter Compensation with internal reference junction (Page 84).</p>	<ul style="list-style-type: none"> <li>• For the connection, use compensating lines that match the thermocouple material.</li> <li>• If the reference junction temperature and the module temperature are identical in your system, you may also use lines made from a different material.</li> <li>• Advantages: <ul style="list-style-type: none"> <li>– Inexpensive</li> <li>– No external reference junction required</li> <li>– No additional wiring required</li> </ul> </li> </ul>

5.3 Compensation for the reference junction temperature

Compensation options	Explanation	Use case / special feature
Reference channel of the module	<p><b>Properties</b> With this type of compensation, the reference junction temperature is determined using an external thermal resistor (RTD).</p> <p><b>Procedure</b> Connect the thermocouple to the supply lines directly at the reference junction, or indirectly using compensating lines. Wire the supply lines to the corresponding terminals of the module. Wire the thermal resistor (RTD) to the reference channel of the module. The thermal resistor (RTD) must be positioned in the area of the reference junction; see chapter Compensation with reference channel of the module (Page 86).</p>	<ul style="list-style-type: none"> <li>• They acquire the temperature directly at the reference junction.</li> <li>• The measured temperatures of all channels that you have configured for this compensation type will be corrected automatically by the temperature value of the reference junction.</li> <li>• Advantages: <ul style="list-style-type: none"> <li>– More precise compared to compensation with internal reference junction; however, you need to install and wire an additional thermal resistor.</li> </ul> </li> </ul>
Reference channel of group 0	<p><b>Properties</b> With the "TC" (thermocouple...) setting, the channel acts as receiver for the reference junction temperature of group 0. The associated transmitter of group 0 is set up to for the RTD channel.</p> <p><b>Procedure</b> Connect the thermocouple to the supply lines directly at the reference junction, or indirectly using compensating lines. Wire the supply lines to the corresponding terminals of the module. Wire the thermal resistor (RTD) to the configured reference channel for group 0 of the module. The thermal resistor (RTD) must be positioned in the area of the reference junction; see chapter Compensation, reference channel of Group 0 (Page 88).</p>	<ul style="list-style-type: none"> <li>• They acquire the temperature directly at the reference junction.</li> <li>• The measured temperatures of all channels that you have configured for this compensation type will be corrected automatically by the temperature value of the reference junction (transmitter).</li> </ul>
Fixed reference temperature	<p><b>Properties</b> With this type of compensation, the reference junction temperature is stored in the module as fixed value.</p> <p><b>Procedure</b> Connect the thermocouple to the supply lines directly at the reference junction, or indirectly using compensating lines. Wire the supply lines to the corresponding terminals of the module. Depending on the module, you can enter a fixed reference junction temperature in the configuration data (e.g. 20 °C), or use the fixed reference junction temperature of the module (0 °C); see chapter Compensation with fixed reference temperature (Page 91).</p>	<ul style="list-style-type: none"> <li>• You keep the reference junction temperature constant and know the temperature value.</li> <li>• To ensure high precision, you must ensure that the temperature remains constant (this can be complicated, depending on the application).</li> </ul>

5.3 Compensation for the reference junction temperature

Compensation options	Explanation	Use case / special feature
Dynamic reference temperature	<p><b>Properties</b> With this type of compensation, the reference junction temperature is determined using a module. Transfer this temperature value to other modules in the user program by means of a data record.</p> <p><b>Procedure</b> Wire the thermal resistor (RTD) for the reference junction to any channel. The reference junction temperature is transferred with a function block by means of data records from the CPU or IM to the module, see section Compensation by means of dynamic reference temperature (Page 94).</p>	<ul style="list-style-type: none"> <li>You are using multiple modules at the reference junction and can therefore compensate for all channels using a common temperature value.</li> <li>You only need a thermal resistor (RTD) or a thermocouple to measure the temperature value.</li> </ul>
No/external compensation	<p><b>Properties</b> With this type of compensation, the reference junction temperature is measured outside the analog input module. You can, for example, connect a compensating box to the thermocouple for this purpose.</p> <p><b>Procedure</b> Connect the compensating box with the connection module of the analog input module with copper cables, see section "None" or external compensation (Page 98).</p>	<ul style="list-style-type: none"> <li>The temperature of the reference junction for this type of compensation is specified as 0 °C. This can be achieved by using a compensating box. A separate compensating box is required for each thermocouple.</li> <li>Thermocouples of type B do not require a compensating box.</li> </ul>
RTD (0)	<p><b>Properties</b> This compensation is based on a measurement of the resistance value of a Pt1000 at the clamping unit of a compensation connector or of an external resistance value Pt1000.</p> <p><b>Procedure</b> Additional information about the connection options with and without compensation connector is available in the section Type of compensation RTD (0) (Page 100).</p>	<ul style="list-style-type: none"> <li>The reference junction temperature is determined with resistance value of the Pt1000.</li> <li>All channels of the analog input module that you select for this type of compensation receive the same reference junction temperature.</li> </ul>

### 5.3.2 Compensation with internal reference junction

#### Function principle

The reference junction for compensation via internal reference junction is at the terminals of the analog input module. Wire the thermocouples or compensating lines directly to the module inputs. The internal temperature sensor acquires the module temperature and returns a compensating voltage.

Note that compensation via internal reference junction will not always reach the precision of external compensation!

#### Procedure

Configuration steps:

1. Open the project in STEP 7.
2. In the device view, select the required analog module and the corresponding channel.
3. Select the "General" tab in the Inspector window of the selected module.
4. Select the "Inputs/Measuring" area.
5. Select the "Thermocouple" value as "Measurement type".
6. As "Reference junction", select the value "Internal reference junction".

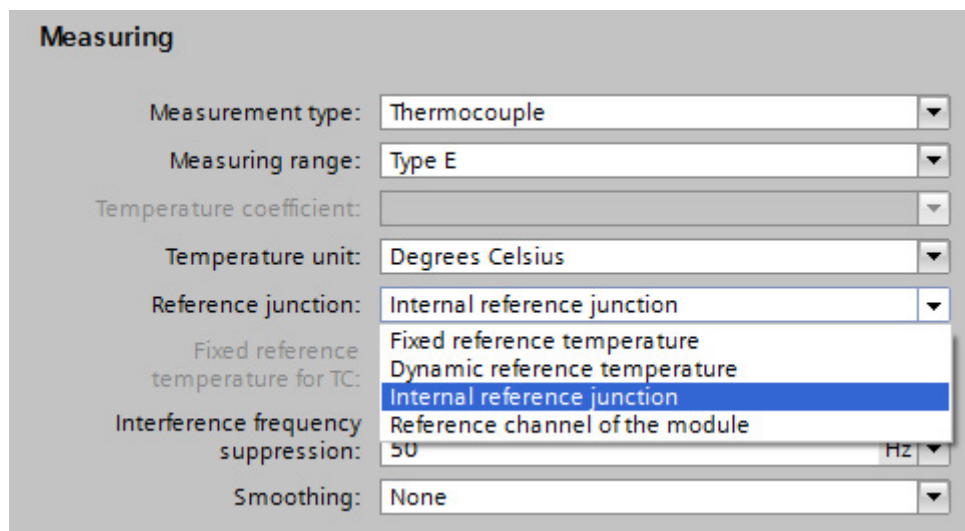

Figure 5-2 Internal reference junction

### Wiring thermocouples

Wire the thermocouples directly or indirectly via compensating lines to the module inputs.

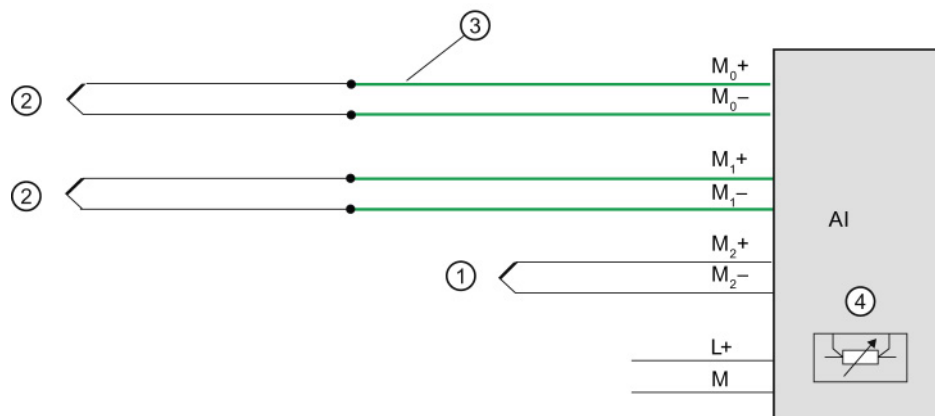

Figure 5-3 Example: Wiring thermocouples for compensation via internal reference junction

### 5.3.3 Compensation with reference channel of the module

#### Function principle

With this type of compensation, the reference junction temperature is determined using an external thermal resistor (RTD). Certain modules provide an internal reference channel.

#### Procedure

Configuration steps:

1. Open the project in STEP 7.
2. In the device view, select the required analog module and the corresponding channel.
3. Select the "General" tab in the Inspector window of the selected module.
4. Select the "Inputs/Measuring" area.
5. Select the "Thermocouple" value as "Measurement type".
6. As "Reference junction", select the value "Reference channel of the module".

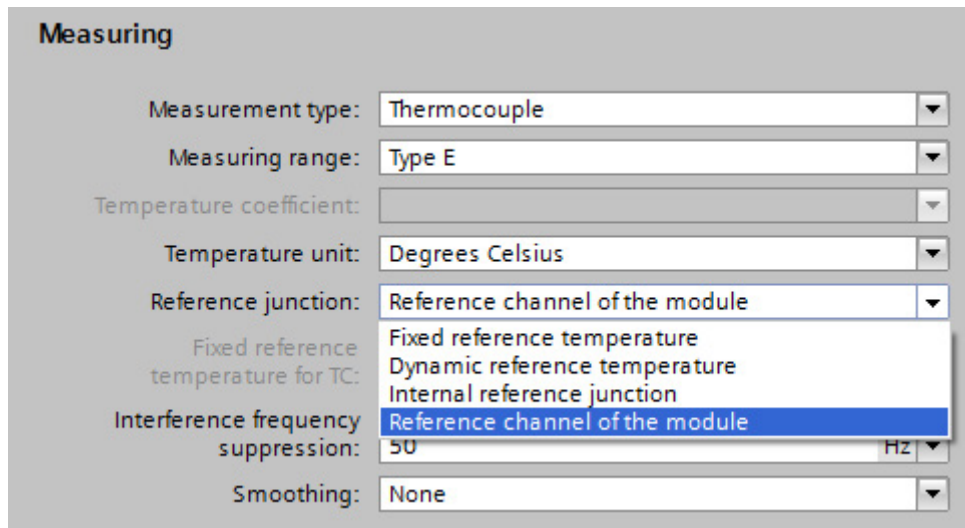
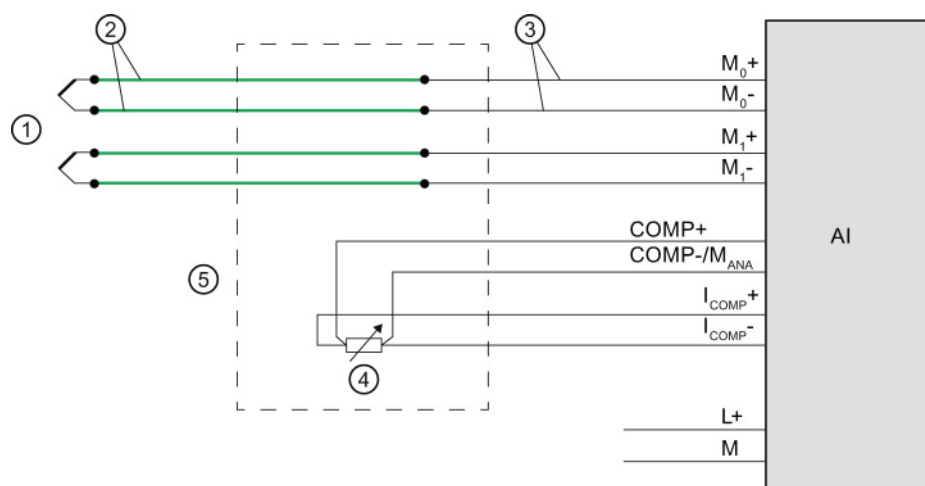

Figure 5-4 Reference channel of the module

### Wiring thermocouples and thermal resistors

Connect the thermocouple to the supply lines directly at the reference junction, or indirectly using compensating lines. Wire the supply lines to the corresponding terminals of the module.

You may use cables made of any material to wire the thermal resistor to the module terminals.



- ① Thermocouple
- ② Compensating line (same material as thermocouple)
- ③ Copper supply cable, for example
- ④ Thermal resistor (RTD)
- ⑤ Reference junction

Figure 5-5 Example: Wiring thermocouples/thermal resistors for compensation by means of reference channel of the module

### 5.3.4 Compensation, reference channel of Group 0

#### Function principle

For this compensation, a module channel with a connected thermal resistor (RTD) acts as "Reference temperature transmitter". Other channels (reference temperature receivers) with connected thermocouples can be compensated using this reference temperature. The measured temperatures of all channels (receivers) that you have configured for this compensation type will be compensated automatically by the temperature value of the reference junction (transmitter).

The reference junction temperature is determined by means of an external thermal resistor (RTD).

#### Procedure

Configuration steps:

1. Open the project in STEP 7.
2. In the device view, select the required analog module and the corresponding channel.
3. Select the "General" tab in the Inspector window of the selected module.
4. Select the area "Inputs/measurement".
5. For the channel of the relevant module, specify as transmitter:

As "Measurement type" select, for example, "Thermal resistor (4-wire)".

As "Reference junction", select the value "Reference channel of group 0".

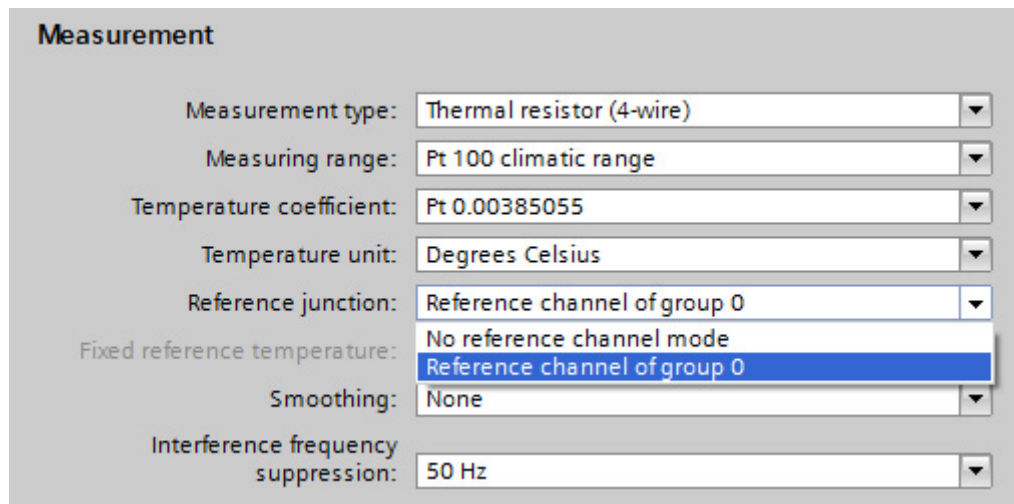

Figure 5-6 Transmitter: Reference channel of group 0



6. For the channels you specify as receivers:

Select the "Thermocouple" value as "Measurement type".

As "Reference junction", select the value "Reference channel of group 0".

The screenshot shows a configuration window titled "Measurement" with the following settings:

- Measurement type: Thermocouple
- Measuring range: Type E
- Temperature coefficient: (empty)
- Temperature unit: Degrees Celsius
- Reference junction: Reference channel of group 0
- Fixed reference temperature: Reference channel of the module, Internal reference junction, Reference channel of group 0 (highlighted), Fixed reference temperature
- Smoothing: Reference channel of group 0 (highlighted), Fixed reference temperature
- Interference frequency suppression: 50 Hz

Figure 5-7 Receivers: Reference channel of group 0

Connecting thermocouples and thermal resistors

The example below shows:

- An analog module with thermal resistor as reference temperature transmitter and
- Two analog modules with thermocouple as reference temperature receivers.

Connect the thermocouples to the supply lines at the reference junction, either directly or with compensating lines. Wire the supply lines to the corresponding terminals of the module.

You may use cables made of any material to wire the thermal resistor to the module terminals.

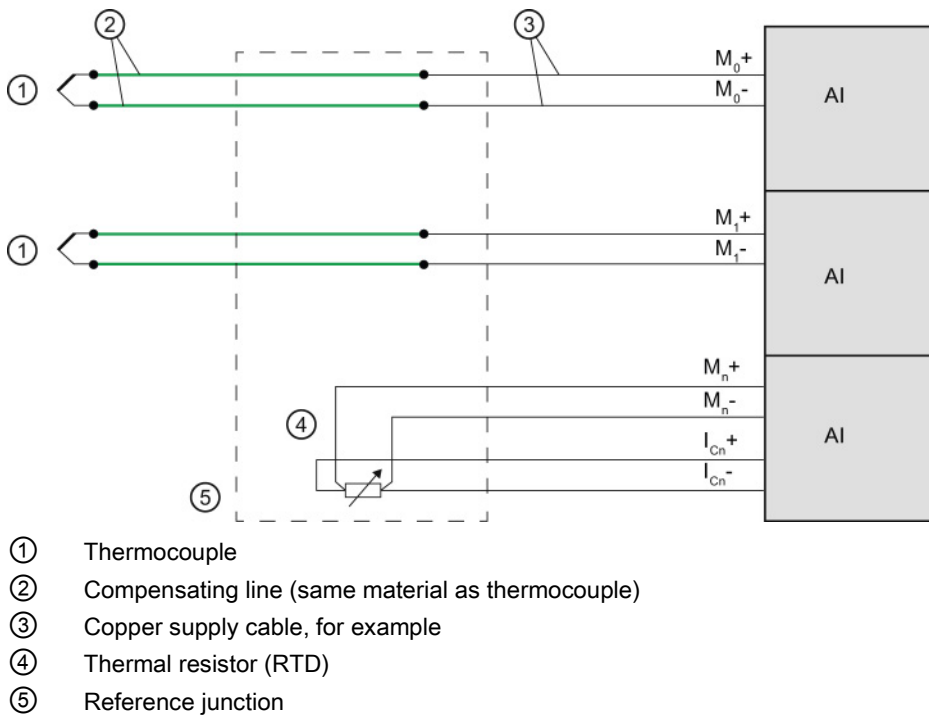

Figure 5-8 Example: Connecting thermocouples/thermal resistors for group 0 compensation

### 5.3.5 Compensation with fixed reference temperature

#### Function principle

With this type of compensation, the reference junction temperature is stored in the module as fixed value.

#### Procedure

Configuration steps:

1. Open the project in STEP 7.
2. Select the required analog module in the Device view.
3. Select the "General" tab in the Inspector window of the selected module.
4. Select the "Inputs/Measuring" area.
5. Select the "Thermocouple" value as "Measurement type".
6. As "Reference junction", select the value "Fixed reference temperature".
7. Specify the temperature of the reference junction in the "Fixed reference temperature" area, for example, 20 °C.

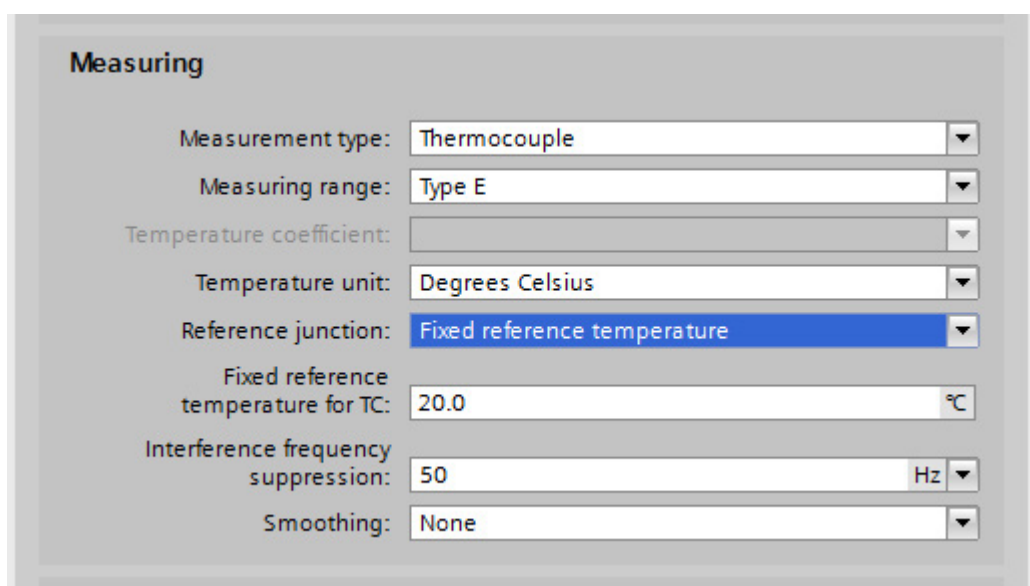
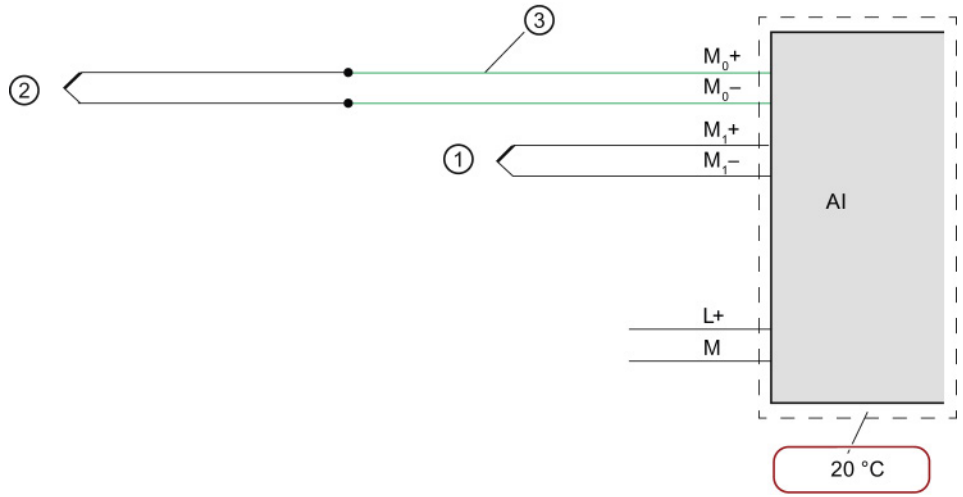

Figure 5-9 Fixed reference temperature

Temperature condition with "Fixed reference temperature" setting

The figure below shows the connection options for thermocouples provided the temperature of the module is kept at a fixed reference temperature (20 °C), for example by installing it in an air-conditioned switch cabinet. The reference junction is in the module.



- ① Thermocouple without compensating line
- ② Thermocouple via compensating line
- ③ Compensating line (same material as thermocouple)

Figure 5-10 Example 1: Connecting a thermocouple to an analog module for compensation with "fixed reference temperature"

The figure below shows the connection options for thermocouples provided the temperature of the reference junction (outside the module) is kept at a fixed reference temperature (20 °C).

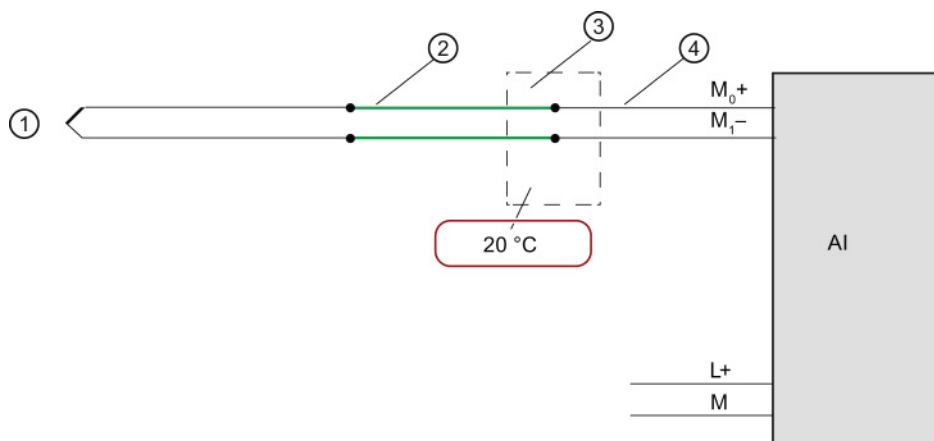

- ① Thermocouple with compensating line and supply line
- ② Compensating line (same material as thermocouple)
- ③ Reference junction
- ④ Copper supply cable, for example

Figure 5-11 Example 2: Connecting a thermocouple to an analog module for compensation with "fixed reference temperature"

### 5.3.6 Compensation by means of dynamic reference temperature

#### Function principle

This compensation type allows you to handle the reference junction temperature for temperature compensation in the user program. You can derive the temperature value from any other module of the station. The reference junction temperature is transferred via data records using the instruction **WRREC** (SFB 53).

The structure of the data records is detailed in the device manual for each module.

#### Requirement

STEP 7 project with the following contents:

- User program with WRREC (SFB 53) instruction for transferring the data records with reference temperature
- Analog module for acquisition of the process temperature using thermocouple (TC)
- Analog module for measuring the process temperature using thermal resistor (RTD)

### Analog module for acquisition of the process temperature using thermocouple (TC)

Configuration steps:

1. Open the project in STEP 7.
2. In the device view, select the required analog module and the corresponding channel.
3. Select the "General" tab in the Inspector window of the selected module.
4. Select the "Inputs/Measuring" area.
5. Select the "Thermocouple" value as "Measurement type".
6. As "Reference junction", select the value "Dynamic reference temperature".

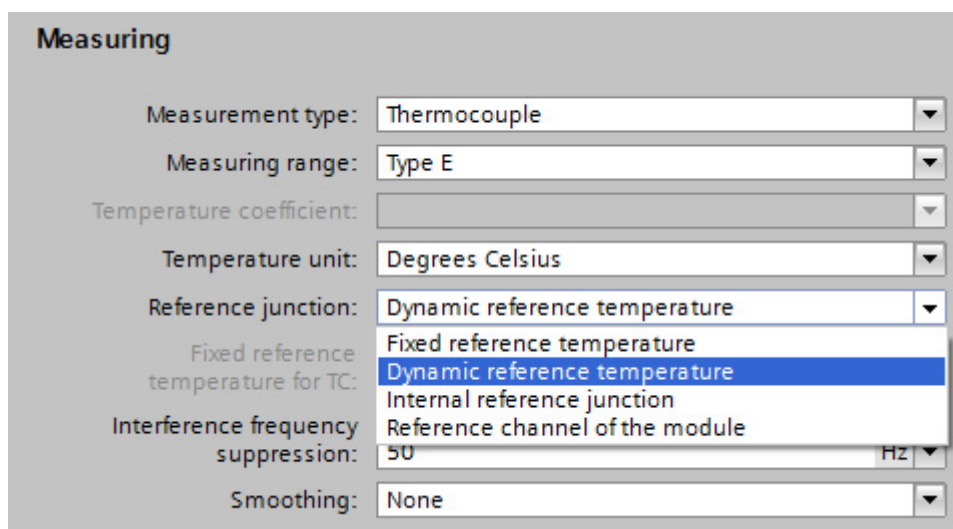

Figure 5-12 Dynamic reference temperature

### Analog module for measuring the process temperature using thermal resistor (RTD)

Configuration steps:

1. Open the project in STEP 7.
2. In the device view, select the required analog module and the corresponding channel.
3. Select the "General" tab in the Inspector window of the selected module.
4. Select the "Inputs/Measuring" area.
5. Select the "Thermal resistor (4-wire connection)" value as "Measurement type".

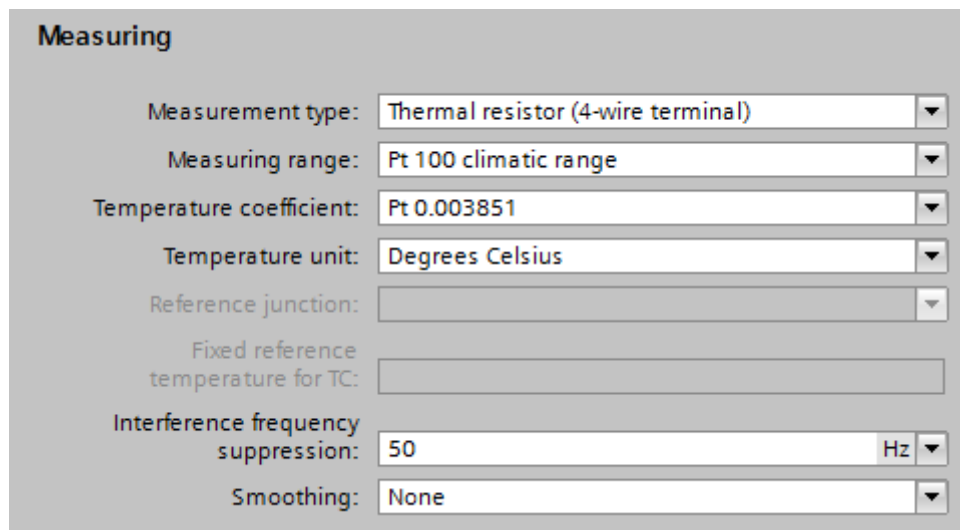
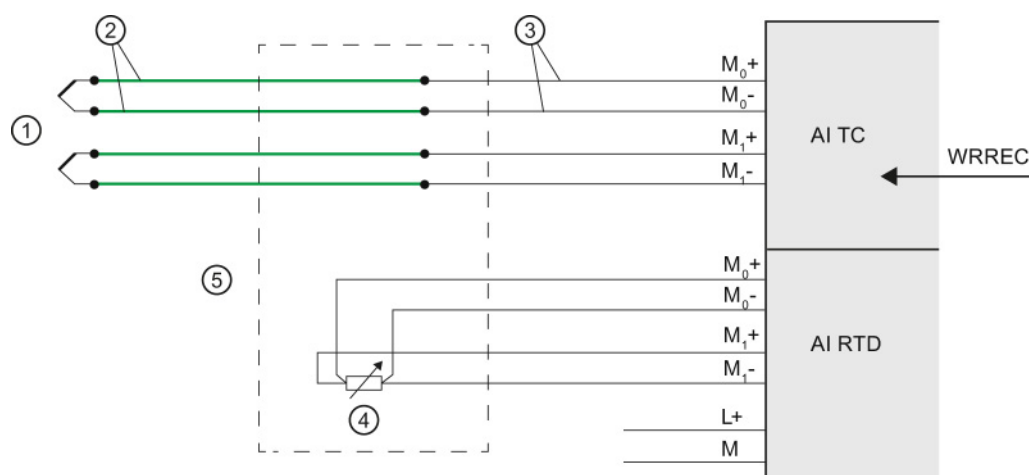

Figure 5-13 Settings for thermal resistor (RTD) type of measurement



### Connecting thermocouples and thermal resistors

Connect the thermocouples, for example, to the module inputs using supply lines for temperature compensation with dynamic reference temperature. In this case, the temperature is acquired at the reference junction by means of a thermal resistor (RTD). This reference junction temperature determined in this way is transferred to the analog module with thermocouple via data records with the WRREC instruction.



- ① Thermocouple
- ② Compensating line (same material as thermocouple)
- ③ Copper supply cable, for example
- ④ Thermal resistor (RTD)
- ⑤ Reference junction

Figure 5-14 Example: Connecting thermocouples/thermal resistors for compensation by means of dynamic reference temperature

### 5.3.7 "None" or external compensation

#### Function principle

The reference junction temperature of the thermocouples is measured outside the analog input module, e.g., by means of a compensating box on the thermocouple. The temperature of the reference junction for this type of compensation is specified as 0° C.

The compensating box includes a bridge circuit that is calibrated for a specific reference junction temperature (compensation temperature). The connectors for the ends of the compensating line of the thermocouple form the reference junction. If the actual comparison temperature deviates from the compensation temperature, the temperature-dependent bridge resistor changes. A positive or negative compensation voltage is generated and added to the thermal voltage.

---

#### Note

Thermocouples of type B do not require a compensating box.

---

#### Procedure

Configuration steps:

1. Open the project in STEP 7.
2. Select the required analog module in the Device view.
3. Select the "Inputs" tab in the Inspector window of the selected module and the respective channel.
4. Select the "Thermocouple" value as "Measurement type" in the "Measuring" area.
5. As "Reference junction", select the value "None" or "External compensation" depending on the used module.

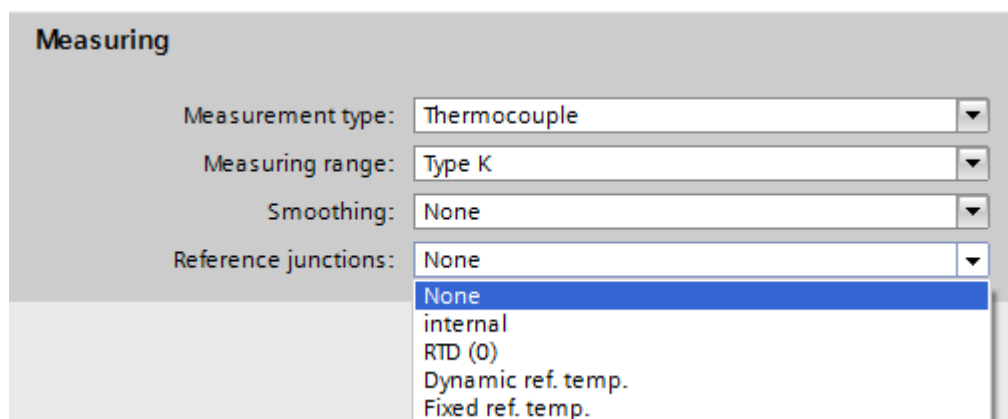

Figure 5-15 No reference junction

### Connection of the compensating box

The compensating box is looped into the supply lines of an individual thermocouple. The compensating box must be supplied isolated. The power supply unit must have a sufficient noise filter, e.g., by means of a grounded shielding winding.

Each channel can use its own thermocouple type supported by the analog module regardless of the other channels. A separate compensating box is required for each channel.

### Connection example "None" or external compensation

Connect the compensating box with the connection module of the analog input module using copper cables.

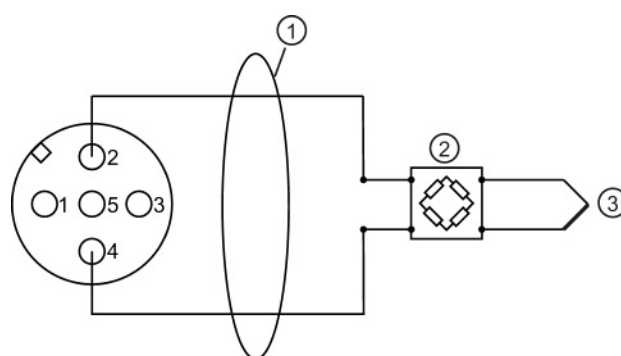

- ① Copper cables
- ② Compensating box (per channel), for example; thermocouple type B does not require a compensating box
- ③ Thermocouple

Figure 5-16 Connection example "No" compensation as reference junction

### 5.3.8 Compensation type RTD (0)

#### Function principle

The reference junction temperature is determined by means of the resistance value of a Pt 1000 at the clamping unit of the M12 compensation connector. The resistance measurement is only permitted at the X1 circular socket (channel 0). All of the module's channels with this type of compensation receive the same reference junction temperature.

#### Procedure

Configuration steps:

1. Open the project in STEP 7.
2. Select the required analog module in the Device view.
3. Select the "Inputs" tab in the Inspector window of the selected module.
4. Select the "Thermocouple" value as "Measurement type" in the "Measuring" area.
5. As "Reference junction", select the value "RTD (0)".

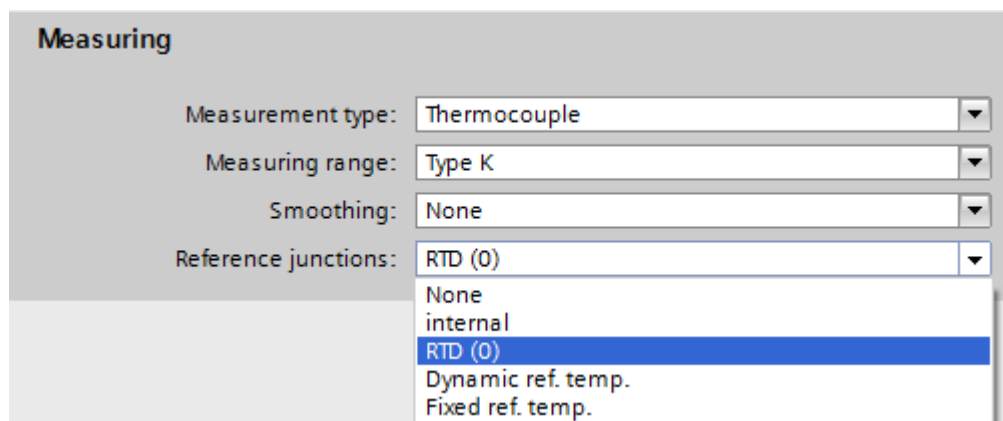

Figure 5-17 Compensation type RTD (0)

## Connection example

### Connection with M12 compensation connector

Connect the thermocouple to the M12 compensation connector directly or with compensating lines. Install the M12 compensation connector to the X1 circular socket (channel 0) of the CM IO 4 x M12 at the 4 AI TC High Feature.

### Connection without M12 compensation connector

To measure the referent junction temperature, connect an external Pt1000 (with  $\alpha = 003851$ ) to terminals 1 and 3 using copper cables. The thermal resistor Pt1000 must be positioned in the area of the reference junction. Connect the thermocouples to terminals 2 and 4 from the reference junction with copper cables.

### Connecting additional thermocouples

You can connect additional thermocouples to the circular sockets X2 to X4 on the CM IO 4 x M12 of the 4 AI TC High Feature. The temperature of reference junction collected by measuring the resistance value at the X1 circular socket applies to all channels of the module that you have selected for this type of compensation.

The figure below shows a connection example "RTD (0)" as reference junction with M12 compensation connector and integrated thermal resistor Pt1000:

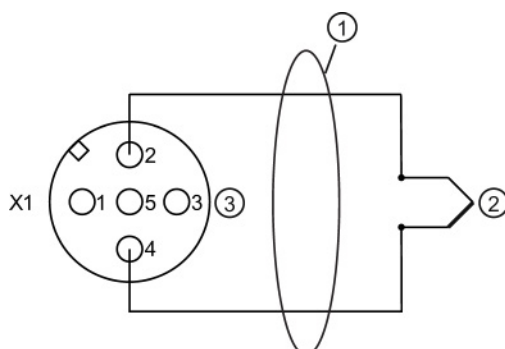

- ① Direct connection of the thermocouple or with compensating lines
- ② Thermocouple
- ③ M12 compensation connector (terminals 1 and 3 with internal Pt1000) only at X1 circular socket. The comparison value of the M12 compensation connector at circular socket X1 also applies to thermocouples at X2, X3 and X4.

Figure 5-18 Connection example "RTD (0)" as reference junction in the M12 compensation connector

5.3 Compensation for the reference junction temperature

The figure below shows a connection example "RTD (0)" as reference junction with external thermal resistor Pt1000:

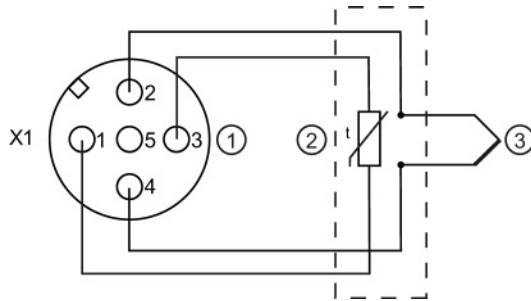

- ① M12 connector only at X1 circular socket
- ② External Pt1000 ( $\alpha = 0.003851$ ) in the area of the reference junction with copper cables at terminals 1 and 3. The comparison value of the external Pt1000 at circular socket X1 also applies to thermocouples at X2, X3 and X4.
- ③ Thermocouple

Figure 5-19 Connection example "RTD (0)" as reference junction with external Pt1000

## Wiring loads/actuators

### 6.1 Overview

#### Introduction

This chapter describes the basic procedure for wiring loads/actuators to analog outputs. Information on specific wiring options is available in the manual of each module.

For detailed information on cable routing and shielding, potential equalization, etc. please refer to the function manual *Configuring interference-free controllers* (<http://support.automation.siemens.com/WW/view/en/59193566>).

#### Abbreviations used in the figures

Key to the abbreviations in the figures below:

AQ	Analog output module
M	Ground connection
L+	Supply voltage connection
$S_n+/S_n-$	Sense line channel n
$QV_n+/QV_n-$	Voltage output channel n
$QI_n+/QI_n-$	Current output channel n
$M_{ANA}$	Reference point of the analog ground
$U_{ISO}$	Insulation voltage

#### Lines for analog signals

Always use shielded twisted-pair cables to wire the analog signals. This improves immunity.

## 6.2 Wiring loads/actuators

### Reference potential for analog output modules with $M_{ANA}$ connection

Analog output modules have no galvanic connection between the reference point of the analog ground  $M_{ANA}$  and the central ground.

Always verify that the admissible potential difference  $U_{ISO}$  between the reference point of the analog ground  $M_{ANA}$  and the central ground is not exceeded.

Potential difference  $U_{ISO}$  may be caused by: Maximum line lengths exceeded.

If you want to ensure the maximum value  $U_{ISO}$  is not exceeded, wire terminal  $M_{ANA}$  and the central ground with an equipotential bonding cable.

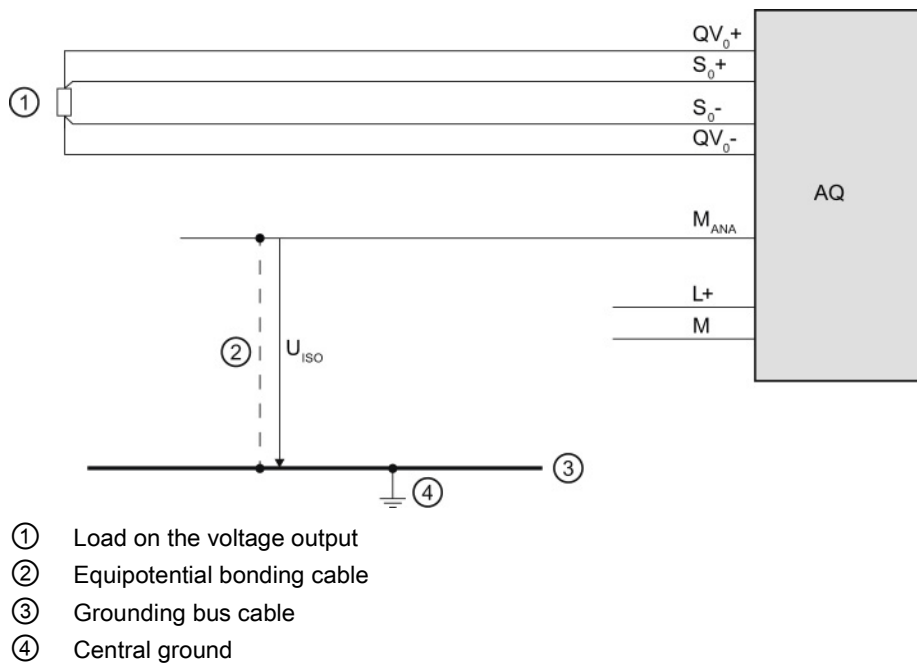

Figure 6-1 Example: Reference potential for an analog output module with  $M_{ANA}$  connection



### Reference potential for analog output modules without $M_{ANA}$ connection

Analog output modules have no galvanic connection between the reference potential of the analog output circuits and central ground.

Always verify that the maximum potential difference  $U_{ISO}$  between the reference points of the analog output circuits and the central ground is not exceeded.

Potential difference  $U_{ISO}$  may be caused by: Maximum line lengths exceeded.

If you want to ensure the maximum value  $U_{ISO}$  is not exceeded, interconnect each analog output circuit with the central ground using an equipotential bonding cable.

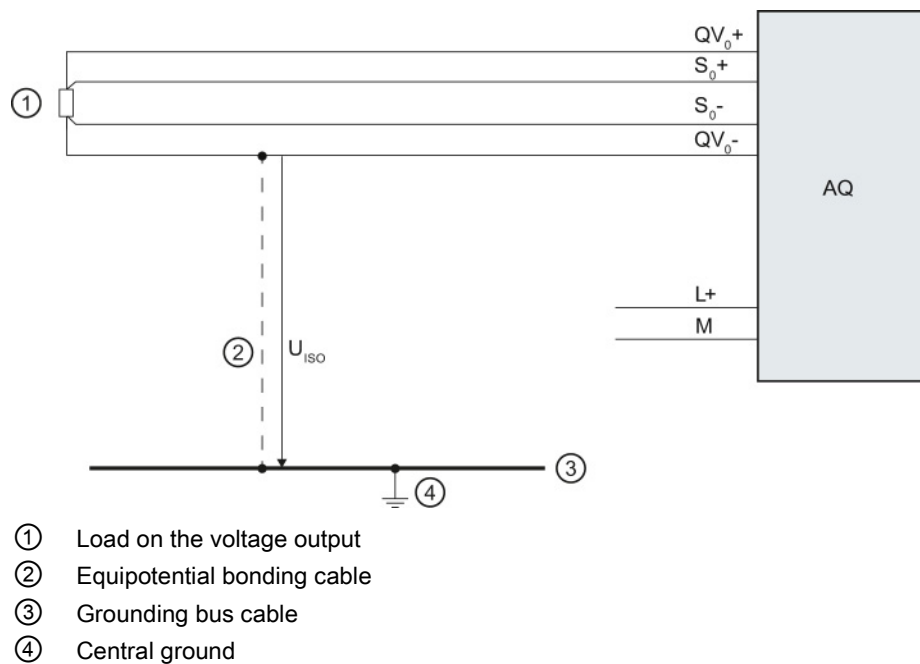

Figure 6-2 Example: Reference potential for an analog output module without  $M_{ANA}$  connection

## Supported functions

### 7.1 Calibrating analog modules

#### 7.1.1 Overview

##### Calibration

A calibration checks the process values measured by the analog input module and the process values output by the analog output module, determines the deviation from the actual values and compensates for any measurement and output errors.

##### Calibrating analog modules

The SIMATIC analog modules were calibrated before being shipped and have excellent long-term stability; calibration is therefore not required during runtime.

But certain regulations and directives, for example from the Food and Drug Administration (FDA), require regular calibration for all components in a measuring circuit. These components include analog input and output modules.

A calibration makes sense especially for plants in which sensors detect and process relatively small voltages or currents. The calibration compensates for influences on the measuring result by cables and/or temperature.

The calibration collects the new values and saves them retentively on the module. But the calibration values determined prior to delivery at the plant are not lost. You can return to these original calibration values at any time.

---

##### Note

The calibration saves the calibration values of each channel for the specific measuring range retentively on the module, which means the values apply to the same measuring range in which the user calibration took place.

If you reconfigure a channel with effective user calibration values to another type of measuring mode, the calibration values saved at the plant for this channel and for this measuring range will become effective.

But the user calibration values are not deleted. They are not overwritten until there is a new user calibration of the channel. If you set the original measuring range for this channel once again without new user calibration, the previously determined user calibration values will become effective.

---

The respective manual will include information whether or not your analog module supports the "Calibration" functionality.

### **Scope of functions**

The "Calibration" group offers the following functions:

- Specifying the current calibration of all channels
- Calibrating a channel
- Canceling a running calibration
- Resetting the calibration of a channel to the factory settings

## **7.1.2 Calibrating analog modules**

### **Manual calibration**

The following requirements must be met to start manual calibration:

- An online connection exists between STEP 7, the respective CPU and the analog module to be calibrated.
- You have opened the "Online & Diagnostics" view for the selected analog module from the shortcut menu of the project and you are now in the "Functions > Calibration" area.
- The configuration reflects the actual structure of the station.
- No calibration process is busy on the module (if you want to launch calibration).
- A 24 V load voltage must be present at each module for the calibration.
- The last step was successfully completed (if you want to continue or conclude calibration).

## Procedure

The basic mask for calibration opens once you start the "Calibration" function. The module reads the following general information data and calibration values after each new selection of a channel:

- **Calibration:** Indicates whether or not the currently effective calibration values are factory calibration values or user calibration values.
- **Measurement type:** Information about the selected measurement type
- **Measuring range:** Currently configured measuring range of the selected channel
- **Gain:** Currently effective gain correction of the analog-digital converter
- **Offset:** Currently effective offset correction of the analog-digital converter

Overview

Channel..	Calibration	Measuring typ	Measuring r..	Gain:	Offset:	Date	
0	Factory	Voltage	+/- 10 V	1	0	12/1...	▲
1	Factory	Voltage	+/- 10 V	1.001	0	12/1...	☰
2	Factory	Voltage	+/- 10 V	1	0	12/1...	
3	Factory	Voltage	+/- 10 V	1.001	0	12/1...	
4	Factory	Voltage	+/- 10 V	1.001	0	12/1...	
5	Factory	Voltage	+/- 10 V	1	0	12/1...	
6	Factory	Voltage	+/- 10 V	1.001	0	12/1...	
7	Factory	Voltage	+/- 10 V	1	0	12/1...	▼

Start manual calibration      Set to factory settings

Figure 7-1 Calibration table

To start the calibration, follow these steps:

1. Select the line associated with the channel to be calibrated in the overview table.
2. Click the "Start manual calibration" button.
3. Now go through the steps in the "Manual calibration" section.
4. Follow the instructions in the "Command" field.
5. Click ""Next".

The required calibration values of the selected channel according to the measuring range configured for this channel are specified once again during the user calibration.

---

**Note**

The calibration can take place in RUN mode as well as STOP mode of the CPU. If the CPU is in RUN, the calibration value that was last collected prior to the start of the calibration is supplied for the duration of the calibration.

The module channel to be calibrated cannot process any new process values during the user calibration. All analog input values of the module are set to 0x7FFF ("Invalid analog value") until the end of the calibration. When the value status is enabled, the value status of the signal is set to "invalid" for the duration of the calibration.

---

You must provide a voltage and/or temperature during a user calibration. To do so, use the corresponding external wiring and an external voltage/temperature transducer. The field "Command" includes numbers of pins to which you can connect the calibration stimulus. The first pin number identifies the positive connector, the second pin number the negative connector. The accuracy of the calibration depends on the accuracy of the provided voltage/temperature.

---

**Note**

To ensure that the module retains the specified measuring accuracy after the user calibration, the provided voltage/temperature must be twice as accurate as specified for the module. Inaccurate voltages or temperature result in a faulty calibration.

---

The figure below shows an example of channel calibration with "Voltage" measurement, measuring range "+/- 10 V".

**Manual calibration**

Step 1 of 2

Command: Please apply a voltage of 10000 mV to terminal 3.  
Please apply the ground to terminal 4.

Status: Calibration started without errors.

Measured value: 10000

Next Cancel

Figure 7-2 Manual calibration

### 7.1 Calibrating analog modules

- **Command:** The field "Command" indicates which actions the user has to execute during the current calibration step. Here you execute the specified actions and confirm them with the "Next" button. The module now executes all actions required for the current calibration step. If the calibration step was error-free, the next calibration step takes place.  
The instructions in the "Command" field are to be performed additively. For example, after you have applied the voltage/ground to the terminals 3/4, these connections must remain in place during the execution of the next calibration step.
- **Status:** Depending on the set type of measurement, several calibration steps are required for calibration of a channel. The field "Status" indicates whether or not the last calibration step included errors. If an error occurs during processing of a calibration step, the error is displayed here and calibration of the channel is aborted. All calibration values recorded up to this point are deleted. The calibration values that were in effect prior to the start of the user calibration are effective once again.

---

#### Note

##### Calibrators

If the "Wire break" diagnostics is activated for analog input modules, a test current is applied to the line for the measuring types "Resistance", "Thermistor" and "Thermocouple". This applied test current can result in inaccurate measured values in some calibrators. The wire break monitoring is therefore automatically disabled in some analog modules during the calibration.

To avoid the risk of inaccurate measured values, we recommend you disable the "Wire break" diagnostics during the calibration of analog input modules.

---

#### Result

Calibration sets new settings for the channel.

#### Error occurrence

If an error occurs during the calibration, the module cancels the calibration. All calibration values recorded up to this point are lost. The channel to be calibrated will then have the same settings as before the start of calibration.

### 7.1.3 Canceling a calibration

#### Requirement

- You have opened the "Online & Diagnostics" view for the selected analog module from the shortcut menu of the project and you are now in the "Functions > Calibration" area.
- The associated CPU is online.
- A calibration is currently running on the analog module.

#### Procedure

Click the "Cancel" button to cancel an ongoing calibration.

#### Result

The active calibration is canceled. The channel to be calibrated will then have the same settings as before the start of calibration.

### 7.1.4 Resetting analog modules to factory settings

#### Requirement

- You have opened the "Online & Diagnostics" view for the selected analog module from the shortcut menu of the project and you are now in the "Functions > Calibration" area.
- The associated CPU is online.

#### Procedure

Proceed as follows to reset the channel of an analog module to factory settings:

1. In the overview table, select the line of the channel to be calibrated.
2. Click the "Set to factory settings" button.

#### Result

The factory settings of the channel are restored.

---

#### Note

When you reset the current channel to the factory settings, the original calibration values that were saved in the delivery state of the module become effective once again. Any existing user calibration values of this channel are lost. You cannot restore these user calibration values.

---



# High-speed analog modules

## 8.1 Basics

High-Speed analog modules (HS) are available for users with high demands regarding performance and speed. The main characteristics of these HS analog modules compared to Standard analog modules (ST) is their shorter cycle times. To achieve this goal, the input and output modules are equipped with components with extremely short throughput and conversion times. In addition, the entire architecture of the modules is designed for faster signal processing.

HS analog modules convert the output of measured values and output values at the same time. Each channel within the module has its own A/D or D/A converter. This means the cycle time is basically the conversion time and independent of the number of activated channels. This is true for analog input modules as well as analog output modules. This means HS modules can be used in fast isochronous mode.

Apart from isochronous mode, the HS analog modules also provide benefits in non-isochronous (free-running) mode. Due to the fast processing of the process signals, HS analog modules are able to detect changes in the process values more quickly and to respond to these events with the appropriate program blocks (for example, hardware interrupt or cyclic interrupt organization blocks). Additional information on the various organizational blocks can be found in the STEP 7 online help.

### Isochronous mode

Isochronous mode refers to synchronous coupling:

- Of signal acquisition and output via the distributed I/O
- Of signal transmission via PROFIBUS or PROFINET
- Of program processing with the constant bus cycle time of PROFIBUS or PROFINET.

The result is a system that acquires its input signals in constant time intervals, processes them and outputs the output signals. Isochronous mode guarantees reproducible and defined process reaction times as well as equidistant and synchronous signal processing with distributed I/O.

The bus system and the I/O modules work synchronously with configured isochronous mode. The transmitted input and output data are linked to an "isochronous task" in the CPU. As a result, the data of a cycle are always consistent. All data of a process image belong together logically and in time. Jitter in the user program caused by the acquisition of outdated values is therefore almost impossible.

Even fast processes can be perfectly controlled by the exact timing reproducibility of all processes. Isochronous mode thus contributes to high control quality and hence to greater manufacturing precision. While possible fluctuations of the process reaction times are drastically reduced. The time-assured processing can be utilized to improve machine cycle times. Shorter cycle times increase the processing speed and help to lower production costs.

### Send clocks

When you configure isochronous mode, the input and output data is synchronized within a send clock (cycle). The data of the input modules is acquired in cycle n and simultaneously transferred to the IM. The data is available in cycle n+1 in the CPU and can be processed. The CPU copies the data to the IM in the next cycle n+2. The output modules then output the data simultaneously in the same send clock. The acquisition – processing – output therefore takes place in three cycles. You can find more information on the configuration of isochronous mode in the STEP 7 online help.

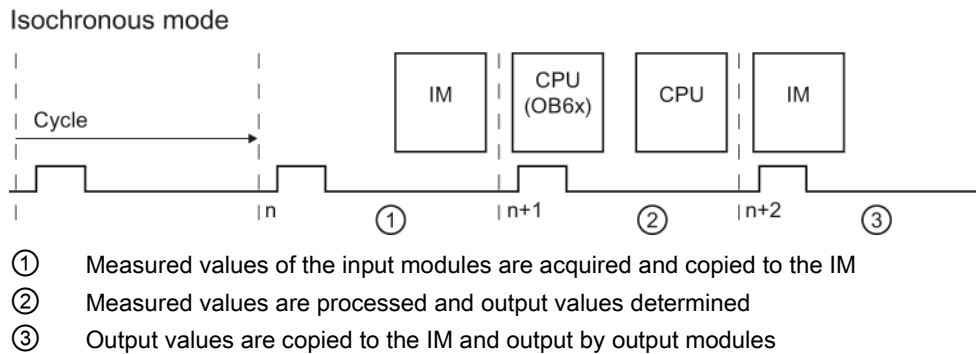

Figure 8-1 3-cycle model

### Oversampling

The use of the oversampling function in analog input or analog output modules requires an isochronous configuration.

With analog input modules, the set send clock is divided into time-equidistant sub-cycles. The send clocks can be subdivided into 2 to 16 sub-cycles. Each sub-cycle reads in a measured value. The read-in measured values of a data cycle are copied to the IM in the next send clock and are then available to the processing CPU one send clock later.

With analog output modules, the set send clock is also divided into time-equidistant sub-cycles. The send clocks can be subdivided into 2 to 16 sub-cycles. Each sub-cycle returns an output value. The output values are copied to the IM by the CPU within the same send clock and are written to the process one send clock later.

The read-in and output values are transmitted in the user data of the analog module. This way, the address space of the module is extended from 2 bytes of user data per channel to 16 x 2 bytes of user data per channel. If you subdivide the send clock into less than 16 sub-cycles, the unused addresses are assigned the error value 0x7FFF during input. For output, the values of the unused addresses are ignored.

Because the sub-cycles have to be within a send clock, oversampling needs an additional send clock to copy the data to the IM, unlike the 3-cycle model of isochronous mode. The result is a 5-cycle model.

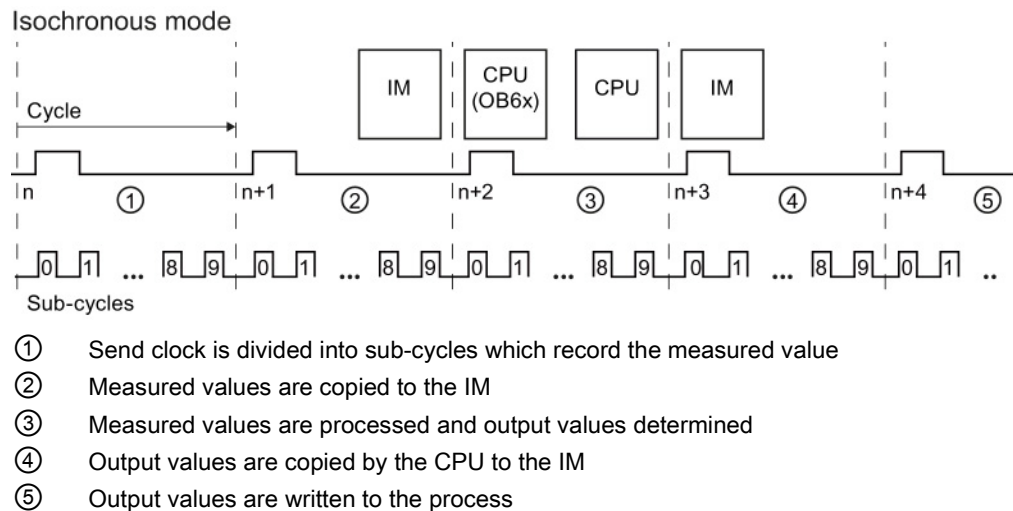

Figure 8-2 5-cycle model

Due to the configured modules, the send clock of an IO device has a minimum possible update time, which means the time interval within which an IO device/IO controller of the PROFINET IO system is supplied with new data. Modules with oversampling functionality, however, offer the option of further reducing the update time for their channels without having to shorten the send clock for the entire S7 station at the same time. The subdivision of the send clock into time-equidistant sub-cycles therefore enables an even faster signal processing speed.

### Example

In practice, the use of oversampling makes sense when the isochronous system works with only one specific specific send clock (for example, 1 ms) due to the modules used and when faster sampling of the process values is required. By using oversampling and a subdivision of the send clock into 4 sub-cycles, for example, you can sample the process values in intervals of 250  $\mu$ s.

### Configuring oversampling

Enable the option "Isochronous mode" in the IO device used and set the corresponding parameters ("Send clock", etc.). You define the number of sub-cycles in the relevant distributed analog module with the "Sampling rate" parameter for analog input modules and the "Output rate" parameter for analog output modules. If, for example, you configure a "Sampling rate" of 4 "Values/cycle" for a "Send clock" of 1 ms, the send clock is subdivided into 4 sub-cycles and the process values are sampled in intervals of 250  $\mu$ s.

### Cycle time of an analog input module

If you have configured the system property "Isochronous mode" for HS modules, all analog input modules are synchronized to a shared time within the send clock (cycle) ①. The cycle time is made up of the following time intervals:  $t_z = t_1 + t_2 + t_3 + t_4$

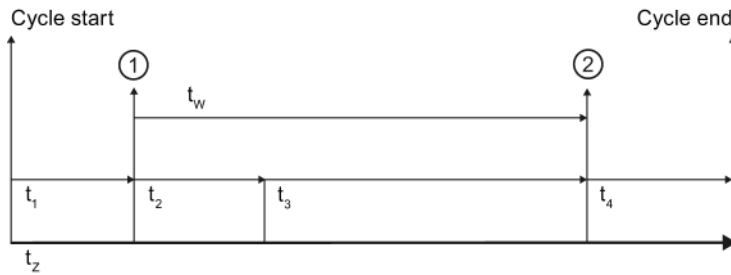

- ① Synchronization time for all analog input modules in isochronous mode and simultaneously time of the converted input signal at the terminal in this cycle
- ② Digitalized input signal is transferred to the backplane bus
- $t_z$  Cycle time
- $t_1$  Time between cycle start and synchronization
- $t_2$  Hardware-related runtime up to the analog-digital converter
- $t_3$  Processing time of digitalized input data in the module
- $t_4$  Transfer time of the backplane bus
- $t_w$  Conversion time of the module

Figure 8-3 Cycle time of the analog input module

## Cycle time of an analog output module

The synchronization time for analog output modules refers to the output of the digital-analog converter ②. Because the impedance of the connected actuator including connection cable is unknown in output modules but has a significant impact on the signal run time, the settling time cannot be added as a fixed value. The respective manuals of the output modules specify the typical load settling times as reference point. But in practice, a measurement with an oscilloscope is required for a precise measurement of the settling time. The settling time may exceed the actual end of the cycle due to very short cycle times and very high capacitive loads. The cycle time is made up of the following time intervals:  $t_z = t_1 + t_2 + t_3$

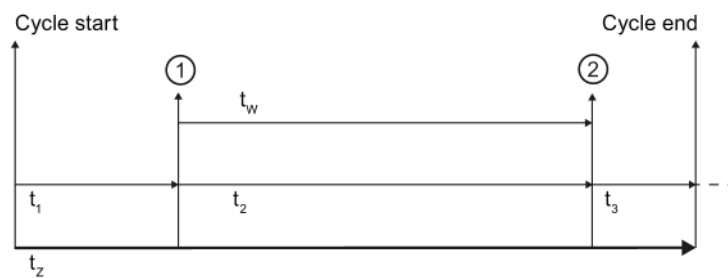

- ① Output data is available in digital form in the module
- ② Synchronization time for all analog output modules in isochronous mode and simultaneously output time of data in the digital-analog converter

$t_z$  Cycle time

$t_1$  Transfer time of the backplane bus

$t_2$  Processing time of data in the module until output at digital-analog converter

$t_3$  Settling time of hardware until setpoint of output value

$t_w$  Conversion time of the module

Figure 8-4 Cycle time of the analog output module

### Typical applications

In principle, isochronous mode is worthwhile whenever measured values must be acquired synchronously, movements must be coordinated, and process reactions must be defined and executed at the same time. There are thus numerous areas in which isochronous mode can be used.

Typical applications include, for example, the acquisition of binary signals for quality assurance at specific times and positions. But hydraulic applications with position and pressure control can benefit as well from the equidistant and isochronous data transmission.

The following example shows the use of isochronous mode within the production process of camshafts. Precise measurements must be made at several measuring points for quality assurance.

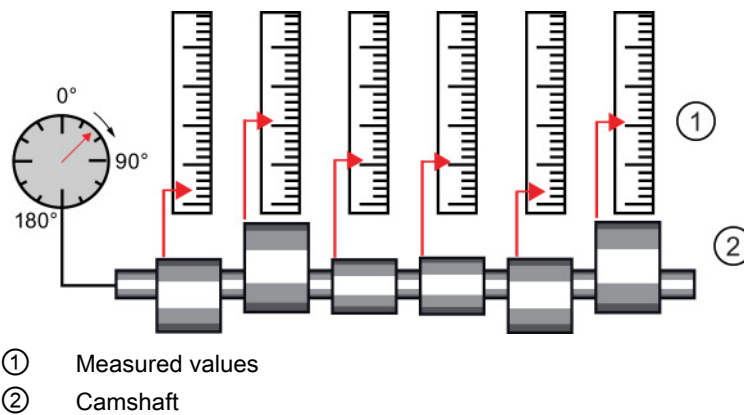

Figure 8-5 Measuring of camshafts

By using the system property "isochronous mode" and the associated simultaneous measured value acquisition, measurement can be performed continuously. The time required for measurement is reduced. Resultant workflow:

- Continuous machining of the camshaft
- During the continuous turning, measure the positions and cam excursion synchronously
- Process the next cam shaft

All camshaft positions and the corresponding measured values are measured synchronously within a single rotation of the camshaft. This increases machine output and maintains or enhances precision of the measurement.

## 8.2 ST modules vs HS modules

This section gives you an overview of other important distinctions between standard and high-speed analog modules. The specified numerical values are examples of selected modules. Keep in mind that the information can vary from module to module. The exact information of specific used analog module is available in the corresponding manual.

### Conversion method

#### **Instantaneous value conversion**

Instantaneous value conversion is often used to convert analog signal into digital information in HS modules. In this type of conversion a very short sample is taken from the measured signal and converted into digital data. This digital information therefore represents an instantaneous value of the measured signal. Instantaneous value conversion is used to acquire fast changes of process values, such as in the area of motion control. The quickly changing physical quantities in this case must be acquired and processed quickly in cooperation with suitable transducers. Input areas are primarily voltage, current and resistance, the latter especially for position potentiometers.

Because the measured signal is converted within a short time, there is a risk of incorrect measurements in case of faulty signals. The analog inputs working with the instantaneous value conversion method cannot detect if the sampled signal value is the target signal or an overlaying disturbing pulse. They always convert the "instantaneously" detected value. This means the pending measurement task should be carefully examined with regard to time constraints.

#### **Integrating conversion**

ST modules usually work according to the integrating conversion principle. The integrating conversion involves the sampling of a measured signal across a specified time period (integration time). Although this method is slower than instantaneous value conversion, it returns a conversion with higher immunity to interference. When you select the time interval for the conversion so that it corresponds to one or several periods of the surrounding network frequency, the omnipresent interference that is possibly also overlaying the signal is basically suppressed. SIMATIC modules give you the option to set the network frequency at which the plant is operated by means of parameter assignment. The resolution and conversion times may change depending on the interference frequency suppression that is set. The technical specifications of the respective module define these dependencies.

Analog inputs with integrating methods can be used universally. Even though the cabling must also be carefully designed with these analog inputs, the requirements are much less than those for analog inputs with instantaneous value conversion due to their slower signal acquisition that is basically immune to interference.

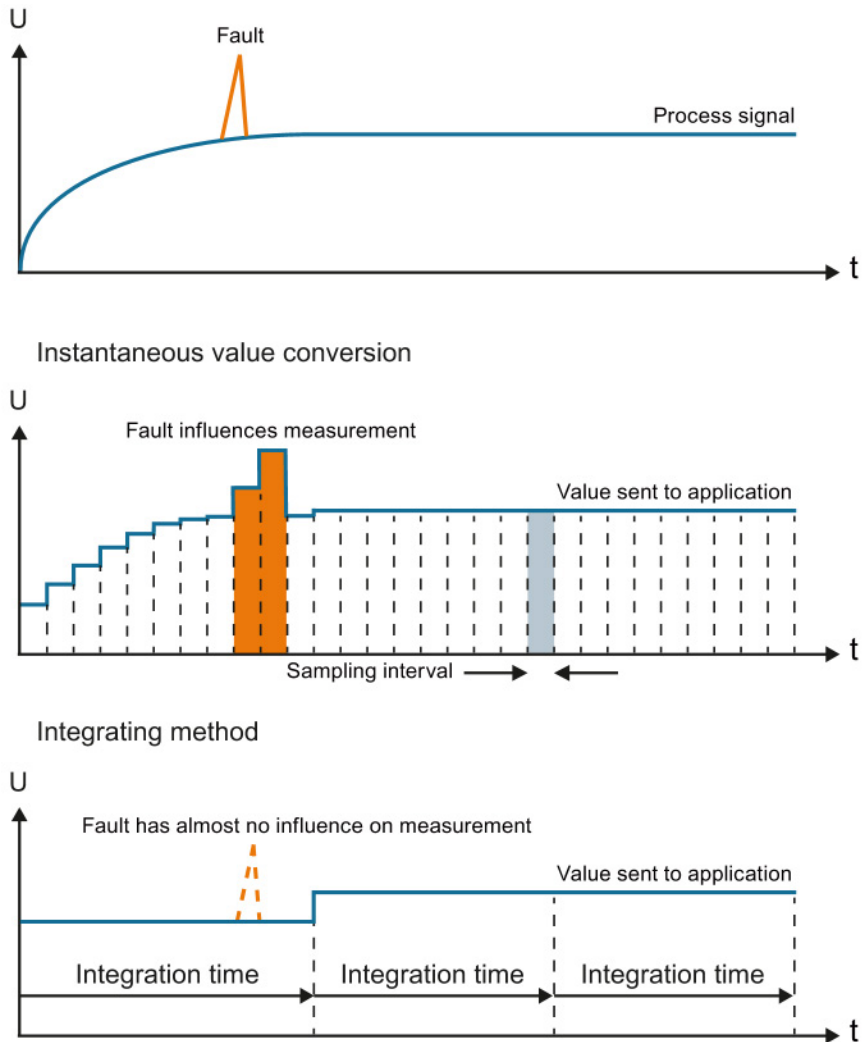

Figure 8-6 While an interference directly influences the value that is supplied to the application with instantaneous value encryption, its influence is negligible for the integrating method.



## **Electromagnetic compatibility**

The entire architecture of HS modules is designed for fast processing of the signals. An interference-free design is therefore critical when using HS modules.

The following rules apply to the wiring of HS modules with sensors and actuators:

- Keep the cables as short as possible
- Use shielded and twisted pair cables
- Low-impedance connection of the cable shield at the respective shield supports
- Short cable loop between shield support and terminal connection

---

### **Note**

#### **Interference-free design**

Make sure that you pay close attention to the notes listed in the function manual Configuring interference-free controllers (<http://support.automation.siemens.com/WW/view/en/59193566>) when using HS modules.

---

**Effect of load on the settling time**

The settling times to the setpoint achieved with analog output modules depend on the applied load, among other things. To take advantage of the faster conversion times, only small loads (e.g., max. 47 nF) are permitted in HS modules as specified in the technical specifications.

The type of load has an effect on the form of settling to the setpoint when using output modules. Capacitive loads reduce the rise time due to the charging process and can cause the output signal to overshoot. Inductive loads result in a delayed current increase due to remagnetization and therefore also a shorter rise time. The figure below shows the output signal with no/small ①, medium ② and high ③ capacitive load.

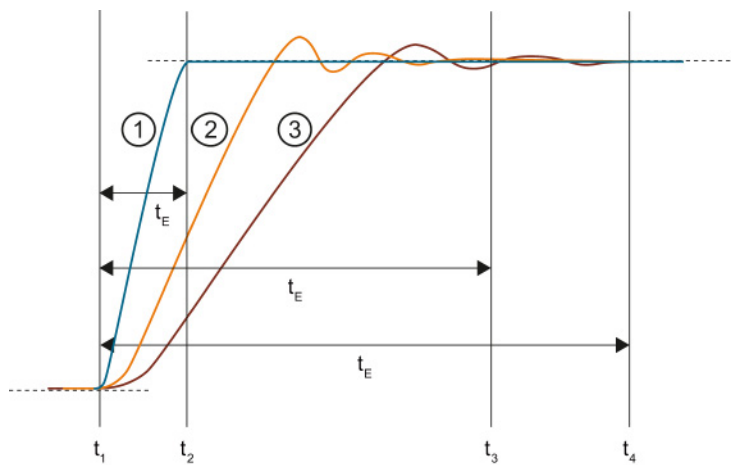

- ① Reference curve of a signal with no/small load capacity
- ② Signal with a load capacity of 47 nF
- ③ Signal with a load capacity of 100 nF
- $t_E$  Settling time
- $t_1$  Module ends conversion at the terminal of the analog output channel and outputs the analog signal
- $t_2$  Signal ① has settled and the specified analog output value has been reached (residual error 1 %)
- $t_3$  Signal ② has settled and the specified analog output value has been reached (residual error 1 %)
- $t_4$  Signal ③ has settled and the specified analog output value has been reached (residual error 1 %)

Figure 8-7 Effect of different loads on the settling time

## Effect of the cable length on the settling time

Long cables between signal source and module are a target for interferences. You should therefore keep the cables as short as possible especially for HS modules. Cables have a capacitive and inductive component and therefore have an effect on the settling behavior of the signal.

The example below shows the jump of the output voltage of an HS output module with small, medium and long cable length. The overshoot of the input signal increases with the length of the cable and therefore the time until it reaches the setpoint.

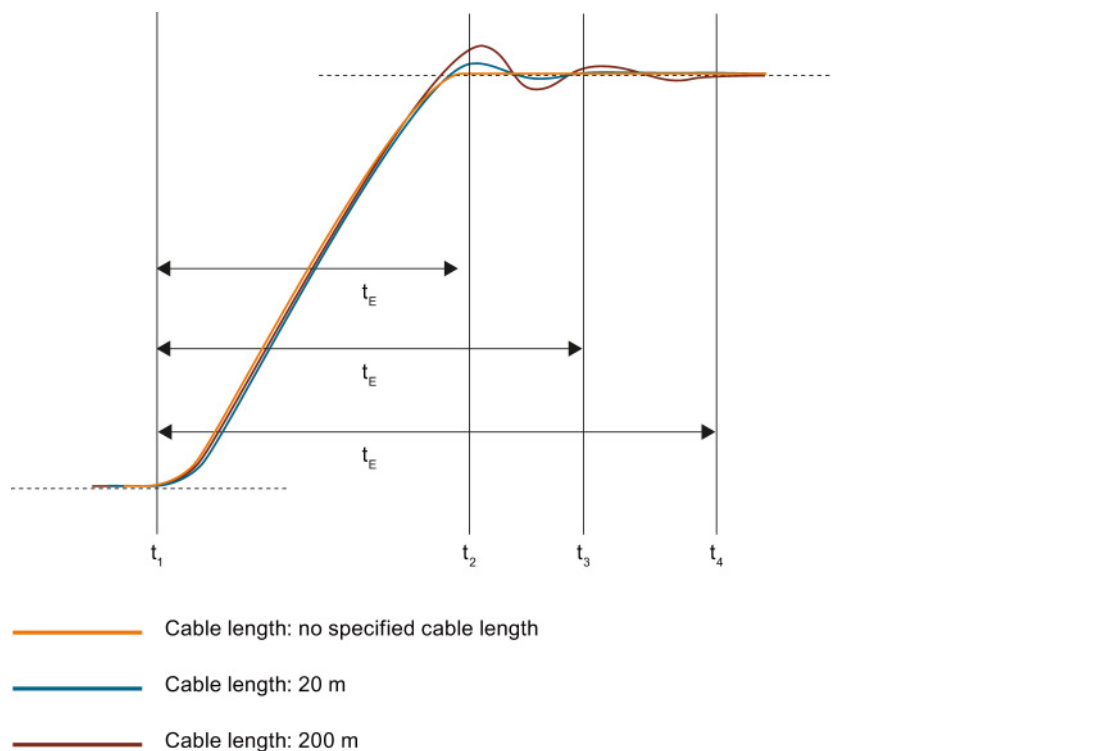

- $t_E$  Settling time
- $t_1$  Module ends conversion at the terminal of the analog output channel and outputs the analog signal
- $t_2$  The signal running through a cable with short length has settled and the specified analog output value has been reached (residual error 1 %)
- $t_3$  The signal running through a 20 m cable has settled and the specified analog output value has been reached (residual error 1 %)
- $t_4$  The signal running through a 200 m cable has settled and the specified analog output value has been reached (residual error 1 %)

Figure 8-8 Effect of different cable lengths on the settling time

### Effect of the value jump on the settling time

The figure below shows the effect of the height of the value jump between different output values on the settling time for analog output modules. The dotted line indicates the time when the signal has reached the setpoint. The higher the value jump, the later the signal reaches the setpoint.

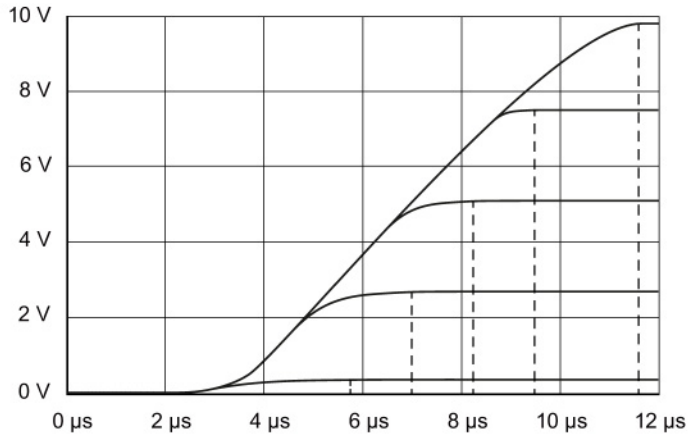

Figure 8-9 Settling time of five different analog signals with different value jumps

# Index

## A

- Abbreviations, 66, 103
- Accuracy, 15
- Actuators, 11, 103, 104
- Additional support, 4
- Analog input modules, 60, 65
- Analog output modules, 60, 104
- Analog value conversion, 60
- Application time, 53

## B

- Basic conversion time, 49
- Basic error limit, 15, 24
- Basic knowledge
  - Required, 3
- Bipolar measuring range, 25
- Blocks
  - SCALE, 17
  - UNSCALE, 19
- Burden, 57

## C

- Calibration, 106
  - Canceling, 111
- Channels
  - Calibrating, 108
  - Resetting to factory settings, 112
- Common mode, 67, 69
- Common mode rejection, 30, 33
- Common mode voltage, 67
- compensation
  - Reference channel of group 0, 88
- Compensation
  - none/external, 98
- Compensation with
  - Dynamic reference temperature, 94
  - fixed reference temperature, 91
  - internal reference junction, 84
  - RDT (0), 100
  - Reference channel of the module, 86
- conversion
  - analog-to-digital, 21, 51

- digital-to-analog, 21
- Conversion
  - analog-to-digital, 11
  - Digital-to-analog, 11
- Conversion time, 27, 49, 53
- coupling
  - capacitive, 34
  - galvanic, 31
  - inductive, 31, 34
- CPU, 11, 60, 67, 69
- Crosstalk, 34
- Crosstalk attenuation, 35
- Current, 10

## D

- Digital multimeter, 59
- Direct voltage, 69
- Documentation
  - additional, 7
- Drift, 26
- Dynamic reference temperature
  - Overview, 83

## E

- EMC, 32
- Error
  - Linearity errors, 21
  - Output error, 25
  - Temperature error, 26
- ET 200AL, 7
- ET 200eco PN, 7
- ET 200MP, 7
- ET 200pro, 7
- ET 200SP, 7
- External compensation
  - Overview, 83

## F

- Factory settings
  - Resetting channels to, 112
- Fixed reference temperature
  - Overview, 82

- G**
  - Ground connection, 31
  - GSD file, 48
- H**
  - High-speed analog modules
    - Isochronous mode, 113
- I**
  - Input impedance, 31
  - Insulation voltage, 67, 69
  - Interference frequency suppression, 27
  - Interference voltage, 31
  - Internal reference junction, 84
    - Overview, 81
  - Isochronous mode
    - Oversampling, 114
- L**
  - Line frequency
    - 16 2/3 Hz, 28
    - 400 Hz, 28
    - 50 Hz, 28
    - 60 Hz, 28
  - Linearity, 21
  - lines
    - for analog signals, 66
  - Lines
    - for analog signals, 103
  - Load, 53
  - Loads, 103, 104
- M**
  - Material composition
    - of thermocouples, 78
  - Measurement point, 79
  - Measuring ranges
    - Overflow, 42
    - Overrange, 42
    - Rated range, 42
    - Underflow, 42
    - Underrange, 42
- O**
  - Online catalog, 4
  - Operating principle
    - of thermocouples, 80
  - Operational limit, 15, 23
- P**
  - Pressure, 9
  - PROFIBUS, 113
  - PROFINET, 113
- Q**
  - Quality Information (QI), 46
- R**
  - Reference channel of group 0
    - Overview, 82
  - Reference channel of the module
    - Overview, 82
  - Reference junction, 79
  - Reference junction temperature, 81
  - Reference potential, 69, 104
  - Repeat accuracy, 22
  - Representation of analog values, 60
    - Binary representation, input ranges, 62, 63
    - Binary representation, output ranges, 63
  - Resistance, 10
  - Resistance thermometers
    - see Thermal resistor, 74
  - Resistance transducers
    - 4-wire connection, 74
  - Resolution, 13, 60
  - Response time, 52
  - RTD (0)
    - Overview, 83
- S**
  - S7-1500, 7
  - Scaling, 17
  - Scope
    - of the documentation, 3
  - Sensors,
  - Series mode rejection, 31, 33
  - Settling time, 53
  - Setup
    - of thermocouples, 79

Sign (S), 60  
 Signals  
   Analog, 9  
   Binary, 9  
   Processing, 12  
 Smoothing  
   exponential, 56  
   Linear, 55  
 Speed, 9  
 Standards  
   EN 61131, 15  
   FDA, 106  
 Step 7, 4  
 Step response, 55

## T

Temperature, 9  
 Temperature measuring range  
   of thermocouples, 78  
 Thermal resistor  
   2-wire connection, 75  
   3-wire connection, 75  
   Connecting, 74  
 Thermocouples  
   Wiring, 76  
 TIA Portal, 4  
 Transducers, 72  
   2-wire, 57, 72  
   4-wire, 73  
   Connecting, 65  
   Current transducers, 10, 57, 72  
   Resistance transducers, 10  
   Thermal resistor, 74  
   Thermocouples, 10, 27, 76, 79  
   Voltage transducers, 10, 71  
   Wiring, 72  
 Types of diagnostics, 36  
   Common mode error, 43  
   No supply voltage, 41  
   Overflow/underflow, 42  
   Overload, 45  
   Reference channel error, 43  
   Reference junction, 44  
   Short-circuit, 44  
   Wire break, 41

## U

Unscaling, 19

## V

Value status, 46  
 Variables  
   Analog, 9  
   physical, 10  
 variance  
   measured value, 22  
 Voltage, 10  
 Voltage drop, 59  
 Voltage measuring ranges  
   Overflow, 14  
   Overrange, 14  
   Rated range, 14  
   Underflow, 14  
   Underrange, 14  
 Voltage range, 27

## W

Wire break, 41

## Z

Zener diode, 59