

SIEMENS

SIMATIC

Distributed I/O System ET 200S

Operating Instructions

Preface

Description

1

Brief instructions on commissioning ET 200S

2

Application planning

3

Installing

4

Wiring and assembly

5

Commissioning

6

Functions

7

General technical specifications

8

Order numbers

A

Dimensional drawings

B

Leakage resistance

C

Interference-free operation

D

Legal information

Warning notice system

This manual contains notices you have to observe in order to ensure your personal safety, as well as to prevent damage to property. The notices referring to your personal safety are highlighted in the manual by a safety alert symbol, notices referring only to property damage have no safety alert symbol. These notices shown below are graded according to the degree of danger.

⚠ DANGER
indicates that death or severe personal injury will result if proper precautions are not taken.
⚠ WARNING
indicates that death or severe personal injury may result if proper precautions are not taken.
⚠ CAUTION
with a safety alert symbol, indicates that minor personal injury can result if proper precautions are not taken.
CAUTION
without a safety alert symbol, indicates that property damage can result if proper precautions are not taken.
NOTICE
indicates that an unintended result or situation can occur if the corresponding information is not taken into account.

If more than one degree of danger is present, the warning notice representing the highest degree of danger will be used. A notice warning of injury to persons with a safety alert symbol may also include a warning relating to property damage.

Qualified Personnel

The device/system may only be set up and used in conjunction with this documentation. Commissioning and operation of a device/system may only be performed by **qualified personnel**. Within the context of the safety notes in this documentation qualified persons are defined as persons who are authorized to commission, ground and label devices, systems and circuits in accordance with established safety practices and standards.

Proper use of Siemens products

Note the following:

⚠ WARNING
Siemens products may only be used for the applications described in the catalog and in the relevant technical documentation. If products and components from other manufacturers are used, these must be recommended or approved by Siemens. Proper transport, storage, installation, assembly, commissioning, operation and maintenance are required to ensure that the products operate safely and without any problems. The permissible ambient conditions must be adhered to. The information in the relevant documentation must be observed.

Trademarks

All names identified by ® are registered trademarks of the Siemens AG. The remaining trademarks in this publication may be trademarks whose use by third parties for their own purposes could violate the rights of the owner.

Disclaimer of Liability

We have reviewed the contents of this publication to ensure consistency with the hardware and software described. Since variance cannot be precluded entirely, we cannot guarantee full consistency. However, the information in this publication is reviewed regularly and any necessary corrections are included in subsequent editions.

Preface

Purpose of the operating instructions

The information in these operating instructions is intended to enable you to operate the ET 200S Distributed I/O System:

- on the PROFIBUS DP as DP Slave
- as a PROFINET IO device on PROFINET

Required level of knowledge

To understand these operating instructions, you should have general experience in the field of automation engineering.

Scope of these operating instructions

These operating instructions are valid for the components of the ET 200S Distributed I/O System.

These operating instructions contain a description of the components which were valid at the time the manual was published. We reserve the right to enclose a product information bulletin containing up-to-date information regarding new components and new versions of components.

Standards and approvals

In Chapter *General technical data*, you will find information about standards, certificates and approvals (Page 127)

Position in the information landscape

The following manuals are available for ET 200S:

Manual
ET 200S Distributed I/O System Operating Instructions (http://support.automation.siemens.com/WW/view/en/1144348)
ET 200S Distributed I/O System Manuals: <ul style="list-style-type: none"> • IM 151-1 Interface Modules (http://support.automation.siemens.com/WW/view/en/10805259/133000) • IM 151-3 PN Interface Modules (http://support.automation.siemens.com/WW/view/en/19241998/133000) • Interface Modules with Integrated CPU (http://support.automation.siemens.com/WW/view/en/10805260/133000) • PM-E Power Modules (http://support.automation.siemens.com/WW/view/en/10805261/133000) • Reserve Modules (http://support.automation.siemens.com/WW/view/en/14902665/133000) • Digital Electronic Modules (http://support.automation.siemens.com/WW/view/en/10805262/133000) • Analog Electronic Modules (http://support.automation.siemens.com/WW/view/en/10805263/133000)
Fail-Safe Modules (http://support.automation.siemens.com/WW/view/en/12461959/133000)
IO-Link Modules and Sensors (http://support.automation.siemens.com/WW/view/en/29773950/133300)
IQ-Sense Modules and Sensors (http://support.automation.siemens.com/WW/view/en/10805264/133000)
Technology modules (http://support.automation.siemens.com/WW/view/en/10805265/133000)
Terminal Modules for Power and Electronic Modules (http://support.automation.siemens.com/WW/view/en/10805266/133000)
Motor Starters and Frequency Converters (http://support.automation.siemens.com/WW/view/en/18687280/133000)
Safety Motor Starters and Fail-Safe Frequency Converters (http://support.automation.siemens.com/WW/view/en/18687280/133000)
PROFINET System Description (http://support.automation.siemens.com/WW/view/en/19292127)
From PROFIBUS DP to PROFINET IO (http://support.automation.siemens.com/WW/view/en/19289930)
ET 200S IM151-7 CPU Interface Module (http://support.automation.siemens.com/WW/view/en/12714722) and Operation List
ET 200S 1 SI Serial Interface Modules (http://support.automation.siemens.com/WW/view/en/9260793)
Weighing Technology for the ET 200S <ul style="list-style-type: none"> • SIWAREX CS (http://support.automation.siemens.com/WW/view/en/19250865) • SIWAREX CF (http://support.automation.siemens.com/WW/view/en/21320470)

Guide

The operating instructions contain the following guides which provide quick access to the specific information you need:

- You will find a table of contents and a list of tables and figures in the document at the beginning of the operating instructions.
- The chapters contain subheadings that provide an overview of the content of the section.
- Following the appendix, you will find a glossary in which important technical terms used in the operating instructions are defined.
- At the end of the operating instructions, there is a comprehensive index enabling rapid access to the information you are looking for.

Other manuals

In addition to these operating instructions, you also need the manual for your DP master or PROFINET IO Controller and the manuals for the modules you are using.

Recycling and disposal

Thanks to the fact that it is low in contaminants, the ET 200S is recyclable. For environmentally compliant recycling and disposal of your electronic waste, please contact a company certified for the disposal of electronic waste.

Information on the Internet

You can find information on the Internet on the following topics:

- Contacts (<http://www.siemens.com/automation/partner>) for SIMATIC
- Contacts for SIMATIC NET (<http://www.siemens.com/simatic-net>)
- Training (<http://www.sitrain.com>)

See also

Order numbers for ET 200S network components (Page 138)

Technical Support, Contacts and

Training (<http://support.automation.siemens.com/WW/view/en/19293011>)

Table of contents

	Preface	3
1	Description.....	11
1.1	What are distributed I/O systems?.....	11
1.2	What is PROFINET IO?	13
1.3	What is the ET 200S distributed I/O system?	14
2	Brief instructions on commissioning ET 200S	21
2.1	Commissioning on PROFIBUS DP	21
2.1.1	Introduction	21
2.1.2	Install the ET 200S.....	23
2.1.3	Wiring and assembling ET 200S.....	24
2.1.4	Configuring ET 200S in the SIMATIC manager.....	25
2.1.5	Creating a user program	26
2.1.6	Switching on ET 200S.....	26
2.1.7	Evaluating diagnostic messages.....	27
2.2	Commissioning on PROFINET IO	30
2.2.1	Introduction	30
2.2.2	Installing and wiring ET 200S	32
2.2.3	Configuring ET 200S in the SIMATIC manager.....	34
2.2.4	Assigning device names for the IO device.....	35
2.2.5	Creating a user program	36
2.2.6	Switching on ET 200S.....	36
2.2.7	Evaluating diagnostic messages.....	37
2.2.8	Evaluating diagnostic messages.....	38
3	Application planning.....	41
3.1	Switching on the ET 200S.....	41
3.2	Use of the ET 200S in a redundant system	42
3.3	Limitation of connectable modules/maximum configuration	43
3.4	Application of power modules	45
3.4.1	Placing power modules and connecting them to common potential.....	45
3.4.2	Example of a configuration: Terminal modules for power modules.....	47
3.4.3	Finding the correct power module for an I/O device	49

4	Installing	51
4.1	Basic principles of installation	51
4.2	Installing the interface module	54
4.3	Installing the TM-P and TM-E terminal modules.....	55
4.4	Installing the terminal modules TM-C for COMPACT modules	57
4.5	Installing add-on terminals	59
4.6	Removing/installing pluggable bridges on the additional terminal.....	63
4.7	Replacing the terminal box on the terminal module.....	64
4.8	Installing the bus terminating module	66
4.9	Installing the shield contact.....	67
4.10	Applying slot number labels and color identification labels.....	69
4.11	Mounting Color Identification Labels for ET 200S and ET 200S COMPACT	71
5	Wiring and assembly	73
5.1	General rules and regulations for operating the ET 200S	73
5.2	Operating the ET 200S on a grounded incoming supply	75
5.3	Electrical configuration of the ET 200S.....	78
5.4	Wiring the ET 200S	79
5.4.1	Wiring rules for the ET 200S	79
5.4.2	Wiring a terminal module with screw-type terminals.....	79
5.4.3	Wiring a Terminal Module with Spring Terminals	80
5.4.4	Wiring terminal modules with Fast Connect.....	81
5.4.5	Wiring terminal modules.....	84
5.4.6	Wiring an interface module with PROFIBUS DP interface (electrically)	87
5.4.7	Wiring an interface module with PROFIBUS DP interface (optically)	88
5.4.8	Wiring an interface module with PROFINET IO interface (electrically)	92
5.4.9	Wiring the power supply.....	94
5.5	Plugging and removing electronic modules and COMPACT modules	95
5.5.1	Plug and label electronic or COMPACT modules.....	95
5.5.2	Removing and inserting modules during operation	99
6	Commissioning	101
6.1	Safety tests prior to commissioning	101
6.2	Commissioning on PROFIBUS DP	102
6.2.1	Configuring ET 200S on PROFIBUS DP	102
6.2.1.1	Basic principles of configuration for the ET 200S on PROFIBUS DP	102
6.2.1.2	Combining modules for configuration	103
6.2.1.3	Grouping of digital input modules	106
6.2.1.4	Grouping of digital output modules	107
6.2.1.5	Grouping of motor starters	108
6.2.1.6	Example of a configuration.....	109
6.2.2	Commissioning and startup of ET 200S on PROFIBUS DP.....	111
6.2.2.1	Setting the PROFIBUS Address	111
6.2.2.2	Commissioning ET 200S on PROFIBUS DP.....	113
6.2.2.3	Startup of the ET 200S on PROFIBUS DP	114

6.3	Commissioning on PROFINET IO	115
6.3.1	Configuring the ET 200S on the PROFINET IO	115
6.3.2	Assigning device names to the I/O device	116
6.3.3	Combining modules for the configuration	118
6.3.4	Commissioning and startup of ET 200S on the PROFINET IO	120
7	Functions	123
7.1	Direct data exchange on PROFIBUS DP	123
7.2	Option handling on the PROFIBUS DP	125
7.2.1	Basic principles of option handling on PROFIBUS DP	125
7.3	Identification data	126
8	General technical specifications	127
8.1	Standards and approvals	127
8.2	Electromagnetic compatibility	131
8.3	Transport and storage conditions	132
8.4	Mechanical and Climatic Ambient Conditions	133
8.5	Specifications concerning insulation tests, protection class, and rated voltage for ET 200S....	135
8.6	Variations in general technical specifications for the ET 200S FC frequency converter	136
8.7	Use of ET 200S in a zone 2 potentially explosive environments	136
A	Order numbers	137
A.1	Order numbers for ET 200S accessories	137
A.2	Order numbers for ET 200S network components	138
B	Dimensional drawings	139
B.1	Interface modules	139
B.2	Terminal module for COMPACT module with COMPACT module inserted	141
B.3	Terminal modules with an electronic module inserted	141
B.4	Terminating module	145
B.5	Shield contact	146
B.6	Additional terminal	146
C	Leakage resistance	147
C.1	Establishing the leakage resistance of an ET 200S station	147
D	Interference-free operation	149
D.1	Special Measures for Interference-Free Operation	149
	Glosary	153
	Index	161

Description

1.1 What are distributed I/O systems?

Distributed I/O systems

When a system is configured the I/Os from and/or to the process are often integrated centrally in the automation system.

Circuitry wiring that covers great distances between the I/O and the automation system may become very complex and confusing. Electromagnetic interference can therefore impair reliability.

Distributed I/O provides the ideal solution for such systems:

- The controller CPU is located centrally
- The I/O systems (inputs and outputs) operate decentrally on-site
- The high-performance PROFIBUS DP system provides high-speed data transmission for reliable communication between the controller CPU and the I/O system

What is PROFIBUS DP?

PROFIBUS DP is an open bus system according to the standard *IEC 61784-1:2002 Ed1 CP 3/1* with the "DP" protocol (DP = Distributed Periphery).

Physically, PROFIBUS DP is either an electrical network based on a shielded two-wire line or an optical network based on a fiber-optic cable.

The "DP" is a high-speed protocol for cyclic data exchange between the controller CPU and the distributed I/O systems.

What is a DP master and what are DP slaves?

The DP master links the controller CPU with the distributed I/O systems. The DP master exchanges data with the distributed I/O systems via PROFIBUS DP. It also monitors the PROFIBUS DP.

The distributed I/O systems (= DP slaves) prepare the encoder and actuator data on site in such a way that it can be transmitted via the PROFIBUS DP to the controller CPU.

Which devices can be connected to PROFIBUS DP?

PROFIBUS DP supports a wide variety of devices for operation such as DP master or DP slave, provided they operate in compliance with the standard *IEC61784-1:2002 Ed1 CP 3/1*. These include devices from the following product families:

- SIMATIC S7/C7
- SIMATIC PD/PC
- SIMATIC HMI (control and monitoring devices OP, OS, TD)
- Devices from other vendors

Structure of a PROFIBUS DP network

The figure below illustrates a typical PROFIBUS DP network structure. The DP master is integrated in the respective device. For example, the S7-400 is equipped with a PROFIBUS DP interface. The DP slaves are the distributed I/O systems that are linked with the DP masters via the PROFIBUS DP.

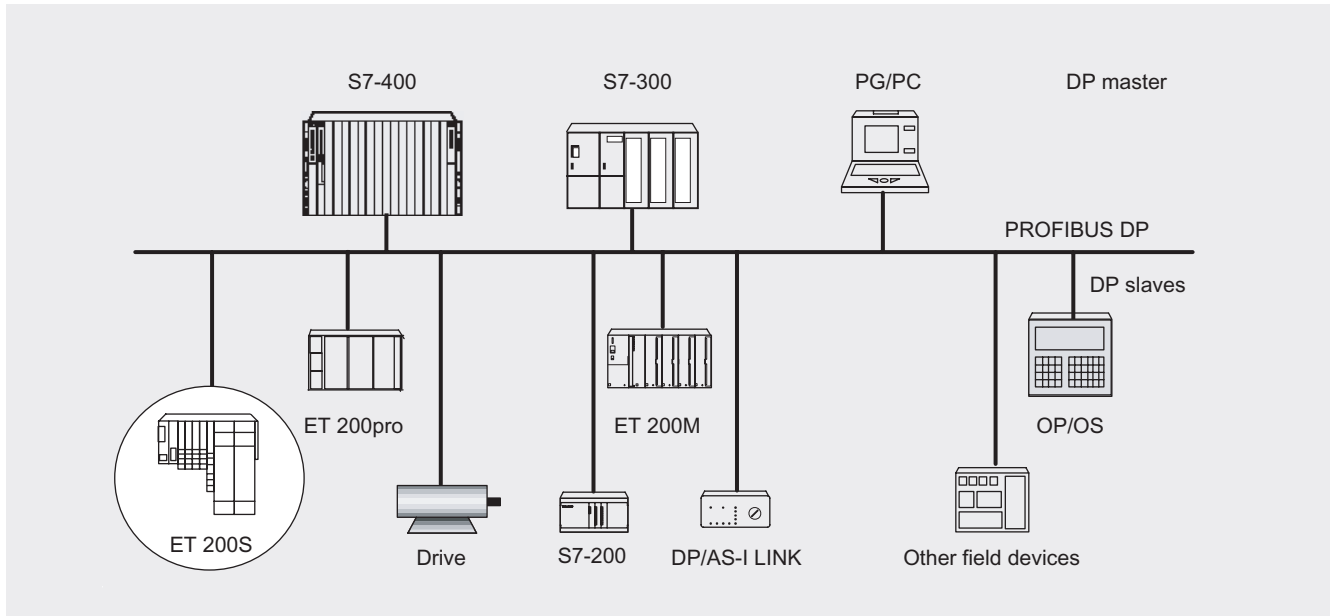

Figure 1-1 The typical structure of a PROFIBUS DP network

1.2 What is PROFINET IO?

Definition

PROFINET IO is an open transmission system with real-time functionality defined in accordance with the PROFINET standard. This standard defines a manufacturer-independent communication, automation and engineering model.

Accessories for wiring the PROFINET components are available in industrial quality.

- PROFINET does not deploy the hierarchical PROFIBUS master/slave principle. A provider/consumer principle is used instead. The planning process specifies which modules of an IO device will be subscribed to by an IO controller.
- The quantities are extended in accordance with the options offered by the PROFINET IO. Parameter limits are not exceeded during configuration.
- The transmission rate is 100 Mbps.
- The user's configuration interface is generally the same as that on PROFIBUS DP (configuration in STEP 7 → HW CONFIG).

Structure of a PROFINET IO network

The figure below illustrates the typical layout of a PROFINET IO network. Existing PROFIBUS slaves can be integrated by using an IE/PB link.

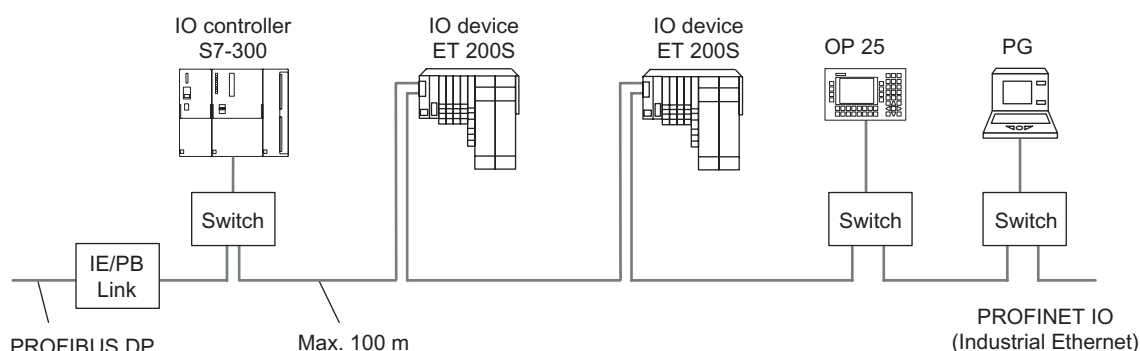

Figure 1-2 Typical structure of a PROFINET IO network

Further information about structuring a PROFINET IO network is available in the *PROFINET System Description* system manual.

1.3 What is the ET 200S distributed I/O system?

Definition

The ET 200S distributed I/O system is a discretely modular, highly flexible DP slave for connection to process signals on a central controller or a field bus. ET 200S supports field bus types PROFIBUS DP and PROFINET IO. ET 200S has protection class IP 20.

Applications

You can connect virtually any number of I/O modules in virtually any combination right next to the interface module that transfers the data to the central controller. You can thus set the focus of your configuration on local requirements.

Depending on the interface module, each ET 200S can consist of up to 63 modules - for example, power modules, I/O modules, and motor starters.

The fact that motor starters can be integrated (switching and protecting any three-phase load up to 7.5 kW) ensures that the ET 200S can be quickly adapted to suit virtually any process-related use of your machine.

The fail-safe modules of the ET 200S ensure the fail-safe reading and output of data to safety category 4 (EN 954-1).

Terminal modules and electronic modules

The ET 200S distributed I/O system is

- Connected to PROFIBUS DP by a cable connector for PROFIBUS DP at the IM151-1 or IM151-1 COMPACT interface module and
- Connected to PROFINET IO by a cable connector for PROFINET IO at the IM151-3 interface module.

Every ET 200S peripheral system is

- A DP slave on the PROFIBUS DP, or
- An IO device on the PROFINET IO.

View

The figure below shows an example configuration of an ET 200S.

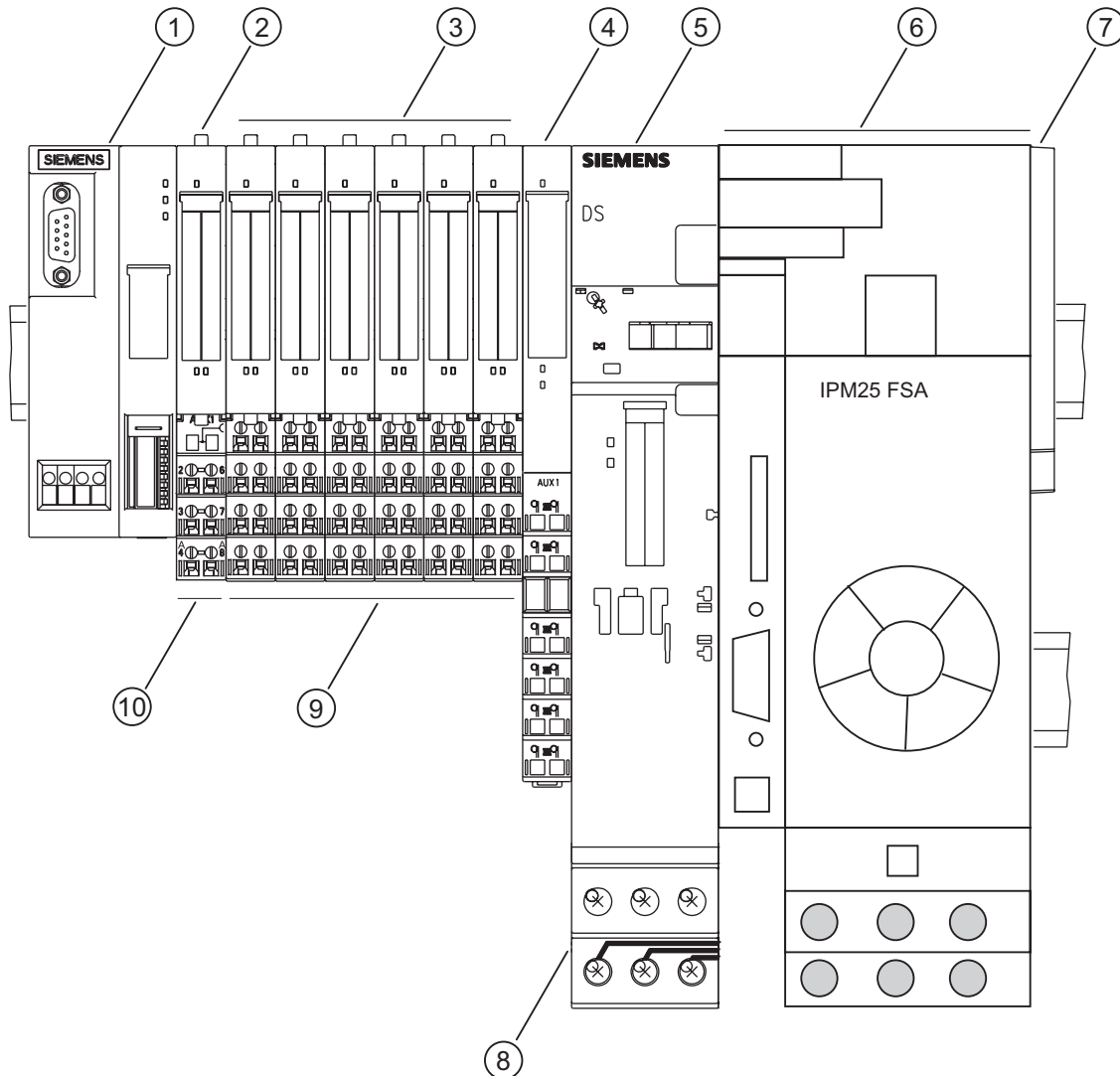

- ① ET 200S IM151-1 interface module
- ② PM-E power module for electronic modules
- ③ Electronic modules
- ④ PM-D power module for motor starters
- ⑤ Direct starter
- ⑥ Frequency converter
- ⑦ Terminating module
- ⑧ Power bus
- ⑨ TM-E terminal modules for electronic modules
- ⑩ TM-P terminal modules for power modules

1.3 What is the ET 200S distributed I/O system?



ET 200S components

The following table provides you with an overview of the most important components of the ET 200S:

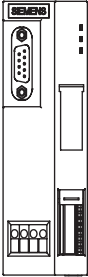
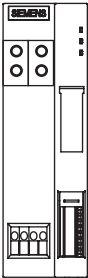
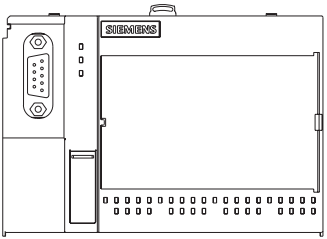
Table 1- 1 ET 200S components

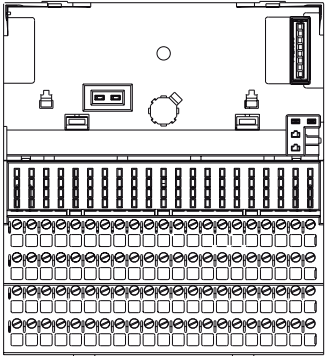
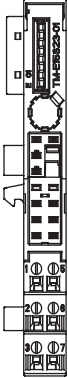
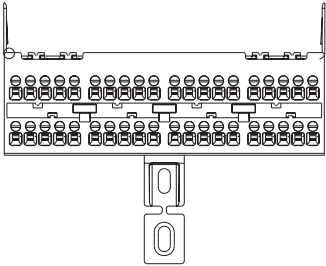

Components	Function	View
Mounting rail according to EN 60715carries the ET 200S. You mount the ET 200S on the rail.	
Interface module <ul style="list-style-type: none"> • IM151-1 BASIC • IM151-1 STANDARD • IM151-1 HIGH FEATURE connects the ET 200S with the DP master and prepares the data for the electronic modules and motor starters.	with RS485 interface: 
<ul style="list-style-type: none"> • IM151-1 FO STANDARD 		with fiber-optic interface: 
COMPACTModule <ul style="list-style-type: none"> • IM151-1 COMPACT 32DI DC24V • IM151-1 COMPACT 16DI/16DO 24 VDC/0.5 A connects the ET 200S with the DP master and prepares the data for the integrated periphery as well as for any electronic modules and motor starters.	with RS485 interface: 



1.3 What is the ET 200S distributed I/O system?

Components	Function	View
<p>Terminal module for COMPACT modules</p>	<p>... carries the wiring and accommodates COMPACT modules. Terminal modules for COMPACT modules are available in the following versions:</p> <ul style="list-style-type: none"> • With screw-type terminal • With spring-loaded terminal 	
<p>Terminal module for power and electronic modules</p>	<p>... provides the electrical and mechanical connection to the ET 200S module. Terminal modules versions available:</p> <ul style="list-style-type: none"> • For power modules • For electronic modules • With screw-type terminal • With spring-loaded terminal • With Fast Connect (quick connection method, no stripping required) 	
<p>Add-on terminal for</p> <ul style="list-style-type: none"> • Terminal module for COMPACT modules • Any terminal modules with a width of 120 mm 	<p>... extends the terminal block and enables the connection of sensors / actuators for the individual channels in 3 or 4 conductor technology. Additional terminals are available in the following variants:</p> <ul style="list-style-type: none"> • With screw-type terminal • With spring-loaded terminal 	
<p>Power module</p>	<p>... Monitors the voltage for all the electronic modules in the potential group. The following power modules are available:</p> <ul style="list-style-type: none"> • For a 24 VDC supply with diagnostics • For a 24 to 48 VDC supply with diagnostics • For a 24 to 48 VDC, 24 to 230 VAC supply with diagnostics and fuse 	

Description

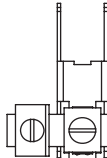
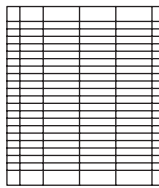
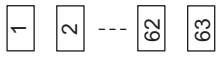
1.3 What is the ET 200S distributed I/O system?

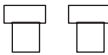
Components	Function	View
Electronic module	<p>... ..is inserted onto the terminal module and determines the function:</p> <ul style="list-style-type: none"> • Digital output modules with 24 VDC, 120 /230 VAC and NAMUR • Digital output modules with 24 VDC and 120/230 VAC • Relay modules • Analog input modules with voltage, current, and resistance measurement, thermoresistor and thermocouple elements • Analog output modules for voltage and current • Technology modules • Weighing modules SIWAREX CS and SIWAREX CF • Fail-safe modules • RESERVE modules 	
Terminating module	<p>... ..terminates the ET 200S and can be used to carry 6 reserve fuses (5 mm x 20 mm).</p>	
Shield contact	<p>... ..is a pluggable mount for 3 x 10 mm standard power busbars and enables a low-impedance cable shielding to be applied with minimal installation time.</p>	
Labeling sheet (DIN A4, perforated, foil)	<p>... ..for machine labeling or printing</p> <ul style="list-style-type: none"> • 80 strips per labeling sheet for interface modules and electronic modules • 10 strips per labeling sheet for COMPACT modules 	
Slot number plates	<p>... ..used to identify the slots of the terminal module.</p>	

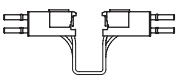
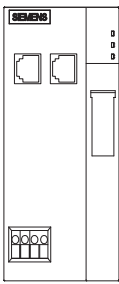
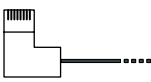
Components	Function	View
Color-coded labelsallow customer/country specific identification of the terminals on the terminal module	
PROFIBUS cable with bus terminal connectorcombines nodes of a PROFIBUS DP configuration with each other.	
Fiber-optic duplex cable with simplex plug (in the plug adaptor for IM151- 1 FO STANDARD)combines nodes of a PROFIBUS DP configuration with each other.	
Interface module <ul style="list-style-type: none"> IM151-3 PN IM151-3 PN HIGH FEATURE connects the ET 200S with PROFINET IO controllers and prepares the data for the electronic modules and motor starters.	With 2 PROFINET interfaces: 
PROFINET connector as per the specifications in the <i>PROFINET Installation Guide</i> and Industrial Ethernet FC installation linesconnects nodes of a PROFINET IO configuration with one another.	

Characteristics and advantages of the ET 200S

The table below presents the properties and benefits of ET 200S.

Table 1- 2 Characteristics and advantages of the ET 200S

Properties	Advantages
About the structure	
Discretely modular design <ul style="list-style-type: none"> 1-, 2-, 4- and 8-channel electronic modules Power modules Integrated motor starters 32-channel COMPACT modules 	<ul style="list-style-type: none"> Function-oriented, cost-optimized station design Significant reduction of cost and effort for configuration and documentation Space saving due to the ability to string modules together in random order
Extensive range of electronic modules	Broad area of application

Description

1.3 What is the ET 200S distributed I/O system?

Properties	Advantages
ET 200S FC frequency converter	<ul style="list-style-type: none"> • Speed control • Fail-safe technology: Safe braking ramp, safe speed reduction • Regeneration into grid when motor in generator mode • No grid commutation reactor required
Communication-capable, system-integrated motor starters: Direct and reversing starter up to 7.5 kW	PLC inputs and outputs, terminal blocks, circuit breakers and contactors in a plug-in module save space and the effort involved in wiring
Permanent wiring due to the separation of mechanical and electronic components	<ul style="list-style-type: none"> • Prewiring possible • Module replacement during operation of the ET 200S ("hot swapping")
Individual connection of power modules to common potential	<ul style="list-style-type: none"> • Individual formation of potential groups (identifiable by color coding of the TM-P terminal modules for power modules) • Simple load interruption
Robust structure for rough industrial conditions (5 g vibration resistance)	High operating reliability when mounted directly on the machine, high availability
Connection system	
Integrated voltage buses	Reduced effort required for wiring
Power bus up to 50 A for motor starters	Minimization of wiring in 400 V range
Screw-type terminals, spring-loaded terminals, and Fast Connect	A change in terminal connection method is not necessary
<ul style="list-style-type: none"> • 2- and 3-conductor connection or • 2-, 3- and 4-conductor connection 	Optimal selection in terms of space and cost
Fast Connect	<ul style="list-style-type: none"> • Connection method with no stripping required • Time saving during wiring
Replaceable terminal box in the terminal module	No need to remove the terminal module in the event of terminal damage
Automatic coding of the I/O modules	Quick and reliable module replacement
Large label plate	Adequate space for clear labeling
High data transmission speed of up to 12 Mbps on PROFIBUS DP and 100 Mbps on PROFINET IO	Short response times
Integrated safety functions For motor starters up to safety category 4 according to EN 954-1	Savings on time-consuming safety engineering
Fail-safe modules	For acquiring and outputting fail-safe signals via PROFINET (PROFIsafe) up to SIL3 in accordance with IEC 61508, Category 4 in accordance with EN 954-1, and Performance Level e in accordance with ISO 13849.

Brief instructions on commissioning ET 200S

2.1 Commissioning on PROFIBUS DP

2.1.1 Introduction

Introduction

The following simple examples will teach you how to commission the ET 200S on the PROFIBUS DP step by step:

- ET 200S installation and wiring up
- Configuring ET 200S in the SIMATIC manager
- Creating a user program
- Switching on ET 200S
- Evaluating diagnostic messages:
 - Removing and inserting of modules
 - Switching off the load voltage on the power module
 - Wire break in the actuator wiring on the digital output module

Requirements

- You have set up an S7 station consisting of a power supply component and a DP master (e.g. CPU 315-2 DP). For this example a CPU 315-2 DP is used as the DP master. You can of course use any other DP master (standard IEC 61784-1:2002 Ed1 CP 3/1).
- *STEP 7* (V5.0 with ServicePack 3 or higher) is installed on your programming device. You know how to work with *STEP 7*.
- The PD must be connected to the DP master.

Components required

The figure below shows which ET 200S components you require for the sample on the PROFIBUS DP:

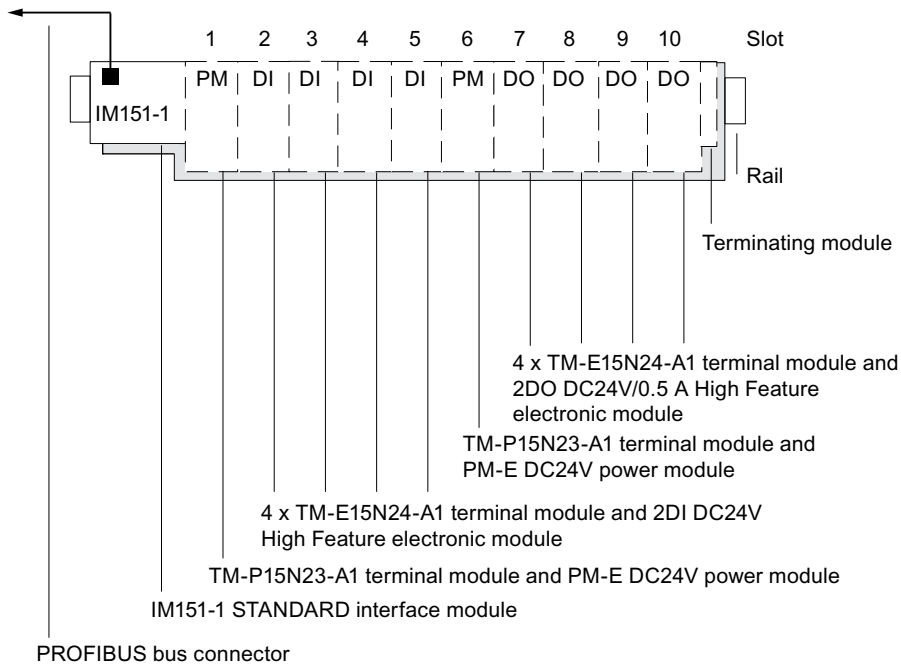

Figure 2-1 Components for the sample on the PROFIBUS DP

Order numbers for the sample configuration on the PROFIBUS DP

Quantity	Ordering data	Order No.:
1 ×	Standard mounting rail 35 mm (length = 483 mm, for example)	6ES710-8MA11
1 ×	IM151-1 STANDARD interface module and terminating module 1 piece	6ES7151-1AA04-0AB0
2 ×	Fast Connect terminal module TM-P15N23-A1, 1 piece	6ES7193-4CC70-0AA0
2 ×	Fast Connect terminal module TM-E15N24-A1, 5 pieces	6ES7193-4CA70-0AA0
2 ×	PM-E DC24V, 1 piece	6ES7138-4CA01-0AB0
1 ×	2DI DC24V HF, 5 pieces	6ES7131-4BB01-0AB0
1 ×	2DO DC24V/0,5A HF, 5 pieces	6ES7132-4BB01-0AB0
1 ×	Bus connector	6ES7972-0BA12-0XA0

2.1.2 Install the ET 200S

Proceed as follows

1. Install the DIN rail (35 x 7.5 mm or 15 mm) with a length of at least 210 mm on a solid surface.
2. Mount the various modules onto the rail, starting on the left side (hang in - swivel down - slide to left.) Follow the following sequence:
 - Interface module IM151-1 STANDARD
 - TM-P15N23-A1 terminal module
 - 4 x TM-E15N24-A1 terminal module
 - TM-P15N23-A1 terminal module
 - 4 x TM-E15N24-A1 terminal module
 - Terminating module
3. Set PROFIBUS address 3 on the IM 151-1 STANDARD interface module.

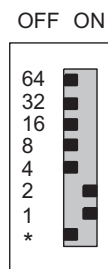

Figure 2-2 Setting PROFIBUS address 3

- * Intended for use with future add ins. Switch must be in OFF position.

2.1.3 Wiring and assembling ET 200S

Proceed as follows

1. Wire the ET 200S as shown below:

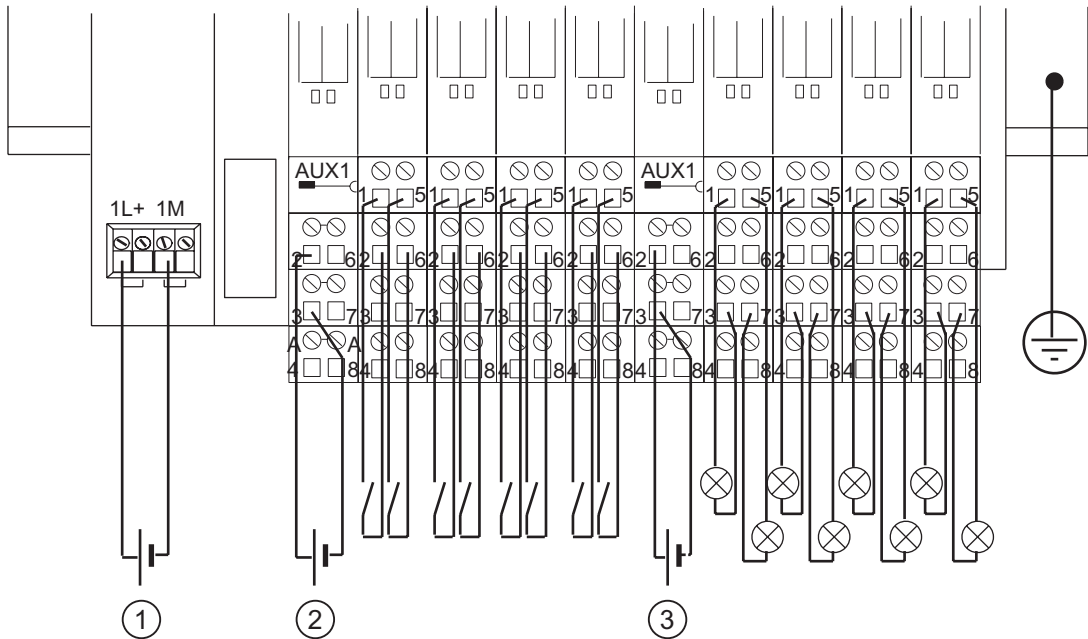

- ① 24 VDC electronic power supply
- ② 24 VDC sensor supply voltage group 1
- ③ 24 VDC load supply voltage group 2

1. Use the PROFIBUS bus connector to connect the DP master with the ET 200S. The PROFIBUS DP interface is located on the IM 151-1 STANDARD.
2. Insert the power and electronic modules into the terminal modules.
3. Switch on the supply voltage for the DP master.
4. Observe the status LEDs on the DP master.

CPU 315-2 DP:

- 5 VDC → lights up
- SF DP → off
- BUSF → off

2.1.4 Configuring ET 200S in the SIMATIC manager

Proceed as follows

1. Start SIMATIC Manager, and create a new project with a DP master (e. g., CPU315-2 DP). Create OB 1, OB 82 and OB 122 for the project.
2. Create the PROFIBUS subnet.
3. Connect the PROFIBUS subnet with the DP master in HW Config.
4. Take the ET 200S from the hardware catalog and put it on the PROFIBUS.
5. Set the PROFIBUS address 3 for the ET200S.
6. Drag the individual ET 200S modules from the hardware catalog to the configuration table.
7. Mark the electronic modules in the configuration table, and click the "Pack addresses" button.

Table 2- 1 Configuration table in HW Config for PROFIBUS DP

Module/ DP identification	Order No.:	I address	Q address	Comment
1	6ES7138-4CA01-0AA0 PM-E DC24V			Power module
2	6ES7131-4BB01-0AB0 2DI DC24V	0		Bytes 0.0 and 0.1
3	6ES7131-4BB01-0AB0 2DI DC24V			Bytes 0.2 and 0.3
4	6ES7131-4BB01-0AB0 2DI DC24V			Bytes 0.4 and 0.5
5	6ES7131-4BB01-0AB0 2DI DC24V			Byte 0.6 and 0.7
6	6ES7138-4CA01-0AA0 PM-E DC24V			Power module
7	6ES7132-4BB01-0AB0 2DO DC24V		0	Bytes 0.0 and 0.1
8	6ES7132-4BB01-0AB0 2DO DC24V			Bytes 0.2 and 0.3
9	6ES7132-4BB01-0AB0 2DO DC24V			Bytes 0.4 and 0.5
10	6ES7132-4BB01-0AB0 2DO DC24V			Byte 0.6 and 0.7

1. Set the following parameters:
 - In the DP slave properties dialog box for ET 200S:
 - Startup for set- <-> actual configuration: enable
 - In the DP slave properties dialog box for the PM-E DC24V, Module/DP ID 1 (in the configuration table)
 - Diagnostics: Missing load voltage
 - In the DP slave properties dialog box for the 2 DO DC24V, Module/DP ID 7 (in the configuration table)
 - Diagnostics: Wire break A0
2. Save the configuration.

2.1.5 Creating a user program

Proceed as follows

1. Create the user program in the LAD/STL/FBD editor in OB 1.

Example 1: Reading an input and triggering an output:

STL	
U I 0.0	If input byte 0.0 and
U M 2.0	memory bit 2.0 is set, then
S O 0.0	set output byte 0.0

Example 2: Transferring an input byte to an output byte:

STL	
L PEB 0	Load I/O input byte 0 in the accumulator (bytes 0.0 to 0.7)
T PAB 0	Transfer the accumulator content to I/O output byte 0 (bytes 0.0 to 0.7)

1. Save the project in SIMATIC Manager.
2. Download the configuration to the DP master.

2.1.6 Switching on ET 200S

Proceed as follows

1. Switch on all the power supplies on the ET 200S.
2. Observe the status LEDs on the DP master and ET 200S.
 - CPU 315-2 DP:
 - DC 5V: lights up
 - SF DP: off
 - BUSF: off
 - ET 200S:
 - SF: off
 - BF: off
 - ON: lights up

2.1.7 Evaluating diagnostic messages

Introduction

In this example, you generate diagnostic messages by provoking errors on the ET 200S. In the event of an error, OB 82 is started. You evaluate the start information in OB 82.

Tip: Call SFC13 in OB 82, and evaluate the diagnostic frame.

Removing and inserting the 2 DI DC24V HF digital electronic module

1. Remove the 2 DI DC24V HF electronic module from the terminal module during operation.

2. Observe the status LEDs on the IM 151-1 STANDARD:

- SF: lights up → there is a diagnostic message.
- BF: off
- ON: lights up

Result: The ET 200S continues to run error-free.

3. Evaluate the diagnostic information:

Result:

- Station status 1 (byte 0): Bit 3 is set → external diagnostics
- ID-related diagnostics: Byte 7.1 is set → slot 2
- Module status: bytes 19.2 / 19.3: 11_B → no module

4. Reinsert the removed electronic module into the terminal module.

Result:

- Status LED on the IM 151-1 STANDARD:
 - SF: off
 - BF: off
 - ON: lights up
- The diagnostic message is deleted.

Switching off load voltage on the power module

1. Switch off the load voltage on the PM-E DC24V (slot 1).
2. Monitor the status LEDs.
IM151-1 STANDARD:
 - SF: lights upPower module:
 - PWR: off → no load voltage available on the power module
 - SF: lights up → there is a diagnostic message.I/O modules in the voltage group:
 - LEDs: light up
3. Evaluate the diagnostics.
Result:
 - Station status 1 (byte 0): Bit 3 is set → external diagnostics
 - ID-related diagnostics: Byte 7.0 is set → slot 1
 - Channel-specific diagnostics:
 - Bytes 35.0 to 35.5: 000000_B → slot 1
 - Bytes 37.0 to 37.4: 10001_B → sensor or load voltage missing
4. Switch on the load voltage back on the power module and re-evaluate the diagnostics.
Result:
 - Status LED on the IM 151-1 STANDARD:
 - SF: off
 - Status LEDs on power module:
 - PWR: on
 - SF: off
 - Status LEDs on I/O modules:
 - LEDs: off
 - The diagnostic message is deleted.

Simulating a wire break in the actuator wiring

1. Remove the cable from terminal 1 on the 2DO DC24V/0.5A HF electronic module (slot 7)
2. Monitor the status LEDs:
 - IM151-1 STANDARD:
 - SF: lights up
 - Electronic module 2DO DC24V/0.5A HF:
 - SF: lights up → there is a diagnostic message
 - 1: off → output is not activated
3. Evaluate the diagnostic information:
 - Result:
 - Station status 1 (byte 0): Bit 3 is set → external diagnostics
 - ID-related diagnostics: Byte 7.6 is set → slot 7
 - Channel-specific diagnostics:
 - Bytes 35.0 to 35.5: 000110_B → slot 7
 - Bytes 36.0 to 35.5: 000000_B → channel 0
 - Bytes 37.0 to 37.4: 00110_B → wire break
4. Reattach the cable to the actuator in terminal 1 and reevaluate the diagnostics:
 - Status LED on the IM 151-1 STANDARD:
 - SF: off
 - Status LEDs electronic module 2DO DC24V/0.5 A HF:
 - SF: off
 - 1: off/on
 - The diagnostic message is deleted.

2.2 Commissioning on PROFINET IO

2.2.1 Introduction

Introduction

The following simple example teaches you step by step how to commission the ET 200S on PROFINET IO:

- Installing and wiring ET 200S
- Configuring in *HW Config* or with the GSDML file
- Transferring device names to the IO device
- Integrating into the user program
- Switching the ET 200S on
- Evaluating the interrupts and diagnostics:
 - Removing and inserting of modules
 - Switching off the load voltage on the power module
 - Wire break in the actuator wiring on the digital output module

Requirements

- You have set up an S7 station consisting of a power supply module and an IO controller (e.g., CPU 317-2 PN/DP). In this example a CPU 317-2 PN/DP is used as the IO controller with firmware version V2.3 and higher.
- *STEP 7* V 5.3 + ServicePack 1 or higher is installed on your programming device. You know how to work with *STEP 7*.
- The programming device connected to the PROFINET IO.

Components required

The figure below shows which ET 200S components you require for the example on the PROFINET IO:

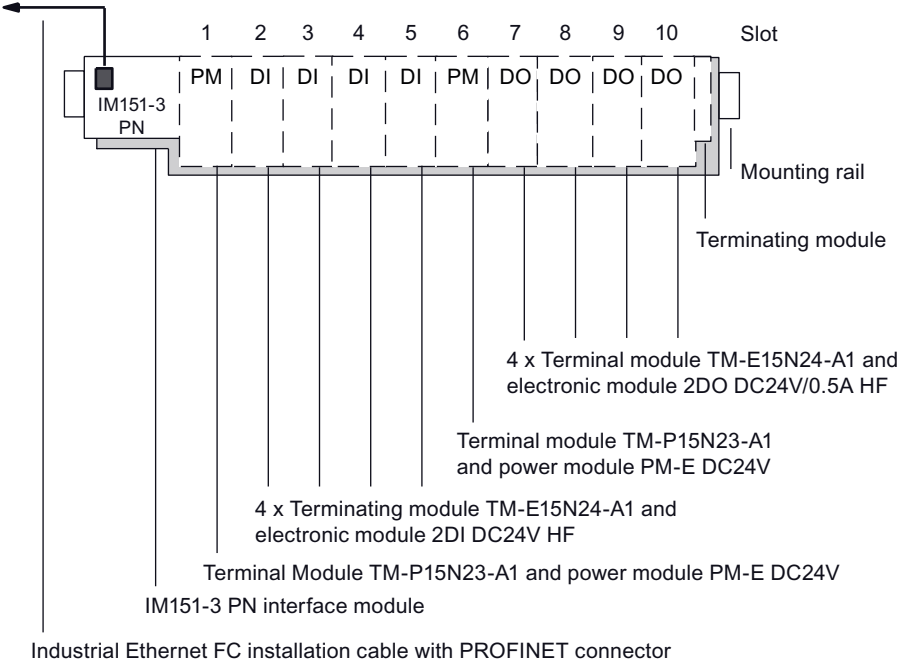

Figure 2-3 Components for the example on PROFINET IO

Order numbers for the example on PROFINET IO

Quantity	Ordering data	Order number
1 ×	Standard mounting rail 35 mm (length = 483 mm, for example)	6ES5710-8MA11
1 ×	IM151-3 PN interface module and terminating module, 1 unit	6ES7151-3AA20-0AB0
1 ×	SIMATIC Micro Memory Card (e.g. 64k)	6ES7953-8LF11-0AA0
2 ×	Fast Connect terminal module TM-P15N23-A1, 1 unit	6ES7193-4CC70-0AA0
2 ×	Fast Connect terminal module TM-E15N24-A1, 5 units	6ES7193-4CA70-0AA0
2 ×	PM-E DC24V, 1 piece	6ES7138-4CA01-0AA0
1 ×	2DI DC24V HF, 5 pieces	6ES7131-4BB01-0AB0
1 ×	2DO DC24V/0,5A HF, 5 pieces	6ES7132-4BB01-0AB0
	PROFINET connector (according to the specifications in the <i>PROFINET Installation Guide</i>)	
	Appropriate installation cables: <ul style="list-style-type: none"> • FC Standard Cable • FC Trailing Cable • FC Marine Cable 	6XV1 840-2AH10 6XV1 840-3AH10 6XV1 840-4AH10

2.2.2 Installing and wiring ET 200S

Installing the DIN rail

1. Install the DIN rail (35 x 7.5 mm or 15 mm, length = at least 210 mm) on a solid surface.
2. Start from the left with the installation of the individual modules on the DIN rail (hook in - swivel in - slide to left). Follow the following sequence:
 - Interface module IM151-3 PN
 - TM-P15N23-A1 terminal module
 - 4 x TM-E15N24-A1 terminal module
 - TM-P15N23-A1 terminal module
 - 4 x TM-E15N24-A1 terminal module
 - Terminating module

Wiring and assembling ET 200S

1. Wire the ET 200S as shown below:

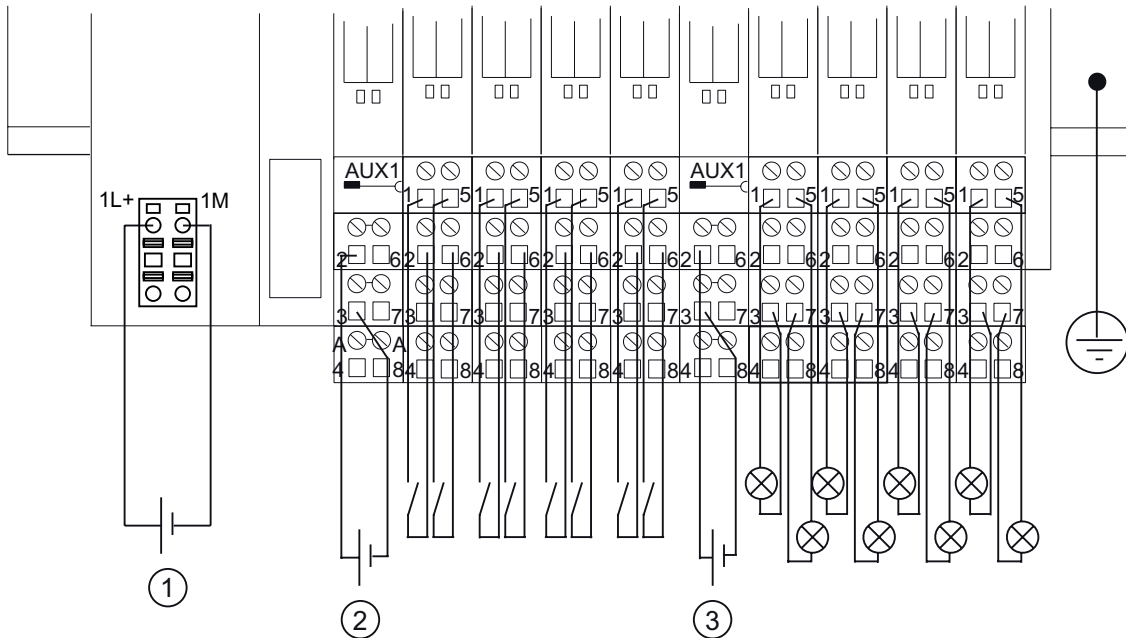

- ① 24 VDC electronic power supply
- ② 24 VDC sensor supply potential group 1
- ③ 24 VDC load supply potential group 2

1. Use the PROFINET connector to connect the ET 200S (IO device) to the IO controller via a switch. The PROFINET interface is located on the IM 151-3 PN interface module.
2. Insert the power and electronic modules into the terminal modules.
3. Switch on the power supply for the IO controller.
4. Observe the status LEDs on the IO controller.

CPU 317-2 PN/DP:

- DC 5V → lights up
- SF → off
- BF2 → off

2.2.3 Configuring ET 200S in the SIMATIC manager

Proceed as follows

1. Start SIMATIC Manager and create a new project with an IO controller (e.g., CPU 317-2 PN/DP). For this project, create the OB 1, the OB 82, the OB 83 and the OB 122.
2. Open the "Properties - Ethernet Interface" window in the HW Config and create a subnet e.g. Ethernet (1).
3. Take the IM151-3 PN from the ET 200S catalog of the hardware catalog and insert it on Ethernet(1):PROFINET IO System (100).
4. Drag the individual ET 200S modules from the hardware catalog to the configuration table.

Table 2- 2 Configuration table in HW Config for PROFINET IO

Module	Order No.:	I address	Q address	Comment
0	6ES7151-3AA20-0AB0 IM151-3 PN			
1	6ES7138-4CA01-0AA0 PM-E DC24V			Power module
2	6ES7131-4BB01-0AB0 2DI DC24V	0		Bytes 0.0 and 0.1
3	6ES7131-4BB01-0AB0 2DI DC24V	1		Bytes 1.0 and 1.1
4	6ES7131-4BB01-0AB0 2DI DC24V	2		Bytes 2.0 and 2.1
5	6ES7131-4BB01-0AB0 2DI DC24V	3		Byte 3.0 and 3.1
6	6ES7138-4CA01-0AA0 PM-E DC24V			Power module
7	6ES7132-4BB01-0AB0 2DO DC24V		0	Bytes 0.0 and 0.1
8	6ES7132-4BB01-0AB0 2DO DC24V		1	Bytes 1.0 and 1.1
9	6ES7132-4BB01-0AB0 2DO DC24V		2	Bytes 2.0 and 2.1
10	6ES7132-4BB01-0AB0 2DO DC24V		3	Byte 3.0 and 3.1

1. Set the following parameters:
 - In the IO device properties dialog box for the PM-E DC24V, module 1 (in the configuration table)

Diagnostics: Missing load voltage
 - In the IO device properties dialog box for the 2 DO DC24V, Module 7 (in the configuration table)

Diagnostics: Wire break A0
2. Compile and save the configuration.

2.2.4 Assigning device names for the IO device

Procedure

1. Insert the SIMATIC Micro Memory Card in the IM151-3 PN.
2. Switch on the power supply for the IM151-3 PN.
3. Open the "Properties - IM151-3 PN" window in HW Config and enter the device name for the IO device there.
4. An online PROFINET connection from the programming device to the IO device via a switch is required for in order to transfer the name to the IM151-3 PN interface module.

The device name is transferred to the IM151-3 PN using "PLC > Ethernet > Assign Device Name". To do so, activate the "Assign name" button in the "Assign device name" window. The device name is stored on the SIMATIC Micro Memory Card in the IM151-3 PN interface module.

Once the name is assigned, it appears in the window.

Alternative procedure:

Alternatively, you can write directly to a SIMATIC Micro Memory Card using a programming device with an EPROM programming device installed or a PC connected to a SIMATIC USB EPROM programming device and then use the memory card to transfer the device name to the IM151-3 PN.

1. Open the "Properties - IM151-3 PN" window in HW Config and enter the device name for the IO device there.
2. Insert the required SIMATIC Micro Memory Card into the EPROM programming device.
3. Select the IM151-3 PN in HW Config.
4. Select "Target system > Save device name to memory card" in HW Config.
5. Insert the SIMATIC Micro Memory Card written with the device name in the IM151-3 PN.
6. Switch on the power supply for the IM151-3 PN.

The device name is transferred to the IM151-3 PN.

2.2.5 Creating a user program

Proceed as follows

1. Create the user program in the LAD/STL/FBD editor in OB 1.

Example 1: Reading an input and triggering an output:

STL	
U I 0.0	If input byte 0.0 and
U M 2.0	memory bit 2.0 is set, then
S O 0.0	set output byte 0.0

Example 2: Transferring an input byte to an output byte:

STL	
L PEB 0	Load I/O input byte 0 in the accumulator (bytes 0.0 to 0.7)
T PAB 0	Transfer the accumulator content to I/O output byte 0 (bytes 0.0 to 0.7)

1. Save the project in SIMATIC Manager.
2. Download the configuration to the IO controller.

2.2.6 Switching on ET 200S

Procedure

1. Switch on all the power supplies of the ET 200S.
2. Observe the status LEDs on the IO controller, ET 200S, and switch.
 - CPU 317-2 PN/DP:
 - DC 5V: lights up
 - SF: off
 - BF2: off
 - LINK: lights up
 - ET 200S:
 - SF: off
 - BF: off
 - ON: lights up
 - LINK: lights up
 - Switch:
 - LINK: lights up

2.2.7 Evaluating diagnostic messages

Introduction

In this example, you generate alarms by provoking errors on the ET 200S.

In the event of an error, OB 83 is started. Evaluate the start information in OB 83.

Tip: Call up the SFB 52 within the OB 83 and evaluate the E002_H diagnostic telegram.

Removing and inserting the 2 DI DC24V HF digital electronic module

1. Remove the 2 DI 24VDC HF electronic module from the terminal module (e.g., from slot 2) during operation.
2. Monitor the status LEDs on the IM 151-3 PN interface module:
 - SF: lights up → there is a diagnostic message.
 - BF: off
 - ON: lights up

Result: The ET 200S continues to run error-free.

3. In the event of a remove interrupt the OB 83 is started. Start the SFB 52 in OB 83. Evaluate the E002_H diagnostic data record.

You can find information about evaluating the diagnostic data record E002_H in the "From PROFIBUS DP to PROFINET IO (<http://support.automation.siemens.com/WW/view/en/19289930>)" programming manual in the sections "Structure of the configuration data record W#16#E002" and "Blocks of the diagnostics and configuration records".

4. Reinsert the removed electronic module into the terminal module.

Result:

- Status LEDs on the IM151-3 PN interface module:
 - SF: off
 - BF: off
 - ON: lights up
- Once the module is inserted, diagnostic data record E002_H no longer indicates a discrepancy between the preset and actual configurations for any slot.

2.2.8 Evaluating diagnostic messages

Introduction

In this example, you generate diagnostic messages by provoking errors in the ET 200S. In the event of an error, OB 83 or OB 82 is started. Evaluate the start information in OB 83. Tip: Call up the SFB 52 within the OB 83 and evaluate the C00A_H diagnostic telegram.

Removal/Insertion Interrupt

1. Remove the 2 DI 24VDC High Feature electronic module from the terminal module (e.g., from slot 2) during operation.
2. Monitor the status LEDs on the IM 151-3 PN interface module:
 - SF: lights up → there is a diagnostic message
 - BF: off
 - ON: lights up

Result: The ET 200S continues to run error-free.

3. In the event of a remove interrupt the OB 83 is started. Start SFB 52 in OB 1. Evaluate the E002_H diagnostic data record.

You can find information about evaluating the diagnostic data record E002_H in the "From PROFIBUS DP to PROFINET IO (<http://support.automation.siemens.com/WW/view/en/19289930>)" programming manual in the sections "Structure of the configuration data record W#16#E002" and "Blocks of the diagnostics and configuration records".

4. Reinsert the removed electronic module into the terminal module.

Result:

- Status LEDs on the IM151-3 PN interface module:
 - SF: off
 - BF: off
 - ON: lights up
- Once the module is inserted, diagnostic data record E002_H no longer indicates a discrepancy between the preset and actual configurations for any slot.

Switching off load voltage on the power module

1. Switch off the load voltage on the PM-E DC24V (slot 1).
2. Monitor the status LEDs.

IM151-3 PN:

- SF: lights up

Power module:

- PWR: off → no load voltage available on the power module
- SF: lights up → a diagnostic message is pending.

I/O modules in the voltage group:

- LEDs: light up

3. Evaluate diagnostic data record C00A_H.

Tip: Call up the SFB 52 within the OB 1 or OB 82 and evaluate the diagnostic message.

You can find information about evaluating the diagnostic data record C00A_H in the "From PROFIBUS DP to PROFINET IO

(<http://support.automation.siemens.com/WW/view/en/19289930>)" programming manual in the section "Structure of diagnostics data records".

4. Switch on the load voltage back on the power module and re-evaluate the diagnostics.

Result:

- Status LEDs on the IM151-3 PN:
SF: off
- Status LEDs on power module:
PWR: on
SF: off
- Status LEDs on I/O modules:
LEDs: off
- The diagnostic message is deleted.

Simulating a wire break in the actuator wiring

1. Remove the cable from terminal 1 on the 2DO DC24V/0.5A HF electronic module (slot 7)
2. Monitor the status LEDs:
 - IM151-3 PN:
 - SF: lights up
 - Electronic module 2DO DC24V/0.5A HF:
 - SF: lights up → there is a diagnostic message
 - 1: off → output is not activated
3. Evaluate diagnostic data record C00A_H.

You can find information about evaluating the diagnostic data record C00A_H in the "From PROFIBUS DP to PROFINET IO (<http://support.automation.siemens.com/WW/view/en/19289930>)" programming manual in the section "Structure of diagnostics data records".
4. Reattach the cable to the actuator in terminal 1 and reevaluate the diagnostics:
 - Status LEDs on the IM151-3 PN:
 - SF: off
 - Status LEDs electronic module 2DO DC24V/0.5 A HF:
 - SF: off
 - 1: off/on
 - The diagnostic message is deleted.

Application planning

3.1 Switching on the ET 200S

Simply put your ET 200S together yourself. A configuration tool supports you in doing so. You can find the tool on the Internet (www.siemens.com/et200).

Using power and electronic modules in terminal modules

Various signals are available on the terminals depending on which terminal module is selected. For more detailed information, refer to the manual for the specific I/O module.

The TM-P and TM-E terminal modules are mixable in the ET 200S configuration.

Usage of COMPACT modules on terminal modules

Various signals are available on the terminals depending on which terminal module is selected. For more detailed information, refer to the *IM 151-1 COMPACT Modules* manual.

The terminal module TM-C must always be connected at the start of an ET 200S configuration. Additional terminal modules TM-E or TM-P are to be connected to the right of terminal module TM-C.

3.2 Use of the ET 200S in a redundant system

Properties

The ET 200S is integrated in a redundant DP system as DPV0 or DPV1 slave via the Y switching.

Requirements

DPV0	DPV1
<ul style="list-style-type: none"> • Possible with all interface modules • from STEP 7 V5.3 SP3 • GSD file 	<ul style="list-style-type: none"> • IM151-1 HIGH FEATURE (from 6ES7151-1BA01-0AB0) • from STEP 7 V5.3 SP3

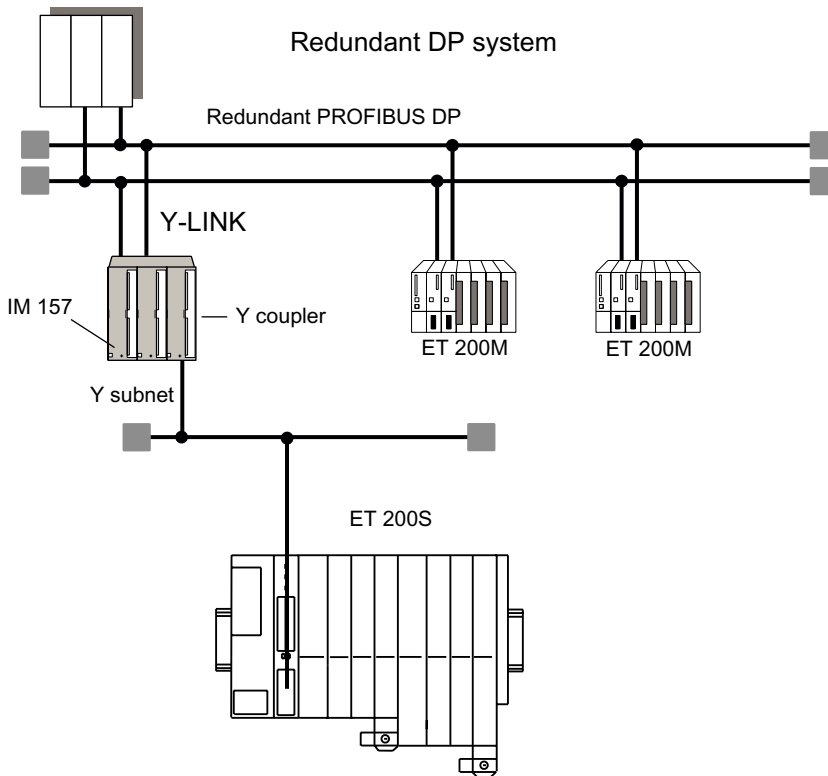

Figure 3-1 ET 200S and Y switching

Procedure

1. Configuration of the redundant DP system (redundant DP master, PROFIBUS DP, slaves)
2. Configure the ET 200S with *STEP 7*

Reference

For additional information see the documentation for the Y-connection (manual or product information (<http://support.automation.siemens.com/WW/view/en/1142696>)).

3.3 Limitation of connectable modules/maximum configuration

Number of modules

The following modules are available for the ET 200S: interface modules, power modules, electronic modules, RESERVE modules, technology modules, motor starters, and frequency converters.

The number of modules you can insert is dependent on the interface module you are using:

- Max. 12 modules with:
 - IM151-1 BASIC
 - IM151-1 COMPACT
- Max. 63 modules with:
 - IM151-1 STANDARD
 - IM151-1 FO STANDARD
 - IM151-1 HIGH FEATURE
 - IM151-3 PN
 - IM151-3 PN FO
 - IM151-3 PN HIGH FEATURE

Bus length of the ET 200S

A maximum bus length of 2 m can be assigned for the ET 200S.

Deviations are noted in the properties of the interface modules.

Parameter length

- For PROFIBUS DP: Depending on the PROFIBUS DP master you are using
- For PROFINET IO: Not relevant for maximum configuration

Address space

- For PROFIBUS DP: Depending on the PROFIBUS DP master you are using
- For PROFINET IO: Not relevant

Maximum configuration per potential group

The number of modules that can be connected depends on the total current of all modules in a potential group. This total current must not exceed the maximum current-carrying capacity of the power modules or COMPACT modules you are using.

The total current is governed in large part by the digital output modules.

Table 3- 1 Maximum configuration per potential group

Power modules/ COMPACT modules	Maximum current-carrying capacity
Power Module PM-E DC24V	10 A
Power Module PM-E DC24..48V	10 A
Power Module PM-E DC24..48V/AC24..230V <ul style="list-style-type: none">• For 24 to 56.7 VDC• For 24 to 48/120/230 VAC	10 A 8 A
IM151-1 COMPACT	5 A, for I/O modules connected after the IM151-1 COMPACT

DP master 32-byte diagnostic message frame length

You can use the ET 200S with DP masters with a diagnostic frame length of 32 bytes because you can set the length of the diagnostic frame in all the interface modules.

Reference

The relevant values can be found in the technical data for the respective modules.

3.4 Application of power modules

3.4.1 Placing power modules and connecting them to common potential

Placing and connecting to common potential

You can choose where to position the power modules in the ET 200S. Every TM-P terminal module (for a power module) that you install in the ET 200S opens a new potential group. All sensor and load supplies of the downstream electronic modules are fed from this TM-P terminal module (for a power module). If you place an additional TM-P terminal module after an electronic module/motor starter, you interrupt the potential buses (P1/P2) and simultaneously open a new potential group. This enables sensor and load supplies to be individually connected to common potential.

AUX(iliary) bus (AUX1)

A TM-P terminal module (for a power module) allows you to connect additional potential (up to the maximum rated load voltage of the module), which you can apply by means of the AUX(iliary) bus.

You can use the AUX(iliary) bus individually:

- As a protective conductor bar
- For additionally required voltage

The AUX1 bus is laid out as follows:

- Maximum current-carrying capacity (at 60°C ambient temperature): 10 A
- Permitted voltage: 230 VAC/DC

Placing power modules and connecting them to common potential

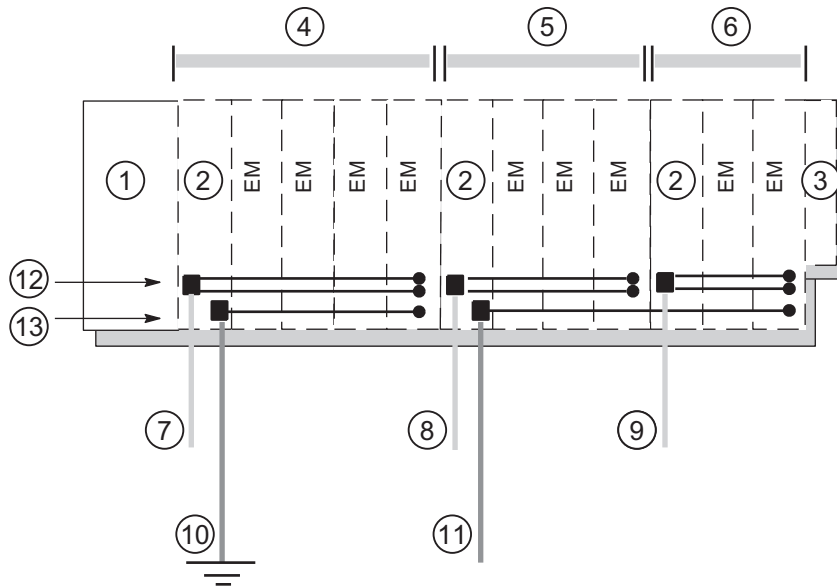

- | | | | |
|---|--------------------|---|-------------------------------|
| ① | Interface module | ⑧ | Supply voltage 2 |
| ② | Power module | ⑨ | Supply voltage 3 |
| ③ | Terminating module | ⑩ | Protective conductor |
| ④ | Potential group 1 | ⑪ | Additionally required voltage |
| ⑤ | Potential group 2 | ⑫ | P1/P2 power buses |
| ⑥ | Potential group 3 | ⑬ | AUX1 bus |
| ⑦ | Supply voltage 1 | | |

⚠ WARNING

If you connect the AUX1 bus to common potential independently of the P1/P2 buses (different voltages), there is no safe electrical separation (in accordance with EN 50178) between the AUX1 bus and the P1/P2 buses.

Connecting different potentials to the AUX1 bus

Note

If you apply different potentials to the AUX1 bus within an ET 200S station, you must separate the potential groups by means of a power module with the TM-P15S23-A0 terminal module.

3.4.2 Example of a configuration: Terminal modules for power modules

Introduction

The following table shows how terminal modules for power modules can be used:

Table 3- 2 Terminal modules for power modules

Terminal module	Structure
TM-P15S22-01 TM-P15C22-01 TM-P15N22-01	<p>Potential group 1 Potential group 2</p> <p>Backplane bus P1 P2</p> <p>PM EM EM EM PM EM EM EM EM EM</p> <p>2 6 3 7</p> <p>AUX1</p>
TM-P15S23-A1 TM-P15C23-A1 TM-P15N23-A1	<p>Potential group 1 Potential group 2</p> <p>Backplane bus P1 P2</p> <p>PM EM EM EM PM EM EM EM EM EM</p> <p>2 6 3 7 4 8</p> <p>AUX1 (PE)</p> <p>Access via terminals on AUX1</p>

Terminal module	Structure
TM-P15S23-A0 TM-P15C23-A0 TM-P15N23-A0	<p>Potential group 1 Potential group 2</p> <p>Backplane bus P1 P2</p> <p>PM EM EM EM PM EM EM EM EM</p> <p>2 6 2 6 3 7 3 7 4 8 4 8 A A A A</p> <p>AUX1</p> <p>Access via terminals on AUX1</p> <p>Open new potential group via AUX1</p>
TM-P30S44-A0 TM-P30C44-A0	<p>Potential group 1 Potential group 2</p> <p>Backplane bus P1 P2</p> <p>PM EM PM EM</p> <p>1 5 1 5 2 6 2 6 3 7 3 7 4 8 4 8 A A A A</p> <p>AUX1</p> <p>Access via terminals to AUX1</p> <p>Open new potential group via AUX1</p>

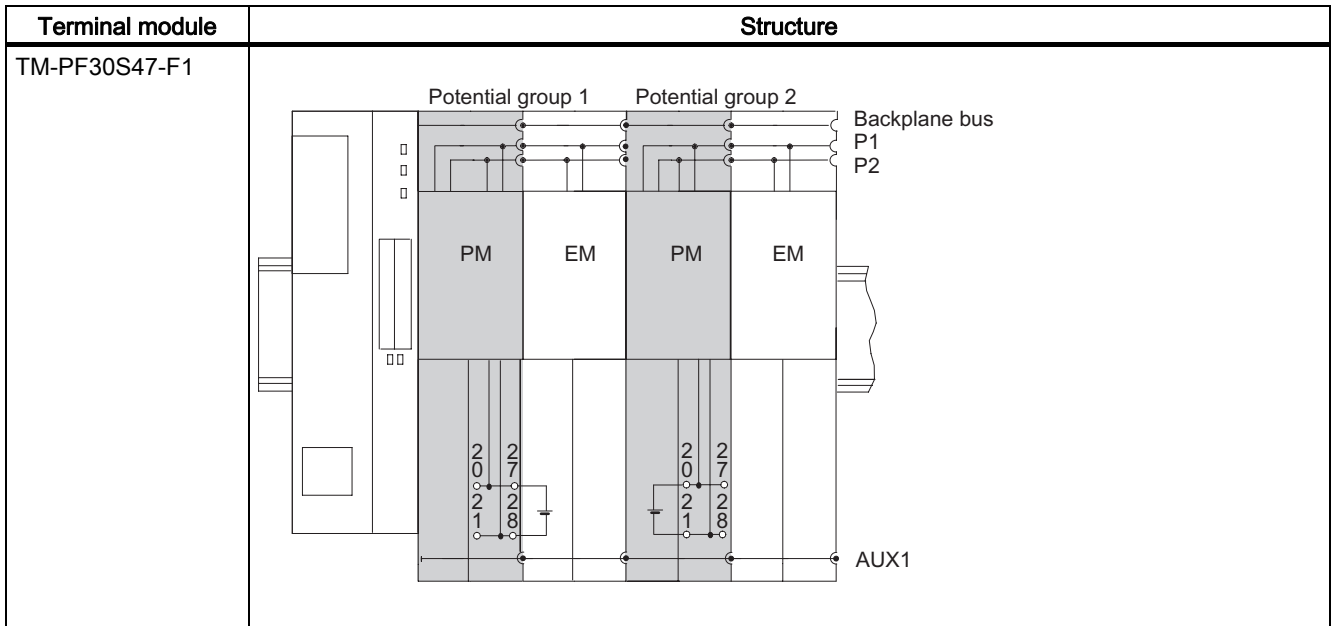

3.4.3 Finding the correct power module for an I/O device

Applicability of power modules

The following table describes which power modules you can use with the different I/O modules:

Power modules	I/O modules
PM-E DC24V	Can be used for all electronic modules that require a maximum load voltage of 24 VDC.
PM-E DC24..48V	Applicable <ul style="list-style-type: none"> Can be used for all electronic modules that require a maximum load voltage of 24 VDC. For UC electronic modules if the maximum load voltage is 48 VDC and AC is not required.
PM-E DC24..48V/ AC24..230V	Can be used with all electronic modules.
PM-E F pm DC24V PROFIsafe	See "ET 200S Distributed I/O System - Fail-Safe Modules (http://support.automation.siemens.com/WW/view/en/12490437)" Manual, Chapter "Assigning Modules of an ET 200S"
PM-E F pp DC24V PROFIsafe	
PM-E F DC24V PROFIsafe	

Power modules	I/O modules
PM-D	For motor starters and frequency converters. See "ET 200S Motor Starters (http://support.automation.siemens.com/WW/view/en/6008567)" Manual or "Frequency Converter ET 200S FC (http://support.automation.siemens.com/WW/view/en/26291825)" Operating Instructions
PM-D F	For fail-safe applications with motor starter or frequency converter. See "ET 200S Motor Starters (http://support.automation.siemens.com/WW/view/en/6008567)" Manual or "Frequency Converter ET 200S FC (http://support.automation.siemens.com/WW/view/en/26291825)" Operating Instructions

Installing

4.1 Basic principles of installation

 WARNING
Open components Modules of an ET 200S are open components. This means that you may only install the ET 200S in cases, cabinets or electrical plant rooms where they will only be accessible with a key or a tool. Only trained or authorized personnel are allowed access to such cubicles, cabinets or electrical operating rooms.

Simple installation

The ET 200S distributed I/O system is designed for simple installation.

Installation rules

- The ET 200S distributed I/O system starts
 - with an interface module or
 - with a TM-C terminal module with COMPACT module.
- A power module comes after the interface module or at the beginning of each potential group.
- After a power module come digital, analog, technological, or RESERVE modules.
- After a COMPACT module, digital, analog, technological, or RESERVE modules may follow. If necessary, power modules may also be deployed.
- The ET 200S distributed I/O system ends with the terminating module.
- The maximum configuration of the distributed I/O system is dependent on the interface modules being used.

Installation position

Preferably, the ET 200S is mounted horizontally on a vertical wall. All other positions are possible, although there are certain restrictions regarding the ambient temperature.

Mounting rail

The ET 200S distributed I/O system is installed on a mounting rail according to EN 60715 (35 x 7.5 mm or 35 x 15 mm).

Appropriate surface designs are:

- Steel strip according to Appendix A of EN 60715, or
- Tinned steel strip. We recommend the following mounting rails for this purpose:
 - 6ES5710-8MA11 (length: 483 mm)
 - 6ES5710-8MA21 (length: 530 mm)
 - 6ES5710-8MA31 (length: 830 mm)
 - 6ES5710-8MA41 (length: 2000 mm)

Note

If you use mounting rails from other manufacturers, please check whether they have the required properties for your climatic ambient conditions.

Note

If the ET 200S distributed IO device is exposed to increased vibrations and shock, we recommend that you screw the mounting rail to the mounting surface at intervals of 200 mm.

To prevent the ET 200S distributed I/O system from slipping sideways, we recommend that you apply a mechanical hold-down (e.g. with grounding terminal, 8WA2011-1PH20) at both ends of the device.

If you install the rail on grounded, zinc-plated mounting plates, there is no need to ground the rail separately.

Minimum clearances for installation, wiring, and ventilation

When installing the ET 200S in a housing, ensure that the distance to the lid of the housing or the front door is at least 1 mm.

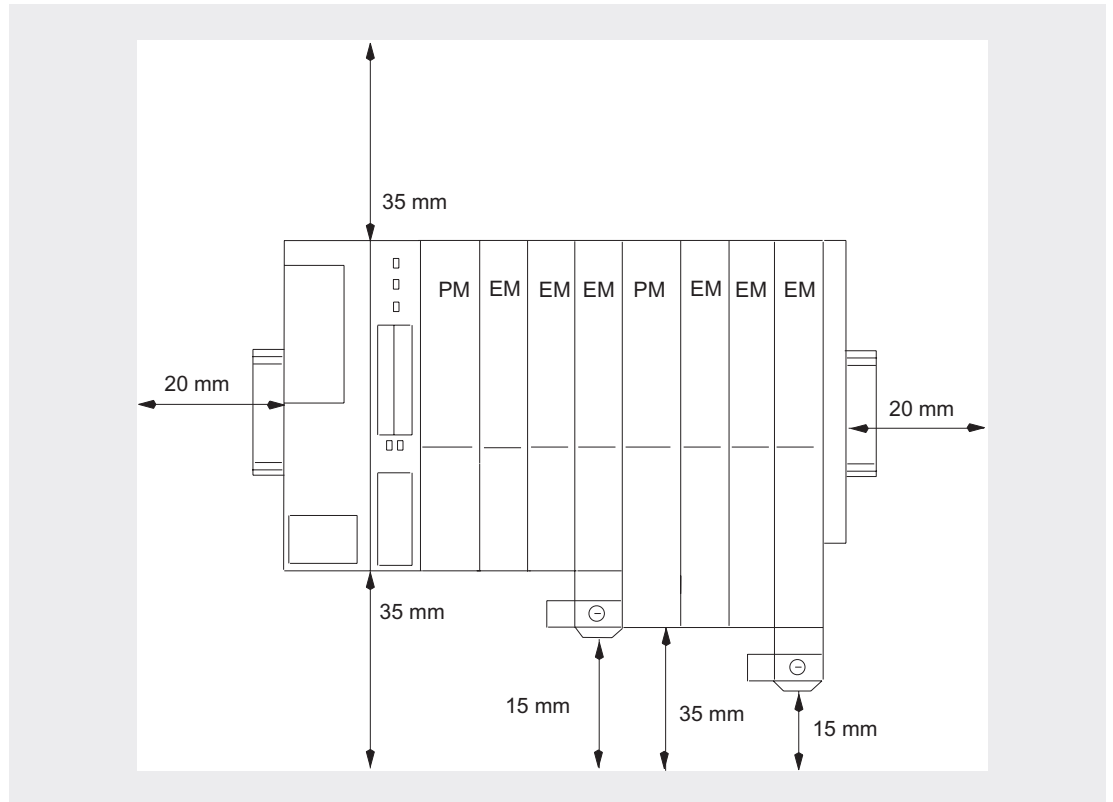

Figure 4-1 Minimum clearances

4.2 Installing the interface module

Introduction

- The interface module connects the ET 200S with the PROFIBUS DP and PROFINET.
- The interface module transfers data between the higher-level controller and the I/O modules.

Requirements

- The DIN rail is installed.
- All terminal modules are installed to the right of the interface module. The maximum configuration of the ET 200S distributed I/O system is 12/63 I/O modules.

Required tools

Screwdriver with 3 mm blade

Installing the interface module

1. Hang the interface module on the rail.
2. Tip the interface module back until you hear the slider engage.

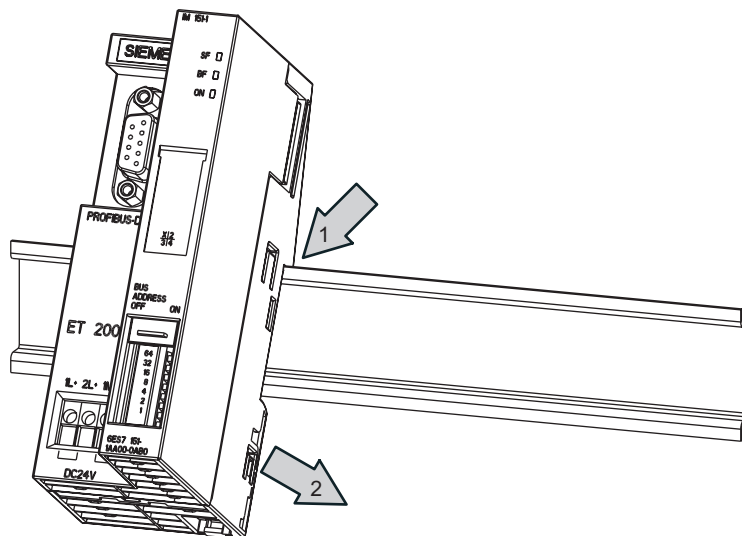

Figure 4-2 Installing the interface module

Removing the interface module

The interface module is wired, and the terminal modules are on the right:

1. Switch off the supply voltage on the interface module.
2. Disconnect the wiring and the bus connector on the interface module.
3. Use a screwdriver to push the slider on the interface module down until the mechanism stops and move the interface module to the left.

Note: The locking mechanism is beneath the interface module.

4. Press down on the slider while taking the interface module off the mounting rail.

4.3 Installing the TM-P and TM-E terminal modules

Introduction

- The terminal modules serve to receive the I/O modules and power modules.
- The terminal modules can be wired (without I/O modules)
- All the terminal modules must be installed to the right of the interface module.

Requirements

- The DIN rail is installed.

Required tools

Screwdriver with 3 mm blade

Installing the terminal module

1. Fit the terminal module onto the rail.
2. Move terminal module backward until the slider can be heard locking in place.
3. Move the terminal module to the left until you hear it snap into place at the previous interface module (if already installed) or the terminal module.

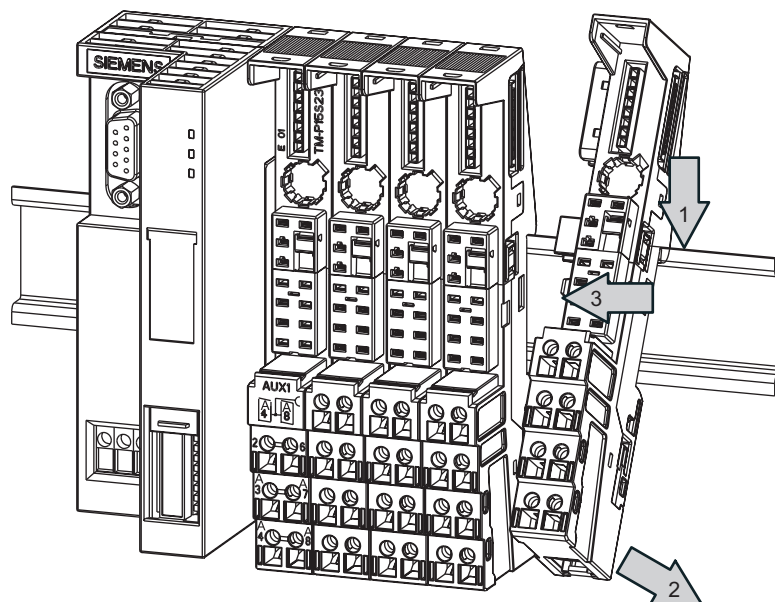

Figure 4-3 Installing the terminal module

Removing the terminal module

The terminal module is wired, and there are other terminal modules on the right and left.

A terminal module in the ET 200S distributed I/O system can only be removed when there is a clearance of approx. 8 mm to the adjacent terminal modules (you achieve this clearance by moving the adjacent modules).

1. Switch off the supply voltage on the terminal module and, if applicable, the power module.
2. Disconnect the wiring on the terminal module.
3. Removing the terminal module (from the right):

Use a screwdriver to press down the slider on the previous (left hand) terminal module / interface module until the mechanism stops then move the interface module to the right.

Removing the terminal module (from the right):

Use a screwdriver to press down the slider on the interface module until the mechanism stops then move the interface module to the left.

Note: The slider is located underneath the terminal module.

4. Press down on the slider while taking the terminal module off the mounting rail.

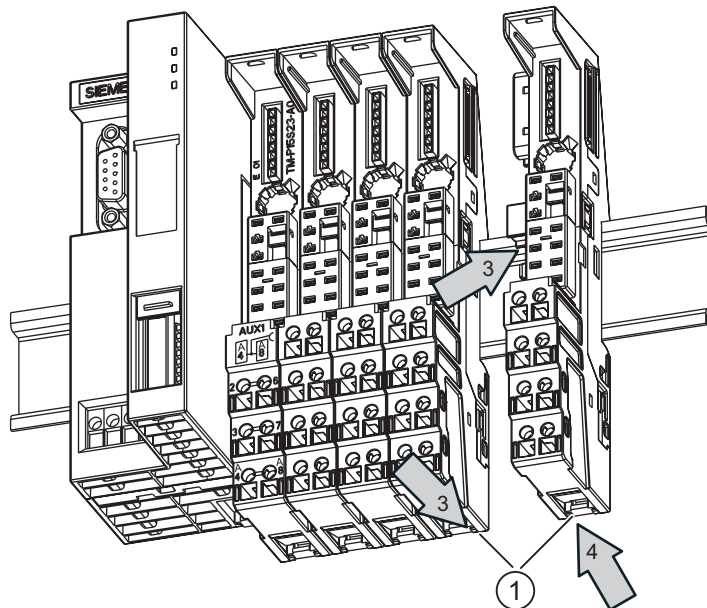

Figure 4-4 Removing the terminal module (from the right)

- ① Slide

Note

It is not necessary to remove the terminal module in order to replace the terminal box.

4.4 Installing the terminal modules TM-C for COMPACT modules

Introduction

- The terminal modules serve to receive COMPACT modules.
- The terminal modules can be prewired (without COMPACT modules).
- All other terminal modules are installed to the right of the terminal module for COMPACT modules.

Requirements

- The mounting rail is installed.

Required tools

Screwdriver with 3 mm blade

Mounting a terminal module for COMPACT modules

1. Insert the terminal module for COMPACT modules in the mounting rail (on the left side).
2. Move terminal module backward until the slider can be heard locking in place.

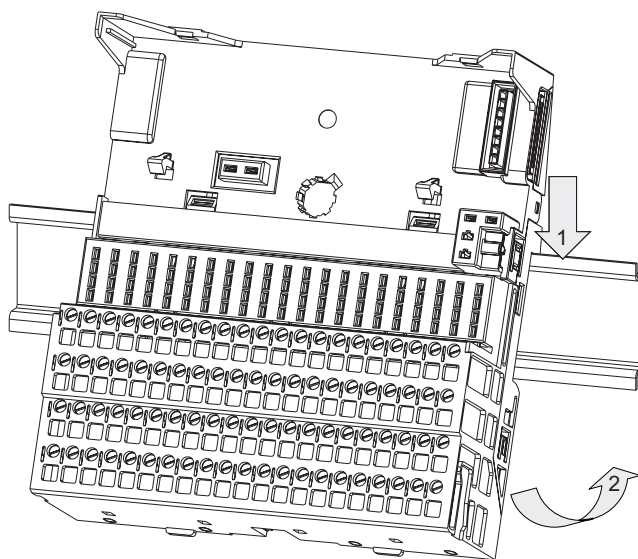

Figure 4-5 Mounting a terminal module for COMPACT modules

Removing a terminal module for COMPACT modules

The terminal module is wired, and there are other terminal modules to the right.

The terminal module for COMPACT modules can only be removed when there is approximately 8 mm space between it and the next terminal module (shift the modules if necessary).

1. Switch off the supply voltage on the terminal module for COMPACT modules or for the power module, if applicable.
2. Disconnect the wiring on the terminal module for COMPACT modules.
3. Use a screwdriver to press down the slider on the interface module for COMPACT modules until the mechanism stops, then move the terminal module to the left.

Note:

- The slider is located underneath the terminal module.
 - This step is not required if no other terminal modules are located to the right of the terminal module for COMPACT modules.
4. Press down on the slider while taking the terminal module off the mounting rail.

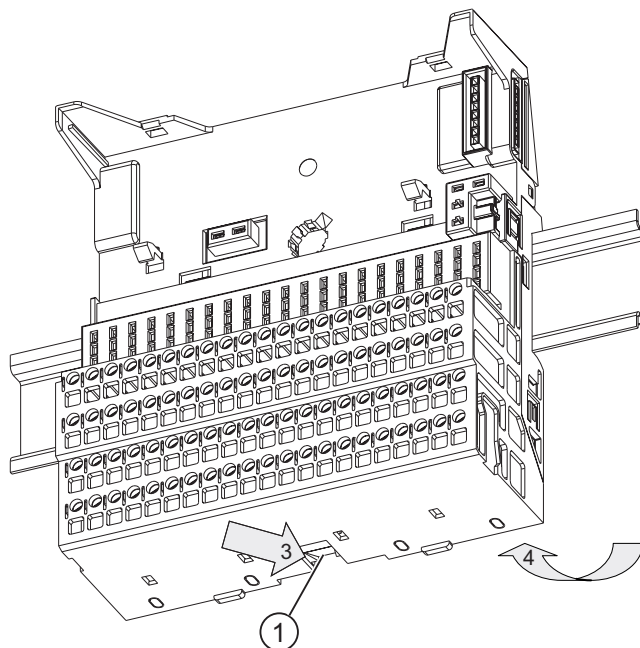

Figure 4-6 Removing a terminal module for COMPACT modules

① Slide

Note

The terminal box can be replaced without first removing the terminal module for COMPACT modules.

4.5 Installing add-on terminals

Introduction

- The add-on terminals expand the function of the terminal modules for ET 200S.
Extra potentials can be applied to the add-on terminal as necessary (for example to connect encoders and actuators using 3- and 4- conductor technology with IM151-1 COMPACT).
The add-on terminal can be cascaded if extra potentials are required.
- Terminal modules and add-on terminal can be prewired (without COMPACT modules or I/O modules).
- Various voltage groups can be configured on the add-on terminal using pluggable bridges.

Requirements

- The mounting rail is installed.
- The terminal module for COMPACT modules is installed or the terminal modules TM-P and TM-E are installed at a width of 120 mm.

Note

Requirements for installing the add-on terminals under terminal modules TM-P and TM-E

Both of the "outside" terminal modules must have the same height. No higher terminal modules are allowed to be mounted between both of these terminal modules.

Required tools

4-mm screwdriver

Installing add-on terminals

1. Slide the add-on terminal from below onto the terminal module for COMPACTmodules or the TM-P and TM-E terminal modules.

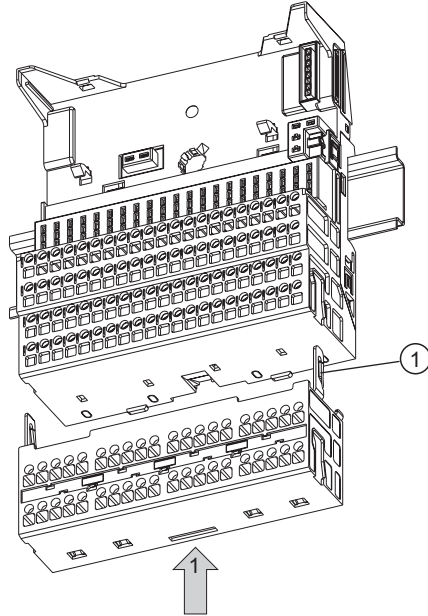

Figure 4-7 Installing add-on terminals

- ① Catch

If your ET 200S modules are exposed to shocks or vibrations they can be stabilized by using the mounting brackets included in the delivery package.

1. Slide the fixing bracket into the slot in the underside of the additional terminal.
2. Screw the fixing bracket firmly onto the base.

The lower part of the mounting bracket can be broken off and used to fill any gap between the add-on terminal and its base by placement under the bracket (as a spacer).

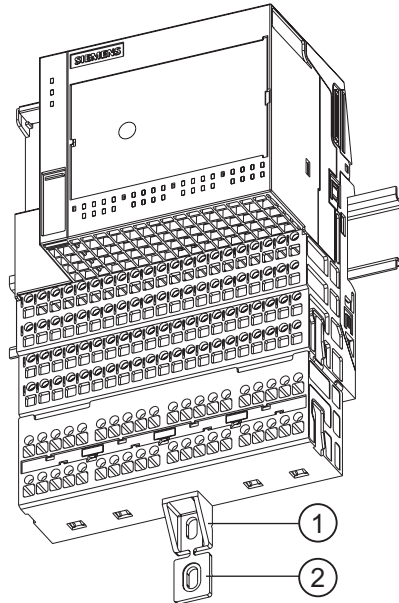

Figure 4-8 Stabilizing an add-on terminal with fixing bracket

- ① Mounting brackets
- ② Spacer

Removing add-on terminals

The add-on terminal is wired up.

1. Switch off the supply voltage on the add-on terminal, the terminal module for COMPACT modules, and the power module, if applicable.
2. If the add-on terminal is stabilized using a mounting bracket, loosen it from the base and pull it out of the add-on terminal.
3. Disconnect the wiring on the add-on terminal.
4. Push the screwdriver in the right hand slot between the terminal module and the add-on terminal. Turn the screwdriver. The catch is released from its bracing when the add-on terminal is pushed away.
5. Repeat this procedure on the left-hand slot.
6. Then pull the add-on terminal downwards and out of the terminal module / terminal modules.

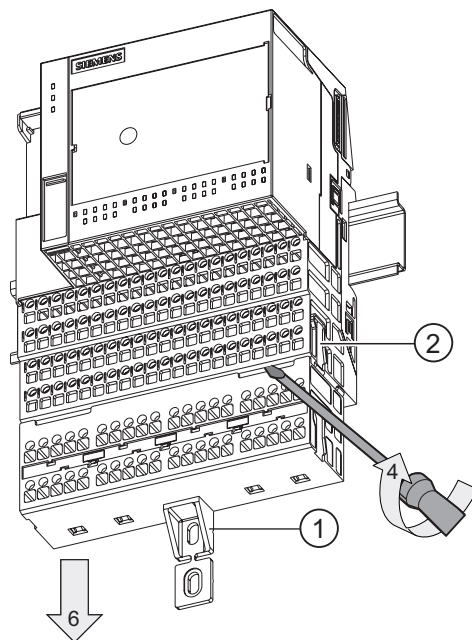

Figure 4-9 Removing add-on terminals

- ① Mounting brackets
- ② Catch

4.6 Removing/installing pluggable bridges on the additional terminal

Introduction

The additional terminal is fitted with three pluggable bridges on delivery.

All of the terminals on the additional terminal have the same potential with the 3 plugged bridges. If additional potentials are required then various potential groups can be configured by removing the pluggable bridges. Detailed information pertaining to the expansion of potential groups can be found in the device manual in the chapter *Terminal modules > Additional terminals TE-U120S4x10 and TE-U120C4x10 (6ES7193-4FLx0-0AA0)*.

Requirements

- The DIN rail is installed.

Required tools

Screwdriver with 3 mm blade

Removing pluggable bridges

1. Pull the labeling strips out of the additional terminals.
2. Insert the screwdriver underneath the pluggable bridge being removed from the side.
3. Loosen the bridge and then pull it out.
4. If necessary, repeat steps 2 and 3.
5. Reinsert the labeling strips.

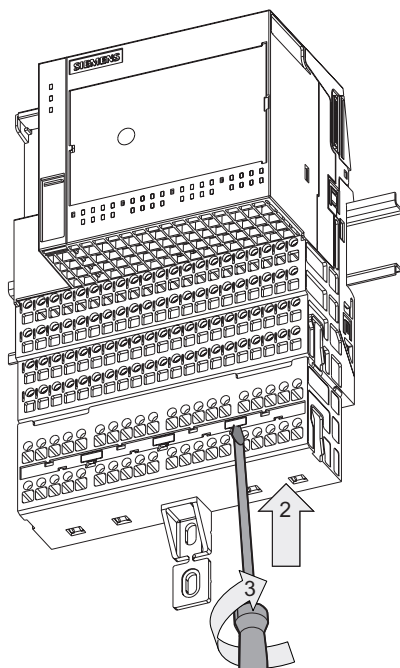

Figure 4-10 Removing the bridges

Installing pluggable bridges

1. Pull the labeling strips out of the additional terminals.
2. Insert the pluggable bridge between the potential groups being connected.
3. If necessary, repeat step 2.
4. Reinsert the labeling strips.

The inserted bridges can be recognized by their labeling strips.

4.7 Replacing the terminal box on the terminal module

Introduction

The terminal box is part of the terminal module. If necessary, you can replace the terminal box. It is not necessary to remove the terminal module.

Requirements

- The terminal module is installed, wired, and fitted with a COMPACTmodule, power module, or electronic module.

Required tools

Screwdriver with 3 mm blade

Proceed as follows

1. Switch off the supply voltage on the terminal module and, if applicable, the power module.
2. Disconnect the wiring on the terminal module.
3. Simultaneously press
 - the upper and lower release buttons of the electronic module or power module, and remove it from the terminal module.
 - The release button located above of the COMPACT module and pull it out of the terminal module.
4. Push the screwdriver at an angle from below into the small opening underneath the slot number. At the same time pull the terminal box downward until it stops. Then pull the terminal box upward and out of the terminal module.
5. Replace the terminal box, and insert the new one into the terminal module from above (see figure). Then push the terminal box upward until it snaps into place.
6. Insert the COMPACT module, power module or electronic module into the terminal module.
7. Wire the terminal module.
8. Switch on the supply voltage on the terminal module and, if applicable, the power module.

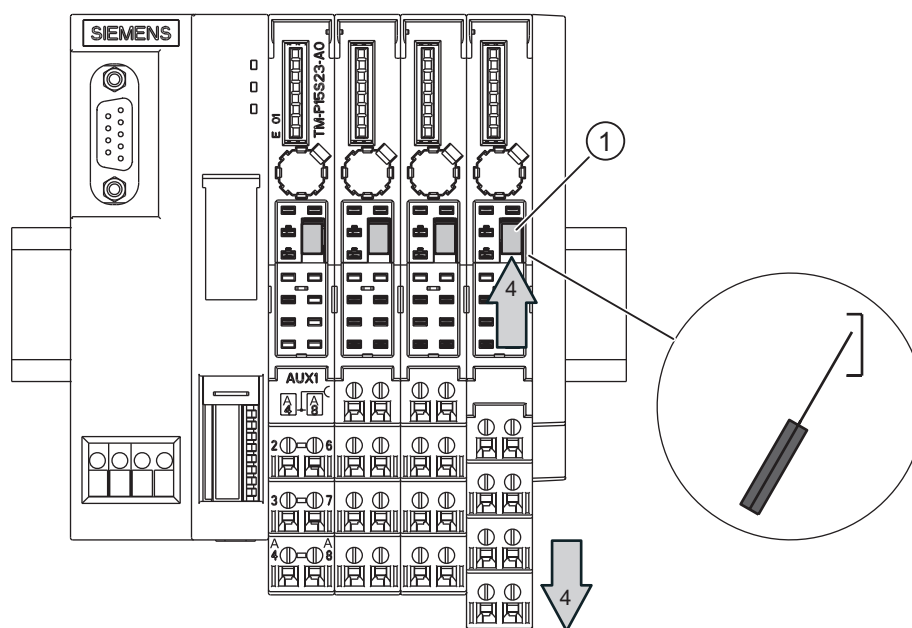

① Slot number label

Figure 4-11 Replacing the terminal box on the terminal module

4.8 Installing the bus terminating module

Introduction

The terminating module on the right end of the ET 200S terminates the ET 200S distributed I/O system. If you have not inserted a terminating module, the ET 200S is not ready for operation.

Requirements

The last terminal module must be installed.

Installing the bus terminating module

1. Fit the bus termination module onto the rail to the right of the last terminal module.
2. Pivot the terminating module backwards onto the DIN rail.
3. Push the bus termination module to the left until you hear it lock into the last terminal module.

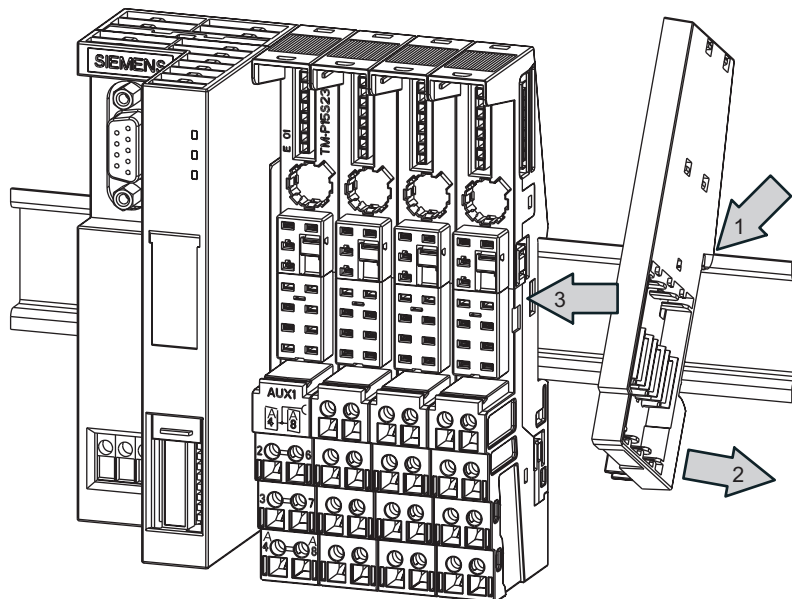

Figure 4-12 Installing the bus terminating module

Removing the Bus Terminating Module

1. Use a screwdriver to push the slider on the last terminal module down until the mechanism stops, and move the terminating module to the right.
2. Pivot the terminating module so that it comes off the DIN rail.

Note

If

- the terminating module of the ET 200S is removed and remounted under voltage, or
- the ET 200S backplane bus is interrupted during operation, e. g. at a terminal module, and then restored to function,

the complete power supply of the ET 200S must be switched off and on again in order to achieve a defined station status.

4.9 Installing the shield contact

Introduction

- You need the shield contact to connect cable shields (for example, analog electronic modules, 1COUNT 24V/100kHz electronic module and 1SSI electronic module).
- Fit the shield connection on the terminal module.
- The shield connection consists of a shield connection element, a power bus (3 x 10 mm), a shield clamp, and a grounding terminal.

Requirements

- The terminal modules are installed.

Required tools

- Screwdriver with 3 mm blade
- Metal-cutting saw

Proceed as follows

1. Push the shield connection element onto the first terminal module from below.
2. Push the shield connection element onto the last terminal module from below.

In order to achieve stability of the busbar between two shield contact elements during installation, you must connect an additional shield contact element after every sixth terminal module (given a width of 15 mm).

3. Saw off the correct length from the busbar. The length of the busbar is: equal to the distance between the shield connection elements + 45 mm.
4. Push the busbar into the shield contact element. The busbar must protrude from the shield contact element by 15 mm on the left or right after installation.
5. Attach the shield terminals to the busbar (between the shield connection elements).
6. Attach the ground connection terminal to the protruding busbar.

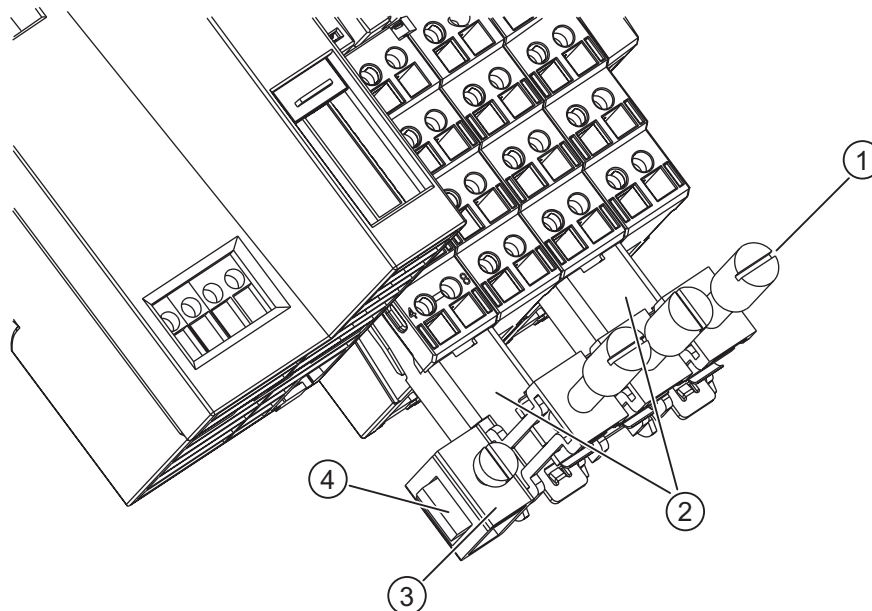

Figure 4-13 Installing the shield contact

- ① Shielding terminals
- ② shield connection elements
- ③ Ground connection terminal
- ④ Power bus

4.10 Applying slot number labels and color identification labels

Introduction

- The slot number labels identify the individual I/O modules with a slot (1 to 63).
- The color identification labels permit individual color coding of the terminals in accordance with company or national conventions. The color identification labels are available in white, red, blue, brown, yellow, yellow-green, and turquoise. Each terminal on the terminal module can be fitted with a color identification label.
- The slot number labels and color identification labels are applied onto the terminal modules.
 - Position of the slot number plate: below the coding element on the terminal module.
 - Position of the color-coding plates: directly next to each terminal on the terminal box.

Requirements

- The terminal modules are installed.
- You can only fit the slot number labels when no electronics modules are installed.
- The terminal modules should not be wired when you apply the color identification labels.

Required tools

3 mm screwdriver (for removal only)

Applying slot number labels and color identification labels

Applying slot number plates:

1. Break the slot number label (1 to 63) off the strip.
2. Use your finger to press the slot number label onto the terminal module.

Applying color-coding plates:

1. You can place the color identification labels in the opening next to the terminal while they are still on the strip and then bend the strip back to pull them off.
2. Use your finger to press the color identification labels onto the terminal module.

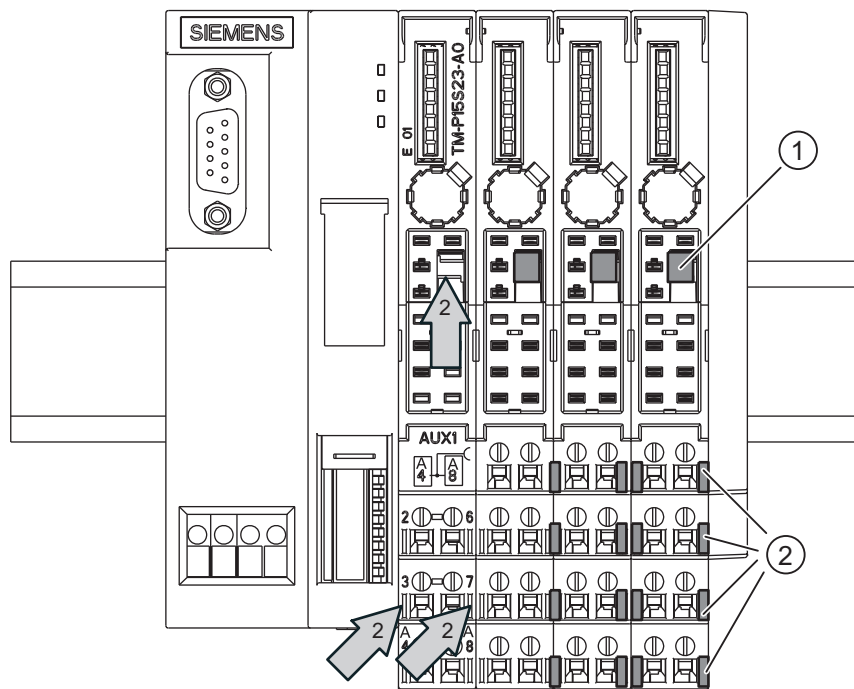

Figure 4-14 Applying slot number labels and color identification labels

- ① Slot number label
- ② Color identification labels

Removing slot number labels and color identification labels

Removing slot number plates:

1. Remove the electronic module from the terminal module.
2. Lever the slot number label out of its mount.

Removing color-coding plates:

Use a screwdriver to lever the color-coding plates from their mounts.

4.11 Mounting Color Identification Labels for ET 200S and ET 200S COMPACT

Properties

- Color-coded labels allow terminals to be identified in the colors white, red, blue, yellow, yellow-green, and turquoise.
- Color-coded labels can be used at the terminal modules TM-E, TM-P and TM-C of the ET 200S and ET 200S COMPACT.
- The packaging unit encompasses 200 color-coded labels (10 star-shaped mounts with 20 piece each).

Introduction

You can provide every terminal at a terminal module with a color-coded label. The color-coded labels are mounted on the terminal module. Color-coded labels are positioned directly next to the terminal.

Requirement

The terminal module should not be wired in order to make mounting of the color-coded labels easier.

Required tools

Screwdriver with 3.5 mm blade

Mounting Color-Coded Labels

1. Press the point of the color-coded label using the screwdriver into the provided opening of the terminal module.
2. Hold the color-coded label during the following steps.
3. Bend the star-shaped mount upwards by approx. 30° to 40°.
4. Detach the color-coded label from the mount by moving the mount back and forth sideways.

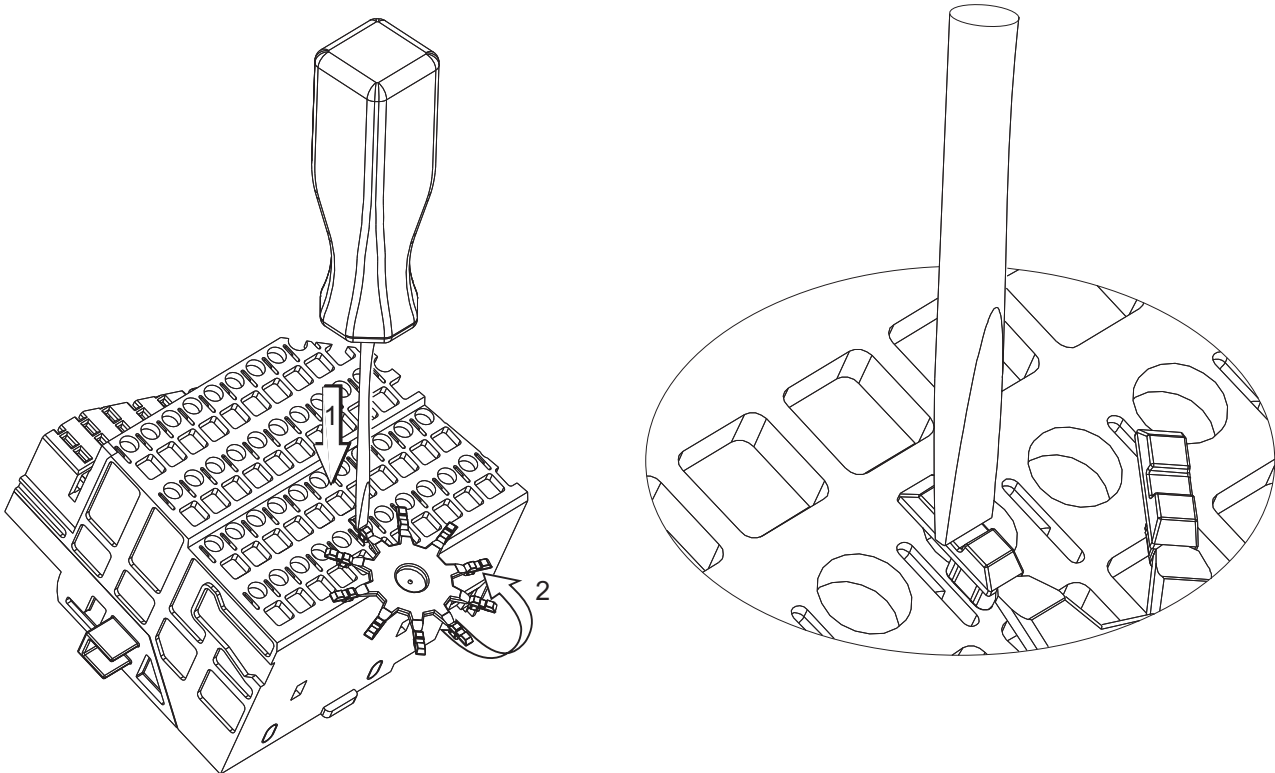

Figure 4-15 Mounting Color-Coded Labels

Removing Color-Coded Labels

Use a screwdriver to lever the color-coded labels from their mounts.

Note

Ensure that the color-coded labels do not fall into the terminal openings. Color-coded labels can only be removed from terminal openings after the COMPACT module has been dismantled.

Wiring and assembly

5.1 General rules and regulations for operating the ET 200S

Introduction

When operating the ET 200S distributed I/O system as part of a plant or system, special rules and regulations have to be followed depending on the field of application.

This chapter provides an overview of the most important rules you must observe when integrating the ET 200S distributed I/O system into a plant or system.

Specific application

Please observe the safety and accident prevention regulations applying to specific applications (e.g. machine protection guidelines).

EMERGENCY-STOP devices

EMERGENCY-STOP devices according to IEC 204 (coincides with VDE 113) must remain effective during all operating modes of the plant or system.

System Startup after Certain Events

The table below shows what you have to observe when restarting a plant after specific events.

If there is ...	then ...
Start-up following a power drop or failure Startup of the ET 200S follows an interruption of the bus communication	No dangerous operating states may occur. If necessary actuate an EMERGENCY-STOP!
Startup follows unlocking of the emergency stop device	There must not be an uncontrolled or undefined startup.

Line voltage

The table below shows what must be monitored respecting supply voltage.

With ...	the ...
Stationary plants or systems without all-pole line voltage disconnect switch	building installation must contain a mains disconnect switch or a fuse.
load power supplies, power supply modules	the set rated voltage range must match the local supply voltage.
All circuits of the ET 200S distributed I/O system	Any fluctuation/deviation in the supply voltage from the rated value must be within the permitted tolerance.

24 VDC supply

The table below shows what must be monitored for 24 VDC power supply.

With ...	you need to observe ...	
Buildings	External lightning protection	Take lightning protection precautions
24 VDC power supply cables, signal cables	internal lightning protection	(for example, lightning protection elements)
24 VDC supply	Safe (electrical) isolation of extra-low voltage	

Protection against outside electrical influences

The table below shows how you must protect your system against electrical interference or faults.

With ...	Make sure that ...
all plants or systems in which the ET 200S is integrated,	The plant or system is connected to a protective conductor for diverting electromagnetic interference.
power supply, signal, and bus cables	the cable routing and installation is correct.
Signal and bus cables	A cable or wire break cannot lead to undefined states in the plant or system.

See also

Mechanical and Climatic Ambient Conditions (Page 133)

5.2 Operating the ET 200S on a grounded incoming supply

Introduction

In this section, you will find information on the overall configuration of an ET 200S distributed I/O system on a grounded incoming supply (TN-S system). The specific subjects discussed are:

- Disconnecting devices, short-circuit and overload protection to VDE 0100 and VDE 0113
- Load voltage supplies and load circuits.

Grounded incoming supply

In grounded incoming supplies, the neutral conductor of the supply line is grounded. A single fault between a live conductor and ground or a grounded part of the installation results in tripping of the protective devices.

Safety isolation

Safe electrical isolation must be provided for:

- Modules that require supply with voltages ≤ 60 VDC or ≤ 25 VAC.
- 24 VDC load circuits

Configuring the ET 200S with ungrounded reference potential

As of IM151-1 BASIC (6ES7151-1CA00-0AB0), IM151-1 STANDARD (6ES7151-1AA02-0AB0), IM151-1 FO STANDARD (6ES7151-1AB01-0AB0), IM151-1 HIGH FEATURE (6ES7151-1BA00-0AB0), IM151-3 PN, IM151-3 PN HIGH FEATURE and IM151-1 COMPACT, the ground M of the nominal supply voltage of the IM151-x is connected to the mounting rail (grounding conductor) via an RC combination, thus making a ground-free installation is possible.

To divert interference current, the reference potential of the IM151-x is connected internally to the mounting rail (protective conductor) via an RC combination ($R = 10 \text{ M}\Omega / C = 22 \text{ nF}$). High-frequency interference currents are thus discharged, and static charge is prevented.

Components and protective measures

Various components and protective measures are specified for assembling a full installation. The type of components and the binding character of protective measures depends on which DIN regulation applies to your plant. The following table refers to the figure below.

Compare ...	Refer to figure	DIN VDE 0100	DIN VDE 0113
Disconnection element for control system, sensors, and actuators	①	... Part 460: Main switch	... Part 1: Disconnecter
Short-circuit / overload protection: In groups for sensors and actuators	②	... Part 725: Single-pole protection of circuits	... Part 1: <ul style="list-style-type: none"> • With grounded secondary circuit: unipolar • otherwise: fuse all poles
	③		
Load current PS for AC power circuits with more than five items of electromagnetic apparatus	②	Isolation by transformer recommended	Isolation by transformer recommended
	③		

ET 200S in the overall configuration

The figure below shows the ET 200S distributed I/O system in the overall configuration (load voltage supply and grounding concept) with incoming supply from a TN-S system.

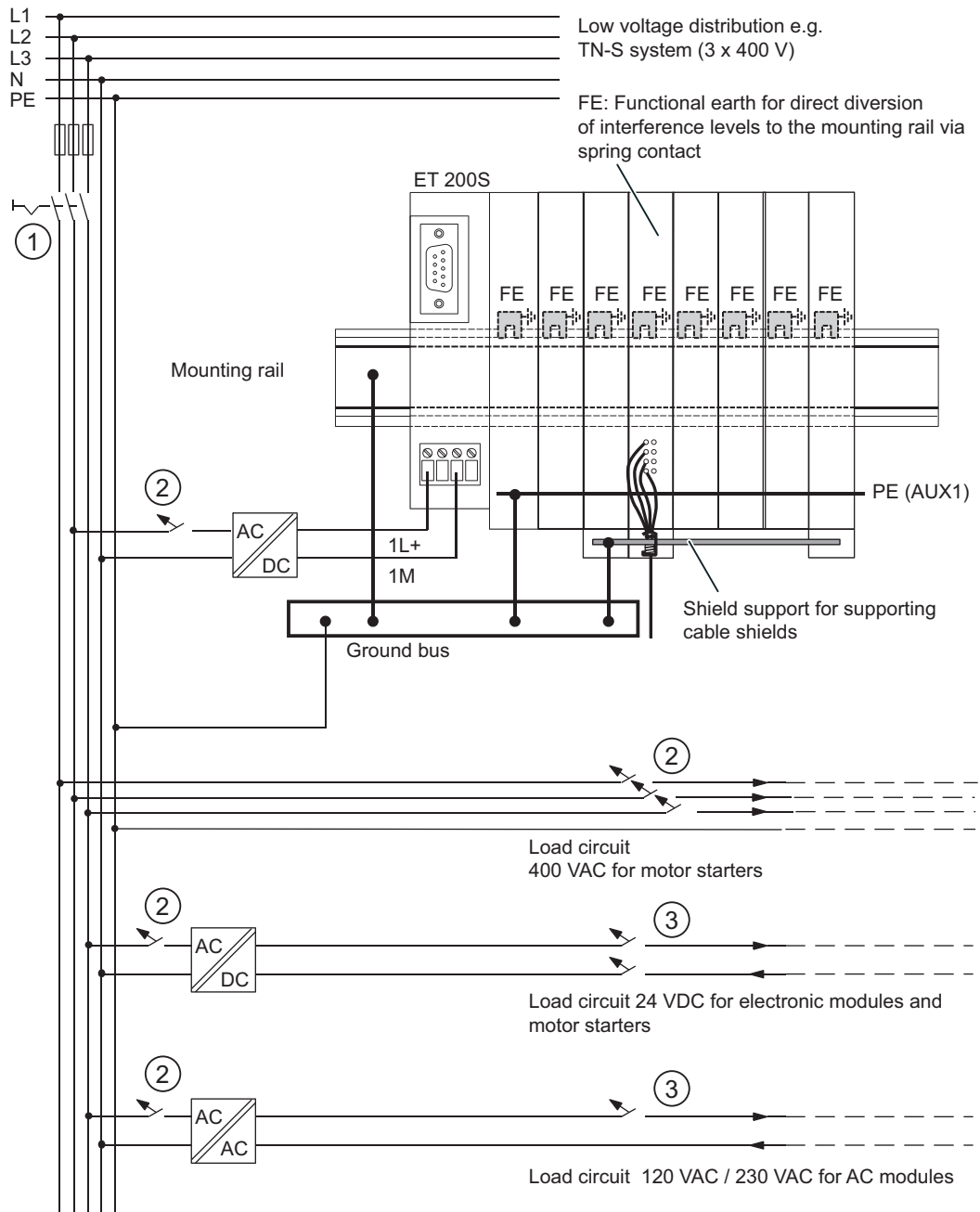

Figure 5-1 Operation of ET 200S with grounded reference potential

5.3 Electrical configuration of the ET 200S

Galvanic isolation

In the ET 200S, isolation exists between:

- The load circuits/process and all other circuit components of the ET 200S
- The PROFIBUS DP interface in the interface module and all other circuit components
- The PROFINET interface in the IM151-3 PN interface module and all other circuit components

The figure below shows the voltage ratios for ET 200S with IM151-1. Only the primary components are shown in the figure.

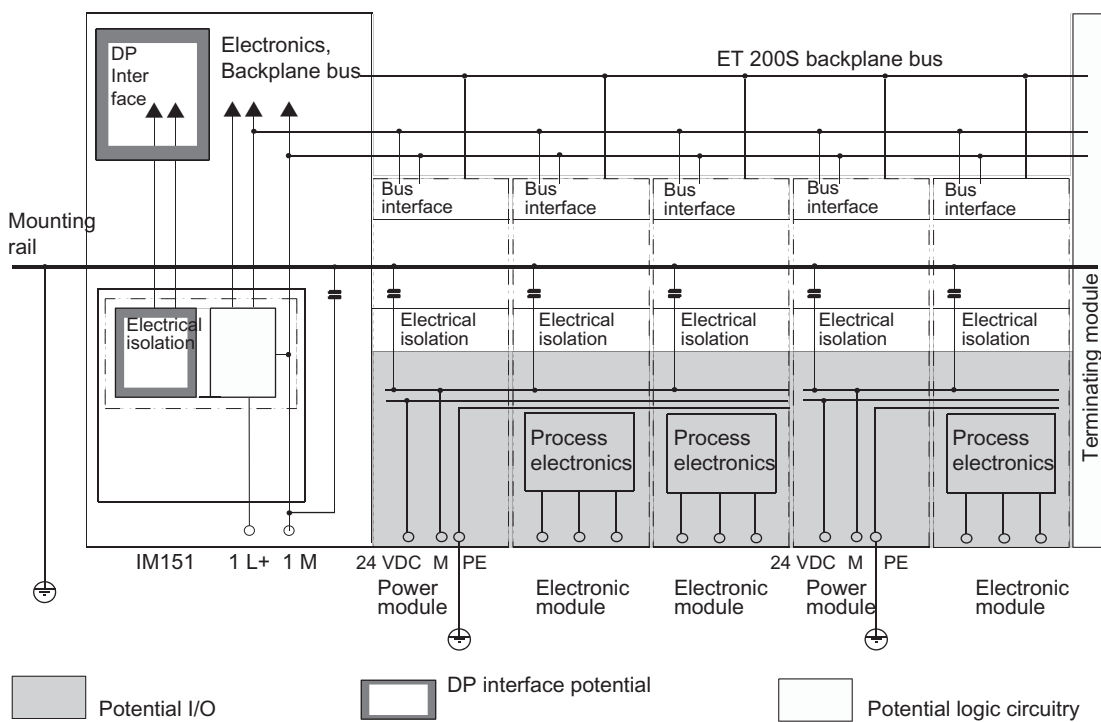

Figure 5-2 Potentials of the ET 200S with IM151-1

5.4 Wiring the ET 200S

5.4.1 Wiring rules for the ET 200S

Wiring rules

Wiring Rules for...		Interface module (supply voltage)	Terminal modules (spring and screw terminals)	Terminal modules (Fast Connect)
connectable cable cross sections for solid cables		No	0.14 mm to 2,5 mm ²	0.5 mm to 1.5 mm ²
permitted cross-sections of flexible conductors	without wire end ferrule	0.25 mm to 2.5 mm ²	0.14 mm to 2,5 mm ²	0.5 mm to 1.5 mm ²
	with wire end ferrule	0.25 mm to 1.5 mm ²	0.14 mm to 1.5 mm ²	---
Number of wires per connection		1 or combination of 2 cables up to 1,5 mm ² (total) in a mutual wire end ferrule		1
Maximum external diameter of the wire insulation		∅ 3.8 mm	∅ 3.1 mm at 1.5 mm ² ∅ 3.8 mm at 2.5 mm ²	∅ 3.2 mm at 1.5 mm ²
Stripping length of the wires		11 mm		---
Wire-end ferrules to DIN 46228	Without insulating collar	Form A, 8 to 12 mm long	Form A, up to 12 mm long	---
	with insulating collar 0.25 to 1.5 mm ²	Form E, up to 12 mm long		---

5.4.2 Wiring a terminal module with screw-type terminals

Introduction

In terminal modules with screw-type terminals, the individual wires are screwed into the terminal.

Requirements

- Adhere to the wiring rules.
- No wire end ferrules required

Required tools

Screwdriver with 3 mm blade

Proceed as follows

1. Strip 11 mm of insulation from the wires.
2. Insert the wires into the terminal.
3. Screw the ends of the individual wires onto the terminal module (torque of 0.4 to 0.7 Nm).

5.4.3 Wiring a Terminal Module with Spring Terminals

Introduction

When wiring terminal modules with spring terminals, the wires are secured in the terminal simply by inserting them into the terminal.

Requirements

Follow the wiring rules.

Required tools

Screwdriver with 3 mm blade

Procedure

1. Strip 11 mm of insulation from the wires.
2. Insert the screwdriver in the upper (round) opening of the terminal.
3. Insert the wire until it stops in the lower (square) opening of the terminal.
4. Release the terminal by pushing the screwdriver into the opening.
5. Push the wire into the released spring terminal, and pull the screwdriver out.

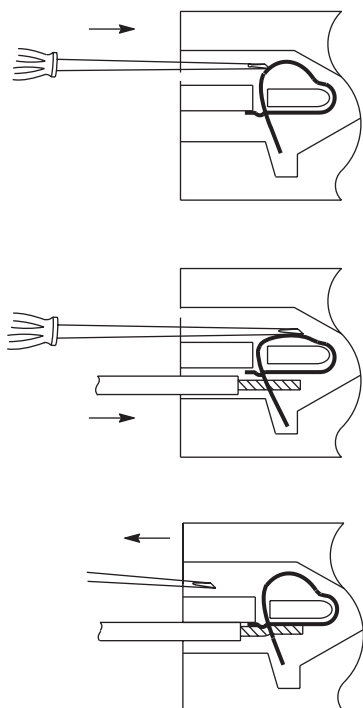
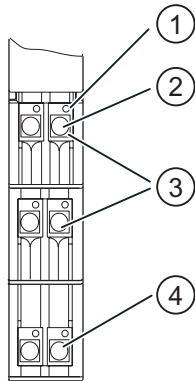

Figure 5-3 Wiring with Spring Terminals

5.4.4 Wiring terminal modules with Fast Connect

Introduction

- In the case of terminal modules with Fast Connect, the individual wires are attached using a quick connection method that requires no stripping.
- Fast Connect is a connection method that requires no conductor preparation (i. e., the conductor insulation does not have to be stripped).
- Each terminal of the terminal module with Fast Connect has a test opening (e.g. for measuring the voltage). The test opening is suitable for test probes with a maximum diameter of \varnothing 1.5 mm.
- Wire end ferrules are not permitted.
- Diagram of the Fast Connect terminal module



- ① Opening for measuring and testing: max. \varnothing 1.5 mm
- ② Opening for 1 conductor: 0.5 ... 1.5 mm²
- ③ Slider open (the cable can be inserted)
- ④ Locking mechanism closed (the wire is connected)

Requirements

- Follow the wiring rules.

Required tools

Screwdriver with 3 mm blade

Connectable wires

You can connect solid and flexible conductors with PVC insulation with a wire cross-section between 0.5 mm² and 1.5 mm² (max. external diameter 3.2 mm). If the cross-section of the conductors is the same they can be wired fifty times. A list of the tested conductors can be found on the Internet (<http://www.idc2.com>).

UL-compliant cables and connections

Wiring range for insulating piercing connection 22-16 AWG solid/stranded PVC insulated conductors, UL style no. 1015 only.

Proceed as follows

1. Insert the unstripped cable in the round opening **until it stops** (the insulation and conductor must form a flat surface).
2. Insert the screwdriver into the opening above the slider **until it stops**.
3. Press the screw driver downwards until the slider reaches the end position.

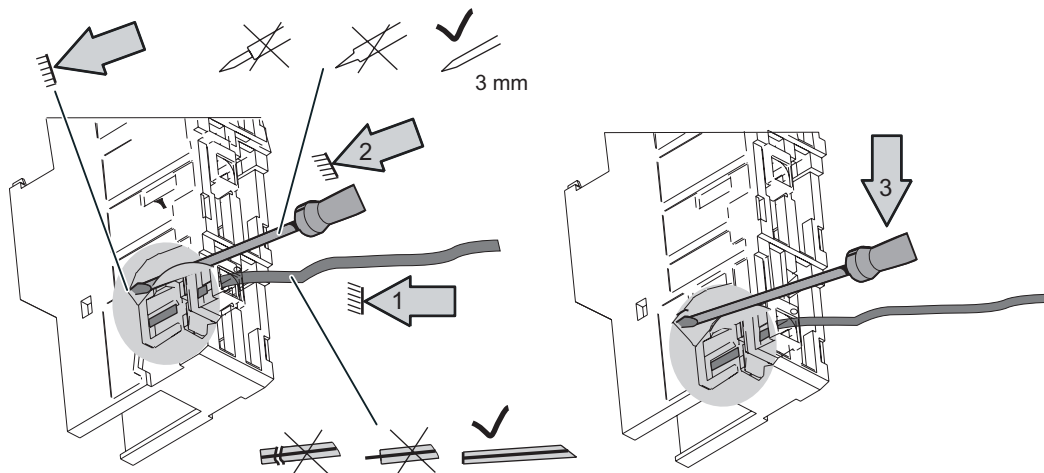

Figure 5-4 Wiring terminal modules with Fast Connect

Result: The wire is connected.

Note

If you would like to reuse a conductor after it was already connected once then it must be recut.

Release the wiring from the terminal module with Fast Connect

1. Insert the screwdriver into the opening below the slider until it stops.
2. Use the screwdriver to lever and push the slider upwards.
3. The wiring is disconnected: Remove the wire.

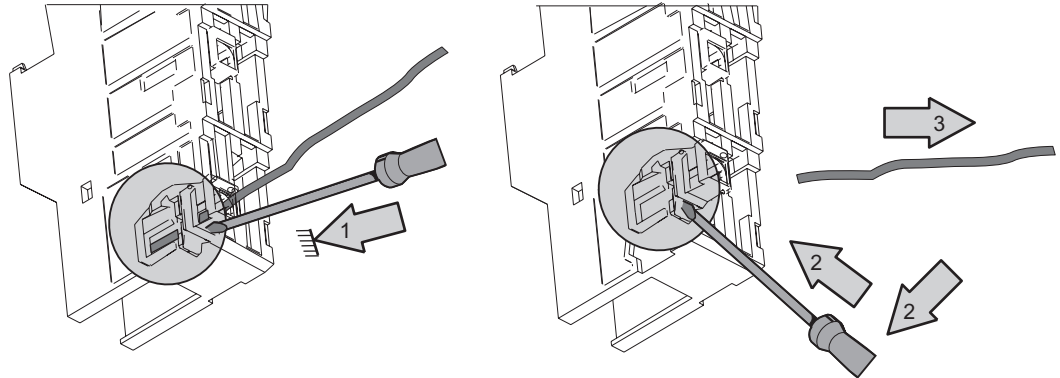

Figure 5-5 Release the wiring from the terminal module with Fast Connect

Removing any conductor remnants (if necessary)

To remove any remains of the conductor (insulation), you can deinstall the slider from the terminal module (see Step 3). To do this, the slider must be open (upper position). You can only insert the slider in the upper position (see Step 4).

1. Insert the screwdriver in the opening below the slider (the tip of the screwdriver is on the lip of the slider).
2. Press the screwdriver downwards to lever the slider out of the terminal module.
3. Remove the locking mechanism from the terminal module. Remove any remnants of the conductor from the locking mechanism.
4. Use your fingers to press the slider back into the opening. Caution: Make sure the slider is inserted in the correct position otherwise you can damage the clamping point.

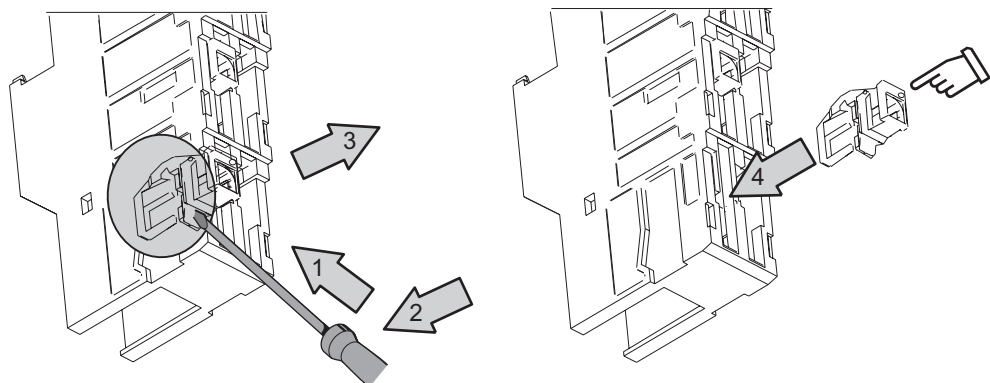

Figure 5-6 Deinstalling the slider from the terminal module

5.4.5 Wiring terminal modules

Introduction

The ET 200S distributed I/O system incorporates terminal modules for power modules, electronic modules and COMPACT modules:

- Connect the supply/load voltage for the respective voltage group for the power terminal modules.
- Terminal modules for electronic modules connect the ET 200S with the process.
- With the terminal modules for electronic modules you can connect cable shielding by means of a shield connection.
- For terminal modules for COMPACT modules, connect:
 - the supply voltage for the interface part
 - the load voltage for the relevant voltage group
 - the connections for the integrated peripherals with the process (with the help of add-on terminals for 3- and 4-conductor technology)

Requirements

- You must wire the terminal modules with the supply/load voltage switched off at the power module and the load voltage switched off at the electronic module.
- Wire terminal modules for COMPACT modules with the supply voltage for the interface part switched off and the supply/load voltage for the potential groups switched off.
- Follow the wiring rules.

Required tools

Screwdriver with 3 mm blade

Wiring terminal modules for power modules

The terminal assignment of the terminal module depends on which power module is inserted. You can find information regarding the terminal and power modules in the *ET 200S* device manual.

Wiring terminal modules for digital, analog, and technological modules

The terminal assignment of the terminal module depends on which electronic module is inserted. You can find information regarding the terminal and electronic modules in the *ET 200S* device manual. You can find information about technological modules in the *Technological Functions* manual.

Wiring terminal modules for COMPACT modules

The terminal assignment of the terminal module depends on which COMPACT module is inserted. You can find information regarding the terminal and COMPACT modules in the chapter entitled *COMPACT- Modules* and in the *ET 200S* device manual.

Connecting the Cable Shielding

We recommend that you use the shield connection to connect cable shielding (e.g. in the case of analog electronic modules, the 1COUNT 24V/100kHz electronic module and the 1SSI electronic module.).

1. Remove the insulation material from the area around the shield terminal, and clamp the cable shield in the shield terminal (above the conductor rail). The shield clamp is suitable for one cable with a maximum diameter of 8 mm or two cables with a maximum diameter of 4 mm each.
2. Tighten the shield terminal (approximately 0.5 Nm)
3. Repeat steps 1 and 2 if you want to connect additional cable shields.

4. Strip the insulation from the ground wire (from 6 mm to 25 mm²), and insert it in the ground connection terminal (under the conductor rail). Tighten the ground connection terminal (2 Nm to 2.5 Nm).
5. Attach the other end to the ground bus.

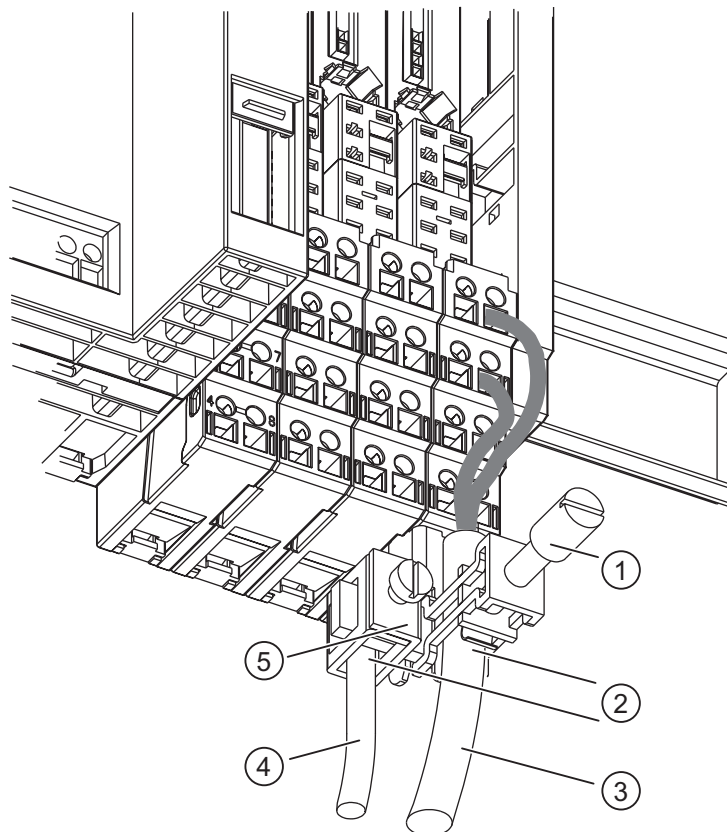

- ① Shield terminal
- ② Insulation material removed
- ③ Cable to the encoder
- ④ Cable to the ground bus
- ⑤ Ground connection terminal

Figure 5-7 Connecting cable shields

Note

To stabilize the shield connection, you must mount and screw in at least one shield terminal above the shield connection element.

5.4.6 Wiring an interface module with PROFIBUS DP interface (electrically)

Introduction

The supply voltage and the bus connector (RS 485) are connected at the IM151-1 BASIC, IM151-1 STANDARD, and IM151-1 HIGH FEATURE interface modules.

Requirements

- Wire the interface module with the supply voltage switched off.
- Follow the wiring rules.

Required tools

Screwdriver with 3 mm blade

Procedure

1. Connecting the supply voltage:
 - Strip the insulation from the wires for the supply voltage of the interface module.
 - Secure the individual wires in the screw-type terminal.
2. Connecting PROFIBUS DP:
 - Insert the bus connector onto the PROFIBUS DP connection.
 - Tighten the screws of the bus connector.

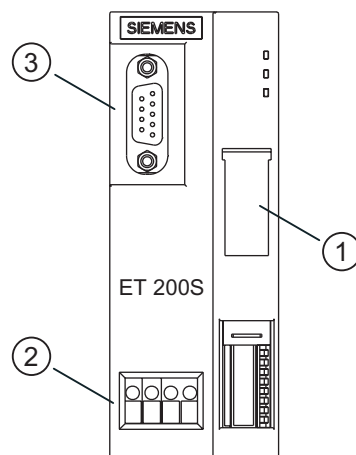

Figure 5-8 Wiring IM151-1 BASIC, IM151-1 STANDARD, and IM151-1 HIGH FEATURE

- ① Labeling strip
- ② Supply voltage (1L+, 2L+, 1M, 2M)
- ③ PROFIBUS DP

See also

Wiring rules for the ET 200S (Page 79)

5.4.7 Wiring an interface module with PROFIBUS DP interface (optically)

Introduction

The supply voltage and the fiber-optic cable are connected at the IM151-1 FO STANDARD interface module via a simplex connector.

Requirements

- Wire the interface module with the supply voltage switched off.
- Follow the wiring rules.

Required tools

3-mm screwdriver

Required accessories

- Package of Simplex connectors and polishing sets (6GK1901-0FB00-0AA0)
- Package of plug adapters (6ES7195-1BE00-0XA0)
- Fiber optic duplex cable see catalog IK PI

Rules for configuring a fiber optic cable network with IM151-1 FO STANDARD

In fiber-optic networks with participants with integrated fiber-optic interfaces:

- The fiber-optic network can only be configured as a line.
- If you remove the fiber-optic cable from an integrated fiber-optic interface or the supply voltage to the IM151-1 FO STANDARD fails, all subsequent nodes will no longer be accessible.

Example configuration of a fiber-optic cable network with IM151-1 FO STANDARD

The figure below presents an example of how to set up a fiber-optic cable network with the ET 200S and the IM151-1 FO STANDARD interface module.

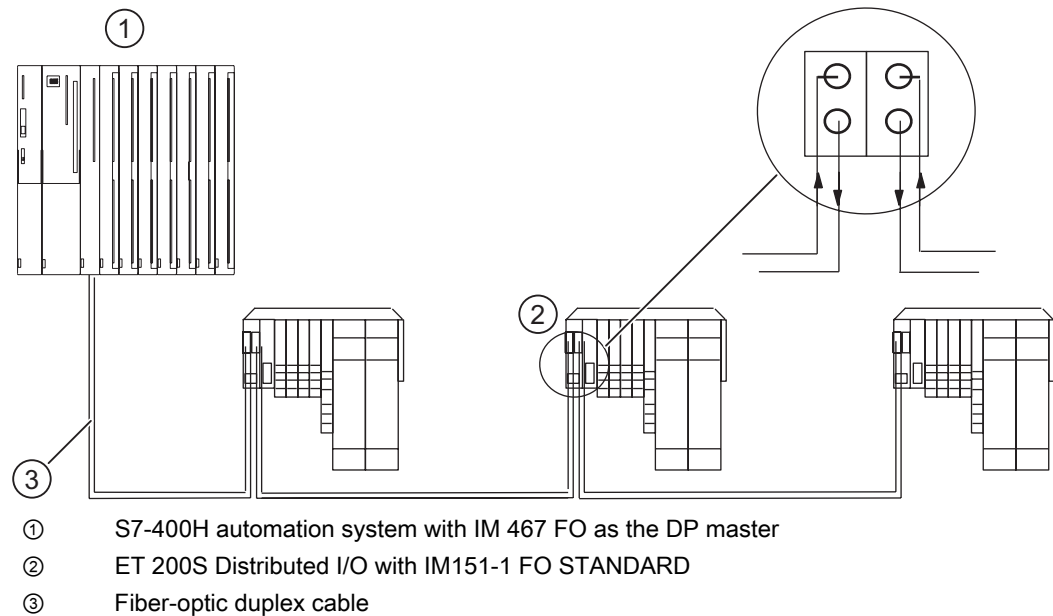

Figure 5-9 Fiber-optic cable network with IM151-1 FO STANDARD

Installing simplex connectors

Note

The fiber-optic duplex cable may have the following maximum lengths:

- PROFIBUS Plastic Fiber Optic standard cable 50 m
- PROFIBUS PCF Fiber Optic standard cable 300 m

1. Remove approximately 30 cm of the jacket of the fiber-optic duplex cable.
2. Attach the fiber-optic duplex cable with the associated simplex plugs. You can find detailed installation instructions in the *SIMATIC NET- PROFIBUS Networks* manual.

Tip: Do not click the 2 simplex plugs closed individually, click them closed together so that they complete a "duplex plug". In this manner you will achieve a better hold in the plug adapter.

IMPORTANT: The smoothed and polished surface of the plastic fibers must be absolutely flat and even. Likewise, the plastic jacket must not protrude or be cut unevenly. Every irregularity causes strong attenuation of the light signal via the fiber-optic cable!

- Place the simplex connectors into the plug adapter for the IM151-1 FO STANDARD interface module and the fiber-optic cable into the designated cable ducts. Snap the plug adapter closed until you can hear clearly that the side panels have engaged.

When inserting the plug in the plug adaptor, pay attention to the correct position:
Transmitter always up and receiver always down!

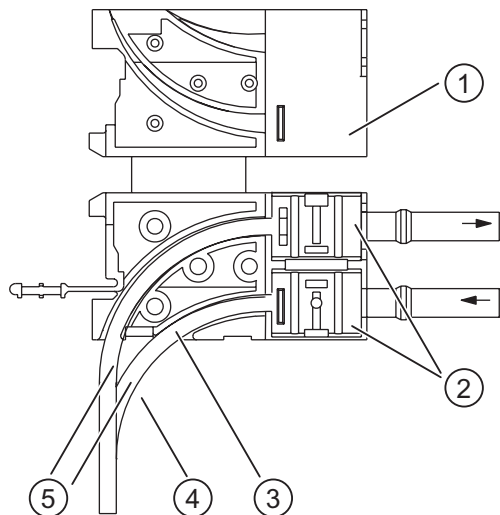

- Plug adapter for IM151-1 FO STANDARD
- Snap the two simplex connectors closed together such that you obtain a "duplex connector."
- Tip: Cut the lower wire approx. 10 mm shorter than the upper wire to achieve a better arrangement of the wiring.
- Maximum 30 mm bending radius!
- Fiber-optic duplex cable

Bending radius for the fiber-optic cable

When placing the fiber-optic duplex core into the plug adapter and routing the cable, be sure not to exceed the permissible bending radius of 30 mm. Refer also to the installation guidelines for fiber-optic cable in the *ET 200 Distributed I/O System* or *SIMATIC NET - PROFIBUS Networks* manual.

Reusing fiber-optic cable

Note

If you insert previously used fiber-optic cable into the plug adapter, you must shorten both fiber-optic cores by the amount of the curved lengths and reinstall the simplex connectors. This will prevent any attenuation losses caused by re-bent, heavily-stressed portions of the fiber-optic duplex core.

Wiring interface module IM151-1 FO STANDARD

1. Connecting the supply voltage:
 - Strip the insulation from the supply voltage wires on the interface module.
 - Secure the individual wires in the screw-type terminal.
2. Connecting PROFIBUS DP:
 - Insert the fiber-optic cable with the mounted plug adapters into the IM151-1 FO STANDARD.
 - Fold the protruding plug adapter grip upward.

Pay attention to the correct position: The transmitter fiber optic cable is inserted into the receiver female connector and the receiver fiber optic cable into the transmitter female connector of the fiber optic cable interface of the IM151-1 FO STANDARD.

If the IM151-1 FO STANDARD interface module is the last node of the fiber-optic cable network, the unoccupied fiber-optic cable interface must be blanked off (blanking plug inserted in IM151-1 FO STANDARD, as supplied).

<p>⚠ CAUTION</p> <p>Do not look directly into the opening of the optical transmit diodes. The emitted light beam could damage your eyes.</p>

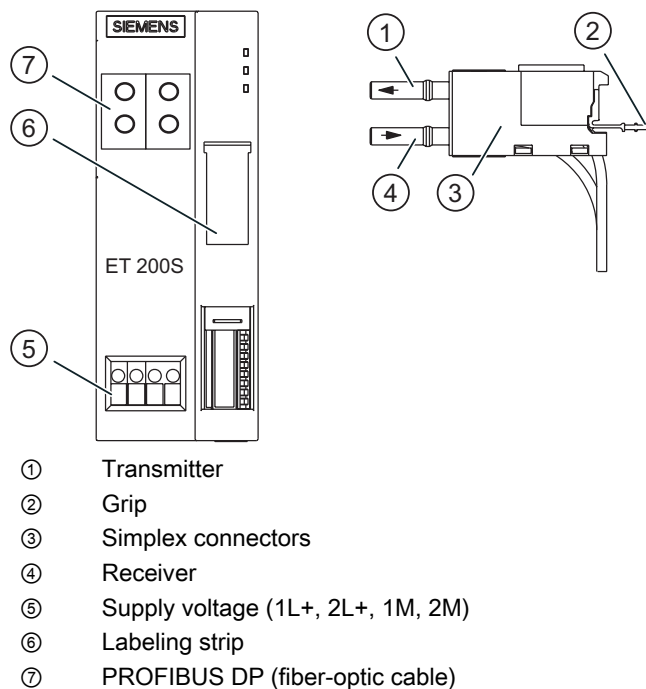

Figure 5-10 Wiring IM151-1 FO STANDARD

See also

Wiring rules for the ET 200S (Page 79)

5.4.8 Wiring an interface module with PROFINET IO interface (electrically)

Introduction

Connect the supply voltage and the bus connectors to the IM151-3 PN interface module.

Requirements

- Wire the interface module with the supply voltage switched off.
- Follow the wiring rules.

Note

Provide a suitable strain relief for the PROFINET connecting cable.

Note

Guideline for setting up modules with PROFINET I/O interfaces

You may only operate modules with PROFINET I/O interfaces in LAN networks if all connected nodes are equipped with SELV/PELV power supplies (or have equivalent protection).

For linking up to the WAN, a data transfer point is prescribed that guarantees this degree of safety.

Note

When using a CPU 315-2 PN/DP or CPU 317-2 PN/DP an industrial-quality switch must be placed directly on the CPU to which the downstream I/O devices must be connected.

Required tools

- Screwdriver with 3 mm blade
- Industrial Ethernet Fast Connect stripping tool (6GK1901-1GA00) (stripping tool for Industrial Ethernet Fast Connect installation cables)

Required accessories

- PROFINET connector (according to the specifications in the *PROFINET Installation Guide*)
- Industrial Ethernet Fast Connect installation cables

The following are suitable:

Fast Connect standard cable	6XV1840-2AH10
Fast Connect trailing cable	6XV1840-3AH10
Fast Connect marine cable	6XV1840-4AH10

Installing a bus connector

Install the PROFINET connector according to the specifications in the *PROFINET Installation Guide*.

Procedure

1. Connecting the supply voltage:
 - Strip the insulation from the supply voltage wires on the interface module.
 - Secure the individual wires in the screw-type terminal.
2. Connecting PROFINET:
 - Insert the bus connector into the PROFINET connection.

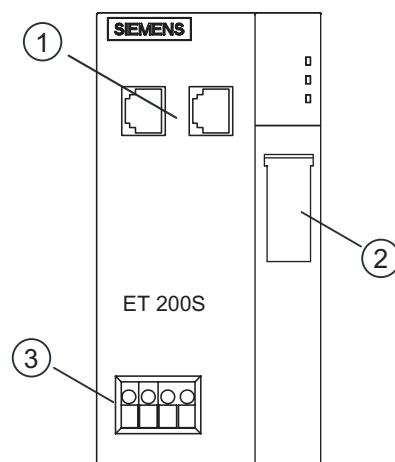

- ① 2-port switch (switched hub) for PROFINET
- ② Labeling strip
- ③ Supply voltage (1L+, 2L+, 1M, 2M)

5.4.9 Wiring the power supply

Required tools

Connect the power supply using a screwdriver with 3 mm blade width.

Power supply unit

You may only use PELV-type power supply units with a guaranteed electrically isolated extra-low voltage (≤ 60 VDC).

Connection for power supply

The power supply connections for the 24 V power supply are located on the front of the interface module. The connections have the following meaning:

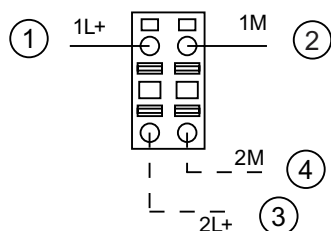

- ① + 24 VDC from the power supply
- ② Ground of the power supply
- ③ + 24 VDC from the power supply for looping through
- ④ Ground of the power supply for looping through

Figure 5-11 Power supply connection

The maximum cross-section of the connection is 2.5 mm². A strain relief is not present. The connection plug allows you to loop through the power supply without interruption even in unplugged condition.

Procedure

1. Strip the wires to a length of 10 mm.
2. Insert the line into the round opening of the connection plug up to the endstop. (The connecting plug is plugged into the power supply connection in the delivery condition.)
3. Insert the wired plug connection onto the power supply connection on the interface module.

5.5 Plugging and removing electronic modules and COMPACT modules

5.5.1 Plug and label electronic or COMPACT modules

Introduction

- The electronic modules or COMPACT modules are inserted in the terminal modules.
- A labeling strip allows you to identify the electronic modules or COMPACT modules.
- Electronic and COMPACT modules are:
 - Self-coding
 - Type-coded

The first time you insert an electronic or COMPACT module, a code element engages on the terminal module. This mechanically prevents the wrong electronic module or COMPACT module from being inserted.

Requirement

Observe the rules regarding inserting electronic modules as detailed in the *Application Planning* chapter.

Inserting electronic and COMPACT modules

1. Insert the electronic module or COMPACT module into the terminal module until you hear it snap into place.
2. For identification purposes, pull the labeling strip
 - upward out of the electronic module.
 - to the right out of the COMPACT module.

You have to lift the labeling strip to the right above the notch (with a 3 mm screwdriver).
3. Then reinsert the labeling strip back into the electronic module or COMPACT module.

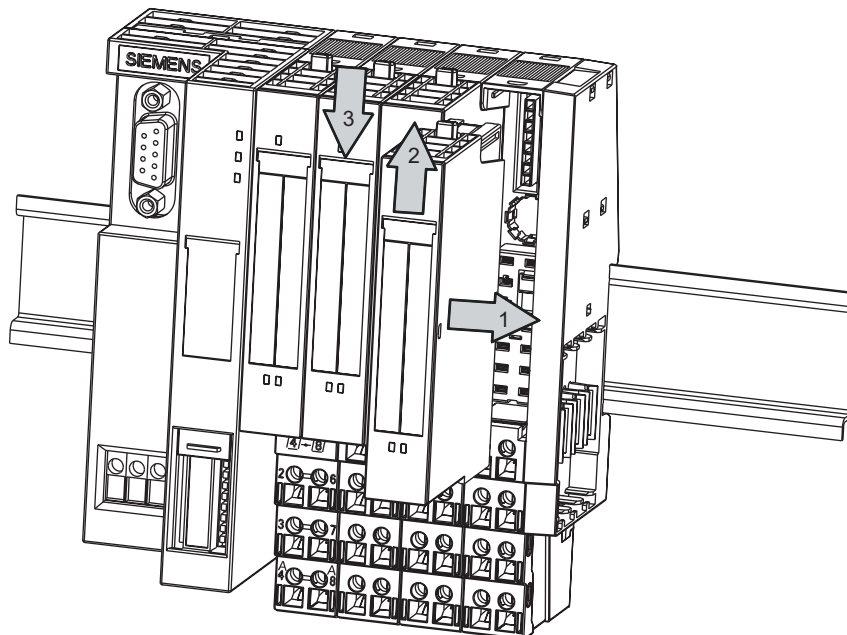

Figure 5-12 Inserting and labeling the electronic modules

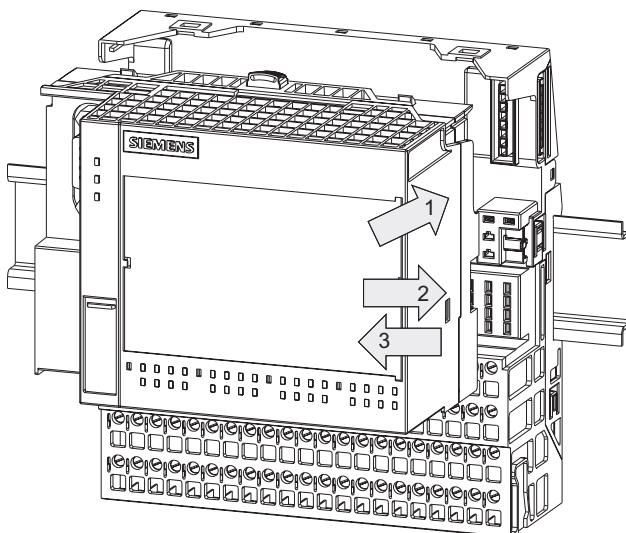

Figure 5-13 Inserting and identifying a COMPACT module

Removing electronic or COMPACT modules

CAUTION
An electronic or COMPACT module may only be removed if the associated load voltages have been switched off.

1. Simultaneously press
 - the two release buttons on the top and bottom of the electronic module.
 - the release button positioned at the top of the COMPACT module.
2. Pull the electronic or COMPACT module forward out of the terminal module.

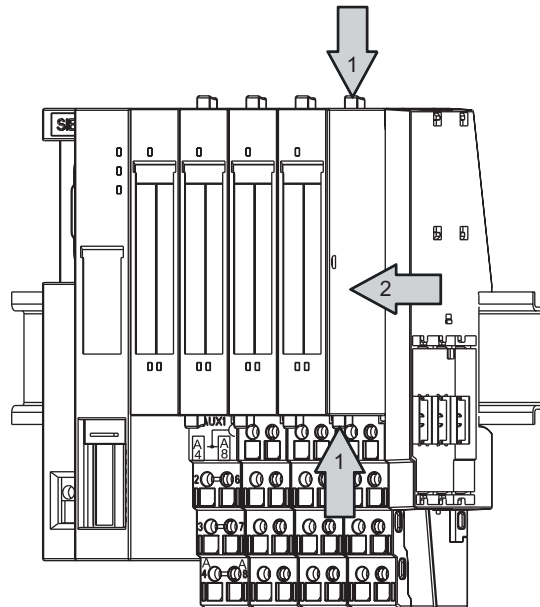

Figure 5-14 Removing electronic modules

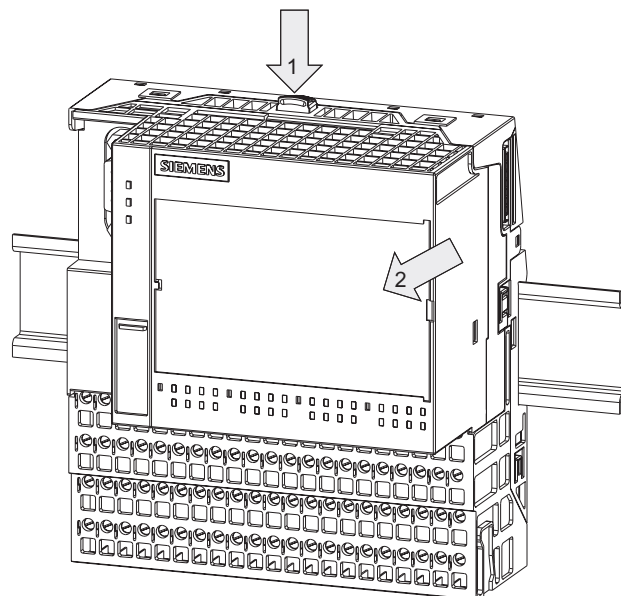
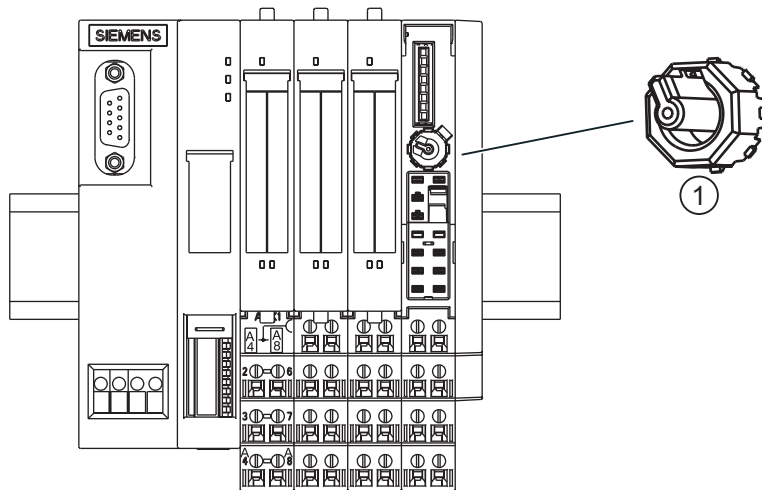

Figure 5-15 Removing the COMPACT module

Implementing an electronic module or COMPACT module type change

You have already removed the electronic module or COMPACT module:

1. Use a screwdriver to push the code element out of the terminal module.
2. Reinsert the code element onto the used electronic module or COMPACT module.
3. Insert the electronic module or COMPACT module (type change) into the terminal module until you hear it snap into place.
4. Label the new electronic module or COMPACT module.



① Code element

Figure 5-16 Removing the code element

<p>⚠ WARNING</p> <p>If you make changes to the code element, dangerous plant conditions can result and the outputs of the ET 200S can be damaged.</p> <p>As a consequence, death or severe personal injury may result if proper precautions are not taken.</p> <p>For this reason, do not make any changes to the code element to avoid damaging the ET 200S.</p>
--

Replacing a defective electronic module or COMPACT module

You have already removed the electronic module or COMPACT module:

1. Remove the code element from the (underside of the) new electronic module or COMPACT module.
2. Insert the new electronic module or new COMPACT module (same type) into the terminal module until you hear it snap into place.
3. Label the new electronic module or COMPACT module.

See also

Switching on the ET 200S (Page 41)

5.5.2 Removing and inserting modules during operation

Introduction

ET 200S supports the removal and insertion of modules during operation (RUN mode). The ET 200S remains in RUN mode when an electronic module is removed. The protective conductor connections of the ET 200S are not interrupted.

Rules

- You cannot remove and insert modules during operation unless the corresponding parameters have been assigned.
- You can remove and insert modules during operation with IM151-1 BASIC, IM151-1 COMPACT, IM151-1 STANDARD (6ES7151-1AA01-0AB0 or higher), IM151-1 FO STANDARD, IM151-1 HIGH FEATURE, IM151-3 PN and IM151-3 PN HIGH FEATURE.
- If **one** module is missing (gap) and the ET 200S POWER ON is switched, the station will **not** start up.
- The removal and insertion of modules affects the cycle synchronization (constant bus cycle time).
- When replacing more than one module, make sure that **only one** gap occurs.

General procedure

The following table indicates which modules you can remove and insert under which conditions:

Table 5- 1 Removing and inserting electronic modules

Module	Removing and inserting	Conditions
Interface module	No	---
IM151-1 COMPACT	No	---
Power modules	yes	The load voltage must be switched off!
Potential distributor module 4POTDIS	yes	The load voltage must be switched off!
Digital electronic modules (input)	yes	---
Digital electronic modules (output)	yes	The load voltage must be switched off by means of an external switch/fuse!
Analog electronic modules	yes	---
4 IQ-SENSE	yes	The sensors can also be replaced during operation. The electronic module then assigns parameters automatically to these sensors.
1COUNT 24V/100kHz	yes	The load voltage must be switched off by means of an external switch/fuse!
1COUNT 5V/500kHz		
1SSI		
1STEP 5V/204kHz		
2PULSE		
1POS INC/Digital		
1POS SSI/Digital		
1POS INC/Analog		
1POS SSI/Analog		
1SI 3964/ASCII	yes	---
1SI Modbus/US\$	yes	---
RESERVE	yes	---

Commissioning

6.1 Safety tests prior to commissioning

Performing tests

Note

You must ensure the safety of your facility. Before a system undergoes final commissioning, you should perform a complete function test and the necessary safety tests.

Incorporate foreseeable errors when planning the tests. In this way, you can avoid exposing your personnel or property to danger during operation.

6.2 Commissioning on PROFIBUS DP

6.2.1 Configuring ET 200S on PROFIBUS DP

6.2.1.1 Basic principles of configuration for the ET 200S on PROFIBUS DP

Introduction

Configuration involves configuring and assigning parameters to the ET 200S.

- Configuration: The systematic arrangement of the different ET 200S modules (setup).
- Assigning parameters: Defining the ET 200S parameters with the configuration software.

Note

The ET 200S is included in the hardware catalog of HW Config:

- IM151-1 BASIC: *STEP 7*V5.2 and higher
- IM151-1 COMPACT: *STEP 7*V5.3 with Service Pack 3 or higher +HSP "ET 200S/COMPACT"
- IM151-1 STANDARD: *STEP 7*V5.0 with Service Pack 3 or higher
- IM151-1 FO STANDARD: *STEP 7*V5.1 with Service Pack 1 or higher
- IM151-1 HIGH FEATURE: from *STEP 7*V5.1 with Service Pack 3 or higher

You will not need a GSD file. Advantages:

- Simplified summary of the devices (via the "Pack addresses" button in HW Config)
- Validity checking of parameters

You can find further information about the procedure in the *STEP 7* Online Help.

DPV1 operation

If you are using IM151-1 STANDARD (6ES7151-1AA04-0AB0 or higher) in DPV1 mode on an S7 CPU that does not support an insert/remove module interrupt, you must not enable the "Operation at preset <> actual configuration" parameter in *STEP 7*. Otherwise, the removal of a module (module failure) always results in a station failure (OB 86).

If it is imperative that you enable "Operation at preset <> actual configuration", you must either select DPV0 mode or configure IM151-1/FO STANDARD using the GSD file (under "Additional field devices - I/O" in the *STEP 7* hardware catalog). "Operation at preset <> actual configuration" is then possible even when the insert/remove module interrupt is disabled.

However, the S7-CPU does not register an insertion or removal (module failure). You can detect such events only by cyclically reading the diagnostic frame and evaluating the module status.

Configuring by means of the GSD file

You configure the ET 200S distributed I/O system using the GSD file. The ET 200S is linked as norm slave in your system via the GSD file. You can download the GSD file for ET 200S from the Internet (<http://support.automation.siemens.com/WW/view/en/652154>):

6.2.1.2 Combining modules for configuration

You can only combine digital modules or motor starters with useful data amounting to less than 1 byte.

Introduction

The ET 200S has a maximum address area of:

- IM151-1 BASIC: up to 88 bytes for inputs and 88 bytes for outputs.
- IM151-1 COMPACT: up to 100 bytes for inputs and 100 bytes for outputs.
- IM151-1 STANDARD (up to 6ES7151-1AA03-0AB0), IM151-1 FO STANDARD (up to 6ES7151-1AB02-0AB0) up to 128 bytes for inputs and 128 bytes for outputs.
- IM151-1 STANDARD (from 6ES7151-1AA04-0AB0), IM151-1 HIGH FEATURE: up to 244 bytes for inputs and 244 bytes for outputs.

To better utilize the available address space of the DP master and reduce data exchange between the ET 200S and the DP master, you can group several electronic modules/load feeders within one byte in the input or output area of the process image. This is achieved by the systematic arrangement and designation of the ET 200S electronic modules/motor starters.

A list of the address space requirements for the individual modules is to be found in the appendix.

You can combine the following device types within one byte:

- Digital input modules
- Digital output modules
- Motor starters (direct starters and reversing starters)

Proceed as follows

1. Integrate the GSD file in your configuration software.
Result: You can identify combinable devices in the hardware catalog of your configuration software by the fact that they are twice present. The devices differ only by a "*" in the name.
2. Configure the ET 200S setup, adhering to the following rules:
 - The modules that you can group within a byte must be of the same module type (see above).
 - **Interface module IM151-1 STANDARD, 6ES7151-1AA00-0AB0 with product version 1 to 4:**
The modules that can be combined within one byte must be inserted right next to each another. Only power modules are permitted between the electronic modules. Power modules do not open a new byte.
 - **After Interface module IM151-1 BASIC; IM151-1 STANDARD, 6ES7151-1AA00-0AB0 with creation state 5, 6ES7151-1AA01-0AB0; IM151-1 FO STANDARD and IM151-1 HIGH FEATURE:**
Other modules may be connected between the modules that can be combined.
 - There can be a total of no more than 8 channels (1 byte).

Note

In STEP 7 applications, if you combine the modules for IM151-1 STANDARD, IM 151-1 FO STANDARD or IM151-1 HIGH FEATURE in the DPV1 mode:

- No insert/remove module interrupts (OB83) are triggered for these modules. In this case, you can recognize that a module has been removed by evaluating the module status in the diagnostic frame in the cyclic user program.
 - Each grouped module then receives its own diagnostic address.
-

3. Select the module designation without "*" from the hardware catalog of your configuration software.
Result: You open a byte and store the first module there.
4. Select the module designation with "*" from the hardware catalog of your configuration software.
Result: You store other modules in the opened byte until all bits are occupied.
5. If a byte is filled, you must configure a module again (that is, open a new byte without "*").

Note

Configuring by means of the GSD file:The configuration software does not check the correct combination of the devices. If you configure more than 8 channels in a byte, the modules that exceed the byte limit are reported as improperly configured in the diagnostics:

Module status → 10_B: wrong module; invalid user data

These modules are not addressed.

No grouping

If you do not want to group digital input modules, digital output modules, or motor starters within a byte when configuring the ET 200S distributed I/O system, use only those module designations without "*" from the hardware catalog of your configuration software.

Each individual electronic module/motor starter will then occupy one byte in the input or output area of the process image.

6.2.1.3 Grouping of digital input modules

General procedure

The figure below illustrates schematically the grouping of digital input modules.

IM151-1 STANDARD, 6ES7 151-1AA00-0AB0 with product version 1 to 4

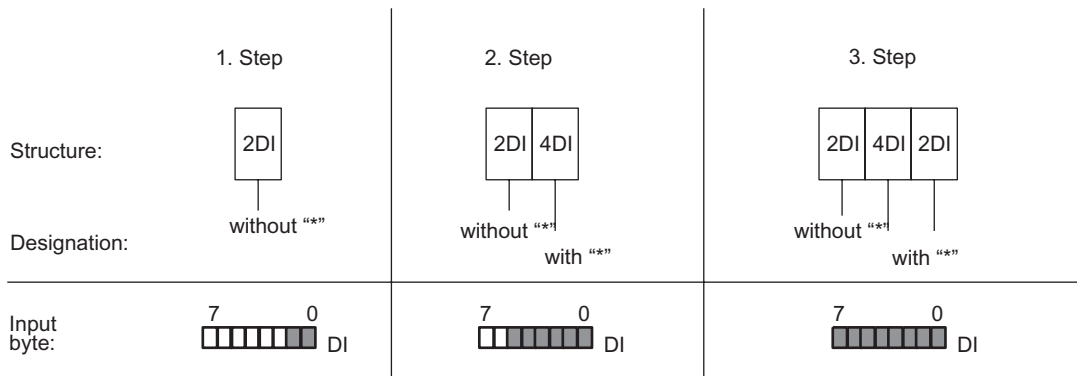

As of IM151-1 BASIC; IM151-1 COMPACT; IM151-1 STANDARD, 6ES7 151-1AA00-0AB0 with product version 5, 6ES7 151-1AA01-0AB0, IM151-1 FO STANDARD und IM151-1 HIGH FEATURE

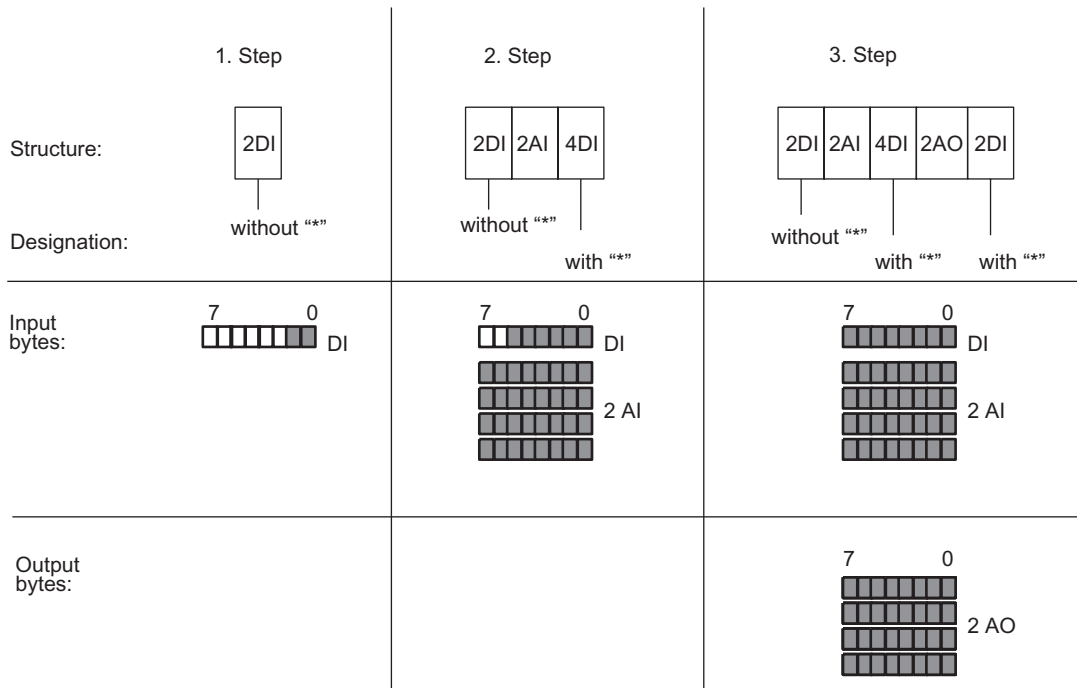

Figure 6-1 Grouping of digital input modules in a single byte

6.2.1.4 Grouping of digital output modules

General procedure

The figure below illustrates schematically the grouping of digital output modules.

IM151-1 STANDARD, 6ES7 151-1AA00-0AB0 with product version 1 to 4

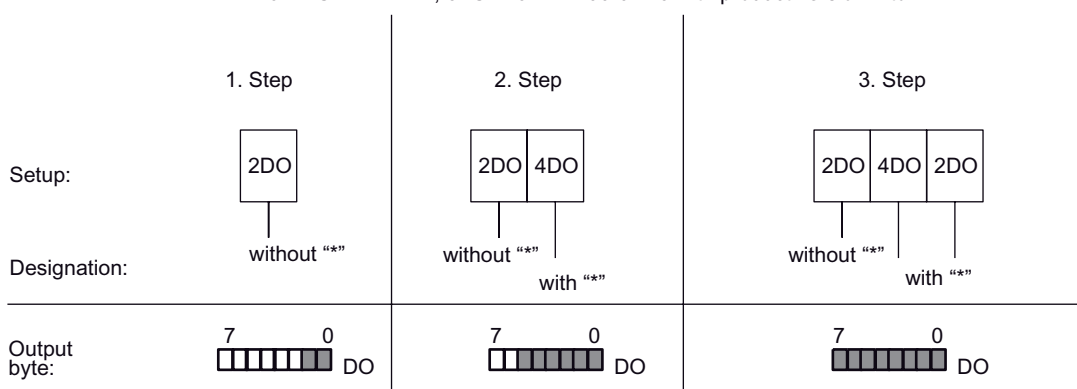

As of IM151-1 BASIC; IM151-1 COMPACT; IM151-1 STANDARD, 6ES7 151-1AA00-0AB0 with product version 5, 6ES7 151-1AA01-0AB0, IM151-1 FO STANDARD and IM151-1 HIGH FEATURE

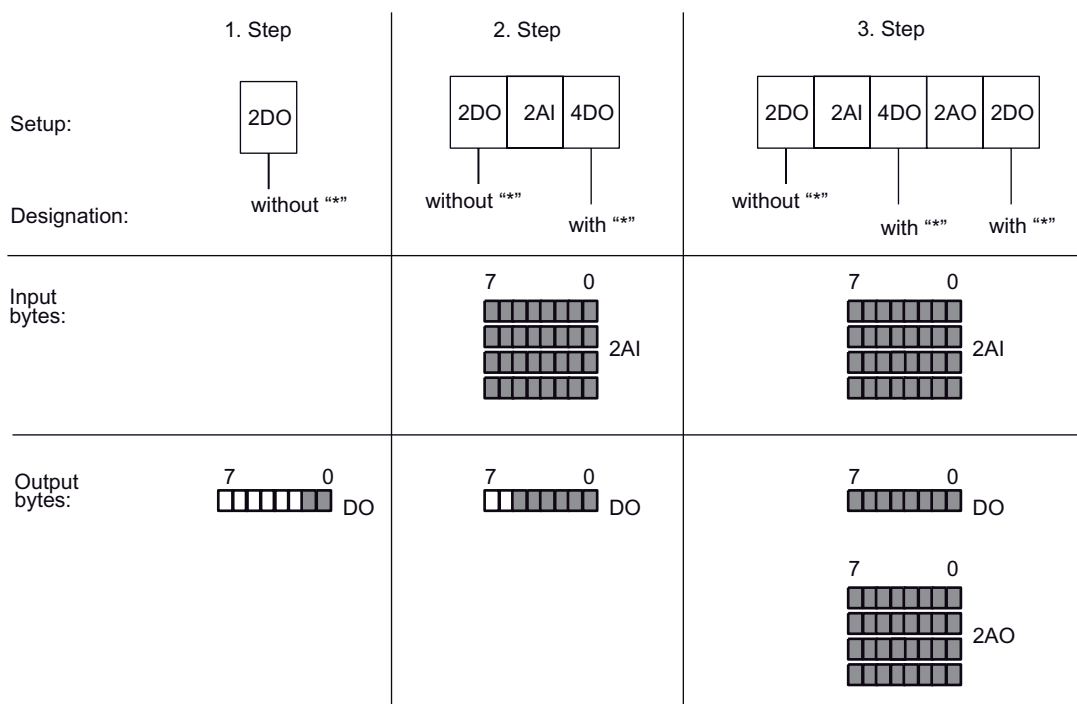

Figure 6-2 Grouping of digital output modules in a single byte

6.2.1.5 Grouping of motor starters

General procedure

The figure below illustrates schematically motor starter grouping.

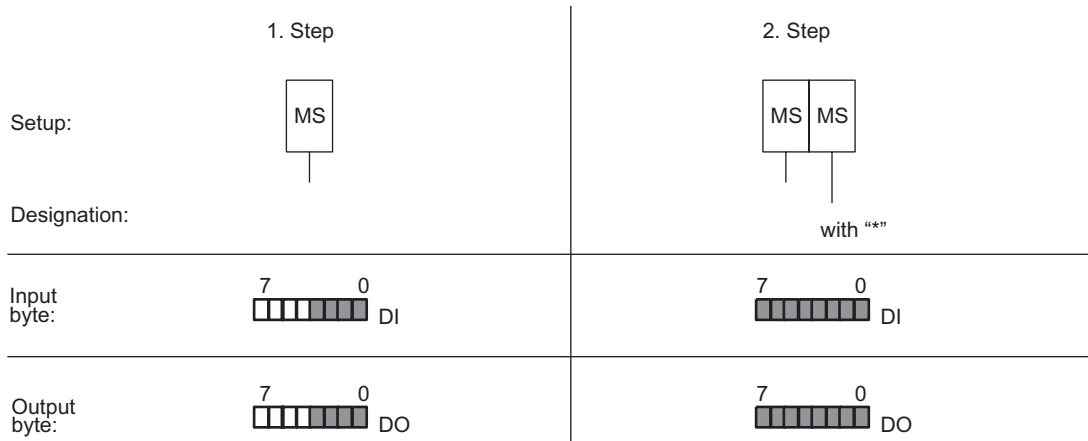

Figure 6-3 Grouping of motor starters within a byte

6.2.1.6 Example of a configuration

Introduction

The following example describes how to design an ET 200S configuration:

ET 200S structure

An example design of an ET 200S configuration is shown in the following figure:

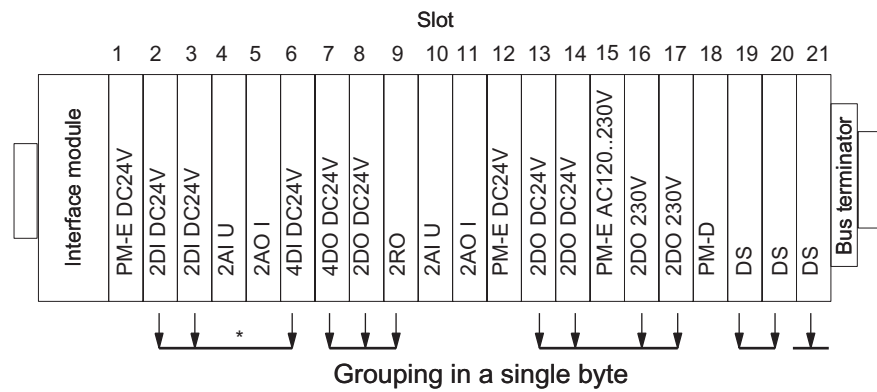

* As of IM151-1 BASIC; IM151-1 COMPACT; IM151-1 STANDARD, 6ES7 151-1AA00-0AB0 with Product version 5, 6ES7 151-1AA01-0AB0, IM151-1 FO STANDARD and IM151-1 HIGH FEATURE

Figure 6-4 ET 200S structure

Configuration table and address space

The user is free to select the byte addresses of the inputs and outputs (if the configuration software supports this). The bit addresses result automatically from the sequence of the grouped modules.

The following table shows which modules have been grouped and the corresponding address space.

Table 6- 1 Configuration table and address space

Slot	Module	Grouping	I/O address	
			Inputs	Outputs
1	6ES7138-4CA01-0AA0 PM-E DC24V	---	---	---
2	6ES7131-4BB01-0AB0 2DI DC24V	yes	0.0 to 0.1	
3	6ES7131-4BB01-0AB0* 2DI DC24V		0.2 to 0.3	
4	6ES7134-4FB01-0AB0 2AI U	No	1 to 4	
5	6ES7135-4GB01-0AB0 2AO I	No		0 to 3
6	6ES7131-4BD01-0AA0* 4DI DC24V	yes	0.4 to 0.7	
7	6ES7132-4BD01-0AA0 4DO DC24V	yes		4.0 to 4.3
8	6ES7132-4BB01-0AB0* 2DO DC24V		4.4 to 4.5	
9	6ES7132-4HB01-0AB0* 2DO Rel.		4.6 to 4.7	
10	6ES7134-4FB01-0AB0 2AI U	No	5 to 8	
11	6ES7135-4GB01-0AB0 2AO I	No		5 to 8
12	6ES7138-4CA01-0AA0 PM-E DC24V	---	---	---
13	6ES7132-4BB31-0AB0 2DO DC24V	yes		9.0 to 9.1
14	6ES7132-4BB31-0AB0* 2DO DC24V	yes		9.2 to 9.3
15	6ES7138-4CB11-0AB0 PM-E AC230	---	---	---
16	6ES7132-4FB01-0AB0* 2DO 230V	yes		9.4 to 9.5
17	6ES7132-4FB01-0AB0* 2DO 230V	yes		9.6 to 9.7
18	3RK1903-0BA00 PM-D	---	---	---
19	3RK1301-xxB00-0AA0 DS	yes	9.0 to 9.3	10.0 to 10.3
20	3RK1301-xxB00-0AA0 *DS		9.4 to 9.7	10.4 to 10.7
21	3RK1301-xxB00-0AA0 DS	yes	10.0 to 10.3	11.0 to 11.3

6.2.2 Commissioning and startup of ET 200S on PROFIBUS DP

6.2.2.1 Setting the PROFIBUS Address

Introduction

The PROFIBUS address is used to specify the address of the ET 200S distributed I/O system on PROFIBUS DP.

- The PROFIBUS DP address for the ET 200S is set on the interface module or COMPACT module by means of DIP switches. The DIP switches are to be found on the front of the interface module, protected by a sliding window.
- Valid PROFIBUS DP addresses are 1 to 125.
- Each address can be assigned only once on PROFIBUS DP.

Requirements

Address setting is not yet assigned on PROFIBUS DP.

Required tools

3-mm screwdriver

Setting the PROFIBUS DP address

1. Slide the window
 - upwards on the interface module.
 - downwards on the COMPACT module.

CAUTION
When open, the window protrudes out from underneath the COMPACT module case. This can cause it to be easily broken off.

2. Use a screwdriver to set the desired PROFIBUS DP address via the DIP switch.
3. Close the window.

Interface module

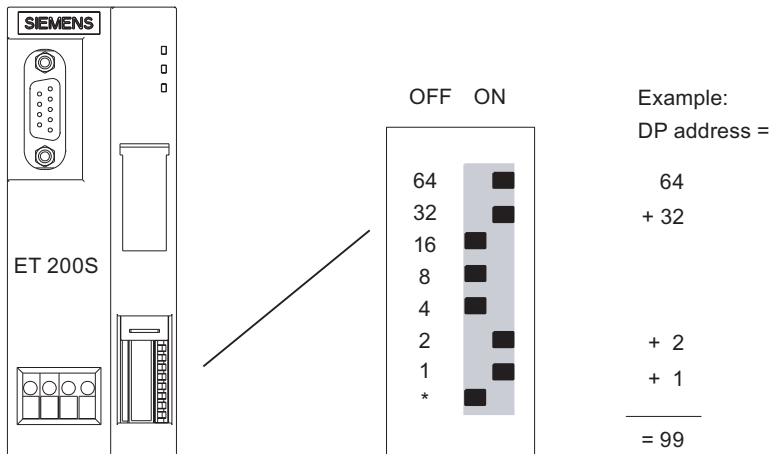

* Only with IM151-1 STANDARD, IM151-1 FO STANDARD:
Reserved for future upgrades. This switch must be in the OFF position.

Figure 6-5 Setting the PROFIBUS Address

Setting the PROFIBUS DP address

You change the PROFIBUS DP address in exactly the same way as you set it. **A change in the PROFIBUS DP address becomes valid for the ET 200S after a POWER ON at the interface module / COMPACT module.**

6.2.2.2 Commissioning ET 200S on PROFIBUS DP

Software Requirements

The table below details the software requirements for commissioning on PROFIBUS DP.

Table 6- 2 Software requirements for commissioning on PROFIBUS DP

Configuration software used	Version	Explanations
<i>STEP 7</i>	from Version 5.0 and ServicePack 3	You use HW Config. With Service Pack 3 or higher the ET 200S is included in the hardware catalog.
Configuration software for a different DP master used		You need the GSD file from ET 200S.

Requirements for commissioning

The following additional requirements must be satisfied for commissioning the ET 200S on PROFIBUS DP:

- DP slave installed
- DP slave wired up
- DP slave is configured (configured and parameters assigned)
- Supply voltage for the DP master is switched on (see manual for the DP master)
- DP master is switched to RUN mode (see manual for the DP master)

Proceed as follows

To commission the DP slave, proceed as follows:

1. Switch on the power supply for the DP slave.
2. If necessary, switch on the supply voltage for the load.

See also

Basic principles of configuration for the ET 200S on PROFIBUS DP (Page 102)

Basic principles of installation (Page 51)

Setting the PROFIBUS Address (Page 111)

Wiring rules for the ET 200S (Page 79)

6.2.2.3 Startup of the ET 200S on PROFIBUS DP

Flow diagram for startup of the ET 200S

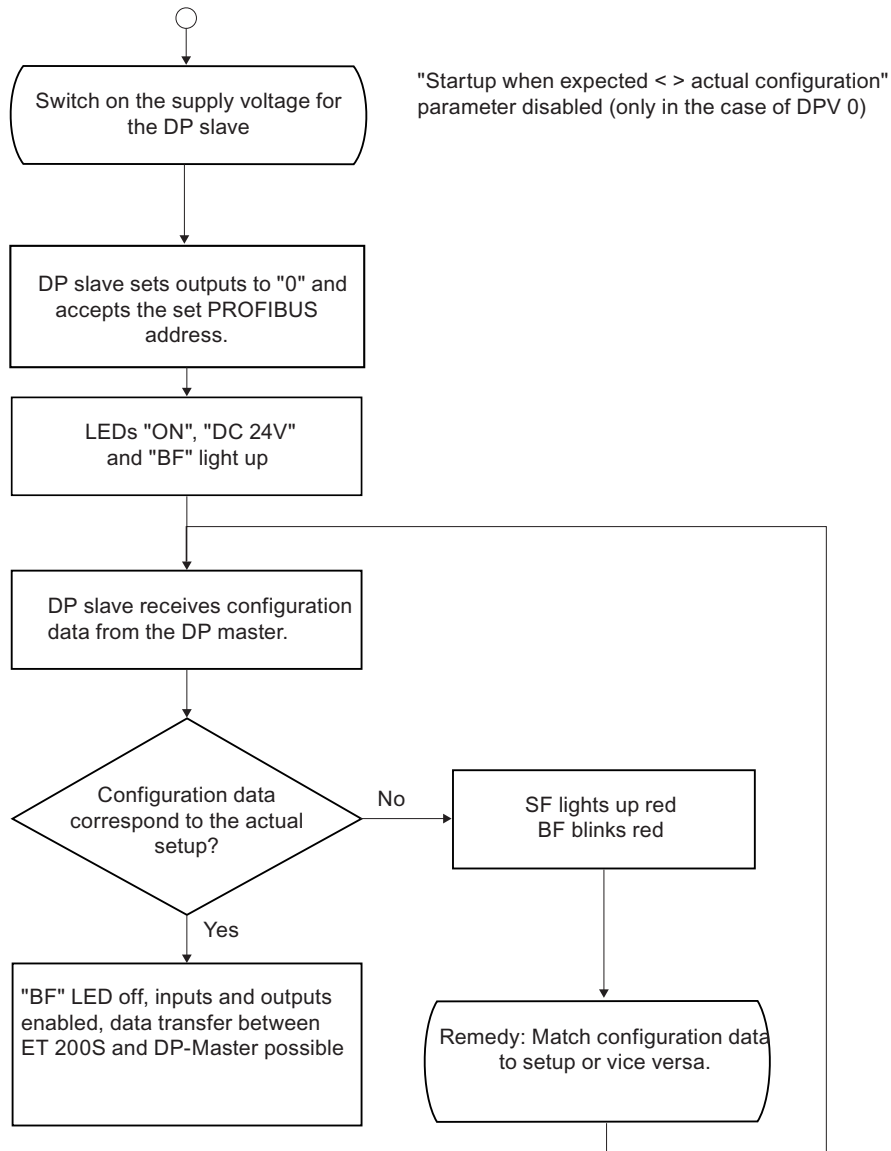

Figure 6-6 Startup of the ET 200S on PROFIBUS DP

Note

All interface modules support the default startup. In other words, configuration using the GSD file or HW Config is not necessary.

The following conditions then apply:

- Preset parameters are used.
 - AKF (general identifier format in compliance with the PROFIBUS standard) in the configuration frame
 - Grouping (packing) of the electronic modules is not possible without parameterization.
 - All supply voltages on the power modules must be switched on.
 - It is not possible to remove or insert modules during operation.
-

Reference

You can find information regarding the parameter assignment of electronic modules in the *Device Manual ET 200S* in the chapters *Digital* or *Analog electronic Modules* in each case under "Parameter for ...".

6.3 Commissioning on PROFINET IO

6.3.1 Configuring the ET 200S on the PROFINET IO

Introduction

The interface module IM151-3 requires a unique device name in order to operate at an IO controller (refer to the following chapter).

Configuration involves configuring and assigning parameters to the ET 200S.

- Configuration: The systematic arrangement of the different ET 200S modules (setup).
- Assigning parameters: Defining the ET 200S parameters with the configuration software.

Note

The ET 200S can be operated with *STEP 7*V5.3 Service Pack 3 and higher.

GSD file

You configure the ET 200S using the GSD file. This file is used to integrate the ET 200S in your system as an IO device. You can download the GSD file for ET 200S from the Internet (<http://support.automation.siemens.com/WW/view/en/19699080>):

The following GSD file is available for the IM151-3 interface module:

GSDML-Vx.y-Siemens-ET200S-"Date in yyyyymmdd format".xml

You can find further information about the procedure in the *STEP 7* Online Help.

6.3.2 Assigning device names to the I/O device

Introduction

Each PROFINET IO device is assigned a unique device ID by the manufacturer (MAC address).

For configuration and in the user program, each ET 200S IO device is addressed with its device name.

For detailed information on addressing in PROFINET IO, refer to the *PROFINET System Description*.

Requirements

- IM151-3 Interface Module
- SIMATIC Micro Memory Card 64k and higher
- The PD must be online on PROFINET to the IO device to let you assign a device name to the interface module.
- The IO device is configured in HW Config and assigned an IP address.

Assigning a device name

1. Insert an empty SIMATIC Micro Memory Card into the module slot on the front of the IM151-3.
2. Switch on the power supply for the IM151-3 PN.
3. Open the **Properties - IM151-3 PN window in the HW Config** or **Properties - IM151-3 PN HIGH FEATURE** and enter the device name for the IO Device there and confirm with **OK**.
Do not use the device name "noname" (not case-sensitive).

Transferring the device name to the interface module

1. In HW Config select **PLC > Ethernet > Assign Device Name**.
2. Click the **Assign name** button in the **Assign device name** window.

Result

The device name is stored on the SIMATIC Micro Memory Card in the IM151-3 interface module.

Alternative procedure

Alternatively, you can write directly to a SIMATIC Micro Memory Card using a programming device with an EPROM programming device installed or a PC connected to a SIMATIC USB EPROM programming device and then use the memory card to transfer the device name to the IM151-3 PN.

Proceed as described in the online help for HW Config under "Assign device name using a memory card".

Forwarding the device name when the interface module is replaced

The device name of the IO device is saved to the SIMATIC Micro Memory Card.

To transfer the device name when exchanging the interface module IM151-3, pull the SIMATIC Micro Memory Card out of the "old" IM151-3 and insert it in the "new one".

The IO device adopts the device name from the SIMATIC Micro Memory Card after switching the power supply off/on. Then the station is addressable again and functions the same as before the exchange.

Station flash test

If you are using multiple IO devices, multiple IO devices are also indicated in the "Assign device name" dialog. In this case, you should compare the MAC address of the device with the indicated MAC address and select the proper IO device.

The identification of IO devices in a system is facilitated by a station flash test. The flash test is activated as follows:

1. In the "Assign device name" dialog, select one of the indicated IO devices.
2. Select a flash duration.
3. Click the "Flash on" button.

The LINK LED on the selected IO device flashes (open the flaps on the front cover of the IM151-3).

Interrupts at removed DI modules

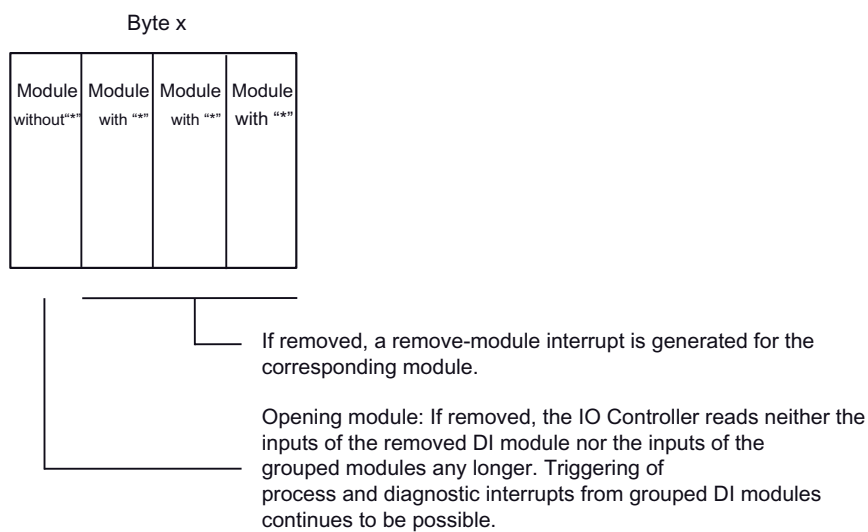

Figure 6-8 Interrupts at removed DI modules

Additional information

You can find additional information on grouping modules during configuration in the chapter *Configuring ET 200S on PROFIBUS DP* (Page 102).

6.3.4 Commissioning and startup of ET 200S on the PROFINET IO

Software Requirements

Table 6- 3 Software requirements for commissioning on PROFINET IO

Configuration software used	Version	Explanations
<i>STEP 7</i>	<ul style="list-style-type: none"> • Version 5.3 and higher and ServicePack 1 for IM151-3 PN (6ES7151-3AA00-0AB0) • Version 5.3 and higher and ServicePack 3 for IM151-3 PN (6ES7151-3AA10-0AB0 and higher) and IM151-3 PN HIGH FEATURE (6ES7151-3BA20-0AB0 and higher) 	You use HW Config and the supplied GSD file.
Configuration software for a different IO controller		You need the GSD file from ET 200S.

Requirements for commissioning

The following additional requirements must be satisfied for commissioning the ET 200S on PROFINET IO:

- IO device installed
- IO device wired up
- IO device has been assigned a device name
- Supply voltage for the DP master is switched on (see manual for the IO controller)
- IO controller is switched to RUN mode (see manual for the IO controller)

Commissioning the ET 200S

To commission the IO device, proceed as follows:

1. Switch on the power supply for the IO device.
2. If necessary, switch on the supply voltage for the load.

Startup of the ET 200S

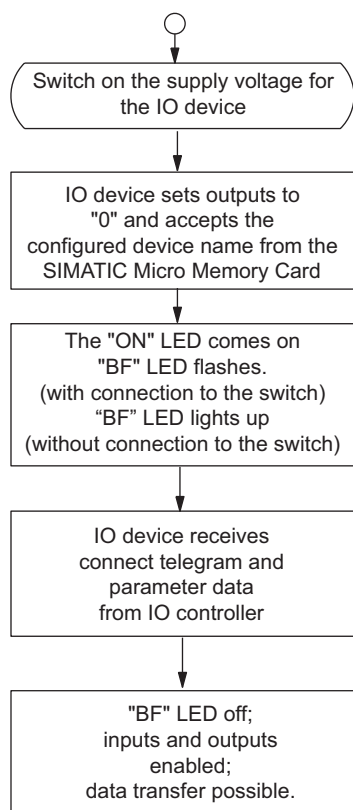

Figure 6-9 Startup of ET 200S on PROFINET IO

Note

The interface modules IM151-3 PN and IM151-3 PN HIGH FEATURE support the default startup.

The following conditions then apply:

- The preset parameters are used (refer to parameters for the electronic modules).
 - All supply voltages on the power modules must be switched on.
-

Functions

7.1 Direct data exchange on PROFIBUS DP

Introduction

The ET 200S can be used as the sender (publisher) for the direct exchange of data (cross traffic). Naturally, the DP master used must also support direct data exchange. You will find information on this in the description of the DP master.

General procedure

Direct data exchange (cross traffic) is characterized by PROFIBUS DP nodes which "listen" on the bus and know which data a DP slave returns to its DP master. This mechanism allows the "listener" (recipient / subscriber) direct access to modified input data from the remote DP slaves.

During configuration in *STEP 7* the respective I/O input addresses are used to specify the address space of the recipient where the sender data is stored.

Example: Direct data exchange with IM151-1

The figure below is an example of the direct data exchange / "relationships" that can be configured with a sender ET 200S and the nodes that can "listen" as possible recipients.

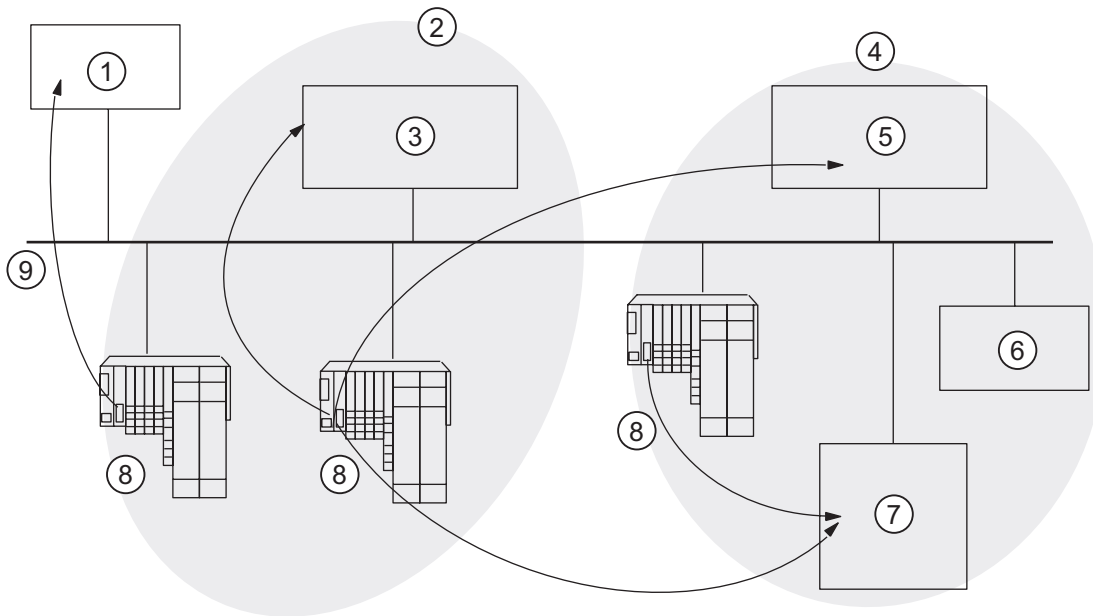

- | | | | |
|---|--------------------------|---|-----------------------|
| ① | CPU 31x-2 | ⑥ | DP slave |
| ② | DP master system 1 | ⑦ | CPU 31x-2 as DP slave |
| ③ | CPU 31x-2 as DP master 1 | ⑧ | ET 200S |
| ④ | DP master system 2 | ⑨ | PROFIBUS DP |
| ⑤ | CPU 31x-2 as DP master 2 | | |

Note

The interface module IM151-1 HIGH FEATURE supports as of 6ES7151-1BA01-0AB0 the safety related I-Slave-Slave-Communication via PROFIBUS DP for the fail-safe module. You can find the description of this function in the *S7 Distributed Safety Configuration and Programming* manual.

7.2 Option handling on the PROFIBUS DP

7.2.1 Basic principles of option handling on PROFIBUS DP

Principle

Option handling enables you to set up the ET 200S for future expansions (options). Option handling means that you install, wire, configure, and program the planned maximum configuration of the ET 200S.

You can choose between two option handling variants, according to your requirements:

- Option handling *with* RESERVE modules
- Option handling *without* RESERVE modules

The two option handling variants are mutually exclusive.

Option handling *with* RESERVE modules

The optional electronic modules are initially replaced with inexpensive RESERVE modules which are then later exchanged with the planned electronic modules.

This means that the ET 200S can be completely prewired ("master cabling") since the RESERVE module is not connected to the terminal module terminals and therefore not to the process.

The RESERVE modules for future expansions at the right-hand end of the station do not have to be mounted. In this case, preparatory installation and wiring are possible but not a prerequisite.

Option handling *without* RESERVE modules

With this variant, the use of RESERVE modules is not necessary. The modules are mounted side-by-side without gaps. Preparatory mounting and wiring are not required for the optional electronic modules.

Note

Mark the modules in your installation with the slot numbers from your configuration.

Reference

Refer to the "Properties" in the manuals for the ET 200S interface modules to find out which interface modules support "Options handling".

7.3 Identification data

Definition

Identification data are data that are stored in a module for assisting the user in:

- Checking the system configuration
- Locating hardware changes in a system
- Correcting errors in a system

Identification data enable modules to be uniquely identified online.

STEP 7 shows the identification data in the "Module information - IM 151" and "Properties - DP Slave" tabs.

Reference

Refer to the "Properties" in the manuals for the ET 200S interface modules to find out which interface modules support "Identification data".

General technical specifications

8.1 Standards and approvals

Introduction

The general technical specifications comprise the standards and test specifications which satisfy the ET 200S distributed I/O system and form the base criteria for testing the ET 200S distributed I/O system.

CE certification



The ET 200S distributed I/O system satisfies the requirements and objectives of the following EC directives and satisfies the Harmonized European Standards (EN) for Programmable Logic Controllers which were published in the official pamphlets of the European Community:

- 73/23/EEC "Electrical Equipment for Use within Fixed Voltage Ranges" (Low-Voltage Directive)
- 89/336/EEC "Electromagnetic Compatibility" (EMC guideline)
- 94/9/EC "Equipment and protective systems intended for use in potentially explosive environments" (ATEX).

The EU conformity declaration certificates are available for the responsible authorities and are kept at the following address:

Siemens Aktiengesellschaft
Industry Sector
IA AS RD ST Type Test
P.O. Box 1963
D-92209 Amberg

UL approval



Underwriters Laboratories Inc. in accordance with

- UL 508 (Industrial Control Equipment)

CSA approval



Canadian Standards Association in accordance with

- C22.2 No 142 (Process control Equipment)

or



Underwriters Laboratories Inc. in accordance with

- UL 508 (Industrial Control Equipment)
- CSA C22.2 No. 142 (Industrial Control Equipment)

or



Underwriters Laboratories Inc. according to

- UL 508 (Industrial Control Equipment)
- CSA C22.2 No. 142 (Process Control Equipment)
- UL 1604 (Hazardous Location)
- CSA-213 (Hazardous Location)

APPROVED for use in
Class I, Division 2, Group A, B, C, D Tx;
Class I, Zone 2, Group IIC Tx

The ET 200S motor starters do not possess cULus for HAZ. LOC. certification.

Note

The certifications currently valid can be found on the nameplate of the specific module.

FM approval



Factory Mutual Research (FM) according to Approval Standard Class Number 3611, 3600, 3810 APPROVED for use in Class I, Division 2, Group A, B, C, D Tx; Class I, Zone 2, Group IIC Tx

The ET 200S motor starters do not possess FM certification. All other modules of the ET 200S are FM certified.



acc. to EN 50021 (Electrical apparatus for potentially explosive atmospheres; Type of protection "n")



II 3 G Ex nA II T4..T5

WARNING

Personal injury and property damage can occur.

There is a risk of injury or damage if you disconnect any plug-in connections in potentially explosive environments while the ET 200S is in operation.

Always de-energize the ET 200S in potentially explosive environments before disconnecting plug-in connections.

WARNING

Explosion Hazard

Components may no longer qualify for Class I, DIV. 2 if they are substituted.

WARNING

This device is only appropriate for use in Class I, Div. 2, Group A, B, C, D, or in non-hazardous areas.

Tick-Mark for Australia



The ET 200S distributed I/O system satisfies the requirements of the standard AS/NZS 2064 (Class A).

IEC 61131

The ET 200S distributed I/O system satisfies the requirements and criteria of the standard IEC 61131-2 (Programmable Logic Controllers, Part 2: Equipment Requirements and Tests).

PROFIBUS standard

The ET 200S distributed I/O system is based on the *IEC 61784-1:2002 Ed1 CP 3/1* standard.

Marine type approval

Classification organizations:

- ABS (American Bureau of Shipping)
- BV (Bureau Veritas)
- DNV (Det Norske Veritas)
- GL (Germanischer Lloyd)
- LRS (Lloyds Register of Shipping)
- Class NK (Nippon Kaiji Kyokai)

Use in industrial environment

SIMATIC products are designed for use in industrial environments.

Table 8- 1 Use in industrial environment

Area of application	Requirement for	
	Emitted interference	Immunity to noise
Industry	EN 61000-6-4 : 2001	EN 61000-6-2 : 2001

Use in residential areas

If ET 200S is used in residential areas you must comply with limit class B in accordance with EN 55011 regarding the emission of radio interference.

Appropriate measures for achieving the radio interference level required by limit class B are:

- Installation of the ET 200S in grounded switch cabinets/switch boxes
- Use of filters in supply lines

8.2 Electromagnetic compatibility

Definition

Electromagnetic compatibility refers to the capability and reliability of electrical equipment in performing its function in an electromagnetic environment without causing interference in the same environment.

The ET 200S distributed I/O system meets all EMC legislation requirements for the European market. As a prerequisite the ET 200S distributed I/O system must satisfy the specifications and guidelines concerning electrical installation.

Pulse-shaped Interference

The following table shows the electromagnetic compatibility of the ET 200S distributed I/O system when compared with pulse-shaped interference.

Pulse-shaped interference	tested with	corresponds with degree of severity
Electrostatic discharge according to IEC 61000-4-2	8 kV 4 kV	3 (air discharge) 2 (contact discharge)
Burst pulse (fast transients) complying with IEC 61000-4-4	2 kV (supply line) 2 kV (signal line)	3 3
High-energy single pulse (surge) according to IEC 61000-4-5 Only with lightning protection elements (see the DP master manual and the description of <i>SIMATIC NET PROFIBUS Networks</i>)		
• asymmetrical coupling	2 kV (supply line) 2 kV (signal / data line)	3
• symmetrical coupling	1 kV (supply line) 1 kV (signal / data line)	

Sinusoidal Interference

The following table shows the electromagnetic compatibility of the ET 200S Distributed I/O System when confronted with sinusoidal interference.

- HF radiation according to IEC 61000-4-3
Electromagnetic HF field, amplitude-modulated
 - 80 MHz to 1000 MHz, 1.4 GHz to 2 GHz
 - 10 V/m
 - 80% AM (1 kHz)
- HF coupling according to IEC 61000-4-6
 - 0.15 MHz to 80 MHz
 - 10 V_{rms} unmodulated
 - 80% AM (1 kHz)
 - 150 Ω source impedance

Emission of Radio Interferences

Emission of interference from electromagnetic fields in compliance with EN 55011: Limit class A, group 1 (measured at a distance of 10 m).

Frequency	Emitted interference
from 30 to 230 MHz	< 40 dB ($\mu\text{V/m}$)Q
from 230 to 1000 MHz	< 47 dB ($\mu\text{V/m}$)Q

8.3 Transport and storage conditions

Transport and storage conditions

The ET 200S distributed I/O system surpasses the IEC 61131-2 requirements of transport and storage conditions. The specifications below apply to modules which are transported and stored in their original packaging.

Type of condition	Permitted range
Free fall	≤ 1 m
Temperature	between -40 °C and $+70$ °C
Rate of temperature change	20 K/h
Air pressure	between 1080 and 660 hPa (corresponds with altitudes of 1000 m to 3500 m)
Relative humidity	From 5 % to 95 %, without condensation

8.4 Mechanical and Climatic Ambient Conditions

Climatic environmental conditions

The following climatic environmental conditions apply:

Ambient conditions	Areas of application	Remarks
Temperature	between 0 and 60°C	for horizontal installation
	From 0 to 40 °C	for all other mounting positions
Rate of temperature change	10 K/h	
Relative humidity	From 15 to a maximum of 95%	Without condensation
Air pressure	from 1080 hPa to 795 hPa	Corresponds to an altitude of -1000 m to 2000 m
Contaminant concentration	SO ₂ : < 0.5 ppm; rel. humidity < 60 %, no condensation	Check: 10 ppm; 4 days
	H ₂ S: < 0.1 ppm; rel. humidity < 60 %, no condensation	1 ppm; 4 days
	ISA-S71.04 serverity level G1; G2; G3	—

Note

Modules for the extended operating range from 0 to 55 °C / 50 °C for vertical installation

A series of ET 200S modules is approved for an extended operating range from 0 to 55 °C or from 0 to 50 °C for vertical installation.

Refer to the "Properties" in the relevant manuals for the ET 200S modules to find out whether a module is approved for the extended operating range.

Note

Any supply or load voltage for the ET 200S may not exceed 24 VDC. This voltage limit must be ensured.

Mechanical ambient conditions

The table below shows the mechanical ambient conditions in the form of sinusoidal oscillation.

ET 200S modules	Frequency range	Constant	Intermittent
All modules except motor starters	10 ≤ f ≤ 58 Hz	0.15 mm amplitude	0.35 mm amplitude
	58 ≤ f ≤ 150 Hz	2 g constant acceleration	5 g constant acceleration

Testing for Mechanical Ambient Conditions

The following table provides information about the type and scope of testing for mechanical ambient conditions.

Testing	Test Standard	Terminal modules and electronic modules
Vibrations	Vibration test to IEC 60068-2-6	Type of vibration: Frequency cycles with a rate of change of 1 octave/minute. 10 Hz ≤ f ≤ 58 Hz, constant amplitude 0.35 mm 58 Hz ≤ f ≤ 150 Hz, constant acceleration 5 g Duration of vibration: 20 frequency cycles per axis in each of the 3 mutually perpendicular axes
Shock	Shock, tested to IEC 60068-2-27	Type of shock: Half-sine Type of shock: 15 g peak value, 11 ms duration Direction of shock: 3 shocks each in +/- direction in each of the 3 mutually vertical axes
Repetitive shock	Shock, tested to IEC 60068-29	Type of shock: Half-sine Type of shock: 25 g peak value, 6 ms duration Direction of shock: 1000 shocks each in +/- direction in each of the 3 mutually vertical axes

8.5 Specifications concerning insulation tests, protection class, and rated voltage for ET 200S

Test voltage

The insulation resistance is tested during routine tests using the following test voltage according to IEC 61131-2:

Circuits with a rated voltage of U_n relative to other circuits or ground	Test voltage
< 50 V	500 VDC
< 150 V	2500 VDC
< 250 V	4000 VDC

Degree of Pollution / Overvoltage Category to IEC 61131

- Pollution level 2
- Overvoltage category
 - When $U_N = 120 / 230$ VAC: III
 - at $U_N = 24$ VDC: II

Protection Class

Protection class I in accordance with IEC 60536

Protection class IP 20

Protection class IP 20 according to IEC 60529 for all ET 200S modules i.e.:

- Protection against touch with standard test fingers
- Protection against foreign bodies with a diameter greater than 12,5 mm
- No specific protection against water

Rated voltage for operation

The ET 200S distributed I/O system works with the rated voltage and corresponding tolerances shown in the following table.

ET 200S modules	Rated voltage	Tolerance range
Everything except motor starters	24 VDC	20.4 to 28.8 VDC ¹
		18.5 to 30.2VDC ²
	120 VAC	93 to 132 VAC (47 to 63 Hz)
	230 VAC	187 to 264 VAC (47 to 63 Hz)

¹ Static value: Generation as functional extra-low voltage with safety isolation in accordance with IEC 60364-4-41
² Dynamic value: Including ripple, e.g., during three phase current bridge rectification

8.6 Variations in general technical specifications for the ET 200S FC frequency converter

Variations in general technical specifications

The table below shows variations in the general technical specifications for the ET 200S FC frequency converter compared to the ET 200S.

Table 8- 2 Variations in general technical specifications for the ET 200S FC frequency converter

Section	Variations
Standards and approvals	The frequency converter is not approved for <ul style="list-style-type: none"> • cULus for HAZ.LOC. • FM (Factory Mutual Research) • Marine
Transport and storage conditions	Free fall: ≤ 0.35 m
Climatic environmental conditions	Temperature for horizontal installation: from 0 to 60 °C
	Temperature for vertical installation: from 0 to 40 °C
Mechanical ambient conditions	See operating instructions for ET 200S FC Frequency Converter (6SL3298-0CA12-0xP0)
Rated voltage for operation	
Use in Zone 2	The frequency converter ET 200S FC is not approved for use in zone 2 potentially explosive environments.

8.7 Use of ET 200S in a zone 2 potentially explosive environments

See product information *Use of subassemblies/modules in a Zone 2 Hazardous Area*.

Order numbers

A.1 Order numbers for ET 200S accessories

The table shows the order numbers for ET 200S accessories.

Table A- 1 Order numbers for ET 200S accessories

Name	Order number
Shield connection	
• Shield connecting element, 5 pieces	6ES7193-4GA00-0AA0
• Power rail, 1 piece · 1 m, 3 x 10 mm	8WA2842
• Shield terminal, 5 pieces	6ES7193-4GB00-0AA0
• Grounding terminal, 1 piece	8WA2868
Add-on terminal	
• TE-U120S4x10 (screw-type terminal), 1 piece	6ES7193-4FL10-0AA0
• TE-U120C4x10 (screw-type terminal), 1 piece	6ES7193-4FL00-0AA0
Labeling sheet for interface modules and electronic modules; DIN A4 10 pieces	
• beige	6ES7193-4BA00-0AA0
• red	6ES7193-4BD00-0AA0
• yellow	6ES7193-4BB00-0AA0
• teal	6ES7193-4BH00-0AA0
Labeling sheet for COMPACT modules; DIN A4 10 pieces	
• beige	6ES7193-4BA10-0AA0
• red	6ES7193-4BD10-0AA0
• yellow	6ES7193-4BB10-0AA0
• teal	6ES7193-4BH10-0AA0
200 color-coded plates per packaging unit (10 star-shaped supports in packs of 20 items per color)	
• white	6ES7193-4LA20-0AA0
• red	6ES7193-4LD20-0AA0
• yellow	6ES7193-4LB20-0AA0
• yellow-green	6ES7193-4LC20-0AA0
• brown	6ES7193-4LG20-0AA0
• blue	6ES7193-4LF20-0AA0
• turquoise	6ES7193-4LH20-0AA0
Slot number labels, 10 x (1 to 20), 200 pieces	8WA8861-0AB
Slot number labels, 5 x (1 to 40), 200 pieces	8WA8861-0AC
Terminating module, 1 piece	6ES7193-4JA00-0AA0

A.2 Order numbers for ET 200S network components

The tables below list all the network components for the ET 200S Distributed I/O System that you may require to use the ET 200S.

Table A- 2 Network components (PROFIBUS DP) for ET 200S order numbers

Name	Order number
RS 485-Repeater, PROFIBUS DP, IP 20	6ES7972-0AA01-0XA0
PROFIBUS bus connector (12 MBaud)	
• Anthracite (without PD plug)	6ES7972-0BA12-0XA0
• Anthracite (with PD plug)	6ES7972-0BB12-0XA0
Bus cable	
• normal	6XV1830-0EH10
• Drum cable	6XV1830-3BH10
• Direct-buried cable	6XV1830-3AH10
Repeater adapter	6GK1510-1AA00
Active RS485 terminating element	6ES7972-0DA00-0AA0
PROFIBUS connecting cable	6ES7901-4BD00-0XA0

Table A- 3 Network components (PROFINET IO) for ET 200S order numbers

Name	Order number
Industrial Ethernet FC RJ45 Plug 90 (RJ45 plug for Industrial Ethernet with robust metal housing and integrated cutting/clamping contacts for connecting the Industrial Ethernet FC installation cables; with 90° cable outlet)	
• 1 unit	6GK1901-1BB20-2AA0
• 10 units	6GK1901-1BB20-2AB0
• 50 units	6GK1901-1BB20-2AE0
Industrial Ethernet Fast Connect installation cables	
• Fast Connect standard cable	6XV1840-2AH10
• Fast Connect trailing cable	6XV1840-3AH10
• Fast Connect marine cable	6XV1840-4AH10
Industrial Ethernet Fast Connect stripping tool	6GK1901-1GA00

Dimensional drawings

B.1 Interface modules

Interface module

Dimensional drawing IM151-1 interface module (dimensions in mm):

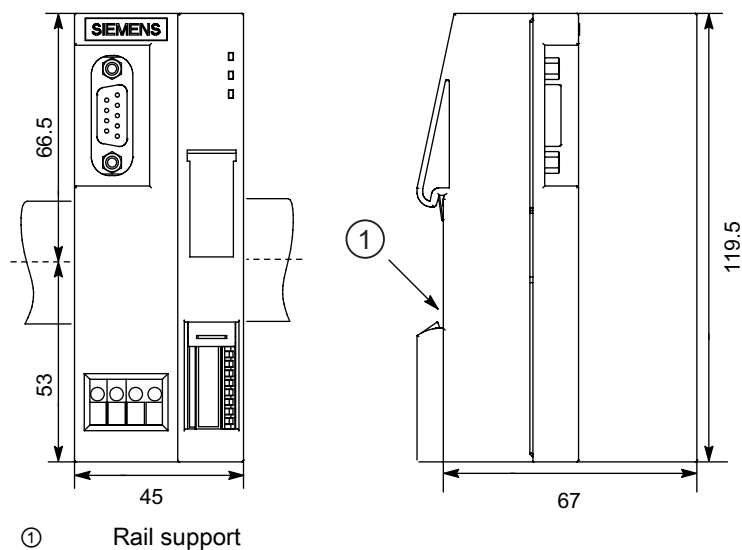

Dimensional drawing IM151-3 PN / IM151-3 PN HIGH FEATURE interface module (dimensions in mm):

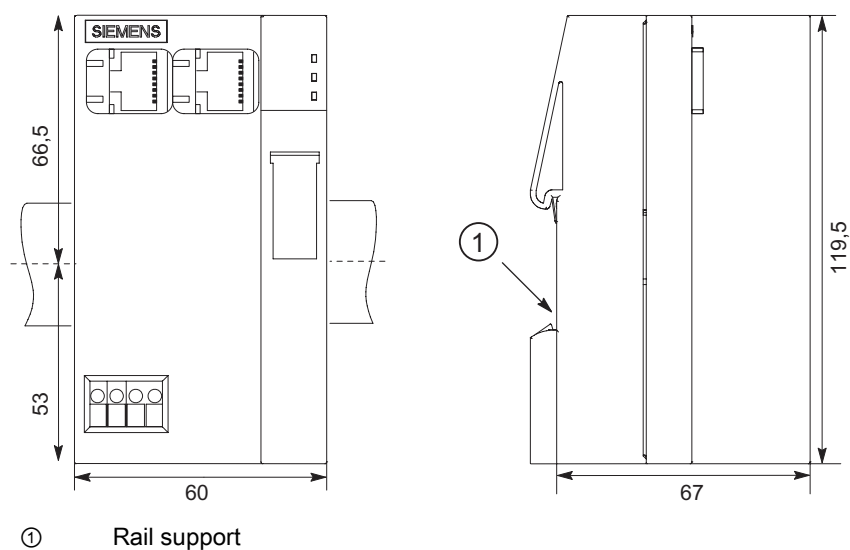

Interface module IM151-3 PN FO

Dimensional drawing IM151-3 PN FO interface module (dimensions in mm):

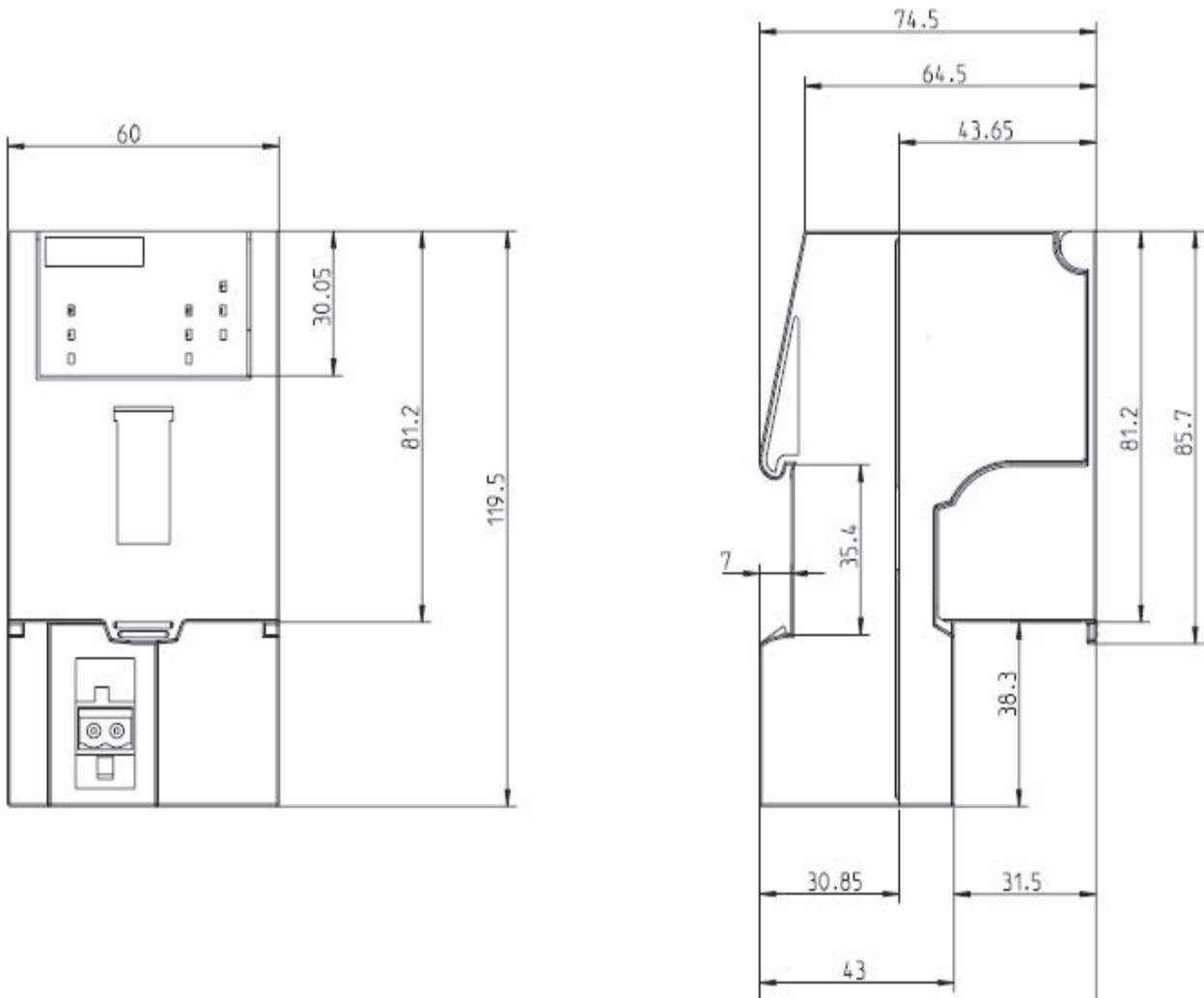

B.2 Terminal module for COMPACT module with COMPACT module inserted

Dimensional drawing of COMPACT modules with COMPACT module inserted:

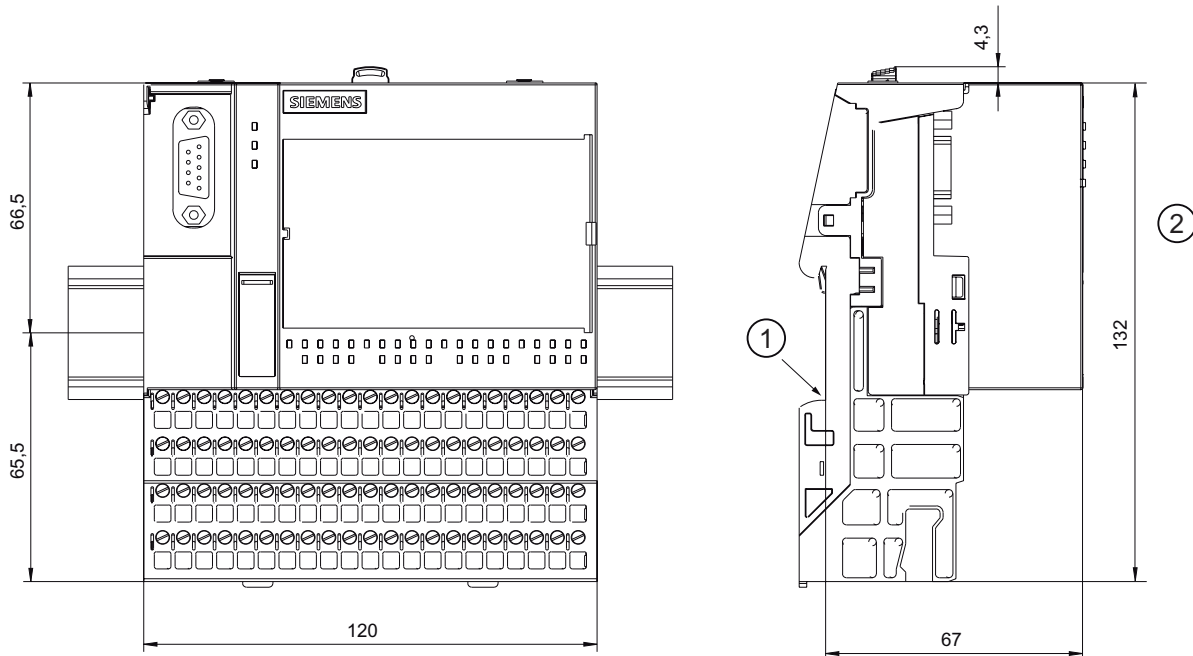

- ① Rail support
- ② with spring terminal / screw-type terminal

B.3 Terminal modules with an electronic module inserted

The dimensions of the terminal modules with inserted power module are identical to those with inserted electronic module.

Dimensional drawing of terminal module (6 terminals in rows with inserted electronic module):

B.3 Terminal modules with an electronic module inserted

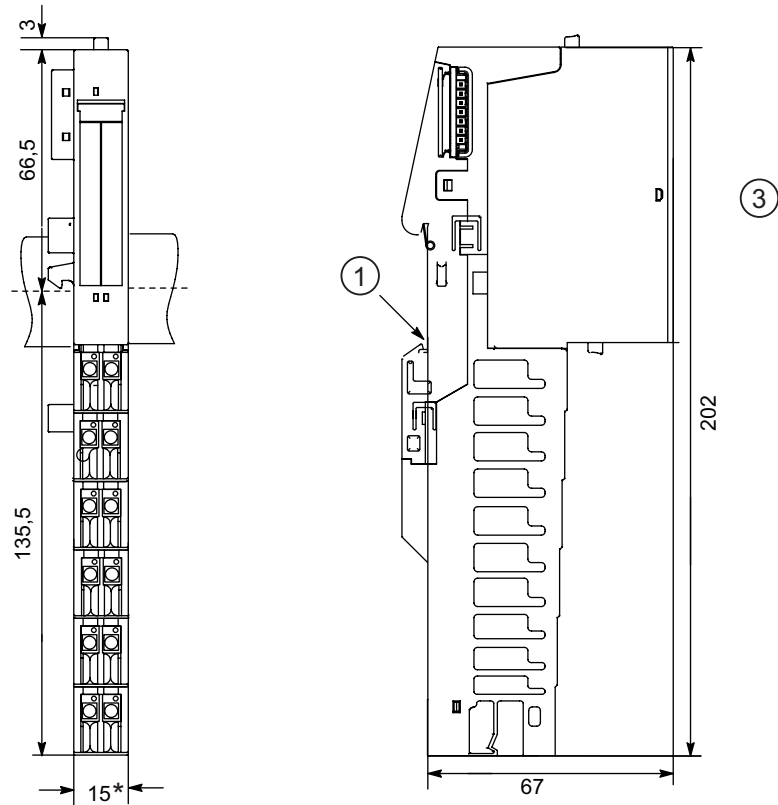
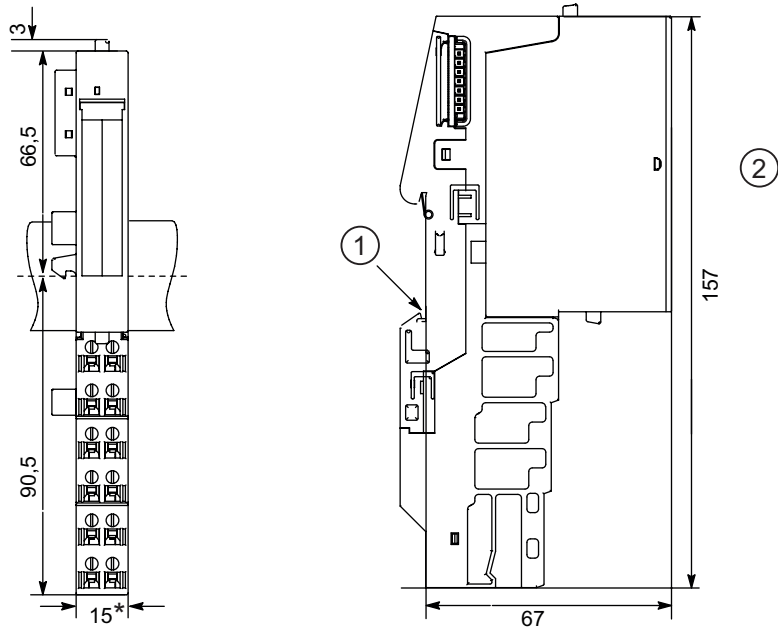

- ① Rail support
 - ② with spring terminal / screw-type terminal
 - ③ with Fast Connect
- * 30 mm for double-width modules

Dimensional drawing of terminal module (4 terminals in rows with inserted electronic module):

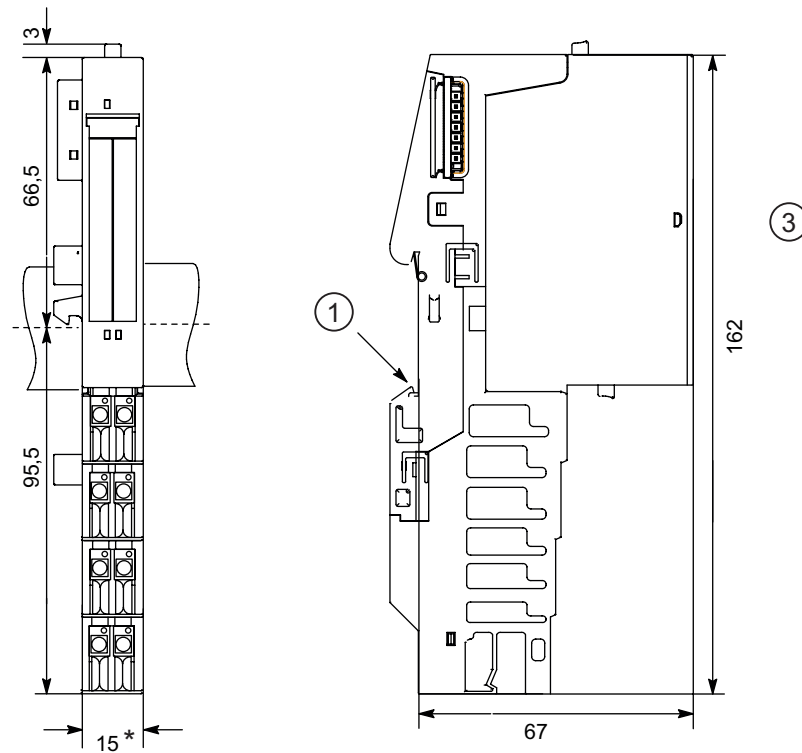
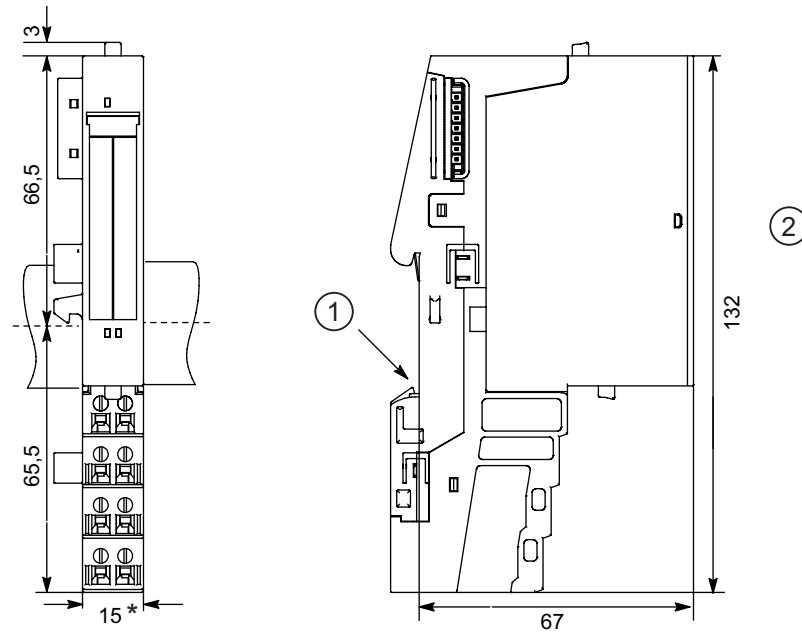

- ① Rail support
- ② with spring terminal / screw-type terminal
- ③ with Fast Connect

* 30 mm for double-width modules

Dimensional drawing of terminal module (3 terminals in rows with inserted electronic module:

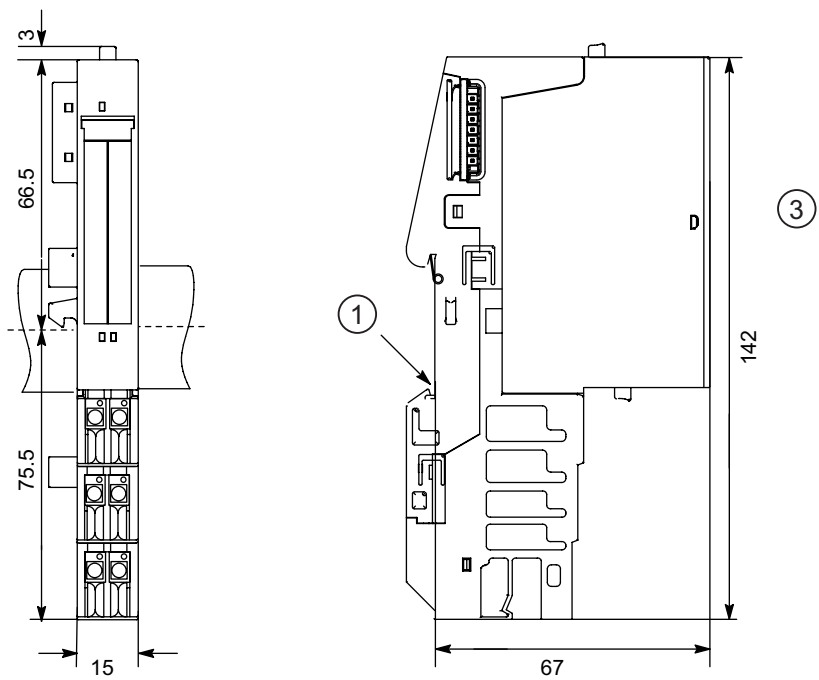
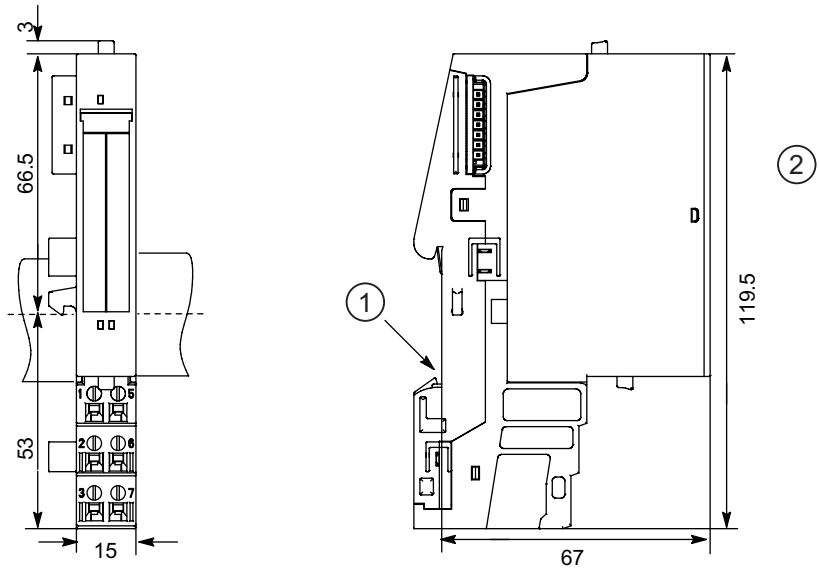

- ① Rail support
- ② with spring terminal / screw-type terminal
- ③ with Fast Connect

Dimensional drawing of terminal module (screw-type terminal) with inserted power module:

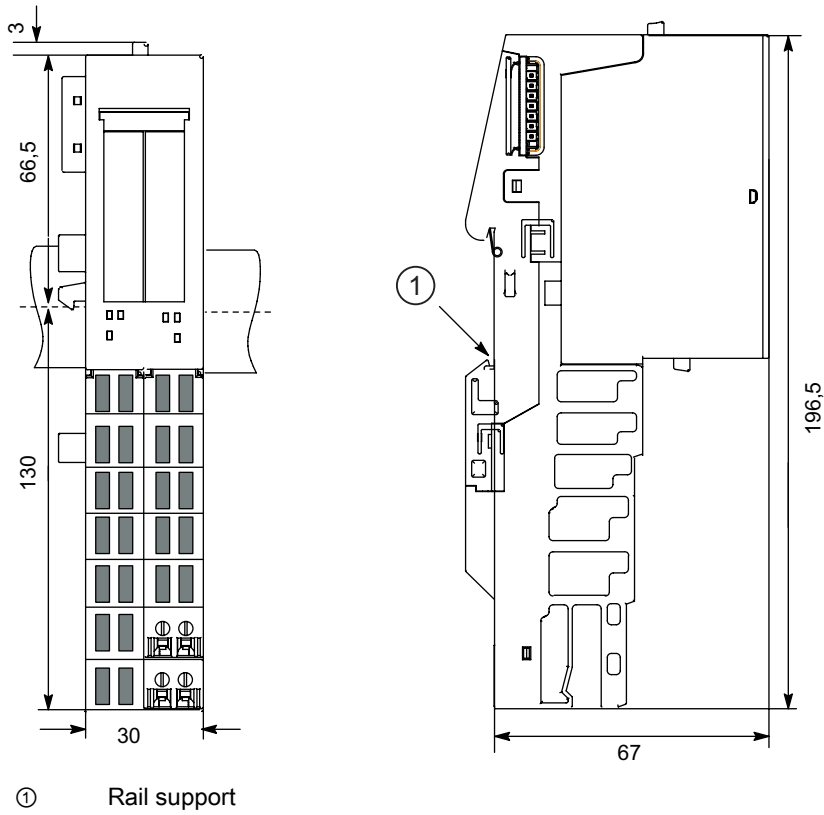

B.4 Terminating module

Dimensional drawing of the terminating module:

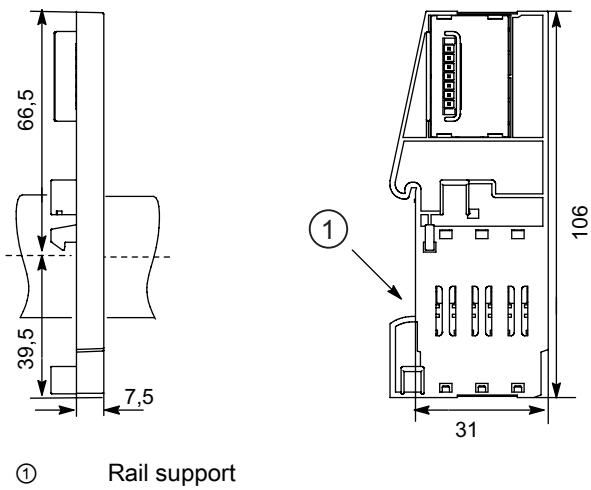

B.5 Shield contact

Dimensional drawing of the shield contact:

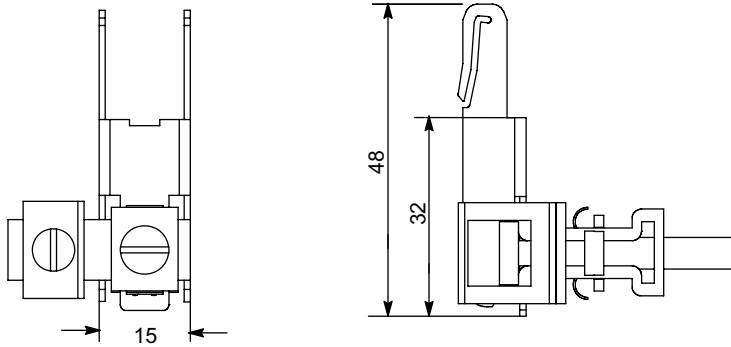

B.6 Additional terminal

Dimensional drawing of the additional terminal:

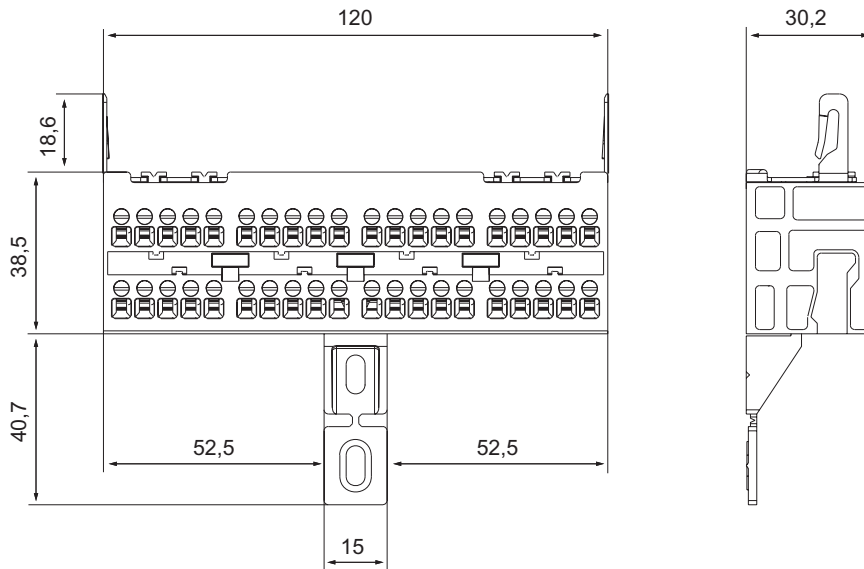

Leakage resistance

C.1 Establishing the leakage resistance of an ET 200S station

Ohmic resistance

When establishing the leakage resistance for an ET 200S station (e.g. for a ground-fault detector) you must take the ohmic resistance from the RC combination of the relevant module into account:

Module	Ohmic resistance from RC network
Interface module	10 M Ω (± 5 %)
IM151-1 COMPACT	10 M Ω (± 10 %)
Power Module PM-E DC24V	10 M Ω (± 5 %)
PM-E DC24V/AC120/230V power module	---

Formula

With the following formula you can calculate the leakage resistance of an ET 200S station if you protect all the aforementioned modules with one ground-fault detector:

$$R_{ET200S} = \frac{R_{Module}}{N}$$

$R_{ET 200S}$ = Leakage resistance of the ET 200S station
 R_{module} = Leakage resistance of a module
 N = Number of power modules and the interface module in the ET 200S station

$R_{IM 151}$ = $R_{PM-E DC24V} = R_{module} = 9.5 M\Omega$
 $R_{IM 151}$ = Leakage resistance of the IM151-1 interface module
 $R_{PM-E DC24V}$ = Leakage resistance of power module PM-E DC24V

If you protect the modules within an ET 200S station listed above with several ground-fault detectors, you must determine the leakage resistance for every single ground-fault detector.

Example

In the setup of an ET 200S there is one IM151-1 STANDARD and two PM-E DC24V power modules and various input and output modules. The entire ET 200S station is protected by **one** ground-fault detector:

$$R_{\text{ET 200S}} = \frac{9.5 \text{ M}\Omega}{3} = 3.17 \text{ M}\Omega$$

Figure C-1 Calculation example for the leakage resistance

Interference-free operation

D.1 Special Measures for Interference-Free Operation

Inductive voltages

Overvoltage occurs when sources of inductance are switched off. Examples of this are relay coils and contactors.

Integrated overvoltage protection

The digital output modules of the ET 200S have an integrated overvoltage protection device.

Additional overvoltage protection

Inductance must only be connected to additional overvoltage protective devices in the following cases:

- If digital output circuits can be switched off by additionally installed contacts (e. g. relay contacts).
- If the inductance cannot be controlled by digital output modules.

Note: Inquire about how the respective overvoltage protective devices must be dimensioned from your inductance supplier.

Example

The following diagram shows an output circuit which makes additional overvoltage protection devices necessary.

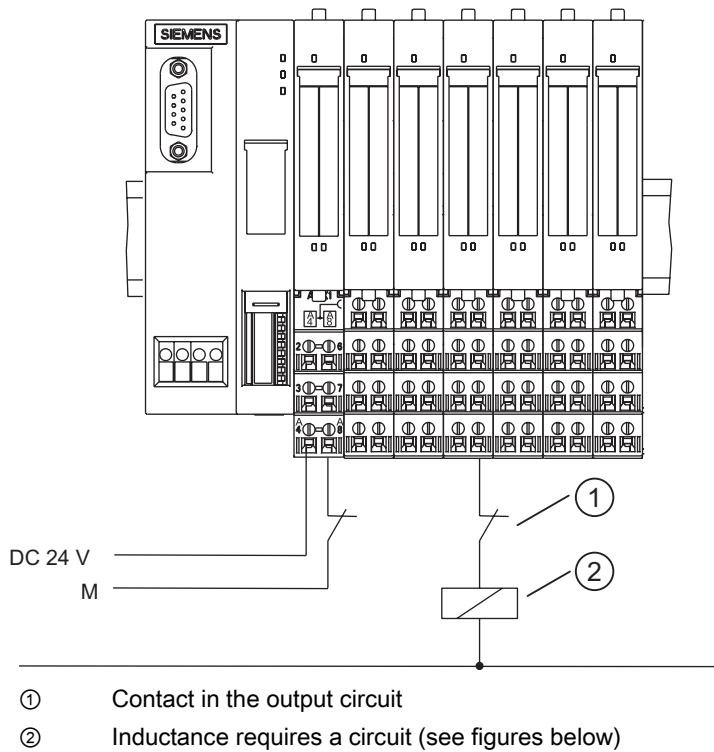
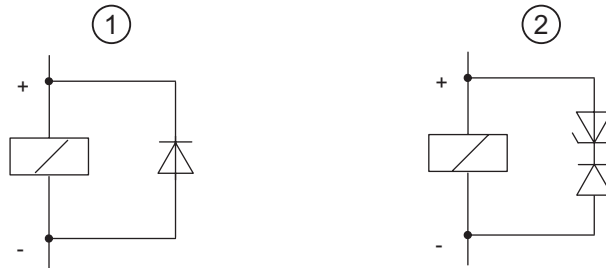

Figure D-1 Relay contact for Emergency-STOP in the output circuit.

Wiring of DC-operated coils

The figure below shows DC-operated coils wired with diode or Zener diode circuits



- ① with diode
② with Zener diode

Diode/Zener diode circuits have the following properties:

- Switch off surge voltage can be totally avoided.
Zener diode has higher switch off voltage.
- High switch-off delay (6 to 9 times higher than without protective circuit).
Zener diode switches off faster than diode circuit

Wiring of DC-operated coils

AC-operated coils are wired with varistors or RC elements as illustrated in the following diagram.



- ① with varistor
- ② with RC element

A circuit with varistors has the following properties:

- The amplitude of the switch off surge voltage is limited, but not dampened.
- The gradient of the overvoltage remains the same.
- The switch-off delay is small.

The properties of RC circuits are:

- Amplitude and gradient of the switch-off power surge are reduced.
- The switch-off delay is small.

Glossary

Automation system

An automation system is a programmable logic controller consisting of at least one CPU, various input and output modules, and operator control and monitoring devices.

AUX1 bus

Power modules allow you to connect additional potential (up to 230 VAC), which you can apply by means of the AUXiliary bus. You can use the AUXiliary bus individually:

- As a protective conductor bar
- For additionally required voltage

Backplane bus

The backplane bus is a serial data bus via which the IM151-1 interface communicates with the electronic modules/motor starters, supplying them with the required voltage. The connection between the individual modules is established by means of the terminal modules.

Bus

A common transfer route connecting all nodes and having two defined ends.
In the case of the ET 200, the bus is a two-wire or fiber-optic cable.

Bus connector

A physical connection between the bus nodes and the bus line.

Chassis ground

Chassis ground refers to all the interconnected inactive parts of a piece of equipment that, even in the event of a fault, cannot carry voltage that is dangerous to the touch.

Configuration

The systematic arrangement of the different ET 200S modules (setup).

Connecting to common potential

The opening of a new potential group by a power module. This permits the individual grouping of the sensor and load supplies.

Device names

Before an IO device can be addressed by an IO controller, it must have a device name. This procedure was selected for PROFINET because names are easier to handle than complex IP addresses.

Assignment of a device name for a concrete IO device can be compared with the setting of the PROFIBUS address for a DP slave.

An IO device does not have a device name upon delivery. An IO device can only be addressed by an IO controller - i.e., for transferring configuration data (including the IP address) during startup or for user data exchange during cyclic operation - after it has been assigned a device name with the programming device/PC.

Diagnostics

Diagnostics involves the identification, localization, classification, display, and further evaluation of errors, faults, and messages.

Diagnostics includes monitoring functions that run automatically while the system is in operation. This increases the availability of systems by reducing setup times and downtimes.

Direct starter

A direct starter is a → motor starter that switches a motor on or off directly. It consists of a circuit breaker and a contactor.

Distributed IO systems

These are input/output units that are not located in the base unit; instead, they are distributed at some distance from the CPU, for example:

- ET 200M, ET 200X, ET 200L, ET 200S
- DP/AS-I Link
- Other DP slaves from either Siemens or other vendors

The distributed IO systems are connected to the DP master by means of PROFIBUS DP.

DP master

A → master that complies with IEC 61784-1:2002 Ed1 CP 3/1 is known as a DP master.

DP slave

A → slave running on the PROFIBUS on the basis of the PROFIBUS DP protocol in accordance with IEC 61784-1:2002 Ed1 CP 3/1 is known as a DP slave.

DP standard

The DP standard is the bus protocol of the ET 200 distributed IO system in accordance with IEC 61784-1:2002 Ed1 CP 3/1.

Electronic modules

Electronic modules provide inputs and outputs for process signals. There are digital and analog electronic modules.

Firmware update

Updating of the firmware of the interface module.

You should update the interface module to the latest firmware version following (compatible) function-related expansions or performance improvements.

FREEZE

This is a control command of the DP master to a group of DP slaves.

When a DP slave receives the FREEZE control command, it freezes the current status of the **inputs** and transfers them cyclically to the DP master.

After each subsequent FREEZE control command, the DP slave freezes the status of the **inputs** again.

The input data is not transferred from the DP slave to the DP master again cyclically until the DP master sends the UNFREEZE control command.

Frequency converter

The frequency converter implements the smooth controlling of the speed of asynchronous motors. It masters both simple (frequency controlling) as well as more complex driving tasks (vector controlling). It can also be used for torque control.

Ground

The conductive mass of earth, the electrical potential of which is equivalent to zero. In the vicinity of grounding electrodes, the potential may not be zero. The term "reference ground" is often used here.

Grounding

Grounding means connecting an electrically conductive part to a grounding electrode by means of a grounding system.

GSD file

The properties of a PROFINET device are described in a GSD (General Station Descriptor) file that contains all required information for configuration.

As with PROFIBUS, you can link a PROFINET device in STEP 7 by means of a GSD file.

In PROFINET IO, the GSD file is always in XML format. The structure of the GSD file corresponds to ISO 15734, the worldwide standard for device descriptions.

In PROFIBUS, the GSD file is in ASCII format (as defined in IEC 61784-1:2002 Ed1 CP 3/1).

Hot swapping

This is the removal and insertion of modules during the operation of the ET 200S.

Isolated

In the case of isolated input/output modules, the reference potentials of the control and load circuit are electrically isolated - for example, by means of optical isolators, relays, or transformers. Input/output circuits can be grouped.

MAC address

Each PROFINET device has a factory-assigned worldwide unique device identification. This 6-byte device identification is the MAC address.

The MAC address consists of:

- 3-byte manufacturer ID and
- 3-byte device ID (serial number)

As a rule, the MAC address can be read on the front of the device, for example: 08-00-06-6B-80-C0

Master

When it has a token, a master can send data to and request data from other nodes (= active participants). Examples of DP masters are the CPU 315-2 DP or the IM308-C.

Motor starter (MS)

Motor starter is the generic term for → direct and → reversing starters. The startup and direction of rotation of a motor are determined by motor starters.

Node

Device that can send, receive or amplify data via the bus, for example, DP master, DP slave, RS 485 repeater.

Non-isolated

In the case of non-isolated input/output modules, the reference potentials of the control and load circuits are electrically connected.

Parameter assignment

Parameter assignment is the transfer of slave parameters from the DP master to the DP slave.

PELV

Protective Extra Low Voltage = extra low voltage with safe isolation

Power buses (P1/ P2)

Two internal buses (P1 and P2) that supply the electronic modules with voltage. The power buses are fed by the power module and connected by means of the terminal modules.

Power modules

Power modules monitor the supply voltage for all the electronic modules in the potential group. The supply voltage is fed in by means of the TM-P terminal module.

Prewiring

The wiring of the terminal modules before the electronic modules are inserted.

Process image

The process image is a component of the system memory of the DP master. The signal states of the input modules are transferred to the process-image input area at the beginning of the cyclic program. At the end of the cyclic program, the values of the process-image output area are transferred to the DP slave as the signal states.

PROFIBUS

PROcess Field BUS, German process field bus standard specified in IEC 61784-1:2002 Ed1 CP 3/1. It defines functional, electrical, and mechanical properties for a bit-serial field bus system.

PROFIBUS is available with the protocols DP (which stands for distributed peripherals, that is, distributed or remote IO), FMS (which stands for field bus message specification), PA (= process automation), or TF (= technological functions).

PROFIBUS address

Each bus node must receive a PROFIBUS address to identify it uniquely on the PROFIBUS.

The PC/programming device has the PROFIBUS address "0".

The PROFIBUS addresses 1 to 125 are permitted for the ET 200S distributed IO system.

PROFINET

Within the context of Totally Integrated Automation (TIA), PROFINET is the systematic development of the following systems:

- PROFIBUS DP, the established field bus and
- Industrial Ethernet, the communication bus for the cell level

Experiences from both systems have been and are being integrated in PROFINET.

PROFINET as the Ethernet-based automation standard of PROFIBUS International (formerly PROFIBUS Nutzerorganisation e.V.) defines a cross-vendor communication, automation, and engineering model.

PROFINET device

A PROFINET device always has at least one Industrial Ethernet connection. In addition, a PROFINET device can also have a PROFIBUS connection and even act as a master with proxy functionality. In exceptions, a PROFINET device can also have a several PROFIBUS connections (for example CP 5614).

Provider-consumer principle

In a PROFINET IO both partners are independent providers in sending data, in contrast to PROFIBUS DP.

Real time

Real time means that a system processes external events within a defined time.

Determinism means that a system responds in a predictable (deterministic) manner.

Both requirements are important for industrial networks. PROFINET satisfies these requirements. Thus, as a deterministic real-time network, PROFINET is designed as follows:

- The transfer of time-critical data between different stations via a network is guaranteed within a defined interval of time.
- To this end, PROFINET has an optimized communication channel for real-time communication: real time (RT): Real time (RT).
- The time of transfer can be accurately determined.
- It is ensured that seamless communication can take place in the same network by means of other standard protocols, such as industrial communication for programming device/PC.

Reference potential

Potential from which the voltages of the circuits involved can be observed and/or measured.

Reversing starter

A reversing starter is a → motor starter that determines the direction of rotation of a motor. It consists of a circuit breaker and two contactors.

Segment

The bus line between two terminating resistors forms a segment. A segment contains 0 to 32 → bus nodes. Segments can be coupled via RS 485 repeaters.

SELV

Safety Extra Low Voltage

Slave

A slave can only exchange data with a → master when requested by it to do so. By slaves we mean, for example, all DP slaves such as ET 200X, ET 200M, ET 200S, etc.

SNMP

SNMP (Simple Network Management Protocol) is the standardized protocol for performing diagnostics and assigning parameters to the Ethernet network infrastructure.

In the office setting and in automation engineering, devices from many different vendors support SNMP on the Ethernet.

SNMP-based applications can be operated on the same network in parallel to applications with PROFINET.

The scope of supported functions depends on the device type. For example, a switch has more functions than a CP 1616.

SSI

The positional information is transferred synchronously on the basis of the SSI (synchronous serial interface) protocol. The SSI protocol is used with absolute encoders.

Stationary wiring

All the wiring-carrying elements (terminal modules) are mounted on a rail. The power and electronic modules are inserted in the terminal modules.

Switch

PROFIBUS is a linear network. The communication nodes are linked by means of a passive cable– the bus.

By contrast, the Industrial Ethernet consists of point-to-point connections: each communication node is interconnected directly with one other communication node.

If a communication node is linked to several communication nodes, this communication node is connected to the port of an active network component – the switch. Additional communication nodes (including switches) can now be connected to the other ports of the switch. The connection between a communication node and the switch remains a point-to-point connection.

A switch also has the task of regenerating and distributing received signals. The switch "learns" the Ethernet address(es) of a connected PROFINET device or additional switches and only forwards those signals that are intended for the connected PROFINET device or switch.

A switch has a specific number of ports. You connect at most one PROFINET device or additional switch to each port.

SYNC

This is a control command of the DP master to a group of DP slaves.

With the SYNC control command the DP master orders the DP slave that the DP slave freeze the states of the outputs to the current value. With the subsequent frames, the DP slave stores the output data, but the statuses of the outputs remain unchanged.

After each new SYNC control command, the DP slave sets the outputs that it has stored as output data. The outputs are not cyclically updated again until the DP master sends the UNSYNC control command.

Technological modules

Modules that are equipped with technological functions, such as counting pulses, positioning, and controlling stepping motor power units.

Terminal modules

Terminal modules implement the electrical and mechanical connection of the I/O modules with the interface module and the terminating module.

The inserted I/O module determines the signals at the terminals of the terminal module. Depending on the selected terminal module only certain terminals are available.

Terminating module

The ET 200S distributed IO system is completed by the terminating module. If you have not inserted a terminating module, the ET 200S is not ready for operation.

Index

2

24 VDC supply, 74

A

Add-on terminal

Installing, 60

removing, 62

Address area, 103, 118

Approval

Standards, 127

Assembly, 67, 68

Shield contact, 67, 68

Assigning a device name, 116

AUX(iliary) bus (AUX1), 45

B

Brief instructions on commissioning

ET 200S on PROFINET IO, 30

ET 200S on the PROFIBUS DP, 21

Burst pulses, 131

Bus cable, 16

C

CE

Certification, 127

Certification

CE, 127

FM, 129

Marine, 130

Changing the PROFIBUS Address, 112

Climatic environmental conditions, 133

Color-coded labels, 16, 71

Mounting, 72

Removing, 72

Commissioning, 102

PROFIBUS DP, 113

PROFINET IO, 120

Requirements for PROFIBUS DP, 113

Requirements for PROFINET IO, 120

Commissioning the ET 200S

on PROFIBUS DP, 113

on PROFINET IO, 120

COMPACT modules, 95, 96, 98

changing type, 98

Exchange, 98

identifying, 95

Mounting, 95

removing, 96

Components and protective measures, 76

Configuration, 102, 115

ET 200S, 102, 115

Configuration examples

Terminal modules for power modules, 47

Connecting cable shields, 85

Connecting PROFIBUS DP, 87, 91

Connecting the supply voltage, 87, 91

Connecting to common potential, 45

D

Diagnostics, 102

Digital input modules, 103, 118

Digital output modules, 103, 118

Dimensions

Additional terminal, 146

Shield contact, 146

Terminal module for COMPACT module with
COMPACT module inserted, 141

Terminal modules with an electronic module
inserted, 141

Terminal modules with inserted power module, 141

Terminating module, 145

Distributed I/O systems, 11

DP master, 11

DP slave, 11

- E**
- Electromagnetic compatibility, 131
 - Electronic module, 16
 - Electronic modules, 95, 96, 98, 99
 - changing type, 98
 - Exchange, 98
 - identifying, 95
 - Mounting, 95
 - removing, 96
 - Removing and inserting during operation, 99
 - Electrostatic discharge, 131
 - EMC, 131
 - EMERGENCY-STOP devices, 73
 - Emission of radio interference, 132
 - ET 200S, 75, 77, 102, 113, 120
 - Characteristics and benefits, 19
 - Configuration, 102, 115
 - Overall configuration, 77
 - with grounded reference potential, 75
 - ET 200S components, 16
 - ET 200S distributed I/O system
 - Applications, 14
 - Definition, 14
 - Terminal modules and electronic modules, 14
 - View, 15
 - ET 200S FC
 - Variations in the technical specifications, 136
 - Example configuration of a fiber-optic cable network with IM151-1 FO STANDARD, 89
 - Example of a configuration, 109
 - Exchange terminal box
 - on terminal module, 64
- F**
- Fiber-optic cable
 - bending radius, 90
 - Fiber-optic duplex cable, 16
 - FM
 - Certification, 129
 - Frequency converter
 - Variations in the technical specifications, 136
- G**
- Galvanic isolation, 78
 - General Rules, 73
 - General technical specifications, 127
 - Grounded incoming supply, 75
 - GSD file, 103, 115
 - Guide
 - for the operating instructions, 5
- H**
- Heat dissipation, 53
- I**
- Identification data, 126
 - IEC 204, 73
 - IEC 61131, 129
 - IEC 61784-1 standard
 - 2002 Ed1 CP 3/1, 11
 - IM151-1 BASIC interface module, 16
 - IM151-1 FO STANDARD interface module, 16
 - IM151-1 HIGH FEATURE interface module, 16
 - IM151-1 STANDARD interface module, 16
 - IM151-3 PN interface module, 16
 - Installation, 54, 66, 69
 - Color identification labels, 69
 - Interface module, 54
 - Slot number plates, 69
 - Terminating module, 66
 - Installation position, 51
 - Installation rules, 51
 - Installing, 51
 - Installing the terminal module
 - TM-C, 57
 - TM-E, 55
 - TM-P, 55
 - Insulation test, 135
 - Interface module IM151-1 FO STANDARD
 - Plug adapters, 89
- L**
- Label sheet, 16
- M**
- Marine
 - Certification, 130
 - Mechanical ambient conditions, 134
 - Minimum clearances, 53
 - Motor starter, 103, 118
 - Mounting rail, 16, 52

O

- Operating instructions
 - Purpose, 3
- Option handling, 125
 - Properties, 125
- Order numbers
 - ET 200S accessories, 137
- Order numbers for sample configuration
 - on PROFIBUS DP, 22
 - on PROFINET IO, 32

P

- Placing and connecting to common potential, 45
- Placing power modules and connecting them to common potential, 45
- Plug adapters
 - for IM151-1 FO STANDARD, 89
- Pollution level, 135
- Potential group, 45
- Power module, 16
- Power supply, 45
 - Connecting, 94
- PROFIBUS DP, 11
 - Devices, 11
- PROFIBUS DP network
 - Structure, 12
- PROFIBUS standard, 129
- PROFINET IO
 - Network structure, 13
- Protection against outside electrical influences, 74
- Protection Class, 135
- Protection class IP 20, 135
- Pulse-shaped Interference, 131

R

- Rated voltage, 135
- Recycling, 5
- Redundancy, 42
- Regulations, 73
- Removing and inserting
 - Electronic modules, 100
- Removing the terminal module
 - TM-C, 58
 - TM-E, 56
 - TM-P, 56
- Repetitive shock, 134
- Required level of knowledge, 3
- Rules for fiber-optic cable network, 88

S

- Safety isolation, 75
- Scope, 3
- Self-coding, 95
- Setting the PROFIBUS Address, 111
- Shield contact, 16
- Shock, 134
- Simplex connectors
 - installing, 89
- Sinusoidal Interference, 131
- Slot number plates, 16
- Software Requirements
 - Commissioning on PROFIBUS DP, 113
 - Commissioning on PROFINET IO, 120
- Specific application, 73
- Standards and approvals, 127
- Startup, 113, 120
- Startup of the ET 200S
 - on PROFIBUS DP, 114
 - on PROFINET IO, 121
- Storage conditions, 132
- System Startup after Certain Events, 73

T

- Technical specifications
 - Climatic environmental conditions, 133
 - Electromagnetic compatibility, 131
 - mechanical ambient conditions, 133
- terminal box on terminal module
 - replace, 64
- Terminal module, 16, 79, 80, 81
 - Wiring with Fast Connect, 81
 - wiring with screw-type terminals, 79
 - wiring with spring terminals, 80
- Terminal modules, 84
- Terminating module, 16
- Test voltage, 135
- Tick-mark for Australia, 129
- Transport conditions, 132
- Type-coded, 95

U

- Use in industrial environment, 130
- Use in residential areas, 130

- V**
- Vibrations, 134
 - Voltage relationships
 - in the ET 200S with IM151-1, 78
- W**
- Wiring, 87, 88, 92
 - IM151-3 PN interface module, 92
 - Interface module IM151-1 BASIC, 87
 - Interface module IM151-1 FO STANDARD, 88
 - Interface module IM151-1 HIGH FEATURE, 87
 - Interface module IM151-1 STANDARD, 87
 - Wiring and assembly, 73
 - Wiring rules, 79
 - Wiring terminal modules, 84
 - for COMPACT modules, 85
 - for digital, analog, and technological modules, 85
 - For power modules, 85
- Y**
- Y switching, 42