

Industrial Controls

Protection devices SIRIUS 3RU thermal overload relays / SIRIUS 3RB electronic overload relays

Equipment Manual

<u>Introduction</u>	1
<u>Safety instructions</u>	2
<u>Standards</u>	3
<u>Product description</u>	4
<u>Product combinations</u>	5
<u>Functions</u>	6
<u>Configuration</u>	7
<u>Mounting</u>	8
<u>Connection</u>	9
<u>Operation</u>	10
<u>Accessories</u>	11
<u>Technical data</u>	12
<u>Circuit diagrams</u>	13
<u>Types of coordination</u>	A
<u>References</u>	B
<u>Dimension drawings (dimensions in mm)</u>	C

Legal information

Warning notice system

This manual contains notices you have to observe in order to ensure your personal safety, as well as to prevent damage to property. The notices referring to your personal safety are highlighted in the manual by a safety alert symbol, notices referring only to property damage have no safety alert symbol. These notices shown below are graded according to the degree of danger.

 DANGER
indicates that death or severe personal injury will result if proper precautions are not taken.

 WARNING
indicates that death or severe personal injury may result if proper precautions are not taken.

 CAUTION
indicates that minor personal injury can result if proper precautions are not taken.

NOTICE
indicates that property damage can result if proper precautions are not taken.

If more than one degree of danger is present, the warning notice representing the highest degree of danger will be used. A notice warning of injury to persons with a safety alert symbol may also include a warning relating to property damage.

Qualified Personnel

The product/system described in this documentation may be operated only by **personnel qualified** for the specific task in accordance with the relevant documentation, in particular its warning notices and safety instructions. Qualified personnel are those who, based on their training and experience, are capable of identifying risks and avoiding potential hazards when working with these products/systems.

Proper use of Siemens products

Note the following:

 WARNING
Siemens products may only be used for the applications described in the catalog and in the relevant technical documentation. If products and components from other manufacturers are used, these must be recommended or approved by Siemens. Proper transport, storage, installation, assembly, commissioning, operation and maintenance are required to ensure that the products operate safely and without any problems. The permissible ambient conditions must be complied with. The information in the relevant documentation must be observed.

Trademarks

All names identified by ® are registered trademarks of Siemens AG. The remaining trademarks in this publication may be trademarks whose use by third parties for their own purposes could violate the rights of the owner.

Disclaimer of Liability

We have reviewed the contents of this publication to ensure consistency with the hardware and software described. Since variance cannot be precluded entirely, we cannot guarantee full consistency. However, the information in this publication is reviewed regularly and any necessary corrections are included in subsequent editions.

Table of contents

1	Introduction	9
1.1	Responsibility of the user for system configuration and functionality.....	9
1.2	Purpose of the manual.....	9
1.3	Advantages through energy efficiency.....	10
1.4	Required basic knowledge.....	10
1.5	Scope of the manual.....	10
1.6	Siemens Industry Online Support.....	11
1.7	Further documentation.....	12
1.8	DataMatrix code.....	12
1.9	Siemens Industry Online Support app.....	13
1.10	Support Request.....	13
2	Safety instructions	15
2.1	General safety notes.....	15
2.2	Security information.....	15
2.3	Intended use.....	16
2.4	Current information about operational safety.....	16
2.5	Electromagnetic compatibility (EMC) according to IEC 60947-4-1.....	16
2.6	Recycling and disposal.....	16
3	Standards	17
3.1	Standards.....	17
3.2	Requirements for switching high-efficiency motors.....	17
3.3	Voltages.....	18
3.4	Notes on the protection of device connections.....	18
4	Product description	19
4.1	Versions.....	19
4.2	Operating principle.....	20
4.3	System integration.....	21
4.4	Connection systems.....	21
4.5	Applications.....	21
4.6	3RU21 thermal overload relays.....	24
4.7	3RB20 electronic overload relays.....	29

4.8	3RB21 electronic overload relays	32
4.9	3RB30 solid-state overload relays	36
4.10	3RB31 solid-state overload relays	41
5	Product combinations	47
6	Functions	49
6.1	Protection against overload, phase failure, and phase asymmetry	49
6.1.1	Functional principle	49
6.1.2	Inverse-time delayed overload release	50
6.1.3	Tripping classes.....	50
6.1.4	Tripping characteristics	51
6.2	Ground-fault protection in the case of 3RB21 / 3RB31	53
6.3	Auxiliary contacts	55
6.4	Indication of the operating state	55
6.5	Self-monitoring (3RB20 / 3RB21 and 3RB30 / 3RB31 only).....	56
6.6	Additional functions.....	56
7	Configuration	59
7.1	TIA Selection Tool	59
7.2	Overload relays in motor feeders	59
7.2.1	Motor protection with overload relay.....	59
7.2.2	Overview of combinable 3RT contactors.....	60
7.2.3	Normal and heavy-duty starting	61
7.2.4	Contactor assembly for star-delta (wye-delta) start	62
7.2.5	Operation with frequency converters	62
7.3	Short-circuit protection	63
7.4	Protecting explosion-protected motors	64
7.5	Safety instructions for use in hazardous areas (3RB).....	65
7.5.1	General information.....	65
7.5.2	Installation and commissioning	66
7.5.3	Safety data	70
7.5.4	Maintenance and repair	70
7.5.5	Warranty.....	71
7.5.6	Further information	71
7.6	Application environment.....	71
8	Mounting	75
8.1	Warning notice	75
8.2	Mounting options	75
8.3	Minimum clearances and mounting position	75
8.4	Mounting/Disassembly.....	76
8.4.1	Mounting the 3RU2.1 / 3RU2.2 thermal overload relay on the 3RT2 contactor	76
8.4.2	Mounting the 3RB3.1 electronic overload relay on the 3RT2 contactor	80
8.4.3	Mounting the 3RB3.2 electronic overload relay on the 3RT2 contactor	83

8.4.4	Mounting the 3RB3.3 electronic overload relay on the 3RT2 contactor	86
8.4.5	Mounting the 3RU2.4 thermal overload relay and 3RB3.4 electronic overload relay on the 3RT2 contactor	89
8.4.6	Mounting the 3RB2.5 electronic overload relay to the 3RT1.5 contactor	92
8.4.7	Mounting the 3RB2.6 electronic overload relay to the 3RT1.6 / 3RT1.7 contactor	97
8.4.8	Replacing the removable terminal on the 3RB3.1 / 3RB3.2 electronic overload relay	100
8.4.9	Replacing the removable terminal on the 3RB3.3 electronic overload relay	101
8.4.10	Replacing the removable terminal on the 3RB3.4 electronic overload relay	102
8.4.11	Replacing the removable terminal on the 3RB2.5 and 3RB2.6 electronic overload relays	103
9	Connection.....	105
9.1	Warning notice	105
9.2	Connection	105
9.3	Connection of 3RU21 overload relay.....	106
9.4	Connection of 3RB20 / 3RB21 and 3RB30 / 3RB31 overload relays	107
9.5	Connection cross-sections	108
9.5.1	Conductor cross-sections for screw-type connection systems	108
9.5.2	Conductor cross-sections for spring-loaded connection systems.....	113
9.5.3	Conductor cross-sections for ring cable lug connection system	114
10	Operation.....	117
10.1	Setting the current.....	117
10.2	Setting the tripping class/ground-fault detection (3RB21 / 3RB31)	117
10.3	RESET after release.....	118
10.4	TEST function	120
10.5	Response of the auxiliary contacts.....	121
11	Accessories	123
11.1	Accessories	123
11.2	Terminal support for stand-alone assembly.....	123
11.2.1	Description	123
11.2.2	Mounting/disassembly	124
11.2.2.1	Mounting the 3RU2.1 / 3RU2.2 thermal overload relay on a terminal support for stand-alone installation	124
11.2.2.2	Mounting the 3RB3.1 electronic overload relay on a terminal support for stand-alone installation	126
11.2.2.3	Mounting the 3RB3.2 electronic overload relay on a terminal support for stand-alone installation	127
11.2.2.4	Mounting the 3RU2.3 / 3RU2.4 thermal overload relay on a terminal support for stand-alone installation	130
11.2.2.5	Mounting the 3RB3.3 electronic overload relay on a terminal support for stand-alone installation	132
11.2.2.6	Mounting the 3RU2.4 thermal overload relay on a terminal support for stand-alone installation	134
11.2.2.7	Mounting the 3RB3.4 electronic overload relay on a terminal support for stand-alone installation	136
11.3	Mechanical remote RESET	139

11.3.1	Release slide	140
11.3.1.1	Description	140
11.3.1.2	Mounting/Disassembly	140
11.3.2	Cable release	143
11.3.2.1	Description	143
11.3.2.2	Mounting/Disassembly	143
11.4	Module for electrical remote RESET (3RU21 only)	148
11.4.1	Description	148
11.4.2	Connecting remote reset	148
11.4.3	Mounting/Disassembly	149
11.5	Sealable cover	150
11.5.1	Description	150
11.5.2	Mounting/disassembly	151
11.5.2.1	Mounting the sealing cover on the 3RU2.1 / 3RU2.2 thermal overload relay	151
11.5.2.2	Mounting the sealing cover on the 3RB3.1 / 3RB3.2 electronic overload relay	152
11.5.2.3	Mounting the sealing cover on the 3RB3.3 electronic overload relay	152
11.5.2.4	Mounting the sealing cover on the 3RB3.4 electronic overload relay	153
11.5.2.5	Mounting the sealing cover on the 3RB2.5 / 3RB2.6 electronic overload relay	153
11.6	Terminal cover for cable lug connection and busbar connection	154
11.6.1	Description	154
11.6.2	Mounting/disassembly	154
11.6.2.1	Mounting the terminal cover for cable lug connection and busbar connection to the 3RB3.4 electronic overload relay	154
11.6.2.2	Mounting the terminal cover for cable lug connection and busbar connection to the 3RU2.4 thermal overload relay	155
11.7	Terminal covers for box terminal block	156
11.7.1	Description	156
11.7.2	Mounting/disassembly	156
11.7.2.1	Mounting the terminal cover to the 3RB3.3 electronic overload relay	156
11.7.2.2	Mounting the terminal cover to the 3RU2.4 thermal overload relay	157
11.8	Box terminal block	158
11.8.1	Description	158
11.8.2	Mounting	158
12	Technical data	161
12.1	Technical data in Siemens Industry Online Support	161
12.2	Overview tables	161
12.3	Performance features	162
12.3.1	General data	162
12.3.2	Protection functions - overview	162
12.3.3	Equipment	163
12.3.4	Features of overload relays	164
13	Circuit diagrams	165
13.1	CAX data	165
13.2	Internal circuit diagrams 3RU2	165
13.3	3RB20 internal circuit diagrams	167

13.4	3RB21 internal circuit diagrams	167
13.5	Internal circuit diagrams 3RB30	168
13.6	Internal circuit diagrams 3RB31	169
13.7	Wiring examples	171
A	Types of coordination	173
B	References	175
B.1	References	175
B.2	Manuals - SIRIUS Modular System	175
C	Dimension drawings (dimensions in mm)	177
C.1	CAX data	177
C.2	Dimension drawings for 3RU21 thermal overload relays	178
C.3	Dimension drawings und drilling plans electronic overload relay 3RB20 / 3RB21	185
C.4	Dimension drawings for 3RB30/3RB31 electronic overload relays	188
C.5	Drilling diagram for 3RT contactors	200
C.6	Dimension drawings and drilling plans for 3RU29.6 stand-alone installation supports	203
	Index	207

Introduction

1.1 Responsibility of the user for system configuration and functionality

3RU21 thermal overload relays have been designed to provide current-dependent protection for loads with normal starting against impermissibly high temperature rises due to overload, phase asymmetry or phase failure.

3RB20 / 3RB21 and 3RB30 / 3RB31 electronic overload relays with internal power supply have been designed to provide current-dependent protection for loads with normal starting and heavy starting against impermissibly high temperature rises due to overload, phase asymmetry or phase failure.

Siemens AG, its regional offices, and associated companies (hereinafter referred to as "Siemens") cannot guarantee all the properties of an overall installation or machine that has not been designed by Siemens.

Nor can Siemens assume liability for recommendations that appear or are implied in the following description. No new guarantee, warranty, or liability claims beyond the scope of the Siemens general terms of supply are to be derived or inferred from the following description.

Note

With regard to the design of a system, comply with all valid national installation specifications and standards.

1.2 Purpose of the manual

This manual describes the 3RU2 and 3RB2 / 3RB3 overload relays and provides the following information:

- Information for integrating the overload relays into the system environment.
- Information on necessary hardware components.
- Information on installing, connecting and operating the overload relays.
- Technical information such as dimension drawings and unit wiring diagrams.

The information in this manual enables you to configure and commission the overload relays.

1.3 Advantages through energy efficiency

Siemens offers you a unique portfolio for efficient energy management in industry – a process that serves to optimally shape your energy requirement. Operational energy management is subdivided into three phases:

- Identifying
- Evaluating
- Realizing

Siemens supports you with suitable hardware and software solutions in every phase of a project.

More information can be found on the Internet (<http://www.automation.siemens.com/mcms/industrial-controls/en/energy-efficiency>).

The 3RB30/3RB31 electronic overload relays make the following contribution to energy efficiency in an overall installation:

- Reduced intrinsic power loss
- Reduced control cabinet heat development
- Smaller control cabinet air conditioning units required

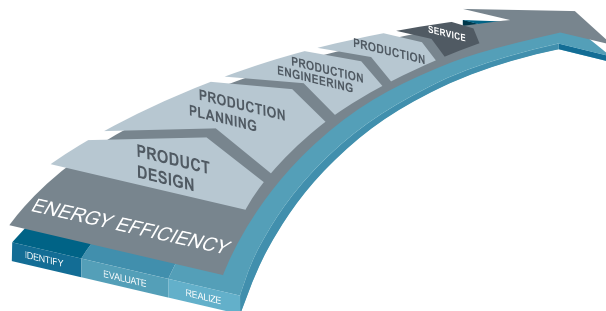

Figure 1-1 Overview of the energy management process

1.4 Required basic knowledge

To understand these operating instructions you should have a general knowledge of automation engineering and low-voltage switchgear.

1.5 Scope of the manual

The manual is valid for these overload relays. It contains a description of the devices that is valid at the time of publication.

1.6 Siemens Industry Online Support

Information and service

At Siemens Industry Online Support you can obtain up-to-date information from our global support database:

- Product support
- Application examples
- Forum
- mySupport

Link: Siemens Industry Online Support (<https://support.industry.siemens.com/cs/de/en>)

Product support

You can find information and comprehensive know-how covering all aspects of your product here:

- **FAQs**
Answers to frequently asked questions
- **Manuals/operating instructions**
Read online or download, available as PDF or individually configurable.
- **Certificates**
Clearly sorted according to approving authority, type and country.
- **Characteristics**
For support in planning and configuring your system.
- **Product announcements**
The latest information and news concerning our products.
- **Downloads**
Here you will find updates, service packs, HSPs and much more for your product.
- **Application examples**
Function blocks, background and system descriptions, performance statements, demonstration systems, and application examples, clearly explained and represented.
- **Technical data**
Technical product data for support in planning and implementing your project

Link: Product support (<https://support.industry.siemens.com/cs/ww/en/ps>)

mySupport

The following functions are available in your personal work area "mySupport":

- **Support Request**
Search for request number, product or subject
- **My filters**
With filters, you limit the content of the online support to different focal points.

- **My favorites**
With favorites you bookmark articles and products that you need frequently.
- **My notifications**
Your personal mailbox for exchanging information and managing your contacts. You can compile your own individual newsletter in the "Notifications" section.
- **My products**
With product lists you can virtually map your control cabinet, your system or your entire automation project.
- **My documentation**
Configure your individual documentation from different manuals.
- **CAX data**
Easy access to CAX data, e.g. 3D models, 2D dimension drawings, EPLAN macros, device circuit diagrams
- **My IBase registrations**
Register your Siemens products, systems and software.

1.7 Further documentation

To install and connect the overload relays, you require the operating instructions of the overload relays used.

You can find a list of operating instructions and an overview of the manuals pertaining to the SIRIUS modular system in the Appendix "References (Page 175)".

1.8 DataMatrix code

A Data Matrix code has been lasered onto 3RB3 electronic overload relay devices and 3RU2 thermal overload relays.

The Data Matrix codes are standardized in ISO/IEC 16022. The Data Matrix codes on Siemens devices use ECC200 coding for powerful error correction.

The following information is stored in the Data Matrix code:

1P	Article number	+	S	Loca- tion	/	Date	Serial number
Data iden- tifier	User content	Separa- tor	User content	Separa- tor	User content	User content	User content

Note

The information content is displayed without spaces.

This machine-readable information simplifies and accelerates handling of the respective devices.

As well as fast access to the serial numbers of the respective devices for unique identification, the Data Matrix codes simplify communication with Siemens Technical Support.

1.9 Siemens Industry Online Support app

Siemens Industry Online Support app

The Siemens Industry Online Support app provides you access to all the device-specific information available on the Siemens Industry Online Support portal for a particular article number, such as operating instructions, manuals, data sheets, FAQs etc.

The Siemens Industry Online Support app is available for Android and iOS:



Android



iOS

1.10 Support Request

After you have registered, you can use the Support Request form in the online support to send your question directly to Technical Support:

Support Request:	Internet (https://support.industry.siemens.com/My/ww/en/requests)
-------------------------	--

Safety instructions

2.1 General safety notes



 DANGER
<p>Hazardous voltage. Will cause death or serious injury.</p> <p>Turn off and lock out all power supplying this device before working on this device.</p>

2.2 Security information

Siemens provides products and solutions with industrial security functions that support the secure operation of plants, systems, machines and networks.

In order to protect plants, systems, machines and networks against cyber threats, it is necessary to implement – and continuously maintain – a holistic, state-of-the-art industrial security concept. Siemens' products and solutions constitute one element of such a concept.

Customers are responsible for preventing unauthorized access to their plants, systems, machines and networks. Such systems, machines and components should only be connected to an enterprise network or the internet if and to the extent such a connection is necessary and only when appropriate security measures (e.g. firewalls and/or network segmentation) are in place.

For additional information on industrial security measures that may be implemented, please visit
<https://www.siemens.com/industrialsecurity>.

Siemens' products and solutions undergo continuous development to make them more secure. Siemens strongly recommends that product updates are applied as soon as they are available and that the latest product versions are used. Use of product versions that are no longer supported, and failure to apply the latest updates may increase customer's exposure to cyber threats.

To stay informed about product updates, subscribe to the Siemens Industrial Security RSS Feed under
<https://www.siemens.com/cert>.

2.3 Intended use

Improper use of 3RU2 thermal overload relays / 3RB2/3RB3 electronic overload relays

Improper use of 3RU2 thermal overload relays / 3RB2/3RB3 electronic overload relays and their accessories will result in danger to life, risk of serious injury, or property damage.

This equipment is only allowed to be used for the applications described in the catalog and in the technical description, and only in conjunction with non-Siemens equipment and components recommended by Siemens.

Correct transport, storage, installation and assembly, as well as careful operation and maintenance, are required to ensure that the product operates safely and without faults.

Before you run any sample programs or programs that you have written yourself, make sure that running the plant cannot cause injury to anyone else or damage to the machine itself.

2.4 Current information about operational safety

Important note for maintaining the operational safety of your system

Please take note of our latest information. Systems with safety-oriented characteristics are subject to special operational safety requirements on the part of the operator. The supplier is also obliged to comply with certain actions when monitoring the product. By subscribing to the appropriate newsletter, you will ensure that you are always up-to-date and able to make changes to your system, when necessary:

For this purpose, go to the page: SIEMENS newsletter (www.siemens.com/sirius/newsletter)

Click "Subscribe to newsletter".

2.5 Electromagnetic compatibility (EMC) according to IEC 60947-4-1

This product is designed for Environment A. It may produce radio interference in domestic environments, in which case the user may be required to take adequate mitigation measures.

2.6 Recycling and disposal

For environmentally-friendly recycling and disposal of your old device, contact a company certified for the disposal of used electrical and electronic equipment, and dispose of the device as specified in the regulations for your particular country.

Standards

3.1 Standards

Applicable standards

3RU21 thermal overload relays and 3RB20 / 3RB21 and 3RB30 / 3RB31 electronic overload relays meet the requirements of the following standards:

Table 3-1 Standards

Device standards	<ul style="list-style-type: none"> • IEC/EN 60947-1 • IEC/EN 60947-4-1 • IEC/EN 60947-5-1 • UL 60947-4-1 • CSA C 22.2
EMC standard	3RB30 ^o / 3RB31 electronic overload relays additionally fulfill the EMC standards specified in IEC 60947-4-1.
Touch protection on the front	IEC 60529
Degree of protection IP20 on the front	IEC 60529

3.2 Requirements for switching high-efficiency motors

The increased requirements for protection devices and switchgear when switching high-efficiency motors are covered by the new utilization category AC-3e introduced in the IEC 60947-4-1 product standard.

The utilization category AC-3e takes into account the higher switch-on characteristic of efficiency-enhanced motors. This is reflected, for example, in a higher starting current when starting squirrel-cage motors.

All SIRIUS protection devices and switchgear that are subject to the IEC 60947-4-1 product standard meet the increased requirements in accordance with utilization category AC-3e and are suitable for use with high-efficiency motors.

3.3 Voltages

The specifications for 3-phase line supply according to IEC 60947-4-1 are valid for the following line system configurations:

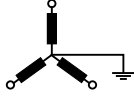
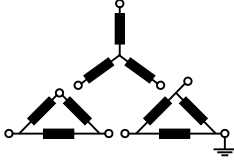
Voltage specification U_e in the Equipment Manual	Line system configurations	
	Three-phase four-wire systems	Three-phase three-wire systems
		
[V]	[V]	[V]
230	--	230
400	230 / 400	400
440	260 / 440	440
500	--	500
690	400 / 690	690 (only from size S3)
1000	--	1000

-- not specified

3.4 Notes on the protection of device connections

The specifications for short-circuit protection (fuses, circuit breakers, or miniature circuit breakers) are available for the device connections of the main circuit and the auxiliary circuit. In order to ensure a holistic view for the protection of the device connections, the manufacturer is obliged to provide all relevant information for short-circuit protection and overcurrent protection.

If, for example, device connections for the control supply voltage, the supply voltage, or digital inputs/digital outputs are not connected to self-limiting current sources or energy sources, you can find the relevant information in the Equipment Manual or the technical data sheet.

Reference

Other standards that 3RU and 3RB overload relays conform to are listed in chapter Technical data (Page 161). SIRIUS components have been approved by a whole range of bodies for various sectors (shipbuilding, etc.). An up-to-date list of approvals is provided in the appendix of the Siemens IC 10 Catalog - "SIRIUS Industrial Controls". You will find more information and downloadable certificates on the Internet (<https://support.industry.siemens.com/cs/ww/en>).

Product description

4.1 Versions

Sizes, setting ranges, and device versions

The table below provides an overview of the various sizes in which 3RU21 thermal overload relays and 3RB20 / 3RB21 and 3RB30 / 3RB31 electronic overload relays are available. The maximum rated currents, the minimum and maximum setting ranges, and the available tripping classes are listed for each individual size.

Table 4-1 3RU21 thermal overload relays

Size	Width	Current range	Rated operating voltage U_e	Rated frequency	Trip class
S00	45 mm	0.11 to 16 A	690 V AC	50/60 Hz	CLASS 10
S0	45 mm	1.8 to 40 A			CLASS 10 or CLASS 10A
S2	55 mm	5.5 ... 80 A			CLASS 10
S3	70 mm	28 ... 100 A	1000 V AC		CLASS 10

Table 4-2 3RB20 / 3RB30 electronic overload relays

	Size	Width	Current range	Rated operating voltage U_e	Rated frequency	Trip class
3RB30	S00	45 mm	0.1 to 16 A	690 V AC	50/60 Hz	CLASS 10E or 20E (fixed)
	S0	45 mm	0.1 to 40 A	690 V AC Through-hole technology: 1000 V AC		
	S2	55 mm	12.5 to 80 A			
	S3	70 mm	12.5 ... 115 A	1000 V AC		
3RB20	S6	120 mm	50 ... 200 A	1000 V AC		
	S10 / S12	145 mm	55 ... 250 A to 160 ... 630 A	1000 V AC		

Table 4-3 3RB21 / 3RB31 electronic overload relays

	Size	Width	Current range	Rated operating voltage U_e	Rated frequency	Trip class
3RB31	S00	45 mm	0.1 to 16 A	690 V AC	50/60 Hz	CLASS 5E, 10E, 20E, 30E (adjustable)
	S0	45 mm	0.1 to 40 A			
	S2	55 mm	12.5 to 80 A	690 V AC Through-hole technology: 1000 V AC		
	S3	70 mm	12.5 ... 115 A	1000 V AC		
3RB21	S6	120 mm	50 ... 200 A	1000 V AC		
	S10 / S12	145 mm	55 ... 250 A to 160 ... 630 A	1000 V AC		

3RB30 / 3RB31 electronic overload relays have approximately the same dimensions as 3RU21 thermal overload relays. As a result, the thermal overload relays can be replaced easily with the electronic variant 3RB30 / 3RB31. This is necessary, for example, if increased overload protection is required (wide setting ranges (1:4), for example, or even reduced power loss and, as a result, minimized energy consumption).

4.2 Operating principle

3RU21 thermal overload relays

3RU21 thermal overload relays up to 100 A have been designed to provide current-dependent protection for loads with normal starting against impermissibly high temperature rises due to overload, phase asymmetry or phase failure.

An overload or phase failure results in an increase of the motor current beyond the set rated motor current. Via heating elements, this current rise increasingly heats up the bimetal strips located inside the device. The deflection of these bimetal strips eventually activates the auxiliary contacts via a release mechanism. The contacts then disconnect the load via a contactor. (The contactor function is not an integral component of the overload relay).

3RB20 / 3RB21 and 3RB30 / 3RB31 electronic overload relays

3RB20 / 3RB21 electronic overload relays up to 115 A and 3RB30 / 3RB31 electronic overload relays up to 630 A with an internal power supply have been designed to provide current-dependent protection for loads with normal and heavy starting against impermissibly high temperature rises due to overload, phase asymmetry or phase failure.

An overload, phase asymmetry or a phase failure results in an increase of the motor current beyond the set rated motor current.

This rise in current is detected by the current transformers integrated into the devices and evaluated by corresponding electronic circuits which then output a pulse to the auxiliary contacts. The contacts then disconnect the load via a contactor. (The contactor function is not an integral component of the overload relay).

In addition to current-dependent protection for loads against impermissibly high temperature rise caused by overload, phase asymmetry, and phase failure, 3RB21 and 3RB31 electronic overload relays feature internal ground-fault detection (not possible in conjunction with contactor assemblies for star-delta (wye-delta) start). This provides protection of loads against high-impedance faults to ground caused by damaged insulation, moisture, condensation, etc.

4.3 System integration

System integration

The overload relays have been matched to the contactors in the 3RT series both electrically and mechanically and can be integrated in the feeder by means of direct mounting. 3RU2 thermal overload relays are available in sizes S00 to S3 up to 100 A. 3RB30 and 3RB31 electronic overload relays are available in sizes S00 to S3 up to 115 A. 3RB20 and 3RB21 electronic overload relays are available in sizes S6 to S10 / S12 up to 630 A.

4.4 Connection systems

Connection systems

The overload relays are available with the following connection system options:

- Screw-type connection system
- Spring-loaded connection system (size S2 to S12, auxiliary circuit only)

3RB3 (sizes S2 and S3) and 3RB2 (size S6) electronic overload relays are also available in through-hole technology with a straight-through transformer. As an alternative, 3RB20 / 3RB21 electronic overload relays in sizes S6 to S10 / S12 can be connected to the main circuit via busbars.

4.5 Applications

Table 4-4 Overview of applications

Applications	3RU21	3RB20 / 3RB21 3RB30 / 3RB31
System protection	✓ ¹⁾	✓ ¹⁾
Motor protection	✓	✓
Alternating current, 3-phase	✓	✓

4.5 Applications

Applications	3RU21	3RB20 / 3RB21 3RB30 / 3RB31
Alternating current, 1-phase	✓	-
DC current	✓	-

¹⁾ In the main circuit, the devices provide overload protection for the assigned electrical loads (e.g. motors), feeder cable, and other switching and protection devices in the respective load feeder. The 3 phases have to be under symmetrical load.

3RU21 thermal overload relays

3RU21 thermal overload relays have been designed to protect three-phase loads, DC loads, and single-phase AC loads.

Note

Protection of DC loads/single-phase AC loads

If a 3RU21 thermal overload relay is to be used to protect DC loads or single-phase AC loads, all the bimetal strips have to be heated. Therefore, all of the relay's main current paths have to be connected in series.

3RB20 / 3RB21 and 3RB30 / 3RB31 electronic overload relays

3RB20 / 3RB21 and 3RB30 / 3RB31 electronic overload relays are designed to protect three-phase loads in sinusoidal 50/60 Hz voltage supplies.

Note

DC loads/Single-phase AC loads

The relay is not suitable for protecting DC loads or single-phase AC loads. On single-pole loads, the 3RU21 thermal overload relay or the 3RB22, 3RB23 and 3RB24 electronic overload relays for higher applications (no protection for DC loads) must be used for IO-Link.

Reference

More information ...	Can be found in the chapter titled ...
About overload relay applications	Configuration (Page 59)

The advantages of load feeders with overload relays

Installing load feeders with overload relays (fuses + contactor + overload relay or MSP for starter combinations/circuit breaker (acc. to UL) + contactor + overload relay) has the following advantages over configurations without overload relays (motor starter protector + contactor):

- Overload release and short-circuit release are signaled separately. In the event of a short circuit the fuses or the MSP for starter combinations/circuit breaker (acc. to UL) limit the short-circuit current and in the event of an overload the overload relay disconnects the contactor (and thus the load).
- The overload relays are especially suitable for use in fused switchgear assemblies. The devices are also used in applications in line networks with operating voltages of more than 400 V. Compared with fuseless design, the fuses still have an extremely high short-circuit breaking capacity in excess of 100 kA, even in these voltage ranges.
- Automatic RESET is easy to implement with the overload relays. Following an overload trip, the load feeder need not be switched on again on-site.
- Attachable electrical or mechanical RESET modules compatible for use with all sizes enable 3RU21 thermal overload relays to be RESET remotely. An electrical remote RESET is an integral component of the 3RB21 / 3RB31 electronic overload relays.
- Applications with lengthy start times can be implemented thanks to the different trip classes of the 3RB20 / 3RB21 and 3RB30 / 3RB31 electronic overload relays.
- 3RB20 / 3RB21 and 3RB30 / 3RB31 electronic overload relays reduce variation and simplify configuring and inventory management thanks to their wide 1:4 setting range.
- MSP for starter combinations/circuit breaker (acc. to UL) + contactor + overload relay combinations have the advantage that the load feeder can be isolated easily and all three poles can be disconnected in the event of a short circuit.

4.6 3RU21 thermal overload relays

3RU2116 thermal overload relay, size S00, 45 mm width

Front view	Description
	Position digits
	① Connection for contactor mounting: In terms of their electrical and mechanical features and their design, these pins are perfectly compatible with the 3RT2 contactors for the direct mounting of overload relays. Stand-alone installation is also an option (in conjunction with a stand-alone assembly module).
	② Switch position indicator and TEST function for wiring: Indicates a trip and facilitates testing of the wiring.
	③ Motor current setting: The large rotary button provides an easy means of setting the device to the rated motor current.
	④ Data Matrix code
	⑤ Feed-through: Contactor coil terminal
	⑥ Feed-through: Contactor auxiliary switch
	⑦ Main circuit terminals: The main circuit can be connected using either a screw-type, spring-loaded, or ring cable lug connection system.
	⑧ Control circuit terminals: A screw-type, spring-loaded or ring cable lug connection system can be used to connect the control circuit terminal.
	⑨ STOP button: Pressing the button opens the NC contact, thereby disconnecting the downstream contactor. The NC contact closes again when the button is released.
	⑩ Mode selector switch for manual/automatic RESET and RESET button: this switch is used to choose between manual and automatic RESET. A device set to manual RESET can be reset locally by pressing the RESET button. The device can be reset remotely using the RESET modules (accessories) which are compatible for use with all sizes.
⑪ Labeling plate	

3RU2116 overload relay equipment

Terminal labels and notes on the protection of device connections

2/T1	Main circuit terminals	For information on the protection of the main circuit of the 3RT2. contactors used, refer to the Equipment Manual - SIRIUS 3RT Contactors / Contactor Assemblies (https://support.industry.siemens.com/cs/ww/en/view/60306557) and the technical data sheet (https://support.industry.siemens.com/cs/ww/en/ps/16132/td).
4/T2		
6/T3		
95	NC contact (NC 95-96)	You can find technical specifications of the product in the Siemens Industry Online Support (https://support.industry.siemens.com/cs/ww/en/ps/16269/td).
96		
97	NO contact (NO 97-98)	You can find technical specifications of the product in the Siemens Industry Online Support (https://support.industry.siemens.com/cs/ww/en/ps/16269/td).
98		

14/22	Feed-through contactor auxiliary switch	For information on the protection of the auxiliary contacts of the 3RT2. contactors used, refer to the Equipment Manual - SIRIUS Contactors / Contactor Assemblies 3RT (https://support.industry.siemens.com/cs/ww/en/view/60306557) and the technical data sheet (https://support.industry.siemens.com/cs/ww/en/ps/16132/td).
A2	Feed-through contactor coil terminal	For information on the protection of the 3RT2. contactor coils, refer to the Equipment Manual - SIRIUS Contactors / Contactor Assemblies 3RT (https://support.industry.siemens.com/cs/ww/en/view/60306557) and the technical data sheet (https://support.industry.siemens.com/cs/ww/en/ps/16132/td).

3RU2126 thermal overload relay, size S0, 45 mm width

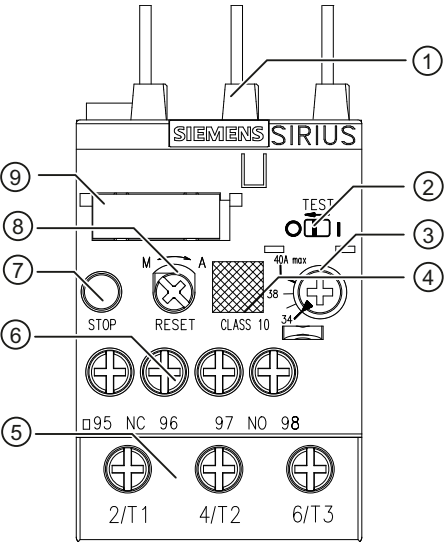
Front view	Description
 <p>3RU2126 overload relay equipment</p>	<p>Position digits</p>
	<p>① Connection for contactor mounting: In terms of their electrical and mechanical features and their design, these pins are perfectly compatible with the 3RT2 contactors for the direct mounting of overload relays. Stand-alone assembly is also an option (in conjunction with a stand-alone assembly module).</p>
	<p>② Switch position indicator and TEST function for wiring: Indicates a trip and facilitates testing of the wiring.</p>
	<p>③ Motor current setting: The large rotary button provides an easy means of setting the device to the rated motor current.</p>
	<p>④ Data Matrix code</p>
	<p>⑤ Main circuit terminals: A screw-type, spring-loaded or ring cable lug connection system can be used to connect the main circuit terminal.</p>
	<p>⑥ Control circuit terminals: A screw-type, spring-loaded or ring cable lug connection system can be used to connect the control circuit terminal.</p>
	<p>⑦ STOP button: Pressing the button opens the NC contact, thereby disconnecting the downstream contactor. The NC contact closes again when the button is released.</p>
	<p>⑧ Selector switch for manual / automatic RESET and RESET button: this switch is used to choose between manual and automatic RESET. A device set to manual RESET can be reset locally by pressing the RESET button. The device can be reset remotely using the RESET modules (accessories) which are compatible for use with all sizes.</p>
	<p>⑨ Label</p>
<p>Terminal labels</p>	
<p>2/T1</p>	<p>Main circuit terminals</p>
<p>4/T2</p>	
<p>6/T3</p>	
<p>95</p>	<p>NC contact (NC 95-96)</p>
<p>96</p>	
<p>97</p>	<p>NO contact (NO 97-98)</p>
<p>98</p>	

3RU2136 thermal overload relay, size S2, 55 mm width

Front view	Description				
<p>3RU2136 overload relay equipment</p>	Position digits				
	<p>① Connection for contactor mounting: In terms of their electrical and mechanical features and their design, these pins are perfectly compatible with the 3RT2 contactors for the direct mounting of overload relays. Stand-alone assembly is also an option (in conjunction with a stand-alone assembly module).</p>				
	<p>② Switch position indicator and TEST function for wiring: Indicates a trip and facilitates testing of the wiring.</p>				
	<p>③ Motor current setting: The large rotary button provides an easy means of setting the device to the rated motor current.</p>				
	<p>④ Data Matrix code</p>				
	<p>⑤ Main circuit terminals: A screw-type connection system can be used to connect the main circuit terminal.</p>				
	<p>⑥ Control circuit terminals: A screw-type or spring-loaded connection system can be used to connect the control circuit terminal.</p>				
	<p>⑦ STOP button: Pressing the button opens the NC contact, thereby disconnecting the downstream contactor. The NC contact closes again when the button is released.</p>				
	<p>⑧ Selector switch for manual / automatic RESET and RESET button: this switch is used to choose between manual and automatic RESET. A device set to manual RESET can be reset locally by pressing the RESET button. The device can be reset remotely using the RESET modules (accessories) which are compatible for use with all sizes.</p>				
	<p>⑨ Label</p>				
Terminal labels	<table border="1"> <tr> <td data-bbox="722 1308 798 1344">2/T1</td> <td data-bbox="798 1308 1479 1344" rowspan="3">Main circuit terminals</td> </tr> <tr> <td data-bbox="722 1344 798 1381">4/T2</td> </tr> <tr> <td data-bbox="722 1381 798 1417">6/T3</td> </tr> </table>	2/T1	Main circuit terminals	4/T2	6/T3
2/T1	Main circuit terminals				
4/T2					
6/T3					
95	NC contact (NC 95-96)				
96					
97	NO contact (NO 97-98)				
98					

3RU2146 thermal overload relays, size S3, 70 mm width

Front view	Description				
	<p>Position digits</p>				
	<p>① Connection for contactor mounting: In terms of their electrical and mechanical features and their design, these pins are perfectly compatible with the 3RT2 contactors for the direct mounting of overload relays. Stand-alone assembly is also an option (in conjunction with a stand-alone assembly module).</p>				
	<p>② Switch position indicator and TEST function for wiring: Indicates a trip and facilitates testing of the wiring.</p>				
	<p>③ Motor current setting: The large rotary button provides an easy means of setting the device to the rated motor current.</p>				
	<p>④ Data Matrix code</p>				
	<p>⑤ Main circuit terminals: A screw-type connection system can be used to connect the main circuit terminal. Ring terminal lug connection or busbar connection after removal of the box terminal block is optionally possible.</p>				
	<p>⑥ Control circuit terminals: A screw-type or spring-loaded connection system can be used to connect the control circuit terminal.</p>				
	<p>⑦ STOP button: Pressing the button opens the NC contact, thereby disconnecting the downstream contactor. The NC contact closes again when the button is released.</p>				
	<p>⑧ Selector switch for manual / automatic RESET and RESET button: this switch is used to choose between manual and automatic RESET. A device set to manual RESET can be reset locally by pressing the RESET button. The device can be reset remotely using the RESET modules (accessories) which are compatible for use with all sizes.</p>				
	<p>⑨ Label</p>				
<p>3RU2146 overload relay equipment</p>	<p>Terminal labels</p>				
	<table border="1"> <tr> <td>2/T1</td> <td rowspan="3">Main circuit terminals</td> </tr> <tr> <td>4/T2</td> </tr> <tr> <td>6/T3</td> </tr> </table>	2/T1	Main circuit terminals	4/T2	6/T3
	2/T1	Main circuit terminals			
	4/T2				
	6/T3				
	<table border="1"> <tr> <td>95</td> <td rowspan="2">NC contact (NC 95-96)</td> </tr> <tr> <td>96</td> </tr> </table>	95	NC contact (NC 95-96)	96	
	95	NC contact (NC 95-96)			
	96				
	<table border="1"> <tr> <td>97</td> <td rowspan="2">NO contact (NO 97-98)</td> </tr> <tr> <td>98</td> </tr> </table>	97	NO contact (NO 97-98)	98	
	97	NO contact (NO 97-98)			
98					

A sealable transparent cover can be optionally mounted on the thermal overload relays in the sizes S00, S0, S2 and S3 (Accessories (Page 123)). It stops the motor setting being tampered with.

Auxiliary contacts

3RU21 thermal overload relays are equipped with an NO contact for the "tripped" message and an NC contact for disconnecting the contactor.

4.7 3RB20 electronic overload relays

3RB2056 electronic overload relay, size S6, 120 mm width

Front view	
3RB2056 overload relay equipment	
Position digits	
①	Connection for contactor mounting: In terms of their electrical and mechanical features and their design, these busbars are perfectly compatible with 3RT1 contactors for the direct mounting of overload relays.
②	Switch position indicator and TEST function for wiring: Indicates a trip and facilitates testing of the wiring.
③	RESET button A device set to manual RESET can be reset locally by pressing the RESET button. On the 3RB21 an electronic remote RESET is integrated.
④	Electronics test (device test): Enables a test of all major device components and functions.
⑤	Control circuit terminal (removable): A screw-type or spring-loaded system can be used to connect the control circuit terminal.

Front view	
⑥	<p>Main circuit connection: The following variants of connection to the main circuit are possible:</p> <ul style="list-style-type: none"> • Bus connection system • Connection with box terminal block • Connection with box terminal block and through-hole technology with straight-through transformer
⑦	<p>Selector switch for manual/automatic RESET and RESET button: The slide switch is used to choose between manual and automatic RESET.</p>
⑧	Data Matrix code
⑨	<p>Motor current setting: The large rotary button provides an easy means of setting the device to the rated motor current.</p>
⑩	Label
Terminal labels	
95	NC contact (NC 95-96)
96	
97	NO contact (NO 97-98)
98	

3RB2066 electronic overload relays, size S10 / 12, 145 mm width

Front view	
3RB2066 overload relay equipment	
Position digits	
①	<p>Connection for contactor mounting: In terms of their electrical and mechanical features and their design, these busbars are perfectly compatible with 3RT1 contactors for the direct mounting of overload relays.</p>
②	<p>Switch position indicator and TEST function for wiring: Indicates a trip and facilitates testing of the wiring.</p>
③	<p>RESET button A device set to manual RESET can be reset locally by pressing the RESET button. On the 3RB21 an electronic remote RESET is integrated.</p>
④	<p>Electronics test (device test): Enables a test of all major device components and functions.</p>
⑤	<p>Control circuit terminal (removable): A screw-type or spring-loaded system can be used to connect the control circuit terminal.</p>
⑥	<p>Main circuit connection: The following variants of connection to the main circuit are possible:</p> <ul style="list-style-type: none"> • Bus connection system • Connection with box terminal block
⑦	<p>Selector switch for manual/automatic RESET and RESET button: The slide switch is used to choose between manual and automatic RESET.</p>
⑧	<p>Data Matrix code</p>

4.8 3RB21 electronic overload relays

Front view	
⑨	Motor current setting: The large rotary button provides an easy means of setting the device to the rated motor current.
⑩	Label
Terminal labels	
95	NC contact (NC 95-96)
96	
97	NO contact (NO 97-98)
98	

Auxiliary contacts

3RB20 / 3RB30 electronic overload relays are equipped with an NO contact for the "tripped" message and an NC contact for disconnecting the contactor.

4.8 3RB21 electronic overload relays

3RB2153 electronic overload relays, size S6, 120 mm width

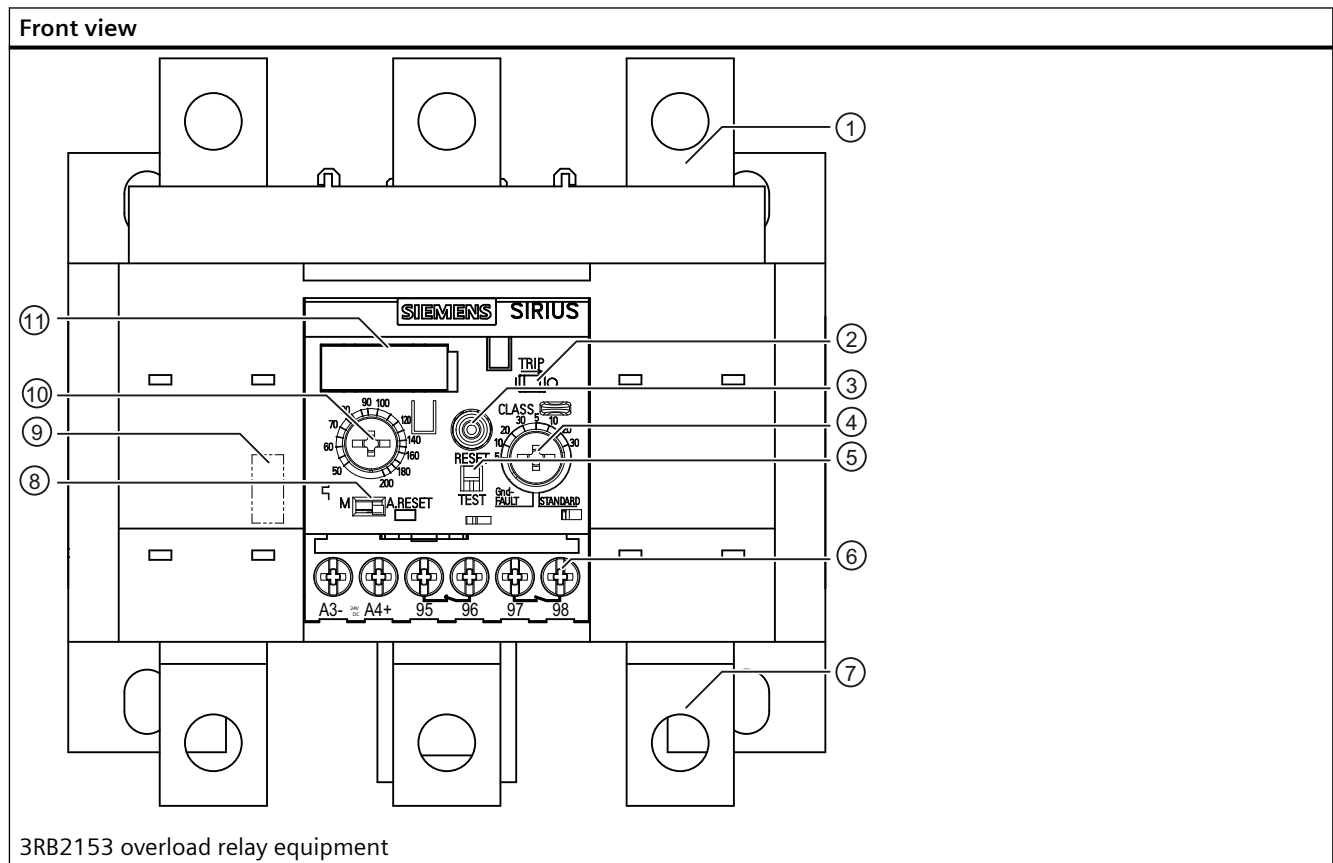

Position digits	
Front view	
①	Connection for contactor mounting: In terms of their electrical and mechanical features and their design, these busbars are perfectly compatible with 3RT1 contactors for the direct mounting of overload relays.
②	Switch position indicator and TEST function for wiring: Indicates a trip and facilitates testing of the wiring.
③	RESET button A device set to manual RESET can be reset locally by pressing the RESET button. On the 3RB21 an electronic remote RESET is integrated.
④	Tripping class setting / internal ground-fault detection (3RB21 only): The rotary switch is used to set the required tripping class dependent upon the starting conditions and activate internal ground-fault detection.
⑤	Electronics test (device test): Enables a test of all major device components and functions.
⑥	Control circuit terminal (removable): A screw-type or spring-loaded system can be used to connect the control circuit terminal.
⑦	Main circuit connection: The following variants of connection to the main circuit are possible: <ul style="list-style-type: none"> • Bus connection system • Connection with box terminal block • Connection with box terminal block and through-hole technology with a straight-through transformer
⑧	Mode selector switch for manual/automatic RESET and RESET button: The slide switch is used to choose between manual and automatic RESET.
⑨	Data Matrix code
⑩	Motor current setting: The large rotary button provides an easy means of setting the device to the rated motor current.
⑪	Labeling plate

Terminal labels and notes on the protection of device connections

95	NC contact (NC 95-96)	You can find technical specifications of the product in the Siemens Industry Online Support (https://support.industry.siemens.com/cs/ww/en/ps/16269/td).
96		
97	NO contact (NO 97-98)	You can find technical specifications of the product in the Siemens Industry Online Support (https://support.industry.siemens.com/cs/ww/en/ps/16269/td).
98		
A3- A4+	Terminals for electrical remote RESET	No additional measures are required for short-circuit protection.

3RB2163 electronic overload relays, size S10 / S12, 145 mm width

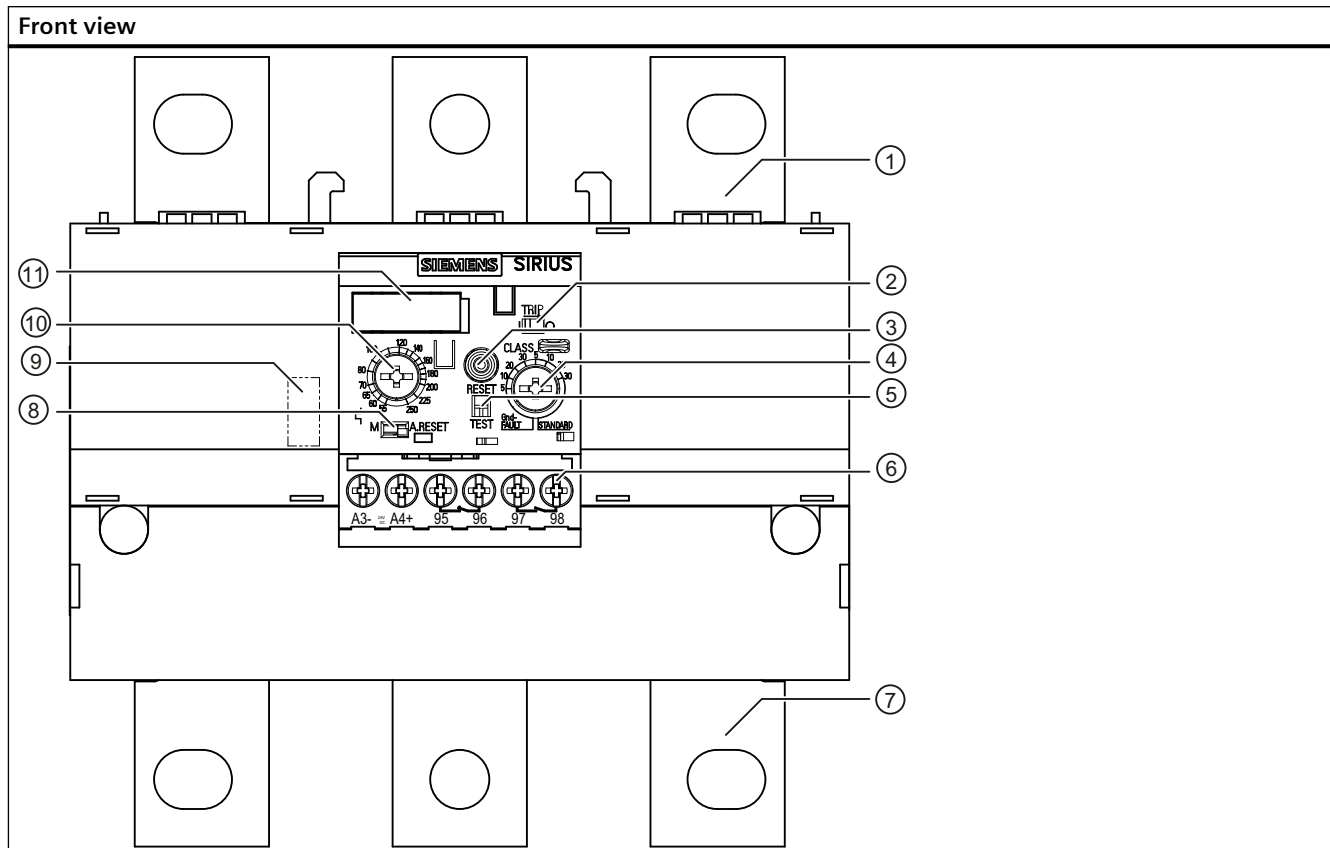

3RB2163 overload relay equipment

Position digits

①	<p>Connection for contactor mounting: In terms of their electrical and mechanical features and their design, these busbars are perfectly compatible with 3RT1 contactors for the direct mounting of overload relays.</p>
②	<p>Switch position indicator and TEST function for wiring: Indicates a trip and facilitates testing of the wiring.</p>
③	<p>RESET button A device set to manual RESET can be reset locally by pressing the RESET button. On the 3RB21 an electronic remote RESET is integrated.</p>
④	<p>Tripping class setting / internal ground-fault detection (3RB21 only): The rotary switch is used to set the required tripping class dependent upon the starting conditions and activate internal ground-fault detection.</p>
⑤	<p>Electronics test (device test): Enables a test of all major device components and functions.</p>
⑥	<p>Control circuit terminal (removable): A screw-type or spring-loaded system can be used to connect the control circuit terminal.</p>
⑦	<p>Main circuit connection: The following variants of connection to the main circuit are possible:</p> <ul style="list-style-type: none"> • Bus connection system • Connection with box terminal block
⑧	<p>Mode selector switch for manual/automatic RESET and RESET button: The slide switch is used to choose between manual and automatic RESET.</p>

Front view	
⑨	Data Matrix code
⑩	Motor current setting: The large rotary button provides an easy means of setting the device to the rated motor current.
⑪	Labeling plate

Terminal labels and notes on the protection of device connections

95	NC contact (NC 95-96)	You can find technical specifications of the product in the Siemens Industry Online Support (https://support.industry.siemens.com/cs/ww/en/ps/16269/td).
96		
97	NO contact (NO 97-98)	You can find technical specifications of the product in the Siemens Industry Online Support (https://support.industry.siemens.com/cs/ww/en/ps/16269/td).
98		
A3- A4+	Terminals for electrical remote RESET	No additional measures are required for short-circuit protection.

Auxiliary contacts

3RB21 / 3RB31 electronic overload relays are equipped with an NO contact for the "tripped" message and an NC contact for disconnecting the contactor.

4.9 3RB30 solid-state overload relays

3RB3016 electronic overload relay, size S00, 45 mm width

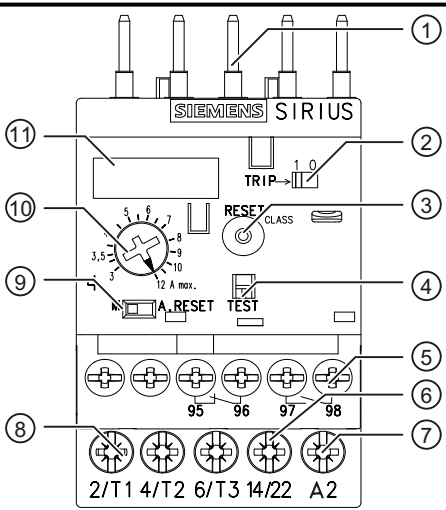
Front view	Description
 <p>3RB3016 overload relay equipment</p>	Position digits
	① Connection for contactor mounting: In terms of their electrical and mechanical features and their design, these pins are perfectly compatible with the 3RT2 contactors for the direct mounting of overload relays. Stand-alone installation is also an option (in some cases in conjunction with a stand-alone assembly module).
	② Switch position indicator and TEST function for wiring: Indicates a trip and facilitates testing of the wiring.
	③ RESET button A device set to manual RESET can be reset locally by pressing the RESET button.
	④ Electronics test (device test): Enables a test of all major device components and functions.
	⑤ Control circuit terminals (removable): A screw-type or spring-loaded system can be used to connect the control circuit terminal.
	⑥ Feed-through: Contactor auxiliary switch
	⑦ Feed-through: Contactor coil terminal
	⑧ Main circuit terminals: Main circuits can be connected using either a screw-type or spring-loaded connection system.
	⑨ Mode selector switch for manual/automatic RESET and RESET button: The slide switch is used to choose between manual and automatic RESET.
	⑩ Motor current setting: The large rotary button provides an easy means of setting the device to the rated motor current.
⑪ Labeling plate / Data Matrix code (behind the labeling plate)	

Terminal labels and notes on the protection of device connections

2/T1	Main circuit terminals	For information on the protection of the main circuit of the 3RT2. contactors used, refer to the Equipment Manual - SIRIUS 3RT Contactors / Contactor Assemblies (https://support.industry.siemens.com/cs/ww/en/view/60306557) and the technical data sheet (https://support.industry.siemens.com/cs/ww/en/ps/16132/td).
4/T2		
6/T3		
95	NC contact (NC 95-96)	You can find technical specifications of the product in the Siemens Industry Online Support (https://support.industry.siemens.com/cs/ww/en/ps/16269/td).
96		
97	NO contact (NO 97-98)	You can find technical specifications of the product in the Siemens Industry Online Support (https://support.industry.siemens.com/cs/ww/en/ps/16269/td).
98		

14/22	Feed-through contactor auxiliary switch	For information on the protection of the auxiliary contacts of the 3RT2. contactors used, refer to the Equipment Manual - SIRIUS Contactors / Contactor Assemblies 3RT (https://support.industry.siemens.com/cs/ww/en/view/60306557) and the technical data sheet (https://support.industry.siemens.com/cs/ww/en/ps/16132/td).
A2	Feed-through contactor coil terminal	For information on protecting 3RT2. contactor coils, refer to the Equipment Manual - SIRIUS Contactors / Contactor Assemblies 3RT (https://support.industry.siemens.com/cs/ww/en/view/60306557) and the technical data sheet (https://support.industry.siemens.com/cs/ww/en/ps/16132/td).

3RB3026 thermal overload relay, size S0, 45 mm width

Front view	Description	
<p>SIEMENS SIRIUS</p> <p>TRIP CLASS 10</p> <p>RESET</p> <p>TEST</p> <p>MIN. A RESET</p> <p>95 96 97 98</p> <p>2/T1 4/T2 6/T3</p>	Position digits	
	①	<p>Connection for contactor mounting: In terms of their electrical and mechanical features and their design, these pins are perfectly compatible with the 3RT2 contactors for the direct mounting of overload relays. Stand-alone assembly is also an option (in some cases in conjunction with a stand-alone assembly module).</p>
	②	<p>Switch position indicator and TEST function for wiring: Indicates a trip and facilitates testing of the wiring.</p>
	③	<p>RESET button A device set to manual RESET can be reset locally by pressing the RESET button.</p>
	④	<p>Electronics test (device test): Enables a test of all major device components and functions.</p>
	⑤	<p>Control circuit terminals (removable): A screw-type or spring-loaded system can be used to connect the control circuit terminal.</p>
	⑥	<p>Main circuit terminals: A screw-type or spring-loaded system can be used to connect the main circuit terminal.</p>
	⑦	<p>Selector switch for manual/automatic RESET and RESET button: The slide switch is used to choose between manual and automatic RESET.</p>
	⑧	<p>Motor current setting: The large rotary button provides an easy means of setting the device to the rated motor current.</p>
	⑨	Label / Data Matrix code (behind the label)
Terminal labels		
2/T1	Main circuit terminals	
4/T2		
6/T3		
95	NC contact (NC 95-96)	
96		
97	NO contact (NO 97-98)	
98		

3RB3026 overload relay equipment

3RB3036 electronic overload relays, size S2, 55 mm width

Front view	Description	
<p>3RB3036 overload relay equipment</p>	Position digits	
	①	<p>Connection for contactor mounting: In terms of their electrical and mechanical features and their design, these pins are perfectly compatible with the 3RT2 contactors for the direct mounting of overload relays. Stand-alone assembly is also an option (in some cases in conjunction with a stand-alone assembly module).</p>
	②	<p>Switch position indicator and TEST function for wiring: Indicates a trip and facilitates testing of the wiring.</p>
	③	<p>RESET button A device set to manual RESET can be reset locally by pressing the RESET button.</p>
	④	<p>Electronics test (device test): Enables a test of all major device components and functions.</p>
	⑤	<p>Control circuit terminal (removable): A screw-type or spring-loaded system can be used to connect the control circuit terminal.</p>
	⑥	<p>Main circuit terminal: The main circuit can be connected using either the screw-type connection system or through-hole technology with straight-through transformer.</p>
	⑦	<p>Selector switch for manual/automatic RESET and RESET button: The slide switch is used to choose between manual and automatic RESET.</p>
	⑧	<p>Motor current setting: The large rotary button provides an easy means of setting the device to the rated motor current.</p>
	⑨	<p>Label / Data Matrix code (behind the label)</p>
Terminal labels		
2/T1	Main circuit terminals	
4/T2		
6/T3		
95	NC contact (NC 95-96)	
96		
97	NO contact (NO 97-98)	
98		

3RB3046 electronic overload relays, size S3, 70 mm width

Front view	Description			
	<p>Position digits</p>			
	<p>① Connection for contactor mounting: In terms of their electrical and mechanical features and their design, these pins are perfectly compatible with the 3RT2 contactors for the direct mounting of overload relays. Stand-alone assembly is also an option (in some cases in conjunction with a stand-alone assembly module).</p>			
	<p>② Switch position indicator and TEST function for wiring: Indicates a trip and facilitates testing of the wiring.</p>			
	<p>③ RESET button A device set to manual RESET can be reset locally by pressing the RESET button.</p>			
	<p>④ Electronics test (device test): Enables a test of all major device components and functions.</p>			
	<p>⑤ Control circuit terminal (removable): A screw-type or spring-loaded system can be used to connect the control circuit terminal.</p>			
	<p>⑥ Main circuit terminal: The main circuit can be connected using either the screw-type connection system or through-hole technology with straight-through transformer. Ring terminal lug connection or busbar connection after removal of the box terminal block is optionally possible.</p>			
	<p>⑦ Selector switch for manual/automatic RESET and RESET button: The slide switch is used to choose between manual and automatic RESET.</p>			
	<p>⑧ Data Matrix code</p>			
	<p>⑨ Motor current setting: The large rotary button provides an easy means of setting the device to the rated motor current.</p>			
<p>⑩ Label</p>				
<p>Terminal labels</p>				
<table border="1"> <tr> <td>2/T1</td> <td rowspan="3">Main circuit terminals</td> </tr> <tr> <td>4/T2</td> </tr> <tr> <td>6/T3</td> </tr> </table>	2/T1	Main circuit terminals	4/T2	6/T3
2/T1	Main circuit terminals			
4/T2				
6/T3				
<table border="1"> <tr> <td>95</td> <td rowspan="2">NC contact (NC 95-96)</td> </tr> <tr> <td>96</td> </tr> </table>	95	NC contact (NC 95-96)	96	
95	NC contact (NC 95-96)			
96				
<table border="1"> <tr> <td>97</td> <td rowspan="2">NO contact (NO 97-98)</td> </tr> <tr> <td>98</td> </tr> </table>	97	NO contact (NO 97-98)	98	
97	NO contact (NO 97-98)			
98				
<table border="1"> <tr> <td>97</td> <td rowspan="2">NO contact (NO 97-98)</td> </tr> <tr> <td>98</td> </tr> </table>	97	NO contact (NO 97-98)	98	
97	NO contact (NO 97-98)			
98				
<table border="1"> <tr> <td>97</td> <td rowspan="2">NO contact (NO 97-98)</td> </tr> <tr> <td>98</td> </tr> </table>	97	NO contact (NO 97-98)	98	
97	NO contact (NO 97-98)			
98				

3RB3046 overload relay equipment

A sealable transparent cover can be optionally mounted on the electronic overload relays in the sizes S00, S0, S2 and S3 (Accessories (Page 123)). It stops the motor setting being tampered with.

Auxiliary contacts

3RB20 / 3RB30 electronic overload relays are equipped with an NO contact for the "tripped" message and an NC contact for disconnecting the contactor.

4.10 3RB31 solid-state overload relays

3RB3113 electronic overload relays, size S00, 45 mm width

Front view	Description
<p>3RB3113 electronic overload relay equipment</p>	<p>Position digits</p> <p>① Connection for contactor mounting: In terms of their electrical and mechanical features and their design, these pins are perfectly compatible with the 3RT2 contactors for the direct mounting of overload relays. Stand-alone installation is also an option (in some cases in conjunction with a stand-alone assembly module).</p> <p>② Switch position indicator and TEST function for wiring: Indicates a trip and facilitates testing of the wiring.</p> <p>③ RESET button A device set to manual RESET can be reset locally by pressing the RESET button. In addition, an electronic remote RESET is integrated into the 3RB31.</p> <p>④ Tripping class setting/internal ground-fault detection: This rotary switch is used to set the required tripping class dependent upon the starting conditions and activate internal ground-fault detection.</p> <p>⑤ Electronics test (device test): Enables a test of all major device components and functions.</p> <p>⑥ Control circuit terminal (removable): A screw-type or spring-loaded system can be used to connect the control circuit terminal.</p> <p>⑦ Feed-through: Contactor auxiliary switch</p> <p>⑧ Feed-through: Contactor coil terminal</p> <p>⑨ Main circuit terminal: The main circuit can be connected using either a screw-type or spring-loaded connection system.</p> <p>⑩ Mode selector switch for manual/automatic RESET and RESET button: The slide switch is used to choose between manual and automatic RESET.</p> <p>⑪ Motor current setting: The large rotary button provides an easy means of setting the device to the rated motor current.</p> <p>⑫ Labeling plate / Data Matrix code (behind the labeling plate)</p>

Terminal labels and notes on the protection of device connections

2/T1	Main circuit terminals	For information on the protection of the main circuit of the 3RT2. contactors used, refer to the Equipment Manual - SIRIUS 3RT Contactors / Contactor Assemblies (https://support.industry.siemens.com/cs/ww/en/view/60306557) and the technical data sheet (https://support.industry.siemens.com/cs/ww/en/ps/16132/td).
4/T2		
6/T3		
95	NC contact (NC 95-96)	You can find technical specifications of the product in the Siemens Industry Online Support (https://support.industry.siemens.com/cs/ww/en/ps/16269/td).
96		
97	NO contact (NO 97-98)	You can find technical specifications of the product in the Siemens Industry Online Support (https://support.industry.siemens.com/cs/ww/en/ps/16269/td).
98		
14/22	Feed-through contactor auxiliary switch	For information on the protection of the auxiliary contacts of the 3RT2. contactors used, refer to the Equipment Manual - SIRIUS Contactors / Contactor Assemblies 3RT (https://support.industry.siemens.com/cs/ww/en/view/60306557) and the technical data sheet (https://support.industry.siemens.com/cs/ww/en/ps/16132/td).
A2	Feed-through contactor coil terminal	For information on the protection of the 3RT2. contactor coils, refer to the Equipment Manual - SIRIUS Contactors / Contactor Assemblies 3RT (https://support.industry.siemens.com/cs/ww/en/view/60306557) and the technical data sheet (https://support.industry.siemens.com/cs/ww/en/ps/16132/td).
A3- A4+	Terminals for electrical remote RESET	No additional measures are required for short-circuit protection.

3RB3123 electronic overload relays, size S0, 45 mm width

Front view	Description	
<p>3RB3123 overload relay equipment</p>	Position digits	
	①	Connection for contactor mounting: In terms of their electrical and mechanical features and their design, these pins are perfectly compatible with the 3RT2 contactors for the direct mounting of overload relays. Stand-alone installation is also an option (in some cases in conjunction with a stand-alone assembly module).
	②	Switch position indicator and TEST function for wiring: Indicates a trip and facilitates testing of the wiring.
	③	RESET button A device set to manual RESET can be reset locally by pressing the RESET button. In addition, an electronic remote RESET is integrated into the 3RB31.
	④	Tripping class setting/internal ground-fault detection: This rotary switch is used to set the required tripping class dependent upon the starting conditions and activate internal ground-fault detection.
	⑤	Electronics test (device test): Enables a test of all major device components and functions.
	⑥	Control circuit terminal (removable): A screw-type or spring-loaded system can be used to connect the control circuit terminal.
	⑦	Main circuit terminal: The main circuit can be connected using either a screw-type or spring-loaded system.
	⑧	Mode selector switch for manual/automatic RESET and RESET button: The slide switch is used to choose between manual and automatic RESET.
	⑨	Motor current setting: The large rotary button provides an easy means of setting the device to the rated motor current.
⑩	Labeling plate / Data Matrix code (behind the labeling plate)	

Terminal labels and notes on the protection of device connections

2/T1	Main circuit terminals	For information on the protection of the main circuit of the 3RT2. contactors used, refer to the Equipment Manual - SIRIUS 3RT Contactors / Contactor Assemblies (https://support.industry.siemens.com/cs/ww/en/view/60306557) and the technical data sheet (https://support.industry.siemens.com/cs/ww/en/ps/16132/td).
4/T2		
6/T3		
95	NC contact (NC 95-96)	You can find technical specifications of the product in the Siemens Industry Online Support (https://support.industry.siemens.com/cs/ww/en/ps/16269/td).
96		
97	NO contact (NO 97-98)	You can find technical specifications of the product in the Siemens Industry Online Support (https://support.industry.siemens.com/cs/ww/en/ps/16269/td).
98		
A3- A4+	Terminals for electrical remote RESET	No additional measures are required for short-circuit protection.

3RB3133 electronic overload relays, size S2, 55 mm width

Front view	Description
	<p>Position digits</p> <p>① Connection for contactor mounting: In terms of their electrical and mechanical features and their design, these pins are perfectly compatible with the 3RT2 contactors for the direct mounting of overload relays. Stand-alone installation is also an option (in some cases in conjunction with a stand-alone assembly module).</p> <p>② Switch position indicator and TEST function for wiring: Indicates a trip and facilitates testing of the wiring.</p> <p>③ RESET button A device set to manual RESETO can be reset locally by pressing the RESET button. In addition, an electronic remote RESETO is integrated into the 3RB31.</p> <p>④ Tripping class setting/internal ground-fault detection (3RB313 only): This rotary switch is used to set the required tripping class dependent upon the starting conditions and activate internal ground-fault detection.</p> <p>⑤ Electronics test (device test): Enables a test of all major device components and functions.</p> <p>⑥ Control circuit terminal (removable): A screw-type or spring-loaded system can be used to connect the control circuit terminal.</p> <p>⑦ Main circuit terminal: The main circuit can be connected using either the screw-type connection system or through-hole technology with a straight-through transformer.</p> <p>⑧ Mode selector switch for manual/automatic RESETO and RESET button: The slide switch is used to choose between manual and automatic RESETO.</p> <p>⑨ Motor current setting: The large rotary button provides an easy means of setting the device to the rated motor current.</p> <p>⑩ Labeling plate / Data Matrix code (behind the labeling plate)</p>
<p>3RB3133 overload relay equipment</p>	

Terminal labels and notes on the protection of device connections

2/T1	Main circuit terminals	For information on the protection of the main circuit of the 3RT2. contactors used, refer to the Equipment Manual - SIRIUS 3RT Contactors / Contactor Assemblies (https://support.industry.siemens.com/cs/ww/en/view/60306557) and the technical data sheet (https://support.industry.siemens.com/cs/ww/en/ps/16132/td).
4/T2		
6/T3		
95	NC contact	You can find technical specifications of the product in the Siemens Industry Online Support (https://support.industry.siemens.com/cs/ww/en/ps/16269/td).
96	(NC 95-96)	
97	NO contact	You can find technical specifications of the product in the Siemens Industry Online Support (https://support.industry.siemens.com/cs/ww/en/ps/16269/td).
98	(NO 97-98)	

A3-	Terminals for electrical remote RESET	No additional measures are required for short-circuit protection.
A4+		

3RB3143 electronic overload relays, size S3, 70 mm width

Front view	Description
<p>3RB3143 overload relay equipment</p>	<p>Position digits</p> <p>① Connection for contactor mounting: In terms of their electrical and mechanical features and their design, these pins are perfectly compatible with the 3RT2 contactors for the direct mounting of overload relays. Stand-alone installation is also an option (in some cases in conjunction with a stand-alone assembly module).</p> <p>② Switch position indicator and TEST function for wiring: Indicates a trip and facilitates testing of the wiring.</p> <p>③ RESET button A device set to manual RESET can be reset locally by pressing the RESET button. In addition, an electronic remote RESET is integrated into the 3RB31.</p> <p>④ Tripping class setting / internal ground-fault detection (3RB31 only): The rotary switch is used to set the required tripping class dependent upon the starting conditions and activate internal ground-fault detection.</p> <p>⑤ Electronics test (device test): Enables a test of all major device components and functions.</p> <p>⑥ Control circuit terminal (removable): A screw-type or spring-loaded system can be used to connect the control circuit terminal.</p> <p>⑦ Main circuit terminal: The main circuit can be connected using either the screw-type connection system or through-hole technology with a straight-through transformer. Ring cable lug connection or busbar connection after removal of the box terminal block is also possible.</p> <p>⑧ Mode selector switch for manual/automatic RESET and RESET button: The slide switch is used to choose between manual and automatic RESET.</p> <p>⑨ Data Matrix code</p> <p>⑩ Motor current setting: The large rotary button provides an easy means of setting the device to the rated motor current.</p> <p>⑪ Labeling plate</p>

Terminal labels and notes on the protection of device connections

2/T1	Main circuit terminals	For information on the protection of the main circuit of the 3RT2. contactors used, refer to the Equipment Manual - SIRIUS 3RT Contactors / Contactor Assemblies (https://support.industry.siemens.com/cs/ww/en/view/60306557) and the technical data sheet (https://support.industry.siemens.com/cs/ww/en/ps/16132/td).
4/T2		
6/T3		
95	NC contact (NC 95-96)	You can find technical specifications of the product in the Siemens Industry Online Support (https://support.industry.siemens.com/cs/ww/en/ps/16269/td).
96		
97	NO contact (NO 97-98)	You can find technical specifications of the product in the Siemens Industry Online Support (https://support.industry.siemens.com/cs/ww/en/ps/16269/td).
98		
A3- A4+	Terminals for electrical remote RESET	No additional measures are required for short-circuit protection.

A sealable transparent cover can be optionally mounted on the electronic overload relays in the sizes S00, S0, S2 and S3 (Accessories (Page 123)). It stops the motor setting being tampered with.

Auxiliary contacts

3RB21 / 3RB31 electronic overload relays are equipped with an NO contact for the "tripped" message and an NC contact for disconnecting the contactor.

Product combinations

Since the products from the innovative SIRIUS modular system are matched to one another both electrically and mechanically, they can be combined quickly and easily.

Reference

More information ...	Is available in the appendix ...
About the possible combinations of standard products from the SIRIUS modular system	"References" under "Manuals - SIRIUS Modular System (Page 175)"

More information ...	can be found in the Chapter ...
on the overload relay and contactor combination options	"Overview of combinable 3RT2 contactors (Page 60)"

Functions

6.1 Protection against overload, phase failure, and phase asymmetry

6.1.1 Functional principle

Overload relays are used for the current-dependent protection of electrical consumers (such as motors) against excessive temperature rises, which may be caused by overloading, asymmetrical power consumption, a phase failure in the line supply conductor or a locked rotor.

In the event of an overload, phase asymmetry or a phase failure, or if a rotor locks, the motor current will rise beyond the set rated motor current. This increased current - which, if sustained over a long period, may damage or even destroy the load - is detected by the overload relay and evaluated with the assistance of a thermal motor model.

The overload relays operate according to two different operating principles:

- Thermally with bimetals: 3RU21
- Electronically with current transformers and evaluation electronics: 3RB20 / 3RB21 and 3RB30 / 3RB31

Functional principle of 3RU21 thermal overload relays

The current rise caused by the overload causes increased heat rise affecting the heating elements. The bimetals respond by deflecting, and actuate the auxiliary contacts via the release mechanism.

Functional principle of 3RB20 / 3RB21 and 3RB30 / 3RB31 electronic overload relays

The current rise is detected by the integrated current transformers and evaluated by corresponding electronic circuits which then supply a pulse to the auxiliary contacts. The contactor and the load are disconnected via the auxiliary contacts.

Note

Protection of DC loads and single-phase AC loads

Only 3RU21 thermal overload relays can provide an assurance of protecting DC loads and single-phase AC loads against overload.

If a 3RU21 thermal overload relay is to be used to protect DC loads or single-phase AC loads, all the bimetal strips have to be heated. Therefore, all of the relay's main current paths have to be connected in series.

Phase-failure protection

3RU21 thermal overload relays and 3RB20 / 3RB21 and 3RB30 / 3RB31 electronic overload relays feature phase loss sensitivity (see Chapter Tripping characteristics (Page 51)) to minimize load temperature rise in two-phase operation in the event of a phase loss.

6.1.2 Inverse-time delayed overload release

The inverse-time-delayed overload release is based on a thermal motor model and will trigger a release dependent upon the extent of the overload.

3RU21 thermal overload relays and 3RB20 / 3RB21 and 3RB30 / 3RB31 electronic overload relays compensate temperatures from -40 °C to 60 °C (3RU21) and -25 °C to 60 °C (3RB20 / 3RB21 and 3RB30 / 3RB31) in accordance with IEC 60947-4-1.

6.1.3 Tripping classes

The tripping classes describe time intervals within which the overload relays have to trip in the case of a symmetrical, 3-pole load from the cold state with 7.2 times the current setting.

3RU21 thermal overload relays

3RU21 thermal overload relays are available for normal starting conditions in the tripping classes CLASS 10 or CLASS 10A. 3RB20 / 3RB30 electronic relays in CLASS 10E or CLASS 20E, or 3RB21 / 3RB31 electronic relays (adjustable in CLASS 5E, CLASS 10E, CLASS 20E or CLASS 30E) are available for heavy-duty starting conditions.

The tripping times according to IEC/EN 60947-4-1 are as follows:

Table 6-1 Tripping times dependent upon tripping classes according to standard IEC/EN 60947-4-1

Trip class	Tripping time t_A in s at $7.2 \times I_e$ from cold
CLASS 10A	$2 < t_A \leq 10$
CLASS 10	$4 < t_A \leq 10$
CLASS 20	$6 < t_A \leq 20$
CLASS 30	$9 < t_A \leq 30$

3RB20 / 3RB21 and 3RB30 / 3RB31 electronic overload relays

3RB20 / 3RB30 electronic overload relays are available for normal starting conditions in tripping class CLASS 10E or for heavy-duty starting conditions in tripping class CLASS 20E (all fixed settings).

3RB21 / 3RB31 electronic relays are suitable for normal and heavy-duty starting conditions. A rotary switch is used to set the required tripping class (CLASS 5E, 10E, 20E or 30E) dependent upon the prevailing starting conditions.

6.1 Protection against overload, phase failure, and phase asymmetry

The tripping times according to IEC/EN 60947-4-1, tolerance band E, are as follows:

Table 6-2 Tripping times dependent upon tripping classes according to standard IEC/EN 60947-4-1, tolerance band E

Trip class	Tripping time t_A in s at $7.2 \times I_e$ from cold
CLASS 5E	$3 < t_A \leq 5$
CLASS 10E	$5 < t_A \leq 10$
CLASS 20E	$10 < t_A \leq 20$
CLASS 30E	$20 < t_A \leq 30$

6.1.4 Tripping characteristics

Introduction

The tripping characteristic curves map the relationship between tripping time and tripping current as a multiple of the current setting I_e ; they are specified for symmetrical 3-pole and for 2-pole loading from cold.

The lowest current at which tripping will occur is known as the minimum tripping current. This must lie within specific defined limits in accordance with IEC / EN 60947-4-1.

The limits for the tripping current in the case of the overload relays with symmetrical three-pole loading are between 105 and 120 % of the current setting.

Tripping characteristics

The limit tripping current determines the progression of the tripping characteristic curve up to higher tripping currents based on the characteristics of the tripping classes (CLASS 10, CLASS 20, etc., see the Chapter Tripping classes (Page 50)).

Tripping characteristic curves for the 3RU21 thermal overload relay

The tripping characteristic curve for the 3RU21 thermal overload relay loaded at 3 poles (see figure below) applies provided all three bimetal strips are loaded symmetrically. If only two bimetal strips are heated following a phase failure, these two strips alone have to generate the force required to trigger the release mechanism and would need a longer tripping time or a higher current if no additional action was taken. If these higher currents are applied over a longer period of time, they usually cause damage to the load. To avoid damage, 3RU21 overload relays feature phase loss sensitivity, which uses a corresponding mechanism to induce accelerated tripping in accordance with the characteristic curve for 2-pole loading from the cold state.

Compared with a cold load, a load at operating temperature obviously has a lower temperature reserve. 3RU21 thermal relays take this into account by reducing the tripping time to approximately a quarter following prolonged loading with the setting current I_e .

6.1 Protection against overload, phase failure, and phase asymmetry

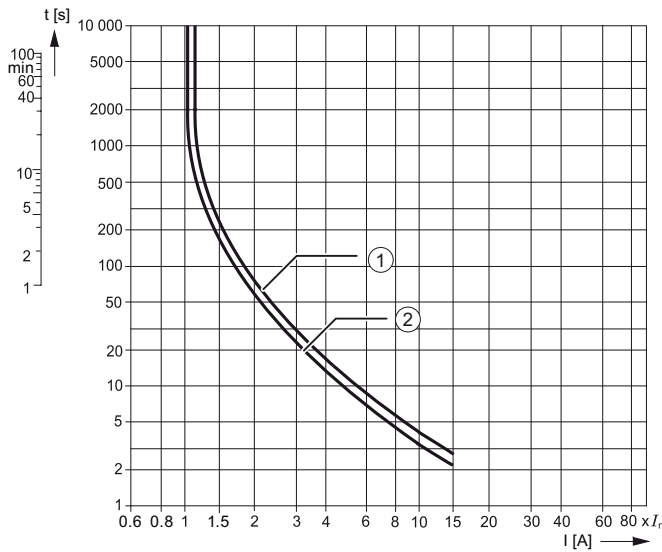

- t [s] Tripping time
- I [A] Current
- 1 3-pole load
- 2 2-pole load

Figure 6-1 Time-current characteristic curve, schematic diagram - 3RU21

Tripping characteristic curves of 3RB20 / 3RB21 and 3RB30 / 3RB31 electronic overload relays

The tripping characteristic curve for an overload relay loaded at 3 poles from cold (see Figure 1) applies subject to the prerequisite that all three phases are loaded symmetrically. In the event of a phase failure, the 3RB20 / 3RB21 and 3RB30 / 3RB31 electronic overload relays disconnect the contactor more quickly to minimize the load's temperature rise in accordance with the tripping characteristic curve for two-pole loading from the cold state (see Figure 2). In the event of phase asymmetry, the devices disconnect dependent upon the extent of the asymmetry between the two characteristic curves.

Compared with a cold load, a load at operating temperature obviously has a lower temperature reserve. It is for this reason that the tripping time of 3RB20 / 3RB21 and 3RB30 /

3RB31 electronic overload relays is reduced to approximately 30 % following prolonged loading with the current setting I_e .

Figure 1

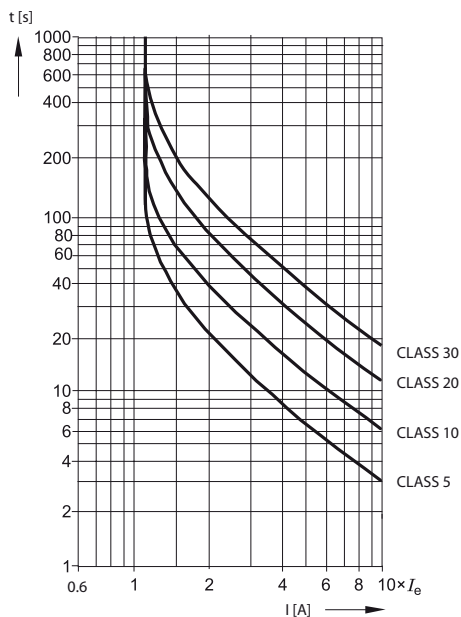

Tripping characteristic 1
 t [s] Tripping time
 I [A] Current
 3-pole load - 3RB20 / 3RB21 and 3RB30 / 3RB31

Figure 2

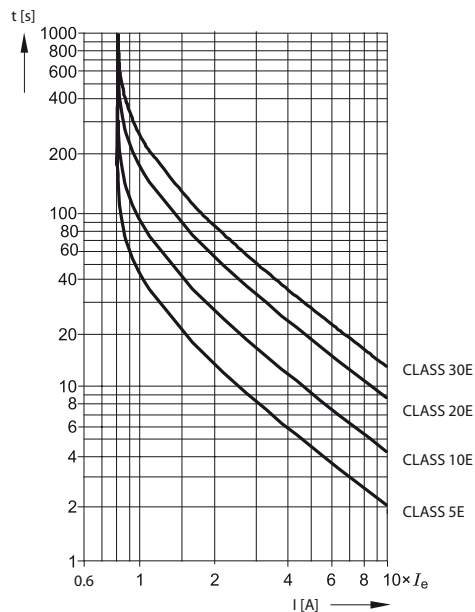

Tripping characteristic 2
 t [s] Tripping time
 I [A] Current
 2-pole load - 3RB20 / 3RB21 and 3RB30 / 3RB31

Reference

The figures are schematic representations of the characteristic curves. The characteristic curves for the individual overload relays can be downloaded from the Internet (<https://support.industry.siemens.com/cs/ww/en/ps/16269/char>).

6.2 Ground-fault protection in the case of 3RB21 / 3RB31

Introduction

In addition to the current-dependent protection of loads against impermissibly high temperature rise resulting from overload, 3RB21 / 3RB31 electronic overload relays offer ground-fault protection.

Ground-fault protection

A ground fault can arise as a result of insulation damage or ingress of moisture or condensate. This results in displacement of the neutral point voltage of the power network, and in an unbalance. The neutral point voltage is simulated virtually in the device and when a neutral point displacement voltage arises, the overload relay switches the contactor off instantaneously. This prevents thermal follow-on damage and a resulting, and significantly more critical, double ground fault.

Note

Contactor assembly for star-delta (wye-delta) start

Internal ground-fault detection is not possible with contactor assemblies star-delta (wye-delta) start.

Table 6-3 Ground-fault protection

Ground-fault protection	The information refers to sinusoidal fault currents at 50/60 Hz
Tripping value I_{Δ}	$> 0.75 \cdot I_{\text{motor}}$
Operating range I	Lower current setting $< I_{\text{motor}} < 3.5 \cdot$ upper current setting
Response time t_{trip} (in settled state)	< 1 s

Reference

More information ...	can be found in the Chapter ...
about ground-fault protection of the electronic overload relays in conjunction with star-delta (wye-delta) assemblies	Contactor assembly for star-delta (wye-delta) start (Page 62)

6.3 Auxiliary contacts

Function

The auxiliary contacts control the contactor and signal overloads.

Auxiliary contact	Response to overload
NC contact (NC 95-96)	Disconnects the contactor, thereby protecting: <ul style="list-style-type: none"> • The contactor • The cables • The load
NO contact (NO 97-98)	Sends a signal, e.g. to the: <ul style="list-style-type: none"> • Control system • Lamp • Other actuators

Note

Contact rating

The contact rating of the auxiliary switches to be taken into account is specified in the Technical data (Page 161).

Reference

More information ...	Can be found in the chapter titled ...
About the response of auxiliary contacts	Response of the auxiliary contacts (Page 121)

6.4 Indication of the operating state

The prevailing operating state of the 3RU21, 3RB20 / 3RB21 and 3RB30 / 3RB31 relays is indicated by the position of the marker on the "TEST function / Switch position indicator" slide.

If the relays are operating without errors, the slide marker will be set to "I". When a device trips, the slide marker moves to "0". An overload relay can trip for the following reasons:

- Overload
- Phase asymmetry
- Phase failure
- Ground fault (3RB21 / 3RB31)
- Internal fault (3RB20 / 3RB21 and 3RB30 / 3RB31)

Resetting

Depending on the setting, the relay is reset manually or automatically after a recovery time has elapsed.

Reference

Additional information...	Can be found in the chapter titled...
About resetting	RESET after release (Page 118)

6.5 Self-monitoring (3RB20 / 3RB21 and 3RB30 / 3RB31 only)

3RB20 / 3RB21 and 3RB30 / 3RB31 electronic overload relays constantly monitor their ability to operate (self-monitoring) and trip in the event of an internal error.

In such cases you need to contact "Technical Support" on the Internet (<https://support.industry.siemens.com/My/ww/en/requests>)

6.6 Additional functions

RESET function

There are various ways to reset the device following an overload release.

Table 6-4 RESET options for for overload relays

Overload relay	Auto RESET	Manual RESET	Mech. remote RESET (accessory)		Elect. remote RESET
			Release slide	Cable release	
3RU21	✓	✓	✓	✓	✓ (accessories)
3RB20 / 3RB30	✓	✓	✓	✓	-
3RB21 / 3RB31	✓	✓	✓	✓	✓ (integrated)

The relay cannot be reset until after the recovery time has elapsed.

Reference

More information ...	can be found in the Chapter ...
about optional mechanical and electrical RESET modules	Accessories (Page 123).

Stop function (3RU21 only)

Pressing the STOP button on the 3RU21 thermal overload relay opens the NC contact, thereby disconnecting the downstream contactor and thus the load. In the case of maintained-contact operation in the auxiliary circuit, the load is switched back on via the contactor when the red STOP button is released.

Test function for the 3RU21 thermal overload relay

The TEST slide can be used to check whether the operational 3RU21 thermal overload relay is working properly. The tripping of the relay can be simulated by moving the slide. This simulation process opens the NC contact (95-96) and closes the NO contact (97-98), thereby checking that the auxiliary circuit has been wired to the overload relay correctly.

Test function for the 3RB20 / 3RB21 and 3RB30 / 3RB31 electronic overload relay

The correct function of the relay when ready for operation can be checked by pressing the TEST button with the motor current flowing (device/electronics test). Current sensing, the motor model, and the tripping unit are tested.

The switch position indicator slide can be used to test the auxiliary contacts and the control current wiring. The tripping of the relay can be simulated by moving the slide, thereby providing a means of checking that the auxiliary circuit has been wired correctly.

Reference

More information ...	Can be found in the Chapter ...
About the RESET function	RESET after release (Page 118).
About the test function	TEST function (Page 120).

Configuration

7.1 TIA Selection Tool

You can select, configure and order devices for Totally Integrated Automation (TIA) with the TIA Selection Tool.

You will find the TIA Selection Tool on the Internet (<http://www.siemens.com/tst>).

7.2 Overload relays in motor feeders

7.2.1 Motor protection with overload relay

The individual overload relay families protect the following loads against the consequences of an overload, a phase failure, and phase asymmetry.

Table 7-1 Overload relays in motor feeders

For the protection of	3RU21	3RB20 / 3RB21 3RB30/3RB31
Three-phase current loads	✓	✓
DC loads	✓	-
Single-phase AC loads	✓	-

Note

In the case of three-phase current loads, only 3-pole circuits (3 phases) are permitted. 4-pole circuits (3 phases + neutral conductor) are not permitted.

Note

Design of motor feeders

An overload relay alone cannot generally protect a load against **overcurrents**. The tripping characteristic curve is too inert for a short-circuit and also the contactor actuated by the relay in the event of tripping is not suitable for reliable breaking in the event of a short-circuit.

A protective device such as a 3RV2 motor starter protector or a fuse must be installed upstream of the load to provide **protection against short-circuits**.

Appropriate contactors are required to protect loads. Chapter Overview of combinable 3RT contactors (Page 60) provides an overview of the coordination between overload relays and contactors, along with their power ratings.

7.2.2 Overview of combinable 3RT contactors

Overload relay with contactor assemblies

Table 7-2 3RT2 thermal overload relay with contactor assemblies

			Contactors				
			Type	3RT201	3RT202	3RT203	3RT204
Thermal overload relays			Size	S00	S0	S2	S3
Type	Size	Current range [A]	Power [kW]	3 / 4 / 5.5 / 7.5	5.5 / 7.5 / 11 / 15 / 18.5	15 / 18.5 / 22 / 30 / 37	37 / 45 / 55
3RU211	S00	0.11 ... 16		✓	-	-	-
3RU212	S0	1.8 ... 40		-	✓	-	-
3RU213	S2	11 ... 80		-	-	✓	-
3RU214	S3	28 ... 100		-	-	-	✓

Table 7-3 3RT2 electronic overload relay with contactor assemblies

			Contactors				
			Type	3RT201	3RT202	3RT203	3RT204
Electronic overload relays			Size	S00	S0	S2	S3
Type	Size	Current range [A]	Power [kW]	3 / 4 / 5.5 / 7.5	5.5 / 7.5 / 11 / 15 / 18.5	15 / 18.5 / 22 / 30 / 37	37 / 45 / 55
3RB3.1	S00	0.1 ... 16		✓	-	-	-
3RB3.2	S0	0.1 ... 40		-	✓	-	-
3RB3.3	S2	12.5 ... 80		-	-	✓	-
3RB3.4	S3	12.5 ... 115		-	-	-	✓

Table 7-4 3RT1 electronic overload relay with contactor assemblies

			Contactors			
			Type	3RT105	3RT106	3RT107
Electronic overload relays			Size	S6	S10	S12
Type	Size	Current range [A]	Power [kW]	55 / 75 / 90	110 / 132 / 160	200 / 250
3RB205 / 3RB215	S6	50 ... 200		✓	-	-
3RB2066 / 3RB216	S10 / S12	55 ... 250 and 160 ... 630		-	✓	✓

The configuration guide entitled "Configuring SIRIUS Modular Systems - Selection data for load feeders in fuseless and fused designs" (<https://support.industry.siemens.com/cs/ww/en/view/39714188>) provides information about the assembly of type-tested motor feeders according to IEC / EN 60947-4-1 with type of coordination 1 or 2.

7.2.3 Normal and heavy-duty starting

Normal starting

Selecting the right overload relay means considering the start time as well as the rated motor current. The start time refers to the time required by the motor between switching on and reaching its rated speed.

Table 7-5 Normal starting

Designation	Start time
Normal starting	< 10 s
Heavy-duty starting	> 10 s

Heavy-duty starting

Note

Overload relays with corresponding tripping classes are required to protect heavy-duty-starting motors (for the acceleration of large centrifuges, for example). In the case of heavy-duty starting, the cables and contactors also have to be dimensioned specifically on account of the increasing thermal load.

7.2.4 Contactor assembly for star-delta (wye-delta) start

Overload relays in contactor assemblies for star-delta (wye-delta) start

When using thermal or electronic overload relays in conjunction with contactor assemblies for star-delta (wye-delta) start, you need to bear in mind that only $1/\sqrt{3}$ times the motor current flows through the line contactor. An overload relay mounted onto a line contactor has to be set to this 0.58-times motor current.

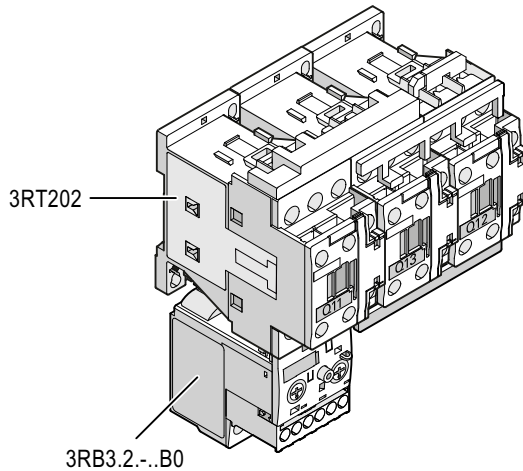

Note

Internal ground-fault detection on the 3RB21 / 3RB31

If you are using the 3RB21 / 3RB31 electronic overload relay in conjunction with contactor assemblies for star-delta (wye-delta) start, internal ground-fault detection must not be activated because third harmonics can arise in the motor during delta operation. The overload relay interprets these harmonics as a ground fault and they produce unintentional tripping.

7.2.5 Operation with frequency converters

3RU21 thermal overload relays

3RU21 thermal overload relays are suitable for operation with frequency converters. Depending on the frequency of the converter, eddy current and skin effects that occur mean that in some cases, a current higher than the rated motor current has to be set.

3RB20 / 3RB21 and 3RB30 / 3RB31 electronic overload relays

3RB20 / 3RB21 and 3RB30 / 3RB31 electronic overload relays are suitable for frequencies of 50 / 60 Hz and their associated harmonics. This makes it possible to use a 3RB20 / 3RB21 and 3RB30 / 3RB31 on the input side of the frequency converter. If motor protection is required on the secondary side of the frequency converter, we recommend 3RN thermistor motor protection devices or 3RU21 thermal overload relays.

Reference

More information ...	can be found on the Internet at
about setting corrections and other factors when using circuit breakers and overload relays on the secondary side of frequency converters	Circuit breakers and overload relays on the secondary side of frequency converters - influences and criteria (http://support.automation.siemens.com/WW/view/en/24232798)
about the influence of frequency converters on thermal motor protection devices in the case of pulsed voltage	about the influence of frequency converters/inverters on thermal motor protection devices in the case of pulsed voltage (http://support.automation.siemens.com/WW/view/de/24153083)

Reference

More information ...	Is available in the appendix ...
About the currents to be set	"References" under "Manuals - SIRIUS Modular System (Page 175)" in the "SIRIUS Innovations - SIRIUS 3RV motor starter protectors" manual.

7.3 Short-circuit protection

Either fuses (fused design) or motor starter protectors/circuit breakers (acc. to UL) (fuseless design) must be used for short-circuit protection. The types of coordination must also be considered when selecting load feeders from the tables.

References

More information	Can be found
About coordination of corresponding short-circuit protective devices with overload relays	in the configuration guide entitled "Configuring SIRIUS Modular Systems - Selection data for load feeders in fuseless and fused designs" (http://support.automation.siemens.com/WW/view/en/50250592)(article no.: 3ZX1012-ORA21-1ACO)

7.4 Protecting explosion-protected motors

SIRIUS components meet a wide range of requirements for operation in hazardous areas and for switching and protecting components used in hazardous areas.

The thermal overload relays are certified in compliance with the European explosion protection directive ATEX and the international explosion protection standard IECEx.

The electronic overload relays are certified in compliance with the European explosion protection directive ATEX.

Explosion protection in compliance with the European ATEX directive 2014/34/EU

3RB20 / 3RB21 and 3RB30 / 3RB31 electronic overload relays and 3RU21 thermal overload relays are suitable for the overload protection of explosion-proof motors with explosion protection type "increased safety" Ex e.

3RB20 / 3RB21 and 3RB30 / 3RB31 electronic overload relays and 3RU21 thermal overload relays are not intended for installation in hazardous areas.

When installed in hazardous areas, 3RB20 / 3RB21 and 3RB30 / 3RB31 electronic overload relays and 3RU21 thermal overload relays must be adapted to the corresponding explosion protection type, e.g. by means of suitable encapsulation.

The relays meet the requirements of EN IEC 60079-0.

3RB20 / 3RB21 and 3RB30 / 3RB31 electronic overload relays and 3RU21 thermal overload relays are approved under Device Group II, Category (2) for overload protection of motors operated in Area "G" (areas in which potentially explosive gas, vapor, mist, and air mixes are present) and additionally in Area "D" (areas containing combustible dust).

For 3RB30 / 3RB31 electronic overload relays in sizes S00 to S3, the EC type-examination certificate is available for Group II, Category (2) G [Ex e] [Ex d] [Ex px] and D [Ex t] [Ex p]. The number is PTB 09 ATEX 3001.

For 3RB20 / 3RB21 electronic overload relays in frame sizes S6 to S10 / S12, the EC type-examination certificate is available for Group II, Category (2) G [Ex db Gb] [Ex eb Gb] [Ex pxb Gb] and Group II, Category (2) D [Ex tb Db] [Ex pxb Db]. The number is PTB 06 ATEX 3001.

For 3RU21 thermal overload relays in sizes S00 to S3, the EC type-examination certificate is available for Group II, Category (2) GD. The number is DMT 98 ATEX G001.

More information and certificates for download are available on the Internet (<http://www.siemens.com/automation/service&support>).

More information on explosion protection (ATEX) can be found online (<http://www.siemens.com/sirius/atex>).

Explosion protection according to international standard IECEx

The 3RU2116, 3RU2126, 3RU2136, and 3RU2146 thermal overload relays are certified according to the IECEx international standard.

You will find certificates of explosion protection in accordance with the IECEx international standard on the Internet (<https://support.industry.siemens.com/cs/ww/en/ps/16271/cert>).

7.5 Safety instructions for use in hazardous areas (3RB)

7.5.1 General information

 DANGER
<p>Hazardous voltage. Will cause death or serious injury.</p> <p>Turn off and lock out all power supplying this device before working on this device.</p>

NOTICE
Safe operation of the equipment is only ensured with certified components.

Information and standards

The increased level of danger in hazardous areas requires that the following notes and standards be observed:

- EN 60079-14 / VDE 0165-1 for electrical equipment for potentially explosive atmospheres
- EN 60079-17 Inspection and maintenance of electrical installations in hazardous areas
- EN 50495 Safety devices required for the safe functioning of equipment with respect to explosion risks

3RB20 / 3RB21 and 3RB30 / 3RB31 electronic overload relays are approved under Device Group II, Category (2) for overload protection of motors operated in Area "G" (areas in which potentially explosive gas, vapor, mist, and air mixes are present) and additionally in Area "D" (areas containing combustible dust).

3RB20 / 3RB21 and 3RB30 / 3RB31 electronic overload relays are not intended for installation in hazardous areas.

When installed in hazardous areas, 3RB20 / 3RB21 and 3RB30 / 3RB31 electronic overload relays must be adapted to the corresponding explosion protection type, e.g. by means of suitable encapsulation.

PTB 06 ATEX 3001		II (2) G [Ex db Gb] [Ex eb Gb] [Ex pxb Gb] II (2) D [Ex tb Db] [Ex pxb Db]
------------------	---	---

Figure 7-1 3RB20 / 3RB21

PTB 09 ATEX 3001		II (2) G [Ex e] [Ex d] [Ex px] II (2) D [Ex t] [Ex p]
------------------	---	--

Figure 7-2 3RB30 / 3RB31

 **WARNING**

Personal injury and damage to property

All work involved in connecting, commissioning and maintenance must be carried out by qualified, responsible personnel. Improper handling may result in serious personal injury and considerable damage to property.

7.5.2 Installation and commissioning

Further documentation

To install and connect the overload relays, you require the operating instructions of the overload relays used.

You can find a list of operating instructions and an overview of the manuals pertaining to the SIRIUS modular system in the Appendix "References (Page 175)".

You can find further information on 3RB30 / 3RB31 electronic overload relays in Catalog IC 10 "SIRIUS Industrial Controls" and on the Internet (<https://support.industry.siemens.com/cs/ww/en>).

Setting the rated motor current

Set the 3RB2. / 3RB3. electronic overload relay to the rated motor current (according to the type plate or design test certificate of the motor).

 **CAUTION**

Trip class and tripping characteristic

Pay attention to the trip class or the tripping characteristic of the 3RB2. / 3RB3. electronic overload relay. Choose the trip class so that the motor is thermally protected even with a blocked rotor. The motor, cables, and contactor must be dimensioned for the selected trip class.

Example

Motor 500 V, 50 / 60 Hz, 110 kW, 156 A, temperature class T3, TE time = 18 s, $I_A / I_N = 5.0$

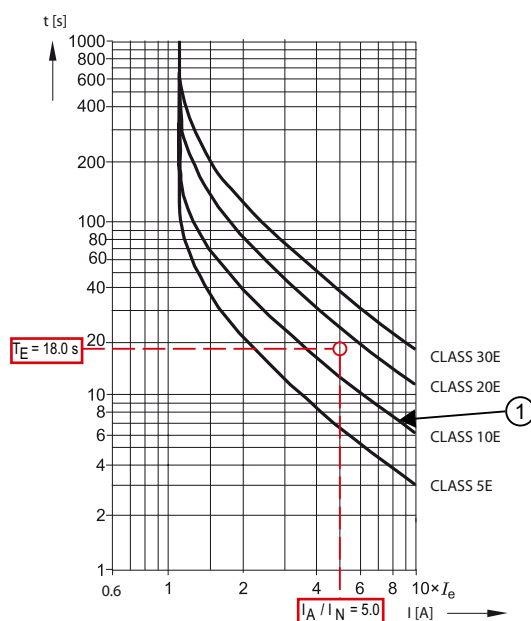

① Switch-off conditions of the EEx motor, selected: CLASS 10E

Further information and certificates are available for download on the Internet (<https://support.industry.siemens.com/cs/ww/en/ps/16027/char>).

Short-circuit protection for type of coordination 2 according to EN 60947-4-1

Short-circuit protection must be provided by separately arranged overcurrent protection devices.

NOTICE

Short-circuit protection

When combining with other contactors, observe the respective maximum fuse protection of the contactor for type of coordination 2.

Line protection

NOTICE

Observe dimensioning of conductor cross-sections

An impermissibly high cable surface temperature must be avoided by correctly dimensioning the cross sections.

An adequate conductor cross section must be chosen for heavy starting (CLASS 20 and CLASS 30).

RESET

Resetting the electronic overload relay is described in the Chapter "RESET after release (Page 118)".

User test (device test)

Testing in accordance with EN 60079-17 can be combined with the user test. Operation of the device must be discontinued if the test result is negative.

 CAUTION
Qualified personnel required
The test must be performed by a qualified person familiar with the specified standards.

Initialization

- The three phase currents that flow through the 3RB electronic overload relay must be largely symmetrical.
- The phase currents must amount to $\geq 80\%$ of the set current I_e .
- The currents must flow for at least the time t_1 before testing.
- The phase currents must be at least as high as the value of the bottom current setting marker.

Required loading with the rated current prior to pressing the TEST button	CLASS 5E	CLASS 10E	CLASS 20E	CLASS 30E
t_1 [minutes]	3	5	10	15

Performing the test

Correct functioning of the relay when ready for operation can only be checked with the motor current flowing (device/electronics test). The test is initiated by pressing the TEST button. Current sensing, the motor model, and the tripping unit are tested. If these components are OK, the device is tripped in accordance with the table below. In the event of an error, the device is not tripped. During the test all the protection functions are still active.

Note

The TEST button must be held down throughout the test. In this case the motor current must be $> 80\%$ of the current setting I_e and equal to at least the value of the lower current setting.

max. phase	CLASS 5E	CLASS 10E	CLASS 20E	CLASS 30E
% of I_e	[seconds] max	[seconds] max	[seconds] max	[seconds] max
100 %	8	15	29	43
90 %	16	31	61	92
80 %	31	61	122	183

The switch position indicator slide can be used to test the auxiliary contacts and the control current wiring. The tripping of the relay can be simulated by moving the slide. This simulation process opens the NC contact and closes the NO contact, thereby checking that the auxiliary circuit has been wired correctly. The relay is reset after a test trip by pressing the RESET button.

Test evaluation

The user test has been completed successfully if the following criteria apply:

- The device has tripped within the maximum permissible time.
- Contact 95-96 has been opened (test for welding).

NOTICE
Damage to property
Correct functioning of the device is ensured only if both criteria are met. The device may no longer be used if the test could not be carried out successfully.

Further safety notices

 CAUTION
Load-side operation on frequency converters
3RB20 / 3RB30 and 3RB21 / 3RB31 electronic overload relays are not suitable for load-side operation on frequency converters.

You will find further information on operation with frequency converters in Chapter "Operation with frequency converters (Page 62)."

Ambient conditions

Permissible ambient temperature range:

- Storage / transport: $-40\text{ °C} \dots +80\text{ °C}$
- Operation: $-25\text{ °C} \dots +60\text{ °C}$

7.5.3 Safety data

Further safety notices

Table 7-6 Safety data - 3RB20 / 3RB30 and 3RB21 / 3RB31 electronic overload relays at $T_U = 40\text{ °C}$

Type	3RB20 / 3RB30 and 3RB21 / 3RB31	
<ul style="list-style-type: none"> The safety data values given below apply for an ambient temperature of 40 °C. 		
SIL		SIL 1
HFT		0
λ_{safe}	1 / h	440×10^{-9}
λ_{DD}	1 / h	105×10^{-9}
λ_{DU}	1 / h	296×10^{-9}
SFF	%	65
DC	%	26
MTBF	Years	130
PFD_{avg} (for < 36 months)		$< 1.0 \times 10^{-2}$
Architecture		1001
T1 value (repeat test)		DIN EN 60079-17 Section 4.4
T_{lifetime}	Years	20

Note

Please inquire about safety data for ambient temperatures that differ from 40 °C.

Ambient temperatures

• Storage / transport	°C	-40 ... +80
• Operation	°C	-25 ... +60
• Temperature compensation	°C	+60
• Permissible rated operating current		
- At 60 °C cabinet interior temperature	%	100
- 70 °C	%	On request

7.5.4 Maintenance and repair

The device is maintenance-free.

7.5.5 Warranty

To meet the conditions of the warranty, you must observe the safety and commissioning instructions and the operating instructions.

You can find a list of operating instructions and an overview of the manuals pertaining to the SIRIUS modular system in the Appendix "References (Page 175)".

7.5.6 Further information

You can find further information on 3RB20 / 3RB21 and 3RB30 / 3RB31 electronic overload relays in Catalog IC 10 "SIRIUS Industrial Controls" and on the Internet (<https://support.industry.siemens.com/cs/ww/en>).

7.6 Application environment

The following information must be taken into account when planning applications involving overload relays.

Installation altitude

The overload relays are approved for installation altitudes up to 2,000 m. The reduced air density at altitudes higher than 2,000 meters affects the overload relays' electrical characteristics. The reduction factors which have to be taken into account when using overload relays at altitudes higher than 2000 m can be obtained on request from Technical Support on the Internet (<https://support.industry.siemens.com/My/ww/en/requests>).

Operating conditions and resistance to extreme climates

The overload relays are climate-proof.

The overload relays are not sensitive to external influences such as shocks, corrosive ambient conditions, ageing, and temperature fluctuations.

Ambient temperatures for 3RU21 overload relays

3RU21 thermal overload relays compensate temperature in the temperature range from –40 °C to +60 °C according to IEC/EN 60947-4-1. At temperatures between +60 °C and +70 °C, the maximum permissible operating current related to the rated operating current must be reduced by a specific factor f in accordance with the table below ($I_{\max} = I_e \times f$).

Table 7-7 Ambient temperatures for 3RU21 overload relays (size S00/S0)

Ambient temperature in °C	Reduction factor applies for rated current ...	
	0.16 ... 20 A	22 ... 40 A
+60	1.0	1.0
+65	0.94	0.97
+70	0.87	0.94

Table 7-8 Ambient temperatures for 3RU2136 overload relays (size S2)

Ambient temperature in °C	Reduction factor applies for rated current ...	
	8 ... 45 A	50 ... 80 A
+60	1.0	1.0
+65	0.94	0.97
+70	0.87	0.94

Table 7-9 Ambient temperatures for 3RU2146 overload relays (size S3)

Ambient temperature in °C	Reduction factor applies for rated current ...		
	25 ... 32 A	40 ... 63 A	75 ... 100 A
+60	1.0	1.0	1.0
+65	0.94	0.95	0.97
+70	0.88	0.90	0.94

Ambient temperatures for the 3RB20 / 3RB21 and 3RB30 / 3RB31 overload relays

3RB20 / 3RB21 and 3RB30 / 3RB31 electronic overload relays compensate temperature in the temperature range from -25 °C to +60 °C in accordance with IEC/EN 60947-4-1.

The reduction factors that have to be taken into account when using electronic overload relays at an ambient temperature higher than 60 °C can be obtained on request from our Technical Support on the Internet (<https://support.industry.siemens.com/My/ww/en/requests>).

Current derating during heavy starting for 3RB30 / 3RB31 overload relays

No reduction in the maximum permissible rated operating current is required for size S00 (to 16 A).

The following maximum rated operating currents are permissible for device versions with the setting range 10 to 40 A for size S0:

Table 7-10 Derating during heavy starting, 3RB30 / 3RB31 overload relays (size S0)

Trip class	Rated operational current
CLASS 20E	$I_{e \max} = 32 \text{ A}$
CLASS 30E	$I_{e \max} = 25 \text{ A}$

The following maximum rated operating currents are permissible for device versions with the setting range 20 to 80 A for size S2:

Table 7-11 Derating during heavy starting, 3RB30 / 3RB31 overload relays (size S2)

Trip class	Rated operational current
CLASS 5E CLASS 10E	$I_{e \max} = 80 \text{ A}$
CLASS 20E	$I_{e \max} = 60 \text{ A}$
CLASS 30E	$I_{e \max} = 50 \text{ A}$

Table 7-12 Derating during heavy starting, 3RB30 / 3RB31 overload relays (size S3)

Trip class	Rated operational current
CLASS 5E CLASS 10E	$I_{e \max} = 115 \text{ A}$
CLASS 20E CLASS 30E	$I_{e \max} = 100 \text{ A}$

Special application environments

SIRIUS components have been approved by a whole range of bodies for various sectors (shipbuilding, etc.). Up-to-date information and certificates are available for download on the Internet (<https://support.industry.siemens.com/cs/ww/en/ps/16269/cert>).

Mounting

8.1 Warning notice



DANGER

Hazardous voltage. Will cause death or serious injury.

Turn off and lock out all power supplying this device before working on this device.

8.2 Mounting options

3RU21, 3RB20 / 3RB21 and 3RB30 / 3RB31 installation options

The 3RU2 thermal overload relays and the 3RB2 / 3RB3 electronic overload relays are matched electrically and mechanically to 3RT contactors. As a result, direct mounting can be achieved easily. Alternatively, the devices are suitable for stand-alone assembly. 3RB2 / 3RB3 electronic overload relays with through-hole technology offer an even simpler installation option. The cable is threaded through and fitted directly on the contactor. 3RB2 / 3RB3 electronic overload relays with through-hole technology are available from size S2 onwards.

8.3 Minimum clearances and mounting position

Minimum clearance

A minimum lateral clearance of > 6 mm must be maintained from live and grounded parts.

Mounting position for 3RU21 thermal overload relay

The diagrams below illustrate the permissible mounting positions for contactor mounting and stand-alone assembly for 3RU21 thermal overload relays.

Table 8-1 Permissible mounting positions for the 3RU21

Overload relay, stand-alone assembly	Contactor + overload relay

The set value is 1.1 times the motor current for a mounting position in the hatched area.

Mounting position of 3RB20 /3RB21 and 3RB30 /3RB31 electronic overload relays

The following diagram shows the permissible mounting position for contactor mounting for 3RB20 / 3RB21 and 3RB30 / 3RB31 electronic overload relays.

Table 8-2 Permissible mounting positions of 3RB20 / 3RB21 and 3RB30 / 3RB31

Overload relay, stand-alone assembly	Contactor + overload relay
<p>3RB20 / 3RB21 and 3RB30 / 3RB31 electronic overload relays can be mounted in any position in stand-alone assembly.</p>	

8.4 Mounting/Disassembly

8.4.1 Mounting the 3RU2.1 / 3RU2.2 thermal overload relay on the 3RT2 contactor

Direct mounting on 3RT contactor (sizes S00 and S0)

The diagram below shows an example mounting scenario based on mounting the 3RU21 thermal overload relay, size S0, on the 3RT2 contactor. The contactor/overload relay combinations can be snapped onto 35 mm DIN rails according to EN 60715.

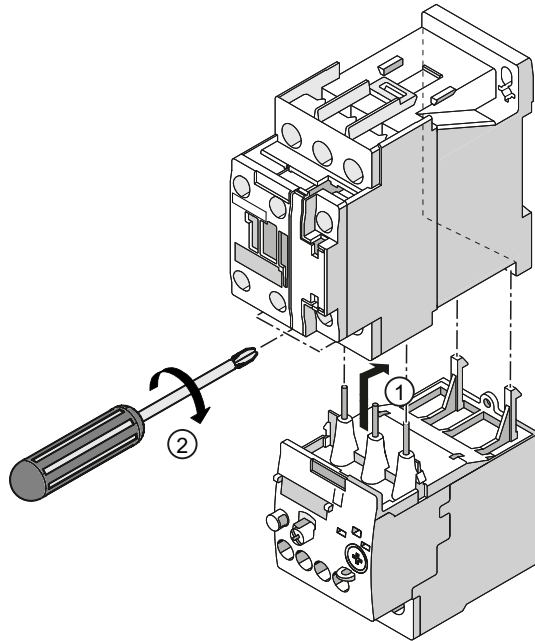
Mounting 3RU21 thermal overload relays with screw connection

- ① Push the overload relay into the contactor from below. Attach the two hooks on the overload relay to the two openings on the rear of the contactor. This pushes the main current contacts into the corresponding socket contacts on the contactor.
- ② Screw the main conductor terminals tight on the contactor. Check that the cable is clamped tight.

Mounting 3RU21 thermal overload relays with spring-loaded connection

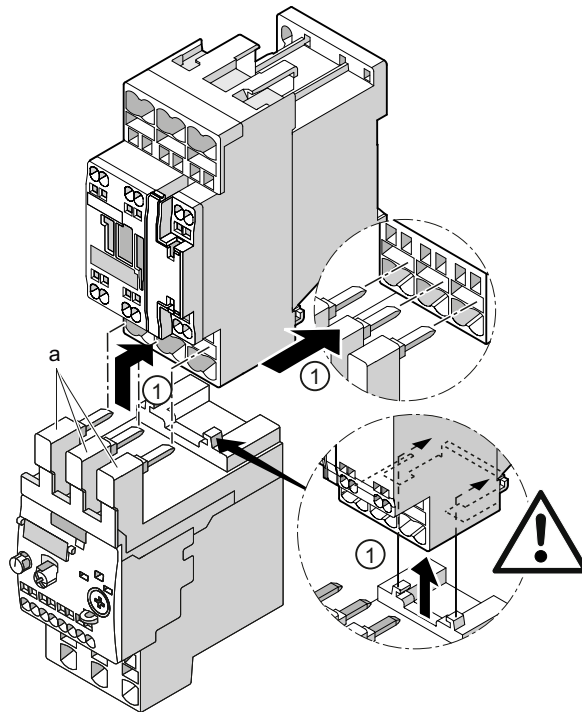

- ① Insert the contacts (a) into the central opening of the main conductor terminals on the contactor (see below, a), with the contacts flush to the right. Make sure that the guide tabs are inserted into the designated slots on the contactor.

The overload relay will sit flush with the contactor on the left- and right-hand sides.

The following illustrations show the openings of the main conductor terminals on the contactor into which the overload relay contacts have to be inserted.

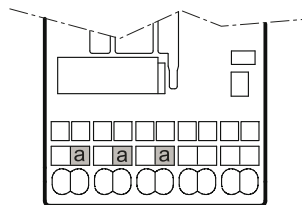

Figure 8-1 Main conductor terminals on the contactor (a) (S00)

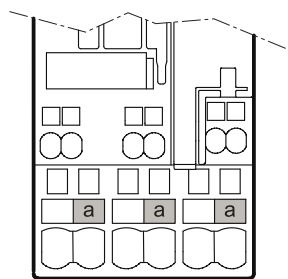

Figure 8-2 Main conductor terminals on the contactor (a) (S0)

Mounting on a mounting plate (sizes S00 and S0)

Screw mounting on a mounting plate is an alternative option to DIN rail mounting. For screw mounting, the contactor first has to be fastened with screws and then the overload relay mounted on the top of the contactor as shown in the figures.

Disassembly (sizes S00 and S0)

To disassemble the contactor/relay combination from the DIN rail, press the contactor down and pull it toward you.

Disassembling 3RU21 thermal overload relays with screw connection

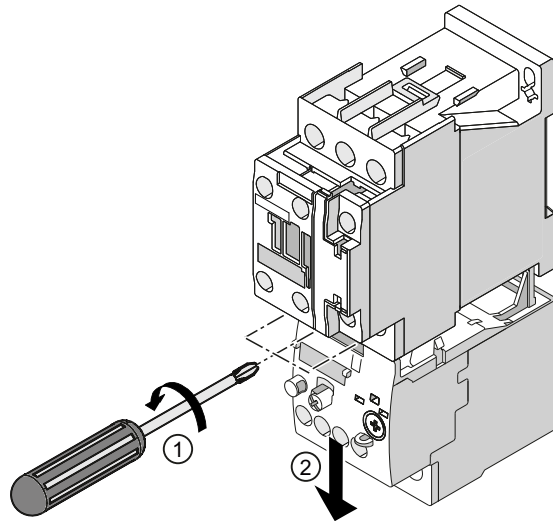

- ① Undo the screw on the main conductor terminals.
- ② Pull the overload relay down and away from the contactor.

Disassembling 3RU21 thermal overload relays with spring-loaded connection

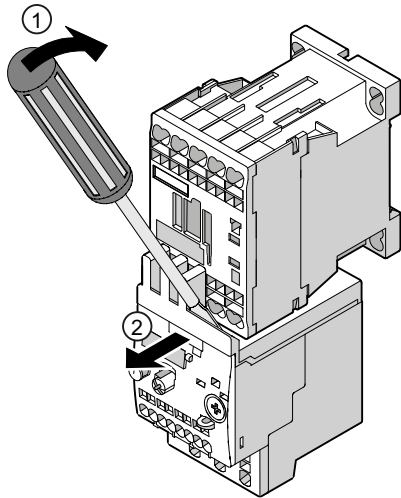

- ① Position the screwdriver on the overload relay as shown in the figure. Carefully dislodge the overload relay from the contactor.
- ② Pull the overload relay toward you and away from the contactor.

8.4.2 Mounting the 3RB3.1 electronic overload relay on the 3RT2 contactor

Direct mounting on the 3RT contactor (size S00)

The contactor/overload relay combinations can be snapped onto 35 mm DIN rails according to EN 60715.

Mounting the 3RB3.2 electronic overload relay, screw-type connection system

The figure below shows an example of how to mount the 3RB3.2 electronic overload relay of size S0 onto the 3RT2 contactor. Mounting the 3RB3.1 electronic overload relays in size S00 is equivalent to the procedure described.

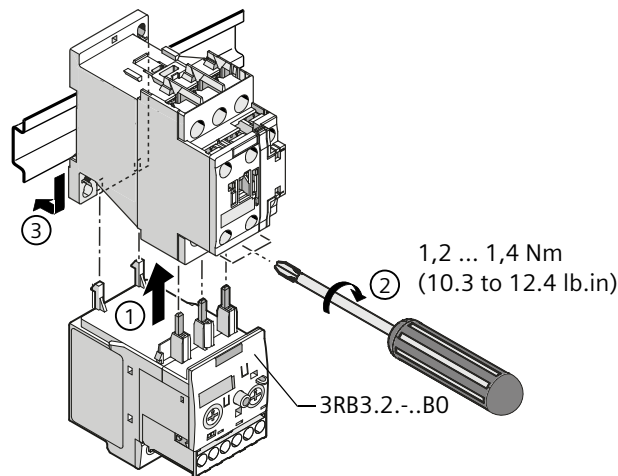

- ① Push the overload relay into the contactor from below. Attach the two hooks on the overload relay to the two openings on the rear of the contactor. This pushes the main current contacts into the corresponding socket contacts on the contactor.
- ② Screw the main conductor terminals tight on the contactor. Check that the cable is clamped tight.
- ③ Position the contactor/relay combination on the top edge of the DIN rail and press it down until it snaps onto the bottom edge of the DIN rail.

Mounting the 3RB3.1 electronic overload relay, spring-loaded connection system

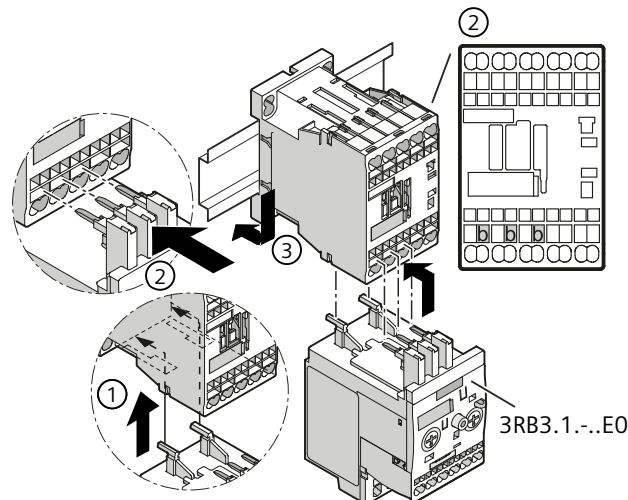

- ① / Insert the contacts into the central opening of the main conductor terminals on the contactor (b),
- ② with the contacts flush to the right. Make sure that the guide tabs are inserted into the designated slots on the contactor.
The overload relay will sit flush with the contactor on the left- and right-hand sides.
- ③ Position the contactor/relay combination on the top edge of the DIN rail and press it down until it snaps onto the bottom edge of the DIN rail.

Mounting on a mounting plate (size S00)

Screw mounting on a mounting plate is an alternative option to DIN rail mounting. For screw mounting, the contactor first has to be fastened with screws and then the overload relay mounted on the top of the contactor as shown in the figures.

Disassembly (size S00)

To disassemble the contactor/relay combination from the DIN rail, press the contactor down and pull it toward you.

Disassembly of the 3RB3.2 electronic overload relay screw-type connection system

The figure below shows an example of how to remove the 3RB3.2 electronic overload relay of size S0 from the 3RT2 contactor. Disassembly of the 3RB3.1 electronic overload relay in size S00 is equivalent to the procedure described.

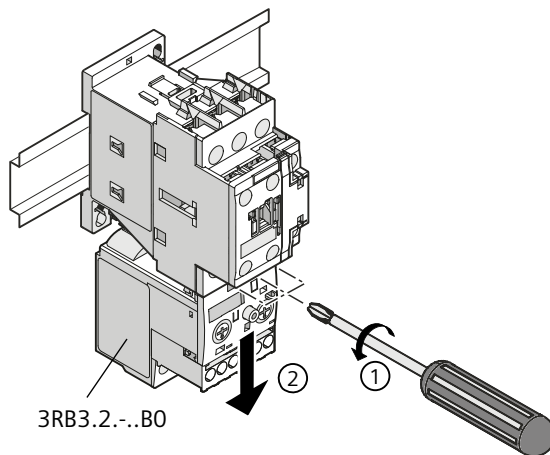

- ① Undo the screw on the main conductor terminals.
- ② Pull the overload relay down and away from the contactor.

Disassembly of the 3RB3.1 electronic overload relay spring-loaded connection system

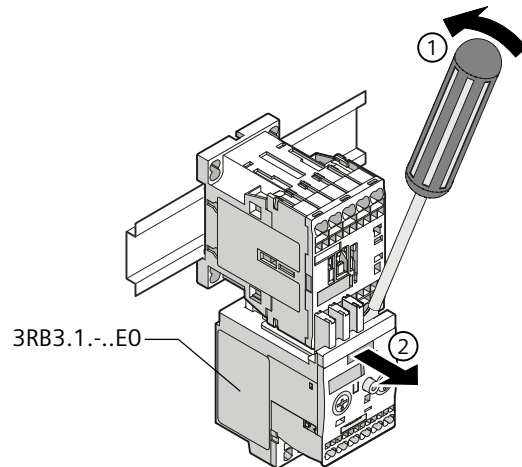

- ① Position the screwdriver on the overload relay as shown in the figure. Carefully dislodge the overload relay from the contactor.
- ② Pull the overload relay toward you and away from the contactor.

8.4.3 Mounting the 3RB3.2 electronic overload relay on the 3RT2 contactor

Direct mounting on the 3RT contactor (size S0)

The contactor/overload relay combinations can be snapped onto 35 mm DIN rails according to EN 60715.

Mounting the 3RB3.2 electronic overload relay, screw-type connection system

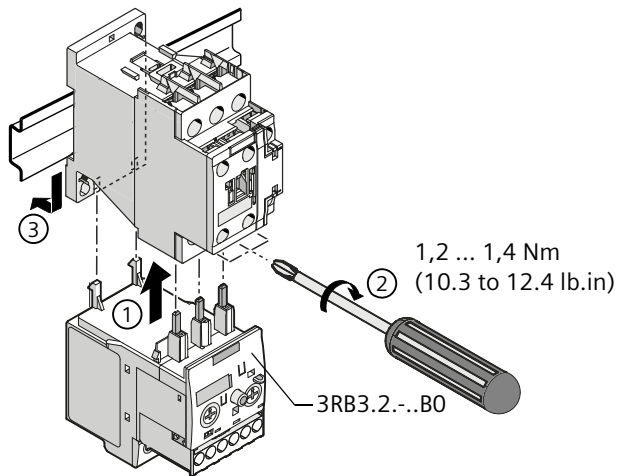

- ① Push the overload relay into the contactor from below. Attach the two hooks on the overload relay to the two openings on the rear of the contactor. This pushes the main current contacts into the corresponding socket contacts on the contactor.
- ② Screw the main conductor terminals tight on the contactor. Check that the cable is clamped tight.
- ③ Position the contactor/relay combination on the top edge of the DIN rail and press it down until it snaps onto the bottom edge of the DIN rail.

Mounting the 3RB3.2 electronic overload relay, spring-loaded connection system

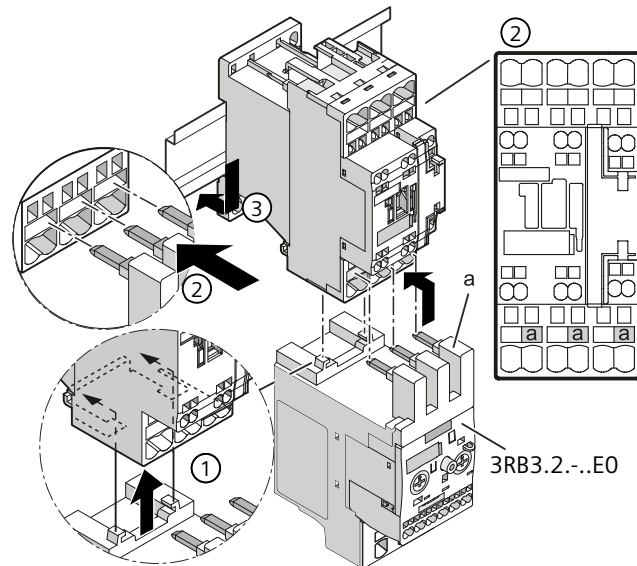

- ① / Insert the contacts into the central opening of the main conductor terminals on the contactor (a), with the contacts flush to the right. Make sure that the guide tabs are inserted into the designated slots on the contactor.
- ② The overload relay will sit flush with the contactor on the left- and right-hand sides.
- ③ Position the contactor/relay combination on the top edge of the DIN rail and press it down until it snaps onto the bottom edge of the DIN rail.

Mounting on a mounting plate (size S0)

Screw mounting on a mounting plate is an alternative option to DIN rail mounting. For screw mounting, the contactor first has to be fastened with screws and then the overload relay mounted on the top of the contactor as shown in the figures.

Disassembly (size S0)

To disassemble the contactor/relay combination from the DIN rail, press the contactor down and pull it toward you.

Disassembly of the 3RB3.2 electronic overload relay screw-type connection system

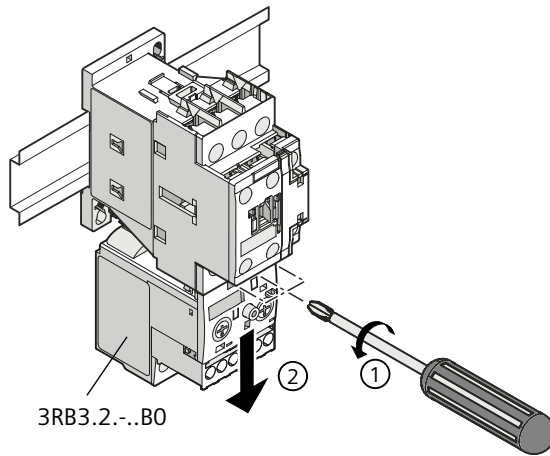

- ① Undo the screw on the main conductor terminals.
- ② Pull the overload relay down and away from the contactor.

Disassembly of the 3RB3.2 electronic overload relay spring-loaded connection system

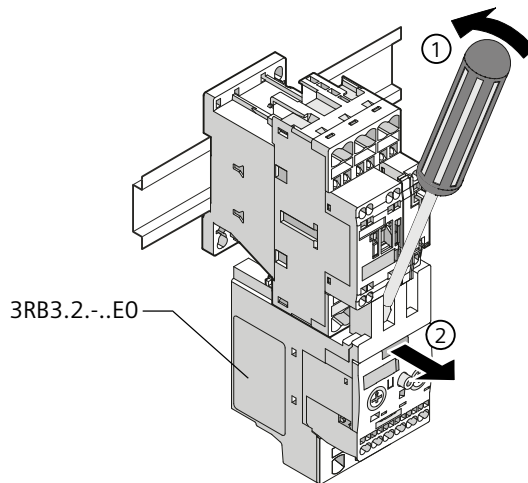

- ① Position the screwdriver on the overload relay as shown in the figure. Carefully dislodge the overload relay from the contactor.
- ② Pull the overload relay toward you and away from the contactor.

8.4.4 Mounting the 3RB3.3 electronic overload relay on the 3RT2 contactor

Direct mounting on the 3RT contactor

The contactor/overload relay combinations can be snapped onto 35 mm DIN rails according to EN 60715.

Mounting the 3RB3.3 electronic overload relay, screw-type connection system

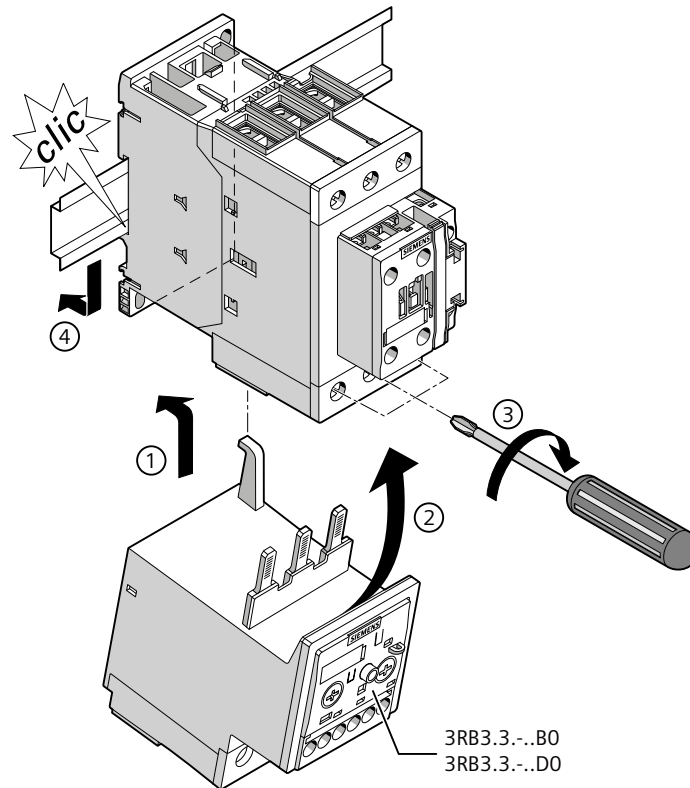

- ① / Push the overload relay into the contactor from below. Attach the two hooks on the overload relay
- ② to the two openings on the rear of the contactor. This pushes the main current contacts into the corresponding socket contacts on the contactor.
- ③ Screw the main conductor terminals tight on the contactor. Check that the cable is clamped tight.
- ④ Position the contactor/relay combination on the top edge of the DIN rail and press it down until it snaps onto the bottom edge of the DIN rail.

Mounting the 3RB3.3 electronic overload relay, stand-alone installation (through-hole technology)

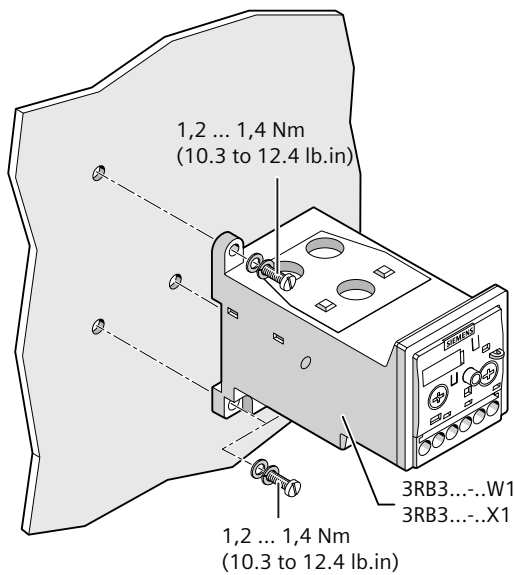

Tighten both screws with a screwdriver.
Tightening torque: 1.2 ... 1.4 Nm

Mounting on mounting plate

Screw mounting on a mounting plate is an alternative option to DIN rail mounting. For screw mounting, the contactor first has to be fastened with screws and then the overload relay mounted on the top of the contactor as shown in the figures.

Disassembly

To disassemble the contactor/relay combination from the DIN rail, press the contactor down and pull it toward you.

Disassembly of the 3RB3.3 electronic overload relay screw-type connection system

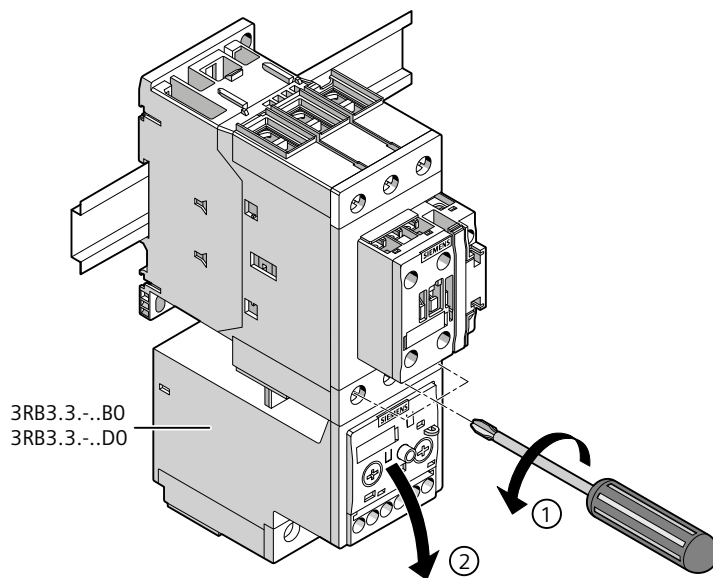

- ① Undo the screw on the main conductor terminals.
- ② Pull the overload relay down and away from the contactor.

8.4.5 Mounting the 3RU2.4 thermal overload relay and 3RB3.4 electronic overload relay on the 3RT2 contactor

Direct mounting on the 3RT2 contactor

The figure below shows mounting on the 3RT2 contactor. The contactor/overload relay combinations can be snapped onto 35 mm DIN rails according to EN 60715 and 75 mm DIN rails (only 3RU2.4 and 3RB3.4).

Mounting and disassembly of 3RU2.4 thermal overload relays is equivalent to the procedure described.

Mounting the 3RB3.4 electronic overload relay

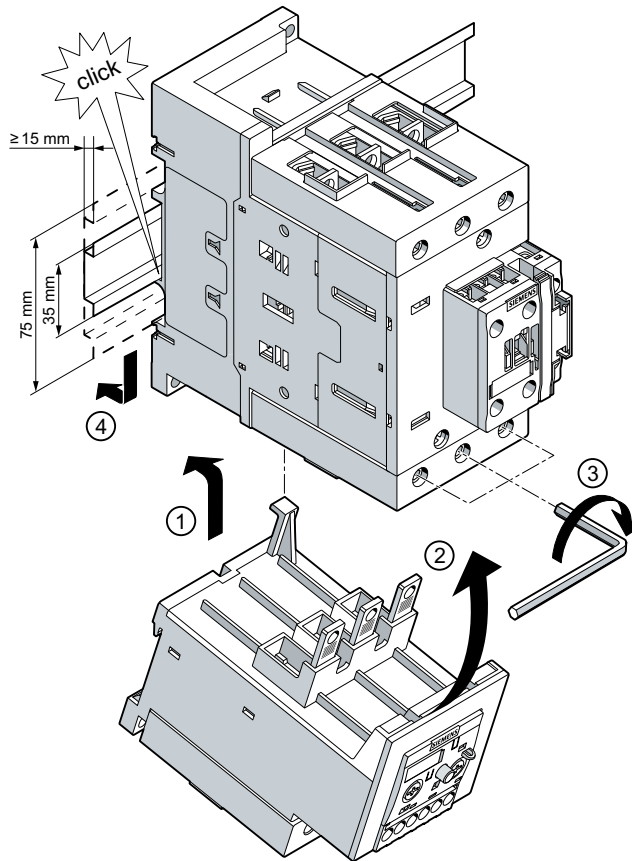

- ① Push the overload relay into the contactor from below. Attach the hook on the overload relay to the opening on the underside of the contactor. This pushes the main current contacts into the corresponding socket contacts on the contactor.
- ②
- ③ Screw the main conductor terminals tight on the contactor. Check that the cable is clamped tight.
- ④ Position the contactor/relay combination on the top edge of the DIN rail and press it down until it snaps onto the bottom edge of the DIN rail.

Mounting the 3RB3.4 electronic overload relay, stand-alone installation (through-hole technology)

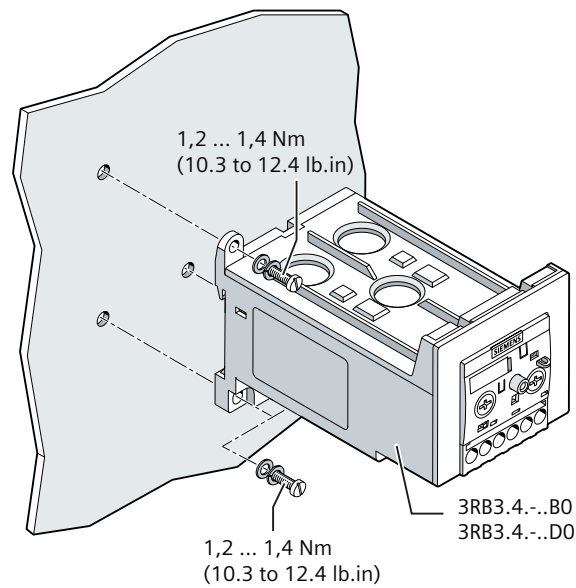

Tighten both screws with a screwdriver.

Tightening torque: 1.2 ... 1.4 Nm

Mounting on mounting plate

Screw mounting on a mounting plate is an alternative option to DIN rail mounting. For screw mounting, the contactor first has to be fastened with screws and then the overload relay mounted on the top of the contactor as shown in the figures.

Disassembly

Disassembly of the 3RB3.4 electronic overload relay

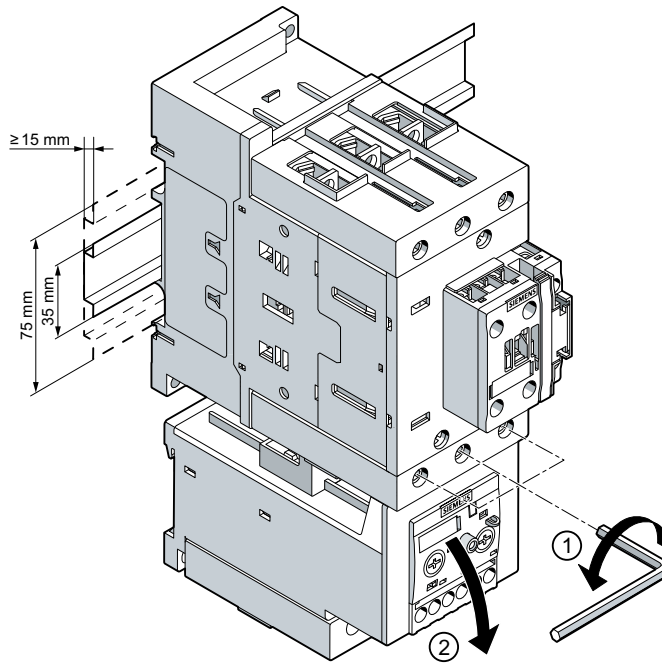

- ① Undo the screws on the main conductor terminals.
- ② Pull the overload relay down and away from the contactor.

8.4.6 Mounting the 3RB2.5 electronic overload relay to the 3RT1.5 contactor

Direct mounting on the 3RT1.5 contactor

The contactor/overload relay combinations are designed for screw mounting on a mounting plate.

The figures below show mounting of the 3RB2.5 electronic overload relay on the 3RT1.5 contactor with the terminal covers and covers for box terminal blocks available as accessories:

- Busbar connection
- Connection with box terminal block
- Connection with box terminal block and through-hole technology

Mounting the 3RB2.5 electronic overload relay (busbar connection)

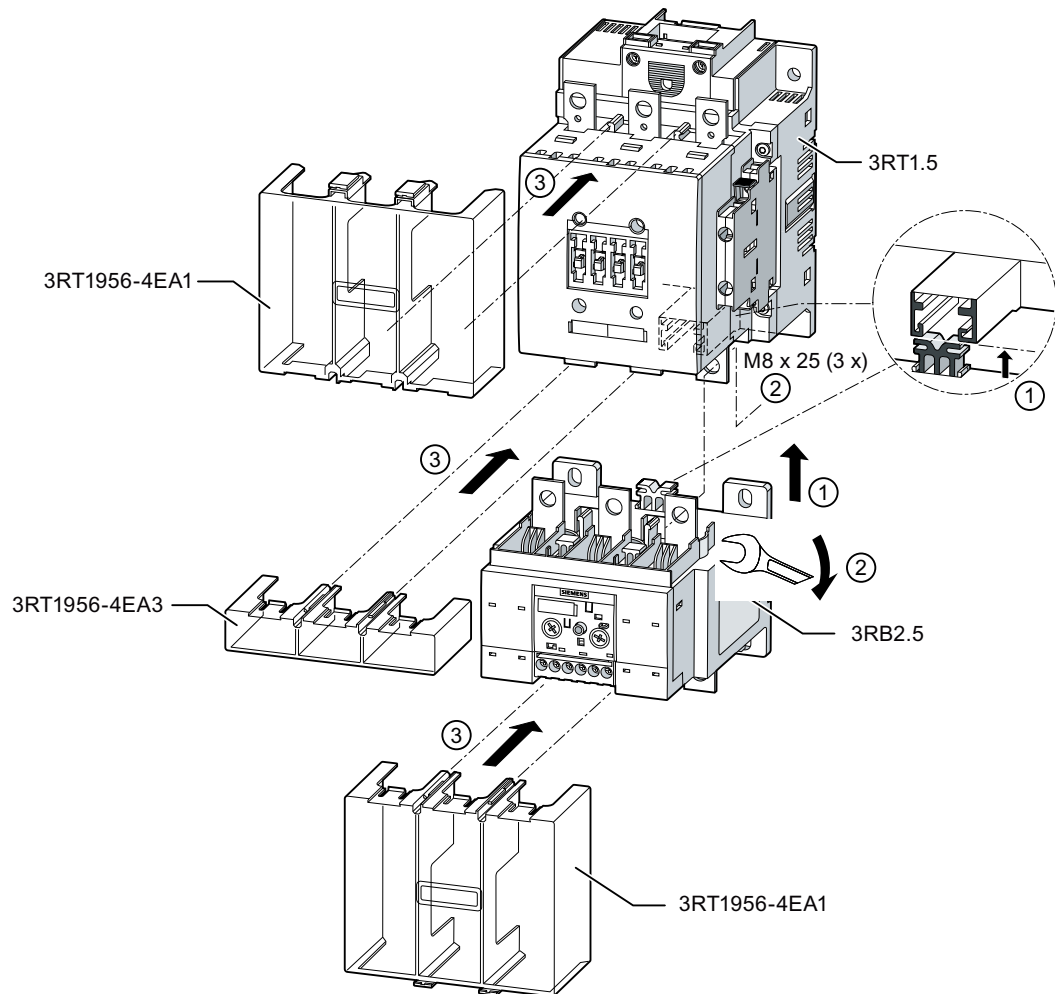

- ① Slide the electronic overload relay onto the contactor from below.
Make sure that the tab on the upper side of the electronic overload relay's enclosure is not inserted into the contactor's guide.
- ② Screw the electronic overload relay onto the contactor with the screws provided for this purpose.
- ③ As shown in the figure, slide the terminal covers for covering the busbars into the openings provided on the box terminal block of the electronic overload relay and on the contactor.

Mounting the 3RB2.5 electronic overload relay (connection with box terminal block)

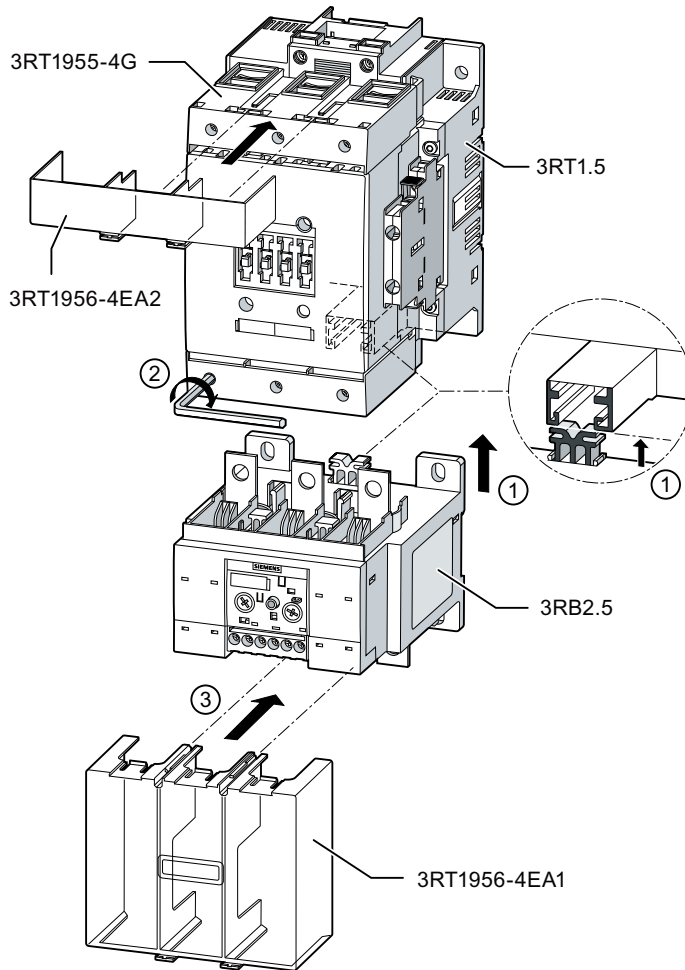

- ① Slide the electronic overload relay onto the contactor from below. Make sure that the tab on the upper side of the electronic overload relay's enclosure is not inserted into the contactor's guide.
- ② Screw the main conductor terminals tight on the contactor. Check that the cable is clamped tight.
- ③ As shown in the figure, slide the cover for the box terminal blocks into the openings provided on the box terminal block of the electronic overload relay and on the contactor.

Mounting the 3RB2.5 electronic overload relay (connection with box terminal block and through-hole technology)

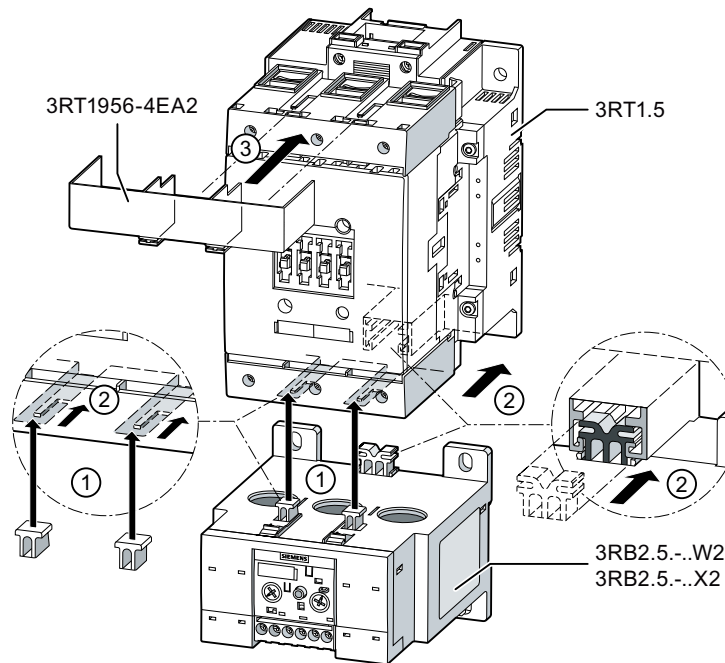

- ① Slide the electronic overload relay onto the contactor from below.
- ② Make sure that the three tabs on the upper side of the electronic overload relay's enclosure are inserted into the contactor's guides.
- ③ As shown in the figure, slide the cover for the box terminal block into the openings provided on the contactor.

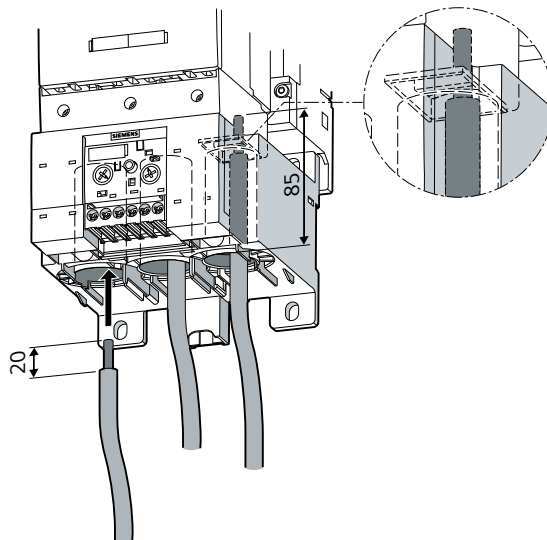

Observe a stripped length of 20 mm when connecting.

Disassembly from the 3RT1.5 contactor

Disassembly of contactor/overload relay combinations with busbar connection and connection with box terminal is done in the reverse order.

The figure below shows the disassembly of the 3RB2.5 electronic overload relay from the 3RT1.5 contactor (connection with box terminal block and through-hole technology).

Disassembly of the 3RB2.5 electronic overload relay (connection with box terminal block and through-hole technology)

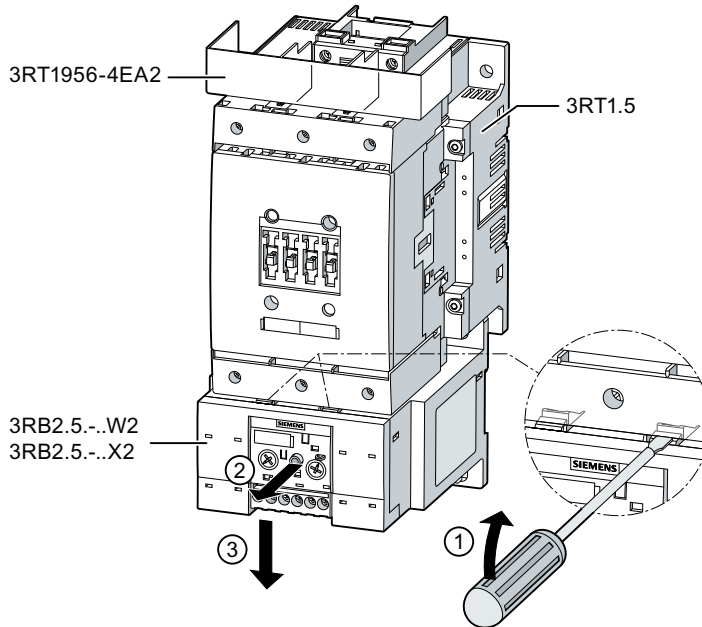

- ① Slide the screwdriver into the opening on the electronic overload relay as shown in the figure and press it down.
- ② Pull the electronic overload relay toward you.
- ③ Pull the electronic overload relay down and away from the contactor.

Stand-alone installation

3RB205 electronic overload relays are suitable for screw mounting and snap-on mounting on 35 mm DIN rails without an additional terminal support for stand-alone installation.

Mounting the 3RB2.5 electronic overload relay on a DIN rail

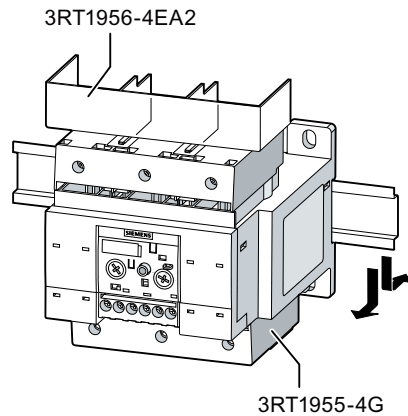

8.4.7 Mounting the 3RB2.6 electronic overload relay to the 3RT1.6 / 3RT1.7 contactor

Direct mounting on the 3RT1.6 / 3RT1.7 contactor

The contactor/overload relay combinations are designed for screw mounting on a mounting plate.

The figure below shows mounting of the 3RB2.6 electronic overload relay on the 3RT1.6 / 3RT1.7 contactor (busbar connection) with the terminal covers and covers for box terminals available as accessories.

Mounting the 3RB2.6 electronic overload relay (busbar connection)

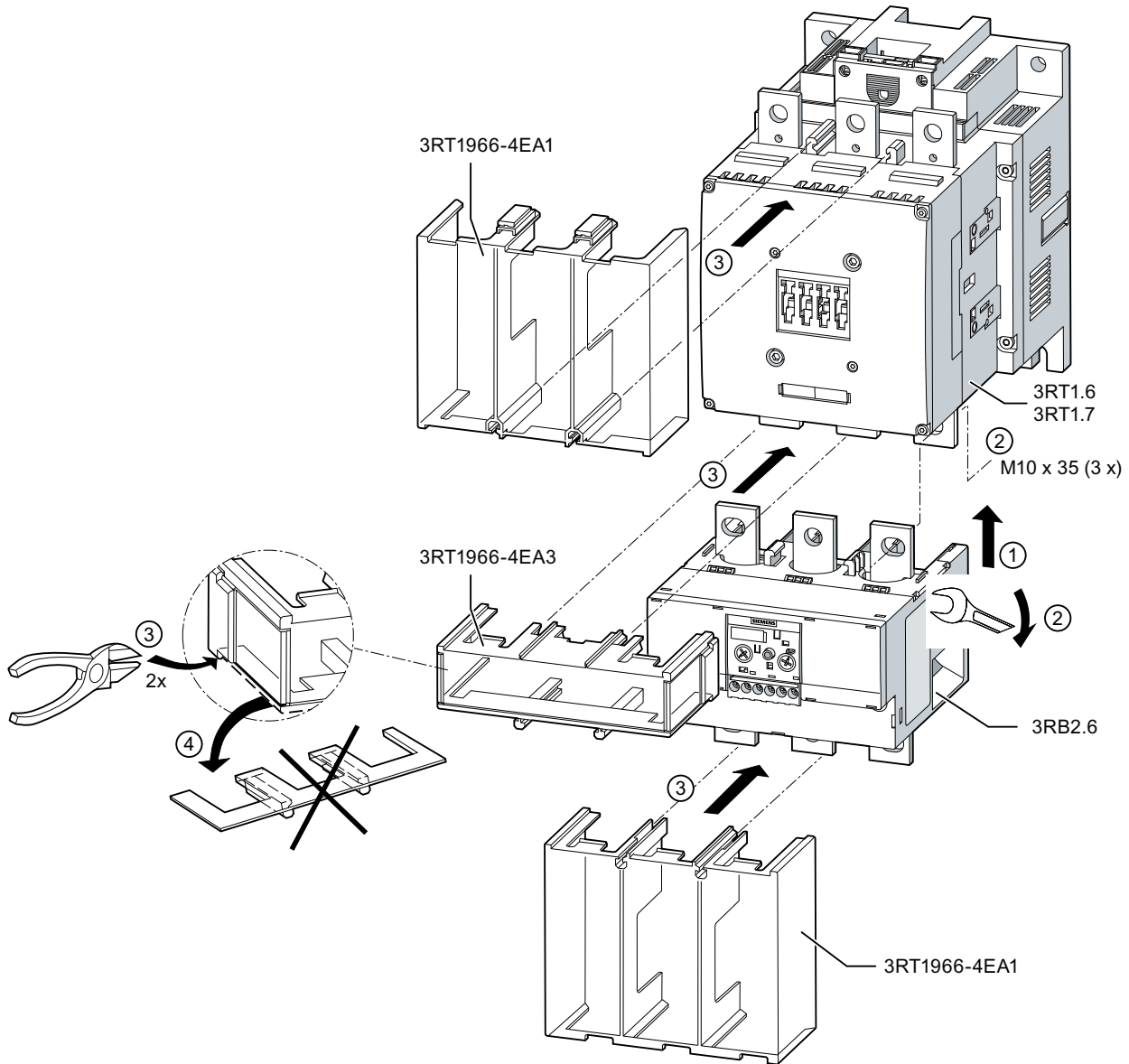

- ① Slide the electronic overload relay onto the contactor from below.
- ② Screw the electronic overload relay onto the contactor with the screws provided for this purpose.
- ③ As shown in the figure, slide the terminal covers for covering the busbars into the openings provided on the box terminal block of the electronic overload relay and on the contactor.
- ④ As shown in the illustration, break a side section out of the terminal cover for covering the busbars.

Disassembly from the 3RT1.6 / 3RT1.7 contactor

Disassembly of contactor/overload relay combinations with busbar connections is done in the reverse order.

Stand-alone installation

3RB206 electronic overload relays are suitable for screw mounting.

The following figures show how to mount and disassemble the box terminal block and the terminal covers for box terminal blocks available as accessories onto the 3RB2 electronic overload relay.

Mounting the 3RB2.6 electronic overload relay (connection with box terminal block)

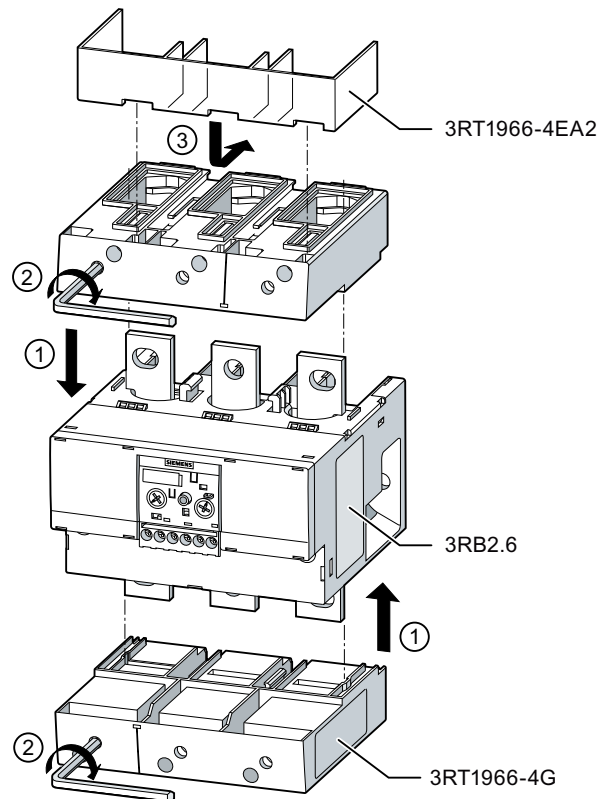

- ① Place the box terminal block on the electronic overload relay.
- ② Screw the box terminal block tight on the contactor. Check whether the box terminal block is fitted firmly.
- ③ As shown in the figure, slide the terminal cover for the box terminal block into the openings provided on the box terminal block of the electronic overload relay.

Disassembly of the 3RB2.6 electronic overload relay (connection with box terminal block)

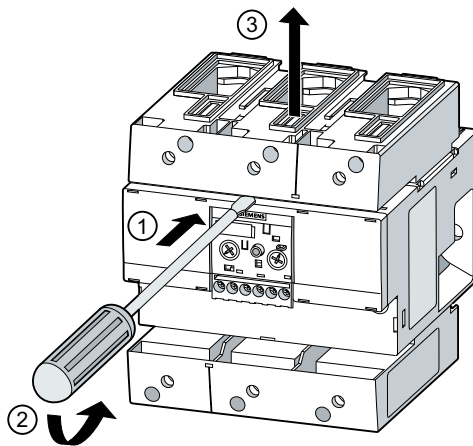

- ① Position the screwdriver on the center of the electronic overload relay as shown in the figure.
- ② Slightly lever open the box terminal block to dislodge it.
- ③ Detach the box terminal block from the electronic overload relay in the upward direction.

8.4.8 Replacing the removable terminal on the 3RB3.1 / 3RB3.2 electronic overload relay

Replacing the removable terminal

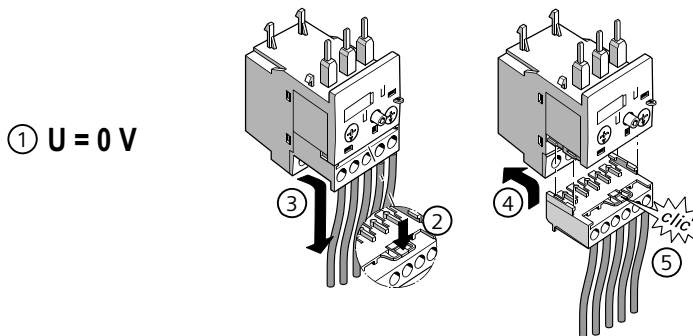

- ① **U = 0 V**
- ② Press the unlocking mechanism down.
- ③ Remove the terminal from the overload relay.
- ④ / Push the terminal into the overload relay until the terminal audibly engages.
- ⑤

8.4.9 Replacing the removable terminal on the 3RB3.3 electronic overload relay

Replacing the removable terminal

① U = 0 V

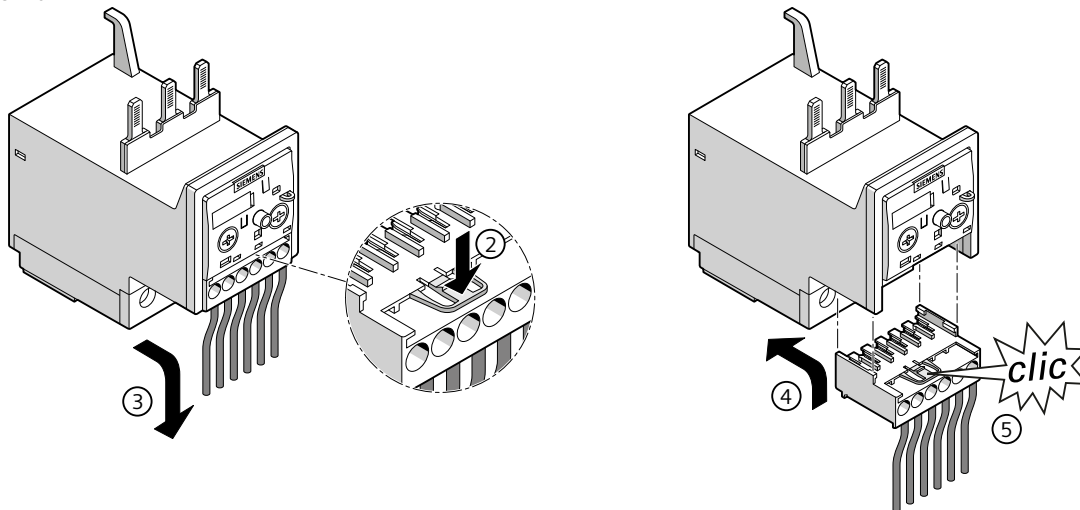

- ① Disconnect the system and the device from the power supply before starting work.
- ② Press the unlocking mechanism down.
- ③ Remove the terminal from the overload relay.
- ④ / Push the terminal into the overload relay until the terminal audibly engages.
- ⑤

8.4.10 Replacing the removable terminal on the 3RB3.4 electronic overload relay

Replacing the removable terminal

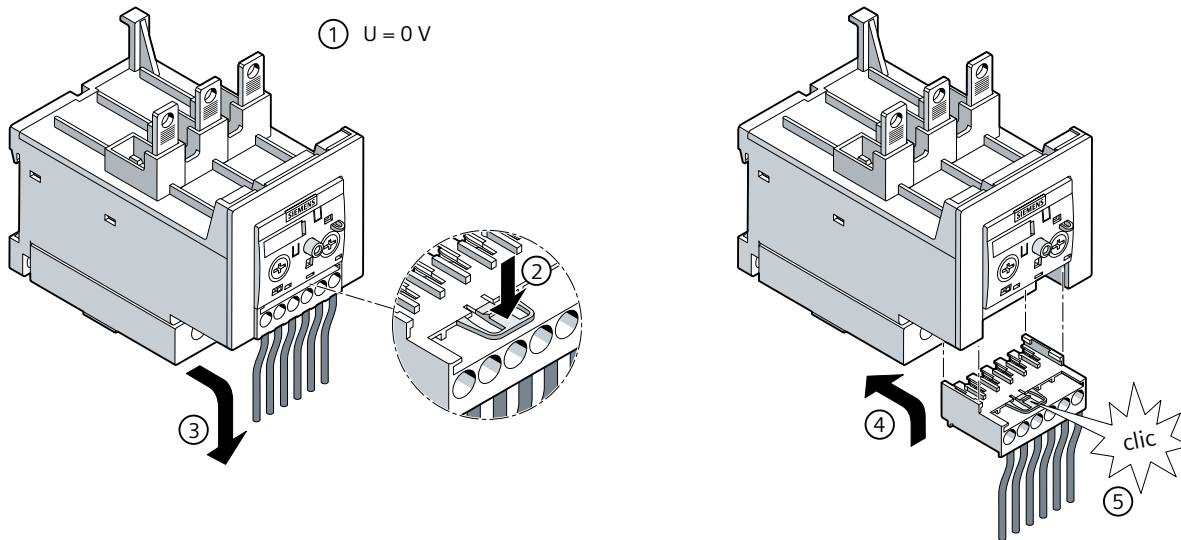

- ① Disconnect the system and the device from the power supply before starting work.
- ② Press the unlocking mechanism down.
- ③ Remove the terminal from the overload relay.
- ④ / Push the terminal into the overload relay until the terminal audibly engages.
- ⑤

8.4.11 Replacing the removable terminal on the 3RB2.5 and 3RB2.6 electronic overload relays

Replacing the removable terminal

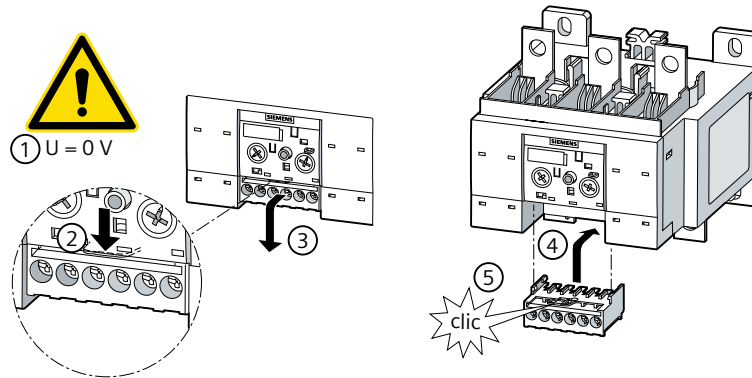

- ① Disconnect the system and the device from the power supply before starting work.
- ② Press the unlocking mechanism down.
- ③ Remove the terminal from the overload relay.
- ④ / Push the terminal into the overload relay until the terminal audibly engages.
- ⑤

Connection

9.1 Warning notice



! DANGER

Hazardous voltage. Will cause death or serious injury.

Turn off and lock out all power supplying this device before working on this device.

9.2 Connection

Connection types

The electronic and thermal overload relays are available with the following connection types.

3RU2 thermal overload relays

- Size S00 and S0:
 - Main and auxiliary circuits: optional screw-type or spring-loaded connection
- Size S2:
 - Main circuit: Screw connection with box terminal
 - Auxiliary circuit: optional screw-type or spring-loaded connection
- Size S3:
 - Main circuit: screw connection with box terminal (ring terminal lug connection or busbar connection after removal of the box terminal block is optionally possible)
 - Auxiliary circuit: optional screw-type or spring-loaded connection

3RB20 and 3RB21 electronic overload relays

- Size S6:
 - Main circuit: busbar connection with through-hole technology
 - Auxiliary circuit: optional screw-type or spring-loaded connection
- Sizes S10 / S12:
 - Main circuit: Bus connection
 - Auxiliary circuit: optional screw-type or spring-loaded connection

3RB30 and 3RB31 electronic overload relays

- Sizes S00 and S0:
 - Main and auxiliary circuits: optionally screw or spring-type terminals
- Size S2:
 - Main circuit: Screw connection with box terminal or through-hole technology
 - Auxiliary circuit: optional screw-type or spring-loaded connection
- Size S3:
 - Main circuit: Screw connection with box terminal or through-hole technology
 - Auxiliary circuit: optional screw-type or spring-loaded connection

Conductor cross-sections

The conductor cross-sections of the devices in the SIRIUS modular system are matched to one another on a size-specific basis.

Coil repeat and auxiliary switch repeat terminal

In the case of size S00 3RU21 thermal overload relays and 3RB30 / 3RB31 electronic overload relays, direct contactor mounting involves the feed-through of the auxiliary switch and coil terminals A2 on the contactor. This makes wiring much easier.

Touch protection

Please observe the information in Chapter "Technical specifications (Page 161)" with regard to touch protection for 3RU21 thermal overload relays and 3RB30 / 3RB31 electronic overload relays (according to IEC 60529). Devices in sizes S00 and S0 with screw-type and spring-loaded connection systems are finger-safe. Additional terminal covers (accessories) are required to ensure devices with busbar connections (sizes S6 to S10 / S12) are finger-safe.

Note

3RU2 and 3RB3 devices (sizes S2 and S3) have degree of protection IP00 in the area of the main circuit connecting terminals.

3RB2 (size S6) and 3RB3 (sizes S2 and S3) devices with through-hole connection technology have degree of protection IP20.

9.3 Connection of 3RU21 overload relay

Control circuit

An additional power supply is not required for the operation of 3RU21 thermal overload relays.

Connection of terminals

The terminal labels and a description of the operator controls of the 3RU21 thermal overload relays can be found in the chapter "3RU21 thermal overload relays (Page 24)".

Reference

More information ...	can be found ...
about connecting the SIRIUS modular system	in the appendix "References" under Manuals - SIRIUS Modular System (Page 175) in the "SIRIUS - System Overview" manual.

9.4 Connection of 3RB20 / 3RB21 and 3RB30 / 3RB31 overload relays

Control circuit

The 3RB20 / 3RB21 and 3RB30 / 3RB31 electronic overload relays do not need an additional supply voltage because they power themselves via the integrated current transformers.

Connection of terminals

The terminal labels and a description of the operator controls of 3RB2 electronic overload relays can be found in Chapters "3RB20 electronic overload relays (Page 29)" and "3RB21 electronic overload relays (Page 32)".

The terminal labels and a description of the operator controls of 3RB3 electronic overload relays can be found in Chapters "3RB30 solid-state overload relays (Page 36)" and "3RB31 solid-state overload relays (Page 41)".

Reference

More information ...	can be found ...
about connecting the SIRIUS modular system	in the appendix "References" under Manuals - SIRIUS Modular System (Page 175) in the "SIRIUS - System Overview" manual.

9.5 Connection cross-sections

9.5.1 Conductor cross-sections for screw-type connection systems

Conductor cross-sections for screw-type connection systems

The tables below define the permissible conductor cross-sections for main terminals and auxiliary conductor connections in sizes S00 to S10 / S12 for screw-type connection systems.

Note

If two different conductor cross-sections are connected to one clamping point, both cross-sections must be located in the range specified.

Table 9-1 Main conductors of size S00

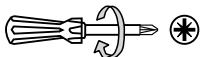
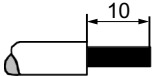
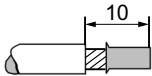
		Overload relay ¹⁾
Tool		Pozidriv size PZ 2, Ø 5 to 6 mm
Tightening torque		0.8 to 1.2 Nm
Solid and stranded		2 x (0.5 to 1.5) mm ²
		2 x (0.75 to 2.5) mm ²
		Max. 2 x 4 mm ²
Finely stranded with end sleeve		2 x (0.5 to 1.5) mm ²
		2 x (0.75 to 2.5) mm ²
AWG		2 x (20 to 16)
		2 x (18 to 14)
		2 x 12

¹⁾ Only 1 conductor can be clamped on the stand-alone assembly support.

Table 9-2 Main conductors of size S0

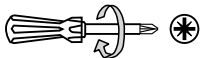
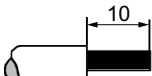
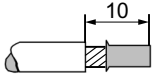
		Overload relay ¹⁾
Tool		Pozidriv size PZ 2, Ø 5 to 6 mm
Tightening torque		2.0 to 2.5 Nm
Solid and stranded		2 x (1.0 to 2.5) mm ²
		2 x (2.5 to 10) mm ²
Finely stranded with end sleeve		2 x (1 to 2.5) mm ²
		2 x (2.5 to 6) mm ²
		Max. 1 x 10 mm ²

		Overload relay ¹⁾
AWG		2 x (16 to 12)
		2 x (14 to 8)



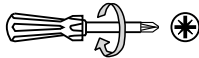
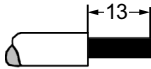
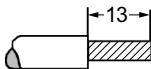
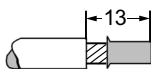

¹⁾ Only 1 conductor can be clamped on the stand-alone assembly support.

Table 9-3 Main conductors of size S2 with box terminal block

		Overload relay ¹⁾
Tool		Pozidriv size PZ 2, Ø 5 to 6 mm
Tightening torque		3.0 to 4.5 Nm
Solid and stranded		2 x (1 to 35) mm ²
		1 x (1 to 50) mm ²
Finely stranded without end sleeve		–
Finely stranded with end sleeve		2 x (1 to 25) mm ²
		1 x (1 to 35) mm ²
AWG		2 x (18 to 2)
		1 x (18 to 1)

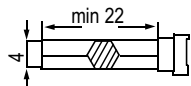
¹⁾ Only 1 conductor can be clamped on the stand-alone assembly support.

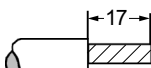
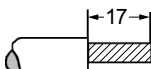
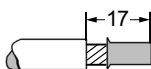
Table 9-4 Main conductors of size S3 with box terminal block

		Overload relays
Tool		4 mm Allen key
Tightening torque		4.5 ... 6.0 Nm
Solid		2 x (2.5 ... 16) mm ²
Stranded		2 x (6 ... 16) mm ²
		2 x (10 ... 50) mm ²
		1 x (10 ... 70) mm ²
Finely stranded without end sleeve		–
Finely stranded with end sleeve		2 x (2.5 ... 35) mm ²
		1 x (2.5 ... 50) mm ²
Ribbon cables		2 x (6 x 9 x 0.8)
AWG		2 x (10 to 1/0)
		1 x (10 to 2/0)

9.5 Connection cross-sections

Table 9-5 Main conductors of size S6 with box terminal block



		Electronic overload relay with box terminal block 3RT1955-4G	Electronic overload relay with box terminal block 3RT1956-4G
Tool		 4 mm Allen key	 4 mm Allen key
Tightening torque		10.0 ... 12.0 Nm	
Solid		-	
Stranded		2 x (max. 70) mm ²	2 x (max. 120) mm ²
		1 x (16 ... 70) mm ²	1 x (16 ... 120) mm ²
Finely stranded without end sleeve		2 x (1 x max. 50, 1 x max. 70) mm ²	2 x (1 x max. 95, 1 x max. 120) mm ²
		1 x (1 ... 70) mm ²	1 x (10 ... 120) mm ²
Finely stranded with end sleeve		2 x (1 x max. 50, 1 x max. 70) mm ²	2 x (1 x max. 95, 1 x max. 120) mm ²
		1 x (1 ... 70) mm ²	1 x (10 ... 120) mm ²
Ribbon cables		2 x (6 x 15.5 x 0.8)	2 x (10 x 15.5 x 0.8)
		1 x (3 x 9 x 0.8 ... 6 x 15.5 x 0.8)	1 x (3 x 9 x 0.8 ... 10 x 15.5 x 0.8)
AWG		2 x (max. 1/0)	2 x (max. 3/0)
		1 x (6 ... 2/0)	1 x (6 ... 250 kcmil)

Table 9-6 Main conductors of size S10 / S12 with box terminal block

		Electronic overload relay with box terminal block 3RT1966-4G
Tool		5 mm Allen key
Tightening torque		20.0 ... 22.0 Nm
Solid		-
Stranded		2 x (70 ... 240) mm ²
		Front clamping point only: 1 x (95 ... 300) mm ² Rear clamping point only: 1 x (120 ... 240) mm ²
Finely stranded without end sleeve		2 x (50 ... 185) mm ²
		Front clamping point only: 1 x (70 ... 240) mm ² Rear clamping point only: 1 x (120 ... 185) mm ²

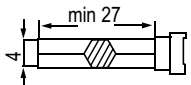
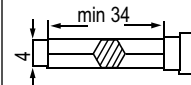
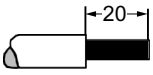
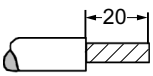
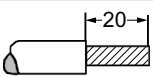
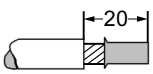

		Electronic overload relay with box terminal block 3RT1966-4G
Finely stranded with end sleeve		2 x (50 ... 185) mm ² Front clamping point only: 1 x (70 ... 240) mm ² Rear clamping point only: 1 x (120 ... 185) mm ²
Ribbon cables		2 x (20 x 24 x 0.5) 1 x (6 x 9 x 0.8 ... 20 x 24 x 0.5)
AWG		2 x (2/0 ... 500 kcmil) Front clamping point only: 1 x (3/0 ... 600 kcmil) Rear clamping point only: 1 x (250 ... 500 kcmil)

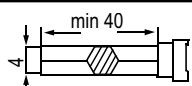
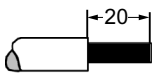
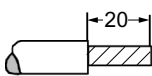
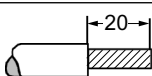
Table 9-7 Main conductor connection of size S2 with through-hole technology

		Electronic overload relay
		The maximum diameter of the opening is 12.8 mm.

Table 9-8 Main conductor connection of size S3 with through-hole technology

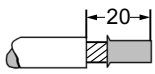
		Electronic overload relay
		The maximum diameter of the opening is 18 mm.

Connection

9.5 Connection cross-sections

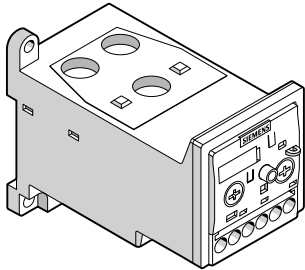
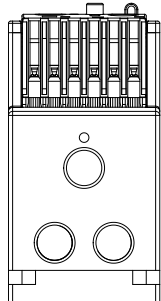
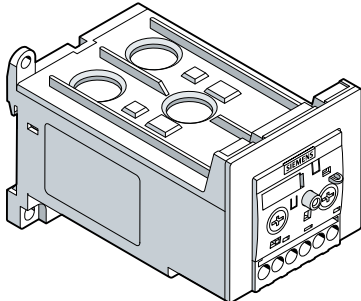
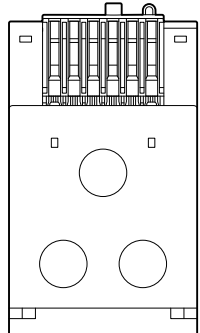
Table 9-9 Main conductor connection of size S6 with through-hole technology

 		<p>Electronic overload relay</p> <p>The maximum diameter of the opening is 24.5 mm.</p>
---	--	--

Table 9-10 Auxiliary conductors of sizes S00 to S3 on the 3RU2 thermal overload relay



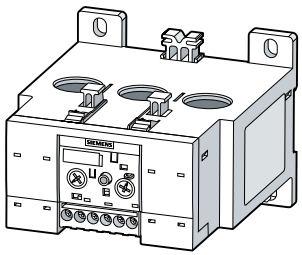
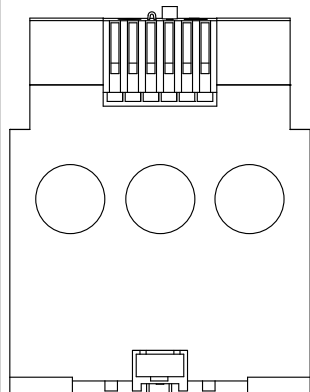

		Overload relay
Tool		Pozidriv size PZ 2, Ø 5 to 6 mm
Tightening torque		0.8 to 1.2 Nm
Solid and stranded		2 x (0.5 to 1.5) mm ²
		2 x (0.75 to 2.5) mm ²
Finely stranded with end sleeve		2 x (0.5 to 1.5) mm ²
		2 x (0.75 to 2.5) mm ²
AWG		2 x (20 to 16)
		2 x (18 to 14)

Table 9-11 Removable terminal for auxiliary conductor on the 3RB3 electronic overload relay

		Removable terminal
Tool		Pozidriv size PZ 2, Ø 6 mm
Tightening torque		0.8 to 1.2 Nm
Solid and stranded		1 x (0.5 to 4) mm ²
		2 x (0.5 to 2.5) mm ²
Finely stranded with end sleeve		1 x (0.5 to 2.5) mm ²
		2 x (0.5 to 1.5) mm ²
AWG		2 x (20 to 14)

9.5.2 Conductor cross-sections for spring-loaded connection systems

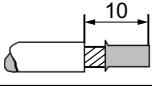
Conductor cross-sections for spring-loaded connection systems

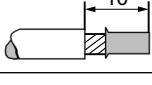
The following tables define the permissible conductor cross-sections for main terminals in sizes S00 and S0, and auxiliary conductor connections in sizes S00 to S3 for spring-loaded connection systems.

Table 9-12 Main conductors of size S00

		Overload relay
Tool		Ø3.0 x 0.5 (3RA2908-1A)
Solid and stranded		1 x (0.5 to 4.0) mm ²
Finely stranded without end sleeve		1 x (0.5 to 2.5) mm ²
Finely stranded with end sleeve		1 x (0.5 to 2.5) mm ²
AWG		1 x (20 to 12)

Table 9-13 Main conductors of size S0

		Overload relay
Tool		Ø3.0 x 0.5 (3RA2908-1A)
Solid and stranded		1 x (1.0 to 10) mm ²
Finely stranded without end sleeve		1 x (1.0 to 6.0) mm ²
Finely stranded with end sleeve		1 x (1.0 to 6.0) mm ²
AWG		1 x (18 to 8)

Table 9-14 Auxiliary conductors of sizes S00 to S3 on the 3RU2 thermal overload relay

		Overload relay
Tool		Ø3.0 x 0.5 (3RA2908-1A)
Solid and stranded		2 x (0.5 to 2.5) mm ²

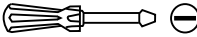
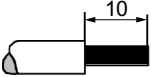
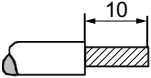
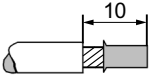
Connection

9.5 Connection cross-sections

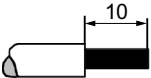
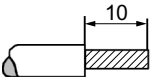
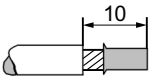
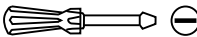
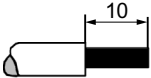

		Overload relay
Finely stranded without end sleeve		2 x (0.5 to 2.5) mm ²
Finely stranded with end sleeve		2 x (0.5 to 1.5) mm ²
AWG		2 x (20 to 14)

Table 9-15 Removable terminal for auxiliary conductor on the 3RB3 electronic overload relay

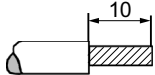
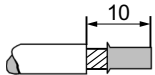
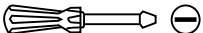

		Removable terminal
Tool		Ø3.0 x 0.5 (3RA2908-1A)
Solid and stranded		2 x (0.25 to 1.5) mm ²
Finely stranded without end sleeve		2 x (0.25 to 1.5) mm ²
Finely stranded with end sleeve		2 x (0.25 to 1.5) mm ²
AWG		2 x (24 to 16)

9.5.3 Conductor cross-sections for ring cable lug connection system

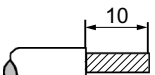
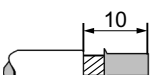
Conductor cross-sections for ring cable lug connection system

The tables below define the permissible conductor cross-sections for main terminals in sizes S3 to S12 for ring cable lug connection systems.

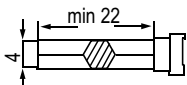
Table 9-16 Main conductors of size S3 with M6 screws

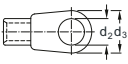
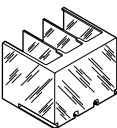
		SIRIUS devices
Tool		4 mm Allen key
Tightening torque		4.5 ... 6.0 Nm
Busbars (M6 x 25)		2 x 12 x 4
Ring cable lug ¹⁾		d ₂ = min. 6.3 mm d ₃ = max. 19.0 mm
Ring cable lug cover		3RT1946-4EA1

¹⁾ The following ring cable lugs are approved for achieving the required clearances and creepage distances:

- For applications according to IEC 60947-1:
 - DIN 46237 (with insulating sleeve)
 - JIS CS805 type RAV (with insulating sleeve)
 - JIS CS805 type RAP (with insulating sleeve)
- For applications according to UL 508:
 - DIN 46234 (without insulating sleeve)
 - DIN 46225 (without insulating sleeve)
 - JIS CS805 (without insulating sleeve)

A shrink-on sleeve must be used to insulate ring cable lugs without an insulating sleeve. The following conditions must be met:

- Operating temperature: -55 °C to +155 °C
- UL 224 approved
- Flame-protected



! DANGER
Hazardous voltage. Will cause death or serious injury.
Only use approved ring cable lugs to meet the required clearances and creepage distances.

Table 9-17 Main conductors of size S6 with M8 screws

Electronic overload relay with busbar connection		
Connecting bars (M8 x 25)		2 x 15 x 4
Tightening torque		10.0 ... 14.0 Nm
Finely stranded with cable lug		16 ... 95 mm ² ¹⁾
Stranded with cable lug		25 ... 120 mm ² ¹⁾
AWG		4 ... 250 kcmil

¹⁾ When connecting cable lugs according to DIN 46235 with conductor cross-sections of 95 mm² and more, the 3RT1956-4EA1 terminal cover must be used to ensure phase clearance.

Table 9-18 Main conductors of size S10 / S12 with M10 screws

Electronic overload relay with busbar connection		
Connecting bars (M10 x 30)		2 x 25 x 6
Tightening torque		14.0 ... 24.0 Nm
Finely stranded with cable lug		50 ... 240 mm ² ¹⁾

Connection

9.5 Connection cross-sections

Electronic overload relay with busbar connection		
Stranded with cable lug		70 ... 240 mm ² ¹⁾
AWG		2/0 ... 500 kcmil

- ¹⁾ When connecting cable lugs in accordance with DIN 46234 for conductor cross-sections from 240 mm², as well as DIN 46235 for cable cross-sections from 185 mm², use the 3RT1966-4EA1 terminal cover to ensure phase spacing.

Operation

10.1 Setting the current

Setting the rated motor current on 3RU21 and 3RB20 / 3RB21, 3RB30 / 3RB31 overload relays

3RU21 thermal overload relays and 3RB20 / 3RB21 and 3RB30 / 3RB31 electronic overload relays are set to the rated motor current with a rotary knob.

Note

The overload relays may only be set between the upper and lower setting marks on the scale. A setting below or above the setting scale is not permissible.

The figure below shows how to set the rated motor current based on the example of the 3RU21 thermal overload relay, size 50.

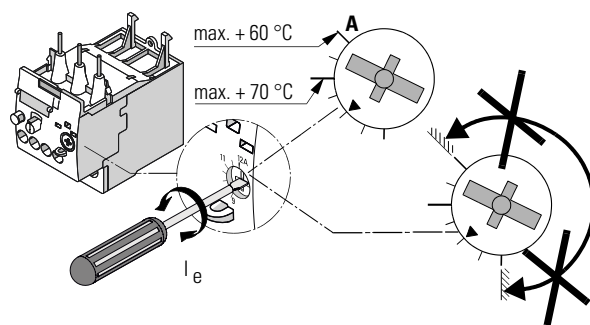

Figure 10-1 Setting the current I_e

10.2 Setting the tripping class/ground-fault detection (3RB21 / 3RB31)

In the case of 3RB21 / 3RB31 electronic overload relays, it is also possible to select the tripping class (CLASS 5E, 10E, 20E or 30E) via a second rotary knob using a screwdriver and activate or deactivate internal ground-fault monitoring.

There are 8 possible settings:

- CLASS 5E, 10E, 20E and 30E without ground-fault detection (STANDARD)
- CLASS 5E, 10E, 20E and 30E without ground-fault detection (Gnd-FAULT)

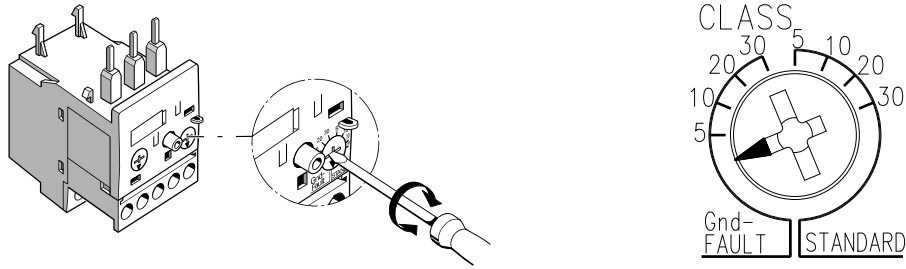

10.3 RESET after release

Manual and automatic reset

If manual reset is selected, resetting can be carried out directly on the device by pressing the RESET button.

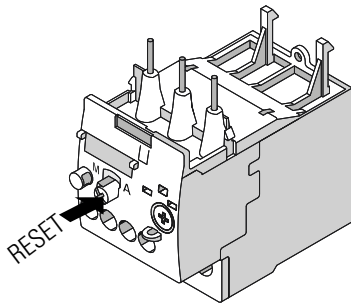

A remote reset (remote RESET) is possible in conjunction with the mechanical and electrical RESET modules, which are available as accessories. If automatic RESET is set on the overload relay, the relay will be reset automatically.

<p>⚠ WARNING</p> <p>Machine restart Can cause death or serious injury.</p> <p>If a switch-on command is present after an overload trip and a manual reset or automatic reset is performed, the machine will start up immediately. People may be injured if they stay in the danger area of the machine.</p> <p>Make sure that the motor does not start up again following an overload trip until a new switch-on command has been issued (e.g. via an additional ON button) and that no one is in the machine danger zone at the time of restarting.</p> <p>If, in the event of an overload trip, the electronic overload relay is used without external thermistor protection (e.g. 3RN thermistor motor protection relay), the motor may only be switched on again by properly qualified personnel.</p>
--

Recovery time following overload release

This time gives the load a chance to cool down.

- 3RU21 thermal overload relays
The device cannot be reset until the bimetal strips have cooled down. The recovery time is dependent upon the tripping characteristic curve and the extent of the tripping current.
- 3RB20 / 3RB21 and 3RB30 / 3RB31 electronic overload relays
In the case of the 3RB20 / 3RB21 and 3RB30 / 3RB31 electronic overload relays, the recovery time is stored as a fixed value and is 3 minutes following a current-dependent trip with automatic RESET selected.
Following a trip, the 3RB20 / 3RB21 and 3RB30 / 3RB31 overload relays can be immediately reset locally on the device.

Setting the RESET function on the 3RU21 thermal overload relay

On the 3RU21 thermal overload relays, automatic and manual resetting is selected by pressing and turning the blue button (RESET button). The figure below shows how to switch between automatic and manual reset on the 3RU21 thermal overload relay, size S0.

Switching between manual and automatic on the 3RU21 thermal overload relay

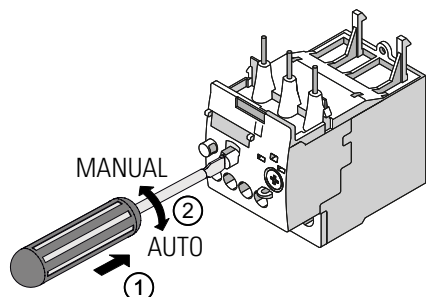

- ① Press the blue RESET button down with a screwdriver.
- ② Turn the blue RESET button to M (manual reset) or A (automatic reset).

Setting the RESET function on the 3RB30 / 3RB31 electronic overload relay

In the case of the 3RB20 / 3RB21 and 3RB30 / 3RB31 electronic overload relays, a slide switch can be used to choose between automatic and manual reset.

As an alternative to the local reset options, an electrical remote RESET (manual/automatic) can be implemented on 3RB21 / 3RB31 electronic overload relays by applying a 24 V DC voltage at terminals A3 and A4, which actuates an internal relay. To ensure that the internal relay will reliably switch, the voltage needs to be applied for at least 200 ms. During switching, the relay's current consumption amounts to as much as 200 mA for up to 20 ms, after which it drops to below 10 mA.

Switching between manual and automatic on 3RB30 / 3RB31 electronic overload relays

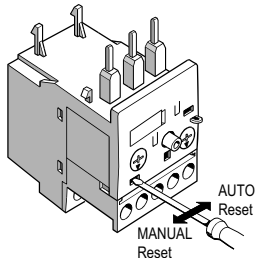

- ① Using a screwdriver, slide the switch to the required position.

Reference

More information ...	Can be found in the Chapter ...
about optional mechanical and electrical RESET modules	Accessories (Page 123)

10.4 TEST function

Test function for the 3RU21 thermal overload relay

Correct functioning of the operational 3RU21 thermal overload relay can only be checked with the TEST slide. The tripping of the relay can be simulated by moving the slide with a screwdriver. This simulation process opens the NC contact and closes the NO contact, thereby checking that the auxiliary circuit has been wired to the overload relay correctly.

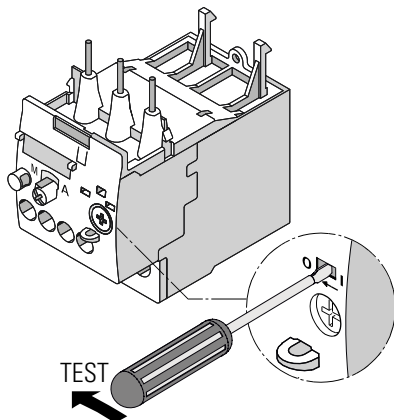

Figure 10-2 Executing a device test

Resetting

If the overload relay has been set to automatic RESET, the overload relay is automatically reset when the TEST slide is released. The relay must be reset with the RESET button if it has been set to manual RESET.

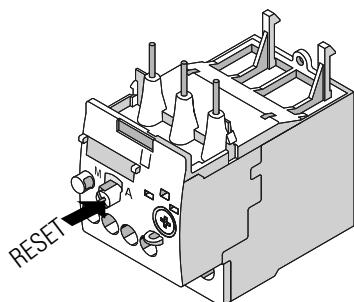

Figure 10-3 Resetting following device test

Test function in the case of 3RB20 / 3RB21 and 3RB30 / 3RB31 electronic overload relays

Correct functioning of the relay when ready for operation can only be checked by pressing the TEST button with the motor current flowing (device/electronics test). Current sensing, the motor model, and the tripping unit are tested.

You will find details of the procedure for conducting the test and the necessary prerequisites in Chapter "Safety instructions for use in hazardous areas (3RB2 and 3RB3) (Page 66)".

10.5 Response of the auxiliary contacts







Auxiliary contacts

The overload relay is equipped with an NO contact (NO 97-98) for the "tripped" signal and an NC contact (NC 95-96) for disconnecting the contactor. The auxiliary contacts have high contact reliability; this makes them suitable for PLCs. Furthermore, the high switching capacity facilitates direct switching of the contactor coil.

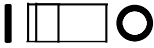
The table below shows how the auxiliary contacts respond when the TEST, STOP (3RU21 only), and RESET buttons are pressed.

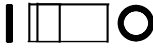
	READY	TEST	STOP	RESET
NC 95/96				
NO 97/98				

10.5 Response of the auxiliary contacts

	READY	TEST	STOP	RESET
Switch position indicator 3RB2 / 3RB3			--	
Switch position indicator 3RU21				

Accessories

11.1 Accessories

For maximum flexibility, accessories can be added to the overload relays as required, easily, and without the need for tools.

Accessories	3RU21	3RB20	3RB30	3RB21	3RB31
Terminal support for stand-alone assembly	✓	✓	✓	✓	✓
Release slide (mechanical remote RESET), compatible for use with all sizes	✓	✓	✓	✓	✓
Cable release (mechanical remote RESET), compatible for use with all sizes	✓	✓	✓	✓	✓
Module for electrical remote RESET, compatible for use with all sizes	✓	--	--	--	--
Integrated electrical remote RESET 24 V DC	--	--	--	✓	✓
Terminal covers for ring terminal lug connections and busbar connection	✓	--	--	--	--
Sealable cover	✓	✓	✓	✓	✓
Terminal covers for ring terminal lug connections and busbar connection (sizes S2, S3, S6 and S10 / 12 only)	--	✓	✓	✓	✓
Terminal covers for box terminals (sizes S3, S6 and S10 / 12 only)	--	✓	✓	✓	✓
Terminal covers for screw connection (sizes S6 and S10 / 12 only)	--	✓	--	✓	--
Box terminal blocks (sizes S6 and S10 / 12 only)	--	✓	--	✓	--

11.2 Terminal support for stand-alone assembly

11.2.1 Description

3RU21 thermal overload relays and 3RB30/3RB31 electronic overload relays in sizes S00 to S3 can also be installed individually with the terminal supports for stand-alone assembly.

The terminal supports for stand-alone assembly are available for the sizes S00 and S0 in screw-type and spring-loaded connection systems. In sizes S2 and S3, the terminal support for stand-alone assembly is available in screw-type connection technology. A terminal support can be mounted on the thermal overload relay as well as on the electronic overload relay.

11.2.2 Mounting/disassembly

11.2.2.1 Mounting the 3RU2.1 / 3RU2.2 thermal overload relay on a terminal support for stand-alone installation

Mounting

The terminal supports can be snapped onto 35 mm DIN rails according to DIN EN 60715. They can also be screw-mounted.

Mounting the terminal support (screw-type connection system) size S00 / S0

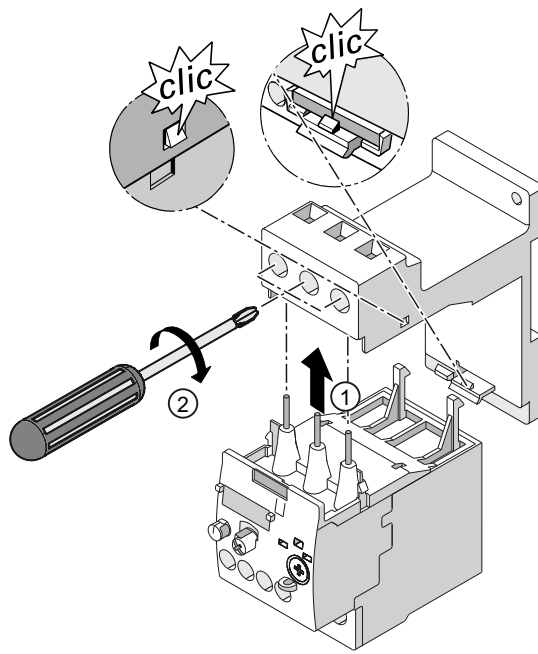

- ① Guide the overload relay into the terminal support from below.
- ② Screw the contacts tight.
Check that the cables are clamped tight.

Mounting the terminal support (spring-loaded connection system) size S00 / S0

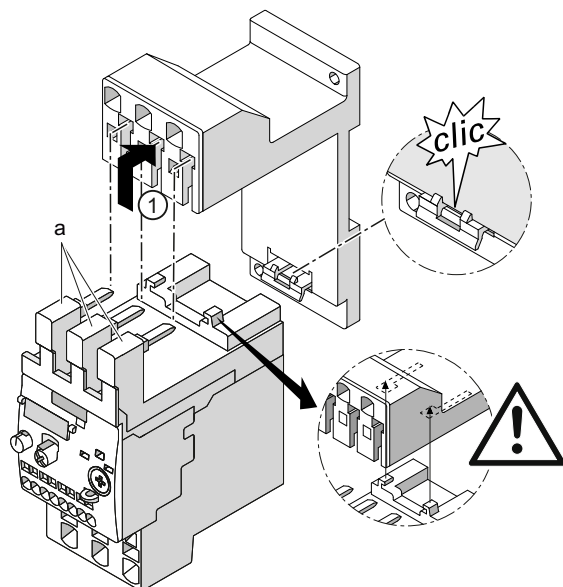

- ① Insert the contacts (a) into the central opening of the main conductor terminals on the terminal support, with the contacts flush to the right.
Make sure that the guide tabs are inserted into the designated slots on the terminal support.

Disassembly

Disassembling the terminal support (screw-type connection system) size S00 / S0

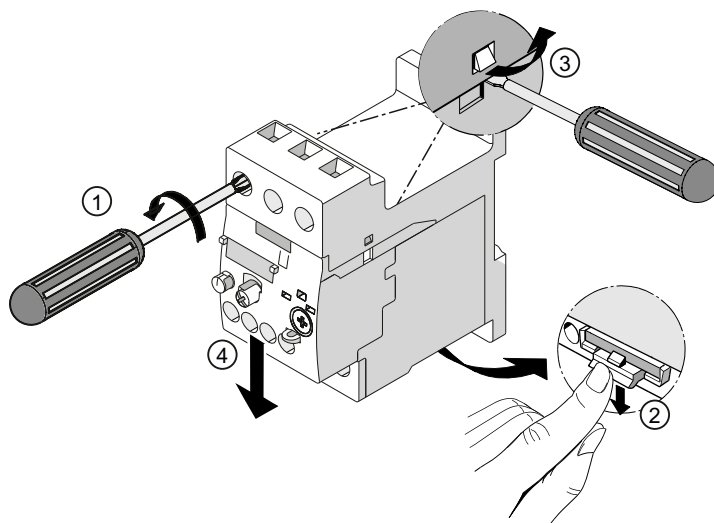

- ① Undo the screws on the main conductor terminals.
- ② Release the overload relay by pushing down the clip on the underside of the terminal support.
- ③ Release the terminal support from the overload relay with a screwdriver (only on size S00 and S0 devices).
- ④ Pull the overload relay down and away from the terminal support.

Disassembling the terminal support (spring-loaded connection system) size S00 / S0

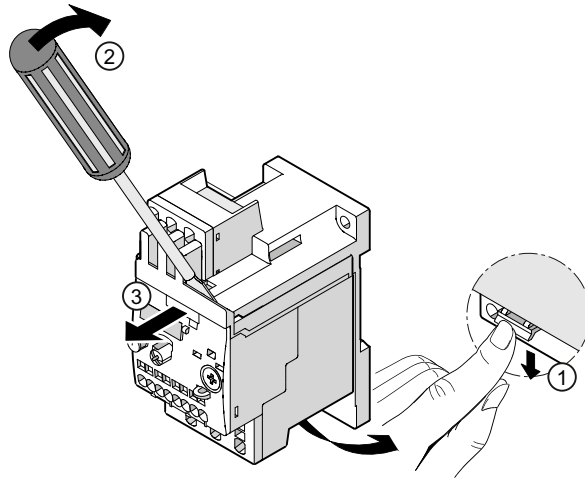

- ① Release the overload relay by pushing down the clip on the underside of the terminal support.
- ② Position the screwdriver on the terminal support as shown in the figure. Carefully dislodge the overload relay from the contactor.
- ③ Pull the overload relay forward and away from the terminal support.

11.2.2.2 Mounting the 3RB3.1 electronic overload relay on a terminal support for stand-alone installation

Mounting

The terminal supports can be snapped onto 35 mm DIN rails according to DIN EN 60715. They can also be screw-mounted.

Mounting the terminal support (spring-loaded connection system) size S00

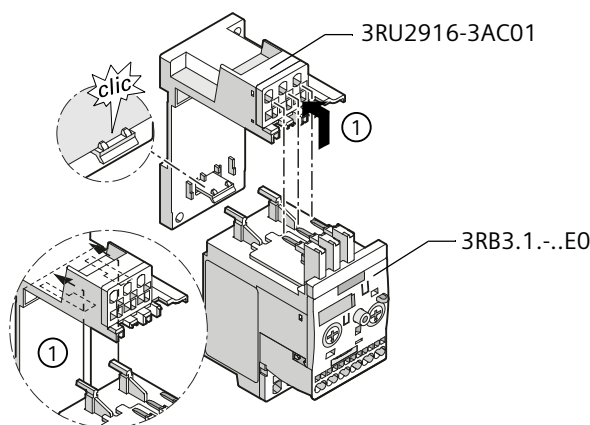

- ① Insert the contacts into the central opening of the main conductor terminals on the terminal support.
Make sure that the guide tabs are inserted into the designated slots on the terminal support.

Disassembly

Disassembling the terminal support (spring-loaded connection system) size S00

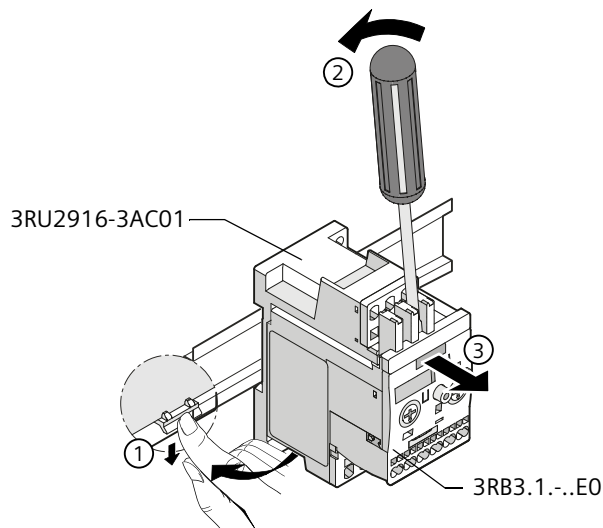

- ① Release the overload relay by pushing down the clip on the underside of the terminal support.
- ② Position the screwdriver on the terminal support as shown in the figure. Carefully dislodge the overload relay from the contactor.
- ③ Pull the overload relay forward and away from the terminal support.

11.2.2.3 Mounting the 3RB3.2 electronic overload relay on a terminal support for stand-alone installation

Mounting

The terminal supports can be snapped onto 35 mm DIN rails according to DIN EN 60715. They can also be screw-mounted.

11.2 Terminal support for stand-alone assembly

Mounting the terminal support (screw-type connection system) size S0

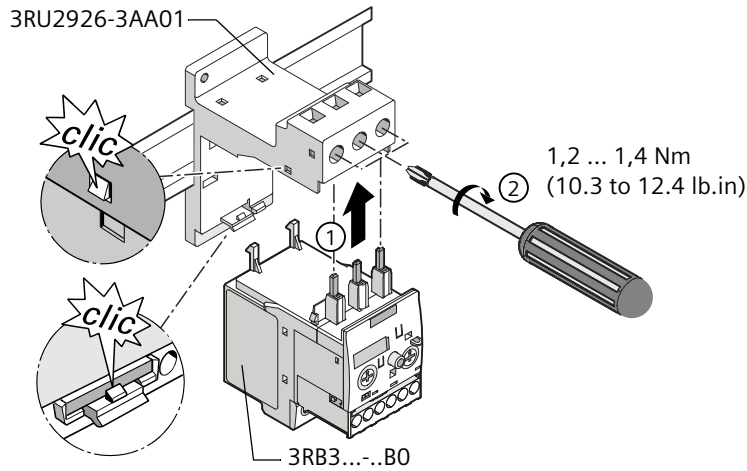

- ① Guide the overload relay into the terminal support from below.
- ② Screw the contacts tight.
Check that the cables are clamped tight.

Mounting the terminal support (spring-loaded connection system) size S0

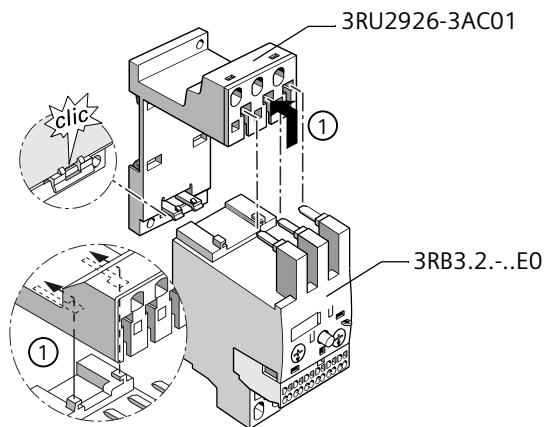

- ① Insert the contacts into the central opening of the main conductor terminals on the terminal support, with the contacts flush to the right.
Make sure that the guide tabs are inserted into the designated slots on the terminal support.

Disassembly

Disassembly of the terminal support (screw-type connection system) size S0

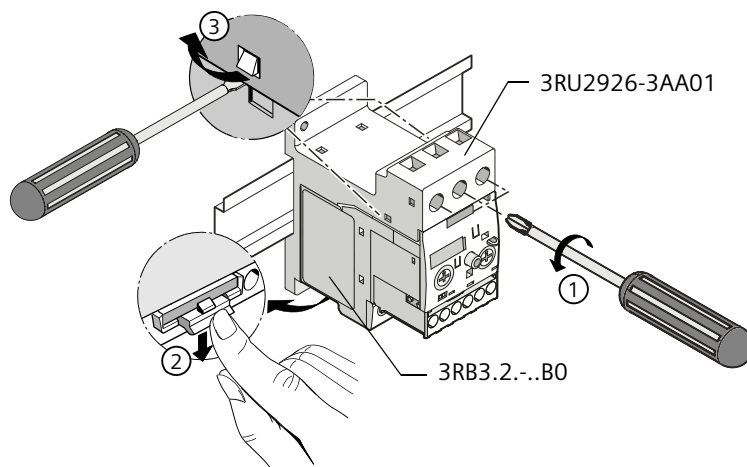

- ① Undo the screws on the main conductor terminals.
- ② Release the overload relay by pushing down the clip on the underside of the terminal support.
- ③ Use a screwdriver to dislodge the terminal support from the overload relay.
Pull the overload relay down and away from the terminal support.

Disassembling the terminal support (spring-loaded connection system) size S0

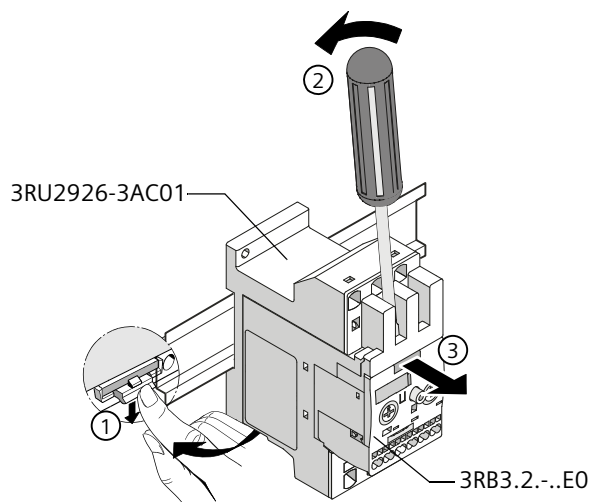

- ① Release the overload relay by pushing down the clip on the underside of the terminal support.
- ② Position the screwdriver on the terminal support as shown in the figure. Carefully dislodge the overload relay from the contactor.
- ③ Pull the overload relay forward and away from the terminal support.

11.2.2.4 Mounting the 3RU2.3 / 3RU2.4 thermal overload relay on a terminal support for stand-alone installation

Mounting

The terminal supports can be snapped onto 35 mm DIN rails according to DIN EN 60715. They can also be screw-mounted.

The figures below show how the terminal support for stand-alone installation is mounted and removed, based on the example of a 3RU21 thermal overload relay (size S3). Mounting and disassembling size S2 devices is equivalent to the procedure described for size S3.

Mounting the terminal support (screw-type connection system) size S2 / S3

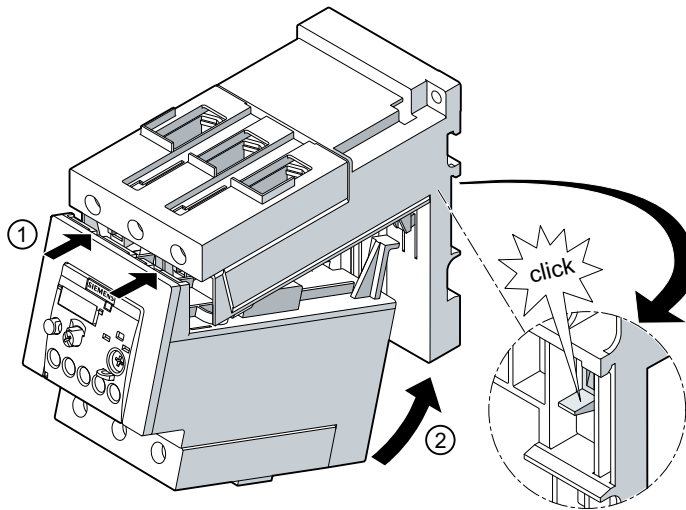

- ① Guide the overload relay into the terminal support from below with a swivel movement.
- ②

Disassembly

Disassembling the terminal support (screw-type connection system) size S2 / S3

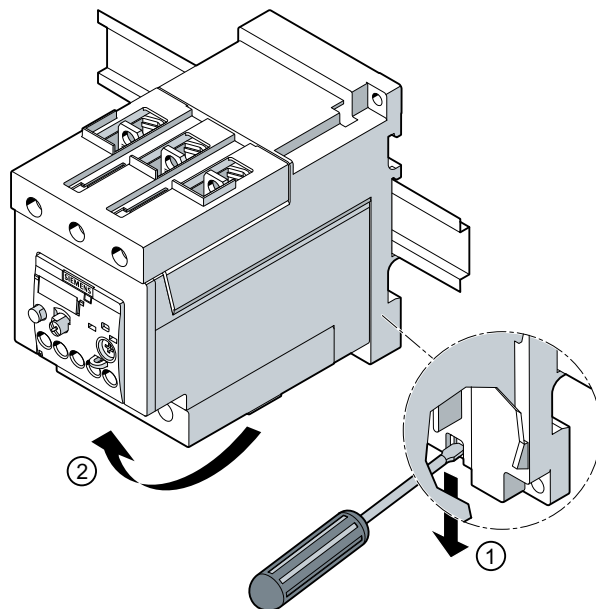

- ① Release the terminal support by pushing down the clip on the underside of the terminal support using a screwdriver.
- ② Remove the terminal support with the mounted overload relay from the mounting rail with a swivel movement to the front.

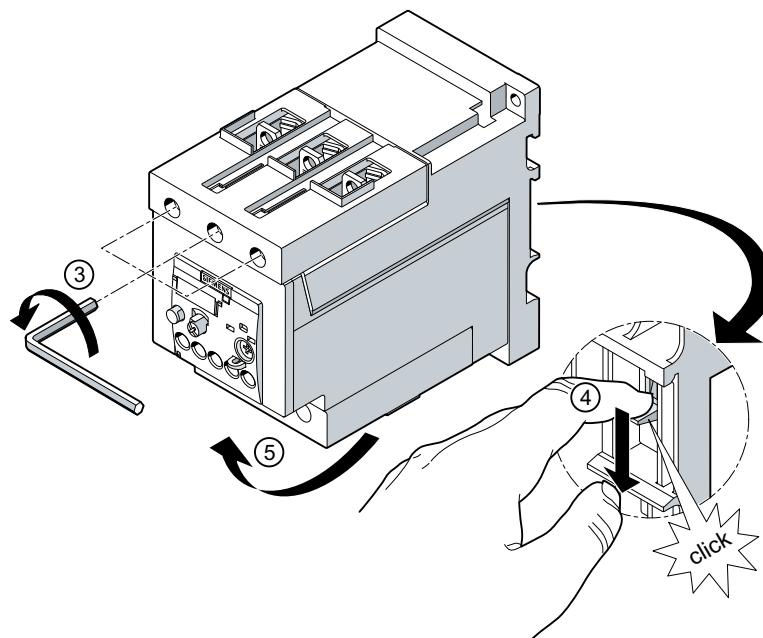

- ③ Undo the screws on the main conductor terminals using an Allen key.
- ④ Release the overload relay by pushing down the clip on the rear of the terminal support.
- ⑤ Pull the overload relay forward and away from the terminal support with a swivel movement.

11.2.2.5 Mounting the 3RB3.3 electronic overload relay on a terminal support for stand-alone installation

Mounting

The terminal supports can be snapped onto 35 mm DIN rails according to DIN EN 60715. They can also be screw-mounted.

Mounting the terminal support (screw-type connection system) size S2

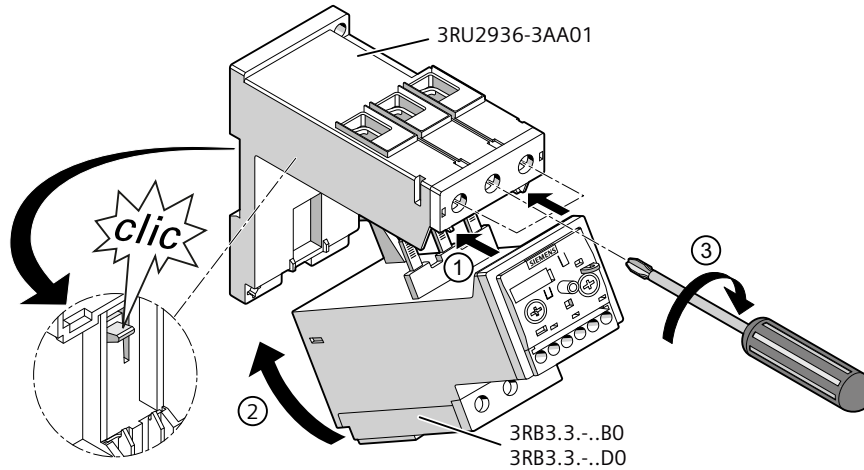

- ① / Guide the overload relay into the terminal support from below with a swivel movement
- ②
- ③ Screw the contacts tight. Check that the cables are clamped tight.

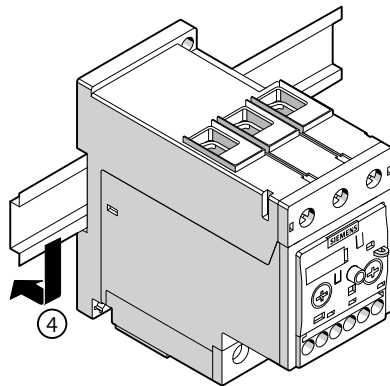

- ④ Position the terminal support with mounted overload relay on the top edge of the DIN rail and press it down until it snaps onto the bottom edge of the DIN rail.

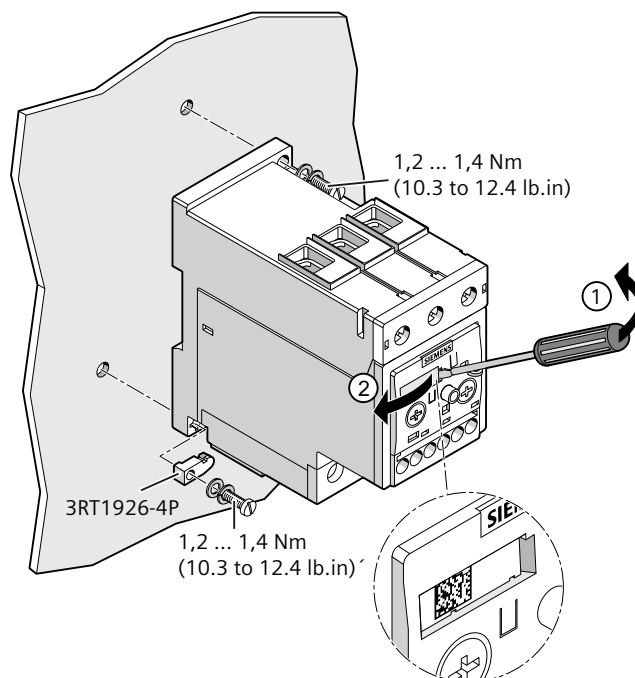
Mounting the 3RB3.3 electronic overload relay, stand-alone installation (screw mounting)

Tighten both screws with a screwdriver. 3RT1924-4P screw mounting adapters can also be used.
Tightening torque: 1.2 ... 1.4 Nm

- ① / To make the Data Matrix code visible, remove the labeling plate using a screwdriver.
②

Disassembly

Disassembly of the terminal support (screw-type connection system) size S3

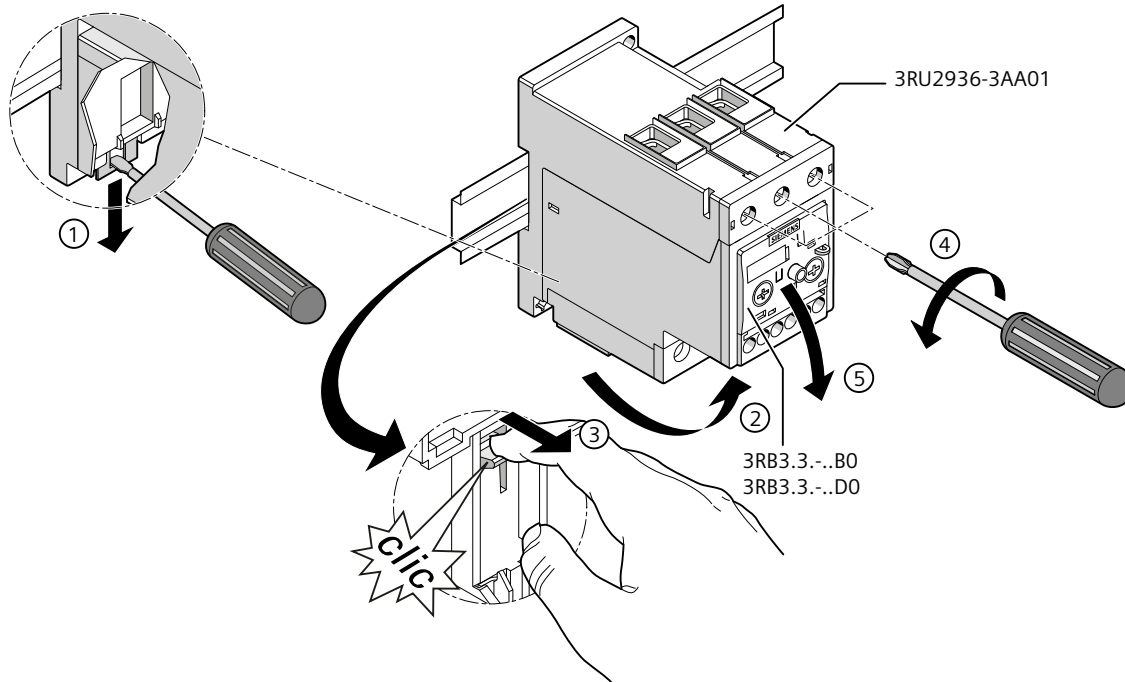

- ① Release the terminal support by pushing down the clip on the underside of the terminal support using a screwdriver.
- ② Remove the terminal support with the mounted overload relay from the mounting rail with a swivel movement to the front.
- ③ Release the overload relay by pushing down the clip on the rear of the terminal support.
- ④ Undo the screws on the main conductor terminals using a screwdriver.
- ⑤ Pull the overload relay forward and away from the terminal support with a swivel movement.

11.2.2.6 Mounting the 3RU2.4 thermal overload relay on a terminal support for stand-alone installation

Mounting

The terminal supports can be snapped onto 35 mm DIN rails according to DIN EN 60715. They can also be screw-mounted.

Mounting the terminal support (screw-type connection system) size S3

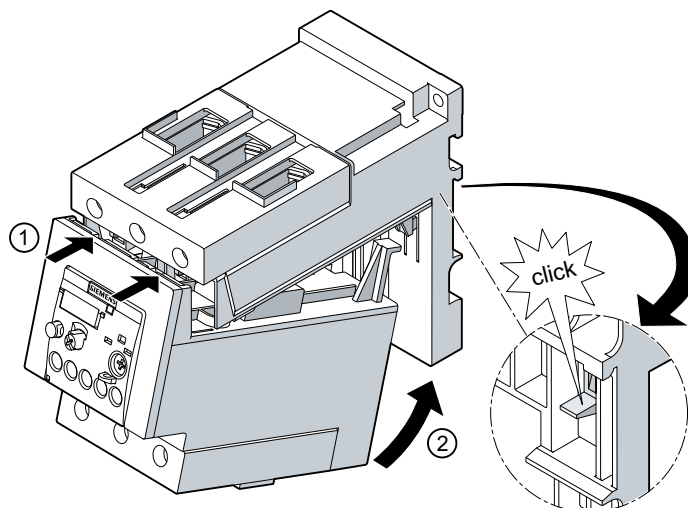

- ① Guide the overload relay into the terminal support from below with a swivel movement.
- ②

Disassembly

Disassembly of the terminal support (screw-type connection system) size S3

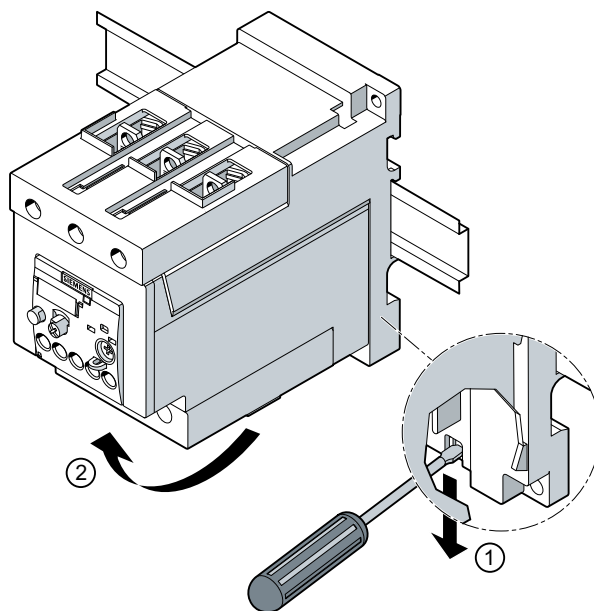

- ① Release the terminal support by pushing down the clip on the underside of the terminal support using a screwdriver.
- ② Remove the terminal support with the mounted overload relay from the mounting rail with a swivel movement to the front.

11.2 Terminal support for stand-alone assembly

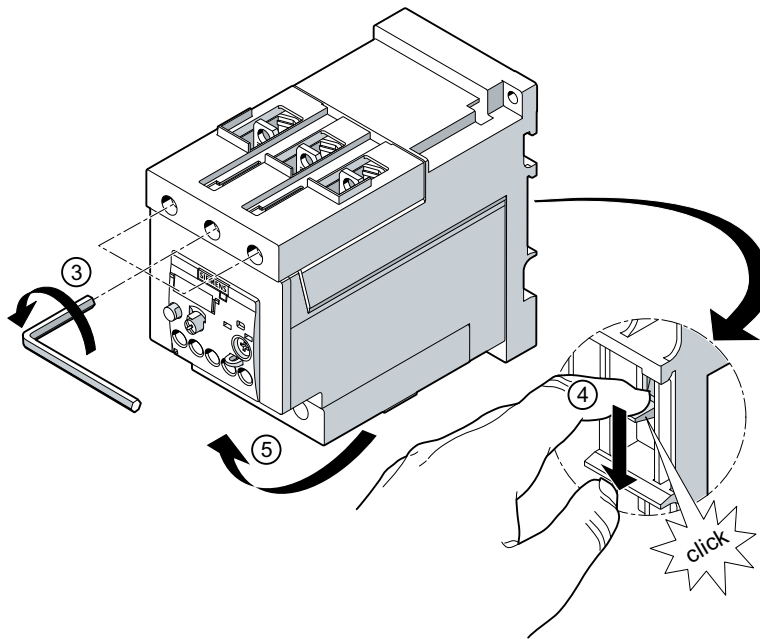

- ③ Undo the screws on the main conductor terminals using an Allen key.
- ④ Release the overload relay by pushing down the clip on the rear of the terminal support.
- ⑤ Pull the overload relay forward and away from the terminal support with a swivel movement.

11.2.2.7 Mounting the 3RB3.4 electronic overload relay on a terminal support for stand-alone installation

Mounting

The terminal supports can be snapped onto 35 mm DIN rails according to DIN EN 60715. They can also be screw-mounted.

Mounting the terminal support (screw-type connection system)

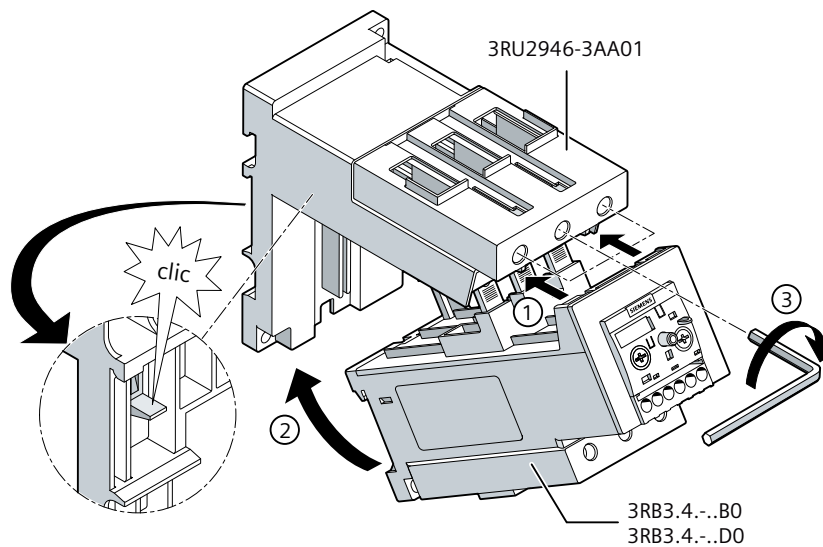

- ① / Guide the overload relay into the terminal support from below with a swivel movement
- ②
- ③ Screw the contacts tight. Check that the cables are clamped tight.

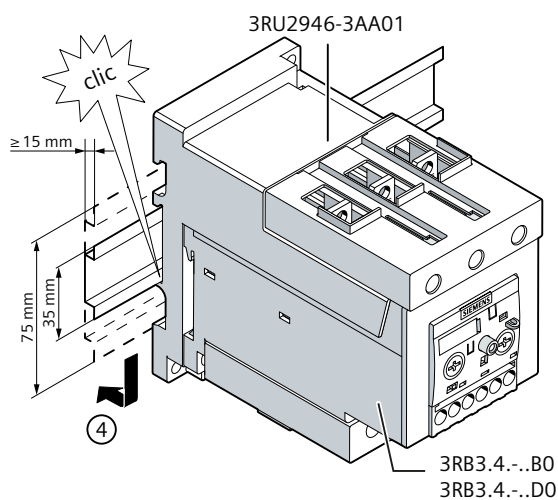

- ④ Position the terminal support with mounted overload relay on the top edge of the DIN rail and press it down until it snaps onto the bottom edge of the DIN rail.

11.2 Terminal support for stand-alone assembly

Mounting the 3RB3.4 electronic overload relay, stand-alone installation (screw mounting)

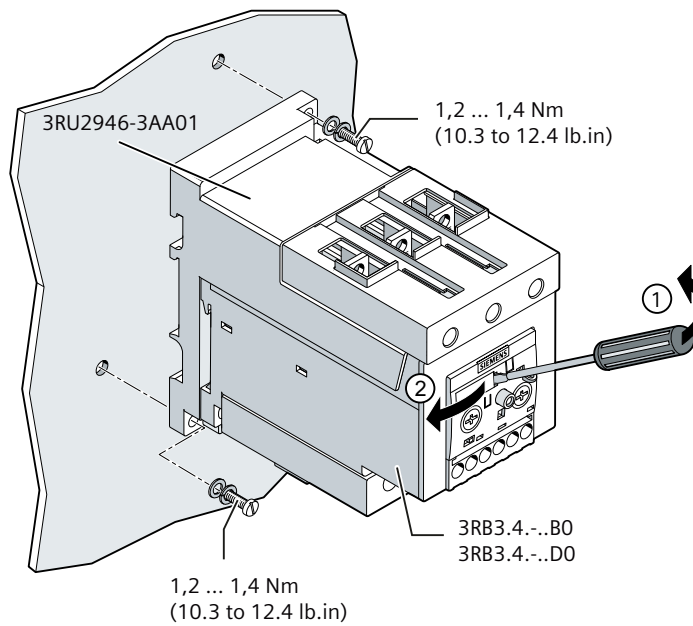

Tighten both screws with a screwdriver. 3RT1924-4P screw mounting adapters can also be used.

Tightening torque: 1.2 ... 1.4 Nm

- ① / To make the Data Matrix code visible, remove the labeling plate using a screwdriver.
- ②

Disassembly

Disassembly of the terminal support (screw-type connection system)

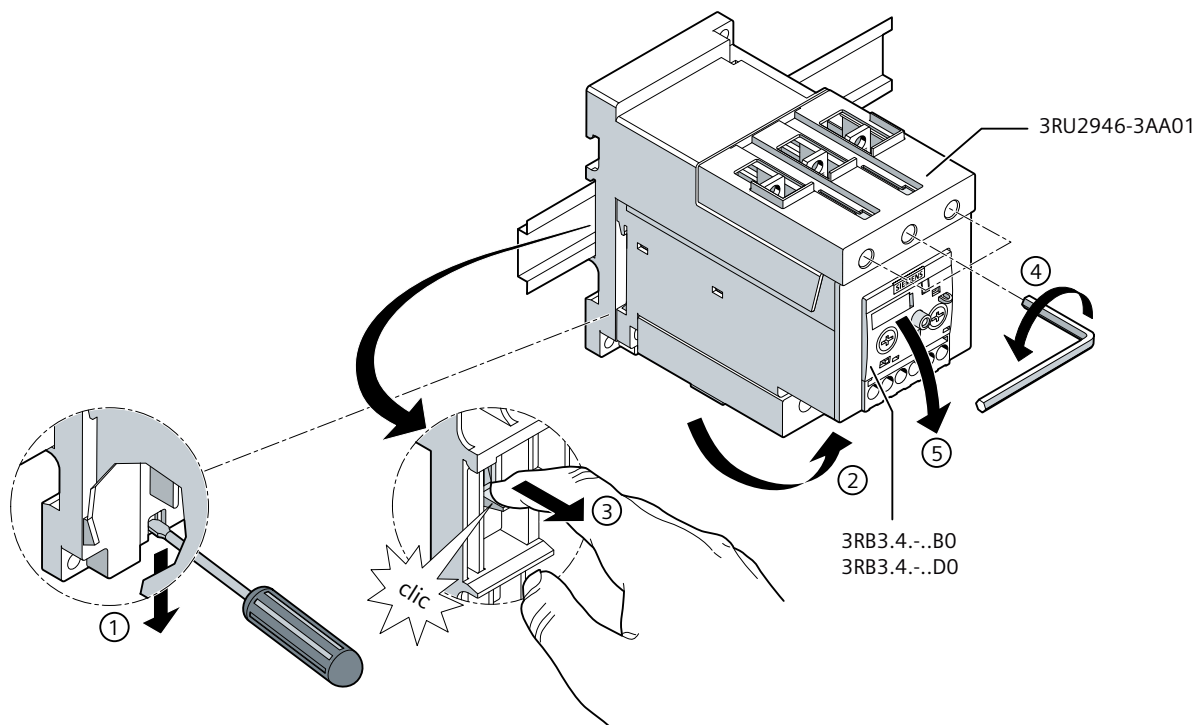

- ① Release the terminal support by pushing down the clip on the underside of the terminal support using a screwdriver.
- ② Remove the terminal support with the mounted overload relay from the mounting rail with a swivel movement to the front.
- ③ Release the overload relay by pushing down the clip on the rear of the terminal support.
- ④ Undo the screws on the main conductor terminals using an Allen key.
- ⑤ Pull the overload relay forward and away from the terminal support with a swivel movement.

11.3 Mechanical remote RESET

Available versions

A mechanical remote reset option is also available for thermal overload relays and solid-state overload relays. There are two options for mechanical remote RESET:

- Release slide (Page 140)
- Cable release with holder for built-in overload relays which are hard to reach (Page 143)

11.3.1 Release slide

11.3.1.1 Description

Release slide

There is one release slide for thermal overload relays and one for solid-state overload relays; both are compatible for use with all sizes. The release slide with holder and former is used to activate the RESET from the control cabinet door; it is shortened to the required length. A pushbutton with extended travel and an extension plunger for compensation of the distance between the pushbutton and the relay's unlocking button are available for the release slide.

11.3.1.2 Mounting/Disassembly

The figure below shows how the release slide, the holder, the funnel, and the pushbutton are mounted.

Prerequisite

Before the release slide can be mounted, the release slide and the optional extension plunger have to be shortened to the required length.

Mounting the release slide

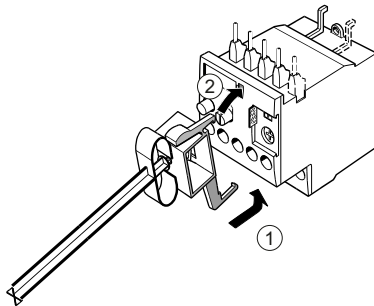

- ① Attach the hook on the release slide to the designated opening on the overload relay.
- ② Fold the module up so that the locking latch snaps into the overload relay.

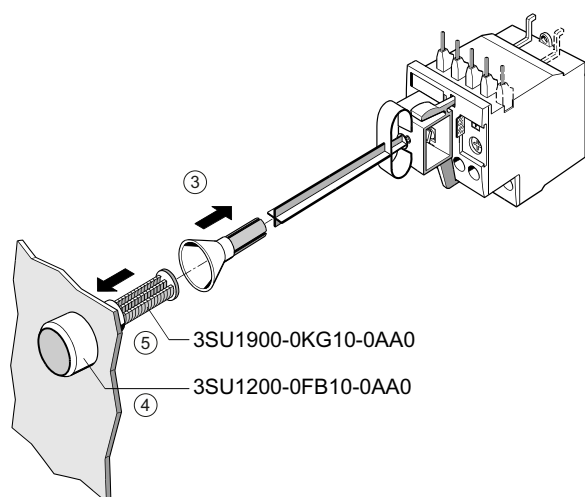

- ③ Attach the funnel to the release slide.
- ④ Fit the pushbutton (3SU1200-0FB10-0AA0) in the front cover.
- ⑤ (Optional) Attach the pushbutton to the extension plunger (3SU1900-0KG10-0AA0).

Note

Continuous operation of the RESET button is not permissible.

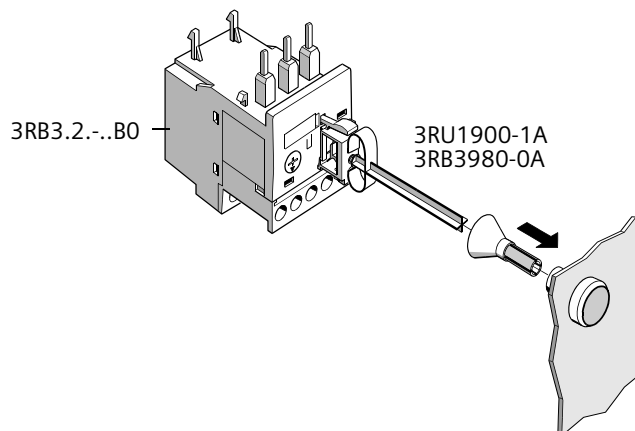

Mounting a mechanical remote RESET to a 3RB3.2 electronic overload relay.

11.3 Mechanical remote RESET

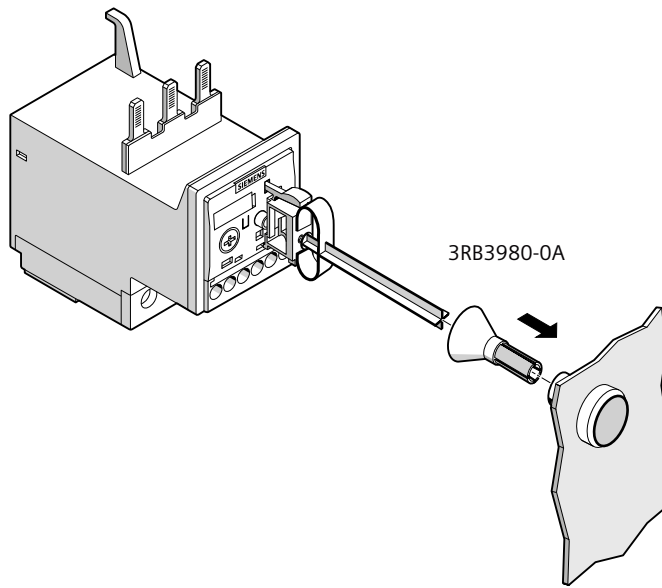

Mounting a mechanical remote RESET to a 3RB3.3 electronic overload relay.

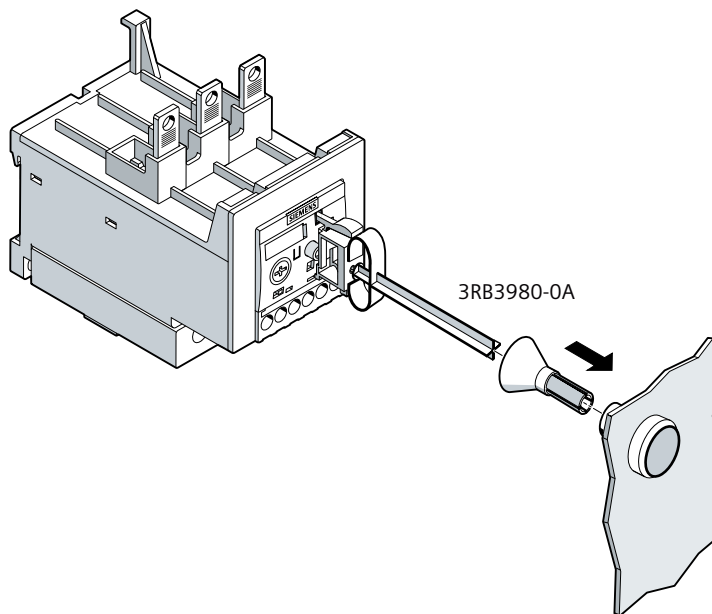

Mounting a mechanical remote RESET to a 3RB3.4 electronic overload relay.

Disassembly

The figure below shows how to disassemble the holder based on the example of the 3RU21 thermal overload relay:

Disassembling the release slide

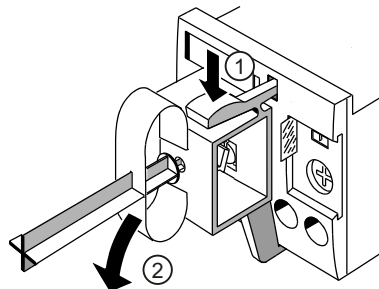

- ① Press the locking latch down.
- ② Tilt the module toward you and take it off the overload relay.

11.3.2 Cable release

11.3.2.1 Description

Cable release (compatible for use with all sizes)

There is one cable release with holder for built-in overload relays which are hard to reach for thermal overload relays and another for solid-state relays; both are compatible for use with all sizes.

The cable is available in the following lengths:

- 400 mm and
- 600 mm

11.3.2.2 Mounting/Disassembly

The following figures show how the cable release with holder is mounted.

Mounting the cable release to a 3RU2.1 thermal overload relay (size S00)

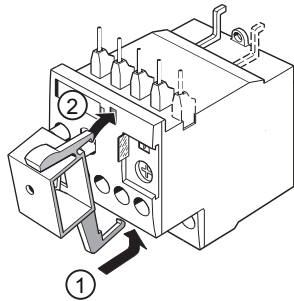

- ① Attach the hook on the release slide to the designated opening on the overload relay.
- ② Fold the module up so that the locking latch snaps into the overload relay.

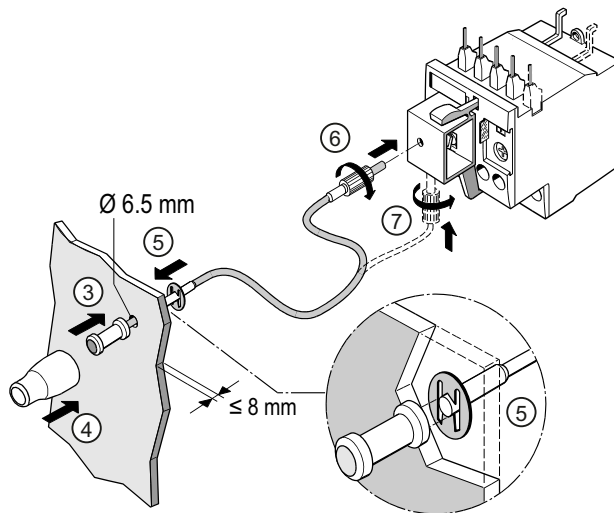

- ③ Fit the actuating element in the front cover.
- ④ Attach the sleeve to the actuating element.
- ⑤ Secure the actuating element with the spring lock washer.
- ⑥ Insert the cable release into the appropriate opening.
- ⑦ Tighten the cable release.

⚠ DANGER

Hazardous voltage. Risk of death or serious injury.

Turn off and lock out all power supplying this device before working on this device.

The Bowden cable must not come into contact with live parts.

Mounting the cable release to a 3RB3.2 electronic overload relay

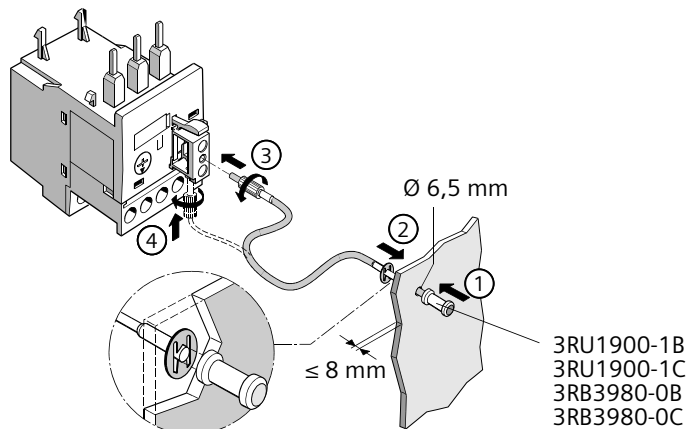

- ① Fit the actuating element into the front cover
- ② Secure the actuating element with the spring lock washer.
- ③ Insert the cable release into the appropriate opening.
- ④ Tighten the cable release.

! DANGER

Hazardous voltage. Risk of death or serious injury.

Disconnect the system and all devices from the power supply before starting work.

The Bowden cable must not come into contact with live parts.

Mounting a mechanical remote RESET to a 3RB3.3 electronic overload relay.

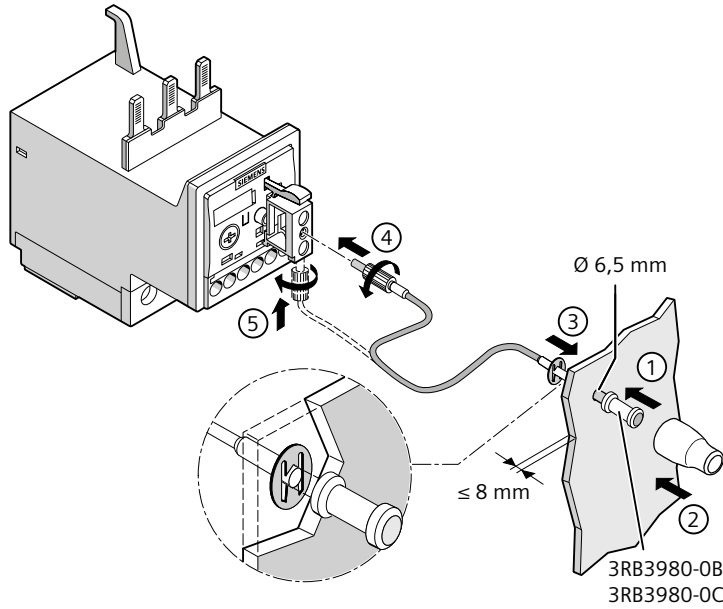

- ① / Fit the actuating element into the front cover
- ②
- ③ Secure the actuating element with the spring lock washer.
- ④ Insert the cable release into the appropriate opening.
- ⑤ Tighten the cable release.

! DANGER

Hazardous voltage. Risk of death or serious injury.

Disconnect the system and all devices from the power supply before starting work.

The Bowden cable must not come into contact with live parts.

Mounting a mechanical remote RESET to a 3RB3.4 electronic overload relay.

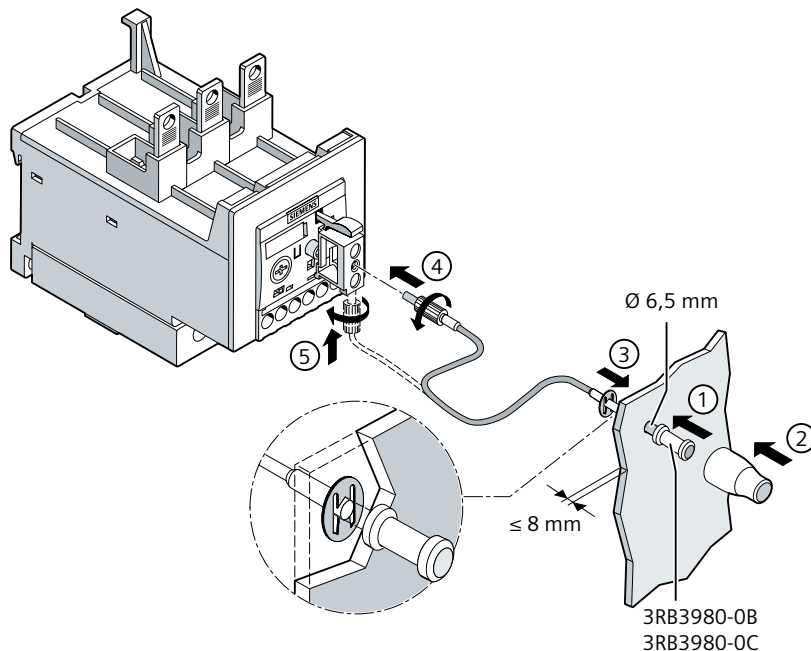

- ① / Fit the actuating element into the front cover
- ②
- ③ Secure the actuating element with the spring lock washer.
- ④ Insert the cable release into the appropriate opening.
- ⑤ Tighten the cable release.

⚠ DANGER

Hazardous voltage. Risk of death or serious injury.

Disconnect the system and all devices from the power supply before starting work.

The Bowden cable must not come into contact with live parts.

Disassembly

The figure below shows how to disassemble the holder for the cable release based on the example of the 3RU21 thermal overload relay:

11.4 Module for electrical remote RESET (3RU21 only)

Cable release disassembly

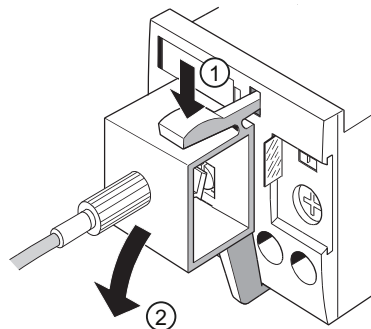

- ① Press the locking latch down.
- ② Tilt the module toward you and take it off the overload relay.

11.4 Module for electrical remote RESET (3RU21 only)

11.4.1 Description

Function

An electrical remote RESET module which is compatible for use with all sizes is available for the 3RU21 thermal overload relay. This module enables the overload relay to be reset electrically from the control room following tripping. The module's coil is dimensioned for an operating duration of 0.2 s to 4 s; maintained-contact operation is not permissible.

11.4.2 Connecting remote reset

Connection

The screw connections on the terminals of the electrical remote RESET module have the same format as the screw connections on the auxiliary contacts of the 3RU21 overload relay.

Table 11-1 Connection data for the remote RESET

Operating range	The operating range of the coil is 0.85 to $1.1 \times U_s$
Power input	The power input of the electrical remote RESET module is: 80 V AC, 70 W DC
Switching frequency	60/h
Voltages	The electrical remote RESET module is available for the following voltages: <ul style="list-style-type: none"> • 24 to 30 V AC/VDC • 110 to 127 V AC/VDC • 220 to 250 V AC/VDC

Note**Protection of device connections E1 / E2**

Observe the relevant standards and regulations for the configuration of control panels and the parts and components contained therein, e.g. when dimensioning the cables.

Select a current-limiting power supply for the protection of these circuits, for example.

When selecting the source and the connecting cable, observe the load characteristics of the remote RESET block. The same applies to the selection of suitable protective devices.

You can find all the technical specifications of the product 3RU1900-2A. in the Siemens Industry Online Support (<https://support.industry.siemens.com/cs/ww/en/ps/16273/td/>).

Further recommendations, e.g. the use of miniature circuit breakers or equipment circuit breakers in control circuits, can be found under the following link:

Control panel tip: Fast, reliable selection and dimensioning of an appropriate power supply unit. (<https://new.siemens.com/global/en/markets/panel-building/tipps/design-and-engineering-in-the-control-circuit.html>)

11.4.3 Mounting/Disassembly

The figure below shows how to assemble the electrical remote RESET module based on the example of size S0.

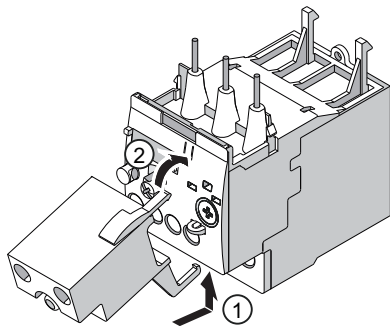
Mounting the electrical remote RESET module on the thermal overload relay

- ① Attach the hook to the designated opening.
- ② Fold the module up so that the locking latch snaps into the overload relay.

Disassembly

Disassembling the electrical remote RESET module from the thermal overload relay

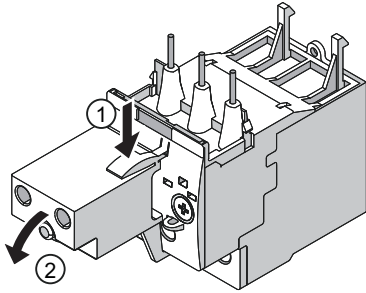

- ① Press the locking latch down.
- ② Tilt the module toward you and take it off the overload relay.

11.5 Sealable cover

11.5.1 Description

Sealable cover

There is one sealable cover for thermal overload relays and one for electronic relays; both are compatible for use with all sizes. The 3RV2908-0P cover can be used as an accessory for 3RU2 thermal overload relays and 3RV2 motor starter protectors/circuit breakers (acc. to UL).

The sealable cover 3RB3984-0 for 3RB2 and 3RB3 electronic overload relays can be used to protect the rotary button for setting the rated motor current and the CO contact for the tripping classes (3RB21 / 3RB31 only) against unauthorized manipulation.

11.5.2 Mounting/disassembly

11.5.2.1 Mounting the sealing cover on the 3RU2.1 / 3RU2.2 thermal overload relay

Mounting the sealing cover on the 3RU2.1 / 3RU2.2 thermal overload relay

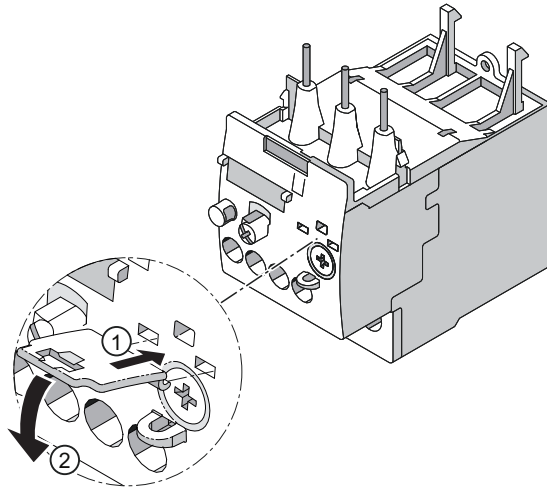

- ① Attach the hooks on the cover in the openings on the overload relay.
- ② Tilt the cover down.

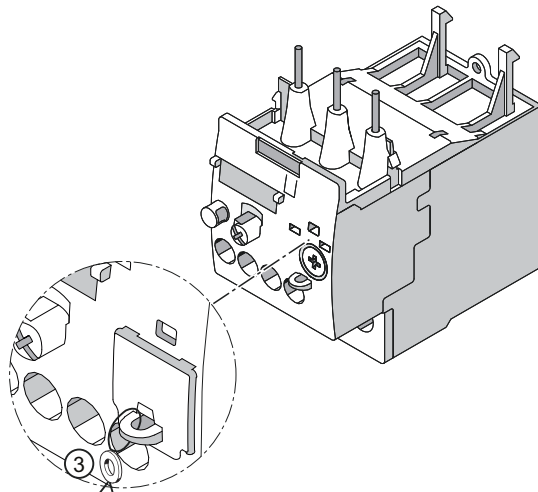

- ③ Seal the cover to secure it against unauthorized removal.

11.5.2.2 Mounting the sealing cover on the 3RB3.1 / 3RB3.2 electronic overload relay

Mounting the sealing cover 3RB3984-0 on the 3RB3.1 / 3RB3.2 overload relay

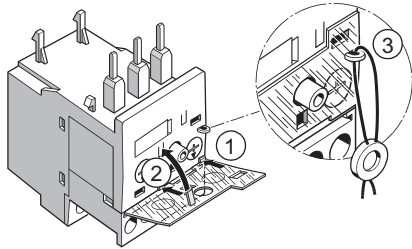

- ① Attach the hooks on the cover in the openings on the overload relay.
- ② Tilt the cover up.
- ③ Seal the cover to secure it against unauthorized removal.

11.5.2.3 Mounting the sealing cover on the 3RB3.3 electronic overload relay

Mounting the sealing cover 3RB3984-0 on the 3RB3.3 electronic overload relay

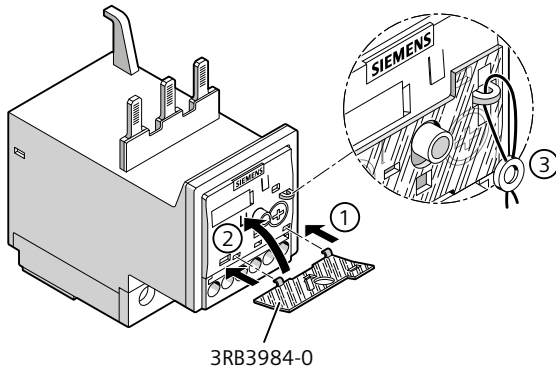

- ① Attach the hooks on the cover in the openings on the overload relay.
- ② Tilt the cover up.
- ③ Seal the cover to secure it against unauthorized removal.

11.5.2.4 Mounting the sealing cover on the 3RB3.4 electronic overload relay

Mounting the sealing cover 3RB3984-0 on the 3RB3.4 electronic overload relay

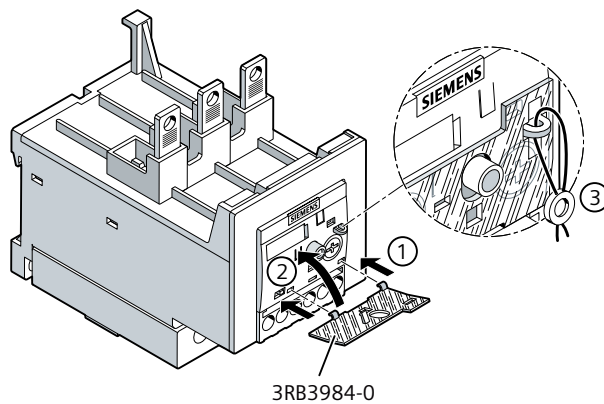

- ① Attach the hooks on the cover in the openings on the overload relay.
- ② Tilt the cover up.
- ③ Seal the cover to secure it against unauthorized removal.

11.5.2.5 Mounting the sealing cover on the 3RB2.5 / 3RB2.6 electronic overload relay

Mounting the sealing cover 3RB3984-0 on the 3RB2.5 / 3RB2.6 electronic overload relay

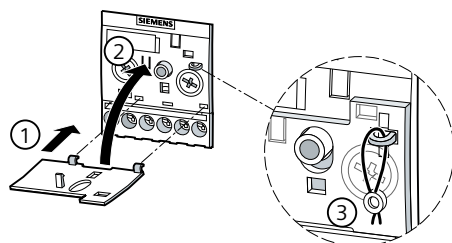

- ① Attach the hooks on the cover in the openings on the overload relay.
- ② Tilt the cover up.
- ③ Seal the cover to secure it against unauthorized removal.

11.6 Terminal cover for cable lug connection and busbar connection

11.6.1 Description

Terminal cover for cable lug connection and busbar connection

For the thermal and the electronic overload relays (sizes S3 to S10 / S12), there is one terminal cover each for cable lug connection and busbar connection.

For connection of conductors with ring cable lugs or connecting bars, the box terminal blocks of the size S3 devices can be detached. The terminal cover is available as touch protection and to ensure the necessary clearances and creepage distances when box terminal blocks have been removed.

11.6.2 Mounting/disassembly

11.6.2.1 Mounting the terminal cover for cable lug connection and busbar connection to the 3RB3.4 electronic overload relay

Mounting the terminal cover for cable lug connection and busbar connection

The figure below shows an example of how to mount the terminal cover for cable lug connection and busbar connection on the 3RB3.4 electronic overload relay.

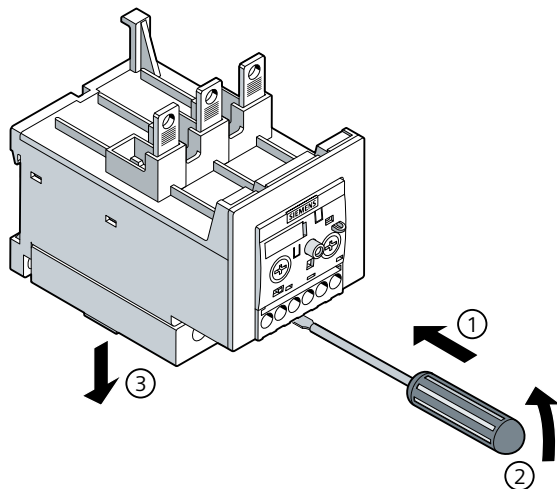

- ① Position the screwdriver on the terminal support as shown in the figure, in the middle between the overload relay and the removable box terminal block.
- ② Carefully lever the detachable box terminal block from the overload relay.
- ③ Detach the detachable box terminal block from the overload relay in the downward direction.

11.6 Terminal cover for cable lug connection and busbar connection

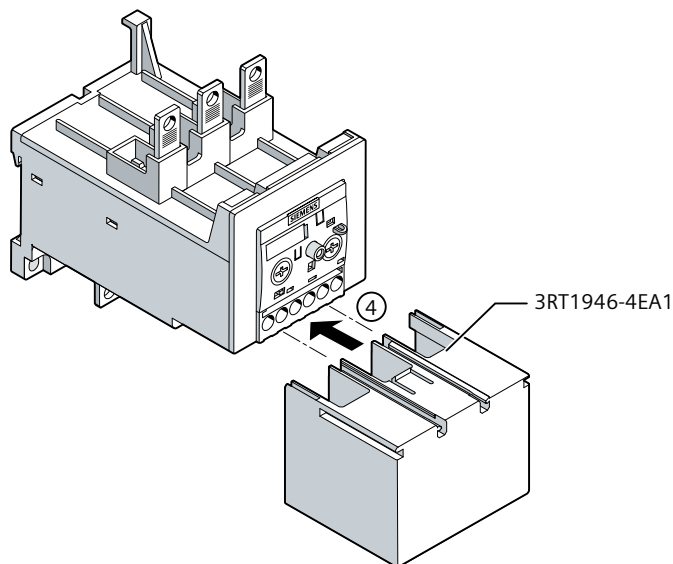

- ④ Slide the terminal cover for cable lug connection and busbar connection into the guide tabs on the overload relay.

11.6.2.2 Mounting the terminal cover for cable lug connection and busbar connection to the 3RU2.4 thermal overload relay

Mounting the terminal cover for cable lug connection and busbar connection

The figure below shows an example of how to mount the terminal cover for cable lug connection and busbar connection on the 3RU2.4 thermal overload relay.

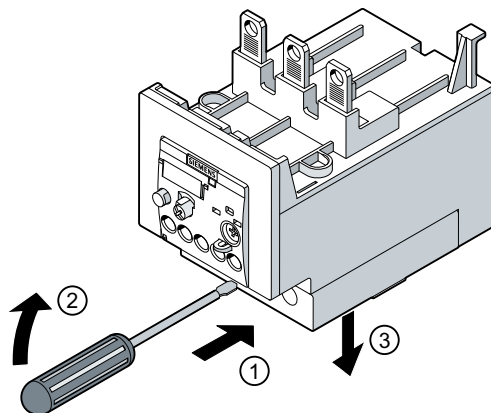

- ① Position the screwdriver on the terminal support as shown in the figure, in the middle between the overload relay and the removable box terminal block.
- ② Carefully lever the detachable box terminal block from the overload relay.
- ③ Detach the detachable box terminal block from the overload relay in the downward direction.

11.7 Terminal covers for box terminal block

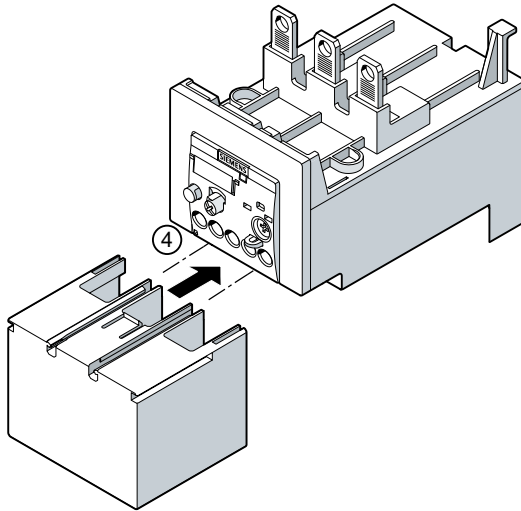

- ④ Slide the terminal cover for cable lug connection and busbar connection into the guide tabs on the overload relay.

11.7 Terminal covers for box terminal block

11.7.1 Description

Terminal covers for box terminal block

Terminal covers for box terminal blocks are available for the overload relays (sizes S2, S3, S6 and up to S10 / S12).

11.7.2 Mounting/disassembly

11.7.2.1 Mounting the terminal cover to the 3RB3.3 electronic overload relay

Mounting the terminal cover for the box terminal block

The figure below shows an example of how to mount the terminal cover for box terminal block connection on the 3RB3.3 electronic overload relay.

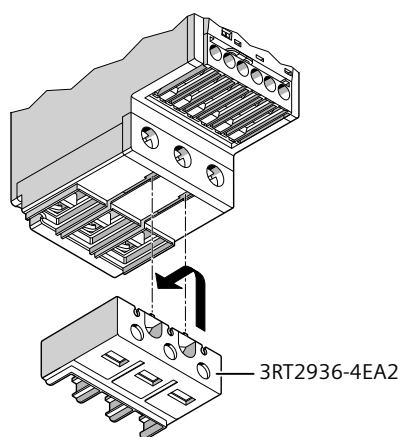

- ① Slide the terminal cover for the box terminal block into the openings provided on the box terminal block of the overload relay.

11.7.2.2 Mounting the terminal cover to the 3RU2.4 thermal overload relay

Mounting the terminal cover for the box terminal block

The figure below shows an example of how to mount the terminal cover for box terminal block connection on the 3RU2.4 thermal overload relay.

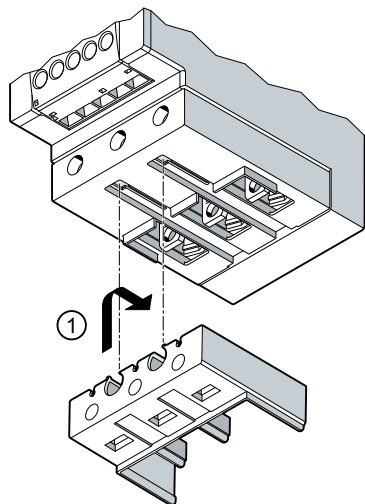

- ① Slide the terminal cover for the box terminal block into the openings provided on the box terminal block of the overload relay.

11.8 Box terminal block

11.8.1 Description

Box terminal block

Box terminal blocks for round conductors and for ribbon cables are each available for the electronic overload relays (sizes S6 and S10 / S12).

11.8.2 Mounting

Mounting the box terminal block

The following figures show how to mount and disassemble the box terminal block and the terminal covers for box terminal blocks onto the 3RB2 electronic overload relay in sizes S10 / S12.

Mounting the 3RB2 electronic overload relay (connection with box terminal block)

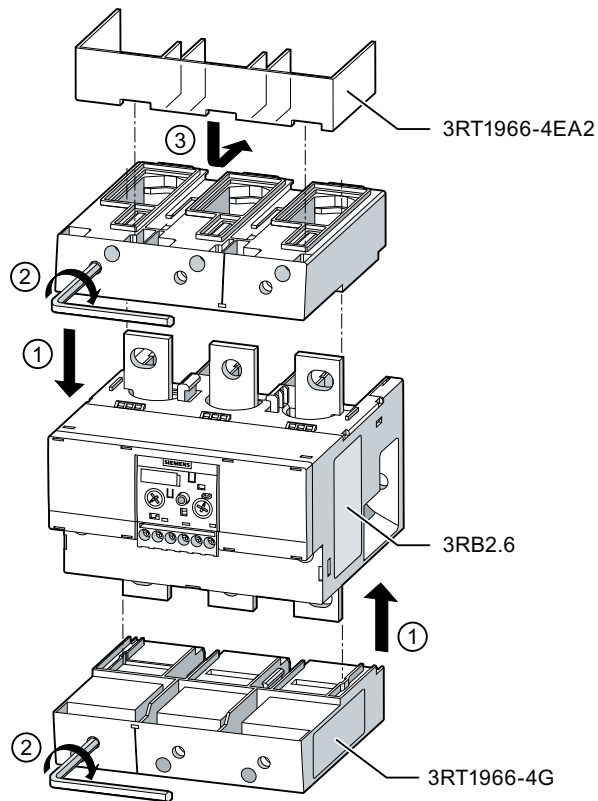

- ① Place the box terminal block on the electronic overload relay.
- ② Screw the box terminal block tight on the contactor. Check whether the box terminal block is fitted firmly.
- ③ As shown in the figure, slide the terminal cover for the box terminal block into the openings provided on the box terminal block of the electronic overload relay.

Disassembling the 3RB2 electronic overload relay (connection with box terminal block)

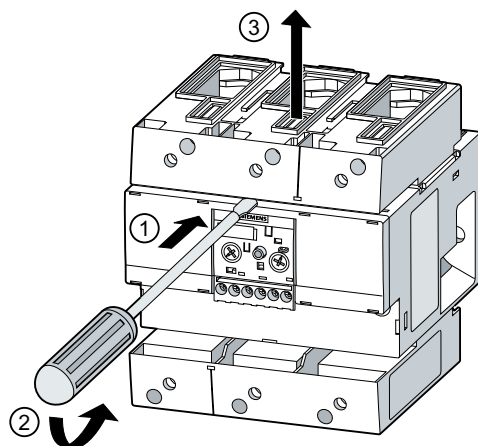

- ① Position the screwdriver on the center of the electronic overload relay as shown in the figure.
- ② Slightly lever open the box terminal block to dislodge it.
- ③ Detach the box terminal block from the electronic overload relay in the upward direction.

Technical data

12.1 Technical data in Siemens Industry Online Support

Technical data sheet

You can also find the technical data of the product at Siemens Industry Online Support (<https://support.industry.siemens.com/cs/ww/en/ps/16269/td>).

1. Enter the full article number of the desired device in the "Product" field, and confirm with the Enter key.
2. Click the "Technical data" link.

The screenshot shows the Siemens Industry Online Support search interface. At the top, there is a search bar with the text "Enter keyword...". Below the search bar, there are three input fields: "Product", "Entry type", and "Date". The "Product" field contains the article number "3RV2031-4BA10" and is highlighted with a red box. The "Entry type" field contains "Technical data (1)" and is also highlighted with a red box. The "Date" field is empty. Below the search bar, there is a "Search product" button. The search results are displayed in a table with one entry for "3RV2031-4BA10". The entry includes a product image placeholder, the product name, and a description: "CIRCUIT BREAKER, SCREW TYPE, 20 A, CIRCUIT BREAKER SIZE S2, FOR MOTOR PROTECTION, CLASS 10, A-RELEASE 14, 20A, N-RELEASE 20DA, SCREW TERMINAL, STANDARD BREAKING CAPACITY". Below the description, there are three links: "Product details", "Technical data" (highlighted with a red box), and "CAx data".

12.2 Overview tables

Overview tables technical data

You will find overview tables with technical data in the "Product information" tab in our online ordering system (<https://mall.industry.siemens.com/mall/en/ww/Catalog/Products/8210541?tree=CatalogTree>).

12.3 Performance features

12.3.1 General data

Table 12-1 General data for 3RU21, 3RB20 / 3RB21 and 3RB30 / 3RB31 overload relays

Feature	Description	3RU21	3RB30/3RB31	3RB20 / 3RB21
Sizes	<ul style="list-style-type: none"> • Are matched to the dimensions, connections and technical features of the other devices in the SIRIUS modular system • Permit the mounting of slim-line and compact load feeders in widths of 45 mm (S00), 45 mm (S0), 55 mm (S2), 70 mm (S3), 120 mm (S6) and 145 mm (S10 / S12) • Make configuration easier 	S00 / S0 / S2 / S3	S00 / S0 / S2 / S3	S6 S10 / S12
Overlapping current range	<ul style="list-style-type: none"> • Allows straightforward and consistent configuration with one series of overload relays (for small to large loads) 	0.11 ... 100 A	0.1 ... 115 A	50 ... 630 A

12.3.2 Protection functions - overview

Table 12-2 Protection functions for 3RU21, 3RB20 / 3RB21 and 3RB30 / 3RB31 overload relays

Feature	Description	3RU21	3RB30/3RB31	3RB20 / 3RB21
Tripping in the event of overload	<ul style="list-style-type: none"> • Provides optimum current-dependent protection of loads against impermissibly high temperature rise due to overload 	✓	✓	✓
Tripping in the event of phase asymmetry	<ul style="list-style-type: none"> • Provides optimum current-dependent protection of loads against impermissibly high temperature rise due to phase asymmetry 	✓	✓	✓
Tripping in the event of phase failure	<ul style="list-style-type: none"> • Minimizes the temperature rise of the three-phase motor in the event of a phase failure 	✓	✓	✓

Feature	Description	3RU21	3RB30/3RB31	3RB20 / 3RB21
Protection of single-phase loads	<ul style="list-style-type: none"> Enables single-phase loads to be protected 	✓	--	--
Tripping in the event of ground fault by means of internal ground-fault detection (can be activated)	<ul style="list-style-type: none"> Provides optimum protection of loads in the event of high-impedance faults to ground caused by moisture, condensation, damaged insulation, etc. Eliminates the need for additional special equipment Saves space in the control cabinet Reduces wiring time and wiring costs 	--	<ul style="list-style-type: none"> ✓ (3RB31 only) 	<ul style="list-style-type: none"> ✓ (3RB21 only)

12.3.3 Equipment

Table 12-3 Features of 3RU21, 3RB20 / 3RB21 and 3RB30 / 3RB31 overload relays

Feature	Description	3RU21	3RB30/3RB31	3RB20 / 3RB21
RESET function	<ul style="list-style-type: none"> Enables manual or automatic resetting of the relay 	✓	✓	✓
Remote RESET function	<ul style="list-style-type: none"> Enables remote resetting of the relay 	<ul style="list-style-type: none"> ✓¹⁾ 	<ul style="list-style-type: none"> ✓²⁾ 	<ul style="list-style-type: none"> ✓²⁾
TEST function for auxiliary contacts	<ul style="list-style-type: none"> Enables simple function testing and wiring 	✓	✓	✓
TEST function for electronics	<ul style="list-style-type: none"> Allows checking of the electronics 	--	✓	✓
Status display	<ul style="list-style-type: none"> Displays the current operating state 	✓	✓	✓
Integrated auxiliary contacts:				
1 NO contact	<ul style="list-style-type: none"> Can be used to output signals 	✓	✓	✓
1 NC contact	<ul style="list-style-type: none"> Enable shutdown of the connected contactor to protect the load 	✓	✓	✓

¹⁾ Via a separate module.

²⁾ Only on the 3RB21 / 3RB31 electrically with 24 V DC.

12.3.4 Features of overload relays

Table 12-4 Additional characteristics of 3RU21 thermal overload relays and 3RB20 / 3RB21 and 3RB30 / 3RB31 electronic overload relays

Feature	Description	3RU21	3RB20 / 3RB21 3RB30/3RB31 ¹
Temperature compensation	<ul style="list-style-type: none"> Allows the use of the relays without derating even at high temperatures Prevents premature tripping Allows compact control cabinet installation without clearance between the devices/load feeders Simplifies configuration Enables space to be saved in the control cabinet 	✓	✓
High long-term stability	<ul style="list-style-type: none"> Provides reliable protection of loads even after years under severe operating conditions 	✓	✓
Wide setting ranges	<ul style="list-style-type: none"> Reduce the number of variants Minimize the engineering outlay and costs Enable savings to be made where storage overheads, storage costs, and tied-up capital are concerned 	--	✓ (1:4)
Variable setting of tripping classes (The required tripping class can be set dependent upon the prevailing starting conditions using a rotary switch.)	<ul style="list-style-type: none"> Reduces the number of versions Minimizes the configuring outlay and costs Minimizes storage overhead, storage costs, and tied-up capital 	--	✓ (3RB21 / 3RB31 only)
Tripping class CLASS 5E	<ul style="list-style-type: none"> Enables solutions for motors which start up very quickly and require special protection measures 	--	✓ (3RB21 / 3RB31 only)
Tripping class > CLASS 10E	<ul style="list-style-type: none"> Enable solutions for heavy-duty starting 	--	✓
Low power loss	<ul style="list-style-type: none"> Reduces power consumption (power consumption is up to 98% less than with thermal overload relays) and thus energy costs Minimizes the temperature rise of the contactor and the control cabinet - in some cases this may eliminate the need for control cabinet cooling Enables space to be saved through direct mounting on the contactor even at high motor currents (i.e. no heat decoupling is required) 	--	✓
Intrinsic supply	<ul style="list-style-type: none"> Eliminates the need for configuration and connecting an additional control circuit 	-- ¹⁾	✓

¹⁾ As SIRIUS 3RU21 thermal overload relays work on the basis of the bimetal principle, they do not require a control supply voltage.

Circuit diagrams

13.1 CAx data

You can find the CAx data in the Siemens Industry Online Support (<https://support.industry.siemens.com/cs/ww/en/ps/16269/td>).

1. Enter the full article number of the desired device in the "Product" field, and confirm with the Enter key.
2. Click the "CAx data link.

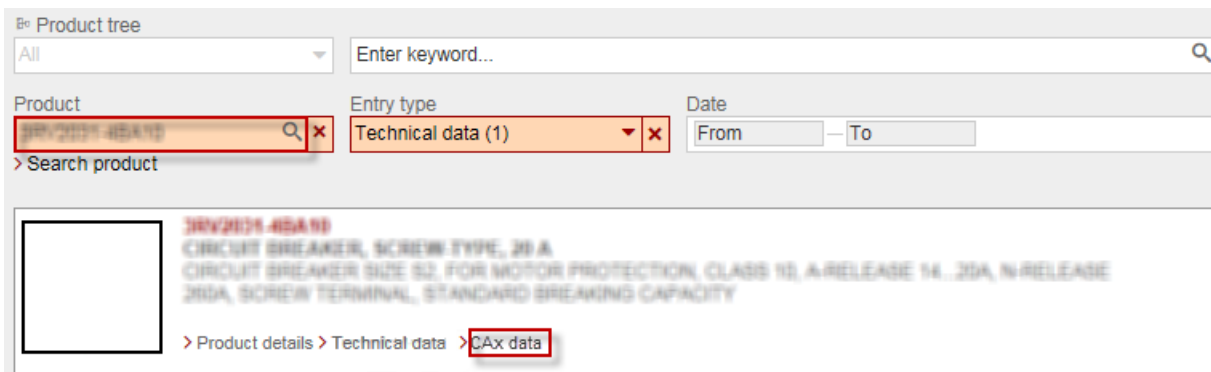

13.2 Internal circuit diagrams 3RU2

Internal circuit diagrams for 3RU21

3RU2116-..B., 3RU2116-..J.

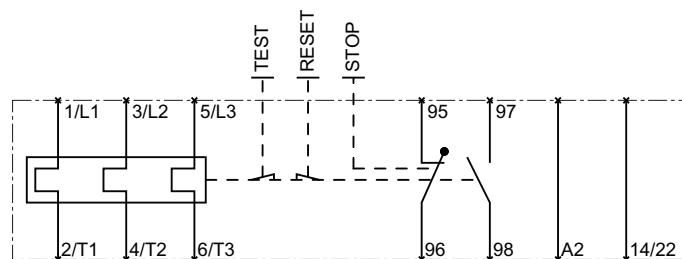

Figure 13-1 Thermal overload relay, screw-type connection, S00

3RU2116-..C.

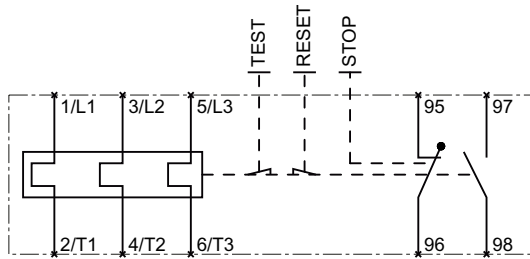

Figure 13-2 Thermal overload relay, spring-loaded connection system, S00

3RU2126-....

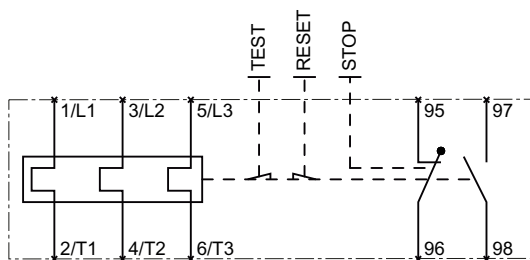

Figure 13-3 Thermal overload relay, S0

3RU2136-....

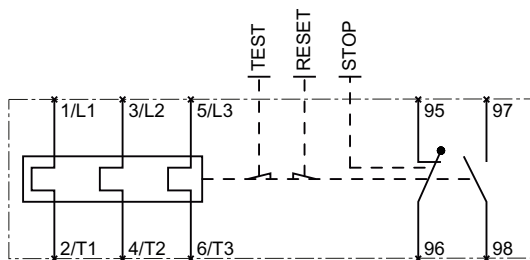

Figure 13-4 Thermal overload relay, S2

3RU2146-....

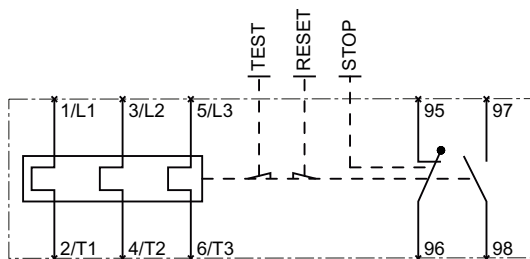

Figure 13-5 Thermal overload relay, S3

13.3 3RB20 internal circuit diagrams

3RB20 internal circuit diagrams

3RB205.

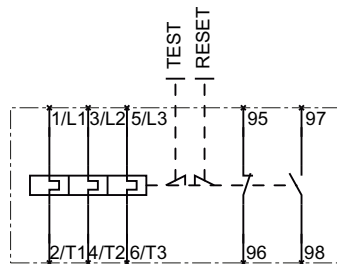

Figure 13-6 3RB20, S6 electronic overload relay

3RB206.

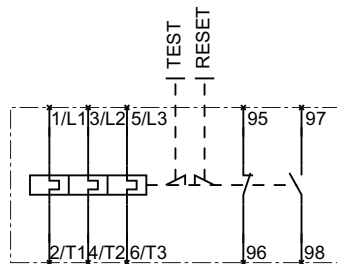

Figure 13-7 3RB20 electronic overload relay, sizes, S10 / S12

13.4 3RB21 internal circuit diagrams

Internal circuit diagrams for 3RB21

3RB2153

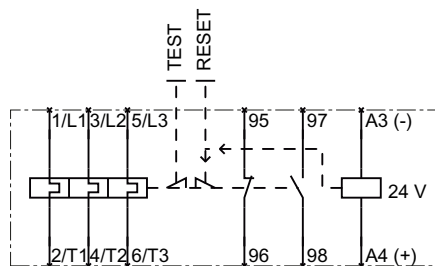

Figure 13-8 3RB21, S6 electronic overload relay

13.5 Internal circuit diagrams 3RB30

3RB2163

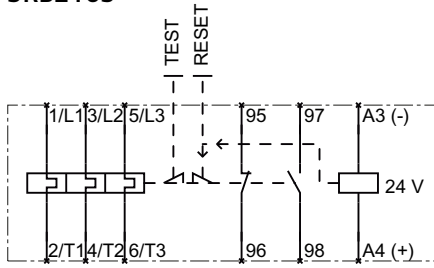

Figure 13-9 3RB21, S10 / S12 electronic overload relay

13.5 Internal circuit diagrams 3RB30

Internal circuit diagrams for 3RB30

3RB3016-...B.

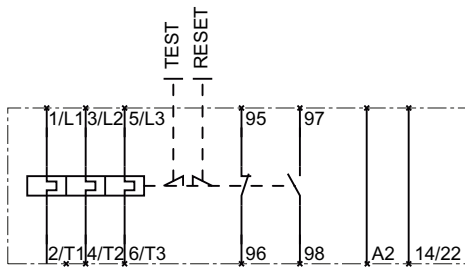

Figure 13-10 3RB30 electronic overload relay, screw-type connection system, S00

3RB3016-...E.

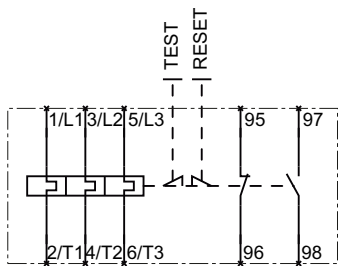

Figure 13-11 3RB30 electronic overload relay, spring-loaded connection system, S00

3RB3026-....

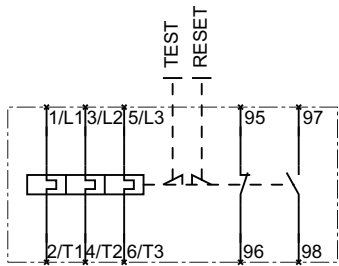

Figure 13-12 3RB30 electronic overload relay, S0

3RB3036-....

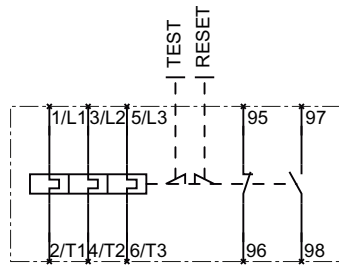

Figure 13-13 3RB30 electronic overload relay, S2

3RB3046-....

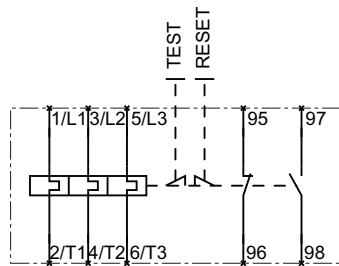

Figure 13-14 3RB30 electronic overload relay, S3

13.6 Internal circuit diagrams 3RB31

Internal circuit diagrams for 3RB31

3RB3113-..B.

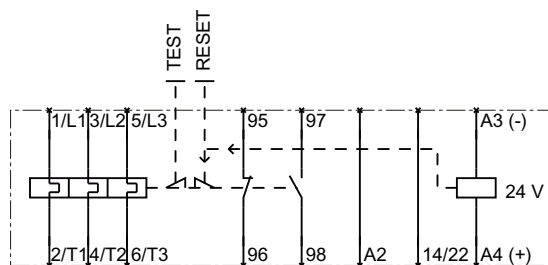

Figure 13-15 3RB31 electronic overload relay, screw-type connection system, S00

3RB3113-..E.

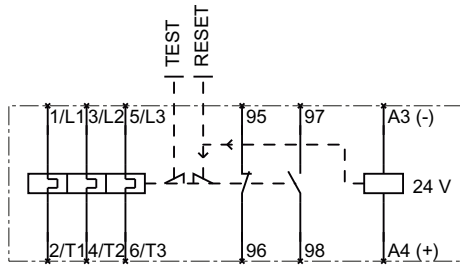

Figure 13-16 3RB31 electronic overload relay, spring-loaded connection system, S00

3RB3123-....

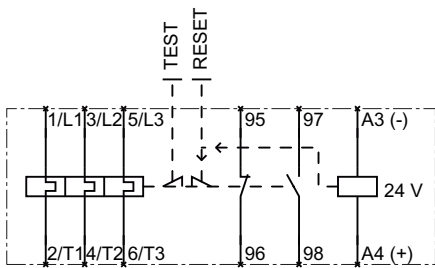

Figure 13-17 3RB31 electronic overload relay, S0

3RB3133-....

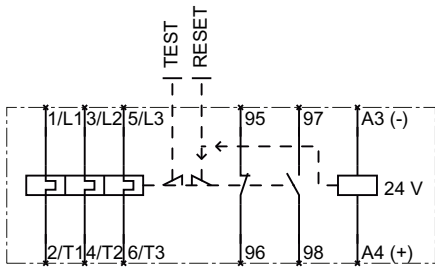

Figure 13-18 3RB31 electronic overload relay, S2

3RB3143-....

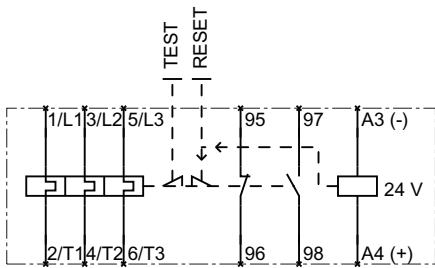

Figure 13-19 3RB31 electronic overload relay, S3

13.7 Wiring examples

Typical circuit diagrams for 3RU

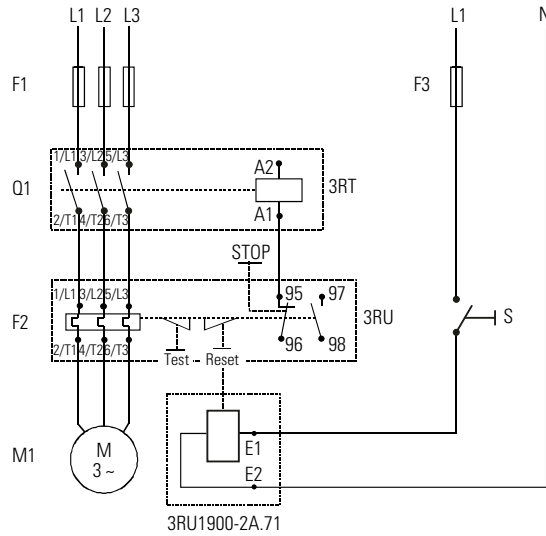
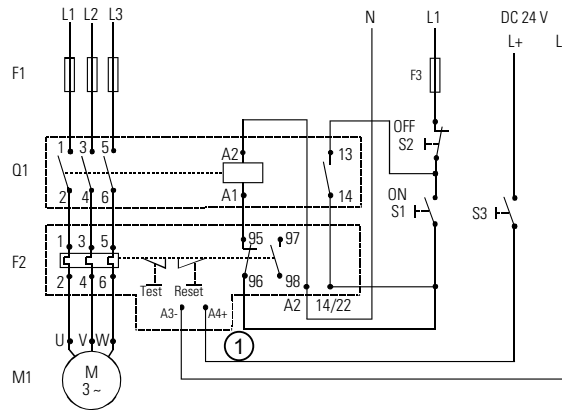

Figure 13-20 3RU

Typical circuit diagrams for 3RB



① Electrical remote RESET (3RB31 only)

Figure 13-21 3RB3.1.-.B0

13.7 Wiring examples

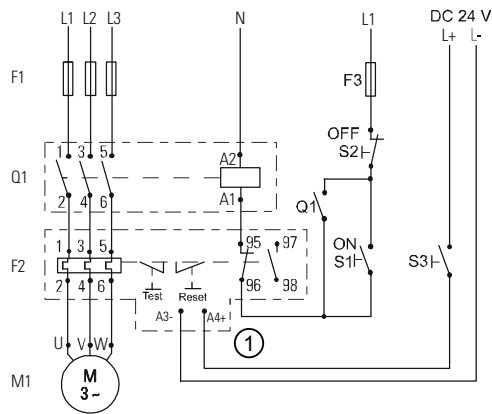

① Electrical remote RESET (3RB21 / 3RB31 only)

Figure 13-22 3RB3.1-..E03RB3.2-..B03RB3.2-..E03RB2.

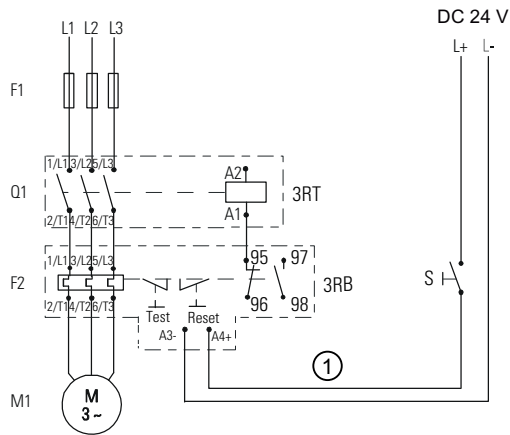

① Electrical remote RESET (3RB31 only)

Figure 13-23 3RB3.3-...

Types of coordination

Types of coordination

Standard DIN EN 60947-4-1 (VDE 0660 Part 102) or IEC 60947-4-1 distinguishes between two types of coordination (type of coordination), which are referred to as coordination type "1" and coordination type "2". In the case of both types of coordination, the short-circuit is reliably mastered. The only differences are in the extent of the damage sustained by the device following a short circuit.

Type of coordination 1

The load feeder may be non-operational after a short circuit has been cleared. Damage to the contactor and the overload release is also permissible.

Type of coordination 2

After short-circuit disconnection, there must be no damage to the overload release or to any other part. The load feeder can resume operation without needing to be renewed. Welding of the contactor contacts only is permitted if these can be separated easily without significant deformation.

References

B.1 References

Further references

You will find further information on the 3RU2 and 3RB2 / 3RB3 overload relays on the Internet (<http://support.automation.siemens.com/WW/view/en/20357459/133300>).

In addition to this manual, please refer to the operating instructions and manuals for any accessories. You can download the relevant documentation from the Internet (<http://www.siemens.com/sirius/manuals>). Simply enter the article number of the relevant item into the search field.

Operating instructions

Title	Article number
SIRIUS thermal overload relay S00 / S0 (3RU2116 / 3RU2126)	3ZX1012-ORU21-1AA1
SIRIUS thermal overload relay S2 (3RU2136)	3ZX1012-ORU21-3AA1
SIRIUS thermal overload relay S3 (3RU2146)	3ZX1012-ORU21-4AA1
SIRIUS electronic overload relay S00 / S0 (3RB301 and 3RB311 / 3RB302 and 3RB312)	3ZX1012-ORB30-1AA1
SIRIUS electronic overload relay S2 (3RB303 and 3RB313)	3ZX1012-ORB30-3AA1
SIRIUS electronic overload relay S3 (3RB303 and 3RB313)	3ZX1012-ORB31-4AA1
SIRIUS electronic overload relay S6 / S10 / S12 (3RB20 and 3RB21)	3ZX1012-ORB20-1BA1
SIRIUS electronic overload relay 3RB22 and 3RB23	3ZX1012-ORB22-1AA1

B.2 Manuals - SIRIUS Modular System

Manuals - SIRIUS Modular System

You can download the SIRIUS manuals from the Internet.

Information about ...	Is available in ...
<ul style="list-style-type: none"> SIRIUS - system overview 	<ul style="list-style-type: none"> "SIRIUS - System Overview" (https://support.industry.siemens.com/cs/ww/en/view/60311318) manual
<ul style="list-style-type: none"> Contactors and contactor assemblies 3RT, 3RH and 3RA 	<ul style="list-style-type: none"> "SIRIUS - SIRIUS 3RT Contactors and Contactor Assemblies" (https://support.industry.siemens.com/cs/ww/en/view/60306557) manual
<ul style="list-style-type: none"> 3RF34 electronic switching devices 	<ul style="list-style-type: none"> "SIRIUS - SIRIUS 3RF34 electronic Switching Devices" (https://support.industry.siemens.com/cs/ww/en/view/60298187) manual

Information about ...	Is available in ...
<ul style="list-style-type: none"> 3RW soft starters 	<ul style="list-style-type: none"> "SIRIUS 3RW30/3RW40 Soft Starter" (https://support.industry.siemens.com/cs/ww/en/view/38752095) manual "SIRIUS 3RW44 Soft Starter" (https://support.industry.siemens.com/cs/ww/en/view/21772518) manual
<ul style="list-style-type: none"> 3RV motor starter protectors 	<ul style="list-style-type: none"> "SIRIUS 3RV Motor Starter Protectors" (https://support.industry.siemens.com/cs/ww/en/view/60279172) manual
<ul style="list-style-type: none"> 3RU, 3RB overload relays 	<ul style="list-style-type: none"> "SIRIUS 3RU Thermal Overload Relays / SIRIUS 3RB Electronic Overload Relays" (https://support.industry.siemens.com/cs/ww/en/view/60298164) manual
<ul style="list-style-type: none"> 3RB24 electronic overload relay 	<ul style="list-style-type: none"> "3RB24 Electronic Overload Relay for IO-Link" (https://support.industry.siemens.com/cs/ww/en/view/46165627) manual
<ul style="list-style-type: none"> 3UG4 monitoring relays / 3RR2 current monitoring relays 	<ul style="list-style-type: none"> "3UG4/3RR2 Monitoring Relay" (https://support.industry.siemens.com/cs/ww/en/view/54397927) manual
<ul style="list-style-type: none"> 3RS1/3RS2 temperature monitoring relays 	<ul style="list-style-type: none"> "3RS1/3RS2 Temperature Monitoring Relays" (https://support.industry.siemens.com/cs/ww/en/view/54999309) manual
<ul style="list-style-type: none"> 3UG48 monitoring relays / 3RR24 current monitoring relays for IO-Link 	<ul style="list-style-type: none"> "3UG48/3RR24 Monitoring Relays for IO-Link" (https://support.industry.siemens.com/cs/ww/en/view/54375430) manual
<ul style="list-style-type: none"> 3RS14/3RS15 temperature monitoring relays for IO-Link 	<ul style="list-style-type: none"> "3RS14/3RS15 Temperature Monitoring Relays for IO-Link" (https://support.industry.siemens.com/cs/ww/en/view/54375463) manual
<ul style="list-style-type: none"> 3RA load feeders 	<ul style="list-style-type: none"> "SIRIUS - SIRIUS 3RA Load Feeders" (https://support.industry.siemens.com/cs/ww/en/view/60284351) manual
<ul style="list-style-type: none"> 3RA6 compact starters 	<ul style="list-style-type: none"> "SIRIUS 3RA6 Compact Starter" (https://support.industry.siemens.com/cs/ww/en/view/27865747) manual
<ul style="list-style-type: none"> 3RA28 function modules for mounting on contactors 	<ul style="list-style-type: none"> "SIRIUS - SIRIUS 3RA28 Function Modules for Mounting on 3RT2 Contactors" (https://support.industry.siemens.com/cs/ww/en/view/60279150) manual
<ul style="list-style-type: none"> 3RA27 function modules for connection to the higher-level control 	<ul style="list-style-type: none"> "SIRIUS - SIRIUS 3RA2712 Function Modules for AS-Interface" (https://support.industry.siemens.com/cs/ww/en/view/39318922) manual "SIRIUS - SIRIUS 3RA2711 Function Modules for IO-Link" (https://support.industry.siemens.com/cs/ww/en/view/39319600) manual

Dimension drawings (dimensions in mm)

C.1 CAx data

You can find the CAx data in the Siemens Industry Online Support (<https://support.industry.siemens.com/cs/ww/en/ps/16269/td>).

1. Enter the full article number of the desired device in the "Product" field, and confirm with the Enter key.
2. Click the "CAx data link.

The screenshot shows the Siemens Industry Online Support search interface. At the top, there is a search bar with the text "Enter keyword...". Below the search bar, there are three main sections: "Product", "Entry type", and "Date". The "Product" field contains the article number "3RV2031-4BA10" and is highlighted with a red box. The "Entry type" dropdown menu is set to "Technical data (1)" and is also highlighted with a red box. The "Date" field has "From" and "To" input boxes. Below these fields, there is a "Search product" button. The search results section shows a product card for "3RV2031-4BA10" with a description: "CIRCUIT BREAKER, SCREW TYPE, 20 A, CIRCUIT BREAKER SIZE S2, FOR MOTOR PROTECTION, CLASS 10, A-RELEASE 14... 20A, N-RELEASE 20DA, SCREW TERMINAL, STANDARD BREAKING CAPACITY". Below the product card, there are navigation links: "> Product details", "> Technical data", and "> CAx data", with the "CAx data" link highlighted by a red box.

Note

All dimensions are specified in mm.

C.2 Dimension drawings for 3RU21 thermal overload relays

3RU2116-..B0 (S00, screw connection, contactor mounting)

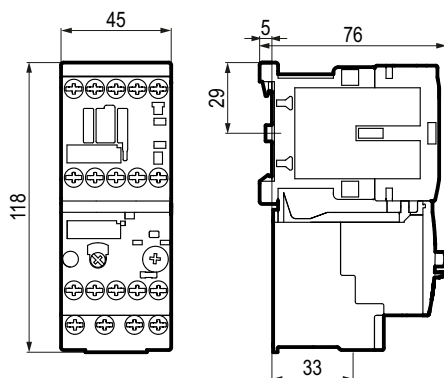

Figure C-1 3RU2116-..B0

3RU2116-4.B1 (S00, screw connection, mounting on stand-alone assembly support)

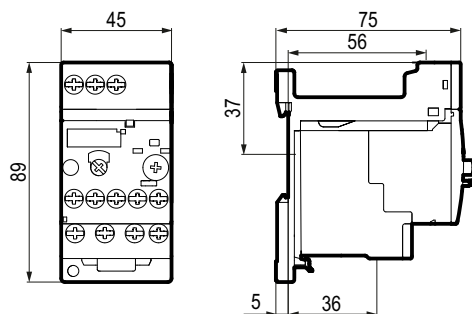

Figure C-2 3RU2116-4.B1

3RU2116-..C0 (S00, spring-loaded connection, contactor mounting)

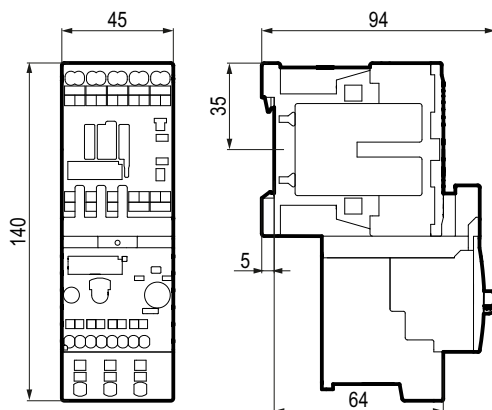

Figure C-3 3RU2116-..C0

3RU2116-..C1 (S00, spring-loaded connection, mounting on stand-alone assembly support)

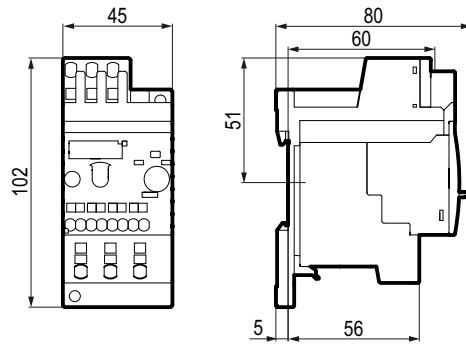
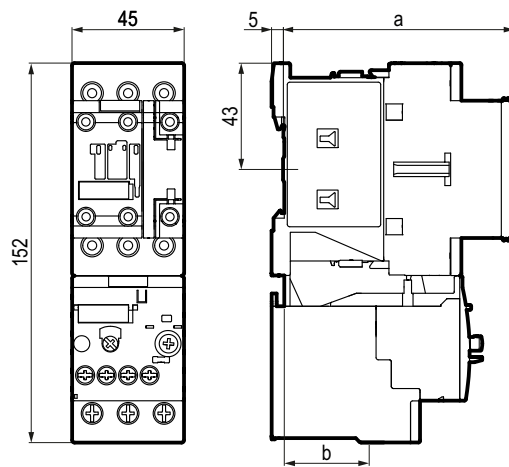

Figure C-4 3RU2116-..C1

3RU2126-..B0 (S0, screw connection, contactor mounting)



a AC: 92; AC / DC: 102

b AC: 34; AC / DC: 44

Figure C-5 3RU2126-..B0

3RU2126-4.B1 (S0, screw connection, mounting on stand-alone installation support)

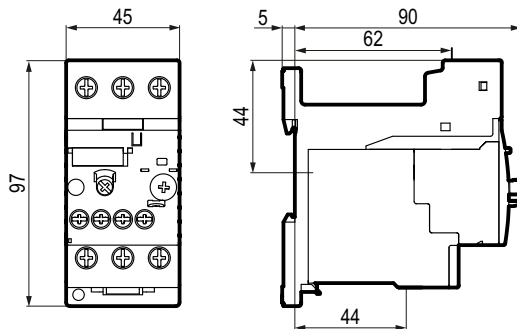
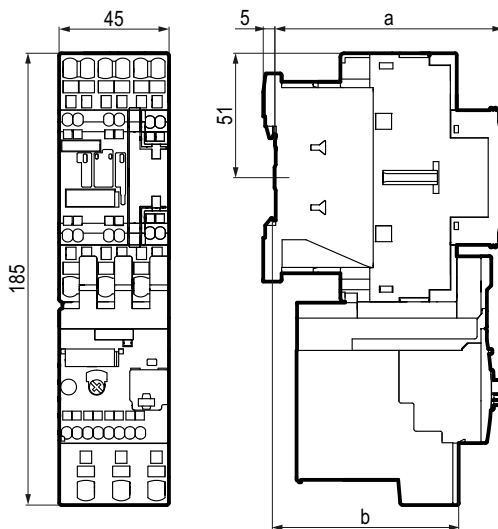

Figure C-6 3RU2126-4.B1

3RU2126-..C0 (S0, spring-loaded connection, contactor mounting)



a AC: 93; AC / DC: 103

b AC: 76; AC / DC: 86

Figure C-7 3RU2126-..C0

3RU2126-4.C1 (S0, spring-loaded connection, mounting on stand-alone installation support)

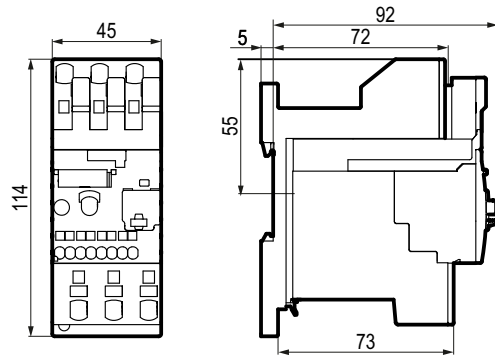

Figure C-8 3RU2126-4.C1

3RU2136-..B0 (S2, screw connection, contactor mounting)

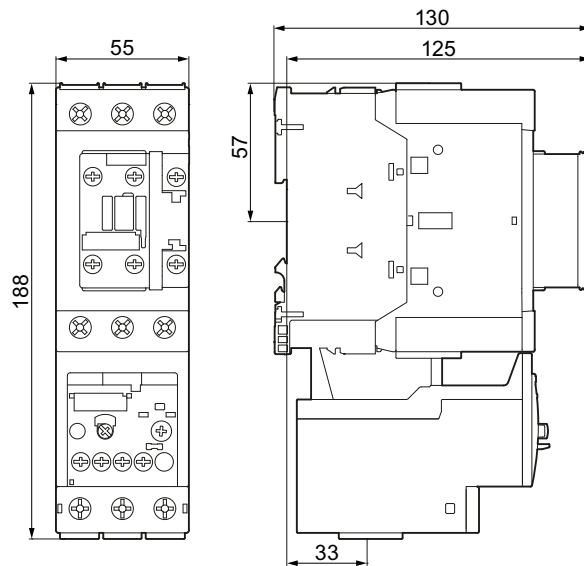

Figure C-9 3RU2136-..B0

3RU2136-..B1 (S2, screw connection, mounting on stand-alone assembly support)

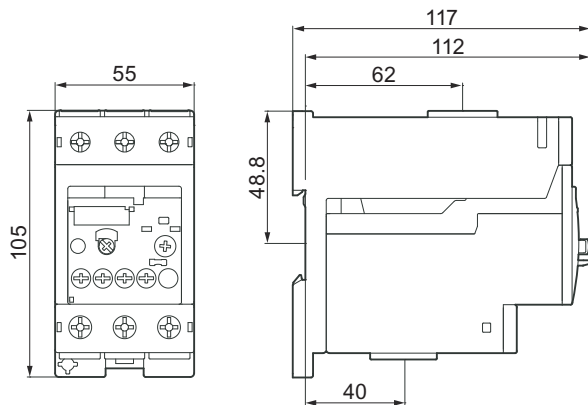

Figure C-10 3RU2136-..B1 and 3RU2936-3AA01

3RU2136-..D0 (S2, spring-loaded connection, contactor mounting)

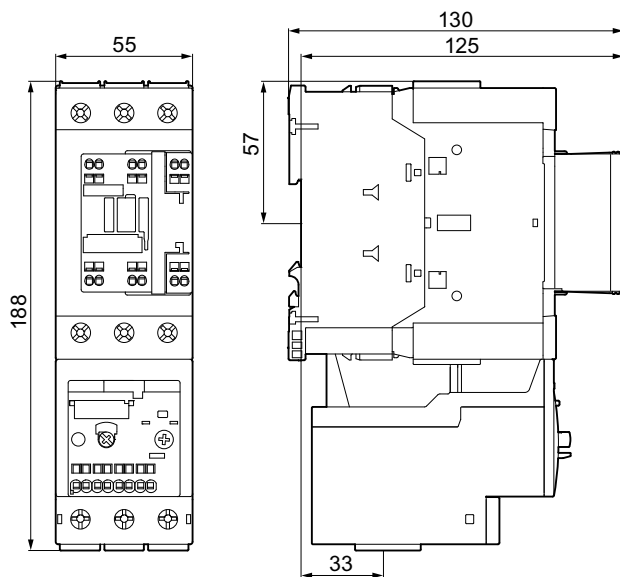

Figure C-11 3RU2136-..D0

3RU2136-..D1 (S2, spring-loaded connection, mounting on stand-alone assembly support)

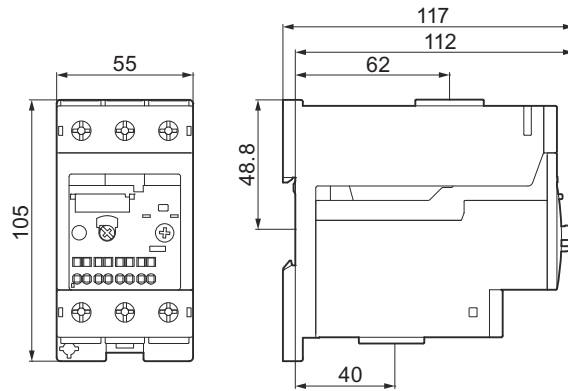

Figure C-12 3RU2136-..D1 and 3RU2936-3AA01

3RU2146-..B0 (S3, screw connection, contactor mounting)

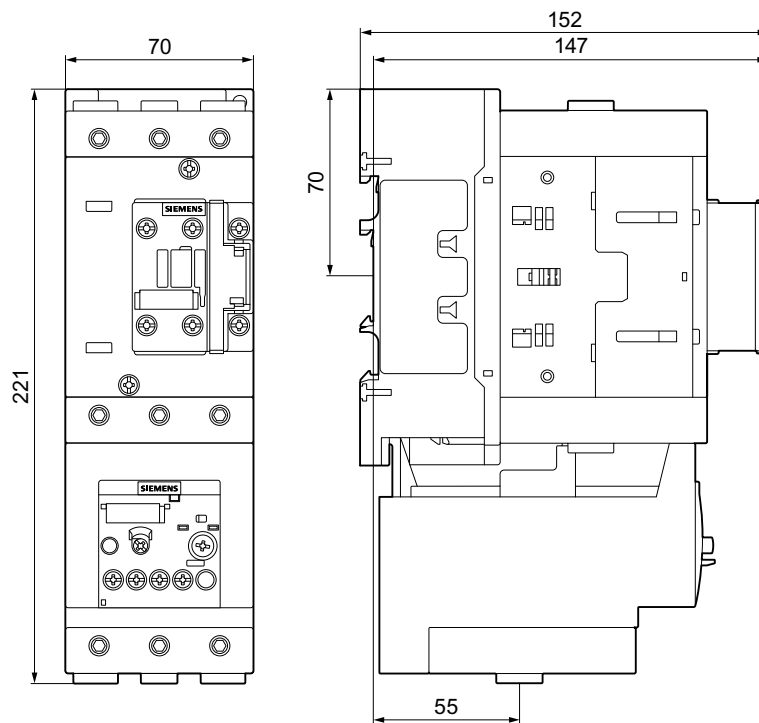

Figure C-13 3RU2146-..B0

3RU2146-..B1 (S3, screw connection, mounting on stand-alone assembly support)

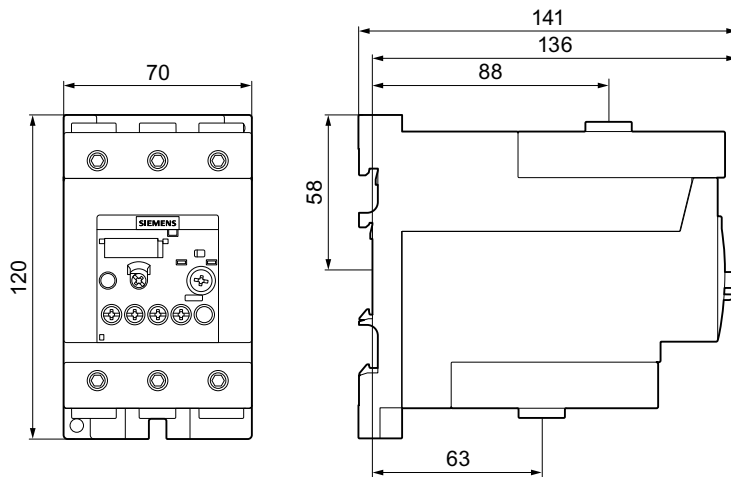

Figure C-14 3RU2146-..B1 and 3RU2946-3AA01

3RU2146-..D0 (S3, spring-loaded connection, contactor mounting)

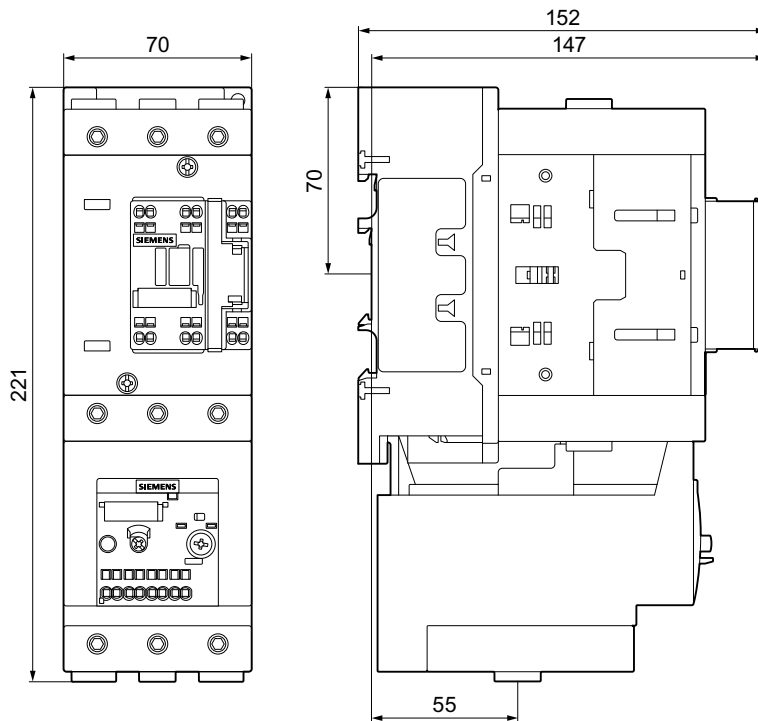

Figure C-15 3RU2146-..D0

3RU2146-..D1 (S3, spring-loaded connection, mounting on stand-alone assembly support)

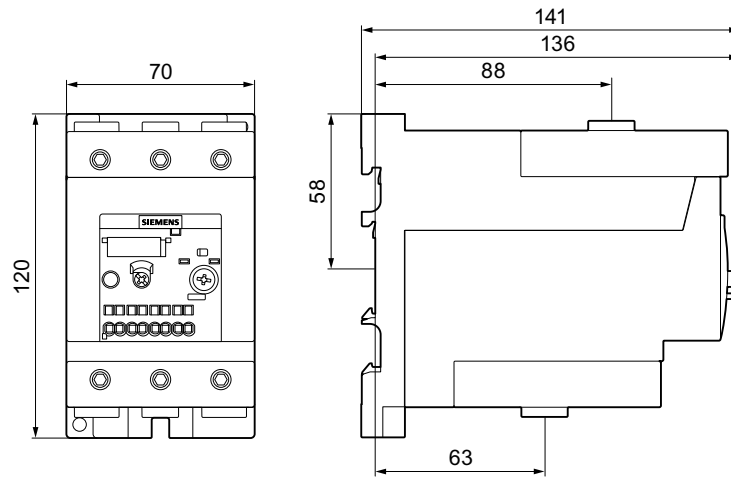

Figure C-16 3RU2146-..D1 and 3RU2946-3AA01

C.3 Dimension drawings und drilling plans electronic overload relay 3RB20 / 3RB21

3RB2.5 (S6, screw connection)

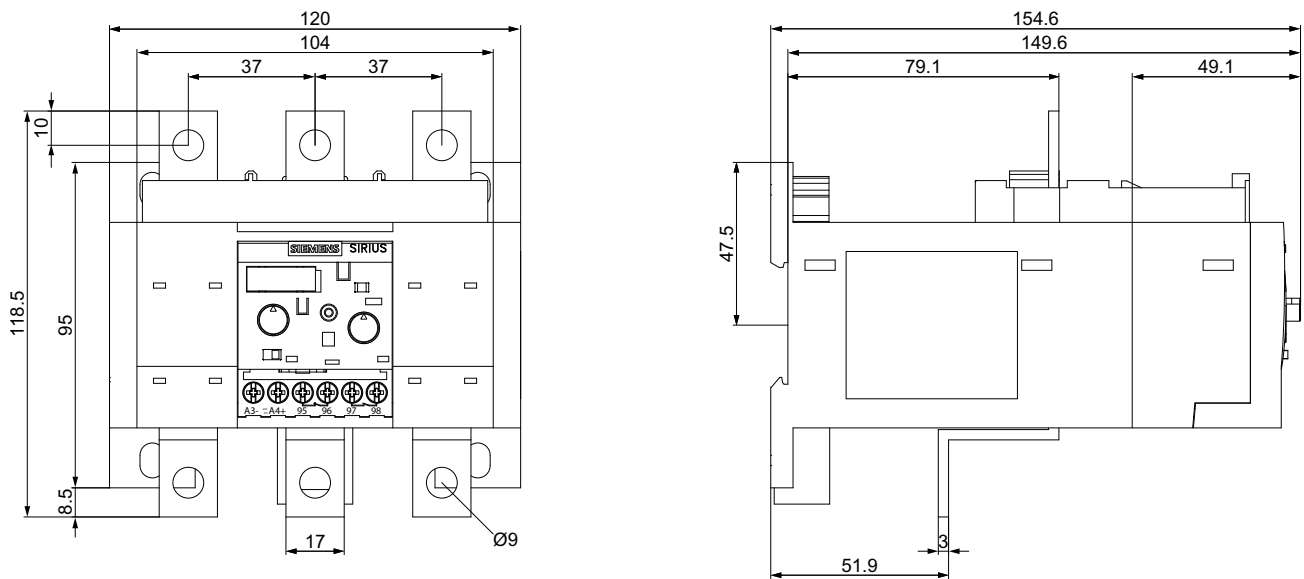

Figure C-17 3RB2.5

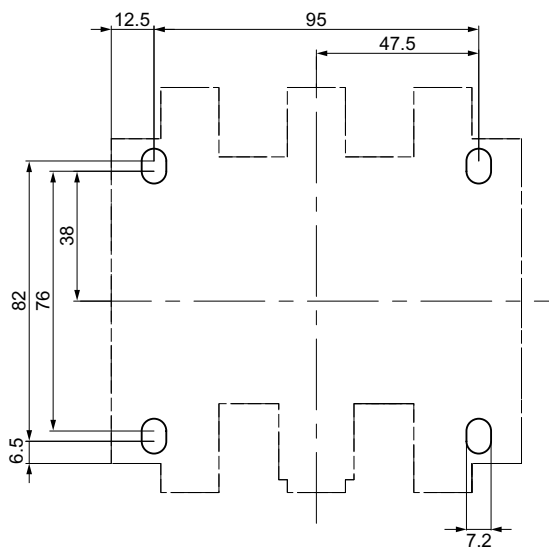

Figure C-18 3RB2.5 drilling plan

3RB2.5-..W. / 3RB2.5-..X. (S6, screw connection, through-hole technology)

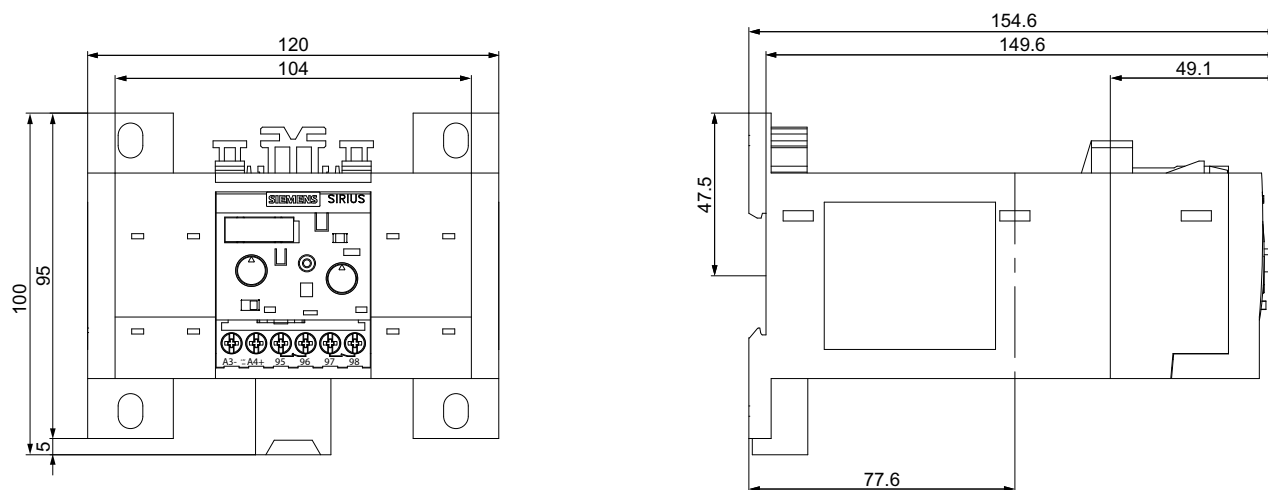

Figure C-19 3RB2.5-..W / 3RB2.5-..X

C.3 Dimension drawings und drilling plans electronic overload relay 3RB20 / 3RB21

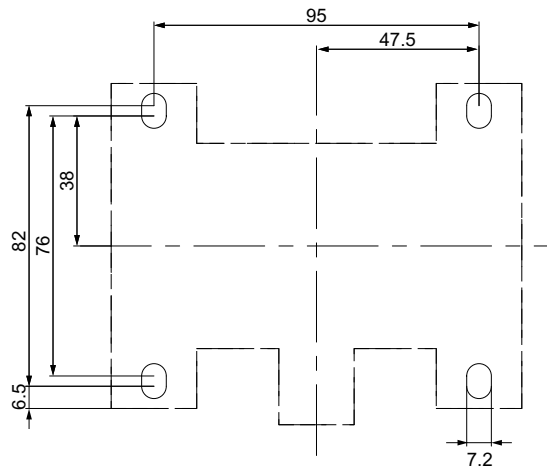

Figure C-20 3RB2.5-..W / 3RB2.5-..X drilling plans

3RB2.6 (S10 / S12, screw connection)

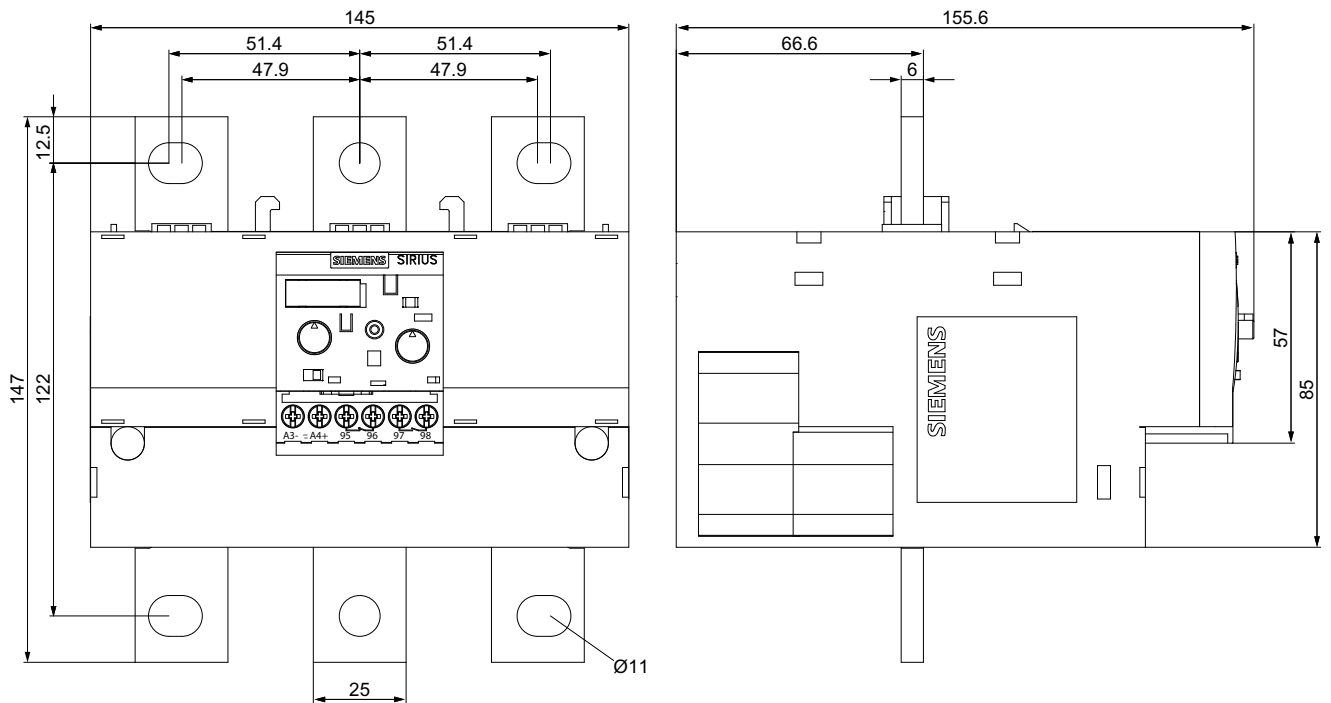

Figure C-21 3RB2.6

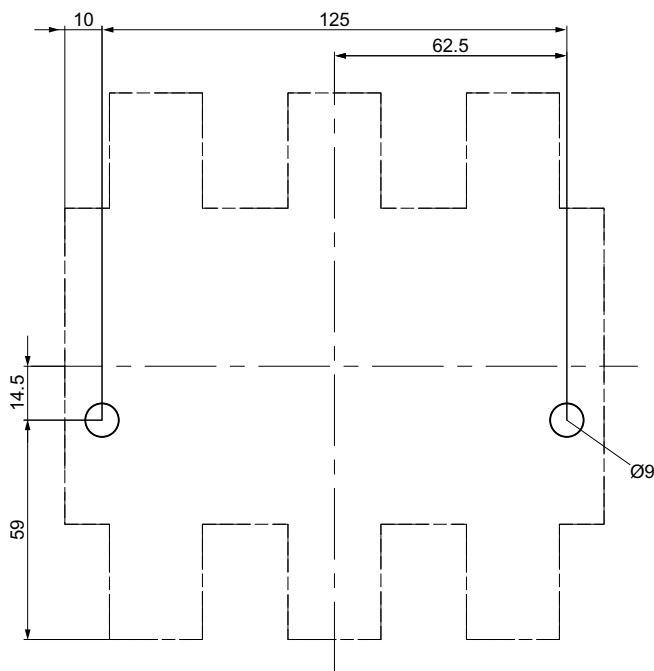

Figure C-22 3RB2.6 drilling plan

C.4 Dimension drawings for 3RB30/3RB31 electronic overload relays

3RB3.1.-..B0 (S00, screw connection, contactor mounting)

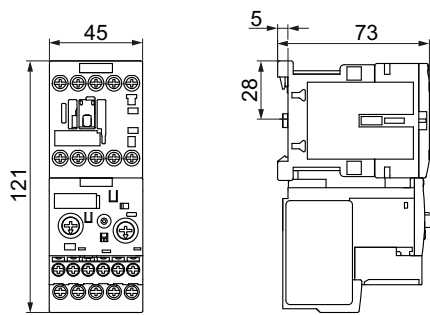

Figure C-23 3RB3.1.-..B0

3RB3.1.-..B0 (S00, screw connection, mounting on stand-alone assembly support)

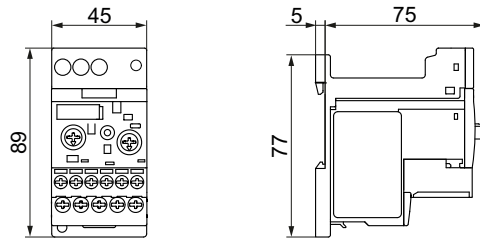

Figure C-24 3RB3.1.-..B0 and 3RU2916-3AA01

3RB3.1.-..E0 (S00, spring-loaded connection, contactor mounting)

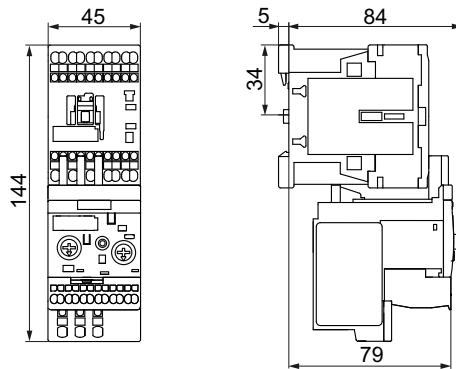

Figure C-25 3RB3.1.-..E0

3RB3.1.-..E0 (S00, spring-loaded connection, mounting on stand-alone assembly support)

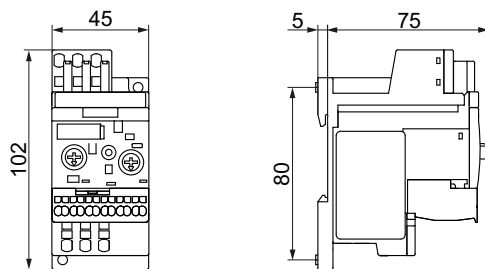
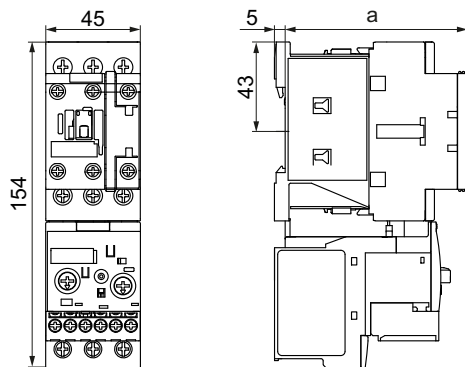

Figure C-26 3RB3.1.-..E0 and 3RU2916-3AC01

3RB3.2-..B0 (S0, screw connection, contactor mounting)



a AC: 87; AC / DC: 97

Figure C-27 3RB3.2-..B0

3RB3.2-..B0 (S0, screw connection, mounting on stand-alone installation support)

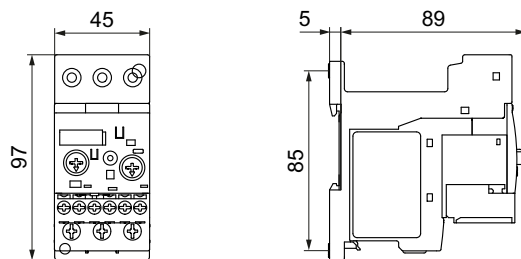
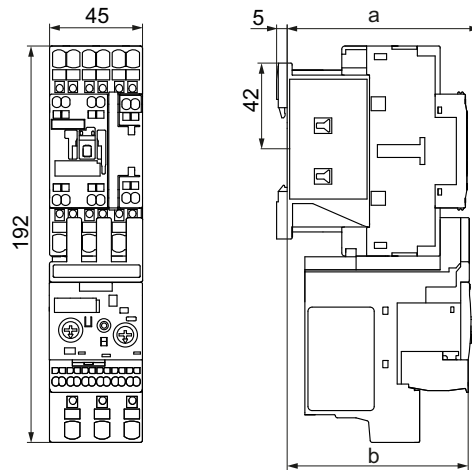

Figure C-28 3RB3.2-..B0 and 3RU2926-3AA01

3RB3.2.-..E0 (S0, spring-loaded connection, contactor mounting)



a AC: 93; AC / DC: 103

b AC: 88; AC / DC: 98

Figure C-29 3RB3.2.-..E0

3RB3.2.-..E0 (S0, spring-loaded connection, mounting on stand-alone installation support)

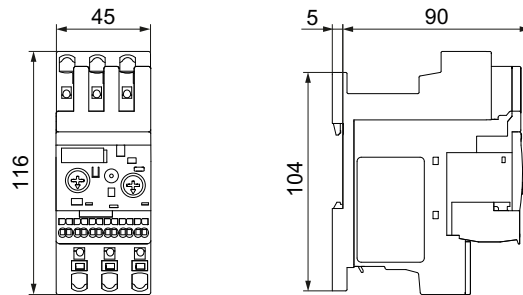

Figure C-30 3RB3.2.-..E0 and 3RU2926-3AC01

3RB3.3-..B0 (S2, screw connection, contactor mounting)

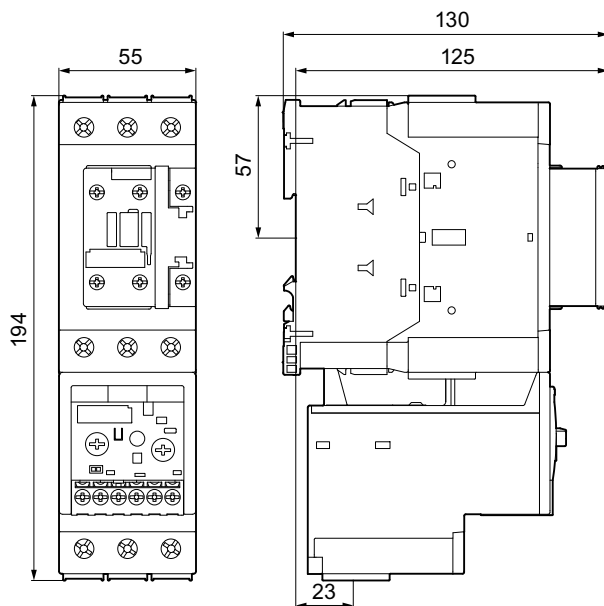

Figure C-31 3RB3.3-..B0

3RB3.3-..B0 (S2, screw connection, mounting on stand-alone assembly support)

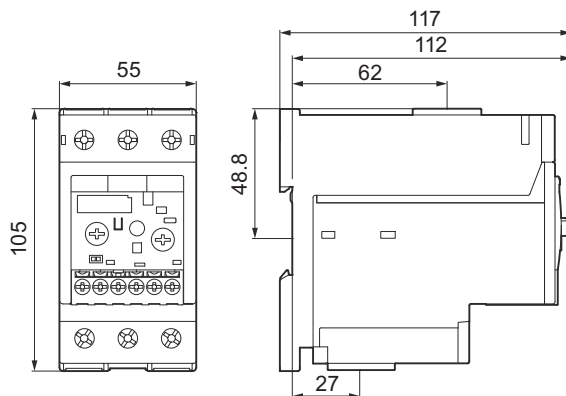

Figure C-32 3RB3.3-..B0 and 3RU2936-3AA01

3RB3.3.-..D0 (S2, spring-loaded connection, contactor mounting)

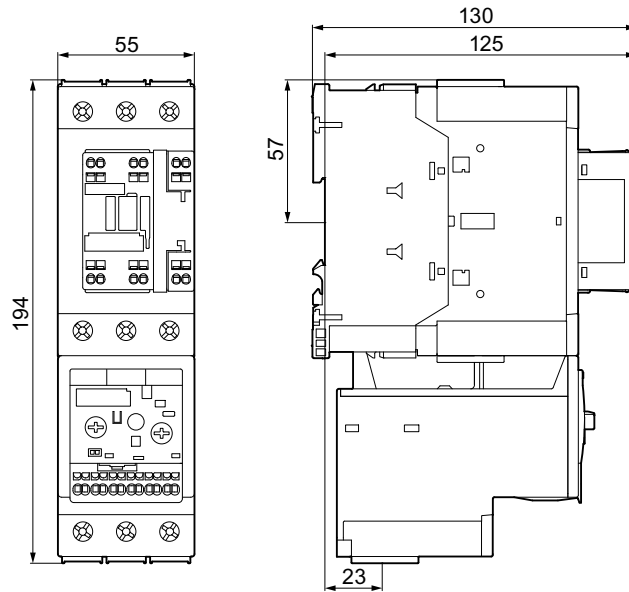

Figure C-33 3RB3.3.-..D0

3RB3.3.-..D0 (S2, spring-loaded connection, mounting on stand-alone assembly support)

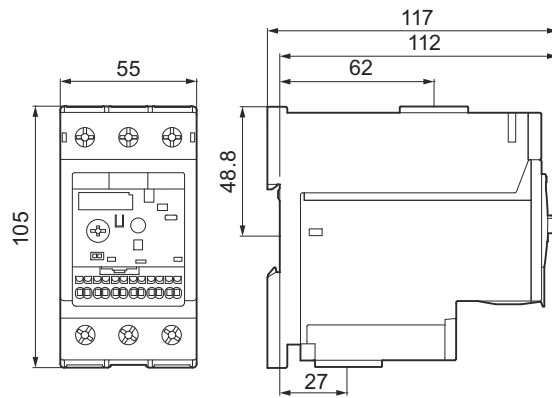

Figure C-34 3RB3.3.-..D0 and 3RU2936-3AA01

3RB3.3-..W. (S2, screw connection, through-hole technology)

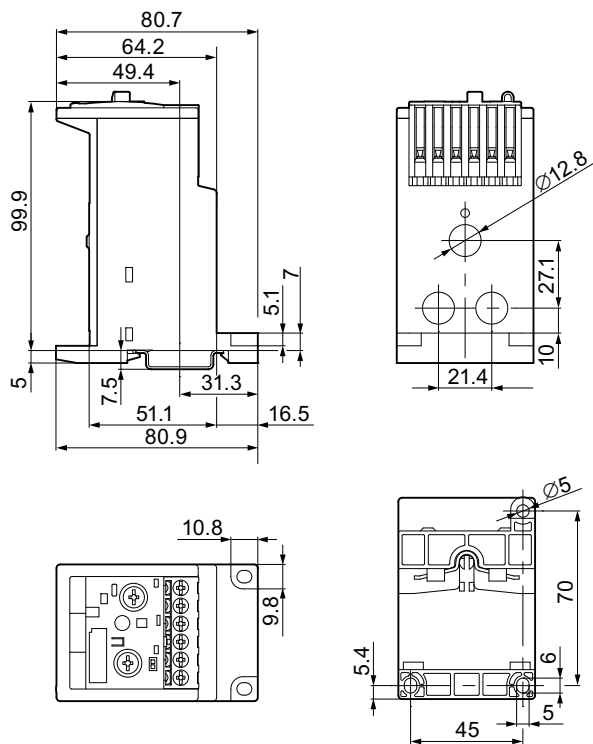

Figure C-35 3RB3.3-..W.

3RB3.3-..X. (S2, spring-loaded connection, through-hole technology)

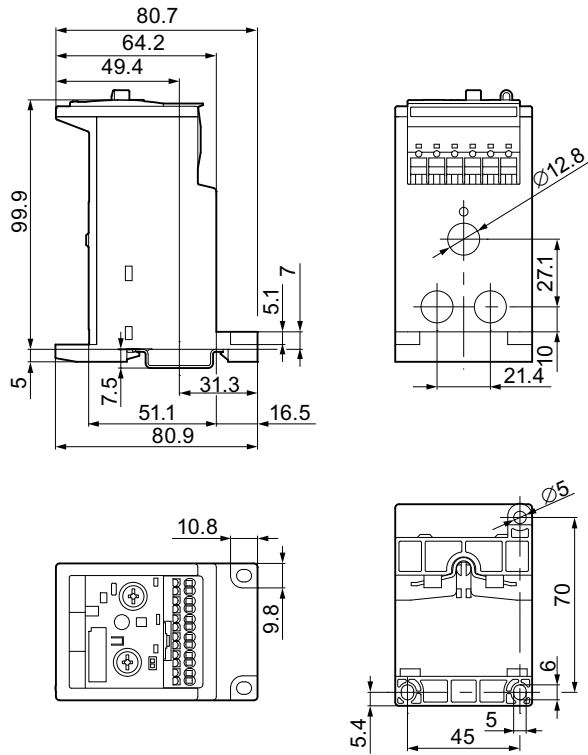

Figure C-36 3RB3.3-..X.

3RB3.4-...B0 (S3, screw connection, contactor mounting)

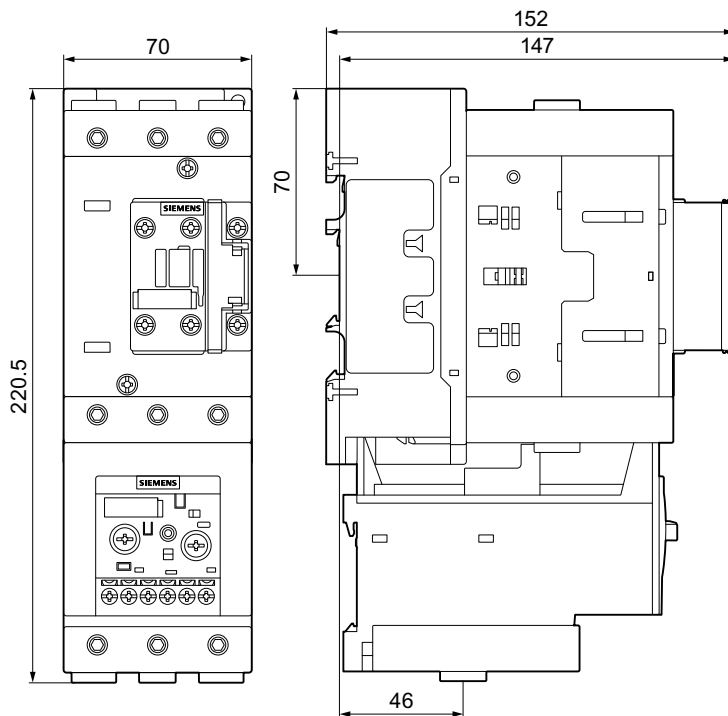

Figure C-37 3RB3.4-...B0

3RB3.4-...B0 (S3, screw connection, mounting on stand-alone assembly support)

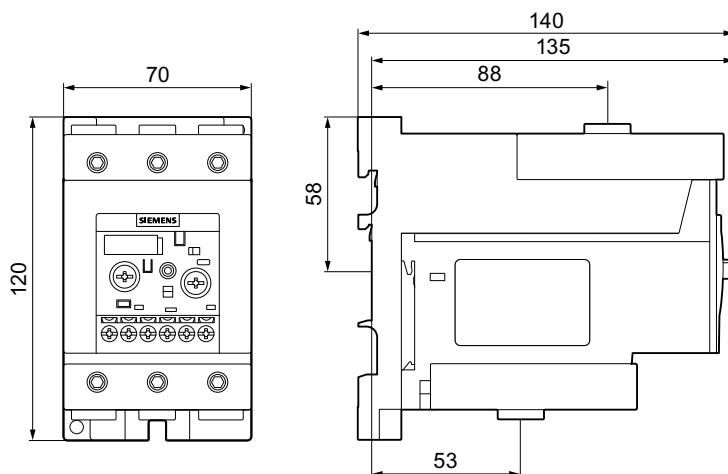

Figure C-38 3RB3.4-...B0 and 3RU2946-3AA01

3RB3.4.-..D0 (S3, spring-loaded connection, contactor mounting)

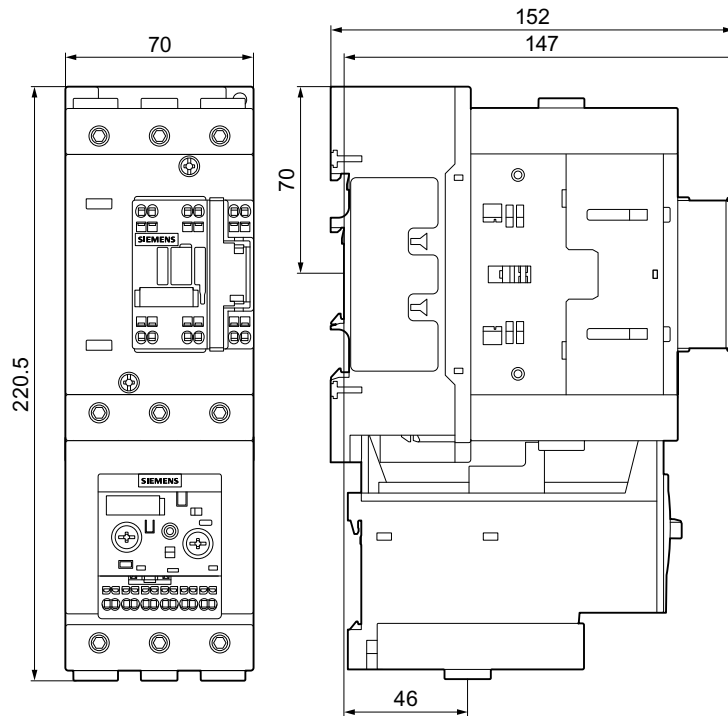

Figure C-39 3RB3.4.-..D0

3RB3.4.-..D0 (S3, spring-loaded connection, mounting on stand-alone assembly support)

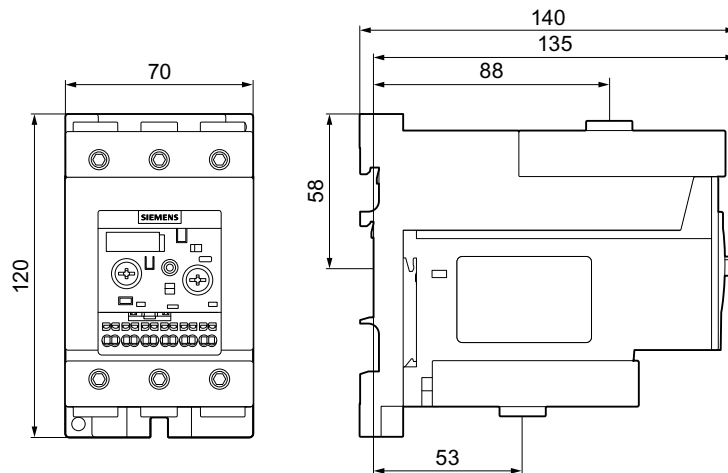

Figure C-40 3RB3.4.-..D0 and 3RU2946-3AA01

3RB3.4.-..W. (S3, screw connection, through-hole technology)

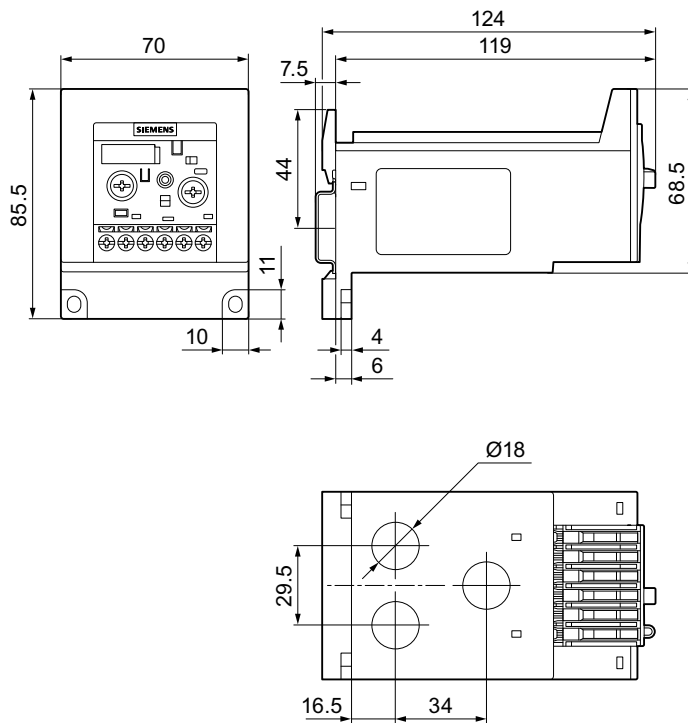

Figure C-41 3RB3.4.-..W.

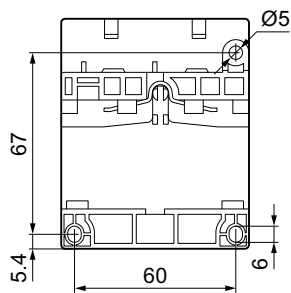

Figure C-42 3RB3.4.-..W. - drilling diagram

3RB3.4.-..X. (S3, spring-loaded connection, through-hole technology)

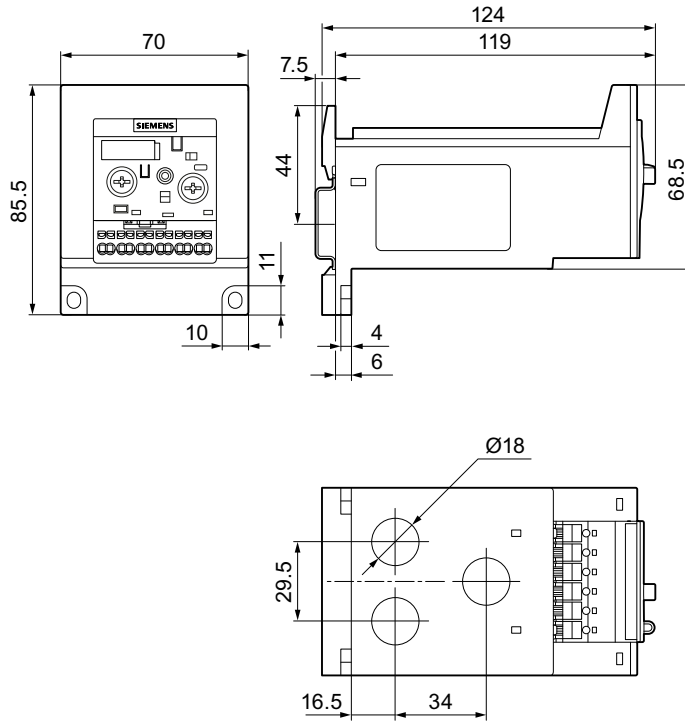

Figure C-43 3RB3.4.-..X.

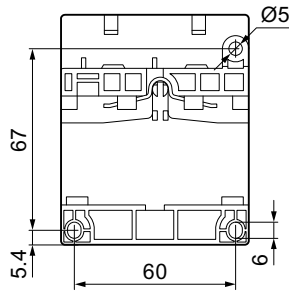

Figure C-44 3RB3.4.-..X. - drilling diagram

C.5 Drilling diagram for 3RT contactors

Drilling plans for 3RT2.1.-1/3RT2.1-4. contactors

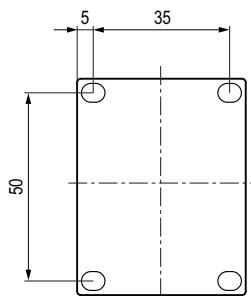

Figure C-45 Drilling plan for contactors with screw-type connections and ring cable lug connections (size S00)

Drilling plan for 3RT2.1.-2 contactors

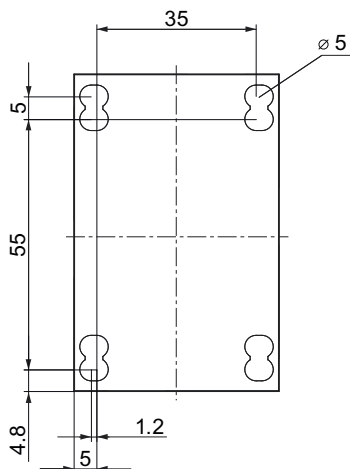

Figure C-46 Drilling plan for contactors with spring-loaded connections (size S00)

Drilling plan for 3RT2.2. contactors

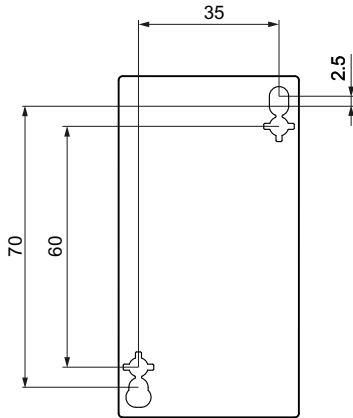

Figure C-47 Drilling plan for 3RT2.2. contactors (size S0)

Drilling plan for 3RT2.3. contactors

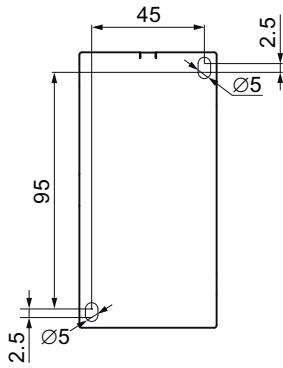

Figure C-48 Drilling plan for 3RT2.3. contactors (size S2)

Drilling diagram for 3RT2.4. contactors

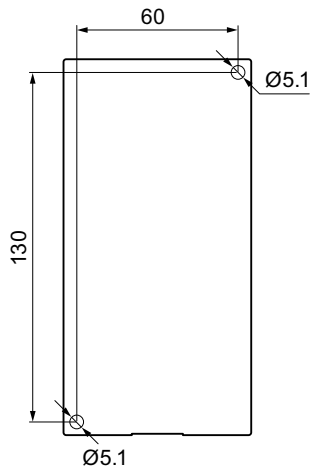

Figure C-49 Drilling diagram for 3RT2.4. contactors (size S3)

Drilling diagram for 3RT1.5. contactors

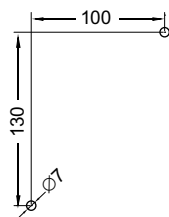

Figure C-50 Drilling diagram for 3RT1.5. contactors (size S6)

Drilling diagram for 3RT1.6. contactors

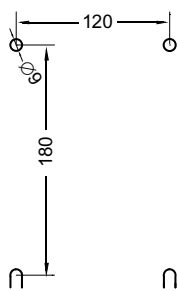

Figure C-51 Drilling diagram for 3RT1.6. contactors (size S10)

Drilling diagram for 3RT1.7. contactors

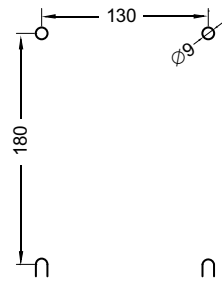

Figure C-52 Drilling diagram for 3RT1.7. contactors (size S12)

C.6 Dimension drawings and drilling plans for 3RU29.6 stand-alone installation supports

3RU2916-3AA01 (S00, screw connection)

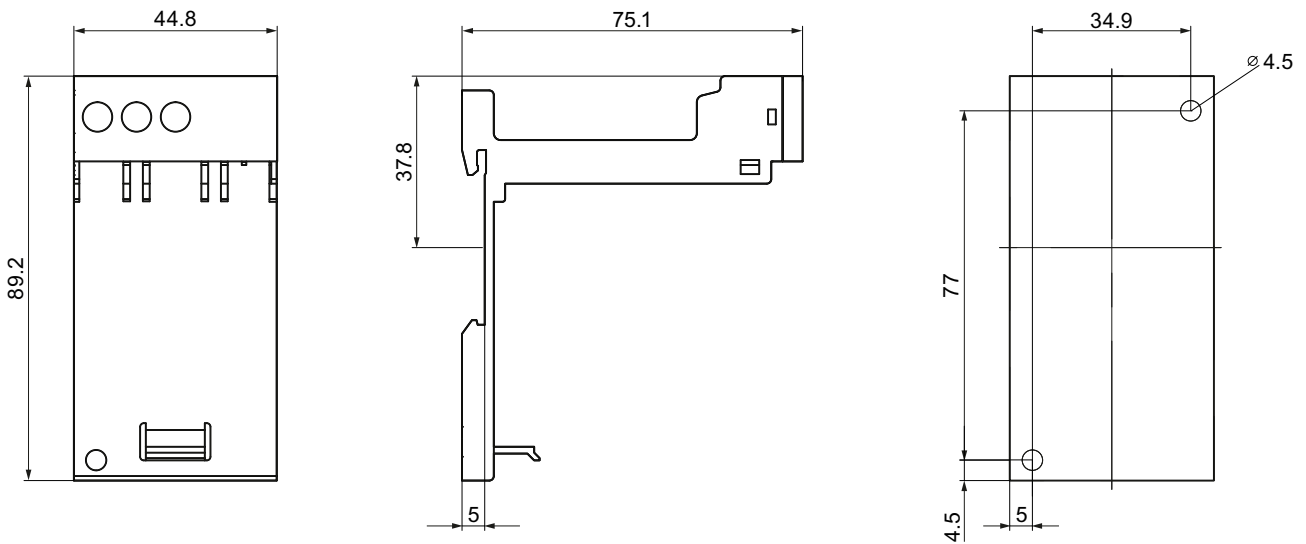

Figure C-53 3RU2916-3AA01

3RU2916-3AC01 (S00, spring-loaded connection)

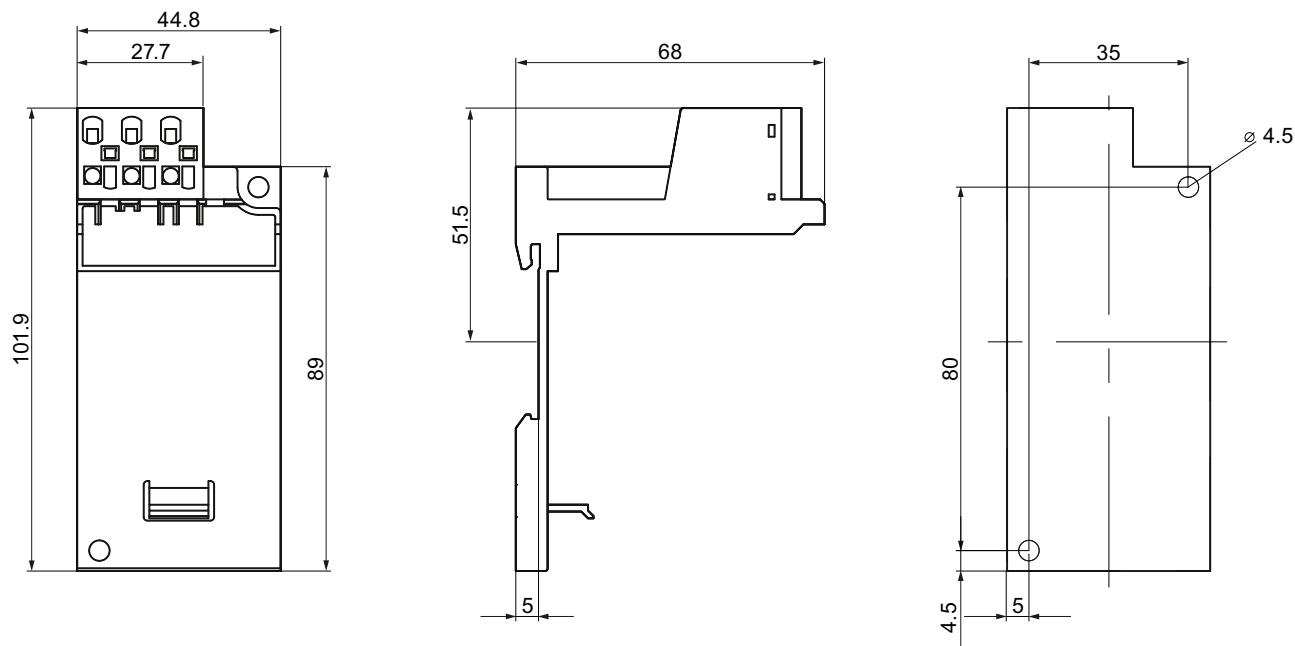

Figure C-54 3RU2916-3AC01

3RU2926-3AA01 (S0, screw connection)

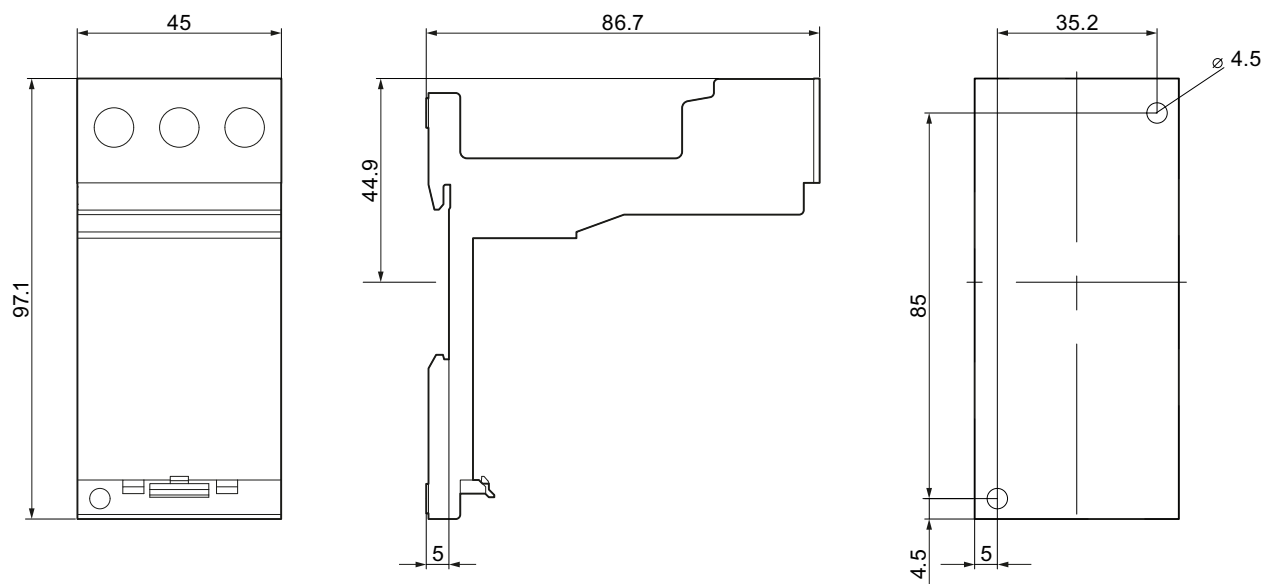

Figure C-55 3RU2926-3AA01

3RU2926-3AC01 (S0, spring-loaded connection)

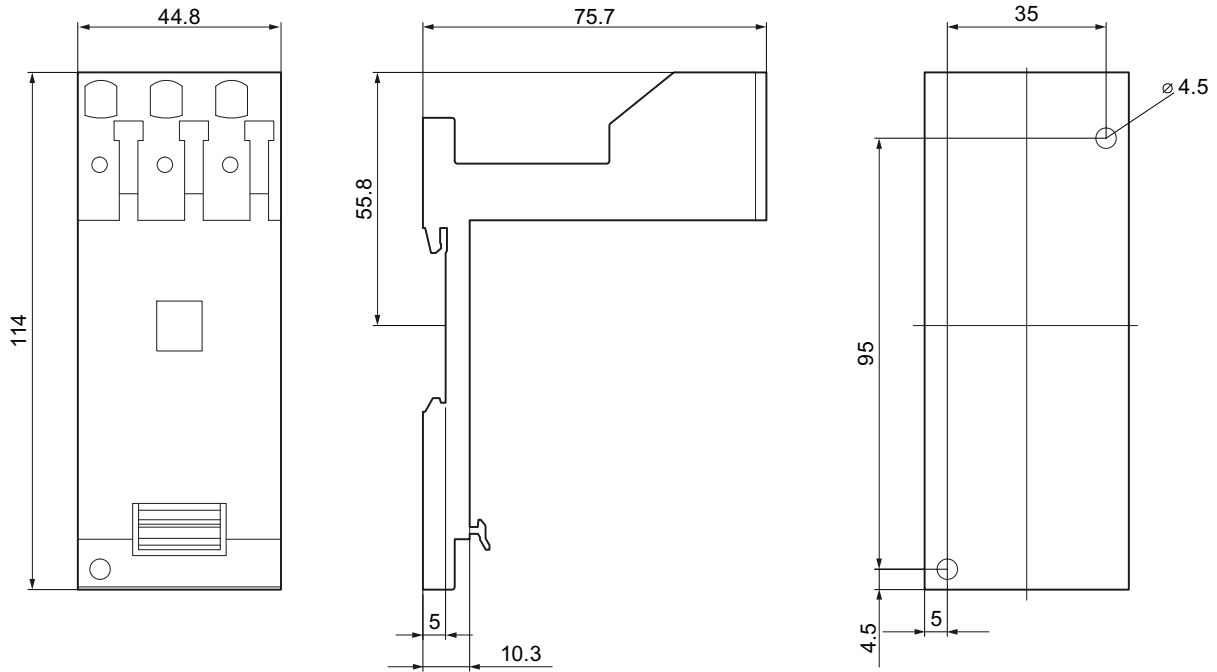

Figure C-56 3RU2926-3AC01

3RU2936-3AA01 (S2, screw connection)

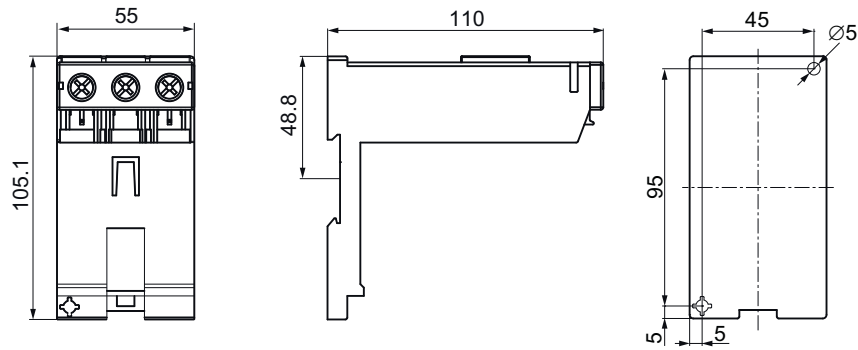

Figure C-57 3RU2936-3AA01

3RU2946-3AA01 (S3, screw connection)

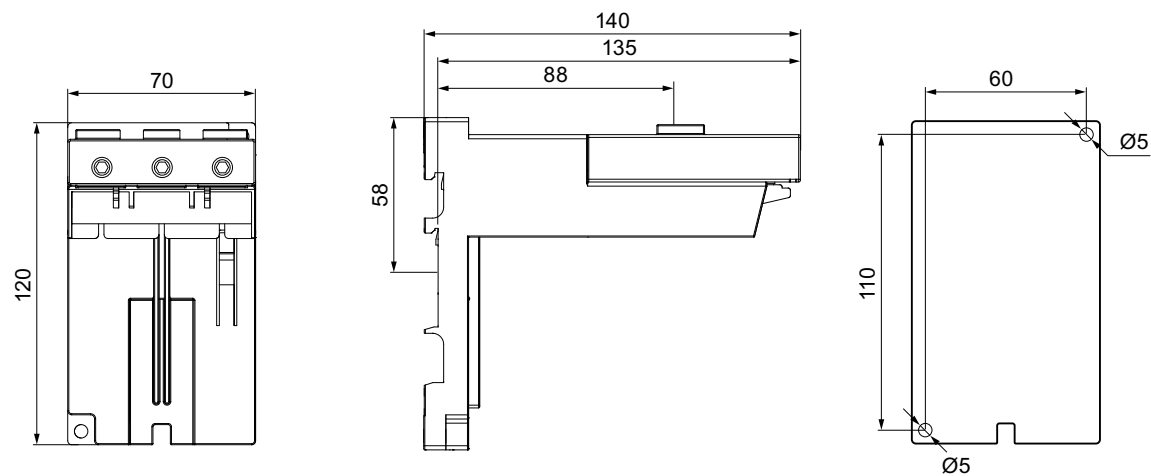

Figure C-58 3RU2946-3AA01

Index

A

- Accessories
 - Overload relay, 123
- Accessories - Overload relays
 - Box terminal block, 158
 - Cable release, 143
 - Mechanical remote RESET, 139, 140, 143
 - Module for electrical remote RESET, 148, 149
 - Release slide, 140
 - Sealable cover, 150, 151, 152, 153
 - Terminal cover for cable lug connection and busbar connection, 154, 155
 - Terminal covers for box terminal block, 156, 157
 - Terminal support for stand-alone assembly, 123
 - Terminal support for stand-alone installation, 124, 126, 127, 130, 132, 134, 136
- Advantages
 - Overload relay, 23
- Ambient temperature
 - 3RB2 and 3RB3 electronic overload relays, 72
 - 3RU21 thermal overload relays, 71
- Applications
 - Overload relay, 21
- Auxiliary contacts (overload relay), 121
- Auxiliary switch
 - Overload relay, 55
- Auxiliary switches
 - Overload relay, 106

B

- Basic knowledge, 10
- Box terminal block
 - Overload relay, 158

C

- Cable release
 - Overload relay, 143
- Coil terminal
 - Overload relay, 106
- Connection systems
 - Overload relay, 21, 105
- Contactors assemblies for star-delta (wye-delta) start
 - Overload relay, 54, 62

D

- DC loads
 - Overload relay, 49
- Derating
 - 3RB3 electronic overload relays, 72
- Device versions
 - Overload relay, 19

E

- Equipment features
 - 3RB2056 electronic overload relay, 29
 - 3RB2066 electronic overload relay, 31
 - 3RB2153 electronic overload relay, 33
 - 3RB2163 electronic overload relay, 34
 - 3RB3016 electronic overload relay, 36
 - 3RB3026 electronic overload relay, 38
 - 3RB3036 electronic overload relay, 39
 - 3RB3046 electronic overload relay, 40
 - 3RB3113 electronic overload relay, 41
 - 3RB3123 electronic overload relay, 43
 - 3RB3133 electronic overload relay, 44
 - 3RB3143 electronic overload relay, 45
 - 3RU2116 thermal overload relay, 24
 - 3RU2126 thermal overload relay, 26
 - 3RU2136 thermal overload relay, 27
 - 3RU2146 thermal overload relay, 28
- Explosion protection
 - Electronic overload relays, 64
 - Thermal overload relays, 64

F

- Frequency converter
 - Overload relay, 62

G

- Ground fault
 - Overload relay, 54, 55, 62

H

- Heavy-duty starting
 - Overload relay, 50, 61

I

- Internal circuit diagrams
 - Overload relay, 165, 167, 168, 169

M

- Mechanical remote RESET
 - Overload relay, 139, 140, 143
- Minimum clearance
 - Overload relay, 75
- Modular System, 175
- Module for electrical remote RESET
 - Overload relay, 148, 149
- Motor feeder (overload relay)
 - Design, 59
- Mounting position
 - Overload relay, 76

N

- Normal starting
 - Overload relay, 50, 61

O

- Operating instructions, 175
- Overload
 - Overload relay, 50, 55

P

- Phase asymmetry
 - Overload relay, 52
- Phase failure
 - Overload relay, 50, 55
- Phase unbalance
 - Overload relay, 55

R

- Recovery time
 - Overload relay, 119
- References, 175
- Release slide
 - Overload relay, 140
- RESET
 - Overload relay, 56, 118, 119

- Ring cable lug connection system, 114

S

- Safety data - 3RB20 / 3RB30 and 3RB21 / 3RB31
 - electronic overload relays, 70
 - Scope of validity
 - Manual, 10
- Screw-type connection system, 108
- Sealable cover
 - Overload relay, 150, 151, 152, 153
- Setting ground-fault detection
 - Overload relay, 117
- Setting the tripping class
 - Overload relay, 117
- Short-circuit protection
 - Overload relay, 63
- Single-phase load
 - Overload relay, 49
- Spring-loaded connection system, 113
- Standards
 - Overload relay, 17

T

- Terminal cover for cable lug connection and busbar connection
 - Overload relay, 154, 155
- Terminal covers for box terminal block
 - Overload relay, 156, 157
- Terminal designations
 - Overload relay, 107
- Terminal labels
 - 3RB2056 electronic overload relay, 30
 - 3RB2066 electronic overload relay, 32
 - 3RB3026 electronic overload relay, 38
 - 3RB3036 electronic overload relay, 39
 - 3RB3046 electronic overload relay, 40
 - 3RU2126 thermal overload relay, 26
 - 3RU2136 thermal overload relay, 27
 - 3RU2146 thermal overload relay, 28
- Terminal support for stand-alone assembly
 - Overload relay, 123
- Terminal support for stand-alone installation
 - Overload relay, 124, 126, 127, 130, 132, 134, 136
- Test function
 - Electronic overload relays, 68
 - Overload relay, 57, 120, 121
- Three-phase current loads
 - Overload relay, 59

Through-hole technology, 111, 112

Touch protection

Overload relay, 106

Trip classes

Overload relay, 50

Tripping characteristics

Overload relay, 51, 52

Types of coordination, 173

Overload relay, 60, 63

W

Wiring examples

Overload relay, 171

