

Industrial Controls

Load feeders Compact starter SIRIUS 3RA6


System Manual


<u>Introduction</u>	1
<u>Safety instructions</u>	2
<u>System description</u>	3
<u>Application planning</u>	4
<u>3RA61/3RA62 compact starter</u>	5
<u>3RA64/3RA65 compact starter with IO-Link</u>	6
<u>Accessories</u>	7
<u>Service</u>	8
<u>Technical data</u>	9
<u>Dimension drawings</u>	10
<u>Circuit diagrams</u>	11
<u>Characteristic curves</u>	12
<u>Data sets for the 3RA64/3RA65 compact starter with IO-Link</u>	A
<u>References</u>	B
<u>List of abbreviations</u>	C


Legal information

Warning notice system

This manual contains notices you have to observe in order to ensure your personal safety, as well as to prevent damage to property. The notices referring to your personal safety are highlighted in the manual by a safety alert symbol, notices referring only to property damage have no safety alert symbol. These notices shown below are graded according to the degree of danger.

 DANGER
indicates that death or severe personal injury will result if proper precautions are not taken.

 WARNING
indicates that death or severe personal injury may result if proper precautions are not taken.

 CAUTION
indicates that minor personal injury can result if proper precautions are not taken.

NOTICE
indicates that property damage can result if proper precautions are not taken.


If more than one degree of danger is present, the warning notice representing the highest degree of danger will be used. A notice warning of injury to persons with a safety alert symbol may also include a warning relating to property damage.

Qualified Personnel

The product/system described in this documentation may be operated only by **personnel qualified** for the specific task in accordance with the relevant documentation, in particular its warning notices and safety instructions. Qualified personnel are those who, based on their training and experience, are capable of identifying risks and avoiding potential hazards when working with these products/systems.

Proper use of Siemens products

Note the following:

 WARNING
Siemens products may only be used for the applications described in the catalog and in the relevant technical documentation. If products and components from other manufacturers are used, these must be recommended or approved by Siemens. Proper transport, storage, installation, assembly, commissioning, operation and maintenance are required to ensure that the products operate safely and without any problems. The permissible ambient conditions must be complied with. The information in the relevant documentation must be observed.

Trademarks

All names identified by ® are registered trademarks of Siemens AG. The remaining trademarks in this publication may be trademarks whose use by third parties for their own purposes could violate the rights of the owner.

Disclaimer of Liability

We have reviewed the contents of this publication to ensure consistency with the hardware and software described. Since variance cannot be precluded entirely, we cannot guarantee full consistency. However, the information in this publication is reviewed regularly and any necessary corrections are included in subsequent editions.

Table of contents

1	Introduction	9
1.1	Siemens Industry Online Support	11
1.2	Support Request	13
1.3	Siemens Industry Online Support app.....	14
2	Safety instructions	15
2.1	Security information	15
2.2	Standards/Regulations/Approvals.....	16
2.3	Use as prescribed	17
2.4	Recycling and disposal	18
3	System description	19
3.1	System overview.....	19
3.2	System configuration	21
3.2.1	Automation environment.....	21
3.2.2	3RA61/3RA62 compact starter without optional AS-i mounting module	22
3.2.3	3RA61/3RA62 compact starter with optional AS-i mounting module	23
3.2.4	3RA64/3RA65 compact starter with IO-Link	24
4	Application planning	27
4.1	General data	27
4.2	Safe isolation	30
4.3	Supply options (main circuit).....	32
4.3.1	Infeed system for 3RA6	32
4.3.2	3RV19 3-phase busbar	37
4.3.3	8US busbar adapter.....	38
4.3.4	Infeed in accordance with UL 508 (Type E)	40
5	3RA61/3RA62 compact starter	43
5.1	Scope of supply	43
5.1.1	Article numbers	43
5.1.2	Scope of supply	44
5.2	Description of the hardware	46
5.2.1	Features	46
5.2.2	3RA61 compact starter (direct starter).....	46
5.2.3	3RA62 compact starter (reversing starter)	49
5.3	Configuring.....	53
5.3.1	SIRIUS configurator	53
5.4	Functions.....	54
5.4.1	Normal switching duty.....	54

5.4.2	Overload protection function	58
5.4.3	Short-circuit protection function.....	59
5.4.4	Shutdown on malfunction	61
5.4.5	Disabling the actuator.....	62
5.5	Installing/removal	63
5.5.1	Installing the 3RA61/3RA62 compact starter.....	63
5.5.1.1	Mounting the compact starter on a DIN rail	63
5.5.1.2	Installing the compact starter on a level surface (screw fastening)	64
5.5.1.3	Installing the compact starter on an infeed system for 3RA6	66
5.5.2	Removing the 3RA61/3RA62 compact starter.....	67
5.5.2.1	Removing the compact starter from a DIN rail.....	68
5.5.2.2	Removing the compact starter from a level surface (screw fastening).....	69
5.5.2.3	Removing the compact starter from an infeed system for 3RA6.....	71
5.6	Connection	73
5.6.1	Connection via terminals.....	73
5.6.2	Connecting terminal blocks.....	75
5.6.3	Connecting the compact starter without optional AS-i mounting module.....	77
5.6.4	Disconnecting terminal blocks.....	80
5.7	Commissioning	82
5.7.1	Settings on the 3RA61/3RA62 compact starter.....	82
5.8	Diagnostics	85
5.8.1	Diagnostics via auxiliary and signaling contacts	85
5.8.2	Diagnostics via display elements	87
6	3RA64/3RA65 compact starter with IO-Link.....	89
6.1	Scope of supply	89
6.1.1	Article numbers	89
6.1.2	Scope of supply	90
6.2	Description of the hardware	92
6.2.1	Features	92
6.2.2	3RA64 compact starter with IO-Link (direct starter)	92
6.2.3	3RA65 compact starter with IO-Link (reversing starter)	95
6.3	Configuring.....	99
6.3.1	SIRIUS configurator	99
6.3.2	Combinations	99
6.3.3	Configuring with STEP 7 and the S7-PCT Port Configuration Tool	100
6.3.3.1	Basic procedure and prerequisites	100
6.3.3.2	Configuration.....	101
6.3.4	Configuring with the S7-PCT port configuration tool (stand-alone)	102
6.3.4.1	Application	102
6.3.4.2	Basic procedure and prerequisites	102
6.3.4.3	Configuration.....	102
6.3.5	Acyclic data exchange with the IO_LINK_DEVICE function block	103
6.3.6	Acyclic data exchange with the IO_LINK_MASTER function block.....	103
6.3.7	Replacing an IO-Link device.....	104
6.3.7.1	Introduction.....	104
6.3.7.2	Replacement of an IO-Link device (according to IO-Link communication specification V1.0)	104
6.3.8	Integration into the SIMATIC environment	106

6.4	Parameters	107
6.4.1	"Starter available" parameter	107
6.4.2	"Type of starter" parameter.....	109
6.4.3	Parameter "Operation at Preset <> Actual Configuration".....	110
6.4.4	Operation with operator panel	111
6.4.4.1	"Operator panel available" parameter	111
6.4.4.2	Parameter "Operation at Preset <> Actual Configuration".....	111
6.5	Process image	113
6.6	Functions.....	115
6.6.1	Normal switching duty.....	115
6.6.2	Overload protection function	116
6.6.3	Short-circuit protection function.....	118
6.6.4	Shutdown on malfunction	118
6.6.5	Disabling the actuator	119
6.7	Diagnostics	120
6.7.1	Diagnostics via display elements	120
6.7.2	Diagnostics via IO-Link	122
6.8	Installing/removal	124
6.8.1	Installing the 3RA64/3RA65 compact starter with IO-Link.....	124
6.8.2	Removing the 3RA64/3RA65 compact starter with IO-Link	126
6.9	Connection	127
6.9.1	Connection via terminals.....	127
6.9.2	Connecting terminal blocks.....	127
6.9.3	Connecting the 3RA64/3RA65 compact starter with IO-Link	127
6.9.4	Connecting limit switches	129
6.9.5	EMERGENCY STOP.....	131
6.10	Commissioning	133
6.10.1	Settings on the 3RA64/3RA65 compact starter with IO-Link	133
7	Accessories	137
7.1	Accessories overview	137
7.2	Adapter for screw fastening.....	141
7.2.1	Scope of supply	141
7.2.2	Installing/removal	141
7.3	Main circuit terminals	142
7.3.1	Scope of supply	142
7.3.2	Installing/removal	142
7.4	Control circuit terminals.....	144
7.4.1	Scope of supply	144
7.4.2	Installing/removal	144
7.5	Control kit.....	147
7.5.1	Scope of supply	147
7.5.2	Description of the hardware	147
7.5.3	Using the control kit.....	148
7.6	External auxiliary switch block.....	150
7.6.1	Scope of supply	150

7.6.2	Description of the hardware	150
7.6.3	Installing/removal	151
7.6.4	Connection	152
7.7	Infeed system for 3RA6	156
7.7.1	Scope of supply	156
7.7.2	Description of the hardware	158
7.7.3	Installing/removal	161
7.7.3.1	Installing the infeed system for 3RA6 on a standard mounting rail	161
7.7.3.2	Installing the infeed system for 3RA6 on a level surface (screw fastening)	166
7.7.3.3	Installing the accessories for the infeed system for 3RA6.....	167
7.7.3.4	Uninstalling the accessories for the infeed system for 3RA6	173
7.7.3.5	Removing the infeed system for 3RA6 from a standard mounting rail.....	174
7.7.4	Coding.....	178
7.7.5	Connection	180
7.8	3-phase busbar	185
7.8.1	Scope of supply	185
7.8.2	Description of the hardware	185
7.8.3	Connection	188
7.9	8US busbar adapter.....	190
7.9.1	Scope of supply	190
7.9.2	Description of the hardware	190
7.9.3	Installing/removal	191
7.9.3.1	Installing	191
7.9.3.2	Removal	195
7.10	Terminal for a Type E self-protected combination motor controller (UL 508)	197
7.10.1	Scope of supply	197
7.10.2	Installing/removal	197
7.10.3	Connection	198
7.11	Door-coupling rotary operating mechanism.....	200
7.11.1	Scope of supply	200
7.11.2	Description of the hardware	200
7.11.3	Installing	201
7.11.4	Commissioning.....	202
7.12	AS-i mounting module for 3RA61/3RA62 compact starter	205
7.12.1	Scope of supply	205
7.12.2	Description of the hardware	205
7.12.3	Communication via AS-Interface	208
7.12.4	Installing/removal	209
7.12.4.1	Installing the AS-i mounting module	209
7.12.4.2	Removing the AS-i mounting module	210
7.12.5	Connection	211
7.12.5.1	Connecting the AS-i mounting module.....	211
7.12.5.2	Connecting the AS-Interface	212
7.12.5.3	Connecting terminals.....	215
7.12.6	Commissioning.....	217
7.12.6.1	Addressing via AS-Interface.....	217
7.12.6.2	Process data and process images	219
7.12.7	Diagnostics.....	224
7.13	Connecting cable for IO-Link	226

7.13.1	Scope of supply	226
7.13.2	Function	226
7.13.3	Installing/removal	227
7.14	Operator panel for 3RA64/3RA65 compact starter with IO-Link	228
7.14.1	Scope of supply	228
7.14.2	Mounting	228
7.14.3	Operator control	230
8	Service	235
8.1	Introduction.....	235
8.2	Malfunction (e.g. end of service life reached)	236
8.3	Replacing the compact starter	237
9	Technical data	239
9.1	Technical data in Siemens Industry Online Support.....	239
9.2	Overview tables	240
10	Dimension drawings	241
10.1	CAX data.....	241
10.2	3RA6 compact starter.....	242
10.2.1	Dimensions (in mm)	242
10.2.2	Minimum distances from neighboring components (dimensions in mm).....	244
10.3	Operator panel	245
10.4	Infeed system for 3RA6	246
10.4.1	Dimensions (in mm)	246
10.4.2	Minimum distances from neighboring components (dimensions in mm).....	249
10.5	8US busbar adapter.....	251
10.5.1	Dimensions (in mm)	251
11	Circuit diagrams.....	253
11.1	CAX data.....	253
11.2	3RA61/3RA62 compact starter internal circuit diagram	254
11.3	Internal circuit diagram of 3RA64/3RA65 compact starter with IO-Link	256
11.4	Control circuit of the 3RA61/3RA62 compact starter	258
11.5	Parallel switching of several 3RA62 compact starters (reversing starters).....	260
11.6	Circuit diagram of the AS-i mounting module for compact starter	261
12	Characteristic curves	263
A	Data sets for the 3RA64/3RA65 compact starter with IO-Link	267
A.1	Structure of the data sets	267
A.2	IO-Link communication parameters.....	268
A.3	Device-specific parameters	269
A.4	Identification data	270

A.5 Group diagnostics - data set (index) 90..... 271

A.6 Actual configuration - data set (index) 105 275

A.7 Target configuration - data set (index) 130 278

B References 281

B.1 References 281

C List of abbreviations 283

C.1 List of abbreviations 283

Glossary 285

Index 287

Introduction

Purpose of this manual

This SIRIUS 3RA6 Compact Starter Manual describes the compact starter and its functions. It contains information about configuration, commissioning and servicing.

As well as providing information about the compact starter itself, the manual also deals with compatible infeed systems. These are the SIRIUS infeed system for 3RA6, the insulated 3RV19 three-phase busbar system and the 8US busbar adapter. The options for connecting to circuit breakers of other sizes and to the 3RV29 infeed system are also presented within this context.

Furthermore, to facilitate configuration the manual contains dimension drawings and technical data of the system components.

Topics

The manual consists of instructive chapters, which are intended for reference purposes. The following table provides an overview of the topics covered:

Table 1-1 Chapter overview

Chapter	Contents
Introduction	Provides an overview of the manual's contents
Product-specific information	Provides product-specific information about the compact starter
System description	Provides an overview of the system components and their integration into the automation environment
Configuring	Provides information (e.g. environmental requirements, use in combination with other products, etc.) about using the compact starter and accessories, which need to be taken into account right from the configuration stage.
3RA61/3RA62 compact starter	Describes the scope of supply, hardware, functions, installation/removal, connection, start-up, and diagnostics of the 3RA61/3RA62 compact starter.
3RA64/3RA65 compact starter with IO-Link	Describes the scope of supply, hardware, functions, installation/removal, connection, start-up, diagnostics, and process data of the 3RA64/3RA65 compact starter with IO-Link.
Accessories	Provides information on the accessories. This information includes a description of the hardware as well as the installation/removal and connection processes.
Service	Provides information about servicing or maintenance activities. This includes exchanging the entire compact starter or the individual terminal blocks. This chapter also explains the article number system used for the compact starter.
Technical data	Provides technical data for the compact starter and its accessories

Chapter	Contents
Dimension drawings	Provides dimension drawings for the compact starter and its accessories
Circuit diagrams	Provides circuit diagrams and information about the characteristic curves.

Required basic knowledge






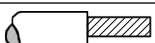
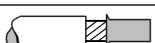
Knowledge of the following areas is needed in order to understand the manual:

- Low-voltage switchgear
- Automation engineering and STEP 7 software
- AS-Interface
- IO-Link

Symbols used in the text

The following table explains the meaning of the various symbols used within this document:

Table 1-2 Symbols

Symbol	Meaning
	LED is illuminated
	LED not illuminated
	Mechanical display is white
	No mechanical display
	Solid and stranded conductors
	Finely stranded conductor without end sleeve
	Finely stranded conductor with end sleeve

Abbreviations used in the text

For a list of all the abbreviations used, please refer to the appendix "List of abbreviations (Page 283)".

1.1 Siemens Industry Online Support

Information and service

At Siemens Industry Online Support you can obtain up-to-date information from our global support database:

- Product support
- Application examples
- Forum
- mySupport

Link: Siemens Industry Online Support (<https://support.industry.siemens.com/cs/de/en>)

Product support

You can find information and comprehensive know-how covering all aspects of your product here:

- **FAQs**
Answers to frequently asked questions
- **Manuals/operating instructions**
Read online or download, available as PDF or individually configurable.
- **Certificates**
Clearly sorted according to approving authority, type and country.
- **Characteristics**
For support in planning and configuring your system.
- **Product announcements**
The latest information and news concerning our products.
- **Downloads**
Here you will find updates, service packs, HSPs and much more for your product.
- **Application examples**
Function blocks, background and system descriptions, performance statements, demonstration systems, and application examples, clearly explained and represented.
- **Technical data**
Technical product data for support in planning and implementing your project

Link: Product support (<https://support.industry.siemens.com/cs/ww/en/ps>)

mySupport

The following functions are available in your personal work area "mySupport":

- **Support Request**
Search for request number, product or subject
- **My filters**
With filters, you limit the content of the online support to different focal points.

- **My favorites**
With favorites you bookmark articles and products that you need frequently.
- **My notifications**
Your personal mailbox for exchanging information and managing your contacts. You can compile your own individual newsletter in the "Notifications" section.
- **My products**
With product lists you can virtually map your control cabinet, your system or your entire automation project.
- **My documentation**
Configure your individual documentation from different manuals.
- **CAX data**
Easy access to CAX data, e.g. 3D models, 2D dimension drawings, EPLAN macros, device circuit diagrams
- **My IBase registrations**
Register your Siemens products, systems and software.

1.2 Support Request

Use the Support Request online form to send your question directly to Technical Support:

Support Request:	Internet (https://support.industry.siemens.com/My/ww/en/requests)
-------------------------	--

1.3 Siemens Industry Online Support app

Siemens Industry Online Support app

The Siemens Industry Online Support app provides you access to all the device-specific information available on the Siemens Industry Online Support portal for a particular article number, such as operating instructions, manuals, data sheets, FAQs etc.

The Siemens Industry Online Support app is available for Android and iOS:



Android



iOS

Safety instructions

2.1 Security information

Siemens provides products and solutions with industrial security functions that support the secure operation of plants, systems, machines and networks.

In order to protect plants, systems, machines and networks against cyber threats, it is necessary to implement – and continuously maintain – a holistic, state-of-the-art industrial security concept. Siemens' products and solutions constitute one element of such a concept.

Customers are responsible for preventing unauthorized access to their plants, systems, machines and networks. Such systems, machines and components should only be connected to an enterprise network or the internet if and to the extent such a connection is necessary and only when appropriate security measures (e.g. firewalls and/or network segmentation) are in place.

For additional information on industrial security measures that may be implemented, please visit

<https://www.siemens.com/industrialsecurity>.

Siemens' products and solutions undergo continuous development to make them more secure. Siemens strongly recommends that product updates are applied as soon as they are available and that the latest product versions are used. Use of product versions that are no longer supported, and failure to apply the latest updates may increase customer's exposure to cyber threats.

To stay informed about product updates, subscribe to the Siemens Industrial Security RSS Feed under

<https://www.siemens.com/industrialsecurity>.



2.2 Standards/Regulations/Approvals

Standards

The compact starter complies with the following standards:

- IEC / EN 60947-6-2
- UL 508 Type E
- CSA C22.2 No. 14 Type E

Approvals/Test reports

The compact starter has UL and CSA approvals. These are indicated on the rating plate by the symbols  and .

In addition, the compact starter has shipbuilding approvals.

Confirmation of approvals, test certificates and characteristic curves is available via the Internet (<https://support.industry.siemens.com/cs/ww/en/ps/16301/cert>).

Compact starter degree of protection

The compact starter's degree of protection is IP20 (IEC 60529) on the front.

Touch protection compact starter

The touch protection of the compact starter on the front (IEC 60529) is finger-safe.

Isolating features

The requirements of IEC / EN 60947-6-2 have been met in respect of the isolating features.

2.3 Use as prescribed

Use as prescribed

Prescribed use in accordance with IEC / EN 60947-6-2.

2.4 Recycling and disposal

For environmentally friendly recycling and disposal of your old device, please contact a company certified for the disposal of old electrical and/or electronic devices and dispose of the device in accordance with the regulations in your country.

System description

3.1 System overview

Features

The SIRIUS compact starter is a universal, weld-free motor feeder in accordance with IEC/EN 60947-6-2. It combines the functions of a circuit breaker, a solid-state overload relay and a contactor within a single enclosure and can be used in any application involving the direct starting of standard three-phase motors with a rating of up to 32 A (approx. 15 kW/400 V).

The compact starter is available as either a direct or a reversing starter.

As an option, an AS-i mounting module can be mounted on the 3RA61/3RA62 compact starter with a 24 V control supply voltage. The AS-i mounting module enables the compact starter to communicate via an AS-Interface.

The 3RA64/3RA65 compact starter with IO-Link can communicate via IO-Link.

Table 3-1 Compact starter communication options

Compact starter	Communication
3RA61/3RA62 compact starter without optional AS-i mounting module	Communication via auxiliary contacts and signaling contacts
3RA61/3RA62 compact starter (24 V) with optional AS-i mounting module	Communication via AS-Interface
3RA64/3RA65 compact starter with IO-Link	Communication via IO-Link

Accessories

In addition to the 3RA61/3RA62 compact starter and the 3RA64/3RA65 compact starter with IO-Link, this document also describes the following accessories:

Table 3-2 Accessories for the compact starter

Accessories	Description	Chapter
Auxiliary switch block for compact starter	Optional auxiliary switch block in the following versions: 2 NO contacts, 2 NC contacts or 1 NO contact + 1 NC contact.	External auxiliary switch block (Page 150)
AS-i mounting module	The AS-i mounting module enables the 3RA61/3RA62 compact starter with 24 V control supply voltage to communicate via an AS-Interface.	AS-i mounting module for 3RA61/3RA62 compact starter (Page 205)
Control kit	Tool for closing the main contacts manually by means of the actuator.	Control kit (Page 147)

3.1 System overview

Accessories	Description	Chapter
Adapter for screw fastening the compact starter	The adapters for screw fastening enable you to install the compact starter on a level surface (screw fastening).	Installing the compact starter on a level surface (screw fastening) (Page 64)
Terminals for "Combination Controller Type E"	The terminals conform to the creepages and clearances stipulated by UL 508 (Type E).	Terminal for a Type E self-protected combination motor controller (UL 508) (Page 197)
Infeed system for 3RA6	The infeed system for 3RA6 is a modular infeed system with an optional PE system. The permanent wiring means that compact starters can be mounted quickly and easily.	Infeed system for 3RA6 (Page 156)
3-phase busbar	The 3-phase busbar enables several compact starters to be fed using a single infeed terminal.	3-phase busbar (Page 185)
8US busbar adapter	The 8US busbar adapter enables the compact starter to be mechanically fastened and electrically connected to a busbar system.	8US busbar adapter (Page 190)
Door-coupling rotary operating mechanism	Door-coupling rotary operating mechanisms enable compact starters to be operated with the control cabinet doors closed.	Door-coupling rotary operating mechanism (Page 200)

3.2 System configuration

3.2.1 Automation environment

Main circuit

The following supply options are available for the compact starter's main circuit:

- Parallel wiring
- Infeed system for 3RA6
(For additional information, please refer to "Infeed system for 3RA6 (Page 156)".)
- 3-phase 3RV19 busbar
(For additional information, please refer to "3-phase busbar (Page 185)".)
- 8US busbar adapter
(For additional information, please refer to "8US busbar adapter (Page 190)".)

Control circuit and supply circuit

The control circuit can be structured as follows:

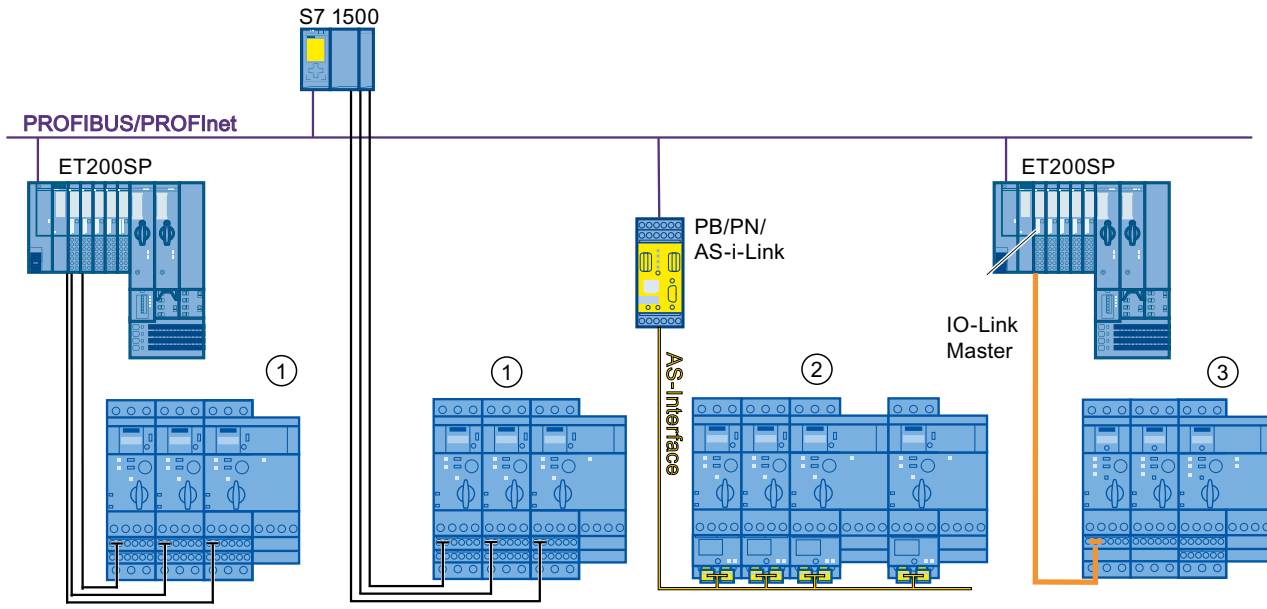
Table 3-3 Control circuit (configuration)

Compact starter	Control system
3RA61/3RA62 compact starter without optional AS-i mounting module	Parallel wiring to control system (e.g. PLC)
3RA61/3RA62 compact starter (24 V) with optional AS-i mounting module	AS-Interface
3RA64/3RA65 compact starter with IO-Link	IO-Link

Note

There are capacitors in the control circuit of the 3RA6 compact starter. As a result, high charging currents can arise briefly upon activation of the control supply voltage.

Examples of how the compact starter can be integrated into the automation environment



- ① 3RA61/3RA62 compact starter without AS-i mounting module
- ② 3RA61/3RA62 compact starter with AS-i mounting module
- ③ 3RA64/3RA65 compact starter with IO-Link

Figure 3-1 Integration into the automation environment

3.2.2 3RA61/3RA62 compact starter without optional AS-i mounting module

Configuration of parallel wiring

The 3RA61/3RA62 compact starter is connected to the control system via parallel wiring. Control takes place via the following terminals:

- Direct starter: A1+, A2-
- Reversing starter: A1+, A2/B2-, B1+

View of parallel wiring

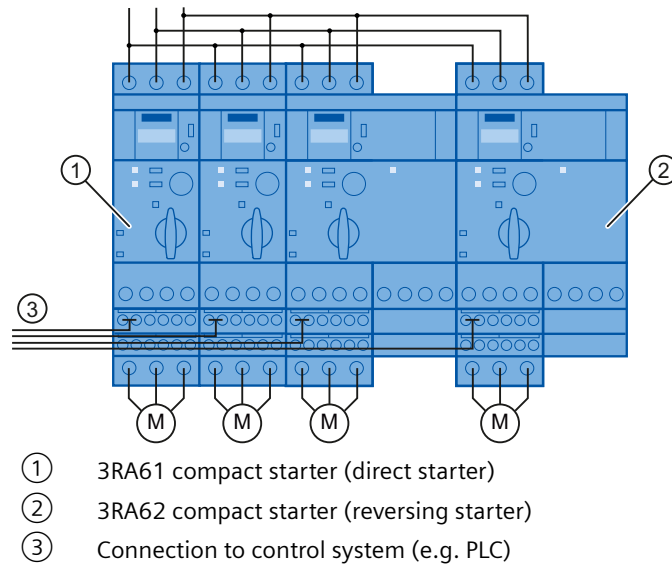


Figure 3-2 System configuration with 3RA61/3RA62 compact starter without AS-i mounting module

3.2.3 3RA61/3RA62 compact starter with optional AS-i mounting module

The 3RA61/3RA62 compact starter with 24 V control supply voltage can be controlled via an AS-Interface. The actuator sensor interface (AS-Interface) is a modular networking system for sensors and actuators at the lowest field level.

Configuration with AS-Interface

If the AS-Interface is being used for control purposes, the AS-i mounting module needs to be installed on the 3RA61/3RA62 compact starter (24 V) instead of the two auxiliary circuit terminals. The AS-i and auxiliary voltage cables are connected to the AS-i mounting module.

An AS-i power supply is used to feed the AS-i voltage into the AS-i cable, which also serves as a communication cable between the AS-i master and slave. The auxiliary voltage is supplied by a 24 VDC PELV power supply in accordance with VDE 0106 safety class III.

For more information on AS-Interface, refer to the "AS-Interface System" manual (article number: 3RK2703-3AB02-1AA1).

More information on connecting the AS-i mounting module can be found in Chapter "Connection (Page 211)".

View with AS-Interface

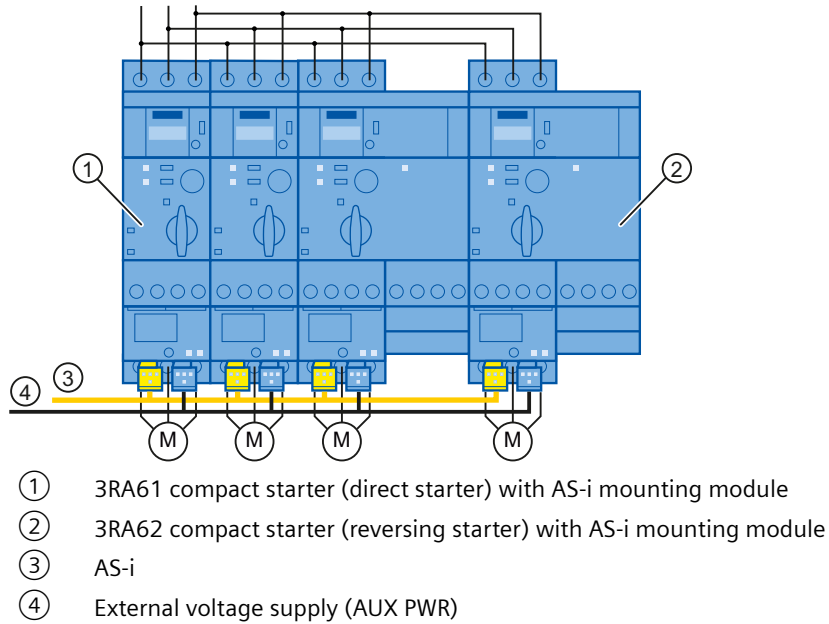


Figure 3-3 System configuration 3RA61/3RA62 compact starter with AS-i mounting module

3.2.4 3RA64/3RA65 compact starter with IO-Link

Configuration with IO-Link

The 3RA64/3RA65 compact starter with IO-Link is controlled via IO-Link. The auxiliary voltage V_{Aux} (24 V DC) is connected via a separate terminal. Direct starters and reversing starters can be combined as desired to form a group of four compact starters. For this purpose, three other compact starters are installed to the right of the first compact starter and linked using a 14-core connecting cable. These three compact starters do not require their own connection to IO-Link via the removable terminal since they are supplied with data and auxiliary voltage V_{Aux} via the 14-core connection cable (8 mm, 200 mm).

View with IO-link

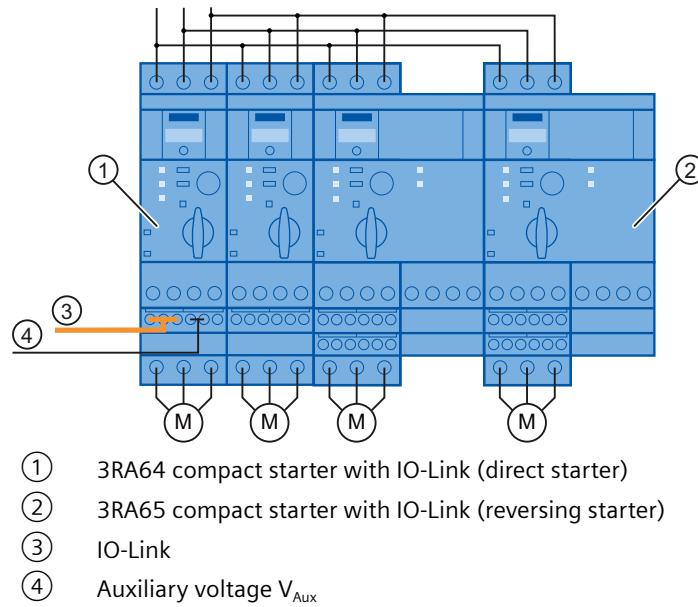


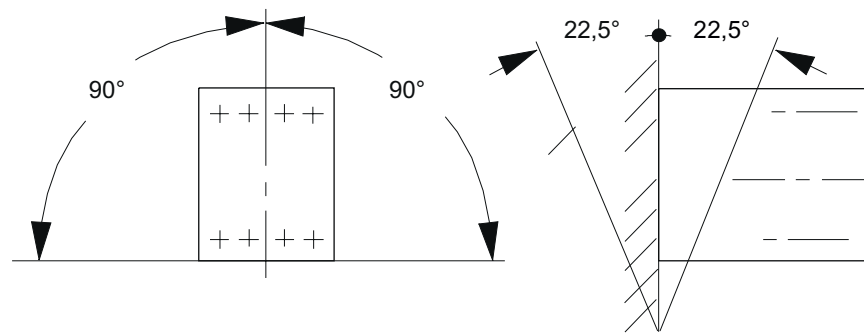
Figure 3-4 System configuration with 3RA64/3RA65 compact starter with IO-Link

Application planning

4.1 General data

Mounting position

The module can be installed vertically (that is, on a horizontally installed standard mounting rail) or horizontally (that is, on a vertically installed rail).



Operating conditions

SIRIUS 3RA6 compact starters are suitable for use in any climate. They are intended for use in enclosed rooms in which no severe operating conditions (such as dust, caustic vapors, hazardous gases) prevail. Suitable covers must be provided for installation in dusty and damp locations.

Cabinet types

The system can be installed inside a central control cabinet or a distributed control box.

Grounding measures

No grounding measures are necessary.

Operating temperature

The compact starter has been designed for use under ambient temperatures ranging from -20 °C to +40 °C without a reduction in the permissible operating current.

Rated operating current I_e

Depending on the current setting range, the following rated operating currents apply to the compact starter:

Table 4-1 Rated operating current for the compact starter

Current setting range	Rated operating current I_e
0.1 to 0.4 A	0.4 A
0.32 to 1.25 A	1.25 A
1 to 4 A	4 A
3 to 12 A	12 A
8 to 32 A	32 A

The permissible operating current of the compact starter reduces depending on the design version and the ambient temperature.

The table below gives the permissible operating current depending on the design version and the ambient temperature T_A .

Design version of the compact starter	Ambient temperature T_A		
	$-20\text{ °C} \leq T_U \leq +40\text{ °C}$	$+41\text{ °C} \leq T_U \leq +60\text{ °C}$	$+61\text{ °C} \leq T_U \leq +70\text{ °C}$
Mounting on a horizontal rail with clearance	100% of I_e	100% of I_e	80 % of I_e
Mounting on horizontal rail side-by-side without clearance	100% of I_e	100% of I_e	70 % of I_e
Mounting on a vertical rail with clearance	100% of I_e	80 % of I_e	70 % of I_e
Mounting on vertical rail side-by-side without clearance	100% of I_e	80 % of I_e	60 % of I_e
Mounting on horizontal 3RA6 in-feed system side-by-side without clearance	100% of I_e	80 % of I_e	60 % of I_e
Mounting on vertical 3RA6 infeed system side-by-side without clearance	100% of I_e	80 % of I_e	60 % of I_e

Operating motors with high motor starting currents

Compact starters with a current setting range from 3 to 12 A are suitable for starting current factors up to 8.5 times the rated motor current, while compact starters with a current setting range from 8 to 32 A are suitable for starting current factors up to 9 times the rated motor current.

If motors are operated that have a higher starting current, refer to the following table for the maximum adjustable motor current:

Max. motor starting current, as a multiple of I_e (I_e at 40 °C)	Maximum settable motor current	
	Current setting range 3 to 12 A	Current setting range 8 to 32 A
≤ 8 times I_e	12	32
8.5 times I_e	12	32
9 times I_e	11,3	32
9.5 times I_e	10,7	30,3
10 times I_e	10,2	28,8

Note

No restrictions need to be observed in the case of compact starters with smaller current setting ranges.

Compact starters with the current setting range from 8 to 32 A can be used as an alternative to compact starters with the current setting range from 3 to 12 A.

Short-circuit protection

The rated service short-circuit breaking capacity I_{CS} of the compact starter is 53 kA at 400 V. The rated service short-circuit breaking capacity I_{CSIT} of the compact starter in IT systems is 1.5 kA up to 690 V.

Combining compact starters with SIRIUS circuit breakers

The compact starters' terminals are compatible with SIRIUS 3RV size S0 circuit breakers/motor starter protectors.

You will find further information on the compact starters' terminals in "Technical data (Page 239)".

Distance from neighboring components

For additional information on clearances to the neighboring components, please refer to "Minimum distances from neighboring components (dimensions in mm) (Page 244)".

4.2 Safe isolation

Safe isolation

To be able to guarantee safe isolation of the circuits from each other in accordance with IEC/EN 60947-1, the following operating voltages are permissible:

Table 4-2 Safe isolation (3RA61/62 compact starter)

		Terminal labeling	Control circuit	Auxiliary circuit				Main circuit
				Internal auxiliary switch	"Fault" signaling contact	"Overload" signaling contact	External auxiliary switch	
		Terminal labeling	A1/A2, B1/B2	13/14, 21/22	77/78	98/95/96	..NO/..NC	1L1/3L2/5L3 2T1/4T2/6T3
Control circuit		A1/A2, B1/B2	—	300 V	300 V	300 V	300 V	400 V
Auxiliary circuit	Internal auxiliary switch	13/14, 21/22	300 V	—	250 V	250 V	250 V	400 V
	"Fault" signaling contact	77/78	300 V	250 V	—	250 V	250 V	400 V
	"Overload" signaling contact	98/95/96	300 V	250 V	250 V	—	250 V	400 V
	External auxiliary switch	..NO/..NC	300 V	250 V	250 V	250 V	—	400 V
Main circuit		1L1/3L2/5L3 2T1/4T2/6T3	400 V	400 V	400 V	400 V	400 V	—

Table 4-3 Safe isolation (3RA64/65 compact starter with IO-Link)

		Terminal labeling	Control circuit and supply circuit			Auxiliary circuit	Main circuit
			IO-Link	Auxiliary power supply	Limit switch	External auxiliary switch	
		Terminal labeling	L+, C/Q, L-	A1+/A2-	Y1/Y2, Y3/Y4	..NO/..NC	1L1/3L2/5L3 2T1/4T2/6T3
Control circuit and supply circuit	IO-Link	L+, C/Q, L-	—	—	—	300 V	690 V
	Auxiliary power supply	A1+, A2-	—	—	—	300 V	690 V
	Limit switch	Y1, Y2, Y3, Y4	—	—	—	—	690 V

			Control circuit and supply circuit			Auxiliary circuit	Main circuit
			IO-Link	Auxiliary power supply	Limit switch	External auxiliary switch	
Auxiliary circuit	External auxiliary switch	..NO/..NC	300 V	300 V	—	—	—
Main circuit		1L1/3L2/5L3 2T1/4T2/6T3	690 V	690 V	690 V	—	—

In order for the "safe isolation" of circuits to be achieved, an individual fault must not be able to trigger a voltage overspill from one circuit into another. The kinds of fault to be taken into account include twisted or loose conductive parts, twisted solder pins, broken winding wire, missing screws or broken barriers within a device.

4.3 Supply options (main circuit)

The following supply options are available for the compact starter's main circuit:

- Infeed via parallel wiring of individual compact starters
- Infeed via SIRIUS infeed system for 3RA6
- Infeed via 3RV19 3-phase busbars
- Infeed via 8US busbar adapter

If the creepages and clearances specified by UL 508 also need to be observed, then special infeed terminals are available for the relevant infeed systems.

According to UL 508, these infeed terminals are not required for MSP (Manual Starter Protector).

4.3.1 Infeed system for 3RA6

Rated current

The following rated currents apply to the components of the SIRIUS infeed system for 3RA6:

Table 4-4 Rated current (infeed system for 3RA6)

Components	Article number	Rated current I_n
Left infeed, 50/70 mm ² screw terminal with three slots, outgoing terminals with screw-type connection technology, incl. PE bar	3RA6813-8AB	100 A
Left infeed, 50/70 mm ² screw terminal with three slots, outgoing terminals with spring-loaded connection technology, incl. PE bar	3RA6813-8AC	100 A
Left infeed, 25/35 mm ² screw terminal with three slots, outgoing terminals with screw-type connection technology, incl. PE bar	3RA6812-8AB	63 A
Left infeed, 25/35 mm ² screw terminal with three slots, outgoing terminals with spring-loaded connection technology, incl. PE bar	3RA6812-8AC	63 A
Left or right infeed, 25/35 mm ² , with spring-loaded connection technology	3RA6830-5AC	63 A
Extension connector	3RA6890-1AB	63 A

NOTICE**Damage to the extension connector!**

The maximum operating current for extension connectors is 63 A. If the maximum operating current is exceeded, the extension connector will be damaged beyond repair.

Make sure that the extension connector is never subjected to a current higher than 63 A.

Operating temperature

The infeed system for 3RA6 has been designed for use with ambient temperatures ranging from -20 °C to +60 °C.

Use with higher ambient temperatures

When a compact starter is mounted on the infeed system for 3RA6, the permissible operating current of the compact starter reduces in the temperature range from +40 °C to +60 °C.

Internal control cabinet temperatures	Permissible operating current of the compact starter
+ 40 °C	100% of I_e
+ 60 °C	80 % of I_e

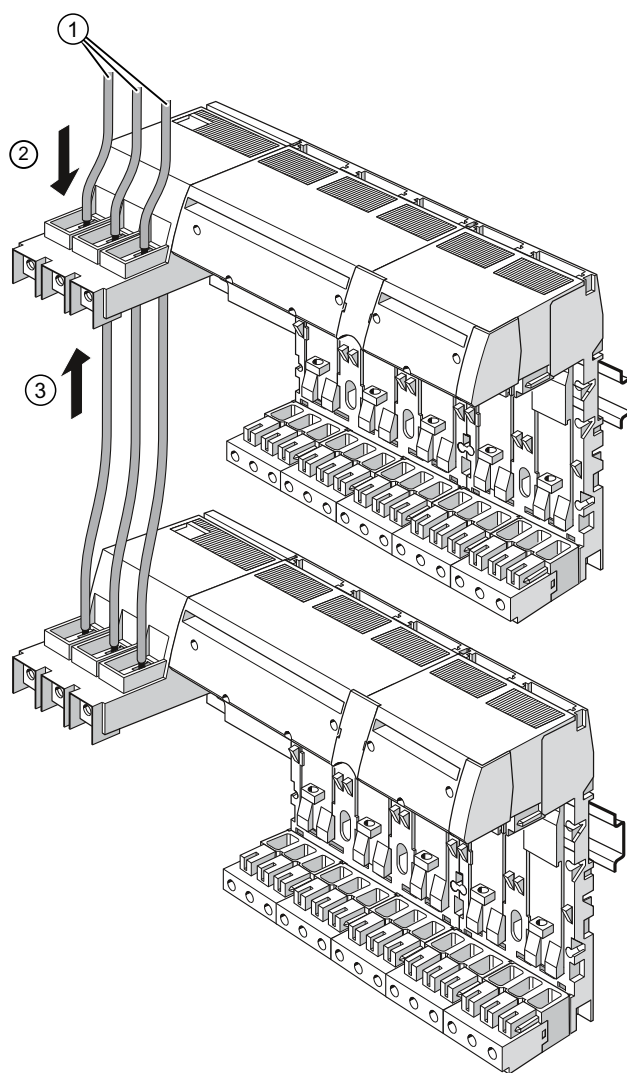
Mounting position

The infeed system for 3RA6 can be installed horizontally or vertically.

Configuration

The main conductors can be connected to the screw-type infeeds of the infeed system from both the top and the bottom.

Therefore, the infeed system for 3RA6 is particularly suitable for multi-tier configuration. Within this context, the bottom terminal openings of the top tier need to be connected to the top terminal openings of the bottom tier using a conductor.



- ① Main conductors (L1, L2, L3)
- ② Connection from the top
- ③ Connection from the bottom

Figure 4-1 Multi-tier configuration of the infeed system for 3RA6

Distance from neighboring components

For additional information on clearances to the neighboring components, please refer to "Minimum distances from neighboring components (dimensions in mm) (Page 249)".

The installation guidelines for compact starters and circuit breakers/fuseless load feeders must also be observed along with the associated clearances.

Short-circuit protection for SIRIUS infeed system for 3RA6

The short-circuit protection device that is installed upstream of the infeed system must be designed in accordance with the table below.

Table 4-5 Short-circuit protection for left or right infeed, 25/35 mm², with spring-loaded connection technology (3RA6830-5AC)

Conductor cross sections	Maximum let-through current $I_{d,max}$	Integral of current I^2t	Recommendation for upstream short-circuit protection device	Maximum prospective short-circuit current I_{KS}
4 mm ²	≤ 9.5 kA	85 kA ² s	3RV2021-4DA10	40 kA
6 mm ²	≤ 12.5 kA	140 kA ² s	3RV2031-4EA10	30 kA
10 mm ²	≤ 15 kA	180 kA ² s	3RV2031-4WA10	25 kA
16 mm ² / 25 mm ²	≤ 19 kA	440 kA ² s	3RV2031-4JA10	65 kA
			3RV2041-4JA10	65 kA
35 mm ²	≤ 21 kA	530 kA ² s	3RV2041-4MA10 NH gG 3NA3; 315 A	50 kA


Short-circuit protection for infeed 3RA681.-8A.

Recommendation for upstream short-circuit protection device (50 kA/400 V AC):
3RV2041-4MA10 NH gG 3NA3; 315 A

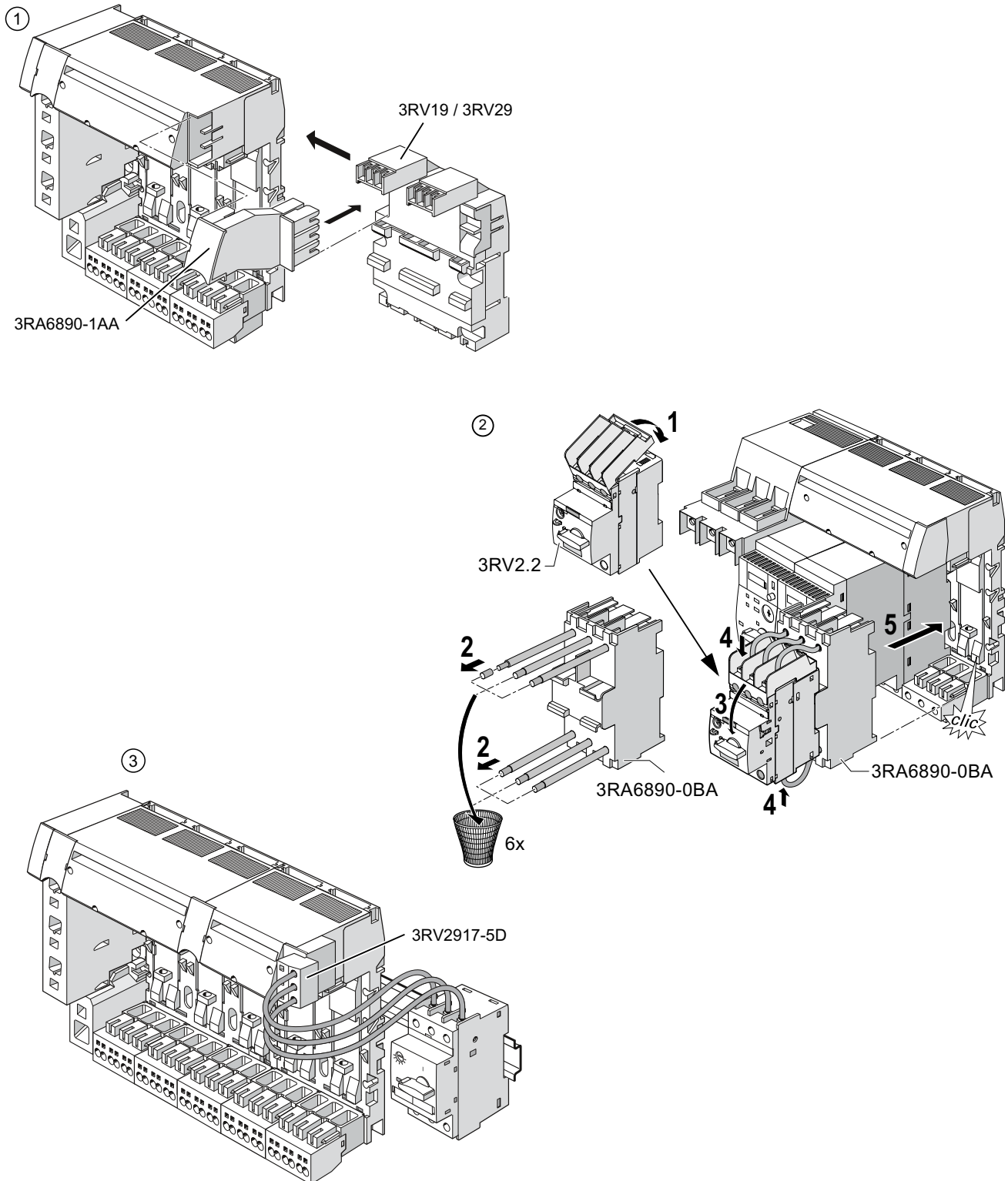
Table 4-6 Short-circuit protection for terminal block (3RV2917-5D)

Conductor cross-sections	Maximum let-through current $I_{d,max}$ for downstream short-circuit protection device
Short-circuit protection for terminal block (3RV2917-5D)	
1.5 mm ²	$I_{d,max} < 7.5$ kA
2.5 mm ²	$I_{d,max} < 9.5$ kA
4 mm ²	$I_{d,max} < 9.5$ kA
6 mm ²	$I_{d,max} < 12.5$ kA

Only size S0 3RV2.2 circuit breakers may be mounted on the 45 mm adapter for the infeed system for 3RA6. Interphase barriers must be mounted. If the short-circuit current at the installation point exceeds the circuit breaker's specified rated service short-circuit breaking capacity, you will need to use a backup fuse.

 WARNING
<p>Short-circuit hazard!</p> <p>The cables shall be arranged in such a manner that an internal short-circuit is not to be expected. They shall be rated at least in accordance with the information concerning the short-circuit withstand strength (IEC 61439-1 Section 8.6.1) and designed to withstand at least the short-circuit stresses limited by the protective device on the supply side of the infeed system.</p>

Options for combining the equipment with other products from the SIRIUS modular system



The SIRIUS infeed system for 3RA6 combined with:

- ① The 3RV29 infeed system using the extension connector for 3RV29 (3RA6890-1AA).

- ② SIRIUS size S0 3RV2.2 circuit breakers using the 45 mm adapter for the infeed system for 3RA6 (3RA6890-0BA).
- ③ Three-phase or single-phase protective devices of other sizes using the terminal block (3RV2917-5D).

Figure 4-2 Combination with other sizes (SIRIUS infeed system for 3RA6)

4.3.2 3RV19 3-phase busbar

Rated current/rated operating voltage

- Rated operating voltage: 690 V
- Rated current: 63 A

Combination with other sizes

The compact starters can be combined with size S0 circuit breakers using the 3RV19 3-phase busbar (3RV1915-1.B) as well as with size S00 circuit breakers using the connection piece (3RV1915-5DB).

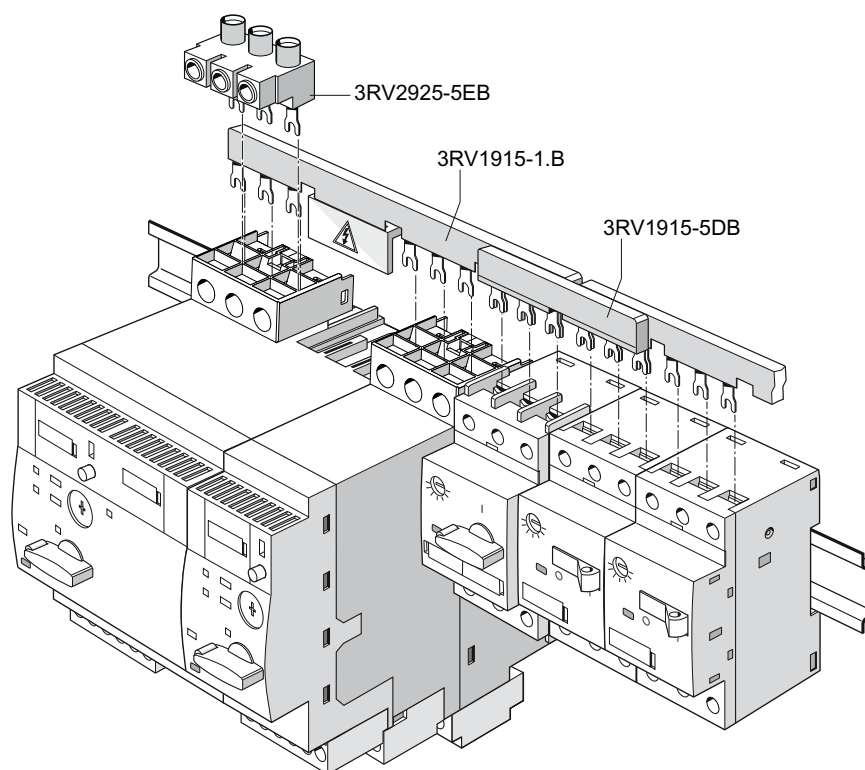


Figure 4-3 Combination with other sizes (3RV19 3-phase busbar)

4.3.3 8US busbar adapter

The compact starters are mounted on the 8US busbar adapter and connected on the line side. This ready-to-use unit plugs directly onto the busbar systems, thereby taking care of mechanical fastening and electrical connection at the same time.

Installation with 8US busbar adapter

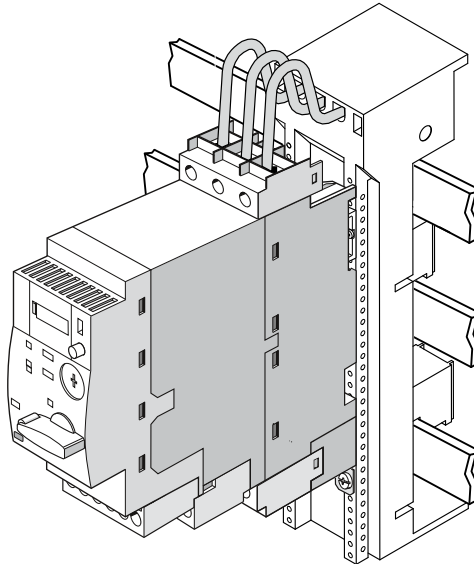


Figure 4-4 Infeed via 8US busbar adapter

Note

The 8US busbar adapter plus compact starters must be arranged side by side on the busbar system without any space in between in order to meet the specified vibratory load and shock load requirements.

You can find more information on the technical data in "Technical data (Page 239)".

4.3.4 Infeed in accordance with UL 508 (Type E)

Function in accordance with UL 508 and CSA 22.2

According to UL 508 and CSA 22.2, a motor feeder as Type E is required to fulfill 4 sub-functions:

Table 4-7 Sub-functions of motor feeders according to UL 508 and CSA 22.2

Sub-function	Description
Disconnect	The feeder component has an actuator, which will only indicate the "OFF" switch position if all the main contacts are open and are isolating the disconnected circuit from the supply system up to the specified voltage U_{imp} . It is not permissible for an overvoltage in the supply system up to the specified voltage U_{imp} to flash over to the disconnected circuit via the contacts.
Branch Circuit Protection	The feeder component must protect the cable running to the motor, the contactor and the overload relay (if installed) in the event of a short circuit.
Motor Control	The feeder component turns the motor "ON" or "OFF" under normal switching duty conditions.
Motor Overload	The feeder component must protect the motor from damage in the event of an overload.

To ensure the provision of these 4 sub-functions, the motor feeder can be made up of various feeder components, e.g. circuit breaker, contactor, fuse, etc. Depending on which feeder components are used and the sub-functions that these components perform, the motor feeders are sorted into the following categories in accordance with UL 508: Type A, B, C, D, E, and Type F.

Table 4-8 Categorization of motor feeders in accordance with UL 508

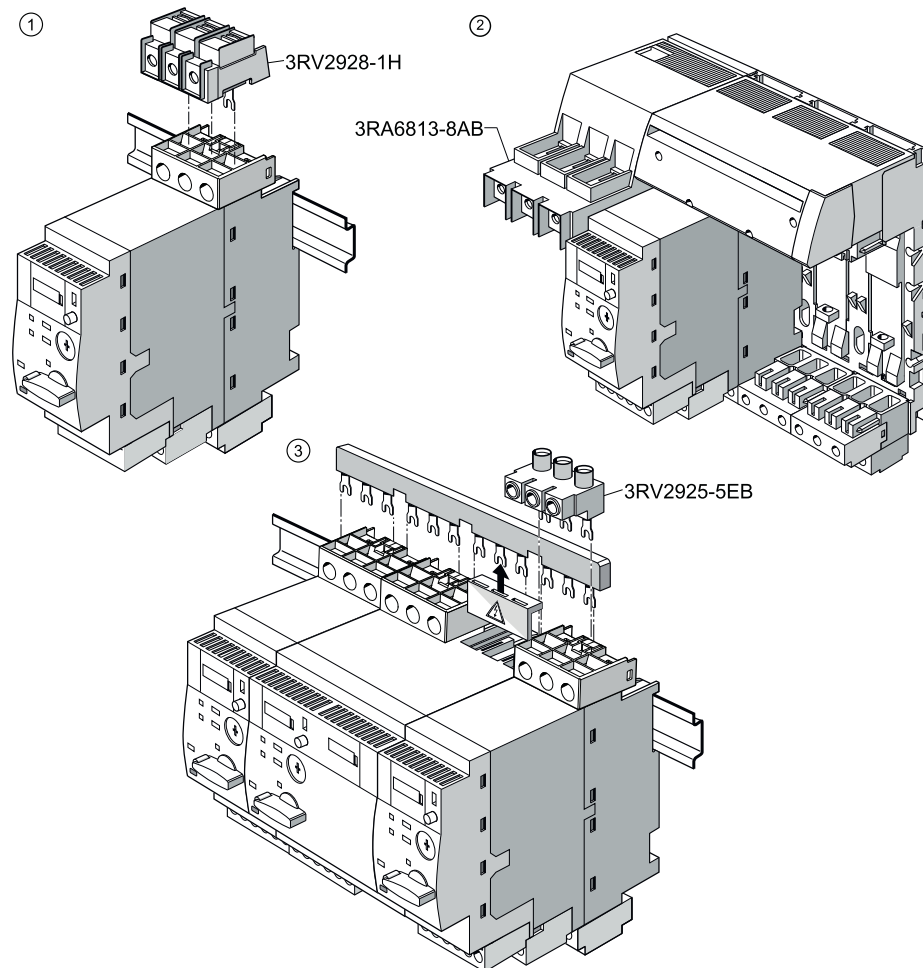
Category	Motor feeder
Type A and Type B	Each sub-function is provided by a separate feeder component. ¹⁾
Type C and Type D	"The Disconnect" and "Branch Circuit Protection" sub-functions are provided by the same feeder component. All other sub-functions are provided by separate feeder components. ¹⁾
Type E	All sub-functions are provided by a single feeder component.
Type F	"Motor Control" is provided by a separate feeder component. All other sub-functions are provided by a single feeder component.
1) For more detailed information, please refer to UL 508.	

The compact starter is a circuit breaker with an integrated contactor operating mechanism. This means that it provides all 4 sub-functions and is, therefore, a member of the Type E category. It differs from the devices in the Type F category in that they switch the motors via a contactor which is connected separately.

Required creepages and clearances

According to UL 508 (Type E), a creepage of 1 inch and clearance of 2 inches are required on the line side for a Combination Motor Controller Type E.

The following supply possibilities are available for ensuring that the creepage and clearance requirements of UL 508 are met:



No.	Type of infeed	Infeed terminal (in accordance with UL 508, Type E)	Article number
①	Parallel wiring	Terminal for Self-Protected Combination Motor Controller (Type E)	3RV2928-1H
②	Infeed system for 3RA6	Left infeed, 50/70 mm ² screw terminal with three slots, outgoing terminal with screw-type or spring-loaded connection technology, incl. PE bar	3RA6813-8AB 3RA6813-8AC
③	3RV19 3-phase busbar	3RV19 3-phase infeed terminal for installing Type E starters, UL 508	3RV2925-5EB

Figure 4-5 Terminals for infeed in accordance with UL 508 (Type E)

Note

According to C22.2-14, terminal blocks are not required for installation in accordance with CSA requirements.

3RA61/3RA62 compact starter

5.1 Scope of supply

5.1.1 Article numbers

Overview of article numbers

The SIRIUS 3RA61/3RA62 compact starter article number is made up of a fixed series of characters plus a number of variables (①, ②, ③, ④ and ⑤):

3RA6 ① 0 - ②③④⑤

The variables can be selected from the following table, depending on the required compact starter options:

Variable	Options SIRIUS 3RA6 compact starter	Character string
①	Compact starter <ul style="list-style-type: none"> • 3RA61 direct starter • 3RA62 reversing starter 	12 25
②	Terminal connection type <ul style="list-style-type: none"> • No terminals • Screw-type connection technology • Spring-loaded connection technology 	0 1 2
③	Current setting range <ul style="list-style-type: none"> • 0.1 to 0.4 A • 0.32 to 1.25 A • 1 to 4 A • 3 to 12 A • 8 to 32 A 	A B C D E

5.1 Scope of supply

Variable	Options SIRIUS 3RA6 compact starter	Character string
④	Control supply voltage range (AC/DC) <ul style="list-style-type: none"> • 24 V • 42 to 70 V • 110 to 240 V 	B3 E3 P3
⑤	Terminal configuration <ul style="list-style-type: none"> • No terminals • With main circuit terminals and control circuit terminals for attachment to a standard mounting rail. • Without main circuit terminals but with control circuit terminals for installation on the SIRIUS infeed system for 3RA6. • With main circuit terminals but without control circuit terminals for attachment to a standard mounting rail and the AS-i mounting module. 	0 2 3 4

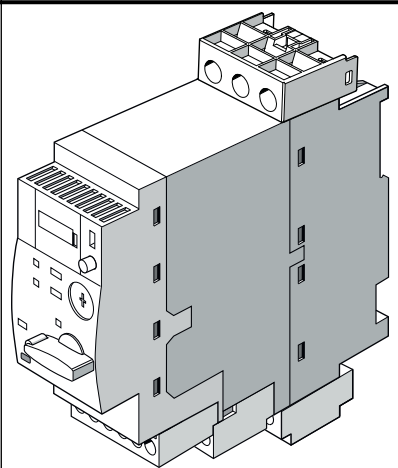
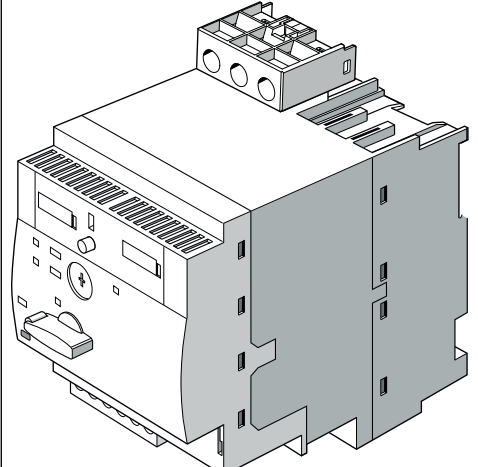
Example

Options SIRIUS 3RA6 compact starter	3RA6	①	0 -	②	③	④	⑤
Compact starter: Direct starter version		① → 12					
Terminal connection type All terminals with screw-type connection technology.				② → 1			
Current setting range 1 to 4 A					③ → C		
Control supply voltage range (AC/DC) 24 V						④ → B3	
Terminal configuration With main circuit terminals and control circuit terminals for attachment to a standard mounting rail.							⑤ → 2
Article number:	3RA6	12	0	1	C	B3	2

5.1.2 Scope of supply

The equipment of the supplied 3RA61/3RA62 compact starter depends on the version ordered.

Scope of supply of the 3RA61/3RA62 compact starter

System component	Article number	Figure
3RA61 compact starter (direct starter)	3RA61.	
3RA62 compact starter (reversing starter)	3RA62.	

5.2 Description of the hardware

5.2.1 Features

General

The 3RA61/3RA62 compact starter is available in the following versions:

- 3RA61 compact starter (direct starter)
- 3RA62 compact starter (reversing starter)

Setting ranges

The compact starter is available with five different current setting ranges and three different control supply voltage ranges. For details of the corresponding compact starter article numbers, please refer to " Article numbers (Page 43) ".

- Current setting ranges:
 - 0.1 to 0.4 A
 - 0.32 to 1.25 A
 - 1 to 4 A
 - 3 to 12 A
 - 8 to 32 A
- Control supply voltage range (AC/DC):
 - 24 V
 - 42 to 70 V
 - 110 to 240 V

5.2.2 3RA61 compact starter (direct starter)

Features

The 3RA61 compact starter (direct starter) is made up of the following components:

- Direct starter
- Two removable main circuit terminals
- Two 6-pin removable control circuit terminals (control supply voltage, "overload" and "short-circuit/malfunction" signaling contact and internal auxiliary contacts)
- Slot for an optional external auxiliary switch block (2 NO contacts, 2 NC contacts or 1 NC contact + 1 NO contact)

Control is either via the control supply voltage connection at terminals "A1+" and "A2-" or via the AS-i mounting module.

For additional information on the AS-i mounting module, please refer to "AS-i mounting module for 3RA61/3RA62 compact starter (Page 205)".

Configuration of 3RA61 compact starter (direct starter)

Front view	No.	Display element/operator control
	(1)	"Overload trip" mechanical display
	(2)	"Reset overload trip" button
	(3)	"Manual/auto reset" selector switch
	(4)	"Current setting I _e " setting wheel
	(5)	"Overload trip class" selector switch
	(6)	"Overload protection function" test button
	(7)	Actuator (can be locked in OFF position)
	(8)	Connection point for auxiliary switch block
	(9)	Control circuit terminals
	(10)	Main circuit terminals
	(11)	"Main contacts closed" LED display
	(12)	"Control supply voltage present" LED display
	(13)	"Short-circuit protection function" test button
	(14)	"Malfunction" mechanical display
	(15)	"Control supply voltage" connection
	(16)	<p>Warnung! Hazardous electrical voltage! Electrical power can result in electric shock and burns. For this reason, switch off the power to the system and the devices before starting to work!</p>

Display elements and operator controls on the 3RA61 compact starter (direct starter)

No.	Display element/operator control	Marking	Explanation ¹⁾
(1)	"Overload trip" mechanical display	TRIP ϵ	<ul style="list-style-type: none"> No display: Loading on motor is within permissible range White display: The motor has been/is being overloaded.
(2)	"Reset overload trip" button	RESET ϵ	Press this button to reset the compact starter following an overload.
(3)	"Manual/auto reset" selector switch	RESET M/A	Select manual or auto reset ²⁾ after an overload.

5.2 Description of the hardware

No.	Display element/operator control	Marking	Explanation ¹⁾
(4)	"Current setting I _e " setting wheel	Setting ranges depending on the article number: <ul style="list-style-type: none"> • 0.1 - 0.4 A_ϕ • 0.32 - 1.25 A_ϕ • 1 - 4 A_ϕ • 3 - 12 A_ϕ • 8 - 32 A_ϕ 	For selecting the current setting I _e .
(5)	"Overload trip class" selector switch	CLASS 10/20	For selecting the overload trip class 10E or 20E.
(6)	"Overload protection function" test button	TEST ϕ	Press this button for at least 5 secs to test the overload protection function. Requirement: <ul style="list-style-type: none"> • Current must flow on the main conducting paths.
(7)	Actuator	<ul style="list-style-type: none"> • ○ OFF • ϕ READY • TRIPPED 	<ul style="list-style-type: none"> • ○ OFF: Compact starter is out of service. • ○ OFF and eye for padlock pulled out: Compact starter is out of service and secured against unauthorized closing. • ϕ READY and "Overload trip" display (1) not white: Compact starter is ready. • ϕ READY and "Overload trip" display (1) white: Compact starter not ready (tripped). • TRIPPED: Short-circuit tripped or malfunction exists.
(8)	Connection point for auxiliary switch block	—	—
(9)	Control circuit terminals	—	—
(10)	Main circuit terminals	—	—
(11)	"Main contacts closed" LED display	ON I	<ul style="list-style-type: none"> • Green: Main contacts are closed. • Off: Main contacts are open.
(12)	"Control supply voltage present" LED display	A1/A2	<ul style="list-style-type: none"> • Green: Control supply voltage is present. • Off: Control supply voltage not present.
(13)	"Short-circuit protection function" test button	TEST I>>	Press this button to test the short-circuit protection function.
(14)	"Malfunction" mechanical display	RLT 0%	<ul style="list-style-type: none"> • No display: Device is OK • White display: Malfunctions detected. Device must be replaced.
(15)	"Control supply voltage" connection	A1+, A2-	—

¹⁾ You can find detailed information on the precise device statuses in "Diagnostics (Page 85)".

²⁾ This function is not available for the versions with 1.25 A and 4 A rated current (article numbers: 3RA6120-.BB.. and 3RA6120-.CB..).

For more information, see Chapter "Overload protection function (Page 58)".

5.2.3 3RA62 compact starter (reversing starter)

Features

The 3RA62 compact starter (reversing starter) is made up of the following components:

- Reversing starter
- Two removable main circuit terminals
- Two 6-pin removable control circuit terminals (A1+ / A2 -, B2 / B1, "overload" and "short-circuit/malfunction" signaling contact and internal auxiliary contacts)
- Two slots for optional external auxiliary switch blocks (2 NO contacts, 2 NC contacts or 1 NO contact + 1 NC contact)

Control is either via the control supply voltage connection at terminals "A1+", "A2/B2-" and "B1+" or via the AS-i mounting module.

For additional information on the AS-i mounting module, please refer to "AS-i mounting module for 3RA61/3RA62 compact starter (Page 205)".

Direction of rotation interlock

The operating mechanisms for the reversing starter's directions of rotation are interlocked. This precaution prevents the operating mechanisms for direction of rotation 1 and direction of rotation 2 from being activated simultaneously, which would result in a short circuit.

Operating mechanism interlocking is implemented on both a mechanical level (against shock loads) and an electrical level (against incorrect activation).

Note

If direction of rotation 1 and direction of rotation 2 are set simultaneously instead of consecutively, the compact starter **does not** switch on.

Note

When switching several 3RA62 reversing starters in parallel, the operating mechanism must be switched via a separate auxiliary contact.

You can find a connection example in "Control circuit of the 3RA61/3RA62 compact starter (Page 258)".

Configuration of 3RA62 compact starter (reversing starter)

Front view	No.	Display element/operator control
	(1)	"Overload trip" mechanical display
	(2)	"Reset overload trip" button
	(3)	"Manual/auto reset" selector switch
	(4)	"Current setting I _e " setting wheel
	(5)	"Overload trip class" selector switch
	(6)	"Overload protection function" test button
	(7)	Actuator (can be locked in OFF position)
	(8a)	Connection point for auxiliary switch block (direction of rotation 1)
	(8b)	Connection point for auxiliary switch block (direction of rotation 2)
	(9)	Control circuit terminals
	(10)	Main circuit terminals
	(11a)	"Main contacts closed" LED display (direction of rotation 1)
	(11b)	"Main contacts closed" LED display (direction of rotation 2)
	(12)	"Control supply voltage present" LED display
	(13)	"Short-circuit protection function" test button
	(14)	"Malfunction" mechanical display
(15)	"Control supply voltage" connection	
(16)	Warnung! Hazardous electrical voltage! Electrical power can result in electric shock and burns. For this reason, switch off the power to the system and the devices before starting to work!	

Display elements and operator controls on the 3RA62 compact starter (reversing starter)

No.	Display element/operator control	Marking	Explanation ¹⁾
(1)	"Overload trip" mechanical display	TRIP ϵ	<ul style="list-style-type: none"> No display: Loading on motor is within permissible range White display: The motor is overloaded.
(2)	"Reset overload trip" button	RESET ϵ	Press this button to reset the compact starter following an overload.
(3)	"Manual/auto reset" selector switch	RESET M/A	Select manual or auto reset ²⁾ after an overload.

No.	Display element/operator control	Marking	Explanation ¹⁾
(4)	"Current setting I_e " setting wheel	Setting ranges depending on the article number: <ul style="list-style-type: none"> • 0.1 - 0.4 A I_n • 0.32 - 1.25 A I_n • 1 - 4 A I_n • 3 - 12 A I_n • 8 - 32 A I_n 	For selecting the current setting I_e .
(5)	"Overload trip class" selector switch	CLASS 10/20	For selecting the overload trip class 10E or 20E.
(6)	"Overload protection function" test button	TEST I_n	Press this button for at least 5 secs to test the overload protection function. Requirement: <ul style="list-style-type: none"> • Current must flow on the main conducting paths.
(7)	Actuator	<ul style="list-style-type: none"> • \bigcirc OFF • \bigcirc READY • TRIPPED 	<ul style="list-style-type: none"> • \bigcirc OFF: Compact starter is out of service. • \bigcirc OFF and eye for padlock pulled out: Compact starter is out of service and secured against unauthorized closing. • READY and "Overload trip" display (1) not white: Compact starter is ready. • READY and "Overload trip" display (1) white: Compact starter not ready (tripped). • TRIPPED: Short-circuit tripped or malfunction exists.
(8a)	Connection point for auxiliary switch block (direction of rotation 1)	—	—
(8b)	Connection point for auxiliary switch block (direction of rotation 2)	—	—
(9)	Control circuit terminals	—	—
(10)	Main circuit terminals	—	—
(11a)	"Main contacts closed" LED display (direction of rotation 1)	ON I 1	<ul style="list-style-type: none"> • Green: Main contacts "direction of rotation 1" closed. • Off: Main contacts "direction of rotation 1" not closed.
(11b)	"Main contacts closed" LED display (direction of rotation 2)	ON I 2	<ul style="list-style-type: none"> • Green: Main contacts "direction of rotation 2" closed. • Off: Main contacts "direction of rotation 2" not closed.
(12)	"Control supply voltage present" LED display	A1/A2 B1/B2	<ul style="list-style-type: none"> • Green: Control supply voltage is present. • Off: Control supply voltage not present.
(13)	"Short-circuit protection function" test button	TEST I>>	Press this button to test the short-circuit protection function.

5.2 Description of the hardware

No.	Display element/operator control	Marking	Explanation ¹⁾
(14)	"Malfunction" mechanical display	RLT 0%	<ul style="list-style-type: none"> No display: Device is OK White display: Malfunctions detected. Device must be replaced.
(15)	"Control supply voltage" connection	A1+, A2/B2-, B1+	Please note the polarity when connecting with DC. Even if the polarity is reversed, the LED "Control supply voltage present" lights up, but the compact starter does not switch on.

¹⁾ You can find detailed information on the precise device statuses in "Diagnostics (Page 85)".

²⁾ This function is not available for the versions with 1.25 A and 4 A rated current (article numbers: 3RA6250-.BB.. and 3RA6250-.CB..).

For more information, see Chapter "Overload protection function (Page 58)".

5.3 Configuring

5.3.1 SIRIUS configurator

Reference

The "Compact Starters 3RA6 and Infeed System for 3RA6" configurator is available on the Internet to assist you with configuration. Here, you can gather together all necessary products before the actual configuration process and you can realize complete projects virtually.

You can find the configurator on the Internet (<http://www.siemens.com/sirius/configurators>).



5.4 Functions

5.4.1 Normal switching duty


Normal switching duty

Compact starters are used primarily for switching and protecting motors. The actuator can be used to switch the compact starter manually; together with the other display elements, it shows the compact starter's current status.

The actuator has three positions:

-  READY: Compact starter is ready.
-  OFF: Compact starter is out of service.
- TRIPPED: Malfunction or short circuit trip.

Actuator OFF

When the actuator is in the  OFF position, the main contacts are open and the active areas of the control electronics are disconnected. Only the thermal motor model and display elements remain in operation.







When the actuator is in the  OFF position, the 3RA61 compact starter (direct starter) can adopt the following statuses:

Table 5-1 Actuator display elements  OFF (3RA61 compact starter)

Actuator	LEDs		Compact starter status
	A1/A2	ON I	
OFF	 OFF	 OFF	Compact starter is switched off: <ul style="list-style-type: none"> • The circuit breaker mechanism is switched off. • Control supply voltage not present. • The main contacts are open.
OFF	 GREEN	 OFF	Compact starter is switched off: <ul style="list-style-type: none"> • The circuit breaker mechanism is switched off. • Control supply voltage is present. • The main contacts are open.









When the actuator is in the  OFF position, the 3RA62 compact starter (reversing starter) can adopt the following statuses:


Table 5-2 Actuator display elements  OFF (3RA62 compact starter)

Actuator	LEDs			Compact starter status
	A1/A2 B1/B2	ON I 1	ON I 2	
OFF	 OFF	 OFF	 OFF	Compact starter is switched off: <ul style="list-style-type: none"> • The circuit breaker mechanism is switched off. • Control supply voltage not present. • The main contacts are open.
OFF	 GREEN	 OFF	 OFF	Compact starter is switched off: <ul style="list-style-type: none"> • The circuit breaker mechanism is switched off. • Control supply voltage is present. • The main contacts are open.



WARNING

Machine start-up!

If the "A1/A2" LED is illuminated and you switch the actuator of the compact starter to , the machine will start up immediately. People may be injured if they stay in the danger area of the machine.

Make sure that the danger area of the machine is kept clear of people.







Actuator READY

The circuit breaker mechanism (breaker latching mechanism) in the compact starter is switched on and the compact starter is ready.

5.4 Functions







When the actuator is in the ◻ READY position, the 3RA61 compact starter (direct starter) can adopt the following statuses:







Table 5-3 Actuator display elements ◻ READY (3RA61 compact starter)

Actuator	LEDs		Compact starter status
	A1/A2	ON I	
READY	 OFF	 OFF	Compact starter is ready: <ul style="list-style-type: none"> The circuit breaker mechanism is switched on. Control supply voltage not present. The main contacts are open.
READY	 GREEN	 GREEN	Compact starter is switched on: <ul style="list-style-type: none"> The circuit breaker mechanism is switched on. Control supply voltage is present. The main contacts are closed.
READY	 GREEN	 OFF	There is a fault. <ul style="list-style-type: none"> "Overload trip" display white: Overload tripped. "Overload trip" display not white: Control supply voltage is outside the working range. The main contacts are open.

When the actuator is in the ◻ READY position, the 3RA62 compact starter (reversing starter) can adopt the following statuses:

Table 5-4 Actuator display elements ◻ READY (3RA62 compact starter)

Actuator	LEDs			Compact starter status
	A1/A2 B1/B2	ON I 1	ON I 2	
READY	 OFF	 OFF	 OFF	Compact starter is ready: <ul style="list-style-type: none"> The circuit breaker mechanism is switched on. Control supply voltage not present. All main contacts are open.
READY	 GREEN	 GREEN	 OFF	Compact starter is switched on: <ul style="list-style-type: none"> The circuit breaker mechanism is switched on. Control supply voltage is present. The main contacts "direction of rotation 1" are closed.

Actuator	LEDs			Compact starter status
	A1/A2 B1/B2	ON I 1	ON I 2	
READY	 GREEN	 OFF	 GREEN	Compact starter is switched on: <ul style="list-style-type: none"> The circuit breaker mechanism is switched on. Control supply voltage is present. The main contacts "direction of rotation 2" are closed.
READY	 GREEN	 OFF	 OFF	There is a fault. <ul style="list-style-type: none"> "Overload trip" display white: Overload tripped. "Overload trip" display not white: <ul style="list-style-type: none"> Control supply voltage is outside the working range. Control supply voltages for both directions of rotation were applied simultaneously. Polarities are reversed in the case of DC connection. All main contacts are open.



Actuator TRIPPED

The compact starter has shut down through tripping of the circuit breaker mechanism because a malfunction or short circuit has been detected.

The actual trigger event can be identified by referring to the "RLT 0%" display window.


When the actuator is in the TRIPPED position, the 3RA61 compact starter (direct starter) and 3RA62 compact starter (reversing starter) can adopt the following statuses:

Table 5-5 Actuator display elements TRIPPED (3RA61/3RA62 compact starter)

Actuator	Mech. display	Compact starter status
	RLT 0%	
TRIPPED	 No display	Short circuit tripped
TRIPPED	 White display	Malfunction (e.g. end of service life reached)

Note

Turning the actuator manually to the TRIPPED position.

The actuator can also be moved to the TRIPPED position manually. In this case, it is not possible to say whether a short circuit has occurred or whether the actuator has been moved to the TRIPPED position manually simply by looking at the display elements. However, if the actuator has been moved to the TRIPPED position manually, the user will be able to turn it back from the TRIPPED position to the  READY position straight away. This will not be possible if a short circuit trip has occurred.

For additional information on eliminating malfunctions, please refer to "Shutdown on malfunction (Page 61)".

For additional information on eliminating short circuits, please refer to "Short-circuit protection function (Page 59)".

5.4.2 Overload protection function

Overload protection function, phase loss protection

The 3RA61/3RA62 compact starter protects three-phase motors against overload. In addition, the compact starter is provided with phase loss protection to prevent excessive heating of the load in single phasing if phase loss occurs. In both cases, the compact starter switches off without opening the breaker latching mechanism.

When operating with single-phase loads, the phase loss protection must be compensated to prevent premature tripping. This is done by selecting the setting current I_e on the compact starter higher than the motor operating current by a factor of 1.6.

Operator controls

The following operator elements are available to you on the compact starter to guarantee optimal overload protection:

- "Current setting I_e " setting wheel: Set the rated operating current of the load on the "Setting current I_e " setting wheel.
- "Manual/auto reset" selector switch: Use the "Manual/auto reset selector switch" to determine how the compact starter is reset after an overload trip.
 - Manual reset "M": You must reset the compact starter manually using the blue reset button.
 - Auto reset "A": The compact starter resets itself autonomously after approximately 3 minutes. If there is voltage on A1/A2 at this point, the compact starter switches on again. Manual reset using the blue reset button is possible in this setting after just 10 seconds. This function is not available for the versions with 1.25 A and 4 A rated current (article numbers: 3RA6120-.BB.. / 3RA6120-.CB.. and 3RA6250-.BB.. / 3RA6250-.CB..). The reset can be alternatively carried out here by disconnecting the supply voltage A1/A2 via the NC contacts 95/96 (overload signaling contact). The auto-reset function is provided with this circuitry.

 **WARNING**

Automatic machine restart!

If the "A1/A2" LED lights up after an overload trip and a manual reset or auto reset is performed, the machine will start up immediately. People may be injured if they stay in the danger area of the machine.

Make sure that the danger area of the machine is kept clear of people.

- "Overload trip class" selector switch: For selecting trip CLASS 10E or CLASS 20E.

Display concept

The "Overload tripped" status is indicated by the following elements:

Table 5-6 Overload trip display elements (direct starter/reversing starter)

Actuator	Mech. display	Compact starter status
	TRIP ζ	
READY	<input type="checkbox"/> White display	Overload tripped

Function test

To test the overload protection function, press the "TEST ζ " button ("Overload protection function" test button). Press the test button for approximately 5 seconds. The compact starter must be switched on while pressing the button and a load current of I_e must flow in the main circuit.

When the test button is pressed, the evaluation electronics simulate an overload that causes tripping and switches the "Overload" signaling contact (95, 96, 98).

Please observe a minimum waiting time of 10 seconds before resetting the compact starter manually using the blue reset button. If the "manual/auto reset" selector switch is set to "A", the compact starter automatically resets after approximately 3 minutes.

Motor model

Depending on the operating time and the current load, the electronics continuously calculate a model of the thermal load of the motor. The motor model charges when the compact starter is switched on. The motor model discharges after switching off. The motor model is fully discharged after approximately 3 minutes.

If you carry out a manual reset within 3 minutes although the motor model has not yet sufficiently discharged, another overload trip can occur when the compact starter is switched on.

5.4.3 Short-circuit protection function

Short-circuit protection function

The compact starter has two short-circuit releases:

- a non-delayed overcurrent release and
- a short-time delayed overcurrent release.

5.4 Functions

In the case of the non-delayed overcurrent release, the tripping current is 14 times the value of the maximum rated operating current I_e . It responds quickly in the case of high short-circuit currents.

Note

Tripping current

In the case of compact starters with $I_e = 0.4\text{ A}$, $I_e = 1.25\text{ A}$ and $I_e = 4\text{ A}$, the tripping current is 56 A.
 In the case of compact starters with $I_e = 12\text{ A}$, the tripping current is 168 A.
 In the case of compact starters with $I_e = 32\text{ A}$, the tripping current is 448 A.


In the case of the short-time delayed overcurrent release, the tripping current is 12 times the set overload current. This overcurrent release thus depends on the set overload current and can be modified using this value. The short-time delayed overcurrent release responds to low short-circuit currents.

The compact starter has a short-circuit breaking capacity I_{CS} of 53 kA at a voltage of 400 V AC.
 Overload trips and short-circuit trips are signaled via two separate signaling contacts so that both signals can be evaluated in their own right. For additional information on terminal assignment, please refer to "Connection (Page 73)".


Display concept

The "Short circuit tripped" status is indicated by the following elements:

Table 5-7 Short circuit trip display elements (direct starter/reversing starter)

Actuator	Mech. display RLT 0%	Compact starter status
TRIPPED	 No display	Short circuit tripped


Resetting the short circuit trip

 **WARNING**

Short-circuit hazard!

If you restart the compact starter after an overload trip and the cause of the short circuit has not been eliminated, a new short-circuit trip will occur. A short circuit can cause burns and plant damage.



Eliminate the cause of the short circuit before you restart the compact starter after a short-circuit trip.

To reset a short circuit trip, turn the actuator to the  OFF position.

Function test

To test the short-circuit protection function, press the "TEST I>>" button ("Short-circuit protection" test button). This can be done when the compact starter is de-energized.

After the "short-circuit protection" test button has been pressed, the breaker latching mechanism trips and the actuator of the compact starter changes to the TRIPPED position. The "Fault" signaling contact (terminals 77/78) opens.

The test can be terminated by turning the actuator first to the  OFF position and then to the  READY position.

5.4.4 Shutdown on malfunction

Type of malfunction


There is a patented mechanism for detecting malfunctions, which opens the main contacts. The following malfunctions can be detected:

- End of service life
Worn switching contacts or switching mechanism.
(For additional information on electrical endurance, please refer to "Technical data (Page 239)".)
- Faults in the control electronics


Display concept

The "Malfunction" status is indicated by the following elements:

Table 5-8 Malfunction display elements (direct starter/reversing starter)

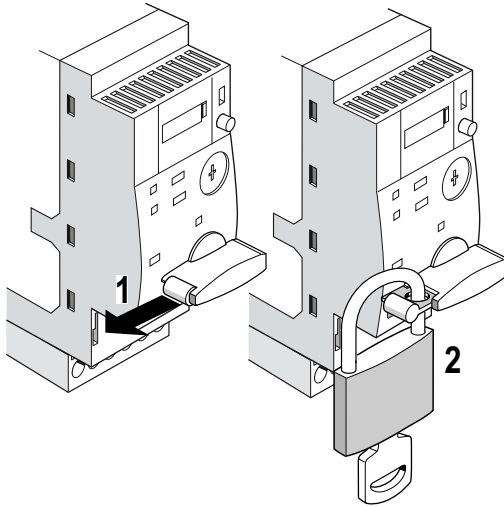
Actuator	Mech. display RLT 0%	Compact starter status
TRIPPED	 White display	Malfunction (e.g. end of service life reached)

Eliminating malfunctions

 WARNING
<p>Compact starter malfunction!</p> <p>A compact starter malfunction will cause the compact starter to shut down. Continuing to operate the compact starter is extremely risky, as it can no longer be considered reliable.</p> <p>Following a shutdown caused by a malfunction, you will need to replace the compact starter.</p>

5.4.5 Disabling the actuator

You can disable the actuator to protect it against unauthorized closing by locking it with a padlock (shackle diameter 3.5 - 4.5 mm). Before you can do this, the actuator must be set to the O OFF position and the actuator eye must be pulled out.



- ① Pull out the eye on the actuator.
- ② Hang the padlock into the eye and close it.

5.5 Installing/removal

Warning notice before installation, wiring, and commissioning



 DANGER	
Hazardous voltage. Will cause death or serious injury.	
Turn off and lock out all power supplying this device before working on this device.	

5.5.1 Installing the 3RA61/3RA62 compact starter

The sections below explain how to install the SIRIUS 3RA6 compact starter on:

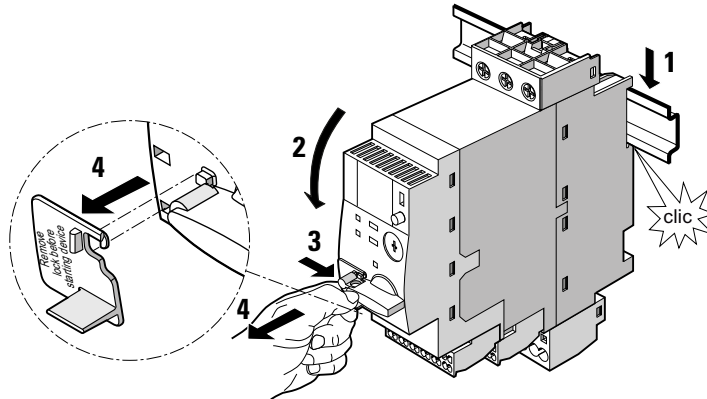
- A standard mounting rail
- A level surface (screw fastening)
- The infeed system for 3RA6

5.5.1.1 Mounting the compact starter on a DIN rail

Requirements

- A 35-mm standard mounting rail in accordance with IEC / EN 60715 must be properly secured at the installation location.
- Observe the information on minimum clearances in "Dimension drawings (Page 241)".
- Remove the transport lock before installation and commissioning:

Procedure



- ① Place the back of the device onto the upper edge of the standard mounting rail.
- ② Press the lower half of the device against the rail until you hear the device engage.
- ③ Release the actuator.
- ④ Remove the transport lock from the compact starter toward the front.

5.5.1.2 Installing the compact starter on a level surface (screw fastening)

Requirements

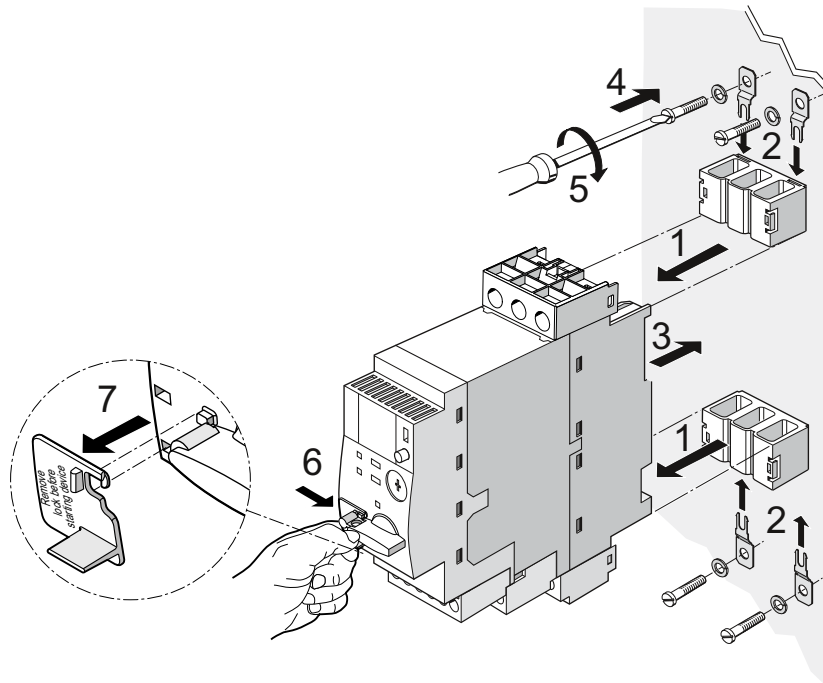
- Look up the article numbers pertaining to the adapters for screw fastening by referring to the list in "Adapter for screw fastening (Page 141)".

Note

The adapters for screw fastening are black and must not be confused with the gray adapters for the infeed system for 3RA6.

- Drill holes with thread or plug on the level surface. For details of the distances between the drilled holes, please refer to the relevant dimension drawing in "Dimension drawings (Page 241)".
- 4 M4 screws for mounting the direct starter on the level surface.
6 M4 screws for mounting the reversing starter on the level surface.
- Observe the information on minimum clearances in "Dimension drawings (Page 241)".

Procedure



- ① Click the adapters for screw fastening the compact starter into position behind the main circuit terminals.
- ② Push the 4 mounting lugs from the top/bottom into the adapters until they engage.
- ③ Hold the device up to the surface prepared for screw fastening.
- ④ Insert each screw through the relevant holes in the mounting lugs.
- ⑤ Screw the device onto the level surface so that it is secure.
- ⑥ Release the actuator.
- ⑦ Remove the transport lock from the compact starter toward the front.

Virtually the same process is used for installing the reversing starter on a level surface as for the direct starter. However, in this case 2 additional adapters just need to be snapped onto the reversing starter and a single lug is used for surface mounting.

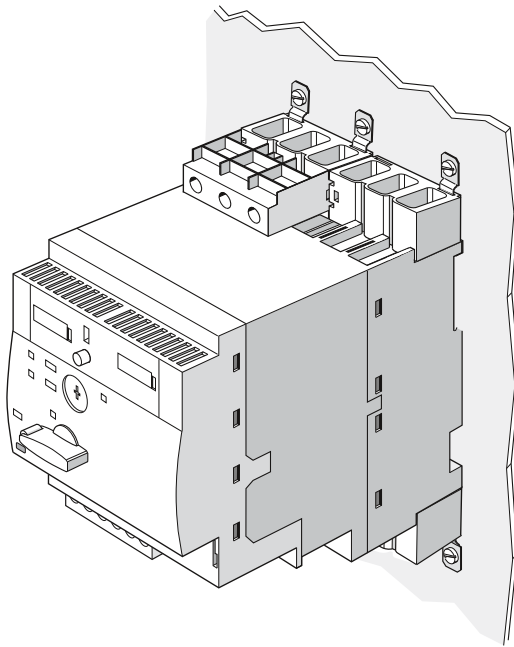


Figure 5-1 Installing a 3RA62 compact starter (reversing starter) on a level surface (screw fastening)

5.5.1.3 Installing the compact starter on an infeed system for 3RA6

Requirements

- The SIRIUS infeed system for 3RA6 must be correctly installed. You can find additional information on installing the infeed system in chapter "Infeed system for 3RA6 (Page 156)".
- The compact starter must be switched off (actuator set to \circ OFF position).

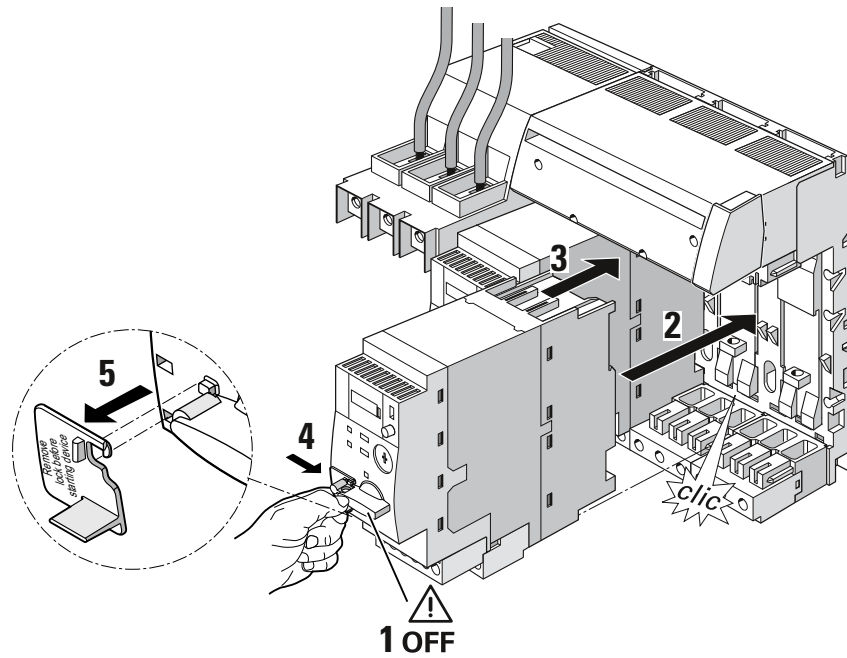
NOTICE

Compact starter and infeed system material damage!

You can damage the compact starter and the infeed system if you insert the compact starter into the infeed system for 3RA6 while the starter is switched on (actuator in the \cup READY position).

Make sure that the compact starter's actuator is set to the \circ OFF position before you insert the compact starter into the infeed system for 3RA6.

Procedure



- ① Ensure that the actuator is in the \circ OFF position.
- ② Attach the compact starter to the front of the infeed system for 3RA6.
- ③ Push the compact starter straight onto the infeed system for 3RA6 until you hear it engage.
- ④ Release the actuator.
- ⑤ Remove the transport lock from the compact starter toward the front.

5.5.2 Removing the 3RA61/3RA62 compact starter

The sections below explain how to remove the SIRIUS 3RA6 compact starter from:

- A standard mounting rail
- A level surface (screw fastening)
- The infeed system for 3RA6

5.5.2.1 Removing the compact starter from a DIN rail

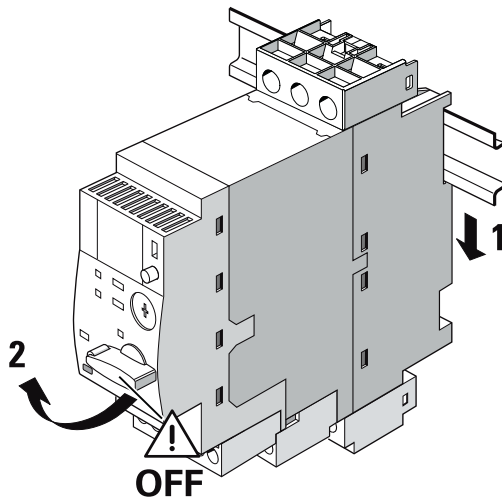
Requirements

- The compact starter must be switched off (actuator set to \circ OFF position).
- The AS-i cables or AS-i mounting module must be removed.

Note

Disassemble the compact starter's main circuit terminals and control circuit terminals before removing the compact starter. as this makes the process easier.

Procedure



- ① Pull the device down until the lower half can be pulled away from the DIN rail.
- ② Pull the lower half of the device away from the standard mounting rail and lift the device off its upper edge.

5.5.2.2 Removing the compact starter from a level surface (screw fastening)

Requirements

- The compact starter must be switched off (actuator set to \circ OFF position).
- The control current terminals must have been disconnected.

**! DANGER****Hazardous voltage!**

Will cause death or serious injury.

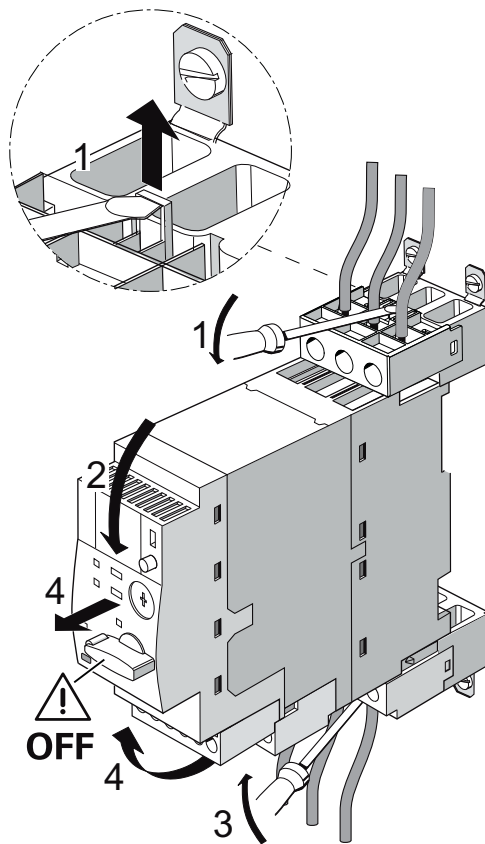
Removing the compact starter while the system is live can damage the compact starter and can also result in an electric shock.

Before starting work, disconnect the system and the device from the power supply.

Procedure

Note

The compact starter can be removed from the wall with the wiring still in place (permanent wiring), i.e. there is no need to disconnect the main circuit terminals.



- ① Use a screwdriver to release the top main circuit terminal.
- ② Tilt the compact starter forwards so that there is no risk of it snapping back into the main circuit terminal.
- ③ Use a screwdriver to release the bottom main circuit terminal.
- ④ Tilt the compact starter upwards and pull it forwards in order to remove it from the main circuit terminals.

5.5.2.3 Removing the compact starter from an infeed system for 3RA6

Requirements

- Screwdriver with max. diameter of 7.5 mm and minimum shaft length of 100 mm for releasing the compact starter
- The compact starter must be switched off (actuator set to \circ OFF position).

NOTICE

Compact starter and infeed system material damage!

You can damage the compact starter and the infeed system if you remove the compact starter from the infeed system for 3RA6 while the starter is switched on (actuator in the \circ READY position).

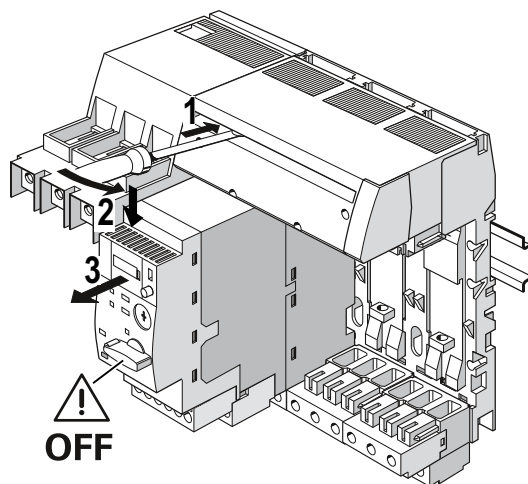
Make sure that the compact starter's actuator is set to the \circ OFF position before you remove the compact starter from the infeed system for 3RA6.

Procedure

For servicing purposes, the compact starter can be removed from the infeed system while the system is live but at zero current.

Note

The fact that the SIRIUS infeed system for 3RA6 features permanent wiring means that there is no need to disconnect the main circuit terminals.

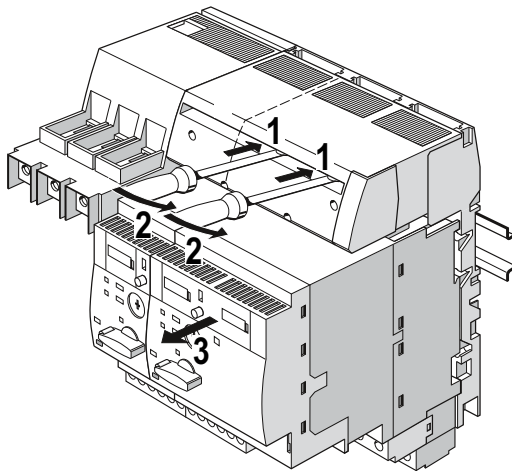


- ① Insert a screwdriver into the opening.
- ② Tilt the screwdriver to the right and then down (see arrow on enclosure lid) so that you can push the compact starter forwards by approx. 5 mm.
- ③ Move the compact starter forwards to remove it from the screw-type infeed or extension block.

Note

The 45 mm adapter for the infeed system for 3RA6 can be removed in the same way.

When removing a reversing starter, you will need to insert two screwdrivers into the neighboring openings at the same time.



- ① Insert 2 screwdrivers into the opening above the reversing starter.
- ② Tilt the screwdrivers to the right and then down (see arrow on enclosure lid) so that you can push the reversing starter forwards by approx. 5 mm.
- ③ Move the reversing starter forwards to remove it from the screw-type infeed or extension block.

5.6 Connection

5.6.1 Connection via terminals

Connection types

There are the following cable connection options for the compact starter:

- Free wiring on screw-type terminals
- Free wiring on spring-loaded terminals

Stripping lengths

A stripping length of 10 mm applies in respect of the main conductor connections and the control conductor connections.

The terminals are marked to make it easier to determine the stripping length. The correct stripping length can be achieved by lining the conductor up with this marking.

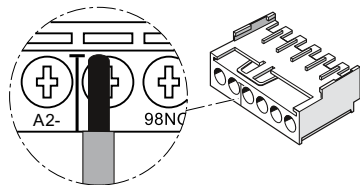


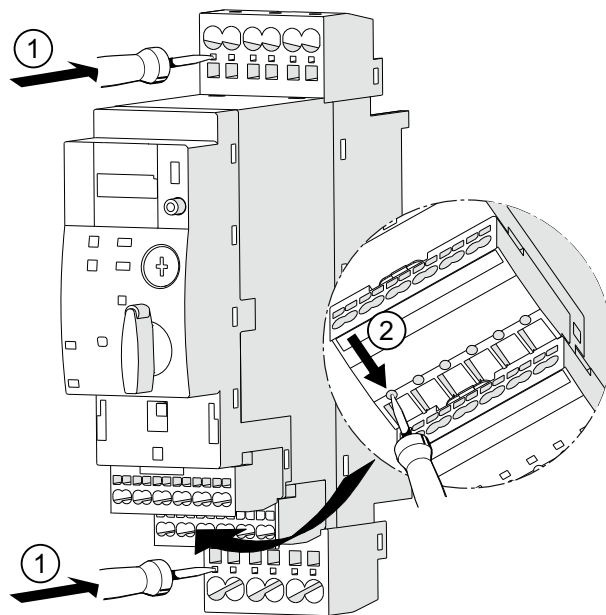
Figure 5-2 Representation of stripping lengths on terminals

Openings for test probes

On the compact starter with screw-type connection technology, the test probes are attached to the terminal screws.

On the compact starter with spring-loaded connection technology, all terminals are equipped with special test probe openings.

5.6 Connection

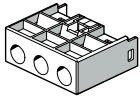
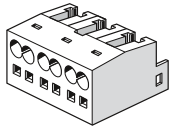
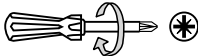
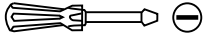
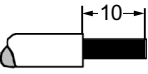
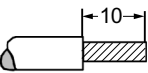


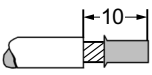
- Openings for test probes on
- ① the main circuit terminals.
 - ② the control circuit terminals.

Figure 5-3 Test probe openings on the 3RA6 compact starter

Conductor cross-sections of main circuit terminals

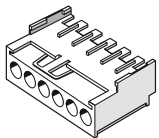
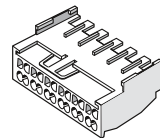

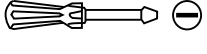
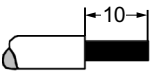
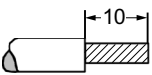
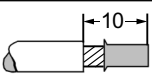
Table 5-9 Conductor cross-sections of main circuit terminals

				
Compact starter	... 12 A	8 to 32 A	... 12 A	8 to 32 A
	 Ø 6 mm/PZ 2		 8WA2 803 (3.5 x 0.5) mm	
	2 to 2.5 Nm (18 to 22 lb-in)		-	
	2 x (1.5 to 2.5) mm ² 2 x (2.5 to 6) mm ² max. 1 x 10 mm ²	2 x (2.5 to 6) mm ² — max. 1 x 10 mm ²	2 x (1.5 to 6) mm ² — max. 1 x 10 mm ²	2 x (2.5 to 6) mm ² — max. 1 x 10 mm ²
	—	—	2 x (1.5 to 6) mm ²	2 x (2.5 to 6) mm ²

	2 x (1.5 to 2.5) mm ² 2 x (2.5 to 6) mm ²	2 x (2.5 to 6) mm ²	2 x (1.5 to 6) mm ²	2 x (2.5 to 6) mm ²
AWG	2 x (16 to 14) 2 x (14 to 10) 1 x 8	2 x (14 to 10) — 1 x 8	2 x (16 to 10) — 1 x 8	2 x (14 to 10) — 1 x 8

Conductor cross-sections of control circuit terminals

Table 5-10 Conductor cross-sections of control circuit terminals


		
		
	Ø 6 mm/PZ 2	(0.5 x 3.0) mm DIN ISO 2380-1A
	0.8 to 1.2 Nm (7 to 10.3 lb·in)	—
	1 x (0.5 to 4) mm ² 2 x (0.5 to 2.5) mm ²	2 x (0.25 to 1.5) mm ² —
	—	2 x (0.25 ... 1.5) mm ²
	1 x (0.5 to 2.5) mm ² 2 x (0.5 to 1.5) mm ²	2 x (0.25 to 1.5) mm ² —
AWG	2 x (20 to 14)	2 x (24 to 16)

Note

A cross-section (2 x 1.5) mm² with end sleeve to DIN 46228-4 is not possible (plastic collar).

5.6.2 Connecting terminal blocks

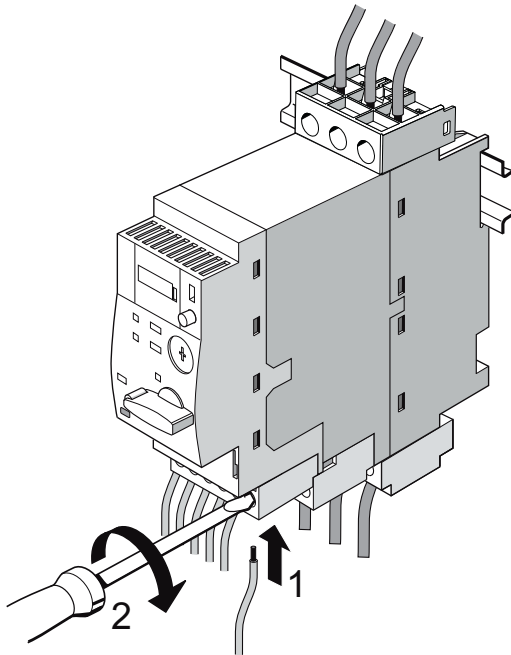


 DANGER
<p>Hazardous voltage!</p> <p>Will cause death or serious injury.</p> <p>Before starting work, disconnect the system and the device from the power supply.</p>

Requirements for screw terminals

- The connection cables must have been bared correctly.
- Pozidriv 2 (Ø 6 mm).

Procedure for screw terminals

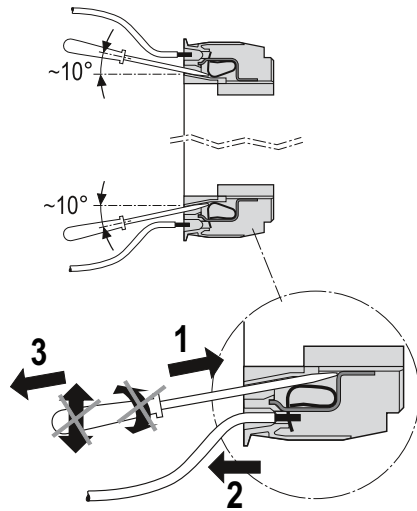


- ① Insert the relevant cable as far as it will go into the screw terminal opening and hold it in place.
- ② Tighten the relevant screw.
Pull on the cable to ensure it is completely secure.

Requirements for spring-loaded terminals

- Main circuit terminals: Flat-head screwdriver with (3.5 x 0.5 mm) blade (8WA2 803)
- Control circuit terminals: Flat-head screwdriver with (3.0 x 0.5 mm) blade (DIN ISO 2380-1A)

Procedure for spring-loaded terminal block



- ① To open the clamping springs of the spring-loaded terminal, insert the flat-head screwdriver into the square opening as far as it will go. Please observe a 10° horizontal angular deviation of the screwdriver to the oval opening.
- ② Insert the cable as far as it will go into the oval opening and hold it in place.
- ③ Remove the screwdriver and pull on the cable to ensure it is completely secure.

5.6.3 Connecting the compact starter without optional AS-i mounting module

Connection types

All control conductor connections on the compact starter converge at the same central point: the outgoing terminal.

The terminals are universally available with screw-type or spring-loaded connection technology. (For additional information on the connection systems, please refer to "Connecting terminal blocks (Page 75)").

Pin assignment

Table 5-11 Pin assignments for 3RA61 compact starter (direct starter)

Terminal	Description	Figure
1L1, 3L2, 5L3	Main contacts (line side)	<p>The diagram shows a terminal block with three rows of terminals. The top row has terminals 1 L1, 3 L2, and 5 L3. The middle row has terminals A1+, A2-, 98NO, 95C, and 96NC. The bottom row has terminals 77 NO, 78, 13 NO, 14, 21 NC, and 22. Below these are terminals 2 T1, 4 T2, and 6 T3. Each terminal is represented by a circle with a cross inside, and some have additional labels like 'NO', 'NC', 'C', or 'T'.</p>
A1+, A2-	Control supply voltage connection (24 V, 42 - 70 V or 110 - 240 V)	
Unlabeled	Unassigned ($U_{i,max} = 300\text{ V}$)	
95, 96, 98	"Overload" signaling contact (CO contact)	
77, 78	"Fault" signaling contact (NO contact). The signaling contact is closed when the actuator is in the ϕ READY position. The signaling contact opens when the actuator is switched to the \circ OFF position, there is a short-circuit or the end of the service life has been reached.	
13, 14	Auxiliary NO contact for querying the position of the main contacts	
21, 22	Auxiliary NC contact for querying the position of the main contacts - mirror contacts to main contacts	
2T1, 4T2, 6T3	Main contacts (on the outgoing side)	

Table 5-12 Pin assignments for 3RA62 compact starter (reversing starter)

Terminal	Description	Figure
1L1, 3L2, 5L3	Main contacts (line side)	
A1+, A2/B2-, B1+	Control supply voltage connection ¹⁾ (24 V, 42 - 70 V or 110 - 240 V AC/DC) A: Direction of rotation 1 B: Direction of rotation 2	
95, 96, 98	"Overload" signaling contact (CO contact)	
77, 78	"Fault" signaling contact (NO contact). The signaling contact is closed when the actuator is in the \circ READY position. The signaling contact opens when the actuator is switched to the \circ OFF position, there is a short-circuit or the end of the service life has been reached.	
13, 14	Auxiliary NO contact for querying the position of the main contacts (direction of rotation 1)	
43, 44	Auxiliary NO contact for querying the position of the main contacts (direction of rotation 2)	
2T1, 4T2, 6T3	Main contacts (on the outgoing side)	

1)

Note

Please note the polarity when connecting the control supply voltage with DC.

Even if the polarity is reversed, the LED "Control supply voltage present" lights up, but the compact starter does not switch on.

Note

Use of a mirror contact.

If you require a mirror contact in accordance with IEC/EN 60947-4-1 (Appendix F) to signal the status of the main contacts, you must use the optional external auxiliary switch block for this purpose. A mirror contact is an NC contact that cannot be closed simultaneously with the main NO contact.

Mirror contact


With the aid of opening auxiliary contacts it is possible to implement a mirror contact query of the main contacts. This requires the previously integrated auxiliary contact 21-22 (NC contact) for compact starter 3RA61 or an external auxiliary switch block with at least one NC contact (3RA6912-1A/3RA6913-1A and 3RA6912-2A/3RA6913-2A) for device variants 3RA62, 3RA64 and 3RA65.

Positively-driven


If the compact starter is designed to act as a direct starter for parallel wiring (3RA61), there is positively driven operation in the basic device between auxiliary circuits 21-22 (normally closed) and 13-14 (normally open). In addition, external auxiliary switch 3RA6913-1A or 3RA6913-2A provides positively driven contact elements with one NC contact and one NO contact each.

5.6.4 Disconnecting terminal blocks

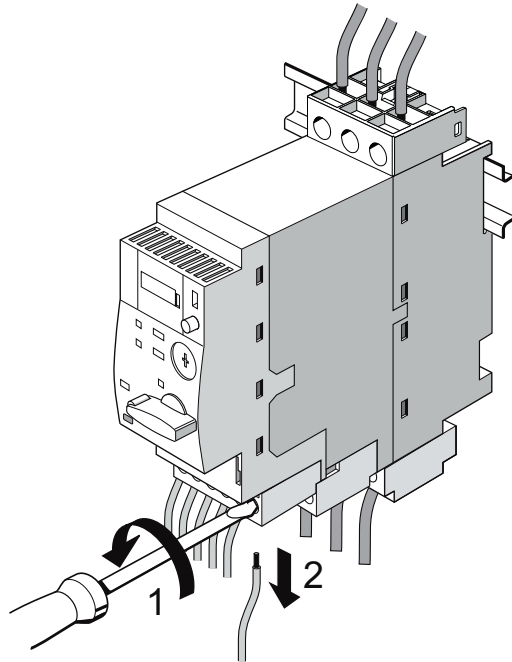
Requirements

- The compact starter must be switched off (actuator set to  OFF position).



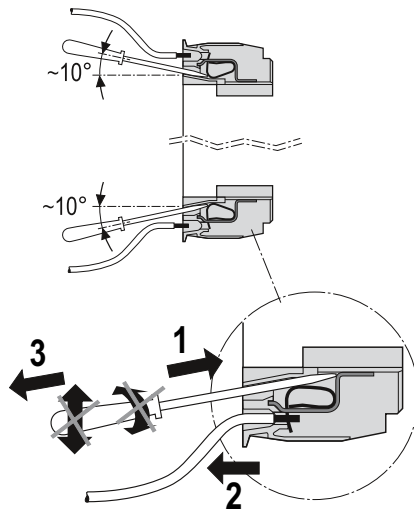
 DANGER
Hazardous voltage!
Will cause death or serious injury.
Before starting work, disconnect the system and the device from the power supply.

Procedure for screw terminals



- ① Undo the screw of the screw terminal.
- ② Remove the cable from the unscrewed screw terminal.

Procedure for spring-loaded terminals



- ① Insert the flat-head screwdriver into the square opening of the spring-loaded terminal as far as it will go. Please observe a 10° horizontal angular deviation of the screwdriver to the oval opening.
- ② Remove the cable from the oval opening.
- ③ Remove the screwdriver.

5.7 Commissioning

5.7.1 Settings on the 3RA61/3RA62 compact starter

All settings are made on the 3RA61/3RA62 compact starter itself.

CLASS 10E / 20E

The CLASS (overload trip class) indicates the tripping time t_A of the compact starter (from cold) at 7.2 times the current setting I_e . As the compact starter has the functionality of a solid-state overload relay, the trip class corresponds to the narrow tolerance band E (IEC / EN 60947-6-2):

- CLASS 10E: $5 \text{ s} < t_A < 10 \text{ s}$
- CLASS 20E: $10 \text{ s} < t_A < 20 \text{ s}$ (for heavy starting)

You can use a slide switch to set the trip class to CLASS 10E or CLASS 20E.

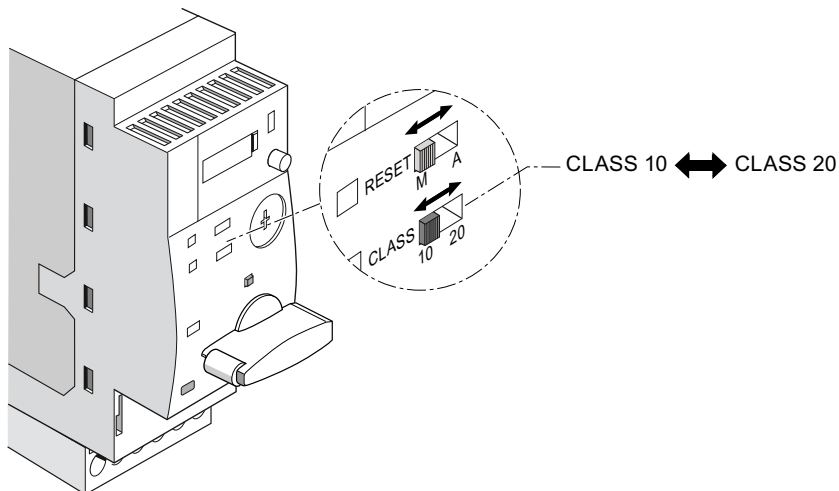


Figure 5-4 Setting CLASS 10E/20E on the compact starter

Current setting I_e

Set the operating current of the motor to be protected on the setting scale.

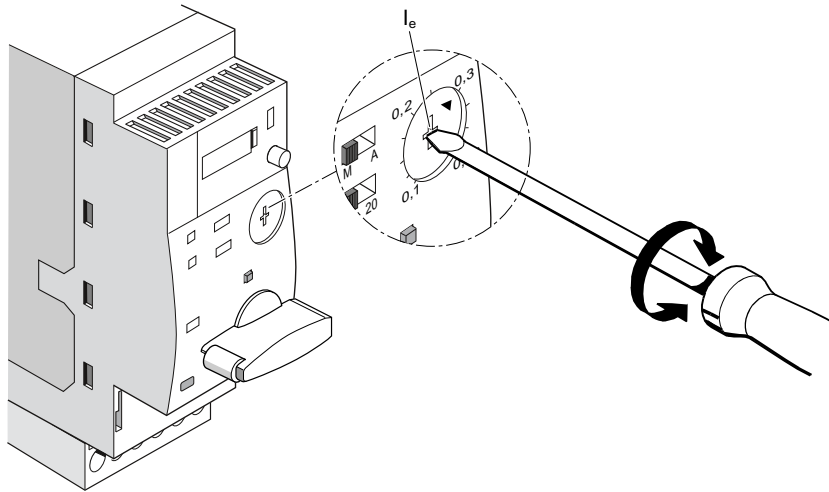


Figure 5-5 Setting the current setting I_e on the compact starter

RESET M/A

Select manual or auto reset following an overload trip on the "RESET M/A" (manual/automatic) selector switch:

- **Manual reset:** Following an overload trip, reset the 3RA61/3RA62 compact starter manually using the blue reset button.
- **Auto reset:** Following an overload trip, the 3RA61/3RA62 compact starter is reset automatically after 3 minutes. However, a manual reset is additionally possible in this setting. This auto reset function is not available for the versions with 1.25 A and 4 A rated current (article numbers: 3RA6120-.BB.. / 3RA6120-.CB.. and 3RA6250-.BB.. / 3RA6250-.CB..). The reset can be alternatively carried out here by disconnecting the supply voltage A1/A2 via the NC contacts 95/96 (overload signaling contact). The auto-reset function is provided with this circuitry.

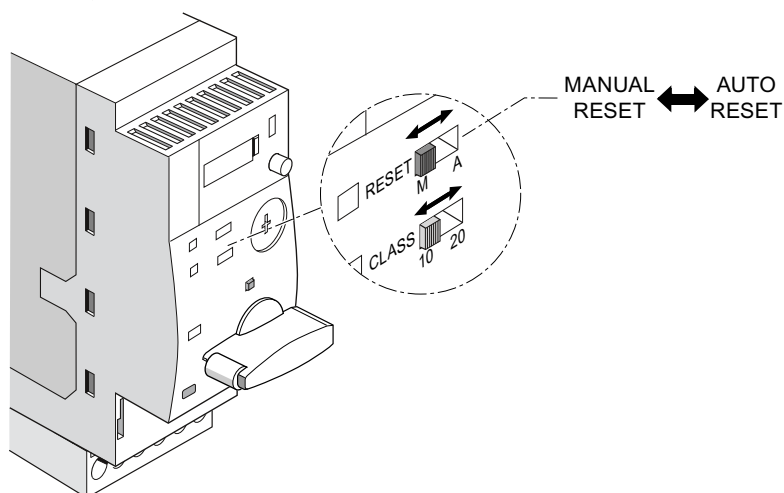


Figure 5-6 Setting RESET M/A on the compact starter

More information on the manual and auto reset functions can be found in Chapter "Overload protection function (Page 58)".

5.8 Diagnostics

5.8.1 Diagnostics via auxiliary and signaling contacts

Signaling contacts on the 3RA61 compact starter (direct starter)

Table 5-13 Status of the signaling contacts on the 3RA61 compact starter (direct starter)

Compact starter status	Actuator	Main contacts	Auxiliary and signaling contacts		
			Auxiliary contacts Querying the position of the main contacts	"Overload" signaling contact	"Fault" signaling contact
Switched off (delivery condition)	○ OFF	Open	13/14: Open	95/96: Closed 95/98: Open	77/78: Open
			21/22: Closed	—	—
Control supply voltage present with actuator set to OFF	○ OFF	Open	13/14: Open	95/96: Closed 95/98: Open	77/78: Open
			21/22: Closed	—	—
Ready	⬇️ READY	Open	13/14: Open	95/96: Closed 95/98: Open	77/78: Closed
			21/22: Closed	—	—
Switched on	⬇️ READY	Closed	13/14: Closed	95/96: Closed 95/98: Open	77/78: Closed
			21/22: Open	—	—
Overload protection function					
Overload tripped	⬇️ READY	Open	13/14: Open	95/96: Open 95/98: Closed	77/78: Closed
			21/22: Closed	—	—
Short-circuit protection function					
Short circuit tripped	TRIPPED	Open	13/14: Open	95/96: Closed 95/98: Open	77/78: Open
			21/22: Closed	—	—
Malfunction (e.g. end of service life reached)					
Malfunction tripped	TRIPPED	Open	13/14: Open	95/96: Closed 95/98: Open	77/78: Open
			21/22: Closed	—	—

Signaling contact 3RA62 compact starter (reversing starter)

Table 5-14 Status of the signaling contacts on the 3RA62 compact starter (reversing starter)





Compact starter status	Actuator	Main contacts		Auxiliary and signaling contacts		
		Direction of rotation 1	Direction of rotation 2	Auxiliary contacts Querying the position of the main contacts	"Overload" signaling contact	"Fault" signaling contact
Switched off (delivery condition)	○ OFF	Open	Open	13/14: Open	95/96: Closed 95/98: Open	77/78: Open
				43/44: Open	—	—
Control supply voltage present with actuator set to OFF	○ OFF	Open	Open	13/14: Open	95/96: Closed 95/98: Open	77/78: Open
				43/44: Open	—	—
Ready	☐ READY	Open	Open	13/14: Open	95/96: Closed 95/98: Open	77/78: Closed
				43/44: Open	—	—
Switched on (direction of rotation 1)	☐ READY	Closed	Open	13/14: Closed	95/96: Closed 95/98: Open	77/78: Closed
				43/44: Open	—	—
Switched on (direction of rotation 2)	☐ READY	Open	Closed	13/14: Open	95/96: Closed 95/98: Open	77/78: Closed
				43/44: Closed	—	—
Overload protection function						
Overload tripped	☐ READY	Open	Open	13/14: Open	95/96: Open 95/98: Closed	77/78: Closed
				43/44: Open	—	—
Short-circuit protection function						
Short circuit tripped	TRIPPED	Open	Open	13/14: Open	95/96: Closed 95/98: Open	77/78: Open
				43/44: Open	—	—
Malfunction (e.g. end of service life reached)						
Malfunction tripped	TRIPPED	Open	Open	13/14: Open	95/96: Closed 95/98: Open	77/78: Open
				43/44: Open	—	—

5.8.2 Diagnostics via display elements

LEDs on the 3RA61 compact starter (direct starter)

Table 5-15 Statuses of the LEDs on the 3RA61 compact starter (direct starter)

Compact starter status	Actuator	LED display		Mechanical display	
		ON I	A1/A2	RLT 0%	TRIP ζ
Switched off (delivery condition)	○ OFF	○	○	■	■
Control supply voltage present with actuator set to OFF	○ OFF	○	☀	■	■
Ready	⏻ READY	○	○	■	■
Switched on	⏻ READY	☀	☀	■	■
Switched on following malfunction	⏻ READY	☀	☀	□	■
Overload protection function					
Overload tripped	⏻ READY	○	☀ OR ○ ¹⁾	■	□
Short-circuit protection function					
Short circuit tripped	TRIPPED	○	☀ OR ○ ¹⁾	■	■
Malfunction (e.g. end of service life reached)					
Malfunction tripped	TRIPPED	○	☀ OR ○ ¹⁾	□	■
Ready following malfunction	⏻ READY	○	○	□	■
Switched on following malfunction	⏻ READY	☀	☀	□	■
¹⁾ Depends on whether control supply voltage is present at the same time ☀ or whether no control supply voltage is present ○					

-  LED: Not illuminated  Mechanical display: No display
 LED: Illuminated green  Mechanical display: White display

LEDs on the 3RA62 compact starter (reversing starter)

Table 5-16 Statuses of the LEDs on the 3RA62 compact starter (reversing starter)

Compact starter status	Actuator	LED display			Mechanical display	
		ON I 1	ON I 2	A1/A2 B1/B2	RLT 0%	TRIP _z
Switched off (delivery condition)	○ OFF	○	○	○	■	■
Control supply voltage (direction of rotation 1 or 2) present with actuator set to OFF	○ OFF	○	○	☀	■	■
Ready	⏻ READY	○	○	○	■	■
Switched on (direction of rotation 1)	⏻ READY	☀	○	☀	■	■
Switched on (direction of rotation 2)	⏻ READY	○	☀	☀	■	■
Switched on following malfunction	⏻ READY	☀ OR ○	○ OR ☀	☀	□	■
Overload protection function						
Overload tripped	⏻ READY	○	○	☀ OR ○ ¹⁾	■	□
Short-circuit protection function						
Short circuit tripped	TRIPPED	○	○	☀ OR ○ ¹⁾	■	■
Malfunction (e.g. end of service life reached)						
Malfunction tripped	TRIPPED	○	○	☀ OR ○ ¹⁾	□	■
Ready following malfunction	⏻ READY	○	○	○	□	■
Switched on following malfunction	⏻ READY	☀ OR ○	○ OR ☀	☀	□	■
¹⁾ Depends on whether control supply voltage is present at the same time ☀ or whether no control supply voltage is present ○						

- LED: Not illuminated
- Mechanical display: No display
- ☀ LED: Illuminated green
- Mechanical display: White display

3RA64/3RA65 compact starter with IO-Link

6.1 Scope of supply

6.1.1 Article numbers

Overview of article numbers

The article number of the 3RA64/3RA65 compact starter with IO-Link is made up of a fixed series of characters plus a number of variables (①, ②, ③, ④ and ⑤):

3RA6 ① 0 - ②③ B4 ④

The variables can be selected from the following table, depending on the required compact starter options:

Variable	Options SIRIUS 3RA6 compact starter	Character string
①	Compact starter <ul style="list-style-type: none"> 3RA64 compact starter with IO-Link (direct starter) 3RA65 compact starter with IO-Link (reversing starter) 	40 50
②	Terminal connection type <ul style="list-style-type: none"> Screw-type connection technology Spring-loaded connection technology 	1 2
③	Current setting range <ul style="list-style-type: none"> 0.1 to 0.4 A 0.32 to 1.25 A 1 to 4 A 3 to 12 A 8 to 32 A 	A B C D E
④	Terminal configuration <ul style="list-style-type: none"> With main circuit terminals and control circuit terminals for attachment to a standard mounting rail. Without main circuit terminals but with control circuit terminals for installation on the SIRIUS infeed system for 3RA6. 	2 3

6.1 Scope of supply

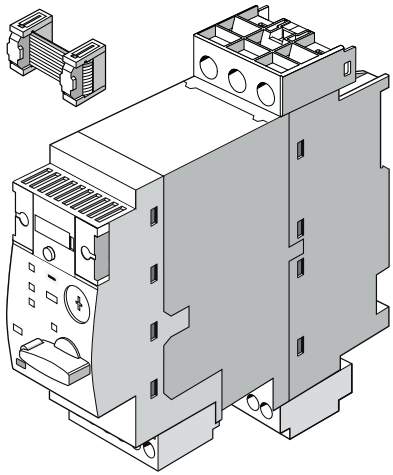
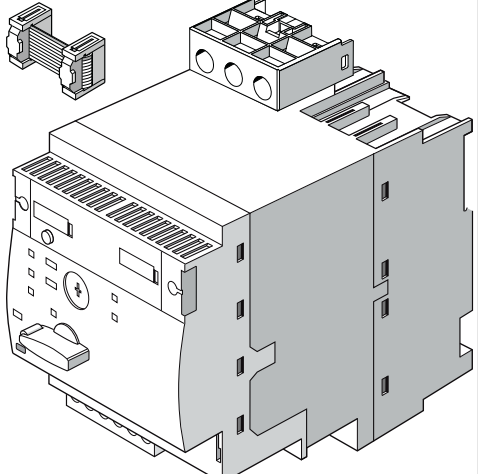
Example

Options SIRIUS 3RA64/3RA65 compact starter	3RA6	①	0 -	②	③	B4	④
Compact starter: Direct starter version		① → 40					
Terminal connection type All terminals with screw-type connection technology.				② → 1			
Current setting range 1 to 4 A					③ → C		
Terminal configuration With main circuit terminals and control circuit terminals for attachment to a standard mounting rail.							④ → 2
Article number:	→ 3RA6	40	0 -	1	C	B4	2

6.1.2 Scope of supply

The equipment of the supplied 3RA64/3RA65 compact starter depends on the version ordered.

Scope of supply of the 3RA64/3RA65 compact starter

System component	Article number	Figure
3RA64 compact starter with IO-Link (direct starter) (incl. connecting cable 14-core, length 8 mm)	3RA64.	
3RA65 compact starter with IO-Link (reversing starter) (incl. connecting cable 14-core, length 8 mm)	3RA65.	

Further accessories for the 3RA64/3RA65 compact starter:

- Connecting cable (Chapter "Connecting cable for IO-Link (Page 226)")
- Operator panel (Chapter "Operator panel for 3RA64/3RA65 compact starter with IO-Link (Page 228)")

6.2 Description of the hardware

6.2.1 Features

General

The 3RA64/3RA65 compact starter with IO-Link is available in the following versions:

- 3RA64 compact starter with IO-Link (direct starter)
- 3RA65 compact starter with IO-Link (reversing starter)

Communication

The 3RA64/3RA65 compact starter with IO-Link communicates via IO-Link.

Setting ranges

The compact starter with IO-Link is available for five current setting ranges and in one control voltage.

- Current setting ranges:
 - 0.1 to 0.4 A
 - 0.32 to 1.25 A
 - 1 to 4 A
 - 3 to 12 A
 - 8 to 32 A
- Control voltage:
 - 24 VDC

6.2.2 3RA64 compact starter with IO-Link (direct starter)

Features

The 3RA64 compact starter (direct starter) with IO-Link is made up of the following components:

- Direct starter
- Two removable main circuit terminals
- One 6-pole control circuit terminal (L+, C/Q, L-, A2-, A1+/Y1, Y2)
- Slot for an optional external auxiliary switch block (2 NO contacts, 2 NC contacts or 1 NC contact + 1 NO contact)

Control takes place via IO-Link.

Configuration of the 3RA64 compact starter with IO-Link (direct starter)

Front view	No.	Display element/operator control
	(1)	"Reset overload trip" button
	(2)	"Manual/auto reset" selector switch
	(3)	"Current setting I_e " setting wheel
	(4)	"Overload trip class" selector switch
	(5)	"Overload protection function" test button
	(6)	Actuator (can be locked in OFF position)
	(7)	Connection point for auxiliary switch block
	(8)	Control circuit terminals
	(9)	Main circuit terminals
	(10)	"Device status" LED display
	(11)	"Main contacts closed" LED display
	(12)	"Group error" LED display
	(13)	"Short-circuit protection function" test button
	(14)	"Malfunction" mechanical display
	(15)	Warning Hazardous electrical voltage! Electrical power can result in electric shock and burns. For this reason, switch off the power to the system and the devices before starting to work!
	(16)	Interface for connecting cable (input)
	(17)	Interface for connecting cable (output)

Display elements and operator controls of the 3RA64 compact starter with IO-Link (direct starter)

No.	Display element/operator control	Marking	Description
(1)	"Reset overload trip" button	RESET ϵ	Press this button to reset the compact starter following an overload.
(2)	"Manual/auto reset" selector switch	RESET M/A	For selecting manual or auto reset following an overload.
(3)	"Current setting I_e " setting wheel	Setting ranges depending on the article number: <ul style="list-style-type: none"> • 0.1 - 0.4 A ϵ • 0.32 - 1.25 A ϵ • 1 - 4 A ϵ • 3 - 12 A ϵ • 8 - 32 A ϵ 	For selecting the current setting I_e .
(4)	"Overload trip class" selector switch	CLASS 10/20	For selecting the overload trip class 10E or 20E.

6.2 Description of the hardware

No.	Display element/operator control	Marking	Description
(5)	"Overload protection function" test button	TEST $\frac{\text{I}}{\text{I}}$	Press this button for at least 5 secs to test the overload protection function.
(6)	Actuator	<ul style="list-style-type: none"> • \bigcirc OFF • \updownarrow READY • TRIPPED 	<ul style="list-style-type: none"> • \bigcirc OFF: Compact starter is out of service. ¹⁾ • \updownarrow READY: Compact starter is ready. ¹⁾ • TRIPPED: Short circuit or malfunction. ¹⁾
(7)	Connection point for auxiliary switch block	—	You can plug an auxiliary switch block into the connection point. ³⁾
(8)	Control circuit terminal	L+, C/Q, L-A2-, A1+/Y1, Y2	Connection terminals for IO-Link and auxiliary voltage and limit switch. ²⁾
(9)	Main circuit terminals	1L1, 3L2, 5L3 2T1, 4T2, 6T3	Connection terminals and main conductor on the line side and outgoing side. ²⁾
(10)	"Device status" LED display	DEVICE	Read the device status of the compact starter: <ul style="list-style-type: none"> • Device OK¹⁾ • Overload, process mapping error, general warning, etc. ¹⁾ • PRESET configuration not equal to ACTUAL configuration ⁴⁾
(11)	"Main contacts closed" LED display	STATE ON I	The LED indicates whether the main contacts are open or closed. ¹⁾
(12)	"Group error" LED display	SF	The LED indicates whether a group error is present. ¹⁾
(13)	"Short-circuit protection function" test button	TEST I>>	Press this button to test the short-circuit protection function.
(14)	"Malfunction" mechanical display	RLT 0%	Indicates either that the compact starter is in order or there is a malfunction. ¹⁾
(15)	Warning notice	—	—
(16)	Interface for connecting cable (input)	—	—
(17)	Interface for connecting cable (output)	—	—

¹⁾ You can find information on the device statuses in "Diagnostics (Page 120)".

²⁾ You can find information on the terminal block pin assignments in "Connecting the 3RA64/3RA65 compact starter with IO-Link (Page 127)".

³⁾ You can find information on the external auxiliary switch block in "External auxiliary switch block (Page 150)".

⁴⁾ Reference to "Parameter "Operation at Preset <> Actual Configuration" (Page 110)".

6.2.3 3RA65 compact starter with IO-Link (reversing starter)

Features

The 3RA65 compact starter (reversing starter) with IO-Link is made up of the following components:

- Reversing starter
- Two removable main circuit terminals
- Two 6-pole control circuit terminals (Type A/B)
(Terminal A: L+, C/Q, L-, A2-, A1+/Y1, Y2
Terminal B: Y3, Y4)
- Two slots for optional external auxiliary switch blocks (2 NO contacts, 2 NC contacts or 1 NO contact + 1 NC contact)

Control takes place via IO-Link.

Direction of rotation interlock

The operating mechanisms for the reversing starter's directions of rotation are interlocked. This precaution prevents the operating mechanisms for direction of rotation 1 and direction of rotation 2 from being activated simultaneously, which would result in a short circuit.

Operating mechanism interlocking is implemented on both a mechanical level (against shock loads) and an electrical level (against incorrect activation).

Note

If direction of rotation 1 and direction of rotation 2 are triggered simultaneously, the compact starter signals a group error and switches off.

6.2 Description of the hardware

3RA65 compact starter with IO-Link (reversing starter)

Front view	No.	Display element/operator control
	(1)	"Reset overload trip" button
	(2)	"Manual/auto reset" selector switch
	(3)	"Current setting I _e " setting wheel
	(4)	"Overload trip class" selector switch
	(5)	"Overload protection function" test button
	(6)	Actuator (can be locked in OFF position)
	(7a)	Connection point for auxiliary switch block (direction of rotation 1)
	(7b)	Connection point for auxiliary switch block (direction of rotation 2)
	(8)	Control circuit terminals
	(9)	Main circuit terminals
	(10)	"Device status" display
	(11)	"Main contacts closed" display
	(12)	"Group error" display
	(13)	"Short-circuit protection function" test button
	(14)	"Malfunction" mechanical display
	(15)	"Direction of rotation 1 triggered" LED display
	(16)	"Direction of rotation 2 triggered" LED display
	(17)	Warning Hazardous electrical voltage! Electrical power can result in electric shock and burns. For this reason, switch off the power to the system and the devices before starting to work!
	(18)	Interface for connecting cable (input)
(19)	Interface for connecting cable (output)	

Display elements and operator controls of the 3RA65 compact starter (reversing starter) with IO-Link

No.	Display element/operator control	Marking	Description
(1)	"Reset overload trip" button	RESET \square	Press this button to reset the compact starter following an overload.
(2)	"Manual/auto reset" selector switch	RESET M/A	For selecting manual or auto reset following an overload.

No.	Display element/operator control	Marking	Description
(3)	"Current setting I_e " setting wheel	Setting ranges depending on the article number: <ul style="list-style-type: none"> • 0.1 - 0.4 A I_e • 0.32 - 1.25 A I_e • 1 - 4 A I_e • 3 - 12 A I_e • 8 - 32 A I_e 	For selecting the current setting I_e .
(4)	"Overload trip class" selector switch	CLASS 10/20	For selecting the overload trip class 10E or 20E.
(5)	"Overload protection function" test button	TEST I_e	Press this button for at least 5 secs to test the overload protection function.
(6)	Actuator	<ul style="list-style-type: none"> • \circ OFF • \cup READY • TRIPPED 	<ul style="list-style-type: none"> • \circ OFF: Compact starter is out of service. ¹⁾ • \cup READY: Compact starter is ready. ¹⁾ • TRIPPED: Short circuit or malfunction. ¹⁾
(7a)	Connection point for auxiliary switch block (direction of rotation 1)	—	You can plug an auxiliary switch block for direction of rotation 1 into the connection point. ³⁾
(7b)	Connection point for auxiliary switch block (direction of rotation 2)	—	You can plug an auxiliary switch block for direction of rotation 2 into the connection point. ³⁾
(8)	Control circuit terminals	L+, C/Q, L-A2-, A1+/Y1, Y2 Y3, Y4	Connection terminals for IO-Link and auxiliary voltage and limit switch (direction of rotation 1) limit switch (direction of rotation 2). ²⁾
(9)	Main circuit terminals	1L1, 3L2, 5L3 2T1, 4T2, 6T3	Connection terminals and main conductor on the line side and outgoing side. ²⁾
(10)	"Device status" display	DEVICE	Read the device status of the compact starter: <ul style="list-style-type: none"> • Device OK¹⁾ • Overload, process mapping error, general warning, etc. ¹⁾ • PRESET configuration not equal to ACTUAL configuration ⁴⁾
(11)	"Main contacts closed" display	STATE ON I	The LED indicates whether the main contacts are open or closed. ¹⁾
(12)	"Group error" display	SF	The LED indicates whether a group error is present. ¹⁾
(13)	"Short-circuit protection function" test button	TEST I>>	Press this button to test the short-circuit protection function.
(14)	"Malfunction" mechanical display	RLT 0%	Indicates either that the compact starter is in order or there is a malfunction. ¹⁾
(15)	"Main contacts closed" LED display (direction of rotation 1)	1 DO 0.0	The LED indicates whether direction of rotation 1 has been triggered. ¹⁾
(16)	"Main contacts closed" LED display (direction of rotation 2)	2 DO 0.1	The LED indicates whether direction of rotation 2 has been triggered. ¹⁾
(17)	Warning notice	—	—

6.2 Description of the hardware

No.	Display element/operator control	Marking	Description
(18)	Interface for connecting cable (input)	—	—
(19)	Interface for connecting cable (output)	—	—

- 1) You can find information on the device statuses in "Diagnostics (Page 85)".
- 2) You can find information on the terminal block pin assignments in "Connecting the 3RA64/3RA65 compact starter with IO-Link (Page 127)".
- 3) You can find information on the external auxiliary switch block in "External auxiliary switch block (Page 150)".
- 4) Reference to "Parameter "Operation at Preset <> Actual Configuration" (Page 110)".

6.3 Configuring

6.3.1 SIRIUS configurator

Reference

The "Compact Starters 3RA6 and Infeed System for 3RA6" configurator is available on the Internet to assist you with configuration. Here, you can gather together all necessary products before the actual configuration process and you can realize complete projects virtually.

You can find the configurator on the Internet (<http://www.siemens.com/sirius/configurators>).

6.3.2 Combinations

IO-Link master and IO-Link device combinations are shown in the following table.

IO-Link master...	IO-Link device...	
	... according to IO-Link communication specification V1.0	... according to IO-Link communication specification V1.1
...according to IO-Link communication specification V1.0	Operation according to specification V1.0	Operation according to specification V1.0
...according to IO-Link communication specification V1.1	Operation according to specification V1.0	Operation according to specification V1.1¹⁾

¹⁾ By selection of IODD V1.0.1, the device can be operated according to IO-Link communication specification V1.0.

Differences between IO-Link communication specifications V1.0 and V1.1

- Usable IO-Link telegram length (not relevant)
- Application-specific name:
 - V1.0: 64 bytes max.
 - V1.1: 32 bytes max.
- IO-Link device LED:
 - V1.0: Green
 - V1.1: Green blinking

6.3 Configuring

- Device ID:
 - V1.0: 0x00
 - V1.1: 0x01
- Parameter server functionality:
 - V1.0: not available
 - V1.1: available

The 3RA64 and 3RA65 compact starters are designed as an IO-Link device according to IO-Link communication specification V1.0.

6.3.3 Configuring with STEP 7 and the S7-PCT Port Configuration Tool

6.3.3.1 Basic procedure and prerequisites

Procedure when configuring IO-Link master and IO-Link devices

Configuration takes place in two steps with STEP 7, V5.4 SP5 or STEP 7 TIA Portal, V12.0 or higher:

1. Configuring the IO-Link master in *HW Config*. You will find IO-Link master on the Internet (<http://www.siemens.com/industrymall>) under "Automation" > "Industrial communication" > "IO-Link" > "Master".
2. With the Port Configuration Tool *S7-PCT*, you configure the connected IO-Link devices.

Note

You will find an application example of how to read and write process data and parameterization data of IO-Link devices on the Internet (<https://support.industry.siemens.com/cs/ww/en/view/90529409>).

Requirements

- STEP 7 V5.4 SP5 or higher (you can download Service Pack 5 from the Internet (<http://support.automation.siemens.com/WW/view/en/36184684>)) or STEP 7 TIA Portal V12.0 or higher.
- The Port Configuration Tool *S7-PCT* is installed on the PG/PC. You can either install *S7-PCT* together with STEP 7, or you can download it from the Internet (<http://support.automation.siemens.com/WW/view/en/37936752>).
- IO-Link IODD (IO Device Description) files are installed in the *S7-PCT hardware catalog*. You can download all current IODD files for the SIRIUS devices from the Internet (<http://support.automation.siemens.com/WW/view/de/29801139/133100>). IODD files for V1.0 and V1.1 are available for the combination of an IO-Link master and an IO-Link device according to the IO-Link communication specification V1.1. You may need IODD files according to the IO-Link communication specification V1.0 when replacing devices in existing installations.

- The GSD files of the IO-Link masters are already installed in *STEP 7 HW Config*. You can download all current GSD files for the Siemens IO-Link masters from the Internet (<http://www.siemens.com/comdec>).
- Optional: Install the IO_LINK_MASTER and IO_LINK_DEVICE function blocks for backing up / restoring IO-Link master parameters, IO-Link device parameters, parameterization of IO-Link devices during operation, and readout of IO-Link port functions. You can find the function blocks on the Internet (<https://support.industry.siemens.com/cs/de/en/view/82981502>). You can find more information about the function blocks in chapters Acyclic data exchange with the IO_LINK_DEVICE (Page 103) function block and Acyclic data exchange with the IO_LINK_MASTER function block (Page 103).

6.3.3.2 Configuration

Configuring the IO-Link master in *HW Config*

1. Start the SIMATIC Manager (*STEP 7*) or the TIA Portal and configure the project as described in the *STEP 7* online help.
2. Select the IO-Link master in the hardware catalog of *HW Config*.
3. Drag and drop the IO-Link master from the hardware catalog to the configuration table.
4. Select the IO-Link master in the configuration table (*STEP 7*)/device view (TIA Portal).
5. Press the right mouse button and select "**Object Properties**" from the shortcut menu.
Result: The "**Properties**" window of the IO-Link master opens.
6. Check the settings of the addresses.
Every IO-Link master port needs a corresponding overall address range depending on the IO-Link device used.

Configuring the IO-Link device with the *S7-PCT* port configuration tool

1. Select the configured IO-Link master.
2. Press the right mouse button and select "**Start device tool**" (*STEP 7* or TIA Portal)/"**Configure IO-Link**" (*STEP 7* or TIA Portal) from the shortcut menu depending on the configuration tool used.
3. Select the IO-Link device in the component catalog of the *S7-PCT* port configuration tool.
4. Drag the IO-Link device out of the component catalog to the required port of the IO-Link master.
5. Start by parameterizing the IO-Link device.
Additional information is available in the *S7-PCT* online help.

6.3 Configuring

6.3.4 Configuring with the S7-PCT port configuration tool (stand-alone)

6.3.4.1 Application

Configuration is always done with the S7-PCT port configuration tool whenever no SIMATIC CPU is available.

6.3.4.2 Basic procedure and prerequisites

Basic procedure when configuring IO-Link master and IO-Link devices with the S7-PCT port configuration tool (stand-alone)

1. You configure the connected IO-Link devices with the *S7-PCT V2.0* port configuration tool.

Requirements

- The *S7-PCT* port configuration tool is installed on the PG/PC. You can either install *S7-PCT* together with STEP 7 V5.4 SP5 or higher or STEP 7 TIA Portal V12.0 or higher, or you can download it from the Internet (<http://support.automation.siemens.com/WW/view/en/37936752>).
- IO-Link IODD files (IO Device Description) are installed in the *S7-PCT* hardware catalog. All current IODD files of the SIRIUS devices are available on the Internet (<http://support.automation.siemens.com/WW/view/en/29801139/133100>). IODD files for V1.0 and V1.1 are available for the combination of an IO-Link master and an IO-Link device according to the IO-Link communication specification V1.1. You may need IODD files according to the communication specification V1.0 when replacing devices in existing installations.

Note

Configuring with *S7-PCT* stand-alone is not possible for the CPU versions of the ET 200.

6.3.4.3 Configuration

Configuring the IO-Link device with the S7-PCT port configuration tool

1. Start the *S7-PCT* port configuration tool.
2. Create a new project or open an existing project as described in the online help.
3. Select a bus category (PROFIBUS DP/PROFINET IO).
4. Select an IO-Link master.
5. Select the IO-Link device in the component catalog of the *S7-PCT* port configuration tool.
6. Drag the IO-Link device out of the component catalog to the required port of the IO-Link master.

7. Load the configuration into the IO-Link master before parameterizing the IO-Link device.
8. Start by parameterizing the IO-Link device.

Additional information is available in the *S7-PCT* online help.

Note

To be able to access the IO-Link master or an IO-Link device online, communication between the ET 200 and the higher-level controller must be active (BF-LED on ET 200 interface module is off).

6.3.5 Acyclic data exchange with the IO_LINK_DEVICE function block

For acyclic data exchange, the IO_LINK_DEVICE function block is available as a download for controllers of the S7 families.

The block supports you in the following tasks:

- Parameterization of an IO-Link device during operation
- Executing IO-Link port functions
- Backing up/restoring IO-Link device parameters

Requirement

- Install the "IO_LINK_DEVICE" function block.
You can download the IO_LINK_DEVICE function block and the description from the Internet (<https://support.industry.siemens.com/cs/ww/en/view/82981502>).

Procedure when using the IO_LINK_DEVICE function block

1. Copy the IO_LINK_DEVICE function block (including data block DB10) to a STEP 7 project.
2. Use the IO_LINK_DEVICE function block as described in the documentation.
3. You can find an application example of how to use the IO-Link devices with the IO_LINK_DEVICE function block on the Internet (<https://support.industry.siemens.com/cs/ww/en/view/90529409>).

6.3.6 Acyclic data exchange with the IO_LINK_MASTER function block

For acyclic data exchange, the IO_LINK_MASTER function block is available as a download for controllers of the S7 families.

With the help of this block, you can back up or restore the device parameters and settings of an IO-Link communication module (e.g. ET 200SP CM 4xIO-Link) via the S7 program.

Requirement

- Install the "IO_LINK_MASTER" function block.
You can download the IO_LINK_DEVIDE function block and the description from the Internet (<https://support.industry.siemens.com/cs/ww/en/view/82981502>).

Procedure when using the IO_LINK_MASTER function block

1. Copy the IO_LINK_MASTER function block (including data block DB10) to a STEP 7 project.
2. Use the IO_LINK_MASTER function block as described in the documentation.
3. You can find an application example of how to use the IO-Link masters with the IO_LINK_MASTER function block on the Internet (<https://support.industry.siemens.com/cs/ww/en/view/90529409>).

6.3.7 Replacing an IO-Link device

6.3.7.1 Introduction

To replace compact starters with IO-Link, the devices must be disconnected and isolated from the communication. The complete group of load feeders becomes inactive. After removal of the connections between the load feeders, the applicable module can be replaced. After the connections have been restored and communication has been resumed, the parameterization can be restored according to the respective IO-Link communication specification:

- IO-Link communication specification V1.0: concerning the IO_LINK_DEVICE function block.

6.3.7.2 Replacement of an IO-Link device (according to IO-Link communication specification V1.0)

Upon replacement of a compact starter with IO-Link, the plug-in connection to the IO-Link port can be removed without isolating the control voltage supply.

Parameter data and configuration data specially optimized by the user for a specific application are stored in an IO-Link-Device. This data deviates in many cases from the default values stored in the IO-Link-Device.

In the event of replacement of an IO-Link-Device (referred to below as a "module"), the optimized data must be transferred to the new module because the parameters are stored only in the IO-Link device itself.

Data can be transferred via two channels:

- Module replacement with PG/PC
- Module replacement without PG/PC

Procedure with PG/PC

In the event of a replacement, a PG/PC is available with the SIMATIC project of the plant.

With the data stored in the SIMATIC project, and the *S7-PCT* port configuration tool, you transfer the parameters belonging to the replaced IO-Link-Device to the new IO-Link-Device.

Procedure without PG/PC

Requirements

- Install the IO_LINK_DEVICE function block.
You obtain the IO_LINK_DEVICE function block and the description on the Internet (<https://support.industry.siemens.com/cs/ww/en/view/82981502>).

After completion of commissioning, a PG/PC with the project is no longer available to the plant. For backing up and restoring the parameter data and configuration data from or to a module, the IO_LINK_DEVICE function block is available for the SIMATIC controllers of the S7 family.

With this function block, you back up all relevant data records of a module after commissioning, in a data block (DB), for example. In the event of a replacement, write the relevant data from the data block to the replaced module with the IO_LINK_DEVICE function block.

Refer to the appendix "Data sets for the 3RA64/3RA65 compact starter with IO-Link (Page 267)" for data records to be backed up for a module.

Procedure

1. Copy the IO_LINK_DEVICE function block (including data block DB10) to a STEP 7 project.
2. Use the IO_LINK_DEVICE function block as described in the documentation.
3. You will find an application example of how to use the IO-Link devices with the IO_LINK_DEVICE function block on the Internet (<http://support.automation.siemens.com/WW/view/en/90529409>).

Note

An IO-Link Device is a module that communicates with the IO-Link master via its communication connection. With the special cases "SIRIUS 3RA64/65 compact starter " and "SIRIUS 3RA2711 function modules", where group formations of up to four starters are possible, the above information refers to the replacement of the first load feeder. Replacement of load feeders 2 to 4 of a group of four does not require any supplementary measures.

6.3.8 Integration into the SIMATIC environment

Integration into the SIMATIC environment

Systematic diagnostics concepts and efficient handling of parameter data are demanded at all levels of automation engineering. It is essential here that sensors and switching devices are integrated into the automation network. The communication standard IO-Link offers new possibilities in this regard by means of intelligent connection of sensors and switching devices to the control level. The core points are switching, protecting, monitoring, commanding and signaling at the field level. A block library is designed to make it easier for end users to connect the IO-Link devices, and to demonstrate use of the library using actual examples

You can download the library from the Internet (<https://support.industry.siemens.com/cs/ww/en/view/90529409>) free of charge.

6.4 Parameters

Parameters

The following parameters can be set:

- Type of starter
- Starter available
- Operation at Preset <> Actual Configuration
- Operator panel available

Notes on parameter assignment

Parameters can only be assigned when the compact starters do not receive any control signals from the bus.

The parameterization is saved in the compact starter of a starter group connected to the IO-Link master via the removable terminal.



WARNING

Danger of uncontrolled motor start-up

The preset configuration of a compact starter group is saved by the compact starter connected to the IO-Link master via the removable terminal.

When this compact starter is replaced, you must ensure that the preset configuration is saved in the new compact starter. In the event of a replacement, the preset configuration can either be transferred to the new device with the "Port Configuration Tool", or it can be copied from the old compact starter to the new compact starter with the help of the function block "IO-Link Call".

6.4.1 "Starter available" parameter

"Starter available" parameter

The "Starter available" parameter enables removal of individual starters from the configuration. This is useful above all when existing configurations are re-used but individual modules are not implemented.

The table below shows the parameter values.

Table 6-1 "Starter available" parameter

Value	Description	Default setting
0	Starter not available	—
1	Starter available	yes ¹⁾

¹⁾ 4 starters are configured in the compact starter as delivered from the factory. If fewer starters are required, this must be configured.

Please note that the "Starter available" parameter affects the PRESET-ACTUAL comparison. If you parameterize 3 or fewer starters in a starter group, the PRESET-ACTUAL comparison automatically becomes active.

Practical implementation

Use the following connecting cable to bridge gaps in the configuration arising from a missing 3RA64/3RA65 compact starter with IO-Link:

- 14-core, 200 mm (3RA6933-0A)
- 10-core, 200 mm (3RA6933-0B)

Note

10-core connecting cable!

If you use the 10-core connecting cable, you must re-supply the auxiliary voltage V_{Aux} after the empty location.

You can find more information on the connecting cables in "Connecting cable for IO-Link (Page 226)".

View

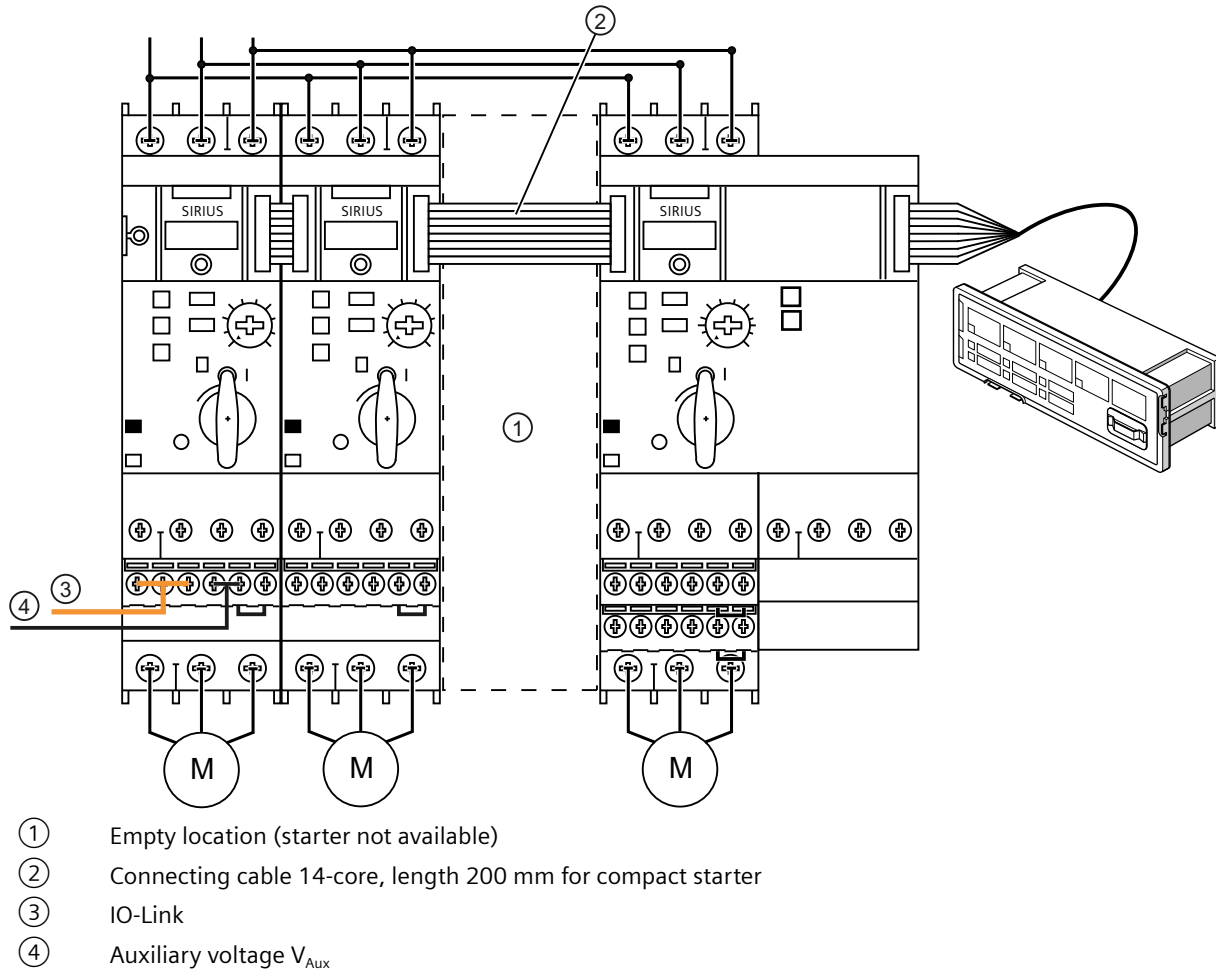


Figure 6-1 Configuration with "Starter available" parameter = nein

6.4.2 "Type of starter" parameter

"Type of starter" parameter

With the "Type of starter" parameter, a compact starter with a defined current setting range is assigned to the starters of a starter group. The table below shows the values for compact starters.

Table 6-2 "Type of starter" parameter

Value	Type of starter	Default setting
1	Any starter type	Any starter type
10	3RA64	—
11	3RA64 (0.1 to 0.4 A)	—

6.4 Parameters

Value	Type of starter	Default setting
12	3RA64 (0.32 to 1.25 A)	—
13	3RA64 (1 to 4 A)	—
14	3RA64 (3 to 12 A)	—
15	3RA64 (8 to 32 A)	—
20	3RA65	—
21	3RA65 (0.1 to 0.4 A)	—
22	3RA65 (0.32 to 1.25 A)	—
23	3RA65 (1 to 4 A)	—
24	3RA65 (3 to 12 A)	—
25	3RA65 (8 to 32 A)	—

If the current setting range of the compact starter is not important for configuring, the value 1 can be assigned to the starter type 3RA64 or 3RA65. The parameter cannot then be used to draw any conclusions regarding the current setting range.

6.4.3 Parameter "Operation at Preset <> Actual Configuration"

Parameter "Operation at Preset <> Actual Configuration"

The "Operation at Preset <> Actual Configuration" parameter determines whether or not the types of starter of the ACTUAL configuration are to be compared with those of the PRESET configuration.

The table below shows the values for the "Operation at Preset <> Actual Configuration" parameter.

Table 6-3 Parameter "Operation at Preset <> Actual Configuration"

Value	Description	Default setting
0	Operation at Preset <> Actual Configuration: disable	disable
1	Operation at Preset <> Actual Configuration: enable	—

If you parameterize 3 or fewer starters in a starter group, the "Operation at Preset <> Actual Configuration" parameter is automatically set to the value 0.

Note

The number of configured compact starters is checked continuously, regardless of the "Operation at Preset <> Actual Configuration" parameter value.

You can find more information on the data sets in "Data sets for the 3RA64/3RA65 compact starter with IO-Link (Page 267)".

6.4.4 Operation with operator panel

6.4.4.1 "Operator panel available" parameter

With the "Operator panel available" parameter, you determine whether or not an operator panel is available for operating the compact starters.

In conjunction with the "Operation at Preset <> Actual Configuration" parameter, operation of the compact starters with or without operator panel can be configured (see Chapter "Parameter "Operation at Preset <> Actual Configuration" (Page 111)").

Use of the operator panel is above all useful if manual intervention in an application is an indispensable requirement for operating the plant, or to enable manual intervention in an emergency.

The table below shows the values for the "Operator panel available" parameter.

Table 6-4 "Operator panel available" parameter

Value	Description	Default setting
0	Operator panel available: No	—
1	Operator panel available: Yes	Yes

The "Operator panel available" parameter can only be modified via IO-Link. It cannot be adjusted at the device.

6.4.4.2 Parameter "Operation at Preset <> Actual Configuration"

The "Operation at Preset <> Actual Configuration" parameter sets the severity level of the test for the "Operator panel available" parameter.

The table below shows the values for the "Operation at Preset <> Actual Configuration" parameter.

Table 6-5 Parameter "Operation at Preset <> Actual Configuration"

Value	Description	Default setting
0	Operation at Preset <> Actual Configuration: disable	—
1	Operation at Preset <> Actual Configuration: enable	enabled

If the parameter value "Operation at Preset <> Actual Configuration" is set to "disable", operation of the compact starters is only possible if the parameter setting "Operator panel available" is fulfilled precisely.

If the parameter value "Operation at Preset <> Actual Configuration" is set to "enable", operation of the compact starters is possible via IO-Link regardless of whether or not an operator panel is connected.

The following table shows the effects of the sample parameter values set:

Table 6-6 Parameter setting - example of operation with operator panel

Set parameter values	Practical implementation		
	Operator panel available	Operator panel not available	Operator panel is disconnected during operation
"Operator panel available" = "Yes" and "Operation at Preset <> Actual Configuration" = "disable"	Operation of the compact starter possible.	Operation of the compact starters not possible.	The compact starter shuts down. Further operation of the device is not possible.

The parameter "Operation at Preset <> Actual Configuration" can only be modified via IO-Link. It cannot be adjusted at the device.

6.5 Process image

Process input image (PII)

The process input image contains the important status information of all compact starters.

You can find the causes of group faults and group warnings via "Group diagnostics - data set (index) 90 (Page 271)".

Table 6-7 Read process data - Status information of the compact starter

Starter	DI (2 bytes)	Meaning
1	DI0.0	1: Ready (automatic)
	DI0.1	1: Motor ON
	DI0.2	1: Group fault
	DI0.3	1: Group warning
2	DI0.4	1: Ready (automatic)
	DI0.5	1: Motor ON
	DI0.6	1: Group fault
	DI0.7	1: Group warning
3	DI1.0	1: Ready (automatic)
	DI1.1	1: Motor ON
	DI1.2	1: Group fault
	DI1.3	1: Group warning
4	DI1.4	1: Ready (automatic)
	DI1.5	1: Motor ON
	DI1.6	1: Group fault
	DI1.7	1: Group warning

Process image output (PIQ)

The process output image contains the control commands for all compact starters.

Table 6-8 Write process data - Control commands for the compact starter

Starter	DO (2 bytes)	Meaning
1	DO0.0	1: Motor direction of rotation 1
	DO0.1	1: Motor direction of rotation 2 ¹⁾
	DO0.2	1: Reserved
	DO0.3	1: Trip reset ²⁾
2	DO0.4	1: Motor direction of rotation 1
	DO0.5	1: Motor direction of rotation 2 ¹⁾
	DO0.6	1: Reserved
	DO0.7	1: Trip reset ²⁾

6.5 Process image

Starter	DO (2 bytes)	Meaning
3	DO1.0	1: Motor direction of rotation 1
	DO1.1	1: Motor direction of rotation 2 ¹⁾
	DO1.2	1: Reserved
	DO1.3	1: Trip reset ²⁾
4	DO1.4	1: Motor direction of rotation 1
	DO1.5	1: Motor direction of rotation 2 ¹⁾
	DO1.6	1: Reserved
	DO1.7	1: Trip reset ²⁾

¹⁾ Only in the case of the reversing starter.

²⁾ You can find information on the trip reset in "Overload protection function (Page 116)".

For additional information, please refer to " Group diagnostics - data set (index) 90 (Page 271) ".



6.6 Functions

6.6.1 Normal switching duty


Normal switching duty

Compact starters are used primarily for switching and protecting motors.

The actuator has three positions:

-  READY: Compact starter is ready.
-  OFF: Compact starter is out of service.
- TRIPPED: Malfunction or short circuit trip.

Actuator OFF

When the actuator is in the  OFF position, the main contacts are open and the active areas of the control electronics are disconnected. Only the thermal motor model, the communication and the display elements remain in operation.

Actuator READY

The circuit breaker mechanism (breaker latching mechanism) in the compact starter is switched on and the compact starter is ready.

 WARNING
<p>Machine start-up!</p> <p>If the "DO 0.0" or the "DO 0.1" LED is illuminated and you switch the actuator of the compact starter to READY, the machine will start up immediately. People may be injured if they stay in the danger area of the machine.</p> <p>Make sure that the danger area of the machine is kept clear of people.</p>

Actuator TRIPPED



The compact starter has shut down because a malfunction or short circuit has been detected.

The actual trigger event can be identified by referring to the "RLT 0%" display window.

6.6 Functions


When the actuator is in the TRIPPED position, the 3RA64 compact starter (direct starter) and the 3RA65 compact starter (reversing starter) can adopt the following statuses:

Table 6-9 Actuator TRIPPED display elements (direct/reversing starter)

Actuator	Mech. display	Compact starter status
	RLT 0%	
TRIPPED	 No display	Short circuit tripped
TRIPPED	 White display	Malfunction (e.g. end of service life reached)

Note

Turning the actuator manually to the TRIPPED position.

The actuator can also be moved to the TRIPPED position manually. In this case, it is not possible to say whether a short circuit has occurred or whether the actuator has been moved to the TRIPPED position manually simply by looking at the display elements. However, if the actuator has been moved to the TRIPPED position manually, you can turn it back from the TRIPPED position to the  READY position straight away. This will not be possible if a short circuit trip has occurred.

For additional information on eliminating malfunctions, please refer to "Shutdown on malfunction (Page 61)".

For additional information on eliminating short circuits, please refer to "Short-circuit protection function (Page 59)".

6.6.2 Overload protection function

Overload protection function, phase loss protection

The compact starter protects three-phase motors against overload. In addition, the compact starter is provided with phase loss protection to prevent excessive heating of the load in single phasing if phase loss occurs. In both cases, the compact starter switches off without opening the breaker latching mechanism.

When operating with single-phase loads, the phase loss protection must be compensated to prevent premature tripping. This is done by selecting the setting current on the compact starter higher than the operating current I_e of the motor by a factor of 1.6.

Operator controls

The following operator elements are available to you on the compact starter to guarantee optimal overload protection:

- "Current setting I_e " setting wheel: Set the rated operating current of the load on the "Setting current I_e " setting wheel.
- "Manual/auto reset" selector switch: Use the "Manual/auto reset selector switch" to determine how the compact starter is reset after an overload trip.
 - **Manual reset "M"**: You must reset the compact starter manually by:
 - sending the control command "Trip Reset" via IO-Link (value change from 0 to 1 or from 1 to 0).
 - pressing the "Reset" button on the operator panel ("Operator panel for 3RA64/3RA65 compact starter with IO-Link (Page 228)").
 - pressing the blue Reset button.
 - **Auto reset "A"**: The compact starter resets itself autonomously after approximately 3 minutes. If an ON command is present via IO-Link from this point, the compact starter switches on again. Manual reset is possible at any time in this setting.



WARNING

Automatic machine restart!

If an ON command via an IO-Link is present after an overload trip and a manual reset or auto reset is performed, the machine will start up immediately. People may be injured if they stay in the danger area of the machine.

Make sure that the danger area of the machine is kept clear of people.

- "Overload trip class" selector switch: For selecting trip CLASS 10E or CLASS 20E.

Display concept

The status "Overload tripped" is indicated via the LEDs on the 3RA64/3RA65 compact starter with IO-Link. For information, please refer to "Diagnostics (Page 120)".

Messages via IO-Link

You can find information about the parameters in Parameters (Page 107).

Function test

To test the overload protection function, press the "TEST $\frac{1}{2}$ " button ("Overload protection function" test button). Press the test button for approximately 5 seconds. The compact starter must be switched on while pressing the button and a load current of I must flow in the main circuit.

When the test button is pressed, the evaluation electronics simulate an overload that causes tripping and activates the overload message via IO-Link. The "Group fault" LED also lights up.

6.6 Functions

Motor model

Depending on the operating time of the motor and the current load, the electronics continuously calculate the thermal load of the motor on the basis of a model. The motor model charges when the compact starter is switched on. The motor model discharges after switching off. The motor model is fully discharged after approximately 3 minutes.

If you carry out a manual reset within 3 minutes although the motor model has not yet sufficiently discharged, another overload trip can occur when the compact starter is switched on.

Interruption of the auxiliary voltage V_{Aux}

If an interruption of the auxiliary voltage ($V_{Aux} = 0$) occurs on the 3RA64/3RA65 compact starter, the motor model is deleted.

If this interruption takes place within 3 minutes after switching off the compact starter, the time until auto reset is extended by the duration of the interruption to the auxiliary voltage.

Note

Danger of another overload trip after an interruption to V_{Aux} !

The motor model is deleted following an interruption to V_{Aux} . If, therefore, a reset is carried out following an interruption to V_{Aux} , another overload trip can result since the motor will not yet have cooled sufficiently.

Do not switch the compact starter on again until the motor has cooled sufficiently.

6.6.3 Short-circuit protection function

Short-circuit protection function

The short-circuit protection function of the 3RA64/3RA65 compact starter functions in the same way as on the 3RA61/3RA62 compact starter.

For additional information, please refer to "Short-circuit protection function (Page 59)".

Messages via IO-Link

You can find information on the data sets in Data sets for the 3RA64/3RA65 compact starter with IO-Link (Page 267).

6.6.4 Shutdown on malfunction

Malfunction

The function "Shutdown on malfunction" on the 3RA64/3RA65 compact starter with IO-Link functions in the same way as on the 3RA61/3RA62 compact starter.

For additional information, please refer to " Shutdown on malfunction (Page 61) ".

Messages via IO-Link

You can find information on the data sets in Data sets for the 3RA64/3RA65 compact starter with IO-Link (Page 267).

6.6.5 Disabling the actuator

You can disable the actuator on the 3RA64/3RA65 compact starter with IO-Link in the same way as on the 3RA61/3RA62 compact starter.

For additional information, please refer to " Disabling the actuator (Page 62) ".




































































6.7 Diagnostics

6.7.1 Diagnostics via display elements

LEDs/actuator/display on the 3RA64/3RA65 compact starter with IO-Link

Table 6-10 LEDs/actuator/display on the 3RA64/3RA65 compact starter with IO-Link

Compact starter status	3RA65 (reversing starter)							
	3RA64 (direct starter)						1 (DO0.0)	2 (DO0.1)
	Actuator	DEVICE	STATE / ON 1	SF	RLT 0%			
Switched off (delivery condition)	○ OFF	○ Off	○ Off	○ Off	□ Off	○ Off	○ Off	
$V_{Aux} = 0$	X	○ Off	○ Off	○ Off	X	○ Off	○ Off	
Control priority								
Control priority via IO-Link (auto-automatic mode)	☺ READY	☀ Green	X	○ Off	□ Off	X	X	
Control priority via IO-Link Group fault occurred	X	☀ Green	○ Off	☀ Red	□ Off	○ Off	○ Off	
Control priority via operator panel (manual mode)	☺ READY	☀ Flashing yellow	X	○ Off	□ Off	X	X	
Control priority via operator panel Group fault occurred during manual operation	X	☀ Flashing yellow	○ Off	☀ Red	□ Off	○ Off	○ Off	
Activation								
Motor direction 1 activated Control priority: IO-Link/ Manual operation	☺ READY	☀ Green/ Flashing yellow	☀ Green	○ Off	□ Off	☀ Green	○ Off	
Motor direction 2 activated Control priority: IO-Link/ Manual operation	☺ READY	☀ Green/ Flashing yellow	☀ Green	○ Off	□ Off	○ Off	☀ Green	
Process image error	☺ READY	☀ Yellow	○ Off	☀ Red	□ Off	☀ Green	☀ Green	
Error messages								

Compact starter status	3RA65 (reversing starter)						
	3RA64 (direct starter)					1 (DO0.0)	2 (DO0.1)
	Actuator	DEVICE	STATE / ON 1	SF	RLT 0%		
The device is defective	X	 Red	X	 Red		X	X
IO-Link power supply missing ¹⁾	X	 Flashing red	X	 Red		X	X
Short-circuit function							
Short circuit tripped	TRIPPED	X	 Off	 Red		X	X
Overload tripping							
Overload tripped (3RA64)	 READY	 Flashing yellow	 Off	 Red	X	X	X
Overload tripped direction of rotation 1	 READY	 Yellow	 Off	 Red		 Green	 Off
Overload tripped direction of rotation 2	 READY	 Yellow	 Off	 Red		 Off	 Green
Limit function							
Limit switch tripped (3RA64) Ready/ Direction 1	 READY	 Green/ Yellow	 Off	 Red		X	X
Limit switch 1 tripped and direction of rotation 1 triggered	 READY	 Yellow	 Off	 Red		 Green	 Off
Limit switch 1 tripped and opposite direction 2 triggered	 READY	 Green	 Green	 Red		 Off	 Green
Limit switch 2 tripped and direction of rotation 2 triggered	 READY	 Yellow	 Off	 Red		 Off	 Green
Limit switch 2 tripped and opposite direction 1 triggered	 READY	 Green	 Green	 Red		 Green	 Off
Malfunction							
First trip on malfunction	TRIPPED	 Red	 Off	 Red	 White	 Off	 Off
Continuous display tripped on malfunction ²⁾	X	X	X	X	 White	X	X

X = not relevant

6.7 Diagnostics

- 1) Check the connection between the connecting terminals (ground) of the IO-Link Master (A3, A4, A7, and A8) and the connecting terminals (ground) of the power module (A1, A4, A7, and A8).
- 2) After setting the actuator to READY.

6.7.2 Diagnostics via IO-Link

Fault types of the 3RA64/3RA65 compact starter

IO-Link errors are mapped to PROFIBUS DP errors. Mapping takes place as described in IO-Link Integration Part 1 or in accordance with vendor-specific definitions from Siemens.

Table 6-11 IO-Link event display

PROFIBUS DP error type		Description (IO-Link error code)	Group error (SF)	Group warn- ing (SW)
0x1	00001: Short-circuit	Circuit breaker tripped n-release	X	—
0x9	01001: Error	Contact block defective	X	—
0x11	10001: No encoder or load voltage	No contact block supply voltage	X	—
0x18	11000: Actuator disconnection	Overload tripped	X	—
0x10	10000: Parameterization error	Target configuration not equal to actual configuration	X	—
0x1A	11010: External error	Input shutdown - Limit direction of rotation 1 or direction of rotation 2	X	—
0x13	10011: Communication fault	Configuration change rejected, PIQ not equal to 0	X	—
—	—	Manual operation connection aborted	—	X
—	—	Manual operation	—	X

Note

You can read out other diagnostics information via the "Group diagnostics - data set (index) 90 (Page 271)".

Note


For IO-Link devices supplied by Siemens, the manufacturer-specific range 0x8CA0 to 0x8CBF will be mapped to the PROFIBUS DP error types 0 to 31.

You can get more information in the manual "IO-Link 4SI SIRIUS Master Electronics Module" (3RK1005-OLB00-0AA0).

6.8 Installing/removal

Warning notice before installation, wiring, and commissioning



 DANGER
Hazardous voltage. Will cause death or serious injury.
Turn off and lock out all power supplying this device before working on this device.

6.8.1 Installing the 3RA64/3RA65 compact starter with IO-Link

Installation

Install the 3RA64/3RA65 compact starter with IO-Link in the same way as the 3RA61/3RA62 compact starter.

You can find information on installing in Chapter "Installing/removal (Page 63)".

Note

Transfer parameter assignment.

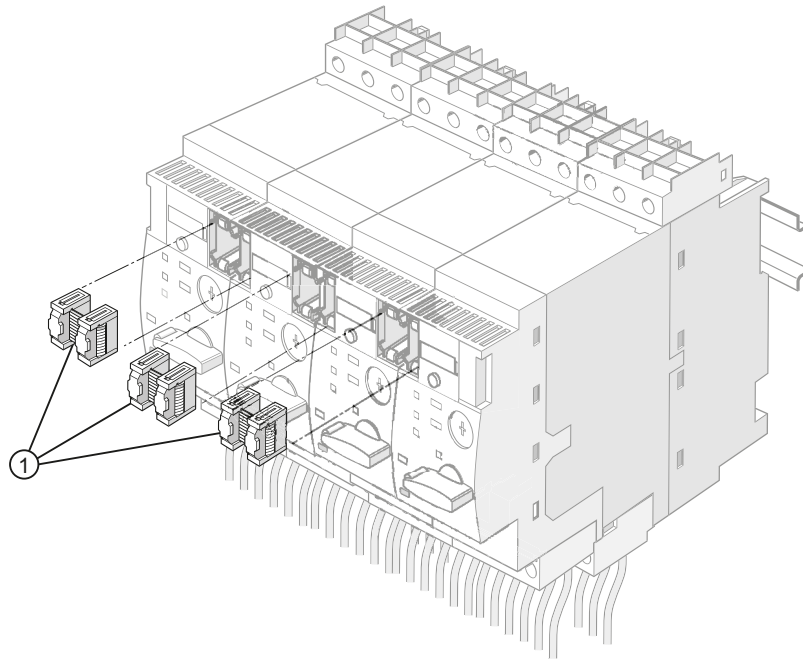
If you replace the 3RA64/3RA65 compact starter with IO-Link with a new compact starter, you must transfer the parameter data and configuration data to the new compact starter.

You can find information on replacing a module in Chapter "Replacing an IO-Link device (Page 104)".

Structure of a compact starter group

Up to 4 compact starters can be connected to one IO-Link master. For this purpose, connect the first compact starter direct with the IO-Link master. You connect the 3 other compact starters in series with each other. A 14-core connecting cable (8 mm) is available for this purpose.

The representation below shows how the compact starters are connected to each other.

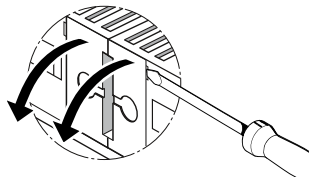


① Connecting cable 14-core (8 mm)

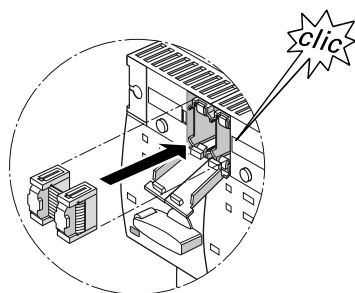
Figure 6-2 Connecting 3RA64/3RA65 compact starters with IO-Link

You can find more information on connecting the operator unit in Chapter "Operator panel for 3RA64/3RA65 compact starter with IO-Link (Page 228)".

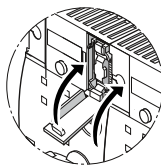
Plugging in the connecting cables



① Open the cover for the interface for the connecting cable.



② Plug the connecting cable into the interface until you hear it engage.



③ Close the interface cover.

6.8.2 Removing the 3RA64/3RA65 compact starter with IO-Link

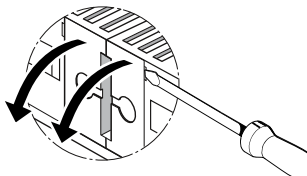
Removal

Remove the 3RA64/3RA65 compact starter with IO-Link in the same way as the 3RA61/3RA62 compact starter.

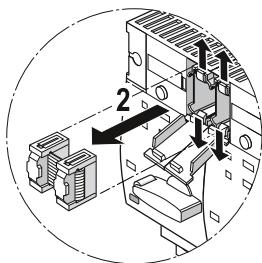
You can find information on removal in Chapter "Removing the 3RA61/3RA62 compact starter (Page 67)".

Disconnecting the compact starters

Removing the connecting cable



① Open the cover for the interface for the connecting cable.



② Remove the connecting cable from the interface.

③ Close the interface cover.

6.9 Connection

6.9.1 Connection via terminals

Connection types

There are the following methods of connecting the conductors for the 3RA64/3RA65 compact starter:

- Free wiring on screw-type terminals
- Free wiring on spring-loaded terminals

Stripping lengths, openings for test probes, conductor cross-sections

The same information applies for the 3RA64/3RA65 compact starter with IO-Link as for the 3RA61/3RA62 compact starter.

You can find information on this in Connection via terminals (Page 73).

6.9.2 Connecting terminal blocks

Connecting the screw-type terminals and the spring-loaded terminals

Connect the terminal blocks on the 3RA64/3RA65 compact starter with IO-Link in the same way as the 3RA61/3RA62 compact starter.

For information, please refer to "Connecting terminal blocks (Page 75)".

6.9.3 Connecting the 3RA64/3RA65 compact starter with IO-Link

The 3RA64 and 3RA65 compact starter is connected to IO-Link via the removable terminal.

6.9 Connection

Pin assignment

The following pin assignment applies for the 3RA64 compact starter (direct starter) with IO-Link with screw-type or spring-loaded terminals.

Terminals	Description	Image
1L1, 3L2, 5L3	Main contacts (line side)	
L+	Supply voltage for IO-Link	
C/Q	Communication signal / DI/DO	
L-	Ground IO-Link	
A2-	Auxiliary voltage -	
A1+/Y1	Auxiliary voltage + / limit switch +	
Y2	Limit switch -	
2T1, 4T2, 6T3	Main contacts (on the outgoing side)	
①	Conductor bridge pre-mounted at factory	

Note

Note the current consumption of the compact starter when selecting the auxiliary power supply (A1+ / A2-).

For additional information, please refer to "Technical data (Page 239)".

Pin assignment

The following pin assignment applies for the 3RA65 compact starter (reversing starter) with IO-Link with screw-type or spring-loaded terminals.

Terminals	Description	Image
1L1, 3L2, 5L3	Main contacts (line side)	
L+	Supply voltage for IO-Link	
C/Q	Communication signal / DI/DO	
L-	Ground IO-Link	
A2-	Auxiliary voltage -	
A1+/Y1	Auxiliary voltage + / limit switch + (direction of rotation 1)	
Y2	Auxiliary voltage - (direction of rotation 1)	
Y3	Limit switch + (direction of rotation 2)	
Y4	Auxiliary voltage - (direction of rotation 2)	
2T1, 4T2, 6T3	Main contacts (on the outgoing side)	
①	Conductor bridge pre-mounted at factory	

Note

Before a limit switch can be connected to terminals Y1 - Y2 or Y3 - Y4, the bridge must be removed.

6.9.4 Connecting limit switches

The following limit switches can be connected to the 3RA64/3RA65 compact starter with IO-Link:

- 3RA64 direct starter: one limit switch
- 3RA65 reversing starter: two limit switches

When the contacts open, the limit switch function immediately shuts down the compact starter. Direction of rotation 1 is shut down via terminals Y1 - Y2, and direction of rotation 2 is shut down via terminals Y3 - Y4 (reversing starter only).

6.9 Connection

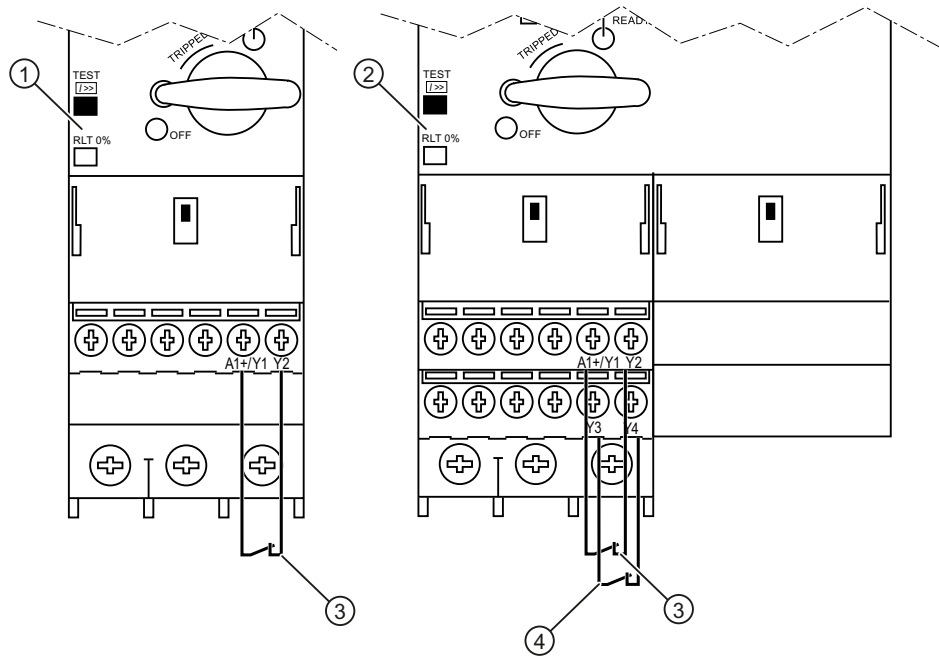
When the limit switch is open, the opposite direction of rotation can be triggered.

Note

Maximum distance to the limit switch.

The maximum conductor length from the compact starter (Y1 - Y2, Y3 - Y4) to the limit switch must not exceed 30 m!

With longer distances, a suitable coupling module must be used!



- ① 3RA64 compact starter with IO-Link (direct starter)
- ② 3RA65 compact starter with IO-Link (reversing starter)
- ③ Limit switch for direction of rotation 1
- ④ Limit switch for direction of rotation 2

Figure 6-3 Connecting limit switches

Note

When delivered, terminals Y1 - Y2 and Y3 - Y4 are bridged as standard by a conductor. For this reason, remove this conductor bridge before connecting a limit switch.

You can find more information on connecting the screw terminals and spring-loaded terminals in chapter Connection via terminals (Page 73).

6.9.5 EMERGENCY STOP

EMERGENCY STOP function

The EMERGENCY STOP function is implemented via shutdown of the auxiliary voltage. For this purpose, integrate an NC contact into the auxiliary voltage circuit. The NC contact is opened via an EMERGENCY STOP button and interrupts the auxiliary voltage. Interruption of V_{Aux} results in shutdown of the compact starters.

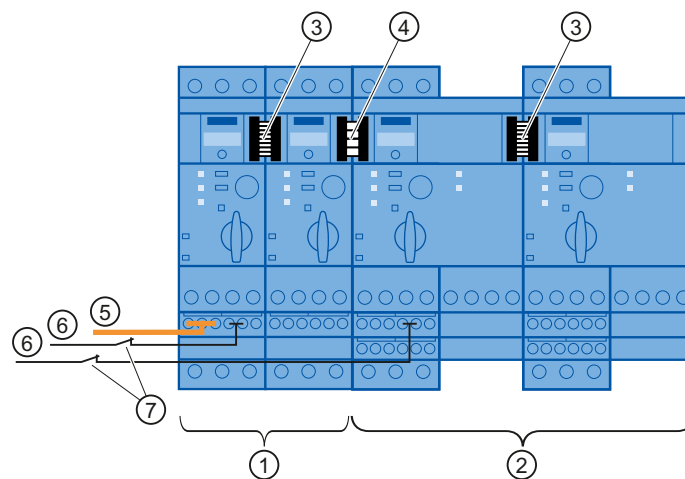
Connecting the EMERGENCY STOP function

The auxiliary voltage V_{Aux} is supplied in the first compact starter of a group via terminals A2- / A1+. The other compact starters are supplied with auxiliary voltage via the 14-core connecting cable.

If the auxiliary voltage is interrupted, all compact starters combined into a group using the 14-core connecting cable are shut down.

So that not all compact starters of a group are switched off by EMERGENCY STOP, you can supply the auxiliary voltage V_{Aux} for individual compact starters or compact starter groups from different systems. Compact starters with their own V_{Aux} supply are connected with the upstream compact starter not via the 14-core connecting cable but via the 10-core connecting cable (3RA6931-0A).

The graphic below shows an example with 2 groups, comprising 2 direct starters and 2 reversing starters. Thanks to the separate supply of the auxiliary voltage V_{Aux} to the 2 groups, shutdown can be carried out separately for direct starters and reversing starters.



- ① Group 1 (2 direct starters)
- ② Group 2 (2 reversing starters)
- ③ Connecting cable 14-core, length 8 mm for compact starter (3RA6931-0A)
- ④ Connecting cable 10-core with 14-core connection, length 8 mm for compact starter (3RA6932-0A)
- ⑤ IO-Link
- ⑥ Auxiliary voltage V_{Aux}
- ⑦ Switch for EMERGENCY STOP

6.9 Connection

Figure 6-4 Connecting the EMERGENCY STOP function

You can find more information on the required connecting cables in "Connecting cable for IO-Link (Page 226)".

6.10 Commissioning

6.10.1 Settings on the 3RA64/3RA65 compact starter with IO-Link

All the settings are made on the 3RA64/3RA65 compact starter with IO-Link.

CLASS 10E / 20E

The CLASS (overload trip class) indicates the tripping time t_A of the compact starter (from cold) at 7.2 times the current setting I_e . As the compact starter has the functionality of a solid-state overload relay, the trip class corresponds to the narrow tolerance band E (IEC / EN 60947-6-2):

- CLASS 10E: $5 \text{ s} < t_A < 10 \text{ s}$
- CLASS 20E: $10 \text{ s} < t_A < 20 \text{ s}$ (for heavy starting)

You can use a slide switch to set the trip class to CLASS 10E or CLASS 20E.

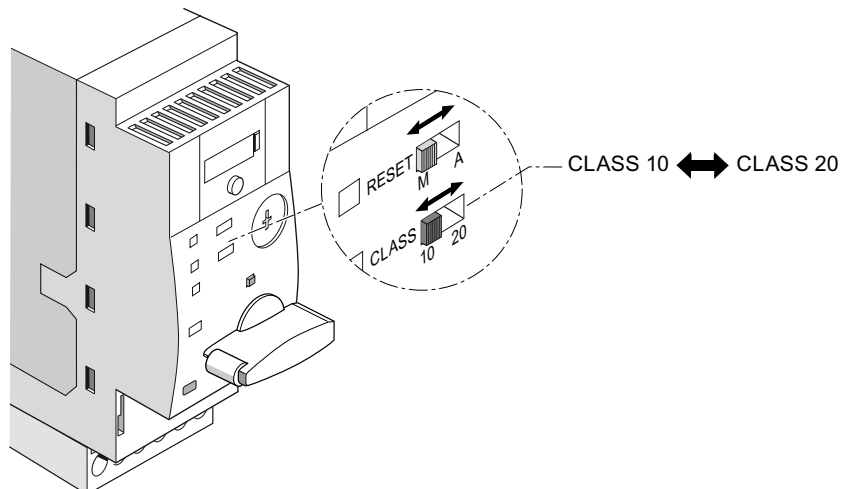


Figure 6-5 Setting CLASS 10E/20E on the compact starter with IO-Link

Current setting I_e

Set the rated operating current of the motor to be protected on the setting scale.

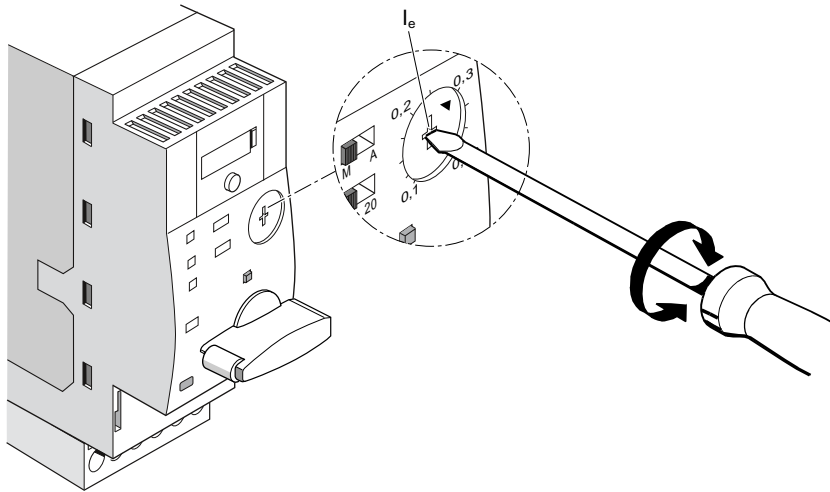


Figure 6-6 Setting the current setting I_e on the compact starter with IO-Link

RESET M/A

Select manual or auto reset following an overload trip on the "RESET M/A" (manual/automatic) selector switch:

- **Manual reset:** Following overload trip, reset the 3RA64/3RA65 compact starter with IO-Link manually by:
 - sending the control command "Remote reset" via IO-Link.
 - pressing the "Reset" button on the operator panel.
 - pressing the blue Reset button.
- **Auto reset:** Following an overload trip, the 3RA64/3RA65 compact starter with IO-Link is reset automatically after 3 minutes. However, a manual reset as described above can still be performed if you have selected this setting.

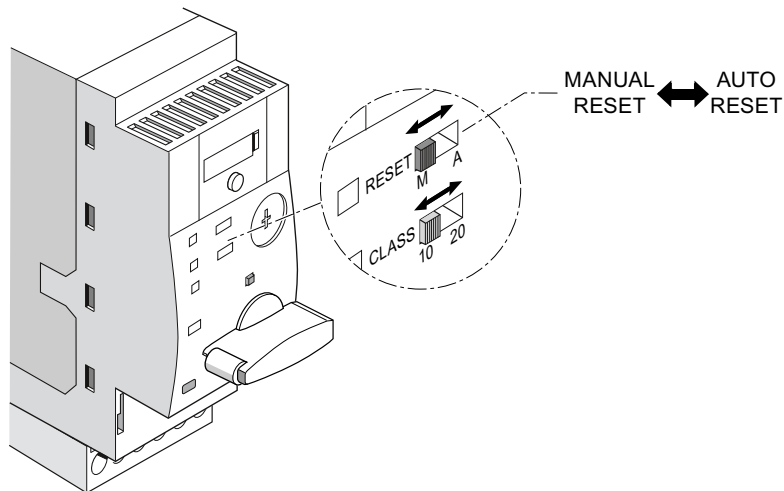


Figure 6-7 Setting RESET M/A on the compact starter with IO-Link

For additional information on the manual and auto reset functions, please refer to "Overload protection function (Page 58)".

Accessories

7.1 Accessories overview

The tables below provide an overview of the accessories for the compact starter. The column "Valid for" specifies the compact starters for which the accessories can be used.

3RA6 compact starter

System component	Article number	Valid for
Main conductor terminal (pack of 2) - Screw-type connections - Spring-loaded connections - Combined connections (1 x spring-loaded connection and 1 x screw-type connection)	3RA6920-1A 3RA6920-2A 3RA6920-3A	3RA61 3RA62 3RA64 3RA65
Terminal for self-protected combination motor controller (Type E) to UL 508	3RV2928-1H	3RA61 3RA62 3RA64 3RA65
Auxiliary switch block for compact starter - Screw-type connection technology: - 2 NO contacts - 2 NC contacts - 1 NO contact + 1 NC contact - Spring-loaded connection technology: - 2 NO contacts - 2 NC contacts - 1 NO contact + 1 NC contact	3RA6911-1A 3RA6912-1A 3RA6913-1A 3RA6911-2A 3RA6912-2A 3RA6913-2A	3RA61 3RA62 3RA64 3RA65
Control kit	3RA6950-0A	3RA61 3RA62 3RA64 3RA65
Adapter for screw fastening the compact starter	3RA6940-0A	3RA61 3RA62 3RA64 3RA65

AS-Interface

System component	Article number	Valid for
AS-i mounting module for compact starter	3RA6970-3A	3RA61 3RA62
AS-i mounting module for compact starter with		
• two local inputs for safe shutdown	3RA6970-3B	3RA61 3RA62

7.1 Accessories overview

System component	Article number	Valid for
<ul style="list-style-type: none"> two additional digital inputs 	3RA6970-3C	3RA61 3RA62
<ul style="list-style-type: none"> one additional digital input and one digital output 	3RA6970-3D	3RA61 3RA62
<ul style="list-style-type: none"> with two additional digital outputs 	3RA6970-3E	3RA61
<ul style="list-style-type: none"> with two digital inputs for manual control of the compact starter 	3RA6970-3F	3RA61 3RA62
AS-Interface addressing unit V3.0	3RK1904-2AB02	3RA6970-3.

IO-Link

System component	Article number	Valid for
Connecting cable, 14-core, 8 mm long for compact starter (pack of 5)	3RA6931-0A	3RA64 3RA65
Connecting cable, 10-core with 14-core connection, 8 mm long for compact starter (pack of 5)	3RA6932-0A	3RA64 3RA65
Connecting cable 14-core, length 200 mm for compact starter	3RA6933-0C	3RA64 3RA65
Connecting cable 10-core, length 2 m for operator panel (connection between operator panel and 3RA6 compact starter with IO-Link)	3RA6933-0A	3RA64 3RA65
Operator panel for compact starter (incl. enabling block for operator panel)	3RA6935-0A	3RA64 3RA65
Enabling block for operator panel for compact starter	3RA6936-0A	3RA64 3RA65
Blanking cover for operator panel	3RA6936-0B	3RA64 3RA65

SIRIUS infeed system for 3RA6

System component	Article number	Valid for
Left infeed, 50/70 mm ² screw terminal with three slots, outgoing terminals with - Screw-type connection technology - Spring-loaded connection technology Incl. PE bar (for installing Type E starters in accordance with UL 508)	3RA6813-8AB 3RA6813-8AC	3RA61 3RA62 3RA64 3RA65
Left infeed, 25/35 mm ² screw terminal with three slots, outgoing terminals with - Screw-type connection technology - Spring-loaded connection technology Incl. PE bar	3RA6812-8AB 3RA6812-8AC	3RA61 3RA62 3RA64 3RA65

System component	Article number	Valid for
Extension module with two slots, outgoing terminals with - Screw-type connection technology - Spring-loaded connection technology Incl. PE bar	3RA6822-0AB 3RA6822-0AC	3RA61 3RA62 3RA64 3RA65
Extension module with three slots, outgoing terminals with - Screw-type connection technology - Spring-loaded connection technology Incl. PE bar	3RA6823-0AB 3RA6823-0AC	3RA61 3RA62 3RA64 3RA65
Left or right infeed, 25/35 mm ² , with spring-loaded connection technology	3RA6830-5AC	—
PE infeed, 25/35 mm ² , with - Screw-type connection technology - Spring-loaded connection technology	3RA6860-6AB 3RA6860-5AC	—
PE tap, 6/10 mm ² , with - Screw-type connection technology - Spring-loaded connection technology	3RA6870-4AB 3RA6870-3AC	—
PE extension connector	3RA6890-0EA	—
Terminal block	3RV2917-5D	—
45 mm adapter for infeed system for 3RA6 with interphase barriers (for mounting 3RV2.2 circuit breakers of size S0 on the infeed system for 3RA6)	3RA6890-0BA	3RV2.2
Extension connector for 3RV29 (connects SIRIUS infeed system for 3RA6 to 3RV29 infeed system)	3RA6890-1AA	—
Extension connector (for reordering an original part that has been lost)	3RA6890-1AB	—
IP 20 terminal cover for screw-type infeeds 25/35 mm ² (pack of 2)	3RA6880-2AB	—
IP 20 terminal cover for screw-type infeeds 50/70 mm ² (pack of 2)	3RA6880-3AB	—

3RV19 3-phase busbar

System component	Article number	Valid for
3RV19 3-phase busbar - 2 partitions - 3 partitions - 4 partitions - 5 partitions	3RV1915-1AB 3RV1915-1BB 3RV1915-1CB 3RV1915-1DB	3RA61 3RA62 3RA64 3RA65
3-phase infeed terminal, connection from the bottom, with screw-type connection technology	3RV2915-5B	3RA61 3RA62 3RA64 3RA65
Connection piece for connecting compact starters to size S00 circuit breakers	3RV1915-5DB	3RA61 3RA62 3RA64 3RA65

7.1 Accessories overview

System component	Article number	Valid for
Cover cap for terminal lugs	3RV1915-6AB	—
3-phase infeed terminal Connection from above, with screw-type connection technology and for installing "Type E starters", UL 508	3RV2925-5EB	3RA61 3RA62 3RA64 3RA65

8US busbar adapter

System component	Article number	Valid for
Busbar adapter for 60 mm system	8US1211-1NS10	3RA61 3RA62 3RA64 3RA65
Device holder for side mounting on busbar adapter	8US1250-1AA10	3RA62 3RA65

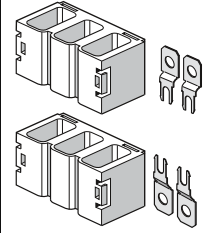
Door-coupling rotary operating mechanism

System component	Article number	Valid for
Door-coupling rotary operating mechanism - 130 mm long	3RV2926-0B	3RA61 3RA62 3RA64 3RA65
EMERGENCY OFF door-coupling rotary operating mechanism - 130 mm long	3RV2926-0C	3RA61 3RA62 3RA64 3RA65

7.2 Adapter for screw fastening

7.2.1 Scope of supply

Scope of supply of adapter for screw fastening

System component	Article number	Figure
Adapter for screw fastening the compact starter (you will need 2 sets for the reversing starter)	3RA6940-0A	

7.2.2 Installing/removal

Installing the adapter for screw fastening

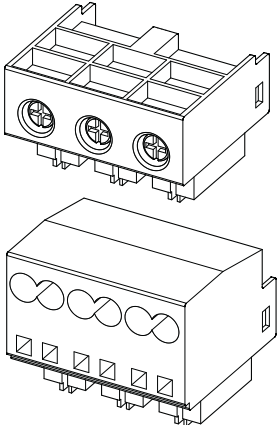
The adapters for screw fastening are required for installing the 3RA61/3RA62/3RA64/3RA65 compact starter on a level surface (screw fastening).

For information, please refer to "Installing the compact starter on a level surface (screw fastening) (Page 64)".

7.3 Main circuit terminals

7.3.1 Scope of supply

Scope of supply of main circuit terminals

System component	Article number	Fig. ¹⁾
Main circuit terminals (pack of 2)		
<ul style="list-style-type: none"> Screw-type connection technology 	3RA6920-1A	
<ul style="list-style-type: none"> Spring-loaded connection technology 	3RA6920-2A	
<ul style="list-style-type: none"> Combined connections (1 x spring-loaded connection and 1 x screw-type connection) 	3RA6920-3A	

7.3.2 Installing/removal

Requirements

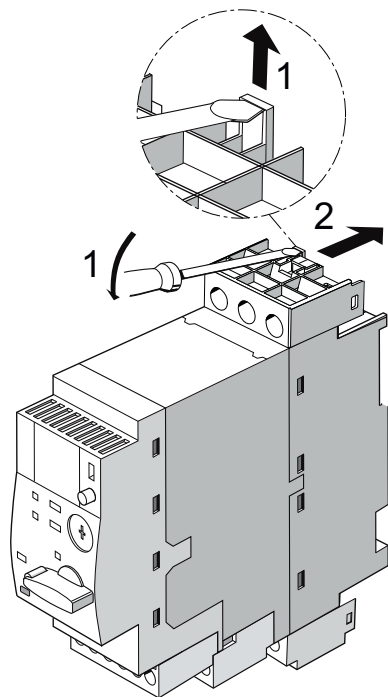


! DANGER

Hazardous voltage!
 Will cause death or serious injury.
 Before starting work, disconnect the system and the device from the power supply.

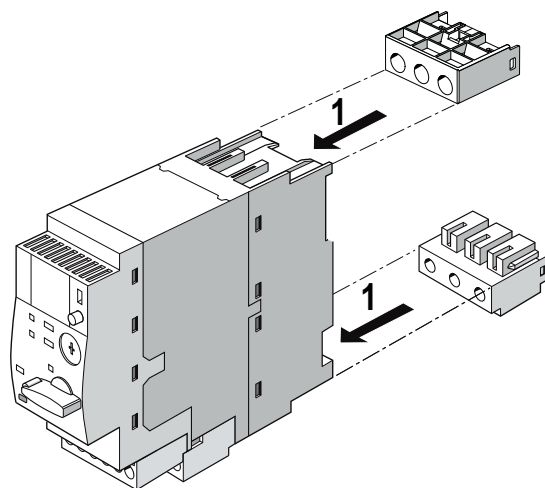
- The main circuit terminals must have been disconnected.

Removing the main circuit terminals



- ① Use a screwdriver to release the latching mechanism on the main circuit terminal.
- ② Pull the main circuit terminal back so that it comes off the compact starter, then lift it away from the device's mechanically coded guiderail.

Instaling main circuit terminals

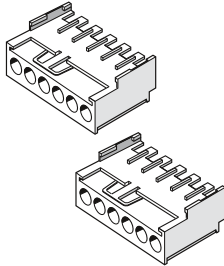


- ① Insert the removable main circuit terminal into the device's mechanically coded guiderail from the back. Then push the main circuit terminal forwards until you hear it engage.

7.4 Control circuit terminals

7.4.1 Scope of supply

Scope of supply of the control circuit terminals

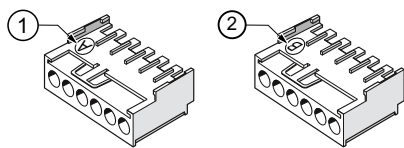
System component	Article number	Figure
Control circuit terminals (pack of 1 set)		
3RA61:		
Screw-type connection technology	3RA6920-1B	
Spring-loaded connection technology	3RA6920-2B	
3RA62:		
Screw-type connection technology	3RA6920-1C	
Spring-loaded connection technology	3RA6920-2C	

You will find the pin assignments in Connecting the compact starter without optional AS-i mounting module (Page 77).

7.4.2 Installing/removal

Installing the control circuit terminals on the compact starter

The mechanical coding on the control circuit terminals prevents mix-ups. The terminals are marked as follows:



- ① A: Top/front mounting position on compact starter
- ② B: Bottom/rear mounting position on compact starter

Figure 7-1 Coding on the control circuit terminals

Note

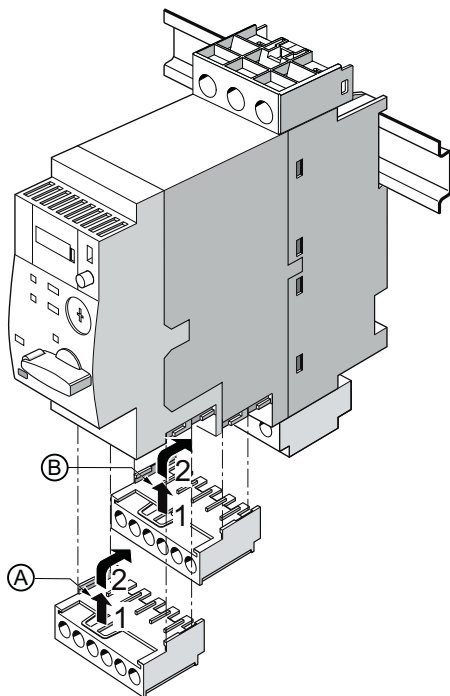
The control circuit terminals can only be installed in the following order because of their arrangement on the compact starter:

1. Control circuit terminal at the bottom or at the back (B)
2. Control circuit terminal at the top or at the front (A)

Requirements

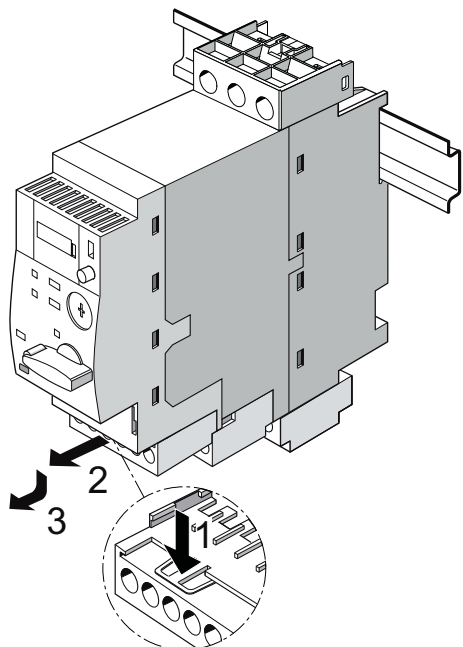
! DANGER
Hazardous voltage! Will cause death or serious injury. Before starting work, disconnect the system and the device from the power supply.

- The compact starter must be switched off (actuator set to \circ OFF position).

Installing the control circuit terminals on the compact starter

- ① Insert the removable terminal block into the device's mechanically coded guiderail from the bottom.
- ② Push the terminal block up and then back until you hear it engage.
Make sure that you install the two terminal blocks in the correct order.

Removing control circuit terminals from the compact starter

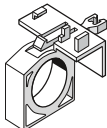


- ① Push the terminal block's release clip down.
- ② Pull the terminal block out to the front.
- ③ Move the terminal block down and out from the compact starter's mechanically coded guiderail.

7.5 Control kit

7.5.1 Scope of supply

Scope of supply of the control kit

System component	Article number	Figure
Control kit	3RA6950-0A	

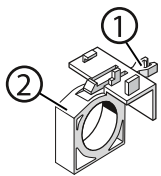
7.5.2 Description of the hardware

Features

The control kit is a tool for checking the wiring of the main and auxiliary circuits as well as the motor direction.

The control kit is installed on the compact starter and bypasses the electromechanical operating mechanism so that electrical control can be simulated for the compact starter. Then the main contacts can be closed using the actuator and the motor will start up.

Configuration

View	No.	Meaning
	(1)	Mechanical connection point
	(2)	Handle

7.5.3 Using the control kit


NOTICE

Cable system and motor material damage!

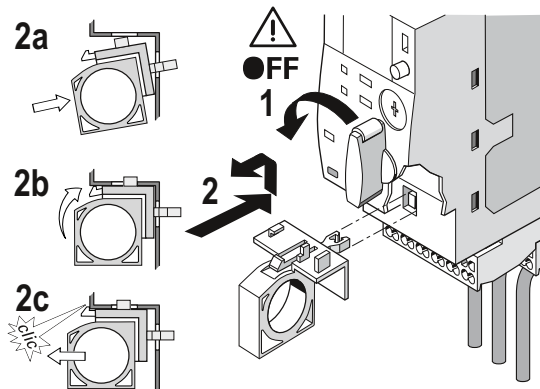
When the control kit is in use, the compact starter's overload protection function is deactivated. The downstream cable system and the motor can be destroyed thermally. Only the short-circuit protection function is active.


Only use the control kit briefly for testing purposes (e.g. checking the direction of rotation or the auxiliary switch wiring). Long-term operation using the control kit is not permissible.

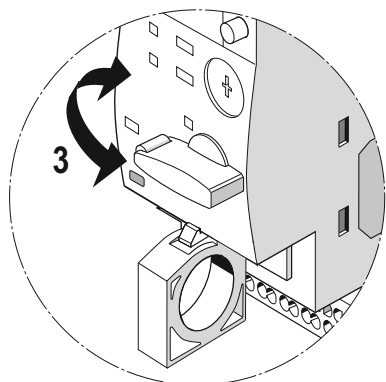
Requirements

- The compact starter must be switched off (actuator set to  OFF position).

Procedure

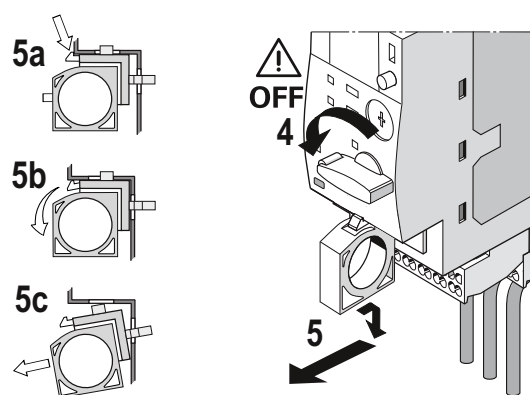


- ① Turn the actuator to the  OFF position.
- ② Plug the control kit into the connection point (2a), inserting it from the bottom at an angle. Tilt the control kit up (2b) until it makes contact with the compact starter. Then pull the control kit forwards and away from the compact starter until it locks into position (2c).



③ **Checking the main and auxiliary circuit wiring:**

Use the actuator to switch the compact starter on (Ⓢ READY) or off (ⓐ OFF) and check the main and auxiliary circuit wiring.



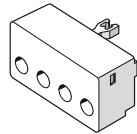
④ Turn the actuator to the ⓐ OFF position.

⑤ Release the latch mechanism (5a). Push the control kit backwards and then tilt it down (5b). Remove the control kit from the compact starter by pulling it down at an angle (5c).

7.6 External auxiliary switch block

7.6.1 Scope of supply

Scope of supply of the auxiliary switch block for compact starter

System component	Article number	Figure
Auxiliary switch block for compact starter		
- Screw-type connection technology:	3RA6911-1A	
2 NO contacts	3RA6912-1A	
2 NC contacts	3RA6913-1A	
1 NO contact + 1 NC contact		
- Spring-loaded connection technology:	3RA6911-2A	
2 NO contacts	3RA6912-2A	
2 NC contacts	3RA6913-2A	
1 NO contact + 1 NC contact		

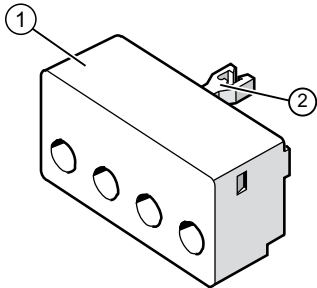
7.6.2 Description of the hardware

An auxiliary switch block can be mounted on the 3RA61/3RA64 compact starter (direct starter). Two auxiliary switch blocks can be mounted on the 3RA62/3RA65 compact starter (reversing starter). The contacts of the auxiliary switch open and close along with the main contacts.

The external auxiliary switch block is available with screw-type or spring-loaded connection technology in the following versions:

- 2 NO contacts
- 2 NC contacts
- 1 NO contact + 1 NC contact

Configuration

View	No.	Meaning
	(1)	Auxiliary switch block for compact starter
	(2)	Mechanical connection point

7.6.3 Installing/removal

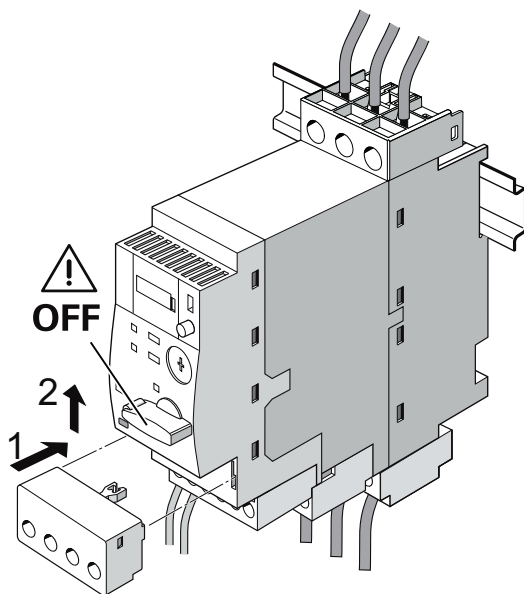
Requirements

- The compact starter must be switched off (actuator set to OFF position).

Note

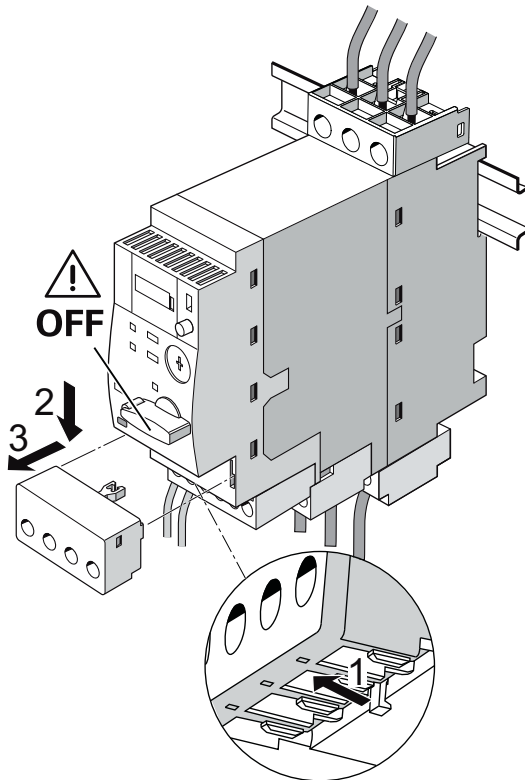
You cannot use the control kit if an external auxiliary switch block is installed on the compact starter.

Installing the auxiliary switch block



- ① Insert the auxiliary switch block into the location holes on the compact starter.
- ② Push the auxiliary switch block up until it engages.

Removing the auxiliary switch block



- ① Release the locking latch on the lower side of the auxiliary switch block.
- ② Push the auxiliary switch block downwards.
- ③ Remove the auxiliary switch block from the compact starter by pulling it forwards and off.

7.6.4 Connection

The terminals on the auxiliary switch block are available with screw-type or spring-loaded connection technology.
For additional information on the connection systems, please refer to "Connecting terminal blocks (Page 75)".

Terminal designation

The designations of the terminals on the external auxiliary switch block are made up of the labeling on the compact starter and on the external auxiliary switch block.

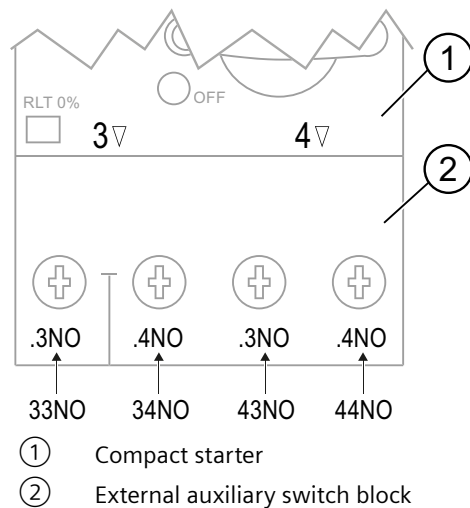
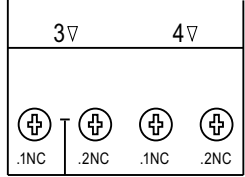
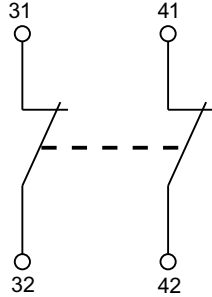
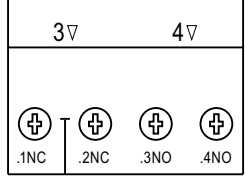
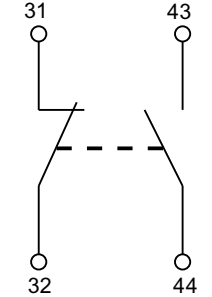
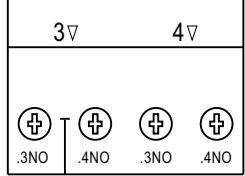
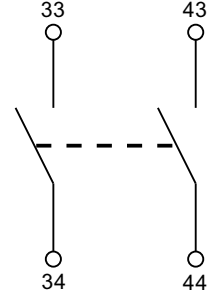


Figure 7-2 Terminal designations external auxiliary switch block

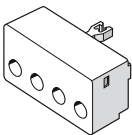
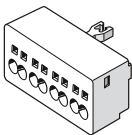
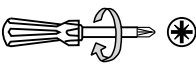
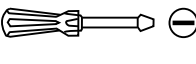


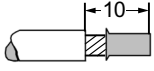
Pin assignment

Table 7-1 Pin assignments on the auxiliary switch block for compact starter

Auxiliary switch block	View	Meaning
2 NC contacts		
1 NC contact + 1 NO contact		
2 NO contacts		

Conductor cross-sections

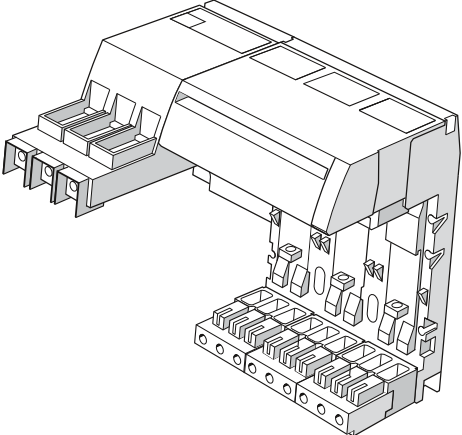
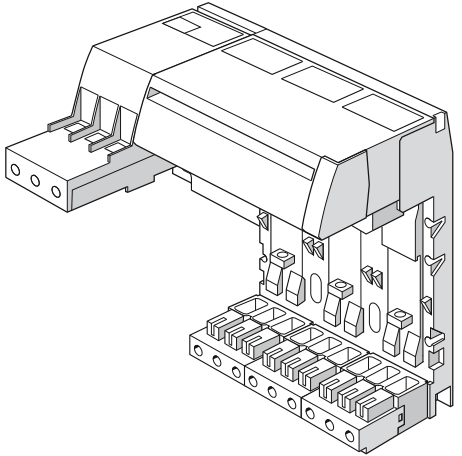
Table 7-2 Conductor cross-section of the terminals on the auxiliary switch block for compact starter

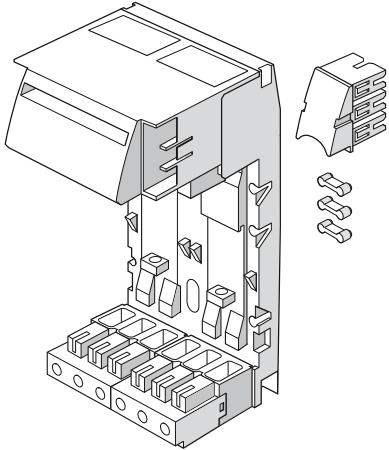
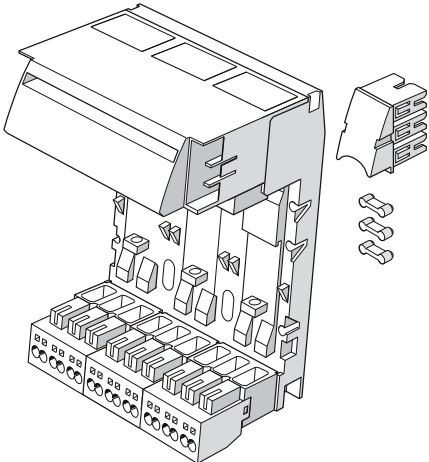
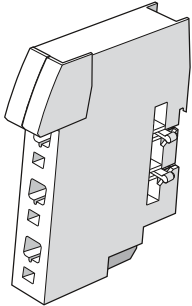
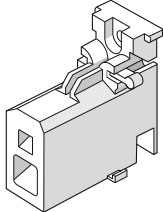
	3RA691.-1A	3RA691.-2A
		
	 Ø 6 mm/PZ 2	 8WA2 807 (2.5 x 0.4) mm
	0,8 ... 1.2 Nm (7 to 10.3 lb-in)	—
	2 x (0.5 to 1.5) mm ² 2 x (0.75 to 2.5) mm ² max. 2 x (1 to 4) mm ²	2 x (0.25 to 2.5) mm ²
	—	2 x (0.25 to 2.5) mm ²
	2 x (0.5 to 1.5) mm ² 2 x (0.75 to 2.5) mm ²	2 x (0.25 to 1.5) mm ²
AWG	2 x (20 to 16) 2 x (18 to 14)	2 x (24 to 14)

7.7 Infeed system for 3RA6

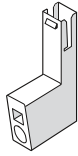

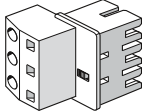
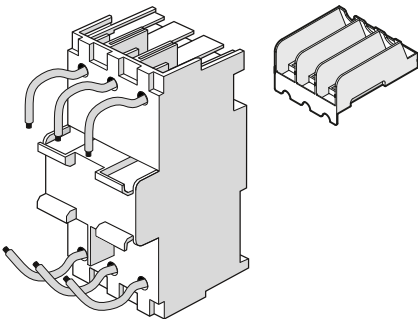
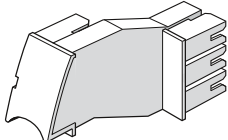
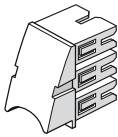
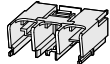
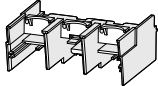
7.7.1 Scope of supply

Scope of supply of the infeed system for 3RA6

System component	Article number	Figure
<p>Left infeed, 50/70 mm² screw terminal with three slots, outgoing terminals with</p> <ul style="list-style-type: none"> - Screw-type connection technology - Spring-loaded connection technology <p>Incl. PE bar (for installing Type E starters in accordance with UL 508)</p>	<p>3RA6813-8AB 3RA6813-8AC</p>	
<p>Left infeed, 25/35 mm² screw terminal with three slots, outgoing terminals with</p> <ul style="list-style-type: none"> - Screw-type connection technology - Spring-loaded connection technology <p>Incl. PE bar</p>	<p>3RA6812-8AB 3RA6812-8AC</p>	

System component	Article number	Figure
Extension module with two slots, outgoing terminals with - Screw-type connection technology - Spring-loaded connection technology Incl. PE bar	3RA6822-0AB 3RA6822-0AC	
Extension module with three slots, outgoing terminals with - Screw-type connection technology - Spring-loaded connection technology Incl. PE bar	3RA6823-0AB 3RA6823-0AC	
Left or right infeed, 25/35 mm ² , with spring-loaded connection technology	3RA6830-5AC	
PE infeed, 25/35 mm ² , with - Screw-type connection technology - Spring-loaded connection technology	3RA6860-6AB 3RA6860-5AC	

7.7 Infeed system for 3RA6

System component	Article number	Figure
PE tap, 6/10 mm ² , with - Screw-type connection technology - Spring-loaded connection technology	3RA6870-4AB 3RA6870-3AC	
PE extension connector	3RA6890-0EA	
Terminal block	3RV2917-5D	
45 mm adapter for infeed system for 3RA6 <ul style="list-style-type: none"> for mounting 3RV2.2 circuit breakers of size S0 on the infeed system for 3RA6 incl. required interphase barriers 	3RA6890-0BA	
Extension connector for 3RV29 (connects the SIRIUS infeed system for 3RA6 with the 3RV29 infeed system)	3RA6890-1AA	
Extension connector (for reordering an original part that has been lost)	3RA6890-1AB	
IP 20 terminal cover for screw-type infeeds 25/35 mm ²	3RA6880-2AB	
IP 20 terminal cover for screw-type infeeds 50/70 mm ²	3RA6880-3AB	

7.7.2 Description of the hardware

Features

The SIRIUS infeed system for 3RA6 is a pre-wired infeed system for the compact starter.

The infeed system for 3RA6 is characterized by the permanent wiring of the main circuit, the PE infeed and PE tap. Compact starters can be removed from the infeed system and reinstalled without having to go to all the trouble of disconnecting and reconnecting the wiring.

Configuration

The infeed system for 3RA6 offers 3 supply possibilities. The following table presents these 3 supply possibilities and lists the short designations used to refer to them in this chapter.

Table 7-3 Short designations for the infeed system for 3RA6

Infeed	Article number	Short designation
Left infeed, 50/70 mm ² screw terminal with three slots, outgoing terminal with screw-type or spring-loaded connection technology, incl. PE bar	3RA6813-8AB 3RA6813-8AC	Screw-type infeed (50/70 mm ²)
Left infeed, 25/35 mm ² screw terminal with three slots, outgoing terminal with screw-type or spring-loaded connection technology, incl. PE bar	3RA6812-8AB 3RA6812-8AC	Screw-type infeed (25/35 mm ²)
Left or right infeed, 25/35 mm ² , with spring-loaded connection technology	3RA6830-5AC	Spring-loaded infeed

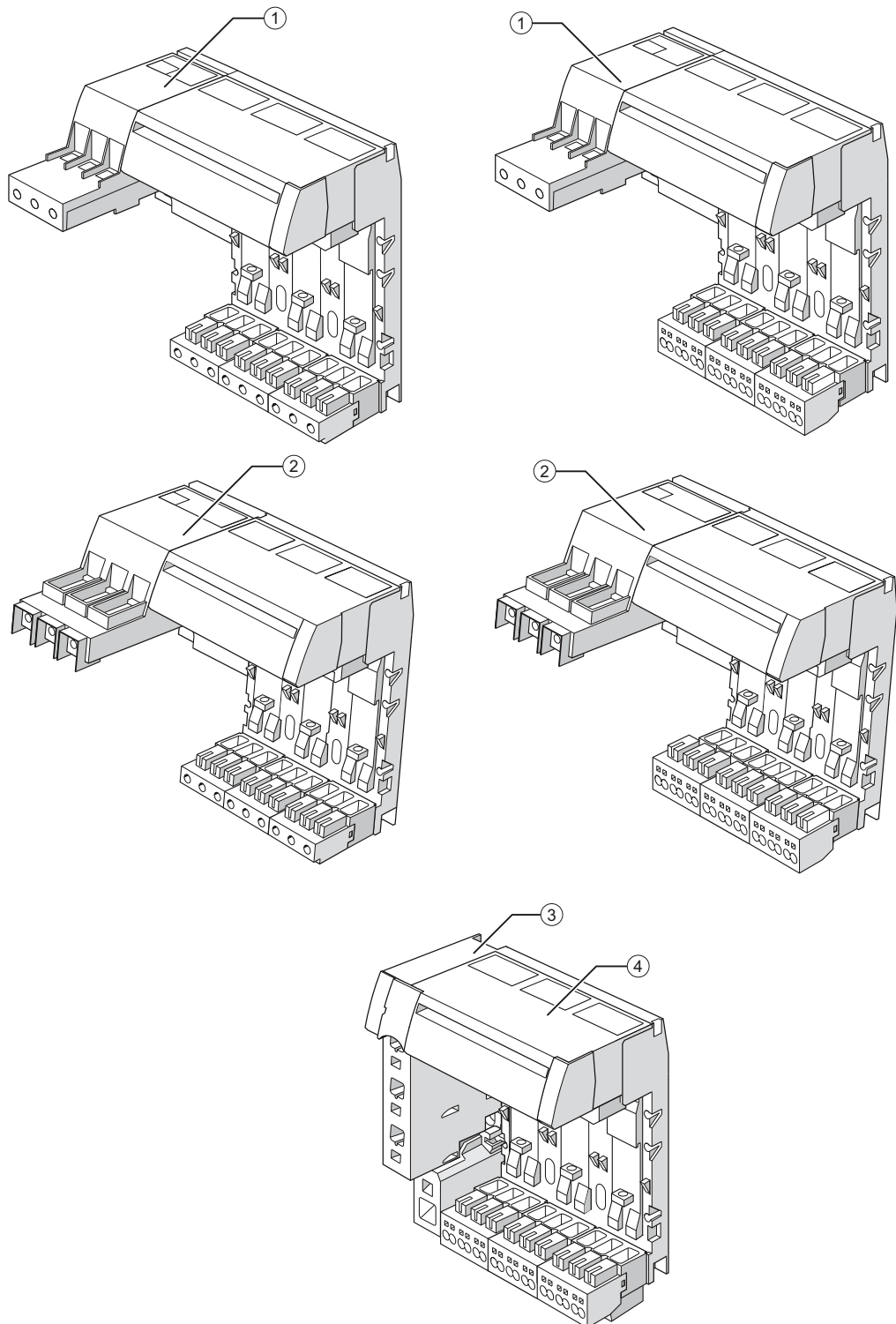
Note

Short designations

For clarity's sake, this manual employs the short designations for the various infeed types that are associated with the infeed system for 3RA6. For a list of all the abbreviations used in the manual, please refer to the appendix "List of abbreviations (Page 283)".

Thanks to the modular design, the infeed blocks can be extended to a total maximum width of 1.20 m using extension modules. For this purpose, the infeed blocks and extension modules are arranged side by side and connected up electrically using an extension connector and an optional PE extension connector.

7.7 Infeed system for 3RA6



- ① Screw-type infeed (25/35 mm²)
- ② Screw-type infeed (50/70 mm²)
- ③ Spring-loaded infeed
- ④ Extension block

Figure 7-3 Infeed system for 3RA6

Combination with other sizes

The infeed system for 3RA6 can be connected to the SIRIUS 3RV29 infeed system using the extension connector for 3RV29 (3RA6890-1AA). SIRIUS 3RV2.2 circuit breakers of size S0 can be installed on the infeed system for 3RA6 using the 45 mm adapter for the infeed system for 3RA6 (3RA6890-0BA).

For additional information on combining the equipment with other sizes, please refer to "Infeed system for 3RA6 (Page 32)".

7.7.3 Installing/removal

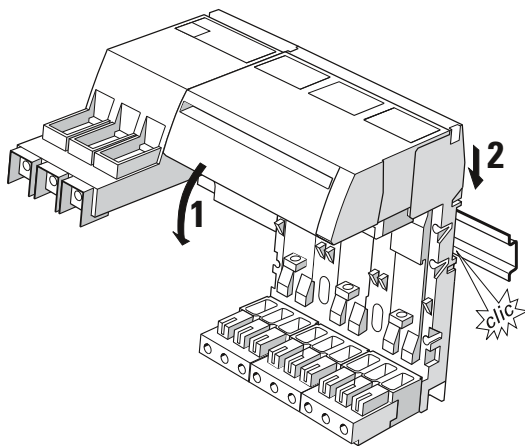
7.7.3.1 Installing the infeed system for 3RA6 on a standard mounting rail

Requirements

- A 35-mm DIN rail in accordance with IEC / EN 60715 must be properly secured at the installation location.

Mounting the screw-type infeed on the DIN rail

The procedure for installing the 25/35 mm² and 50/70 mm² screw-type infeeds is the same in both cases.



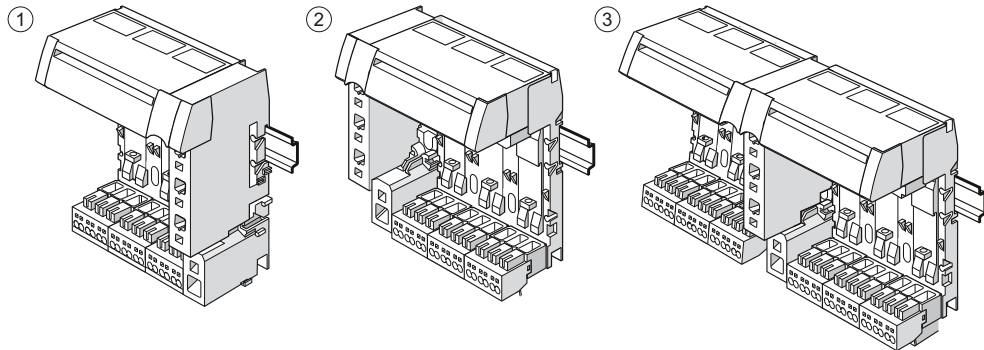
- ① Place the back of the screw-type infeed onto the upper edge of the DIN rail
- ② Press the lower half of the screw-type infeed against the DIN rail until you hear it engage.

Installing a spring-loaded infeed with 2-slot or 3-slot expansion module on a DIN rail

The spring-loaded infeed and expansion module are 2 separate components.

7.7 Infeed system for 3RA6

The 2-slot and 3-slot expansion modules can be mounted to the right or left or to the right and left of the spring-loaded infeed.



Expansion modules installed

- ① To the left of the spring-loaded infeed
- ② To the right of the spring-loaded infeed
- ③ To the right and left of the spring-loaded infeed

Figure 7-4 Installation scenarios involving the spring-loaded infeed

NOTICE

Damage to the extension connector!

The maximum rated current for extension connectors is 63 A. If the rated current is exceeded, the extension connector will be damaged beyond repair.

Make sure that the extension connector is never subjected to a current higher than 63 A.



! DANGER

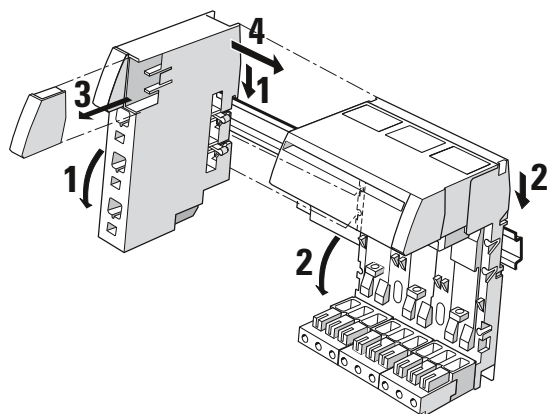
Hazardous voltage!

Will cause death or serious injury.

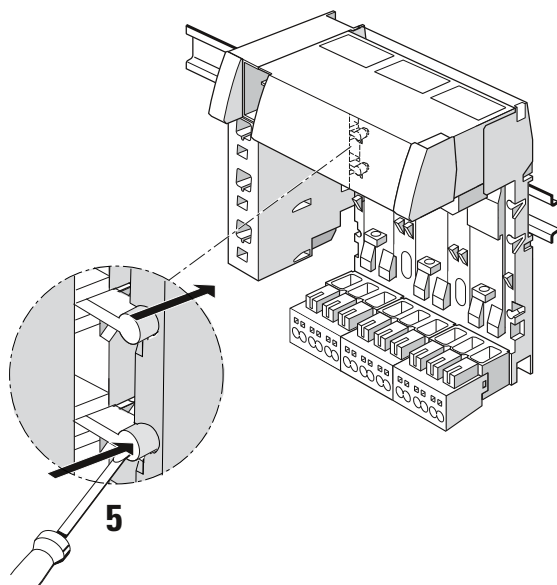
If extension connectors or end covers are missing, direct contact with live parts is possible.

The electrical interface for the expansion module must be fitted with an extension connector or an end cover at all times when the power supply is energized.

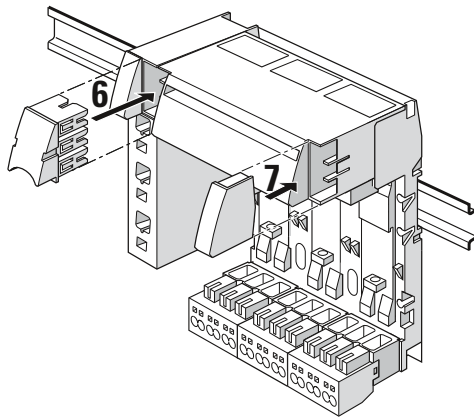
When installing/removing an extension connector or an end cover the system power supply must be switched off.



- ① Snap the spring-loaded infeed onto the DIN rail.
- ② Snap the expansion module onto the DIN rail.
- ③ Remove the right or left end cover from the spring-loaded infeed.
- ④ Push together the expansion module and spring-loaded infeed.



- ⑤ Establish a mechanical connection between the spring-loaded infeed and expansion module by pressing the 2 link wedges on the spring-loaded infeed down and into the expansion module.



- ⑥ Use an extension connector to establish an electrical connection between the expansion module and spring-loaded infeed.
- ⑦ Attach the end cover to the right or left of the expansion module.

Expanding the SIRIUS infeed system for 3RA6 by means of additional expansion modules

Screw-type infeeds and extension blocks can be expanded by adding additional 3-slot and 2-slot expansion modules.

The screw-type infeeds can only be expanded by adding modules to the right.

With spring-loaded connection technology, the expansion module can be added to the right or left, depending on which side the spring-loaded infeed has been installed.

NOTICE

Damage to the extension connector!

The maximum rated current for extension connectors is 63 A. If the rated current is exceeded, the extension connector will be damaged beyond repair.

Make sure that the extension connector is never subjected to a current higher than 63 A.



! DANGER

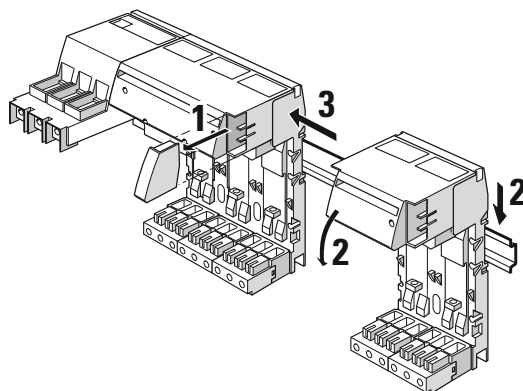
Hazardous voltage!

Will cause death or serious injury.

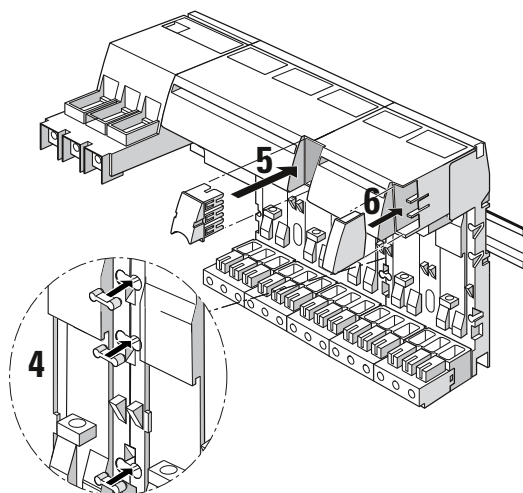
If extension connectors or end covers are missing, direct contact with live parts is possible.

The electrical interface for the expansion module must be fitted with an extension connector or an end cover at all times when the power supply is energized.

When installing/removing an extension connector or an end cover the system power supply must be switched off.



- ① Remove the end cover.
- ② Snap the expansion module onto the DIN rail until you hear it engage.
- ③ Push together the expansion module and the module that has already been installed.



- ④ Use the 3 link wedges to establish a mechanical connection between the 2 modules.
- ⑤ Use an extension connector to establish an electrical connection between the 2 modules.
- ⑥ Attach the end cover to the additional expansion module.

Note

If the infeed system is being mounted on a vertical mounting rail, a suitable stopper must be installed underneath the infeed system to keep it in place.

7.7.3.2 Installing the infeed system for 3RA6 on a level surface (screw fastening)

Requirements

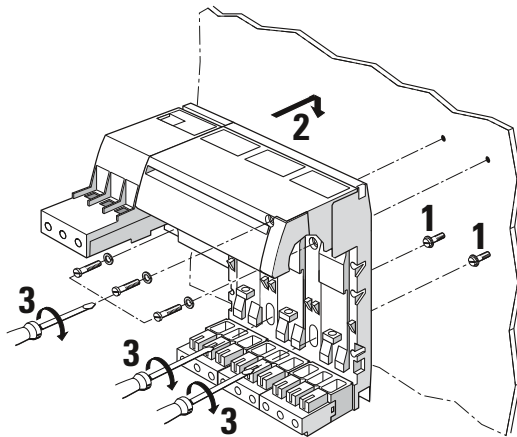
- Drill holes with thread or plug on the level surface. For details of the distances between the drilled holes, refer to the relevant dimension drawing in Chapter "Dimension drawings (Page 241)".
- Screws:
 - Screw-type infeed (25/35 mm²) or screw-type infeed (50/70 mm²): Five M4x16 screws incl. washers
 - 3-slot expansion module: Four M4 x16 screws incl. washers
 - 2-slot expansion module: Two M4 x16 screws incl. washers
 - PE infeed: One M4 x 16 screw incl. washer

Procedure

Not only can the infeed system for 3RA6 be attached to a DIN rail, but it can also be installed on a level surface using screws.

Note

Slots make the screw-type infeeds and expansion modules easier to install. You can mount and install the screw-type infeeds and expansion modules using the slots on pre-assembled screws.



- ① Screw the 2 screws for the 2 slots into the level surface.
- ② Mount the screw-type infeed/expansion module on the pre-assembled screws.
- ③ Insert each of the remaining screws through the relevant holes in the screw-type infeed/expansion module and screw the device onto the level surface.

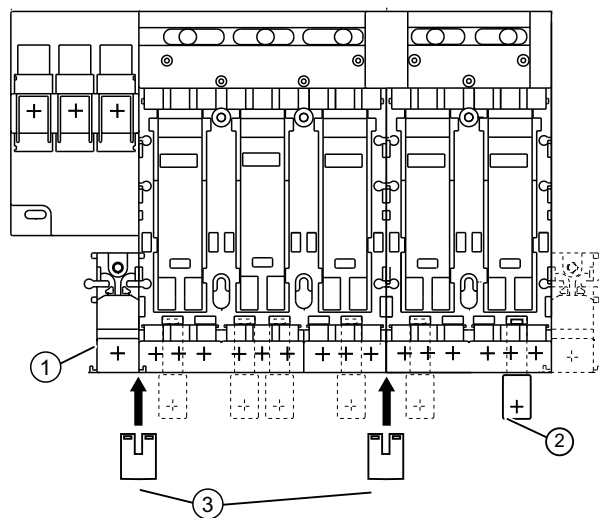
7.7.3.3 Installing the accessories for the infeed system for 3RA6

Installing PE accessories

The PE infeeds and taps are available with screw-type or spring-loaded connection technology. The PE infeed can be mounted to the right or left of the screw-type infeeds and expansion modules. The PE tap is inserted into the relevant slots from the bottom. The modules offer the following slot options:

- Screw-type infeed (25/35 mm²), screw-type infeed (50/70 mm²), 3-slot expansion module: 4 slots
- 2-slot expansion module: 2 slots

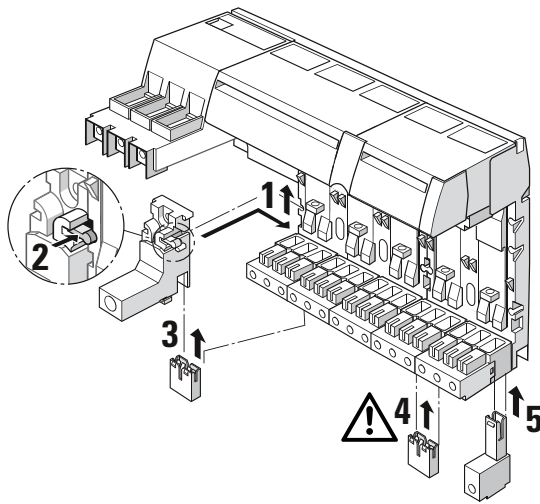
The figure below provides an overview of the mounting options available for the PE infeed and PE tap.



- ① PE infeed, 25/35 mm², with screw-type or spring-loaded connection technology
- ② PE tap, 6/10 mm², with screw-type or spring-loaded connection technology
- ③ PE extension connector

Figure 7-5 Mounting options for PE infeed and PE tap

7.7 Infeed system for 3RA6



- ① Push the PE infeed against the right-hand/left-hand side of the screw-type infeed or expansion module and then push it upwards.
- ② Press the link wedge down.
- ③ Use the PE extension connector to connect the PE infeed and screw-type infeed/expansion module.
- ④ Use the PE extension connector to connect each additional expansion module to its predecessor.
- ⑤ Working from the bottom, push the PE tap into the relevant slot on the infeed or expansion module until you hear it engage.



! DANGER

Hazardous voltage!

Will cause death or serious injury.

Unless the expansion modules are connected using a PE extension connector, the infeed system will **NOT** be grounded.

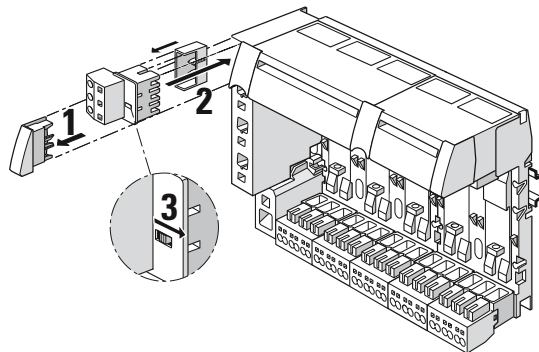
If you are using the PE infeed and PE tap and decide to expand the infeed system for 3RA6 by adding expansion modules, you will need to use a PE extension connector for the purpose of connecting each additional expansion module to its predecessor.

Note

If you are installing the PE infeed on a level surface (screw fastening), it will also need to be fixed to the surface using an M4 x 16 screw.

Installing the terminal block

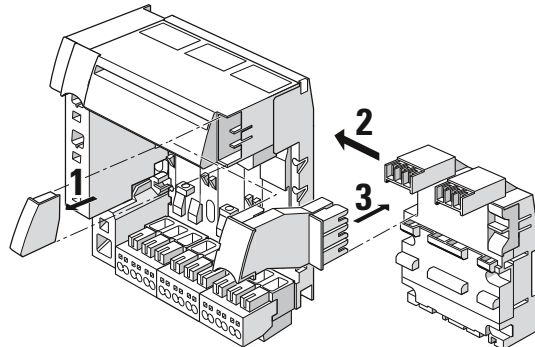
The terminal block is available with spring-loaded connection technology. It can be installed on the right or left-hand side of the expansion module.



- ① Remove the end cover from the expansion module.
- ② Mount the terminal block on the expansion module.
- ③ Lock the terminal block.

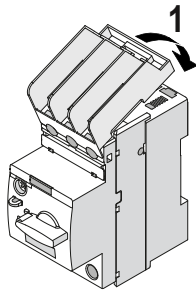
Connecting the SIRIUS infeed system for 3RA6 and SIRIUS 3RV29 infeed system

The 3RV29 infeed system can be mounted on the right-hand side of the infeed system for 3RA6 with the extension connector for 3RV29 (3RA6890-1AA).

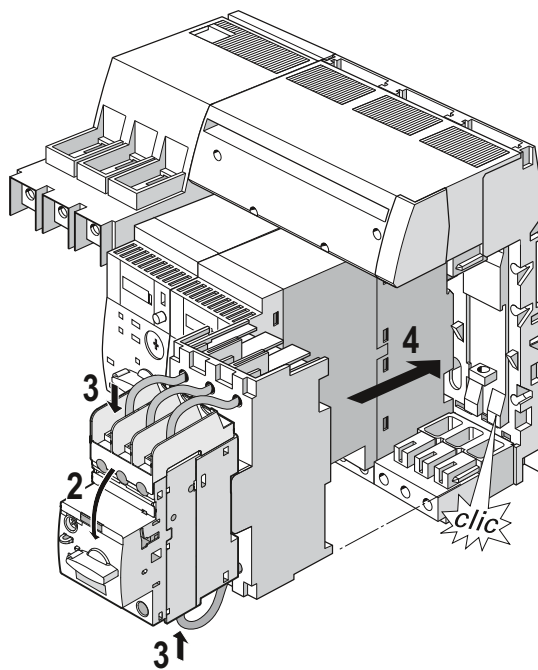


- ① Remove the end cover from the infeed system for 3RA6.
- ② Push together the infeed system for 3RA6 and the 3RV29 infeed system.
- ③ Connect the infeed system with the extension connector for 3RV29.

Installing the 45 mm adapter for infeed system for 3RA6



- ① Snap interphase barriers onto circuit breaker.



- ② Snap the back of the circuit breaker onto the upper edge of the DIN rail, connecting it to the 45 mm adapter for 3RA6 infeed systems.
- ③ Connect the circuit breaker to the adapter cables.
- ④ Working from the front, mount the adapter on the screw-type infeed/expansion module and push the adapter backwards until you hear it engage.

**WARNING****Hazardous voltage!**

Will cause death or serious injury.

If a circuit breaker that is not permitted is mounted on the 45 mm adapter for the infeed system for 3RA6 this may result in damage to the circuit breaker and to the infeed system for 3RA6 and may cause an electric shock.

Mount only 3RV2.2 circuit breakers of size S0 on the 45 mm adapter for the infeed system for 3RA6. In addition, interphase barriers must be installed.

Mounting terminal cover for screw-type infeeds

For the 3-phase screw-type infeeds 25/35 mm² and 50/70 mm², universally designed terminal covers for increased finger protection are available.

- Terminal cover 3RA6880-2AB for screw-type infeeds 25/35 mm² (3RA6812-8AB / 3RA6812-8AC)
- Terminal cover 3RA6880-3AB for screw-type infeeds 50/70 mm² (3RA6813-8AB / 3RA6813-8AC)

The terminal covers can be used in two ways on the supply terminals of the infeeds with screw connection 25/35 mm² and 50/70 mm²:

- The cables of occupied terminals are also covered:
 - Approximately 14 mm coverage with terminal cover 3RA6880-2AB
 - Approximately 18 mm coverage with terminal cover 3RA6880-3AB
- For clamping points not occupied with cables, the covers can be turned over once and pushed over the clamping points, thereby covering the metal parts so they are safe-to-touch.

Mounting of terminal cover 3RA6880-2AB for screw-type infeeds 25/35 mm²

The following representations show the mounting options for the terminal cover for screw-type infeeds 25/35 mm²:

7.7 Infeed system for 3RA6

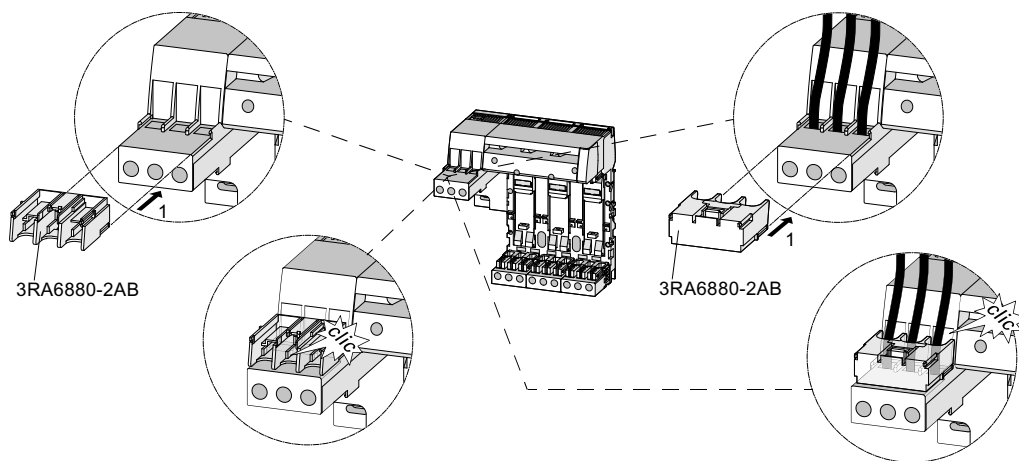


Figure 7-6 Top mounting of terminal cover for screw-type infeeds 25/35 mm²

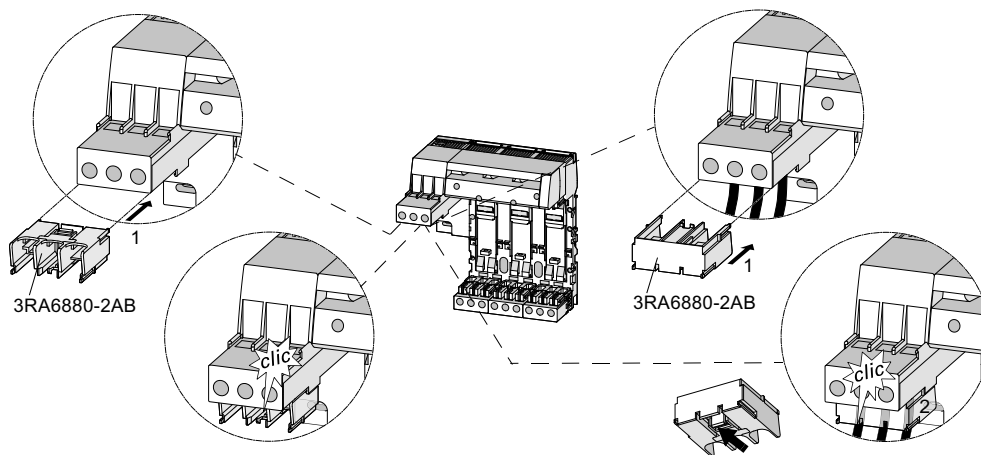


Figure 7-7 Bottom mounting of terminal cover for screw-type infeeds 25/35 mm²

Mounting of terminal cover 3RA6880-3AB for screw-type infeeds 50/70 mm²

The following representations show the mounting options for the terminal cover for screw-type infeeds 50/70 mm²:

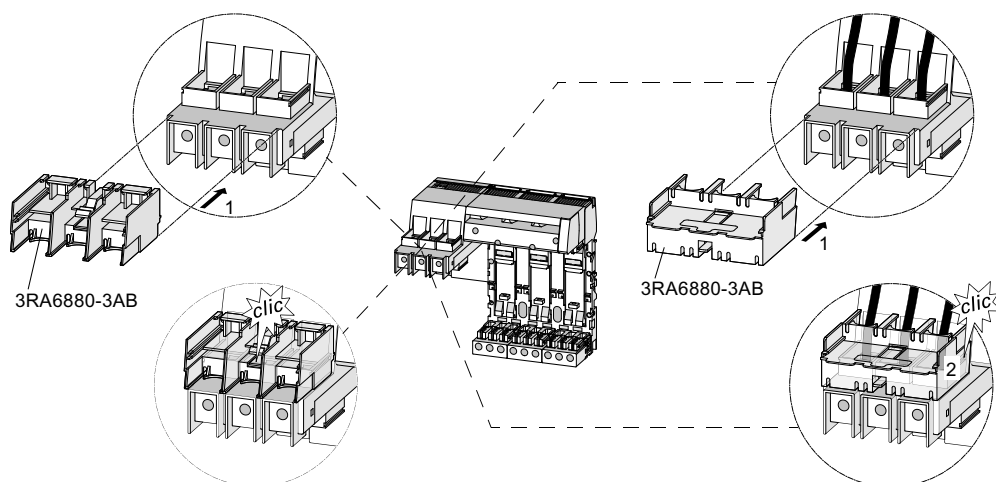


Figure 7-8 Top mounting of terminal cover for screw-type infeeds 50/70 mm²

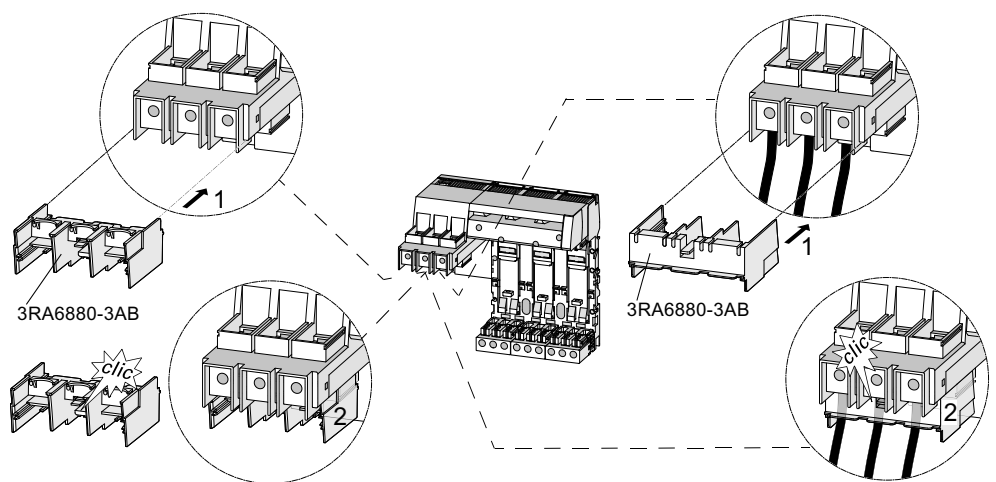


Figure 7-9 Bottom mounting of terminal cover for screw-type infeeds 50/70 mm²

7.7.3.4 Uninstalling the accessories for the infeed system for 3RA6

Requirements



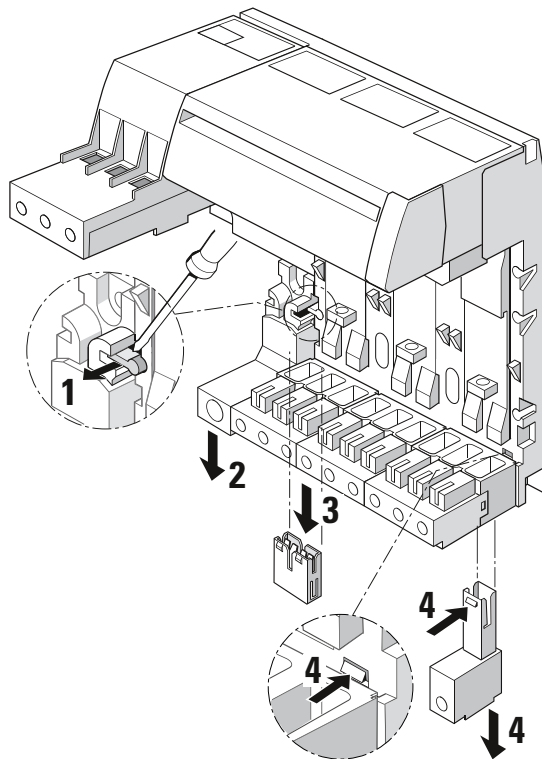
<p>! DANGER</p>
<p>Hazardous voltage!</p> <p>Will cause death or serious injury.</p> <p>Before starting work, disconnect the system and the device from the power supply.</p>

7.7 Infeed system for 3RA6

- The compact starters and circuit breakers must have been removed from the infeed system for 3RA6. For more information on this topic, see Chapter "Removing the compact starter from an infeed system for 3RA6 (Page 71)".
- Flat-head screwdriver with max. blade width of 3 mm and total max. length of 120 mm for levering out the link wedges and releasing the PE tap and PE extension connectors.

Removing PE accessories

The PE infeed is mounted on the right or left of the base carrier.



- ① Use a screwdriver to lever out the link wedge.
- ② Push the PE infeed downwards.
- ③ Pull the PE extension connector down and out and then remove the PE infeed sideways.
- ④ Press the clip on the PE tap backwards and then pull the PE tap down and out of the infeed or expansion module.

7.7.3.5 Removing the infeed system for 3RA6 from a standard mounting rail

The infeed system for 3RA6 is either installed on a DIN rail or on a level surface (screw fastening). The removal process is basically the same for both mounting types. The only difference between the two is how the expansion modules are fastened. As the infeed system for 3RA6 is meant to be mounted on a mounting rail as standard, the information below describes removal from a mounting rail.

Requirements



! DANGER

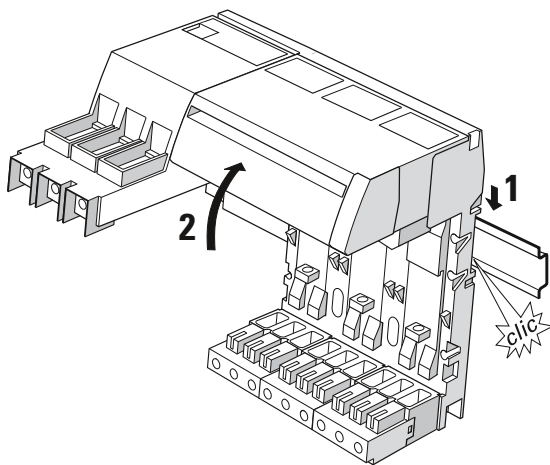
Hazardous voltage!

Will cause death or serious injury.

Before starting work, disconnect the system and the device from the power supply.

- The terminal blocks must have been disconnected.
- The compact starters and circuit breakers must have been removed.
- The PE infeed and PE tap must have been removed.

Removing screw-type infeed (25/35 mm²) or screw-type infeed (50/70 mm²) from a DIN rail



- ① Pull the screw-type infeed down until it can be pulled away from the DIN rail.
- ② Pull the screw-type infeed away from the DIN rail and lift it off the rail's upper edge.

Removing a spring-loaded infeed with expansion module from a DIN rail

The spring-loaded infeed is mounted on the right or left of a 3-slot or 2-slot expansion module.



! DANGER

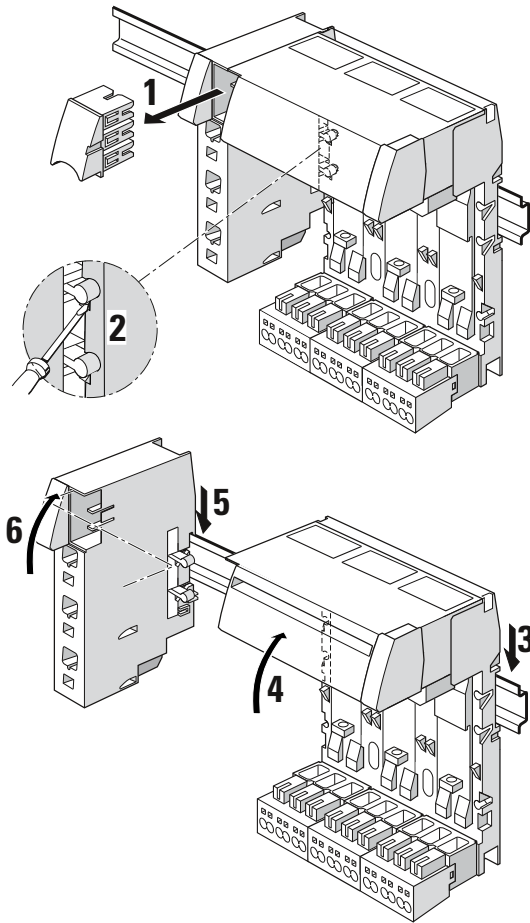
Hazardous voltage!

Will cause death or serious injury.

If extension connectors or end covers are missing, direct contact with live parts is possible.

When installing/removing an extension connector or an end cover the system power supply must be switched off.

7.7 Infeed system for 3RA6



- ① Remove the extension connector that has been used to connect the expansion module to the spring-loaded infeed.
- ② Use a screwdriver to lever out the 2 link wedges that have been used for the mechanical connection between the expansion module and the spring-loaded infeed.
- ③ Pull the expansion module down until it can be pulled away from the DIN rail.
- ④ Pull the expansion module away from the DIN rail and lift it off the rail's upper edge.
- ⑤ Pull the spring-loaded infeed down until it can be pulled away from the DIN rail.
- ⑥ Pull the spring-loaded infeed away from the DIN rail and lift it off the rail's upper edge.

Removing additional expansion modules

Screw-type and spring-loaded infeeds can be expanded by means of additional 3-slot and 2-slot expansion modules. Screw-type infeeds can only be expanded by adding modules to the right. Spring-loaded infeeds can be expanded by adding modules to the right or left, depending on which side the spring-loaded infeed has been installed.



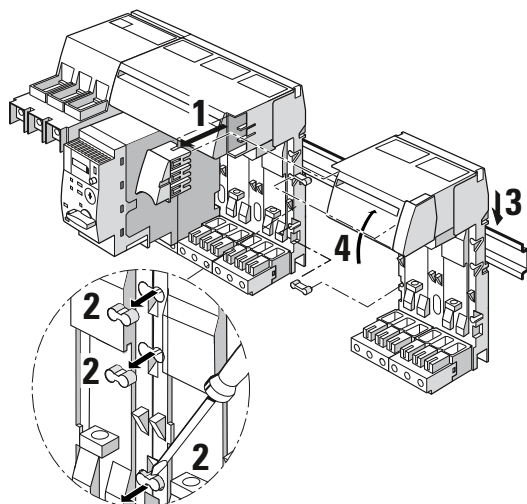
! DANGER

Hazardous voltage!

Will cause death or serious injury.

If extension connectors or end covers are missing, direct contact with live parts is possible.

When installing/removing an extension connector or an end cover the system power supply must be switched off.



- ① Remove the extension connector that has been used for the electrical connection between the expansion modules.
- ② Use a screwdriver to lever out the 3 link wedges that have been used for the mechanical connection between the expansion modules.
- ③ Pull the expansion module down until it can be pulled away from the DIN rail.
- ④ Pull the expansion module away from the DIN rail and lift it off the rail's upper edge.

7.7.4 Coding

The infeed system for compact starters can be locked by disabling the slots with a padlock (shackle diameter 3.5 - 4.5 mm). Simply attach a padlock to the fixture on the infeed system.

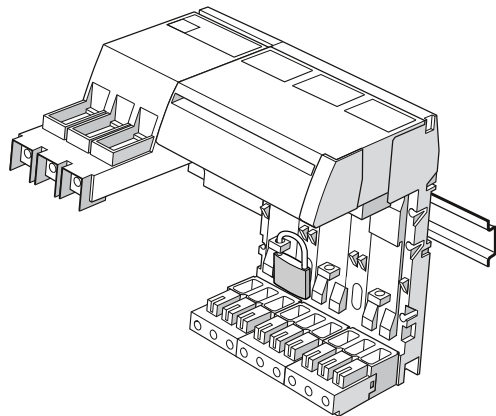


Figure 7-10 Locking the SIRIUS infeed system for 3RA6 for compact starters

Alternatively, the infeed system for 3RA6 can be coded to only allow installation of compact starters with a defined maximum rated current. This function prevents compact starters being installed on the infeed system if their current setting range is too high, thereby eliminating the problem of infeed system current overload, for example.

The infeed system for 3RA6 can be locked against compact starters with the following current setting ranges:

- 3 to 12 A
- 8 to 32 A
- 3 to 12 A and 8 to 32 A

Procedure

Coding is achieved by means of cylindrical pins (DIN EN ISO 8734-2x8). The cylindrical pins are inserted into special holes in the infeed system's base carrier. The cylindrical pins are used as spacers and prevent compact starters from being snapped onto certain slots of the infeed system.

Each slot is individually coded for compact starters with a particular current setting range.

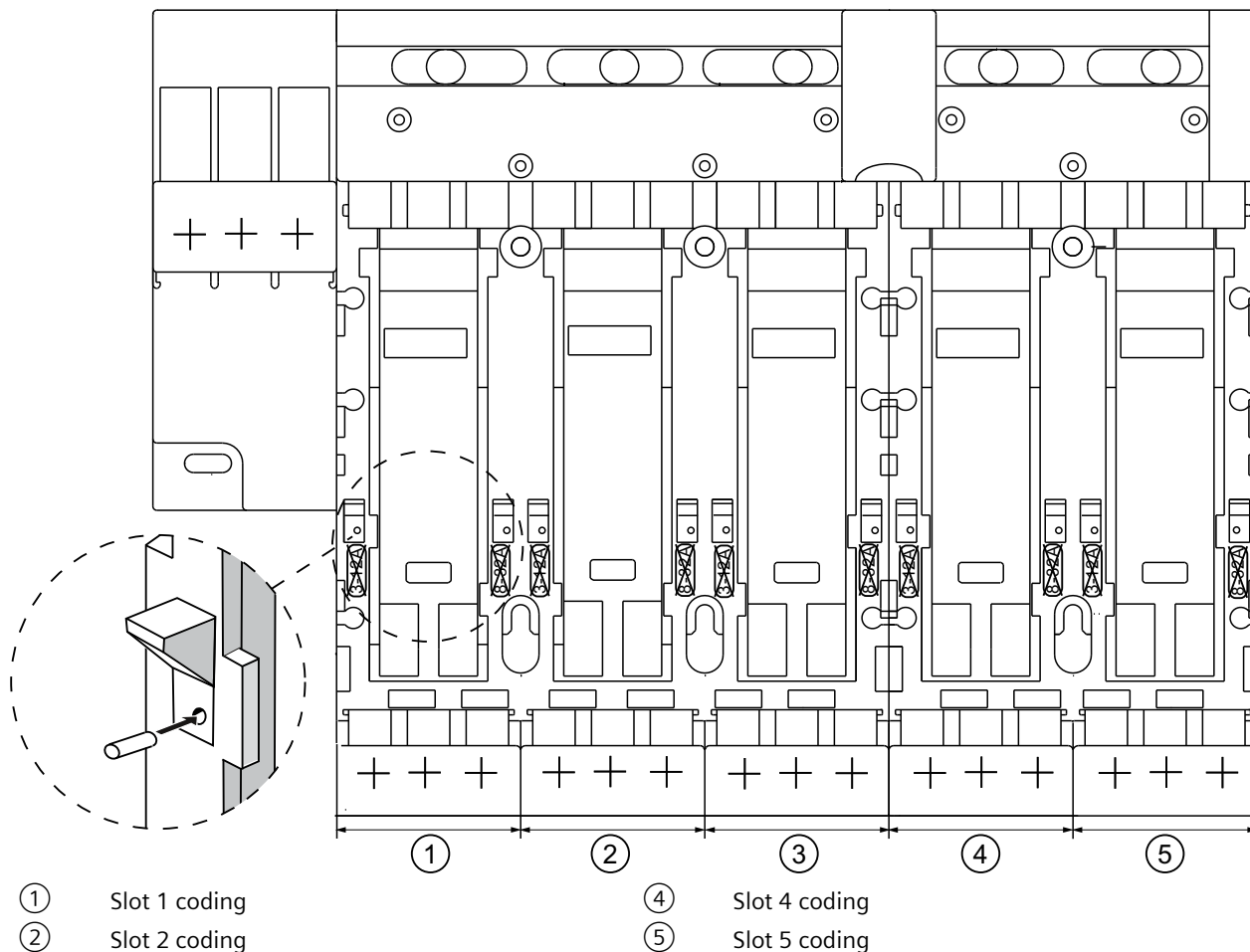


Figure 7-11 Coding the SIRIUS infeed system for 3RA6

The following options are available for coding the infeed system slots:

Table 7-4 Coding the infeed system for 3RA6

Coding	Procedure
No locking. i.e. all types of compact starter can be installed	No measures required, i.e. no cylindrical pin needs to be inserted into the infeed system slot
Compact starters for the current setting range 3 - 12 A must not be used.	Insert the cylindrical pin into the hole (3-12A) .

7.7 Infeed system for 3RA6

Coding	Procedure
Compact starters for the current setting range 8 - 32 A must not be used.	Insert the cylindrical pin into the hole (8-32A)
Compact starters for the current setting range 3 - 12 A and 8 - 32 A must not be used.	Insert the cylindrical pins into the holes (3-12A) and (8-32A) .

7.7.5 Connection

The SIRIUS infeed system for 3RA6 is available with screw-type and spring-loaded connection technology.

The main conductors (L1, L2, L3) can be connected to the screw-type infeed (25/35 mm²) and screw-type infeed (50/70 mm²) from both the top and the bottom.

Stripping lengths

The following stripping lengths apply to the SIRIUS infeed system for 3RA6:

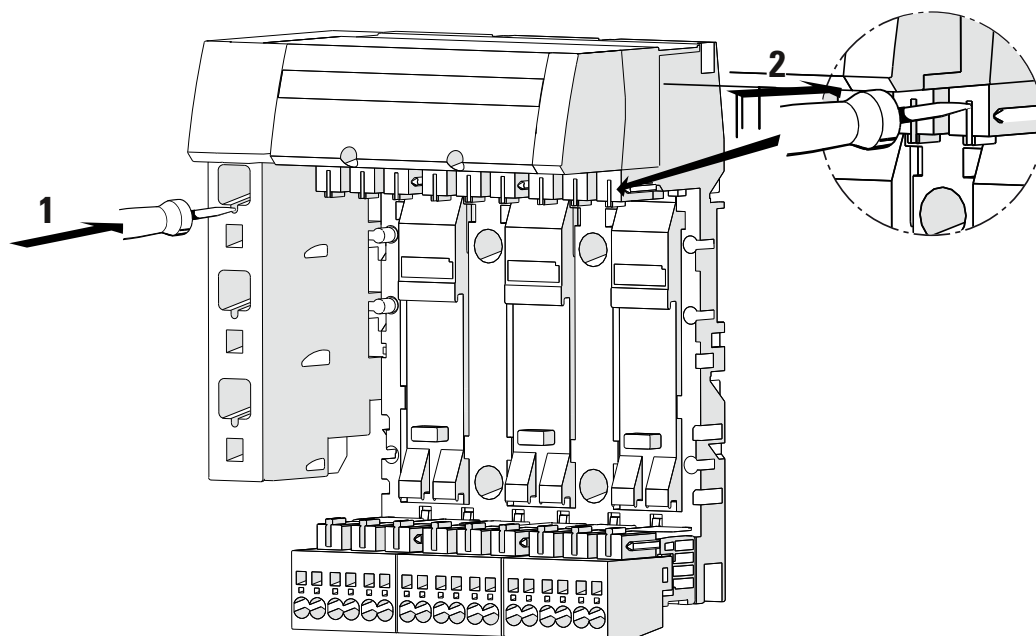
Table 7-5 Stripping lengths (infeed system for 3RA6)

Connecting terminal	Article number	Stripping length
Screw-type infeed (25/35 mm ²)	3RA6812-8AB 3RA6812-8AC	Infeed: 13 mm and motor outgoing feeder: 10 mm
Screw-type infeed (50/70 mm ²)	3RA6813-8AB 3RA6813-8AC	Infeed: 17 mm and motor outgoing feeder: 10 mm
Extension modules with screw-type and spring-loaded connection technology	3RA6822-0AB 3RA6822-0AC 3RA6823-0AB 3RA6823-0AC	10 mm
Spring-loaded infeed	3RA6830-5AC	23 mm
PE infeed, 25/35 mm ² , screw-type connection technology	3RA6860-6AB	13 mm
PE infeed, 25/35 mm ² , spring-loaded connection technology	3RA6860-5AC	23 mm
PE tap	3RA6870-4AB 3RA6870-3AC	10 mm
Terminal block	3RV2917-5D	12 mm

Openings for test probes

On the infeed system with screw-type connection technology, the test probes are attached to the terminal screws.

On the infeed system with spring-loaded connection technology, all terminals are equipped with special test probe openings.



- Openings for test probes on
- ① The spring-loaded infeed
 - ② The extension blocks

Figure 7-12 Test probe openings on the infeed system

Conductor cross-sections

Table 7-6 Screw-type infeed (25/35 mm²) (L1, L2, L3) and PE infeed, 25/35 mm², with screw-type connection technology

	3RA6812-8AB (L1, L2, L3) 3RA6812-8AC (L1, L2, L3) 3RA6860-6AB		
 Ø 6 mm/PZ 2	3 ... 4.5 Nm (27 ... 40 lb·in)		
	2.5 ... 35 mm ²	2.5 ... 35 mm ²	Max. (2 x 25) mm ²
	2.5 ... 25 mm ²	2.5 ... 25 mm ²	Max. (2 x 16) mm ²
	2.5 ... 25 mm ²	2.5 ... 25 mm ²	Max. (2 x 16) mm ²
AWG	12 to 2	12 to 2	Max. 2 x (16 to 2)

7.7 Infeed system for 3RA6

Table 7-7 Screw-type infeed (50/70 mm²) (L1, L2, L3)




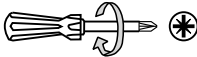
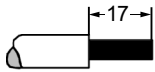
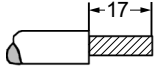
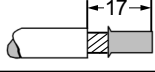
	3RA6813-8AB (L1, L2, L3) 3RA6813-8AC (L1, L2, L3)		
			
 SW4	6 ... 8 Nm (53 ... 71 lb-in)		
	2.5 ... 70 mm ²	2.5 ... 70 mm ²	Max. (2 x 50) mm ²
	4 ... 50 mm ²	10 ... 50 mm ²	Max. (2 x 35) mm ²
	2.5 ... 35 mm ²	2.5 ... 50 mm ²	Max. (2 x 35) mm ²
AWG	10 to 2/0	10 to 2/0	Max. 2 x (10 to 1/0)

Table 7-8 Spring-loaded infeed (L1, L2, L3) and PE infeed, 25/35 mm², with spring-loaded connection technology

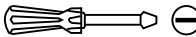
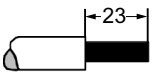
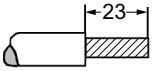
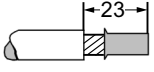
	3RA6830-5AC 3RA6860-5AC
	 8WA2 806 (5.5 x 0.8 mm)
	4 ... 35 mm ²
	6 ... 25 mm ²
	4 ... 25 mm ²
AWG	10 to 3

Table 7-9 Screw-type infeed (25/35 mm²) (T1, T2, T3), screw-type infeed (50/70 mm²) (T1, T2, T3), 2-slot/3-slot extension modules (T1, T2, T3) and PE tap, 6/10 mm², with screw-type connection technology

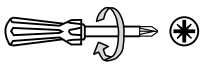
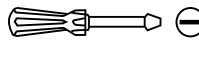
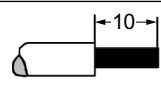
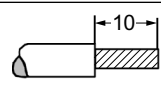
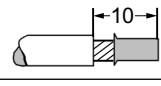
	3RA6813-8AB (T1, T2, T3) 3RA6812-8AB (T1, T2, T3) 3RA6822-0AB (T1, T2, T3) 3RA6823-0AB (T1, T2, T3) 3RA6870-4AB		3RA6822-0AC (T1, T2, T3) 3RA6823-0AC (T1, T2, T3) 3RA6813-8AC (T1, T2, T3) 3RA6812-8AC (T1, T2, T3)	
Compact starter	... 12 A	8 ... 32 A	... 12 A	8 ... 32 A
	 Ø 6 mm/PZ 2		 8WA2 803 (3.5 x 0.5) mm	
	2 to 2.5 Nm (18 to 22 lb·in)		-	
	2 x (1.5 ... 2.5) mm ² 2 x (2.5 ... 6) mm ² max. 1 x 10 mm ²	2 x (2.5 ... 6) mm ² max. 1 x 10 mm ²	2 x (1.5 ... 6) mm ² max. 1 x 10 mm ²	2 x (2.5 ... 6) mm ² max. 1 x 10 mm ²
	-	-	2 x (1.5 ... 6) mm ²	2 x (2.5 ... 6) mm ²
	2 x (1.5 to 2.5) mm ² 2 x (2.5 to 6) mm ²	2 x (2.5 ... 6) mm ²	2 x (1.5 ... 6) mm ²	2 x (2.5 ... 6) mm ²
AWG	2 x (16 to 14) 2 x (14 to 10) 1 x 8	2 x (14 to 10) 1 x 8	2 x (16 to 10) 1 x 8	2 x (14 to 10) 1 x 8

Table 7-10 PE tap, 6/10 mm², with spring-loaded connection technology

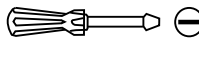

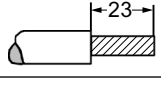
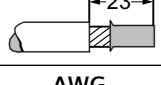

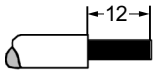
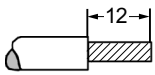
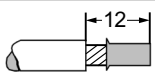
	3RA6870-3AC
	 8WA2 803 (3.5 x 0.5) mm
	1,5 ... 10 mm ²
	1,5 ... 6 mm ²
	1,5 ... 6 mm ²
AWG	16 to 10 1 x 8

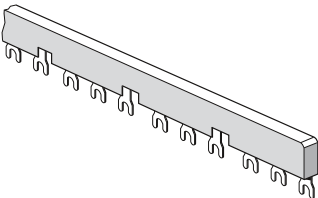
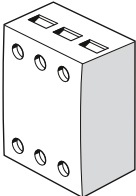
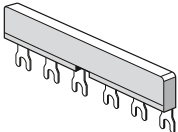
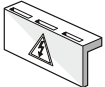
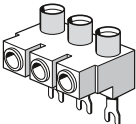
Table 7-11 Terminal block

	3RV2917-5D
	 8WA2 803 8WA2 804 (3.5 x 0.5 mm)
	1,5 ... 6 mm ²
	1,5 ... 6 mm ²
	1,5 ... 4 mm ²
AWG	15 to 10

7.8 3-phase busbar

7.8.1 Scope of supply

Scope of supply 3RV19 3-phase busbar

System component	Article number	Figure
3RV19 3-phase busbar		
- 2 divisions	3RV1915-1AB	
- 3 divisions	3RV1915-1BB	
- 4 divisions	3RV1915-1CB	
- 5 divisions	3RV1915-1DB	
3-phase infeed terminal, connection from the bottom, with screw-type connection	3RV2915-5B	
Connection piece for connecting compact starters to size S00 circuit breakers	3RV1915-5DB	
Cover cap for terminal lugs	3RV1915-6AB	
3-phase infeed terminal, connection from above, with screw-type connection technology and for installing "Type E starters", UL 508	3RV2925-5EB	

7.8.2 Description of the hardware

3RV19 3-phase busbars enable several compact starters to be fed using a single infeed terminal. The 3RV19 3-phase busbars are finger-safe in terms of touch protection. They have been dimensioned to withstand the level of short-circuit stress that can occur on the output side of the connected compact starters.

Rated current/rated operating voltage

- Rated operating voltage: 690 V
- Rated current: 63 A

Versions

Depending on the version selected, the 3RV19 3-phase busbars can be used to connect between 2 and 5 compact starters.

Combining compact starters with SIRIUS circuit breakers

You can combine compact starters with size S0 circuit breakers.

If you wish to combine compact starters with size S00 circuit breakers you will need to use a connection piece (3RV1915-5DB). This connection piece is required, because the compact starters and size S00 circuit breakers have different depths.

For additional information on combining the compact starter with SIRIUS size S00 circuit breakers, please refer to "3RV19 3-phase busbar (Page 37)".

Extending 3-phase busbars

The 3-phase busbar can be extended by adding another busbar (rotated by 180°) and pushing the terminal lugs of this new busbar underneath the terminals of the last compact starter (see **Configuration**).

NOTICE
Material damage to the busbar and connecting terminals!
Thermal overloads can damage the busbar and connecting terminals.
When extending the 3-phase busbar, please remember to observe its current carrying capacity.

Accessories

- Connection piece (3RV1915-5DB): A connection piece is used to connect two 3-phase busbars with 45 mm modular spacing if you are using compact starters together with size S00 circuit breakers.
- Cover cap for terminal lugs (3RV1915-6AB): Cover caps provide touch protection for reserved slots as well as any that are not in use (e.g. for reversing starters). These cover caps need to be removed before extending the busbars.

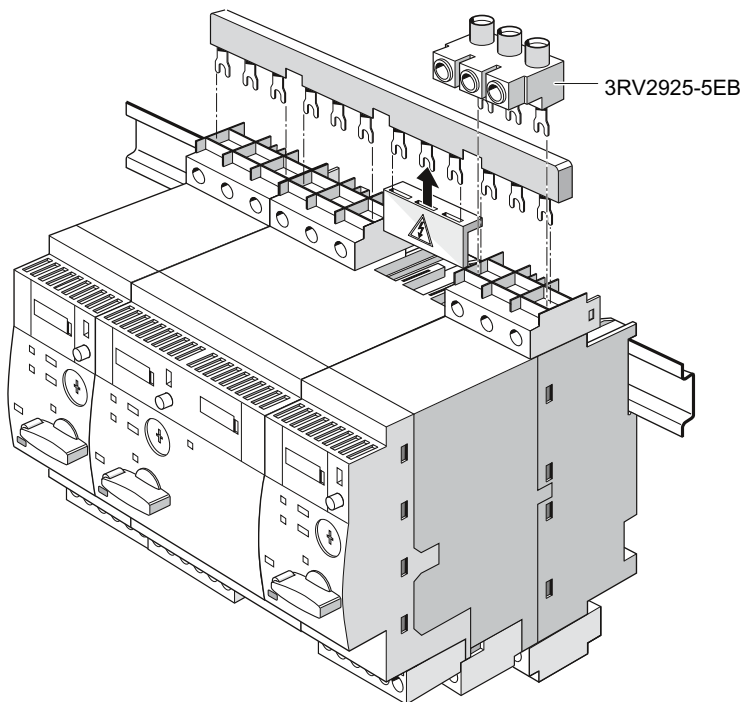


Figure 7-14 3-phase busbar and 3-phase infeed terminal (Type E)

7.8.3 Connection

The 3-phase infeed terminals are available with screw-type connection technology.

3-phase infeed terminals 3RV19

There are two infeed possibilities available for the 3-phase busbar:

- 3-phase infeed terminal, connection from the bottom, with screw-type connection technology (3RV2915-5B)
- 3-phase infeed terminal, connection from above, with screw-type connection technology and for installing "Type E starters", UL 508 (3RV2925-5EB)

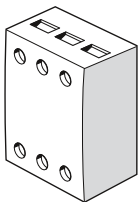
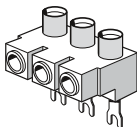
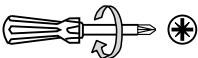
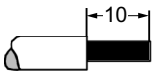
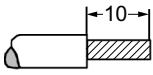
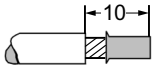
3-phase infeed terminal – connection from the bottom

Note

The 3-phase infeed terminal with connection from the bottom is connected instead of a compact starter. You will therefore need to take the space requirements into account when configuring the 3-phase busbar.

Conductor cross-sections of 3-phase infeed terminals

Table 7-12 3-phase infeed terminal

	3RV2915-5B	3RV2925-5EB
		
 Ø 5 ... 6 mm / PZ 2	Input: 4 Nm (35.2 lb·in) Output: 2 ... 2.5 Nm (17.6 ... 22 lb in)	3 ... 4 Nm (26.4 ... 35.2 lb·in)
	(2.5 ... 25) mm ²	(2.5 ... 25) mm ²
	(2.5 ... 25) mm ²	(2.5 ... 25) mm ²
	(2.5 ... 16) mm ²	(2.5 ... 16) mm ²
AWG	10 ... 4	10 ... 4

7.9 8US busbar adapter

7.9.1 Scope of supply

Scope of supply of the 8US busbar adapter

System component	Article number	Figure
Busbar adapter for 60 mm system Note: Except for the adapter for screw fastening, fastening parts are prefitted.	8US1211-1NS10	
Device holder for side mounting on busbar adapter (only if installing a 3RA62 reversing starter)	8US1250-1AA10	

7.9.2 Description of the hardware

To save space when installing compact starters and to save time as far as the infeed is concerned, busbar adapters are used to mount the compact starters directly onto busbar systems.

The compact starter is mounted on the 8US busbar adapter and connected on the line side. This ready-to-use unit plugs directly onto the busbar systems, thereby taking care of mechanical fastening and electrical connection at the same time.

Busbar systems

The 8US busbar adapter has been designed for use with the following system:

Table 7-13 Bus bar system

Busbar system with center-to-center clearance	For copper busbar in accordance with DIN EN/EN 13601	
	Width	Thickness
60 mm systems	12 mm to 30 mm	5 mm and 10 mm

Accessories

The following accessory is available for the 8US busbar adapter:

- Device holder for lateral mounting on busbar adapter (8US1250-1AA10).
You only need the device holder when installing a 3RA62 compact starter reversing starter.

7.9.3 Installing/removal

7.9.3.1 Installing

Requirements

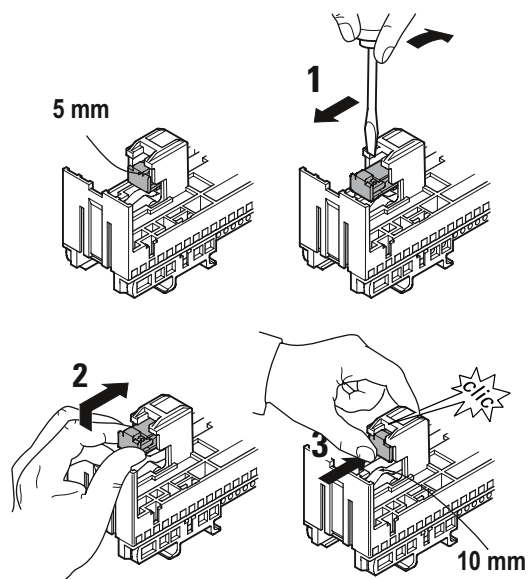
- The compact starter must be switched off (actuator set to \circ OFF position).
- The busbars must be disconnected from the power supply when the 8US busbar adapter is mounted on the busbars.

Adjusting the 8US busbar adapter for the busbar system

The busbar adapter can be adjusted to suit the following busbar thicknesses:

- 5 mm (delivery condition)
- 10 mm

7.9 8US busbar adapter



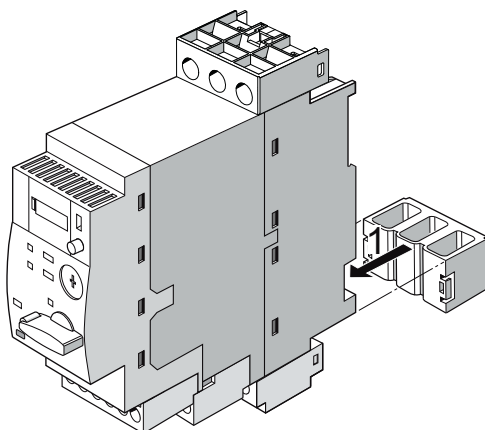
- ① Push the 3 fastening blocks down.
- ② Adjust the fastening blocks in accordance with the busbar thickness (5 mm/10 mm).
- ③ Push the fastening blocks up until they engage.

Procedure for 3RA61 compact starter direct starter

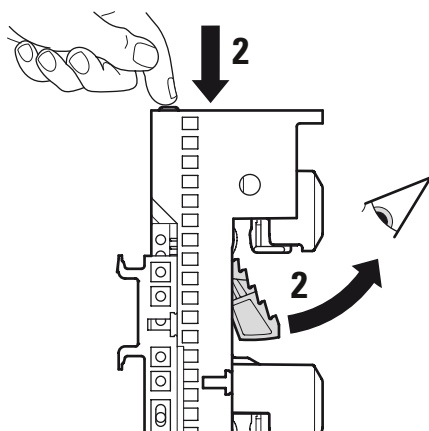
Note

The 8US busbar adapter plus compact starters must be arranged side by side on the busbar system without any space in between in order to meet the specified vibratory load and shock load requirements.

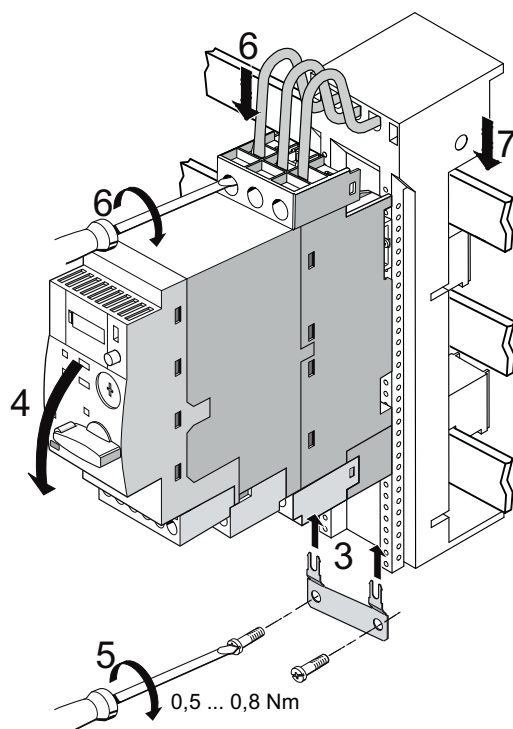
You can find more information on the technical data in Chapter "Technical data (Page 239)".



- ① Click the adapter for screw fastening the compact starter into position behind the lower main circuit terminal.



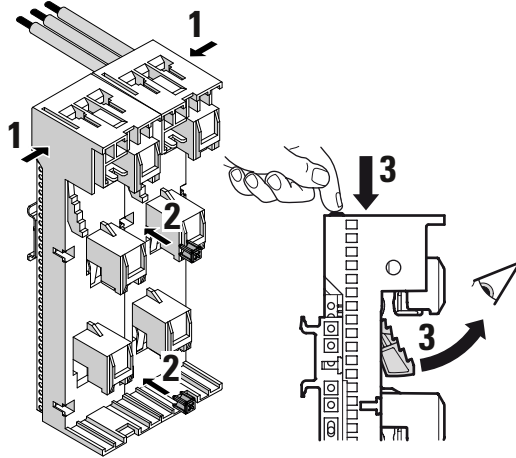
- ② Press the button on the top side of the busbar adapter to release the holder. The holder should flip out from the front of the busbar adapter.



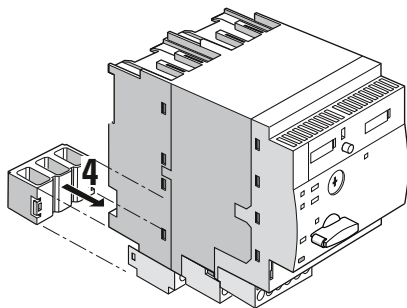
- ③ Push the mounting lug into the adapter from the bottom.
- ④ Snap the compact starter onto the DIN rail, connecting it to the busbar adapter.
- ⑤ Insert each of the screws through the relevant holes in the mounting lug and screw the compact starter onto the busbar adapter.
- ⑥ Connect the wiring from the busbar adapter to the compact starter's main circuit terminal.
- ⑦ Mount the busbar adapter on the busbars from the top.

Procedure for 3RA62 compact starter reversing starter

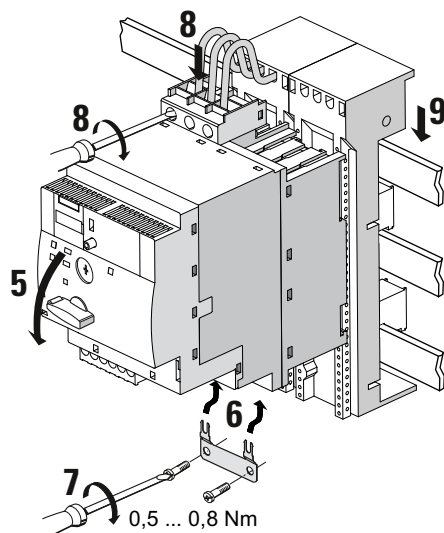
If you are mounting a reversing starter on the 8US busbar adapter, the reversing starter's width means that it will need to be mounted on a device holder (8US1250-1AA10) as well.



- ① Position the device holder next to the 8US busbar adapter.
- ② Press the 2 connecting plugs into the relevant openings from behind to connect the device holder to the 8US busbar adapter.
- ③ Press the button on the top side of the busbar adapter and device holder to release the holders. The holders should flip out from the front of the busbar adapter and device holder.



- ④ Click the adapter for screw fastening the reversing starter into position behind the lower main circuit terminal.



- ⑤ Snap the reversing starter onto the DIN rail, connecting it to the busbar adapter and device holder.
- ⑥ Push the mounting lug into the adapter from the bottom.
- ⑦ Insert each of the screws through the relevant holes in the mounting lug and screw the reversing starter onto the busbar adapter.
- ⑧ Connect the wiring from the busbar adapter to the reversing starter's main circuit terminal.
- ⑨ Mount the busbar adapter plus device holder on the busbars from the top.

7.9.3.2 Removal

Requirements

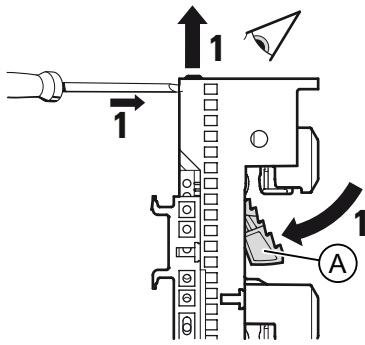
- The compact starter must be switched off (actuator set to \circ OFF position).
- The busbars must be disconnected from the power supply when the 8US busbar adapter is removed from the busbars.

Procedure

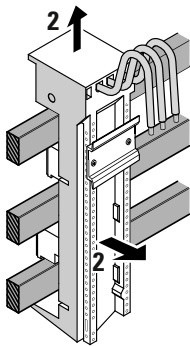
Note

The compact starter can be detached from the 8US busbar adapter either before or after the 8US busbar adapter has been removed from the busbars.

7.9 8US busbar adapter



- ① From the front, insert a screwdriver into the right-hand opening on the busbar adapter and lock the holder (A). The button on the top side of the busbar adapter should spring up.



- ② Remove the busbar adapter from the busbars. To do this, you will first need to push it up slightly so that you can remove it by pulling it off towards you.

Note

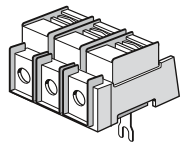
Removing the busbar adapter plus mounted device holder

When removing the busbar adapter along with a mounted device holder, you will need to release both holder (A) on the busbar adapter and the one on the device holder.

7.10 Terminal for a Type E self-protected combination motor controller (UL 508)

7.10.1 Scope of supply

Scope of supply of the terminal for Type E

System component	Article number	Figure
Terminal for self-protected combination motor controller (Type E) to UL 508	3RV2928-1H	

7.10.2 Installing/removal

According to UL 508 (Type E), line-side clearances of 1 and 2 inches are required for Type E combination motor controllers. If parallel wiring is used for the compact starter, the terminal for the self-protected combination motor controller (Type E) (3RV2928-1H) must be used.

Note

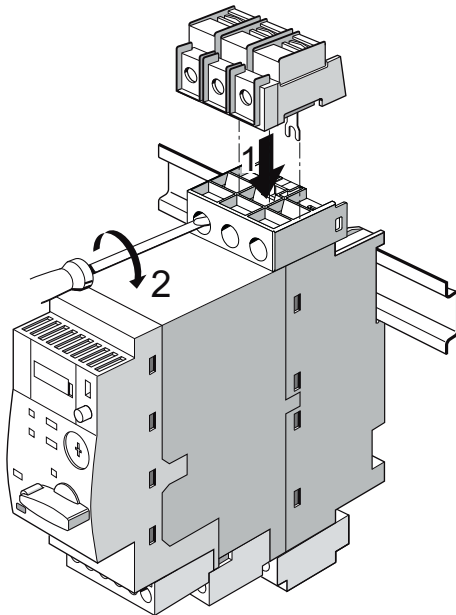
According to C22.2-14, terminal blocks are not required for installation in accordance with CSA requirements.

Note

Supply options in accordance with UL 508 (Type E) are still available when compact starters are installed with a 3RV19 3-phase busbar and the infeed system for 3RA6. You will find more information in Chapter "Infeed in accordance with UL 508 (Type E) (Page 40)".

7.10 Terminal for a Type E self-protected combination motor controller (UL 508)

Procedure

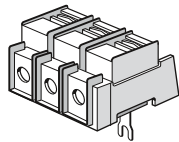



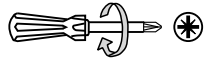
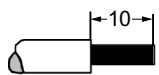


- ① Attach the terminal to the compact starter's main circuit terminal from the top.
- ② Screw the screw terminals tight.

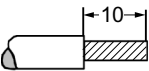
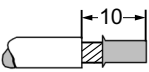
7.10.3 Connection

Conductor cross-sections

Table 7-14 Conductor cross-sections of the terminal for a self-protected combination motor controller (Type E) to UL 508

3RV2928-1H			
			
			
 Ø 5 ... 6 mm/PZ 2	2.5 ... 3 Nm (22 to 26.5 lb·in)		
	(1 ... 10) mm ²	(1 ... 10) mm ²	Max. 10 + max. 10 mm ²

7.10 Terminal for a Type E self-protected combination motor controller (UL 508)

3RV2928-1H			
	(2.5 ... 25) mm ²	(1.5 ... 25) mm ²	Max. 10 + max. 25 mm ²
	(1 ... 16) mm ²	(1 ... 16) mm ²	Max. 10 + max. 10 mm ² Max. 6 + max. 16 mm ²
AWG	14 to 3	16 to 3	Max. 6 + max. 3

7.11 Door-coupling rotary operating mechanism

7.11.1 Scope of supply

Scope of supply of the door-coupling rotary operating mechanism

System component	Article number	Figure
Door-coupling rotary operating mechanism; 130 mm long	3RV2926-0B	
EMERGENCY OFF door-coupling rotary operating mechanism; 130 mm long	3RV2926-0C	

7.11.2 Description of the hardware

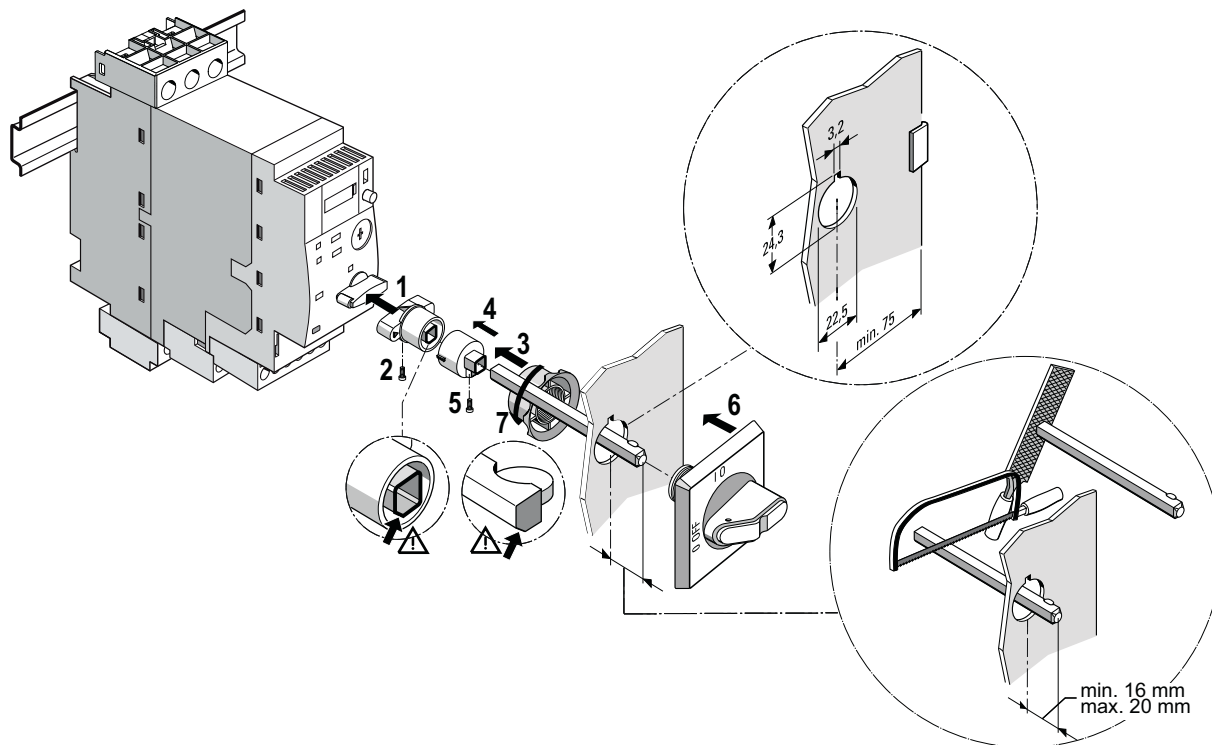
Door-coupling rotary operating mechanisms consist of a lockable rotary operating mechanism with a removable door coupling, an extension shaft and a connection piece that joins onto the switch mechanism. There are two basic versions available:

- Door-coupling rotary operating mechanism for standard applications (article number: 3RV2926-0B)
- Door-coupling rotary operating mechanism for EMERGENCY OFF applications (black/red actuator) (article number: 3RV2926-0C)

Both versions have been designed to provide IP64 degree of protection and can be locked in the OFF position using up to 3 padlocks.

7.11.3 Installing

Installing the door-coupling rotary operating mechanism



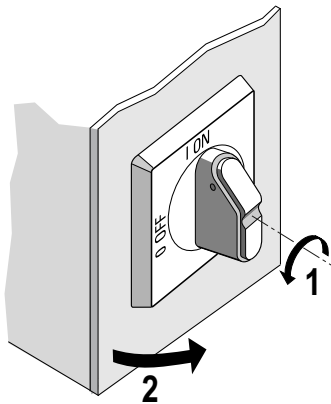
 Remember to observe the mechanical coding of the connecting rod!

Figure 7-15 Installing the door-coupling rotary operating mechanism

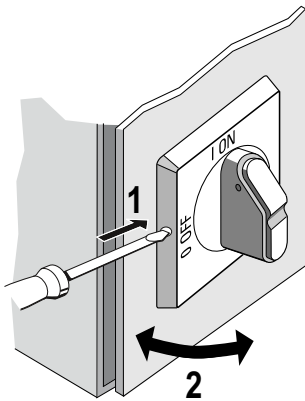
7.11.4 Commissioning

Opening the door

The following table explains how to open the control cabinet door with the door-coupling rotary operating mechanism.



- ① To open the control cabinet door, set the compact starter to the OFF position. This will release the extension shaft from the rotary operating mechanism so that you can open the door.
- ②



- ① If you want to open the control cabinet door during operation, press the button to the side of the bypass finger-grip knob (step 1).
- ② To close the door during operation press the button again so that the extension shaft reengages.

Note

When the compact starter is in the READY position and the door is opened with a force of $> 150 \dots 200 \text{ N}$, the extension shaft cap will separate from the compact starter's rotary switch to prevent major damage to the compact starter.

The compact starter will remain in the READY position.

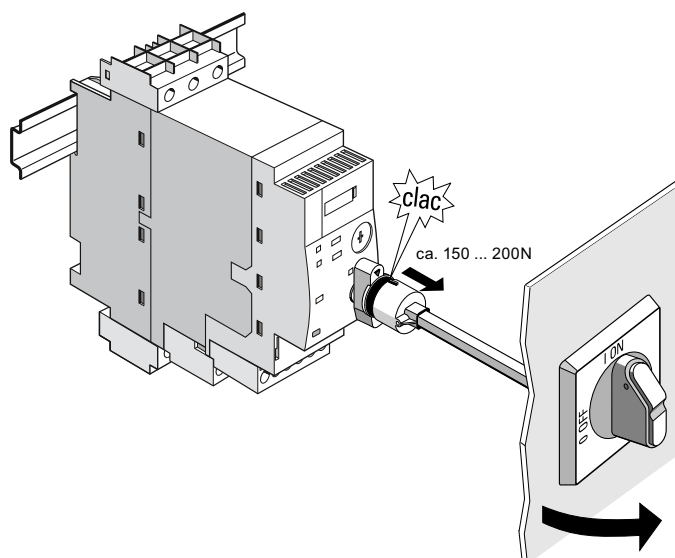
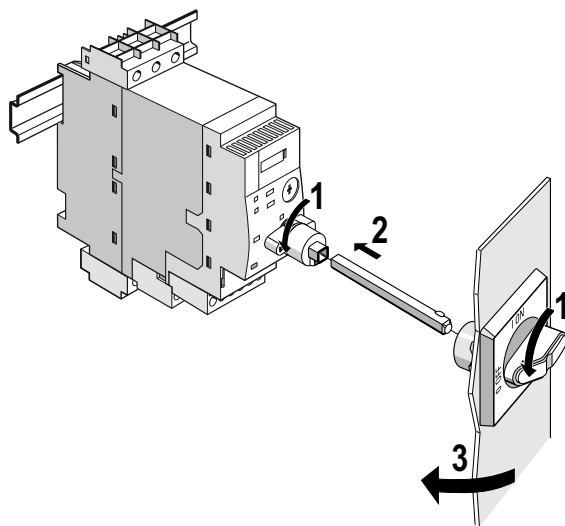



Figure 7-16 Door-coupling rotary operating mechanism; operating information

The extension shaft then needs to be attached to the compact starter and door-coupling rotary operating mechanism as described below:



- ① Switch off the compact starter (○ OFF) and turn the rotary switch of the door-coupling rotary operating mechanism to ○ OFF.
- ② Attach the extension shaft cap to the rotary switch and then insert the extension shaft into the cap.
- ③ Close the control cabinet door.

Disabling the actuator

In the  OFF position, the rotary operating mechanism can be secured using up to 3 locks, e.g. while maintenance work is carried out on the system.

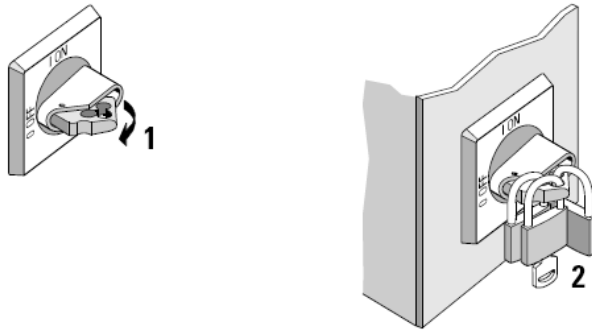
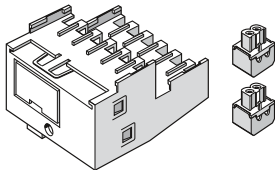
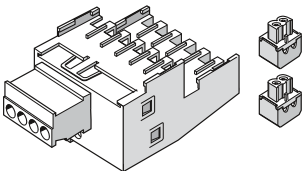



Figure 7-17 Door-coupling rotary operating mechanism, securing

7.12 AS-i mounting module for 3RA61/3RA62 compact starter

7.12.1 Scope of supply

Scope of supply of the AS-i mounting module

System component	Article number	Figure
AS-i mounting module for compact starter	3RA6970-3A	
AS-i mounting module for compact starter with		
• two local inputs for safe shutdown	3RA6970-3B	
• two additional digital inputs	3RA6970-3C	
• one additional digital input and one digital output	3RA6970-3D	
• with two additional digital outputs	3RA6970-3E	
• with two digital inputs for manual control of the compact starter	3RA6970-3F	
AS-Interface addressing unit V3.0 for AS-i mounting module	3RK1904-2AB02	
<ul style="list-style-type: none"> • For active AS-Interface modules, intelligent sensors and actuators • In accordance with AS-Interface Version 3.0 • Including extended addressing mode • Scope of supply including addressing line (1.5 m stereo jack) 		

7.12.2 Description of the hardware

Features

The AS-i mounting module is mounted on the compact starter with 24 V control supply voltage, thereby enabling it to be controlled via an AS-Interface. The following components are required for this purpose:

- AS-i master
- AS-i power supply unit

7.12 AS-i mounting module for 3RA61/3RA62 compact starter

- 24 VDC PELV power supply unit
- Cables and connection plugs

The AS-i mounting module is available in 6 versions:

- AS-i mounting module for compact starter (article number: 3RA6970-3A)
- AS-i mounting module with two local inputs for safe shutdown (article number: 3RA6970-3B). With this version of the AS-i mounting module, a Category 2 architecture in accordance with EN ISO13849-1 can be achieved with suitable installation. A limit switch, for example, can be connected via the screw-type terminals.

Note

Classification of the safety components

Depending on the safety components selected, the safety system as a whole can be classified in a lower safety category in accordance with EN ISO 13849-1:2007.

- AS-i mounting module with two additional digital inputs (article number: 3RA6970-3C)
- AS-i mounting module with one additional digital input and one digital output (article number: 3RA6970-3D)
- AS-i mounting module with two additional digital outputs (article number: 3RA6970-3E)
- AS-i mounting module with two digital inputs for manual control of the compact starter (article number: 3RA6970-3F).

For additional information on connecting the AS-i mounting module, please refer to "Connecting the AS-i mounting module (Page 211)".

Configuration of the AS-i mounting module for compact starter (3RA6970-3A)

View	No.	Function
	(1)	Connection of 24 V DC (PELV power supply unit)
	(2)	AS-i cable connection
	(3)	AS-i/Fault LED
	(4)	AUX Power LED
	(5)	Addressing socket

Configuration of AS-i mounting module with 2 local inputs for safe shutdown (3RA6970-3B)

View	No.	Function
	(1)	Connection of 24 V DC (PELV power supply unit)
	(2)	AS-i cable connection
	(3)	AS-i/Fault LED
	(4)	AUX Power LED
	(5)	Addressing socket
	(6)	Terminal block for connecting limit switches

Design of the AS-i mounting module with up to 2 digital inputs and/or outputs (3RA6970-3C, -3D, -3E)

View	No.	Function
	(1)	Connection of 24 V DC (PELV power supply unit)
	(2)	AS-i cable connection
	(3)	AS-i/Fault LED
	(4)	AUX Power LED
	(5)	Addressing socket
	(6)	Terminal block for connecting floating switches or resistive loads

Design of the AS-i mounting module with up to two digital inputs for manual control of the compact starter (3RA6970-3).

View	No.	Function
	(1)	Connection of 24 V DC (PELV power supply unit)
	(2)	AS-i cable connection
	(3)	AS-i/Fault LED
	(4)	AUX Power LED
	(5)	Addressing socket
	(6)	Terminal block for connecting floating mechanical switches for manual control of the compact starter

Display elements and operator controls on the AS-i mounting module

Element	Description
AS-i/Fault LED	<ul style="list-style-type: none"> • Off: No AS-i voltage on AS-Interface chip. • Flashing red/yellow: The address of the AS-i mounting module is "0". • Green: Ready/communication OK. • Red: Communication error
AUX Power LED	<ul style="list-style-type: none"> • Off: No AUX Power. • Green: AUX Power present.

You can find more information on the LED statuses in "Diagnostics (Page 224)".

7.12.3 Communication via AS-Interface

The actuator sensor interface (AS-Interface) is a modular networking system for sensors and actuators at the lowest field level.

As far as the program in the control system is concerned, it makes no difference whether parallel wiring is used or whether the AS-Interface is used. As a result, it is possible to switch over to the AS-Interface even on existing systems, as you can continue to use any programs that are already installed. The entire system can be operated without additional software. You do not need to know about the internal workings of the AS-Interface.

Replacement for cable harness

If parallel wiring is used for the compact starter, a large amount of wiring will be required for the purpose of transferring process signals to the control system. This means that each compact starter has to be connected to the control system by means of its own separate line. However, if the AS-Interface is used instead, this cable harness can be replaced by a single two-wire line that is shared by all compact starter groups (up to a maximum of 62 compact starters).

Data and power via one two-wire line

The master communicates with the nodes via the AS-Interface lines. As well as being used for data exchange, this line also carries the supply voltage for the electronics and the check-back signals of the compact starter. The voltage is fed into the AS-Interface line by a special AS-Interface power supply unit with data decoupling circuit.

Replacement

Upon replacement of a compact starter, the plug-in connections of the data line and for the power supply of the electronics can be removed without influencing the communication of other devices in the AS-Interface network.

Auxiliary power

The AS-i mounting module requires an external additional supply (AUX Power) for the output circuits that must comply with Protection Class I in accordance with VDE 0106 (PELV).

Maximum system configuration

For detailed installation and mounting guidelines, please refer to the manual entitled "AS-Interface System" (article number: 3RK2703-3AB02-1AA1).

Up to 62 nodes (e.g. compact starters) can be connected to the AS-Interface line. This is possible thanks to the use of A/B technology, whereby the maximum 31 addresses are split into two completely separate sub-addresses (e.g. 1A and 1B).

Addressing

Before it can participate in data exchange with the master, each node must be assigned an address prior to commissioning of the AS-Interface network. To facilitate this, an addressing unit is available.

For additional information on addressing, please refer to "Addressing via AS-Interface (Page 217)".

Certification by the AS-International association

The AS-i mounting module for compact starter is tested at an accredited test laboratory in accordance with the relevant testing regulations and certified by the AS-International association.

7.12.4 Installing/removal

7.12.4.1 Installing the AS-i mounting module

Requirements

NOTICE**Damage to the AS-i mounting module!**

If you install the AS-i mounting module on a compact starter that has a control supply voltage of more than 24 V, the AS-i mounting module will be supplied with too much power. This will damage the AS-i mounting module.


Only install the AS-i mounting module on a compact starter with a control supply voltage of 24 V.

Note

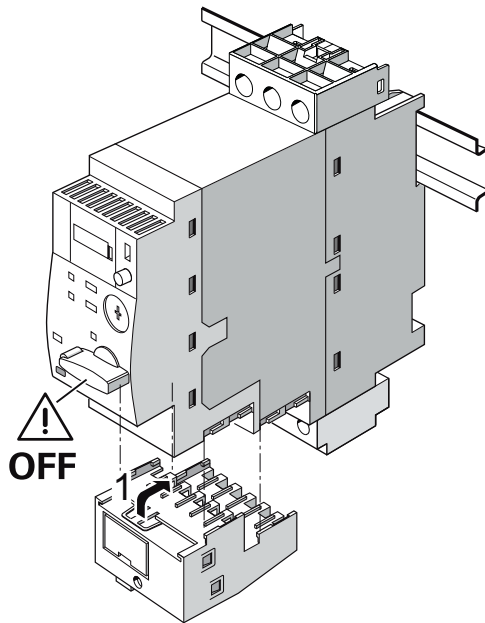
Damage to the AS-i mounting module!

This will damage the AS-i mounting module if it is electrostatically charged.

Please observe the ESD regulations when working with the AS-i mounting module.

- The control circuit terminals must be removed from the compact starter (24 V) (for information on removing the control circuit terminals, see Chapter "Installing/removal (Page 144)").
- The compact starter must be switched off (actuator set to  OFF position).

Procedure



- ① Insert the AS-i mounting module into the mechanically coded guiderail on the device from the bottom and then push it back until you hear it engage.

7.12.4.2 Removing the AS-i mounting module

Requirements

Note

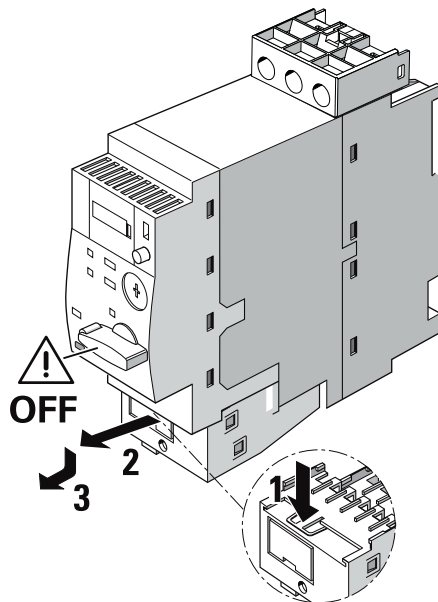
Damage to the AS-i mounting module!

This will damage the AS-i mounting module if it is electrostatically charged.

Please observe the ESD regulations when working with the AS-i mounting module.

- AS-i cable is disconnected from the AS-i mounting module.
- AUX PWR 24 VDC must be disconnected from the AS-i mounting module.
- The compact starter must be switched off (actuator set to OFF position).

Procedure



- ① Push the release clip down.
- ② Take hold of the recessed grip on the lower side of the AS-i mounting module and pull the AS-i mounting module forwards.
- ③ Move the AS-i mounting module down and out through the mechanically coded guiderail on the device.

7.12.5 Connection

7.12.5.1 Connecting the AS-i mounting module

To enable communication via an AS-Interface, the AS-i mounting module must first be installed on the compact starter (24 V). Then the AS-i mounting module can be connected to the AS-Interface using the AS-i cable.

7.12.5.2 Connecting the AS-Interface

Connection method

The following cables are required:

- AS-Interface cable.
- 24 VDC AUX PWR cable for supplying the final controlling element

In order for the cables to be secured within the connectors, they must have a conductor cross-section of $2 \times (0.5 \dots 0.75) \text{ mm}^2$.

ESD directives

ESD components are destroyed by voltage and energy far below the limits of human perception. Voltages of this kind occur as soon as a device or an assembly is touched by a person who is not electrostatically discharged. ESD components which have been subject to such voltage are usually not recognized immediately as being defective, because the malfunction does not occur until after a longer period of operation.

NOTICE

Damage to the AS-i mounting module from electrostatic charging!

The AS-i mounting contains components sensitive to electrostatic charge. These modules will be destroyed or damaged by improper handling.

- You must discharge your body electrostatically immediately before touching an electronic component. To do this, touch a conductive, grounded object, e.g., a bare metal part of a switch cabinet or the water pipe.
- Always hold the component by the plastic enclosure.
- Electronic modules should not be brought into contact with electrically insulating materials such as plastic film, plastic parts, insulating table supports or clothing made of synthetic fibers.
- Always place electrostatic sensitive devices on conductive bases.
- Always store and transport electronic modules or components in ESD-safe conductive packaging, e.g. metallized plastic or metal containers. Leave the component in its packaging until installation.

Contact

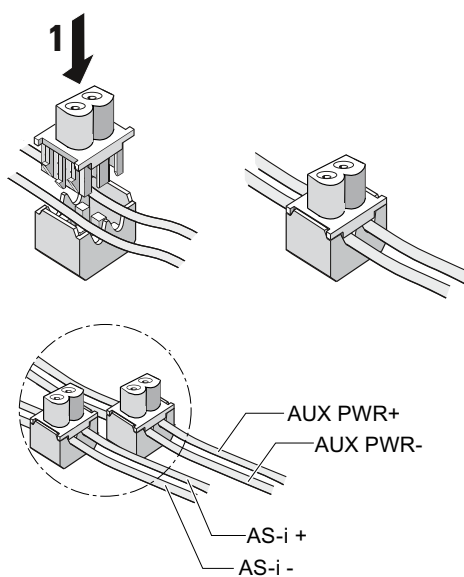
Note

Damage to the AS-i mounting module!

This will damage the AS-i mounting module if it is electrostatically charged.

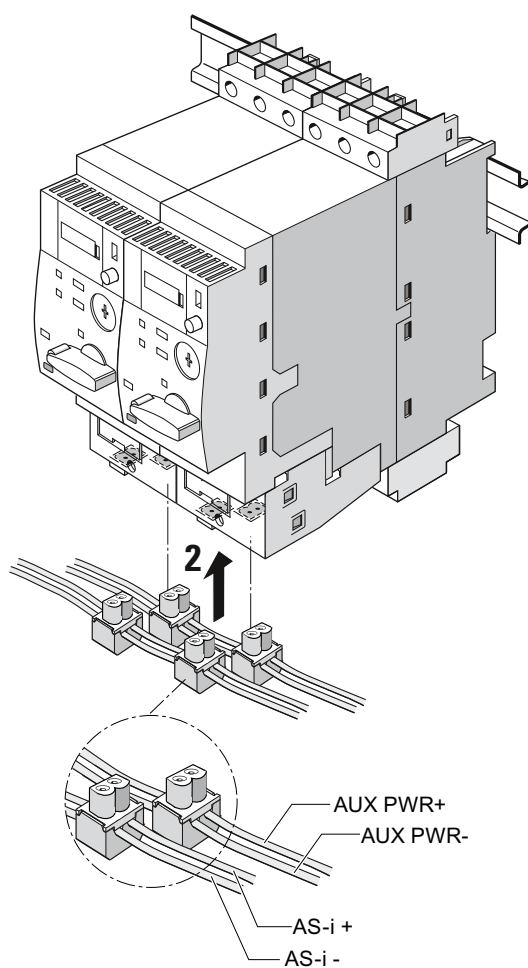
Please observe the ESD regulations when working with the AS-i mounting module.

7.12 AS-i mounting module for 3RA61/3RA62 compact starter



- ① Contact the cables by applying the cover of the connector.
Please note the connector pin assignment.

7.12 AS-i mounting module for 3RA61/3RA62 compact starter



- ② Insert the connector from below into the AS-i mounting module.

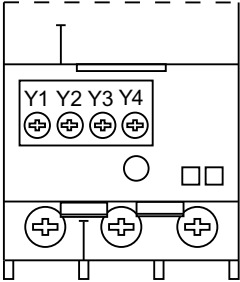
7.12.5.3 Connecting terminals

You can connect limit switches, for example, via the terminals on the AS-i mounting module. The following options are available to you:

- **3RA6970-3B:** When the contacts open, the limit switch function immediately shuts down the compact starter. The direct starter is shut down via terminals Y1 - Y2. In the case of the reversing starter, direction of rotation 1 is shut down via terminals Y1 - Y2, and direction of rotation 2 is shut down via terminals Y3 - Y4.
The safety function implemented by the shutdown must be tested by the plant operator at suitable intervals in accordance with risk analysis. The installation environment must meet the requirements of an IP54 environment. Suitable cabling and a suitable NC contact must be used.
- **3RA6970-3C, -3D, -3E:** The inputs and/or outputs can be switched as follows:
 - Inputs: floating switches (IN4, IN2)
 - Outputs: resistive loads (OUT2, OUT3)
- **3RA6970-3F:** The local inputs Y1 - Y2 and Y3 - Y4 are used for switching from automatic to manual mode and for manual control of the compact starter.

Pin assignment of the terminals for 2 local inputs for safe shutdown (3RA6970-3B)

Table 7-15 Terminals for 2 local inputs for safe shutdown (3RA6970-3B)

Terminals	Meaning	Image
Y1, Y2	Connecting terminals for limit switch 1 for safe shutdown of "direction of rotation 1"	
Y3, Y4	Connecting terminals for limit switch 2 for safe shutdown of "direction of rotation 2" (only if mounting a reversing starter)	

Note

If the terminals Y1-Y2 and/or Y3-Y4 are not used these must be bridged irrespective of the compact starter (direct starter or reversing starter).

Pin assignment of the terminals for two additional digital inputs (3RA6970-3C)

Table 7-16 Terminals for two additional digital inputs (3RA6970-3C)

Terminals	Meaning	Image
IN 4	Connection terminals for a digital input	
IN 2	Connection terminals for a digital input	

Pin assignment of the terminals for an additional digital input and a digital output (3RA6970-3D)

Table 7-17 Terminals for an additional digital input and a digital output (3RA6970-3D)

Terminals	Meaning	Image
IN 4	Connection terminals for a digital input	
OUT 3	Connection terminals for a digital output	

Pin assignment of the terminals for two additional digital outputs (3RA6970-3E)

Table 7-18 Terminals for two additional digital outputs (3RA6970-3E)

Terminals	Meaning	Image
OUT 2	Connection terminals for a digital output	
OUT 3	Connection terminals for a digital output	

PIN assignment of the terminals for two local inputs for manual control of the compact starter (3RA6970-3F)

Table 7-19 Terminals for two local inputs for manual control of the compact starter (3RA6970-3F)

Terminals	Meaning	Image
Y1, Y2	Connecting terminals for switching between automatic and manual mode for manual control of direction of rotation 1	
Y3, Y4	Connecting terminals for switching between automatic and manual mode for manual control of direction of rotation 2	

Conductor cross-sections of terminals

Table 7-20 Conductor cross-sections of terminals

	Terminals
 (0.5 x 3.0) mm DIN ISO 2380-A	0.5 ... 0.6 Nm (4.5 to 5.3 lb·in)
	0.5 ... 2.5 mm ²
	0.5 ... 2.5 mm ²
AWG	20 to 12

7.12.6 Commissioning

7.12.6.1 Addressing via AS-Interface

Before it can participate in data exchange with the master, each module must be assigned an individual address on the AS-Interface. Each address can only be used once on each AS-i network.

On the AS-i mounting module, extended address mode (A/B technology) can be used with an AS-i master in accordance with Specification 2.1 (or higher). The 31 addresses that are supported by an AS-Interface network can be split into two completely separate sub-addresses, e.g. 1A and 1B. If you do decide to use this facility for all 31 slaves, there will be a maximum of 62 nodes on one AS-Interface network.

AS-i profile

Table 7-21 AS-i profile (AS-i mounting module)

Article number	3RA6970-3A, -3B, -3C, -3D, -3E, -3F
Slave type	A/B slave
Suitable for AS-i master to Spec.... (or higher)	2.1 or higher
AS-i slave profile IO.ID.ID2	7.A.E
ID1 code (factory setting)	7 *)

*) User-adjustable

Requirements

! DANGER

Hazardous voltage!

Will cause death or serious injury.

Electrical voltage can result in electric shocks or burns.

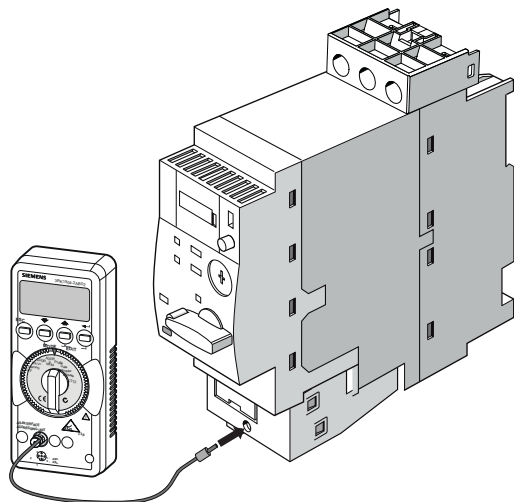
Disconnect the AS-i voltage before you start the addressing process.

To carry out the AS-i mounting module addressing, you will need the following (example):

- An AS-Interface addressing unit (3RK1904-2AB02)
- A connecting cable for connecting the AS-Interface addressing unit to the AS-i mounting module.

Procedure

The AS-i mounting module is addressed via an addressing socket, e.g. using the AS-Interface addressing unit. The connecting cable is used to connect this unit to the addressing socket.



- ① Disconnect the AS-i voltage.
- ② Connect the AS-Interface addressing unit to the addressing socket.
- ③ Set the required address.

For more detailed information on the AS-Interface and on addressing of AS-i slaves, please refer to the operating instructions "AS-Interface addressing unit V3.0" (3ZX1012-0RK10-4BA1).

Note

The module address can be changed as often as required.

7.12.6.2 Process data and process images

Logical assignment

The tables below contain the process data and process images for the different AS-i mounting modules:

Table 7-22 3RA6970-3A

Compact starter status	Inputs				Outputs	
	D0	D1	D2	D3	D0	D1
	AS-i mounting module ready ¹⁾	Motor ON	Group fault	Group warning	Motor "direction of rotation 1"	Motor "direction of rotation 2"
Normal operation	X					
AUX Power OFF, undervoltage, overvoltage			X		X ²⁾	X ²⁾

7.12 AS-i mounting module for 3RA61/3RA62 compact starter

Compact starter status	Inputs				Outputs	
	D0	D1	D2	D3	D0	D1
	AS-i mounting module ready ¹⁾	Motor ON	Group fault	Group warning	Motor "direction of rotation 1"	Motor "direction of rotation 2"
Direction of rotation 1 switched on	X	X			X	
Direction of rotation 2 switched on	X	X				X
Overload tripped	X		X	X		
Short circuit tripped	X		X			
Direction of rotation 1 and direction of rotation 2 simultaneously switched on	X		X		X	X

¹⁾ The AS-i mounting module is ready when

- the AS-i mounting module is snapped onto a functionally ready compact starter and
- AS-i communication and AUX PWR are available.

²⁾ The bit is only set if the output was already set before the undervoltage or overvoltage was detected.

X: Bit set

Table 7-23 3RA6970- 3B

Compact starter status	Inputs				Outputs	
	D0	D1	D2	D3	D0	D1
	AS-i mounting module ready ¹⁾	Motor ON	Group fault	Group warning	Motor "direction of rotation 1"	Motor "direction of rotation 2"
Normal operation	X					
AUX Power OFF, undervoltage, overvoltage			X		X ²⁾	X ²⁾
Direction of rotation 1 switched on	X	X			X	
Direction of rotation 2 switched on	X	X				X
Overload tripped	X		X	X		
Short circuit tripped	X		X			

7.12 AS-i mounting module for 3RA61/3RA62 compact starter

Compact starter status	Inputs				Outputs	
	D0	D1	D2	D3	D0	D1
	AS-i mounting module ready ¹⁾	Motor ON	Group fault	Group warning	Motor "direction of rotation 1"	Motor "direction of rotation 2"
Limit switch open: • Direct starter Y1-Y2 • Reversing starter Y1-Y2 or Y3-Y4	X		X		X	X
Direction of rotation 1 and direction of rotation 2 simultaneously switched on	X		X		X	X

¹⁾ The AS-i mounting module is ready when
- the AS-i mounting module is snapped onto a functionally ready compact starter and
- AS-i communication and AUX PWR are available.

²⁾ The bit is only set if the output was already set before the undervoltage or overvoltage was detected.

X: Bit set

Table 7-24 3RA6970-3C

Compact starter status	Inputs				Outputs	
	D0	D1	D2	D3	D0	D1
	AS-i mounting module ready ¹⁾	IN2	Group fault	IN4	Motor "direction of rotation 1"	Motor "direction of rotation 2"
Normal operation	X					
AUX Power OFF, undervoltage, overvoltage			X		X ²⁾	X ²⁾
Direction of rotation 1 switched on	X				X	
Direction of rotation 2 switched on	X					X
Overload tripped	X		X			
Short circuit tripped	X		X			
Direction of rotation 1 and direction of rotation 2 simultaneously switched on	X		X		X	X
Checkback signal IN2	X	X				
Checkback signal IN4	X			X		

¹⁾ The AS-i mounting module is ready when
- the AS-i mounting module is snapped onto a functionally ready compact starter and
- AS-i communication and AUX PWR are available.

²⁾ The bit is only set if the output was already set before the undervoltage or overvoltage was detected.

X: Bit set

7.12 AS-i mounting module for 3RA61/3RA62 compact starter

Table 7-25 3RA6970-3D

Compact starter status	Inputs				Outputs		
	D0	D1	D2	D3	D0	D1	D2
	AS-i mounting module ready ¹⁾	Motor ON	Group fault	IN4	Motor "direction of rotation 1"	Motor "direction of rotation 2"	OUT3
Normal operation	X						
AUX Power OFF, undervoltage, overvoltage			X		X ²⁾	X ²⁾	
Direction of rotation 1 switched on	X	X			X		
Direction of rotation 2 switched on	X	X				X	
Overload tripped	X		X				
Short circuit tripped	X		X				
Direction of rotation 1 and direction of rotation 2 simultaneously switched on	X		X		X	X	
Checkback signal IN4	X			X			
OUT3 set	X						X

¹⁾ The AS-i mounting module is ready when
 - the AS-i mounting module is snapped onto a functionally ready compact starter and
 - AS-i communication and AUX PWR are available.

²⁾ The bit is only set if the output was already set before the undervoltage or overvoltage was detected.

X: Bit set

Table 7-26 3RA6970-3E

Compact starter status	Inputs				Outputs		
	D0	D1	D2	D3	D0	D1	D2
	AS-i mounting module ready ¹⁾	Motor ON	Group fault	Group warning	Motor "direction of rotation 1"	OUT2	OUT3
Normal operation	X						
AUX Power OFF, undervoltage, overvoltage			X		X ²⁾		
Direction of rotation 1 switched on	X	X			X		
Direction of rotation 2 switched on	X						
Overload tripped	X		X	X			
Short circuit tripped	X		X				

7.12 AS-i mounting module for 3RA61/3RA62 compact starter

Compact starter status	Inputs				Outputs		
	D0	D1	D2	D3	D0	D1	D2
	AS-i mounting module ready ¹⁾	Motor ON	Group fault	Group warning	Motor "direction of rotation 1"	OUT2	OUT3
OUT2 set	X					X	
OUT3 set	X						X

- ¹⁾ The AS-i mounting module is ready when
- the AS-i mounting module is snapped onto a functionally ready compact starter and
 - AS-i communication and AUX PWR are available.

- ²⁾ The bit is only set if the output was already set before the undervoltage or overvoltage was detected.

X: Bit set

Table 7-27 3RA6970-3F

Compact starter status	Inputs				Outputs	
	D0	D1	D2	D3	D0	D1
	AS-i mounting module ready ¹⁾	Motor ON	Group fault	Group warning	Motor "direction of rotation 1"	Motor "direction of rotation 2"
Normal operation	X					
AUX Power OFF, undervoltage, overvoltage			X		X ²⁾	X ²⁾
Direction of rotation 1 switched on	X	X			X	
Direction of rotation 2 switched on	X	X				X
Overload tripped	X		X	X		
Short circuit tripped	X		X			
Direction of rotation 1 and direction of rotation 2 simultaneously switched on	X		X		X	X
Local input Y1-Y2 or Y3-Y4 open in automatic mode	X		X			
Direction of rotation 1 controlled in automatic mode, that is, local input Y3-Y4 opened	X		X		X	
Direction of rotation 2 controlled in automatic mode, that is, local input Y1-Y2 opened	X		X			X
Manual mode ready for manual control via local inputs				X		
Direction of rotation 1 switched on manually		X		X		
Direction of rotation 2 switched on manually		X		X		

7.12 AS-i mounting module for 3RA61/3RA62 compact starter

Compact starter status	Inputs				Outputs	
	D0	D1	D2	D3	D0	D1
	AS-i mounting module ready ¹⁾	Motor ON	Group fault	Group warning	Motor "direction of rotation 1"	Motor "direction of rotation 2"
Direction of rotation 1 and direction of rotation 2 controlled manually in succession			X	X		
Direction of rotation 1 switched on manually, that is, local input Y3-Y4 opened			X	X		
Direction of rotation 2 switched on manually, that is, local input Y1-Y2 opened			X	X		

- ¹⁾ The AS-i mounting module is ready when
- the AS-i mounting module is snapped onto a functionally ready compact starter and
 - AS-i communication and AUX PWR are available.
- ²⁾ The bit is only set if the output was already set before the undervoltage or overvoltage was detected.

X: Bit set

Undervoltage and overvoltage detection

If an undervoltage or overvoltage is detected when an AS-i output bit (D0 or D1) is set, the compact starter switches off. The compact starter can only be switched on again when the AUX PWR returns to the normal range of 24 V ± 20% and the AS-i output bit (D0 or D1) has been reset.

	Undervoltage detection takes place via	Overvoltage detection takes place via
Compact starter not controlled	the AS-i mounting module from approx. 24 V - 20%	the AS-i mounting module from approx. 24 V + 20%
Compact starter controlled	the compact starter. AS-i mounting module is deactivated.	the AS-i mounting module from approx. 24 V + 20%

7.12.7 Diagnostics

The status of the AS-i mounting module is indicated by means of two LEDs, which will either light up continuously or flash. Making straightforward diagnostics available directly on the AS-i mounting module in this way enables the user to troubleshoot quickly and efficiently.

Display concept on the AS-i mounting module

Table 7-28 Display concept of the "AS-i/FAULT" LED







LED AS-i/FAULT	Possible cause	Possible remedial measures
 Green	Normal operation, AS-i communication OK	—
 Red	No AS-i communication: - Master switched off or offline - Slave not configured in the master - Wrong slave type connected - Slave has incorrect address	Ensure AS-i communication: - Switch master on or set it online - Re-configure the master - Connect correct module - Check/correct slave address
 Red-yellow	Slave has address 0 (As-delivered state)	Assign an address that is not 0
 OFF	No AS-i voltage, AS-i voltage connected with incorrect polarity, AS-i voltage too low	Switch on the AS-i voltage, connect it properly, measure the AS-i voltage (approx. 30 V DC)

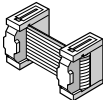
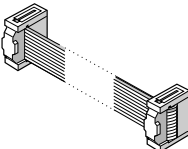
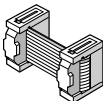
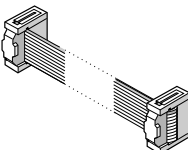
Table 7-29 Display concept of the "AUX PWR" LED

LED AUX PWR	Possible cause	Possible remedial measures
 Green	Normal operation, 24 V DC auxiliary voltage OK	—
 OFF	- No auxiliary voltage, - Auxiliary voltage connected with incorrect polarity, - Auxiliary voltage too low	- Switch on 24 V DC auxiliary voltage, - Connect properly, - Measure auxiliary voltage (approx. 24 V DC)

7.13 Connecting cable for IO-Link

7.13.1 Scope of supply

Scope of supply of the connecting cable for IO-Link

System component	Article number	Figure
Connecting cable 14-core, length 8 mm for compact starter (pack of 5)	3RA6931-0A	
Connecting cable 14-core, length 200 mm for compact starter	3RA6933-0C	
Connecting cable, 10-core with 14-core connection, 8 mm long for compact starter (pack of 5)	3RA6932-0A	
Connecting cable 10-core, length 200 mm for compact starter	3RA6933-0B	

7.13.2 Function

14-core connecting cable

You connect the compact starters of a group to each other using the 14-core connecting cable. The 14-core connecting cable forwards both the IO-Link signals and the auxiliary voltage V_{Aux} to the next compact starter.

10-core connecting cable

You also connect the compact starters of a group to each other using the 10-core connecting cable. However, the 10-core connecting cable only forwards the IO-Link signals to the next compact starter. The auxiliary voltage must be connected to the next compact starter separately via the removable terminal.

The separate auxiliary voltage infeed enables the implementation of an EMERGENCY STOP function. You can find additional information on the EMERGENCY STOP function in "EMERGENCY STOP (Page 131)".

7.13.3 Installing/removal

Installing connecting cables

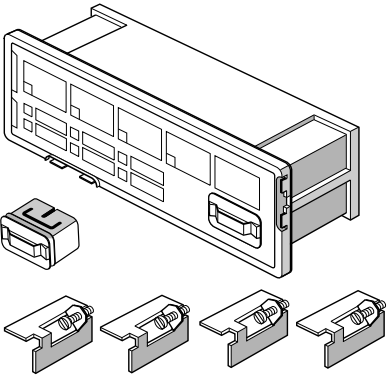


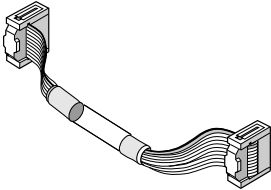
Up to 4 compact starters with IO-Link are connected to form a group using the connecting cables.

For information, please refer to " Installing/removal (Page 124) ".

7.14 Operator panel for 3RA64/3RA65 compact starter with IO-Link

7.14.1 Scope of supply

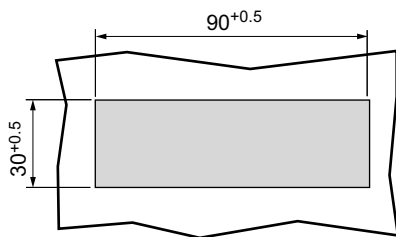
Scope of supply of operator panel

System component	Article number	Figure
Operator panel for compact starter (incl. enabling block for operator panel, blanking cover and mounting bracket)	3RA6935-0A	
Enabling block for operator panel	3RA6936-0A	
Blanking cover for operator panel	3RA6936-0B	
Connecting cable 10-core, length 2 m for operator panel (connection between operator panel and 3RA6 compact starter with IO-Link)	3RA6933-0A	

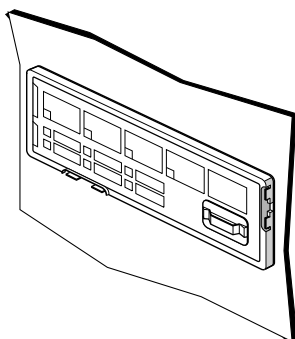
7.14.2 Mounting

The operator unit is designed, for example, for use in the front panels of motor control centers or in control cabinet doors.

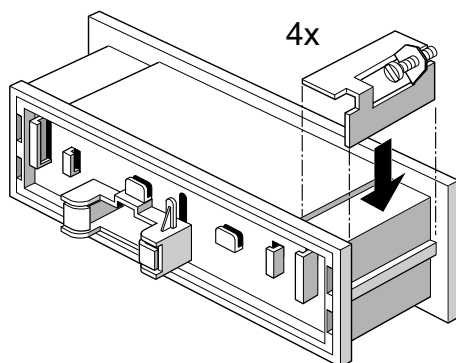
Procedure



- ① Make a cutout in the front panel, for example, or in the control cabinet door.



- ② Insert the operator unit in the cutout.



- ③ Snap the four mounting brackets onto the operator unit.
- ④ Lock the operator unit in position by tightening the four screws on the mounting bracket.

WARNING

Restricted functionality of the operator unit!

The IP54 seal and correct functional capability of the operator unit are not guaranteed if the tightening torque of the supplied screws is too high.

Make sure that the selected tightening torque of the supplied screws is not too high.

7.14.3 Operator control

The operator panel can be used to scan the device statuses of up to 4 3RA64/3RA65 compact starters with IO-Link. In addition, the compact starters can be operated in manual mode of the operator panel. For this purpose, the 4 compact starters must be connected to each other and to an IO-Link master via a connecting cable (10-core, length 2 m for operator panel).

You can find more information on the configuration of the compact starter groups in "Installing the 3RA64/3RA65 compact starter with IO-Link (Page 124)".

Connection

The operator panel is connected to the last free interface for connecting cable (output) of a compact starter group using the 10-core connecting cable for the operator panel.

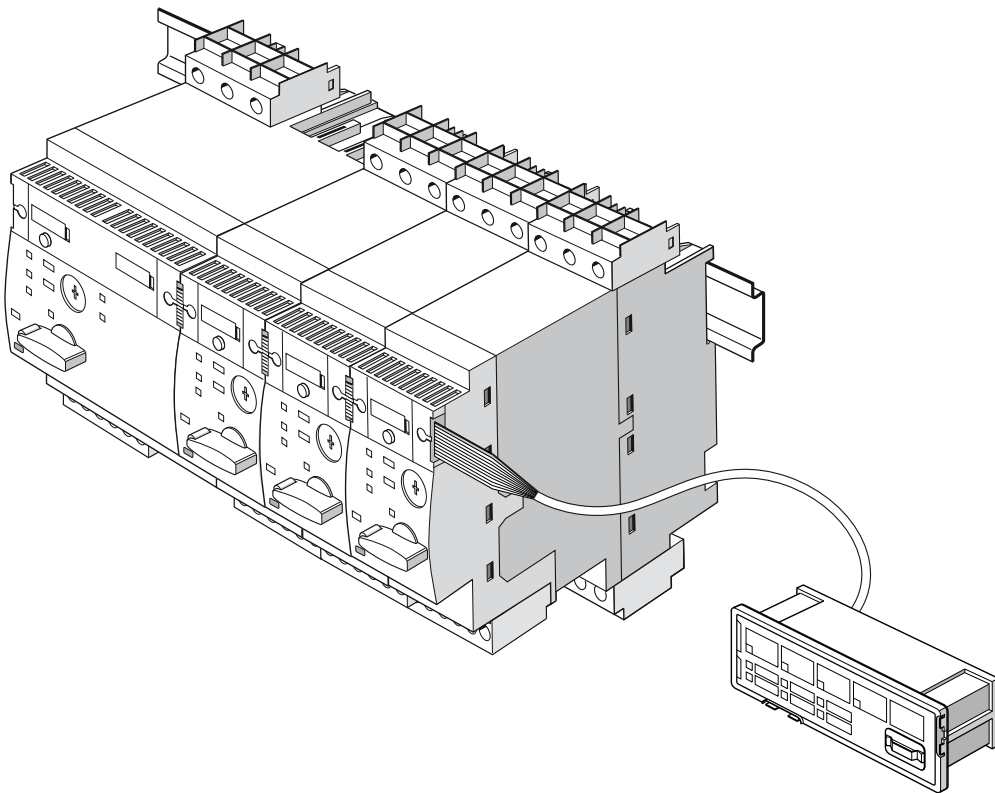


Figure 7-18 Connecting the operator panel

NOTICE

Compact starter and operating panel material damage!

Inserting or removing the 10-core connecting cable under voltage results in momentary failure of the internal bus connection of the compact starter 3RA64 / 3RA65.

Ensure that no auxiliary voltage is applied to the compact starter before inserting or removing the connecting cable.

Design

The representation below explains the operator controls and display elements of the operator panel.





Table 7-30 Design of the operator panel

(1)	DEVICE LED	The DEVICE LED indicates whether the operator panel is ready to run: - Green: Operator panel is ready. - Red: Operator panel is not ready.
(2)	FAULT LED	The FAULT LED indicates whether communication between the compact starter and the operator panel is functioning properly: - Red: No communication between motor starter and operator panel. - Off: Communication between compact starter and operator panel functioning properly.
(3)	SF button and SF LED	You use the SF button to reset the selected compact starter following an overload trip. The SF LED shows a RED light if there is a general fault.
(4)	LED 1 - 4	LEDs 1 to 4 indicate which compact starter has been selected: - Yellow: Compact starter selected. - Off: Compact starter not selected. There is always only one compact starter selected.
(5)	SELECT button	If you press the SELECT button for less than 5 secs, you switch between compact starter 1 to 4. Gaps in the configuration are skipped. The compact starter selected in each case is indicated by LEDs 1 to 4. If you press the SELECT button for more than 5 secs, you switch the entire compact starter group between jog mode and continuous mode. The change to the operating mode is confirmed by the "MANUAL MODE" LED flashing.
(6)	Manual Mode button and LED	You isolate the individual compact starters for manual mode using the MANUAL MODE button. Isolation of a compact starter is confirmed by the MANUAL MODE LED flashing.
(7)	↻ Button and LED	You use the ↻ button to drive the currently selected compact starter in direction of rotation 1 (clockwise). The ↻ LED lights up to confirm this.
(8)	↺ Button and LED	You use the ↺ button to drive the currently selected compact starter in direction of rotation 2 (counter-clockwise). The ↺ LED lights up to confirm this.
(9)	Slot for enabling block	Plug the enabling block into the slot to take control priority of the compact starters.

Monitoring mode

The operator panel is always in monitoring mode as standard. The user can read the selected direction of rotation and detect general faults.

Table 7-31 Monitoring mode of the operator panel



Action	Procedure
Reading the selection	<ol style="list-style-type: none"> 1. Select a compact starter. To do so, press the SELECT button until the desired LED (1, 2, 3 or 4) lights up. 2. Read off the selection: <ul style="list-style-type: none"> –  LED shows a yellow light: Direction of rotation 1 (clockwise) on. –  LED shows a yellow light: Direction of rotation 2 (counterclockwise) on. –  LED and  LED are off: No selection.
Detecting general faults	<ol style="list-style-type: none"> 1. Select a compact starter. To do so, press the SELECT button until the desired LED (1, 2, 3 or 4) lights up. 2. Check whether a general fault is present: <ul style="list-style-type: none"> – SF LED red: General fault present. – SF LED off: No general fault

Manual mode

In manual mode, the user can take control of the compact starters. This enables the user to set the compact starters using the operator panel.

To activate manual mode, users require an enabling block to authorize manual mode.

Table 7-32 Manual mode of the operator panel

Action	Procedure
Activating manual mode	<ol style="list-style-type: none"> 1. Insert the enabling block into the slot in the operator panel. 2. Select a motor starter. To do so, press the SELECT button until the desired LED (1, 2, 3 or 4) lights up. 3. Press the MANUAL MODE button to activate manual mode. Successful activation is confirmed by lighting up of the MANUAL MODE LED.
Activate the motor starter to jog mode	<ol style="list-style-type: none"> 1. Activate the motor starter by <ul style="list-style-type: none"> – pressing the  button for direction of rotation 1 (clockwise). – pressing the  button for direction of rotation 2 (counterclockwise). 2. Hold the button pressed while activating. Activation stops as soon as you release the button.
Change from jog mode ¹⁾ to continuous mode ²⁾	Change to continuous mode by pressing the SELECT button for longer than 5 secs. The changeover is confirmed by the flashing of the MANUAL MODE LED.

7.14 Operator panel for 3RA64/3RA65 compact starter with IO-Link

Action	Procedure
Activating the motor starter in continuous mode	<ol style="list-style-type: none"> 1. Activate the motor starter by <ul style="list-style-type: none"> – pressing the ↻ button for direction of rotation 1 (clockwise). – pressing the ↺ button for direction of rotation 2 (counter-clockwise). 2. Press the ↻ or ↺ button again to stop activation.
Change from continuous mode ²⁾ to jog mode ¹⁾	Change to jog mode by pressing the SELECT button for longer than 5 secs. The changeover is confirmed by the flashing of the MANUAL MODE LED.
Resetting to automatic mode	<ol style="list-style-type: none"> 1. Make sure that the compact starter is not activated. 2. Press the MANUAL MODE button to activate automatic mode. If activation is successful, the LED MANUAL MODE goes out. 3. Remove the enabling block from the operator panel.

¹⁾ Jog mode: The compact starter is only activated while you press the ↻ or ↺ button. Activation stops as soon as you release the button.

²⁾ Continuous operation: If you press the ↻ or ↺ button, the compact starter is activated until you press the button again.

Note**Resetting to automatic mode!**

If you remove the enabling block from the operator panel or the connecting cable between the operator panel and the starter while in manual mode, the compact starter switches to the safe state and the "DEVICE" LED flashes yellow.

For this reason, reset the compact starter to automatic mode before removing the enabling block or the connection cable.

Note

If manual mode is activated for a starter while it is in continuous mode and you select a different starter on the operator panel, the first starter will remain in continuous mode.

⚠ WARNING**Machine start-up!**

If you reset the operator panel to automatic mode while an ON command is simultaneously pending via the IO-Link, the compact starter switches back on immediately and the machine starts up. People may be injured if they stay in the danger area of the machine.

Make sure that the danger area of the machine is kept clear of people.

7.14 Operator panel for 3RA64/3RA65 compact starter with IO-Link

Service

8.1 Introduction

The SIRIUS 3RA6 compact starter and SIRIUS infeed system for 3RA6 have been designed to be maintenance-free.

8.2 Malfunction (e.g. end of service life reached)

The SIRIUS 3RA6 compact starter features a patented mechanism for detecting malfunctions. If a malfunction is detected, it could mean, for example, that the compact starter has reached the end of its service life.

For additional information, please refer to "Shutdown on malfunction (Page 61)".

Instructions for dealing with malfunctions, e.g. end of service life reached





WARNING

Compact starter malfunction!

A compact starter malfunction will cause the compact starter to shut down. Continuing to operate the compact starter is extremely risky, as it can no longer be considered reliable.

Following a shutdown caused by a malfunction, you will need to replace the compact starter.

If the SIRIUS 3RA6 compact starter shuts down following a malfunction (e.g. end of service life), you will need to replace it.

In order to achieve a safe system status for the purpose of replacing the compact starter, you can continue operating the compact starter for a short time. For this purpose, you will have to set the compact starter to "ready" again by turning the actuator to the  OFF position and then to the  READY position.

Note

Following a malfunction (e.g. end of service life), the white display will be retained in the "RLT 0%" display window and you will not be able to reset it. The compact starter must be replaced.

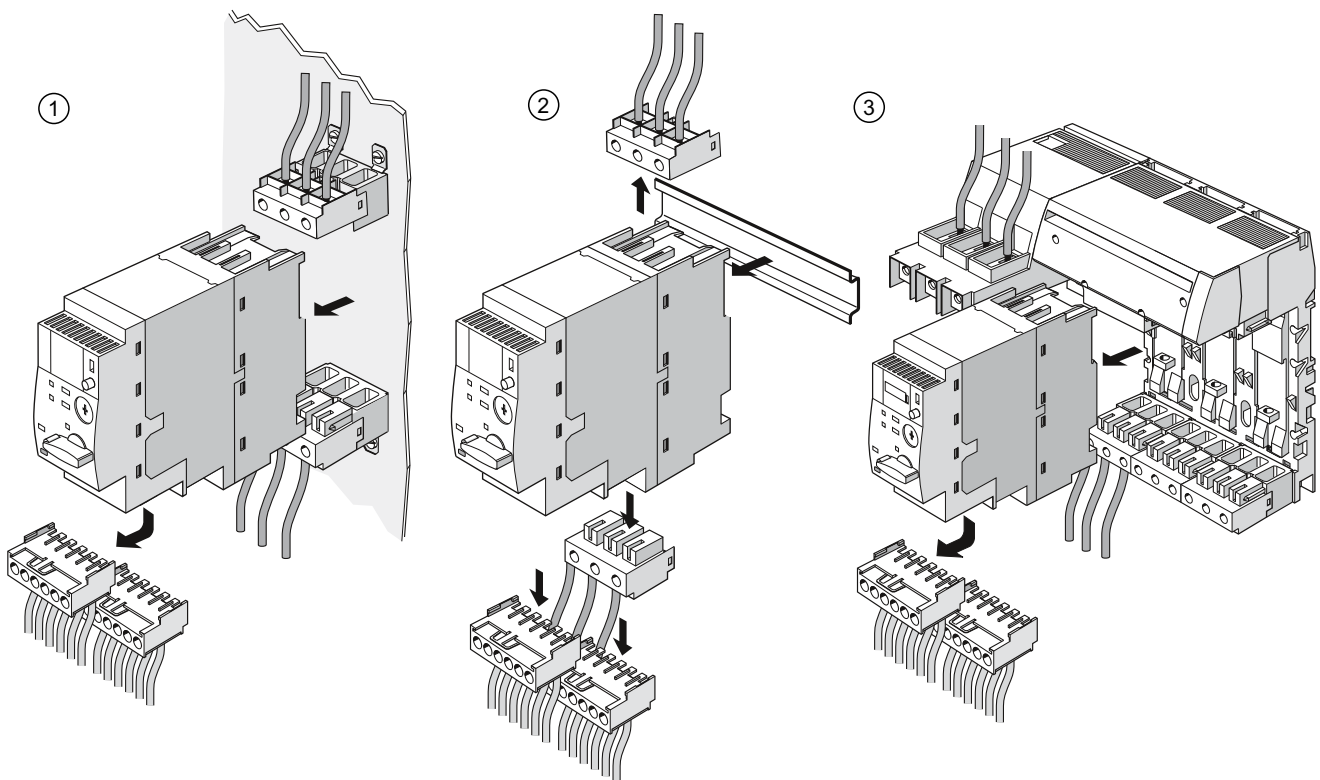
For additional information on replacing the SIRIUS 3RA6 compact starter, please refer to "Replacing the compact starter (Page 237)".

8.3 Replacing the compact starter

When service work becomes necessary or there is a malfunction (e.g. end of service life reached), the SIRIUS 3RA6 compact starter will need to be replaced.

The permanent wiring means that the main circuit terminals will be disconnected automatically when the compact starter is removed.

The procedure for removing the compact starter differs according to the mounting type. The method you should use to remove it depends on whether it has been installed on a standard mounting rail, a level surface (screw fastening) or the infeed system for 3RA6. The relevant requirements will need to be met in each case.



- ① Replacement when installed on a level surface (screw fastening)
- ② Replacement when installed on a standard mounting rail
- ③ Replacement when installed on the infeed system for 3RA6

Figure 8-1 Replacing the compact starter

Requirements when the compact starter is installed on a standard mounting rail or level surface (screw fastening)



! DANGER

Hazardous voltage!

Will cause death or serious injury.

Before starting work, disconnect the system and the device from the power supply.

- The compact starter must be switched off (actuator set to \circ OFF position).

Requirements when the compact starter is installed on the infeed system for 3RA6

The good thing about removing the compact starter from the infeed system for 3RA6 is that you do not need to disconnect the entire system from the power supply. The compact starter can be removed from the infeed system while the system is live, but the starter must be switched off.

NOTICE

Compact starter and infeed system material damage!

You can damage the compact starter and the infeed system if you insert the compact starter into the infeed system for 3RA6 while the starter is switched on (actuator in the \circ READY position).

Make sure that the compact starter's actuator is set to the \circ OFF position before you insert the compact starter into the infeed system for 3RA6.

- The compact starter must be switched off (actuator set to \circ OFF position).

For additional information on removing the individual components, please refer to the following chapters:

- "Removing the compact starter from a DIN rail (Page 68)"
- "Removing the compact starter from a level surface (screw fastening) (Page 69)"
- "Removing the compact starter from an infeed system for 3RA6 (Page 71)"
- "Installing/removal (Page 144)"
- "Disconnecting terminal blocks (Page 80)"

Technical data

9.1 Technical data in Siemens Industry Online Support

Technical data sheet

You can also find the technical data of the product at Siemens Industry Online Support (<https://support.industry.siemens.com/cs/ww/en/ps/16301/td>).

1. Enter the full article number of the desired device in the "Product" field, and confirm with the Enter key.
2. Click the "Technical data" link.

The screenshot shows the Siemens Industry Online Support search interface. At the top, there is a search bar with the text "Enter keyword...". Below the search bar, there are three filters: "Product" with the value "3RV2031-4BA10", "Entry type" with the value "Technical data (1)", and "Date" with "From" and "To" fields. A "Search product" button is located below the filters. The search results section shows a product card for "3RV2031-4BA10" with a description: "CIRCUIT BREAKER, SCREW TYPE, 20 A, CIRCUIT BREAKER SIZE S2, FOR MOTOR PROTECTION, CLASS 10, A-RELEASE 14...30A, N-RELEASE 20DA, SCREW TERMINAL, STANDARD BREAKING CAPACITY". Below the product card, there are navigation links: "> Product details > Technical data > CAx data".

9.2 Overview tables

Overview tables technical data

You will find overview tables with technical data in the "Product information" tab in our online ordering system (<https://mall.industry.siemens.com/mall/en/ww/Catalog/Products/10041648?tree=CatalogTree>).

Dimension drawings

10.1 CAx data

You can find the CAx data in the Siemens Industry Online Support (<https://support.industry.siemens.com/cs/ww/en/ps/16301/td>).

1. Enter the full article number of the desired device in the "Product" field, and confirm with the Enter key.
2. Click the "CAx data link.

The screenshot shows the Siemens Industry Online Support search interface. At the top, there is a search bar with the text "Enter keyword...". Below the search bar, there are three main sections: "Product", "Entry type", and "Date". The "Product" field contains the text "3RV2031-4BA10" and is highlighted with a red box. The "Entry type" field contains the text "Technical data (1)" and is also highlighted with a red box. The "Date" field contains the text "From" and "To". Below these fields, there is a search button labeled "> Search product".

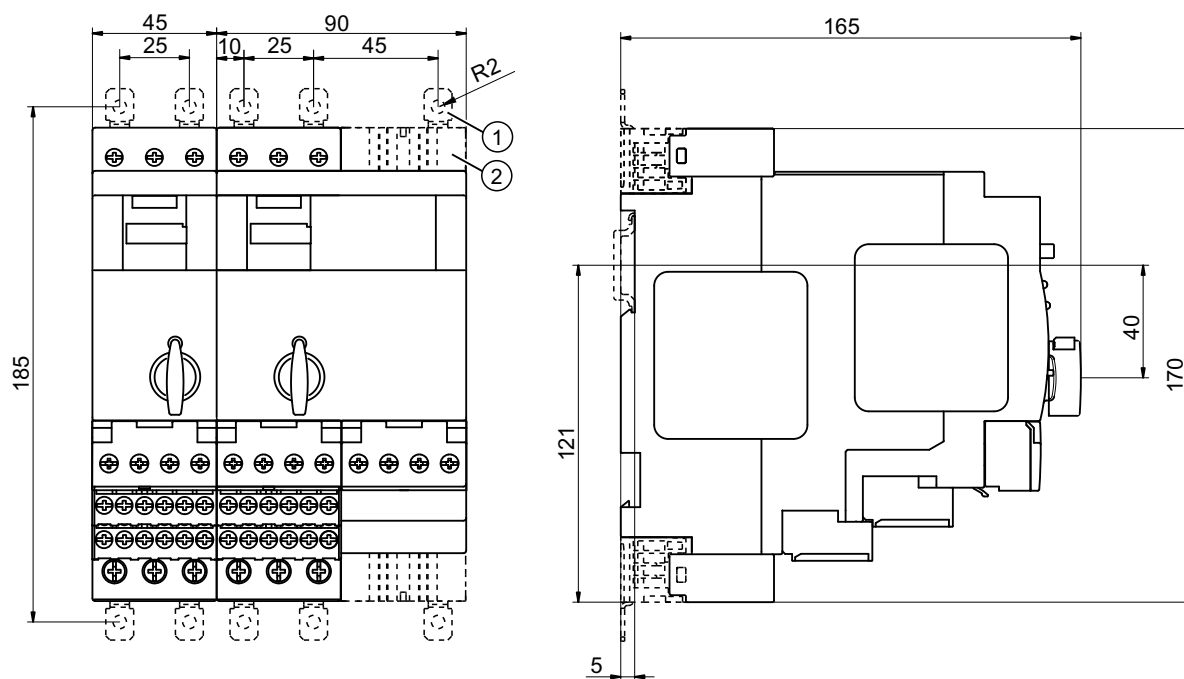
The search results are displayed in a table. The first result is for the product "3RV2031-4BA10". The product description is "CIRCUIT BREAKER, SCREW TYPE, 20 A, CIRCUIT BREAKER SIZE S2, FOR MOTOR PROTECTION, CLASS 10, A-RELEASE 14...30A, N-RELEASE 20DA, SCREW TERMINAL, STANDARD BREAKING CAPACITY". Below the product description, there is a navigation menu with the following items: "> Product details", "> Technical data", and "> CAx data". The "CAx data" item is highlighted with a red box.

10.2 3RA6 compact starter

10.2.1 Dimensions (in mm)

The dimensions given apply for the 3RA61/3RA62 compact starter and the 3RA64/3RA65 with IO-Link

3RA6 compact starter (screw-type connection technology)

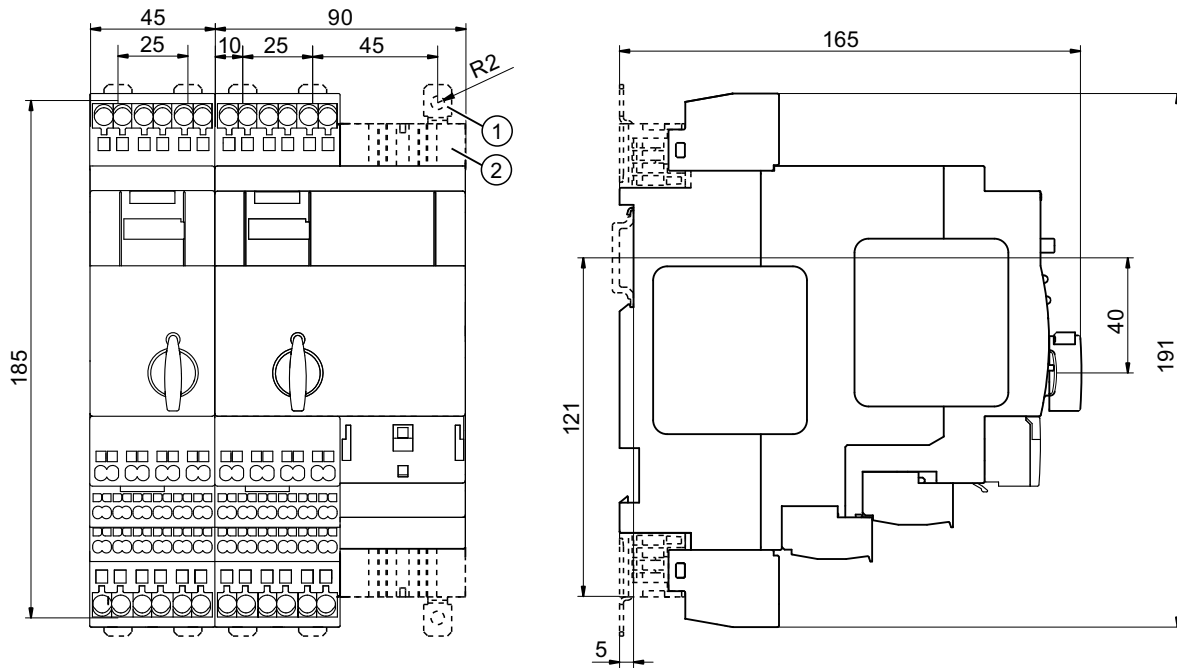


Dimensions in mm

- ① Push-in lug for screw fastening
- ② Adapter for screw fastening

Figure 10-1 Side view of the 3RA6 compact starter (screw-type connection technology)

3RA6 compact starter (spring-loaded connection technology)



Dimensions in mm

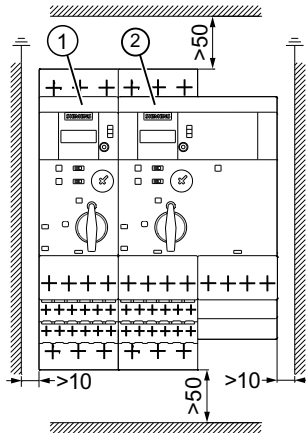
- ① Push-in lug for screw fastening
- ② Adapter for screw fastening

Figure 10-2 Side view of the 3RA6 compact starter (spring-loaded connection technology)

10.2.2 Minimum distances from neighboring components (dimensions in mm)

Distance from neighboring components

When installing compact starters, the following distances from grounded or live parts and from neighboring components must be observed in accordance with IEC/EN 60947-6-2.



- (1) 3RA61/3RA64 compact starter (direct starter)
- (2) 3RA62/3RA65 compact starter (reversing starter)

Figure 10-3 Distances from neighboring components (3RA6 compact starter)

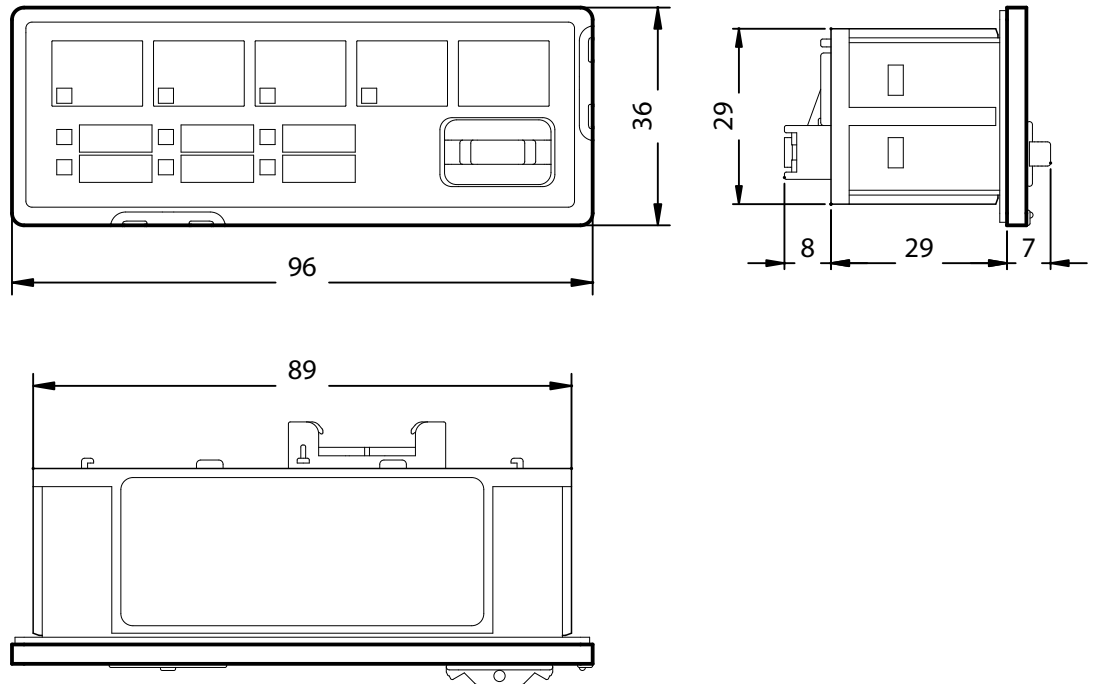
Note

The lateral distances are minimum distances from grounded components.

The distances at the top and bottom are required in order to provide an arcing space!

10.3 Operator panel

Operator panel



10.4 Infeed system for 3RA6

10.4.1 Dimensions (in mm)

3RA6813-8AB

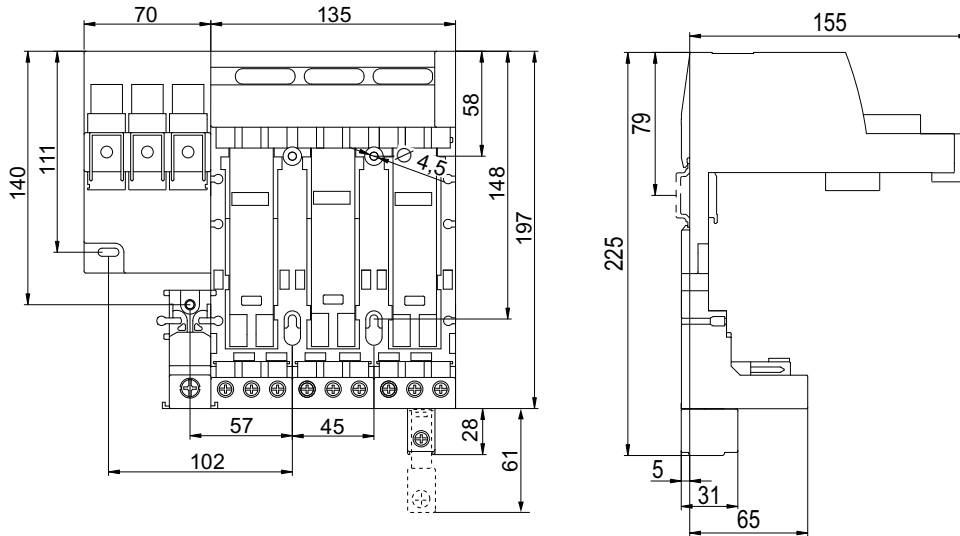
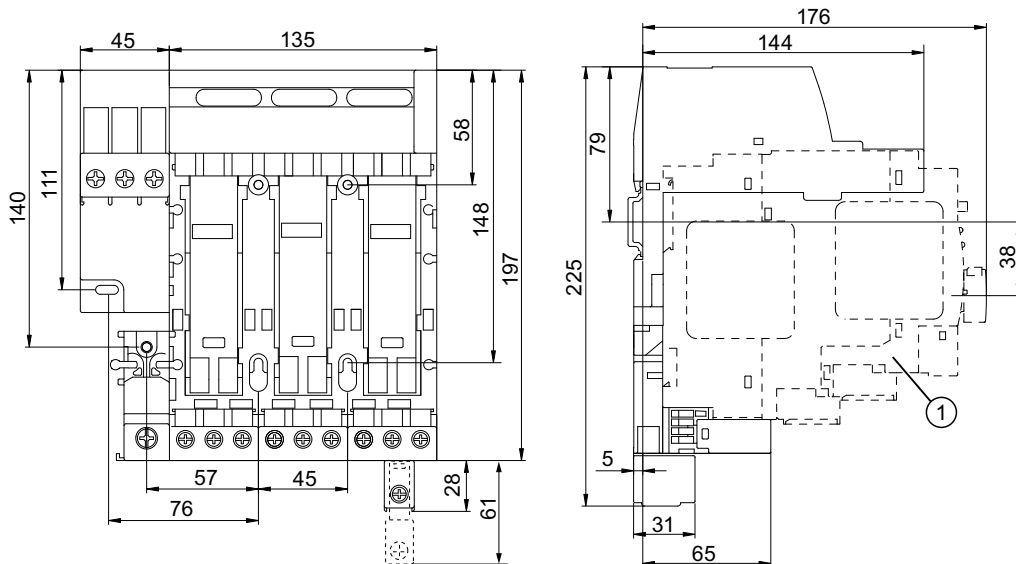


Figure 10-4 Dimension drawing of screw-type infeed (50/70 mm²) featuring outgoing terminals with screw-type connection technology

3RA6812-8AB



① 3RA6 compact starter

Figure 10-5 Dimension drawing of screw-type infeed (25/35 mm²) featuring outgoing terminals with screw-type connection technology

3RA6813-8AC

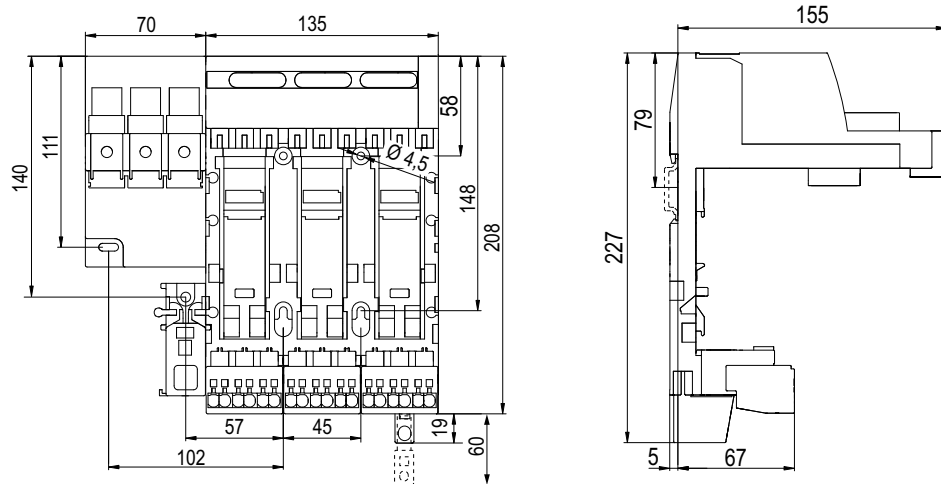
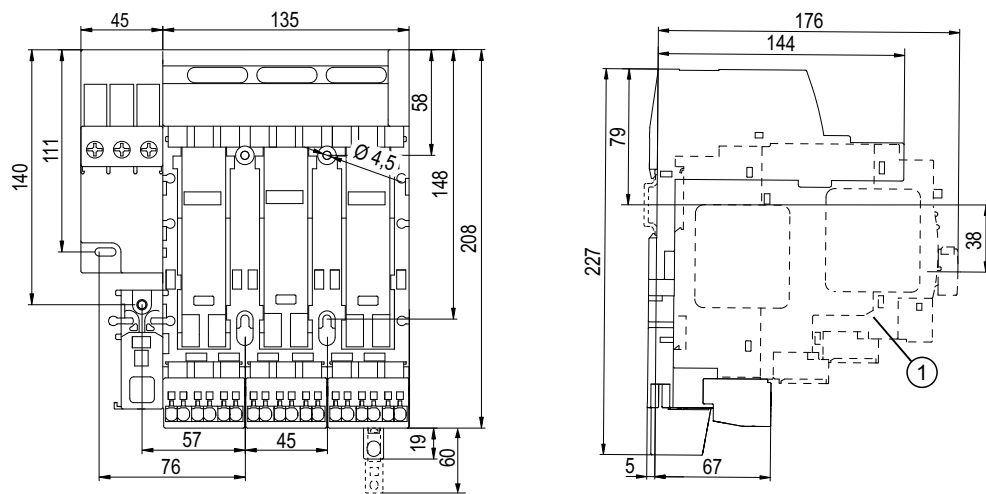


Figure 10-6 Dimension drawing of screw-type infeed (50/70 mm²) featuring outgoing terminals with spring-loaded connection technology

3RA6812-8AC



① 3RA6 compact starter

Figure 10-7 Dimension drawing of screw-type infeed (25/35 mm²) featuring outgoing terminals with spring-loaded connection technology

3RA6830-5AC

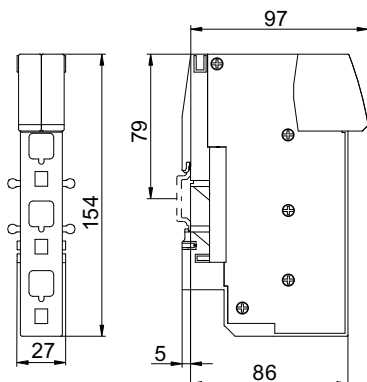


Figure 10-8 Dimension drawing of spring-loaded infeed

3RA6823-0AC, 3RA6822-0AC

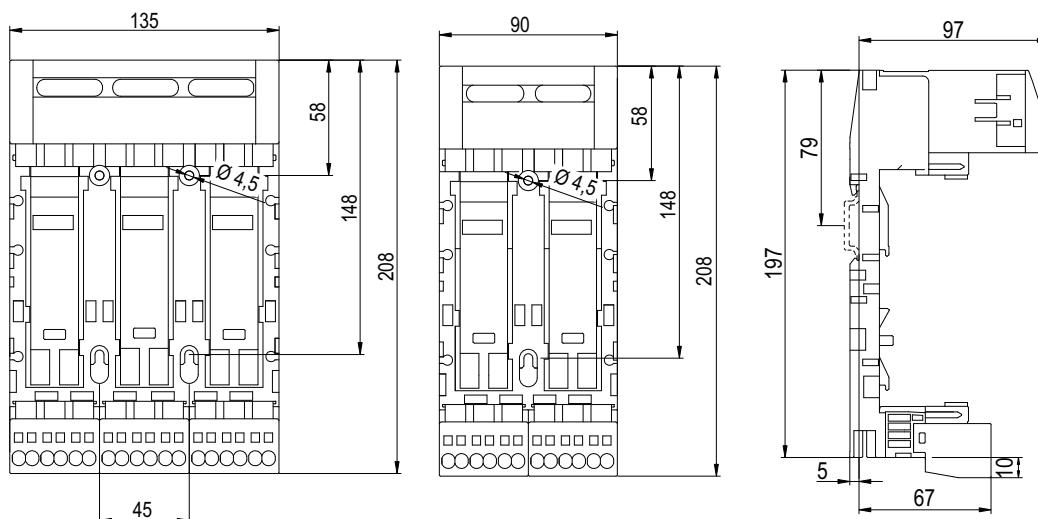


Figure 10-9 Dimension drawing of extension blocks featuring outgoing terminals with spring-loaded connection technology

3RA6823-0AB, 3RA6822-0AB

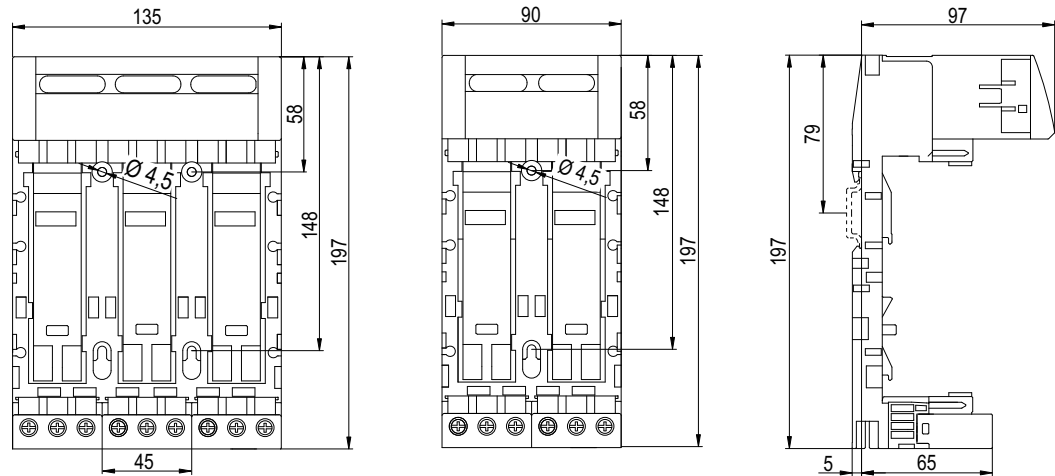


Figure 10-10 Dimension drawing of extension blocks featuring outgoing terminals with screw-type connection technology

10.4.2 Minimum distances from neighboring components (dimensions in mm)

Distance from neighboring components

When installing the infeed system for 3RA6, the following distances from neighboring parts must be observed.

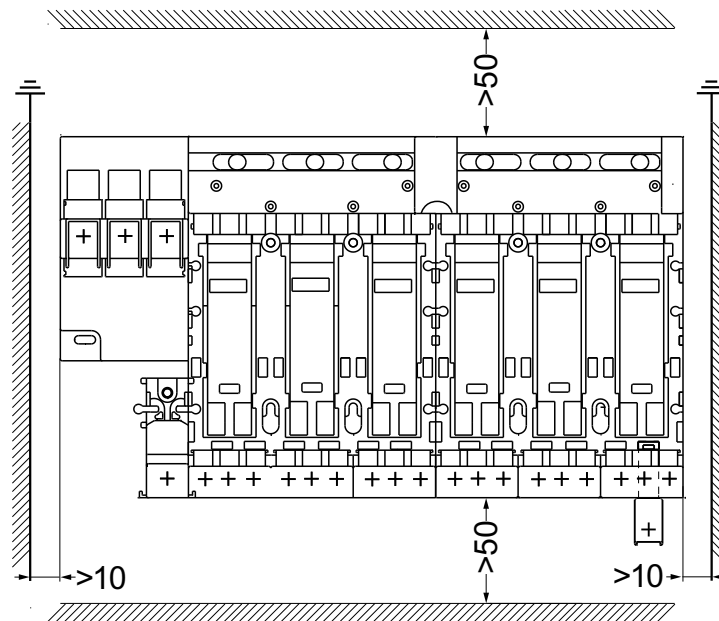


Figure 10-11 Distances from neighboring components (infeed system for 3RA6)

Note

The lateral distances are minimum distances from grounded components.

The distances at the top and bottom are required in order to provide an arcing space!

The installation guidelines for compact starters, circuit breakers and fuseless load feeders must also be observed along with the associated clearances.

10.5 8US busbar adapter

10.5.1 Dimensions (in mm)

8US1211-1NS10

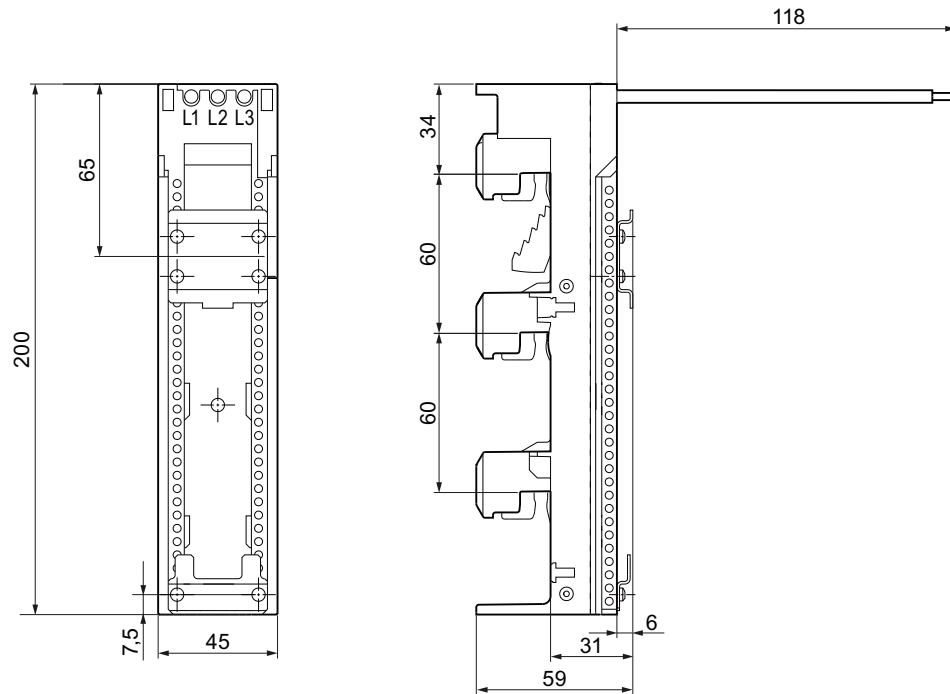


Figure 10-12 Dimension drawing of the 8US busbar adapter

8US1250-1AA10

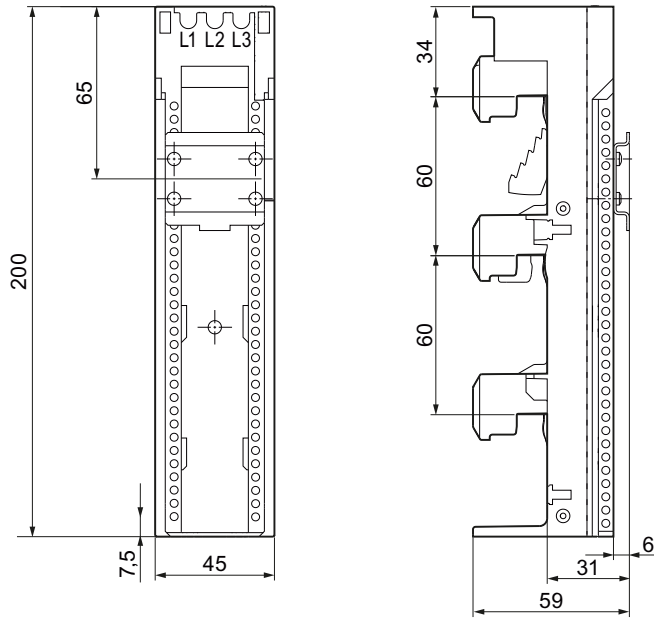


Figure 10-13 Dimension drawing of the 8US device holder

Circuit diagrams

11.1 CAx data

You can find the CAx data in the Siemens Industry Online Support (<https://support.industry.siemens.com/cs/ww/en/ps/16301/td>).

1. Enter the full article number of the desired device in the "Product" field, and confirm with the Enter key.
2. Click the "CAx data link.

The screenshot shows the Siemens Industry Online Support search interface. At the top, there is a search bar with the text "Enter keyword...". Below the search bar, there are three main sections: "Product", "Entry type", and "Date". The "Product" field contains the article number "3RV2031-4BA10" and is highlighted with a red box. The "Entry type" dropdown menu is set to "Technical data (1)" and is also highlighted with a red box. The "Date" field has "From" and "To" input boxes. Below these fields, there is a "Search product" button. The search results are displayed in a table with one entry for "3RV2031-4BA10". The entry includes a product image placeholder, the product name, and a detailed description: "CIRCUIT BREAKER, SCREW TYPE, 20 A, CIRCUIT BREAKER SIZE S2, FOR MOTOR PROTECTION, CLASS 10, A-RELEASE 14... 30A, N-RELEASE 20DA, SCREW TERMINAL, STANDARD BREAKING CAPACITY". At the bottom of the entry, there are navigation links: "> Product details > Technical data > CAx data", with the "CAx data" link highlighted by a red box.

11.2 3RA61/3RA62 compact starter internal circuit diagram

3RA61 compact starter (direct starter)

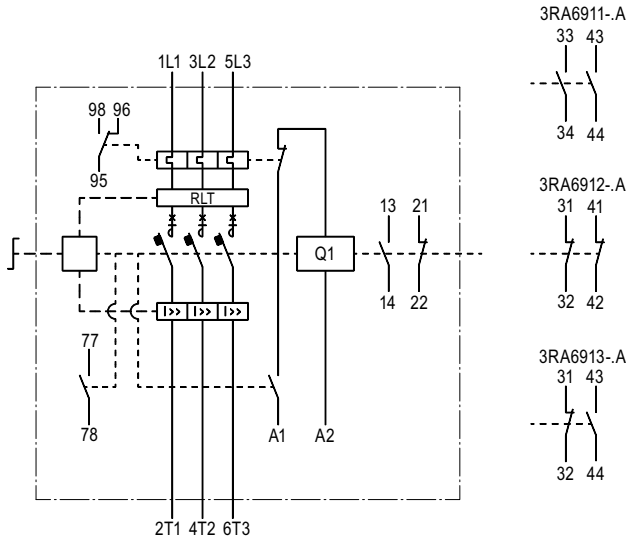


Figure 11-1 Schematic internal circuit diagram for the 3RA61 compact starter (direct starter)

3RA62 compact starter (reversing starter)

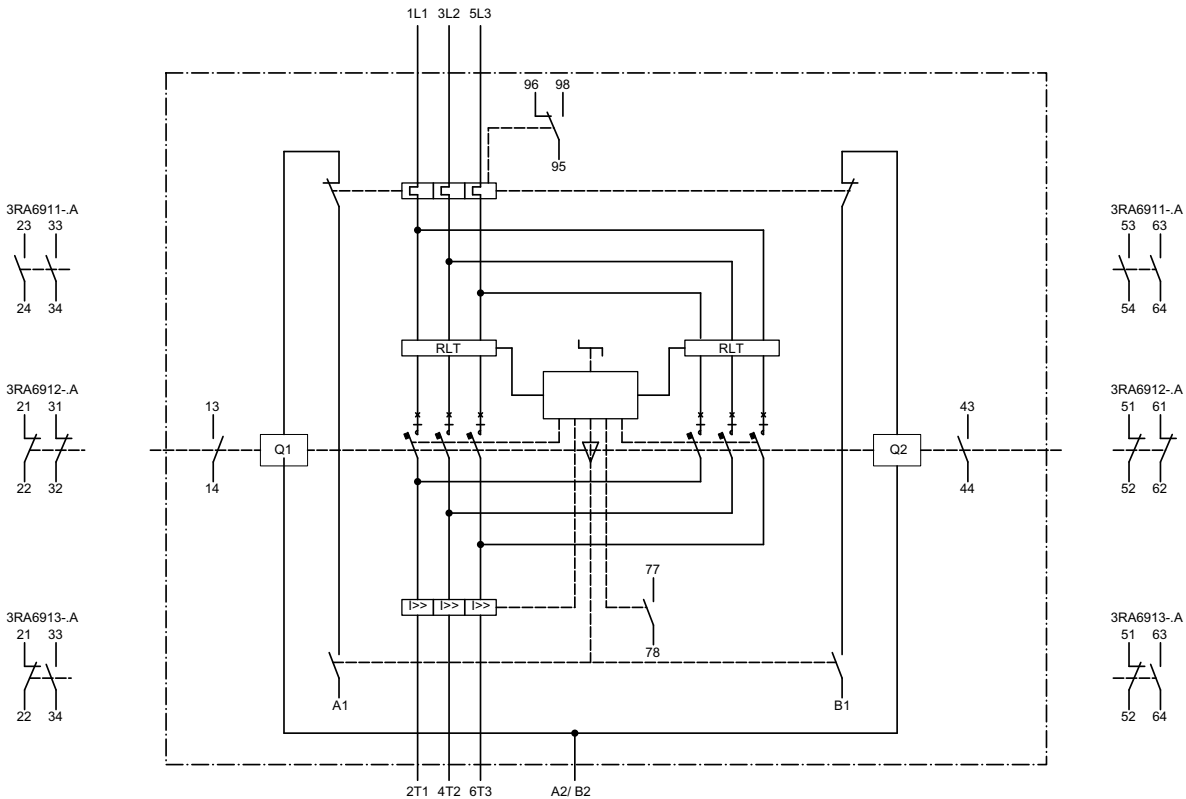
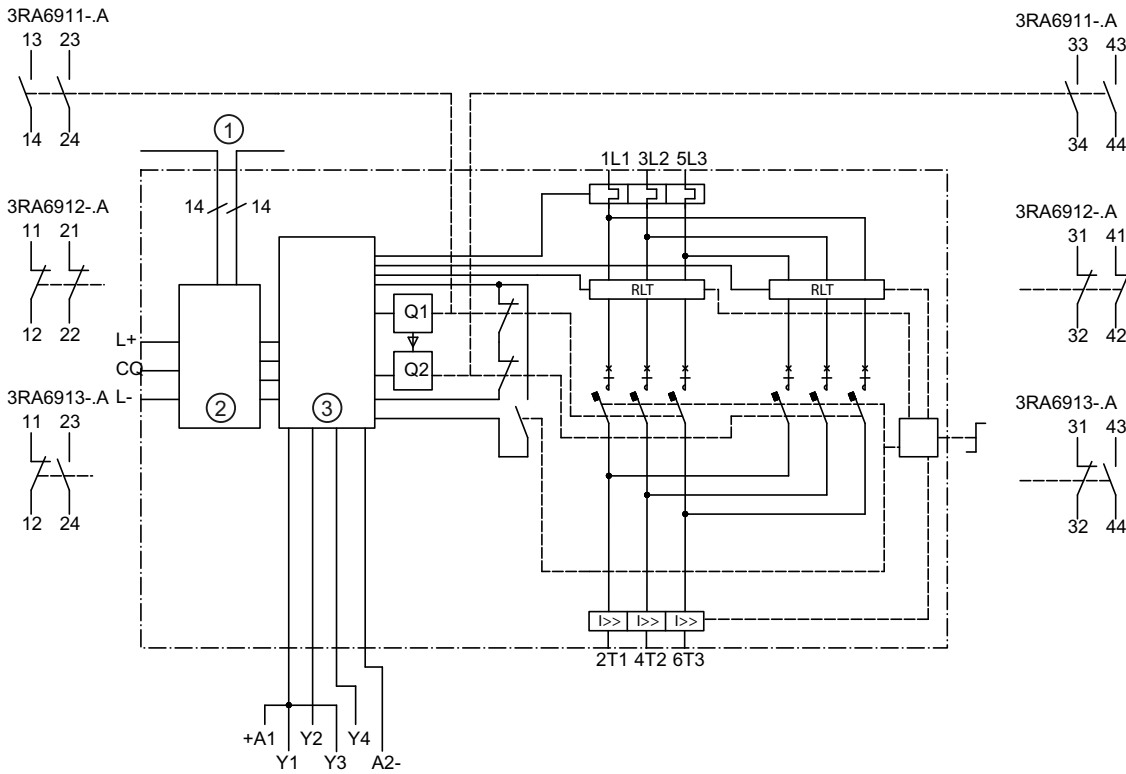


Figure 11-2 Schematic internal circuit diagram for the 3RA62 compact starter (reversing starter)

3RA65 compact starter with IO-Link (reversing starter)



- ① Connecting cable, 14-core, for compact starter
- ② IO-Link
- ③ Control system

Figure 11-4 Schematic internal circuit diagram for the 3RA62 compact starter with IO-Link (reversing starter)

11.4 Control circuit of the 3RA61/3RA62 compact starter

3RA61 compact starter (direct starter)

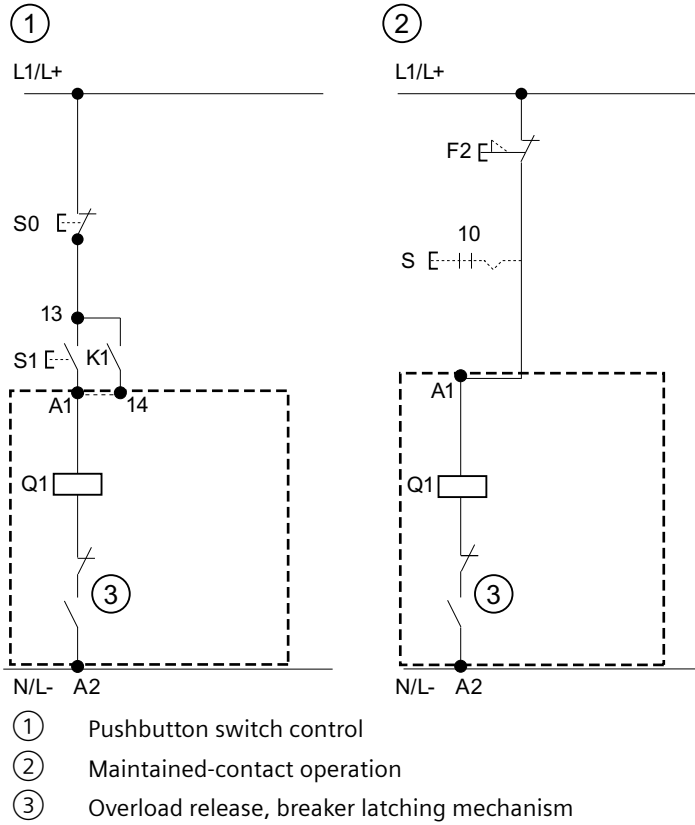
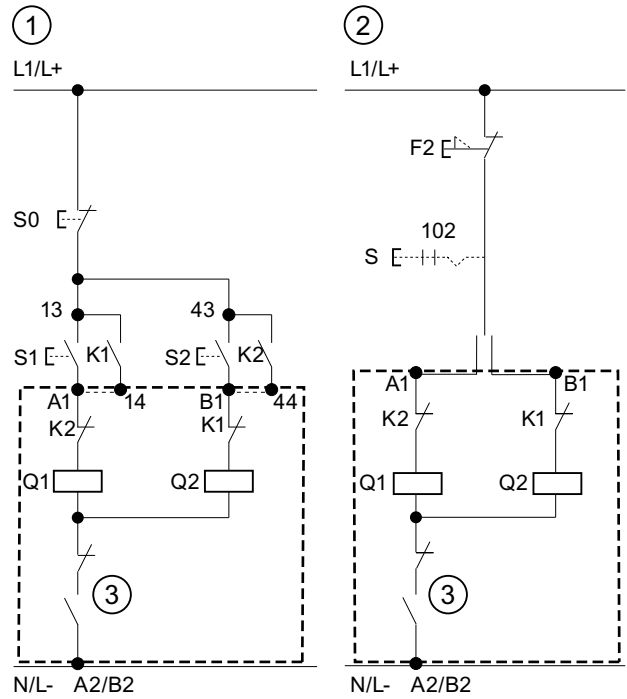


Figure 11-5 Control circuit of the 3RA61 compact starter (direct starter)

3RA62 compact starter (reversing starter)



- ① Pushbutton switch control
- ② Maintained-contact operation
- ③ Overload release, breaker latching mechanism

Figure 11-6 Control circuit of the 3RA62 compact starter (reversing starter)

11.5 Parallel switching of several 3RA62 compact starters (reversing starters)

Parallel switching of several 3RA62 compact starters (reversing starters)

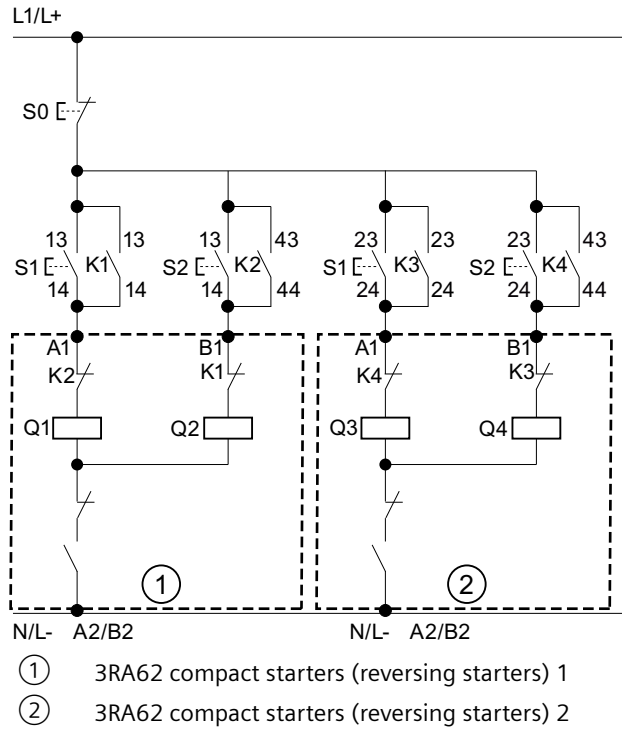
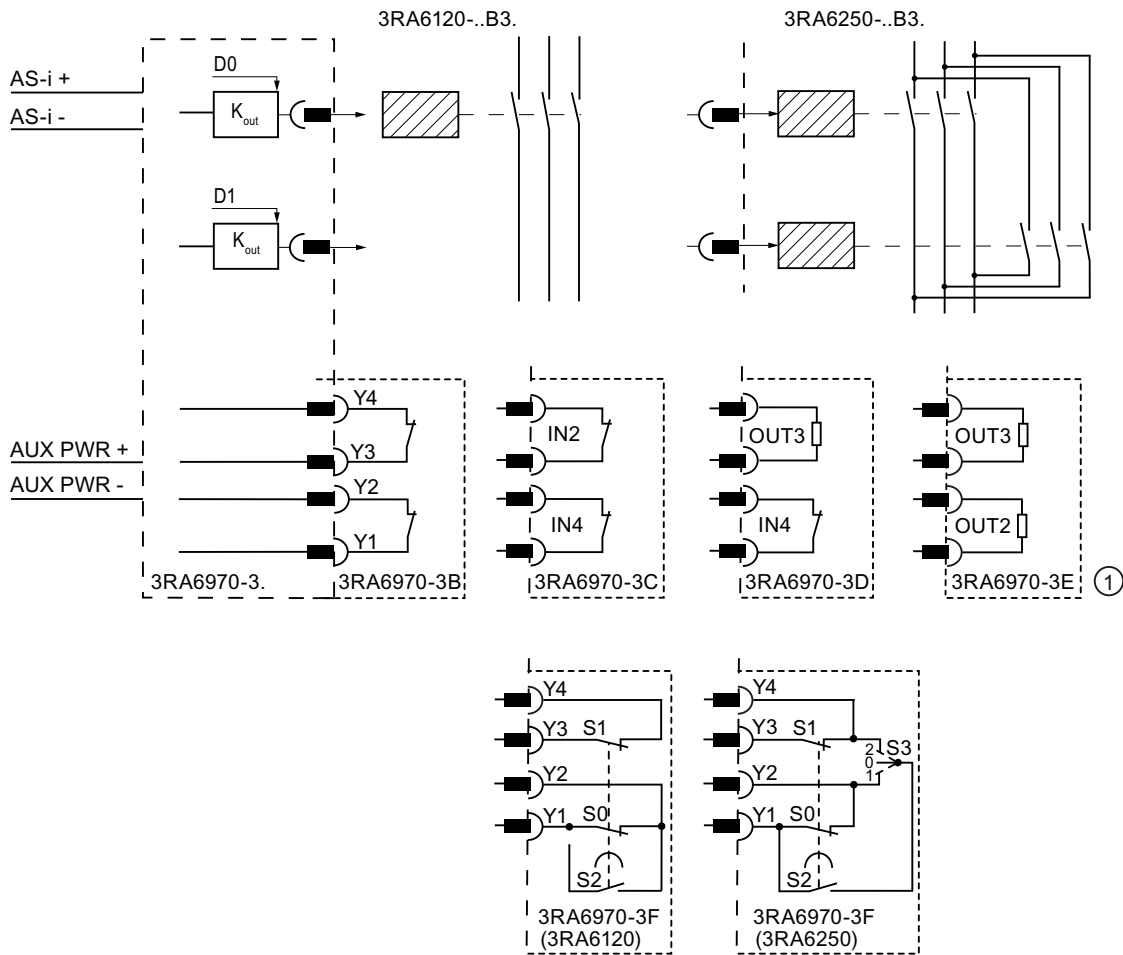


Figure 11-7 Parallel switching of several 3RA62 compact starters (reversing starters)

11.6 Circuit diagram of the AS-i mounting module for compact starter

AS-i mounting module for 3RA6 compact starter (24 V) (3RA6970-3A, -3B, -3C, -3D, -3E, -3F)



① The AS-i 3RA6970-3E mounting module is only mounted on 3RA6120... (24 V).

Figure 11-8 Circuit diagram of AS-i mounting module for 3RA6 compact starter (24 V) (3RA6970-3A, -3B, -3C, -3D, -3E, -3F)

The AS-i 3RA6970-3F mounting module controls the operating mode and the direction of rotation via the settings of the switches S0, S1, S2 and S3 (S3 only in the case of the 3RA6250 reversing starter).

Table 11-1 Settings of switches S0, S1 and S2

Switch	Automatic mode	0	Manual mode
S0	Closed	Open	Open
S1	Closed	Open	Open
S2	Open	Open	Closed

Table 11-2 Settings of the switch S3 (only in the case of the 3RA6250 reversing starter)

Switch	Counterclockwise rotation	Clockwise rotation
S3/1	Open	Closed
S3/2	Closed	Open

Characteristic curves

Tripping functions

The 3RA6 compact starter has 3 characteristic tripping functions implemented using the following releases:

1. The current-dependent delayed overcurrent release (electronic)
2. The short-time delayed overcurrent release (electronic)
3. The instantaneous short-circuit release (electromagnetic)

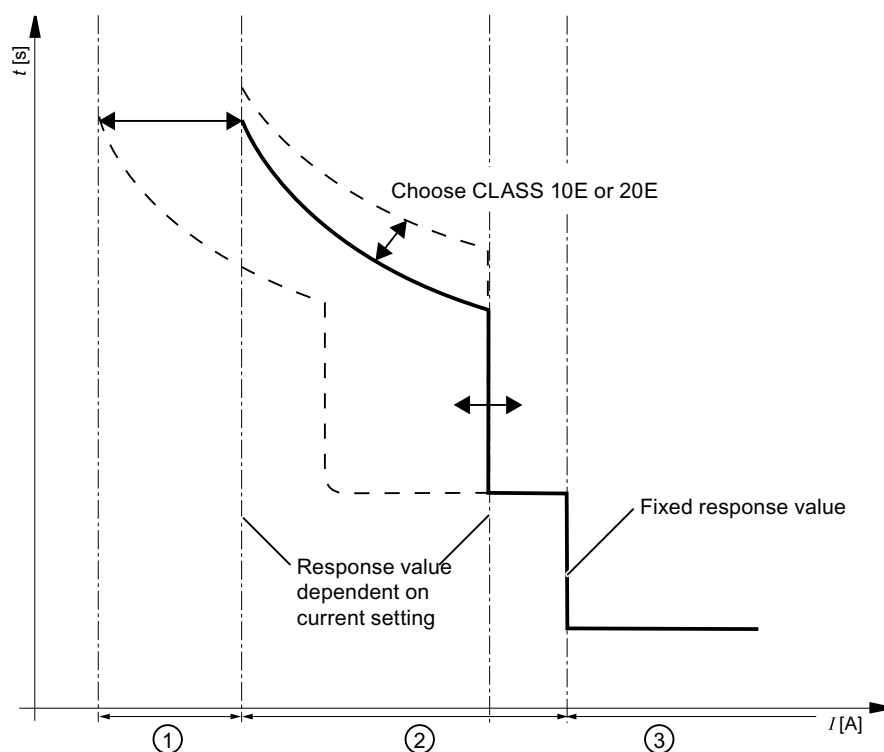


Figure 12-1 Schematic circuit diagram of the time-current characteristic curve for 3RA6

- ① Inverse-time delayed overload release (electronic)
- ② Short-time delayed overcurrent release (electronic)
- ③ Instantaneous short-circuit release (electromagnetic)

Setting options

You can influence the 3 tripping functions via different settings.

1. Inverse-time delayed overload release (electronic)

- Select the tripping current as the setting current in accordance with the load to be protected. The compact starter offers a wide setting range in the ratio 1:4 for this function. In accordance with IEC 60947-6-2, the response value is between 1.05 times and 1.2 times the value of the current setting.
- For selecting trip CLASS 10E or CLASS 20E.

2. Short-time delayed overcurrent release (electronic)

- Like the inverse-time delayed overcurrent release, the short-time delayed overcurrent release is also dependent on the selected setting current. The response value is 12 times the setting value and is also variable in the ratio 1:4 in accordance with the wide setting range.

3. Instantaneous short-circuit release

- The instantaneous short-circuit release is set to a fixed value in the individual device versions. This value corresponds to 14 times the value of the rated operational current I_e of the device.
- Exception: The device versions with the rated operational currents 0.4 A and 1.25 A have the same response value as the device version with 4 A.

You will find further information on the functions in the following chapters:

- Chapter "Functions (Page 54)" for the 3RA61/3RA62 compact starters
- Chapter "Functions (Page 115)" for the 3RA64/3RA65 compact starters

You will find further information on the settings of the compact starter in the following chapters:

- Chapter "Commissioning (Page 82)" for the 3RA61/3RA62 compact starters
- Chapter "Commissioning (Page 133)" for the 3RA64/3RA65 compact starters

Overview of response values

Table 12-1 Response settings of the tripping functions

Device version I_e	Inverse-time delayed overload release ¹⁾	Short-time delayed overcurrent release	Instantaneous short-circuit release
0.4 A	0.11 - 0.45 A	1.2 - 4.8 A	56 A
1.25 A	0.36 - 1.41 A	3.8 - 15 A	56 A
4 A	1.13 - 4.5 A	12 - 48 A	56 A
12 A	3.38 - 13.5 A	36 - 144 A	168 A
32 A	9 - 36 A	96 - 384 A	448 A

¹⁾ The specification refers to the ideal response threshold of $1.125 \times I_e$ (normative tripping window between $1.05 \times I_e$ and $1.2 \times I_e$)

Displays and messages

Tripping of the **inverse-time delayed overload release** and the **short-time delayed overcurrent release** is shown by the displays and messages in the table below.

Table 12-2 Overload release (displays and messages)

3RA61/3RA62	3RA64/3RA65 (Device version with IO-Link)
<ul style="list-style-type: none"> The mechanical "overload release" display (TRIP ρ) is white. 	<ul style="list-style-type: none"> The "Group error" LED is red.
<ul style="list-style-type: none"> The signaling contact "Overload" indicates overload (contact 95/96 is open and contact 95/98 is closed). 	<ul style="list-style-type: none"> The message "overload tripped" is signaled to the controller via IO-Link.

Short-circuit release is signaled by the displays and messages in the following table.

Table 12-3 Short-circuit release (displays and messages)

3RA61/3RA62	3RA64/3RA65 (Device version with IO-Link)
<ul style="list-style-type: none"> The handle is in the TRIPPED position and 	<ul style="list-style-type: none"> The handle is in the TRIPPED position and
<ul style="list-style-type: none"> The "Fault" signaling contact 95/96 is open. 	<ul style="list-style-type: none"> The "Group error" LED is red and
	<ul style="list-style-type: none"> The message "circuit breaker tripped" is signaled to the controller via IO-Link.

You will find further information on the displays and messages in the following chapters:

- "Diagnostics (Page 85)" for 3RA61/3RA62 compact starters
- "Diagnostics (Page 120)" for 3RA64/3RA65 compact starters

Characteristic curve reference

Time-current characteristics, let-through current characteristics and I^2t characteristics can be requested from Technical Support at Characteristic curve reference (<https://support.industry.siemens.com/My/ww/en/requests>) as required.

Data sets for the 3RA64/3RA65 compact starter with IO-Link

A

A.1 Structure of the data sets

Overview of the data sets

Table A-1 Data sets - overview

Data set			Name	Access	Value	Length (bytes)
Index (dec)	Index (hex)	Subindex supported				
0	0	Yes	Parameter Page 0	r	—	16
1	1	Yes	Parameter Page 1	r/w	—	16
16	10	No	Vendor Name	r	Siemens AG	10
17	11	No	Vendor Text	r	Industry Automation, Low-Voltage Controls and Distribution	58
18	12	No	Product Name	r	SIRIUS Compact Starter IO-Link	30
19	13	No	Product ID	r	3RA64 / 3RA65	8
20	14	No	Product Text	r	—	2
21	15	No	Serial number	r	—	8
22	16	No	Hardware Revision	r		4
23	17	No	Firmware Revision	r		4
24	18	No	Application Specific Name	r/w		Max. 64
90	5A	No	Group diagnostics	r	—	53
105	69	No	Actual configuration	r	—	43
130	82	No	Target configuration	r/w	—	43

A.2 IO-Link communication parameters

Parameter Page 0 - IO-Link communication parameters

Table A-2 Parameter Page 0

Address	Parameter name	Access	Value
0x00	Master Command	r/w	—
0x01	Master Cycle Time	r/w	—
0x02	Min. Cycle Time	r	0x19
0x03	Frame Capability	r	0x03
0x04	IO-Link Revision ID	r	0x10
0x05	Process data IN	r	0x50
0x06	Process data OUT	r	0x10
0x07	Vendor ID 1	r	0x00
0x08	Vendor ID 2	r	0x2A
0x09	Device ID 1	r	0x09
0x0A	Device ID 2	r	0x02
0x0B	Device ID 3	r	0x00
0x0C	Function ID 1	r	0x00
0x0D	Function ID 2	—	0x00
0x0E	Reserved	—	—
0x0F	Reserved	—	—

A.3 Device-specific parameters

Parameter Page 1 - device-specific parameters

Note

The "compact starter" is referred to as "starter" in the table below.

Table A-3 Parameter Page 1 - device-specific parameters (byte 0 to 11)

Byte.Bit		Meaning
0.0...0.7		Product family SIRIUS nG (0x60)
		Starter status
1.0	Starter 1	0: Preset/actual comparison: yes 1: Preset/actual comparison: No
1.1		0: Starter available 1: Starter not available
1.2	Starter 2	See 1.0
1.3		See 1.1
1.4	Starter 3	See 1.0
1.5		See 1.1
1.6	Starter 4	See 1.0
1.7		See 1.1
2.0	Operator panel	See 1.0
2.1		See 1.1
2.2		0: Reserved
2.3		0: Reserved
2.4...2.7	Profile version	1: Starter group
3	Starter 1	Type of starter ¹⁾
4.0...4.7		Starter version
5	Starter 2	Type of starter ¹⁾
6.0...6.7		Starter version
7	Starter 3	Type of starter ¹⁾
8.0...8.7		Starter version
9	Starter 4	Type of starter ¹⁾
10.0...10.7		Starter version
11	Operator panel	210: Operator panel

¹⁾ You can find additional information on the "Type of starter" parameter in ""Type of starter" parameter (Page 109)".

A.4 Identification data

Identification data

Identification data refers to data stored in a compact starter that supports users in the following areas:

- When checking the system configuration
- When locating modified system hardware
- When troubleshooting a system.

Compact starters can be uniquely identified with the identification data.

Identification data

DPP ¹⁾	Data set	Access	Parameter	Length (bytes)	Value
Index	Index				
0x07	—	r	Vendor ID	2	0x00
0x08	—	r			0x2A
0x09	—	r	Device ID	3	0x09
0x0A	—	r			0x02
0x0B	—	r			0x00
—	0x10	r	Vendor Name	10	Siemens AG
—	0x11	r	Vendor Text	58	Industry Automation, Low Voltage Controls and Distribution
—	0x12	r	Product Name	30	SIRIUS Compact Starter IO-Link
—	0x13	r	Product ID	8	3RA64/3RA65
—	0x14	r	Product Text	2	—
—	0x15	r	Serial Number	8	—
—	0x16	r	Hardware Revision	4	
—	0x17	r	Firmware Revision	4	
—	0x18	r/rw	Application Specific Name	Max. 64	

¹⁾ Direct Parameter Page

A.5 Group diagnostics - data set (index) 90

Data set (index) 90 - group diagnostics

Note

The "compact starter" is referred to as "starter" in the table below.

Note

Bits that are not described in the tables below are reserved and should be ignored.

Table A-4 Data set (index) 90 - group diagnostics: Starter group

Data set	Byte.Bit	Designation
Index		
Diagnosis of the starter group		
90	4.0...4.6	Number of starters (compact starters and operator panel)
90	5.0	Preset <> actual configuration

Starter 1

Table A-5 Data set (index) 90 - starter 1

Data set	Byte.Bit	Designation
Index		
Specific module diagnostics - starter 1		
90	9.0...9.6	Starter 1 (item number)
90	10.0	Reserved
90	10.1	Starter available
90	10.2	Reserved
Specific diagnostics - starter 1		
90	15.0	Contact block defective
90	15.1	Contact block supply voltage missing
90	15.2	Reserved
90	15.3	Motor overload tripping
90	15.4	Circuit breaker tripped
90	15.5	Switch off - end position right
90	15.6	Switch off - end position left
90	15.7	Process image error
90	16.0	Manual operation local
90	16.1	Manual operation connection aborted

A.5 Group diagnostics - data set (index) 90

Data set	Byte.Bit	Designation
Index		
90	16.2	Contact block cooling time active
90	16.3	Remaining life time (RLT 0%)

Starter 2

Table A-6 Data set (index) 90 - starter 2

Data set	Byte.Bit	Designation
Index		
Specific module diagnostics - starter 2		
90	18.0...18.6	Starter 2 (item number)
90	19.0	Reserved
90	19.1	Starter available
90	19.2	Reserved
Specific diagnostics - starter 2		
90	24.0	Contact block defective
90	24.1	Contact block supply voltage missing
90	24.2	Reserved
90	24.3	Motor overload tripping
90	24.4	Circuit breaker tripped
90	24.5	Switch off - end position right
90	24.6	Switch off - end position left
90	24.7	Process image error
90	25.0	Manual operation local
90	25.1	Manual operation connection aborted
90	25.2	Contact block cooling time active
90	25.3	Remaining life time (RLT 0%)

Starter 3

Table A-7 Data set (index) 90 - starter 3

Data set	Byte.Bit	Designation
Index		
Specific module diagnostics - starter 3		
90	27.0...27.6	Starter 3 (item number)
90	28.0	Reserved
90	28.1	Starter available
90	28.2	Reserved
Specific diagnostics - starter 3		
90	33.0	Contact block defective
90	33.1	Contact block supply voltage missing

Data set	Byte.Bit	Designation
Index		
90	33.2	Reserved
90	33.3	Motor overload tripping
90	33.4	Circuit breaker tripped
90	33.5	Switch off - end position right
90	33.6	Switch off - end position left
90	33.7	Process image error
90	34.0	Manual operation local
90	34.1	Manual operation connection aborted
90	34.2	Contact block cooling time active
90	34.3	Remaining life time (RLT 0%)

Starter 4

Table A-8 Data set (index) 90 - starter 4

Data set	Byte.Bit	Designation
Index		
Specific module diagnostics - starter 4		
90	36.0...36.6	Starter 4 (item number)
90	37.0	Reserved
90	37.1	Starter available
90	37.2	Reserved
Specific diagnostics - starter 4		
90	42.0	Contact block defective
90	42.1	Contact block supply voltage missing
90	42.2	Reserved
90	42.3	Motor overload tripping
90	42.4	Circuit breaker tripped
90	42.5	Switch off - end position right
90	42.6	Switch off - end position left
90	42.7	Process image error
90	43.0	Manual operation local
90	43.1	Manual operation connection aborted
90	43.2	Contact block cooling time active
90	43.3	Remaining life time (RLT 0%)

Operator panel

Table A-9 Data set (index) 90 - operator panel

Data set	Byte.Bit	Designation
Index		
Specific module diagnostics - operator panel		
90	45.0..45.6	Operator panel (item number)
90	46.1	Operator panel available

For additional information, please refer to "Process image (Page 113)".

A.6 Actual configuration - data set (index) 105

Data set (index) 105 (actual configuration)

Note

The "compact starter" is referred to as "starter" in the table below.

Table A-10 Data set (index) 105 (actual configuration) - diagnostics of the starter group

Data set	Byte.Bit	Designation
Index		
105	0.0...0.7	Fixed value 0x21
105	1.0...1.7	Fixed value 0x00
105	2.0...2.7	Fixed value 0x00
105	3.0...3.7	Fixed value 0x00
Diagnosis of the starter group		
105	4.0...4.6	Fixed value 0x05
105	8.0...8.7	Fixed value 0x07

Data set (index) 105 - (actual configuration) - starter 1

Table A-11 Data set (index) 105 - (actual configuration) - starter 1

Data set	Byte.Bit	Designation
Index		
105	9.0...9.6	Starter 1 (item number)
105	10.0...10.7	Fixed value 0x60
105	11.0	Starter OK
105	11.1	Starter available
105	12.0...12.7	Type of starter ²⁾
105	13.0...14.7	Starter version (To differentiate between versions in the case of identical article numbers)
—	15.0...15.7	Fixed value 0x07

Data set (index) 105 - (actual configuration) - starter 2

Table A-12 Data set (index) 105 - (actual configuration) - starter 2

Data set	Byte.Bit	Designation
Index		
105	16.0...16.6	Starter 2 (item number)
105	17.0...17.7	Fixed value 0x60
105	18.0	Starter OK
105	18.1	Starter available
105	19.0...19.7	Type of starter ²⁾
105	20.0...21.7	Starter version (To differentiate between versions in the case of identical article numbers)
—	22.0...22.7	Fixed value 0x07

Data set (index) 105 - (actual configuration) - starter 3

Table A-13 Data set (index) 105 - (actual configuration) - starter 3

Data set	Byte.Bit	Designation
Index		
105	23.0...23.6	Starter 3 (item number)
105	24.0...24.7	Fixed value 0x60
105	25.0	Starter OK
105	25.1	Starter available
105	26.0...26.7	Type of starter ²⁾
105	27.0...28.7	Starter version (To differentiate between versions in the case of identical article numbers)
—	29.0...29.7	Fixed value 0x07

Data set (index) 105 - (actual configuration) - starter 4

Table A-14 Data set (index) 105 - (actual configuration) - starter 4

Data set	Byte.Bit	Designation
Index		
105	30.0...30.6	Starter 4 (item number)
105	31.0...31.4	Fixed value 0x60
105	32.0	Starter OK
105	32.1	Starter available
105	33.0...33.7	Type of starter ²⁾

Data set	Byte.Bit	Designation
Index		
105	34.0...35.7	Starter version (To differentiate between versions in the case of identical article numbers)
—	36.0...36.7	Fixed value 0x07

Data set (index) 105 (actual configuration) - operator panel


Table A-15 Data set (index) 105 (actual configuration) - operator panel

Data set	Byte.Bit	Designation
Index		
105	37.0...37.6	Operator panel (item number)
105	38.0...38.7	Fixed value 0x60
105	39.1	Operator panel available
105	40.0...40.7	Fixed value 0xD2
105	41.0...42.7	Reserved

¹⁾ You can find additional information on the "Starter available" parameter in ""Starter available" parameter (Page 107)".

²⁾ You can find additional information on the "Type of starter" parameter in ""Type of starter" parameter (Page 109)".

A.7 Target configuration - data set (index) 130

 WARNING
Danger of uncontrolled motor start-up
Uncontrolled motor start-up can result in injury to personnel.
The preset configuration of a compact starter group is saved by the compact starter connected to the IO-Link master via the removable terminal.
When this compact starter is replaced, you must ensure that the preset configuration is saved in the new compact starter. In the event of a replacement, the preset configuration can either be transferred to the new device with the "Port Configuration Tool", or it can be copied from the old compact starter to the new compact starter with the help of the function block "IO-Link Call".

Note

The "compact starter" is referred to as "starter" in the table below.

Data set (index) 130 (preset configuration)

Table A-16 Data set (index) 130 (preset configuration) - diagnostics of the starter group

Data set	Byte.Bit	Designation
Index		
130	0.0...0.7	Fixed value 0x21
130	1.0...1.7	Fixed value 0x00
130	2.0...2.7	Fixed value 0x00
130	3.0...3.7	Fixed value 0x00
Diagnosis of the starter group		
130	4.0...4.6	Fixed value 0x05
130	8.0...8.7	Fixed value 0x07

Data set (index) 130 - (preset configuration) - starter 1

Table A-17 Data set (index) 130 - (preset configuration) - starter 1

Data set	Byte.Bit	Designation
Index		
130	9.0...9.6	Starter 1 (item number)
130	10.0...10.7	Fixed value 0x60
130	11.0	Preset <> Actual configuration ¹⁾
130	11.1	Starter available ²⁾
130	12.0...12.7	Type of starter ³⁾
130	13.0...14.7	Starter version
130	15.0...15.7	Fixed value 0x07

Data set (index) 130 - (preset configuration) - starter 2

Table A-18 Data set (index) 130 - (preset configuration) - starter 2

Data set	Byte.Bit	Designation
Index		
130	16.0...16.6	Starter 2 (item number)
130	17.0...17.7	Fixed value 0x60
130	18.0	Preset <> Actual configuration ¹⁾
130	18.1	Starter available ²⁾
130	19.0...19.7	Type of starter ³⁾
130	20.0...21.7	Starter version
130	22.0...22.7	Fixed value 0x07

Data set (index) 130 - (preset configuration) - starter 3

Table A-19 Data set (index) 130 - (preset configuration) - starter 3

Data set	Byte.Bit	Designation
Index		
130	23.0...23.6	Starter 3 (item number)
130	24.0...24.7	Fixed value 0x60
130	25.0	Preset <> Actual configuration ¹⁾
130	25.1	Starter available ²⁾
130	26.0...26.7	Type of starter ³⁾
130	27.0...28.7	Starter version
130	29.0...29.7	Fixed value 0x07

Data set (index) 130 - (preset configuration) - starter 4

Table A-20 Data set (index) 130 - (preset configuration) - starter 4

Data set	Byte.Bit	Designation
Index		
130	30.0...30.6	Starter 4 (item number)
130	31.0...31.4	Fixed value 0x60
130	32.0	Preset <> Actual configuration ¹⁾
130	32.1	Starter available ²⁾
130	33.0...33.7	Type of starter ³⁾
130	34.0...35.7	Starter version
130	36.0...36.7	Fixed value 0x07

Data set (index) 130 (preset configuration) - operator panel

Table A-21 Data set (index) 130 (preset configuration) - operator panel

Data set	Byte.Bit	Designation
Index		
130	37.0...37.6	Operator panel (item number)
130	38.0...38.7	Fixed value 0x60
130	39.0	Preset <> Actual configuration ¹⁾
130	39.1	Operator panel available

¹⁾ You can find additional information on "Operation at preset <> actual" in chapters "Parameter "Operation at Preset <> Actual Configuration" (Page 110)" and "Operation with operator panel (Page 111)".

²⁾ You can find additional information on the "Starter available" parameter in ""Starter available" parameter (Page 107)".

³⁾ You can find additional information on the "Type of starter" parameter in ""Type of starter" parameter (Page 109)".

References

B.1 References

Further references

Further information on the compact starter can be found on the Internet (<http://www.siemens.com/compactstarter>).

In addition to this manual, please refer to the operating instructions and manuals for any accessories. You can download the relevant documentation from the Internet (<http://www.siemens.com/sirius/manuals>). Simply enter the article number of the relevant documentation into the search field.

Operating instructions

Title	Article number
SIRIUS infeed system for 3RA6	3ZX1012-ORA68-1AA1
SIRIUS 3RV infeed system	3ZX1012-ORV10-2BA1
AS-i mounting module	3ZX1012-ORA60-3AA1
AS-Interface addressing unit V3.0	3ZX1012-ORK10-4BA1
Busbar adapter	8ZX1012-0US12-1NA1
Door-coupling rotary operating mechanism	3ZX1012-ORV10-6AA1

Manuals

Title	Article number
AS-Interface system	3RK2703-3AB02-1AA1

List of abbreviations

C.1 List of abbreviations

Table C-1 List of abbreviations

Abbreviation	Term
Screw-type infeed (50/70 mm ²)	Left infeed, 50/70 mm ² screw terminal with three slots, outgoing terminals with screw-type or spring-loaded connection technology, incl. PE bar
Screw-type infeed (25/35 mm ²)	Left infeed, 25/35 mm ² screw terminal with three slots, outgoing terminals with screw-type or spring-loaded connection technology, incl. PE bar
Spring-loaded infeed	Left or right infeed, 25/35 mm ² , with spring-loaded connection technology
2-slot extension module	Extension module with two slots, outgoing terminals with screw-type or spring-loaded connection technology, incl. PE bar
3-slot extension module	Extension module with three slots, outgoing terminals with screw-type or spring-loaded connection technology, incl. PE bar
PZ	Pozidriv
SW	Width across flats
V _{Aux}	Auxiliary power supply
I _e	Rated operating current
I _E	Current setting
V _e	Rated operating voltage
f	Rated frequency
V _{Imp}	Rated surge voltage
V _i	Rated insulation voltage
P _{vmax}	Power loss
d	Diameter
a	Acceleration
I _K	Short-circuit current rating
AWG	American Wire Gauge

Glossary

3RV29 3-phase busbar

The 3-phase busbar enables several compact starters to be fed using a single infeed terminal.

8US busbar adapter

The 8US busbar adapter enables the compact starter to be mechanically fastened and electrically connected to a busbar system.

Adapter for screw fastening

The adapters for screw fastening enable you to install the compact starter on a level surface.

AS-Interface

The actuator sensor interface (AS-Interface) is a modular networking system for sensors and actuators at the lowest field level.

Auxiliary switch block for compact starter

Optional auxiliary switch block in the following versions: 2 NO contacts, 2 NC contacts or 1 NO contact + 1 NC contact.

Control kit

Tool for closing the main contacts manually by means of the actuator.

Door-coupling rotary operating mechanism

Door-coupling rotary operating mechanisms enable compact starters to be operated with the control cabinet doors closed.

Infeed system for 3RA6

The infeed system for 3RA6 enables several compact starters to be fed using a modular infeed system with permanent wiring.

Terminals for Type E combination controller

The terminals conform to the creepages and clearances stipulated by UL 508 (Type E).

Index

A

Abbreviations, 283
Abbreviations used, 10
Actuator
 OFF, 54, 115
 READY, 55, 115
 TRIPPED, 57, 115
Approvals, 16
Article numbers
 3RA61/3RA62 compact starter, 43
 3RA64/3RA65 compact starter with IO-Link, 89
AS-i mounting module, 210, 211
 Addressing, 217
 Limit switch, 215
 Pin assignment, 216, 217
AS-i mounting module addressing, 217
AS-i mounting module, 205
AS-Interface, 212
AS-Interface, 205
Auto reset, 83, 135
Automation environment, 22

B

Busbar systems, 191

C

Cabinet types, 27
Characteristic curve reference, 265
Circuit diagram of main circuit
 3RA64/3RA65 compact starter with IO-Link, 256
Circuit diagram of the control circuit
 3RA61/3RA62 compact starter, 258
CLASS 10E / 20E, 82, 93, 133
Combination involving 3-phase busbar, 38
Combination with other sizes
 Infeed system for 3RA6, 161
Combining compact starters with SIRIUS circuit breakers, 29
Communication IO-Link, 92
Conductor cross-sections
 3-phase infeed terminal, 189
 Auxiliary switch block for compact starter, 155
 Compact starter (auxiliary and control conductor terminals), 75, 127

 Compact starter (main conductor terminals), 74, 127
 Infeed system for 3RA6, 181
 Limit switch, 217
 Terminal for Type E, 198
Configuration
 3-phase busbar, 187
 3RA61 compact starter, 47
 3RA62 compact starter, 50
 3RA64 compact starter with IO-Link, 93
 3RA65 compact starter with IO-Link, 96
 8US busbar adapter, 39
 Auxiliary switch block for compact starter, 150
 Control kit, 147
 Infeed system for 3RA6, 33, 159
 IO-Link function block, 103, 104
 System configuration with AS-Interface, 23
 System configuration with IO-Link, 24
 System configuration with parallel wiring, 22
Configurator, 53, 99
Connection
 Screw terminals, 76, 127
 Spring-loaded terminals, 76, 127
Connection types
 Compact starter, 73, 77, 127
Control circuit, 21
Control circuit terminals, 144
Control supply voltage ranges
 3RA61/3RA62 compact starter, 46
 3RA64/3RA65 compact starter, 92
Control kit, 148
Creepages and clearances, 40
CSA 22.2, 40
Current setting, 83, 134
Current setting ranges
 3RA61/3RA62 compact starter, 46
 3RA64/3RA65 compact starter, 92

D

Degree of protection
 Compact starter, 16
Derating
 Motor starting currents, 28
Design
 Operator panel, 231

Diagnostics

- Fault types, 122
- LEDs on the 3RA64/3RA65 compact starter with IO-Link, 120

Dimension drawings

- 8US busbar adapter, 251
- Compact starter (screw-type connection technology), 242
- Compact starter (spring-loaded connection technology), 243
- Infeed system for 3RA6, 246
- Operator panel, 245

Direction of rotation interlock, 49, 95**Disabling the actuator, 119**

- 3RA6 compact starter, 62

Disconnecting

- Screw terminal, 81
- Spring-loaded terminal, 81

Display elements and operator controls

- 3RA61 compact starter, 47
- 3RA62 compact starter, 50
- 3RA64 compact starter with IO-Link, 93
- 3RA65 compact starter with IO-Link, 96

Distance from neighboring components

- Compact starter, 29, 244
- Infeed system for 3RA6, 34, 249

Door-coupling rotary operating mechanism, 200

- Disabling the actuator, 204
- Opening the door, 202

E**EMERGENCY STOP**

- Connection, 131
- Function, 131

End of service life, 236**F****Features**

- 3RA61 compact starter, 46
- 3RA62 compact starter, 49
- 3RA64 compact starter with IO-Link, 92
- 3RA65 compact starter with IO-Link, 95
- Compact starter, 19
- Control kit, 147

Function in accordance with UL 508 and CSA 22.2, 40**G****Grounding measures, 27****I****Increased ambient temperatures**

- Infeed system for 3RA6, 33

Infeed system for 3RA6, 158

- Coding, 178

Installation

- 3RA64/3RA65 compact starter with IO-Link, 124
- 3RV29 infeed system, 169
- 45 mm adapter for infeed system for 3RA6, 170
- 8US busbar adapter, 191
- Auxiliary switch block for compact starter, 151
- Compact starter on a level surface, 65
- Compact starter on infeed system for 3RA6, 67
- Compact starter on standard mounting rail, 64
- Connecting 3RA64/3RA65 compact starters with IO-Link, 124
- Control circuit terminals, 145
- Control kit, 148
- Door-coupling rotary operating mechanism, 201
- Infeed system for 3RA6 on flat surface, 166
- Main circuit terminals, 143
- Operator unit, 229
- PE accessories, 167
- Plugging in the connecting cables, 125
- Screw infeed on DIN rail, 161
- Spring-loaded infeed on DIN rail, 161
- Terminal block, 169
- Terminal covers for screw-type infeeds, 171
- Terminal for Type E, 198

Integration into the automation environment, 22**Internal circuit diagram**

- 3RA61/3RA62 compact starter, 254
- 3RA64/3RA65 compact starter with IO-Link, 254

Isolating features, 16**L****LEDs on the**

- 3RA61 compact starter, 87
- 3RA62 compact starter, 88

Limit switch, 215

- Connecting, 129
- Max. conductor length, 130

M

- Main circuit, 21
- Malfunction, 118, 236
 - Display concept, 61
 - eliminating, 61
 - Messages via IO-Link, 119
 - Type, 61
- Manual reset, 83, 135
- Manuals, 281
- Mirror contact, 79
- Motor model, 59, 118
- Mounting position
 - Compact starter, 27
 - Infeed system for 3RA6, 33

N

- Normal switching duty, 54, 115

O

- Openings for test probes
 - Compact starter, 73, 127
 - Infeed system for 3RA6, 180
- Operating conditions, 27
- Operating instructions, 281
- Operating temperature
 - Compact starter, 27
 - Infeed system for 3RA6, 33
- Operator panel
 - Connecting to the compact starter, 230
 - Manual mode, 232
 - Monitoring mode, 232
- Overload protection function, 58, 116
 - Display concept, 59
 - Function test, 59, 117
 - Interruption of the auxiliary voltage, 118
 - Messages via IO-Link, 117
 - Operator controls, 58, 117

P

- Parameter
 - Actual configuration, 275
 - Device-specific parameters, 269
 - Identification data, 270
 - IO-Link communication parameters, 268

Module

- does not exist, 107
- Operation at Preset <> Actual Configuration, 110
- Operator panel available, 111
- Overview of the data sets, 267
- Preset configuration, 278
- Process input image, 113
- Process output image, 113
- Phase loss protection, 58
- Phase-failure protection, 116
- Pin assignment
 - 3RA61/3RA62 compact starter, 78
 - Auxiliary switch block for compact starter, 154
 - Limit switch on the AS-i mounting module, 215
- Positively-driven, 80

R

- Rated current
 - 3-phase busbar, 37, 185
 - Infeed system for 3RA6, 32
- Rated operating current
 - Compact starter, 28
- Rated operating voltage
 - 3-phase busbar, 37, 185
- References, 281
- Removal
 - 3RA64/3RA65 compact starter with IO-Link, 126
 - 8US busbar adapter, 195
 - Auxiliary switch block for compact starter, 152
 - Compact starter from a level surface, 69
 - Compact starter from DIN rail, 68
 - Compact starter from infeed system for 3RA6, 71
 - Control circuit terminals, 146
 - Expansion modules, 175, 177
 - Main circuit terminals, 143
 - PE accessories, 173
 - Removing the connecting cable, 126
 - Screw-type infeed, 175
 - Spring-loaded infeed, 175
- Required basic knowledge, 10
- Reset
 - Auto reset, 117
 - Manual reset, 117
- RESET M/A, 83, 135

S

- Safe isolation, 30
- Scope of supply
 - 3RA61/3RA62 compact starter, 45

- 3RA64/3RA65 compact starter with IO-Link, 91
- 3RV19 3-phase busbar, 185
- 8US busbar adapter, 190
- Adapter for screw fastening, 141
- AS-i mounting module, 205
- Auxiliary switch block for compact starter, 150
- Connecting cable (IO-Link), 226
- Control circuit terminals, 144
- Control kit, 147
- Infeed system for 3RA6, 156
- Main circuit terminals, 142
- Operator panel, 226, 228
- Terminal for Type E, 197
- Setting ranges
 - 3RA61/3RA62 compact starter, 46
 - 3RA64/3RA65 compact starter with IO-Link, 92
- Short-circuit protection
 - Compact starter, 29
 - Infeed system for 3RA6, 35
- Short-circuit protection function, 59, 118
 - Display concept, 60
 - Function test, 61
 - Messages via IO-Link, 118
 - Resetting the short-circuit release, 60
- Signaling contacts
 - 3RA61 compact starter, 85
 - 3RA62 compact starter, 86
- Single-phase loads, 116
- Standards, 16
- Stripping lengths
 - Compact starter, 73, 127
 - Infeed system for 3RA6, 180

T

- Terminal designation
 - Auxiliary switch block for compact starter, 153
- Test reports, 16
- Touch protection
 - Compact starter, 16
- Tripping current, 60

U

- UL 508, 40
- Use as prescribed, 17
- Used symbols, 10