

3D Control

## FAYb Laser Marker

LP-M<sub>SERIES</sub>

FDA  
Conforming to  
FDA regulations

CE

GB  
Conforming to  
GB standard



# *Productivity and safety in one* *New 3D fiber laser marker LP-M series*

Since its release of fiber laser marker in 1999, constantly evolving Panasonic products have contributed to improve productivity. These days new safety standards are established and more strict safety measures are required, because manufacturing equipment powered by laser is widely spread. Safety functions included on the **LP-M** series comply with new safety standards. The **LP-M** series contributes to establish safer equipment design, in addition to improve productivity.

## HIGH POWER

The 40 W high-power laser enables deeper and faster marking and processing. Takt time reduction significantly improves productivity.



## 3D CONTROL

Mark based on the size or shape of a workpiece. Production lines are easy to design and stages can be changed smoothly.

## FAYb Laser Marker *LP-M series*







Panasonic

LP-M series  
FAYb LASER MARKER



# SAFETY

Redundant safety measures for controlling the hazard source (laser beam) make it easier to improve safety level.



# HIGH POWER

Panasonic Industry's top-level 40 W high output FAYb laser marker marks or processes deeper and faster on metallic workpieces. Handles an expanded range of laser marker marking / processing applications.

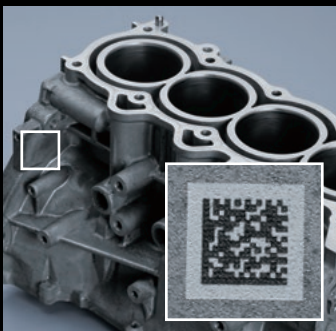

Engine block [marking]



Connecting rod [marking]



Engine part [marking]

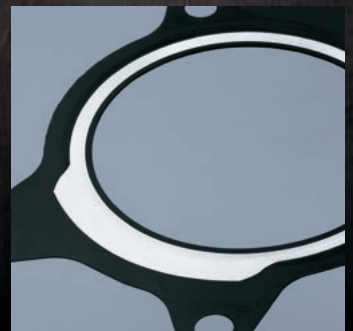

Gasket [coating removal]



# High power laser for deep engraving and high-speed marking

## Deep engraving marking / laser processing

Allows deeper and sharper marking and processing to handle demanding applications. No blade is used for high-quality, stable processing.

### Deep engraving sample [image]

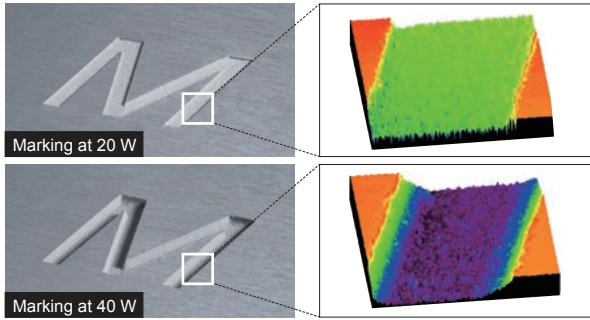

### Laser processing sample [image]

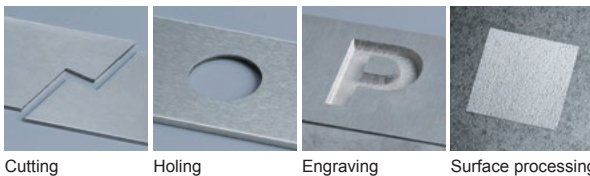

## High-speed marking

The larger the energy amount sent to the workpiece, the faster and deeper the marking / processing. Takt time reduction greatly enhances productivity.

### Image of high-speed deep engraving

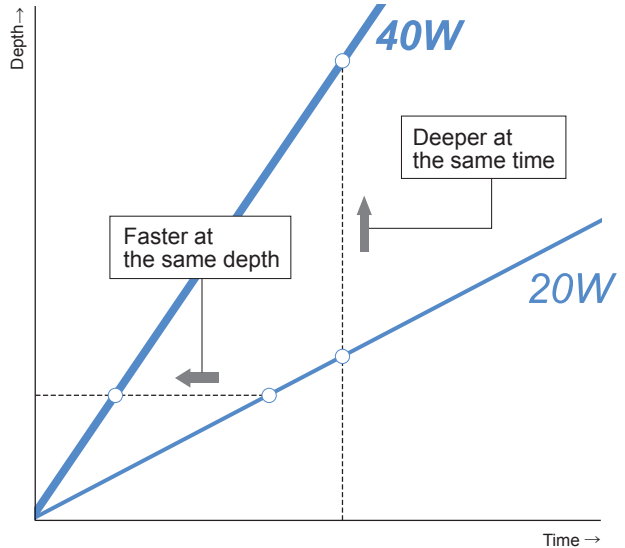

## PLUS More Environmental resistance

Durable protective structure is a benefit in harsh environments containing dust and water  
**IP64 fanless small head**

### Fanless small head

Significant improvements in radiation performance enabled a small and fanless head design which is capable of high output. Install with confidence, free from worry about fan clogs.

### IP64 Head Protective Design

Employs an inner and outer layer Double Protective Design for better airtightness inside the head. The complete air tight seal prevents dust and water entering from any direction for stable operation on the production floor.

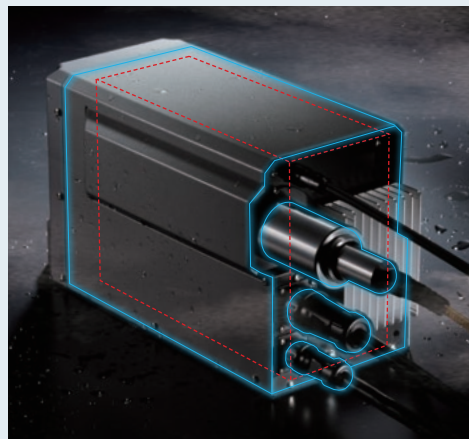

### What is IP?

IP indicates the degree of protection from water, the human body, or solid foreign objects, based on IEC / JIS standards.

Dust does not enter the interior. (Completely prevented)

**IP 6 4**

Does not receive adverse effects from water spray from any direction.

\*Anti-dust / waterproof design as per conditions stipulated in IEC / JIS standards. \*Parts must be attached correctly to realize the FAYb laser environmental resistance properties.

### Principles and features of FAYb laser oscillation

In a revolutionary method, the FAYb laser amplifies a weak laser beam from a master oscillator as it passes through a fiber treated with the element Ytterbium to emit a strong laser beam. Conversion loss is minimal as the FAYb laser amplifies laser beams in the fiber and achieves an excellent beam-to-beam conversion efficiency of approximately 50%. Power consumption is minimized despite high output and contributes to reduced carbon footprint.

Weak pulse laser beams are amplified by absorbing low-output LD beams as they pass through the fiber.

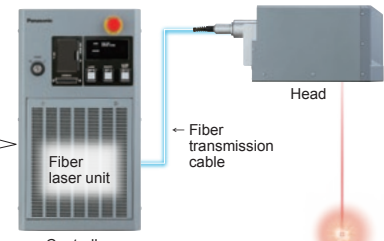
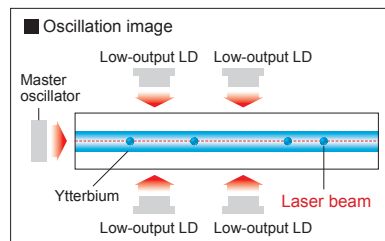



Panasonic  
LP-M series  
FAYb LASER MARKER

# 3D CONTROL

3D Control capability allows marking on various types of products and complicated shapes to meet a large number of application needs. Enables the best marking on every product type. The LP-M series contributes to production efficiencies, equipment miniaturization and reduced costs.



# Optimum marking quality on every workpiece

## High performance Z-axis stroke mechanism

The Z-axis stroke mechanism controls the laser beam focal point in the Z-direction to enable marking on an item with height differences. Marks clearly with no distortion on slanted, curved and stepped surface shapes. Spot average marking enables control of the laser beam spot diameter for uniform marking thickness and depth.

### Variable control of focus distance via Z-axis stroke

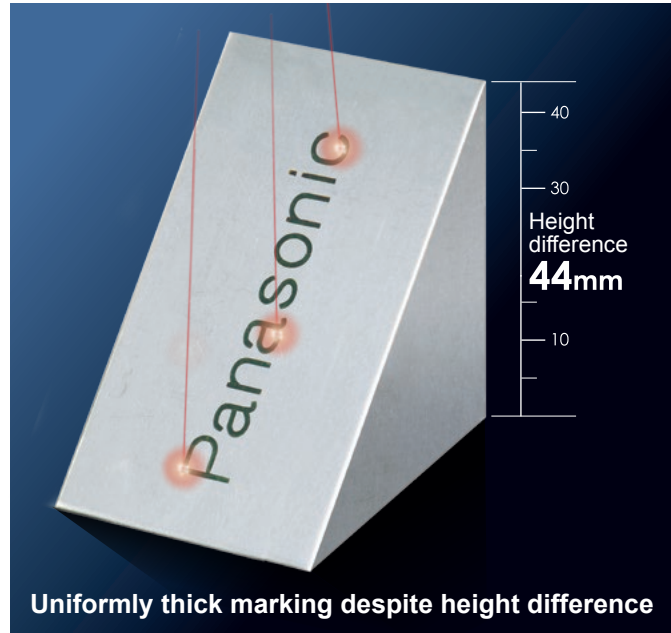
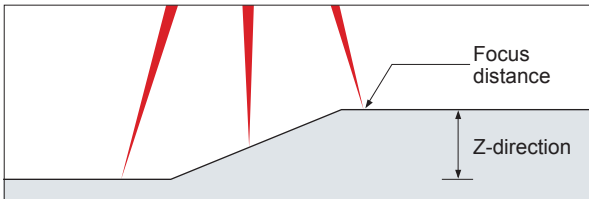

## Simple 3D settings: NAVI LINK-3D Optional

Easy-to-use software enables you to create marking data by simply overlapping a workpiece shape with the characters and shape data to mark. Check the workpiece from any angle on the image screen to make simple adjustments. For use in overseas factories, English is also available in addition to Japanese.

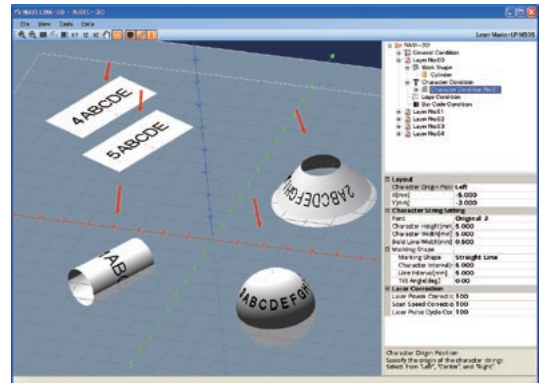

## PLUS More Marking stability features



Use the displacement sensor for the best marking on every piece

### Displacement input

Varying workpiece heights during production causes discrepancies in printing quality. The LP-M series can measure workpiece height data directly with the displacement sensor. All workpiece heights can be checked before marking for stable production quality.

■ Sample marked at a position 2mm away from the correct height



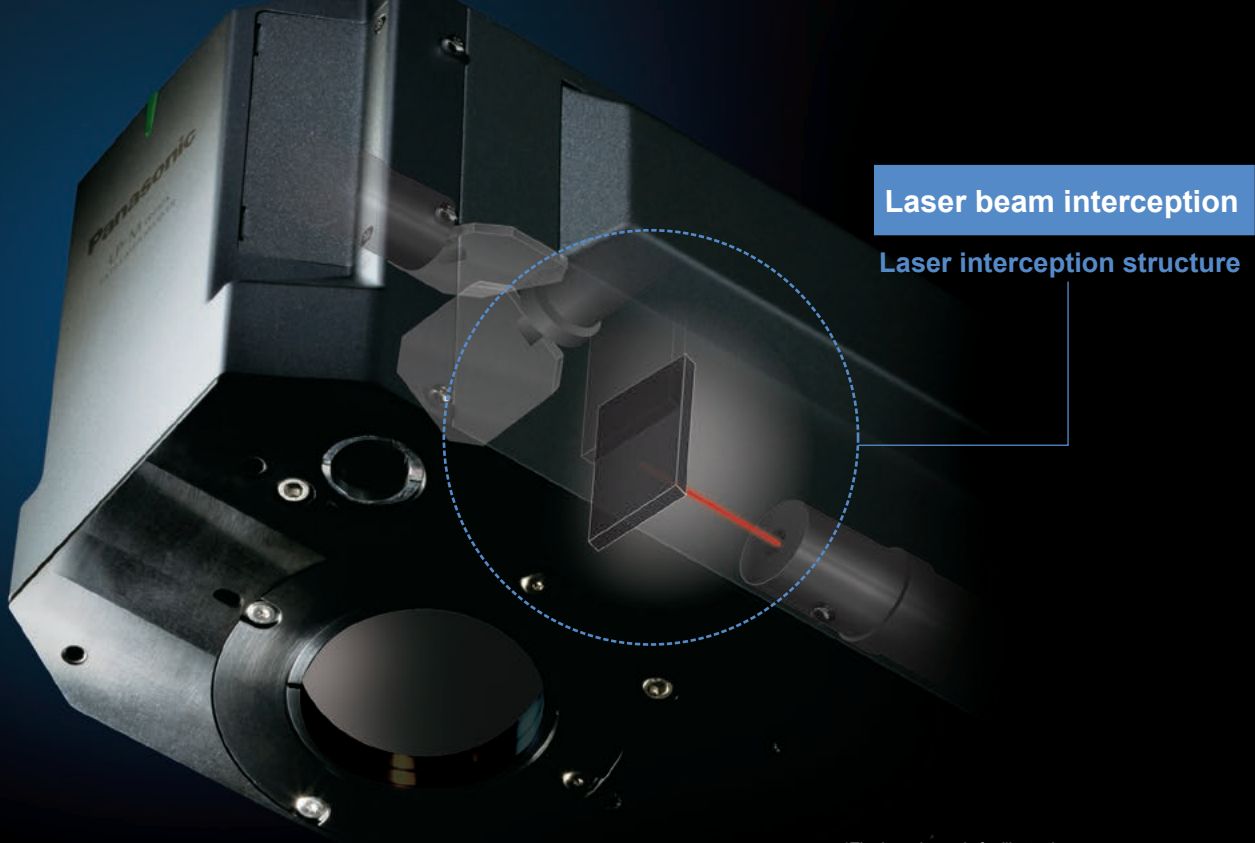

**Laser beam interception**

Laser interception structure

\*The laser beam is for illustration purposes. An intercepted laser beam is not reflected.

# SAFETY

Concern for machine safety has increased as globalization progresses.

A way to safely intercept or stop the laser beam, which is a hazard source in a laser device, is essential. (Compliant with international standard ISO 11553-1)

Two newly mounted safety mechanisms improve both Productivity and Safety.

**Stopping the laser power source**

Duplicate interlock circuits

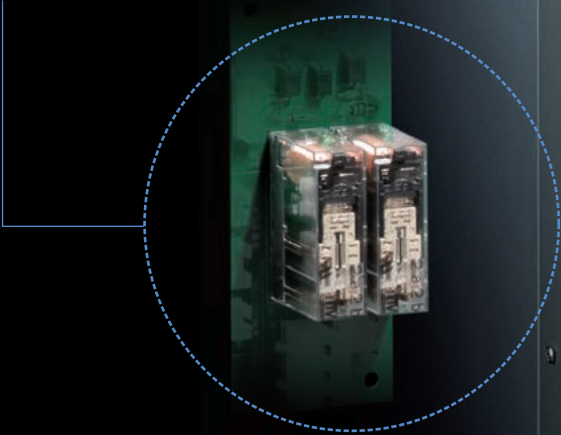



# Two new functions simplify safe circuit design

## Laser interceptor [-S type only]

Durability has vastly improved since the first laser interceptor developed. Two outputs can be monitored to check laser interception. Safety is ensured even when the laser power source is on, preventing productivity losses.

### Laser interception image

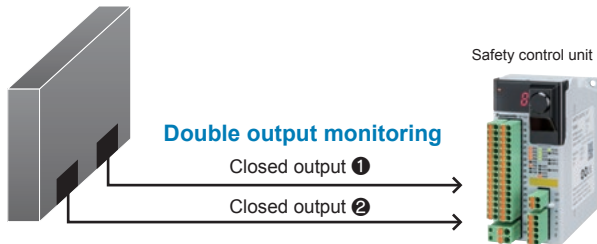

## Duplicate interlock circuits

Mounted with 2 interlock circuits instead of one. A safety relay is also deployed to ensure the laser power source is stopped.

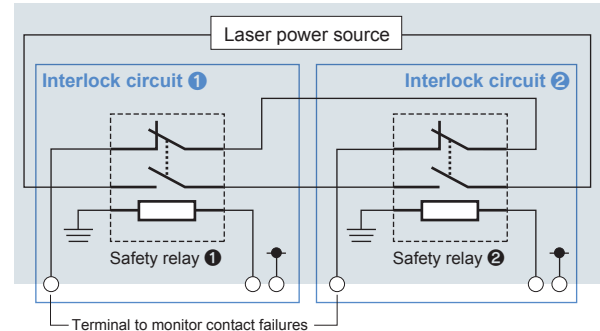

## Safety control system structure

International standard ISO 13849-1 (JIS B 9705-1) regulates safety function of safety-related parts of control systems, and requires safeguards be taken for an entire system embedded with a laser marker.

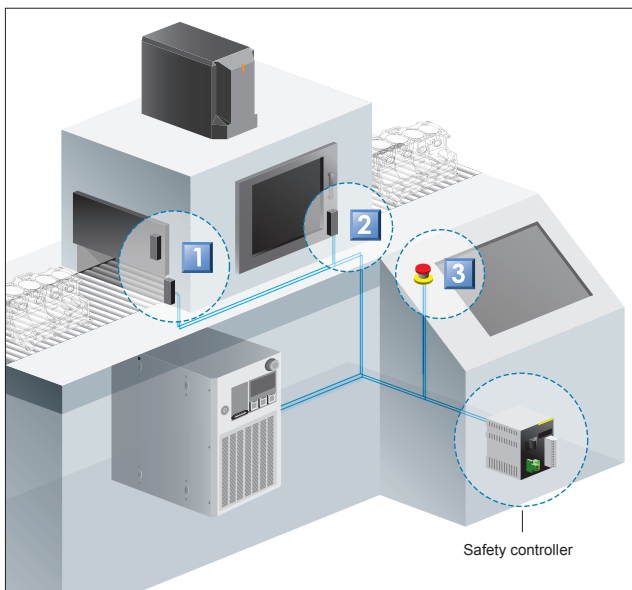

### 1 Safeguards for the shutter where workpiece is loaded / unloaded

#### Safe structure with Laser Intercept Feature

Each time a workpiece is loaded or unloaded, the shutter opens and closes. When the shutter is open, the laser intercept mechanism closes to ensure safety. Impacts on production efficiency during mass production are avoided because the laser power source does not need to be stopped each time it opens or closes.

[Operation safety device] Safety magnetic switch, etc.

### 2 Safeguards for Maintenance Shutter

#### Safe structure with Laser Intercept Feature

The shutter opens and closes during maintenance or fine tuning. When the shutter is open, the laser intercept mechanism closes to ensure safety. Work efficiency during mass production is not lost because the laser power source does not need to be stopped each time it opens or closes.

[Operation safety device] Safety door switch, etc.

### 3 Safeguards for Emergencies

#### Safe structure with Interlock Circuits

In an emergency, forces the laser power source (hazard source) to stop.

[Operation safety device] Emergency stop switch

## PLUS More Useful, reassuring features to prevent accidents

### Reassuring features used in production

#### Marking energy measurement

Measures the power when marking, when outside a set range, uses error output to notify.

#### Broken line notification

Stops laser immediately if a severed fiber line is detected.

#### Erroneous irradiation detection

Stops laser immediately if unforeseen laser irradiation is detected.

#### Emergency stop switch

Also equipped to the laser marker controller. Can be stopped individually.

### Convenient safety inspection functions

#### Laser output measurement

Measures the current laser output.

#### Laser output check

Monitor laser output attenuation from the time of purchase.

#### Laser output correction

Calibrate with a commercially available power meter.

#### Error history view

Displays error time, date and details.

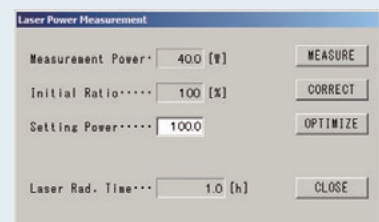



# PLUS More User-friendliness

Multiple functions added to the design make work on the factory floor easier.

## Supports Ethernet

Simple connection to multiple laser markers and peripherals.

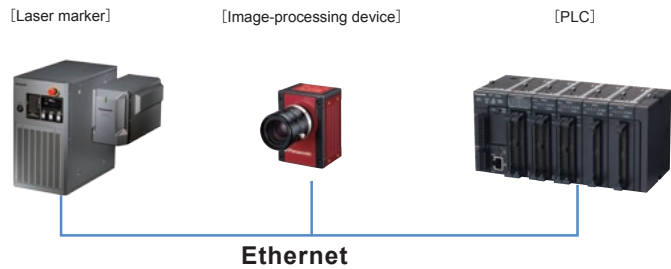

## PC software: laser marker NAVI plus

Includes PC software for simple configuration of marking data. Data can even be created off-site (Multiple languages supported). Package includes software to create logos, software to create fonts, and Adobe® Illustrator® Plug-In. Create any kind of data.

\*Adobe® and Illustrator® are registered trademarks of Adobe Systems Incorporated.

## Monitor display

Connect a monitor and mouse to operate the unit using a large screen.

## USB connector standard feature

Settings can be saved to a commercially available USB flash drive source to backup marking conditions, or copy data to multiple laser markers.

\*Requires an operation check in advance.

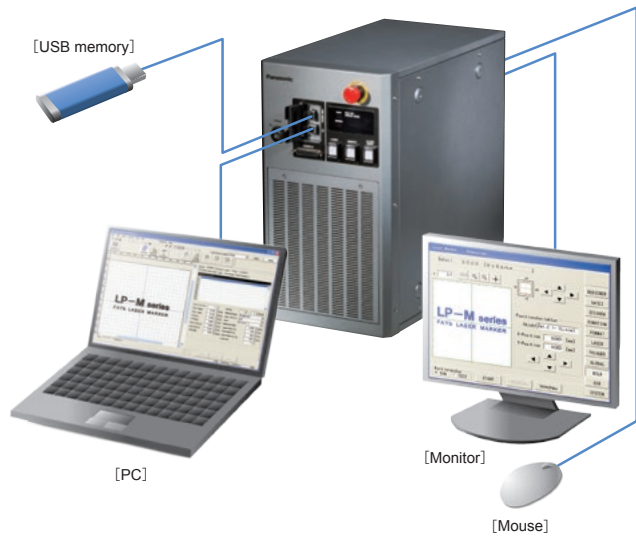

## Multiple language support

Easily switch among Japanese, English, simplified Chinese, Korean and German.

\*The console is optional.



## I/O check monitor

Connector I/O can be checked on a monitor. Signals can be quickly checked at equipment startup.



## Guide image display

The marking area or characters to be marked are traced with a red light. Time required for marking can be measured in advance, aiding pre-marking check tasks.

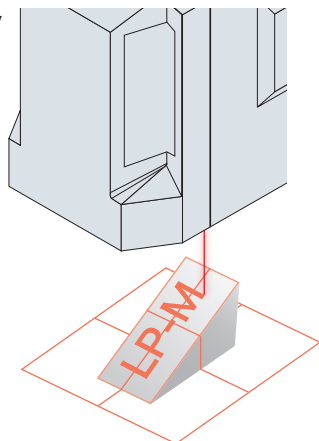

## Protective glass

The laser beam port is constructed of double-layered protective glass. The outer layer of protective glass is removable, and cleaning is easy. If an extra protective glass\* procured in advance and used, the production line does not have to be stopped even during cleaning. The laser beam port is protected from dust or damage, reducing maintenance costs.

\*Extra protective glass is optional.

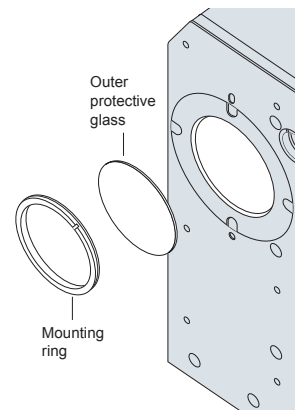



# Specifications

Model No.	LP-M500				LP-M200						
	LP-M500	LP-M500-S	LP-M505	LP-M505-S	LP-M200	LP-M200-S	LP-M205	LP-M205-S			
Work distance	190 ±22 mm 7.480 ±0.866 in		220 ±22 mm 8.661 ±0.866 in		190 ±22 mm 7.48 ±0.866 in		220 ±22 mm 8.661 ±0.866 in				
Marking field	120 × 120 mm 4.724 × 4.724 in		220 × 220 mm 8.661 × 8.661 in		120 × 120 mm 4.724 × 4.724 in		220 × 220 mm 8.661 × 8.661 in				
Marking laser	Class 4 Yb fiber laser, λ= 1,064 nm 0.0419 mil laser										
	Average output*1				40 W ±5 % (pulse oscillation)				16 W ±5 % (pulse oscillation)		
Guide laser / pointer	Red semiconductor laser, λ= 655 nm 0.026 mil, Class 2 laser: Maximum output 1 mW or less										
Scanning method	X-, Y- and Z-axis directions, 3D scanning method										
Scan speed	Maximum 12,000 mm/sec. 472.441 in/sec.										
Character settings (character height, width)	0.1 to 120 mm 0.004 to 4.724 in (configurable in 0.001 mm 0.0004 in steps)		0.1 to 220 mm 0.004 to 8.661 in (configurable in 0.001 mm 0.0004 in steps)		0.1 to 120 mm 0.004 to 4.724 in (configurable in 0.001 mm 0.0004 in steps)		0.1 to 220 mm 0.004 to 8.661 in (configurable in 0.001 mm 0.0004 in steps)				
Setting range (Straight Line, Proportional, Justify)	Character spacing	0 to 120 mm 0 to 4.724 in		0 to 220 mm 0 to 8.661 in		0 to 120 mm 0 to 4.724 in		0 to 220 mm 0 to 8.661 in			
	Line pitch	0 to 999.999 mm 0 to 39.370 in (configurable in 0.001 mm 0.0004 in steps)									
Setting range (Arc)	Radius	0 to 999.999 mm 0 to 39.370 in (configurable in 0.001 mm 0.0004 in steps)									
	Angle	-180° to +180° (configurable in 0.01° steps)									
Setting range (Arc)	Line pitch radius	0 to 120 mm 0 to 4.724 in (configurable in 0.001 mm 0.0004 in steps)		0 to 220 mm 0 to 8.661 in (configurable in 0.001 mm 0.0004 in steps)		0 to 120 mm 0 to 4.724 in (configurable in 0.001 mm 0.0004 in steps)		0 to 220 mm 0 to 8.661 in (configurable in 0.001 mm 0.0004 in steps)			
	Logo data	VEC*2, DXF, BMP, HPGL, JPEG, AI, EPS									
Marking shape	Straight Line, Arc, Proportional, Justify										
Character types	English uppercase letters, English lowercase letters, numerals, katakana, hiragana, kanji (JIS No. 1 and No. 2 standards), symbols, user-registered characters (up to 50)										
Barcodes	CODE39, CODE128, ITF, NW-7, EAN / UPC, GS1 DataBar (GS1 DataBar Limited, GS1 DataBar Stacked, etc.), GS1 composite code (GS1 DataBar Limited CC-A, GS1 DataBar Stacked CC-A, GS1-128 CC-A, etc.)										
2D codes	QR Code, Micro QR Code, Data Matrix, GS1 Data Matrix										
I/O port	I/O terminal, I/O connector, interlock connector, displacement sensor input connector, laser gate terminal (-S type only)										
Serial communication interface	EIA-RS-232C, Ethernet										
Displacement sensor input	Analog current input (4 to 20 mA)										
Cooling method	Head: Naturally air cooling, Controller: Forced air cooling										
Power supply	90-132 V AC, or 180-264 V AC (including voltage fluctuation range of ±10 %), 50/60 Hz (Auto-switching)										
Power consumption	580 VA or less (100 V AC), 720 VA or less (200 V AC)				390 VA or less (100 V AC), 510 VA or less (200 V AC)						
Laser gate	Not equipped	Equipped in Head	Not equipped	Equipped in Head	Not equipped	Equipped in Head	Not equipped	Equipped in Head			
Ambient temperature	0 to +40 °C +32 to +104 °F (Controller, Head) (No dew condensation or icing allowed)										
Ambient temperature for storage	-10 to +60 °C +14 to +140 °F (Controller, Head) (No dew condensation or icing allowed)										
Ambient humidity	35 to 85 % RH (Controller, Head) (No dew condensation or icing allowed)										
Protection degree	IP64*3										
Applicable standards	FDA Regulations, CE Marking (Low Voltage Directive, EMC Directive, RoHS Directive), GB standard, KC mark										
Net weight	Head: 12 kg approx., Controller: 28 kg approx.										
Supported OS*4	Laser Marker Utility*5	Microsoft Windows® 10 Pro (32-bit / 64-bit) / 8.1 Pro (32-bit / 64-bit)									
	NAVILINK-3D*5 (sold separately)	Microsoft Windows® 10 Pro (32-bit / 64-bit) / 8.1 Pro (32-bit / 64-bit)									

\*1 Output at product processing edge (at configured power of 100, standard factory settings).

\*2 File format (logo file) that can be used by the laser marker.

\*3 The head is IP64 only in regions where an electrical or optical part is deployed.

\*4 OS versions of which Microsoft has ended support are excluded.

\*5 To use Export Vec, Adobe® Illustrator® must be installed. Please contact us about the version corresponding to Adobe® Illustrator®. Microsoft and Windows are either registered trademarks or trademarks of Microsoft Corporation in the United States and/or other countries.

China models are available, too. Please contact our sales office.

## Dimensions [Unit: mm in]

\*The CAD data with the dimensions listed can be downloaded from our website.

### Head

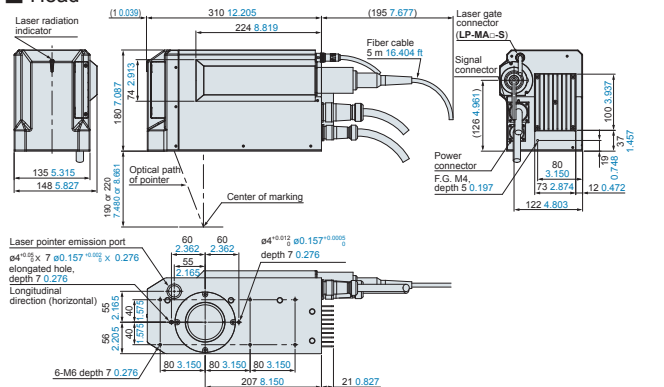

### Controller

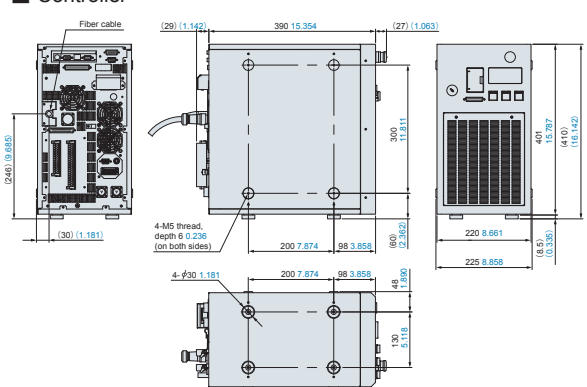

### Console LP-ADP50 [sold separately]

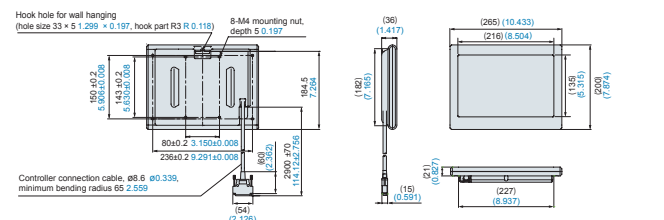

## Precautions for Proper Use

### Laser safety

- This product is classified as a Class 4 Laser Product in IEC/JIS/FDA regulations 21 CFR 1040.10 and 1040.11. Never look at or touch the direct laser beam and its reflection.
- The following labels are attached to the **LP-M500** series. Handle the product according to the instruction given on the warning labels.  
(Warning labels are not shown in the product photographs in this catalog.)
- The laser used by this product generates infrared light that is invisible to the human eye. Use particular caution when the laser is operating.

### Maintenance

- Air filter:** Regularly clean the air filter attached to the FAYb Laser Marker to maintain cooling effects.
- Laser pointer emission port:** Dust or chips adhering to the laser pointer emission port may affect the printing quality or seriously damage the laser marker. Clean the laser pointer emission port regularly.

### Recommended use of a dust collector

- Depending on the object being marked, harmful gasses or smoke that have a detrimental effect on the human body or the laser marker may be generating during marking. If your application falls under this description, use a dust collector.

\*For more information, contact your sales representative.

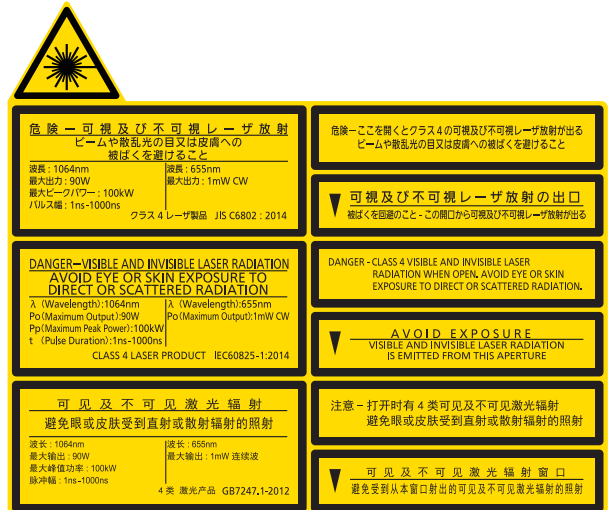

## Laser Marker Lineup

A full series for every application.

Short Pulse Fiber Laser

FAYb LASER MARKER

### LP-RV SERIES

Through adopting our new technology, the **LP-RV** series with fiber system has achieved to generate a short pulse with the pulse duration of 1 ns. The expressive power has been overwhelmingly improved.



Simple & High Quality

FAYb LASER MARKER

### LP-RF SERIES

Panasonic Industry's laser marker sets a new choice for "simple" laser markers and responds to customers' needs.

- Compact head featuring IP64 rating
- Controller offering high resistance to noise
- Removable head
- Smart condition setting function
- Direct linkage with image processing device



## Disclaimer

The applications described in the catalog are all intended for examples only. The purchase of our products described in the catalog shall not be regarded as granting of a license to use our products in the described applications. We do NOT warrant that we have obtained some intellectual properties, such as patent rights, with respect to such applications, or that the described applications may not infringe any intellectual property rights, such as patent rights, of a third party.

**Panasonic**  
INDUSTRY

**Panasonic Industry Co., Ltd.**

Industrial Device Business Division

7-1-1, Morofuku, Daito-shi, Osaka 574-0044, Japan

[industrial.panasonic.com/ac/e/](http://industrial.panasonic.com/ac/e/)