

DOC. N. 1SQC900018M0201

ReliaGear™ neXT Circuit Breakers

Circuit Breaker Testing

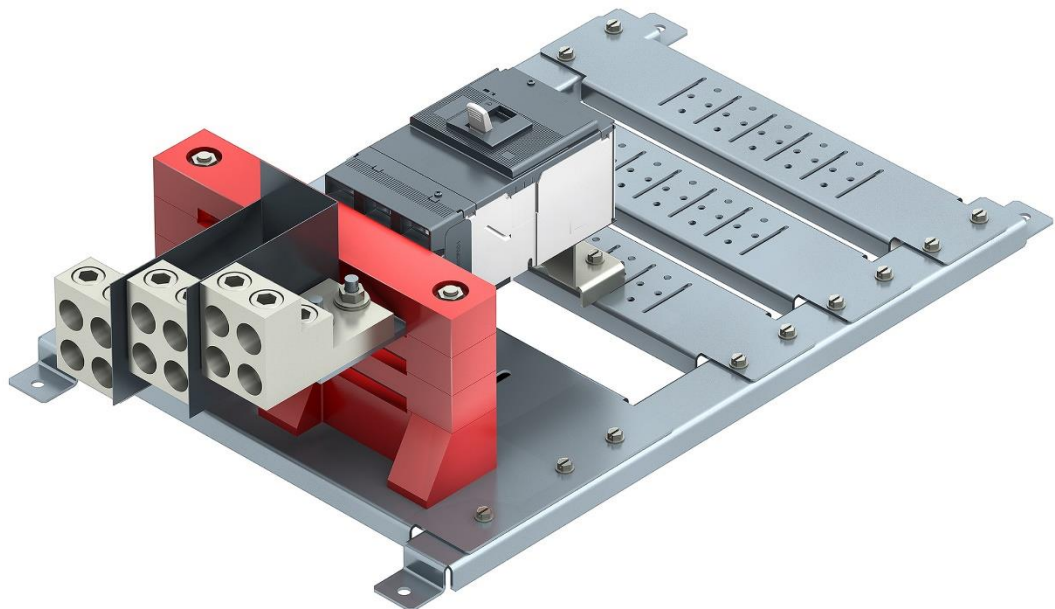

Productivity, reliability and efficiency are key to minimizing downtime and keeping your business running.

Welcome to ABB and to the many benefits of circuit breaker innovation.

ABB is investing in the future of NEMA rated power distribution. Our new line of ReliaGear smart power distribution products utilize world class SACE® Tmax® XT circuit breaker technology, enhancing every level of protection for your project.

As a pioneering technology leader in circuit breaker protection, ABB has nearly 100 years of research and experience in virtually every sector, including: critical power applications, buildings, industrials, utilities, infrastructure and transportation. The SACE® Tmax® XT all-in-one advanced breaker technology sets a new standard for edge technologies and simplifies electrical protection, measurement and control.

Enhanced safety, quality and reliability under pressure are fundamental to all ABB products and the SACE Tmax XT portfolio is no exception.

- High performance in a small package (up to 200kAIC) across a 100-1200A portfolio
- Eight communication protocols including IEC 61850
- Configurable trip units featuring digital metering and display are easily integrated into any monitoring, control and protection scheme
- Power measurement, monitoring and data logging
- Field configurable options and spare parts to simplify maintenance and operations
- 100,000 testing hours per year
- 30+ certifications

And now, MCCB and ACB installation and commissioning are easier than ever thanks to the revolutionary EPiC mobile app from ABB. Users are able to configure settings remotely and drop them in from a mobile device*, saving time and money and helping less-experienced employees configure breakers with confidence and transparency.

- Configure settings from outside the arc flash boundary
- Export breaker settings so you can easily reuse them across multiple installations
- Find relevant documentation quickly using QR codes on the breakers
- Get installation guidance with Augmented Reality
- Pull trip unit reports for troubleshooting and recordkeeping

The SACE Tmax XT circuit breaker portfolio delivers extreme performance, ease of use, integration and connectivity built to deliver safety, reliability and quality to any application. If you need testing assistance, contact at ABB Technical Support by email or call 1-888-385-1221, Option 1.

**Breakers must be paired to mobile device via Bluetooth®*

This instruction guide and test fixture have been created for you, the tester, to help you properly test your ABB SACE® Tmax® XT circuit breakers to confirm they are operational and within applicable standards and tolerances and are installed in accordance with design specifications. Safe and proper testing of your circuit breakers will help ensure proper operation for years to come and reduce unintentional damage that may occur when improperly connecting to the breakers. Our goal is that every breaker pass acceptance testing and provide years of safe and reliable service for our customers. Reliability and quality should never be taken lightly and is essential to ensure proper operation of your electrical equipment.

Connections between electrical devices within equipment play a critical role in the efficiency and longevity of an installation. A poor connection results in a higher resistance, which prevents the efficient flow of current and creates heat. Heat means wasted energy and higher risk of failure. A strong connection reduces resistance and heating and, most importantly, increases longevity and enhances safety.

The ReliaGear plug-in design represents a significant improvement over the classic bolted-joint method of device installation and connection. Our design uses a fixed (vertical) panel board bus that incorporates slots into its geometry. In addition, the circuit-breaker connectors (line side connectors) feature a clip with matching geometry that engages the slots in the vertical bus assembly. Installing the ReliaGear breaker into the test fixture drastically reduces the chance of damaging the clip and thus provides better test results. Please reference the following whitepaper for more information, [1SQC900001G0201](#).

Assurance through testing

Established testing procedures help provide assurance that supplied equipment will perform safely and reliably for many years to come. Tmax XT molded case circuit breakers are UL listed and comply with the temperature rise requirements per the UL 489 Standard.

Test setup

Install fixture on flat surface. Tighten 3/8" bolt and nut to 15 ft-lb to secure fixture to table. Alternatively, clamp all four tabs of fixture to table to secure.

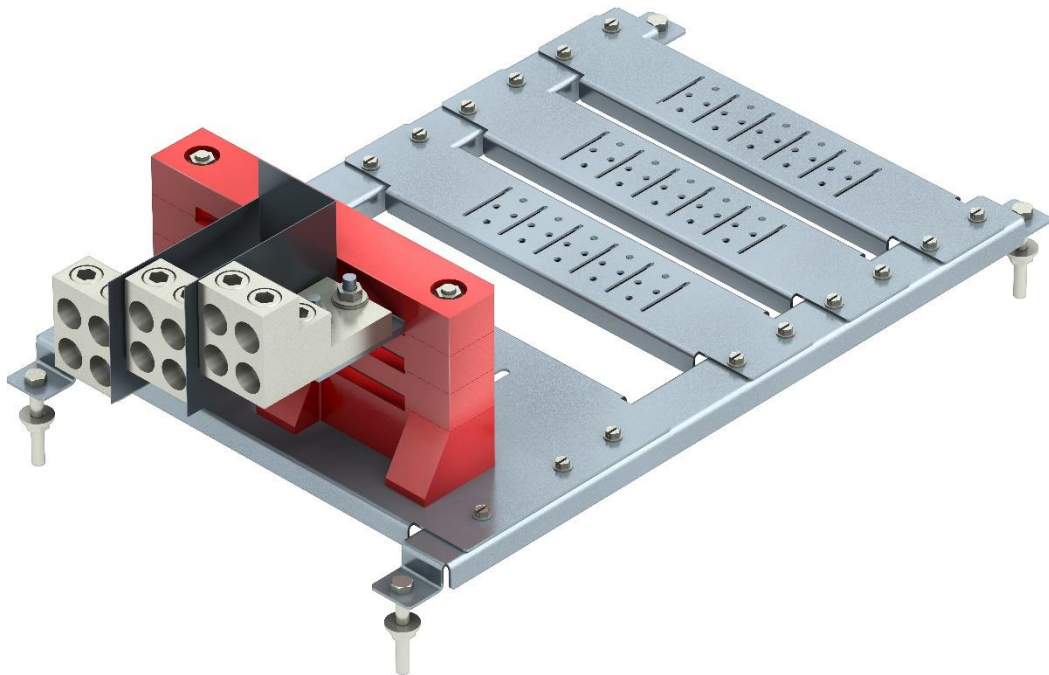

Install breaker into test fixture

1. Install appropriate supplied lug(s) for breaker being tested onto bus bar of text fixture

Lug Cable Range	Max. Cables per Lug	Breaker Amperage	Breaker Frame
14 AWG – 2/0 AWG	1	15A – 125A	XT1/XT2
2 AWG – 600MCM	4	25A – 1200A	XT4/XT5/XT6/XT7

Cable(s) shall be sized according to Table 310.15(B)(16) of NFPA 70

2. Place breaker into fixture and slide into bus. If needed, use screwdriver to leverage breaker into bus until mounting hole in breaker bracket aligns with mounting hole in fixture.

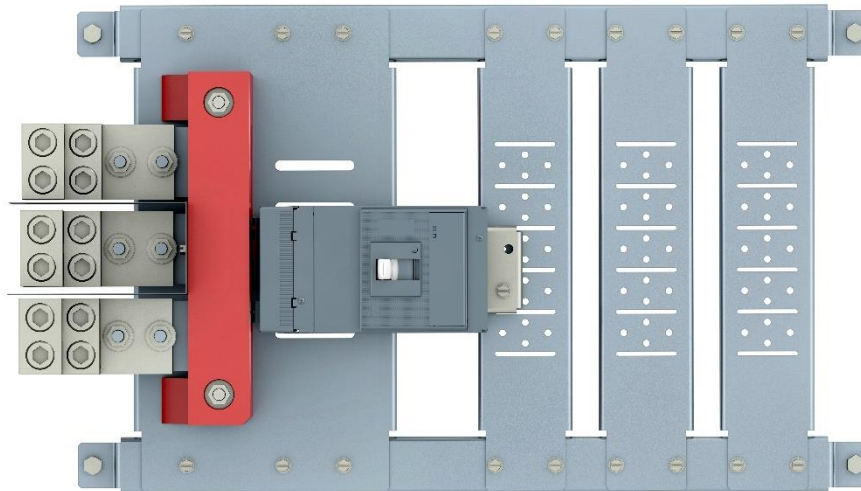
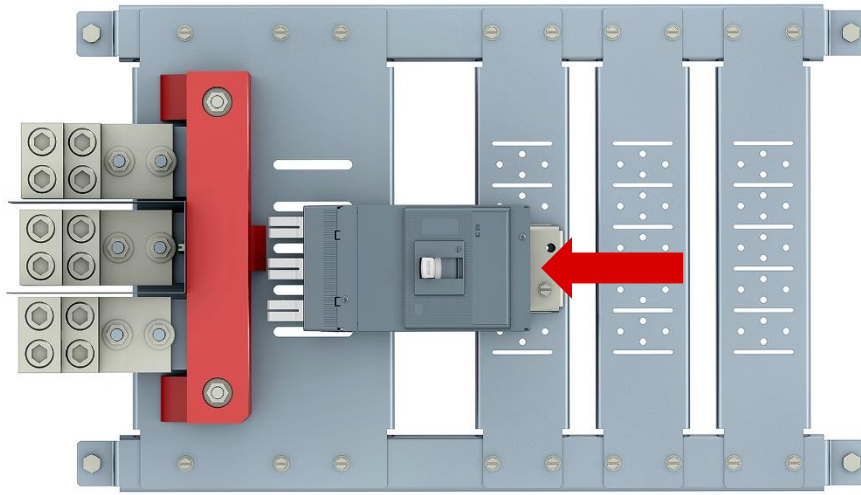

ReliaGear neXT Circuit Breaker Installation



Overview**ALL TEST SHALL BE PERFORMED AFTER ALL RELEVANT SAFETY PROCEDURES FOR INSPECTION OF LOW VOLTAGE ELECTRICAL EQUIPMENT ARE EXECUTED**

ALL tests shall be executed sequentially, on a new sample, respecting the order provided

The summary of the sequence of tests to be performed are:

- Visual inspection
- Mechanical operations
- Pole resistance measurements
- Primary current injection test for long-time protection
- Primary current injection test for short-time protection (if required)
- Primary current injection test for instantaneous protection (if required)
- Primary current injection test for ground-fault protection (if required)
- Insulation-resistance tests

Visual

1. Visually inspect the breaker and check for evident signs of damage
2. Record the type of the breaker, the trip unit and serial number on the testing document

Mechanical

1. The test shall be performed without injecting current
2. Perform 8 open-close operations
3. Perform 2 trip-test operations
 - a. Press the “TEST” button located to the right of the OFF position

Pole resistance

Resistance of a circuit breaker pole can vary significantly due to the extremely low values being measured and to the number of transient factors that may affect the measured value. For this reason, pole resistance tests shall not be used as the sole criteria for determination of the acceptability (NEMA AB-4).

Test procedure

1. The test shall be performed on a new sample
2. The circuit breaker needs to be properly electrically isolated and in the closed position
3. Manually operate circuit breaker 5 times
4. Apply the test current across the circuit breaker terminal (remove any terminal lug(s) installed)
 - a. The test current shall be equal to, but not to exceed the amperage rating of the circuit breaker
 - b. Test current values must not be applied for longer than 1 minute
 - c. Alternatively, 10A for circuit breakers rated less than 100A, 100A for circuit breakers between 100A-500A, 500A for circuit breakers rated more than 500A
 - d. DC current should be used
5. Record measured value
 - a. Measurements shall be taken one phase at a time using a digital low resistance ohmmeter (DLRO) at the locations shown in the following image.
 - b. The calculated average values shall be lower than the values indicated in the Pole Resistance document provided with NETA Testing Kit as provided by ABB
6. Reinstall terminal lugs

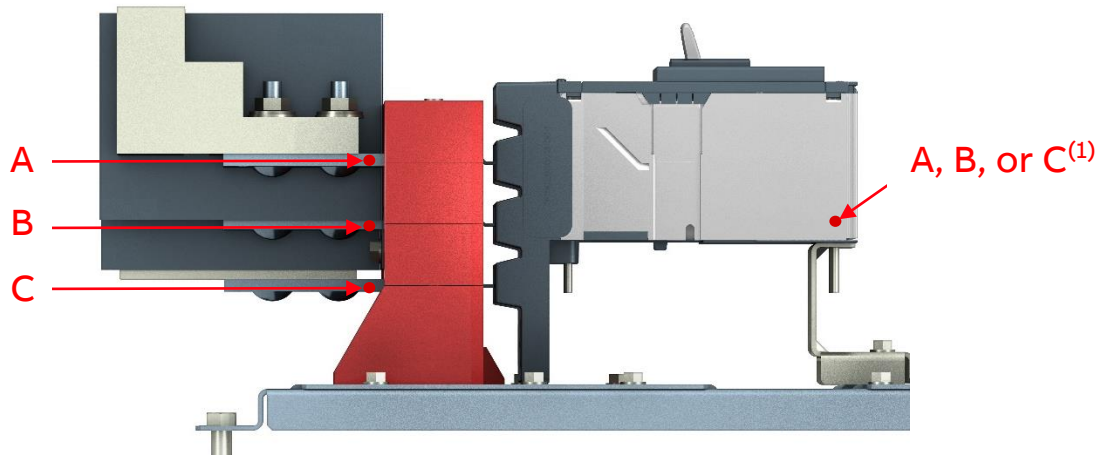
**NOTE:**

⁽¹⁾ Probe should be placed on breaker load terminal and measurements taken one phase at a time. Load side of breaker will be labeled to identify A, B, and C phases.

⁽²⁾ For pole resistance values please refer to the NETA Testing Kit as provided by ABB.

⁽³⁾ For measurement discrepancies please contact ABB.

Primary current tests

Primary current injection tests shall be performed with an electronically controlled low-voltage current generator that supplies AC symmetrical current and shall not create a current for more than 20 cycles. Settings of the primary current injector must assure that the current generated is not higher (peak or RMS) than the desired current needed for the test.

Long-time test

- Protection settings should be set as defined in the coordination study
- Cable(s) shall be sized according to Table 310.15(B)(16) of NFPA 70
- Poles shall be connected in series
- The current generator shall be set to produce 3 times the long-time protection setting
- The circuit breaker shall trip within the published trip curve along with the associated tolerances. Please refer to 1SDC210199D0206 for trip curves and other technical information.
- Let breaker cool before performing any additional tests

Test procedure

1. Set long-time protection
2. Connect cables
 - a. 4 feet, from test station to pole L1/line
 - b. 8 feet, from pole L1/load to pole L2/load
 - c. 8 feet, from pole L2/line to pole L3/line
 - d. 4 feet, from pole L3/load to the test station
 - e. Inject current
3. Record protection setting, injected current value and trip time

Short-time test (If required)

- Protection settings should be set as defined in the coordination study
- Cable(s) shall be sized according to Table 310.15(B)(16) of NFPA 70
- Each pole shall be tested individually
- The current generator shall be set to produce 130% the short-time protection setting
- The circuit breaker shall trip within the published trip curve along with the associated tolerances. Please refer to 1SDC210199D0206 for trip curves and other technical information.
- Let breaker cool before performing any additional tests

Test procedure

1. Set short-time protection
2. Connect cables
 - a. 4 feet, from the test station to pole on the line side
 - b. 4 feet, from pole on the load side to the test station
3. Record protection setting, injected current value and trip time

Instantaneous test (If required)

- Protection settings should be set as defined in the coordination study
- Cable(s) shall be 4 feet in length and sized according to Table 310.15(B)(16) of NFPA 70
- The current generator shall be set to produce 130% the instantaneous protection setting
- The circuit breaker shall trip within the published trip curve along with the associated tolerances. Please refer to 1SDC210199D0206 for trip curves and other technical information.
- Let breaker cool before performing any additional tests

Test procedure

1. Set short-time protection
2. Connect cables
 - a. 4 feet, from the test station to pole on the line side
 - b. 4 feet, from pole on the load side to the test station
3. Record protection setting, injected current value and trip time

Ground-fault test (If required)

- Protection settings should be set as defined in the coordination study
- Cable(s) shall be 4 feet in length and sized according to Table 310.15(B)(16) of NFPA 70
- The current generator shall be set to produce 130% the ground-fault protection setting
- The circuit breaker shall trip within the published trip curve along with the associated tolerances. Please refer to 1SDC210199D0206 for trip curves and other technical information.
- Let breaker cool before performing any additional tests

Test procedure

1. Set short-time protection
2. Connect cables
 - a. 4 feet, from the test station to pole on the line side
 - b. 4 feet, from pole on the load side to the test station
3. Record protection setting, injected current value and trip time

Dielectric test/Insulation resistance

Dielectric test equipment capable of producing 1000VDC for 5 seconds shall be used and the breaker shall be placed installed in the test kit. Alternatively, an insulation resistance test can be performed. Test data should result in a resistance value of 100 Megaohms.

Test procedure

1. Connect to the breaker as follows:
2. Between line and load terminals of each individual pole with the circuit breaker in the closed position and tripped position
 - a. Record insulation resistance value
3. Between terminals of adjacent poles with the circuit breaker in the open position
 - a. Record insulation resistance value
4. From line side terminals to the metal baseplate with the circuit breaker in the open position
 - a. Record insulation resistance value