

LLT100 laser level transmitter hygienic model



The LLT100 hygienic model provides all the advantages of laser level measurement to the food and beverage and pharmaceutical industries.

Measurement made easy

01 LLT100 laser level polycarbonate plastic window

Overview

The LLT100 laser level transmitter is offered to customers requiring a hygienic model with a tri-clover flange interface (product flange code H).

With a diameter of 10.16 cm (4 in.), this interface provides an easy and fast way to connect or disconnect the product from the process. The materials exposed to the process are stainless steel and polycarbonate. Both materials and their surface finish are FDA approved.

The window enabling the emission of the laser beam is made of polycarbonate plastic. This is a safe, recognized material for hygienic applications. The instrument housing is offered both in painted aluminum or stainless steel.

Non-contact measurement provides significant benefits for hygienic applications, as the problem of contamination is much reduced.

Using lasers for performing level measurement on any liquid or solid also provides improved reliability and less maintenance since no echo mapping is required, which is especially useful in applications requiring mixing blades or with heavy vessel build-up or sticky materials.

The narrow laser pulses used are not interacting with the surrounding environment, and therefore immune to changes. Laser pulses also allow the measurement of very low dielectric constant materials, and also measure turbulent liquids. This makes measuring level easy and reliable.



Maintenance

The LLT100 hygienic model is the only model having the possibility of removing components for cleaning.

To clean the window of the hygienic model:

- 1 Remove the four set screws and clean them.
- 2 Dismantle the flange using two hook spanner wrenches with a diameter of 100 mm. The user provides these wrenches.
- 3 Remove the window O-ring.
- 4 Clean the window, the O-rings, the flange adapter and the flange. Replace the O-rings, if damaged (product code G901).
 - * Do not dismantle the window. Opening the instrument voids the warranty.
- 5 Lay down the flange on the table and install the O-ring.
- 6 Screw the instrument on the flange by hand.
- 7 Make sure that the window O-ring remains well in place.
- 8 Tighten firmly with the hook wrenches.
- 9 Put back the four set screws.

Cleaning in place

Steam cleaning in place can be done while the instrument is still connected to the process. Measurement won't be possible during cleaning. Observe the following limitations during CIP.

CIP cleaning	T _{max}	T _{max} minutes	T _{amp}
Steam	100 °C (212 °F)	30	25 °C (77 °F)

01

Summary

The LLT100 hygienic model allows users in the food and beverage and pharmaceutical industry to use laser level measurement while meeting their sanitary requirements.

Laser level measurement provides an easy and reliable way of performing non-contact level measurement, especially in industrial applications.

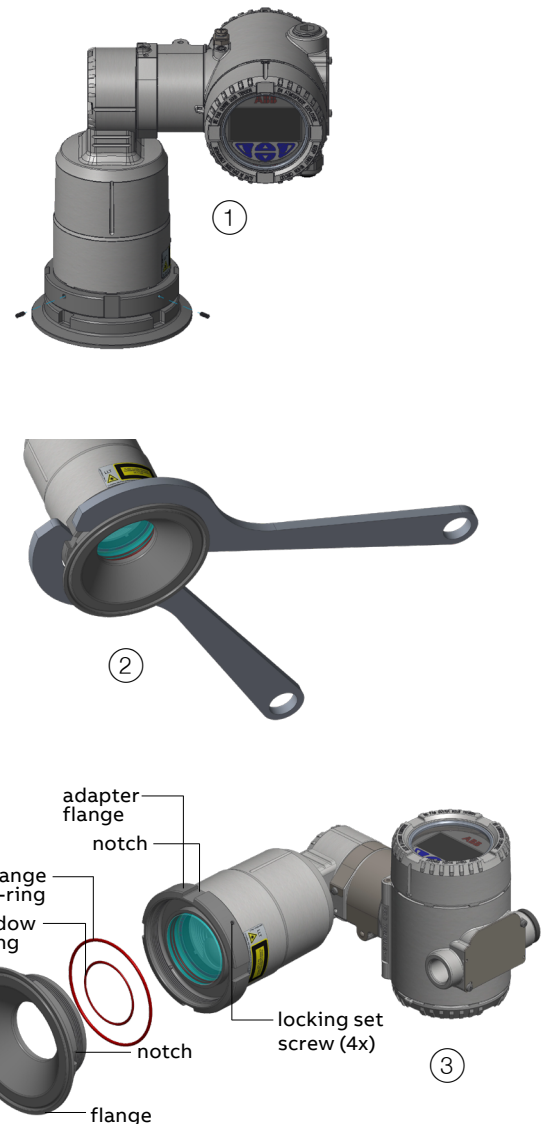

- ① Removing the set screws
- ② Dismantling the flange
- ③ Exploded view of inner components