

# Application and Module Description

# PROCONTROL P Input, Output, Signal Conditioning

## Input Module for Binary Signals

16-fold, for Contacts  
or Electronic Signals

## 81EB02 – E/R1020/R1122

---

Publication No.  
D KWL 6302 90 E, edition 01/90  
Replacing D AT 1639 85 E, edition 06/88

### Application

The input module is used to connect contacts and electronic module outputs. Any of the following three categories may be connected to the module:

- 16 changeover contacts or single contacts with line monitoring
- 16 single contacts without monitoring
- 16 binary outputs from electronic modules

Two module versions are available. They differ with respect to the module input section and the monitoring programs of the processing section:

|              |   |
|--------------|---|
| 81EB02/R1020 | for changeover and single contacts  |
| 81EB02/R1122 | for binary outputs from electronic modules or single contacts without monitoring. |

### Features

The module can be plugged into any multi-purpose processing station of the PROCONTROL bus system. It incorporates a standard interface to the PROCONTROL station-bus.

The module transfers the binary input signals to the PROCONTROL bus system via the PROCONTROL station-bus in the form of telegrams. The telegrams are monitored and provided with parity bits before transfer. This ensures monitoring for error-free transfer on the part of the receiving module.

The connected contacts are supplied by the input section of the module with

|                          |       |
|--------------------------|-------|
| US Operating voltage     | +24 V |
| UV Negative bias voltage | –28 V |

in such a way that any interaction is precluded (not in version R1122). UV is used to increase the communication voltage to the contacts. This improves the switching reliability of the contacts. The UV voltage is derived from US by a DC/DC converter integrated in the module (except version R1122).

The module terminals to which US and UV are connected are short-circuit-proof; therefore, these voltages are not fuse-protected within the module.

The input signals are supplied potential-isolated to the processing section to preclude any interaction between the process side and the bus side.

Disturbances in the transmitter lines and the processing section are indicated as disturbances (ST) at the front of the module.

## Signal conditioning and monitoring

The first function unit is described below. The other functions operate similarly.

### Signal input via contacts (Version R1020)

A contact is connected to the input module in 2-wire arrangement. This allows both a single contact and a changeover contact to be used on site. The contact is supplied with the positive voltage US via output S1. An external power supply to the contact is not permissible (see "Connection diagrams"). This output incorporates a circuit providing protection against excess currents in the event of a short circuit. The contact position is scanned via input R1.

The input signal is conditioned and fed to the processing section via a potential-isolation facility. It is transferred in the data telegram, together with the other input signals, to the PROCONTROL bus system.

Input R1 is connected to the negative bias voltage UV via a resistor. This provides a switching voltage of approx. 40 V across the open contact to increase the switching reliability of the contact, and a nominal current of 5 mA flows via the closed contact.

If the negative bias voltage UV fails, the disturbance bits are set in the data telegrams, and the module disturbance annunciation is generated (see "Annunciation functions"). This does not apply, however, to version R1122.

The locally used resistor 81ES05/R0100...R0300 (parallel to the contact) is for line monitoring.

### Signal input for binary signals and single contacts (Version R1122)

A binary signal from an electronic module is connected through a signal line to input E101. The signal is processed in the same way as a signal arriving from contacts.

With this module version, a single contact can also be connected by using the output S1. However, an external power supply for the contact is here permitted (see "Connection diagrams"). As the negative bias voltage UV is missing, only a contact voltage of 24 V is available. Also, the module version does not incorporate a line monitoring feature. The resistor must therefore be omitted for signal input via contact.

## Effect of interference voltages

Interference voltages on the input lines are suppressed by means of protective circuits integrated in the module.

## Signal monitoring

The signals are monitored in the processing section by the micro-processor. When the monitor responds, the red light-emitting diode ST emits a steady light.

### Transmitter monitoring

In the case of contacts (version R1020), the monitor responds in the event of:

- Open circuit in transmitter supply line (SX)
- Open circuit in transmitter line (RX)
- Earth connection in transmitter supply line
- Earth connection in transmitter line
- Breaking of the resistor with open contact
- Breaking of changeover contact

Immediate response of the hardware monitor causes

- the associated individual disturbance annunciation Mxx is set after 0.5 s
- the respective general disturbance annunciation SMx is set after 0.5 s
- the associated data Rxx are set to "Zero" within 10 ms

(see also "Technical data, Transfer values")

### Voltage monitoring

Version R1020 incorporates a monitoring feature for the voltages US and UV. Failure of one or both voltages causes

- All individual disturbance annunciations Mxx to be set
- All general disturbance annunciations SMx to be set
- All data Rxx to be set to "Zero"

### Unused function units

To avoid the initiation of disturbance annunciations from unused function units, the inputs of these function units are provided with a protective circuit at the module connector (see connection diagrams). In this way, a connected transmitter is simulated for the processing section. This applies, however, only to versions R1020 (contact input).

### Contact bouncing

Provision has been made by internal measures in the input section and the processing section to preclude the transfer of false data during the contact bounce time.

## Formation of events

The input module is normally requested cyclically by the PROCONTROL system to transfer its measured values. If these values change within the cycle time, such a change is treated as an "Event".

The input module recognizes the following occurrences as events:

- Change of the binary signal (switching of a contact or change in an electronic signal)
- Response of the line monitor
- Response of the voltage monitor

If an event occurs, the new values are transferred with priority to the PROCONTROL bus.

## Signal output

The module transfers the data telegrams to the station–bus via its standard interface. Data transfer takes place in serial mode. Therefore, the processing section performs a parallel/serial conversion of the data.

### Designation of the signals

The conditioned and digitized input signals are written to specific registers (see "Data communication ..."). The processing section writes the following data into the address section of the data telegram:

- System address (possible 0 ... 3)
- Station address (possible 1 ... 249)
- Module address (possible 1 ... 58)
- Register address (possible 0 ... 3 for signals  
246 for diagnosis data)
- Bit address (possible 0 ... 15)

## Operating modes

The short–circuit socket SPU is located at the front of the module. It is allocated to the line monitoring function. The monitoring functions can be switched off in common for all function units by means of a short–circuit plug (only for module version R1020).

The following allocation applies here:

- Plug removed: Monitoring function active
- Plug in place: Monitoring function switched off

The short–circuit socket is omitted in module version R1122 for binary signals.

### Diagnosis

The processing section of the module continuously monitors the input signals, processing and generation of the data telegrams (self–diagnosis).

In the event of a disturbance, the type of disturbance is filed in the diagnosis register (see "Data communication...") and a disturbance annunciation is sent to the PROCONTROL bus system. The diagnosis register is then read out from the control system operator station for evaluation.

It is also possible to scan the current status of the module at any time from the control system operator station (remote diagnosis).

## Data communication with the module

### Address formation

The system and station addresses are identical for all modules in a multi–purpose processing station. They are set on the modules jointly and automatically via the station–bus control module.

The module address is set automatically by plugging the module into the slot provided within the multi–purpose processing station.

The input signals and the diagnosis results are written to specific registers in the shared memory. The number of the register is also the register address. A specific register location is permanently allocated to each input value. This takes place automatically by connecting a process signal to the process connector of the module.

### Reading out of data

Address information is necessary in the telegram to read out the register contents. Table 1 below shows this address information and the contents of the relevant register. The addresses identified by 'a' are freely selectable and are based on the place of installation of the module.

## Annunciation functions

### Disturbance annunciations on the module

The red light-emitting diode ST is provided at the front of the module. It emits a steady light if disturbances occur in the module or if the monitor for a function unit responds.

### Annunciation functions to the station bus

Events or disturbances are recognized in the processing section. Events are signalled immediately. Disturbances are stored and the signal "Common disturbance Station" is output simultaneously. The diagnosis register is then read out from the control system operator station for evaluation.

| Type of Information   | Address Word |              |             |                    | Data Word (Bit Address)          |    |    |      |                        |      |     |       |                     |       |       |       |                        |       |       |      | DA |
|-----------------------|--------------|--------------|-------------|--------------------|----------------------------------|----|----|------|------------------------|------|-----|-------|---------------------|-------|-------|-------|------------------------|-------|-------|------|----|
|                       | Sy-<br>stem  | Sta-<br>tion | Mo-<br>dule | Re-<br>gi-<br>ster | 15                               | 14 | 13 | 12   | 11                     | 10   | 9   | 8     | 7                   | 6     | 5     | 4     | 3                      | 2     | 1     | 0    |    |
| Single Contacts 1-4   | a            | a            | a           | 0                  | 0                                | 0  | 0  | R 04 | NR 04                  | M 04 | R03 | NR 03 | M 03                | R02   | NR 02 | M 02  | R01                    | NR 01 | M 01  | SM 1 | 3  |
| Single Contacts 5-8   | a            | a            | a           | 1                  | 0                                | 0  | 0  | R 08 | NR 08                  | M 08 | R07 | NR 07 | M 07                | R06   | NR 06 | M 06  | R05                    | NR 05 | M 05  | SM 2 | 3  |
| Single Contacts 9-12  | a            | a            | a           | 2                  | 0                                | 0  | 0  | R 12 | NR 12                  | M 12 | R11 | NR 11 | M 11                | R10   | NR 10 | M 10  | R09                    | NR 09 | M 09  | SM 3 | 3  |
| Single Contacts 13-16 | a            | a            | a           | 3                  | 0                                | 0  | 0  | R 16 | NR 16                  | M 16 | R15 | NR 15 | M 15                | R14   | NR 14 | M 14  | R13                    | NR 13 | M 13  | SM 4 | 3  |
| Binary Signals 1-8    | a            | a            | a           | 0                  | 0                                | 0  | 0  | 0    | 0                      | 0    | 0   | E 108 | E 107               | E 106 | E 105 | E 104 | E 103                  | E 102 | E 101 | SM 1 | 1  |
| Binary Signals 9-16   | a            | a            | a           | 1                  | 0                                | 0  | 0  | 0    | 0                      | 0    | 0   | E 208 | E 207               | E 206 | E 205 | E 204 | E 203                  | E 202 | E 201 | SM 1 | 1  |
| Diagnosis Register    | a            | a            | a           | 246                | Processing and Process Disturbed |    |    |      | Bus Adaption Disturbed |      |     |       | Reception Disturbed |       |       |       | Transmitting Disturbed |       |       |      |    |

Table 1

Explanation:

SMx = General disturbance Single telegram

Rxx = Contact input

NRxx = Inverted value of Rxx

Mxx = Individual disturbance annunciation

DA = Type of data

a = Address freely selectable  
(depending on place of installation)

Note:

$\overline{NRxx}$  is the inverted value of Rxx formed within the module.

The following applies if the transmitter monitor responds:

Mxx = "1": Rxx = NRxx = "0"

Functional diagram version R1020

Terminal designations: The module consists of a printed circuit board (see "Mechanical design") and is equipped with connectors X1 and X2.

Connector X1 contains all process inputs. Connector X2 incorporates the standard interface to the station – bus and the operating voltages for the module.

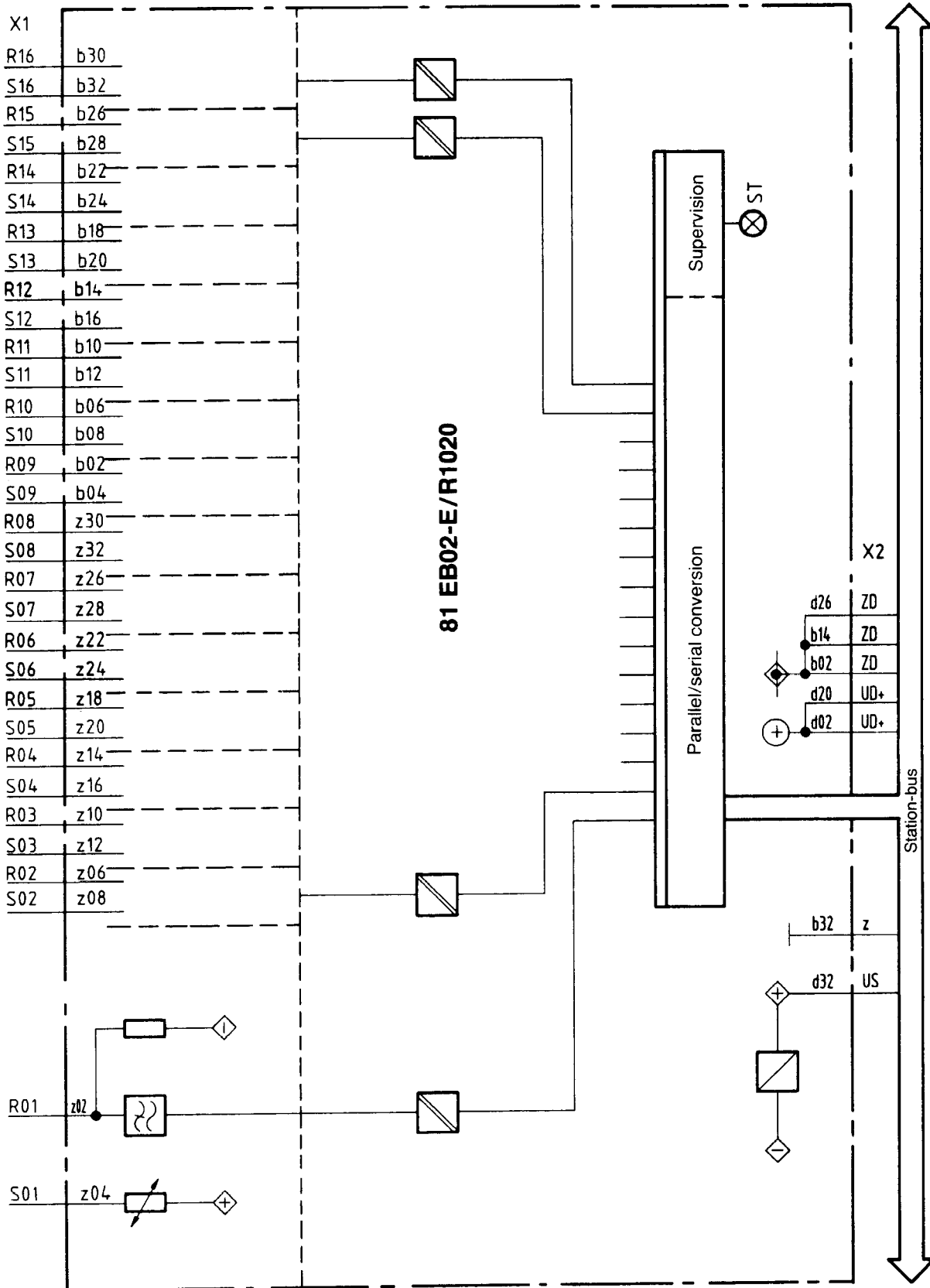

Functional diagram version R1122

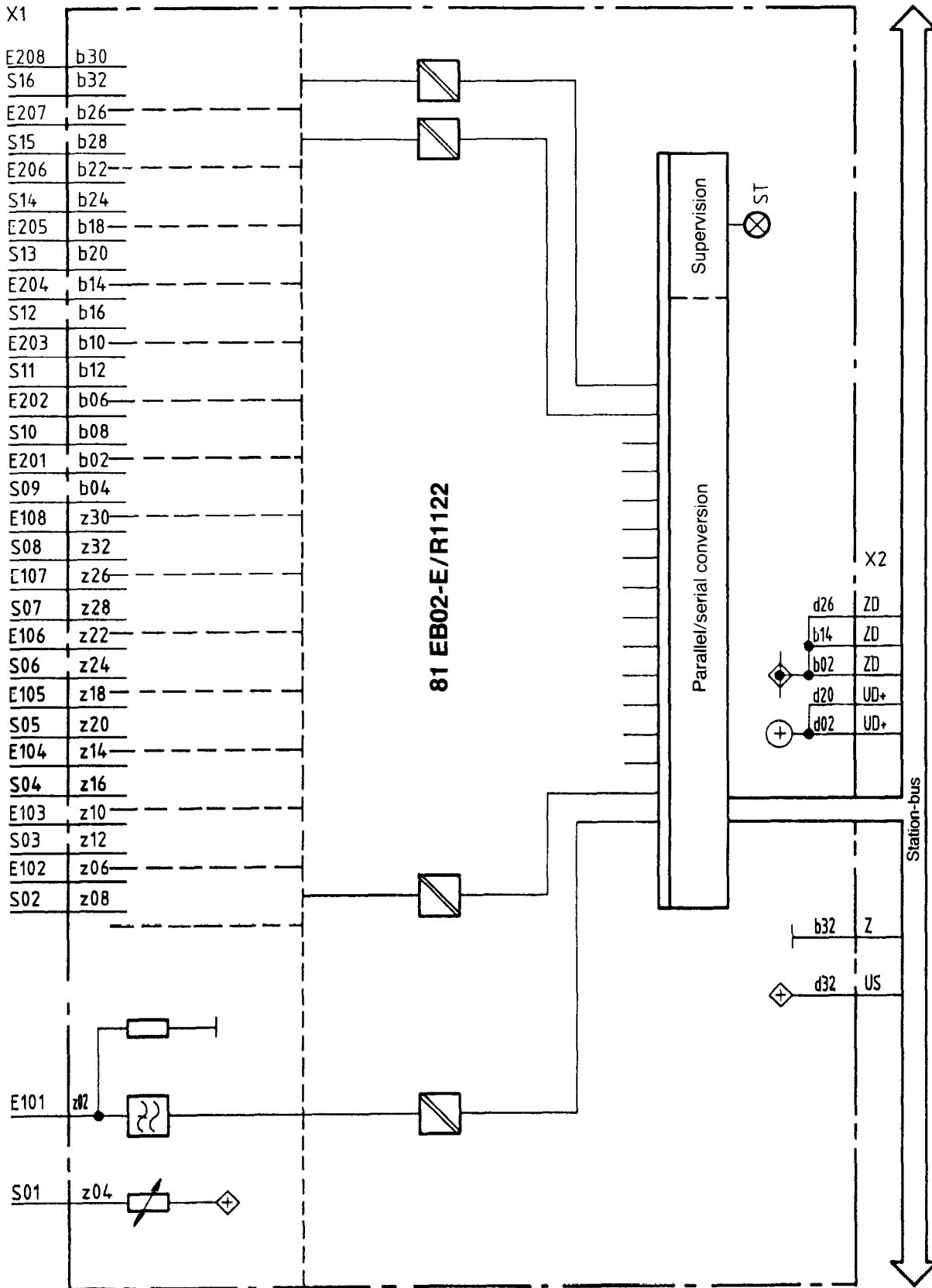

### Connection diagrams

#### Contacts with line monitoring

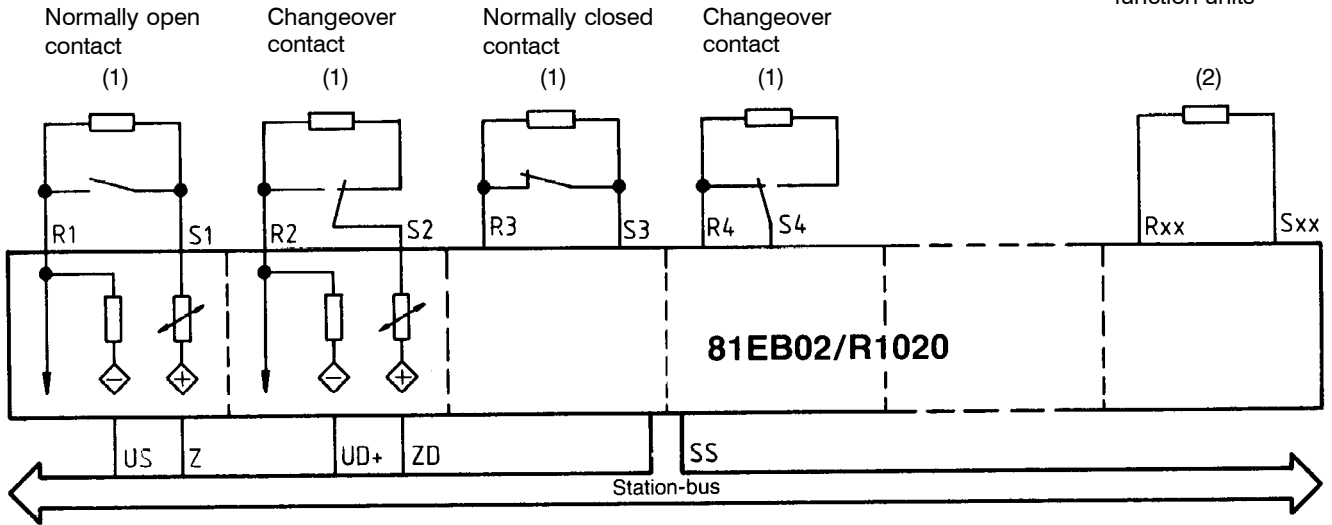

- (1) The resistor arranged parallel to the contacts (81ES05/R0100 ... R0300) is available in 3 versions (See "Technical Data")
- (2) The resistors for wiring unused function units (81ES01/R0200) are mounted on small pluggable PCBs and must be ordered separately (see "Technical Data").

#### For binary signals

#### For single contacts without monitoring, without bias voltage

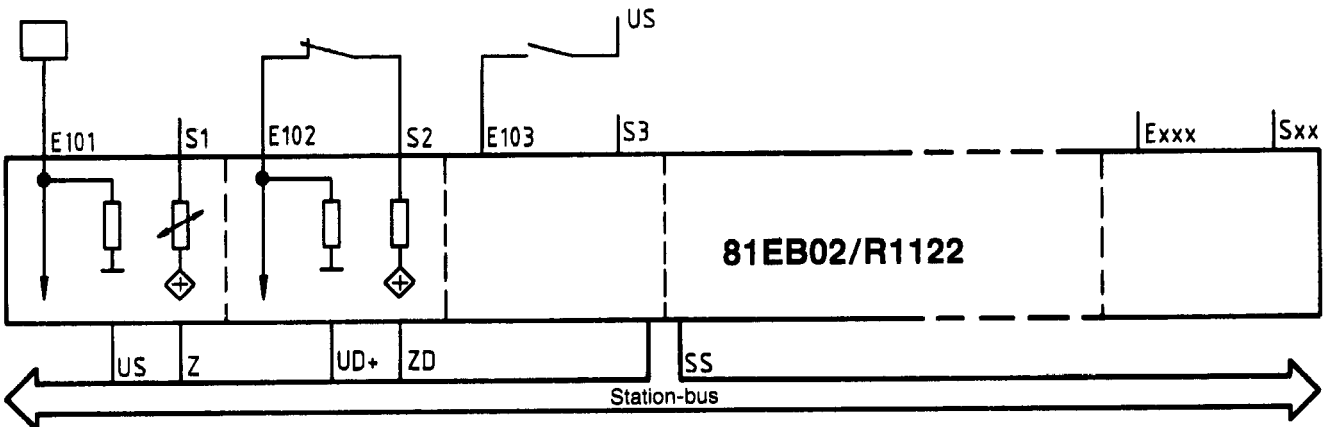

## Mechanical design

Board size: 6 units, 1 division, 160 mm deep

Connector: to DIN 41 612

1 x for station–bus connection,  
48–pole, edge–connector type F  
(connector X2)

1 x for process connection,  
32–pole, edge–connector type F  
(connector X1)

Weight: approx. 0.73 kg

View of connector side:





Position of the memory module and of the short-circuit socket on the PCB and on the front

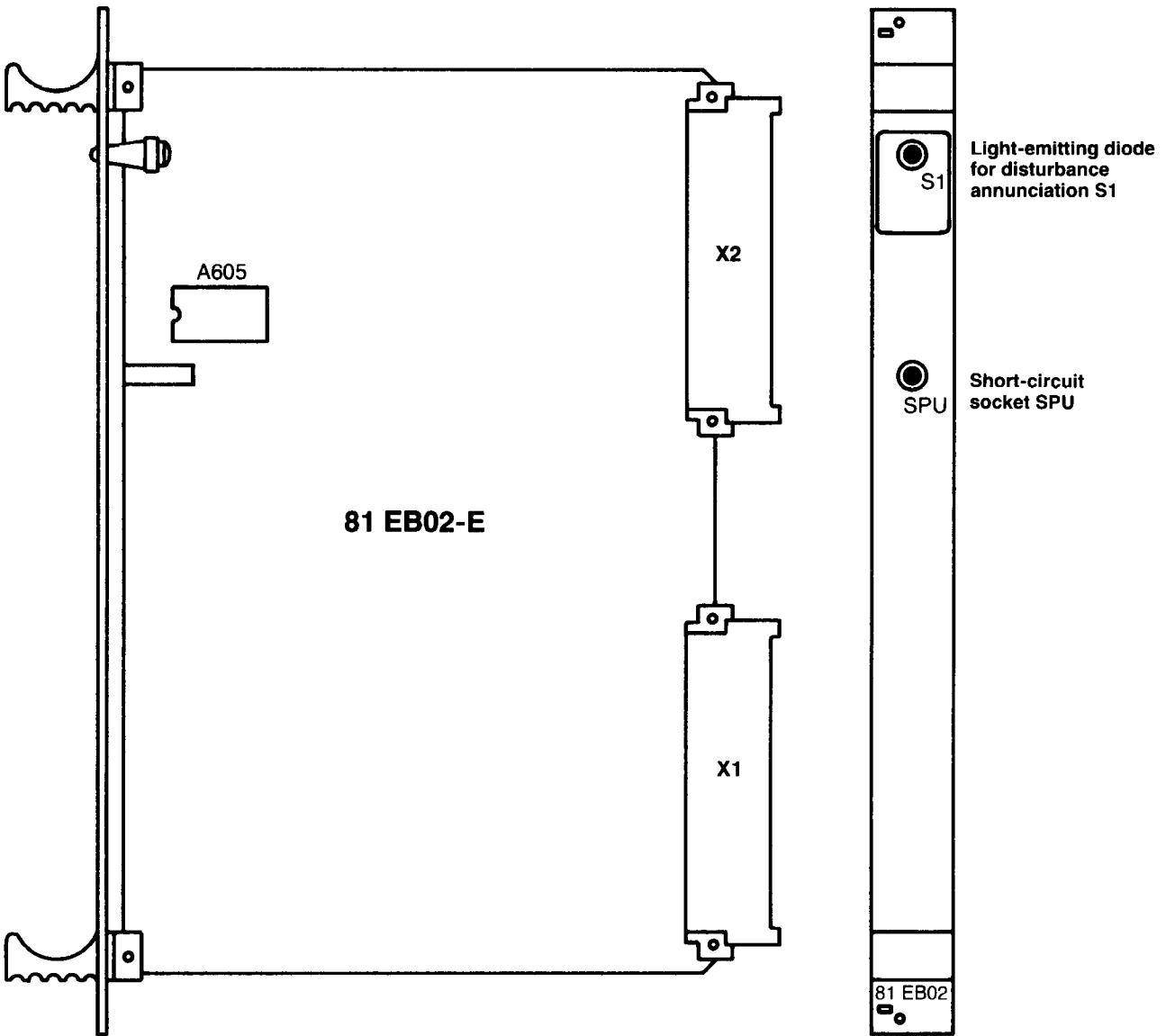

| Memory module        | Version        | Order number (Component)                       | Order number (Programmed PROM)     |
|----------------------|----------------|--|------------------------------------|
| A 605 Module program | R1020<br>R1122 | GJTN160212P1 (2764-3)<br>GJTN160212P1 (2764-3) | GJR2352204Pxxxx<br>GJR2352206Pxxxx |

Notes:

The mounting position of the component is marked by an imprint on the printed circuit board.

xxxx = Position number according to the applicable revision status

## Technical data

In addition to the system data, the following values apply

Version:

**R1020**

**R1122**

### Power supply

|  |                            |                     |
|--|----------------------------|---------------------|
| Operating voltage, process section       | US = +24 V                 | +24 V               |
| Operating voltage, bus section           | UD+ = + 5 V                | + 5 V               |
| Current consumption                      | IS = 110 mA + n x 11 mA *) | 30 mA + n x 2 mA *) |
| Power dissipation (all 16 FE = log. "1") | Pv = max. 11.8 W           | 6.5 W               |
| Reference potential process section      | Z = 0 V                    | 0 V                 |
| Reference potential bus section          | ZD = 0 V                   | 0 V                 |

\*) n = Number of function units, to which signal "1" is applied at module input.

### Inputs

|                                  |            |               |
|----------------------------------|------------|---------------|
| Number of function units         | 16         | 16            |
| Input designation contacts       | R1 ... R16 | –             |
| Input designation binary signals | –          | E101 ... E208 |

### Input values of contacts

|   |                                 |   |
|---|---------------------------------|---|
| Max. voltage range of contact inputs  | – 33 V... + 33 V                | – |
| Input current at +24 V  | Ie = 5 mA                       | – |
| Contact voltage   | Uk = 40 V                       | – |
| Static minimum period of input signals for error-free recognition                                       | ts > 10 ms                      | – |
| Fixed value of resistor parallel to the contacts  | R = 47 (47.5) kOhm              |   |
| Power dissipation   | ≥ 0.25 W                        | – |
| Tolerance on delivery   | ≤ +/- 1 %                       | – |
| Time inconstancy  | ≤ +/- 1 %                       | – |
| Temperature coefficient (–55...+155 °C)   | ≤ +/- 100 x 10 <sup>-6</sup> /K | – |
| Total tolerances  | ≤ +/- 5 %                       | – |
| A metal-oxide resistor 0.25 W +/- 1 % should be inserted when using other-make transmitters, Order no.: | XN 400 324 P36                  |   |

### Input values binary signals

|  |   |                    |
|--|---|--------------------|
| Input values for log. "0"  | – | – 33.0 V ... + 3 V |
| Input values for log. "1"  | – | +11.2 V ... +60 V  |
| Input current (range –33 V... +60 V)   | – | Ie = 1.6 mA        |
| Static minimum period of the input signals for error-free recognition (Input pulses < 10 ms duration are suppressed) | – | ts > 10 ms         |

### Outputs

|                         |            |   |
|-------------------------|------------|---|
| Contact input           | S1 ... S16 | – |
| SS – standard interface |            |   |

### Output values

|                                    |               |   |
|------------------------------------|---------------|---|
| Contact input, short-circuit-proof | Ua = US – 1 V | – |
| Max. contact current               | Ia = 10 mA    | – |

| Version:   | R1020                      | R1122                  |
|--|----------------------------|------------------------|
| <b>Error specification</b>   |                            |                        |
| Reaction time of the module<br>(the time between a local signal status change and the instant of writing to the shared memory) | $t_r \leq 10 \text{ ms}$   | $\leq 10 \text{ ms}$   |
| Response time of monitor<br>(Setting the disturbance bit in the telegram)  | $t_u = 0.5 \text{ s}$      | 0.5 s                  |
| Maximum permissible resistance for each single line  | $R_L \leq 100 \text{ Ohm}$ | $\leq 100 \text{ Ohm}$ |
| <b>Allowable temperature ranges</b>  |                            |                        |
| Operating temperature  | 0 °C ... 70 °C             | 0 °C ... 70 °C         |
| Storage temperature  | -40 °C ... 85 °C           | -40 °C ... 85 °C       |

**ORDERING DATA**

## 1. Complete module:

Type designation: 81EB02-E/R1020  
(Changeover and single contacts)

Order no.: GJR2349000R1020

81EB02-E/R1122  
(Electronic signals and  
single contacts without monitoring)

Order no.: GJR2349000R1122

## 2. Memory modules: see "Mechanical design"

## 3. Transmitter simulation module for wiring unused function units:

Type designation: 81ES01/ R0200

Order no.: GJR2355800R0200

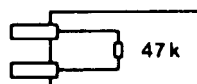

Wiring (as shown for version R1020):

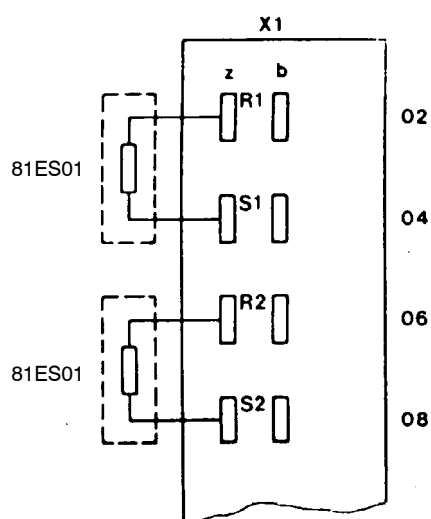

## 4. Protective circuit resistor for contact inputs:

Type designation: 81ES05/R0100  
(with tab connector)

Order no.: GKWE601766R0100

81ES05/R0200  
(with wire ferrules)

Order no.: GKWE601766R0200

81ES05/R0300  
(with free wire ends)

Order no.: GKWE601766R0300

Technical data are subject to change without notice!



---

ABB Kraftwerksleittechnik GmbH

P. O. Box 100351, D-68128 Mannheim  
Phone (0621) 381 2712, Telefax (0621) 381 4372  
Telex 462 411 107 ab d