

—
FOR RECYCLING PURPOSES ONLY

Disassembly Instructions

Motorized switch-disconnectors OTM1000–1600



Table of contents

003	Important information
004–005	Disassembly of the motorized switch- disconnecter
006–007	Disassembly of the handle kit
008	Disassembly of the switch-disconnector
009–011	Disassembly of the pole
012	Disassembly of the mechanism
013–015	Component list
016	Recycling information in accordance with the WEEE

Important information

This document shows the disassembly process of OTM1000–1600 motorized switch-disconnectors. Accessories, such as shafts, clamps, shrouds, neutral links and auxiliary contacts are not included. **Note! This document is for recycling purposes only.**

Safety Notes

Before starting the disassembly process it is mandatory to put the motorized switch-disconnector in open position.

Disassembly of motorized switch-disconnectors must be performed by qualified and skilled personnel in the electrical field (IEV 195-04-01: person with relevant education and experience to enable him or her to perceive risks and to avoid hazards which electricity can create) and having a detailed knowledge of motorized switch-disconnectors.

Disassembly must be done in an ergonomic workspace which can ensure the protection of the person doing the disassembling.

Applicable national legislation and international standards in force at the time of the disassembly of the motorized switch-disconnectors must be taken into account in addition to the prescriptions illustrated in this document.

ABB declines any responsibility for injury to people or damage to property resulting from a failure to comply with the instructions set out in this document and with any applicable safety standard.

Personal Protective Equipment (PPE)

When doing the disassembling following safety Personal Protective Equipment (PPE) must be worn:

Glasses



Gloves



Safety shoes



Protective clothes



Tools

The disassembly process requires the use of tools (e.g. screwdriver, torx key, pliers). Tools to be used are specified inside each phase of the disassembly process.

Disassembly process

For each phase of the disassembly process the following information is provided:

- Part/parts to be disassembled (title of the phase)
- Tools to be used
- Description of actions to be performed
- Pictures showing actions to be performed
- List, quantity and picture of disassembled parts with an indication about separate treatment (when applicable)
- In case of potential hazards signal below is reported:



Disassembly of the motorized switch-disconnector

Phase 1,2,3,4 – End plates, mounting plates, contact guide support, handle kit

1. Use a torx key (size 25) to unscrew the 4 screws fixing the 2 end plates to the motorized switch-disconnector.

2. Use a socket wrench (13 mm) to unscrew the 4 screws fixing the 2 mounting plates to the motorized switch-disconnector.

3. Remove the contact guide support manually.

4. Separate the handle kit from the switch-disconnector (see instructions on the page 6).

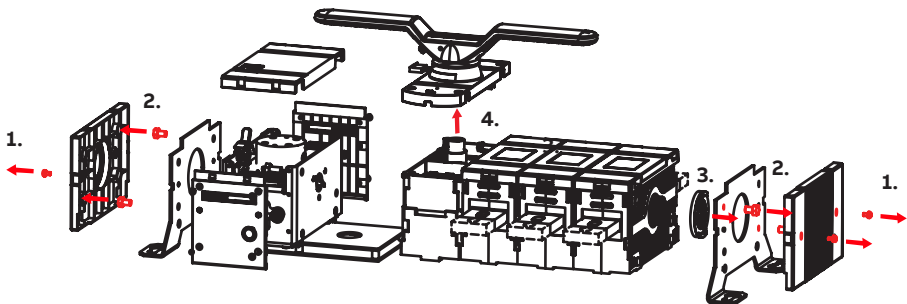

Tools

Torx key (size 25)

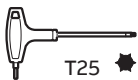

Socket wrench



socket 13 mm

Disassembled parts



- 2 mounting plates
- 2 end plates
- 4 screws
- 1 contact guide support
- 4 screws
- 1 handle kit

Phase 5,6,7,8 – Transmission shaft, top cover, side covers, motor operator

5. Use pliers to separate circlip and transmission shaft from the motor operator.

6. Remove the top cover of the motor operator with the help of a flat screwdriver.

7. Use a torx key (size 20) to unscrew the 8 screws fixing the side covers to the motor operator.

8. Use a socket wrench (13 mm) to unscrew the 4 screws fixing the switch-disconnector to the motor operator.

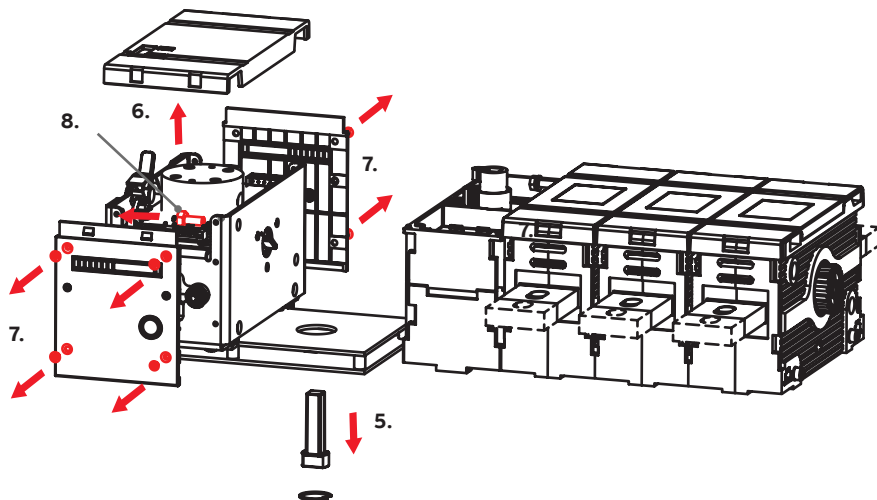

Tools

Torx key (size 20)

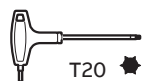

Socket wrench



socket 13 mm

Flat screwdriver



Pliers



Disassembled parts

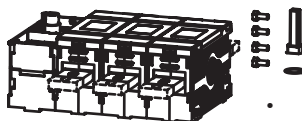

- 1 top cover
- 8 screws
- 4 screws
- 1 switch-disconnector
- 1 motor operator
- 2 side covers (upper)
- 1 transmission shaft
- 1 circlip

Disassembly of the handle kit

Phase 1,2,3 – Handle and other parts

1. Remove the handle by pressing on the clip (marked with red) and pulling the handle up.

2. Use a torx key (size 20) to unscrew the 4 screws.

3. Unscrew the 1 screw. Separate the parts from each other. Use pliers if needed.

Tools

Torx key (size 20)

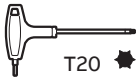

Pliers

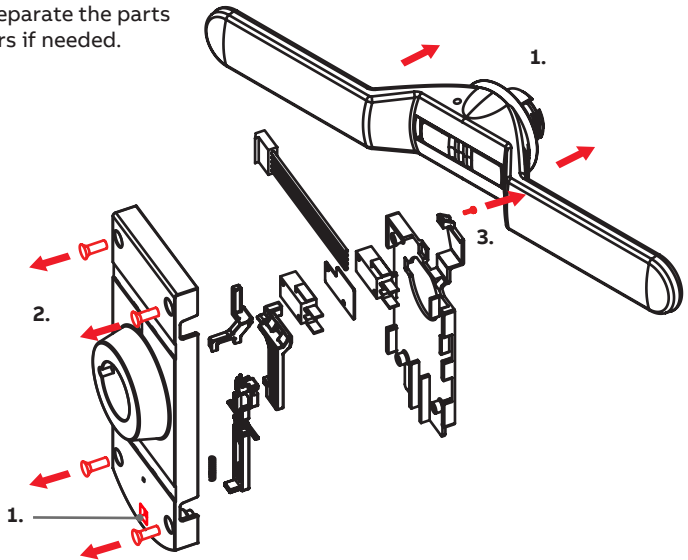

Disassembled parts

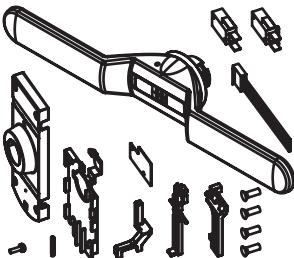

- 4 screws
- 1 screw
- 1 cover
- 1 guide
- 1 compression spring
- 1 lock
- 1 bottom plate
- 1 mechanism for micros
- 1 electric harness
- 1 insulator
- 1 handle

Phase 4 & 5 – Handle parts

4. Use a torx key (size 8) to unscrew the 6 screws and to separate the shaft from the handle.

5. Separate rest of the parts from each other.

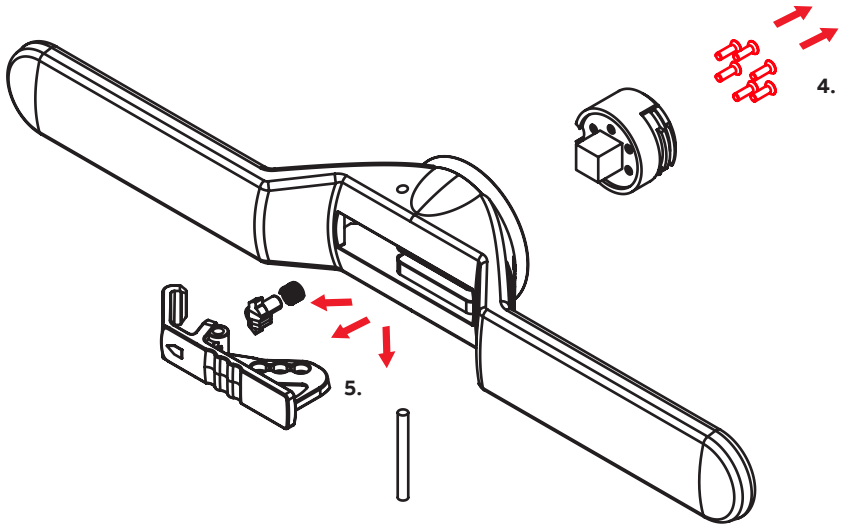

Tools

Torx key (size 8)

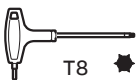

Disassembled parts

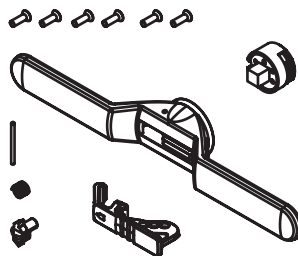

- 1 handle
- 1 compression spring
- 1 locking pin
- 1 lock plunger
- 1 slotted plug
- 1 shaft
- 6 screws

Disassembly of the switch-disconnector

Phase 1 – Stud screws

1. Use a flat screwdriver to unscrew the stud screws fixing the poles to the mechanism.

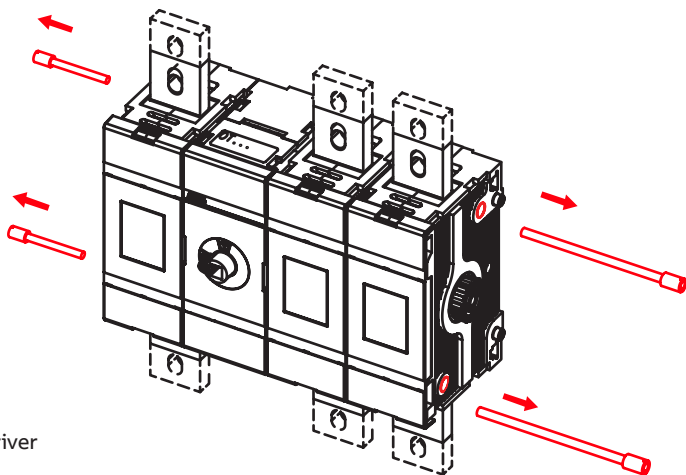

Tools

Flat screwdriver



Disassembled parts

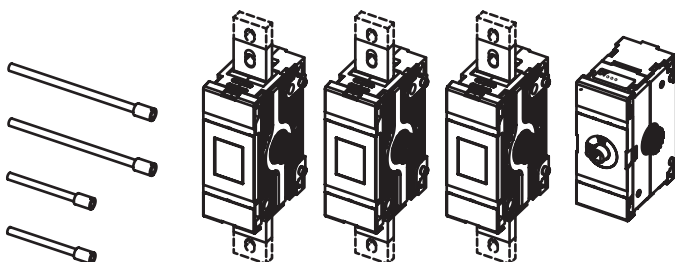

- 2-4 stud screws
- 1 mechanism
- 1-4 poles
- (8-14 filling plates + 8-14 guide wheels)*

*Filling plate and guide wheel only in UL / Wide phase distance products

Disassembly of the pole

Phase 1 & 2 – Cover and frame

1. Use a flat screwdriver to remove the cover.

2. Use a torx key to unscrew the screw fixing the frames to each other.

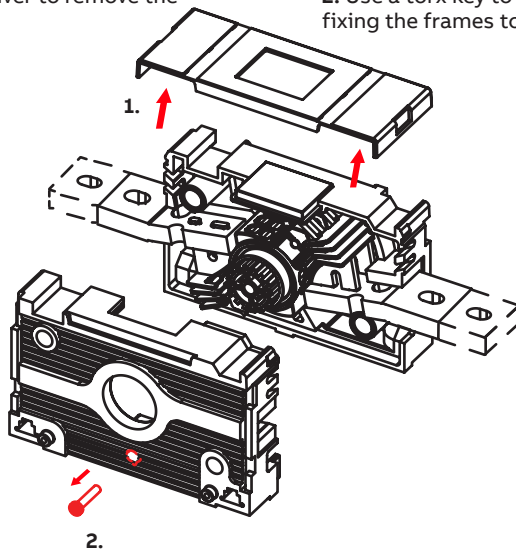

Tools

Torx key (size 25)

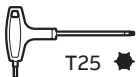

Flat screwdriver



Disassembled parts

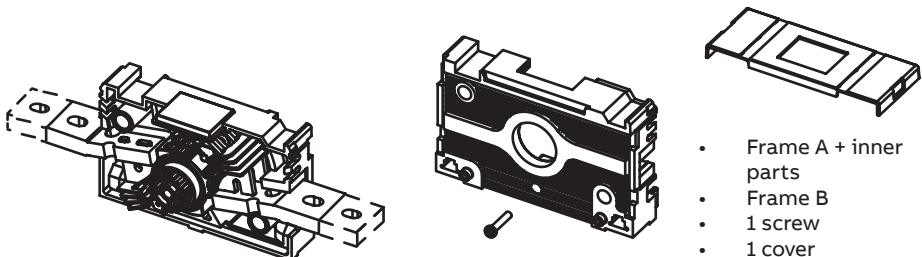

Phase 3 – Inner components of the pole

Remove rest of the components (arc plates, roll with knife structure, fixed contacts and window) from frame A manually.

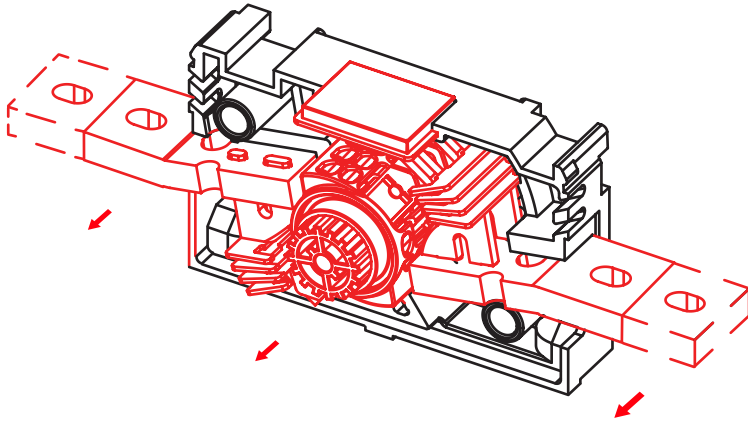

Disassembled parts

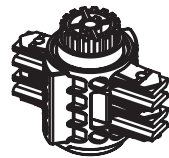
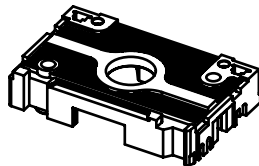
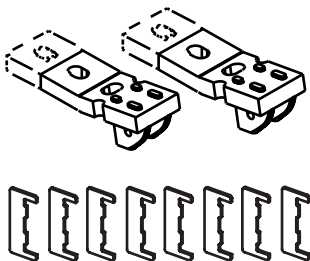

- Frame A
- Roll + knife structure
- Window
- 8 arc plates
- 2 fixed contacts

Phase 4 & 5 – The contact construction

4. Remove the knife structure from the roll with a hammer.

5. Separate contact knives, contact springs and contact irons from each other by removing the guide support of spring.

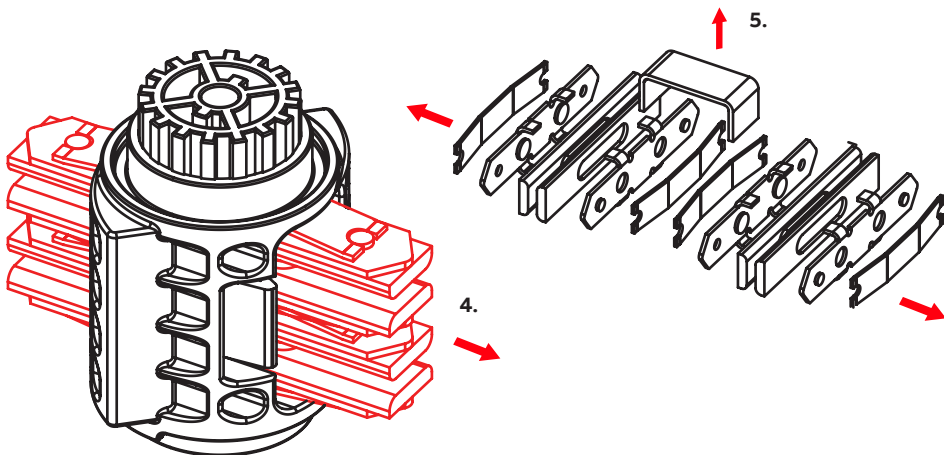

Tools

Hammer

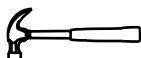

Disassembled parts

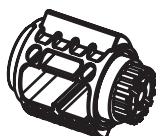

- Roll
- 4 contact knives
- 4 contact springs
- 4 contact irons
- Guide support of spring

Disassembly of the mechanism

1. Remove the cover with the help of a flat screwdriver.

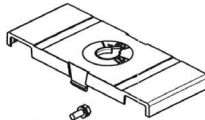

2. Unscrew the 4 screws with a torx key to remove the frame.

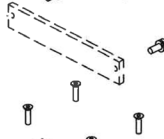

3. Remove hexnuts and contact guide support.

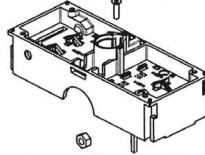

4. Remove the lever.

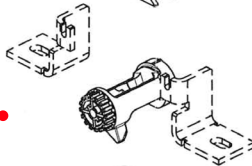

5. Remove pipeshaft, lever and rhythm spring.

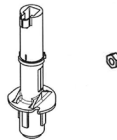

6. Remove the springs using pliers.

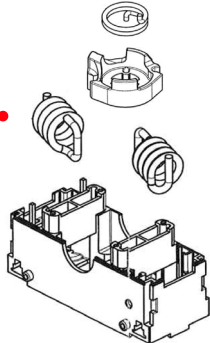

Note! Pay special attention to tensioned springs. Use personal protective equipment.

Tools

Torx key (size 20)

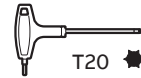

Flat screwdriver



Pliers



Disassembled parts

- Frame
- 2 springs
- 4 steel hex nuts
- Lever
- Pipeshaft
- Lever
- Rhythm spring
- Frame
- 4 screws
- Cover
- Contact guide support

Component list

Motorized switch-disconnector

Component name	Quantity	Material(s)	Weight (g/pc)
Switch-disconnector	1	See component list	
Motor operator	1	Assembly	8839
Mounting plate	2	Steel	1000
End plate	2	Polycarbonate	137
Contact guide support	1	Polyamide	18
Handle kit	1	See component list	680
Steel hex screw	2	Steel	6
Steel hex screw	4	Steel	5
Screw	4	Steel	1
Screw	8	Steel	1
Top cover	1	Polycarbonate	100
Side cover upper	2	Polycarbonate	100
Screw	4	Steel	6

Handle kit

Component name	Quantity	Material(s)	Weight (g/pc)
Cover	1	Polycarbonate	108
Guide	1	Polycarbonate	1
Lock	1	Polyamide	5
Compression spring	1	Steel	1
Screw	1	Steel	1
Bottom plate	1	Polycarbonate	25
Screw	4	Steel	1
Mechanism for micros	1	Polycarbonate	5
Insulator	1	Polycarbonate	1
Electric harness	1	Assembly	1
Handle	1	Assembly	500

—
Handle

Component name	Quantity	Material(s)	Weight (g/pc)
Handle	1	Polyamide	265
Compression spring	1	Steel	1
Locking pin	1	Zinc	1
Lock plunger	1	Polycarbonate	12
Slotted plug	1	Chromium steel	1
Shaft	1	Steel	100
Screw	6	Steel	1

—
Switch-disconnector

Component name	Quantity	Material(s)	Weight (g/pc)
Mechanism	1	See component list	2200
Pole	2-4	See component list	4250
Stud screw	2	Steel	62-110

—
Pole

Component name	Quantity/pole	Material(s)	Weight (g/pc)
Frame A	1	Polyester	672
Frame B	1	Polyester	722
Contact knife	4	Copper	86
Contact iron	4	Steel	36
Contact spring	4	Steel	15
Spring guide	1	Steel	1
Roll	1	Polyamide	164
Arc plate	8	Steel	15
Fixed contact	2	Copper	1005
Window	1	Polycarbonate	99
Cover	1	Polycarbonate	47
Screw	1	Steel	1

Mechanism

Component name	Quantity	Material(s)	Weight (g/pc)
Frame	1	Polyamide	533
Frame	1	Polyamide	201
Contact guide support	1	Polyamide	15
Cover	1	Polycarbonate	60
Pipeshaft	1	Zinc	250
Lever	1	Zinc	270
Lever	1	Zinc	360
Spring	2	Steel	190
Rhythm spring	1	Steel	40
Steel hex nut	4	Steel	7
Screw	4	Steel	1

Recycling information in accordance with the WEEE

The product is marked with the wheelie bin symbol. It indicates that at the end of life the product should enter the recycling system.

You should dispose of it separately at an appropriate collection point and not place it in the normal waste stream.

The figure below shows the wheelie bin symbol indicating separate collection for electrical and electronic equipment (EEE).



The horizontal bar underneath the crossed-out wheelie bin indicates that the equipment has been manufactured after the Directive came into force in 2005.

The wheelie bin symbol is added to the type designation label of the product since 2017.



Contact us

ABB Oy

P.O. Box 622
FI-65101 Vaasa
Finland

abb.com/lowvoltage