

Original instructions

Orion3 Extended

Safety light grids

Type 4 Active Opto-electronic Protective Device (AOPD)



Read and understand this document

Please read and understand this document before using the products. Please consult your ABB JOKAB SAFETY representative if you have any questions or comments.

WARRANTY

ABB JOKAB SAFETY's exclusive warranty is that the products are free from defects in materials and workmanship for a period of one year (or other period if specified) from date of sale by ABB JOKAB SAFETY.

ABB JOKAB SAFETY MAKES NO WARRANTY OR REPRESENTATION, EXPRESSED OR IMPLIED, REGARDING NON-INFRINGEMENT, MERCHANTABILITY, OR FITNESS FOR PARTICULAR PURPOSE OF THE PRODUCTS, ANY BUYER OR USER ACKNOWLEDGES THAT THE BUYER OR USER ALONE HAS DETERMINED THAT THE PRODUCTS WILL SUITABLY MEET THE REQUIREMENTS OR THEIR INTENDED USE. ABB JOKAB SAFETY DISCLAIMS ALL OTHER WARRANTIES, EXPRESSED OR IMPLIED.

LIMITATIONS OF LIABILITY

ABB JOKAB SAFETY SHALL NOT BE RESPONSIBLE FOR SPECIAL, INDIRECT, OR CONSEQUENTIAL DAMAGES, LOSS OF PROFITS OR COMMERCIAL LOSS IN ANY WAY CONNECTED WITH THE PRODUCTS, WHETHER SUCH CLAIM IS BASED ON CONTRACT, WARRANTY, NEGLIGENCE, OR STRICT LIABILITY.

In no event shall responsibility of ABB JOKAB SAFETY for any act exceed the individual price of the product on which liability asserted.

IN NO EVENT SHALL ABB JOKAB SAFETY BE RESPONSIBLE FOR WARRANTY, REPAIR, OR OTHER CLAIMS REGARDING THE PRODUCTS UNLESS ABB JOKAB SAFETY'S ANALYSIS CONFIRMS THAT THE PRODUCTS WERE PROPERLY HANDLED, STORED, INSTALLED, AND MAINTAINED AND NOT SUBJECT TO ABUSE, MISUSE, OR INAPPROPRIATE MODIFICATION OR REPAIR.

SUITABILITY FOR USE

ABB JOKAB SAFETY shall not be responsible for conformity with any standards, codes, or regulations that apply to the combination of products in the customer's application or use of the product. At the customer's request, ABB JOKAB SAFETY will provide applicable third party certification documents identifying ratings and limitations of use that apply to the products. This information by itself is not sufficient for a complete determination of the suitability of the products in combination with the end product, machine, system, or other application or use.

The following are some examples of applications for which particular attention must be given. This is not intended to be an exhaustive list of all possible uses of the products, nor is it intended to imply that the uses listed may be suitable for the products:

- Outdoor use, uses involving potential chemical contamination or electrical interference, or conditions or uses not described in this document.
- Nuclear energy control systems, combustion systems, railroad systems, aviation systems, medical equipment, amusement machines, vehicles, and installations subject to separate industry or government regulations.
- Systems, machines, and equipment that could present a risk to life or property.

Please know and observe all prohibitions of use applicable to the products.

NEVER USE THE PRODUCTS FOR AN APPLICATION INVOLVING SERIOUS RISK TO LIFE OR PROPERTY WITHOUT ENSURING THAT THE SYSTEM AS A WHOLE HAS BEEN DESIGNED TO ADDRESS THE RISKS, AND THAT THE ABB JOKAB SAFETY PRODUCT IS PROPERLY RATED AND INSTALLED FOR THE INTENDED USE WITHIN THE OVERALL EQUIPMENT OR SYSTEM.

PERFORMANCE DATA

While every effort has been taken to ensure the accuracy of the information contained in this manual ABB JOKAB SAFETY cannot accept responsibility for errors or omissions and reserves the right to make changes and improvements without notice. Performance data given in this document is provided as a guide for the user in determining suitability and does not constitute a warranty. It may represent the result of ABB JOKAB SAFETY's test conditions, and the users must correlate it to actual application requirements. Actual performance is subject to the ABB JOKAB SAFETY Warranty and Limitations of Liability.

Table of Contents

1	Introduction	5
1.1	Scope	5
1.2	Audience	5
1.3	Prerequisites	5
1.4	Abbreviations.....	5
1.5	Special notes.....	5
2	Overview	6
2.1	General description	6
2.2	Resolution	7
2.3	Protected height	7
2.4	Minimum installation distance	9
2.4.1	Vertically assembled AOPD	9
2.4.2	Horizontally assembled AOPD	10
2.4.3	Angled assembled AOPD.....	10
2.4.4	Practical examples	10
2.5	Safety information	11
3	Installation	12
3.1	Precautions to observe for the choice and installation of the AOPD	12
3.2	General Information on positioning the AOPD	12
3.2.1	Minimum installation distance	12
3.2.2	Minimum distance to reflecting surfaces	12
3.2.4	Minimum distance between adjacent devices.....	15
3.2.5	Installation of several adjacent devices.....	17
3.2.6	Active and passive unit orientation.....	18
3.2.7	Use of deviating mirrors	18
3.3	Checks after first installation	19
4	Mechanical mounting.....	20
4.1	Mounting with angled fixing brackets	20
5	Electrical connections.....	21
5.1	Active unit.....	21
5.2	Important notes on connections.....	22
5.3	Connection examples.....	23
6	Alignment procedure	26
6.1	Alignment mode	27
6.2	Correct alignment procedure.....	28
7	Functions	30

7.1	Dip-switch selectable functions	30
7.2	Reset function	31
7.3	Acknowledge function	32
7.4	EDM function	33
7.5	Muting.....	34
7.5.1	Typical muting application and connection of the AOPD	34
7.5.2	Muting direction	37
7.5.3	T / X muting	38
7.5.4	L-muting.....	41
7.6	Override.....	43
7.6.1	Override at start-up.....	44
7.6.2	Override at run time.....	45
7.6.3	Reset mode of the Override function.....	46
8	Diagnostic functions	47
8.1	Visualization of the status of the AOPD	47
8.2	Diagnostic messages	47
8.2.1	Active unit.....	47
9	Periodical checks	50
10	Device maintenance	51
11	Technical data	52
12	Model overview.....	54
13	Dimensions.....	55
13.1	Profiles	55
13.2	Angled fixing bracket.....	56
13.3	Fixing bracket with profile.....	56
14	EC Declaration of conformity	57

1 Introduction

1.1 Scope

The purpose of these instructions is to describe the Orion3 Extended light grids and to provide the necessary information required for selection, installation and operation of the safety devices.

1.2 Audience

This document is intended for authorized installation personnel.

1.3 Prerequisites

It is assumed that the reader of this document has knowledge of the following:

- Basic knowledge of ABB Jokab Safety products.
- Knowledge of machine safety.

1.4 Abbreviations

ACM: Advanced Configuration Mode

AOPD: Active Opto-electronic Protective Device

BCM: Basic Configuration Mode

EDM: External Device Monitoring

MPCE: Machine Primary Control Element

OSSD: Output Signal Switching Device (switching output)

RX: Receiver

TX: Transmitter

1.5 Special notes

Pay attention to the following special notes in the document:

- | | |
|---|--|
|  Warning! | Danger of severe personal injury!
An instruction or procedure which, if not carried out correctly, may result in injury to the operator or other personnel. |
| Caution! | Danger of damage to the equipment!
An instruction or procedure which, if not carried out correctly, may damage the equipment. |
| NB: | Notes are used to provide important or explanatory information. |

2 Overview

2.1 General description

The Orion3 Extended light grids are Active Opto-electronic Protective Devices (AOPDs) that are used to protect working areas that, in presence of machines, robots, and automatic systems in general, can become hazardous for operators that get in touch, even accidentally, with moving parts.

The Orion3 Extended light grids are Type 4 intrinsic safety systems used as accident-prevention protection devices and are manufactured in accordance with the international standards in force for safety, in particular:

EN 61496-1:2013	Safety of machinery – Electro-sensitive protective equipment – Part 1: General requirements and tests
IEC 61496-2:2013	Safety of machinery – Electro-sensitive protective equipment – Part 2: Particular requirements for equipment using active opto-electronic protective devices (AOPDs)
EN ISO 13849-1:2008	Safety of machinery – Safety-related parts of control systems – Part 1: General principles for design
EN 61508-1:2010	Functional safety of electrical/electronic/programmable electronic safety-related systems – Part 1: General requirements
EN 61508-2:2010	Functional safety of electrical/electronic/programmable electronic safety-related systems – Part 2: Requirements for electrical/electronic/programmable electronic safety-related systems
EN 61508-3:2010	Functional safety of electrical/electronic/programmable electronic safety-related systems – Part 3: Software requirements
EN 61508-4:2010	Functional safety of electrical/electronic/programmable electronic safety-related systems – Part 4: Definitions and abbreviations
EN 62061:2005/A1:2013	Safety of machinery – Functional safety of safety-related electrical, electronic and programmable electronic control systems

The device, consisting of one active and one passive unit housed inside strong aluminum profiles, generates infrared beams reflected by the mirrors in the passive unit and detects any opaque object interrupting a beam. The active unit is composed by one or several transmitting and receiving modules.

The active unit is equipped with the command and control functions. It checks the control operations and safety actions. The passive unit is composed of a sturdy aluminum profile containing pre-assembled and pre-aligned mirrors.

The connections are made through a M12 connector located in the lower side of the profile of the active unit.

The microprocessors guarantee the check and the management of the beams that are sent and received and the microprocessors inform the operator about the general conditions of the AOPD via a display (see paragraph 8 “Diagnostic functions”). During installation, a display facilitates the alignment of both units (see paragraph 6 – “Alignment procedure”).

As soon as an object, a limb or the operator’s body accidentally interrupts one or several of the infrared beams sent by the transmitter, the OSSD outputs switch off and block the Machine Primary Control Element, MPCE (if correctly connected to the OSSD outputs).

2.2 Resolution

The resolution of the AOPD is the minimum dimension that an opaque object must have in order to interrupt at least one of the beams that constitute the detection zone.

$$R = l + d$$

where:

- l Distance between the centers of two adjacent optics.
- d Diameter of the lens

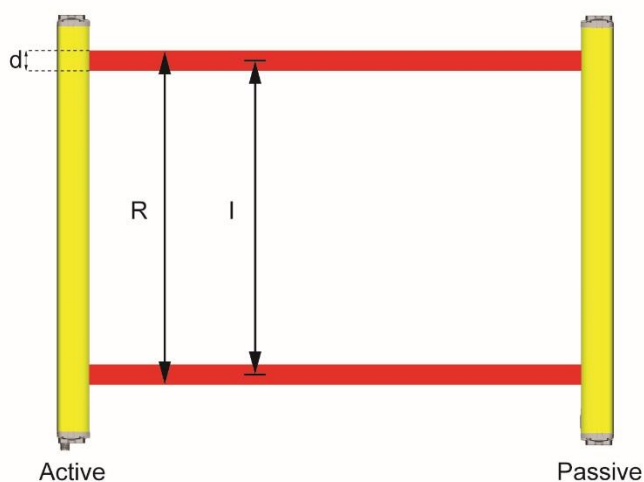

Figure 1 – Resolution

Therefore, the resolution depends only on the geometrical characteristics of the lenses, diameter and distance between centers, and is independent of any environmental and operating conditions of the AOPD.

See paragraph 12 – “Model overview” for the resolution of each model.

2.3 Protected height

The following figures illustrate what is meant with protected height (H_p) for Orion3 Extended.

For the values of H_p for each model, see paragraph 12 – “Model overview”.

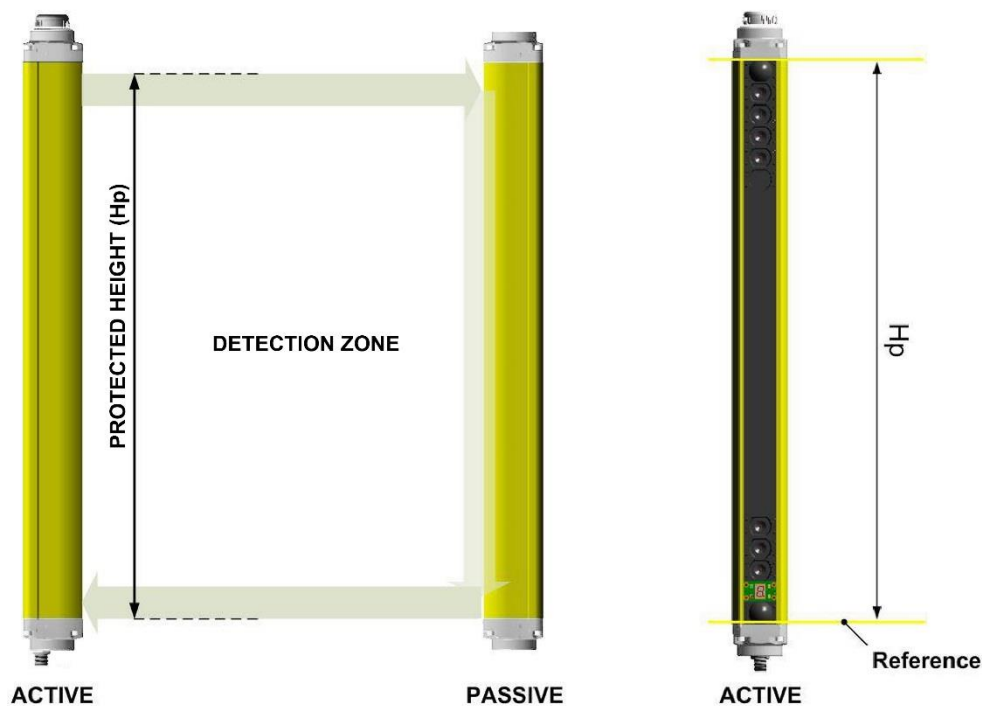

Figure 2 – Orion3 Extended with 2 beams

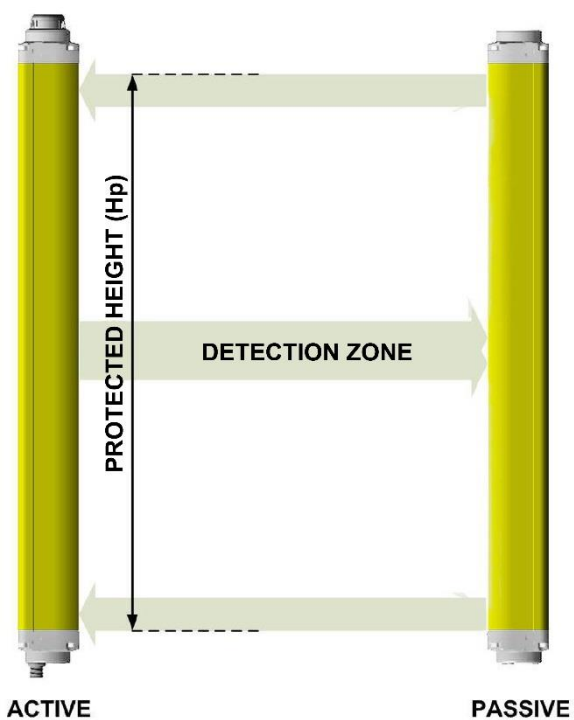

Figure 3 – Orion3 Extended with 3 beams

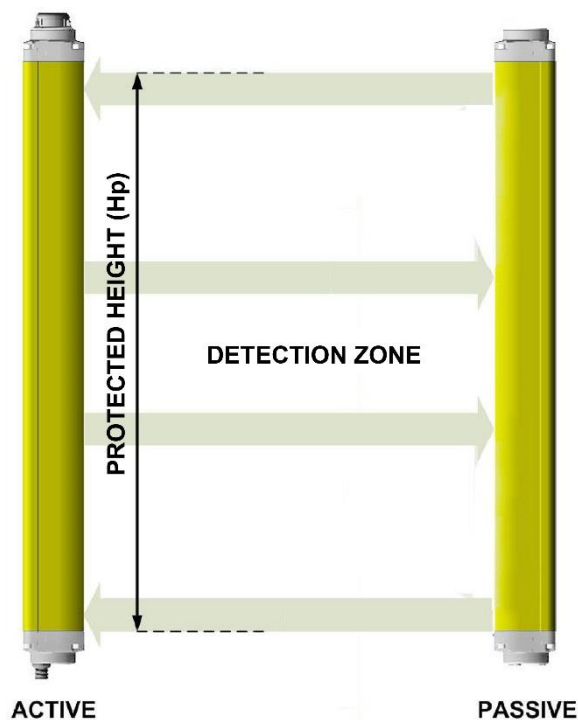

Figure 4 – Orion3 Extended with 4 beams

Model	Protected height (mm)
Orion3-4-K1C-050-E	500
Orion3-4-K2C-080-E	800
Orion3-4-K2C-090-E	900
Orion3-4-K2C-120-E	1200

2.4 Minimum installation distance

Warning! The information given in this chapter shall be considered as an overview. For correct positioning, please refer to the latest version of the complete standard EN ISO 13855 "Safety of machinery – Positioning of safe guards with respect to the approach speeds of parts of the human body".

The safety device must be positioned at a distance that prevents a person or part of a person to reach the hazard zone before the hazardous motion of the machine has been stopped by the AOPD.

According to EN ISO 13855:2010, the minimum distance to the hazard zone is calculated using:

$$S = (K \times T) + C$$

S Minimum distance (mm) between safeguard and hazard zone.

K Approach speed of body parts towards the hazard zone (mm/s). See below for values.

T Overall system stopping performance (s) with $T = T1 + T2$, where:

T1 = response time of the AOPD (s).

T2 = stopping time of the machine, including the response time of the safety control system (s).

C Intrusion distance (mm). C depends on the resolution d and the position of the detection zone. See below.

2.4.1 Vertically assembled AOPD

The minimum distance S for a vertically assembled AOPD is determined in three steps:

- Calculation of the minimum distance for reaching through the detection zone, S_{RT} .
- Calculation of the minimum distance for reaching over the detection zone, S_{RO} .
- Comparison of S_{RT} and S_{RO} . The minimum distance S is the greater of the two.

NB: If access to the hazard zone by reaching over the AOPD can be excluded, e.g. by the provision of guards or other protective measures, steps b) and c) are not necessary

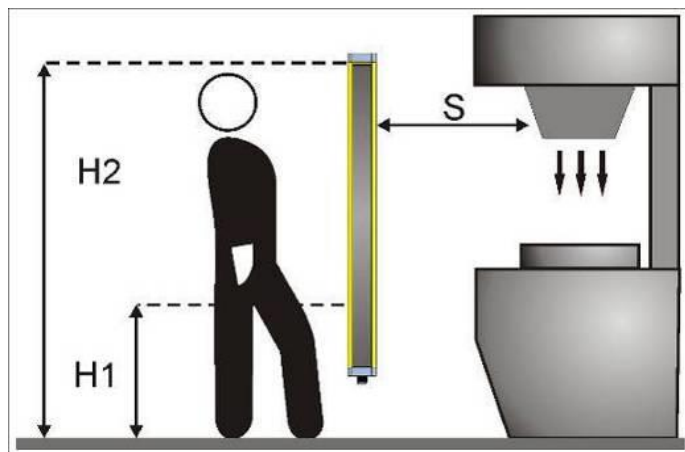

Figure 5 – Minimum distance for a vertically assembled AOPD

S = minimum distance in mm

$H1$ = height of the lowest beam

$H2$ = height of the uppermost beam

$H1 \leq 300 \text{ mm}^*$

$H2 \geq 900 \text{ mm}$

*400 mm can be used for 2 beams when the risk assessment allows it.

a) $S_{RT} = (K \times T) + C_{RT}$

$C_{RT} = 850$ mm for devices with resolution $d > 40$ mm

$K = 1600$ mm/s for devices with resolution $d > 40$ mm

b) $S_{RO} = (K \times T) + C_{RO}$

K and T according to a).

C_{RO} = Intrusion distance when reaching over the AOPD towards the hazard zone prior to the actuation of the AOPD. This value depends on the height of the hazard zone and the height of the uppermost beam, see EN ISO 13855:2010.

2.4.2 Horizontally assembled AOPD

Orion3 cannot be used horizontally.

2.4.3 Angled assembled AOPD

See the latest version of EN ISO 13855.

2.4.4 Practical examples

Let's suppose we have an Orion3 Extended light grid in a vertical position and with no risk of reaching over it.

$$S = K \times (T1 + T2) + C$$

	Orion3-4-K1C-050-E	Orion3-4-K2C-120-E
T1, response time of AOPD (see paragraph 12 – Model overview")	0.011 s	0.012 s
T2, stopping time machine + safety control system (value as ex.)	0.380 s	0.380 s
C, for AOPD with resolution > 40 mm	850 mm	850 mm
K, for AOPD with resolution > 40 mm	1600 mm/s	1600 mm/s
S, minimum installation distance	1475.6 mm	1477.2 mm

2.5 Safety information

Warning!

For a correct and safe use of the Orion3 Extended light grids, the following points must be observed:

- The stopping system of the machine must be electrically controlled.
- This control system must be able to stop the hazardous movement of the machine within the total machine stopping time T as per paragraph “2.4 – “Minimum installation distance“, and during all working cycle phases.
- Mounting and connection of the AOPD must be carried out by qualified personnel only, according to the indications included in the special sections (refer to paragraphs 3, 4, 5, 6) and in the applicable standards.
- The AOPD must be securely placed in a particular position so that access to the hazard zone is not possible without the interruption of the beams (see paragraph 3 - “Installation”).
- The personnel operating in the hazard zone must be well trained and must have adequate knowledge of all the operating procedures of the AOPD.
- The RESET button must be located outside the hazard zone because the operator must check the hazard zone during all the reset and override operations. It must be impossible to reach the button from the hazard zone.
- The external lamp signaling that muting is active must be visible from all operating sides.
- Please carefully respect the mounting instructions for the muting sensors, see paragraph 7.5 – “Muting”.
- If the external device monitoring (EDM) function is to be used, it must be activated with the dip-switches.

Please carefully read the instructions for the correct functioning before powering the AOPD.

3 Installation

3.1 Precautions to observe for the choice and installation of the AOPD

- The outputs (OSSD) of the AOPD must be used as machine stopping devices and not as command devices. The machine must have its own Start command.
- The dimension of the smallest object to be detected must be larger than the resolution of the AOPD.
- The AOPD must be installed in a room complying with the technical characteristics indicated in paragraph 11 “Technical data”.
- Do not place the AOPD near strong and/or flashing light sources or similar devices.
- Strong electromagnetic interferences can jeopardize the function of the AOPD. Please contact your ABB Jokab Safety representative for advice.
- The operating distance of the device can be reduced in presence of smog, fog or airborne dust
- A sudden change in environment temperature, with very low minimum peaks, can generate a small condensation layer on the lenses and so jeopardize the function.
- The Muting/Override function is signaled by a muting/override lamp. Make sure that the lamp has sufficient lighting and is visibly positioned near the hazard zone.
- Make sure to correctly use the muting sensors as described in the instructions supplied hereinafter.
- Avoid incongruent connections that cannot be controlled and thus, exclude undesired potentially dangerous activations.

3.2 General Information on positioning the AOPD

The AOPD should be carefully positioned, in order to offer effective protection: access to the hazard zone must only be possible by passing through the detection zone of the AOPD.

3.2.1 Minimum installation distance

See paragraph 2.4 – “Minimum installation distance”.

3.2.2 Minimum distance to reflecting surfaces

Reflecting surfaces placed near the light beams of the AOPD (over, under or laterally) can cause passive reflections. These reflections can compromise the recognition of an object inside the detection zone (see Figure 6).

For example, if the receiver (RX) detects a secondary beam (reflected by the side-reflecting surface), the object might not be detected, even if the object interrupts the main beam.

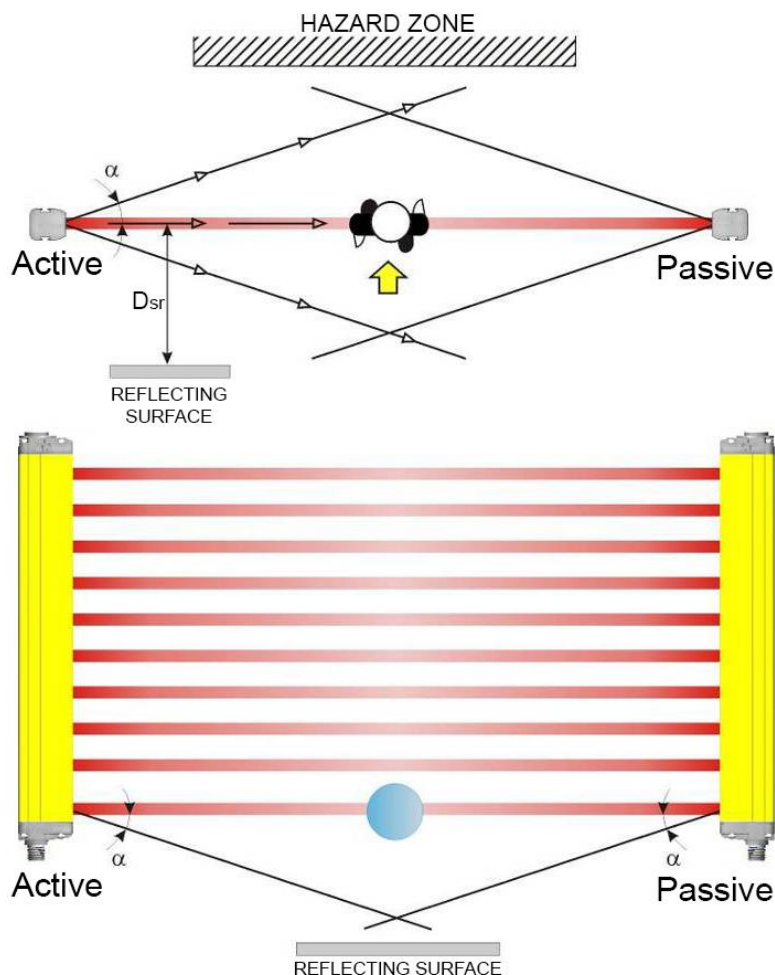

Figure 6 – Distance to reflecting surfaces

It is thus important to respect a minimum distance between the AOPD and reflecting surfaces. The minimum distance, D_{sr} , depends on the:

- operating distance between active and passive units,
- effective aperture angle (EAA) of the AOPD:

For a type 4 AOPD, $EAA_{MAX} = 5^\circ$ ($\alpha = \pm 2.5^\circ$).

Figure 7 below shows the minimum distance to the reflecting surface (D_{sr}), based on the operating distance for a Type 4 AOPD:

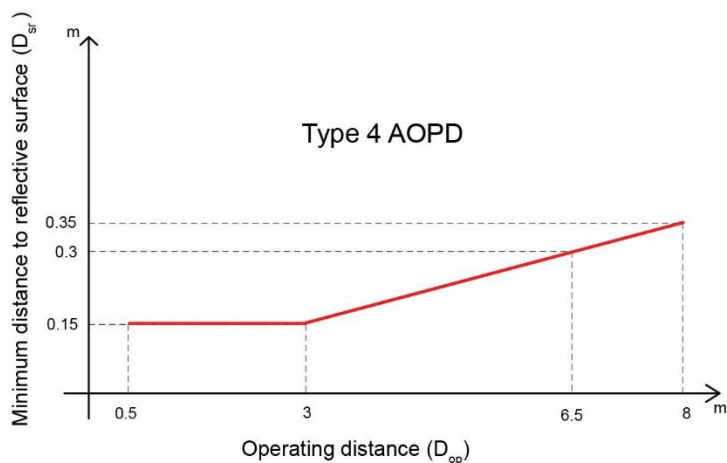

Figure 7 – Minimum distance to a reflective surface as a function of the operating distance

The formula to get D_{sr} for a Type 4 AOPD is the following:

$$D_{sr} \text{ (m)} = 0.15 \quad \text{for operating distances} < 3 \text{ m}$$

$$D_{sr} \text{ (m)} = 0.5 \times \text{operating distance (m)} \times \tan(2\alpha) \quad \text{for operating distances} \geq 3 \text{ m}$$

Warning! If the reflecting surface is the floor, whatever the calculated D_{sr}, the minimum installation distance to the floor must still be respected, see paragraph 2.4.

The correct function of the AOPD is guaranteed and certified up to a maximum operating distance of 6.5 m for Orion3-4-K2C-090-E, and 8 m for Orion3-4-K1C-050-E, Orion3-4-K2C-080-E and Orion3-4-K2C-120-E. The use of the AOPD at longer distances is not recommended. Always check the correct function and that no dangerous reflections are generated by shiny objects (See Figure 8).

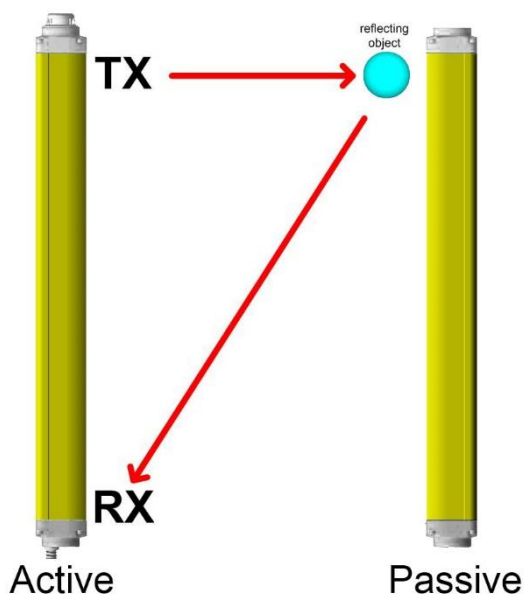

Figure 8 – Reflection by shiny objects

3.2.4 Minimum distance between adjacent devices

When several AOPDs must be installed close to each other, the transmitter of one device must not interfere hazardously with the receiver of the other device.

Interfering Passive B device must be positioned outside a minimum D_{do} distance from the axis of the Active A – Passive A couple, see Figure 9 below.

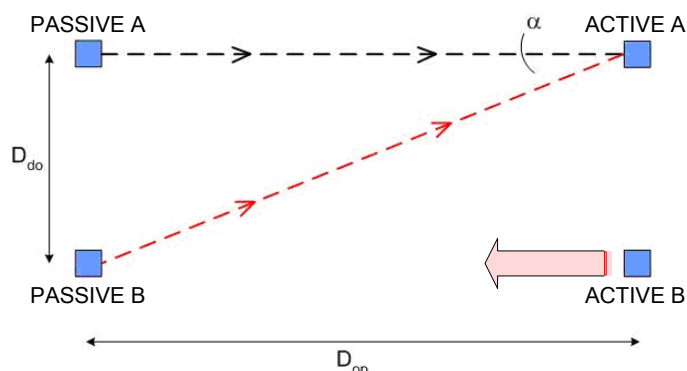

Figure 9 – Distance between adjacent devices

This minimum D_{do} distance depends on:

- the operating distance between Passive A and Active A,
- the effective aperture angle of the AOPD (EAA):

For a Type 4 AOPD, $EAA_{MAX} = 5^\circ$ ($\alpha = \pm 2.5^\circ$).

The diagram below shows the minimum distance to the interfering devices (D_{do}) based on the operating distance (D_{op}) of the couple Passive A – Active A for a Type 4 AOPD.

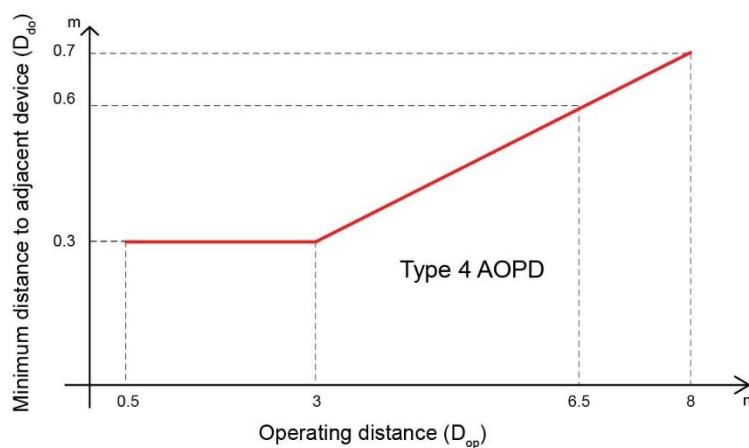



Figure 10 – Minimum distance to an adjacent device as a function of the operating distance

The formula to get D_{do} for a Type 4 AOPD is the following:

$$D_{do} \text{ (m)} = 0.3 \quad \text{for operating distance} < 3 \text{ m}$$

$$D_{do} \text{ (m)} = \text{operating distance (m)} \times \tan(2\alpha) \quad \text{for operating distance} \geq 3 \text{ m}$$

 **Warning!** Please note that the Passive A can interfere with Active B in the same way as Passive B with Active A and, if the two pairs of AOPD have different operating distances, the longest one should be used for the calculation of D_{do} .

3.2.5 Installation of several adjacent devices

When several AOPDs have to be installed close to each other, interferences between the transmitter of one device and the receiver of the other must be avoided.

Figure 11 provides some examples of correct and incorrect installations when it comes to interferences.

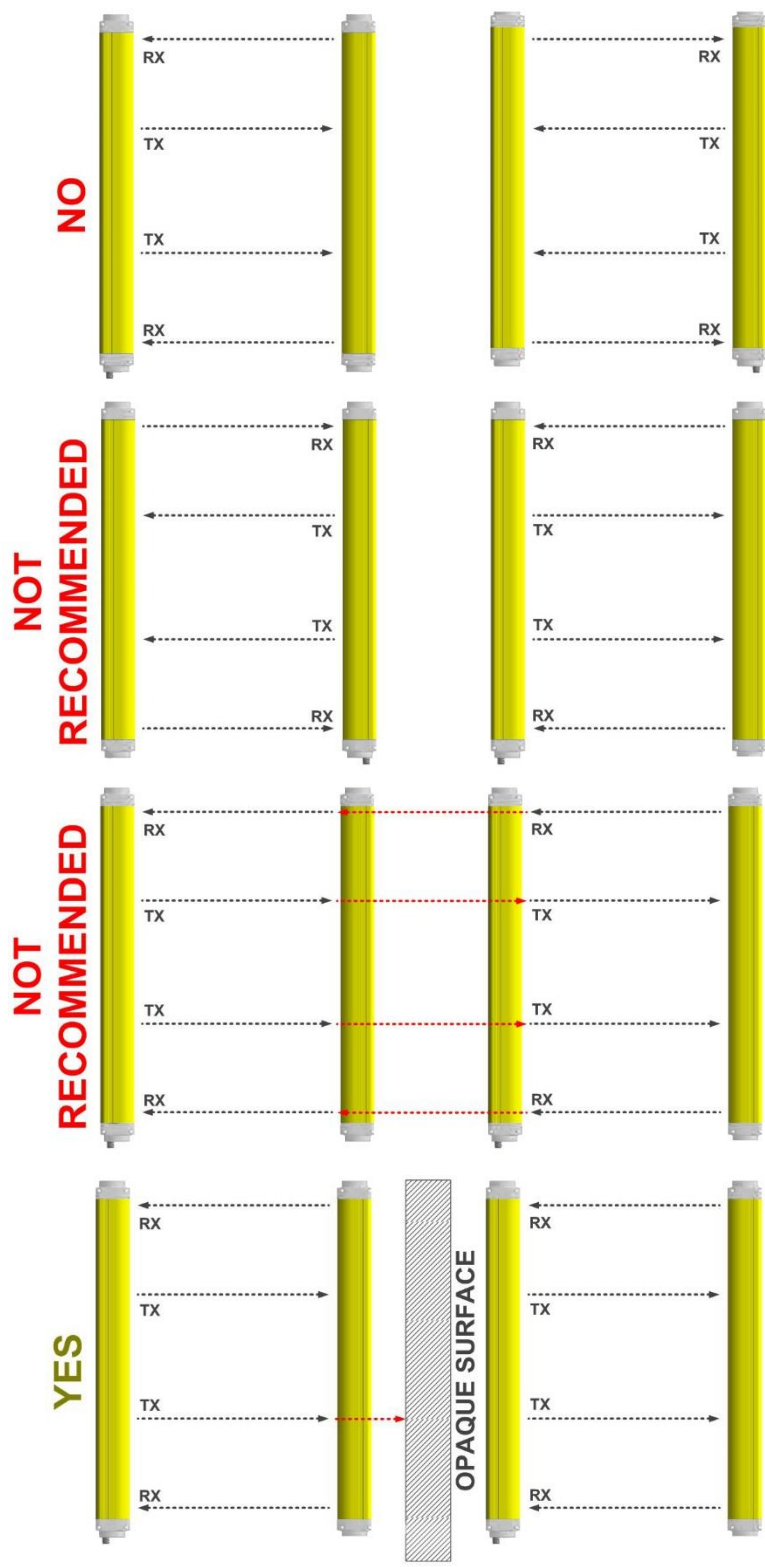

Figure 11 – Installation of several devices close to each other

3.2.6 Active and passive unit orientation

The two units shall be assembled parallel to each other and with the markings on active and passive units on the same side, both up or both down for example.

The configurations shown in Figure 12 must be avoided.

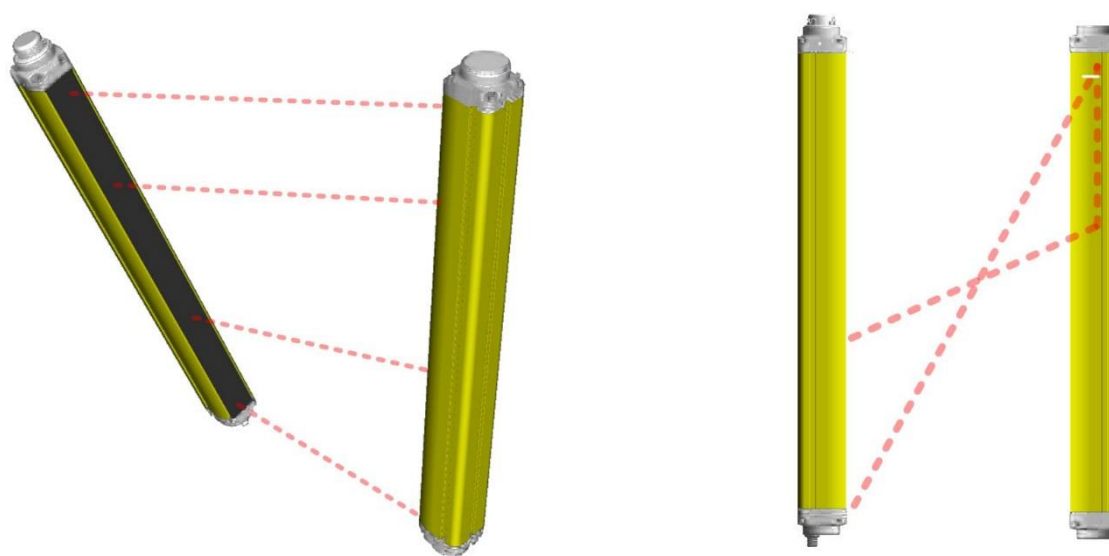

Figure 12 – Incorrect orientation

3.2.7 Use of deviating mirrors

NB: The following precautions must be respected when using the deviating mirrors:

- The alignment of the active and passive units can become a very critical operation when deviating mirrors are used. Even a very small displacement of the mirror is enough to loose alignment. The use of an Orion laser pointer (available as accessory) is recommended in these conditions.
- The minimum installation distance (S) must be respected for each single section of the beams.
- The effective operating range decreases by about 15 % by using only one deviating mirror, the percentage further decreases by using 2 or more mirrors (for more details, refer to the technical specifications of the mirrors used).
- Do not use more than three mirrors for each device.
- The presence of dust or dirt on the reflecting surface of the mirror causes a drastic reduction in the range.

3.3 Checks after first installation

The control operations to carry-out after the first installation and before machine start-up are listed hereinafter. The controls must be carried-out by qualified personnel, either directly or under the strict supervision of the person in charge of machinery safety.

Check that:

- The AOPD remains in OSSD OFF state (➡) during beam interruption along the entire detection zone, using the suitable “Test piece” and following the Figure 13 scheme. The suitable “Test Piece” has one dimension identical with the resolution of the AOPD, a cylinder with a 14 mm diameter for a light curtain with a 14 mm resolution for example.

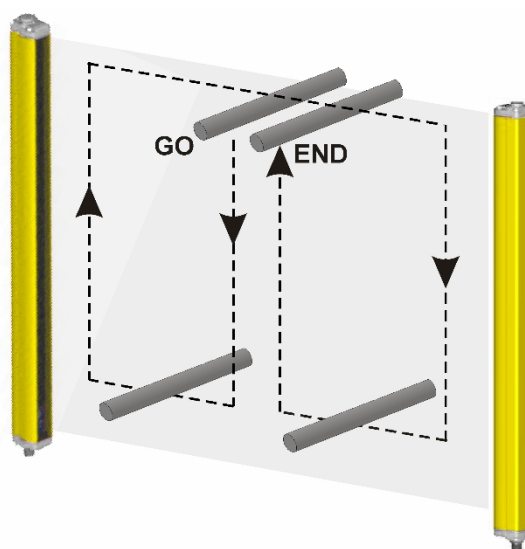

Figure 13 – Scheme for checking the function

- The AOPD is correctly aligned: press slightly the product side in both directions and check that the red LED ➡ does not turn on.
- The stopping time of the machine, including the response times of the AOPD and of the machine, is within the limits defined when calculating the minimum installation distance (see paragraph 2.4 – “Minimum installation distance”).
- The minimum installation distance between the hazard zone and the AOPD is in accordance with the instructions included in paragraph 2.4 – “Minimum installation distance”).
- Access of a person between the AOPD and the hazard zone of the machine is not possible, nor is it possible for him/her to stay there without being detected.
- Access to the hazard zone of the machine from any unprotected area is not possible.
- The AOPD is not disturbed by external light sources: it should remain in OSSD ON state for at least 10-15 minutes and, after placing the specific test piece in the detection zone, remain in the OSSD OFF state for the same period of time.
- All additional functions behave as expected by activating them in different operating conditions.

4 Mechanical mounting

The active and passive units must be installed with the relevant sensitive surfaces facing each other. The distance between the two units must be within the operating range of the model used (see paragraph 11 – “Technical data”).

The two units must be aligned and as parallel as possible. The next step is the fine alignment, as shown in paragraph 6 – “Alignment procedure”.

4.1 Mounting with angled fixing brackets

Angled fixing brackets are supplied with all Orion3 Extended models. To mount the AOPD, insert the supplied “double nut plate” (M5) into the grooves on the two units (see Figure 14).

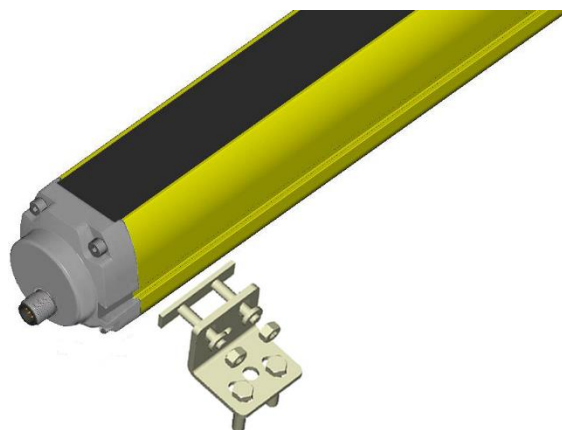
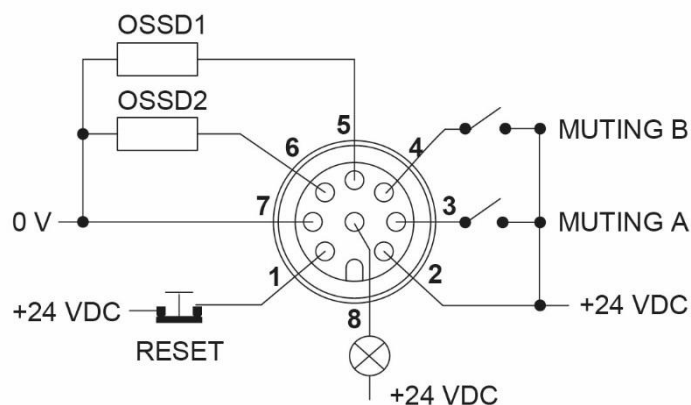

Figure 14 – Mounting with the angled fixing brackets

5 Electrical connections

All electrical connections to the active unit are made through male M12-8 pole connector located on the lower part of the active unit.

5.1 Active unit



Pin	Wire ¹	Function	Connection to	Refer to	
1	White	RESET	Auto. Reset with no function	+24 VDC	7.2, 7.3, 7.4
		ACKN.	Auto. Reset with EDM	NC contact of force-guided relay to +24 VDC	
		EDM	Manual Reset with no function	NC contact to +24 VDC	
			Manual Reset with EDM	NC contact in series with NC contact of force-guided relay to +24 VDC	
2	Brown	Supply	+24 VDC		
3	Green	MUTING A	Muting sensor A	7.5	
4	Yellow	MUTING B	Muting sensor B		
5	Grey	OSSD1	Safety control module for ex.		
6	Pink	OSSD2	Safety control module for ex.		
7	Blue	Supply	0 V		
8	Red	Muting lamp	Muting lamp and +24 VDC		

¹Colours according to ABB Jokab Safety standard cables

5.2 Important notes on connections

For the correct functioning of the Orion3 Extended light grids, the following precautions regarding the electrical connections have to be respected:

- Use a suitably insulated low-voltage supply system type SELV or PELV.
- Do not place connection cables in contact with or near high-voltage cables and/or cable undergoing high current variations (e.g. motor power supplies, inverters, etc.).
- Do not connect the OSSD wires of different AOPDs in the same multi-pole cable.
- If used, the RESET button should be a NC push-button connected to the supply voltage of the AOPD.

 **Warning!** The RESET button must be located in such a way that the operator can check the entire hazard zone during any reset, acknowledge and override operation (see paragraph 7 – “Functions”).

- If the EDM function is to be used, the normally closed contacts of the monitored external devices should be connected to pin 1 and +24 VDC before powering. If the EDM function is activated and the wire is not correctly connected at powering, the device enters Error mode. See paragraph 7.4– “EDM function”.
- The Muting function is activated when the muting sensors connected to the AOPD are activated according to the expected sequence, see paragraph 7.5 – “Muting”. The Muting lamp integrated to the active unit is activated accordingly.
- Read about the Muting function and the positioning of the muting sensors in paragraph 7.5 – “Muting”.
- The device is already equipped with internal overvoltage and overcurrent suppression devices. The use of other external components is not recommended.

5.3 Connection examples

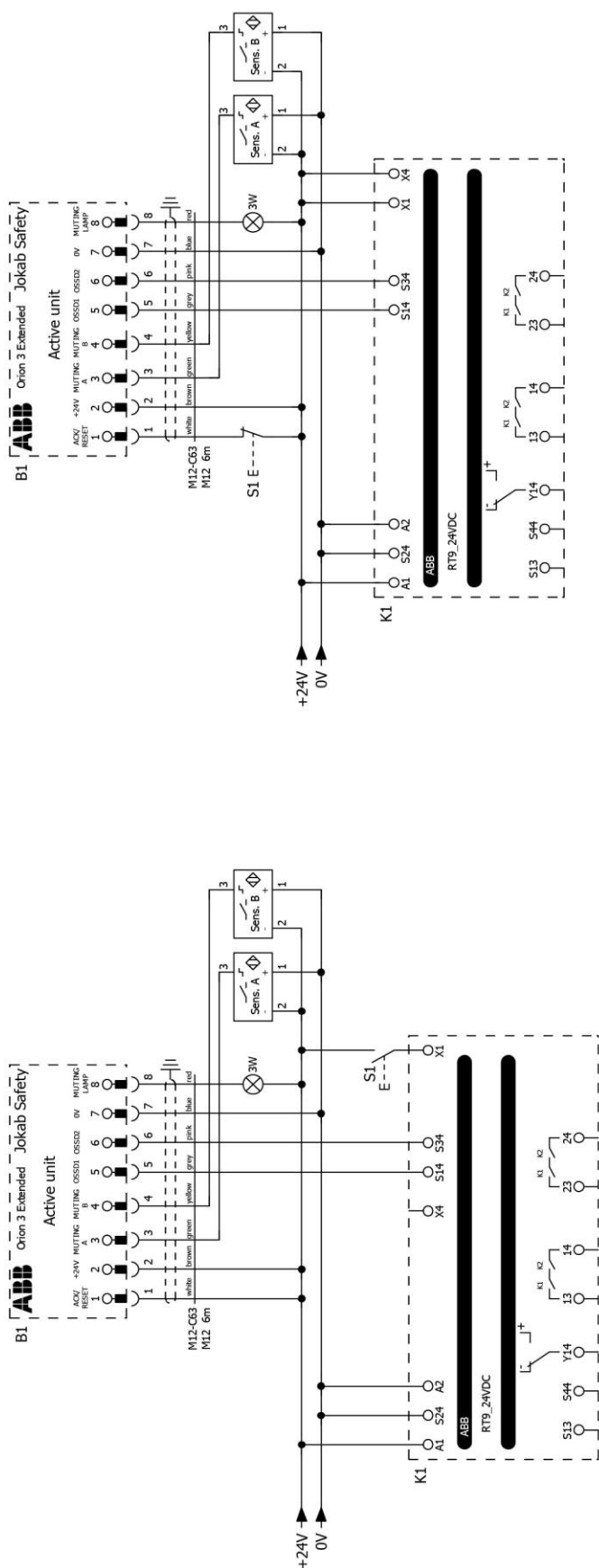

Figure 15 – Connection to a RT9 safety relay

ORION3 Extended with muting sensors

Reset button connected to the light guard

Configuration of the light guard:
 - Manual reset
 - EDM deactivated

ORION3 Extended with muting sensors

Reset button connected to the safety relay

Configuration of the light guard:
 - Automatic reset
 - EDM deactivated

NB: Do not use varistors, RC circuits or LEDs in parallel with relay inputs or in series with OSSD outputs.

NB: The OSSD1 and OSSD2 safety contacts cannot be connected in series or in parallel, but can be used separately (See Figure 16) conforming to the safety requirements of the plant.

If one of the configurations of Figure 17 is erroneously used, the device enters Error mode (OSSD error, see paragraph 8 – “Diagnostic functions”).

NB: Connect both OSSD outputs to the activating device. Failure to connect an OSSD to the activating device jeopardizes the SIL and/or PL of the system that the AOPD controls.

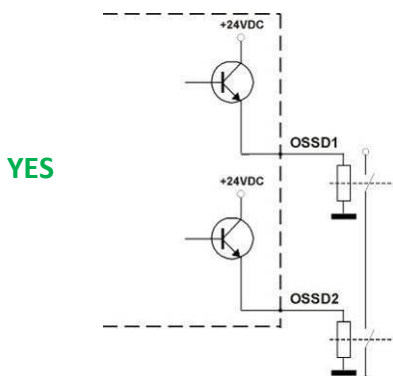

Figure 16 – Correct connection of OSSD outputs

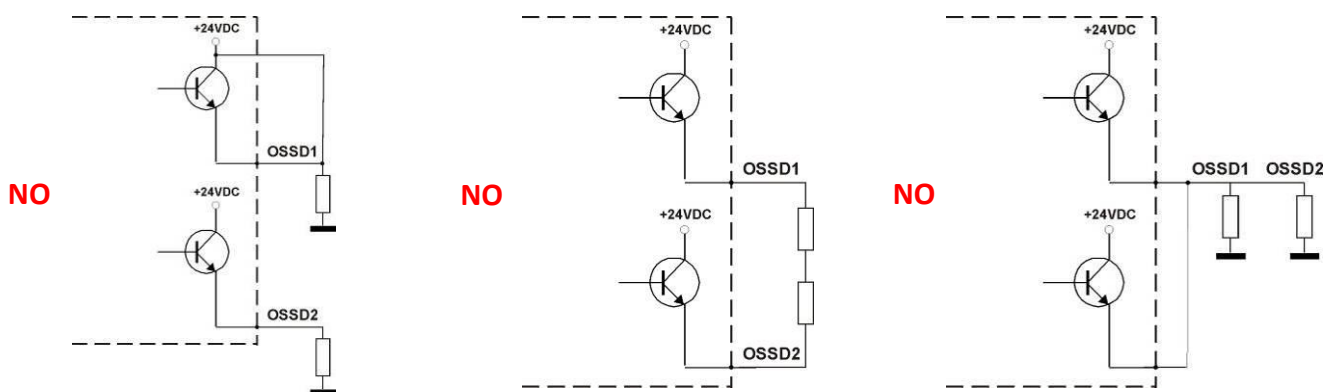

Figure 17 – Incorrect connection of OSSD outputs

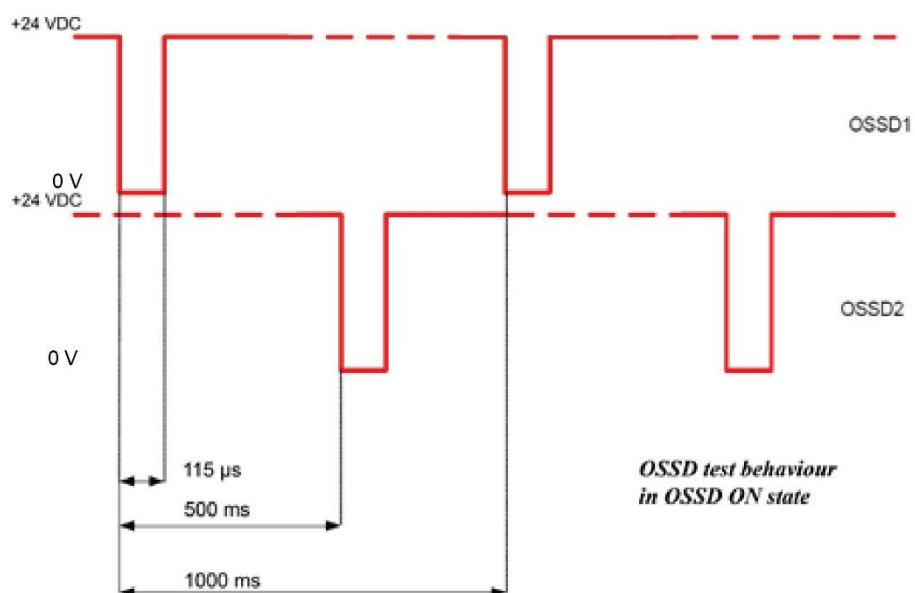

Figure 18 – Time chart of the OSSD outputs

6 Alignment procedure

The alignment between the active and the passive unit is necessary to obtain the correct functioning of the AOPD. A good alignment prevents outputs instability due to dust or vibration.

The alignment is perfect if the optical axes of the beams of the active unit coincide with the optical axes of the corresponding mirrors on the passive unit.

It is important to understand the symbols present on the display. The symbols are easily interpreted whatever the orientation of the AOPD.

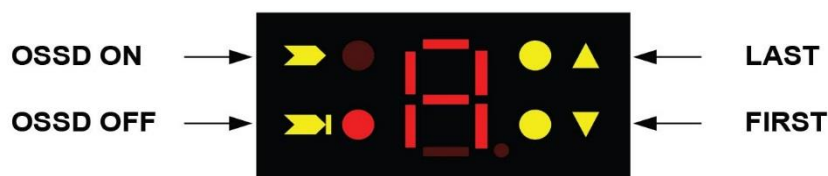

Figure 19 – Display

Each arrow is associated to a yellow LED and refers to either the first or the last transmitter/receiver couple. Figure 20 shows that the first transmitter/receiver couple is the nearest to the M12 connector and the last transmitter/receiver couple is the farthest from the M12 connector.

A 7-segment display informs the user of the level of alignment reached.

The standard installation described hereinafter is the one shown in Figure 20, i.e. with the connectors pointing down. Obviously, the first and the last couples coincide when the AOPD has only 2 beams.

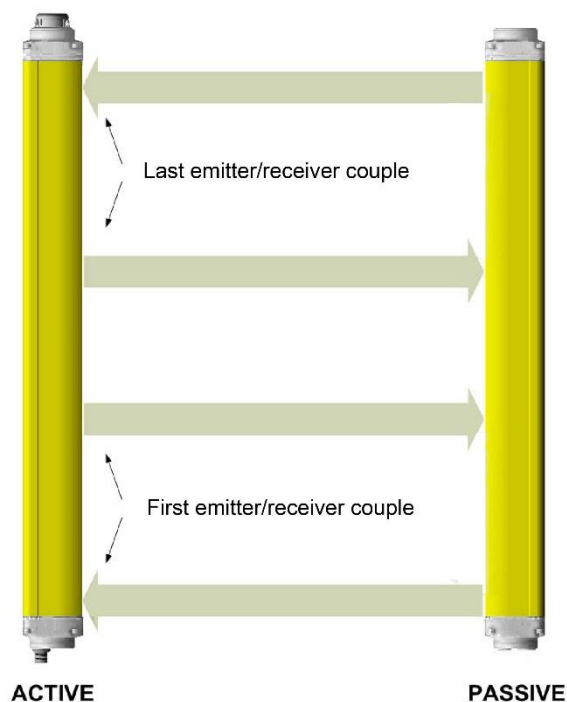

Figure 20 – First and last transmitter/receiver couple

For longer distances, the Orion laser pointer (available as accessory) can be attached to the active or the passive unit in order to obtain the best alignment (see Figure 21).



Figure 21 – Orion laser pointer

6.1 Alignment mode

The Alignment mode is activated by pushing the RESET push-button for at least 0.5 s at power on, see Figure 22.

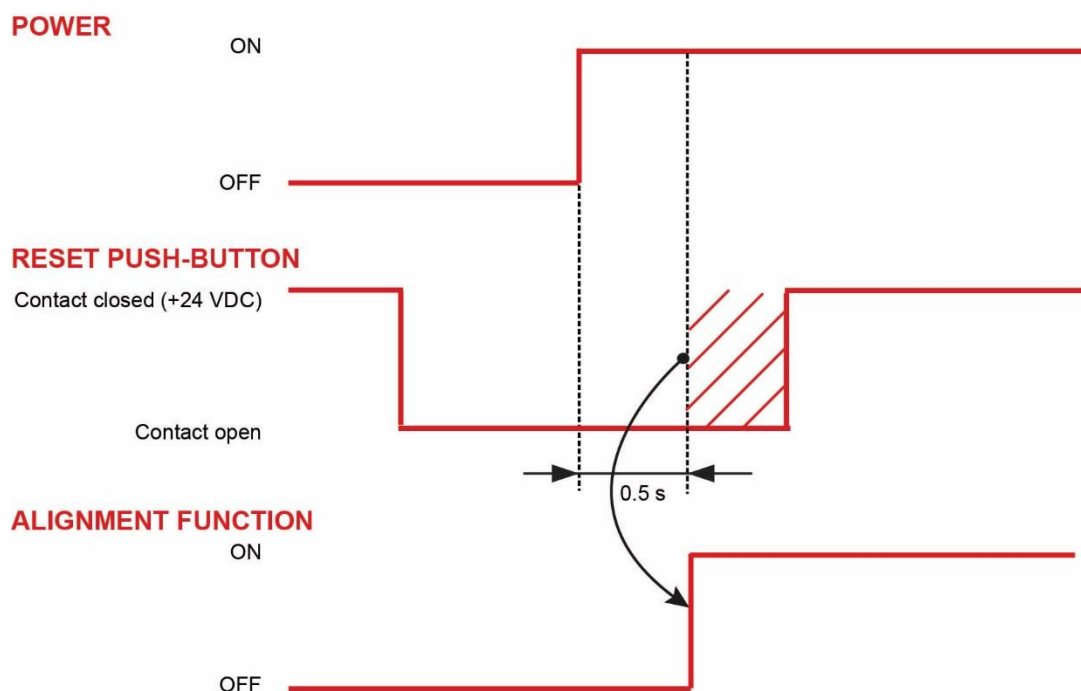

Figure 22 – Time chart of the Alignment mode

Once the optimal alignment has been reached, the device is returned to normal function by turning the active unit off and on.

NB: The OSSD outputs are off in alignment mode.

6.2 Correct alignment procedure

The alignment is performed after having completed the mechanical installation and the electrical connections as described above. Compare alignment results with those given in the following table.

Enter the alignment mode as described above. In alignment mode:

- The internal and external muting lamps flash: the better the alignment level, the faster the flashing.
- The display informs the user of the level of alignment reached.

Display	Alignment status	Alignment quality	Output status when out of alignment mode
	First and last couple are not aligned	Bad	OSSD OFF
	Last couple is not aligned	Bad	OSSD OFF
	First couple is not aligned	Bad	OSSD OFF
	Every couple over the lower light reception threshold and no couple over the upper light reception threshold	Good	OSSD ON
	Every couple over the lower light reception threshold and one couple over the upper light reception threshold		OSSD ON
	Every couple over the upper light reception threshold		OSSD ON
	Maximum light reception		Excellent

- 1) Keep the active unit in a steady position and adjust the passive unit until the yellow LED (▼ FIRST) turns off. This condition shows the alignment of the first transmitter/receiver couple.
- 2) Rotate the passive unit, pivoting around the lower optics axis, until the yellow LED (▲ LAST) turns off.

NB: Make sure that the green LED (➡) is on and steady.

- 3) Slightly turn both units both ways to find the limits of the area in which the green LED (➡) is steady and “4” is displayed (Maximum alignment). Place both units in the centre of this area.
- 4) Fix the two units firmly using brackets.

Check that the green LED (➡) on the active unit is on when the beams are not interrupted. Then check that the red LED (➡I) turns on when one single beam is interrupted. This check shall be made with the special cylindrical “Test Piece” having a suitable size for the resolution of the device used (see paragraph 3.3 – “Checks after first installation”).

- 5) Switch the device off and on to normal operating mode.

The alignment level is also monitored during normal operating mode and visualized on the display.

Once the AOPD has been aligned and correctly fastened, the signal on the display is useful both to check the alignment and to show a change in the environmental conditions (presence of dust, light disturbance and so on). The behavior is summarized in the next table.

Display	Alignment status	Alignment quality
	Every couple over the lower light reception threshold and no couple over the upper light reception threshold	
	Every couple over the lower light reception threshold and one couple over the upper light reception threshold	
	Every couple over the upper light reception threshold	

7 Functions

7.1 Dip-switch selectable functions

Unscrew the cap on top of the active unit to access the dip-switches.

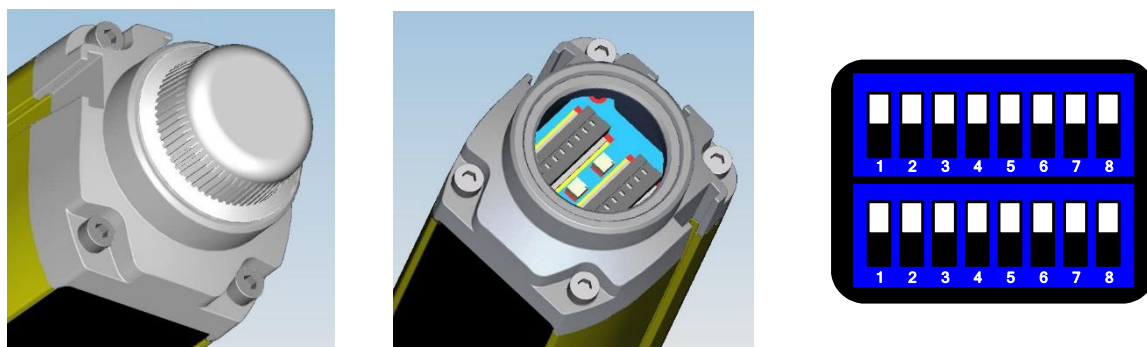

Figure 23 – Location of the dip-switches

NB: Each function is associated with two different dip-switches: the top and bottom dip-switches must be configured in the same manner. The “ON” position is the position at delivery.

The dip-switches allows to set the functions as described in the following table:

Dip-switches	Function	ON*	OFF
1	Muting timeout	10 min	∞
2	T / X or L-muting	T / X-muting	L-muting
3	Muting filter	Deactivated	Activated
4	Reset of the Override	Manual	Automatic
5	Not used	-	-
6	EDM	Deactivated	Activated
7	Reset	Automatic	Manual
8	Not used	-	-

*Factory default configuration

Warning! An infinite muting (timeout = ∞) is not compliant with EN 61496-1:2013. Therefore, all possible risks must be considered and related precautions undertaken before selecting the option “ ∞ ”.

Warning! The device does not accept configuration changes during normal operation. A change is taken into account after the next powering of the device. Therefore, the management and the use of the configuration dip-switches should be performed with great care.

7.2 Reset function

The interruption of a beam by an opaque object causes the OSSD outputs to switch off (OSSD OFF state ➡ I).

The AOPD can be reset to the OSSD ON state ➡ I in two different ways:

- **Automatic Reset:**

When activated, the AOPD returns to OSSD ON once the object has been removed from the detection zone.

- **Manual Reset:**

When activated, the AOPD returns to OSSD ON once the RESET button has been pushed, provided that the object has been removed from the detection zone. The condition when the object has been removed and the system is waiting for reset is called interlock and is signaled on the display (see paragraph 8.2 – “Diagnostic messages”).

Warning!! Carefully assess risk conditions and reset modes. In applications protecting access to hazardous zones, the Automatic Reset function is unsafe when the operator can stand in the hazard zone without being detected. In this case, the Manual Reset of the AOPD or the safety relay is necessary (see paragraph 5.2 – “Important notes on connections”).

Warning! The RESET button must be located in such a way that the operator can check the entire hazard zone during any reset operation.

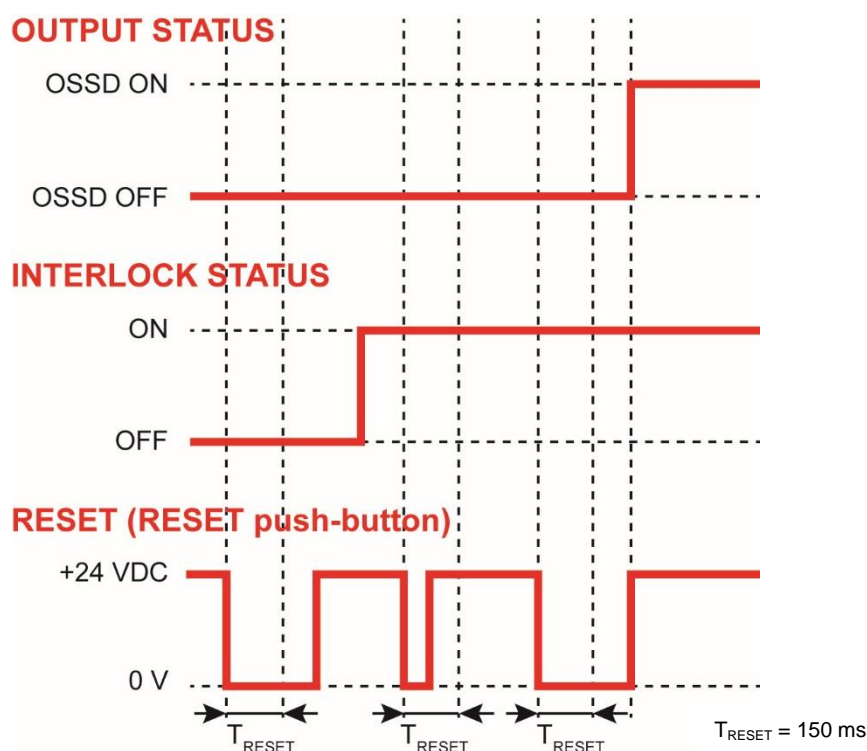

Figure 24 – Time chart for the Manual Reset function

Select Automatic or Manual Reset with dip-switches 7, see paragraph 7.1 – “Dip-switch selectable functions”.

7.3 Acknowledge function

The Acknowledge function is used in presence of an internal error like an optical error, an OSSD error, a muting lamp error or an EDM error.

The Acknowledge function is activated by pressing the RESET push-button for at least 5 s in Error mode. The AOPD then returns to normal operation mode.

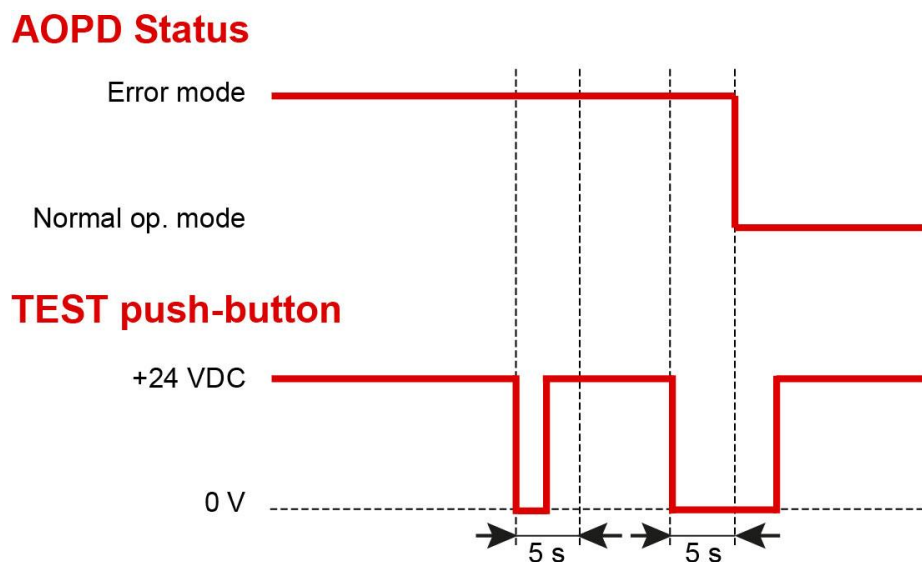

Figure 25 – Time chart of the Acknowledge function

If the error is not solved before the Acknowledge, the AOPD remains in the same error mode, whatever the error.

NB: Some errors are critical errors and the device must be turned off and on to return to normal operation mode:

- Microprocessor error
- Reset selection error
- Override sequence error
- Dip switch error

7.4 EDM function

The AOPD has a function for monitoring actuation external devices (EDM). This function can be activated or deactivated with dip-switches 6.

To correctly use this function:

- activate it using the corresponding dip-switches,
- connect pin1 to +24 VDC through the normally closed contacts of the device to be monitored.

This function checks that the normally closed contacts switch state when the OSSD outputs change state.

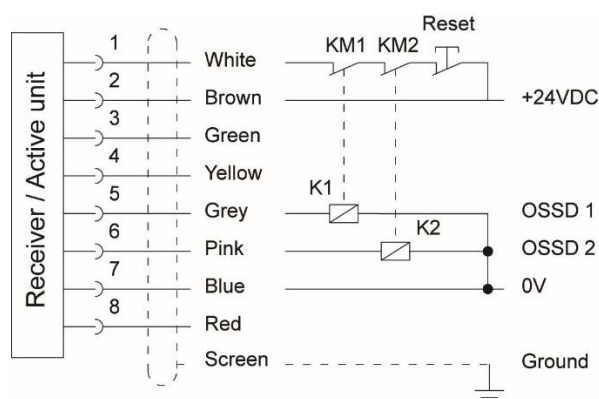

Figure 26 – Connection of EDM, e.g. external contactors K1 and K2

OUTPUT STATUS

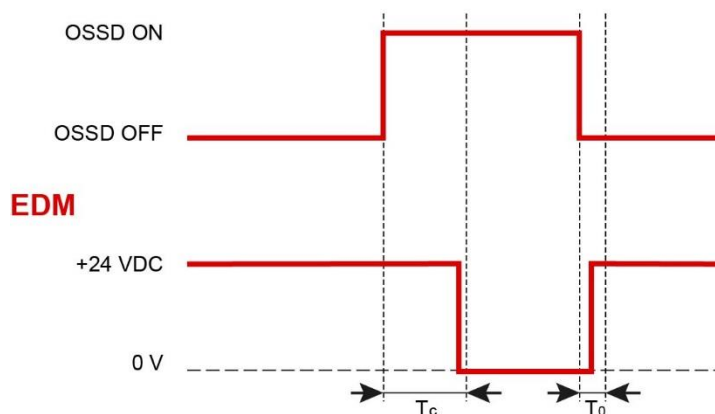

Figure 27 – Time chart of the EDM function

T_c and T_0 are the times between the change of state of the OSSD outputs and the change of state of the NC contact of the external device.

$T_c \leq 350$ ms: the external NC contacts must open within this time after the OSSD outputs have switched on.

$T_0 \leq 100$ ms: the external NC contacts must close within this time after the OSSD outputs have switched off.

7.5 Muting

The Muting function allows automatic bypassing of the safety function on the whole protected height in order to carry out specific operations without stopping the machine.

The most common application is in and out feeding of material. The muting sensors must be able to recognize the passing material (pallets, vehicles, etc.) and their placement will depend on the length and speed of the material. In case of different transport speeds in the muting area, their effect on the total muting duration must be considered.

This function is particularly suitable when an object, but not a person, has to pass through the hazard zone, under certain conditions.

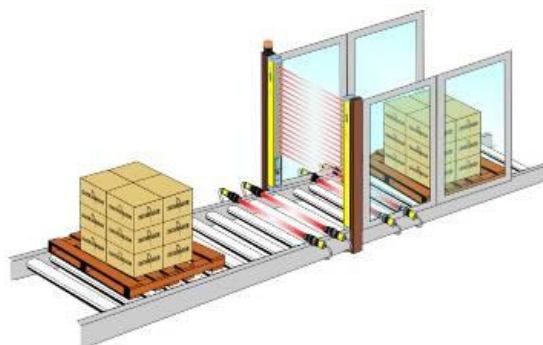

Figure 28 – Linear version with external Muting sensors

Warning! It is important to remember that the Muting function represents a forced system condition and therefore has to be used with the necessary precautions.

7.5.1 Typical muting application and connection of the AOPD

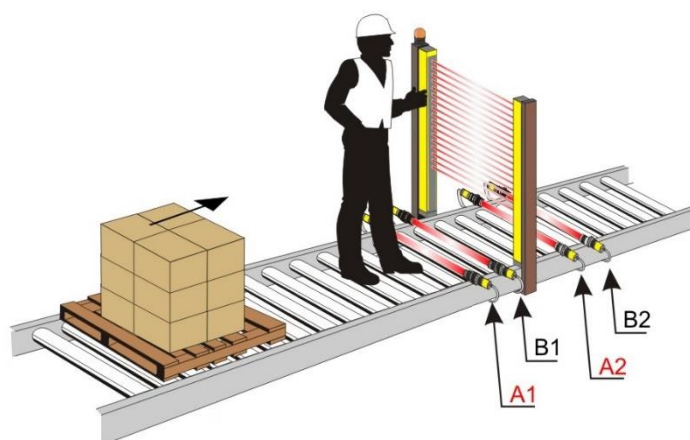

Figure 29 – Typical muting application

The figure above shows a typical muting application: the box on the conveyor may go through the AOPD without stopping the machine but the worker may not. Following a correct activation sequence of the A1, B1, A2 and B2 sensors, the AOPD is temporarily bypassed.

Warning! The muting sensors must be positioned in such a way that the Muting function cannot be activated by the accidental passing of a person. Particular attention must be paid to the use of the one-way L-muting mode: the muting sensors must be positioned to allow the passage of the material coming out of the hazard zone protected by the AOPD.

- The AOPD has two inputs (MUTING A and MUTING B) for the activation of this function, according to the current standards.
- The output of the muting sensors (A1, B1, A2 and B2) are connected to the Muting A and Muting B inputs.
- The outputs of the muting sensors should be high when the object is detected.
- The muting sensors can be optical sensors, mechanical sensors, proximity sensors, etc.
- Following a correct activation sequence of these sensors, the AOPD is temporarily bypassed.
- If MUTING A and MUTING B inputs are activated by two muting sensors or actuators, these should be correctly connected and positioned in order to avoid undesired muting or potentially dangerous conditions for the operator.
- MUTING A and MUTING B cannot be activated simultaneously.
- Muting cannot be requested when the OSSD outputs are off.
- A muting filter can be activated with dip-switches 3. When activated, low-high or high-low transitions of the MUTING signals are considered valid if maintained for t_F seconds ($t_F \geq 0.1$ s), as shown in the following figure.

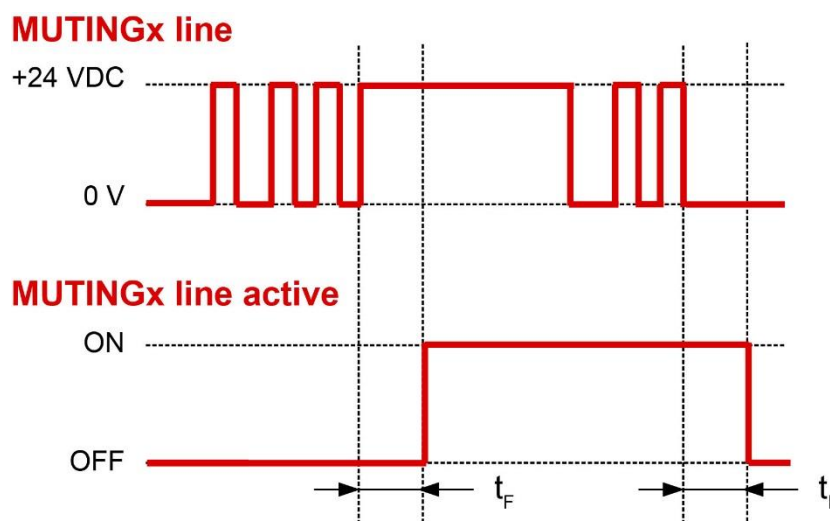

Figure 30 – Time chart of the Muting filter function

- . The value of the muting timeout is chosen between 10 min and infinite with dip-switches 1.

Warning! An infinite muting (timeout = ∞) is not compliant with EN 61496-1:2013. Therefore, all possible risks must be considered and related precautions undertaken before selecting the option “ ∞ ”.



Figure 31 – Integrated lamp

- When the Muting function is on, the integrated lamp on the top of the receiver is on and the lamp output (pin 8) is driven.
- If both the integrated lamp and the external lamp are broken and/or not connected, the muting request causes the AOPD to enter Error mode and the OSSD outputs to switch off. The corresponding error is indicated.

Warning! The lamp should be as visible as possible.

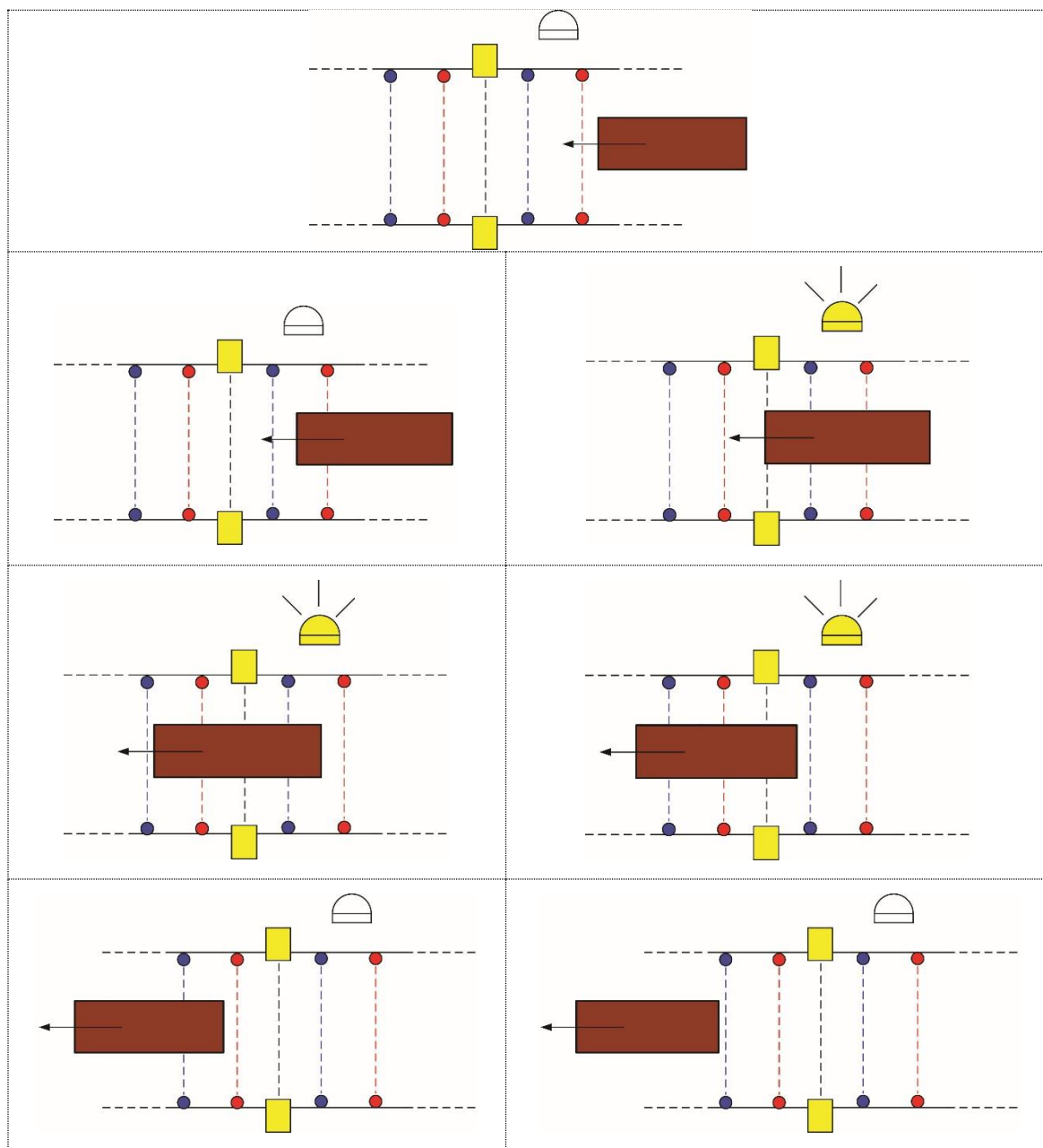

Figure 32 – The muting lamp is on when the muting function is activated

7.5.2 Muting direction

The AOPD can be used with

- T/X-muting when the “boxes” can move in both directions. This is the default setting. T-muting demands four muting sensors and X-muting only two.
- L-muting when the “boxes” move in one direction only. L-muting demands two sensors.

The muting direction is chosen with the dip-switches 2 and T / X-muting is the configuration at delivery (both 2 ON).

⚠ Warning! Select the configuration carefully: an incorrect configuration can cause a reduction of the SIL/PL reached by the system. For a correct use of the muting, please refer to the relevant standards.

7.5.3 T / X muting

Suitable when the objects/"boxes" can move in both directions. This is the default setting.

NB: Dip-switches 2 should be ON.

- T-muting demands four muting sensors, A1, B1, A2 and B2.
- X-muting demands two muting sensors, A1 and B2.

The sensors named A1/A2 are connected to MUTING A and the sensors named B1/B2 are connected to MUTING B. The sensors that end with "1" are on the same side of the AOPD and the sensors that end with "2" are on the opposite side of the AOPD.

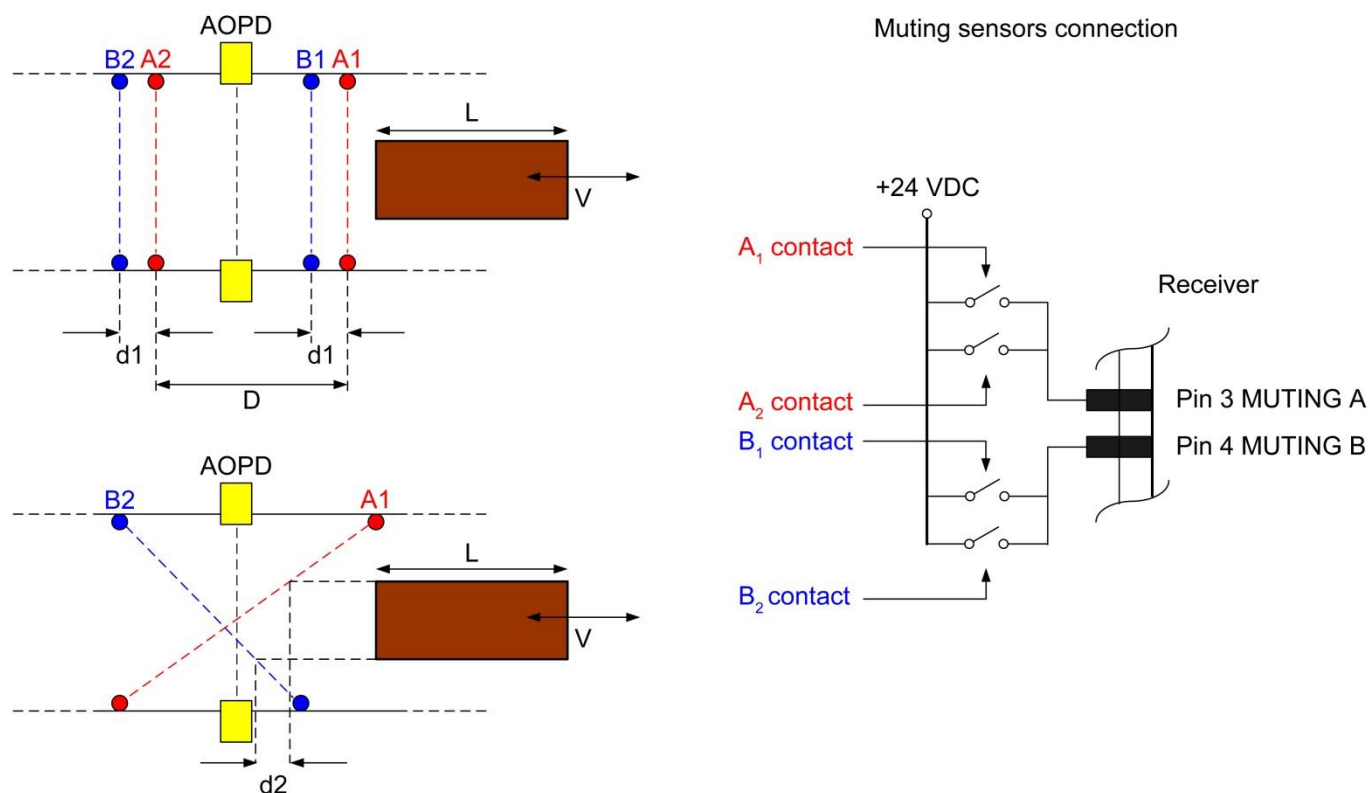

Figure 33 – Connection of T / X-muting

Warning! In X-muting, the crossing point of the two muting sensors must be within the hazard zone.

If

- L = The length of the “box”.
- D = The distance at which the sensors A1/A2 or B1/B2 have to be mounted. (D depends on L, see below.)
- V = The speed of the “box”.
- d1 = The distance between the muting sensors. (d1 depends on V, see below.)
- d2 = The distance for the muting request to be accepted. (d2 depends on V, see below.)
- T_{AB max} = The maximum activation delay allowed between MUTING A and MUTING B.

Then

D must be less than L, $D < L$

$$d1_{max} [cm] = V [m/s] \times T_{AB \ max} [s] \times 100$$

$$d2_{max} [cm] = V [m/s] \times T_{AB \ max} [s] \times 100$$

NB: guidance in the positioning of the muting sensors can be found in IEC/TS 62046.

In T/X-muting, the Muting function is activated when the signal on MUTING B goes high within a fixed t_{AB} max time after the rise of the signal on MUTING A or vice versa.

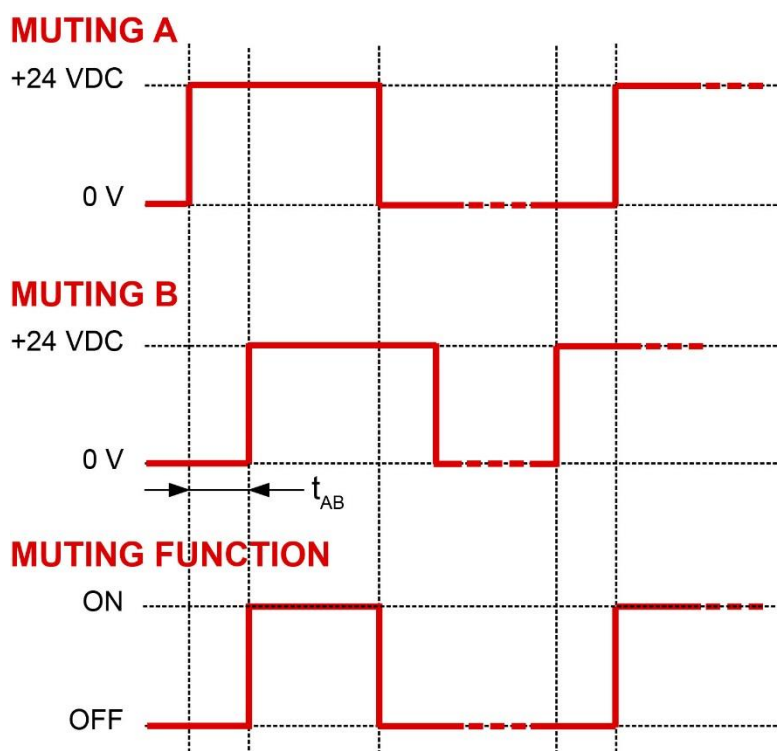

Figure 34 – Time chart of the T / X-Muting function

T and X-muting	
t_{AB} min	0,01 s
t_{AB} max	4 s
End of muting	As soon as A or B goes low
Muting timeout (maximum muting time if the conditions of muting persist, e.g. if the “box” stops during the transit)	10 minutes if dip-switches 1 ON Infinite if dip-switches 1 OFF (“10 min” is the default value, see paragraph 7.1)

Warning! An infinite muting (timeout = ∞) is not compliant with EN 61496-1:2013. Therefore, all possible risks must be considered and related precautions undertaken before selecting the option “ ∞ ”.

7.5.4 L-muting

Suitable when the objects/“boxes” move in one direction only.

NB: Dip-switches 2 should be OFF

- L-muting demands two muting sensors, A and B.

The sensor named A is the farthest from the AOPD and must be activated first. If the sensor named B is activated first, the Muting function is not activated. In the following figure, this means that the “box” has to move from the right to the left.

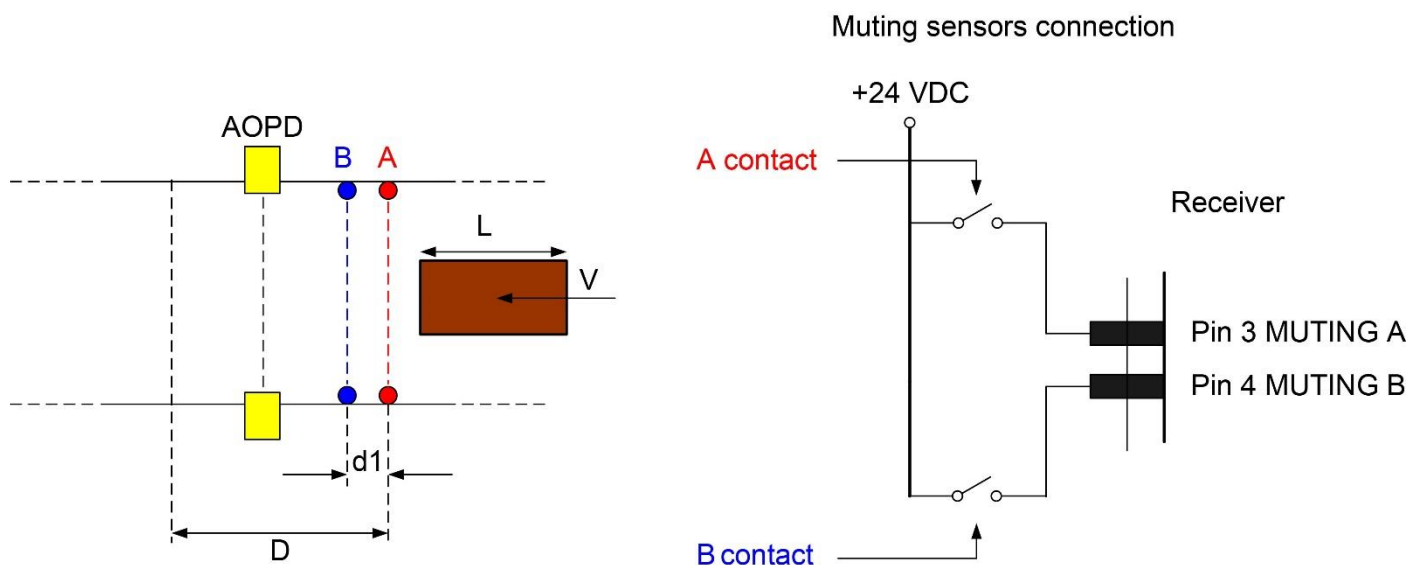

Figure 35 – Connection of L-muting

⚠ Warning! In L-muting, the two muting sensors must be within the hazard zone and the “box” shall be allowed to go out of the hazard zone only.

If

- L = The length of the “box”.
- V = The speed of the “box”.
- d1 = The distance between the muting sensors. (d1 depends on V, see below.)
- T_{AB max} = The maximum activation delay allowed between MUTING A and MUTING B.

Then

$$d1_{max} [cm] = V [m/s] \times T_{AB \ max} [s] \times 100$$

NB: guidance in the positioning of the muting sensors can be found in IEC/TS 62046.

In L-muting mode, the Muting function is activated when the signal on MUTING B goes high within a fixed t_{AB} max time after the rise of the signal on MUTING A.

NB: MUTING A has to go high first. If MUTING B goes high before MUTING A, the Muting function is not activated.

Warning! L-muting must be used exclusively for materials going out of the hazard zone.

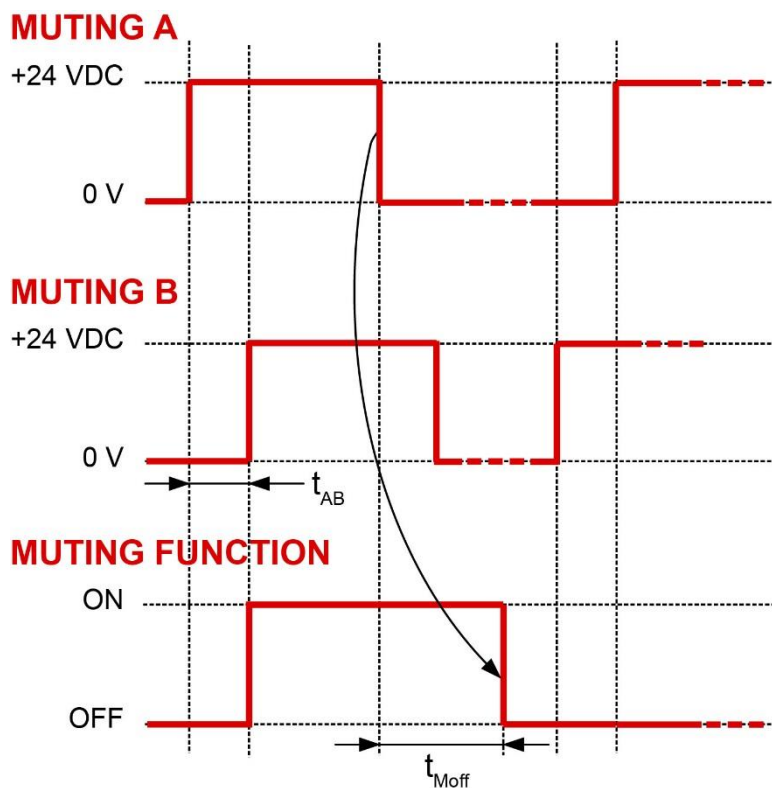

Figure 36 – Time chart of the L-Muting function

	L-muting
t_{AB} min	0,01 s
t_{AB} max	4 s
End of muting (t_{Moff})	$2 \times t_{AB}$ from when MUTING A goes low
Muting timeout (maximum muting time if the conditions of muting persist, e.g. if the “box” stops during the transit)	10 minutes if dip-switches 1 ON Infinite if dip-switches 1 OFF (“10 min” is the default value, see paragraph 7.1)

Warning! An infinite muting (timeout = ∞) is not compliant with EN 61496-1:2013. Therefore, all possible risks must be considered and related precautions undertaken before selecting the option “ ∞ ”.

7.6 Override

The override function is used to bypass the AOPD completely and switch on the OSSD outputs when it is necessary to start the machine despite one or more beams of the AOPD being interrupted. The purpose is usually to clear the detection zone and move a “box” that has stopped there because of a cycle anomaly.

⚠ Warning! Make sure that the operator can check the entire hazard zone during the whole override operation.

- To start override, the OSSD outputs must be switched off and at least one beam must be interrupted.
- If the entire detection zone is free for more than 2 s, the override function is immediately deactivated.
- The maximum timeout for the override function is 600 s.
- The standard requires the use of a device like a hold-to-run device so that it is impossible to enter the hazardous zone while maintaining the action on the device.
- When the Override function is on, the integrated lamp on the top of the receiver is on and the lamp output (pin 8) is driven.
- If both the integrated lamp and the external lamp are broken and/or not connected, the override request causes the AOPD to enter Error mode and the OSSD outputs to switch off. The corresponding error is indicated.

⚠ Warning! The lamp should be as visible as possible.



Figure 37 – Integrated lamp

When the requirements are met, the display informs the user that an override is possible and required.

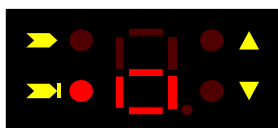

Figure 38 – Indication that the Override function can be activated

7.6.1 Override at start-up

- Switch off the power supply.
- Restore the power supply and press the RESET button after approx. 5 s but within 9 s and keep it pressed for at least 5 s. The OSSD outputs switch on and remain activated for a maximum time of 600 s.
- The override function is now activated and the integrated lamp flashes. So does the external lamp if connected.
- If the AOPD is in Automatic Reset, the OSSD outputs remain on after the end of the override.
- If the AOPD is in Manual Reset, it is possible to choose between a Manual Reset and an Automatic Reset for the Override function. See paragraph 7.6.3.

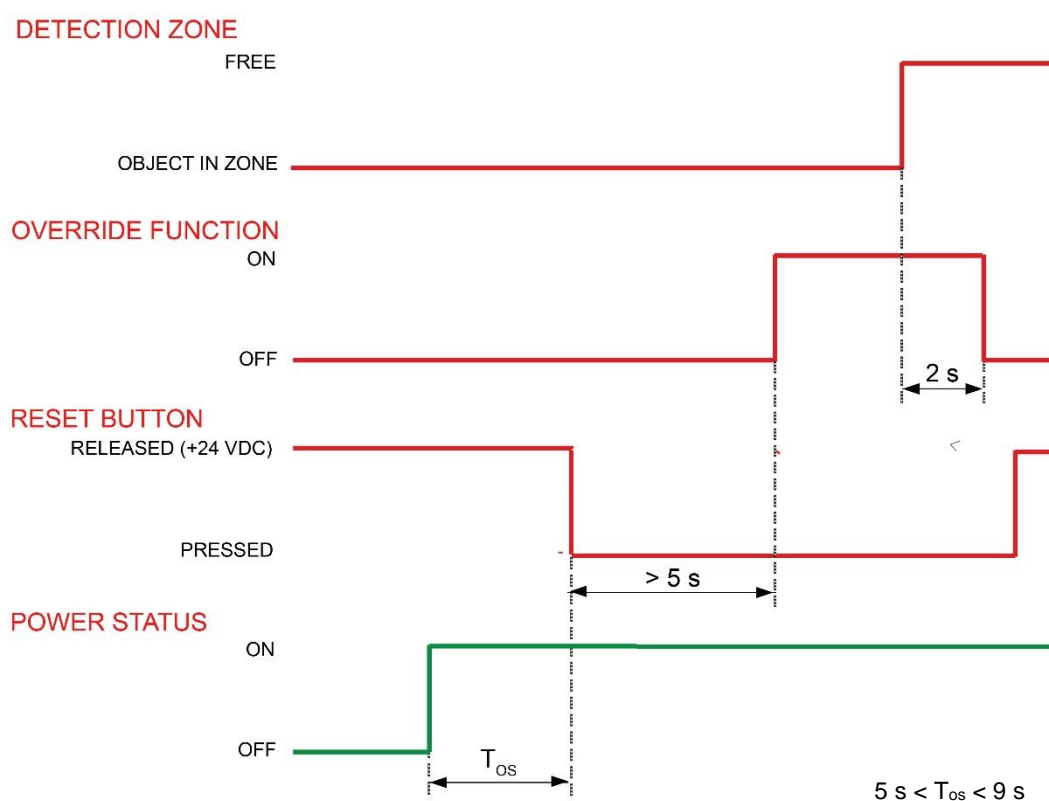

Figure 39 – Time chart for the Override function at start-up

7.6.2 Override at run time

- One or both muting inputs must be active.
- Press and release the RESET button 3 times < 1 s. The OSSD outputs will be activated for more than 2 s and 600 s max.
- The override function is now activated and the integrated muting lamp flashes. So does the external lamp if connected.
- If the AOPD is in Automatic Reset, the OSSD outputs remain on after the end of the override.
- If the AOPD is in Manual Reset, it is possible to choose between a Manual Reset and an Automatic Reset for the Override function. See paragraph 7.6.3.

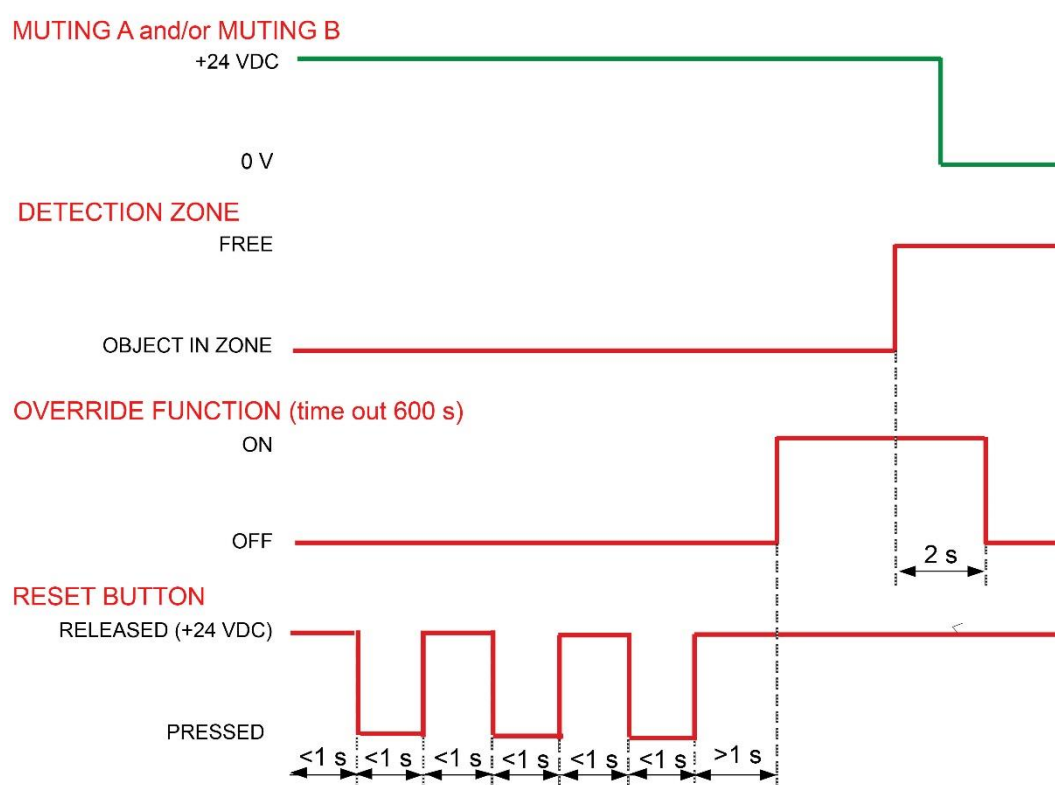

Figure 40 – Time chart for the Override function at run time

7.6.3 Reset mode of the Override function

When the AOPD is configured in Manual Reset, it is possible to choose between a manual reset and an automatic reset of the Override function with dip-switches 4.

If the Automatic Reset is chosen for the Override function, the OSSD outputs remain on at the end of the override function, provided that the detection zone is free, see Figure 41.

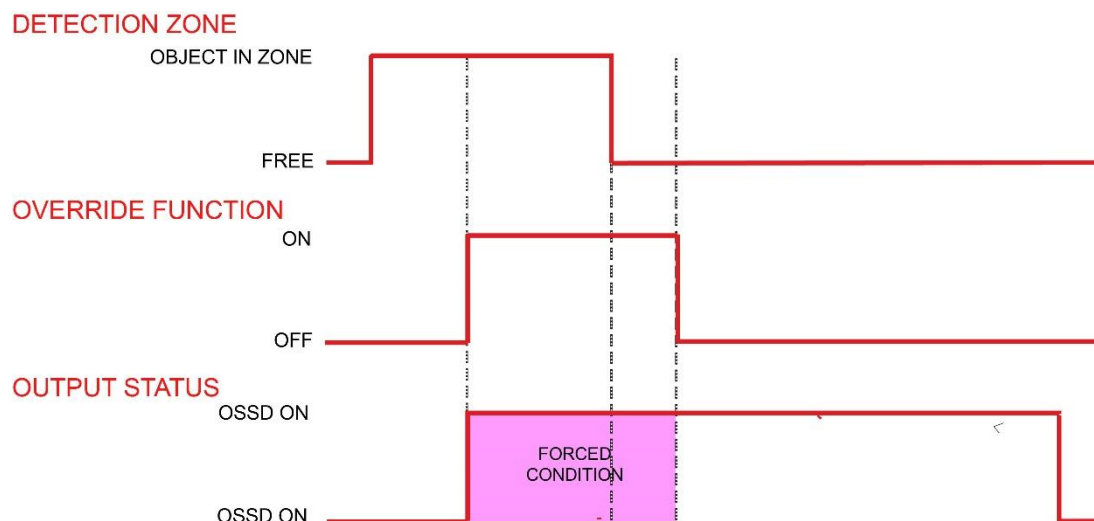

Figure 41 – Time chart of the Override function when configured in Automatic Reset

Warning! Automatic Reset of the Override function allows to return automatically to normal operation mode when the detection area (AOPD and muting sensors) is cleared. This function does not comply with the requirements of EN 61496-1:2013.

Therefore, all possible risks must be considered and related precautions undertaken. It is recommended to:

- Assign all control operations to a well-trained and skilled personnel,
- Make sure that the operator running the override function has a total visibility of the whole area.

8 Diagnostic functions

8.1 Visualization of the status of the AOPD

A display helps the user control and check the status of the AOPD, in Alignment mode, in normal operation mode and when troubleshooting. The display consists in four LEDs and a 7-segment display on the active unit.

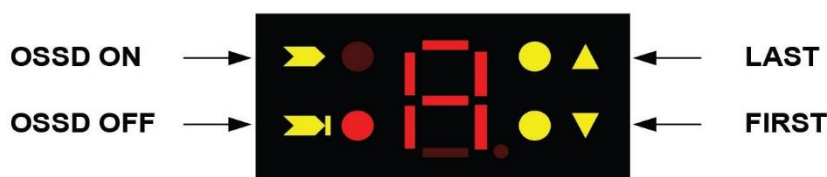

Figure 42 – LEDs on the display

8.2 Diagnostic messages

8.2.1 Active unit

All the possible cases of visualization are explained in the table below except those relative to the Alignment mode (see paragraph 6 – "Alignment procedure").

Display	Status	Description	Action
	Interlock	Detection zone free. OSSD outputs off.	Push the RESET button to return to OSSD ON.
	Interlock	Beam(s) interrupted. OSSD outputs off.	Remove the object from the detection zone and push the RESET button.
	OSSD ON	OSSD outputs on.	
	OSSD OFF	OSSD outputs off.	
	Normal operation mode, OSSD OFF, interlock	EDM function activated.	

	<p>Normal operation mode, OSSD OFF, interlock</p>	<p>EDM function deactivated.</p>	
	<p>OSSD OFF, interlock</p>	<p>Override function ready to be activated</p>	<p>Activate the Override function according to paragraph 7.6.</p>
	<p>Error mode</p>	<p>OSSD error, one or both. OSSD outputs off.</p>	<p>Check the wiring and connections of the OSSD outputs. Make sure that there is no short-circuit between them or with the supply voltage. Then Acknowledge. If the error persists, contact your ABB Jokab Safety representative.</p>
	<p>Error mode (critical)</p>	<p>Microprocessor error. OSSD outputs off.</p>	<p>Turn AOPD off and on. If the error persists, contact your ABB Jokab Safety representative.</p>
	<p>Error mode</p>	<p>Optical error. OSSD outputs off.</p>	<p>Acknowledge the error. If the error persists, contact your ABB Jokab Safety representative.</p>
	<p>Error mode</p>	<p>EDM error. OSSD outputs off.</p>	<p>Check the wiring and the connections of EDM SELECTION and EDM as well as the time sequence (see the Time chart, Figure 27). Acknowledge the error. If the error persists, contact your ABB Jokab Safety representative.</p>
	<p>OSSD OFF</p>	<p>Override sequence error, OSSD outputs off</p>	<p>Check the time sequence of the Override function (see the Time chart in paragraph 7.6). If the error persists, contact your ABB Jokab Safety representative.</p>



	<p>Error mode (critical)</p>	<p>Dip switch error, OSSD outputs off</p>	<p>Check the settings of the dip-switches and turn the AOPD on and off. If the error persists, contact your ABB Jokab Safety representative.</p>
	<p>Error mode</p>	<p>Internal and external lamp error, OSSD outputs off</p>	<p>Check the connection of the external lamp and acknowledge. If the error persists, contact your ABB Jokab Safety representative</p>
	<p>AOPD OFF</p>	<p>Power supply error. OSSD outputs off.</p>	<p>Check the wiring and connections of the power supply. Check that its value is within the allowed range. If the error persists, contact your ABB Jokab Safety representative.</p>

It is not possible to acknowledge a critical error. The device must be switched off and on. If the error persists, contact your ABB Jokab Safety representative.

9 Periodical checks

The following is a list of recommended checks and maintenance operations that should be periodically carried-out by qualified personnel.

Check that:

- The AOPD remains in OSSD OFF state () during beam interruption along the entire detection zone, using the suitable “Test piece” according to the Figure 13 scheme (paragraph 3.3 – “Checks after first installation”).
- The AOPD is correctly aligned: press slightly the product side, in both directions, and check that the red LED  does not turn on.
- The stopping time of the machine, including the response times of the AOPD and of the machine, is within the limits defined when calculating the minimum installation distance (see paragraph 2.4 – “Minimum installation distance”).
- The minimum installation distance between the hazard zone and the AOPD is in accordance with the instructions included in paragraph 2.4 – “Minimum installation distance”.
- Access of a person between the AOPD and the hazard zone of the machine is not possible, nor is it possible for him/her to stay there without being detected.
- Access to the hazard zone of the machine from any unprotected area is not possible.
- The AOPD and the external electrical connections are not damaged.

The frequency of the checks depends on the particular application and on the operating conditions of the AOPD.

10 Device maintenance

Orion3 Extended light grids do not require special maintenance operations.

To avoid the reduction of the operating distance, optic protective front surfaces must be cleaned at regular intervals. Use soft cotton cloths damped in water. Do not apply too much pressure on the surface in order to avoid making it opaque.

Do not use the following on plastic surfaces or on painted surfaces:

- Alcohol or solvents
- Wool or synthetic cloths
- Paper or other abrasive materials

11 Technical data

Manufacturer	
Address	ABB JOKAB SAFETY Varlabergsvägen 11 SE-434 39 Kungsbacka Sweden
Electrical data	
Power supply:	+24 VDC ± 20 %
Active unit consumption (RX):	2.5 W max (normal operation without load)
Outputs:	2 PNP
Short-circuit protection:	1.4 A max at 55 °C
Output current	0.5 A max / output
Output voltage – status ON:	Power supply value less 1 V
Output voltage – status OFF	0.2 V
Capacitive load	2.2 µF at +24 VDC max
Current for external lamp:	20 mA min, 250 mA max
Response times:	From 11 to 12 ms. See paragraph 12 – “Model overview”
Protected height:	From 500 mm to 1200 mm. See paragraph 12 – “Model overview”
Electrical protection:	Class III - use SELV/PELV
Connections:	M12-8 poles male connector
Cables length (for power supply):	70 m. max
Pollution degree	2
Optical data	
Emitting light (λ):	Infrared, LED (860 nm)
Resolution:	See paragraph 12 – “Model overview”
Operating distance:	From 0.5 to 8 m. See paragraph 12 – “Model overview”
Ambient light rejection:	According to IEC-61496-2:2013

Mechanical and environmental data		
Operating temperature:	0...+ 55 °C	
Storage temperature:	- 25...+ 70 °C	
Temperature class:	T6	
Humidity:	15...95 % (no condensation)	
Protection class:	IP65 (EN 60529: 2000)	
Vibrations:	Width 0.35 mm, Frequency 10 ... 55 Hz 20 sweep per axis, 1 octave/min (EN 60068-2-6:2008)	
Shock resistance:	16 ms (10 G) 10 ³ shocks per axis (EN 60068-2-29: 2008)	
Housing material:	Painted aluminum (yellow RAL 1003)	
Front glass material:	PMMA	
Caps material:	PBT Valox 508 (grey RAL 7035)	
Weight, single unit without package:		
Orion3-4-K1C-050-E	1.3 Kg	
Orion3-4-K2C-080-E	1.8 Kg	
Orion3-4-K2C-090-E	2.1 Kg	
Orion3-4-K2C-120-E	2.6 Kg	
Orion3-4-M1C-050 (passive)	1.2 Kg	
Orion3-4-M2C-080 (passive)	1.7 Kg	
Orion3-4-M2C-090 (passive)	1.9 Kg	
Orion3-4-M2C-120 (passive)	2.5 Kg	
Functional safety data		
EN ISO 13849-1:2008	PL e, Cat 4	
EN IEC 61508-1:2010, EN IEC 61508-2:2010, EN IEC 61508-3:2010, EN IEC 61508-4:2010	SIL 3	
EN IEC 62061:2005/A1:2013	SIL CL 3	
Prob. of Dangerous Failure/Hour (1/h)	PFH _d	8.57x10 ⁻⁹
Life span (years)	T1	20
Mean Time to Dangerous Failure (years)	MTTF _d	439

12 Model overview

Model	Article number	Protected height (mm)	Number of beams	Response time (ms)	Interaxis (mm)	Operating distance (m)	Resolution (mm)
Orion3-4-K1C-050-E	2TLA022307R0000	500	2	11	500	0.5..8	519,75
Orion3-4-K2C-080-E	2TLA022307R0100	800	3	12	380	0.5..8	399,75
Orion3-4-K2C-090-E	2TLA022307R0200	900	4	12	300	0.5..6.5	319,75
Orion3-4-K2C-120-E	2TLA022307R0300	1200	4	12	400	0.5..8	419,75
Orion3-4-M1C-050	2TLA022306R1000	500	-	-	-	-	-
Orion3-4-M2C-080	2TLA022306R1100	800	-	-	-	-	-
Orion3-4-M2C-090	2TLA022306R1300	900	-	-	-	-	-
Orion3-4-M2C-120	2TLA022306R1400	1200	-	-	-	-	-

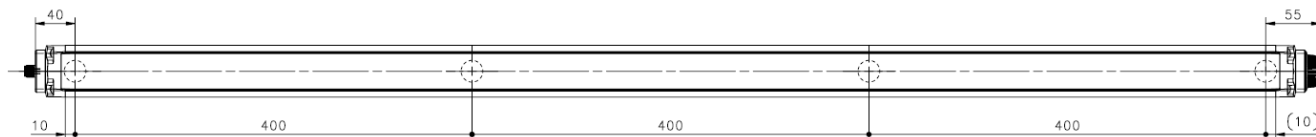
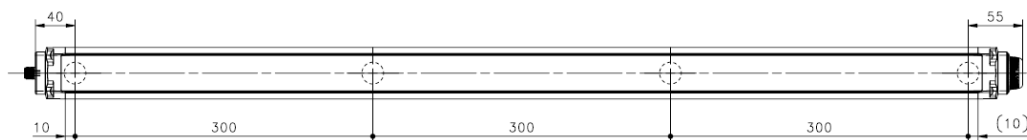
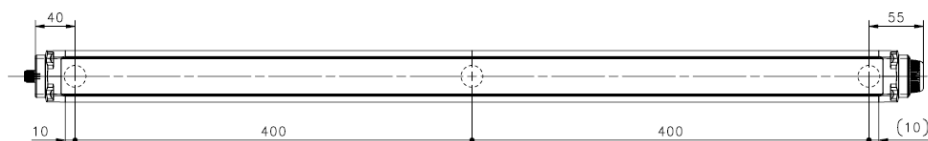

13 Dimensions

13.1 Profiles

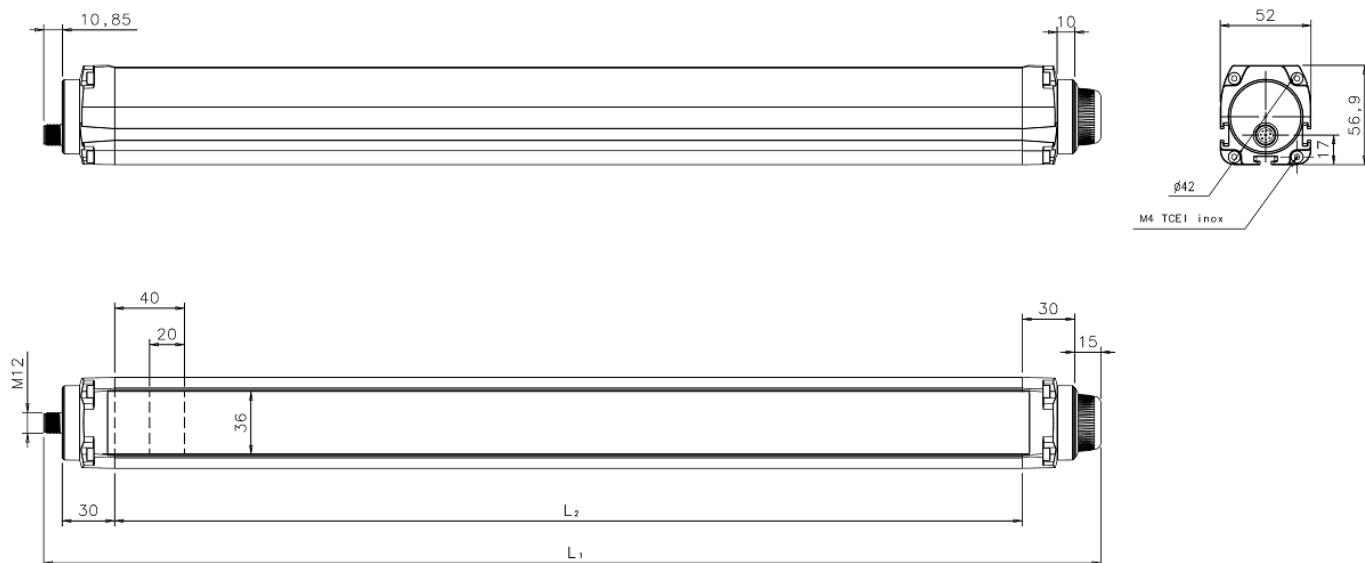

Figure 43 – Active unit



Figure 44 – Passive unit

NB: All dimensions in millimeters.

Model	L ₁ [mm]	L ₂ [mm]
Orion3-4-K1C-050-E (See Figure 43)	606.35	520.5
Orion3-4-K2C-080-E (See Figure 43)	906.35	820.5
Orion3-4-K2C-090-E (See Figure 43)	1006.35	920.5
Orion3-4-K2C-120-E (See Figure 43)	1306.35	1220.5
Orion3-4-M1C-050 (See Figure 44)	580.5	520.5
Orion3-4-M2C-080 (See Figure 44)	880.5	820.5
Orion3-4-M2C-090 (See Figure 44)	980.5	920.5
Orion3-4-M2C-120 (See Figure 44)	1280.5	1220.5

13.2 Angled fixing bracket

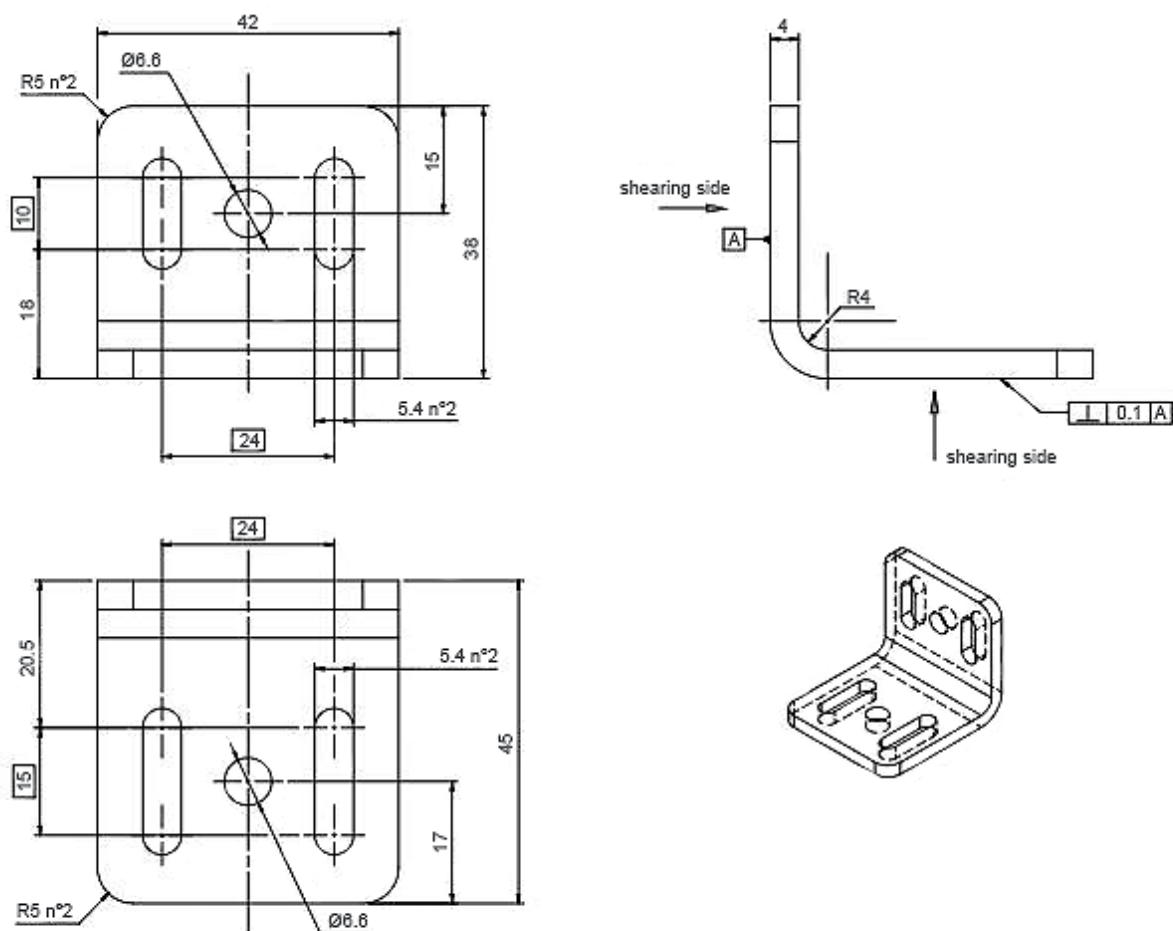

Figure 45 – Dimensions of the angled fixing bracket

13.3 Fixing bracket with profile



Figure 46 – Dimensions of the angled fixing bracket with a profile

NB: All dimensions in millimeters.

14 EC Declaration of conformity



EC Declaration of conformity

(according to 2006/42/EC, Annex2A)

We **ABB AB**
JOKAB Safety
Varlabergsvägen 11
SE-434 39 Kungsbacka
Sweden

declare that the safety components of ABB make with type designations and safety functions as listed below, is in conformity with the Directives

2006/42/EC
2004/108/EC

Authorised to compile the technical file

ABB AB
JOKAB Safety
Varlabergsvägen 11
SE-434 39 Kungsbacka
Sweden

Product
Light curtain/light beam
Orion, all models

Certificate
Z10 15 02 49833 011

Certification Body

TÜV Süd Product Service GmbH
Ridlerstrasse 65
80339 München
Germany

Used harmonized standards EN 61496-1:2013, EN ISO 13849-1:2008, EN 62061:2005/A1:2013

Other used standards EN 61496-2, EN 61508-1:2010, EN 61508-2:2010,
EN 61508-3:2010, EN 61508-4:2010



Jesper Kristensson
PRU Manager
Kungsbacka 2015-03-19

www.abb.com
www.jokabsafety.com

Original