

EasyLine EL3000

Continuous gas analyzers



So smart, they're simple

Measurement made easy

—
EasyLine EL3020
EasyLine EL3040

Introduction

EasyLine is a powerful yet cost-effective line of devices for the measurement of gas concentrations in numerous applications.

Automatic calibration and the use of superior ABB calibration cell technology in the photometer avoids the use of expensive test gas cylinders in most applications.

Zero-point calibration with ambient air

Various analyzer types available:
Combining different analyzers in a single housing enables optimum economy and operational efficiency for your application.

Additional Information

Additional documentation on EasyLine EL3000 is available for download free of charge at www.abb.com/analytical.

Alternatively simply scan this code:



Table of contents

1	Safety	5	5	Installation	44
	General information and instructions.....	5		Unpacking the Gas Analyzer	44
	Warnings.....	5		Name plate.....	44
	Warranty provisions.....	5		Analyzer data sheet	44
	Intended use	6		Mounting the fittings on the gas analyzer.....	45
	Improper use.....	6		Position and design of the gas connections	46
	Safety instructions.....	7		Gas Analyzer Installation	86
	Fidas24 – Information for safe operation.....	9		Connecting the gas lines	87
	Cyber security disclaimer	10		Fidas24 – Connect gas lines.....	88
	Software downloads	10		Fidas24 – Connecting the combustion gas line	89
	Services and ports on the Ethernet interface	11		Fidas24 – Connecting the sample gas line to the heated sample gas connection.....	90
	Access authorizations	11		Fidas24 – Connecting the sample gas line to the unheated sample gas connection.....	92
	Manufacturer’s address.....	11			
	Service address.....	11			
2	Use in potentially explosive atmospheres	12	6	Electrical connections	94
	Notes on use in potentially explosive atmospheres.....	12		Safety instructions	94
	Ex marking.....	13		General Notes.....	94
	Description.....	13		Model EL3020	95
	Special conditions.....	14		Model EL3040.....	96
3	Design and function	15		Cable glands	97
	Housing designs.....	15		Analog output modules	98
	Available analyzer modules	16		Digital I/O module.....	99
	Available analyzer combinations	16		Modbus®-Module.....	101
4	Preparation for Installation	17		PROFIBUS®-Module	101
	Scope of delivery	17		Connecting the Signal Lines	102
	Material required for installation	17		Connecting the power supply	102
	Requirements for the installation site	19	7	Commissioning	104
	Power supply.....	20		Safety instructions	104
	Uras26	21		Installation Check	104
	Limas23	23		Purge sample gas path and analyzer housing.....	105
	Magnos206.....	25		Gas analyzer start-up.....	105
	Magnos28	27	8	Operation	109
	Magnos27	29		Safety instructions	109
	ZO23	30		LCD indicator.....	109
	Caldos27.....	33		Menu Overview	112
	Fidas24.....	35		Notes on the operating concept.....	113
	Sample gas input and output conditions	37		Communication between gas analyzer and computer ..	114
	Pressure sensor	38		Setting the IP address	114
	Housing purge	39			
	Dimensions.....	40			
	Special conditions for the measurement of flammable gases	43			

9 Calibration.....	117	11 QAL3 monitoring.....	161
Calibration control.....	117	General information	161
Test gases	118	Control cards.....	162
Set test gas concentration.....	119	Configuration of QAL3 monitoring	163
Automatic calibration: Control.....	120	Display and print control chart	164
Automatic calibration: settings.....	121	Edit or delete QAL3 values	165
Automatic calibration: manual start.....	125	Exporting or deleting QAL3 data	165
Manual calibration: calibration method.....	125	12 Diagnosis / Troubleshooting	166
Manual calibration: execution.....	127	Safety instructions	166
Uras26 – Instructions for calibration.....	128	The Dynamic QR Code	166
Limas23 – Instructions for calibration	130	Status messages – Explanations	168
Magnos206 – notes for calibration.....	132	Status messages on the LCD display.....	169
Magnos28 – notes for calibration	133	Possible status messages.....	170
Magnos27 – notes for calibration.....	135	Troubleshooting	175
ZO23 – Checking the reference point and end point	136	Fidas24 – Troubleshooting	176
Caldos27 – Notes for calibration	136	Notify Service	178
Fidas24 – Notes for calibration	138	Returning devices	178
Fidas24 – Substitute gas calibration.....	139	13 Maintenance	179
Fidas24 – Response factors and other		Safety instructions	179
relevant variables	140	Inspection	179
Fidas24 – Conversion of concentration data	141	Maintenance switch	180
Oxygen sensor – Notes for calibration.....	142	Perform calibration reset	180
10 Configuration.....	143	Uras26, Limas23 – measuring the calibration cell.....	181
Measuring range switchover.....	143	Limas23 – Intensity display	181
Measuring range configuration with ECT.....	144	Limas23 – Clean the sample cell.....	182
Measuring range configuration in the gas analyzer	146	Limas23 – Replacing the UV lamp (EDL)	185
Uras26 – Change measuring range limits	147	ZO23 – Function Test	190
Limas23 – Change measuring range limits.....	147	Fidas24 – Standby / Restart	191
Magnos206 – Change measuring range limits	148	Fidas24 – replace the sample gas filter in the heated	
Magnos28 – Change measuring range limits	148	sample gas connection.....	192
Caldos27 – Change measuring range limits	149	Cleaning the Fidas24 air jet injector	193
Oxygen sensor – Changing measuring range limits	149	Check the integrity of combustion gas path.....	194
Limit values	149	Drift indicator.....	196
Set low-pass time constant	150	Pressure correction	196
Active component selection.....	151	Device test	197
Externally controlled measured component switch	151	Instrument information.....	200
Changing the physical unit for a sample component....	152	Operate pump	200
Sample components.....	152	Checking gas path leak tightness	201
Configuring signal inputs and outputs	154	Important instructions for measuring flammable	
Setting the IP address	155	gases.....	201
Setting the date and time	156	Important instructions for explosion-proof design in	
Selecting the user interface language.....	156	degree of protection II 3G.....	202
Configuring the user interface language.....	157	Replacing the battery.....	202
Password	158		
Software updates.....	159		

14 Decommissioning	202
Decommissioning the gas analyzer	202
Fidas24 – Shutting down the gas analyzer	203
Packing the Gas Analyzer	203
15 Recycling and disposal.....	204
16 Specification	204
Uras26	205
Limas23	206
Magnos206.....	207
Magnos28	208
Magnos27	209
ZO23	210
Caldos27.....	211
Fidas24.....	212
Oxygen sensor	213
17 Additional documents	214
18 Appendix.....	215
Return form	215

1 Safety

General information and instructions

These instructions are an important part of the product and must be retained for future reference.

Installation, commissioning, and maintenance of the product may only be performed by trained specialist personnel who have been authorized by the plant operator accordingly. The specialist personnel must have read and understood the manual and must comply with its instructions.

For additional information or if specific problems occur that are not discussed in these instructions, contact the manufacturer. The content of these instructions is neither part of nor an amendment to any previous or existing agreement, promise or legal relationship.

Modifications and repairs to the product may only be performed if expressly permitted by these instructions.

Information and symbols on the product must be observed. These may not be removed and must be fully legible at all times. The operating company must strictly observe the applicable national regulations relating to the installation, function testing, repair and maintenance of electrical products.

Warnings

The warnings in these instructions are structured as follows:

DANGER

The signal word '**DANGER**' indicates an imminent danger. Failure to observe this information will result in death or severe injury.

WARNING

The signal word '**WARNING**' indicates an imminent danger. Failure to observe this information may result in death or severe injury.

CAUTION

The signal word '**CAUTION**' indicates an imminent danger. Failure to observe this information may result in minor or moderate injury.

NOTICE

The signal word '**NOTICE**' indicates possible material damage.

Note

'**Note**' indicates useful or important information about the product.

Warranty provisions

Using the device in a manner that does not fall within the scope of its intended use, disregarding this manual, using underqualified personnel, or making unauthorized alterations releases the manufacturer from liability for any resulting damage. This renders the manufacturer's warranty null and void.

... 1 Safety

Intended use

The gas analyzer is designed for continuous measurement of the concentration of individual components in gases or vapors.

Any other use is not approved.

The intended use also includes taking note of this operating instruction.

Note

The version for the measurement of flammable gases and the explosion-proof design in degree of protection II 3G is designed for various variants of the gas analyzer and for different applications.

Measurement of flammable gases

DANGER

Explosion hazard

Explosion hazard when operating the gas analyzer in potentially explosive atmospheres.

- Only operate the gas analyzer in the version with stainless steel gas lines and gas connections (models EL3020 and EL3040), for the measurement of flammable gases and vapors, outside hazardous areas.

Observe the following information when measuring flammable gases*:

- The gas analyzer may only be used for the measurement of non-incendive gas / air or gas / oxygen mixtures.
- The special conditions for the measurement of flammable gases (see **Special conditions for the measurement of flammable gases** on page 43) must be observed.
- The oxygen sensor, as well as the assemblies of the integral gas feed (option "Integrated gas feed option – only in model EL3020, not for Limas23, ZO23, Fidas24) may not be used for the measurement of flammable gases.

* A flammable gas is a gas that can be ignited by adding air.

Operation in hazardous areas

DANGER

Explosion hazard

Explosion hazard when measuring flammable gases in hazardous areas.

- The gas analyzer in the explosion-proof design (model EL3040) may only be used for the measurement of **non-flammable** gases and vapors.

The model EL3040 gas analyzer is available in explosion-proof design with degree of protection II 3G (see **Use in potentially explosive atmospheres** on page 12).

Important safety instructions

In accordance with the EU Directive 2014/34/EU and the general requirements for explosion protection and as specified in the IEC 60079-0 standard, the scope of approvals for our explosion-protected apparatus is limited to **atmospheric conditions**, unless expressly stated otherwise in the certificates.

This also includes the sample gas that is fed in.

Definition of atmospheric conditions

Temperature	-20 to 60 °C
Pressure p_{abs}	80 to 110 kPa (0.8 to 1.1 bar)
Ambient air with standard oxygen content, typically 21% vol.%	

If the **atmospheric conditions are not complied with**, the operator is obliged to guarantee the safe operation of our devices in the absence of the recommended atmospheric conditions, by means of further measures (e.g. evaluation of the gas mixture or explosion pressure) and / or supplementary protective devices.

Improper use

The following are considered to be instances of especially improper use of the device:

- The measurement of gases that attack materials of parts in contact with the sample medium. See the notes in the section **Corrosive gases** of the individual analyzer modules in **Preparation for Installation** on page 17.
- For use as a climbing aid, for example for mounting purposes.
- For use as a bracket for external loads, for example as a support for piping, etc.
- Material application, for example by painting over the housing, name plate or welding/soldering on parts.
- Material removal, for example by spot drilling the housing.

Safety instructions

Requirements for safe operation

In order to operate in a safe and efficient manner the device should be properly handled and stored, correctly installed and set-up, properly operated and correctly maintained.

Personnel qualifications

Only persons familiar with the installation, set-up, operation and maintenance of comparable devices and certified as being capable of such work should work on the device.

Special information and precautions

These include:

- The content of this operating instruction,
- The safety information affixed to the device,
- The applicable safety precautions for installing and operating electrical devices,
- Safety precautions for working with gases, acids, condensates, etc.

National regulations

The regulations, standards and guidelines cited in this operator's manual are applicable in the Federal Republic of Germany. The applicable national regulations should be followed when the device is used in other countries.

Safety of the equipment and safe operation

The device was built and tested in accordance with EN 61010 Part 1 'Safety regulations for electrical measuring, control and laboratory equipment' and it left the factory in perfect condition.

To maintain this condition and to assure safe operation, read and follow the safety instructions in this operating instruction. Failure to do so can put persons at risk and can lead to device damage as well as damage to other systems and devices.

Protective lead connection

The protective lead (ground) should be attached to the protective lead connector before any other connection is made.

Risks of a disconnected protective lead

The device can be hazardous if the protective lead is interrupted inside or outside the device or if the protective lead is disconnected.

Potential equalization

- The external potential equalization connection of the analyzer housing must be connected to the local potential equalization.
- The local potential equalization must be connected before any other connections are made.
- The connectors have a clamping range of max. 4 mm².

Danger of interrupted potential equalization

The device can be hazardous if the protective lead is interrupted inside or outside the device or if the protective lead is disconnected.

DANGER

Explosion hazard

Explosion hazard when working on the potential equalization or the potential equalization connection in an existing hazardous atmosphere.

- Work on the potential equalization or the potential equalization connection is prohibited if there is a hazardous atmosphere.

... 1 Safety

... Safety instructions

Stopping the supply of sample gas

In the case of flammable and toxic sample gases, the supply of sample gas must be stopped and the sample gas feed path purged with nitrogen before the device housing is opened.

Risks involved in opening the covers

Current-bearing components can be exposed when the covers or parts are removed, even if this can be done without tools. Current can be present at some connection points.

Risks involved in working with an open device

All work on a device that is open and connected to power should only be performed by trained personnel who are familiar with the risks involved.

Comply with the safety regulations

The safety regulations for explosion protection must be complied with without fail before carrying out any work on the device.

DANGER

Explosion hazard

There is a risk of explosion if the device is opened in a potentially explosive atmosphere.

Please take note of the following information before opening the device:

- A valid fire permit must be present.
- Make sure that there is no explosion hazard.
- Before opening the device, switch off the power supply.

Work prohibited when there is an explosion hazard

Carrying out work on live parts, and with auxiliary equipment which represents a danger of ignition is prohibited if there is a risk of explosion.

When safe operation can no longer be assured

If it is apparent that safe operation is no longer possible, the device should be taken out of operation and secured against unauthorized use.

The possibility of safe operation is excluded:

- If the device is visibly damaged,
- If the device no longer operates,
- After prolonged storage under adverse conditions,
- After severe transport stresses.

Fidas24 – Information for safe operation

DANGER

Explosion hazard

Explosion hazard due to leaking combustion gas (hydrogen).

- All the information and instructions contained in this Operating Instruction must be complied with without fail to guarantee safe operation of the gas analyzer!

Measures of the manufacturer

The following measures ensure that the enrichment of combustion gas or an explosive mixture of combustion gas and ambient air cannot occur inside the gas analyzer during normal operation:

- The tightness of the combustion gas feed path is checked for a leakage rate of $< 1 \times 10^{-4}$ hPa·l/s before delivery.
- The combustion gas/air mixture (before and after the ignition point) is diluted in the detector with compressed air.
- The combustion gas feed is not connected to the supply during commissioning until the internal nominal pressures have been set.
- The combustion gas feed is switched off if the internal nominal pressures cannot be set during the ignition phase (e.g. because of insufficient compressed air or combustion air feed).
- The combustion gas feed is switched off after several unsuccessful ignition attempts.
- If the flame goes out during operation, the combustion gas feed is switched off if the following ignition attempts are unsuccessful.

The interior of the gas analyzer cannot be allocated to an (explosion protection-) zone; an explosive gas mixture cannot escape to the outside.

Conditions to be complied with by the end user

The end user must comply with the following prerequisites and conditions to ensure safe operation of the gas analyzer:

- The gas analyzer may be used for the measurement of flammable gases provided that the flammable portion does not up-scale 15 Vol.-% CH₄ oder C1 equivalents.
- The relevant safety regulations for working with combustion gases must be complied with.
- The gas connection diagram (see **Gas connections and electrical connections Fidas24 (model EL3020)** on page 84 and **Gas connections and electrical connections Fidas24 (model EL3040)** on page 85) must be complied with when connecting the combustion gas and combustion air.
- The combustion gas path in the gas analyzer must not be opened! The combustion gas path can become leaky as a result! Escaping combustion gas can cause fires and explosions, also outside the gas analyzer!
- If the combustion gas path in the gas analyzer has been opened nonetheless, it must be checked for leakage (refer to **Check the integrity of combustion gas path** on page 194), using a leak detector (leak rate $< 1 \times 10^{-4}$ hPa l/s), once it has been closed again.
- The tightness of the combustion gas supply line (see **Check the tightness of the combustion gas line** on page 194) outside the gas analyzer as well as the combustion gas path (see **Check the integrity of combustion gas path** on page 194) in the gas analyzer must be checked regularly.
- The maximum pressures of combustion gas and combustion air (see **Operational gases** on page 35) may not be up-scaled.
- The maximum combustion gas flow (see **Combustion gas** on page 36) may not be up-scaled.

... 1 Safety

... Fidas24 – Information for safe operation

- The combustion gas flow rate must be limited to a maximum of 10 l/h H₂ or 25 l/h H₂/He mixture. Suited measures (see **Combustion gas** on page 36) outside the gas analyzer must be provided by the operator for this purpose.
- In order to increase the safety level under the following operational conditions, a shut-off valve (refer to **Combustion gas** on page 36) must be installed in the combustion gas supply line:
 - when shutting down the gas analyzer,
 - in case of instrument air supply failure,
 - in case of a leak in the combustion gas path, inside the gas analyzer.

This shut-off valve should be installed outside the analyzer house in the vicinity of the combustion gas supply (cylinder, line).
- Should the combustion gas supply to the analyzer module not shut off automatically in the event of an instrument air supply failure, an alarm that is visible or audible to the operator must be triggered (refer to **In case of instrument air supply failure** on page 177).
- When measuring combustion gases, it must be ensured that if either the instrument air supply or the analyzer module should fail, the sample gas supply to the analyzer module will be shut off and the sample gas path purged with nitrogen.
- The unobstructed exchange of air with the environment must be possible around the gas analyzer. The gas analyzer must not be directly covered. The openings in the housing towards the top and at the side may not be closed. Spacing to adjacent built-in components to the sides must be at least 3 cm.
- If the gas analyzer is installed in a closed cabinet, adequate ventilation of the cabinet must be provided (at least 1 change of air per hour). The distance to adjacent built-in components towards the top and at the side must be at least 3 cm.

Cyber security disclaimer

This product is designed to be connected to and to communicate information and data via a network interface. It is operator's sole responsibility to provide and continuously ensure a secure connection between the product and your network or any other network (as the case may be).

Operator shall establish and maintain any appropriate measures (such as but not limited to the installation of firewalls, application of authentication measures, encryption of data, installation of anti-virus programs, etc.) to protect the product, the network, its system and the interface against any kind of security breaches, unauthorized access, interference, intrusion, leakage and/or theft of data or information.

ABB and its affiliates are not liable for damages and/or losses related to such security breaches, any unauthorized access, interference, intrusion, leakage and/or theft of data or information.

Software downloads

By visiting the web page indicated below, you will find notifications about newly found software vulnerabilities and options to download the latest software. It is recommended that you visit this web page regularly:

www.abb.com/cybersecurity

Services and ports on the Ethernet interface

Port	Description
22/tcp	Used only for software updates. No direct access to the device.
502/tcp	Used for Modbus/TCP. The device allows connection to any Modbus client. The port needs to be activated using this configuration software: ECT 'EasyLine Configuration Tool'; the port is deactivated upon delivery.
8100/tcp	Used for test and calibration software Optima TCT Light. Binary proprietary protocol. The port is deactivated. It can be activated for TCT access via a secure connection, and deactivated when the TCT access is terminated

Access authorizations

Access to both the calibration functions and those functions used to change the instrument configuration can be restricted by means of password protection.

The password protection is not activated at the factory (except in the case of gas analyzers used for emission monitoring).

It is recommended that the factory-set passwords be changed by the operator, by means of the ECT software tool ECT "EasyLine Configuration Tool", see **Configure password** on page 158. This limits access to both the ECT software tool itself and to the calibration and configuration functions of the device.

Manufacturer's address

ABB AG

Measurement & Analytics

Stierstädter Str. 5
60488 Frankfurt am Main
Germany
Tel: +49 69 7930-4666
Email: cga@de.abb.com

Service address

If the information in this Operating Instruction does not cover a particular situation, ABB Service will be pleased to supply additional information as required.

Please contact your local service representative.

For emergencies, please contact:

Customer service center

Tel: +49 180 5 222 580
Email: automation.service@de.abb.com

2 Use in potentially explosive atmospheres

Notes on use in potentially explosive atmospheres

Installation in accordance with IEC/EN 60079-14 (VDE 0165 Part 1)

The electric equipment must be installed in potentially explosive atmospheres in accordance with IEC/EN 60079-14 (VDE 0165 Part 1) "Electric Equipment for Hazardous Gas Areas, Part 14: Electric Systems in Potentially Explosive Atmospheres."

Potential equalization

With regard to potential equalization, the provisions of IEC/EN 60079-14 as well as DIN VDE 0100 Part 410 "Protection against electric shocks" and Part 540 "Grounding, Protective ground, Potential equalization conductors" must be observed.

Electrostatic charges

Electrostatic charges must be avoided. The professional association rules for the "Prevention of ignition hazards due to electrostatic charges (BGR 132) must be observed here.

Monitoring and review

Electric systems in potentially explosive atmospheres must be monitored for proper condition.

As necessary, but at least every three years, they must be inspected by an electrician, provided they are not constantly monitored under the supervision of a responsible engineer.

Work on electric systems

Before any maintenance work is carried out on electric installations in potentially explosive atmospheres, the installations must be disconnected from the power supply.

The disconnect point must be identified with an appropriate warning sign, for example, "Do not power-up – explosion hazard" This does not apply to devices that may be opened as part of normal operation, such as registration devices, or for which it is expressly noted in the type examination certificate.

Maintenance work on the device where opening the housing or part of the housing is necessary is only permitted in a non-hazardous atmosphere.

Explosion hazard

Before repairs, the explosion hazard must have been eliminated.

Competent personnel

Repair work may only be performed by competent personnel.

Original spare parts

Only original spare parts may be used for repairs.

Inspection prior to recommissioning

If repair work is carried out on parts of electric equipment on which explosion protection depends, a specialist needs to inspect and certify before recommissioning that the attributes of the equipment in terms of design and version which are essential for explosion protection match the equipment described in the declaration.

Repairs by the manufacturer

Repairs can also be carried out by the manufacturer, for example on-site by an ABB Service employee or at the manufacturing plant.

In this case, a marking showing the performed repairs with subsequent routine testing is affixed to the name plate. Testing by a specialist is not required then.

DANGER

Risk of explosion!

There is an explosion hazard if the housing is opened in a potentially explosive atmosphere:

- Before opening the housing, make sure that no flammable or potentially explosive atmospheres are present.

Ex marking

Note

All documentation, declarations of conformity, and certificates are available in ABB's download area.

www.abb.com/analytical

Explosion protection

The gas analyzers are designed for use in potentially explosive atmospheres.

The gas analyzers are certified in accordance with European Directive 2014/34/EU ('ATEX Directive') as well as in accordance with the relevant IEC standards.

Standards and directives

The gas analyzer was designed and manufactured in accordance with the following standards:

- EN/IEC 60079-0
- EN/IEC 60079-7
- EN/IEC 60079-15

The gas analyzer must be designed, installed and operated in accordance with the following standards and directives:

- EN/IEC 60079-14
- EN/IEC 60079-17
- EN/IEC 60079-19

Note

The full designation of the applied standards, including the date of issue, is included in the declaration of conformity supplied with the device.

Certification in accordance with the ATEX directive

Gas analyzer model EL3040

EC type examination certificate	BVS 16 ATEX E 085 X
Marking	II 3G Ex ec nC IIC T4 Gc

Note

The measuring function in accordance with Directive 2014/34/EU, Annex II, Section 1.5.5 is not the subject of the present EU type examination certificates.

Description

Note

The version for the measurement of flammable gases and the explosion-proof design in degree of protection II 3G is designed for various variants of the gas analyzer and for different applications.

The model EL3040 gas analyzer in degree of protection II 3G is tested for explosion protection and is suited for use in potentially explosive atmospheres, with consideration of the specification and the special conditions (see **Special conditions** on page 14).

The gas analyzer is intended for indoor installation only.

In the gas analyzer, the Uras26, Magnos206, Magnos28 and Caldos27 analyzers can be installed individually and in these combinations: Uras26 with Magnos206 or Magnos28 or Caldos27 or oxygen sensor.

The gas analyzer may be used for measurement of **non-flammable** gases and vapors.

In undisturbed operation there cannot be any sparking, arcing or impermissible temperatures inside the device.

Explosion protection through: increased safety as well as gasketed or encapsulated equipment.

... 2 Use in potentially explosive atmospheres

... Description

Characteristic values

System bus, computer interfaces	
Supply voltage	100 to 240 V AC
Power consumption	Maximum 187 VA
Pneumatic data	
Purge gas	
Inlet pressure	Maximum 1104 hPa
Measured gas	
Non-flammable sample gas	
Inlet pressure	Magnos28: Maximum 1600 hPa absolute pressure All other analyzer modules: Maximum 1100 hPa absolute pressure or maximum 100 hPa gauge pressure
Flow rate (gas output atmospheric)	Maximum 100 l/h
Temperature data	
Ambient temperature	5 to 45 °C (41 to 113 °F)

Important safety instructions

In accordance with the EU Directive 2014/34/EU and the general requirements for explosion protection and as specified in the IEC 60079-0 standard, the scope of approvals for our explosion-protected apparatus is limited to **atmospheric conditions**, unless expressly stated otherwise in the certificates.

This also includes the sample gas that is fed in.

Definition of atmospheric conditions	
Temperature	-20 to 60 °C
Pressure p_{abs}	80 to 110 kPa (0.8 to 1.1 bar)
Ambient air with standard oxygen content, typically 21% vol.%	

If the **atmospheric conditions are not complied with**, the operator is obliged to guarantee the safe operation of our devices in the absence of the recommended atmospheric conditions, by means of further measures (e.g. evaluation of the gas mixture or explosion pressure) and / or supplementary protective devices.

Special conditions

- The cables must be inserted into the cable glands properly and gasketed by tightening the screws so that the IP 65 housing protection is maintained. Unused cable glands must be sealed with suited sealing plugs, so that the IP 65 housing protection is guaranteed here as well.
- During operation, the unused purge gas connections must be sealed with sealing plugs.
- If there is an explosion hazard at the installation site of the gas analyzer, the housing must not be opened when live and the connectors must not be disconnected when live.
- Due to the low mechanical stability of the viewing glass, the gas analyzer must be designed and operated in such a way that mechanical damage to the viewing glass with an energy greater than 2 J can be excluded. If the viewing glass becomes nevertheless damaged to the point that the IP 65 housing protection is no longer met, the gas analyzer must be decommissioned, secured against recommissioning and repaired.
- Due to the low UV resistance of the plastic parts of the housing, the gas analyzer must be designed and operated in such a way that the effect of UV radiation can be excluded. If the housing is nevertheless damaged by UV radiation to the point that the housing protection IP 65 is no longer maintained, the gas analyzer must decommissioned, secured against recommissioning and repaired.

3 Design and function

Housing designs

EL3020, 19" plug-in unit in IP 20 (IP 40) design

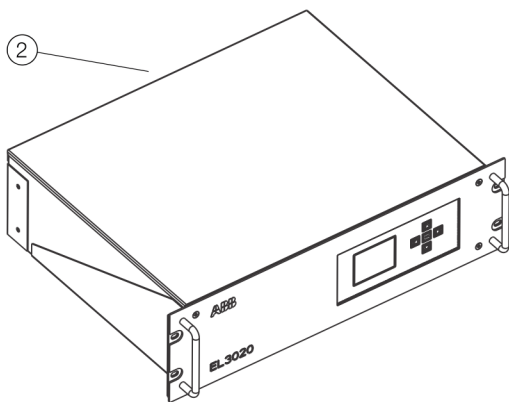
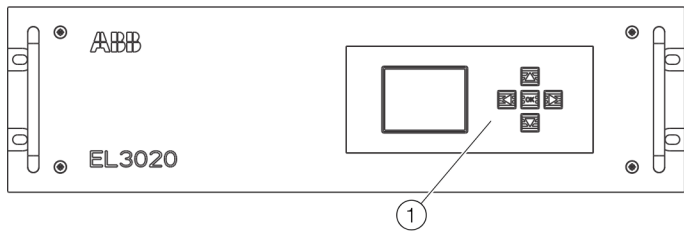

① LCD indicator

EL3040, field mount housing in IP 65 design
optionally as an explosion proof variant

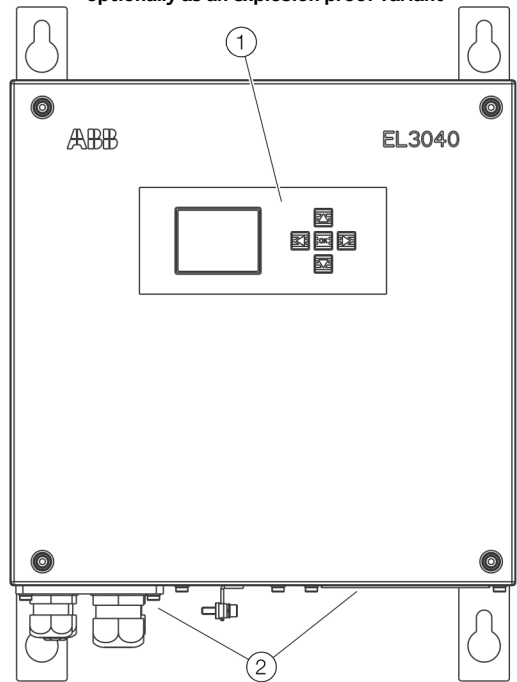

② Gas and electrical connections

Figure 1: EasyLine EL3000 housing designs

The EL3020 gas analyzer model features a 19" housing with 3 HU (4 HU with Magnos27) and IP rating IP 20 (IP 40 in the version for emissions monitoring).

The housing for the EL3040 gas analyzer model is designed as wall-mount housing with an IP rating of IP 65.

... 3 Design and function

Available analyzer modules

The following analyzer modules are available for selection:

- Uras26 infrared photometer
for the measurement of infrared-active gas components, such as CO, NO, SO₂
- Limas23 Ultraviolet photometer
for the measurement of NO, NO₂ and SO₂
- Magnos206 oxygen analyzer
for the measurement of O₂ in process gas or in N₂
- Magnos28 oxygen analyzer
for the measurement of O₂ in process gas or in N₂
- Magnos27 oxygen analyzer
for the measurement of O₂ in flue gas or in N₂
- ZO23 trace oxygen analyzer
for the measurement of O₂ in pure gases (N₂, CO₂, Ar)
- Caldos27 thermal conductivity analyzer
for the measurement of binary gas mixtures with different thermal conductivity, such as Ar in O₂, H₂ in Ar, CH₄ in N₂
- Fidas24 flame-ionization detector
for the measurement of hydrocarbons
- Electrochemical oxygen sensor
for the measurement of O₂

Available analyzer combinations

Analyzer combination	EL3020	EL3040
Uras26 with Magnos206	•	•
Uras26 with Magnos28	•	•
Uras26 with oxygen sensor	•	•
Limas23 with Magnos206	•	•
Limas23 with Magnos28	•	•
Limas23 with oxygen sensor	•	•
Magnos28 with Magnos28	•	•
Magnos28 with Caldos27	•	•
Caldos27 with Caldos27	•	•
Uras26 with Magnos27	•	—
Uras26 with 2× oxygen sensors	•	—

Note

The Fidas24 and ZO23 analyzer modules cannot be combined with other analyzer modules.

4 Preparation for Installation

Scope of delivery

- Gas analyzer model EL3020 (19" housing) or model EL3040 (wall housing)
- Screwed fittings with tubing connectors for the connection of flexible tubes
- Power cable, length 5 m, see **Connecting the power supply** on page 102.
- Counter plug (socket housing) for the electrical connection of the I/O modules (plugged into the I/O module connections)
- Screwdriver (required for attaching the electric lines in the counter plugs)
- Fine filtration (pre-assembled), see **Installing the fine filter** on page 87.
- Commissioning Instruction
- Analyzer data sheet

Fidas24

- Power cable, length 5 m, with 4-pin female connector and separate grounding connector for the power supply to the detector heating and the heated sample gas connection. Refer to **Grid connection cable Fidas24** on page 103.
- Accessory bag with fittings and O-rings for the connection of the sample gas lines
- Exhaust air pipe with connecting nut and locking ring

Commissioning Instruction

The gas analyzer is delivered with a commissioning manual.

The commissioning instruction is an extract from the operating instruction, and it contains all the information required to install, commission and operate the gas analyzer safely, for its intended purpose.

The commissioning manual does not contain information regarding calibration, configuration and maintenance of the gas analyzer or about the Modbus® and PROFIBUS® interface.

Analyzer data sheet

The design of the gas analyzer that has been supplied is documented in detail in the analyzer data sheet.

Material required for installation

Note

The materials listed below are not included in the scope of delivery of the device, and must be provided by the customer.

Gas connections

For the connection of piping:

Threaded connections with 1/8" NPT thread and PTFE sealing tape.

Fidas24: Gas lines

Process gases, test gases and waste air

- PTFE or stainless steel tubes with 4 mm inside diameter and PTFE or stainless steel tube with min. 10 mm inside diameter for waste air
- Tube fittings
- Pressure regulator
- Flow restrictors in the combustion gas supply line, see **Flow restrictor in the combustion gas supply line** on page 36.
- Shut-off valve in the combustion gas supply line, see **Shut-off valve in the combustion gas supply line** on page 36.

Sample gas

Heated sample gas line (recommended: TBL 01) or unheated sample gas line (PTFE or stainless steel tube with inside/outside diameter 4/6 mm).

The fittings and O-rings required for the connection are included within the scope of delivery of the gas analyzer.

Flowmeter/flow controller

Flowmeters or flow controllers with needle valve for setting and monitoring the sample gas flow as well as purge gas flow, if necessary.

Information for the selection and use of flowmeters:

- Measuring range 7 to 70 l/h
- Pressure drop < 4 hPa
- Needle valve open

Recommendation:

Flowmeter 7 to 70 l/h,
Order number 23151-5-8018474

... 4 Preparation for Installation

... Material required for installation

Shut-off valve

Install a shut-off valve in the sample gas line (recommended when the sample gas is pressurized).

Purging of the gas line system

Provide a means for purging the gas line system by feeding in an inert gas, e.g. nitrogen, from the gas sampling point.

Installation Material

19" housing (model EL3020)

- 4 raised head screws
(recommendation: M6; this depends on the cabinet/ rack system)
- 1 pair mounting rails (design depending on the cabinet/ frame system), length approx. 240 mm corresponding to approx. $\frac{2}{3}$ the housing depth

Wall-mount housing (model EL3040)

4 M8 or M10 screws

Signal Lines

Select conductive material which is appropriate for the length of the lines and the predictable current load.

Notes concerning the cable cross-section for connection of the I/O modules:

- The maximum capacity of terminals for stranded or solid conductors is 1 mm² (17 AWG).
- The stranded conductor may be tinned on the tip or twisted for simplified connection.
- When using wire end ferrules the total section must not exceed 1 mm², i.e. the maximum stranded conductor section cannot be greater than 0.5 mm². The Weidmüller PZ 6/5 crimping tool must be used for crimping the ferrules.

Lengths and types of cables for the RS485 lines

- Maximum 1,200 m (transfer rate, maximum 19,200 bit/s).
- Three-core twisted-pair cable, conductor cross section 0.25 mm² (e.g. order number 746620)

Length of the RS232 lines

Maximum 15 m.

Mating connector (socket housing)

The required mating connector (socket housing) for the plug-in terminal strips on the I/O modules is included in the scope of delivery.

Power supply lines

- If the supplied power cable is not used, select conductive material which is appropriate for the length of the lines and the predictable current load.
- Provide a supply circuit isolator or a switched socket outlet to be able to disconnect the power supply at all phases from the gas analyzer if required.

Requirements for the installation site

Note

For the analyzers ZO23 and Fidas24, the instructions specified in **ZO23** on page 30 or **Fidas24** on page 35 must be observed.

- The gas analyzer is intended for indoor installation only.
- The mounting surface must be sufficiently stable to support the weight of the gas analyzer!
- For safe installation and disassembly, we recommend supporting the 19" housing in the cabinet or rack with slide rails!

Short gas paths

- Install the gas analyzer as close as possible to the sampling location.
- Install the gas conditioning and calibration modules as close as possible to the gas analyzer.

Adequate air circulation

Provide for adequate natural air circulation around the gas analyzer. Avoid heat build-up.

Model EL3020 – 19" housing

With the EL3020 in the 19" housing, the distance from neighboring housings must be at least 1RU (rack unit) upwards and downwards and 3 cm to the rear.

Model EL3040 – wall-mounted enclosure

With the EL3040 in the wall housing, the distance to the neighboring housings must be at least 3 cm.

Installation in closed cabinets

When a gas analyzer is installed in a closed cabinet, the cabinet must be sufficiently ventilated (at least 1 x air change per hour).

Protection from adverse ambient conditions

Protect the gas analyzer from the following influences:

- Cold,
- Exposure to heat from e.g. the sun, furnaces, boilers,
- Temperature variations,
- Strong air currents,
- Accumulation of dust and ingress of dust,
- Corrosive atmosphere,
- Vibration.

Climatic Conditions

Relative humidity

Maximum 75 %, no condensation

Air Pressure

Atmospheric conditions

Installation location altitude

Maximum 2000 m (6560 ft) above sea level (over 2000 m (6560 ft) on request)

Ambient temperature

- During operation:
5 to 45 °C
- Uras26 in combination with another analyzer, Limas23, Fidas24:
5 to 40 °C

Transport-/Storage temperature

-25 to 65 °C

Housing protection (IP rating)

Model EL3020 (19" housing)

IP 20, IP 40 (with version for emissions measurement)

Model EL3040 (wall-mounted enclosure)

IP 65

Housing design

Model	Housing design	IP rating	Weight
EL3020	19" housing	IP 20	approx. 7 to 15 kg
EL3040	Wall-mount housing	IP 65	approx. 13 to 21 kg

... 4 Preparation for Installation

... Requirements for the installation site

Special conditions for the model EL3020 gas analyzer for the measurement of flammable gases

Unrestricted exchange of air with the environment must be provided around the gas analyzer from the bottom (floor plate) and from the rear (gas connections).

The gas analyzer may not be placed directly on a table.

The housing openings may not be closed.

Special conditions for the model EL3040 gas analyzer in degree of protection II 3G

Protection against mechanical influences

Due to the low mechanical stability of the viewing glass, the gas analyzer must be designed and operated in such a way that mechanical damage to the viewing glass is excluded with an energy greater than 2 J.

UV radiation protection

Due to the low UV resistance of the plastic parts of the housing, the gas analyzer must be designed and operated in such a way that the effect of UV radiation can be excluded.

Power supply

Electric information (entire device)

The power supply built into the system housing is used to supply 24 V DC to the analyzer module and the associated electronics.

Input voltage

100 to 240 V AC, -15/+10 %;

50 to 60 Hz, ±3 Hz

Power

Maximum 187 VA (without heaters from Fidas24)

Connection

3-pole cold device plug in accordance with EN 60320-1/C14
(Power cable included in scope of supply)

Battery

Application

Supply to the built-in clock in case of a voltage failure.

Type

- Varta CR 2032 type no. 6032 or
- Renata type no. CR2032 MFR

Note

Only the original types specified above may be used as a spare part.

Electric information (analyzer modules)

Input voltage

24 V DC, ±5 %

Power consumption analyzer modules (DC)

Uras26:	Max. 95 W	Magnos206:	max. 50 W
Limas23:	max. 100 W	ZO23:	max. 35 W
Magnos28:	max. 50 W	Caldos27:	max. 17 W
Magnos27:	max. 35 W	Fidas24:	max. 50 W

Fidas24 Analyzer Module (AC)

Detector and Sample Gas Inlet Heaters

Input voltage	115 V AC or 230 V AC, ±15 % (max. 250 V AC), 50 to 60 Hz, ±3 Hz
Power consumption	125 VA for detector 125 VA for sample gas inlet (option)
Connection	4-pin male connector (connection cable included in scope of supply)

Uras26

Sample gas

Sample gas inlet conditions

DANGER

Explosion hazard

Explosion hazard when measuring ignitable gas / air or gas / oxygen mixtures

- The gas analyzer may not be used for the measurement of ignitable gas / air or gas / oxygen mixtures

Uras26 – sample gas input conditions

Temperature

If the sample gas taken from the process is hotter than the coldest point in the sample gas path, there may be condensation at this point, if the gas contains components that can condense. The sample gas dew point should be at least 5 °C below the temperature throughout the sample gas path.

Designation of gas connections

The analyzer is operated under atmospheric pressure; the sample gas outlet is open to atmosphere.

Internal pressure drop:	< 5 hPa at standard flow rate of 60 l/h
Permissible absolute pressure range:	800 to 1250 hPa Operation under lower absolute pressure (e.g. at altitudes above 2000 m) on request
Gauge pressure in the sample cell:	max. 500 hPa
Flow rate	20 to 100 l/h

Corrosive gases

The analyzer may not be used for measurement in corrosive gases. Associated gases, such as chlorine (Cl₂) or hydrogen chlorides (such as wet HCl) as well as gases or aerosols containing chlorine must be cooled or pre-absorbed.

Flammable gases

In the version with gas lines and gas connectors made of stainless steel, the analyzer is suited for the measurement of flammable gases in non-explosive environments.

The notes on measuring flammable gases must be observed, see **Special conditions for the measurement of flammable gases** on page 43.

Flowing reference gas

Gas inlet conditions as for sample gas

Pressure sensor

The pressure sensor is installed in the gas analyzer as standard, see **Pressure sensor** on page 38.

The pressure sensor is connected to the sample gas path or a connection socket at different positions depending on the design of the gas analyzer, see **Position and design of the gas connections** on page 46.

The connection of the pressure sensor is also documented in the pneumatic diagram included in the device data sheet.

Gas connections

See **Gas connections Uras26 (model EL3020)** on page 47 and **Gas connections Uras26 (model EL3040)** on page 49.

... 4 Preparation for Installation

... Uras26

Test gases – Uras26

Analyzer(s)	Test gas for the zero calibration	Test gas for the end-point calibration
Uras26 with calibration cells (automatic calibration)	N ₂ or air or sample component-free gas	— (calibration cells)
Uras26 without calibration cells (automatic calibration)	N ₂ or air	Span gas*
Uras26 without calibration cells (manual calibration)	N ₂ or air	Test gas for each sample component
Uras26 + Magnos206 / Magnos28 (automatic calibration, i.e. Magnos206 / Magnos28 with single-point calibration)	IR sample component-free test gas with O ₂ concentration in an existing measuring range or ambient air.	Calibration cells or span gas*
Uras26 + Magnos206 / Magnos28 (manual calibration)	Zero point gas for Uras26 or Magnos206 / Magnos28, or for single-point calibration for Magnos206 / Magnos28, IR sample component-free test gas with O ₂ concentration in an existing measuring range or ambient air.	Span gas for all sample components in the Uras26 and in the Magnos206 / Magnos28 (possibly only for the Uras26 if a single-point calibration is carried out for the Magnos206 / Magnos28)
Uras26 + Magnos27 (automatic calibration)	IR sample component-free test gas with O ₂ concentration in an existing measuring range or ambient air.	Calibration cells or span gas*
Uras26 + Magnos27 (manual calibration)	Zero point gas for Uras26 or Magnos27, or IR sample component-free test gas with O ₂ -concentration in an existing measuring range or ambient air.	Span gas for all sample components in Uras26 and Magnos27
Uras26 + Caldos27 (automatic calibration, i.e. Caldos27 with single-point calibration)	IR sample component-free test gas with a known and constant rTC value (possibly also dried room air)	Calibration cells or span gas*
Uras26 + Caldos27 (manual calibration)	Zero reference gas for Uras26 or Caldos27, or IR sample component-free test gas with a known rTC value	Span gas for all sample components in the Uras26 and Caldos27 (possibly only for the Uras26 if a single-point calibration is carried out for the Caldos27)
Uras26 + oxygen sensor (automatic calibration)	IR sample component-free test gas with O ₂ concentration in an existing measuring range or ambient air.	Calibration cells or span gas*
Uras26 + Oxygen sensor (manual calibration)	IR sample component-free test gas with O ₂ concentration in an existing measuring range or ambient air.	Span gas for all sample components in Uras26

* Test gas mixture for multiple sample components possible if no or negligible cross-sensitivity is present

Dew point

The dew point of the test gases must be approximately equal to the dew point of the sample gas.

Note

The instructions for calibration must be observed, see **Uras26 – Instructions for calibration** on page 128.

Limas23

Sample gas

Sample gas inlet conditions

DANGER

Explosion hazard

Explosion hazard when measuring flammable gases and ignitable gas / air or gas / oxygen mixtures

- The gas analyzer must not be used for measurement of flammable gases and ignitable gas / air or gas / oxygen mixtures.

Limas23 – sample gas input conditions

Temperature

If the sample gas taken from the process is hotter than the coldest point in the sample gas path, there may be condensation at this point, if the gas contains components that can condense. The sample gas dew point should be at least 5 °C below the temperature throughout the sample gas path.

Designation of gas connections

The analyzer is operated under atmospheric pressure; the sample gas outlet is open to atmosphere.

Internal pressure drop:	< 5 hPa at standard flow rate of 60 l/h
Permissible absolute pressure range:	800 to 1250 hPa Operation under lower absolute pressure (e.g. at altitudes above 2000 m) on request
Gauge pressure in the sample cell:	max. 500 hPa
Flow rate	20 to 100 l/h

Corrosive gases

The analyzer may not be used for measurement in corrosive gases. Associated gases, such as chlorine (Cl₂) or hydrogen chlorides (such as wet HCl) as well as gases or aerosols containing chlorine must be cooled or pre-absorbed.

Pressure sensor

The pressure sensor is installed in the gas analyzer as standard, see **Pressure sensor** on page 38.

The pressure sensor is connected to the sample gas path or a connection socket at different positions depending on the design of the gas analyzer, see **Position and design of the gas connections** on page 46.

The connection of the pressure sensor is also documented in the pneumatic diagram included in the device data sheet.

Gas connections

See **Gas connections Limas23 (model EL3020)** on page 62 and **Gas connections Limas23 (model EL3040)** on page 63.

... 4 Preparation for Installation

... Limas23

Test gases – Limas23

Analyzer(s)	Test gas for the zero calibration	Test gas for the end-point calibration
Limas23 with calibration cells (automatic calibration)	N ₂ or air or UV sample component-free gas	Calibration cells or test gas for each sample component
Limas23 without calibration cells (automatic calibration)	N ₂ or air or UV sample component-free gas	Test gas for each sample component
Limas23 without calibration cells (manual calibration)	N ₂ or air or UV sample component-free gas	Test gas for each sample component
Limas23 + Magnos206 / Magnos28 or oxygen sensor with calibration cells (automatic calibration, i.e. Magnos206 / Magnos28 with single-point calibration)	N ₂ or oxygen and UV sample component-free gas	Either calibration cells and test gas for oxygen detector or test gas for each sample component or for each detector
Limas23 + Magnos206 / Magnos28 or oxygen sensor without calibration cells (automatic calibration)	N ₂ or oxygen and UV sample component-free gas	Test gas for each sample component or for each detector
Limas23 + Magnos206 / Magnos28 or oxygen sensor without calibration cells (manual calibration)	N ₂ or oxygen and UV sample component-free gas	Test gas for each sample component or for each detector

Dew point

The dew point of the test gases must be approximately equal to the dew point of the sample gas.

Note

The instructions for calibration must be observed, see **Limas23 – Instructions for calibration** on page 130.

Magnos206

Sample gas

Sample gas inlet conditions

DANGER

Explosion hazard

Explosion hazard when measuring ignitable gas / air or gas / oxygen mixtures

- The gas analyzer may not be used for the measurement of ignitable gas / air or gas / oxygen mixtures

Magnos206 – sample gas input conditions

Temperature

- If the sample gas taken from the process is hotter than the coldest point in the sample gas path, there may be condensation at this point, if the gas contains components that can condense. The sample gas dew point should be at least 5 °C below the temperature throughout the sample gas path.
- When there is a direct connection to the sample chamber, the maximum sample gas dew point is 55 °C.
- Water vapor content variations cause volume errors.

Designation of gas connections

The analyzer is operated under atmospheric pressure; the sample gas outlet is open to atmosphere.

Internal pressure drop:	< 5 hPa at standard flow rate of 60 l/h.
Permissible absolute pressure range:	800 to 1250 hPa. Operation under lower absolute pressure (e.g. at altitudes above 2000 m) on request.
Operation under higher pressure:	A pressure sensor is required to compensate for pressure influences.
Absolute pressure ≤ 1250 hPa:	An optional internal pressure sensor can be connected to the sample gas path.
Absolute pressure ≥ 1250 hPa:	An external pressure sensor must be connected to the sample gas path. The pressure compensation must be calculated externally.

The analyzer module is function-tested for 5000 hPa internal pressure without damage.

Flow rate	30 bis 90 l/h Abrupt changes in the sample gas flow rate should be avoided when using highly suppressed measurement ranges.
------------------	--

Corrosive gases

If the sample gas contains Cl₂, HCl, HF or other corrosive components, the analyzer may only be used if the sample gas composition has been taken into account by the manufacturer for the configuration of the analyzer.

Flammable gases

The analyzer is suited for measuring flammable gases in a non-explosive environment.

The notes on measuring flammable gases must be observed, see **Special conditions for the measurement of flammable gases** on page 43.

Pressure sensor

The pressure sensor is optionally installed in the gas analyzer, see **Pressure sensor** on page 38.

The pressure sensor is connected to a connection socket, see **Position and design of the gas connections** on page 46.

Gas connections

See **Gas connections Magnos206 (model EL3020)** on page 70 and **Gas connections Magnos206 (model EL3040)** on page 71.

... 4 Preparation for Installation

... Magnos206

Test gases – Magnos206

Analyzer	Test gas for zero point calibration and single-point calibration	Test gas for the end-point calibration
Magnos206	Oxygen-free process gas	Process gas with a known O ₂ concentration
Magnos206 suppressed measuring range	<ul style="list-style-type: none"> • Zero point calibration: pure nitrogen or hydrogen-free operating gas • Single-point calibration: 100 Vol.-% O₂ or test gas with O₂ concentration in the measuring range 	Test gas with O ₂ concentration near the end point of the measuring range
Magnos206 with single-point calibration	Test gas with O ₂ concentration in an existing measuring range or ambient air.	—
Magnos206 with substitute gas calibration	Oxygen-free process gas or substitute gas (O ₂ in N ₂)	Substitute gas, for example dried air

Dew point

The dew point of the test gases must be approximately equal to the dew point of the sample gas.

Note

The instructions for calibration must be observed, see **Magnos206 – notes for calibration** on page 132.

Magnos28

Sample gas

Sample gas inlet conditions

DANGER

Explosion hazard

Explosion hazard when measuring ignitable gas / air or gas / oxygen mixtures

- The gas analyzer may not be used for the measurement of ignitable gas / air or gas / oxygen mixtures

Magnos28 – sample gas input conditions

Temperature

- If the sample gas taken from the process is hotter than the coldest point in the sample gas path, there may be condensation at this point, if the gas contains components that can condense. The sample gas dew point should be at least 5 °C below the temperature throughout the sample gas path.
- When there is a direct connection to the sample chamber, the maximum sample gas dew point is 55 °C.
- Water vapor content variations cause volume errors.

Designation of gas connections

The analyzer is operated under atmospheric pressure; the sample gas outlet is open to atmosphere.

Internal pressure drop:	< 5 hPa at standard flow rate of 60 l/h
Permissible absolute pressure range:	800 to 1600 hPa Operation under lower absolute pressure (e.g. at altitudes above 2000 m) on request
Operation under higher pressure:	A pressure sensor is required to compensate for pressure influences.
Absolute pressure ≤ 1250 hPa:	An optional internal pressure sensor can be connected to the sample gas path.
Absolute pressure ≥ 1250 hPa:	An external pressure sensor must be connected to the sample gas path. The pressure compensation must be calculated externally.

The analyzer module is function-tested for 5000 hPa internal pressure without damage.

Flow rate	30 bis 90 l/h Measuring ranges ≤ 0 to 3 vol % O ₂ : 60l/h For highly suppressed measuring ranges and measuring ranges of ≤ 0 to 3 vol % O ₂ , changes of the sample gas flow should be avoided.
-----------	---

Corrosive gases

If the sample gas contains Cl₂, HCl, HF or other corrosive components, the analyzer may only be used if the sample gas composition has been taken into account by the manufacturer for the configuration of the analyzer. If the sample gas contains NH₃, FFKM75 gaskets must be used; in this case, the integral gas feed cannot be connected to the analyzer. The pressure sensor must not be connected to the sample gas path.

Flammable gases

The analyzer is suited for measuring flammable gases in a non-explosive environment.

The notes on measuring flammable gases must be observed, see **Special conditions for the measurement of flammable gases** on page 43.

Pressure sensor

The pressure sensor is optionally installed in the gas analyzer, see **Pressure sensor** on page 38.

The pressure sensor is connected to a connection socket, see **Position and design of the gas connections** on page 46.

Gas connections

See **Gas connections Magnos28 (model EL3020)** on page 72 and **Gas connections Magnos28 (model EL3040)** on page 76.

... 4 Preparation for Installation

... Magnos28

Test gases – Magnos28

Analyzer	Test gas for zero point calibration and single-point calibration	Test gas for the end-point calibration
Magnos28	Oxygen-free process gas	Process gas with a known O ₂ concentration
Magnos28 with a suppressed measuring range	<ul style="list-style-type: none"> • Zero point calibration: pure nitrogen or hydrogen-free operating gas • Single-point calibration: 100 Vol.-% O₂ or test gas with O₂ concentration in the measuring range 	Test gas with O ₂ concentration near the end point of the measuring range, or pure oxygen
Magnos28 with single-point calibration	Test gas with O ₂ concentration in an existing measuring range or ambient air.	—
Magnos28 with substitute gas calibration	Oxygen-free process gas or substitute gas (O ₂ in N ₂)	Substitute gas, for example dried air
Magnos28 + Caldos27 (manual calibration)	In addition to the above mentioned test gases for Magnos28, additional test gases are needed for the calibration of Caldos27. The requirements are shown in the table in section Test gases – Caldos27 on page 34.	
Magnos28 + Caldos27 (automatic calibration)	See the table in section Test gases – Caldos27 on page 34 for instructions on test gases and possible limitations in automatic calibration.	

Dew point

The dew point of the test gases must be approximately equal to the dew point of the sample gas.

Note

The instructions for calibration must be observed, see **Magnos28 – notes for calibration** on page 133.

Magnos27

Sample gas

Sample gas inlet conditions

DANGER

Explosion hazard

Explosion hazard when measuring flammable gases and ignitable gas / air or gas / oxygen mixtures

- The gas analyzer must not be used for measurement of flammable gases and ignitable gas / air or gas / oxygen mixtures.

Magnos27 – sample gas input conditions

Temperature

- If the sample gas taken from the process is hotter than the coldest point in the sample gas path, there may be condensation at this point, if the gas contains components that can condense. The sample gas dew point should be at least 5 °C below the temperature throughout the sample gas path.
- When there is a direct connection to the sample chamber, the maximum sample gas dew point is 55 °C.
- Water vapor content variations cause volume errors.

Designation of gas connections

The analyzer is operated under atmospheric pressure; the sample gas outlet is open to atmosphere.

Internal pressure drop:	< 5 hPa at standard flow rate of 60 l/h.
Permissible absolute pressure range:	800 to 1250 hPa. Operation under lower absolute pressure (e.g. at altitudes above 2000 m) on request.
Gauge pressure in the measuring chamber:	max. 500 hPa.
Flow rate	20 bis 90 l/h

Pressure sensor

The pressure sensor is optionally installed in the gas analyzer (see **Pressure sensor** on page 38).

The pressure sensor is connected to a connection socket via an FPM tube.

Gas connections

See **Gas connections Magnos27 (model EL3020)** on page 77 and **Gas connections Magnos27 with Uras26 (model EL3020)** on page 78.

Tests gases – Magnos27

Analyzer	Test gas for the zero calibration	Test gas for the end-point calibration
Magnos27	Oxygen-free process gas	Process gas with a known O ₂ concentration
Magnos27 with substitute gas	Oxygen-free process gas or substitute gas (O ₂ in N ₂)	Substitute gas, for example dried air

Dew point

The dew point of the test gases must be approximately equal to the dew point of the sample gas.

Note

The instructions for calibration must be observed, see **Magnos27 – notes for calibration** on page 135.

... 4 Preparation for Installation

ZO23

Sample gas

Sample gas inlet conditions

DANGER

Explosion hazard

Explosion hazard when measuring ignitable gas / air or gas / oxygen mixtures

- The gas analyzer may not be used for the measurement of ignitable gas / air or gas / oxygen mixtures

ZO23 – sample gas input conditions

Temperature	5 to 50 °C
Inlet pressure	$p_e \leq 70$ hPa
Flow rate	4 to 20 l/h

- The sample gas flow rate must be kept constant within the specified range at ± 0.2 l/h.
- The sample gas must be taken unpressurized from a bypass. If the sample gas flow is too low, contamination effects from the gas lines (leaks, permeability, de-sorption) will lead to inaccuracies in the measurement result.

If the sample gas flow is too high, asymmetrical cooling of the sensor may cause measurement errors. This can also cause quicker aging or damage to the measuring cell.

Note

The temperature, pressure and flow of the sample gas must be kept constant, to such an extent that the influence of variations on the measuring accuracy is acceptable, refer to **ZO23** on page 210.

Corrosive gases

The presence of corrosive gases and catalyst poisons, such as halogens, gases containing sulfur and heavy-metal dust, leads to quicker aging and / or the destruction of the ZrO_2 cell.

Flammable gases

The analyzer module is suitable for measuring flammable gases in a non-explosive environment. The concentration of flammable gases in the sample gas must not exceed 100 ppm.

Associated gas effect

Inert gases (Ar, N_2) have no effect. Flammable gases (CO , H_2 , CH_4) in stoichiometric concentrations to the oxygen content: conversion $O_2 < 20$ % of the stoichiometric conversion. If higher concentrations of flammable gases are present, higher O_2 conversions must be expected.

Requirements for the sample gas outlet

The outlet pressure must be the same as the atmospheric pressure.

Test gases

Reference point (electric zero point)

Clean ambient air;

its oxygen concentration is obtained from the dry air value and the factor for consideration of the water vapor content.

Example:

Water vapor content at 25 °C and 50 % relative humidity =

1.56 Vol.-% $H_2O \Rightarrow$ Factor 0.98

Oxygen concentration =

$20.93 \text{ vol. } \% O_2 \times 0.98 = 20.6 \text{ Vol.-% } O_2$

End position

Test gas with oxygen concentration in the smallest measurement range (for example, 2 ppm O_2 in N_2).

Note

The pressure conditions at the reference point and the end point must be identical.

The instructions for checking the reference point and the end point (see **ZO23 – Checking the reference point and end point** on page 136) must be observed.

Purge gas

If housing purging is selected (for IP65 design only), the purging may only be carried out using air (not with nitrogen), since the ambient air is used as a reference gas.

Gas connections

See sections **Gas connections ZO23 (model EL3020)** on page 79 and **Gas connections ZO23 (model EL3040)** on page 80.

Installation and sample handling

NOTICE

Damage to the measuring cell

The ingress of liquids into the analyzer module can cause serious damage including destruction of the sample cell.

Note

The following information on installation and the sample handling must be considered for the measurement and the execution of controlled calibrations (manual, automatic and externally controlled calibration).

Manually operated cocks and valves must be replaced by controlled valves suitable for the oxygen trace measurement, as required.

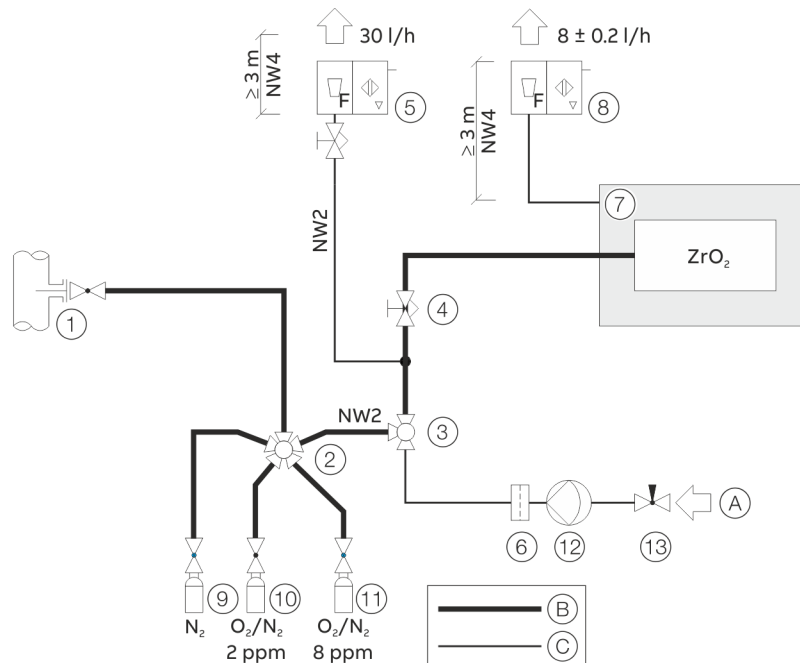

(A) Reference air

(B) Stainless steel pipe

(C) FPM hose

(1) Sampling point with primary shut-off valve

(2) Multi-way ball valve

(3) 3/2-way ball valve*

(4) Fine-control and shut-off valve

(5) Flowmeter with needle valve and fault-signalling contact

(6) Air filter*

(7) Gas analyzer

* Option

** A hard-mounted test gas cylinder is normally adequate.

The annual check of the reference point can also be carried out with a non-stationary air supply.

(8) Flowmeter without needle valve, with fault-signalling contact

(9) Purge gas cylinder N₂*

(10) Test gas cylinder with for example 2 ppm O₂ in N₂**

(11) Test gas cylinder with 8 ppm O₂ in N₂*

(12) Pump*

(13) Needle valve*

Figure 2: Sample handling example

... 4 Preparation for Installation

... Z023

Gas sampling

The nominal diameter of the line from the sampling point to the first switch-over valve should be 4 mm.

A bypass can be positioned upstream of the first switch-over valve, in order to obtain a faster analysis.

With a nominal diameter of 4 mm, the bypass should be longer than 3 m, in order to prevent back diffusion from the ambient air.

The sample gas pressure must be reduced at the sampling point. An evaporating pressure regulator must be provided for sampling from liquid gas lines.

Sample gas feed

The sample gas supply line must consist of stainless steel tubing, be as short as possible and have as few transitions as possible.

The diameter of tube from the beginning of the first switch-over valve should be 3 mm on the outside and 2 mm on the inside.

The sample gas connection on the gas analyzer is intended for a pipe with a 3 mm outside diameter.

The connectors should be made as Swagelok® fittings.

The Z023 oxygen trace analyzer module may not be connected in series with other Z023 analyzer modules or other gas analyzers.

Gas outlet line

The gas outlet line can be executed as a flexible tube.

With a nominal diameter of 4 mm, its length should be more than 3 m, in order to prevent back diffusion from the ambient air.

Bypass

The gas analyzer is connected to a gas flow in the bypass at a constant flow rate (approx. 30 l/h).

The needle valve is installed upstream of the branch to the gas analyzer and the bypass flowmeter downstream of the branch to the gas analyzer.

The gas analyzer draws gas flow 8 l/h. An excess of approx. 20 l/h remains. If several Z023 analyzer modules are supplied with gas in parallel (redundant measurement), the flow must be set so large that the bypass has an excess of 20 l/h.

With a nominal diameter of 4 mm, the bypass from the outlet of the gas analyzer should be longer than 3 m, in order to prevent back diffusion from the ambient air.

On account of possible leaks, the flowmeters are always placed in the bypass feed path downstream of the branch to the gas analyzer, respectively, downstream of the gas analyzer; they may on no account be installed in the sample gas supply line upstream of the sample cell.

Waste gas

The sample gas and the bypass must be conducted into the atmosphere or into an unpressurized waste gas collecting system at an adequate distance from the gas analyzer.

Long line runs and pressure variations must be avoided.

For metrological and technical safety reasons, sample gas and bypass may not be discharged into the atmosphere in the vicinity of the gas analyzer, since the ambient air serves as reference air and also to exclude suffocation through a lack of oxygen.

It must be ensured that the waste gas only reaches respiratory air when adequately diluted.

Caldos27

Sample gas

Sample gas inlet conditions

DANGER

Explosion hazard

Explosion hazard when measuring ignitable gas / air or gas / oxygen mixtures

- The gas analyzer may not be used for the measurement of ignitable gas / air or gas / oxygen mixtures

Caldos27 – sample gas input conditions

Temperature

- If the sample gas taken from the process is hotter than the coldest point in the sample gas path, there may be condensation at this point, if the gas contains components that can condense. The sample gas dew point should be at least 5 °C below the temperature throughout the sample gas path.
- Water vapor content variations cause volume errors

Designation of gas connections

The analyzer is operated under atmospheric pressure; the sample gas outlet is open to atmosphere.

Internal pressure drop: < 5 hPa at standard flow rate of 60 l/h.

Permissible absolute pressure range: 800 to 1250 hPa
Operation under lower absolute pressure (e.g. at altitudes above 2000 m) on request

Gauge pressure in the measuring chamber: max. 100 hPa

Flow rate: Typically 10 to 90 l/h,
minimum 1 l/h

Corrosive gases

If the sample gas contains Cl₂, HCl, HF, SO₂, NH₃, H₂S or other corrosive components, the analyzer may only be used if the sample gas composition has been taken into account by the manufacturer for the configuration of the analyzer.

Flammable gases

The analyzer is suited for measuring flammable gases in a non-explosive environment.

The notes on measuring flammable gases must be observed, see **Special conditions for the measurement of flammable gases** on page 43.

Pressure sensor

The pressure sensor is installed in the gas analyzer at the factory, see **Pressure sensor** on page 38.

The pressure sensor is connected to a connection socket via an FPM tube.

Gas connections

See sections **Gas connections Caldos27 (model EL3020)** on page 81 and **Gas connections Caldos27 (model EL3040)** on page 83.

... 4 Preparation for Installation

... Caldos27

Test gases – Caldos27

Analyzer	Test gas for zero point calibration and single-point calibration	Test gas for the end-point calibration
Caldos27	Sample component-free test gas or process gas	Test gas or process gas with a known sample component concentration
Caldos27 with a suppressed measuring range	Test gas with a sample component concentration near the starting point of the measuring range	Test gas with a sample component concentration near the end point of the measuring range
Caldos27 with single-point calibration	Test gas with a known and constant rTC value (standard gas; possibly also dried room air)	—
Caldos27 + Magnos28 (manual calibration)	In addition to the above mentioned test gases for Caldos27, additional test gases are needed to calibrate Magnos28. The requirements are provided in the table in Test gases – Magnos28 on page 28.	
Caldos27 + Magnos28 (automatic calibration)	Same as manual calibration, with the following limitation: Zero point and single point calibrations are performed for all sample components simultaneously, since for this purpose, only one common digital output can be used for valve control (unlike with end point calibration) for this purpose (Automatic calibration: settings on page 121). This results in limitations with regard to the possible test gases, which in particular depend on the configuration of the <ul style="list-style-type: none"> • Measurement components • Measuring ranges • Gas paths (series or isolated) Depending on these conditions, certain automatic calibration methods cannot be performed in a practical sense.	As in the case with manual calibration, a separate end point gas valve must be available for each sample component without a single point calibration, which is controlled via a correspondingly configured digital output (Automatic calibration: settings on page 121).

Dew point

The dew point of the test gases must be approximately equal to the dew point of the sample gas.

Note

The instructions for calibration must be observed, see **Caldos27 – Notes for calibration** on page 136.

Fidas24

Sample gas

Sample components

Hydrocarbons. The concentration of the gas components in the sample gas path must not exceed the temperature-dependent lower explosion limit.

Sample gas inlet conditions

Fidas24 – sample gas input conditions	
Temperature	≤ Thermostat temperature (thermostat temperature for sample gas path, detector and air injector ≤ 200 °C, factory-set at 180 °C)
Inlet pressure	$p_{abs} = 800$ to 1100 hPa
Outlet pressure	The outlet pressure must be the same as the atmospheric pressure.
Flow rate	approx. 80 to 100 l/h at atmospheric pressure (1000 hPa)
Humidity	≤ 40 % H ₂ O

Note

The temperature, pressure and flow of the sample gas must be kept constant, to such an extent that the influence of variations on the measuring accuracy is acceptable.

Refer to **Fidas24** on page 212.

Flammable gases

The gas analyzer may be used for the measurement of flammable gases provided that the flammable portion does not up-scale 15 Vol.-% CH₄ or does not up-scale C1 equivalents.

Further properties of the sample gas

The sample gas must not be explosive at any time.

The analyzer module must not be used for the measurement of gases containing organometallic compounds, e.g. lead-containing fuel additives or silicone oils.

Operational gases

Instrument air

Parameter	Value/Description
Quality	According to ISO 8573-1 Class 2 Particle size: max. 1 µm, Particle density: max. 1 mg/m ³ , Oil content: max. 0.1 mg/m ³ , Dew point: At least 10 °C below the lowest expected ambient temperature
Inlet pressure p_e	4000 hPa, ±500 hPa
Flow rate	Typically approx. 1800 l/h (1200 l/h for the air jet injector and approx. 600 l/h for the housing purge), max. approx. 2200 l/h (1500 l/h + 700 l/h)

Combustion air

Parameter	Value/Description
Quality	<ul style="list-style-type: none"> Synthetic air or catalytically purified air Organic hydrocarbon content: < 1 % of the measuring range
Inlet pressure p_e	1200 hPa, ±100 hPa
Flow rate	< 20 l/h

... 4 Preparation for Installation

... Fidas24

Combustion gas

DANGER

Explosion hazard

Explosion hazard due to high combustion gas flow rate.

- The maximum combustion gas flow rate specified in the following table **Combustion gas parameter** on page 36 must not be up-scaled.
- For this purpose, the operator must install a suited flow restrictor and a shut-off valve in the combustion gas line.

NOTICE

Destruction of the detector

Destruction of the detector due to overheating caused by incorrect combustion gas.

- For a design for H₂/He mix as a combustion gas, never use H₂ as a combustion gas!

Note

An H₂/He mixture may only be used if the gas analyzer has been ordered and delivered in the intended version.

Combustion gas parameter

Quality	Hydrogen (H ₂), Quality 5.0	H ₂ /He mix (40%/60%) Quality 5.0
Inlet pressure p _e	1200 hPa, ±100 hPa	1200 hPa, ±100 hPa
Maximum combustion gas flow	approx. 3 l/h	approx. 10 l/h

Flow restrictor in the combustion gas supply line

The combustion gas flow rate must be limited to a maximum of 10 l/h H₂ or 25 l/h H₂/He mixture.

For this purpose, the operator has to provide suited measures outside the gas analyzer.

ABB recommends using a bulkhead fitting with an integrated flow restrictor to be installed in the combustion gas supply line.

This bulkhead fitting can be supplied by ABB.

- Combustion gas H₂: order number 8329303,
- Combustion gas H₂/He mix: order number 0769359.

Shut-off valve in the combustion gas supply line

A shut-off valve must be installed in the combustion gas supply line to increase safety in the following operating conditions:

- when shutting down the gas analyzer,
- in case of instrument air supply failure,
- in case of a leak in the combustion gas path, inside the gas analyzer.

This shut-off valve should be installed outside the analyzer house in the vicinity of the combustion gas supply (cylinder, line), see

Connection of process gases and test gases on page 88.

ABB recommends the use of a pneumatic shut-off valve that is actuated by the instrument air. This shut-off valve can be supplied by ABB.

Order number 0769440.

If such a pneumatic shut-off valve cannot be installed, precautions must be taken to monitor the overall status or the "failure" status of the gas analyzer, see **In case of instrument air supply failure** on page 177.

Test gases

Test Gases for Zero Calibration

Quality	Nitrogen, Quality 5.0, synthetic air or catalytically cleaned air with an organic C < 1 % MBU
Inlet pressure p_e	Depressurized
Flow rate	At least 20 l/h more than the sample gas flow

Test gases for endpoint calibration

Quality	Test gas in nitrogen or synthetic air with concentration adjusted to the measuring range
Inlet pressure p_e	Depressurized
Flow rate	At least 20 l/h more than the sample gas flow

Zero point offset

If the zero point gas is not completely free of hydrocarbons (even purified nitrogen contains fractions of hydrocarbons), negative measured values may be displayed in small measuring ranges.

In this case, the sample gas contains a lower proportion of hydrocarbons than the zero point gas.

Note

The calibration information under **Fidas24 – Notes for calibration** on page 138 must be taken into account.

Gas connections

See sections **Gas connections and electrical connections Fidas24 (model EL3020)** on page 84 and **Gas connections and electrical connections Fidas24 (model EL3040)** on page 85.

Sample gas input and output conditions

Analyzers

Analyzer	Additional Information
Uras26	See page 21
Limas23	See page 23
Magnos206	See page 25
Magnos28	See page 27
Magnos27	See page 29
ZO23	See page 30
Caldos27	See page 33
Fidas24	See page 35

Oxygen sensor

Flammable gases

The oxygen sensor may not be used for the measurement of flammable gases.

Additional conditions

The H₂O dew point of the sample gas must be at least 2 °C.

The oxygen sensor may not be used if the sample gas contains the following components:

H₂S, compounds containing chlorine or fluorine, heavy metals, aerosols, mercaptans, alkaline components.

Integrated gas feed

Flammable gases

If the gas analyzer is equipped with the integrated gas feed, it must not be used for the measurement of flammable gases.

Note

Integrated gas feed can be used as an option in the EL3020 model. It cannot be used in the EL3040 model and not together with the Limas23, ZO23 and Fidas24 analyzers.

... 4 Preparation for Installation

... Sample gas input and output conditions

Special conditions for the model EL3040 gas analyzer in degree of protection II 3G

Flammable gases

The gas analyzer in explosion-proof design may be used for measurement of non-flammable gases and vapors.

Sample gas input pressure

Magnos28:

Absolute pressure: Maximum 1600 hPa

Gauge pressure: Maximum 600 hPa

All other analyzer modules:

Absolute pressure: Maximum 1100 hPa

Gauge pressure: Maximum 100 hPa

Pressure sensor

In which analyzer modules is a pressure sensor installed?

Gas analyzer	Pressure sensor
Uras26, Limas23, Caldos27	Factory-installed as standard
Magnos206, Magnos28, Magnos27	Factory-installed as an option
Fidas24, ZO23	Not required

Information for the safe and correct operation of the pressure sensor

DANGER

Explosion hazard

Explosion hazard when measuring flammable or ignitable gases with the pressure sensor.

- The pressure sensor must not be connected to the sample gas path if the sample gas contains flammable or ignitable components.

NOTICE

Damage to the pressure sensor

Damage to the pressure sensor by corrosive gases.

- For the measurement of corrosive gases, the terminal of the pressure sensor must not be connected to the sample gas path.
- Prior to the commissioning of the gas analyzer, the yellow plastic screw plug has to be screwed out of the connectors of the pressure sensor.
- For a precise pressure correction, the connection of the pressure sensor and sample gas outlet should be connected with each other via a T-piece and short lines. The lines must be as short as possible or – in the case of a greater length – have a sufficiently large inside diameter (min. 10 mm) so that the flow effect is minimized. If the pressure sensor is not connected to the sample gas output, the pressure sensor and sample gas output must be at the same level of pressure.
- Pressure sensor working range:
 $p_{abs} = 600 \text{ to } 1250 \text{ hPa}$.

Housing purge

Housing design

Housing purging is only possible with the wall-mounted housing (model EL3040). The purge gas connectors ($\frac{1}{8}$ NPT female thread) are factory-installed in accordance with the order.

Note

Housing purging in combination with Fidas24 is described separately, see **Housing purge with Fidas24** on page 39.

When is a housing purge necessary?

A housing purge is necessary when the sample gas contains flammable, corrosive or toxic components, see **Special conditions for the measurement of flammable gases** on page 43.

Purge gas

DANGER

Risk of suffocation

Risk of suffocation due to leaking purge gas. Purge gas can escape from the housing if there are any leak points.

- When using nitrogen as the purge gas, take all required precautions against suffocation.

NOTICE

Damage to the device

If the purge gas flow is not restricted until after the purge gas outlet, the full pressure of the purge gas will affect the housing seals which can destroy the operator panel keypad!

- The purge gas flow must always be restricted upstream of the purge gas inlet!

Suited purge gases

- Nitrogen for the measurement of flammable gases and
- Nitrogen or instrument air for the measurement of corrosive or toxic gases
(Instrument air quality, based on ISO 8573-1 Class 3, i.e. particle size max. 40 μm , oil content max. 1 mg/m^3 , dew point max. +3° C).

Note

For Uras26, the purge gas must not contain any fractions of the sample components!

Any sample components in the purge gas can cause false readings.

Initial purging upon commissioning

Housing purge*

Purge gas	Nitrogen
Purge gas flow	Maximum 200 l/h
Purge time	Approx. 1 hour

* Not for Fidas24, see for a separate description at **Housing purge with Fidas24** on page 39.

If the purge gas flow is lower than specified, the duration of the purging must be extended accordingly.

Housing purge during operation

Purge gas flow	At the device input max. 20 l/h (constant)
Purge gas overpressure	$p_e = 2$ to 4 hPa

For a purge gas flow rate of 20 l/h at the device inlet, the purge gas flow rate at the device outlet is approx. 5 to 10 l/h.

Housing purge during operation when measuring flammable gases

The housing must be purged using nitrogen. Purge gas flow rate 1 to 20 l/h. The purge gas flow must be monitored at the purge gas output.

Housing purge with Fidas24

In the Fidas24 gas analyzer, the housing purge is provided in such a way that a part (approx. 600 to 700 l/h) of the instrument air is conducted continuously through the housing as purge air.

Thus it is guaranteed that no ignitable gas mixture can form within the housing in case of a leak in the combustion gas path. The housing purge is always active when pressurized air is on, that is also when the instrument air valve is closed.

... 4 Preparation for Installation

Dimensions

19" housing (model EL3020)

Dimensions in mm (in)

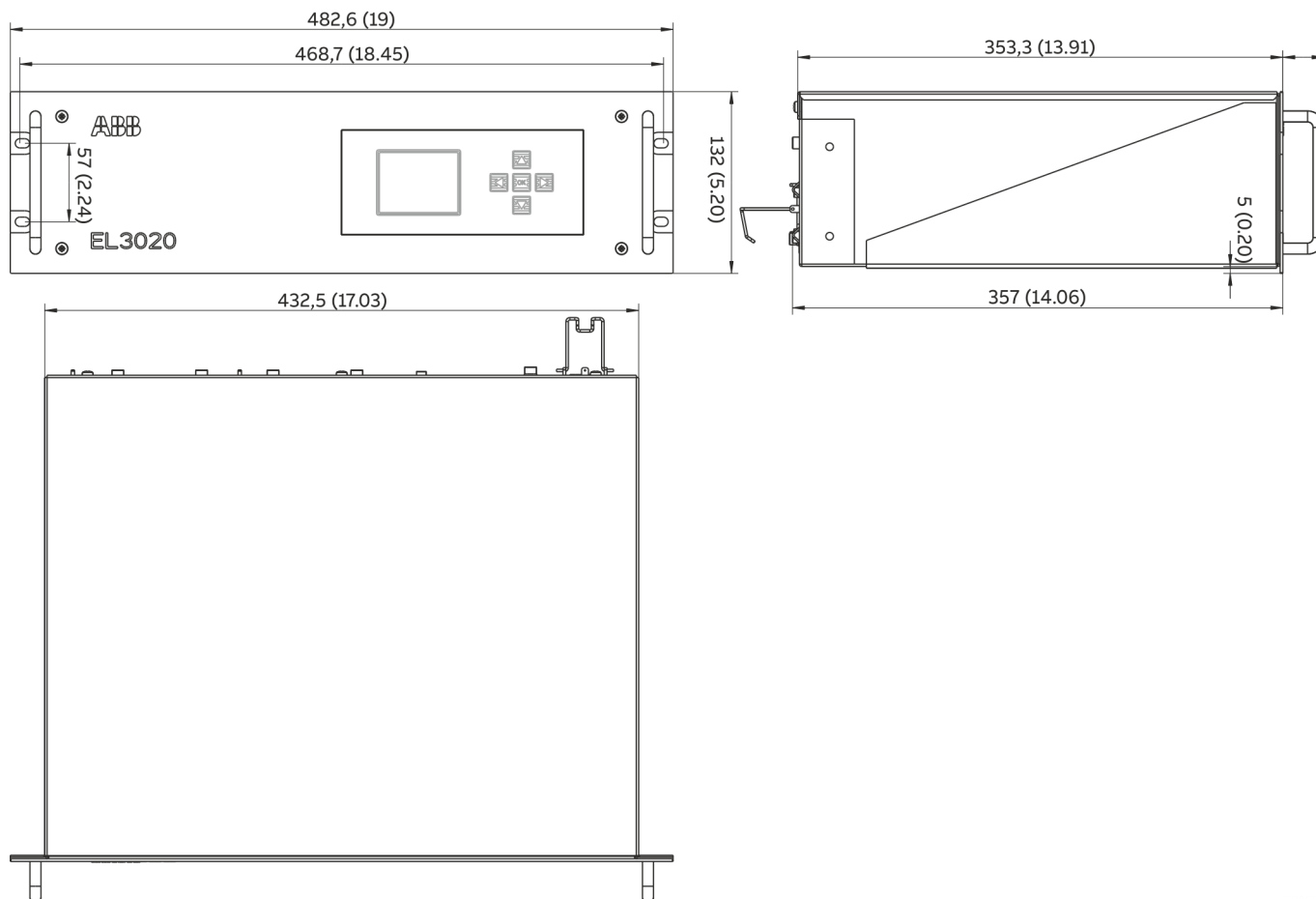

Figure 3: 19" housing (model EL3020)

19" housing (model EL3020 with Magnos27)

Dimensions in mm (in)

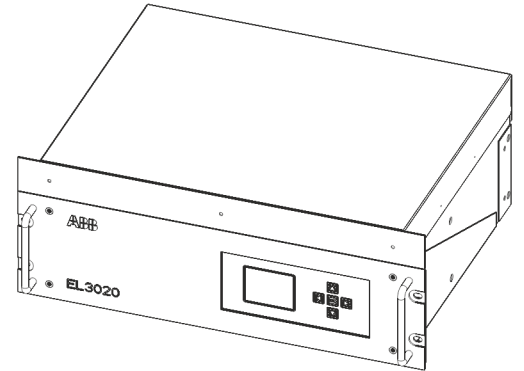
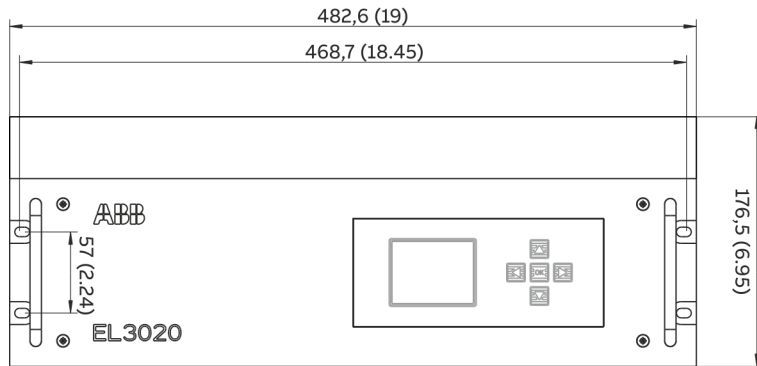

Figure 4: 19" housing (model EL3020 with Magnos27)

Note

Only the front view of the housing (with its height differing from the standard dimension) is depicted in this dimensional drawing. Additional views and dimensions of the 19" housing are shown in Figure 3.

... 4 Preparation for Installation

... Dimensions

Wall-mount housing (model EL3040)

Dimensions in mm (in)

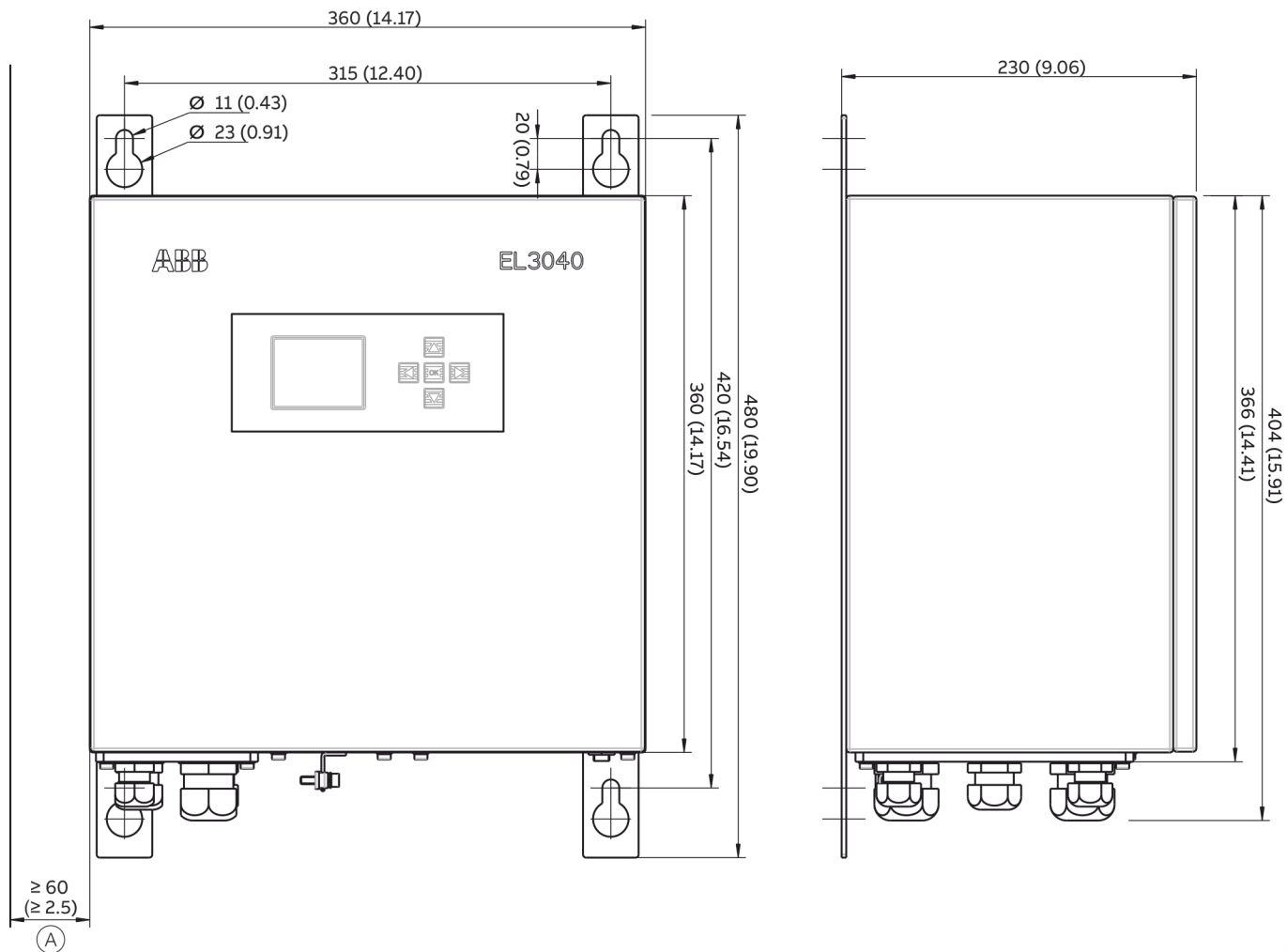

(A) Consider free space to swivel the door

Figure 5: Wall-mount housing (model EL3040)

Special conditions for the measurement of flammable gases

DANGER

Explosion hazard

Explosion hazard due to the formation of explosive gas mixtures when measuring flammable gases and connecting oxygen-containing test gases (such as air).

- Before connecting an oxygen-containing test gas, the gas path must be rinsed with an inert gas, such as nitrogen.
- Observe the following **safety instructions regarding calibration**.

Safety instructions regarding calibration

When measuring flammable gases, observe the following instructions:

- When calibrating the analyzers, air must not directly be connected as a test gas after operation with flammable gases.
- Alternatively, where possible, use nitrogen as test gas for calibration instead of air (for example, for zero point calibration of Uras26 or single point calibration of Magnos206 and Magnos28).
This must be particularly considered for automatically controlled calibration processes, since no automatic purging with an inert gas is possible.

Note

The version for the measurement of flammable gases and the explosion-proof design in degree of protection II 3G (see **Use in potentially explosive atmospheres** on page 12) are designed for various variants of the gas analyzer and for different applications.

Installation of the gas analyzer

- The pressure sensor must not be connected to the sample gas path.
- The sample gas lines and connections must be made of stainless steel.
- Before using the gas analyzer, corrosion resistance against the specific sample gas must be checked.
- Adequate air circulation must be ensured by observation of the minimum distances to neighboring housings, see **Adequate air circulation** on page 19.
- The **Special conditions for the model EL3020 gas analyzer for the measurement of flammable gases** on page 20 and **Special conditions for the model EL3040 gas analyzer in degree of protection II 3G** on page 20 must be observed.

Commissioning of the gas analyzer

- The sample gas path must be purged with inert gas before the gas analyzer is commissioned (see **Purge sample gas path and analyzer housing** on page 105).

Operation and Maintenance of the Gas Analyzer

- Only model EL3040:
 - The housing must be purged using nitrogen.
 - Purge gas flow rate 1 to 20 l/h.
 - The purge gas flow must be monitored at the purge gas output.
- The gauge pressure in the sample gas feed path may not upscale the maximum value of 100 hPa in standard operation and a maximum value of 500 hPa in the event of a fault.
 - The gas analyzer with Uras26 or Caldos27 can be used up to an absolute pressure of 1100 hPa.
 - The gas analyzer with Magnos28 can be used up to an absolute pressure of 1200 hPa.
- The leak tightness of the sample gas path must be checked regularly (see **Checking gas path leak tightness** on page 201).
- After the sample gas path within the gas analyzer has been opened, the following measures (see **Measures to take after each opening of the gas paths within the gas analyzer** on page 201) must be taken:
 - The leak tightness of the sample gas path must be checked.
 - The sample gas path must be purged with inert gas before the power supply is switched on.

5 Installation

Unpacking the Gas Analyzer

CAUTION

Injury hazard due to heavy weight

Depending on the version, the gas analyzer weighs 7 to 15 kg (19" housing – model EL3020) or 13 to 21 kg (wall-mounted housing – model EL3040)!

- Two persons are required for unpacking and transportation!

Check the devices immediately after unpacking for possible damage that may have occurred from improper transport. Details of any damage that has occurred in transit must be recorded on the transport documents. All claims for damages must be submitted to the shipper without delay and before installation.

1. Remove the accessories (refer to **Scope of delivery** on page 17) from the transport carton. Take care not to lose any of the accessories.
2. Remove the gas analyzer from the carton, together with the padding material.
3. Remove the padding material and place the gas analyzer in a clean area.
4. Clean the adhesive packaging residue from the gas analyzer.

Note

Keep the shipping carton and cushioning material for future transportation.

Name plate

Contents of the name plate

The name plate contains the following information:

- Production Number (P-No.),
- Order Number (O-No.),
- Power supply (voltage, frequency, max. power consumption),
- Installed analyzers with measurement components and measuring ranges.

Analyzer data sheet

Contents

The analyzer data sheet contains the following information:

- Order Number (O-No.),
- Job number (J-No.)
- Production Number (P-No.),
- Production Date,
- Power supply (voltage, frequency, max. power consumption),
- Measuring components and measuring ranges,
- Serial numbers of the installed modules.

Storage of the Analyzer Data Sheet

- on the left-hand side panel inside the 19"-housing (model EL3020) and
- on the door glued inside the wall-mount housing (model EL3040).

Note

- Keep the analyzer data sheet in the gas analyzer so that it is always at hand, especially in case of service/maintenance, refer to **Notify Service** on page 178.
- During commissioning, observe the information in the analyzer data sheet. The information given in the analyzer data sheet may differ from the general information in this regard Operating Instruction.

Mounting the fittings on the gas analyzer

General information

To connect the gas lines to the gas analyzer, screw-in sockets (fittings) are used in different designs.

Depending on the design, the fittings are included in the scope of delivery or must be provided during the assembly.

The different designs of gas connections are listed in Table **Position and design of the gas connections** on page 46.

Note

It is recommended that the fittings be installed on the analyzer module before the gas analyzer is mounted, as the connection ports are still easily accessible before the analyzer is mounted.

Fittings

- The fittings used must be clean and free of grease and residue!
 - Impurities from the fittings can enter the analyzer and damage it. They could also falsify the measurement result.
- Observe the installation instructions provided by the manufacturers of the fittings!
- Hold back the screw connections when connecting the gas lines!

Gaskets

- Do not use sealing compound to seal the fittings!
 - Components of the sealing compound could falsify the measurement results.
- The sealing material must be free of grease.

Requisite Material

Screw-in spud with hose nozzles (supplied) or screw-in fittings with 1/8 NPT thread and PTFE sealing tape.

Installing the fittings

1. Screw out the yellow plastic screwing caps (5 mm hexagon socket) from the connection ports.
2. Wrap PTFE sealing tape tightly around the thread of the screw-in fitting twice, clockwise, and screw it into the connection socket.

After mounting, approx. 2 threads usually remain visible

Note

Screw the fittings in carefully, and not too tightly!

Checking gas path leak tightness

The leak tightness of the sample gas path and the reference gas path, if applicable, is factory-tested with a helium leak test for a leak rate of $< 1 \times 10^{-4}$ hPa·l/s.

However, since the leak tightness may be impaired when transporting the gas analyzer (for example due to severe vibrations), we recommend that you check it prior to commissioning at the installation site.

Refer to **Checking gas path leak tightness** on page 201.

Note

We strongly recommend checking the tightness of the gas feed paths before the gas analyzer is assembled, since the housing must be opened in the event of a leak.

... 5 Installation

Position and design of the gas connections

The following pages list the location and execution of the gas connections of the individual analyzer modules and their combinations. The table below is used as an aid in navigating the connection descriptions.

Position and design of the gas connections		
Analyzer module	Model EL3020	Model EL3040
Uras26	see page 47	see page 49
Uras26 with Magnos206	see page 50	see page 52
Uras26 with Magnos28	see page 54	see page 56
Uras26 with Caldos27	see page 58	see page 60
Limas23	see page 62	see page 63
Limas23 with Magnos206	see page 64	see page 65
Limas23 with Magnos28	see page 67	see page 68
Magnos206	see page 70	see page 71
Magnos28	see page 72	see page 76
Magnos28 with Magnos28	see page 73	—
Magnos28 with Caldos27	see page 74	—
Magnos27	see page 77	—
Magnos27 with Uras26	see page 78	—
ZO23	see page 79	see page 80
Caldos27	see page 81	see page 83
Caldos27 with Caldos27	see page 82	—
Fidas24	see page 84	see page 85

Gas connections Uras26 (model EL3020)

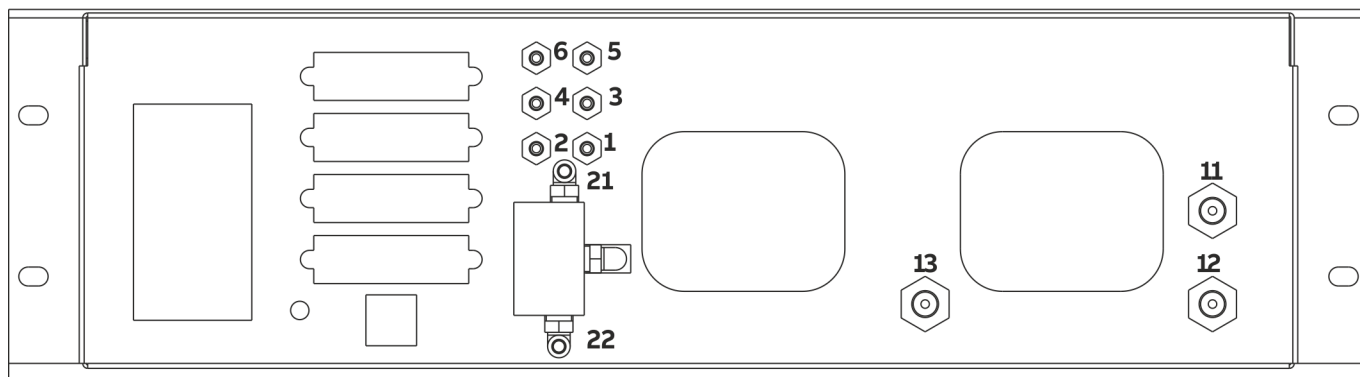

Figure 6: Gas connections Uras26 (EL3020)

Uras26: Gas connections for hose lines (internal gas lines made using hoses)

Pos.	Connection	Supplementary information	Version
1	Sample gas inlet (gas path 1)	Without 'integrated gas feed' option	Screwed connections with hose nozzles (stainless steel 1.4305) for hoses with 4 mm inside diameter (included in scope of supply)
2	Sample gas outlet (gas path 1)	—	
3	Sample gas outlet (gas path 1)	For 'Integrated gas feed' option, factory-connected to sample gas inlet Pos. 1 (gas path 1)	
4	Sample gas inlet (gas path 1)	For 'Integrated gas feed' option with flow sensor only (without solenoid valve)	Screwed fittings with hose nozzles (PVDF) for hoses with 4 mm inside diameter (included in scope of supply)
	Pressure sensor	For 'Pressure sensor connected to the outside by hose' option	
5	Sample gas inlet (gas path 2)	For second sample gas or flowing reference gas, sample cell	Screwed fittings with hose nozzles (PVDF) for hoses with 4 mm inside diameter (included in scope of supply)
6	Sample gas outlet (gas path 2)	1 (depending on the design of the analyzer)	
21	Sample gas inlet (gas path 1)	On solenoid valve with 'integral gas feed' option with solenoid valve, pump, filter, capillary and flow sensor	Screwed fittings with hose nozzles (PVDF) for hoses with 4 mm inside diameter (included in scope of supply)
22	Test gas inlet (gas path 1)		

Note

The pressure sensor (standard, not for the 'pressure sensor connected to outside by hose' option), and the oxygen sensor (option) are internally connected as follows:

- In the output of the measuring cell 1, with a measuring cell and in the case of separate gas paths.
- In the output of measuring cells 2 for two measuring cells in series.
- The second O₂ sensor (option for version with separate gas paths) is connected downstream of the sample cell 2 outlet.

... 5 Installation

... Position and design of the gas connections

Uras26: Gas connections for pipelines

(internal gas lines made stainless steel pipes)

Pos.	Connection	Supplementary information	Version
6	Pressure sensor	—	Screwed connections with hose nozzles (stainless steel 1.4305) for hoses with 4 mm inside diameter (included in scope of supply)
11	Sample gas inlet	—	½ NPT female thread (stainless steel 1.4305) for threaded connections
12	Sample gas outlet	For a sample cell	
13	Sample gas outlet	For two sample cells in series	(not included in scope of supply)

Note

The oxygen sensor, the 'integrated gas feed' option and the version with separated gas paths are not possible.

Gas connections Uras26 (model EL3040)

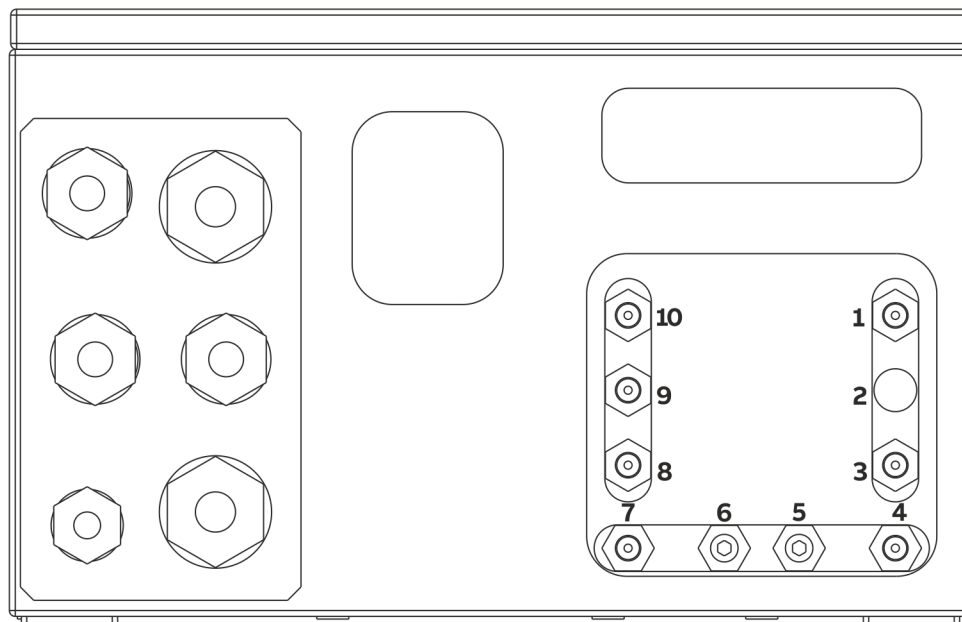

Figure 7: Gas connections Uras26 (model EL3040)

Uras26: Gas connections

Pos.	Connection	Supplementary information	Version
1	Pressure sensor	The pressure sensor is connected to the Pos. 1 terminal if the internal gas lines are designed as stainless steel pipes, or if the 'Pressure sensor connected outside by hose' option is ordered.	<ul style="list-style-type: none"> • $\frac{1}{8}$ NPT female thread (stainless steel 1.4305) • Connection of hose lines: straight screw-in socket (PP) with hose nozzles for hoses with inside diameter 4 mm (included in scope of delivery) • Connection of piping: screw-in fittings (not included in scope of delivery)
2	Not assigned	—	
3	Sample gas inlet (gas path 1)	—	
4	Sample gas outlet (gas path 1)	For a measuring cell and for two measuring cells with separate gas paths	
5	Purge gas inlet (housing)	—	
6	Purge gas outlet (housing)	—	
7	Sample gas inlet (gas path 2)	—	
8	Sample gas outlet (gas path 2)	—	
	Sample gas outlet (gas path 1)	For two sample cells in series	
9	Reference gas inlet	Sample cell 1 flowing reference gas	
10	Reference gas outlet		

Note

- If the internal gas lines are designed as hoses, the pressure sensor (standard, not for the 'pressure sensor connected to outside by hose' option), and the oxygen sensor (option) are internally connected as follows:
 - In the output of measuring cell 1, for one measuring cell and for two measuring cells with separate gas paths.
 - In the output of measuring cell 2 for two measuring cells in a series.
 - The second oxygen sensor (option for version with separate gas paths) is connected in the outlet of sample cell 2.
- If the internal gas lines are designed as stainless steel pipes, the oxygen sensor and the version with separated gas paths are not possible.

... 5 Installation

... Position and design of the gas connections

Gas connections Uras26 with Magnus206 (model EL3020)

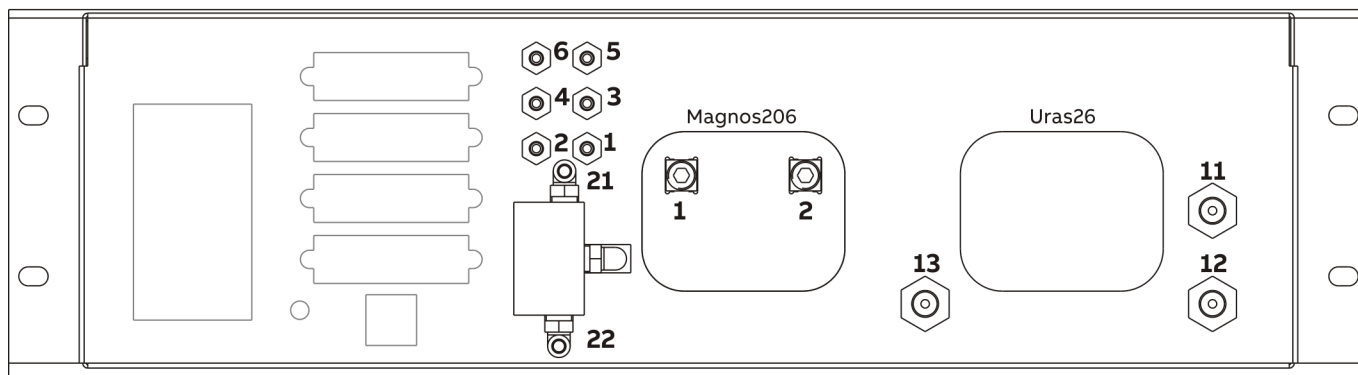

Figure 8: Gas connections Uras26 with Magnus206 (model EL3020)

Uras26: Gas connections for hose lines (internal gas lines made using hoses)

Pos.	Connection	Supplementary information	Version
1	Sample gas inlet (gas path 1)	Without 'integrated gas feed' option	Screwed connections with hose nozzles (stainless steel 1.4305) for hoses with 4 mm inside diameter (included in scope of supply)
2	Sample gas outlet (gas path 1)	—	
3	Sample gas outlet (gas path 1)	For 'Integrated gas feed' option, factory-connected to sample gas inlet Pos. 1 (gas path 1)	
4	Sample gas inlet (gas path 1)	For 'Integrated gas feed' option with flow sensor only (without solenoid valve)	
	Pressure sensor	For 'Pressure sensor connected to the outside by hose' option	
5	Sample gas inlet (gas path 2)	For second sample gas or flowing reference gas, sample cell 1 (depending on the design of the analyzer)	
6	Sample gas outlet (gas path 2)		
21	Sample gas inlet (gas path 1)	On solenoid valve with 'integral gas feed' option with	Screwed fittings with hose nozzles (PVDF) for hoses with 4 mm inside diameter (included in scope of supply)
22	Test gas inlet (gas path 1)	solenoid valve, pump, filter, capillary and flow sensor	

Note

- The oxygen sensor is not possible in combination with Magnus206
- The pressure sensor (standard, not for the 'pressure sensor connected to outside by hose' option) are internally connected as follows:
 - In the output of the measuring cell 1, with a measuring cell and in the case of separate gas paths.
 - In the output of measuring cell 2 for two measuring cells in a series.

Uras26: Gas connections for pipelines
(internal gas lines made stainless steel pipes)

Pos.	Connection	Supplementary information	Version
6	Pressure sensor	—	Screwed connections with hose nozzles (stainless steel 1.4305) for hoses with 4 mm inside diameter (included in scope of supply)
11	Sample gas inlet	—	1/8 NPT female thread (stainless steel 1.4305) for threaded connections
12	Sample gas outlet	For a sample cell	
13	Sample gas outlet	For two sample cells in series	(not included in scope of supply)

Note

The oxygen sensor, the 'integrated gas feed' option and the version with separated gas paths are not possible.

Magnos206: Gas Connections

Pos.	Connection	Supplementary information	Version
1	Sample gas inlet	—	1/8 NPT female thread (stainless steel 1.4305)
2	Sample gas outlet	—	<ul style="list-style-type: none"> • Connection of hose lines: straight screw-in socket (PP) with hose nozzles for hoses with inside diameter 4 mm (included in scope of delivery) • Connection of piping: screw-in fittings (not included in scope of delivery)

Note

The sample gas inlet of Magnos206 can be connected to the sample gas output (gas path 1) of Uras26 at the factory or have a separate sample gas path without connection to Uras26.

... 5 Installation

... Position and design of the gas connections

Gas connections Uras26 with Magnos206 (model EL3040)

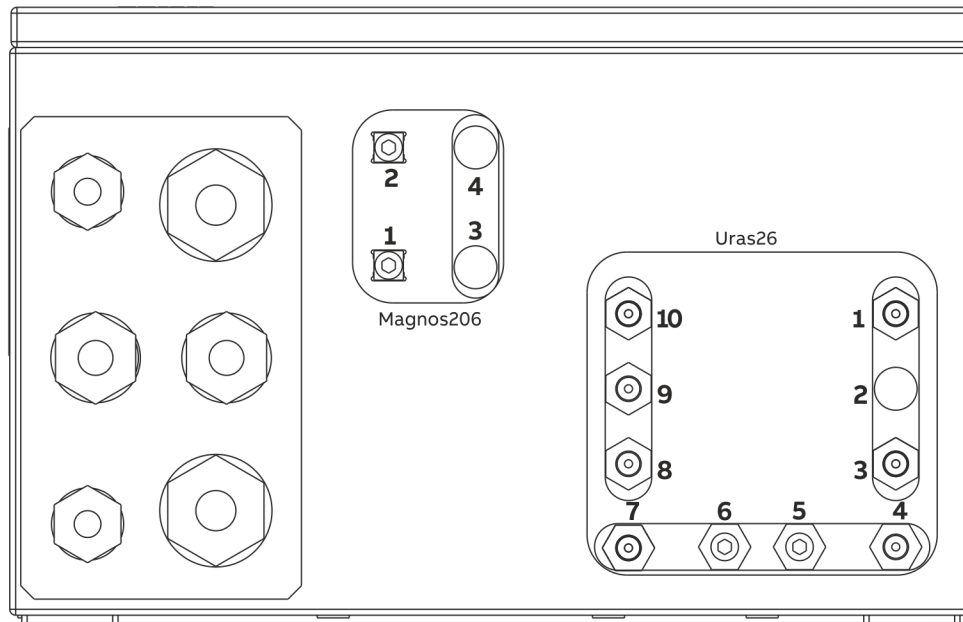

Figure 9: Gas connections Uras26 with Magnos206 (model EL3040)

Uras26: Gas connections

Pos.	Connection	Supplementary information	Version
1	Pressure sensor	The pressure sensor is connected to the Pos. 1 terminal if the internal gas lines are designed as stainless steel pipes, or if the 'Pressure sensor connected outside by hose' option is ordered.	<ul style="list-style-type: none"> • ½ NPT female thread (stainless steel 1.4305) • Connection of hose lines: straight screw-in socket (PP) with hose nozzles for hoses with inside diameter 4 mm (included in scope of delivery) • Connection of piping: screw-in fittings (not included in scope of delivery)
2	Not assigned	—	
3	Sample gas inlet (gas path 1)	—	
4	Sample gas outlet (gas path 1)	For a measuring cell and for two measuring cells with separate gas paths	
5	Purge gas inlet (housing)	—	
6	Purge gas outlet (housing)	—	
7	Sample gas inlet (gas path 2)	—	
8	Sample gas outlet (gas path 2)	—	
	Sample gas outlet (gas path 1)	For two sample cells in series	
9	Reference gas inlet	Sample cell 1 flowing reference gas	
10	Reference gas inlet		

Note

- The oxygen sensor is not possible in combination with Magnos206
- If the internal gas lines are designed as hoses, the pressure sensor (standard, not for the 'pressure sensor connected to outside by hose' option), and the oxygen sensor (option) are internally connected as follows:
 - In the output of measuring cell 1, for one measuring cell and for two measuring cells with separate gas paths.
 - In the output of measuring cells 2 for two measuring cells in series.
- If the internal gas lines are designed as stainless steel pipes, the version with separate gas paths is not possible.

Magnos206: Gas Connections

Pos.	Connection	Supplementary information	Version
1	Sample gas inlet	—	1/8 NPT female thread (stainless steel 1.4305)
2	Sample gas outlet	—	<ul style="list-style-type: none"> • Connection of hose lines: straight screw-in socket (PP) with hose nozzles for hoses with inside diameter 4 mm (included in scope of delivery) • Connection of piping: screw-in fittings (not included in scope of delivery)
3	Not assigned	—	
4	Not assigned	—	

Note

The sample gas inlet of Magnos206 can be connected to the sample gas output (gas path 1) of Uras26 at the factory or have a separate sample gas path without connection to Uras26.

... 5 Installation

... Position and design of the gas connections

Gas connections Uras26 with Magnos28 (model EL3020)

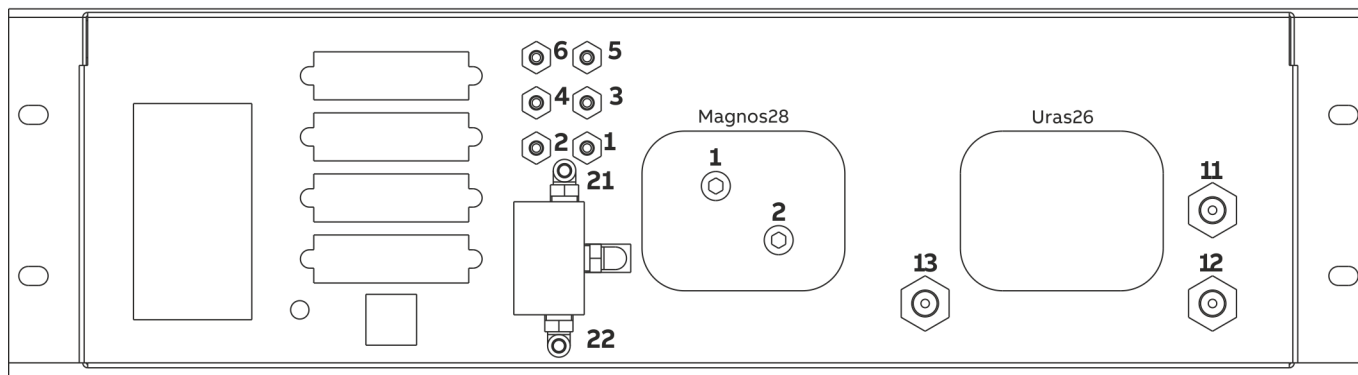

Figure 10: Gas connections Uras26 with Magnos28 (EL3020)

Uras26: Gas connections for hose lines (internal gas lines made using hoses)

Pos.	Connection	Supplementary information	Design
1	Sample gas inlet (gas path 1)	Without 'integrated gas feed' option	Screwed connections with hose nozzles (stainless steel 1.4305) for hoses with 4 mm inside diameter (included in scope of supply)
2	Sample gas outlet (gas path 1)	—	
3	Sample gas outlet (gas path 1)	For 'Integrated gas feed' option, factory-connected to sample gas inlet Pos.1 (gas path 1)	
4	Sample gas inlet (gas path 1)	For 'Integrated gas feed' option with flow sensor only (without solenoid valve)	Screwed fittings with hose nozzles (PVDF) for hoses with 4 mm inside diameter (included in scope of supply)
	Pressure sensor	For 'Pressure sensor connected to the outside by hose' option	
5	Sample gas inlet (gas path 2)	For second sample gas or flowing reference gas, sample cell 1 (depending on the design of the analyzer)	
6	Sample gas outlet (gas path 2)		
21	Sample gas inlet (gas path 1)	On solenoid valve with 'integral gas feed' option with	Screwed fittings with hose nozzles (PVDF) for hoses with 4 mm inside diameter (included in scope of supply)
22	Test gas inlet (gas path 1)	solenoid valve, pump, filter, capillary and flow sensor	

Note

- The oxygen sensor is not possible in combination with Magnos28
- The pressure sensor (standard, not for the 'pressure sensor connected to outside by hose' option) are internally connected as follows:
 - In the output of the measuring cell 1, with a measuring cell and in the case of separate gas paths.
 - In the output of measuring cell 2 for two measuring cells in a series.

Uras26: Gas connections for pipelines
(internal gas lines made stainless steel pipes)

Pos.	Connection	Supplementary information	Version
6	Pressure sensor	—	Screwed connections with hose nozzles (stainless steel 1.4305) for hoses with 4 mm inside diameter (included in scope of supply)
11	Sample gas inlet	—	1/8 NPT female thread (stainless steel 1.4305) for threaded connections
12	Sample gas outlet	For a sample cell	
13	Sample gas outlet	For two sample cells in series	(not included in scope of supply)

Note

The oxygen sensor, the 'integrated gas feed' option and the version with separated gas paths are not possible.

Magnos28: Gas Connections

Pos.	Connection	Supplementary information	Version
1	Sample gas inlet	—	1/8 NPT female thread (stainless steel 1.4305)
2	Sample gas outlet	—	<ul style="list-style-type: none"> • Connection of hose lines: straight screw-in socket (PP) with hose nozzles for hoses with inside diameter 4 mm (included in scope of delivery) • Connection of piping: screw-in fittings (not included in scope of delivery)

Note

The sample gas inlet of Magnos28 can be optionally connected at the factory to the sample gas output (gas path 1) of Uras26 or have a separate sample gas path without connection to Uras26.

... 5 Installation

... Position and design of the gas connections

Gas connections Uras26 with Magnos28 (model EL3040)

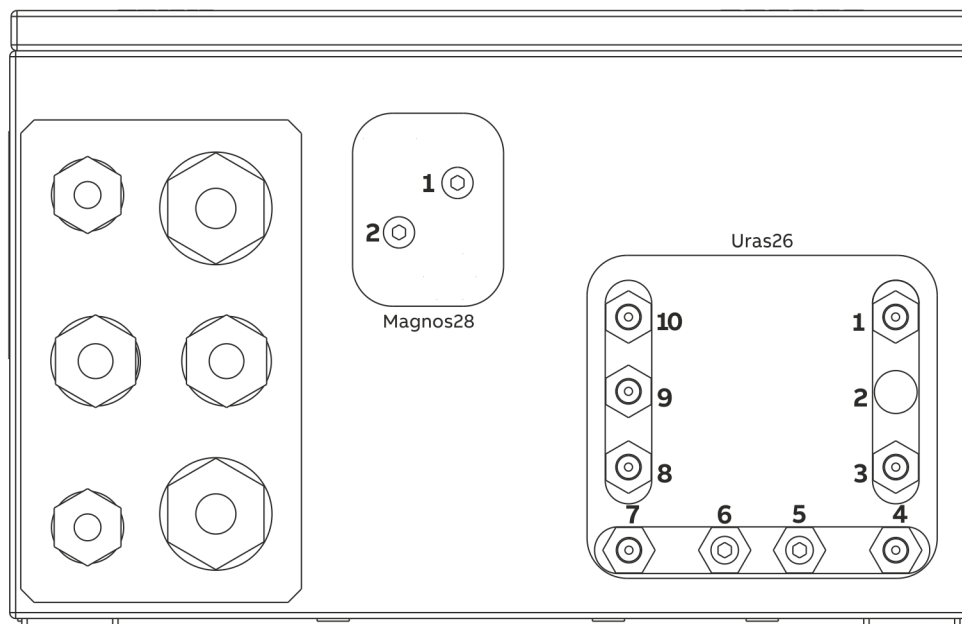

Figure 11: Gas connections Uras26 with Magnos28 (model EL3040)

Uras26: Gas connections

(internal gas lines made using hoses or stainless steel pipes)

Pos.	Connection	Supplementary information	Version
1	Pressure sensor	The pressure sensor is connected to the Pos. 1 terminal if the internal gas lines are designed as stainless steel pipes, or if the 'Pressure sensor connected outside by hose' option is ordered.	<ul style="list-style-type: none"> • ½ NPT female thread (stainless steel 1.4305) • Connection of hose lines: straight screw-in socket (PP) with hose nozzles for hoses with inside diameter 4 mm (included in scope of delivery) • Connection of piping: screw-in fittings (not included in scope of delivery)
2	Not assigned	—	
3	Sample gas inlet (gas path 1)	—	
4	Sample gas outlet (gas path 1)	For a measuring cell and for two measuring cells with separate gas paths	
5	Purge gas inlet (housing)	—	
6	Purge gas outlet (housing)	—	
7	Sample gas inlet (gas path 2)	—	
8	Sample gas outlet (gas path 2)	—	
	Sample gas outlet (gas path 1)	For two sample cells in series	
9	Reference gas inlet	Sample cell 1 flowing reference gas	
10	Reference gas inlet		

Note

- The oxygen sensor is not possible in combination with Magnos28
- If the internal gas lines are designed as hoses, the pressure sensor (standard, not for the 'pressure sensor connected to outside by hose' option), and the oxygen sensor (option) are internally connected as follows:
 - In the output of measuring cell 1, for one measuring cell and for two measuring cells with separate gas paths.
 - In the output of measuring cells 2 for two measuring cells in series.
- If the internal gas lines are designed as stainless steel pipes, the version with separate gas paths is not possible.

Magnos28: Gas Connections

Pos.	Connection	Supplementary information	Version
1	Sample gas inlet	—	½ NPT female thread (stainless steel 1.4305)
2	Sample gas outlet	—	<ul style="list-style-type: none"> • Connection of hose lines: straight screw-in socket (PP) with hose nozzles for hoses with inside diameter 4 mm (included in scope of delivery) • Connection of piping: screw-in fittings (not included in scope of delivery)

Note

The sample gas inlet of Magnos28 can be optionally connected at the factory to the sample gas output (gas path 1) of Uras26 or have a separate sample gas path without connection to Uras26.

... 5 Installation

... Position and design of the gas connections

Gas connections Uras26 with Caldos27 (model EL3020)

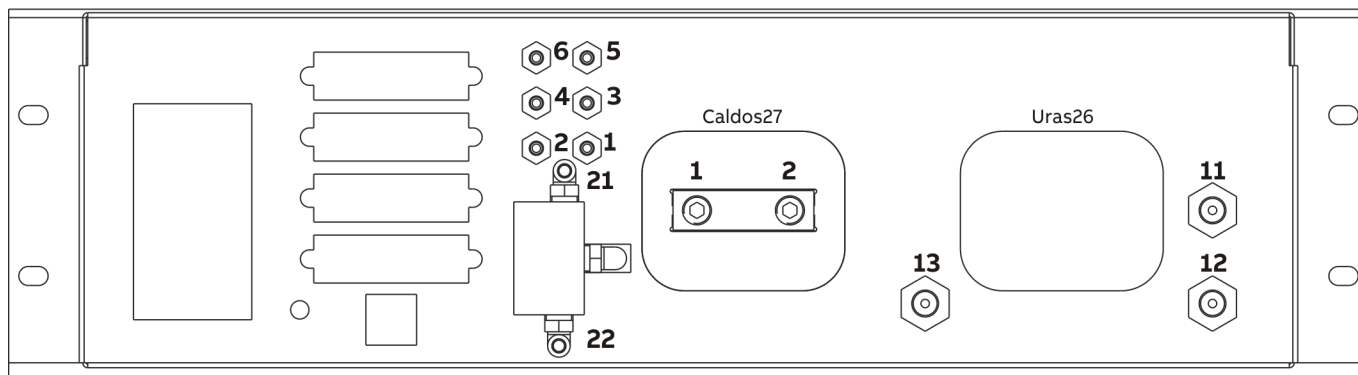

Figure 12: Gas connections Uras26 with Caldos27 (model EL3020)

Uras26: Gas connections for hose lines

(internal gas lines made using hoses)

Pos.	Connection	Supplementary information	Version
1	Sample gas inlet (gas path 1)	Without 'integrated gas feed' option	Screwed connections with hose nozzles (stainless steel 1.4305) for hoses with 4 mm inside diameter (included in scope of supply)
2	Sample gas outlet (gas path 1)	—	
3	Sample gas outlet (gas path 1)	For 'Integrated gas feed' option, factory-connected to sample gas inlet Pos. 1 (gas path 1)	
4	Sample gas inlet (gas path 1)	For 'Integrated gas feed' option with flow sensor only (without solenoid valve)	Screwed fittings with hose nozzles (PVDF) for hoses with 4 mm inside diameter (included in scope of supply)
	Pressure sensor	For 'Pressure sensor connected to the outside by hose' option	
5	Sample gas inlet (gas path 2)	For second sample gas or flowing reference gas, sample	Screwed fittings with hose nozzles (PVDF) for hoses with 4 mm inside diameter (included in scope of supply)
6	Sample gas outlet (gas path 2)	cell 1 (depending on the design of the analyzer)	
21	Sample gas inlet (gas path 1)	On solenoid valve with 'integral gas feed' option with	Screwed fittings with hose nozzles (PVDF) for hoses with 4 mm inside diameter (included in scope of supply)
22	Test gas inlet (gas path 1)	solenoid valve, pump, filter, capillary and flow sensor	

Note

- The oxygen sensor is not possible in combination with Caldos27
- The pressure sensor (standard, not for the 'pressure sensor connected to outside by hose' option) are internally connected as follows:
 - In the output of the measuring cell 1, with a measuring cell and in the case of separate gas paths.
 - In the output of measuring cell 2 for two measuring cells in a series.

Uras26: Gas connections for pipelines
(internal gas lines made stainless steel pipes)

Pos.	Connection	Supplementary information	Version
6	Pressure sensor	—	Screwed connections with hose nozzles (stainless steel 1.4305) for hoses with 4 mm inside diameter (included in scope of supply)
11	Sample gas inlet	—	1/8 NPT female thread (stainless steel 1.4305) for threaded connections
12	Sample gas outlet	For a sample cell	
13	Sample gas outlet	For two sample cells in series	(not included in scope of supply)

Note

The oxygen sensor, the 'integrated gas feed' option and the version with separated gas paths are not possible.

Caldos27: gas connections

Pos.	Connection	Supplementary information	Version
1	Sample gas inlet	—	1/8 NPT female thread (stainless steel 1.4305)
2	Sample gas outlet	—	<ul style="list-style-type: none"> • Connection of hose lines: straight screw-in socket (PP) with hose nozzles for hoses with inside diameter 4 mm (included in scope of delivery) • Connection of piping: screw-in fittings (not included in scope of delivery)

Note

The sample gas inlet of Caldos27 can be connected to the sample gas output (gas path 1) of Uras26 at the factory or have a separate sample gas path without connection to Uras26.

... 5 Installation

... Position and design of the gas connections

Gas connections Uras26 with Caldos27 (model EL3040)

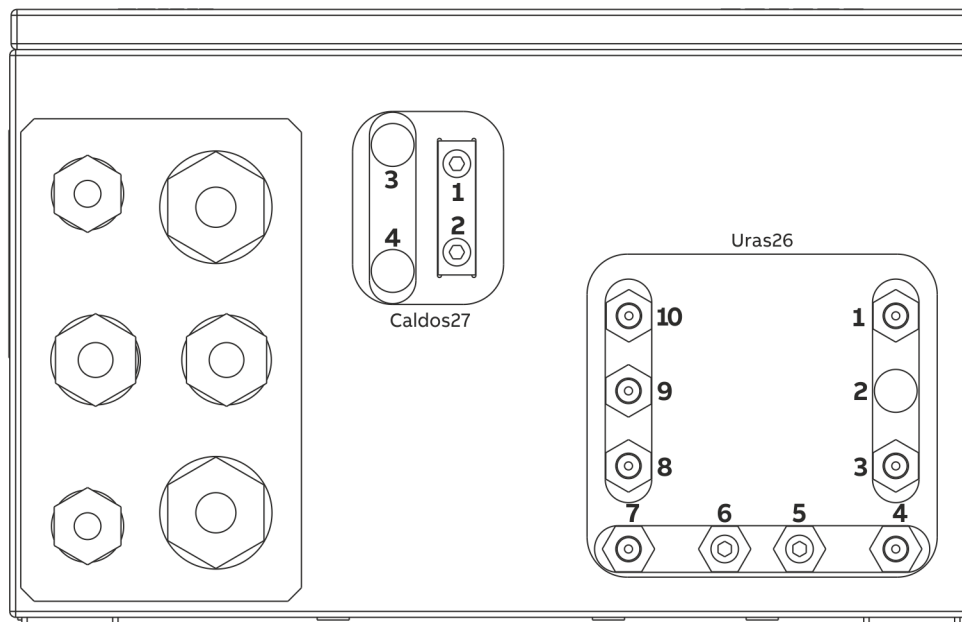

Figure 13: Gas connections Uras26 with Caldos27 (model EL3040)

Uras26: Gas connections

Pos.	Connection	Supplementary information	Version
1	Pressure sensor	The pressure sensor is connected to the Pos. 1 terminal if the internal gas lines are designed as stainless steel pipes, or if the 'Pressure sensor connected outside by hose' option is ordered.	<ul style="list-style-type: none"> • ½ NPT female thread (stainless steel 1.4305) • Connection of hose lines: straight screw-in socket (PP) with hose nozzles for hoses with inside diameter 4 mm (included in scope of delivery)
2	Not assigned	—	
3	Sample gas inlet (gas path 1)	—	<ul style="list-style-type: none"> • Connection of piping: screw-in fittings (not included in scope of delivery)
4	Sample gas outlet (gas path 1)	For a measuring cell and for two measuring cells with separate gas paths	
5	Purge gas inlet (housing)	—	
6	Purge gas outlet (housing)	—	
7	Sample gas inlet (gas path 2)	—	
8	Sample gas outlet (gas path 2)	—	
	Sample gas outlet (gas path 1)	For two sample cells in series	
9	Reference gas inlet	Sample cell 1 flowing reference gas	
10	Reference gas inlet		

Note

- The oxygen sensor is not possible in combination with Caldos27
- If the internal gas lines are designed as hoses, the pressure sensor (standard, not for the 'pressure sensor connected to outside by hose' option), and the oxygen sensor (option) are internally connected as follows:
 - In the output of measuring cell 1, for one measuring cell and for two measuring cells with separate gas paths.
 - In the output of measuring cells 2 for two measuring cells in series.
- If the internal gas lines are designed as stainless steel pipes, the version with separate gas paths is not possible.

Caldos27: Gas Connections

Pos.	Connection	Supplementary information	Version
1	Sample gas inlet	—	½ NPT female thread (stainless steel 1.4305)
2	Sample gas outlet	—	<ul style="list-style-type: none"> • Connection of hose lines: straight screw-in socket (PP) with hose nozzles for hoses with inside diameter 4 mm (included in scope of delivery) • Connection of piping: screw-in fittings (not included in scope of delivery)
3	not used	—	
4	not used	—	

Note

The sample gas inlet of Caldos27 can be connected to the sample gas output (gas path 1) of Uras26 at the factory or have a separate sample gas path without connection to Uras26.

... 5 Installation

... Position and design of the gas connections

Gas connections Limas23 (model EL3020)

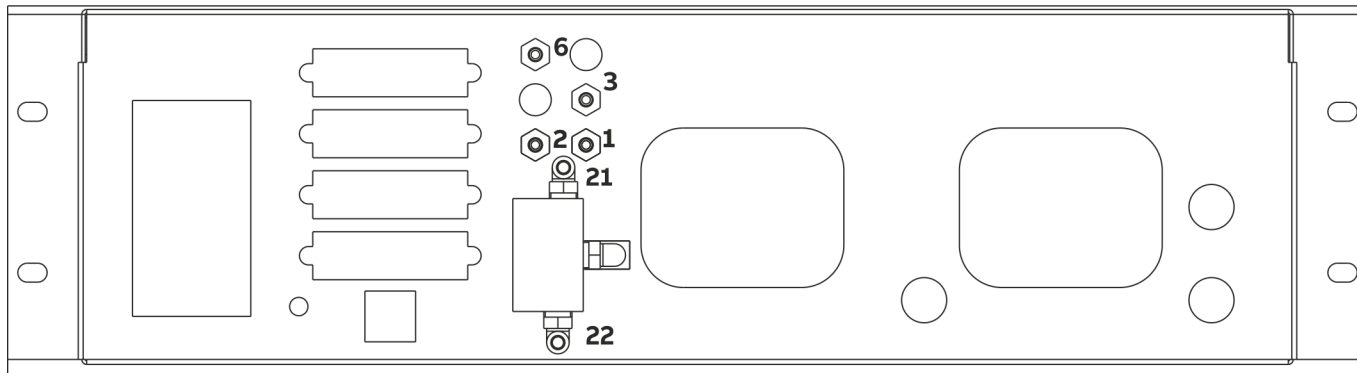

Figure 14: Gas connections Limas23 (model EL3020)

Limas23: Gas connections

Pos.	Connection	Supplementary information	Version
1	Sample gas inlet	Without optional solenoid valve	Screwed connections with hose nozzles (stainless steel 1.4305) for hoses with 4 mm inside diameter
2	Sample gas outlet	—	(included in scope of supply)
3	Sample gas outlet	With optional solenoid valve, factory-connected to sample gas input Pos. 1	
6	Pressure sensor	For 'Pressure sensor connected to the outside by hose' option	
21	Sample gas inlet	With optional solenoid valve	Screwed fittings with hose nozzles (PVDF) for hoses with 4 mm inside diameter
22	Test gas inlet		(included in scope of supply)

Note

The pressure sensor (standard, not for the 'pressure sensor connected to outside by hose' option), and the oxygen sensor (option) are internally connected in the outlet of the sample cell.

Gas connections Limas23 (model EL3040)

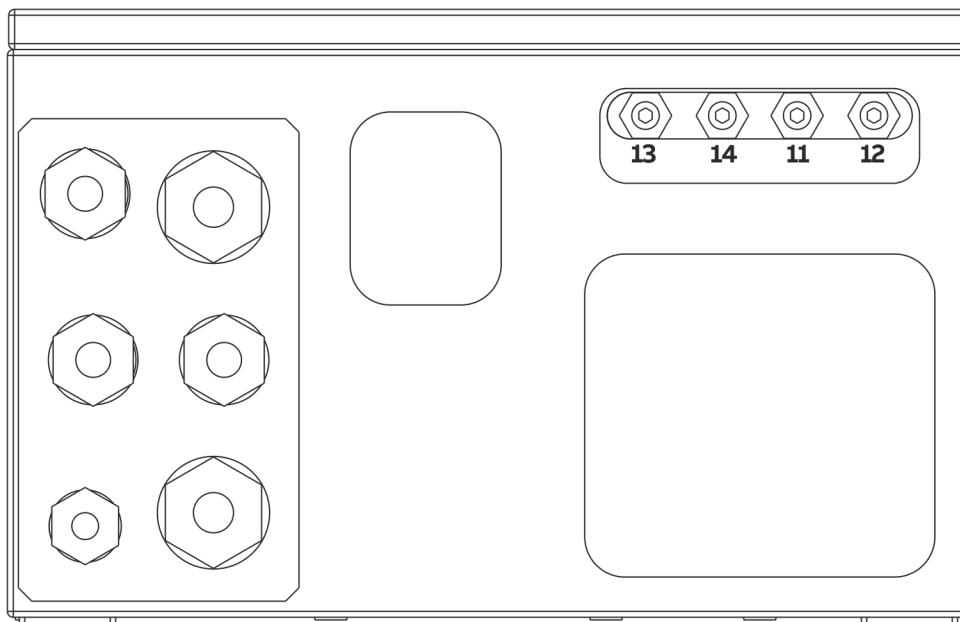

Figure 15: Gas connections Limas23 (model EL3040)

Limas23: Gas connections

Pos.	Connection	Supplementary information	Version
13	Sample gas inlet	—	½ NPT female thread (stainless steel 1.4305)
14	Sample gas outlet	—	• Connection of hose lines:
11	Pressure sensor	For 'Pressure sensor connected to the outside by hose' option	straight screw-in socket (PP) with hose nozzles for hoses with inside diameter 4 mm (included in scope of delivery)
	Purge gas inlet (housing)	Not for 'Pressure sensor connected to the outside by hose' option	• Connection of piping:
12	Purge gas outlet (housing)	Not for 'Pressure sensor connected to the outside by hose' option	screw-in fittings (not included in scope of delivery)

Note

The pressure sensor (standard, not for the 'pressure sensor connected to outside by hose' option), and the oxygen sensor (option) are internally connected in the outlet of the sample cell.

... 5 Installation

... Position and design of the gas connections

Gas connections Limas23 with Magnos206 (model EL3020)

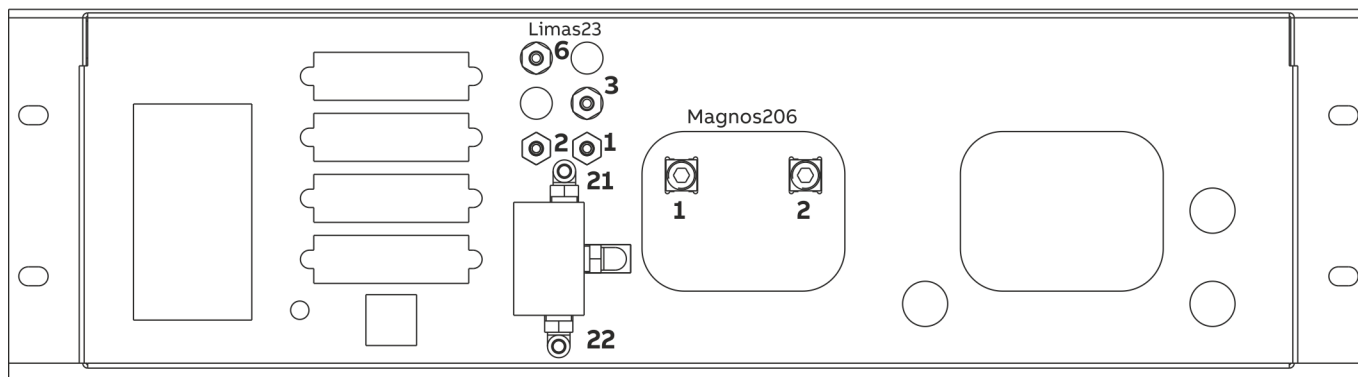

Figure 16: Gas connections Limas23 with Magnos206 (model EL3020)

Limas23: Gas connections

Pos.	Connection	Supplementary information	Version
1	Sample gas inlet	Without optional solenoid valve	Screwed connections with hose nozzles (stainless steel 1.4305) for hoses with 4 mm inside diameter
2	Sample gas outlet	—	(included in scope of supply)
3	Sample gas outlet	With optional solenoid valve, factory-connected to sample gas inlet Pos. 1	
6	Pressure sensor	For 'Pressure sensor connected to the outside by hose' option	
21	Sample gas inlet	With optional solenoid valve	Screwed fittings with hose nozzles (PVDF) for hoses with 4 mm inside diameter
22	Test gas inlet		(included in scope of supply)

Note

- The oxygen sensor is not possible in combination with Magnos206
- The pressure sensor (default, not used with the "pressure sensor outwards" option is internally connected at the output of the sample cell.

Magnos206: Gas Connections

Pos.	Connection	Supplementary information	Version
1	Sample gas inlet	—	½ NPT female thread (stainless steel 1.4305)
2	Sample gas outlet	—	<ul style="list-style-type: none"> • Connection of hose lines: straight screw-in socket (PP) with hose nozzles for hoses with inside diameter 4 mm (included in scope of delivery) • Connection of piping: screw-in fittings (not included in scope of delivery)

Note

The sample gas inlet of Magnos206 can be connected to the sample gas output of Limas23 at the factory or have a separate sample gas path without connection to Limas23.

Gas connections Limas23 with Magnos206 (model EL3040)

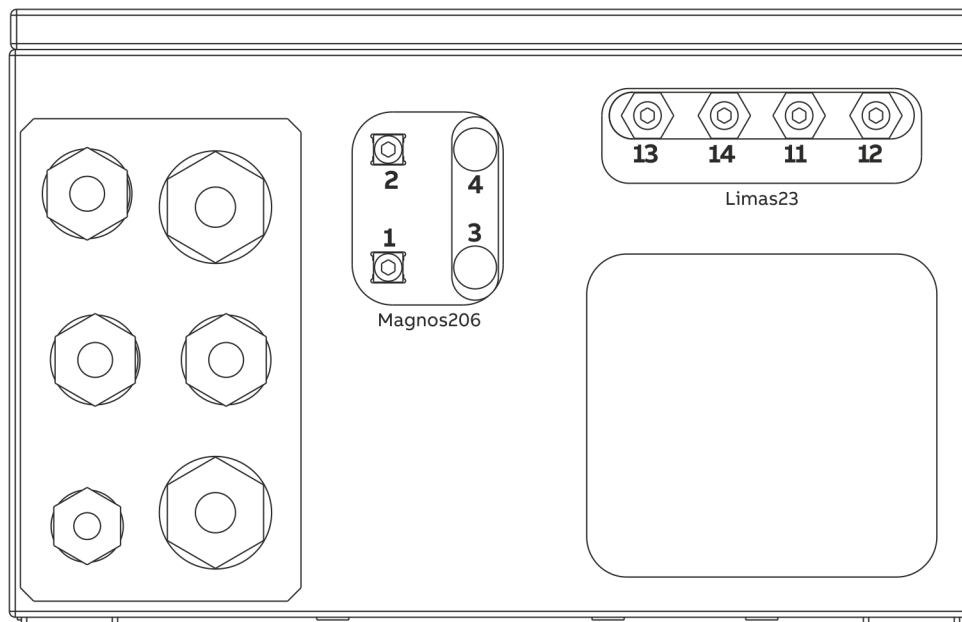

Figure 17: Gas connections Limas23 with Magnos206 (model EL3040)

Limas23: Gas connections

Pos.	Connection	Supplementary information	Version
13	Sample gas inlet	—	½ NPT female thread (stainless steel 1.4305)
14	Sample gas outlet	—	• Connection of hose lines:
11	Pressure sensor	For 'Pressure sensor connected to the outside by hose' option	straight screw-in socket (PP) with hose nozzles for hoses with inside diameter 4 mm (included in scope of delivery)
	Purge gas inlet (housing)	Not for 'Pressure sensor connected to the outside by hose' option	
12	Purge gas outlet (housing)	option	• Connection of piping: screw-in fittings (not included in scope of delivery)

Note

- The oxygen sensor is not possible in combination with Magnos206
- The pressure sensor (default, not used with the "pressure sensor outwards" option is internally connected at the output of the sample cell.

... 5 Installation

... Position and design of the gas connections

Magnos206: Gas Connections

Pos.	Connection	Supplementary information	Version
1	Sample gas inlet	—	½ NPT female thread (stainless steel 1.4305)
2	Sample gas outlet	—	<ul style="list-style-type: none"> • Connection of hose lines: straight screw-in socket (PP) with hose nozzles for hoses with inside diameter 4 mm (included in scope of delivery) • Connection of piping: screw-in fittings (not included in scope of delivery)
3	Not assigned	—	
4	Not assigned	—	

Note

The sample gas inlet of Magnos206 can be connected to the sample gas output of Limas23 at the factory or have a separate sample gas path without connection to Limas23.

Gas connections Limas23 with Magnos28 (model EL3020)

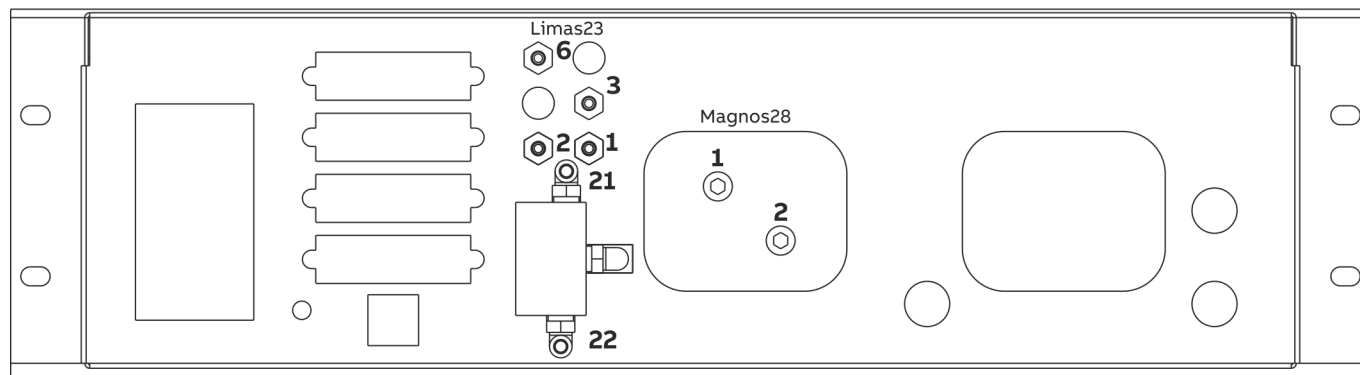

Figure 18: Gas connections Limas23 with Magnos28 (model EL3020)

Limas23: Gas Connections

Pos.	Connection	Supplementary information	Design
1	Sample gas inlet	Without optional solenoid valve	Screwed connections with hose nozzles (stainless steel 1.4305) for hoses with 4 mm inside diameter
2	Sample gas outlet	—	
3	Sample gas outlet	With optional solenoid valve, factory-connected to sample gas inlet Pos. 1	(included in scope of supply)
6	Pressure sensor	For 'Pressure sensor connected to the outside by hose' option	
21	Sample gas inlet	With optional solenoid valve	Screwed fittings with hose nozzles (PVDF) for hoses with 4 mm inside diameter
22	Test gas inlet		(included in scope of supply)

Note

- The oxygen sensor is not possible in combination with Magnos28
- The pressure sensor (default, not used with the "pressure sensor outwards" option is internally connected at the output of the sample cell.

Magnos28: Gas Connections

Pos.	Connection	Supplementary information	Version
1	Sample gas inlet	—	½ NPT female thread (stainless steel 1.4305)
2	Sample gas outlet	—	<ul style="list-style-type: none"> • Connection of hose lines: straight screw-in socket (PP) with hose nozzles for hoses with inside diameter 4 mm (included in scope of delivery) • Connection of piping: screw-in fittings (not included in scope of delivery)

Note

The sample gas inlet of Magnos28 can be connected to the sample gas output of Limas23 at the factory or have a separate sample gas path without connection to Limas23.

... 5 Installation

... Position and design of the gas connections

Gas connections Limas23 with Magnos28 (model EL3040)

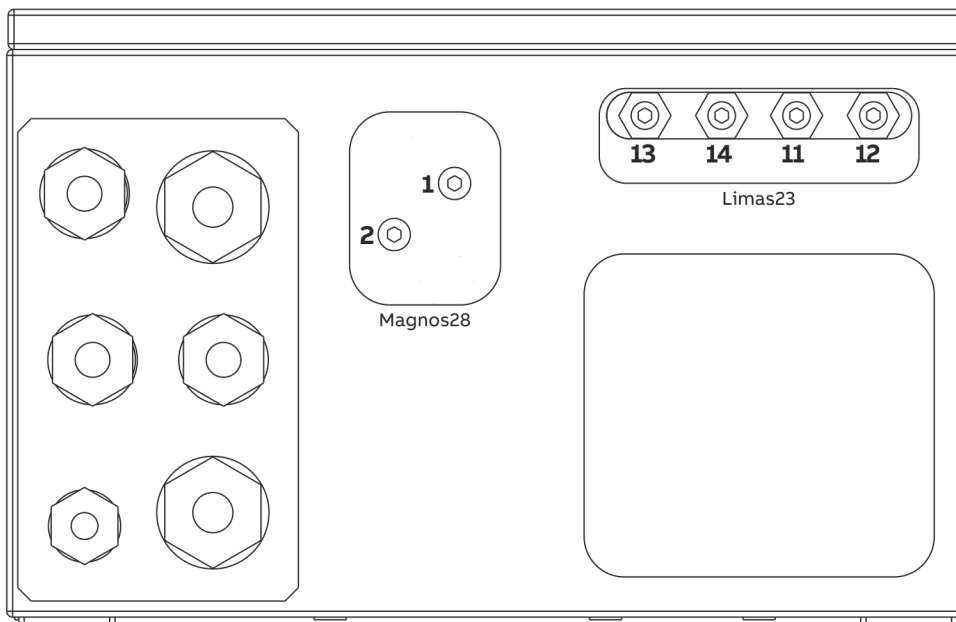

Figure 19: Gas connections Limas23 with Magnos28 (model EL3040)

Limas23: Gas connections

Pos.	Connection	Supplementary information	Version
13	Sample gas inlet	—	½ NPT female thread (stainless steel 1.4305)
14	Sample gas outlet	—	• Connection of hose lines:
11	Pressure sensor	For 'Pressure sensor connected to the outside by hose' option	straight screw-in socket (PP) with hose nozzles for hoses with inside diameter 4 mm (included in scope of delivery)
	Purge gas inlet (housing)	Not for 'Pressure sensor connected to the outside by hose' option	
12	Purge gas outlet (housing)	option	• Connection of piping: screw-in fittings (not included in scope of delivery)

Note

- The oxygen sensor is not possible in combination with Magnos28
- The pressure sensor (default, not used with the "pressure sensor outwards" option is internally connected at the output of the sample cell.

Magnos28: Gas Connections

Pos.	Connection	Supplementary information	Version
1	Sample gas inlet	—	½ NPT female thread (stainless steel 1.4305)
2	Sample gas outlet	—	<ul style="list-style-type: none"> • Connection of hose lines: straight screw-in socket (PP) with hose nozzles for hoses with inside diameter 4 mm (included in scope of delivery) • Connection of piping: screw-in fittings (not included in scope of delivery)

Note

The sample gas inlet of Magnos28 can be connected to the sample gas output of Limas23 at the factory or have a separate sample gas path without connection to Limas23.

... 5 Installation

... Position and design of the gas connections

Gas connections Magnos206 (model EL3020)

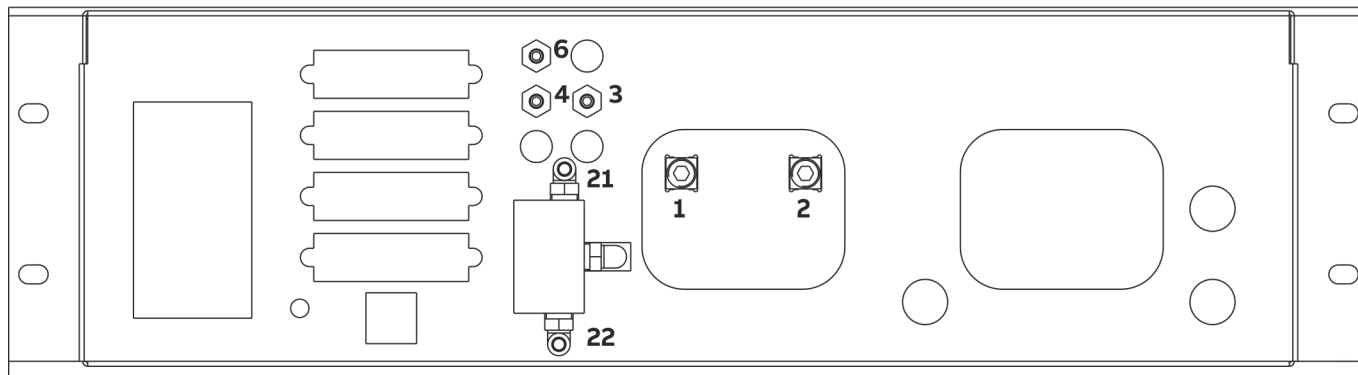

Figure 20: Gas connections Magnos206 (model EL3020)

Magnos206: Gas Connections

Pos.	Connection	Supplementary information	Version
1	Sample gas inlet	—	1/8 NPT female thread (stainless steel 1.4305) <ul style="list-style-type: none"> • Connection of hose lines: straight screw-in socket (PP) with hose nozzles for hoses with inside diameter 4 mm (included in scope of delivery) • Connection of piping: screw-in fittings (not included in scope of delivery)
2	Sample gas outlet	—	Screwed connections with hose nozzles (stainless steel 1.4305) for hoses with 4 mm inside diameter (included in scope of supply)
3	Sample gas outlet	For 'Integrated gas feed' option, factory-connected to 1 sample gas inlet	Screwed connections with hose nozzles (stainless steel 1.4305) for hoses with 4 mm inside diameter (included in scope of supply)
4	Sample gas inlet	For 'Integrated gas feed' option with flow sensor only (without solenoid valve)	Screwed connections with hose nozzles (stainless steel 1.4305) for hoses with 4 mm inside diameter (included in scope of supply)
6	Pressure sensor	—	
21	Sample gas inlet	On solenoid valve with 'integral gas feed' option with solenoid valve, pump, filter, capillary and flow sensor	Screwed fittings with hose nozzles (PVDF) for hoses with 4 mm inside diameter (included in scope of supply)
22	Test gas inlet	—	Screwed connections with hose nozzles (stainless steel 1.4305) for hoses with 4 mm inside diameter (included in scope of supply)

Note

The pressure sensor (see **Pressure sensor** on page 38) is installed as an option.

For a precise pressure correction as well as for measurements in suppressed measuring ranges, the sensor and sample gas outlet have to be connected to each other via a T-piece and with the use of short conductors.

The lines must be as short as possible or – in the case of a greater length – have a sufficiently large inside diameter (min. 10 mm) so that the flow effect is minimized.

Gas connections Magnos206 (model EL3040)

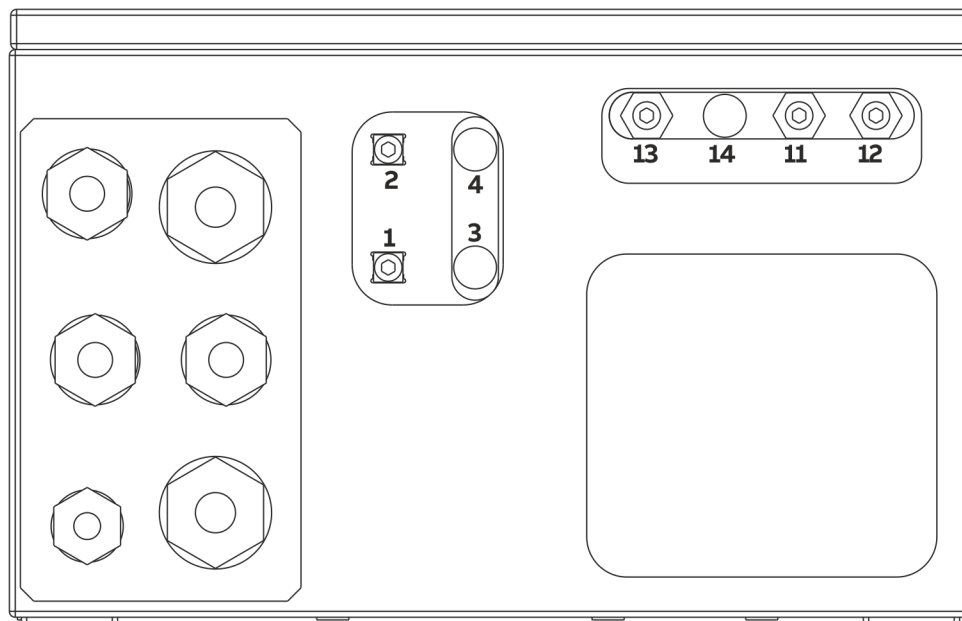

Figure 21: Gas connections Magnos206 (model EL3040)

Magnos206: Gas Connections

Pos.	Connection	Supplementary information	Version
1	Sample gas inlet	—	½ NPT female thread (stainless steel 1.4305)
2	Sample gas outlet	—	<ul style="list-style-type: none"> • Connection of hose lines: straight screw-in socket (PP) with hose nozzles for hoses with inside diameter 4 mm (included in scope of delivery) • Connection of piping: screw-in fittings (not included in scope of delivery)
3	Not assigned	—	
4	Not assigned	—	
11	Purge gas inlet (housing)	—	
12	Purge gas outlet (housing)	—	
13	Pressure sensor	—	
14	Not assigned	—	

Note

The pressure sensor (see **Pressure sensor** on page 38) is installed as an option.

For a precise pressure correction as well as for measurements in suppressed measuring ranges, the sensor and sample gas outlet have to be connected to each other via a T-piece and with the use of short conductors.

The lines must be as short as possible or – in the case of a greater length – have a sufficiently large inside diameter (min. 10 mm) so that the flow effect is minimized.

... 5 Installation

... Position and design of the gas connections

Gas connections Magnos28 (model EL3020)

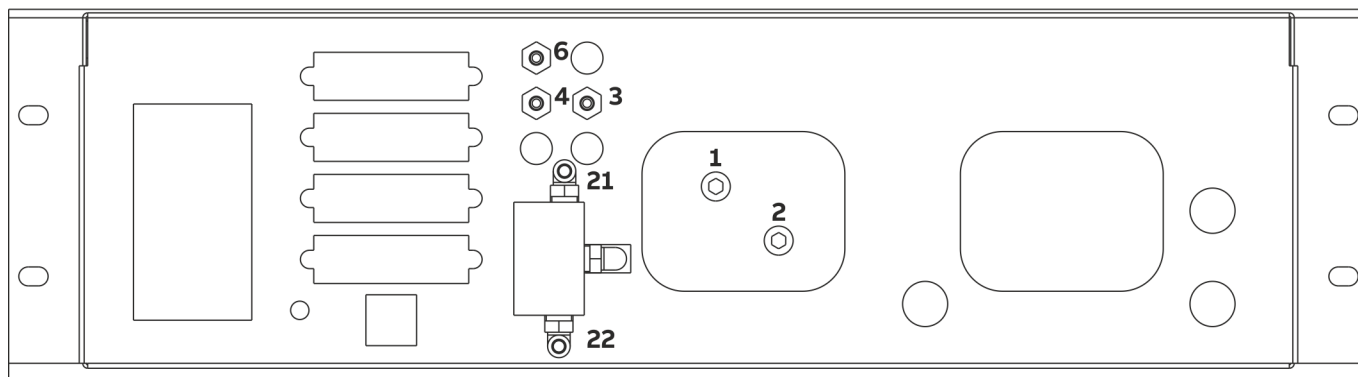

Figure 22: Gas connections Magnos28 (model EL3020)

Magnos28: Gas Connections

Pos.	Connection	Supplementary information	Design
1	Sample gas inlet	—	1/8 NPT female thread (stainless steel 1.4305)
2	Sample gas outlet	—	<ul style="list-style-type: none"> • Connection of hose lines: straight screw-in socket (PP) with hose nozzles for hoses with inside diameter 4 mm (included in scope of delivery) • Connection of piping: screw-in fittings (not included in scope of delivery)
3	Sample gas outlet	For 'Integrated gas feed' option, factory-connected to sample gas inlet Pos. 1	Screwed connections with hose nozzles (stainless steel 1.4305) for hoses with 4 mm inside diameter (included in scope of supply)
4	Sample gas inlet	For 'Integrated gas feed' option with flow sensor only (without solenoid valve)	
6	Pressure sensor	—	
21	Sample gas inlet	On solenoid valve with 'integral gas feed' option	Screwed fittings with hose nozzles (PVDF) for hoses with 4 mm inside diameter
22	Test gas inlet	with solenoid valve, pump, filter, capillary and flow sensor	(included in scope of supply)

Note

The pressure sensor (see **Pressure sensor** on page 38) is installed as an option.

For a precise pressure correction as well as for measurements in suppressed measuring ranges, the sensor and sample gas outlet have to be connected to each other via a T-piece and with the use of short conductors.

The lines must be as short as possible or – in the case of a greater length – have a sufficiently large inside diameter (min. 10 mm) so that the flow effect is minimized.

Gas connections Magnos28 with Magnos28 (model EL3020)

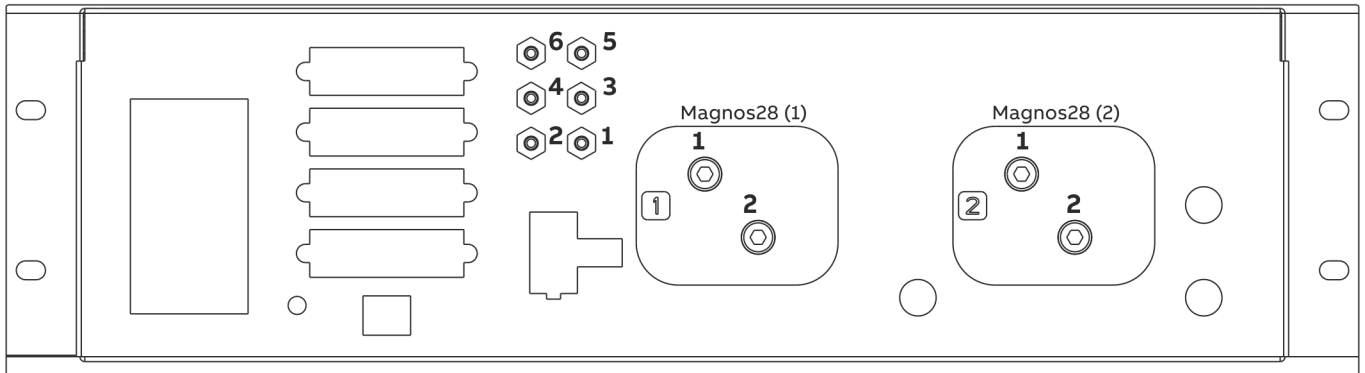

Figure 23: Gas connections Magnos28 with Magnos28 (model EL3020)

Magnos28 – gas connections for direct connection (applies to both analyzer modules)

Pos.	Connection	Supplementary information	Design
1	Sample gas inlet	—	½ NPT female thread (stainless steel 1.4305)
2	Sample gas outlet	—	Connection of hose lines: straight screw-in socket (PP) with hose nozzles for hoses with inside diameter 4 mm (included in scope of delivery)
5	Pressure sensor (option)	For analyzer module (2), not for flammable sample gases	Screwed connections with hose nozzles (stainless steel 1.4305) for hoses with 4 mm inside diameter
6	Pressure sensor (option)	For analyzer module (1). For flammable sample gases: Common sensor for analyzer module (1) and analyzer module (2). Caution Do not connect the pressure sensor in the sample gas path!	(included in scope of supply)

Magnos28 with Magnos28 – gas connections with ‘Integral gas feed’ option with flow sensor

Pos.	Connection	Supplementary information	Design
1	Sample gas output (gas path 1 / module 1)	Factory-connected to analyzer module (1) sample gas inlet 1	Screwed connections with hose nozzles (stainless steel 1.4305) for hoses with 4 mm inside diameter (included in scope of supply)
2	Sample gas inlet (gas path 1 / module 1)	—	
3	Sample gas output (gas path 2 / module 2)	Factory-connected to analyzer module (2) sample gas inlet 1	
4	Sample gas inlet (gas path 2 / module 2)	—	
5	Pressure sensor (option)	For analyzer module (2)	
6	Pressure sensor (option)	For analyzer module (1)	

... 5 Installation

... Position and design of the gas connections

Gas connections Magnos28 with Caldos27 (model EL3020)

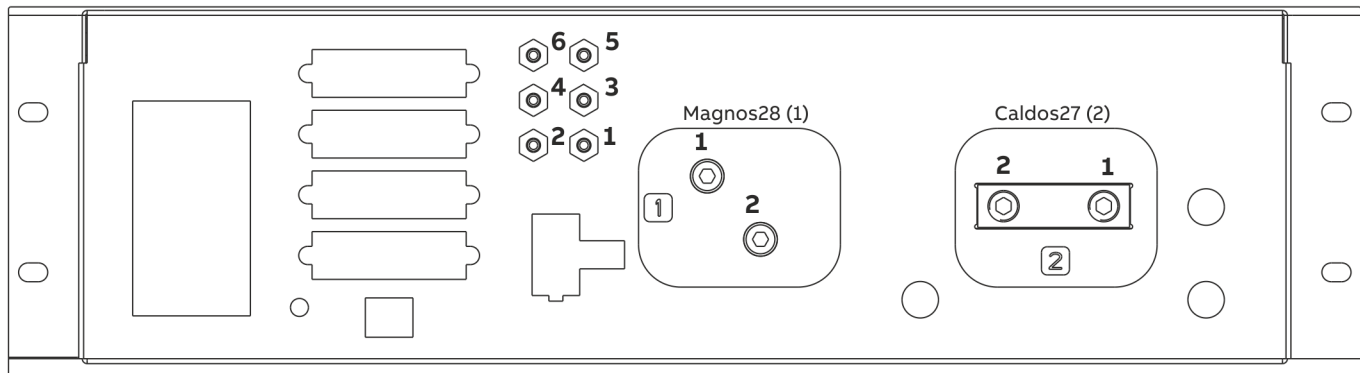

Figure 24: Gas connections Magnos28 with Caldos27 (model EL3020)

Magnos28 – gas connections for direct connection

Pos.	Connection	Supplementary information	Design
1	Sample gas inlet	—	½ NPT female thread (stainless steel 1.4305)
2	Sample gas outlet	—	Connection of hose lines: straight screw-in socket (PP) with hose nozzles for hoses with inside diameter 4 mm (included in scope of delivery)
6	Pressure sensor (option)	For flammable sample gases: common sensor for Magnos28 and Caldos27. Caution Do not connect the pressure sensor in the sample gas path!	Screwed connections with hose nozzles (stainless steel 1.4305) for hoses with 4 mm inside diameter (included in scope of supply)

Caldos27 – gas connections for direct connection

Pos.	Connection	Supplementary information	Design
1	Sample gas inlet	—	½ NPT female thread (stainless steel 1.4305)
2	Sample gas outlet	—	Connection of hose lines: straight screw-in socket (PP) with hose nozzles for hoses with inside diameter 4 mm (included in scope of delivery)
5	Pressure sensor	Not for flammable sample gases	straight screw-in socket (PP) with hose nozzles for hoses with inside diameter 4 mm (included in scope of delivery)
6	Pressure sensor	For flammable sample gases: common sensor for Magnos28 and Caldos27. Caution Do not connect the pressure sensor in the sample gas path!	straight screw-in socket (PP) with hose nozzles for hoses with inside diameter 4 mm (included in scope of delivery)

Magnos28 with Caldos27 – gas connections for ‘Integral gas feed’ option with flow sensor

Pos.	Connection	Supplementary information	Design
1	Sample gas outlet (gas path 1 / Magnos28)	Factory-connected to Magnos28 sample gas inlet 1	Screwed connections with hose nozzles (stainless steel 1.4305) for hoses with 4 mm inside diameter (included in scope of supply)
2	Sample gas inlet (gas path 1 / Magnos28)	—	
3	Sample gas outlet (gas path 2 / Caldos27)	Factory-connected to Caldos27 sample gas inlet 1	
4	Sample gas inlet (gas path 2 / Caldos27)	—	
5	Pressure sensor	For Caldos27	
6	Pressure sensor (option)	For Magnos28	

... 5 Installation

... Position and design of the gas connections

Gas connections Magnos28 (model EL3040)

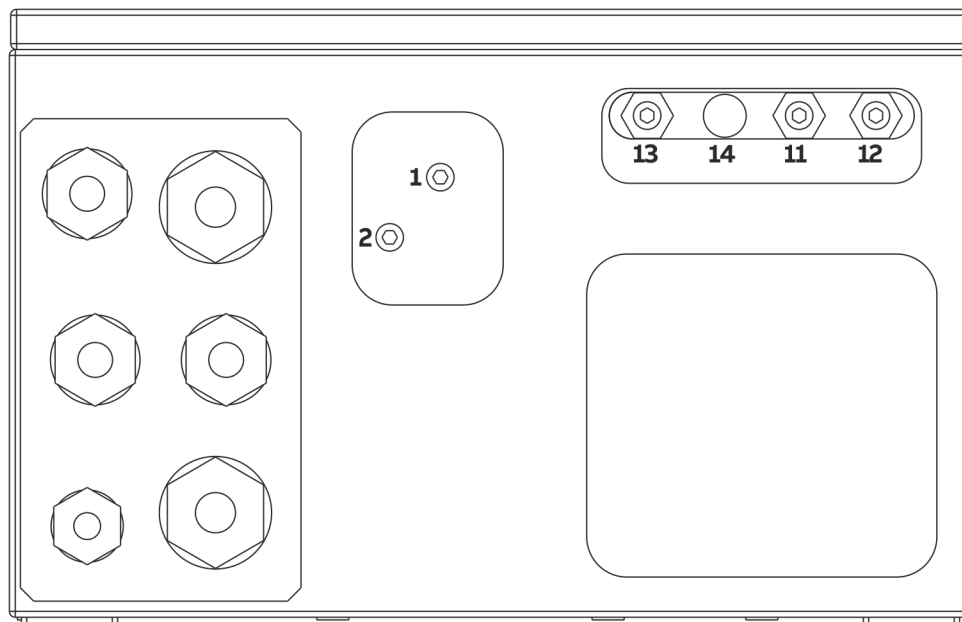

Figure 25: Gas connections Magnos28 (model EL3040)

Magnos28: Gas Connections

Pos.	Connection	Supplementary information	Version
1	Sample gas inlet	—	½ NPT female thread (stainless steel 1.4305)
2	Sample gas outlet	—	• Connection of hose lines:
11	Purge gas inlet (housing)	—	straight screw-in socket (PP) with hose nozzles
12	Purge gas outlet (housing)	—	for hoses with inside diameter 4 mm
13	Pressure sensor	—	(included in scope of delivery)
14	Not assigned	—	• Connection of piping:
			screw-in fittings
			(not included in scope of delivery)

Note

The pressure sensor (see **Pressure sensor** on page 38) is installed as an option.

For a precise pressure correction as well as for measurements in suppressed measuring ranges, the sensor and sample gas outlet have to be connected to each other via a T-piece and with the use of short conductors.

The lines must be as short as possible or – in the case of a greater length – have a sufficiently large inside diameter (min. 10 mm) so that the flow effect is minimized.

Gas connections Magnos27 (model EL3020)

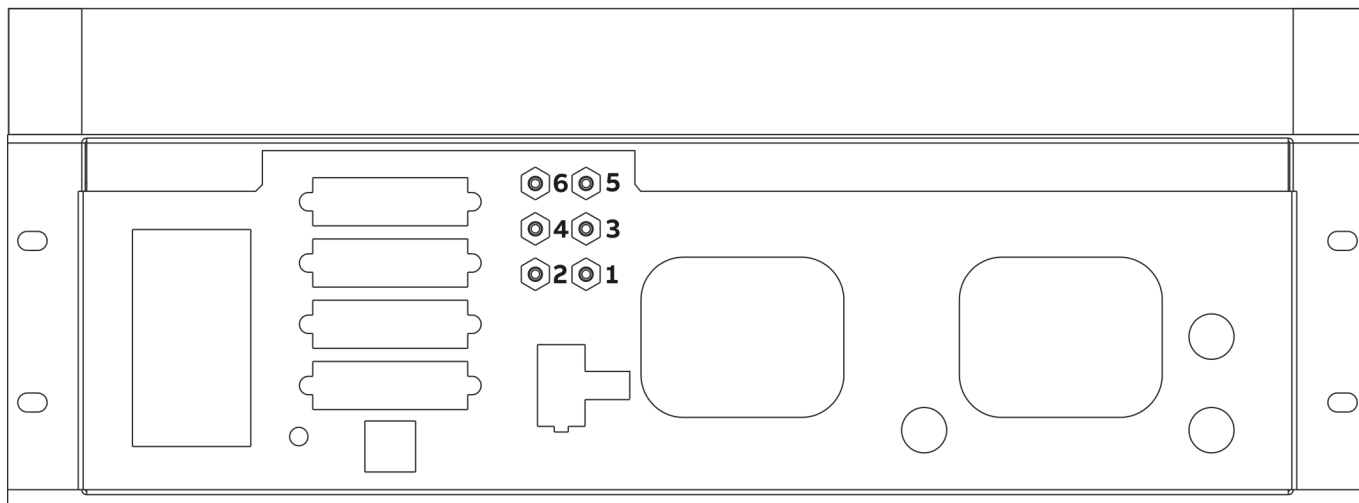

Figure 26: Gas connections Magnos27 (model EL3020)

Magnos27: Gas Connections

Pos.	Connection	Supplementary information	Version
1	Pressure sensor	—	Screwed connections with hose nozzles (stainless steel 1.4305) for hoses with 4 mm inside diameter (included in scope of supply)
2	Not assigned	—	
3	Sample gas inlet	—	
4	Sample gas outlet	—	
5	Purge gas inlet analyzer	—	
6	Purge gas outlet analyzer	—	

Note

The pressure sensor (see **Pressure sensor** on page 38) is installed as an option.

For a precise pressure correction as well as for measurements in suppressed measuring ranges, the sensor and sample gas outlet have to be connected to each other via a T-piece and with the use of short conductors.

The lines must be as short as possible or – in the case of a greater length – have a sufficiently large inside diameter (min. 10 mm) so that the flow effect is minimized.

... 5 Installation

... Position and design of the gas connections

Gas connections Magnos27 with Uras26 (model EL3020)

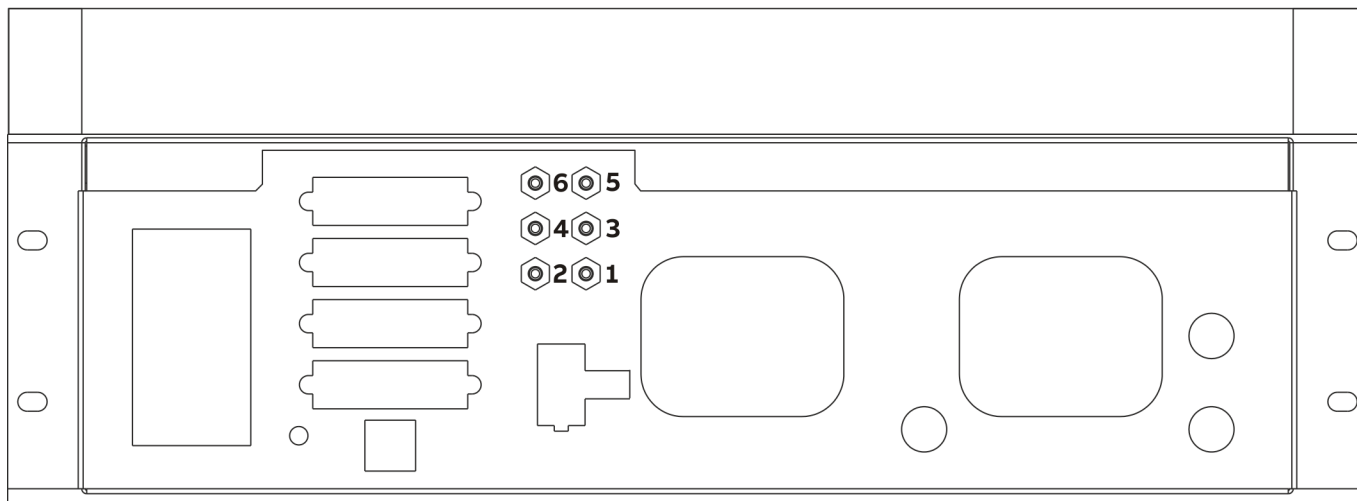

Figure 27: Gas connections Magnos27 with Uras26 (model EL3020)

Magnos27: Gas Connections

Pos.	Connection	Supplementary information	Version
3	Sample gas inlet	—	Screwed connections with hose nozzles (stainless steel 1.4305) for hoses with 4 mm inside diameter
4	Sample gas outlet	—	(included in scope of supply)
5	Purge gas inlet analyzer	Not for the 'pressure sensor connected to the outside by hose' option, not in combination with Uras26 with two cells and separate gas paths	
6	Purge gas outlet analyzer		
	Pressure sensor	For the 'pressure sensor connected to the outside by hose' option, not in combination with Uras26 with two cells and separate gas paths	

Uras26: Gas connections

Pos.	Connection	Supplementary information	Version
1	Sample gas inlet (gas path 1)	—	Screwed connections with hose nozzles (stainless steel 1.4305) for hoses with 4 mm inside diameter
2	Sample gas outlet (gas path 1)	—	(included in scope of supply)
5	Sample gas outlet (gas path 2)	For optional second sample gas for Uras26 with two cells and separate gas paths	
6	Sample gas inlet (gas path 2)		

Note

The pressure sensor (standard, not for the 'pressure sensor connected to outside by hose' option) is internally connected as follows:

- In the output of the sample cell 1, for a sample cell and for two sample cells with separate gas paths.
- In the output of sample cell 2 for two sample cells in series.

Gas connections Z023 (model EL3020)

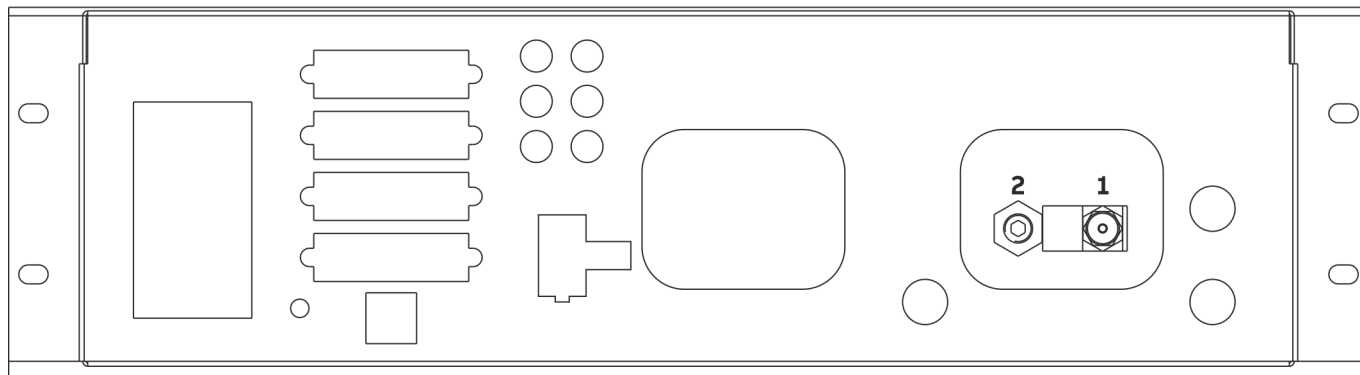

Figure 28: Gas connections Z023 (Model EL3020)

Z023: Gas Connections

The measuring chamber is connected to the sample gas inlet connection via a stainless steel tube (inlet side) and to the sample gas outlet connection via a FPM hose (outlet side).

Pos.	Connection	Supplementary information	Version
1	Sample gas inlet	—	3 mm Swagelok®
2	Sample gas outlet	—	1/8 NPT female thread for threaded connections (not included in scope of supply)

... 5 Installation

... Position and design of the gas connections

Gas connections ZO23 (model EL3040)

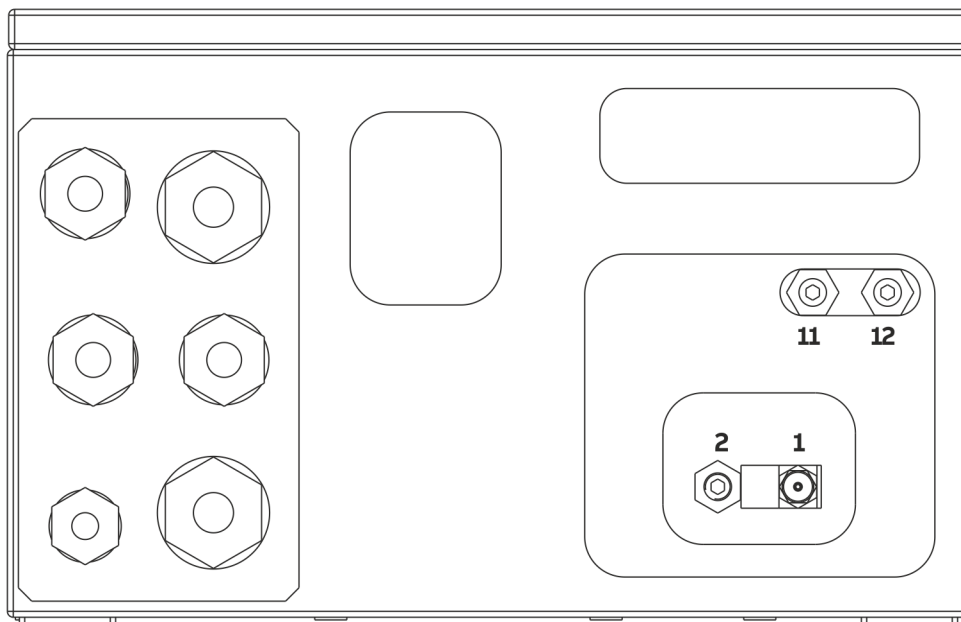

Figure 29: Gas connections ZO23 (model EL3040)

ZO23: Gas Connections

The measuring chamber is connected to the sample gas inlet connection via a stainless steel tube (inlet side) and to the sample gas outlet connection via a FPM hose (outlet side).

Pos.	Connection	Supplementary information	Version
1	Sample gas inlet	—	3 mm Swagelok®
2	Sample gas outlet	—	½ NPT female thread for threaded connections
11	Purge gas inlet (housing)	—	(not included in scope of supply)
12	Purge gas outlet (housing)	—	

Gas connections Caldos27 (model EL3020)

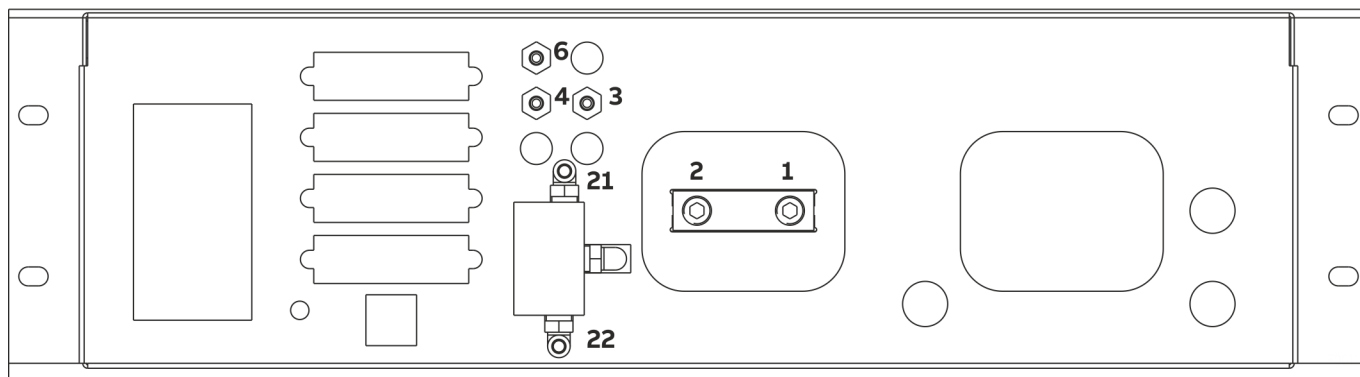

Figure 30: Gas connections Caldos27 (model EL3020)

Caldos27: gas connections

Pos.	Connection	Supplementary information	Version
1	Sample gas inlet	—	½ NPT female thread (stainless steel 1.4305) <ul style="list-style-type: none"> • Connection of hose lines: straight screw-in socket (PP) with hose nozzles for hoses with inside diameter 4 mm (included in scope of delivery) • Connection of piping: screw-in fittings (not included in scope of delivery)
2	Sample gas outlet	—	
3	Sample gas outlet	For 'Integrated gas feed' option, factory-connected to 1 sample gas inlet	Screwed connections with hose nozzles (stainless steel 1.4305) for hoses with 4 mm inside diameter (included in scope of supply)
4	Sample gas inlet	For 'Integrated gas feed' option with flow sensor only (without solenoid valve)	
6	Pressure sensor	—	
21	Sample gas inlet	On solenoid valve with 'integral gas feed' option	Screwed fittings with hose nozzles (PVDF) for hoses with 4 mm inside diameter
22	Test gas inlet	with solenoid valve, pump, filter, capillary and flow sensor	(included in scope of supply)

... 5 Installation

... Position and design of the gas connections

Gas connections Caldos27 with Caldos27 (model EL3020)

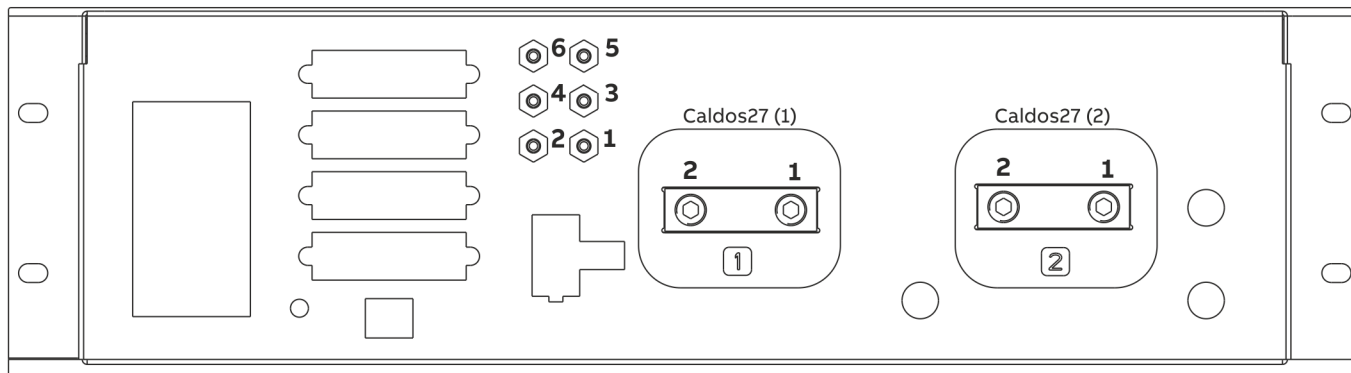

Figures 31: Gas connections Caldos27 with Caldos27 (model EL3020)

Caldos27 – gas connections for direct connection (applicable for both analyzer modules)

Pos.	Connection	Supplementary information	Version
1	Sample gas inlet	—	½ NPT female thread (stainless steel 1.4305) Connection of hose lines:
2	Sample gas outlet	—	straight screw-in socket (PP) with hose nozzles for hoses with inside diameter 4 mm (included in scope of delivery)
5	Pressure sensor	For analyzer module (2), not for flammable sample gases	Screwed connections with hose nozzles (stainless steel 1.4305) for hoses with 4 mm inside diameter
6	Pressure sensor	For analyzer module (1), for flammable sample gases: Common sensor for analyzer module (1) and analyzer module (2). Caution Do not connect the pressure sensor in the sample gas path!	(included in scope of supply)

Caldos27 with Caldos27 – gas connections for ‘Integral gas feed’ option with flow sensor

Pos.	Connection	Supplementary information	Version
1	Sample gas output (gas path 1 / module 1)	Factory-connected to analyzer module (1) sample gas inlet 1	Screwed connections with hose nozzles (stainless steel 1.4305) for hoses with 4 mm inside diameter (included in scope of supply)
2	Sample gas inlet (gas path 1 / module 1)	—	
3	Sample gas output (gas path 2 / module 2)	Factory-connected to analyzer module (2) sample gas inlet 1	
4	Sample gas inlet (gas path 2 / module 2)	—	
5	Pressure sensor	For analyzer module (2)	
6	Pressure sensor	For analyzer module (1)	

Gas connections Caldos27 (model EL3040)

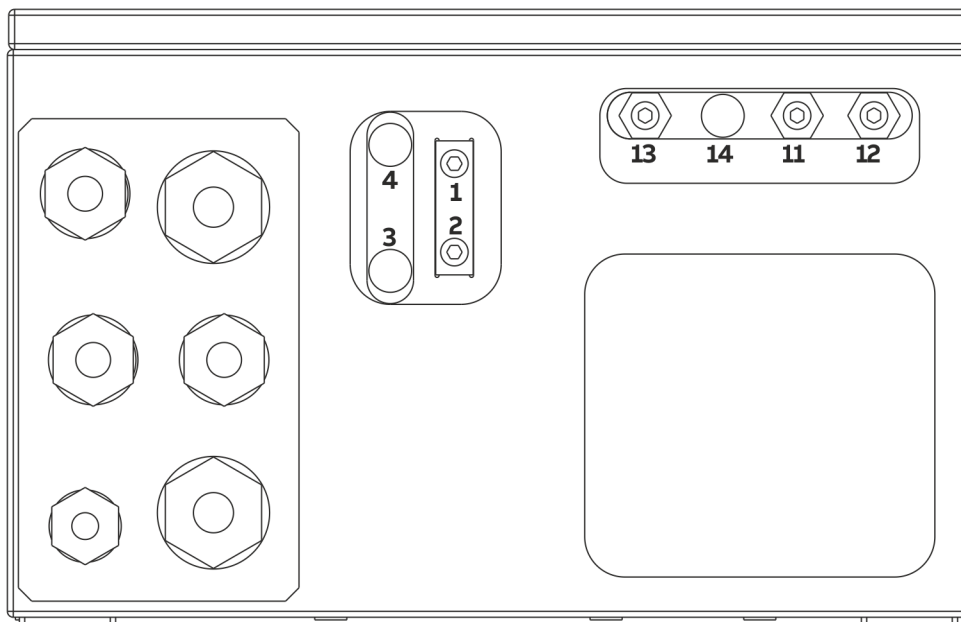

Figure 32: Gas connections Caldos27 (model EL3040)

Caldos27: gas connections

Pos.	Connection	Supplementary information	Version
1	Sample gas inlet	—	½ NPT female thread (stainless steel 1.4305)
2	Sample gas outlet	—	• Connection of hose lines:
3	Not assigned	—	straight screw-in socket (PP) with hose nozzles
4	Not assigned	—	for hoses with inside diameter 4 mm
11	Purge gas inlet (housing)	—	(included in scope of delivery)
12	Purge gas outlet (housing)	—	• Connection of piping:
13	Pressure sensor	—	screw-in fittings
14	Not assigned	—	(not included in scope of delivery)

... 5 Installation

... Position and design of the gas connections

Gas connections and electrical connections Fidas24 (model EL3020)

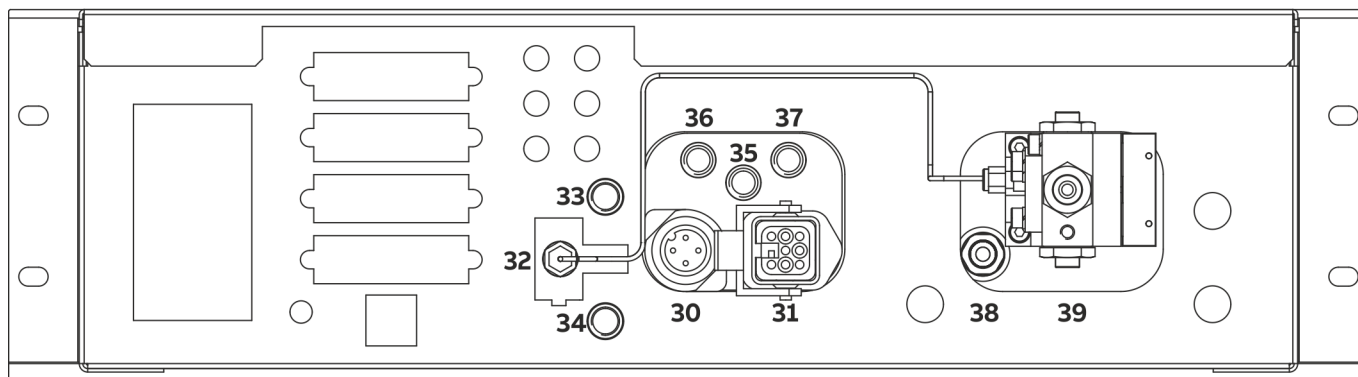

Figure 33: Gas connections and electric connections Fidas24 (model EL3020)

Fidas24: Gas and electrical connections

Pos.	Connection	Supplementary information	Version
30	Power supply (input)	115 V AC or 230 V AC for heating the detector and sample gas inlet	4-pin male connector, connection cable included in scope of supply
31	Power supply (output)	Electrical connection to the heated sample gas connection	Permanently connected
32	Test gas outlet	—	1/8 NPT female thread for threaded connections (not included in scope of supply)
33	Zero-point gas inlet	—	
34	End-point gas inlet	—	
35	Combustion air inlet	—	
36	Combustion gas inlet	—	
37	Instrument air inlet	—	
38	Exhaust outlet	—	Male thread for connection of the exhaust air pipe (stainless steel tube with an outside diameter of 6 mm, included in the scope of supply of the gas analyzer)
39	Sample gas inlet	Heated or unheated	Threaded connection for PTFE or stainless steel tubing with a 6 mm outer diameter

Gas connections and electrical connections Fidas24 (model EL3040)

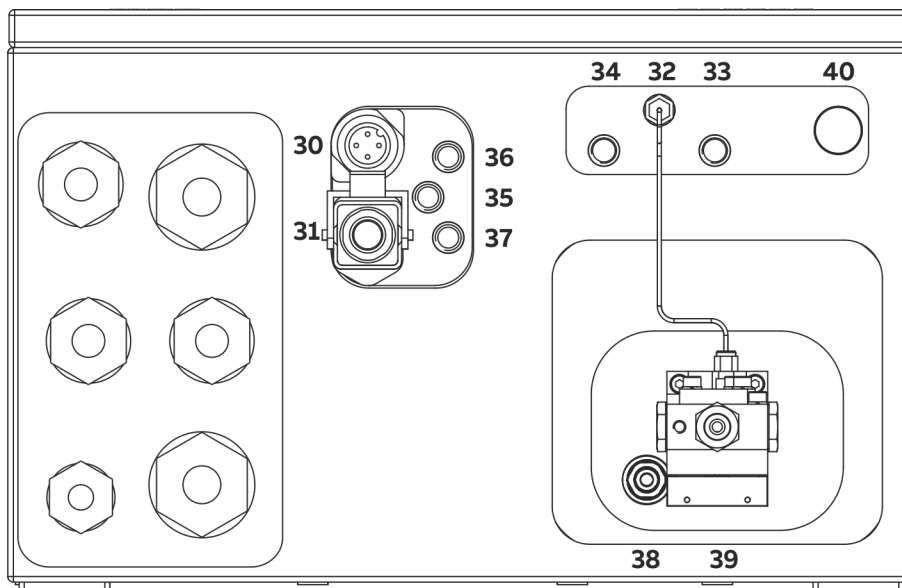

Figure 34: Gas connections and electrical connections Fidas24 (model EL3040)

Fidas24: Gas and electrical connections

Pos.	Connection	Supplementary information	Version
30	Power supply (input)	115 V AC or 230 V AC for heating the detector and sample gas inlet	4-pin male connector, connection cable included in scope of supply
31	Power supply (output)	Electrical connection to the heated sample gas connection	Permanently connected
32	Test gas outlet	—	1/8 NPT female thread for threaded connections
33	Zero-point gas inlet	—	(not included in scope of supply)
34	End-point gas inlet	—	
35	Combustion air inlet	—	
36	Combustion gas inlet	—	
37	Instrument air inlet	—	
38	Exhaust outlet	—	Male thread for connection of the exhaust air pipe (stainless steel tube with an outside diameter of 6 mm, included in the scope of supply of the gas analyzer)
39	Sample gas inlet	Heated or unheated	Threaded connection for PTFE or stainless steel tubing with a 6 mm outer diameter
40	Pressure equalizing opening	With protective filter (the protective filter must be protected against humidity)	—

... 5 Installation

Gas Analyzer Installation

NOTICE

Damage to the device due to unsuited installation site

- The installation site must be sufficiently stable to support the weight of the gas analyzer (see **Housing design** on page 19)
- The 19" housing must be supported in the cabinet or on the rack with mounting rails!

⚠ CAUTION

Injury hazard due to heavy weight

Depending on the version, the gas analyzer weighs 7 to 15 kg (19" housing – model EL3020) or 13 to 21 kg (wall-mounted housing – model EL3040)!

- Two persons are required for unpacking and transportation!

Materials required (not included in the scope of delivery)

19" housing (model EL3020)

- 4 raised head screws (recommendation: M6; this depends on the cabinet/rack system)
- 1 pair mounting rails (design depending on the cabinet/frame system), length approx. 240 mm corresponding to approx. $\frac{2}{3}$ of the housing depth

Wall-mount housing (model EL3040)

- 4 screws M8 or M10

Gas Analyzer Installation

Mount the gas analyzer in the cabinet / rack or on the wall. Observe the dimension diagram (see **Dimensions** on page 40). Mount several 19" housings with a minimum distance of 1 HE between each housing,

Special conditions for the Fidas24 gas analyzer

The notes under **Fidas24 – Information for safe operation** on page 9 should be observed.

Special conditions for the model EL3020 gas analyzer for the measurement of flammable gases

Unrestricted exchange of air with the environment must be provided around the gas analyzer from the bottom (floor plate) and from the rear (gas connections).

The gas analyzer may not be placed directly on a table. The housing openings may not be closed.

Special conditions for the model EL3040 gas analyzer in degree of protection II 3G

Protection against mechanical influences

Due to the low mechanical stability of the viewing glass, the gas analyzer must be designed and operated in such a way that mechanical damage to the viewing glass is excluded with an energy greater than 2 J.

UV radiation protection

Due to the low UV resistance of the plastic parts of the housing, the gas analyzer must be designed and operated in such a way that the effect of UV radiation can be excluded.

Connecting the gas lines

NOTICE

Potential adverse effect on the IP rating

Yellow sealing plugs (transport protection) are applied to the gas connections on the analyzer and housing to secure them during transport. The yellow sealing plugs do not guarantee a sufficient IP rating.

- Remove the yellow sealing plugs before commissioning.
- Close unused gas connections with suited sealing plugs to guarantee the IP rating.

NOTICE

Damage to the gas analyzer

Damage to the gas analyzer due to condensing sample gas during commissioning.

- Observe the condition of the sample gas inlet of the analyzer modules.
- Purge the sample gas path before commissioning, see **Purge sample gas path and analyzer housing** on page 105.
- Do not connect the sample gas until the gas analyzer has reached room temperature and after the warm-up phase has elapsed, see **Duration of the Warm-up Phase** on page 105.

Connecting the hose lines

Slide the hoses with an inside diameter of 4 mm onto the hose nozzles and fasten with hose clamps.

Connecting the piping

Connect stainless steel pipes professionally to the screwed connection, taking into account the tightness requirements.

Installing the fine filter

A preinstalled fine filter is included in the scope of delivery (see **Scope of delivery** on page 17) of the gas analyzer (one-way filter, order number 769144 – not for Fidas24).

When installing the fine filter, attach the short hose piece to the sample gas inlet; connect the sample gas line to the long hose piece with the hose nozzle.

Installing the flowmeter

Install a flowmeter or flow monitor with needle valve before the sample gas inlet and if necessary before the purge gas inlet to be able to adjust and monitor the gas flow.

Provide for sample gas line purging

Install a shut-off valve in the sample gas line (highly recommended for pressurized sample gas) and provide the option of introducing an inert gas, such as nitrogen, from the gas sampling point, for purging of the sample gas line.

Exhaust gas lines

The exhaust gases of the gas analyzers are dissipated via the sample gas outlets. The exhaust gases can be discharged into the atmosphere via a common exhaust gas line.

Note

Dispose of corrosive, toxic or combustion exhaust gases according to the regulations!

Observe the following points when connecting the exhaust gas lines:

- Guide the exhaust gases from the gas analyzer directly into the atmosphere or in depressurized state through the shortest possible line with a large inside diameter, or into an exhaust pipe.
- Do not install any throttle sections or shut-off valves in the exhaust gas line!
- For Fidas24, also observe the information in **Connecting the exhaust air line** on page 89!

... 5 Installation

Fidas24 – Connect gas lines

Safety instructions

⚠ DANGER

Explosion hazard

Explosion hazard due to leaking combustion gas in the gas analyzer.

- The leak tightness of the combustion gas supply line outside the gas analyzer as well as the combustion gas path in the gas analyzer must be checked regularly.
- The relevant safety regulations for working with combustion gases must be complied with!
- The screwed connections of the gas paths in the gas analyzer may not be opened! The gas paths can become leaky as a result.
 - However, if the screwed connections of the gas paths in the gas analyzer have been opened (only by trained personnel), a leak tightness test must be performed using a hydrogen detector (for example, based on thermal conductivity) must always be carried out after they have been sealed again. The leakage rate must not exceed 10^{-4} hPa·l/s.
- The lines and fittings must be clean and free of any residues (for example, particles left from manufacturing)!
 - Contaminants can enter the analyzer and damage it or lead to false measurement results!

Notes

- The installation of gas connections is described in **Mounting the fittings on the gas analyzer** on page 45.
- Follow the manufacturer's installation instructions for the fittings! In particular, hold the male fittings (gas connections) in place when connecting the gas lines.
- When laying and connecting the gas lines, adhere to the installation instructions provided by the manufacturers of the piping!
- If gas lines made of stainless steel are connected to the analyzer modules, the lines must be connected to the building-side potential equalization.
- Never connect more than three analyzer modules in a series!

Connection of process gases and test gases

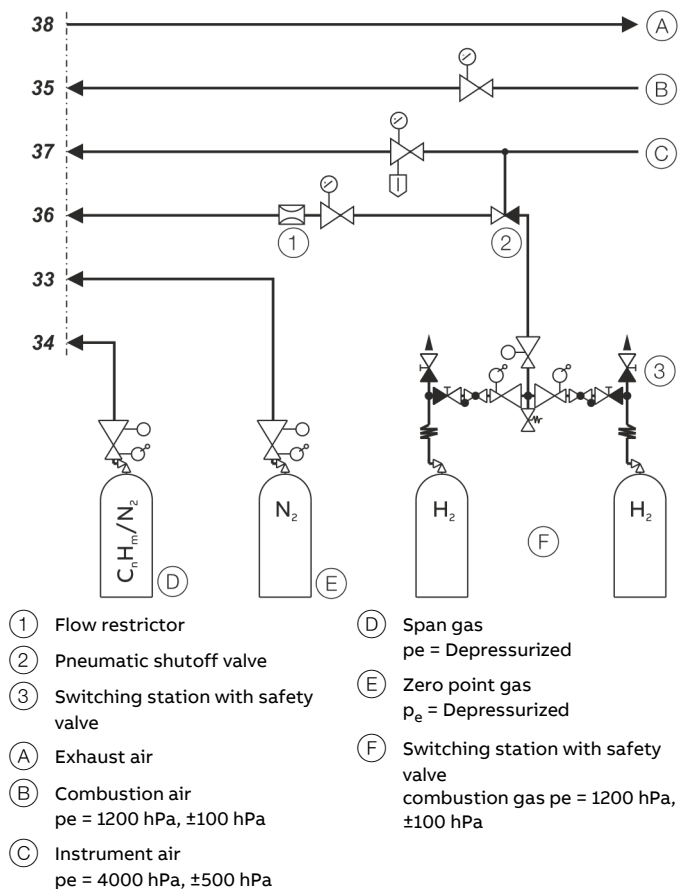

Figure 35: Connection of process gases and test gases

The numbering of the gas connections corresponds to the numbering in **Figure 33** and **Figure 34** as well as the labeling on the rear of the gas analyzer.

Instrument Air Connection

The instrument air is used as propulsion air for the air jet injector, and as purging air for the housing purging, see **Housing purge with Fidas24** on page 39.

Connect the instrument air line to the instrument air inlet **37** of the gas analyzer via a pressure reducer (0 to 6 bar).

Combustion air connection

Connect the combustion air line to the combustion air inlet **35** of the gas analyzer via a pressure reducer (0 to 1.6 bar).

Combustion gas connection

See section **Fidas24 – Connecting the combustion gas line** on page 89.

Test gas connection

The test gas outlet is connected to the sample gas connection at the factory.

If the test gases are to be fed directly at the gas sampling point, the connection between the test gas outlet and the test gas inlet at the sample gas connection should be removed, and the corresponding opening at the sample gas connection is to be sealed gas-tight with an M6 screw.

Connecting the exhaust air line

Observe the following points when connecting the exhaust air pipe:

- Conduct exhaust gases from the gas analyzer directly into the atmosphere or through a de-pressurized pipe with a large inside diameter which is as short as possible, or into an exhaust pipe.
- Use PTFE or stainless steel as the material for the exhaust air line!

The temperature of the exhaust air can be up to 200 °C!

- Install the exhaust air line at a gradient, leading away from the gas analyzer.
- At a maximum of 30 cm after the exhaust air outlet, the exhaust air pipe must have an inside diameter of ≥ 10 mm!

If the exhaust air pipe is very long, its inside diameter must be much larger than 10 mm, otherwise you might have problems with pressure control in the gas analyzer.

- Do not install any throttle sections or shut-off valves in the exhaust air line!

Note

Dispose of corrosive, toxic or combustion exhaust gases according to the regulations!

Fidas24 – Connecting the combustion gas line

Clean combustion gas line.

1. Pump a cleaning agent (alkaline cleaner, stainless steel pickling solution) through the stainless steel pipe.
2. Rinse the pipe thoroughly with distilled water.
3. Purge the pipe with synthetic air or nitrogen, at a > 100 °C, for several hours (10 bis 20 l/h).
4. Seal the ends of the pipe.

Connect combustion gas pipe

See also **Connection of process gases and test gases** on page 88.

1. Connect a two-stage cylinder pressure reducer (a model suitable for high purity gases) to the combustion gas cylinder.
2. Connect the combustion gas pipe to the cylinder pressure reducer.
3. Install a flow restrictor in the combustion gas supply line which limits the combustion gas flow to 10 l/h H₂ or 25 l/h H₂/He mixture, see **Flow restrictor in the combustion gas supply line** on page 36. This means that the operation of the gas analyzer is safe even in the event of a fault in the combustion gas path (such as leakage).
4. Install a shut-off valve in the combustion gas supply line.
 - It is recommended that a pneumatic shut-off valve be installed.
 - The pneumatic shut-off valve must be controlled by the instrument air supply, so that the combustion gas supply is interrupted in the event of a failure of the instrument air supply.
 - See also **Shut-off valve in the combustion gas supply line** on page 36.
5. Connect the combustion gas line to the combustion gas inlet **36** of the analyzer module, via a pressure reducer (0 to 1.6 bar) refer to **Position and design of the gas connections** on page 46.

Check the tightness of the combustion gas line

Check the combustion gas line for tightness, refer to **Check the integrity of combustion gas path** on page 194.

... 5 Installation

Fidas24 – Connecting the sample gas line to the heated sample gas connection

NOTE

Damage to the gas analyzer

Damage to the gas analyzer, due to melting of the factory-mounted plastic plugs in the sample gas inlets.

- Remove the plastic plugs from the sample gas inlets before commissioning.

Material of the sample gas line

Use a PTFE or stainless steel sample gas line! (Recommended: use heated sample gas line TBL 01) The medium temperature can be up to 200 °C!

Sample gas line connection

The heated sample gas line must be connected directly to the sample gas inlet. Make sure that the O-rings are seated correctly and that the sample gas pipe has been inserted into the sample gas connection until it stops.

Unused sample gas inlets

- When the analyzer draws in the sample gas through the sample gas line, the unused sample gas inlets must be sealed using appropriate screw plugs.
- When the sample gas is under gauge pressure, a sample gas inlet must be open and connected to an exhaust gas line so that there is no gauge pressure in the analyzer.

Screwed connections and O-rings

The required screwed connections and o-rings are included in the supplied accessories bag.

Maximum length of the sample gas line

The maximum length of a heated sample gas line (inner diameter 4 mm) is 60 m.

Provide for Sample Gas Line Purging

Install a shut-off valve in the sample gas line (highly recommended for pressurized sample gas) and provide the option of introducing an inert gas, e.g. nitrogen, from the gas sampling point, for purging of the sample gas line.

Heated sample gas connection

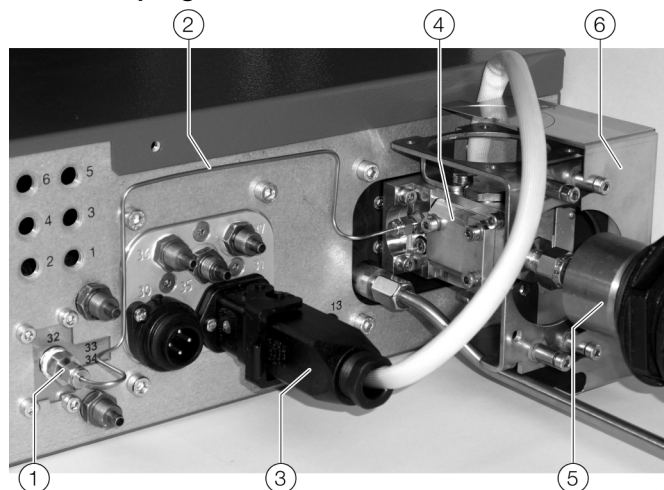

- | | |
|---|------------------------------------|
| ① Test gas outlet | ④ Heated sample gas connection |
| ② Connection of test gas outlet-sample gas connection | ⑤ Heated sample gas line (example) |
| ③ Electrical connection to the heated sample gas connection | ⑥ Sample gas connection cover* |

* Only half of the sample gas connection cover is shown in the figure.

Figure 36: Heated sample gas connection

Connection of the sample gas line to the heated sample gas connection

Wall-mount housing (view from bottom right)

19" housing (view from top left)

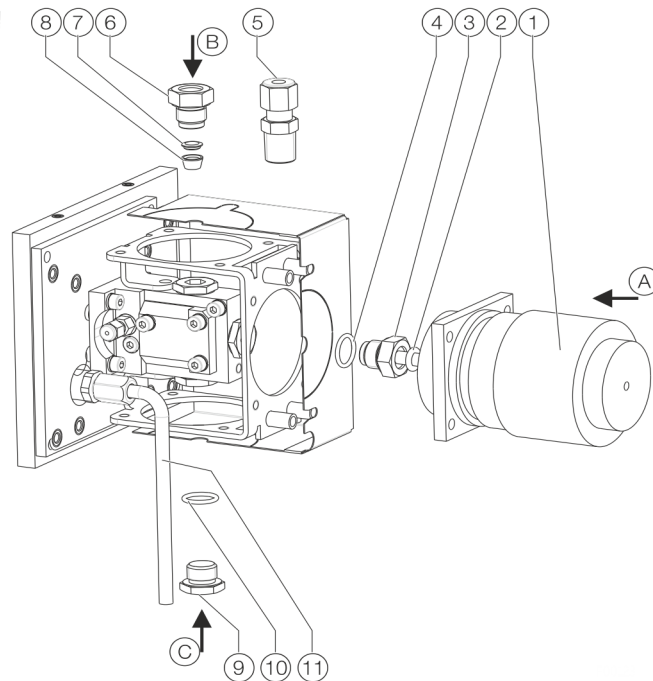
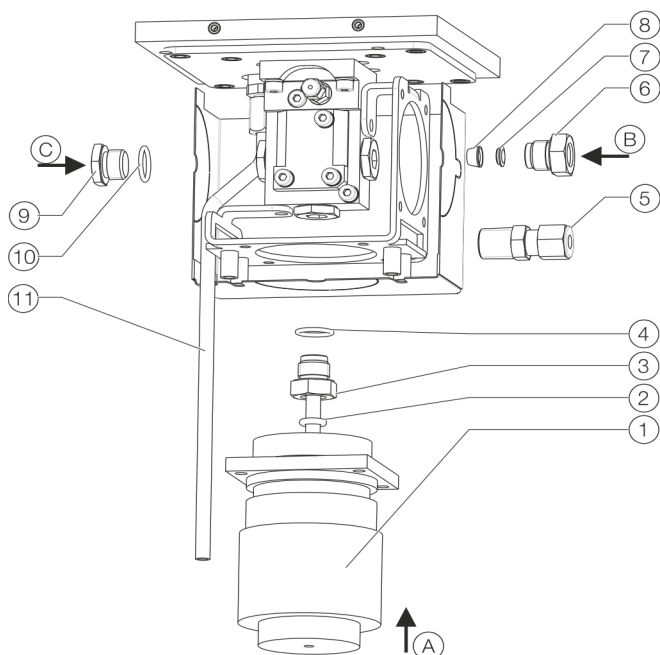

- ① Heated sample gas line
(tube with inside/outside diameter 4 / 6 mm)
- ② O-ring 6.02 × 2.62
- ③ Socket
- ④ O-ring 12.42 × 1.78

- Closure:**
- ⑨ Screw plug
 - ⑩ O-ring 12.42 × 1.78
 - ⑪ Waste gas tube

**Connection of an additional sample gas line
(tube with outside diameter 6 mm) either with:**

- ⑤ Screw-in connector G¹/₄"

Alternatively, with:

- ⑥ Socket
- ⑦ Wedge ring
- ⑧ Clamping ring

Figure 37: Connecting the sample gas line

Sample gas inlets	Sample gas line connection	
	on 19" housing	on wall-mount housing
(A)	from the rear	from below
(B)	from above	from the right
(C)	from below	Not possible – the sample gas inlet must always be closed

... 5 Installation

Fidas24 – Connecting the sample gas line to the unheated sample gas connection

NOTE

Damage to the gas analyzer

Damage to the gas analyzer, due to melting of the factory-mounted plastic plugs in the sample gas inlets.

- Remove the plastic plugs from the sample gas inlets before commissioning.

Sample gas line connection

The unheated sample gas connection has only one sample gas inlet.

If the sample gas is under positive pressure, a T-piece must be connected between the sample gas line and the sample gas inlet.

The free connection of the T-piece must be connected to an exhaust gas discharge line, so that no positive pressure builds up in the analyzer module.

Maximum length of the sample gas line

The maximum length of the unheated sample gas line (inside diameter 4 mm) is 50 m.

Provide for Sample Gas Line Purging

Install a shut-off valve in the sample gas line (highly recommended for pressurized sample gas) and provide the option of introducing an inert gas, e.g. nitrogen, from the gas sampling point, for purging of the sample gas line.

Connection of the sample gas line to the unheated sample gas connection

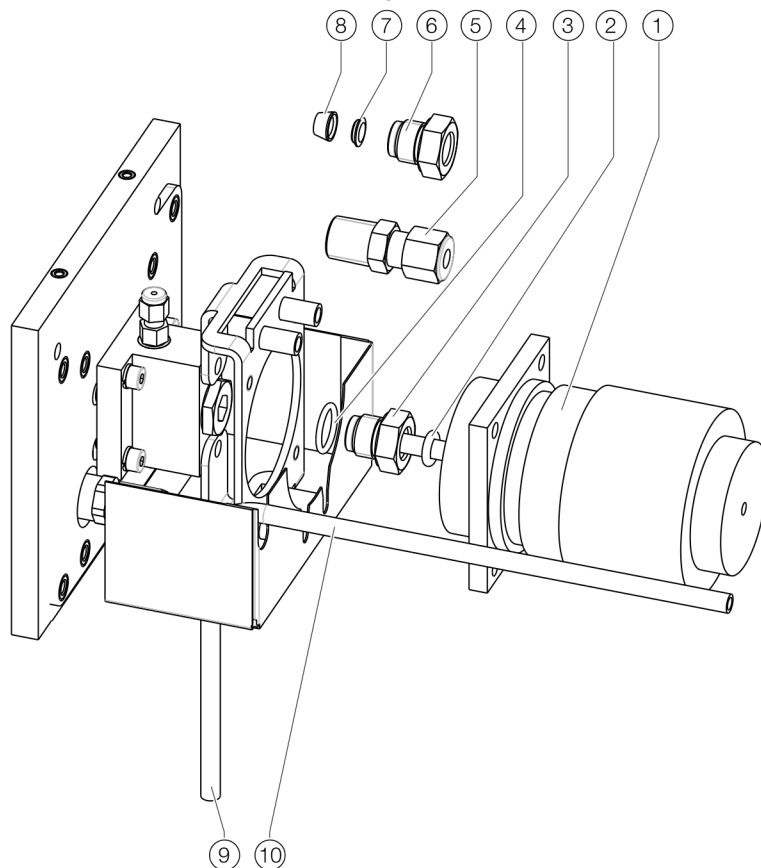

- ① Sample gas line (heated or unheated, PTFE or stainless steel tubing with a 4/6 mm inside/outer diameter)

Connection either with:

- ② O-ring 6.02 × 2.62
 ③ Socket
 ④ O-ring 12.42 × 1.78

Alternatively, with:

- ⑤ Screw-in connector G $\frac{1}{4}$ "

Alternatively, with:

- ⑥ Socket
 ⑦ Wedge ring
 ⑧ Clamping ring
 ⑨ Exhaust gas tube for 19" housing
 ⑩ Exhaust gas tube for wall-mount housing

Figure 38: Connection of the sample gas line

6 Electrical connections

Safety instructions

DANGER

Explosion hazard

There is a risk of explosion if the device is opened in a potentially explosive atmosphere.

Please take note of the following information before opening the device:

- A valid fire permit must be present.
- Make sure that there is no explosion hazard.
- Before opening the device, switch off the power supply.

WARNING

Risk of injury due to live parts.

Improper work on the electrical connections can result in electric shock.

- Connect the device only with the power supply switched off.
- Observe the applicable standards and regulations for the electrical connection.

General Notes

Protective lead connection

The protective lead (ground) should be attached to the protective lead connector before any other connection is made.

Risks of a disconnected protective lead

The device can be hazardous if the protective lead is interrupted inside or outside the device or if the protective lead is disconnected.

Model EL3020

Safety instructions

Observe the relevant national safety regulations for installing and operating electric systems.

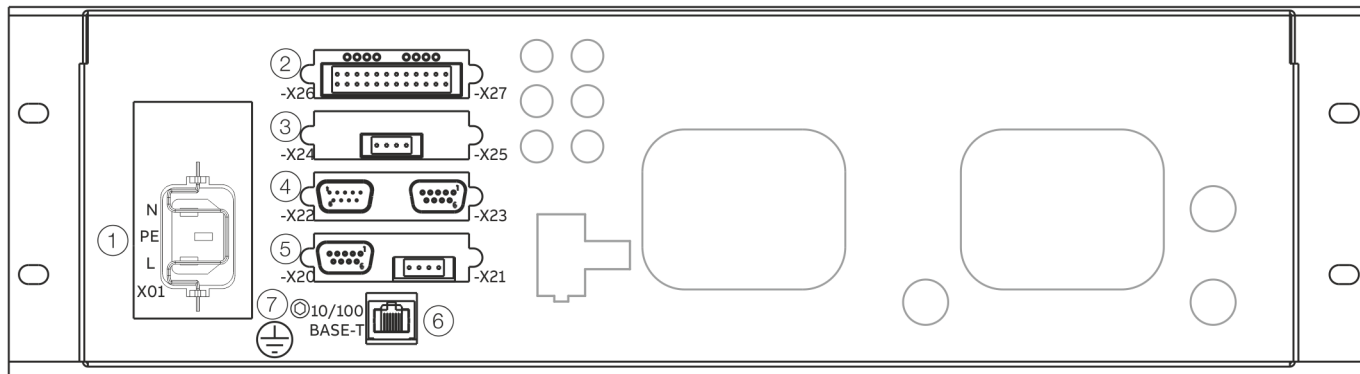

- | | |
|--|---|
| <p>① Power supply connection
(see Connecting the power supply on page 102)
(3-pin grounded instrument connector in accordance with EN 60320-1/C14; connection cable included in scope of supply)</p> <p>② Digital I/O module
(see Digital I/O module on page 99)</p> <p>③ Analog output module
(see Analog output modules on page 98)</p> | <p>④ Modbus module
(see Modbus®-Module on page 101)</p> <p>⑤ Profibus module
(siehe PROFIBUS®-Module on page 101)</p> <p>⑥ Ethernet 10/100BASE-T interface (for configuration and software update as well as for transferring the QAL3 data)</p> <p>⑦ Potential equalization connection (terminal capacity max. 4 mm²)</p> |
|--|---|

Figure 39: Electrical connections model EL3020

Note

The figure shows all available I/O module types and shows only an example of the assembly with I/O modules (max. 4). The actual assembly of a delivered gas analyzer may differ from this; it is documented in the device data sheet.

... 6 Electrical connections

Model EL3040

Safety instructions

Observe the relevant national safety regulations for installing and operating electric systems.

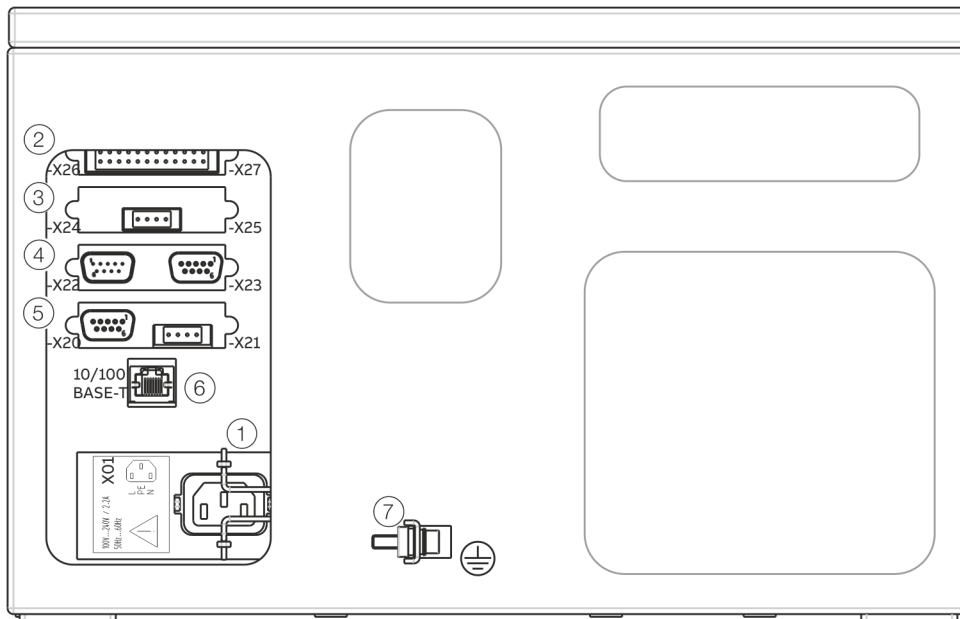

- | | |
|--|---|
| <p>① Power supply connection
(see Connecting the power supply on page 102)
(3-pin grounded instrument connector in accordance with EN 60320-1/C14; connection cable included in scope of supply)</p> <p>② Digital I/O module
(see Digital I/O module on page 99)</p> <p>③ Analog output module
(see Analog output modules on page 98)</p> | <p>④ Modbus module
(see Modbus®-Module on page 101)</p> <p>⑤ Profibus module
(see PROFIBUS®-Module on page 101)</p> <p>⑥ Ethernet 10/100BASE-T interface (for configuration and software update as well as for transferring the QAL3 data)</p> <p>⑦ Potential equalization connection (terminal capacity max. 4 mm²)</p> |
|--|---|

Figure 40: Electrical connections model EL3040

Note

The figure shows all available I/O module types and shows only an example of the assembly with I/O modules (max. 4). The actual assembly of a delivered gas analyzer may differ from this; it is documented in the device data sheet.

Cable glands

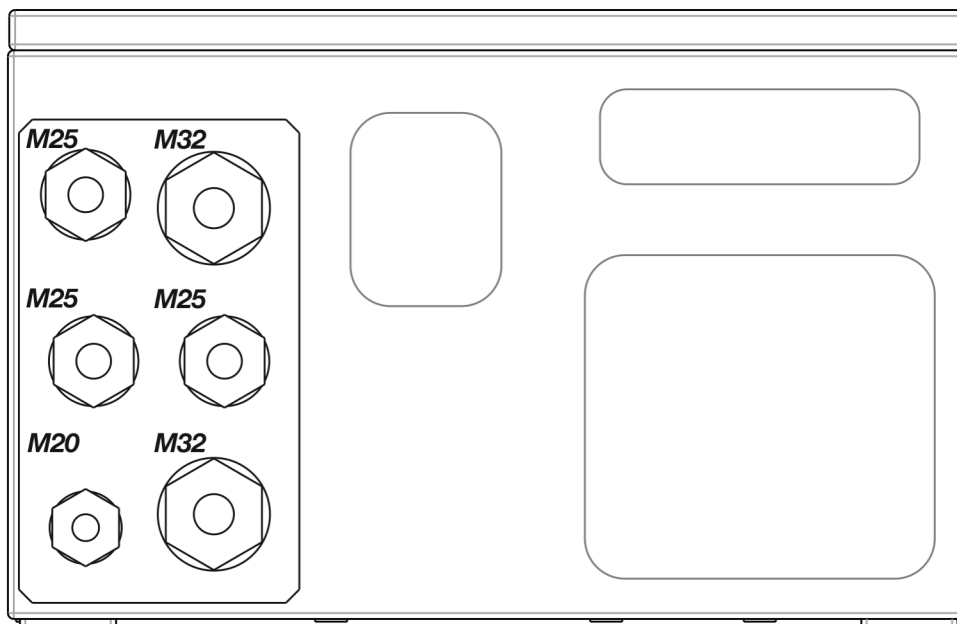

Figure 41: Cable glands model EL3040

Type	Application (recommended)	Permissible cable diameter
M20	Power supply	5 to 13 mm
M25	Modbus / Profibus	8 to 17 mm (insert 5 × 4 mm)
M25	Network	8 to 17 mm
M25	3 × analog outputs	8 to 17 mm (insert 3 × 7 mm)
M32	Digital inputs/outputs	12 to 21 mm
M32	Digital inputs/outputs	12 to 21 mm

Cable glands for use in potentially explosive atmospheres

During installation, the clamping range for lines as well as the tightening torques of the cable glands must be observed. The cable glands have several gasket rings which need to be removed as needed depending on the cable diameter.

Cable gland	Clamping range for lines and tightening torque					
	Sealing ring 1+2+3		Sealing ring 1+2		Sealing ring 1	
M20×1.5	Ø 5.5 mm / 1.5 Nm	Ø 7.0 mm / 1 Nm	Ø 7.0 mm / 1.5 Nm	Ø 9.0 mm / 1.4 Nm	Ø 9.5 mm / 1.0 Nm	Ø 13 mm / 1.7 Nm
M32×1.5	—	—	Ø 14 mm / 3.0 Nm	Ø 17 mm / 4.0 Nm	Ø 17.5 mm / 1.5 Nm	Ø 21 mm / 1.3 Nm
M25×1.5 2-way	—	—	—	—	Ø 2×4.5 mm / 2.0 Nm	Ø 2×7 mm / 2.0 Nm

Note

Only suited and cable glands and reduction nozzles approved for the Ex Zone may be used as spare parts.

- The use of other cable glands and blind plugs lead to a loss of Ex-approval!

Specifications for the selection of cable glands

Thread sizes in the connection box	M20×1.5; M32×1.5; M25×1.5
Sealing	Gasketing via sprayed-on sealing ring on the contact surface of the cable gland
Maximum surface roughness of the connection box	max. Ra = 8 µm
Wall thickness range of the connection box	4 to 5 mm

... 6 Electrical connections

Analog output modules

Terminal layout

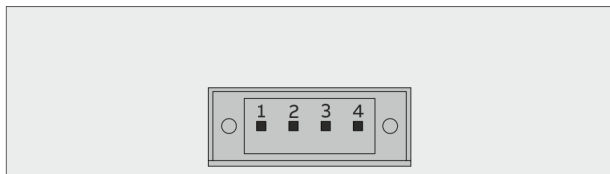

Figure 42: 2-way analog output module

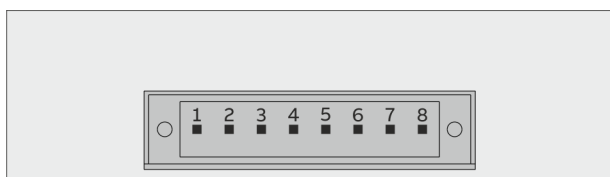

Figure 43: 4-way analog output module

Pin	Signal
1	AO1+
2	AO1-
3	AO2+
4	AO2-
5	AO3+
6	AO3-
7	AO4+
8	AO4-

Analog outputs AO1 to AO4

0/4 to 20 mA (factory-set to 4 to 20 mA), common negative pole, electrically isolated from ground, freely connectible to ground, max. gain relative to protective ground potential 50 V, max. load 750 Ohm. Resolution 16 bit.

The output signal cannot be lower than 0 mA.

Version

4-pole or 8-pole plug-in terminal strip with counter plug (included in the scope of delivery).

Terminal assignment

An analog output is allocated in the sequence of the sample components for each sample component.

The sequence of the sample components is documented in the analyzer data sheet and on the name plate.

Note

The allocation of the terminals can be changed in the configurator.

Refer to **Configuring signal inputs and outputs** on page 154.

Digital I/O module

Terminal layout

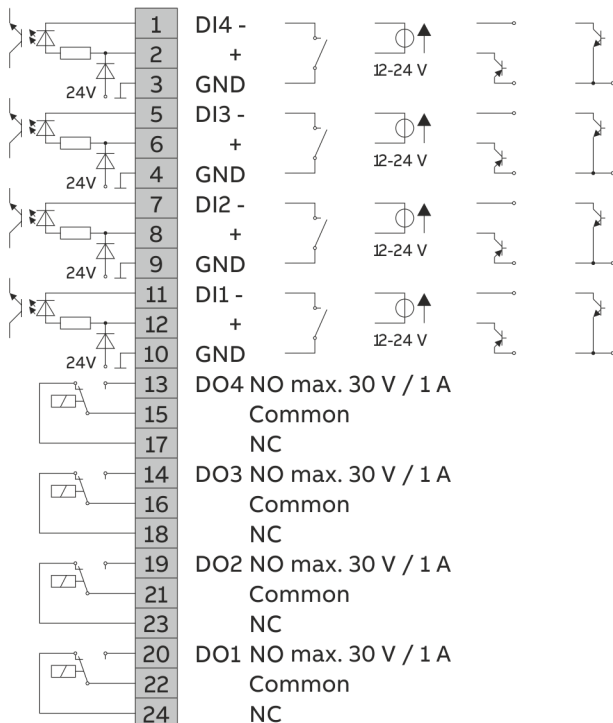
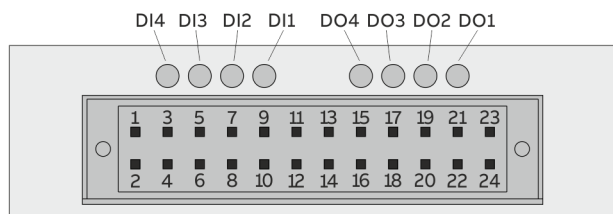

Digital inputs D11 to D14

Optocouplers with internal 24 V DC power supply. Control system alternatively available with potential-free contacts, with external voltage 12 to 24 V DC or with PNP or NPN open-collector driver.

Digital outputs DO1 to DO4

Potential-free changeover contacts, maximum contact load capacity 30 V/1 A.

Relays must at all times be operated within the specified data range.

Inductive or capacitive loads are to be connected with suitable protective measures (self-induction recuperation diodes for inductive loads and series resistors for capacitive loads).

Relays are shown in the unpowered state.

The unpowered state corresponds to the state in the event of a fault ("fail safe").

Version

2 × 12-pole plug-in terminal strip with mating connector (included in the scope of delivery).

Figure 44: Electrical connections, digital I/O module

... 6 Electrical connections

... Digital I/O module

Standard assignment of digital inputs and digital outputs

Function	Digital I/O Module 1	Digital I/O Module 2
Failure		
Maintenance required		
Maintenance mode		
Overall status	DO1	
Start automatic calibration	DI1	
Stop automatic calibration		
Disable automatic calibration	DI2	
Sample gas valve	DO4	
Zero point gas valve		
Span gas valve 1		
Span gas valve 2		
Span gas valve 3		
Span gas valve 4		
Span gas valve 5		
Pump, on/off*		
Limit 1	DO2	
Limit 2	DO3	
Limit 3		DO1
Limit 4		DO2
Limit 5		DO3
Limit 6		DO4
Limit 7		
Limit 8		
Limit 9		
Limit 10		
Measuring range switch-over		
Measuring range feedback		
Measuring component switch-over		
Measuring component feedback		
Bus-DI 1		
Bus-DI 2		
Bus-DI 3		
Bus-DI 4		
Bus-DI 5		
Bus-DI 6		
Bus-DI 7		
Bus-DI 8		
External failure**	DI3	
External maintenance request**	DI4	

* If a pump is installed ('Integral gas feed' option – only in model EL3020, not for Limas23, ZO23, Fidas24).

** Multiple external status signals can be configured depending on the number of free digital inputs.

Note

The allocation of the terminals (see **Configuring signal inputs and outputs** on page 154) can be changed in the configurator.

Modbus®-Module

Terminal layout

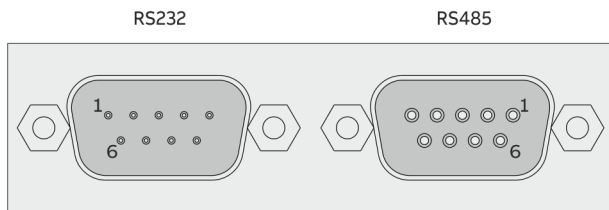

Figure 45: Modbus module

RS232 Interface

Version: 9-pin sub-D male connector

Pin	Signal
2	RxD
3	TxD
5	GND

RS485 interface

Version: 9-pin sub-D female connector

Pin	Signal
2	RTxD-
3	RTxD+
5	GND

Note

You can find detailed information regarding Modbus® in the 'COM/EL3000/MODBUS' interface description.

Note

The Modbus® protocol is an unsecured protocol, as such the intended application should be assessed to ensure that these protocols are suitable before implementation.

PROFIBUS®-Module

Terminal layout

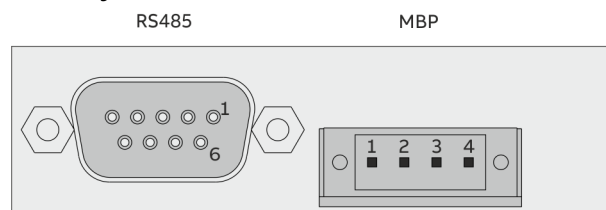

Image 46: PROFIBUS® module

RS485 interface

Version: 9-pin sub-D female connector

Pin	Signal	Description
1	—	not assigned
2	M24	24 V output voltage, ground
3	RxD/TxD-P	Receive/transmit data plus, B-line
4	—	not assigned
5	DGND	Data transmission potential (Reference potential for VP)
6	VP	Supply voltage plus (5 V)
7	P24	24 V output voltage plus, max. 0.2 A
8	RxD/TxD-N	Receive/transmit data N, A-line
9	—	not assigned

MBP Interface (not intrinsically safe)

Model: 4-pole plug-in terminal strip with mating connector (included in the scope of delivery).

Pin	Signal
1	+
2	Shield
3	-
4	not used

Note

You will find detailed information regarding PROFIBUS® in the '30/24-415' technical information.

Note

The PROFIBUS® protocol is an unsecured protocol (in the context of IT or cyber security), therefore the intended application should be assessed before implementation, in order to ensure that the protocol is suitable.

... 6 Electrical connections

Connecting the Signal Lines

Safety instructions

- Follow local regulations on installing and connecting electrical wiring.
- Lay the signal lines separately from the power supply lines.
- Lay analog and digital signal lines separately from each other.
- Label cables or counter plug so that they can be clearly allocated to the corresponding I/O modules.

Requisite Material

Refer to **Signal Lines** on page 18.

Connecting the Signal Lines

1. Only for the wall-mounted housing (model EL3040):
Feed the cables through the cable glands and strip them over a length of approx. 18 cm, see **Figure 41** on page 97.
 - M20 and M32 cable gland:
Remove the plug from the insert; leave the ring in the gland to act as a gasket and to provide strain relief.
 - Cable gland M25:
Remove the plug from the gland. Remove the drilled insert from the accessory bag and if necessary, slit it open and press it over the cable; close any free drill holes with dowel pins from the accessory bag.
2. Connect the cables to the opposite connectors, according to the connection diagrams of the I/O modules.
 - Analog output module, see **Analog output modules** on page 98
 - Digital-I/O module, see **Digital I/O module** on page 99
3. Connect the opposite connectors to the plug-in terminal strips on the I/O modules.

Connecting the power supply

NOTICE

Damage to the gas analyzer

Damage to the gas analyzer due to condensing sample gas during commissioning.

- Observe the condition of the sample gas inlet of the analyzer modules.
- Purge the sample gas path before commissioning, see **Purge sample gas path and analyzer housing** on page 105.
- Do not connect the sample gas until the gas analyzer has reached room temperature and after the warm-up phase has elapsed, see **Duration of the Warm-up Phase** on page 105.

NOTICE

Heater damage

Damage to the detector heater and the heated sample gas connection due to an improper connection.

- Attach or disconnect the connector **30** of the power supply for heating the detector and the heated sample gas connection only if the gas analyzer is de-energized.

Requisite Material

If the supplied mains lead is not used, select conductive material which is appropriate for the length of the lines and the predictable current load.

Potential equalization

The gas analyzer has a terminal marked with the symbol \oplus for connection with the building-side potential equalization. The connector has a clamping range of max. 4 mm².

Grid connection cable EL3000

For the power supply of the gas analyzer, a connection cable (length 5 m, conductor cross section $3 \times 1.5 \text{ mm}^2$) with a 3-pole cold device plug is included in the scope of supply.

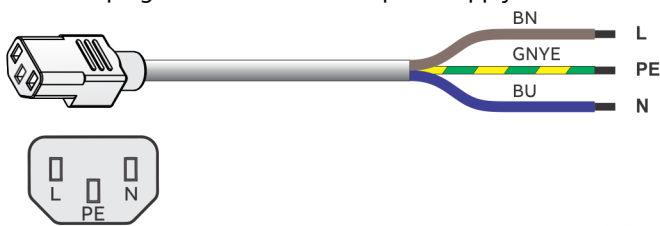

Figure 47: Pin side of the plug 30

Grid connection cable Fidas24

A connection cable is provided for the power supply (115 / 230 V AC) for heating the detector and, if necessary, the heated sample gas connection (length 5 m, cable cross-section $3 \times 1.5 \text{ mm}^2$) with a 4-pole socket connector for the connection to the analyzer module.

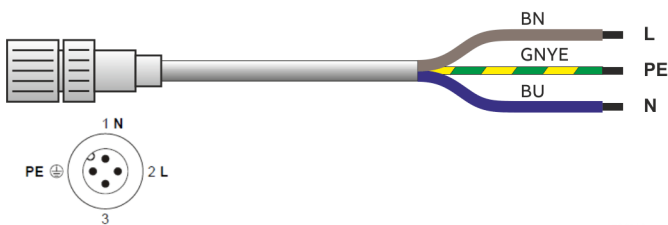

Figure 48: Pin side of the plug 30

The illustration shows the pin side of the plug **30** on the analyzer (see **Figure 33** on page 84).

The operating voltage of the detector heating is automatically detected and switched. The set voltage can be identified through two LEDs on the mains distribution card.

Connect power supply lines

1. Ensure that the power supply feeder has an adequately dimensioned protective device (circuit-breaker).
2. Install an easily accessible mains isolator or a switched socket in the power supply line, close to the gas analyzer, so that all the poles of the gas analyzer can be disconnected from the power supply if necessary. Label the supply circuit isolator to make it clear that it is associated with the device that needs to be isolated.
3. Plug the cold device power cable into the power supply connection **X01** (see **Model EL3020** on page 95 and **Model EL3040** on page 96) of the gas analyzer and fasten the plug with the bracket.
4. Attach the Fidas24 power cable to the power supply connection **30** (see **Gas connections and electrical connections Fidas24 (model EL3020)** on page 84 and **Gas connections and electrical connections Fidas24 (model EL3040)** on page 85) of the Fidas24 analyzer module and tighten.
5. Connect the other ends of the power cable to the power supply.
6. If stipulated by the relevant installation regulations, connect the gas analyzer to the building's equipotential grounding system.

Note

The supply circuit isolator must mutually isolate the power supply of the gas analyzer and the Fidas24.

Note

The gas analyzer can be put into operation as soon as it is connected to the power supply of the building.

7 Commissioning

Safety instructions

NOTICE

Damage to the gas analyzer

Damage to the gas analyzer due to condensing sample gas during commissioning.

- Observe the condition of the sample gas inlet of the analyzer modules.
- Purge the sample gas path before commissioning, see **Purge sample gas path and analyzer housing** on page 105.
- Do not connect the sample gas until the gas analyzer has reached room temperature and after the warm-up phase has elapsed, see **Duration of the Warm-up Phase** on page 105.

When safe operation can no longer be assured

If it is apparent that safe operation is no longer possible, the device should be taken out of operation and secured against unauthorized use.

The possibility of safe operation is excluded:

- If the device is visibly damaged,
- If the device no longer operates,
- After prolonged storage under adverse conditions,
- After severe transport stresses.

Installation Check

NOTICE

Potential adverse effect on the IP rating

Yellow sealing plugs (transport protection) are applied to the gas connections on the analyzer and housing to secure them during transport. The yellow sealing plugs do not guarantee a sufficient IP rating.

- Remove the yellow sealing plugs before commissioning.
- Close unused gas connections with suited sealing plugs to guarantee the IP rating.

1. Is the gas analyzer securely fastened, see **Gas Analyzer Installation** on page 86?
2. Are all gas lines including that of the pressure sensor correctly connected and installed, see **Connecting the gas lines** on page 87?
3. Are all signal lines and power supply lines correctly connected and installed, see **Connecting the Signal Lines** on page 102 and **Connecting the power supply** on page 102?
4. Are all devices and equipment needed for gas conditioning, calibration and exhaust gas disposal correctly connected and ready for use?
5. When measuring flammable gases: are the special conditions complied with, see **Special conditions for the measurement of flammable gases** on page 43?
6. When using the explosion-proof design in degree of protection II 3G: are the special conditions complied with, see **Special conditions** on page 14?

Purge sample gas path and analyzer housing

Before the gas analyzer is commissioned and the sample gas is connected, the sample gas path and, if necessary, the wall housing must be purged.

First of all, this makes sure that before commissioning, the sample gas paths and wall-mounted housing are free from contaminants, e.g. corrosive gases and accumulations of dust.

Secondly, this prevents any explosive gas / air mixture present in the sample gas paths or wall-mounted housing from being ignited when the power supply is powered-up.

Initial purging upon commissioning

Pre-purging the gas path

Purge gas	Nitrogen
Purge gas flow	Maximum 100 l/h
Purge time	approx. 20 s

Housing purge*

Purge gas	Nitrogen
Purge gas flow	Maximum 200 l/h
Purge time	Approx. 1 hour

* Not for Fidas24, see for a separate description at **Housing purge with Fidas24** on page 105.

If the purge gas flow is lower than specified, the duration of the purging must be extended accordingly.

Housing purge with Fidas24

In the Fidas24 gas analyzer, the housing purge is provided in such a way that a part (approx. 600 to 700 l/h) of the instrument air is conducted continuously through the housing as purge air.

Thus it is guaranteed that no ignitable gas mixture can form within the housing in case of a leak in the combustion gas path. The housing purge is always active when pressurized air is on, that is also when the instrument air valve is closed.

Gas analyzer start-up

Note

For the analyzers ZO23 and Fidas24, the instructions specified in **ZO23 – Commissioning the gas analyzer** on page 106 or **Fidas24 – Commissioning the gas analyzer** on page 106 must be observed.

General description of commissioning

1. Turn on the gas analyzer power supply.
2. During the start-up phase ('Booting'), the LCD display shows the name of the gas analyzer and the number of the software version.
3. At the end of the start-up phase, the LCD display switches over to display the measured values.

Example:

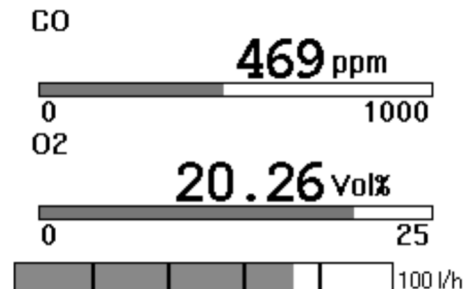

4. Check the gas analyzer configuration and change if necessary, see **Configuration** on page 143.
5. Once the warm-up phase is complete, the gas analyzer is ready to begin the measurement process, see see Table **Duration of the Warm-up Phase** on page 105..
6. Check the gas analyzer calibration, see **Calibration** on page 117.
The gas analyzer is factory calibrated. However, transport influences as well as the pressure and temperature conditions at the installation site can influence the calibration.
7. Turn on the sample gas supply.

Duration of the Warm-up Phase

Analyzer	Duration of the Warm-up Phase
Uras26	Without thermostat: approx. ½ h With thermostat: approx. 2 h
Limas23	Approx. 2 hours
Magnos206	< 1 hours
Magnos28	< 5 h, The value may be elevated during first commissioning or after a longer service life.
Magnos27	2 to 4 h
Caldos27	Approx. ½ h
Fidas24	Approx. 2 hours
ZO23	approx. 2 h, see for detailed information ZO23 – Commissioning the gas analyzer on page 106.

... 7 Commissioning

... Gas analyzer start-up

Z023 – Commissioning the gas analyzer

Note

We recommend starting the first calibration procedure at the installation site on the day before the actual measurement operation is started, so that the gas paths and valves can be purged as long as possible.

Commissioning the gas analyzer, first calibration at the installation site:

1. Power-up the power supply on the gas analyzer.
 - After 15 min, the operating temperature of the cell has been reached, the corresponding status message goes out. From this moment on, the gas can be connected.
2. Supply ambient air for setting the reference point (= electric zero point) and wait for the measured value to stabilize (time approx. 2 h).
 - During this time, flush the test gas valves and the gas inlet line with oxygen-free gas (for example, with nitrogen from a ring line) or with sample gas (flow rate 5 to 10 l/h).
3. Set the reference point to the oxygen content of the ambient air, taking into account the air humidity. See calculation example in **Test gases** on page 30.
4. Use nitrogen to flush the entire gas path and the valves, which was previously blown with air. It's best to do this for at least 12 hours, for example overnight.
5. Feed in the span gas and wait for the measured value to stabilize (max. duration 2 h).
6. Set the end point value in accordance with the analysis certificate of the test gas cylinder used.
7. The gas analyzer is ready for measurement; connect sample gas.

Note

For information on the test gases, refer to **Test gases** on page 30.

Fidas24 – Commissioning the gas analyzer

Power-up the power supply, heat-up phase, connect operating gases

1. Switch on the power supply of the gas analyzer and the heaters of the Fidas24.
2. During the start-up phase 'Booting', the LCD display shows the name of the gas analyzer and the number of the software version. At the end of the start-up phase, the LCD display switches over to display the measured values.
3. Select the 'Controller Values' menu item:
 - ▼ Maintenance / ▼ Diagnosis / ▼ Device Status / ► Analyzer Status / ▲ Controller Values'
 Under this menu item, both the actual and setpoint values and the manipulated variables of the internal temperature controllers are displayed:

T-Re.D: Detector temperature

T-Re.E: Temperature of the heated sample gas connection

T-Re.K: Internal combustion air conditioning temperature

TR.VV1: Temperature of the pre-amplifier

The temperature values increase slowly after activating the power supply.

4. Switch on the instrument air, combustion air and combustion gas (H₂ or H₂/He mixture). Adjust the pressure to the value specified in the Device Data Sheet with the corresponding external pressure regulator.
5. The 'Controller Values' menu item also displays both the actual and set point values and the manipulated variables of the internal pressure controllers:

C Air: Combustion air pressure

C Gas: Combustion gas pressure (H₂ or H₂/He mixture)

MGE: Pressure at the sample gas nozzle

MGA: Pressure in the combustion chamber (output)

Note

The following status messages are active during the heating-up phase:

6. During the heating phase, the following status messages are displayed:

Message	Description
Working temperature	the temperature of the detector has not yet reached the threshold.
Flame error	the flame has not yet ignited.
Temperature limit value 1, 2	The temperature of the detector (T-Re.D) and if applicable the heated sample gas connection (T-Re.E) up-scales or down-scales the upper or lower limit value 1 or 2.
Pressure limit value 1, 2	The pressure at one of the internal pressure regulators for instrument air (inlet, outlet), combustion air (air) or combustion gas (H₂) up-scales or down-scales the upper or lower limit value 1 or 2.

7. As soon as the temperature of the detector reaches the threshold value (150 °C), the corresponding solenoid valve in the analyzer automatically switches off the instrument air. The negative pressure regulation and the combustion air regulation attempt to adjust the pressures to the respective set point. The sample gas begins to flow through the analyzer after the instrument air is connected.
8. After the pressures have been adjusted to the respective set point, the respective solenoid valve in the analyzer automatically connects the combustion gas. The combustion gas regulation attempts to adjust the pressure to the set point.

Adjust output variables of the internal pressure controllers

If the analyzer cannot be commissioned automatically with the pressure values specified in the device data sheet, the manipulated variables of the internal pressure controllers must be adjusted.

Note

In order to bring the pressure regulators into a more favorable control range, the external supply pressures can be adapted with the aid of the manipulated variables. However, this should only be done once the flame has been ignited.

In general, this is not necessary.

9. Instrument air:

Use the external pressure regulator to set the controlled variable for Outlet to approx. 60 % (max. 70 %).

Manipulated variable too high → Reduce pressure.

Manipulated variable too low → Increase pressure.

(The controlled variable for "Inlet" depends on the sample gas flow rate.)

10. Combustion air:

Use the external pressure regulator to set the control variable for "air" to approx. 55 % (max. 60 %).

Manipulated variable too high → increase pressure.

Controlled variable too low → reduce pressure.

11. Combustion air:

Use the external pressure regulator to set the manipulated variable for 'H₂' to approx. 42 % (max. 52 %).

Manipulated variable too high → increase pressure.

Controlled variable too low → reduce pressure.

... 7 Commissioning

... Gas analyzer start-up

Igniting the flame

12. Flame ignition is automatic.

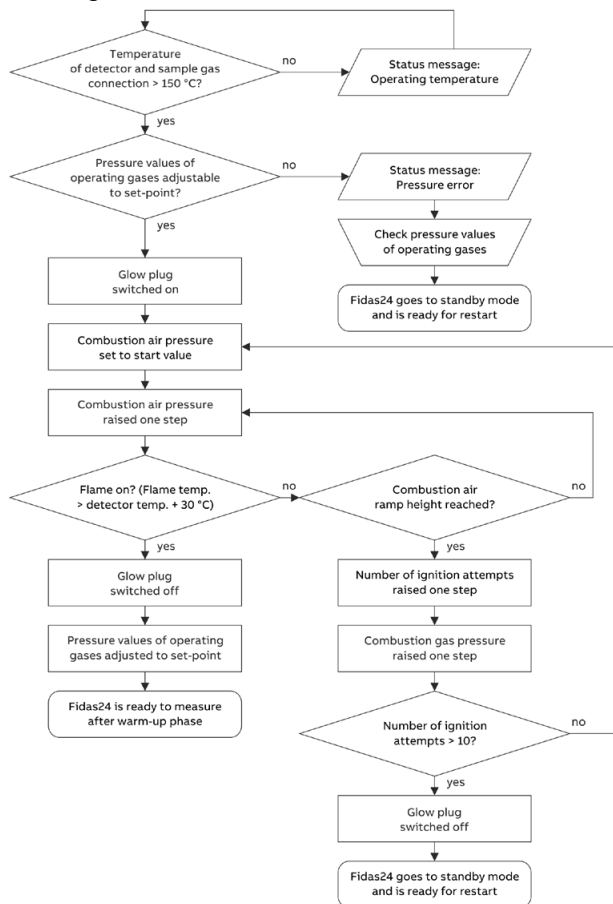

Image 49: Igniting the flame

Depending on the number of ignition attempts, flame ignition can take up to 10 minutes.

On initial commissioning of the gas analyzers, it may occur that, depending on the position of the combustion gas line, there is not sufficient combustion gas available to ignite the flame at first. In this case, you need to go to the 'Fidas Restart' menu to restart the ignition of the flame, see **Fidas24 – Standby / Restart** on page 191.

The flame temperature is also displayed in this menu. The flame is considered to be 'on' when the flame temperature is at least 30 °C higher than the detector temperature.

With the ignition of the flame, the actual commissioning of the gas analyzers is ended.

Note

Unused sample gas lines and sampling probes may continue to emit hydrocarbons for an extended period after initial operation. As a result, it can take much longer for the measured value drift to reach an acceptable value.

Recommissioning the gas analyzer

CAUTION

Risk of burns

Risk of burns on the hot (> 70 °C) cover of the heated sample gas connection.

- Do not touch the cover of the heated sample gas connection.

NOTICE

Heater damage

Damage to the detector heater and the heated sample gas connection due to an improper connection.

- Attach or disconnect the connector **30** of the power supply for heating the detector and the heated sample gas connection only if the gas analyzer is de-energized.

- Feed in instrument air and combustion air and purge the gas analyzer for **at least 20 minutes**
- Check the leak tightness of the combustion gas supply line, see **Check the integrity of combustion gas path** on page 194.
- Turn on the gas analyzer power supply.
- Power-up the combustion gas supply and check the combustion gas pressure.
- Turn on the sample gas supply.

8 Operation

Safety instructions

When safe operation can no longer be assured

If it is apparent that safe operation is no longer possible, the device should be taken out of operation and secured against unauthorized use.

The possibility of safe operation is excluded:

- If the device is visibly damaged,
- If the device no longer operates,
- After prolonged storage under adverse conditions,
- After severe transport stresses.

LCD indicator

Note

All representations of the LCD indicator in these Operating Instruction are examples.

The indications on the IED will usually differ from this.

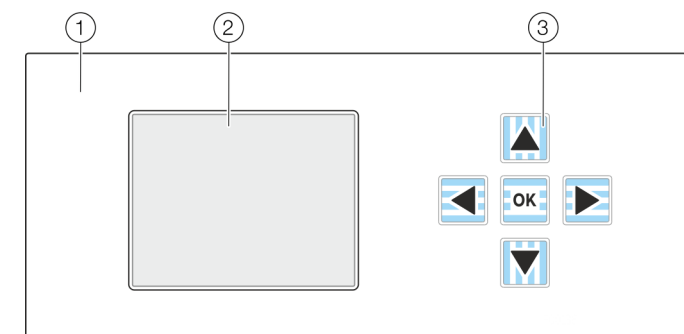

① LCD indicator

② LCD display

③ Operating buttons for menu navigation

Figure 50: LCD indicator on the device

The gas analyzer is operated via the LCD indicator on the device.

LCD display in measurement mode

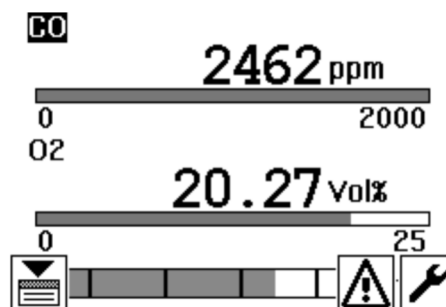

Figure 51: LCD display in measurement mode (example)

In measurement mode, the LCD display displays the name, the measured value in numbers and the physical unit of the measured value for each sample component.

If the name of the sample component flashes alternately with the inverted display, this signals that the measured value is outside the measuring range limits.

Status icons provide information on the operating condition of the gas analyzer.

... 8 Operation

... LCD indicator

Status Icons

Icon	Description
	An automatic calibration is in progress, see page 120. The icon also appears in menu mode in the menu title line, see LCD display in menu mode on page 110.
	A status message is active, see page 168.
	The status signal 'Maintenance required' is active, see page 168. The icon also appears in menu mode in the menu title line, see page 110.
	The status signal 'Failure' is active (see page 168) or the maintenance switch (see page 180) is set to 'On'. The icon is flashing. The icon also appears in menu mode in the menu title line, see page 110.
	The configuration has been saved. The icon is flashing. Do not turn off the power supply of the gas analyzer while the icon is displayed!

Key functions in measurement mode

Button	Description
◀ ▶	Toggle to display each individual measured value; in addition to the number display, an analog bar with an indication of the measuring range limits appears on this indicator.
▲ ▼	Decrease or increase the contrast of the LCD display. If a status message is active: First, press the ▲ button.
OK	Switch to menu mode (see 110).
▼	If a status message is active : Press the button to display the message list (see " Status messages " table on page 170).

Number of decimal places

When displaying the measured value in physical units (such as ppm), the number of decimal places depends on how large the span of the set measuring range is.

Measuring span	Decimal places
≤ 0,05	5
≤ 0,5	4
≤ 5	3
≤ 50	2
≤ 500	1
> 500	0

The number of decimal places when setting the parameters is the same as in the display in measuring mode.

LCD display in menu mode

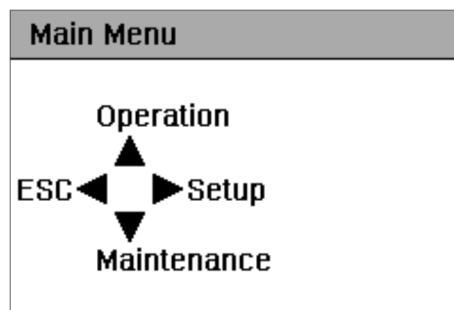

Figure 52: Main menu

Structure of the menu

Each menu (see **Menu Overview** on page 112) from the main menu contains a maximum of three menu items ('3-tier menu').

Each menu item is assigned to one of three buttons ▲, ▶ and ▼, therefore each menu item can be selected directly. The ◀ button is always used to return to the next higher menu.

The most commonly needed functions are arranged in the menu in a way that they can be called up by pressing each of the keys repeatedly:

- '▲ Operation / ▲ Calibration / ▲ Manual Calibration / ▲ Zero point / Single point'
- '▶ Setup / ▶ Calibration Data / ▶ Test gas set points'
- '▼ Maintenance / ▼ Diagnosis / ▼ Device status / ▼ Status messages'

Button functions in menu mode

Button	3-tier menu
▲ ► ▼	Select menu item
◀	Return to the next higher menu
OK	Return to measurement mode
Component list	
▲ ▼	Select component
► or OK	Call up selected component for editing
◀	Return to the next higher menu
Parameter list ('Selector')	
▲ ▼	Select parameter
►	Call up value change
OK	Accept all displayed values and return to the next higher menu
◀	Discard all displayed values and return to the next higher menu
Change in value	
▲ ▼	Change selected item
►	Select items to be changed
OK	Confirm changed value and return to the parameter list
◀	Discard changed value and return to the parameter list

Enter password

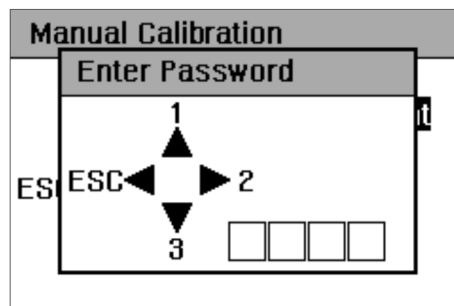

Figure 53: Password entry

As soon as the user wants to access a password-protected menu or a password-protected value change, password entry is prompted.

For this purpose, as shown on the LCD display, the digits 1, 2 and 3 are assigned to three buttons ▲, ► and ▼.

Example

If the password set is '1213', the user needs to push the buttons ▲, ►, ▲ and ▼ one after the other. Each push of a button is acknowledged by displaying the '*' symbol.

The password entered remains active until the user returns to measuring mode or until the gas analyzer automatically switches to measuring mode through the time-out function.

Time out function

If the user does not press a button for more than 5 minutes while selecting menu items, the gas analyzer automatically switches back to measurement mode (see **LCD display in measurement mode** on page 109).

The time-out function is disabled as soon as the user changes the value of a parameter or starts a calibration.

... 8 Operation

Menu Overview

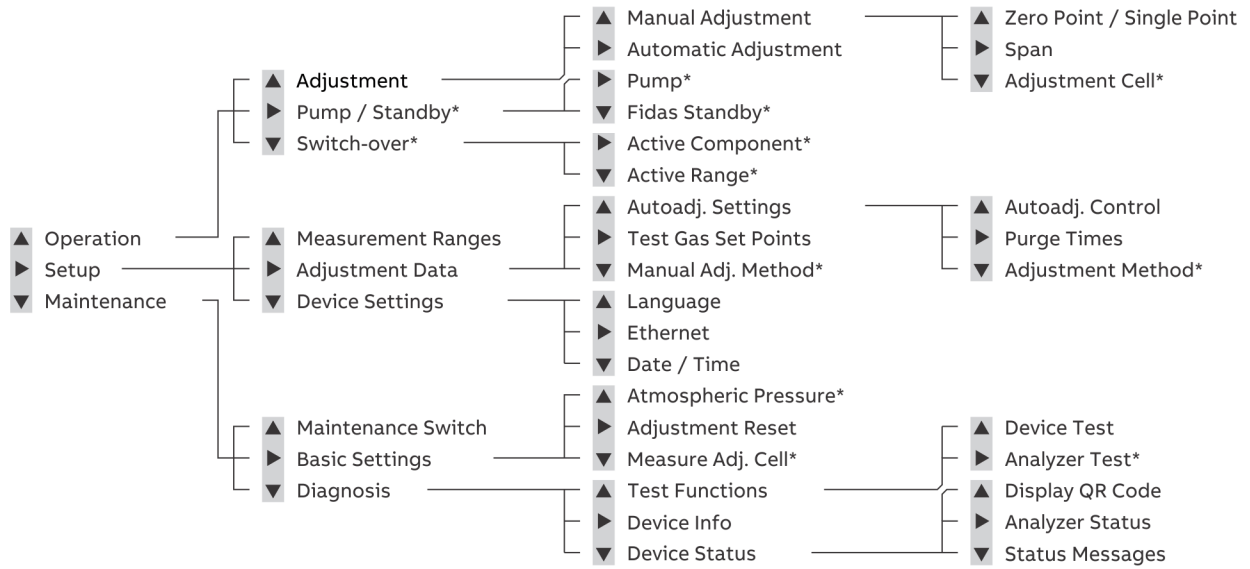

* This menu depends on the configuration of the gas analyzer

Figure 54: Menu overview

Notes on the operating concept

The operating concept of the gas analyzer requires that the functions needed in normal operating mode are operated and configured directly on the device.

On the other hand, those functions that are seldom needed, for example when commissioning the device, are named, configured and then loaded into the gas analyzer offline using the ECT 'EasyLine Configuration Tool' software tool, also referred to as the 'Configurator' in this instruction.

Overview of functions

Function	Device	Configurator	Modbus
Automatic Calibration			
Start/cancel automatic calibration (can also be done via digital inputs)	X		X
Power-up/power-down a cyclically timed automatic calibration, see Automatic calibration: Control on page 120	X	X	X
Cycle time of automatic calibration.		X	
End-point calibration together with zero point calibration		X	X
Date and time of next automatic calibration (start of cycle)	X	X	
Test gas concentration, see Set test gas concentration on page 119	X	X	X
Purge time	X	X	
Output current behavior (for automatic and manual calibration)		X	
Calibration method (Magnos206, Magnos28)	X	X	
Pump on during calibration		X	
Manual Calibration			
Calibration method	X	X	
Test gas concentration, see Set test gas concentration on page 119	X	X	
Perform calibration	X		
Maintenance functions			
Pump control, see Operate pump on page 200	X	X	
Calibration reset, see Perform calibration reset on page 180	X		
Calibrate pressure sensor / set air pressure value, see Pressure correction on page 196	X		
Measuring the calibration cell, see Uras26, Limas23 – measuring the calibration cell on page 181	X		
Drift, Delta drift, see Drift indicator on page 196 (display)	X		X
Software version, see Instrument information on page 200	X	X	
Status information, see Possible status messages on page 170	X		X
Component parameters			
Measuring range parameters, (see Measuring range configuration in the gas analyzer on page 146)	X	X	
Limit value parameters, see Limit values on page 149		X	
Low pass time constant, T90 time, filter, see Set low-pass time constant on page 150		X	X
Active component, (see Active component selection on page 151)	X	X	X
Measuring range, (see Sample components on page 152)		X	
Modbus parameters*		X	
PROFIBUS parameters**		X	
Ethernet parameters, see Setting the IP address on page 155	X	X	
Signal inputs and outputs, see Configuring signal inputs and outputs on page 154		X	

* You will find detailed information regarding Modbus® in the interface description 'COM/EL3000/MODBUS'.

** You will find detailed information regarding PROFIBUS® in the technical information '30/24-415'.

... 8 Operation

Communication between gas analyzer and computer

Ethernet communication

The communication between the gas analyzer and the computer runs via an Ethernet connection either as a point-to-point connection or via a network.

The Ethernet connection enables communication

- using the test and calibration software Optima TCT Light,
- using the ECT configuration software,
- for QAL3 data transfer if the 'QAL3 monitoring' option is integrated in the gas analyzer,
- For reading the measured values and calibration and control of the gas analyzer via the Modbus® TCP/IP protocol.

Establishing communication between the gas analyzer and the computer

To establish the communication between the gas analyzer and the computer, the following steps must be performed in particular:

1. Check and set the TCP/IP parameters in the gas analyzer and the computer.
2. Establish and test the Ethernet connection.
3. Establish communication between the gas analyzer and the computer.

Check the TCP/IP parameters in the gas analyzer and in the computer

For operation of the configurator, the TCP/IP parameters must be checked in both the gas analyzer and the computer and changed, if necessary.

In the case of a point-to-point connection, the IP addresses in the gas analyzer and in the computer must be matched.

Example:

Gas analyzer: 192.168.1.4,
Computer: 192.168.1.2

Note

If the gas analyzer is connected to a network without a DHCP server, then the parameter 'DHCP' should be set to 'off'.

This also applies if the gas analyzer is not connected to a network via Ethernet.

This is to prevent the gas analyzer from continuously attempting to establish a network connection.

Setting the IP address

Menu Path

► Setup / ▼ Device Settings / ► Ethernet'

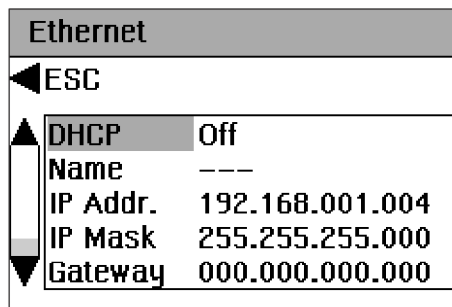

Illustration55: 'Ethernet' Menu

Parameters

It depends on the DHCP settings what parameters need to be integrated:

DHCP setting	Parameter
DHCP on	Network name (max. 20 characters, no empty and special characters),
DHCP off	IP address, IP address mask and IP gateway address.

The network name can only be changed in the Configurator. The default network name consists of 'EL3K' and the last six characters of the MAC address (for example, 'EL3KFF579A').

If the parameter 'DHCP' is set to 'off', the Ethernet configuration is set to the default configuration (default IP address) in order to avoid unintentional assignment of an IP address from a DHCP pool.

Addresses

The IP address, IP address screen and IP gateway address need to be queried from the system administrator.

Note

The address bits variable from the address screen may not be set to 0 or 1 (broadcast addresses).

MAC address

The 12 character MAC address is unique worldwide and is stored in the device during manufacture. It cannot be changed.

Setting the IP address in the computer

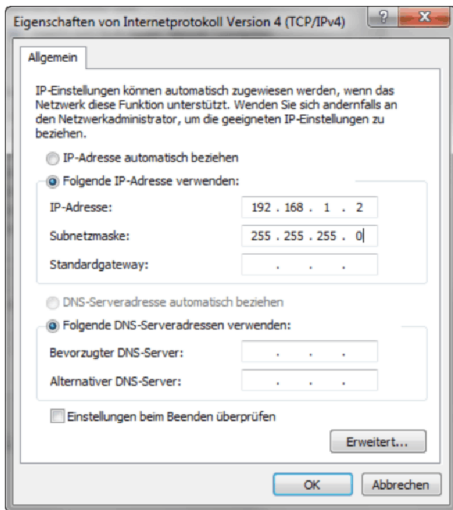

Figure 56: Microsoft Windows® IP properties (example)

1. Call up 'Start' → 'System control' → 'Network and release center'.
2. Click on 'Change adapter settings'.
3. Right-click on 'Ethernet' (Windows 10®) or 'Local Area Connection' (Windows 7®) → 'Properties'
4. in the network tab → double-click on 'Internet Protocol Version 4 (TCP/IPv4)'
5. In the 'General' tab, you can configure the IP settings (see **Setting the IP address** on page 155) appropriate for the configuration of the gas analyzer and confirm the settings by clicking on 'OK'.

Establishing and testing the Ethernet connection Cables

The cables are standard Ethernet cables and are in the scope of delivery of the gas analyzer.

Testing the Ethernet connection

1. Call up 'Start' → 'Input request'.
2. Enter 'ping IP-Adresse' (along with the IP address of the gas analyzer) and press the Enter button.

If the connection is OK, the gas analyzer reports: 'Response from IP address: Bytes=32 Time<10ms TTL=255"
(the numbers are device-specific).

If the message 'Request timeout' appears, the connection is not OK.

The network name of the gas analyzer can also be entered instead of the IP address.

Establish communication between configurator and gas analyzer

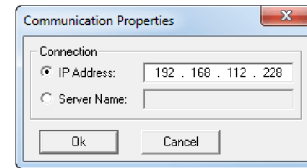



Figure 57: 'Communication Properties' menu in ECT

The communication between the configurator and the gas analyzer is established in the 'Options / Communication Properties...' menu or by clicking on the  icon.

Either the IP address or the network name (server name) of the gas analyzer should be entered.

Receiving configuration data

Once communication is established, configuration data can be received from the gas analyzer.

'File / Receive Data' menu or  icon.

Sending configuration data

Once the configuration data has been processed, it can be sent to the gas analyzer.

The configuration is active after an automatic restart of the gas analyzer.

Menu 'File / Send Data' or  icon.

Saving configuration data

The gas analyzer configuration data can be stored on the computer.

The saved configuration file can be processed later and sent to the gas analyzer.

'File / Save As...' menu or  icon.

... 8 Operation

... Setting the IP address

Release of communication via Modbus® TCP/IP

In the EasyLine EL3000, communication via Modbus® TCP/IP is blocked on all Ethernet interfaces by default.

Note

The Modbus® protocol is an unsecured protocol (in the meaning of IT security or cybersecurity), as such the intended application should be assessed before implementation to make sure that the protocol is suited.

Release communication via Modbus® TCP/IP

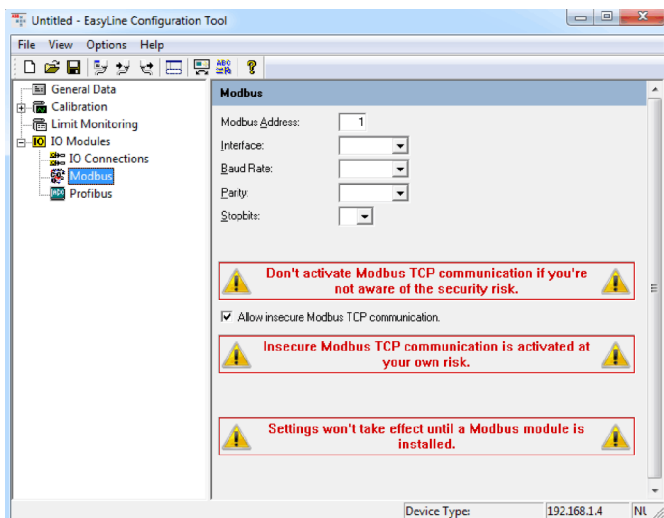

Figure 58: Modbus configuration in ECT

Implement the following steps to release communication via Modbus TCP/IP:

1. Select '...\IO Modules\Modbus' in the menu tree of the ECT Controller.
2. Select the ' Allow insecure Modbus TCP communication' checkbox.
3. Set the required Modbus parameters, save the settings and transfer them to the gas analyzer.
4. Communication via the Modbus TCP/IP protocol has now been released.

Note

You will find detailed information regarding the Modbus® in the description of the interface 'COM/EL3000/MODBUS'.

9 Calibration

Calibration control

Manual and automatic calibration

Manual Calibration

Manual calibration is normally controlled on the display and operation unit of the gas analyzer separately for each sample component.

Refer to **Manual calibration: execution** on page 127.

Automatic calibration

Automatic calibration is usually started cyclically on a time-controlled basis by the internal clock of the gas analyzer jointly for all sample components.

- Automatic calibration can also be started by an external control signal or via the Modbus as well as manually on the display and operation unit of the gas analyzer.
- Automatic calibration can be blocked by an external control signal or via the Modbus.

Refer to **Automatic calibration: Control** on page 120.

Status signal during calibration

The 'Function check' status signal is set during calibration.

For automatic calibration, this is the time period from the gas switch from sample gas to test gas to maximum 4× the longest set low-pass time constant (see **Set low-pass time constant** on page 150) plus the purge time after the new gas switch from test gas to sample gas.

There are two cases distinguished for manual calibration:

- If no valves are configured, the status signal goes out when leaving the calibration menu.
- If at least one sample gas valve (or a digital output with valve function) is configured, the status signal goes out after a maximum of 4× the longest set low pass time constant plus the purge time after the new gas switch from test gas to sample gas.

Depending on the configuration of the signal inputs and outputs (see **Configuring signal inputs and outputs** on page 154), the status signal is issued with the 'Function check' function on a digital output.

Current output signal during calibration

In the configurator, it is possible to set whether the current signals on the analog outputs

- can follow measurement value changes during calibration.
- are held at the last measured value prior to starting calibration or

If the current signals are configured to 'Hold', the analog outputs are held until the 'Function check' status signal has been cleared.

Limit values during calibration

If limit values are activated, they are also active during calibration, see **Limit values** on page 149.

Limit value monitoring is not active during calibration if the current signals are configured to 'Hold', see **Current output signal during calibration** on page 117.

Plausibility Check during calibration

If during calibration, the gas analyzer finds implausible values (e.g. if the end-point and zero point values are equal), the calibration is aborted and the device issues a status message 503 (see **Possible status messages** on page 170).

The values stored for the last calibration remain in effect.

... 9 Calibration

... Calibration control

Wait until the warm-up phase has ended

Analyzer module may not be calibrated until the warm-up phase has ended.

Duration of the Warm-up Phase

Analyzer	Duration of the Warm-up Phase
Uras26	Without thermostat: approx. ½ h With thermostat: approx. 2 h
Limas23	Approx. 2 hours
Magnos206	< 1 hours
Magnos28	< 5 h, The value may be elevated during first commissioning or after a longer service life.
Magnos27	2 to 4 h
Caldos27	Approx. ½ h
Fidas24	Approx. 2 hours
ZO23	approx. 2 h, see for detailed information ZO23 – Commissioning the gas analyzer on page 106.

Air pressure effect

The current air pressure must be taken into consideration during the calibration.

- Air pressure correction is automatically performed when a pressure sensor is fitted to the analyzer, see **Pressure sensor** on page 38.
- In the case of analyzers without a pressure sensor, the current air pressure must be entered via the 'Atmospheric Pressure' menu before calibration, see **Pressure correction** on page 196.

Test gases

DANGER

Explosion hazard

Explosion hazard due to the formation of explosive gas mixtures when measuring flammable gases and connecting oxygen-containing test gases (such as air).

- Before connecting an oxygen-containing test gas, the gas path must be rinsed with an inert gas, such as nitrogen.
- Observe the following **safety instructions regarding calibration**.

Safety instructions regarding calibration

When measuring flammable gases, observe the following instructions:

- When calibrating the analyzers, air must not directly be connected as a test gas after operation with flammable gases.
- Alternatively, where possible, use nitrogen as test gas for calibration instead of air (for example, for zero point calibration of Uras26 or single point calibration of Magnos206 and Magnos28).

This must be particularly considered for automatically controlled calibration processes, since no automatic purging with an inert gas is possible.

Note

For the analyzers ZO23 and Fidas24, the instructions specified in **ZO23 – Checking the reference point and end point** on page 136 or **Fidas24 – Notes for calibration** on page 138 must be observed.

Dew point of the test gases

The dew point of the test gases must be approximately equal to the dew point of the sample gas, i.e. it must be at least 5 °C lower than the lowest ambient temperature in the entire gas path.

Test gas flow rate

30 to 60 l/h, keep constant at ±5 l/h

Test gas supply

If the gas analyzer is equipped with a solenoid valve ('Integral gas feed' option – only in model EL3020, not for Limas23, ZO23, Fidas24), the test gas must be connected at test gas inlet **22** of the solenoid valve.

Otherwise, the test gases must be connected to the sample gas inlet of the gas analyzer:

- Either with an external solenoid valve controlled via digital output DO4 on digital I/O module 1 (standard configuration), see **Digital I/O module** on page 99.
- Or with external solenoid valves for sample gas, zero point gas and span gas, each controlled via an appropriately configured digital output, see **Digital I/O module** on page 99.
- Or with a multi-way valve.

Test gas supply control for automatic calibration

The prerequisite for the automatic calibration procedure is that

- Either the gas analyzer is equipped with a solenoid valve 'Integral gas feed' option – only in model EL3020, not for Limas23, ZO23, Fidas24)
- or at least one external solenoid valve is installed, controlled by an appropriately configured digital output.

Especially in the case where automatic calibration is performed as a simplified calibration (calibration cells, single-point calibration), the required test gas (zero point gas, air or standard gas) must be either applied to the built-in solenoid valve or to an external solenoid valve.

Set test gas concentration

Menu path

► Setup / ► Calibration Data / ► Test Gas Set Points'

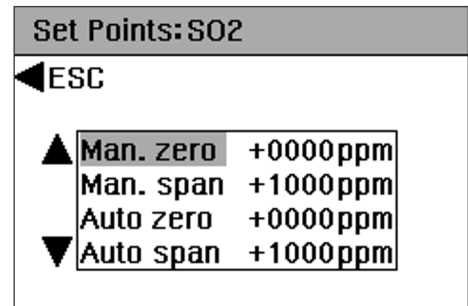

Figure 59: "Set points' menu

Test gas concentration

The set points of the test gas concentrations for zero and end-point calibration must be set separately for manual and automatic calibration.

The set points of the test gas concentrations for the manual calibration can also be set during the calibration process as well as in the configurator.

Zero point set point

Value range: Initial value of the physical measuring range minus 20 % of the measuring span to the final value of the physical measuring range.

Refer to **Configuration** on page 143.

End-point set point

Value range: Initial value of the physical measuring range up to the final value of the physical measuring range plus 20 % of the measuring span.

Refer to **Configuration** on page 143.

... 9 Calibration

Automatic calibration: Control

Starting automatic calibration

Cyclic timed start

Automatic calibration is normally started cyclically on a time-controlled basis by the internal clock of the gas analyzer. The cycle time is set in the configurator.

Externally controlled start

For external starting of the automatic calibration, a control signal is required at the digital input DI1 'Start automatic calibration' on the digital I/O module 1 (default configuration).

Control signal requirements:

Refer to **Digital I/O module** on page 99.

The control signal must be present for at least 1 s.

To stop the automatic calibration externally, another digital input must be configured.

The control signal must fulfill the same requirements as the signal for the external start.

Automatic calibration can also be started and stopped via Modbus.

Manual Start

The automatic calibration can be manually started on the display and control unit.

Refer to **Automatic calibration: manual start** on page 125.

Blocking automatic calibration

To block automatic calibration, a control signal (high level) at the digital input DI2 'Block automatic calibration' on the Digital I/O module 1 (default configuration) is needed.

- As long as the control signal is present (high level), automatic calibration is blocked.
- If the control signal is activated at a point in time at which a cyclically controlled automatic calibration would start, this calibration will be suppressed.
 - In this case, the automatic calibration is triggered immediately after switching to the low level.
 - if the automatic calibration cycle set in the configurator is not affected by this, the interval to the next automatic calibration will then be shorter.
- Powering up the control signal causes an ongoing automatic calibration to be aborted. After switching the control signal to low level, the next automatic calibration takes place according to the cycle time set in the configurator.

Control signal requirements:

Refer to **Digital I/O module** on page 99.

The control signal must be present for at least 1 s.

Automatic calibration can also be blocked via the Modbus.

Process display

The status icon  appears on the LCD display during automatic calibration, see **Status Icons** on page 110.

The status message 'Autocalibration running' is active and the status signal 'Function check' is set.

Note

- The automatic calibration must not be triggered while the gas analyzer is being operated using the test and calibration software Optima TCT Light.
- When an automatic calibration is running, it is not possible to perform a manual calibration, measure a calibration cell, perform a calibration reset and operate the pump.

Automatic calibration: settings

Menu path

► Setup / ► Calibration Data / ▲ Autocal. Settings'

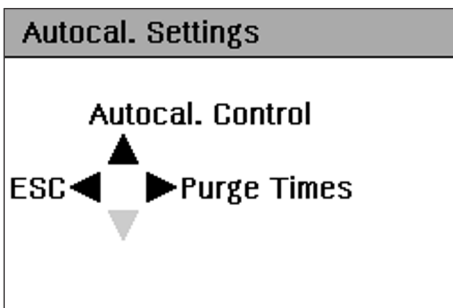

Figure 60: 'Auto Calibration -settings' menu

Settings in the configurator and in the device

All automatic calibration parameters can be set in the configurator.

Part of the settings can also be made directly on the device.

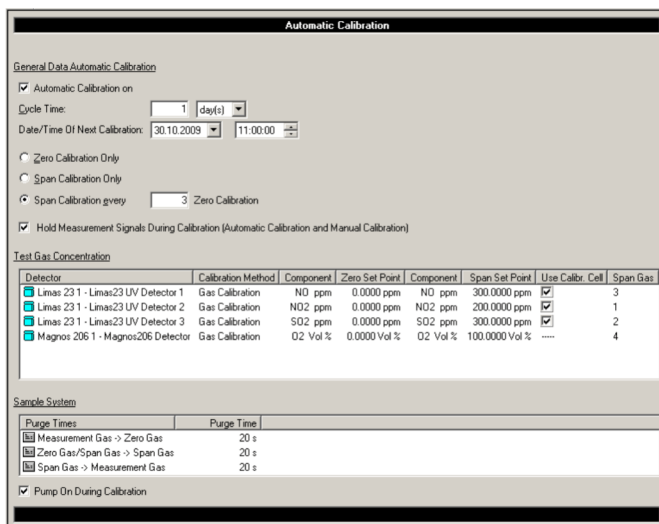

Figure 61: The 'Automatic Calibration' menu in the ECT configurator

Controlling the automatic calibration

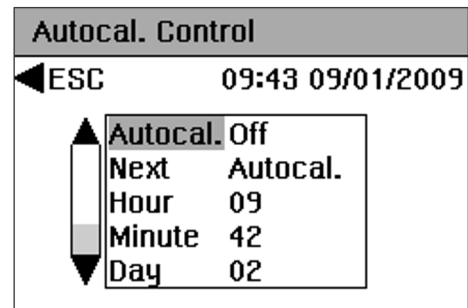

Figure 62: 'Automatic calibration Control' menu

Activation

Automatic calibration is completed only when it is activated. This 'Open' setting is valid for the cyclically time-controlled start of the automatic calibration; it does not refer to the externally controlled or manual start.

Cycle time

The cycle time must be set in the configurator. The cycle time shows the time intervals over which automatic adjustment is completed.

Date and time of next automatic calibration

The analyzer system completes the next automatic calibration at the time specified here.

From this moment in time, the cycle period starts to run.

End-point calibration together with zero point calibration

In the configurator, it is necessary to set the cycles in which an end-point calibration is to be performed together with a zero point calibration.

Example:

End-point calibration for each 7th zero-point calibration
With a cycle time of 24 hours, this setting initiates a zero point calibration every day and a end-point calibration once a week.

Note

If the automatic calibration is started manually, a zero point and end-point calibration is always performed; the configured cycle for time-controlled calibration is therefore unaffected.

... 9 Calibration

... Automatic calibration: settings

Output current response

In the configurator, you need to set whether during the calibration process, the signals at the current outputs (analog outputs) are held at the last measured value before the calibration was started or if they follow the measured value changes during calibration.

If the current signals are configured to 'Hold', the limit value monitor is not active during the calibration.

Setting the output current response is effective for both automatic and manual calibration.

Uras26 and Limas23: Automatic calibration with or without calibration cells

If the Uras26 or Limas23 analyzer is equipped with calibration cells, automatic calibration using calibration cells is enabled by default.

If automatic calibration with calibration cells is deactivated in the configurator for individual sample components and if calibration should be performed with test gases instead, the following must be observed:

- The test gases for zero point and end-point calibration must be connected via solenoid valves; control of the solenoid valves via digital outputs must be configured (see **Configuring signal inputs and outputs** on page 154).
- Automatic calibration is performed in the following steps:
 1. The zero point gas is connected in and all sample components are calibrated at the zero point.
 2. The zero point gas remains connected and the sample components with the activated calibration cell are calibrated at the end-point.
 3. The span gases are connected and the sample components with the deactivated calibration cells are calibrated at the end-point.

In the process, the span gas valves are switched in the sequence specified in the configurator in dialog 'Automatic Calibration' column 'Span Gas Valve' (1 to 5).

Oxygen sensor

If an electrochemical oxygen sensor is installed in the gas analyzer together with the Uras26 or Limas23 analyzer, you need to configure how the end-point calibration of the oxygen sensor is carried out:

End-point calibration	Entry in 'Span gas valve' column
With zero point gas during zero point calibration	0
With test gas during end-point calibration	1 to 5, depending on which span gas valve is used to connect the test gas (oxygen)

Gas feed system

Autocal. Purge Times	
◀	ESC
▲	Meas→Cal Gas 020sec.
	Zero→Span Gas 020sec.
▼	Cal→Meas Gas 020sec.

Figure 63: 'Automatic calibration purge times'

Purge times

The purge time settings for each calibration phase determines the time

- after switching from sample gas to zero point gas until the start of zero point calibration,
- after switching from zero point gas to end-point gas or between the end-point gases until the start of end-point calibration, and
- after switching from end-point gas to sample gas until the 'Function check' status signal disappears

so that gas residues do not distort the calibration or the measurement result.

The total purge time for each phase is the sum of each purge time set plus a maximum $4 \times$ the longest set low pass time constant, see **Set low-pass time constant** on page 150.

Note

The purge time should be set to at least three times the T_{90} -time of the **entire** analyzer system.

Pump

It must be set whether the built-in pump ('Integral gas feed' option – in model EL3020 only, not for Limas23, ZO23, Fidas24) is set to on or off during automatic calibration.

... 9 Calibration

... Automatic calibration: settings

Calibration method (automatic)

Analyzer	Calibration method	Remark
Uras26	Zero point / end-point calibration	Cannot be changed.
Limas23	Zero point / end-point calibration	Cannot be changed.
Magnos206	Zero point / end-point calibration or substitute gas calibration or single-point calibration	If a substitute gas component is set up in the Magnos206 analyzer, the calibration method is factory-set to substitute gas calibration, otherwise the zero point / end-point calibration is set. Alternatively, single-point calibration can be selected. See also page 132.
Magnos28	Zero point / end-point calibration or substitute gas calibration or single-point calibration	If a substitute gas component is set up in the Magnos28 analyzer, the calibration method is factory-set to substitute gas calibration, otherwise the zero point / end-point calibration is set. Alternatively, single-point calibration can be selected. See also page 133.
Magnos27	Zero point / end-point calibration or substitute gas calibration	If a substitute gas component is set up in the Magnos27 analyzer, the calibration method is factory-set to substitute gas calibration, otherwise the zero point / end-point calibration is set. See also page 135.
Caldos27	Zero point / end-point calibration or single-point calibration	With standard gas, this cannot be changed.
Fidas24	Substitute gas calibration	Cannot be changed.
Oxygen sensor	Single-point calibration	Cannot be changed.

Automatic calibration: manual start

Menu path

▲ Operation / ▲ Calibration / ► Automatic Calibration'

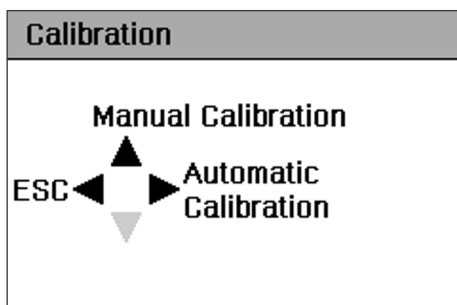

Figure 64: 'Calibration' Menu

Wait until the warm-up phase has ended

Analyzer module may not be calibrated until the warm-up phase has ended.

Duration of the Warm-up Phase

Analyzer	Duration of the Warm-up Phase
Uras26	Without thermostat: approx. ½ h With thermostat: approx. 2 h
Limas23	Approx. 2 hours
Magnos206	< 1 hours
Magnos28	< 5 h, The value may be elevated during first commissioning or after a longer service life.
Magnos27	2 to 4 h
Caldos27	Approx. ½ h
Fidas24	Approx. 2 hours
ZO23	approx. 2 h, see for detailed information ZO23 – Commissioning the gas analyzer on page 106.

Manually starting the automatic calibration

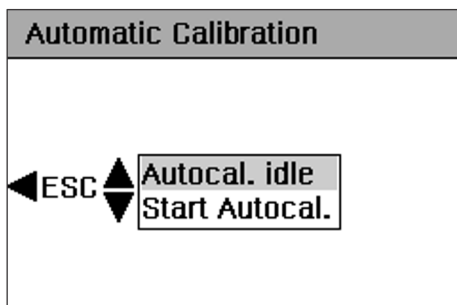

Figure 65: Menu 'Automatic Calibration

Manually aborting the automatic calibration

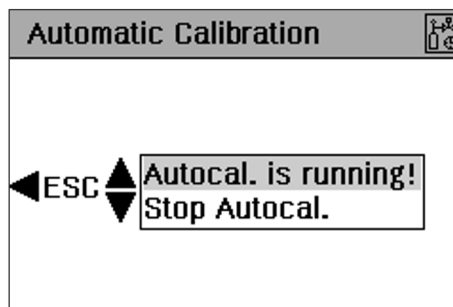

Figure 66: Menu 'Automatic Calibration

Note

When automatic calibration is aborted, the analyzer module is in an undefined state (in reference to the calibration).

For example, the zero point calibration may have been completed and calculated, but the end-point calibration has not yet been carried out. For this reason, automatic calibration will have to be restarted and allowed to run to completion after any cancellation of automatic calibration.

Manual calibration: calibration method

Menu path

► Setup / ► Calibration Data / ▼ Manual Cal. Method'

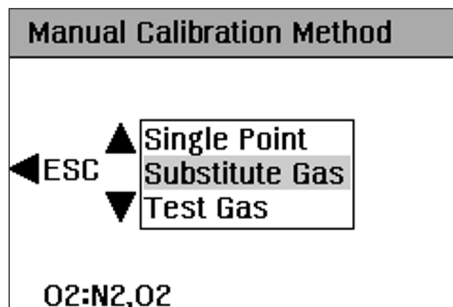

Figure 67: 'Manual calibration method' menu

The calibration method can also be set in the Configurator.

... 9 Calibration

... Manual calibration: calibration method

Calibration method (manual)

Analyzer	Calibration method	Remark
Uras26	Zero point / final point calibration (test gas)	Cannot be changed.
Limas23	Zero point / final point calibration (test gas)	Cannot be changed.
Magnos206	Zero point / final point calibration (test gas) or Substitute gas or single point calibration	If a substitute gas component is set up in the Magnos206 analyzer, the calibration method is factory-set to substitute gas calibration, otherwise the zero point / end-point calibration (test gas) is set. Alternatively, single-point calibration can be selected. See also page 132.
Magnos28	Zero point / final point calibration (test gas) or Substitute gas or single point calibration	If a substitute gas component is set up in the Magnos28 analyzer, the calibration method is factory-set to substitute gas calibration, otherwise the zero point / end-point calibration (test gas) is set. Alternatively, single-point calibration can be selected. See also page 133.
Magnos27	Zero point / final point calibration (test gas) or Substitute gas calibration	If a substitute gas component is set up in the Magnos27 analyzer, the calibration method is factory-set to substitute gas calibration, otherwise the zero point / end-point calibration (test gas) is set. See also page 135.
Caldos27	Zero point / final point calibration (test gas) or Single-point calibration	Factory set or With standard gas
Fidas24	Substitute gas calibration	Factory set
Oxygen sensor	Zero point / end-point calibration	Cannot be changed, the oxygen sensor is only calibrated at the end point. See also page 142.

Manual calibration: execution

Menu path

▲ Operation / ▲ Calibration / ▲ Manual Calibration*

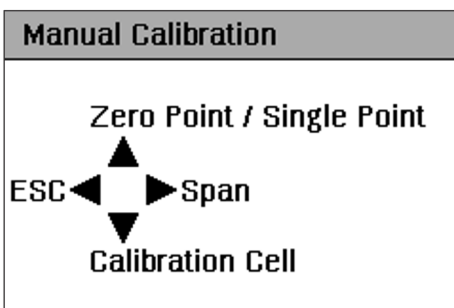

Figure 68: 'Manual calibration' menu

Wait until the warm-up phase has ended

Analyzer module may not be calibrated until the warm-up phase has ended.

Duration of the Warm-up Phase

Analyzer	Duration of the Warm-up Phase
Uras26	Without thermostat: approx. ½ h With thermostat: approx. 2 h
Limas23	Approx. 2 hours
Magnos206	< 1 hours
Magnos28	< 5 h, The value may be elevated during first commissioning or after a longer service life.
Magnos27	2 to 4 h
Caldos27	Approx. ½ h
Fidas24	Approx. 2 hours
ZO23	approx. 2 h, see for detailed information ZO23 – Commissioning the gas analyzer on page 106.

Note

- Zero-point calibration must always precede end-point calibration. Zero-point calibration can also be performed on its own.
- Manual calibration cannot be performed while an automatic calibration is in progress.

Manually calibrating measurement components

Zero point / single point calibration

1. Select the 'Zero Point / Single Point' menu.
2. Select individual sample components or 'All' (according to the configuration in the 'Manual Calibration' ECT dialog).
3. Check zero point set point* and set if necessary.
4. Connect zero point gas (if it is not automatically connected).
5. Once the measured value display is stable, start the calibration.
6. Save calibration or repeat calibration**.

End-point calibration

1. Select the 'Span' menu.
2. Select the Sample component.
3. Check end point set point* and set if necessary.
4. Connect end-point gas (if it is not automatically connected).
5. Once the measured value display is stable, start the calibration.
6. Save calibration or repeat calibration.

End-point calibration with calibration cell (option with Uras26 and Limas23)

1. Select the 'Calibration Cell' menu.
2. Select sample component or 'All' (only possible with Uras26).
3. Connect zero point gas (if it is not automatically connected).
4. Once the measured value display is stable, start the calibration.
5. Save calibration or repeat calibration.

* The parameterized test gas concentration is displayed. If the setpoint is altered here, the parameterized test gas concentration is overwritten.

** A calibration may have to be repeated if the measured value is still not stable after initiation of the calibration. The repeated calibration is based on the measured value obtained in the preceding calibration.

... 9 Calibration

Uras26 – Instructions for calibration

Calibration methods

- Automatic calibration:
zero point/end-point calibration
- Manual calibration:
zero point/end-point calibration

Calibration Cells

The use of calibration cells (option) allows the end-point calibration of the Uras26 without using test gas containers.

A calibration cell is installed in each beam path of the analyzer in accordance with the order. Each calibration cell is filled with a test gas, the composition and concentration of which is adapted to the sample components and measuring ranges, which are set up in the respective beam path.

The calibration cells are retracted into the beam path during the end-point calibration.

Information about the installed calibration cells is included in the device data sheet.

The concentration set points of the test gases in the calibration cells should be checked at large intervals (see **Uras26, Limas23 – measuring the calibration cell** on page 181) (recommended: once a year).

Manual Calibration

In the 'Manual Calibration' you need to select if each sample component should be calibrated individually or all sample components jointly during the zero point calibration of the Uras26.

You also need to select if the end-point calibration of the Uras26 is done with calibration cells or with test gases.

Calibration of the Uras26 together with Magnos206 or Magnos28 or Caldos27 or oxygen sensor

Automatic calibration

When performing a zero point calibration of the Uras26, a single-point calibration of the Magnos206 (see **Single-point calibration** on page 132) or the Magnos28 (see **Single-point calibration** on page 133) or Caldos27 (see **Single-point calibration** on page 136) or oxygen sensor (see **Calibration methods** on page 142) (if configured) is performed at the same time. The test gas must be selected accordingly.

Manual Calibration

For the Uras26 (infrared) sample components, the zero point/end-point calibration is fixed as the calibration method. The calibration method for the (non-infrared) measurement component of the Magnos206 or Magnos28 or Caldos27 needs to be configured.

With manual calibration, you can select whether the single-point calibration should be carried out individually or together with the zero-point calibration of the Uras26.

Uras26 calibration with internal cross-sensitivity correction

During the calculation of the calibration, possible electronic cross-sensitivity corrections are switched off by other sample components measured with the Uras26.

The following information should therefore be noted in particular: The following information should therefore be noted in particular:

Zero-point calibration

All the sample components must always be calibrated in the following sequence for the zero point calibration:

- First the sample component which is not corrected.
- afterwards the sample component which is affected by the smallest number of corrections.
- up to the sample component which is affected by the largest number of corrections.

End-point calibration

All the sample components must also always be calibrated in the end-point calibration.

Here, a corrected sample component may only be calibrated using a test gas contain no components which cause cross-sensitivity, i.e. which only consists of the sample component and an inert gas, such as N₂.

Test gases – Uras26

Analyzer(s)	Test gas for the zero calibration	Test gas for the end-point calibration
Uras26 with calibration cells (automatic calibration)	N ₂ or air or sample component-free gas	— (calibration cells)
Uras26 without calibration cells (automatic calibration)	N ₂ or air	Span gas*
Uras26 without calibration cells (manual calibration)	N ₂ or air	Test gas for each sample component
Uras26 + Magnos206 / Magnos28 (automatic calibration, i.e. Magnos206 / Magnos28 with single-point calibration)	IR sample component-free test gas with O ₂ concentration in an existing measuring range or ambient air.	Calibration cells or span gas*
Uras26 + Magnos206 / Magnos28 (manual calibration)	Zero point gas for Uras26 or Magnos206 / Magnos28, or for single-point calibration for Magnos206 / Magnos28, IR sample component-free test gas with O ₂ concentration in an existing measuring range or ambient air.	Span gas for all sample components in the Uras26 and in the Magnos206 / Magnos28 (possibly only for the Uras26 if a single-point calibration is carried out for the Magnos206 / Magnos28)
Uras26 + Magnos27 (automatic calibration)	IR sample component-free test gas with O ₂ concentration in an existing measuring range or ambient air.	Calibration cells or span gas*
Uras26 + Magnos27 (manual calibration)	Zero point gas for Uras26 or Magnos27, or IR sample component-free test gas with O ₂ -concentration in an existing measuring range or ambient air.	Span gas for all sample components in Uras26 and Magnos27
Uras26 + Caldos27 (automatic calibration, i.e. Caldos27 with single-point calibration)	IR sample component-free test gas with a known and constant rTC value (possibly also dried room air)	Calibration cells or span gas*
Uras26 + Caldos27 (manual calibration)	Zero reference gas for Uras26 or Caldos27, or IR sample component-free test gas with a known rTC value	Span gas for all sample components in the Uras26 and Caldos27 (possibly only for the Uras26 if a single-point calibration is carried out for the Caldos27)
Uras26 + oxygen sensor (automatic calibration)	IR sample component-free test gas with O ₂ concentration in an existing measuring range or ambient air.	Calibration cells or span gas*
Uras26 + Oxygen sensor (manual calibration)	IR sample component-free test gas with O ₂ concentration in an existing measuring range or ambient air.	Span gas for all sample components in Uras26

* Test gas mixture for multiple sample components possible if no or negligible cross-sensitivity is present

Dew point

The dew point of the test gases must be approximately equal to the dew point of the sample gas.

... 9 Calibration

Limas23 – Instructions for calibration

Calibration methods

- Automatic calibration:
zero point/end-point calibration
- Manual calibration:
zero point/end-point calibration

Calibration Cells

The use of calibration cells (option) allows the end-point calibration of the Limas23 without the need to use test gas containers.

There is a calibration cell available for each measured component. It is filled with a test gas; its concentration is matched with the measuring range of the measured component. The calibration cells are located on the calibration wheel, which is installed before the sample detector. The calibration cells are retracted into the emission path during the end-point calibration.

Information about the installed calibration cells is included in the device data sheet.

The concentration set points of the test gases in the calibration cells should be checked at large time intervals (see **Uras26, Limas23 – measuring the calibration cell** on page 181) (recommended: once a year).

Manual Calibration

In the 'Manual calibration' menu, you choose whether during the end-point calibration of Limas23 all measured components are calibrated together (typical case) or if each measured component is calibrated individually (special case).

You also need to select whether the end-point calibration of the Limas23 is done with calibration cells or with test gases.

Calibration of the Limas23 together with Magnos206 or Magnos28 or oxygen sensor

Automatic calibration

When performing a zero point calibration of the Limas23, a single-point calibration of the Magnos206 (see **Single-point calibration** on page 132) or the Magnos28 (see **Single-point calibration** on page 133) or the oxygen sensors (see **Calibration methods** on page 142) (if configured) runs at the same time.

The test gas must be selected accordingly.

Manual Calibration

For the Limas23 sample components, the zero point/end-point calibration is fixed as the calibration method.

The calibration method for the measurement component of the Magnos206 or Magnos28 needs to be configured.

When single-point calibration is configured, it is possible to choose during manual calibration whether this sample component should be calibrated individually or together with the Limas23 sample components.

Limas23 calibration with internal cross-sensitivity correction

During the calculation of the calibration, possible electronic cross-sensitivity corrections are switched off by other sample components measured with the Limas23.

The following information should therefore be noted in particular: The following information should therefore be noted in particular:

Zero-point calibration

All the available sample components must also always be calibrated during end-point calibration.

When performing the calibration, all measured components are normally calibrated together ('All' menu selection).

In special cases, each sample component must be calibrated individually in the following order:

1. the sample component which is not corrected
2. the sample component which is affected by the smallest number of corrections,
3. the sample component which is affected by the largest number of corrections.

Example:

Sample components	NO, SO ₂ , NO ₂
Cross-sensitivity correction Cross-sensitivity correction	NO by SO ₂ and NO ₂ , SO ₂ by NO ₂ , NO ₂ is not corrected
Resulting sequence for zero-point calibration	1. NO ₂ 2. SO ₂ 3. NO

End-point calibration

All the available sample components must also always be calibrated during the end-point calibration.

Here, a corrected sample component may only be calibrated using a test gas contain no components which cause cross-sensitivity, i.e. which only consists of the sample component and an inert gas, such as N₂.

Test gases – Limas23

Analyzer(s)	Test gas for the zero calibration	Test gas for the end-point calibration
Limas23 with calibration cells (automatic calibration)	N ₂ or air or UV sample component-free gas	Calibration cells or test gas for each sample component
Limas23 without calibration cells (automatic calibration)	N ₂ or air or UV sample component-free gas	Test gas for each sample component
Limas23 without calibration cells (manual calibration)	N ₂ or air or UV sample component-free gas	Test gas for each sample component
Limas23 + Magnos206 / Magnos28 or oxygen sensor with calibration cells (automatic calibration, i.e. Magnos206 / Magnos28 with single-point calibration)	N ₂ or oxygen and UV sample component-free gas	Either calibration cells and test gas for oxygen detector or test gas for each sample component or for each detector
Limas23 + Magnos206 / Magnos28 or oxygen sensor without calibration cells (automatic calibration)	N ₂ or oxygen and UV sample component-free gas	Test gas for each sample component or for each detector
Limas23 + Magnos206 / Magnos28 or oxygen sensor without calibration cells (manual calibration)	N ₂ or oxygen and UV sample component-free gas	Test gas for each sample component or for each detector

Dew point

The dew point of the test gases must be approximately equal to the dew point of the sample gas.

... 9 Calibration

Magnos206 – notes for calibration

Calibration methods

- Automatic calibration:
zero point/end-point calibration or substitute gas calibration (factory-set if the substitute gas component is set up) or single point calibration
- Manual calibration:
Zero point/end-point calibration or substitute gas calibration (factory-set if the substitute gas component is set up) or single point calibration

Substitute gas calibration

If the test gases for the calibration are not available, e.g. because they cannot be filled in test gas bottles or because their components are not compatible with one another, the Magnos206 can be factory-set in accordance with the order for calibration with a substitute gas.

In addition to the measuring range of the sample component, a measuring range for the substitute gas component is then set up at the factory; normally this is O₂ in N₂. This setting is documented in the device data sheet.

Substitute gas calibration is a zero point / end-point calibration of the substitute gas component. The zero points and end points of the measuring ranges of all sample components in Magnos206 are then corrected electronically by the values established during the calibration.

Note

- If the analyzer is set to calibration with a substitute gas, the substitute gas calibration must always be carried out in order to calibrate all sample and substitute gas components.
- A zero point/end point calibration either only in the sample components or in the substitute gas measuring ranges results in an erroneous calibration of the analyzer module.

Test gases – Magnos206

Analyzer	Test gas for zero point calibration and single-point calibration	Test gas for the end-point calibration
Magnos206	Oxygen-free process gas	Process gas with a known O ₂ concentration
Magnos206 suppressed measuring range	<ul style="list-style-type: none"> • Zero point calibration: pure nitrogen or hydrogen-free operating gas • Single-point calibration: 100 Vol.-% O₂ or test gas with O₂ concentration in the measuring range 	Test gas with O ₂ concentration near the end point of the measuring range
Magnos206 with single-point calibration	Test gas with O ₂ concentration in an existing measuring range or ambient air.	—
Magnos206 with substitute gas calibration	Oxygen-free process gas or substitute gas (O ₂ in N ₂)	Substitute gas, for example dried air

Dew point

The dew point of the test gases must be approximately equal to the dew point of the sample gas.

Single-point calibration

Magnos206 long-term sensitivity drift is less than 0.25 % of measured value per year.

Therefore, in measuring ranges from 0 to 5 vol.-% to 0 to 100 vol.-% O₂, it is sufficient to perform an offset correction routinely only.

This so-called single-point calibration can be done at any point of the characteristic curve as this causes a parallel shift of the characteristic curve.

It is recommended to additionally perform an end-point calibration at least once a year, depending on the measurement task.

Note

Sensitivity drift can be short-term up to 1 % of the measured value per week.

Suppressed measuring ranges

If suppressed measuring ranges are set up in the Magnos206 analyzer with a suppression ratio greater than 1:5, then a special adjustment of the standard built-in pressure sensor has been made at the factory; in this case, no substitute gas calibration has been set up in the analyzer.

Highly suppressed measuring ranges ≥ 95 to 100 Vol.-% O₂ should be calibrated for maximum possible accuracy with N₂ at the zero point and 100 Vol.-% O₂ at the end point.

Single-point calibration is also preferable with 100 Vol.-% O₂ or a test gas concentration within the measuring range is possible.

Magnos28 – notes for calibration

Calibration methods

- Automatic calibration:
zero point/end-point calibration or substitute gas calibration (factory-set if the substitute gas component is set up) or single point calibration
- Manual calibration:
Zero point/end-point calibration or substitute gas calibration (factory-set if the substitute gas component is set up) or single point calibration

Substitute gas calibration

If the test gases for the adjustment are not available, e.g. because they cannot be filled in test gas bottles or because their components are not compatible with one another, the Magnos28 can be set at the factory for calibration with a substitute gas in accordance with the order.

In addition to the measuring range of the sample component, a measuring range for the substitute gas component is then set up at the factory; normally this is O₂ in N₂. This setting is documented in the device data sheet.

Substitute gas calibration is a zero point / end-point calibration of the substitute gas component.

The zero and final points of the measuring ranges of sample components in Magnos28 are then corrected electronically by the values established during this calibration.

Note

- If the analyzer is set to calibration with a substitute gas, the substitute gas calibration must always be carried out in order to calibrate all sample and substitute gas components.
- A zero point/end point calibration either only in the sample components or in the substitute gas measuring ranges results in an erroneous calibration of the analyzer module.

Single-point calibration

The long-term sensitivity drift of the Magnos28 is less than 0.15 % of measured value per three months (at least 0.03 vol. % O₂ per three months).

Therefore, in measuring ranges from 0 to 5 vol.-% to 0 to 100 vol.-% O₂, it is sufficient to perform an offset correction routinely only.

This so-called single-point calibration can be done at any point of the characteristic curve as this causes a parallel shift of the characteristic curve.

It is recommended to additionally perform an end-point calibration at least once a year, depending on the measurement task.

Note

Sensitivity drift can be short-term up to 1 % of the measured value per week.

Suppressed measuring ranges

If suppressed measuring ranges are set up in the Magnos28 analyzer with a suppression ratio greater than 1:5, then a special adjustment of the standard built-in pressure sensor has been made at the factory; in this case, no substitute gas calibration has been set up in the analyzer.

Highly suppressed measuring ranges ≥ 95 to 100 Vol.-% O₂ should be calibrated for maximum possible accuracy with N₂ at the zero point and 100 Vol.-% O₂ at the end point. Single-point calibration is also preferable with 100 Vol.-% O₂ or a test gas concentration within the measuring range is possible.

... 9 Calibration

... Magnos28 – notes for calibration

Test gases – Magnos28

Analyzer	Test gas for zero point calibration and single-point calibration	Test gas for the end-point calibration
Magnos28	Oxygen-free process gas	Process gas with a known O ₂ concentration
Magnos28 with a suppressed measuring range	<ul style="list-style-type: none"> • Zero point calibration: pure nitrogen or hydrogen-free operating gas • Single-point calibration: 100 Vol.-% O₂ or test gas with O₂ concentration in the measuring range 	Test gas with O ₂ concentration near the end point of the measuring range, or pure oxygen
Magnos28 with single-point calibration	Test gas with O ₂ concentration in an existing measuring range or ambient air.	—
Magnos28 with substitute gas calibration	Oxygen-free process gas or substitute gas (O ₂ in N ₂)	Substitute gas, for example dried air
Magnos28 + Caldos27 (manual calibration)	In addition to the above mentioned test gases for Magnos28, additional test gases are needed for the calibration of Caldos27. The requirements are shown in the table in section Test gases – Caldos27 on page 34.	
Magnos28 + Caldos27 (automatic calibration)	See the table in section Test gases – Caldos27 on page 34 for instructions on test gases and possible limitations in automatic calibration.	

Dew point

The dew point of the test gases must be approximately equal to the dew point of the sample gas.

Magnos27 – notes for calibration

Calibration methods

- Automatic calibration:
zero point/end-point calibration or substitute gas calibration
(factory-set if the substitute gas component is set up)
- Automatic calibration:
zero point/end-point calibration or substitute gas calibration
(factory-set if the substitute gas component is set up)

Substitute gas calibration

If the test gases for the adjustment are not available, e.g. because they cannot be filled in test gas bottles or because their components are not compatible with one another, the Magnos27 can be set at the factory for calibration with a substitute gas in accordance with the order.

In addition to the measuring range of the sample component, a measuring range for the substitute gas component is then set up at the factory; normally this is O₂ in N₂. This setting is documented in the device data sheet.

Substitute gas calibration is a zero point / end-point calibration of the substitute gas component.

The zero points and end points of the measuring ranges of sample components in Magnos27 are then corrected by the values established during this calibration.

Note

- If the analyzer is set to calibration with a substitute gas, the substitute gas calibration must always be carried out in order to calibrate all sample and substitute gas components.
- A zero point/end point calibration either only in the sample components or in the substitute gas measuring ranges results in an erroneous calibration of the analyzer module.

Tests gases – Magnos27

Analyzer	Test gas for the zero calibration	Test gas for the end-point calibration
Magnos27	Oxygen-free process gas	Process gas with a known O ₂ concentration
Magnos27 with substitute gas calibration	Oxygen-free process gas or substitute gas (O ₂ in N ₂)	Substitute gas, for example dried air

Dew point

The dew point of the test gases must be approximately equal to the dew point of the sample gas.

... 9 Calibration

ZO23 – Checking the reference point and end point

Checking the end point

We recommend checking the end point approx. 4 weeks after commissioning.

Further checks of the end-point should be carried out as required.

Checking the reference point

It is recommended that the reference point is checked once a year or as required.

Test gases

Reference point (electric zero point)

Clean ambient air;

its oxygen concentration is obtained from the dry air value and the factor for consideration of the water vapor content.

Example:

Water vapor content at 25 °C and 50 % relative humidity =

1.56 Vol.-% H₂O ⇒ Factor 0.98

Oxygen concentration =

20.93 vol. % O₂ × 0.98 = 20.6 Vol.-% O₂

End position

Test gas with oxygen concentration in the smallest measurement range (for example, 2 ppm O₂ in N₂).

Note

The pressure conditions at the reference point and the end point must be identical.

Caldos27 – Notes for calibration

Calibration methods

- Automatic calibration:
single-point calibration
- Manual calibration:
zero point/end point calibration (factory-set) or single point calibration

Single-point calibration

Due to the operating principle of the sensor in the Caldos27 analyzer, the zero point and end point do not drift independently.

Therefore routine calibration of the Caldos27 can be performed as a so-called single-point calibration using standard gas.

This technique leaves out safety- related measurements.

Depending on the measurement task involved, the zero point and end point should be checked periodically (recommendation: once a year).

Standard gas

The 'Standard gas' component is always configured as the last of the maximum five sample components (see **Active component selection** on page 151) in Caldos27

Single-point calibration with standard gas affects all other sample components configured in Caldos27

At the factory, a standard gas N₂ with the measured value 10000 rTC is set.

If another standard gas is used during manual calibration, its rTC set point must be entered as the calibration progresses.

Standard gas	rTC set point
N ₂	10000 rTC
Air	10070 rTC
Ar	7200 rTC
CO ₂	7500 rTC
CH ₄	14000 rTC
He	50000 rTC
H ₂	60000 rTC

After the standard gas has been changed, the zero point and end point of the sample components configured in Caldos27 must be checked and recalibrated, if necessary.

Associated gas effect

The Caldos27 analyzer measurement technique is based on the differing thermal conductivity of various gases.

Since this technique is non-selective, the concentration of a sample component can be accurately measured only in a binary or quasi-binary gas mixture.

If other associated gas components are present in the sample gas their effect on initial factory calibration must be considered.

Test gases – Caldos27

Analyzer	Test gas for zero point calibration and single-point calibration	Test gas for the end-point calibration
Caldos27	Sample component-free test gas or process gas	Test gas or process gas with a known sample component concentration
Caldos27 with a suppressed measuring range	Test gas with a sample component concentration near the starting point of the measuring range	Test gas with a sample component concentration near the end point of the measuring range
Caldos27 with single-point calibration	Test gas with a known and constant rTC value (standard gas; possibly also dried room air)	—
Caldos27 + Magnos28 (manual calibration)	In addition to the above mentioned test gases for Caldos27, additional test gases are needed to calibrate Magnos28. The requirements are provided in the table in Test gases – Magnos28 on page 28.	
Caldos27 + Magnos28 (automatic calibration)	Same as manual calibration, with the following limitation: Zero point and single point calibrations are performed for all sample components simultaneously, since for this purpose, only one common digital output can be used for valve control (unlike with end point calibration) for this purpose (Automatic calibration: settings on page 121). This results in limitations with regard to the possible test gases, which in particular depend on the configuration of the <ul style="list-style-type: none"> • Measurement components • Measuring ranges • Gas paths (series or isolated) Depending on these conditions, certain automatic calibration methods cannot be performed in a practical sense.	As in the case with manual calibration, a separate end point gas valve must be available for each sample component without a single point calibration, which is controlled via a correspondingly configured digital output (Automatic calibration: settings on page 121).

Dew point

The dew point of the test gases must be approximately equal to the dew point of the sample gas.

... 9 Calibration

Fidas24 – Notes for calibration

Sample components and measurement ranges

The Fidas24 analyzer has always at least 1 sample component with 2 measuring ranges.

Up to 4 sample components with up to 2 measuring ranges are possible for each measuring component.

Setting measuring ranges

The measuring ranges are factory-set per customer order.

The measuring range can be varied as follows depending on the adjusted amplification:

- Small amplification: from 10000 ppm C1 to 100 ppm C1
- Large amplification:: from 3000 ppm C1 to 10 ppm C1

The smallest measuring range is 0 to 5 mg org. C/m³ corresponding to 0 to 10 ppm CH₄.

Note

The associated amplification levels are set at the factory during calibration. They can only be changed using the Optima TCT Light test and calibration software.

Test gases

Test Gases for Zero Calibration

Quality	Nitrogen, Quality 5.0, synthetic air or catalytically cleaned air with an organic C < 1 % MBU
Inlet pressure p _e	Depressurized
Flow rate	At least 20 l/h more than the sample gas flow

Test gases for endpoint calibration

Quality	Test gas in nitrogen or synthetic air with concentration adjusted to the measuring range
Inlet pressure p _e	Depressurized
Flow rate	At least 20 l/h more than the sample gas flow

Zero point offset

If the zero point gas is not completely free of hydrocarbons (even purified nitrogen contains fractions of hydrocarbons), negative measured values may be displayed in small measuring ranges.

In this case, the sample gas contains a lower proportion of hydrocarbons than the zero point gas.

Test gas supply

The test gases for the zero and span calibration must be fed in via solenoid valves; the test gases are connected automatically by means of the integral valves.

If the test gas is connected at the sample gas inlet the zero gas and span inlet gas must be sealed.

Test gas flow monitoring (pressure switch)

Test gas pressure and Test gas flow

If the test gas pressure is set in such a way that the test gas flow at the sample gas inlet complies with the gas inlet conditions (130 to 250 l/h), then the test gas surplus flows in the direction of the gas sampling point and thus prevents sample gas fractions from falsifying the calibration result.

If the test gas is fed directly at the sample gas inlet, see **Fidas24 – Connect gas lines** on page 88, it must also be supplied in depressurized state with an excess (130 to 250 l/h).

Test gas flow monitoring during automatic calibration (pressure switch)

If the test gases are connected at the separate test gas inlets, the built-in pressure switch can be activated during automatic calibration to monitor the flow of the test gases.

If the flow is insufficient, calibration is stopped.

The pressure switch can be activated for

- Zero point gas
- end-point gas and
- zero point and end-point gas
-

The activation of the pressure switch is configured using the ECT software tool in the 'Automatic Calibration' dialog.

Test gas connection at the sample gas inlet during manual calibration

If the test gas is connected directly at the sample gas inlet during manual calibration, when the pressure switch is activated the following message appears in the LCD display:

'Error. Pressure switch has not detected any calibration gas!'

Check test gas flow and repeat calibration with ►.

This message can be bypassed by pressing ▲ **ESC**.

Wait until the warm-up phase has ended

Analyzer module may not be calibrated until the warm-up phase has ended.

Fidas24 – Substitute gas calibration

Example

Substitute gas calibration in the Fidas24 is described using the 'Acetone measurement in room air' example.

Acetone measurement in room air

Acetone (C_3H_6O) in higher concentrations cannot be filled in test gas containers.

For this reason, the analyzer module is factory-set for calibration with the substitute gas propane (C_3H_8) in N_2 .

Measuring ranges

Component	Measuring range	Range
Component 1 C_3H_6O in room air	Measuring range 1	0 to 10,000 ppm
Component 2 C_3H_8 in N_2 (substitute gas)	Measuring range 1	0 to 10,000 ppm

Calibration data

Calibration method	Substitute gas calibration	
Zero component*	Component 1 C_3H_6O	Measuring range 1 or
	Component 2 C_3H_8	Measuring range 1
Span component*	Component 1 C_3H_6O	Measuring range 1 or
	Component 2	Measuring range 1
	C_3H_8	

* We recommend that a zero point/end point calibration should be carried out with component 2, as the analyzer module is set for this at the factory.

Calibration

- Calibrate zero point with air (Component 1 or Component 2).
- Calibrate end point with test gas propane in N_2 .

Other measurement tasks

For other measurement tasks select the test gases and measurement ranges in a similar manner according to the sample gas composition.

... 9 Calibration

Fidas24 – Response factors and other relevant variables

Response factors

Definition

$$\text{Response factor} = \frac{\text{Measured value display}}{\text{Concentration}}$$

or

$$\text{Concentration} = \frac{\text{Measured value display}}{\text{Response factor}}$$

The response factor of Propane (C₃H₈) is equal to 1.00 in accordance with the definition.

Response factors for Fidas24 analyzer module

sample component		Response factor*
Toluol	C ₇ H ₈	0.95
Chlorobenzene	C ₆ H ₅ Cl	0.95
p-Xylol	C ₈ H ₁₀	0.92
Benzol	C ₆ H ₆	0.99
Ethylbenzene	C ₈ H ₁₀	0.92
Propane	C ₃ H ₈	1.00
n-Hexane	C ₆ H ₁₄	0.97
n-Octane	C ₈ H ₁₈	0.93
iso-Octane	C ₈ H ₁₈	1.04
Trichloroethylene	C ₂ HCl ₃	0.96
Tetrachloroethylene	C ₂ Cl ₄	1.00
Ethane	C ₂ H ₆	1.01
Butane	C ₄ H ₁₀	0.97
Methanol	CH ₃ OH	0.74
Butanol	C ₄ H ₉ OH	0.83
Acetic acid	C ₂ H ₄ O ₂	0.52
Dichloromethane	CH ₂ Cl ₂	1.00
Methane	CH ₄	1.13

* Measurement of the components in synthetic air

Note

The response factors for an individual analyzer module may differ slightly from the values indicated in the table.

Response factors for additional sample components

If a measuring component is added with a response factor which was not factory-set, we recommend determining this as follows:

$$\text{Response factor}_{\text{component}} = \frac{\text{Measured value display}_{\text{component}} \times \text{Test gas concentration}_{\text{propane}}}{\text{Measured value display}_{\text{propane}} \times \text{Test gas concentration}_{\text{component}}}$$

The following information should therefore be noted in particular:

- The zero point should not differ essentially from the calibrated zero point, in particular when measuring with small concentrations. Otherwise the measurement display must be offset against the deviation from the calibration of the zero point.
- The response factors of a gas in nitrogen and in synthetic air may differ considerably from each other.
- The measurements should always be performed with the same sample component and the same measuring range, for example THC in ppm C1. When calculating the test gas concentration, the number of C-atoms must be considered.
- Test gas cylinders with high accuracy (1 % and better) should be used.

Other relevant variables

The following variables must be stored in the software of the gas analyzer for each measuring component:

Molar mass, number of C-atoms, response factor and strip factor* (K factor).

- * Ratio of the concentration of a component in the water to the concentration of the same component in the gas flow after the strip event.

These variables are stored for the standard sample components; they must be entered when adding a user component.

Molar mass

$$M_C = 12.011 \text{ g/mol}$$

$$M_H = 1.008 \text{ g/mol}$$

Molar volumes

$$V_m = 22.414 \text{ l/mol for } 0 \text{ }^\circ\text{C and } 1013 \text{ hPa}$$

$$V_m = 24.05 \text{ l/mol for } 20 \text{ }^\circ\text{C and } 1013 \text{ hPa}$$

Fidas24 – Conversion of concentration data

Various units for concentration details

When measuring organic carbon compounds (total C) the concentration is indicated in various units.

The most important units are:

- mg C/m³ (e.g. for measurements in accordance with 17 BlmSchV)
- mg C_nH_m/m³
- ppm C_nH_m (e.g. for measurements in accordance with Federal German Regulations on Air Purity, details on test gas cylinders)
- ppm C1 (for THC or methane CH₄)

Examples for the conversion of units and concentration details

Conversion of ppm in mg C_nH_m/m³

$$\text{mg C}_n\text{H}_m/\text{m}^3 = \text{ppm} \times \frac{\text{Molar mass}}{V_m}$$

Conversion of ppm in mg C/m³

$$\text{mg C}/\text{m}^3 = \text{ppm} \times \frac{\text{Number of C atoms} \times M_c}{V_m}$$

Conversion ppm @ ppm C1

$$\text{ppmC1} = \text{ppm} \times \text{Number of C atoms}$$

Example 1

The analyzer module has a measuring range (MR) of 0 to 50 mg C/m³. As a test gas, propane (C₃H₈) in N₂ or in air is used.

What is the maximum test gas concentration in ppm or mg/m³ so that the measuring range is not up-scaled?

$$\text{C}_3\text{H}_8[\text{ppm}] = \frac{\text{MR}_{\text{max}} \times V_m}{\text{Number of C atoms} \times M_c} = \frac{50 \times 22.414}{3 \times 12.011} = 31,102$$

$$\begin{aligned} \text{C}_3\text{H}_8[\text{mg}/\text{m}^3] &= \frac{\text{C}_3\text{H}_8[\text{ppm}] \times (\text{Number C-Atoms} \times M_c + \text{Number H-Atoms} \times M_H)}{V_m} \\ &= \frac{31,102 \times (3 \times 12.011 + 8 \times 1.008)}{22.414} = 61.19 \end{aligned}$$

Example 2

If a test gas other than propane is used, its response factor (see **Fidas24 – Response factors and other relevant variables** on page 140) must be considered.

What is the maximum test gas concentration in ppm or mg/m³ if methane (CH₄) is used?

$$\text{CCH}_4[\text{ppm}] = \frac{\text{MR}_{\text{max}} \times V_m}{\text{Number C Atoms} \times M_c} = \frac{50 \times 22.414}{1 \times 12.011} = 93.306$$

$$\begin{aligned} \text{CCH}_4[\text{mg}/\text{m}^3] &= \frac{\text{CCH}_4[\text{ppm}] \times (\text{Number of C atoms} \times M_c + \text{Number of H atoms} \times M_H)}{V_m} \\ &= \frac{93.306 \times (1 \times 12.011 + 4 \times 1.008)}{22.414} = 66.785 \end{aligned}$$

The response factor for methane is Rf_{CH₄} = 1.13; i.e. the measured value display is too great by this factor.

In order to determine the maximum test gas concentration to avoid exceeding the measuring range, the measured value display must be divided by the response factor.

$$C_{\text{max CH}_4}[\text{ppm}] = \frac{C_{\text{CH}_4}[\text{ppm}]}{\text{Rf}_{\text{CH}_4}} = \frac{93.306}{1.13} = 82.572$$

$$C_{\text{max CH}_4}[\text{mg}/\text{m}^3] = \frac{C_{\text{CH}_4}[\text{mg}/\text{m}^3]}{\text{Rf}_{\text{CH}_4}} = \frac{66.785}{1.13} = 59.102$$

A test gas cylinder with approx. 80 ppm CH₄ has been ordered.

The test gas concentration in the test gas cylinder is 81.2 ppm CH₄ in accordance with the certificate.

This is equivalent to a concentration of

$$\begin{aligned} C_{\text{CH}_4}[\text{mgC}/\text{m}^3] &= \frac{C_{\text{cylinder}} \times \text{Number of C atoms} \times M_c}{V_m} \\ &= \frac{81.2 \times 1 \times 12.011}{22.414} = 43.513 \end{aligned}$$

Considering the response factor, the indication should be adjusted to

$$C_{\text{max CH}_4}[\text{mg}/\text{m}^3] = C_{\text{CH}_4} \times \text{Rf}_{\text{CH}_4} = 43.513 \times 1.13 = 49.1697$$

... 9 Calibration

Oxygen sensor – Notes for calibration

Calibration methods

- Automatic calibration:
single-point calibration
- Manual calibration:
zero point/end-point calibration

Note

The zero point of the oxygen sensor is not calibrated, as it is stable owing to the principle.

10 Configuration

Measuring range switchover

Description

Two measuring ranges per measuring component are set up in the gas analyzer.

The calibration always refers to both measuring ranges.

Limits of measuring ranges

The limits of the measuring ranges can be set by following the rules applicable to the respective analyzer within the physical measuring range:

In addition, the following conditions apply for the combination of measuring ranges.

Two initial measuring ranges



Figure 69: Two initial measuring ranges

- **Measuring range 2 (MR2):**
Initial measuring range (\leq physical measuring range)
- **Measuring range 1 (MR1):**
Initial measuring range (\leq physical measuring range)
- **Condition:**
Measuring span MR1 \leq measuring span MR2

One measuring range with suppressed zero point, one initial measuring range



Figure 70: A measuring range with suppressed zero point, an initial measuring range

- **Measuring range 2 (MR2):**
Measurement ranges with suppressed zero point
- **Measuring range 1 (MR1):**
Initial measuring range
- **Condition:**
End value MR1 $>$ Initial value MR2

Two measurement ranges with suppressed zero point



Figure 71: Two measuring ranges with suppressed zero point

- **Measuring range 2 (MR2):**
Measurement ranges with suppressed zero point
- **Measuring range 1 (MR1):**
Measurement ranges with suppressed zero point
- **Conditions:**
 - Start value MR1 \leq Start value MR2
 - End value MR1 $>$ Initial value MR2

Note

Other measuring range combinations are not possible.

Measuring range switchover and feedback

There are three ways of executing the measuring range switchover:

- Manually on the gas analyzer,
- Automatic 'Aurorange' using correspondingly configured switching thresholds,
- Externally controlled via appropriately configured digital inputs (see **Configuration of inputs and outputs for measuring range switchover and feedback** on page 145).

The measuring range feedback can be implemented via appropriately configured digital outputs (see **Configuration of inputs and outputs for measuring range switchover and feedback** on page 145); it is independent of the selected type of measuring range switchover.

The gas analyzer is factory-set to measuring range 2 and to manual measuring range switchover.

... 10 Configuration

... Measuring range switchover

Measuring range configuration

The measuring ranges can be configured either in the configurator (see **Measuring range configuration with ECT** on page 144) or in the gas analyzer (see **Measuring range configuration in the gas analyzer** on page 146):

Configuration	Configurator	Gas analyzer
Type of measuring range switchover	X	X
Measurement range limits	X	X
Switch-over thresholds for autorange	X	X
Digital inputs/outputs	X	—

Note

In Magnos27, the measuring range limits cannot be changed.

Manual measuring range switchover

Menu Path

▲ Operation / ▼ Switch-Over / ▼ Active Range'

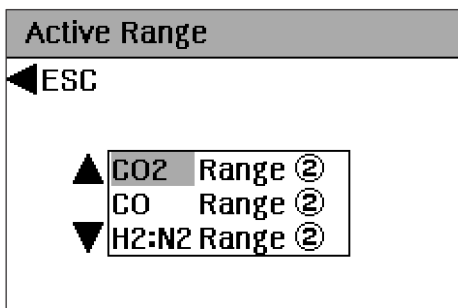

Figure 72: 'Active measuring range' menu

Measuring range configuration with ECT

Measuring range parameters

Measuring range switchover

The type of measuring range switchover 'Range Mode' is configured in the 'Component' components dialog:

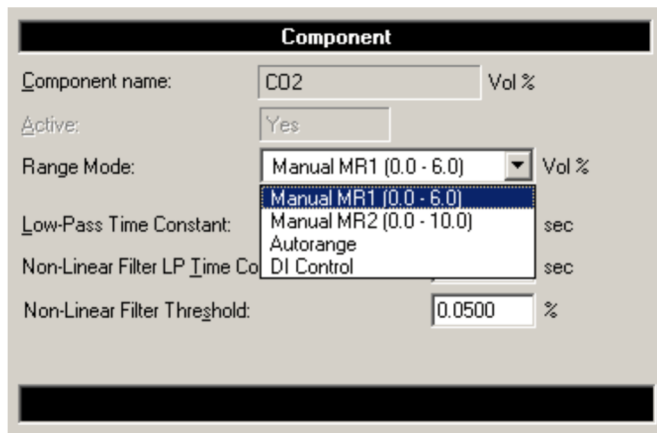

Figure 73: 'Component' menu

Note

The automatic measuring range switchover 'Autorange' can only be configured if an analog output is assigned to the detector. The externally controlled measuring range switchover 'DI Control' can only be configured if an analog output and a digital input are assigned to the detector, see Figure 75.

Measuring range limits and autorange switching thresholds
 The lower range values and upper range values as well as the autorange switching thresholds are configured in the 'Measurement Range' measuring range limit dialog:

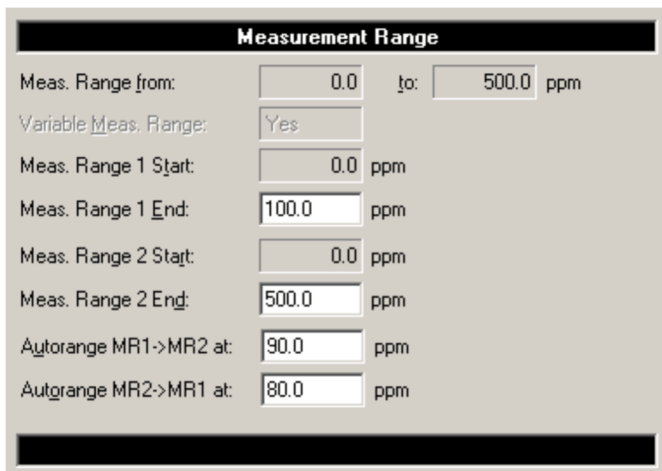

Figure 74: 'Measurement Range' menu

Note

- The values of the autorange switchover thresholds must both be in the 'Measuring range 2 initial value to measuring range 1 end value' range.
- The value of the autorange switching threshold MR2->MR1 must be less than the value of the switching threshold MR1->MR2.

The conditions for the limits and combinations of the measuring ranges must be observed, see **Limits of measuring ranges** on page 143.

Configuration of inputs and outputs for measuring range switchover and feedback

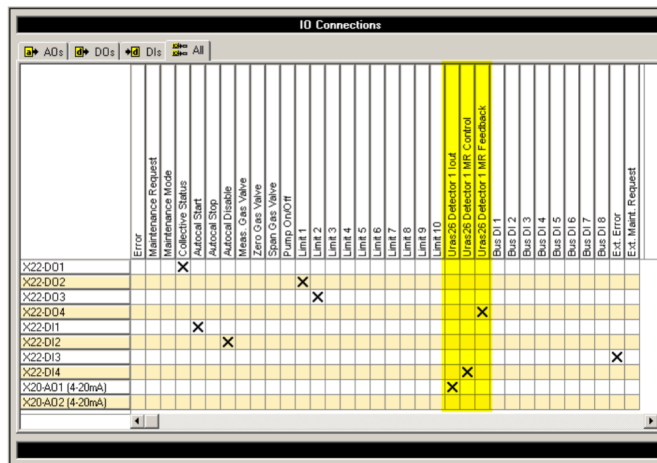

Figure 75: 'IO Connections' menu

In the example shown in the figure, the following inputs and outputs are assigned to the Uras26 detector 1 (see yellow marking):

- the X20-AO1 analog output for the measured value output ('Iout'),
- the X22-D14 digital input for external control of the measuring range switchover ('MR Control'),
- The X22-DO4 digital output for the measuring range feedback ("MR Feedback").

Functionality of digital inputs and outputs for measuring range switchover and feedback

Active measuring range	Switching state*	Digital input**	Digital output**
Measuring range 1	0	open	Relays de-energized
Measuring range 2	1	closed	Relays energized

* Inputs and outputs are not inverted

** For possible wiring of the inputs and outputs see **Digital I/O module** on page 99

... 10 Configuration

Measuring range configuration in the gas analyzer

Menu Path

► Setup / ▲ Measurement Ranges'

The measuring range parameters must be set individually for each sample component.

Measuring range parameters

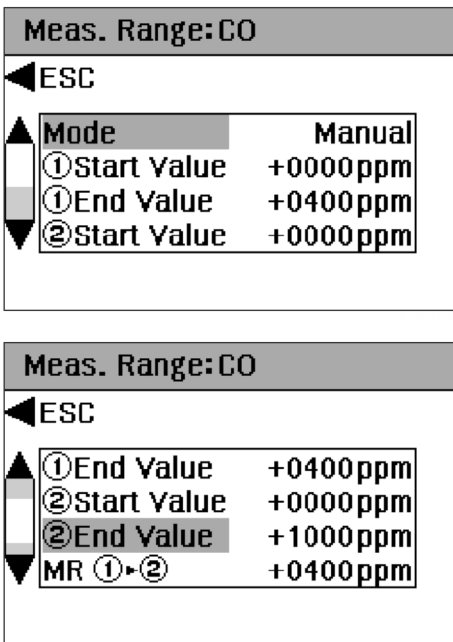

Figure 76: 'Measuring range' menu

Measuring range switchover mode

- Manual
- Automatic (Aurorange)
- Externally controlled (DI control)

Measurement range limits

- Measuring range 1 initial value
- Measuring range 1 final value
- Measuring range 2 initial value
- Measuring range 2 final value

Autorange switchover thresholds

- Switchover from measuring range 1 to measuring range 2
- Switchover from measuring range 2 to measuring range 1

Note

- The automatic measuring range switchover ('Autorange') can only be configured if an analog output is assigned to the detector.
- The externally controlled measuring range switchover ('DI Control') can only be configured if an analog output and a digital input are assigned to the detector, see **Figure 75** on page 145.
- The values of the autorange switchover thresholds must both be in the 'Measuring range 2 initial value to measuring range 1 end value' range.
- The value of the autorange switching threshold MR2->MR1 must be less than the value of the switching threshold MR1->MR2.

The conditions for the limits and combinations of the measuring ranges must be observed, see **Limits of measuring ranges** on page 143.

Manual measuring range switchover

Menu Path

►▲ Operation / ▼ Switch-Over / ▼ Active Range'

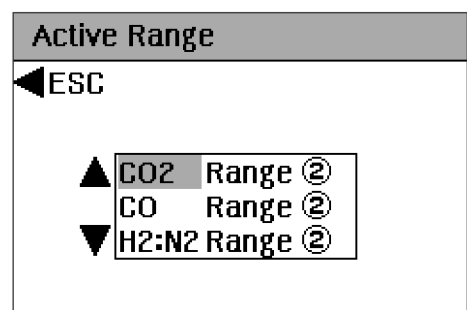

Figure 77: 'Active measuring range' menu

Uras26 – Change measuring range limits

Menu Path

' ► Setup / ▲ Measurement Ranges'

The measuring range limits can also be set in the Configurator, see **Measuring range configuration with ECT** on page 144.

Note

- Measuring ranges may not be specified within ignition limits.
- After changing the measuring range limits, the calibration of the relevant measuring range needs to be checked.

Measurement range limits

- The **lower range value** cannot be changed.
- The **upper range value** must be within the physical measuring range.

Adjustment range

The measuring range can be freely set within the limits of the physical measuring range (see table).

Physical measuring range

The analyzer has one physical measurement range per sample component. The standard measuring ranges are:

Smallest measurement range	Largest measurement range
0 to 100 ppm	0 to 500 ppm
(NO: 0 to 150 ppm)	(NO: 0 to 750 ppm)
0 to 200 ppm	0 to 1000 ppm
0 to 600 ppm	0 to 3000 ppm
0 to 2000 ppm	0 to 10000 ppm
0 to 0.6 Vol.-%	0 to 3 Vol.-%
0 to 2 Vol.-%	0 to 10 Vol.-%
0 to 6 Vol.-%	0 to 30 Vol.-%
0 to 20 Vol.-%	0 to 100 Vol.-%

An individual measurement range within the limits shown in the table can be factory-set on special order.

Calibration Cells

If the analyzer is equipped with calibration cells, the set points for each measured component are about 80 % of the physical measuring range or 80 % of the measuring range set according to the order.

Limas23 – Change measuring range limits

Menu Path

' ► Setup / ▲ Measurement Ranges'

The measuring range limits can also be set in the Configurator, see **Measuring range configuration with ECT** on page 144.

Note

Measurement ranges should not be set within ignition limits. After changing the measuring range limits, the adjustment of the relevant measuring range needs to be verified.

Measurement range limits

- The **lower range value** cannot be changed.
- The **upper range value** must be within the physical measuring range.

Setting range

The measuring range can be freely set within the limits of the physical measuring range (see table).

Physical measuring range

The analyzer has one physical measurement range per sample component. The standard measuring ranges are:

	Smallest measurement range	Largest measurement range
NO	0 to 50 ppm	0 to 250 ppm
	0 to 100 ppm	0 to 500 ppm
	0 to 200 ppm	0 to 1000 ppm
	0 to 400 ppm	0 to 2000 ppm
	0 to 1000 ppm	0 to 5000 ppm
NO₂	0 to 50 ppm	0 to 250 ppm
	0 to 100 ppm	0 to 500 ppm
SO₂	0 to 100 ppm	0 to 500 ppm
	0 to 200 ppm	0 to 1000 ppm
	0 to 400 ppm	0 to 2000 ppm
	0 to 1000 ppm	0 to 5000 ppm
	0 to 4000 ppm	0 to 20000 ppm
	0 to 1 Vol.-%	0 to 5 Vol.-%

... 10 Configuration

Magnos206 – Change measuring range limits

Menu Path

' ► Setup / ▲ Measurement Ranges'

The measuring range limits can also be set in the Configurator, see **Measuring range configuration with ECT** on page 144.

Note

- Measuring ranges may not be specified within ignition limits.
- After changing the measuring range limits, the calibration of the relevant measuring range needs to be checked.

Measurement range limits

The **lower range value** and the **upper range value** must be within the physical range.

Setting range

The measuring range can be freely set within the limits of the physical measuring range.

- The measuring range set at the factory can be found on the name plate or device data sheet.
- The minimum measuring range is 0 to 2 Vol.-% O₂

Measuring range with suppressed zero point ('suppressed measuring range')

- The minimum measuring span of the suppressed measuring range is 2 Vol.-% O₂.
- The measuring range set at the factory can be found on the name plate or device data sheet.
- If the analyzer has been ordered with the suppressed measuring range, a pressure sensor is installed at the factory.

Physical measuring range

The analyzer has a physical measuring range. The limits of this measuring range are 0 Vol.-% O₂ or 100 Vol.-% O₂.

Magnos28 – Change measuring range limits

Menu Path

' ► Setup / ▲ Measurement Ranges'

The measuring range limits can also be set in the Configurator, see **Measuring range configuration with ECT** on page 144.

Note

- Measuring ranges may not be specified within ignition limits.
- After changing the measuring range limits, the calibration of the relevant measuring range needs to be checked.

Measurement range limits

The **lower range value** and the **upper range value** must be within the physical range.

Setting range

The measuring range can be freely set within the limits of the physical measuring range.

- The measuring range set at the factory can be found on the name plate or device data sheet.
- The minimum measuring range is 0 to 0.5 Vol.-% O₂.

Measuring range with suppressed zero point ('suppressed measuring range')

The minimum measuring span of the suppressed measuring range is 0.5 Vol.-% O₂

- The measuring range set at the factory can be found on the name plate or device data sheet.
- If the analyzer has been ordered with the suppressed measuring range, a pressure sensor is installed at the factory.

Physical measuring range

The analyzer has a physical measuring range.

The limits of this measuring range are 0 Vol.-% O₂ or 100 Vol.-% O₂.

Caldos27 – Change measuring range limits

Menu Path

' ► Setup / ▲ Measurement Ranges'

The measuring range limits can also be set in the Configurator, see **Measuring range configuration with ECT** on page 144.

Note

- Measuring ranges may not be specified within ignition limits.
- After changing the measuring range limits, the calibration of the relevant measuring range needs to be checked.

Measurement range limits

The **lower range value** and the **upper range value** must be within the physical range.

Setting range

The measuring range can be freely set within the valid limits for the measured component.

- For the 'relative thermal conductivity' component set at the factory, the measuring range is fixed to rTC = 0 to 64.000..
- The widest measuring range is 0 to 100 vol.-% or 0 vol.-% until saturation, depending on the measurement task.

Physical measuring range

Each analyzer has one physical measuring range for each sample component. The limits of this measuring range are usually 0 vol.-% or 100 vol.-%.

Oxygen sensor – Changing measuring range limits

Menu Path

' ► Setup / ▲ Measurement Ranges'

The measuring range limits can also be set in the Configurator, see **Measuring range configuration with ECT** on page 144.

Setting range

The measurement range is freely adjustable from 0 to 5 vol.-% O₂ to 0 to 25 vol.-% O₂.

The lower range value cannot be changed.

Limit values

Setup

Figure 78: Menu 'Limit'

The limit values can only be set in the configurator and not in the gas analyzer.

Parameters

Parameter	Description
Limit Name (Limit value name)	The name of the limit value.
<input checked="" type="checkbox"/> Limit Active (<input checked="" type="checkbox"/> Limit value active)	Limit value monitoring can be activated or deactivated.
Assigned Component (Assigned sample component)	Selection of all measured components present in the gas analyzer.
Limit Value (Limit value)	Value range: within the physical measuring range of the analyzer.
Direction (Direction of action)	The alarm signal is given when the measured value is larger or smaller than the set limit value.
Hysteresis (Hysteresis)	Value range: within the physical measuring range of the analyzer.
Delay Time (Delay time)	Waiting time after the limit value event (come or go) has occurred until the output is updated. Value range 0 to 60.000 ms.
<input checked="" type="checkbox"/> Confirmation required (<input checked="" type="checkbox"/> Acknowledgment required)	If a limit value is up-scaled, the output signal is not reset until the limit value has been down-scaled again and the user has acknowledged the status message.

... 10 Configuration

... Limit values

Note

If several measured components are configured in the gas analyzer and these measured components are assigned limit values, the status of the inactive measured components is set to 'normal' upon changing the active measured component and the active measured component is monitored.

Standard configuration

As a rule, limit value monitoring for those measured components to be measured by the gas analyzer is factory-set.

This requires that there be a sufficient number of digital outputs on the digital I/O modules to handle the number of sample components, see **Digital I/O module** on page 99.

Set low-pass time constant

Setup

The screenshot shows a configuration window titled 'Component'. It contains the following fields:

- Component name: N2:H2 Vol %
- Active:
- Measurement Range(s): 0.000 - 100.000 Vol %
- Low-Pass Time Constant: 3.0000 s
- Non-Linear Filter LP Time Constant: 0.0000 s
- Non-Linear Filter Threshold: 0.1000 %

Figure 79: Menu 'Component'

The low pass time constants can only be set in the configurator and not in the gas analyzer.

Parameters

A non-linear filter with 2 low-pass time constants and a switching threshold can be configured for each measured component.

Parameter	Description
Low-Pass Time Constant (Low-pass time constant)	Value range: 0 to 60 s
Non-Linear LP Time Constant (Low pass time constant for non-linear filter)	Value range: 0 to 60 s
Non-Linear Filter Threshold (Switching threshold for non-linear filter)	Value range: 0 to 9.99 % of the measuring span of the physical measuring range. If the switching threshold is up-scaled during a measured value change, the low pass time constant for non-linear filters takes effect.

Active component selection

Menu Path

'▲ Operation / ▼ Switch-Over / ► Active Component'

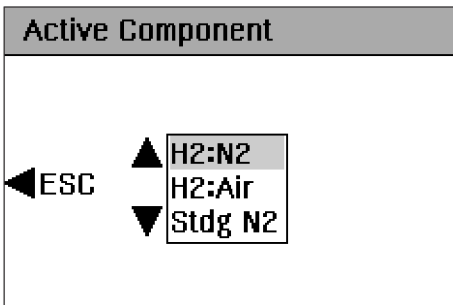

Figure 80: Menu 'Active Component'

Active component

The 'Active Component' parameter appears in the Magnos206, Magnos28 and Caldos27 analyzer.

Several sample components can be calibrated for these analyzers. However, there is always only one component measured and displayed.

Magnos206, Magnos28

For Magnos206 and Magnos28, the measured components are factory-configured. In the 'Active Component' menu, select a measured component to be measured and displayed.

Caldos27

Selection of the active measured component is done in two steps:

1. In the configurator, up to four sample components can be selected from the context menu of the Caldos27 detector, which are then loaded into the gas analyzer. The factory-configured 'Standard Gas' component cannot be deleted. It is also not possible to delete a 'user component' which was factory-configured in the analyzer.
2. In the 'Active Component' menu of the gas analyzer, select a sample component to be measured and displayed from the maximum five sample components.

Calibration

All measured components are pre-calibrated at the factory. After the initial activation of a sample component, zero point and end point must be checked and recalibrated if necessary.

Externally controlled measured component switch

Description

The externally controlled switch of the active sample component is possible via appropriately configured digital inputs (see **Digital I/O module** on page 99). Appropriately configured digital outputs are required for the sample component feedback.

Functionality

The sample component is activated via a signal at the digital input assigned to the sample component switchover. The correspondingly configured digital output is set for the feedback of the active sample component.

If there is no signal at any of the configured digital inputs upon restart of the gas analyzer, the last sample component stored as active becomes active again.

Configuration using ECT

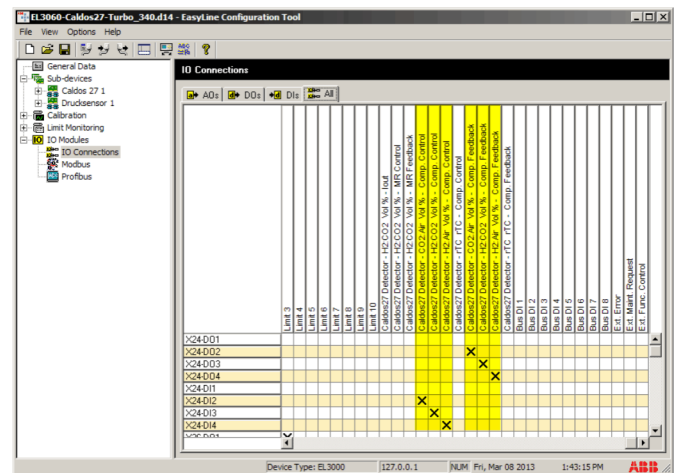

Figure 81: Menu 'IO Connections'

In the example shown in the figure, the following digital inputs and outputs are assigned to the Caldos27 detector (see yellow marking):

- Digital inputs X24-DI2 to X24-DI4 for external control of the sample component switchover ('Comp. Control') and
- The digital outputs X24-DO2 to X24-DO4 for the sample component feedback ('Comp. Feedback').

... 10 Configuration

Changing the physical unit for a sample component

Setup

The physical unit used for the measured value display of a sample component, e.g. ppm or mg/m³, can be changed 'Configurator'.

- One of the units defined at the factory can be selected for system components.
- For user components, the choice of units depends on which of the parameters required for the calculation have been entered during configuration of the components.

The unit for a component can be changed for the following analyzers:

Analyzer	Physical units
Uras26	ppm, vol%, mg/m ³ , g/m ³
Limas23	ppm, vol%, mg/m ³ , g/m ³
Magnos206	ppm, vol.%
Magnos28	ppm, vol.%
Magnos27	ppm, vol.%
ZO23	ppm, vol.%
Fidas24	ppmC1, ppm, vol%, mgC/m ³ , gC/m ³ , mg/m ³ , g/m ³ , %UEG, mgC/l, gC/l, mg/l, g/l

Procedure

1. In ECT, register the communication with the gas analyzer and transfer the configuration data from the gas analyzer to the computer.
2. In the tree structure, left-click the sample component for which the physical unit needs to be changed.
3. Select the desired physical unit in the 'Component' dialog for the 'Component Name:' parameter.
4. Transfer the configuration data from the computer to the gas analyzer.

Sample components

Setup

The sample components can only be configured in the Configurator and not on the gas analyzer.

Note

Configuration of the sample components is currently only possible in the Fidas24 analyzer.

Overview

The following functions are included to configure the sample components (hereinafter referred to in short as 'Components'):

- Adding a component:
 - Adding a system component
 - Adding a user component
- Changing a component:
 - Changing a component parameter
 - Replacing one component with another component
- Deleting a component

System components

System components are components configured in the gas analyzer at the factory. They are assigned specific properties (such as response factor) and a default measuring range at the factory; only the physical unit for displaying the measured value can be changed.

User components

User components are components configured by the user; the relevant properties must be entered during configuration. A maximum of 10 user components can be configured.

Component Selection List

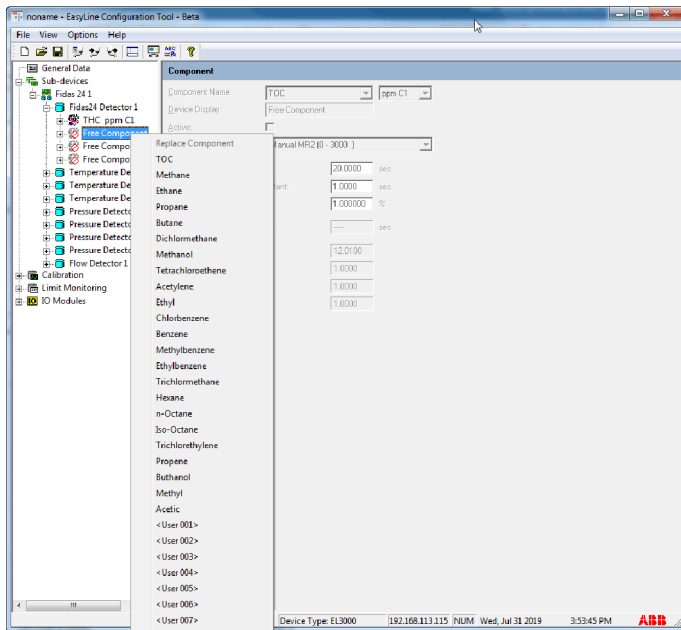

Figure 82: Component Selection List in ECT

The Component Selection List contains all system and user components. A maximum of 4 sample components can be selected from this list, configured as needed and (as a component list) transmitted to the gas analyzer; one of these sample components is selected as the active component (see **Active component selection** on page 151).

Requirements

The ECT software tool has been started, communication to the gas analyzer has been made, and the configuration data has been transferred from the gas analyzer to ECT.

Adding a Component

Adding a System Component:

1. In ECT, in the tree structure, right-click on a 'Free Component' entry.
2. Select a system component in the component selection list and left-click it with mouse to transfer it to the tree structure.
3. Check and change the physical unit as needed.
4. Check the measuring range and configure if necessary.

Adding a User Component

1. In ECT, in the tree structure, right-click on a 'Free Component' entry.
 2. In the component selection list, select a user component, for example <User 001>, by left-clicking with the mouse in the tree structure.
 3. Overwrite the entry (e.g. <User 001>) in the 'Component Name' field with the component name.
The text that appears in the display of measured values will be displayed in the 'Device Display' field.
- Note**
The physical unit cannot be selected until the parameters have been configured in step 4.
4. Enter the values for the molar mass, response factor C-atom count and K-factor parameters.
 5. Select the physical unit.
 6. Check and change the other parameters as needed.
 7. Check the measuring range and configure if necessary.

... 10 Configuration

... Sample components

Changing a Component

Note

A component that is activated for calibration cannot be changed.

Changing a component parameter

1. In ECT in the tree structure, left-click the component for which the parameters should be changed.
2. Change the desired parameters.

Note

The molar mass, response factor, C-atom count and K factor parameters cannot be changed for a system component.

Replace one component with another component

1. In ECT in the tree structure, right-click the component that should be replaced.
2. Select a component in the component selection list and left-click it with mouse to transfer it to the tree structure.
3. Check and change the parameters as needed.
4. Check the measuring range and configure if necessary.

Deleting a component

Note

A component that is activated for calibration cannot be deleted.

A (system or user) component can be deleted from the tree structure. After deletion, the component is no longer available for display or calibration; however, it is still included in the component selection list and can be added to the component list again later on.

1. In ECT in the tree structure, right-click the component that should be deleted.
2. In the component selection list, left-click the 'Delete Entry' entry.
3. The 'Free Component' entry is displayed in the tree structure instead of the deleted component.

Completing the configuration

When the configuration is completed, the configuration data must be transferred from ECT to the gas analyzer using the 'Send Data' command.

Configuring signal inputs and outputs

Setup

The signal inputs and outputs (I/O connections) can only be configured in the Configurator and not on the gas analyzer.

Function

Assignments for the following are configured

- the analog outputs (AOs),
- the digital outputs (DOs) and
- the digital inputs (DIs).

Assignment

	Error	Maintenance Request	Maintenance Mode	Collective Status	Autocal Start	Autocal Stop	Mess. Gas Valve	Zero Gas Valve	Span Gas Valve 1	Span Gas Valve 2	Span Gas Valve 3	Span Gas Valve 4	Span Gas Valve 5	Limit 1	Limit 2	Limit 3	Limit 4	Limit 5	Limit 6	Limit 7	Limit 8	Limit 9	Limit 10	Limas23 UV Detector 1 Iout	Limas23 UV Detector 2 Iout	Limas23 UV Detector 3 Iout	Virtual Detector 1 Iout	Magnos206 Detector Iout
X22-D01				X																								
X22-D02															X													
X22-D03																X												
X22-D04									X																			
X22-D11				X																								
X22-D12							X																					
X22-D13																												
X22-D14																												
X20-A01 (4-20mA)																									X			
X20-A02 (4-20mA)																										X		

Figure 83: 'I/O Connections' menu

Only one function can be assigned to each signal input or output. A function can be assigned to several signal inputs or outputs. Multiple external status signals can be configured depending on the number of free digital inputs.

Analog outputs

By default, the measured values are assigned to the analog outputs AO1, AO2, etc. in the order of configuration, see **Digital I/O module** on page 99.

Right-clicking on the name of the analog output opens a context menu where you can switch between '0–20 mA' and '4–20 mA':

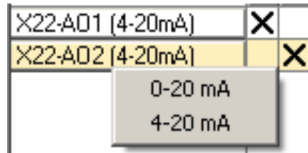

Digital outputs, digital inputs

The default configuration of the digital outputs and inputs is shown in **Digital I/O module** on page 99.

Right-clicking on the name of the digital output- or input -opens a context menu where you can switch between 'No Invert' and 'Invert':

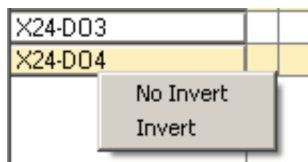

Setting the IP address

Menu Path

► Setup / ▼ Device Settings / ► Ethernet'

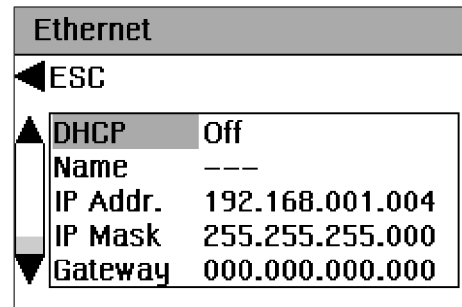

Illustration84: 'Ethernet' Menu

Parameters

It depends on the DHCP settings what parameters need to be integrated:

DHCP setting	Parameter
DHCP on	Network name (max. 20 characters, no empty and special characters),
DHCP off	IP address, IP address mask and IP gateway address.

The network name can only be changed in the Configurator. The default network name consists of 'EL3K' and the last six characters of the MAC address (for example, 'EL3KFF579A').

If the parameter 'DHCP' is set to 'off', the Ethernet configuration is set to the default configuration (default IP address) in order to avoid unintentional assignment of an IP address from a DHCP pool.

... 10 Configuration

... Setting the IP address

Addresses

The IP address, IP address screen and IP gateway address need to be queried from the system administrator.

Note

The address bits variable from the address screen may not be set to 0 or 1 (broadcast addresses).

MAC address

The 12 character MAC address is unique worldwide and is stored in the device during manufacture. It cannot be changed.

Note

If the gas analyzer is connected to a network without a DHCP server, then the parameter 'DHCP' should be set to 'off'.

This also applies if the gas analyzer is not connected to a network via Ethernet.

This is to prevent the gas analyzer from continuously attempting to establish a network connection.

Setting the date and time

Menu Path

▶ Setup / ▼ Device settings / ▼ Date/time'

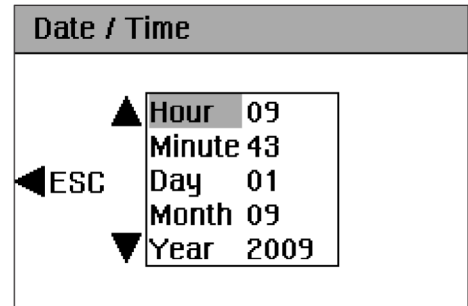

Figure 85: 'Date/Time' menu

Selecting the user interface language

Menu Path

▶ Setup / ▼ Device Settings / ▲ Language'

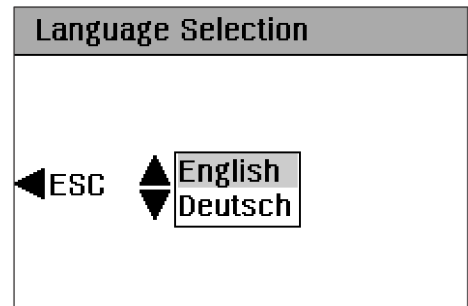

Figure 86: 'Language selection' menu

Language Selection

The gas analyzer has two user interface languages available which can be switched as needed.

The factory-set language is English; the second language can be configured using the ECT software tool ECT (see **Configuring the user interface language** on page 157).

Configuring the user interface language

Downloading the language file to the gas analyzer

Requirements:

The ECT software tool ('Configurator') is installed on the computer, and the current language files are saved in the 'C:\Program Files (x86)\Analyze IT\ECT\Languages' folder.

1. Open the ECT software tool.
2. In the 'Options' menu, either click on the 'Communication Properties...' command or select the  icon on the toolbar.

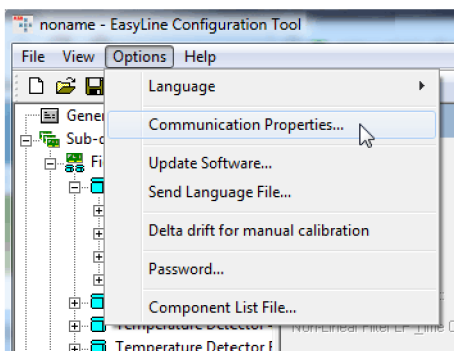

3. In the 'Communication Properties' dialog, enter either the network name (server name) or the IP address of the gas analyzer.

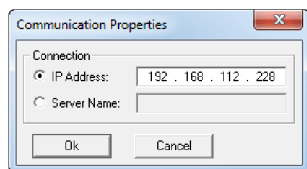

4. Close the dialog by clicking 'Ok'.
5. In the 'File' menu, either click on the 'Receive Data' command or select the  icon on the toolbar.
The configuration data is transferred from the gas analyzer to the computer.

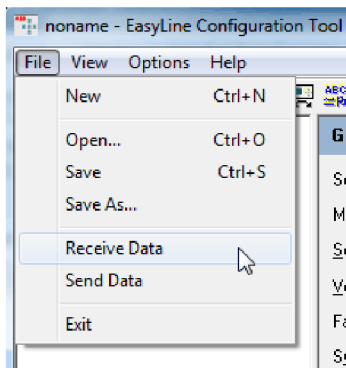

6. In the 'Options' menu, either click on the 'Send Language File...' command or select the  icon on the toolbar.

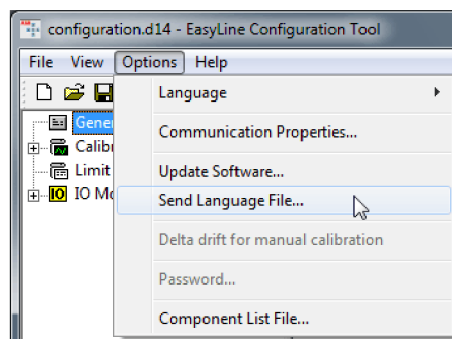

7. In the 'Send Language File' dialog under 'Select Language', click on the drop-down field and select the desired language.

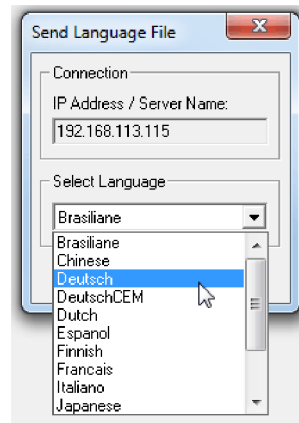

8. Close the dialog by clicking 'Ok'.
The selected language is transferred from the computer to the gas analyzer.

Password

Password protection

Access to the calibration as well as to the menus where the configuration of the device can be changed can be password-protected. Password protection is not activated at the factory.

Password protection variants:

- Access to calibration can be excluded from password protection.
- Access to all device functions can be password-protected (for devices with SIL certification).

Configure password

The password is set in the Configurator in menu 'Options – Password...'. It consists of a 4-digit number; each of the digits may only assume the values of 1, 2 and 3 (for example: '1213'. The setting '0000' means that password protection is not enabled.



Enter password

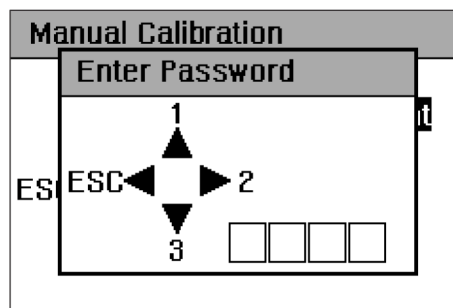

Figure 87: Password entry

As soon as the user wants to access a password-protected menu or a password-protected value change, password entry is prompted.

For this purpose, as shown on the LCD display, the digits 1, 2 and 3 are assigned to three buttons ▲, ► and ▼.

Example

If the password set is '1213', the user needs to push the buttons ▲, ►, ▲ and ▼ one after the other. Each push of a button is acknowledged by displaying the '*' symbol.

The password entered remains active until the user returns to measuring mode or until the gas analyzer automatically switches to measuring mode through the time-out function, see **Time out function** on page 111.

Software updates

Software updates

With the software update, the current data set is transmitted from the gas analyzer to the computer and, together with the new software, it is reloaded to the gas analyzer. Additional changes to the configuration of the gas analyzer using the ECT software tool must be performed in a separate step.

Perform software update

1. Open the ECT software tool.
2. In the 'Options' menu, either click on the 'Communication Properties...' command or select the  icon on the toolbar.

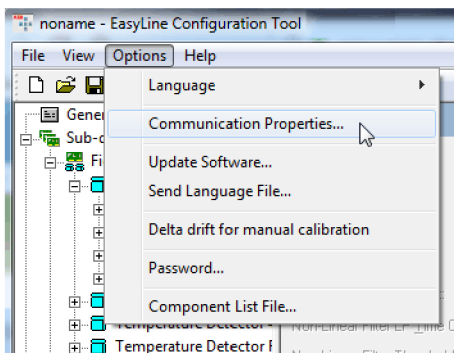

3. In the 'Communication Properties' dialog, enter either the network name (server name) or the IP address of the gas analyzer.

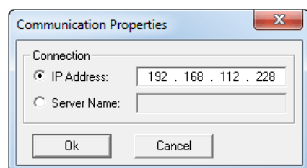

4. Close the dialog by clicking 'OK'.
5. In the 'File' menu, either click on the 'Receive Data' command or select the  icon on the toolbar. The configuration data is transferred from the gas analyzer to the computer.

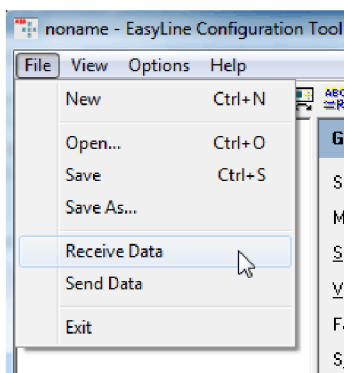

6. We recommend making a backup of the configuration data before loading the software update:

In the 'File' menu, click on the 'Save' or 'Save as...' command or select the  icon on the toolbar and save the configuration data under a suited file name.

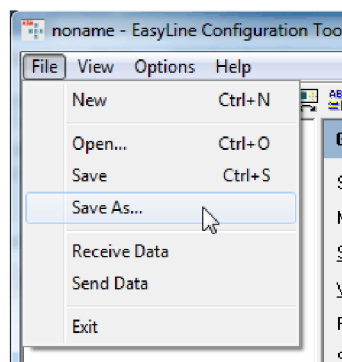

7. In the 'Options' menu, either click on the 'Update Software...' command or select the  icon on the toolbar.

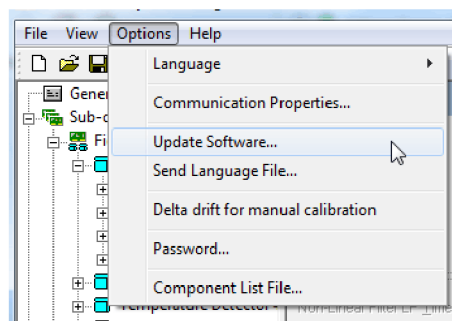

8. Confirm the question 'Configuration will be overwritten – continue?' by clicking 'Yes'.

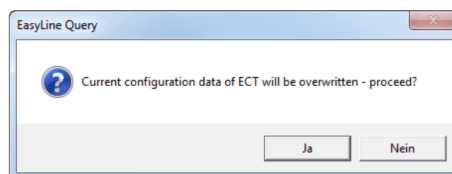

... 10 Configuration

... Software updates

9. The address of the gas analyzer set in Step 3 and the software version to be transmitted are displayed in the 'Update Software' dialog. Close the dialog by clicking 'Ok'.

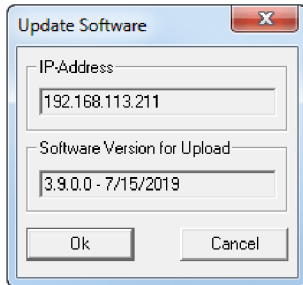

10. Confirm the update of software in the 'EasyLine Query' dialog by clicking 'Ok'.

The new software is loaded onto the gas analyzer.

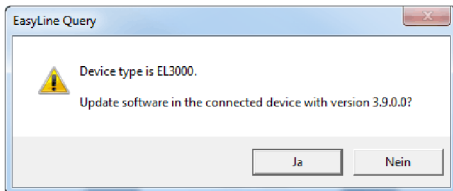

11. After the update has been completed, the information 'New software successfully installed. Wait for the gas analyzer to restart. After the restart, a new language can be loaded onto the gas analyzer' appears.

Close the window by clicking 'Ok'.

The gas analyzer has been restarted ('Booting').

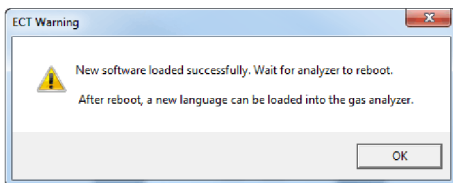

Note

The software update and restart of the gas analyzer can take several minutes

11 QAL3 monitoring

General information

Application

The QAL3 monitoring is used to continuously monitor the quality of the measurement results of an automatic measuring system (AMS) during normal operation.

The requirements for the various methods of quality assurance are described in the European standard for quality assurance EN 14181:2004 "Emissions from stationary sources – quality assurance for automatic measuring systems.

The quality assurance level QAL3 defined in this standard concerns the control of the AMS during operation; it forms the basis for the functional scope of QAL3 monitoring.

Description

QAL3 monitoring is integrated into the gas analyzer as an option on a memory card.

QAL3 monitoring features the following functions:

- Automatic acquisition, verification and documentation of drift and precision at zero point and reference point.
- Reporting via CUSUM and Shewhart control charts (see **Control cards** on page 162).
- Storage of QAL3 data in the gas analyzer (approx. 1 year)
- Display and query of QAL3 data as well as configuration (see **Configuration of QAL3 monitoring** on page 163) using a web browser.
- Status messages in the case of deviations beyond requirements
- Data export for further processing, for example in a spreadsheet program.

Requirements

The prerequisites for the operation of QAL3 monitoring are:

- The gas analyzer must be connected to a PC via the Ethernet interface.
- The current version of a web browser must be installed on the PC.
- In the web browser you must have Cookies and JavaScript enabled.
- The memory card with the 'QAL3 monitoring' option must be installed in the gas analyzer.

Is the 'QAL3 monitoring' option integrated in the gas analyzer?

Do the following to determine whether the 'QAL3 monitoring' option is integrated in the gas analyzer:

- 'Option QAL3:OK' is displayed in the '▼ Maintenance / ▼ Diagnosis / ► Device info' menu

Device Information	
◀ ESC	
Date	Jan 18 2008
HW Ind.	K
Option	QAL3:OK
Module	Uras 26
SerialNo	01400300003806

- The memory card with the 'QAL3 monitoring' option is located in a bracket on the AMC board (behind the front panel).

... 11 QAL3 monitoring

Control cards

CUSUM Control Cards

CUSUM control cards allow the isolated determination of accuracy and drift of the AMS at the zero point and reference point.

Parameters to determine the precision

hs	$hs = 6.90 s_{AMS}^2$	Test value to detect loss of precision
ks	$ks = 1.85 s_{AMS}^2$	Constant used to calculate the preliminary total for standard deviation
dt	Difference between the current device display of the AMS and the reference value (observe the sign)	
sp	Preliminary normalized sum of AMS standard deviations	
st	Preliminary normalized sum of the AMS standard deviations at time t	
N(s)t	Number of device displays since the occurrence of a standard deviation different than zero	

Parameters to determine drift

hx	$hx = 2.85 s_{AMS}$	Test value to detect drift
kx	$kx = 0.501 s_{AMS}$	Constant for calculating the total amount of positive and negative differences and calculating the correction needed for the AMS
dt	Difference between the current device display of the AMS and the reference value (observe the sign)	
Sum(pos)p	Preliminary normalized total of the AMS positive drift	
Sum(pos)t	Normalized total of the positive drift of the AMS at time t	
N(pos)t	Number of device displays since a positive deviation occurred	
Sum(neg)p	Preliminary normalized total of the negative drift of the AMS	
Sum(neg)t	Normalized total of the negative drift of the AMS at time t	
N(neg)t	Number of device displays since a negative deviation occurred	

Test for acceptance of the precision ('Decrease of Precision')

st less than or equal to hs for both zero point and end point	AMS is working in the control area, carry out drift testing
st greater than hs for zero point or end point	Determine the cause of the failure, notify the manufacturer in case of device defects (drift check not necessary)

Drift check

Sum(pos)t less than or equal to hx and AMS is working in the control area	
Sum(neg)t less than or equal to hx for both the zero point and the end point	
Sum(pos)t greater than hx or sum(neg)t larger than hx for zero point or end point	Measured value is out of the control range ('Out of Control'), perform re-alignment of the AMS

Shewhart Control Cards

Shewhart control cards are used to determine the combined accuracy and drift of the AMS.

The differences dt between the measured values and the set values at the zero point and reference point are determined. These differences must be less than or equal to standard deviations s_{AMS} multiplied by extension factor 2.

If the difference for a measured value is greater, the measured value is marked with a status 'Out of Control' (outside the control range).

Configuration of QAL3 monitoring

NOTICE

Data loss of the QAL3 data!

The QAL3 data stored on the memory card will be lost if the gas analyzer configuration is changed using the ECT or Optima TCT Light software tools, or if the memory card is mounted in another gas analyzer.

- In these cases the QAL3 data must be exported first (see **Exporting or deleting QAL3 data** on page 165).

Note

- By default set at the factory, QAL3 monitoring is disabled for all measured components, i.e. no QAL3 data is stored.
- If a password (see **Password** on page 158) is configured in the gas analyzer, this password must also be entered when configuring the QAL3 monitoring.

Opening the QAL3 monitoring web interface

1. Make sure that the gas analyzer is connected to a PC via the Ethernet interface.
2. Open the web browser on the PC, enter the IP address of the gas analyzer (if necessary, contact the network administrator) and establish the connection.
The web interface of the QAL3 monitoring of EasyLine EL3000 is open.

Configuration of sample components

1. In the QAL3 monitoring web interface, click 'QAL3 Monitoring'.
2. On the 'QAL3 Monitoring' page, click 'Components' (sample components).
3. On the 'Components' page, click on the sample component to configure.
4. On the 'Edit Component' page (edit sample components), enter the following information and values:
 - 'Active' (QAL3 monitoring of the sample component enabled),
 - 'Installation' (installation location),
 - 'Technician' (technician),
 - 'Comment' (comment),
 - 'sAMS Zero' (s_{AMS} -value for zero point),
 - 'sAMS Span' (s_{AMS} -value for reference point).
5. Leave the page by clicking 'Save' (save) or 'Cancel' (cancel).

Configuration of pressure output

1. In the QAL3 monitoring web interface, click 'QAL3 Monitoring'.
2. On the 'QAL3 Monitoring' page, click on 'Settings' (settings).
3. In the 'Printing' window (print output), check and if necessary change the number of lines on the first page ('Number of lines on first page' – recommendation for high format: 35) and on the following pages, ('Number of lines on all other pages' – recommendation for high format: 50).
4. Leave the page by clicking 'Save' (save) or 'Cancel' (cancel).

... 11 QAL3 monitoring

... Configuration of QAL3 monitoring

Configuration of data storage

1. In the QAL3 monitoring web interface, click 'QAL3 Monitoring'.
2. On the 'QAL3 Monitoring' page, click on 'Settings' (settings).
3. The following data is displayed in the 'Data storage' (save data) window:
 - 'Current number of data entries' (current number of data sets, additionally in percent of the maximum number),
 - 'Maximum number of data entries' (maximum number of data sets, sufficient for at least 'n' calibrations of all sample components).

Note

'n' is calculated and displayed by the system on the basis of the components that are set up in the analyzer and activated for QAL3 (see **Sample components** on page 152).

4. Check the value for 'Display warning when percentage reached is' (display warning when the percentage value set here is reached) and change if necessary.
5. Leave the page by clicking 'Save' (save) or 'Cancel' (cancel).

Note

The configuration changes are stored in a memory secured against power outages if the user does not enter anything for more than a minute or if the user stops the configuration by clicking on 'Logout'.

Display and print control chart

Display control chart

1. In the QAL3 monitoring web interface, click 'QAL3 Monitoring'.
2. Select the type of display on the 'QAL3 Monitoring' page:
 - 'Zero point simple' (simple zero point),
 - 'Reference point simple' (simple reference point),
 - 'Zero point details' (detailed zero point),
 - 'Reference point details' (detailed reference point).
3. Select the type of control chart (see '**Control cards** on page 162') ('Control Chart to Display') for the desired sample component.
4. The QAL3 values are displayed chronologically sorted in ascending order.
5. If necessary, at the end of the page, change the number of rows to be displayed per page in the 'Display n lines per page.' field.

Print control chart

1. At the bottom of the 'QAL3 Monitoring' page click on 'Print list'.
2. The listing is displayed in a new window in the web browser.
3. Recommendation: To print the detailed control boards, select the 'Querformat' page orientation.
4. Print the displayed list using the print function of the web browser.
5. The QAL3 values are printed chronologically sorted in ascending order.

Edit or delete QAL3 values

Edit a single QAL3 value

1. On the 'QAL3 Monitoring' page in the display of the control chart (see **Display and print control chart** on page 164), click on the number of the QAL3 value (column 'No.')
2. The following information and values can be changed on the 'Edit Data' page:
 - 'Technician' (technician),
 - 'Comment' (comment),
 - 'sAMS' (s_{AMS} -value for zero point or reference point).
3. Leave the page by clicking 'Save' (save) or 'Cancel' (cancel).

Deleting a single QAL3 value

1. On the 'QAL3 Monitoring' page in the display of the control chart (see **Display and print control chart** on page 164), click on the number of the QAL3 value (column 'No.')
2. On the 'Edit Data' page, click on 'Delete' (delete).
3. Confirm the following question (Do you really want to delete this value?) by clicking on 'OK'.
4. The value is deleted and the control chart is displayed again.

Exporting or deleting QAL3 data

Exporting QAL3 data

The QAL3 data can be exported from the gas analyzer to archive it or to for example edit it in a spreadsheet program.

1. In the QAL3 monitoring web interface, click 'QAL3 Monitoring'.
2. Select the type of display on the 'QAL3 Monitoring' page:
 - 'Zero point simple' (simple zero point),
 - 'Reference point simple' (simple reference point),
 - 'Zero point details' (detailed zero point),
 - 'Reference point details' (detailed reference point).
3. Select the type of control chart (see '**Control cards** on page 162') ('Control Chart to Display') for the desired sample component.
4. At the bottom of the page, click on 'Export data' (Export data).
The QAL3 data from the displayed control chart is exported to a text file (.txt).
5. Open the text file or save it under a new name as needed.
6. If necessary, repeat steps 2 to 5 for additional control charts.

Deleting QAL3 data

1. In the QAL3 monitoring web interface, click 'QAL3 Monitoring'.
2. On the 'QAL3 Monitoring' page, click on 'Settings' (settings).
3. In the 'Data storage' window (save data), click on 'Delete all data' (Delete all data).
4. A warning appears:
'Do you really want to delete all the data? This operation cannot be undone.
Make sure all data has been exported before proceeding.'
5. Click on 'OK'. The QAL3 data is deleted.
6. Leave the page by clicking 'Save' (save) or 'Cancel' (cancel).

12 Diagnosis / Troubleshooting

Safety instructions

WARNING

Risk of injury

Risk of injury due to improperly performed error correction. The remedial measures described in this chapter require special knowledge and may require work to be done on the gas analyzer while it is open and under voltage!

- Work on the gas analyzer may only be performed by qualified and specially trained personnel!

CAUTION

Risk of burns

Risk of burns at the heated sample gas connection (temperature approx. 180 °C)!

- Before working on the heated sample gas connection, switch off the power supply and allow the sample gas connection to cool for about 30 minutes.

The Dynamic QR Code

Application

Dynamic QR Code is a unique feature for displaying dynamically generated QR codes on the gas analyzer display.

The QR code displayed contains static system information as well as dynamically generated information regarding system configuration and the status of the gas analyzer.

Static data for the identification of the device includes, for example:

- Manufacturing number
- Production date
- Software version
- Serial numbers of the analyzer modules and assemblies that have been installed

Dynamic data for diagnostic purposes in the case of a fault include, for example:

- Status Messages
- Measured values
- Temperature, pressure and flow-rate values
- Drift values
- Analyzer-specific values

In combination with mobile devices (smartphone, tablet, etc.), Dynamic QR Code represents an innovative communication path for the user, enabling improved, case-specific assistance from the ABB service team.

This helps to shorten response times in the event of a fault, thereby increasing the availability of your gas analyzers.

Dynamic QR Code is compatible with both the ABB app “my Installed Base” and standard QR Code scanner apps

Handling

The QR code is accessed in the Diagnostic Menu of the gas analyzer and indicated on the display.

The QR Code Scanner App installed in the mobile device scans the QR Code that is displayed. The text information that is then displayed on the mobile device is sent to the local service contact specified in the "Measurement Care" contract, by email or other means of transmission.

Alternatively, it is possible to take a photograph of the displayed QR code and send the photograph to the service contact.

Dynamic QR Code Accessing

Menu Path

'▼ Maintenance / ▼ Diagnosis / ▼ Device Status / ▲ Display QR-Code'

Procedure

1. Select system overview or the required analyzer module.
2. Access the QR code by pressing **OK**.
3. If necessary, change the resolution of the QR code with ►.
4. Scan QR code.
5. Return to the menu selection by clicking on ◀.

Recommended QR code scanner apps

ABB recommends using the following QR code scanner apps (available free of charge for iOS and Android devices):

"my Installed Base" from ABB

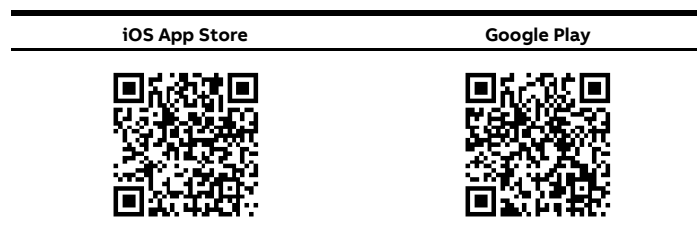

"QR Scanner" from Kaspersky

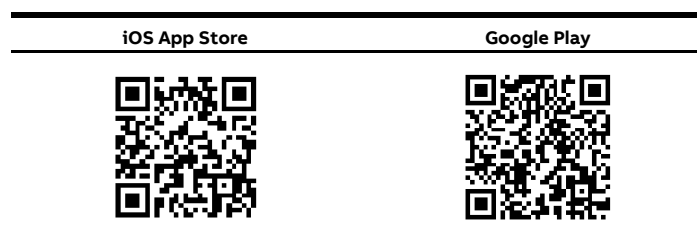

... 12 Diagnosis / Troubleshooting

Status messages – Explanations





Status Signals

The status messages (see **Possible status messages** on page 170) set the 'Failure', 'Maintenance required', 'Function control' as well as 'Total status' status signals.

The assignment of the status signals to the digital outputs can be configured (see **Configuring signal inputs and outputs** on page 154).

Status message	Description
Failure	The analyzer is in a state that requires immediate user intervention. The measured value is invalid.
Maintenance required	The analyzer is in a state that will soon require user intervention. The measured value is valid.
Check function	A calibration is performed on the gas analyzer or the maintenance switch is on. The measured value is not a process measured value and is to be discarded.
Overall status	The overall status is always set together with the 'Failure' status, as well as for individual messages, together with the 'Maintenance required' status, and is not set together with the 'Function check' status.

Status Icons

Icon	Description
	An automatic calibration (see page 120) is in progress. The icon also appears in menu mode in the menu title line (see page 110).
	A status message (see page 170) is active.
	The status signal (see page 168) 'Maintenance required' is active. The icon also appears in menu mode in the menu title line (see page 110).
	The status signal 'Failure' is active (page 168) or the maintenance switch (page 180) is set to 'On'. The icon is flashing. The icon also appears in menu mode in the menu title line (page 110).
	The configuration has been saved. The icon is flashing. Do not turn off the power supply of the gas analyzer while the icon is displayed!

Status Message Categories

In terms of operator reaction, there are three categories of status messages:

- Status messages not requiring acknowledgment,
- Status messages requiring acknowledgment,
- Status messages requiring acknowledgment and troubleshooting.

Category	Description
Status Messages Not Requiring Acknowledgement	The device operates normally after the status has been cleared. When the status is cleared, the status signal is reset and the status message disappears. Example: Temperature error during the warm-up phase.
Status Messages Requiring Acknowledgment	The instrument operates normally after the status has been cleared; however, the operator must be informed of the status. When the status is cleared, the status signal is reset. The status message disappears as soon as the operator has acknowledged it. The operator is thus informed about the malfunction of the instrument. Example: No new measured values from the analog/digital converter.
Status Messages Requiring Acknowledgment and Intervention	The device may not operate normally after the status has been cleared; the operator must therefore acknowledge the status and eliminate the cause of the status message. The status signal is reset and the status message disappears as soon as the operator has acknowledged it, and the cause of the status message has been eliminated. Example: The offset drift between two calibrations exceeds the permissible range.

Presentation of the categories

In the status message list and the detailed view of the individual status messages, the categories are displayed by the following icons:

Symbol	Status Messages Requiring Acknowledgment	Status Messages Not Requiring Acknowledgement
<input type="checkbox"/>	The status message is not acknowledged.	The status message has occurred (detailed view).
<input checked="" type="checkbox"/>	The status message is acknowledged.	—
<input type="checkbox"/>	—	The status message has expired (detailed view). The status message is inactive (message list).

Acknowledging status messages

Status messages subject to acknowledgment must be acknowledged by selecting 'OK'.

This can be done in the message list as well as in the detailed view.

Status messages on the LCD display

Menu path

'▼ Maintenance / ▼ Diagnosis / ▼ Device Status / ▼ Status Messages'

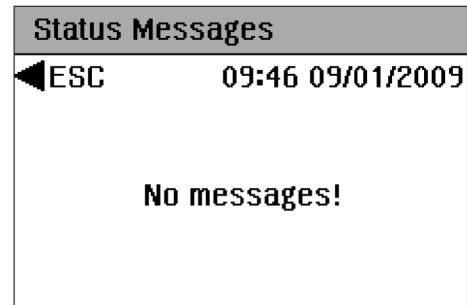

Figure 88: Menu 'Status Messages'

When a status message is active, the message list display is called up directly by pressing the ▼ button once.

Message list and detailed view

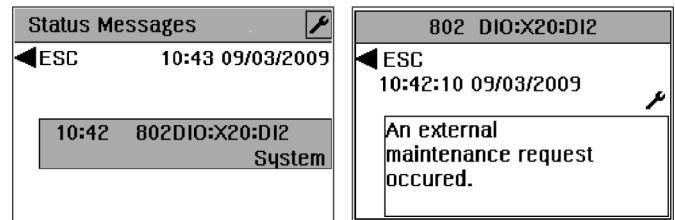

Figure 89: List of status messages and detailed view

The message list with the short text of the status messages is displayed in the 'Status Messages' menu.

By pressing the ► button, the detailed view of the individual status messages is displayed; in the detailed view, the time and date of occurrence, as well as cancellation or acknowledgment of the status message are displayed.

Note

For a detailed description of errors and troubleshooting instructions, please see **Possible status messages** on page 170.

... 12 Diagnosis / Troubleshooting

Possible status messages

Legend for the 'status messages' table

Status Signals

A	'Failure' status	The analyzer is in a state that requires immediate user intervention. The measured value is invalid.
W	'Maintenance required' status	The analyzer is in a state that will soon require user intervention. The measured value is valid.
F	'Function check' status	A calibration is performed on the gas analyzer or the maintenance switch is on. The measured value is not a process measured value and is to be discarded.
S	Overall status	The overall status is always set together with the 'Failure' status, as well as for individual messages, together with the 'Maintenance required' status, and is not set together with the 'Function check' status.

Status Message Categories

a	Active status message not requiring acknowledgment
aQ	Active status message requiring acknowledgment
aL	Active status message requiring acknowledgment and troubleshooting
iQ	Inactive status message requiring acknowledgment

"Status messages" table

No.	Status	Message	Reaction/troubleshooting
110	A S a	The device is booting.	
116	A S a	The PROFIBUS® module has been installed in a wrong slot!! The interface is therefore not functional. Please install the PROFIBUS® module in slot X20/X21.	install the PROFIBUS® module in slot X20/X21.
119	A S iQ	The configuration could not be loaded! This device does not currently contain a configuration. Please load a configuration using Optima TCT Light .	Load the configuration using Optima TCT Light . Notify Service if this occurs again.
120	F a	The maintenance switch is ON.	
121	aL	The limit value has alarm status.	
122	A S a	The IO module is faulty.	Replace the IO module.
123	A S a	Communication error while accessing the IO module.	Replace the IO module.
124	iQ	The configuration data was corrupt! The configuration has been restored using backup data.	
125	a	The limit value has alarm status.	
126	W a	The QAL3 data memory is full. Please export the data.	Export QAL3 data.
127	W a	The drift values up-scale the QAL3 limits.	Repeat calibration. Initiate maintenance of the AMS.
250	A S aQ	The analyzer could not be found.	Check plug connection and wiring.
251	A S aQ	The connection to the analyzer was lost!	Check plug connection and wiring.
252	A S aL	The EEPROM data of the analyzer are faulty.	Check the configuration using Optima TCT Light .
253	A S aL	The communication with the analyzer is disrupted!	Check plug connection and wiring.
254	A S a	The boot program of the analyzer is faulty! Notify Service!	Notify Service.
255	A S a	The program of the analyzer is faulty! Notify Service!	Notify Service.

No.	Status	Message	Reaction/troubleshooting
300	A S aL	No new measured values from the analog/digital converter.	Notify Service.
301	A S a	The measured value exceeds the value range of the analog/digital converter.	Check sample gas concentration. Check connectors on the gas analyzer. Notify Service.
302	W aQ	The offset drift up-scales half of the range permissible.	Observe drift. As long as the drift is below the value specified in the measurement data, the measured value is OK. As soon as the drift exceeds this value, notify Service.
303	A S aQ	The offset drift up-scales the permissible range.	Notify Service. Perform a basic calibration (with Optima TCT Light).
304	W aQ	Amplification drift up-scales half of allowed range.	Observe drift. As long as the drift is below the value specified in the measurement data, the measured value is OK. The detector concerned will need to be changed soon. Calibrate the detector displayed manually at the zero point and span point. Permissible range: 50% of the sensitivity of the detector. As soon as the drift exceeds this value, notify Service.
305	A S aQ	The amplification drift up-scales the permissible range.	Have affected detectors replaced. Notify Service. Perform a basic calibration (with Optima TCT Light).
306	W aQ	The offset drift between two calibrations exceeds the permissible range.	Adjust detector displayed manually at the zero point (This message is created by the automatic calibration) Permissible range: 15 % of the smallest measuring range that has been installed; 6 % of the smallest measuring range that has been installed for measurements on systems subject to approval and systems of the 27th and 30th. BlmSchV
307	W aQ	The offset drift between two calibrations up-scales the permissible range.	Calibrate the detector displayed manually at the end point. (This message is created by the automatic calibration) Permissible range: 15 % of sensitivity; 6 % of the sensitivity when measuring on installations that are subject to approval and installations of 27 and 30 BlmSchV
308	A S aQ	A calculation error occurred while calculating the measured value.	Power-up and power-down the power supply. Notify Service.
309	W a	The thermostat works erroneously.	Notify Service.
310	W a	The temperature correction for this component was deactivated because the temperature measured value is faulty.	Notify Service.
311	A S a	The pressure regulator works erroneously.	see status message of the relevant pressure detector
312	W a	The pressure correction for this component was deactivated because the pressure measured value is faulty.	Notify Service.
313	W a	No excess sensitivity correction for this component is possible, as the correction value is faulty.	Check with Optima TCT Light .
314	W a	No carrier gas correction for this component is possible, as the correction value is faulty.	Check with Optima TCT Light .
315	W aL	No new measured values from the analog/digital converter.	Notify Service.

... 12 Diagnosis / Troubleshooting

... Possible status messages

No.	Status	Message	Reaction/troubleshooting
316	W a	The measured value exceeds the value range of the analog/digital converter.	Notify Service.
317	W a	A calculation error occurred while calculating the measured value.	Notify Service.
321	A S a	The temperature of the detector falls below the minimum temperature.	Status message during the warm-up phase. If the status message occurs after the warm-up phase: check fuse and replace, if necessary.
322	A S a	The flame is off.	Status message during the warm-up phase. If the status message occurs after the warm-up phase: check process gases, check glow plug.
323	A S a	The analyzer is currently in the fail-safe status.	Causes: flame temperature > Detector set point + 220 °C, hardware errors, Pt-100 line break or short-circuit. Switch power supply off and back on after ≥ 3 seconds. If the status message recurs, notify Service. Note Fail-safe status: Heater off, combustion gas valve closed, instrument air valve closed, housing purging on, zero gas valve open.
324	W a	The temperature exceeds or falls below the top or bottom limit value 1.	Status messages during the warm-up phase. If the status message occurs after the warm-up phase: check whether the permissible ambient temperature range is observed. Check the connection leads and connectors. Check the fit of the leads in the wire end ferrules. Check the overheating protection in the analyzer module and replace it if necessary.
325	W a	The temperature exceeds or falls below the top or bottom limit value 2.	
326	A S aL	No new measured values from the analog/digital converter.	Notify Service.
327	A S a	The measured value exceeds the value range of the analog/digital converter.	Notify Service.
328	A S a	A calculation error occurred while calculating the measured value.	Notify Service.
329	W a	The pressure up-scales or down-scales the top or bottom limit value 1.	Fidas24: Check process gas pressures.
330	W a	The pressure up-scales or down-scales the top or bottom limit value 2.	Fidas24: Check process gas pressures.
331	A S a	The position value of the flow controller is outside the valid area.	Fidas24: Check process gas pressures.
342	W a	The flow rate down-scales the limit value 1.	Check sample conditioning. Limit value 1 = 25 % MBU.
343	A S a	The flow rate down-scales the limit value 2.	Check sample conditioning. Limit value 2 = 10 % MBU. The automatic calibration has been interrupted and blocked.
357	A S a	Limas Motor Optimization is running.	If the status message is pending for more than 5 minutes, the filter wheel is blocked. Notify Service.

No.	Status		Message	Reaction/troubleshooting	
358	W	a	The intensity measured at the receiver up-scales or down-scales the limit value 1.	Notify Service.	
359	A	S	a	The intensity measured at the receiver up-scales or down-scales the limit value 2.	Notify Service.
360	A	S	a	The filter wheel could not be initialized.	If the status message is pending for more than 5 minutes, the filter wheel is blocked. Notify Service.
362	A	S	a	The calibration filter wheel could not be initialized.	If the status message is pending for more than 5 minutes, the calibration filter wheel is blocked. Notify Service.
378	A	S	aL	Chopper wheel is blocked.	Visual inspection. Notify Service.
379	A	S	aL	Chopper wheel speed not OK.	Notify Service.
380	A	S	aL	Faulty IR beam or electronics.	Notify Service.
381	A	S	aL	High voltage defective on the preamplifier.	Notify Service.
382	A	S	aL	Measured value is influenced by vibrations.	
390	A	S	aQ	Failure of the internal power supply. Notify Service!	Notify Service.
397	A	S	a	The temperature controller sensor is faulty.	Notify Service.
398	A	S	aL	No new measured values from the analog/digital converter.	Notify Service.
399	A	S	a	The measured value exceeds the value range of the analog/digital converter.	Check sample gas concentration. Check connectors on the gas analyzer. Notify Service.
400	A	S	a	A calculation error occurred while calculating the measured value.	Power-up and power-down the power supply. Notify Service.
401	W	a		The flow up-scales or down-scales the top or bottom limit value 1.	Check measuring gas path. Notify Service.
402	A	S	a	The flow up-scales or down-scales the top or bottom limit value 2.	Check measuring gas path. Notify Service.
403	A	S	a	The position value of the flow controller is outside the valid area.	Notify Service.
404	A	S	a	The temperature exceeds or falls below the top or bottom limit value 2.	Notify Service.
411	F	S	a	The analyzer is in standby. Reactivation in menu: 'Operation / Pump/Standby / Fidas/Standby / Fidas /Restart'	Restart Fidas24.
412	F	S	a	Ignition failed. The analyzer needs to be reactivated manually. Reactivation in menu: 'Operation / Pump/Standby / Fidas/Standby / Fidas /Restart'	Check operating gases. Restart Fidas24.
413	A	S	aL	Failure of auxiliary current in the analyzer hardware.	Notify Service.
414	F	S	a	The position value of this controller is below the permissible range. (< 20%)	Check operating gases and connection leads. Restart Fidas24, where applicable. Notify Service.
415	F	S	a	The position value of this controller is above the permissible range. (> 90%)	

... 12 Diagnosis / Troubleshooting

... Possible status messages

No.	Status	Message	Reaction/troubleshooting
500	iQ	An internal calibration error has occurred.	Repeat calibration. Check the configuration using Optima TCT Light . Notify Service.
501	iQ	The requested functionality is not available in the device.	Check the configuration using Optima TCT Light .
502	iQ	A calibration error occurred in the device.	Calibration interrupted. Notify Service.
503	W S	iQ The sensitivity is too low! The calibration was aborted.	Incorrect test gas! Check test gas supply and connection; repeat calibration.
508	iQ	Unknown calibration error. Check configuration.	Message during automatic calibration. Check the configuration using Optima TCT Light .
511	iQ	Auto calibration aborted.	for information
512	F	a Autocalibration running.	for information
513	iQ	An internal calibration error has occurred.	Repeat calibration. Check the configuration using Optima TCT Light . Notify Service.
517	F	a Device is being serviced.	
518	iQ	Calibration could not be performed because the measured value is unstable.	Check test gas supply and connection; repeat calibration.
519	iQ	Calibration could not be performed because the preamplifier is overranged.	Check test gas supply and connection; repeat calibration.
529	W S	iQ The calibration was canceled, as no raw measured values can be entered.	Check test gas supply and connection; repeat calibration.
538	W S	iQ The zero calibration was aborted because the analyzer is dirty! (Reference detector)	Clean sample cell. Notify Service.
539	W S	iQ The zero calibration was aborted because the analyzer is dirty! (measuring detector)	Clean sample cell. Notify Service.
801	A S	a An external failure has occurred.	Input signal at the correspondingly configured digital input.
802	W	a An external maintenance need has occurred.	Input signal at the correspondingly configured digital input.
803	F	a Maintenance Mode defined by the user occurred at:	

Troubleshooting

Note

For the Fidas24 analyzer, the instructions under **Fidas24 – Troubleshooting** on page 176 must be observed.

Flow error

Gas lines or filter contaminated, clogged up or leaky

- disconnect the gas analyzer from the gas treatment system.
- blow out the lines with compressed air or unblock them mechanically.
- replace filter inserts and fill material.
- check gas lines for leaks.

Gas paths in the gas analyzer kinked or leaky

- disconnect the gas analyzer from the gas treatment system.
- Check whether the gas lines in the gas analyzer are kinked or have become detached from the connections.
- Check the gas feed paths in the gas analyzer for leak tightness (see **Checking gas path leak tightness** on page 201).

Outlet pressure not the same as atmospheric pressure

- Make sure that the outlet pressure is the same as the atmospheric pressure.
- Guide exhaust gases directly into the atmosphere or through a line with a large internal diameter which is as short as possible, or into a gas discharge line.
- Do not guide exhaust gases via restrictions or shut-off valves.

Unstable display of measured value

Vibrations

- Provide measures to reduce the vibrations.
- Increase the low pass time constant (see **Set low-pass time constant** on page 150).

Leaks in the gas feed paths

- Check the gas feed paths in the gas analyzer for leak tightness (see **Checking gas path leak tightness** on page 201).

Loss of sensitivity

- Check amplification drift display of the sample component (see **Drift indicator** on page 196).

Uras26: Emitter modulation uneven

- Have the emitter and modulator checked by Service.

Limas23: emission intensity of UV lamp too low or sample cell contaminated

- Check the intensity display (see **Limas23 – Intensity display** on page 181).
- Replace the UV lamp (see **Limas23 – Replacing the UV lamp (EDL)** on page 185) or clean the sample cell (see **Limas23 – Clean the sample cell** on page 182).

... 12 Diagnosis / Troubleshooting

Fidas24 – Troubleshooting

Flow error

Sample gas inlet nozzle or sample gas filter clogged

- Checking the sample gas connection for blockages of the sample gas inlet nozzle and the sample gas filter.
- Replace sample gas filter (refer to **Fidas24 – replace the sample gas filter in the heated sample gas connection** on page 192).

Temperature Problem

Connection leads of the temperature sensor or the heater disconnected

- Check the connection leads and connectors.
- Check the fit of the leads in the wire end ferrules.
- Checking the power supply to the heating system.

Unstable display of measured value

Vibrations

- Reduce vibration at the installation site.

Sample gas path leaking

- Checking for leaks in the sample gas path in the analyzer module and the sample extraction system.

Loss of sensitivity

- Having the service team replace the sample gas nozzle.

Sample gas outlet pressure too high

- Check the air jet injector for blocks, and clean it where applicable (refer to **Cleaning the Fidas24 air jet injector** on page 193). Increase instrument air pressure. Check air discharge line; it must have a large inside diameter.

Combustion air contaminated

- Check combustion gas supply

Fluctuating process gas pressures

- Check the supply of instrument air, combustion air and combustion gas

Pressure regulator fault

Unstable pressure values

- Set the external pressure of the process gases such that the manipulated variable are as follows:
Instrument air 'Output' approx. 60 %,
for combustion air 'Air' approx. 55 %,
for combustion gas 'H₂' approx. 42 % ,
see **Adjust output variables of the internal pressure controllers** on page 107.
- Have the pressure regulator modules checked.

Pressure regulator output variables not equal to set points

Manipulated variable	Measures
Air	Manipulated variable $\leq 50\%$ Reduce combustion air primary pressure.
	Manipulated variable $\leq 90\%$ Increase combustion air primary pressure.
H ₂	Manipulated variable $\leq 40\%$ Reduce combustion gas primary pressure.
	Manipulated variable $\leq 90\%$ Increase combustion gas primary pressure.
Input	Manipulated variable $\leq 50\%$ Reduce sample gas inlet pressure.
Output	Manipulated variable $\leq 50\%$ Increase the instrument air pressure. Cleaning the air jet injector (refer to Possible status messages on page 170). Reduce length of the gas discharge line or increase cross-section.
	Manipulated variable $\leq 90\%$ Reduce instrument air pressure.

Zero point drift

Sample gas line contaminated

- Cleaning the sample gas line.

Combustion air catalyst is not operating adequately

- Reduce hydrocarbon content.
- Exchange catalyst.

Combustion gas line contaminated

- Clean combustion gas line.

Flame does not ignite

Air in the combustion gas line

When connecting or replacing the combustion gas bottle make sure that no air penetrates into the combustion gas supply line. Air which has penetrated the gas supply line results in the flame in the analyzer going out.

The analyzer automatically tries to reignite the flame up to 10 times in a period of approx. 10 minutes with increased combustion gas pressure each time. If this is unsuccessful, the analyzer switches to operating condition "Wait for restart".

In this case, ignition of the flame must be restarted:

‘▲ Operation / ► Pump / Standby / ▼ Fidas Standby /
▼ Fidas Restart’

Note

The "Wait for Restart" operating condition means: heating on, combustion gas valve closed, instrument air valve open, housing purging on.

Combustion air pressure too high

- Reducing the combustion air inlet pressure
(Note the information given in the analyzer data sheet).

Fidas24 in fail-safe status

If a serious error occurs in the analyzer, the device is automatically set to the fail-safe state.

Note

The Fail-safe status means: heater off, combustion gas valve closed, instrument air valve closed, housing purging on, zero gas valve open.

The cause of the failure must be determined from the status messages (refer to **Possible status messages** on page 170).

It is not possible to restart the analyzer in the "Fidas Restart" menu; after the error has been eliminated, the gas analyzer must be restarted by switching it off and on again.

In case of instrument air supply failure

It must be ensured that the gas supply to the analyzer module is shut off if the instrument air supply fails.

This is generally ensured by the installation of a pneumatic shut-off valve in the combustion gas supply line (refer to **Shut-off valve in the combustion gas supply line** on page 36); this valve must be controlled by the instrument air supply in such a way that, should it fail (and therefore, also in the event of failure of the continuous purging of the housing) the combustion gas supply is automatically shut off (refer to **Housing purge with Fidas24** on page 39).

If such a pneumatic shut-off valve is not installed, the following precautions and measures must be taken:

- The Overall Status or the "Failure" status of the gas analyzer must be monitored.
- If the status appears, the cause must be verified in the gas analyzer on site:
 - if the gas analyzer is not in operation (for example as a result of a voltage failure), the operating gases must be shut off (see **Fidas24 – Shutting down the gas analyzer** on page 203).
 - If the gas analyzer is in operation, an adequate instrument air supply must be verified. If this is the case, the status messages must be verified. If this is not the case, proceed as follows:
 1. Shut off the combustion gas supply.
 2. Reestablish instrument air supply.
 3. Purge gas analyzer for 20 minutes.
 4. Turn on combustion gas supply.
 5. Gas analyzer starts automatically.

Note for measuring combustion gases

When measuring combustion gases, it must be made sure that in case of a failure of the instrument air supply or of the analyzer module itself the sample gas supply to the analyzer module is shut off and the sample gas path is purged with nitrogen.

... 12 Diagnosis / Troubleshooting

Notify Service

Who should you contact for further help?

Please contact your local service representative. For emergencies, please contact:

To find your local ABB contact visit:

www.abb.com/contacts

For more information visit:

www.abb.com/measurement

Before you notify Service ...

Before contacting the service department regarding a malfunction or a status message, please check whether there is, in fact, a fault in the sense that the gas analyzer is not complying with the metrological data (refer to data sheet).

When you notify Service ...

When you notify Service because of a malfunction or a status message, have the following information available:

- The Manufacturing number r (M-No.) of the gas analyzer - you will find it on the name plate and in the analyzer data sheet;
- the software version for the gas analyzer - you will find it in the analyzer data sheet and in the menu item '▼ Maintenance / ▼ Diagnosis / ► Device Info';
- an exact description of the problem or status as well as the status message number.

This information will enable the service personnel to help you quickly.

Have the analyzer Data Sheet ready – it contains important information that will help the Service personnel to find the cause of the malfunction.

Returning devices

Use the original packaging or a secure transport container of an appropriate type if you need to return the device for repair or recalibration purposes.

Fill out the return form (see **Return form** on page 215) and include this with the device.

In accordance with the EU Directive governing hazardous materials, the owner of hazardous waste is responsible for its disposal or must observe the following regulations for shipping purposes:

All devices delivered to ABB must be free from any hazardous materials (acids, alkalis, solvents, etc.).

Address for the return:

ABB AG

Service Analysentechnik – Parts & Repair

Stierstädter Straße 5

60488 Frankfurt, Deutschland

Fax: +49 69 7930-4628

E-Mail: repair-analytical@de.abb.com

Transport-/Storage temperature

-25 to 65 °C

13 Maintenance

Safety instructions

DANGER

Explosion hazard

There is a risk of explosion if the device is opened in a potentially explosive atmosphere.
Please take note of the following information before opening the device:

- A valid fire permit must be present.
- Make sure that there is no explosion hazard.
- Before opening the device, switch off the power supply.

DANGER

Risk of explosion during maintenance of the device

While the device or its components are being maintained/serviced, there is no explosion protection.

- ensure that no potentially explosive atmosphere can occur.

WARNING

Risk of injury

Risk of injury due to maintenance work being carried out incorrectly.

The work described in this chapter require special knowledge and may require work to be done on the gas analyzer while it is open and under voltage!

- Maintenance work on the gas analyzer should be performed by qualified and specially trained personnel only !

Use in potentially explosive Atmospheres

The inspection and maintenance of the explosion-protected version of the gas analyzer requires special knowledge.

- Repairs and replacement of parts on the device may only be done by ABB service.
- For information on returning the device, refer to **Returning devices** on page 178.

Inspection

Regular inspection

Proceed according to the checklist under **Installation Check** on page 104.

Check leak tightness of the gas paths

The leak tightness of the sample gas path and, if applicable, the reference gas path must be checked at least once a year during operation.

The leak tightness of the sample gas path must always be checked after the sample gas path has been opened inside the gas analyzer (see **Measures to take after each opening of the gas paths within the gas analyzer** on page 201).

If incoming measured values are creeping during operation (e.g. after test gas is switched on) or implausible measured values appear, a leak in the sample gas path is the possible cause.

... 13 Maintenance

Maintenance switch

Menu path

▼ Maintenance / ► Maintenance Switch'

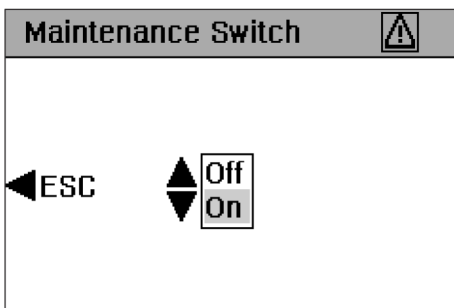



Figure 90: 'Maintenance switch' Menu "

Function of the maintenance switch

The maintenance switch is used to set the "Function check" status (see **Status messages – Explanations** on page 168) as long as maintenance is carried out on the gas analyzer, such as a leak tightness test.

While the maintenance switch is set to 'On', the  icon on the LCD display flashes.

The 'Function check' status signal is issued; thus, the gas analyzer signals that the current measured values are to be discarded as process measured values.

Perform calibration reset

Menu path

▼ Maintenance / ► Basic Settings / ► Calibration Reset'

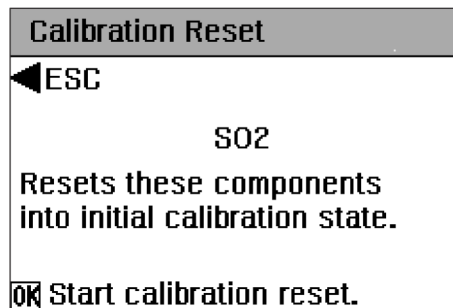

Figure 91: 'Calibration reset' menu

When should the calibration reset be performed?

A calibration reset should only be performed if an analyzer module can no longer be calibrated by normal means. A possible cause of this could be that for example, the gas analyzer was calibrated with the incorrect test gases.

What does the calibration reset do?

The calibration reset restores the calibration of the gas analyzer to a factory-set base calibration state. Furthermore, the offset drift and amplification drift are electronically returned to base calibration values.

Status signal

The 'Function check' status signal is set during the calibration reset, see **Status messages – Explanations** on page 168.

Note

The calibration reset cannot be performed while an automatic calibration is in progress.

Uras26, Limas23 – measuring the calibration cell

Menu Path

▼ Maintenance / ► Basic Settings / ▼ Measure Cal. Cell'

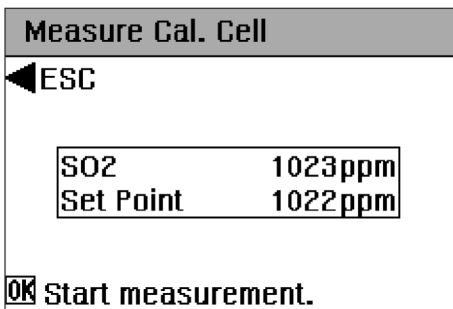

Figure 92: 'Measure calibration cell' menu

Definition

When measuring the calibration cell, the current concentration of the calibration cell is determined by test gases. The measured concentration is stored as a set point for calibration with the calibration cell.

When do calibration cells need to be measured?

We recommend measuring the calibration cells once a year. In addition, we recommend measuring the calibration cell after the measuring range set by the user has been calibrated with test gases for the first time and whenever the test gas has been changed.

Before measuring the calibration cells

Prior to measuring the calibration cells, the zero and end points of the applicable sample components must be calibrated with test gases.

Connect the zero gas supply.

During calibration cell measurement, the zero gas supply must be connected.

Status Signal

While the calibration cell is being calibrated, the 'Function check' status signal is active (see **Status messages – Explanations** on page 168).

Limas23 – Intensity display

Menu path

▼ Maintenance / ▼ Diagnosis / ▼ Device Status /
► Analyzer Status / ▼ Limas Intensity'

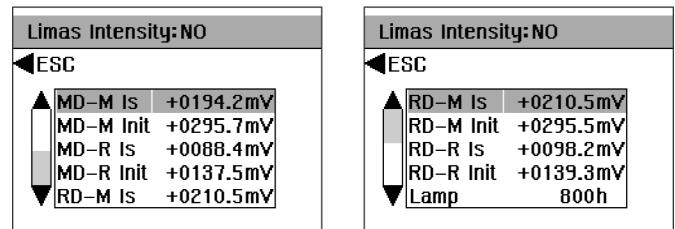

Figure 93: 'Limas Intensity' menu

Emission intensity

The emission intensity at the test receiver and reference receiver gives indications about the aging condition of the built-in UV lamp and possible contamination of the sample cell.

Display of the emission intensity

For each measured component, various values for the radiation intensity are displayed in mV. The abbreviations have the following meaning:

MD	Test receiver
RD	Reference receiver
-M	Measurement phase
V	Comparison phase
Is	Value in measurement mode (actual value)
Init	Value in the intensity standardization of the built-in UV lamp

Additionally, the operation time of the built-in UV lamp is indicated.

Note

- The serial number as well as the operating time of the built-in UV-lamp are displayed in the 'Device Information' menu (see **Instrument information** on page 200).
- Intensity standardization has been performed at the factory. It must be repeated after the UV lamp is replaced.

... 13 Maintenance

... Limas23 – Intensity display

Emission intensity too low

If the actual values of the emission intensity are significantly reduced compared to the init values (approx. factor 10 or more), this is the probable reason for an unstable display of measured values.

The following cases should be distinguished:

- If both actual values dropped on the test receiver, the sample cell is probably contaminated. The sample cell needs to be cleaned.
- If all four actual values have dropped in approximately the same ratio on both the test receiver and the reference receiver, the lamp intensity has probably dropped. The UV lamp must be replaced.

If the emission intensity has become too low for proper function, this is also indicated by corresponding status messages (see **Possible status messages** on page 170).

Limas23 – Clean the sample cell

When should the sample cell be cleaned?

The sample cell must be cleaned when the display of measured values has become unstable (drift or disruption) and the analysis of the intensity display (see **Limas23 – Intensity display** on page 181) has shown that the sample cell has been contaminated.

Required are:

- Cross recess screwdriver PZ 2
- Hexagon socket wrench 3 mm
- Allen key 4 mm
- Slot wrench 8 mm
- For cleaning:
Neutral detergent, de-ionized water, ethanol
- For drying:
Oil and dust-free (instrument) air or nitrogen
- Spray bottle
- Plug for sealing the sample cell
- FPM hose

Sample cell removal

1. Disconnect the supply of sample gas to the gas analyzer!
2. Switch off the gas analyzer power supply!
3. Open the door of the wall housing (hexagon socket 4 mm) or remove the cover of the 19" housing (cross recess PZ 2).

Remove light protection hoods

⚠ CAUTION

Risk of burns

Risk of burns due to the hot lamp and sample cell (approx. 55 to 60 °C).

- Before working on the lamp and the sample cell, allow the components to cool.

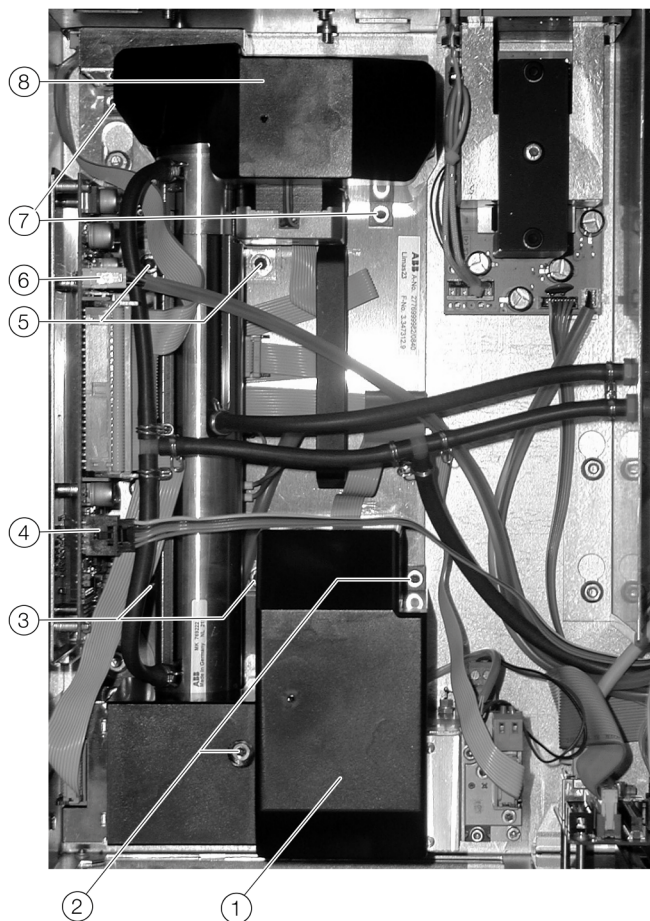

Figure 94: Removing the light protection hoods

4. Loosen 2 fixing screws ② and ⑦ (hexagon socket 3 mm) and lift out the light protection hoods ① and ⑧.

Loosen electrical connections and gas lines

5. Disconnect plugs ④ and ⑥ from the electrical connections.
6. Loosen all gas lines from the connection socket of the sample cell and in the housing and pull out of the housing.

NOTICE

Pollution and damage of components

Pollution of the device and damage to components due to improper handling.

- When removing the sample gas lines make sure no contaminants contained in the pipes fall into the housing. The sample gas pipes removed should not be reused since they are polluted; follow the appropriate rules for disposal.
- The quartz glass sample cell must be handled with extreme care!
The connection sockets in particular can easily break in case of improper handling!

Remove the sample cell

7. Loosen 2 screws ③ and ⑤ (hexagon socket 4 mm) and remove the sample cell with heater block from the housing.
8. Loosen 2 screws ⑨ (hexagon socket 3 mm) and remove heater block from the sample cell.

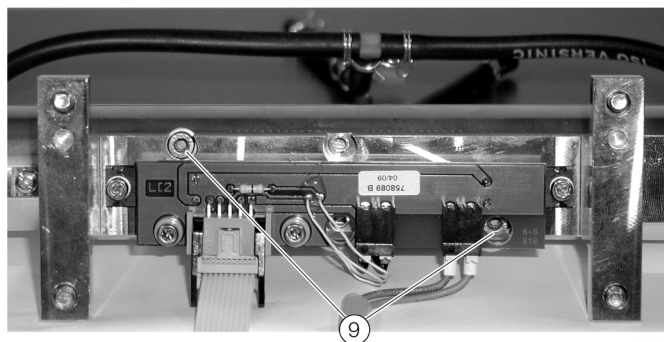

Figure 95: Removing the heater block

... 13 Maintenance

... Limas23 – Clean the sample cell

Sample cell cleaning

CAUTION

Risk of fire and poisoning

Risk of fire and poisoning in case of improper handling with ethanol.

- Ethanol is flammable and toxic!
Observe the relevant instructions for special risks and safety advice!

NOTICE

Damage to the sample cell

Damage to the sample cell due to unsuited cleaning agents.

- Only clean the sample cell according to the following instructions:
- Clean the sample cell with a warm detergent/water mixture.
 - Rinse the sample cell thoroughly with de-ionized water.
 - Then rinse the sample cell thoroughly with water-free ethanol.
 - Dry the sample cell with nitrogen or air which is free of oil, dust and water at a flow rate of 30 to 100 l/h.
 - Check that the contamination has been removed.

Note

Also clean the sample gas lines outside the gas analyzer!

Sample cell installation

- Perform steps 4 to 8. (see **Sample cell removal** on page 182) in reverse order.
Observe the following information in the process:
 - Use new gas lines!
 - For a sample cell with center connection, the sample gas inlet is located in the middle and the sample gas outlets are located at the ends of the sample cell.
 - When installing the sample cell, make sure that the plastic insulating strips are positioned correctly at the mounting points.
 - When installing the sample cell and placing the light protection hood, make sure that the connection cables are not crushed or damaged.
- Check the leak tightness of the gas paths in the gas analyzer (see **Checking gas path leak tightness** on page 201).

Recommissioning the gas analyzer

- Close the housing tightly.
Notice
Light penetration during operation leads to erroneous measurement values and overranging.
- Turn on the gas analyzer power supply and wait for the warm-up phase to end.-up.
- Check zero point and end points as well as linearity, if necessary.

Limas23 – Replacing the UV lamp (EDL)

When should the UV lamp be replaced?

The UV lamp must be cleaned when the display of measured values has become unstable (drift or disruption) and the analysis of the intensity display (see **Limas23 – Intensity display** on page 181) has shown that the emission intensity of the UV lamp has become too small.

Note

In the UV lamp (EDL = Electrodeless Discharge Lamp = electrodeless discharge lamp), the filling gas is emitted in the plasma discharge over a period of about 2 to 3 years, thereby decreasing the emission intensity.

Determining UV lamp service life

The operation time of the UV lamp is shown in the following menus:

‘▼ Maintenance / ▼ Diagnosis / ▼ Device status / ► Analyzer status / ▼ Limas Intensity’

or

‘▼ Maintenance / ▼ Diagnosis / ► Device info’

Overview of the work to be carried out:

- Replacing the UV lamp:
 - Remove the old lamp,
 - Install the new lamp,
 - Recommission the gas analyzer.
- Configure and calibrate the gas analyzer.
 - Enter the serial number of the new lamp,
 - Adjust the zero point of the electronic SO₂ cross-sensitivity correction if necessary,
 - Intensity standardization.
- Other calibration activities (recommended):
 - Check the sensitivity of all measured components,
 - Check the linearity of the SO₂ sample component,
 - Check the installed calibration cells.

Required are:

- Cross recess screwdriver PZ 2
- Hexagon socket wrench 2.5 mm
- Hexagon socket wrench 3 mm
- Allen key 4 mm
- Slot wrench 8 mm
- Open-end wrench or ring wrench 8 mm

Replacing the UV lamp – Remove the old lamp

1. Disconnect the supply of sample gas to the gas analyzer!
2. Switch off the gas analyzer power supply!
3. Open the door of the wall housing (hexagon socket 4 mm) or remove the cover of the 19" housing (cross recess PZ 2).

Remove light protection hood

CAUTION

Risk of burns

Risk of burns due to the hot lamp and sample cell (approx. 55 to 60 °C).

- Before working on the lamp and sample cell, allow the components to cool.

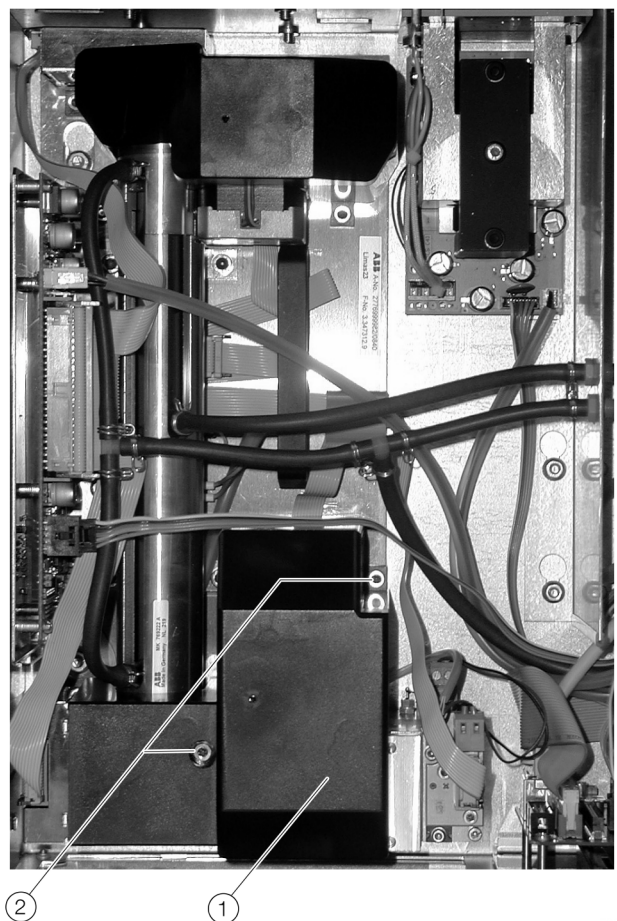

Figure 96: Removing the light protection hood

4. Loosen 2 fixing screws (2) (hexagon socket 3 mm) and lift out the light protection hood (1).

... 13 Maintenance

... Limas23 – Replacing the UV lamp (EDL)

Remove the lamp from the bracket



Figure 97: Removing the lamp

- Loosen 3 mounting nuts ③ (8 mm) of the bracket.

Notice

Loosen the nuts as far as possible but do not completely unscrew them from the threaded bolts!

- Disconnect connection cable ⑦ of the lamp heater from the heater block.
- Unscrew 2 fixing screws ⑥ (hexagon socket 3 mm) and remove from bracket ⑤, lift out the bracket and remove lamp ④ downwards and to the side out of the bracket.

Remove heater from the lamp

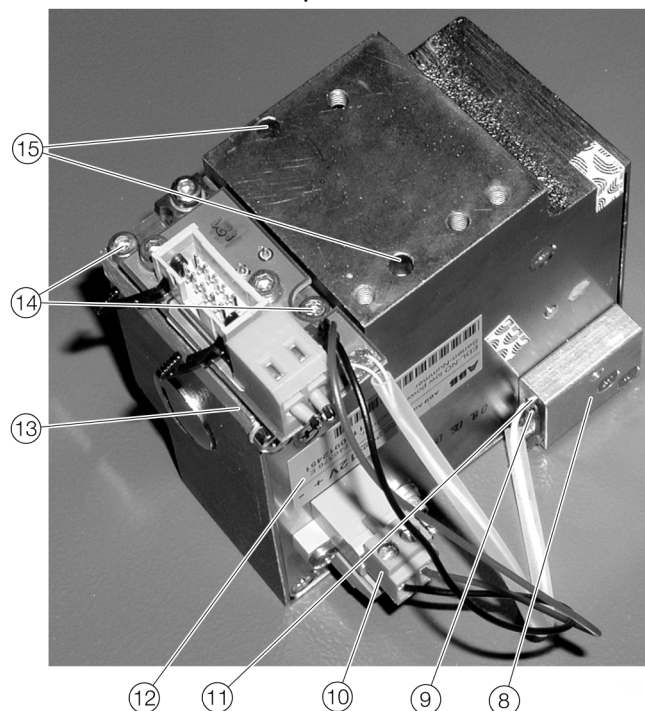

Figure 98: Removing the heater

- Remove fixing screw ⑨ (hexagon socket 2.5 mm) with washer and retaining bracket for temperature sensor ⑪.

Notice

These parts are needed to fasten the temperature sensor to the new lamp!

- Carefully lift out the temperature sensor ⑪ from the hole of the temperature sensor block ⑧.
- Disconnect the plug for the 12 V supply ⑩, remove the 2 fixing screws ⑭ (hexagon socket 2.5 mm) on the heating block ⑬ and remove the complete heater block from the lamp.

NOTICE

Damage to components

Damage to components due to improper disassembly.

- Only the two screws ⑭ securing the heater block ⑬ to the lamp may be loosened!

Replacing the UV lamp – Installing the new lamp

1. Before installing the new lamp, record the serial number shown on the name plate (12). It will need to be provided during subsequent configuration and calibration.
2. Perform steps 4 to 10. (see **Replacing the UV lamp – Remove the old lamp** on page 185) in reverse order. Observe the following information in the process:
 - Insert the new UV-lamp into the lifted bracket from below so that the two guide pins on the bracket fit in the appropriate holes (15) in the lamp.
 - When placing the light protection hood, make sure that the connection cables are not crushed or damaged.

Recommissioning the gas analyzer

1. Close the housing tightly.

Notice

Light penetration during operation leads to erroneous measurement values and overranging.

2. Turn on the gas analyzer power supply and wait for the warm-up phase to end.-up.
3. Configure and calibrate the gas analyzer (see **Configuring and calibrating the gas analyzer** on page 187).

Configuring and calibrating the gas analyzer

After replacing the UV lamp, the following work must be carried out:

- Enter the serial number of the new lamp,
- Adjust the zero point of the electronic SO₂ cross-sensitivity correction if necessary,
- Intensity standardization.

Required are:

- Software tool Optima TCT Light
- Ethernet connection between the gas analyzer and the computer
- Zero point gas: either nitrogen or sample component-free ambient air

Enter new lamp number

1. Open the software tool Optima TCT Light.
2. Click on the command 'Configuration mode...' in the 'Options' menu. In the 'Configuration Mode' dialog, click on 'AMC module' and close the dialog by clicking 'OK'.
3. Click the command 'Establish communication...' in the 'File' menu. In the 'Establish communication' dialog, select the 'Network' communication mode, enter the IP address or the server name (see **Setting the IP address** on page 155) of the gas analyzer, click on 'Connection' and close the dialog by clicking on 'OK'. In the following query, click 'Yes'.
Communication is established and the data from the gas analyzer is read.

... 13 Maintenance

... Limas23 – Replacing the UV lamp (EDL)

- In the menu tree, click on 'Limas23 UV Detector 1' and double-click on the 'Limas23 Configuration Parameters' in the 'Detector' window in the 'Correction Functions' tab.

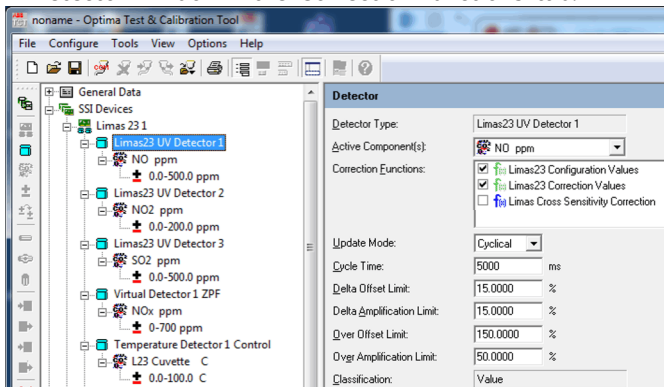

Figure 99: Optima TCT Light – Configuration parameters

- Enter the serial number of the new lamp in the 'Limas23 Configuration Parameters' dialog (without using the three leading digits '111') and close the dialog by clicking on 'OK'.

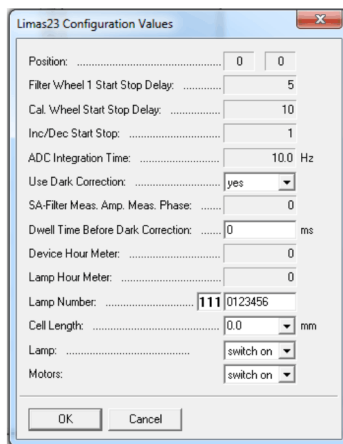

Figure 100: Entering the lamp number

- In the 'File' menu, click the 'Send module data' command and send the changed data record to the gas analyzer.

Adjusting the zero point of the electronic SO₂ cross-sensitivity correction

An electronic SO₂ cross-sensitivity correction can be configured in a gas analyzer that only measures the sample component NO ('Limas cross-sensitivity correction' is activated in the 'Detector' window under 'Correction functions').

In this case, SO cross-sensitivity correction must be adjusted before the intensity normalization:

- Wait for the gas analyzer to warm-up.
- Feed in zero gas and wait until the display of measured value is stable.
- Click on Optima TCT Light the 'Calibration' command in the 'Overview' menu.
- In the 'Calibration – Overview' window, click on the 'Limas cross-sensitivity zero gas' function.

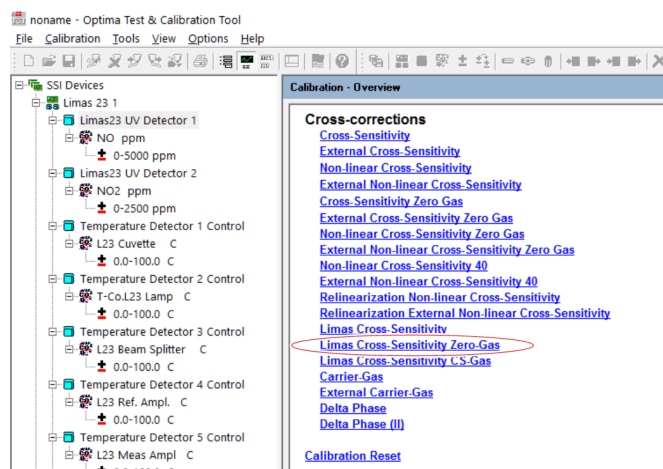

Figure 101: Optima TCT Light – Cross-sensitivity correction

- Select the detector and start the calibration by clicking the ▶ icon. Perform the calibration step by step.
- Then carry out the intensity standardization for the measured component NO.

Carry out intensity standardization

The intensity standardization allows the raw measured values of the sample components with zero point gas to be scaled to zero. At the same time, for each measured component, the init values of the emission intensity of the sample phase and the reference phase are determined and stored on both receivers for the new lamp.

1. Wait for the gas analyzer to warm-up.
2. Feed in zero gas and wait until the display of measured value is stable.
3. Reassume communication with the gas analyzer via Optima TCT Light.
4. Click on the 'Calibration' command in the 'Overview' menu.
5. In the 'Calibration' menu, click the 'Limas Intensity Standardization...' command or, in the 'Calibration – Overview window, click on the 'Intensity Standardization' function.

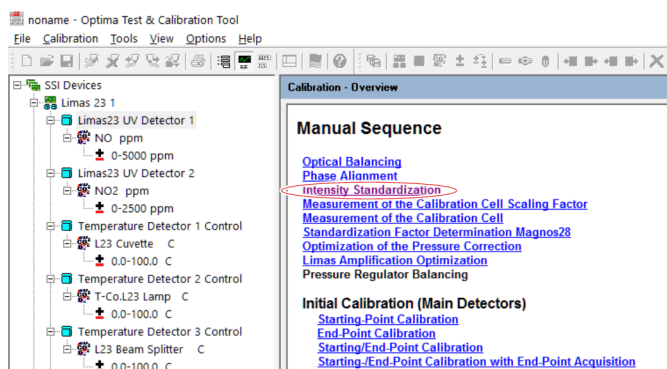



Figure 102: Optima TCT Light – Intensity standardization

6. In the 'Calibration – Intensity Standardization' window, select the detectors and start the intensity normalization by clicking on the  icon.

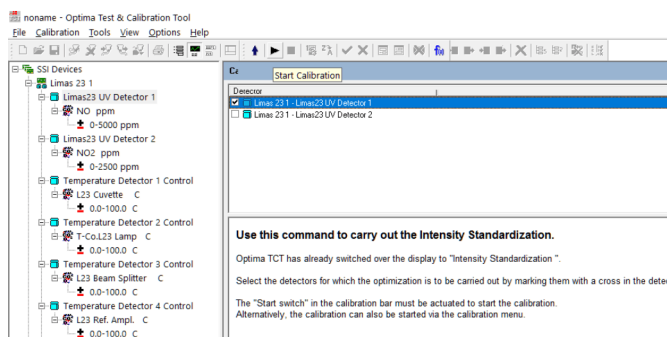



Figure 103: Optima TCT Light – Starting the intensity standardization

7. For each detector, the connection of the zero point gas as well as the stabilization of the measured value must be confirmed by clicking on the  symbol.

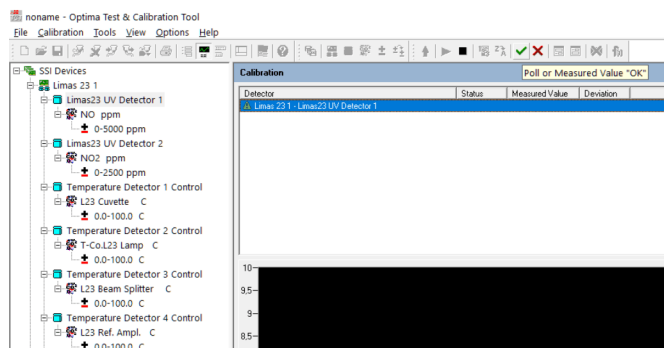

Figure 104: Optima TCT Light – Connect zero gas

The procedure can be aborted by clicking on the  icon.

Other calibration activities (recommended)

It is recommended that the following work is carried out after the intensity standardization, depending on the configuration of the gas analyzer. This work can either be carried out using Optima TCT Light or directly on the gas analyzer.

1. Check the sensitivity of all measured components with the respective end point gas. If necessary, calibrate end points.
2. Check the linearity of the SO₂ sample component at approx. 50 % of the measuring range with the corresponding test gas. If necessary, perform a post-linearization (only possible with Optima TCT Light).
3. Check the installed calibration cells (zero point gas required). If necessary, measure calibration cells (see **Uras26, Limas23 – measuring the calibration cell** on page 181).

... 13 Maintenance

ZO23 – Function Test

Description

The function test is used to carry out a rapid and regular check of the response time of the sample cell.

The function test can be carried out without any test gases by feeding the sample gas with constant concentration.

The function test has a very high correlation to a check with test gases. In case of doubt, the latter is decisive, however.

The function test facilitates the preventive maintenance of the gas analyzer, since a requisite exchange of the sample cell becomes plannable through the change in the response time.

Procedure

In the function test, the build-up of an oxygen potential in the sample cell is simulated through the connection of an electrical test current.

The change in the oxygen potential correlates with the response time of the sample cell. A small change in the oxygen potential points to a relatively fast response time of the measuring cell.

In this case, the result of the function test is 'Test Passed'.

If the value deviates from the value before the completion of the test by more than 10 % of the value before the beginning of the test, the result is rejected, since it is assumed that the change in the sample gas was too high during the test.

Test factor

The test result can be tailored to the required response time. For this purpose, the test factor can be set by the user within the range 1 to 200 %. A test factor of 100 % is set ex works.

Test Factor	T ₉₅ -time for gas change in 0 to 10 ppm measuring range
30 %	100 s
100 %	60 s
150 %	30 s
200 %	20 s

If the test criteria are not met, the test factor must either be changed or the sample cell checked by means of test gases.

Check of the sample cell using test gases

To check the T₉₅-time, two test gases with differing concentrations are required in the measuring range (see **Sample gas** on page 30), for example a test gas with 2 ppm O₂ and a test gas with 8 ppm O₂.

The T₉₅-time is determined through alternating application of the test gases.

Beforehand, purge the test gas valves and the gas lines with oxygen-free gas (e.g. with nitrogen from a loop feeder) or with sample gas (flow rate 5 to 10 l/h, duration approx. 2 h).

Performing the function test

The function test takes approx. 15 minutes. It is therefore recommended that it is carried out at a time when the process control is not adversely affected thereby.

The function test is executed in 2 phases:

1. After start-up, the test current is applied to the sample cell for approx. 400 s.
2. The test current is then switched off, and the function test is ended after another 400 s.

Menu path

- ▼ Maintenance / ▼ Diagnosis / ▲ Test Functions /
- ▶ Analyzer Test / ▲ ZO23 Function Test'

▲ Change Test Factor	Factory setting 100 %
▶ Show Test Result	Passed: End test. Failure: change test factor. Impossible: Keep measured gas concentration stable or use test gas.
▼ Execute Test	Start function test by selecting OK ; the remaining time is displayed.

Fidas24 – Standby / Restart

Definitions

- **Standby mode:**
Heater on, combustion gas valve closed, combustion air valve closed, instrument air valve closed, housing purging on, zero gas valve opened in standby mode with purging of the detector.
- **Fail-safe mode:**
Fail-safe means: heater off, combustion gas valve closed, instrument air valve closed, housing purging on, zero gas valve open.

Set Fidas24 in Standby mode

- ▲ Operation / ► Pump / Standby / ▼ Fidas Standby
► Fidas Standby'

In the 'Fidas Standby' menu, you can choose between the 'Standby & Purge' and 'Standby' operating modes:

Standby	Standby mode is activated.
Standby & Purge	Standby mode with opening of the zero gas valve for purging the detector is activated (only when executing with test gas connection).

In standby mode, there is a 'Function check' status signal (see **Status Signals** on page 168) and the status message no. 411 'Fidas24 Standby mode' (see **Possible status messages** on page 170) is issued; the measured values are invalid.

Note

If the Fidas24 is in fail-safe mode (see **Fidas24 in fail-safe status** on page 177), it cannot be set to standby mode.

Setting Fidas24 back to measurement mode

- ▲ Operation / ► Pump / Standby / ▼ Fidas Standby
▼ Fidas Restart'

The menu 'Fidas Restart' shows the most important operating parameters of the Fidas24:

F-D1	Flame temperature
B-Air	Combustion air pressure
B-Gas	Combustion gas pressure

The restart is initiated by pressing **OK**. After initiating the restart, you can leave the menu by selecting ◀; the restart sequence will continue to be executed. The restart sequence can, however, also be observed further in the menu.

Note

If the Fidas24 is in fail-safe mode (see **Fidas24 in fail-safe status** on page 177), it cannot be set to measurement mode.

... 13 Maintenance

Fidas24 – replace the sample gas filter in the heated sample gas connection

When is it necessary to replace the filter?

The sample gas filter in the heated sample gas connection must be replaced whenever it is polluted, resulting in the sample gas flow rate being too low.

Requisite Material

- Sample gas filters with O-rings (Part Number 0768649)
- Allen key 4 mm

Replace sample gas filter

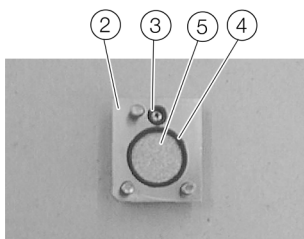
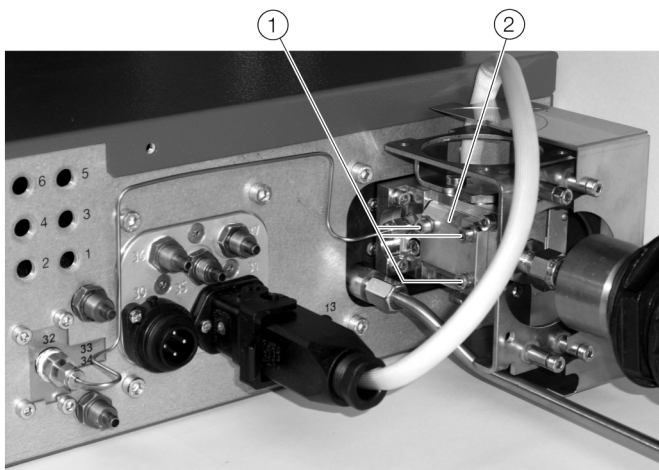

- | | |
|----------------------------|---------------------|
| ① Fixing screws | ④ O-ring |
| ② Sample gas filter holder | ⑤ Sample gas filter |
| ③ O-ring | |

Figure 105: Sample gas filter on the sample gas connection point (example, image of EL3000)

⚠ CAUTION

Risk of burns

Risk of burns at the heated sample gas connection (temperature approx. 180 °C)!

- Before working on the heated sample gas connection, switch off the power supply and allow the sample gas connection to cool for about 30 minutes.

1. Disconnect the supply of sample gas to the analyzer module! Power-down the 115 / 230 V AC power supply to the gas analyzer and heater, as well as the separate 24 V DC supply to the analyzer module, if applicable!
2. Loosen the three fastening screws ① and remove the sample gas filter holder ② from the sample gas connection block.
3. Remove the O-rings ③/④ and the polluted sample gas filter ⑤ from the sample gas filter holder ②.
4. Insert the new sample gas filter ⑤ and new O-rings ③/④ into the sample gas filter holder ②.

Note

Always change the O-rings when replacing the sample gas filter. Contaminated or damaged O-rings impair the seal integrity of sample gas path; this leads to erroneous measured values.

5. Place the sample gas filter holder ② onto the sample gas connection block and fasten it with the three fastening screws ①. Only tighten the fastening screws until the sample gas filter holder is resting on metal. Make sure that the O-rings ③/④ do not fall out of the sample gas filter holder in the process.
6. Restore the sample gas supply to the analyzer module.
7. Switch on the power supply.
8. Check the manipulated variables of the internal pressure regulators for the operational gases, and adjust as necessary (refer to **Fidas24 – Commissioning the gas analyzer** on page 106).
9. Once the warm-up phase is complete, calibrate the gas analyzer.

Cleaning the Fidas24 air jet injector

When does a housing purge become necessary?

It is necessary to clean the air jet injector when the sample gas outlet pressure is too high, i.e. when the negative pressure can no longer be adjusted to $p_{\text{abs}} < 600 \text{ hPa}$.

Requisite Material

- Open-ended spanner 12 mm and 14 mm
- O-ring set for the detector (order number 769343)
- Ultrasonic bath with aqueous cleaner (e.g. Extran® MA 01 alkaline)
- High-temperature grease (order number 772341)

Clean air jet injector



- ① Exhaust air outlet with the air jet injector screwed in
- ② Exhaust pipe
- ③ O-ring
- ④ O-ring
- ⑤ O-ring
- ⑥ The removed air jet injector

Figure 106: Removing the air jet injector (example, image of EL3000)

⚠ CAUTION

Risk of burns

Risk of burns at the heated sample gas connection (temperature approx. 180 °C)!

- Before working on the heated sample gas connection, switch off the power supply and allow the sample gas connection to cool for about 30 minutes.

1. Disconnect the supply of sample gas to the analyzer module! Power-down the 115 / 230 V AC power supply to the gas analyzer and heater, as well as the separate 24 V DC supply to the analyzer module, if applicable!
2. Unscrew the exhaust air pipe ② from the exhaust air outlet ① (open-end wrench 12 mm).
3. Unscrew the air jet injector from the exhaust air outlet ① (open-end wrench 14 mm).
4. Clean the air jet injector in an ultrasonic bath. Use an aqueous cleaner (e.g. Extran®).
5. Replace O-rings ③/④/⑤ with new O-rings.

Note

- When cleaning the air jet injector, always replace all three O-rings! Dirty or damaged O-rings impair the suction power of the air jet injector; this can lead to the failure of the Fidas24.
 - Lightly grease all three O-rings with high temperature grease (part number 772341) before inserting them.
6. Screw the air jet injector ⑥ into the exhaust air outlet . Ensure that the O-rings are seated correctly.
 7. Screw the exhaust air pipe ② onto the exhaust air outlet ①.
 8. Restore the sample gas supply to the analyzer module.
 9. Switch on the power supply.
 10. Check the manipulated variables of the internal pressure regulators for the operational gases, and adjust as necessary, refer to **Fidas24 – Commissioning the gas analyzer** on page 106.
 11. Once the warm-up phase is complete, calibrate the gas analyzer.

... 13 Maintenance

Check the integrity of combustion gas path

DANGER

Explosion hazard

Explosion hazard due to improper leak tightness test.

- The leak tightness check may be carried out by qualified and specially trained persons only.
- If these conditions are not provided or the prescribed materials are not available, a seal integrity test must be carried out by ABB Service.

Check the tightness of the combustion gas line

The seal integrity of the combustion gas feed line must be regularly checked in accordance with the two following instructions, depending on whether the combustion gas is offered from a bottle or a central supply.

Combustion gas supply from a cylinder

1. Switch off the gas analyzer power supply. Ensure that the shut-off valve in the combustion gas supply line is open.
2. Set the combustion gas pressure at 1.1 x the normal pressure of the combustion gas, i.e. at approx. 1.3 bar.
3. Mark bottle pressure display on the high-pressure manometer.
4. Close the valve of the combustion gas bottle.
5. Observe the display on the high-pressure manometer – it should not change measurably in 10 minutes.
 - A measurable change in the display is an indication of a leak in the combustion gas path between the bottle pressure reducer and the combustion gas inlet valve of the gas analyzer.

In this case the following measures are to be taken:

 - Check the combustion gas line between the bottle and gas analyzer with a leak detection spray. A leak in this area must be remedied and another leak test must be performed before the gas analyzer is put into operation again.
 - If no leak is found, that means the gas analyzer combustion gas inlet valve is leaky.

DANGER

Explosion hazard

Explosion hazard if there is a leak in the combustion gas inlet valve.

If a leak is detected at the combustion gas inlet valve:

- Disconnect the combustion gas supply.
- Do not restart the gas analyzer.
- Have the combustion gas valve replaced by the ABB Service team.

6. After conclusion of the seal integrity test, set the combustion gas pressure to normal pressure again, i.e. 1.2 bar.

Combustion gas supply from a central unit

1. Switch off the gas analyzer power supply. Ensure that the shut-off valve in the combustion gas supply line is open.
2. Set the combustion gas pressure at 1.1 x the normal pressure of the combustion gas, i.e. at approx. 1.3 bar.
3. Mark pressure indication on the manometer of the pressure reducer.
4. Shut off the combustion gas supply.
5. Observe the display on the manometer – it should not change measurably in 10 minutes.
 - A measurable change in the display is an indication of a leak in the combustion gas path between the pressure reducer and the combustion gas inlet valve of the gas analyzer.
In this case the following measures are to be taken:
 - Check the combustion gas line between the pressure reducer and gas analyzer with a leak detection spray. A leak in this area must be remedied and another leak test must be performed before the gas analyzer is put into operation again.
 - If no leak is found, that means the gas analyzer combustion gas inlet valve is leaky.

DANGER

Explosion hazard

Explosion hazard if there is a leak in the combustion gas inlet valve.

If a leak is detected at the combustion gas inlet valve:

- Disconnect the combustion gas supply.
- Do not restart the gas analyzer.
- Have the combustion gas valve replaced by the ABB Service team.

6. After conclusion of the seal integrity test, set the combustion gas pressure to normal pressure again, i.e. 1.2 bar.

Combustion gas path in the gas analyzer

DANGER

Explosion hazard

Explosion hazard if there is a leak in the combustion gas path of the gas analyzer.

If a leak is detected in the combustion gas path within the gas analyzer:

- Shut down the gas analyzer and do not restart it under any circumstances.
- The cause of the leak must be determined and remedied by ABB Service.

CAUTION

Risk of electric shock

Risk of electric shock during the leak tightness test.

The leak tightness test described in this section requires special training and under some circumstances involves working with the gas analyzer open and powered up.

- The leak tightness check may be carried out by qualified and specially trained persons only.
- If these conditions are not provided or the prescribed materials are not available, a seal integrity test must be carried out by ABB Service.

1. The gas analyzer must be in operation (flame on).
2. Inspection of combustion gas feed path with positive pressure (combustion gas inlet to combustion gas nozzle):
 - Check all connection points with a hydrogen detector (for example, based on thermal conductivity) for leakage of combustion gas.
 - The leakage rate may not up-scale 1×10^{-4} hPa l/s.
3. Inspection of the combustion gas feed path with negative pressure (in the detector, after the combustion gas nozzle):
 - Connect zero gas at the sample gas inlet.
 - Shroud all joints successively with a small cloud of a gas that contains hydrocarbons (e.g. with a cold spray or a test gas that contains hydrocarbons, or a cloth soaked in acetone).
 - Observe the measured value display; if the measured value changes to a positive value, the relevant connection is **leaking**.

... 13 Maintenance

Drift indicator

Menu Path

'▼ Maintenance / ▼ Diagnosis / ▼ Device Status /
▶ Analyzer Status / ▶ Drift'

Drift SO2	
◀ ESC	
Offset	-0.76%
Amplification	5.95%
Delta Offset	0.00%
Delta Ampl.	0.00%

Figure 107: 'Drift indicator' menu

Drift

The offset and amplification drift values are calculated cumulatively starting from the last basic calibration.

Delta drift

The offset and amplification Delta drift values are calculated between the last and next to last automatic calibration. They are deleted by manual zero point or end-point calibration.

Note

The drift values are displayed in percent of the customer measuring range, i.e. the factory-set measuring range (see **Limits of measuring ranges** on page 143) (see **Analyzer data sheet** on page 17).

The drift values are cleared by a calibration reset.

Pressure correction

Menu Path

'▼ Maintenance / ▶ Basic Settings / ▲ Atmospheric Pressure'

Atmospheric Pressure	
◀ ESC	
Pressure	1008hPa
OK Set pressure.	

Figure 108: Menu 'Atmospheric Pressure'

Air pressure effect

A change in the atmospheric air pressure compared to the calibration time results in a change in the measured value.

Automatic pressure correction with pressure sensor

If a pressure sensor is installed in the gas analyzer (see **Calibrating the pressure sensor** on page 197), automatic internal pressure correction minimizes the influence of air pressure changes on the measured value.

Pressure correction with Magnos206 / Magnos28

The Magnos206 / Magnos28 without built-in pressure sensor has been calibrated at the factory for an air pressure of 1013 hPa. If the air pressure at the installation site deviates from 1013 hPa, the current air pressure can be entered manually to correct it.

NOTICE

Impairment of the measuring accuracy of Magnos206 / Magnos28!

The pressure sensor of Magnos206 / Magnos28 is specifically adjusted at the factory for measuring ranges with suppressed zero point.

- A recalibration of the pressure sensor reduces the measuring accuracy of Magnos206 / Magnos28.

Calibration of pressure sensor

If the reading of the built-in pressure sensor differs from the actual air pressure, the pressure sensor can be recalibrated.

Note

- When measuring non-flammable sample gases, the pressure sensor can be connected to the sample gas output line via an external T-piece. In this case, when calibrating the pressure sensor, the sample gas flow must be interrupted so that the sample gas pressure does not falsify the pressure reading.
- After calibration of the pressure sensor, zero point and final point must be checked and recalibrated if necessary.
- The pressure sensor cannot be calibrated while an automatic calibration is in progress.

Calibrating the pressure sensor

1. Select the 'Air pressure' menu item.
2. Set the pressure set point.
3. Start adjustment.
4. Calibration in progress.
5. Press **OK** to return to the display of measured value.

Status Signal

While calibrating the pressure sensor, the 'Function check' status signal is active, see **Status Signals** on page 168.

Device test

Menu Path

'▼ Maintenance / ▼ Diagnosis / ▲ Test Functions / ▲ Device Test'

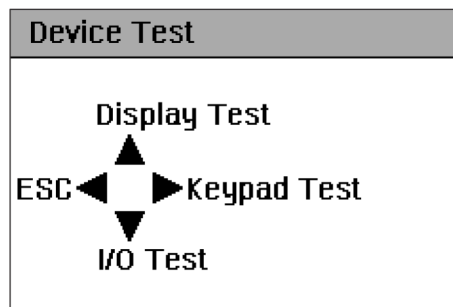

Figure 109: Menu 'Device Test'

Display Test



Figure 110: Display test

Test:

On the indicator, a gray level field runs horizontally from right to left over which a text box moves.

The display test is terminated by pressing any button.

... 13 Maintenance

... Device test

Keypad Test

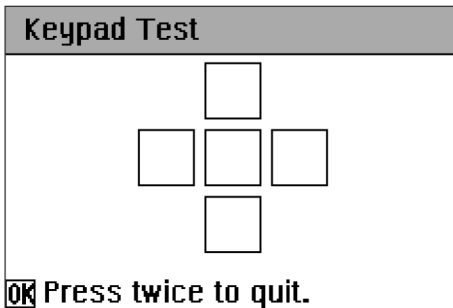

Figure 111: Keypad Test

5 square fields appear on the display.

Test:

If the user presses any button, the respective field that is assigned to the button is inverted (becomes dark) for as long as the button remains pressed.

The keyboard test is terminated by pressing the **OK** key twice.

I/O Test (Test of inputs and outputs)

Testing the digital inputs

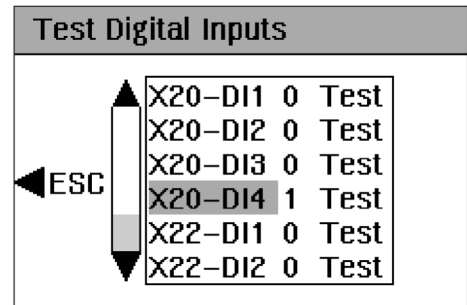

Figure 112: Menu 'Test Digital Inputs'

The list shows the digital inputs (DI) that are available on the digital I/O modules installed in the device, see **Digital I/O module** on page 99.

They are designated according to the installation locations of the digital I/O modules (X20, X22, X24, X26).

Test:

1. Disconnect the plug with the connected signal lines from the Digital I/O module.
2. Close the digital input to be tested with a wire jumper or similar.

Result:

The status indication changes from 'OK' to 'Test' and the 'Function check' status signal is set.

The function assigned to the digital input is not activated during the test.

3. Test another digital input in the same manner.

The digital inputs test is terminated by pressing the ◀ button or after approximately 5 minutes by the time-out function, which resets all digital inputs to the 'OK' state and deletes the 'Function check' status signal.

Digital output test

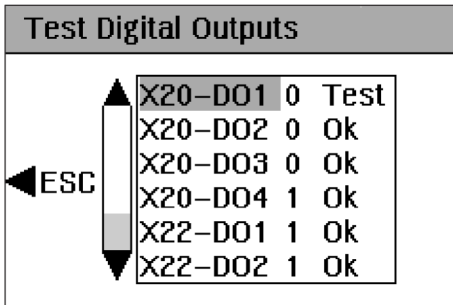

Figure 113: Menu 'Test Digital Outputs'

The list shows the digital outputs (DO) that are available on the digital I/O modules installed in the device, see **Digital I/O module** on page 99.

They are designated according to the installation locations of the digital I/O modules (X20, X22, X24, X26).

Test:

1. Disconnect the plug with the connected signal lines from the Digital I/O module.
2. Select the digital output to be tested with ▲ or ▼.
3. Call up the value change using ►.
4. Change the displayed value with ▲ or ▼, and confirm the change by selecting **OK**.

Result:

The relay at the digital output is switched, the status indication changes from 'OK' to 'Test' and the 'Function Check' status signal is set.

5. You can either test another digital output or reset the tested digital output in the same manner.

The digital outputs test is terminated by pressing the ◀ button or after approximately 5 minutes by the time-out function, which resets all digital inputs to the 'OK' state and deletes the 'Function check' status signal.

Test of analog outputs

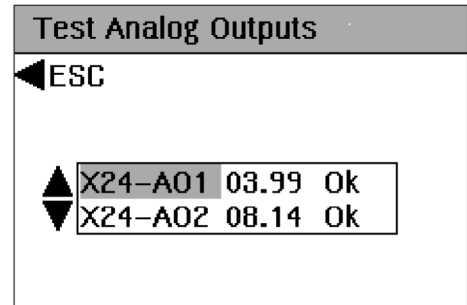

Figure 114: Menu 'Test Analog Outputs'

The list shows the analog outputs (AO) that are available on the analog output modules installed in the device, see **Analog output modules** on page 98.

They are designated according to the installation locations of the analog output modules (X20, X22, X24, X26).

Test:

1. Disconnect the plug with the connected signal lines from the analog output module.
2. Select the analog output to be tested with ▲ or ▼.
3. Call up the value change using ►.
4. Change the displayed value digit for digit with ▲ or ▼ and confirm the change by selecting **OK**.

Result:

The current signal at the analog output changes its value, changes the status indication from 'OK' to 'Test' and sets the 'Function check' status signal on the analog output.

5. You can either test another analog output or reset the tested analog output in the same manner.

The analog output test is terminated by pressing the ◀ button or after approximately 5 minutes by the time-out function, which resets all digital inputs to the 'OK' state and deletes the 'Function check' status signal.

... 13 Maintenance

Instrument information

Menu Path

'▼ Maintenance / ▼ Diagnosis / ► Device Info'

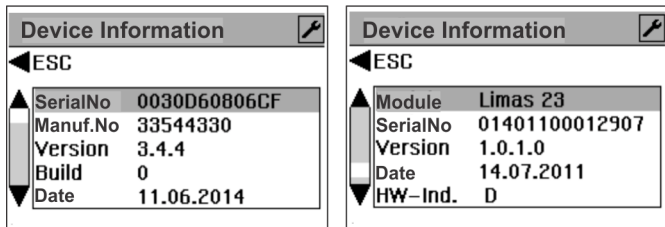

Figure 115: 'Device information' Menu

Display

Both the serial number and the version number, the date of the software and the hardware index are shown for the device and the integrated assemblies.

Operate pump

Menu Path

'▲ Operation / ► Pump'

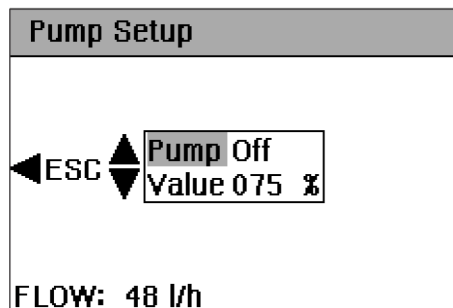

Figure 116: 'Pump settings' menu

It is also possible in the configurator to power-up and power-down the pump and to change the pump power.

Pump as a component of the 'Integral gas feed' option

A pump can be installed in the model EL3020 gas analyzer as a component of the 'Integral gas feed' option (not available for Limas23).

Note

In this case, a flow sensor is also installed.

Power-up and power-down of the pump

The pump can be powered-up and powered-down manually, for example for maintenance reasons or in an emergency. The emergency shutdown cannot be overridden by the automatic calibration.

Setting the pump power

The pump power can be changed manually when the pump is switched on. The measured value of the integrated flow sensor is displayed for setting the pump power.

Note

The pump cannot be operated while an automatic calibration is in progress.

Checking gas path leak tightness

When should gas paths be checked for leak tightness?

The leak tightness of the sample gas path should be checked on a regular basis.

We recommend that you check the leak tightness of the sample gas path prior to commissioning at the installation site, as it may have been affected during transport of the gas analyzer (for example, due to high vibrations).

The leak tightness of the sample gas path must always be checked after the sample gas path has been opened inside the gas analyzer.

Requisite Material

- Pressure gauge
- Hose, length approx. 1 m
- T-piece with stop cock
- Air or nitrogen

DANGER

Explosion hazard

Explosion hazard due to mixing of air and flammable sample gas residues in the sample gas path.

- If the leak tightness test is to be carried out with air and the sample gas or test gas is flammable, the sample gas path must be rinsed with nitrogen beforehand!
- Otherwise the leak tightness test can be performed with nitrogen.

Check leak tightness

1. Close off the sample gas output so it is gas-tight.
2. Connect the T-piece with stop cock to the sample gas inlet with the hose.
3. Connect the free end of the T-piece to the pressure gauge.
4. Blow air or nitrogen through the stop cock until the sample gas feed path is under a gauge pressure of approx. 50 hPa. Maximum gauge pressure = 150 hPa.
5. Close the shut-off valve.
 - Within 15 mins, the pressure must not drop more than 1 hPa. A sharp pressure drop is an indication of a leak inside the sample gas path.
6. Repeat steps 1 to 5 for all sample gas paths in the gas analyzer.

Important instructions for measuring flammable gases

Measures to take after each opening of the gas paths within the gas analyzer

- If the sample gas path inside the gas analyzer has been opened, leak tightness should be checked afterwards with a helium leak test for a leakage rate of $< 1 \times 10^{-4}$ hPa l/s.
- As an alternative to the helium leak test, the pressure drop method can be used, see **Checking gas path leak tightness** on page 201.
 - For this purpose, a test pressure of $p_e \sim 400$ hPa for a test duration of 15 min should be applied. Within this time, the pressure must not drop more than 1 hPa.
- Every time the sample gas path is opened, it needs to be pre-rinsed before you power-up the power supply. That way, any explosive gas/air mixture which might be present should be removed.
 - Purge gas: nitrogen
 - Purge gas volume: 5 times the volume of the gas paths
 - Purge gas flow rate: approx. 30 l/h
 - Purge duration: at least 3 min

... 13 Maintenance

Important instructions for explosion-proof design in degree of protection II 3G

Visual inspection

- If the viewing glass is damaged to the point that the IP65 housing protection is no longer met, the gas analyzer must be decommissioned, secured against recommissioning and repaired.
- If the housing is damaged by UV radiation to the point that the housing protection IP 65 is no longer maintained, the gas analyzer must be decommissioned, secured against recommissioning and repaired.

Replacing the battery

- The battery may only be replaced in a non-hazardous atmosphere.
- This battery may only be replaced with the original battery type:
 - Varta CR 2032 type no. 6032 or
 - Renata Type No. CR2032 MFR

14 Decommissioning

Decommissioning the gas analyzer

In the case of a temporary shutdown:

1. Shut off the sample gas.
2. Purge the gas lines and gas feed paths in the gas analyzer with dry air or nitrogen for at least 5 minutes.
3. Switch off the gas analyzer power supply.

In the case of a long-term shutdown, carry out the following in addition:

4. Remove the gas lines from the gas analyzer ports. Tightly seal the gas ports.
5. Disconnect the electrical leads from the gas analyzer.

Fidas24 – Shutting down the gas analyzer

In the case of a temporary shutdown:

1. Shut off the sample gas supply at the sampling point.
2. Purge the sample gas line with nitrogen for at least 5 minutes, from the sampling point.
3. Set the gas analyzer to standby mode, refer to **Fidas24 – Standby / Restart** on page 191.

In case of corrosive and combustion gases set the gas analyzer to standby operation with detector purging.

4. Shut off combustion air supply and combustion gas supply.

In the case of a long-term shutdown, carry out the following in addition:

5. Shut off instrument air supply.
6. Switch off the gas analyzer power supply.
7. Remove the gas lines from the gas analyzer ports. Tightly seal the gas ports.
8. Disconnect the electrical leads from the gas analyzer.

Packing the Gas Analyzer

1. Remove adapters from the gas ports and tightly seal the gas ports.
2. If the original packaging is not available, wrap the gas analyzer in bubble wrap or corrugated cardboard. For overseas shipment, always add a desiccant (e.g., silica gel) and hermetically seal the gas analyzer plus desiccant in a layer of polythene that is 0.2 mm thick. The amount of drying agent should be appropriate for the package volume and the expected shipping duration (at least 3 months).
3. Pack the gas analyzer in an adequately sized box lined with shock-absorbing material (foam or similar). The thickness of the shock-absorbing material should be adequate for the weight of the gas analyzer and the mode of dispatch. When shipping overseas, additionally line the box with a double layer of bitumen paper.
4. Mark the box as "Fragile Goods".

Note

If the device is returned to ABB Service (e.g. for repair), the following points must be observed:

- It is essential that the gases that were introduced into the gas analyzer are specified on the return form (see **Return form** on page 215).
- See the information in **Returning devices** on page 178!

Transport-/Storage temperature

-25 to 65 °C

15 Recycling and disposal

Note



Products that are marked with the adjacent symbol may **not** be disposed of as unsorted municipal waste (domestic waste).

They should be disposed of through separate collection of electric and electronic devices.

This product and its packaging are manufactured from materials that can be recycled by specialist recycling companies.

Bear the following points in mind when disposing of them:

- As of 8/15/2018, this product will be under the open scope of the WEEE Directive 2012/19/EU and relevant national laws (for example, ElektroG - Electrical Equipment Act - in Germany).
- The product must be supplied to a specialist recycling company. Do not use municipal waste collection points. These may be used for privately used products only in accordance with WEEE Directive 2012/19/EU.
- If there is no possibility to dispose of the old equipment properly, our Service can take care of its pick-up and disposal for a fee.

16 Specification

Note

The device data sheet is available in the ABB download area at www.abb.com/analytical.

Note regarding the analyzers performance characteristics

- The metrological data of the analyzers is determined according to IEC 61207-1:2010 “Expression of performance of gas analyzers – Part 1: General”.
- The metrological data are based on operation at atmospheric pressure (1013 hPa) and nitrogen as the associated gas.
- Compliance with these characteristics when measuring other gas mixtures can only be assured if their composition is known.
- The physical detection limit is the lower limit of the measurement-related data relative to the measuring range span.

Uras26

Stability

The following data only applies if all the influence variables (e.g. flow, temperature and air pressure) are constant. They relate to the smallest measurement range.

Linearity error

≤ 1 % of measuring span

Repeatability

≤ 0.5 % of span

Zero drift

≤ 1 % of span per week

Span drift

≤ 1 % of measured value per week

Output signal fluctuation (2 σ)

≤ 0.2 % of span at electronic T₉₀-time (static/dynamic) = 5/0 sec

Detection limit (4 σ)

≤ 0.4 % of span at electronic T₉₀-time (static/dynamic) = 5/0 sec

Influences

Flow effect

Flow rate in the 20 to 100 l/h range:
within the detection limit

Associated gas effect / Cross-sensitivity

Analyzer calibration should be based on an analysis of the sample gas.

Selectivation measures to reduce the associated gas effect (options): incorporation of interference filters or filter cells, internal electronic cross-sensitivity or carrier gas correction for one sample component by other sample components measured with the gas analyzer.

Temperature effect

Ambient temperature in permissible range.

- At zero point:
≤ 2 % of span per 10 °C
- On the sensitivity without thermostat effect:
≤ 3 % of the measured value per 10 °C;
- On the sensitivity with thermostat effect (optional):
≤ 2 % of the measured value per 10 °C

Thermostat temperature = 55 °C

Air pressure effect

- At the zero point:
no influence effect
- On sensitivity with pressure correction using an integrated pressure sensor:
≤ 0.2 % of the measured value per 1 % of air pressure change

Dynamic response

Warm-up time

Approx. 30 minutes without thermostat; approx. 2 hours with thermostat

T₉₀ time

T₉₀ ≤ 2.5 sec for sample gas flow = 60 l/h and electronic T₉₀ time (static/dynamic) = 5/0 sec

... 16 Specification

Limas23

Stability

The following data only applies if all the influence variables (e.g. flow, temperature and air pressure) are constant. They relate to the smallest measurement range.

Linearity error

≤ 1 % of measuring span

Repeatability

≤ 0.5 % of span

Zero drift

- For NO:
≤ 2 % of span per week
- For NO₂ and SO₂:
≤ 3 ppm per week for measuring ranges ≤ 100 ppm (daily automatic zero-point check is recommended), ≤ 2.5 % of span per week for measuring ranges > 100 ppm

Span drift

≤ 1 % of measured value per week

Output signal fluctuation (2 σ)

≤ 0.5 % of span at electronic T₉₀-time = 20 sec

Detection limit (4 σ)

≤ 1 % of span at electronic T₉₀-time = 20 sec

Influences

Flow effect

Flow rate in the 20 to 100 l/h range:
Within the detection limit

Associated gas effect / Cross-sensitivity

Analyzer calibration should be based on an analysis of the sample gas. Selectivation measures to reduce the associated gas effect (options): internal adjustment or internal electronic cross-sensitivity correction for one sample component by other sample components measured with the gas analyzer.

Temperature effect

Ambient temperature in permissible range.

- At zero point:
≤ 1 % of span per 10 °C
- on the sensitivity
≤ 1.5 % of the measured value per 10 °C

Air pressure effect

- at the zero point:
no influence effect
- On sensitivity with pressure correction using an integrated pressure sensor:
≤ 0.2 % of the measured value per 1 % of air pressure change

Dynamic response

Warm-up time

Approx. 2 hours

T₉₀time

T₉₀ ≤ 3 s at sample gas flow = 60 l/h and electronic

T₉₀time = 0 s

Magnos206

Stability

The following data only applies if all the influence variables (e.g. flow, temperature and air pressure) are constant.

Linearity error

≤ 0.5 % of span

Repeatability

≤ 50 ppm O₂ (time base for gas exchange ≥ 5 min)

Zero drift

≤ 3 % of the span of the smallest measuring range (in accordance with order) per week, at least 300 ppm O₂ per week;

After longer transport/storage times, the drift can be higher in the first weeks.

Span drift

- ≤ 0.1 vol.-% O₂ per week or ≤ 1 % of the measured value per week (not cumulative), whichever value is smaller;
- ≤ 0.25 % of measured value per year, at least 0.05 vol.-% O₂ per year

Output signal fluctuation (2 σ)

≤ 25 ppm O₂ at electronic T₉₀-time (static/dynamic) = 3/0 s

Detection limit (4 σ)

≤ 50 ppm O₂ at electronic T₉₀-time (static/dynamic) = 3/0 s

Influences

Flow effect

≤ 0.1 vol.-% O₂ in the 30 to 90 l/h range

Associated gas effect

Information on the influence of associated gases can be found in IEC 61207-3:2002 'Gas analyzers – Expression of performance – Part 3: Paramagnetic oxygen analyzers'.

Temperature effect

Ambient temperature in permissible range.

- on the zero point:
≤ 1 % of the span per 10 °C, ≤ 2 % of the span per 10 °C in combination with Uras26;
- on the sensitivity:
≤ 0.3 % of the measured value per 10 °C

Thermostat temperature = 64 °C

Air pressure effect

- on sensitivity without pressure correction:
≤ 1 % of the measured value per 1 % of air pressure change
- On sensitivity with pressure correction using integrated pressure sensor (option):
≤ 0.1 % of measured value per 1 % air pressure change;
for highly suppressed measuring ranges:
≤ 0.01 % of measured value per 1 % air pressure change or
≤ 0.002 vol. % O₂ per 1 % air pressure change, whichever is greater.

Position effect

Zero-point shift ≤ 0.05 vol.% O₂ per 1° deviation from horizontal location.

Position has no effect on the hard-mounted unit.

Dynamic response

Warm-up time

< 1 hours

T₉₀ time

T₉₀ approx. 4 sec at a sample gas flow = 90 l/h and electronic T₉₀ time (static/dynamic) = 3/0 sec, gas change from nitrogen to air

... 16 Specification

Magnos28

Stability

The following data only applies if all the influence variables (e.g. flow, temperature and air pressure) are constant.

Linearity error

≤ 0.5 % of the span or 0.005 vol.-% O₂, the greater value applies

Repeatability

≤ 50 ppm O₂

Zero drift

≤ 3 % of span of the smallest measuring range (in accordance with order) per week, or 0.03 Vol.-% O₂ per week, whichever value is greater

The value may be elevated during first commissioning or after a longer service life.

Span drift

- ≤ 0.1 vol. % O₂ per week or ≤ 1 % of the measured value per week (not cumulative), whichever is smaller;
- ≤ 0.15 % of the measured value per three months or 0.03 vol.-% O₂ per 3 months, the larger value applies

Output signal fluctuation (2 σ)

≤ 25 ppm O₂ at electronic T₉₀ time (static/dynamic) = 3/0 sec

Detection limit (4 σ)

≤ 50 ppm O₂ at electronic T₉₀ time (static/dynamic) = 3/0 sec

Influences

Flow effect

- Sample gas N₂:
≤ 0.1 Vol.-% O₂ in the range 30 to 90 l/h;
- Sample gas air:
≤ 0.1 vol.-% O₂ at a flow rate change of 10 l/h

Associated gas effect

Information on the influence of associated gases can be found in IEC 61207-3:2002 'Gas analyzers – Expression of performance – Part 3: Paramagnetic oxygen analyzers'.

Temperature effect

Average temperature effect in permissible ambient temperature range:

- at zero point:
≤ 0.02 vol. % O₂ per 10 °C
- on the sensitivity
≤ 0.3 % of the measured value per 10 °C
- For highly suppressed measuring ranges (when factory configured):
≤ 0.01 vol.-% per 10 °C in the entire measuring range

Thermostat temperature = 60 °C (140 °F)

For highly suppressed measuring ranges (≥ 99 to 100 vol.-% O₂) and very small measuring ranges (≤ 0 to 1 vol.-% O₂) greater temperature fluctuations (≥ 5 °C) at the installation site should be avoided.

Air pressure effect

- on sensitivity without pressure correction:
≤ 1 % of the measured value per 1 % of air pressure change
- on sensitivity with pressure correction using integrated pressure sensor (option):
≤ 0.1 % of the measured value per 1 % air pressure change;
for highly suppressed measurement ranges
≤ 0.01 % of measured value per 1 % air pressure change or
≤ 0.002 vol. % O₂ per 1 % air pressure change, whichever is greater.

Position effect

Zero-point shift ≤ 0.05 vol. % O₂ per 1° deviation from horizontal location.

Position has no effect on the hard-mounted unit.

Dynamic response

Warm-up time

< 5 hours

The value may be elevated during first commissioning or after a longer service life.

T₉₀ time

T₉₀ ≤ 3 sec at a sample gas flow of 90 l/h and electronic T₉₀ time (static/dynamic) = 3/0 sec, gas change from nitrogen to air (applies to a gas analyzer only with Magnos28)

Magnos27

The following data is valid under the condition that all influencing quantities (for example, flow, temperature and air pressure) are constant.

Stability

Linearity error

≤ 2 % of measuring span

Repeatability

≤ 1 % of measuring span

Zero drift

≤ 1 % of span per week

Span drift

≤ 2 % of measured value per week

Output signal fluctuation (2 σ)

≤ 0.5 % of smallest measurement range span at electronic
T₉₀ time = 0 sec

Detection limit (4 σ)

≤ 1 % of the measuring span of the smallest measuring range
at electronic T₉₀ time = 0 sec

Influences

Flow effect

≤ 1 % of span at a flow change of ±10 l/h. At an identical flow rate for test and sample gases, the flow rate effect is automatically compensated.

Associated gas effect

Magnos27 calibration applies only to the sample gas shown on the identification plate (= sample component + associated gas).

Temperature effect

Ambient temperature in permissible range.

- At zero point:
≤ 2 % of span per 10 °C
- on the sensitivity:
≤ 0.5 % of the measured value per 10 °C

based on temperature at the time of calibration. Thermostat temperature = 63 °C.

Air pressure effect

- at zero point:
< 0.05 vol. % O₂ per 1 % air pressure;
- on sensitivity without pressure correction:
≤ 1.5 % of the measured value per 1 % of air pressure change;
- On sensitivity with pressure correction using an integrated pressure sensor (option):
≤ 0.25 % of the measured value per 1 % of air pressure change

Operating altitude over 2000 m

Position effect

Approx. 3 % of the span of the smallest measurement range per 1° deviation from horizontal orientation. Position has no effect on the hard-mounted unit.

Dynamic response

Warm-up time

2 to 4 h

T₉₀time

T₉₀ = 10 to 22 s, depending on sample gas flow and on the sample chamber connection (applies to a gas analyzer only with Magnos27)

... 16 Specification

ZO23

The following data is valid under the condition that all Influencing quantities (for example, flow, temperature and air pressure) are constant.

Stability

Linearity error

Owing to the measurement principle, zirconium dioxide cells are base linear.

Repeatability

< 1 % of the measuring span or 100 ppb O₂, whichever is greater

Zero drift

The zero point (reference point) is displayed if ambient air is present on the sample gas side. The value for air of 20.6 vol.-% O₂ (at 25 °C and 50 % relative humidity) may deviate through aging of the cell.

< 1 % of the measuring range per week or 250 ppb O₂, whichever is greater

Span drift

Depends on possible interfering components (catalyst poisons) in the sample gas and the aging of the cell.

For pure gas measurements in N₂, CO₂ and Ar: < 1 % of the measuring range per week or 250 ppb O₂, whichever is greater

Output signal fluctuation (2 σ)

< 0.5 % of the measured value or 50 ppb O₂ (whichever is greater)

Influences

Flow effect

≤ 300 ppbv O₂ in the range from 5 to 10 l/h

Associated gas effect

Inert gases (Ar, CO₂, N₂) have no effect.

Flammable gases (CO, H₂, CH₄) in stoichiometric concentrations to the oxygen content:

conversion O₂ < 20 % of the stoichiometric conversion.

If higher concentrations of flammable gases are present, higher O₂ conversions must be expected. The concentration of flammable gases in the sample gas must not exceed 100 ppm.

Temperature effect

The effect of the ambient temperature in the permissible range of 5 to 45 °C is < 2 % of the measured value or 50 ppb O₂ per 10 °C change in the ambient temperature, whichever value is greater

Air pressure effect

No effect through a change in air pressure; sample gas must flow out of the outlet without back pressure.

Position effect

No position effect for permanently installed instruments

Dynamic response

Warm-up time

- The operating temperature of the cell is reached after approx. 15 minutes. Offset calibration with reference gas (ambient air) after 2 hours flow.
- The measurement is ready-to-run after valves and lines have been purged with sample gas. Typical purging time for valves and lines: approx. 2 to 5 hours.

T₉₀ time

T₉₀ < 60 sec for the alternation of 2 test gases in the measuring range 10 ppm with a sample gas flow rate = 8 l/h and electronic T₉₀ time = 3 sec

Caldos27

Stability

The following data only applies if all the influence variables (e.g. flow, temperature and air pressure) are constant. They are based on the smallest measuring ranges given in the data sheet; the deviations may be larger for smaller measuring ranges.

Linearity error

$\leq 2\%$ of measuring span

Repeatability

$\leq 1\%$ of measuring span

Zero drift

$\leq 2\%$ of smallest possible measuring range per week

Span drift

$\leq 0.5\%$ of the smallest provided measuring range per week

Output signal fluctuation (2 σ)

$\leq 0.5\%$ of smallest measurement range span at electronic
T₉₀ time = 0 sec

Detection limit (4 σ)

$\leq 1\%$ of the measuring span of the smallest measuring range
at electronic T₉₀ time = 0 sec

Influences

Flow effect

$\leq 0.5\%$ of span at a flow change of ± 10 l/h. At an identical flow rate for test and sample gases, the flow rate effect is automatically compensated.

Associated gas effect

Analyzer calibration should be based on an analysis of the sample gas.

If the sample gas contains components in addition to the sample component and associated gas (binary gas mixture), this will result in erroneous measurements.

Temperature effect

Ambient temperature in permissible range.

In any point of the measuring range:

$\leq 1\%$ of span per 10 °C, based on the temperature at the time of calibration.

Thermostat temperature = 60 °C.

Air pressure effect

$\leq 0.25\%$ of span per 10 hPa for the smallest ranges; for larger spans, the influence effect is correspondingly lower.

Position effect

$< 1\%$ of span up to 30° deviation from horizontal orientation

Dynamic response

Warm-up time

Approx. 30 minutes

T₉₀time

T₉₀ ≤ 2 sec for sample gas flow = 60 l/h and electronic T₉₀
time (static/dynamic) = 0/0 sec

... 16 Specification

Fidas24

Stability

The following data only applies if all the influence variables (e.g. flow, temperature and air pressure) are constant.

They apply to measurement ranges ≥ 50 mg org. C/m³; for smaller measuring ranges these only apply if they are factory-set in accordance with the order.

Linearity error

≤ 2 % of span to 5000 mg org. C/m³,
this value applies in one (calibrated) measuring range

Repeatability

≤ 0.5 % of measurement range

Zero drift

≤ 0.5 mg org. C/m³ per week

Span drift

≤ 0.5 mg org. C/m³ per week

Output signal fluctuation (2 σ)

≤ 0.5 % of span at electronic T₉₀time = 20 sec, not smaller than 10 μ g org. C/m³

Detection limit (4 σ)

≤ 1 % of span at electronic T₉₀time = 20 sec, not smaller than 20 μ g org. C/m³

Influences

Oxygen dependence

≤ 2 % of measured value for 0 to 21 vol. % O₂ or
 ≤ 0.3 mg org. C/m³, the larger value applies in each case

Temperature effect

Ambient temperature in permissible range.

- At zero point:
 ≤ 2 of the measuring span per 10 °C in the measuring range 0 to 15 mg org. C/m³
- On the sensitivity:
 ≤ 2 % of the measured value per 10 °C

Pressure effect

No effect of ambient pressure or process pressure fluctuations within the permissible sample gas inlet pressure range

Dynamic response

Warm-up time

≤ 2 hours

T₉₀time

T₉₀ < 1.5 s at sample gas flow = 80 l/h and electronic T₉₀time = 1 sec

Oxygen sensor

Stability

The following data only applies if all the influence variables (e.g. flow, temperature and air pressure) are constant.

Linearity error

Linear in the range > 1 vol.% O₂

Repeatability

≤ 0.5 % of span

Zero drift

Stable over long-term due to absolute zero point

Span drift

≤ 1 % of the measurement range per week

Output signal fluctuation (2 σ)

≤ 0.2 % of the total measurement range at electronic

T₉₀-time (static/dynamic) = 5/0 sec

Detection limit (4 σ)

≤ 0.4 % of the total measuring range with electronic T₉₀-time

(static/dynamic) = 5/0 sec

Influences

Flow effect

Flow rate in the 20 to 100 l/h range:

≤ 2 % of the total measuring range

Temperature effect

Ambient temperature in the range of 5 to 40 °C:

≤ 0.2 vol.% O₂ per 10 °C

Air pressure effect

- at the zero point:
no influence effect
 - on sensitivity without pressure correction:
≤ 1 % of the measured value per 1 % of air pressure change
 - on sensitivity with pressure correction:
≤ 0.2 % of the measured value per 1 % of air pressure change
- Pressure correction is possible only if the oxygen sensor is connected to the Uras26 infrared photometer with integrated pressure sensor,

Dynamic response

T₉₀time

T₉₀ ≤ 30 sec for sample gas flow = 60 l/h and electronic T₉₀

time (static/dynamic) = 5/0 sec

17 Additional documents

Note

All documentation, declarations of conformity, and certificates are available in ABB's download area.

www.abb.com/analytical

Trademarks

Extran is a registered trademark of Merck KGaA, Darmstadt, Germany

Modbus is a registered trademark of Schneider Automation Inc.

PROFIBUS, PROFIBUS PA and PROFIBUS DP are registered trademarks of PROFIBUS & PROFINET International (PI)

Windows is a registered trademark of Microsoft Corporation.

18 Appendix

Return form

Statement on the contamination of devices and components

Repair and/or maintenance work will only be performed on devices and components if a statement form has been completed and submitted.

Otherwise, the device/component returned may be rejected. This statement form may only be completed and signed by authorized specialist personnel employed by the operator.

Customer details:

Company: _____

Address: _____

Contact person: _____

Telephone: _____

Fax: _____

Email: _____

Device details:

Type: _____

Serial no.: _____

Reason for the return/description of the defect: _____

Was this device used in conjunction with substances which pose a threat or risk to health?

Yes No

If yes, which type of contamination (please place an X next to the applicable items):

biological

corrosive / irritating

combustible (highly / extremely combustible)

toxic

explosive

other toxic substances

radioactive

Which substances have come into contact with the device?

1. _____

2. _____

3. _____

We hereby state that the devices/components shipped have been cleaned and are free from any dangerous or poisonous substances.

Town/city, date

Signature and company stamp

ABB Measurement & Analytics

For your local ABB contact, visit:
www.abb.com/contacts

For more product information, visit:
www.abb.com/analytical

We reserve the right to make technical changes or modify the contents of this document without prior notice. With regard to purchase orders, the agreed particulars shall prevail. ABB does not accept any responsibility whatsoever for potential errors or possible lack of information in this document.

We reserve all rights in this document and in the subject matter and illustrations contained therein. Any reproduction, disclosure to third parties or utilization of its contents – in whole or in parts – is forbidden without prior written consent of ABB.