

ABB Drives

User's Manual Modbus Adapter Module NWPM-01



Modbus Adapter Module
NWPM-01

User's Manual

3AUA0000020296 Rev A
EN
EFFECTIVE: 28.04.2008

Safety instructions

Overview

This chapter states the general safety instructions that must be followed when installing and operating the NWPM-01 Modbus Adapter module.

The material in this chapter must be studied before attempting any work on the unit.

In addition to the safety instructions given below, read the complete safety instructions of the specific drive you are working on.

General safety instructions



WARNING! All electrical installation and maintenance work on the drive should be carried out by qualified electricians. The drive and adjoining equipment must be properly earthed.

Do not attempt any work on a powered drive. After switching off the mains, always allow the intermediate circuit capacitors to discharge for 5 minutes before working on the frequency converter, the motor or the motor cable. It is good practice to check (with a voltage indicating instrument) that the drive is in fact discharged before beginning work.

The motor cable terminals of the drive are at a dangerously high voltage when mains power is applied, regardless of motor operation.

There can be dangerous voltages inside the drive from external control circuits even when the drive mains power is shut off. Exercise appropriate care when working on the unit. Neglecting these instructions can cause physical injury or death.

Table of contents

Safety instructions	5
Overview	5
General safety instructions	5
 Table of contents	 7
 Introduction to this manual	 11
Overview	11
Intended audience	11
What this manual contains	11
Conventions used in this manual	12
Parameter	12
Communication Module	12
NWPM-01 Modbus Adapter module	12
Data sets and data words	12
Broadcast write	12
4XXXX Register area	12
Product and service inquiries	12
Product training	13
Providing feedback on ABB Drives manuals	13
 Overview	 15
Overview	15
Introduction to Modbus	15
The NWPM-01 Modbus Adapter module	15
Compatibility	16
Delivery check	17
Warranty and liability information	17
 Mechanical installation	 19
Overview	19
Mounting outside the drive	19
Mounting inside the drive	20
 Electrical installation	 21
Overview	21
General cabling instructions	21
Bus termination	21
NWPM-01 connections	22

Earthing the module	23
Earthing the Modbus cable shields	23
Drive configuration	25
Overview	25
Configuring the system	25
Modbus connection configuration	25
MODULE TYPE	26
MODBUS MODE	26
STATION NUMBER	26
BAUD RATE	26
PARITY	26
GOOD MESSAGES	27
BAD MESSAGES	27
DDCS CHANNEL	27
Control locations	27
Communication	29
Overview	29
Register read and write	29
Register mapping	29
Addresses within messages	29
Exception codes	30
Data update	31
Parameter handling	31
Data set communication	31
Fault tracing	33
Overview	33
Installation problems	33
Drive setup	33
PLC programming	33
Status LEDs	33
Module diagnostics	34
Technical data	37
DDCS link	37
Fieldbus link	38
NWPM-01	38
Modbus protocol	41
Introducing Modbus protocol	41
Transactions on Modbus networks	41
The two serial transmission modes	42

RTU mode	42
Modbus message framing	43
RTU framing	43
How the address field is handled	44
How the function field is handled	44
Contents of the data field	44
Contents of the checking field	45
ASCII	45
RTU	45
How characters are transmitted serially	45
Error checking methods	46
Parity checking	46
CRC checking	47
Modbus function formats	47
How numerical values are expressed	47
Data addresses in Modbus messages	47
Field contents in Modbus messages	48
Function codes	49
03 Read holding registers	49
Query	49
Response	50
06 Preset single register	51
Query	51
Response	51
16 (10 Hex) Preset multiple regs	52
Query	52
Response	53
Exception responses	54
CRC generation	56
Placing the CRC into the message	57
Example	57
Ambient conditions	61
Ambient conditions, operation	61
Ambient conditions, storage	61
Ambient conditions, transportation	61

Introduction to this manual

Overview

This chapter contains a description of the User's Manual for the NWPM-01 Modbus Adapter module.

Intended audience

The manual is intended for the people who are responsible for installing, commissioning and using an Modbus Adapter module with an ABB drive. The reader is expected to have a basic knowledge of electrical fundamentals, electrical wiring practices, the drive, the use of the drive control panel, and the Modbus protocol family.

What this manual contains

The installation and start-up of the NWPM-01 Modbus Adapter module is introduced in this manual.

It is assumed that the drive is installed and ready to operate before starting the installation of the adapter module. For more information on the installation and start-up procedures of the drive, please refer to its user documentation.

Safety instructions are featured in the first few pages of this manual.

Introduction to this manual contains a short description of the manual.

Overview contains a short description of the NWPM-01 Modbus Adapter module, a delivery checklist, and information on the manufacturer's warranty.

Mechanical installation contains placing and mounting instructions for the module.

Electrical installation contains wiring, bus termination and earthing instructions.

Drive configuration explains how to program the master station and the drive before the communication through the adapter module can be started.

Communication contains a description of how data is transmitted through the NWPM-01 module.

Fault tracing explains how to trace faults with the Status LEDs on the NWPM-01 module.

Technical data contains information on the Modbus module.

Modbus protocol describes the Modbus protocol.

Ambient conditions contains a specification of the ambient conditions allowed during transportation, storage and use of the Modbus module.

Conventions used in this manual

Parameter

A parameter is an operating instruction for the drive. Parameters can be read and programmed with the drive control panel, or through the NWPM-01 Module.

Communication Module

Communication Module is a parameter name/parameter selection name for a device (e.g. a fieldbus adapter) through which the drive is connected to an external serial communication network (e.g. a fieldbus). The communication with the communication module is activated with a drive parameter.

NWPM-01 Modbus Adapter module

The NWPM-01 (N-series Wind Power Modbus) Adapter Module is one of the optional fieldbus adapter modules available for ABB drives. The NWPM-01 is a device through which an ABB drive is connected to a Modbus serial communication bus.

Data sets and data words

Data sets are clusters of data sent through the DDCS link between the NWPM-01 Adapter Module and the drive. Each data set consists of three 16-bit words, i.e. data words. The Control Word (sometimes called the Command Word) and the Status Word, References and Actual Values (see chapter [Communication](#)) are types of data words; the contents of some data words are user-definable.

Broadcast write

Modbus network allows the Modbus master to perform a write to every slave station at the same time. This write is called Broadcast. This service does not give verification back to the master that the value has been received by each one of the slaves properly.

4XXXX Register area

Modicon PLCs have a signed integer data table area, which is used for Analogue Output modules and for storing temporary or set-point values. These registers are in the address area starting from 40001. The last register address available on PLCs depends on the available memory, but is less than 49999. The drive simulates this area by providing a read and write access to its parameters through this register address area.

Product and service inquiries

Address any inquiries about the product to your local ABB representative, quoting the type code and serial number of the unit in question. A listing of ABB sales, support and service contacts can be found by navigating to www.abb.com/drives and selecting *Sales, Support and Service network*.

Product training

For information on ABB product training, navigate to www.abb.com/drives and select *Training courses*.

Providing feedback on ABB Drives manuals

Your comments on our manuals are welcome. Go to www.abb.com/drives and select *Document Library – Manuals feedback form (LV AC drives)*.

Overview

Overview

This chapter describes the NWPM-01 Modbus Adapter module, and gives the warranty and liability information of the manufacturer. (Information about the Modbus protocol see the chapter [Modbus protocol](#)).

Introduction to Modbus

Modbus is a serial, asynchronous protocol. The Modbus protocol does not specify the physical interface. The typical physical interfaces are RS-232 and RS-485. The NWPM-01 uses the RS-485 interface.

Modbus is designed for integration with Modicon PLCs or other automation devices, and the services closely correspond to the PLC architecture. The NWPM-01 and its associated drive can be seen on the network as a "Modicon PLC", which contains holding registers in the range 40001...49999.

The NWPM-01 uses the RS-485 two-wire interface.

The NWPM-01 Modbus Adapter module

The NWPM-01 Modbus Adapter module is an optional device for ABB Drives which enables the connection of the drive to a Modbus system. The Drive is considered as a slave in the Modbus network. Through the NWPM-01 Modbus Adapter module it is possible to:

- Give control commands to the drive (Start, Stop, Run enable, etc.)
- Feed a motor speed or torque reference to the drive
- Give a process actual value or a process reference to the PID controller of the drive
- Read status information and actual values from the drive
- Change drive parameter values
- Reset a drive fault.

The Modbus commands and services supported by the NWPM-01 Modbus Adapter module are discussed in chapter [Communication](#). Please refer to the user documentation of the drive as to which commands are supported by the drive.

The adapter module is mounted onto a standard mounting rail inside or outside the drive unit, depending on drive type and configuration. See the user's manual of the drive for module placement options.

The main differences between the NWPM-01 Modbus Adapter and the "Standard" Modbus Adapter NMBA-01 are:

- NWPM-01 operates at communication speeds of 2400...38400 baud (NMBA-01 supported 1200...19200 baud)
- NWPM-01 has different mapping between the holding register addresses to the dataset addresses of ABB Drives systems.

The main reason for new mapping is that the input and output datasets of ABB Drives are interleaved, and this fact was not considered in design of NMBA-01.

The messages from the PLC to the drive should be sent to holding registers 40028...40051 (i.e. to addresses 27...50), which are mapped to datasets 10, 12, 14, 16, 18, 20, 22 and 24.

The messages from the drive to the PLC should be read from holding registers 40073...40096 (i.e. addresses 72...95), which are mapped from datasets 11, 13, 15, 17, 19, 21, 23 and 25.

The NWPM-01 offers a higher communication speed and the possibility to transfer efficiently more than 3 values in one message in the same direction, which increases the throughput of ABB drives' Modbus interface considerably.

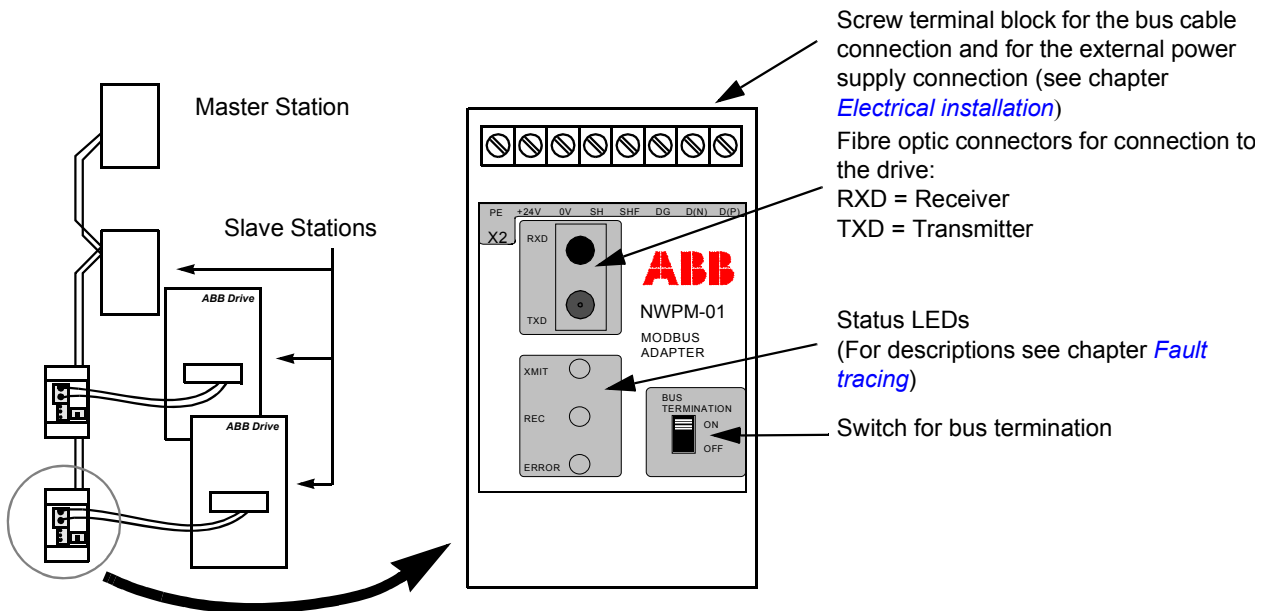

The construction of the Modbus link and the NWPM-01 Adapter module.

Compatibility

The NWPM-01 is compatible with:

- ACS800 SingleDrive
- ACS800 MultiDrive
- ACS 600 Drives
- All master stations that support the Modicon-defined Modbus serial communication protocol.

Delivery check

The option package for the NWPM-01 Modbus Adapter module contains:

- Modbus Adapter module, type NWPM-01
- two pairs (four pieces) of fibre optic cables for connecting the adapter to the drive
- mounting rail
- this manual.

Warranty and liability information

The manufacturer warrants the equipment supplied against defects in design, materials and workmanship for a period of twelve (12) months after installation or twenty-four (24) months from date of manufacturing, whichever first occurs. The local ABB office or distributor may grant a warranty period different to the above and refer to local terms of liability as defined in the supply contract.

The manufacturer is not responsible for

- any costs resulting from a failure if the installation, commissioning, repair, alternation, or ambient conditions of the drive do not fulfil the requirements specified in the documentation delivered with the unit and other relevant documentation.
- units subjected to misuse, negligence or accident
- units comprised of materials provided or designs stipulated by the purchaser.

In no event shall the manufacturer, its suppliers or subcontractors be liable for special, indirect, incidental or consequential damages, losses or penalties.

If you have any questions concerning your ABB drive, please contact the local distributor or ABB office. The technical data, information and specifications are valid at the time of printing. The manufacturer reserves the right to modifications without prior notice.

Mechanical installation

Overview

This chapter contains module mounting instructions. Depending on the drive, the module can be installed either inside or outside the drive housing or cabinet. See the user's manual of the drive for module placement options.

Mounting outside the drive

Choose the location for the module. Note the following:

- The cabling instructions in chapter [Electrical installation](#) must be followed. Also, the length of the fibre optic cables included in the option package restrict the distance between the module and the drive.
- Observe the free space requirements for the module^{*} (see the figure next page) and the drive (see the drive documentation).
- The ambient conditions should be taken into account (see chapter [Ambient conditions](#)). The degree of protection of the module is IP 20.
- Module earth is connected to the mounting rail by means of an earthing clip (see the figure next page). The mounting rail onto which the option module is to be mounted must be earthed to a noiseless earth. If the rail is not mounted on a properly earthed base, a separate earthing conductor must be used. The conductor must be as short as possible and its cross-sectional area must be 6 mm² at least.

Note: No solid copper conductor may be used (stranded wire allowed only).

Mounting instructions:

- Switch off all dangerous voltages in the enclosure that the module is to be mounted in.
- Fasten the rail and ensure the proper earthing as described above.

- Push the module onto the rail. The module can be released by pulling the locking spring with a screwdriver (see below).

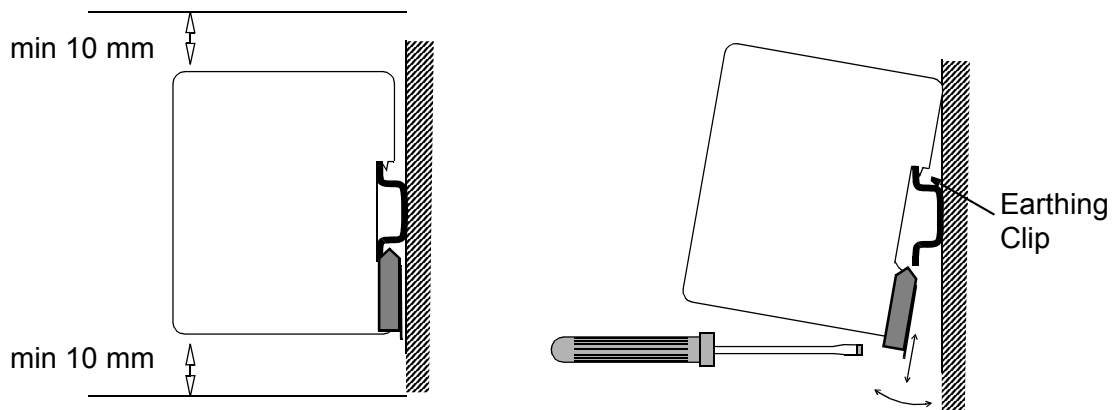

*) Minimum of 10 mm from adjoining equipment or wall.

Mounting inside the drive

Only a qualified electrician should carry out the work inside the drive.



WARNING! Pay attention to the slowly discharging voltage of the capacitor bank and the voltages that are connected from external control circuits to the inputs and outputs of the drive.



WARNING! Do not touch the printed circuit boards. The integrated circuits are extremely sensitive to electrostatic discharge.

Mounting instructions:

- Stop the drive.
- Switch off the power supply of the drive and all dangerous voltages connected to the inputs and outputs.
- Wait for five minutes to ensure that the capacitors in the intermediate circuit have discharged.
- Remove the front cover of the drive.
- Ensure that the mains cable, motor cable and capacitor bank (UDC+ and UDC-) are not powered.
- Locate the position for the module (see the drive documentation). Fasten the mounting rail to its place if not already installed. Observe the free space requirements for the module (see the figure above).
- Push the module onto the rail. The module can be released by pulling the locking spring with a screwdriver (see the figure above).

Electrical installation

Overview

This chapter contains:

- General cabling instructions
- Instructions for bus termination
- Connection and earthing instructions for the NWPM-01 Module and earthing instructions for the bus cable.



WARNING! Before installation, switch off the drive power supply. Wait for five minutes to ensure that the capacitor bank of the drive is discharged. Switch off all dangerous voltages connected from external control circuits to the inputs and outputs of the drive.

General cabling instructions

Arrange the bus cables as far away from the motor cables as possible. Avoid parallel runs. Use bushings at cable entries.

Handle fibre optic cables with care. When unplugging optic cables, always grab the connector, not the cable itself. Do not touch the ends of the fibres with bare hands, as the fibre is extremely sensitive to dirt.

The maximum long-term tensile load for the fibre optic cables is 1 N.
The minimum short-term bend radius is 25 mm.

Bus termination

The built-in terminating resistors must be switched on if the NWPM-01 module is installed at the end of the bus. Otherwise the resistors must be switched off. Terminating resistors prevent signal reflections from the bus cable ends.

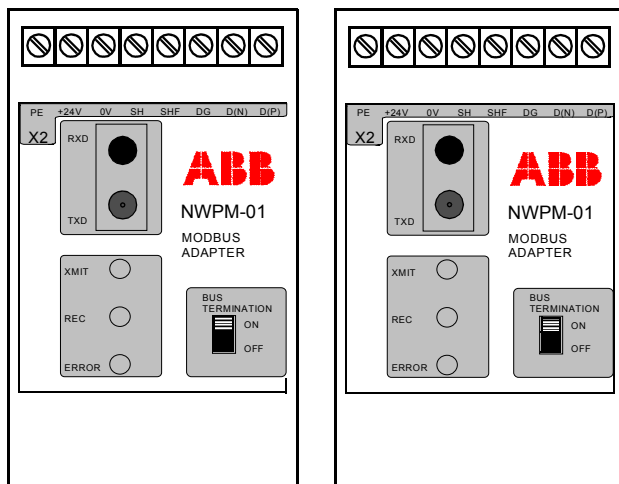

Terminating resistors on (left) and off (right).

NWPM-01 connections

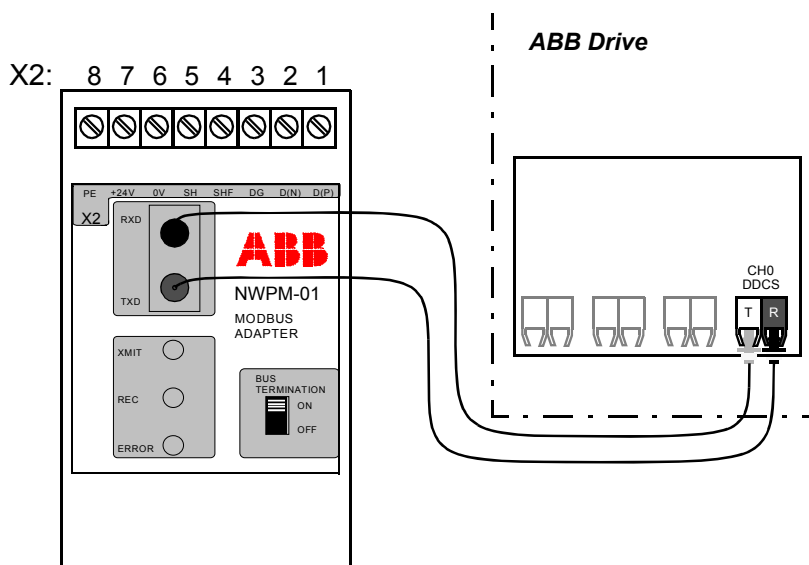

Fibre optic link connecting the NWPM-01 adapter to the drive.

The NWPM-01 module is connected to the drive using a fibre optic cable link. Consult the drive documentation as to the corresponding terminals inside the drive.

The bus cable and the external power supply are connected to terminal block X2 on the NWPM-01.

Description of terminal block X2.

X2		Description
1	D(P)	D(P) = B = Data Positive (Conductor 1 in twisted pair) D(N) = A = Data Negative (Conductor 2 in twisted pair) DG = Data Ground
2	D(N)	
3	DG	
4	SHF	Cable screen AC earthing (via an RC filter)
5	SH	Cable screen earthing (directly earthed)
6	0V	Power supply for the module (24 V DC. \pm 10%); screened cable.
7	+24 V	
8	PE	Earth

Earthing the module

The NWPM-01 module earth is connected to the rail onto which the module is mounted. If the rail is fastened to an earthed metallic assembly plate, the module is automatically earthed, and no external earthing wire is needed. If the rail is fastened to a base that is not earthed, the rail must be connected to the nearest earthing terminal. However, the earthing wire should not be connected to the same terminal as the power cable screens. (See the mounting instructions in chapter [Mechanical installation](#).)

In the NWPM-01 module there are several built-in earthing terminals (see figures [Two-wire connection](#) and [Three-wire connection. \(Preferred Practice.\)](#) on page 24):

- The **PE** terminal is internally connected to the NWPM-01 module earth. Normally, no external wires need to be connected to this terminal.
- The **SH** terminal is internally connected to the NWPM-01 module earth. The SH terminal is normally used for earthing the Modbus cable shield if there is no other station at which the cable shield is directly earthed.
- The **SHF** terminal is internally connected to the NWPM-01 module earth via an RC filter. The SHF terminal is typically used for earthing the Modbus cable shield.
- The **DG** terminal is isolated from the NWPM-01 module earth. This terminal is used for connecting the third conductor of the bus cable. The third conductor – Data Ground – offers a common reference or comparison potential to all modules on the bus.

Note: The use of Data Ground is recommended as it improves noise immunity. See figures [Two-wire connection](#) and [Three-wire connection. \(Preferred Practice.\)](#) on page 24.

Earthing the Modbus cable shields

The Modbus cable shield may be directly earthed at one station only. At other stations the cable shield should be earthed via an RC filter.

There are two wiring examples in the figures below. The three-wire connection is the preferred one because of its the better noise immunity.

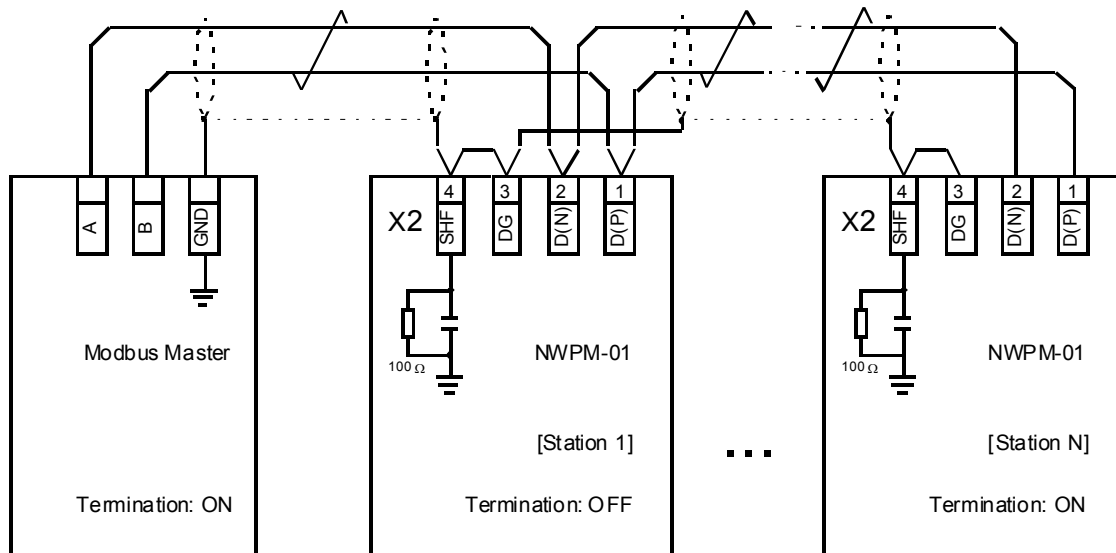

Two-wire connection

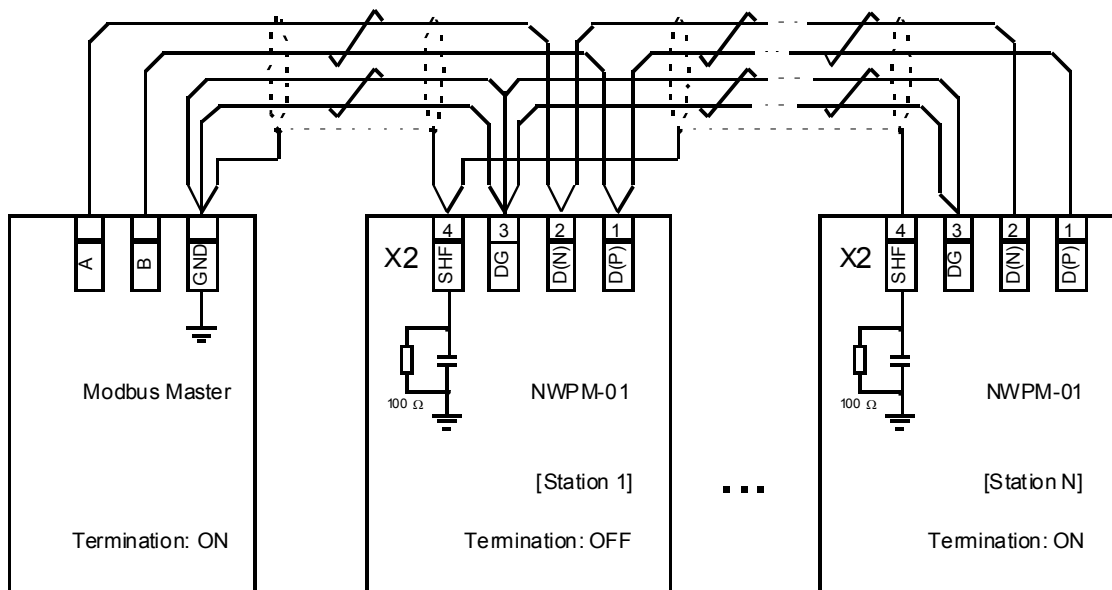

Three-wire connection. (Preferred Practice.)

Drive configuration

Overview

This chapter gives information on configuring the Modbus master station and the drive for communication through the NWPM-01 Modbus Adapter module.

Configuring the system

After the NWPM-01 Modbus Adapter module has been mechanically and electrically installed according to the instructions in chapters [Mechanical installation](#) and [Electrical installation](#), the master station and the drive must be prepared for communication with the module.

Please refer to the master station documentation for information on configuring the system for communication with the NWPM-01.

Modbus connection configuration

The detailed procedure of activating the module for communication with the drive is dependent on drive type. (Normally, a parameter must be adjusted to activate the communication. See the drive documentation.)

As communication between the drive and the NWPM-01 is established, several configuration parameters are copied to the drive. These parameters – shown in table [The NWPM-01 configuration parameters](#) – must be checked first and adjusted if necessary. The alternative selections for these parameters are discussed in more detail below the table. (Note that the new settings take effect only when the module is powered up for the next time.)

Note: The grouping, numbering, and adjustment procedure of parameters vary from drive to drive. See the drive documentation for information.

The NWPM-01 configuration parameters.

Fieldbus Par. No.	Parameter name	Alternative settings	Default setting
1	MODULE TYPE		NWPM-01 Vx.x
2	MODBUS MODE	(0) RTU wdg:flt; (1) RTU wdg:rst	(0) RTU wdg:flt
3	STATION NUMBER	1 – 247	1
4	BAUD RATE	(0) 2400; (1) 4800; (2) 9600; (3) 19200; (4) 38400	(3) 19200
5	PARITY	(0) EVEN; (1) ODD; (2) NONE 2 S.BIT; (3) NONE 1 S.BIT	(2) NONE 2 S.BIT
6	GOOD MESSAGES	0 – 32767	0
7	BAD MESSAGES	0 – 32767	0
8	DDCS CHANNEL	(0) CH0; (1) CH3	(0) CH0

MODULE TYPE

This parameter shows the module type and SW version number as detected by the drive. The value cannot be adjusted by the user. (If this parameter is undefined, the communication between the drive and the module has not been established.)

MODBUS MODE

Shows the logical protocol on the hardware communication option module (the NWPM-01 supports only the RTU mode) and the operating mode of the watch-dog reset. There are two selections:

RTU wdg:flt

Remote Terminal Unit (RTU) mode. On a watch-dog error, the module will indicate a watch-dog error. The module has to be reset (power off) manually.

RTU wdg:rst

Remote Terminal Unit (RTU) mode. On a watch-dog error, the module will reset itself.

STATION NUMBER

Each device on the Modbus link must have a unique station number. This parameter is used to define a station number for the drive it is connected to.

BAUD RATE

Defines the communication speed in Baud. There are five selections: **2400**, **4800**, **9600**, **19200** and **38400** Baud.

PARITY

Defines the parity to be used with the Modbus communication. This parameter also defines the number of stop bits in use. Typically with Modbus communication the number of stop bits is 2 with no parity bit, and 1 with even or odd parity. There are

four selections:

EVEN, ODD, NONE 1 S.BIT and NONE 2 S.BIT.

GOOD MESSAGES

This diagnostics counter increases by one every time a valid Modbus message has been received by the NWBM-01. This counter will roll over from 32767 back to 0. During normal operation, this counter is increasing constantly. However, this counter variable is not updated to the drive except if there are new BAD MESSAGES, too.

So, if there are only good messages, their number cannot be seen, except by monitoring the blinking rate of the green XMIT and REC lights on the module front panel.

This "anomaly" is intentional, and its purpose is to maximize the throughput of the communication module.

BAD MESSAGES

This diagnostics counter increases by one every time the NMBA-01 Module finds any kind of communication error. This counter will roll over from 32767 back to 0. During normal operation, this counter hardly ever increases.

DDCS CHANNEL

Selects the DDCS CHANNEL of the drive to which the fibre optics are connected. This parameter is only used with ACS 600.

Note: The changes to the parameters do not take effect immediately. To change the module settings, the power must be disconnected from the NWPM-01.

Control locations

ABB drives can receive control information from multiple sources including digital inputs, analogue inputs, the drive control panel and a communication module (e.g. NWPM-01). ABB drives allow the user to separately determine the source for each type of control information (Start, Stop, Direction, Reference, Fault Reset, etc.). In order to give the fieldbus master station the most complete control over the drive, the communication module must be selected as source for this information. See the user documentation of the drive for information on the selection parameters.

Communication

Overview

This chapter describes the Modbus communication with the drive.

Register read and write

The drive parameter and data set information is mapped into a 4xxxx register area. This holding register area can be read from an external device, and an external device can modify the register values by writing to them.

There are no setup parameters for mapping the data to the 4xxxx register. The mapping is pre-defined and corresponds directly to the drive parameter grouping which is being used by the local drive panel.

All parameters are available for both reading and writing. The parameter writes are verified for correct value, and for valid register addresses. Some parameters never allow writes (including actual values), some parameters allow write only when the drive is stopped (including setup variables), and some can be modified at any time (including actual reference values).

Register mapping

The drive parameters are mapped to the 4xxxx area so that:

- 40001...40096 are reserved for data sets.
- 40101...49999 are reserved for parameters.

In this mapping, the thousands and hundreds correspond to the group number, while the tens and ones correspond to the parameter number within a group. Register addresses 4GGPP are shown in table [Parameter mapping](#) on page 30. In this table GG is the group number, and PP is the parameter number within the group.

Addresses within messages

Register addresses 40001...49999 are modified (= must be modified), according to the Modbus specification, to range 0...9998 before they are sent to down to slave stations (e.g NMBA-01 or NWPM-01) via the serial line.

The modification is done by subtracting 40001 from holding register addresses. This subtraction must be done in the master station of Modbus communication system (typically a Modicon PLC).

Parameter mapping

4GGPP	Address in message	GG	PP
40028 – 40051	27 – 50	00 Reference Data sets	27 Data word 10.1 28 Data word 10.2 29 Data word 10.3 30 Data word 12.1 31 Data word 12.2 32 Data word 12.3 33 Data word 14.1 ... 48 Data word 24.1 49 Data word 24.2 50 Data word 24.3
40073 – 40096	72 – 95	00 Feedback Data sets	72 Data word 11.1 73 Data word 11.2 74 Data word 11.3 75 Data word 13.1 76 Data word 13.2 77 Data word 13.3 78 Data word 15.1 ... 93 Data word 25.1 94 Data word 25.2 95 Data word 25.3
40101 – 40199	100 – 198	01 Group 01	01 Parameter 01 02 Parameter 02 ... 99 Parameter 99
40201 – 40299	200 – 298	02 Group 02	01 Parameter 01 02 Parameter 02 ... 99 Parameter 99
...
49901 – 49999	9900 – 9998	99 Group 99	01 Parameter 01 ... 99 Parameter 99

The register addresses which are not allocated to any drive parameter or data set are invalid. No reads or writes are allowed for these addresses. If there is an attempt to read or write outside the parameter addresses, the Modbus interface will return an exception code to the controller.

Refer to the drive manuals for its data sets, group and parameter numbers supported.

Exception codes

The NWPM-01 supports the Modbus exception codes shown in table [Exception codes](#) on page 31.

Exception codes

Code	Name	Reason
01	ILLEGAL FUNCTION	Unsupported Command.
02	ILLEGAL DATA ADDRESS	Address does not exist or is read/write protected.
03	ILLEGAL DATA VALUE	Value is outside min-max limits. Parameter is read-only.
04	SLAVE DEVICE FAILURE	Reading a multiple parameter register, which includes one or more read protected parameters.
06	SLAVE DEVICE BUSY	DDCS channel timeout.

Data update

The NWPM-01 module has been designed for time-optimised, reliable data transfer between the Modbus network and the drive.

Function codes

Code	Name	Meaning
03	Read Holding Registers	Reads the binary contents of holding registers (4X references) in the slave.
06	Preset Single Register	Presets a value into a single holding register (4X reference). When broadcast, the function presets the same register reference in all attached slaves.
16 (10 Hex)	Preset Multiple Regs	Presets values into a sequence of holding registers (4X references). When broadcast, the function presets the same register references in all attached slaves.

Data set registers are updated in a fast cyclic interval. Updating of parameter registers happens in a slower interval. In case of a single parameter register read or write request, the parameter value is updated directly from the drive's internal memory. In case of a multiple parameter register read or write request, the parameter values are updated from the internal memory of the NWPM-01.

Parameter handling

The NWPM-01 can read and write up to 99 parameters in one frame if these are in the same parameter group.

Broadcast messages cannot be used for changing parameters.

Data set communication

Data sets 10, 12, 14, 16, 18, 20, 22 and 24 can only be used for sending data from NWPM-01 to drive. Data sets 11, 13, 15, 17, 19, 21, 23 and 25 can only be used for receiving data from drive to the NWPM-01 fieldbus adapter.

Fault tracing

Overview

This chapter gives step-by-step diagnostics information for finding out the root causes and corrections to the most common problems with the NWPM-01 module.

This section is divided into different sections, which lists first the symptoms, then possible causes, and remedies for them.

Installation problems

Verify all the connections on the module. Check that

- the Modbus cable is connected correctly to terminal block X2.
- 24 V DC power is connected to the power connectors.
- the fibre cables between the drive and the NWPM-01 are correctly connected.
- the fibre link connector colours match the drive and NWPM-01 connector colours.

Drive setup

Fieldbus parameter group is not visible on the control panel.

- Activate the fieldbus module according to the instructions in the drive manual.

Drive parameters can be read, but control commands (Start/Stop or Reference) do not work.

- Check that the drive has the fieldbus adapter selected as the source of these commands (see the drive manual).
- DDCS communication is set to regeneration mode. In ACS800 System Control program parameter 70.19 CH0 HW CONNECTION = RING.
- Drivebus mode is disabled. In ACS800 System Control program parameter 71.01 CH0 DRIVEBUS MODE = NO.
- Control location is selected to data set 10. In ACS800 System Control program parameter 98.02 COMM. MODULE = ADVANT/N-FB.

PLC programming

PLC program is beyond ABB support. Contact the manufacturer for assistance.

Status LEDs

The NWPM-01 has three status LEDs. These are from top to bottom:

- *XMIT* LED. This LED will flash each time the NWPM-01 transmits a response or an exception on the Modbus network.

- **REC** LED. This LED will flash each time the NWPM-01 receives a command from the Modbus network.
- **ERROR** LED for combined error and module status indication. This LED will flash for the following reasons:
 - If the received command had a parity error.
 - If the received command had a CRC error.
 - If the received command was not supported by the NWPM-01 module. In this case the *XMIT* LED will also flash.
 - If the NWPM-01 module has found an error. The error codes are described in table [Modbus error codes during operation](#) below.

Module diagnostics

On module power-up, the NWPM-01 goes through a power-up self-test sequence. During this, the test state is indicated by the front three LEDs. The normal power-up procedure is as follows:

- All LEDs are turned on for the duration of the RAM/ROM test. If the test is passed, all LEDs will be turned off.
- The **ERROR** LED will flash rapidly for few seconds as the DDCS link between the NWPM-01 and the drive is initialised.
- **REC** and **XMIT** LEDs will flash according to the data transferred between the NWPM-01 and the drive.

Modbus error codes during initialization

Flash Code	Status	Correction
XMIT, REC, and ERROR LEDs on	ROM checksum test failed	Hardware failure. Replace NWPM.
REC and ERROR LEDs on	RAM test failed	Hardware failure. Replace NWPM.
ERROR LED on	DDCS ASIC register access test failed	Hardware failure. Replace NWPM.

Modbus error codes during operation

Flash Code	Status	Correction
Occasional flash on Error LED	Module on-line. Parity, CRC or unsupported command received.	Check the wiring and earthing of the module. Verify that only supported commands are sent to the module.
Error LED flashes continuously	NWPM is OK, no response from the drive on fibre link.	Power on the drive. Check the fibre link wiring.

Flash Code	Status	Correction
All LEDs flash continuously at the same time.	Watchdog time out.	Hardware failure on NWPM module. Switch power off and wait a few seconds before switching the power on again; if the problem persists, check that fieldbus parameter 02 <i>MODBUS MODE</i> is set to RTU wdg:rst.
Continuous reboot. Fast blinking of <i>ERROR</i> LED for approx. 2 sec. repeated every few sec.	Drive configuration write failed (DDCS link communication fault).	Check fibre optics, DDCS channel and SW version of the drive.

Technical data

DDCS link

Compatible devices: All ABB Fieldbus Adapter modules, ACS800, ACS 600, DCS 500 Drives.

Size of the link: 2 stations (3 to 248 in Multiple Drive Control)

Medium: Fibre optic cable

- Construction: Plastic core, diameter 1 mm, sheathed with plastic jacket
- Attenuation: 0.31 dB/m
- Maximum Length between Stations: 10 m
- Specifications:

Parameter	Minimum	Maximum	Unit
Storage Temperature	-55	+85	°C
Installation Temperature	-20	+70	°C
Short Term Tensile Force		50	N
Short Term Bend Radius	25		mm
Long Term Bend Radius	35		mm
Long Term Tensile Load		1	N
Flexing		1000	cycles

Topology: Point-to-point (Ring in Multiple Drive Control)

Serial communication type: Asynchronous, half Duplex

Transfer rate: 4 Mbit/s

Protocol: Distributed Drives Communication System (DDCS)

Connectors: Blue – receiver; grey – transmitter

Fieldbus link

Compatible devices: Any Modbus device capable of Modbus communication as a master.

Size of the link: 247 stations including repeaters (31 stations and 1 repeater per segment)

Medium: Shielded, twisted pair RS485 cable

- Termination: built in the NWPM-01 module
- Modbus cable: Belden 9841 (typical)
- Maximum bus length: 1200 m

Topology: Multi-drop

Serial communication type: Asynchronous half Duplex

Transfer rate: 2400, 4800, 9600, 19200 and 38400 bit/s

Protocol: Modbus

NWPM-01

Enclosure: Plastic, dimensions 45 × 75× 105 mm (H×W×D); degree of protection IP 20

Mounting: Onto a standard mounting rail

Settings: Via drive interface (control panel)

Current consumption: 65 mA at 24 V DC

Connectors:

- Light transmitter (grey) and receiver (blue) (Hewlett-Packard Versatile Link) for connection to the drive
- One Combicon MVSTBW 2.5/8-ST-5,08 (8-pole, cross-section 2.5 mm² max.) screw terminal block for the fieldbus and power supply):

X2	Description
1 D(P)	D(P) = B = Data Positive (Conductor 1 in twisted pair) D(N) = A = Data Negative (Conductor 2 in twisted pair) DG = Data Ground
2 D(N)	
3 DG	
4 SHF	Cable screen AC earthing (via an RC filter)
5 SH	Cable screen earthing (directly earthed)
6 0V	Power supply for the module (24 V DC ± 10%); screened cable.
7 +24 V	
8 PE	Earth

General:

- All materials are UL/CSA approved
- Complies with EMC Standards EN 50081-2 and EN 50082-2

Modbus protocol

This chapter describes the serial Modbus protocol. This chapter is intended for people who need to program a serial Modbus master for their own control system.

The material of this chapter is copyrighted by Modicon, and is used by permission of AEG Schneider Automation (Modicon). This material is included in the Modicon publication *Modicon Modbus Protocol Reference Guide* (PI-MBUS-300 Rev. E). The latest revision is available at Modicon internet homepage <http://www.modicon.com>.

Introducing Modbus protocol

The Modbus protocol is a serial master–slave protocol. This appendix describes the Modbus protocol only to the level which is required to fully access the ABB drives. The Modbus protocol defines what is serially transmitted on the communication link. The physical interface to the NWPM-01 is half-duplex RS-485.

Transactions on Modbus networks

Standard Modbus ports on Modicon controllers use an RS-232C compatible serial interface that defines connector pinouts, cabling, signal levels, transmission baud rates, and parity checking. Controllers can be networked directly or via modems.

Controllers communicate using a master – slave technique, in which only one device (the master) can initiate transactions (called ‘queries’). The other devices (the slaves) respond by supplying the requested data to the master, or by taking the action requested in the query. Typical master devices include host processors and programming panels. Typical slaves include programmable controllers.

The master can address individual slaves, or can initiate a broadcast message to all slaves. Slaves return a message (called a ‘response’) to queries that are addressed to them individually. Responses are not returned to broadcast queries from the master.

The Modbus protocol establishes the format for the master’s query by placing into it the device (or broadcast) address, a function code defining the requested action, any data to be sent, and an error-checking field. The slave’s response message is also constructed using Modbus protocol. It contains fields confirming the action taken, any data to be returned, and an error-checking field. If an error occurred in receipt of the message, or if the slave is unable to perform the requested action, the slave will construct an error message and send it as its response.

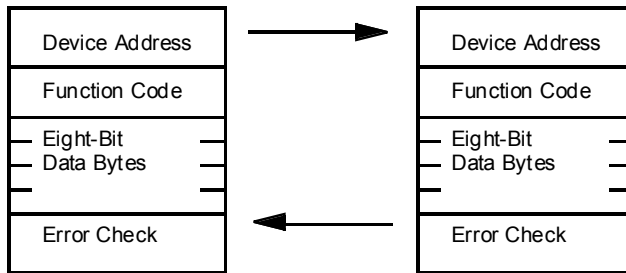
Query message from Master**Response message from Slave****Master-Slave Query-Response cycle**

The Query: The function code in the query tells the addressed slave device what kind of action to perform. The data bytes contain any additional information that the slave will need to perform the function. For example, function code 03 will query the slave to read holding registers and respond with their contents. The data field must contain the information telling the slave which register to start at and how many registers to read. The error check field provides a method for the slave to validate the integrity of the message contents.

The Response: If the slave makes a normal response, the function code in the response is an echo of the function code in the query. The data bytes contain the data collected by the slave, such as register values or status. If an error occurs, the function code is modified to indicate that the response is an error response, and the data bytes contain a code that describes the error. The error check field allows the master to confirm that the message contents are valid.

The two serial transmission modes

Controllers can be setup to communicate on standard Modbus networks using either of two transmission modes: ASCII or RTU. Users select the desired mode, along with the serial port communication parameters (baud rate, parity mode, etc.), during configuration of each controller. The mode and serial parameters *must be the same for all devices on a Modbus network*. The selection of ASCII or RTU mode pertains only to standard Modbus networks. It defines the bit contents of message fields transmitted serially on those networks. It determines how information will be packed into the message fields and decoded.



The NWPM-01 supports only the RTU mode. Only the RTU mode is described in this document.

RTU mode

When controllers are setup to communicate on a Modbus network using RTU (Remote Terminal Unit) mode, each 8-bit byte in a message contains two 4-bit hexadecimal characters. The main advantage of this mode is that its greater

character density allows better data throughput than ASCII for the same baud rate. Each message must be transmitted in a continuous stream.

The format for each byte in RTU mode is:

Coding systems:	8-bit binary, hexadecimal 0-9, A-F Two hexadecimal characters contained in each 8-bit field of the message
Bits per byte:	1 start bit 8 data bits, least significant bit sent first 1 bit for even/odd parity; no bit for no parity 1 stop bit if parity is used; 2 bits if no parity
Error check field:	Cyclical Redundancy Check (CRC)

Modbus message framing

In either of the two serial transmission modes (ASCII or RTU), a Modbus message is placed by the transmitting device into a frame that has a known beginning and ending point. This allows receiving devices to begin at the start of the message, read the address portion and determine which device is addressed (or all devices, if the message is broadcast), and to know when the message is completed. Partial messages can be detected and errors can be set as a result.

RTU framing

In RTU mode, messages start with a silent interval of at least 3.5 character times. This is most easily implemented as a multiple of character times at the baud rate that is being used on the network (shown as T1-T2-T3-T4 in the figure [Message frame](#) below). The first field then transmitted is the device address.

The allowable characters transmitted for all fields are hexadecimal 0-9, A-F. Networked devices monitor the network bus continuously, including during the 'silent' intervals. When the first field (the address field) is received, each device decodes it to find out if it is the addressed device.

Following the last transmitted character, a similar interval of at least 3.5 character times marks the end of the message. A new message can begin after this interval.

The entire message frame must be transmitted as a continuous stream. If a silent interval of more than 1.5 character times occurs before completion of the frame, the receiving device flushes the incomplete message and assumes that the next byte will be the address field of a new message.

Similarly, if a new message begins earlier than 3.5 character times following a previous message, the receiving device will consider it a continuation of the previous message. This will set an error, as the value in the final CRC field will not be valid for the combined messages. A typical message frame is shown below.

Message frame

START	ADDRESS	FUNCTION	DATA	CRC CHECK	END
T1-T2-T3-T4	8 BITS	8 BITS	n × 8 BITS	16 BITS	T1-T2-T3-T4

How the address field is handled

The address field of a message frame contains eight bits (RTU). Valid slave device addresses are in the range of 0...247 decimal. The individual slave devices are assigned addresses in the range of 1...247. A master addresses a slave by placing the slave address in the address field of the message. When the slave sends its response, it places its own address in this address field of the response to let the master know which slave is responding.

Address 0 is used for the broadcast address, which all slave devices recognise. When Modbus protocol is used on higher level networks, broadcasts may not be allowed, or may be replaced by other methods. For example, Modbus Plus uses a shared global database that can be updated with each token rotation.

How the function field is handled

The function code field of a message frame contains eight bits (RTU). Valid codes are in the range of 1...255 decimal. Of these, some codes are applicable to all Modicon controllers, while some codes apply only to certain models, and others are reserved for future use. The NWPM-01 supports the function codes 3, 6, and 16 (0x03, 0x06, and 0x10 Hex) only.

When a message is sent from a master to a slave device the function code field tells the slave what kind of action to perform. Example is to read a group of outputs.

When the slave responds to the master, it uses the function code field to indicate either a normal (error-free) response or that some kind of error occurred (called an exception response). For a normal response, the slave simply echoes the original function code. For an exception response, the slave returns a code that is equivalent to the original function code with its most significant bit set to a logic 1.

For example, a message from master to slave to read a group of holding registers would have the following function code:

0000 0011 Hexadecimal 03

If the slave device takes the requested action without error, it returns the same code in its response. If an exception occurs, it returns:

1000 0011 Hexadecimal 83

In addition to its modification of the function code for an exception response, the slave places a unique code into the data field of the response message. This tells the master what kind of error occurred, or the reason for the exception.

The master device's application program has the responsibility of handling exception responses. Typical processes are to post subsequent retries of the message, to try diagnostic messages to the slave, and to notify operators.

Contents of the data field

The data field is constructed using sets of two hexadecimal digits, in the range of 00 to FF hexadecimal. These are made from one RTU character, according to the network's serial transmission mode.

The data field of messages sent from a master to slave devices contains additional information which the slave must use to take the action defined by the function code.

This can include items like discrete and register addresses, the quantity of items to be handled, and the count of actual data bytes in the field.

For example, if the master requests a slave to read a group of holding registers (function code 03), the data field specifies the starting register and how many registers are to be read. If the master writes to a group of registers in the slave (function code 10 hexadecimal), the data field specifies the starting register, how many registers to write, the count of data bytes to follow in the data field, and the data to be written into the registers.

If no error occurs, the data field of a response from a slave to a master contains the data requested. If an error occurs, the field contains an exception code that the master application can use to determine the next action to be taken.

The data field can be nonexistent (of zero length) in certain kinds of messages. For example, in a request from a master device for a slave to respond with its communications event log (function code 0B hexadecimal), the slave does not require any additional information. The NWPM-01 does not support the function code 0B hexadecimal. The function code alone specifies the action.

Contents of the checking field

Two kinds of error-checking methods are used for standard Modbus networks. The error checking field contents depend upon the method that is being used.

ASCII

When ASCII mode is used for character framing, the error checking field contains two ASCII characters. The error check characters are the result of a Longitudinal Redundancy Check (LRC) calculation that is performed on the message contents, exclusive of the beginning 'colon' and terminating CRLF characters.

The LRC characters are appended to the message as the last field preceding the CRLF characters.

RTU

When RTU mode is used for character framing, the error checking field contains a 16-bit value implemented as two 8-bit bytes. The error check value is the result of a Cyclical Redundancy Check calculation performed on the message contents.

The CRC field is appended to the message as the last field in the message. When this is done, the low-order byte of the field is appended first, followed by the high-order byte. The CRC high-order byte is the last byte to be sent in the message.

Additional information about error checking is contained later in this appendix.

How characters are transmitted serially

When messages are transmitted on standard Modbus serial networks, each character or byte is sent in this order (left to right):

Least Significant Bit (LSB) ... Most Significant Bit (MSB)

With RTU character framing, the bit sequence is:

With parity checking

Start	1	2	3	4	5	6	7	8	Par	Stop
-------	---	---	---	---	---	---	---	---	-----	------

Without parity checking

Start	1	2	3	4	5	6	7	8	Stop	Stop
-------	---	---	---	---	---	---	---	---	------	------

Error checking methods

Standard Modbus serial networks use two kinds of error checking. Parity checking (even or odd) can be optionally applied to each character. Frame checking (CRC) is applied to the entire message. Both the character check and message frame check are generated in the master device and applied to the message contents before transmission. The slave device checks each character and the entire message frame during receipt.

The master is configured by the user to wait for a predetermined time-out interval before aborting the transaction. This interval is set to be long enough for any slave to respond normally. If the slave detects a transmission error, the message will not be acted upon. The slave will not construct a response to the master. Thus the time-out will expire and allow the master's program to handle the error. Note that a message addressed to a nonexistent slave device will also cause a time-out. A proper time-out value for the NWPM-01 is 100 ms.

Parity checking

Users can configure controllers for Even or Odd Parity checking, or for No Parity checking. This will determine how the parity bit will be set in each character.

If either Even or Odd Parity is specified, the quantity of 1 bits will be counted in the data portion of each character (eight for RTU). The parity bit will then be set to a 0 or 1 to result in an Even or Odd total of 1 bits.

For example, these eight data bits are contained in an RTU character frame:

1100 0101

The total quantity of 1 bits in the frame is four. If Even Parity is used, the frame's parity bit will be a 0, making the total quantity of 1 bits still an even number (four). If Odd Parity is used, the parity bit will be a 1, making an odd quantity (five).

When the message is transmitted, the parity bit is calculated and applied to the frame of each character. The receiving device counts the quantity of 1 bits and sets an error if they are not the same as configured for that device. All devices on the Modbus network must be configured to use the same parity check method.

Note that parity checking can only detect an error if an odd number of bits are picked up or dropped in a character frame during transmission. For example, if Odd Parity checking is employed, and two 1 bits are dropped from a character containing three 1 bits, the result is still an odd count of 1 bits.

If No Parity checking is specified, no parity bit is transmitted and no parity check can be made. An additional stop bit is transmitted to fill out the character frame.

CRC checking

In RTU mode, messages include an error-checking field that is based on a Cyclical Redundancy Check (CRC) method. The CRC field checks the contents of the entire message. It is applied regardless of any parity check method used for the individual characters of the message.

The CRC field is two bytes, containing a 16-bit binary value. The CRC value is calculated by the transmitting device, which appends the CRC to the message. The receiving device recalculates a CRC during receipt of the message, and compares the calculated value to the actual value it received in the CRC field. If the two values are not equal, an error results.

The CRC is started by first pre-loading a 16-bit register to all 1's. Then a process begins of applying successive 8-bit bytes of the message to the current contents of the register. Only the eight bits of data in each character are used for generating the CRC. Start and stop bits, and the parity bit if one is used, do not apply to the CRC.

During generation of the CRC, each 8-bit character is exclusive ORed with the register contents. Then the result is shifted in the direction of the least significant bit (LSB), with a zero filled into the most significant bit (MSB) position. The LSB is extracted and examined. If the LSB was a 1, the register is then exclusive ORed with a preset, fixed value. If the LSB was a 0, no exclusive OR takes place.

This process is repeated until eight shifts have been performed. After the last (eighth) shift, the next 8-bit byte is exclusive ORed with the register's current value, and the process repeats for eight more shifts as described above. The final contents of the register, after all the bytes of the message have been applied, is the CRC value.

In ladder logic, the CKSM function calculates a CRC from the message contents. For applications using host computers, a detailed example of CRC generation is contained later in this appendix.

Modbus function formats

This chapter describes in detail the data content on every Modbus message supported by the NWPM-01.

How numerical values are expressed

Unless specified otherwise, numerical values (such as addresses, codes, or data) are expressed as *decimal values in the text of this section*. They are expressed as *hexadecimal values in the message fields of the figures*.

Data addresses in Modbus messages

All data addresses in Modbus messages are referenced to zero. The first occurrence of a data item is addressed as item number zero. For example:

- The coil known as 'coil 1' in a programmable controller is addressed as coil 0000 in the data address field of a Modbus message.
- Coil 127 decimal is addressed as coil 007E hex (126 decimal).
- Holding register 40108 is addressed as register 006B hex (107 decimal).

Field contents in Modbus messages

Table *'Master query with RTU framing'* shows an example of a Modbus query message. Table *'Slave response with RTU framing'* is an example of a normal response. Both examples show the field contents in hexadecimal, and also show how a message is be framed in RTU mode.

The master query is a Read Holding Registers request to slave device address 06. The message requests data from three holding registers, 40108 through 40110. Note that the message specifies the starting register address as 0107 (006B hex).

The slave response echoes the function code, indicating this is a normal response. The 'Byte Count' field specifies how many *8-Bit data items* are being returned. It shows the count of 8-bit bytes to follow in the data for RTU.

For example, the value 63 hex is sent as one 8-bit byte in RTU mode (01100011). The 'Byte Count' field counts this data as one 8-bit item, regardless of the character framing method (ASCII or RTU).

How to use the byte count field: When you construct responses in buffers, use a Byte Count value that equals the count of 8-bit bytes in your message data. The value is exclusive of all other field contents, including the Byte Count field. Table *'Slave response with RTU framing'* shows how the byte count field is implemented in a typical response.

Master query with RTU framing

QUERY		
Field name	Example (Hex)	RTU 8-bit field
Header		None
Slave address	06	0000 0110
Function	03	0000 0011
Starting address Hi	00	0000 0000
Starting address Lo	6B	0110 1011
No. of registers Hi	00	0000 0000
No. of registers Lo	03	0000 0011
Error check		CRC (16 bits)
Trailer		None
	Total bytes:	8

Slave response with RTU framing

RESPONSE		
Field name	Example (Hex)	RTU 8-bit field
Header		None
Slave address	06	0000 0110
Function	03	0000 0011
Byte count	06	0000 0110
Data Hi	02	0000 0010
Data Lo	2B	0010 1011
Data Hi	00	0000 0000
Data Lo	00	0000 0000
Data Hi	00	0000 0000
Data Lo	00	0000 0000
Error check		CRC (16 bits)
Trailer		None
	Total bytes	11

Function codes

The NWPM-01 supports three Modbus function codes. These allow the Master to read and write 16-bit integer values to the drive.

03 Read holding registers

Reads the binary contents of holding registers (4X references) in the slave. Broadcast is not supported.

Query

The query message specifies the starting register and quantity of registers to be read. Registers are addressed starting at zero: registers 1...16 are addressed as 0...15.

Here is an example of a request to read registers 40108...40110 from slave device 17:

Read holding registers - query

QUERY	
Field name	Example (Hex)
Slave address	11
Function	03
Starting address Hi	00
Starting address Lo	6B
No. of points Hi	00
No. of points Lo	03
Error check CRC	CRC (16-bits)

Response

The register data in the response message are packed as two bytes per register, with the binary contents right justified within each byte. For each register, the first byte contains the high order bits and the second contains the low order bits.

Data is scanned in the slave at the rate of 125 registers per scan for 984-X8X controllers (984–685, etc.), and at the rate of 32 registers per scan for all other controllers. The response is returned when the data is completely assembled.

Here is an example of a response to the previous query:

Read holding registers - response

RESPONSE	
Field Name	Example (Hex)
Slave Address	11
Function	03
Byte Count	06
Data Hi (Register 40108)	02
Data Lo (Register 40108)	2B
Data Hi (Register 40109)	00
Data Lo (Register 40109)	00
Data Hi (Register 40110)	00
Data Lo (Register 40110)	64
Error Check CRC	CRC (16-Bits)

The contents of register 40108 are shown as the two byte values of 02 2B hex, or 555 decimal. The contents of registers 40109–40110 are 00 00 and 00 64 hex, or 0 and 100 decimal.

06 Preset single register

Presets a value into a single holding register (4X reference). When broadcast, the function presets the same register reference in all attached slaves.

Query

The query message specifies the register reference to be preset. Registers are addressed starting at zero: register 1 is addressed as 0.

The requested preset value is specified in the query data field. The NWPM-01 uses 16-bit values.

Here is an example of a request to preset register 40002 to 00 03 hex in slave device 17:

Preset single register - query

QUERY	
Field Name	Example (Hex)
Slave Address	11
Function	06
Register Address Hi	00
Register Address Lo	01
Preset Data Hi	00
Preset Data Lo	03
Error Check CRC	CRC (16-Bits)

Response

The normal response is an echo of the query, returned after the register contents have been preset.

Here is an example of a response to the query on the opposite page:

Preset single register - response

RESPONSE	
Field Name	Example (Hex)
Slave Address	11
Function	06
Register Address Hi	00
Register Address Lo	01
Preset Data Hi	00
Preset Data Lo	03
Error Check CRC	CRC (16-Bits)

16 (10 Hex) Preset multiple regs

Presets values into a sequence of holding registers (4X references). When broadcast, the function presets the same register references in all attached slaves.

The NWPM-01 allows one or multiple registers to be written at one time using one Preset Multiple Regs function. Only registers within one group can be written at one time. If a write to one of the registers fails, the module will try to write to other registers, but the response will contain a corresponding exception message.

Query

The query message specifies the register references to be preset. Registers are addressed starting at zero: register 1 is addressed as 0.

The requested preset values are specified in the query data field. The NWPM-01 uses 16-bit values. Data is packed as two bytes per register.

Here is an example of a request to preset one register starting at 40002 to 00 0A in slave device 17:

Preset multiple registers - query

QUERY	
Field Name	Example (Hex)
Slave Address	11
Function	10
Starting Address Hi	00
Starting Address Lo	01
No. of Registers Hi	00
No. of Registers Lo	01
Byte Count	02
Data Hi	00
Data Lo	0A
Error Check CRC	CRC (16-Bits)

Response

The normal response returns the slave address, function code, starting address, and quantity of registers preset.

Here is an example of a response to the query shown above.

Preset multiple registers - response

RESPONSE	
Field Name	Example (Hex)
Slave Address	11
Function	10
Starting Address Hi	00
Starting Address Lo	01
No. of Registers Hi	00
No. of Registers Lo	01
Error Check CRC	CRC (16-Bits)

Exception responses

Except for broadcast messages, when a master device sends a query to a slave device it expects a normal response. One of four possible events can occur from the master's query:

1. If the slave device receives the query without a communication error, and can handle the query normally, it returns a normal response.
2. If the slave does not receive the query due to a communication error, no response is returned. The master program will eventually process a time-out condition for the query.
3. If the slave receives the query, but detects a communication error (parity, LRC, or CRC), no response is returned. The master program will eventually process a time-out condition for the query.
4. If the slave receives the query without a communication error, but cannot handle it (for example, if the request is to read a non-existent coil or register), the slave will return an exception response informing the master of the nature of the error. The exception response message has two fields that differentiate it from a normal response:

Function code field: In a normal response, the slave echoes the function code of the original query in the function code field of the response. All function codes have a most-significant bit (MSB) of 0 (their values are all below 80 hexadecimal). In an exception response, the slave sets the MSB of the function code to 1. This makes the function code value in an exception response exactly 80 hexadecimal higher than the value would be for a normal response. With the function code's MSB set, the master's application program can recognise the exception response and can examine the data field for the exception code.

Data field: In a normal response, the slave may return data or statistics in the data field (any information that was requested in the query). In an exception response, the slave returns an exception code in the data field. This defines the slave condition that caused the exception. Table '[Master query and slave exception response](#)' on page 55 shows an example of a master query and slave exception response.

The field examples are shown in hexadecimal.

Master query and slave exception response

QUERY		
Byte	Contents	Example
1	Slave Address	0A
2	Function	01
3	Starting Address Hi	04
4	Starting Address Lo	A1
5	No. of Coils Hi	00
6	No. of Coils Lo	01
7	LRC	4F
EXCEPTION RESPONSE		
1	Slave Address	0A
2	Function	81
3	Exception Code	02
4	LRC	73

In this example, the master addresses a query to slave device 10 (0A hex). The function code (01) is for a Read Coil Status operation. It requests the status of the coil at address 1245 (04A1 hex). Note that only that one coil is to be read, as specified by the number of coils field (0001).

If the coil address is non-existent in the slave device, the slave will return the exception response with the exception code shown (02). This specifies an illegal data address for the slave. For example, if the slave is a 984-385 with 512 coils, this code would be returned.

A listing of Modicon exception codes is in table [Standard exception codes](#) below.

Standard exception codes

Code	Name	Meaning
01	ILLEGAL FUNCTION	The function code received in the query is not an allowable action for the slave. If a Poll Program Complete command was issued, this code indicates that no program function preceded it.
02	ILLEGAL DATA ADDRESS	The data address received in the query is not an allowable address for the slave.
03	ILLEGAL DATA VALUE	A value contained in the query data field is not an allowable value for the slave.

Code	Name	Meaning
04	SLAVE DEVICE FAILURE	An unrecoverable error occurred while the slave was attempting to perform the requested action.
05	ACKNOWLEDGE	The slave has accepted the request and is processing it, but a long duration of time will be required to do so. This response is returned to prevent a time-out error from occurring in the master. The master can next issue a Poll Program Complete message to determine if processing is completed.
06	SLAVE DEVICE BUSY	The slave is engaged in processing a long duration program command. The master should retransmit the message later when the slave is free.
07	NEGATIVE ACKNOWLEDGE	The slave cannot perform the program function received in the query. This code is returned for an unsuccessful programming request using function code 13 or 14 decimal. The master should request diagnostic or error information from the slave.
08	MEMORY PARITY ERROR	The slave attempted to read extended memory, but detected a parity error in the memory. The master can retry the request, but service may be required on the slave device.

CRC generation

The Cyclical Redundancy Check (CRC) field is two bytes, containing a 16-bit binary value. The CRC value is calculated by the transmitting device, which appends the CRC to the message. The receiving device recalculates a CRC during receipt of the message, and compares the calculated value to the actual value it received in the CRC field. If the two values are not equal, an error results.

The CRC is started by first preloading a 16-bit register to all 1's. Then a process begins of applying successive 8-bit bytes of the message to the current contents of the register. Only the eight bits of data in each character are used for generating the CRC. Start and stop bits, and the parity bit if one is used, do not apply to the CRC.

During generation of the CRC, each 8-bit character is exclusive ORed with the register contents. Then the result is shifted in the direction of the least significant bit (LSB), with a zero filled into the most significant bit (MSB) position. The LSB is extracted and examined. If the LSB was a 1, the register is then exclusive ORed with a preset, fixed value. If the LSB was a 0, no exclusive OR takes place.

This process is repeated until eight shifts have been performed. After the last (eighth) shift, the next 8-bit character is exclusive ORed with the register's current value, and the process repeats for eight more shifts as described above. The final contents of the register, after all the characters of the message have been applied, is the CRC value.

A procedure for generating a CRC is:

1. Load a 16-bit register with FFFF hex (all 1's). Call this the CRC register.
2. Exclusive OR the first 8-bit byte of the message with the low-order byte of the 16-bit CRC register, putting the result in the CRC register.
3. Shift the CRC register one bit to the right (toward the LSB), zero-filling the MSB. Extract and examine the LSB.
4. (If the LSB was 0): Repeat Step 3 (another shift).
(if the LSB was 1): Exclusive OR the CRC register with the polynomial value A001 hex (101 0 0000 0000 0001).
5. Repeat Steps 3 and 4 until 8 shifts have been performed. When this is done, a complete 8-bit byte will have been processed.
6. Repeat Steps 2 through 5 for the next 8-bit byte of the message. Continue doing this until all bytes have been processed.
7. The final contents of the CRC register is the CRC value.

Placing the CRC into the message

When the 16-bit CRC (2 8-bit bytes) is transmitted in the message, the low-order byte will be transmitted first, followed by the high-order byte. For example, if the CRC value is 1241 hex (0001 0010 0100 0001):

CRC byte sequence

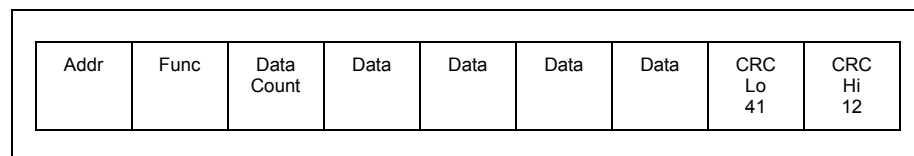

Example

An example of a C language function performing CRC generation is shown on the following pages. All of the possible CRC values are preloaded into two arrays, which are simply indexed as the function increments through the message buffer. One array contains all of the 256 possible CRC values for the high byte of the 16-bit CRC field, and the other contains all of the values for the low byte. Indexing the CRC in this way provides faster execution than would be achieved by calculating a new CRC value with each new character from the message buffer.

The function takes two arguments:

unsigned char *puchMsg

A pointer to the message buffer containing binary data to be used for generating the CRC

unsigned short usDataLen

The quantity of bytes in the message buffer.

The function returns the CRC as a type unsigned short.

```

/* Table of CRC values for high-order byte */
static unsigned char auchCRCHi [ ] = {
0x00,0xC1,0x81,0x40,0x01,0xC0,0x80,0x41,0x01,0xC0,0x80,0x41,0x00,0xC1,0x81,
0x40,0x01,0xC0,0x80,0x41,0x00,0xC1,0x81,0x40,0x00,0xC1,0x81,0x40,0x01,0xC0,
0x80,0x41,0x01,0xC0,0x80,0x41,0x00,0xC1,0x81,0x40,0x00,0xC1,0x81,0x40,0x01,
0xC0,0x80,0x41,0x00,0xC1,0x81,0x40,0x01,0xC0,0x80,0x41,0x01,0xC0,0x80,0x41,
0x00,0xC1,0x81,0x40,0x01,0xC0,0x80,0x41,0x00,0xC1,0x81,0x40,0x00,0xC1,0x81,
0x40,0x01,0xC0,0x80,0x41,0x00,0xC1,0x81,0x40,0x01,0xC0,0x80,0x41,0x01,0xC0,
0x80,0x41,0x00,0xC1,0x81,0x40,0x00,0xC1,0x81,0x40,0x01,0xC0,0x80,0x41,0x01,
0xC0,0x80,0x41,0x00,0xC1,0x81,0x40,0x01,0xC0,0x80,0x41,0x00,0xC1,0x81,0x40,
0x00,0xC1,0x81,0x40,0x01,0xC0,0x80,0x41,0x01,0xC0,0x80,0x41,0x00,0xC1,0x81,
0x40,0x00,0xC1,0x81,0x40,0x01,0xC0,0x80,0x41,0x00,0xC1,0x81,0x40,0x01,0xC0,
0x80,0x41,0x01,0xC0,0x80,0x41,0x00,0xC1,0x81,0x40,0x00,0xC1,0x81,0x40,0x01,
0xC0,0x80,0x41,0x01,0xC0,0x80,0x41,0x00,0xC1,0x81,0x40,0x01,0xC0,0x80,0x41,
0x00,0xC1,0x81,0x40,0x00,0xC1,0x81,0x40,0x01,0xC0,0x80,0x41,0x00,0xC1,0x81,
0x40,0x01,0xC0,0x80,0x41,0x01,0xC0,0x80,0x41,0x00,0xC1,0x81,0x40,0x01,0xC0,
0x80,0x41,0x00,0xC1,0x81,0x40,0x00,0xC1,0x81,0x40,0x01,0xC0,0x80,0x41,
0x00,0xC1,0x81,0x40,0x01,0xC0,0x80,0x41,0x01,0xC0,0x80,0x41,0x00,0xC1,0x81,
0x40
};

/* Table of CRC values for low-order byte*/
static char auchCRCLo [ ] = {
0x00,0xC0,0xC1,0x01,0xC3,0x03,0x02,0xC2,0xC6,0x06,0x07,0xC7,0x05,0xC5,0xC4,
0x04,0xCC,0x0C,0x0D,0xCD,0x0F,0xCF,0xCE,0x0E,0x0A,0xCA,0xCB,0x0B,0xC9,0x09,
0x08,0xC8,0xD8,0x18,0x19,0xD9,0x1B,0xDB,0xDA,0x1A,0x1E,0xDE,0xDF,0x1F,0xDD,
0x1D,0x1C,0xDC,0x14,0xD4,0xD5,0x15,0xD7,0x17,0x16,0xD6,0xD2,0x12,0x13,0xD3,
0x11, 0xD1,0xD0,0x10,0xF0,0x30,0x31,0xF1,0x33,0xF3,0xF2,0x32,0x36,0xF6,0xF7,
0x37,0xF5,0x35,0x34,0xF4,0x3C,0xFC,0xFD,0x3D,0xFF,0x3F,0x3E,0xFA,0x3A,
0x3B,0xFB,0x39,0xF9,0xF8,0x38,0x28,0xE8,0xE9,0x29,0xEB,0x2B,0x2A,0xEA,0xEE,
0x2E,0x2F,0xEF,0x2D,0xED,0xEC,0x2C,0xE4,0x24,0x25,0xE5,0x27,0xE7,0xE6,0x26,
0x22,0xE2,0xE3,0x23,0xE1,0x21,0x20,0xE0,0xA0,0x60,0x61,0xA1,0x63,0xA3,0xA2,
0x62,0x66,0xA6,0xA7,0x67,0xA5,0x65,0x64,0xA4,0x6C,0xAC,0xAD,0x6D,0xAF,0x6F,
0x6E,0xAE,0xAA,0x6A,0x6B,0xAB,0x69,0xA9,0xA8,0x68,0x78,0xB8,0xB9,0x79,0xBB,
0x7B,0x7A,0xBA,0xBE,0x7E,0x7F,0xBF,0x7D,0xBD,0xBC,0x7C,0xB4,0x74,0x75,0xB5,
0x77,0xB7,0xB6,0x76,0x72,0xB2,0xB3,0x73,0xB1,0x71,0x70,0xB0,0x50,0x90,0x91,
0x51,0x93,0x53,0x52,0x92,0x96,0x56,0x57,0x97,0x55,0x95,0x94,0x54,0x9C,0x5C,
0x5D,0x9D,0x5F,0x9F,0x9E,0x5E,0x5A,0x9A,0x9B,0x5B,0x99,0x59,0x58,0x98,0x88,
0x48,0x49,0x89,0x4B,0x8B,0x8A,0x4A,0x4E,0x8E,0x8F,0x4F,0x8D,0x4D,0x4C,0x8C,
0x44,0x84,0x85,0x45,0x87,0x47,0x46,0x86,0x82,0x42,0x43,0x83,0x41,0x81,0x80,
0x40
};

```

```
unsigned short CRC16(puchMsg, usDataLen)
unsigned char *puchMsg ;           /* message to calculate CRC upon* /
unsigned short usDataLen;         /* quantity of bytes in message*/
{
    unsigned char uchCRCHi = 0xFF; /* high byte of CRC initialized*/
    unsigned char uchCRCLo = 0xFF; /* low byte of CRC initialized*/
    unsigned ulIndex;             /* will index into CRC lookup table*/

    while (usDataLen--)           /* pass through message buffer*/
    {
        ulIndex = uchCRCHi ^ *puchMsg++; /* calculate the CRC*/
        uchCRCHi = uchCRCLo ^ uchCRCHi [ulIndex] ;
        uchCRCLo = uchCRCLo [ulIndex] ;
    }

    return (uchCRCHi << 8 | uchCRCLo);
}
```

Ambient conditions

Ambient conditions, operation

Ambient operating conditions refer to the conditions the option module is subjected to when installed for stationary use.

Air temperature: 0 to +50 °C

Relative humidity: 5 to 95%, no condensation allowed. Maximum allowed relative humidity is 60% in the presence of corrosive gases.

Contamination levels:

Chemical gases: IEC 721-3-3, Class 3C2

Solid particles: IEC 721-3-3, Class 3S2

Installation site altitude: 0 to 2000 m above sea level. If the installation site is higher than 2000 m above sea level, please contact your local ABB distributor or office for further information.

Vibration: Max 0.3 mm (2 to 9 Hz), max 1 m/s² (9 to 200 Hz) sinusoidal (IEC 68-2-6)

Shock: Max 70 m/s², 22 ms (IEC 68-2-27)

Ambient conditions, storage

Ambient storage conditions refer to the conditions the option module is subjected to during storage in the protective package.

Temperature: -40 to +70 °C.

Relative humidity: Less than 95%, no condensation allowed

Atmospheric pressure: 70 to 106 kPa

Vibration: Max 0.3 mm (2 to 9 Hz), max 1 m/s² (9 to 200 Hz) sinusoidal (IEC 68-2-6)

Shock: Max 100 m/s², 11 ms (IEC 68-2-27)

Ambient conditions, transportation

Ambient transportation conditions refer to the conditions the option module is subjected to during transportation in the protective package.

Temperature: -40 to +70 °C

Relative humidity: Less than 95%, no condensation allowed.

Atmospheric pressure: 60 to 106 kPa

Vibration: Max 3.5 mm (2 to 9 Hz), max 15 m/s² (9 to 200 Hz) sinusoidal (IEC 68-2-6)

Shock: Max 100 m/s², 11 ms (IEC 68-2-27)

Bump: Max 300 m/s², 6 ms (IEC 68-2-29)

Free fall: 250 mm



3AJA0000020296 REV A / EN
EFFECTIVE: 28.04.2008

ABB Oy

AC Drives
P.O. Box 184
FI-00381 HELSINKI
FINLAND
Telephone +358 10 22 11
Fax +358 10 22 22681
Internet www.abb.com

ABB Inc.

Automation Technologies
Drives & Motors
16250 West Glendale Drive
New Berlin, WI 53151
USA
Telephone 262 785-3200
800-HELP-365
Fax 262 780-5135

ABB Beijing Drive Systems Co. Ltd.

No. 1, Block D, A-10 Jiuxianqiao Beilu
Chaoyang District
Beijing, P.R. China, 100015
Telephone +86 10 5821 7788
Fax +86 10 5821 7618
Internet www.abb.com