



## The Company

We are an established world force in the design and manufacture of instrumentation for industrial process control, flow measurement, gas and liquid analysis and environmental applications.

As a part of ABB, a world leader in process automation technology, we offer customers application expertise, service and support worldwide.

We are committed to teamwork, high quality manufacturing, advanced technology and unrivalled service and support.

The quality, accuracy and performance of the Company's products result from over 100 years experience, combined with a continuous program of innovative design and development to incorporate the latest technology.

The UKAS Calibration Laboratory No. 0255 is just one of the ten flow calibration plants operated by the Company and is indicative of our dedication to quality and accuracy.

EN ISO 9001:2000



Cert. No. Q 05907

EN 29001 (ISO 9001)



Lenno, Italy – Cert. No. 9/90A

Stonehouse, U.K.



0255

## Electrical Safety

This equipment complies with the requirements of CEI/IEC 61010-1:1993 "Safety requirements for electrical equipment for measurement, control, and laboratory use". If the instrument is used in a manner NOT specified by the Company, the protection provided by the instrument may be impaired.

## Symbols

One or more of the following symbols may appear on the equipment labelling:

	<b>Warning</b> – Refer to the manual for instructions		Direct current supply only
	<b>Caution</b> – Risk of electric shock		Alternating current supply only
	Protective earth (ground) terminal		Both direct and alternating current supply
	Earth (ground) terminal		The equipment is protected through double insulation

Information in this manual is intended only to assist our customers in the efficient operation of our equipment. Use of this manual for any other purpose is specifically prohibited and its contents are not to be reproduced in full or part without prior approval of the Technical Publications Department.

### Health and Safety

To ensure that our products are safe and without risk to health, the following points must be noted:

1. The relevant sections of these instructions must be read carefully before proceeding.
2. Warning labels on containers and packages must be observed.
3. Installation, operation, maintenance and servicing must only be carried out by suitably trained personnel and in accordance with the information given.
4. Normal safety precautions must be taken to avoid the possibility of an accident occurring when operating in conditions of high pressure and/or temperature.
5. Chemicals must be stored away from heat, protected from temperature extremes and powders kept dry. Normal safe handling procedures must be used.
6. When disposing of chemicals ensure that no two chemicals are mixed.

Safety advice concerning the use of the equipment described in this manual or any relevant hazard data sheets (where applicable) may be obtained from the Company address on the back cover, together with servicing and spares information.

# CONTENTS

Section	Page	Section	Page
<b>1 INTRODUCTION</b> .....	<b>2</b>	<b>7 CALIBRATION</b> .....	<b>29</b>
1.1 Description .....	2	7.1 Calibration Sequence .....	29
1.2 Training .....	2	<b>8 MAINTENANCE</b> .....	<b>30</b>
1.3 Location and Function of Main Components .....	2	8.1 Chemistry .....	30
<b>2 INSTALLATION</b> .....	<b>3</b>	8.1.1 Reagent Solution .....	30
2.1 Accessories .....	3	8.1.2 Standard Solutions .....	30
2.2 Location .....	3	8.1.3 Reference Salt Bridge Solution .....	30
2.3 Mounting .....	3	8.2 Scheduled Servicing .....	30
2.4 Sampling Requirement .....	3	8.2.1 Regular Visual Checks .....	30
2.5 Sample Connections .....	3	8.2.2 Four Weekly .....	30
2.6 Connections, General .....	4	8.2.3 Four Monthly .....	31
2.7 External Electrical Connections .....	5	8.2.4 Twelve Monthly .....	31
2.8 Relay Contact Protection and Interference Suppression .....	6	8.2.5 Cleaning Sample Pipework .....	31
<b>3 SETTING UP</b> .....	<b>7</b>	8.2.6 Consumables Spares Kit .....	32
<b>4 LIQUID HANDLING SECTION</b> .....	<b>8</b>	8.2.7 Fitting the Electrode .....	32
4.1 Principle of Operation .....	8	8.2.8 Peristaltic Pump .....	33
4.2 General Operation .....	9	8.2.9 Replacement of Plumbing Tubing .....	33
<b>5 ELECTRONICS SECTION</b> .....	<b>9</b>	8.3 Shutdown Procedure .....	34
5.1 Electronic Layout .....	9	8.3.1 Short Term .....	34
5.2 User Junction Box .....	9	8.3.2 Long Term .....	34
5.3 Microprocessor Unit .....	9	8.4 Unscheduled Servicing .....	34
5.4 Front Panel Controls .....	10	8.4.1 Malfunction of the Monitor .....	34
5.5 Displays .....	10	8.4.2 Monitor Diagnostic Information .....	35
5.6 L.E.D. Indication .....	10	8.5 Refurbishing the Electrode .....	35
<b>6 PROGRAMMING</b> .....	<b>11</b>	8.6 Microprocessor Unit Error Messages .....	36
6.1 Normal Operation .....	12	<b>9 SPECIFICATION</b> .....	<b>37</b>
6.2 Programming Pages .....	12	<b>10 SPARES LIST</b> .....	<b>38</b>
6.2.1 Operating Page 1 .....	13	<b>APPENDIX A – REPLACING SOFTWARE EPROM</b> .....	<b>40</b>
6.2.2 Operating Page 2 .....	14	A.1 Access the Transmitter Unit .....	40
6.2.3 Security Code Page .....	15	A.2 Access the PCB .....	40
6.2.4 Set Up Input Page .....	16	A.3 Removing the PCB .....	41
6.2.5 Current Output Page .....	17	A.4 Changing the EPROM .....	41
6.2.6 Set Up Alarms Page .....	20	A.5 Completing the Procedure .....	41
6.2.7 Set Up Clock Page .....	22	<b>NOTES</b> .....	<b>42</b>
6.2.8 Calibration User Code Page .....	24		
6.2.9 Set Up Temperature Control Page .....	25		
6.2.10 Electrical Calibration .....	25		
6.2.11 Electrical Calibration Page .....	26		

# 1 INTRODUCTION

## 1.1 Description

The Model 8236 Nitrate Monitor is a microprocessor based analyser using an ABB nitrate ion-selective probe. This equipment is used for environmental water monitoring.

## 1.2 Training

Due to the specialised nature of the above instrument, it is recommended that, where the end users personnel have had no previous experience of maintaining this equipment, training be provided by this Company.

Such training is available via the local Company in the UK, or Overseas Agent elsewhere and may be carried out either on the users premises or at the factory.

## 1.3 Location and Function of Main Components – Fig. 1.1

Monitoring of any sample by ion-selective electrodes usually requires certain conditioning to be performed on the sample to allow accurate, trouble-free measurement. Such conditioning involves regulating flow, controlling temperature and adjusting chemical composition prior to presentation of the sample to the point of measurement. This monitor carries out these adjustments for each parameter in simple and easily understood steps. The sample is presented from the user's pipework to a constant head unit and any excess is allowed to overflow. This

allows sample, under controlled pressure conditions, to be presented to a multi-channel peristaltic pump which proportions sample and reagent solutions through the monitor to the mixing point. The resulting combined solution is then temperature controlled to remove the effects of sample and ambient temperature variations. The conditioned solution is then delivered to the flowcell, under constantly flowing conditions, where the ion measurement takes place. This measurement is carried out using an ion-selective sensing electrode.

The sensor generates a millivolt output which is proportional to the ion concentration. This output is processed by the microprocessor-based electronics section to calculate the actual sample concentration.

To maintain optimum measurement accuracy it is necessary to introduce standard solutions of known concentration for calibration purposes. The monitor utilises solenoid valves to introduce these standard solutions automatically, at predetermined intervals, under the control of the microprocessor.

The electronics section consists of the main Microprocessor Unit situated at the top left and a User Junction Box at the top right behind the hinged case.

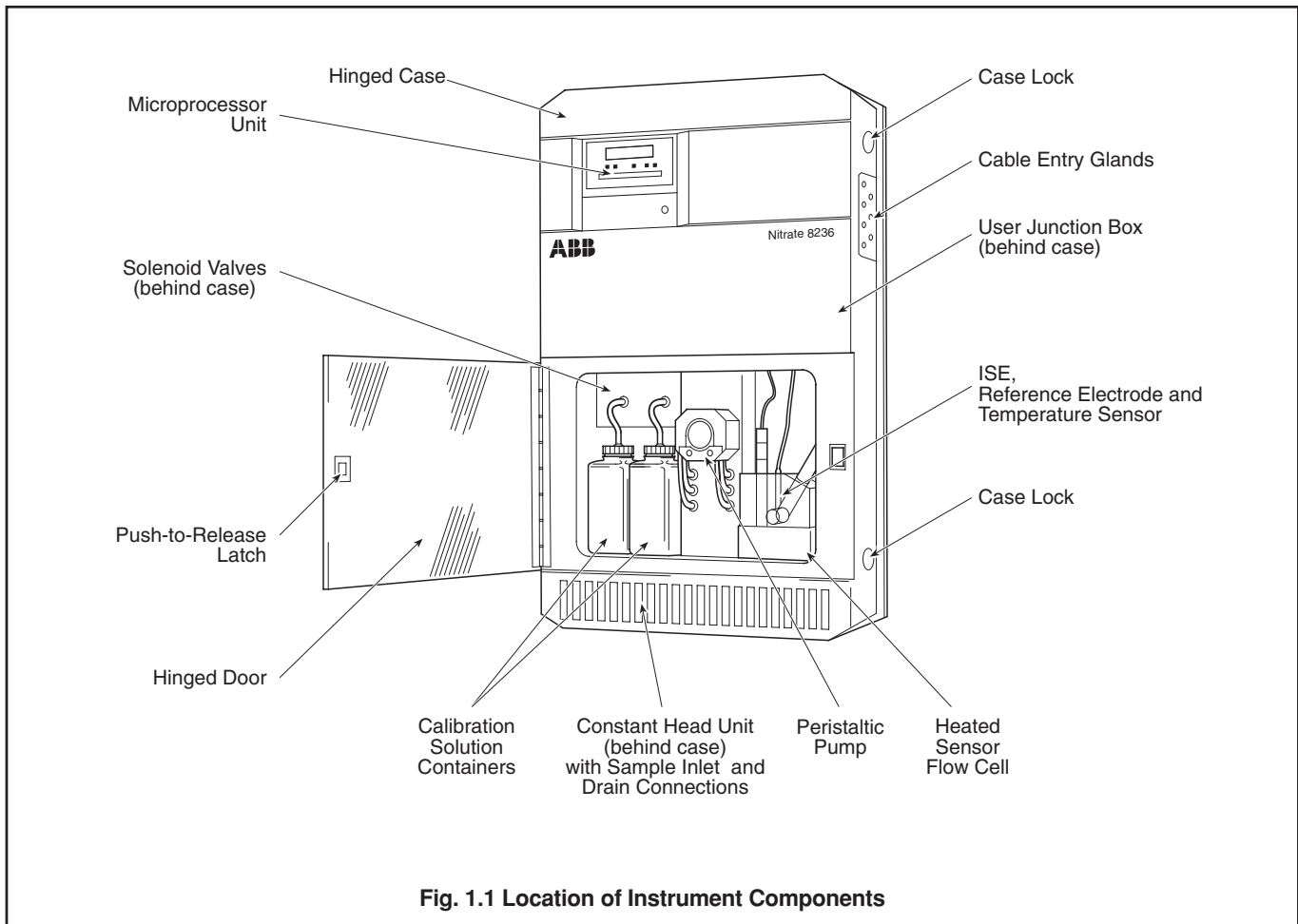

## 2 INSTALLATION

### 2.1 Accessories

1 x reagent bottle	1 x nitrate refurbishing kit
4 x calibration bottles	1 x double junction
1 x nitrate inner electrode	reference electrode
1 x spares kit	

### 2.2 Location

The monitor should be installed in a clean, dry, well ventilated and vibration-free location giving easy access, and where short sample lines can be used. Rooms containing corrosive gases or vapours (e.g., chlorination equipment or chlorine gas cylinders) should be avoided. It is also advisable to have adjacent drains near ground level, so that the waste outlet from the monitor can be as short as possible, together with maximum fall. Power supplies should also be adjacent. Ambient temperature: within the range 5 to 40°C.

### 2.3 Mounting – Fig. 2.1

The monitor has a moulded plastic case, mounted onto a flat metal panel. To provide access, the case is hinged on the left hand side and has two lockable catches on the right hand to hold the case in position in normal operation.

One keyhole slot is provided at the top of the flat panel to provide easy mounting on a wall or framework. Two further fixing holes are provided at the bottom of the flat panel. All holes are designed to take 8 mm bolts or studs.

Mains and signal cables are connected through cable glands in the User Junction Box on the right hand side with the exception of the optional serial interface which connects directly into the Microprocessor Unit. Sample and drain pipework are brought in through the bottom of the case.

### 2.4 Sampling Requirement

In addition to being as close as possible to the monitor, the sampling point must provide a thoroughly mixed representative sample. The sample must also conform to the following conditions:

- Sample flow rates must be between 5 ml min<sup>-1</sup> and 1250 ml min<sup>-1</sup>.
- Sample temperature should be within 20 °C of the ambient temperature and within the range 0 to 40°C.
- Particles must be less than 10 mg l<sup>-1</sup> and the size must not exceed 60 µm. Above these levels it is essential that the filter supplied is fitted in both the sample and emergency inlets.

### 2.5 Sample Connections – Fig. 2.2 (overpage)

The inlet and outlet pipe connections are both located at the bottom of the case. A 6 mm (1/4") hose adaptor is provided for the sample inlet and a 9 mm (3/8") hose connection for the drains. It is recommended that the pipes used should be of inert material, e.g., silicone rubber or p.v.c. The inlet pipe must incorporate a shut-off valve at its upstream end, while the drain outlet pipes should be short, venting to atmosphere as soon as possible.

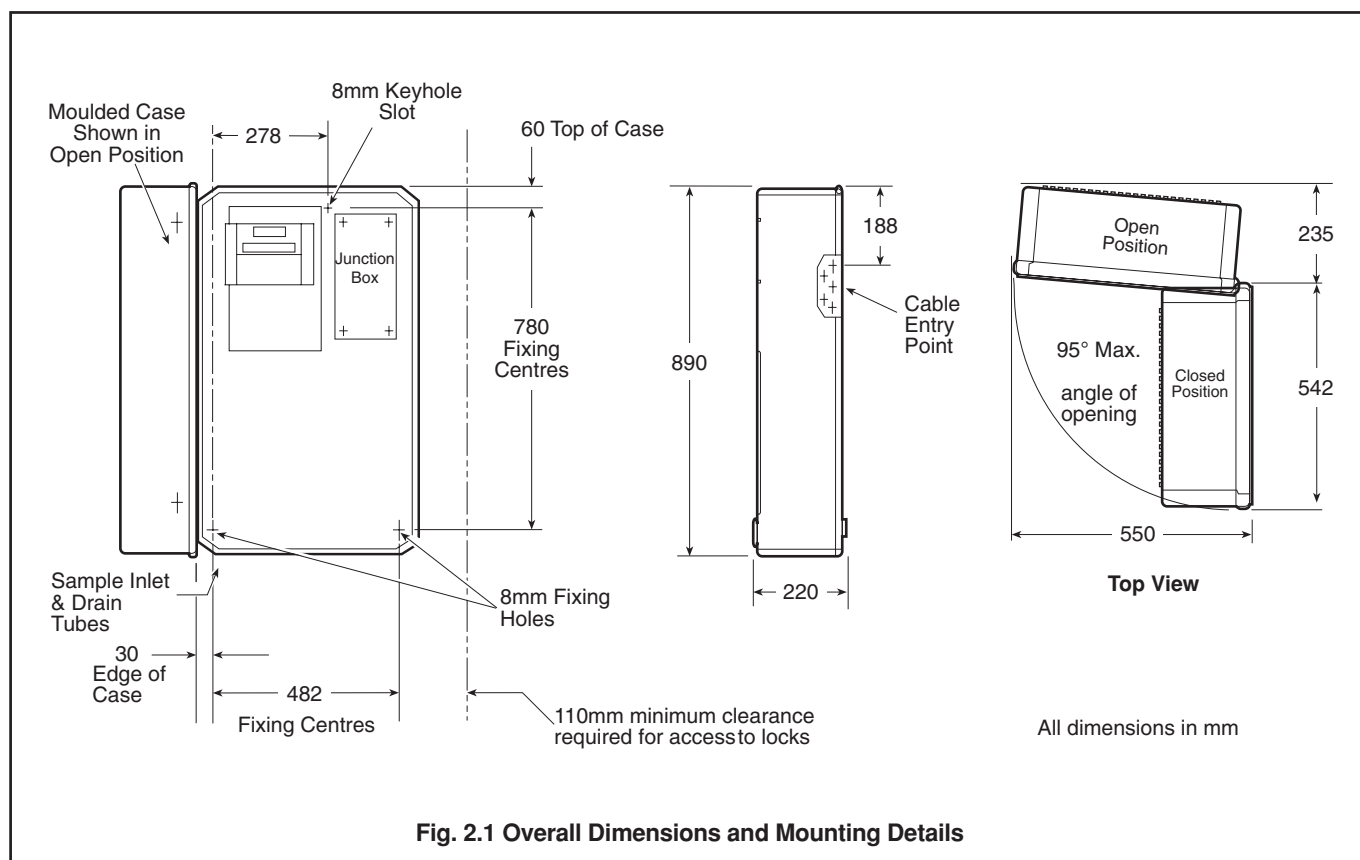

---

## ...2 INSTALLATION

---

### 2.6 Connections, General



#### Warnings.

- A disconnecting device such as a switch or circuit breaker conforming to local safety standards must be fitted to the final installation. It must be fitted in close proximity to the instrument within easy reach of the operator and must be marked clearly as the disconnection device for the instrument.
- Although certain instruments are fitted with internal fuse protection, a suitably rated external protection device, e.g. a 3A fuse or miniature circuit breaker (m.c.b.), must also be fitted by the installer.
- Remove all power from supply, relay and any powered control circuits and high common mode voltages before accessing or making any connections.
- The power supply earth (ground) **must** be connected to ensure safety to personnel, reduction of the effects of RFI interference and correct operation of the power supply interference filter.
- The power supply earth (ground) **must** be connected to the earth (ground) stud on the junction box case – see Fig. 2.3.
- Use cable appropriate for the load currents. The terminals accept cables up to 14AWG (2.5mm<sup>2</sup>).
- The instrument conforms to Mains Power Input Insulation Category III. All other inputs and outputs conform to Category II.
- All connections to secondary circuits must have basic insulation.
- After installation, there must be no access to live parts, e.g. terminals.
- Terminals for external circuits are for use only with equipment with no accessible live parts.
- The relay contacts are voltage-free and must be appropriately connected in series with the power supply and the alarm/control device which they are to actuate. Ensure that the contact rating is not exceeded. Refer also to Section 2.8 for relay contact protection details when the relays are to be used for switching loads.
- Do not exceed the maximum load specification for the selected analog output range.  
The analog output is isolated, therefore the –ve terminal must be connected to earth (ground) if connecting to the isolated input of another device.
- If the instrument is used in a manner not specified by the Company, the protection provided by the equipment may be impaired.
- All equipment connected to the instrument's terminals must comply with local safety standards (IEC 60950, EN61010-1).

---

#### Notes.

- An earthing (grounding) – stud terminal is fitted to the junction box case for bus-bar earth (ground) connection – see Fig. 2.3.
  - Always route signal output and mains-carrying/relay cables separately, ideally in earthed (grounded) metal conduit. Use twisted pair output leads or screened cable with the screen connected to the case earth (ground) stud.  
Ensure that the cables enter the analyzer through the glands nearest the appropriate screw terminals and are short and direct. Do not tuck excess cable into the terminal compartment.
  - Ensure that the IP65 rating is not compromised when using cable glands, conduit fittings and blanking plugs/bungs (M20 holes). The M20 glands accept cable of between 5 and 9mm (0.2 and 0.35 in.) diameter.
-

### 2.7 External Electrical Connections – Fig. 2.3

The external electrical connections are to be found in the User Junction Box with the exception of the optional serial interface which is connected directly into the Microprocessor Unit. The cables are passed through the cable glands on the right hand side of the junction box which are adjacent to the internal electrical terminals.

**Caution.** Slacken the terminal screws fully before making connections.

The connections are as follows:

- Mains input 115 V or 240 V. The mains voltage is selected by means of the voltage selector – see Fig. 2.3.
  - Current outputs 1 and 2 – two independent current outputs for external recording or control. One output is supplied as standard, the second is supplied as an optional extra – see Fig. 2.4 for details of current output range.
- Information.** Because the current output is isolated, the negative terminal **must** be connected to earth (ground) if connecting to the isolated input of another device.
- Relay 1 and 2 – two concentration alarms.
  - Relay 3 – calibration mode indication. This indicates when the instrument is off line during a calibration.
  - Relay 4 – instrument 'OUT OF SERVICE' indication. This indicates that the monitor readings are suspect and it is in need of attention.
  - Relay 5 – 'OUT OF SAMPLE' – indication of loss of sample.
  - Optional serial interface – connected into the Microprocessor Unit. See supplementary instruction manual for details.

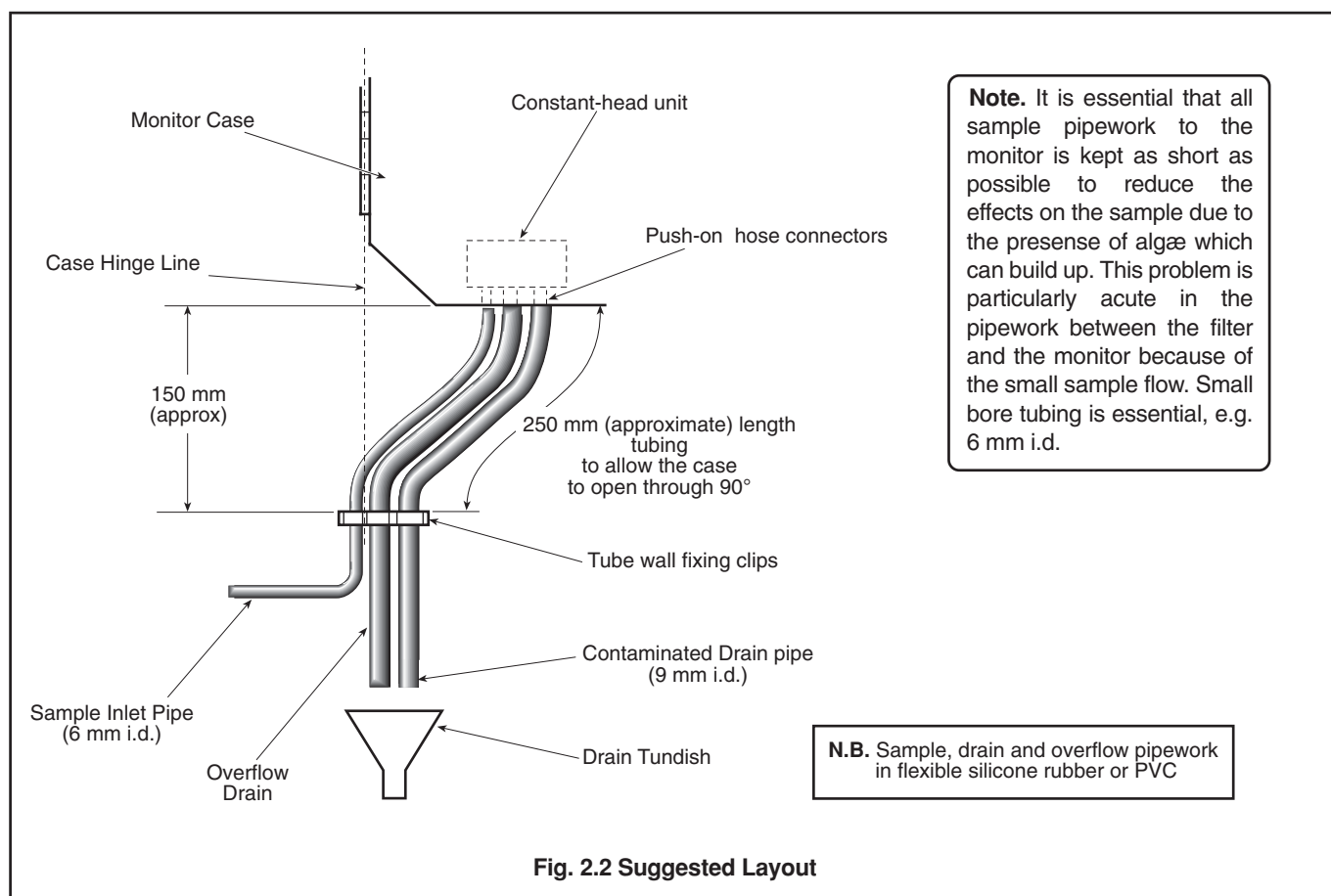

Fig. 2.2 Suggested Layout



## ...2 INSTALLATION

### 2.8 Relay Contact Protection and Interference Suppression – Fig. 2.5

If the relays are used to switch loads on or off the relay contacts can become eroded due to arcing. Arcing also produces radio frequency interference (r.f.i.) which can cause instrument malfunctions and incorrect readings. To minimize the effects of r.f.i., arc suppression components are required; these are resistor/capacitor networks for a.c. applications, or diodes for d.c. applications. These components can be connected either across the load or directly across the relay contacts.

For **a.c. applications** the value of the resistor/capacitor network depends on the load current and inductance that is switched. Initially fit a 100 R/0.022  $\mu$ F RC suppressor unit (part no. B9303)

as shown in Fig. 2.5A. If the instrument malfunctions the value of the RC network is too low for suppression and an alternative value must be used. If the correct RC suppressor unit cannot be obtained, contact the manufacturer of the switched device for details of the RC unit required.

For **d.c. applications** fit a diode as shown in Fig. 2.5B. For general applications use an alternative IN5406 type (600 V peak inverse voltage at 3 A – part no. B7363).

**Note.** For reliable switching the minimum voltage must be greater than 12 V and the minimum current greater than 100 mA.

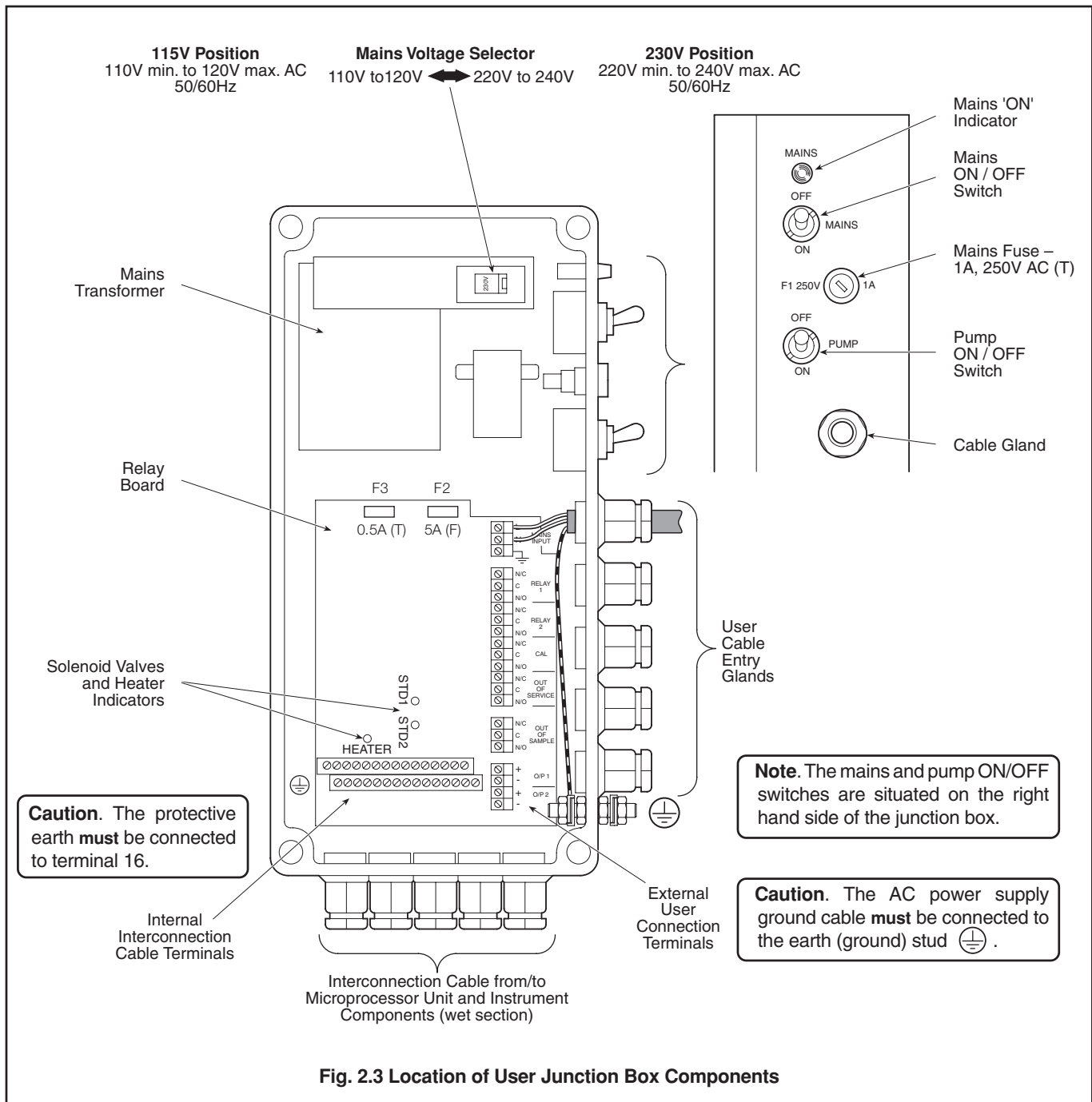

**Fig. 2.3 Location of User Junction Box Components**



## 2 INSTALLATION

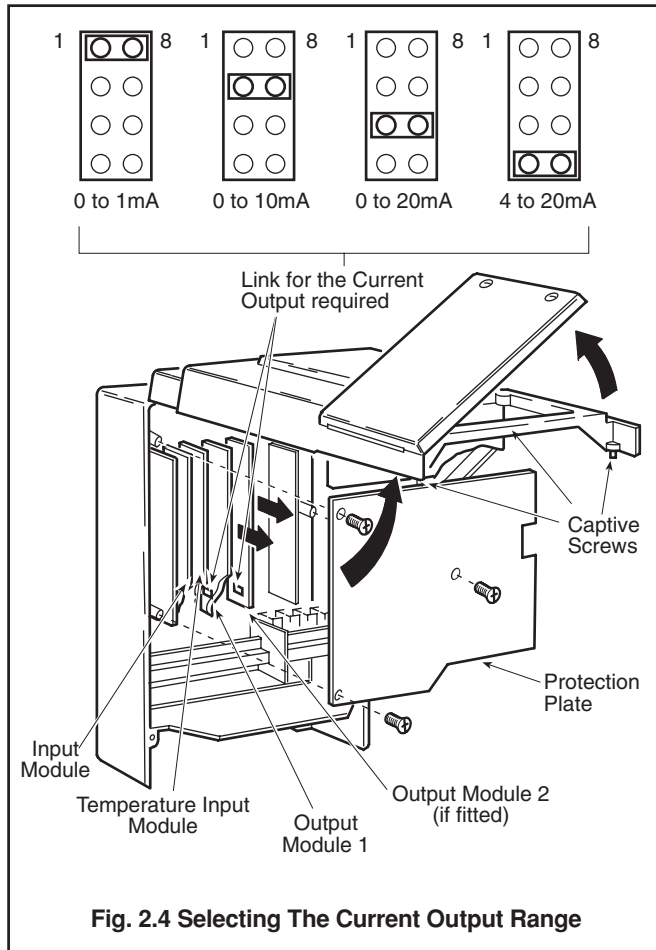

## 3 SETTING UP

**Note.** Before proceeding any further, ensure that all switches are set to OFF on the right hand side of the electronics unit – see Fig. 2.3.

- Ensure that all external electrical and plumbing connections have been made correctly.
- Fill reagent and standard solution bottles and connect them to the monitor. (See Section 8.1 for details of these solutions.)
- Fit the probe according to the instructions in Section 8.2.6.
- Connect the electrical supply and switch on.

**Note.** The temperature controlled block requires up to half an hour to reach the normal control temperature. During this time, 'Temp. Control Error' is indicated on the display. Any calibrations are prevented by the microprocessor during this time.

- Verify that there is an adequate supply of sample to the monitor constant head unit.
- Fit the pump platen on the peristaltic pumps (see Section 8.2.7) and switch the pumps on with the switch on the side of the monitor. Ensure that the peristaltic pumps rotate, and check that sample and reagents are being drawn into the monitor by observing the progress of any small bubbles present in the inlet tubes.
- Run the monitor for at least one hour to allow the temperature to stabilize, solutions to be pumped into the system and to purge the air from the pipework. Check for any leaks around the pipe connections and rectify as necessary.
- If the monitor exhibits good stability, i.e.  $\pm 2\%$  of reading, carry out a calibration – see Programming Page.
- Check the condition of the sample filter and replace it if necessary. Ensure that new filters are fitted correctly by taking note of the flow directions indicated on the filter bodies.

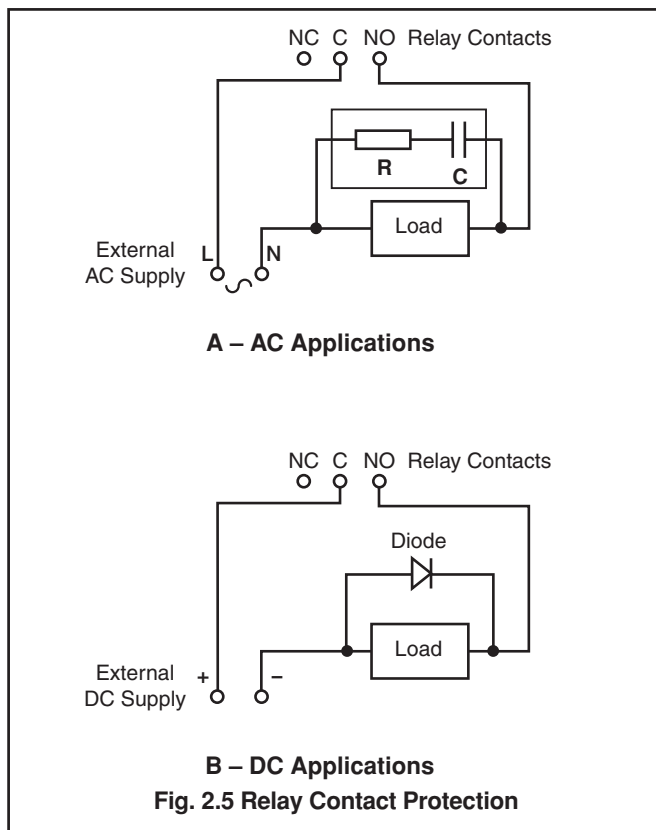

4.1 Principle of Operation – Figs. 4.1

The monitor uses a Nitrate Ion-Selective Electrode in conjunction with a double junction Reference Electrode. The Nitrate Electrode is a liquid membrane type sensor employing an ion-exchange liquid in contact with the sample via a porous membrane. A reservoir of liquid behind the membrane ensures a constant feed of exchanger. An inner central electrode containing a gelled filling solution makes liquid contact with the back of the membrane. The inner electrode is connected to main electronic unit via a screened cable. It is useful to remember that the output from the sensor is logarithmic with respect to the nitrate ion concentration.

The electro-chemical cell is completed by the reference electrode, which generates a stable reference potential and is also connected to the main electronic unit. It comprises a reference element in a salt bridge container which is in contact with an outer electrolyte via a porous ceramic junction. The outer electrolyte then contacts the sample via another ceramic junction. This double junction arrangement protects the inner element from contamination.

Range of measurement can be set to any two consecutive decades of concentration between 0.2 to 1000 mg l<sup>-1</sup> as N or 1 to 5000 mg l<sup>-1</sup> as NO<sub>3</sub><sup>-</sup>.

Under typical circumstances, with appropriate standard solutions and calibration frequencies, accuracies better than ±5% of reading or 0.1 mg l<sup>-1</sup> as N or 0.5 mg l<sup>-1</sup> as NO<sub>3</sub><sup>-</sup> whichever is the greater, can be achieved.

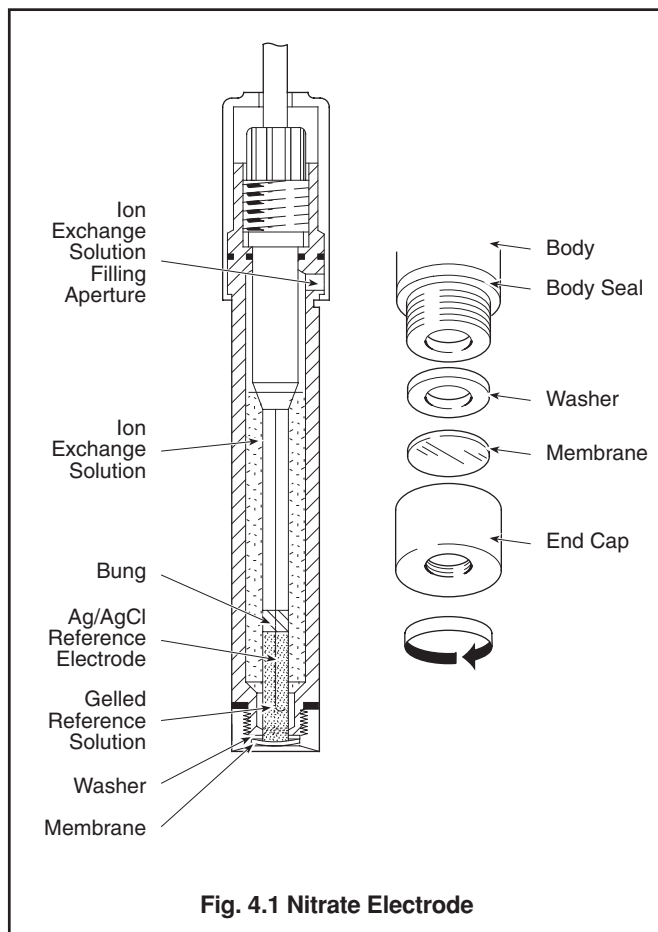

Fig. 4.1 Nitrate Electrode

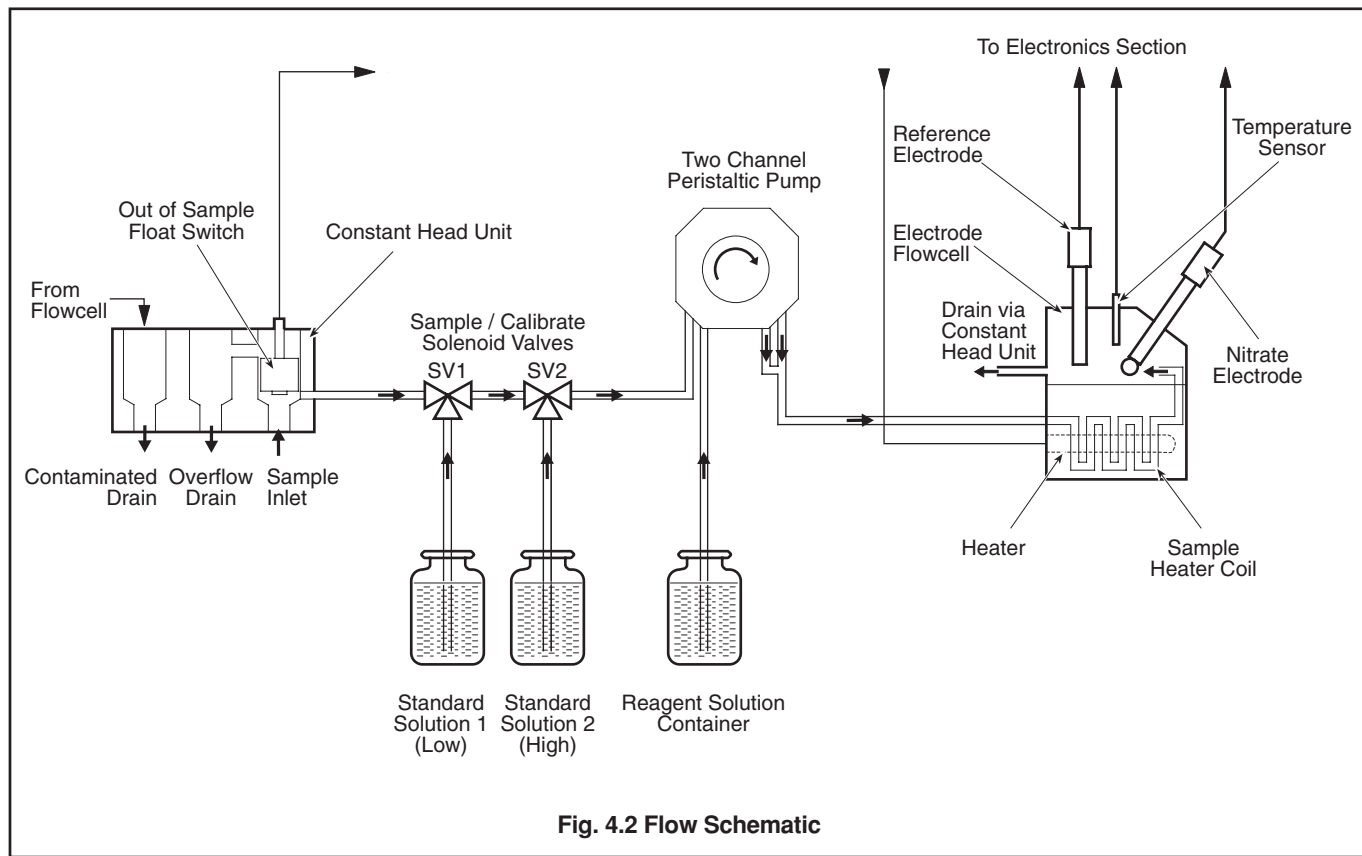

Fig. 4.2 Flow Schematic

## ...4 LIQUID HANDLING SECTION

### 4.2 General Operation – Fig. 4.2

The sequence of events is:

- The sample enters the constant head unit from below and any excess is allowed to overflow to drain.  
The constant head unit is fitted with a float switch to signal an 'Out of Sample' condition. This switch is used by the monitor to initiate the 'Out of Sample' alarm.
- From the constant head unit the sample is drawn through the normally open ports of the solenoid valves SV1 and SV2 by one channel of the peristaltic pump.
- The reagent is drawn through another channel of the peristaltic pump, and is then mixed with the sample. The tube diameters are arranged so as to obtain the correct ratio of sample and reagent.
- The electrodes are housed in a temperature controlled flowcell which includes a heat exchanger to remove the effects of sample and ambient temperature variations. The electrode pair generates an electrical potential when exposed to the reacted sample which changes in proportion to changes in concentration of the ion being measured. The probe is connected to the electronic section where, after digital conversion, the signal is processed by the microprocessor.
- After measurement the sample flows to waste via the contaminated drain connection.
- During calibration the monitor introduces two calibration solutions sequentially in place of the sample by means of the solenoid valves SV1 and SV2.

## 5 ELECTRONICS SECTION

### 5.1 Electronic Layout – Fig. 5.1

The electronic section comprises two separate sections:

- The User Junction Box at the top right hand side.
- The Microprocessor Unit at the top left hand side.

### 5.2 User Junction Box

The User Junction Box contains the relays for the heater, solenoid valves and alarms, and all the user external connection terminals, with the exception of the serial interface (if fitted).

Once installed there should be no need to remove the junction box cover on a regular basis. However, to assist in any fault finding procedure, there are l.e.d.'s on the p.c.b. to indicate if the relays and heater are being energised.

Switches for the mains and pump/heater are situated on the right hand side of the junction box, together with a mains indication lamp and mains fuse – see Fig. 2.3.

Two additional fuses (F2 and F3) are located within the junction box. These are connected in the 24V AC circuits.

### 5.3 Microprocessor Unit

The Microprocessor Unit contains the analogue input processing, microprocessor, alarm and current output generation, and (if fitted) the serial interface output.

The programme controls, digital and dot-matrix displays, alarm indication and status l.e.d.'s are all mounted on the front panel of the microprocessor unit.

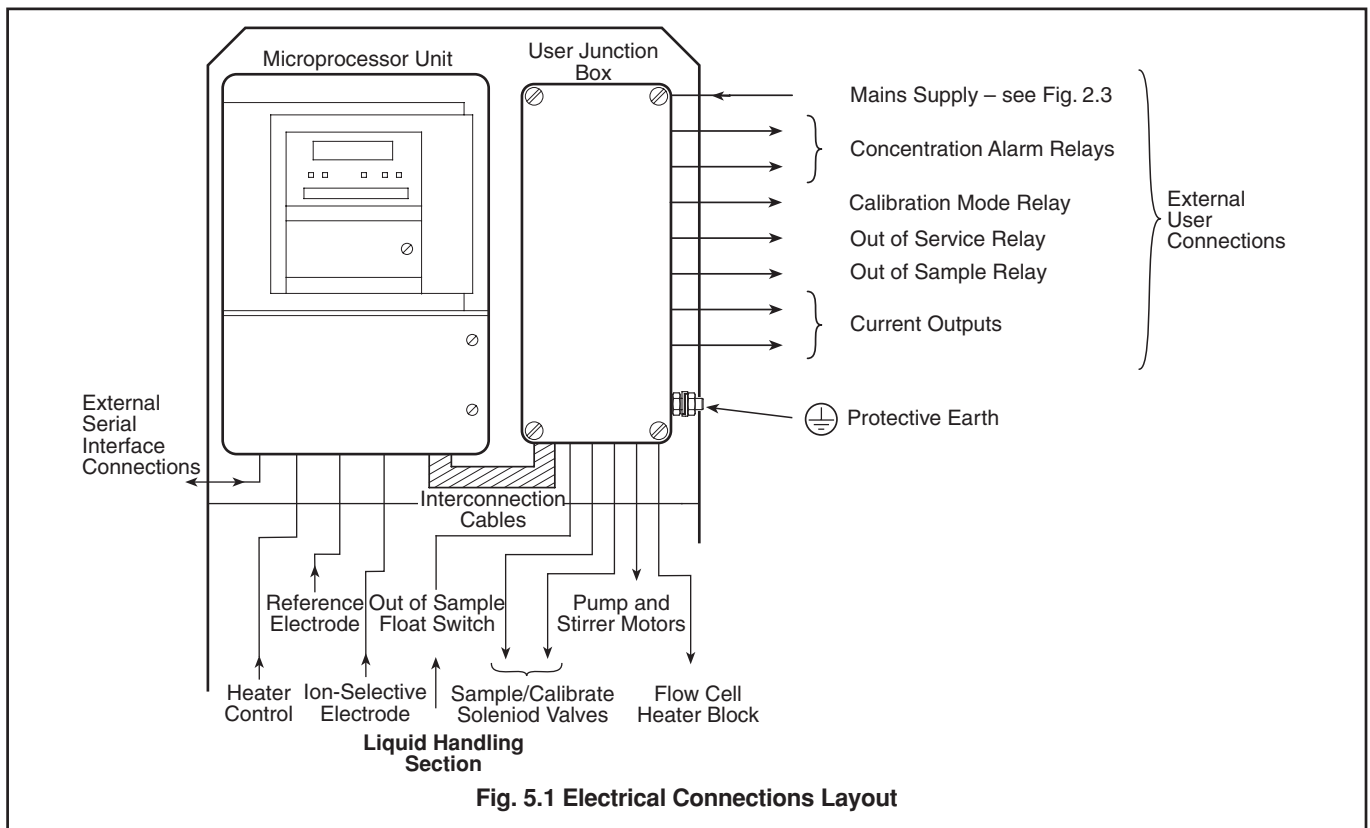

Fig. 5.1 Electrical Connections Layout

## ...5 ELECTRONICS SECTION

### 5.4 Front Panel Controls – Fig. 5.2

The programme controls comprise eight tactile membrane switches. These switches are situated behind a hinged door below the display, access is via a screwdriver-operated catch. In normal operation the switches are used to view the measured ion concentration value, initiate a manual calibration, or to activate the 'alarm hold' facility.

When programming, the switches are used to sequence through a programming procedure as detailed. The procedure is set out in programming pages for Input, Current Output, Alarms, Real Time Clock and Monitor Calibration. Each programme page contains the programme functions, the values or parameters of which are programmable.

Switch functions are as follows:

#### Mode

Used for viewing the fluoride concentration, electrode mV output, flowcell control temperature, sensor slope, date, time, the time to the next calibration and the time from the last calibration.

#### Cal

Used to enable or disable the automatic calibrations, enter the standard solution values and manually initiate a calibration sequence. Operating 'Cal' during a calibration aborts the sequence and returns to normal operation.

#### Hold

Used to inhibit any change in the alarm relay/l.e.d. status and the start of any auto calibration. The feature is used during maintenance ('Hold' l.e.d. illuminated).

**Note.** If the 'Hold' facility is inadvertently left switched-in, it is automatically cancelled after a period of approximately 3 hours has elapsed.

#### Enter

Used for storing the programmed function parameters and values in the instrument's nonvolatile memory.

**Note.** The instrument responds instantly to any programme change but the new value is lost in the event of a power interruption if it has not been 'Entered'.



Parameter Advance – used for selecting a particular parameter from a programme page.



Used for increasing or decreasing a parameter value or stepping up or down through a selection of parameters applicable to a particular function.



**Note.** Continued pressure on the 'Raise' or 'Lower' switches causes the rate of change of the displayed value to increase. To make small adjustments, operate the switches momentarily.



Page Advance – used, via the security code, for selection of individual programme pages.

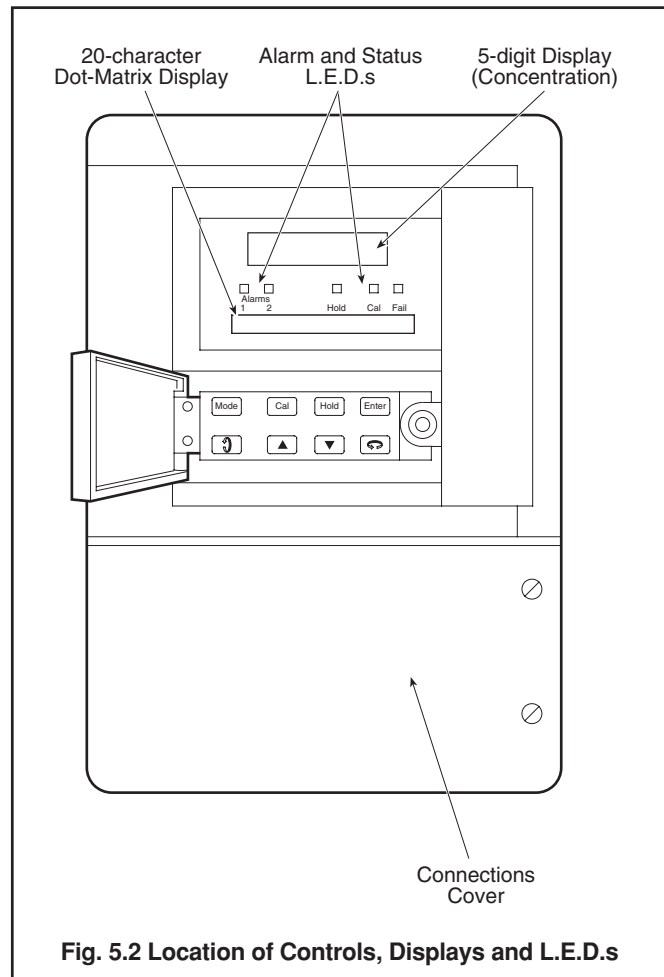

Fig. 5.2 Location of Controls, Displays and L.E.D.s

### 5.5 Displays – Fig. 5.2

Two blue vacuum fluorescent displays are provided:

- The upper is a 5-digit 7-segment type display which indicates the measured variable.
- The lower is a 20-character dot matrix type which provides user information during setting up and in normal operation.

### 5.6 L.E.D. Indication – Fig. 5.2

There are five l.e.d's (indicators situated between the two displays) which provide information on the current status of the monitor. From left to right the indicators are as follows:

- A1 or A2** Used to indicate a concentration alarm state (either high or low). This indicator is used in association with an external alarm relay output.
- Hold** Used to indicate when the 'Hold' button has been operated.
- Cal** Indicates when a calibration sequence is taking place.
- Fail** Indicates when the monitor was unable to carry out a successful calibration.

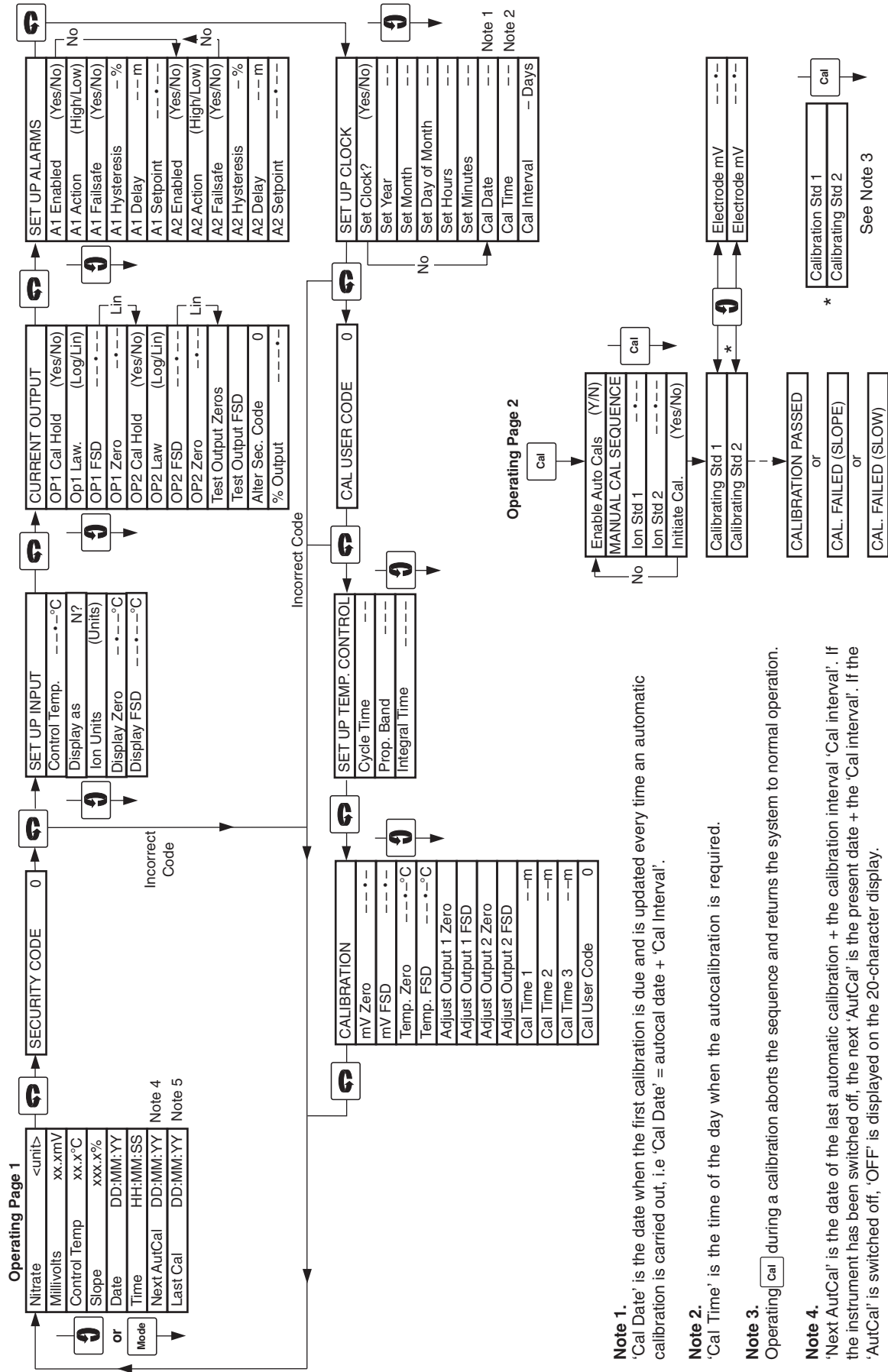

- Note 1.** 'Cal Date' is the date when the first calibration is due and is updated every time an automatic calibration is carried out, i.e 'Cal Date' = autocal date + 'Cal Interval'.
- Note 2.** 'Cal Time' is the time of the day when the autocalibration is required.
- Note 3.** Operating  during a calibration aborts the sequence and returns the system to normal operation.
- Note 4.** 'Next AutCal' is the date of the last automatic calibration + the calibration interval 'Cal interval'. If the instrument has been switched off, the next 'AutCal' is the present date + the 'Cal interval'. If the 'AutCal' is switched off, 'OFF' is displayed on the 20-character display.
- Note 5.** 'Last Cal' is the date of the last automatic or manual calibration.





Fig. 6.1 Overall Programme Chart

---

## ...6 PROGRAMMING





---

### 6.1 Normal Operation

In normal operation (Operating Page 1) the lower, dot matrix, display gives indication of the units of measurement, millivolt value, sensor slope and time. Selection is made using the  switch. Operation of the  switch gives access to a second Operating Page (Operating Page 2) in which the standard solution values can be set and a manual calibration can be initiated. Either page can be selected at any time by using the  or  switches.

### 6.2 Programming Pages

Operation of the  switch enables a series of 'programming' pages to be displayed. Unauthorised entries to this page are inhibited by a 5-digit security code which is displayed immediately after the page header.

In the programming pages, displayed values indicated 'xxxxx' are for viewing only and cannot be altered by the operator. Displayed values indicated '— —' can be altered using the  and  switches. When the desired reading is displayed, operate the  switch. The l.e.d's flash momentarily, to indicate that the value has been stored in the nonvolatile memory. Although the instrument appears to operate satisfactorily, if the  switch is not operated, in the event of power interruption, the programmed values are lost. If previously programmed values are to be viewed only, it is unnecessary to operate the  switch.

6.2.1 Operating Page 1

The values displayed in Operating Page 1 are for viewing only and cannot be altered in this page.

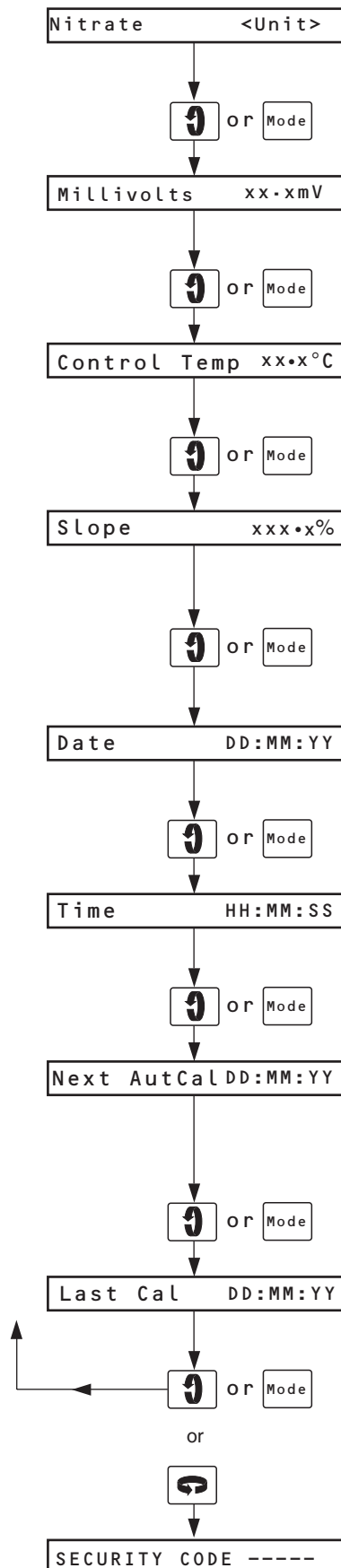

**Measurement Units**

The measurement units are displayed, e.g. Nitrate ppm.

Advance to next parameter.

**Sensor Output**

The sensor output is displayed in millivolts.

Advance to next parameter.

**Control Temperature**

The heater block control temperature is displayed in degrees Celsius.

Advance to next parameter.

**Slope Check Value**

The slope value should be between 70 and 110%. If the value is outside these limits check the electrode.

Advance to next parameter.

**Date**

The date is displayed.

Advance to next parameter.

**Time**

The time is displayed.

Advance to next parameter.

**Next Calibration Date**

The date when the next automatic calibration is to be carried out is displayed. If the automatic calibration is disabled, 'OFF' is displayed in place of the date.

Advance to next parameter.

**Last Calibration Date**

The date of the last automatic or manual calibration is displayed.

Return to top of **Operating Page**.

or

Advance to **Security Page** (Section 6.2.3).



## ...6 PROGRAMMING

### 6.2.2 Operating Page 2

To gain access to the Calibration Page (Operating Page 2), operate the  Cal switch.

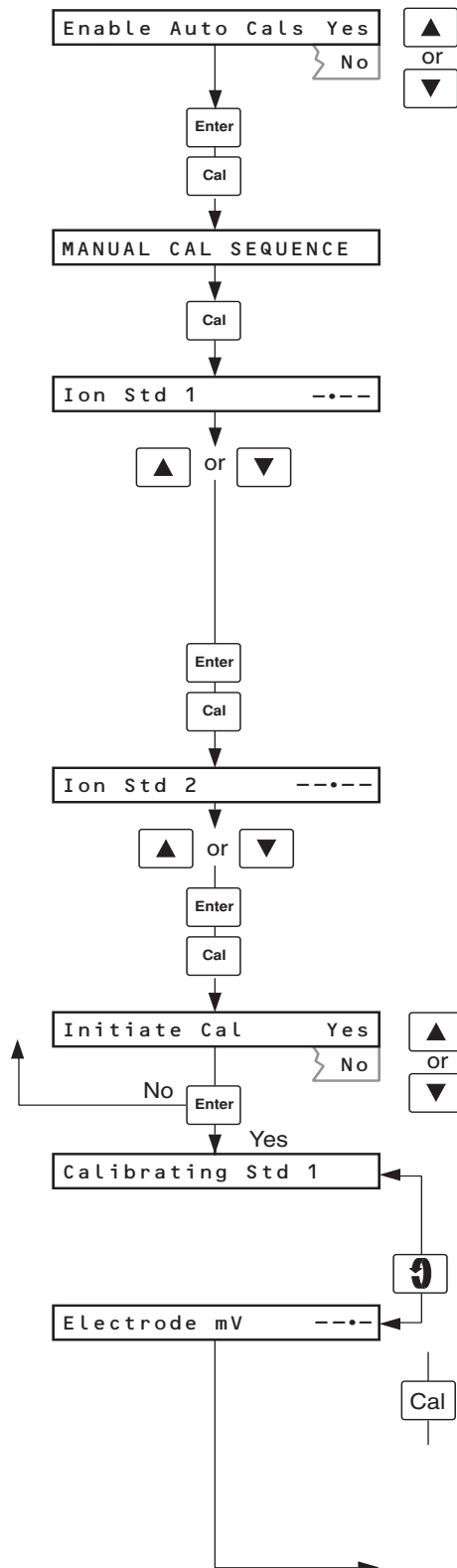

#### Enable Automatic Calibrations

Select 'Yes' to enable or 'No' to disable the automatic calibrations.

Store.

Advance to next parameter.

#### Page header.

Advance to next parameter.

#### Ion Standard 1

Set the value of the 'Low' standard solution (Std 1).

Store.

Advance to next parameter.

#### Ion Standard 2

Set the value of the 'High' standard solution (Std 2). The concentrations of the two standard solutions must differ from each other by a factor of at least four.

Store.

Advance to next parameter.

#### Initiate Calibration (manual)

Select 'Yes' to carry out a manual calibration or 'No' to return to the top of the page.

Enter must be pressed to initiate a manual calibration.

#### Calibrating Standard 1

The upper display shows the nitrate concentration value. The display remains until a stable output is obtained from the probe.

Toggle between the two displays.

#### Electrode Millivolts

**Note.** Pressing  Cal during a calibration aborts the sequence and returns to normal operation.

When a stable probe output is detected the display automatically advances to the next parameter.

Continued on next page.

...6.2.2 Operating Page 2  
Continued from previous page.

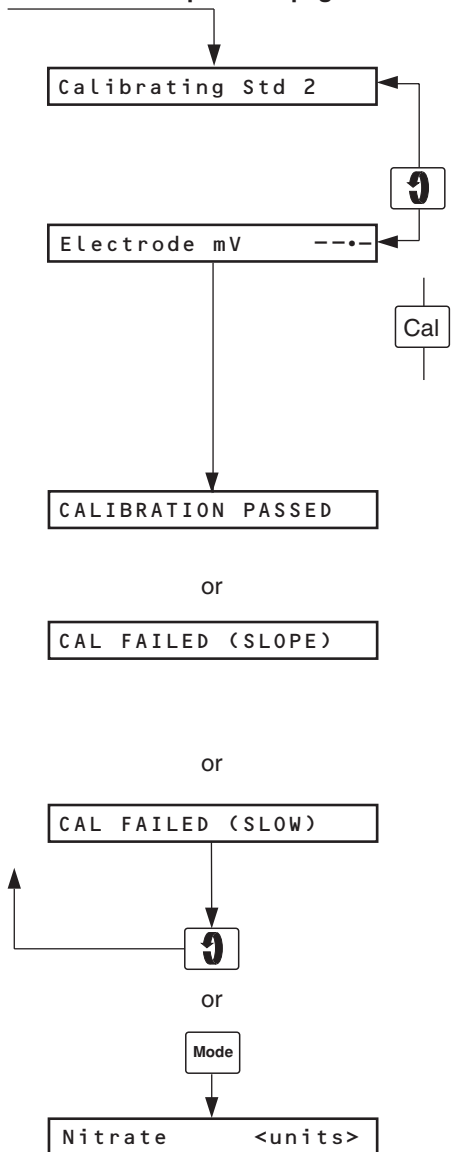

**Calibrating Standard 2**

The upper display shows the nitrate concentration value. The display remains until a stable output is obtained from the probe.

Toggle between the two displays.

**Electrode Millivolts**

The probe output can also be displayed during calibration

**Note.** Pressing **Cal** during a calibration aborts the sequence and returns to normal operation.

When a stable probe output is detected the display automatically advances to the next parameter.

**Calibration Passed**

A satisfactory calibration has been carried out.

or

**Calibration Failed (slope)**

The monitor was unable to obtain an adequate slope value during calibration. The slope value required is 70 to 110%.

or

**Calibration Failed (slow)**

The monitor was unable to obtain a stable output from the probe during calibration.

Return to top of **Operating Page 2**.

or

Return to **Operating Page 1**.

**6.2.3 Security Code Page**

A security code is required to gain access to all subsequent programming pages. The code is preset at the factory to '0' but can be changed if required in the Current Output Page – see Section 6.2.5.

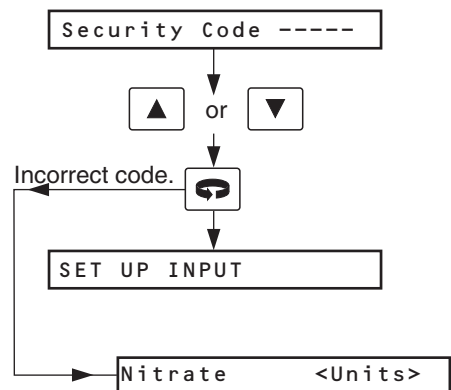

**Security Code**

Set the correct security code.

Advance to the first of the programming pages – **Set Up Input Page**.

Return to **Operating Page 1**.

## ...6 PROGRAMMING

### 6.2.4 Set Up Input Page

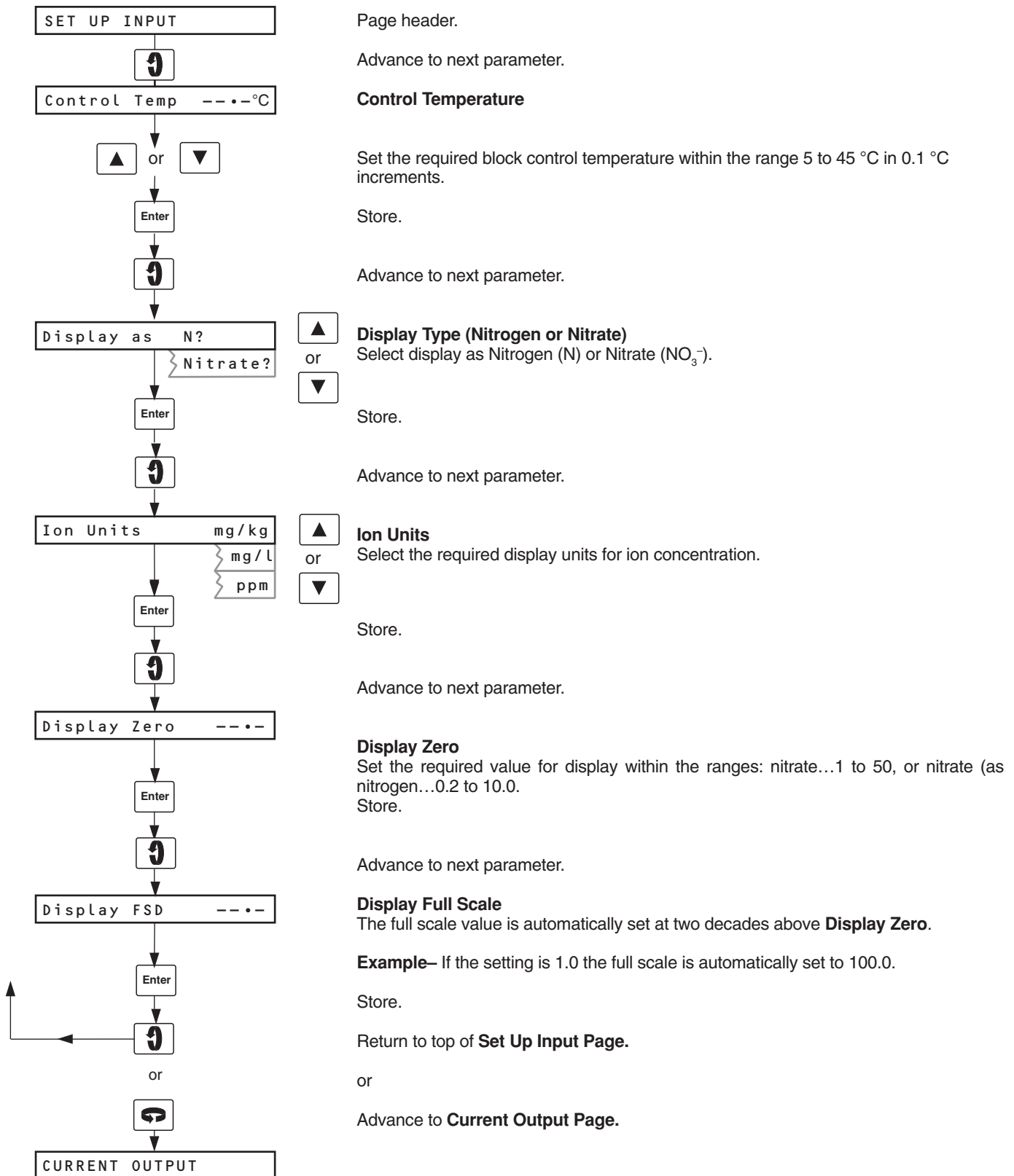

6.2.5 Current Output Page

The current output is assigned to the nitrate concentration but is only operative if the relevant output modules are fitted – see Fig. 2.4.

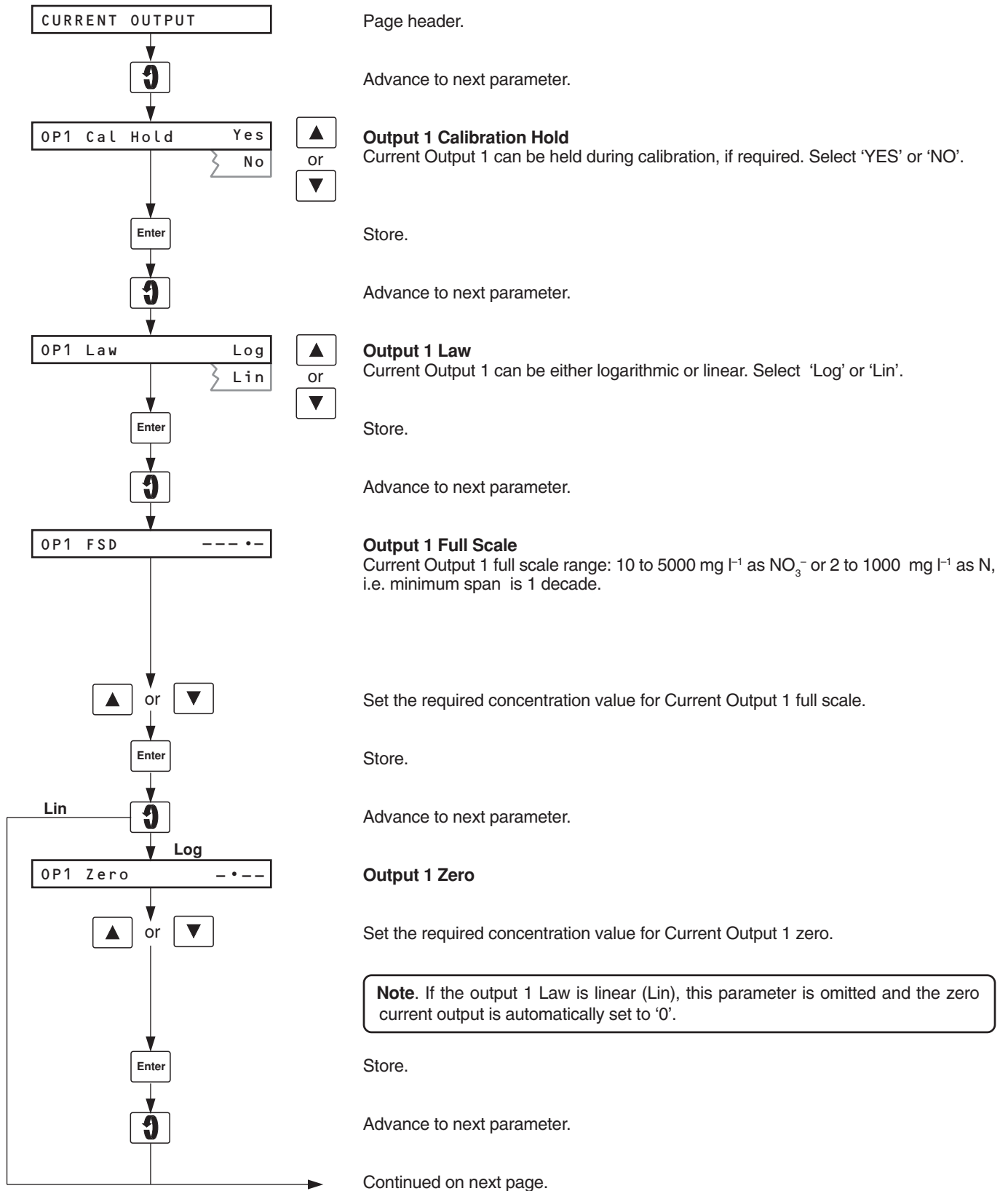

## ...6 PROGRAMMING

### ...6.2.5 Current Output Page

Continued from previous page.

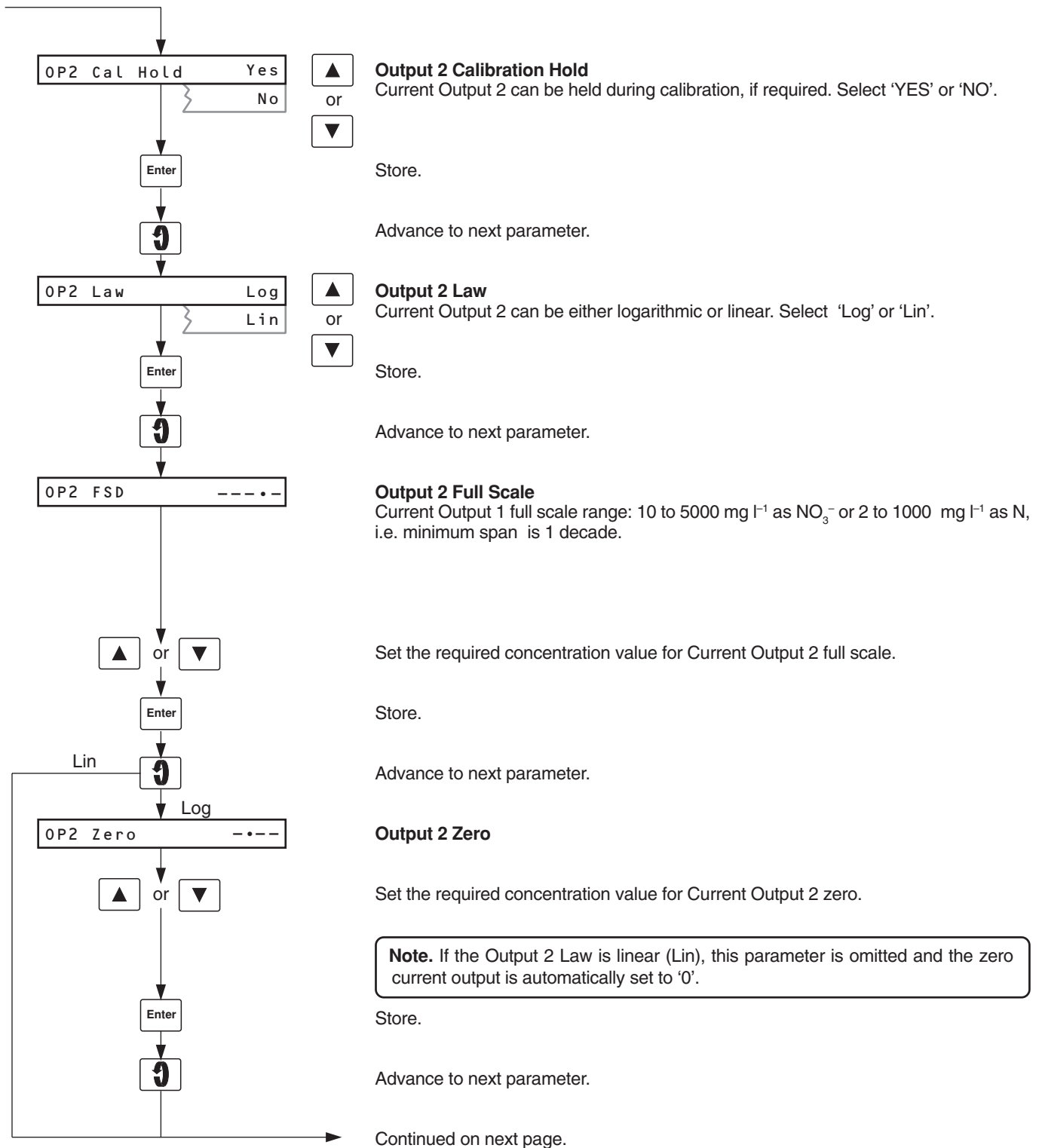

Continued from previous page.

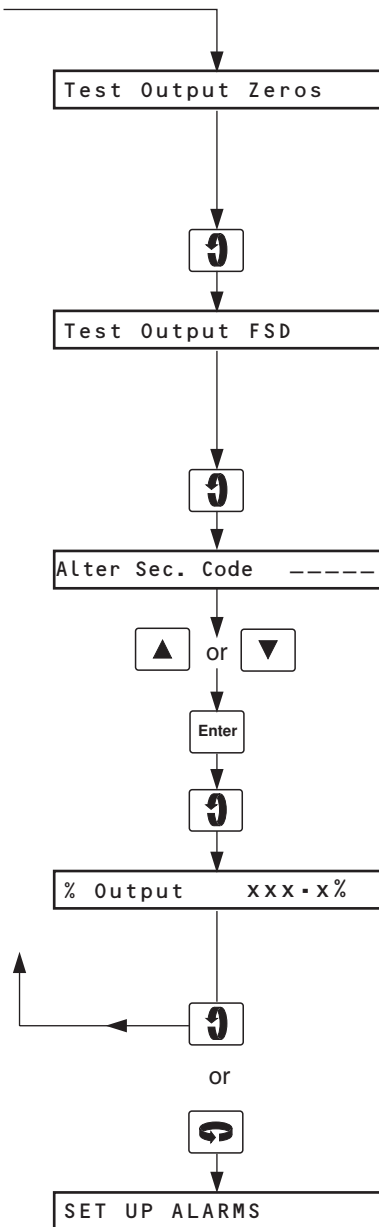

**Test Current Output Zeros**

The instrument automatically transmits a current output zero test signal on both outputs.

**Example** – For a 4 to 20 mA current output range, 4 mA is transmitted.

Advance to next parameter.

**Test Current Output Full Scale**

The instrument automatically transmits a current output full scale test signal on both outputs.

**Example** – For a 4 to 20 mA current output range, 20 mA is transmitted.

Advance to next parameter.

**Alter Security Code**

Set the Security Code required, between 0 and 19999. This value must then be entered again to access the secure parameters from Operating Page 1.

Store.

Advance to next parameter.

**Proportional Output Percentage (to heater)**

Used as a diagnostic check to indicate the proportionally controlled current output (%) to the heater.

Return to top of **Current Output Page**.

or

Advance to **Set Up Alarms Page**.

## ...6 PROGRAMMING

### 6.2.6 Set Up Alarms Page

Alarm l.e.d. indication and relay output can be assigned either to the nitrate concentration or switched off.

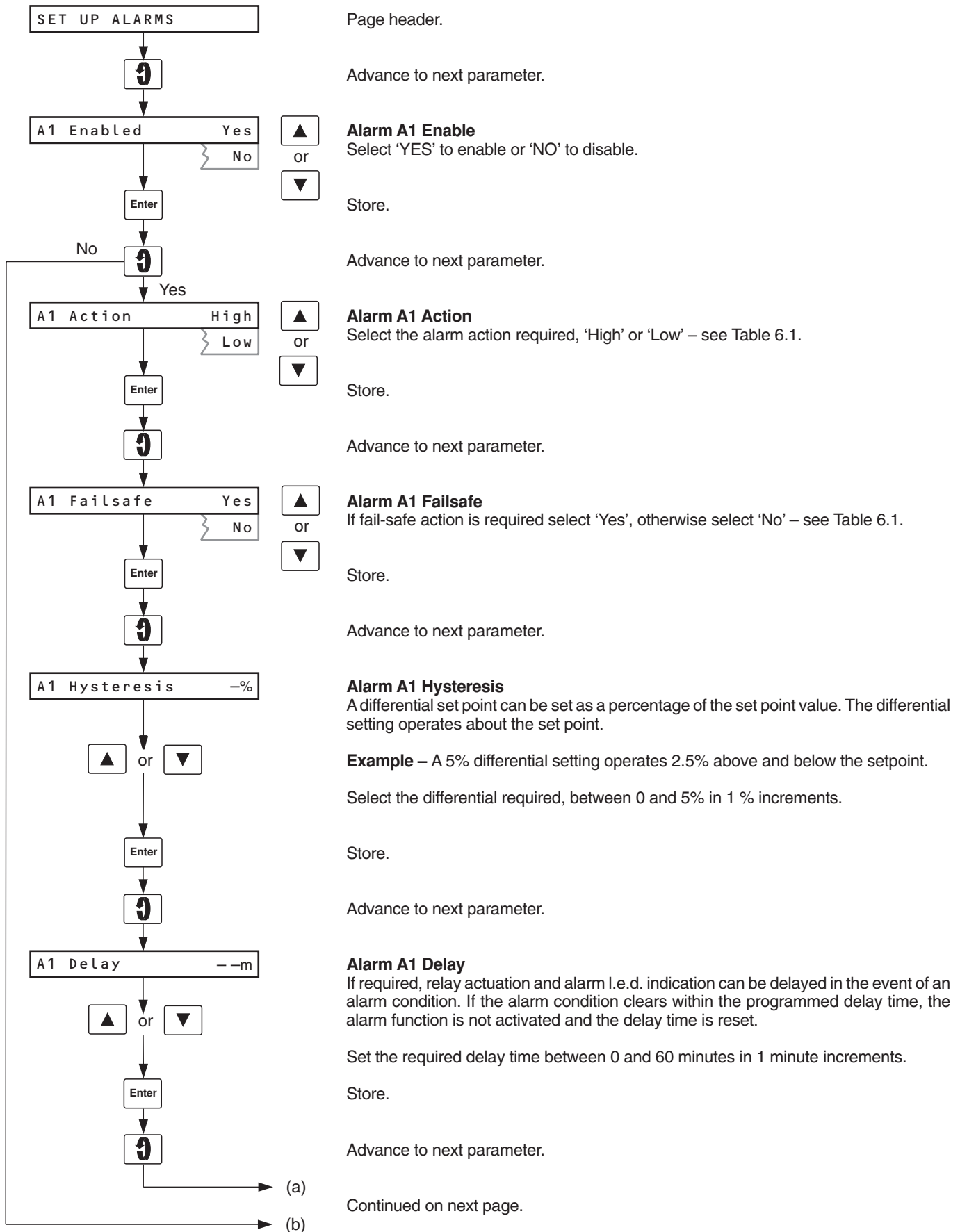



Continued from Previous page.

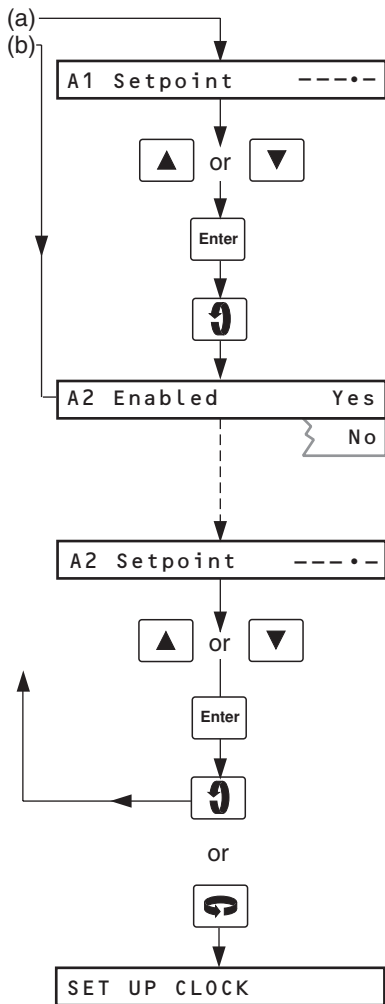

**A1 Setpoint**

Set the required setpoint value.

Store.

Advance to next parameter.

**A2 Enabled**

Repeat the programming procedures as for Alarm Relay 1.

**A2 Setpoint**

Set the required set point value.

Store.

Return to top of **Set Up Alarms Page**.

or

Advance to **Set Up Clock Page**.

Action	Failsafe	Measured Value	Relay Status	L.E.D. Indication
High	YES	Above Setpoint Below Setpoint	De-energised Energised	Flashing Off
High	NO	Above Setpoint Below Setpoint	Energised De-energised	Flashing Off
Low	YES	Above Setpoint Below Setpoint	Energised De-energised	Off Flashing
Low	NO	Above Setpoint Below Setpoint	De-energised Energised	Off Flashing

Table 6.1 Relay Action and Alarm Indication

6.2.7 Set Up Clock Page

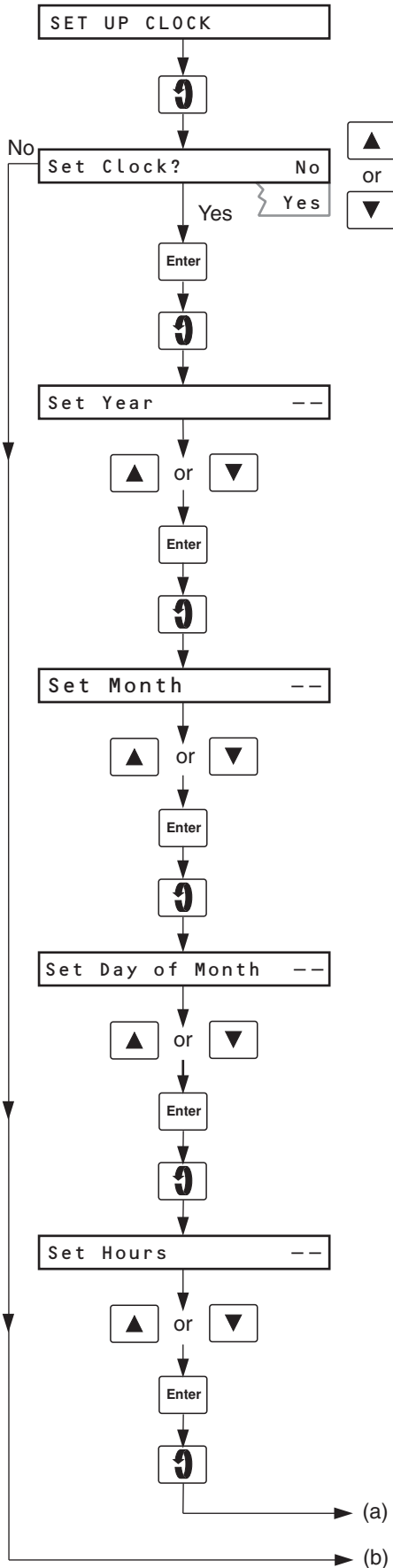

Page header.

Advance to next parameter.

**Set Up Real Time Clock**

Select 'Yes' to set up the clock, otherwise select 'No'.

Store.

Advance to next parameter.

**Set Year**

Set the appropriate year.

Store.

Advance to next parameter.

**Set Month**

Set the appropriate month.

Store.

Advance to next parameter.

**Set Day**

Set the appropriate day of the month.

Store.

Advance to next parameter.

**Set Hours**

Set the appropriate hour – (24 hour clock).

Store.

Advance to next parameter.

Continued on next page.

Continued from previous page.

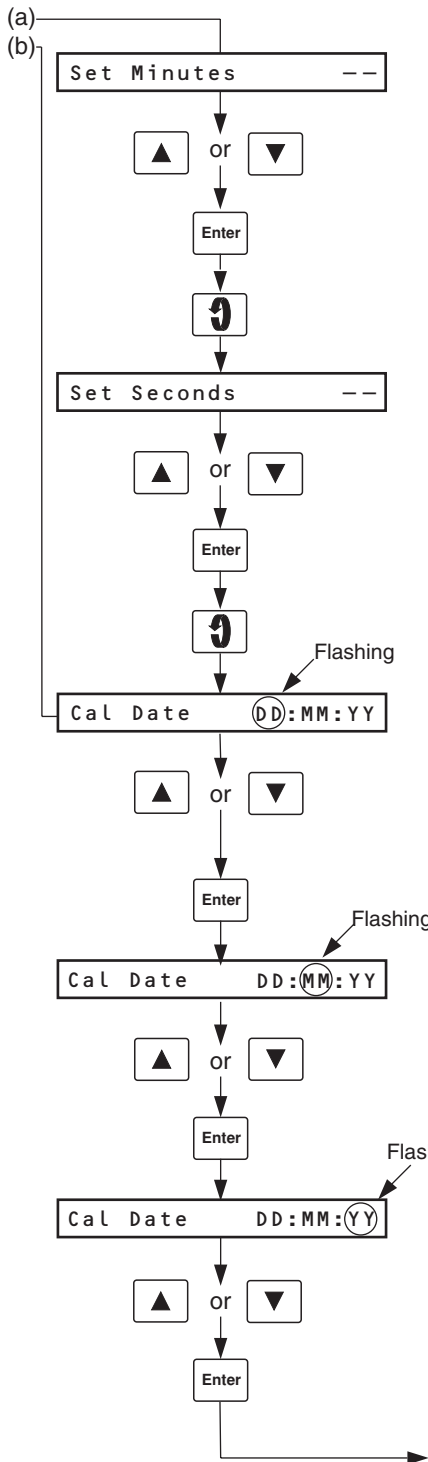

**Set Minutes**

Set the appropriate minutes.

Store.

Advance to next parameter.

**Set Seconds**

Set the appropriate seconds.

Store.

Advance to next parameter.

**Calibration Date (day of the month)**

Set the day of the month when the first automatic calibration is to be carried out.

Store and advance to next parameter.

**Calibration Date (month)**

Set the month when the first automatic calibration is to be carried out.

Store and advance to next parameter.

**Calibration Date (year)**

Set the year when the first automatic calibration is to be carried out.

Store and advance to next parameter.

Continued on next page.

## ...6 PROGRAMMING

...Set Up Clock Page  
Continued from previous page.

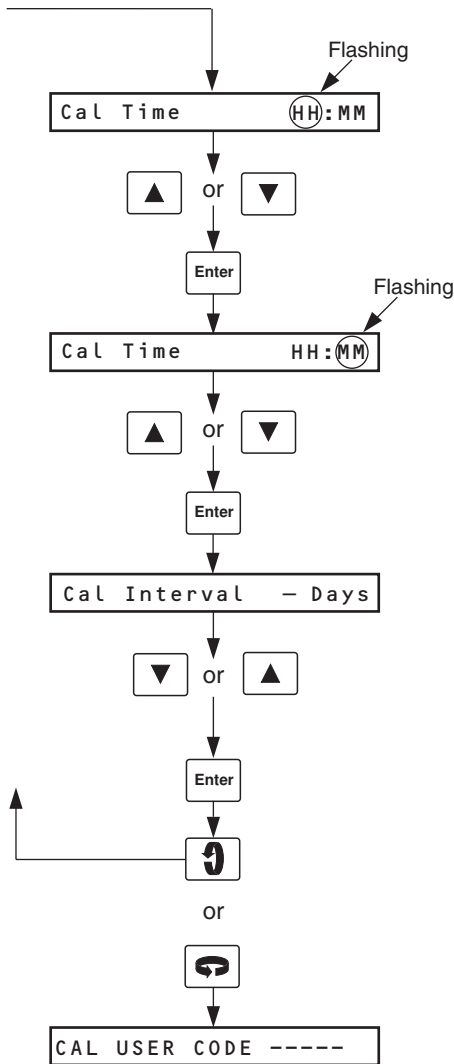

### Calibration Time (hour – 24 hour clock)

Set the hour of the day when the first automatic calibration is to be carried out.

Store and advance to next parameter.

### Calibration Time (minutes)

Set the minute of the hour when the first automatic calibration is to be carried out.

Store and advance to next parameter.

### Calibration Interval

Set the calibration interval required between automatic calibrations, starting from the calibration date (6 hours, 12 hours or 1 to 7 days in 1 day increments).

Store.

Return to top of **Set Up Clock Page**.

or

Advance to **Calibration User Code Page**.

### 6.2.8 Calibration User Code Page

The calibration user code is required to gain access to the Set Up Temperature Control and Calibration Pages. The access code can be altered in the Calibration Page, if required – see Section 6.2.11.

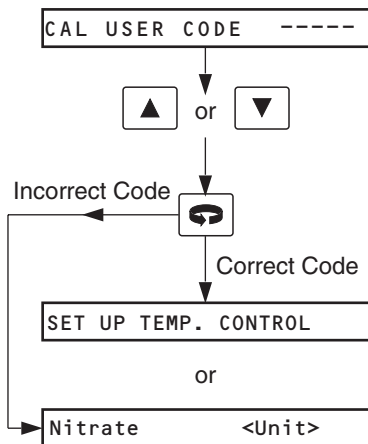

### Calibration User Code

Set the correct user code.

Advance to next programming page.

**Set Up Temperature Control Page.**

or

Return to **Operating Page 1**.

### 6.2.9 Set Up Temperature Control Page

The parameters within this page are factory preset and should not require any adjustment.

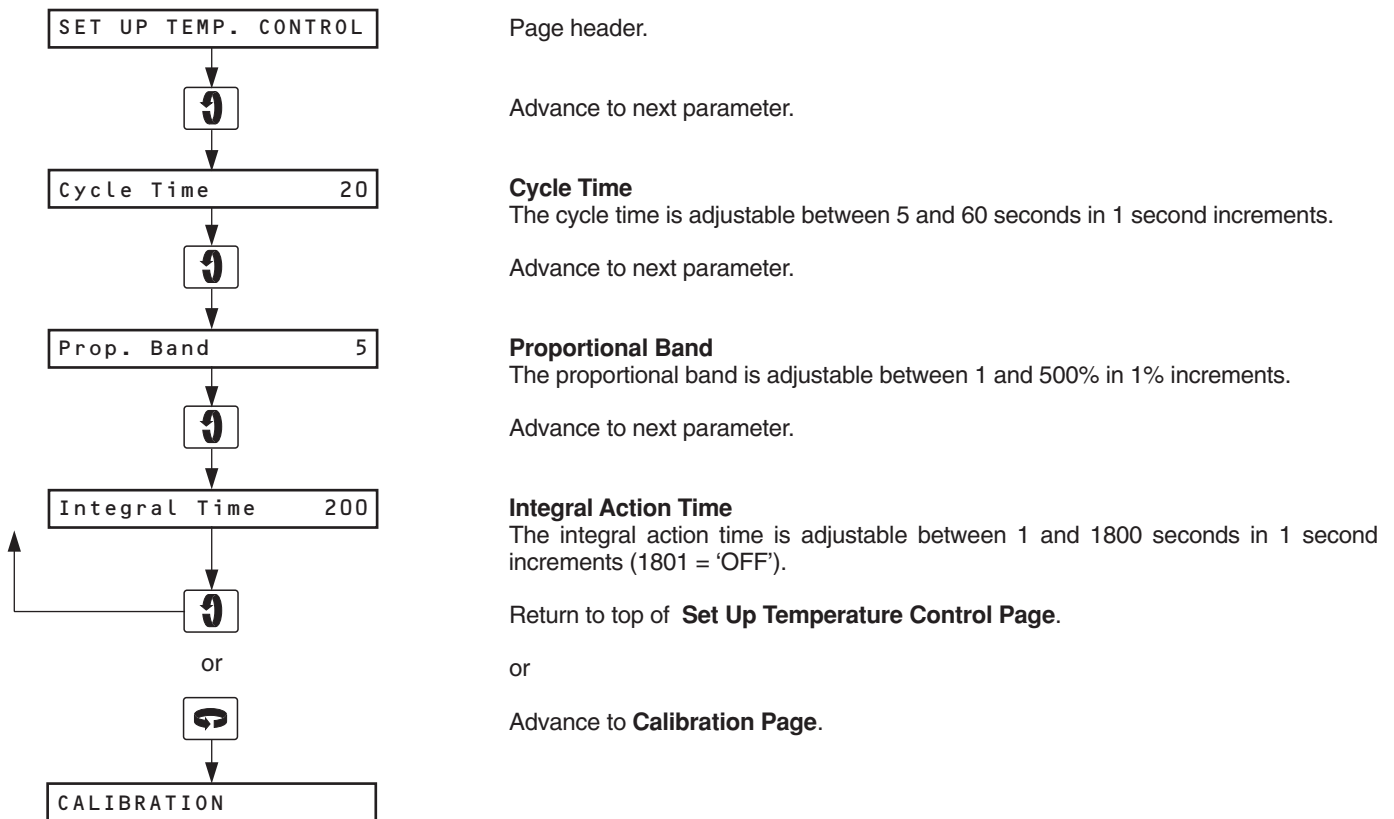

### 6.2.10 Electrical Calibration

Electrical calibration is carried out prior to despatch and should require no subsequent adjustment. However, if measurements become suspect or if the contents of the 'CALIBRATION' page are inadvertently altered, recalibrate as detailed in the following sections.

**Note.** The calibration procedure involves modifying part of the original programme but, **provided that changed values are not stored using the 'Enter' switch**, the original programme, which was stored in the nonvolatile memory, can easily be reinstated at the end of calibration by switching off the instrument and switch on again.

If there is thought to be any risk that the original programme could be lost, it is advisable to make a note of the normal parameter settings. If the changed programme values are inadvertently 'Entered', the instrument can be reprogrammed on completion of the calibration procedure.

#### Equipment Required

- Millivolt source, range -400 to +400 mV.
- Electrode coaxial plug/lead assembly – supplied with monitor;
- Decade resistance box<sup>†</sup>, 0 to 1 k $\Omega$  in 0.01  $\Omega$  increments.

<sup>†</sup>Resistance boxes have an inherent residual resistance which may range from a few milliohms to one ohm. This value must be taken into account when simulating input levels, as must the overall tolerances of the resistors within the box.

- Digital milliammeter, 0 to 20 mA – refer to Fig. 2.4 to identify the output range.

#### Preparation

- Switch off the supply and disconnect the temperature sensor leads from terminals 1, 2 and 3 in the Microprocessor Unit. Make the following connections:
 

1 & 3 (temperature sensor)	}	decade box
2 (temperature sensor)		
- Insert the coaxial plug into the ISE socket above the flowcell and connect the millivolt source (inner +ve, outer -ve).
- Connect the milliammeter in place of the appropriate current output connections in the junction box – see Section 2.6.
- Switch on the supply and allow two minutes (30 minutes from cold) for the circuits to stabilise.
- Select the appropriate **Cal User Code** to gain access to the programming pages – see Section 6.2.8.

## ...6 PROGRAMMING

### 6.2.11 Electrical Calibration Page

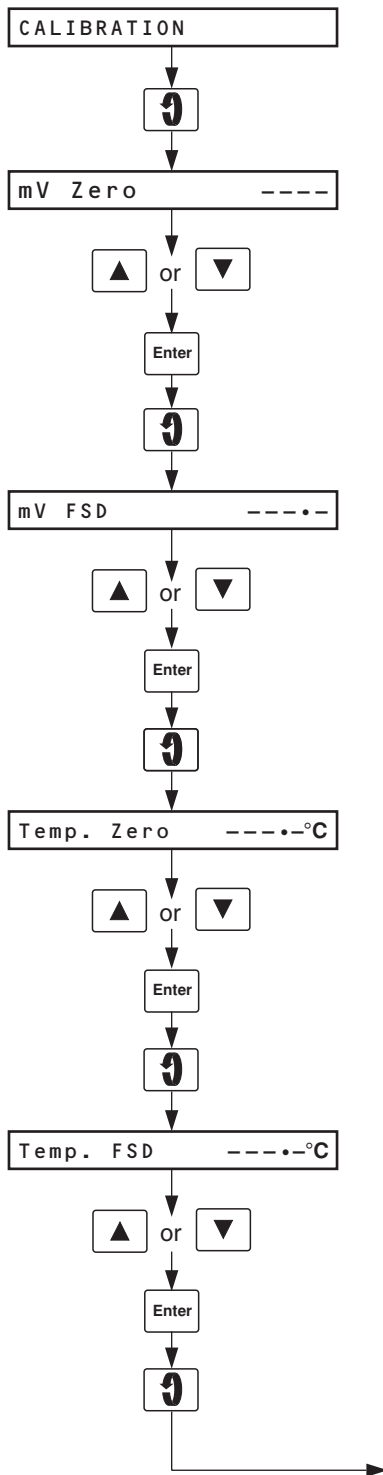

Page header.

Advance to next parameter.

#### Millivolt Input Zero

Set the millivolt source to  $-400$  mV.

Set the display to ' $-400$ ' mV.

Store. New value is accepted only when input is stable.

Advance to next parameter.

#### Millivolt Input Full Scale

Set the millivolt source to  $+400$  mV.

Set the display to ' $+400$ ' mV.

Store. New value is accepted only when input is stable.

Advance to next parameter.

#### Temperature Zero

Set the resistance box to  $96.09 \Omega$  (resistive equivalent of  $-10$  °C).

Set the display to ' $-10$ ' °C.

Store. New value is accepted only when input is stable.

Advance to next parameter.

#### Temperature Full Scale

Set the resistance box to  $142.29 \Omega$  (resistive equivalent of  $110$  °C).

Set the display to ' $110$ ' °C.

Store. New value is accepted only when input is stable.

Advance to next parameter.

Continued on next page.

Continued from previous page.

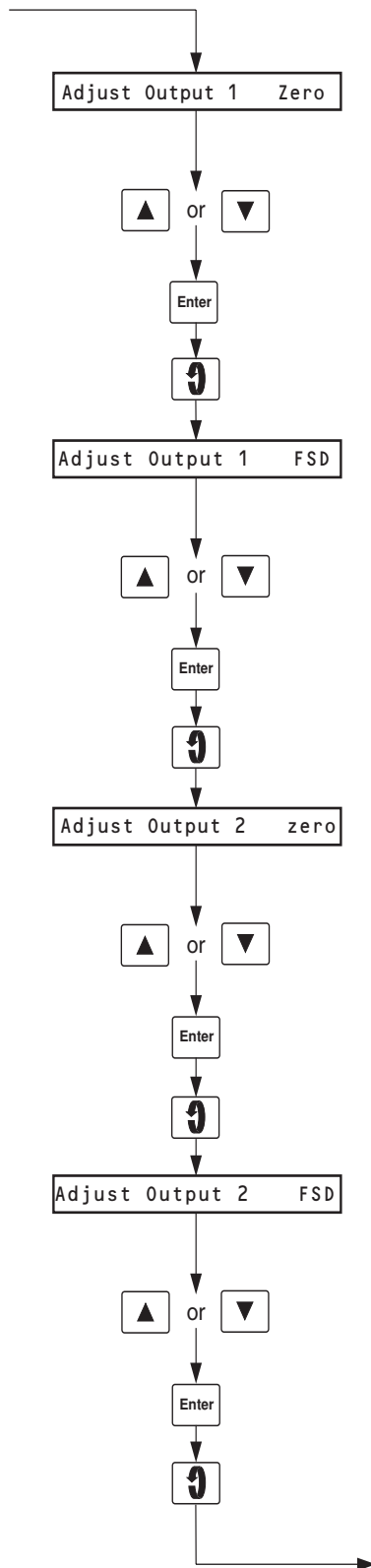
**Adjust Current Output 1 Zero**

The monitor transmits a zero signal, e.g. for a 4 to 20 mA output range, 4 mA is transmitted.

Set the milliammeter reading to the current output 1 zero level, i.e. 0 mA (zero-based ranges) or 4 mA (4 to 20 mA range).

Store.

Advance to next parameter.

**Adjust Current Output 1 Full Scale**

The monitor transmits a span signal, e.g. for a 4 to 20 mA output range, 20 mA is transmitted.

Set the milliammeter reading to the current output 1 full scale level, i.e. 1 mA, 10 mA or 20 mA as applicable.

Store.

Advance to next parameter.

**Adjust Current Output 2 Zero**

The monitor transmits a zero signal, e.g. for a 4 to 20 mA output range, 4 mA is transmitted.

Set the milliammeter reading to the current output 2 zero level, i.e. 0 mA (zero-based ranges) or 4 mA (4 to 20 mA range).

Store.

Advance to next parameter.

**Adjust Current Output 2 Full Scale**

The monitor transmits a span signal, e.g. for a 4 to 20 mA output range, 20 mA is transmitted.

Set the milliammeter reading to the current output 2 full scale level, i.e. 1 mA, 10 mA or 20 mA as applicable.

Store.

Advance to next parameter.

Continued on next page.



## ...6 PROGRAMMING

### ...Electrical Calibration Page

Continued from previous page.

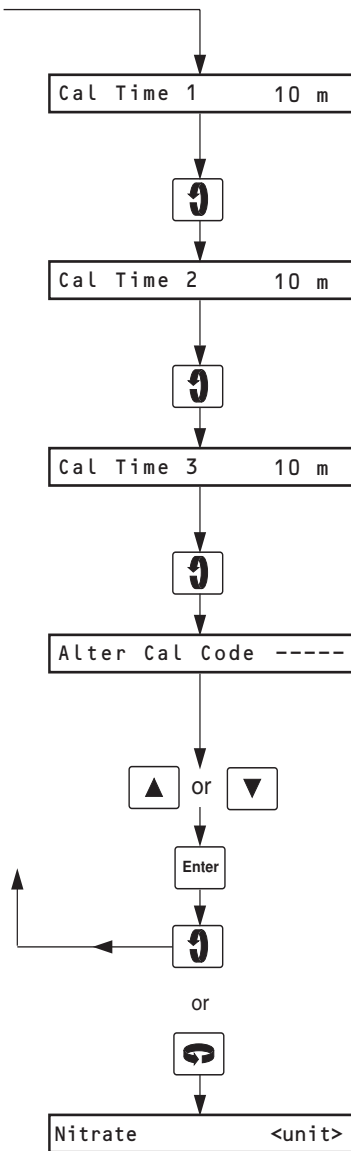

#### Calibration Time 1

The displayed value is preset at the factory and must not be altered. See Table 7.1.

Advance to next parameter.

#### Calibration Time 2

The displayed value is preset at the factory and must not be altered. See Table 7.1.

Advance to next parameter.

#### Calibration Time 3

The displayed value is preset at the factory and must not be altered. See Table 7.1.

Advance to next parameter.

#### Alter Calibration Code

The calibration user code inhibits access to the **Set Up Temperature Control Page** and the **Calibration Page** – see Section 6.2.8.

Set a suitable user code, between 0 and 19999.

Store.

Return to top of **Electrical Calibration Page**.

or

Return to **Operating Page 1**.

## 7 CALIBRATION

### 7.1 Calibration Sequence

Calibration of the monitor is carried out by replacing the sample solution sequentially with two standard solutions of known concentration. This calibration sequence (see Table 7.1) can be initiated automatically at preset times, or manually on demand.

The sensor outputs obtained during calibration are used to calculate the calibration graph for the monitor and the accuracy of the standard solutions will, therefore, have a direct effect upon the overall accuracy of the monitor. Given accurate standards, it is clear that the best accuracy would be expected at the two calibration points. Ideally, the concentrations of the two standards should bracket the expected sample concentration closely, but the latter often varies quite widely. In practice it is convenient, and often the best compromise, to use standards whose concentrations are one decade apart, i.e. differ by a factor of 10, and bracket the expected range of sample concentrations. For example, if the range of sample concentrations is expected to be 5 to 10 ppm, then standards of 2 and 20 ppm could be used

**Note.** The concentrations of the two standard solutions must differ from each other by a factor of at least four.

On initiation of the calibration sequence, either manual or automatic, the 'Cal' l.e.d. is illuminated and the Calibration Mode relay is energised. Two solenoid valves, SV1 and SV2 operate

sequentially to shut off the sample and admit standard solutions of known concentration, one low and one high (STD1 and STD2), to the sample path.

Once a valve is energised, sufficient time (preset to suit the sensor response time) is allowed for the previous solution to be displaced, and for the sensor to respond to the new solution, before the sensor output is evaluated for stability by the microprocessor. When a stable output is achieved the next stage in the sequence is initiated.

After calibration the sensor outputs corresponding to the two standard solutions are used to calculate a new calibration graph for the monitor, thus compensating for any drift in sensor or liquid handling performance characteristics since the last calibration, and the new slope value can be displayed in Operating Page 1 (100% slope is the theoretical value).

If the values are within limits, 'CALIBRATION PASSED' is displayed.

'CAL FAILED (SLOPE)' is displayed if the slope value is outside acceptable limits and 'CAL FAILED (SLOW)' is displayed if the sensor output failed to stabilise within 15 minutes after the end of Cal Time 1 or Cal Time 2.

Activity	Introduce STD1	Sensor Stabilises	Introduce STD2	Sensor Stabilises	Introduce Sample	Normal Operation
Valve Open	SV1	SV1	SV2	SV2	None	None
Timing	Preset (Cal Time 1)	Variable *	Preset (Cal Time 2)	Variable *	Preset (Cal Time 3)	None

\*15 min. max.

**Table 7.1 Calibration Sequence Summary**

## 8 MAINTENANCE

### 8.1 Chemistry

The reagent is phosphate based and is added to the sample at the flowcell in order to provide pH and ionic strength adjustment. EDTA is included to prevent precipitation of hardness salts.

The reagent and standard solutions described below are required to maintain the monitor in operation. Where possible, they should be freshly made and stored in plastic (e.g. polythene) bottles. Typical reagent solution consumption for a continuously operating monitor is approximately 10 litres per month. The monitor uses 50 to 80 ml of each standard solution each calibration cycle; consumption of the standard solution, also depends on the frequency with which this cycle is carried out.

#### 8.1.1 Reagent Solution

Dissolve 215 ( $\pm 5$ ) g of analytical reagent grade potassium di-hydrogen phosphate in approximately 5 litres of high purity water (distilled or de-ionised water containing less than 0.01 mg/l nitrate nitrogen). Add to this solution 160 ( $\pm 5$ ) g laboratory reagent grade EDTA (di-sodium salt).

Make the solution up to 10 litres with more high purity water and add 50 ( $\pm 5$ ) ml of 10% 'Brij 35' solution. 'Brij 35' (polyoxyethylene lauryl ether, a non-ionic surfactant) is available as a solid or as a 30% solution from Merck Ltd.

#### 8.1.2 Standard Solutions

Two standard solutions of known nitrate concentration appropriate to the measuring range are required. To prepare a stock solution of 1000 mg l<sup>-1</sup> follow instructions below:

##### Nitrate as NO<sub>3</sub><sup>-</sup>

a) Dissolve 1.371 ( $\pm 0.001$ ) g analytical reagent grade sodium nitrate in high purity water and make up to one litre with more high purity water.

##### Nitrate as N

b) Dissolve 6.070 ( $\pm 0.001$ ) g analytical reagent grade sodium nitrate in high purity water and make up to one litre with more high purity water.

c) Dilute the stock solution appropriately with more high purity water to make up the two standard solutions for the measuring range of the monitor. Store in plastic bottles.

Low value nitrate standard solutions should be avoided. The lowest practical standard is 1 mg l<sup>-1</sup> NO<sub>3</sub><sup>-</sup> (approximately 0.2 mg l<sup>-1</sup> N).

**Note.** The mass relationship of nitrate (NO<sub>3</sub><sup>-</sup>) to nitrogen (N) is 62/14).

#### 8.1.3 Reference Salt Bridge Solution

The Reference Electrode contains a salt bridge solution of 1 M sodium sulphate. Prepare as follows:

- Dissolve 14.2 ( $\pm 0.1$ ) g of analytical reagent grade, anhydrous sodium sulphate (Na<sub>2</sub>SO<sub>4</sub>) in approximately 80 ml of high purity water.
- Dilute the solution to 100 ml with more high purity water.
- Store the solution in a tightly stoppered plastic bottle.

**Note.** Bottles of solution are available from ABB – see Section 10.

### 8.2 Scheduled Servicing

The following servicing schedule has been produced as a general guide only. Because the monitor has been designed for a very wide range of applications, where the nature of the sample can vary considerably, it may be necessary to amend the schedule to suit the particular installation and sample conditions.

#### 8.2.1 Regular Visual Checks

It is recommended that the monitor and the sampling system is visually inspected on a regular basis to assure correct functioning of the system and to check the integrity of the readings.

- Check for leaks, particularly around the sample and drain pipework connections.
- Confirm sample flow by checking delivery to the constant head unit and effluent from the drain.
- Check liquid flow through sensor flowcell.
- Check for excessive buildup of air in the flowcell.
- Check liquid levels in the reagent and standard solution containers.
- Check for malfunction indications on the instrument display.

**Note.** The mains and pump/heater switches are situated on the right hand side of the User Junction Box.

#### 8.2.2 Four Weekly

- Inspect all tubing and flowcell for leaks and deterioration.
- Examine all tubing and flowcell for signs of accumulation of solid deposits. These tend to accumulate in the reference electrode compartment of flowcells and may be cleaned to drain by squirting high purity water from a 'squeeze' bottle into the de-bubbler vent on top of the flowcell, and the use of small bottle brush.
- Clean monitor pipework if there are signs of algae visible.
- Check the salt bridge solution in the reference electrode and top-up if necessary.
- Discard old reagent and standard solutions. Clean containers thoroughly before refilling with fresh solutions – see Section 8.1.

**Note.** It is vital that the containers are not topped up.

- f) Examine the sample input pipe for leaks and deterioration.
- g) Ensure the drain is in good order and free from obstruction.

### 8.2.3 Four Monthly

Refurbish nitrate electrode – see Section 8.5.

### 8.2.4 Twelve Monthly

- a) Service pump, tubing and capstans – see Section 8.2.8.
- b) Replace all internal plumbing tubing – see Section 8.2.9.
- c) Carry out the normal 4 weekly schedule not already covered above.

### 8.2.5 Cleaning Sample Pipework

A common problem in measuring water samples from rivers, treatment works, etc., is the presence of bacteriological growth in the sample.

In the form of algae it creates a problem by growing inside tubing supplying sample to analysers, as well as in the monitors and associated ABB Instrumentation Ultrafilters, if used. If severe, this growth may cause blockages in tubing or valves and/or fouling of flowcells and sensors.

In addition, the algae may affect the concentration of the measured parameter in the sample. This is particularly severe in ammonia monitors, where algal growth in supply lines causes 'ammonia stripping' and a reduction in the measured concentration. Other parameters, however, may also be affected.

It is therefore essential to maintain sterile conditions. This requires periodic cleaning, at a frequency dependent on sample conditions. It is suggested that a regular maintenance programme is introduced, rather than wait for visible signs of the presence of algal growth.

**Note.** Once growth is visible the problem is already serious.

The recommended agent for cleaning tubing and pipework is sodium hypochlorite solution containing about 0.1% (1000 mg l<sup>-1</sup>) available chlorine.

#### Cleaning Solution

To prepare 500 ml of cleaning solution, dilute 5 ml of concentrated sodium hypochlorite (NaOCl) solution (containing approximately 10% available chlorine) with de-ionised water and make up to 500 ml with more de-ionised water.

**Note.** The solution is unstable. Make only enough for immediate requirements and discard any surplus after use.

**Warning.** Sodium hypochlorite is an irritant. Contact with acids liberates toxic gas. Avoid contact with skin and eyes. If contact occurs, wash with plenty of clean water.

#### Method

Where an Ultrafilter is used, clean according to the manual with a 0.05% (500 mg l<sup>-1</sup>) chlorine solution (i.e. half the concentration of the above solution). Tubing between the Ultrafilter and the analyser should also be flushed through, along with the constant head tank.

- a) Remove sensors for short-term storage before cleaning – see Section 8.3.1
- b) Remove the reagent and calibration solution take-up tubes from their respective containers. Fill a calibration container with the sodium hypochlorite cleaning solution, place it in the calibration container recess and immerse the take-up tubes in the solution.
- c) Operate 'Cal' to initiate a calibration sequence to draw the solution through the solenoid valves tubing and flowcell.
- d) Remove any dislodged debris from the flowcell and clean the constant-head unit with the cleaning solution using the bottle brush provided. The tube between the constant-head unit and SV1 can be cleaned with the cleaning solution using the syringe.
- e) Repeat the process using high purity water to flush out the sodium hypochlorite solution.

If, after cleaning, there are still signs of discoloration or deposits in the monitor tubing, it should be discarded and replaced with new tubing throughout. In cases where the monitor tubing is blocked or very heavy deposits are found, it may be necessary to simply replace the tubing without attempting to clean it.

#### Cleaning Solution Containers

Great care should be taken to ensure that reagent and standard solution containers are thoroughly cleaned whenever their contents are changed, as algal growth can also occur in them. Under normal circumstances thorough rinsing of the containers with high purity water may be adequate. However, if there is any evidence of algal growth, the containers should be rinsed with sodium hypochlorite solution (containing about 0.1% available chlorine) and thoroughly flushed out with water afterwards. A bottle brush may be useful to remove stubborn deposits.

It is advisable when changing standard or reagent solutions to replace the container and remove the empty/used one for thorough cleaning.

**Note.** It must be emphasised that containers which are to be used for ammonia standard solutions must be very thoroughly washed out after chlorine treatment because any residual chlorine will react with ammonia and hence change the standard concentration. In addition to thorough washing with water, it is suggested that the containers are rinsed with a portion of the ammonia standard before finally filling.

## ...8 MAINTENANCE

### 8.2.6 Consumables Spares Kit

If one is not supplied, it should be ordered before the end of the first year of operation. This kit includes all the components which are recommended for replacement annually (see Section 10). This annual refurbishment ensures a high level of reliability from the monitor over a period of many years. Another kit should be ordered when this one is used so that all the items are available throughout the following year's operation. The consumable spares kit is in addition to the electrode spares kit.

The kit contains the following:

- one set of pump tubing
- one set of pump capstans
- a complete set of plumbing tubing
- sundry items – 'O' rings, tube connectors, pump tube bungs and fuses
- plastic syringe and bottle brush – for cleaning pipework, valves, flowcell and constant-head unit.

### 8.2.7 Fitting the Electrode

#### Assembly

The monitor is supplied with an electrode body, an inner electrode and a refurbishing kit. These must be assembled as follows:

- Unpack the inner electrode. Remove the protective teat and place the electrode horizontally on the bench.
- Remove the protective cap from the plastic syringe containing gelled filling solution in the refurbishing kit and fit the plastic tube, supplied in the kit, to the nozzle.
- Insert the free end of the tube into the cavity housing the chloridised silver wire element at the tip of the electrode. Take care not to damage the chloridised silver wire, but make sure that the tube reaches the end of the cavity.
- Holding the inner electrode steady, slowly inject the gel into the cavity, gradually withdrawing the tube as the gel is injected. Finish with a slightly convex gel surface at the orifice.
- Remove the end cap from the electrode body and insert the inner electrode, taking care not to touch the gel surface on the top collar of the body as the electrode is inserted.
- Hold the electrode vertically and screw the central electrode in until the end of the glassware is flush with the end face of the electrode body.
- Withdraw the electrode four complete turns.

**Warning.** Wear protective gloves and perform the following steps under a fume hood. Avoid skin contact with the ion exchanger solution; if contact occurs, wash off immediately with soapy water.

- Using tweezers place the membrane (coloured white) into the end cap.

- Take a washer from the spares pack in the kit and place it over the membrane, carefully centralising it in the end cap.
- Fit the end cap assembly onto the body, screwing up tightly.
- Support the electrode vertically with its end cap lowermost. Using the 1 ml glass syringe, extract 1.5 ml of ion exchange liquid from its container and inject it carefully into the body through the filling hole provided. The electrode must remain in a near vertical position from now on.
- Screw the inner electrode down four complete turns and then a further  $\frac{1}{2}$  turn ( $\pm 0.1$  turn). The tip of the electrode should now be pressing against the membrane.
- Blot the membrane with an absorbent tissue to remove excess exchanger.
- Push the cap onto the electrode body so that it covers the filling hole.

**Note.** The electrode will not show its best performance until it has been in use in a stirred nitrate solution, in the monitor for 2 to 3 hours. Response and stability improves over a 3 day period following assembly.

- Ensure that the ion exchange liquid and membranes are at room temperature before use.
- Ensure that the protective cap is refitted to the plastic syringe to preserve its contents. Rinse the plastic tube with distilled water.
- Store the electrode in a standard nitrate solution (e.g. 10 mg l<sup>-1</sup>) when not in use.
- Rinse syringes, etc., in methanol and allowed to air-dry.

**Warning.** Methanol is highly flammable. Avoid contact with skin and eyes. Do not inhale the vapour.

- The ion exchange liquid level will require topping up periodically. The level must be maintained at least 5 mm above the body seal 'O' ring.

#### Fitting the Electrodes

When the Nitrate Electrode has been prepared for use in accordance with the assembly procedure, fit it and the Reference Electrode as follows:

- Fit the Nitrate Electrode into the plastic holder supplied, slide the retaining 'O' ring over the end of the electrode body and insert it into the sloping aperture of the flowcell. Screw down to compress the 'O' ring.
- Connect the electrode lead into the co-axial socket above the flowcell on the right hand side.

- c) Remove the teat from the reference electrode and the stopper from the refill aperture. Top up with salt bridge solution if required.
- d) Fit the 'O' ring supplied over the reference electrode body and insert the electrode into the left hand chamber of the flowcell, so that the ceramic plug is between 5 and 10 mm from the bottom.
- e) Connect the electrode lead into the coaxial socket above the flowcell on the left hand side.

### 8.2.8 Peristaltic Pump – Fig. 8.1

It is recommended that the pump tubing and pump capstans, supplied in the Consumable Spares Kit, are replaced after one year of operation. Carry out the following procedure ① to ⑧:

### 8.2.9 Replacement of Plumbing Tubing

All necessary items are included in the Consumable Spares Kit.

- a) Remove sensors for short term storage.
- b) Remove each section of the sample and reagent plumbing tubing in turn and replace with new tubing of the same length.
- c) Remove drain tubing and replace with new tubing of the same length.
- d) Clean the constant head unit, solenoid valves and sample heating coil in the flowcell with a syringe filled with sodium hypochlorite solution.
- e) It is recommended that the sample and drain tubing to and from the monitor is inspected and replaced if the tubing is in poor condition or shows evidence of any build up of solids.

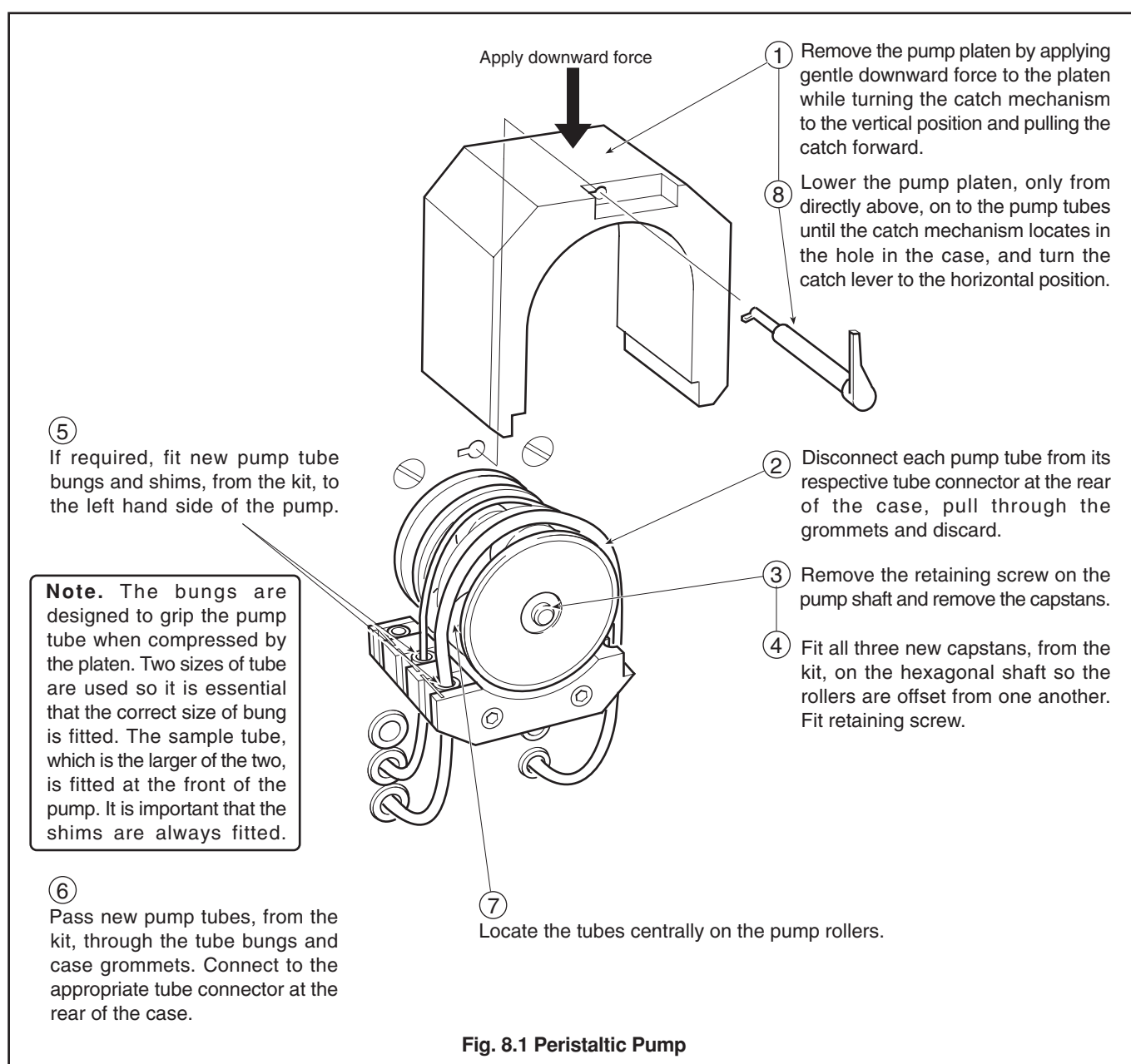



## ...8 MAINTENANCE

### 8.3 Shutdown Procedure

#### 8.3.1 Short Term

The nitrate ion-selective electrode may be stored dry or immersed in a dilute nitrate solution, e.g. 100 mg l<sup>-1</sup>, when not in use. It must not be left in the monitor flowcell. Rinse the tip thoroughly with de-ionised water immediately on removal. Remember to maintain the ion exchange liquid level 5 mm above the body seal – see Section 8.2.7 (s).

The reference electrode may be stored in de-ionised water or the correct salt bridge solution (1 M sodium sulphate) for short periods. Ensure that the electrode cannot dry out; failure to observe this results in a blocked ceramic junction, causing considerable delay when restarting the monitor.

#### 8.3.2 Long Term

For periods longer than one month, the nitrate electrode should be completely dismantled, rinsed out and returned to the box in which it was supplied. Proceed as follows:

- Withdraw the inner electrode, wipe the tip with a tissue and wash out the gelled filling solution with distilled water. Allow to air dry and refit the protective rubber teat.

#### Warning.

- Wear protective gloves and perform the following steps under a fume hood. Avoid skin contact with the ion exchanger solution; if contact occurs, wash off immediately with soapy water.
- Methanol is highly flammable. Avoid contact with skin and eyes. Do not inhale the vapour.

- Hold the electrode body over a small beaker of methanol; unscrew the end cap and allow the end cap assembly and ion-exchanger solution to fall into the methanol.

- Wash the end cap and washer in more methanol; allow to air dry. Discard the membrane.

- Wash the electrode body, inside and out, with methanol and allow to air dry.

The reference electrode is stored with its ceramic junction covered by a protective teat filled with salt bridge solution. Fit the fill hole stopper in the salt bridge solution refill aperture.

### 8.4 Unscheduled Servicing

The monitor indicates abnormal operation by means of signals on the 20 character dot matrix display and l.e.d's. The indications are listed in Table 8.1.

#### 8.4.1 Malfunction of the Monitor

It should always be remembered that any unpredictable problems may be due to the standard or reagent solutions, or their flow through the flowcell. If any doubts exist regarding the integrity of the solutions, they should be replaced with freshly prepared solutions in the early stages of the fault finding investigations.

**Note.** The accuracy of the monitor is governed by the condition of these solutions which may be incorrectly made or contaminated.

In general, any problems are likely to be due to the electrodes, which may require refurbishment (see Section 8.4.3), but may be due to other parts of the liquid handling section of the monitor.

Display	Possible Cause
'CALIBRATING Std 1 (or 2) Cal L.E.D. flashing 'CALIBRATION PASSED'	Normal when calibration is taking place. 'Std 1' or 'Std 2' refers to the standard solution being admitted at the time.  A recent two point calibration has been successfully carried out.
'CAL. FAILED (SLOPE) Fail L.E.D. flashing	The slope value calculated from the outputs of the sensors in the two standard solutions was outside the acceptable limits.
'CAL. FAILED (SLOW) Fail L.E.D. flashing	The monitor was unable to achieve a stable output from the sensors.
'TEMP. CONTROL ERROR'	The sensor flowcell temperature is significantly different from the Control Temperature.
'OUT OF SAMPLE'	Indicates loss of sample.
Hold L.E.D. 'ON'	This indicates the Hold button has been pressed to freeze the concentration alarm states and to activate the Out of Service alarm relay. Pressing the button again returns the monitor to normal operation after a period of 3 hours.

Table 8.1 Unscheduled Servicing Messages

Mechanical components which are involved with the liquid handling, for example, pumps, valves, tubing and tubing connections etc., should be systematically checked for correct operation, and for leaks or blockages which change the chemical conditions around the sensor. The majority of all problems are found to be associated with the chemistry and the liquid handling section.

#### 8.4.2 Monitor Diagnostic Information Out of Service Alarm

This alarm relay output is a normally energised relay which de-energises in the following circumstances:

- Loss of mains supply.
- Calibration Failed – the calculated electrode slope value is outside the acceptable limits or the response of the electrode is too slow. The 'CAL FAIL' l.e.d. on the front panel is illuminated with the appropriate text on the 20-character display.
- Block temperature out of limits – the measured temperature of the Block is not within 5 °C of the Control Temperature. 'TEMP. CONTROL ERROR' is indicated on the 20-character display.
- 'OUT OF SAMPLE' alarm – a float switch in the constant head unit detects the loss of sample. 'OUT OF SAMPLE' is indicated on the 20-character display.
- 'OUT OF SERVICE' alarm – displayed when the pump is switched off.

**Note.** The heater is switched off by the software when an 'OUT OF SAMPLE' condition is detected.

#### Calibration Fail Alarm

A calibration failed condition occurs after a two point calibration if the calculated slope value is less than 80% or if the sensor output is unstable. The failure could be caused by a number of factors which should be investigated.

In the 'CAL. FAILED (SLOPE)' case some indication of the problem may be obtained from the slope value.

#### Slope Value Just Below 80%

- Check for surface deposits on membrane of nitrate electrode.
- Refurbish the nitrate electrode – see Section 8.5.

#### Slope value grossly abnormal –

- Check for air bubbles trapped on nitrate electrode membrane.
- Check for surface deposits on membrane of nitrate electrode.
- Check, and top up as necessary, the ion-exchange solution in the nitrate electrode. Maintain the level in the electrode at a depth of approximately 15 mm. Use the syringe in the refurbishing kit and clean with methanol.
- Check level of salt bridge solution in reference electrode.

- Check that the fill hole stopper has been moved away from the salt bridge filling solution hole in the reference electrode.
- Refurbish nitrate electrode – see Section 8.5.
- Reference electrode liquid junction partially or completely blocked, replace if required.

#### Noisy, unstable response or slow response –

- Check for air bubbles trapped on nitrate electrode membrane.
- Check for surface deposits on membrane of nitrate electrode.
- Check level of salt bridge solution in reference electrode.
- Check that the fill hole stopper has been moved away from the salt bridge refill aperture in the reference electrode.
- Nitrate electrode fouled or poisoned, refurbish the nitrate electrode – see Section 8.5.
- Reference electrode liquid junction partially or completely blocked, replace if required.

**Note.** Electrodes exposed to high levels of interfering ions e.g. chloride, may drift for some time on returning to a nitrate standardising solution.

In the 'CAL. FAILED (SLOW)' case the failure is usually due to slow sensor response, but may be due to an unstable (noisy or drifting) sensor output:

- Check sensor connections in the coaxial plugs and sockets, and inside the microprocessor unit.
- Refurbish the nitrate electrode – see Section 8.5.

#### 8.5 Refurbishing the Electrode

- Withdraw the inner electrode, wipe the tip with a tissue and wash out the gelled filling solution with distilled water.

#### Warning.

- Wear protective gloves and perform the following steps under a fume hood. Avoid skin contact with the ion exchanger solution; if contact occurs, wash off immediately with soapy water.
- Methanol is highly flammable. Avoid contact with skin and eyes. Do not inhale the vapour.

- Hold the electrode body over a small beaker of methanol; unscrew the end cap and allow the end cap assembly and ion-exchanger solution to fall into the methanol.
- Wash the end cap and washer in more methanol; allow to air dry. Discard the membrane.
- Wash the electrode body, inside and out, with methanol and allow to air dry.
- Follow procedure in Section 8.2.7.



### 8.6 Microprocessor Unit Error Messages

The instrument incorporates an automatic self-diagnostic checking facility for detection of input and output errors. If such a fault occurs, one of the error messages detailed below is shown on the dot matrix display.

#### 'CHAN 1 INPUT ERROR'

This error message is usually caused by an open circuit sensor input allowing the input to drift outside the range of  $\pm 400$  mV. This may be due to any of the following:

- a) Loss of solution flow through the flowcell breaking the electrical connection between the electrode pair.
- b) Low level of salt bridge solution in the reference electrode.
- c) Open circuit electrode internally, e.g. broken connection, blocked liquid junction in reference electrode etc.
- d) Broken electrical connections between the sensor and the Microprocessor Unit sensor input.
- e) Sensor coaxial plugs not correctly inserted.

#### 'TEMP INPUT ERROR'

#### 'PRT OUT OF LIMITS'

#### 'TEMP REF. ERROR'

#### 'THIRD LEAD ERROR'

The above four error messages refer to electrical problems with the temperature sensor input – usually an open or short-circuited connection.

## 9 SPECIFICATION

### Range

**Nitrate** Any two consecutive decades of concentration between 0.2 and 1000mgL<sup>-1</sup> as N, or 1.0 and 5000mgL<sup>-1</sup> as NO<sub>3</sub><sup>-</sup>

### Repeatability

±2% of reading

### Reproducibility

±3% of reading

### Response time

Less than 5 minutes for 90% step change

### Millivolt range

-400mV to +400mV

### Millivolt resolution

±0.1mV

### Control temperature range

30 to 45°C (86 to 113°F)

### Temperature resolution

±0.1°C (±0.2°F)

### Displays

**Concentration** 5-digit blue fluorescent

**Information** 20-character dot matrix blue fluorescent

### Status indication

Two flashing LED's in alarm state

Single LED lit when 'HOLD' switch operated

Single LED lit when calibration is in progress

Single LED lit when the monitor is 'Out of Service'

### Current outputs

As standard one isolated current output 0 to 1, 0 to 10, 0 to 20 or 4 to 20mA selectable via plug-in links

Optional 2<sup>nd</sup> current output

Maximum voltage load 15V

### Current output span

Any 1 to 2 decades of display range, logarithmic or linear

### Computer interface

Modbus via RS433/RS423 serial interface

### Alarms

Two high or low concentration alarms

Remote calibration mode indication

Remote monitor 'Out of Service' indication,

includes: Loss of Mains Supply

Loss of Sample

Calibration Failed

Electronic Failure

All voltage-free 250V 5A non-inductive changeover relay contacts

### Concentration alarm adjustment

Programmable over assigned range

### Concentration alarm differential

Programmable 0 to 5%

### Concentration alarm delay

Programmable 0 to 60 minutes

### Calibration

Fully automatic two-point, plus manual initiation on demand

### Routine maintenance

Four-weekly: replenish reagents, clean flow system

Twelve-monthly: replace plumbing, pump tubing and pump capstans

### Power supply

110 to 120V or 220 to 240V 50/60Hz 100VA

### Power supply tolerance

+6% to -10%

### Isolation voltage

Input, output and power supply 1.5kV

### Weight

Approximately 35kg (77lb)

### Dimensions

Height 893mm (35.2 in.)

Width 541mm (21.3 in.)

Depth 207mm (8.2 in.)

### Degree of protection

Electronics section IP65

Liquid handling Case IP31

Critical internal components IP65

SS/8230 Issue 9

## 10 SPARES LIST

### Consumable Spares

Part No.	Description	Qty
8230 020	Consumable spares kit comprising pump tubes, pump capstans, plumbing tubing, tube connectors and 'O' rings etc.	1
8006 892	Nitrate electrode consumables kit (containing membranes + solutions)	1

### Refurbishment Spares

Part No.	Description	Qty
8006 893	Nitrate electrode refurbishing kit (containing consumables and applicators)	1
8006 837	Nitrate electrode inner electrode	1
1433 830	Reference electrode – silver (1 M sodium sulphate) double junction	1
8236 245	Electrode retaining sleeve	1
8002 780	Electrode body	1
8002 820	Probe clamp	1
8236 235	Sample heater coil	1
8236 260	Reagent solution container assembly	1
8230 221	Standard solution container assembly – 'High'	1
8230 220	Standard solution container assembly – 'Low'	1
8063 710	Container tube sinker	3
0214 514	Hose connector – sample inlet 6 mm i.d.	1
0214 526	Hose connector – monitor drain 9 mm i.d.	1
8022 990	Tube connector – 9 mm i.d. flowcell drain	1
8231 240	Flowcell stirrer magnet	1
8230 240	Temperature sensor assembly	1
0234 019	Solenoid valve ('Burkert' type)*	1

\*This valve replaces 'Fluid Automation Systems' valve (part number 0232 092). To convert to the Burkert valve, order solenoid valve assembly, part number 8230 207, which includes the valve and mounting bracket.

### Strategic Spares

Part No.	Description	Qty
8232 280	Constant head unit	1
8061 864	Float switch – 'Out of Sample'	1
8230 208	Pump motor including 10 $\mu$ F capacitor (4 r.p.m. @ 50 Hz)*	1
0232 033	Stirrer motor	1
8035 870	Pump motor coupling assembly	1
0216 244	Heater assembly	1
0234 712	Heater thermal cut-out	1
8231 239	Flowcell assembly	1
0232 325	Mains transformer – User Junction Box	1
0234 726	Toggle switch – mains and pump switch	2
0234 714	Toggle switch boot	2
8230 130	P.C.B. assembly – User Junction Box	1
0239 117	Electrode coaxial plug	2
0239 118	Electrode coaxial socket	2
4500 0845	Processor Board (without EPROM)	1

\*This motor replaces 0232 069 (5 r.p.m. @ 50 Hz), thus reducing reagent consumption.

## ...10 SPARES LIST

### ...Strategic Spares

#### Specify EPROM below as required

N.B. EPROM's require a special PLCC extraction tool

Part No.	Description	Qty
8231 170	EPROM (English)	1
8231 171	EPROM (German)	1
8231 175	EPROM Serial Comm (English)	1
8231 176	EPROM Serial Comm (German)	1
4500 0817	Power supply board assembly	1
4500 0140	Display board pack assembly	1
4500 0255	Current O/P board	1
8230 055	mV input board	1
4500 0265	Temp. input board	1
4500 0625	Output module	1
4500 0285	Power supply board	1
4500 0275	5-digit 7-segment display board	1
4500 0443	5-digit display flexi-circuit	1
4500 0603	Display flexi-circuit	1
4500 0395	Membrane switch	1
4500 0855	Serial Modbus PCB assembly	1
4500 0715	Power supply board assembly (Fitted to pre CE marked monitors only)	1

### Fuses (Junction Box)

Part No.	Description	Qty.
0231 558	F1 – 1A 20 x 5mm Anti-surge 250V AC	1
B10208	F2 – 5A 20 x 5mm Quick Blow 250V AC	1
0231 596	F3 – 0.5A 20 x 5mm Anti-surge 250V AC	1

### Fuse (Transmitter Power Supply Board 4500/0817)

Description	Qty.
F1 – Not a site-serviceable fuse, contact the company	1

# APPENDIX A – REPLACING SOFTWARE EPROM

**Warning.** Switch off the monitor and electrically isolate it before carrying out the following steps.

## A.1 Access the Transmitter Unit – Fig. A.1

**Caution.** Employ normal antistatic precautions while handling chips and PCBs.

**Caution.** To avoid damaging EPROM, base or PCB, it is essential that you use an approved IC extractor in this procedure.  
For example, a PLCC Extractor, RS Stock Number: 404-727

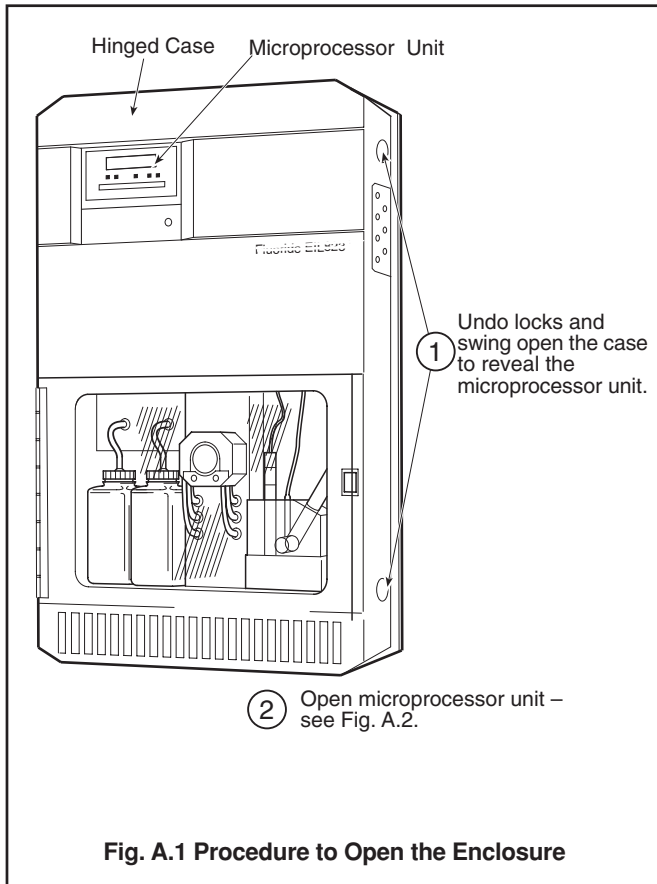

## A.2 Access the PCB – Fig. A.2

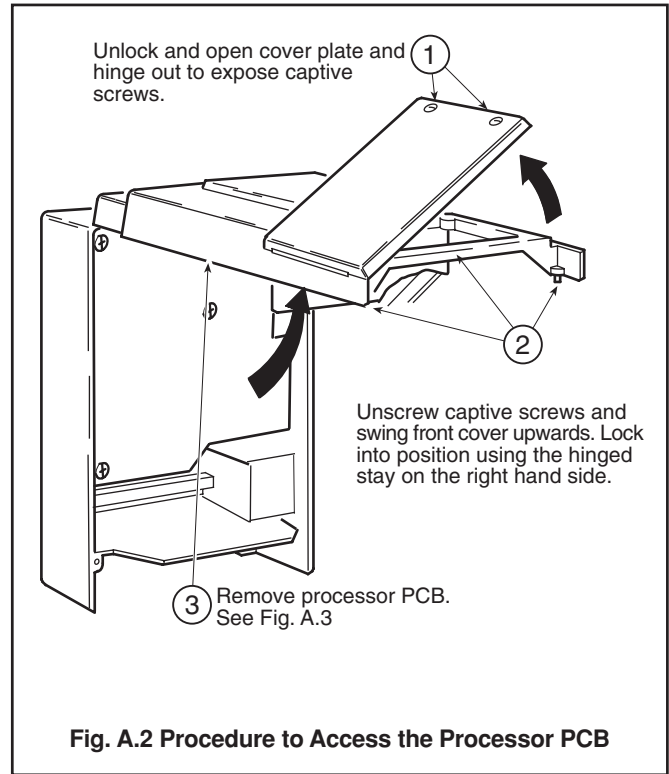

**A.3 Removing the PCB – Fig. A.3**

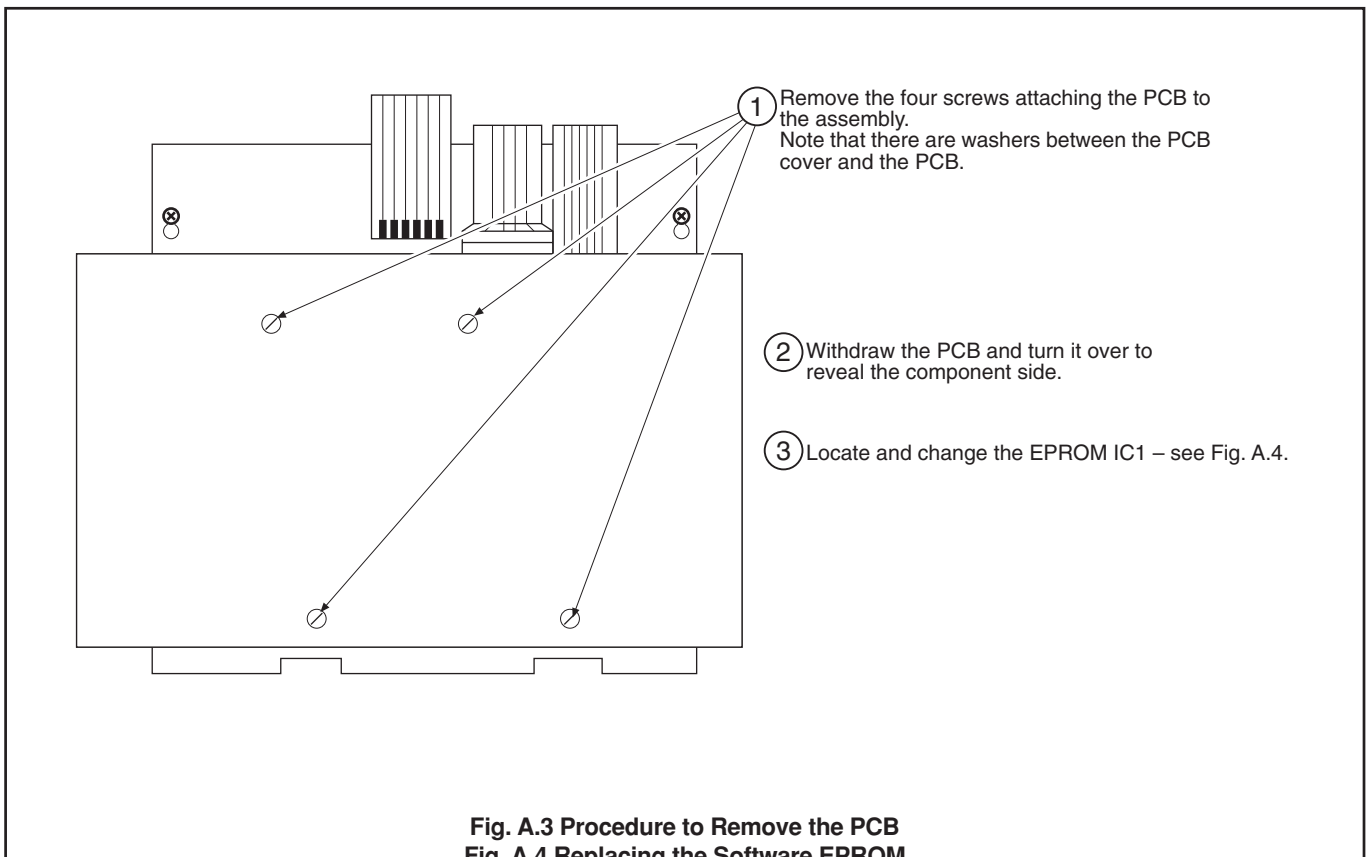

**Fig. A.3 Procedure to Remove the PCB**  
**Fig. A.4 Replacing the Software EPROM**

**A.4 Changing the EPROM – Fig. A.4**

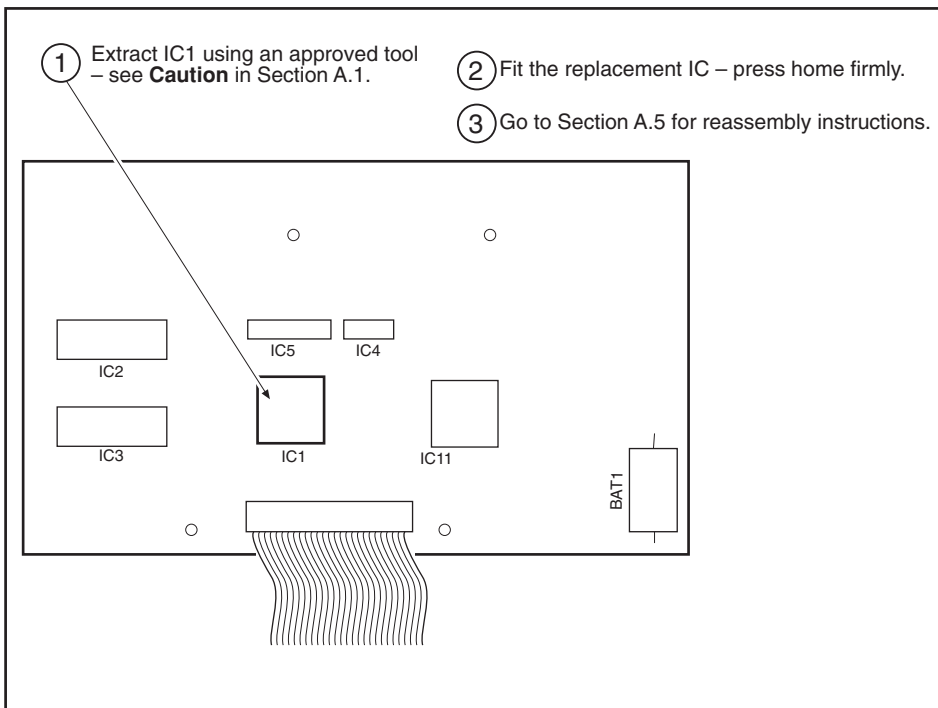

**A.5 Completing the Procedure**

- 1) Fit the PCB using the reverse procedure in Fig. A.3.

**Important Note.** Ensure that the washers are fitted between the PCB cover and the PCB.

- 2) Close the microprocessor section using the reverse procedure in Fig. A.2.
- 3) Close and lock the hinged cover – Fig. A.1.
- 4) The monitor may now be put into service.
- 5) Check program parameters – see Section 6.
- 6) Carry out a routine 2-point calibration.

---

## NOTES

---







# PRODUCTS & CUSTOMER SUPPORT

## Products

### Automation Systems

- *for the following industries:*
  - Chemical & Pharmaceutical
  - Food & Beverage
  - Manufacturing
  - Metals and Minerals
  - Oil, Gas & Petrochemical
  - Pulp and Paper

### Drives and Motors

- *AC and DC Drives, AC and DC Machines, AC motors to 1kV*
- *Drive systems*
- *Force Measurement*
- *Servo Drives*

### Controllers & Recorders

- *Single and Multi-loop Controllers*
- *Circular Chart and Strip Chart Recorders*
- *Paperless Recorders*
- *Process Indicators*

### Flexible Automation

- *Industrial Robots and Robot Systems*

### Flow Measurement

- *Electromagnetic Flowmeters*
- *Mass Flow Meters*
- *Turbine Flowmeters*
- *Flow Elements*

### Marine Systems & Turbochargers

- *Electrical Systems*
- *Marine Equipment*
- *Offshore Retrofit and Refurbishment*

### Process Analytics

- *Process Gas Analysis*
- *Systems Integration*

### Transmitters

- *Pressure*
- *Temperature*
- *Level*
- *Interface Modules*

### Valves, Actuators and Positioners

- *Control Valves*
- *Actuators*
- *Positioners*

### Water, Gas & Industrial Analytics Instrumentation

- *pH, conductivity, and dissolved oxygen transmitters and sensors*
- *ammonia, nitrate, phosphate, silica, sodium, chloride, fluoride, dissolved oxygen and hydrazine analyzers.*
- *Zirconia oxygen analyzers, katharometers, hydrogen purity and purge-gas monitors, thermal conductivity.*

## Customer Support

We provide a comprehensive after sales service via a Worldwide Service Organization. Contact one of the following offices for details on your nearest Service and Repair Centre.

### United Kingdom

ABB Limited  
Tel: +44 (0)1453 826661  
Fax: +44 (0)1453 829671

### United States of America

ABB Inc.  
Tel: +1 775 850 4800  
Fax: +1 775 850 4808

#### Client Warranty

Prior to installation, the equipment referred to in this manual must be stored in a clean, dry environment, in accordance with the Company's published specification.

Periodic checks must be made on the equipment's condition. In the event of a failure under warranty, the following documentation must be provided as substantiation:

1. A listing evidencing process operation and alarm logs at time of failure.
2. Copies of all storage, installation, operating and maintenance records relating to the alleged faulty unit.

---

ABB has Sales & Customer Support  
expertise in over 100 countries worldwide

[www.abb.com](http://www.abb.com)

The Company's policy is one of continuous product  
improvement and the right is reserved to modify the  
information contained herein without notice.

Printed in UK (01.07)

© ABB 2007



**ABB Limited**  
Oldends Lane, Stonehouse  
Gloucestershire  
GL10 3TA  
UK  
Tel: +44 (0)1453 826661  
Fax: +44 (0)1453 829671

**ABB Inc.**  
Analytical Instruments  
9716 S. Virginia St., Ste. E  
Reno, Nevada 89521  
USA  
Tel: +1 775 850 4800  
Fax: +1 775 850 4808