

DEH-41671 Installation Instructions

**EntelliGuard® G Circuit Breaker
Accessories**

Shutter Key Interlock

Introduction

Shutter Key Interlock Kit:

The locking device has the following functionality:

Shutter key interlock can be activated when the breaker moving portion is removed from the cassette or is in the DISCONNECTED position.

In the above conditions, the device:

- locks the shutter of the cassette main terminals in closed position,
- locks the entry aperture of the racking handle in closed position,
- locks the breaker in 'OFF' position and prevents it from being switched ON (when breaker is inside the cassette),
- locks the possibility of moving breaker to the DISCONNECT position (in case of active interlock when breaker was removed from the cassette).

Four types of key locks can be placed:

- type HBA90DPS5000 (star key)
- type PBA90DPS3000 (star key)
- type ABA90DEL5000 (flat key)
- type RBA90DEL3000 (flat key)

All locks have the same characteristic of work:
90 degree clockwise rotation to trap the key.

Catalog Number:

Catalog No	Description
GTCPONSV1	Shutter key interlock kit (star key type)
GTCRONSV1	Shutter key interlock kit (flat key type)

	WARNING
	Potential arc flash and shock hazard Turn Off and Lockout power prior to working on equipment
	Before installing or testing any accessories gear shall be de-energized

Installation of shutter key interlock on the cassette.

1. Dismantle the cassette front panel, by removing the two M5 nuts and ribbed washers (Fig. 1).

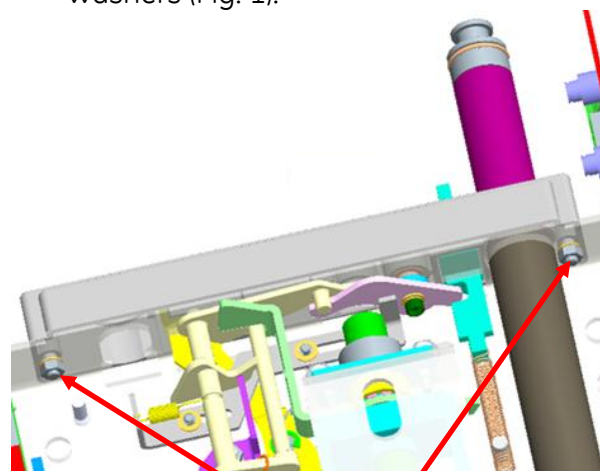

Figure 1

M5 nuts and ribbed washers

- Remove the knock-out feature on the cassette front panel (Fig. 2) and clean the flash with any sharp pointed Tool. Ensure no flash or projections left out and cavity is free for insertion the lock.

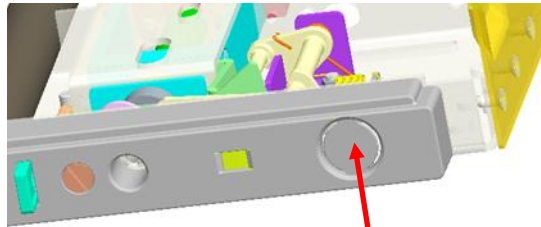

Figure 2

Knock-out feature

- Remove both nuts (small-M11 and big-M22) from the lock (Fig. 3.).

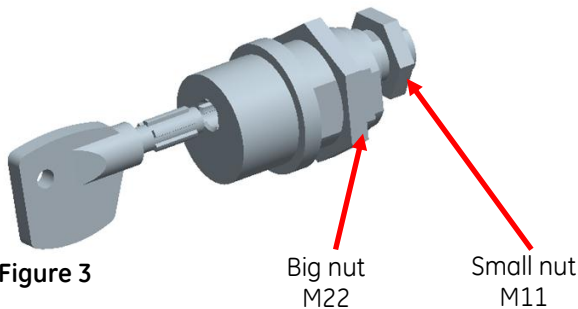

Figure 3

Big nut
M22

Small nut
M11

- Insert the lock body in to the cut-out in metal base plate along with the both spacers (Fig. 4). Assemble M22 nut on to lock body from inside of the cassette.

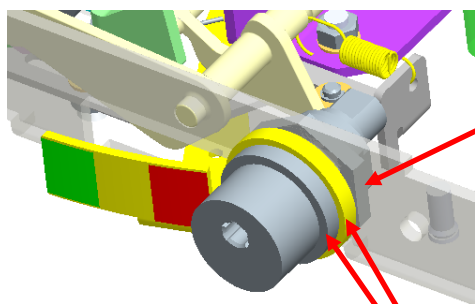

Figure 4

Spacers

- Assemble the key lock lever and special M11 nut on to the lock body (orient on the lever as shown on Fig. 5.).

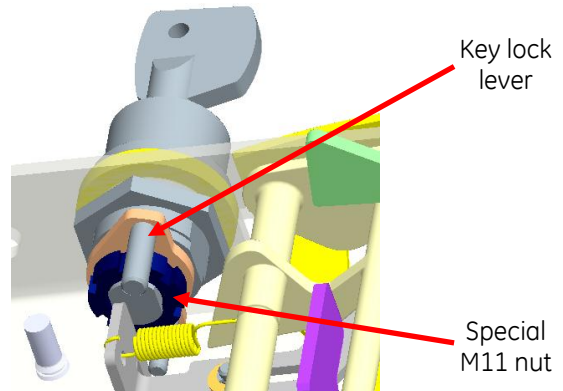

Figure 5

- Tighten M22 nut and special nut using nut wrench from the set.

- Keep the lock in closed position and remove the key from the lock body (Fig 6).

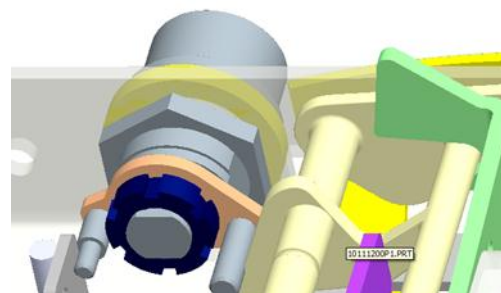

Figure 6

- Assemble back the front panel and fix them using two spring washers and two M5 nuts (Fig 7).

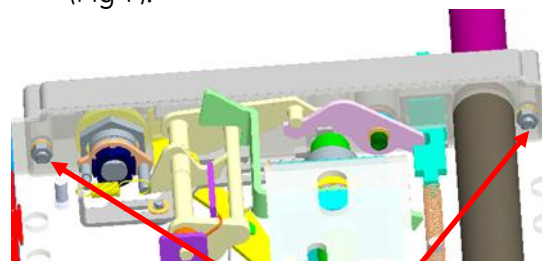

Figure 7

M5 nuts and ribbed washers

- Insert the key to the lock body and rotate 90 degree clockwise to trap the key and unlock the cassette mechanism (Fig. 8a and 8b).



Figure 8a

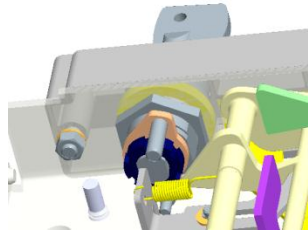

Figure 8b

- Assembly the front lock support on threaded pin in base plate (Fig 9)

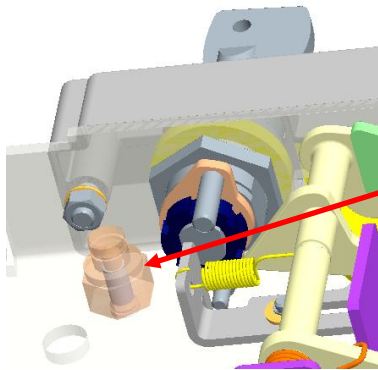

Figure 9

Front lock support

- Assembly the front lever on the front lock support (Fig 10).

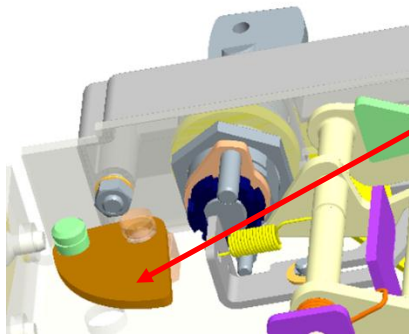

Figure 10

Lever

- Assembly the rear lock bracket on the cassette - tighten them to the rear channel using M6 nut and ribbed washer and to the base plate using two M6 screws, ribbed washers and M6 nuts (as shown in Fig 11).



Figure 11

M6 nut and
M6 ribbed washer

Rear lock
bracket

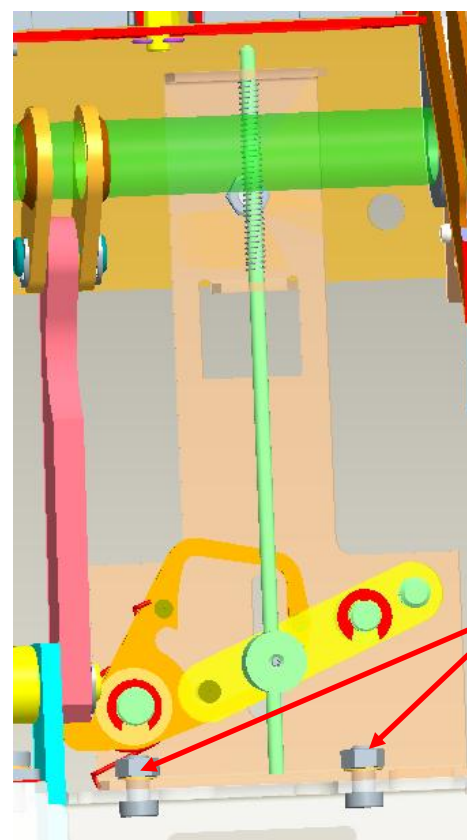

Figure 12

M6 screw
M6 ribbed washer
M6 nut

13. Using pulling rod, connect lever from the base plate with the lever from the rear lock bracket. Secure pulling rod and front lever with circlips (as shown on Fig. 13).

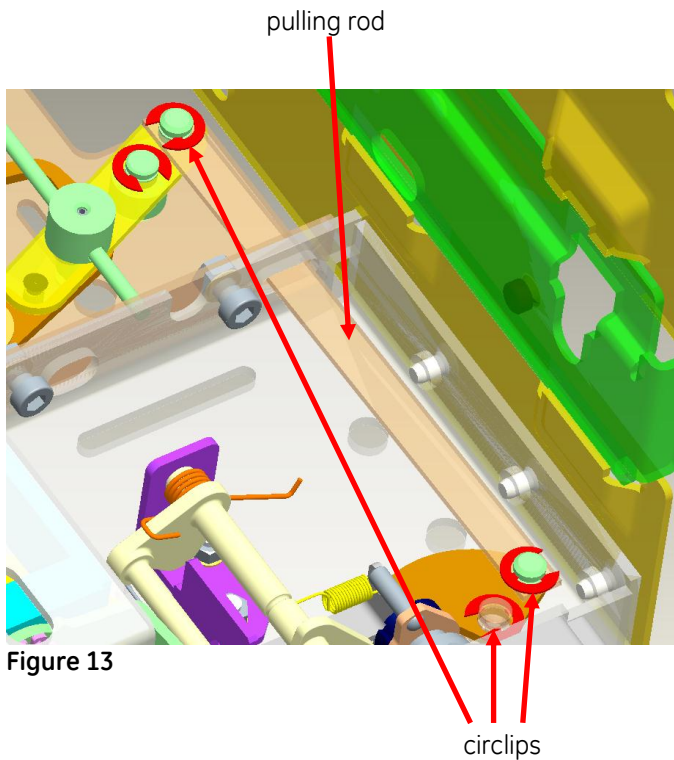

Figure 13

Quality check before breaker roll-in.

1. Remove the breaker from the cassette.
2. Ensure racking mechanism is in DISCONNECTED position and handle is removed from the crank insertion aperture.
3. Rotate the key by 90 degree anticlockwise, till it reaches dead stop and next remove the key from the lock.
4. In locked condition:
 - It should not be possible to open the racking handle aperture and will not be able to insert the handle.
 - It should not be possible to move cassette shutters up (round rod of the rear lock bracket shall block shutter vertical motion possibility).
 - Dimension "A" (measured, as shown in figure 17) should be greater than 42,5mm.

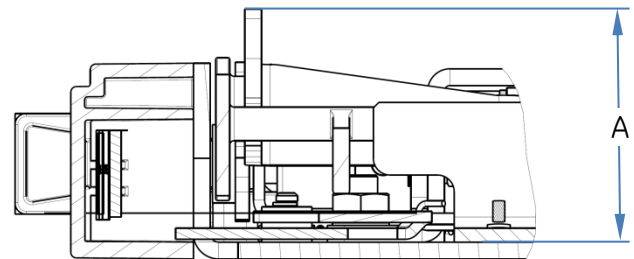

Figure 17

**REMARK:
BRAEKER CAN BE INSERTED TO THE
CASSETTE ONLY IN UNLOCK CONDITION**

Functional check of the lock.

1. Ensure breaker is in DISCONNECT position and handle is removed from the crank insertion aperture.
2. Press the OFF button on the breaker fascia and open the breaker if closed.
3. With the OFF button in pressed condition rotate the key by 90 degree anticlockwise, till it reaches dead stop and next remove the key.
The device is now locked out.
4. It should not be possible to open the racking handle aperture shutter.
Verify this by attempting to open the shutter drive by placing a screwdriver and rotating it clockwise.
5. It should not be possible to close the breaker.
Verify this by attempting to turn the breaker ON by depressing the ON button on the breakers front fascia.
6. Rack in the breaker to TEST, CONNECTED or any intermediate position.
It should not be possible to turn and remove the key from the lock in any other position of the breaker, except for DISCONNECTED.

These instructions do not cover all details or variations in equipment nor do they provide for every possible contingency that may be met in connection with installation, operation, or maintenance. Should further information be desired or should particular problems arise that are not covered sufficiently for the purchaser's purposes, the matter should be referred to the ABB Inc.

—
ABB Inc.
305 Gregson Drive
Cary, NC 27511.
electrification.us.abb.com

—
We reserve the right to make technical changes or modify the contents of this document without prior notice. With regard to purchase orders, the agreed particulars shall prevail. ABB Inc. does not accept any responsibility whatsoever for potential errors or possible lack of information in this document.

We reserve all rights in this document and in the subject matter and illustrations contained therein. Any reproduction or utilization of its contents – in whole or in parts – is forbidden without prior written consent of ABB Inc.
Copyright© 2019 ABB
All rights reserved