

ACV 700
DCF 500/700
DCS 500
DCV 700
TSU

DDCTool

User's Manual



User's Manual

DDCTool

ABB Drives

Code: 3AFE 61041486 REV A EN

EFFECTIVE:15.10.2004
SUPERSEDES:14.08.1996

Table of Contents

Table of Contents	i
Chapter 1 - Introduction	1-1
About this Manual	1-3
Chapter 2 - Installation of the DDCTool	2-1
Installing the DDCTool Software	2-1
Installing the DDCTool Hardware	2-1
Use of multiple DDCs	2-2
Setting of DDC node numbers.....	2-5
Creation of the DDCLIST.TXT file	2-6
Chapter 3 - Using the DDCTool	3-1
Starting the DDCTool.....	3-1
Screen Layout of the DDCTool	3-1
Status Panel	3-3
ACV 700.....	3-3
DC Drives.....	3-5
Numeric Monitoring of Actual Values.....	3-6
Object Button	3-7
Object Selection List	3-8
Value Buttons	3-9
Changing Values.....	3-10
Chapter 4 – File Menu	4-1
Open Configuration.....	4-1
Open Graph	4-2
Save Configuration	4-2
Save Configuration As	4-3
Save Graph As.....	4-3
Print Graph.....	4-6
About DDCTool.....	4-6
Exit	4-6
Chapter 5 – ActValues Menu	5-1
Graph Display (Single DDC)	5-1
Automatic Scaling	5-3
Graph Display (Multiple DDCs)	5-4
Triggering.....	5-6
Stop/Restart Graph Display	5-7
Define Value 1 ... 4	5-7
Define Object	5-7
Set Object Value	5-7
Undo Object Value.....	5-7
Show Descriptions	5-7
Define Step A and Step B	5-8
Start Value Recorder	5-10
Stop Recorder	5-11
Chapter 6 – Params Menu	6-1

Table of Contents

Processing the Parameters (Immediate update)	6-1
Processing the Parameters (No immediate update)	6-4
Chapter 7 – Diagrams Menu	7-1
Diagrams	7-1
Diagram Window	7-2
Chapter 8 – DataLogger Menu	8-1
Use of the Data Logger	8-1
Copy Value Definitions to Ch 1 ... 4	8-1
Define Channel 1 ... 6	8-2
Common Definitions	8-2
Control	8-3
Upload	8-4
Automatic Scaling	8-4
Graph Display of Uploaded Samples	8-5
Expand Graph Display	8-5
Numeric Display of Uploaded Samples	8-6
Monitoring (ACV 700 only)	8-7
Chapter 9 – Control Menu	9-1
Local/Remote Control	9-1
Local Control	9-1
Remote Control	9-2
Chapter 10 – Faults Menu	10-1
Reading the Last DDC Fault/alarm Code	10-1
Uploading/clearing the Fault Logger	10-2
Chapter 11 – Other Menu	11-1
Use of Multiple DDCs	11-1
Restart Communication with the DDC	11-2
Read the DDC Communication Statistics	11-3
Clear Graph Area	11-3
Set Y-axis Zero to	11-3
Copy Curr Graph to Ref	11-3
Show/Hide Ref Graph	11-3
Ref Graph Shift	11-3
Window Calculator	11-4
Set DDC Time	11-4
Lock Value Changes	11-5
I/O Test (ACV 700 only)	11-6
Chapter 12 – Exit Menu	12-1
Exit	12-1
Chapter 13 - Appendix 1	13-1
Startup Parameters	13-1
Chapter 14 - Appendix 2	14-1
Error Messages	14-1
Chapter 15 - Appendix 3	15-1
Monitoring of Single APC	15-1
Monitoring of Multiple APCs	15-1

Chapter 16 - Appendix 4	16-1
Creation of Diagram Files	16-1
Method 1	16-2
Method 2	16-3
Chapter 17 - Appendix 5	17-1
Related Documents	17-1

Chapter 1 - Introduction

The DDCTool is a Windows based (Windows 2000 or Windows XP) commissioning and maintenance tool for single and multiple DDCs (Digital Drive Controller).

The PC where the DDCTool runs is connected optically to one or more DDCs by means of the optic data communications card SNAT 624 CMT.

The DDCTool program can be used with the following DDC types:

- ACV 700
- DCV 700
- DCF 500 / 700
- DCS 500
- TSU

The program automatically recognises the type of the DDC it is connected to.

When the DDCTool is connected to DCS 500, then the DDCTool works as described in the separate *CMT / DCS 500 User's Manual*. This manual (*DDCTool User's Manual*) describes the operation of the DDCTool when it is connected to one of the DDCs mentioned above, other than DCS 500.

The following functions can be performed by using the DDCTool:

- monitoring of the DDC's actual values in real time (min sample interval is 3 ms) in the graphical and numeric form
- setting of the DDC's parameters and other values
- display of schematic diagrams with real time monitoring of the DDC's actual values
- control of the DDC's data logger operation and display of the sample values collected by the data logger in graphical and numeric form
- saving of the current measurement configuration and the screen's graphical display to a disk file

- local control of the DDC
- display and clear of the contents of the DDC's fault logger
- uploading/downloading of all DDC's parameters; changing their values and saving/restoring them to/from a disk file
- testing of the I/O connections (ACV 700 only)

If there are several DDCs (max. 249) connected to the PC by optical distributors then the following functions are available:

- selection of the DDC that will be the target DDC for the above mentioned functions
- simultaneous graphical monitoring (max. 5 curves) or file recording (max. 250 channels) of actual values from multiple DDCs
- automatic stop of graphical monitoring in an user-defined triggering situation

About this Manual

Chapter 2 - Installation of the DDCTool describes the installation of the DDCTool software and hardware in single and multiple DDC configurations.

Chapter 3 - Using the DDCTool describes the basic functions of the DDCTool program.

Chapter 4 – File Menu describes how you can save and open graph and configuration information.

Chapter 5 – ActValues Menu describes how you can monitor actual values in the graphical and numeric form.

Chapter 6 – Params Menu describes how you can upload, download, save, open, print, compare and update the whole parameter set of the DDC and how you can change values of individual parameters.

Chapter 7 – Diagrams Menu describes how you can display schematic diagrams with real time monitoring of the DDC's actual values.

Chapter 8 – DataLogger Menu describes how you can define the data logger channels and other data logger control parameters and how you can upload, display and save the collected data logger samples.

Chapter 9 – Control Menu describes how you can control the DDC in local control mode.

Chapter 10 – Faults Menu describes how you can upload, display and save the content of the fault logger.

Chapter 11 – Other Menu describes the rest of the DDCTool functions (e.g. use of multiple DDCs, reference graphs, window calculator and value change lock).

Chapter 12 – Exit Menu tells how you exit the DDCTool program.

Appendices 1 ... 5 describe the startup parameters, error messages, monitoring of actual values of APC(s), creation of diagram files and related documents.

Chapter 2 - Installation of the DDCTool

The DDCTool is designed to run under the Microsoft Windows 2000 or Windows XP operating environment on IBM-compatible PCs.

NOTE: If there are no PCMCIA slots in your PC (and there is a free PCI slot), you must first install a PCI / PCMCIA adapter. Please follow the installation instructions of the PCI / PCMCIA adapter (these instructions are in the *Readme.txt* file of the adapter).

Do not insert the SNAT 624 CMT PCMCIA card before you have installed the DDCTool software.

Installing the DDCTool Software

NOTE: You must have Administrator privileges to your PC.

Insert the DDTool CD-ROM into the CD drive of your PC.

Read file *Readme.txt* from the CD-ROM. It may contain additional installation information.

Start the *Control Panel* program (**Start -> Settings -> Control Panel**) and double click its *Add/Remove Programs* icon.

Click the **Add New Programs** button and follow the instructions that appear on the screen (select file *Setup.exe* from the CD-ROM).

When the software installation is ready, you can add startup parameters (normally no startup parameters are needed). The startup parameters are described in *Appendix 1*.

Installing the DDCTool Hardware

WARNING

ABB Oy cannot guarantee that the DDCTool PCMCIA card will work in every PC. ABB Oy assumes no responsibility for any indirect damages that may occur in connection with the use of the DDCTool PCMCIA card.

Insert the SNAT 624 CMT PCMCIA card into a vacant PCMCIA slot.

After few seconds the "Found New Hardware" box is displayed on the screen for a while.

The installation of the SNAT 624 CMT PCMCIA card is now ready.

Connect optical cable between the PCMCIA card and a DDC.

You can now start the DDCTool program (**Start -> Programs -> DriveWare -> DDCTool**).

If the DDCTool program displays the "*Cannot start drive communication*" error box during its startup, try one or more of the following before attempting to start the DDCTool program again (NOTE: If error message "*PC OVERLOAD*" appears on the screen or DDCTool fails during parameter upload then this means that the PCMCIA works OK but you must increase the value of the startup parameter **M**, see *Appendix 1*):

- Check that you have pushed the PCMCIA card to the bottom of the PCMCIA slot.
- Check that the connector between the flat PCMCIA card and the optical cable adapter is connected properly.
- Read the *Readme.txt* file from the DDCTool CD-ROM. It may contain additional information.
- Check that the DDC has auxiliary power switched on (see the drive commissioning manual).
If an APC application controller is connected to the DDC and it is able to control it, the communication circuits in SNAT 601/609 TAI or SDCS-COM-1 are OK. The fault then could be in the fibre optic receiver, in the optical cable or transmitter circuits of SNAT 601/609 TAI or SDCS-COM-1. In this case, replace SNAT 601/609 TAI or SDCS-COM-1.
If the APC cannot control the DDC, in the case of an ACV 700 the fault could be in SNAT 601/609 TAI or SNAT 603 CNT or in the case of a DC drive in SDCS-COM-1 or SDCS-CON-1.

Use of multiple DDCs

In the case of only one DDC, a direct connection between the PCMCIA card and the DDC is sufficient.

If there are several DDCs and only one PC, YPC111A optical distributors can be used between the DDCTool board and the DDCs. YPC111A has one connection for the DDCTool board and four connections for the DDCs or lower level optical distributors. When using the YPC111A board and plastic fibre cable, the maximum length between the boards is 20 metres.

If the lengths between the DDCTool boards are over 20 metres the YPC115A board and glass fibre cable should be used. The maximum length in this case is 1000 metres.

Optical distributors can be connected to a tree or chain form. The height of the tree / length of the chain depends on the number of DDCs in the system (max number of DDCs is 249).

Optical distributors use +24 V auxiliary power.

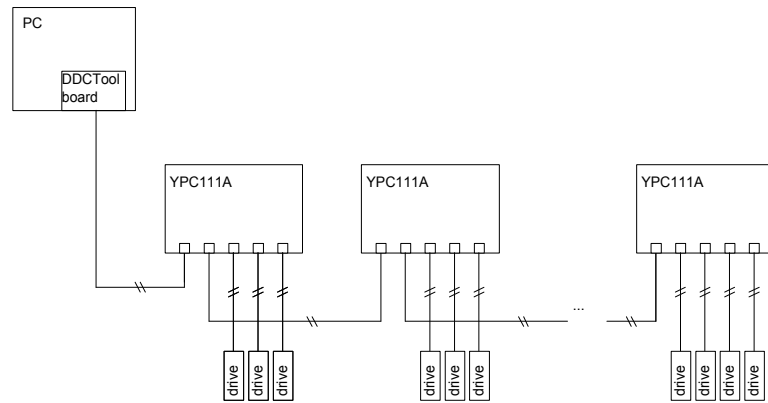

Figure 2 - 1. Chain form of the YPC111A optical distributor. When using plastic fibre cable the maximum length is 20 metres.

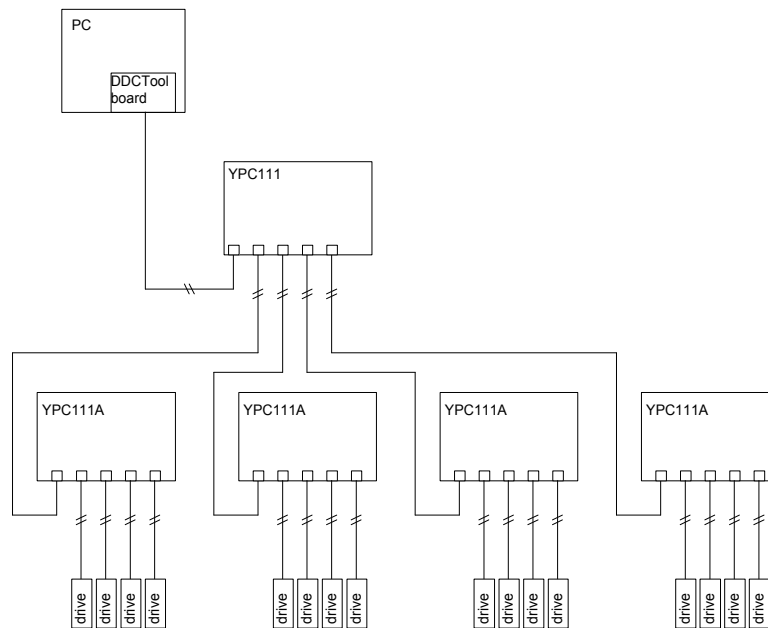

Figure 2 - 2. Tree form of the YPC111A optical distributor. When using plastic fibre cable the maximum length is 20 metres.

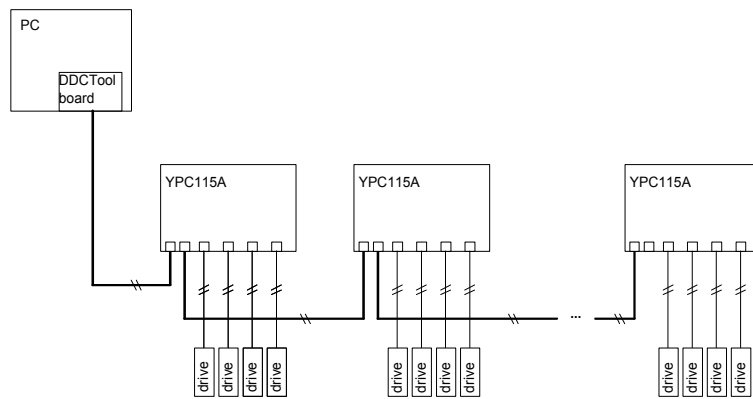

Figure 2 - 3. The chain form of the YPC115A. When using glass fibre cable the maximum length is 1000 metres (the dark lines).

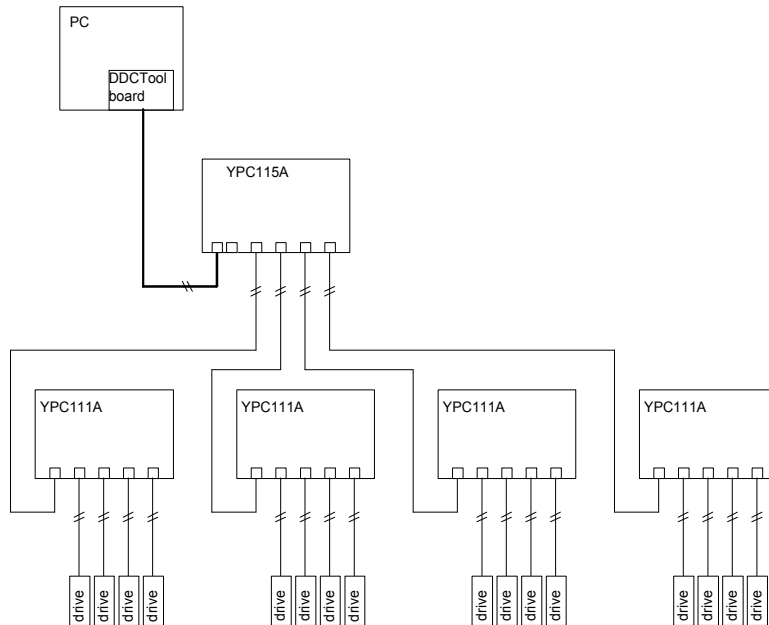

Figure 2 - 4. The tree form of one YPC115A and four YPC111As.

Setting of DDC node numbers

Connect the PC *directly* to the first DDC. Start the connected DDC (power on).

By using the DDCTool program (see Chapter *Using the DDCTool / Changing Values*) set parameter **23-02** = the identifier of the connected DDC (the identifier must be in the range 1...249).

NOTE: Save the new value of parameter 23-02 into the non-volatile memory by means of parameter 11-07, see ACV 700 Firmware 1.0 or DCV 700 Software Description 1.0.

Stop the DDCTool. Stop the connected DDC (power off). **The value of parameter 23-02 will be in effect only after DDC power off!** Disconnect the DDC from the PC.

Repeat the above described operations with the other DDCs.

NOTE: The values of the DDC identifiers must be unique!

After setting the identifier of the last DDC, restore the structure of the optical cable network.

Finally, create the DDCLIST.TXT file as described in the next chapter.

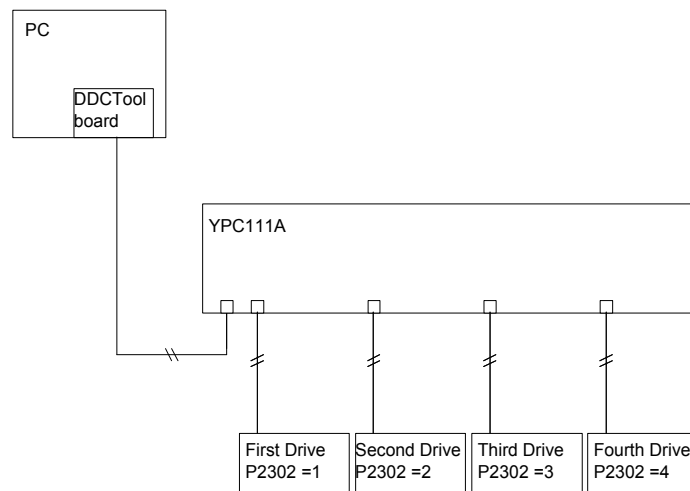

Figure 2 - 5. Multiple DDCs parameter example.

**Creation of the
DDCLIST.TXT
file**

This file is used only with multiple DDCs.

The DDCLIST.TXT file can be created by the *Notepad* program to the DDCTOOL directory (do not use *Word* or some other word processing program that uses special formatting characters).

In the DDCLIST.TXT file there is a text line for every DDC. The format of a DDC line is as follows:

```
identifier description_text<Enter>
```

There must be at least one space between the *DDC identifier* and the optional *DDC description text*. If the first character of a line is not numeric (or the line is empty) then this line is a comment line. There is no need to list the identifiers in ascending order.

NOTE: Do not forget to press *Enter* at the end of the last line, too!

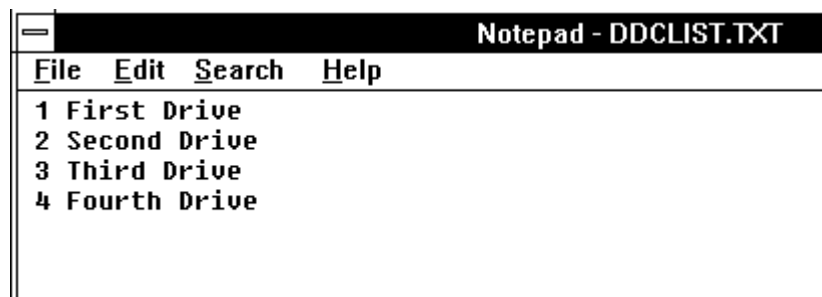

Figure 2 - 6. DDCLIST.TXT file example. The values of the identifiers must be the same as the values of parameters 2302 in the DDCs.

When the DDCTool program is started, after the creation of the DDCLIST.TXT file, then the target DDC will automatically be the *first* DDC in the file.

NOTE: If the DDCLIST.TXT file does not exist then there can be *only one* DDC connected to the PC. If there are more DDCs and the DDCLIST.TXT file does not exist then the DDCTool does not know which of the DDCs it is dealing with.

Chapter 3 - Using the DDCTool

Starting the DDCTool

You start the DDCTool program by using the **Start** button in the *Taskbar* (**Start -> Programs -> DriveWare -> DDCTool**).

If the DDC connection is not working properly then the "*Cannot start drive communication*" error box will appear on the screen (see Chapter *Installation of the DDCTool / Installing the DDCTool Hardware*).

If error message "*PC OVERLOAD*" appears on the screen (or DDCTool fails during parameter upload) then you must increase the value of the startup parameter **M** (see *Appendix 1*).

Screen Layout of the DDCTool

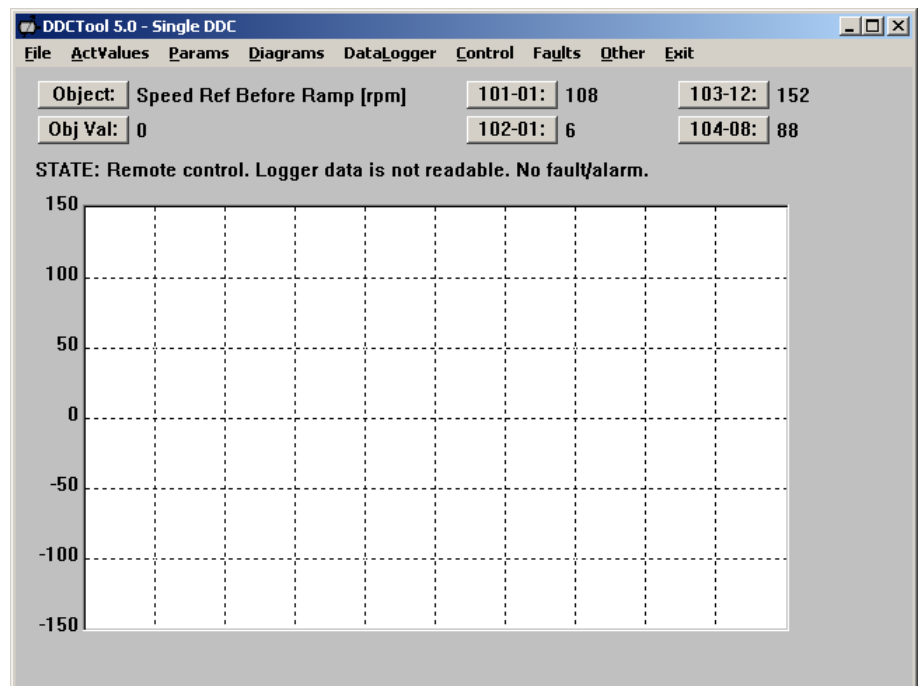

Figure 3 - 1. Screen layout of the DDCTool.

If the PC is directly connected to a DDC then the text *Single DDC* appears on the top of the screen.

If there are several DDCs connected to the PC then the identifier of the current target DDC is displayed on the top of the screen and the DDC selection tabs are displayed at the bottom of the screen (the ? tab brings up on the screen a DDC selection dialog box, see Chapter *Other Menu / Use of Multiple DDCs*).

The actual values to be monitored in real time (in the numeric form) are displayed in the upper part of the screen.

In the middle of the screen there is a graphical display area with scale lines.

On the STATE line above the graphical display area, the following DDC status information is displayed:

- control mode (remote / local control) (see Chapter *Control Menu*)
- data logger state (sample values are readable / cannot be read) (see Chapter *DataLogger Menu*)
- fault state (fault or alarm / no fault or alarm). The fault and/or alarm code that was last in the DDC can be read by means of the **Read Last Fault/Alarm Codes** or **Upload Fault Logger** command in the **Faults** menu (see Chapter *Faults Menu*).

If the DDC connection does not exist then it is possible to perform only such operations that do not need communication with the DDC.

If there is a CONFIG.QDC file (see Chapter *File Menu / Save Configuration*) in the DDCTOOL directory then the settings in this file are automatically copied to the initial configuration settings of the DDCTool program.

Status Panel

ACV 700 If you define **Value4** = signal 101-04 (MAIN_STATUS_WORD) then the status information of this ACV 700 signal is shown on the right side of the screen (gray text = inactive state):

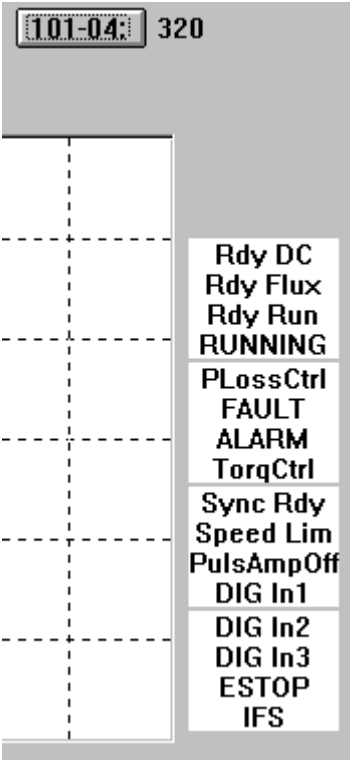

Figure 3 - 2. ACV 700 status panel on the right side of the screen.

If you define **Value4** = signal 101-05 (AUX_STATUS_WORD) then the status information of this ACV 700 signal is shown on the right side of the screen (gray text = inactive state):

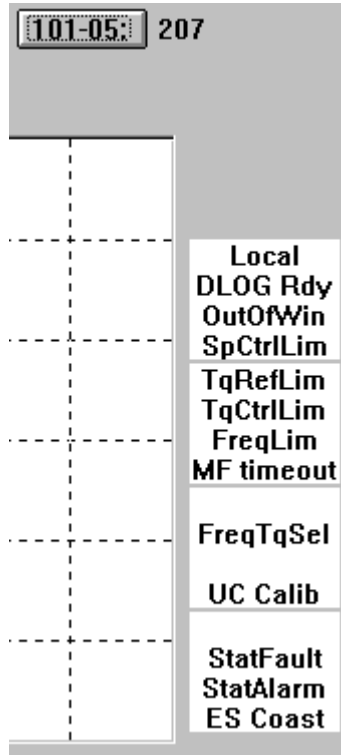

Figure 3 - 3. ACV 700 status panel on the right side of the screen.

DC Drives If you define **Value4** = signal 101-04 (MAIN_STATUS_WORD) then the status information from the DC drive is shown on the right side of the screen (gray text = inactive state):

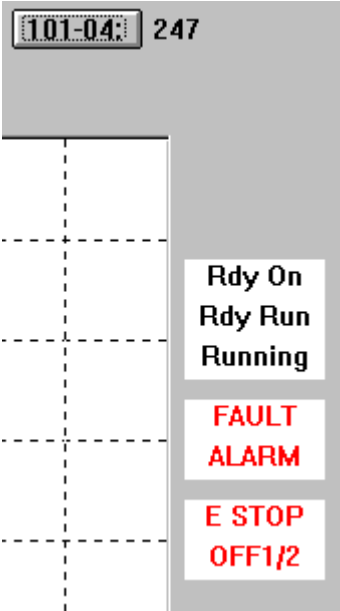

Figure 3 - 4. DC status panel on the right side of the screen.

Numeric Monitoring of Actual Values

The actual values to be monitored in real time are selected with the **Object** button and with the **Value1**, **Value2**, **Value3** and **Value4** buttons. The buttons have the following differences:

Object button	Value buttons
Updating interval = the DDC message interval (see <i>Appendix 1</i> , parameter M). The minimum is the message processing interval of the DDC (over 20 ms).	Updating interval = the DDC message interval (see <i>Appendix 1</i> , parameter M). The minimum is 3 ms.
The value as such is the actual value.	The value can also be the difference between two actual values (or between an actual value and a constant value).
The value of an object selected with the button can be changed with the ObjVal button.	Values cannot be changed.
During some button and menu functions, a value can be momentarily other than the correct value .	The value is always correct.

The **Object** button is generally used only for selecting objects whose contents are to be changed. The **Value** buttons are used to select actual values that are to be monitored numerically and/or graphically.

The current definitions of the above mentioned buttons can be displayed on the screen by using the **F9** function key (or by selecting the command **Show Descriptions** in the **ActValues** menu).

Object Button

After the **Object** button has been clicked, a dialog box is displayed on the screen.

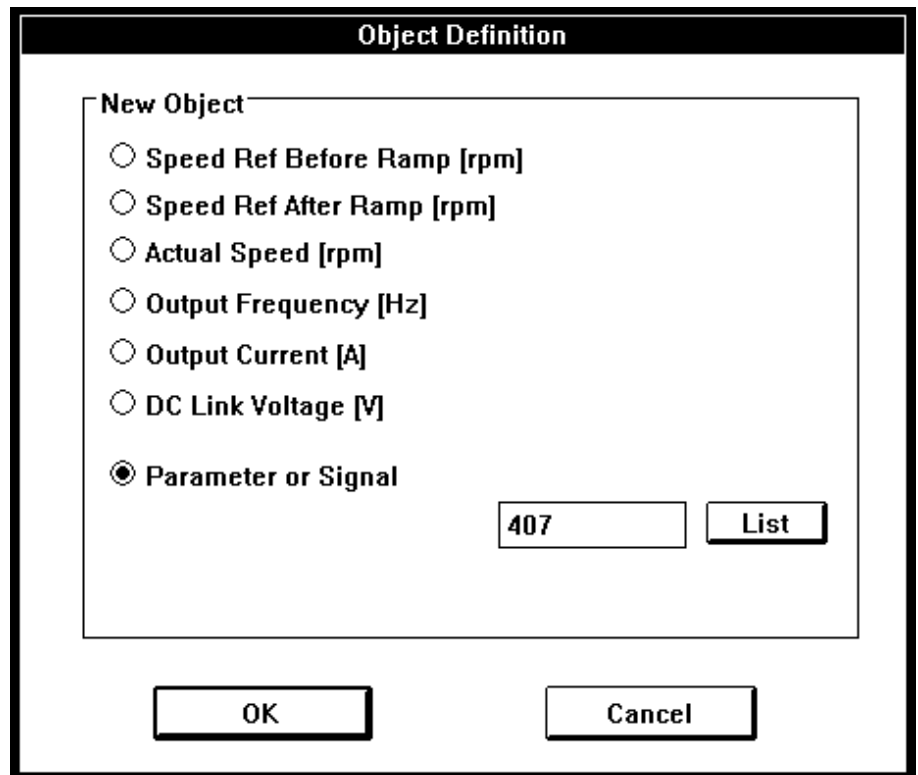

Figure 3 - 5. Defining the **Object** button (ACV 700).

From the list one of the following actual values can be selected for monitoring:

- a pre-programmed actual value. The names and display formats of these actual values are pre-defined, and because these values are calculated by the DDC, they cannot be changed with the DDCTool program.
- a parameter or signal. With the **List** button you can select the desired parameter or signal from the parameter/signal list (either with a double click of the mouse or by pressing the space bar).

When the selection has been made, click the **OK** button. The name of selected parameter/signal will be displayed at the right side of the **Object** button and at the right side of the **ObjVal** button there will appear the actual value of the selected object (selection of the actual value's display format is explained below in Chapter *Changing Values*).

Object Selection List

By clicking on the object name (at the right side of the **Object** button) the Object Selection List window can be displayed.



Figure 3 - 6. Object Selection List.

If you *click* on a list item (parameter/signal) then this item will be the new object.

If you *double click* on a list item then this item will be the new object and the value change dialog box is automatically displayed for value change (see below Chapter *Changing Values*).

By means of the **Add** button you add new items to the end of the item list.

You can select one or more parameters/signals from the dialog box that appears when you click the **Add** button. Click the **OK** button of the dialog box when you have selected the item(s) you want (if you want to clear the item list of the object selection list window before addition then click the **OK (with clear)** button).

By means of the **Del** button you delete the selected item from the list.

By means of the **Save** button you save the object list to a disk file (name extension must be .QDO).

By means of the **Open** button you read a previously saved object list from a disk file.

You can move back from the selection list window to the main window, and the selection list window will remain visible on the screen. By means of the **Done** button you remove the selection list window.

Value Buttons

After you have clicked a **Value** button, a dialog box will be displayed on the screen.

The dialog box titled "Definition for Value 1" contains the following elements:

- New Data Location:** A radio button labeled "Parameter or Signal" is selected. To its right is a text box containing "10101" and a button labeled "List".
- New Reference Data Location:** Two radio buttons are present: "Constant Ref Value" (selected) and "Parameter or Signal". To the right of the "Parameter or Signal" radio button is a text box containing "0".
- New Display Format:** Three radio buttons are present: "Signed Integer" (selected), "Unsigned Integer", and "Hex".
- At the bottom of the dialog are two buttons: "OK" and "Cancel".

Figure 3 - 7. Defining a **Value** button.

This box contains the following information (either default values or values selected earlier):

- the value to be monitored. This is a signal (or a parameter).
- a reference value. This can be a constant value (e.g. zero) or a signal (or a parameter).
- the display format (a signed integer, an unsigned integer or a hexadecimal number)

When the above mentioned selections have been made, click the **OK** button. Next to the **Value** button clicked there will appear the actual value, in the selected format or the difference between the value to be monitored and the reference value.

If the value to be monitored is a signal (or a parameter) and the reference value is zero, the identifier of the signal (or a parameter) will be displayed on the top of the **Value** button (instead of the *Value n* text).

Changing Values

The parameter (or signal) to be changed is first selected with the **Object** button (or with the Object Selection List).

Next click the **ObjVal** button, which brings up on the screen a dialog box with a selection list for the display format and a data entry field for entering the new value.

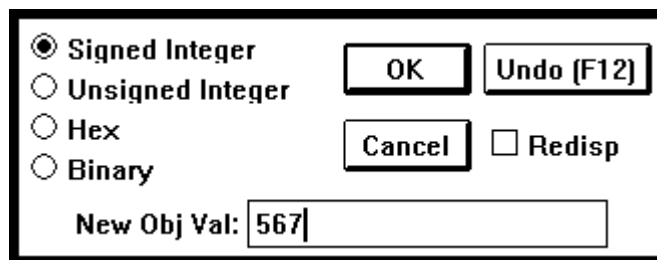

Figure 3 - 8. Value change.

If you wish to change the display format, select a new format from the list of formats (a signed integer, an unsigned integer, a hexadecimal number or a binary number).

If you wish to change the value, write the new value in the data entry field.

Finally, click the **OK** button (or press the **Enter** key).

NOTE: *If you wish to change only the display format, leave the data entry field blank!*

If you have selected the **Redisp** check box then DDCTool redisplay the dialog box so that you can change the value of the same object again. Click the **Cancel** button (or press the **Esc** key) when you want remove the dialog box from the screen.

You can restore the previous value back if you press the **F12** function key (or click the **Undo** button of the dialog box if the box is visible) as the first operation after value change.

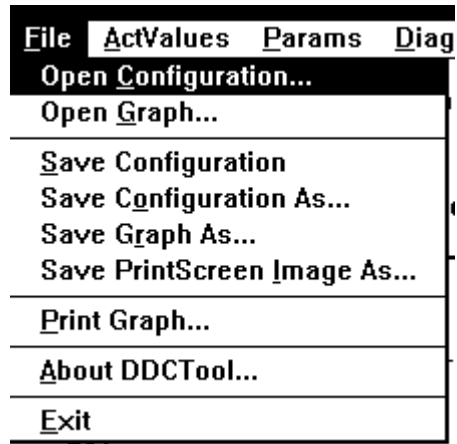

Figure 4 - 1. Pull-down menu for File. Note that some menu commands may be inactive if it is not possible to use them in the current situation.

Open Configuration

By means of the command **Open Configuration** in the **File** menu you can restore previously saved measurement configuration definitions.

Open Graph

By means of **Open Graph** in the **File** menu you can restore any previously saved graph file. When you have selected the file you want to restore then a dialog box will be displayed on the screen.

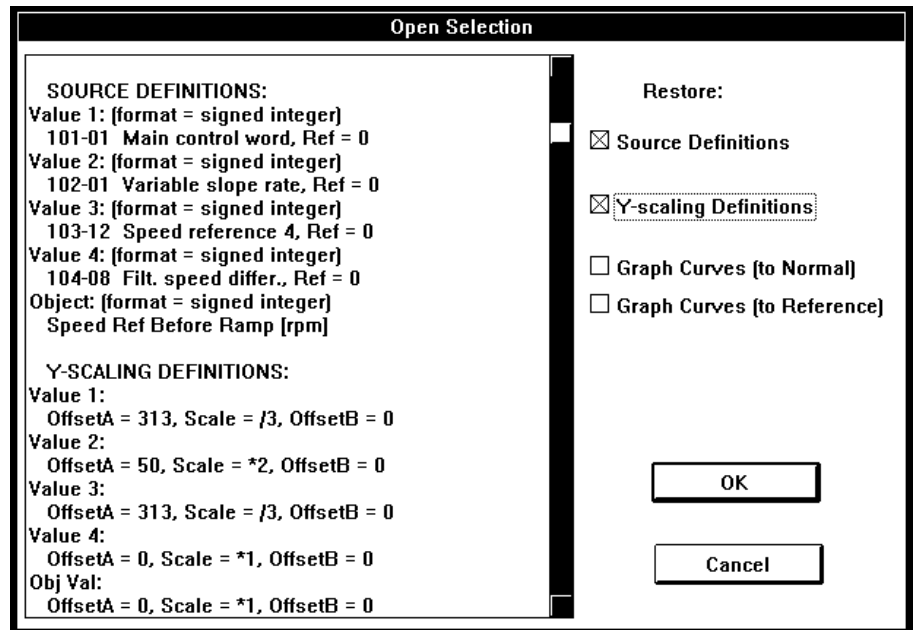

Figure 4 - 2. Open graph dialog box.

With this dialog box you can restore the graph source and/or scaling definitions and/or the graph curves. Graph curves can be copied to normal curves or reference curves. You can make a copy to reference curves only if the current X- and Y-axis values are the same as they were when the graph curves to be copied were saved (use of reference curves, see Chapter *Other Menu / Show/Hide Ref Graph*).

Save Configuration

When you select this command all measurement configuration definitions of the DDCTool (**Object** button, **Value** buttons, **Step** buttons etc.) are saved for later use to the file CONFIG.QDC in the DDCTOOL directory. If the file CONFIG.QDC already exists then its old content is overwritten.

If there are multiple DDCs connected to the PC then this command saves the measurement configuration definitions of all DDCs you have used.

Save Configuration As

When you select this command a dialog box will be displayed on the screen. By this box you define a file (extension must be .QDC) and all measurement configuration definitions (**Object** button, **Value** buttons, **Step** buttons etc.) are saved to this file for later use.

If there are multiple DDCs connected to the PC then this command saves the measurement configuration definitions of all DDCs you have used.

Save Graph As

You can save the current graphical display information to a disk file for later use. When you select this command a dialog box will be displayed on the screen.

Figure 4 - 3. Save graph dialog box.

With this dialog box you select the graph bitmap file mode, graph line width type and the desired file directory, write the base part of the file name (e.g. MEAS23) and write the *Comment* line (e.g. customer name, application etc.).

If the saved graph will be printed in a black-and-white format then it is usually better to use *dissimilar* line widths.

If a saved graph will be shown by an overhead projector then *double* line widths should be used.

When you click the **OK** button two or three disk files will be created:

- binary file (extension .QDG, e.g. MEAS23.QDG). The content of this file is: graph type (actual values or data logger samples), comment text, source definitions, graph scaling definitions and actual graph curves.
- text file (extension .TXT, e.g. MEAS23.TXT). The content of this file is: graph type (actual values or data logger samples), comment text, date and time, source definitions and graph scaling definitions.
- bitmap file (extension .BMP, e.g. MEAS23.BMP). This file is not created if you selected the No Graph Bitmap File mode from the Graph Bitmap File Mode list. The content of this file is: comment text, date and time, source definitions, graph scaling definitions and actual graph curves. Source and graph scaling definitions are missing if you selected the Graph Bitmap File w/o Definitions mode from the Graph Bitmap File Mode list (in this mode the bitmap file is smaller and you can use this alternative if you have not much free disk space left).

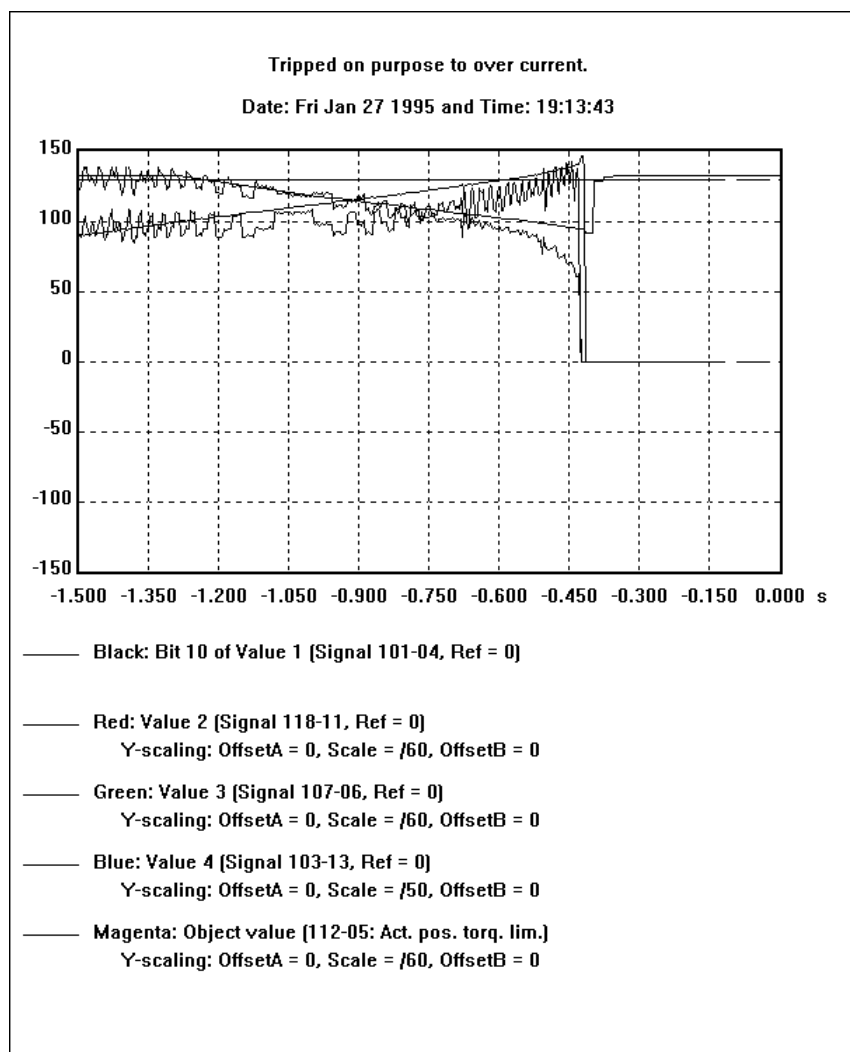

Figure 4 - 4. Graph display bitmap file (.BMP) example.

The above-mentioned files are used as follows:

- binary (.QDG) file: By means of the command Open Graph in the File menu you can restore the definitions and graph curves of this file.
- text (.TXT) file: When you are creating a document (e.g. with the WinWord program) you can insert the content of this file into the document.
- bitmap (.BMP) file: When you are creating a document (e.g. with the WinWord program) you can insert the content of this file into the document.

Print Graph

If you have a printer connected to your PC then the current graphical display can be printed with source and scaling definitions by means of the command **Print Graph** in the **File** menu.

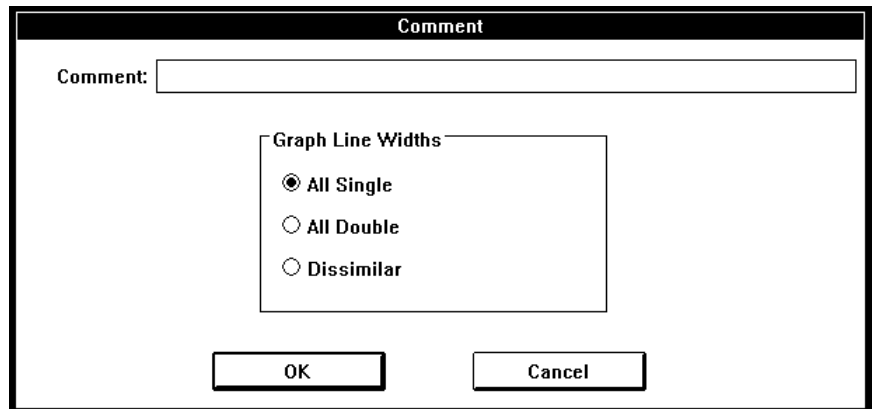

Figure 4 - 5. Print graph.

The printer settings can be changed by the Windows **Control Panel (Printers)**.

About DDCTool

An **About DDCTool** box will appear. The DDCTool version and the DDC type are shown there.

Exit

See Chapter *Exit Menu*.

Chapter 5 – ActValues Menu

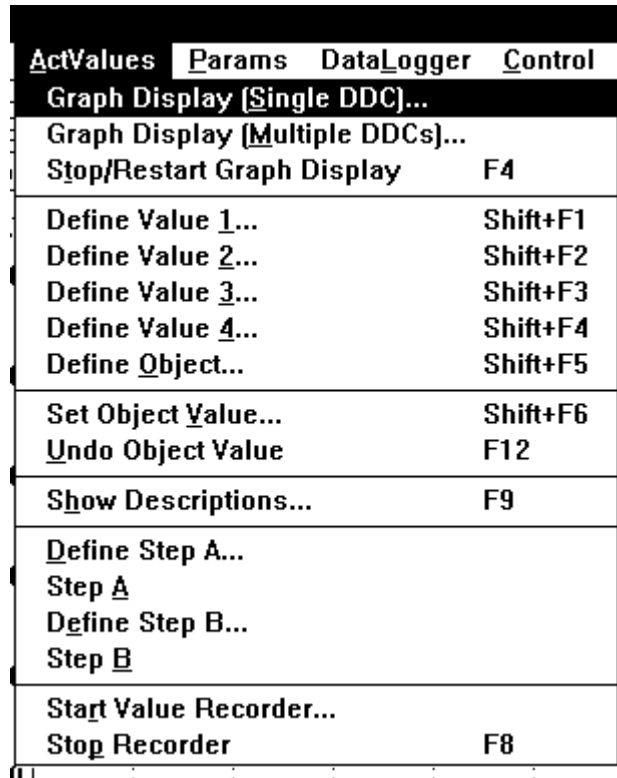

ActValues	Params	DataLogger	Control
Graph Display (Single DDC)...			
Graph Display (Multiple DDCs)...			
Stop/Restart Graph Display			F4
Define Value 1...			Shift+F1
Define Value 2...			Shift+F2
Define Value 3...			Shift+F3
Define Value 4...			Shift+F4
Define Object...			Shift+F5
Set Object Value...			Shift+F6
Undo Object Value			F12
Show Descriptions...			F9
Define Step A...			
Step A			
Define Step B...			
Step B			
Start Value Recorder...			
Stop Recorder			F8

Figure 5 - 1. Pull-down menu for ActValues. Note that some menu commands may be inactive if it is not possible to use them in the current situation.

Graph Display (Single DDC)

The graphical monitoring of actual values of several DDCs is described in the next chapter.

The width of the display area is 500 pixels and it is divided into 10 parts by broken lines. If the updating interval of the actual values to be monitored is e.g. 3 ms (the fastest possible), then the width of the entire area corresponds to a time of 1.5 seconds (500 * 3 ms).

The actual values to be monitored are first selected by means of the **Value1**, **Value2**, **Value3** and **Value4** buttons (and possibly also with the **Object** button) in the manner described in the Chapters *Using the DDCTool / Object Button* and *Using the DDCTool / Value Buttons*.

Next you select the **Graph Display (Single DDC)** command from the **ActValues** menu. The actual values to be monitored graphically are selected from the curve list to be displayed on the screen.

Definition for the Graph Display of Actual Values (Single DDC)

$Y\text{-value} = [\text{ActualValue} - Y\text{-offsetA}] * Y\text{-scale} + Y\text{-offsetB}$

		Y-offset A	Y-scale	Y-offset B
<input checked="" type="checkbox"/> Black:	<input checked="" type="radio"/> Value 1 <input type="radio"/> Bit:	100	/3	0
<input checked="" type="checkbox"/> Red:	<input checked="" type="radio"/> Value 2 <input type="radio"/> Bit:			
<input type="checkbox"/> Green:	<input type="radio"/> Value 3 <input type="radio"/> Bit:			
<input checked="" type="checkbox"/> Blue:	<input type="radio"/> Value 4 <input checked="" type="radio"/> Bit: 3:12			
<input type="checkbox"/> Magenta:	<input type="radio"/> Obj Val [5] <input type="radio"/> Bit:			

Graph Sample Interval: * 3 ms

Figure 5 - 2. Graph display selection (single DDC).

A curve can display either an *analog value* or a *bit value*. If you want to display an analog value then you can define the scalings and offsets to be used in the display (the computational formula is presented above the list).

If you want to display a bit value then you must define the bit to be displayed as follows:

`value_number(1...5):bit_number(0...15)`

The scaling and offsets of the bit display are fixed.

Finally, you can define the display interval as a multiple of the DDC communication rate (see *Appendix 1*, parameter **M**). The *Graph Sample Interval* thus expresses whether each actual value transmitted by the DDC is to be displayed (in which case the curve has maximum precision but covers a short time span) or whether the actual values transmitted by the DDC are to be sampled only at certain intervals (in which case the curve is less precise but covers a longer time span).

The descriptions of the actual values to be monitored can be displayed on the screen by using the **Descriptions** button.

When you have done all the definitions you click the **OK** button to start the real-time graphical display (at the left side of the buttons, corresponding to the analog values selected, there will be a # sign). During display, the display interval, the scaling and the number of curves to be displayed can be changed by means of the command **Graph Display (Single DDC)** in the **ActValues** menu.

The display can be stopped by using the **F4** function key (or by selecting the command **Stop/Restart Graph Display** in the **ActValues** menu). The short horizontal broken colour lines at the right-hand edge of the graph display show the values of *Y-offset Bs* (analog graphs) or *0-levels* (bit graphs).

You can continue the display operation by pressing the **F4** function key again.

You can copy the current graph curves to the reference curve memory by means of the command **Copy Curr Graph to Ref** in the **Other** menu (see Chapter *Other Menu / Copy Curr Graph to Ref*).

Automatic Scaling

If you click the **OK (autoscal)** button then all selected analog graphs are autoscaled.

If you clear the *Y-offset A*, *Y-scale* and *Y-offset B* fields in one or more analog graph definitions and then click the "normal" **OK** button then the graphs with the empty scaling fields are autoscaled.

Graph Display (Multiple DDCs)

Graphical monitoring of actual values of a single DDC is described in the previous chapter.

The actual values to be monitored are first defined by means of the **Value1**, **Value2**, **Value3** and **Value4** buttons in each DDC that will be present in the graphical monitoring (see Chapters *Other Menu / Use of Multiple DDCs* and *Using the DDCTool / Value Buttons*).

Next you select the **Graph Display (Multiple DDCs)** command from the **ActValues** menu. The actual values to be monitored graphically are selected from the curve list to be displayed on the screen.

Definition for the Graph Display of Actual Values (Multiple DDCs)

$Y\text{-value} = [\text{ActualValue} - Y\text{-offsetA}] * Y\text{-scale} + Y\text{-offsetB}$

		Y-offset A	Y-scale	Y-offset B
<input checked="" type="checkbox"/> Black:	<input checked="" type="radio"/> Value: <input style="width: 60px;" type="text" value="7:2"/> <input type="radio"/> Bit:	<input style="width: 40px;" type="text" value="-500"/>	<input style="width: 40px;" type="text" value="*3"/>	<input style="width: 40px;" type="text" value="0"/>
<input checked="" type="checkbox"/> Red:	<input checked="" type="radio"/> Value: <input style="width: 60px;" type="text" value="5:4"/> <input type="radio"/> Bit:	<input style="width: 40px;" type="text" value="0"/>	<input style="width: 40px;" type="text" value="/2"/>	<input style="width: 40px;" type="text" value="0"/>
<input type="checkbox"/> Green:	<input type="radio"/> Value: <input type="radio"/> Bit:			
<input checked="" type="checkbox"/> Blue:	<input type="radio"/> Value: <input checked="" type="radio"/> Bit: <input style="width: 60px;" type="text" value="5:2:15"/>			
<input type="checkbox"/> Magenta:	<input type="radio"/> Value: <input type="radio"/> Bit:			

Graph Sample Interval (1...250): * 3 ms

Figure 5 - 3. Defining the multiple DDC values.

A curve can display either an *analog value* or a *bit value*. If you want to display an analog value then you must define the value to be displayed as follows:

`DDC_identifier(1...249):value_number(1...4)`

You can define the scalings and offsets to be used in the display (the computational formula is presented above the list).

If you want to display a bit value then you must define the bit to be displayed as follows:

```
DDC_identifier:value_number:bit_number(0...15)
```

The scaling and offsets of the bit display are fixed.

Finally, you can define the display sample interval as a multiple of 3 ms.

The descriptions of the actual values to be monitored can be displayed on the screen by using the **Descriptions** button.

When you have done all the definitions you click the **OK** button to start the real-time graphical display (all samples that belong to one measurement batch are taken at the same moment in every DDC). The brief definitions of the selected curves are displayed on the STATE line. By pressing the **F9** function key you can see the full definitions (if the text "*Description not found*" is shown it means that you have never selected this DDC as a target DDC after the startup of DDCTool).

If the sample interval time is not long enough during the monitoring then an error message **SAMPLE INTERVAL (n/m ms) TOO SHORT** is displayed on the STATE line (if this happens too often then the monitoring is automatically stopped). If this error message is displayed seldomly then the reason may be an error in the communication between the PC and the DDCs.

The display can be stopped by using the **F4** function key (or by selecting the command **Stop/Restart Graph Display** in the **ActValues** menu). The short horizontal broken colour lines at the right-hand edge of the graph display show the values of *Y-offset Bs* (analog graphs) or *0-levels* (bit graphs).

You can continue the display operation by pressing the **F4** function key again.

You can copy the current graph curves to the reference curve memory by means of the command **Copy Curr Graph to Ref** in the **Other** menu (see Chapter *Other Menu / Copy Curr Graph to Ref*).

Triggering

By using the **Trig** button you can define a triggering condition.

Figure 5 - 4. Definition of a triggering condition.

The *Trig Reference Value* can be either a constant value in the value entry field of the Trig dialog box (if the **Red value** box is not checked) or the current value of the red graph curve (if the **Red value** box is checked).

Trig definition example: Assume that you want to trig if the actual value of **Value1** of DDC 5 is greater than the actual value of **Value3** of DDC 8 minus 100.

First, define the above mentioned **Values** of DDCs 5 and 8. Set *Reference value* = constant 100 in the **Value3** definition of DDC 8.

Then go to **Graph Display (Multiple DDCs)** dialog box and define *Black* curve = Value 5:1 and *Red* curve = Value 8:3. Click the **Trig** button and select *Black value is greater than the Trig Reference value*. Check the **Red value** box and write the desired *Sample Count After Trig* value (1...500 samples). Click **OK** and again **OK** in the graph display dialog box.

Graphical monitoring starts and when the triggering condition is met then the monitoring stops after the delay given above.

Stop/Restart Graph Display

The display can be stopped by using the **F4** function key (or by selecting the command **Stop/Restart Graph Display** in the **ActValues** menu).

You can continue the display operation by pressing the **F4** function key again.

Define Value 1 ... 4

See Chapter *Using the DDCTool / Value Buttons*.

If you define **Value4** = *signal 101-04* (MAIN_STATUS_WORD) or *signal 101-05* (AUX_STATUS_WORD) then the status information from the DDC is shown on the right side of the screen (see Chapter *Using the DDCTool / Status Panel*).

Define Object

See Chapter *Using the DDCTool / Object Button*.

Set Object Value

See Chapter *Using the DDCTool / Changing Values*.

Undo Object Value

See Chapter *Using the DDCTool / Changing Values*.

Show Descriptions

The current definitions of the **Value** and **Object** buttons can be displayed on the screen by using the **F9** function key (or by selecting the command **Show Descriptions** in the **ActValues** menu).

If the graph display (multiple DDC) or value recording is on then the **F9** function key displays the definitions of the selected graph or record items.

If the text "*Description not found*" is shown it means that you have never selected this DDC as a target DDC after the startup of DDCTool.

Define Step A and Step B

For the purpose of measuring step responses, you can define two step buttons (**Step A** and **Step B**) by means of the commands **Define Step A** and **Define Step B** in the **ActValues** menu.

Definition for Step A

Step Signal: 408

Signal Value After Step: 100

Sample Count After Step (1...500): 400 (optional)

Show Ref Graph After Step Stop

Figure 5 - 5. Definition of step A.

Definition for Step B

Step Signal: 408

Signal Value After Step: 0

Restart Graph Display

Figure 5 - 6. Definition of step B.

The step buttons are visible only after the definition has been made. The **Step A** button is generally used for making the actual step (positive or negative), whereas the **Step B** button is used to restore the changed value back to its initial state so that a new step can be made.

Before making a step, you must start the graphical monitoring of the desired actual values. If you check the box **Restart Graph Display** in the **Define Step B** dialog box then the monitoring starts automatically every time when you click the **Step B** button.

When a step has been made, the graphical display can be stopped manually by means of the **F4** function key. If you set the value of the optional *Sample Count After Step* field in the **Define Step A** dialog box then the graphical display stops automatically at the desired point (in this case you must define **Value1** so that the value to be monitored is the same as the step signal and the reference value is zero).

If you check the box **Show Ref Graph After Step Stop** in the **Define Step A** dialog box then the reference curves (if you have defined them) are automatically shown on the screen after the graphical display has stopped (you cannot use this check box if the *Sample Count After Step* field is empty).

You can remove a previously defined **Step** button from the screen by clearing the **Step Signal** field in the step definition dialog box of the **Step** button before clicking the **OK** button of the dialog box.

Start Value Recorder

The actual values to be recorded are first defined by means of the **Value1**, **Value2**, **Value3** and **Value4** buttons in each DDC that will be present in the recording (see Chapters *Other Menu / Use of Multiple DDCs* and *Using the DDCTool / Value Buttons*).

Next you select the **Start Value Recorder** command from the **ActValues** menu.

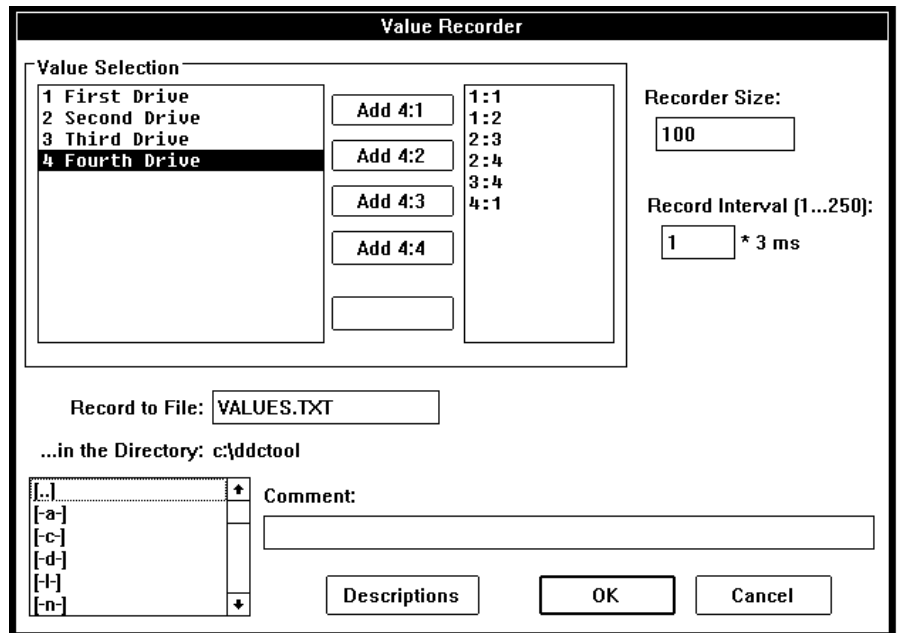

Figure 5 - 7. In the Value Recorder dialog box value(s), to be recorded, are defined.

This brings up on the screen a dialog box by means of which you can carry out the following definitions:

- identifiers of the actual values to be recorded (max. 250 identifiers). A new identifier is added to the identifier list by means of the **Add** buttons and the identifier selected from the list is removed by means of the **Remove** button.
- number of sample batches that can be in the file (Recorder Size). The max size depends on the size of your free disk space.
- record (sample) interval (multiple of 3 ms)
- filename (extension is .TXT) and directory

The descriptions of the actual values to be recorded can be displayed on the screen by using the **Descriptions** button.

Recording starts when you click the **OK** button (if there are multiple DDCs connected to the PC then all samples that belong to one sample batch are taken at the same moment in every DDC). By pressing the **F9** function key you can see the definitions of the selected record items (if the text "*Description not found*" is shown it means that you have never selected this DDC as a target DDC after the startup of DDCTool).

If the record interval time is not long enough during the recording then an error message **SAMPLE INTERVAL (n/m ms) TOO SHORT** is displayed on the STATE line (if this happens too often then the recording is automatically stopped). If this error message is displayed seldomly then the reason may be an error in the communication between the PC and the DDCs.

If there is only one DDC and the value of the startup parameter **M** is 1 (see *Appendix 1*) then the actual values of **Value1...4** are displayed at the right sides of the **Value** buttons during the record. Otherwise, the actual value of the *first* item to be recorded is displayed at the right side of the **ObjVal** button during the record.

The recording format is the same as in the *Excel* program (sample value lines are separated by NewLine characters and sample values in a sample value line are separated by Tab characters). The last sample value line is always at the end of the file. When the record file becomes full, then the oldest sample value line will be removed in order to make room for the new sample value line.

Stop Recorder

The recording can be stopped by pressing the **F8** function key (or by selecting the **Stop Recorder** command from the **ActValues** menu).

Chapter 6 – Params Menu



Figure 6 - 1. Pull-down menu for Params. Note that some menu commands may be inactive if it is not possible to use them in the current situation.

Processing the Parameters (Immediate update)

Use of the command **Parameters (Immediate Update)** in the **Params** menu brings up on the screen a dialog box (if graphical monitoring of the actual values is running, it must first be stopped by pressing the **F4** function key).

The screenshot shows the 'Parameters' dialog box. At the top, there is a 'Comment:' field with the value 'xx'. Below this is a table with columns: ID, Description, Actual, Min, Max, Init, and Type. The table is divided into two groups: 'Parameter Group 2' and 'Parameter Group 4'. Below the table is a 'Value edit [ON-LINE]' section with a text input field for 'New value (0...10000):' containing the value '500'. To the right of this field are buttons for 'OK', 'Next group', 'Undo (F12)', and 'Previous group'. At the bottom of the dialog are several buttons: 'File Open', 'File Save', 'Compare', 'Print', 'Done', 'Upload', 'Download', and 'Version Update'.

ID	Description	Actual	Min	Max	Init	Type
Parameter Group 2:						
2-01:	Acceleration time	1	1	30000	200	I2
2-02:	Decelaration time	20	1	30000	200	I2
2-03:	Speed softening time	0	0	20000	0	I2
Parameter Group 4:						
4-01:	Proportional gain 2	0	0	32000	1000	I2
4-02:	Integrat.time const.	50	0	32000	5000	I2
4-03:	Proportional gain 1	123	0	32000	0	I2 *
4-04:	KPS switching point	0	0	10000	0	I2
4-05:	TC of KPS filter	500	0	10000	500	I2
4-06:	TC:speed diff filter	0	0	1000	0	I2
4-07:	Drooping	0	0	4000	0	I2
4-08:	Width of the Window	0	0	20000	0	I2

Figure 6 - 2. Parameter dialog box. The text ON-LINE indicates that all value changes you make are immediately transmitted to the DDC.

The parameter list of the dialog box has the following columns:

ID	Identification number of the parameter
Description	Description text of the parameter
Actual	Actual value (you can change this)
Min	Minimum value
Max	Maximum value
Init	Default value
Type	Data type: <i>I2</i> = 16 bit signed integer <i>PB</i> = packed Boolean value (16 bits) <i>U2</i> = 16 bit unsigned integer
*	Actual value has been changed after upload or after file open

You can select a parameter from the parameter list by means of the **Up** and **Down** arrow keys and/or the mouse. By means of the **New value** data entry field and the **OK** button (or the **Enter** key) you can change the value of the selected parameter (an asterisk will be displayed after changed parameters). This change is immediately transmitted to the DDC. You can restore the previous value back if you click the **Undo** button (or press the **F12** function key) as the first operation after value change.

Sequential changes: You can change values of sequential parameters in the ascending order as follows:

- select the first parameter you want to change
- press the Caps Lock key down and hold it down
- write the new value of the selected parameter and press the Enter key. Now the value of the selected parameter changes and the selection moves automatically to the next parameter.
- continue by writing the new value of the selected parameter and pressing the Enter key until all changes have been made (you can skip parameters that you do not want to change by pressing the Enter key without writing the new value).
- release the Caps Lock key

By means of the **File Open** button you can read a parameter file that has previously been saved (see below) and display the parameters in the parameter list of the dialog box.

By means of the **Upload** button you can upload all the DDC parameters and display them in the parameter list of the dialog box.

By means of the **File Save** button you can save the parameter list of the dialog box to a disk file (extension must be .QDP). On the *Comment* line you can write, for example, the customer's name, the application, etc.

By means of the **Download** button you can set all the DDC parameters to the values specified in the parameter list of the dialog box.

By means of the **Compare** button you can compare the current parameter list of the dialog box with another parameter list (saved by the **File Save** button).

By means of the **Version Update** button you can convert an old parameter list file into a new format when the parameter version number in the DDC firmware has changed. The procedure is as follows:

- Upload parameters (click the **Upload** button) from the new firmware or open a parameter list file (click the **File Open** button) that you have uploaded from the new firmware.
- Click the **Version Update** button and select a parameter list file that you have uploaded from the old firmware. After your selection the DDCTool scans the new parameter list on the screen and if it finds a parameter that is in the selected old file then the DDCTool copies the actual value of that parameter from the disk file to the the screen list. An asterisk (*) is displayed after every modified parameter on the screen.
- When all parameters have been processed the DDCTool displays a list of all modified parameters. This list can be printed or saved to disk.
- Now you can download and/or save the updated parameter list (check the correctness of the list before you do this!)

It is also possible to convert a new parameter list file into an old format (simply change the words "new" and "old" in the previous procedure).

By means of the **Print** button you can print the current parameter list (if you have a printer connected to your PC).

***Processing the
Parameters (No
immediate update)***

Use of the command **Parameters (No Immediate Update)** in the **Params** menu brings up on the screen a dialog box by means of which you can execute the same operations as in the previous chapter. The only difference is that now a change made in the parameter list (by the **New Value** data entry field and the **OK** button) is not transmitted to the DDC.

Chapter 7 – Diagrams Menu

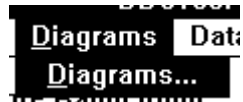

Figure 7 - 1. Pull-down menu for Diagrams. Note that the menu command may be inactive if it is not possible to use it in the current situation.

Diagrams

A diagram is usually a schematic representation of the target DDC software but in general diagrams can contain any graphical line and text information. Diagrams are stored on the disk as diagram files (filename extension is .QDD).

Use of the command **Diagrams** in the **Diagrams** menu brings up on the screen a *Diagram* window with menu commands of its own (if graphical monitoring of the actual values is running, it must first be stopped by pressing the **F4** function key):

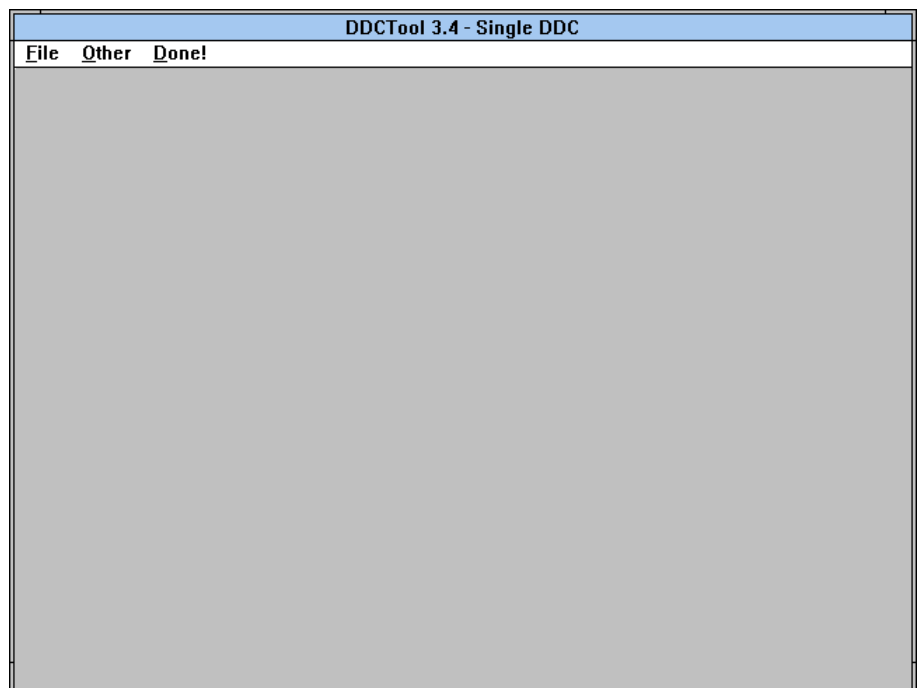

Figure 7 - 2. Diagram window.

Diagram Window

By means of the **Open Diagrams** command in the **File** menu of the *Diagram* window you read a diagram file.

One diagram file includes usually several separate diagram sheets and you can select the diagram sheet you want to see on the screen by the commands in the **Other** menu of the *Diagram* window (or by pressing the CTRL key and either the right or the left arrow key).

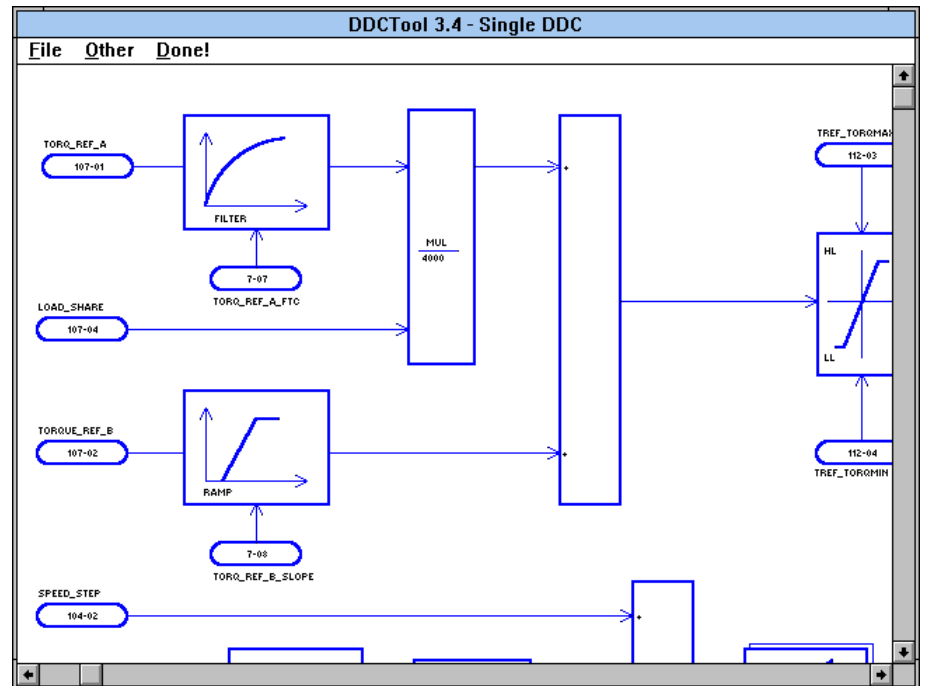

Figure 7 - 3. A schematic diagram in the Diagram window.

Mouse functions in the *Diagram* window work as follows:

- if you press the CTRL key and click on a line that is connected to a parameter/signal then the actual value of this parameter/signal is shown on the screen in real time. If you do this when the cursor is not on a parameter/signal line (or there are no such lines at all in the diagram) then you can define any parameter/signal you want to monitor in the click position. If you press the F10 function key then you can see in the diagram the indices of the parameters/signals you have defined (press F10 again to restore the normal display state). By means of the Save Diagrams As command in the File menu of the Diagram window you can save the current diagram file with the display definitions you have made.
- if you click on a previously defined actual value display (see above) then you see the information box of this parameter/signal and you can change its value (or display format) ON-LINE. If you click somewhere else on the screen (or press the F11 function key) then the diagram is minimized so that it is totally visible. If you click anywhere on a minimized diagram then the diagram is restored to its normal size and the click position is in the center of the screen.
- If you press the SHIFT key and click on a previously defined actual value display then this display disappears from the screen.

By clicking on the **Done!** menu command of the *Diagram* window you can hide this window.

Chapter 8 – DataLogger Menu

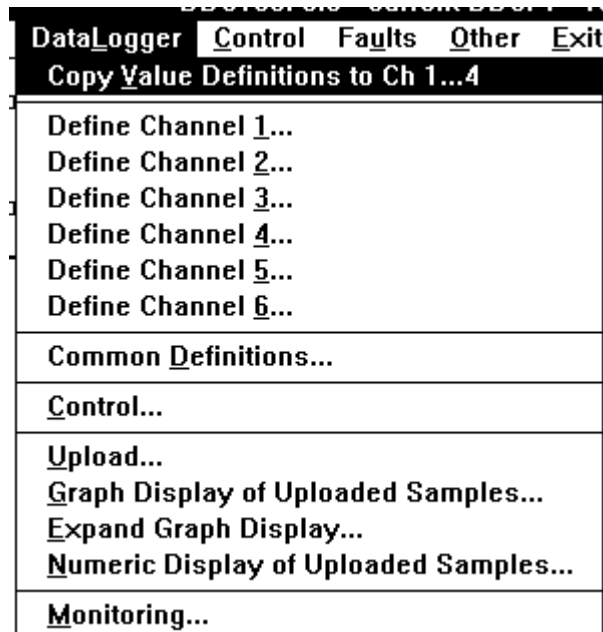

Figure 8 - 1. Pull-down menu for DataLogger. Note that some menu commands may be inactive if it is not possible to use them in the current situation.

Use of the Data Logger

The data logger resides in the DDC. You can control its operation and upload its contents by the DDCTool program.

Data logger has six logging channels. The maximum number of sample values in one channel is 1000.

Copy Value Definitions to Ch 1 ... 4

Command **Copy Value Definitions to Ch 1...4** in the **DataLogger** menu copies the signal and scaling definitions of *Values 1...4* to data logger channels 1...4 (see Chapter *Using the DDCTool / Value Buttons* and Chapter *ActValues Menu / Graph Display (Single DDC)*).

Define Channel 1 ... 6

A data logger channel is defined by means of a command **Define Channel 1 ... Define Channel 6** in the **DataLogger** menu.

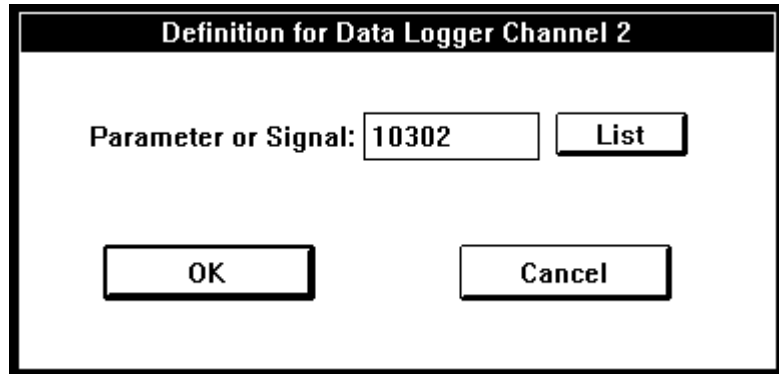

Definition for Data Logger Channel 2

Parameter or Signal:

Figure 8 - 2. Definition of a data logger channel.

Common Definitions

Command **Common Definitions** in the **DataLogger** menu is used to set the data logger's common definitions: *triggering condition, triggering condition's reference value, number of samples to be collected after triggering and sampling interval.*

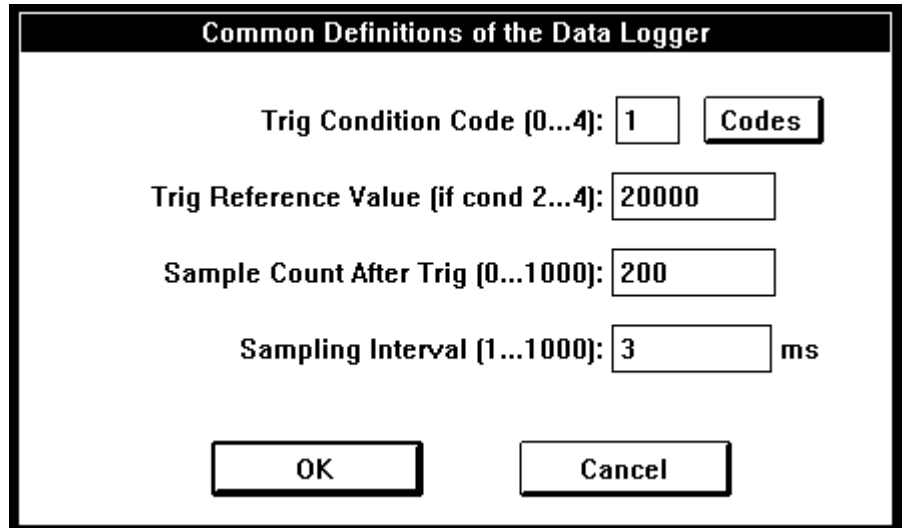

Common Definitions of the Data Logger

Trig Condition Code (0...4):

Trig Reference Value (if cond 2...4):

Sample Count After Trig (0...1000):

Sampling Interval (1...1000): ms

Figure 8 - 3. Common definitions of the data logger.

With the **Codes** button you can select the trig condition code.

Control

The data logger is controlled by means of the command **Control** in the **DataLogger** menu. A dialog box will appear which displays the data logger's status and the buttons corresponding to possible control functions in the given situation.

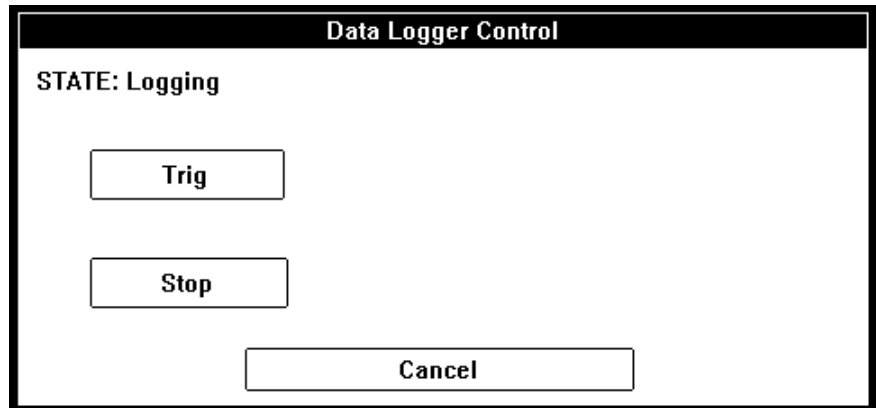

Figure 8 - 4. Control dialog box when the data logger is logging.

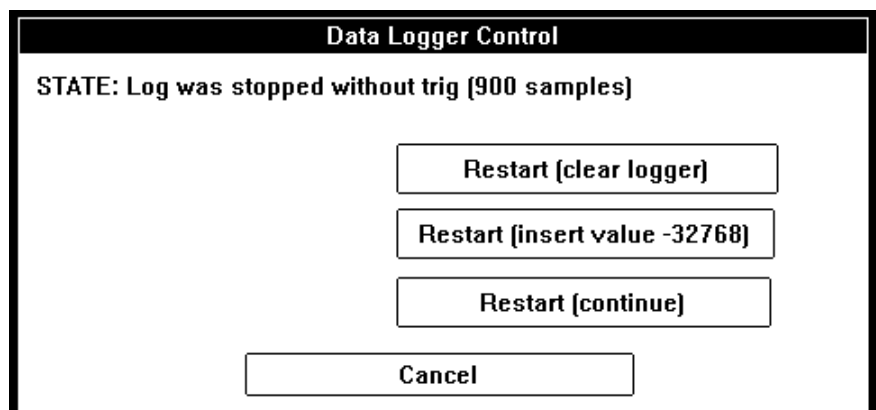

Figure 8 - 5. Control dialog box when the data logger is not logging.

Click the button corresponding to the desired function (or the **Cancel** button if you only want to find out the data logger's status and you do not wish to carry out any control action).

Upload

When the logging has stopped, the sample values logged to the data logger channels are uploaded from the DDC by means of the command **Upload** in the **DataLogger** menu (if graphical monitoring of the actual values is in progress, it must first be stopped with the **F4** function key).

Definition for the Graph Display of New Samples

$Y\text{-value} = [\text{SampleValue} - Y\text{-offsetA}] * Y\text{-scale} + Y\text{-offsetB}$

	Y-offset A	Y-scale	Y-offset B
<input checked="" type="checkbox"/> Ch 1 = 103-01 Acceleration compens	0	*1	0
<input checked="" type="checkbox"/> Ch 2 = 103-02 Torque reference 1			
<input type="checkbox"/> Ch 3 = 103-12 Speed reference 4			
<input checked="" type="checkbox"/> Ch 4 = 103-11 Speed reference 3	1000	/20	0
<input type="checkbox"/> Ch 5 = 103-06 Torque reference 5			
<input type="checkbox"/> Ch 6 = 103-03 Torque reference 2			

Figure 8 - 6. Upload of the data logger sample values.

The sample values to be displayed graphically are selected from a list that is displayed on the screen. When the selection is made, you must define the scalings and offsets to be used in the display (the computational formula is presented above the list).

Finally, click the **OK** button, whereupon the program uploads the logged values from the DDC and displays them graphically (since there are only 500 pixels in the display area and there are 1000 sample values, the average value of two adjacent sample values is displayed in one pixel).

The time scale is displayed below the X axis in such a way that the 0 point is at the triggering point (or at the right-hand edge if no triggering has taken place). The short horizontal broken colour lines at the right-hand edge of the graph display show the values of *Y-offset Bs*.

Automatic Scaling

If you click the **OK (autoscal)** button then all selected channels are autoscaled.

If you clear the *Y-offset A*, *Y-scale* and *Y-offset B* fields in one or more channels and then click the "normal" **OK** button then the channels with the empty scaling fields are autoscaled.

Graph Display of Uploaded Samples

By means of the command **Graph Display of Uploaded Samples** in the **DataLogger** menu the scaling and offset values of the uploaded samples can be changed if needed.

You can copy the current graph curves of the uploaded data logger sample values to the reference curve memory by means of the command **Copy Curr Graph to Ref** in the **Other** menu (see Chapter *Other Menu / Copy Curr Graph to Ref*).

Expand Graph Display

The sample value curves can be expanded horizontally by clicking in the graph area at the X-point you want to expand (during the expansion, the expansion point remains where it is on the screen). With each click the curves expand to double their previous size until they have expanded 64-fold compared with their initial size (with each click the expansion point can be located in a different place). If a mouse is not in use, the same function can be performed by means of the **Expand Graph Display** command in the **DataLogger** menu.

An expanded display can be restored to normal size by clicking the mouse's *right-hand* button anywhere in the graph area. If a mouse is not available, the same function can be performed by means of the **Expand Graph Display** command in the **DataLogger** menu.

NOTE: When the expansion is in effect then the graph shown is based on actual sample values (instead of the average value of two adjacent sample values).

Numeric Display of Uploaded Samples

The uploaded sample values can also be displayed in numerical form by means of the command **Numeric Display of Uploaded Samples** in the **DataLogger** menu.

Numeric Display of Uploaded Data Logger Samples						
Position:	Ch 1	Ch 2	Ch 3	Ch 4	Ch 5	Ch 6
488:	-8800	-8800	---	-8800	---	-8800
489:	-8900	-8900	---	-8900	---	-8900
490:	-9000	-9000	---	-9000	---	-9000
491:	-9100	-9100	---	-9100	---	-9100
492:	-9200	-9200	---	-9200	---	-9200
493:	-9300	-9300	---	-9300	---	-9300
494:	-9400	-9400	---	-9400	---	-9400
495:	-9500	-9500	---	-9500	---	-9500
496:	-9600	-9600	---	-9600	---	-9600
497:	-9700	-9700	---	-9700	---	-9700
498:	-9800	-9800	---	-9800	---	-9800
499:	-9900	-9900	---	-9900	---	-9900
Triqq:	-10000	-10000	---	-10000	---	-10000
501:	-120	-120	---	-120	---	-120
502:	-240	-240	---	-240	---	-240
503:	-360	-360	---	-360	---	-360
504:	-480	-480	---	-480	---	-480
505:	-600	-600	---	-600	---	-600
506:	-720	-720	---	-720	---	-720
507:	-840	-840	---	-840	---	-840

Comment:

Figure 8 - 7. Numeric display of the uploaded data logger samples.

By means of the **Print** button you can print the sample values (if you have a printer connected to your PC).

By means of the **FileSave** button you can save the sample values to a disk file (extension is .TXT). The save format is the same as in the *Excel* program (sample value lines are separated by NewLine characters and sample values in a sample value line are separated by Tab characters).

You quit the displaying of the numeric values by clicking the **Done** button.

Monitoring (ACV 700 only)

Command **Monitoring** in the **DataLogger** menu (available only with ACV 700 version 60M or later) brings up on the screen a dialog box.

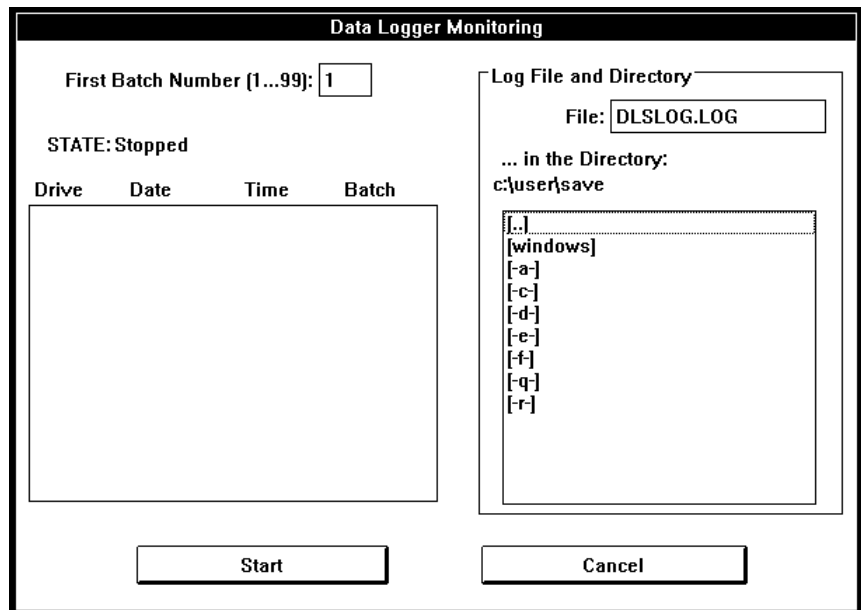

Figure 8 - 8. Start of the data logger monitoring operation (ACV 700 only).

Now you can select the number of the first sample file batch (1...99) and the name and directory of the log file (all sample files will be written to this directory, too).

When you click the **Start** button then DDCTool continuously polls data logger statuses of all connected DDCs (one or more).

WARNING! *If there are only a few DDCs connected to the DDCTool then this polling may increase processor load of these DDCs too much. Load increase in a DDC is (approx.) = $10 / n$ %, where n = number of DDCs.*

After start the text on the **Cancel** button is changed to **Stop**.

On the STATE line the current monitoring status information is displayed.

If a data logger in one of the DDCs has been triggered then DDCTool:

- triggers data loggers in all other DDCs.
- uploads all collected data logger samples from all DDCs to disk files. The name format of a sample file is:

DL**S**bbddd . TXT

where **bb** is the batch number 01...99 and **ddd** is a DDC ID number 001...249 (or 250 if single DDC). The save format of samples is the same as in the Excel program (sample value lines are separated by NewLine characters and sample values in a sample value line are separated by Tab characters).

If a sample file batch with this batch number already exists on the disk then the sample files of this batch are overwritten.

If the disk becomes full then the sample files of the oldest file batch are removed from the disk before the new sample files are written.

- writes log information (ID of the DDC that has been triggered, date, time and batch number) to the log list on the screen and to the user-specified log file.
- increments the batch number (after number 99 comes number 1).
- waits until the triggering condition is off in the DDC that has been triggered at the beginning of this sequence (no wait if the condition is now on but it has been in the off state for a while after the beginning of this sequence).
- clears and restarts data loggers of all DDCs.
- restarts the polling of data logger statuses of all DDCs.

This monitoring mode is on until you stop it by means of the **Stop** button.

Chapter 9 – Control Menu



Figure 9 - 1. Pull-down menu for Control. Note that the menu command may be inactive if it is not possible to use it in the current situation.

Local/Remote Control

Select the command **Local/Remote Control** from the **Control** menu. The control window appears on the screen.

You can move back from the control window to the main window, and the control window will remain visible on the screen. If you wish to hide the control window, click the **Done** button.

Local Control

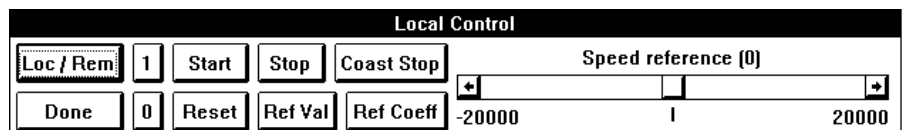

Figure 9 - 2. Local control (buttons **1** and **0** are only with DC drives).

By means of the **Loc/Rem** button you switch from local control to remote control.

By means of the **1** button you switch the main controller ON (DC drives only).

By means of the **0** button you switch the main controller OFF (DC drives only).

By means of the **Start** button you start the DDC.

By means of the **Stop** button you bring the DDC down as it is programmed.

By means of the **CoastStop** button you stop the DDC immediately (stops modulation in AC; blocks firing pulses in DC).

By means of the **Reset** button you reset DDC faults.

By means of the **RefVal** button you set the DDC's speed reference value.

By means of the **SpeedReference** scroll bar you change the DDC's speed reference value. The speed reference is changed by pressing the control's left or right-hand button. The speed of change increases the longer the button is held down.

The change increment size of the speed reference can be set by means of the **RefCoeff** button (the initial increment size is 100). It is also possible to change the speed reference value by dragging the thumb with the mouse.

WARNING! *If the DDCTool is stopped while in the local mode, the drive will be without any control.*

If an ACV 700 drive is stopped in local mode the drive does not notice it but continues to do what it was doing.

Remote Control

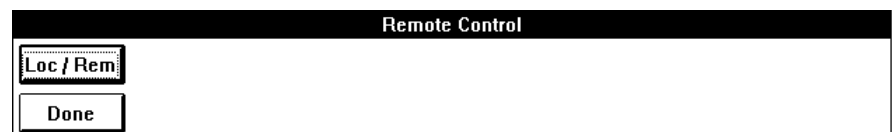

Figure 9 - 3. Remote control.

By means of the **Loc/Rem** button you switch from remote control to local control.

Chapter 10 – Faults Menu



Figure 10 - 1. Pull-down menu for Faults. Note that some menu commands may be inactive if it is not possible to use them in the current situation.

Reading the Last DDC Fault/Alarm Code

By means of the command **Read Last Fault/Alarm Codes** in the **Faults** menu, you can read the fault/alarm code corresponding to the last fault/alarm situation that has occurred in the DDC (if the fault/alarm has already disappeared a copy of the fault/alarm code is stored in the DDC). The read operation removes the fault/alarm code's copy if the fault/alarm situation has already disappeared.

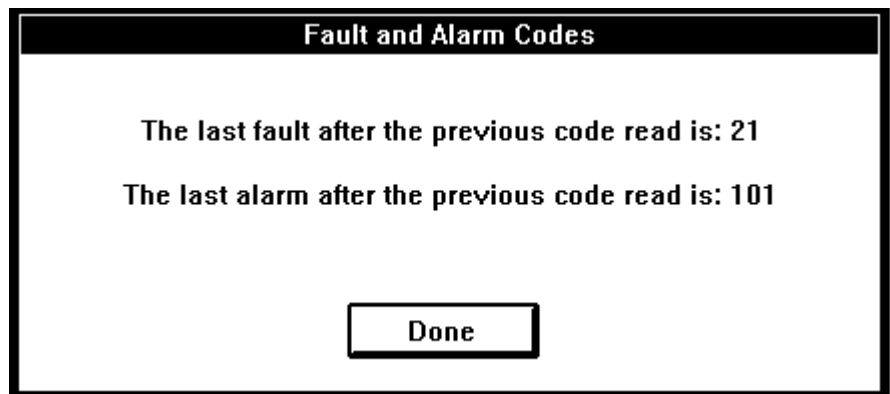

Figure 10 - 2. Latest fault and alarm codes.

Uploading/clearing the Fault Logger

If the graphic monitoring of the actual values is running, it must first be stopped with the **F4** function key before you can do the upload. By means of the command **Upload Fault Logger** in the **Faults** menu, you can read the content of the DDC's fault logger (a maximum of the 100 latest faults, alarms or events). When the entire content has been read, above the fault list will appear the DDC's date and the clock time at the instant of the last fault uploaded. In the Fault Logger the date, time of the fault, the fault code and the description of it are in the faults list; latest fault on top.

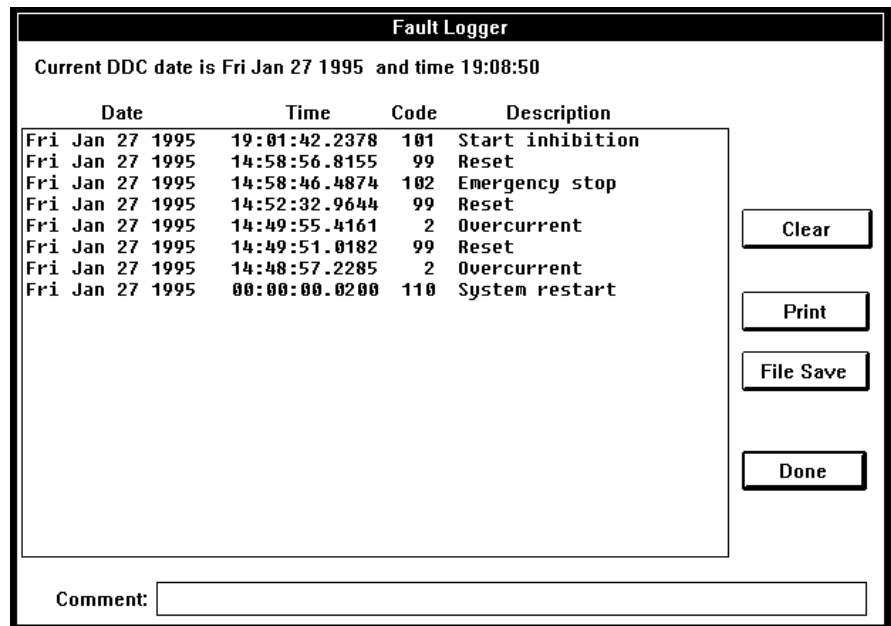

Figure 10 - 3. Fault Logger shows last 100 faults, alarms or events.

If the time of DDC has not been set (see Chapter *Other Menu / Set DDC Time*) or the APC board has not been connected to the DDC, times and dates in the Fault Logger can be invalid.

The codes can be found in
 ACV 700: *Firmware 1.0* (code 58054399),
 ACV 700: *Service Instruction* (code 58054499),
 DCV 700: *Software Description 1.0* (code 61101446) and
 DCF 500/700 manuals.

Example: Codes under 99 are faults, code 99 is a reset and codes over 100 are alarms. Some of the codes are events e.g. 110 is a system restart. The outgoing alarm code has a minus (-) sign in front of it.

By means of the **Print** button you can print the content of the fault logger (if you have a printer connected to your PC).

By means of the **FileSave** button you can save the content of the fault logger to a disk file.

By means of the **Clear** button you can clear the content of the fault logger.

After you wish to leave the fault logger dialog box click the **Done** button

Chapter 11 – Other Menu

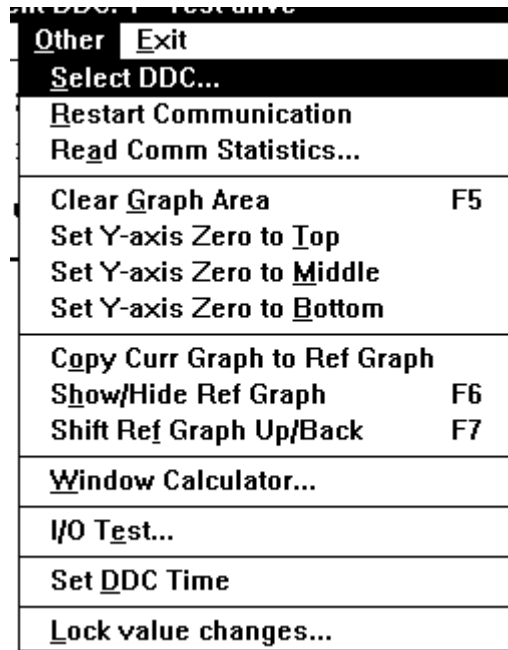

Figure 11 - 1. Pull-down menu for Other. Note that some menu commands may be inactive if it is not possible to use them in the current situation.

Use of Multiple DDCs

If the file DDCLIST.TXT (see Chapter *Installation of the DDCTool / Creation of the DDCLIST.TXT file*) is missing then the text *Single DDC* is displayed at the top of the screen and the multi-DDC functions are not available.

If the DDCLIST.TXT file exists when you start the DDCTool program then the first DDC in the DDCLIST.TXT file will be automatically the target DDC. The identifier of the current target DDC is displayed on the top of the screen and the DDC selection tabs are displayed at the bottom of the screen.

The ? tab at the bottom of the screen (or the command **Select DDC** in the **Other** menu) brings up on the screen a DDC list. From this list you can select (either with a double click of the mouse or by pressing the space bar) the DDC that will be the target for the DDCTool functions.

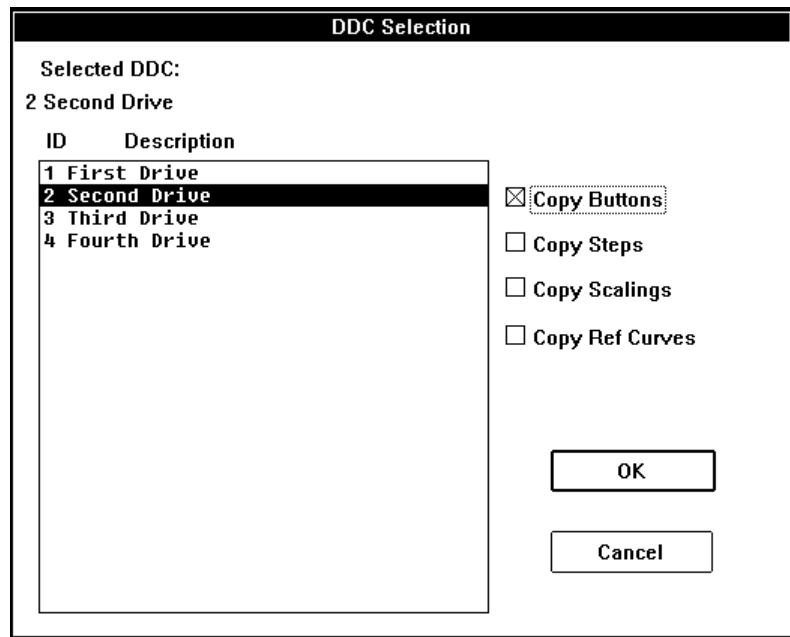

Figure 11 - 2. Selection of the target DDC.

Every DDC has a measurement configuration of its own and the DDCTool program holds the configuration of a DDC in its memory when the DDC is not visible on the screen. When you select a new DDC then you can copy the desired configuration definitions of the current target DDC to the new target DDC as follows:

- by checking the box **Copy Buttons** at the right side of the DDC list, the definitions of the **Object** and **Value** buttons are copied to the new DDC
- by checking the box **Copy Steps** the definitions of the **Step** buttons are copied to the new DDC
- by checking the box **Copy Scalings** the definitions of the scalings and offsets of graph displays are copied to the new DDC
- by checking the box **Copy Ref Curves** the reference graph curves are copied to the new DDC

Restart Communication with the DDC

The DDC communication link can be restarted following a break in the link by means of the command **Restart Communication** in the **Other** menu.

Read the DDC Communication Statistics

By means of the command **Read Comm Statistics** in the **Other** menu you can see the number of communication errors.

Clear Graph Area

You can, if needed, remove the *stopped* graphical display from the screen with the **F5** function key (or by selecting the command **Clear Graph Area** in the **Other** menu).

Set Y-axis Zero to...

The height of the graphical display area is 300 pixels, and it is divided into six parts by broken lines. By means of the **Set Y-axis Zero to...** commands in the **Other** menu the zero point on the Y axis can be set to the *top* of the area, to the *middle*, or to the *bottom*. By scaling the display curves can be placed inside the area in the Y direction. You can use these commands only if the graph area is empty.

Copy Curr Graph to Ref

You can copy the current (stopped) graph curves (*actual values* or *data logger samples*) to the reference curve memory by means of the **Copy Curr Graph to Ref** command in the **Other** menu (in addition to this you can copy the graph curves from a saved disk file to the reference curve memory, see Chapter *File Menu / Open Graph*). Each copy replaces the previously copied reference curves.

Show/Hide Ref Graph

You can show (or hide) the reference curves on the screen with the **F6** function key (or by means of the **Show/Hide Ref Graph** command in the **Other** menu). The display of the reference curves is impossible if the current X- and Y-axis values *are not the same* as they were when the graph curves were copied to the reference curve memory.

Ref Graph Shift

If normal curves hide the reference curves, then you can temporarily raise the reference curves higher with the **F7** function key (or by means of the **Ref Graph Shift** command in the **Other** menu).

Window Calculator

The window calculator is started by means of the command **Window Calculator** in the **Other** menu.

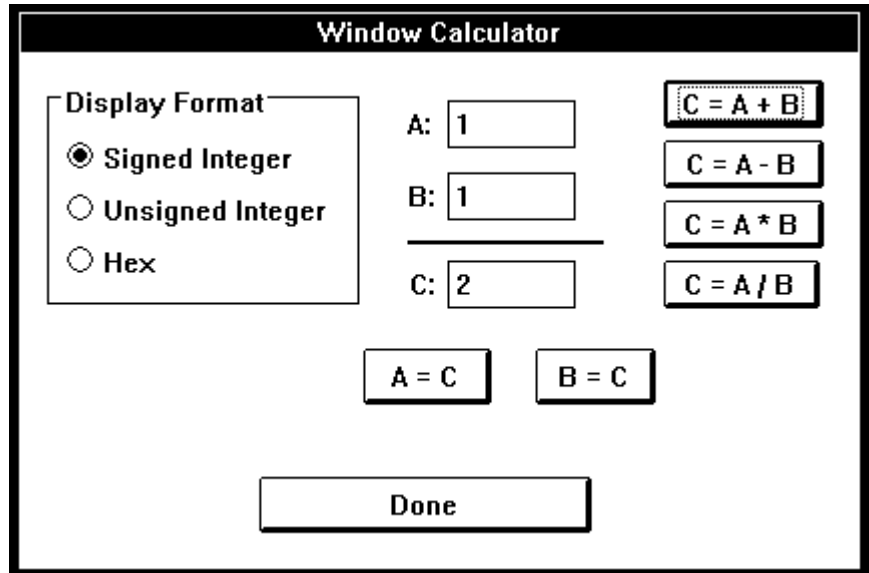

Figure 11 - 3. Window calculator.

The calculator allows you to carry out addition, subtraction, multiplication and division with signed integers, unsigned integers and hex numbers. You can also use the calculator to carry out conversions between the different forms of numbers.

When you no longer need to use the calculator, click the **Done** button.

Set DDC Time

The command **Set DDC Time** in the **Other** menu copies the date and time of the PC to the date and time of the DDC.

NOTE: If an APC is connected to the DDC, it will send date and time every two seconds to the DDC and this overrides the date and time sent by DDCTool.

Lock Value Changes

By means of the command **Lock Value Changes** in the **Other** menu you can prevent all changes of DDC values by the DDCTool program.

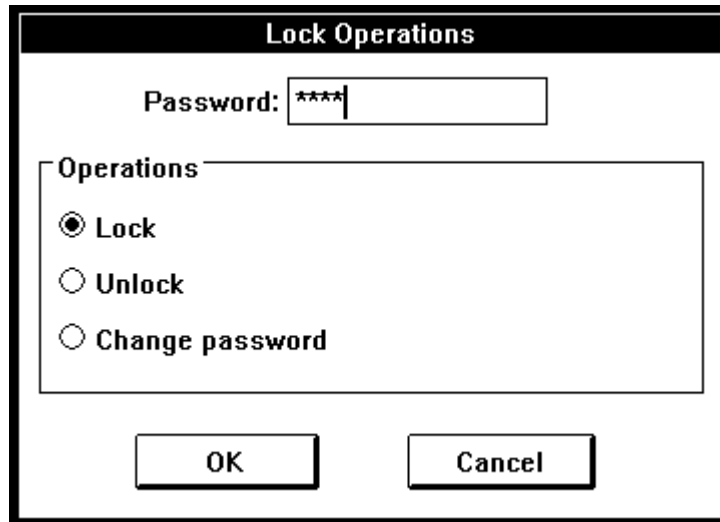

Figure 11 - 4. Lock operations.

When the dialog box appears, write the current password.

If you want to lock/unlock then click the **OK** button (or press the **Enter** key).

If you want to change your password then select *Change password*, write your new password and click the **OK** button. Password length must be 4...8 characters, passwords are case-insensitive.

Remember your new password because you cannot lock/unlock without it!

The default password after the installation of the DDCTool program is *DDCTOOL*. You must change this before you can use the lock.

I/O Test (ACV 700 only)

Use of the command **I/O Test** in the **Other** menu brings up on the screen a dialog box where the values of the analog and digital inputs and outputs of the DDC are displayed (if the graphic monitoring of the actual values is running, it must first be stopped with the **F4** function key).

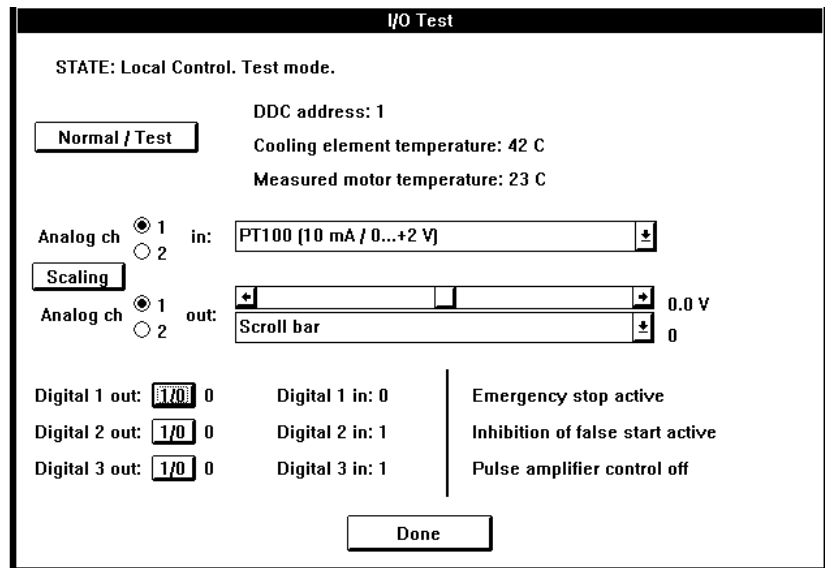

Figure 11 - 5. I/O test dialog box (ACV 700 only).

By means of the **Normal/Test** button you can start the test mode. In this mode you can change state of the analog and digital outputs by the controls in the dialog box. By clicking the **Normal/Test** button again you return to the normal mode.

By means of the **Scaling** button you can set the maximum and minimum values used in the scaling of the analog channels.

Finally, click the **Done** button.

Chapter 12 – Exit Menu



Figure 12 - 1. Pull-down menu for Exit.

Exit

The **Exit** command in the **Exit** menu is used to stop the program. If desired, the current configuration settings of the DDCTool can be copied into a CONFIG.QDC file in the DDCTOOL directory.

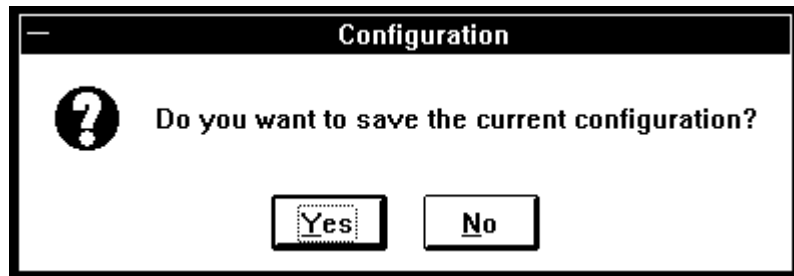

Figure 12 - 2. You can save the current configuration when you exit.

You can stop and restart the DDCTool program (and PC) without stopping the DDC when the DDC is running in the remote control mode.

WARNING! If the DDCTool is stopped while in the local mode, the drive will be without any control.

If an ACV 700 drive is stopped in local mode the drive does not notice it but continues to do what it was doing.

If the DDC is in local mode, DDCTool wants to know if it is really your intention to exit the program because the DDC(s) then has no control.

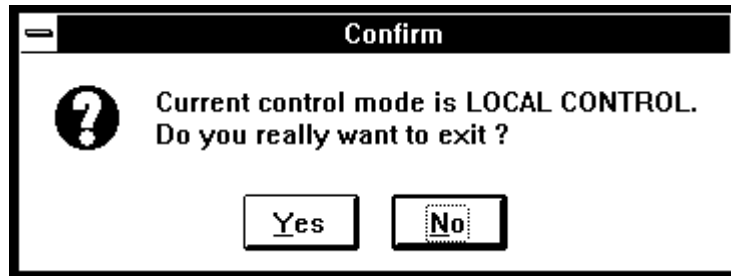

Figure 12 - 3. If you exit the DDCTool while in the local mode the DDC has no control.

Startup Parameters

By startup parameters you can customize your copy of the DDCTool program.

Startup parameters are in the *Target* line of the *Properties* definition of the **DDCTool** text in the **Start** menu.

You set/change values of startup parameters as follows:

- stop DDCTool (if it is running)
- right-click the **DDCTool** text (**Start -> Programs -> DriveWare -> DDCTool**)
- click *Properties*
- add the required startup parameters to the end of the *Target* line as follows :

`"path\DDCTOOL.EXE" /Xnnn /Ymmm . . .`

where **x** and **y** are identifier letters of the startup parameters (see below) and **nnn** and **mmm** are the values to be assigned to these parameters.

- click the **OK** button
- start DDCTool

PARAM

MEANING AND VALUES

M

The message transmit interval (in 3 ms multiples) of the values transmitted by the DDC.

The *permissible values* are 1 ... 250.

The *default* is 1 (= 3 ms).

If e.g. the parameter/signal upload in your PC does not work (*PC OVERLOAD* error is displayed) with the default value of this startup parameter then you must increase the value of **M** until the DDC communication works without problems.

Example: **/M2**

C

The light intensity of the optical cable.

The *permissible values* are 1 (min) ... 15 (max).

The *default* is 10.

Example: **/C7**

PARAM**MEANING AND VALUES**

- L** Language selection.
- The *default* is EN (English).
- Texts for other languages are implemented as separate *DDCTLNXX.DLL* files (where *XX* represents the first two letters of a language name, e.g. *FI*). You must copy the desired DLL files to your DDCTool directory before you can use this startup parameter. The parameter **L** is followed by the two characters that replaces characters *XX* in the actual DLL filename.
- Example: **/LFI**
-
- F** Upload mode of parameters, signals and faults (ACV 700 only).
- The *permissible values* are 0 (fast) and 1 (slow).
- The *default* is 0.
- The value of this parameter must be 1 if the version of your ACV 700 is older than 60A.
- Example: **/F1**

Error Messages

If you make a mistake when you use the DDCTool then the program displays an error message box. These error messages are self-explanatory.

On the STATE line of the main window there can be one of the following error messages:

- **SAMPLE INTERVAL (n/m ms) IS TOO SHORT.**
You specified a shorter sample interval than it is possible to use because of communication timing limitations (see Chapter *ActValues Menu / Graph Display (Multiple DDCs)* or Chapter *ActValues Menu / Start Value Recorder*). Value **n** is the shortest possible sample interval and value **m** is the interval you specified.
- **PC OVERLOAD (text).**
Your PC is so slow (or some other simultaneously running program causes a high processor load) that it cannot receive all the messages the DDC is transmitting.
If graphical monitoring or file recording of actual values (multiple DDCs) was running then you must increase the sample interval (this error stops the monitoring).
Otherwise, you must stop the DDCTool program and increase the value of startup parameter **M** before restarting the program (see Appendix 1).
- **DDC CONNECTION IS BROKEN.**
Communication between the DDCTool and DDC(s) is broken. The same text is shown in a dialog box, which has to be acknowledged before going on.

Monitoring of Single APC

In addition to the actual values of a DDC, it is also possible to monitor numerically and graphically (min sample rate is 3 ms) values of the output pins of APC function blocks as follows:

- add a DRTRA function block to the APC application program and connect the output pins to be monitored (max. 8) to the IN input pins of this block. The execution cycle time of the DRTRA block will be the sample rate of the actual values (min 3 ms). Set values 12108...12115 to the IND input pins of the DRTRA block. The value of call parameter C1 must be 1 and the value of call parameter C2 is the number of the output pins to be monitored (1...8).
- when the APC application program is executing, define the desired **Value** buttons of the DDCTool so that the data location of a button is one of the signals 121-08...121-15. The actual value of the APC output pin corresponding to this signal will now be displayed on the right side of the **Value** button. If desired, this value can also be displayed graphically.
- it is possible to connect more output pins to the IN pins of the DRTRA block by using MUX blocks. You can control the operation of the MUXs from the DDCTool by signals 121-16 and 121-17 and function block DRREC.
- if you want to monitor an output pin that is not connected to an IN pin of the DRTRA block then you can connect the desired output pin to an IN pin of the DRTRA block by the APC.

Monitoring of Multiple APCs

If there are several DDCs (and APCs) connected to the PC then it is possible to use the principle described above to:

- record actual values from multiple APCs (max. 250 channels) to a disk file
- monitor graphically actual values from multiple APCs (max. 5 curves)

Creation of Diagram Files

NOTE: If you have a DCS 500 DDC then use the instructions in the User's Manual of CMT / DCS500.

If your diagram is so large that you want to divide it into separate diagrams (sheets) then you must put all these sheets into one diagram file.

If you want that the CTRL-click operation (see Chapter *Diagrams Menu*) works on a diagram line then you must place a parameter/signal identifier text (or a bit identifier text) near an end (or a side) of this line or you can break the line into two parts and place the identifier text between the parts (see the existing diagrams).

The format of a parameter/signal identifier text is:

`gg-ii`

where:

`gg` = group number (range 1...199)

`ii` = index in the group (always two digits, range 01...99).

The format of a bit identifier text of a parameter/signal is:

`gg-ii:bb`

where `bb` = bit number (range 0...15).

You can use two different methods to create a new diagram file as described on the following pages:

Method 1

Use this method if you have the GAD program.

- Draw the diagram sheet(s) by the Graphical Application Designer (GAD) program (use existing diagram sheets as a model).
You can use user-defined symbols in your diagrams (the type of a symbol must be either CELL or MASTER).
You can use only lines, rectangles, circles, arcs and texts in your diagrams and symbols (you cannot use e.g. wires, pins and netnames).
Save the diagram sheet(s) into a schematic file (extension SCH).
- Convert the schematic file (and symbol file(s), if any) into ASCII text file(s) (extensions ASC and ASY) by the GAD program.
- Compile the converted schematic file by the DDCTDC.EXE program.
This program is in your DDCTOOL directory and you can start it e.g. by double-clicking its name in the File Manager display.
- Rename the filename extension (QOD) of the compiled file into QDD.
- Use *Notepad* (or some other text editor program) and replace the first line of the compiled file (CMT DIAGRAM VERSION 1) with line

```
DDCTOOL DIAGRAM VERSION 1 (ACV700)
```

(if your drive is not ACV 700 then use one of the following lines:

```
DDCTOOL DIAGRAM VERSION 1 (DCV700)  
DDCTOOL DIAGRAM VERSION 1 (DCF500/700)  
DDCTOOL DIAGRAM VERSION 1 (TSU)
```

instead).

IMPORTANT: Do not use *Word* or some other word processing program that uses special formatting characters!

Method 2

Use this method if you do not have the GAD program.

Because diagram files are ASCII text files you can write a new diagram file by using *Notepad* (or some other text editor program).

IMPORTANT: Do not use *Word* or some other word processing program that uses special formatting characters!

The filename extension of a diagram file must be QDD.

You can use existing diagram files as a model.

The *first line* of a diagram file must be:

```
DDCTOOL DIAGRAM VERSION 1 (ACV700)
```

(if your drive is not ACV 700 then use one of the following lines:

```
DDCTOOL DIAGRAM VERSION 1 (DCV700)
DDCTOOL DIAGRAM VERSION 1 (DCF500/700)
DDCTOOL DIAGRAM VERSION 1 (TSU)
```

instead).

The *last line* of a diagram file must be:

```
** last line **
```

(do not forget to press *Enter* at the end of this line!)

The following lines can be used between the above mentioned first and last lines:

```
ZSHEET ECS sht_number sht_width sht_height
ZLINE ECS line_width x1 y1 x2 y2
ZRECTANGLE ECS line_width x1 y1 x2 y2
ZCIRCLE ECS line_width x1 y1 x2 y2
ZARC ECS line_width x1 y1 x2 y2 x3 y3 x4 y4
ZTEXT ECS x y justification size text_string
```

where:

```
line_width = NORMAL or WIDE
justification = LEFT, CENTER or RIGHT
size = 0, 1 or 2 (0 = smallest size)
```

Chapter 17 - Appendix 5

Related Documents

For Information on:	See Document:
ACV 700; Firmware 1.0	58054399
ACV 700; Service Instruction	58054499
DCV 700; Software Description 1.0	61101446
DCF 500 / 700	
DCS 500; CMT / DCS 500 User's Manual	61178775



3AFE 61041486 REV A EN
EFFECTIVE: 15.10.2004

ABB Oy
AC Drives
P.O.Box 184
FIN-00381 HELSINKI
FINLAND
Telephone
Telefax
Internet

+ 358 10 22 11
+ 358 10 22 22681
<http://www.abb.com>