

Electronic timer CT-YDE

Star-delta change-over with 1 c/o (SPDT) contact

The CT-YDE is an electronic time relay with star-delta change-over. It is from the CT-E range. The CT-E range is the economic range of ABB's time relays and offers a cost effective price-performance ratio for OEM users. This is achieved by simplified functionality and results in the simplest of setup procedures. The CT-E range is ideally suited for repeat applications.



1SVR 550 207 F4100

Characteristics

- 6 versions:
 - 3 different single time ranges (0.1-10 s, 0.3-30 s and 3-300 s) and
 - 2 different rated control supply voltage ranges (24 V AC/DC / 220-240 V AC and 110-130 V AC)
- Single-function timer with star-delta change-over
- Starting time (star) adjustable
- Transition time 50 ms fixed
- 1 c/o (SPDT) contact
- 22.5 mm (0.89 in) width
- 2 LEDs for the indication of operational states

Order data

Type	Rated control supply voltage	Time range	Order code
CT-YDE	24 V AC/DC, 220-240 V AC	0.1-10 s	1SVR 550 207 R1100
		0.3-30 s	1SVR 550 207 R4100
		3-300 s	1SVR 550 207 R2100
	110-130 V AC	0.1-10 s	1SVR 550 200 R1100
		0.3-30 s	1SVR 550 200 R4100
		3-300 s	1SVR 550 200 R2100

Functions

Operating controls

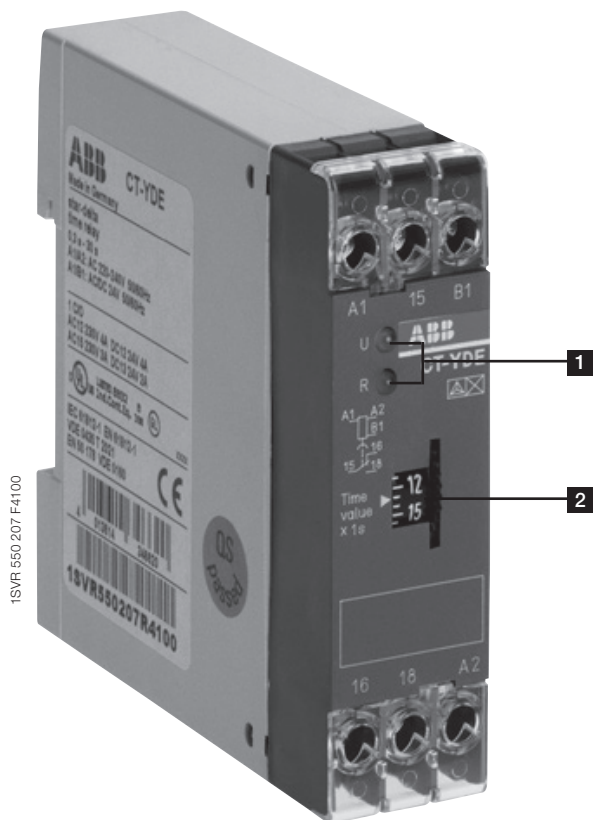

1 Indication of operational states

U: green LED – Control supply voltage applied

R: red LED – Output relay energized

2 Thumbwheel for the fine adjustment of the starting time

Application

Their conception makes the CT-E range timers ideal for repeat applications.

Operating mode

The fine adjustment of the time delay is made via the front-face thumbwheel.

Examples of application

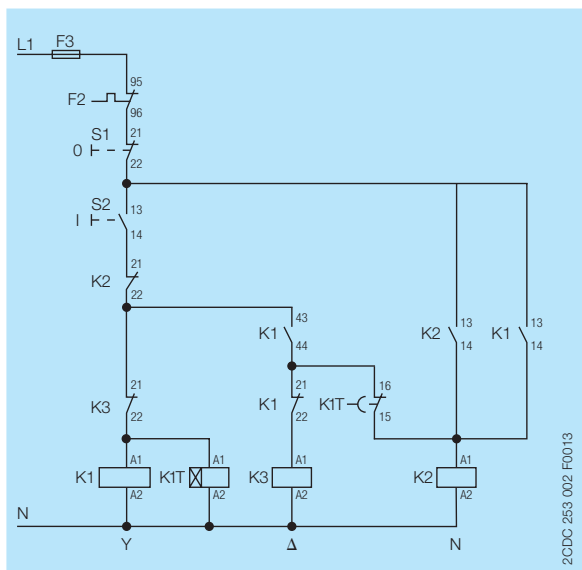

Star-delta change-over, control circuit diagram

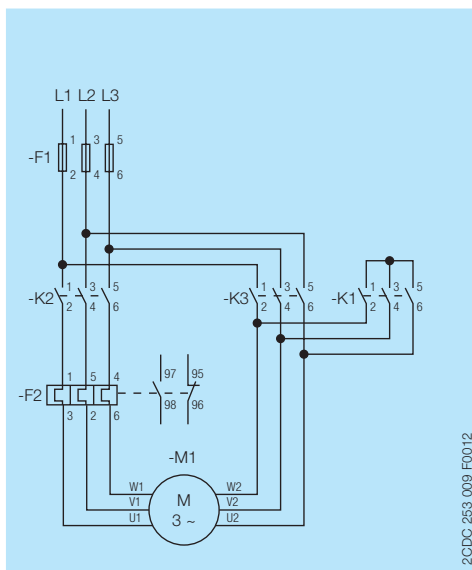

Star-delta change-over, power circuit diagram

Function diagram

Star-delta change-over (Star-delta starting)

Applying control supply voltage energizes the star contactor (K1) and the line contactor (K2) and begins the set starting time. When the starting time is complete, contact 15-16 de-energizes the star contactor (K1). Now, the fix transition time starts. When the transition time is complete, contact 15-16 energizes the delta contactor (K3).

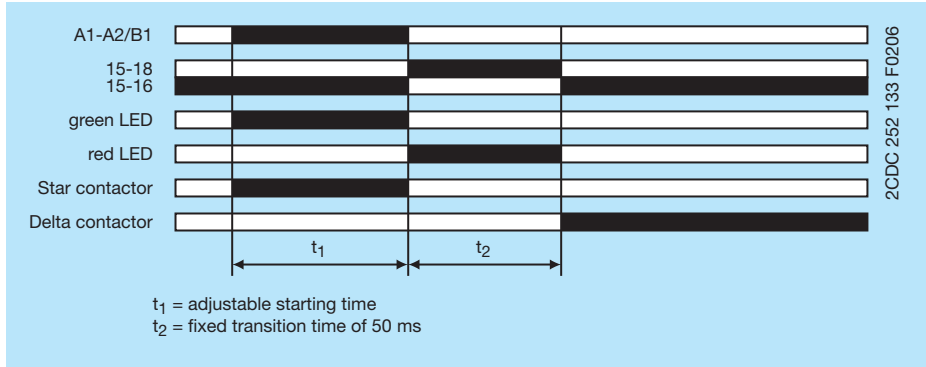

Electrical connection

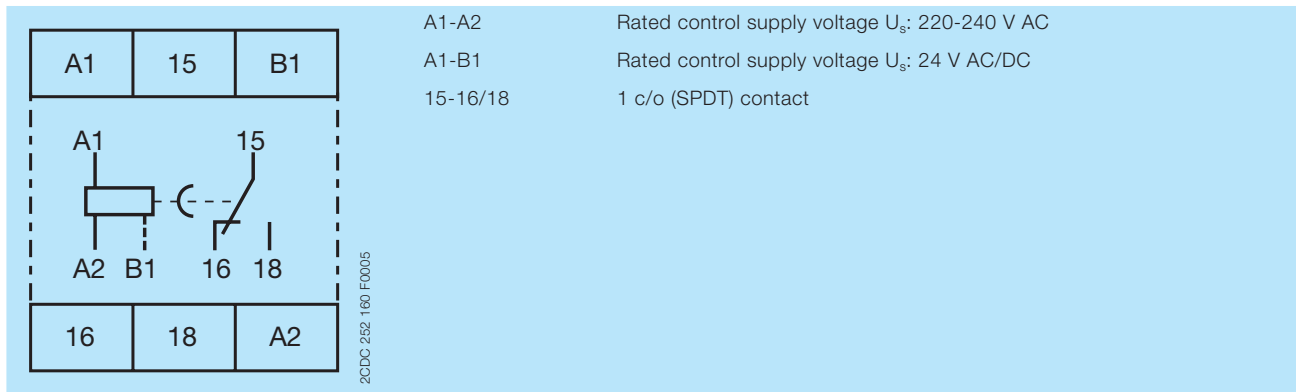

Connection diagram
 1SVR 550 207 R1100, 1SVR 550 207 R4100, 1SVR 550 207 R2100

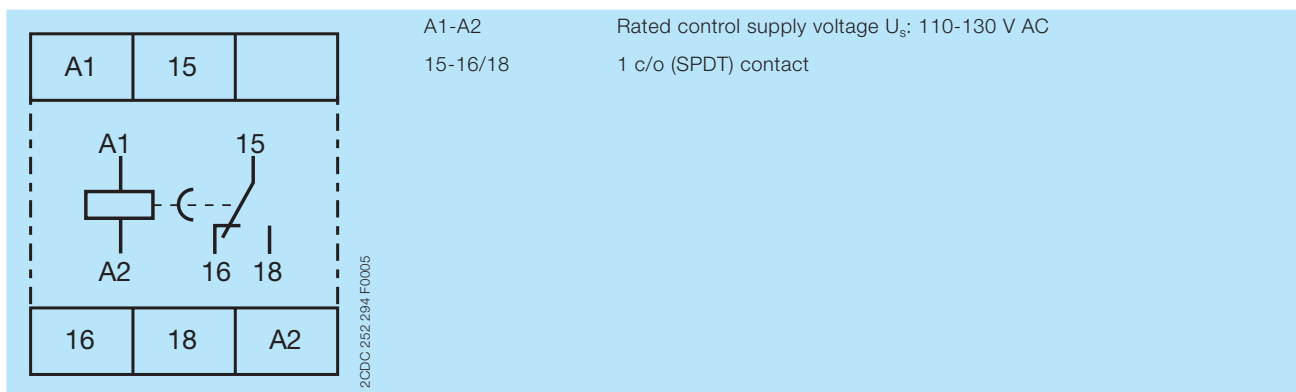

Connection diagram
 1SVR 550 200 R1100, 1SVR 550 200 R4100, 1SVR 550 200 R2100

Technical data



Data at $T_a = 25\text{ °C}$ and rated values, unless otherwise indicated

Input circuits

Supply circuit		
Rated control supply voltage U_s	A1-A2	220-240 V AC
	A1-A2	110-130 V AC
	A1-B1	24 V AC/DC
Rated control supply voltage U_s tolerance		-15...+10 %
Rated frequency	AC/DC version	DC or 50/60 Hz
	AC version	50/60 Hz
Typical current / power consumption	24 V AC/DC	approx. 1.0 VA/W
	110-130 V AC	approx. 2.0 VA
	220-240 V AC	approx. 2.0 VA
Release voltage		> 10 % of the minimum control supply voltage

Timing circuit	
Starting time	depending on device: 0.1-10 s, 0.3-30 s or 3-300 s
Star-delta transition time	50 ms fixed
Recovery time	< 500 ms
Repeat accuracy (constant parameters)	$\Delta t < 1\%$
Accuracy within the rated control supply voltage tolerance	$\Delta t < 0.5\% / V$
Accuracy within the temperature range	$\Delta t < 0.1\% / \text{°C}$
Setting accuracy of time delay	$\pm 10\%$ of full-scale value

User interface

Indication of operational states		
Control supply voltage	U: green LED	 : control supply voltage applied
Relay status	R: red LED	 : output relay energized

Output circuit

Kind of output	15-16/18	relay, 1 c/o (SPDT) contact
Contact material		silver alloy
Rated operational voltage U_e		250 V
Minimum switching voltage / current		12 V / 100 mA
Maximum switching voltage / current		see 'Load limit curves'
Rated operational current I_e	AC-12 (resistive) at 230 V	4 A
	AC-15 (inductive) at 230 V	3 A
	DC-12 (resistive) at 24 V	4 A
	DC-13 (inductive) at 24 V	2 A
AC rating (UL 508)	Utilization category (Control Circuit Rating Code)	B 300
	max. rated operational voltage	300 V AC
	Maximum continuous thermal current at B300	5 A
	max. making/breaking apparent power at B300	3600 VA / 360 VA
Mechanical lifetime		10×10^6 switching cycles
Electrical lifetime	AC-12, 230 V, 4 A	0.1×10^6 switching cycles
Frequency of operation	with/without load	$360/72000^{-1}$
Maximum fuse rating to achieve	n/c contact	10 A fast
short-circuit protection	n/o contact	10 A fast

General data

MTBF	on request		
Duty time	100 %		
Dimensions	see 'Dimensional drawings'		
Weight	net weight	24 V AC/DC, 220-240 V AC	0.067 kg (0.148 lb)
		110-130 V AC	0.079 kg (0.174 lb)
	gross weight	24 V AC/DC, 220-240 V AC	0.065 kg (0.143 lb)
		110-130 V AC	0.077 kg (0.170 lb)
Mounting	DIN rail (IEC/EN 60715), snap-on mounting without any tool		
Mounting position	any		
Minimum distance to other units	not necessary		
Material of housing	lower section	UL 94 V-0	
	upper section	UL 94 V-2	
Degree of protection	housing	IP50	
	terminals	IP20	

Electrical connection

Connecting capacity	fine-strand with wire end ferrule	2 x 0.75-1.5 mm ² (2 x 18-16 AWG)
	fine-strand without wire end ferrule	2 x 1-1.5 mm ² (2 x 18-16 AWG)
	rigid	2 x 0.75-1.5 mm ² (2 x 18-16 AWG)
Stripping length	10 mm (0.39 in)	
Tightening torque	0.6-0.8 Nm (5.31-7.08 lb.in)	

Environmental data

Ambient temperature ranges	operation	-20...+60 °C
	storage	-40...+85 °C
Relative humidity range	4 x 24 h cycle, 40 °C, 93 % RH	
Vibration, sinusoidal	IEC/EN 60068-2-6	20 m/s ² , 10-58/60-150 Hz
Shock, half-sine	IEC/EN 60068-2-27	150 m/s ² , 11 ms, 3 shocks/direction

Isolation data

Rated insulation voltage U _i	between all isolated circuits	Control supply voltage up to 240 V: 300 V
		Control supply voltage up to 440 V: 500 V
Rated impulse withstand voltage U _{imp}	between all isolated circuits	4 kV / 1.2-50 μs
Power frequency withstand voltage (test voltage)	between all isolated circuits	2.5 kV, 50 Hz, 1 min.
Basic insulation (IEC/EN 61140)	input/output	300 V
Protective separation (IEC/EN 61140, EN 50178)	input/output	-
Pollution degree	3	
Overvoltage category	III	

Standards / Directives

Standards	IEC/EN 61812-1
Low Voltage Directive	2014/35/EU
EMC Directive	2014/30/EU
RoHS Directive	2011/65/EU

Electromagnetic compatibility

Interference immunity to		IEC/EN 61000-6-2
electrostatic discharge	IEC/EN 61000-4-2	Level 3 (6 kV / 8 kV)
radiated, radio-frequency, electromagnetic field	IEC/EN 61000-4-3	10 V/m (1 GHz), 3 V/m (2 GHz), 1 V/m (2.7 GHz)
electrical fast transient / burst	IEC/EN 61000-4-4	Level 3 (2 kV / 5 kHz)
surge	IEC/EN 61000-4-5	Level 4 (2 kV L-L)
conducted disturbances, induced by radio-frequency fields	IEC/EN 61000-4-6	Level 3 (10 V)
Interference emission		IEC/EN 61000-6-3
high-frequency radiated	IEC/CISPR 22, EN 55022	Class B
high-frequency conducted	IEC/CISPR 22, EN 55022	Class B

Technical diagrams

Load limit curves

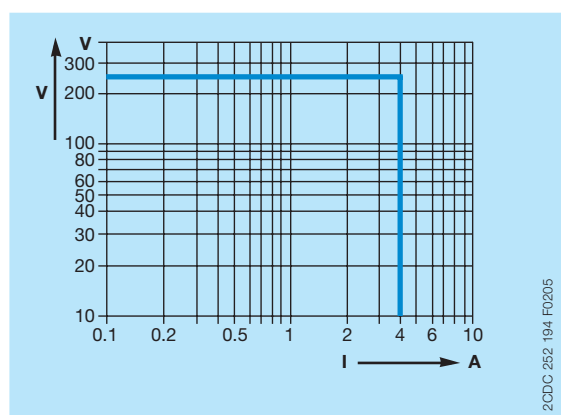

AC load (resistive)

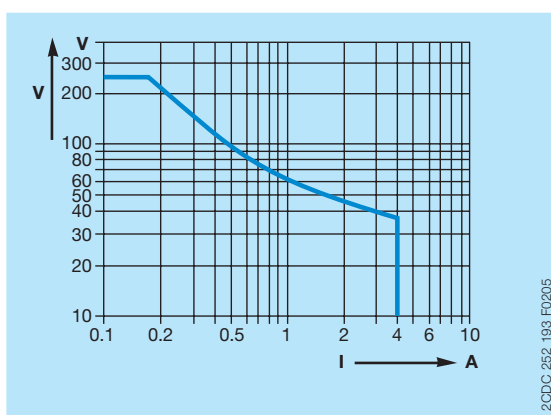

DC load (resistive)

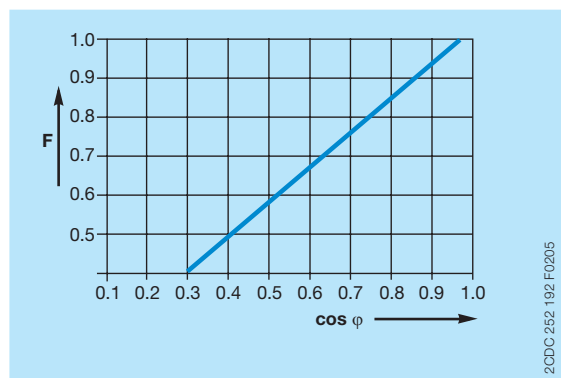

Derating factor F for inductive AC load

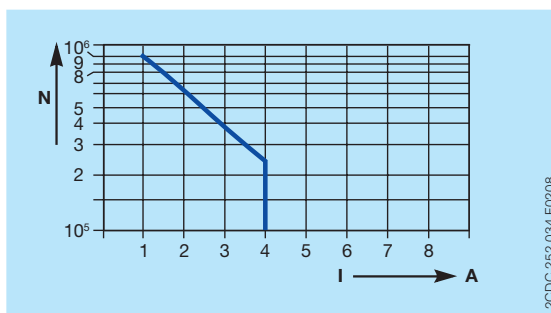

Contact lifetime /switching cycles N
220 V 50 Hz AC1, 360 cycles/h

Dimensions

in **mm** and *inches*

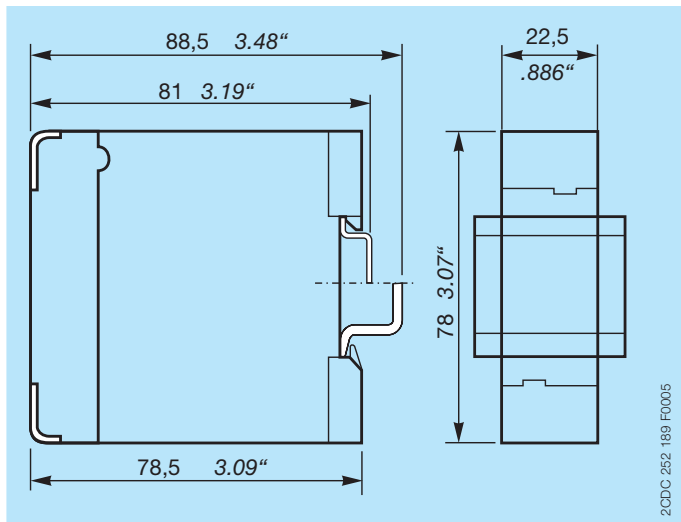

Further documentation

Document title	Document type	Document number
Electronic relays and controls	Catalog	2CDC 110 004 C02xx

You can find the documentation on the internet at www.abb.com/lowvoltage
-> Automation, control and protection -> Electronic relays and controls -> Time relays.

CAD system files

You can find the CAD files for CAD systems at <http://abb-control-products.partcommunity.com>
-> Low Voltage Products & Systems -> Control Products -> Electronic Relays and Controls.

Contact us

ABB STOTZ-KONTAKT GmbH

P. O. Box 10 16 80
69006 Heidelberg, Germany
Phone: +49 (0) 6221 7 01-0
Fax: +49 (0) 6221 7 01-13 25
E-mail: info.desto@de.abb.com

You can find the address of your
local sales organisation on the
ABB home page
<http://www.abb.com/contacts>
-> Low Voltage Products and Systems

Note:

We reserve the right to make technical changes or modify the contents of this document without prior notice. With regard to purchase orders, the agreed particulars shall prevail. ABB AG does not accept any responsibility whatsoever for potential errors or possible lack of information in this document.

We reserve all rights in this document and in the subject matter and illustrations contained therein. Any reproduction, disclosure to third parties or utilization of its contents – in whole or in parts – is forbidden without prior written consent of ABB AG.

Copyright© 2017 ABB
All rights reserved