

AO2000

Continuous gas analyzers



Integrated analyzer system

Measurement made easy

—
AO2020, AO2040

Introduction

The Advance Optima process gas analyzers have a modular design that offers a long-term security in your investment.

Analyzer modules can be freely combined into tailor-made solutions and upgraded or extended with new features at any time.

Remote modules are easily attached and centrally operated.

Additional Information

Additional documentation on AO2000 is available for download free of charge at www.abb.com/analytical. Alternatively simply scan this code:



Contents

Preface	5
Guideline for installation and commissioning	7
Safety information	8
Intended application	8
Special requirements for the operator	9
Safety information	10
Fidas24: Information on the safe operation of the gas analyzer.....	12
Version with type of protection II 3G for measurement of non-flammable gases and vapors	14
Version with type of protection II 3G for measurement of flammable gases ('Safety Concept') and non-flammable gases	17
Intended application	17
Important information for the operator	18
Description	20
Internal and external explosion protection.....	22
Technical data	23
Special requirements for operation.....	25
Limas11 IR, Uras26: Version for the 'Safety Concept'	26
Caldos25, Caldos27, Magnos206: Version for the 'Safety Concept'	28
Purge gas flow monitoring.....	30
Version for use in Class I Div. 2 explosion hazard areas	31
Preparation for installation	32
Scope of supply and delivery.....	32
Material required for the installation (not supplied).....	33
Installation location.....	35
Pressure sensor.....	37
Housing purge.....	38
Power supply	41
Caldos25: Preparation for installation.....	43
Caldos27: Preparation for installation.....	45
Fidas24: Preparation for installation	47
Fidas24 NMHC: Preparation for installation.....	50
Limas11 IR, Limas21 UV: Preparation for installation.....	53
Limas21 HW: Preparation for installation.....	56
Magnos206: Preparation for installation	58
Magnos28: Preparation for installation.....	61
Magnos27: Preparation for installation.....	64
Uras26: Preparation for installation.....	66
ZO23: Preparation for installation.....	68
Oxygen sensor: Preparation for installation.....	72
Unpacking the gas analyzer and installation	74
Unpacking the gas analyzer	74
Dimensional diagrams	75
Gas connection installation.....	77
Gas analyzer installation.....	79
Gas line connection	80
Caldos25: Gas connections	80
Caldos27: Gas connections.....	82

Fidas24, Fidas24 NMHC: Gas and electrical connections	83
Limas11 IR, Limas21 UV, Limas21 HW: Gas connections.....	84
Magnos206: Gas connections.....	88
Magnos28: Gas connections	89
Magnos27: Gas connections.....	90
Uras26: Gas connections	92
ZO23: Gas connections	94
Gas line connection	95
Fidas24: Connecting the gas lines.....	97
Fidas24: Connecting the combustion gas line	100
Fidas24: Connecting the sample gas line (heated sample gas connection)	101
Fidas24: Connecting the sample gas line (unheated sample gas connection)	105
Connecting the electrical leads	107
Electronics module connection diagram.....	107
Profibus module: Electrical connections.....	108
Modbus module: Electrical connections.....	109
Analog output module: Electrical connections.....	110
Analog input module: Electrical connections	111
Digital I/O module: Electrical connections	112
Standard terminal connections	114
Connecting the signal lines	116
System bus connection.....	119
Power supply line connection – Safety notes	122
Power supply line connection to an analyzer module.....	123
Power supply line connection	125
Fidas24: Power supply line connection.....	126
Gas analyzer start-up	127
Installation check.....	127
Gas path and housing initial purge	128
Power supply activation.....	129
Fidas24: Gas analyzer start-up.....	130
Limas21 HW: Gas analyzer start-up.....	134
ZO23: Gas analyzer start-up.....	135
Warm-up phase.....	136
Operation.....	137
Menu tree.....	139
Inspection and maintenance.....	140
Checking gas path seal integrity	140
Fidas24: Checking the combustion gas supply line for seal integrity.....	142
Fidas24: Checking the combustion gas feed path in the gas analyzer for seal integrity.....	144
Dynamic QR code.....	145
Gas analyzer shutdown and packing	147
Gas analyzer shutdown.....	147
Packing the gas analyzer	149
Disposal.....	150

Preface

Content of the commissioning instruction

This commissioning instruction contains all the information necessary for the safe and compliant installation and start-up of the gas analyzer.

Information on operation, calibration, configuration and maintenance of the gas analyzer is documented in the operating instruction. The operating instruction can be found on the DVD-ROM "Software tools and technical documentation", which is supplied with the gas analyzer (see below).

NOTE

Descriptions and instructions for the Fidas24 analyzer module in this operating instruction generally also apply for the Fidas24 NMHC analyzer module. Divergent and supplementary descriptions and instructions for the Fidas24 NMHC analyzer module are added if applicable.

Further information

Analyzer data sheet

The version of the delivered gas analyzer is described in the "Analyzer data sheet" supplied with the gas analyzer.

DVD-ROM "Software tools and technical documentation"

The DVD-ROM "Software tools and technical documentation" with the following contents is included in the scope of supply of the gas analyzer:

- Software tools
- Operating instructions
- Data sheets
- Technical information
- Certificates

Internet

You will find information on ABB Analytical products and services on the Internet at "<http://www.abb.com/analytical>".

Service contact

If the information in this operating instruction does not cover a particular situation, ABB Service will be pleased to supply additional information as required.

Please contact your local service representative. For emergencies, please contact

ABB Service,
Telephone: +49-(0)180-5-222 580, Telefax: +49-(0)621-381 931 29031,
E-mail: automation.service@de.abb.com

Symbols and typefaces in this operating instruction

ATTENTION identifies safety information to be heeded during gas analyzer operation, in order to avoid risks to the user.

NOTE identifies specific information on the operation of the gas analyzer as well as on the use of this operating instruction.

1, 2, 3, ...	Identifies reference numbers in figures.
Display	Identifies a display on the screen.
Input	Identifies a user entry <ul style="list-style-type: none"> • either by pressing a soft key • or by selecting a menu item • or via the numeric keypad
Function block	Identifies a function block designation.
'Name'	Identifies a function block name assigned by the gas analyzer or entered by the user.
p_e	Gauge pressure
p_{abs}	Absolute pressure
p_{amb}	Atmospheric pressure

Guideline for installation and commissioning

Basic steps

The following basic steps should be followed for the installation and commissioning of the gas analyzer:

- 1** Note the information on the intended application (see page 8).
- 2** Follow safety precautions (see page 10).
- 3** Prepare for the installation, provide the requisite material (see page 32).
- 4** Unpack the gas analyzer (see page 74).
- 5** Check gas path seal integrity (see page 140).
- 6** Install the gas analyzer (see page 79).
- 7** Connect the gas lines (see page 80).
- 8** Connect the electrical leads (see page 107).
- 9** Check the Installation (see page 127).
- 10** Purge the gas paths and housing (see page 128).
- 11** Start-up the gas analyzer (see page 129).

Safety information

Intended application

Intended application

The AO2000 Series gas analyzers are designed for continuous measurement of the concentration of individual components in gases or vapors.

Any other use is not as specified.

The specified use also includes taking note of this operating instruction.

The AO2000-Fidas24 and Fidas24 NMHC gas analyzers may not be used for the measurement of ignitable mixtures during normal service. Special measures must be taken to prevent an explosion hazard during the measurement of flammable gas which can form an explosive mixture in association with air or oxygen.

The AO2000 Series gas analyzers as well as the models with type of protection II 3G for measurement of non-flammable gases and vapors must not be used for measurement of explosive mixtures. Explosion-protected models of the gas analyzers are available for this application.

Please note the information on intended application for versions

- with type of protection II 3G for measurement of non-flammable gases and vapors (see page 14),
- with type of protection II 3G for measurement of flammable and non-flammable gases (see page 17) and
- for use in Class I Div. 2 explosion hazard areas (see page 31).

Improper use

The following are considered to be instances of especially improper use of the device:

- Use as a climbing aid, for example for mounting purposes.
- Use as a support for external loads, e.g., as a support for piping, etc.
- Material application, for example by painting over the housing, name plate or welding/soldering on parts.
- Material removal, for example by spot drilling the housing.

The gas analyzer may not be used for measuring gases that attack the materials of the wetted parts (e.g. gases containing chlorine).

Special requirements for the operator

Special requirements for the operator

- The operator must ensure that the gas analyzer is operated only with a sample gas mixture in which the concentration of flammable sample gas is below the LEL.
- No explosive gas mixture may be introduced into the gas analyzer – taking into account pressure, temperature and gas matrix.
- Before commissioning the gas analyzer, the sample gas path must be purged to remove any potentially explosive gas mixtures from the sample gas path.
- The operator is obliged to subject the gas analyzer to a leak test at regular intervals, but at least once a year and after any work on the sample gas path.
- The operator must ensure that when the gas analyzer is switched off, the sample gas supply is interrupted and the sample gas path is purged with compressed air or an inert gas.

Safety information

Requirements for safe operation

In order to operate in a safe and efficient manner the device should be properly handled and stored, correctly installed and set-up, properly operated and correctly maintained.

Personnel qualifications

Only persons familiar with the installation, set-up, operation and maintenance of comparable devices and certified as being capable of such work should work on the device.

Special information and precautions

These include

- The content of this operating instruction,
- The safety information affixed to the device,
- The applicable safety precautions for installing and operating electrical devices,
- Safety precautions for working with gases, acids, condensates, etc.

National regulations

The regulations, standards and guidelines cited in this operating instruction are applicable in the Federal Republic of Germany. The applicable national regulations should be followed when the device is used in other countries.

Device safety and safe operation

The device is designed and tested in accordance with the relevant safety standards and has been shipped ready for safe operation. To maintain this condition and to assure safe operation, read and follow the safety information in this operating instruction. Failure to do so can put persons at risk and can lead to device damage as well as damage to other systems and devices.

Protective lead connection

The protective lead (ground) should be attached to the protective lead connector before any other connection is made.

Risks of a disconnected protective lead

The device can be hazardous if the protective lead is interrupted inside or outside the device or if the protective lead is disconnected.

Risks involved in opening the covers

Current-bearing components can be exposed when the covers or parts are removed, even if this can be done without tools. Current can be present at some connection points.

Risks involved in working with an open device

All work on a device that is open and connected to power should only be performed by trained personnel who are familiar with the risks involved.

When safe operation can no longer be assured

If it is apparent that safe operation is no longer possible, the device should be taken out of operation and secured against unauthorized use.

The possibility of safe operation is excluded:

- If the device is visibly damaged,
- If the device no longer operates,
- After prolonged storage under adverse conditions,
- After severe transport stresses.

Fidas24: Information on the safe operation of the gas analyzer

ATTENTION

The gas analyzer uses hydrogen as a combustion gas!
All the information and instructions contained in this operating instruction must be complied with without fail to ensure safe operation of the gas analyzer!

Measures of the manufacturer

The following measures ensure that the enrichment of combustion gas or an explosive mixture of combustion gas and ambient air cannot occur inside the gas analyzer during normal operation:

- The seal integrity of the combustion gas feed path is checked for a leakage rate of $< 1 \times 10^{-4}$ hPa l/s before delivery.
- The combustion gas/air mixture (before and after the ignition point) is diluted in the detector with compressed air.
- The combustion gas feed is not connected to the supply during start-up until the internal nominal pressures have been set.
- The combustion gas feed is switched off if the internal nominal pressures cannot be set during the ignition phase (e.g. because of insufficient compressed air or combustion air feed).
- The combustion gas feed is switched off after several unsuccessful ignition attempts.
- If the flame goes out during operation the combustion gas feed is switched off if the following ignition attempts are unsuccessful.

The interior of the gas analyzer is not assigned to an (explosion protection) zone; no explosive gas mixture can escape from it to the outside.

Conditions to be complied with by the end user

The end user must comply with the following prerequisites and conditions to ensure safe operation of the gas analyzer:

- The gas analyzer may be used for the measurement of flammable gases provided that the flammable portion does not exceed the following limit values:
Fidas24: 15 vol.% CH₄ or C1 equivalents,
Fidas24 NMHC: 5 vol.% CH₄ or C1 equivalents.
- The relevant safety regulations for working with flammable gases must be complied with.
- The gas connection diagram (see page 83) must be complied with when connecting the combustion gas and combustion air.
- The combustion gas feed path in the gas analyzer may not be opened! The combustion gas feed path can become leaky as a result! Escaping combustion gas can cause fires and explosions, also outside the gas analyzer!
- If the combustion gas feed path in the gas analyzer has been opened, however, it must always be checked for seal integrity (see page 144) with a leak detector after it has been sealed again (leakage rate $< 1 \times 10^{-4}$ hPa l/s).
- The seal integrity of the combustion gas line (see page 142) outside the gas analyzer and the combustion gas feed path (see page 144) in the gas analyzer must be checked on a regular basis.
- The maximum pressures of combustion gas and combustion air (see page 47) may not be exceeded.

- The maximum combustion gas flow (see page 47) may not be exceeded.
- The combustion gas flow rate must be limited to a maximum of 10 l/h of H₂ or 25 l/h of H₂/He mixture. For this purpose, the end user has to provide suitable measures (see page 47) outside the gas analyzer.
- A shut-off valve (see page 47) must be installed in the combustion gas supply line to increase the safety in the following operating states:
 - Shutting down the gas analyzer,
 - Failure of the instrument air supply,
 - Leakage in the combustion gas feed path inside the gas analyzer.This shut-off valve should be installed outside the analyzer house in the vicinity of the combustion gas supply (cylinder, line).
- If there is no automatic shut-off of the combustion gas supply to the gas analyzer in case of an instrument supply failure, a visible or audible alarm must be triggered.
- When measuring flammable gases, it must be made sure that in case of a failure of the instrument air supply or of the analyzer module itself the sample gas supply to the analyzer module is shut off and the sample gas path is purged with nitrogen.
- The unobstructed exchange of air with the environment must be possible around the gas analyzer. The gas analyzer may not be directly covered. The openings in the housing towards the top and at the side may not be closed. The distance to laterally adjacent built-in components must be at least 4 mm.
- If the gas analyzer is installed in a closed cabinet, adequate ventilation of the cabinet must be provided (at least 1 change of air per hour). The distance to adjacent built-in components towards the top and at the side must be at least 4 mm.

Version with type of protection II 3G for measurement of non-flammable gases and vapors

Intended application

The AO2000 Series gas analyzers with analyzer modules Uras26, Magnos206, Magnos27, Caldos25 and Caldos27 with type of protection II 3G have been tested for explosion protection and are suitable for use in hazardous areas in compliance with the technical data (see page 35) and the special conditions for operation (see below). They are suitable for continuous measurement of the concentration of individual components in non-flammable gases or vapors.

Any other use is not as specified.

The specified use also includes taking note of this operating instruction.

Important safety instructions

In accordance with the EU Directive 2014/34/EU and the general requirements for explosion protection and as specified in the IEC 60079-0 standard, the scope of approvals for our explosion-protected apparatus is limited to **atmospheric conditions**, unless expressly stated otherwise in the certificates.

This also includes the sample gas that is fed in.

The **atmospheric conditions** are defined as follows:

- Temperature -20 to $+60$ °C
- Pressure $p_{\text{abs}} = 0$ to 110 kPa (0.8 to 1.1 bar)
- Ambient air with a standard oxygen content, typically 21 vol.%

If the **atmospheric conditions are not complied with**, the operator is obliged to guarantee the safe operation of our devices in the absence of the recommended atmospheric conditions, by means of further measures (e.g. evaluation of the gas mixture or explosion pressure) and / or supplementary protective devices.

NOTICE

Use in potentially explosive atmospheres

The inspection and maintenance of the explosion-protected version of the gas analyzer requires special knowledge.

Repairs and replacement of parts on the device may only be done by ABB service.

Description

The explosion-protected version with type of protection II 3G for the measurement of non-flammable gases and vapors is a special version of the AO2000 Series gas analyzers.

This version is different from other versions by the following designation on the identification plate:

 II 3G Ex nA nC IIC T4 Gc

Operating the gas analyzer under regular conditions cannot cause any ignitable sparks, arcs or impermissible temperatures inside the device.

NOTE

For further information please refer to the Declaration of Conformity. The Declaration of Conformity can be found on the DVD-ROM "Software tools and technical documentation" which is delivered together with the gas analyzer.

Standards and directives

The gas analyzer was designed and manufactured in accordance with the following standards:

- EN/IEC 60079-0
- EN/IEC 60079-15

The gas analyzer must be designed, installed and operated in accordance with the following standards and directives:

- EN/IEC 60079-14
- EN/IEC 60079-17
- EN/IEC 60079-19

NOTICE

The full designation of the applied standards, including the date of issue, is included in the declaration of conformity supplied with the device.

Special requirements for operation

- The gas analyzer must be switched off if it is obviously faulty (is not operating smoothly).
- The connectors may not be plugged in or unplugged while the power is on.
- The gas analyzer housing may not be opened while the power is on.
- In order to comply with degree of case protection IP54,
 - Cables have to be properly inserted in the screwed cable glands and sealed by screwing the nut firmly,
 - Cable connectors not in use have to be closed with suitable vent plugs,
 - System bus and 24 VDC power supply terminals not in use have to be closed with the provided seals.
- Only the original battery types Varta CR2032 type no. 6032 or Renata type no. CR2032 MFR may be used as replacement for the battery on the system controller.

Battery

Application

Supply to the built-in clock in case of a voltage failure.

Type

- Varta CR 2032 type no. 6032 or
- Renata type no. CR2032 MFR

NOTICE

Only the original types specified above may be used as a spare part.

Version with type of protection II 3G for measurement of flammable gases ('Safety Concept') and non-flammable gases

Intended application

Intended application

The gas analyzers are designed for continuous measurement of the concentration of individual components in

- non-flammable gases and vapors,
- flammable gases and vapors of Group IIC and Temperature Class T4, which can seldom and then only briefly form a potentially explosive atmosphere (zone 2).

Any other use is not as specified.

The specified use also includes taking note of this operating instruction.

Important safety instructions

In accordance with the EU Directive 2014/34/EU and the general requirements for explosion protection and as specified in the IEC 60079-0 standard, the scope of approvals for our explosion-protected apparatus is limited to **atmospheric conditions**, unless expressly stated otherwise in the certificates.

This also includes the sample gas that is fed in.

The **atmospheric conditions** are defined as follows:

- Temperature -20 to +60 °C
- Pressure $p_{abs} = 0$ to 110 kPa (0.8 to 1.1 bar)
- Ambient air with a standard oxygen content, typically 21 vol.%

If the **atmospheric conditions are not complied with**, the operator is obliged to guarantee the safe operation of our devices in the absence of the recommended atmospheric conditions, by means of further measures (e.g. evaluation of the gas mixture or explosion pressure) and / or supplementary protective devices.

NOTICE

Use in potentially explosive atmospheres

The inspection and maintenance of the explosion-protected version of the gas analyzer requires special knowledge.

Repairs and replacement of parts on the device may only be done by ABB service.

Important information for the operator

Limiting the purge gas pressure

The purging system of the gas analyzer has no relief opening. Therefore, the maximum internal pressure must be limited by the operator. The standard EN 60079-2 requires the safe limitation of the purge gas pressure even in the single-fault mode. The control of the purge gas pressure is therefore to be performed in single-fault proof mode by the operator.

Purge gas outlet and sample gas outlet

In order to ensure an overpressure of 7 hPa in the purge gas path as compared with the sample gas path at a minimum purge gas flow of 15 l/h, the outlet of the sample gas and the outlet of the purge gas have to be discharged against the same pressure level (atmospheric). The common discharging of sample gas and purge gas (for example, into a common exhaust gas line / flare) is not permissible, since this leads to the risk of the backflow of flammable gases into the purge gas path.

Emergency supply of purge gas

If, in the event of failure of the primary supply, an emergency supply with an ignition protective gas is provided (for example, in order to continue operating the gas analyzer), each supply point must be able to maintain the required pressure level or the required amount of ignition protection gas independently of each other. The two supply points may have common pipes or lines.

Installation of the gas analyzer and the supply lines

When installing the gas analyzer as well as the supply and exhaust air lines, the requirements according to EN 60079-2 Annex D as well as according to EN 60079-14 must be fulfilled. The requirements listed below are an excerpt from these standards. They are explicitly listed here because of their importance for safe operation of the gas analyzer. However, this list of requirements in the above standards does not exempt the operator from his obligation to perform the installation of the gas analyzer and the associated supply lines in accordance with relevant national and international standards and regulations, including any additional requirements.

In particular the requirements of IEC/TR 60070-16 "Electrical apparatus for explosive gas atmospheres. Part 16: Artificial ventilation for the protection of analyzer(s) houses" and IEC 61285 "Industrial-process control – Safety of analyzer houses" shall be taken into account as appropriate.

Requirements of EN 60079-2 Annex D

- Temperature of protective gas at the inlet: If necessary, measures should be taken to avoid condensation and freezing.
- If the compressor intake line passes through a hazardous area, it should be constructed of non-combustible material and protected against mechanical damage and corrosion.
- Power for protective gas supply: The electrical power for the protective gas supply (blower, compressor, etc.) should be either taken from a separate power source or taken from the supply side of the electrical isolator (e.g. disconnect) for the pressurized enclosure.
- The maximum pressure and flow of the flammable substance into the containment system should not exceed the ratings specified by the manufacturer (see Section "Technical data").
- The supply pressure of the sample gas and the protective gas must be limited by the operator according to the maximum pressure values (see Section "Technical data").

Requirements of EN 60079-14

- All ducts and their connecting parts shall be able to withstand a pressure equal to 1.5 times the maximum overpressure, specified by the manufacturer of the pressurized equipment, for normal operation:
Sample gas supply $3 \text{ hPa} \times 1.5 = 4.5 \text{ hPa}$, purge gas supply $50 \text{ hPa} \times 1.5 = 75 \text{ hPa}$.
- The materials used for the ducts and connecting parts shall not be adversely affected by the specified protective gas nor by the flammable gas or vapors in which they are to be used.
- Ducting should be located in a non-hazardous area as far as is reasonably practicable.
- Ducts for exhausting the protective gas should preferably have their outlets in a non-hazardous area.
- If the internal pressure or flow of protective gas falls below the minimum prescribed value, the loss of pressure is signaled by an error status at the digital output (see analyzer data sheet). It must be ensured that this signal is indicated in a manner that it is immediately apparent to the operator. The pressurization system shall be restored as soon as possible, or else the electrical supply shall be switched off manually.
- The predefined minimum pre-purge time for the pressurized volume of the analyzer comprises the pipelines within the gas analyzer. The purging time shall be extended by the time required to purge the free volume of the connected pipes (supply pipes) which are not part of the device with at least five times their volume at the lowest flow rate of 15 l/h.
- Care should be taken to keep the temperature of the protective gas below 40 °C at the inlet of the enclosure.

Description

Gas analyzers for the 'Safety Concept'

Gas analyzers for the 'Safety Concept' consist of analyzer modules

- Limas11 IR, Uras26 (see page 26) in the version with safety cell and purged sample cell windows,
- Caldos25, Caldos27, Magnos206 (see page 28) in the version with direct sample chamber connection and purged thermostat room,

each mounted in the 19-inch housing (Model AO2020) or wall-mounted housing (Model AO2040).

The purge gas flow monitoring (see page 30) is a constituent part of the 'Safety Concept', including a control and evaluation, it is fully integrated into the gas analyzer.

Design

The gas analyzer consists of the central unit (system housing with display and operator control unit, power supply unit and electronics module) and the analyzer module.

The analyzer module is installed in the central unit or in a separate housing.

The version complies with the provisions of the European Directive 2014/34/EU (ATEX directive).

NOTE

The Declaration of Conformity can be found on the DVD-ROM "Software tools and technical documentation" which is delivered together with the gas analyzer.

The temperature class of the analyzer is T4.

The measurement function of the gas analyzers was not checked for suitability for influencing of other devices in hazardous areas.

Remark: Non-flammable gas is a gas mixture with a proportion of flammable components which is always – therefore even in the event of an error – smaller than the lower explosive limit (LEL).

Designation

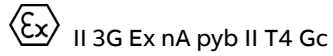

Standards and directives

The gas analyzer was designed and manufactured in accordance with the following standards:

- EN/IEC 60079-0
- EN/IEC 60079-15

The gas analyzer must be designed, installed and operated in accordance with the following standards and directives:

- EN/IEC 60079-14
- EN/IEC 60079-17
- EN/IEC 60079-19

NOTICE

The full designation of the applied standards, including the date of issue, is included in the declaration of conformity supplied with the device.

Internal and external explosion protection

No release of flammable sample gas

A release of flammable sample gas from the sample gas path ("containment system") into the system housing is reliably prevented by the following measures:

- The sample gas paths of the analyzer module are technically sealed, connected by metal tubes and tested for seal integrity.
- The sample cell of the Uras26 Analyzer Module is designed to be fail-safe (with the exception of windows and seals). Connection pipes and sample cell are metallic, welded to each other and routed from the system housing without additional cable glands.
- A gas purge curtain encloses all the parts of the sample gas path which are not fail-safe, e.g. windows or seals. It is designed in pressurized enclosure type "py". When operated in accordance with the technical data, the purging gas pressure is usually at least 0.5 hPa above sample gas pressure. In this way, the sample gas path meets the basic requirements for "no release" as specified in EN 60079-2:2005, Section 11.1.
- At appropriate intervals the sample gas pressure and function of the pressurized enclosure are checked.
- At appropriate intervals the sample gas path and purge gas path are checked for leak tightness.

Remark: The term "purging gas" is used in the sense of "inert gas" in accordance with EN 60079-2.

No electrical ignition sources in the system housing

The electrical components in the system housing are non-arcing assemblies and components or "sealed devices" as per EN 60079-15. Thus there are no electrical ignition sources in the system housing during normal operation.

If sample gas is released in spite of the measures described above and a dangerous explosive atmosphere forms briefly inside the system housing, explosion protection is nevertheless assured.

No ignition sources in the sample gas path

There are no ignition sources in the sample gas path during normal operation.

External explosion protection

Only non-hot assemblies and components are located inside the system housing.

Technical data

Electrical specifications

Power supply	System housing with central unit and analyzer module: 100 to 240 V AC (- 15 %, + 10 %), 2,2 to 0,7 A, 47 to 63 Hz; System housing with 2 analyzer modules: 24 V DC, max. 95 W per module, Functional extra-low voltage "PELV"
Signal inputs and outputs	Functional extra-low voltage "PELV"
System bus, computer interfaces	Functional extra-low voltage "PELV"

For further electrical data, see "Advance Optima AO2000 Series" data sheet.

System housing

Housing protection type	IP54 as per EN 60529
-------------------------	----------------------

Ambient temperature

	during operation with analyzer module installed in a system housing	
	without electronics module	with electronics module
Limas11 IR	+5 to +45 °C	+5 to +45 °C, +5 to +40 °C with I/O modules
Uras26	+5 to +45 °C	+5 to +40 °C
Caldos25	+5 to +45 °C	+5 to +45 °C
Caldos27	+5 to +50 °C	+5 to +45 °C
Magnos206	+5 to +50 °C	+5 to +45 °C

Sample gas path ("containment system")

Sample gas	Flammable and non-flammable gases and vapors under atmospheric conditions ($p_{abs} \leq 1.1$ bar, oxygen content ≤ 21 vol.-%); Temperature Class T4, for Limas11 IR: T6; not potentially explosive under normal conditions, if potentially explosive in the event of a fault, then only seldom and briefly (in accordance with Zone 2); (only for Limas11 IR:) occasionally potentially explosive under normal conditions (in accordance with Zone 1), Temperature Class T4. Mixtures of flammable gases and vapors and oxygen that are not explosive under normal conditions or in the event of a fault. As a rule, these can be achieved if the oxygen content is reliably limited to max. 2 vol.% or the flammable component is reliably limited to max. 50 % LEL. Flammable gases and vapors that are explosive under the conditions encountered during analysis, even when oxygen is excluded, may be present in the mixture to be analyzed only in concentrations that are considered non-critical according to safety regulations.
Flow	max. 40 l/h
Pressure	At sample gas inlet: max. positive pressure $p_e \leq 3$ hPa, at sample gas outlet: atmospheric
Turning off the sample gas	by user when shutting down the analyzer and in case of an alarm (pressurized enclosure failure) additional special conditions for operation with flammable sample gas (see page 25)

Purge curtain / purge gas / pressurized enclosure

Designation of gas connections	Purge gas inlet: "Analyzer Purge In", Purge gas outlet: "Analyzer Purge Out"
Purge gas	Inert gas (N ₂)
Flow	During operation: 15 to 20 l/h, during initial purge: 15 to 40 l/h
Initial purging	Manually controlled; initial purge duration: Limas11 IR, Uras26: 1.6 minutes at min. 15 l/h; Caldos25, Caldos27, Magnos206: 18 minutes at min. 15 l/h or 7 minutes at min. 40 l/h. An initial purge is not necessary, if it has been proved that no flammable sample gas is present in the sample gas path or purge gas path.
Operation	A capillary located in the purge gas path monitors that the required positive pressure of the purge curtain is ≥ 0.5 hPa above that of the sample gas at the above purge gas flow rates.
Monitoring	Compliance with the above purge gas flow rate is monitored in the gas analyzer. Alarm signal at digital output in accordance with data in the analyzer data sheet if the minimum flow rate of 15 l/h (corresponds to approx. 7 hPa) is undershot and the maximum flow rate of 40 l/h (corresponds to approx. 50 hPa) is overshoot.

Special requirements for operation

Special requirements

- All cables must enter via the specified cable fittings and be sealed by tightening the nuts in accordance with IP54. Cable connectors not in use have to be closed with suitable vent plugs.
- If the installation site of the gas analyzer is hazardous,
 - The external connectors on the analyzer module "Power supply 24 V DC" and "System bus" which are accessible without having to open the system housing may not be plugged in or unplugged while the power is on.
 - The system housing may not be opened while the power is on.

Additional special requirements for operation with flammable sample gas

- The sample gas pressure in the gas analyzer must correspond to the atmospheric conditions in all operational conditions and in the event of faults (positive pressure ≤ 3 hPa).
- If pressurized enclosure fails (supply of purge gas to the purge curtain) and an alarm is triggered, the fault must be corrected quickly. The gas analyzer can remain in operation. If the fault cannot be eliminated quickly, supply of the sample gas must be cut off.
- If the gas analyzer is not in operation, then the supply gases must be cut off.
- Tests:
 - At start-up, after failure of the pressurized enclosure and at regular intervals, a test for proper functioning of the pressurized enclosure must be conducted by a technically competent person. At this time, the conditions stipulated in the section "Technical data" should be checked and established.
 - The alarm output must be checked.
 - The seal integrity of the sample gas path and purge gas path must be checked at suitable intervals
- If the gas analyzer contains several analyzer modules, the pressurized enclosure must be installed as well as monitored and checked separately for each individual analyzer module. In the event of a fault, an alarm must be triggered in each individual analyzer module.

NOTES

The pressurized enclosure (supply of purge gas to the purge curtain) and if required, a housing purge must be provided separately.

The pressurized enclosure is not required if the gas analyzer is used to the measure non-flammable gases.

Limas11 IR, Uras26: Version for the 'Safety Concept'

Purging the cell windows

Purge at a slight positive pressure flows through the sample cell windows of the safety cell. In the event of a leak in the sample gas path, e.g. cracking of the sample cell window, the purge gas flows into the sample cell and, in this way, prevents flammable gases from emerging from the analyzer module.

The purge gas is introduced to the purge curtain at a flow rate of 15 to 20 l/h and at a positive pressure of $p_e \leq 50$ hPa. As a result of the capillary, a positive pressure of $p_e = 7$ to 20 hPa is established. The purge gas flow is measured by a flow meter located downstream from a capillary in the sample gas path. The outlet pressure should be open to atmospheric pressure.

The signal from the flow sensor is monitored and evaluated by a function block application (see section "Monitoring of purge gas flow", see page 30).

Purge curtain

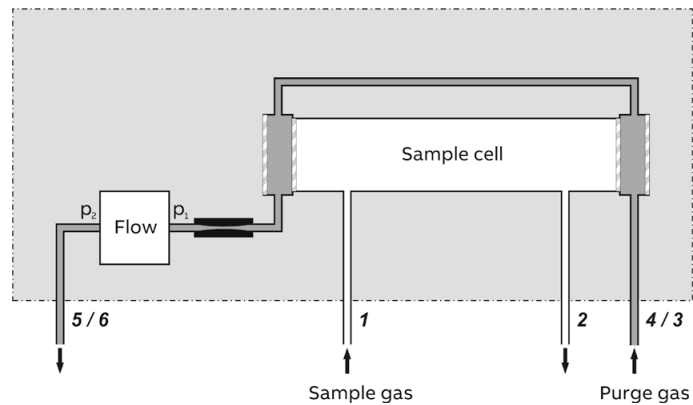

Limas11 IR	Uras26	
1	1	Sample gas inlet
2	2	Sample gas outlet
4	3	Purge gas inlet sample cell windows "Analyzer Purge In"
5	6	Purge gas outlet flow monitoring "Analyzer Purge Out"

Gas connections

Limas11 IR

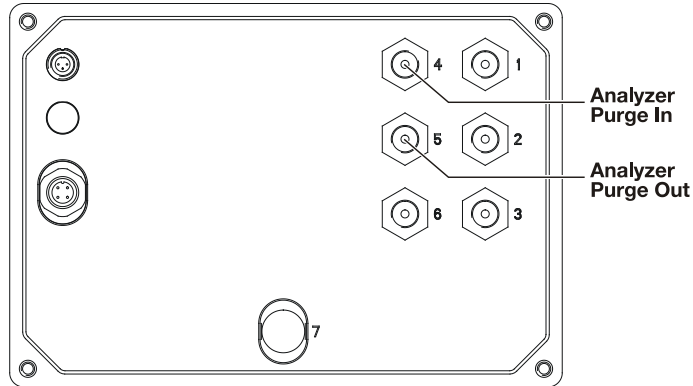

- 1 Sample gas inlet
- 2 Sample gas outlet
- 3 Purge gas inlet for housing
- 4 Purge gas inlet sample cell windows **"Analyzer Purge In"**. Connect needle valve upstream to adjust the purge gas flow rate to 15 to 20 l/h
- 5 Purge gas outlet flow monitoring **"Analyzer Purge Out"**
- 6 Purge gas inlet for housing
- 7 Pressure sensor (option)

Uras26

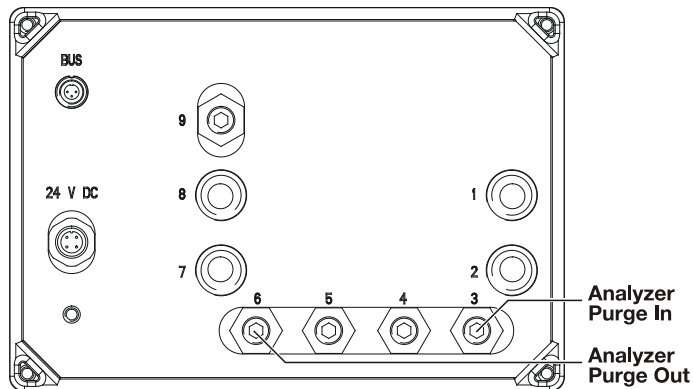

- 1 Sample gas inlet optical beam path 1
- 2 Sample gas outlet optical beam path 1
- 3 Purge gas inlet sample cell windows **"Analyzer Purge In"**. Connect needle valve upstream to adjust the purge gas flow rate to 15 to 20 l/h
- 4 Purge gas inlet for housing
- 5 Purge gas inlet for housing
- 6 Purge gas outlet flow monitoring **"Analyzer Purge Out"**
- 7 Sample gas outlet optical beam path 2
- 8 Sample gas inlet optical beam path 2
- 9 Pressure sensor (option)

Caldos25, Caldos27, Magnos206: Version for the 'Safety Concept'

Purging of the thermostat chamber

The thermostat chamber that encloses the analyzer is flushed with purge gas at a slight positive pressure. The purge curtain formed in this manner comprises all of the parts of the sample gas path. In the event of a leak in the sample gas path, the purge gas flows into the analyzer and, in this way, prevents flammable gases from emerging from the analyzer module.

The purge gas is introduced at a flow rate of 15 to 20 l/h and a positive pressure of $p_e \leq 50$ hPa to the thermostat chamber. As a result of the capillary, a positive pressure of $p_e = 7$ to 20 hPa is established. The purge gas flow is measured by a flow meter located downstream from a capillary in the sample gas path. The outlet pressure should be open to atmospheric pressure.

The signal from the flow sensor is monitored and evaluated by a function block application (see section "Monitoring of purge gas flow", see page 30).

Purge curtain

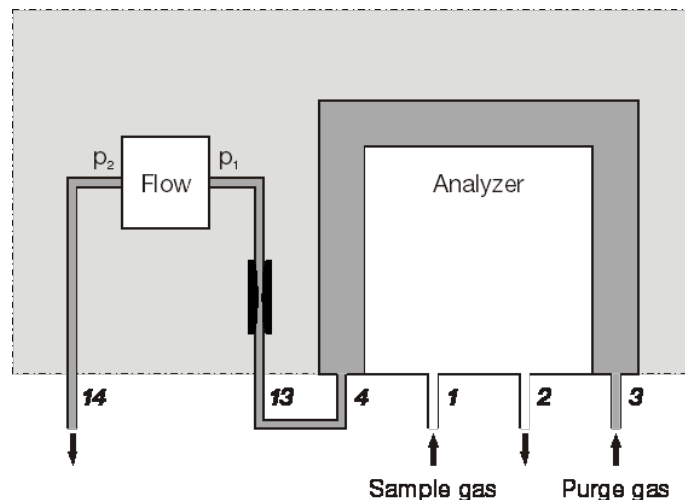

- 1 Sample gas inlet
- 2 Sample gas outlet
- 3 Purge gas inlet thermostat chamber "**Analyzer Purge In**"
- 4 Purge gas outlet thermostat chamber, ex works tubed with 13
- 13 Purge gas inlet flow monitoring
- 14 Purge gas outlet flow monitoring "**Analyzer Purge Out**"

Gas connections

Caldos25, Caldos27

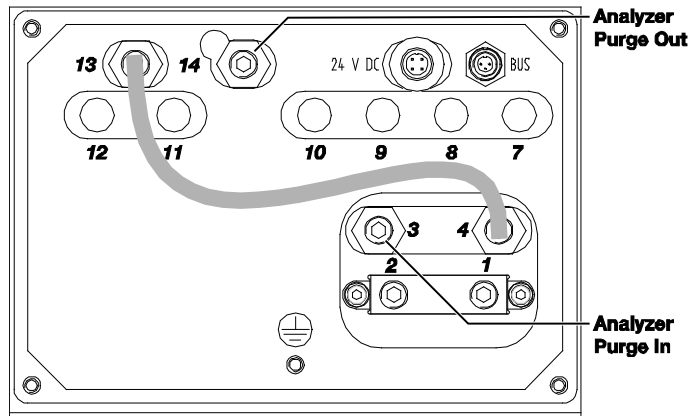

Magnos206

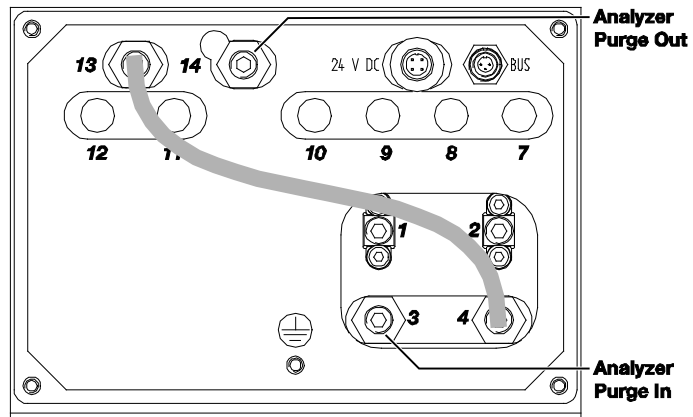

- 1 Sample gas inlet
- 2 Sample gas outlet
- 3 Purge gas inlet thermostat chamber "**Analyzer Purge In**". Connect needle valve upstream to adjust the purge gas flow rate to 15 to 20 l/h.
- 4 Purge gas outlet thermostat chamber, ex works tubed with **13**
- 7 Purge gas inlet for housing
- 8 Purge gas inlet for housing
- 9 Pressure sensor
- 10 Pressure sensor
- 11 unused, closed off
- 12 unused, closed off
- 13 Purge gas inlet flow monitoring
- 14 Purge gas outlet flow monitoring "**Analyzer Purge Out**"

Purge gas flow monitoring

Purge gas flow monitoring

The purge gas flow is continuously measured by a flow sensor. The signal of the flow sensor is monitored and evaluated by a function block application. This function block application is configured ex works. The monitoring and evaluation is designed individually for each analyzer module.

Function block application for purge gas flow monitoring

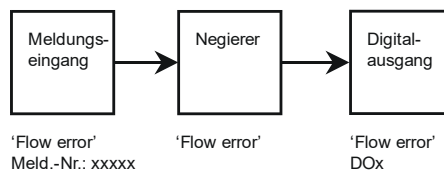
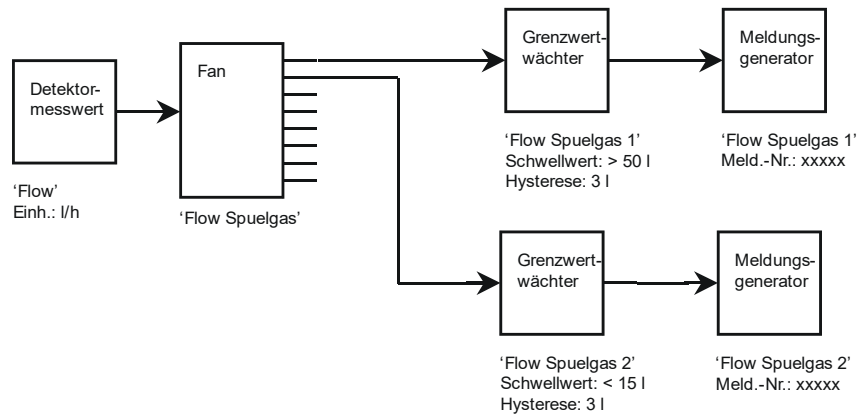

Output of a status signal

In the event of a flow error in the purge gas feed path, a status signal is output via a digital output (see "Analyzer data sheet"). The user must connect the status signal so that a visible or audible alarm is triggered.

Version for use in Class I Div. 2 explosion hazard areas

Intended application

The AO2000 Series gas analyzers with analyzer modules Caldos25, Caldos27, Limas21 UV, Limas21 HW, Magnos206, Magnos28, Magnos27 and Uras26 are certified for use in Class 1, Div. 2 explosion hazard areas, Groups A, B, C, and D, Temperature code T4.

Housing versions not equipped with conduit entries must be installed in a suitable enclosure, cabinet or rack with provision for connection of Div. 2 wiring methods, acceptable to the local inspection authority having jurisdiction.

Certificate

Certificate No. 1105720

Warnings

WARNING – EXPLOSION HAZARD
 Substitution of components may impair suitability for Class I Division 2.
 Secure all connectors with fasteners provided.
 Relay contacts rated 30 V/1 A.
 I/O connectors must only be connected to Class2 circuits.

Ratings and ambient temperature

Analyzer module	Rating	Ambient temperature
Caldos25	max. 25 W	+5 to +45 °C
Caldos27	max. 17 W	+5 to +50 °C
Limas21 UV	max. 100 W	+5 to +45 °C
Limas21 HW	max. 100 W	+15 to +35 °C
Magnos206	max. 50 W	+5 to +50 °C
Magnos28	max. 50 W	+5 to +50 °C
Magnos27	max. 35 W	+5 to +45 °C
Uras26	max. 95 W	+5 to +45 °C

Preparation for installation

Scope of supply and delivery

Standard scope of supply and delivery

- Gas analyzer Model AO2020 (19-inch housing) or Model AO2040 (wall-mount housing)
- Screwed fittings with tubing connectors for the connection of flexible tubes
- Mains lead, length 5 m, grounded-instrument connector and separate grounding connector
- Mating plugs (socket housing) for the electrical connection of the I/O modules (plugged on the I/O modules)
- Screwdriver (required for attaching the electric lines in the mating plugs)
- System bus terminating resistor
- DVD-ROM "Software tools and technical documentation" with software tools and technical documentation
- Commissioning instruction
- Analyzer Data Sheet

Also in the scope of supply and delivery depending on version

- Connecting cable for the 24 V DC supply to analyzer modules which are not installed in the central unit
- Connecting cable, T-pieces and terminating resistors for the system bus (according to order)
- Inserts for the M32 screwed cable glands (only IP54 version)

Fidas24:

- Mains lead, length 5 m, with 4-pin socket connector and separate grounding connector for the power supply to the heating of the detector and the heated sample gas connection
- Accessories pack with fittings and O-rings for connection of the sample gas line
- Exhaust pipe with fitting nut and compression fitting

Material required for the installation (not supplied)

Gas connections

- Threaded connections with $\frac{1}{8}$ NPT threads and PTFE sealing tape
Fidas24: Only use threaded connections of metal!

Fidas24: Gas lines

Process gases, test gases and waste air

- PTFE or stainless steel tubes with 4 mm inside diameter and PTFE or stainless steel tube with ≥ 10 mm inside diameter for waste air
- Tube fittings
- Pressure regulator
- Flow restrictor in the combustion gas supply line (see page 47)
- Shut-off valve in the combustion gas supply line (see page 47)

Sample gas

- Heated sample gas line (recommended: TBL 01) or unheated sample gas line (PTFE or stainless steel tube with inside/outside diameter 4/6 mm).
The fittings and O-rings-required for the connection are included in the scope of supply and delivery of the gas analyzer.

Flowmeter

- In the Caldos25 and Uras26 analyzer modules with flowing reference gas, a flowmeter with a needle valve must be installed in the sample gas line and in the reference gas line, in order to adjust the flow rate in the two lines to the optimum value.

Assembly

19-inch housing

- 4 oval head screws (Recommendation: M6; this depends on the cabinet/rack system).
- 1 pair of mounting rails (execution depends on the cabinet/rack system).

Wall-mount housing

- 4 screws M8 or M10.

Signal lines

- Select required conductive material which is appropriate for the length of the lines and the predictable current load.
- Notes concerning the cable cross-section for connection of the I/O modules:
 - The max. capacity of terminals for stranded wire and solid wire is 1 mm² (17 AWG).
 - The stranded wire can be tinned on the tip or twisted to simplify the assembly.
 - When using wire end ferrules, the total cross-section may not be more than 1 mm², i.e. the cross-section of the stranded wire may not be more than 0.5 mm². The PZ 6/5 crimping tool of Weidmüller & Co. must be used for crimping the ferrules.
- Max. length of the RS485 leads 1200 m (max. transmission rate 19200 bit/s).
- Max. length of the RS232 leads 15 m.

24V supply to the analyzer modules

Extension cable

- Min. cable cross-section 2.5 mm².
- Max. length 30 m.

Power supply unit

- If 2 analyzer modules are installed in a system housing, a separate power supply be provided for their power supply. This power supply unit must comply with the specifications of the AO2000 power supply unit.

Power supply lines

- If the supplied mains lead is not used, select conductive material which is appropriate for the length of the lines and the predictable current load.
- Provide a mains isolator or a switched socket-outlet, in order to be able to disconnect all the power from the gas analyzer if required.

Installation location

Installation location requirements

The gas analyzer is only intended for installation indoors.

The technical data of the gas analyzer (see data sheet and section "Analyzer module operating specifications") are valid for an installation location altitude up to 2000 meters above sea level.

The installation site must be stable enough to bear the weight of the gas analyzer!

Short gas paths

Install the gas analyzer as close as possible to the sampling location.

Install the gas conditioning and calibration modules as close as possible to the gas analyzer.

Adequate air circulation

Provide for adequate natural air circulation around the gas analyzer. Avoid heat build-up.

When installing several system housings in a 19-inch housing, maintain a minimum spacing of 1 height unit between housings.

The complete surface of the system housing is used to dissipate the heat losses.

Protection from adverse conditions

Protect the gas analyzer from

- Cold,
- Exposure to heat from e.g. the sun, furnaces, boilers
- Temperature variations
- Strong air currents
- Accumulation of dust and ingress of dust
- Corrosive atmosphere
- Vibration.

Climatic conditions

Relative humidity	max. 75 %	
Ambient temperature for storage and transport	-25 to +65 °C	
Ambient temperature range during operation with		
Analyzer module	installed in a system housing without electronics module	installed in a system housing with electronics module or with power supply only
Caldos25	+5 to +45 °C	+5 to +45 °C
Caldos27	+5 to +50 °C	+5 to +45 °C
Fidas24	+5 to +45 °C	+5 to +45 °C
Fidas24 NMHC	+5 to +40 °C	+5 to +40 °C
Limas11 IR	+5 to +45 °C	+5 to +45 °C ¹⁾
Limas21 UV	+5 to +45 °C	+5 to +45 °C ¹⁾
Limas21 HW	+15 to +35 °C	+15 to +35 °C
Magnos206	+5 to +50 °C	+5 to +45 °C
Magnos28	+5 to +50 °C	+5 to +45 °C
Magnos27	+5 to +45 °C ²⁾	+5 to +45 °C
Uras26	+5 to +45 °C	+5 to +40 °C
ZO23	+5 to +45 °C	+5 to +45 °C
Oxygen sensor	+5 to +40 °C	+5 to +40 °C

1) +5 to +40 °C, when I/O modules are installed

2) +5 to +50 °C for sample chamber direct connection and installation in housing without electronics module or Uras26

Vibrations/shocks

If the gas analyzer is installed in a cabinet, the maximum acceleration amplitude may not exceed 0.01 ms^{-2} in a frequency range of 0.1 to 200 Hz.

If the gas analyzer is not installed in a cabinet, the following data for the individual analyzer modules apply.

Analyzer module	Vibrations/shocks
Caldos25	max. ± 0.04 mm for 5 to 30 Hz
Caldos27	max. ± 0.04 mm for 5 to 55 Hz; 0.5 g for 55 to 150 Hz
Fidas24	max. 0.5 g, max. 150 Hz
Fidas24 NMHC	max. 0.5 g, max. 150 Hz
Limas11 IR	max. ± 0.04 mm at 5 to 55 Hz, 0.5 g at 55 to 150 Hz
Limas21 UV	max. ± 0.04 mm at 5 to 55 Hz, 0.5 g at 55 to 150 Hz
Limas21 HW	max. ± 0.04 mm / 0.5 g at 5 to 150 Hz
Magnos206	max. ± 0.04 mm at 5 to 20 Hz
Magnos28	max. ± 0.04 mm at 5 to 20 Hz
Magnos27	max. ± 0.04 mm at 5 to 60 Hz
Uras26	max. ± 0.04 mm at 5 to 55 Hz; 0.5 g at 55 to 150 Hz; slight transient effect on measured value in the region of the beam modulation frequency
ZO23	max. ± 0.04 mm at 5 to 55 Hz, 0.5 g at 55 to 150 Hz

Remark: Compliance with the metrological data can only be assured if data on vibration amplitude and frequency range at the installation site are available and suitable means are employed to decouple the analyzer.

Pressure sensor

In which analyzer modules is a pressure sensor installed?

Analyzer module	Pressure sensor
Limas11 IR, Limas21 UV, Limas21 HW, Caldos27, Uras26	installed ex works
Magnos206, Magnos28, Caldos27	installed ex works as an option
Caldos25, Fidas24, ZO23	not required

The information as to whether a pressure sensor has been installed in an analyzer module can be found in the

MENU → Diagnosis/Information → System Overview menu item after selecting the respective analyzer module.

Information on the connection of the pressure sensor can be found in the "Gas connections" (see page 80) sections of the individual analyzer modules.

Information for the proper operation of the pressure sensor

The following information should be noted for the correct operation of the pressure sensor:

- Prior to the commissioning of the analyzer module, the screw cap has to be screwed out of the connectors of the pressure sensor.
- For a precise pressure correction the connection of the pressure sensor and sample gas outlet have to be connected to each other via a T-piece and short lines. The lines must be as short as possible or - in the case of a greater length – have a sufficiently large internal diameter (≥ 10 mm) so that the flow effect is minimized. If the pressure sensor connection is not connected to the sample gas outlet, the pressure sensor and the sample gas outlet must be on the same pressure level.
- If the pressure sensor is connected to the sample gas feed path, the sample gas must not contain any corrosive, flammable or ignitable components.
- Pressure sensor working range: $p_{\text{abs}} = 600$ to 1250 hPa

Housing purge

When does a housing purge become necessary?

A housing purge becomes necessary when the sample gas contains flammable, corrosive or toxic components.

Prerequisite for housing purge

A housing purge is possible if the system housing is protected to IP54 (with connection box) or IP65 (without power supply). The purging gas connectors ($\frac{1}{8}$ -NPT female thread) are factory-installed based on orders.

Caldos25, Caldos27, Magnos206, Magnos28, Magnos27 analyzer modules

In gas analyzers with the Caldos25, Caldos27, Magnos206, Magnos28 and Magnos27 analyzer modules there is a gas-tight separation of the central unit and the analyzer. As a result, the central unit and the analyzer can be purged both separately (in parallel) and jointly (in series).

Limas11 IR, Limas21 UV, Limas21 HW, Uras26 and ZO23 analyzer modules

In gas analyzers with the Limas11 IR, Limas21 UV, Limas21 HW, Uras26 and ZO23 analyzer modules there is no gas-tight separation of the central unit and the analyzer. They can therefore only be purged together. If separate purging of the central unit and the analyzer is required, the analyzer module must be installed in a separate system housing protected to IP54.

Fidas24 and Fidas24 NMHC analyzer modules

In gas analyzers with the Fidas24 and Fidas24 NMHC analyzer modules the housing purge is provided in such a way that a part (approx. 600 to 700 l/h) of the instrument air is conducted continuously through the housing as purge air. Thus it is made sure that no ignitable gas mixture can form within the housing in case of a leak in the combustion gas path.

NOTE

The analyzer modules Caldos25, Caldos27, Limas11 IR, Limas21 UV, Limas21 HW, Magnos206, Magnos28, Magnos27, Uras26 and ZO23 may not be purged in series with the analyzer module Fidas24 and Fidas24 NMHC on account of the different requirements for the purge gas supply.

Central unit with housing purge

A central unit with no analyzer module installed can also be ordered in the version "with housing purge". In this case, the purging gas connectors are installed ex works in the end plate. This closes the system housing to the rear and at the bottom instead of the analyzer module.

ATTENTION

In the case of joint purging of the central unit and analyzer, the purge gas must first of all be conducted through the central unit and then through the analyzer. If the flow is in the opposite direction and there are leaks in the sample gas feed path, corrosive sample gas components can destroy the electronic components!

An analyzer module which is used to measure corrosive sample gas components must always be positioned last in the line!

Purge gas

The following is to be used as purge gas:

- Nitrogen when measuring flammable gases and
- Instrument air when measuring corrosive gases (quality per ISO 8573-1 Class 3, i.e. max. particle size of 40 µm, max. oil content 1 mg/m³, max. dew point +3 °C).

NOTE

The purge gas may not contain any sample gas components! Any sample components in the purge gas can cause false readings.

Purge gas flow rate during initial purge

The purge gas flow and the duration of the purge process depend on the volume to be purged (see the following table). If the purge gas flow is lower than specified, the duration of the purging must be extended accordingly.

Volume to be purged	Purge gas flow rate	Duration
Gas path	100 l/h (max.)	approx. 20 s
Central unit with or without analyzer module	200 l/h (max.)	approx. 1 h
Analyzer separately: Caldos25, Caldos27, Magnos206, Magnos28, Magnos27	200 l/h (max.)	approx. 3 min

Purge gas flow rate during operation

Purge gas flow rate at device inlet max. 20 l/h (constant), purge gas positive pressure: $p_e = 2$ to 4 hPa.

For a purge gas flow rate at the device inlet of 20 l/h, the purge gas flow rate at the device outlet is approx. 5 to 10 l/h.

Information for the selection and use of flowmeters:

- Measuring range 7 to 70 l/h
- Pressure drop < 4 hPa
- Needle valve open
- Recommendation: Flowmeter 7 to 70 l/h, Part Number 23151-5-8018474

ATTENTION

Purge gas can escape from the housing if there are any leak points. When using nitrogen as the purge gas, take all required precautions against suffocation.

The purge gas flow must always be restricted upstream of the purge gas inlet! If the purge gas flow is not restricted until after the purge gas outlet, the full pressure of the purge gas will affect the housing seals which can destroy the operator panel keypad!

Power supply

Gas analyzer power supply

A power supply is installed in the central unit of the gas analyzer. It provides the supply voltage to power the electronics module

Analyzer module power supply

The analyzer module requires a 24 V DC voltage supply $\pm 5\%$.

If the analyzer module is installed in the central unit, power can be supplied by the central unit power supply.

If the analyzer module is installed in a separate system housing rather than in the central unit, a distinction has to be made between three housings:

- The analyzer module can be powered by the central unit power supply if the optional power line filter -Z01 is installed in the central unit and no analyzer module is installed in the central unit.
- If only one analyzer module is installed in the system housing, an AO2000 power supply can be installed in the same system housing.
- If two analyzer modules are installed in the (separate) system housing, a power supply outside the system housing must be provided. This power supply unit must comply with the specifications of the AO2000 power supply unit.

NOTE

Only 1 analyzer module may be supplied with 24 VDC from the central unit power supply! A separate 24 VDC supply is required for additional analyzer modules.

Power supply

The central unit power supply provides 24 VDC for the electronics module and one analyzer module installed in the central unit or one external analyzer module.

Input voltage	100 to 240 VAC, -15% , $+10\%$
Input current	max. 2.2 A
Line frequency range	50 to 60 Hz ± 3 Hz
Power consumption	max. 187 VA
Output voltage	24 V DC $\pm 3\%$
Connection	3-pin grounded-instrument connector to EN 60320-1/C14, connecting cable supplied

Fidas24, Fidas24 NMHC: Detector and sample gas inlet heaters

Input voltage	115 VAC or 230 VAC, $\pm 15\%$ (max. 250 VAC)
Line frequency range	47 to 63 Hz
Power consumption	125 VA for detector Fidas24, approx. 200 VA for detector Fidas24 NMHC, 125 VA for sample gas inlet (option)
Connection	4-pin connector, connecting cable supplied

Module power consumption

Module	Power consumption
System controller	approx. 15 W
I/O modules	each approx. 10 W
Caldos25	max. 25 W
Caldos27	max. 12 W
Fidas24	max. 40 W
Fidas24 NMHC	max. 40 W
Limas11 IR	max. 100 W
Limas21 UV	max. 100 W
Limas21 HW	max. 100 W
Magnos206	max. 50 W
Magnos28	max. 50 W
Magnos27	max. 35 W
Uras26	max. 95 W
ZO23	approx. 12/35 W in continuous/starting operation
Pneumatic module	approx. 20 W

Safety

Test	to EN 61010-1:2010
Class of protection	Central unit with electronics module (power supply): I; Analyzer module without electronics module (power supply): III
Overvoltage category / degree of pollution	Power supply: II/2
Safe isolation	The electronics module power supply is galvanically isolated from other circuits by means of reinforced or double insulation. Functional extra-low voltage (PELV) on the low-voltage side.

Electromagnetic compatibility

Interference immunity	Tested to EN 61326-1:2013. Inspection severity: Industrial area, fulfills at least the rating to Table 2 of EN 61326.
Emitted interference	Tested to EN 61326-1:2013. Limit value class B for interference field strength and interference voltage is met.

Caldos25: Preparation for installation

Installation site

Ambient temperature

During operation with analyzer module installed in a system housing

+5 to +45 °C without electronics module

+5 to +45 °C with electronics module or with power supply only

Vibrations/shocks

max. ± 0.04 mm at 5 to 30 Hz

Sample gas

Sample gas inlet conditions

Temperature	<p>The dew point of the sample gas must be at least 5 °C lower than the lowest ambient temperature in the overall sample gas path. Otherwise, a sample gas cooler or condensate trap is required.</p> <p>When there is a direct sample chamber connection the maximum sample gas dew point is 55 °C.</p> <p>Fluctuations in water vapor content cause volume errors.</p>
Pressure	<p>The analyzer module is operated under atmospheric pressure; the sample gas outlet is open to atmosphere. Internal pressure drop < 5 hPa with standard flow rate 60 l/h. Permissible absolute pressure range: 800 to 1250 hPa. Operation under lower absolute pressure (e.g. at altitudes above 2000 m) on request. Overpressure in the sample chamber max. 100 hPa.</p>
Flow	<p>10 to 90 l/h, max. 90 to 200 l/h for option T90 < 6 s</p>

Remark: Sample gas temperature, pressure and flow rate should be maintained constant to such a degree that the fluctuation influence on the accuracy of measurement is acceptable.

Flammable gases

The analyzer module is suitable for the measurement of flammable gases and vapors under atmospheric conditions ($p_{abs} \leq 1.1$ bar, oxygen content ≤ 21 vol.%). Temperature class: T4.

The sample gas may not be potentially explosive in normal operation; if it is potentially explosive in the event of faults in the sample gas supply, then only rarely and for a short time (corresponding to Zone 2).

Pressure in the sample gas path in normal operation $p_e \leq 100$ hPa; in the event of faults in the sample gas supply, the pressure may not exceed the maximum value of $p_e = 500$ hPa.

A housing purge with nitrogen must be provided for the measurement of flammable gases and vapors. Flame barriers can be used as an option (with the exception of the 'Safety Concept' version, see page 17). Pressure drop at the flame barriers approx. 40 hPa with a sample gas flow rate of 50 l/h. Material of the flame barriers: Stainless steel 1.4571.

Prior to using the analyzer module, the corrosion resistance of the sample gas must be tested.

Flowing reference gas

Gas inlet conditions as for sample gas

Test gases

Zero-point calibration

Sample-component-free process gas or substitute gas

End-point calibration

Process gas with a known sample gas concentration or substitute gas

Dew point

The dew point of the test gases must be approximately the same as the dew point of the sample gas.

NOTE

The notes for calibrating must be considered.

Gas connections

see section "Caldos25: Gas connections" (see page 80)

Caldos27: Preparation for installation

Installation site

Ambient temperature

During operation with analyzer module installed in a system housing

+5 to +50 °C without electronics module

+5 to +45 °C with electronics module or with power supply only

Vibrations/shocks

max. ± 0.04 mm at 5 to 55 Hz, 0.5 g at 55 to 150 Hz

Sample gas

Sample gas inlet conditions

Temperature The dew point of the sample gas must be at least 5 °C lower than the lowest ambient temperature in the overall sample gas path. Otherwise, a sample gas cooler or condensate trap is required.
When there is a direct sample chamber connection the maximum sample gas dew point is 55 °C.
Fluctuations in water vapor content cause volume errors.

Pressure The analyzer module is operated under atmospheric pressure; the sample gas outlet is open to atmosphere. Internal pressure drop < 5 hPa with standard flow rate 60 l/h. Permissible absolute pressure range: 800 to 1250 hPa. Operation under lower absolute pressure (e.g. at altitudes above 2000 m) on request. Overpressure in the sample chamber max. 100 hPa.

Flow 10 to 90 l/h, min. 1 l/h

Remark: Sample gas temperature, pressure and flow rate should be maintained constant to such a degree that the fluctuation influence on the accuracy of measurement is acceptable.

Corrosive gases

If the sample gas contains Cl₂, HCl, HF, SO₂, NH₃, H₂S or other corrosive components, ABB Analytical must be consulted.

If the sample gas contains NH₃, flexible tubes of FPM may not be used; flexible tubes of FFKM must be used instead. In this case, the pneumatic module cannot be connected to the analyzer module.

Flammable gases

The analyzer module is suitable for the measurement of flammable gases and vapors under atmospheric conditions ($p_{\text{abs}} \leq 1.1$ bar, oxygen content ≤ 21 vol.%). Temperature class: T4.

The sample gas may not be potentially explosive in normal operation; if it is potentially explosive in the event of faults in the sample gas supply, then only rarely and for a short time (corresponding to Zone 2).

Pressure in the sample gas path in normal operation $p_e \leq 100$ hPa; in the event of faults in the sample gas supply, the pressure may not exceed the maximum value of $p_e = 500$ hPa.

A housing purge with nitrogen must be provided for the measurement of flammable gases and vapors. Flame barriers can be used as an option (with the exception of the 'Safety Concept' version, see page 17). Pressure drop at the flame barriers approx. 40 hPa with a sample gas flow rate of 50 l/h. Material of the flame barriers: Stainless steel 1.4571.

Prior to using the analyzer module, the corrosion resistance of the sample gas must be tested.

Test gases**Zero point calibration**

Test gas, sample-component-free process gas or substitute gas

End-point calibration

Test gas, process gas with a known sample gas concentration or substitute gas

Caldos27 with standard gas calibration

Standard gas with a defined relative thermal conductivity (rTC)

Dew point

The dew point of the test gases must be approximately the same as the dew point of the sample gas.

NOTE

The notes for calibrating must be considered.

Pressure sensor

The pressure sensor is installed in the gas analyzer ex works. It is connected to a connection port via an FPM tube.

Working range of the pressure sensor: $p_{\text{abs}} = 600$ to 1250 hPa

Gas connections

see section "Caldos27: Gas connections" (see page 82)

Fidas24: Preparation for installation

Installation site

Ambient temperature

During operation with analyzer module installed in a system housing

+5 to +45 °C without electronics module

+5 to +45 °C with electronics module or with power supply only

Vibrations/shocks

max. 0.5 g, max. 150 Hz

Sample gas

Sample components

Hydrocarbons. The concentration of the gas components in the sample gas path must not exceed the temperature-dependent LEL. The analyzer temperature is 180 °C.

Sample gas inlet conditions

Temperature ≤ Thermostat temperature (thermostat temperature for sample gas path, detector and air jet injector ≤ 200 °C, pre-set ex works to 180 °C)

Inlet pressure $p_{\text{abs}} = 800$ to 1100 hPa

Flow approx. 80 to 100 l/h at atmospheric pressure (1000 hPa)

Humidity ≤ 40 % H₂O

Remark: Sample gas temperature, pressure and flow rate should be maintained constant to such a degree that the fluctuation influence on the accuracy of measurement is acceptable.

Sample gas outlet conditions

The outlet pressure must be the same as the atmospheric pressure.

Flammable gases

The gas analyzer may be used for the measurement of flammable gases provided that the flammable portion does not exceed 15 vol.% CH₄ or C1 equivalents.

Further sample gas inlet conditions

The sample gas may not be explosive at any time.

The analyzer module must not be used for measurement of gases containing organometallic compounds, e.g. leaded gasoline additives or silicone oils.

Process gases

Instrument air

Quality	as per ISO 8573-1 Class 2 (max. particle size 1 μm , max. particle density 1 mg/m^3 , max. oil content 0.1 mg/m^3 , dew point at least 10 $^{\circ}\text{C}$ below the lowest expected ambient temperature)
Inlet pressure	$p_e = 4000 \pm 500 \text{ hPa}$
Flow	typically approx. 1800 l/h (1200 l/h for air jet injector and approx. 600 l/h for housing purge), maximum approx. 2200 l/h (1500 l/h + 700 l/h)

Combustion air

Quality	Synthetic air or catalytically cleaned air with an organic C content < 1 % of span
Inlet pressure	$p_e = 1200 \pm 100 \text{ hPa}$
Flow	< 20 l/h

Combustion gas

Quality	Hydrogen (H_2), quality 5.0	H_2/He mixture (40 %/60 %)
Inlet pressure	$p_e = 1200 \pm 100 \text{ hPa}$	$p_e = 1200 \pm 100 \text{ hPa}$
Flow	$\leq 3 \text{ l/h}$	approx. 10 l/h

NOTE

H_2/He mixture may only be used if the gas analyzer has been ordered and supplied in the execution specified for this. If the gas analyzer has been supplied in the execution for H_2/He mixture, H_2 may not be used as a combustion gas under any circumstances. This would cause overheating and therefore the destruction of the detector!

ATTENTION

A flow restriction and a shut-off valve must be installed in the combustion gas supply line by the end user, so that safe operation of the gas analyzer is ensured.

Flow restrictor in the combustion gas supply line

The combustion gas flow must be restricted to a maximum of 10 l/h of H_2 or 25 l/h of H_2/He mixture. Suitable measures outside the gas analyzer must be provided by the end user for this purpose.

ABB recommends the use of a bulkhead fitting with an integrated flow restrictor which must be installed in the combustion gas supply line. This bulkhead fitting can be purchased from ABB:

- Combustion gas H_2 : Part Number 8329303,
- Combustion gas H_2/He mixture: Part number 0769359.

Shut-off valve in the combustion gas supply line

A shut-off valve must be installed in the combustion gas supply line to increase the safety in the following operating states:

- Shutting down the gas analyzer,
- Failure of the instrument air supply,
- Leakage in the combustion gas feed path inside the gas analyzer.

This shut-off valve should be installed outside the analyzer house in the vicinity of the combustion gas supply (cylinder, line).

ABB recommends the use of a pneumatic shut-off valve which is actuated by the instrument air. This shut-off valve can be purchased from ABB: Part number 0769440.

If a pneumatic shut-off valve of this kind cannot be installed, precautionary measures must be taken, so that the overall status or the "failure" status of the gas analyzer is monitored.

Test gases

Zero-point calibration

Quality	Nitrogen, Quality 5.0, synthetic air or catalytically cleaned air with an organic C content < 1 % of span
Inlet pressure	$p_e = 1000 \pm 100$ hPa
Flow	130 to 250 l/h

End-point calibration

Quality	Sample component or substitute gas component in nitrogen or synthetic air with concentration adjusted to the measuring range
Inlet pressure	$p_e = 1000 \pm 100$ hPa
Flow	130 to 250 l/h

NOTE

The notes for calibrating must be considered.

Gas connections

see section "Fidas24: Gas connections" (see page 83)

Fidas24 NMHC: Preparation for installation

Installation site

Ambient temperature

During operation with analyzer module installed in a system housing

+5 to +40 °C without electronics module

+5 to +40 °C with electronics module or with power supply only

Vibrations/shocks

max. 0.5 g, max. 150 Hz

Sample gas

Sample components

Hydrocarbons. The CH₄:NMHC ratio must be in the 1:9 to 9:1 range.

Maximum concentration CH₄: 26500 mg org. C/m³ or 50000 ppm C1.

Maximum concentration NMHC: 5000 mg org. C/m³ or 9330 ppm C1.

The concentration of the gas components in the sample gas path must not exceed the temperature-dependent LEL. The analyzer temperature is 180 °C.

Sample gas inlet conditions

Temperature ≤ Thermostat temperature (thermostat temperature for sample gas path, detector and air jet injector ≤ 200 °C, pre-set ex works to 180 °C)

Inlet pressure $p_{abs} = 850$ to 1100 hPa

Flow Approx. 80 to 100 l/h at atmospheric pressure (1000 hPa)

Humidity ≤ 40 % H₂O

Remark: Sample gas temperature, pressure and flow rate should be maintained constant to such a degree that the fluctuation influence on the accuracy of measurement is acceptable.

Sample gas outlet conditions

The outlet pressure must be the same as the atmospheric pressure.

Flammable gases

The analyzer module may be used for the measurement of flammable gases provided that the flammable portion does not exceed 5 vol.% CH₄ or C1 equivalents.

Further sample gas inlet conditions

The sample gas may not be explosive at any time.

The analyzer module must not be used for measurement of gases containing organometallic compounds, e.g. leaded gasoline additives or silicone oils.

Catalyst poisons in the sample gas (e.g. SO₂, HCl, H₂S, halogenated hydrocarbons, heavy metals) will shorten the converter service life. Their respective concentration should always be < 20 mg/m³.

Process gases

Instrument air

Quality	as per ISO 8573-1 Class 2 (max. particle size 1 µm, max. particle density 1 mg/m ³ , max. oil content 0.1 mg/m ³ , dew point at least 10 °C below the lowest expected ambient temperature)
Inlet pressure	$p_e = 4000 \pm 500$ hPa
Flow	typically approx. 1800 l/h (1200 l/h for air jet injector and approx. 600 l/h for housing purge), maximum approx. 2200 l/h (1500 l/h + 700 l/h)

Combustion air

Quality	Synthetic air or catalytically cleaned air with an organic C content < 1 % of span
Inlet pressure	$p_e = 1200 \pm 100$ hPa
Flow	< 20 l/h

Combustion gas

Quality	Hydrogen (H ₂), Quality 5.0	H ₂ /He mixture (40 %/60 %)
Inlet pressure	$p_e = 1200 \pm 100$ hPa	$p_e = 1200 \pm 100$ hPa
Flow	≤ 3 l/h	approx. 10 l/h

NOTE

H₂/He mixture may only be used if the gas analyzer has been ordered and supplied in the execution specified for this. If the gas analyzer has been supplied in the execution for H₂/He mixture, H₂ may not be used as a combustion gas under any circumstances. This would cause overheating and therefore the destruction of the detector!

ATTENTION

A flow restriction and a shut-off valve must be installed in the combustion gas supply line by the end user, so that safe operation of the gas analyzer is ensured.

Flow restrictor in the combustion gas supply line

The combustion gas flow must be restricted to a maximum of 10 l/h of H₂ or 25 l/h of H₂/He mixture. Suitable measures outside the gas analyzer must be provided by the end user for this purpose.

ABB recommends the use of a bulkhead fitting with an integrated flow restrictor which must be installed in the combustion gas supply line. This bulkhead fitting can be purchased from ABB:

- Combustion gas H₂: Part number 8329303,
- Combustion gas H₂/He mixture: Part number 0769359.

Shut-off valve in the combustion gas supply line

A shut-off valve must be installed in the combustion gas supply line to increase the safety in the following operating states:

- Shutting down the gas analyzer,
- Failure of the instrument air supply,
- Leakage in the combustion gas feed path inside the gas analyzer.

This shut-off valve should be installed outside the analyzer house in the vicinity of the combustion gas supply (cylinder, line).

ABB recommends the use of a pneumatic shut-off valve which is actuated by the instrument air. This shut-off valve can be purchased from ABB: Part number 0769440.

If a pneumatic shut-off valve of this kind cannot be installed, precautionary measures must be taken, so that the overall status or the "failure" status of the gas analyzer is monitored.

Test gases

Zero calibration

Quality	Synthetic air or catalytically purified air with an org. C content of < 1 % span
Inlet pressure	$p_e = 1000 \pm 100$ hPa
Flow rate	130 to 250 l/h

Span calibration

Components	Sample component CH ₄ : CH ₄ in air Sample component THC: C ₃ H ₈ in air or CH ₄ in air Substitute gas component (when configured per order): CH ₄ in air
Inlet pressure	$p_e = 1000 \pm 100$ hPa
Flow rate	130 to 250 l/h

Converter effectiveness testing

Components	CH ₄ in air or C ₂ H ₆ in air (separate test gas containers), connection via bypass
Inlet pressure	$p_e = 1000 \pm 100$ hPa
Flow rate	130 to 250 l/h

NOTE

The notes for calibrating must be considered.

Gas connections

see section "Fidas24: Gas connections" (see page 83)

Limas11 IR, Limas21 UV: Preparation for installation

Installation site

Ambient temperature

During operation with analyzer module installed in a system housing

+5 to +45 °C without electronics module

+5 to +45 °C with electronics module or only with power supply

+5 to +40 °C with electronics module, if I/O modules are installed, or only with power supply

Vibrations/shocks

max. ± 0.04 mm at 5 to 55 Hz; 0.5 g at 55 to 150 Hz

Sample gas

Sample gas inlet conditions

Temperature The dew point of the sample gas must be at least 5 °C lower than the lowest ambient temperature in the overall sample gas path. Otherwise, a sample gas cooler or condensate trap is required.

Pressure The analyzer module is operated under atmospheric pressure; the sample gas outlet is open to atmosphere. Internal pressure drop < 5 hPa with standard flow rate 60 l/h. Permissible absolute pressure range: 800 to 1250 hPa. Operation under lower absolute pressure (e.g. at altitudes above 2000 m) on request. Overpressure in the sample cell max. 500 hPa.

Flow 20 to 100 l/h

Remark: Sample gas temperature, pressure and flow rate should be maintained constant to such a degree that the fluctuation influence on the accuracy of measurement is acceptable.

Flammable, corrosive or toxic gases

Depending on which sample cell has been installed in the analyzer module, the following application restrictions and notes must be observed:

	Standard cell	Quartz cell	Safety cell
Suitable for measurement of ...	Non-corrosive gases	Corrosive gases, e.g. wet Cl ₂ wet HCl, H ₂ SO ₄ , SO ₃ , ozone	Corrosive gases, e.g. dry HCl, dry COCl ₂ (< 50 ppm H ₂ O)
Not suitable for measurement of ...	Highly corrosive gases, e.g. gases containing chlorine, H ₂ SO ₄ , SO ₃ , fluorine compounds	Fluorine compounds	Wet gases containing chlorine, H ₂ SO ₄ , SO ₃ , fluorine compounds
Toxic gases	Housing purge ³⁾ with sample component-free air or with N ₂	Housing purge ³⁾ with sample component-free air or with N ₂	Sample cell purge ¹⁾ with N ₂ or with sample component-free air under negative pressure and flow monitoring; additional monitoring for sample gas traces possible
Corrosive gases	PTFE gas lines, housing purge ³⁾ with sample component-free air or with N ₂	Housing purge ³⁾ with sample component-free air or with N ₂	Sample cell purge ¹⁾ with N ₂ or with sample component-free air under positive pressure ²⁾ with flow monitoring
Flammable gases ⁴⁾	Gas lines of stainless steel, housing purge ³⁾ with N ₂	Housing purge ³⁾ with N ₂	Sample cell purge ¹⁾ with N ₂

1) "Purge curtain"

2) $p_e = 7$ to 20 hPa, 15 to 20 l/h

3) ≤ 20 l/h

4) See the following section for further information

Flammable gases

The analyzer module is suitable for the measurement of flammable gases and vapors under atmospheric conditions ($p_{abs} \leq 1.1$ bar, oxygen content ≤ 21 vol.%). Temperature class: T4.

The sample gas may not be potentially explosive in normal operation; if it is potentially explosive in the event of faults in the sample gas supply, then only rarely and for a short time (corresponding to Zone 2).

Pressure in the sample gas feed path in normal operation $p_e \leq 100$ hPa; in the event of faults in the sample gas supply, the pressure may not exceed the maximum value of $p_e = 500$ hPa.

For the measurement of flammable gases and vapors, the version with internal gas lines made of stainless steel should be selected and a housing purge with nitrogen provided.

Prior to using the analyzer module, the corrosion resistance of the sample gas must be tested.

Test gases

Zero-point calibration

Nitrogen or air or UV sample component-free gas

End-point calibration

Calibration cells or test gas for each sample component

Dew point

The dew point of the test gases must be approximately the same as the dew point of the sample gas.

NOTE

The notes for calibrating must be considered.

Pressure sensor

The pressure sensor is installed in the gas analyzer ex works.

The pressure sensor is located in the sample gas feed path if the internal gas lines are executed as FPM flexible tubes. The connection of the pressure sensor is led to the outside via an FPM hose if the internal gas lines are executed as tubes. The connection of the pressure sensor is documented in the pneumatic diagram contained in the analyzer data sheet.

Pressure sensor working range: $p_{abs} = 600$ to 1250 hPa

Gas connections

see section "Limas11 IR, Limas21 UV, Limas21 HW: Gas connections" (see page 84)

Limas21 HW: Preparation for installation

Installation site

Ambient temperature

+15 to +35 °C with installation in a system housing with or without an electronics module

Vibrations/shocks

max. ± 0.04 mm / 0.5 g at 5 to 150 Hz

Sample gas

Sample gas composition

Stack gas from incinerators without sulfur content, SO₂ concentration < 25 ppm, H₂O concentration < 20 vol.%, filtered with pore size ≤ 0.5 μ m

Sample gas inlet conditions

Temperature Sample gas dew point ≤ 65 °C

Pressure The analyzer module is operated under atmospheric pressure; the sample gas outlet is open to atmosphere. Internal pressure drop < 5 hPa with standard flow rate 60 l/h. Permissible absolute pressure range: 800 to 1250 hPa. Operation under lower absolute pressure (e.g. at altitudes above 2000 m) on request. Overpressure in the sample cell max. 500 hPa.

Flow 20 to 90 l/h

Remark: Sample gas temperature, pressure and flow rate should be maintained constant to such a degree that the fluctuation influence on the accuracy of measurement is acceptable.

Test gases

Zero-point calibration

Nitrogen or air or UV sample component-free gas

End-point calibration

Calibration cells or test gas for each sample component

Dew point

The dew point of the test gases must be approximately the same as the dew point of the sample gas.

NOTE

The Notes for calibrating must be considered.

Pressure sensor

The pressure sensor is installed in the gas analyzer ex works.

The pressure sensor is located in the sample gas feed path if the internal gas lines are executed as FPM flexible tubes. The connection of the pressure sensor is led to the outside via an FPM hose if the internal gas lines are executed as tubes. The connection of the pressure sensor is documented in the pneumatic diagram contained in the analyzer data sheet.

Pressure sensor working range: $p_{\text{abs}} = 600$ to 1250 hPa

Gas connections

see section "Limas11 IR, Limas21 UV, Limas21 HW: Gas connections" (see page 84)

Sample conditioning system requirements

Sample gas feed-in

The various applications require sample gas feed-in to the gas analyzer at temperatures of 150 to 190 °C. The formation of condensation and sublimation must be excluded without fail, since NO_2 and NH_3 are highly soluble in water or can cause salt formation. In addition, any low-boiling hydrocarbons present must be prevented from precipitating.

Sample gas inlet temperature (from the process)

150 to 190 °C

Sample gas filter

for the measurement of NO and NO_2 : sintered metal; for the measurement of NH_3 : ceramic; pore size $\leq 0.5 \mu\text{m}$

Materials of the gas-bearing components

PTFE, PVDF or silicosteel

Installation note

Route the exhaust gas line declining to allow for condensate drain-off.

NOTE

Please refer to the special information for the gas line connection (see page 84), start-up (see page 134), calibration and shutting down (see page 147)!

Magnos206: Preparation for installation

Installation site

Ambient temperature

During operation with analyzer module installed in a system housing

+5 to +50 °C without electronics module

+5 to +45 °C with electronics module or with power supply only

Vibrations/shocks

max. ± 0.04 mm at 5 to 20 Hz

Sample gas

Sample gas inlet conditions

Temperature	<p>The dew point of the sample gas must be at least 5 °C lower than the lowest ambient temperature in the overall sample gas path. Otherwise, a sample gas cooler or condensate trap is required.</p> <p>When there is a direct sample chamber connection the maximum sample gas dew point is 55 °C.</p> <p>Fluctuations in water vapor content cause volume errors.</p>
Pressure	<p>Operation under atmospheric pressure: The sample gas outlet is open to atmosphere. Internal pressure drop < 5 hPa with standard flow rate 60 l/h. Permissible absolute pressure range: 800 to 1250 hPa. Operation under lower absolute pressure (e.g. at altitudes above 2000 m) on request.</p> <p>Operation under elevated pressure: A pressure sensor is required for pressure influence compensation. Absolute pressure ≤ 1250 hPa: An optional internal pressure sensor can be connected to the sample gas path. Absolute pressure ≥ 1250 hPa: An external pressure sensor must be connected to the sample gas path.</p> <p>The analyzer module is function-tested for 5000 hPa internal pressure without damage.</p>
Flow	<p>30 to 90 l/h</p> <p>Abrupt changes in the sample gas flow rate should be avoided when using highly suppressed measurement ranges.</p>

Remark: Sample gas temperature, pressure and flow rate should be maintained constant to such a degree that the fluctuation influence on the accuracy of measurement is acceptable.

Corrosive gases

If the sample gas contains Cl_2 , HCl, HF or other corrosive components, the analyzer may only be used if the sample gas composition has been taken into account by the manufacturer for the configuration of the analyzer.

Flammable gases

The analyzer module is suitable for the measurement of flammable gases and vapors under atmospheric conditions ($p_{\text{abs}} \leq 1.1$ bar, oxygen content ≤ 21 vol.%). Temperature class: T4.

The sample gas may not be potentially explosive in normal operation; if it is potentially explosive in the event of faults in the sample gas supply, then only rarely and for a short time (corresponding to Zone 2).

Pressure in the sample gas path in normal operation $p_e \leq 100$ hPa; in the event of faults in the sample gas supply, the pressure may not exceed the maximum value of $p_e = 500$ hPa.

A housing purge with nitrogen must be provided for the measurement of flammable gases and vapors. Flame barriers can be used as an option (with the exception of the 'Safety Concept' version, see page 17). Pressure drop at the flame barriers approx. 40 hPa with a sample gas flow rate of 50 l/h. Material of the flame barriers: Stainless steel 1.4571.

Prior to using the analyzer module, the corrosion resistance of the sample gas must be tested.

Test gases

Zero-point calibration

Oxygen-free process gas or nitrogen

End-point calibration

Process gas with a known oxygen concentration or a substitute gas, e.g. dried air

Magnos206 with a suppressed measuring range

Test gas with an oxygen concentration in the selected measuring range

Magnos206 with single-point calibration

Test gas with an oxygen concentration in an existing measuring range or nitrogen or ambient air. Same moisture content as process gas.

ATTENTION

In order to avoid accumulations of explosive gas mixtures, do not use air as a test gas for single-point calibration when measuring flammable gases!

Dew point

The dew point of the test gases must be approximately the same as the dew point of the sample gas.

NOTE

The notes for calibrating must be considered.

Pressure sensor

The pressure sensor is installed in the gas analyzer as an option. It is connected to a connection port via an FPM tube.

With measurements in suppressed measuring ranges the connection of the pressure sensor and the sample gas outlet are to be connected to each other via a T-joint and short lines.

Particular care should be taken that the gas discharge line is as short as possible or - in the case of a greater length – has a sufficiently wide inside diameter (at least 10 mm).

Gas connections

see section "Magnos206: Gas connections" (see page 88)

Magnos28: Preparation for installation

Installation site

Ambient temperature

During operation with analyzer module installed in a system housing

+5 to +50 °C without electronics module

+5 to +45 °C with electronics module or with power supply only

Vibrations/shocks

max. ± 0.04 mm at 5 to 20 Hz

Sample gas

Sample gas inlet conditions

Temperature	<p>The dew point of the sample gas must be at least 5 °C lower than the lowest ambient temperature in the overall sample gas path. Otherwise, a sample gas cooler or condensate trap is required.</p> <p>When there is a direct sample chamber connection the maximum sample gas dew point is 55 °C.</p> <p>Fluctuations in water vapor content cause volume errors.</p>
Pressure	<p>Operation under atmospheric pressure: The sample gas outlet is open to atmosphere. Internal pressure drop < 5 hPa with standard flow rate 60 l/h. Permissible absolute pressure range: 800 to 1250 hPa. Operation under lower absolute pressure (e.g. at altitudes above 2000 m) on request.</p> <p>Operation under elevated pressure: A pressure sensor is required for pressure influence compensation. Absolute pressure ≤ 1250 hPa: An optional internal pressure sensor can be connected to the sample gas path. Absolute pressure ≥ 1250 hPa: An external pressure sensor must be connected to the sample gas path.</p>
Flow	<p>30 to 90 l/h</p> <p>Abrupt changes in the sample gas flow rate should be avoided when using highly suppressed measurement ranges.</p>

Remark: Sample gas temperature, pressure and flow rate should be maintained constant to such a degree that the fluctuation influence on the accuracy of measurement is acceptable.

Corrosive gases

If the sample gas contains Cl_2 , HCl, HF or other corrosive components, the analyzer may only be used if the sample gas composition has been taken into account by the manufacturer for the configuration of the analyzer.

Flammable gases

The analyzer module is suitable for the measurement of flammable gases and vapors under atmospheric conditions ($p_{\text{abs}} \leq 1.1$ bar, oxygen content ≤ 21 vol.%). Temperature class: T4.

The sample gas may not be potentially explosive in normal operation; if it is potentially explosive in the event of faults in the sample gas supply, then only rarely and for a short time (corresponding to Zone 2).

Pressure in the sample gas path in normal operation $p_e \leq 100$ hPa; in the event of faults in the sample gas supply, the pressure may not exceed the maximum value of $p_e = 500$ hPa.

A housing purge with nitrogen must be provided for the measurement of flammable gases and vapors. Flame barriers can be used as an option. Pressure drop at the flame barriers approx. 40 hPa with a sample gas flow rate of 50 l/h. Material of the flame barriers: Stainless steel 1.4571.

Prior to using the analyzer module, the corrosion resistance of the sample gas must be tested.

Test gases

Zero-point calibration

Oxygen-free process gas or nitrogen

End-point calibration

Process gas with a known oxygen concentration or a substitute gas, e.g. dried air

Magnos28 with a suppressed measuring range

Test gas with an oxygen concentration in the selected measuring range

Magnos28 with single-point calibration

Test gas with an oxygen concentration in an existing measuring range or nitrogen or ambient air. Same moisture content as process gas.

ATTENTION

In order to avoid accumulations of explosive gas mixtures, do not use air as a test gas for single-point calibration when measuring flammable gases!

Dew point

The dew point of the test gases must be approximately the same as the dew point of the sample gas.

NOTE

The notes for calibrating must be considered.

Pressure sensor

The pressure sensor is installed in the gas analyzer as an option. It is connected to a connection port via an FPM tube.

With measurements in suppressed measuring ranges the connection of the pressure sensor and the sample gas outlet are to be connected to each other via a T-joint and short lines.

Particular care should be taken that the gas discharge line is as short as possible or - in the case of a greater length – has a sufficiently wide inside diameter (at least 10 mm).

Gas connections

see section "Magnos28: Gas connections" (see page 89)

Magnos27: Preparation for installation

Installation site

Ambient temperature

During operation with analyzer module installed in a system housing

+5 to +45 °C without electronics module

+5 to +45 °C with electronics module or with power supply only

+5 to +50 °C without electronics module or Uras26 and version with sample chamber direct connection

Vibrations/shocks

max. ± 0.04 mm at 5 to 60 Hz

Sample gas

Sample gas inlet conditions

Temperature The dew point of the sample gas must be at least 5 °C lower than the lowest ambient temperature in the overall sample gas path. Otherwise, a sample gas cooler or condensate trap is required. When there is a direct sample chamber connection the maximum sample gas dew point is 55 °C. Fluctuations in water vapor content cause volume errors.

Pressure The analyzer module is operated under atmospheric pressure; the sample gas outlet is open to atmosphere. Internal pressure drop < 5 hPa with standard flow rate 60 l/h. Permissible absolute pressure range: 800 to 1250 hPa. Operation under lower absolute pressure (e.g. at altitudes above 2000 m) on request. Overpressure in the sample chamber max. 100 hPa.

Flow 20 to 90 l/h

Remark: Sample gas temperature, pressure and flow rate should be maintained constant to such a degree that the fluctuation influence on the accuracy of measurement is acceptable.

Flammable gases

The gas analyzer may not be used for the measurement of flammable gases.

Test gases

Zero-point calibration

Oxygen-free process gas or Nitrogen

End-point calibration

Process gas with a known oxygen concentration or a substitute gas, e.g. dried air

Dew point

The dew point of the test gases must be approximately the same as the dew point of the sample gas.

NOTE

The notes for calibrating must be considered.

Pressure sensor

The pressure sensor is installed in the gas analyzer as an option. It is connected to a connection port via an FPM tube.

Gas connections

see section "Magnos27: Gas connections" (see page 90)

Uras26: Preparation for installation

Installation site

Ambient temperature

During operation with analyzer module installed in a system housing

+5 to +45 °C without electronics module

+5 to +40 °C with electronics module or with power supply only

Vibrations/shocks

max. ± 0.04 mm at 5 to 55 Hz, 0.5 g at 55 to 150 Hz; slight transient effect on measured value in the region of the beam modulation frequency

Sample gas

Sample gas inlet conditions

Temperature The dew point of the sample gas must be at least 5 °C lower than the lowest ambient temperature in the overall sample gas path. Otherwise, a sample gas cooler or condensate trap is required.

Pressure The analyzer module is operated under atmospheric pressure; the sample gas outlet is open to atmosphere. Internal pressure drop < 5 hPa with standard flow rate 60 l/h. Permissible absolute pressure range: 800 to 1250 hPa. Operation under lower absolute pressure (e.g. at altitudes above 2000 m) on request. Overpressure in the sample cell max. 500 hPa.

Flow 20 to 100 l/h

Remark: Sample gas temperature, pressure and flow rate should be maintained constant to such a degree that the fluctuation influence on the accuracy of measurement is acceptable.

Corrosive gases

Highly corrosive associated gas components such as chlorine (Cl₂ or hydrogen chlorides (e.g. wet HCl) as well as gases or aerosols containing chlorine must be cooled or pre-absorbed. A housing purge must be provided.

Flammable gases

The analyzer module is suitable for the measurement of flammable gases and vapors under atmospheric conditions ($p_{\text{abs}} \leq 1.1$ bar, oxygen content ≤ 21 vol.%). Temperature class: T4.

The sample gas may not be potentially explosive in normal operation; if it is potentially explosive in the event of faults in the sample gas supply, then only rarely and for a short time (corresponding to Zone 2).

Pressure in the sample gas feed path in normal operation $p_e \leq 100$ hPa; in the event of faults in the sample gas supply, the pressure may not exceed the maximum value of $p_e = 500$ hPa.

For the measurement of flammable gases and vapors, the version with internal gas lines made of stainless steel should be selected and a housing purge with nitrogen provided.

Prior to using the analyzer module, the corrosion resistance of the sample gas must be tested.

Flowing reference gas

Gas inlet conditions as for sample gas

Test gases

Zero-point calibration

Nitrogen or air or IR sample component-free gas

End-point calibration

Calibration cells or test gas for each sample component or test gas mixture for multiple sample components if no cross-sensitivity is present. Concentration of the span gas 70 to 80 % of the final value of the larger measurement range. For suppressed measurement ranges: concentration of the span gas within the suppressed measurement range, if possible equal to the final value.

Dew point

The dew point of the test gases must be approximately the same as the dew point of the sample gas.

NOTE

The notes for calibrating must be considered.

Pressure sensor

The pressure sensor is installed in the gas analyzer ex works.

The pressure sensor is located in the sample gas feed path if the internal gas lines are executed as FPM flexible tubes. The connection of the pressure sensor is led to the outside via an FPM hose if the internal gas lines are executed as tubes. The connection of the pressure sensor is documented in the pneumatic diagram contained in the analyzer data sheet.

Pressure sensor working range: $p_{abs} = 600$ to 1250 hPa

Gas connections

see section "Uras26: Gas connections" (see page 92)

ZO23: Preparation for installation

Installation site

Ambient temperature

during operation with analyzer module installed in a system housing

+5 to +45 °C without electronics module

+5 to +45 °C with electronics module or with power supply only

Vibrations/shocks

max. ± 0.04 mm at 5 to 55 Hz; 0.5 g at 55 to 150 Hz

No heat sources or magnetic fields

No heat sources or devices which generate strong magnetic fields (e.g. electric motors or transformers) may be located in the vicinity of the installation site.

Sample gas

ATTENTION

The gas analyzer may not be used for the measurement of ignitable gas/air or gas/oxygen mixtures.

Sample gas inlet conditions

Temperature +5 to +50 °C

Inlet pressure $p_e \leq 70$ hPa

Flow 4 to 20 l/h

The sample gas flow rate must be kept constant at ± 0.2 l/h in the specified range. The sample gas must be taken from a bypass at zero pressure. If the sample gas flow rate is too low, the effects of contaminants from the gas lines (leaks, permeabilities, desorptions) have an adverse effect on the measurement result. If the sample gas flow rate is too high, asymmetrical cooling of the sensor can cause measuring errors. This can also cause faster aging of or damage to the sample cell.

Remark: Sample gas temperature, pressure and flow rate should be maintained constant to such a degree that the fluctuation influence on the accuracy of measurement is acceptable.

Corrosive gases

The presence of corrosive gases and catalyst poisons, e.g. halogens, gases containing sulphur and heavy metal dusts, causes faster aging and/or or destruction of the ZrO_2 cell.

Flammable gases

The analyzer module is suitable for the measurement of flammable gases in a non-hazardous environment. The concentration of flammable gases in the sample gas may not exceed 100 ppm.

Associated gas effect

Inert gases (Ar, N₂) have no effect. Flammable gases (CO, H₂, CH₄) in stoichiometric concentrations for the oxygen content: Conversion of O₂ < 20 % of the stoichiometric conversion. If there are higher concentrations of flammable gas, higher O₂ conversion rates must be expected.

Sample gas outlet conditions

The outlet pressure must be the same as the atmospheric pressure.

Test gases

Reference point (= electrical zero)

Clean ambient air; its oxygen concentration can be calculated from the value for dry air and the factor for the consideration of the water vapor content.

Example:

Water vapor content at 25 °C and 50 % relative humidity = 1.56 Vol.-% of H₂O

⇒ factor 0.98

Oxygen concentration = 20.93 Vol.-% of O₂ × 0.98 = 20.6 Vol.-% of O₂

End-point

Test gas with oxygen concentration in the smallest measurement range (e.g. 2 ppm O₂ in N₂)

NOTES

The pressure conditions at reference point and end-point must be identical. Notes for checking the reference point and end-point must be considered.

Purge gas

If a housing purge is selected (only in IP54 version), purging may only be carried out with air (not with nitrogen) as the ambient air serves as a reference gas.

Gas connections

see section "ZO23: Gas connections" (see page 94)

Installation and sample conditioning

ATTENTION

The ingress of liquids into the analyzer module can cause serious damage including destruction of the sample cell.

NOTE

The following information on installation and the sample conditioning must be considered for the measurement and the execution of controlled calibrations (manual, automatic and externally controlled calibration). Manually operated cocks and valves must be replaced by controlled valves suitable for the oxygen trace measurement, as required.

Example of sample conditioning

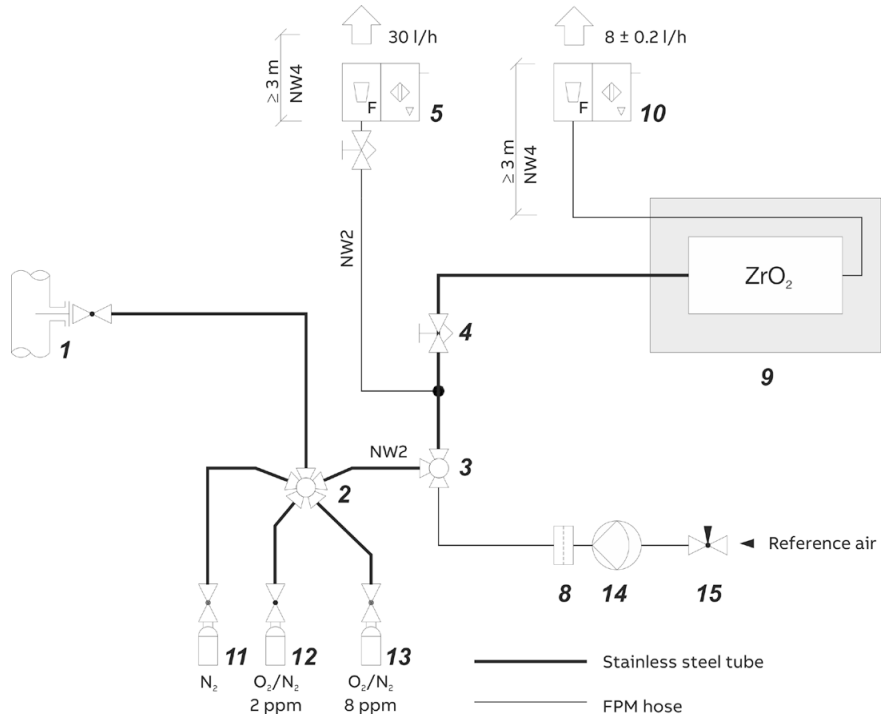

- 1** Sampling point with primary shut-off valve
- 2** Multi-way ball valve
- 3** 3/2-way ball valve¹⁾
- 4** Fine-control valve
- 5** Flowmeter with needle valve and alarm contact
- 6** 2-way ball valve¹⁾
- 7** 2-way ball valve¹⁾
- 8** Air filter¹⁾
- 9** Gas analyzer
- 10** Flowmeter without needle valve, with alarm contact
- 11** Purge gas cylinder with N₂¹⁾
- 12** Test gas cylinder with e.g. 2 ppm of O₂ in N₂²⁾
- 13** Test gas cylinder with 8 ppm O₂ in N₂¹⁾
- 14** Pump¹⁾
- 15** Needle valve¹⁾

1) Option

2) A hard-mounted test gas cylinder is normally adequate.
The annual check of the reference point can also be carried out with a non-stationary air supply.

Gas sampling

The nominal diameter of the line from the sampling point to the first switch-over valve should be 4 mm.

A bypass can be positioned upstream of the first switch-over valve, in order to obtain a faster analysis. With a nominal diameter of 4 mm, the bypass should be longer than 3 m, in order to prevent back diffusion from the ambient air.

The sample gas pressure must be reduced at the sampling point. An evaporating pressure regulator must be provided for sampling from liquid gas lines.

Sample gas supply line

The sample gas supply line must consist of stainless steel tubing, be as short as possible and have as few transitions as possible.

The diameter of tube from the beginning of the first switch-over valve should be 3 mm on the outside and 2 mm on the inside. The sample gas connection to the gas analyzer is specified for a tube with an outside diameter of 3 mm. The connections should be executed as Swagelok® fittings.

The ZO23 oxygen trace analyzer module may not be connected in series with other ZO23 analyzer modules or other gas analyzers.

Gas outlet line

The gas outlet line can be executed as a flexible tube. With a nominal diameter of 4 mm, its length should be more than 3 m, in order to prevent back diffusion from the ambient air.

Bypass

The gas analyzer is connected to a gas flow in the bypass at a constant flow rate (approx. 30 l/h). The needle valve is installed upstream of the branch to the gas analyzer and the bypass flowmeter downstream of the branch to the gas analyzer.

The gas analyzer takes 8 l/h from the gas flow. A surplus of approx. 20 l/h remains. If several ZO23 analyzer modules are supplied with gas in parallel (redundant measurement), the flow rate must be set, so that the bypass has a surplus of 20 l/h.

With a nominal diameter of 4 mm, the bypass from the outlet of the gas analyzer should be longer than 3 m, in order to prevent back diffusion from the ambient air.

On account of possible leaks, the flowmeters are always placed in the bypass feed path downstream of the branch to the gas analyzer, respectively, downstream of the gas analyzer; they may on no account be installed in the sample gas supply line upstream of the sample cell.

Waste gas

The sample gas and the bypass must be conducted into the atmosphere or into an unpressurized waste gas collecting system at an adequate distance from the gas analyzer. Long line runs and pressure variations must be avoided.

For metrological and technical safety reasons, sample gas and bypass may not be discharged into the atmosphere in the vicinity of the gas analyzer, since the ambient air serves as reference air and also to exclude suffocation through a lack of oxygen. It must be ensured that the waste gas only reaches respiratory air when adequately diluted.

Oxygen sensor: Preparation for installation

Installation site

Ambient temperature

During operation with the oxygen sensor installed

+5 to +35 °C in a wall-mount housing

+5 to +40 °C in a 19-inch housing

NOTE

The oxygen sensor is always assigned to an analyzer module and must be installed in the same housing as this analyzer module.

Sample gas

ATTENTION

The gas analyzer may not be used for the measurement of ignitable gas/air or gas/oxygen mixtures.

Sample gas inlet conditions

Temperature The dew point of the sample gas must be at least 5 °C lower than the lowest ambient temperature in the overall sample gas path. Otherwise, a sample gas cooler or condensate trap is required.

Inlet pressure $p_e = 2$ to 500 hPa

Flow 20 to 100 l/h

Remark: Sample gas temperature, pressure and flow rate should be maintained constant to such a degree that the fluctuation influence on the accuracy of measurement is acceptable.

Moisture content

H₂O dew point ≥ 2 °C. The oxygen sensor may not be used with dry sample gases.

Associated gases

The oxygen sensor may not be used if the associated gas contains the following components: H₂S, compounds containing chlorine or fluorine, heavy metals, aerosols, mercaptans, alkaline components.

Flammable gases

The oxygen sensor may not be used for the measurement of flammable gases.

Sample gas outlet conditions

The outlet pressure must be the same as the atmospheric pressure.

Test gases

Zero-point calibration

Zero is not calibrated since it is fundamentally stable.

End-point calibration

Ambient (non-process) air with constant oxygen content (20.96 Vol.-%) or synthetic air

Dew point

The dew point of the test gases must be approximately the same as the dew point of the sample gas.

NOTE

The notes for calibrating must be considered.

Unpacking the gas analyzer and installation

Unpacking the gas analyzer

ATTENTION

Depending on its design, the gas analyzer weighs from 18 to 25 kg! Unpacking and transporting requires two persons!

Unpacking

- 1 Remove the gas analyzer and foam packing or other packaging materials from the shipping box.
- 2 Take off the foam packing and other packaging and place the gas analyzer in a clean area.
- 3 Clean the adhesive packaging residue from the gas analyzer.

NOTES

If there is shipping damage which points to improper handling, file a damage claim with the shipper (railway, mail or freight carrier) within seven days. Make sure that none of the enclosed accessories are lost during unpacking (see section "Scope of delivery", see page 32).

Keep the shipping box and packaging material for future shipping needs.

Dimensional diagrams

19-inch housing (model AO2020)

Dimensions in mm (inch)

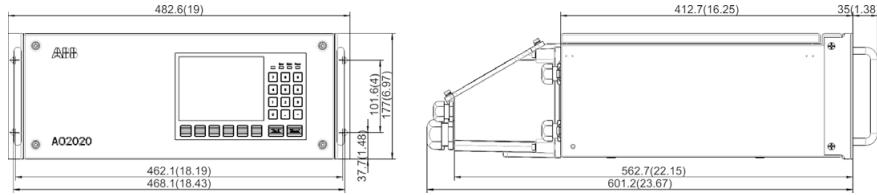

Wall-mount housing (model AO2040)

Dimensions in mm (inch)

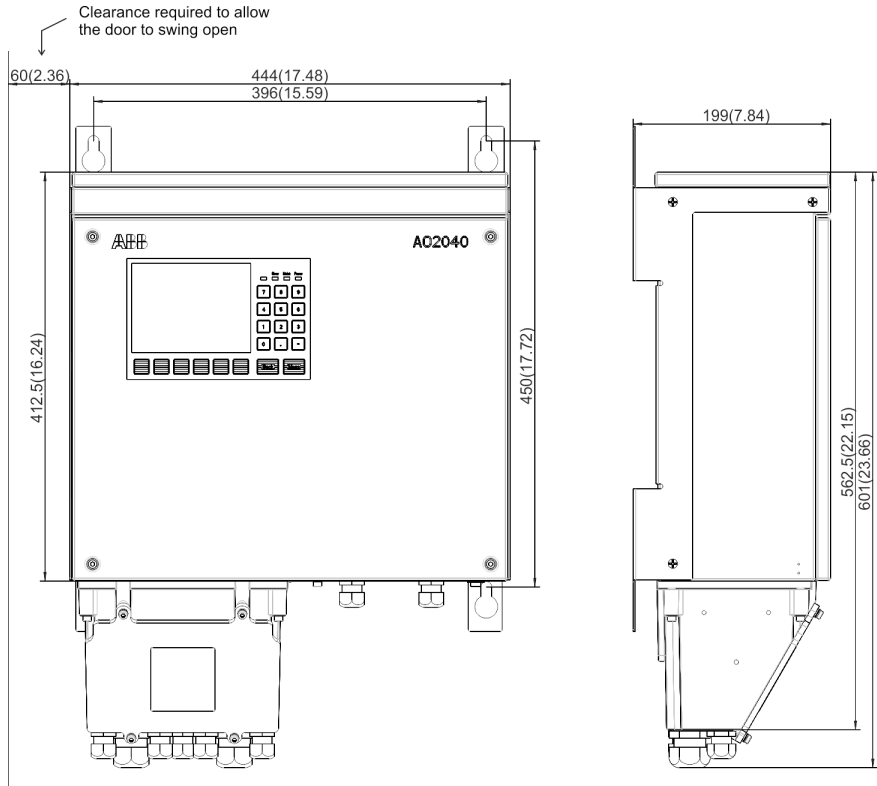

Additional notes

- The connection box shown in the dimensional diagrams is flange-mounted to the IP-54 housing.
- Observe the installation location requirements (see page 35).
- The connecting lines require additional installation clearance (approx. 100 mm).
- When installing the Fidas24 gas analyzer with heated sample gas connection, note that clearance is required for the heated sample gas line (comply with minimum bending radius in accordance with manufacturer's instructions).
- When installing the wall-mount housing, note that clearance is required on the left side to allow the door to swing open (approx. 60 mm).
- When installing the wall-mount housing, note that additional clearance is required above the housing, since some modules are only accessible from above (approx. 300 mm).
- The 19-inch housing and the wall-mount housing should be installed with vertical orientation of the display.
- Multiple system housings in a 19-inch housing should be installed with a separation of at least one height unit to ensure adequate air circulation.

Gas connection installation

Design of the gas connections

The analyzer module gas ports have 1/8"-NPT internal threads (connection diagrams, see Chapter "Gas line connection", see page 80).

Fidas24: The sample gas connection is executed as fitting for PTFE or stainless steel tube with an outside diameter of 6 mm. The exhaust air connection has an external thread for connection of the exhaust air tube (stainless steel tube with terminal nut and clamp ring, outside diameter = 6 mm, supplied with the gas analyzer).

Requisite material

Material	supplied
Tubing connectors with 1/8" NPT thread and PTFE sealing tape	yes no
or	
Threaded connections with 1/8" NPT threads and PTFE sealing tape	no no

ATTENTION

The fittings must be clean and free of residue! Contaminants can enter the analyzer and damage it or lead to false measurement results!
Do not use sealing compound to seal the gas connections! Constituents of the sealing compound can lead to false measurement results!
Pneumatic module: The gas connection ports are made of plastic (PVDF). Do not use metal tubing connectors or threaded connectors.
Caldos25: The analyzer module gas connection ports in the version for flowing reference gas or for corrosive sample gas are made of plastic (PVC-C). Do not use metal tubing connectors or threaded connectors.
Fidas24: Only use threaded connections of metal!

Gas connection installation

- 1 Screw out the yellow plastic screwing caps (5 mm hexagon socket) from the connection ports.
- 2 Screw in the tubing or threaded connectors with sealing material in the connection ports.

NOTES

We strongly recommend that the gas lines are connected to the analyzer module before the gas analyzer is installed, since the gas ports are now easily accessible. Screw in the fittings carefully and not too tightly! Follow the manufacturer's installation instructions for the fittings!

Gas path seal integrity verification

The leak tightness of sample gas path and (if applicable) reference gas path is checked at the factory. Since the gas path seal integrity can be affected during shipping, the leak tightness should be checked (see page 140) at the installation site.

NOTE

We strongly recommend that the tightness of the gas feed paths are checked for leak tightness before the gas analyzer is assembled, since the system housing must be opened in the event of a leak.

Gas analyzer installation

ATTENTION

Depending on its design, the gas analyzer weighs from 18 to 25 kg! Two persons are needed for installation!

The installation location (e.g. bay, 19-inch rack, wall) must be capable of supporting the gas analyzer's weight.

The 19-inch housing must be supported with rails in the bay or rack.

Neither the 19-inch nor the wall-mount housings use hinges to secure the housing cover! The cover can drop when opened.

Requisite material

19-inch housing

- 4 oval head screws (Recommendation: M6; this depends on the cabinet/rack system).
- 1 pair of mounting rails (execution depends on the cabinet/rack system).

Wall-mount housing

- 4 screws M8 or M10.

Installation

Install the system housing in the cabinet/rack or using the selected mounting accessories. Refer to the dimensional diagrams (see page 75).

Gas line connection

Caldos25: Gas connections

Gas connections

Standard version

The sample chamber is connected directly to the gas connections.

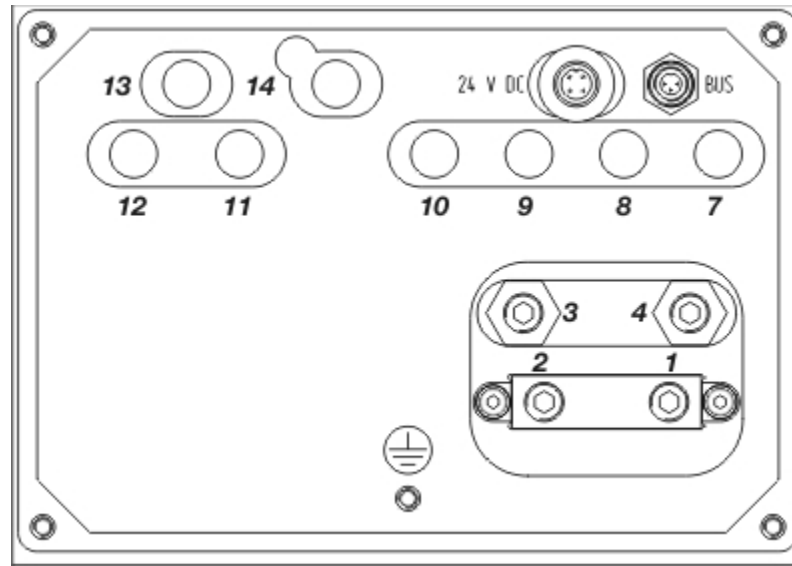

Versions for corrosive sample gas or for flowing reference gas

The sample chamber is connected directly to the gas connections.

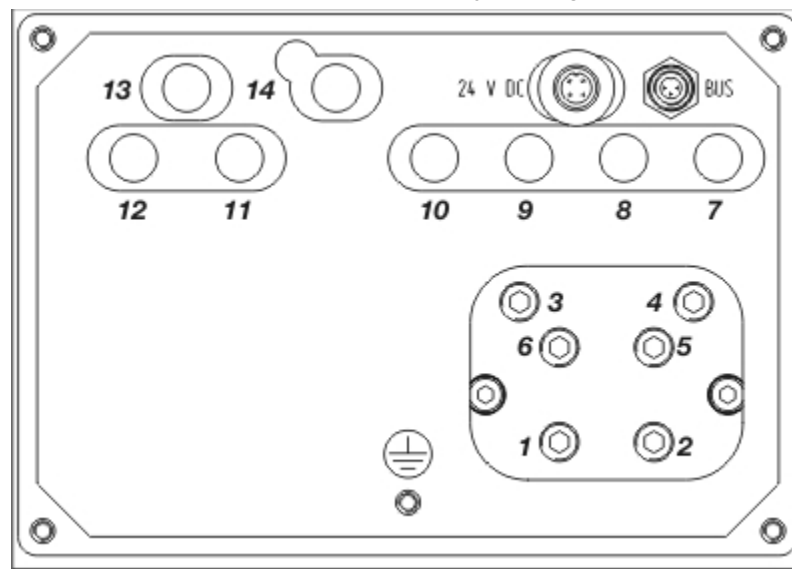

- 1** Sample gas inlet
 - 2** Sample gas outlet
 - 3** Purge gas inlet analyzer
 - 3** Purge gas outlet analyzer
 - 5** Reference gas inlet ²⁾
 - 6** Reference gas outlet ²⁾
 - 7** Housing purge gas inlet ¹⁾
 - 8** Purge gas outlet housing ¹⁾ (also with flow sensor)
 - 9** Pressure sensor 1 ¹⁾
 - 10** Pressure sensor 2 ¹⁾
Pneumatic module ^{1) 2)}:
 - 11** Sample gas inlet
 - 12** Span gas inlet (with 3 solenoid valves)
 - 13** Test gas/zero-point gas inlet (with 1 or 3 solenoid valves)
 - 14** Sample gas outlet – to be connected to sample gas inlet 1
- 1) Option
2) Not in the version for corrosive sample gas

Design of the gas connections unless stated otherwise:
 $\frac{1}{8}$ NPT female thread for threaded connections (not supplied)

NOTE

The gas connections **1** to **6** in the versions for corrosive sample gas or for flowing reference gas are of PVC-C. Do not use metal tubing connectors or adapters!

Additional gas connections, see section "Caldos25, Caldos27, Magnos206: Design for the 'Safety Concept'" (see page 28).

Caldos27: Gas connections

Gas connections

The sample chamber is connected directly to the gas connections.

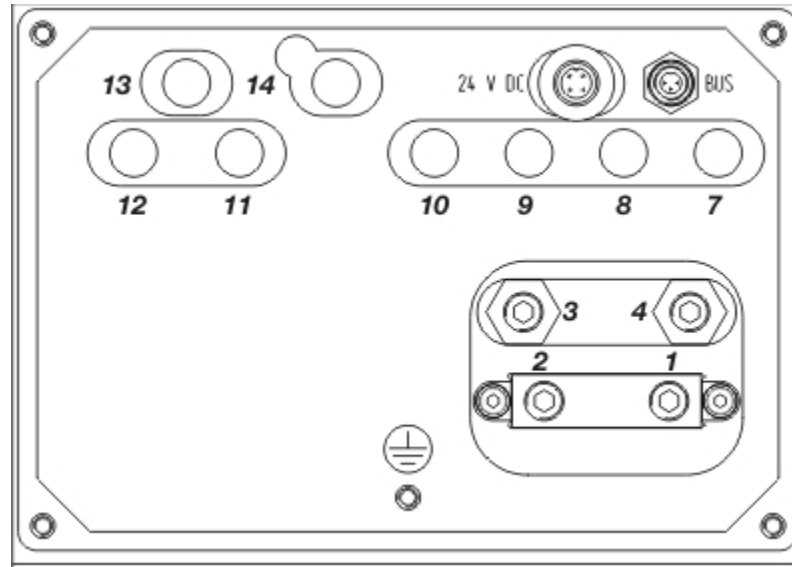

- 1** Sample gas inlet
- 2** Sample gas outlet
- 3** Purge gas inlet analyzer
- 4** Purge gas outlet analyzer
- 7** Purge gas inlet for housing¹⁾
- 8** Purge gas outlet for housing¹⁾ (also with flow sensor)
- 9** Pressure sensor 1
- 10** Pressure sensor 2
- Pneumatic module¹⁾:
- 11** Sample gas inlet
- 12** Span gas inlet (with 3 solenoid valves)
- 13** Test gas/zero-point gas inlet (with 1 or 3 solenoid valves)
- 14** Sample gas outlet – to be connected to sample gas inlet 1
- 1) Option

Design of the gas connections unless stated otherwise:

$\frac{1}{8}$ NPT female thread for threaded connections (not supplied)

Additional gas connections, see section "Caldos25, Caldos27, Magnos206: Design for the 'Safety Concept'" (see page 28).

Fidas24, Fidas24 NMHC: Gas and electrical connections

Gas and electrical connections

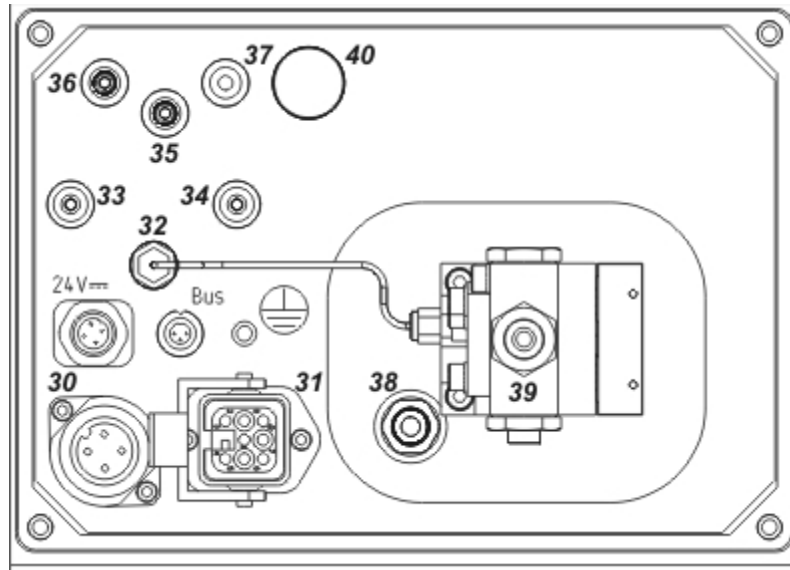

- 30** Power supply 115 V AC or 230 V AC for heating the detector and sample gas inlet (4-pin plug connector, connecting cable supplied)
- 31** Electrical connection to the heated sample gas inlet (hard mounted)
- 32** Test gas outlet
- 33** Zero gas inlet
- 34** Span gas inlet
- 35** Combustion air inlet
- 36** Combustion gas inlet
- 37** Instrument air inlet
- 38** Exhaust air outlet (screw joint for PTFE or stainless steel tube with outside diameter = 6 mm. The inside diameter of the exhaust air line must be widened to max. 30 cm downstream of the exhaust air outlet to ≥ 10 mm.
- 39** Sample gas inlet, heated or unheated (screw joint for PTFE or stainless steel tube with outside diameter = 6 mm)
- 40** Pressure equalizing opening with protective filter (the protective filter must be protected against moisture)
- 24 V External power supply 24 V DC (4-pin plug connector)
- Bus System bus (3-pin socket connector)

Design of the gas connections unless stated otherwise:
 $\frac{1}{8}$ NPT female thread for threaded connections (not supplied)

Limas11 IR, Limas21 UV, Limas21 HW: Gas connections

Gas connections

Limas11 IR, Limas21 UV:

Standard cell with FPM or PTFE hoses

Quartz cell with FPM hoses

Center connection cell made of aluminum with FPM or Cr hoses (60 °C)

Center connection cell made of quartz with PTFE/FPM or PTFE/Cr hoses (60 °C)

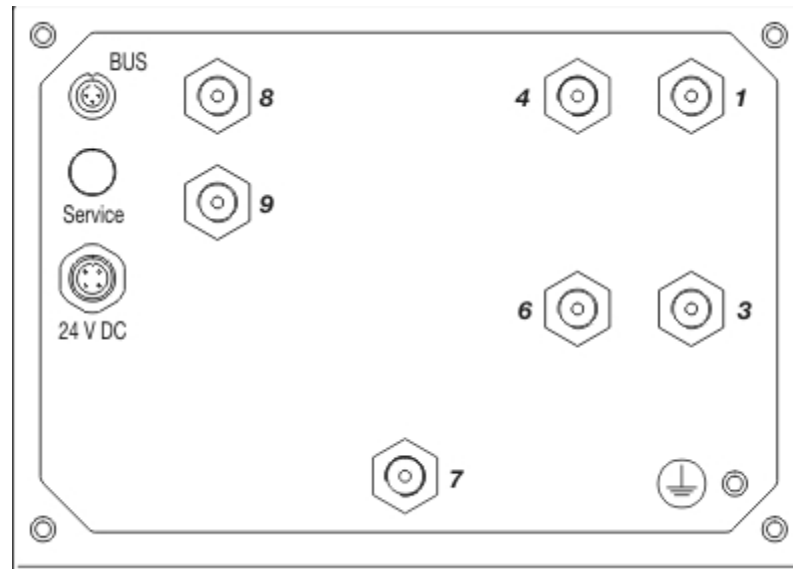

- 1** Sample gas inlet
- 3** Housing purge gas inlet ¹⁾
- 4** Sample gas outlet
- 6** Purge gas outlet for housing ¹⁾
- 7** Pressure sensor ²⁾
- 8** Span gas inlet (with 3 solenoid valves) ^{1) 3)}
- 9** Zero gas inlet (with 1 or 3 solenoid valves) ^{1) 3)}

1) Option

2) External connection, not for the standard cell with FPM hoses

3) not for version with PTFE hoses

Design of the gas connections unless stated otherwise:

1/8 NPT female thread for threaded connections (not supplied)

**Limas11 IR, Limas21 UV:
Quartz cell with PFA tubes**

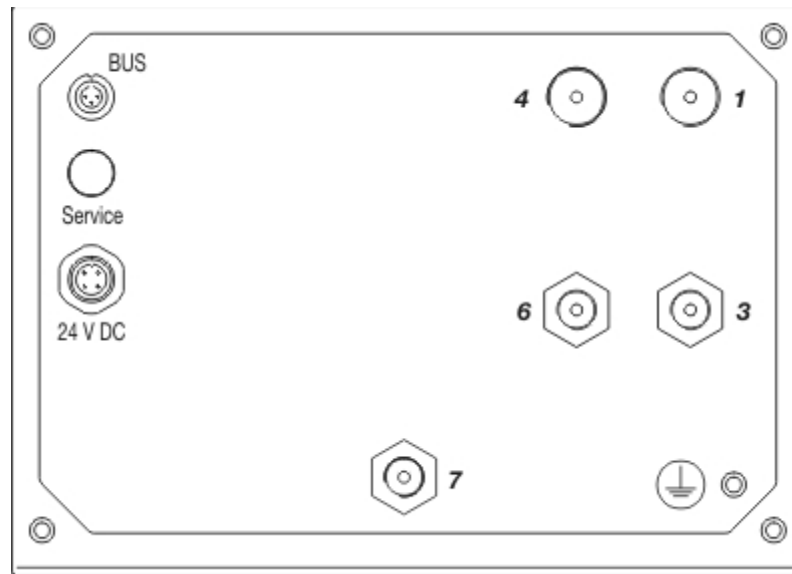

- 1** Sample gas inlet (PFA tube 6/4 mm)
- 3** Housing purge gas inlet¹⁾
- 4** Sample gas outlet (PFA tube 6/4 mm)
- 6** Purge gas inlet for housing¹⁾
- 7** Pressure sensor
- 1) Option

Design of the gas connections unless stated otherwise:
1/8 NPT female thread for threaded connections (not supplied)

**Limas11 IR, Limas21 UV:
Safety cell**

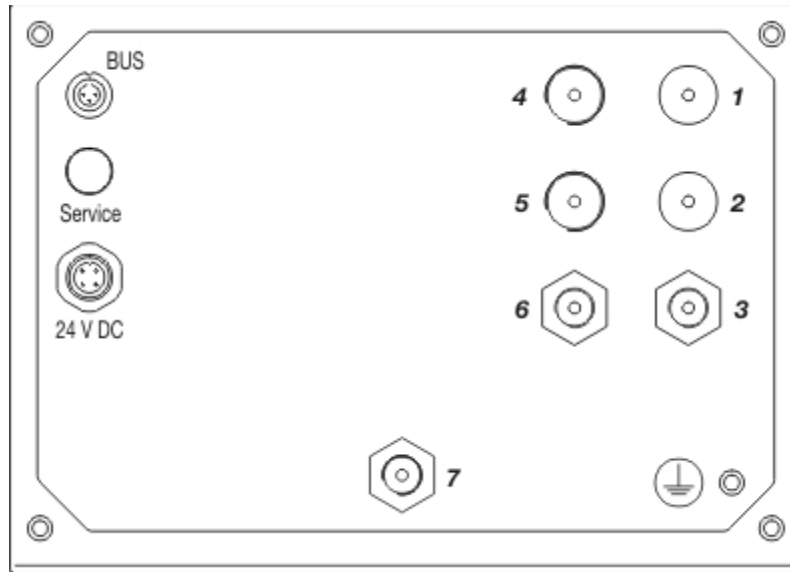

- 1** Sample gas inlet (stainless steel tube with 4 mm outside diameter)
- 2** Sample gas outlet (stainless steel tube with 4 mm outside diameter)
- 3** Housing purge gas inlet ¹⁾
- 4** Purge gas inlet sample cell (FPM tube 4x1.5)
- 5** Purge gas outlet sample cell (FPM tube 4x1.5)
- 6** Housing purge gas outlet ¹⁾
- 7** Pressure sensor
- 1) Option

Design of the gas connections unless stated otherwise:
 $\frac{1}{8}$ NPT female thread for threaded connections (not supplied)

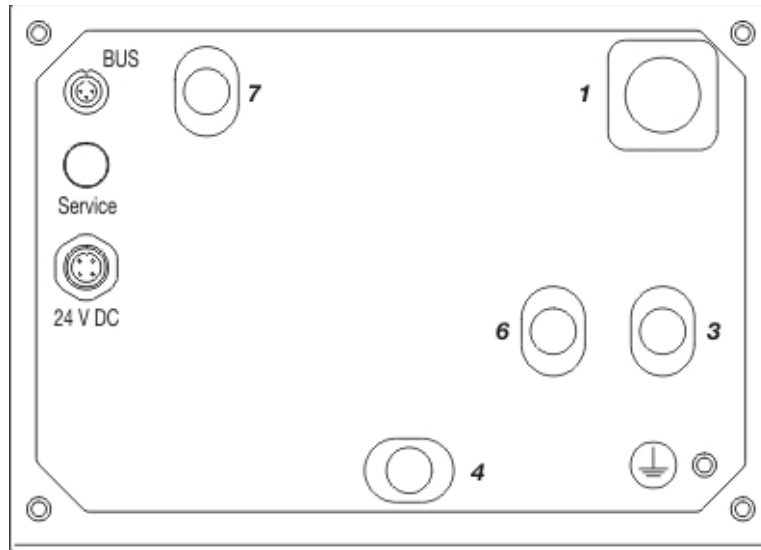
**Limas21 HW:
Quartz cell**

- 1** Sample gas inlet
- 3** Purge gas inlet for housing
- 4** Sample gas outlet
- 6** Purge gas outlet for housing
- 7** Pressure sensor

Design of the gas connections unless stated otherwise:
 $\frac{1}{8}$ NPT female thread for threaded connections (not supplied)

Magnos206: Gas connections

Gas connections

The sample chamber is connected directly to the gas connections.

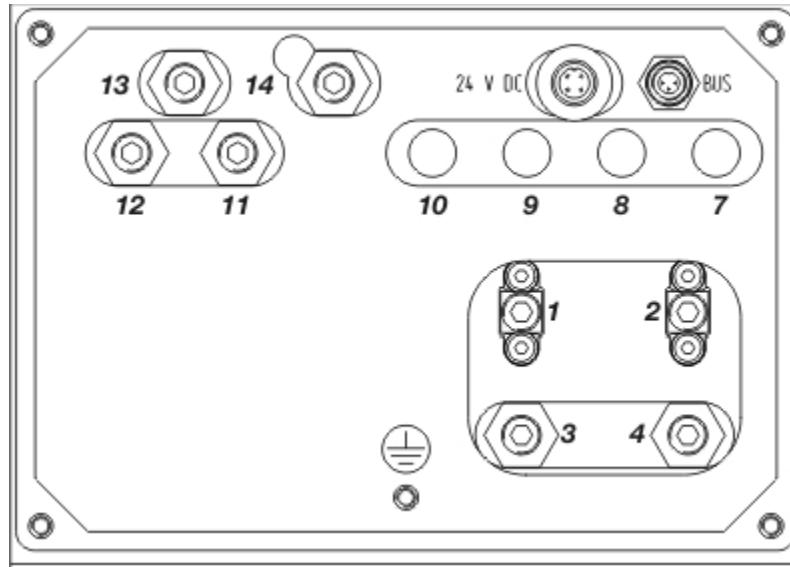

- 1** Sample gas inlet
 - 2** Sample gas outlet
 - 3** Purge gas inlet for analyzer²⁾
 - 4** Purge gas outlet for analyzer²⁾
 - 7** Purge gas inlet for housing¹⁾
 - 8** Purge gas inlet for housing¹⁾ (also with flow sensor)
 - 9** Pressure sensor 1¹⁾
 - 10** Pressure sensor 2¹⁾
 - Pneumatics module¹⁾:
 - 11** Sample gas inlet
 - 12** Span gas inlet (with 3 solenoid valves)
 - 13** Test gas/zero-point gas inlet (with 1 or 3 solenoid valves)
 - 14** Sample gas outlet – to be connected to inlet **1**
- 1) Option
2) not in version with performance test for emission monitoring

Design of the gas connections unless stated otherwise:

1/8 NPT female thread for threaded connections (not supplied)

Additional gas connections, see section "Caldos25, Caldos27, Magnos206: Design for the 'Safety Concept'" (see page 28).

Magnos28: Gas connections

Gas connections

The sample chamber is connected directly to the gas connections.

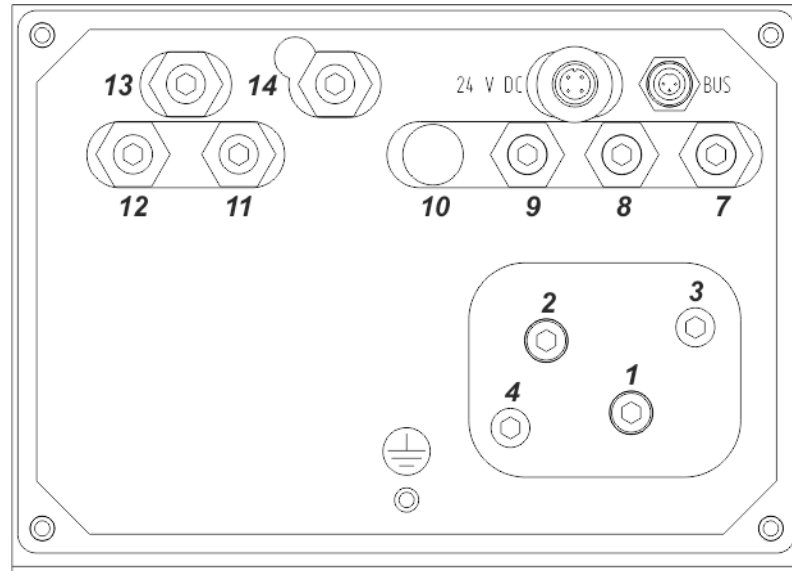

- 1** Sample gas inlet
 - 2** Sample gas outlet
 - 3** Purge gas inlet for analyzer²⁾
 - 4** Purge gas outlet for analyzer²⁾
 - 7** Purge gas inlet for housing¹⁾
 - 8** Purge gas inlet for housing¹⁾ (also with flow sensor)
 - 9** Pressure sensor 1¹⁾
 - 10** Pressure sensor 2¹⁾
Pneumatics module¹⁾:
 - 11** Sample gas inlet
 - 12** Span gas inlet (with 3 solenoid valves)
 - 13** Test gas/zero-point gas inlet (with 1 or 3 solenoid valves)
 - 14** Sample gas outlet – to be connected to inlet **1**
- 1) Option
2) not in version with performance test for emission monitoring

Design of the gas connections unless stated otherwise:
 $\frac{1}{8}$ NPT female thread for threaded connections (not supplied)

Magnos27: Gas connections

Gas connections

Sample chamber connection to FPM hoses

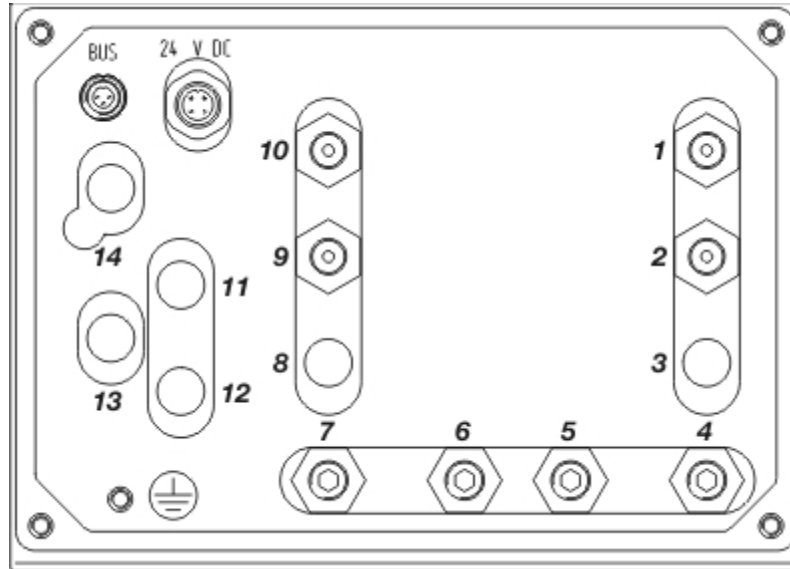

Sample chamber direct connection

The sample chamber is directly connected to the gas connections (only in the wall-mount housing). Application e.g. for connection of an external gas feed and for a short T90 time.

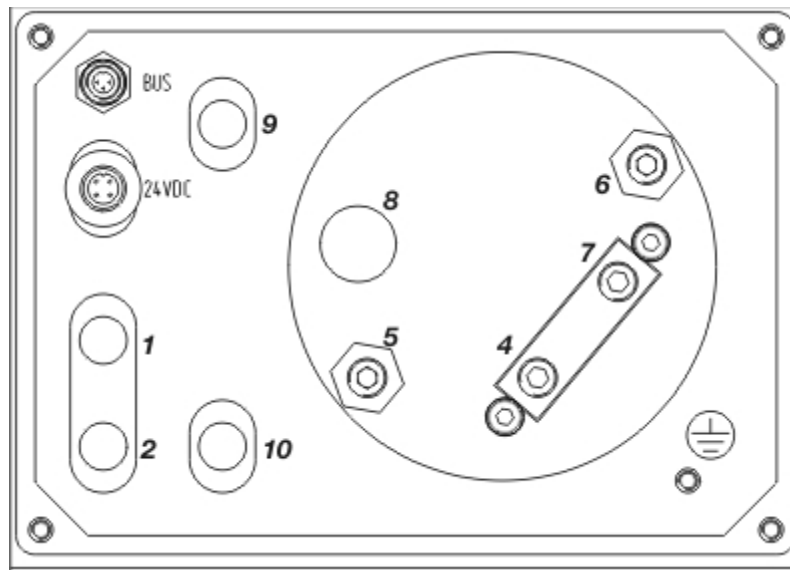

- 1** Purge gas inlet for housing¹⁾
- 2** Purge gas outlet for housing¹⁾ (also with flow sensor)
- 3** –
- 4** Sample gas inlet
- 5** Purge gas inlet for analyzer
- 6** Purge gas outlet for analyzer
- 7** Sample gas outlet
- 8** –
- 9** Pressure sensor 1¹⁾
- 10** Pressure sensor 2¹⁾
- Pneumatic module²⁾:
- 11** Sample gas inlet
- 12** Span gas Inlet (with 3 solenoid valves)
- 13** Test gas/zero-point gas inlet (with 1 or 3 solenoid valves)
- 14** Sample gas outlet – to be connected to sample gas inlet **4**

1) Option

2) Option – not in the version with sample chamber direct connection

Design of the gas connections unless stated otherwise:

$\frac{1}{8}$ NPT female thread for threaded connections (not supplied)

Uras26: Gas connections

Gas connections

The following illustration shows the assignment of the gas connections as an example for the three variants

- A** 1 gas path with 1 sample cell,
- B** 1 gas path with 2 sample cells in series and
- C** 2 separate gas paths with 1 sample cell each.

The assignment of the gas connections of a supplied analyzer module is documented in the analyzer data sheet enclosed with the gas analyzer.

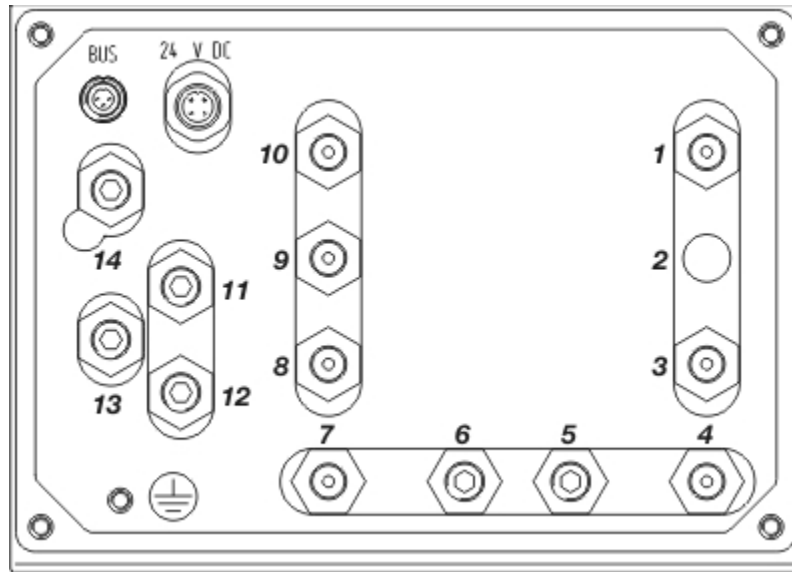

- 1** Pressure sensor for external pressure measurement ¹⁾
 - 2** –
 - 3** Sample gas inlet **A** or **B** or **C** gas path 1
 - 4** Sample gas outlet **A** or **C** gas path 1
 - 5** Purge gas inlet for housing ¹⁾
 - 6** Purge gas inlet for housing ¹⁾ (also with flow sensor)
 - 7** Sample gas inlet **C** gas path 2 ¹⁾
 - 8** Sample gas outlet **B** or **C** gas path 2 ¹⁾
 - 9** Reference gas inlet for sample cell 1 ¹⁾
 - 10** Reference gas outlet for sample cell 1 ¹⁾
- Pneumatics module ¹⁾:
- 11** Sample gas inlet **A** or **B** or **C** gas path 1
 - 12** Span gas inlet (with 3 solenoid valves)
or sample gas inlet **C** gas path 2 (only with flow sensor)
 - 13** Test gas/zero-point gas inlet (with 1 or 3 solenoid valves)
or sample gas outlet **C** gas path 2 (only with flow sensor) – in this case
to be connected to sample gas inlet **7**
 - 14** Sample gas outlet **A** or **B** or **C** gas path 1 – to be connected to sample
gas inlet **3**

1) Option

Design of the gas connections unless stated otherwise:

$\frac{1}{8}$ NPT female thread for threaded connections (not supplied)

Additional gas connections, see Section "Uras26: Design for the 'Safety Concept'" (see page 26).

ZO23: Gas connections

Gas connections

The sample chamber is connected to the sample gas inlet connection via a stainless steel tube on the inlet side and to the sample gas outlet connection via an FPM hose on the outlet side.

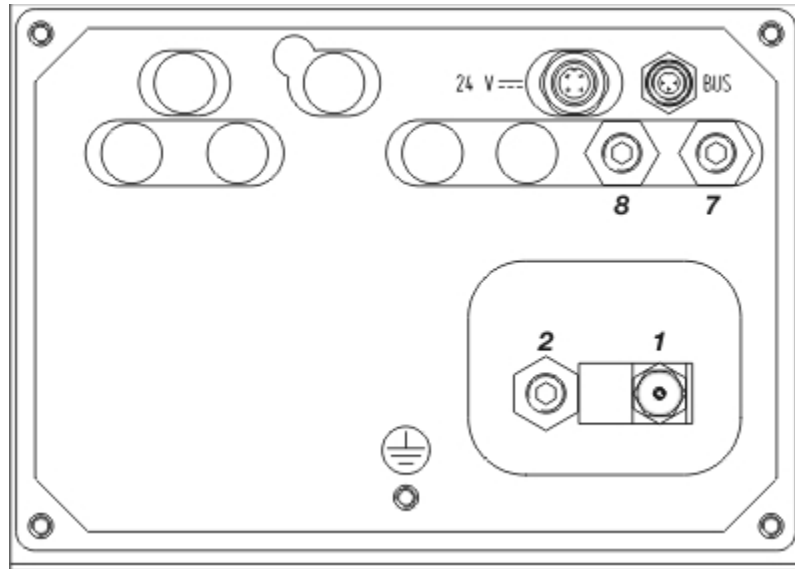

- 1** Sample gas inlet (3 mm Swagelok®)
- 2** Sample gas outlet (1/8 NPT female thread)
- 7** Purge gas inlet for housing (only in IP54 version)
- 8** Purge gas outlet for housing (only in IP54 version)

Design of the gas connections unless stated otherwise:
 1/8 NPT female thread for threaded connections (not supplied)

Gas line connection

ATTENTION

The lines and fittings must be clean and free of any residues (e.g. particles left over from manufacturing). Contaminants can enter the analyzer and damage it or lead to false measurement results!

NOTES

The installation of gas connections is described in section "Installing the gas connections" (see page 77).

Follow the manufacturer's installation instructions for the fittings! In particular, hold the male fittings (gas connections) in place when connecting the gas lines.

Follow the manufacturer's instructions when laying and connecting the gas lines.

If gas lines made of stainless steel are connected to the analyzer modules, the lines must be connected to the building-side equipotential bonding.

Never connect more than three analyzer modules in series!

Gas line connection

Connect the gas lines – made of a material appropriate for the measurement task – to the installed gas ports.

Evacuate exhaust gases

Conduct exhaust gases directly into the atmosphere or through a line with a large internal diameter which is as short as possible, or into a gas discharge line. Do not conduct exhaust gases via restrictions or shut-off valves.

NOTE

Dispose of corrosive, toxic or combustible exhaust gases according to the regulations!

Provide for sample gas line purging

Install a shut-off valve in the sample gas line (definitely recommended with pressurized sample gas), in order to provide a means for purging the gas line system by feeding in an inert gas, e.g. nitrogen, from the gas sampling point.

Flowmeter installation in the reference gas line

In the Caldos25 and Uras26 analyzer modules with flowing reference gas, a flowmeter with a needle valve must be installed in the sample gas line and in the reference gas line, in order to adjust the flow rate in the two lines to the optimum value.

Limas21 HW: Special information for gas line connection

- Lay heated sample gas line without any mechanical stresses and connect to the sample gas inlet.
- Insulate the connection between the sample gas line and the gas analyzer to prevent the formation of cold bridges.
- Ensure that no sample gas can flow through the sample gas line, before the temperature has stabilized at the setpoint of 180 °C!
- Lay the sample gas outlet line with a downward gradient, so that any condensate can run off.

Fidas24: Connecting the gas lines

ATTENTION

The relevant safety regulations for working with flammable gases must be complied with.

The fittings of the gas paths in the gas analyzer may not be opened. The gas paths can become leaky as a result.

However, if the fittings of the gas paths in the gas analyzer have been opened (only by trained personnel), a seal integrity test with a leak detector (thermal conductivity) must always be carried out after they have been sealed again.

The seal integrity of the combustion gas supply line outside the gas analyzer must be checked regularly.

Combustion gas which escapes through leak points in the gas paths in the instrument can cause fires and explosions, also outside the gas analyzer.

The lines and fittings must be clean and free of any residues (e.g. particles left over from manufacturing). Contaminants can enter the analyzer and damage it or lead to false measurement results!

NOTES

The installation of gas connections is described in section "Installing the gas connections" (see page 77).

Follow the manufacturer's installation instructions for the fittings! In particular, hold the male fittings (gas connections) in place when connecting the gas lines.

Follow the manufacturer's instructions when laying and connecting the gas lines.

If gas lines made of stainless steel are connected to the analyzer modules, the lines must be connected to the building-side equipotential bonding.

Never connect more than three analyzer modules in series!

Connection of process gases and test gases

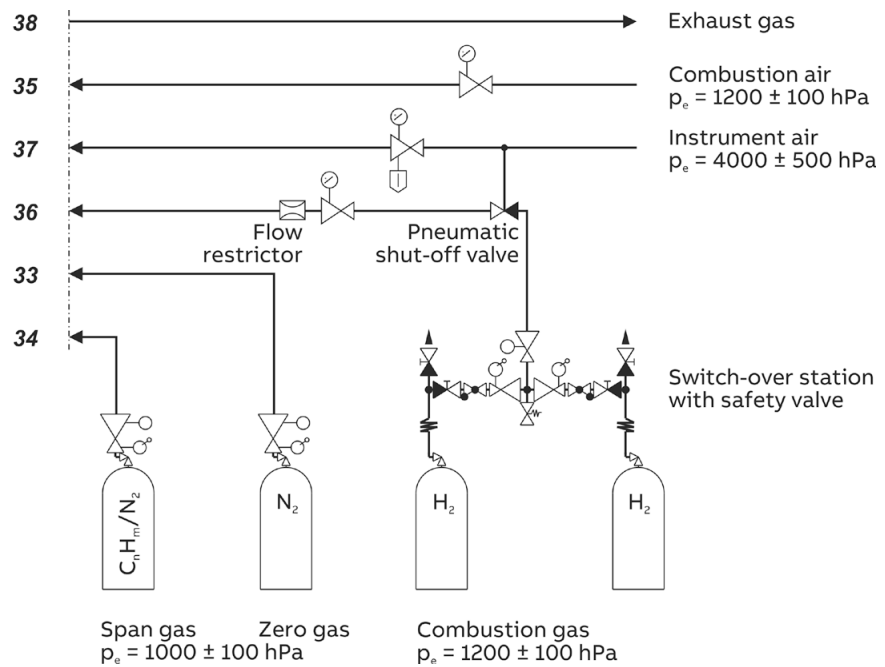

The numbering of the gas connections corresponds to the numbering in the connection diagram (see page 83) as well as the labeling on the rear of the analyzer module.

Instrument air connection

Instrument air is used as propellant for the air jet injector and as purging air for the housing purge (see page 38).

Connect (see page 83) the instrument air line to the instrument air inlet of the analyzer module via a pressure regulator (0 to 6 bar).

Combustion air connection

Connect (see page 83) the combustion air line to the combustion air inlet of the analyzer module via a pressure regulator (0 to 1.6 bar).

Combustion gas connection

See section "Fidas24: Connecting the combustion gas line" (see page 100)

Test gas connection

The test gas outlet is connected to the sample gas connection ex works.

If the test gases are to be introduced directly into the gas sampling point, the connection between the test gas outlet and the test gas inlet on the sample gas connection must be removed, and the respective opening in the sample gas connection must be sealed with an M6 screw, so that it is gas-tight.

Exhaust air connection

Conduct exhaust air directly into the atmosphere at zero pressure through a line with a large internal diameter which is as short as possible, or into a gas discharge line.

Use an exhaust air line of PTFE or stainless steel! The temperature of the medium can be up to 200 °C! Lay the exhaust air line with a downward gradient.

The inside diameter of the exhaust line should be increased to ≥ 10 mm within no more than 30 cm from the exhaust outlet. If a very long exhaust air line is used, its inside diameter must be much larger than 10 mm; otherwise the pressure regulation in the gas analyzer may not work properly.

Do not conduct waste air via restrictions or shut-off valves!

NOTE

Dispose of corrosive, toxic or combustible exhaust gases according to the regulations!

Fidas24: Connecting the combustion gas line

Connecting the combustion gas line

Cleaning the combustion gas line

- 1 Pump cleaning agent (alkaline cleaner, stainless steel pickling agent) through the stainless steel tube.
- 2 Thoroughly rinse the tube with distilled water.
- 3 Purge the tube for several hours at a temperature of > 100 °C with synthetic air or with nitrogen (10 to 20 l/h).
- 4 Seal the ends of the tube.

Connecting the combustion gas line

- 5 Connect a two-stage cylinder pressure reducer (version for high purity gases) to the combustion gas cylinder.
- 6 Connect the combustion gas line to the cylinder pressure reducer.
- 7 Install a flow restrictor in the combustion gas supply line which restricts the combustion gas flow to 10 l/h of H₂ or 25 l/h of H₂/He mixture. This means that operation of the gas analyzer is safe even with a defect in the combustion gas feed path (e.g. leaks).
- 8 Install a shut-off valve in the combustion gas supply line. It is recommended that a pneumatic valve is installed; this valve must be controlled by the instrument air supply in such a way that the combustion gas feed is automatically shut off if the instrument air supply fails (and the continuous housing purge therefore fails).
- 9 Connect (see page 83) the combustion gas line to the combustion gas inlet of the analyzer module via a pressure regulator (0 to 1.6 bar).

Check the seal integrity of the combustion gas line

- 10 Check (see page 142) the seal integrity of the combustion gas line after connection.

Fidas24: Connecting the sample gas line (heated sample gas connection)

ATTENTION

If a plastic vent plug has been inserted in the sample gas inlet in the factory, it must be removed without fail before commissioning the analyzer module!

Material of the sample gas line

Use a sample gas line of PTFE or stainless steel! (Recommendation: use a heated sample gas line TBL 01.) The temperature of the medium can be up to 200 °C!

Connecting the sample gas line

The heated sample gas line is connected directly to the sample gas inlet. In this respect, the correct seat of the O-rings must be ensured and also that the sample gas tube is inserted all the way in into the sample gas connection.

Unused sample gas inlets

If the analyzer module draws in the sample gas through the sample gas line, the unused sample gas inlets must be sealed with the screw plugs (screwed in in the factory).

If the sample gas is under positive pressure, a sample gas inlet must be open and connected to a gas discharge line, so that no positive pressure builds up in the analyzer module.

Fittings and O-rings

The requisite fittings and O-rings are included in the supplied accessories pack.

Heated sample gas connection

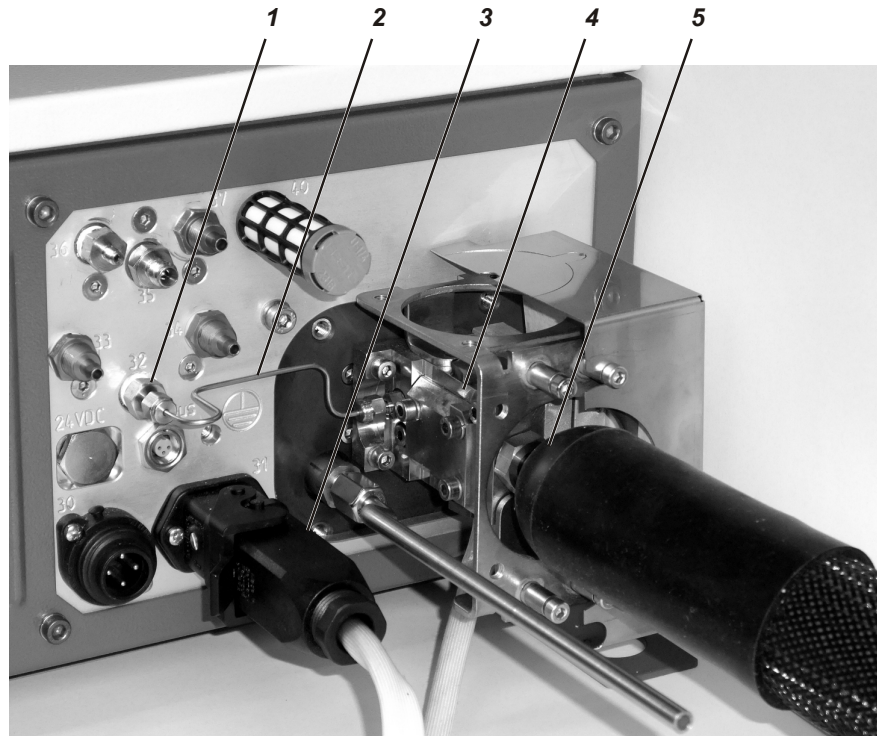

- 1** Test gas outlet
- 2** Connection of test gas outlet - sample gas connection
- 3** Electrical connection to the heated sample gas connection
- 4** Heated sample gas connection
- 5** Heated sample gas line (example)

Remark: One half of the cover of the heated sample gas connection has been removed in the picture.

Connection of the sample gas line to the heated sample gas connection

Wall-mount housing (view from bottom right)

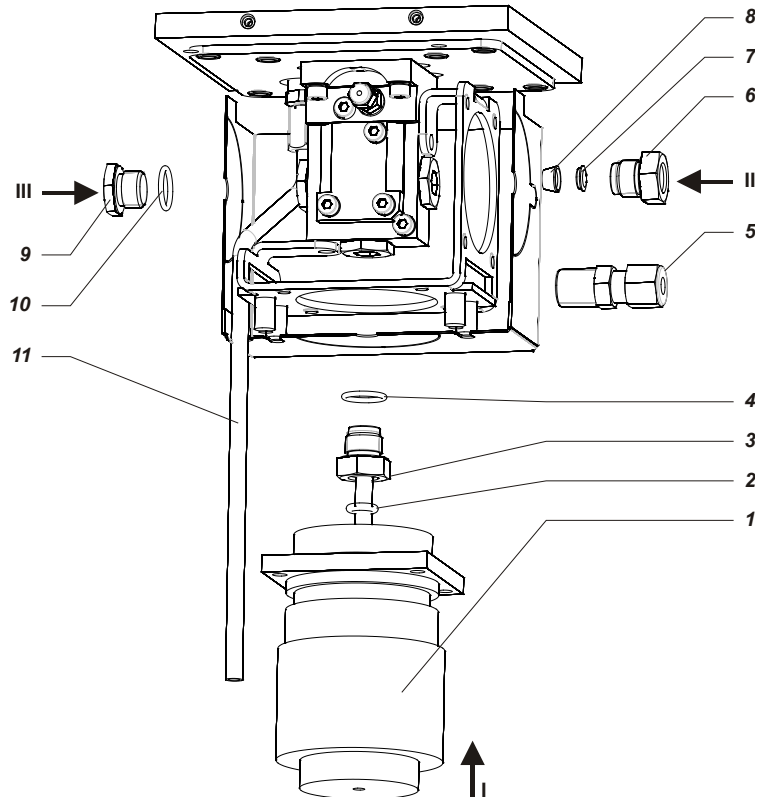

19-inch housing (view from top left)

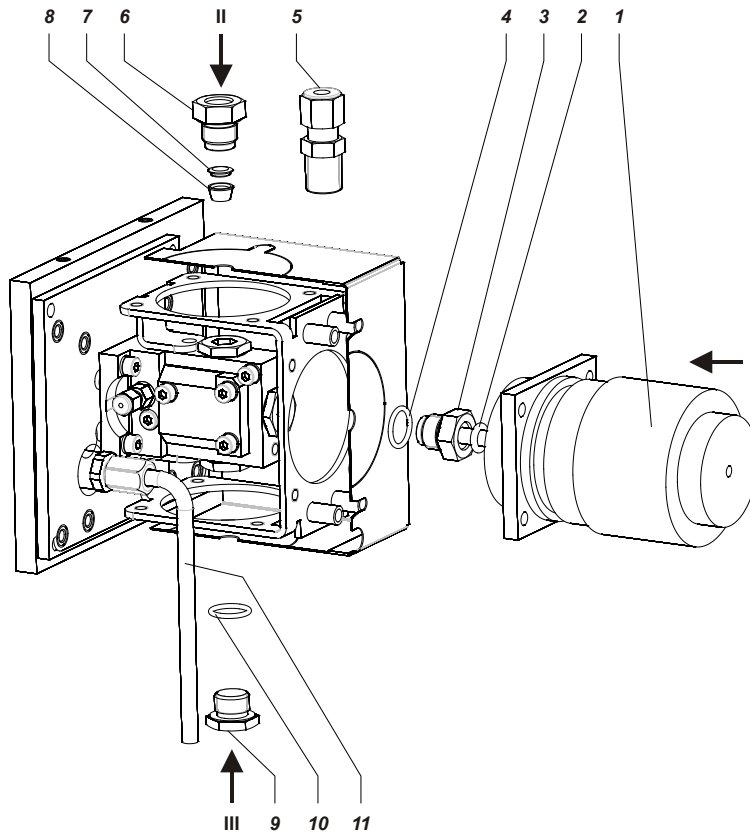

Connection of the sample gas line

- 1 Heated sample gas line (tube with inside/outside diameter 4/6 mm)
 - 2 O-ring 6.02 x 2.62
 - 3 Socket
 - 4 O-ring 12.42 x 1.78
- Connection of a further sample gas line (tube with outside diameter 6 mm):
- either with
- 5 Male fitting G $\frac{1}{4}$ "
- or with
- 6 Socket
 - 7 Tapered ring
 - 8 Compression fitting
- Closure:
- 9 Screw cap
 - 10 O-ring 12.42 x 1.78
-
- 11 Exhaust gas tube

Sample gas inlets:	Connection of the sample gas line	
	on 19-inch housing:	on wall-mount housing:
I	from the rear	from below
II	from above	from the right
III	from below	not possible – the sample gas inlet must always be closed

Maximum length of the sample gas line

The maximum length of the heated sample gas line (inside diameter 4 mm) is 60 m.

Provide for sample gas line purging

Install a shut-off valve in the sample gas line (definitely recommended with pressurized sample gas), in order to provide a means for purging the gas line system by feeding in an inert gas, e.g. nitrogen, from the gas sampling point.

Fidas24: Connecting the sample gas line (unheated sample gas connection)

ATTENTION

If a plastic vent plug has been inserted in the sample gas inlet in the factory, it must be removed without fail before commissioning the analyzer module!

Connection of the sample gas line

The unheated sample gas connection has only one sample gas inlet. If the sample gas is under positive pressure, a T-piece must be connected between the sample gas line and the sample gas inlet. The free connection of the T-piece must be connected to a exhaust gas discharge line, so that no positive pressure builds up in the analyzer module.

Connection of the sample gas line to the unheated sample gas connection

19-inch housing (view from top left)

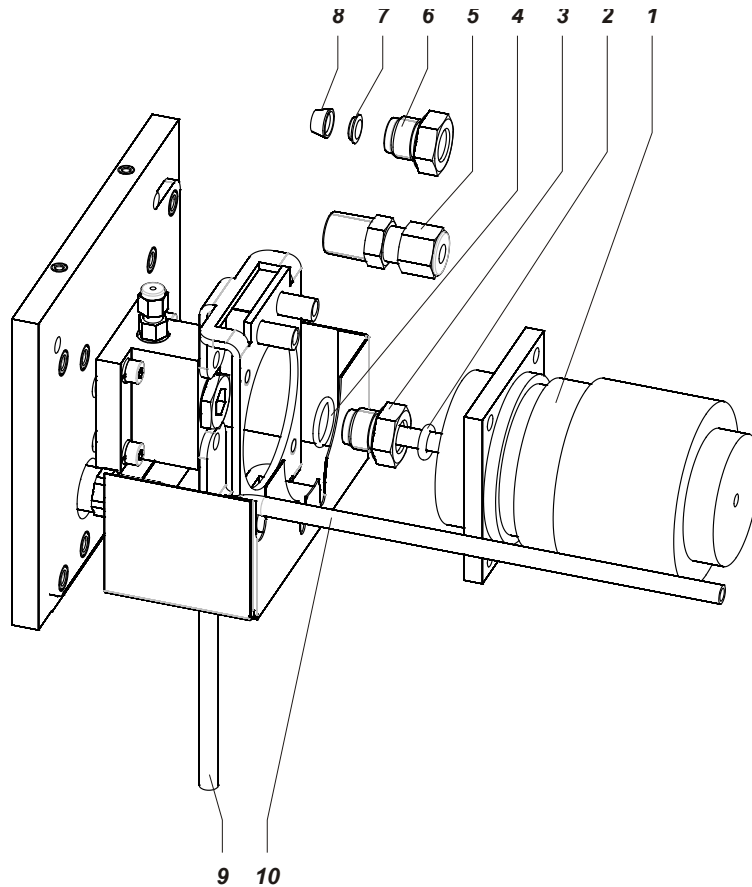

Connection of the sample gas line

- 1** Sample gas line (heated or unheated, PTFE or stainless steel tube with inside/outside diameter 4/6 mm)
Connection either with
- 2** O-ring 6.02 x 2.62
- 3** Socket
- 4** O-ring 12.42 x 1.78
or with
- 5** Male fitting G $\frac{1}{4}$ "
or with
- 6** Socket
- 7** Tapered ring
- 8** Compression fitting

- 9** Exhaust gas tube for 19-inch housing
- 10** Exhaust gas tube for wall-mount housing

Maximum length of the sample gas line

The maximum length of the unheated sample gas line (inside diameter 4 mm) is 50 m.

Provide for sample gas line purging

Install a shut-off valve in the sample gas line (definitely recommended with pressurized sample gas), in order to provide a means for purging the gas line system by feeding in an inert gas, e.g. nitrogen, from the gas sampling point.

Connecting the electrical leads

Electronics module connection diagram

Electronics module connection diagram

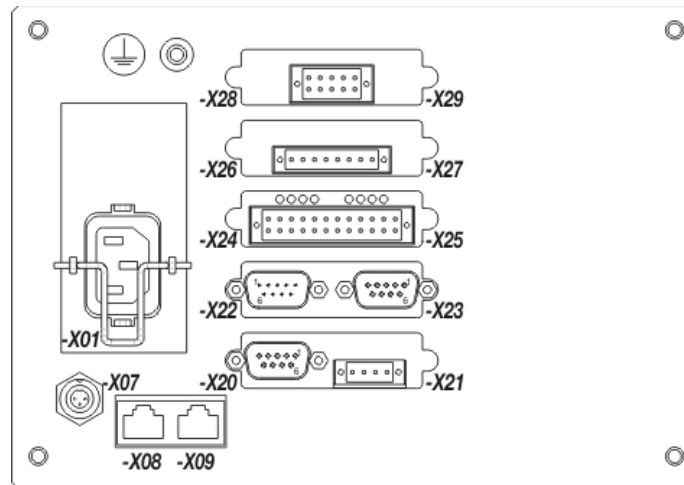

-X01 Power supply connection (see page 125)

-X07 System bus connection (see page 119)

-X08, -X09 Ethernet 10/100/1000BASE-T connection

-X20 to -X29 I/O Modules (5 slots), options:

- Profibus module (see page 108)
- Modbus module (see page 109)
- 2-way analog output module (see page 110)
- 4-way analog output module (see page 110)
- 4-way analog input module (see page 111)
- Digital I/O module (see page 112)



Potential compensation connection (see page 125)

The connection diagram shows an example for the equipment of the electronics module with I/O modules.

Profibus module: Electrical connections

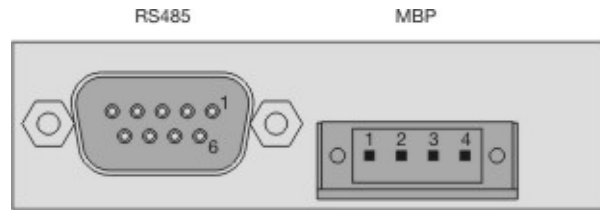

RS485 interface

Pin	Signal	Explanation
1	–	not assigned
2	M24	24 V output voltage, ground
3	RxD/TxD-P	Receive/send data plus, B line
4	–	not assigned
5	DGND	Data transmission potential (reference potential for VP)
6	VP	Supply voltage plus (5 V)
7	P24	24 V output voltage plus, max. 0.2 A
8	RxD/TxD-N	Receive/send data N, A line
9	–	not assigned

Design: 9-pole female Sub-D plug

MBP interface (not intrinsically safe)

Pin	Signal
1	+
2	Shield
3	–
4	not assigned

Design: 4-pole plug-in terminal strip. Please refer to the information about the requisite material (see page 116)!

NOTE

For additional information on "Profibus", refer to the Technical Information "AO2000 Profibus DP/PA Interface".

Modbus module: Electrical connections

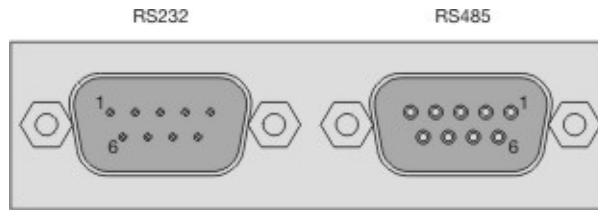

RS232 interface

Pin	Signal
2	RxD
3	TxD
5	GND

Design: 9-pole male Sub-D plug

RS485 interface

Pin	Signal
2	RTxD-
3	RTxD+
5	GND

Design: 9-pole female Sub-D plug

NOTE

For additional information on "Modbus", refer to the Technical Information "AO2000 Modbus and AO-MDDE".

Analog output module: Electrical connections

2-Way Analog Output Module



4-Way Analog Output Module

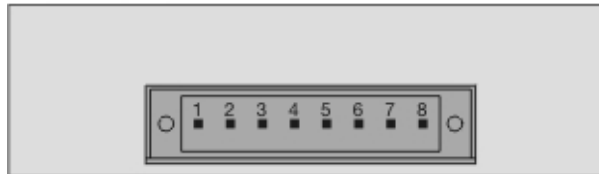

Pin	Signal
1	AO1+
2	AO1-
3	AO2+
4	AO2-
5	AO3+
6	AO3-
7	AO4+
8	AO4-

Analog outputs AO1 to AO4

0/4 to 20 mA (pre-set ex works to 4 to 20 mA), common negative pole, electrically isolated to ground, can be connected to ground as required, in this regard, max. gain compared to local protective ground potential 50 V, working resistance max. 750 Ω . Resolution 16 bit. The output signal may not be less than 0 mA.

Design

4-pole or 8-pole plug-in terminal strip. Please refer to the information about the requisite material (see page 116)!

Terminal layout

An analog output is allocated in the sequence of the sample components for each sample component. The sequence of the sample components is documented in the analyzer data sheet and on the identification plate.

Analog input module: Electrical connections

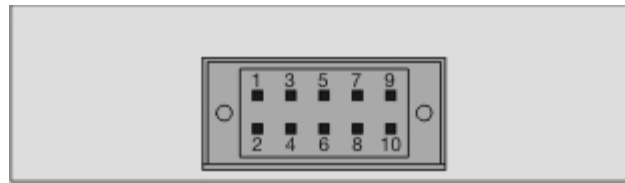

50 Ω	1	AI1	I	-20 to +20 mA into 50 Ω ,
	2		C	to 10 V mutually isolated
50 Ω	3	AI2	I	-20 to +20 mA into 50 Ω ,
	4		C	to 10 V mutually isolated
50 Ω	5	AI3	I	-20 to +20 mA into 50 Ω ,
	6		C	to 10 V mutually isolated
50 Ω	7	AI4	I	-20 to +20 mA into 50 Ω ,
	8		C	to 10 V mutually isolated
	9	+24 V		Power supply for
	10	GND		external sensor

Analog inputs AI1 to AI4

0 to 20 mA, load 50 Ω

Current output +24 V

+24 V DC for supply of an external sensor, fused with 100 mA (self-resetting fuse)

Design

2x5-pin terminal strip. Please refer to the information about the requisite material (see page 116)!

Digital I/O module: Electrical connections

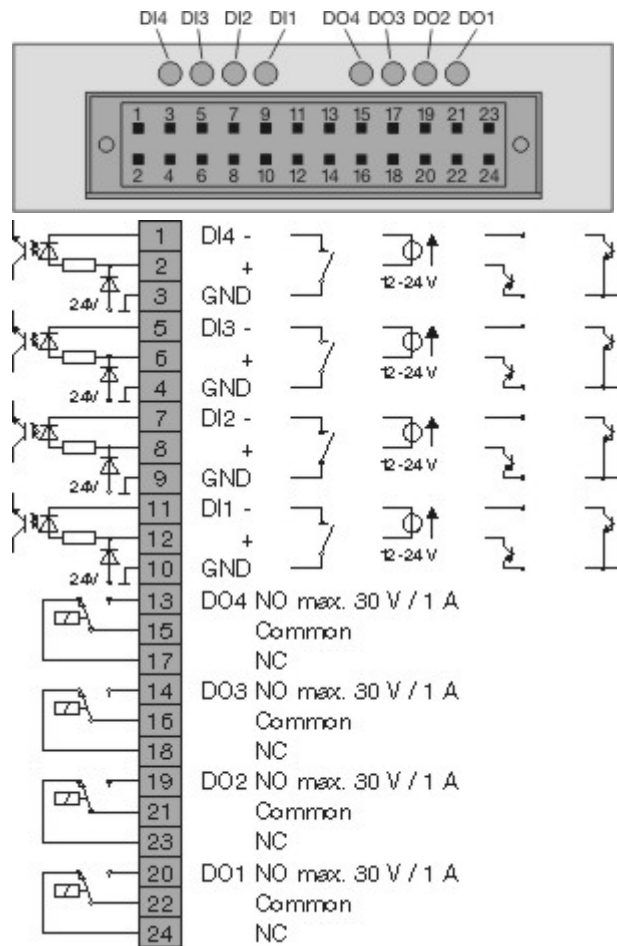

Digital inputs DI1 to DI4

Opto-electronic coupler with 24 V DC. As an alternative, activation by floating contacts with an external voltage of 12 to 24 V DC or by Open-Collector drivers PNP or NPN.

Digital outputs DO1 to DO4

Floating double-throw contacts, max. contact load rating 30 V/1 A. The relays must always be operated within the specified data. Inductive or capacitive loads are to be connected with appropriate protective measures (freewheeling diodes for inductive and series resistors with capacitive loads).

Relays are shown in the unpowered state. The unpowered state corresponds to the state in the event of a fault ("fail safe").

Design

2x12-pole plug-in terminal strip. Please refer to the information about the requisite material (see page 116)!

Connections of the standard function block applications

Status signals/Externally controlled calibration:

	Single status signals:	Overall status signal:
DO1	Failure	Overall status
DO2	Maintenance mode	Limit value
DO3	Maintenance request	Limit value
DO4	External solenoid valve	External solenoid valve
DI1	Start automatic calibration	Start automatic calibration
DI2	Inhibit automatic calibration	Inhibit automatic calibration
DI3	Adjust zero-point	Adjust zero-point
DI4	Adjust end-point	Adjust end-point

Measuring range control:

DO1	Measuring range feedback
DO2	Measuring range feedback
DO3	Measuring range feedback
DO4	Measuring range feedback
DI1	Measuring range switchover
DI2	Measuring range switchover
DI3	Measuring range switchover
DI4	Measuring range switchover

Limit values:

DO1	Limit value
DO2	Limit value
DO3	Limit value
DO4	Limit value
DI1	Calibration cells in/out
DI2	Hold current output
DI3	Pump on/off
DI4	External failure

Calibration control:

DO1	External solenoid valve sample gas
DO2	External solenoid valve zero gas
DO3	External solenoid valve span gas
DO4	External pump on/off
DI1	Pump on/off
DI2	External failure
DI3	External failure
DI4	External failure

Standard terminal connections

Basic principles

The terminal connections are allocated

- in the order of the registered analyzer modules and
- within an analyzer module, in the order of the sample components.

The order of the analyzer modules and sample components is documented in the analyzer data sheet and on the type plate. Beginning with analyzer module 1 and sample component 1, the input and output functions are first of all allocated in turn to available free connections of the I/O modules (slots **-X20** to **-X29**).

Profibus, Modbus

The slot of the optional Profibus module (see page 108) is always **-X20**. The slot of the optional Modbus module (see page 109) is **-X20**, or **-X22** if a Profibus module is present.

Analog outputs

Analog outputs are available at the 2-way analog output module or the 4-way analog output module (see page 110). Analog output is allocated for each sample component in the order of the sample components.

Alarm values

Alarm values are available at the Digital I/O module (see page 112) with the standard function block application "Status signals/ext. calibration" (if the gas analyzer has been set to collective status during the installation of an analyzer module) or on the Digital I/O module with the standard function block application "Alarm values". An alarm value is allocated for each sample component in the order of the sample components.

Standard application "Measuring range control"

Measuring range control can be implemented for all sample components with more than one measuring range. Each Digital I/O module includes

- 4 digital inputs (DI) for the measuring range switch-over and
- 4 digital outputs (DO) for the measuring range feedback signal.

Sample component with	Assignment	DI and DO configuration
2 measuring ranges	1 DI and 1 DO	NO open: Measuring range 1, NO closed: Measuring range 2
3 measuring ranges	3 DI and 3 DO	NO closed: Active meas. range
4 measuring ranges	4 DI and 4 DO	NO closed: Active meas. range

The measuring range control is not installed across I/O modules.

Example: A gas analyzer contains 4 sample components with the following number of measuring ranges:

Sample components	Number of measuring ranges
Sample component 1 (SC1)	3 measuring ranges (MR1, MR2, MR3)
Sample component 2 (SC2)	3 measuring ranges (MR1, MR2, MR3)
Sample component 3 (SC3)	2 measuring ranges (MR1, MR2)
Sample component 4 (SC4)	2 measuring ranges (MR1, MR2)

The following connection assignments result from this:

Assignment for 1st Digital I/O Module	Assignment for 2nd Digital I/O Module
DI/DO 1: SC1: MR1	DI/DO 1: SC2: MR1
DI/DO 2: SC1: MR2	DI/DO 2: SC2: MR2
DI/DO 3: SC1: MR3	DI/DO 3: SC2: MR3
DI/DO 4: SC3: MR1, MR2	DI/DO 4: SC4: MR1, MR2

Connecting the signal lines

NOTES

Follow local regulations on installing and connecting electrical wiring.
Lay the signal lines separately from the power supply lines.
Lay analog and digital signal lines separately from each other.
Mark the cables or mating plugs in such a way that they can be clearly assigned to the corresponding I/O modules.

Requisite material

- Select conductive material which is appropriate for the length of the lines and the predictable current load.
- Notes concerning the cable cross-section for connection of the I/O modules:
 - The max. capacity of terminals for stranded wire and solid wire is 1 mm² (17 AWG).
 - The stranded wire can be tinned on the tip or twisted to simplify the assembly.
 - When using wire end ferrules, the total cross-section may not be more than 1 mm², i.e. the cross-section of the stranded wire may not be more than 0.5 mm². The PZ 6/5 crimping tool of Weidmüller & Co. must be used for crimping the ferrules.
- Max. length of the RS485 leads 1200 m (max. transmission rate 19200 bit/s). Cable type: 3-core twisted-pair cable, cable cross-section 0.25 mm² (e.g. Thomas & Betts, Type LiYCY).
- Max. length of the RS232 leads 15 m.
- The mating plugs (socket housing) for the plug-in terminal strips on the I/O modules are supplied.

Connection box

In the IP-54 version of the system housing, the back of the electronics module is protected with a connection box.

The connection box has:

- EN version: Five M20 and two M32 threaded cable connections
- CSA version: One 1-1¼-inch and two ¾-inch conduits.

Two M32 threaded cable connections are provided to route system bus, Modbus, Profibus and Ethernet cables.

During installation, the clamping range for lines as well as the tightening torques of the cable glands must be observed. The cable glands have several gasket rings which need to be removed as needed depending on the cable diameter.

Cable gland	Clamping range for lines and tightening torque			
	Sealing ring 1+2+3	Sealing ring 1+2	Sealing ring 1	
M20×1.5	Ø 5.5 mm / 1.5 Nm	Ø 7.0 mm / 1 Nm	Ø 7.0 mm / 1.5 Nm	Ø 9.0 mm / 1.4 Nm Ø 9.5 mm / 1.0 Nm Ø 13 mm / 1.7 Nm
M32×1.5	—	—	Ø 14 mm / 3.0 Nm	Ø 17 mm / 4.0 Nm Ø 17.5 mm / 1.5 Nm Ø 21 mm / 1.3 Nm

NOT/CE

Only suited and cable glands and reduction nozzles approved for the Ex Zone may be used as spare parts.

The use of other cable glands and blind plugs lead to a loss of Ex-approval!

Specifications for the selection of cable glands

Thread sizes in the connection box	M20×1.5; M32×1.5
Sealing	Gasketing via sprayed-on sealing ring on the contact surface of the cable gland
Maximum surface roughness of the connection box	max. Ra = 8 µm
Wall thickness range of the connection box	4 to 5 mm

Protective cap

A protective cap is factory-installed on the rear of the electronics module when the Limas21 UV analyzer module is installed in the central unit.

NOTE

It is imperative to re-install the protective cap after connection of the electrical lines. Otherwise light penetration during operation may lead to erroneous measurement values and measurement range overflows.

Connecting the signal lines

- 1** Only for the wall-mount housing (model EL3040): Pass the cables through the screwed cable glands and strip to a length of approx. 20 cm.
M20: Remove the plugs from the insert; and leave the ring in the screwed cable glands for sealing and strain relief.
M32: Remove the plugs from the screwed cable glands. If required, slit open the insert with drill holes from the accessories pack and press over the cable; seal any open drill holes with dowel pins from the accessories pack.
- 2** Connect the lines to the mating plugs as shown in the connection diagrams of the I/O modules.
- 3** Attach the mating plug to the plug-in terminal strips on the I/O modules.

System bus connection

System bus

The functional components of the gas analyzer, i.e. the electronics module, the external I/O devices and the analyzer modules communicate with each other via the system bus.

The system bus structure is linear with a maximum length of 350 m.

One system housing

The system bus connection is established at the factory if the electronics module and an analyzer module are installed in one system housing.

In this case a terminating resistor should be installed in the system bus connector of the electronics module (supplied with the unit).

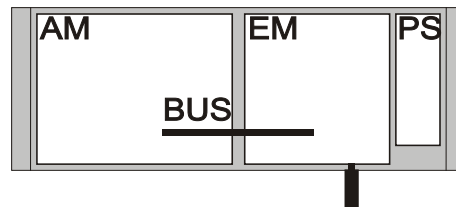

- AM** Analyzer module
- EM** Electronics module
- PS** Power supply
- BUS** System bus (internal)
- Terminating resistor

Multiple system housings

If the electronics module and the analyzer module are accommodated in several system housings, they must be interconnected externally via the system bus.

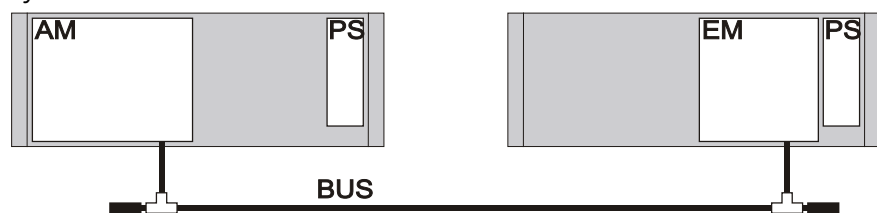

- AM** Analyzer module
- EM** Electronics module
- PS** Power supply
- BUS** System bus (external)
- Terminating resistors

ATTENTION

Only one electronics module should be connected to a system bus structure. Multiple electronics modules should never be interconnected via the system bus!

Requisite material

The required system bus cables, T-joints and terminating resistors are supplied per the order.

ATTENTION

For system bus connections use only the yellow system bus cables, T-joints and terminating resistors. Do not use the violet connectors as they are only for Modbus connections.

The modules should never be interconnected without using T-joints and terminating resistors.

System bus connection

- 1 Place a T-joint on the system bus connection (designated "BUS") of each module (electronics and analyzer).
- 2 Connect the T-joints with the system bus cables.
- 3 Place a terminating resistor on the open ends of each T-piece.

Extension of the system bus cable

Note the following information if using other than the standard system bus cables and plugs to extend the system bus:

- A shielded cable with twisted pairs and the following specifications is to be used as an extension cable.

Number and section of conductors	2 x 2 x 0.25 mm ²
Inductance	approx. 0.67 mH/km
Impedance	approx. 80 Ω
Coupling (1 kHz)	approx. 300 pF/100 m
Operating capacitance	Conductor–conductor approx. 120 nF/km, Conductor–shield approx. 160 nF/km

- For EMC purposes route the system bus cable via metal connection boxes with metallic cable threaded connections. Connect the shield to the threaded connections. Connect the unused wires in the 4-conductor extension cable in the connection box to a PE clamp.

System bus plug layout

(Seen from pin side of cable plug)

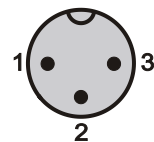

Pin	Wire color	Signal
1	green	System Bus LOW
2	brown	System Bus HIGH
3	white	System Bus GROUND

Adding an analyzer module to the system bus

- 1 Open the internal system bus connection between the existing analyzer module and the electronics module in the gas analyzer.
- 2 Place a T-joint on the system bus connection (designated "BUS") of each module (electronics and analyzer modules).
- 3 Connect the T-joints with the system bus cables.
- 4 Place a terminating resistor on the open ends of each T-piece.
- 5 Set up the added analyzer module.

Several analyzer modules: Connection via the system bus

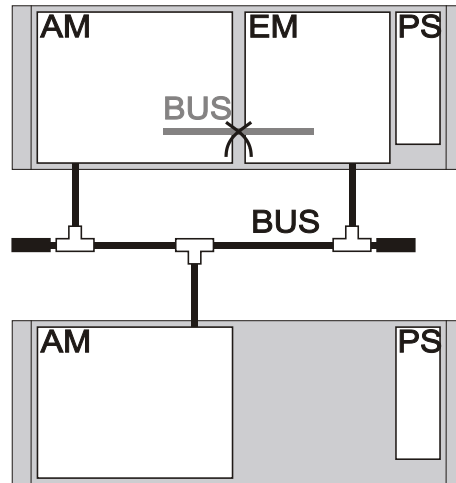

- AM** Analyzer modules
EM Electronics module
PS Power supply
BUS System bus (external)
■ Terminating resistors

Power supply line connection – Safety notes

ATTENTION

Follow all applicable national safety regulations for the installation and operation of electrical devices as well as the following safety precautions. The protective lead (ground) should be attached to the protective lead connector before any other connection is made. The protective lead connection is assured when the power cable supplied is used.

The gas analyzer can be hazardous if the protective lead is interrupted inside or outside the gas analyzer or if the protective lead is disconnected. Only fuses of the specified type and rated current should be used as replacements. Never use patched fuses. Do not short-circuit the fuseholder contacts.

If the power supply fuse fails, some power supply switch components can still carry current.

Never connect line voltage to a 24-VDC analyzer module input. This will destroy the analyzer module electronics.

An easily accessible mains isolator must be installed near the gas analyzer in order to be able to completely disconnect the latter from the power supply. Mark the mains isolator in such a way that assignment to the devices to be separated can be clearly identified.

ATTENTION

Fidas24: The gas analyzer and the analyzer module must be de-energized before the connector of the 115/230 V AC power supply for heating the detector and the heated sample gas connection is connected or disconnected. Otherwise the heating may be damaged.

Power supply line connection to an analyzer module

NOTES

The following information and instructions should be followed when connecting the 24-VDC power supply to an analyzer module that is not installed in the central unit but in a separate system housing. The notes on the power supply (see page 41) must also be considered.

24-VDC connecting cable

If an analyzer module is not installed in the central unit but in a separate system housing a 24-VDC connecting cable (length 5 m (16.4 feet), cross section 2 x 0,5 mm²) will be supplied.



The receptacle on one cable end is designed to connect to the 24-VDC male plug on the analyzer module

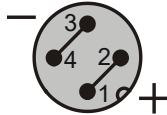

The illustration shows the pin side of the analyzer module plug and thus the solder side of the matching female jack.

The wires on the free end of the connecting cable are intended for connection to

- the power supply filter -Z01 in the central unit or
- an external power supply.

Connecting 24-VDC power from the central unit power supply to a separate analyzer module

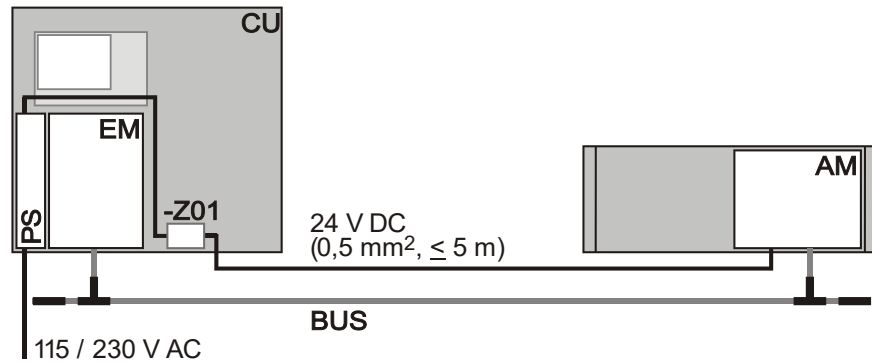

AM	Analyzer module
CU	Central unit
EM	Electronics module
PS	Power supply
-Z01	Power line filter
BUS	System bus

24-VDC connection

- 1 Connect the supplied connection cable with receptacle to the 24-V DC connection on the analyzer module.
- 2 Connect the wires on the free end of the cable to the power supply filter -Z01 in the central unit or to the external power supply.

Extending the 24-VDC connection cable

The 24-VDC connection cable has a wire section of 0.5 mm²; it is limited to a length of 5 meters (16.4 feet).

Note the following conditions if the connection cable has to be extended:

- The extension cable must have a wire section of at least 2.5 mm².
- The extension cable should be no more than 30 meters (100 ft) long.
- The extension cable should be connected as close as possible to the receptacle of the supplied 24-VDC connection cable, i.e. the supplied 24-VDC connection cable should be made as short as possible.

Power supply line connection

Requisite material

The gas analyzer is supplied with a power cord and a separate two-prong grounded plug. The power cord is 5 meters (16.4 feet) long and has a three-prong grounded-instrument plug for connection to the power supply. If the supplied mains lead is not used, select conductive material which is appropriate for the length of the lines and the predictable current load.

Power supply connection

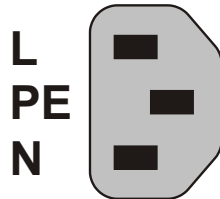

The illustration shows the pin side of the plug in the power supply.

Power supply line connection

- 1 Ensure that the power supply feeder has an adequately dimensioned protective device (circuit-breaker).
- 2 Install an easily accessible mains isolator in the power supply feeder near the gas analyzer, or a switched socket-outlet, in order to be able to completely disconnect the gas analyzer from the power supply if required. Mark the mains isolator in such a way that the assignment of the devices to be disconnected can be clearly recognized.
- 3 Connect the power cord supplied to the **-X01** with grounded-instrument connector on the power supply connector of the electronics module and secure it with the clip.
- 4 Connect the other end of the power cord to the power source.

NOTE

The gas analyzer may start when the power supply is connected.

Connecting equipotential bonding

The electronics module and the analyzer modules have a potential compensation connector designated by the symbol \oplus . The connection has a M5 female thread for screwing in suitable screws or terminals.

Use this connection to link each module to the building's potential compensator in accordance with local regulations.

Fidas24: Power supply line connection

ATTENTION

The gas analyzer and the analyzer module must be de-energized before the connector of the 115/230 V AC power supply for heating the detector and the heated sample gas connection is connected or disconnected. Otherwise the heating may be damaged.

115/230-V-AC connecting cable

A connecting cable is supplied for the 115/230 V AC power supply for heating the detector and, if applicable, the heated sample gas connection (length 5 m, cable cross-section 3 x 1.5 mm²) with a 4-pole socket connector for the connection to the analyzer module.

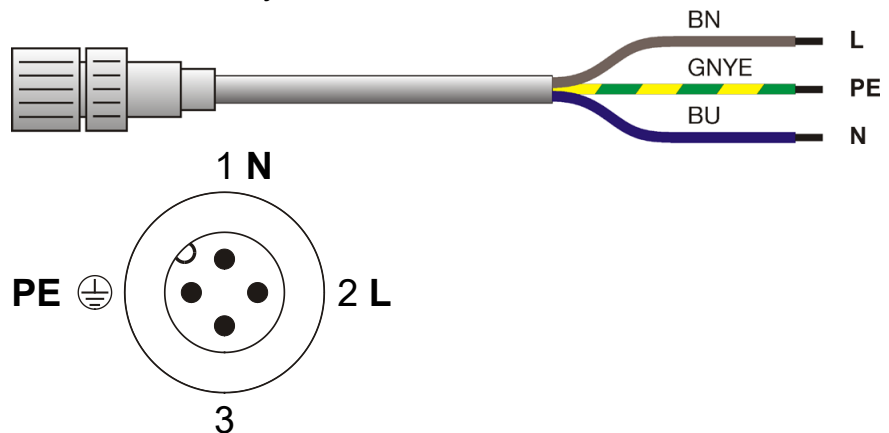

The illustration shows the pin side of the plug **30** in the analyzer module (see page 83).

The operating voltage of the detector heating is automatically detected and switched. The set voltage can be identified through two LEDs on the mains distribution card.

115/230 V AC connection to the analyzer module

- 1 Ensure that the power supply feeder has an adequately dimensioned protective device (circuit-breaker).
- 2 Install an easily accessible mains isolator in the power supply feeder near the gas analyzer, or a switched socket-outlet, in order to be able to completely disconnect the heating of the detector and the heated sample gas connection from the power supply if required. Mark the mains isolator in such a way that the assignment of the devices to be disconnected can be clearly recognized.
- 3 Make sure that the gas analyzer and the analyzer module are de-energized.
- 4 Attach the supplied 115/230-V-AC connecting cable with the 4-pole socket connector to the power supply connection **30** of the analyzer module and screw tight.
- 5 Connect the wires on the free end of the power cable to the power supply.

Gas analyzer start-up

Installation check

Installation check

Check that the gas analyzer has been correctly installed before the starting it up.

Test	✓
Is the gas analyzer securely fastened (see page 79)?	<input type="checkbox"/>
Are all gas lines including that of the pressure sensor correctly connected (see page 80)?	<input type="checkbox"/>
Have all the signal, control and interface lines, the power supply lines and, if applicable, the system bus been correctly laid and connected (see page 107)?	<input type="checkbox"/>
Are all devices needed for gas conditioning, calibration and waste gas disposal correctly connected and ready for use?	<input type="checkbox"/>

Gas path and housing initial purge

Purge before commissioning

The gas paths and if necessary, the system housing should be purged prior to starting the gas analyzer.

Firstly this ensures that the gas paths and system housing are free from contaminants e.g. corrosive gases, and accumulations of dust on start-up.

Secondly this prevents any explosive gas/air mixture present in the gas paths or system housing being ignited when the power supply is connected.

Purge gas

Nitrogen or instrument air should be used as a purge gas.

Purge gas flow rate during initial purge

The purge gas flow and the duration of the purge process depend on the volume to be purged (see the following table). If the purge gas flow is lower than specified, the duration of the purging must be extended accordingly.

Volume to be purged	Purge gas flow rate	Duration
Gas path	100 l/h (max.)	approx. 20 s
Central unit with or without analyzer module	200 l/h (max.)	approx. 1 h
Analyzer separately: Caldos25, Caldos27, Magnos206, Magnos28, Magnos27	200 l/h (max.)	approx. 3 min

NOTE

The purge gas flow rates given in the table only apply to the initial purge. Other values apply during operation (see page 137).

ATTENTION

Purge gas can escape from the housing if there are any leak points. When using nitrogen as the purge gas, take all required precautions against suffocation.

The purge gas flow must always be restricted upstream of the purge gas inlet! If the purge gas flow is not restricted until after the purge gas outlet, the full pressure of the purge gas will affect the housing seals which can destroy the operator panel keypad!

Power supply activation

NOTE

The gas analyzer may not be calibrated until the warm-up phase has been concluded.

Power supply activation

- 1 Turn on the power supply of the gas analyzer with the external breaker switch.
- 2 If necessary, turn on the separate 24-VDC power supply of the analyzer module.
- 3 The following events will occur after the power supply is turned on:
 - 1 The three "Power", "Maint" and "Error" LEDs light up.
 - 2 The different booting phases are displayed on the screen. Also the software version is displayed.
 - 3 After a brief time the screen switches to measurement mode.
 - 4 The softkey  appears on the screen. This indicates the possibility of a temperature or flow problem during the warm-up phase. By pressing the softkey the user can recall the status message summary and view status message details.

Fidas24: Gas analyzer start-up

Gas analyzer start-up

Switch on the power supply, heating-up phase, feed in supply gases

- 1 Switch on the power supply of the gas analyzer and the heaters of the Fidas24.
If the analyzer module is not installed in the central unit, switch on the separately installed 24 V DC supply of the analyzer module.
- 2 The following events will occur after the power supply is turned on:
 - 1 The three "Power", "Maint" and "Error" LEDs light up.
 - 2 The different booting phases are displayed on the screen. Also the software version is displayed.
 - 3 After a brief time the screen switches to measurement mode.
 - 4 The softkey  appears on the screen. This indicates the possibility of a temperature or flow problem during the warm-up phase. By pressing the softkey the user can recall the status message summary and view status message details.
- 3 Select the Controller measured values menu item:
MENU → Diagnostics/Information → Module-specific → Controller Measured Values
Amongst other things, the controlling variables of the temperature regulator are displayed in this menu option:
T-Re.D Detector temperature
T-Re.E Temperature of the heated gas connection
T-Re.K Temperature of the internal combustion air preparation
TR.VV1 Temperature of the preamplifier
The temperature values slowly increase after the power supply is switched on.
- 4 Feed in instrument air, combustion air and combustion gas (H₂ or H₂/He mixture). Adjust the pressure to the value specified in the Analyzer Data Sheet with the corresponding external pressure regulator.

- 5 The controlled variables of the internal pressure regulator are also displayed in the Controller measured values menu item; the pressures of the supply gases are set by means of the controlled variables:

MGE Pressure at the sample gas nozzle

MGA Pressure in the combustion chamber (outlet)

C-Air Combustion air

C-Gas Combustion gas (H₂ or H₂/He mixture)

To begin with, any values can be displayed for the controlled variables. The values are updated for the first time approx. 10 s after selecting the menu option and then approx. every 10 s. The pressure control is in progress in the background. It may take some time to set the pressures depending on the setting of the inlet pressure.

The gas analyzer automatically reverts to the measurement mode to display values if the operator has not pressed a key in menu mode in the last five minutes.

- 6 The following status messages are active during the heating-up phase:
"Operating temperature": the temperature of the detector has not yet reached the threshold.

"Flame error": the flame has not yet ignited.

"Temperature limit value 1, 2": the temperature of the detector (T-Re.D) and possibly of the heated sample gas connection (T-Re.E) is over or below the upper or lower limit value 1 (2).

"Pressure limit value 1, 2": the pressure at one of the internal pressure regulators for instrument air (inlet, outlet), combustion air (air) or combustion gas (H₂) is over or below the upper or lower limit value 1 (2).

- 7 As soon as the temperature of the detector reaches the threshold value (150 °C) the corresponding solenoid valve in the analyzer module automatically switches off the instrument air. The negative pressure regulation and the combustion air regulation attempt to adjust the pressures to the respective setpoint.
The sample gas begins to flow through the analyzer after the instrument air is connected.

- 8 After the pressures have been adjusted to the respective setpoint, the respective solenoid valve in the analyzer module automatically connects the combustion gas. The combustion gas regulation attempts to adjust the pressure to the setpoint.

Adjustment of the controlled variables of the internal pressure regulators

If the analyzer module is not automatically put into service with the pressure values specified in the analyzer data sheet, the controlled variables of the internal pressure regulators must be adjusted. If the controlled variables of the internal pressure regulators deviate, the inlet pressures of instrument air, combustion air and combustion gas must be changed (steps 9 to 11).

- 9 Instrument air: use the external pressure regulator to set the controlled variable for Outlet to approx. 60 % (max. 70 %).
Controlled variable too high ⇒ reduce pressure.
Controlled variable too low ⇒ increase pressure.
(The controlled variable for Inlet depends on the sample gas flow rate.)
- 10 Combustion air: use the external pressure regulator to set the controlled variable for Air to approx. 55 % (max. 60 %).
Controlled variable too high ⇒ reduce pressure.
Controlled variable too low ⇒ increase pressure.
- 11 Combustion gas: use the external pressure regulator to set the controlled variable for H₂ to approx. 42 % (max. 52 %).
Controlled variable too high ⇒ increase pressure.
Controlled variable too low ⇒ reduce pressure.

Ignition of the flame

12 The flame ignites automatically:

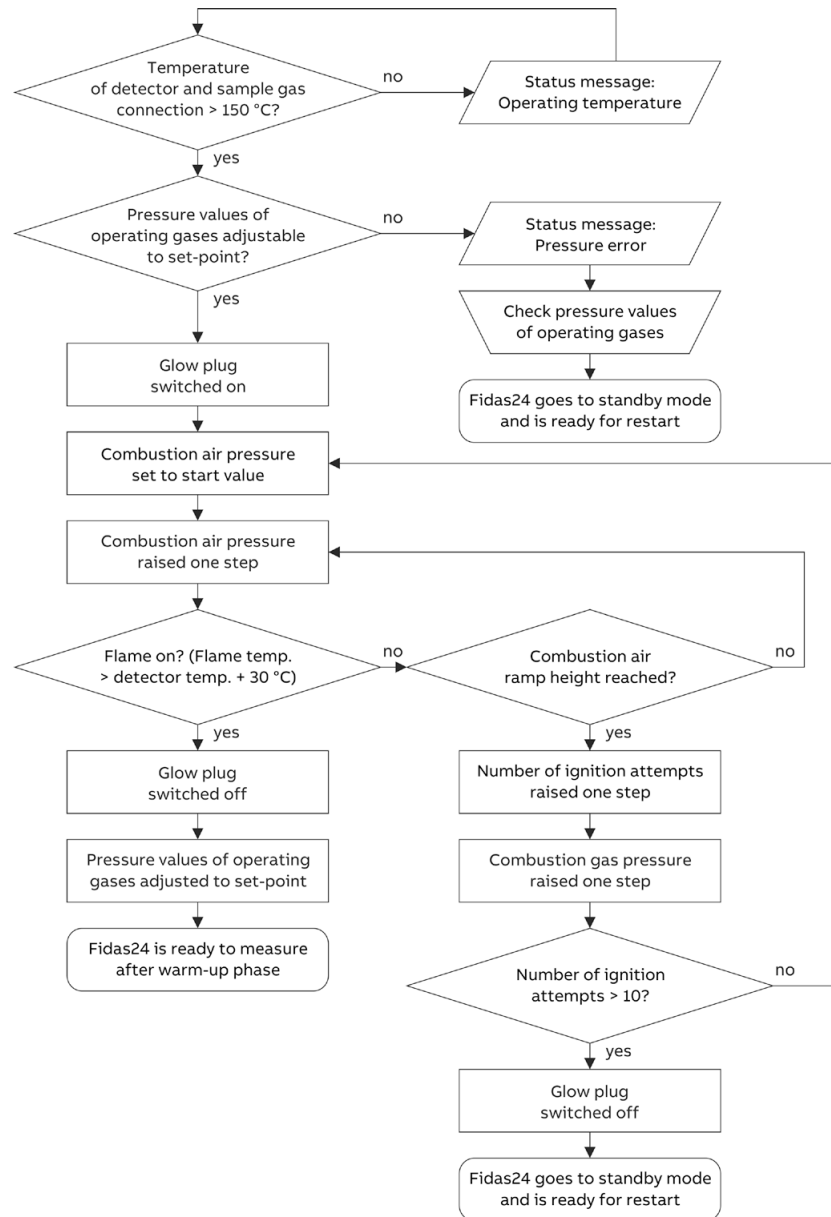

Depending on the number of ignition attempts, the flame can take up to 10 minutes to ignite.

Depending on the length of the combustion gas supply line, it is possible that not enough combustion gas is available to ignite the flame at first during the initial start-up of the gas analyzer. In this case, the ignition of the flame must be restarted in the menu Standby/Restart FID.

The temperature of the flame is displayed in the Raw measured values auxiliary variables menu option in the Flame parameter; the flame is regarded as "on" when the flame temperature is at least 30 °C higher than the detector temperature.

The actual start-up of the gas analyzer is concluded with the ignition of the flame.

Restarting the gas analyzer

- 1 Feed in instrument air and combustion air and purge the gas analyzer **for at least 20 minutes.**
- 2 Turn on the gas analyzer power supply.
- 3 Turn on the combustion gas supply and check the combustion gas pressure.
- 4 Carry out a seal integrity test on the combustion gas line (see page 142).
- 5 Turn on the sample gas supply.

ATTENTION

The gas analyzer and the analyzer module must be de-energized before the connector of the 115/230 V AC power supply for heating the detector and the heated sample gas connection is connected or disconnected. Otherwise the heating may be damaged.

The cover of the heated sample gas terminal is hot during operation. It reaches a temperature of more than 70 °C!

Limas21 HW: Gas analyzer start-up

Gas analyzer start-up

- 1 Turn on the gas analyzer power supply.
- 2 Wait for the warm-up phase to end. Wait at least 2 hours until the temperature of the heated sample gas line has stabilized at 180 °C.
- 3 Purge the complete sample gas feed path (sample gas line and gas analyzer) for at least 1 h with clean and dust-free ambient air.
- 4 Turn on the sample gas supply.

ZO23: Gas analyzer start-up

Gas analyzer start-up procedure, initial calibration at the installation site

- 1** Turn on the gas analyzer power supply.
After approx. 15 minutes, the sample cell has reached its operating temperature. If required, the gas analyzer can be calibrated at the reference point (see step 3) and the end-point (see step 5).
- 2** For setting the reference point (= electrical zero), feed ambient air and wait until the measured value has stabilized (duration approx. 2 hrs). Meanwhile, purge the test gas valves and the gas supply line with oxygen-free gas (e.g. with nitrogen from a loop feeder) or with sample gas (flow rate 5 to 10 l/h).
- 3** Set reference point to 20.6 vol.% of O₂.
- 4** Feed span gas and wait until the measured value has stabilized (duration max. 2 hrs.).
- 5** Set end-point value in accordance with the certificate of analysis of
- 6** The gas analyzer is ready for performing measurements; feed sample gas.

NOTE

Information for test gases can be found in the section "ZO23: Preparation for installation" (see page 68).

Warm-up phase

Warm-up phase

The duration of the warm-up phase depends on which analyzer module is installed in the gas analyzer.

Analyzer module	Duration of the warm-up phase
Caldos25	1.5 hours
Caldos27	30/60 minutes for class 1/2 measurement ranges ¹⁾
Fidas24	≤ 2 hours
Fidas24 NMHC	≤ 2 hours
Limas11 IR	Approx. 2.5 hours
Limas21 UV	Approx. 2.5 hours
Limas21 HW	Approx. 4 hours
Magnos206	≤ 1 hour
Magnos28	≤ 1 hour
Magnos27	2 to 4 hours
Uras26	Approx. 0.5/2 hours without/with thermostat
ZO23	Approx. 15 minutes

1) See "AO2000 Series" data sheet (publication number DS/AO2000-EN) for class details.

NOTES

The warm-up phase can take longer if the gas analyzer was not brought to room.

During the warm-up phase measurement values can be outside the ranges specified in the data sheet.

Warm-up phase duration

The warm-up phase is deemed to be over when the measured value drift indication is acceptable. This depends on the size of the measurement range.

NOTE for Fidas24

Unused sample gas lines and sampling probes can release hydrocarbons after the first start-up over a longer period. Therefore, it can take a longer time until the measured value drift has reached an acceptable value.

Operation

Ready to perform measurements

At the end of the warm-up phase the gas analyzer is ready to carry out measurements.

Verify the calibration

The gas analyzer is calibrated ex works. However, transport stresses and the pressure and temperature conditions at the installation site may influence the calibration. Thus it is recommended to verify the gas analyzer calibration at the installation location.

Turn on the sample gas supply

The sample gas supply should be turned on only after calibration.

Adjusting sample gas flow rate

Analyzer module	Sample gas flow rate
Caldos25	10 to 90 l/h (for option T90 < 6 s: max. 90 to 200 l/h)
Caldos27	10 to 90 l/h min. 1 l/h
Fidas24	80 to 100 l/h with atmospheric pressure (1000 hPa)
Fidas24 NMHC	80 to 100 l/h with atmospheric pressure (1000 hPa)
Limas11 IR	20 to 100 l/h
Limas21 UV	20 to 100 l/h
Limas21 HW	20 to 90 l/h
Magnos206	30 to 90 l/h
Magnos28	30 to 90 l/h
Magnos27	20 to 90 l/h
Uras26	20 to 100 l/h
ZO23	5 to 10 l/h The flow rate must be kept constant to ± 0.2 l/h in this range. The sample gas must be taken from a bypass at zero pressure.

Adjusting reference gas flow rate

In the Caldos25 and Uras26 analyzer module versions with flowing reference gas, the sample gas flow rate and the reference gas flow rate must be set to the optimal value.

For special applications of the Caldos25 the reference gas flow rate must be set to lower values down to 1 l/h.

Adjusting purge gas flow rate

The purge gas flow rate should be set as follows in gas analyzers with the housing purge capability:

Purge gas flow rate at device inlet max. 20 l/h (constant), purge gas positive pressure: $p_e = 2$ to 4 hPa.

For a purge gas flow rate at the device inlet of 20 l/h, the purge gas flow rate at the device outlet is approx. 5 to 10 l/h.

Fidas24: Housing purge during operation

A part (approx. 600 to 700 l/h) of the instrument air for the air jet injector is conducted continuously through the housing as purge air.

Date and time check

A correct date and time setting is required for proper operation of functions such as automatic calibration and logging of error messages.

- 1 Select the Date/Time menu item:
MENU → Configure → System → Date/Time
- 2 Check and, if necessary, correct the date and time.

NOTE

The gas analyzer is factory-set to the GMT+1 time zone.

Menu tree

Menu tree

Menu		
Calibrate		
Manual calibration	0	
Automatic calibration	0	
Configure		
Component specific	0	
Measurement range	1	
Filter	2	
Pressure controller	1	
Aurorange	1	
Alarm values	0	
Active component	2	
Module text		
Calibration data	1	
Manual calibration	1	
Automatic calibration	1	
Ext. controlled cal.	1	
Output current response	1	
Function blocks	3	
Miscellaneous	3	
Inputs	3	
Outputs	3	
Mathematics	3	
Multiplexer/Demultiplexer	3	
Measurement	3	
Sample system	3	
Calibration/Correction	3	
System	2	
Date/Time	2	
Language		
Change password		
Setup system modules	2	
Save configuration	1	
Status signals	2	
Network	2	
Display	2	
Maintenance/Test		
System		
Atm. pressure	2	
Display test	0	
Keyboard test	0	
Analyzer spec. adjustm.		
Pump	1	
Atm. press. anz	2	
Calibration reset	1	
Basic calibration	2	
Measure cal. cell	1	
Optical adjustm.	2	
Phase adjustm.	2	
Relinearization	2	
Amplification optimization	2	
Cross sensitivity adjustm.	2	
Carrier gas adjustm.	2	
Electr. zero cal. FID	2	
Restart FID	1	
Diagnostics/Information		
System overview	0	
Module specific		
Raw values	0	
Auxiliary raw values	0	
Status	0	
Controller values	0	
Lamp intensity	0	
Uras26 Status	0	
Logbook	0	

For reasons of brevity only the top level parameters and functions are shown; the menu branches more extensively at most menu items, e.g. into the various measurement components or into the selection and adjustment of values.

Some menu items are analyzer-specific, i.e. they only appear when particular analyzer modules are integrated into the gas analyzer.

Password levels

For each menu item its password level (0, 1, 2, 3) is shown in the table.

For some menu items, individual sub-menu items are on a higher password level. These apply especially to those sub-menu items which allow access to function block applications.

Remark: The "Change password" menu item is not assigned to a specific password level.

Inspection and maintenance

ATTENTION

The tasks described in this chapter require special training and under some circumstances involve working with the gas analyzer open and powered up. Therefore, they should only be performed by qualified and specially trained personnel.

Checking gas path seal integrity

When should gas paths checked for seal integrity?

Gas path seal integrity should be checked periodically. It must be verified after the gas paths inside or outside the gas analyzer have been opened (e.g. after removing or installing an analyzer module).

Requisite material

1 pressure gauge, 1 plastic tubing, (3 feet in length), 1 T-piece with shut-off valve, air or nitrogen

CAUTION

If the seal integrity test is to be carried out with air and there is the possibility of a combustion gas being present in the gas paths or if a combustion gas is to be introduced later, the gas paths should first be purged with nitrogen. Otherwise seal integrity test can be performed with nitrogen.

NOTE

The following instructions apply to all gas paths in the gas analyzer, therefore to all sample gas paths and – in the Caldos25 and Uras26 analyzer modules – to the reference gas path.

Checking gas path seal integrity

Example: Sample gas path in Magnos27

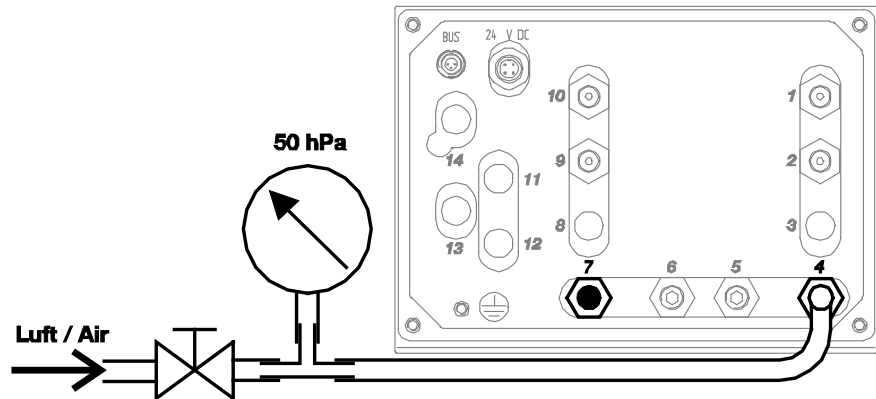

- 1 Seal the outlet of the gas path to be tested (7 in the example) so it is gas-tight.
- 2 Connect plastic tubing with the T-piece fitted with a shut-off valve to the inlet of the gas path to be tested (4 in the example).
- 3 Connect the free end of the T-piece to the pressure gauge.
- 4 Blow air or nitrogen through the shut-off valve until the sample gas feed path is under a positive pressure of $p_e \approx 50 \text{ hPa}$ ($= 50 \text{ mbar}$). Close the shut-off valve. Maximum positive pressure $p_e = 150 \text{ hPa}$ ($= 150 \text{ mbar}$).
Limas11 IR, Limas21 UV, Limas21 HW with quartz sample cell: Gauge pressure $p_e \approx 400 \text{ hPa}$ ($= 400 \text{ mbar}$), Maximum positive pressure $p_e = 500 \text{ hPa}$ ($= 500 \text{ mbar}$).
- 5 The pressure should not change measurably in 3 minutes (pressure drop $\leq 3 \text{ hPa}$). A sharp pressure drop is a sign of a leak in the gas path being tested.
Limas11 IR, Limas21 UV, Limas21 HW with quartz sample cell: Test duration 15 minutes.
- 6 Repeat steps 1 to 5 for all gas paths in the gas analyzer.

Fidas24: Checking the combustion gas supply line for seal integrity

ATTENTION

The seal integrity test described in this section should only be performed by qualified and specially trained personnel. If these conditions are not provided or the prescribed materials are not available, a seal integrity test must be carried out by ABB after sales service.

Regular seal integrity check of the combustion gas supply line

The seal integrity of the combustion gas supply line must be checked regularly according to one of the two following instructions, depending on whether the combustion gas is supplied from a cylinder or from a central unit.

Combustion gas from a cylinder

- 1 Switch off the gas analyzer power supply. Ensure that the shut-off valve in the combustion gas supply line is open.
- 2 Set the combustion gas pressure to 1.1 x the normal pressure of the combustion gas, i.e. approx. 1.4 bar.
- 3 Mark cylinder pressure indication on the high pressure gauge.
- 4 Close the valve of the combustion gas cylinder.
- 5 The display on the high pressure gauge – it should not change measurably in 10 minutes.
A measurable change in the display is an indication of a leak in the combustion gas feed path, between the cylinder pressure reducer and the combustion gas inlet valve of the gas analyzer. In this case, the following measures must be taken:
 - 1 Check the combustion gas line between the cylinder and gas analyzer with a leak-detecting spray. A leak in this area must be remedied and another leak test must be performed before the gas analyzer is put into operation again.
 - 2 If a leak cannot be found in the combustion gas line, the combustion gas inlet valve of the gas analyzer is leaking. **In this case, the gas analyzer may not be returned to service on any account!** The combustion gas inlet valve must be replaced by ABB Service.
- 6 After conclusion of the seal integrity test, set the combustion gas pressure to normal pressure again, i.e. 1.2 bar.

Combustion gas supply from a central unit

- 1 Switch off the gas analyzer power supply. Ensure that the shut-off valve in the combustion gas supply line is open.
- 2 Set the combustion gas pressure at 1.1 x the normal pressure of the combustion gas, i.e. at approx. 1.4 bar.
- 3 Mark pressure indication on the gauge of the pressure reducer.
- 4 Shut off the combustion gas supply.
- 5 Observe the display on the pressure gauge – it should not change measurably in 10 minutes.

A measurable change in the display is an indication of a leak in the combustion gas path between the pressure reducer and the combustion gas inlet valve of the gas analyzer. In this case the following measures are to be taken:

- 1 Check the combustion gas line between the pressure reducer and gas analyzer with a leak detection spray. A leak in this area must be remedied and another leak test must be performed before the gas analyzer is put into operation again.
- 2 If no leak is found that means the gas analyzer combustion gas inlet valve is leaky. **In this case, the gas analyzer may not be returned to service on any account!** The combustion gas inlet valve must be replaced by ABB Service.
- 6 After conclusion of the seal integrity test, set the combustion gas pressure to normal pressure again, i.e. 1.2 bar.

Fidas24: Checking the combustion gas feed path in the gas analyzer for seal integrity

ATTENTION

The seal integrity test described in this section requires special training and under some circumstances involves working with the gas analyzer open and powered up. Therefore, it must only be performed by qualified and specially trained personnel. If these conditions are not provided or the prescribed materials are not available, a seal integrity test must be carried out by ABB Service.

Regular seal integrity check of the combustion gas path in the gas analyzer

The gas analyzer must be in operation (flame on).

- 1** Inspection of combustion gas feed path with positive pressure (combustion gas inlet to combustion gas nozzle):
With a leak detector (measurement principle thermal conductivity) sniff all the connection points.
- 2** Inspection of the combustion gas feed path with negative pressure (in the detector, after the combustion gas nozzle):
Connect zero gas at the sample gas inlet.
Envelope all the connection points one after the other with a small gas cloud containing hydrocarbons (e.g. with coolant or test gas containing hydrocarbons or an acetone-soaked rag).
Observe the measured value display while doing so; if there is a positive change in the measured value, the connection concerned is leaking.

If there is a leak, shut down the gas analyzer

If a leak has been established in the combustion gas feed path inside the gas analyzer, **the gas analyzer must be put out of operation; it may under no circumstances be put into operation again.** The cause of the leak must be determined and remedied by ABB Service.

Dynamic QR code

Application

Dynamic QR Code is a unique feature to display dynamically generated QR codes on the gas analyzer screen.

The QR code contains static information for device identification as well as dynamically generated information on system configuration and gas analyzer health status .

Static data for device identification are among other data:

- Production number
- Production date
- Software version
- Serial numbers of built-in analyzer modules and components

Dynamic data for error diagnosis are among other data:

- Status messages
- Measured values
- Temperature, pressure and flow values
- Drift values
- Analyzer-specific values

In combination with mobile devices (smartphone, tablet, etc.) Dynamic QR Code represents an innovative way of customer's communication which allows, for instance, improved case-specific support by ABB resulting in an increased availability of analyzer assets.

Dynamic QR Code is compatible with the ABB application "my Installed Base" as well as with standard QR code scanner applications.

Handling

The QR code is selected in the gas analyzer's diagnosis menu and displayed on the gas analyzer's screen.

There is a direct link from the status messages overview to the diagnosis menu. In addition, the QR code can be selected in Remote HMI and scanned from the computer screen.

The displayed QR code is scanned using the QR code scanner application installed in the mobile device. The resulting text information displayed on the mobile device's screen is then sent by e-mail or a suitable messenger service to the local service representative defined in the "Measurement Care" agreement.

As an alternative, a photo of the displayed QR code can be sent to the service representative.

Select QR code

Menü path

Menu → **Diagnosis/Info.** → **QR Code Display**

Procedure

- 1 Select system overview or specific analyzer module.
- 2 Select QR code with **ENTER**.
- 3 Scan QR code.
- 4 Return to selection with **Back**.

The diagnosis menu can be selected directly from the status messages overview.

The QR code can also be selected in Remote HMI and scanned from the computer screen.

Recommended QR code scanner applications

ABB recommends the use of the following QR code scanner applications (available free of charge for iOS and Android):

"my Installed Base" by ABB

Download in App Store:



Download in Google Play:



"QR Scanner" by Kaspersky

Download in App Store:



Download in Google Play:



Gas analyzer shutdown and packing

Gas analyzer shutdown

Gas analyzer shutdown

In the case of a temporary shutdown:

- 1 Turn off the sample gas supply and reference gas supply, if applicable.
- 2 Purge the gas lines and gas feed paths in the analyzer module with dry fresh air or nitrogen for at least 5 minutes.
Limas21 HW: Purge sample gas feed path gas lines and gas feed paths in the analyzer module with at least with clean and dust-free air for at least 1 hour.
- 3 Switch off the gas analyzer power supply.

In the case of a long-term shutdown, carry out the following in addition:

- 4 Remove the gas lines from the gas analyzer ports. Tightly seal the gas ports.
- 5 Disconnect the electrical leads from the gas analyzer.

Fidas24: Gas analyzer shutdown

In the case of a temporary shutdown:

- 1 Turn off the sample gas supply.
- 2 Purge sample gas line with nitrogen for at least 5 minutes from the sampling point.
- 3 Set the gas analyzer to standby operation. In case of corrosive and flammable gases set the gas analyzer to standby operation with detector purging.
- 4 Shut off combustion air supply and combustion gas supply.

In the case of a long-term shutdown, carry out the following in addition:

- 5 Shut off instrument air supply.
- 6 Switch off the gas analyzer power supply.
- 7 Remove the gas lines from the gas analyzer ports. Tightly seal the gas ports.
- 8 Disconnect the electrical leads from the gas analyzer.

Fidas24: Gas analyzer restart

- 1** Feed in instrument air and combustion air and purge the gas analyzer **for at least 20 minutes**.
- 2** Turn on the gas analyzer power supply.
- 3** Turn on the combustion gas supply and check the combustion gas pressure.
- 4** Carry out a seal integrity test on the combustion gas line (see page 142).
- 5** Turn on the sample gas supply.

See also the instructions in the section "Fidas24: Gas analyzer start-up" (see page 130).

Ambient temperature

Ambient temperature during storage and transport: -25 to +65 °C

Packing the gas analyzer

ATTENTION

Depending on its design, the gas analyzer weighs from 18 to 25 kg! Two persons are needed for removal.

Packing the gas analyzer

- 1 Remove the system bus terminating resistor from the electronics module and secure it to the housing, e.g. with adhesive tape. If the terminating resistor remains in the electronics module it can be broken during shipment causing damage to the resistor as well as to the system bus ports on the electronic module.
- 2 In the IP-54 version of the system housing close off the connection box cable openings by inserting the appropriate plates.
- 3 Remove adapters from the gas ports and tightly seal the gas ports.
- 4 If the original packaging is not available, wrap the gas analyzer in bubble wrap or corrugated cardboard. When shipping overseas, additionally shrink-wrap the gas analyzer air-tight in 0.2 mm thick polyethylene film adding a drying agent (such as silica gel). The amount of drying agent should be appropriate for the package volume and the expected shipping duration (at least 3 months).
- 5 Pack the gas analyzer in an adequately sized box lined with shock-absorbing material (foam or similar). The thickness of the shock-absorbing material should be adequate for the weight of the gas analyzer and the mode of dispatch. When shipping overseas, additionally line the box with a double layer of bitumen paper.
- 6 Mark the box as "Fragile Goods".

Ambient temperature

Ambient temperature during storage and transport: -25 to +65 °C

CAUTION

When you return the gas analyzer to the service department, e.g. for repair, please state which gases have been supplied to the gas analyzer. This information is needed so that service personnel can take any requisite safety precautions for harmful gases.

Disposal

Notes for disposal

Products that are marked with the adjacent symbol may not be disposed of as unsorted municipal waste (domestic waste). They should be disposed of through separate collection of electric and electronic devices.



This product and its packaging are manufactured from materials that can be recycled by specialist recycling companies.

Bear the following in mind when disposing of this product and its packaging:

- This product is under the open scope of the WEEE Directive 2012/19/EU and relevant national laws.
- The product must be supplied to a specialist recycling company. Do not use municipal waste collection points. These may be used for privately used products only in accordance with WEEE Directive 2012/19/EU.
- If there is no possibility to dispose of the old equipment properly, ABB service can take care of its pick-up and disposal for a fee. To find your local ABB service contact visit abb.com/contacts or call +49 180 5 222 580.

ABB Measurement & Analytics

For your local ABB contact, visit:
www.abb.com/contacts

For more product information, visit:
www.abb.com/analytical

We reserve the right to make technical changes or modify the contents of this document without prior notice. With regard to purchase orders, the agreed particulars shall prevail. ABB does not accept any responsibility whatsoever for potential errors or possible lack of information in this document.

We reserve all rights in this document and in the subject matter and illustrations contained therein. Any reproduction, disclosure to third parties or utilization of its contents – in whole or in parts – is forbidden without prior written consent of ABB.