

BATTERY CHARGER

BORDLINE® BC_24V

Battery charger for Electrical Multiple Unit



The BORDLINE® BC battery charger is a compact, lightweight unit designed to charge the batteries and supply DC loads.

—
BORDLINE® BC_24V
for Electrical Multiple Unit

System overview

The battery charger is based on modern SiC power semiconductor technology.

BORDLINE® BC_24V contains:

- N°3 BORDLINE BC power modules
- EMI filter and rectifier for AC inputs
- Simplified power factor correction (PFC) stage to adjust current and voltage phase
- Resonant DC/DC converter providing galvanic isolation
- Digital control based on microprocessor/DSP
- Customer Interface based on MVB
- Speed controlled ultra-long-life fans for cooling (inside BORDLINE BC power modules)

Functionality

The BORDLINE® BC battery charger is fed by a three phase AC input and generates a DC voltage to charge the vehicle batteries and/or supply DC loads. The device is configured to start up as soon as the supply line is present (dead battery start). The converter operates at high switching frequencies allowing for low ripple voltage and compact build size. Charging characteristics can be made battery temperature dependent using the provided temperature sensing input.

Characteristics

- High power density and compact design
- Built with silicon carbide (SiC) power semiconductors
- Three phase AC voltage input
- Integrated active output diode
- Customized cabinet
- Efficiency > 95 %
- Full redundancy to increase output power and functionalities availability

Technical data	BORDLINE® BC_24V
AC Voltage Input	3 x 400 Vac, 50 Hz
DC Voltage Output	24 Vdc (16,8...30 Vdc)
Max DC Output Power	17 kW
Protection degree	IP20
Operating temperature range	-25°...+70°
TCMS interface	MVB
Diagnostic Interface	MVB, CANOpen
Dimension	600 x 650 x 588 mm
Weight	65 kg

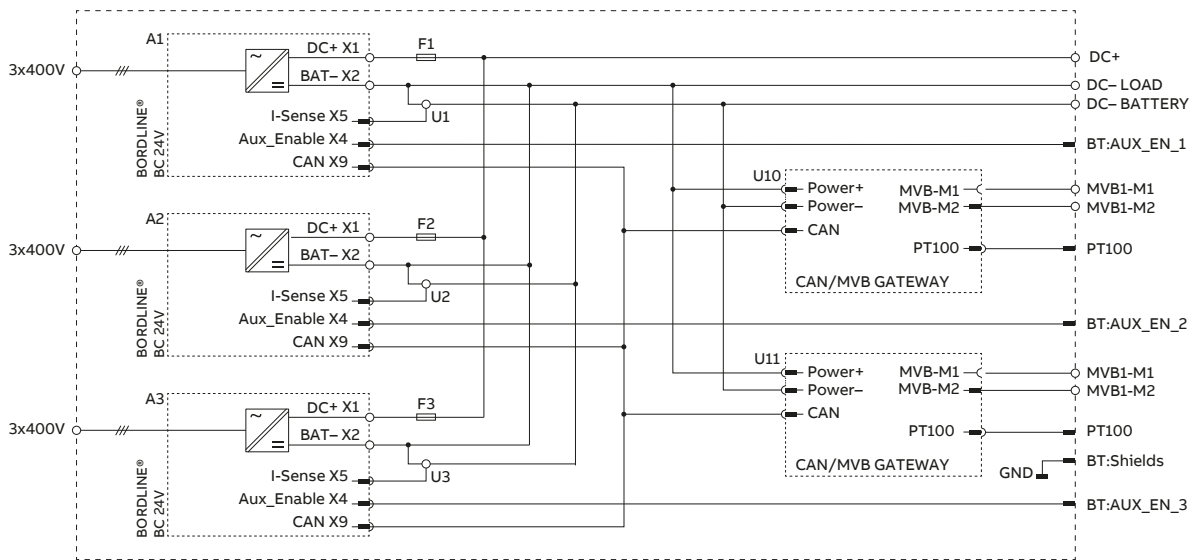

01

01 Block diagram of BORDLINE[®]BC_24V

Control and monitoring

The converter is fully digital controlled by using a digital signal processor (DSP). The control unit monitors voltages, currents and internal temperatures to protect the device. External overload conditions such as short circuit, excessive ambient temperature, overvoltage are handled safely. The driver electronics supply the trigger signals for the power semiconductors and are also responsible for the protection of the power semiconductors. All outputs are short-circuit proof.

Control interface

Monitoring of the battery charger is provided by means of a redundant MVB interface; configuration is based on CANOpen protocol.

Cooling system

Each BORDLINE BC module is cooled by forced air. Fan speed is controlled by the needs of the device (depending on load conditions and current ambient temperature).

Mechanical design

The converter is mounted inside train machine room at both ends of the train (Two units for each train). It is installed on bearing slide to allow an easy mounting procedure. All electrical interfaces are located on the back for easy and fast extraction of the mechanical assembly.

Diagnostics and service

For maintenance, a diagnostic information (such as current loading, temperature, errors and warnings) is provided via MVB interface. Additional diagnostic interface for each BORDLINE BC module, via CANOpen interface.

Application example

BORDLINE BC_24V has been installed in regional EMU trains running in Italy for revamping projects.