

Why use a Retort Control System ?

- ▶ Retorting (thermal processing) destroys organisms which generate spoilage spores and harmful bacteria (e.g. thermophiles).
- ▶ Overcooking canned food adversely affects both taste and appearance, while undercooking can result in spoilage.
- ▶ Some cans, because of their size and internal pressure, will distort if exposed to atmospheric pressure immediately after being cooked. These cans must be pressure cooled before the retort pressure is reduced to atmospheric. (Cooling is achieved by circulating cool water through the retort while maintaining the cooking pressure in the retort.)
- ▶ The product should be cooled as rapidly as possible to prevent overcooking and to minimize retort production time.
- ▶ Automatic control of retort systems allows the plant to operate independently and maximises output.

Why use ABB Instrumentation ?

- ▶ ABB are a market leader in Retort Control Systems
- ▶ Proven reliability and system integrity – over 100 years of process instrumentation experience.
- ▶ Comprehensive range of products suitable for all monitoring and control requirements.

What ABB Products are Suitable ?

- ▶ COMMANDER 1900 Recorder/Controllers.
- ▶ COMMANDER 300/310 Controllers.
- ▶ MODCELL Advanced Controllers.
- ▶ 600T Pressure transmitter
- ▶ TIP Current to pressure converters

Retorts and the Canning Process

The food processor provides a sterile and palatable canned product that is prepared by cooking, at some value of temperature, for a specified time. Processing is done in batches using a cylindrical pressurized vessel called a retort. A retort is classified as either vertical or horizontal depending on the position of its long axis. Vertical retorts are loaded from the top, while horizontal retorts are loaded from one end.

Product in metal containers is cooked under pressure in a steam atmosphere. Following the cooking period, cooling water is circulated through the retort while cooking pressure is maintained. When the contents in the containers has been cooled sufficiently so as not to cause distortion, the pressure in the retort is relieved.

Control System Objective

The objective of the control system is to control the time, temperature and pressure within the retort for the canning cycle. This is essential in order that food can be properly preserved.

Objective

- ▶ The retort control system can be divided into three major groups of components:
- ▶ Temperature control system used to control product temperature during the cook period.
- ▶ Cycle control components used to control On/Off types of functions and timing portions of the cycle.
- ▶ Pressure control to maintain cook pressure during the pressure cool period.
- ▶ The various control functions are described best by discussing them as they appear in the normal sequence of events of a standard control cycle. The control cycle is graphically displayed below.
- ▶ After the retort is loaded with can-filled retort baskets the cover, or lid, is screwed down and the cycle is started.

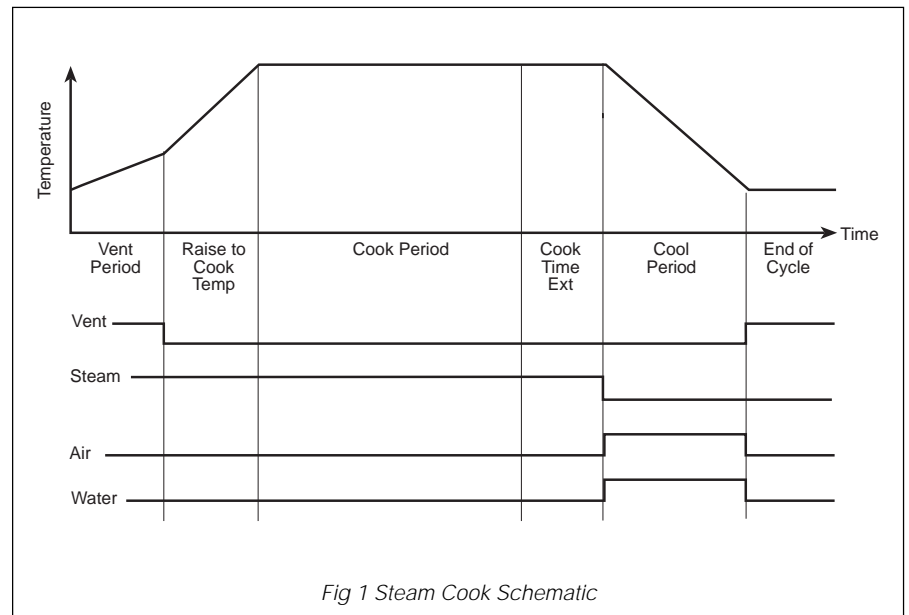

Fig 1 Steam Cook Schematic

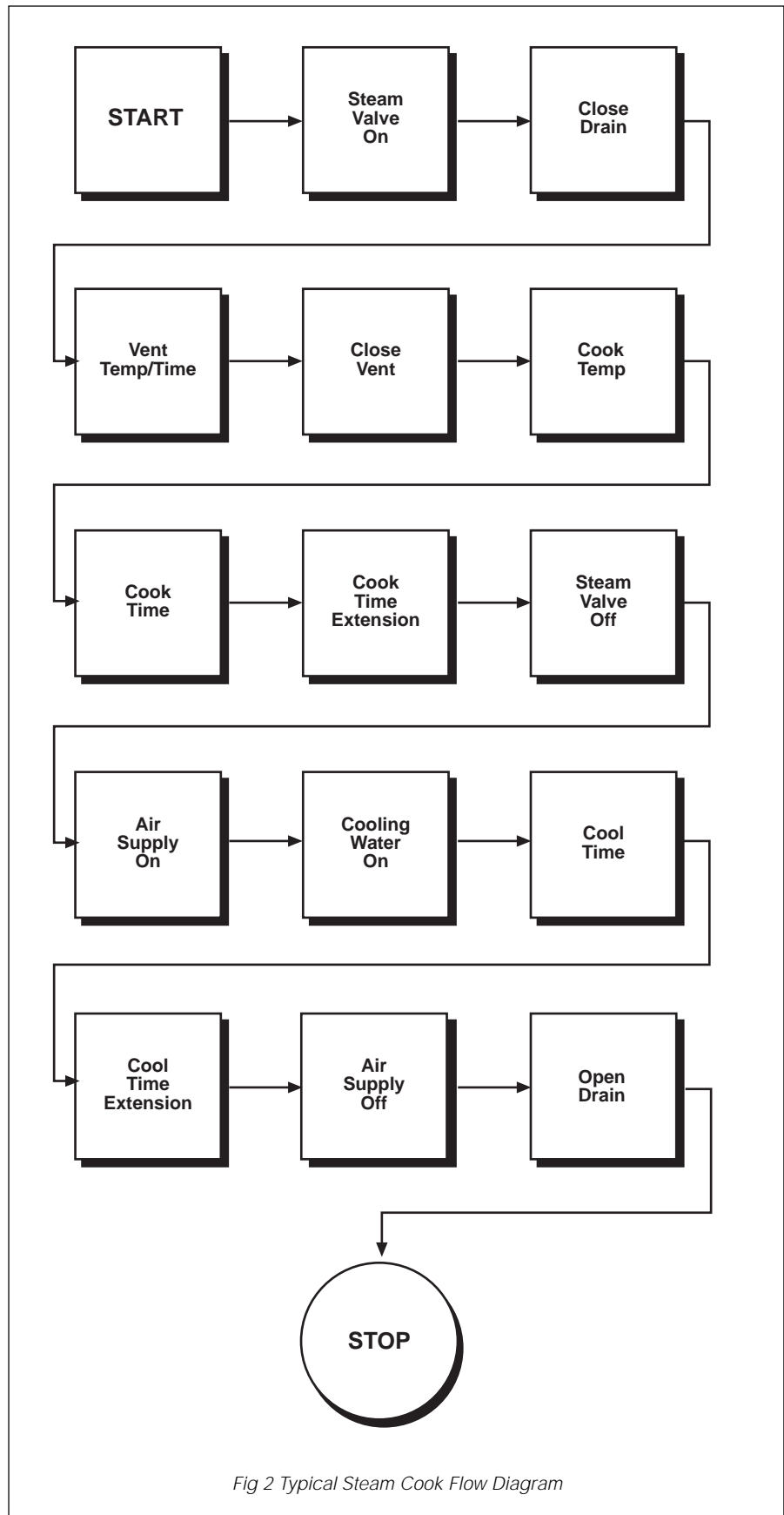

Fig 2 Typical Steam Cook Flow Diagram

Process Description

Vent Period

Steam is used to purge the air from the retort. This is important to ensure uniform cooking throughout the retort. Proper venting occurs when steam is blown through the retort for a preset time period and the retort temperature reaches a required value. Both time and temperature conditions must be realized before venting is considered complete.

Refer to Figures 3a and 3b. When the cycle is initiated, the steam valve, TCV-I, and the vent valve, VCV-I, are fully opened. Steam purges air from the retort through the vent valve until the vent timer, KS-2, times out, and the vent temperature switch, TSH-I, is closed. This energizes the solenoid valve, KY-I, which applies the air pressure required to close the vent valve, VCV-I.

Raise to Cook Temperature Period

When the vent valve closes, the retort temperature reaches the preset cook temperature very quickly. When the desired retort temperature is reached, the temperature controller, TIC-I, output to the steam valve, TCV-I, is reduced, the steam throttled back and the temperature controller begins maintaining correct temperature for the cook period.

Cook Period

The reduction in controllers output pressure is detected by a pressure switch, PSL-I, inside the temperature controller and its contact closure activates the cook timer, KS-I. This timer controls the period of time during which the product is held at cooking temperature.

It is most essential that the cook period timing begins when the retort temperature reaches the preset control point. Overcooking canned food adversely affects both taste and appearance, whereas, undercooking can result in spoilage.

Pressure Cool Period

Some cans, because of their size and internal pressure, will distort when exposed to atmospheric pressure immediately after being cooked. These cans must be pressure cooled before the retort pressure is reduced to atmospheric. Cooling is done by circulating cool water through the retort while maintaining the cooking pressure in the retort.

The product is cooled as rapidly as possible to prevent overcooking and to minimize retort production time. When the cook timer, KS-I, times out, its contacts close to activate solenoid valve, KY-2, which supplies air to the pressure controller, PIC-I.

Because of different valving arrangements, the control of the vertical retort, during the pressure cool period, is different from the control of the horizontal retort.

...Process Description (cont'd)

Vertical Retort

In the case of the vertical retort, the pressure controller controls the retort pressure by operating the pressurizing air valve, PCV-1, and the vent valve VCV-1. At the same time the pressure controller is activated, the cooling water valve, TCV-2, is opened. Cooling water enters the retort through this valve and exits through the vent

Horizontal Retort

In the case of the horizontal retort, the pressure controller controls the retort pressure by operating pressurizing air valve, PCV-1, and overflow valve, PCV-2. At the same time the pressure controller is activated, the cooling water valve, TCV-2, is opened. Cooling water enters the retort through this valve and exits through the overflow valve.

To prevent loss of the cook pressure in the retort, the rate at which cooling water is initially introduced is limited. The cooling period is terminated when the cooling water exiting from the retort drops to a predetermined value. The temperature is detected by the low temperature switch, TSL-1.

Pressure Relief Period

At the conclusion of the pressure cool period, the retort pressure must be relieved before the retort can be opened and emptied. The pressure relief period is initiated when the cooling water temperature switch, TSL-1, contacts close to shut off the air supply to the pressure controller. The vertical retort is vented through the vent valve; the horizontal retort is vented through the overflow valve.

End of Cycle

The retort is opened by the operator, who either removes the retort baskets and places them in a cooling area or manually introduces additional cooling water into the retort to cool the cans prior to removing the baskets. After the retort has been emptied, the next baskets of cans scheduled for cooking are loaded and the cycle is repeated.

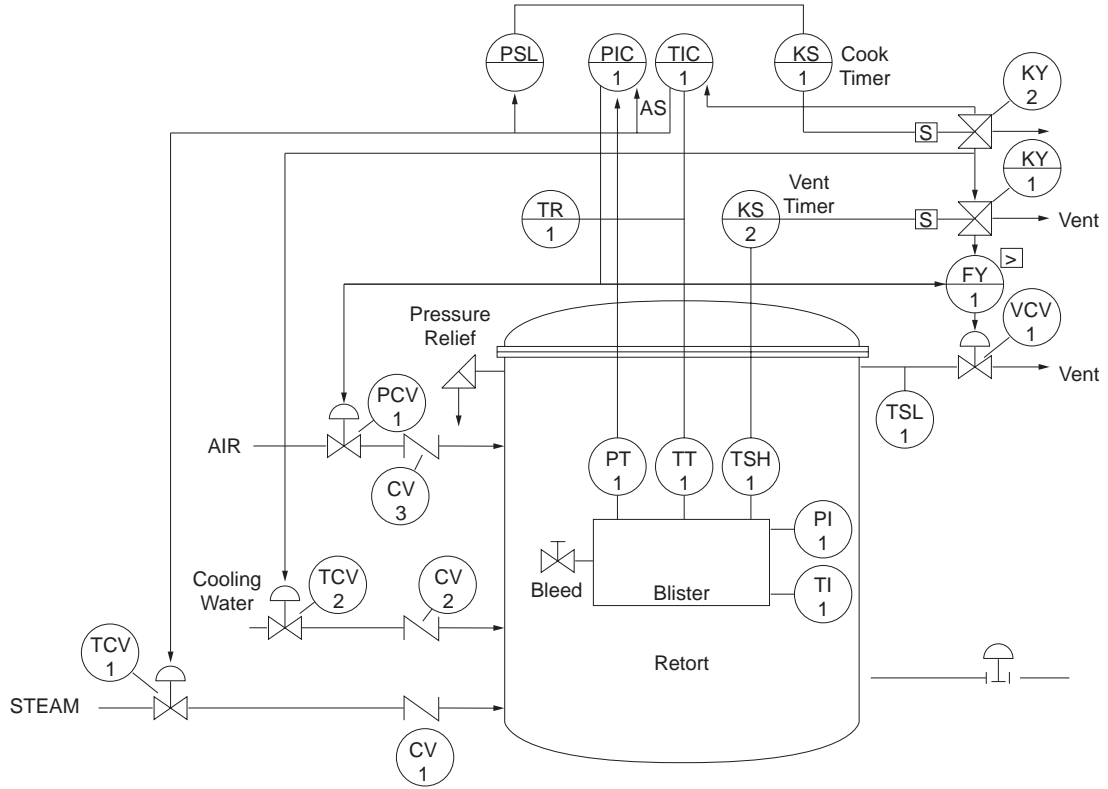

Fig 3a Retort Control – Vertical Retort

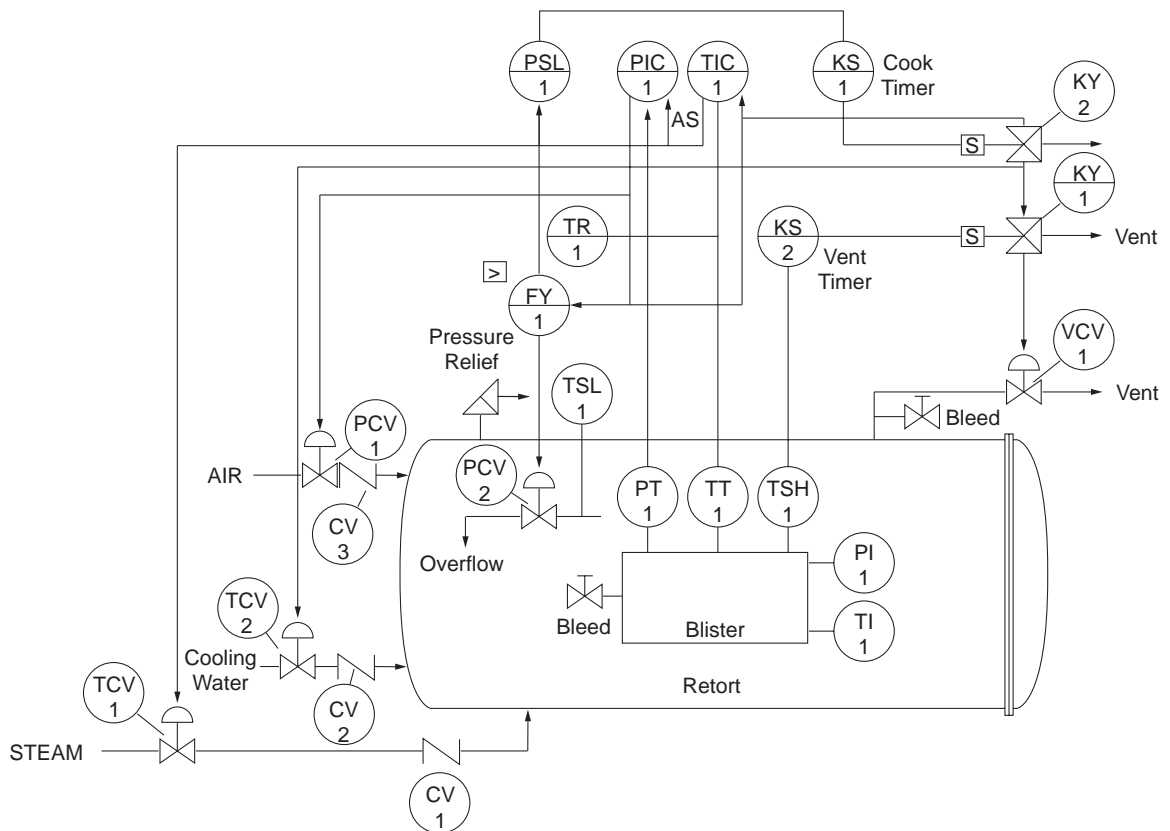

Fig 3b Retort Control – Horizontal Retort



ABB Kent-Taylor Ltd.

St. Neots
Cambs.
England, PE19 3EU
Tel: +44 (0) 1480 475321
Fax: +44 (0) 1480 217948

ABB Instrumentation Inc.

PO Box 20550, Rochester
New York 14602-0550
USA
Tel: +1 716 292 6050
Fax: +1 716 273 6207

ABB Kent-Taylor SpA

22016 Lenno
Como
Italy
Tel: +39 (0) 344 58111
Fax: +39 (0) 344 56278

The Company's policy is one of continuous product improvement and the right is reserved to modify the information contained herein without notice.

© ABB 1997

(8.97)